



Samuel Chamberlain
WITH DIXON'S TYPHONITE ELDERADO

BELL-TOWERS OF ROSTOV CATHEDRAL

TECHNIQUE USED

This drawing is made on Strathmore Paper, principally with the 3B Typhonite Eldorado pencil. Darkest tones blocked in with a 6B, and shadows washed in with wedge-shaped B pencil. Light texture tones are washed in with a 2H, worn to a flat, smooth edge.

"WILIGHT AND EVENING BELL"

From the scorching path of battle stands the cathedral of the Assumption in Rostov Veliki. Samuel Chamberlain here pictures the great bells and domes typical of seventeenth century Russia. Still safe today, the ancient bells continue to ring in the time. Sixth in the 1943 Eldorado-Chamberlain series brought to you by Pencil Sales Dept. 225-J11, SEPH DIXON CRUCIBLE CO., JERSEY CITY 3, N. J.

TYPHONITE ELDERADO

PC Glass Blocks

FOR HOMES DESIGNED WITH AN EYE TO THE FUTURE

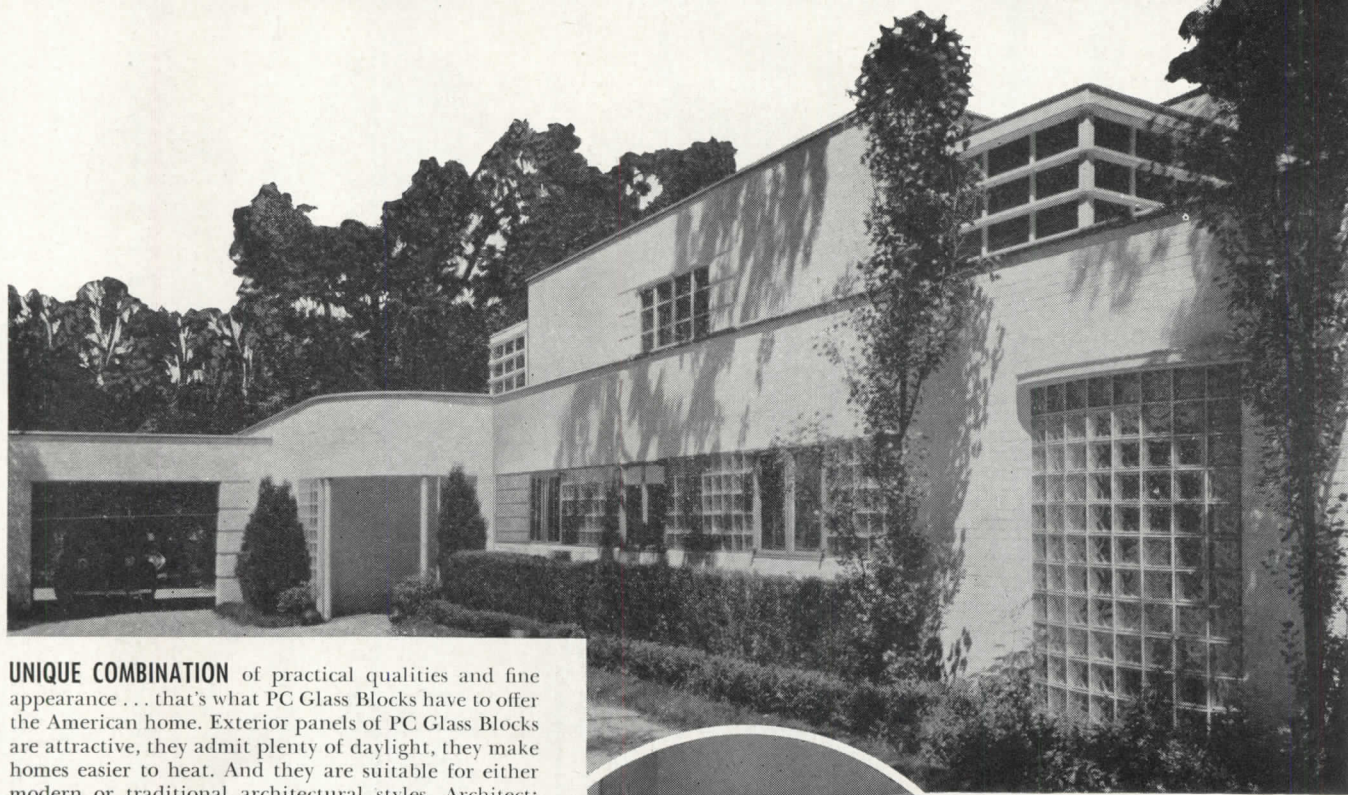

UNIQUE COMBINATION of practical qualities and fine appearance . . . that's what PC Glass Blocks have to offer the American home. Exterior panels of PC Glass Blocks are attractive, they admit plenty of daylight, they make homes easier to heat. And they are suitable for either modern or traditional architectural styles. Architect: Philip B. Maher.

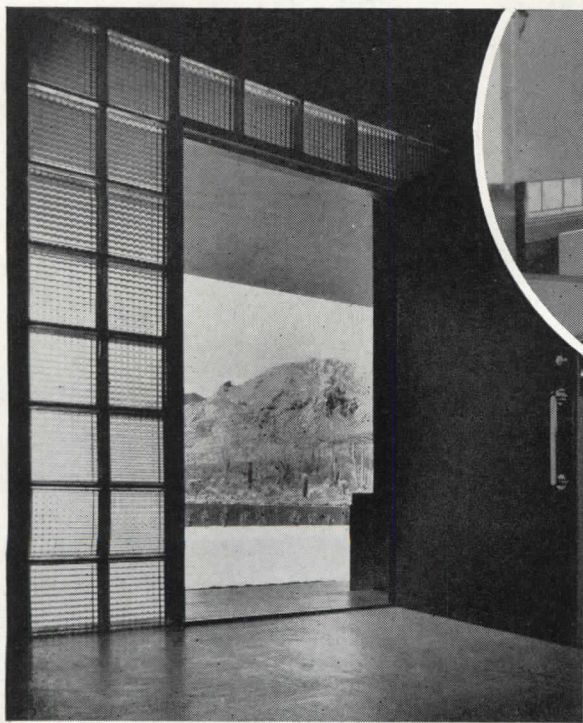

KITCHEN CORNER, practical style . . . but very good-looking, too. PC Glass Blocks flood stove and adjacent work surfaces with light. They also keep out prying eyes.



GLASS BLOCKS

Distributed by
PITTSBURGH PLATE GLASS COMPANY
and by *W. P. Fuller & Co.* on the Pacific Coast

PITTSBURGH CORNING CORPORATION
GRANT BUILDING - PITTSBURGH, PA.

A CHEERFUL FRAME for any entrance door is a course or two of PC Glass Blocks. They help to solve the problem of lighting the entrance hall by day . . . and by night, indoor illumination streams through them to charm the passerby.



Lightweight aluminum doors—easy to open and fine in appearance—nourish the invitation proffered by attractive building fronts and intriguing store windows. Alert merchandisers recognized this fact and, before the war sidetracked all aluminum for military uses, aluminum doors were gaining great popularity.

The lightness of aluminum has made this versatile metal equally popular

for many other architectural uses. With aluminum spandrels, for example, construction proceeds faster because there's so much less weight to handle. Aluminum skylights, enclosures, marquees, and so on, are lighter, saving on erection and material costs.

In preparing your postwar plans, count on giving your clients the advantages to be gained by using aluminum. ALUMINUM COMPANY OF AMERICA, 2167 Gulf Building, Pittsburgh, Pennsylvania.

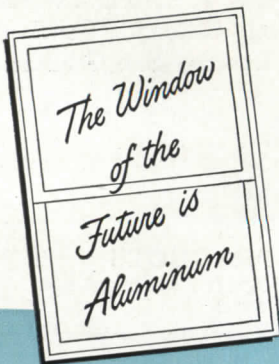

ALCOA ALUMINUM



Reg. U. S. Pat. Off.

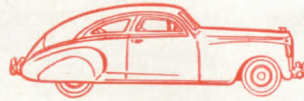

ULTRA-MODERN OR TRADITIONAL

Your clients can still enjoy

Byers Radiant Heating

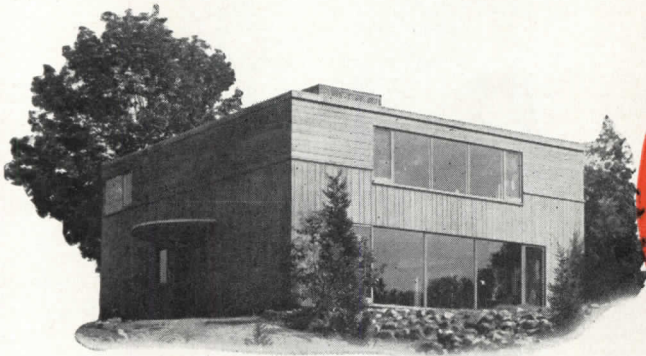

One of the most important things to remember about Byers Radiant Heating is that application is not limited to any particular style of architecture or type of construction.

The ultra-modern whose dream home is a blue-print of the most advanced design for living, and the conservative citizen whose tastes incline to the vine-covered cottage, can both have Byers Radiant Heating . . . as the pictures above very definitely show.

Both homes are located in Massachusetts, and so are exposed to the famous New England winters. Both are basementless, having been constructed on a concrete mat in which Byers Wrought Iron pipe coils are placed. Both were completed early in 1942, and so have gone through a complete heating season.

The cottage at right is 1-story, 4-room, cost \$5,000 and has a wood floor, nailed to sleepers be-

tween which the heating coils are laid. The structure at left is 6-room, 2-story, and cost \$10,000. The first floor heating coils are embedded in concrete. On the second story, they are installed under wood flooring.

The occupants of both homes are enthusiastic about the comfort and the economy of Radiant Heating. These houses illustrate another very important point, also: the adaptability of Byers Radiant Heating not only to any architectural treatment, but to a wide price range.

Because Byers Radiant Heating means Byers Wrought Iron in the coils, comfort and economy advantages are protected. The combination of high purity base metal and

glass-like silica slag fibers in wrought iron retard the speed of corrosion, and diffuse its attack. The superior durability of the material has been repeatedly demonstrated.

Our technical bulletin, "Byers Wrought Iron for Radiant Heating Installations," digests much helpful information on the subject. Several jobs have been installed with no other instruction. We will be glad to send you a copy . . . and to answer any questions you may have in connection with specific projects.

A. M. Byers Company. Established 1864. Offices in Pittsburgh, Boston, New York, Philadelphia, Washington, Chicago, St. Louis, Houston, Seattle, San Francisco.

Corrosion costs you more than Wrought Iron

BYERS
GENUINE WROUGHT IRON
TUBULAR AND HOT ROLLED PRODUCTS
ELECTRIC FURNACE ALLOY STEELS • OPEN HEARTH ALLOY STEELS
CARBON STEEL TUBULAR PRODUCTS

ARCHITECTURAL RECORD

COMBINED WITH AMERICAN ARCHITECT AND ARCHITECTURE

VOL. 94

NO. 5

NOVEMBER • 1943

CONTENTS

COVER: Ranch House in California (see pages 75-80) (Julius Shulman photograph)	
YOU CAN START YOUR BUILDING NOW!	41
An Editorial . . . by Kenneth K. Stowell	
PRACTICAL URBAN REDEVELOPMENT	42
By Thomas S. Holden. A practical alternative to proposals that the federal government finance assembly of property for redevelopment.	
PLANNED FOR CARGO PLANES	47
Plant for Curtiss-Wright Corp., Louisville, Ky. Albert Kahn Associated Architects and Engineers, Inc.	
WORTHY IDEAS FROM WARTIME HOUSING	55
Normont Terrace Housing Project, Los Angeles, Cal. Winchton L. Risley, Stanley R. Gould, Architects.	
PROGRESS IN HOUSE PLANNING	61
. . . BUILDING TYPES STUDY NO. 83	
1. Flexibility Under the Roof. By Douglas Haskell.	
2. Arched Roof Structure Gives Convertibility. Paul Lester Wiener, J. L. Sert, Paul Schultz.	
3. Vacation House. House for Frank Belcher, Saratoga, Cal. William Wilson Wurster, Architect.	
4. Cross-Contour Placing with a Purpose. House on San Francisco Bay for Mr. and Mrs. Oliver B. Lyman. William Wilson Wurster, Architect.	
5. "Cool Calmness" with Innovations. Twin Ranch Houses for the Maurice Berkson Family, at Encino, Cal. J. R. Davidson, Designer.	
6. Electrified Traditional. House for C. W. Stuart, Southport, Conn. Victor Civkin, Architect.	
TIME-SAVER STANDARDS . . . Household Closets	83
Part I: Basic Elements	
THE RECORD REPORTS . . . News from the field	7
REQUIRED READING . . . Reviewed by Elisabeth Coit, A.I.A.	26
FOR BETTER BUILDING . . . News of materials, equipment and methods	88
INDEX TO ADVERTISEMENTS	122

H. JUDD PAYNE, Vice-President in charge of Magazine Division



Copyright 1943 with all rights reserved F. W. DODGE CORPORATION

EDITOR-IN-CHIEF, Kenneth Kingsley Stowell, A.I.A.; **Managing Editor,** Emerson Goble; **Associate Editor,** Douglas Haskell; **Associate in South America,** Edmund J. Whiting, A.I.A.; **Desk Editor,** Florence A. van Wyck; **Art Director,** W. K. Allen.

CONSULTANTS: Industry Relations Consultant: Thomas S. Holden. Statistical Consultant: Clyde Shute. Building Economics Consultant: Norbert Brown. Field Research Consultant: Clifford Dunnells, Jr.

Architectural Record (combined with American Architect and Architecture) is published monthly by F. W. Dodge Corporation, 34 No. Crystal St., East Stroudsburg, Pa., with Editorial and Executive Offices at 119 West 40th Street, New York, N. Y. **Thomas S. Holden,** Pres.; **Howard J. Barringer,** Vice-Pres. and Treas.; **Irving W. Hadsell,** Vice-Pres.; **Chauncey L. Williams,** Vice-Pres.; **Sanford D. Stockton, Jr.,** Secy.; **Walter F. De Saix,** Asst. Treas.; **Edwin H. Freed,** Asst. Treas. Member Audit Bureau of Circulation and Associated Business Papers, Inc. Architectural Record is indexed in Reader's Guide, Art Index and

Industrial Arts Index. Subscription rates: United States and Possessions, Canada, Cuba, Mexico, Central and South America, \$3 the year, \$5 for two years, \$6 for three years; elsewhere, \$5 the year; single copy, \$1. Circulation Mgr.: Elisabeth Chandler. Every effort will be made to return material submitted for possible publication (if accompanied by stamped, addressed envelopes); but the editors and the corporation will not be responsible for loss or damage. **Other Dodge Services:** Real Estate Record & Builders' Guide, Sweet's Catalog Files, Home Owner's Catalogs, Dodge Reports & Dodge Statistical Research Service.

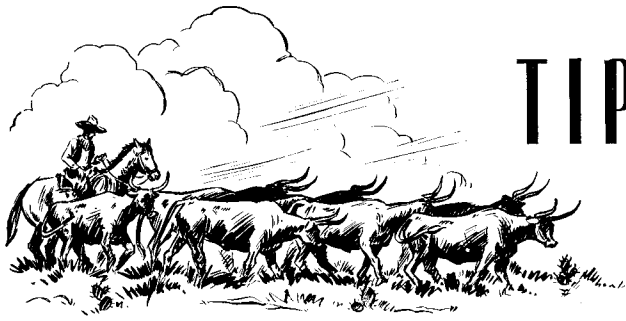

TIPS ON TOMORROW *from* TEXAS

★ Probably the most recently completed of all skyscrapers is the new Mercantile Bank Building in Dallas, Texas.

Designed to anticipate the banking needs and the requirements of modern business for years to come in a lusty, growing city, this new skyscraper has been termed by some "the building of tomorrow".

New materials, new ideas and the latest thoughts on functional design found widespread use in this forward-looking building. In keeping with its use of the finest in equipment, Watrous Flush Valves were installed throughout.

In this choice of Watrous there is further evidence that for postwar buildings, more and more attention will be given to the selection of flush valves that—

- (a) can be readily adjusted to give maximum water savings with each individual fixture.
- (b) provide a simple, single-step method of servicing.
- (c) can be supplied with efficient, enduring silent-action equipment.

In planning buildings for tomorrow, you can count on Watrous for dependable flush valves that will match fully the latest developments in building construction.

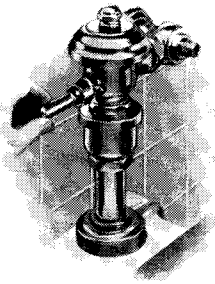

THE IMPERIAL BRASS MFG. CO.
1240 W. Harrison Street, Chicago 7, Illinois

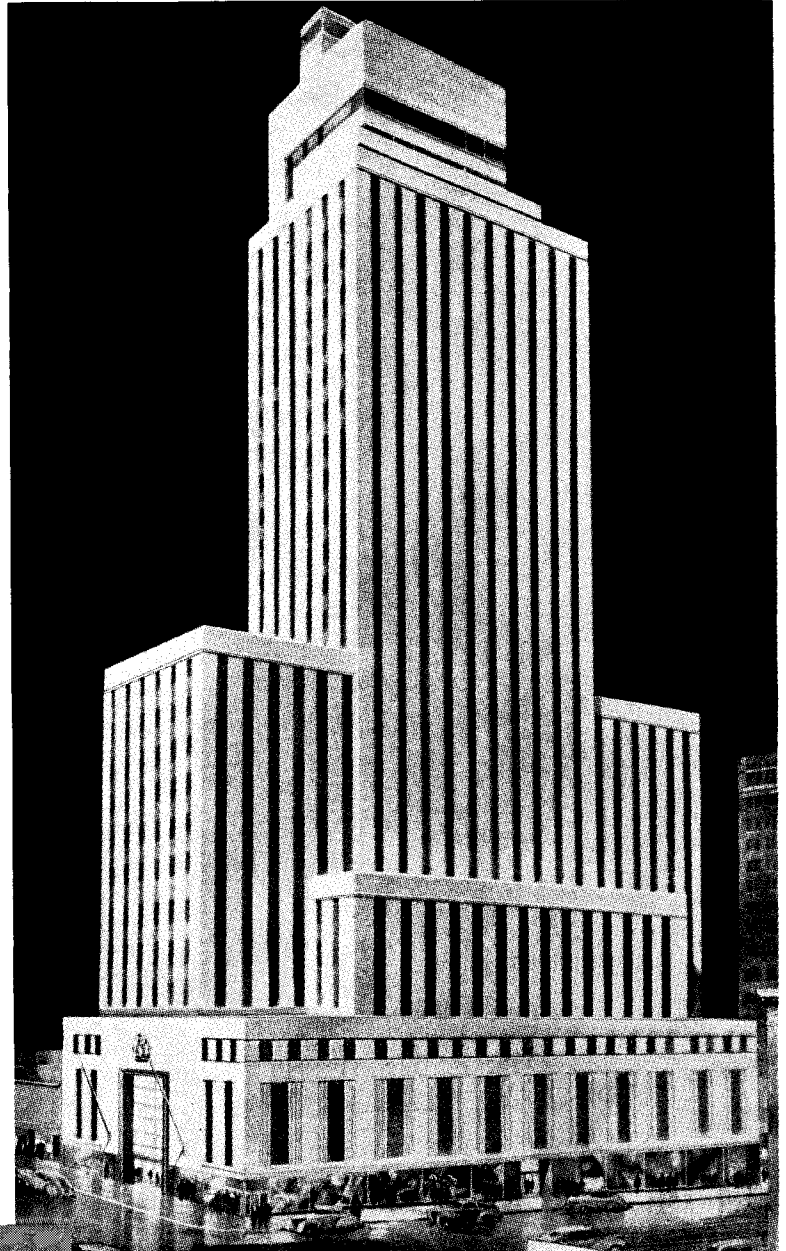

Mercantile Bank Building, Dallas, Texas, is equipped throughout with Watrous Flush Valves.

W. W. Ahlschlager & Company, Architect.
C. Wallace Plumbing Co., Plbg. Contractor.

And for your WARTIME projects —
Sweet's Catalog File—Section 27, Catalog No. 39—covers both "V" model Watrous Flush Valves for essential wartime applications and the complete line of models and combinations for postwar planning . . . Or write for Bulletin 858-W and Catalog 448.



Watrous Flush Valves

WASHINGTON NEWS

Quick payment for terminated contracts? Wage policy and board for construction industry. No more necessity certificates.

The intricate problems of war contract terminations take first place on the agenda of the House Military Affairs Committee. The fact that there are now some 100,000 prime contracts, and many more subcontracts, with "unfinished work" value of between \$60 and \$75 billion, makes termination the most serious problem confronting wartime business. World War I on Armistice Day showed some 32,000 contracts with an uncompleted value of \$5 billion.

At that time less than a thousand of the claims landed in the Court of Claims, where average elapsed time for settlement was three and a half years. Unless proper preparations are made for termination of contracts following victory on one or another front, many firms will find themselves transformed from producers into plaintiffs.

At present two types of settlement are being used. One is known as "negotiated," the other as "formula." Settlements of both types are made by the armed services, but the latter are subject to General Accounting Office final audit.

Legislation to be adopted may either remove the GAO entirely from termination procedures and provide an over-all uniform termination policy—or bluntly restore full authority to GAO. The inherent danger of the situation is that anywhere from three to eight months may elapse before any final legislative action will result. The position of business in the event, again, of an unexpected German collapse before the adoption of a firm and uniform contract "wind-up" policy would be most difficult.

Pending such legislation, the best course to follow in the event of termination is avoidance of "formula" termination, which relegates the contractor to the ponderous movement of GAO and perhaps to years of litigation. Opinion at present is that weight of events will force adoption of liberal, speedy and uniform termination legislation under the armed services.

No More Necessity Certificates

War production facilities now have reached their peak. Verification of this fact is found in Army and Navy action amending their regulations to provide for practical stoppage of issuance of necessity certificates in connection with the amortization of facilities after October 5. The new rules declare that no such certificates will be forthcoming unless construction, reconstruction, erection or installation of the facility was (1) begun before, or (2) acquired before, or (3) an application was filed before that date.

Army and Navy are later going to announce what constitutes "beginning" construction, or "acquiring" a facility. Whether actual physical work or transfer of legal title must have occurred before the named date in order to come within the rule or not must be settled. The thing to do is to file applications as quickly as possible.

Wage Policy and Board for Construction Industry

The National War Labor Board has given the private and government-financed building construction industries a wage policy. Its chief points are: (1) no employee or group of employees is entitled automatically to a full "Little Steel" formula increase; (2) workers with relatively high rates of pay should be given smaller percentage adjustments than those receiving lower rates; (3) some or all of the full 15 per cent otherwise allowable should be withheld where allowance of the full amount would have an unstabilizing effect on an industry's or area's wages; (4) no adjustment to be permitted in excess of the amount allowable under "Little Steel," even if the final rate is below a Davis-Bacon rate.

In addition the order declares that "brackets of sound and tested going rates" provided for in the May 12 supplement to Executive Order No. 9328 are not applicable to the building construction industry. The Wage Adjustment Board (reconstituted by the same order) is in addition given authority to approve adjustment neces-

(Continued on page 10)



"They said something about a perfect example of an integrated, demountable, prefabricated dwelling unit . . ."

—Drawn for the RECORD by Alan Dunn

WHAT HAVE WEATHER MAPS TO DO WITH POST-WAR WINDOWS?

The answer is—PLENTY! For *weather-tightness* is most important in post-war window design. The windows of tomorrow must reduce air infiltration . . . must bar out chilling air currents . . . regardless of what the weather map indicates!

It takes more than a clever brain and a set of drawing instruments to design such a window.

It takes engineering research—repeated tests—extensive laboratory facilities. And it takes *experience*—data gained from actual installations over a long period.

Curtis has made this investment in research and time. That is why the Curtis Silentite Window is, in the opinion of many, today's closest approach to a truly weather-tight modern window.

For here—in Silentite—is a window manufactured to high precision standards. A window made of wood, with all of wood's natural insulating advantages. A window pre-fit for weather-tightness and ease of operation. A window that operates without weights and pulleys, requiring no cuts in the jamb. An *insulated* window, embodying one of the most efficient methods of weather-stripping known. And it's available through leading lumber dealers everywhere in America—sold as part of a complete line of stock architectural woodwork.

Today, Curtis research is continuing to explore window weather-tightness. To keep up to date on post-war windows, keep up with Curtis! Send for complete information about Curtis Silentite windows and Curtis stock Architectural Woodwork! Curtis Companies Service Bureau, Dept. AR-10R, Curtis Building, Clinton, Iowa.



Handsome, modern windows such as this are characteristic of Curtis design and construction. These are the famous Silentite windows—the first basic improvement in window manufacture in nearly 300 years.

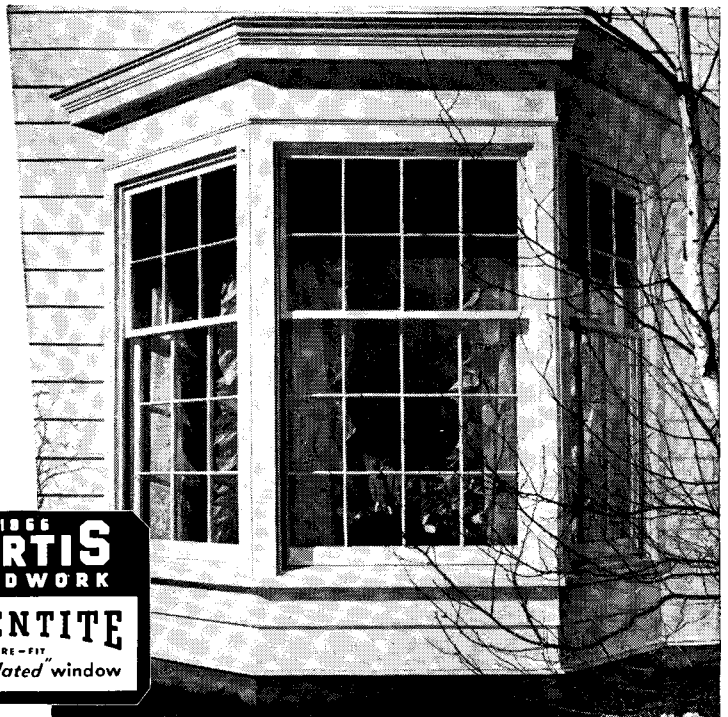

TOMORROW'S WINDOWS WILL HAVE GREATER WEATHER-TIGHTNESS



Girls had to be Half Fiji — Half Eskimo

Until Allen Engineers Stepped In . . .

THE EXCESSIVE heat and humidity inherent in this big commercial laundry's operation posed them a real problem. On certain days the plant's central area would be a steaming jungle while windows and outer walls were glazed with ice. Employment agencies could not supply the Fiji-Islander-Eskimo combination needed to endure these extremes. Then Allen came in.

Competent Allen men made a thoroughgoing study of the plant—submitted a recommendation to

management. They got the go-ahead, cooperated with the local sheet metal contractor on the installation. Results — *as expected* — were delivered. The "as expected" is in no wise boastful. Allen men "measured" the moisture to be removed from this particular plant—provided ventilation "measured" for the job. Gone was the South Seas humidity in the center of the building and North Pole icicles on the walls and windows.

Allen personnel have a long history of first hand acquaintance with

the engineering principles and construction practices involved in ventilation. They are specialists in the removal of excess heat, dust, fumes and moisture from commercial and industrial buildings of all types. Their experience has qualified them to meet and master ordinary and extraordinary ventilation problems with equal facility. Allen men are always available to cooperate with you in determining ventilation needs and installing the proper gravity and/or power equipment to meet the specific situation. *The Allen Corporation, 9751 Erwin Avenue, Detroit 13, Michigan.*

THE *Allen* CORPORATION

ENGINEERED VENTILATION FOR INDUSTRY



(Continued from page 7)

sary to correct substandards of living. In very rare cases, adjustments which could not be given under "Little Steel" and substandards provisions, but which are needed for the critical needs of war production, may be approved, but must be submitted through the National War Labor Board for approval of the Economic Stabilization Director. All other applications for wage adjustment should be filed directly with the Wage Adjustment Board in Washington.

Three members for industry, three for labor, have already been appointed, as well as two of the three representing the public. NWLB's action was taken through the issuance of General Order No. 13.

—*J. Maxwell Dickey*
Washington Correspondent

* * *

GREEK REVIVAL EXHIBITION

A special loan exhibition, "The Greek Revival in the United States," currently on view at the Metropolitan Museum of Art, New York, provides for the first time a broad survey of American arts and architecture during those years of the past century when the influence of ancient Greece was a vital force.

A number of the prominent architects who brought the Greek Revival style to perfection—such men as Benjamin Latrobe, Robert Mills, William Strickland, Gideon Shryock, Alexander J. Davis—are represented in the exhibition by their original drawings as well as by photographs and contemporary prints of their major works. The practical execution of such designs is represented by architectural elements from the Clarkson House, long a landmark of the Flatbush section of Brooklyn, N. Y., which have been lent by the Brooklyn Museum for installation as a typical interior of the period.

The several hundred photographs in the exhibition—of buildings from Maine to California—show that the ancient Greek types were used more as a source of inspiration than as models to be copied. Occasional buildings such as the sub-Treasury building in downtown New York or Girard College in Philadelphia closely resemble Greek temples in their outward



Frances B. Johnston
The Maguire house, Alexandria, Va.
From the "Greek Revival" exhibition

aspects, but on the whole Greek forms and motives were adapted with initiative and imagination for such varied constructions as bridges, factories, public buildings, city apartments and country homes.

The Museum has devoted five galleries to the exhibition, and material in many media—architecture, sculpture, paintings, furniture and other furnishings—is included. To round out a picture of the period, figures garbed in contemporary costumes have been posed against a selection of photomurals of the outstanding monuments of the time.

The exhibition will remain on view at least through the end of December.

DIMENSIONAL COORDINATION PROPOSED

The American Standards Association has announced a proposed American Standard Basis for the Coordination of Dimensions of Building Materials and Equipment. Developed by ASA Sectional Committee A62, the project was initiated early in 1939 with the American Institute of Architects and the Producers' Council as sponsors.

The standard covers (a) the basis for the coordination of dimensions of building materials and equipment; (b) the basis for the correlation of building plans with such dimensions; (c) the basis for the correlation of assembly details with such plans; and (d) the method for the establishment

of standard coordinated sizes and dimensions of building materials and equipment. The basis adopted for dimensional coordination is the standard module of 4 in.

The project will be discussed at the semi-annual meeting of the Producers' Council to be held Nov. 10 and 11 in New York, according to a statement by J. W. Follin, the Council's managing director.

"This project, which provides a means for specifying standard sizes of building materials and equipment that can be used in the finished structure with a minimum of cutting and fitting, is coming to be widely recognized as a principal means of eliminating waste in construction," the statement said. "To a considerable extent, this waste arises from the fact that the hundreds of individual building products generally have not been designed with adequate regard for the sizes of other products with which they must be fitted in the completed building.

"The first requirement is to correlate building plans and details with the standard dimensions through modular design. The second step is the production of standard sizes of materials and equipment.

"The coming period of reconversion from production of war materials to the manufacture of civilian products offers a highly favorable opportunity for changing to dimensional coordination, inasmuch as the change can be made with minimum expense or interruption to plant output."

Practical application of dimensional coordination already has been started for masonry units, while specific studies are under way with regard to wood and metal doors and windows and other materials.

The ASA Committee, of which Max H. Foley, A.I.A., of New York, is chairman, has sent the proposed standard to professional and trade organizations in the building industry for review and comment.

OKLAHOMA CITY AIRPORT

Plans for a \$25,000,000 mid-continent air freight and passenger terminal at Oklahoma City to provide coordinated postwar facilities for handling

(Continued on page 12)

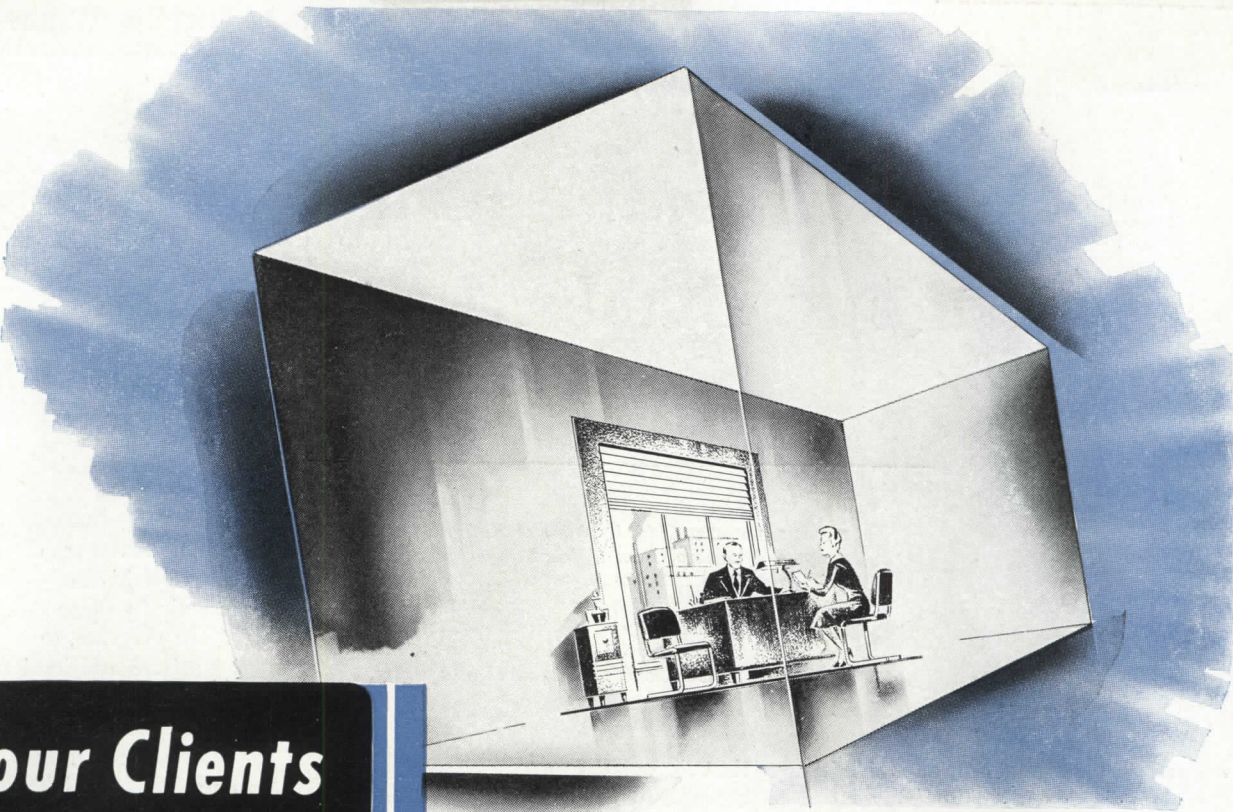

**Your Clients
will take it
for granted**

Your plans and specifications for buildings for post-war America will undoubtedly include air conditioning. Because your clients are now accepting air conditioning as a basic requirement on a par with heating and ventilating . . . In stores, air conditioning draws customers, increases sales. In office buildings, it attracts tenants. In factories, it increases employee efficiency.

As your own planning progresses, you will be counting on incorporating the most modern air conditioning equipment. You can turn to Worthington with confidence. In consultation with you, Worthington will bring 50 odd years of refrigeration machinery specialization plus industrial and commercial air conditioning and refrigeration installations that would have staggered the imagination a few years ago.

This experience is back of the Worthington Air Conditioning equipment being designed today for your post-war clients.

CA3-28A



WORTHINGTON PUMP AND MACHINERY CORPORATION, HARRISON, N. J.

Looking Ahead in Air Conditioning with Frank R. Zumbro

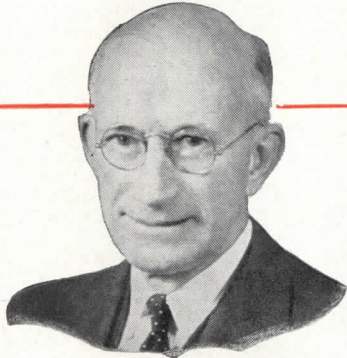

FRANK R. ZUMBRO, Chief Engineer of the Frick Company, Waynesboro, Penna., has been active in the Refrigerating Industry for 25 years. Mr. Zumbro was a contributor to the first of the Data Books published by the American Society of Refrigerating Engineers and served for years on the Board of Directors of this Society. He is the author of numerous technical papers.

BEFORE THE WAR, air conditioning for human comfort had developed into a large industry. The pioneer work necessary to obtain its general acceptance had by that time become a matter of history. Air conditioning was adding to the comfort of many people, not only as a tool to better their efficiency, but also adding to the comfort and inspiration of the buyer of commodities. Large department stores, office buildings, and hotels, all had generally accepted it as a necessary addition to their services.

"Now the needs of warfare have brought forth many new applications of air conditioning, particularly in the industrial field. In extremely fine and delicate work, evenly maintained temperatures and humidities enable special processes to be carried on economically for the first time. Gage blocks, for example, are now being produced in quantities, with accuracies measured in millionths of an inch.

"AFTER THE WAR, one can visualize

that air conditioning will be applied generally to homes, and to the majority of those buildings where people congregate either for pleasure or for work. In this respect it will doubtless become an architectural fixture just as indispensable as a heating plant.

"THE EFFECT OF MAN-MADE WEATHER conditions upon the human mind has not been thoroughly investigated. Nor does it need to be, since a person doing either manual or mental work is aware of the beneficial effects of a clean, comfortable atmosphere. The effect is immediately noticeable and creates a desire for more air conditioning.

"If the history of air conditioning in its total effect upon the production of materials useful to mankind could be written, it would prove a most enlightening story. Suffice it to say that this great branch of applied science has already opened a new day, and promises to add much as man marches toward a better and safer living."



REMEMBER—"Freon" refrigerants are non-toxic, non-explosive, non-flammable, non-irritating. They cannot harm food or clothing. By every measure they are the world's safest refrigerants. Kinetic Chemicals, Inc., Tenth and Market Sts., Wilmington, Del.

FREON
REG. U. S. PAT. OFF.
safe refrigerants

"Freon" is Kinetic's registered trade mark for its fluorine refrigerants.

THE RECORD REPORTS

(Continued from page 10)

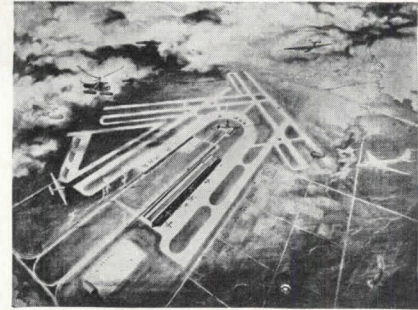

Roy Christian

Proposed Oklahoma City airport

highway, rail and air traffic at the geographical center of America's trans-continental airways were announced recently by Mayor R. A. Hefner.

The program, to be financed entirely by private and local funds, calls for a terminal layout covering six square miles, within nine miles of the city's business center, and a seaplane base on a 2,500 acre lake adjoining.

Preliminary plans already completed by the Austin Company call for the construction of two 11,000 ft. runways, 500 ft. wide, to serve glider tow-trains and planes carrying up to 400 passengers or 160,000 lb. of freight. Four other runways for commercial planes, a civilian flying field, a helicopter base, a passenger terminal with 100-room hotel and hangars would complete the aviation facilities. Railroad and truck lines would enter the terminal on a level below the apron devoted to loading cargo planes, for direct transfer of mail and freight between land and airborne transports by gravity conveyors and elevators.

The city already owns more than half of the land for the proposed terminal, Mayor Hefner said, and is in a position to acquire the balance.

MAINTENANCE OF FACILITIES URGED BY INDUSTRY

At a meeting of the Construction Industry Committee in September the Industry Advisory Group stressed the necessity of maintaining all existing facilities at a high level of efficiency. In a statement released following the meeting the Committee said:

"Successful prosecution of the war requires that all of our physical facilities, including industrial, commercial, housing, railway transportation, highways and streets, food production, water supply and sanitation and other

(Continued on page 96)

HUGE NEW AIRCRAFT PLANT

Temperatures Effectively

Controlled by Johnson

In a recently completed southwestern Aircraft Plant—already producing bombers for our air armada—an intricate system of air conditioning maintains exact temperatures to keep personnel efficiency high and facilitate delicate manufacturing operations.

The Automatic Temperature Control equipment, manufactured and installed by Johnson, stands vigil over the entire system.

"Heating-cooling" thermostats, actually two thermostats built into one case, are the "brain" of the installation. During winter heating, a rise in temperature closes louvred dampers in the conditioning system. For summer cooling, the action is reversed, rising temperature causing the system to introduce more cool air.

Whatever your problem in air conditioning, heating, humidifying or process control, contact the nearest Johnson office, or write for bulletins covering equipment in which you are interested. In either instance there is no obligation.

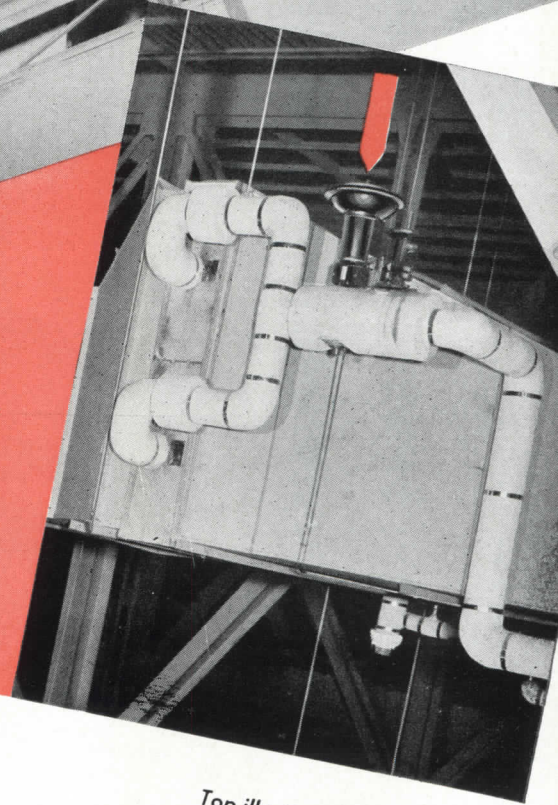

Top illustration: Johnson piston-type damper control actuates the Johnson return air dampers.

Lower illustration: Johnson valve on booster heater coils in ducts which carry super-heated air to outside walls, where winter heat losses are greatest.

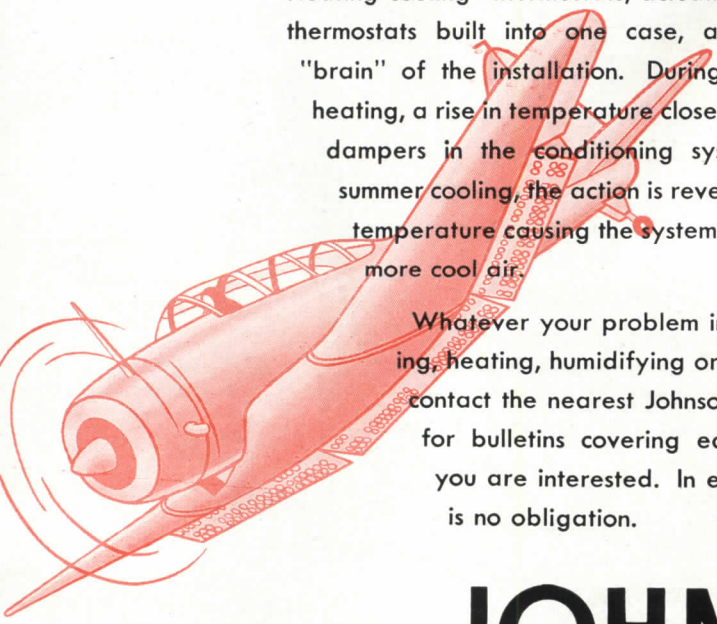

BACK THE ATTACK—BUY MORE BONDS

JOHNSON

Automatic TEMPERATURE AND AIR CONDITIONING *Control*

JOHNSON SERVICE COMPANY, MILWAUKEE 2, WIS. DIRECT BRANCHES IN ALL PRINCIPAL CITIES

MAPS . . .



MOTORS . . .

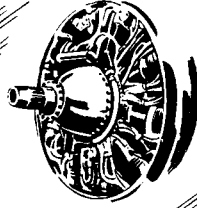

MINESWEEPERS . . .

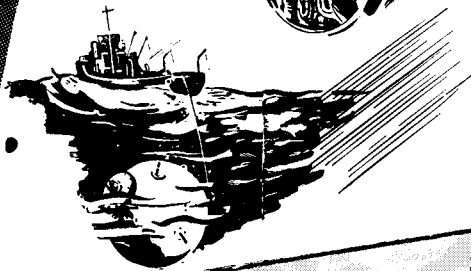

begin with

**WINNER Techno-TONE
DRAWING
PENCILS**

In the hands of American genius, WINNER Techno-TONE Drawing Pencils are writing the death knell to Axis aggression.

For here is a precision-milled pencil that gives craftsmen every quality essential to war designing. Its graphite is purified of all grit. Amazingly smooth in the hardest degree, WINNER Techno-TONE is free from flake and smudge in the softest. Accurately graded in 17 tones of rich black. We will gladly send you a sample of your favorite degree.

Ever Wash an Atom?

Fantastic? No, indeed! The finest graphite and clay is milled to microscopic minuteness—then washed and cleansed with water and chemicals. Then purified in huge filter presses. Baked until

white hot in electric furnaces for strength. Encased in finest cedar wood casings. Only then is it worthy of A. W. FABER'S imprint—WINNER Techno-TONE Drawing Pencil.

Write Dept. AR-11, A. W. Faber, Inc., Newark, N. J.



FABER Inc.

NEWARK, N. J.

13c each 2 for 25c \$1.25 dozen

AT ALL DRAWING AND ARTISTS MATERIAL DEALERS AND LEADING STATIONERS

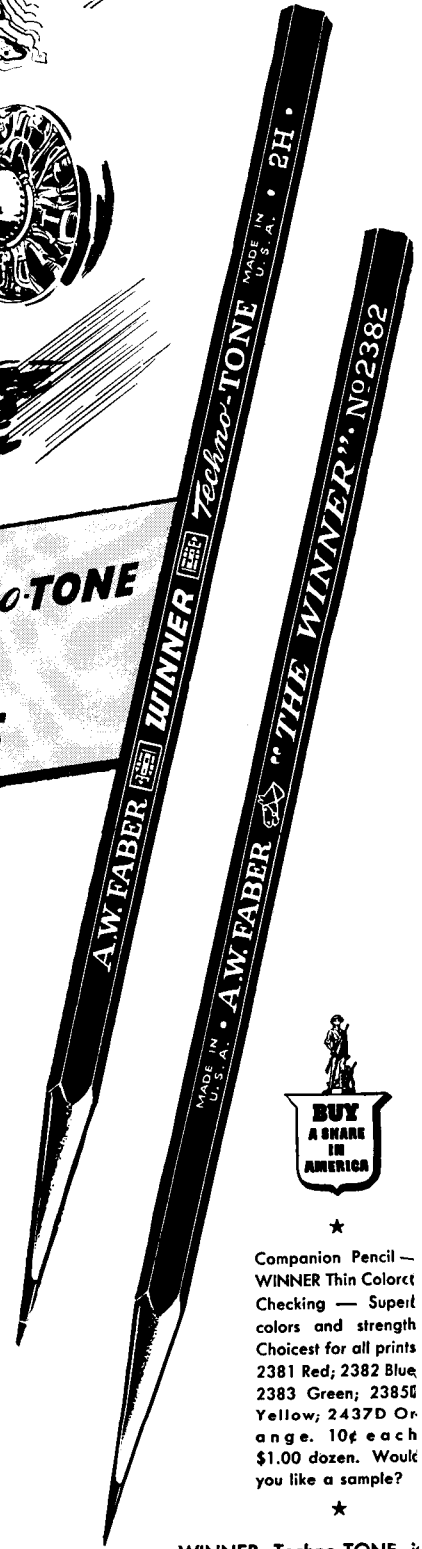

★
Companion Pencil — WINNER Thin Colorct Checking — Supert colors and strength Choicest for all prints 2381 Red; 2382 Blue; 2383 Green; 2385 Yellow; 2437D Orange. 10¢ each \$1.00 dozen. Would you like a sample?
★

WINNER Techno-TONE is available in 17 scientifically graded tones—6B to 9H Polished rich green. Made in U.S.A.

EXPANDING THE SCOPE OF STEEL

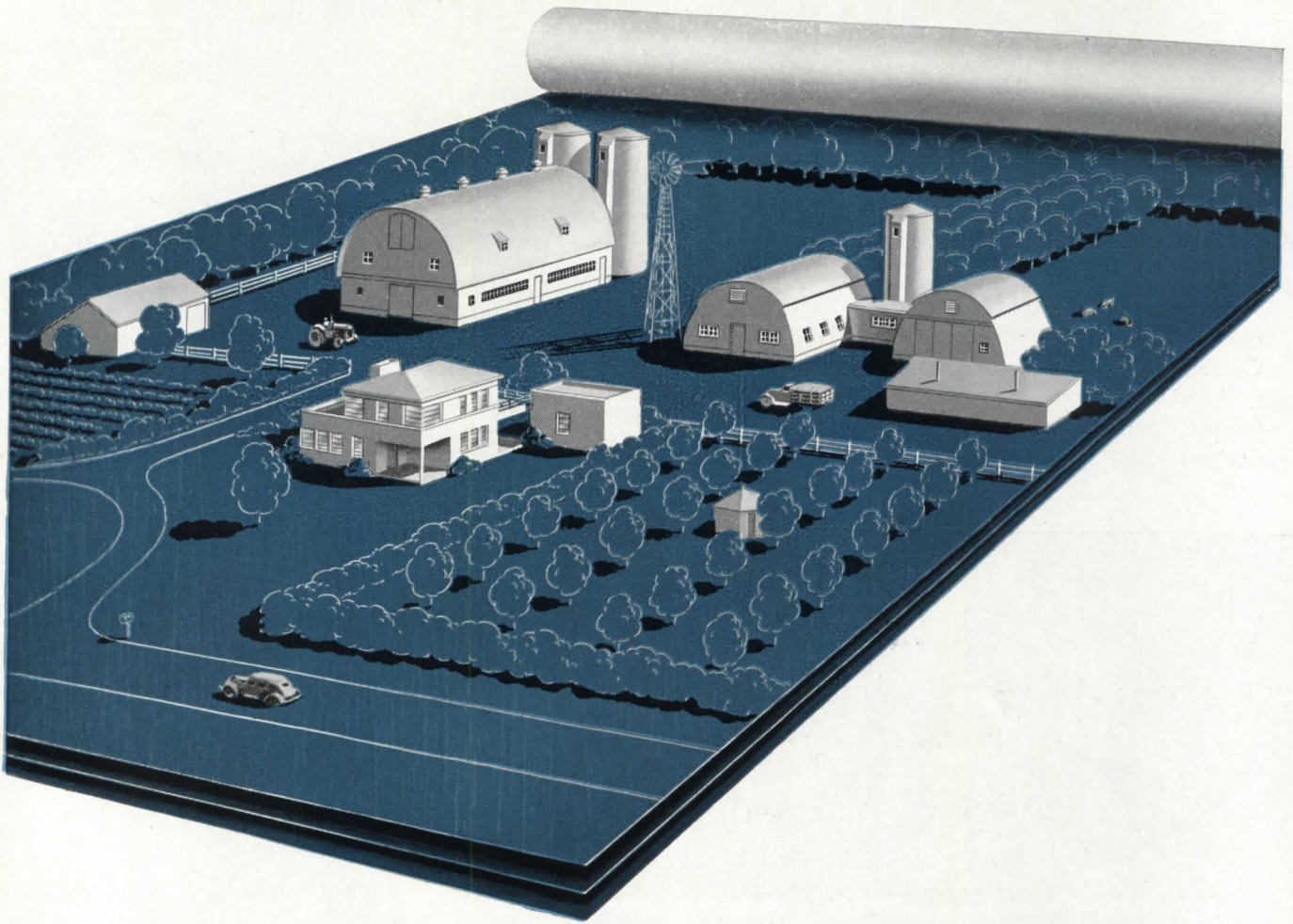

While new materials will play an important part in the post-war world, their promise for the future is no more inspiring than that of established materials for which new uses and new methods of application are being developed in war production.

Strip steel by Stran-Steel is a case in point.

It is not a new material, yet under the stimulus of important military building assignments its scope has been greatly expanded. Stran-Steel engineering and experience make strip steel a more versatile, more economical material . . . well qualified to serve the building industry in the era that lies ahead.

STRAN STEEL

DIVISION OF GREAT LAKES STEEL CORPORATION
1130 PENOBSCOT BUILDING, DETROIT 26, MICHIGAN

UNIT OF NATIONAL STEEL CORPORATION

Check these Bigelow Carpet Counsel features for your after-the-war carpet buying

THE RIGHT CARPET FOR THE RIGHT TRAFFIC AREAS

Theater entrance carpet has to take it. The owners of the Fairfax Theater in Oakland, California, wanted carpet that would look well and wear long. They got it from Bigelow Carpet Counsel in a special Bigelow Wilton Carpet.



"When it comes to carpet — come to Bigelow"

COLORS AND PATTERNS FOR EVERY TYPE OF ROOM

Long narrow halls or large bare lobbies can be made warm and inviting. It's all a matter of the right design and color. Bigelow Carpet Counsel, after the war, will again give you expert advice.



"When it comes to carpet — come to Bigelow"

NO EXTRA COST PER SQUARE YARD

In such installations as the Embassy Hotel in Chicago, expert laying of carpet around posts and in corners saved carpet waste. When Bigelow looms again weave contract carpet, Carpet Counsel will eliminate time-and-money-wasting guesswork.



"When it comes to carpet — come to Bigelow"



BIGELOW-SANFORD CARPET CO., Inc.
140 MADISON AVENUE, NEW YORK 16, N. Y.

MEMO FOR POST WAR PLANNING

✍ Household operating and upkeep expenses come out of the same pocketbook as mortgage amortization payments. High-quality equipment, as supplied by General Electric, usually reduces monthly operating bills more than it increases monthly payments on the house... so actually it costs less to live better.

Remember, General Electric high-quality equipment will best serve the interests of your after-Victory clients or customers.

GENERAL  ELECTRIC
Home Bureau Bridgeport, Conn.



1. LAND



2. STRUCTURE



3. OPERATING EQUIPMENT



A HOME

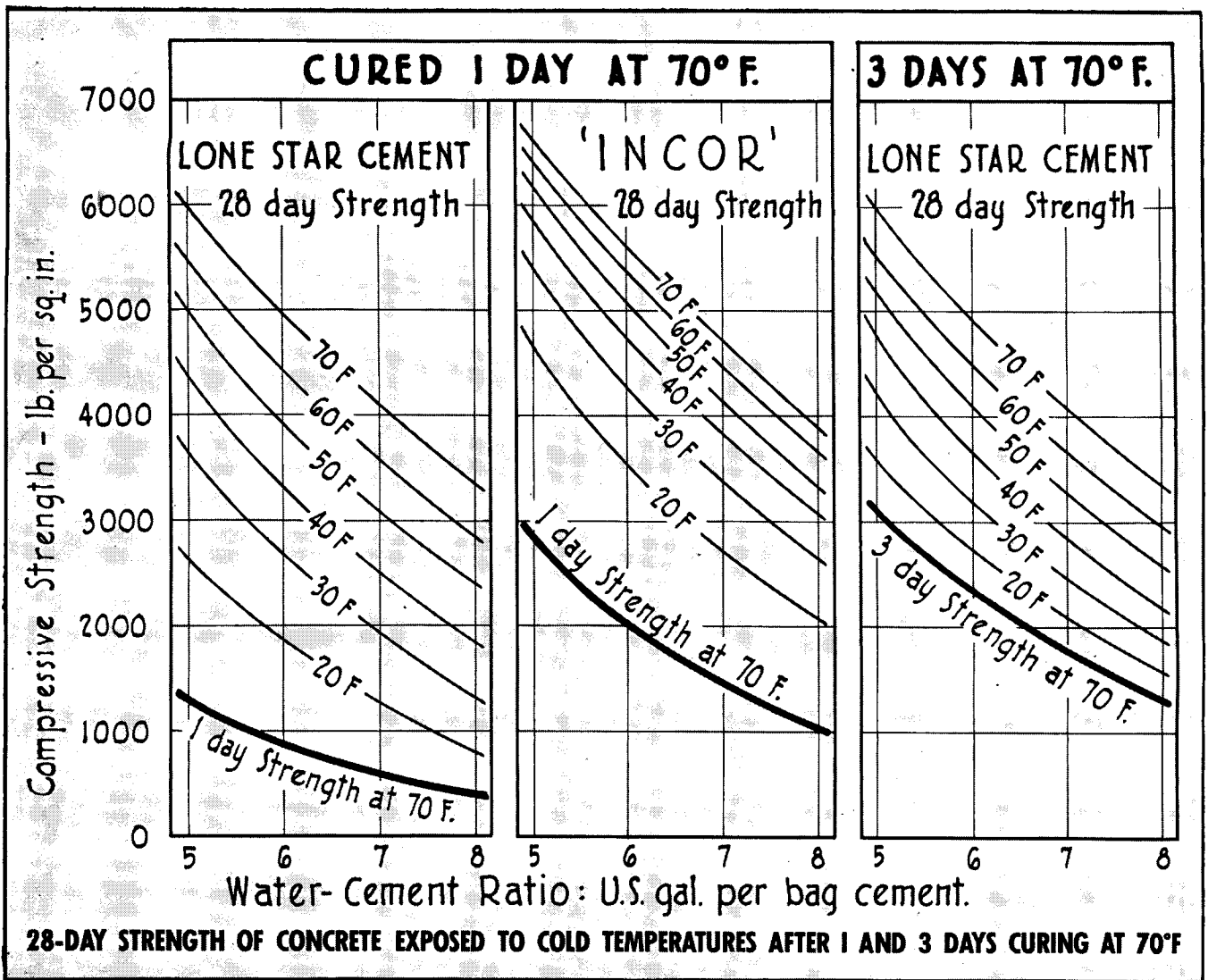

'Incor' Solves Winter Problems

CUTS CONCRETING COSTS...SPEEDS JOB SCHEDULES

SPECIFY
'INCOR' 24-HOUR CEMENT
FOR

EARLIER OCCUPANCY IN
BUILDINGS OF ALL TYPES

WATERTIGHT CONCRETE—
BASEMENTS, TANKS, STUCCO, ETC.

CONCRETE FLOORS—HEAVY-DUTY,
NON-DUSTING—READY FOR
SERVICE IN 24 HOURS

LOW temperatures retard the hardening of concrete—it must be protected against freezing and heat-cured until service strong. This graph shows the effect of cold weather on 28-day strengths of concrete cured at 70°—ONE DAY FOR 'INCOR' . . . 1 and 3 days for Lone Star Cement—and then exposed to winter temperatures.

'Incor', heat-cured one day, produces 28-day strengths 25% to 30% greater than Lone Star Cement concrete heat-cured 3 days. 'Incor' makes concrete safe for winter work . . . reduces freezing risk . . . saves at least 2 days heat-curing on each pour . . . speeds job schedules. Save time, money, worry . . . keep job speed up and job costs down . . . specify 'Incor'* 24-Hour Cement on cold weather work.

Continuous research in Lone Star Cement Research Laboratories provides valuable performance data. We shall be glad to furnish specific information on request.

*Reg. U.S. Pat. Off.

LONE STAR CEMENT CORPORATION

Offices: ALBANY • BIRMINGHAM • BOSTON • CHICAGO • DALLAS • HOUSTON • INDIANAPOLIS • JACKSON, MISS.
KANSAS CITY, MO. • NEW ORLEANS • NEW YORK • NORFOLK • PHILADELPHIA • ST. LOUIS • WASHINGTON, D. C.

LONE STAR CEMENT, WITH ITS SUBSIDIARIES, IS ONE OF THE WORLD'S LARGEST CEMENT PRODUCERS: 15 MODERN MILLS, 25-MILLION BARRELS ANNUAL CAPACITY



**BUY
U. S. WAR BONDS
AND STAMPS**

The Army-Navy "E" pennant now flies over the Fitzgibbons plant, emblem of sustained endeavor by the men and women of Fitzgibbons, and of their determination to maintain the Fitzgibbons standard of wartime production, until the forces of international banditry are smashed.

Fitzgibbons Boiler Company, Inc.
101 PARK AVENUE, NEW YORK 17, N. Y. WORKS: OSWEGO, N. Y.
OFFICES IN PRINCIPAL CITIES



No "SHADOWTAGE" here

"Shadowtage" means sabotage due to shadows on the working plane — especially when they blur delicate machining operations held to tolerances of 1/10,000th of an inch.

The best-known answer to "shadowtage" is the scientific installation of shadowless and glare-free fluorescent lighting.

It is our job to supply the fluorescent and incandescent lighting equipment that is helping to speed war production all over the country.

Aggressive and independent Sylvania research developed and introduced the first successful fluorescent installation — forerunner of war plant fluorescent by the thousands of miles of lamps today.

And now — years ahead of time — Sylvania is producing the fluorescent fixture of the future. A revelation in simplicity and adaptability, *one* standard fixture meets any industrial lighting requirement. Similar developments may bring economical fluorescent lighting into American homes after the war.

For industrial fluorescent lighting equipment, designed to work together, specify Sylvania Fluorescent Lamps, Fixtures and Accessories for replacements and authorized new installations.

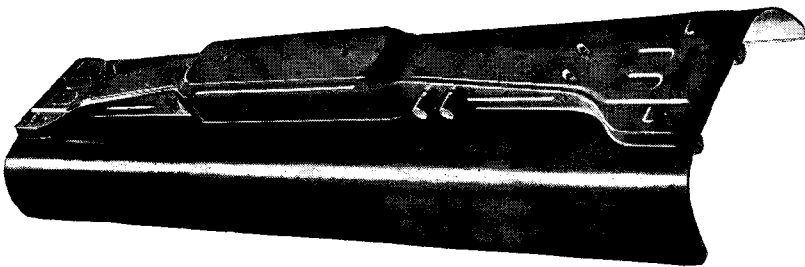

THE FIXTURE OF THE FUTURE. This new fixture, which can challenge comparison with any other in the fluorescent field, is much more than a design to save critical war materials. Its non-metallic reflector has an efficiency of 86 per cent — actually more than that of enameled metal. The streamlined top housing, constructed like a cantilever bridge, encloses the ballast—protects it from dust—provides cooler performance.

SYLVANIA ELECTRIC PRODUCTS INC.

Executive Offices, 500 Fifth Ave., New York, 18, N. Y.

*Incandescent Lamps, Fluorescent Lamps,
Fixtures and Accessories, Radio Tubes,
Cathode Ray Tubes, Other Electronic Devices*

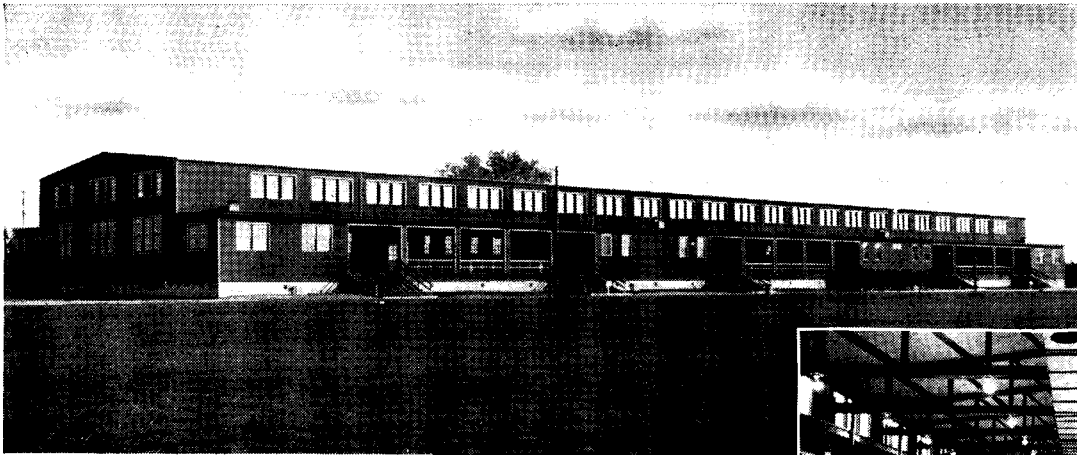

One of seven, 5000-men Mess Halls at Sampson, New York. Architect-Engineers Shreve, Lamb & Harmon.

Below: Interior of huge 435-foot Mess Hall.



MESS HALLS DESIGNED AND BUILT FOR

Feeding 35,000 Men

IN ONE HOUR AT NAVAL STATION

The largest naval training station in the East is equipped to serve 105,000 meals in 24 hours.

CONSIDERED the finest naval training station in the world and substantially completed in six months, this great naval station of 35,000 inhabitants with its utilities, facilities, laundries, bakeries, schools, drill halls, swimming pools, etc., was ready to receive the first group of recruits after a night and day work period of four months.

Other substantial contracts selected from approximately 50 U. S. Government war

projects totaling 130 million dollars in two years:

- Camp Kilmer, Stelton, N. J.
- Cantonments, Fort Dix, N. J.
- Tilden Hospital, Fort Dix, N. J.
- Dormitories (Farm Security Administration)
—in many different localities
- Navy Housing—South Charleston,
West Virginia
- Defense Housing—Point Pleasant,
West Virginia
- Cantonments—Camp Upton, New York
- Cantonments—Mitchell Field, New York
- Cantonments—Fort Hamilton, New York
- Housing Projects—Philadelphia, Pa., Reading, Pa., Sampson, N. Y., Harrison, N. J.

Send for illustrated brochure No. 39

GENERAL CONTRACTORS

JOHN A. JOHNSON CONTRACTING CORP.

A Firm Foundation Since 1896

270—41st STREET • BROOKLYN, N. Y.

BROOKLYN, N. Y. • WASHINGTON, D. C. • ATLANTA, GA. • KNOXVILLE, TENN.

If Buildings Were Designed by Ear...



YOU'D USE SABINITE "M"

The practiced *eye* of the architect senses the beauty of proportion and symmetry of design. But today he must also have a "sensitive ear" . . . to plan buildings that include sound-control as a part of the original conception—not tacked on afterward. For noisy, "boiler-shop" buildings with noise bouncing back and forth are in the "old-fashioned" class as soon as they are built.

Sabinite "M"* places no penalty on construction, design or price, because Sabinite "M" is

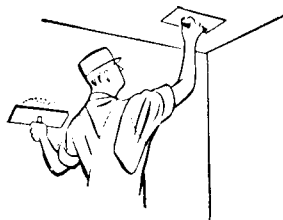

ACOUSTICAL
PLASTER
FINISH

an acoustical plaster finish, requires no special construction, goes on like any other plaster finish applied by any skilled plaster craftsman. It is high in light reflectivity. May be had in prepared colors or decorated to suit. Trowels to a smooth texture surface.

In fact, Sabinite "M" is the present day solution to your combined needs of one material that decorates, protects against fire and quiets sound in one operation . . . and at an extremely reasonable cost.

*Trademark Reg. U. S. Pat. Off.

TODAY'S "QUIET" WAY

One material that decorates, protects against fire and quiets sound in one operation — Sabinite "M".



UNITED STATES GYPSUM

300 W. ADAMS ST., CHICAGO, ILL.

This famous trademark identifies products of the United States Gypsum Company—where for 40 years research has developed better, safer building materials.

FIREPROOF GYPSUM

The most widely used mineral in the world for building "Fire-Protected" Walls and Ceilings.

PLASTER • LIME • KEENE'S CEMENT • STUCCO • GYPSUM AND METAL LATH • GYPSUM TILE

CAN YOU GUESS?

What America Wants in Postwar Housing

QUIZ ON CRANE PUBLIC PREFERENCE POLL

Check your guess with the answers shown below.

WE asked 200,000 home owners and prospective home owners to vote on their preferences in equipment for the home they plan to build after the war.

The main purpose of this survey was to aid Crane designers and engineers in developing a postwar line of plumbing and heating which would suit the tastes and desires of tomorrow's home owners.

However, the thousands of answers we received are so indicative of the thinking your clients are doing now on the home they are planning that we believe you would be interested in

learning more about it.

Obviously, no survey can cover all the factors that influence final selection such as cost, desires of other members of the family, etc. The replies, however, do represent an interesting cross-section of public opinion and as such can be of great value to anyone interested in postwar design or construction.

You might like to check your thinking with this expressed opinion of America's future home market. You will find the actual percentages of the questions in this quiz at the bottom of this page.

- 1 ...% What percent prefer a single bathroom with combination tub and shower as against two bathrooms with shower stalls?
- 2 ...% What percent want a powder room?
- 3 ...% What percent want a shower over the tub?
- 4 ...% What percent prefer a small kitchen? (6x9 Ft.)
- 5 ...% What percent prefer a medium-sized kitchen? (9x12 Ft.)

- 6 ...% What percent prefer a large kitchen? (14x16 Ft.)
- 7 ...% What percent want a breakfast nook in the kitchen?
- 8 ...% What percent prefer storage cabinets in the kitchen rather than a separate pantry?
- 9 ...% What percent want the sink under the window?
- 10 ...% What percent want a basement?

- 11 ...% What percent want a utility room instead of a basement?
- 12 ...% What percent prefer steam or hot water heating?
- 13 ...% What percent prefer warm air heating?

ANSWERS

- | | | | |
|-----------|-----------|-----------|------------|
| 1 ... 72% | 4 ... 12% | 7 ... 61% | 10 ... 62% |
| 2 ... 79% | 5 ... 53% | 8 ... 74% | 11 ... 31% |
| 3 ... 73% | 6 ... 32% | 9 ... 90% | 12 ... 47% |
| | | | 13 ... 42% |



THE questions shown are only a few taken from the Crane Survey. A more complete digest of the results of this poll augmented with statistical data is presented in an interesting book which will be sent without charge to anyone desiring a copy.

CRANE CO., 836 S. Michigan Ave.
Chicago 5, Ill.

Please send me a copy of "What America Wants in Postwar Housing."

Name

Address

City State

CRANE

CRANE CO., GENERAL OFFICES: 836 S. MICHIGAN AVENUE, CHICAGO 5
PLUMBING • HEATING • PIPE • PUMPS • FITTINGS • VALVES
NATION-WIDE SERVICE THROUGH BRANCHES, WHOLESALERS PLUMBING AND HEATING CONTRACTORS



The women

They know that this is war, and that the price of victory will be high. They have sent off their sons, brothers and husbands to the armed forces, and they are coming out of beauty shops and offices, stores and homes, and are taking war jobs in steel mills and shipyards. The deft hands that in peacetime wielded the skillet and the dryer are now managing the boring mill and the welding torch—and to very good effect.

Ever try keeping traffic flowing smoothly in and out of the main entrance of a big steel plant? Ever knock a "hot top" off an ingot? Or rough-bore a gun forging? Or weld a ship's hull? Not women's work? Women are every day doing these and dozens of other jobs in Bethlehem shipyards and steel plants, and doing them superbly.

At Bethlehem and Lackawanna, at Baltimore, at Fore River and Hingham, on the Pacific Coast—and at other locations where this company operates plants and shipyards—former clerks and beauty-shop operators, salesgirls and housewives, are applying themselves to their new, challenging tasks with wonderful spirit and skill. They are helping to swell the mighty output of steel and ships and ordnance. The results of their efforts are being painfully felt in Tokyo and Berlin. Hats off to them!



Woman "patrolman" at a Bethlehem steel plant. Here is a job calling for plenty of tact and skill! Women are serving on patrol duty at gates, parking lots, offices, and other locations with efficiency and aplomb.



Once a dancer, now she runs a machine in a Bethlehem shipyard.

This "buggy" operator is hauling naval shells in a Bethlehem plant.

Upswept hairdo, red finger-nails, don't keep this girl welder from doing a man-size job at a Bethlehem shipyard.



William Lescaze, architect, is credited with the first modern skyscraper (for the Philadelphia Savings Fund Society), and the first use of glass brick in a facade. Outstanding examples of his work include Columbia Broadcasting's Hollywood Studios, the Ansonia (Conn.) High School, and Longfellow Bldg., Washington, D. C.

FROM A PILOT SEAT... AND RUBBER-LIKE SAFLEX... SOLID COMFORT, MASS PRODUCED?

STRONG, lightweight pilot seats of plastics-bonded plywood now in quantity production for the U. S. Air Forces were the principal inspiration for this interesting suggestion for 194X by well-known, New York Architect William Lescaze.

Wartime success, however, in converting Monsanto's Saflex from its original function as a tough, resilient interlayer for safety glass into what amounts to a new and promising synthetic rubber,

also interested Mr. Lescaze and led him to include Saflex in his "specifications".

Making use of war-stimulated bag-molding techniques, the chair Mr. Lescaze visualizes would be quickly and easily formed on inexpensive molds with little or no waste of material. It would be upholstered with a resilient, sponge-like Saflex and covered with a waterproof, washable, Saflex-coated fabric.

The sketches below illustrate details.



Wood plies, coated with a Resinox phenolic bonding resin, would be laid up on simple, inexpensive wood molds, tacked in place.



Molds would be covered with rubber bag and air evacuated to form snug fit. Entire assembly then goes into pressure chamber.



Removed from mold, chair is one tough, resilient, monolithic piece. Sponge-Saflex cushion would be slipped on frame like an envelope.



The Broad and Versatile Family of Monsanto Plastics

(Trade names designate Monsanto's exclusive formulations of these basic plastic materials)

LUSTRON (polystyrene) • SAFLEX (vinyl acetal) • NITRON (cellulose nitrate) • FIBESTOS (cellulose acetate) • OPALON (cast phenolic resin) RESINOX (phenolic compounds)

Sheets • Rods • Tubes • Molding Compounds • Castings • Vuepak Rigid Transparent Packaging Materials



FACTS TO HELP YOU SHAPE THE FUTURE

No one can say today with certainty that a chair such as Mr. Lescaze has suggested will ever be produced. It is certain, however, that wartime advances in plastics materials and techniques will exert a strong influence over the shape of many things to come. That is why it will pay you to add "The Family of Monsanto Plastics, A Guide for Product Designers," to your postwar file now. Its 24 pages are packed with facts on one of the largest and most versatile groups of plastics produced by any one manufacturer. Simply write: MONSANTO CHEMICAL COMPANY, Plastics Division, Springfield, Massachusetts.

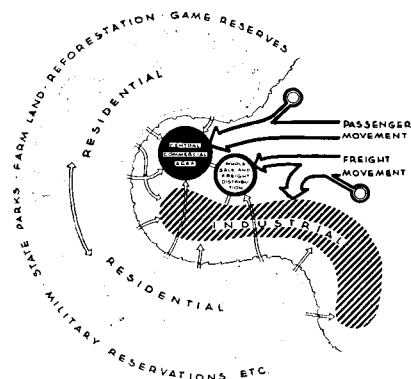

Diagram of general functional relationships for Tacoma, Wash. From "Action for Cities"

ACTION FOR CITIES.

A Guide for Community Planning. Chicago (1313 East 60th St.), Public Administration Service, 1943. 77 pp. 7¼ by 10½ in. illus. \$1.00.

The technique for long term comprehensive community development worked out by the Urban Section of the National Resources Planning Board and tested in Corpus Christi, Salt Lake City and Tacoma, recorded in amazingly ingenious and attractive form, is here published under the joint sponsorship of the American Municipal Association, the American Society of Planning Officials, and the International City Managers' Association.

Even those communities which had long run plans before the war must now revise them; few communities have ever made adequate plans; some well made professional plans have remained ineffective for want of enabling legislation and financial support; and even when a community has vision, skilled personnel is usually lacking.

Realizing this, the authors of the Guide have combined comprehensiveness and simplicity in such a way as to appeal to public agencies and administrators, to the civic-conscious private persons who form citizens organizations, and the individuals who dream planning as an escape from political and social confusion.

In striking type and open type-pages, with simple and arresting diagrams, the material is arranged so that on one page is outlined what to do and why, and on the facing page who is to do it and how and when, and what sources of information may be used.

Good psychology, happiness of expression, use of simple words, give a stimulating and inspiring tone to an analytic study: "A community can obtain in months instead of years an essentially sound outline of its needs . . ." "Planning is for people." "What do we want?" "Who will do what?" "Do not depend on the staff to do all the thinking; farm it out." Throughout, the sense of logical progression is strong: from a study of the number and kind of people, through what they do for a living and for personal development and for play, the area at their disposal and the physical development desirable and possible, on to what steps to take and how the program will be paid for.

GREEK TEMPLES.

By Isabel Hoopes Grinnell. New York (Fifth Ave. at East 82nd St.), Metropolitan Museum of Art, 1943. xxi+60 pp., 54 pl. 10¼ by 14¼ in. illus. \$7.50.

Twenty-five of the most interesting temples erected during eight centuries well described in a beautiful book by a recent member of the Museum's Department of Greek and Roman Art. An introduction gives the history and function of the temple, its plan and methods of construction, and explains architectural styles; the illustrated chapter with plan devoted to each of the 25 temples is supplemented by a list of references for further study; there is a glossary; and nearly two hundred illustrations are arranged on 54 large collotype plates. These—photographs, prints, drawings—have been selected with a view to showing each building as it stands today and to give some idea of the temple as it was in its prime with its significant decorations.

The book as a whole is designed for the student and the more cultivated general reader; but it will also delight and inform even the reader who scarcely glances at the text pages.

HOUSING AND CITY PLANNING.

Reprinted from *Social Work Year Book for 1943.* New York (130 East 22nd St.), Russell Sage Foundation. 16 pp. 15c.

This article summarizes data pertaining to housing conditions as shown by the 1940 U. S. Census, gives estimates of the housing shortage in the United States and discusses the municipi-

pal and federal housing programs in operation throughout the country. The article contains sections on the public regulation of dwellings, war housing and rent control, peacetime housing and slum clearance, semi-public housing, and a review of rural housing needs. A section on city and regional planning to which the postwar world should give a new impetus, sets forth principles of town and country planning.

HOUSING PRODUCTION.

First Report of the Committee for the Industrial and Scientific Provision of Housing. London W. 1 (3 Albemarle St.), 1943. 96 pp. 6 by 9½ in.

The aim of the report is to show the need for a Housing Production Council to be concerned with all phases of the industry. An outline of the duties and a proposed constitution for such a Council are included, and the factors required in building up a complete prefabrication industry are analyzed. Much of the well-ordered report is devoted to problems of research, financing, marketing, public relations and industrial structure; and there is an analysis of basic prefabrication system for various materials: wood, metal, masonry and composites.

PRACTICAL PERSPECTIVE DRAWING.

By Philip J. Lawson. New York (330 West 42nd St.), McGraw-Hill, 1943. 6¼ by 9¼ in. illus. \$2.75.

In a book easy to use both as text and for reference the principles of perspective drawing are explained by a Pratt Institute instructor; and the variety of practical application is such as to make the work valuable to architect, commercial artist, industrial designer, painter and others.

The figures numbered to 170 contain twice to three times that number of drawings; there is an abundance of graphically contrasted wrong and right solutions; examples chosen include many modern subjects such as airplanes and "plastic and soft forms"; there is advice as to the viewpoint from which the most interesting or the most effective drawing may be made; the dynamic possibilities of three point perspective, long used by fiction and advertising illustrators, are

(Continued on page 28)

FOREMOST TECHNICAL SCHOOLS

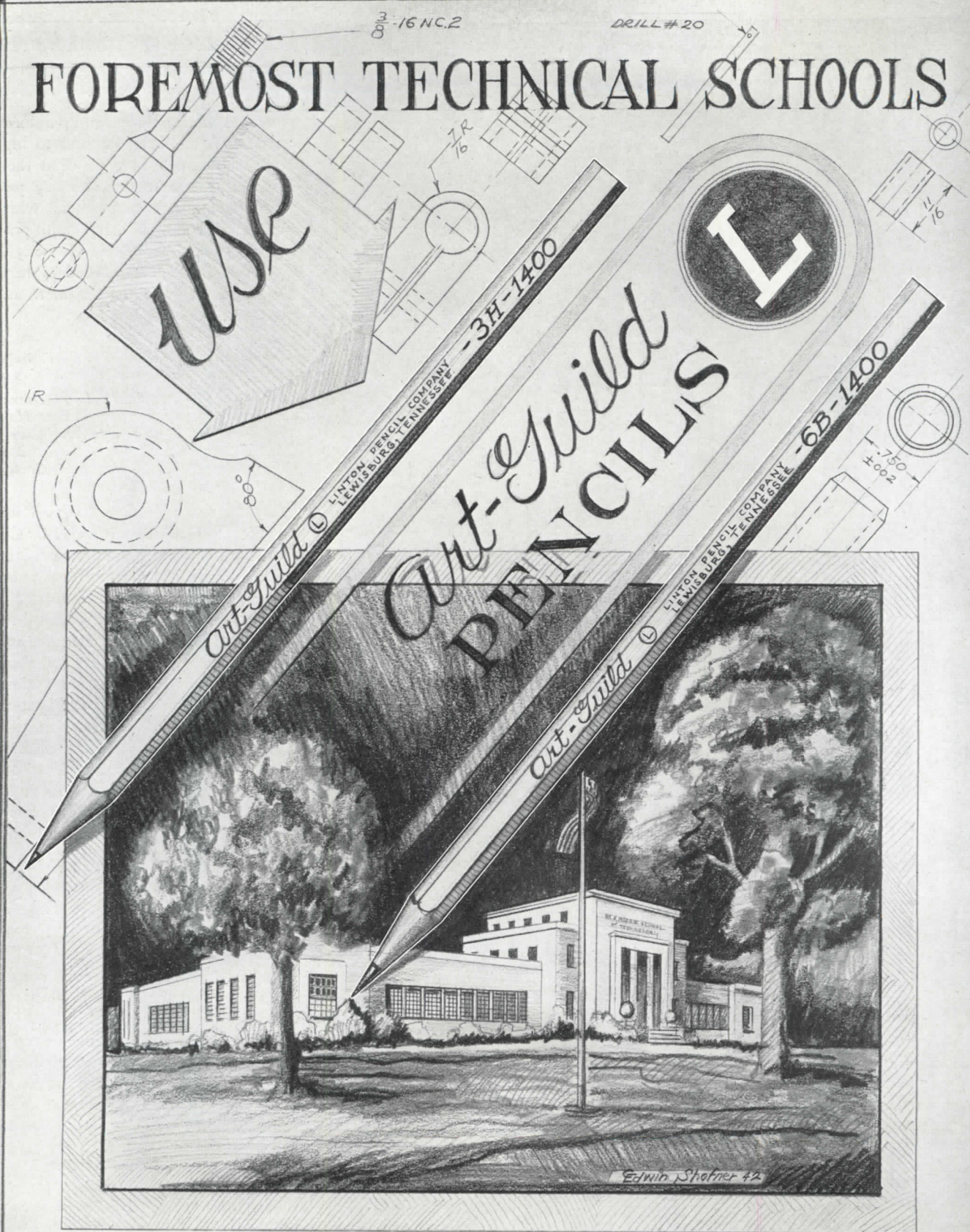

— WM. R. MOORE SCHOOL OF TECHNOLOGY, MEMPHIS, TENNESSEE —

This drawing is one of a series made with *Art-Guild* BONDED LEAD drawing pencils

Art Guild pencils are available in 17 precision-milled degrees — 6B to 9H. Beautifully finished in green lacquer, they come neatly packed in a metal box.

Try them at our expense. We will gladly send you a few Art Guild pencils for personal test. Just drop us a note on your letterhead, specifying the degrees you prefer.

LINTON PENCIL CO., Lewisburg, Tenn.

SALES OFFICES

112 West Ninth Street
Los Angeles, California

38 South Dearborn Street
Chicago, Illinois

3525 Southwestern Boulevard
Dallas, Texas

**POOR VISION
SURRENDERS**
when you attack it with

Guth **SUPER ILLUMINATORS**

U. S. T. M. REG. & PATS. PENDING

The Newest and Best in
FLUORESCENT LIGHTING

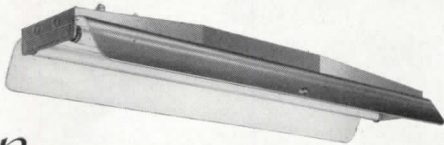

Because of its unique design, the GUTH Super Illuminator is thoroughly rigid and durable, without violating any present-day metal restriction.

Stamped from a single sheet of steel, the Top Housing is attractive, simple, practical—a sleek, efficient unit that does the job right! The Masonite "Reflector Board" Reflector is formed in our own plant, and finished "300° White" for high lighting efficiency.

Attack darkness—the enemy of production—with light—with GUTH Super Illuminators! Write today for detailed Bulletin.

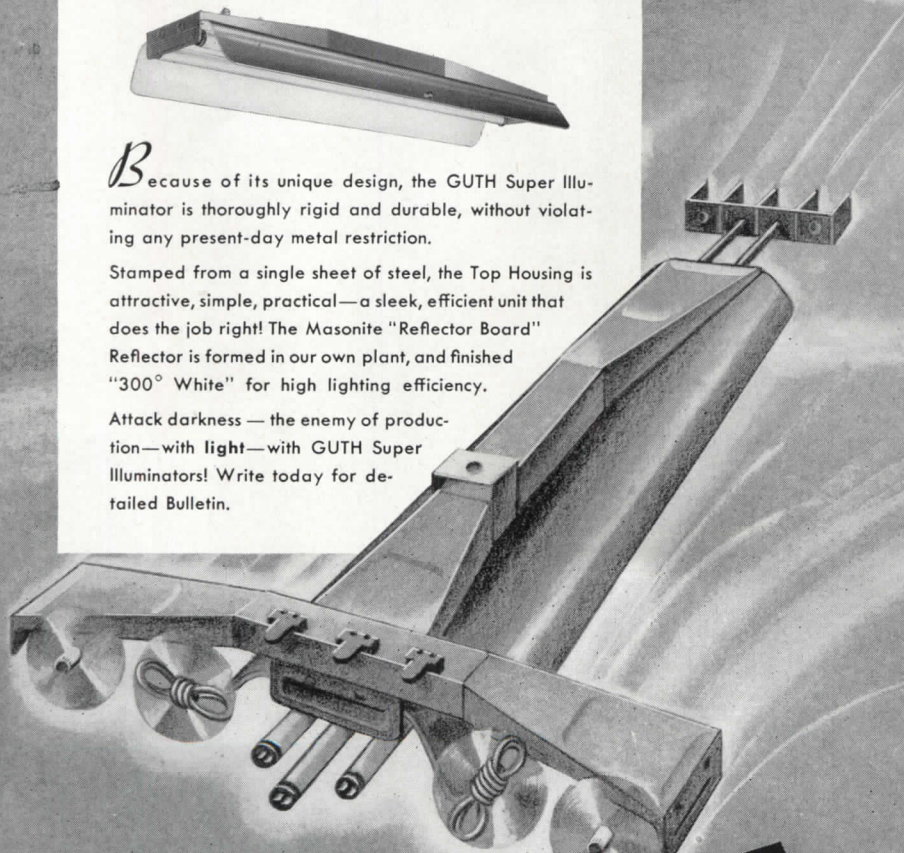

☆ *Leaders in Lighting Since 1902* **Guth** ☆

THE EDWIN F. GUTH CO. 2615 Washington Ave. St. Louis 3, Mo.

REQUIRED READING

(Continued from page 26)

presented for architect and engineer; reference is made throughout to high precision methods as well as to those sufficiently accurate for ordinary purposes; and the two chapters which summarize common errors and practical suggestions treated in the body of the work are well calculated to leave the reader at once on the alert and reassured.

MEXICO, CENTRAL AND SOUTH AMERICA.

New World Guides to the Latin American Republics. Ed. by Earl Parker Hanson. New York (270 Madison Ave.), Duell, 1943. v. p. 4½ by 7⅞ in. 2 v. \$2.50 each. (v. 1 Mexico and Central America; v. 2 South America.)

These general guides, designed under the sponsorship of the U. S. Coordinator of Inter-American Affairs ("The Rockefeller Committee") for business travelers and tourists, greatly augment and enhance the scattered information on Latin American Art and architecture now available. For there are chapters by specialists on various subjects, those on art and architecture being ably written for the most part by Robert C. Smith, assistant director of the Library of Congress Hispanic Foundation; furthermore the exact location and descriptions—often fairly detailed—of architectural monuments are found in the body of the text.

RECORDING RUIN.

By Andrew S. G. Butler. London W. C. 2 (10-12 Orange St., Leicester Sq.), 1942. 147 pp. 5 by 7½ in. illus. 7s 6d.

An architect spends several months examining for the Chelsea Borough Council buildings damaged in the London Blitz, and records in fine crisp style the behavior of houses of different types variously damaged: many of them ugly when complete made quite picturesque ruins.

SLIDE RULE SIMPLIFIED.

By Charles O. Harris. Chicago (Drexel Ave. at 58th St.), Amer. Technical Soc., 1943. 258 pp. 5½ by 8½ in. illus. \$2.50; with slide rule, \$3.50.

A good practical explanation by the assistant professor of mechanics at Illinois Institute of Technology, designed chiefly for the beginner but useful also to the somewhat more advanced worker. Each chapter includes many practice problems; and the chapter of

(Continued on page 100)

Where do you stand on these **7 keys** to post-war profits?

The president of the nation-wide organization which compiles building construction statistics wrote recently that the principal factors which should produce great post-war economic expansion and prosperity are these seven. They are the markets which you should cultivate now for future orders.

1 *"Automotive revival..."*

(This could result in construction or basic changes in buildings all over the country, as well as in Detroit and might mean business for you in your own community).

2 *"Aviation"*

(The development of private flying, the growth of aerial freight lines may bring the need for all sorts of building construction, much of this, too, in your community).

3 *"Synthetic materials, etc..."*

(Despite the great wartime expansion in manufacturing facilities for synthetic rubber, plastics, lighter metals, etc., the post-war conversion period will bring need for new construction, new roofs, etc).

4 *"Low-cost buildings—"*

(Many of these low-cost buildings will have flat roofs and this will open up new need for coal tar pitch built-up roofs. Many of them will want pressure-treated timber as a protection against decay and termites).

5 *"Better houses—"*

(If national income continues high it is expected to bring a bigger demand for homes over \$6,000. Customers for these homes will expect dry basements, which may mean a bigger market for coal tar waterproofing. They will also expect decay-resistant, termite-proof woodwork, which will call for pressure-treated timber).

6 *"Blighted urban areas"*

(This can lead to large-scale demolition of run-down districts, and housing, commercial and industrial construction. Much of it may be planned as a self-liquidating guarantee of post-war employment).

7 *"Public works—"*

(The virtual suspension of many civilian public works projects during the war has created a potential reserve of work which would normally have been done this year or last year. This adds to the deferred construction market).

In almost every community, there are post-war planning bodies which are working on one or more of these sources of future business.

We are sure you will interest yourself in their work and take a part in it. From it may spring your orders in the future.

We also hope in the post-war planning work you do, you will raise your voice in favor of durable construction . . . and, in roofing, that may mean coal tar pitch materials, and in general building construction, the use of pressure-treated timber products.—Koppers Company and Affiliates, Pittsburgh, Pa.

KOPPERS

THE INDUSTRY THAT SERVES ALL INDUSTRY

Speakman

INVITES YOUR IDEAS

There are many promises of remarkable advancements in building methods and new uses of many materials for the post-war era. No doubt a great many will take place in time. For Speakman Showers and Fixtures we can see only gradual, progressive changes in fundamental designs, construction features and materials. What you think on this subject is naturally of exceptional interest to us. If you would write us *your* ideas we'd be grateful.

The Speakman products shown here have proved their merit in construction—in performance. They will be available post-war, and your specifications on future projects can be prepared now with that assurance.

SPEAKMAN COMPANY
WILMINGTON • DELAWARE

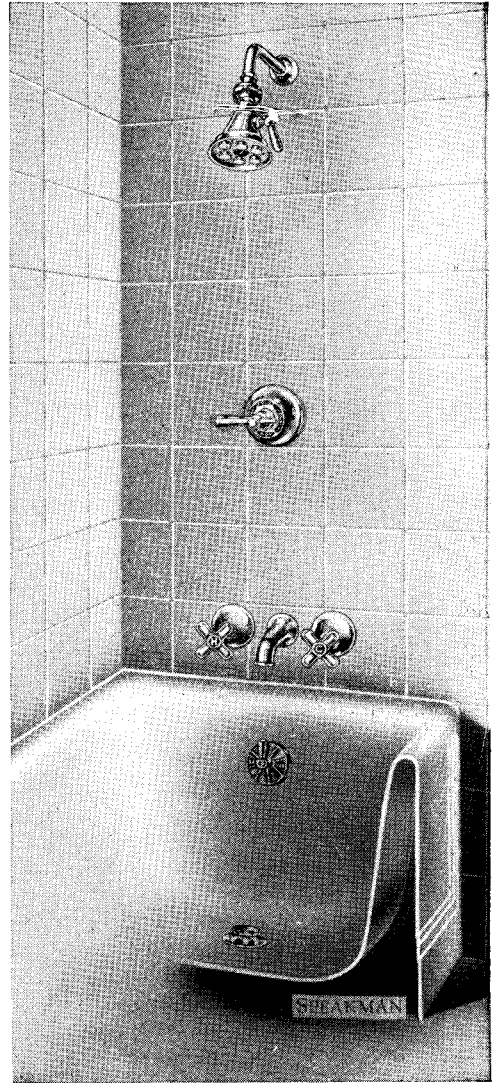

S-3000 SPEAKMAN Built-in Mixometer Shower and Bath Combination with Anystream Self-Cleaning Shower Head.



K-450 Si-Flo Flush Valve and Closet Combination.

S-768 Wilmington Vitreous China Shelf Back Lavatory. Size 22" x 18". Complete as illustrated.

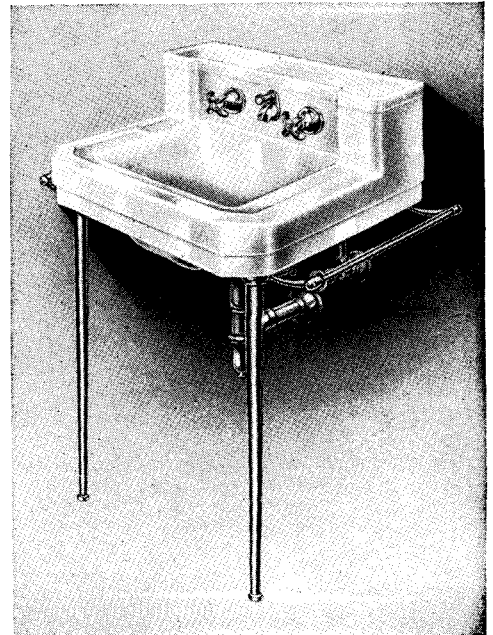



UNDER THE NATION'S ROOF

November, 1943

The war will end19.... ! Great building program assured immediately thereafter. What about postwar planning on roofs?



The principle of bituminous built-up roof construction is so basically sound that its efficiency and economy have never been seriously challenged. But maximum built-up roofing protection depends on the right MATERIALS ... the proficiency of the MEN applying them and the correct METHODS for the particular problem. Ruberoid offers all three as one service.



Real gardens on roofs, solar heating, water-covered roofs to aid air-conditioning efficiency -- yes, even roofs as parking areas for autos and auto-giros -- unusual now, but destined to play a large part in postwar building. Ruberoid Built-Up Roofing Specifications cover all of them.



A good man to know is the Ruberoid Approved Roofer. He is selected on the basis of his integrity, experience and craftsmanship. He is not wedded to any particular type of roof because in handling Ruberoid materials he is familiar with, and does apply all types of built-up roofs. When it comes to roofs, he's the best man in his community.



All danger of blisters -- caused by vapors trapped in mopping the felt -- is greatly minimized by the use of Ruberoid Perforated Felt. Outlet valves release these vapors. Inlet valves provide a complete bituminous bond between the layers of felt.



Corrugated Eternit Sheets ... made of imperishable asbestos-cement ... are non-critical and available. They are the logical answer for modern plant buildings, where low cost, fast construction is needed. Fireproof, weatherproof and pleasing to the eye. Particularly well adapted for large shell-like structures such as paper mills, chemical plants, foundries, sheds and piers. 32-page data and specification book upon request.

The RUBEROID Co.

For up-to-the-minute information on your roofing and building problems consult our nearest sales office:

NEW YORK—500 Fifth Ave. • CHICAGO—307 North Michigan Ave. • BALTIMORE • ERIE • MILLIS (Boston) • MINNEAPOLIS • MOBILE

Gas, Gasoline, and Diesel Engines... TODAY'S BEST POWER SOURCE

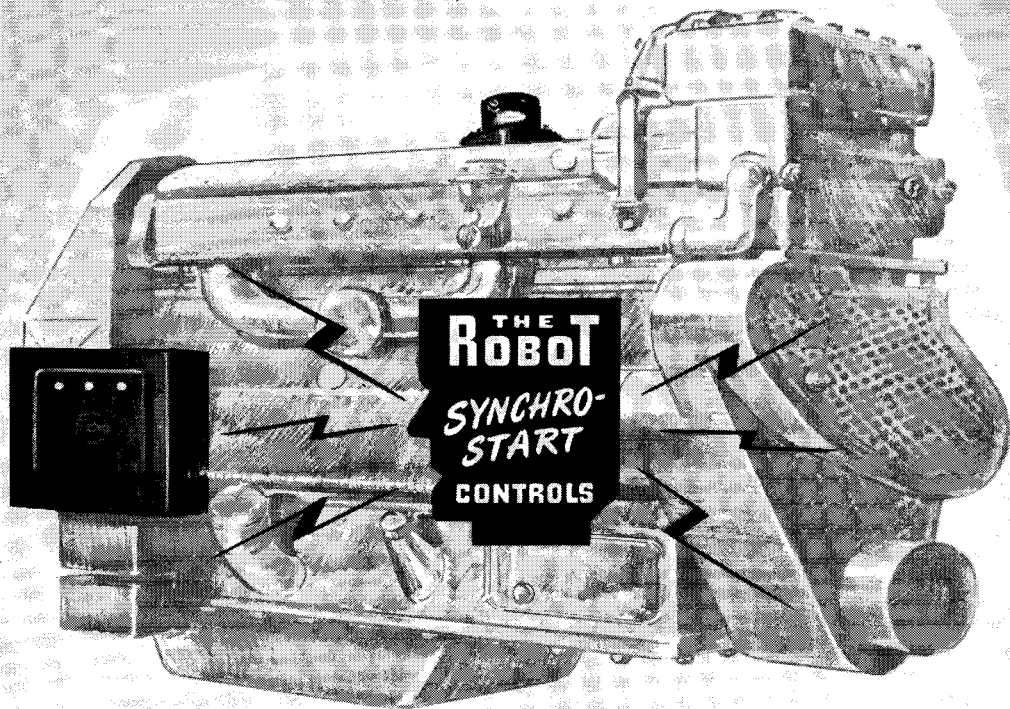

● During the past 10 years, internal combustion engines and SYNCHRO-START CONTROLS have been successfully replacing old fashioned methods of power generation and transmission, to provide a more dependable source of flexible, instantaneous, economical, automatic power. Such engines are today's best power source.

● As exclusive manufacturers of these Automatic Controls for internal combustion engines and as specialists in their adaptation to any power problem, we offer the experience of our engineers to both equipment manufacturers and power users, or,—better yet,—consult your engine manufacturer for complete information.

SYNCHRO-START PRODUCTS, INC.

221 EAST CULLERTON ST.

CHICAGO, ILLINOIS

SYNCHRO-START *AUTOMATIC ENGINE* **CONTROLS**

MAKE THIS TEST -
Prove **BRIXMENT** *is* **BEST!**



1 Butter one brick with Brixment mortar, colored with any good black mortar color. Then butter another brick with mortar made with 50-50 lime and cement, and the *same* mortar color.

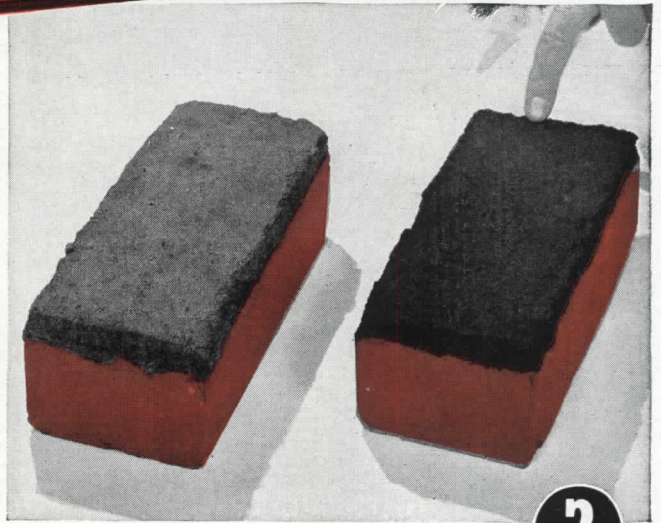

2 Set both brick aside for a couple of weeks. You'll find that the sample made with Brixment mortar retains its full, rich color (right), while the other turns dull or pale.

BRIXMENT Does Not Fade Mortar Colors!

The permanence of the mortar color in the joint depends not only upon the pigment selected but also upon the mortar materials. Too frequently a good job of brickwork is spoiled by the use of a mortar that fades the color or that leaves a white scum of efflorescence on the mortar joint.

Brixment helps prevent this condition. For Brixment is practically free from the aggressive chemical compounds or soluble salts so frequently the cause of fading and of efflorescence.

The waterproofing material combined with Brixment during manufacture is a further protection to the color because it helps prevent moisture

from penetrating the mortar joint and leaching out the pigments.

Brixment is therefore recommended by manufacturers of both mortar colors and face brick, for use with their products.

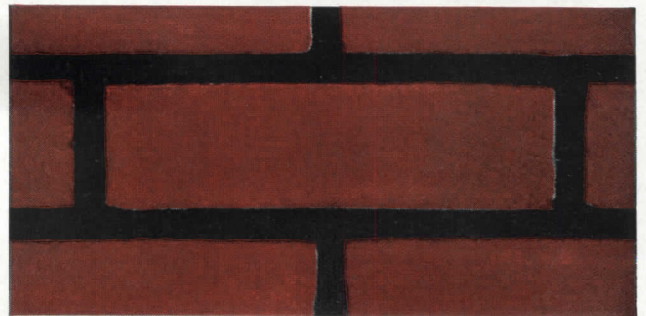

BRIXMENT

For Mortar and Stucco

Louisville Cement Company, Incorporated, Louisville, Kentucky. Cement Manufacturers for Over a Century.



Does the Office Efficiency of Your Clients suffer from **NEEDLESS NOISE?**

EMployees who work in a noisy office are bound to make mistakes. For even those who are not consciously bothered by it, excessive noise, according to medical authorities, makes the muscles more tense, the blood pressure higher.

And when working under the strain of wartime conditions, needless noise becomes an even greater menace to efficiency . . . can cause serious errors.

Help your clients step up office efficiency by bringing noise below the level of disturbance with J-M Acoustical Materials. Installation can be made easily, inexpensively and with no interruption to

routine. They are attractive and require little if any maintenance. Their scientific sound absorbing qualities are based on J-M's more than a quarter-century of experience in sound control.

Without obligation, we'll be glad to send you our Sound Control Brochure, No. AC-25A. Address: Johns-Manville, 22 E. 40th St., New York, 16, N.Y.

* * *

J-M Acoustical Materials—J-M Movable Transite Partitions and J-M Asphalt Tile Flooring are helping to speed up war-production work in busy offices all over the country.



Johns-Manville

Acoustical Materials

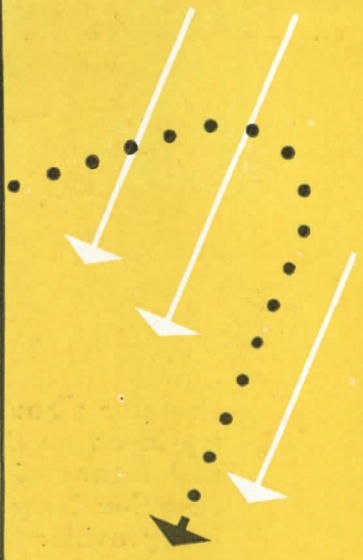
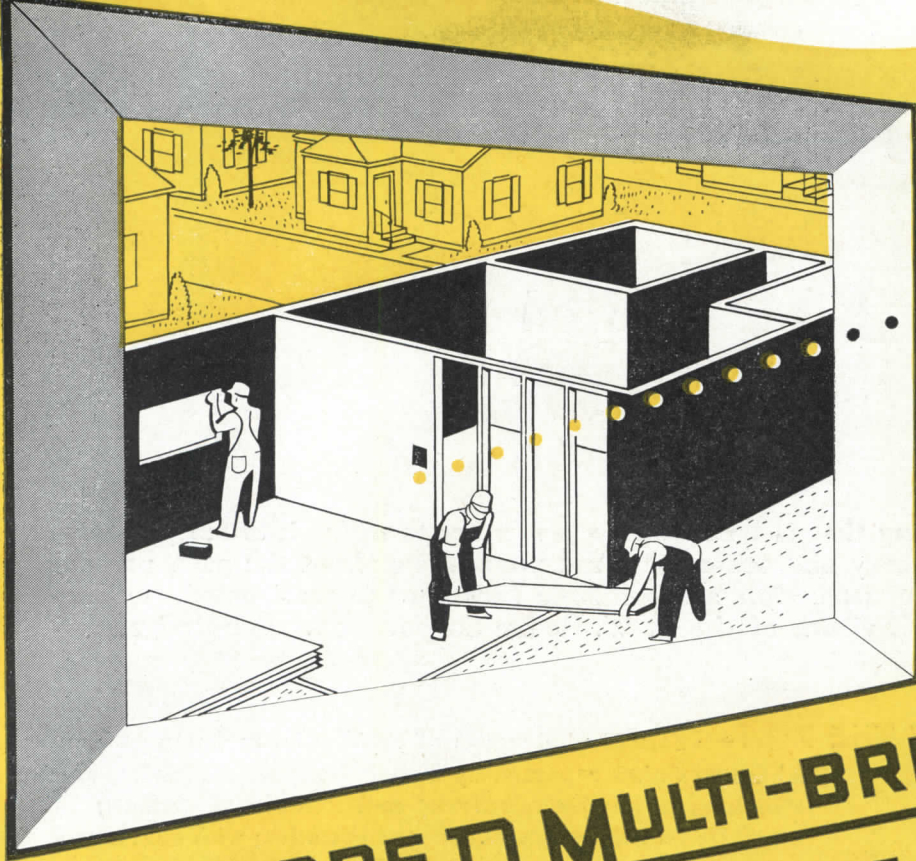

THE **SQUARE D** MULTI-BREAKER FITS INTO EVERY PICTURE OF MULTIPLE HOUSING

large units—small units—prefabricated or otherwise

WHETHER it's a small group of cottages or a planned community, complete from homes to schools, stores and churches, there is a Square D Multi-breaker installation to fit the picture . . . exactly.

The annoyance of changing fuses simply isn't in keeping with tomorrow's scheme of things—especially since Multi-breaker convenience and protection costs little more than the fusible equipment it replaces—often actually less.

Your nearby Square D Field Engineer will be glad to work with you in arriving at the best electrical specifications for any project you are planning.

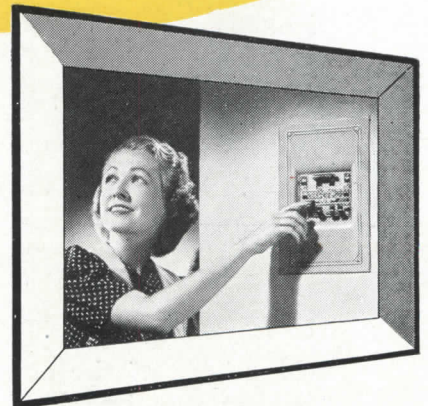

Currently, every Multi-breaker we produce is assigned to wartime service. But the same features which make it so valuable to the war effort, earn it a place in the homes which will be built in the future.

The Multi-breaker eliminates fuses completely. When a short circuit or dangerous overload occurs, the circuit is cut off automatically. A simple movement of the shockproof lever restores current. There are no delays—nothing to replace.

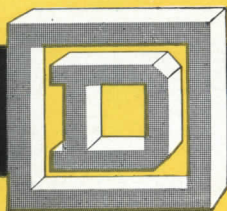

ELECTRICAL EQUIPMENT

• KOLLSMAN AIRCRAFT INSTRUMENTS

SQUARE D COMPANY

DETROIT

• MILWAUKEE

• LOS ANGELES

WHO HAS FACTS

about POST-WAR construction?

Post-war planning that is based on facts is more to the point than pen-service based on theory and schemes. And many facts about the past, present and future of construction are available through the services of the Construction News Division of the F. W. Dodge Corporation. For Dodge services provide:

FACTS ABOUT THE PAST— Statistical Records of residential and non-residential construction reported by Dodge, by types, numbers, and valuations of projects; current and cumulative figures; by states, Dodge Districts and selected counties; with charts and comprehensive comments. Information tabulated and interpreted from Dodge Reports Service.

FACTS ABOUT THE PRESENT— Selective Information about specific projects to be built in both war-time and post-war periods; provided daily by Dodge Reports to direct members of the building industry to timely opportunities for developing business; facts that help merge war-time activities with post-war planning.

FACTS ABOUT THE FUTURE— Several billion dollars worth of new post-war construction already reported by Dodge; volume increasing steadily; owners and other buying factors may be contacted now.

Members of the construction industry, who seek ways and means of developing war-time business in sufficient volume to maintain production levels—and who are making plans now for post-war operations—are invited to consult with a Dodge representative at any of the addresses listed below.

DODGE REPORTS

Issued by F. W. DODGE CORPORATION—119 West 40th Street, New York, N. Y.

ATLANTA Mortgage Guarantee Bldg.
BALTIMORE Court Square Building
BIRMINGHAM Martin Building
BOSTON Park Square Building
BUFFALO Curtiss Building
CHICAGO 700 Merchandise Mart
CINCINNATI American Building
CLEVELAND Hanna Building
COLUMBUS 12 North Third Street
DALLAS Construction Building
DAYTON 11 West Monument Ave.
DES MOINES Hubbell Building

DETROIT 2457 Woodward Ave.
GREENSBORO Southeastern Building
HOUSTON Merchants and Mfrs. Bldg.
INDIANAPOLIS Architects & Bldrs. Bldg.
JACKSONVILLE Florida Theater Bldg.
KANSAS CITY, MO. New York Life Building
LOS ANGELES 400 East Third Street
LOUISVILLE Heyburn Building
MIAMI Postal Building
MILWAUKEE 125 East Wells Street
MINNEAPOLIS Plymouth Building
NASHVILLE Union Bus Terminal Bldg.

NEW ORLEANS 333 St. Charles St.
OKLAHOMA CITY Petroleum Building
OMAHA Sunderland Building
PHILADELPHIA 1321 Arch Street
PITTSBURGH Professional Building
RALEIGH Insurance Building
ST. LOUIS 721 Olive Street
SAN ANTONIO Milam Building
TOLEDO 1220 Madison Avenue
WASHINGTON 501 Thirteenth Street, N.W.
WICHITA Murdock Building

The DAY-LINE... For Single Unit or Continuous Installations

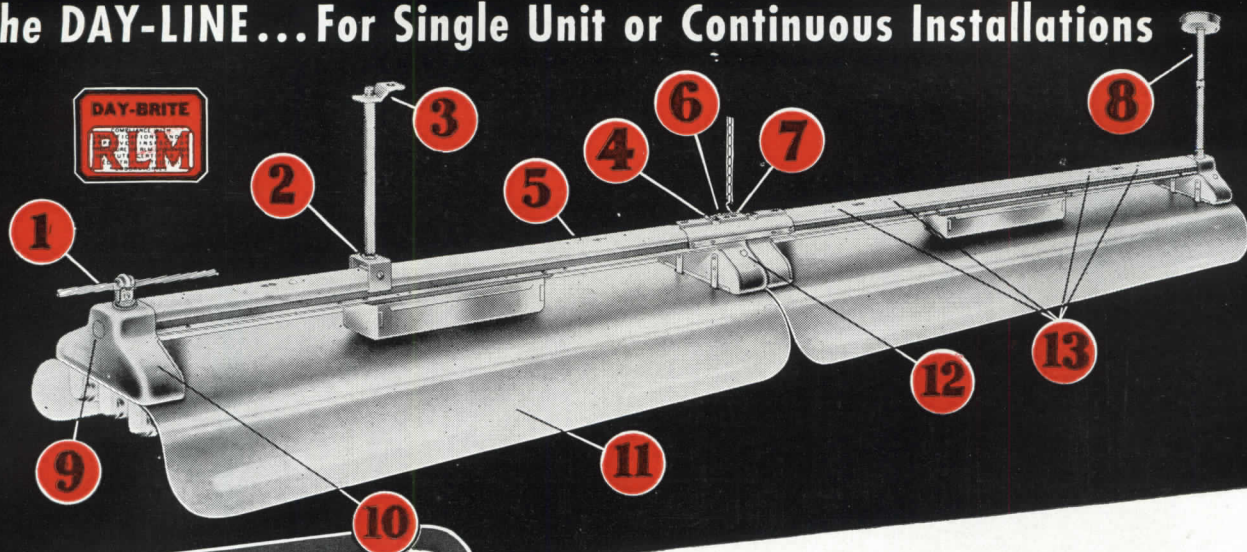

- 1 1/2" K.O. for cable clamp installation direct to fixture.
- 2 Slide channel clamps for rod or pipe hangers can be located at any point on channel.
- 3 Swivel type hanger strap is adjustable for pipe or rod alignment.
- 4 K.O.'s for pipe.
- 5 K.O. for cord.
- 6 Rigid one-piece coupling converts, single units to continuous fixtures.
- 7 Chain hanger slots in top of channel and in center of coupling.
- 8 Complete pipe hangers with ceiling canopy and all fittings.
- 9 K.O. in end for through feed.
- 10 Rigid, one-piece, die-formed end boxes welded to channel assure rigidity and proper alignment of all parts.
- 11 Non-metallic reflectors (RLM and U. S. Bureau of Standards approved). Reflection factor, 85% or more. Angle of cutoff, 14°.
- 12 K.O. for switch.
- 13 Screw holes for direct surface mounting. No couplings needed.

13 POINTS OF FLUORESCENT LIGHTING SUPERIORITY

In this new Day-Line Industrial Fluorescent Fixture, thirteen superior features give you the ultimate in lighting—now and from now on! Day-Brite's "Super-White" baked enamel finish on non-metallic reflectors assures continuously high illumination efficiency. Unusual mechanical, installation and maintenance features are illustrated above and briefly described in the panel at the left.

The same basic Day-Line Fixtures are supplied for single unit mounting or continuous runs for 2-40 Watt, 3-40 Watt and 2-100 Watt lamps. Send for helpful dimensional, specification, and illumination data contained in Bulletin F-69.

DAY-BRITE LIGHTING, INCORPORATED

5491 Bulwer Ave. — Saint Louis, Missouri



The Sign of Quality
Look for this Label



COMMERCIAL • INDUSTRIAL and SPECIAL DESIGNS *Nationally distributed through all leading electrical supply houses*

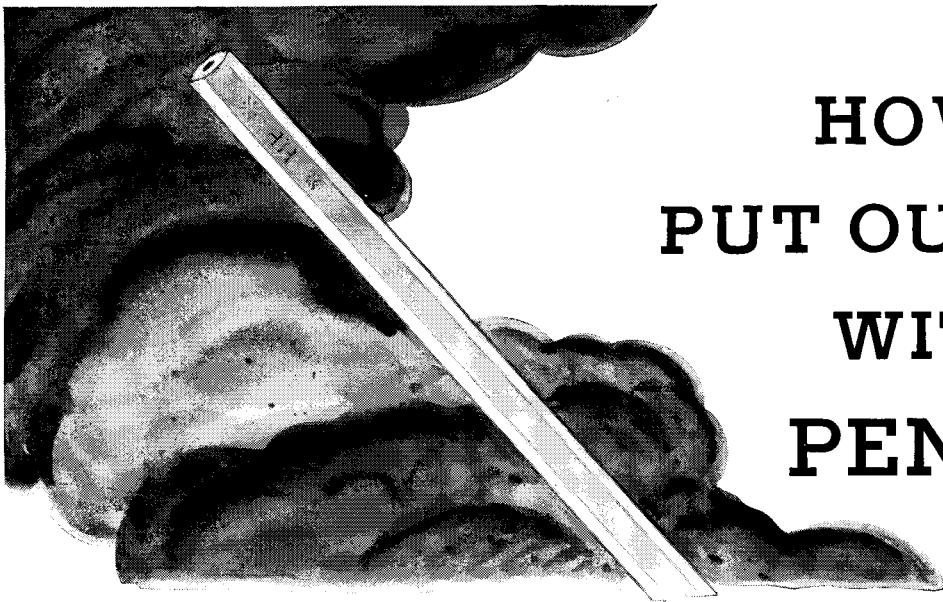

HOW TO PUT OUT A FIRE WITH A PENCIL!

THE answer is to design fire protection right into the house from the start! With Gold Bond Gypsum Sheathing and Rock Wool products this is easy. And both are ideally suited to

today's construction methods where complete wall sections are often fabricated right on the job. Ample supplies of both are available now for your wartime projects. Write for information.

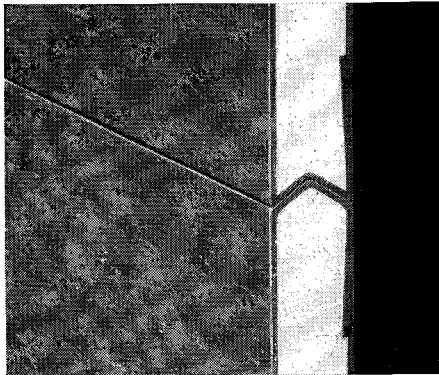

GOLD BOND GYPSUM SHEATHING . . . insures permanent fire protection for wood frame houses at low cost. It won't warp, expand or contract. Comes full 1/2" thick with core of solid gypsum rock. Long edges are Tongue and Groove for snug, windproof, joints. May be used with any exterior finish.

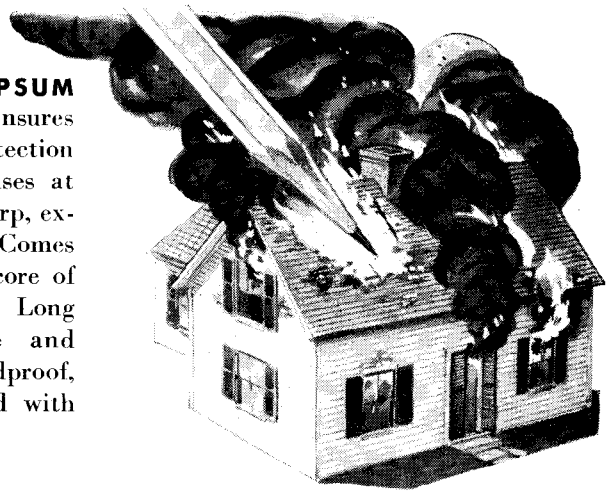

GOLD BOND ROCK WOOL PRODUCTS . . . absolutely fireproof. For the first time even low-cost houses will enjoy the comforts and savings of new high-efficiency home insulation. Supplied in batts or sealed blankets.

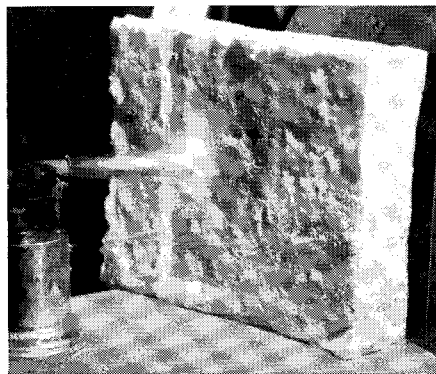

**WRITE TODAY
FOR DETAILS**

BUILD BETTER WITH

Gold Bond

Everything - for walls & ceilings



More than 150 different products for
MODERN CONSTRUCTION
AND WAR PRODUCTION

WALLBOARD...LATH...PLASTER...LIME
METAL PRODUCTS...WALL PAINT
INSULATION...SOUND CONTROL

NATIONAL GYPSUM COMPANY . . . EXECUTIVE OFFICES, BUFFALO, N. Y.

21 Plants from Canada to the Gulf . . . Sales offices in principal cities

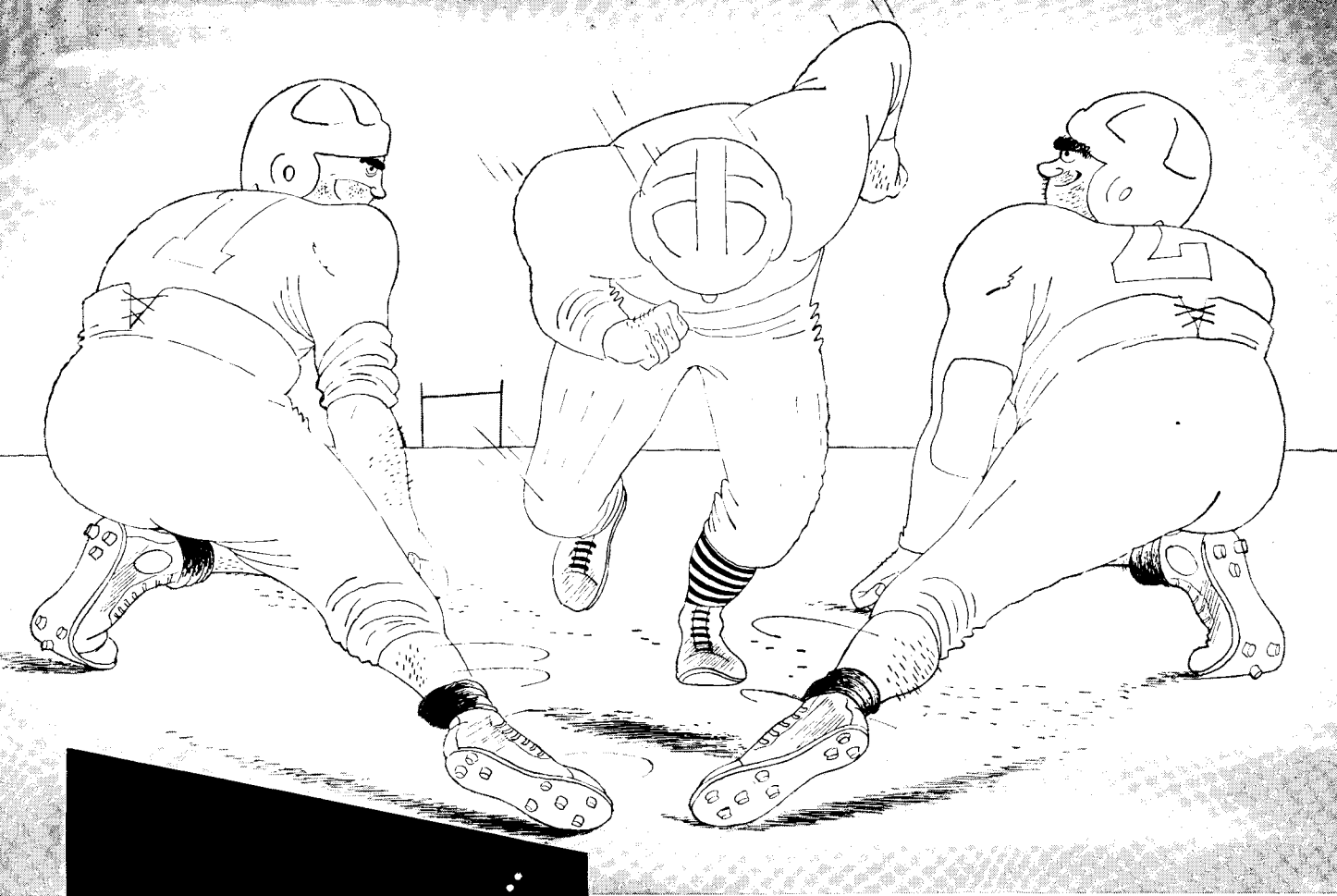

“MOUSE-TRAP”

FOR US!

Gridiron fans know the “mouse trap”... the “sucker play” that lures an unsuspecting lineman through a big hole... then traps him from behind.

We're carrying the ball strong for war now. Our factory wheels are a-buzz with activity to get out an ever-mounting volume of precision small parts for planes, tanks and fighting machines.

But we're not running with our head down. Even with the mounting crescendo of busy machinery in their ears, our engineers are

preparing the blue prints for peace... getting ready to quickly take up the slack of eventually slowing war production by a speedy switch to new and better products for YOU to use and sell.

When that day comes, LCN and far sighted business men all over America will avoid another “mouse trap”... the need for make-work programs. In their place we will have real jobs and real opportunity for every worker... the American answer to the start of a new era.

NORTON LASIER COMPANY • 466 West Superior Street • Chicago

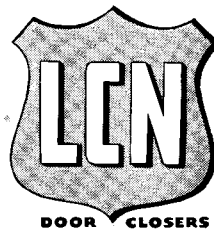

TOMORROW is well on its way!

When days of peace and reconstruction come, remember to specify equipment of NESBITT make to answer your heating, ventilating and air-conditioning problems.

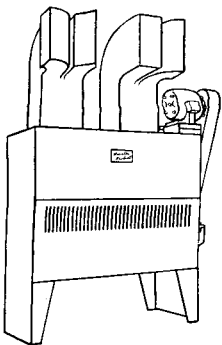
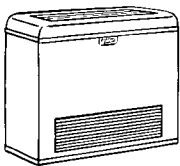
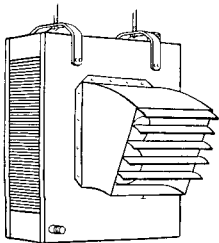
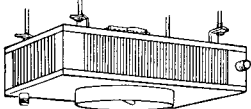
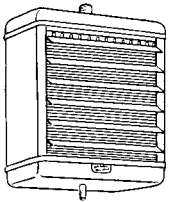
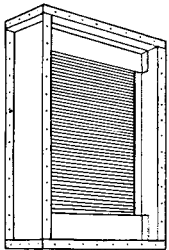
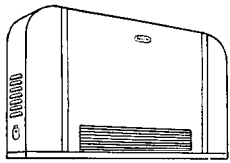

NESBITT-MADE
EQUIPMENT

W-N UNIT HEATERS

THE **W-N** PRINCIPLE:

CIRCULATE LARGE VOLUMES OF AIR AT COMPARATIVELY LOW TEMPERATURES, AND AT A VELOCITY TO CAUSE THE HEATED AIR TO MIX THOROUGHLY WITH THE ROOM AIR.

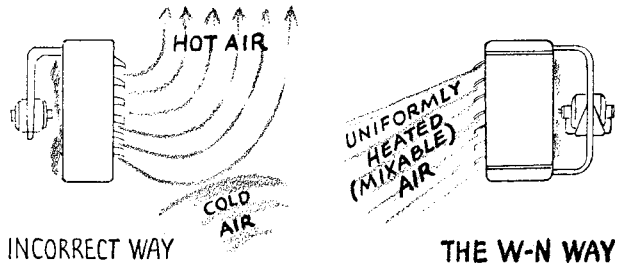

*Webster
Nesbitt*

PROPELLER-FAN UNIT HEATERS

PREVENT TEMPERATURE STRATIFICATION AND OVERHEATING OF UPPER AREAS.
ASSURE QUICKER HEATING, LOWER FUEL COST, AND GREATER COMFORT.
FOR SMALL AND MEDIUM-SIZE ENCLOSURES NOT HAVING HIGH CEILINGS.

SOLD EXCLUSIVELY IN THE UNITED STATES BY
WARREN WEBSTER & COMPANY
CAMDEN, N.J.

OFFICES IN PRINCIPAL CITIES

CATALOG W-N-111

NESBITT

JOHN J. NESBITT, INC., HOLMESBURG, PHILADELPHIA, PA.

Manufacturers of the Nesbitt Syncretizer Heating and Ventilating Unit, Nesbitt Heating and Cooling Surfaces, and Webster-Nesbitt Unit Heaters

The Nesbitt Syncretizer is sold by John J. Nesbitt, Inc., and American Blower Corporation - Nesbitt Surfaces are sold by leading manufacturers of fan-system apparatus - Webster-Nesbitt Unit Heaters are sold by Warren Webster & Company

YOU CAN START YOUR BUILDING NOW!

The questions of when and if and why and how to build boil down in the end to questions of money—how (and when) you can get the most for your money. If you are going to need new facilities—a new building, a house or a hospital, a remodeling or an addition, a factory or a farm—there are good reasons for *starting now*. You'll get a better building at lower cost—a building more economical to maintain and operate, better in material and workmanship, more convenient in arrangement—and you'll get it sooner than the next fellow who doesn't get started 'til the armistice. By being the owner with plans in your pocket, you will be in the best position to get the "breaks."

◆ First, you will save money on cost of construction. The present trend of prices is definitely upward and leading economists believe that it will continue to rise. The general price level is already some 35 per cent above 1939 and is expected to be 70 to 75 per cent higher by the end of 1946. Prices will be lowest for those who are ready with their blueprints early in the game.

◆ Second, if you start now you'll have time to live and work in the building before it's up—to mentally use it, test it, find how well it works, try another scheme if you like, to compare both. Every building is built on paper first and then with brick and mortar, and it costs a lot less to change pencil lines on paper than to tear out a column or girder.

◆ Third, it will be "first come, first served" in labor and materials too, which means skilled craftsmen and the best of the new materials and equipment will be employed on and in your building. Skilled labor will be scarce and the best will be the first employed. You can bank on the fact that the development of building materials and equipment is *evolutionary*, not *revolutionary*. Your architect is keeping his mind and eye on all such improvements, analyzing them, judging them, adopting those that are sound to incorporate in the designs for your building.

◆ Fourth, your building will be better planned and designed. You can now get the personal and individual attention of the architect-engineer in studying your problem, with time to produce the best possible solution to your entire building problem. You can save money by having a thoroughly-thought-out-in-advance building—a building efficiently planned to save time and useless traffic, built of materials and equipment selected for minimum maintenance, operating and repair costs. The time spent in this careful planning now can mean the saving of costly extras or changes after actual construction starts.

◆ A preliminary talk with your architect now will clarify your special problems, and indicate the best course of action. You can easily arrive at an equitable arrangement with him for whatever services may be indicated, on a time, percentage, fixed-fee, or cost-plus basis. He can start your building *now* on paper—plans and specifications ready when the time is ripe for you to get the most for your money.

PRACTICAL

URBAN REDEVELOPMENT

By THOMAS S. HOLDEN

PRESIDENT, F. W. DODGE CORPORATION

The slogan that won the first presidential election after World War I was "back to normalcy." That appeared to mean that our country, whose status was greatly changed by circumstances attending the war, should operate on economic policies that were valid in 1913. It seems to me that those postwar planners who envisage vast federal spending programs as a solution of the economic problems of the coming postwar period really want us to get back to the normalcy of 1933. It looks to me like planning, not for a prosperous future, but for the great depression that is now happily past. The "back-to-normalcy" boys of 1920, to the extent that they planned at all, at least planned for prosperity.

Biggest problem of the federal government, in managing its fiscal policy for maximum benefit to our economy, will be controlling inflation and controlling the postwar boom. Of equal importance in the immediate period of change-over to a peacetime economy will be the orderly release of critical materials to manufacturers of consumer goods and of building materials and equipment so that overwhelming demands can be met as promptly as possible. Purchasing power will be distributed through systematic redemption of war bonds, by ordinary distribution of income to persons then gainfully employed, and, to some extent, by payment of unemployment benefits. Whenever price, rent and wage ceilings are lifted, purchasing power will continue to be greatly in excess of available goods and services; the threat of inflation will thus be far greater after the war than during the war. Unnecessary federal spending at that time would simply increase the inflation pressure, thus aggravating the major economic problem of the time rather than solving any problem.

It has been estimated that liquid savings in the hands of individuals will amount to \$50,000,000,000 by the end of 1943: this total includes an estimated \$24,000,000,000 of war bonds, other savings to the amount of \$18,000,000,000, and potential consumer credit of \$8,000,000,000. The Treasury Department estimated some months ago that there were then 50,000,000 individual holders of war bonds, half of them employed persons who have bought bonds by the payroll deduction method. States and cities, like individuals, have been saving money and reducing debt; some have built up postwar reserves, some have invested in war bonds. Ten years ago the depression put many people, institutions and local governments in hock to the federal government; the war has put the government in hock to us. We don't have to go back on the dole; if we do, it will be our own fault.

It seems necessary to sketch this postwar situation, as it now appears to be shaping up, in order to refute the

theory that federal subsidies, avowed or camouflaged, for urban rehabilitation are necessary and desirable as vehicles of public spending.

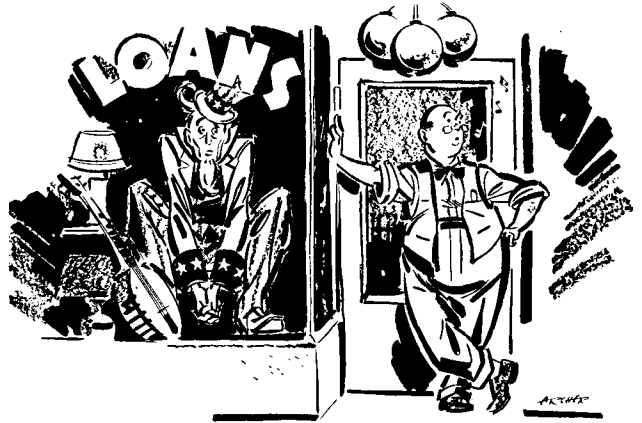

"... the war has put the government in hock to us ..."

The other argument for federal intervention in this purely local problem is that there is no hope that local communities can accomplish anything for themselves, that the states can do little to help them, and that the job can't be done without federal aid; the idea seems to be that, in order to redevelop the blighted urban areas of our cities, somebody has got to bail out the owners of insolvent property. In passing, I would like to remark that the principal problem to which Congress, the fiscal agencies of government and the American people should address themselves is the problem of bailing out the government. More to the point, however, is the probability that time will likely show that the amount of necessary bailing out of overvalued real estate is apt to be much less than many people think.

Present values of real estate are not frozen for all time. This is true of fictitious and arbitrary values, as well as of real values. It is true of the values of presently desirable sites and of presently undesirable ones. Some properties due to appreciate are only waiting for rent-ceilings to be lifted.

As sure as you are a foot high, the general postwar price level is going to be substantially above that of 1939. Our experience of previous postwar adjustments and our present knowledge of excess purchasing power, seem to place this proposition beyond debating. One reputable economist has gone on record with a carefully studied estimate that the Bureau of Labor Statistics all-commodity price index, will by the end of 1946, assumed as being

two years after the cessation of hostilities in Europe, be 70 to 75 per cent over the 1939 average. Another equally able economist told me privately some months ago that he was thinking in terms of a 100 per cent rise.

I don't know just how to translate this anticipated rise in the general price-level into figures on probable increases in property values. It may be useful to recall some things that happened after World War I. After a sky-rocketing postwar price inflation and a severe deflation, prices reached a comparatively stable level persisting from the latter part of 1921 through to 1929. In the peak year 1925, the commodity price index averaged 48 per cent over 1913, and the Labor Bureau's index of house rents averaged 65 per cent over 1913. I do not know whether postwar rents will this time advance by larger or by smaller percentages than commodity prices. They seem practically certain to advance in quite substantial degree, carrying property values along on their upward swing.

Obviously, the process of real estate revaluation operates selectively. On an upswing the more desirable properties appreciate, and less desirable properties lag behind, stand still, or even depreciate. Consequently, it is a more than fair expectation that in the postwar period present differentials in value between blighted property in central areas and vacant land in outlying districts will be considerably lessened, thus reducing the present competitive advantage of outlying property. It is also quite likely that when municipal governments find it possible to collect more tax-dollars from outlying property, they can more readily respond to insistent demands for realistic assessments on centrally-located properties. I would not claim that postwar inflation will solve the problem of urban redevelopment. It will change the arithmetic of costs among competitive properties, but will neither tear down slum dwellings, reclaim neighborhoods nor build new buildings. It may reduce or even eliminate the supposed necessity of bailing out.

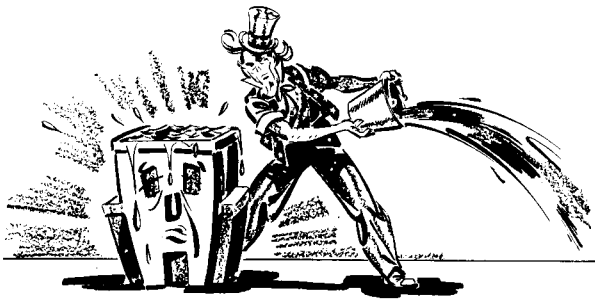

If Uncle Sam bails out property, who will bail out Uncle Sam?

Why should we bail out insolvent real estate with government money, any more than we bail out insolvent shoeshine parlors, grocery stores, manufacturing enterprises, or railroads? There are well-established procedures for reorganizing and refinancing insolvent enterprises which have, I believe, an entirely practical application to the problem of redevelopment of blighted urban areas by private enterprise, if sound inducements to investment of private capital and sound profit incentives can be created.

Now, the basic philosophy of the Urban Redevelopment Corporations Law, as enacted in the State of New York in 1941, is the principle of reorganization of the man-

gerial and financial structure of insolvent properties. This law was the pioneer state redevelopment law enacted in this country. Some of the other state laws follow its philosophy; others have adopted much of its terminology. Consequently, an exposition of its philosophy and its provisions affords the best starting point for discussing state legislation in this field. Furthermore, as chairman of the committee of business and professional men which, under the sponsorship of the Commerce and Industry Association of New York, drafted the bill and steered it through two sessions of the legislature, I got many of my own ideas into the bill, and may perhaps now have a slight partiality for it. Since another law, of somewhat different tenor, was enacted in New York in 1942, with the very similar title "Urban Redevelopment Companies Law," I will hereafter refer to the earlier law as the 1941 act in order to avoid confusion.

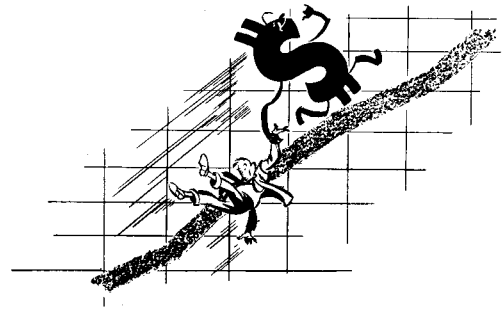

"... postwar price level . . . substantially above that of 1939."

By common consent, the first necessity for reorganizing insolvent properties in blighted neighborhoods is to consolidate properties under unified ownership and management; in other words property must be assembled in order to make up units large enough for modern economic development and use. The New York 1941 law provides for the use of powers of eminent domain for assembling property, as do all the other state laws enacted and proposed. The 1941 act provides that condemnation may be exercised either by a private redevelopment corporation or by the city for a corporation; it stipulates, however, that as a prerequisite to institution of condemnation proceedings, the corporation must have acquired a majority control (51 per cent by area and by assessed valuation) of the property within the area to be developed. The Illinois law has a minimum condemnation requirement of 60 per cent of the property to be redeveloped, and for condemnation by neighborhood redevelopment corporations but not by the municipalities. No other state law that I am familiar with has a minimum condemnation requirement. The recently enacted Missouri law and the most recent draft of the proposed Massachusetts law, neither of which has a minimum requirement, provide for condemnation by the private corporations but not by the municipality. The 1942 New York law (to be explained later) and the enactments of Michigan, Kentucky and Wisconsin require condemnation by the municipality. The mechanics of condemnation are important, but less so than other features of these various measures. In reciting these provisions I wish to point out how, even in this particular, the 1941 New York law embodies the principles of a business reorganization.

Of basic importance in the 1941 New York law are the financing provisions. On the theory that it is not necessary that a big investor be found who can and will purchase all the property for a redevelopment outright for cash, the law permits and encourages present equity holders and mortgagees to exchange their property or claims for stock and debentures of the redevelopment corporation. By this device, existing mortgages can be subordinated to a new mortgage and the actual cash outlay

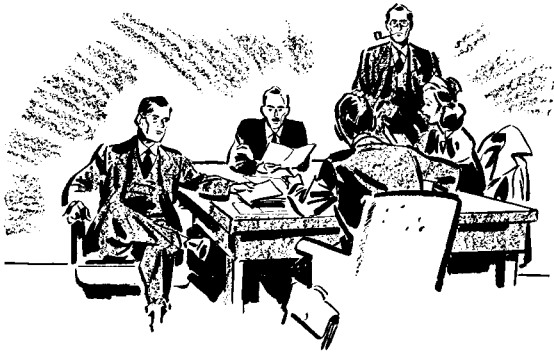

"encourages equity holders to exchange property for stock . . ."

for acquisition of property, under favorable conditions, need not be more than a moderate fraction of the total project cost. No specific formula for capital set-up is provided, nor is there any limitation of dividends; there is, however, provision for limitation on disbursements of earnings, for the sole purpose of preventing the milking of the property. During the tax exemption period (to be explained hereafter) disbursements to cover all interest and dividends may not exceed 5 per cent of development cost. Earnings over that amount might be used to retire debt, to retire equity stock, or to build up surplus. Such surplus would be owned by the stockholders and would not be paid over to the city, as some other redevelopment laws require. I see no reason why the stockholders of a soundly managed company, which has been able to meet its operating expenses, build up necessary reserves and reduce its indebtedness should not own the equity appreciation thus earned by good management; why they should not own the property they have gradually paid for.

This anti-milking provision should not be regarded as a serious limitation. For illustration, a project whose development cost is \$1,000,000 may pay out for interest and dividends \$50,000 in a year when that amount is actually earned over and above operating costs, required reserves and contracted amortization. A \$650,000 first-mortgage at 4 per cent would require \$26,000 of the \$50,000, leaving \$24,000 for other distribution. Perhaps there would be \$150,000 in 3 per cent debentures, which would call for another \$4,500; this would leave \$19,500 available for distribution to holders of the securities representing the remaining \$200,000 of equity, or 9¾ per cent. In theory, an even higher return might be worked out for holders of certain classes of equity stock, which would preferably be the suppliers of new venture capital.

As mortgage debt is amortized out of earnings (but not out of the 5 per cent permitted for income and dividend disbursements), as income debentures or certain classes of stock are retired, a larger and larger share of the permitted disbursement fund would be available to share-

holders, so long as earnings are adequate. This would make possible the initial issuance of something which might be called class B no-par-value stock, which might not receive dividends at first but would have an expectation of receiving dividends later. An offer to a present owner or mortgagee of low-interest debentures plus class B no-par stock in exchange for his property, now presumably operating in the red, would be an offer of a modest return now plus a prospect of a share in future profits if the venture is successful. Thus might the principle of business reorganization be made to function.

It should be understood that the procedure just described is one illustration of what might be done under the Act, which prescribes no formula for capital set-up. The permitted flexibility in capital structure and in dividend disbursements seems necessary in order to attract venture capital. In addition, it offers a way to capitalize the prospective improvement in the equity position as senior claims on earnings are gradually reduced. The limited-dividend idea, copied from earlier housing legislation in some state redevelopment laws, fails to take this factor into account; for this reason I question whether those laws permit projects that would prove attractive to venture capital.

Privileges offered to redevelopment corporations which thus far have been described (powers of condemnation and flexibility for the reorganized financial structure) offer no direct financial inducements to private capital. Such an inducement is offered in the tax exemption feature of the 1941 New York Law. This feature was introduced in recognition of the fact that one of the strongest deterrents to investment in income-producing real estate has been the tendency of local government to place upon improved properties such high taxes as to jeopardize the possibility of reasonable net earnings. Under the provisions of the 1941 act, increments of value due to assembly, replanning and reconstruction of the development area may be exempted from local taxation up to a maximum period of ten years. After the tax-exemption period is over, the corporation has no accumulated obligation to the city and is released from further public supervision of its operations, except for departures from the approved physical plan. It is considered worth the city's while, on a strictly business basis, to make this much of a contribution to the improvement of the community. The city is one of the principal creditors of the insolvent property; in fact, by exercising its prior lien on earnings in collection of taxes on the basis of fictitious valuations, it has contributed to the insolvency of the property. As any other intelligent creditor might do in the case of reorganizing an insolvent debtor enterprise, it can afford to make concessions in order to help the enterprise get back into the black; frequently, a creditor can not, as a practical matter, refuse to make reasonable concessions for restoring the debtor's solvency.

It scarcely seems necessary to go into details as to the law's provision for public supervision of physical plans and of operating policies of redevelopment corporations. It should be mentioned, however, that an approved development plan may contemplate any type of building suited to the area in question, residential, commercial or industrial or combinations of them. It may consist of a program for modernization and gradual replacement of existing buildings over a scheduled period, if such a pro-

gram is approved as sounder economically than immediate demolition and replacement.

The fact that no projects have been undertaken under this 1941 act proves nothing as to whether the law is workable. Two things happened shortly after enactment that put a stop to people's thinking about plans to take advantage of the law. In the summer of 1941 came the first intimations of war restrictions on construction, and in October 1941 came the first actual restrictive order. This had the effect of discouraging plans for any kind of large-scale project. Some projects were placed before the New York City Planning Commission for tentative consideration and the Commission had started drafting rules and regulations covering such projects. It was not long after that however, when Mr. Rex Tugwell resigned as chairman of the Commission and Mr. Robert Moses came on as a member of and dominant influence in the commission. He had opposed the 1941 act, believing the only way to get the job done was through a type of legislation specially framed to get life insurance companies to invest in large-scale housing projects. He, with others, secured enactment in 1942 of the Urban Redevelopment Companies Law. With liberalizing amendments in 1943 this became the legal sanction for the widely publicized Stuyvesant Town Project of the Metropolitan Life Insurance Company. The 1942 Act (as amended in 1943) differs in many particulars from the 1941 Act; it does not supersede it, nor conflict with it except that the confusion of titles and the more recent publicity received by this later law has tended to obscure the earlier one.

The principal aim of the 1942 law is to offer inducements to life insurance companies to make direct investments in large-scale housing projects in blighted areas. There are two principal inducements offered: (1) exemption from local taxes, up to a maximum period of 25 years, on increments of value created by assembly of the

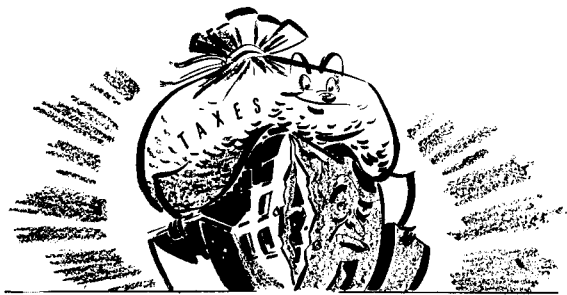

"the city . . . has contributed to the insolvency of the property"

property and replanning and redevelopment of the area; and (2) the right of condemnation, up to 100 per cent of the needed property, to be exercised by the municipality for the redevelopment company. Life insurance companies may invest up to 80 per cent of project cost in bonds and mortgages of the redevelopment company; they may also invest in equity stock or income debentures, which together shall not represent less than 20 per cent of actual project cost. Mortgage and bond interest may not exceed 5 per cent; holders of stocks and income debentures may not receive more than 6 per cent. Earned surplus that may exist at the time of dissolution of a company must be paid into the treasury of the municipality. This could be avoided by the company, which could exercise its right

to buy itself out of this obligation and out of public supervision by paying to the city all the accumulated taxes that have been remitted from the beginning with 5 per cent interest; this right may be exercised at any time. It seems to me that the limitation on dividends and disposition of earned surplus make this type of investment unattractive to venture capital, though possibly it would prove advantageous to a large institutional or individual investor.

The liberalizing amendments enacted this year met with very severe criticism. Even those who supported them admit that, while the public interest is not likely to be flouted by the Metropolitan Life Insurance Company, there might be opportunities for less scrupulous investors to use condemnation powers to assemble land, pay up all taxes at some early date after acquisition of the property and sell the property so acquired at a speculative profit. It is generally agreed that the act needs review and further revision at the next session of the legislature.

Shortly after this year's amendments were enacted the Metropolitan Life Insurance Company filed an application with the New York City Planning Commission for approval of its proposed Stuyvesant Town Housing Development. This development, to be built after the war, is to be located in the Borough of Manhattan, in an area bounded by 14th and 20th Streets, East River Drive and Avenue C. The area comprises 18 blocks or 67 acres, including the beds of the streets. There are to be 35 apartment buildings, mostly 10 to 13 stories high, and a number of 1-story garages built on the periphery to accommodate 3,000 cars. There will be 8,842 apartments in the development, with a total of 31,000 rooms. The present population of the area (about 11,000) will be increased to approximately 25,000.

This increase of population will give a density of 132 families, or 373 persons to the acre, a feature of the project plan that has been severely criticized. Other features, however, are being criticized more severely than that. In the contract between the city and the company, the city donates all the existing streets to the company and permits the new thoroughfares to be laid out within the boundaries of the projects to be maintained as private thoroughfares. No school is to be provided within the project. Children living in Stuyvesant Town will have to cross the busy widened streets surrounding the project; persons living outside will have to walk around it. To many people this drastically violates sound principles of neighborhood planning; they have called it a medieval walled town. Unless this plan, which has been approved by the City Planning Commission, is radically changed, it will give to New York a vast monumental institution, for which in turn the city stands to remit taxes on the improvements for a period of 25 years and to give up control of thoroughfares essential to the convenience of occupants of the surrounding area. Some people have said that Stuyvesant Town may become a shining example of what not to do in urban redevelopment. In addition to features of the project itself which are considered questionable, the procedures that have been followed in the legislation itself and in approving the plans have been criticized as reducing the City Planning Commission to mere rubber-stamp status, which would not augur well for the future development of New York City. Criticisms have been directed principally toward the terms of the

city's contract with the company, less toward the Metropolitan Life Insurance Company or its motives in undertaking the project.

It is unfortunate that this spectacular first project should be one which does not appear to command wholehearted commendation from all those interested in sound redevelopment of our cities. Be it said here, that the Commerce and Industry Association of New York, with which I am identified and which was responsible for drafting the 1941 Law, supported the first Hampton-Mitchell Bill (which was enacted as the Urban Redevelopment Companies Law) in 1942, though it took no action on the amendments that were put through this year. Our group has never felt that there was one right formula for doing this job or that we were the only people with constructive ideas on the subject. There is a serious question in my mind whether the Stuyvesant Town project, as now planned, creates a pattern that can or should be followed by others, either in New York City or in the other cities of the State.

I see no valid objection to direct investment by life insurance companies and savings banks of a reasonable proportion of their funds in well-conceived housing projects. The trouble is, as I see it, that too many people have gotten the notion that, barring federal subsidy, this is the only way the job can be done. I believe the insurance companies and the savings banks are neglecting one obvious public service which it is their duty to perform. Savings and loan societies recognize a two-fold obligation: (1) to invest their funds wisely; and (2) to promote sound home-ownership. I think the larger thrift institutions have a similar duty to promote sound equity investment in income-producing real estate, thus restoring the general investment status of real estate to the position it should occupy in a well-ordered society. This obligation has not yet been recognized.

Although the 1941 Urban Redevelopment Corporations Law has been overshadowed in the past year by the widespread publicity given to schemes for federal subsidy and by the furors over the later New York law I firmly believe that people will find it necessary to recognize the validity of the basic philosophy of the earlier law and to make use of its provisions. It is entirely possible, of course, that some revisions of that law may be required in order to make it workable.

I will review briefly the redevelopment laws enacted by states other than New York. The Michigan law was enacted in 1941 very shortly after enactment of the first New York Law. It follows the pattern of the New York law. It follows the pattern of the New York 1941 Act very closely, with minor differences; it applies only to cities of 500,000 population and up (thereby meaning Detroit); it omits the possibility of granting powers of condemnation under eminent domain to redevelopment corporations and omits any minimum condemnation requirement.

The Wisconsin law is also patterned largely upon the 1941 New York law. However, it does not grant condemnation powers to the private corporations; its limitation of disbursements for interest plus dividends to 3 per cent of development cost seems drastic; unlikely to invite venture capital. Being enacted this year, it acknowledges the effectiveness of recent propaganda for federal subsidies

by including a paragraph permitting redevelopment corporations to accept them.

The Illinois and Kentucky laws give powers of condemnation to private corporations, but offer no tax exemption. Under the Illinois law condemnation by private neighborhood redevelopment corporations only is provided for; the minimum condemnation requirement is 60 per cent of the total area. The Kentucky law provides for condemnation by the city only.

The recently enacted Missouri bill follows the 6 per cent limited-dividend idea, as does also the proposed Massachusetts bill, not yet enacted, which is strictly a housing bill. I have no enthusiasm for the 6 per cent limited-dividend idea; it does not reward investors for amortizing debt out of earnings, a practice which was not customary when the first 6 per cent limited-dividend housing laws were enacted; it, therefore, does not attract venture capital. It can presumably attract the type of large investor who merely wants a safe moderate income and the return of his capital. These two bills also permit the private corporations whose creation they authorize to accept federal subsidies.

The Maryland Act is different from the other state laws. It merely creates for the City of Baltimore a public agency authorized to accept federal loans and grants to be used in acquisition of land for redevelopment purposes.

The state legislation here reviewed thus exhibits four basic concepts:

1. The principles of business reorganization (the 1941 New York law, the Michigan law, the Wisconsin law).

2. The principles of granting powers of eminent domain for public purposes, without financial inducements (Illinois and Kentucky).

3. The principles of limited-dividend housing corporations (the 1942 New York law with 1943 amendments, the Missouri law and the proposed Massachusetts law).

4. The principle of bailing out with subsidies (the Maryland law, and as an incidental but not primary feature, the Wisconsin and Missouri laws).

As I stated earlier, I am partial to enactments based upon the principles of business reorganization, exemplified in the 1941 New York Act, either as it now stands or as it may be improved by future amendments. I am not sure whether the laws which offer no more than powers of condemnation for land-assembly, or those based on the limited dividend principle will attract venture capital. I am positively opposed to federal subsidy.

I readily admit, however, that it is not to be expected that private redevelopment corporations can undertake a project that goes beyond providing improved or new facilities for income-producing private uses; redevelopment for public uses will necessarily be largely financed, both as to first cost and maintenance, by the municipalities. The 1941 New York law assumes that the larger plans for reclaiming a whole blighted district would be worked out by the City Planning Commission, which would have the responsibility of determining whether a proposed private project fits into the district plan.

I also admit that those cities which have not yet gotten their finances in satisfactory shape, which have difficulty balancing their budgets, which are close to their debt limits, may not find it entirely easy to finance their proper share of the overall redevelopment that is necessary. But

(Continued on page 104)



Hedrich-Blessing photos

PLANNED FOR CARGO PLANES

PLANT FOR CURTISS-WRIGHT CORPORATION, LOUISVILLE, KY.

ALBERT KAHN ASSOCIATED ARCHITECTS AND ENGINEERS, INC.

ONE OF THE FIRST projects in America designed exclusively for the building of huge cargo planes, this plant was sponsored by the Defense Plant Corporation for operation by the Airplane Division of Curtiss-Wright Corporation at Louisville, Kentucky.

The construction work was completed early this year, and much of the construction interval fell into that period where scarcities and priorities were most severe. Design plans had to be changed for various sections of the project to meet new restrictions and to take advantage of immediately available materials; the boiler house had to be designed and built around the available equipment.

In the project are a main manufacturing and assembly building, a flight hangar, administration building, truck garage, fire protection reservoir, boiler house and oil storage house. All buildings are of reinforced concrete, brick and wood, with structural steel used only for columns and roof trusses in the two main assembly bays and the flight hangar.

The site is adjacent to the modern Army-operated Standiford airport, facilitating flight delivery of cargo

planes, and is serviced by a main truck highway and a railway spur line.

The main building has a clear height under trusses of 35 ft. in the two main assembly aisles, with a concrete floor throughout. On each side of these two aisles is a two-story reinforced concrete section 72 ft. in depth for light manufacturing, sub-assemblies and storage.

The one row of steel columns down the center divides the main area into two assembly aisles each with a span of 125 ft. and bays of 50 ft. A complete system of craneways extends to all parts of the assembly area, comprised of two lines of five-ton cranes hung from the trusses in each assembly aisle with a possible combined lift of 20 tons.

Exterior walls are brick 8 ft. above the floor line, with a horizontal band of wood Victory sash and a Cemesto board facing above the sash to the roof line. On the two-story concrete portion, two bands of Victory sash light the individual floors.

The roofs of all except the reinforced concrete buildings are covered with wood plank nailed to wood purlins—the plank in turn covered with ½-in. impregnated fiberboard

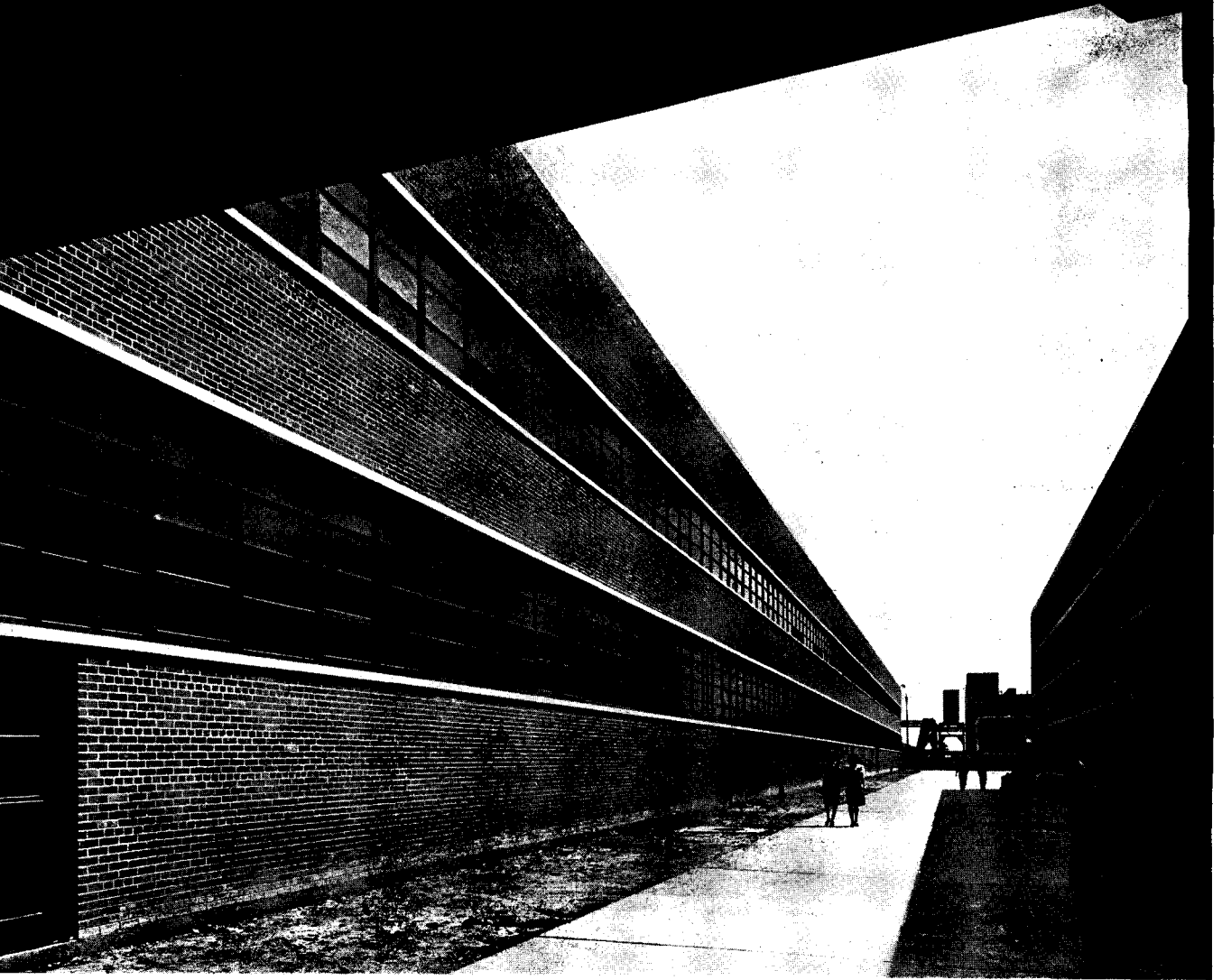

Administration building parallels main assembly building, with 35-ft. court between. There are several overhead passageways

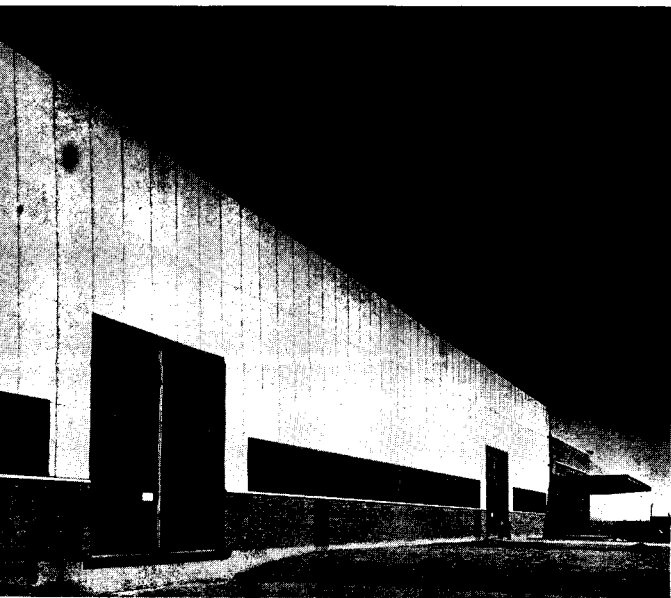

to prevent tearing of the composition roofing material due to buckling and shrinkage of green lumber.

Men's and women's toilets are all located along the exterior walls, three on either side of the main assembly section and on both floors of the two two-story sections. Because the percentage of men to women employees could not be foreseen, provision was made for shifting of toilet partitioning to meet a fluctuating ratio.

An unloading dock 225 ft. long extends along the south end and east side of the building, with large freight elevators supplying the mezzanine. On the opposite end of the building, adjacent to the flight hangar and final assembly is a 275-ft. loading dock, with a 50-ft. section reserved exclusively for trucks. There are two railroad sidings covered by a canopy at each dock, and a gantry crane for quick handling of freight to and from the cars.

The flight hangar building is 375 by 180 ft., with a clear height of 40 ft. under the roof trusses. Construction and architectural detail follow the same general plan of the main factory building. There are three clear spans, each of 125 ft., with no interior columns. Three mechanically

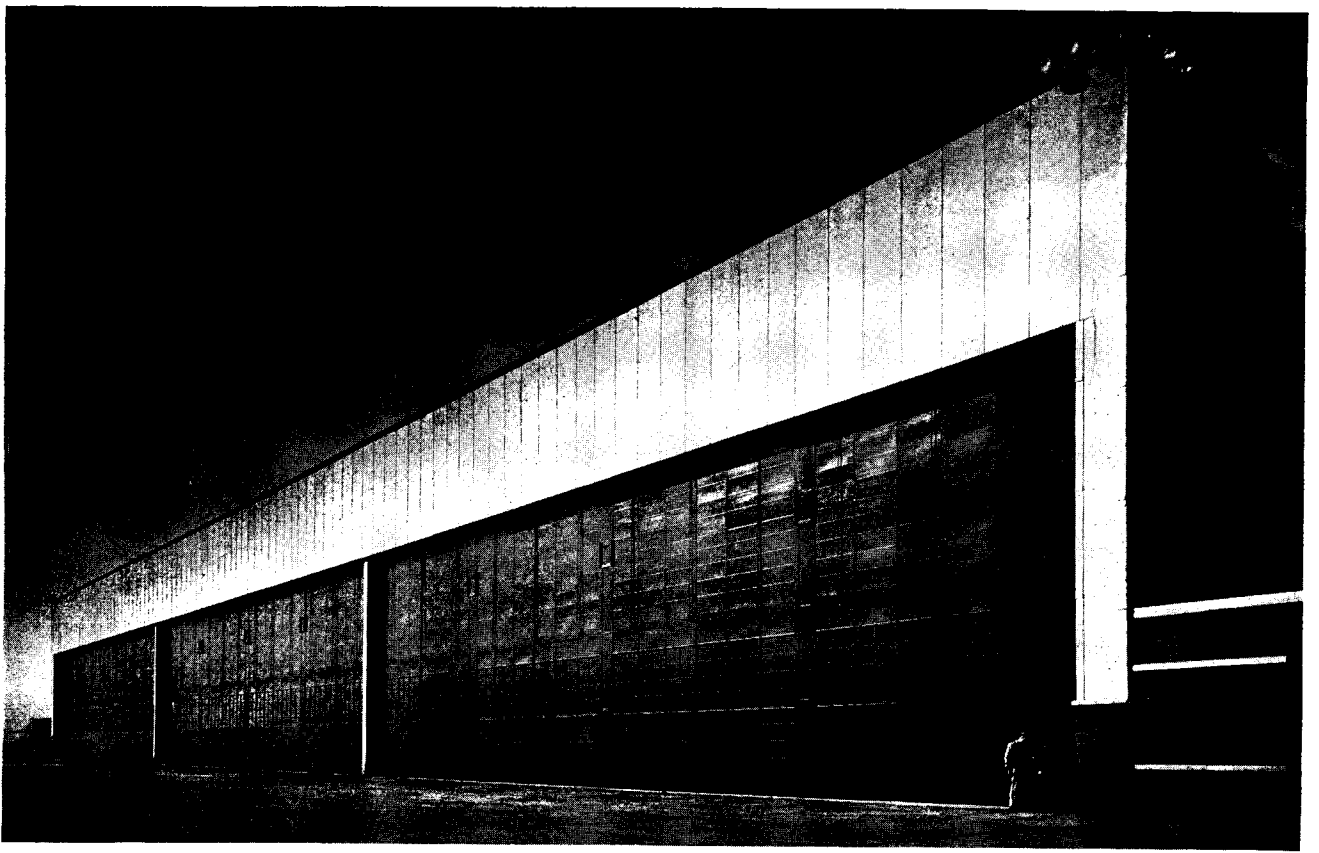

Flight hangar building has three clear spans of 125 ft. Matching these spans are three mechanically operated overhead doors

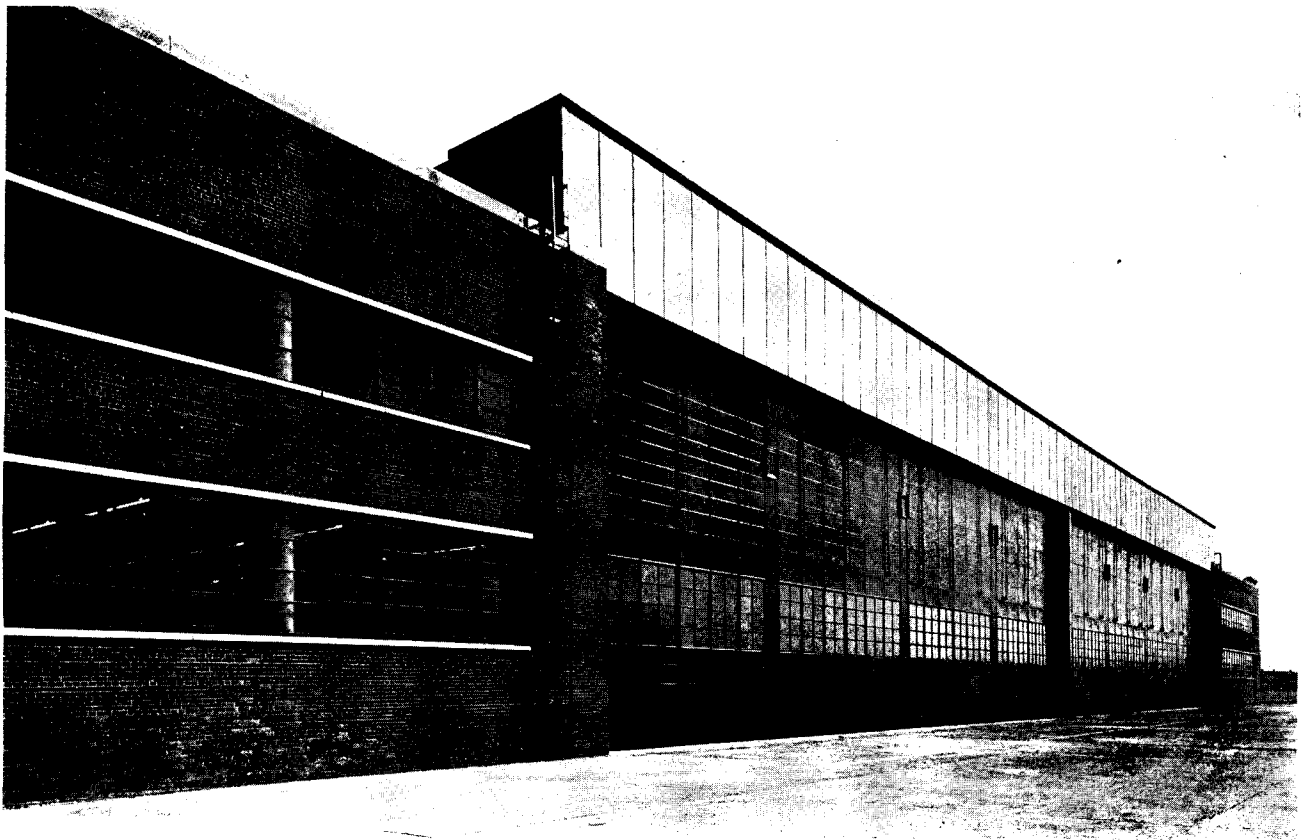

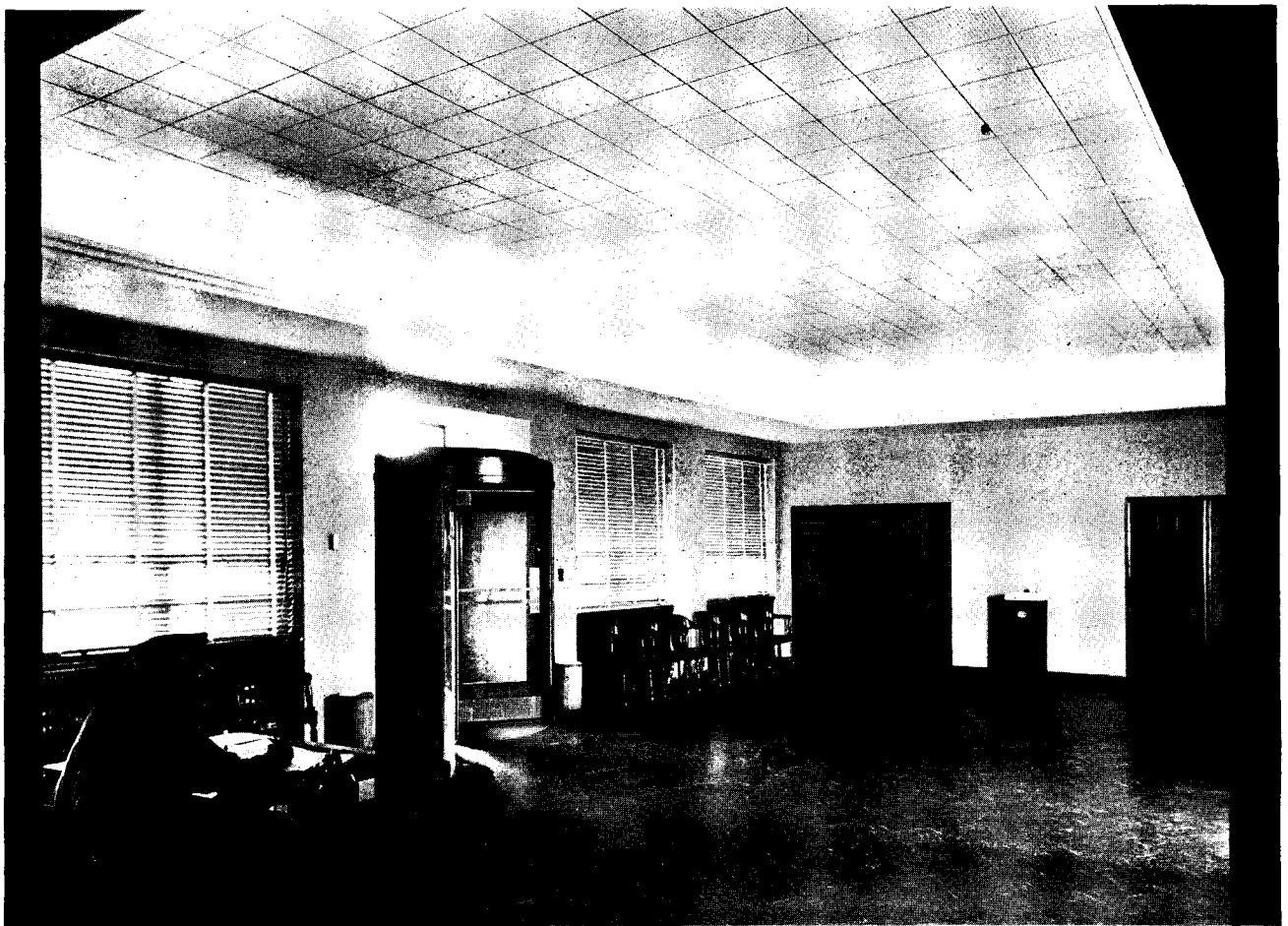

Administration building has 13-ft. first story height, with acoustic ceiling applied directly to the slab

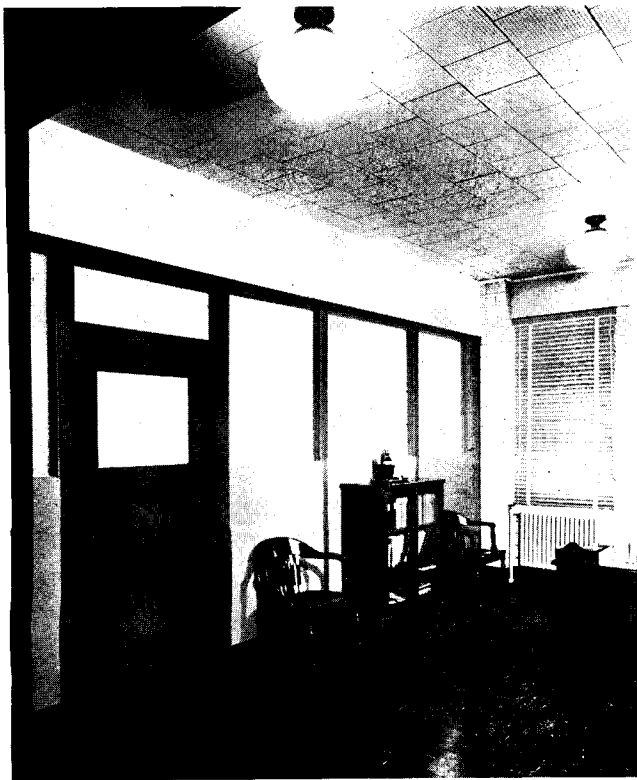

operated canopy type doors allow the entire east end to be opened. Because of the fire hazard, the building is equipped with a deluge sprinkler system.

The administration building is off the west side of the assembly building, facing the highway, with a court 35 ft. wide between the two buildings to provide air and light. Several overhead bridge passageways connect the second floor of the administration building with the mezzanine floor of the plant. A two-story connecting passageway at the center of the administration building affords access to a freight elevator arranged to serve both buildings.

The toilet, rest room and vault groups are arranged along the east wall of the administration building, projecting as towers into the court. This arrangement permits the first and second floors to be unobstructed by these necessary units and presents a clear usable floor space. Above these towers and the central passageway are the fan rooms housing the necessary heating and ventilating units.

The dimensions of the administration building are 80 by 910 ft., with a 13-ft. story height first to second floor and 10 ft. 6 in. ceiling height on the second floor. This building is of masonry and concrete construction up to and including the second floor, with wall-bearing masonry supporting wood trusses above the second floor. A line of wood columns down the center of the second floor divides the area into bays 16 by 40 ft., giving a large usable area

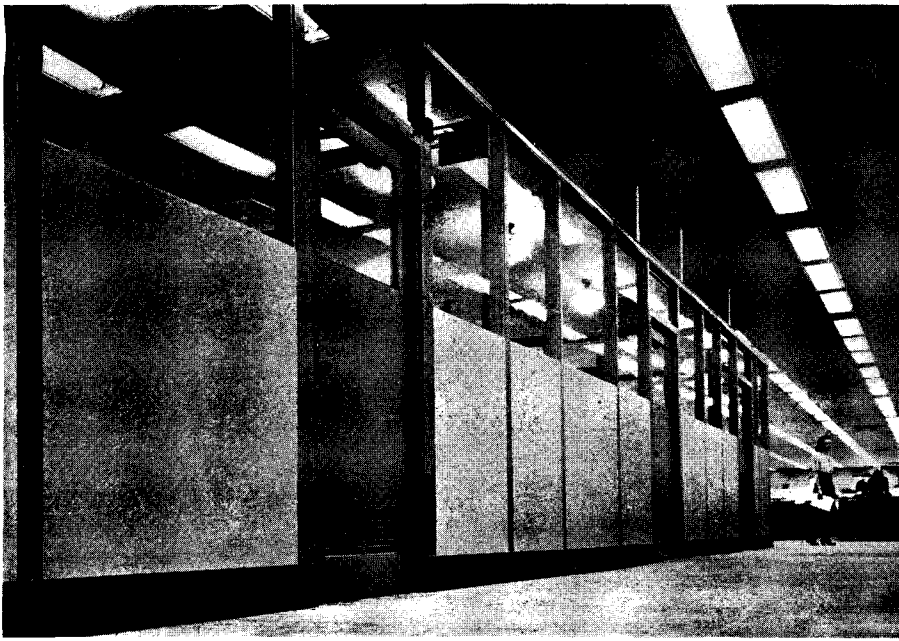

Wood and glass office partitions are representative of the efforts to conserve all possible metals

Fluorescent lighting was permitted in engineering department; other offices have incandescent lighting





Kitchen and cafeteria, in the administration building, has facilities for serving 1,500 people at once. There is also a small executives' dining room

An unusually complete industrial health department has, besides first aid room, men's and women's wards and small operating room for emergencies





Beyond the administration building, and paralleling the main plant, are truck garage and boiler house

with a minimum number of column obstructions.

An acoustic ceiling is applied directly to the underside of the concrete second floor slab throughout the first floor, and suspended under the trusses on the second floor.

The executive and general offices as well as engineering and accounting sections occupy the second floor, while on the first floor are purchasing and production planning sections, a kitchen and cafeteria capable of seating 1,500 persons at one time, a small executive dining room, and a well-arranged personnel section including an unusually complete industrial health department. This unit consists of first aid rooms, men's and women's wards and a small operating room in case of an emergency operation. The personnel offices are adjacent to this hospital unit so that a new job applicant can be given an immediate physical check with the same medical staff serving both.

Because of priorities and restrictions on materials, non-metal materials were used for flashings, expansion joints, etc., with very satisfactory results. To conserve steel, all office partitions are of wood and glass.

Fluorescent lighting was permitted in the engineering

departments and in necessary factory operating departments. All other lights are incandescent.

Ventilation is provided through plywood ducts, material for which was largely salvaged from forms used in the concrete construction.

The boiler house is a reinforced concrete and brick building, with suspended concrete coal bunkers. As already mentioned, this building had to be designed and built around the available equipment. Two are used boilers, and one is new. All are of different capacity and the used boilers were delivered on the grounds lacking certain vital equipment. An ingenious three-way hookup was designed and from the time the first boiler went on the line steam service to the plant has not faltered.

Two of the boilers of 60,000 and 75,000 lb. steam capacity are fired with pulverized coal, while the smaller boiler of 30,000 lb. capacity is stoker fired.

The available land area was so utilized that if future expansion is necessary a similar manufacturing layout can be duplicated on the opposite side of the manufacturing building utilizing existing spur lines and service facilities.



Boiler house was designed around available boilers—two burning powdered coal (left, below), one with chain grates (right)

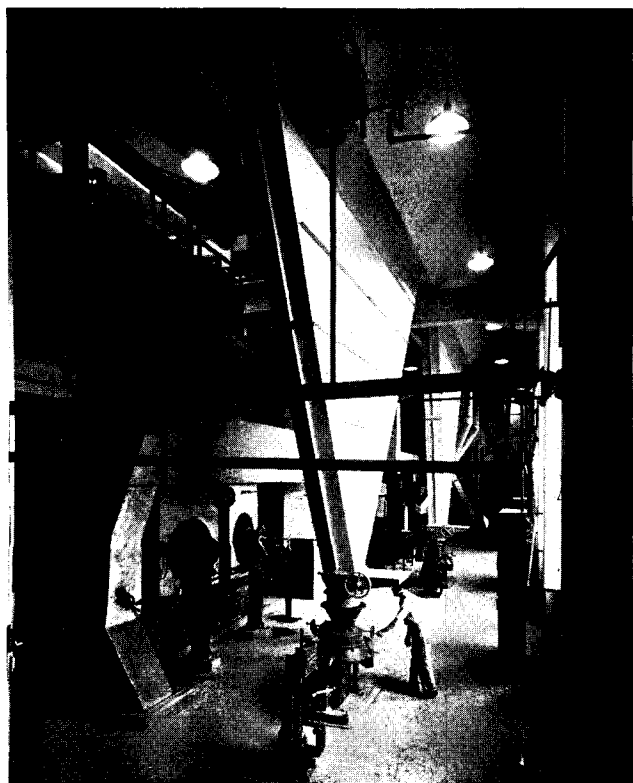



WORTHY IDEAS FROM WARTIME HOUSING

NORMONT TERRACE HOUSING PROJECT, LOS ANGELES, CAL.

WINCHTON L. RISLEY, STANLEY R. GOULD, ARCHITECTS

THE CHALLENGE of two familiar wartime dictates—speed and conservation—produced in this FWA housing development a number of ideas which are not so familiar. One is a method of reworking the soil to provide uniform bearing conditions. Another is the recessing of foundation walls to save materials. Another, a precast concrete step and platform unit to save in both cost and time. A fourth, a method of erecting the buildings without scaffolding.

The site, of 37.6 acres, had a southerly slope, with three different soil conditions, from the standpoint of bearing values. One part had a heavy clay material capable of supporting heavy loads when dry, but of negligible value when wet. Another area, with good drainage, showed good bearing value. The third was covered with approximately two feet of very light silt, not sufficiently stable to be considered safe, but capable of favorable development under compaction.

With reinforcing steel prohibited in foundations, the apparent solution within the budget was to rework the soil to provide a uniform bearing throughout, thereby

permitting a typical footing section for all buildings. This was accomplished by stripping the silt from the one area, and placing controlled compacted fill, of not less than two feet below the bottom of the foundations, over the clay area. In this manner sufficient protection was provided from dampness affecting the clay and high bearing value was maintained. Apparently the method was sound in fact as well as in theory, as no foundation cracks have developed in a year.

In keeping with the established policy of conservation, the foundation walls were recessed, reducing the quantity of concrete required, also reducing the size of first floor joists through the smaller span and the stiffening effect of the cantilever. With gutters and downspouts prohibited, the recessed foundation walls prevented the unsightliness of mud spattered walls.

The precast concrete step and platform units (detail on page 57) were designed not only to keep down costs but also to save time. These units could be manufactured simultaneously with the construction of the building and

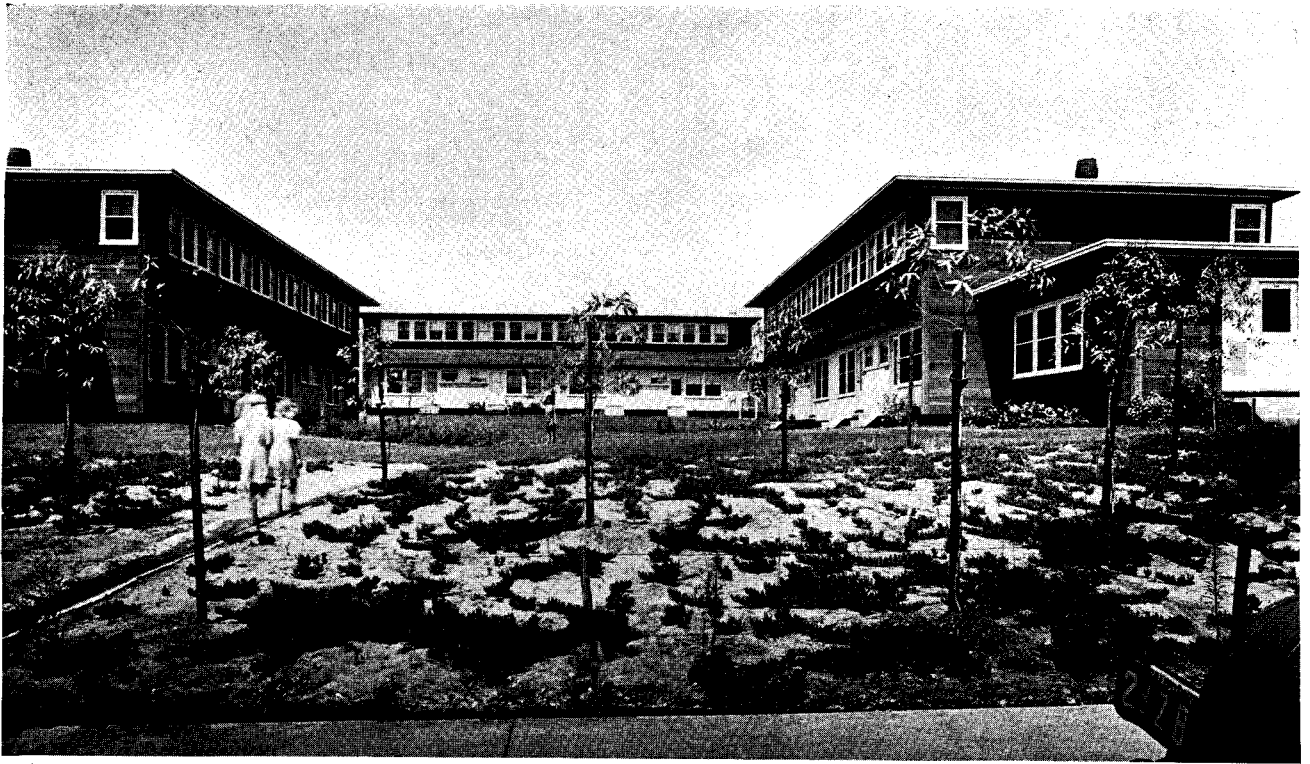

Julius Schulman photos

**PLOT
PLAN**

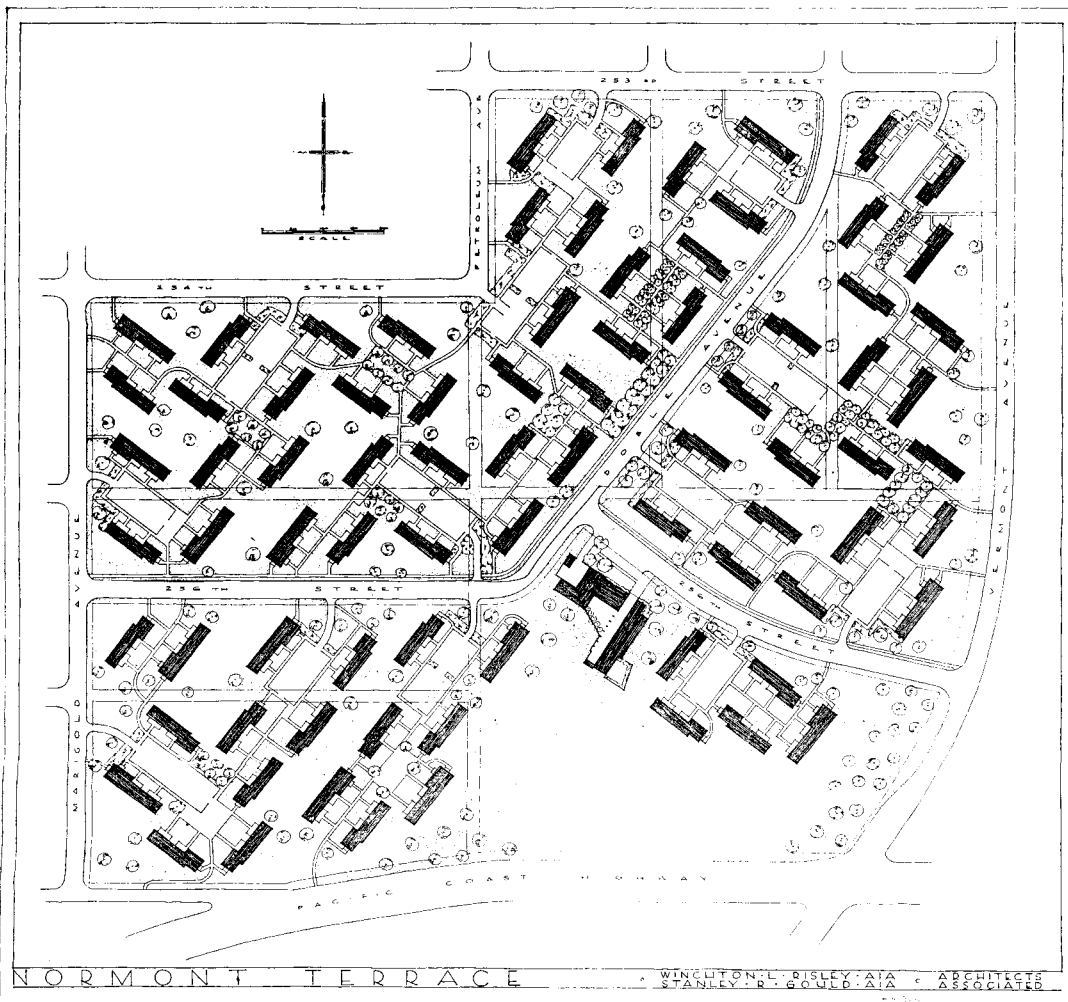

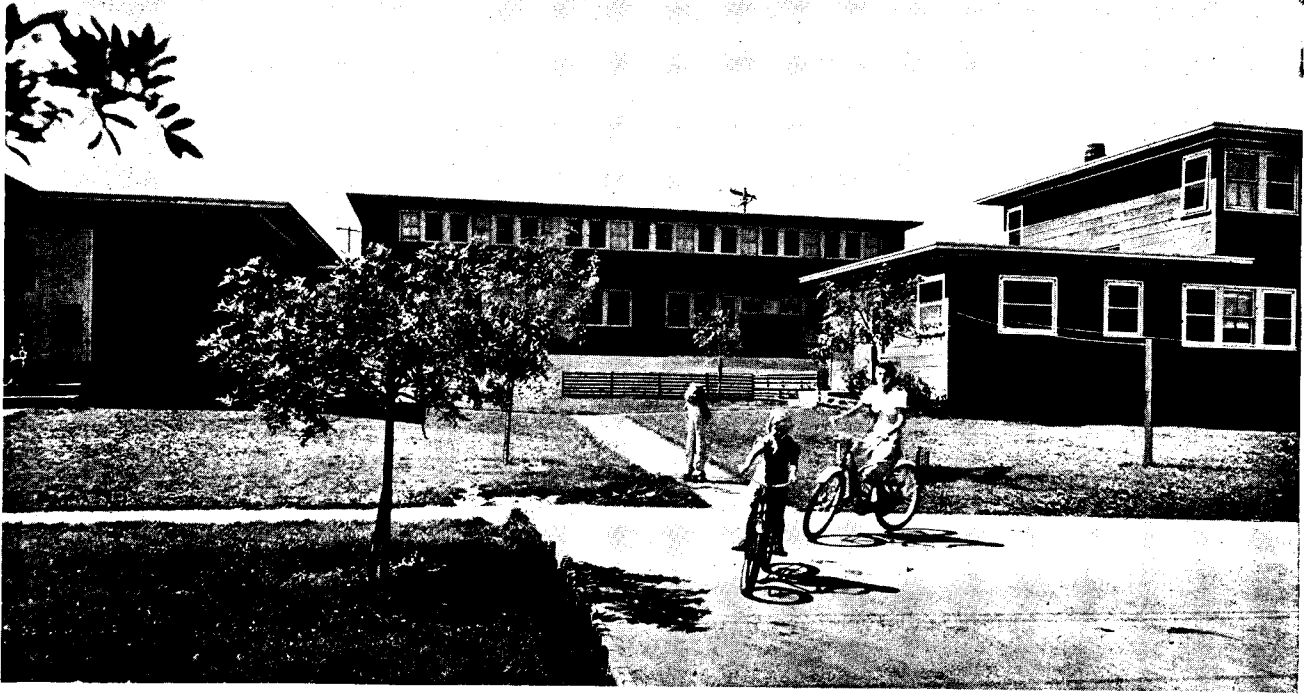

**FLOOR
PLANS
AND
DETAILS**

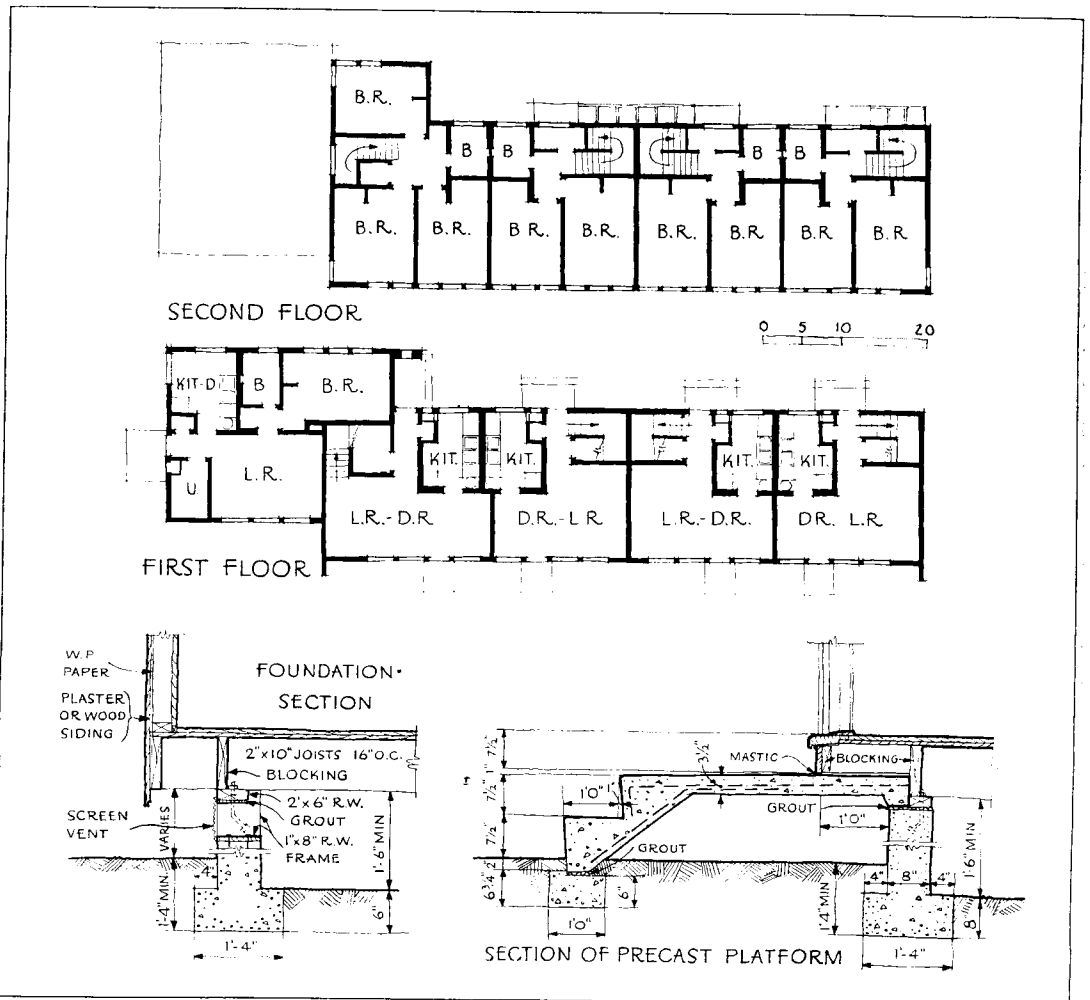



Typical housing building; exterior finish is cement plaster and redwood flush shiplap siding

One-story wing provides relief for roof lines and fronts, and provides one four-bedroom unit



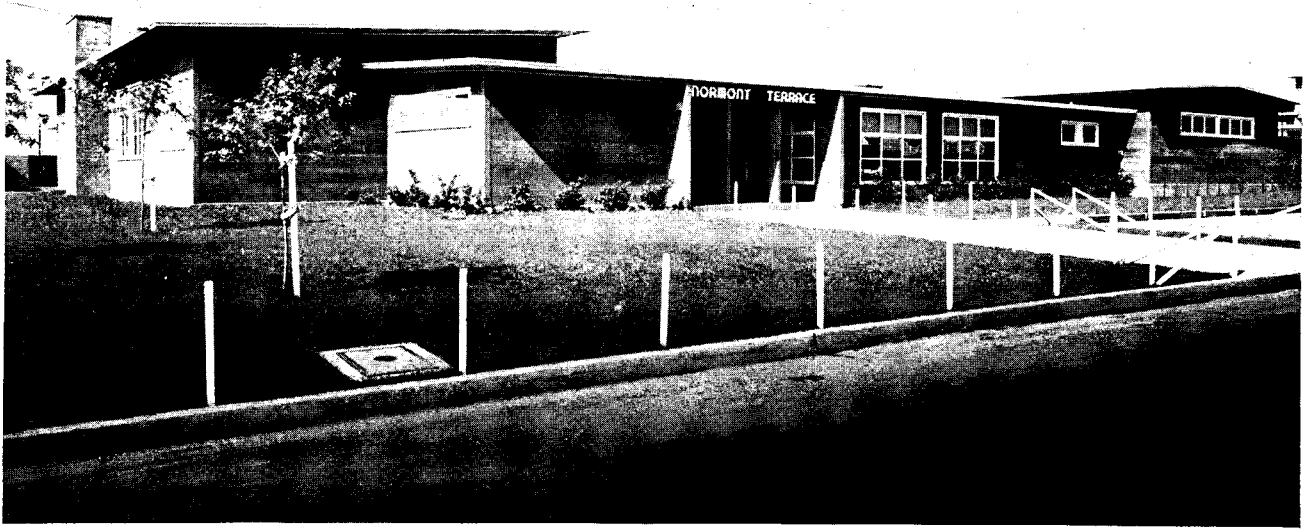

Main-entrance view of community building

Administration-community building plan

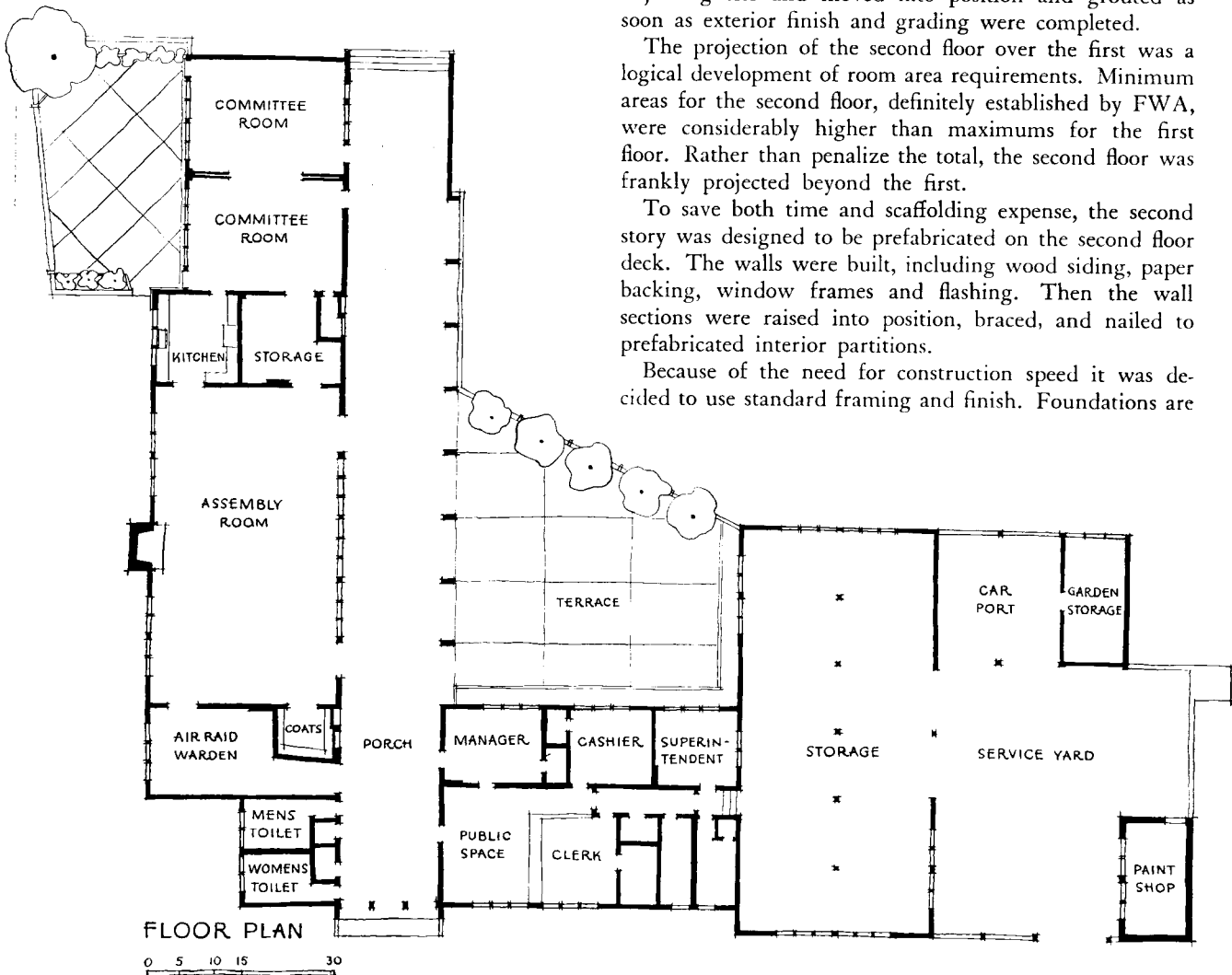

the development of the site. They were fabricated on an adjoining site and moved into position and grouted as soon as exterior finish and grading were completed.

The projection of the second floor over the first was a logical development of room area requirements. Minimum areas for the second floor, definitely established by FWA, were considerably higher than maximums for the first floor. Rather than penalize the total, the second floor was frankly projected beyond the first.

To save both time and scaffolding expense, the second story was designed to be prefabricated on the second floor deck. The walls were built, including wood siding, paper backing, window frames and flashing. Then the wall sections were raised into position, braced, and nailed to prefabricated interior partitions.

Because of the need for construction speed it was decided to use standard framing and finish. Foundations are



non-reinforced concrete, poured on the compacted fill. Exterior walls are of wood frame, with cement plaster and redwood siding with flush shiplap joints. The exterior plaster is finished with two coats of bonding cement paint; the wood siding with one coat of creosote stain.

Interior walls are of stucco, with in-

Wide covered porch and terrace adds to usefulness of community center, separates the social and administrative functions

With playground facilities in the enclosed yard outside, the "Committee Room" finds its greatest use as a day nursery

Whether or not by design, the administrative offices command a view of comings and goings around community building



tegral color. Walls and ceilings of baths and kitchens have three coats of enamel over the stucco.

Equipment includes console-type gas-fired space heaters; gas-fired water heaters; domestic gas ranges; electric refrigerators.

Assisting the architects were: Howard Annin, consulting structural engineer; C. G. Holmes, consulting civil engineer; Herbert J. Summers, consulting electrical engineer; Katherine Bashfold and Fred Barlow, Jr., landscape architects; and Dames and Moore, consulting engineers on soil analysis.

Normont Terrace contains 400 housing units, 60 with one bedroom, 240 with two, 100 with three. Total construction cost was \$1,344,124; or 35c a cubic foot.



PROGRESS IN HOUSE PLANNING

ARCHITECTURAL RECORD'S BUILDING TYPES STUDY NO. 83

FLEXIBILITY UNDER THE ROOF By Douglas Haskell

ARCHED ROOF STRUCTURE Paul Lester Wiener, J. L. Sert, Paul Schultz

VACATION HOUSE William Wilson Wurster

CROSS-CONTOUR WITH A PURPOSE William Wilson Wurster

"COOL CALMNESS" WITH INNOVATIONS J. R. Davidson

ELECTRIFIED TRADITIONAL Victor Civkin

FLEXIBILITY UNDER THE ROOF

By DOUGLAS HASKELL

PLANS BY A. N. CLOUGH

IT MIGHT BE HELPFUL to think of the future house in terms of what the architect himself might do for it, working with resources already available. He need not wait for other people's inventions. Planning and structure are in the architect's own hands, far more so than equipment is. If an architect started out to make full use of the structural resources turned up by the thirties, in order to do advanced planning for the families of the forties, he might find himself plentifully occupied with basic work. He need not even consider any hypothetical new materials or approaching miracles.

The fact that the new families are on the way is beyond question. Some of the most manifest characteristics of these new families are the characteristics that are receiving least attention. One of these obvious but unattended facts is that the families of the forties and thereafter will usually grow and then decline. How plan for this? The question is rarely asked because there seem to be two such simple answers to it. One is that we have larger and smaller houses side by side so that the family, as it grows or declines, can move over. The other is that the house can expand as the family does, so that, in effect, the house "moves over."

Both of these answers involve a few inconveniences, no

less real because they are so customary as to pass unnoticed. For instance, if the family moves from one house to another it loses the continuity of home. On the other hand, although an addition can be performed easily on the house as the family grows, the corresponding subtraction when the family declines again is not so easy, leaving unused rooms.

Might there not be possible a third answer, predicated on recent advances? So many new "flexibilities" have characterized recent house-planning: might it not be possible to add another? Could not the architect, exercising his ingenuity, provide for a fair amount of family expansion and contraction within the original house structure, so that the family would neither be obliged to move to a new house nor to add rooms that would be an encumbrance after the children had grown up and moved away?

The Key to Flexible Planning is the Roof

Needless to say, this third answer to the requirements of family growth and decline would not be a substitute for the other answers but an additional or complementary solution, not narrowing but enlarging the possibilities.

The key to any major new advance in flexible house-

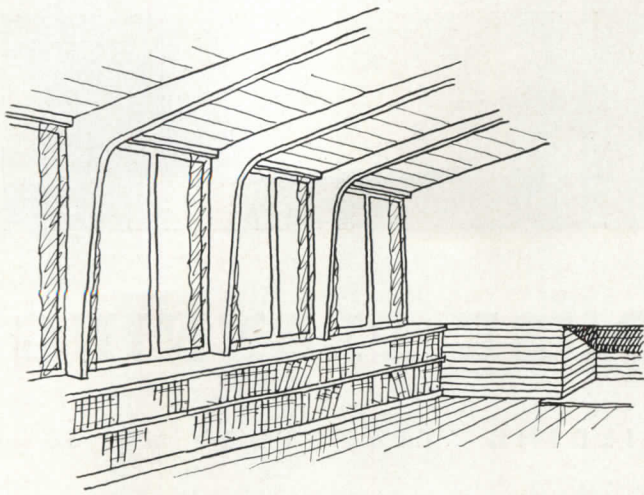

Figure 1. Wide spacing and simplification in the house frame can evolve until the plate is suppressed altogether by use of the three-hinged laminated arch. Windows can be set tight to the ceiling and structure revealed in larger rooms

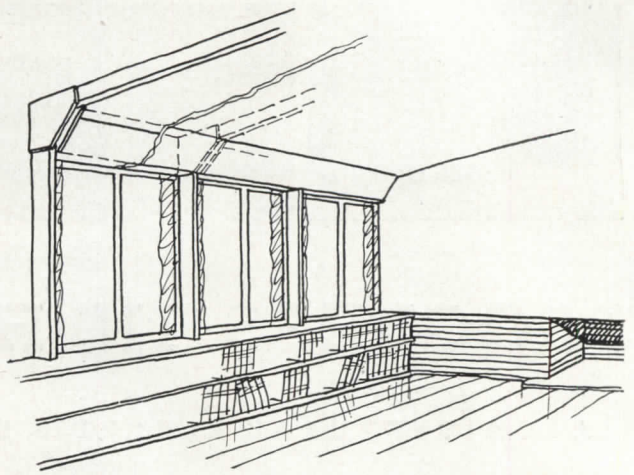

Figure 2. Three-hinged arches could be assembled in the field by means of gussets and new timber connectors or perhaps glue. In the sketch a splayed ceiling section has been carried across the gussets; the pocket could serve as a light cove

planning is to be found in structure. More specifically, it is to be found in the structure of the roof. What architect has not wished that he could hang his roof from skyhooks or from a balloon? If only he could, what freedom this would give him with his plans and openings! All partitions, even to the exterior walls, would be non-bearing. The architect could move them as partitions are moved in offices or lofts, to make up any new required combination.

Unhappily, not even the most exalted dreamers about the post-victory house have dropped out of the clouds with a practical skyhook, but the last two decades have nevertheless assembled a large assortment of new materials and devices available to the architect working on the ground.

It is rather curious that the last two decades, which have been so concerned with new materials and construction methods, have not addressed themselves more directly to the problem of economically spanning the roof, surely the largest single structural problem in the house. Perhaps a main reason why so little has been done to date about the roof is that structural thinking has been so wrapped up with prefabrication systems. After the pioneers of prefabrication had burnt their fingers (as all pioneers will) with strange looking houses, later prefabricators tended to give up all basic analysis of the house and turned to making just as conventional a product as they could. Moreover, they concentrated so heavily on walls and floors that anyone whose knowledge of house construction was gained from prefab literature might easily think that all progress is to be made in the walls. There were a few roof experiments such as the flat stressed-skin box girder of the Forest Products Laboratory in its first experimental model, but the ordinary war housing scheme often groans under the old forest of trusses.

American invention, in fact, seems to evolve new designs more rapidly in behalf of process engineering than in behalf of product engineering. The two major contributions of North America to the house-building art have both been of this sort. The kind of wooden house-frame that now appears on every street was a spectacular ad-

vance a century ago, replacing the old Colonial frame with its widely spaced, individually shaped and jointed timbers. The beauty of the new American frame (derisively called a "balloon" frame because of its lightness) lay in its admirable adaption to the production methods of the day. It was a design that could safely be assembled by any wood-butcher using ready-dimensioned lumber from the power mill and that new miracle, the mass-produced common nail. The other major American contribution, the stressed-skin box girder of the 1930's, was a translation of the balloon frame into the new production process involving widely dispersed power mills, large wall sheets, and the new glues and plastic binders. Neither one of these structural designs was specifically devised for the purpose of creating a better planned or more agreeable house. Both have served mainly to make possible the creation of more houses faster.

Roof structure has now become a live problem in part because it has become a production problem. Suddenly confronted for the first time in their history with material shortages, and with a shortage of shipping space, American engineers are going to work to substitute something more economical and efficient for the old forest of trusses. But this progress can be of direct service to the architect. New roof structure can definitely yield great new resources of interior planning.

Wide Roof Spans are of Many Possible Types

Progress in roof spanning does not all stem out of the much advertised stressed-skin box girder. Interestingly enough, one promising line of development comes closer to being a revival of the old Colonial framing system with its widely spaced supports. It can be traced in the work of individual architects. Relying on increased accuracy made possible by power tools either in local lumber mills or on the site, and on an increase of millwork methods replacing carpentry, these architects have dared to simplify the frame and spread the members farther apart, no longer counting on holding up the roof by sheer numbers of

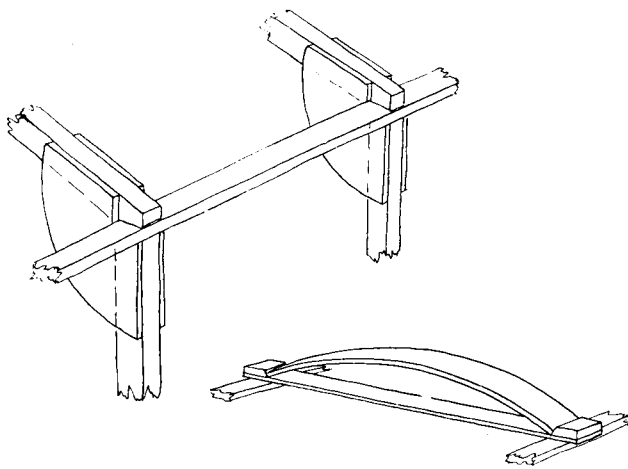

Figure 3. Above, the typical present-day connection of wide-spaced stud and rafter, by a gusset across the plate. Could the plate not be omitted? Below, an elastic-arch roof truss formed by springing a light timber; said to be strong enough

wood-butchered studs. In the house by W. W. Wurster, shown on page 71, the studs are on two-foot spacing and the work is clean enough to be exposed on the interior. (Incidentally, this calls for closer architectural engineering. Every stud has to be indicated on the plan and in some instances counted in the specifications.) A better example yet for this purpose might be found in a house by Paul Schweikher published in the *RECORD* for March, 1941. Here the studs are on four-foot spacing; no special headers are needed over openings. Here, too, the architect chose to give his roof trusses good finish and leave them exposed; but had he chosen to use less finish and to put in a ceiling, he could have subdivided the interior at any time in any direction. Such wide spacing of studs and roof trusses is appearing in the work of so many architects as to constitute a new vernacular of construction. (Figure 3.)

Continuity of Rafter and Stud Suggests Arch

Now an interesting feature of these frames of wide spacing is that the rafter is always above the stud, and there is generally a plywood gusset somewhere in the scheme for bracing. From here on it is just one step more to make a single continuity out of the stud and rafter, leaving out the interruption of the intervening plate altogether. The stud and rafter assembly then becomes in effect a series of three-hinged arches. These have already been used in churches and schools, where it has been found economical to make them of laminated structure, prefabricated. In both instances the effect has been to leave the floor and interior area structurally free, and there have been certain incidental qualities, such as the chance to put windows very tight to the ceiling (because there is no "plate") and to leave a very clean structure where it is desired, as in a large room, to expose the underside of the roof. (Figure 1.) These prefabricated laminated arches can as yet be made satisfactorily by only a limited number of manufacturers. The alternative is to assemble the arches on the site, using gussets and the new types of timber connectors. (Figure 2.) The three-hinged

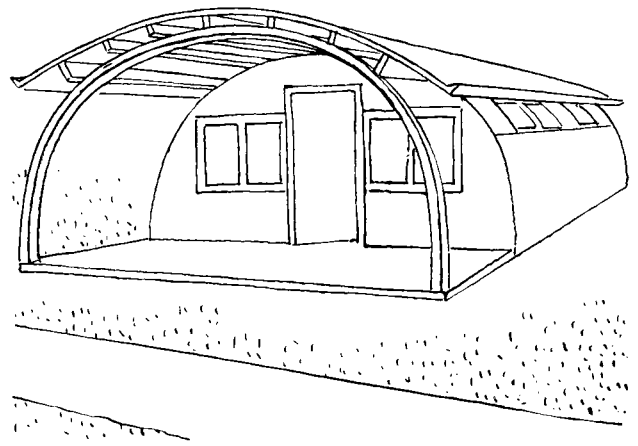

Figure 4. Carrying round laminated arches down to the ground, on the precedent of Army and Navy huts, makes an inexpensive structure with the one drawback of low space next to the wall. (Victory house of the John B. Pierce Foundation)

arch cannot be listed yet as a finished economical achievement for use in houses but is indicated as a line of advance. Architects of imagination can turn it to many new uses in houses of the well-to-do while the refinements are worked out that might make it available for more general use. If this is done, a cycle will be completed that began in the 1880's in huge market halls built of steel, was translated into wood and brought into schools, churches, and cantonments in the 1930's, and can finally be domesticated in the house. Granted success, then the inside space of the house will be free of structural duties, like that of the market hall or church, and can be partitioned in any direction that changed requirements call for.

Once wooden (or metal) arches are accepted for household use, there is opened a veritable new continent of structural exploration. By far the cheapest and simplest wooden arch is of course the round one made familiar in cantonments by the war. Such structure has been brought to a high finish in strip steel by the Navy Bureau of Yards and Docks, and is being adapted to wood by the Pierce Foundation. Traditionally speaking, the barrel-roofed house is one of the oldest forms which this country can boast; during thousands of years the Indians bent saplings into arches to form the framework of their shelter. Technologically speaking, if the round arch is carried to full circle, it becomes a component of one of the most up-to-date of modern forms, the airplane fuselage. It has its drawbacks. Against its cheapness stands the fact that it produces inferior space next to the wall. Also, it involves a problem of public acceptance. American traditionalism is very single-tracked. If experience abroad has rendered our soldiers receptive to a multiplicity of forms such as the barrel-vaulted roofs of North Africa and Southern Italy, then all will be well for arched construction at home. But if the effect of foreign experience has been merely to deepen the yearning for the old Kentucky home, construction will have to reckon with milder departures.

Not all the available arched roof supports will be continuous to the ground. A very simple arched roof truss has been experimented with, which is made simply by

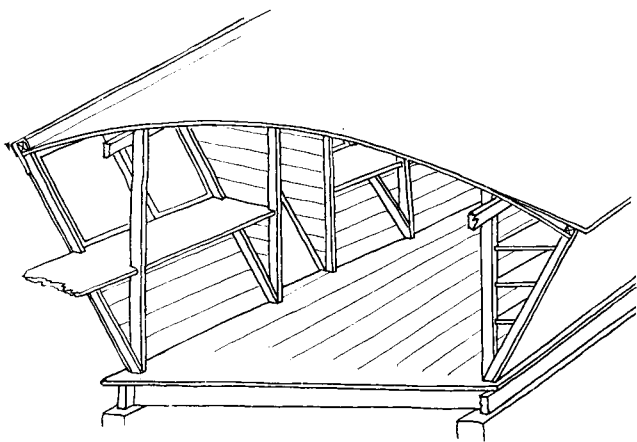

Figure 5. Rafterless curved roof, sprung over the plate, the ends held down and hooked under tension members. Good for spans up to about 16 feet. Patents applied for

bending a light-weight timber and springing its ends into notches in the tie-beam or tension member. The arching action is said to give exceptional strength with the light weight. (Figure 3.) For short spans there are possibilities in an entirely rafterless construction that has been tried by this writer on a small cabin in the woods. For lack of plywood it was done with ordinary tongue and groove. In principle the roof panel is sprung as you would bend a small sheet of material in your hands. The usual studs and plate serve as a fulcrum, like your thumbs. The ends are held down by tension members. It made an amusing little structure with an entirely unobstructed curved ceiling, and might work nicely in structures spanning up to 16 feet. (Figure 5.) (See, also, page 66 for a new arched roof structure suitable to wider spans.)

These ideas are thrown forth not as finished accomplishments but as indications of a line of work. The glues and connectors developed in recent years have made possible a large-scale future development in wide-span roofing structure. Lightweight metal framing may easily come into the picture, especially since lightweight alloys have been developed on an enormous scale by the war. So, too, there are many possibilities in waves or corrugations introduced longitudinally in sheet materials, as in various types of "frameless" walls or in Nissen huts, to cut down or eliminate framing members. So far as walls are concerned, structures that support themselves by virtue of their curvature are appearing with increasing frequency in competitions—as if Jefferson's famous snake fences, built of a single thickness of brick, were being revived in new materials at greatly increased scale. In relation to the roof, this subject, though open, is still speculative. Then there are the various cantilever proposals, which may have considerable usefulness in certain special plans but which do not suggest a generalized solution because they obstruct the interior of the house right down the middle.

Family Growth and Decline are Basic to Planning

The important fact to observe is that progress in wide-span roof framing is possible in terms of materials and methods that are available now. This kind of progress

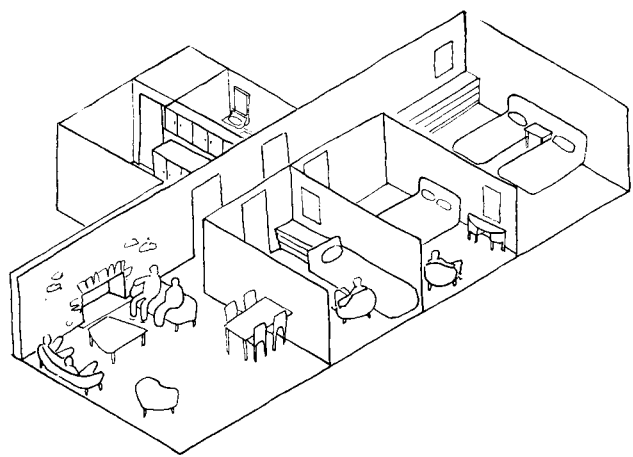

Once the house plan is free of roof structure, the architect can provide for changed family requirements in the original house. Here son and daughter are both at home growing up

does not demand new invention or new materials before it can take place. It depends directly on the architect and the architectural engineer. It lies in the field of practical realism.

Flexibility of interior planning is the main reason for demanding that interior partitions be made structurally independent of the roof. With all the recent talk about flexibility of planning, it is curious how little of it has been concerned with factors that are basic. Surely there are few factors in planning more important than the size of the family; and since the size is not static, planning is basically concerned with the phenomenon of change. Not all families have children but it was calculated at the Pierce Foundation that among the large majority of families that do have them, an average of 3.8 children per family would be required, under present circumstances, simply to prevent a diminution of the race. If the population is to remain stable, then every American family with children must at some time or other, on an average, stow four young Americans within the walls of its dwelling. How seriously such simple facts can be neglected is illustrated in housing sponsored by the insurance companies themselves. Some of these projects fall very wide of furnishing space for four youngsters per family, and raise the question whether these companies, with all their interest in vital statistics, are encouraging the birthrate in their actual building projects.

In behalf of aesthetic purposes and in behalf of changed living habits, flexibility has become familiar. This is richly illustrated in the houses presented in the succeeding pages. Cantilevering had already been in use since the early 1900's, in the hands of the pioneer Frank Lloyd Wright, to extend the shelter of the house over the surrounding area. From that time onward the possibilities of indoor-outdoor living have been richly exploited. W. W. Wurster's house for the Belcher family (page 67), shows one way of using large sliding doors to achieve this purpose, and J. R. Davidson's houses for the Berkson family (page 75), show another. In numerous large houses, outside walls and inside partitions have come to be run very freely in deviation from the conventional rectangle. The Berkson houses, referred to above, make use of a curved

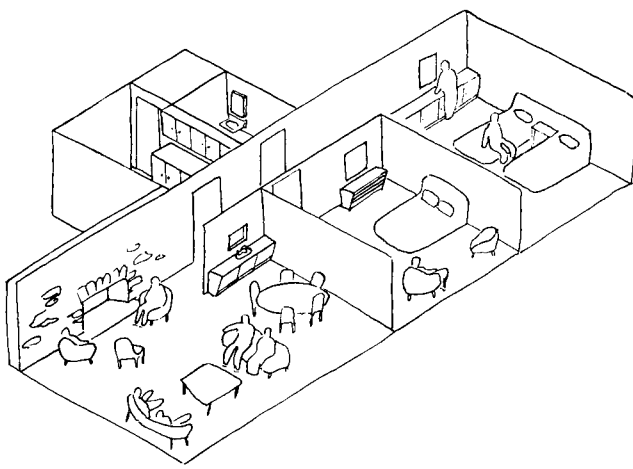

Here the son has left, and his room has accordingly been removed. The daughter's room has been somewhat enlarged, assuming that partitions can be shifted as easily as screens

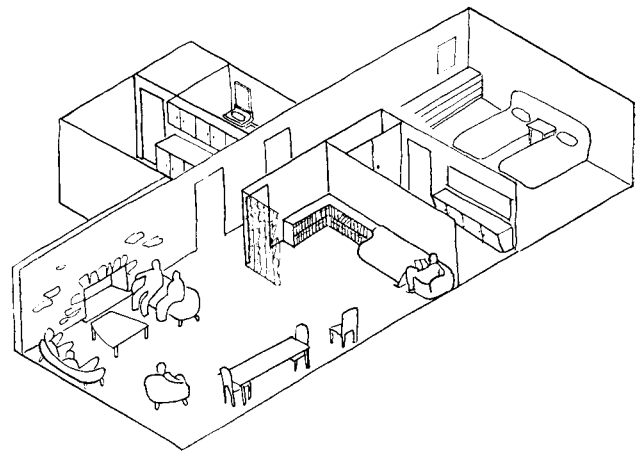

Both children have gone; the parents like to invite friends. They now have a dressing room and more entertaining space; on visits the children still have a screened alcove to sleep in

plan with a lack of ostentation that indicates the progress which has been made since the time when innovators found it necessary to call attention to their innovations. "Splayed" interior divisions, changes in height, use of clerestory lighting, all have contributed to the advance of flexibility.

In all the recombinations that have been made, rarely has there been any multiplication of rooms. The number of separate rooms has tended to decrease, as has the spatial content of the whole house. If such trends continue undiminished, the future house will come to approximate the present-day apartment. The Berkson houses follow the accepted new manner of combining the dining area with the living area; and in the Lyman house (page 71) this is carried even farther, so that the kitchen itself is only partly separated from the dining-living area. This is definitely in line with war housing trends. Whether informal living has its roots in the difficulty of employing domestic servants, or whether it is a preferred taste, it seems to be a trend that will continue. The weekend house for the Lymans is so arranged that the living room can be used conveniently by extra guests to sleep in, and this without the awkwardness of either folding beds or narrow improvised couches. A dressing room has been nicely planned for them. Assuming the further rapid development of accessories such as inflated mattresses and electric blankets, the auxiliary use of living areas to sleep in may increase measurably. The main danger is that at lower cost levels such double use may be made compulsory, a regular feature for the family itself, without the accompanying amenities. (A family, it is to be presumed, will continue for a long time to cherish the private bedroom, where one can sleep or be sick or whatever he wants to be, undisturbed; and one really effective use of the new sleeping devices might be to permit getting them out of the way so that children could more easily use their combined bedrooms to play in or entertain their friends.)

However useful the new flexibility has been in behalf of aesthetic purposes or sociability, it is still true that the need for flexible planning is more pressing in behalf of family changes.

It was already envisioned by such a profound student

as the late Henry Wright that families do not remain stationary in size. The children are born usually one at a time, and, having eventually grown up and married or taken jobs, they go away usually one at a time, leaving not only a vacant feeling in their parents' hearts but a vacancy in the dwelling. Few are the house designs in which special attention has been paid to the children in the first place—let alone paying attention to their ultimate departure. In a rental project it is at least possible to provide different sizes and kinds of dwelling side by side, so that the changing family can "move over" without leaving its accustomed neighborhood. An individual house rarely has been fitted to accommodate itself to shifts within the family. Different combinations have been worked out in different houses, not in the same house. Structural rigidities have made it difficult.

"Declining" Years Should Be the Best

The chance for rearranging the house, once structural freedom is at hand, is enhanced by certain economic factors. Families are usually better off at the later stage rather than the earlier. The tightness produced in living rooms by the early introduction of many bedrooms comes at a time when the young couple has fewer objections to tightness. As these bedrooms for children are later removed, the parents, now older and possessed of more social ties, may well relish the extra space in which, for the first time, they can commodiously entertain their friends.

It is not asserted that planning for family change, all under the same original roof, would be easy. Indeed this is the kind of thing that a contractor's draftsman could scarcely handle, and that would require the skill of a truly competent architect.

Nor is it implied that freedom to change under the original roof should remove any other older freedom. There will still be changes that can best be made by expanding the house, other changes that will require that the family move to a new house. But in making it possible for the family to change size conveniently within its original home, the structural advances of the thirties have given the forties a new realistic opportunity.

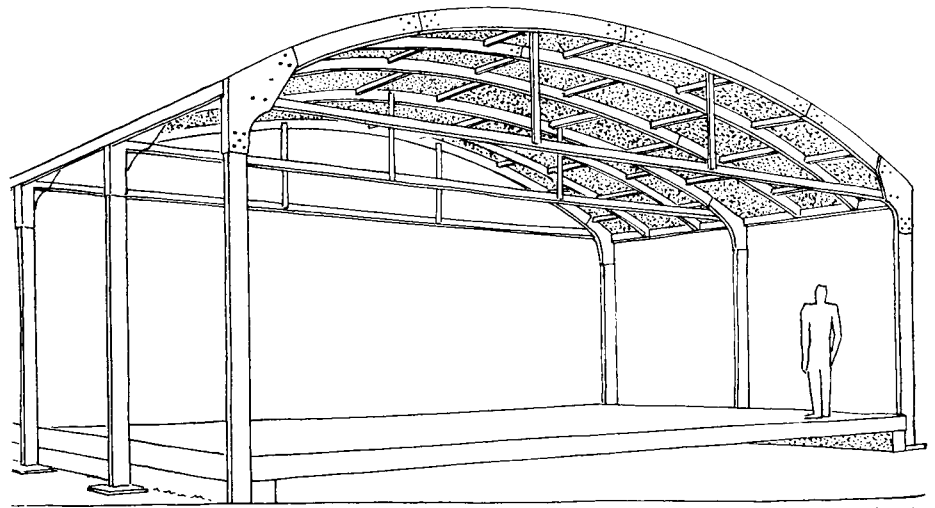

Patents applied for

ARCHED ROOF STRUCTURE GIVES CONVERTIBILITY

PAUL LESTER WIENER

J. L. SERT AND PAUL SCHULTZ

AT FIRST GLANCE, the arched roof structure shown in the accompanying illustrations suggests a shed, shop, farm building or storage unit. Actually, it is a decided innovation in structure for 24 housing units being erected at Sidney, New York, in a publicly financed 160-family war project. The roof support has been so completely separated from the walls that complete freedom is left to the planner, who not only can partition the interior according to family needs, but can re-adapt the interior easily to family change.

The comparison with small industrial or farm structures is not entirely beside the point. When the usefulness of the structures for housing purposes has expired, they can be removed and put to industrial or agricultural use with no loss of efficiency.

The structural system is based upon the small plywood-covered curved panels illustrated in the photograph. The posts are at ten-foot intervals, on independent pier foundations. The roof "pans" are erected in a staggered pattern. When a small structure is put up, the roof is started with a row of alternating pans and half-pans and erection proceeds step-wise. In larger structures, one complete arch at a time is assembled on the ground and then lifted into place.

The design is such that the arch can be carried, with no design changes, to any desired span, in four-foot multiples of dimension. The sections illustrate the roof at 28-foot and at 32-foot span. Cross-ties are inserted at the posts. In the section it may be noticed that the exterior wall and the hung ceiling are independent of the arch.

This roof structure is part of a pre-fabrication scheme of considerable interest, which will be described and illustrated in the RECORD in full detail upon completion.

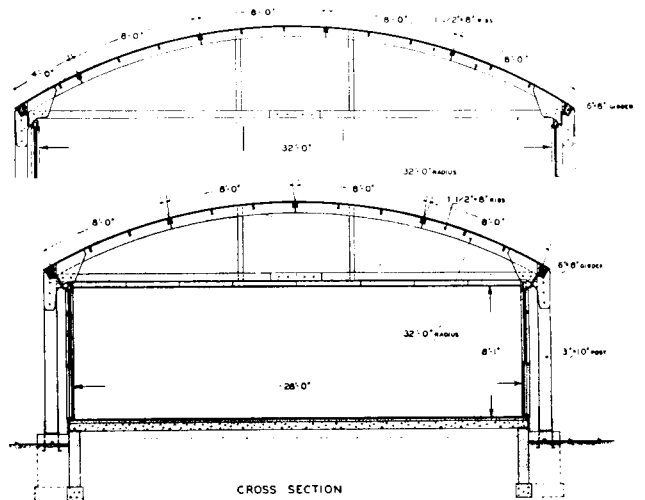

CROSS SECTION

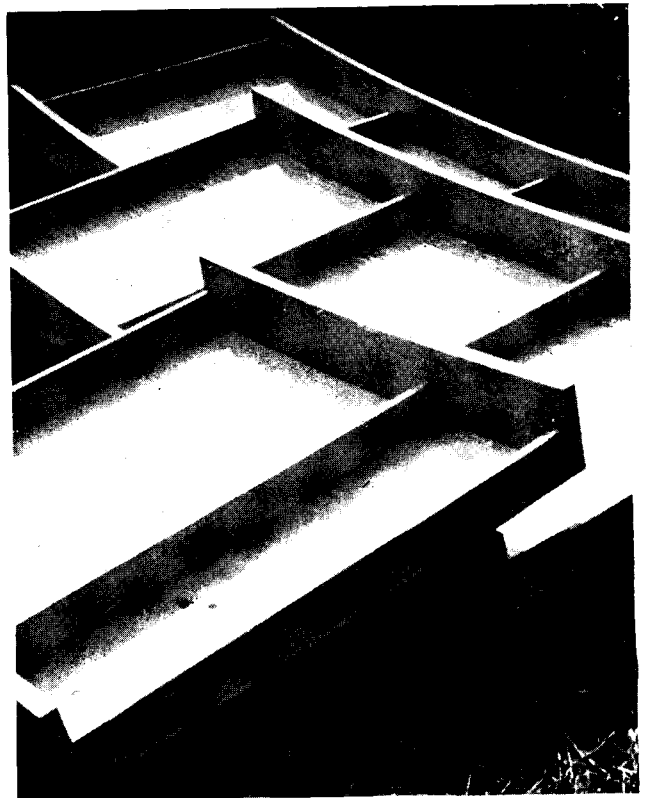



VACATION HOUSE

HOUSE FOR FRANK BELCHER, SARATOGA, CAL.

WILLIAM WILSON WURSTER, ARCHITECT

DESIGNED to be used on week ends, and for longer periods in the summer, this little house is oriented to take full advantage of two magnificent views to the north and the south. Thus it is long and narrow, its rooms lined up as if along an observation balcony. And thus it is opened up with large sliding windows and doors, to bring in not only the view of the mountains and orchards, but also their fragrance. The opening-up idea extends practically

Roger Sturtevant photos



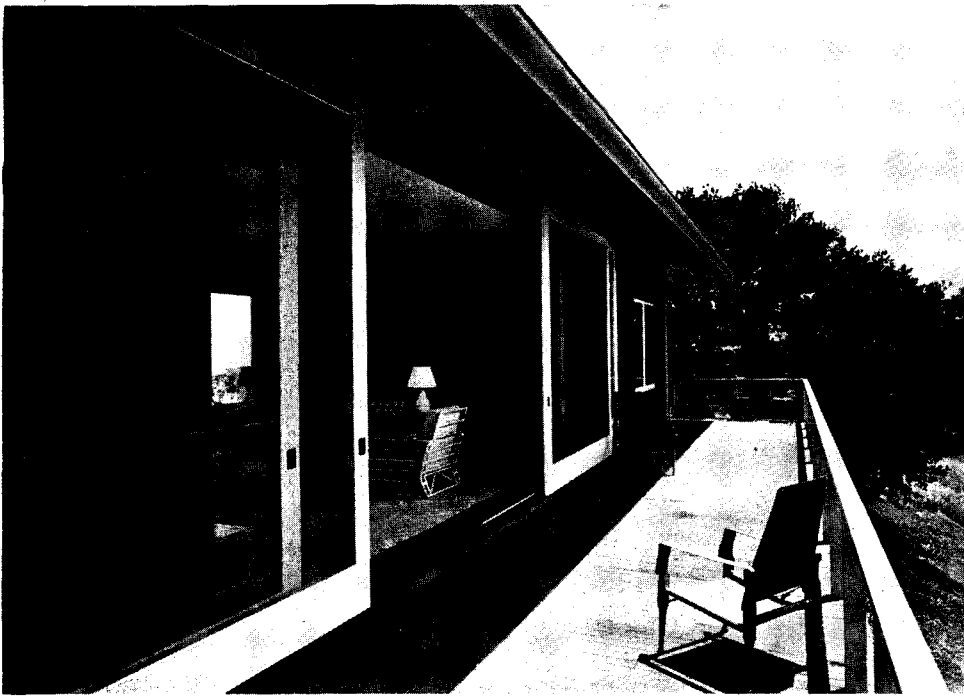

Large sliding doors and screens completely open the living room to the porch-deck and the views beyond

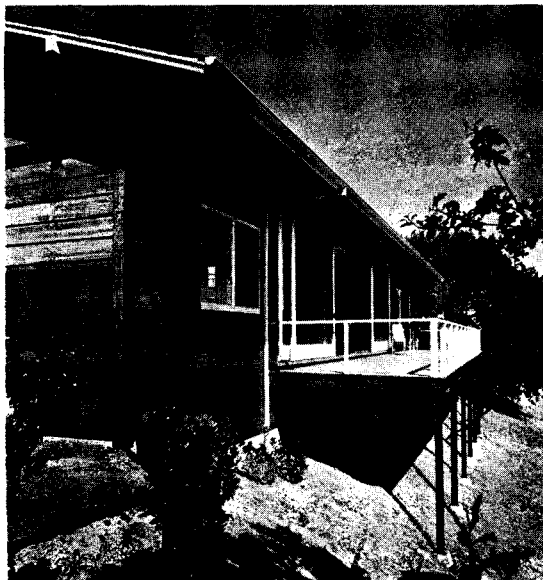

to 100 per cent in the living room. Except for a fireplace panel, the north wall is comprised of large sliding windows. The south wall is nothing but huge sliding doors (and sliding screens), which move far enough to clear the opening completely. An outside terrace being impractical because of the grade, a long porch-deck was built along the south wall, to further interlink outdoors and indoors. The deck goes on around to the north side as an entrance way. And, finally, the owner had the south view pictured on the roller shades, so that it would still be there at night when doors were closed and shades drawn.

The exterior is of redwood shiplap (clapboard type), resawed and oiled. Sash are white. The interior is of flush redwood boarding in natural tone (it seems to have been lacquered later to make it easier to clean). Floors are of Douglas fir, painted a dark green.

All sash are side-sliding, which, the architect comments, "permit of a better shaping of windows than the double-hung," and yet do not introduce screen problems.

The elongated plan avoids entirely any obstruction to the views of mountains and orchards to north and south

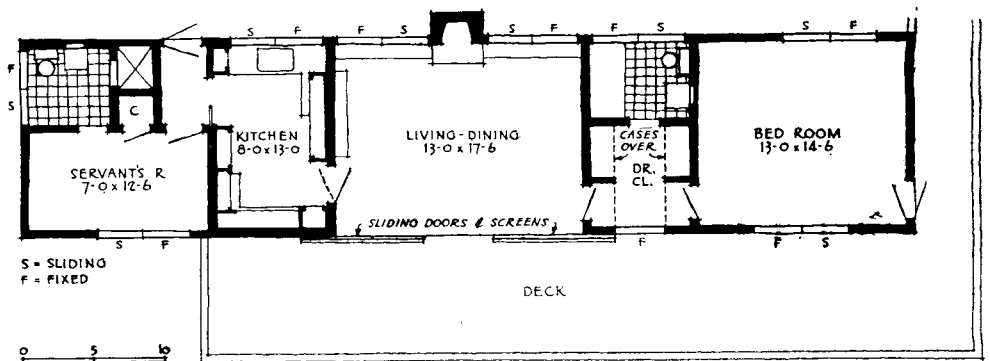

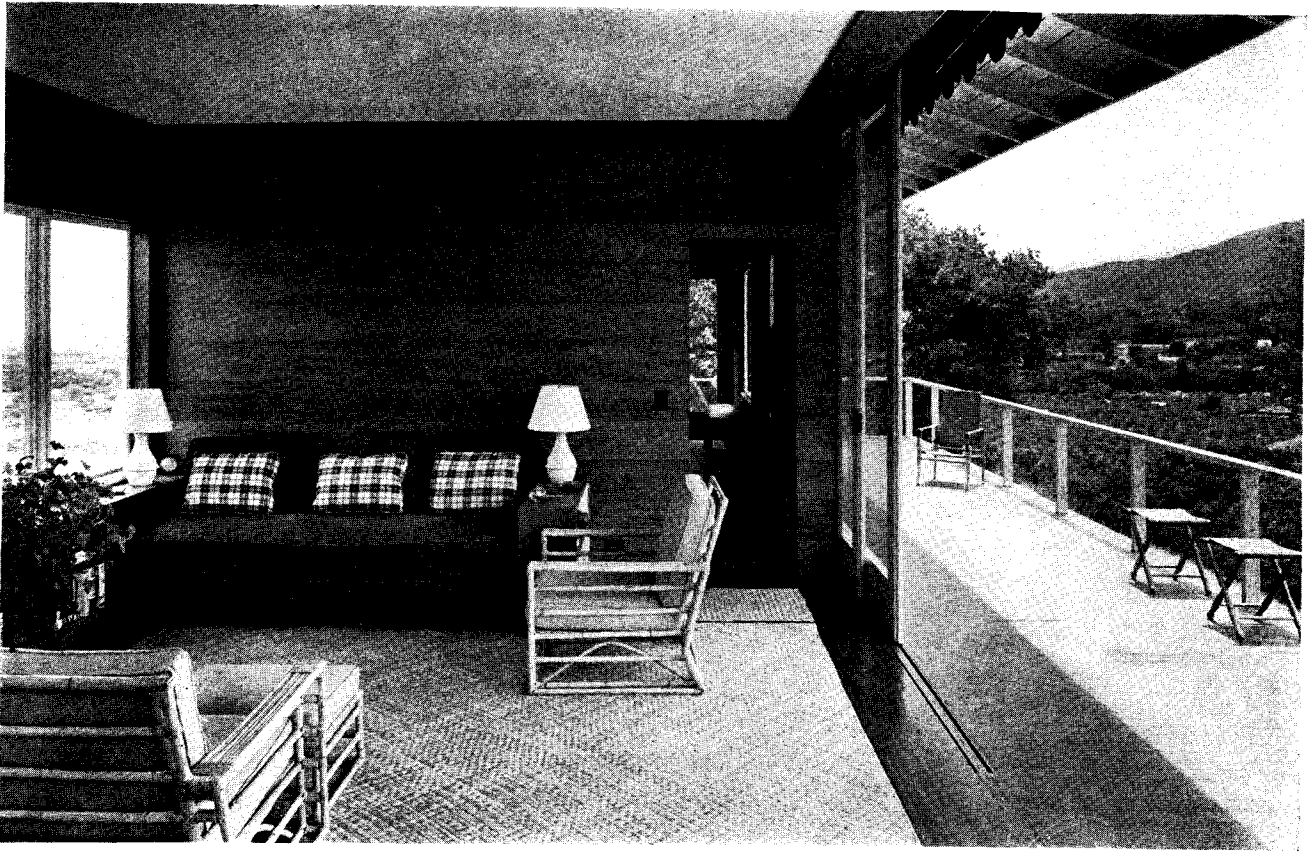

Sliding doors on one side and large windows (also sliding) on the other make the living room an open gallery for outdoor views

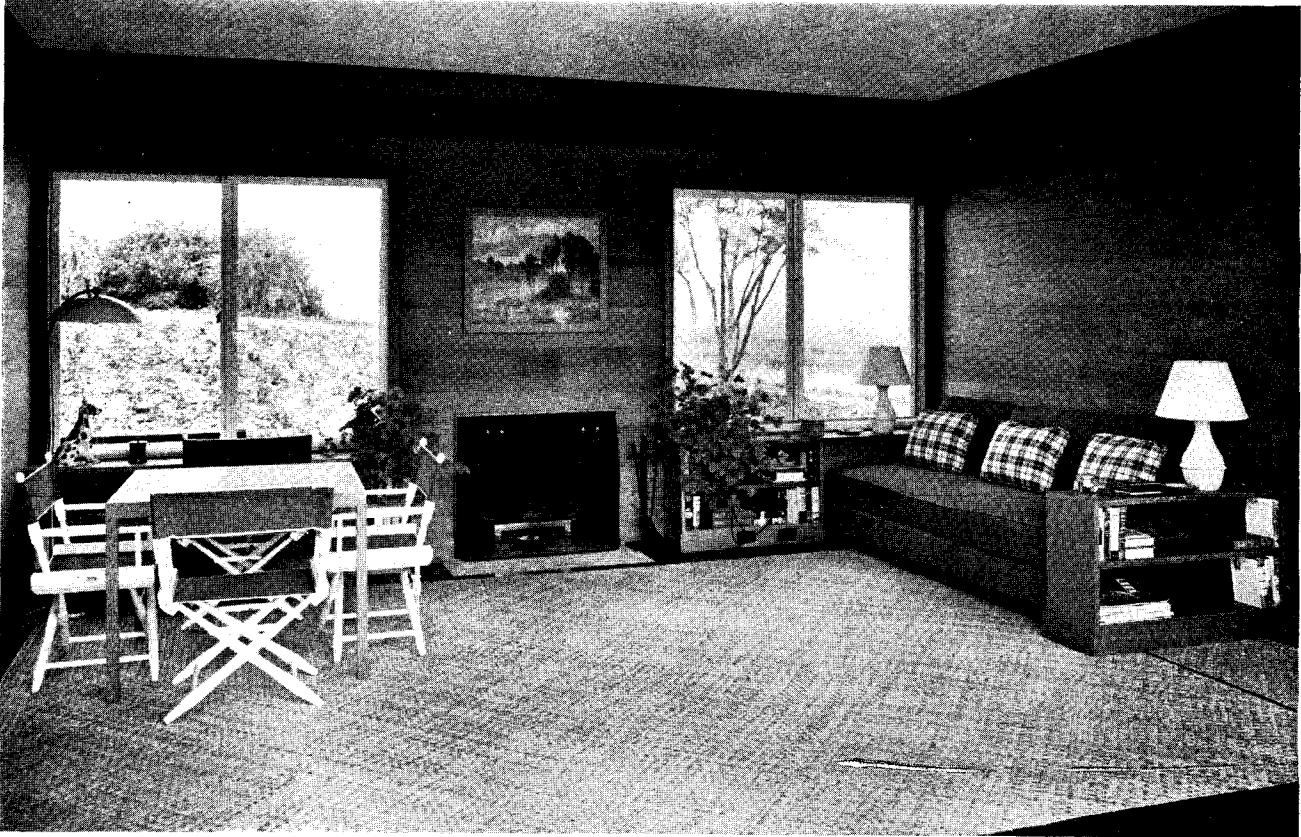

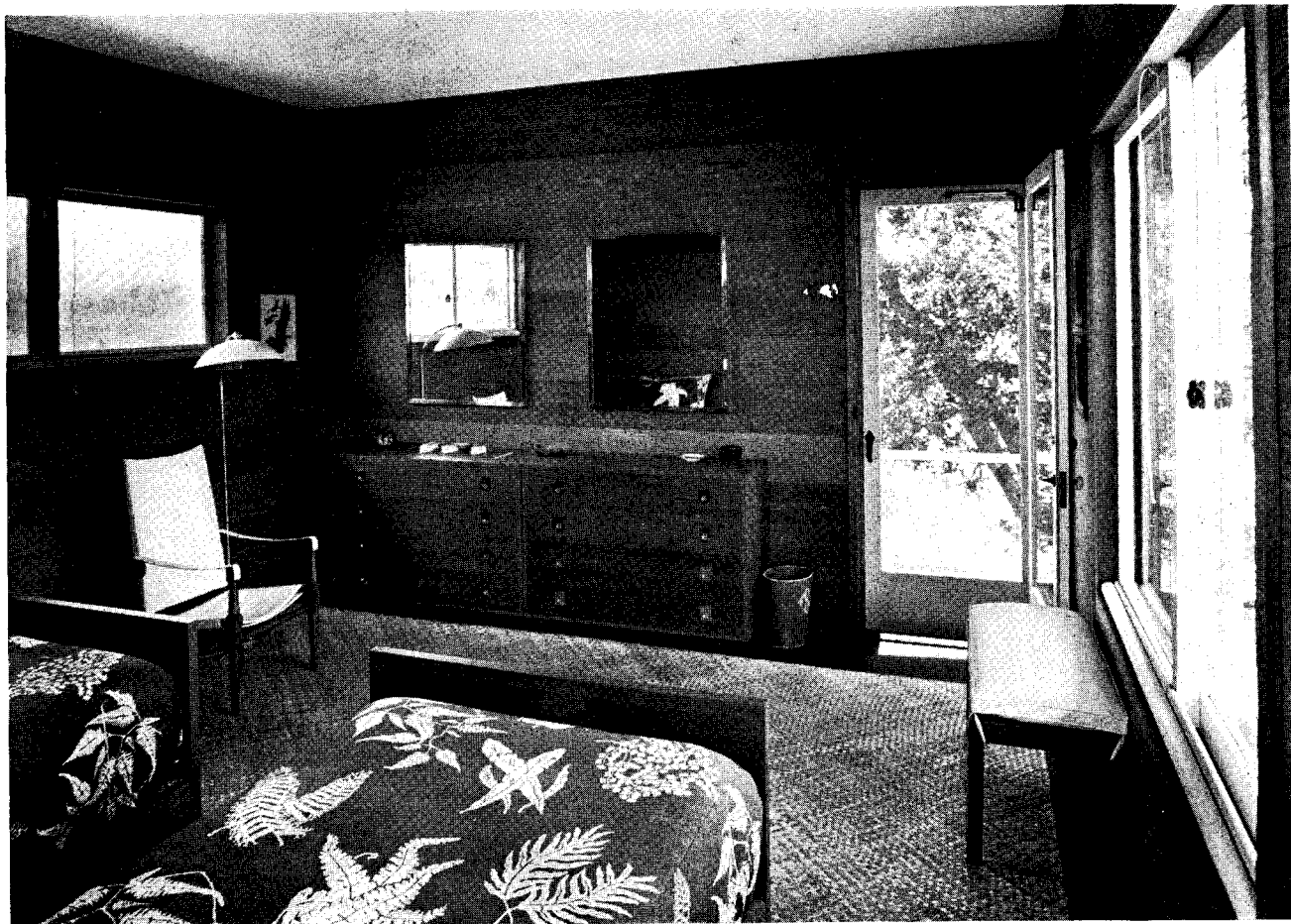

Bedroom interior (like others) is flush redwood boarding in natural tone. Floor is fir, painted dark green

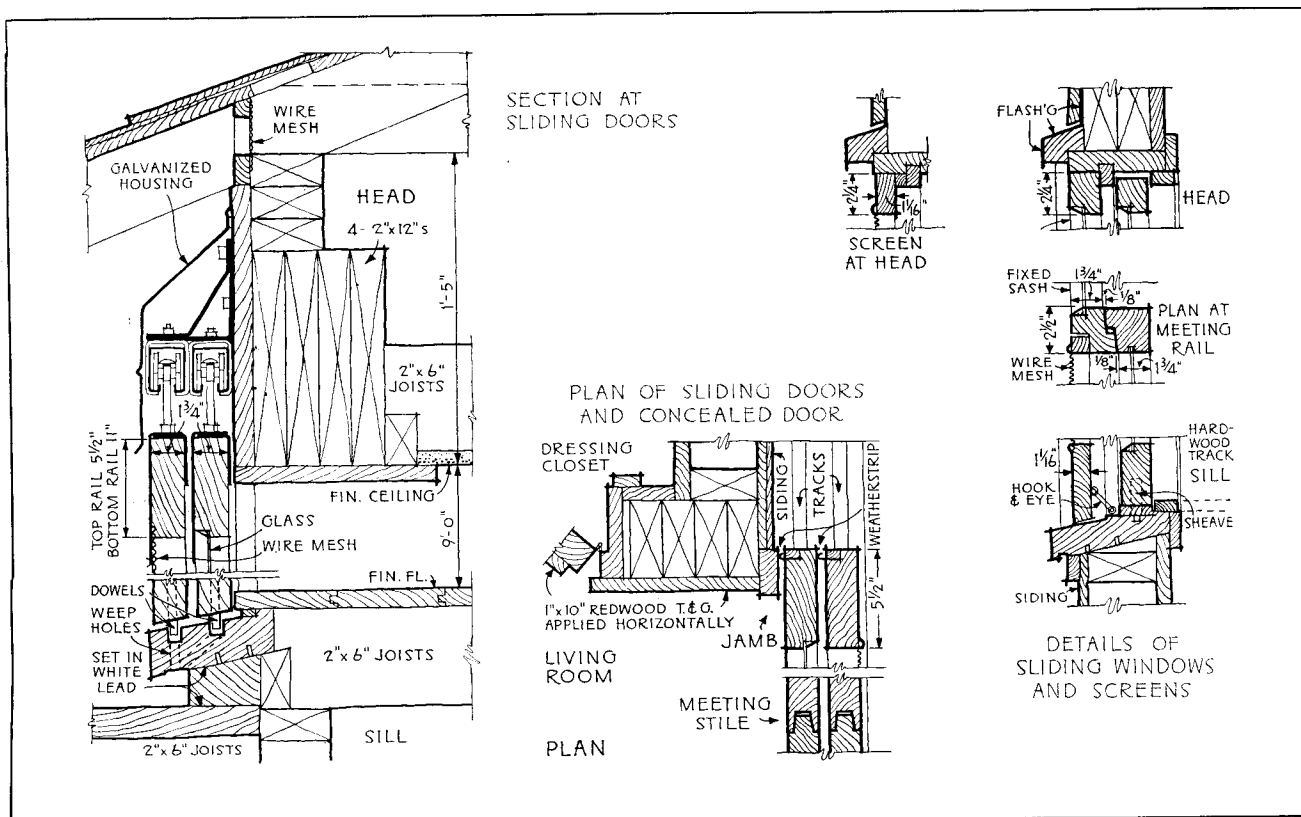

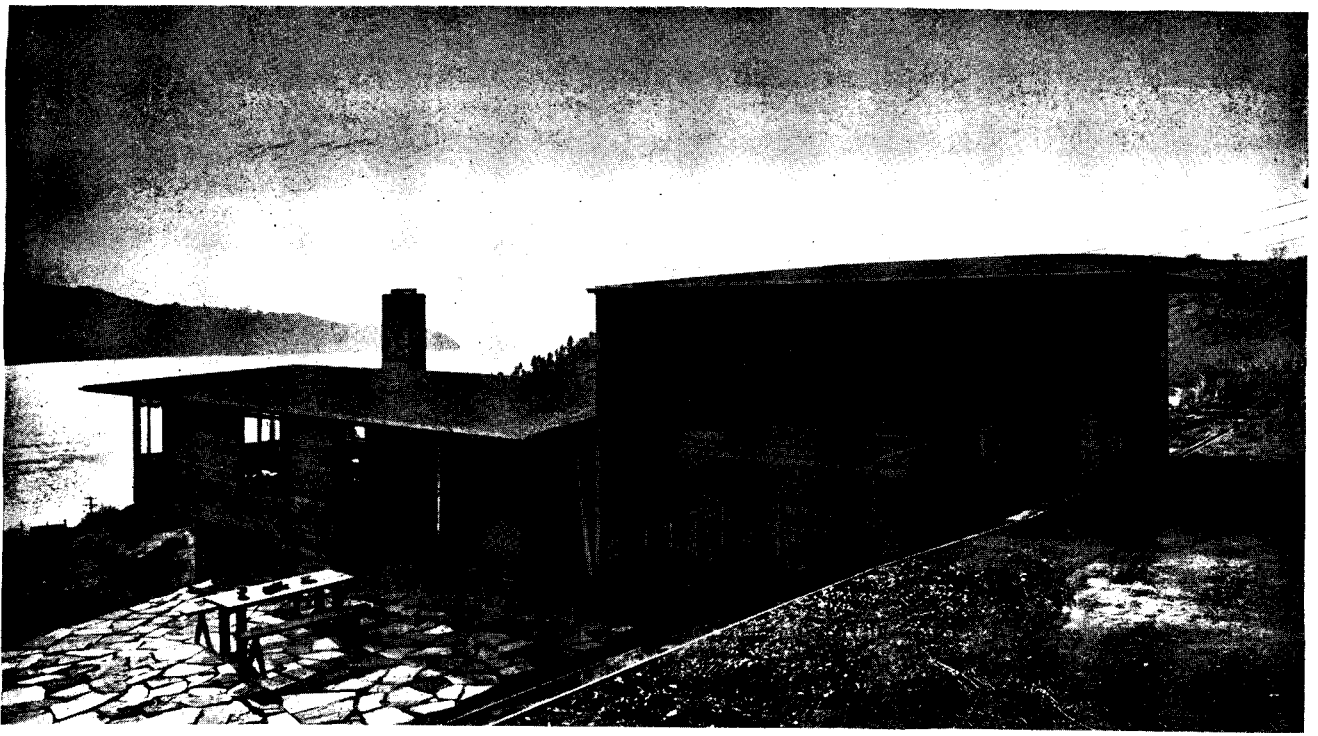

CROSS-CONTOUR PLACING WITH A PURPOSE

HOUSE ON SAN FRANCISCO BAY FOR MR. AND MRS. OLIVER B. LYMAN

WILLIAM WILSON WURSTER, ARCHITECT

Roger Sturtevant photos



THE most obvious fact about this vacation house overlooking the San Francisco Bay is its placement against the hillside contours instead of with them. "The site has a strong prevailing afternoon west wind," writes the architect, "and we used the house as a buttress against it. We wanted protected out-of-door living with the earth at the main floor level. Both of these ends were gained by placing the house as you see it. Then, too, if a house is oriented in the usual manner parallel to the contours, any level area for out-of-door living space has to be dug into the hill, bringing expense and water problems."

The house was built as a weekend place for the young son of the family, for the swimming and boating to be had at Tiburon and Belvedere on the Marin County side of the Bay. The site, overlooking Raccoon Straits and Angel Island, is the identical spot where the sailors came to get water from springs in *Two Years Before the Mast* by Charles Dana. The view out across the bay is like that from a ship's bridge, but there are no "nautical" effects.

The plan (page 73) is devised to provide double-decker beds for a pair of campers, and to provide good informal accommodations for the parents on their occasional visits. The salt water atmosphere has made it necessary to build a full garage, from which an outside stairway leads down to the house. The resawed redwood siding is brushed with two coats of bleaching oil. Doors and sash are painted a color between coral and terra cotta.

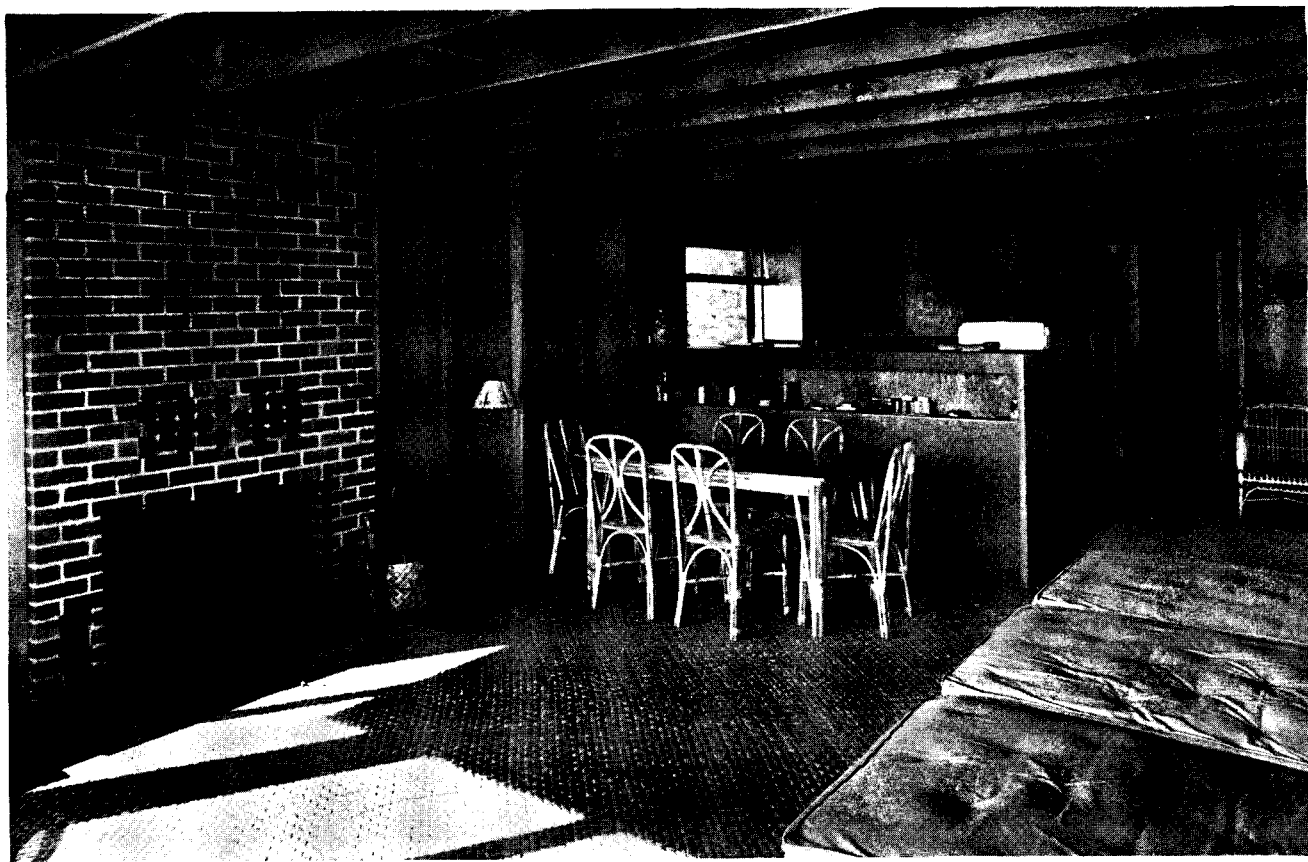

The dining area is part of the living room and so is the kitchen with its breast-high partition

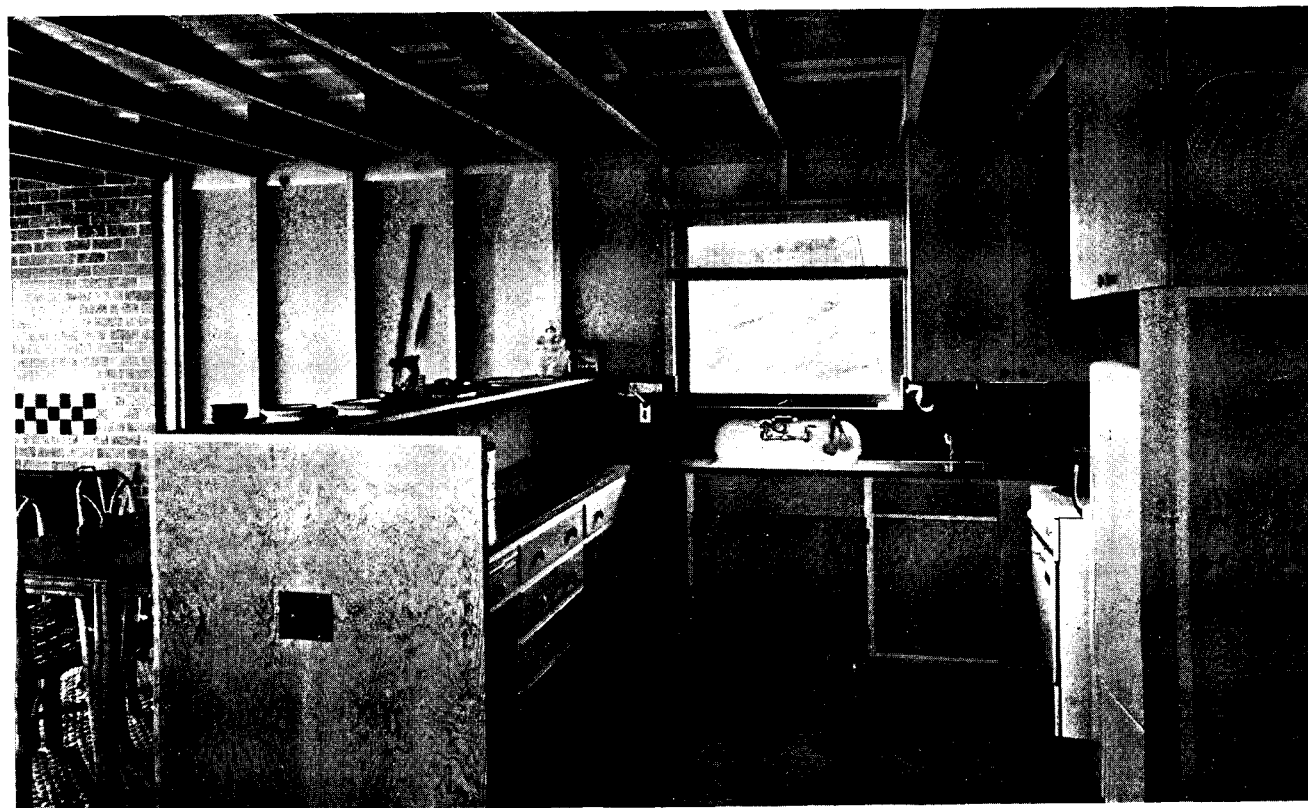

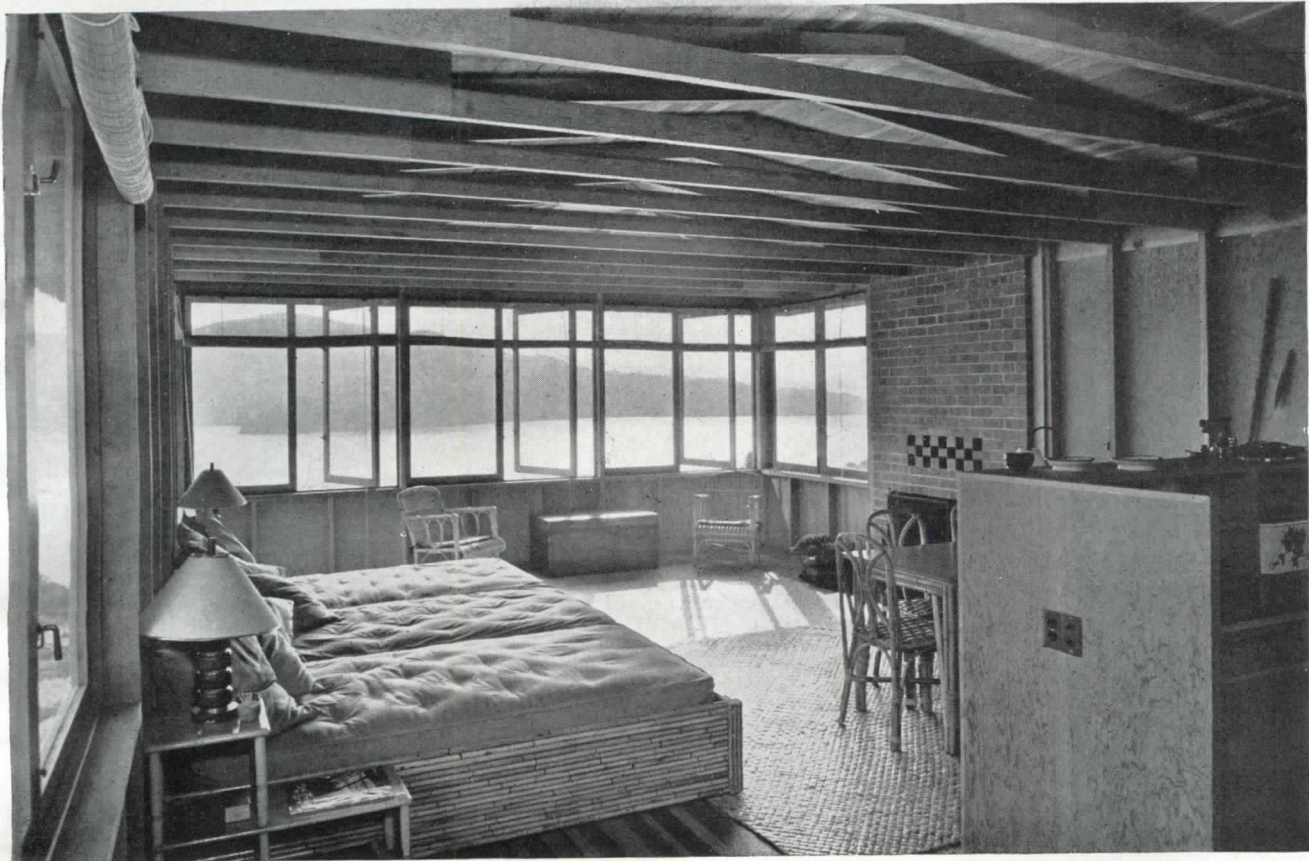

The living room can serve as a secondary bedroom by use of the hiki'e or "sleeping platform"

This kind of a house illustrates the kind of recombination of space that may be expected to increase after the war. As may be seen on the lefthand page, the kitchen has been cut to a minimum. As in much war work, the kitchen is treated as part of the living room, but with a back and shelf placed high enough to cut off the view of the necessary untidiness of preparing meals or cleaning up after them.

When parents or other guests visit the place at the same time as the son, they use the Hawaiian *hiki'e* or "sleeping platform" in the living room, shown prominently in the view above. Storage shelves are provided for such

guests in the bathroom, so that they can use it as a dressing room.

To simplify the plan, one either goes outside the living room to the bedroom or through the bathroom. Space that would normally be assigned to a corridor is thus made available for the entryway.

The architect declares that if he were doing such a plan again, with a downward view, he might drop the windowsills another six inches to make for easier seeing from low seats.

The wood of the interior has been left natural except for a coat of wallpaper lacquer for easy cleaning.

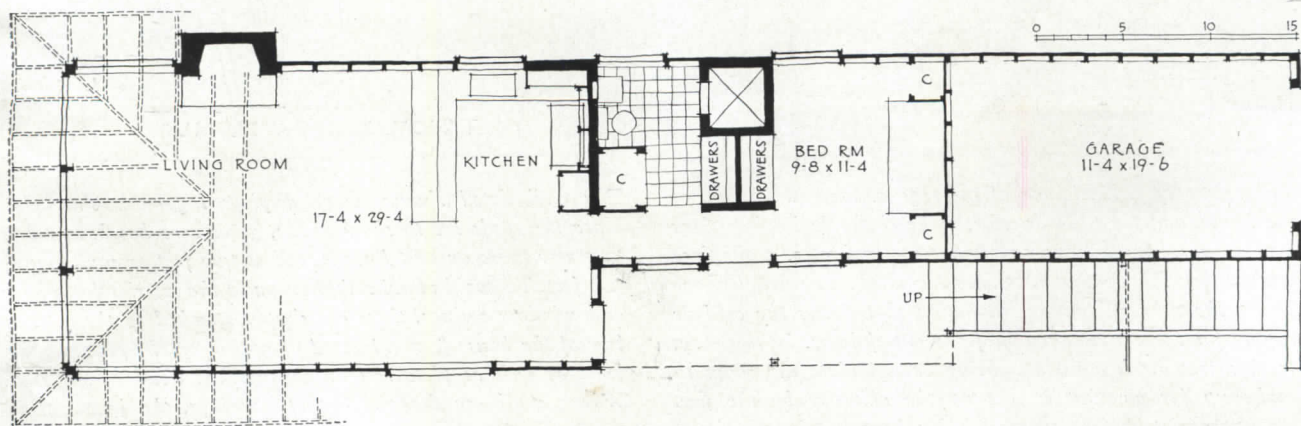

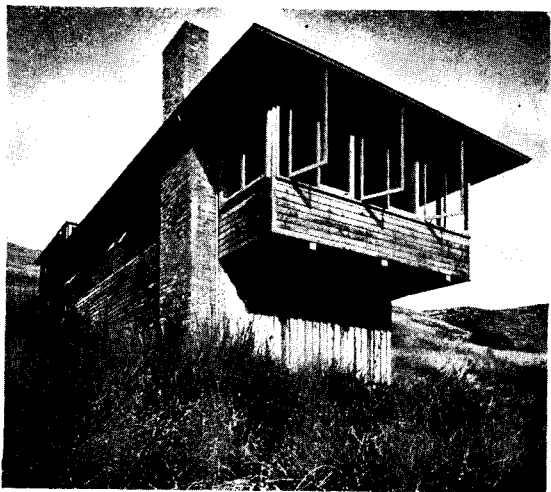

Built for vacation use, the house is economical of foundations and compact in the bedroom

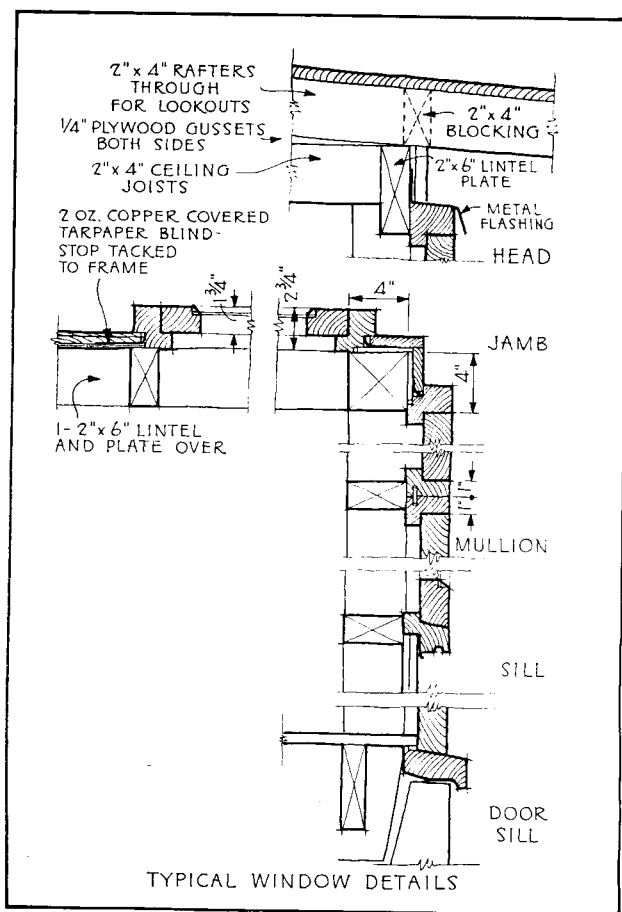
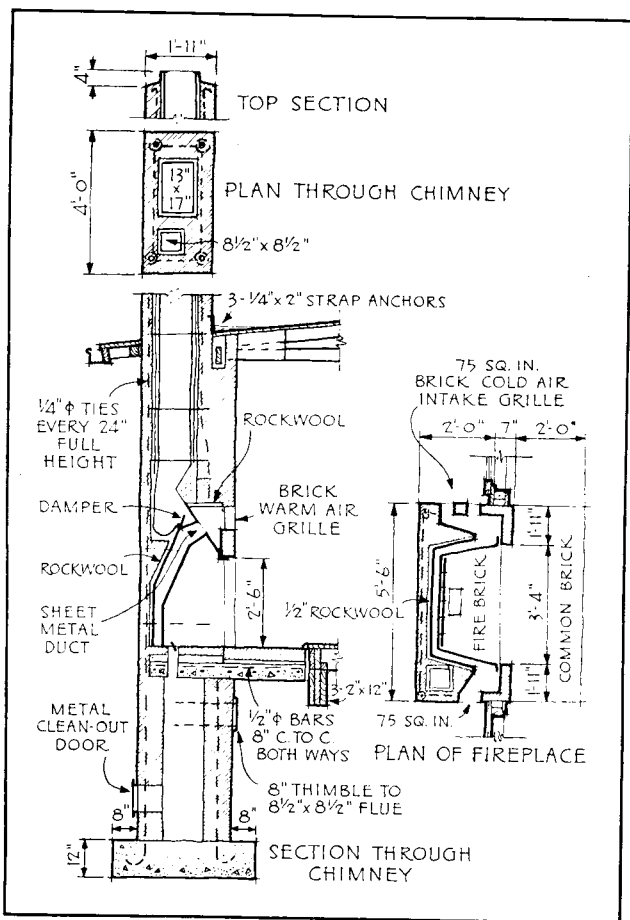

The relatively mild climate of the region, the vacation use of the house, and the tight exterior, make elaborate heating plans unnecessary. Apart from an electric water heater, a fireplace with convection heating unit does the work. The detail above shows the proper kind of installation that draws the cold-air supply for the convection unit from out-of-doors. In this way, fresh warm air is constantly being brought into the room to make up for air that is sent up the chimney by the fire. An appropriately deep windcatch has been left in the throat

The wall detail shown above displays ingenious simplicity. Since the studs are to show inside, great care has been taken to center them on unit lines spaced at two feet or multiples of two feet. To avoid visual complication in the interior from door and window casings, these are simply attached to the exterior face of the house frame. Instead of resting on the plate, ceiling joists as well as plate rest on the notched head of the stud. Where studs are dropped out at openings, the joist is held partly by the plywood gusset in suspension from the rafter



Julius Shulman photos

“COOL CALMNESS” WITH INNOVATIONS

TWIN RANCH HOUSES FOR THE MAURICE BERKSON FAMILY, AT ENCINO, CALIFORNIA

J. R. DAVIDSON, DESIGNER

A “calm and cool atmosphere” was desired by the clients, and the designer provided it for them with a wealth of innovation. In houses such as these, completed just before the war, strictly contemporary design reached a stage of maturity. As further progress is made after the war, further innovation need not be flaunted spectacularly to win acceptance.

The houses, one for the parents, one for the daughter, were built from almost identical drawings for similar needs and economy. Sufficient variation was obtained through landscaping, color, and a few exterior details.

A touch of a button opens the electrically controlled gate. The first house to come into view is the daughter’s house (marked “1” on the plot plan), its stucco exterior a delicate green. It is placed nearest the sports facilities. At the end of the drive is the parents’ house (“2”), colored a light dove blue. Both houses face alike to the desirable southeast exposure and the preferred outlook.

The construction is of stuccoed frame on a concrete slab, which is either left in its natural tan color or integrally colored a deep purple-red, and waxed.

In plan, each of the houses is clearly but unobtrusively divided into three functional units. Social facilities include the vestibule (extended to quite unusual size), the living room, and the dining area; service facilities branch off to the north, and bedrooms with their generous dressing rooms to the east.

In addition to the interior provisions, each of the houses has terraces both to the southeast and to the northwest of the living-dining room, so that there is always a choice between one that is sunny and one that is shaded. The manner of opening up terraces with large sliding doors has become a special characteristic of the work of this designer.

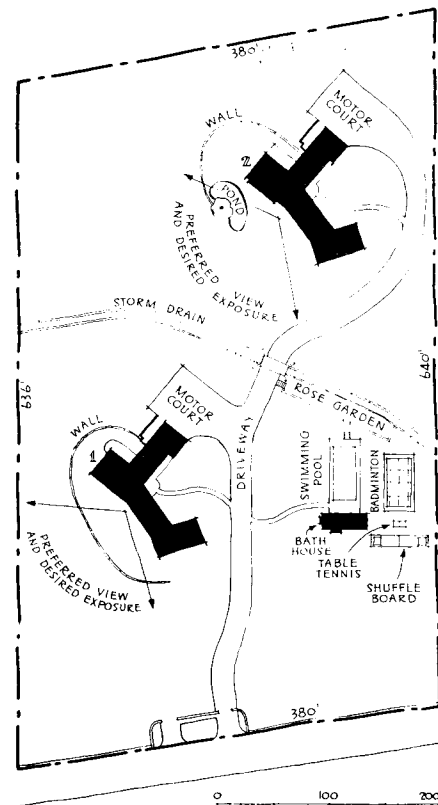



Above: Entrance hall looking toward living room. Soft fluorescent cove lighting against outdoor fluorescent soffit lighting. Cushions are white lamb, goat skin, calf skin on a woven cane seat. Below: Dining area. Muslin curtains to match egg-shell walls. Table, bleached mahogany with copper legs



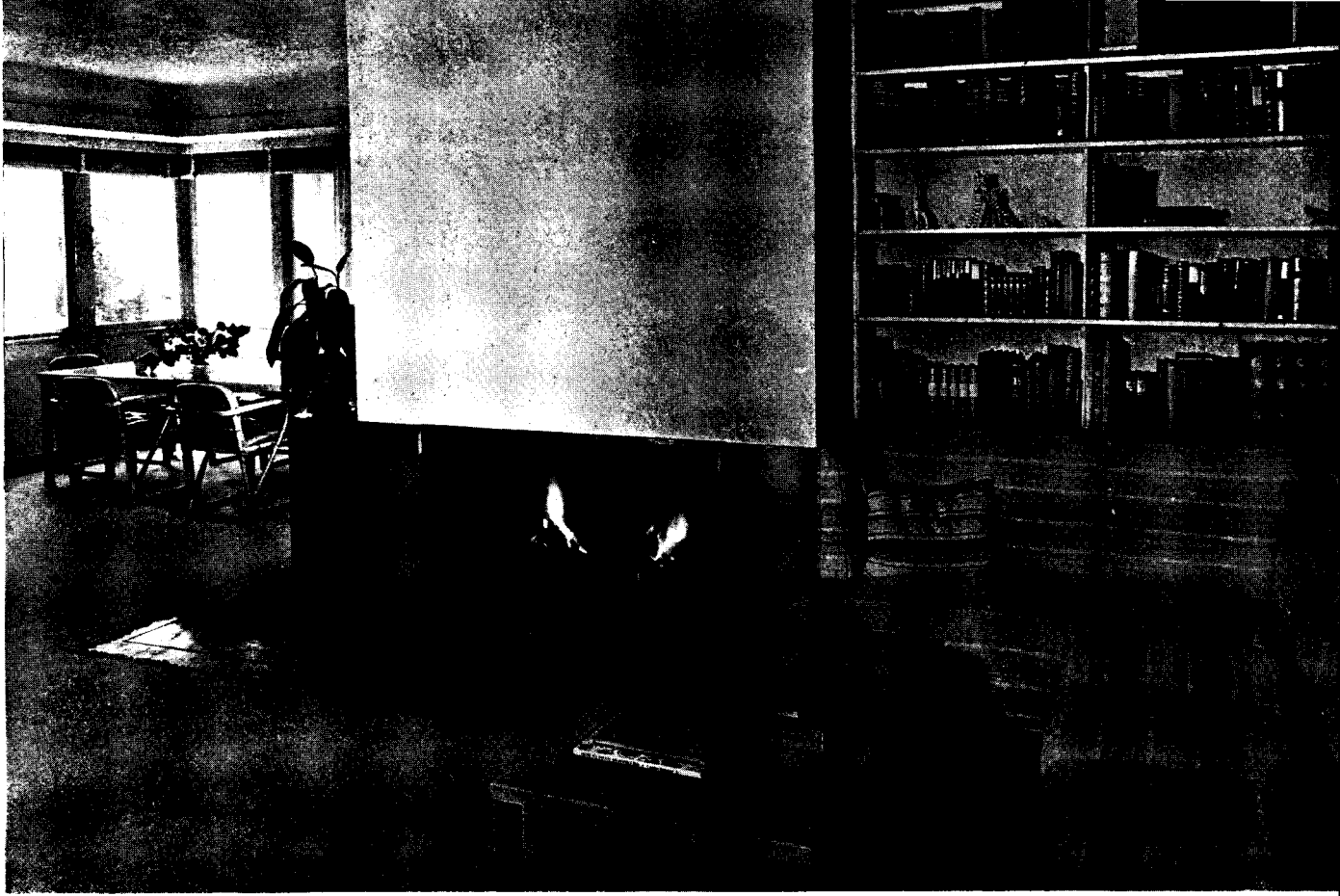

Above: Living room looking toward entrance hall. The rug is natural cotton in a rough weave. Below: Copper-faced (prewar) fireplace and another copper legged table, carrying out the scheme of green and copper accents against an egg-shell base. The other house is in delicate blues, mulberry, and dusty pink

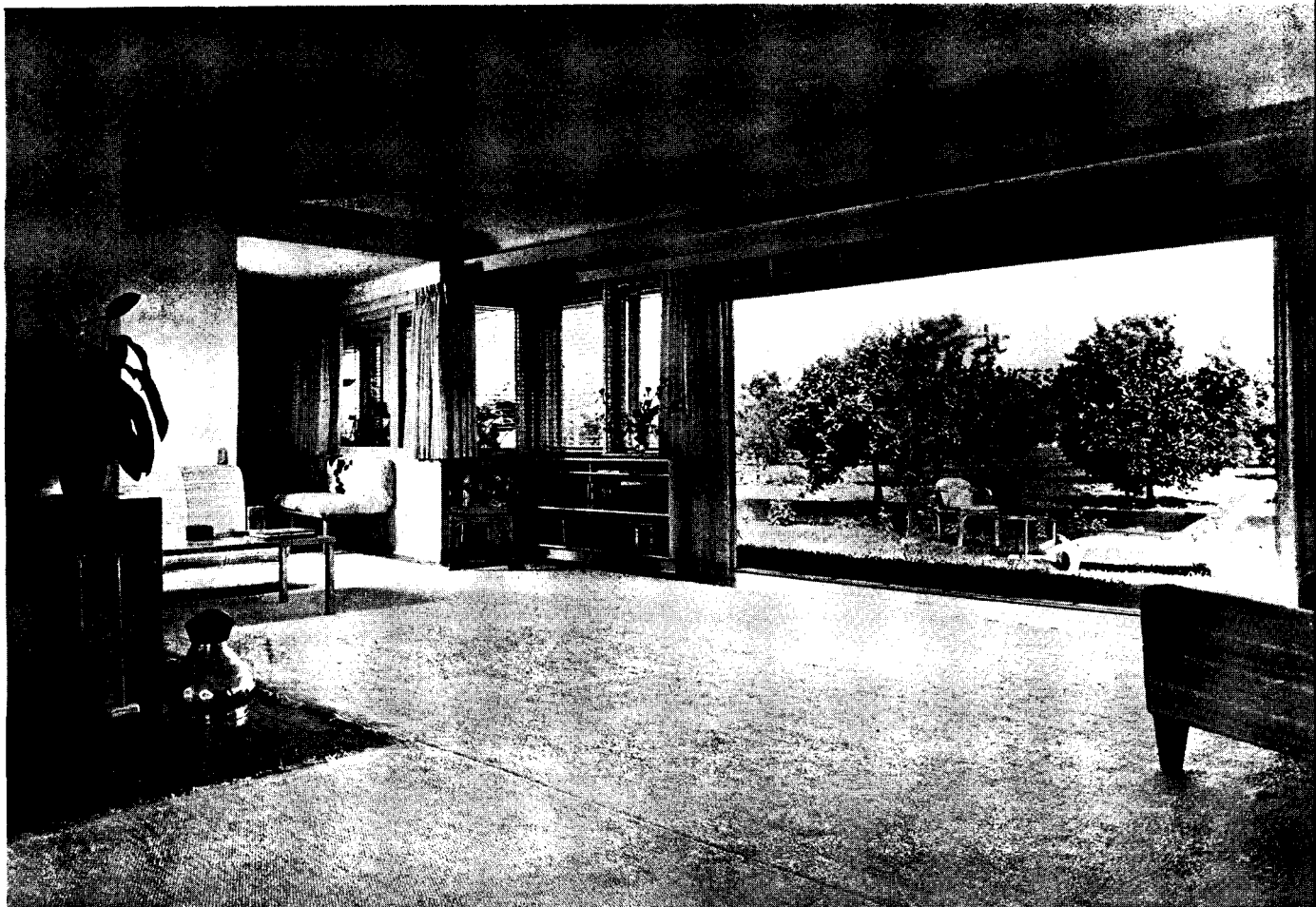



The electric kitchens in the Berkson houses foreshadow postwar progress. They include built-in electric cooking units, bake-ovens and plate-warming compartments. The top of the cooking space as well as of all working areas is of stainless steel. The entire cooking side is finished in white; the ceiling and opposite side pale blue in one house, pale green in the other. And to harmonize, the floors are of a deep blue or deep green asphalt tile

Below is shown the man's dressing room in House Number 2. Walls are dove-blue Bestile, with aluminum trim. Note the trimness of the draw-front design, overlapping the compartment divisions for continuity. An undercut serves as the pull

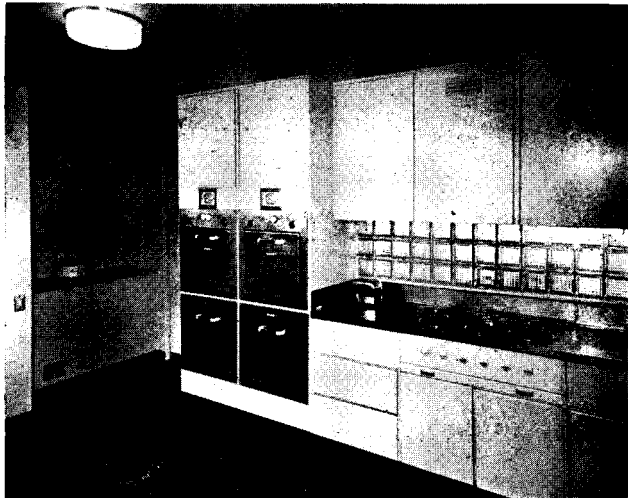

Padilla Studios

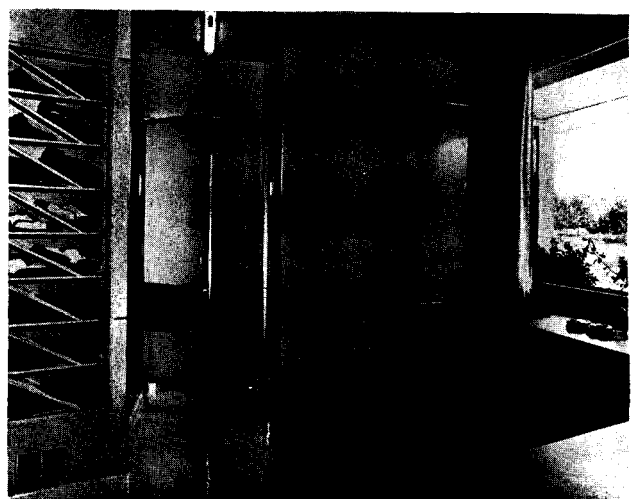
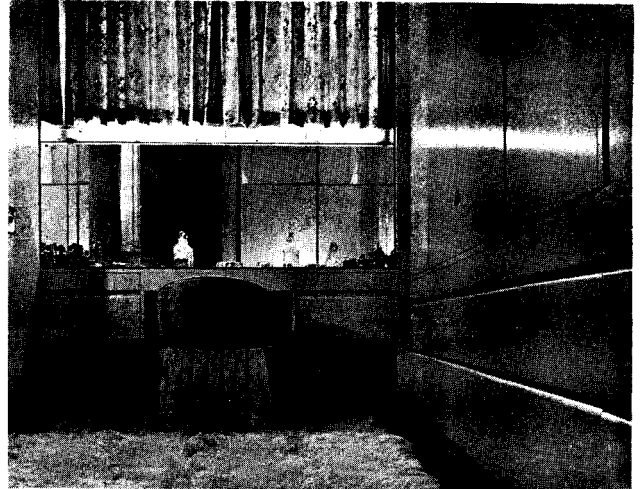



ELECTRIFIED TRADITIONAL

HOUSE FOR C. W. STUART, SOUTHPORT, CONN

VICTOR CIVKIN, ARCHITECT

AFTER the war, many houses will continue to be built as before, which will house the most advanced conveniences in a traditional shell. This house has broken through to the extent of a corner window; otherwise it preserves the traditional virtues. It has compact space organization, good circulation, full use of the basement, large convenient bedrooms, abundant closet space. Electric wiring has been used to the full, floodlighting the outdoor terrace, providing frequency-modulation radio in the living room, radio connections in every room, and electric kitchen.



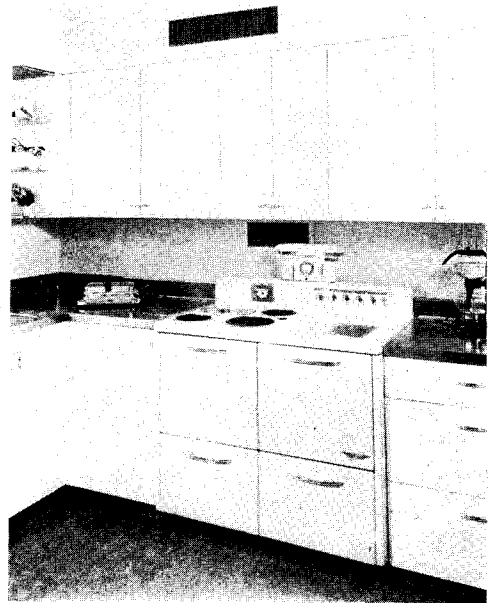

Second floor plan. The master bedroom, though familiar in styling, has every convenience and a sun porch

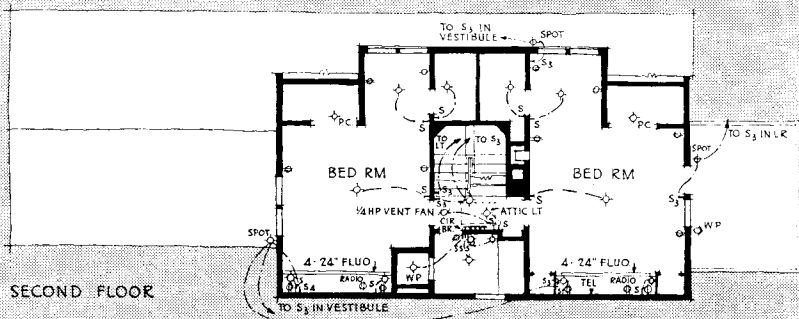

First floor plan. The family, driving home from the theater, comes through the kitchen and can pick up a snack

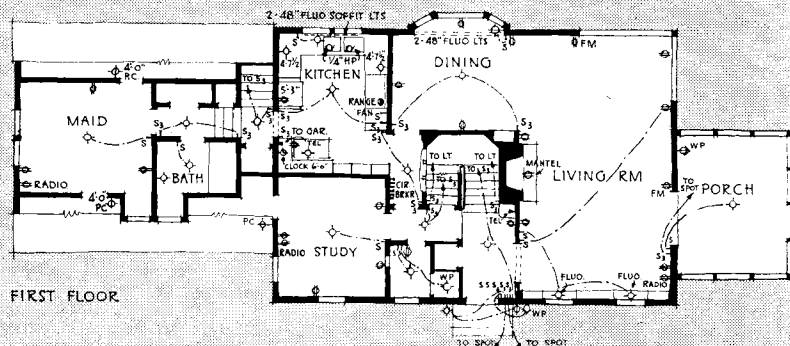

Basement Plan. The rolling site, sloping sharply downward, brings this almost to ground level at the terrace

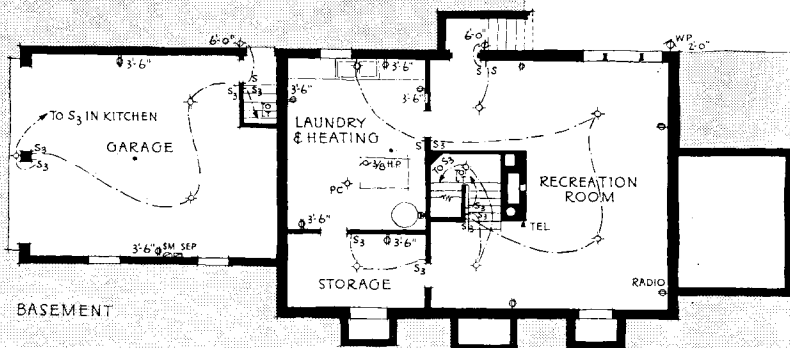

Basic Elements — **SHELVES** Research by Larch Renshaw

PURPOSE

The standards given on these four pages show the usual elements or fixtures that are assembled to produce an efficient storage space or closet. The choice and arrangement of the fixtures depend on the amount and nature of the materials to be stored. Data relating to elements of closet fixtures or equipment are thus made available for easy reference and for grouping to fit any particular purpose.

The standard elements are, 1. Shelves, 2. Poles, 3. Drawers, 4. Hooks, and 5. Special Fixtures. Practically any object can be stored efficiently by one or other of these means. For convenience and quick reference one page has been devoted to each of the standard elements, and the variations in sizes and types have been indicated by key numbers.

GENERAL CONSIDERATIONS

"A place for everything and everything in its place" is the slogan for closet designers as well as housewives. Modern closets should be planned for the storage of the particular clothing or objects of the individual or the group using the

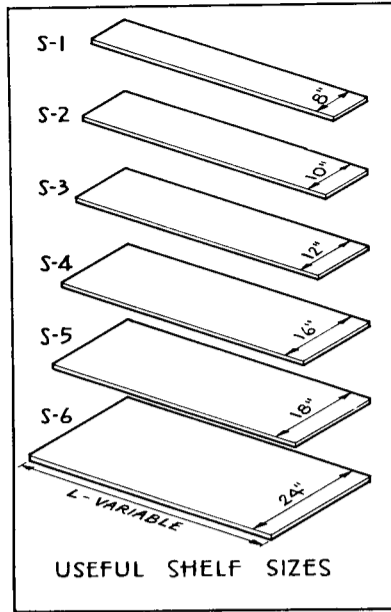

space for storage. An accurate list of the objects to be stored is necessary for the scientific allotment and arrangement of space and facilities. A "margin of safety" of some 25 per cent increased capacity should be allowed for the usual accumulation of additional

belongings. It is better to have too much space than not enough. Much can be stored in little space if sufficient thought is given to the arrangement of the space and the equipment. Too many closets have unused and unusable space, due to poor planning.

TYPES OF CLOSETS

Closets may be classified according to purpose, place or user, or all three. The various types of closets and their particular arrangements will be considered in subsequent Time-Saver Standards. Most types are, however, equipped with the major elements here shown.

Modern closets by the efficient arrangement of space and fixtures accommodate much more clothing and material than the inconvenient, dark, space-wasting closets of a few decades ago. The modern closet thus often replaces pieces of furniture and provides a greater amount of free, uncluttered space in the room.

DOORS

Doors should open the full width of the closet wherever possible, two doors for a five foot closet. This eliminates dark, inaccessible,

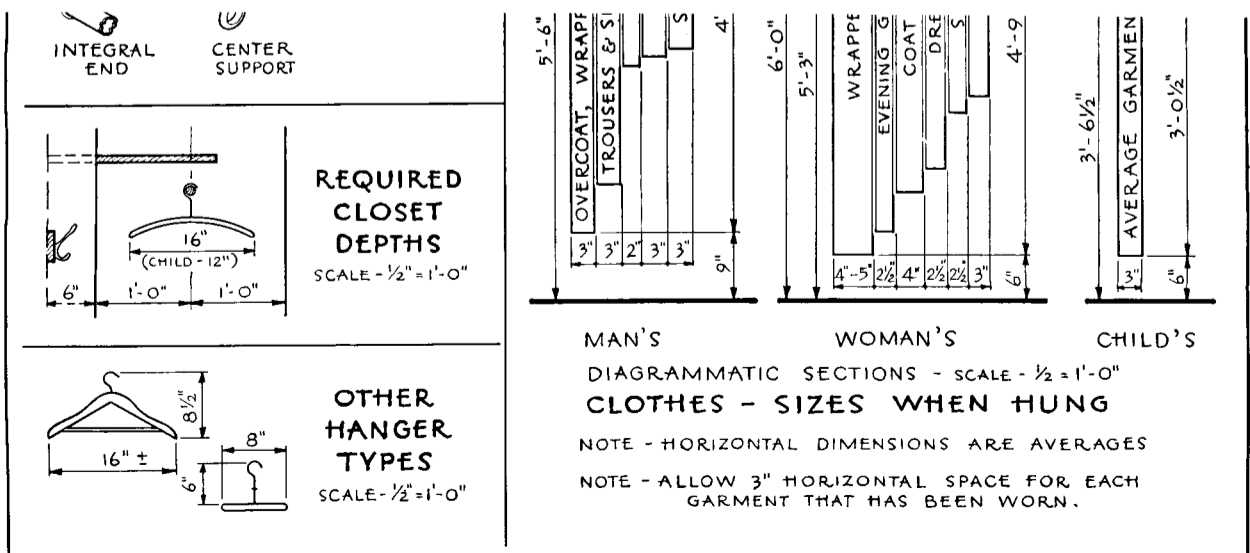
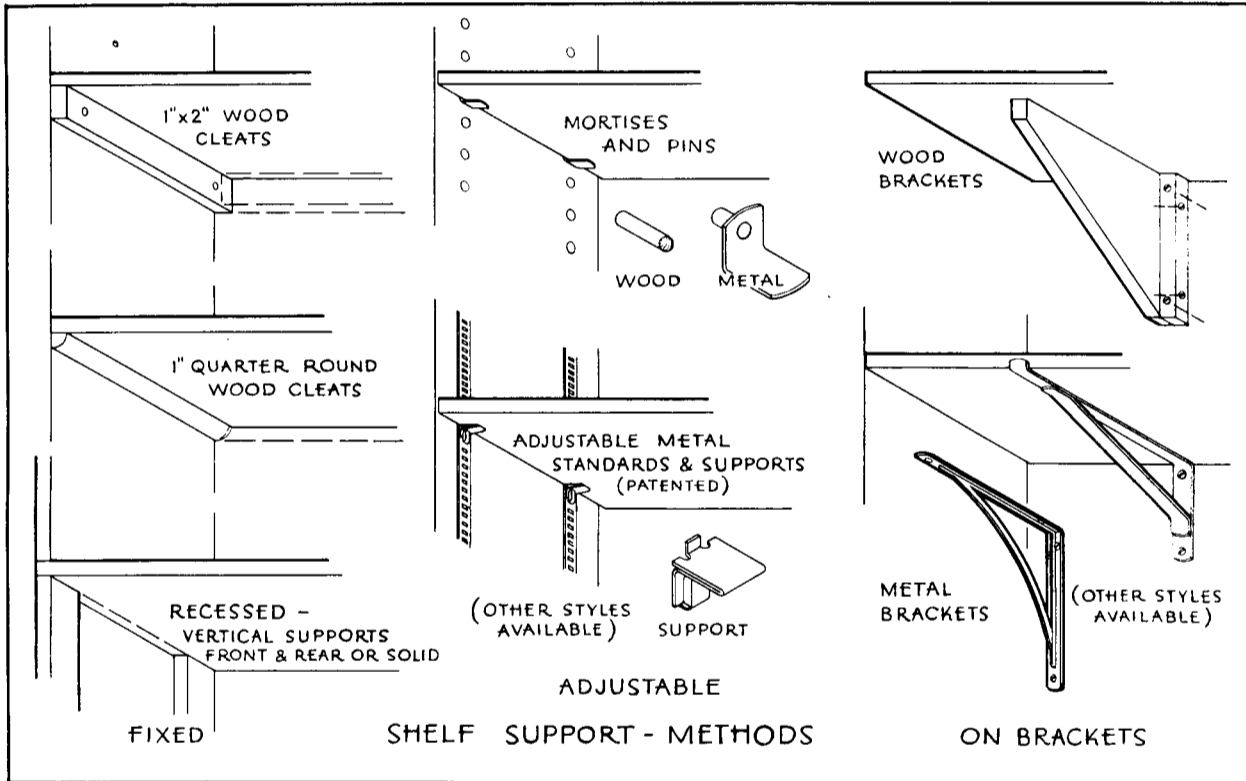

HOUSEHOLD CLOSETS, PART I

Basic Elements — DRAWERS Research by Larch Renshaw

hard-to-clean corners. By the use of sliding doors the entire interior of the closet is exposed to view and every inch of space is immediately accessible. Such doors do not block traffic, bark shins or provide excuse for black eyes.

Sliding doors do not permit the use of special door fixtures such as tie racks, shoe racks or bags, hat hangers, mirror and the like, which are handy and easily reached when attached to a hinged closet-door.

SIZES

For general closets, bedroom or dressing-room closets, 2 ft.-0 in. is standard depth (2 ft.-6 in. if a hook-strip is to be used). This permits clothing to be on hangers on poles, with sufficient clearance. Clothes closet width, parallel to the doors, should be from 3 to 6 ft. per person depending on amounts of clothing

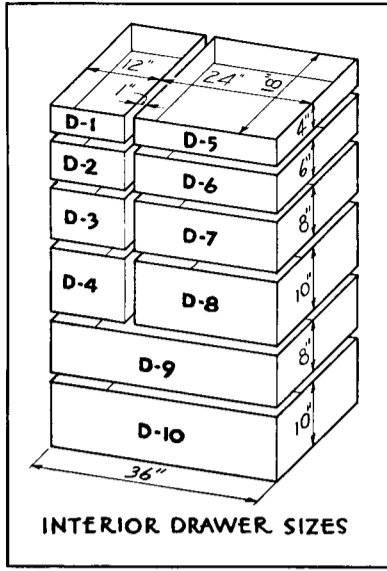

the closet proper to easy reaching height (7 ft. max.) and placing cupboards above for seasonal storage, things that are "put away" for the summer or winter.

LIGHTING AND VENTILATION

Lighting is now considered essential and standard in the modern closet unless room lights are so located as to fully illuminate all portions of the closet. A single tubular or bulb light placed just above the door at the front of the closet, with a diffusing reflector is usually sufficient. Automatic door switches are convenient.

Ventilation has rarely been considered necessary in closets as clothing is usually dry, clean and aired before being placed in the closet. Where such is not the case, ventilation can be supplied by

HOUSEHOLD CLOSETS, PART I

Basic Elements — HOOKS, RACKS, ETC. Research by Larch Renshaw

HOOKS

SPACING - 4" TO 6" O.C.
 HOOK STRIP NECESSARY IN PLASTERED CLOSETS

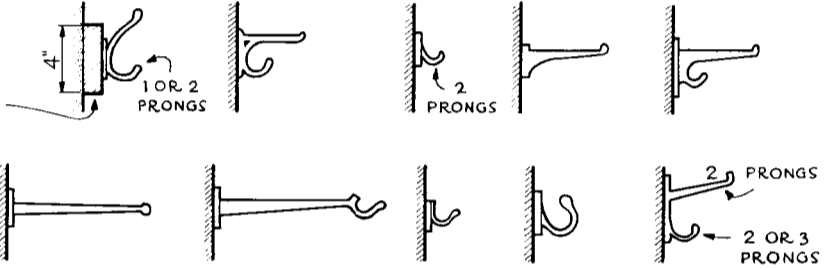

MISCELLANEOUS RACKS

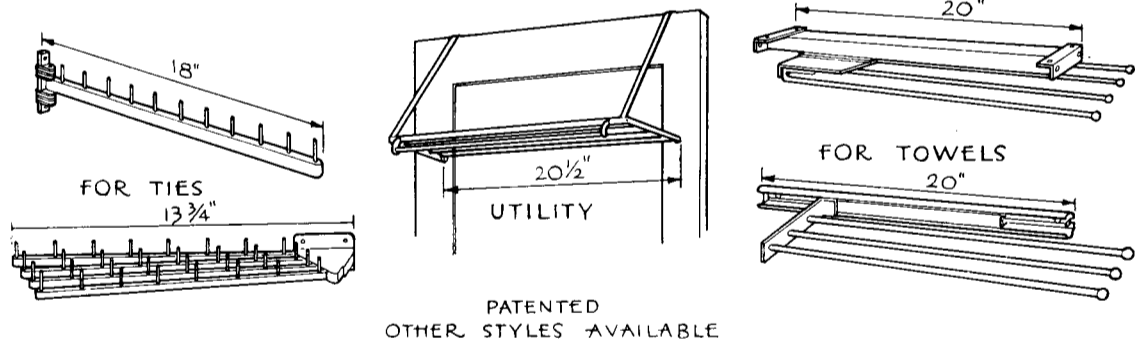

SHOE RACKS

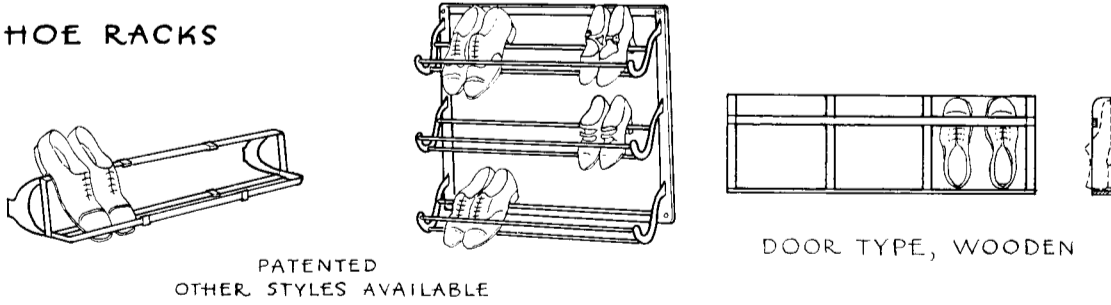

HAT RACKS

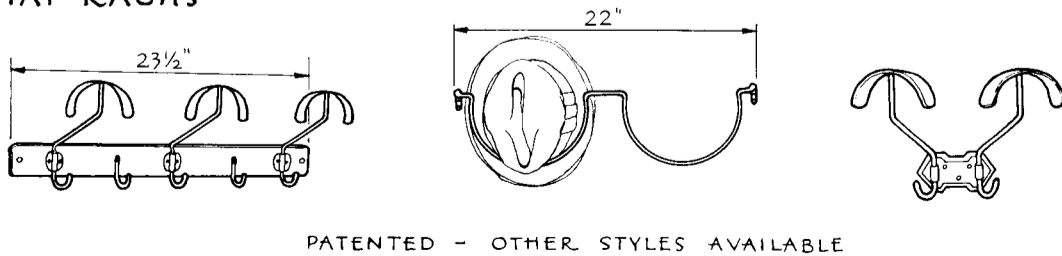

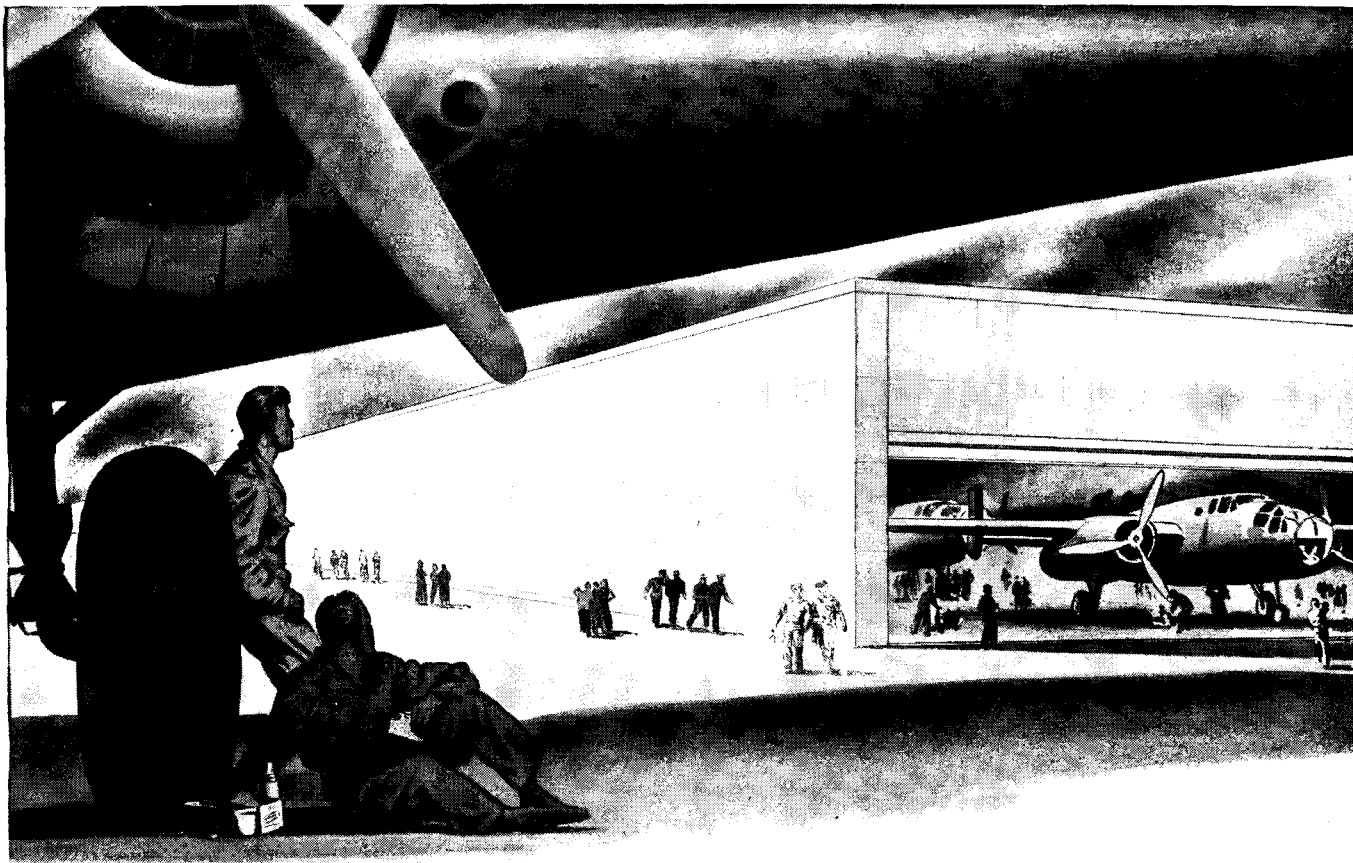

**"BOY, NOTHING HERE BUT A VACANT LOT
98 DAYS AGO!"**

"Yes, sir," says Joe Wingworker, "Three months ago she was just a vacant lot, full of weeds and old tin cans. And now look at her! That asbestos lumber made a plane plant spring up mighty quick. And they tell me the stuff won't rot or rust or ever need paint."

Righto, Joe! That "Stuff" is Keasbey & Mattison's "Century" Apac Board, and if you have anything to do with construction or maintenance after this war, you'd better make a note of it. Why, it's not only maintenance-free, it actually gets tougher with age and it's fire-resistant and weather-resistant.

Also remember, Joe, that Apac is an all purpose board . . . it is designed for roofing or siding and for interior walls, ceilings and partitions. No wonder millions of square feet have been used in essential war construction to date. "Century" Apac Board goes up fast . . . it is trouble-free thereafter.

Total war has shown manufacturers in all fields how to produce faster and better. This, coupled with the fact that wartime building needs have lessened considerably, means that this material is now available again for wide-spread use.

If industry has its way, this new production efficiency will be kept at work after the war, making all the things a peacetime world will want and need—new things resulting from vision and research today.

* * *

*Nature made asbestos;
Keasbey & Mattison, America's asbestos pioneer,
has made it serve mankind . . . since 1873*

KEASBEY & MATTISON
COMPANY, AMBLER, PENNSYLVANIA



★Our Ambler plants proudly fly the Army-Navy "E" flag—an honor awarded K&M employees "for outstanding production of war materials."

**GAS OPERATED
AIR CONDITIONING UNIT**

Anticipating a tremendous postwar expansion of the market for air conditioning, Servel, Inc., of Evansville, Ind., has announced a new all-year gas-operated air conditioning unit (Figure 1) for homes and small commercial establishments. The unit combines in one package all the functions

of complete air conditioning, including winter heating and summer cooling.

Although public introduction cannot be made until after the war, as the company is now entirely converted to war production, distribution, advertising and sales promotion plans are now being discussed with utility outlets. Twenty-seven large gas utility companies already have more than 300 test

installations in the territories they serve, according to Servel officials, and field reports indicate quiet and economical operation and superior consumer acceptance.

Louis Ruthenburg, president of Servel, points out that plans for the new unit are being pushed by the company in line with the Committee for Economic Development's goal of high levels of employment and productivity immediately after the war. "That objective can be reached," Mr. Ruthenburg said, "only by *immediate* bold, effective planning on the part of the employers of America."

KITCHEN PLAN NO. 5: Fifth of a series of successful mass-feeding kitchen plans.

This cooking equipment layout produces food for 15,000 employees at a time in a huge aircraft plant.

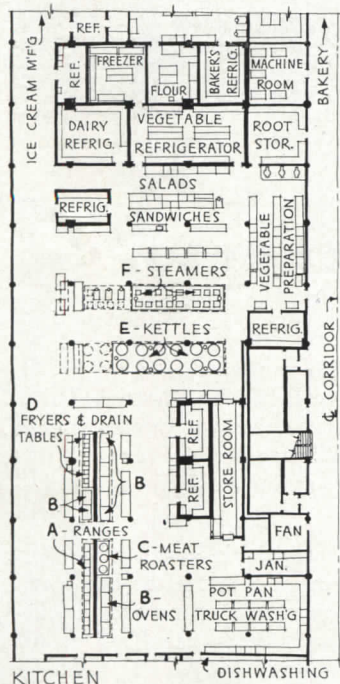

**KEEP FOR
HANDY
REFERENCE!**

**COOKING EQUIPMENT
USED:**

- (a) 11 Ranges
- (b) 12 No. 952 BLODGETT GAS-FIRED ROASTING OVENS
- (c) 3 Roasting Kettles
- (d) 6 Fryers
- (e) 12 Stock Kettles
- (f) 16 Vegetable Steamers

Designed by J. Earle Stevens for, and F. E. Sroman of, Albert Kahn Associates, Architects and Engineers.

THE TWELVE No. 952 BLODGETT ROASTING OVENS in this installation provide twenty-four separate 12"-high chambers with 224 sq. ft. of shelf area. **THIS AREA IS DOUBLED** by the use of **EXTRA REMOVABLE SHELVES** for shallow roasts—more than 50% of normal roasting. Loading capacity, without extra shelves, over 3600 lbs. Used for meats, fish, vegetables, puddings, baked beans, etc. For details and specifications of Blodgett Ovens, consult your equipment house or write



The G. S. BLODGETT CO., Inc.

53 Maple Street

Burlington, Vermont

Reprints of this series now available to architects on request.

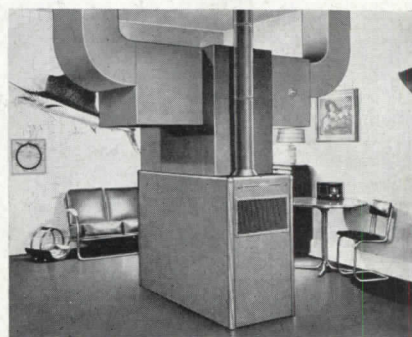

Figure 1

PLASTIC BOARD

A new development in the plastics field is a plastic board, already in wide war use, which is said to weigh only half as much as aluminum, yet to be able to withstand strains as well as the best metal alloys. It can be bent, cut and formed into almost limitless shapes, its developers report, is a non-conductor of electricity, and is unaffected by gasoline, oils, acids, most alkalis, and other solvents. U. S. Rubber Co., Mishawaka, Ind.

FLOOR PATCHING MATERIAL

A permanent floor patching material called Emeri-Crete, intended primarily for use in filling cracks, small depressions, ruts or other imperfections and inequalities in concrete or cement floors, was developed to meet a demand for a ready-mixed material which could be applied immediately after water has been added. It is composed of pure emery, only the smaller particles being used, mixed with a special quick-setting binder which permits use of the floor in six or seven hours after the repair has been made, (Continued on page 90)

SERVICES TECO HAS FOR YOU

WHEN YOU BUILD WITH WOOD



CONSULTING SERVICE. Teco maintains a staff of engineers to consult with architects and engineers on their design problems. Teco Connector distributors and fabricators in all parts of the country also render helpful services.

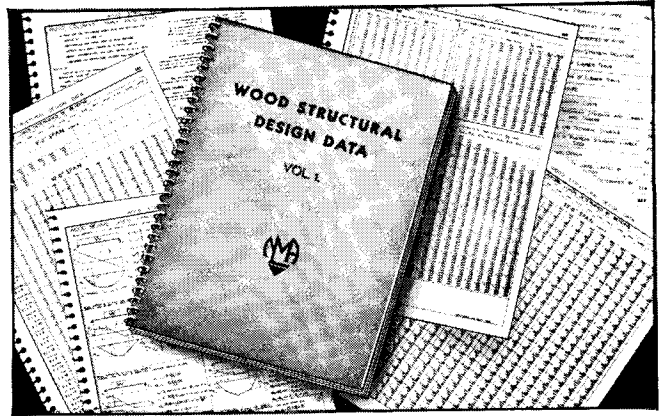

DESIGN DATA SERVICE. Teco has available for architects and engineers complete data on all phases of timber design, including tables and charts on timber beams, columns, floors, connector loads, bolt loads, stresses, etc.

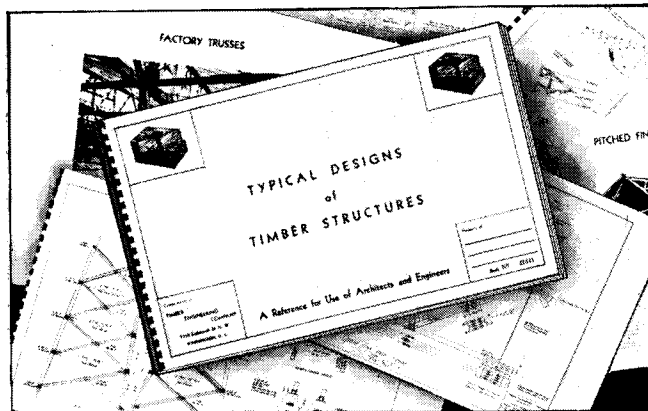

TYPICAL DESIGN SERVICE. "Typical Designs of Timber Structures"—a 100-page book—is available to architects and engineers free upon request. Copies of several hundred other designs of typical Teco Timber Structures are also available on request.

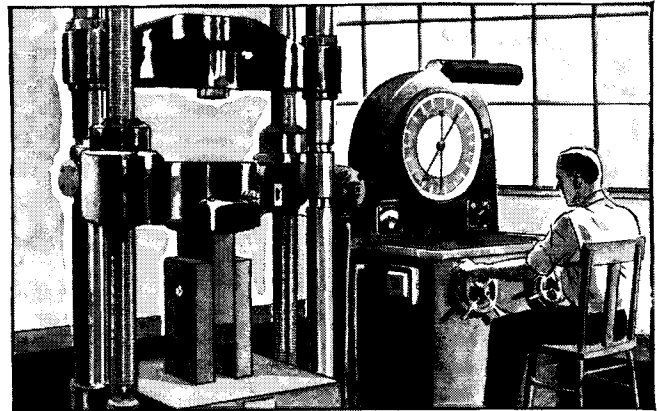

RESEARCH SERVICE. Teco conducts a continuous research program through laboratories as well as sponsoring research at outstanding engineering colleges to increase the design knowledge of timber designers.

Wood is often referred to as the *rediscovered* material, due to its development by science for plastics, laminations and heavy construction.

Engineering science that developed the Teco Connector System of timber construction is responsible for the position timber occupies as a leading heavy construction material.

The Teco timber system serves our war effort . . . it will *serve you* in peace times too.

TIMBER ENGINEERING COMPANY
—Washington—Chicago—
Minneapolis—Portland.

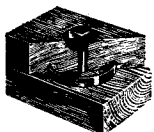

The **TECO** Ring Connector spreads the load on a timber joint over practically the entire cross-section of the wood . . . brings the full structural strength of lumber into play.

Specify
TECO
CONNECTORS
★ **TOOLS** ★
ENDORSED BY LEADING LUMBER MANUFACTURERS
AND FABRICATORS



(Continued from page 88)

according to the manufacturers. It is packed in small, economical packages permitting the use of just the right amount of material to do the job at hand with no waste.

Emeri-Crete patches will not shrink, it is claimed, and if applied in accordance with directions will make repairs permanent. Walter Maguire Co., Inc., 330 W. 42nd St., New York 18.

PAINT BRUSH RESTORER

A non-inflammable paint brush cleaner called Prestorer is ready for instant use, contains no caustic alkalis, and gives off no poisonous fumes, the manufacturers report. As the hard paint pigment is not dissolved, but merely cracks off following the absorption of part of the solution into the bristles, the solution may be

strained through cheese cloth and used over and over again. Technical Development Laboratories, Tenafly, N. J.

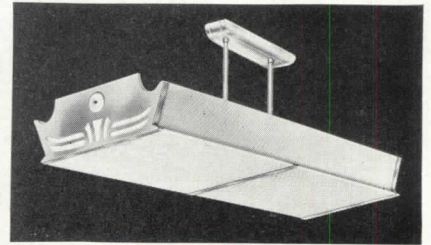

Figure 2

RESEARCH LUMINAIRE

A new, improved lightweight Mitchell U.R.C. Research Luminaire, designed to use less than 6 lb. of metal in accordance with the latest WPB regulations, is now available for stores, offices, buildings and institutions on a priority of A-1-J or higher, it has been announced.

This shielded 200-watt 4-light commercial fluorescent fixture combines high intensity illumination with low surface brightness. It is said to be adaptable for every type of interior, for surface or pendant mounting, for individual or continuous row lighting. According to the manufacturers the unit is easy to relamp and maintain; glass panels are readily removed for cleaning or relamping, without the use of tools. (Figure 2) Mitchell Mfg. Co., 2525 Clybourn Ave., Chicago 14.

COKE WINDOW SCREENS

The postwar home will have window screens made from coke, limestone and salt, and so rustproof and flexible that they may be left in place throughout the year and rolled up like a roller shade, L. H. Chenoweth of the B. F. Goodrich Company told a meeting of department store and retail trade executives in Chicago recently.

The screens, made possible by the properties of the company's polyvinyl resin synthetic known as "koroseal," will be available in almost any tint to match the decorating scheme, or in an almost transparent finish, Mr. Chenoweth said.

HEAT-RESISTANT LUCITE

A new formulation of Lucite methyl methacrylate resin molding powder has been developed by E. I. du Pont
(Continued on page 92)

War Housing with *Post-War* HEATING

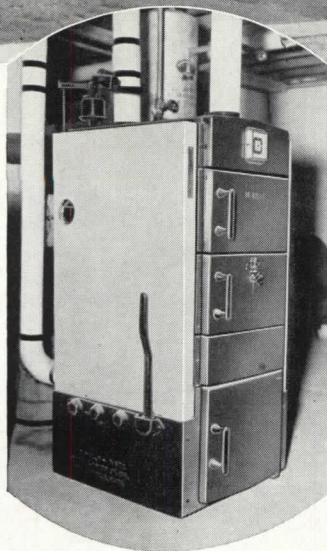

STURDY • DURABLE • EFFICIENT

H.B. *Smith* BOILERS

installed in this attractive Springfield, Mass., Defense Housing Project assure home buyers of heating that is up to pre-war and post-war standards.

The hand-fired "15" SMITH-MILLS boiler installed in each home can be converted to automatic firing when the war is over.

In Springfield, Massachusetts, the name of "Penno-Built Homes" has become synonymous with "value received." Equipment for the last completed Penno development built expressly to house a portion of Springfield's swollen war worked population was carefully selected to make sure that purchasers were buying homes that would represent an investment of continuing value — not merely temporary shelter.

The installation of H. B. SMITH cast-iron boilers throughout this project is assuring a low consumption of hard-to-get fuel for the winter ahead, and modern, comfortable heating for the years to come.

THE H. B. SMITH COMPANY, INC., WESTFIELD, MASS.
BOSTON NEW YORK PHILADELPHIA

Heat Loss Studies in Four Identical Buildings to Determine the Effect of Insulation



FIG. 2 Plot and floor plan of the four test houses.

What Improvements Will Come From These NEW Insulation Facts?

Two purposes are served by the recent extensive insulation tests made by the Wood Conversion Company with four identical test houses.

The first is the compiling of new facts about insulation . . . new findings on such important subjects as heat loss, insulation thickness and fuel saving.

A copy of the report on the Wood Conversion insulation tests as it appeared in the journal of the American Society of Heating and Ventilating Engineers is yours for the asking. Keep up to date on insulation—mail the coupon for your copy.

The second purpose is a substantial addition to the vast body of research which has made Balsam-Wool a leading insulation in the past . . . and which will make it outstanding in the postwar era. For the new findings are just another step in the Balsam-Wool program of constant improvement.

WOOD CONVERSION COMPANY
Dept. 115-11, First National Bank Bldg.
St. Paul, Minnesota

Please send me complete scientific data on the Wood Conversion Company insulation tests.

Name.....

Address.....

City..... State.....

Balsam-Wool

SEALED INSULATION

(Continued from page 90)

de Nemours & Co., Arlington, N. J., to meet the wartime need for a molded methyl methacrylate thermoplastic with increased heat stability. Designated as heat-resistant Lucite molding powder, it was developed for use in existing compression, injection and extrusion equipment. The yield temperature of articles molded from it may be 30 to 40° F. higher than for articles molded

of other acrylic powders. It is not recommended, however, for articles which are to be subjected to boiling or to temperatures in excess of 200° F. Among the proposed uses are flying-light lenses, dial and meter faces, medical and dental instruments, airport signal-light lenses, electric switchboard color caps, and railroad signal-light lenses.

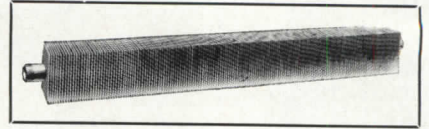

Figure 3

HEATING ELEMENT

Said to be suitable for many installations where standard-type radiators are not desirable, the Type OTS heating element (Figure 3) is a long narrow all-steel unit. Each element is made up of 1¼ in. pipe, with No. 22 gage fins, mechanically attached, each fin interlocking with the preceding fin.

The elements are manufactured in lengths from 18 to 72 in. Multiple lengths can be supplied by coupling two or more lengths together with pipe couplings or by welding. Covers are available for all lengths; they are constructed of No. 16 gage metal and extend the entire fin length of the unit.

The Type OTS Convactor is an adaptation of the OTS heating element to a deluxe enclosure. The unit casing is constructed of No. 18 gage metal with punched-in grille in the sloping top. C. A. Dunham Co., 450 E. Ohio St., Chicago, Ill.

PLASTIC HOOK

Another new use of plastic materials has been developed in the Tenite coat hook now being manufactured for use in the ships of the Navy and Merchant Marine. At present manufactured only in the regulation Navy copper-brown color, these hooks are promised for postwar civilian use in standard hardware colors of red, green, blue, ivory and black. Each hook is injection-molded in one piece in a four-cavity mold die, with a molding cycle of approximately fifty seconds. Tenite is a cellulose acetate butyrate product of Tennessee Eastman Corp., Kingsport, Tenn. The coat hooks are molded for the Bureau of Ships, U. S. Navy, by Pyro Plastics Co., Westfield, N. J.

CEDAR WALLPAPER

A new ready-pasted wallpaper made from cedar wood and treated with a patented application to enhance and retain the fresh cedar odor, is said to transform an ordinary clothes closet
(Continued on page 94)



They are working for health on

***Tile-Text* floors**

in America's Hospitals



The hospitals of this nation are carrying a heavy burden these days. War casualties, industrial accidents, and over-all war strain are taxing the hospitals to capacity. Proper floors for these institutions are essential if they are to maintain efficient hospital service with the restricted amount of manpower available.

Tile-Text is helping to solve hospital floor problems. It is first of all easy to install, either in new or old buildings. It is tough and long-wearing and, what is extremely important, its sanitary surface is simple and inexpensive to keep clean.

Tile-Text is well adapted to practically all hospital areas. Its low first cost makes it attractive from a budget standpoint and, above all, it is still available in spite of wartime restrictions on many floorings.

It will cost you nothing to have an experienced Tile-Text contractor survey your floors. Why not find out all the facts about how Tile-Text can improve your hospital operating conditions? Write us for the name of the approved Tile-Text contractor in your vicinity.

★ *The Tile-Text Company*

101 Park Avenue, New York City • Chicago Heights, Illinois



Helping them to
BETTER HOMES



**85 WAYS TO MAKE
A BETTER HOME**



*... whether you plan to build,
remodel or buy*

YOUR post-war clients are already looking over plans and sketches. Millions of families, according to Government figures, are planning to build, buy, remodel or improve their homes when necessary materials are again available.

The more wisely you guide their selection of materials, the more surely you can give them snug, comfortably efficient homes, fire resistant, weather-proof, good-looking—throughout the years to come.

We are advising these people to consult you in the opening sentences of the new brochure "85 Ways to Make a Better Home". Its sixteen big, colorfully illustrated pages are a veritable treasure house of suggestive

information, telling your clients how they can have better looking, more durable homes.

This home builders' guide sets you up as the authority on the many applications of steel products in home building. You will want to have a copy at your elbow to show your clients the many advantages of steel as a construction material—how steel saves time in construction, especially the prefabricated steel items that can be installed so quickly and easily.

Your free copy of "85 Ways to Make a Better Home" awaits your request. Just fill in this convenient coupon and drop it in the mail today.

ONE AIM . . . VICTORY . . . BUY BONDS

SEND NO MONEY *It's Free*

United States Steel Subsidiaries
621 Carnegie Building, Pittsburgh, Pa.

Please send my free copy of "85 Ways to Make a Better Home".

Name.....

Address.....

City..... State..... AR43A

CARNEGIE-ILLINOIS STEEL CORPORATION, Pittsburgh and Chicago
COLUMBIA STEEL COMPANY, San Francisco
TENNESSEE COAL, IRON & RAILROAD COMPANY, Birmingham

United States Steel Supply Company, Chicago, Warehouse Distributors
United States Steel Export Company, New York



UNITED STATES STEEL

(Continued from page 92)

into a cedar closet. It is also designed for lining chests, bureau drawers and other clothes storage units.

Easily applied and washable, cedar closet wallpaper has a satin-smooth finish and the appearance of real cedar planking. It is sold in boxes of one roll each, 48 ft. long and 15 in. wide. The Trimz Co., Inc., 1012 Spaulding Ave., Chicago.

FIRE SHIELD

For fighting fires out in the open, in tank farm, refinery, and particularly for use on airplane landing fields, the new Foamite Fire Shield is ruggedly built of sheet steel, reinforced with strong angle irons, and intended for hard, tough service. Between the front and back plates is an insulating

mineral wool blanket one inch thick. Three observation ports and four nozzle ports are equipped with pivoted cover doors controlled from the rear of the shield. Anchoring chains are provided for securing playpipes in place. American - LaFrance - Foamite Corp., Elmira, N. Y.

NEW STANDARD

Printed copies of Old Growth Douglas Fir Standard Stock Doors (Second Edition), Commercial Standard CS73-43, are now available, according to the National Bureau of Standards.

This standard, effective for new production since June 15, provides minimum specifications for four grades of stock fir doors in four thicknesses, 3/4, 1 1/8, 1 3/8 and 1 3/4 in. It covers construction, defects, and the grading tolerances for these requirements. There are standard stock layouts and designs covered in various door sizes for cupboard doors, side lights, house doors and garage doors, in accordance with detailed schedules of Douglas fir stock door list included in the pamphlet.

NEW CHEMICAL TREATMENTS FOR WOOD

New chemical treatments that virtually endow wood with the properties of a plastic and give it added strength, wearing qualities, hardness, and warp and swell resistance were described recently by Dr. J. F. T. Berliner of the Ammonia department of E. I. du Pont de Nemours & Company.

Treatment by these new chemical methods develops such unusual properties that "actually we are no longer dealing with wood," he declared in an address before the Eastern Lumber Salesmen's Association at the University Club, Philadelphia.

By impregnating the wood with resin-forming chemicals, Dr. Berliner said, poplar can be made as hard as or harder than hard maple and given form stability and other desirable properties, and soft maple thus treated may even be used to replace dogwood in textile shutters.

If green wood is soaked in a water solution or subjected to heat and pressure in the presence of urea, and then heated to temperatures near the boiling point of water, it "becomes plastic and is readily bent," Dr. Berliner said.

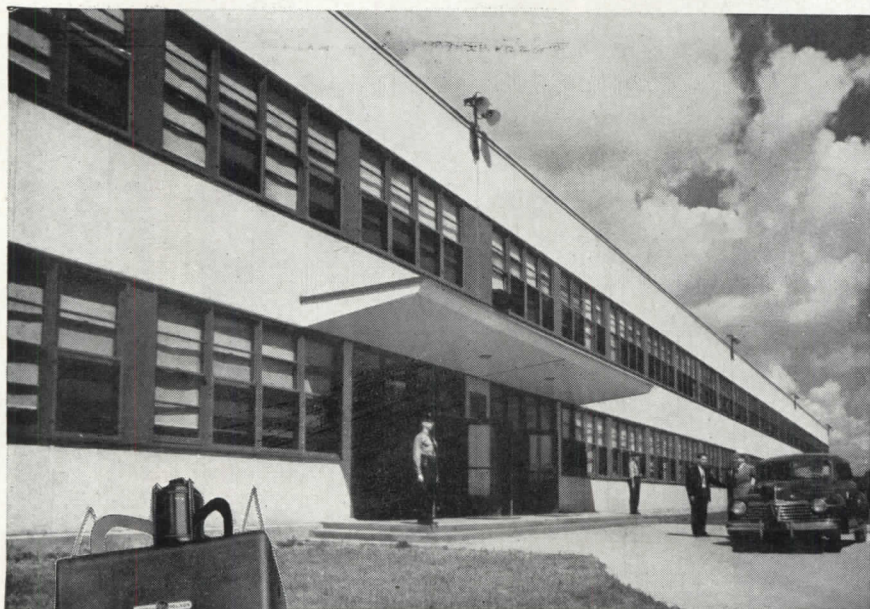

**HERMAN NELSON
hiJet HEATERS**

installed at Douglas Aircraft Chicago Plant

Over 400 Herman Nelson Vertical Shaft Propeller-Fan Type hiJet Heaters are supplying comfortable temperatures in working areas at the mammoth new Chicago Plant of the Douglas Aircraft Company. Because Herman Nelson hiJet Heaters provide heat where it is wanted and when it is wanted, without waste of fuel or space, they are vitally important to the world's largest exclusive cargo-plane manufacturing plant. In addition to many models, sizes and arrangements of hiJet Heaters, The Herman Nelson Corporation manufactures Autovent Fans and Blowers for industrial, commercial and public buildings. Thus practically any heating or ventilating problem can be most satisfactorily and economically solved with Herman Nelson equipment.



The Chicago Douglas Plant is scheduled to produce great numbers of these C-54 "Skymasters."



THE HERMAN NELSON CORPORATION
MOLINE, ILLINOIS

AUTOVENT FAN AND BLOWER DIVISION · CHICAGO, ILLINOIS
Manufacturers of Quality Heating, Ventilating and Air-Conditioning Products

Celotex Products

NOW AVAILABLE

For Various Construction Purposes

EVEN IN WARTIME there is some essential building that needs to be done. Many materials are scarce. Some are absolutely unobtainable. To help ease the situation, The Celotex Corporation has developed a number of products which successfully take the place of critical materials. All of them have been proved by actual use. All are now available at your local Celotex Dealer.

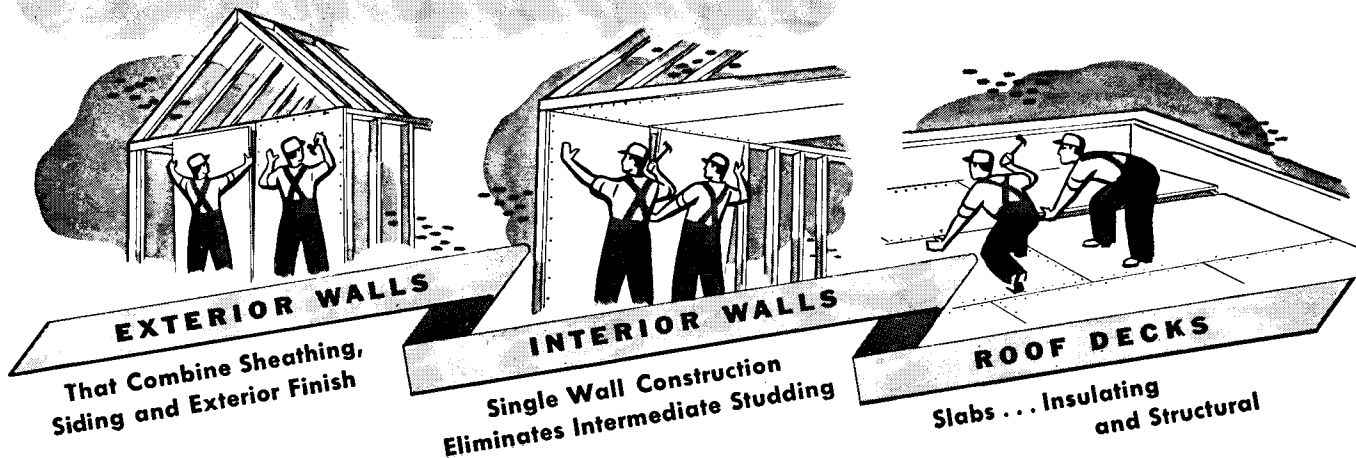

Cemesto ... A composite insulating board with cane fibre core and asbestos-cement surfaces. Provides both exterior and interior finish.

Celo-Siding ... $\frac{7}{8}$ " cane fibre board coated on all sides and edges with asphalt and surfaced with mineral granules.

Celo-Rock Exterior Wall Units ... $\frac{1}{2}$ " or 1" thick gypsum board with exterior surface of smooth or mineral surfaced roofing.

Celo-Rock Weather-Proof Siding ... 1" thick gypsum wall board treated on all sides and edges with a waterproof compound. Green exterior finish.

EXTERIOR FACINGS

Asbestos Board ... $\frac{3}{16}$ " or $\frac{1}{4}$ " thick asbestos cement board. Rigid, abrasive-proof, fire-proof.

Corrugated Siding ... $\frac{1}{8}$ " thick asphalt saturated felt corrugated under pressure. Rigid, durable, weatherproof.

Mineral Surfaced Backer Board ... Asphalt saturated felt with mineral granule surface, $\frac{3}{16}$ " thickness. Weatherproof.

Cemesto ... (See description under "Exterior Walls")

Celo-Rock Interior Wall Units ... Gypsum wall board laminated to thicknesses of 1" and $1\frac{1}{2}$ ".

Conventional Double Wall Construction

Celo-Rock Wall Boards ... $\frac{3}{8}$ ", $\frac{1}{2}$ " thick gypsum wall boards. Square, recessed or beveled edge. $\frac{1}{4}$ "—square edge only.

Asbestos Board ... (See description under "Exterior Facings")

Cemesto ... (See description under "Exterior Walls")

Slabs ... Structural

Celo-Rock Roof Slabs ... 1", $1\frac{1}{2}$ ", 2" thick gypsum slabs covered with tough-fibred paper—strong, durable, fire-resisting.

Monolithic ... Poured Gypsum Concrete

Celo-Rock Poured Deck ... a combination job application of gypsum wall board, reinforcing wire and gypsum concrete. Economical, non-combustible.

For complete information regarding the use and application of these Celotex Products, write direct to the Architectural Department, The Celotex Corporation, Chicago, Illinois. Sweet's Catalog Files, or call your local Celotex Dealer.

CELOTEX

REG. U. S. PAT. OFF.

ROOFING • INSULATING BOARD • ROCK WOOL

GYPSON WALL BOARD • LATH • PLASTER

SOUND CONDITIONING PRODUCTS

THE CELOTEX CORPORATION • CHICAGO

(Continued from page 12)

facilities essential to the public health, welfare and safety, be maintained in safe and efficient service. This is the minimum need, if maximum war production is to be maintained. Maintenance alone will not hold all of them at an efficient level indefinitely, and some reconstruction and replacement, some expansion and new construction are becoming increasingly necessary.

"To attain these ends it seems highly desirable that the WPB and those engaged in lines of endeavor essential to providing these facilities, make a realistic appraisal periodically to determine what portion of our manpower and materials can be allocated to maintaining and improving the facilities cited without interference with the production of material re-

quired for the support of our armed forces.

"During the period of tuning up for war production, the construction industry satisfactorily fulfilled its obligation and provided plants, housing, and military establishments with a rapidity and efficiency heretofore unexcelled in the world's history. The construction industry is now prepared and should be maintained in a position to perform the obligations which lie ahead.

"Few of the nation's basic peacetime industries have experienced more drastic wartime restriction than that which has seemed necessary in the field of private building and construction. . . . If, as and when war conditions permit, opportunity should be afforded to resume gradually an accelerated rate of civilian construction so that we may regain as much as may be the loss which has been sustained due to the substandard maintenance of such facilities which has prevailed during the last two years and provide the replacements and new facilities, the need for which is becoming increasingly apparent.

"Therefore it seems highly desirable now that we start to plan this program of orderly reconversion from maximum war production on a step by step basis, to the end that, as war workers and service men are released they may be absorbed in our economy and their talents devoted to useful enterprise."

PRACTICAL CITY

PLANNING URGED

Bold and practical city planning is needed in evolving urban development programs for the postwar period, E. S. Draper, Deputy Commissioner of the FHA declared recently before the convention of the Mortgage Bankers Association in Chicago.

"We need the kind of practical city planning that will be bold enough and honest enough to point out not only the difficulties attendant upon urban redevelopment in central cities, but also the positive values which will follow from taking action," Mr. Draper said.

Wartime production has altered the size and layout of many cities beyond



**Operate Garage Doors
by Barber-Colman RADIO CONTROL**

JUST press a button on the instrument panel of the car—and the garage door opens, or closes, from a radio impulse. The car can be standing still in the garage or moving down the driveway. Now this is no new gadget; it was played up in the feature sections 'way back in 1928. But it has been vastly improved and simplified since then, to the point where it is reliable, easy to install and service, and so lowered in cost that owners of even modest homes can afford it. Get our literature now, describing the operation and the safety and privacy features . . . so that you will be ready to specify "Barber-Colman RADIO CONTROL" for garage doors when the right time comes . . .



FACTORY-TRAINED SALES and SERVICE REPRESENTATIVES IN PRINCIPAL CITIES

BARBER-COLMAN COMPANY
102 MILL ST. • ROCKFORD, ILL.

pre-war recognition, Mr. Draper pointed out. The enormous population shifts have intensified urban problems both for the cities with a large influx of war workers and for the cities the workers left.

In Mr. Draper's opinion no satisfactory and well-balanced urban building program will be forthcoming after the war if building takes place almost exclusively on the outer rings of urban areas. The building of new or rebuilding of old sections, he said, should proceed simultaneously for the best results and long-term stability.

"FHA cannot go into the city planning business," he added, "but FHA is a strong supporter of planning principles and techniques, and welcomes the steps being taken now in numerous cities to prepare advance studies and community master plans for post-war residential construction and rebuilding on a large scale."

FHA READY TO RESUME INSURANCE ACTIVITIES

No new legislation is needed by FHA for resumption of its peacetime mortgage insurance activities the moment wartime restrictions are lifted. Abner H. Ferguson, Commissioner of the FHA told the Mortgage Bankers Association at their convention in Chicago.

"The law now on the books is sufficient," he said, "and FHA is prepared for immediate action."

Approximately half a billion dollars of unused insurance authorization under Title II of the National Housing Act, enough to finance the construction of at least 100,000 houses, is still available, he declared, and the law also authorizes the President to make available an additional billion dollars of Title II authorization if and when it becomes necessary.

Not only is Title II of the National Housing Act still in existence for the insuring of mortgages, he added, but it also still requires that FHA insure only those projects which are determined to be "economically sound."

WPB BUILDING NOTES *Simplified Material List*

A simplified material list has been provided to accompany the WBP application form for authorization to construct under Order L-41 and for priorities to obtain building materials, WPB and NHA have announced.

Property owners, builders and others planning conversion of houses and

other structures into additional living units will use the new form, designated as WPB 2897.1, "Bill of Materials to be Installed in Residential Remodeling, Rehabilitation or Additions and New Housing under \$10,000 Total Cost." The form takes up only a single sheet of paper and replaces WPB 2897 (formerly PD-105-A) for construction of this type. It is used to accompany the application form WPB 2896 (formerly PD-105).

The new form is applicable for use in three types of war housing construction: (1) privately financed conversion,

rehabilitation or additions; (2) publicly financed conversion; and (3) new private housing projects where all units involved amount to less than \$10,000 total cost exclusive of land.

Simplification Measures

Thousands of application forms formerly routed to the War Production Board in Washington will now be processed in the field as a result of specific measures announced recently by Operations Vice Chairman H. G. Batcheller to implement the decentralization policy announced earlier.

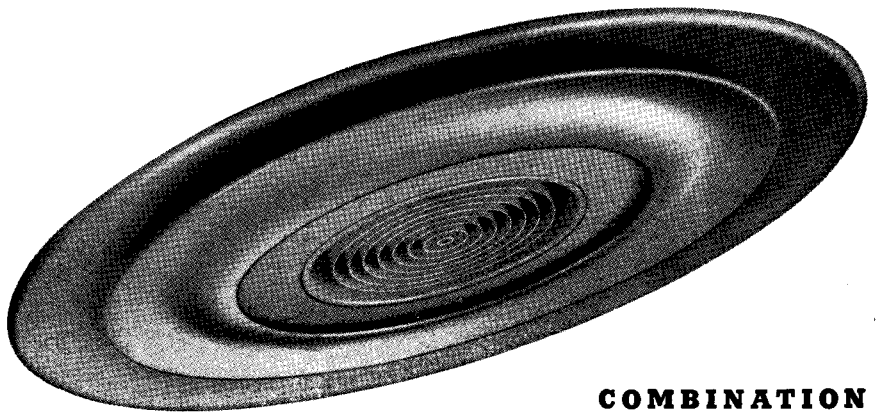

COMBINATION SUPPLY and EXHAUST

Venturi-flo

AIR DIFFUSERS

★ **CANNOT SHORT-CIRCUIT**

As shown in the drawing, the incoming and outgoing air streams are so nearly at right angles that supply air is not sucked into the exhaust duct.

★ **LOW PRESSURE DROP**

Contours of the distribution plates were experimentally determined to provide minimum resistance to air flow, quiet air delivery, and a "venturi" action to produce desired diffusion.

★ **GUARANTEED AIR DISTRIBUTION**

From comprehensive laboratory and service test data, exactly the proper unit for any conditions can be selected, and satisfactory results guaranteed.

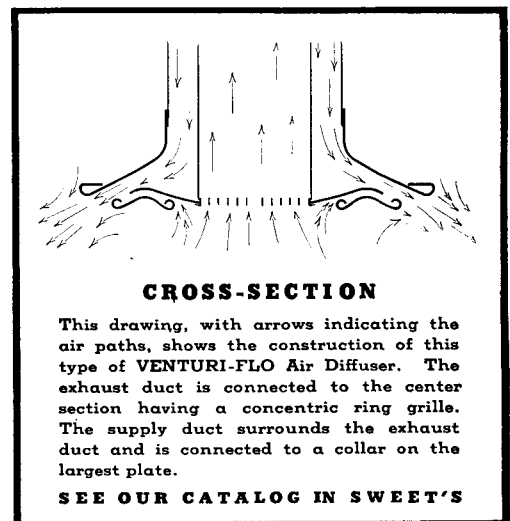

BARBER-COLMAN COMPANY 1232 ROCK STREET
ROCKFORD, ILLINOIS

Coincidentally, Mr. Batcheller revealed a reduction in CMP paper work which will have the result, after the first quarter of 1944, of eliminating two out of every three CMP 4-B quarterly applications, with authorizations made on an annual basis.

Under the new arrangements, field offices will have increased functions to perform in processing PD-1A applica-

tions; industrial projects under \$10,000; Emergency Assistance Applications (PD-333); and appeals under WPB orders.

Small Order Provisions

Changes were also announced involving controlled materials allotments and preference ratings under form CMP-H-1. Under these, the Small

Order provisions of CMP Regulation 6 are applicable to all projects where the amount of controlled materials to be bought is less than 2,000 lb. of steel or 100 lb. of copper. In such cases the contractor need not make an exact estimate of materials by the quarter in which the materials are to be used. Instead, all materials are charged against the quarter in which the project is started.

WILEY BOOKS in ARCHITECTURE

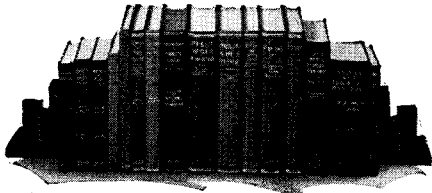

YOU'LL find these Wiley books practical, authoritative and up to date. Whether you want a "refresher" or want to increase your knowledge—look over the

Wiley books listed below. Select the books you need and mail the coupon now. Keep abreast of new developments in architecture. Act today!

- 1) **ARCHITECTURAL GRAPHIC STANDARDS**,
By Charles G. Ramsey and Harold R. Sleeper
Third Edition—344 PAGES \$6.00
A real time-saver for draftsmen, architects and engineers. Data, standards and information needed daily at work are found quickly and easily. Information is shown graphically so that pictures tell the story.
- 2) **SIMPLIFIED DESIGN OF REINFORCED CONCRETE**
By Harry Parker
249 PAGES \$2.75
Contains simple, succinct explanations of all the usual reinforced concrete members in buildings. Includes numerous worked-out examples of design.
- 3) **SIMPLIFIED DESIGN OF ROOF TRUSSES FOR ARCHITECTS AND BUILDERS**
By Harry Parker
195 PAGES \$2.75
A compact, thorough treatment of the essential principles and methods behind the design of the most common types of roof trusses. While comprehensive, it is not too advanced and complicated for beginners.
- 4) **SIMPLIFIED ENGINEERING FOR ARCHITECTS AND BUILDERS**
By Harry Parker
214 PAGES \$2.75
A practical book you will want to own. Contains the important terms and basic principles employed in the design of structural members in buildings.
- 5) **MATERIALS AND METHODS OF ARCHITECTURAL CONSTRUCTION**
By Charles M. Gay and Harry Parker
Second Edition—636 PAGES \$6.00
This book gives the latest uses of pressed wood, plastics, and structural glass, as well as the newest tables on the strength of materials and properties of structural steel. Also includes floor and roof construction, reinforced concrete, concrete design and many other subjects.
- 6) **STANDARD PLUMBING DETAILS**
By Louis J. Day
119 PLATES \$5.00
In this volume are the many facts and details concerning plumbing obtainable formerly only after exhaustive research. There is no text description—the drawings tell the complete story.

- 7) **MECHANICAL AND ELECTRICAL EQUIPMENT FOR BUILDINGS**
By Charles M. Gay and Charles DeV. Fawcett
429 PAGES \$5.00
The only book which combines in one volume approved methods of heating, plumbing, air conditioning, electric wiring, power distribution and many other important subjects, together with explanations of electric theory and machines.
- 8) **BUILDING CONSTRUCTION**,
By Whitney C. Huntington
Second Edition—674 PAGES \$6.00
For everyday use—a book describing the most recent and approved methods of construction followed by leading engineers. Includes building materials, masonry construction, steel construction, reinforced concrete construction, roofing materials, heat insulation, acoustics, paints, protective coverings of all kinds.
- 9) **PLUMBING PRACTICE AND DESIGN**
By Svend Plum
Vol. I 315 PAGES Illustrated \$4.50
Vol. II 329 PAGES Illustrated \$4.50
These volumes represent a complete working library on plumbing. Volume I contains material on corrosion, materials, pipes and fittings, valves and controls, fixtures, pumps, fire protection, air piping and equipment. Volume II covers physical and chemical terms, codes and regulations, architectural practice, water supply, sewage disposal, gas piping and appliances, water heating, etc.
- 10) **ARCHITECTURAL SPECIFICATIONS**
By Harold R. Sleeper
822 PAGES \$10.00
Everything the architect wants to know about specifications, in one volume! Covers general conditions, excavation and preparing of sites, demolition, materials—used in every phase of construction, exterior and interior—instructions to bidders, making outline specifications, and budgets.
- 11) **ARCHITECTS' and BUILDERS' HANDBOOK**
By Frank E. Kidder and Harry Parker
18th Edition—2,315 PAGES \$8.00
Presents a thorough handbook treatment of foundations, masonry walls, retaining walls, stability of piers and buttresses, stresses in roof trusses, heating and ventilation, and many other items.

PRACTICAL ART OF PLANNING

More than a thousand people gathered in Philadelphia last month to hear Acting Mayor Bernard Samuel and William C. Bullitt, leading contestants for mayor of that city, speak on city planning at a luncheon meeting of the Citizens' Council on City Planning.

The meeting was the public debut of the Citizens' Council, organized last summer by professional, neighborhood, civic and welfare organizations. Over 50 organizations have joined the Council in an effort to make Philadelphia planning conscious and to enable the citizens of the city to participate in the process of planning.

CONFERENCE A SUCCESS

The Conference on City and Regional Planning held at the Massachusetts Institute of Technology September 7-18 (See ARCHITECTURAL RECORD, July, 1943, pages 90 and 92) was attended by more than double the usual number of registrants, attracting participants from sixteen states and the Dominion of Canada. The Conference is now in its seventh year.

Planning principles, techniques, legislation and administration were covered in the various sessions, particular emphasis being placed on the application of technical and administrative procedures to specific problems in the field of city and regional planning. Proposed solutions to problems in housing, urban redevelopment, transportation, etc., were discussed and consideration was given to bills now before Congress dealing with various aspects of postwar planning. Other topics discussed included improvements in zoning procedures and municipal taxation policies.

ON APPROVAL COUPON

JOHN WILEY & SONS, INC.
440 Fourth Avenue, New York 16, N. Y.
Please send me on ten days' approval the books whose numbers I have circled below.

1—\$6.00	5—\$6.00	9a—\$ 4.50
2—\$2.75	6—\$6.00	9b—\$ 4.50
3—\$2.75	7—\$5.00	10—\$10.00
4—\$2.75	8—\$6.00	11—\$ 8.00

At the end of that time, if I decide to keep the books, I will remit indicated price plus postage; otherwise I will return the books postpaid.

Name

Address

City and State

Employed by

AR-11-43

READY → → →



→ → DROP IT!



There is Toughness and Strength to Spare in This Full-Wall Size Panel

See the dramatic proof pictured above?

A 60-pound bag of sand was dropped again and again from a distance of 6 feet on to a Strong-Bilt Panel supported on 28 inch centers. Result: *no harm to the panel.*

Can you visualize what would have happened to boards made of a brittle or crumbly material? The fact is that Strong-Bilt Panels will withstand an impact up to 6 times that of boards with a mineral core, as verified by an independent testing laboratory.

This is the board which, after years of testing, has scored such an amazing success on great housing projects from coast to coast—the board which brought *dry-built, full-wall construction* to the front.

In full wall sizes, Strong-Bilt Panels have enabled designers and builders of mass housing to reduce building time, provide efficient insulation, cut comparative costs, and produce *crackproof* walls of lasting beauty. Their use eliminates the 1,000 pounds of moisture which may be introduced into the building of an average six-room house.

In like manner, Upson Strong-Bilt Panels will enable you to design a better postwar home—*faster*, and with *added* dollar value whether you are planning one or a thousand homes.

Booklets picturing advantages and methods applicable both to conventional and prefabricated construction will be sent on request. Write The Upson Company, Lockport, N. Y.

Upson Quality Products Are Easily Identified By the Famous Blue-Center

copyright 1943 —The Upson Company

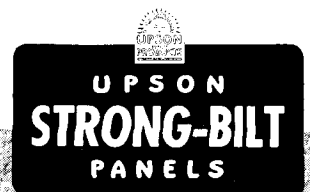

THE CRACKPROOF BEAUTY SURFACE WITH EFFICIENT INSULATING VALUE

(Continued from page 28)

answers makes the work especially useful to the student giving himself a refresher course, or for some other reason working without an instructor. The widely used Mannheim slide rule with CI and K scales is used as a basis; but mention is made where necessary of differences in other slide rules.

HOUSE AND GARDEN'S WARTIME MANUAL.

New York (1260 Sixth Ave.), Simon & Schuster, 1943. 128 pp. 8¼ by 11½ in. illus. \$1.00.

More comprehensive and correspondingly less detailed than similar books recently noted, this manual includes

emergency items such as temporary repairs, suggestions for wartime quarters, for making extra partitions, closets, etc., converting the furnace from oil to coal, insulating to save heat, installation of auxiliary heating devices.

PERIODICAL LITERATURE

BUILDING IN CHALK.

A tested experiment in an old tradition. By Robert O. Mennell. *Country Life*, London W. C. 2 (Tower House, Southampton St., Strand), Sept. 10, 1943. pp. 458-60.

Satisfactory experience with a chalk cob (crushed chalk and straw) house built in 1920 when usual building materials were scarce, reported here in anticipation of similar conditions after the present war.

Local material and mainly unskilled labor built an architect-designed house measuring roughly 45 by 28 ft., with cubage about 20,000, at a cost slightly more than one third that of a brick house of the time. The only skilled workers were those who constructed the slate roof. During more than 20 years no unusual maintenance or repair problems have arisen: the lime and tallow waterproof finish and creosoted window frames show no appreciable deterioration and the house remains warm and dry.

HOUSING IN SOUTH AFRICA.

South African Architectural Record, Johannesburg (75 Marshall St.), June, 1943.

The entire number is devoted to various aspects of the housing problem in some of the states forming the Union of South Africa; the presentation is to be continued in July.

The great demand in cities and towns for native labor, skilled and unskilled, and the great number of urban-born natives who have never known tribal life, create a peculiar housing problem. Under competent supervision natives can do much of the construction of their own homes, and, while mass production of houses for rental would be simpler economically and administratively, home building and ownership are encouraged because they develop community interest.

(Continued on page 102)

Revolving Unit Heaters are the Answer

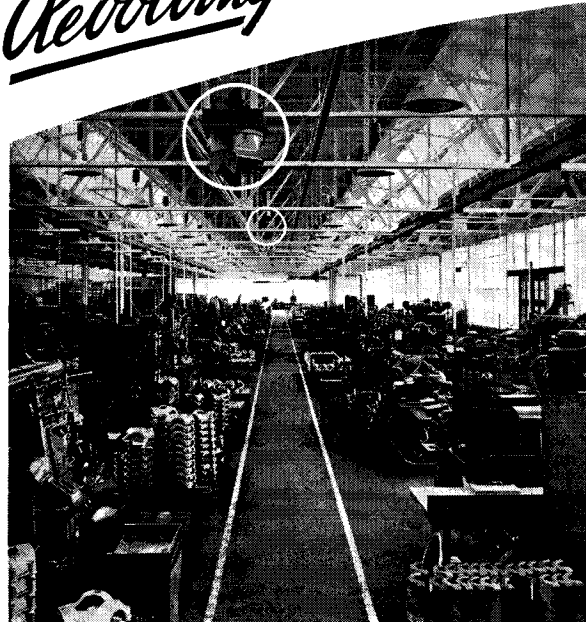

Albert Kahn Associated Architects & Engineers, Inc.
27 Wing Revolving Unit Heaters are installed in this typically congested manufacturing plant.

REVOLVING Unit Heaters are the scientific answer to the problem of heating industrial plants—whether that problem concerns itself with bringing up-to-date unsatisfactory heating conditions in today's war plants or planning for the industrial plant of a post-war world.

Wing Revolving Unit Heaters are being specified by more and more architects, engineers and contractors because these heaters solve the most difficult of factory heating situations.

L. J. Wing Mfg. Co.

151 W. 14th St. New York City
Factories: Newark, N. J.

WING TIPS:
Save critical materials and installation time with Revolving Unit Heaters.



1 Start. Smoke from bomb at top of heater is drawn through heating element and is discharged in slowly moving streams to the working level.



2 Note how the streams of heated air flow gently even to remote corners of the room and around obstructions.

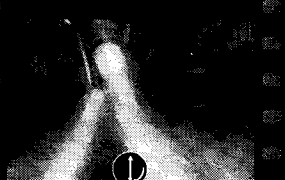

3 The discharge outlets have slowly revolved through 180°, building up a blanket of uniformly warmed air.



4 Still turning through 270° the streams of heated air are covering every part of the working level.

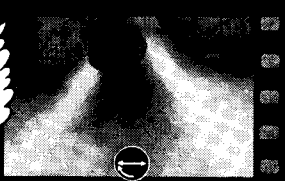

5 The discharge outlets have completed one revolution, demonstrating conclusively the thorough coverage of the WING Revolving Heater.

WING *Revolving* **UNIT HEATERS**

Now you can get all the facts on the FIRE-RESISTANCE OF "CZC"-TREATED WOOD

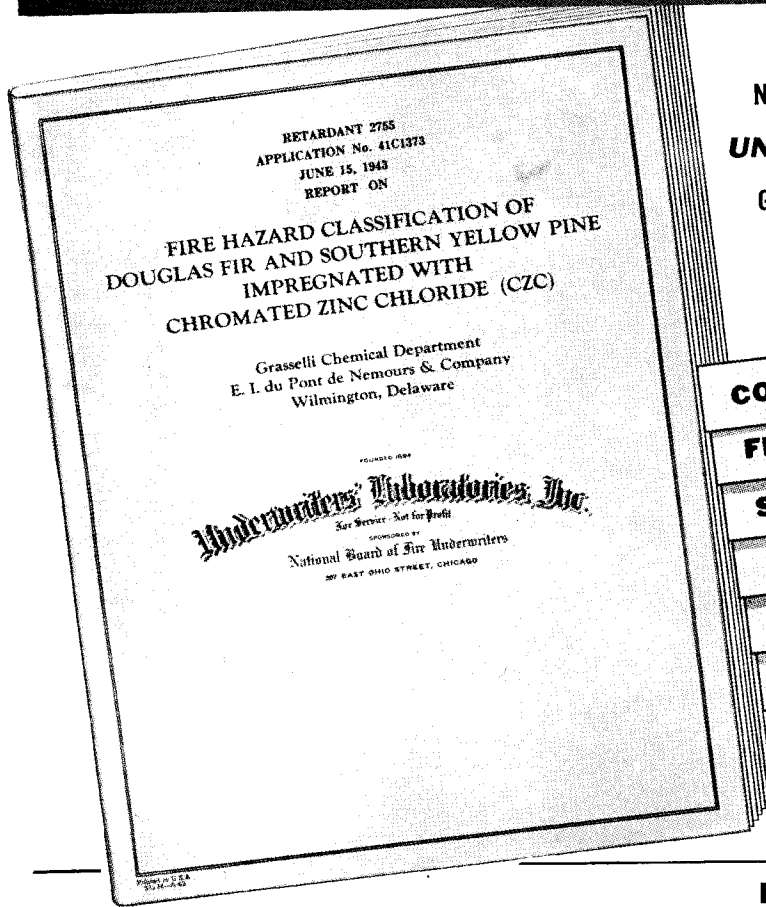

NEW AUTHORITATIVE 64-PAGE REPORT ISSUED BY
UNDERWRITERS' LABORATORIES, INC.,
GIVES DETAILED ANSWERS TO THESE QUESTIONS
ABOUT "CZC"-TREATED WOOD:

- COMBUSTIBILITY
- FIRE RETARDANT RATINGS
- SPREAD OF FIRE
- FUEL CONTRIBUTED
- DENSITY OF SMOKE
- TOXICITY OF FUMES
- DEGREE OF PERMANENCE

This chart shows the rating applied to varying amounts of "CZC" in treated wood. Untreated wood is rated 100. Incombustible asbestos-cement board is rated 0.

FIRE HAZARD CLASSIFICATION

Factors	Retention of Dry Salts Per Cu. Ft.			
	1 lb.	2 lbs.	3 lbs.	4 lbs.
Flame spread	60	40	35	30
Fuel contributed	50	35	30	25
Smoke developed	Less than with untreated lumber.			

• This report gives you distinctly useful information—new facts valuable in designing construction projects. Send for

your copy today. E. I. du Pont de Nemours & Co. (Inc.), Grasselli Chemicals Department, Wilmington, Delaware.



CZC

CHROMATED ZINC CHLORIDE

WOOD PRESERVATIVE

BETTER THINGS FOR BETTER LIVING...THROUGH CHEMISTRY

E. I. du Pont de Nemours & Co. (Inc.),
Grasselli Chemicals Department
5017 Du Pont Bldg., Wilmington 98, Delaware

Please send me the Underwriters' Laboratories, Inc. report on "CZC"-treated wood.

Name _____

Address _____

City _____ State _____

BACK THE ATTACK WITH WAR BONDS

ARE THERE
"DIM-OUT AREAS"
 INSIDE YOUR PLANT?



Reflecting floors made with Atlas White cement would materially increase illumination on this vertical work surface.

The proven value of considering the floor as a contributing factor to effective lighting is an outgrowth of wartime airplane production.

Lighting tests made by General Electric engineers in a bomber plant showed that a Light-Reflecting Floor, made with Atlas White cement, reflected 61% more light than an adjacent gray cement floor under identical lighting conditions, which were on the order of 35 foot-candles. This resulted in an increase of 61% in the illumination on underwing surfaces and of 20% on vertical work surfaces, where a large part of normal industrial work is done. Shadows and dark areas were reduced, and seeing was made easier, more comfortable and more efficient, by reducing the contrast in brightness between the surrounding areas and the visual task.

For complete information about Light-Reflecting Floors, for war and post-war construction or conversion, write for a copy of the 24-page booklet, "Light from Floors." Atlas White Bureau, Universal Atlas Cement Company (United States Steel Corporation Subsidiary), Chrysler Building, New York 17, N. Y.

HOW ABOUT MAINTENANCE?

Experience shows white-cement floors are easy to clean, easy to keep clean, and retain their reflection advantage. Maintenance is simple—frequent sweeping, occasional damp mopping, periodic scrubbing.

AR-F-23

**ATLAS
 WHITE CEMENT**
 For Light-Reflecting Floors



REQUIRED READING

(Continued from page 100)

SWEDEN: OUTPOST OF PEACE IN WAR.

Architectural Review. Cheam, Surrey, Eng. (45 The Avenue), Sept. 1943.

The entire number is devoted to Swedish buildings, for the most part constructed since 1939, and the majority of the fourscore photographs have not appeared before. "Prefabrication is used more widely and sensibly than anywhere else . . . most public buildings are pleasant, light-hearted. . . . A few larger buildings have achieved a true monumentality in terms of the 20th century," and as for buildings not particularly distinguished, such as a block of apartments, "the way they are placed on the site provides an example for the town planner and the landscape architect."

RESERVOIR ROOF OF REINFORCED ARCHES.

Engineering News-Record. New York (330 West 42nd St.), Sept. 23, 1943. pp. 103-5. illus.

A 600,000 gallon reservoir built with walls, columns and roof of plain concrete, the roof consisting of a series of groined arches. The cost of excavating 6,000 cu. yd. of earth and 1,849 of rock, placing 1,363 cu. yd. of class A concrete and 67 of B was \$52,000. After the walls had been constructed for the greater part of their height and the columns to full height, the roof was built in alternate sections. The 24 in. columns 14 ft. 3 in. high were spaced 17 ft. 7 in. each way.

THE TRANSIENT HOTEL BEDROOM.

By Jac Lessman. Interiors. New York 17 (11 East 44th St.), Sept. 1943. pp. 29-33. illus.

By reason alike of plan, lighting, and furniture the typical city hotel bedroom is inadequate for the needs of many clients, who may want to use it not only for sleeping, dressing and resting, but also for reading and writing, informal entertainment of business or social friends, perhaps as a temporary business office or even a small showroom. Here are given suggestions for lighting and equipment costing little for maintenance and calculated to make serviceable and pleasant instead of barely enduring the rooms which for the duration and long after must be made to do.



... with
**MONTGOMERY
 ELEVATORS**



THOUSANDS of passenger and freight installations throughout the country have proven that Montgomery Elevators are more efficient and economical. Accurate records on Montgomery installations show that practically no major repairs have ever been required. Too, original cost of Montgomery Elevators is generally lower than that of other makes. New buildings and remodeling projects now being planned will require the finest in elevators.

To assist you in solving new problems, Montgomery maintains a special Elevator Planning Service for your convenience. Remember, by far the greater percentage of all Montgomery Elevators go to previously satisfied customers.

★ ★ ★

BUY WAR BONDS AND STAMPS



HOME OFFICE • Moline, Illinois
 Branch Offices and Agents in Principal Cities

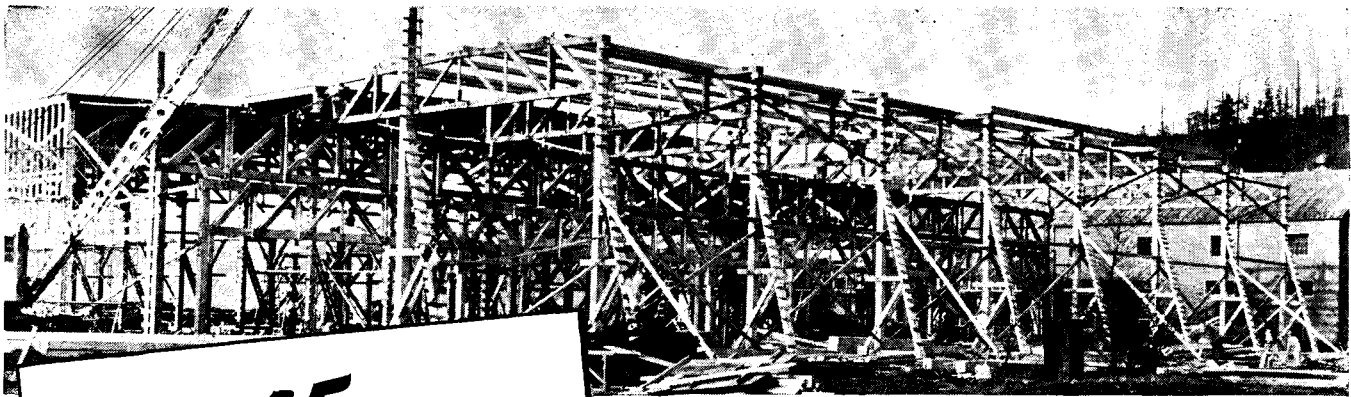

SHIPYARDS are rush jobs. Timber Structures, Inc. designed, fabricated and assembled trusses and other items for major buildings in this modern yard.

TIME IS IMPORTANT- USE TIMBER STRUCTURES

Buildings are erected quickly when you specify roof trusses by Timber Structures. Coupled with construction speed are advantages of economy, strength, permanence.

This organization specializes on design, fabrication, assembly and erection of trusses and other timber items. All types of industrial construction are served—from small business buildings, bridges and factories to huge army depots and aviation housing. We welcome the opportunity of submitting suggestions on trusses of timber or other structural materials in your projects. For illustrated book of Timber Structures jobs in various industries please use the coupon.

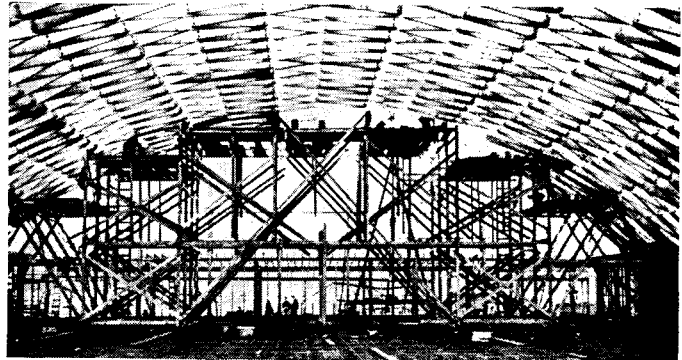

IN 10 DAYS the Lamella type roof was erected for this 100'x80' army sports arena. Designed by U. S. Engineers. Contractor: Henry Boyer Son & Co., Olympia, Wn.

BY ADAPTING CUSTOMER'S EQUIPMENT already on the premises—thus cutting waste motion and expense—the 46-94' trusses on this storage shed for Shelvin-Hixon Lumber Co., Bend, Oregon, were economically erected in a few days. Building designed and supervised by Gerry Horskotte, Shelvin-Hixon Engineer.

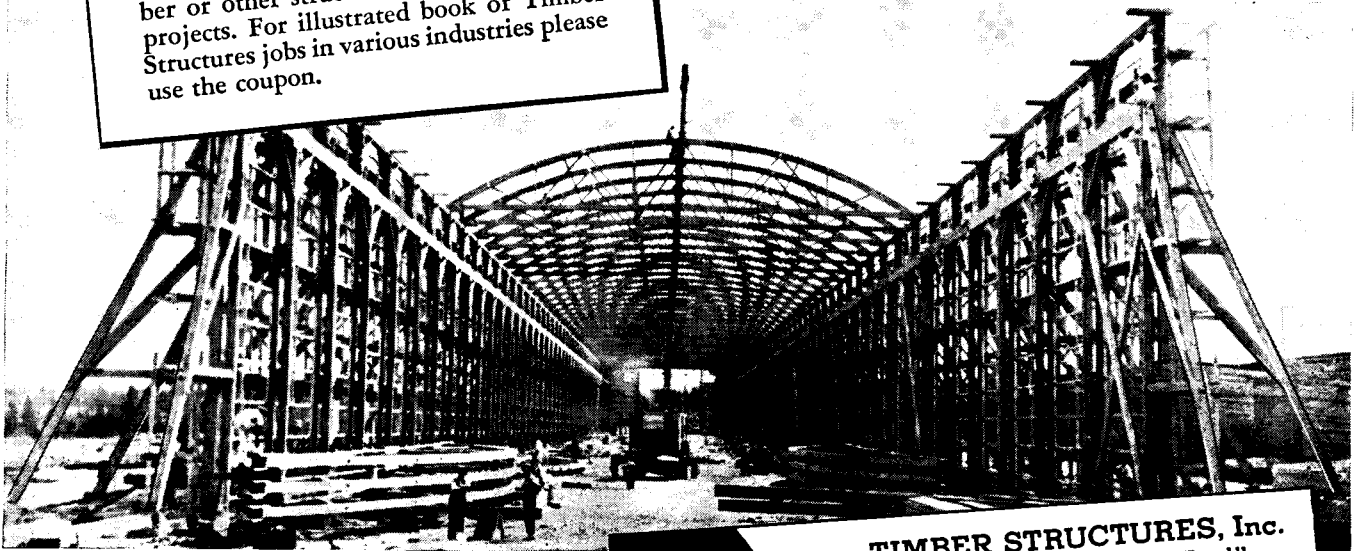

TIMBER
WARD MAYER
STRUCTURES
INCORPORATED
Portland 8, Oregon • New York 17, N.Y.
ENGINEERING IN WOOD

★
MAIL
COUPON FOR
LITERATURE
★

TIMBER STRUCTURES, Inc.
Send Book "Engineering in Wood"

Name _____

Address _____

Type of building or business . . . _____

If west of the Mississippi, send to Portland 8, Oregon. If east of the Mississippi, send to 535 Fifth Avenue, New York 17, N. Y.

(Continued from page 46)

GRADUAL CONTROL

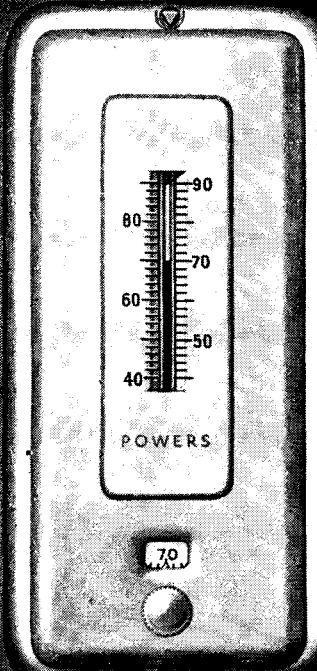

has been an outstanding feature of Powers regulation since 1891. With this type of control, valves or dampers are opened or closed **gradually**, which results in exceedingly close regulation and the maximum of comfort obtainable with automatic control.

● THE POWERS REGULATOR CO., 2752 Greenview Ave., Chicago—231 E. 46th St., New York. Offices in 47 Cities. 45

WRITE FOR BULLETIN NO. 200

POWERS TEMPERATURE and HUMIDITY CONTROL

I do not consider it desirable or necessary for the federal treasury to underwrite, directly or indirectly, such municipal extravagances as New York City's subway deficit or overgrown municipal bureaucracies or relief rolls. Beyond the evils of financial dependence upon Washington is the threat to our American system which is inherent in increasing political subserviency of local political organizations to the party which may at any particular time be in power in Washington.

It is quite possible, however, that municipalities may require in the future some special credit facilities for orderly financing of the improvement programs they may undertake in that portion of blighted area redevelopment to be devoted to future public uses. In connection with the PWA programs of the 1930's, certain rudimentary banking facilities were provided. It will be recalled that



States and cities may need special credit facilities

WAR HOUSING EXPERIENCE YOU CAN USE—

TYPICAL HOUSING PROJECTS WITH KITCHENS BY KITCHEN MAID

Project	Location	Kitchens	
Red Hook Housing Project	New York, N. Y.	2581	212
Woodhill Homes Project	Cleveland, Ohio	568	423
Vineyard Hill Project	Wheeling, W. Va.	302	1252
Prospect Hill Housing Project	Fawtucket, R. I.	310	267
Ordnance Plant Houses	Charleston, Ind.	36	440
Newfoundland Base	Newfoundland	80	600
Home Building Corp.	Kansas City, Mo.	800	110
Colonial Hills & Dales Housing	Columbus, Ohio	200	20
Army Staff Residences	Crab Orchard, Ill.	15	138
Lone Star Ordnance Plant Houses	Leary, Texas	60	449
Parklabrea Housing	Los Angeles, Cal.	2649	240
St. Charles Apartments	Silver Springs, Md.	77	135
Cartridge Loading Plant Houses	Alton, Ill.	50	250
Wills Homes, Inc.	Dayton, Ohio	10	346
Seminary Heights Project	Arlington, Va.	3550	397
First National Development Co.	Chicago, Ill.	30	160
Parkmerced Housing	San Francisco, Cal.	2394	1703
Gulf Port Mortgage Co.	Galena Park, Texas	39	727
			50
			1287
			108
			299

In a few short years, more than 33,000 Kitchen Maid kitchens have been sold for housing projects of practically all types—everywhere. This exceptional experience in advanced cabinetry design and low cost composite construction should be of great value to you on any war housing job. It's yours for the asking. Just write The Kitchen Maid Corp., 611 Snowden Street, Andrews, Indiana.



non-federal public works projects were financed with 45-per cent grants and 55-per cent loans. In many cases municipalities and other local governments put up their bonds with the Public Works Administrator to cover their 55-per cent share of project costs; these bonds were sold to the RFC, which in turn placed them at more favorable times with private investors. This was a banking service. It is also of interest to note in this connection that the Credit Foncier of France, a home-loan bank system, which operated successfully for many years and furnished a pattern for other national mortgage systems including our own, had as one of its functions the making of direct loans to municipalities. This may indicate appropriateness of linking banking facilities for municipalities to the mortgage banking system.

A comprehensive study of the many existing fiscal agencies of the federal government, and of their relationship to the future long-term credit needs of the country, which Congress will be obliged to make, may reveal a need for providing regular banking facilities for states and local governments. Such a study might also answer the question as to whether, in case such new facilities are needed, they can be provided by private banking institutions or whether they will have to be provided by an agency of the federal government. In any case, it is to be hoped that such institutions as may be hereafter created or empowered to furnish these banking services will be authorized to make good loans on good security, in accordance with sound credit principles, and not ordered to make bad loans on bad security, as provided for in the

(Continued on page 106)

CARRIER 5-WAY UNIT HEATER
—discharges heat from 4 sides
and downward. Gives greater
heating coverage and maxi-
mum flexibility.

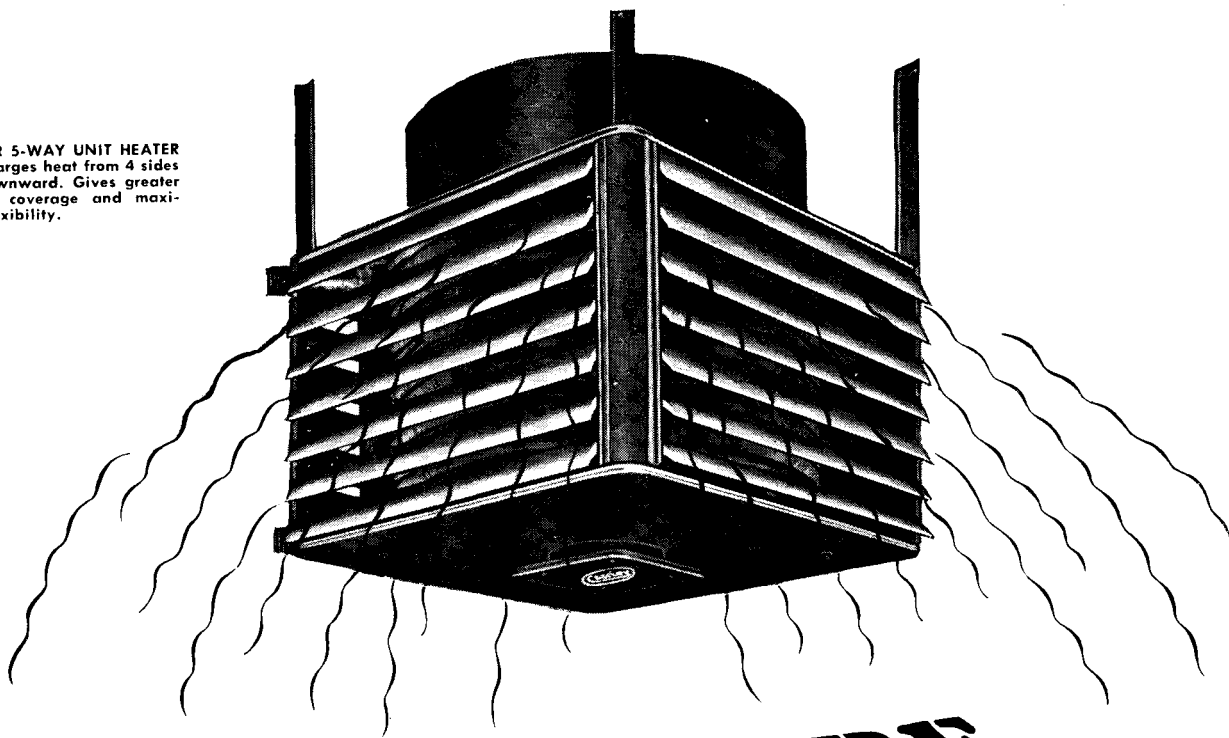

HEAT WHERE YOU WANT IT

War plant workers, especially women and older employees, must be kept comfortably warm by adequate heating and ventilating facilities if they are to work at maximum efficiency during winter months.

One of the reasons why absenteeism increases so sharply is the prevalence of colds resulting from lack of proper heating. Cold fingers, too, hinder war production.

Carrier Unit Heaters and Heat Diffusers offer many important advantages in flexibility of arrangement, efficiency, economy—and quick, simple installation. They supply plenty of warm air directly to working areas just where heat is needed. They save fuel and floor space—they save in first cost, installation, operating,

and maintenance cost.

A wide range of propeller and centrifugal fan type units, for steam and hot water, is available for every purpose.

Now is the time to check on the heating needs of your clients for next winter. If departments or machinery have been relocated, working areas changed . . . if old heating equipment is obsolescent . . . if workers were not comfortably warm last winter—Carrier unit heating and heat diffusing equipment can be used to advantage.

Carrier engineers will be glad to discuss your requirements and make a recommendation regarding type of equipment that will best serve your needs.

CARRIER CORPORATION, Syracuse, N.Y.

Carrier
UNIT HEATING

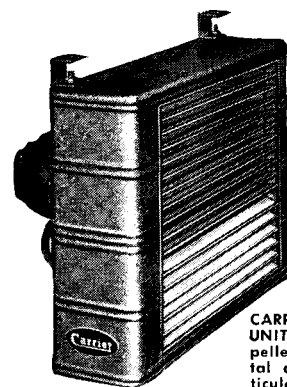

CARRIER TYPE 46 E UNIT HEATER—propeller fan; horizontal discharge. Particularly suitable for installation where headroom is limited.

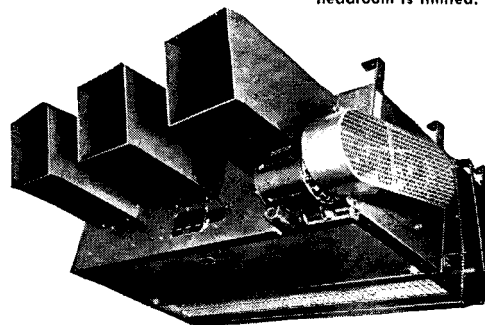

CARRIER TYPE 46 R HEAT DIFFUSING UNIT—for economical heating and ventilating of large enclosures. Designed for horizontal suspension from ceiling or truss-work, floor-mounting, or vertical suspension.

(Continued from page 104)

two redevelopment bills which have been introduced in Congress, the Thomas Bill and the Wagner Bill.

The problem of urban redevelopment has been discussed for a long time. The state laws that have been enacted are experimental; the war emergency has prevented any real test of whether the earlier one will actually function in peacetime. In any case, redevelopment programs will be long-range programs. If wisely projected now, when there is no early prospect of a return of the 1933 type of emergency, they can be projected on a sound long-term basis free from the confusion begotten by depression hangovers. It is to be noted that such great depression-emergency agencies of the federal government as the WPA, the PWA, the CCC and NYA have been liquidated by Congress. Even the National Resources Planning Board, an agency for long-term planning, was liquidated because, apparently, Congress could not stomach some of its depression-born philosophies. It should also be noted that the governors and legislatures of our states are very much aroused about recent encroachments of the federal government upon their prerogatives and powers. These straws in the wind indicate to me that the philosophy of business reorganization of insolvent urban real estate as part of a plan for postwar prosperity has a stronger appeal to legislators everywhere than will have a defeatist philosophy of bailing-out, which seems to draw its inspiration from the dear dead days of the great depression.

Abesto

ABESTO IS THE COLD PROCESS ROOFING MATERIAL THAT IS REVOLUTIONIZING CONSTRUCTION TODAY

Building contractors and architects are specifying Abesto for essential new construction and essential maintenance work because—

1. By eliminating hot kettles and hot mopping valuable time is saved.
2. Abesto uses exclusive formulas and thus their specifications give a better, longer-lasting roof that resists oxidation to a high degree and retains its elasticity in the winter and remains firm, yet elastic in hot weather.
3. Abesto sells for the reasonable cost of a good product and it allows a larger margin of profit to the contractor.

We will be glad to furnish you detailed specifications for each type of roof construction and damp-proofing which our engineers have made for your better understanding of our cold process.

ABESTO MANUFACTURING CO.

Michigan City, Indiana, U. S. A.



KIMBERLY

DRAWING PENCILS

KIMBERLY 21 DEGREES 6B to 9H AND TRACING 1-2-3-4

SEMI-HEX COLORED, FOR CHECKING AND BLUE PRINT WORK

made with the scientifically developed

Carbo-weld LEAD

KIMBERLYS delight the draftsman— assure him of these unfailing qualities

STRENGTH! — when pressure is applied.

SMOOTHNESS! — lead that glides over the paper "with the greatest of ease."

DENSITY! — deep opaque blacks with less tendency to smudge.

UNIFORMITY! — 21 perfectly graded degrees.

Add these up and you get

ECONOMY! — right down to the last inch.

The SEMI-HEX Carbo-Weld Thin Colored is another indispensable pencil in the drafting room. The white, lemon yellow, and red are best for checking and blue print work. Made in many colors.

You may try these excellent pencils by simply writing us on a penny postal card giving your name and title, firm name, and mention this magazine. We will send you free your selection of one Kimberly drawing and one Semi-Hex colored pencil.

Kimberly refill drawing leads for draftsmen's and artists' lead holders available in 14 degrees (5B to 7H).

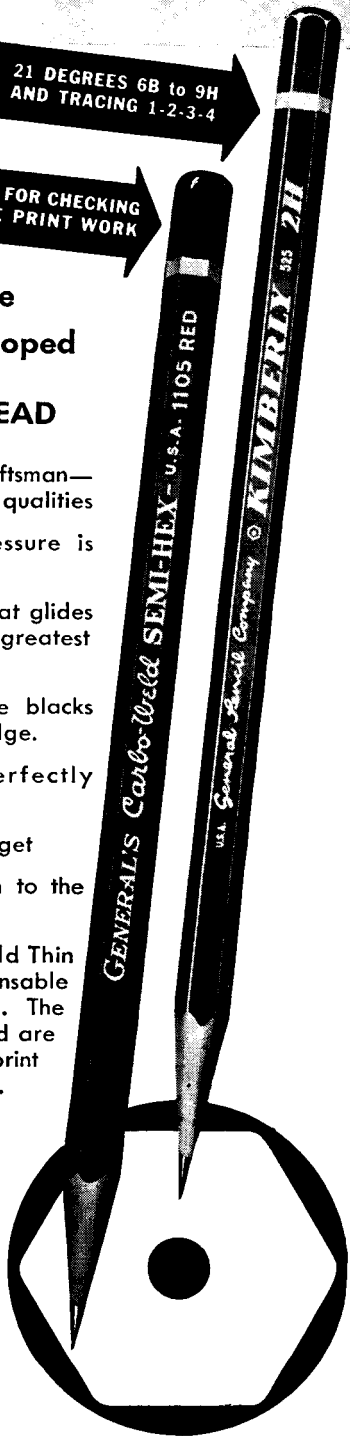

General Pencil Company

JERSEY CITY 6  NEW JERSEY

Makers of Fine Pencils since 1889

The Best Laid Plans

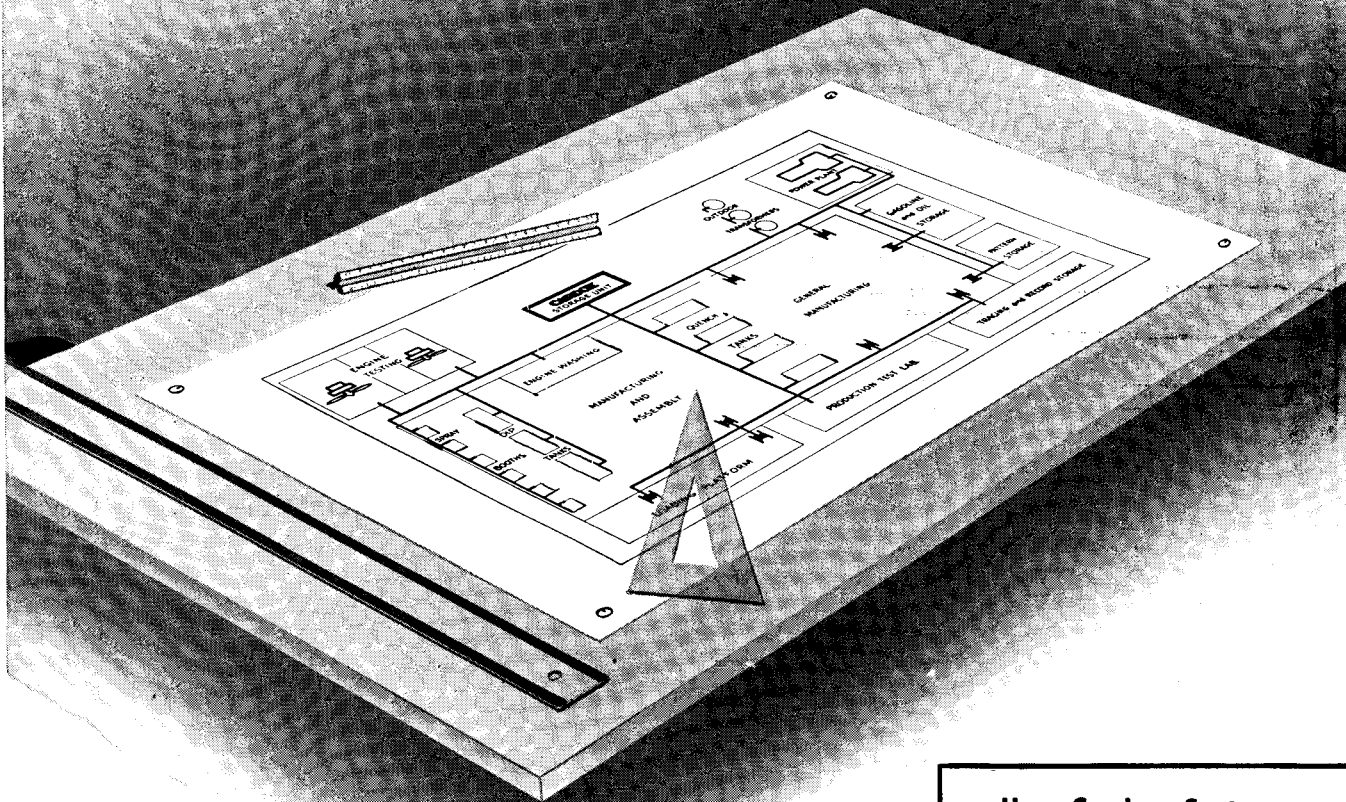

Include FIRE PROTECTION by CARDOX

War has taught many lessons. One, for example, that has been emphasized by the vast war construction program is this: The time to provide for fire protection is during the planning stage . . . whether for new buildings or remodeling . . . with fire extinguishing systems engineered for the specific hazards they cover.

For example, here are some of the advantages you provide when you make Cardox Fire Extinguishing Systems an integral part of your building plans:

1. Flexibility of Cardox engineering makes possible protection for one or many hazards—of similar or diverse nature—by one complete system . . . with each application engineered for the specific hazard it covers.

2. Mass discharge of Cardox CO₂ at high rate of flow and in pounds or tons, provides a system of fire protection which "cools out" and extinguishes large or small fires in the shortest possible time . . . with no damage to the building or its contents by the extinguishing medium.

3. Cardox Systems . . . because they are engineered for the specific hazards they cover . . . can be readily incorporated into your plans, whether these plans

relate to new construction or the remodeling of existing buildings.

Many of America's largest war production plants are protected by Cardox Systems specified for the job, engineered to the job. The accumulated large-scale experience gained in developing this fire protection for vital industries producing Airplanes, Aviation Engines, Plastics, Rubber Products, Solvents, Motor Fuel, Electric Power, etc., is available to architects planning buildings for essential war production and postwar activities. Write on business letterhead for Bulletin 15113.

CARDOX CORPORATION
BELL BUILDING • CHICAGO 1, ILLINOIS
District Offices in New York • Washington
Detroit • Cleveland • Atlanta • Pittsburgh
San Francisco • Los Angeles • Seattle

How Cardox Systems Protect War Industries

- Timed discharges, as needed, through built-in piping systems . . . supplied instantly from a single storage unit holding tons (if required) of liquid Cardox CO₂.
- Mass discharge of Cardox CO₂ "knocks out" fire, by . . .
- Reducing oxygen content of the atmosphere below the concentration necessary for combustion, and . . .
- Cooling combustibles and fire zone below ignition temperature . . .
- Extinguishing fire quickly and completely *without* damage from extinguishing medium.

CARDOX—CO₂ Systems with Enhanced Fire Extinguishing Performance

- A. Uniformity of CO₂ characteristics.
- B. Extinguishing medium with uniformly greater cooling effect.
- C. Accurate projection of CO₂ through greater distances.
- D. Timed discharges, as needed, through built-in piping systems . . . supplied quickly from a single tank holding tons of liquid Cardox CO₂.

MASS DISCHARGE OF CO₂ ENHANCED COOLING EFFECT CENTRAL STORAGE UNIT AMPLE CO₂ RESERVE ENGINEERED SYSTEMS MANUAL OR AUTOMATIC CONTROL

CARDOX

NON-DAMAGING FIRE EXTINGUISHING SYSTEMS

MORE WOMEN ON AMERICA'S PRODUCTION LINE . . .

Well planned "HEALTH ZONES" keep them there!

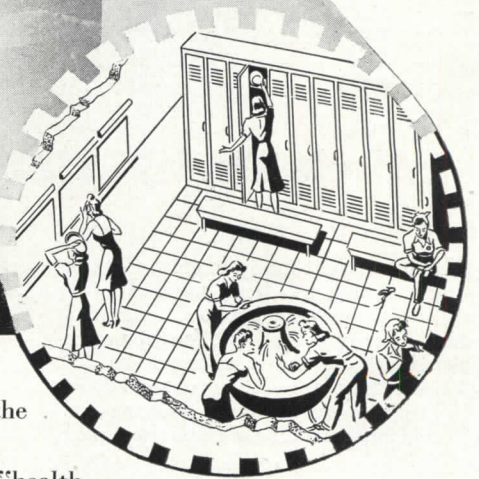
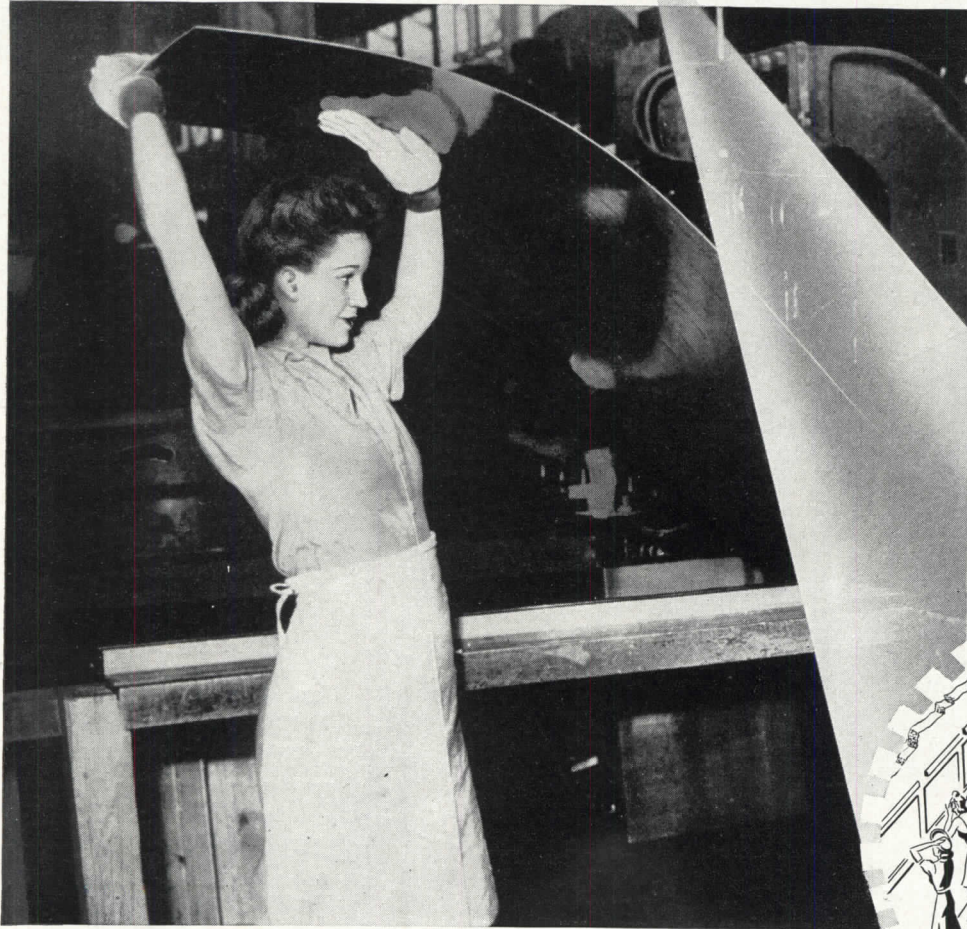

TODAY, each production hour finds more women replacing men in vital home-front jobs. Each hour finds, too, illness continuing to take a tremendous toll of industry's efficiency—a toll averaging one week's production time a year!

To hygiene-conscious architects, these facts mean plenty. Because *at least half* this serious loss is due to minor contagions like common colds and their complications. In other words, the type of disease which *your planning* can help check among these women workers. For health records definitely prove that properly equipped washrooms with adequate supplies of soap, hot water, and indi-

vidual tissue towels cut down the spread of minor illnesses.

Such washrooms are literally "health zones." They combat absenteeism at its most important source.

And Scott Paper Company can help you design them. The second edition of the Scott Washroom Advisory Service Manual gives basic washroom layouts and suggestions that insure maximum sanitation . . . effective use of all equipment . . . a smooth flow of traffic.

For your copy, and a set of Don Graf Data Sheets on washroom planning, write Scott Paper Co., Chester, Pa.



SCOTT WASHROOM ADVISORY SERVICE

BETTER WALLS

WITH AR-KE-TEX CERAMIC GLAZED STRUCTURAL TILE

PUBLISHED MONTHLY FOR THE INFORMATION OF ARCHITECTS AND ENGINEERS

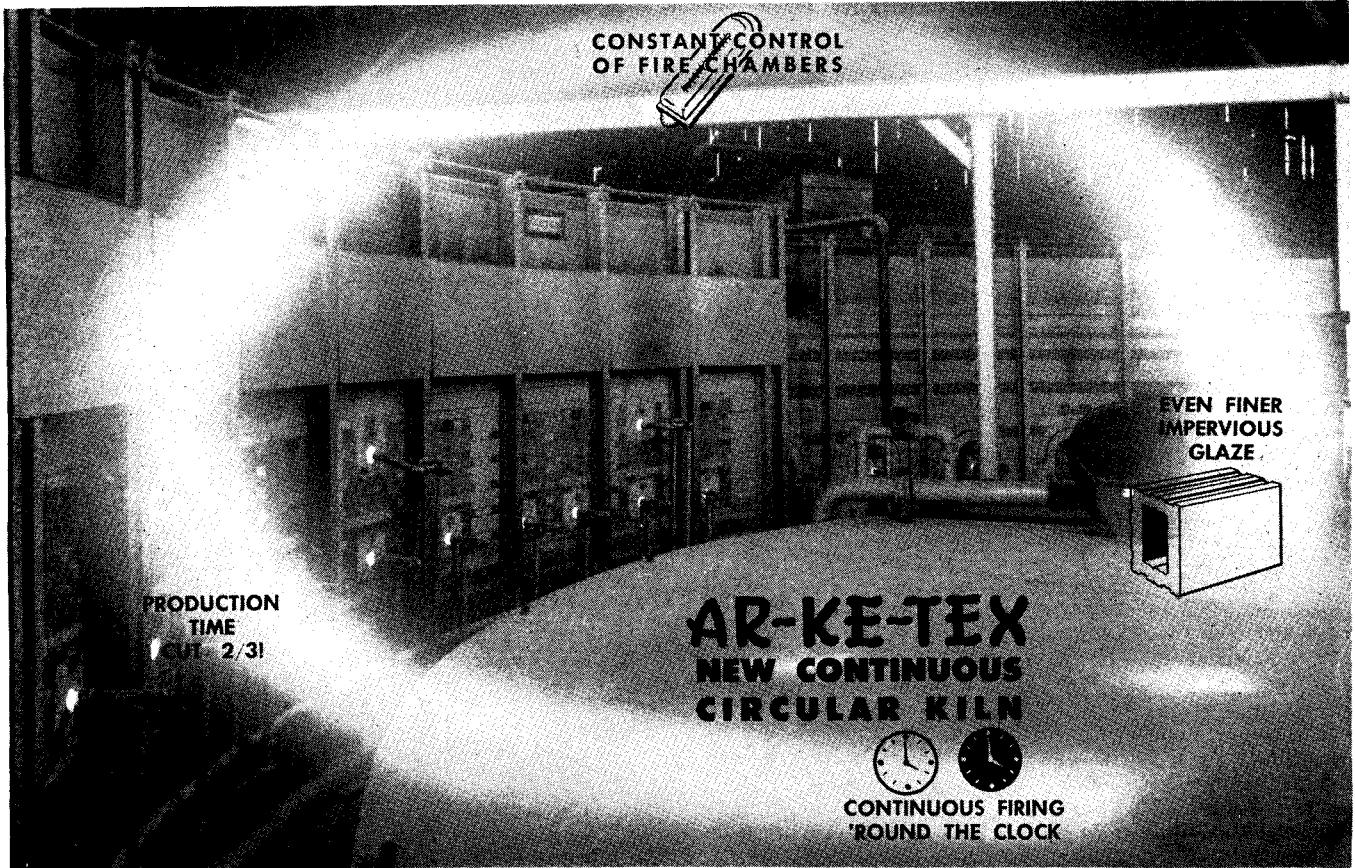

For more than twenty years, the Arketex Ceramic Corporation has produced the finest Ceramic Glazed Structural tile. Now—with our new Circular Continuous kiln—we produce an even finer tile.—and produce it faster!

Production time has been cut 2/3! Because firing is continuous—'round the clock. Constant control of fire chambers eliminates the possibility of variations in size and color tone. No under burn or no non-vitrified pieces can ever come out of this kiln. The permanent, impervious glaze is

non absorbptive and a finish that will not craze or peel is guaranteed.

Ar-Ke-Tex Ceramic Glazed Structural Tile for either interior or exterior walls, is available in more than a dozen everlasting colors, a variety of textures and a number of sizes and shapes. Each one is impervious to moisture, acids, alkalis, grease or oil. With our accurate control system, we can give definite shipping promises within 24 hours after receipt of your inquiry. See our Catalog in Sweets or write for further information and detailed specifications.

SPECIAL ENGINEERING SERVICE

Our Engineering Research Department is at your service whenever we can be of assistance in planning walls to accomplish your objectives.



ARKETEX CERAMIC CORPORATION • BRAZIL, INDIANA

Why an ARCHITECT

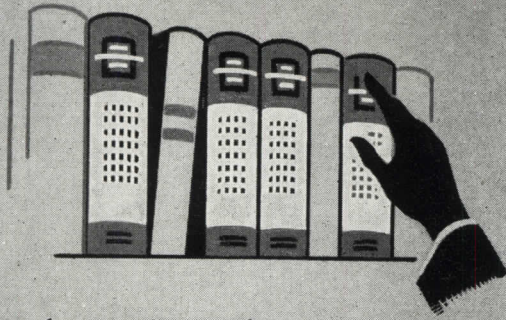

should know his

WIREMOLD

Because Wiremold Surface Metal Raceway Wiring Systems and Fittings offer the most practical and economical way to assure BOTH present and future wiring adequacy in many types of industrial, commercial and special purpose buildings.

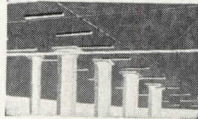

Because, in PLUGMOLD "plug-in-anywhere" Wiring Systems, Wiremold offers a tried and proved method of providing all the outlets needed exactly where they are needed in industrial plants, hospitals, offices, public buildings or homes. PLUGMOLD in Army mobile units has successfully passed the tough test of field service.



Because "Pancake" Wiremold meets a functional need wherever it is necessary to extend wiring overfloor to desks, machines or appliances in factories, offices, etc.



Because Wiremold "3000" System Wiring finds increasingly wide application in architectural built-in lighting installation; as a complete wiring installation for fluorescent lighting; and as an industrial outlet system.

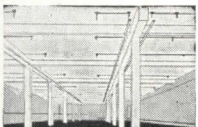

Wiremold Raceways and Fittings conform to Federal Specification W-R-32 and are listed by U. L. Available for immediate delivery for essential uses on suitable priorities.

We will be glad to send you Engineering Data Sheets and other Wiremold literature listed below. A condensed information catalog will also be published for your convenience in Sweet's for 1944. Write to The Wiremold Company, Hartford 10, Conn.

SEE OUR CATALOG IN SWEET'S

FOR 1944

WIREMOLD



IS HELPING AMERICA PRODUCE FOR WAR AND PLAN FOR PEACE!

"HELPING HAND" LITERATURE FOR ARCHITECTS

- Bulletin, "Wiremold Industrial System-Wiring Speeds War Production".
- Engineering Data Sheets No. "3000" System Wiring for Industrial plants.
- Engineering Data Sheets, Plugmold Multi-Outlet Wiring Systems.
- "Pancake" Wiremold Overfloor Wiring System for Office and factory.
- Wiremold Catalog and Wiring Guide

CHECK and return with your name and address

Quick Toilet Partitioning . . . WITHOUT CUTTING, HARDWARE FITTING OR FINISHING ON THE JOB . . .

Milwaukee
PREFAB-PLYWOOD
PARTITIONS

Completely PREFABRICATED, attractive, sturdy, rigid MILWAUKEE PREFAB-PLYWOOD Partitions are made for speedy labor-saving installation.

They provide YOUR answer to the need for modern Toilet and Dressing Room enclosures—in a hurry. They're all ready to move into place—ready to assemble quickly and easily—avoiding any extra work in cutting, fitting hardware or painting . . . And you'll be proud of the finished job, for PREFAB-PLYWOOD Partitions are built to the finest wartime standards of design, quality, and durability.

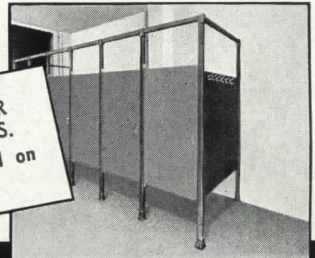

WIRE OR WRITE FOR PRICES AND DETAILS. Prompt delivery assured on any quantity.

MILWAUKEE STAMPING COMPANY
814 - P South 72nd Street Milwaukee 14, Wisconsin

HARDWARE for the "After the Victory" GAME ROOM

Since gas rationing changed the traveling American into a "stay-at-home" many people are studying their homes—finding improvements to make, or thinking of how they will build their new homes, once the war is over.

One of the rooms that will get careful consideration is the playroom. Here, home owners are inclined to give way to their originality. Pine paneling with built-in closets for games and sports equipment, benches with hinged tops to hold toys, cabinets for bar supplies, and other ingenious features will be devel-

oped by home-planners.

Whatever the hardware requirements of a post-war building are, STANLEY will be in a position to fill them.

Due to government restrictions on metals it is impossible to supply all civilian needs in hardware at the present time. We are certain that you and your customers understand why the present shortage exists, and realize that when our big war job is done you will have all the STANLEY hardware you need. The Stanley Works, New Britain, Connecticut.

Typical Stanley Hardware Items for the Game Room

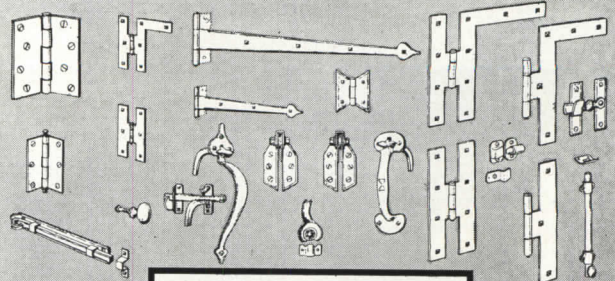

1843

STANLEY

1943



We'd like to thank two soldiers and a farmer in South Carolina

Somewhere in South Carolina, during recent Army maneuvers, two soldiers took shelter in a farmer's barn. There they came upon a copy of *The Saturday Evening Post*, dated exactly twenty years ago.

They leafed through the yellowed pages and paused over a headline: "There's a roof that's off my mind until 1943 at least."

It was an advertisement for Barrett Specification Roofs.

The coincidence of dates was striking, but soldiers are practical fellows, so they wrote us a letter to find out just how good was that promise of twenty years ago?

Actually, the advertisement of twenty years ago might just as well appear today. The basic story has not changed. Barrett Specification Roofs are still bonded against repair

and maintenance expense, and still outlast their bonds by decades.

But today, the Barrett story has even greater significance to architects, engineers and others concerned with building maintenance. For Barrett is supplying dependable roofing and waterproofing materials for new Army barracks and depots, for giant industrial plants, for war housing units and other essential structures, as well as for the all-important maintenance of all types of existing buildings necessary to our war effort.

In these critical times, Barrett Specification Roofs continue to provide a degree of certainty of performance unsurpassed in the building industry. Consult with us or your Barrett Approved Roofer on any roofing or waterproofing problem.

THE BARRETT DIVISION
ALLIED CHEMICAL & DYE CORPORATION

40 Rector Street, New York 6, N. Y.

2800 So. Sacramento Ave.
Chicago 23, Ill.

Birmingham
Alabama



*Reg. U. S. Pat. Off.



—taken from The Saturday Evening Post, August 18, 1923.

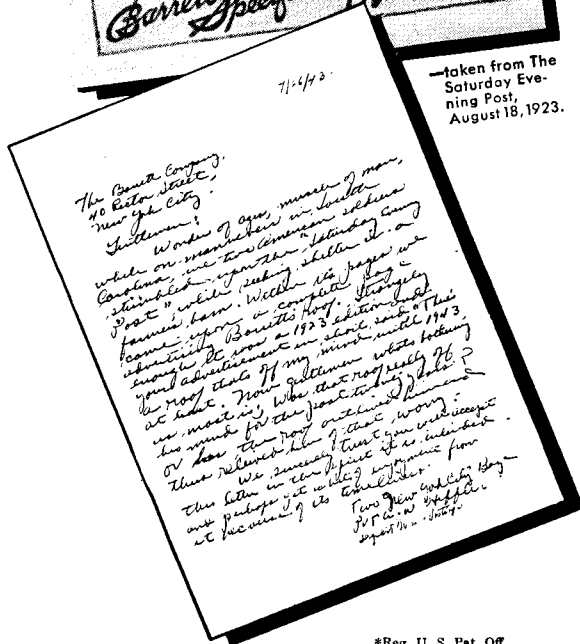

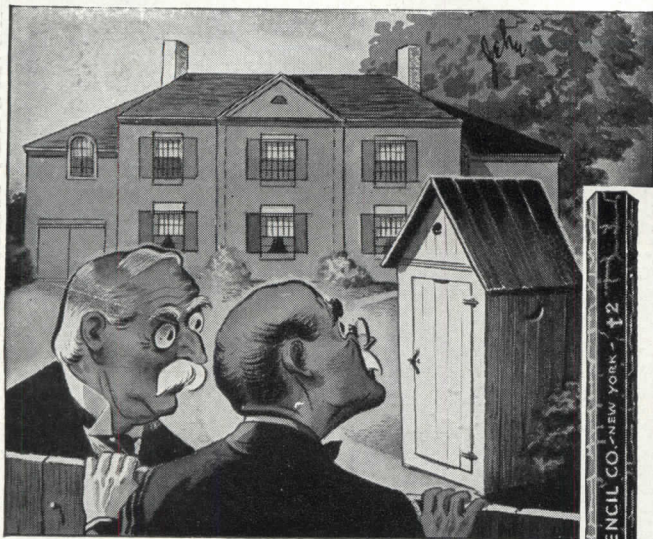

"PRIORITIES, YOU KNOW"

Top priority goes to the pencil that produces perfect blueprints direct from drawings.

That's why draftsmen, architects and engineers like the Venus Tracing Pencil. Specially made for a special job, Venus Tracing gives intense, opaque black lines on any kind of tracing paper or cloth. Result: sharp, clear white lines on the blueprints.

And Venus Tracing does not smear. It erases cleanly and completely—hence blueprints are free from ghosts.

The Venus Tracing Pencil comes in four degrees of hardness—from t¹ (medium) for smoothest surfaces to t⁴ (hardest) for hard-tooth surfaces.

May we send you free samples of all four degrees? Just mail us the coupon below.



VENUS Tracing PENCILS

American Pencil Company
Dept. 178, 500 Willow Ave., Hoboken, N. J.
In Canada: Venus Pencil Company, Ltd., Toronto

Please send FREE samples of Venus Tracing Pencils in all four degrees.

NAME and title _____

FIRM NAME _____

ADDRESS _____

CITY _____ STATE _____



*The Modern
Electric Door*

EXCLUSIVELY HORN

Tomorrow's design . . . available
now for lasting service

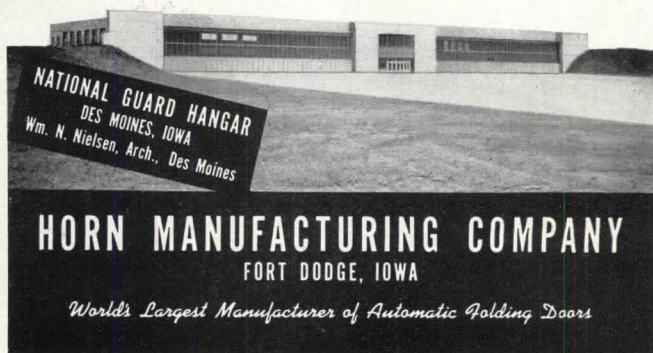

**VARNISHED
CAMBRIC INSULATION**
is one answer to the rubber shortage

A recent WPB ruling has forbidden the use of natural rubber in the manufacture of electrical wires and cables for most commercial purposes. To help satisfy your wiring needs, why not consider the use of Okonite Varnished Cambric insulated wires and cables?

V.C. CABLES ARE —
STABLE — LONG-LIVED — EASY TO HANDLE
RESISTANT TO OIL — HEAT — OZONE

V.C. CABLES ARE SUGGESTED FOR —

- High or low voltage power circuits
- Switchboard and control wire
- Generator or motor leads

— and other applications.

NOT MERELY A WARTIME SUBSTITUTE —
Okonite has been a leading manufacturer of a complete line of Varnished Cambric insulated wires and cables for over 30 years.

Send for Bulletin OK-1013A containing 36 pages of information on the selection, capacity and installation of Okonite Varnished Cambric wires and cables.

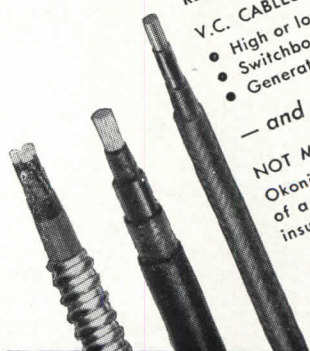

3420

THE **OKONITE** COMPANY
PASSAIC, NEW JERSEY
INSULATED WIRES AND CABLES

The Johns-Manville Radio Program recently broadcast this message about the Architects of America

8:55 p.m. EWT -- CBS
Here's Five Minutes of the Latest News
Brought to you by JOHNS-MANVILLE

NEWS ... reported by Bill Henry

Tony Marvin:
Tonight, Johns-Manville pays a tribute to the Architects of America. Their special knowledge and skillful planning have been of great value in speeding the completion of our huge war-time construction program. In addition, thousands of our architects are now in the armed forces. Still others are serving in far corners of the world on highly specialized missions for the Army and Navy. As a manufacturer of building materials, Johns-Manville is proud to have been closely associated with the architectural profession for a long period of years. And Johns-Manville feels sure that when peace returns, these men will play a new and vitally important role in the design and construction of better homes and the planning of better communities.

CBS

FOR NEARLY 2 YEARS Johns-Manville has talked to millions of people on the radio, five nights a week, at the best listening period of the entire 24 hours . . . 8:55 P.M., Eastern War Time. This program, 5 minutes of the latest news reported by C.B.S. correspondent, Bill Henry, is broadcast on a coast-to-coast network of the Columbia Broadcasting System.

Our objective is to constantly build good-will not only for Johns-Manville but for the architects, dealers, and contractors who sell or recommend J-M products.

As an architect, we believe you will be interested in the above wartime message. It is typical of the manner in which this powerful J-M advertising campaign can serve as your spokesman during this critical period.

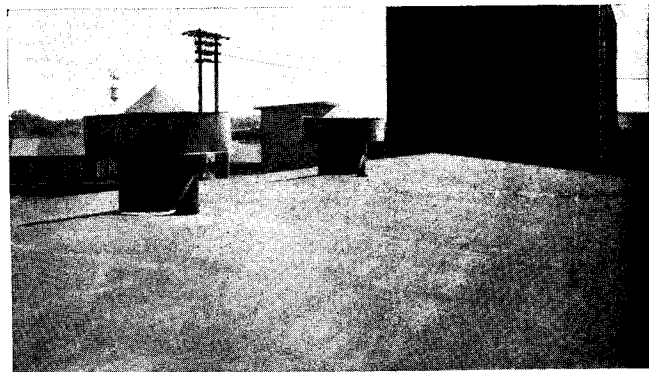

This is but one of the many Johns-Manville products which help architects carry out their wartime and post-war projects. It's J-M Asbestos Built-Up Roofing . . . fireproof, rotproof and long-lasting.

JOHNS-MANVILLE
JM
PRODUCTS

Johns-Manville

Building Materials



Douglas Fir Plywood INVASION BARGES made for United Nations!

● Add invasion barges to the long list of war jobs Douglas Fir Plywood is doing. This sturdy, lightweight engineered lumber is being used for transportation equipment of all kinds, for military and war worker housing, for factory construction and scores of other purposes. Because of this wide and varied experience, you're sure to find Douglas Fir Plywood one of your most useful post-war construction materials.

● Here's another type of plywood barge — officially known as a lighter — built by Higgins Industries, Inc., of New Orleans. Sides and decks of these 18x64-foot barges are covered with 2 layers of 5/8-inch Exterior-type Douglas Fir Plywood. This Miracle Wood adds rigidity, is quickly applied and easily repaired if damaged.

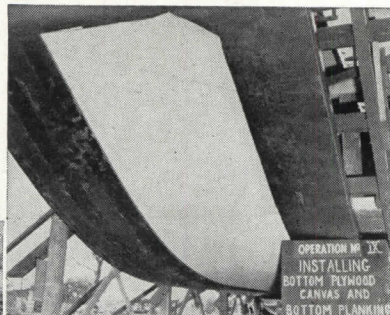

● (Above) The bottom skin of these Higgins lighters consists of (from left) outer planking, a layer of thoroughly water-proofed canvas and an underlay of 5/8-inch Exterior-type Douglas Fir Plywood. The Higgins Industries use vast quantities of plywood in the many types of auxiliary vessels they are building.

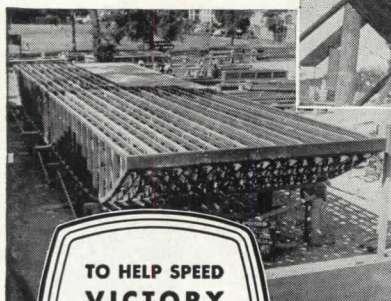

TO HELP SPEED VICTORY
the Douglas Fir Plywood Industry is devoting its entire capacity to war production. We know this program has your approval.

DOUGLAS FIR PLYWOOD
Real Lumber
**MADE LARGER, LIGHTER
SPLIT-PROOF
STRONGER**

SEND FOR FREE WAR USE FOLDER
Scores of actual photographs show plywood's busy war career. Write Douglas Fir Plywood Association, Tacoma Bldg., Tacoma, Washington, for YOUR copy.

*More Air
for the
Money*

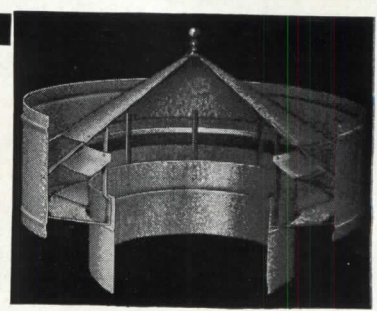

BURT Standard Gravity VENTILATORS

Where cost is a factor, but effective operation and durability are required, BURT Standard Gravity Ventilators will meet your specifications. Advanced design gives you more air for the money — quality materials insure long, trouble-free operation. BURT makes a ventilator for every use, in a complete range of sizes and in a wide selection of materials. Burt Engineers will be glad to cooperate with you in planning and estimating. See Sweet's for further details or write for catalog and data sheets today.

THE BURT MFG. CO.
ROOF VENTILATORS • OIL FILTERS
EXHAUST HEADS
177 Main St., Akron 11, Ohio

SEND FOR CATALOGS
Burt Engineers are glad to help on plans

Is This Destruction Necessary?

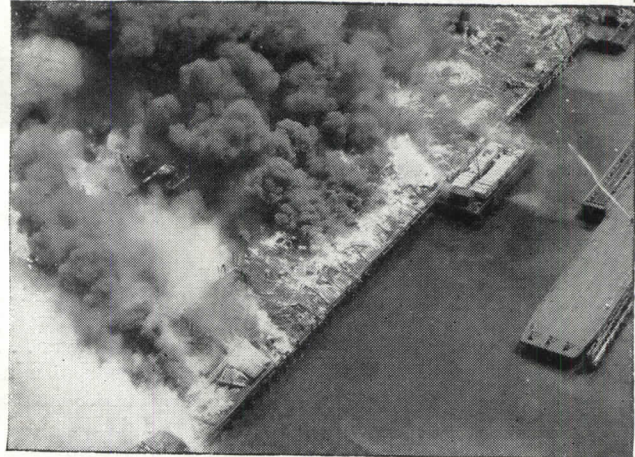

Protection for so little.
One Grinnell Sprinkler Head protects 100 square feet of building space. Installed, it requires only about 50 lbs. of pipe, fittings, hangers and valves to serve it, yet it can save tons of structural steel and other critical materials.

Why take chances when protection requires so little?
Call in an experienced Grinnell engineer to help you protect your warehouse or plant against fire. Grinnell Co., Inc., Executive Offices, Providence, R. I. Branch offices in principal cities

GRINNELL
AUTOMATIC SPRINKLERS for Production Protection

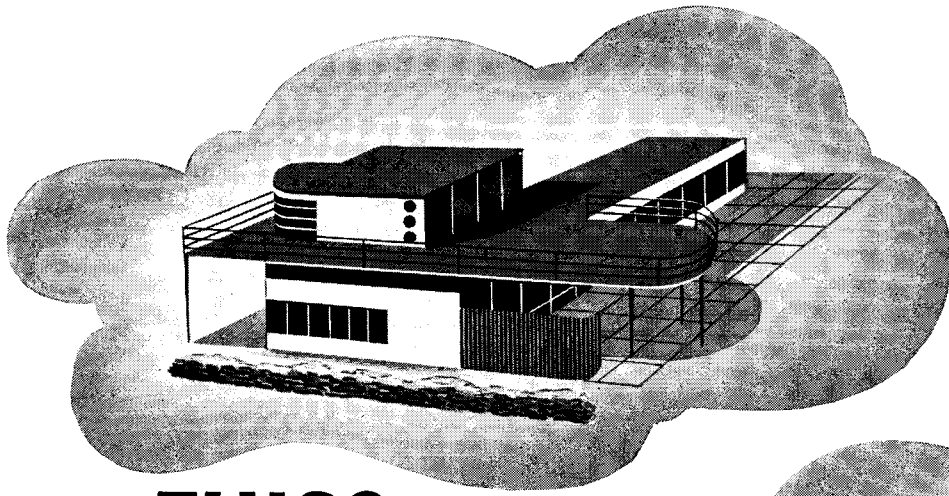

THIS?



THIS?



How do YOU picture the post-war home?

YOUR ideas on the house of the future are of tremendous importance to us. How do you think it will look? What materials will it use most extensively... glass blocks, steel, concrete, masonry? Will it have more exposed areas, more insulation?

The time is approaching when General Electric engineers will want to know your ideas, to help give direction to their own thinking. Before long we plan to ask your opinion on a number of questions about post-war housing. Your answers can directly influence the way we design our post-war

heating and air conditioning equipment.

Your advice and assistance will aid us in shortening the period of post-war adjustment to new heating and air conditioning problems... in making available as quickly as possible an advanced line of compact, efficient equipment.

☆ BUY WAR BONDS ☆

General Electric Company, Heating and Air Conditioning Equipment Divisions, Section 34411, Bloomfield, New Jersey.

GENERAL  **ELECTRIC**

Hear the General Electric Radio Programs: The "G-E ALL-GIRL ORCHESTRA," Sunday 10 P. M., EWT, N B C. . . "THE WORLD TODAY" News, Every Weekday 6:45 P. M., EWT, CBS

Swimming Pool Service

WAR production has very rightly set up priorities which make new W&T equipment for swimming pool chlorination unavailable for the duration, although priorities are obtainable for essential chlorine control apparatus where needed for water supplies, sewage plants and war industries. Meantime the Wallace & Tiernan organization is co-operating with architects and engineers in keeping present installations in top working condition.

Ask us about this service; also for W&T swimming pool technical publications.

WALLACE & TIERNAN CO., INC.

Manufacturers of Chlorine and Ammonia Control Apparatus
Newark, New Jersey
Represented in Principal Cities



STATEMENT OF THE OWNERSHIP, MANAGEMENT, CIRCULATION, ETC., REQUIRED BY THE ACTS OF CONGRESS OF AUGUST 24, 1912, AND MARCH 3, 1933

OF ARCHITECTURAL RECORD, combined with American Architect and Architecture, published monthly at East Stroudsburg, Pa., for November, 1943.

State of New York } ss.
County of New York }

Before me, a Notary Public in and for the State and county aforesaid, personally appeared H. Judd Payne, who, having been duly sworn according to law, deposes and says that he is the Vice President & Genl. Mgr. of the ARCHITECTURAL RECORD combined with American Architect and Architecture and that the following is, to the best of his knowledge and belief, a true statement of the ownership, management, etc., of the aforesaid publication for the date shown in the above caption, required by the Act of August 24, 1912, as amended by the Act of March 3, 1933, embodied in section 537, Postal Laws and Regulations, printed on the reverse of this form, to wit:

1. That the names and addresses of the publisher, editor, managing editor, and business managers are:

Publisher, F. W. Dodge Corporation, 119 West 40th Street, New York, N. Y.; Editor, Kenneth K. Stowell, 113 West 40th Street, New York, N. Y.; Managing Editor, Emerson Gobare; Business Manager, None.

2. That the owner is: (If owned by a corporation, its name and address must be stated and also immediately thereunder the names and addresses of stockholders owning or holding one per cent or more of total amount of stock. If not owned by a corporation, the names and addresses of the individual owners must be given. If owned by a firm, company, or other unincorporated concern, its name and address, as well as those of each individual member, must be given).

F. W. Dodge Corporation, 119 West 40th Street, New York, N. Y., whose stockholders, owning 1% or more of the total amount of its stock, are: Paul Abbott, 1 Wall Street, New York, N. Y.; Dana T. Ackerly, 15 Broad Street, New York, N. Y.; May Gibson Baker, c/o Mrs. L. G. Collins, Apt. 5J, 78-12 35th Avenue, Jackson Heights, Long Island, N. Y.; Howard J. Barringer, Box 736, Brightwaters, New York; James McV. Breed, 15 Broad Street, New York, N. Y.; Jane Curtiss Breed, 850 Park Avenue, New York, N. Y.; William C. Breed, 15 Broad Street, New York, N. Y.; Mary F. Broadwell, 423 West 120th Street, New York, N. Y.; Eddy and Company, P. O. Box 708, Church Street Annex, New York; Sumner Ford, 15 Broad Street, New York, N. Y.; Irving W. Hadsell, 119 West 40th Street, New York, N. Y.; Thomas S. Holden, 119 West 40th Street, New York, N. Y.; Helen D. Morgan, 399 Park Avenue, New York, N. Y.; Laura O. Morgan, 1011 Bluff Road, Glencoe, Ill.; T. Oliver Morgan, Trustee, 700 Merchandise Mart, Chicago, Ill.; Cordelia Dana Nash, 60 East 96th Street, New York, N. Y.; Minnie C. Ort, Port Murray, N. J.; Frances M. McIntosh, 194 Brewster Road, East, Bronxville, New York; Jane A. Pratt, c/o Manufacturers Trust Co., 741 Fifth Avenue, New York, N. Y.; William J. Quinn, 15 Broad Street, New York, N. Y.; Marcus Wayne, 2489 Overlook Road, Cleveland Heights, Ohio; Chauncey L. Williams, 119 West 40th Street, New York, N. Y.; George A. Wilson, Trustee, 15 Broad Street, New York, N. Y.; Laura Morgan Jackson, R. F. D. #1, Ridgefield, Connecticut; Sumner Ford & Underwriters Trust Co., Trustee, c/o Trust Department, 50 Broadway, New York, N. Y.; Frances M. McIntosh, 194 Brewster Road, Scarsdale, New York; T. Oliver Morgan, 1011 Bluff Road, Glencoe, Ill.; Delex Morgan Young, Colonial Heights, 2 Primrose St., Tuckahoe, New York.

3. That the known bondholders, mortgagees, and other security holders owning or holding 1 per cent or more of total amount of bonds, mortgages, or other securities are: (If there are none, so state.) None.

4. That the two paragraphs next above, giving the names of the owners, stockholders, and security holders, if any, contain not only the list of stockholders and security holders as they appear upon the books of the company but also, in cases where the stockholder or security holder appears upon the books of the company as trustee or in any other fiduciary relation, the name of the person or corporation for whom such trustee is acting, is given; also that the said two paragraphs contain statements embracing affiant's full knowledge and belief as to the circumstances and conditions under which stockholders and security holders who do not appear upon the books of the company as trustees, hold stock and securities in a capacity other than that of a bona fide owner; and this affiant has no reason to believe that any other person, association, or corporation has any interest direct or indirect in the said stock, bonds, or other securities than as so stated by him.

[SEAL] H. JUDD PAYNE, Genl. Mgr.

Notary Public, Nassau County, Nassau County Clerk's No. 2344. Certificate filed in New York County Clerk's No. 862. Commission expires March 30, 1944.



SYMBOL OF QUALITY IN WIRING DEVICES AND CONTROL APPARATUS

for 53 years

Available now for dependable control of light, heat and power if ordered with proper priorities . . . Send for current Catalogs for war service installations.

HART & HEGEMAN DIVISION
ARROW-HART & HEGEMAN ELECTRIC COMPANY, HARTFORD, CONN.

STRIPPED FOR ACTION...

Architectural Concrete helps give distinction to buildings designed primarily for rugged strength, fire resistance and economy. Its use helps save scarce materials, transportation, equipment, construction time.

The assistance of our technical staff is available to designers and builders of all types of war construction. Portland Cement Association, Dept. A11-8, 33 W. Grand Ave., Chicago 10, Illinois.

Get the job done
Faster.. Better
 with
USAIRCO

**BLOWERS • WASHERS
 COILS**

The big task now is to get the job done quickly, efficiently—to get the types of blowers you need to produce the result you want.

USAIRCO can meet your needs now with a complete line of blowers—the result of twenty years of experience in the design and manufacture of air handling equipment.

USAIRCO products are functioning today for every phase of the war effort—for the Army, Navy and Maritime Commission—in war plants, airplane factories and processing industries. They are demonstrating their ability to meet the job requirement and the operating budget.

Write today for complete details, prices and delivery dates. Individual catalogs and ratings on all USAIRCO units are available.

**UNITED STATES
 AIR CONDITIONING CORPORATION**

*Manufacturers of the most complete line of air-handling equipment.
 Factory representatives in principal cities.*

Northwestern Terminal • Minneapolis, Minnesota

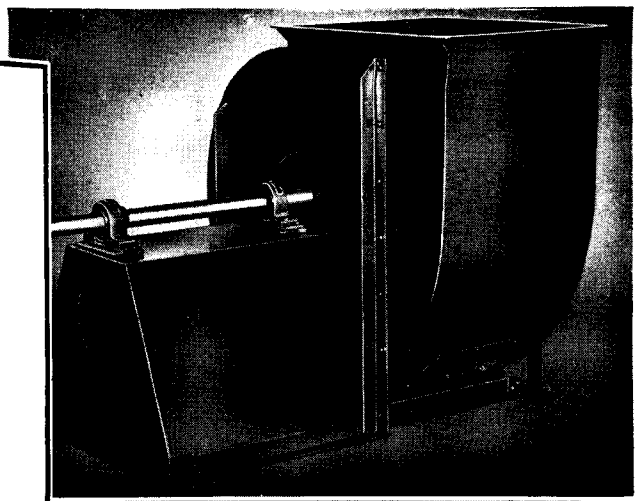

HEAVY DUTY BLOWERS

For industrial and commercial applications USAIRCO has a complete line in all popular arrangements. Pictured above is arrangement number one Blower, with both bearings outside air stream.

Below is arrangement number four Blower. Available in both backwardly inclined blade and forwardly curved blade types—sturdily constructed for industrial and other heavy-duty requirements.

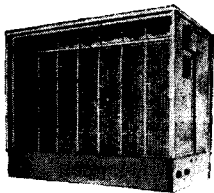
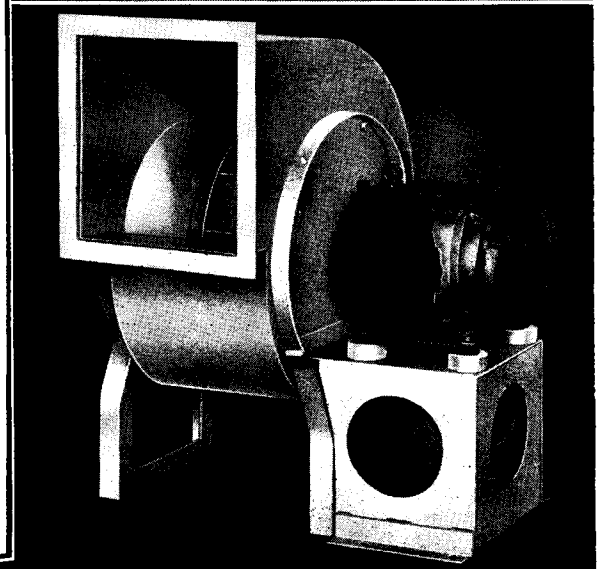

AIR WASHERS

Single and double stage air washers in various capacities for all needs. Used in installations where dependable equipment is required for air cleaning, cooling, humidifying or dehumidifying. Air Washers operate with cold water or refrigerating apparatus.

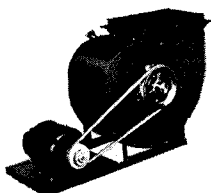

"E" BLOWERS

Belt-driven exhaust blower for light duty work where static resistance is low. Type "E" Blowers are easy to service; are available in several discharge arrangements. An adjustable pulley permits 30% speed variation to handle air as required in different installations.

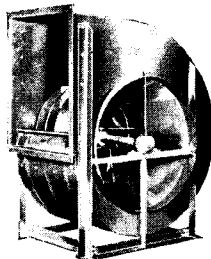

HEAVY BLOWERS

Backwardly curved blade type shown (also blowers with forwardly curved blades), available in types and capacities ranging from 2,000 to 70,000 c.f.m. Used for large scale air handling jobs. Made in single and double inlet, and in varied discharge arrangements.

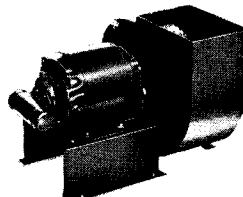

"SU" BLOWERS

Direct-driven exhaust blowers are designed for use where space is limited. Built strongly, mounted rigidly to prevent vibration. Slow speed motor operates the wheel. Efficient for exhaust applications in warehouses, factories, barracks or mess halls.

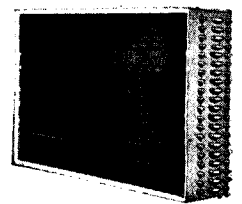

COILS

Cooling, heating and air conditioning Coils—fin type with high heat transfer efficiency. Now constructed of steel to conform with wartime regulations.

CABOT'S COLLOPAKES

GIVE GREATER PROTECTION LONGER!



Cabot's Collopakas are not ordinary paints. By an exclusive patented process the pigments in Cabot's Collopakas are reduced to sub-microscopic fineness and colloiddally compounded in the oil. Pigments and oil do not separate but penetrate together forming a tough uniform film—with greater hiding power, greater covering power and longer lasting. Colors are fresher, livelier, non-fading. You can depend, too, on the quality of Cabot's Collopakas.

Free

"White Book" Interesting, colorful factual. Filled with prize-winning houses painted with Cabot's Old Virginia White, Double White and Gloss Collopakas. Write for your copy. Samuel Cabot, Inc., 1287 Oliver Bldg., Boston, Mass.



Cabot's DOUBLE-WHITE and Gloss Collopakas

The paints for the homes of America



For Sanitation today and a long time after...

It was during the last war that Halsey Taylor Fountains were popularly accepted for their exclusive qualities of health-safety. Today they are still the logical choice for essential school replacement and repairs. While their specification is naturally limited by today's restrictions, yet they give you the same proven sanitation and convenience . . . advantages that will last for years after their installation. Write.

THE HALSEY W. TAYLOR CO.
WARREN, OHIO

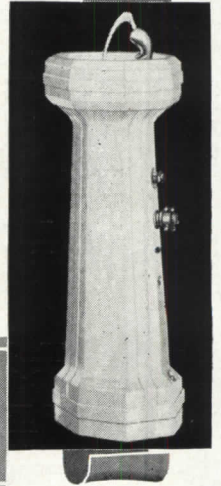

HALSEY TAYLOR
Drinking Fountains

5-STAR PERFORMANCE

There's real drama wherever American marines fight for freedom—
wherever American navy men are keeping sea-lanes safe—
wherever American soldiers press forward toward Victory—
wherever American merchantmen keep essential supplies moving to all fronts—
wherever Jamison-Built Doors protect their food supply.

JAMISON
COLD STORAGE
DOOR CO.
HAGERSTOWN, MARYLAND

JAMISON,
STEVENSON and
VICTOR DOORS



JAMISON-
BUILT COLD STORAGE DOORS

See our catalog in Sweet's Catalog File

An Open Letter to

ARCHITECTS

Should you require APPROVAL or ENDORSEMENT before you recommend and specify

VERD-A-RAY

read September Issue of OHIO STATE MEDICAL JOURNAL -- in an article it says that eyestrain is relieved through use of this lamp.

Also read SAFETY ENGINEERING MAGAZINE for March 1943 and learn how one war plant in one month in one department reduced hospital treated headaches by 69.13%, hospital dressed minor injuries by 54%, and saved 367 productive man hours, by proper installation of this new lamp.

Ask the sales clerk in any chain variety store what customers say about this new lamp when THEY COME BACK TO BUY MORE.

SAVE ELECTRIC CORP. -- TOLEDO 5, OHIO

An Architect's Comment

on the functioning of OIL BURNING SYSTEMS



J. Floyd Yewell, of New York, is well known as an architect and an architectural renderer. Among his outstanding industrial jobs, are the new plant for Walter Kidde & Company in Belleville, New Jersey; the New York, Susquehanna and Western Railroad Station in Paterson, New Jersey; and the plant for Ciba Pharmaceutical Products in Summit, New Jersey. Mr. Yewell makes these following comments on oil heating. Among other installations of Petro equipment, he is personally acquainted with the Petro domestic burner which he used in his own home.

"In my opinion, the economy of labor saving and the simplicity of operation which have distinguished oil heating in our prewar building will carry on in postwar construction when these attributes will be even more in demand . . . I have found that Petro Oil Burning Systems possess an attractive record for fuel and labor economy together with long term service, and my experience is fortified by the advice of engineers."

Mr. Yewell's remarks indicate the importance of operating simplicity in oil heating. The different systems and burners offer varying degrees of simplicity, and these variations affect both labor and fuel costs.

Where the system is installed to burn the low-cost heavy oils which require pre-heating, the simplicity factor is vital because proper and constant control of oil temperature is a fundamental for efficient combustion and reliable burner operation.

Petro's Thermal Viscosity principle provides this correct oil temperature by automatically governing the application of heat to the fuel oil rather than by adding mechanical accessories to the burner. This in turn eliminates need for manual adjustment during firing periods or on "cold starts."

And, since this Thermal Viscosity system automatically maintains the fuel oil at correct temperature and volume for efficient combustion, it is a definite economy factor in a season's fuel cost.

OIL IS AMMUNITION USE IT WISELY

Full data on Petro Industrial Burners are in Sweet's—or Domestic Engineering—catalog files, or we will gladly send copies on request.

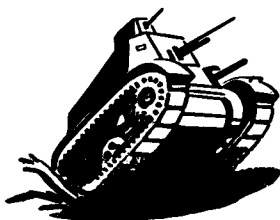

PETRO

Cuts Steam Costs



PETROLEUM HEAT AND POWER COMPANY





STAMFORD

Makers of good Old Burning Equipment since 1903

CONNECTICUT

"the best possible information on products and services now available or to be available after the war" —

That's what you'll find in Sweet's

Sweet's File  architectural	Sweet's File  architectural	Sweet's File  architectural	Sweet's File  architectural
contractors and special services 1 foundations 2 structural systems and equipment 3 masonry materials 4 waterproofing 5	roofing 6 skylights and ventilators 7 lumber and woodwork 8 lath, plaster and wallboard 9 thermal insulation 10 acoustical materials 11 flooring and wall materials 12	metals and metalwork 13 doors 14 windows 15 hardware, door and window equipment 16 paint 17 glass 18 store fronts 19 partitions and wirework 20	furnishings and special equipment 21 elevators 22 electrical supplies and equipment 23 lighting 24 communication 25 heating and air conditioning 26 plumbing and bathroom equipment 27 kitchen and service equipment 28
1943	1943	1943	1943

Many of the products you see cataloged in Sweet's you can get today. Many others won't be available until peace comes. But these also have been included in Sweet's because their manufacturers realize that when you prepare plans and specifications for future building projects you need more than just promises of new and improved materials and equipment.

Since the beginning of the war, Sweet's has urged all of its clients to give you the best available information. You have seen their response in

the Sweet's File now in your office. In the 1944 file, now in preparation, the response is still better — 12 per cent better — which means that your new file will contain useful catalogs totalling five thousand pages.

Whenever you have need of contracting, engineering and other special services, consult the greatly expanded Section I in Sweet's. There you will find data on personnel, equipment, specialization, labor relations, financial background, etc., on scores of leading firms located all over the country.

Sweet's Catalog Service

BLUE PRINTS

There is no time to spare in producing any of today's requirements. Readable blue prints must be rushed to production departments without delay and the fabrication of parts started.

For any important task, KOH-I-NOOR Drawing Pencils have long been the unanimous choice of discriminating draftsmen. You will most certainly approve their smooth, long wearing qualities and their ability to produce well defined, light, impervious lines, resulting in clearer, more legible blue prints.

*
#930 AVIATOR COLORED PENCILS are made in 24 brilliant colors and are entirely suitable for all color work where only a limited range of colors are required.
*

SEND FOR FREE BOOKLET No. 3



The RIGHT pencil for the RIGHT job

KOH-I-NOOR PENCIL COMPANY, INC.,
BLOOMSBURY, NEW JERSEY

HOST TO MOST *Wartime* WHO VISIT A BALTIMORE

Baltimore is knee-deep in war! Surrounded by war production industries . . . located near the Washington scene . . . Baltimore has become a focal point of wartime activities.

This has created problems . . . problems that you can help to solve. Make your room reservation in advance . . . cancel it promptly if you cannot use it . . . be patient if the service is not as smooth and speedy as in pre-war times.

As Americans we are proud we have these problems . . . as hotelmen we ask your indulgence.

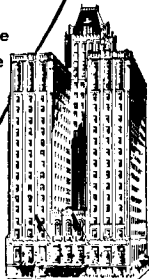

700 rooms — each with radio, tub and shower.

The **LORD BALTIMORE HOTEL**
BALTIMORE-1 ★ MARYLAND



SAMSON SPOT SASH CORD

*the most durable
material for hanging
windows*

★
WHERE THE NEED IS GREATEST
Samson Braided Cords Serve Best
Now and Always

SAMSON CORDAGE WORKS
BOSTON 10, MASS.

SAMSON SPOT SASH CORD



Reg. U.S. Pat. Off.

A Book That Belongs In Every Architect's Office

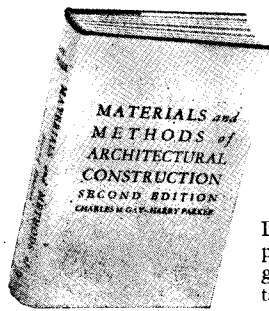

MATERIALS and METHODS of ARCHITECTURAL CONSTRUCTION

*By Charles M. Gay and
Harry Parker*

Do you know the latest uses of pressed wood, plastics, structural glass? Do you have the latest tables on strength of materials and properties of structural steel?

This vital information is included in this practical book, rewritten to keep architects and builders abreast of current practices in architectural construction. Also discusses foundations, floor and roof construction, metal timber connectors, reinforced concrete and concrete design. Every architect and builder should own a copy. Send for yours today!

Second Edition 636 Pages Illustrated \$6.00

FREE TEN DAYS' TRIAL

..... ON APPROVAL COUPON

JOHN WILEY & SONS, INC.,
440 Fourth Avenue, New York 16, N. Y.
Please send me a copy of Gay and Parker's MATERIALS AND METHODS OF ARCHITECTURAL CONSTRUCTION on ten days' approval. At the end of that time, if I decide to keep the book, I will remit \$6.00 plus postage; otherwise I will return the book postpaid.

Name

Address

City and State

Employed by

AR-11-43

BOOKS FOR CHRISTMAS GIFTS

Architects, engineers, draftsmen . . . head your gift-suggestion list this year with books relating to your profession! For convenience in ordering, use the form below.

1. **THE RESTORATION OF COLONIAL WILLIAMSBURG \$1.50**
Textual story by the Restoration architects and designers. 104 pages, 9 x 12. Blue cloth cover.
2. **NEW ARCHITECTURE IN MEXICO by Esther Born now \$2.50**
A reference source for every important type of building. Photographs and floor plans, 159 pages, 9 x 12. Canary cloth cover.
3. **SIMPLIFIED ENGINEERING FOR ARCHITECTS AND BUILDERS by Harry Parker \$2.75**
Textbook with theory and tables. 214 pages, 96 illustrations. 5 x 7 3/4. Flexible cover.
4. **ARCHITECTS' AND BUILDERS' HANDBOOK by Kidder and Parker \$8**
Fifty years of reliable service, yet modern in every detail, conforming with latest research and accepted practice. 18th Edition, 2315 pages, 4 1/2 x 7. Flexible cover.

SPECIAL!

5. **COMBINATION OFFER \$9**
(Purchased separately, each \$5)
6. **DESIGN OF MODERN INTERIORS**
7. **THE MODERN HOUSE IN AMERICA**
by James Ford and Katherine Morrow Ford. Beautifully illustrated! The modern house, exterior and interiors—choice of colors, materials, designs, etc. 8 1/2 x 10 3/4. Cloth bound.

ARCHITECTURAL RECORD
119 West 40th Street, New York 18, N. Y.

Please send 1. 2. 3. 4.
5. 6. 7.

Check or money order for is enclosed.

Name

Address

City and State

Check the numbers of the books you want, and mail to Architectural Record with your remittance—no extra charge for postage

Sorry—No COD's AR 11-43

INDEX TO ADVERTISEMENTS

Catalogs of concerns marked (s) are filed in Sweet's File (1943)

Page	Page
ABESTO MFG. CO.	106
AIR REDUCTION SALES	123
Agency: G. M. Basford Co.	
ALLEN CORPORATION	9
Agency: Ralph L. Wolfe & Associates	
(s) ALLIED CHEMICAL & DYE DIVISION	111
Agency: McCann Erickson	
(s) ALUMINUM COMPANY OF AMERICA	3
Agency: Fuller & Smith & Ross, Inc.	
AMERICAN PENCIL COMPANY	112
Agency: Doremus & Company	
(s) ARKETEX CERAMIC CORPORATION	109
Agency: Kane Advertising Co.	
(s) ARROW HART & HEGEMAN ELECTRIC CO.	116
Agency: Norris L. Bull	
(s) BARBER-COLMAN COMPANY	96-97
Agency: Cummings, Brand & McPherson	
(s) BARRETT DIVISION	111
Agency: McCann Erickson	
(s) BETHLEHEM STEEL COMPANY	24
BIGELOW SANFORD CARPET CO., INC.	16
Agency: Newell-Emmett Company	
BLODGETT, G. S., CO., INC.	88
Agency: Townsend Adv. Service	
(s) BURT MFG. CO.	114
Agency: McDaniel-Fisher & Spielman	
(s) BYERS, A. M., COMPANY	4
Agency: Ketchum, MacLeod & Grove, Inc.	
(s) BYRNE DOORS, INCORPORATED	3rd Cover
Agency: Ralph Wolfe & Associates	
(s) CABOT, SAMUEL, INC.	118
Agency: Harold Cabot & Company, Inc.	
CARDOX CORPORATION	107
Agency: Evans Associates	
(s) CARNegie-ILLINOIS STEEL CORPORATION	93
Agency: Batten, Barton, Durstine & Osborn	
(s) CARRIER CORPORATION	105
Agency: Chas. Dallas Reach Co.	
(s) CELOTEX CORPORATION	95
Agency: MacFarland, Aveyard & Company	
CRANE COMPANY	23
Agency: Buchen Company	
(s) CURTIS COMPANIES SERVICE BUREAU	8
Agency: Buchen Company	
(s) DAY-BRITE LIGHTING, INCORPORATED	37
Agency: Anfenger Adv. Agency	
(s) DIXONS TYPHONITE ELBORADO PENCILS	1
Agency: Federal Advertising Agency	
(s) DODGE REPORTS	36
(s) DOUGLAS FIR PLYWOOD ASSOCIATION	114
Agency: McCann Erickson	
(s) DU PONT, E. I., DE NEMOURS & CO.	101
Agency: Batten, Barton, Durstine & Osborn	
FABER, A. W., INC.	14
Agency: Advertising Associates	
(s) FITZGIBBONS BOILER COMPANY, INC.	19
Agency: Peterson & Kempner, Inc.	
(s) GENERAL ELECTRIC AIR CONDITIONING	115
Agency: Newell-Emmett Co.	
(s) GENERAL ELECTRIC HOME BUREAU	17
Agency: Maxon, Inc.	
GENERAL PENCIL COMPANY	106
Agency: Frederick Smith	
(s) GRASSELLI CHEMICALS DEPARTMENT	101
Agency: Batten, Barton, Durstine & Osborn	
(s) GREAT LAKES STEEL CORPORATION	15
Agency: Campbell-Ewald Company	
(s) GRINNELL COMPANY, INC.	114
Agency: Horton-Noyes Company	
(s) GUTH, EDWIN F., CO.	28
Agency: Ridgway Company	
(s) HART & HEGEMAN DIVISION	116
Agency: Norris L. Bull	
(s) HORN MANUFACTURING CO	112
Agency: Cary-Ainsworth, Inc.	
(s) IMPERIAL BRASS MFG. CO.	6
Agency: Kreicker & Meloan, Inc.	
(s) JAMISON COLD STORAGE DOOR CO.	118
Agency: Charles Blum Adv. Corp.	
(s) JOHNS MANVILLE	34-113
Agency: J. Walter Thompson Company	
JOHNSON, JOHN A., CONTRACTING CORP.	21
Agency: Ruthrauff & Ryan	
(s) JOHNSON SERVICE COMPANY	13
Agency: K. E. Shepard	
KEASBEY & MATTISON COMPANY	87
Agency: Geary-Marston, Inc.	
KINETIC CHEMICALS INC.	12
Agency: Batten, Barton, Durstine & Osborn	
(s) KITCHEN MAID CORPORATION	104
Agency: Carter Jones & Taylor	
KOH-I-NOOR PENCIL CO., INC.	121
Agency: Roeding & Arnold	
(s) KOPPERS COMPANY	29
Agency: Ketchum, MacLeod & Grove	
(s) LCN DOOR CLOSERS	39
Agency: J. R. Hamilton Adv. Agency	
LINTON PENCIL COMPANY	27
LONE STAR CEMENT CORPORATION	18
Agency: Cowan & Dangler	
LORD BALTIMORE HOTEL	121
Agency: Emery Advertising Co.	
(s) LOUISVILLE CEMENT COMPANY, INC.	33
Agency: Doe-Anderson Adv. Agency	
(s) MILLER COMPANY	2nd Cover
Agency: J. M. Hickerson, Inc.	
(s) MILWAUKEE STAMPING COMPANY	110
Agency: Morrison Adv. Agency	
MONSANTO CHEMICAL COMPANY	25
Agency: Gardner Advertising Co.	
MONTGOMERY ELEVATOR COMPANY	102
Agency: L. W. Ramsey Company	
(s) NATIONAL GYPSUM COMPANY	38
Agency: Batten, Barton, Durstine & Osborn	
(s) NELSON HERMAN CORPORATION	94
Agency: L. W. Ramsey Company	
(s) NESBITT, JOHN J., INC.	40
Agency: George Moll, Advertising	
OKONITE COMPANY	112
Agency: Doyle, Kitchen & McCormick	
(s) PETROLEUM HEAT & POWER COMPANY	119
(s) PITTSBURGH PLATE GLASS COMPANY	2
Agency: Batten, Barton, Durstine & Osborn	
(s) PORTLAND CEMENT ASSOCIATION	116
Agency: Roche Williams & Cunningham, Inc.	
(s) POWERS REGULATOR COMPANY	104
Agency: Earle Ludgin & Co.	
(s) RUBEROID CO.	31
Agency: Ferry-Ilanly Company	
(s) SAMSON CORDAGE WORK	121
Agency: Callaway Associates	
SAVE ELECTRIC CORPORATION	118
Agency: Gere Burns	
(s) SCOTT PAPER COMPANY	108
Agency: J. Walter Thompson Co.	
SLOAN VALVE COMPANY	4th Cover
Agency: Reincke, Ellis, Younggreen & Finn	
SMITH, H. B., COMPANY, INC.	98
Agency: Bordeaux Company	
SPEAKMAN COMPANY	30
Agency: John Gilbert Craig	
(s) SQUARE D COMPANY	35
Agency: Reincke, Ellis, Younggreen & Finn	
(s) STANLEY WORKS	110
Agency: Horton-Noyes Co.	
(s) STRAN STEEL DIVISION	15
Agency: Campbell Ewald Company	
(s) SWEETS CATALOG SERVICE	120
SYLVANIA ELECTRIC PRODUCTS, INC.	20
Agency: Arthur Kudner, Inc.	
SYNCHRO-START PRODUCTS, INC.	32
Agency: Bradford & Company	
(s) TAYLOR, HALSEY W., CO.	118
Agency: William Cohen	
TILE-TEX COMPANY	92
Agency: L. W. Ramsey Company	
(s) TIMBER ENGINEERING COMPANY	89
Agency: Campbell-Ewald Company	
TIMBER STRUCTURES, INC.	103
Agency: Botsford, Constantine & Gardner	
(s) TRANE COMPANY	124
Agency: Batten, Barton, Durstine & Osborn	
UNITED STATES AIR CONDITIONING CORP.	117
Agency: Alfred Collie Company	
(s) UNITED STATES GYPSUM	22
Agency: Fulton, Home & Morrissey Co.	
(s) UNITED STATES STEEL CORPORATION SUBSIDIARIES	93-102
Agency: Batten, Barton, Durstine & Osborn	
(s) UNIVERSAL ATLAS CEMENT CO.	102
Agency: Batten, Barton, Durstine & Osborn	
(s) UPSON COMPANY	99
Agency: McCann Erickson	
(s) WALLACE & TIERNAN COMPANY, INC.	116
Agency: G. M. Basford Company	
WILEY, JOHN, & SONS, Inc.	98-121
Agency: S. Duane Lyon, Inc.	
(s) WING, L. J., MFG. CO.	100
Agency: Willard G. Myers	
WIREMOLD COMPANY	110
Agency: Edward W. Robotham & Co.	
(s) WOOD CONVERSION COMPANY	91
Agency: Buchen Company	
(s) WORTHINGTON PUMP & MACHINERY CORP.	11
Agency: James Thomas Chirburg Co.	

New York—General Manager: H. Judd Payne. Advertising Manager: Tom Tredwell. B. B. Orwig, 119 West 40th Street. Boston—Robert Marshall, 855 Park Square Bldg.; Chicago—C. B. Riemersma, F. H. Bowes, 700 Merchandise Mart; Cleveland—John C. Jackson, 321 Hanna Bldg.; Los Angeles—W. R. McIntyre, 400 East Third St.; Philadelphia—Tom Tredwell, 1321 Arch Street.

SIMPLICITY IS THE KEYNOTE OF WELDED DESIGN

...in buildings as well as ships

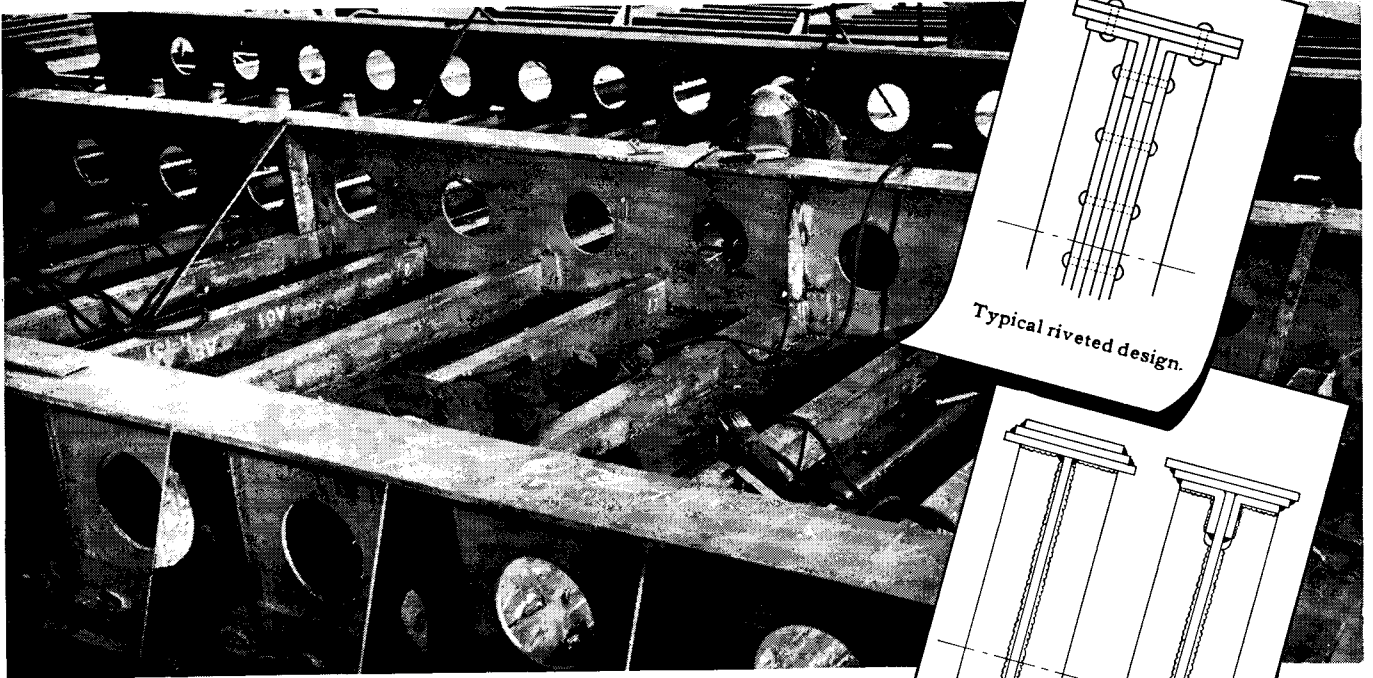

Typical riveted design.

Welded designs unduly influenced by riveting precedent.

Efficient welded design characterized by simplicity.

Modern structural welding eliminates many of the complex details necessary with older steel-joining methods. This point is clearly illustrated in the sketches shown at right. Note the extreme simplicity of the welded design — simplicity which greatly increases the efficiency of the welded joint and reduces the cost of fabrication.

By taking full advantage of the basic simplicity of welded design, naval architects have achieved increased structural strength in welded cargo ships, while at the same time conserving valuable steel and labor. In the same way welded details for buildings should be planned with simplicity as the keynote, to take fullest advantage of the efficiency and savings which welding provides.

Air Reduction's Applied Engineering Department has acquired extensive experience in the use of welding for both ship and building construction. Architects, engineers, and designers are invited to call upon Air Reduction engineers for assistance in working out problems of structural welding design.

★ BUY UNITED STATES WAR BONDS ★



AIR REDUCTION

General Offices: 60 EAST 42nd STREET, NEW YORK 17, N. Y.

In Texas: MAGNOLIA AIRCO GAS PRODUCTS CO. • General Offices: HOUSTON, TEXAS



The shell that plays ping pong inside a tank

HEAAT Treating—the process of using controlled temperature to put the pierce into anti-tank gun shells, is gradually sounding the death knell of the once invincible weapon of war. The armor plate of the tank that once shed bullets like rain drops, is being drilled into destruction by modern shot. Not only is the armor being pierced, but as the projectile enters the tank it blunts its drilling nose. Then taking advantage of the very armor it has just entered, it strikes and restrikes inside walls, like a ping pong ball, as many as 500 times.

In many heat treating processes, Trane Equipment

is being used to rapidly cool oils and liquids used in quenching. In so doing, Trane Products speed ordinance production and ultimate victory.

Today Trane Air Engineers are sending Trane Equipment to war on every war production front. They are utilizing heat, cold, air movement, moisture control—all the elements of weather itself to help win the battles of production.

Tomorrow these men and this equipment will again turn to peace, using the development of today for the comfort and better living of tomorrow.



TRANE

AIR[®]

THE TRANE COMPANY LA CROSSE, WISCONSIN
 TRANE COMPANY OF CANADA, LTD., TORONTO
 AIR CONDITIONING • HEAT TRANSFER • AIR HANDLING EQUIPMENT