

# ARCHITECTURAL RECORD

BUILDING TYPES STUDY NUMBER 203

SHOPPING CENTERS



OCTOBER 1953

Hotel Copan, São Paulo, Brazil  
Henrique E. Mindlin, Architect  
Holabird & Root & Burgee, Associate Architects



**G** **GRINNELL** announces its new line of

# GAS-FIRED UNIT HEATERS



Available in 7 sizes  
— with input ratings  
from 25,000 to  
200,000 Btu's.

All parts readily  
accessible for  
periodic servicing.

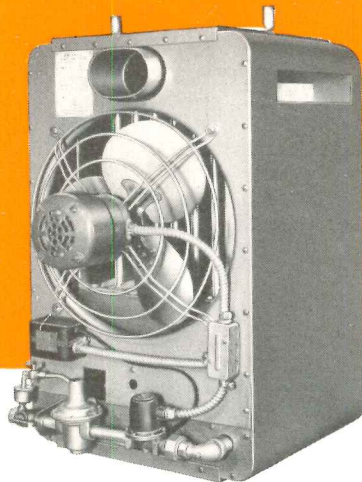

## **AUTOMATIC! EFFICIENT! ASSURE YEARS OF DEPENDABLE SERVICE**

Grinnell gas-fired unit heaters are easy to install, simple to operate and maintain. Efficient performance assured — with any type of gas — by modern design of burners and heat exchanger, proper motor and fan unit.

Automatic safety pilot operates to shut off main gas supply if pilot burner goes out. Flash-back and extinction noise prevented by the burners' raised port design and proper port size for the gas used. Low speed motors have built-in thermal overload protection and automatic reset.

## **Additional features of Grinnell gas-fired unit heaters . . .**

- Casing die-formed of heavy steel, with baked-on enamel finish
- Heat exchanger tubes and draft diverter of aluminized steel
- Combustion chamber of heavy steel, welded
- Burners of close-grained iron castings
- Adjustable louvers
- Burners and control assembly removable as a unit
- Hinged bottom pan permits cleaning interior of tubes
- Threaded pipe hangers for easy suspension
- Only wiring required is connection to room thermostat or manual switch
- Approved by the American Gas Association

**GRINNELL**  
UNIT HEATERS FOR STEAM, HOT WATER, GAS

**WRITE FOR CATALOG**



Grinnell Company, Inc., Providence, Rhode Island

Coast-to-Coast Network of Branch Warehouses and Distributors

Manufacturer of: pipe fittings • welding fittings • forged steel flanges • steel nipples • engineered pipe hangers and supports  
Thermolier unit heaters • Grinnell-Saunders diaphragm valves • prefabricated piping • Grinnell automatic fire protection systems

ARCHITECTURAL RECORD (Vol. 114, No. 4, October, 1953) is published monthly by F. W. Dodge Corp., 10 Ferry Street, Concord, N. H., with editorial and executive offices at 119 W. 40th St., New York 18, N. Y. \$4.50 per year; Foreign, \$6.50.

Entered as second-class matter at the Post Office, Concord, N. H., March 16, 1946, under the Act of March 3, 1879.



# ARCHITECTURAL RECORD



Copyright 1953 by F. W. DODGE CORPORATION, with all rights reserved • Publishing Director, Magazine Division, H. Judd Payne • General Manager, Robert F. Marshall • **EDITORS:** Executive Editor, Joseph B. Mason; Managing Editor, Emerson Goble; Senior Associate Editors, Frank G. Lopez, A.I.A., James S. Hornbeck A.I.A.; Associate Editors: Robert E. Fischer (Engineering), Florence A. van Wyck, Herbert L. Smith, Jr., A.I.A., Jeanne M. Davern (News), Elisabeth Kendall Thompson (Western); Contributing Editors: Ernest Mickel (Washington), John Caulfield Smith, M.R.A.I.C. (Canada); Assistant Editors: Jeanne G. Whitbeck (Reader Service), Enid Belding (Books), Carl Sciarenco (Technical); Editorial Assistant, Marjorie Blake • **DESIGN:** Consultant, M. Peter Piening; Director, Alfred Petersen; Assistants: Donald Ervin, Joseph D'Amato; Drafting, Sigman-Ward • **CONSULTANTS:** Industry Relations Consultant, Thomas S. Holden; Statistical Consultant, Clyde Shute; Field Consultant, Clifford Dannels, Jr.; Public Relations Consultant, Samuel C. Pace.

Architectural Record (combined with American Architect and Architecture) is published monthly by F. W. Dodge Corporation, 10 Ferry Street, Concord, N. H., with editorial and executive offices at 119 West 40th Street, New York 18, N. Y. Western editorial office, 2877 Shasta Road, Berkeley 8, Calif.

Chairman of the board, James McV. Breed; vice chairmen of the board: Paul Abbott, Thomas S. Holden; president, Howard Barringer; secretary, Sanford D. Stockton, Jr.; executive vice presidents: Irving W. Hadsell, Chauncey L. Williams; vice president and treasurer, Howard M. Thompson; vice presidents: H. Judd Payne, T. Oliver Morgan, Julius T. Little, Robert F. Marshall; assistant secretaries: George W. Morgan, Jr., William C. Breed, Jr.; assistant vice president and comptroller, Edwin H. Freed; assistant vice presidents: Clyde Shute, Clifford G. Dannels, Jr., Marc Wayne, Walter F. DeSaix; assistant treasurer, Irving B. Safin; regional vice presidents: Carl S. Bennett, Ralph M. Hairston, Richard H. Ray.

Subscription rates in U.S., U.S. Possessions, and Canada: \$5.50 for one year, \$9.00 for two years, \$11.00 for three years. Elsewhere, subscriptions from those who by title are architects or engineers, \$6.50 for one year, \$11.50 for two years, \$15.00 for three years; subscriptions from all others outside U.S., U.S. Possessions and Canada, \$20.00 a year. Single copy price, \$2.00. Circulation Manager: Marshall T. Ginn.

Change of Address: Subscribers are requested to furnish both old and new addresses, sending if possible the stencil impression from magazine wrapper. Allow four weeks for change.

Member of Audit Bureau of Circulations and Associated Business Publications. Architectural Record is indexed in Readers' Guide to Periodical Literature, Art Index, Industrial Arts Index and Engineering Index.

Every effort will be made to return material submitted for possible publication (if accompanied by stamped, addressed envelope), but the editors and the corporation will not be responsible for loss or damage.

Other Dodge services: Dodge Reports and Dodge Statistical Research Service, Sweet's Files, "Planning Kit for Our New House," Chicago Construction News, Daily Pacific Builder, Denver Daily Journal, Real Estate Record & Builders' Guide.

**COVER**

Photograph of Hotel Copan, São Paulo, Brazil; Henrique E. Mindlin, Architect, Holabird and Root and Burgee, Associate Architects. Photograph by Bill Hedrich, Hedrich-Blessing.

<b>THE RECORD REPORTS</b> .....	9
Perspectives .....	9
News from Canada. By John Caulfield Smith .....	24
News from Washington. By Ernest Mickel .....	40
Construction Cost Indexes .....	42
Current Trends in Construction .....	366
 <b>REQUIRED READING</b> .....	46
 <b>HOTEL COPAN, SÃO PAULO, BRAZIL</b> .....	135
Henrique E. Mindlin, Architect; Holabird and Root and Burgee, Associate Architects	
 <b>BOSTON BACK BAY CENTER</b> .....	following page 142
 <b>"THE SPIRIT OF THE NEW ARCHITECTURE"</b> .....	143
By Pietro Belluschi	
 <b>SANDERLING BEACH CLUB, SARASOTA, FLA.</b> .....	150
Paul Rudolph, Architect	
 <b>REPAIR SHOP COMBINES EFFICIENCY, FLEXIBILITY</b> .....	156
Anniston Ordnance Depot Vehicle Maintenance Shop, Anniston, Ala. Sherlock, Smith and Adams, Architects and Engineers	
 <b>SMALL HOUSE — LOTS OF SPACE</b> .....	162
Residence for Mr. and Mrs. John E. Schacht, Portchester, N. Y. Carl Koch and Associates, Architects	
 <b>TUBERCULOSIS HOSPITAL IN HAWAII ACCENTS CHEERFUL SURROUNDINGS</b> .....	166
Puumaile Hospital, Hilo, Hawaii. Merrill, Simms and Roehrig, Architects	
 <b>ARCHITECTURAL INTERIORS</b> .....	173
Offices for Cunningham and Walsh, Inc., New York City. Carson and Lundin, Architects	
 <b>BUILDING TYPES STUDY NO. 203: SHOPPING CENTERS</b> .....	178
<b>INTRODUCTION</b> .....	178
<b>A PLACE TO BEGIN</b> .....	180
<b>WHAT MAKES A SHOPPING CENTER</b> .....	181
<b>SITE SELECTION</b> .....	181
<b>PLANNING THE SITE</b> .....	186
<b>THE NECESSARY PARKING</b> .....	192
<b>SERVICES, AMENITIES</b> .....	197
<b>VARIATIONS</b> .....	200
 <b>ARCHITECTURAL ENGINEERING</b> .....	202
<b>ECONOMIES IN AIR CONDITIONING FOR SHOPPING CENTERS</b> 202	
A general discussion of the considerations involved in selecting the best system. By Francis A. Welch	
<b>EMPLOYEE CAFETERIAS</b> .....	206
How to plan for seating and service requirements. By Arthur W. Dana	
<b>PRODUCT REPORTS</b> .....	209
Products chosen for 1953 Good Design Exhibition	
<b>OFFICE LITERATURE</b> .....	210
<b>TIME-SAVER STANDARDS</b> .....	213
 <b>INDEX TO ADVERTISING</b> .....	368



# CHEM-O-GLAS

NEW SHATTERPROOF TRANSLUCENT REINFORCED GLASS-FIBER BUILDING PANELS FOR STRUCTURAL AND DECORATIVE USES WITH EXCLUSIVE, DISTINCTIVE **RIBBED** DESIGN SO EASY TO INSTALL.

*See* the new shades — "FROSTED GREEN" and "COPPERGLO" — especially created for patio use where glare and heat are undesirable. Give restful, glare-free light. Heat rays screened out by exclusive new Chem-O-Filter Compound "XO." Also in natural blonde and marbled yellow. Colorful. Colorfast. Virtually indestructible.

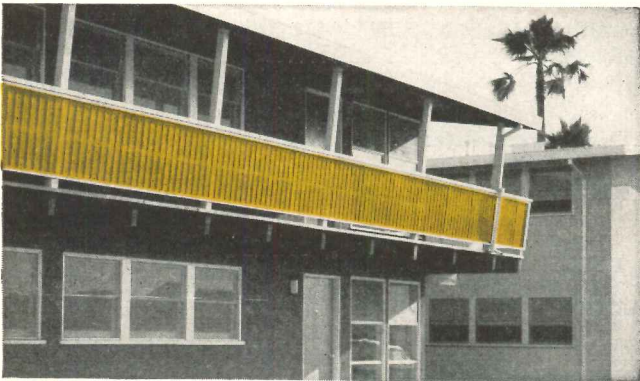

CHEM-O-GLAS (pronounced Kem-O-Glass) is precision molded in 8' lengths, 32 $\frac{1}{2}$ " wide, (32" wide from c/c of outside ribs when overlapped.) Some jobber-dealer territories still open.

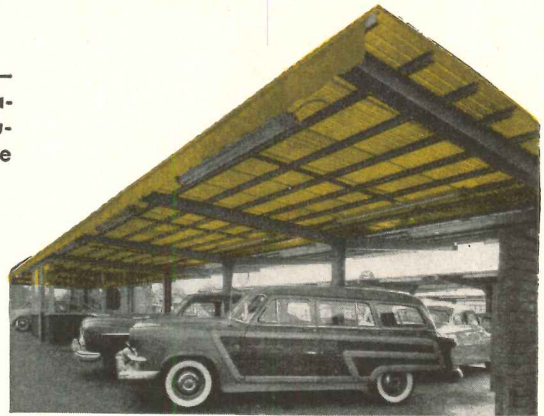

CHEM-O-GLAS UPS SALES — Outdoor showroom of J. A. Eisele Sales, Inc., one of west coast's largest Lincoln-Mercury dealers, showing utilization of CHEM-O-GLAS ribbed structural panels as roofing for structural steel carports.

**Everlasting ... Everlovely ...**

*Hundreds of Uses*

**No need to paint - or repaint - ever!  
"Your first cost is your last cost"**



**CHEMOLD** *Company*

2308-10 BROADWAY  
SANTA MONICA, CALIF.

"LARGEST MATCHED METAL MOLD PRESSES IN THE WEST"

CHEM-O-GLAS is available in flat sheets or the distinctive new RIBBED design. Many architects and builders have found ribbed CHEM-O-GLAS the answer to inside and outside structural and decorative problems where canvas, porcelain, tile, wood, plastic, glass, aluminum or plywood have proved impractical. Inquiries invited.

**CUSTOM MOLDING:** Manufacturers are invited to submit production problems to us for estimate.

*Write for information today*

CHEMOLD COMPANY, DEPT. AR-10  
2310 Broadway, Santa Monica, Calif.

Send details on CHEM-O-GLAS

NAME \_\_\_\_\_  
FIRM \_\_\_\_\_  
ADDRESS \_\_\_\_\_  
CITY \_\_\_\_\_



# THE RECORD REPORTS

## P E R S P E C T I V E S

ANSWER, ECHOES, ANSWER: ACROSS the sea in England *The Architects' Journal's* anonymous columnist "Astragal" took his own editors to task for suggesting in their editorial on a speech by Lewis Mumford that "tolerance" of "contemporary clichés" had "gone on long enough" and "Mumford's talk is the signal for a purge within the ranks of so-called modern architecture" — a pair of conclusions which must have horrified Mr. Mumford, whose talk had taken no such slant. Thus Astragal: "Let's have no talk, please, about decreasing tolerance — the very word reeks of witch-hunting. Who are to be the unpurged élite, and who is there objective enough or imprudent enough to choose them? Of course there are plenty of second-rate architects — there always have been; and of course much so-called modern architecture is no more than an assembly of clichés — so it has always been in any period. Could we not — just for a moment — remember that all bad design is no more than imitation good design, and that those who fail in their attempts are not necessarily scheming blackguards, deviationists, imperialistic hyenas, etc., nibbling away at the foundations of 'True Architecture,' but merely the fumlbers and the purblind?"

THE "CONTEMPORARY CLICHÉ" has been the subject of honest concern on both sides of the Atlantic. Minoru Yamasaki, addressing the Detroit Chapter of the A.I.A. some months ago, had this to say: "With overemphasis on esthetics we tend to do exactly what we have been criticizing our predecessors for doing; that is to start with a particularly desired form and stuff the functions into it naturally or unnaturally. Whether the form is a Greek temple or a clean glass box, the error is deliberate and unworthy. Unfortunately, many of our more beautiful modern buildings are guilty of this sin. We have another regrettable inheritance from our predecessors, and that is the

habit of promiscuous monumentality. Monumentality was the universal prescription for everything from banks to fire stations to garages by the architects of our fake-classic era and we seem to be having difficulty completely eradicating the disease."

WHO IS FRANK LLOYD WRIGHT? The answer would have been worth \$1600 to a young couple on a recent television quiz program. *Would have been*, public relations experts please note: they didn't know.

IT'S 100 YEARS since the founder of the Otis Elevator Company was riding up and down (see cut below) in his elevator at the Crystal Palace Exposition in New York and "occasionally cutting the rope," as *The New York Times* reported, to convince a dubious public that his automatic safety device really worked. And the company last month marked the 100th anniversary of Elisha Graves Otis' first sales — two "safety" freight elevators, hoist-type; price, \$300 each.

U. S. ARCHITECTURAL SCHOOLS don't know anything about each other, says Schlomo Sha'ag. Sha'ag, who is about to set up and head the first architecture department of the Israel Institute of Technology at Haifa, is preparing himself with a 12-month tour of established architectural

schools — and his trek through this country, where he visited 23 schools, convinced him that some system of communication between educators is a crying need. He saw two influences, and two only, reflected in American architecture — Wright and Mies. New York's Lever House and the United Nations Headquarters were by all odds the outstanding buildings — the U. N., he said, is THE BUILDING; none in the world to compare. It was Sha'ag's first visit to the U. S. He was going from here to England and then to France, Italy and Germany before returning to Israel. Sha'ag has been until now a practicing architect and president of the Israeli Architects Association.

STRUCTURAL MILESTONE: The first wrought iron structural beams ever rolled in America (shadowgraph shows cross-section of one) were fabricated 100 years ago for New York's Cooper Union, which celebrated the 100th anniversary of its cornerstone ceremony last month. The beams, 20 ft long and 7 in. deep, were made in specially-designed rolling mills at Trenton Iron Works at the instance of Founder Peter Cooper, who felt he could not afford the expense of the typical stone structure for his six-story building. The first beams, however, were sold off the building site — at a neat profit — to Harper and Brothers, the publishers; and a second batch was sold in the same way to the U. S. Assay Office in New York. On the third try, in 1857, Cooper Union got its own beams and it is now — its two predecessors having been destroyed — the oldest building in the United States supported by rolled structural beams. Cooper Union had two other structural "firsts": it was the first building to include an elevator shaft in the original plans and it had a fan and duct-system for ventilating its Great Hall. Both are still in use.

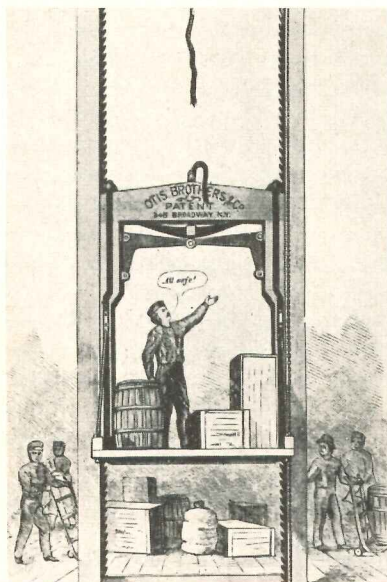
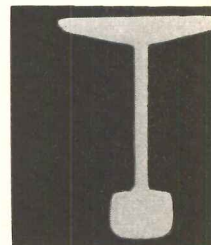



1954 BUILDING NEWS: A GLASS BANK AND

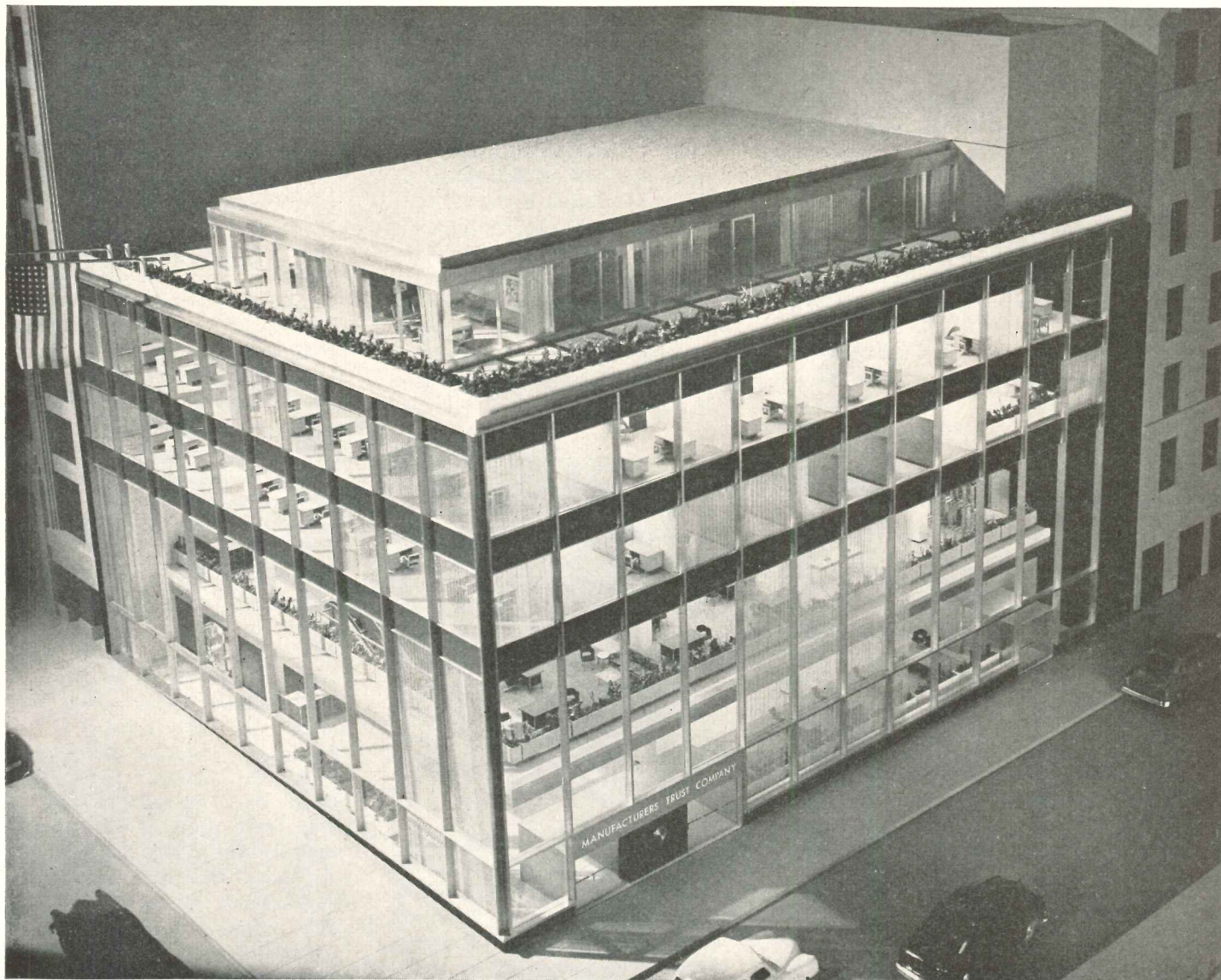

© Ezra Stoller

THE THREE PROJECTS shown on these pages are sure to make major construction news in 1954 — one because it is a major departure in bank design for the nation's financial capital; another because it is New York's biggest commercial building project since Rockefeller Center; and the third for at least two reasons — as a tall building on a 120-acre site and as a bow by the Ford Motor Company to public relations values in architecture. All three projects will be well under way by next year; the bank is to be completed by mid-1954, the other two buildings in 1955.

The bank is not the first glass bank;

but it is the first in New York and it reflects a growing consciousness in the most conservative quarters that — to quote Manufacturers Trust President Horace C. Flanigan — “banking today is selling a service, and is to a great extent comparable with department stores and specialty shops where the aim is to provide inviting quarters and an attractive atmosphere as well as to sell quality merchandise.” The bank will have no entrance on Fifth Avenue. The main entrance will be on Forty-third Street and the Fifth Avenue Façade will be a 100-ft expanse of glass interrupted only by the thin aluminum

mullions of the structure. Prominent in the view of passersby will be the bank's safety deposit vault. The building is expected to cost \$3 million.

The 42-story office building, to cost \$45-50 million, is the first of several office projects planned in major American cities by John Galbreath and Associates. The New York building, which takes its name from its principal tenant, will be erected on land leased from the Goelet estate.

The Ford project revives with some modifications plans first announced in 1950 and then postponed because of the Korean emergency.



## TWO NEW OFFICE BUILDINGS

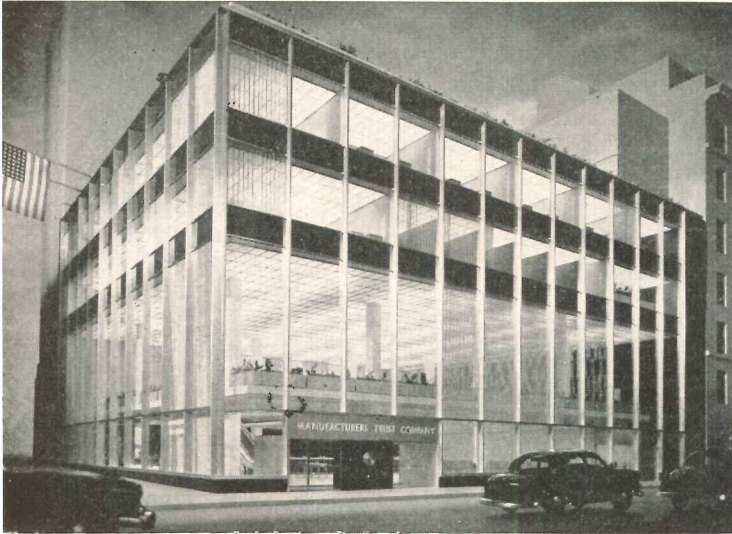

© Ezra Stoller



Above: "Socony-Vacuum Building," New York's biggest commercial project since Rockefeller Center, will go up at Lexington and Third, Forty-first and Forty-second streets. Architects: Harrison & Abramowitz; John Peterkin, associate

Across-page and top left: Skidmore, Owings & Merrill have designed glass and aluminum box for Manufacturers Trust Company, Fifth Avenue and Forty-third Street, New York City. At left: the bank's present quarters just across Fifth

Below: also a Skidmore, Owings & Merrill project is the 12-story administration building to be erected for Ford Motor Company on a 120-acre site in Dearborn, Mich. Three-story annex at left will provide parking and dining space

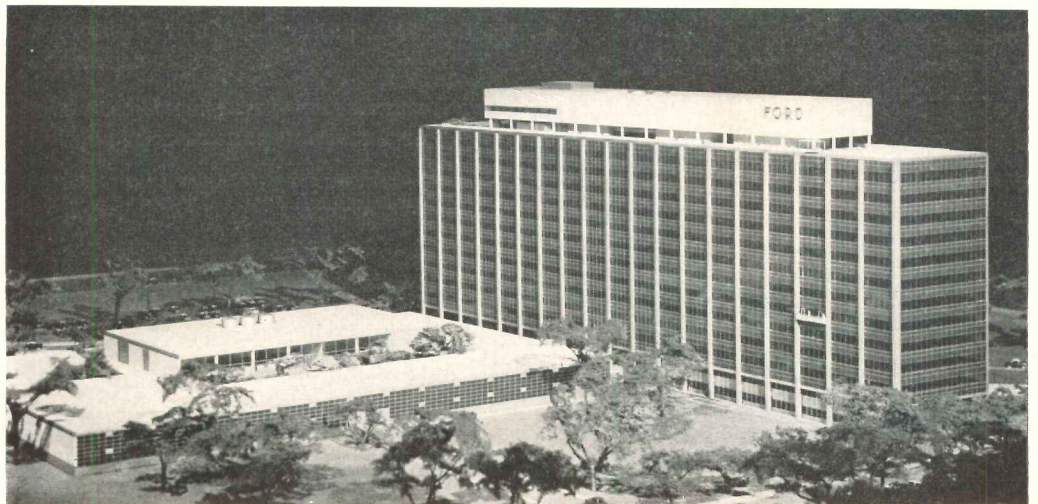





Above: Hotel Victoria Plaza, Montevideo, Uruguay, opened December 1952; 400 rooms; cost \$5 million; collaborating architect, Federico Peralta Ramos. Below: Hotel Tequendama, Bogota, Colombia, opened May 1953; 400 rooms; cost \$8.75 million; collaborating architect, Cuellar, Serrano, Gomez and Company



Above: Hotel de Lago, Maracaibo, Venezuela, opened August 1953; 150 rooms; cost \$3 million; Holabird & Root & Burgee had no associate. Below: Hotel Tamanao, Caracas, Venezuela, opening this month; 400 rooms; cost \$7.12 million; collaborating architect, Gustavo Guinand

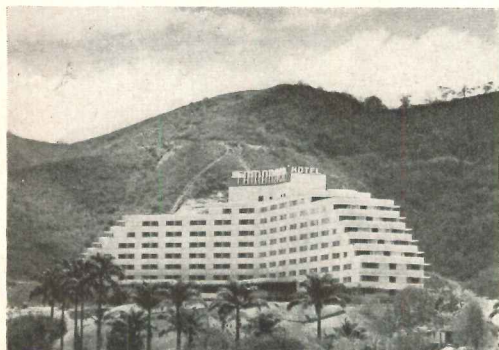

## INTERCONTINENTAL HOTELS: DESIGN FOR TOURISM

INTERCONTINENTAL HOTELS Corporation is one organization that probably rates the overworked adjective "unique." Founded in 1945 as a wholly-owned subsidiary of Pan American World Airways, I.H.C. has been responsible for financing, planning, design and construction of the four hotels shown on this page; it has a fifth, the Hotel Copan in Sao Paulo, Brazil (see pages 135-142) under way, and a sixth, as yet unnamed, under contract in Tokyo; and it manages five others.

The key to I.H.C. activities is a financing arrangement worked out through the efforts of the United States Government, which wished to encourage international tourism and recognized lack of hotel facilities in many parts of the world as a major barrier. The Export-Import Bank of Washington, D. C., agreed to make available, to groups in Latin American countries in particular and other countries in general, long-term loans to assist in financing hotel construction. I.H.C. finds local sponsorship for each new hotel project and then acts as agent for securing of necessary loans and credits in the United States. Although local products are used where possible, the larger part of materials and equipment required is not available locally; and it is estimated that well over half the funds expended for these items, including interior furnishings, is spent in this country.

### *New Tourists, New Hotels*

The international tourist of today and tomorrow is the specific target of the I.H.C. program; and design of the hotels is carefully geared to I.H.C.'s concept of the "new tourist": a middle-income American whose regard for comfort and mechanical conveniences that work far outweighs his reverence for hand-carved furniture and crystal chandeliers.

### *Prelude to Planning*

I.H.C. decides to build a new hotel only after a team of architects, engineers and men thoroughly versed in the operations side of hotel management has made a detailed, on-the-ground survey, including types of architecture, sales possibilities both as to food and rooms, climate and possible local trade.

### *Evolving the Design*

I.H.C. architecture, for which Holo-

bird & Root & Burgee and Associates of Chicago, as consulting architects on all I.H.C. projects, are mainly responsible, is the product of a painstaking application of that favorite maxim of the contemporary idiom — how often honored in the breach only its detractors like to say — designing "from the inside out." Design begins in fact with the selection of furniture for a single-unit guest room. After the requirements of furniture and equipment are determined, miniature scale furniture is built and moved around on a scale plan. Next miniature rooms are built and finally a full-scale mockup is constructed of plywood panels and temporary fasteners — a method which makes it possible to expand the walls while different layouts are tried. Suites and finally complete floor plans are developed with the unit rooms as a basis.

In the design of I.H.C. kitchens, the "inside" starts with the menu — types and quantities of food which will be required are estimated on the basis of a detailed survey of the hotel's potential customers, native, transient and tourist, and a typical week's menus are prepared. These are studied to determine the type and quantity of kitchen equipment needed and from this information space requirements are calculated.

Holabird & Root & Burgee work with I.H.C. staff architects and engineers and usually with a local collaborating architect. Contractors of any country can and do bid on the construction. Under a separate agreement I.H.C. will act as purchasing agent; and under a separate operating agreement I.H.C. manages the completed hotel.

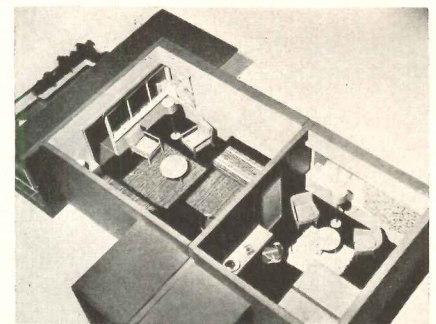

Typical miniature model of a single-unit guest room complete with exact replicas to scale of all furniture to be used: early step in the design of every hotel as I.H.C. develops it



**Architects Are Meeting**

THE SEASON OF MEETINGS is on and a glance at the October calendar suggests that more architects may be called to order this month than in any other month of the year. There are three regional conferences of the American Institute of Architects — the Northwest, at Sun Valley, October 9–11; the Central States, at Des Moines, October 15–17; and the Middle Atlantic, in Washington, October 21–23. Also on the schedule are meetings of architects' state organizations in New York, Ohio and California. Two of the programs look especially interesting — the Middle Atlantic with its "Urban Design and Re-development" effort and the Central States, which has "That Human Being Called the Client" as its theme.

**Ships Designed for Sailors**

THE U. S. NAVY is testing a new theory that more comfortable sailors make better sailors. Its rejuvenated 2200-ton destroyer *Meredith*, which goes on view at the Naval Gun Factory in Washington this month, is described as a "guinea pig" designed to demonstrate that "the fighting efficiency of a Navy ship actually is increased by improving her 'habitability.'" The Navy's "habitability" program began in 1951 with a survey of some 200 ships of all types in the Atlantic fleet, with civilian designers Henry Dreyfuss, Raymond Loewy

and Lippincott & Margulies helping the Navy planners to the official conclusion that "living conditions aboard Navy war vessels are definitely and without qualification in need of improvement." The *Meredith* was selected as the prototype for improvements to existing ships and Dreyfuss became consultant on re-design of her living spaces. New ships may give "the human element" (in the Navy's own phrase) an even better break — if the *Meredith's* sailors come through.

**The Move to the Country**

OUR LARGER CITIES are not being decentralized and there is no indication that they will be, according to the Urban Land Institute. Fringe developments — "principally urban growth which has been freed from limitations of location and distance formerly dictated by the streetcar line, the horsedrawn carriage and the physical endurance of human legs."

**Solar Energy: How Soon?**

FIFTY SCIENTISTS gathered for a conference on solar energy last month heard a prediction that all usable supplies of coal, gas and oil will be exhausted by 2023 and usable supplies of uranium and thorium, sources of atomic energy, by 2198. Harnessing energy from the sun would then be man's only resource for heat and power, they were told.

There were no predictions, however, as to when solar power might be expected to be captured on a commercially usable scale. The solar-heated house at Dover, Mass. (ARCHITECTURAL RECORD, March 1949, pp. 136–137), was cited as an example of direct capture of solar heat on a small scale; but Dr. Maria Telkes of New York University, its director, also pointed out that the solar-heated house is not yet commercially feasible.

**Hudnut Goes to Colby**

JOSEPH V. HUDNUT, the retired dean of Harvard's Graduate School of Design, has been appointed to the Whitney Visiting Professors Program for 1953–54 and will be a guest professor at Colby College, Waterville, Me., for this year. The Whitney program is jointly sponsored by the New York Foundation and the John Hay Whitney Foundation.

**What Kind of Church?**

FOUR ARCHITECTS will participate in a symposium "Contemporary vs. Traditional in Church Architecture" to be held as part of the second annual International Churchman's Exposition October 6–9 in the Chicago Coliseum. The architects: Albert F. Heino, F. J. Ditrlich, Ralph Stoetzel and C. W. Marshall. In the exposition's "Hall of Church Designs" over 100 panels, plus several models, will comprise the architectural exhibit.

**Home Builders' Show**

THE National Association of Home Builders has announced it will hold its tenth annual convention January 17–21 at the Conrad Hilton and Sherman hotels in Chicago.

**How Much Remodeling?**

EXPENDITURES in 1954 for alterations, repairs and maintenance of existing buildings may reach \$6.5 billion, according to a recent prediction by the United States Chamber of Commerce. This figure is expected for residential building alone, and the Chamber believes prospects for a big volume of commercial remodeling are also strong.

**Prefabrication Research**

A NEW ENGINEERING, Design and Research Committee headed by Richard B. Pollman of Detroit has been named to lead a major research program in the

(Continued on page 16)



— Drawn for the RECORD by Alan Dunn

"Dinner will be slightly delayed — jammed partition —"



field of house prefabrication for the Prefabricated Home Manufacturers' Institute of Washington, D. C. The committee's major functions will include improvements in home design and planning "for better family living," and a complete study of technical advances in manufacturing, distribution and construction for better values in prefabricated homes. The committee also will work to establish engineering standards and test procedures that will be universally recognized and accepted by buyers, mortgage lenders, government agencies and building inspectors. Another effort will be encouragement of more technical research among P.H.M.I. member companies, material suppliers and private, state and Federal research laboratories.

**Housing Design Standards  
Issued by Budget Bureau**

A NEW CONCEPT of design and construction of housing accommodations for Federal personnel stems from mandatory standards issued recently by the Bureau of the Budget.

Great significance lies in the fact that the Bureau's design standards apply to military as well as civilian housing, primarily to construction going on in the United States but wherever practicable to foreign housing for U. S. government employes as well.

Military barracks as a type are excluded from the new Budget orders, but just about every other type of housing for Army, Navy, Air Force and other Federal government units is encompassed. A rough estimate places at 90 per cent the proportion of all Federal housing construction that is military in nature.

These facts place the new Budget Bureau standards, applicable as they are to all walk-up structures not over four stories and basement in height, in a position to supersede the advisory standards that have been worked out at cost of much time and great endeavor on some types of similar housing by the Director of Installations of the Department of Defense.

Text of the Bureau's standards deals only with structures, not with site improvements. The document makes many references to established codes or standards and on many points goes into fine detail in specifying precise criteria.

While housing of a permanent nature only is meant to be considered under the new rules, housing for the employes of government contractors is brought under the recent mandate. Two conditions were outlined to govern agency action concerning justification of housing projects and these apply equally to military and civilian shelter. Budget officials said construction of housing is normally justified only for the housing of the permanent complement of stations expected to be in operation at least 25 years. The two conditions:

1. At remote stations or foreign service posts where no private quarters are available for rent.

2. Where it is determined that necessary service cannot be rendered or property of the United States cannot be adequately protected unless government quarters are constructed at or near the station.

Agencies were told by the Bureau that their proposals for housing that didn't qualify under these conditions would not receive favorable consideration unless it could be shown that some other "unusual condition" justified construction. At stations where emer-

gency conditions exist, temporary housing will be permitted if the stations are to be in operation for less than 25 years; but such construction still must qualify under the above two conditions.

The idea of economy in the housing efforts of Uncle Sam is apparent everywhere in the new standards, particularly in the policy governing their application. Uniform design standards are to be followed — the standards developed by the Housing and Home Finance Agency at the request of the Budget Bureau. These standards have been developed to assure that government housing will be economical to build and maintain. No uniformity in appearance is required, and uniform plans are not available.

In its directions to agencies, the Bureau insists that multi-family units such as apartments, row, or twin-type dwellings be constructed rather than detached dwellings except where it is "clearly impracticable" to do so. Multiple-family dwellings, it is pointed out, are not only more economical to construct and to maintain, but also can be designed so as to afford flexibility in the number of rooms per dwelling unit, thus accommodating shifts that occur from time to time in the family pattern of the station complement.

Types of dwellings also will be governed by the amount of rent occupants can afford. Rents are required to be based on prevailing rates in the local market for comparable accommodations. Agencies are advised that care must be taken to avoid construction of units that would rent at rates beyond the means of the occupants.

If there was any doubt about requirements for compliance, it was dispelled by this paragraph in Circular A-18 which announced that plan to heads of executive departments and establishments:

"Budget requests and apportionment requests for money for the construction of family housing shall be based upon compliance with the approved design standards. Exceptions, if any, should be plainly set forth in the budget request or apportionment request."

The standards themselves deal with space and arrangement, structural design principles, footings and foundations, floors, exterior wall coverings, interior coverings, roofing, stairs and exits, fire resistance, sound resistance, condensation control, termite and decay resistance, plumbing, heating, electrical and miscellaneous equipment. These are set out in 80 pages of detail. — *E. M.*

(More news on page 20)

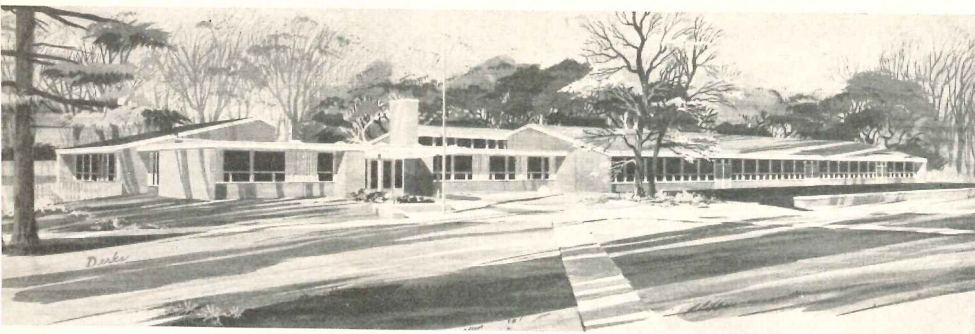

Above: the "one-story school" of the story on page 292 of the August issue—Mohawk Elementary School, now nearing completion in Park Forest, Ill.; Loebli, Schlossman and Bennett are the architects. Apologies to them and to Herbert Banse of Chicago, architect for the three-story laboratory for G. D. Searle Company which mysteriously found its way into the Park Forest story



Keeping pace with the completion of the building program of Caterpillar Tractor Co. in Joliet, Illinois are Barber-Colman unitary temperature control systems, each with its own electric "Control Center."

Starting with building "A" and "B" in 1950, continuing through extensions to building "B" and new building "C" in 1953, there are now 63 independent "Control Centers" operating heating, ventilating, and air conditioning systems throughout the plant. General offices, first aid rooms, and the shop office, auditorium, cafeteria, and metallurgical laboratory are air conditioned. As a safety precaution, the office temperature control system is interlocked with the autocall and fire alarm systems. In an emergency, a warning signal is given, all exhaust

fans stop, and all air intake dampers are closed.

Over 1,500,000 cfm are handled by the 59 ventilating units in the factory area. Each has its own "Control Center," operating independently of the others. Should trouble develop in one area, there is no need for a complete plant shutdown. Three boilers, two of 80,000 lbs., and one of 100,000 lbs. per hour capacity, furnish steam for heating and processing. Electrical consumption per month is now over 3,000,000 kw.

For the complete story on how electric "Control Centers" can modernize your temperature control systems . . . and bring you substantial savings in time and materials . . . phone nearby Field Office or send coupon today.

Building "A" and "B": Giffels, Vallet & L. Rossetti, Detroit, architects and engineers. Building "B" extension: Lyle V. DeWitt, Decatur, architect; E. O. Hull, Peoria, engineer. Building "C": Crenshaw & Jost, Pekin, architects; Caterpillar Engineering Dept., engineers. For all buildings: Stanley-Carter Co., Detroit, heating contractor; Gould Electric Co., Chicago, electrical contractor for temperature controls installation.

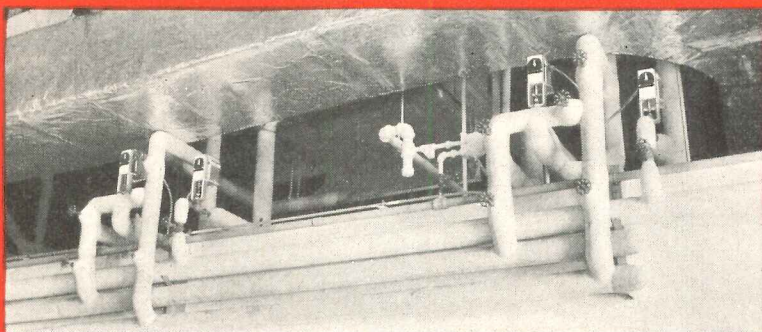
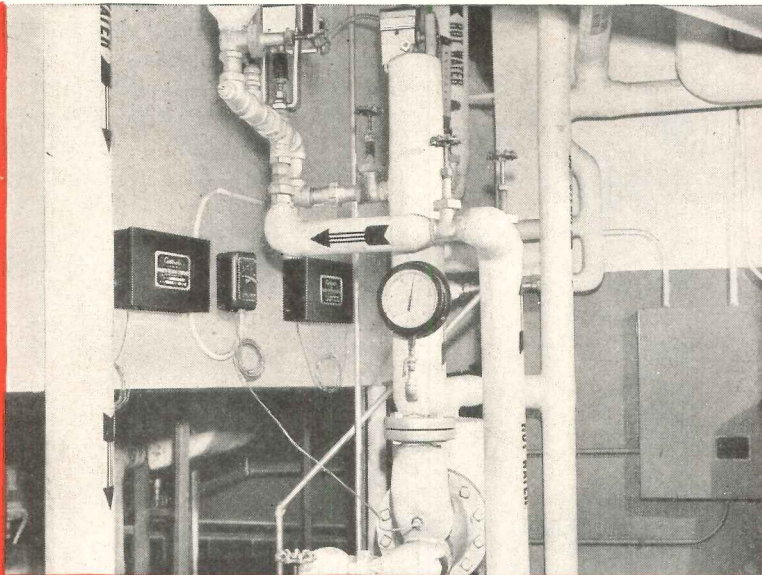

◀ **Left**—in keeping with modern design of plant, Caterpillar ordered the finest of electric control equipment. For example, all motor-operated valves have oil-submerged operators.

**Below**—space is saved by installing an individual "Control Center" cabinet in the web of a column in each control area.



◀ **Left**—battery of motor-operated valves with oil-submerged operators in building "C," controlling heating and cooling operations.



## ELECTRIC Control Center

Automatic Controls • Air Distribution Products • Industrial Instruments  
Aircraft Controls • Small Motors • OVERdoors and Operators • Molded  
Products • Metal Cutting Tools • Machine Tools • Textile Machinery

BARBER-COLMAN COMPANY, ROCKFORD, ILL., U. S. A.  
Dept. J, 1304 Rock St. • Field offices in principal cities

Send free copy new booklet "How You Can Simplify Control Problems and Save Money with 'Control Centers'."

Name \_\_\_\_\_

Firm Name \_\_\_\_\_

Address \_\_\_\_\_

City \_\_\_\_\_ State \_\_\_\_\_



WRIGHT MAKES NEW YORK!

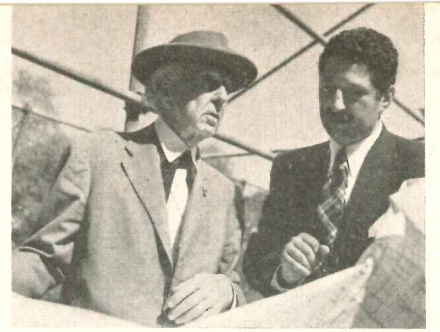

Architect and builder — Wright and David Henken

NOT ONE BUT TWO buildings by Frank Lloyd Wright were going up last month on the Fifth Avenue and Eighty-ninth Street site of the Guggenheim Museum project — neither one of them the spiral museum New York's Department of Buildings has for so long so intrepidly resisted. New York's first Wright buildings are a glass pavilion to house a retrospective exhibit of his work and a "Usonian" house designed as a full-scale example of his residential architecture.

They are temporary structures: they will be razed next month to make way for the museum, if that project is by

then purified of its much-publicized transgressions of the city's code.

The pavilion was designed as an asymmetrical translucent tent, 145 ft long by 50 ft wide, composed of alternating horizontal panels of corrugated glass and asbestos cement, with a structural system entirely of ordinary two-in. pipe, and illumination at night not only from within but also from lamps suspended above the roof. The house, of plywood, glass and brick-like concrete blocks, has a 32 x 28-ft living room with a 12-ft-high ceiling and the famous corner windows. While disciples of organic archi-

ture were, it is to be hoped, looking the other way, special trees and plants were brought from Wright's Wisconsin and the Guggenheims' Long Island to landscape the site. Building of the project was supervised by David Henken, a former pupil of Wright. Most of the building materials were contributed by their manufacturers.

Together the pavilion and the house, covering a total area of some 10,000 sq ft, provide the most comprehensive single exhibit ever assembled of Wright's work. The display includes more than a score of models, the 16-ft-sq miniature of Broadacre City among them, and 800 original drawings, plans and photo-murals of the most famous Wright buildings, from the Imperial Hotel in Tokyo to the Price Tower, now under way in Oklahoma City. Much of the material has been on tour abroad for the last two years and after the New York exhibition closes it will go on to Tokyo, New Delhi and Manila.

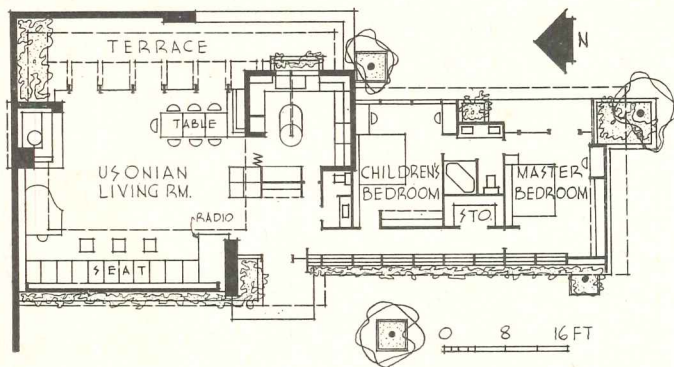

EAST

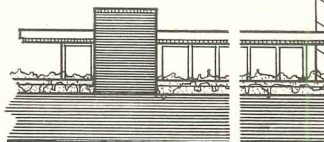

NORTH

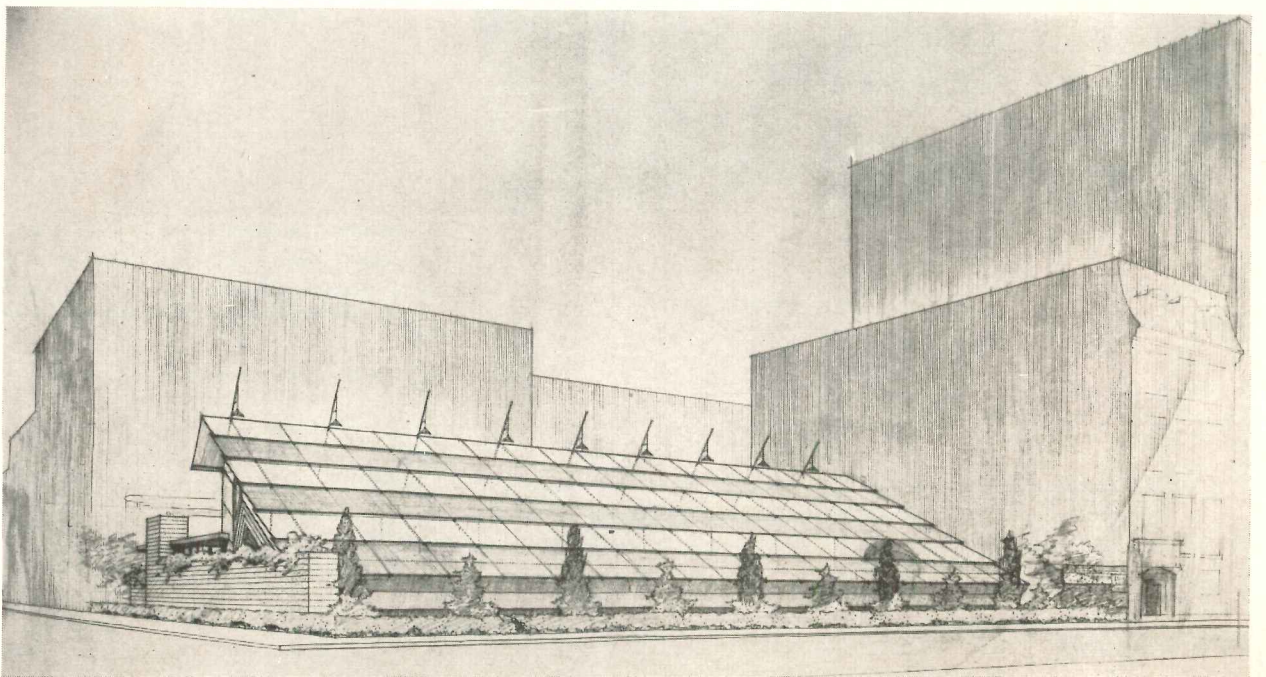
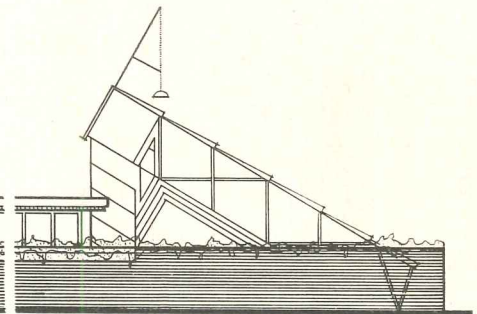



# HOTEL COPAN

SÃO PAULO, BRAZIL

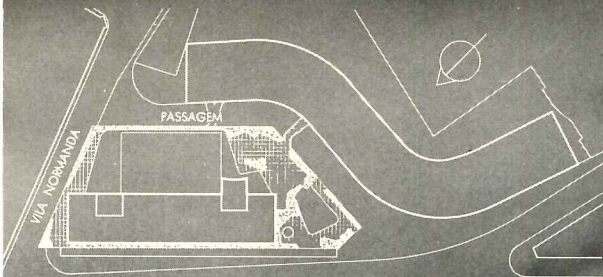

AVENIDA IPIRANGA

10 0 20 40 60 80 FT.  
5 0 5 10 15 20 M.

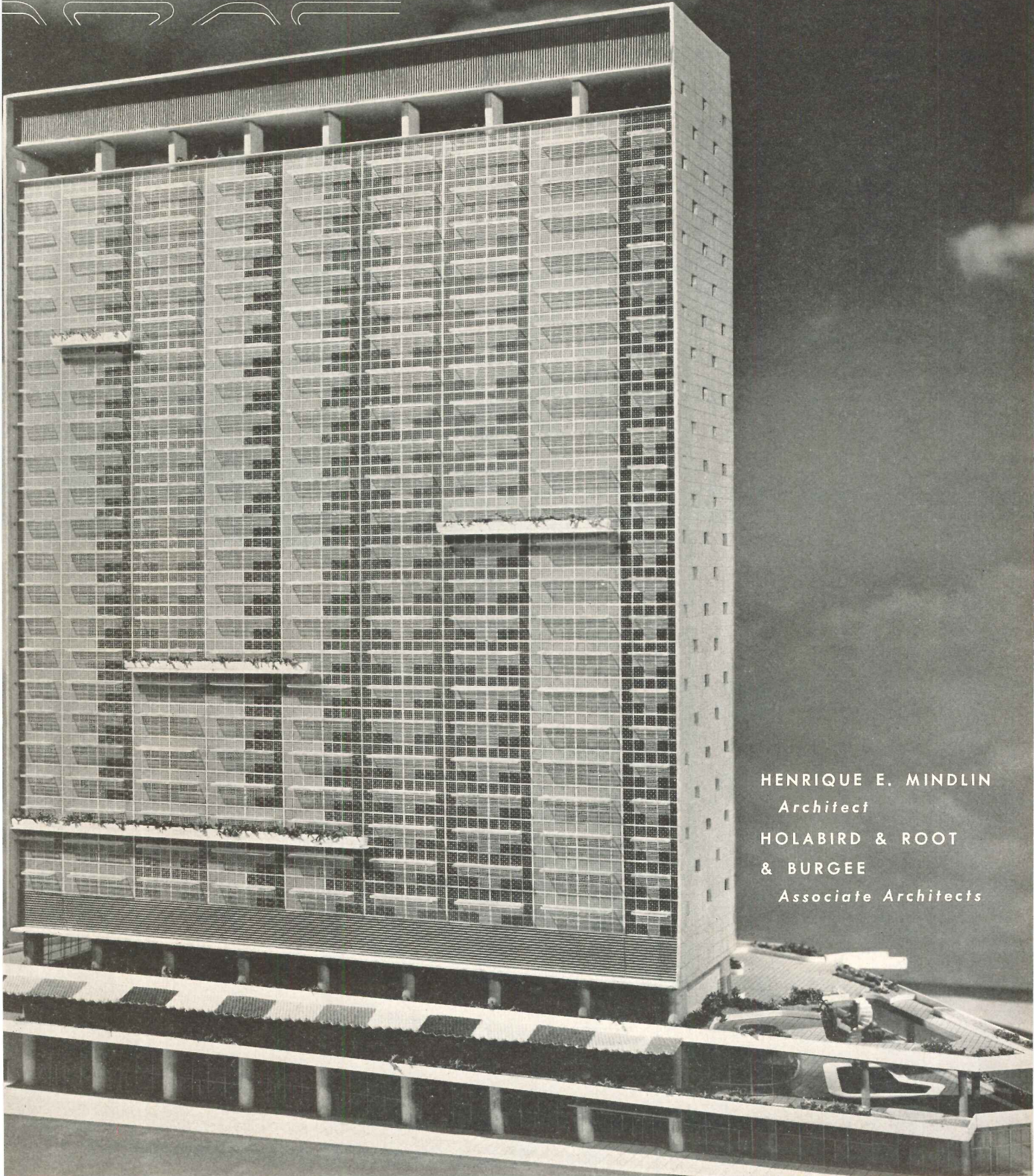

HENRIQUE E. MINDLIN  
*Architect*  
HOLABIRD & ROOT  
& BURGEE  
*Associate Architects*



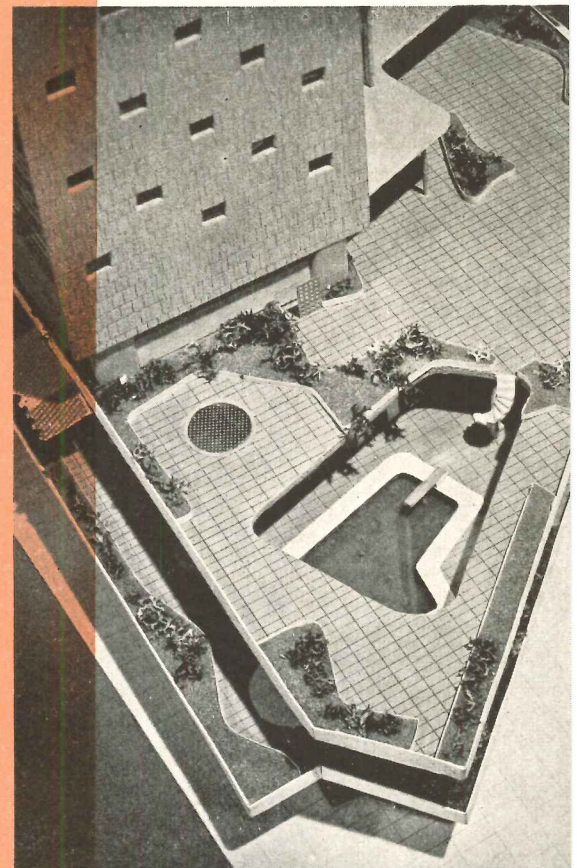
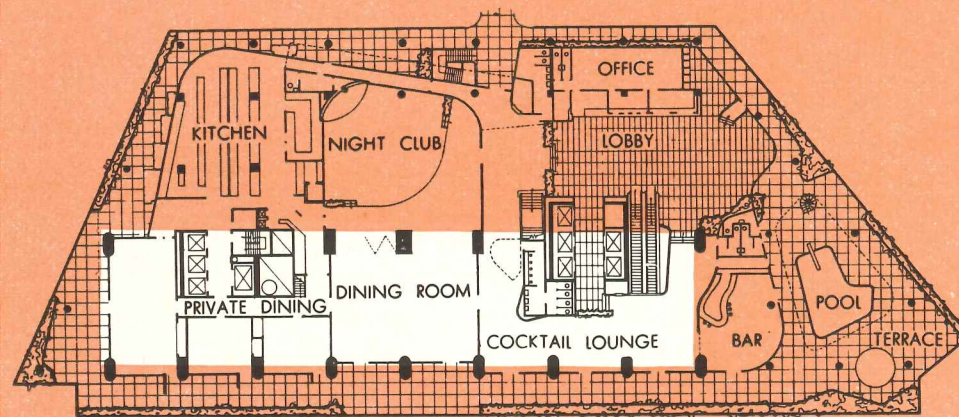
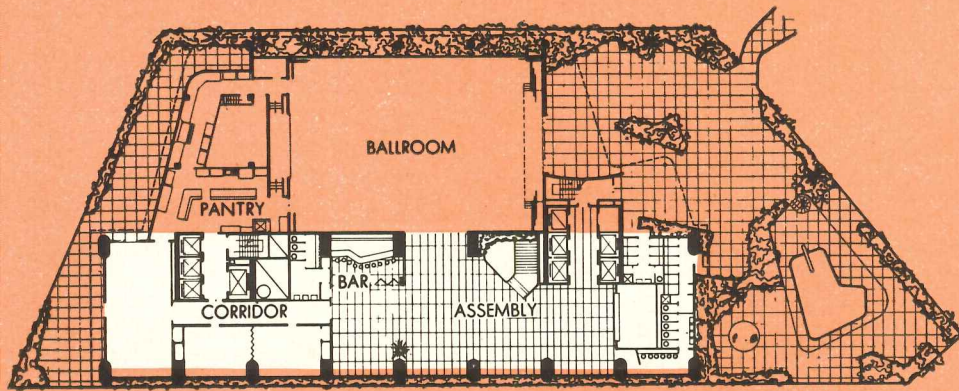

Bill Hedrich, Hedrich-Bles

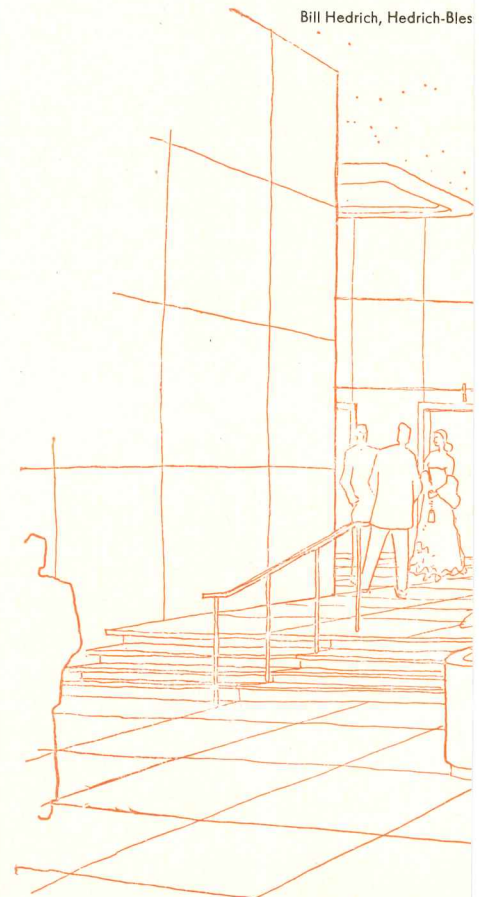
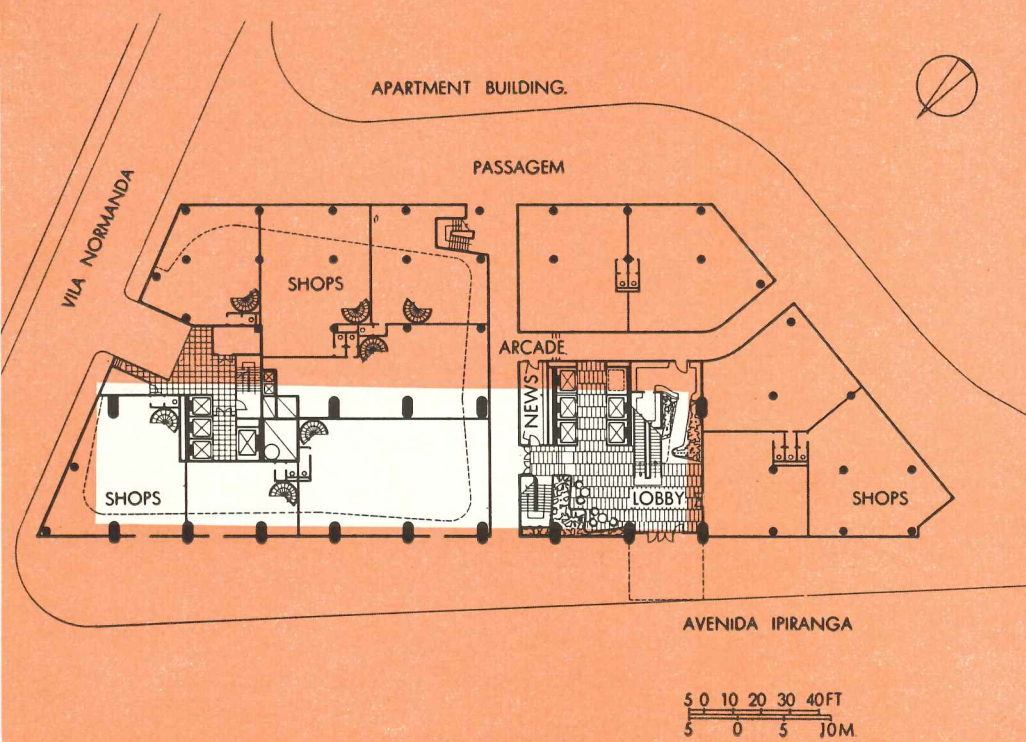



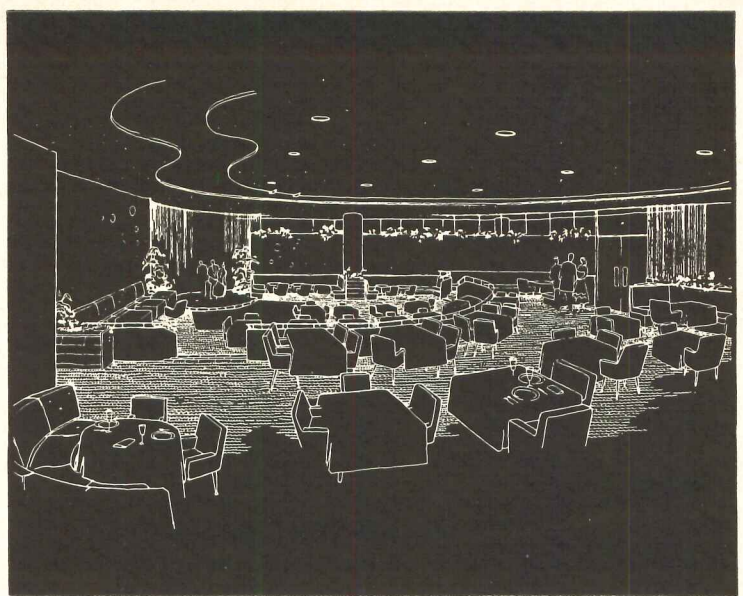
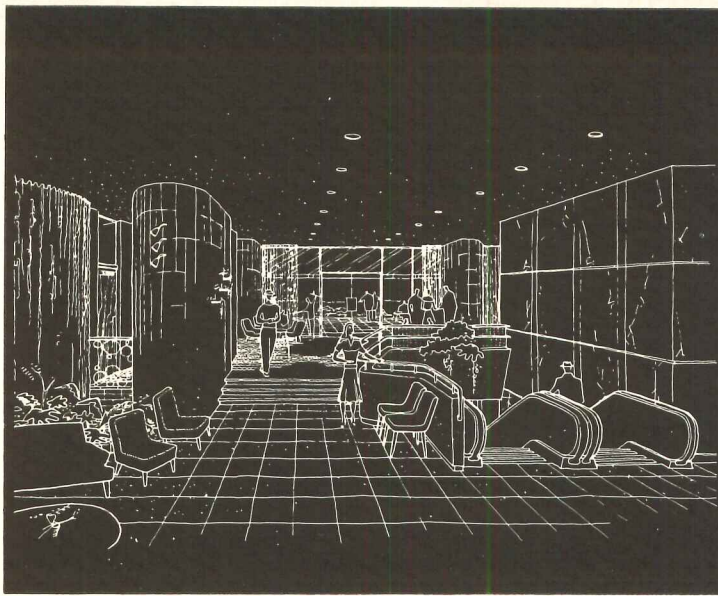

### HOTEL COPAN : SHOPS, PUBLIC AREAS

SÃO PAULO, which has two and a half million people and is growing, is the center of Brazil's industrial area, the greatest concentration of industry in South America. Yet it has lacked adequate hotel accommodations; and due to its location, climate and transportation as well as the city's progressive character, it needs social and convention facilities. One evidence of this is the extraordinary amount of outstandingly progressive new building in São Paulo, which will celebrate its bicentennial next year.

Recognizing these factors, a Brazilian company, Companhia Pan-América-Hotéis e Turismo "Copan," was formed to develop this hotel and an adjoining cooperative apartment building (the serpentine form outlined in the plans; Oscar Niemeyer designed the apartment). Copan is financing the hotel's construction; Intercontinental Hotels Corp., of New York, is overseeing design and construction, and will operate the hotel.

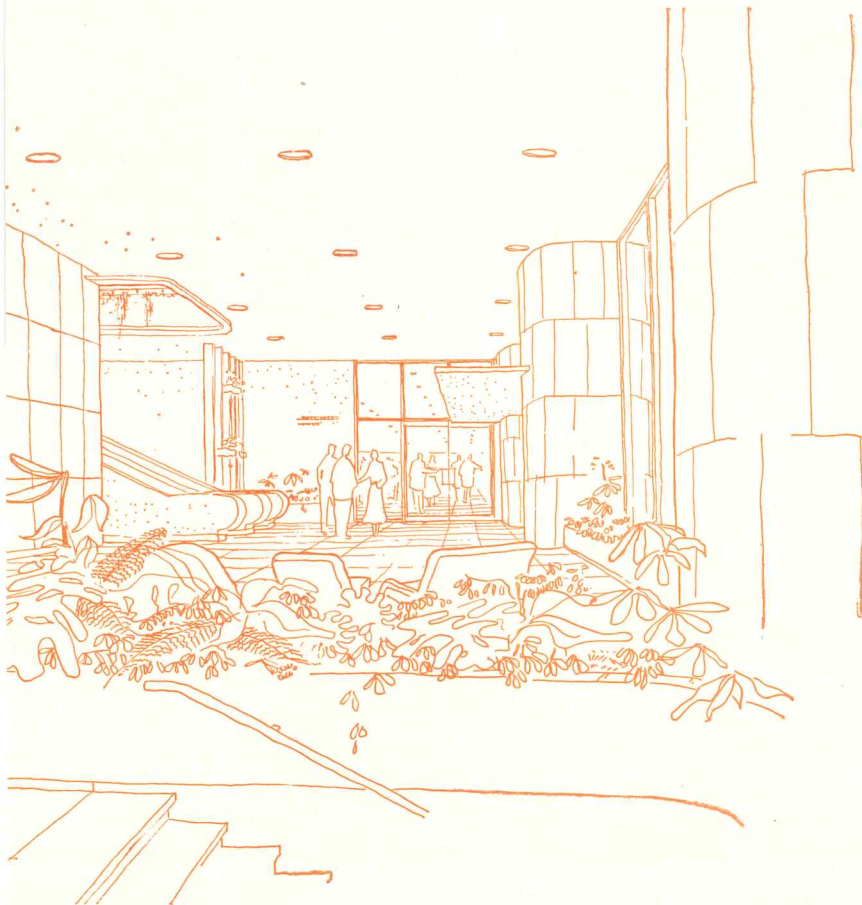

*Ground floor and mezzanines are entirely shopping arcades. Two main hotel floors, immediately above, are treated like decks of a cruise ship with a variety of outdoor cafes, terraces, pool, gardens and arcades directly accessible to interior lounges, lobbies, front desk, dining rooms, night club*



The site selected for Hotel Copan, at the intersection of Avenida Ipiranga and Vila Normanda in the heart of São Paulo, is close to the best shopping districts, principal theaters, other hotels, and night clubs. Avenida Ipiranga is the main thoroughfare to good residential areas and the airport. Three fifths of the site is occupied by the cooperative apartments previously mentioned, which are now under construction and which will become another source of hotel revenue. To an extent — in respect to use of the parking garage and public facilities — the two buildings will be interconnected.

There was left for the hotel about 29,350 sq ft of land, roughly oval in shape

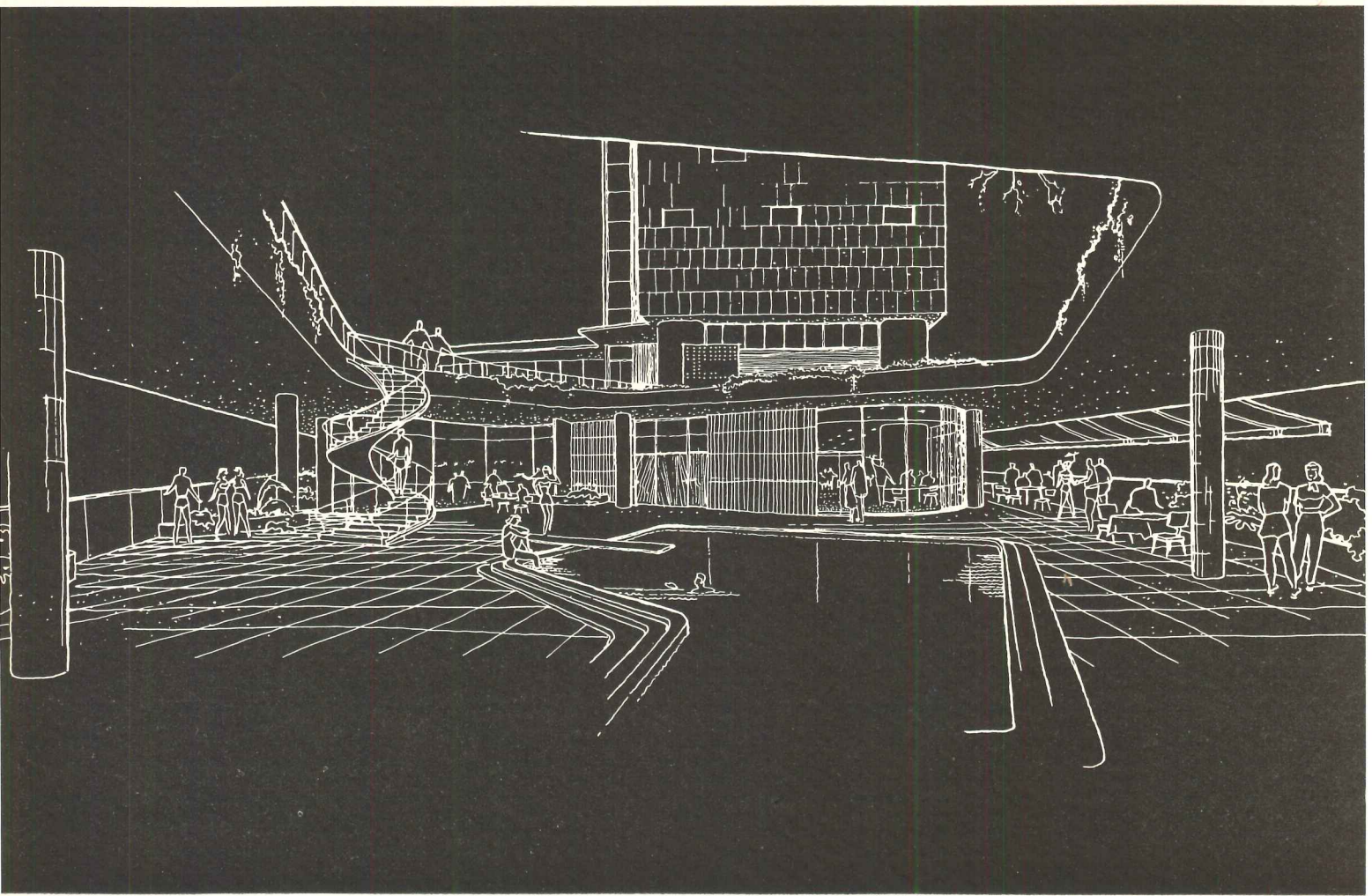

and surrounded by streets, one of them a pedestrian way. This gave the designers an opportunity to produce a building without, so to speak, a front or back.

The design as developed provides 600 guest rooms in a variety of sizes, arrangements, appointments and rates. To serve its thriving community, it has a complete floor of facilities for conventions, exhibitions and public functions beyond the generous provision of lounges, terraces, dining, and allied services on the floor below. Being quite different in character and in operation, the two principal units — guest rooms and public areas — are treated architecturally as distinct yet complementary parts of the whole.



# HOTEL COPAN:

PUBLIC AREAS, ROOM FLOORS

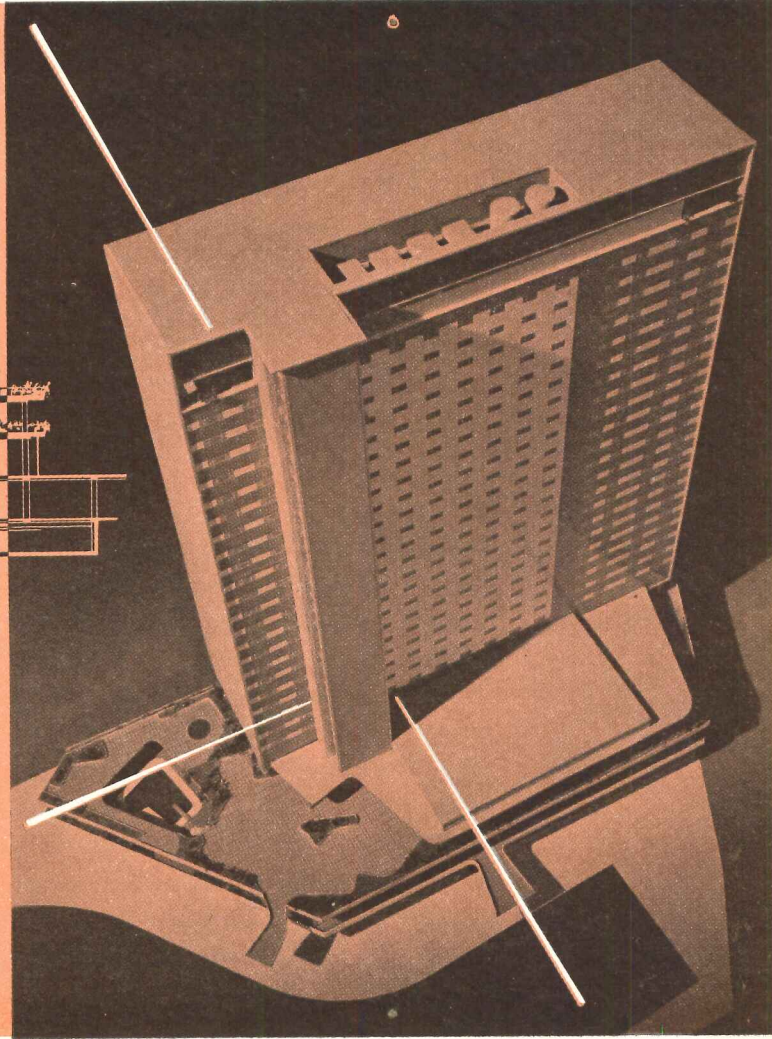
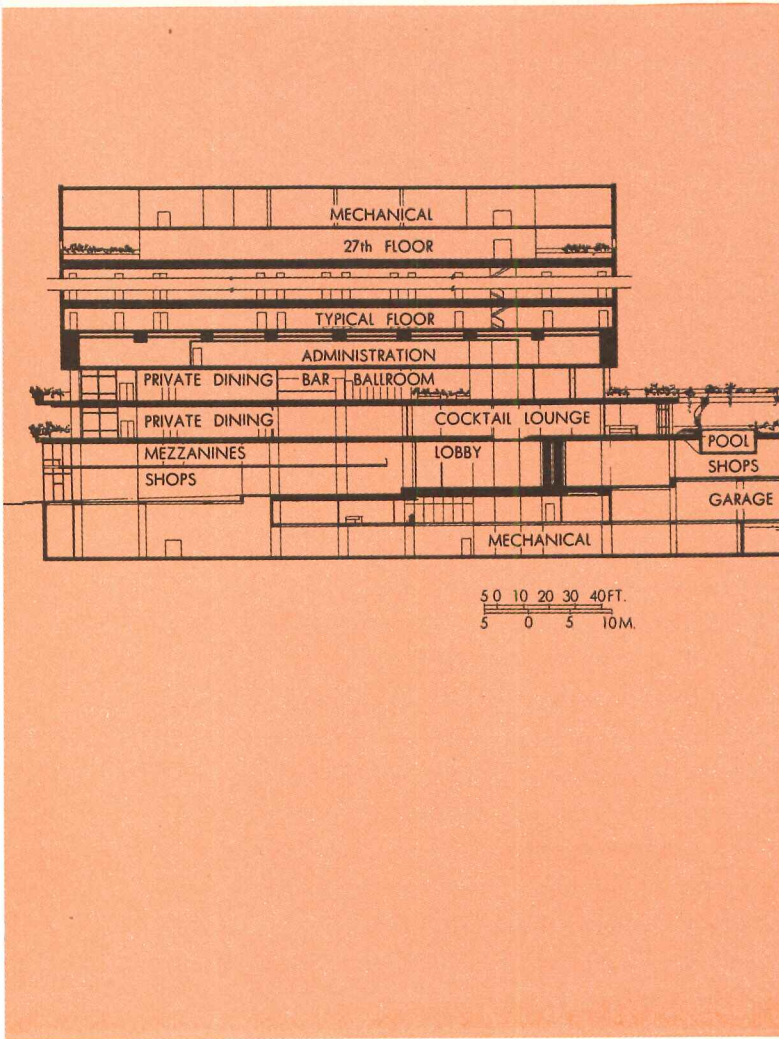
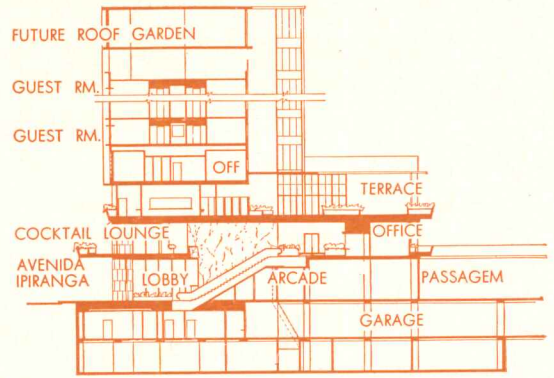

Bill Hedrich, Hedrich-Blessing

*Above the 7-meter-high ground floor required by local regulations and the “decks” of public areas, the 22 floors containing 600 guest rooms form a colorfully treated vertical slab (see following pages). Drawing opposite shows swimming pool*

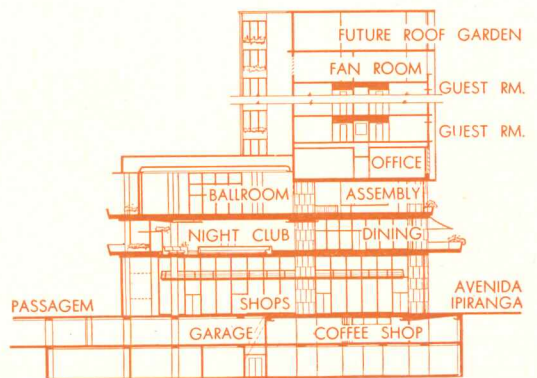



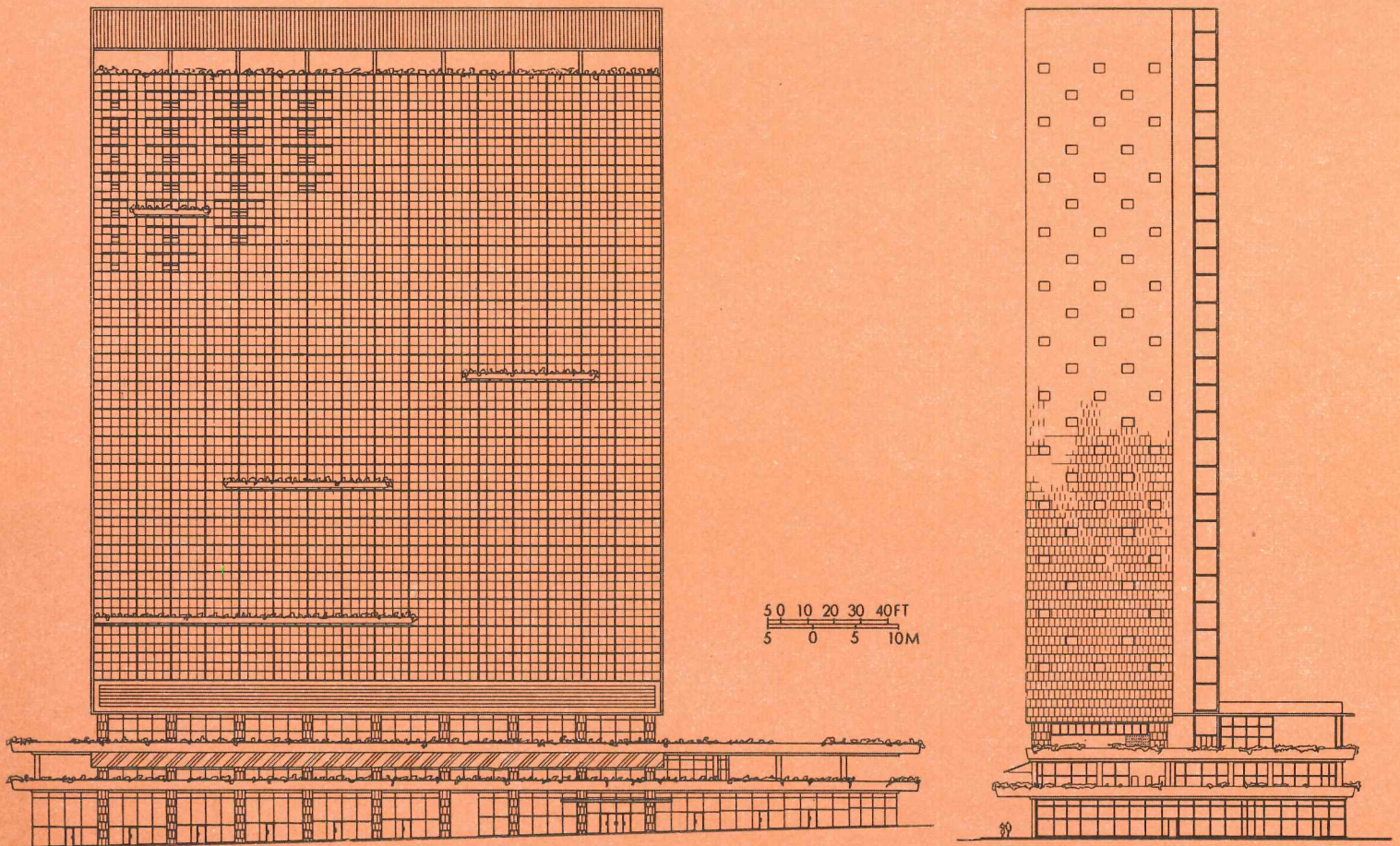

In arriving at decisions on design, Intercontinental and the architects evaluated not only local needs but also increasing tourist travel and its possible effects; for instance, guests from abroad will probably demand heating and air conditioning; these have been included although they are relatively new to São Paulo. Physically, the building is a vertical slab of guest rooms surmounting three horizontal decks of shops and public areas, topped by a future roof garden (see plan, top of facing page) and with a basement garage. The guest room block, structurally the work of Brazilian engineers, has no conventional columns; instead it consists of bearing walls and flat slabs. Below this is a transition floor (not shown) containing offices and equipment space; here loads are transmitted to the lower pairs of huge columns visible in the plans. Foundations are piling.

Design was the joint responsibility of Henrique Mindlin of Brazil, Holabird & Root & Burgee of Chicago, with Helmuth Bartsch of the U. S. firm in charge, and Intercontinental Hotels Corporation of New York. The building now being erected is colorful, commercially feasible and — with its sparkling multitone facade and gay lower decks — a distinctive addition to its city's architecture.

#### HOTEL COPAN : DEVELOPMENT OF DESIGN



*Main guest room block, free of lower "decks," rests on pairs of columns each about 8 by 4 ft and 25 ft apart. Basement garage (plan, lower right) for 130 cars continues under adjoining apartment building*

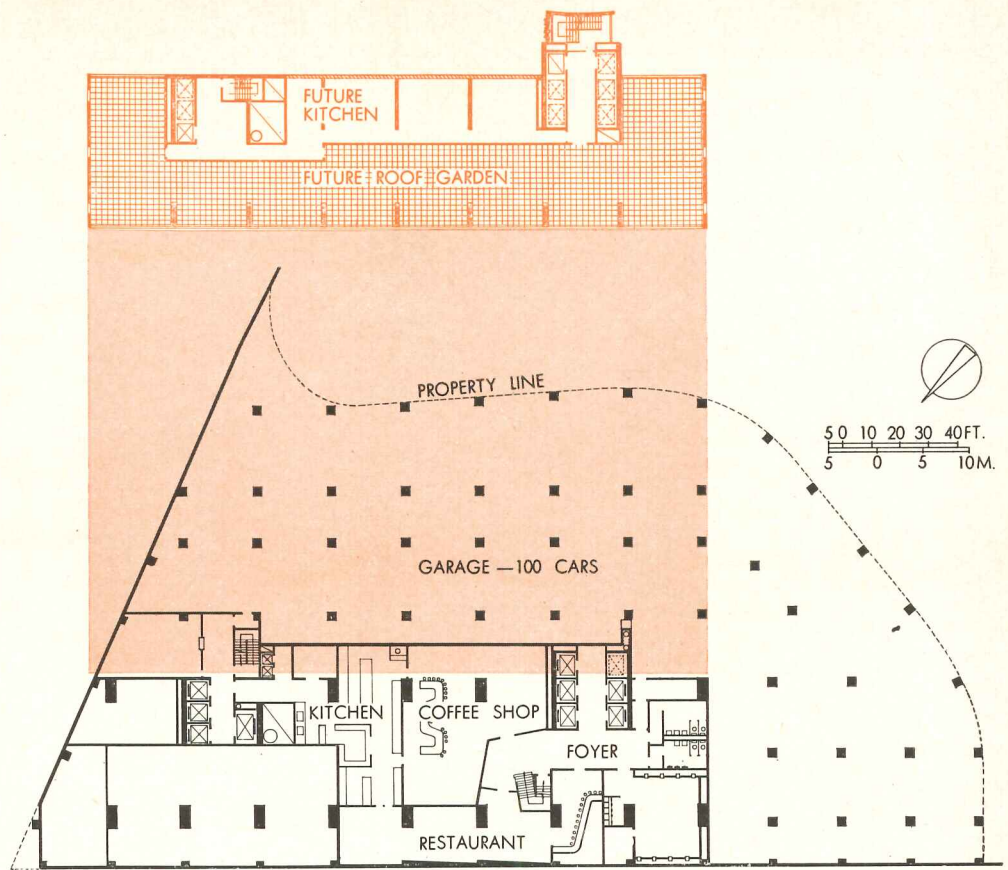

Bill Hedrich, Hedrich-Blessing

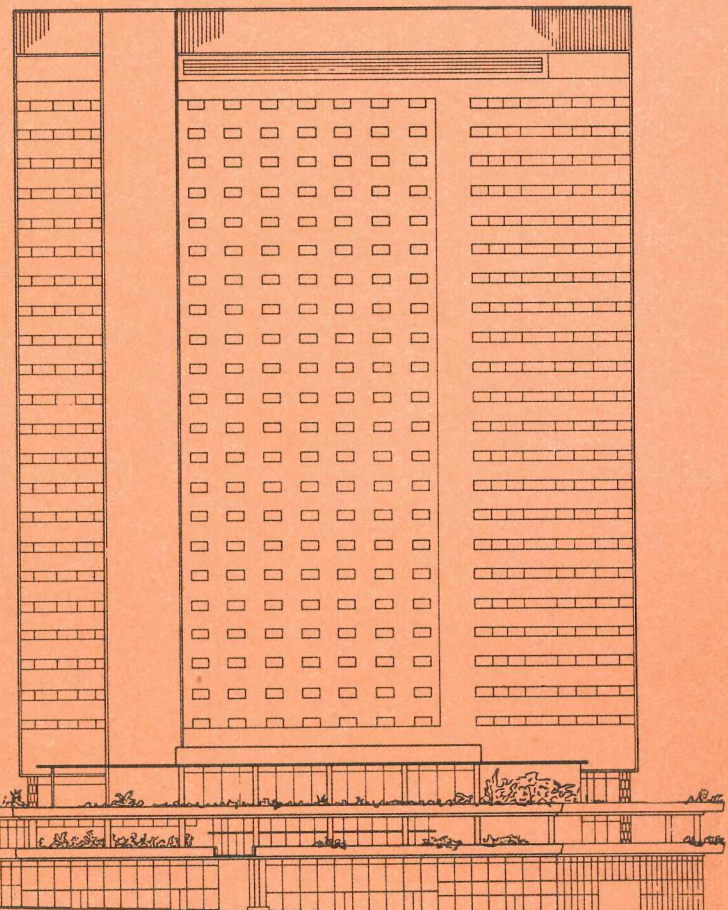
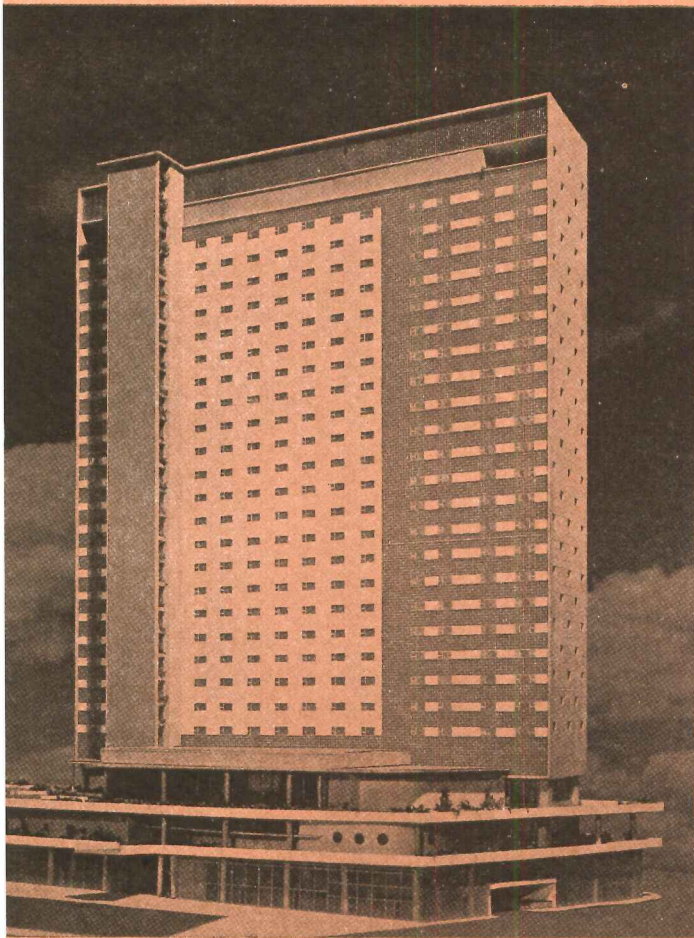

5 0 10 20 30 40 FT  
5 0 5 10 M.



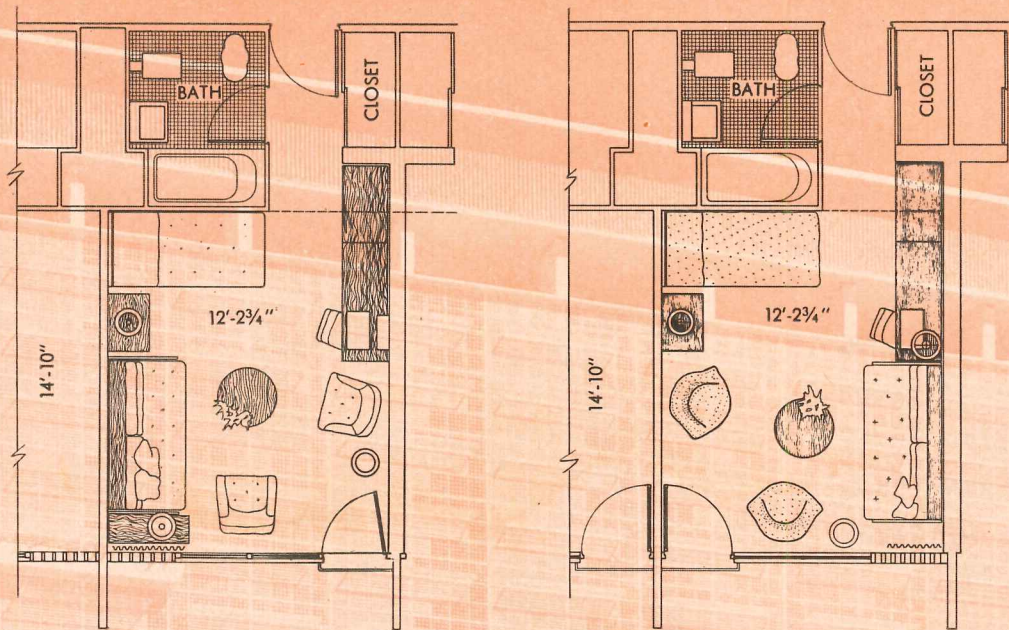

HOTEL COPAN: GUEST ROOMS, FACADE

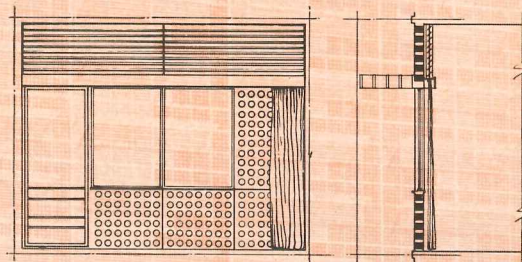

Typical room plans and sections, above; each room has a view window, horizontal sliding sash. Non-glass exterior wall areas are concrete block, 3 by 3 ft, interspersed with 2½-in. round colored glass

inserts which will harmonize with interior and form a varying exterior pattern, particularly at night when lights are lit. Area of a single room is shown by dark brown rectangle, above at right

Typical Guest Room Floor

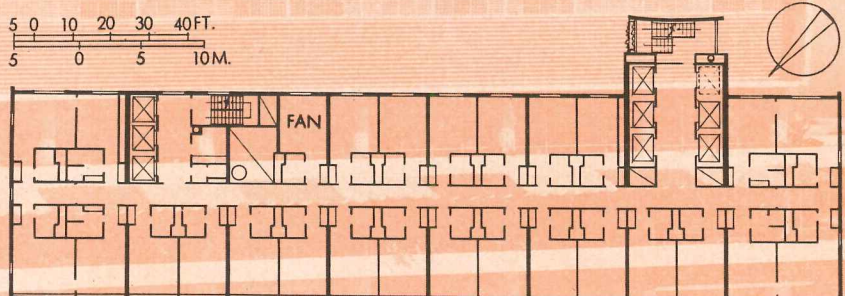
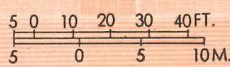



## BOSTON'S BACK BAY CENTER (Continued)

A great architectural charette was finished just in time to present, last month, an early model of the Boston Center, a contemporary version of the Rockefeller Center concept. The proposed center, a great gleam in the eyes of Roger L. Stevens, realty mogul, and Mayor John B. Hynes of Boston, is to occupy the 30-acre site of the Boston & Albany Railroad yards in the Back Bay section. It will be developed with a group of four office buildings, combined hotel and motel, department store and shopping center, convention hall, exhibit building, and the world's largest underground parking area, to house 6000 cars. Costs are estimated at \$75,000,000.

It all started with an announcement that the railroad yard was available, and actually the first gleam was put on paper by a class of architectural students at Harvard. Others soon realized that

this site presented a once-in-a-lifetime opportunity for civic development, and it is now blessed with the combined push of five famous names in architecture, the mayor, the interested promoters and an imposing array of real estate talent.

While some shaking down is still indicated in the design, the model carries initial planning pretty well through the major problems, toughest of all being the traffic of some 70,000 people and 6000 cars per day, on a site that will still be bisected by a railroad. The scheme contemplates a ring road around the site, with various drives to reach the two- and three-level underground parking, with elevator and moving stairway access to the upper levels and various buildings.

A midtown motel, hooked onto a large hotel, is a bold proposal. It will be a true motel, designed to encircle the hotel

garden with a roadway and two levels of motel rooms.

A midtown shopping center is another innovation seeking to prove that the automobile belongs in the city. It is said that the short distance from parking to shops is unequalled in any shopping center outside the city. All shops will be within a 500-ft circle and adjoining the department store. There will be a pedestrian-only shopping plaza with pools, trees and promenades, all covered over with a huge skylight and air conditioned.

A convention hall, designed by Samuel Glaser, architect, is proposed as the city's undertaking, in an area west of the Center itself.

If the project is exciting to staid old Boston, it will be extremely interesting to architects, not only for its attempts to civify the automobile but also to brighten the downtown scene.

*Early studies concentrated especially on traffic and parking. There are two sub-grade parking levels over the entire site, a third level over roughly half. The railroad track will bisect the site, from corner to corner*

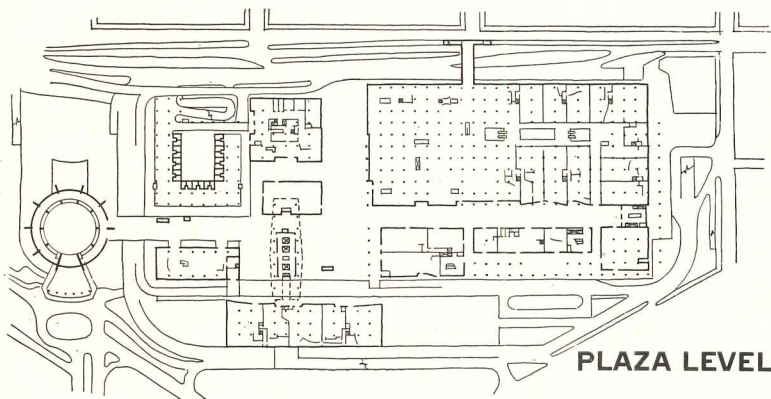

*Office buildings are tentatively planned, but façades and fenestration wait on final determination of space use and occupancy*

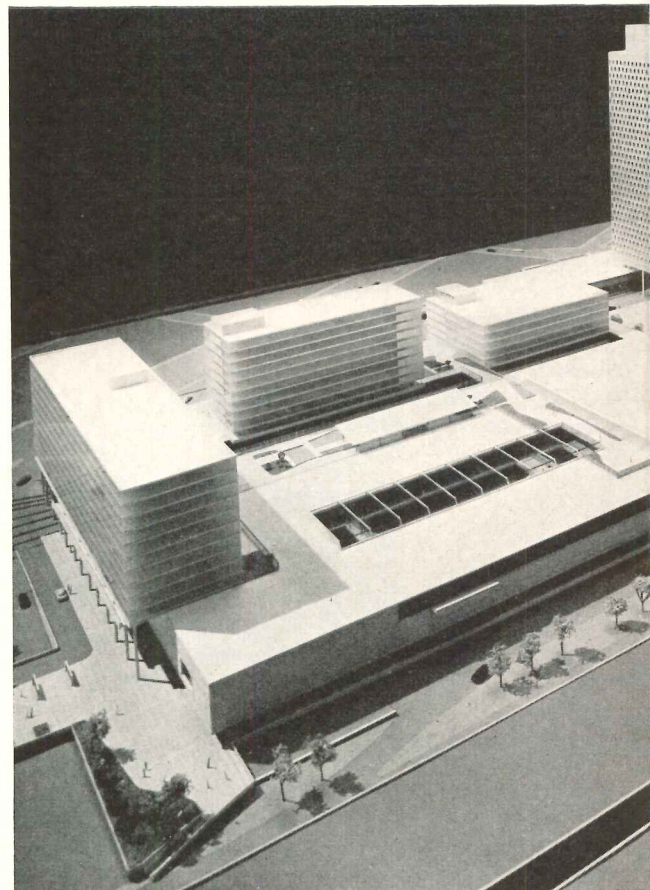
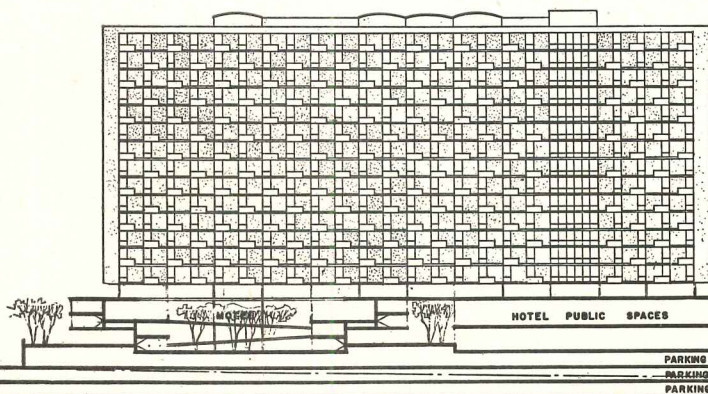

**LONGITUDINAL SECTION TOWARD BO**

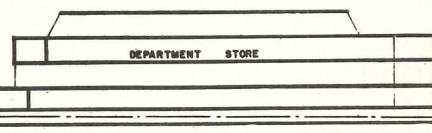



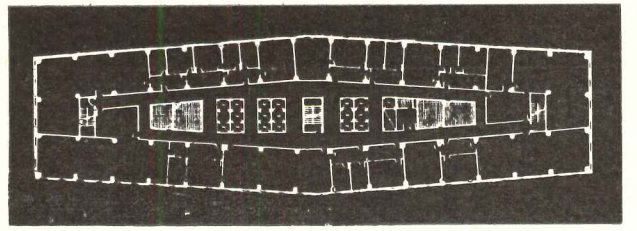
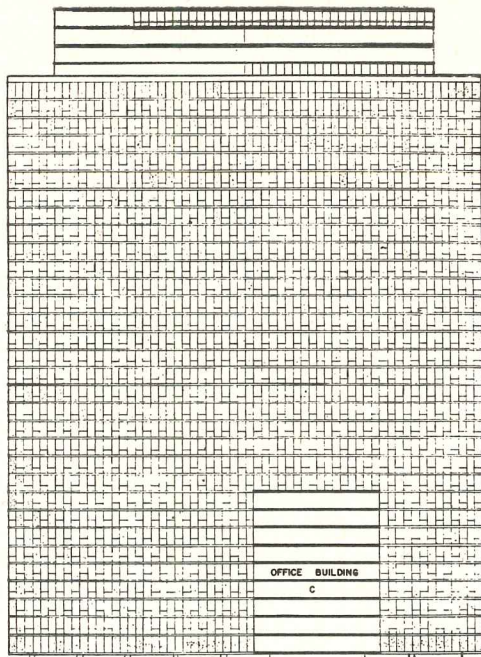

TRANSVERSE SECTION

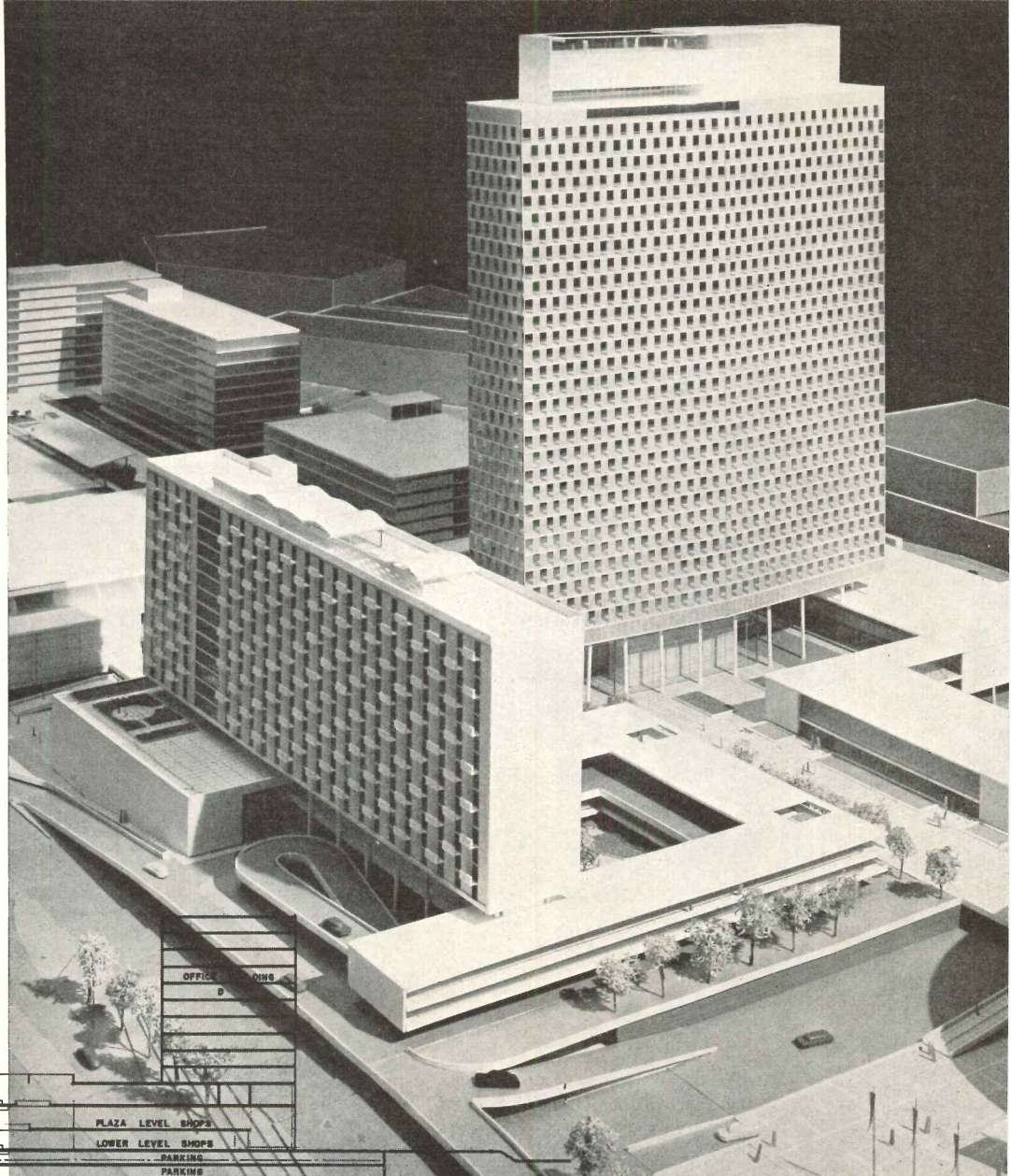
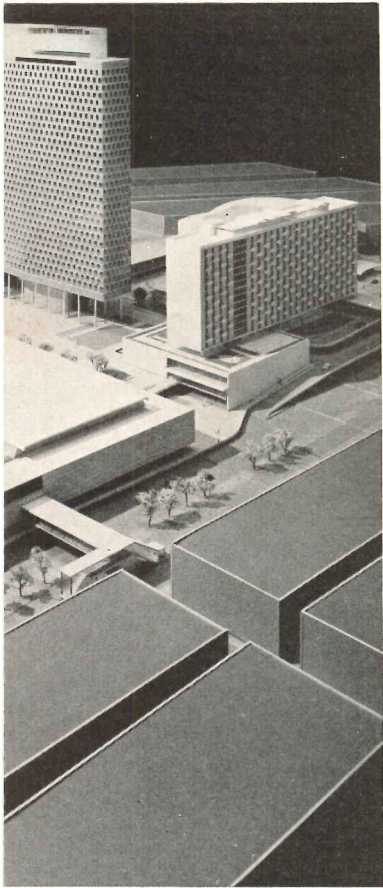
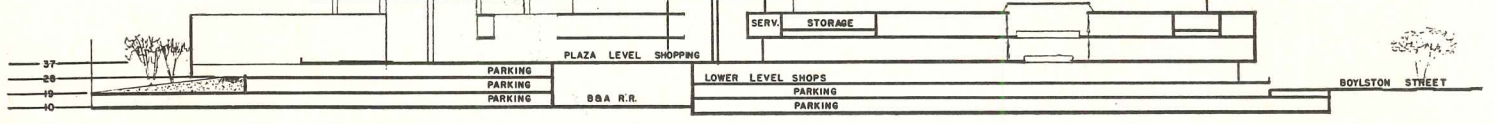

BOYLSTON STREET

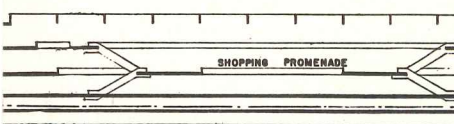



# "THE SPIRIT OF THE NEW ARCHITECTURE"

by PIETRO BELLUSCHI

**I**N SPEAKING OF NEW ARCHITECTURE, I shall not be satisfied to list recent buildings, or to argue on the Museum of Modern Art's selections, or to describe unfamiliar or fashionable externals which may have caught the eyes, fancy, or indignation of our magazines.

I shall keep the number of introductory words to a minimum — in fact I will say just enough to explain what is least susceptible of explanation, namely: "The Spirit of New Architecture." Great architecture is always a Unity and cannot be explained or dissected into parts. Only historians dare formularize its expressive power; yet we may find it expedient to view such a Unity from three different vantage points.

Nor shall I take the time to define the more obvious virtues of architecture, be it new or old, such as space, scale, divine proportions or color, textures, and ornament; because I take for granted that they form a permanent vocabulary without which architecture could not make itself manifest. Today I would rather like to point out to you what I believe to be the more fundamental attempts of our age to express itself

*An address by Pietro Belluschi, Dean, School of Architecture and Planning, Massachusetts Institute of Technology, before the recent national convention of the American Institute of Architects*

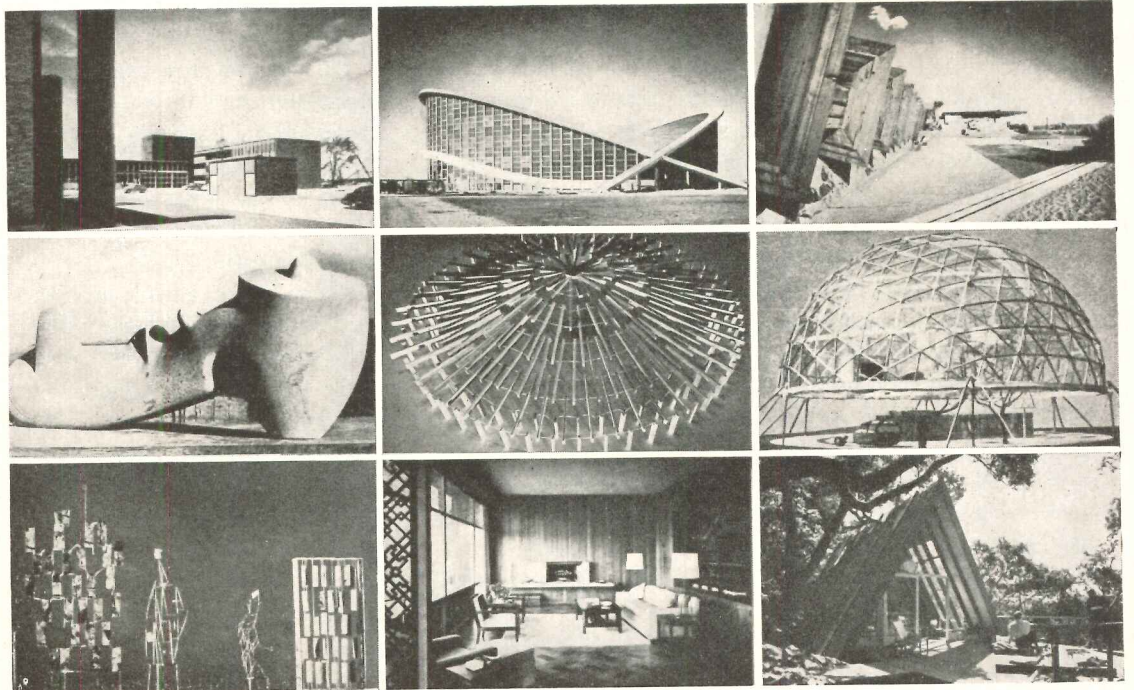



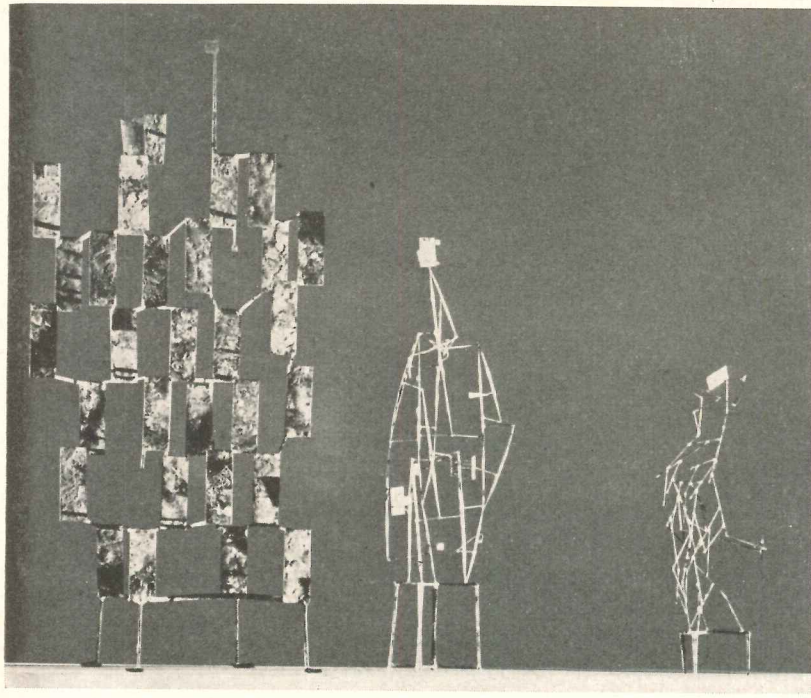

1

“NEW ARCHITECTURE” — PIETRO BELLUSCHI



2

through new forms and the process which we ourselves must undergo to allow such forms to be absorbed into our esthetic tradition.

In so doing I shall be careful not to assume that all changes are for the better or that all are worth being recorded and absorbed. I could, for instance, show photographs of prominent skyscrapers built 30 years ago or more and compare them with others of recent vintage and find little or no real advance. But I do not wish to be cynical or destructive because our general belief in ascending progress is one of the sources of our strength and vitality as a nation, and furthermore we need all the optimism we can muster to proceed in our work.

I have often said to anyone willing to listen that architecture must give satisfaction to the mind as well as to the senses in order to be of lasting significance, but we all have found that logic alone is not enough — like the virtue of simplicity, logic can be the last refuge of the dullard and of the ungifted; and he who has nothing but common sense will be apt to be moving within the limits of mediocrity, although conversely lack of logic and abuse of fantasy can also be the last refuge of the charlatan and the unsensitive.

I have also repeatedly and rather belligerently stated my belief that Architecture is not a Pure Art since it has practical boundaries and duties which it must acknowledge, satisfy, and respect.

At the risk of appearing inconsistent, I shall say to you that Architecture could not long last as a non-pure Art if it did not forever tend to trespass into the preserves of Pure Art. So we must accept and record as one of the aspects of “New Architecture” the striving of a few great artist-architects towards new and valid esthetic symbols by which future generations may remember us.

This search for symbolic expression has been an instinctive and universal urge of mankind from time immemorial, and has generally defied precedent and the limitations of daily practicality. In the past it has given us the dome, the spire, the colonnade, and all the other familiar appendages of the traditional cityscape beautiful.

In its pure form, architecture is poetry, music, and imaginative release. We owe all creative artists and poets our deepest respect; we should forgive their protective arrogance and consider them the mirrors of the human spirit of our age, which as in other ages likes to reveal itself under a cloak of dissent.

On the other hand, it must be equally clear that if architecture were allowed to take permanent flight from the realities of life, it would not only soon become decadent for lack of the nourishment which its roots must have from life, but it would also leave a large void in the everyday physical environment of human society which is itself built of earthy motives



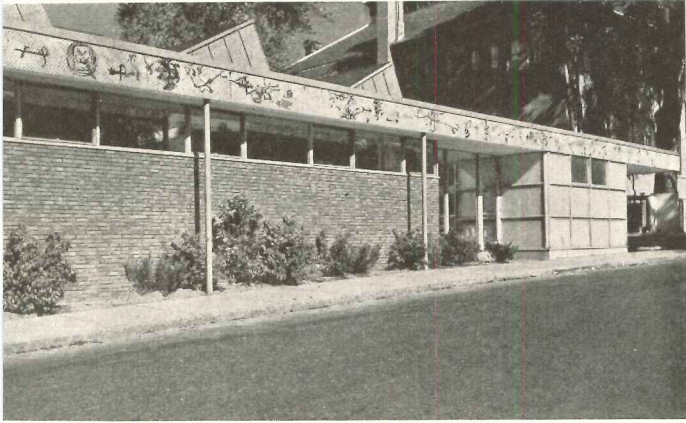

3



4

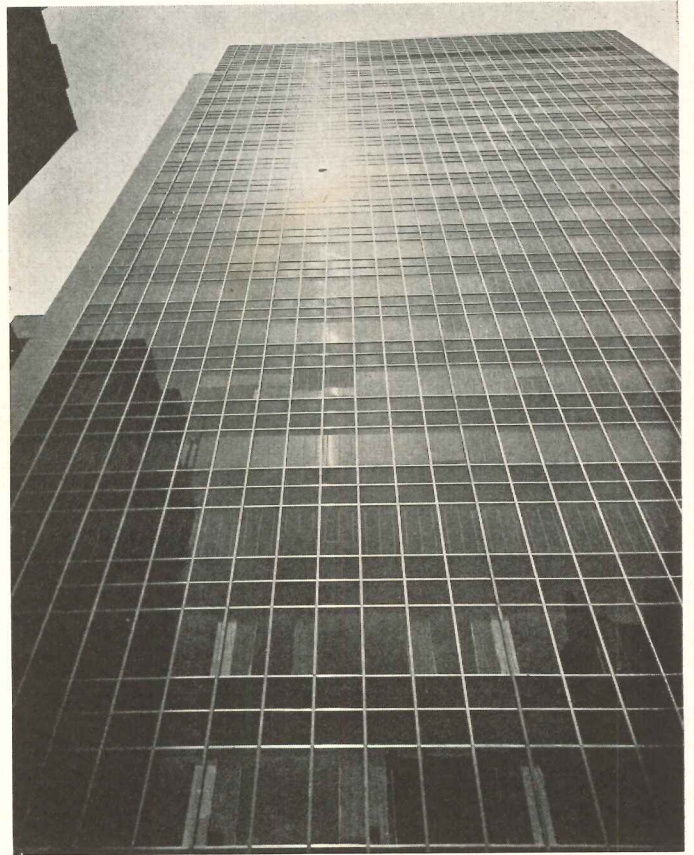

5

and necessarily moves within earthy boundaries.

Some 90 years ago, upon founding the first School of Architecture in America at the Massachusetts Institute of Technology, William Ware remarked that "architecture resembles literature in that both range all the way from mere work of necessity, such as shelter from the elements for one and communication for the other, up to pure form, such as the monument or the poem, at which level they may consort with the pure arts of music, sculpture, and painting; but they have an intermediate level above utility and still utilitarian, and below poetry but still artistic — the region of good sense, good taste, of knowledge, and skill — in literature as clear, graceful, and intellectual style — in building simplicity, elegance, and common sense — in both a work which cannot wait, but which must be done."

It seems to me that the test of greatness of any artist-architect is not that he be also practical but that he allow his inspiration never to be too far removed from the demands of his age, and the emotional needs of his contemporaries. There is no doubt in my mind that in the end the fruits of pure creativeness, to serve their full purpose, must filter down and fertilize the environment of our daily lives. Similarly the esthetic symbols of our age cannot aspire to be of enduring quality unless they grow from the earth and from man, from structure and from humanity.

1. *Sculpture by Harry Bertoia*  
(photo, H. Matter)
2. *Leisure house, Campbell & Wong, architects*  
(photo, Morley Baer)
3. *Fitchburg Children's Library,*  
*Carl Koch, architect (photo, Ezra Stoller)*
4. *Showroom for Knoll Associates*  
(photo, Robert Damora)
5. *Lever House, Skidmore, Owings & Merrill,*  
*architects (photo, Ezra Stoller)*



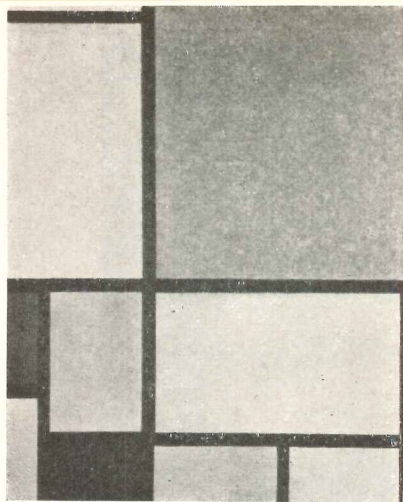

6

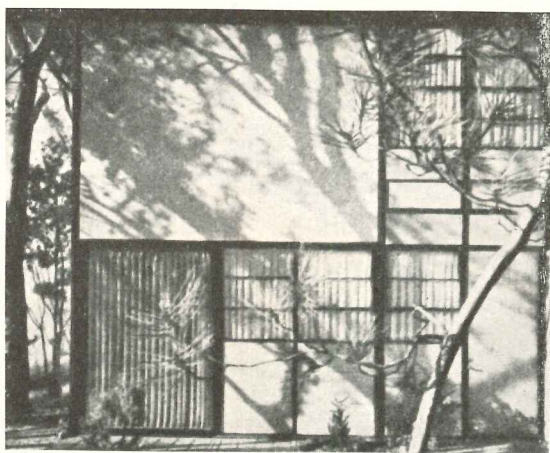

7

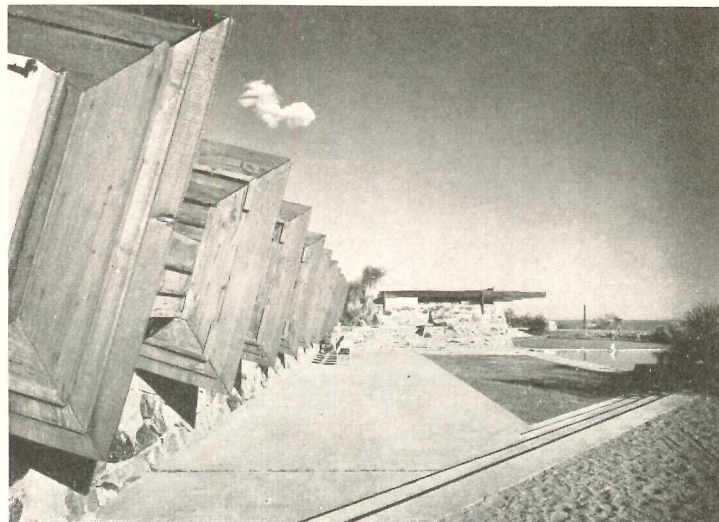

8

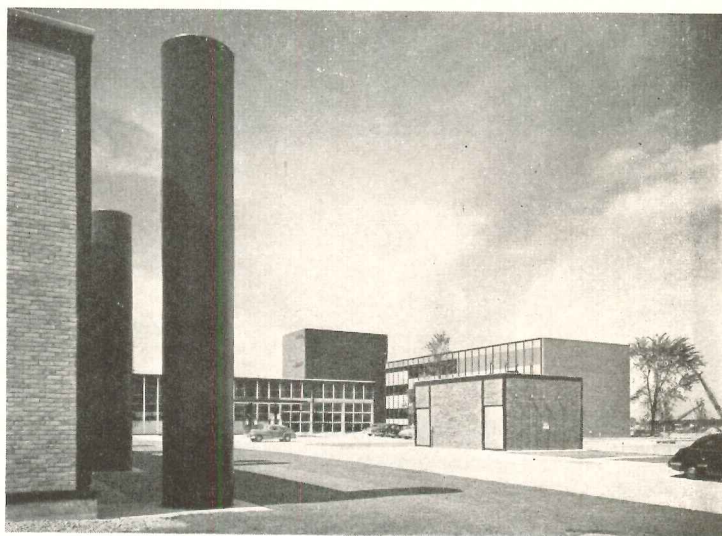

9

If you agree with me thus far, then the three vantage points from which we may review our collective efforts toward a “New Architecture” are these:

*First:* The exploration of structure as source of form. Nature offers the greatest wealth of forms brought to life and beauty by the intrinsic need of their structure. In this age of scientific and technological advances, infinite possibilities are opening for us to exercise our imaginative powers by observing and by daring to process much of what we see into esthetic forms. Many of my slides will implicitly prove this point.

*Second:* Our attempts to more deeply understand human nature and to provide forms which will satisfy man’s physical and emotional demands; in short, to make the nature of modern man the reference of our architectural thinking. Since the advent of the common man there has been a growing concern on the part of architects and artists to improve the environment within which the various social groups must spin the thread of their lives. This concept includes the home, the shelter of man and his family, an element full of

emotional implications; it includes also the understanding and acceptance of regional architecture as a sympathetic manifestation, and as a recognition of human values peculiar to certain people and places. It also includes the development of new forms for the large urban unit — the city, brought about by the growing demands of our machine age.

*Third:* As I have already indicated, the attempts by the very few creative intellects to find visual esthetic symbols in a world which is in the way of losing the meaning of his destiny, in the many conflicts raised by science. Their role is to find new synthesis where there is now confusion. It is clear that our society needs poets as much as it does document writers, discoverers as much as journeymen, singers as much as speakers.

It needs men who can help bring about new and deeper understanding, who can help restore the relationship between form and matter in the spirit of poetry, which needs continually a new language to express itself. To these creative men goes the task to fill archi-



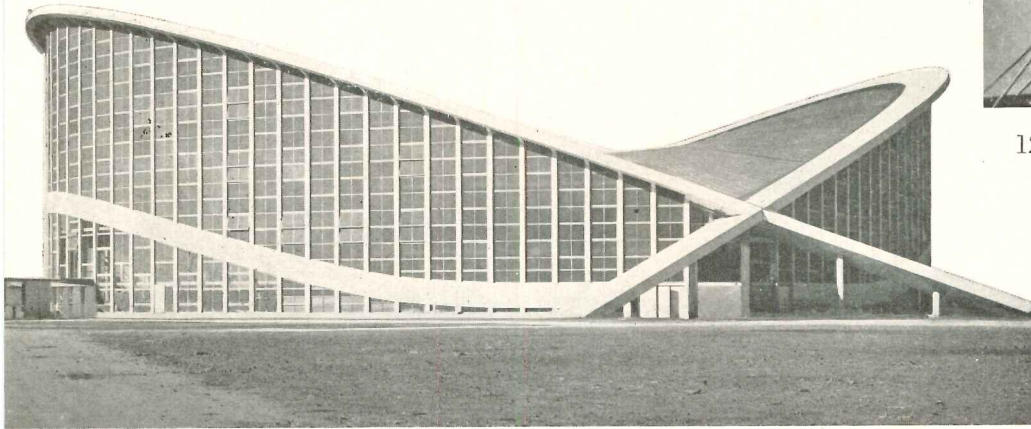

10

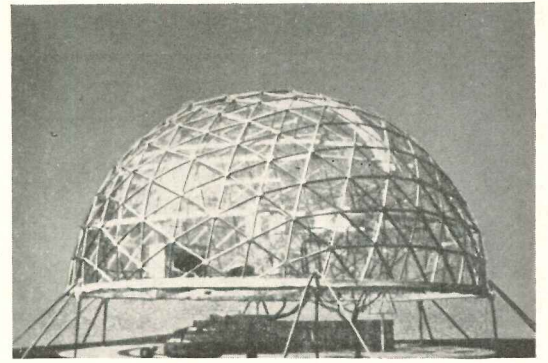

12

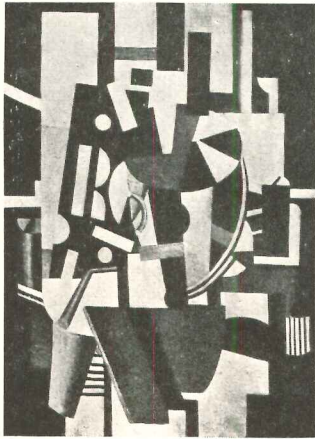

11

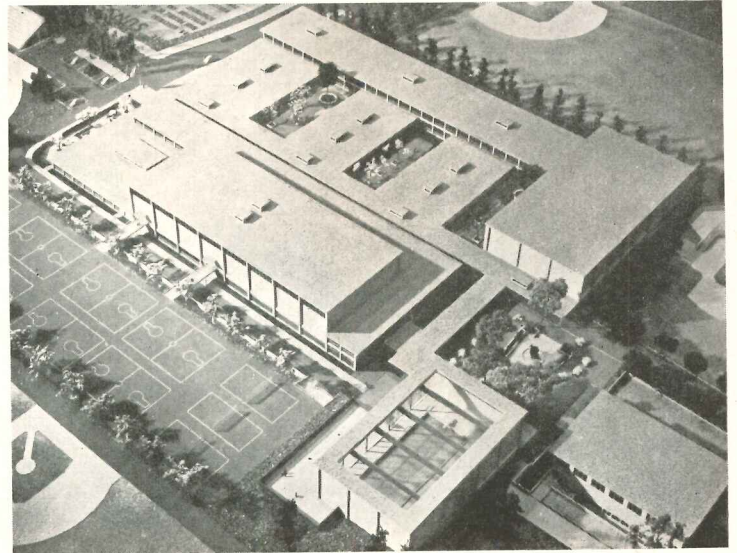

13

ecture with ever-changing poetic grace and make it a great civilizing force in our midst.

This showing of new ways and of new understandings can be done not only by architects but by any artist worth being called such. Any of the great moderns such as Cezanne, Picasso, Matisse, Mondrian, Moore, and Lèger have deeply affected our architecture in many unexpected ways; and we owe them more than we can repay. This point I can barely touch today, but it would be interesting to explore in greater detail.

The slides \* I am about to show you are of different size and origin and not in good order and some of them relate only indirectly to architecture, but from them I hope it will be possible for you to see the three points about which I have just spoken. I shall not comment at length on any of them, and you may even draw conclusions different from my own but you will find in them what seems to me at least, a stimulus to "New Architecture."

\* Mr. Belluschi showed almost a hundred slides: see full list on page 149.

6. *Composition by Piet Mondrian*
7. *House by Charles Eames*
8. *Taliesin West, Frank Lloyd Wright, architect (photo, Ezra Stoller)*
9. *General Motors Technical Center, Eero Saarinen, architect (photo, Ezra Stoller)*
10. *North Carolina State Fair Pavilion, Mathew Nowicki and William Dietrick, architects (photo, Lewis P. Watson)*
11. *Composition by Fernand Lèger*
12. *Geodesic Dome, Buckminster Fuller*
13. *Sunset Community Center, Wurster, Bernardi and Emmons, et al., architects (photo, Ernest Braun)*



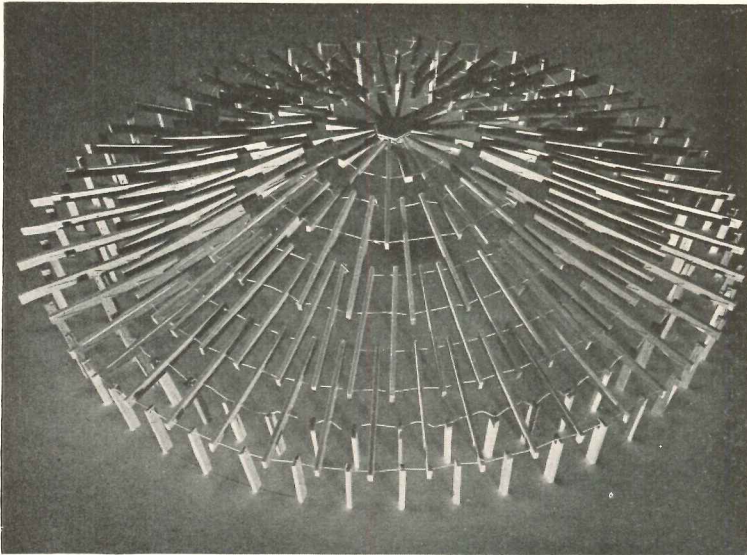

14

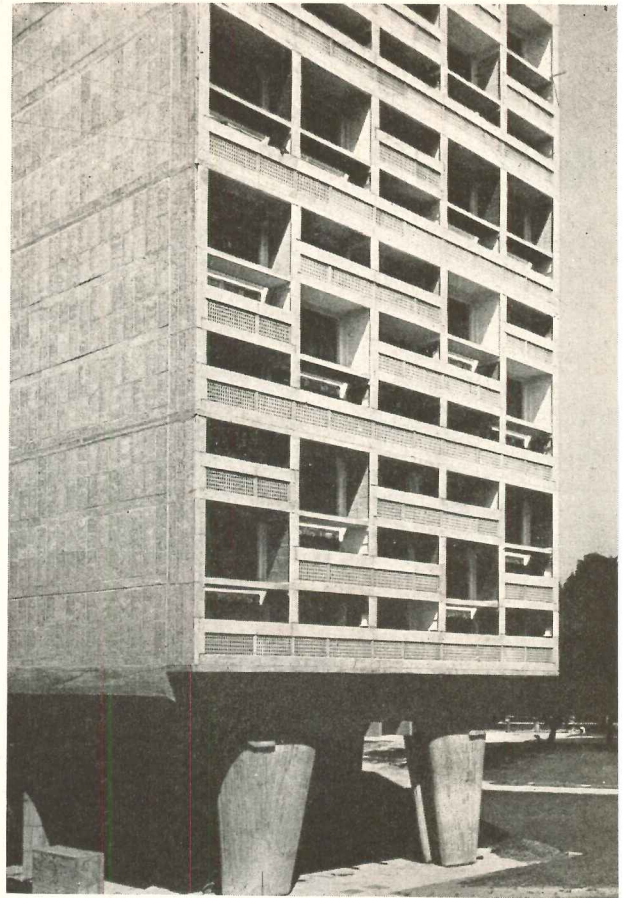

15

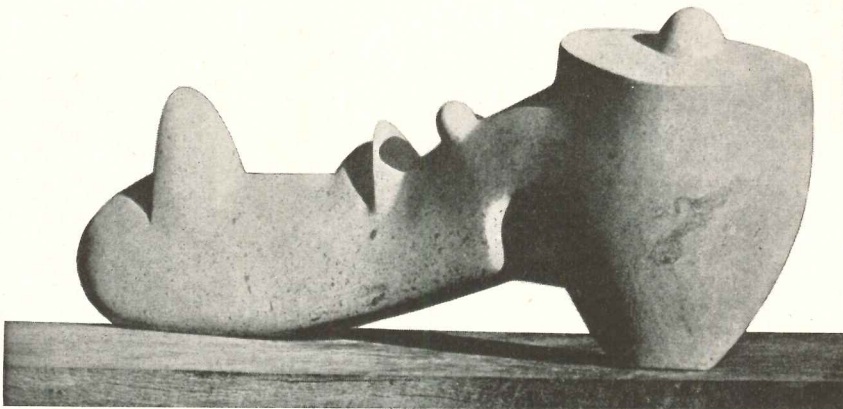

16

17

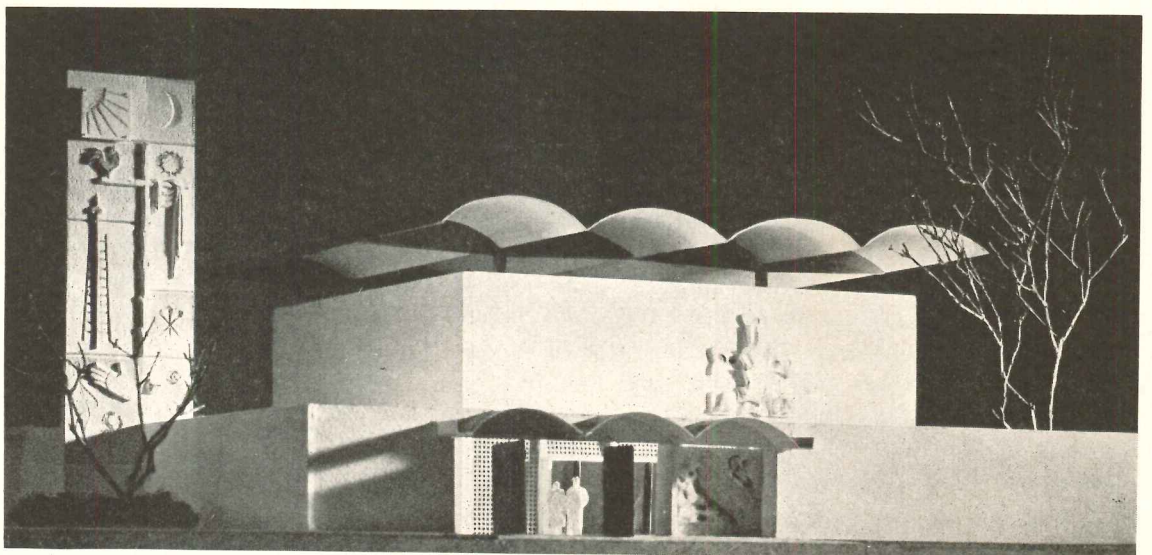



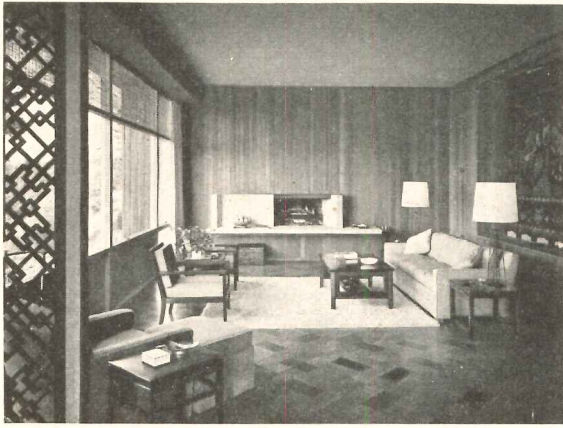

18

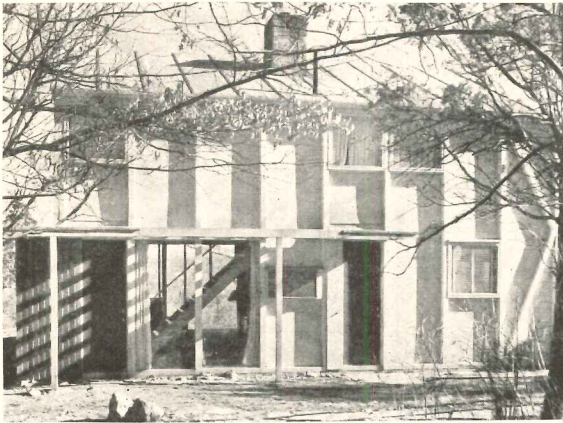

19

20

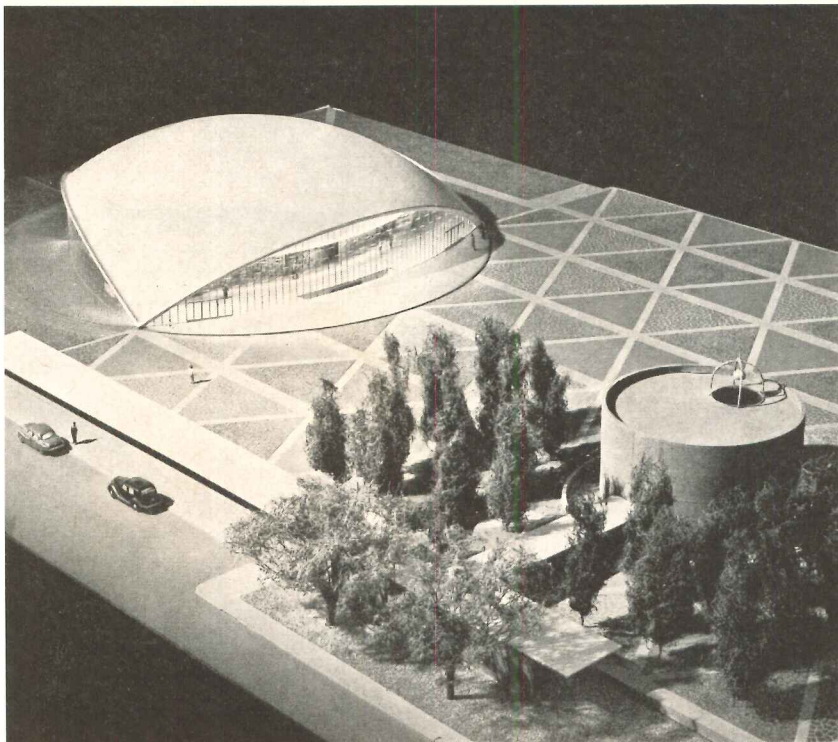

*Complete list of slide illustrations used by Mr. Belluschi in his address, "The New Architecture," at national convention of A.I.A.*

- Grand Coulee Dam
- Golden Gate Bridge
- Sculpture by Bertoia (five slides)
- Electric distribution structures at Grand Coulee Dam
- Geodesic Dome, Buckminster Fuller (13 slides)
- Unite d'Habitation, Le Corbusier (two slides)
- General Motors Technical Center, Eero Saarinen (three slides)
- Models of structure, Catalano (five slides)
- Model of M.I.T. auditorium, Saarinen
- Lever House, Skidmore, Owings & Merrill (three slides)
- Garage building in Mexico
- Precast lamella concrete roof, P. L. Nervi
- North Carolina State Fair Pavilion, Mathew Nowicki and William Dietrick (four slides)
- Model of structure, M.I.T. students
- Taliesin West, Frank Lloyd Wright (two slides)
- Structural ducts, Wachsman
- House, Campbell & Wong (five slides)
- Houses, Carl Koch (four slides)
- House, George Rockrise
- Sawyer house, Anshen & Allen (three slides)
- Miravista school, Carl Warnecke
- Sunset Community Center, Wurster, Bernardi and Emmons, et al.
- University of Mexico, Gorman (three slides)
- Shopping Center in Baltimore
- Movie theater with Diego Rivera murals
- Stone mosaic, Diego Rivera
- Fitchburg Library, Carl Koch (five slides)
- Planning, Wiener and Sert (three slides)
- Church, Wiener and Sert (three slides)
- Van Doesburg painting
- Mondrian painting
- Earth pattern
- New York at night
- Charles Eames house
- Color photo time exposure by M.I.T.
- Fernand Lèger painting
- Knoll display room

- 
- 14. *Problem in structures, various M.I.T. students*
  - 15. *Unite d'Habitation, Marseille, Le Corbusier, architect (photo, Brassai)*
  - 16. *Reclining Figure by Henry Moore*
  - 17. *Model of church for Ciudad Piar, Venezuela, Paul Lester Wiener and Jose Sert, architects (photo, Richard H. Althoff)*
  - 18. *Underwood House, Campbell & Wong, architects (photo, Morley Baer)*
  - 19. *Cemesto House, Carl Koch, Huson Jackson, Robert Kennedy, architects*
  - 20. *Model for auditorium and chapel, M.I.T., Eero Saarinen, architect*



# SANDERLING BEACH CLUB, SARASOTA, FLA.

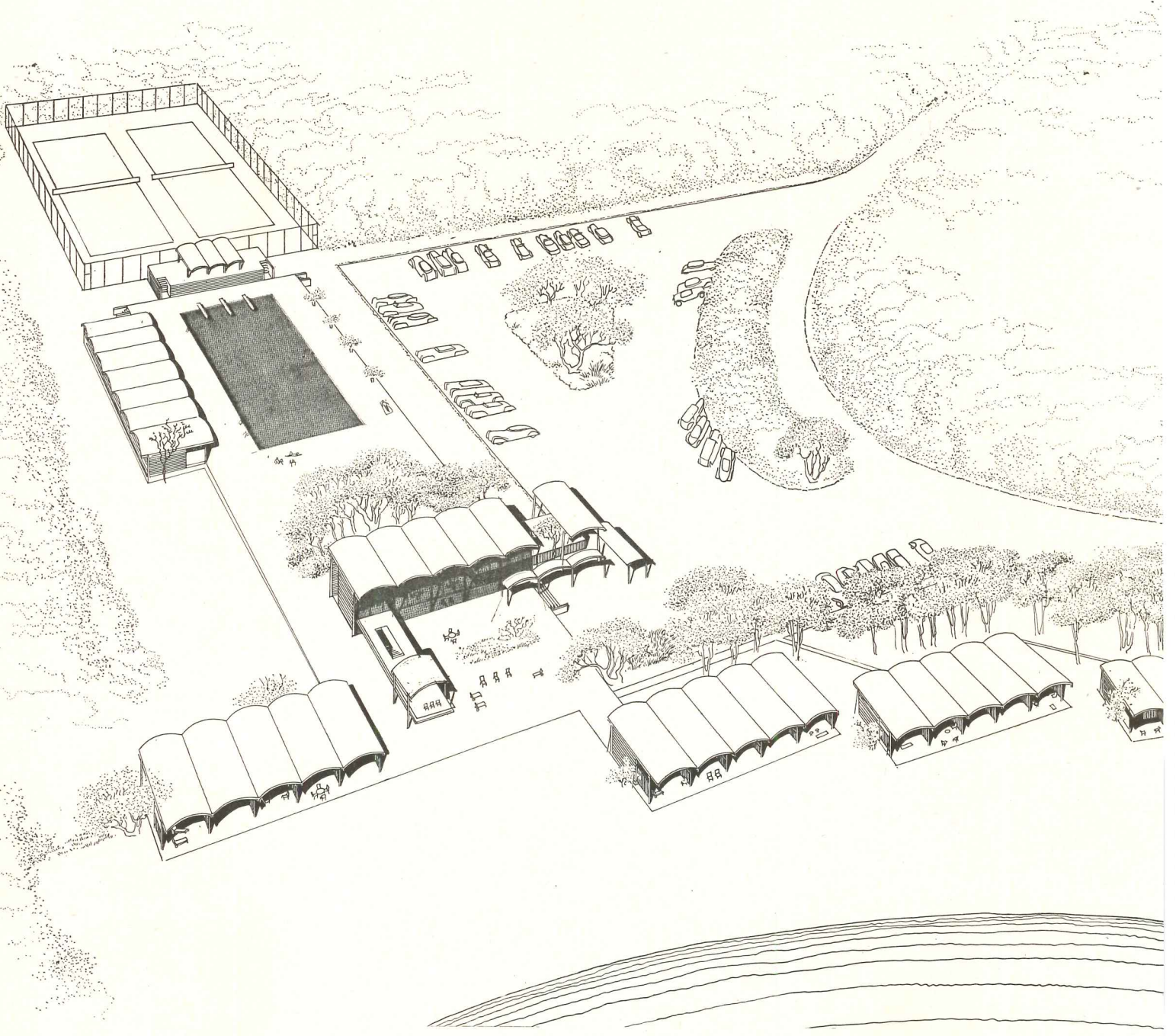

*Paul Rudolph, Architect; Landscaping, Edward Shields*





THE CABANA CLUB designed for Sanderling Beach, Inc., at Siesta Key is simple, appropriately gay in concept, and architecturally of much interest as an example of technical excellence applied with a sure esthetic sense to a common design problem. At first glance the plywood shell roofs — which are detailed on the following pages — would seem to command the most attention. These are exciting, it is true; but of at least equal importance are such matters as the careful organization of the units on the site, so that the identically repetitive cabanas and groups of cabanas are not monotonous; the use throughout of standard framing lumber sizes in ways that average labor can execute with little difficulty; and a certain reverence for the essence of architectural tradition which may not be obvious. Rudolph says he prefers things which, like the classic column, have “a beginning, a middle and an end”; one can almost find here the satisfactions afforded by the traditional capital, tympanum and architrave. The economy of means is also in the classic spirit.

Siesta Key is a restricted development; this is its beach club, and several resident-members participated in its construction.



© Ezra Stoller

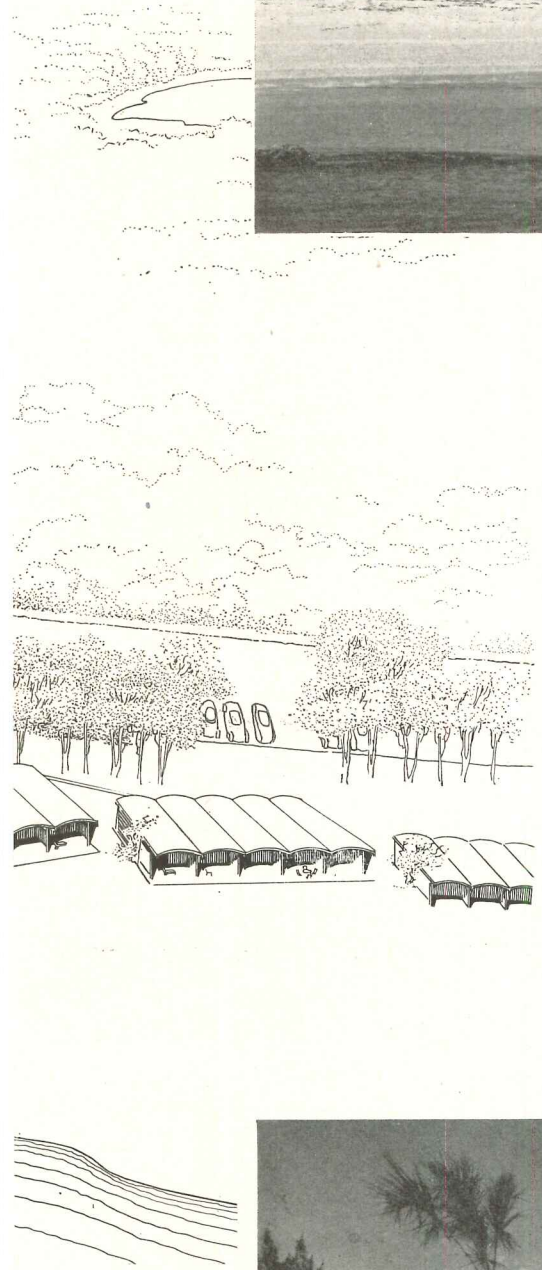



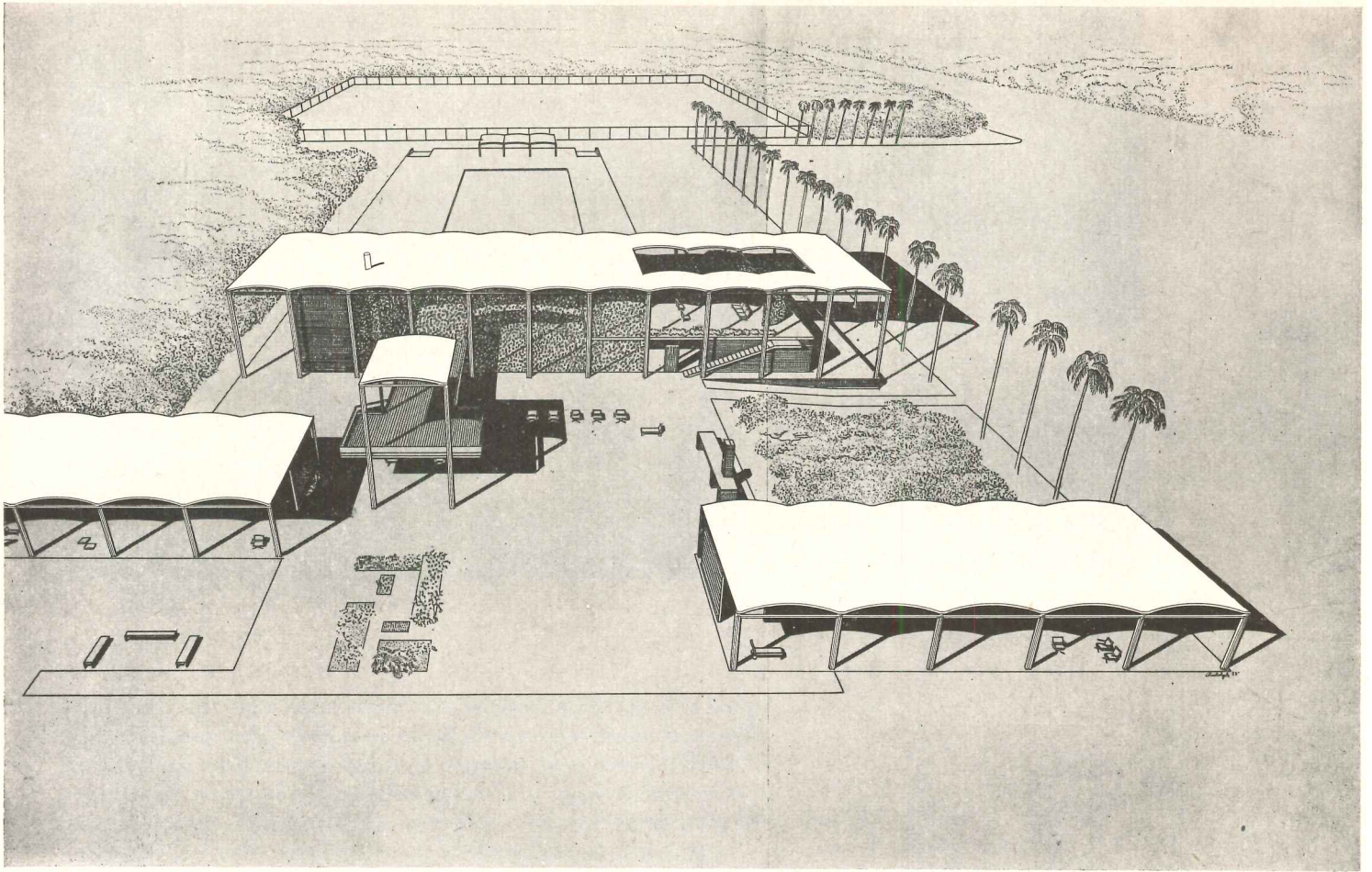

**FLORIDA BEACH CLUB**

*The rendering on the preceding two pages shows one of the first schemes for the central pavilion. Above is the final design, not yet built*





Barrel-vaulted roof is formed of two lapped, glued sheets of 1/2-in. plywood, held by edge members bolted down to withstand lifting action of wind. Tie rods, at first thought necessary, were omitted because method of forming made thrust negligible: plywood sheets were bound to a short radius while glue set; when released they expanded to final curvature

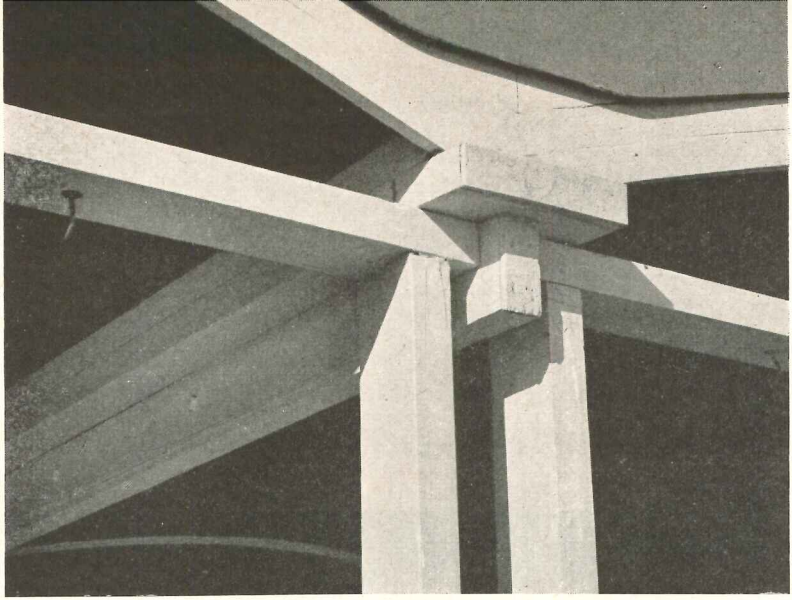

© Ezra Stoller

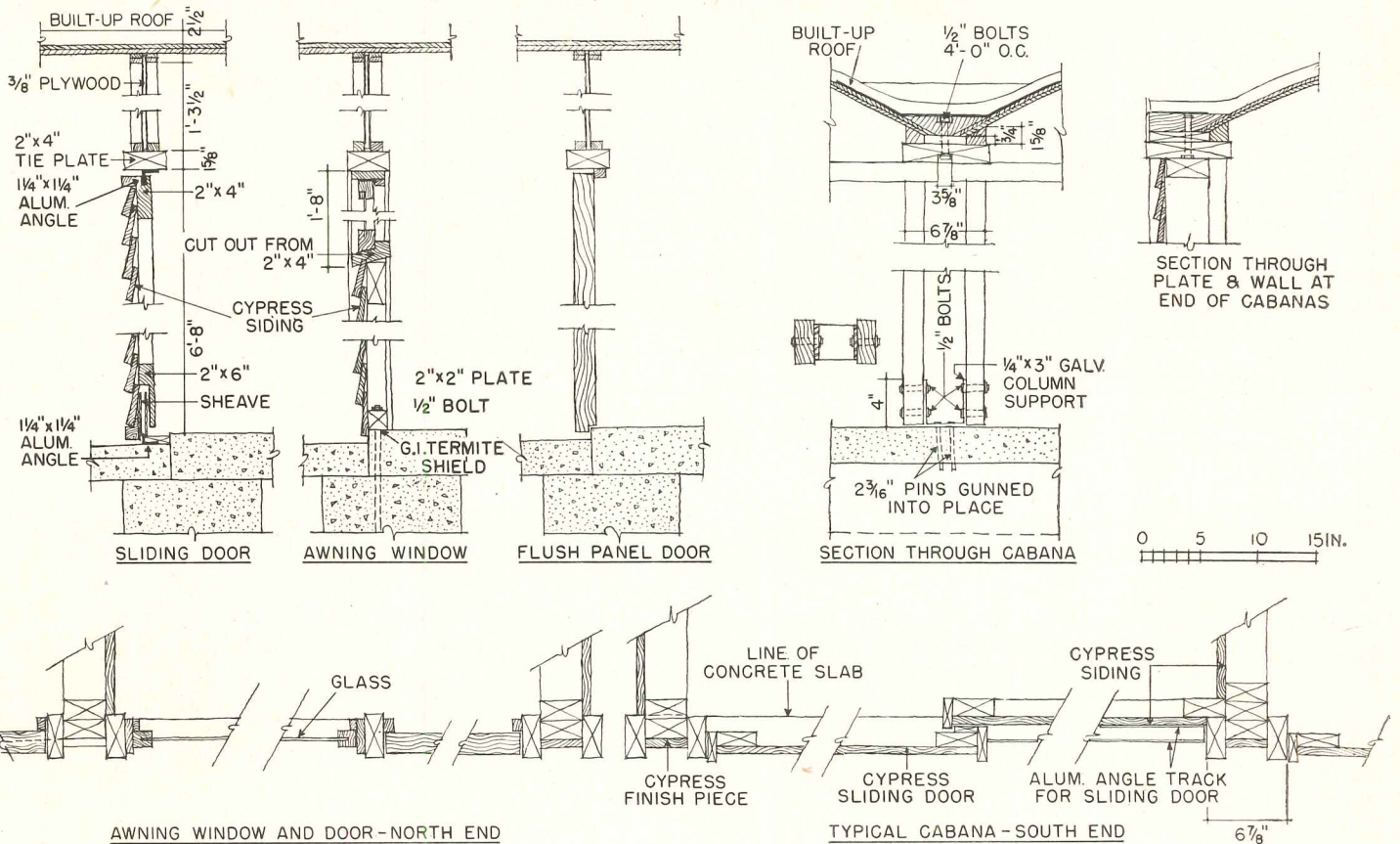

A 20-year-bonded built-up roof was used after "cocoon" roofing (used in moth-balling naval equipment) had been considered and discarded because initial and amortized cost were both high

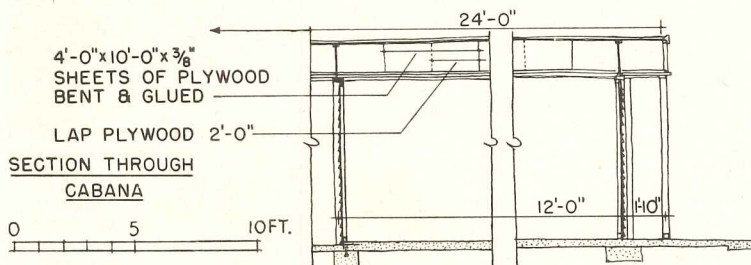



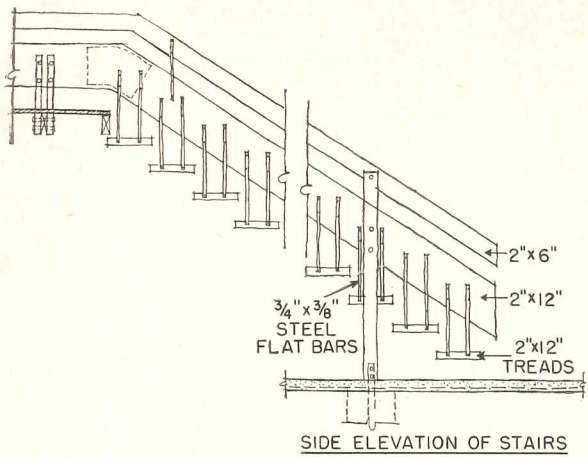

The central pavilion (facing page; photo below taken from beneath it) is also deceptively simple — the result of careful refinement and detailing. As in cabanas, all members are standard framing lumber so placed that each piece does its job economically and directly. Steel cables in tension brace the structure diagonally. The only concealed fastenings occur in stair and platform railing, where the corners are joined with 1/4-in.-thick steel plates mortised into the abutting wood members like splines.

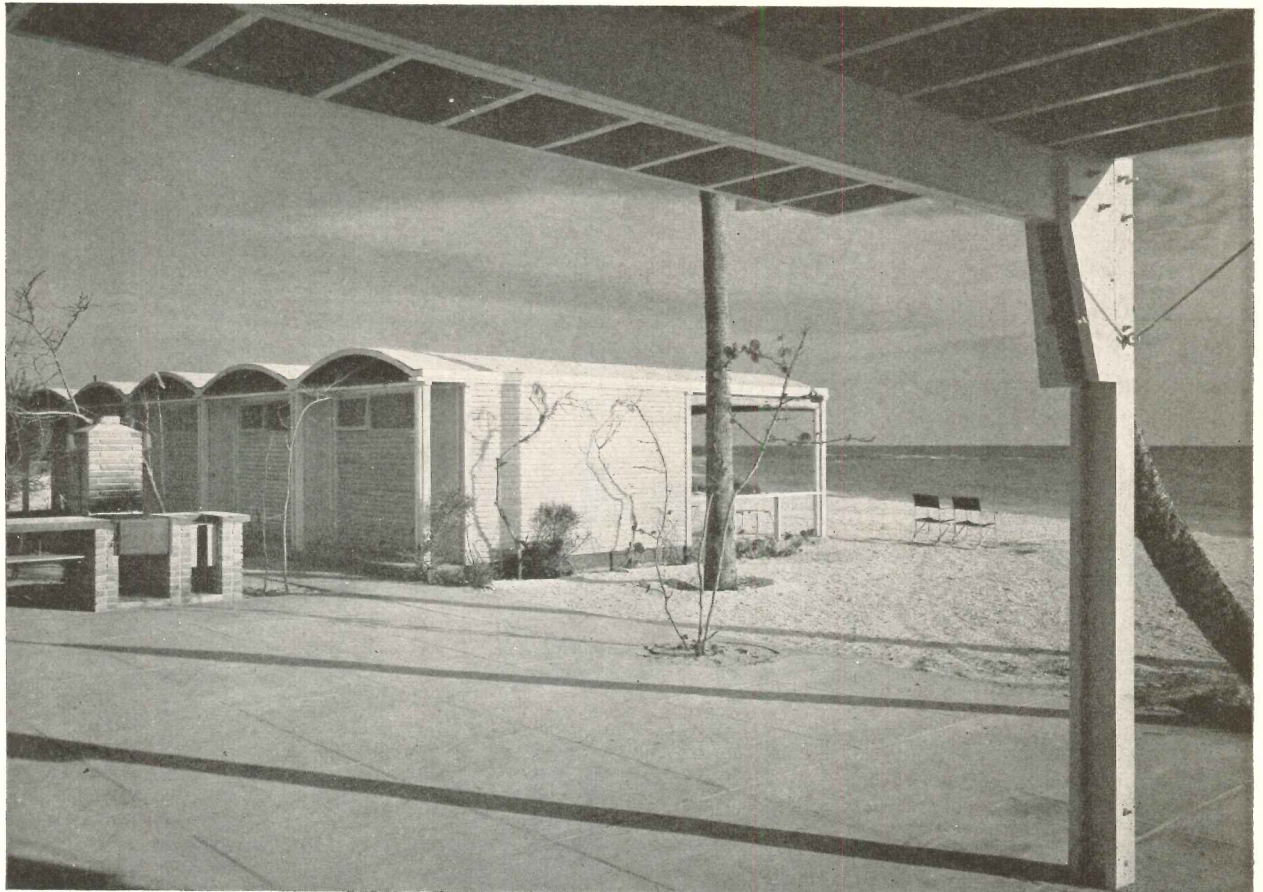

© Ezra Stoller

**FLORIDA BEACH CLUB**

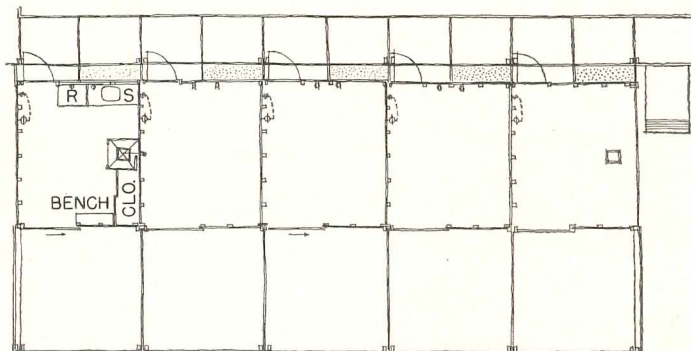

*Cabanas are in small groups around the pavilion; more may be built in the future. Each cabana is equipped as the permanent occupant wishes, including such items as refrigerator, sink, bar storage, shower, closet, etc. Doors at both ends (see details on preceding page) and canopies front and back provide welcome ventilation and shade. Toilets are in a separate unit behind the pavilion*







# REPAIR SHOP COMBINES EFFICIENCY, FLEXIBILITY

*Anniston Ordnance Depot Vehicle Maintenance Shop, Anniston, Alabama*

*Sherlock, Smith & Adams, Architects & Engineers*

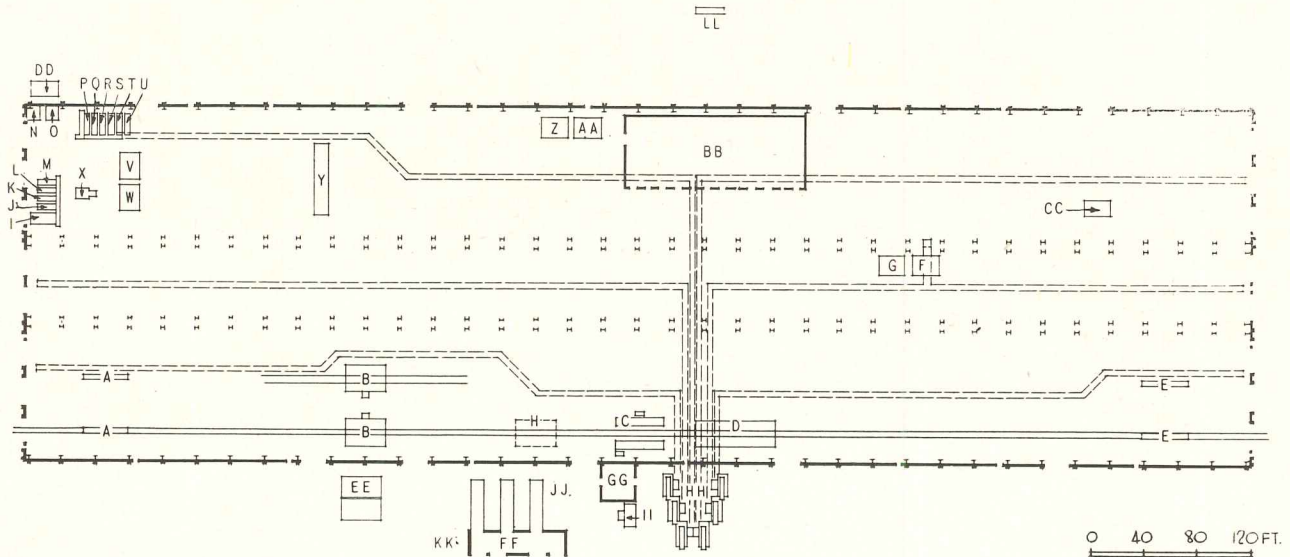

THE clean-cut simplicity of this immense Vehicle Maintenance Shop, planned to augment facilities at the Anniston Ordnance Depot, reflects considerable skill in organizing complex program requirements. Although specifically intended for repairing and rebuilding Army tanks, the shop also required a maximum flexibility to allow rearrangement into new types of maintenance or assembly production lines, or for conversion to other military operations.

To efficiently provide for this combination of specific and relatively undefined functions, the architects have devised a well integrated scheme, adaptable to most any type of production flow line.

The basic structure is a lightweight steel frame resting on heavy crane supports and sheathed with corrugated asbestos and glass on the upper portion, concrete block below for protection against damage. In cross section, it is divided into three bays — 60 ft in the center, 100 ft at the sides — each of which is spanned by cranes. Bridges or crossovers at 75-ft intervals through the center bay make it possible for a crane to transport a heavy piece of equipment over the entire floor area of the 270 by 900-ft. building.

To keep the shop area as open and flexible as possible, prefabricated box-car-like units were designed for use as toilets, offices and first aid stations. These can be shifted about by the cranes. The number of permanently fixed room divisions or equipment placements within the building was kept to a minimum.

All utilities and an exhaust system to remove gas fumes are carried in underground trunk lines, with floor outlets placed in a 25-ft grid pattern. For safety, all combustible fuels, paints, etc., are stored outside the building proper.

Military personnel in charge of the project include: W. K. Wilson, Jr., Col., Corp of Engineers — District Engineer, Mobile District; Mr. G. B. Weston — Chief of Engineering Division; Mr. Arthur J. Dunn — Chief of Military Branch; Earl W. Aldrup, Col., Ordnance Corps — Commanding, Anniston Ordnance Depot.

## LEGEND

A. Lubrication Pit	T. Preservative
B. Large Shot Blast	U. Drain Table
C. Paint Booth	V. Paint Booth
D. Drying Oven	W. Drying Oven
E. Lubrication Pit	X. Small Shot Blast
F. Paint Booth	Y. Van Norman Grinder
G. Drying Oven	Z. Paint Booth
H. Wash Rack	AA. Drying Oven
I. Degreaser	BB. Dynamometer Room
J. Acid Tank	CC. Inspection Pit
K. Rinse Tank	DD. Small Dust Collector
L. Acid Tank	EE. Large Dust Collector
M. Rinse Tank	FF. Boiler House
N. Twin Vapor Tank	GG. Paint House
O. Wheelabrator	HH. General Ventilation Fans
P. Acid Tank	II. Paint Booth Fans
Q. Rinse Tank	JJ. Ash Reservoir
R. Acid Tank	KK. Coal Storage Silo
S. Rinse Tank	LL. Pump House

*Concrete and concrete block around the lower portion of the building form a protective shield against blows from heavy equipment (below)*

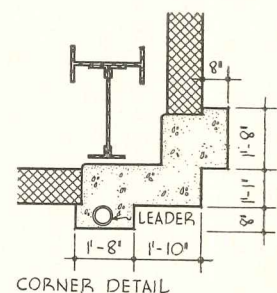

CORNER DETAIL



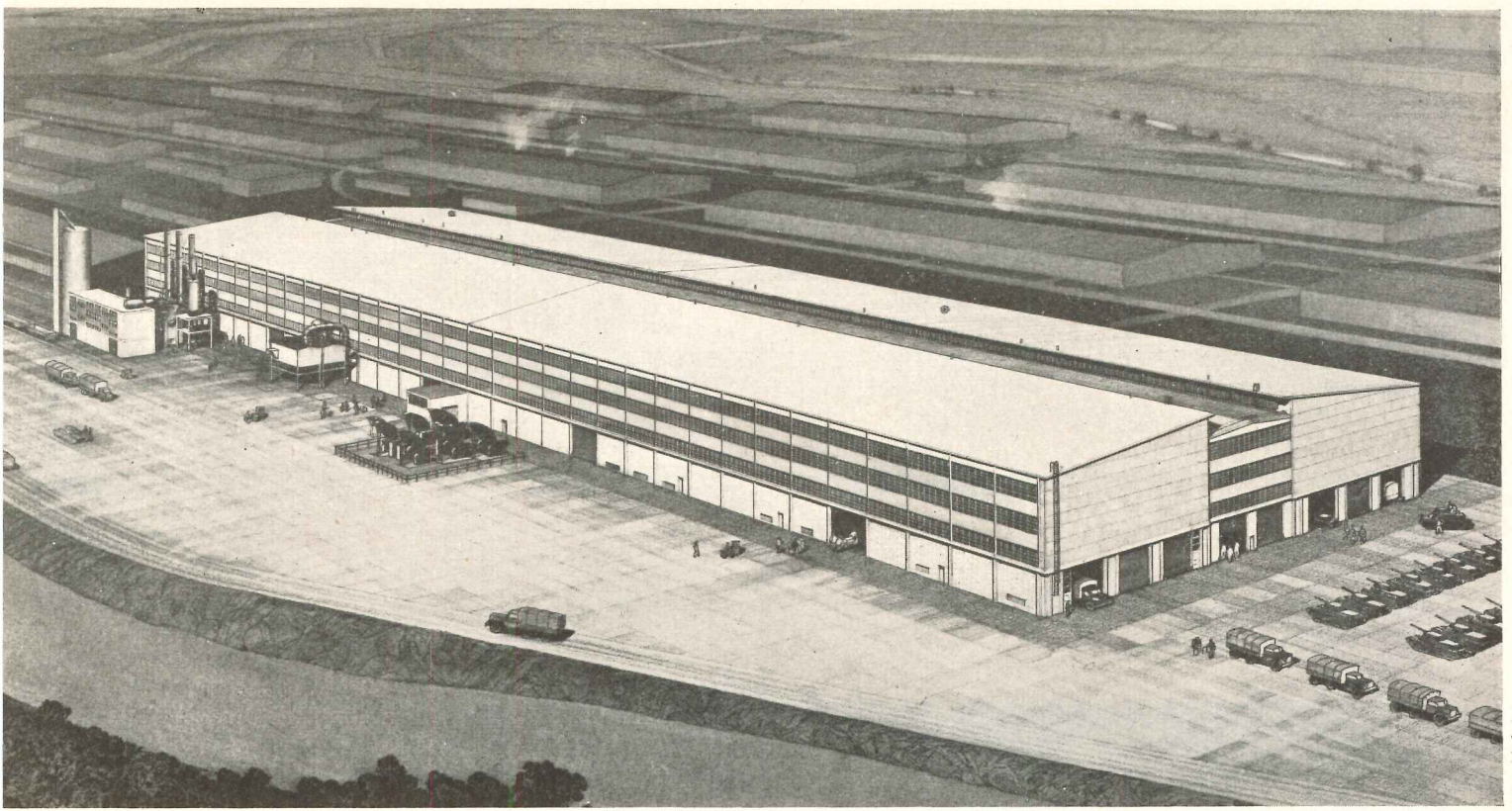

Julian Michele

*Maintenance shop has broad hard-surface surround for parking vehicles*

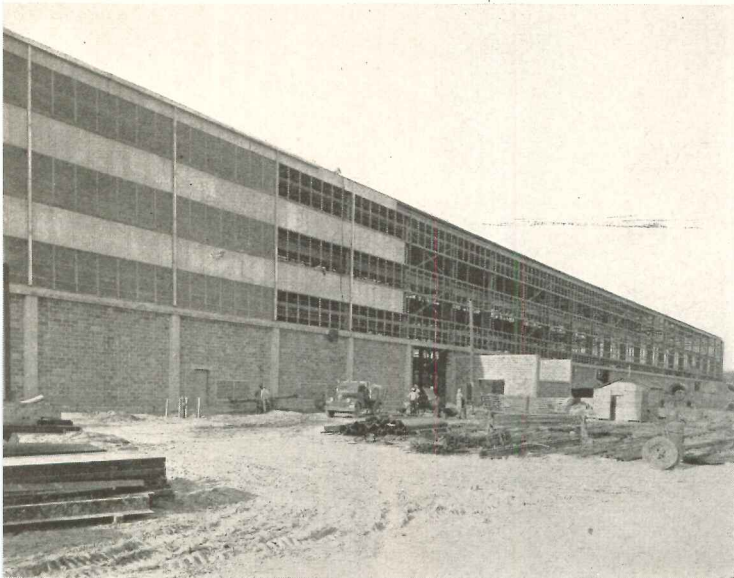

*Curtain walls sheath upper portions*

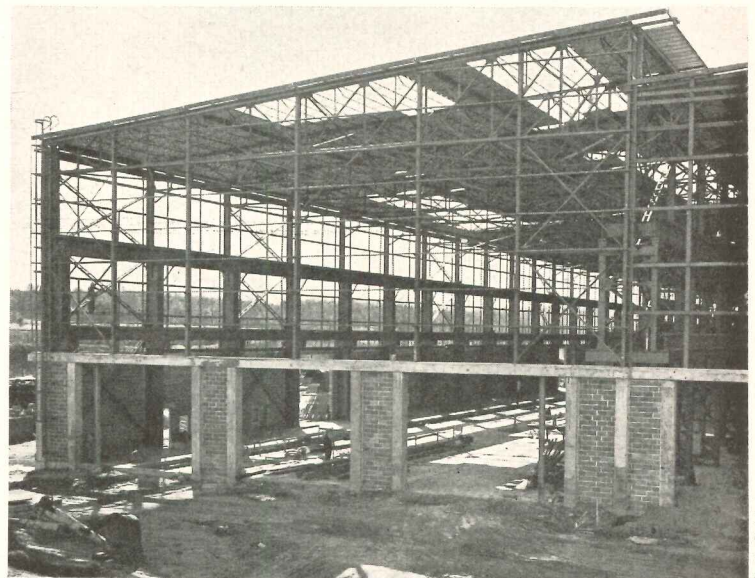

Betty Baldwin

*Lightweight steel frame rests on crane supports*



OCTOBER 1953



Joseph Mollitor



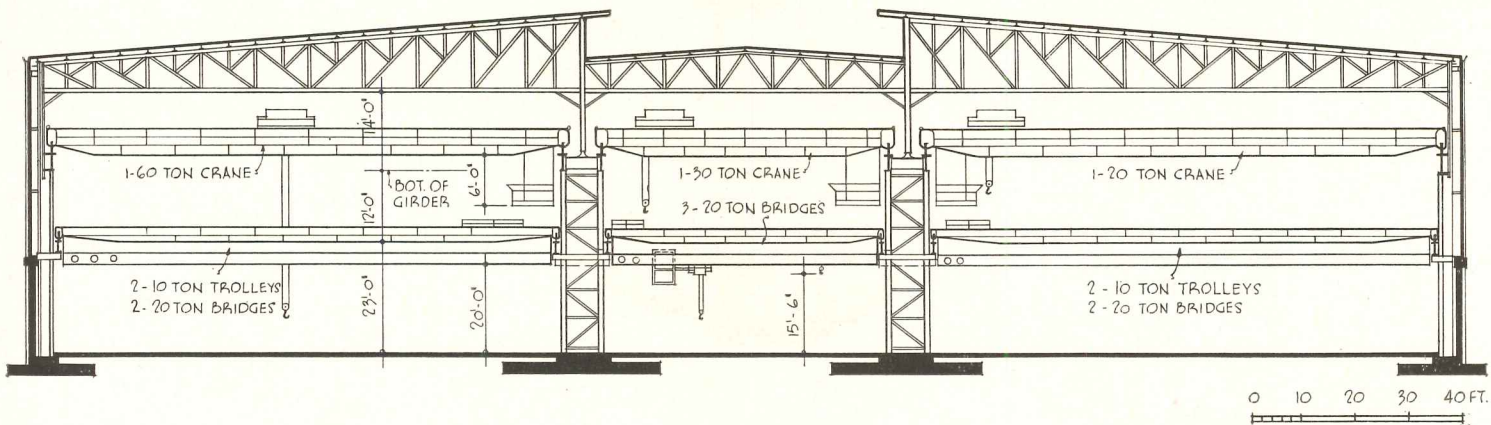

ANNISTON ORDNANCE DEPOT VEHICLE MAINTENANCE SHOP

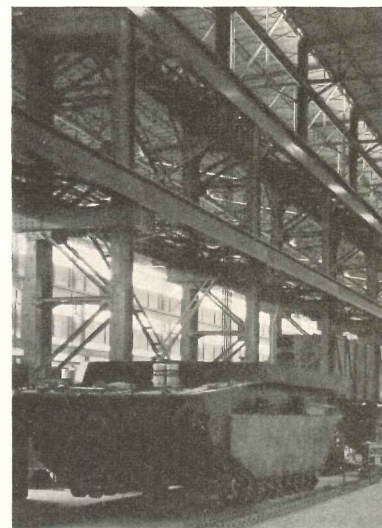

Joseph W. Molitor

Julian Michele



The cross section of the building was determined in large part by requirements of the cranes needed to carry the heavy tanks and machinery. Heights of the lower cranes were set to permit them to lift a turret from the largest of the Army tanks and clear the framework of the tank itself. The upper cranes were spaced to give clearance with a load over the lower ones. Electrical control devices are used to prevent collision of cranes traveling on the transverse bridges or crossovers. The structural frame system carrying the cranes was designed for at least a 50 per cent overload on any of the cranes, which can also be used in multiple to handle heavier loads. The heavy supports also carry the load of the light framework for the shell of the building.

Perhaps the most novel aspect of the building is the development of the self-contained, prefabricated units for toilets, offices and first aid stations. All use a basic shell with different interior arrangements; office units, however, are provided with windows for supervision. The unit frameworks are designed to take stresses in any direction so that the cranes can pick them up and move them quickly from one location to another without damage. Brackets on the central rows of columns in the building permit the placement of the units 8 ft above floor level to clear the working space. Soil and waste lines, water lines and electric service are provided with flexible connections at each of the locations where a unit might be set. Cast iron spiral stairs fit in steel ferrules in the concrete floor, and may be moved with the pre-fab units or separately. First aid units are placed directly on the floor for easier access.

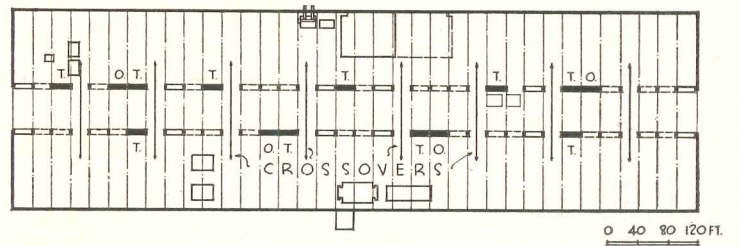

Plan above shows locations for pre-fab units, crane crossovers

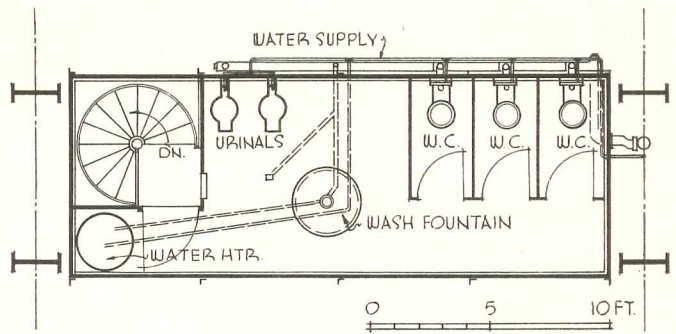

Details of a pre-fab unit fitted as toilet

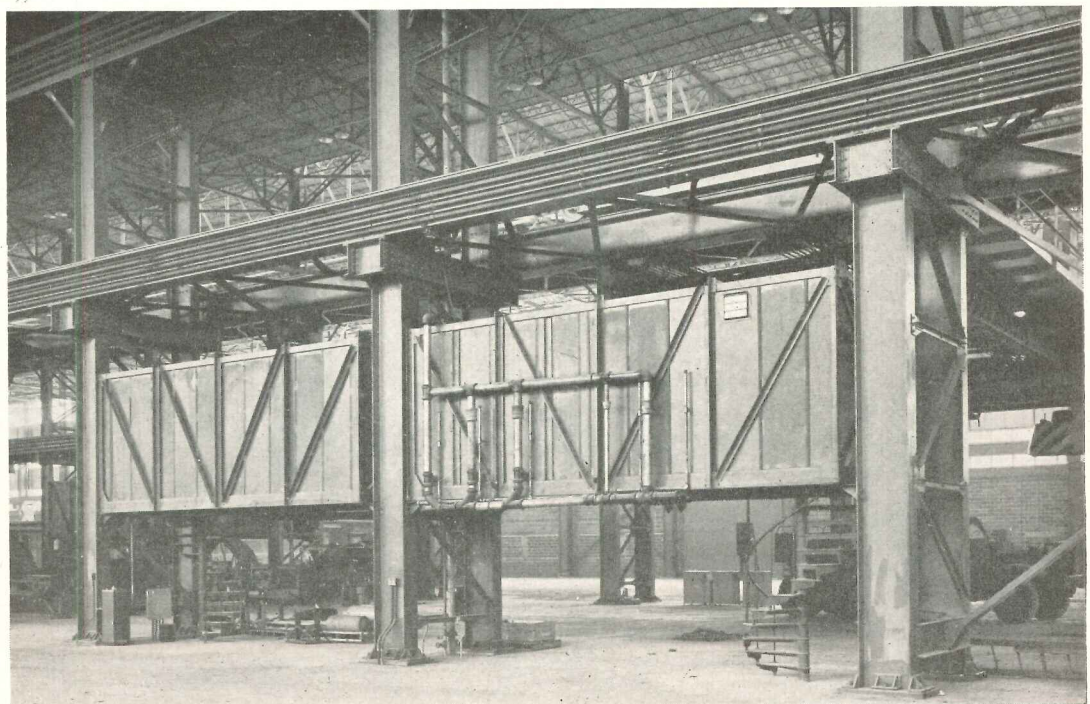
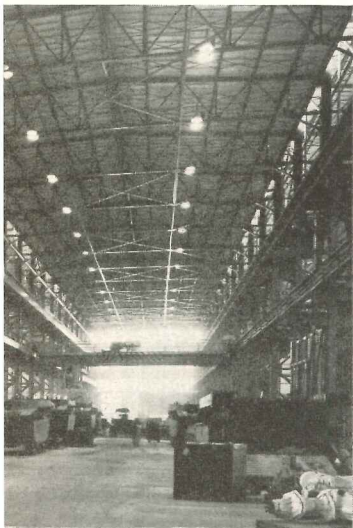
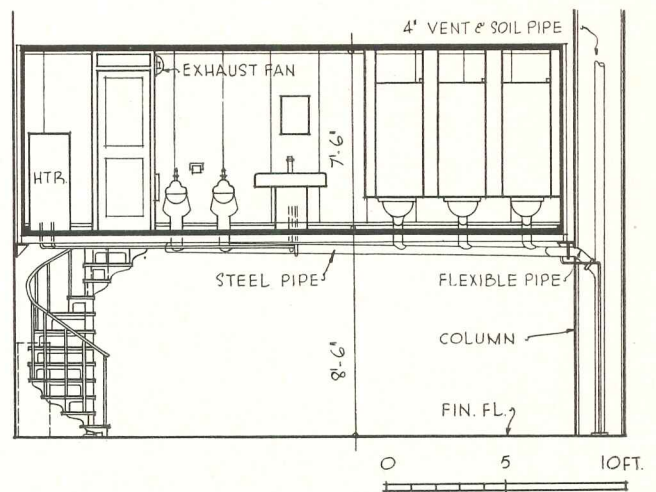



ANNISTON ORDNANCE DEPOT VEHICLE MAINTENANCE SHOP

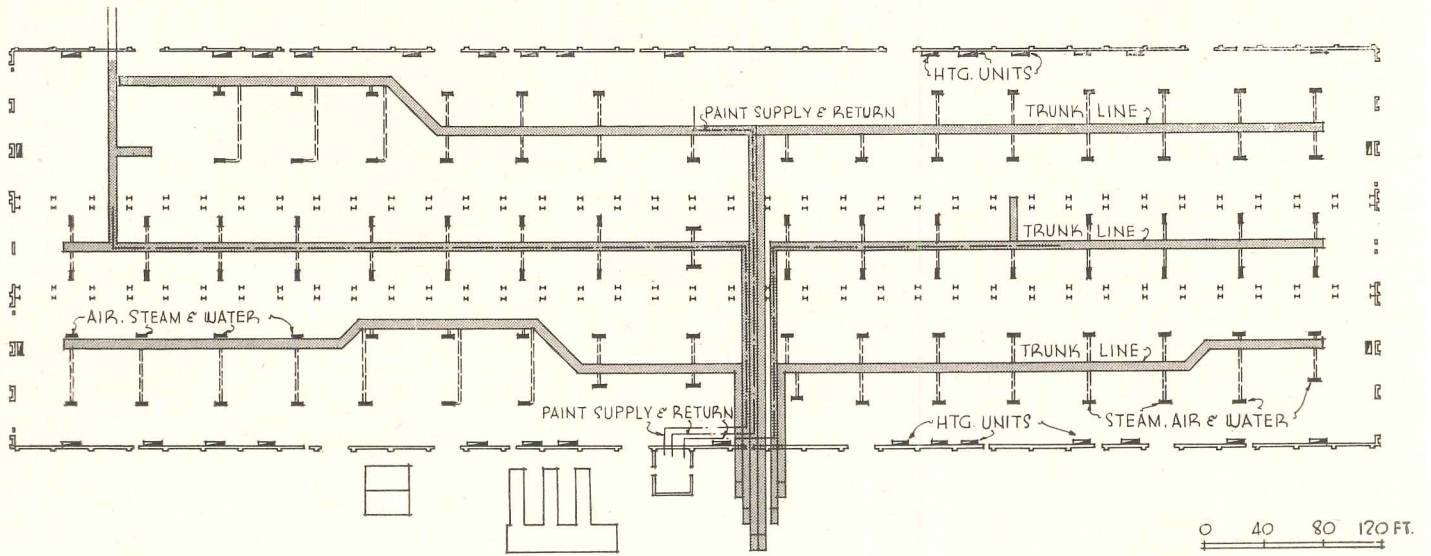

*Six trunk lines under the floor of the building house utilities and air exhaust system. Branch lines connect with floor outlets (visible in photo below). Wall mounted unit heaters supply air in winter. Large blower fans outside building (across page) pull air through exhaust system*





Outlet boxes for the utility system are at 25 ft intervals in the floor (detail below). Side floor chases are covered with steel plates; center portion has screened grill to prevent debris from dropping into exhaust system, water spray to reduce explosion hazard

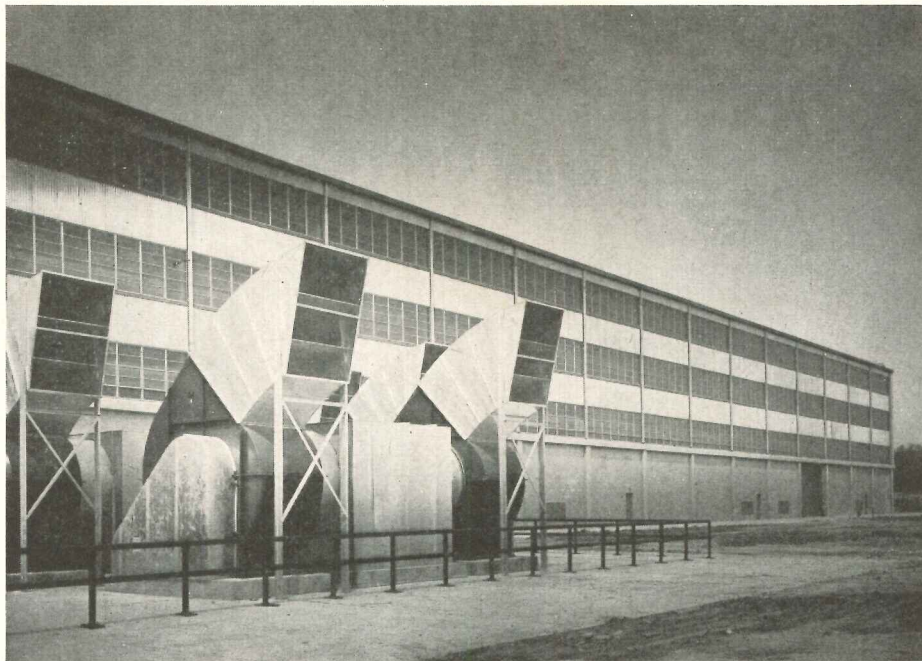
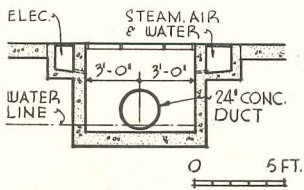

Joseph W. Molitor

*Inverted monitor in center bay gives clerestory windows to augment natural and artificial lighting*

An extremely well organized system for utilities was developed to give flexibility to whatever type of operation might be used within the building. Large trunk lines carry leads and returns for cold water, compressed air, processed steam and electricity. All these are available through floor outlets every 25 ft, with the exception of steam, which is available at every other outlet. Paints and fuels are also carried through the system to certain parts of the building.

However, a major function of the underfloor trunk lines is as exhaust ducts for any obnoxious or toxic gas fumes generated within the building during the repair work. Fresh air is pulled into the building through windows and doors, then exhausted through the ducts by six blower fans located outside the building. At the floor outlets, screens and water sprays are used to minimize hazards of explosion; baffles in the ducts and automatic cut-offs control the water level. Automatic controls also regulate the air pressure within the building. In winter, the fresh air supply is provided through wall-mounted unit heaters.

Daylighting is provided by an inverted monitor down the center of the building and by three continuous strips of steel sash running the length of the structure. All sash are mechanically operated and provided with explosion-proof hardware. Artificial lighting is provided by units at the bottom of the trusses about 60 ft above floor level. Each unit contains a mercury vapor lamp and an incandescent lamp, and gives about 40 foot-candles intensity at work level.

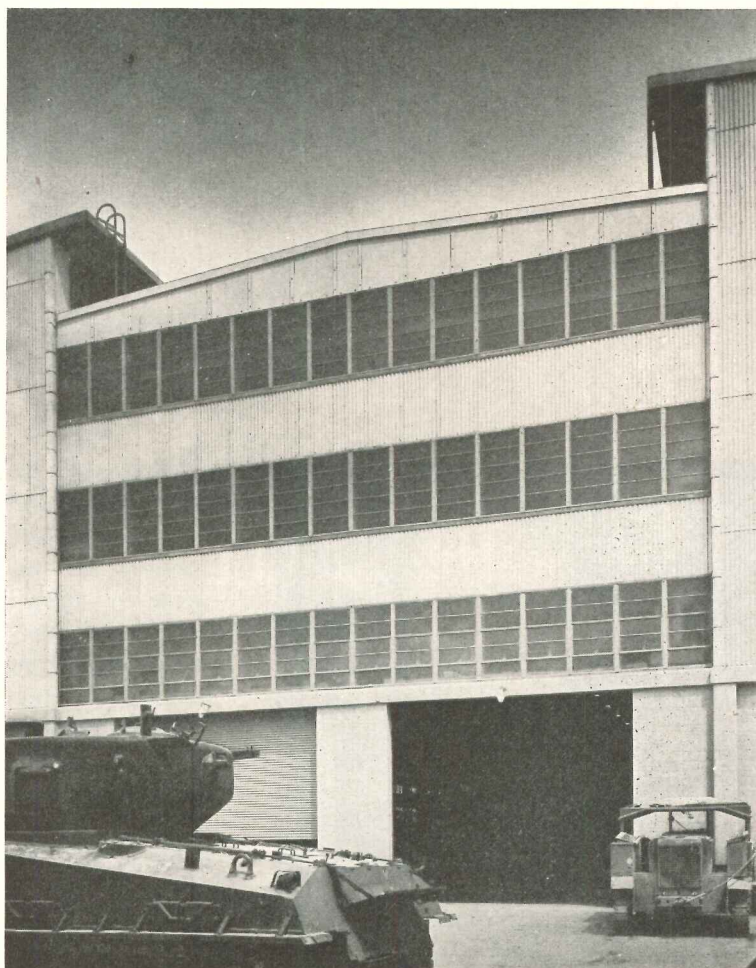



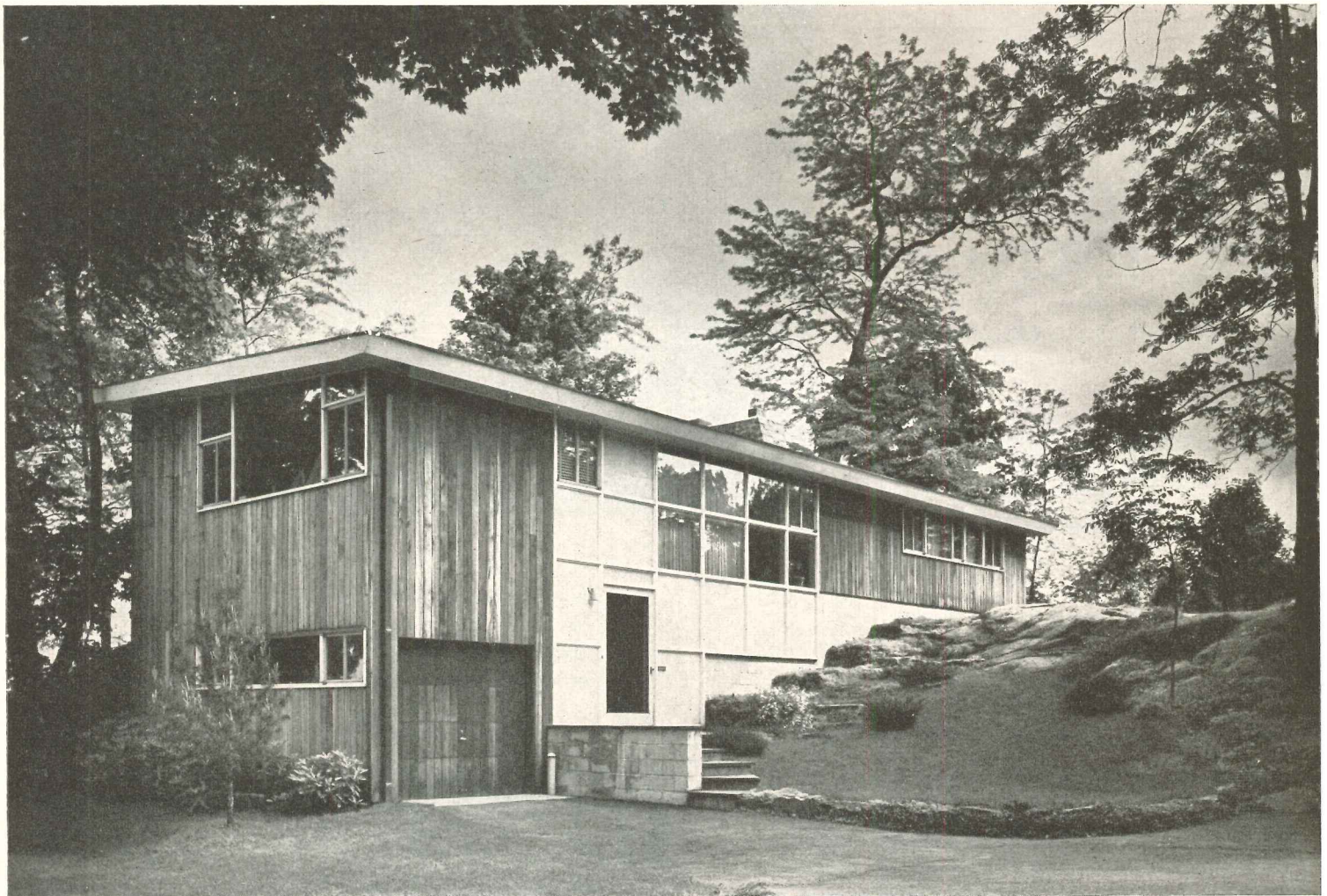

## SMALL HOUSE—LOTS OF SPACE

ONE OF THE MORE ACUTE PROBLEMS in small house planning these days is the difficulty in realizing adequate living space and equipment at a reasonable cost. The theories of open planning have solved part of the problem, but in their extreme forms little, if any, provision has been made to satisfy the average person's yen for some individual privacy. In this compact little house a rather happy balance has been made. Central living, dining and service areas join into an open area for activities and entertaining; the space is further increased by a terrace and glass walls overlooking a magnificent view of Long Island Sound. At each end of the house is a room set apart from the living area by soundproofed walls, one a bedroom, the other a study with a guest-bedroom alcove which can be closed off. Placement of the house at right angles to a rocky ledge gives room for garage and entry at a lower level.





*Residence for  
Mr. and Mrs. John E. Schacht  
Port Chester, New York*

*Carl Koch & Associates, Architects  
Margaret M. Ross, Associate  
Charles Tilton, Architect in charge  
of construction*

Marc Neuhof

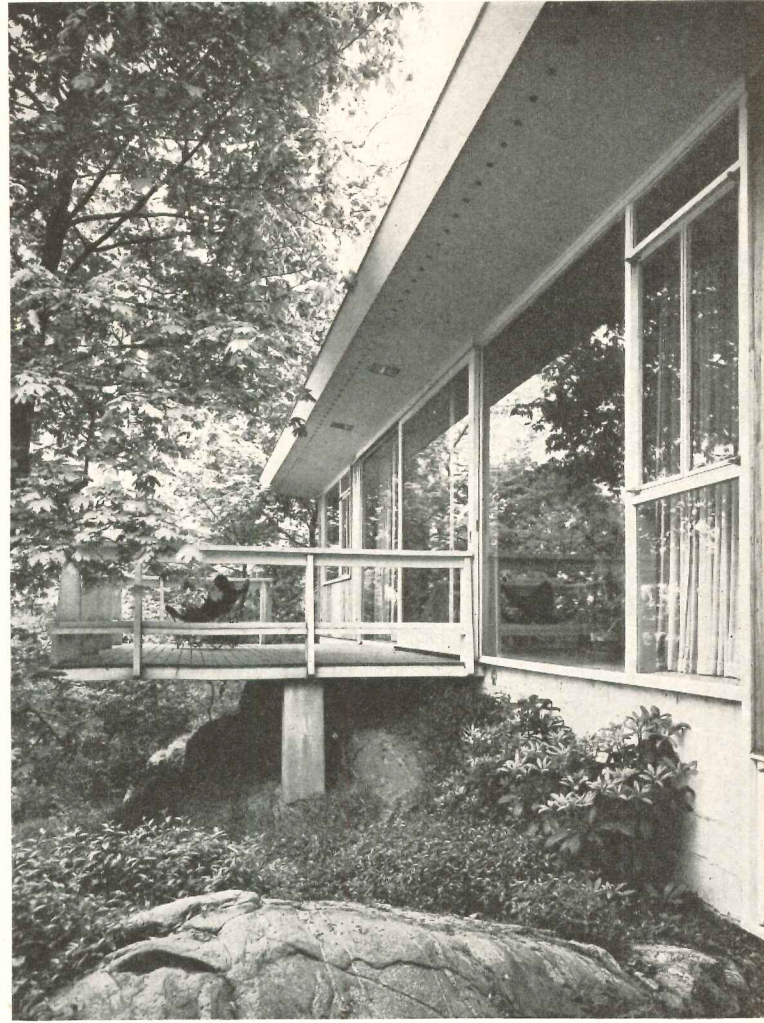
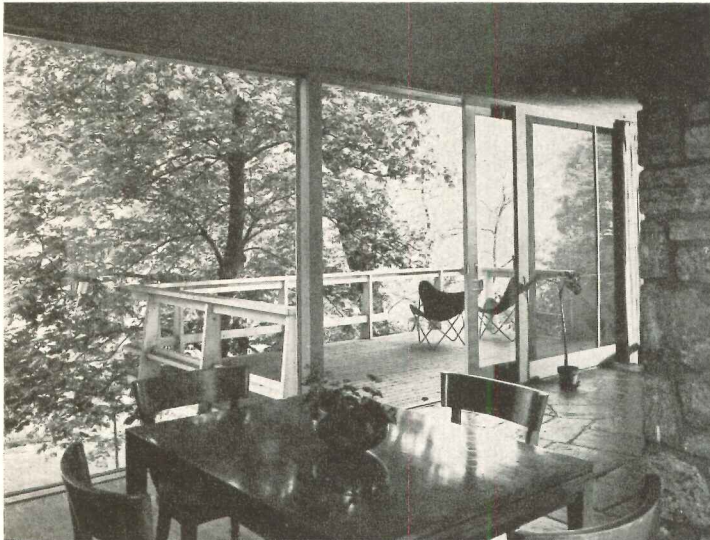

*Placement of large glass areas has been carefully studied to center on view, retain privacy*

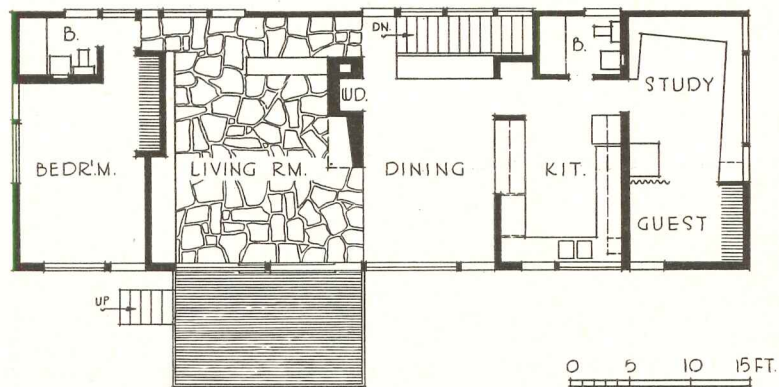

*Circulation patterns in the plan are very convenient, waste little floor space*



**SCHACHT HOUSE, PORT CHESTER, N.Y.**

*The interiors of the house have been worked out to permit convenient arrangements of furniture out of traffic paths. Well organized natural-finish wood storage cabinets in each room have been used to reduce the amount of furniture required. The entire character of the house, inside and out, has been kept informal and simple in keeping with the rocky, tree-strewn site*



*The structure of the house is conventional wood frame with poured concrete foundations, vertical redwood siding, built-up roof. Interior walls are finished with a textured plaster left unpainted; floors are flagstone or linoleum; ceilings are plaster. Heating is by steel pipe panels using hot water; boiler is at lower level. All storage cabinets are custom-made*



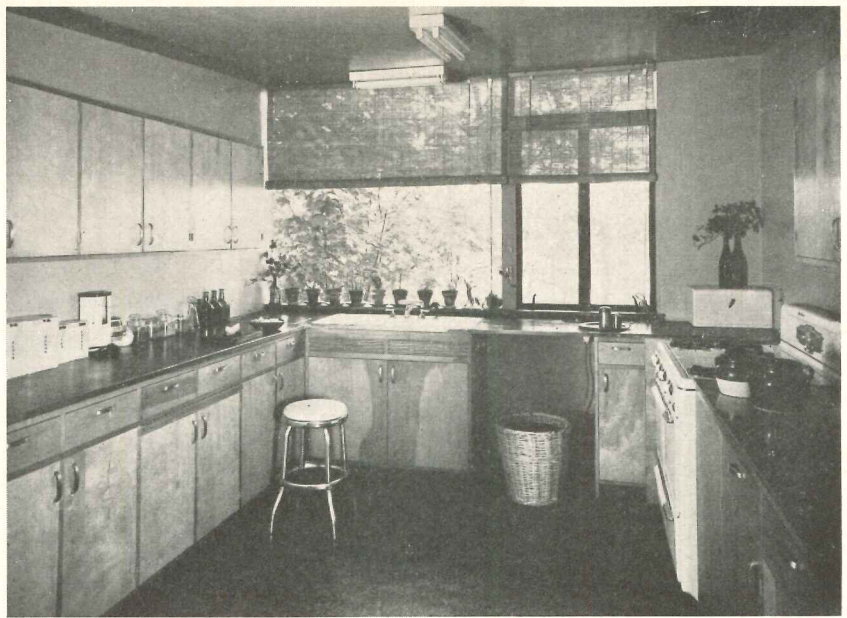

Marc Neuhof

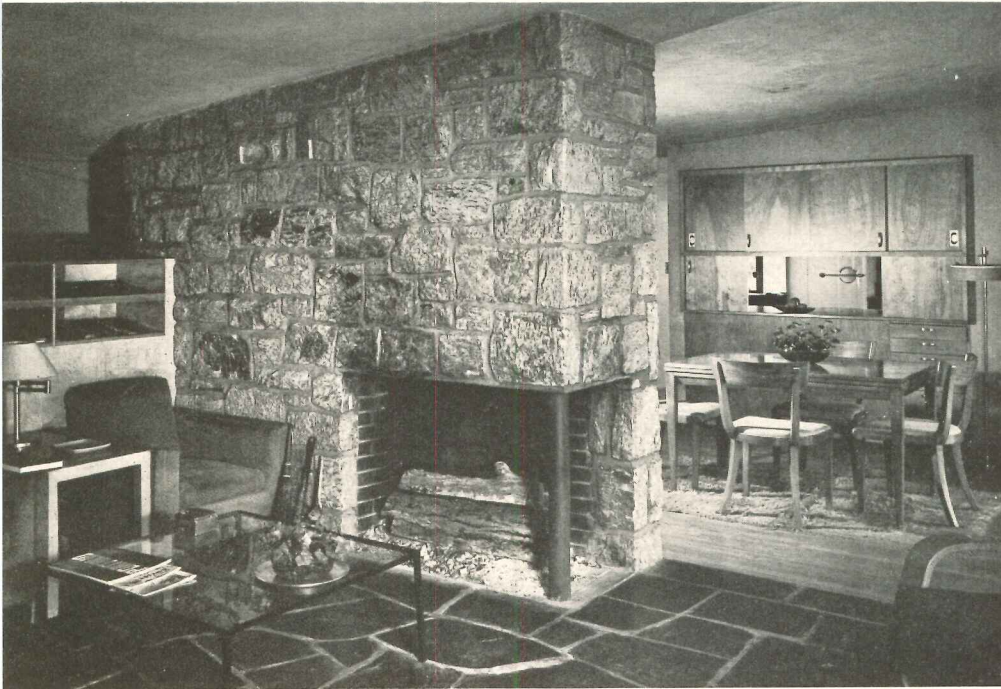

*The living and dining rooms (above and left) form large open area with pass-through into kitchen (top photo). The studio and bedroom (below) provide quiet and privacy for working and sleeping, ample storage for equipment and clothing*

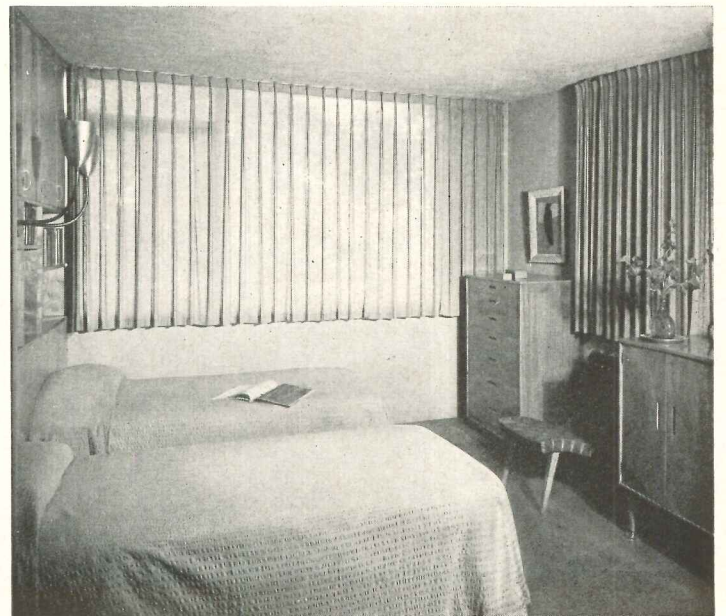
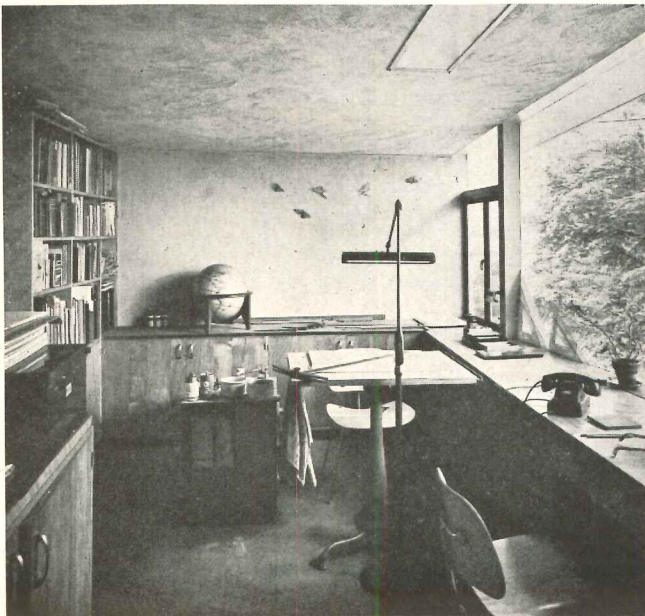





R. Wenkam

## TUBERCULOSIS HOSPITAL IN HAWAII ACCENTS

*Puumaile Hospital; Hilo, Hawaii*

*Quarters for staff are all well away from patient accommodations: nurses' residence in foreground; male and female employes' quarters in center*

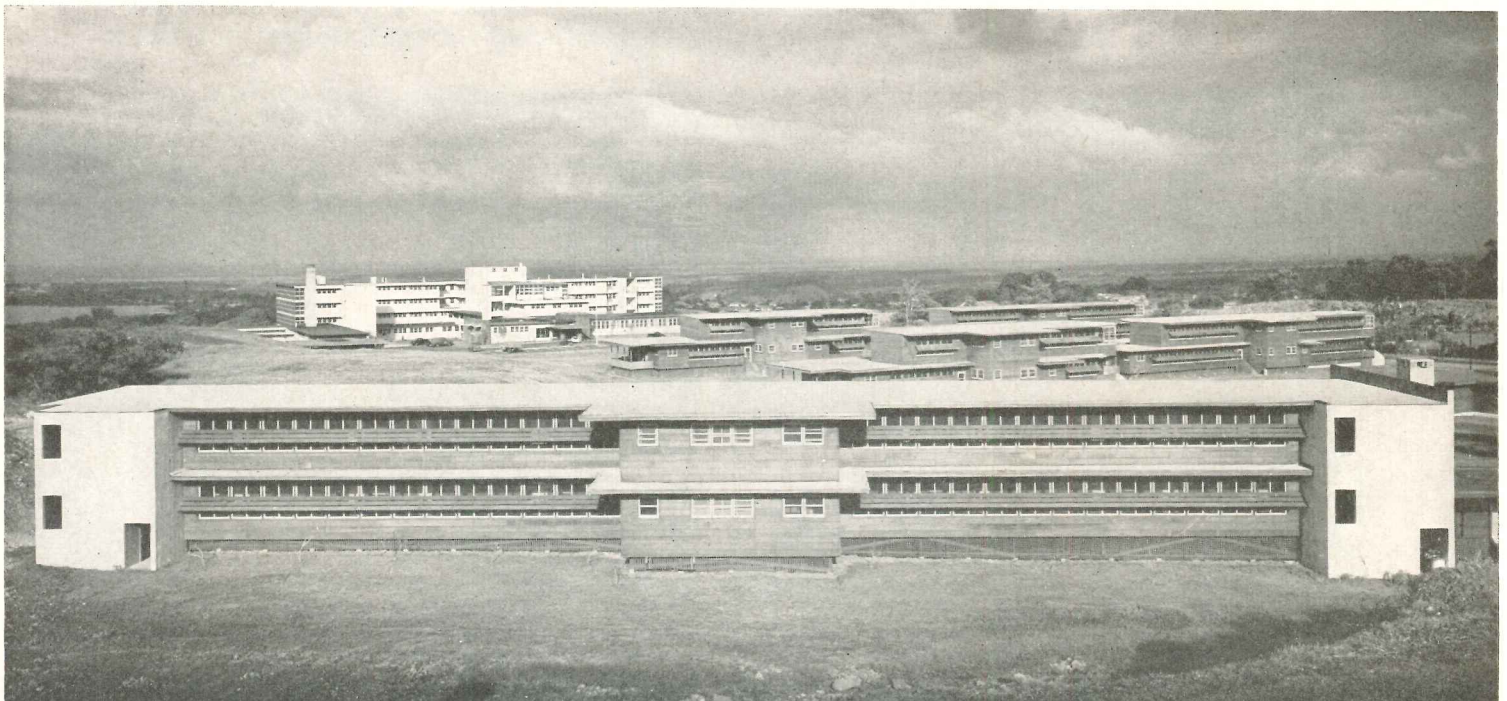



**T**HE NEED for pleasant and cheerful surroundings is probably nowhere in the world more acute than in a tuberculosis hospital, where a patient's stay is counted not in weeks, but in months and sometimes years. Yet because of the contagiousness of TB, such a building must be every inch a hospital. The two requirements do not always go hand in hand.

When this building on the "Big Island" of Hawaii was first presented in ARCHITECTURAL RECORD (April 1951, pp. 150-153), it was under construction and showed every promise of meeting both requirements. It kept that promise, as the photos on these seven pages prove.

Puumaile is blessed first of all with a splendid site on the Wailukee River immediately above Rainbow Falls. From its windows patients can look out on both river and falls, plus the sea, surrounding sugar cane

fields, and the craters of Mauna Kea and Mauna Loa, the latter still occasionally active. The best view, by great good luck, is to the northeast — the sector from which the cool trade winds blow for most of the year, and toward which the patients' rooms had to be oriented since the semi-tropical climate and relatively high humidity made good ventilation all-important.

Despite the fact that this is a 216-bed institution with many of the facilities of a general hospital, it is a pleasant and friendly building, thanks to its open walks, screened lanais and general design. Of rigid frame concrete construction, it is earthquake resistant with expansion joints, control joints and weakened planes. Facilities include x-ray and pneumothorax rooms, an operating room, morgue, laboratory, dentist's office, barber and beauty shops, canteen, and auditorium.

## CHEERFUL SURROUNDINGS

*Merrill, Simms & Roehrig, Architects*

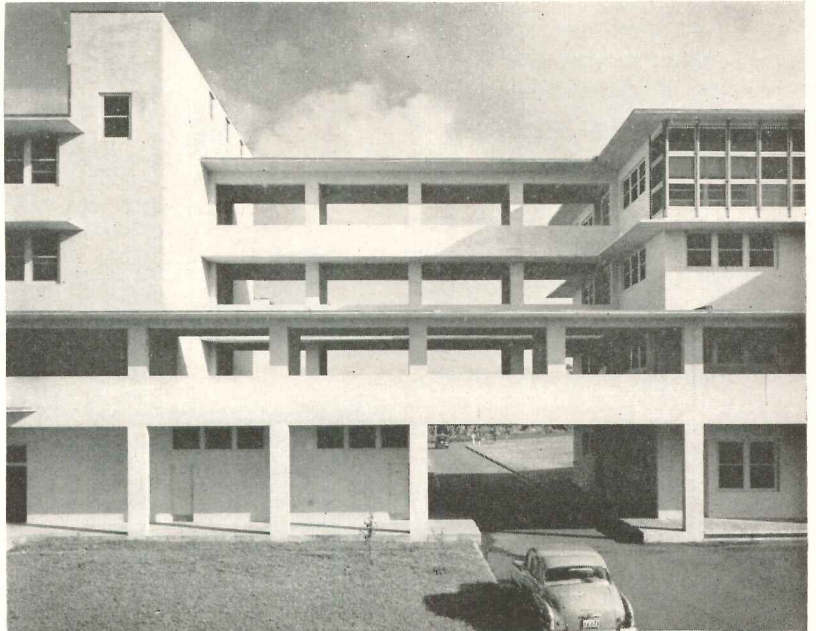

11

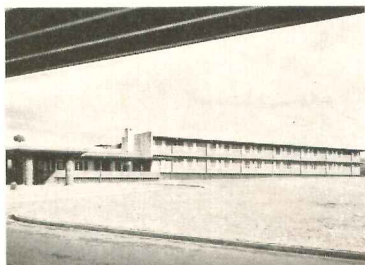

15

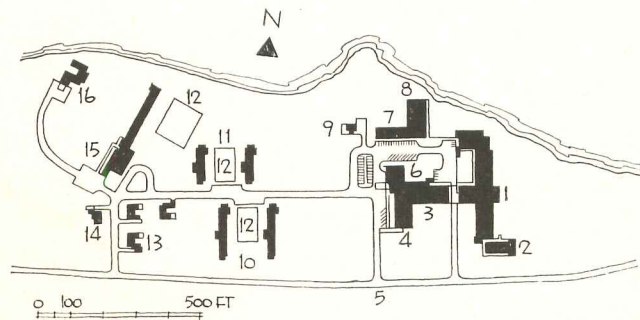

- 1 Nursing
- 2 Assembly
- 3 Diagnostic, Therapeutic
- 4 Out-Patient
- 5 Main Entrance
- 6 Administration
- 7 Shop, Service Building
- 8 Laundry
- 9 Animal House
- 10 Male Personnel
- 11 Female Personnel
- 12 Tennis Courts
- 13 Doctors
- 14 Nurse Director
- 15 Nurses' Home
- 16 Medical Director



10



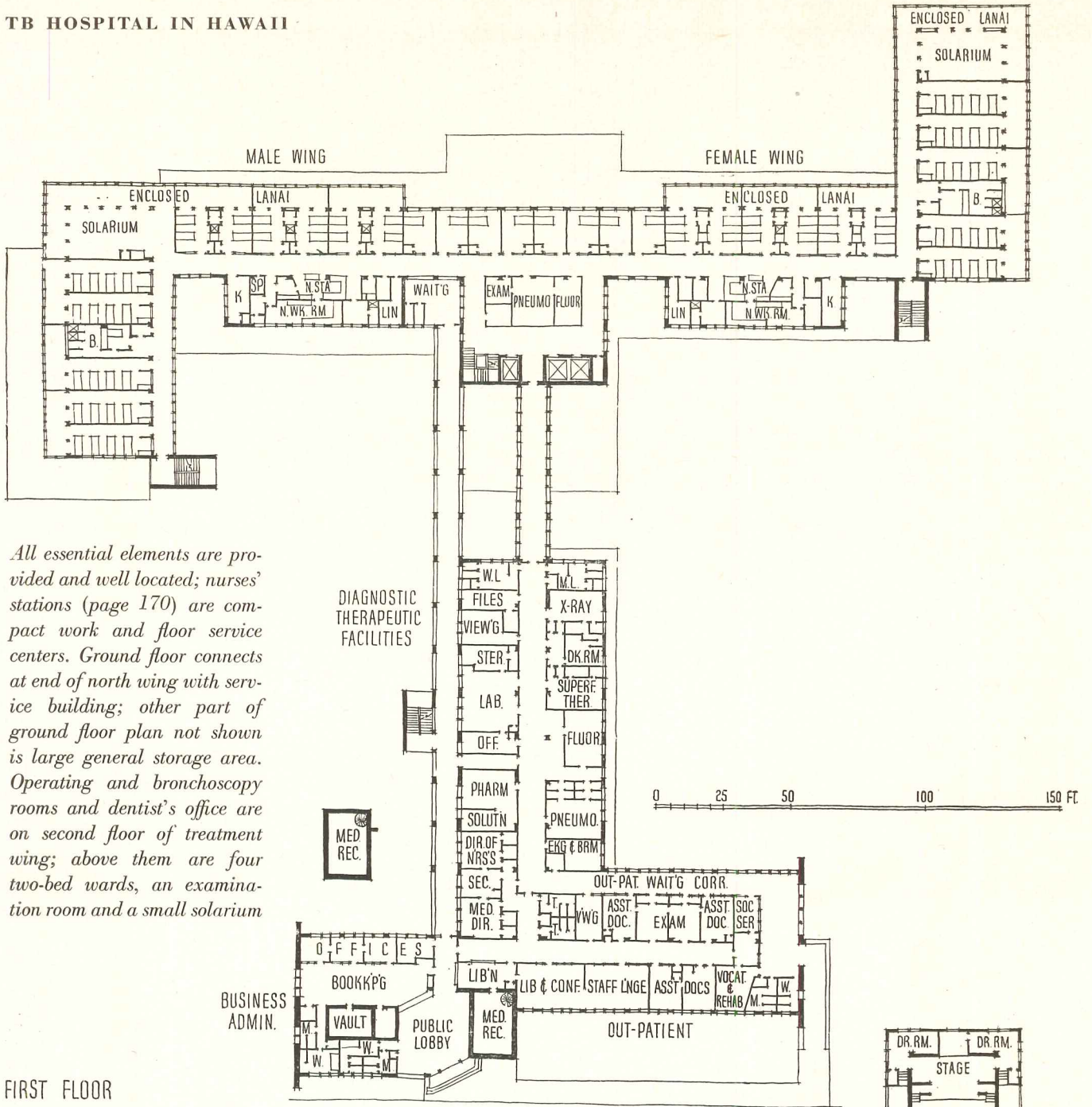

FIRST FLOOR

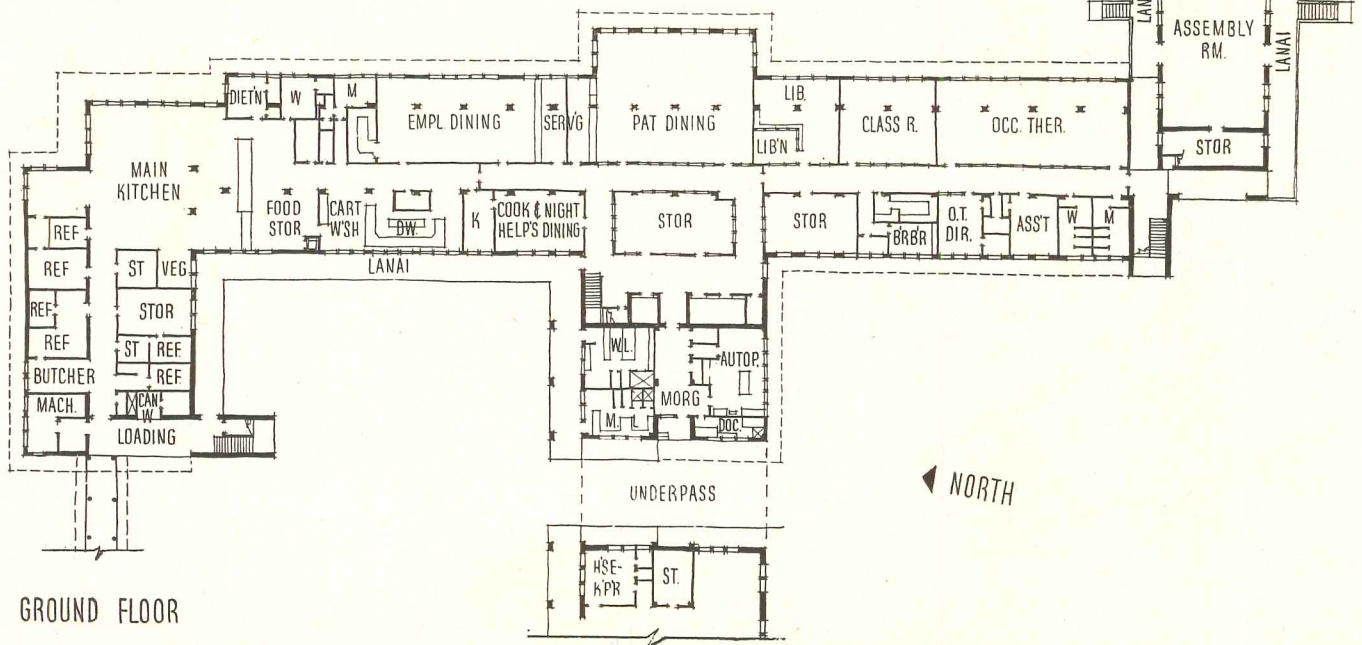

GROUND FLOOR

All essential elements are provided and well located; nurses' stations (page 170) are compact work and floor service centers. Ground floor connects at end of north wing with service building; other part of ground floor plan not shown is large general storage area. Operating and bronchoscopy rooms and dentist's office are on second floor of treatment wing; above them are four two-bed wards, an examination room and a small solarium



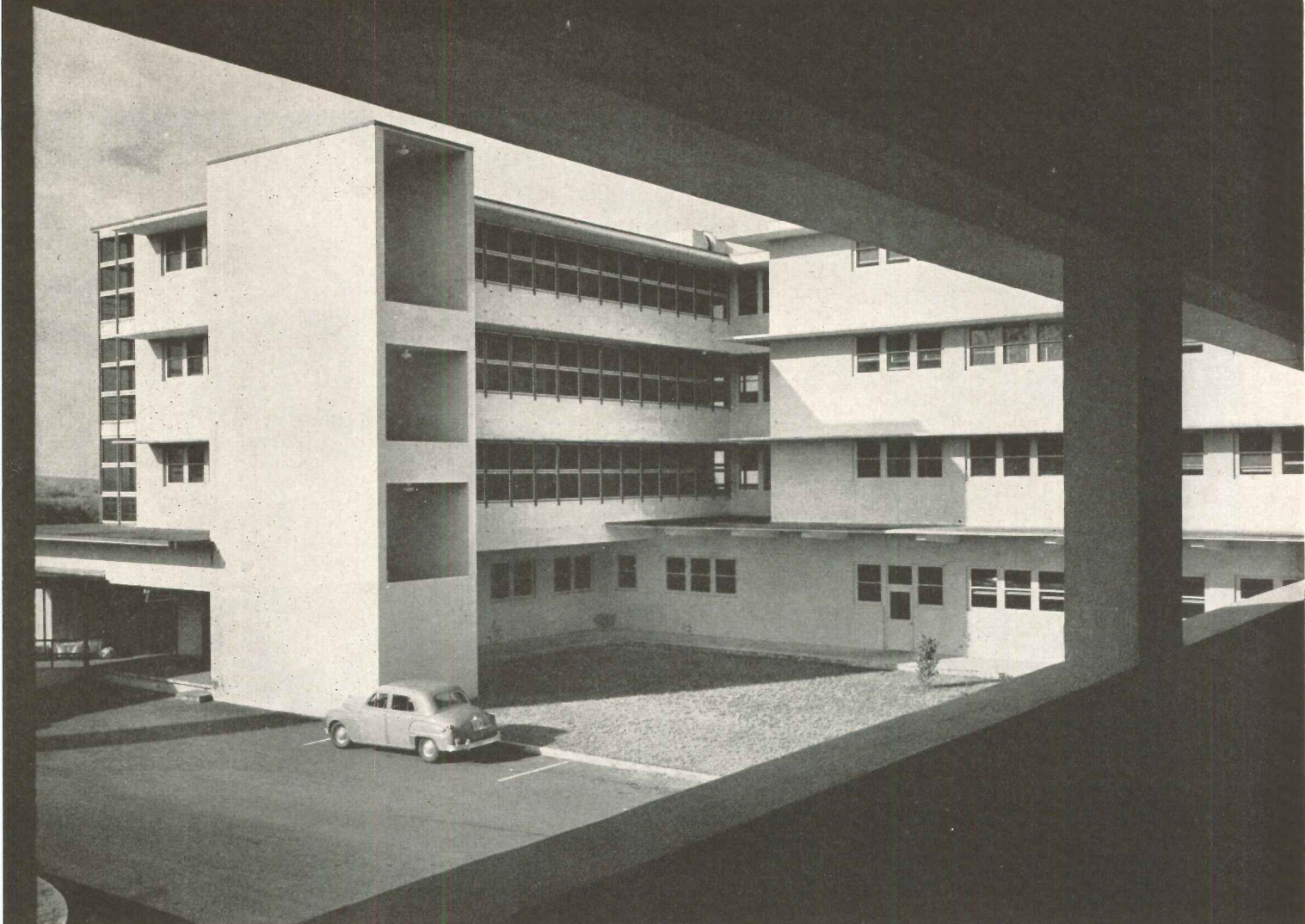

*Above: north arm of nursing wing, seen from covered walk to treatment wing; this walk doubles as secondary corridor for visitor traffic, which is easily controlled from information desk in main lobby. Below: main lobby, looking out toward personnel quarters. Exterior of building is painted a warm sandstone with aqua eyebrows*

R. Wenkam





TB HOSPITAL IN HAWAII



*Nurses' stations are compactly surrounded by necessary floor services such as utility and sputum disposal rooms, janitor's closets; change in wall color at station reminds staff of entrance to sterile area. Cane fiberboard insulation on corridor ceilings keeps noise out of wards despite ventilation space above partitions*

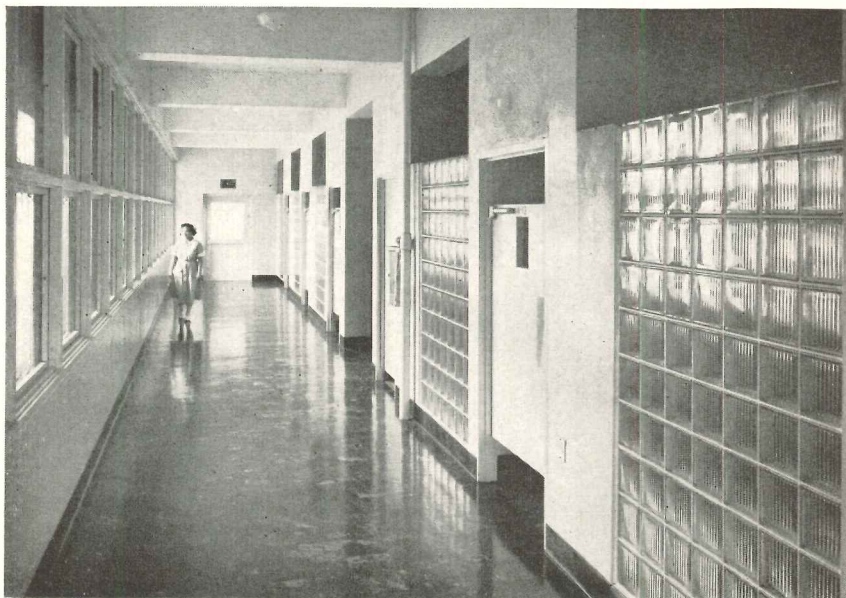



Typical Four-Bed Ward

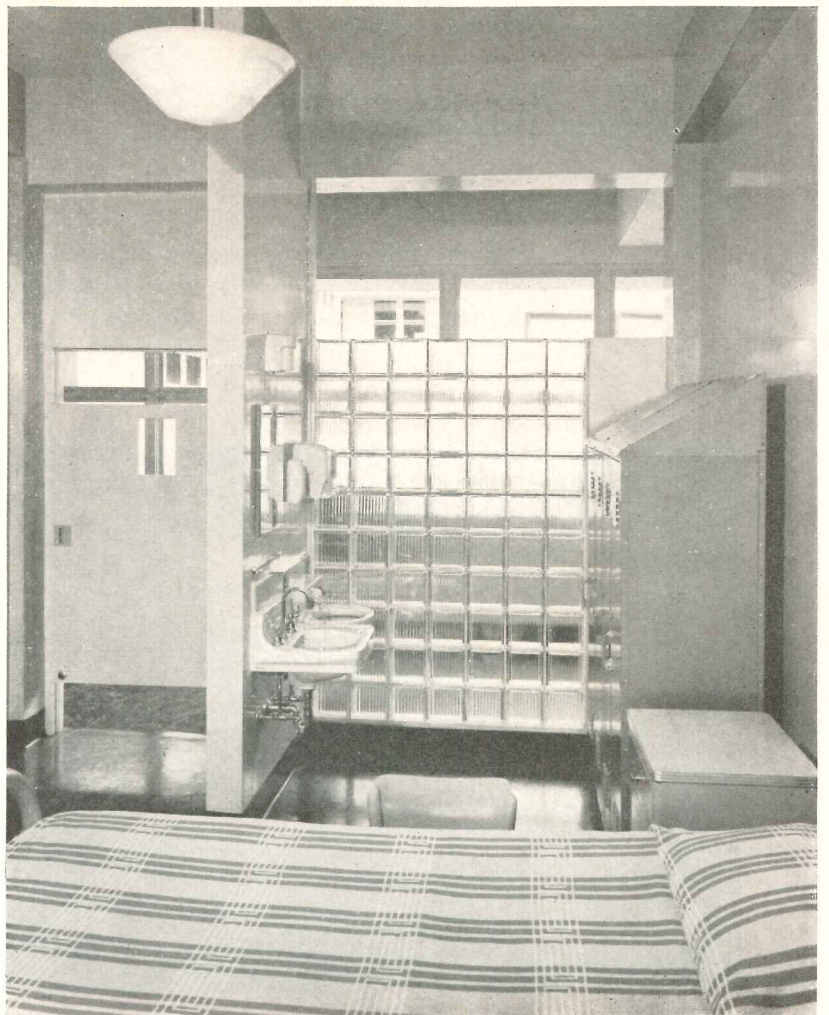
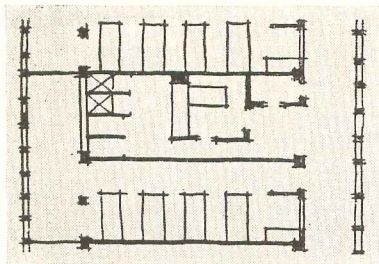

Except for a few private rooms, patients' accommodations are two- and four-bed wards, each opening to a screened lanai. Windows in all patients' rooms are triple-hung wood louvers extending room width. Window walls are painted in very light colors to reduce brightness contrast; walls behind and facing beds are gray-green, corridor walls are champagne buff

R. Wenkam





TB HOSPITAL IN HAWAII

*Facilities for ambulatory patients include a solarium at each end of every nursing floor, a library, dining room, barber and beauty shops, canteen, chapel-auditorium, occupational therapy room and classroom. Bottom of page: hospital kitchen and corner of dietitian's office*

R. Wenkam

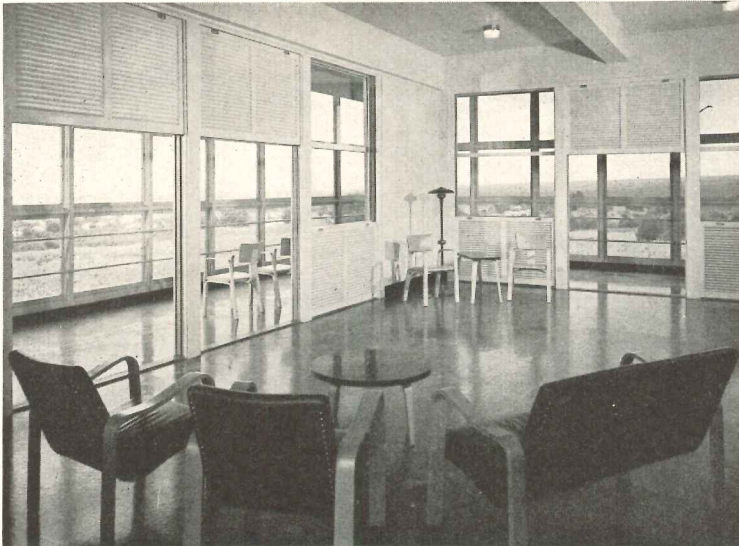



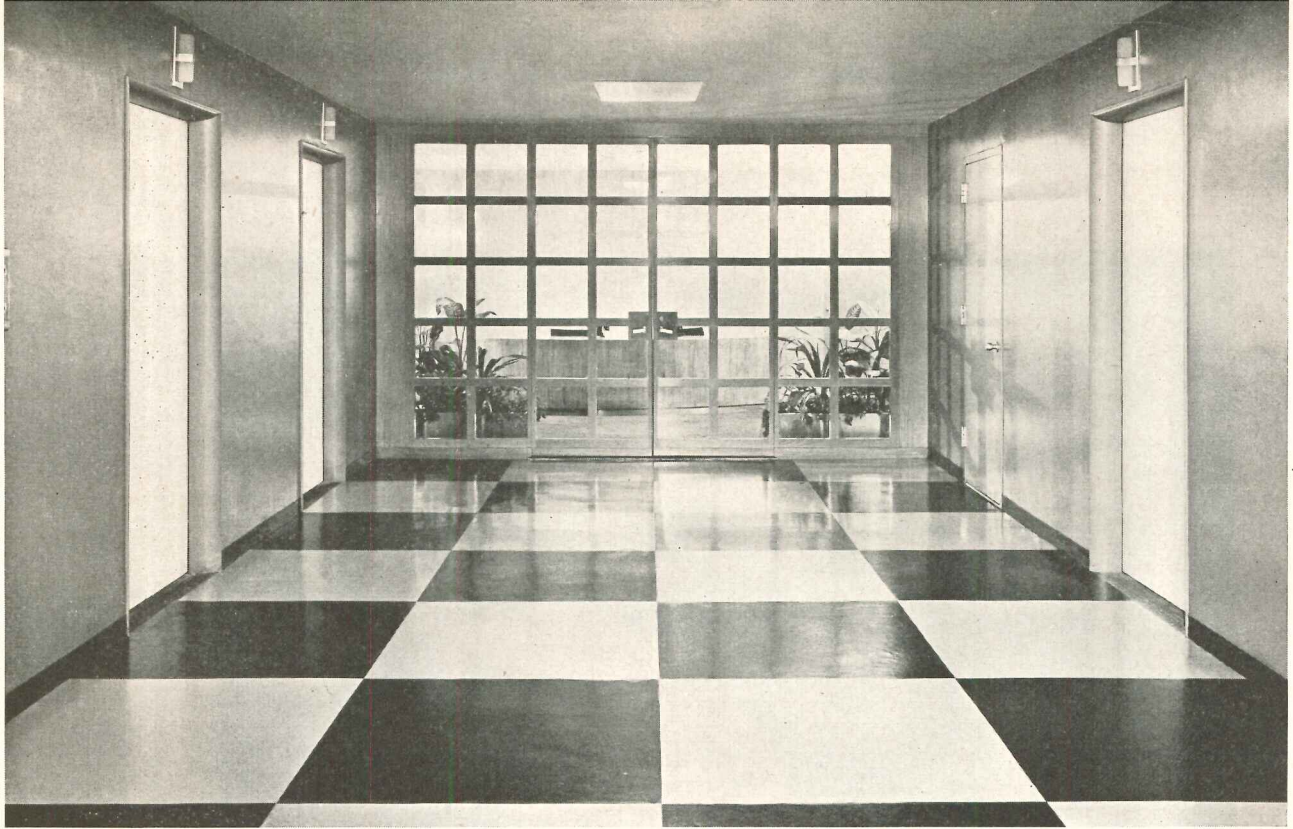

Ben Schnall

## ARCHITECTURAL INTERIORS

*Design* | *Details* | *Materials* | *Equipment*

*Offices for Cunningham & Walsh, Inc.*

*New York City*

## COLOR ENLIVENS OFFICES

*Carson & Lundin, Architects*

*Alfred Rummler, Inc., Custom Furniture*

*Smith & Silverman, Electrical Engineers*

*Sears & Kopf, Mechanical Engineers*

**B**OLD USE OF COLOR marks these offices for a large advertising agency. From the elevator lobbies (the company has two floors, treated alike) to the innermost corridors, the colors are unorthodox and highly effective. In the lobbies, for instance, walls are covered with a deep olive green plastic sheeting, and floors with huge black and beige vinyl squares; elevator doors are painted parchment white. Gray, yellow, blue, terra cotta and green are used in varying combinations to relieve the monotony of long corridors and large working areas; corridors seem wider than they are because opposite walls are in different colors.



# ARCHITECTURAL INTERIORS

Design | Details | Materials | Equipment

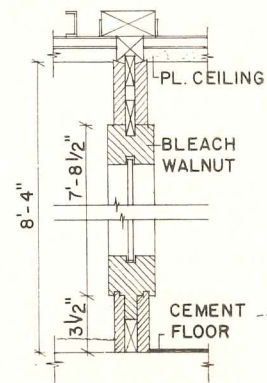
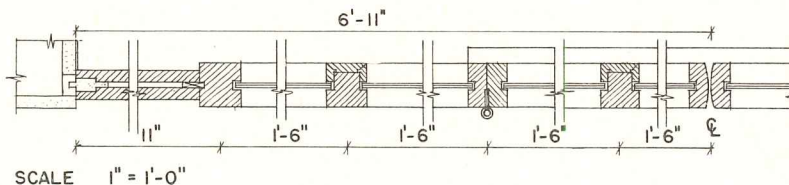

Particularly nice feature on executives' floor is bleached walnut and glass screen (detailed plan and section above and right) separating reception room and elevator lobby. Wall behind curved reception desk is bleached walnut, carpeting is olive green, wall drapery black on beige. Upholstery is bright orange, black leather, black and white tweed. Below: plan of zoning and traffic flow on executives' floor

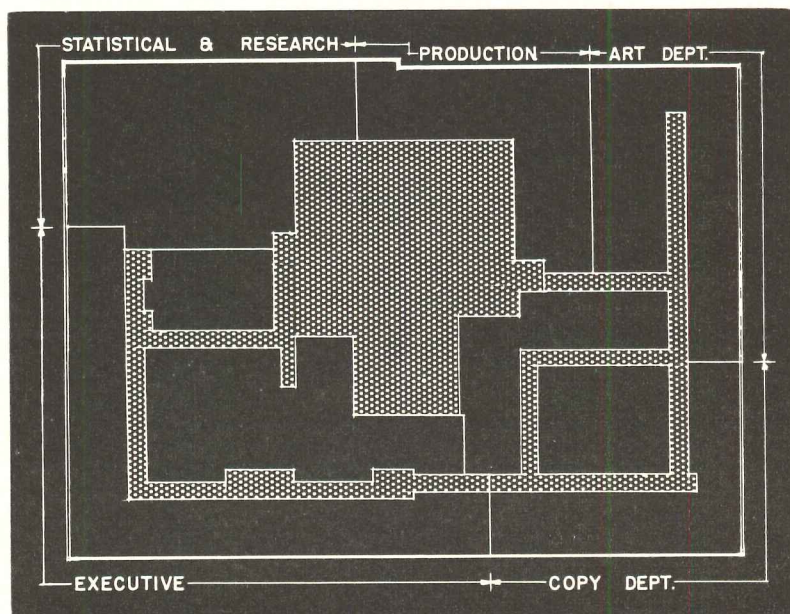

Drafting by Mogens Leih



*Oval conference room and connecting clients' room on executives' floor have walls of Burma teak, pale gray carpeting. Large panels of cork on side walls of conference room provide display space for advertising material; table and chairs are bleached mahogany, chair upholstery is deep blue leather. Clients' room has wall drapery of yellow and black print on gray; furniture fabrics are in varying shades of blue, yellow and gray*



Ben Schnall

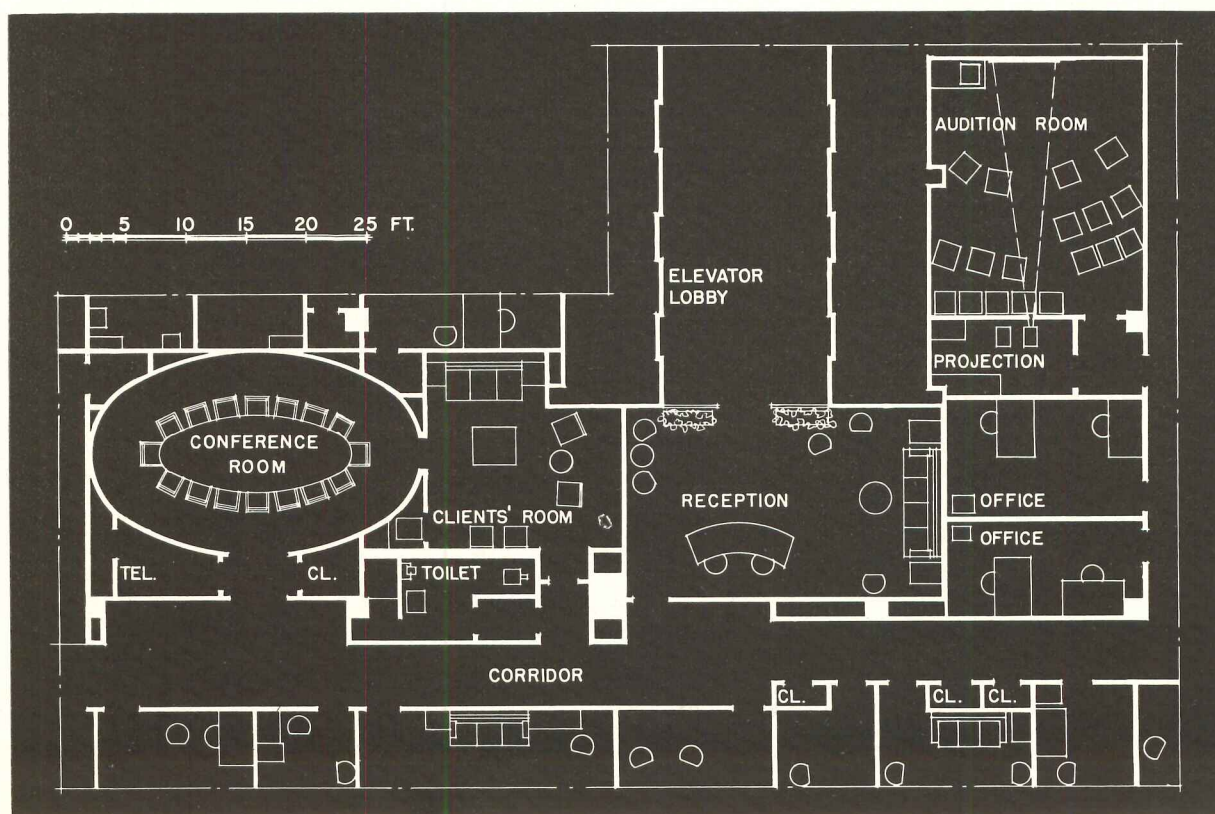



# ARCHITECTURAL INTERIORS

Design | Details | Materials | Equipment

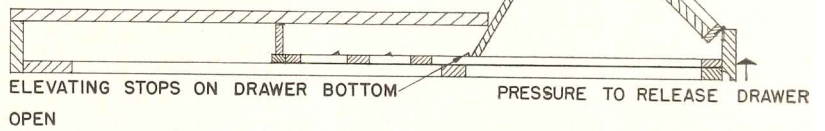
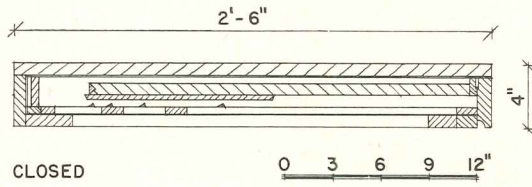

*L-shaped desk in account executives' office gives exceptionally good working area and ample conference space; built-in drawing table (details above photos) is convenient for swift sketch layouts. Like conference room, this office has cork wall panels for display. Skylight-type fixture over desk provides good light without surface glare*

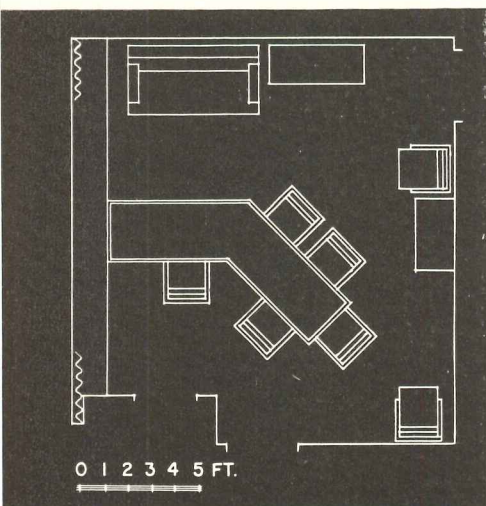





Ben Schnall

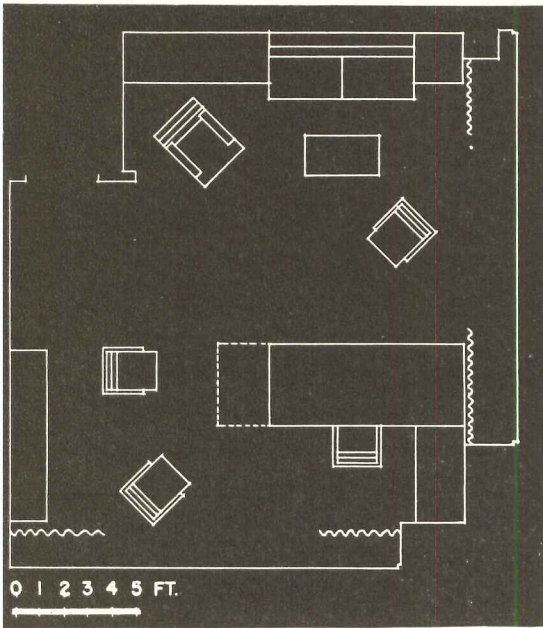

*J. P. Cunningham's office has some wall areas in paneled cherry; one wall is painted a deep brown. Carpeting is cocoa, draperies are brown and orange on natural background. Plaid on couch picks up predominant colors in rest of room. Large desk has hinged side panel for use in conferences*





The Bettmann Archive



A 16th century market from an old engraving

Photo from Pix — Ed Goldman



Push-cart market, Lower East Side, New York

## SHOPPING CENTERS

### Introduction

The sudden mushrooming of suburban shopping centers is one of the most interesting aspects of the postwar building boom — for here is a new concept and a new building type non-existent only a few years ago which is now abuilding at crossroads all over the land. Where did these come from and why? What happens downtown when one is built in a suburban fringe? Have any sound planning principles been evolved? The answers to these and many other related questions are of interest to architects when they enter upon this extremely active field.

In a recent news story, the Urban Land Institute had this to say, "It is true that the central portions of cities are not growing rapidly. Increases in population are taking place in the suburbs and in the fringes outside corporate city limits. With this new pattern of urban growth, shopping centers are coming into being by reason of the increase in suburban population and the resultant increase in purchasing power located there rather than by reason of any flight of downtown business. The impact of the automobile makes possible a redistribution of expanded commercial and industrial activity over a greater area surrounding the metropolitan core.

"Downtown areas are holding their dominant position . . . by reason of the pulling power built up during the mass transportation era. Whether this magnetism will continue depends on the central business district's ability to safeguard its wide selection of goods and concentrated purchasing power.

"The real resource of downtown is the crowd — the shoppers, the workers, the transients, the public seeking services. The crowd is important to the retailers, the newspapers, the banks, the property owners, to the community as a whole. To hold this asset in an era of individual mobility means that the central business district cannot rely on tradition but must make deliberate improvements.

"The required improvements include freedom from congestion, provision

In its long and useful series of Building Types Studies, ARCHITECTURAL RECORD has published much material on the retail store. Now, with suburban retailing occupying a new type of building recently evolved, ARCHITECTURAL RECORD presents herewith its third study of Shopping Centers.



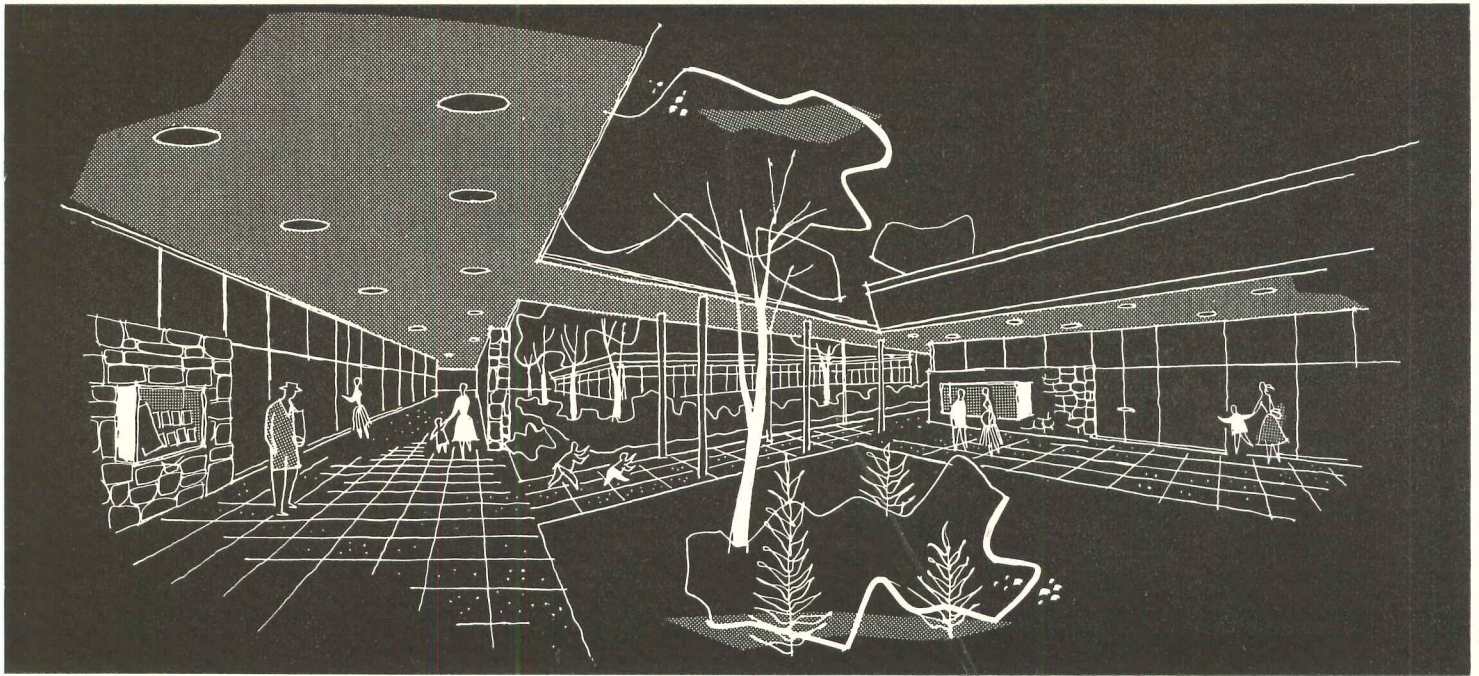

The mall, Fairless Hills Shopping Center, Pa., Tully & Hobbs, Architects

for offstreet parking spaces in ample number, convenient access, better and faster mass transit, attractive modernized buildings, and attention to the amenities including elimination of garishness, unnecessary noise and impediments to easy circulation. The suburban shopping center incorporates these criteria.

“Established business districts must not only look to their laurels; they must initiate positive action. Otherwise the planned regional shopping center, with its full range and depth of goods for comparison shopping and with its facilities for easy marketing and customer appeal may become a direct competitor of and not a supporting complement to the downtown district.”

A prominent architect who is actively engaged in shopping center work has said that the most important single element in successfully designing such projects lies in the architect's state of mind. He explained that the architect must make every effort to approach the work as though he were the *owner* of the project — and design accordingly. This does not imply the giving up of high artistic and professional standards; on the contrary, they must simultaneously be held at the highest level. To express it in another way — the center must *first* be planned for successful financial operation and within this discipline should then provide all the amenities and attractiveness possible.

Comprising information in this vein which should prove both useful and interesting to architects, the main body of our text will present the latest ideas of owners, market analysts, real estate men, and merchandising consultants insofar as these ideas bear directly upon the activities of the architect. Certain portions of the recent study\* on the subject compiled by the Urban Land Institute, Max S. Wehrly, director, will be quoted. Additional material from our own or other sources will be interspersed in a *different type face* to amplify certain points.

\* *Technical Bulletin No. 20, Shopping Centers; Planning Principles and Tested Policies Based on Experience from the Community Builders' Council. Compiled by J. Ross McKeever and published by the Urban Land Institute, Washington, D. C. \$6.00.*



L shape two-level shopping wraps around a free-standing Macy  
“puller” in Architect Victor Gruen’s Bay-Fair, San Francisco

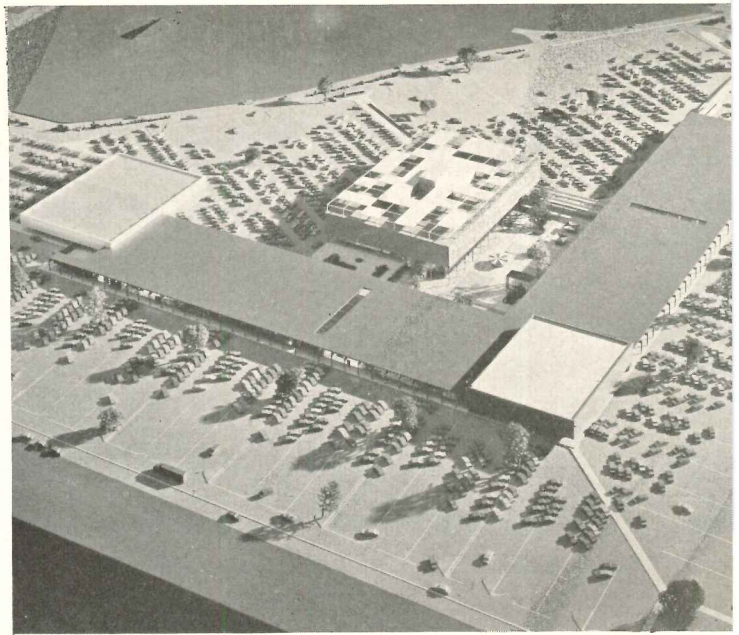

Harry H. Bask

## A Place to Begin

The present day shopping center began as an experiment to go with suburban living. It grew out of the early Sears and Wards branches built on a lot with a place for parking customers' cars. It evolved from a single unit into a series of stores under one management. Then, later, the series took on clear characteristics as try-outs became successful practices. Early developments were the ventures in Baltimore at Roland Park, in Kansas City by J. C. Nichols, in Dallas by Hugh Prather, in Houston by Hugh Potter. The pioneers of the Twenties and Thirties created the pattern for the merchandising phenomenon that is the shopping center of today.

The development of shopping centers has progressed . . . to the extent that such construction . . . can be called a building type. Even so, there is not much long-term practice to set hard and fast rules. At best, we have rules of thumb. But developers . . . have tested theories about shopping center planning based on their own experiences. An account of experience is a good place to begin.

The planning and operation of a shopping center include more than high hopes or hunches. The development has moved from a single operation to one involving research, planning and promotion by a team of specialists.

**first — economic analysis:** Ultimate success will depend upon the care taken to evaluate the market. Market analysis is the substitute for the golden hunches of the real estate genius. Hugh Potter says, “When the shopper was at the mercy of mass transit lines ‘100 per cent locations’ were a safe substitute for market analysis. But when widespread auto ownership liberated the customer . . . it became evident . . . that the shopper could be pulled almost anywhere by a strong merchandising attraction and by what the downtown district so signally lacked — a place to park the car.” The market analysis determines the kind and size of project, and is a job for an expert in that field.

**second — site selection:** Decision on the site is the next step, and the decision relates to all the factors of suitability. These will be discussed in detail later.



*Too often the architect is not consulted early enough in the selection of the site when his advice to the owner might be invaluable. Such considerations as shape, orientation, access, slopes, drainage, soil conditions, etc. should be his direct concern from the beginning.*

**third — preliminary site planning:** The next operation includes preparation of preliminary plans for the building and site layout, and requires the services of the architect. The project begins to take form in its eventual adaptation to the physical characteristics of the site and the trade area. Site engineering studies and tests are made to learn the sub-surface conditions. During the planning phase the time is ripe for preliminary negotiations with prospective tenants. After there has been agreement on the land usage of the site, the traffic planning and the merchandising setup, the project is ready to move towards its next stage.

**fourth — detailed architectural plans:** "Do we want air conditioning; are our costs in line?" At this stage, the project starts shaping toward reality. Final plans must clear with municipal authorities; the architectural, structural, and mechanical drawings assume final form; parking and traffic handling arrangements become fixed; a prospectus is prepared for lease negotiations with tenants. After leases with major tenants are signed, the project is ready to move toward ground breaking and actual construction.

## What Makes a Shopping Center

In general these are the ingredients for a good shopping center:

A site layout that will provide a store group with minimum walking distances, both from parking areas and within the store group itself

A store group that can be merchandised to provide the greatest interplay between stores

An arrangement that eliminates all poor store locations and difficult parking stations

Separation of foot traffic and automobile traffic and elimination of all service facilities from the public consciousness

A management that is efficient and capable of obtaining cooperation from individual tenants for the benefit of the whole center

A unified architectural building group that looks like a shopping center and not an assemblage of miscellaneous stores.

Omitted from the above listing are the inflections, the interpretations, the innovations that must be made in order to apply these ingredients to your site and . . . local conditions.

## Site Selection

In site selection, the same principles will hold, but in varying degrees, whether the center is to be a small neighborhood development or a regional giant. The points to evaluate are:

**location** is of primary importance. Hugh Prather, owner-developer of Dallas, says, "The most important point in determining location is to be sure that your site is located near a well populated residential area or one that is growing so rapidly



Emporium Department Store, Stonestown Center, San Francisco, Welton Becket & Associates, Architects and Engineers



that it gives promise of soon being able to support the size of shopping center you contemplate.”

Charles E. Joern of LaGrange Park, Ill., gives these five points in determining location: “Purchasing power to be tapped, stability of income in the trade area, location and size of competition, future growth, and accessibility.”

Another point is added by Walter S. Schmidt of Cincinnati: “The side of the street . . . can spell profit or loss. If the center is in an outlying area, retail stores should be on the right side of the outbound street to catch going-home traffic.”

**access** is a very important consideration. Mr. Schmidt says, “A location at the intersection of two heavily traveled highways is not the best. If entrances and exits are too near a major intersection, the interference with through traffic can create a congestion problem. Traffic planning must make it easy to turn right into the center. It is better if the location is accessible to major highways rather than on them, though the ability to see the center from the highway is of great benefit for its advertising value.”

As for regional centers, Mr. Schmidt adds, “To achieve the maximum accessibility the site should be at, near, or readily convenient to at least two main highways. If the location is adjacent to a high speed expressway, the turn-in facilities are important.” A cloverleaf intersection is not best for convenience of access.

*Driving time distance plays a leading role in the accessibility of a site. According to studies made by the United States Bureau of Public Roads in cooperation with state highway departments,\* most shoppers are reluctant to travel more than 25 minutes by private automobile or more than six miles or 20 minutes by bus. The time element often plays a more important part than mere nearness, especially for the medium sized development. For more careful study of this factor, it is extremely revealing to plot driving times as contours on a map. Such an approach points up the fallacies of the old concentric circle method.*

**size** should be at least sufficient to provide the minimum acreage set up by the preliminary estimates from the market analysis. In estimating area needs, Mr. Seward H. Mott uses these guides as rules of thumb: “For an acre of ground, 10,000 sq ft can be allowed for gross store area. A car parking space takes at least 300 sq ft (including a proportion for travel lanes). On this basis about 100 cars can be parked per acre — this allows a 3 to 1 ratio.”

The allowance of space to grow is a safeguard for the future, particularly with centers in mushrooming suburbs. Too often, a successful center is built without reserving extra land for future growth — not only for an increase in customer parking but also for additional sales area.

Another note: the site should be all in one piece. Mr. Potter adds for emphasis “Do not divide the shopping area by any cross traffic streets.” Note, though, that a *minor* road through a site does not always interfere if carefully handled.

*Another factor to consider is the **shape** of the site, for it can often exert undue influence upon the resulting layout of buildings. Beware of the odd shaped area that can be purchased cheaper, for it may make good planning difficult to impossible, and it is often wise to pay a little more for logical trade lines and shorter walking distances.*

As for **topography**, the older idea that the flat, open site is best no longer holds. Two-level parking which permits two-level entrance to department stores is today a popular arrangement; some developers even create such a multi-level scheme when they

\* *New York Herald Tribune, March 10, 1953.*

Driving time map reveals fallacy of old concentric-circle distance map in studying site accessibility. The Center, Omaha; see right page

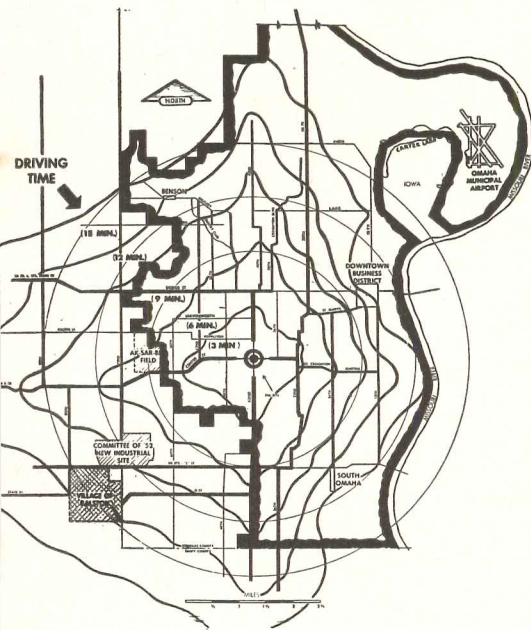



have a level plot. Under certain conditions, a sloping site can also make construction of delivery truck tunnels easier and cheaper.

**sub-surface soil conditions** should be investigated at the earliest opportunity, for if unfavorable, they may make foundation work unduly expensive. Caution is advisable when such hazards as hydrostatic pressure, rock blasting, deep excavation, or others must be dealt with.

**utilities** should ideally be near or in place. The problems of obtaining water, sewers, storm drainage, and power should be looked into before property acquisition proceeds too far.

*If utilities are not in place, the cost of bringing them to the site must be added to the cost of the land.*

**Customer comfort in Nebraska's rugged climate provided by all weather air conditioned shopping space reached from two level parking. The Center, Omaha, Nebr.; Kenneth C. Welch and J. & G. Daverman, Architects, John A. Wiebe Co., Developer**

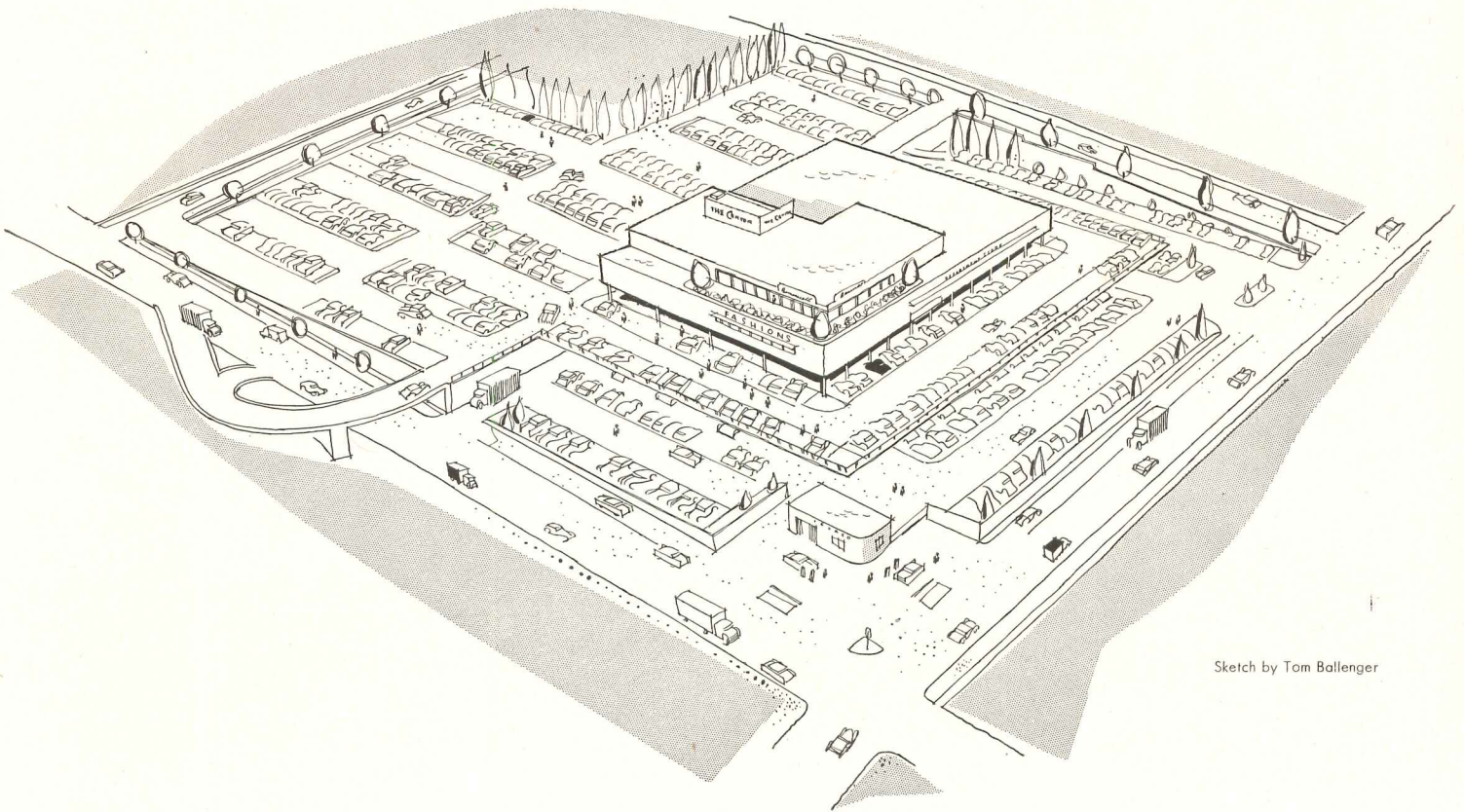

Sketch by Tom Ballenger

**zoning** for strip business locations along major traffic streets is the usual rule today unless the community has recently revised its zoning ordinance and map. Since such existing locations are unsuitable for the modern shopping center due to insufficient depth and cross cutting streets, new zoning or re-zoning, brought about by petition, will usually be necessary.

Sometimes there may be local opposition to re-zoning a tract of land for shopping center development, particularly if the center is to be close to a built-up single-family residential section. In such a local atmosphere, the developer must sell his ideas to the authorities and to the community. He must judge the local temper





Moulin Studio

A "cluster" plan with central mall and careful store grouping, above, features Architect Welton Becket's scheme for Hillsdale, San Mateo, Calif., as opposed to the ample garden and patio areas which impart an informal character to Pereira & Luckman's design, below, for Lancaster-Palmdale, California

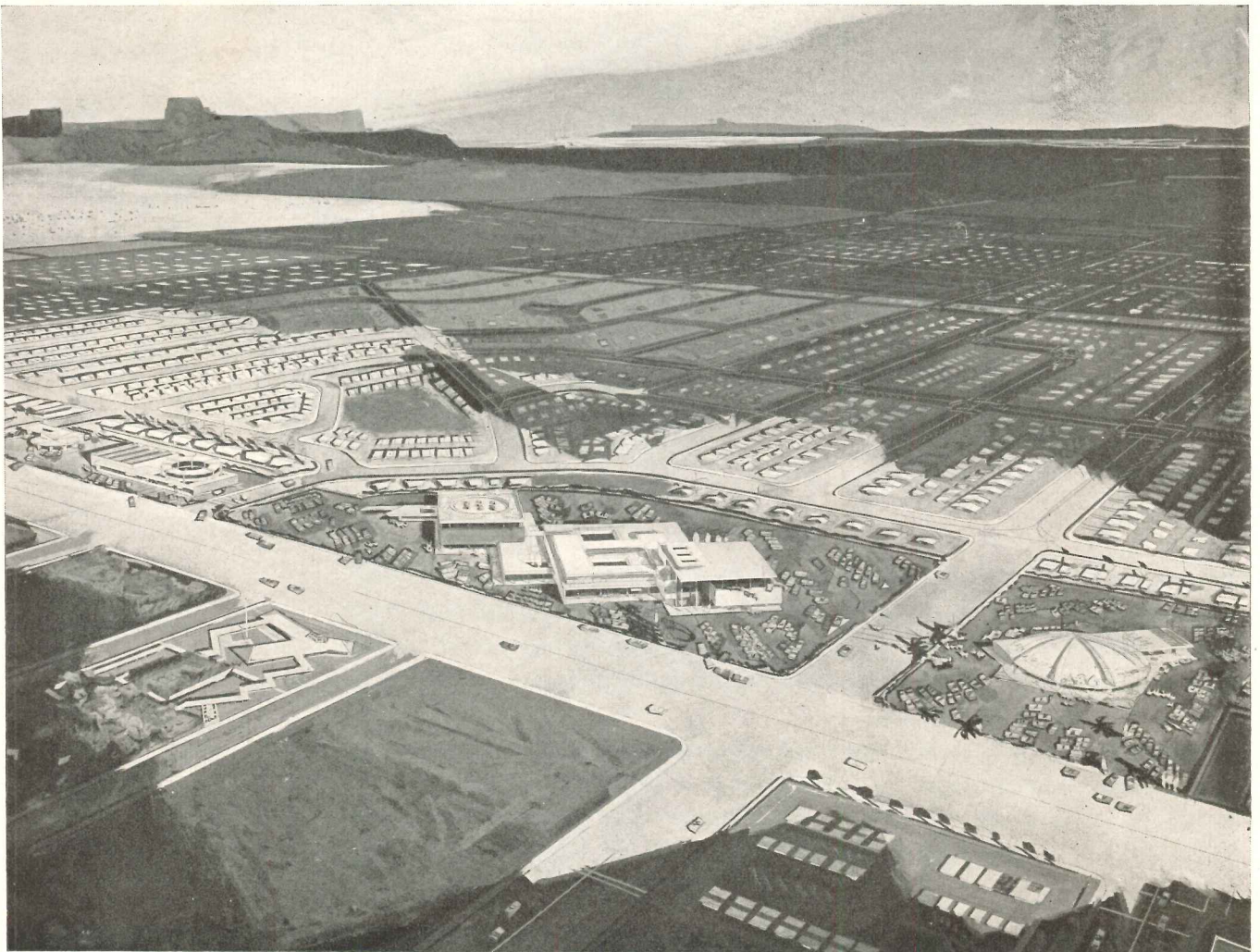



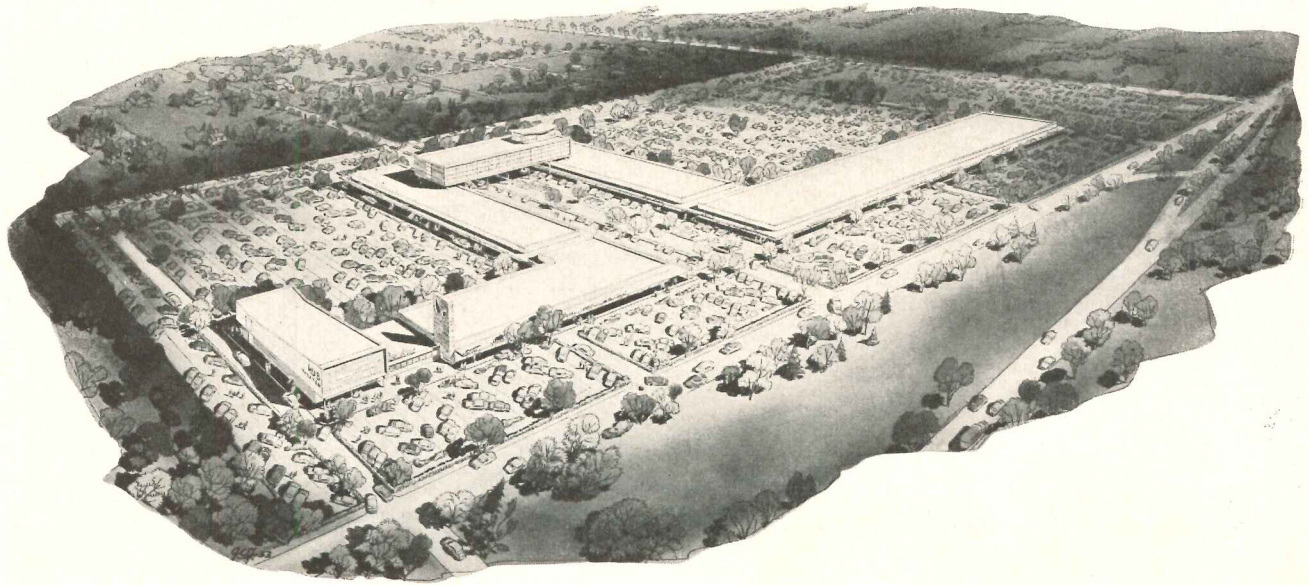

Spanning a bisecting street with a two-story unit on stilts gains building area with smaller land coverage in **The Hub**, Hicksville, L.I., Morris Lapidus, Architect

before he goes too far. Where the center is to be located close to existing residences, buffer planting strips are essential to prevent adverse effect upon residential values.

*In overcoming local opposition it is sometimes advisable to offer certain concessions to the authorities and the citizens. Perhaps a portion of the site can be set aside as a public park, playground, or for some other community use; sometimes it is wise to have local civic leaders serve on a committee to approve the building and landscaping designs for the new center.*

There is a distinct trend in cities to incorporate in their zoning a "shopping center district" — the district defined as "developed as a unit under single ownership." This new use is in line with similar provisions for a "planned community district." Both these "districts" are an attempt to allow for large scale development geared to an overall plan. The objective is commendable for it seeks a way alternative to the conventional provisions of zoning geared to the single lot, and which only indifferently helped to promote large scale development. The waiver of single lot regulations for the above is the way shopping centers should be zoned.

**the final choice** involves being sure the site is the best possible from every point of view. Weigh the points on this check list:

- 1 — Properly located; nearby residential walk-in trade is valuable
- 2 — Easily accessible by automobile and bus
- 3 — Sufficient size; room for expansion; all in one piece
- 4 — The right shape; no grading or sub-surface problems
- 5 — Utilities in place or at least nearby
- 6 — Favorable zoning
- 7 — The right price



## Planning the Site

### customer circulation

The store grouping starts with thinking about the key tenants and ways to place them so that advantage can be gained from the pull of customers to and through the center. Mr. L. E. Fite, owner-developer of Jefferson Village, San Antonio, points out: "The important thing is to distribute the pull and to lead the customer past the smaller tenants as they are drawn to the pullers."

### the number one tenant

In speaking about shopping center problems, Dr. Homer Hoyt, eminent market analyst, makes a useful classification of centers by means of designating their number one tenant. He says, "We may divide them into four types:

Class 1 — The large regional center with large department store (or two)

Class 2 — The center with a junior department store as the largest unit

Class 3 — The center with a variety store as the largest unit

Class 4 — The center with a supermarket as the largest tenant."

For the neighborhood center (Class 4) the Council believes that the best location should be filled by the drugstore with the supermarket placed for convenience to parking. In the suburban or community center, the number one tenant may be either the junior department store (Class 2) or the variety store (Class 3). The Council is thinking of some tenant such as Sears, Ward, or Penney in the department store field. In this kind of center with 20 to 40 stores, it is well to have both the department store and the variety store together with a super food market — each in prominent spots.

In a large regional center, the large department store is the number one tenant — the only variation being whether to have one or two department stores.

In the Community Builders' Council, there has been a lot of discussion about the most valuable businesses in a center. Local conditions naturally cause variations but the Council finds the most popular types of businesses in existing centers are in order: drugs; food market; variety stores; bakery; dry cleaner; beauty parlor; women's wear; shoes; gift and bookstores; children's clothing; jewelry; barber; men's wear; candy shop; and shoe repair.

- A - SPECIALTY SHOPS
- B - MARKET & SHOPS
- C - RESTAURANT & PHARMACY
- D - JR. DEPT. STORE
- E - MEDICAL BLDG

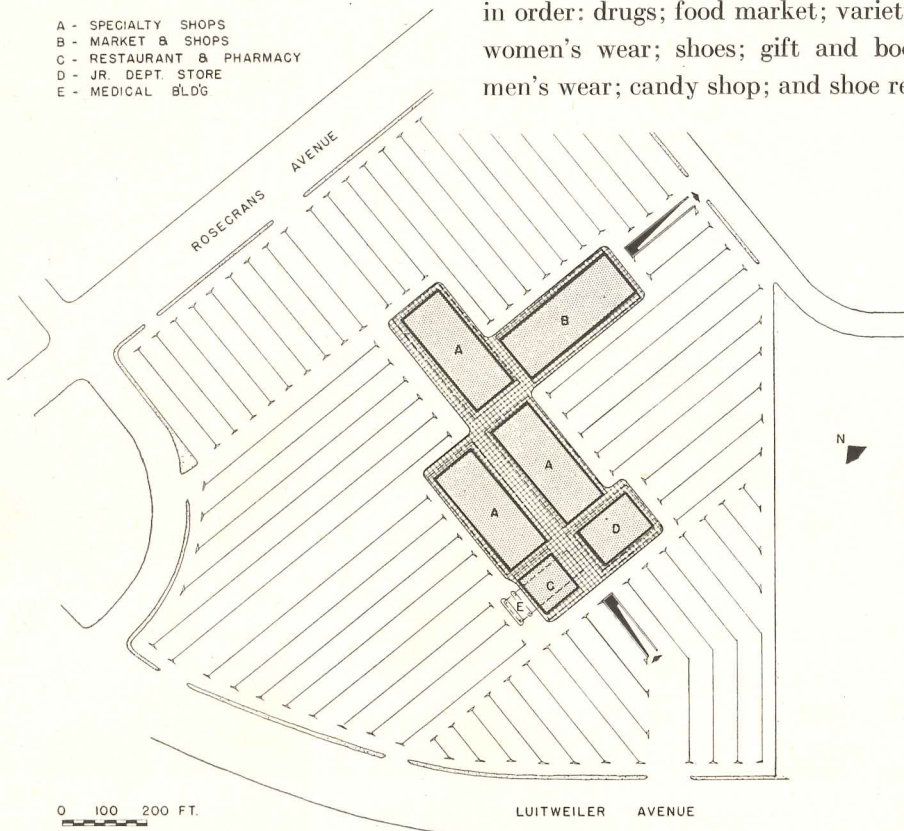

With a supermarket and junior department store at mall extremities, pedestrian traffic is pulled past specialty shops in Welton Becket's scheme for La Mirada, Calif.



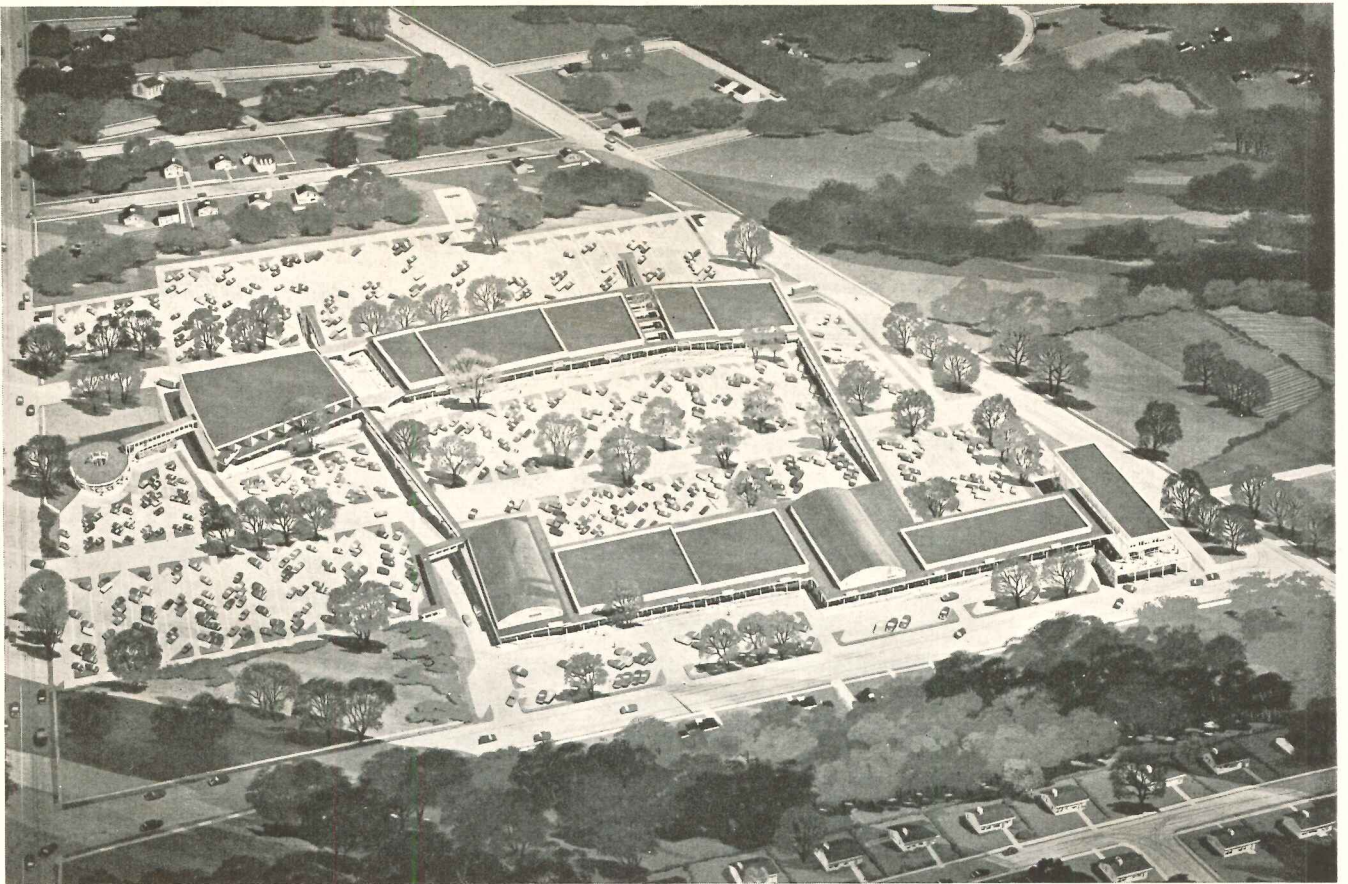

Architect Morris Lapidus copes with two bisecting streets by means of pedestrian overpasses in his design for the Falls Shopping Center, Fallsington, Pa.

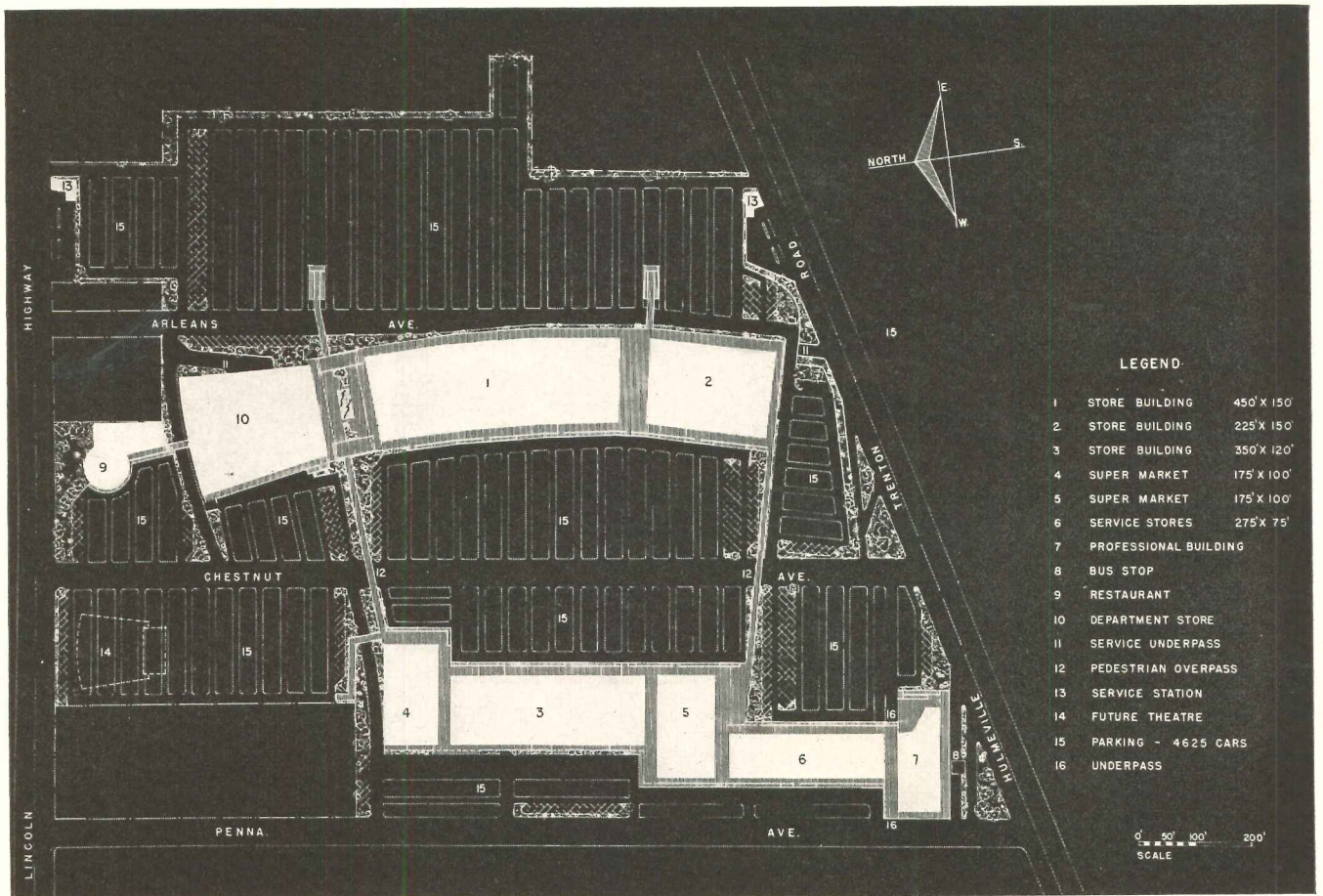



### store grouping — in general

With the number one tenant selected, the next step is the site layout. There are varying arrangements for buildings. They are: the strip, the L, the U, the ring, the mall, and the cluster. Adaptations of these change in order to fit the site. The mall and cluster are more suited for use in large regional centers, while the strip, L, and U are more usual in smaller centers. The ring is rarely circular but rather is descriptive of a group spaced about a central open area.

In designating stores within a grouping, the first consideration is proper selection and arrangement to draw more customers to all the stores.

*It is difficult to overestimate the importance of locating the "puller" stores in such a manner that pedestrian traffic is routed past the smaller stores handling impulse items. This makes for the success of the entire center.*

Another principle in store grouping lies in taking care that all convenience goods stores are as close as possible to parking. John Taylor remarks, "The grouping of stores in a successful center will be the result of planning store locations so that their relationship one to another will be of the utmost benefit to all."

J. W. York, owner-developer of Cameron Village in Raleigh, emphasizes this idea: "Experience shows that it is the supermarket that helps the department store." Theoretically, it would seem that the department store would be the big frog, but the supermarket is proving to be the department store's best neighbor.

The Council has said repeatedly that stores complementing each other should be placed together. For example, shops catering to women should be close together; service and repair shops may be grouped; groceries, services and 5-and-10's complement each other. In assigning locations to prospective tenants, it should be noted that the Council urges second floor locations for doctors and dentists; or better still, a separate, detached "medical clinic" type of building for them.

An L shaped plan on an L shaped lot which incorporates three department stores and truck tunnel service particularizes the Park Central Center in Phoenix, Ariz., Welton Becket & Associates, Architects

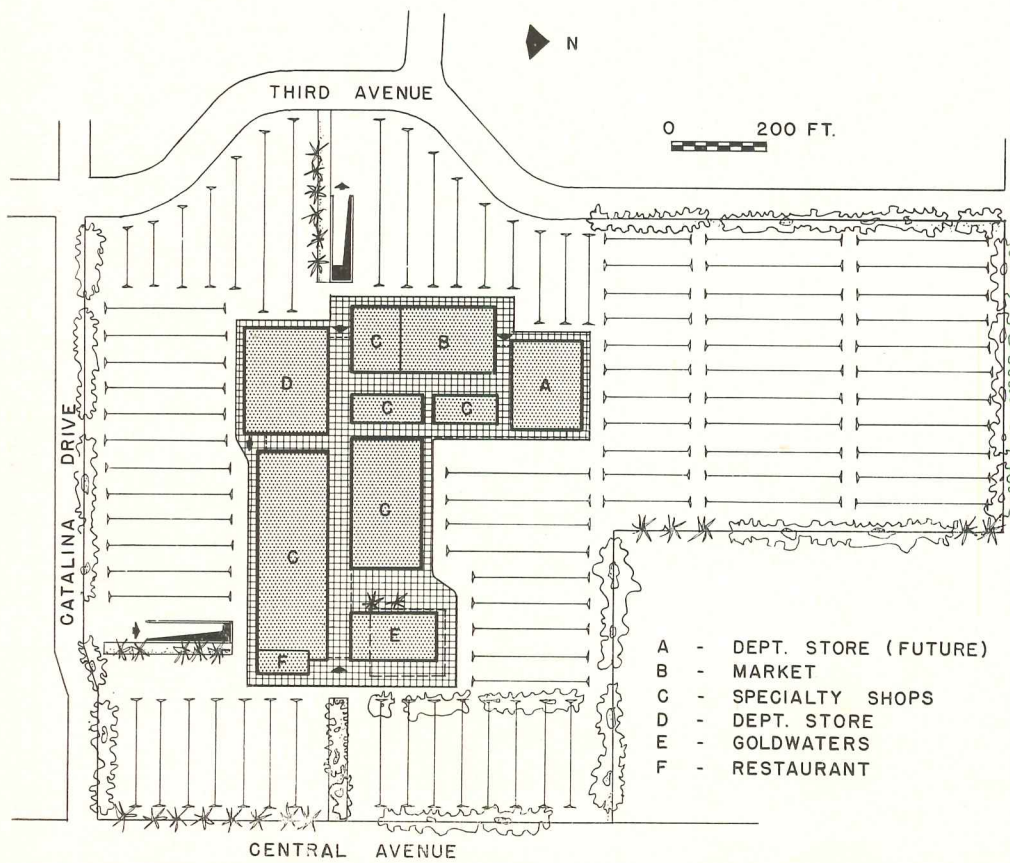



*In strictly architectural terms, the site design should be based primarily upon a free flow for four kinds of traffic: shoppers in automobiles; shoppers walking to and from parking; service and freight trucks; and pedestrians within the building group proper. The object, of course, is to eliminate interference between any of these and at the same time provide maximum shopper flow past all the stores so that all the locations become "100 per cent locations."*

### **store grouping in regional centers**

In the big center, the architectural plan must place small tenants in the path of pedestrian traffic moving between the larger tenants — department stores, supermarkets and drugstores.

"A regional center must be self-sufficient," Mr. Flaherty emphasizes. This characteristic underlines the importance of proper grouping. This "self-sufficiency" means that in addition to the big pullers, there must be a full range of merchandise available to the shopper — including everything found downtown. This completeness implies competition within the center — which is good for the center and good for the merchants. It keeps merchants on their toes and gives shoppers the comparison they want to be able to make when shopping. James B. Douglas, president of Northgate, says: "Put in two markets, two dress shops, two drugstores."

*To say it another way: the center should be like another "downtown," the size of which depends upon estimated volume based on the market analysis. Having competitive stores close together is what makes downtown go — yet this widely accepted fact is sometimes lost sight of in shopping center layouts.*

### **to combine or to separate?**

The big problem here comes in locating the stores within the group. For example: is it desirable to group all the food stores or to separate the two supermarkets? This query brings into focus the basic problem of grouping — whether to bring stores

Architects Weinberg & Teare's double bow shaped mall provides a pleasant openness for the O'Neil Sheffield Center, Sheffield Township, Ohio

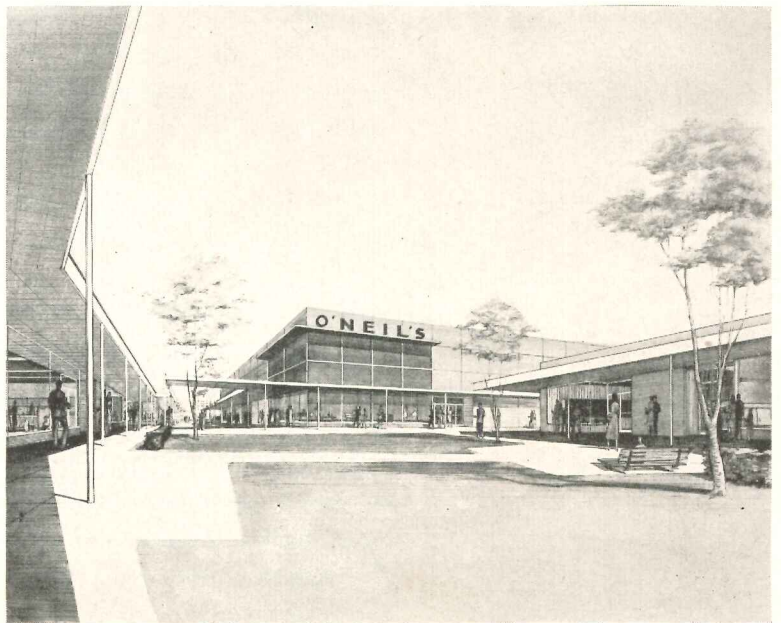
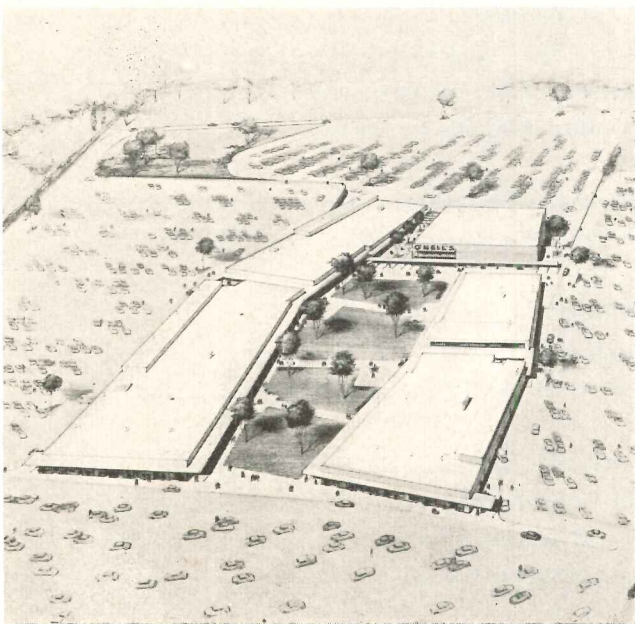



of one kind into close relationship for convenience and competition or to separate them to spread pedestrian traffic.

When the supermarkets adjoin, the load on the parking space is unduly concentrated; this is one good reason for separation. Placed together, servicing is easier to arrange; besides, comparison shopping is easier for the housewife.

Hugh Prather's experience speaks for grouping: "We put a supermarket and a service grocery together and it works beautifully. Food store grouping is important — they complement each other. In high grade centers women wearing slacks buy groceries in the morning, return for luncheon and go dress shopping in the afternoon."

Mr. Seltzer of Philadelphia also votes for grouping: "In our large center we group fashion shops and have the less expensive type of merchandise in another section. When the department store was asked about having a food store nearby, they replied that they would take *one* high grade food store for a neighbor. The load on parking was the reason for their objection.

The smaller neighborhood center in strip form, with separated service, is illustrated by the Bissell Hills Center, St. Louis County, Mo., as drawn by P. John Hoener & Associates, Architects

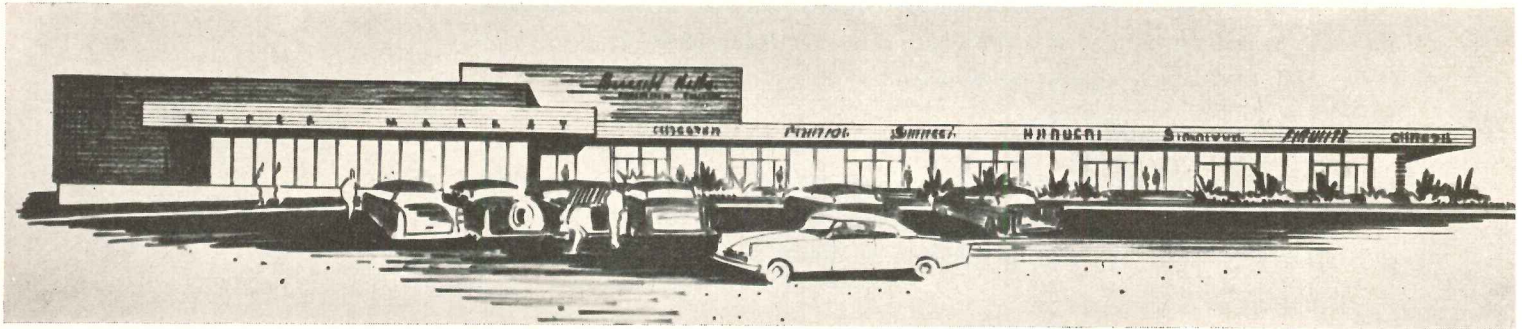

Mr. Bohannon favors separation: "At Hillsdale, we dislike putting food stores together even though it may be a service to the public to do so. The parking required is greater than for any other kind of soft line store. We are planning one big supermarket at either end of the mall with a Sears and Penny at either side. Women won't go to two supermarkets on the same day; one-day-a-week food shopping is the trend, and we want to encourage other shopping on the same trip.

*Here we find the experts in disagreement about the question of grouping or segregating similar kinds of stores, and no pat answer seems apparent. More experience may tell.*

#### **where to place the department store**

In a regional center, the department store is the puller. A junior department store should be separated from the large store, as should the second large store, should there be one.

Larry Smith, economic analyst, points out: "The shopping center developer should be sure he gets the maximum benefit from the pedestrian traffic the department store creates. If the smaller stores do not benefit from the foot traffic to and from the large store, the owner has lost the very thing for which he negotiates in signing the department store lease. Be sure that the plan provides maximum benefit to all stores resulting from the pull of the department store."



### small service shops

Locating small stores comprising 500 to 1000 sq ft of sales area is important, for these stores pay high rentals, add interest for the shopper, and contribute to the completeness of the center. One suggestion for a frontage location for shops of this type is the pedestrian passageways leading from parking to mall, as at Northgate. In this manner, blank walls are avoided and good spots are provided for the little shops and for impulse buying. Such shops — yarn, dress pattern, costume jewelry — generally receive stock shipments by parcel post and do not need to be directly accessible to truck service.

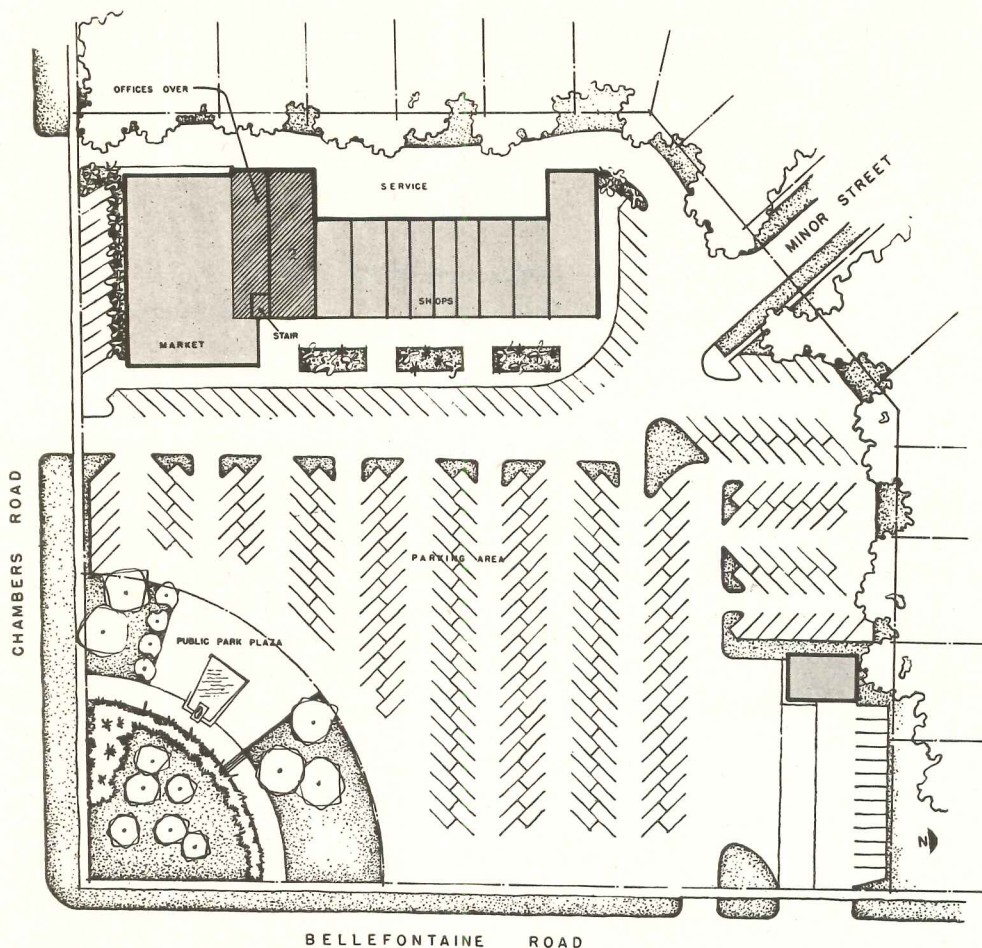

### store sizes

Walter Schmidt says: "Store depth should be 100 to 140 ft. A depth of 120 ft is thin for major stores. Many chains ask for 140 ft and self-service drugstores now want 160 ft. Where there are no basements, such stores require nearly as much storage area as sales space. Stores of 125 to 150 ft in depth are needed."

Optimum size for supermarkets seems to run from 18 to 20 thousand sq ft. The Council cautions that supermarkets can become too big; a long trip from the check-out stand to pick up a forgotten item will cause the shopper to go next door or wait until the next trip. The supermarket area is often divided 80 per cent sales space and 20 per cent storage and produce space. Self-service packaged meats reduce the latter figure 65 per cent.

A department store in a center should not occupy more than one third of the total gross building area. In one regional center having a 600,000 sq ft total gross building area, a department store of 200,000 sq ft seems to be about right.

As mentioned previously, a rule of thumb guide for estimating purposes is to figure about 10,000 sq ft of gross building area for each acre of site.



## The Necessary Parking

The space for parking is an indispensable element in shopping center design, and in providing it, the two main questions are: how much? and how best to arrange it?

### how much parking?

To describe the area needed, a measure has come into being: **the parking ratio.** This ratio is the relationship of the parking area to the building area. The building area may be the gross building area or the net sales area.

For preliminary planning, the ratio of parking area to gross building area is the most practical way of gauging the desirable amount of parking, for it is impossible to determine the net sales area accurately until the building is complete. The attempt to determine a relationship based on complicated formulae of average sales, customers per car, and turnover per car space entails too many assumptions. Ultimately, however, the ratio should be based on the number of car spaces provided for the total sq ft of sales space.

A ratio of car spaces per 1000 sq ft of gross building area (first floor area, basements, mezzanines, and upper floors, but excluding service areas outside the stores,

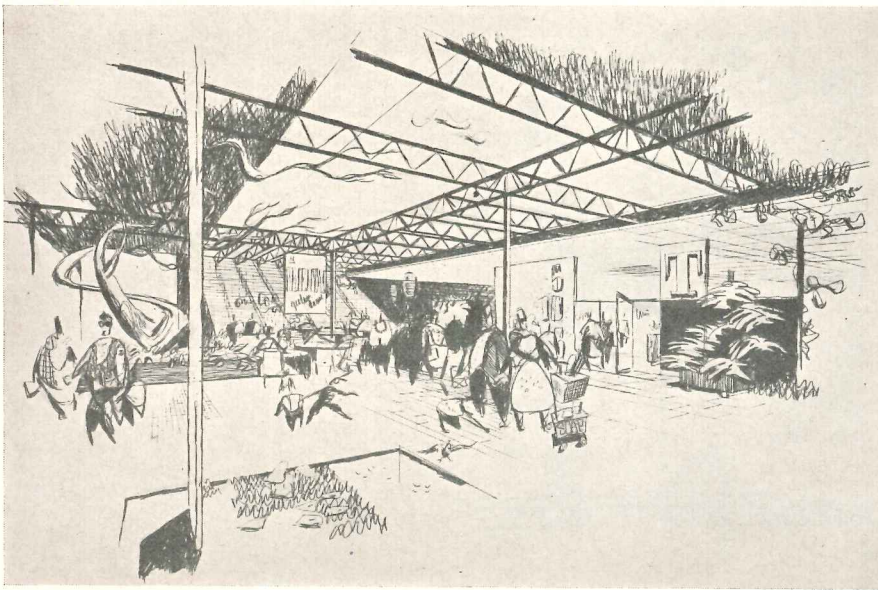

Renderings and plans of the Waialae Shopping Center, near Honolulu, are shown on these two pages. Victor Gruen, Architect; Rothwell & Lester, Associated Resident Architects; Larry Smith & Co., Economic Consultants.

The open three-part plan will be constructed in nearly equal increments, and the generous site will provide ample parking area and buffer zones.

The structural system features open-web steel joists on a lightweight post and lintel system arranged on a modular pattern. Open-web joists will support tropical flowers and hanging plants

such as boiler rooms, truck tunnels, truck docks, etc.) is an accurate way of arriving at the parking required. A ratio of 2 sq ft of parking to 1 sq ft of gross building area (a 2 to 1 ratio) produces 6.7 cars (say 6) for each 1000 sq ft of building. A ratio of 3 sq ft of parking to 1 sq ft of building area (a 3 to 1 ratio) produces 10 cars per 1000 sq ft of building.

The 2 to 1 ratio is suitable only for a neighborhood center with a high parking turnover and a large percentage of walk-in trade. Elsewhere, the minimum satisfactory ratio is 3 to 1, and more is preferable.

In determining area, at least 300 sq ft must be allowed for each car. This figure includes a percentage assignable to moving lanes. But where there are access drives, pedestrian walks, storage magazine areas and landscaped areas to be incorporated, 400 sq ft per car is the correct allotment for estimating.

*At Shoppers' World in Framingham the ratio is 15 cars per 1000 sq ft of store area or a ratio of 4.5 to 1. Such an arrangement is satisfactory even for the December peak.*



- A - SPECIALTY SHOPS
- B - DEPT. STORE
- C - SUPERMARKET

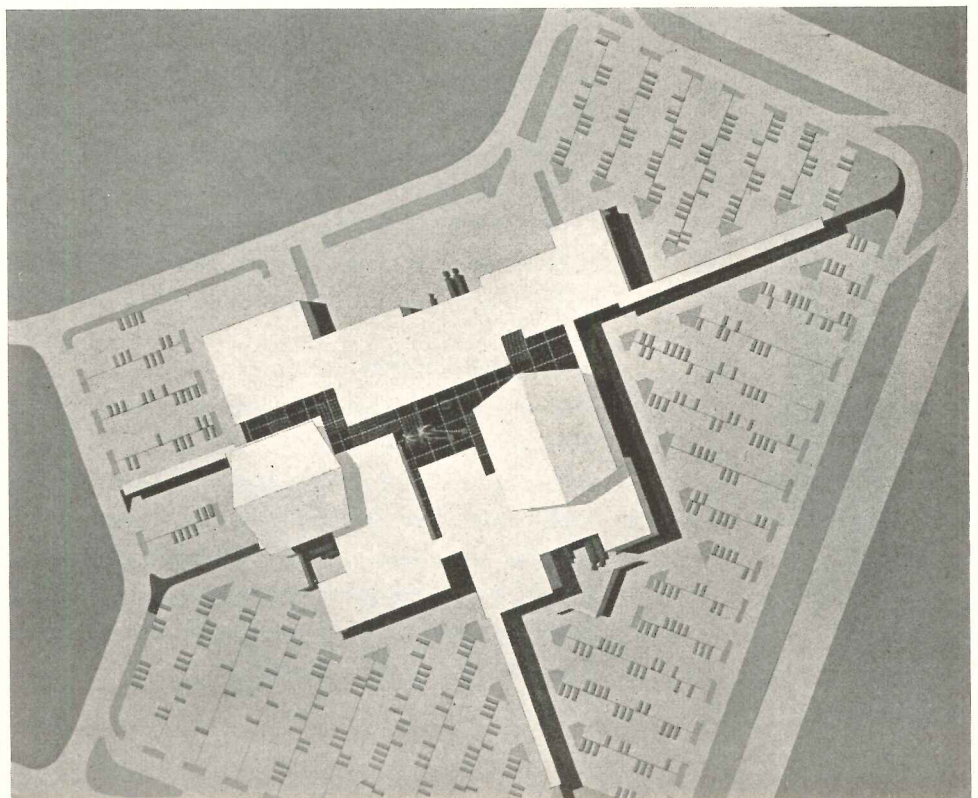
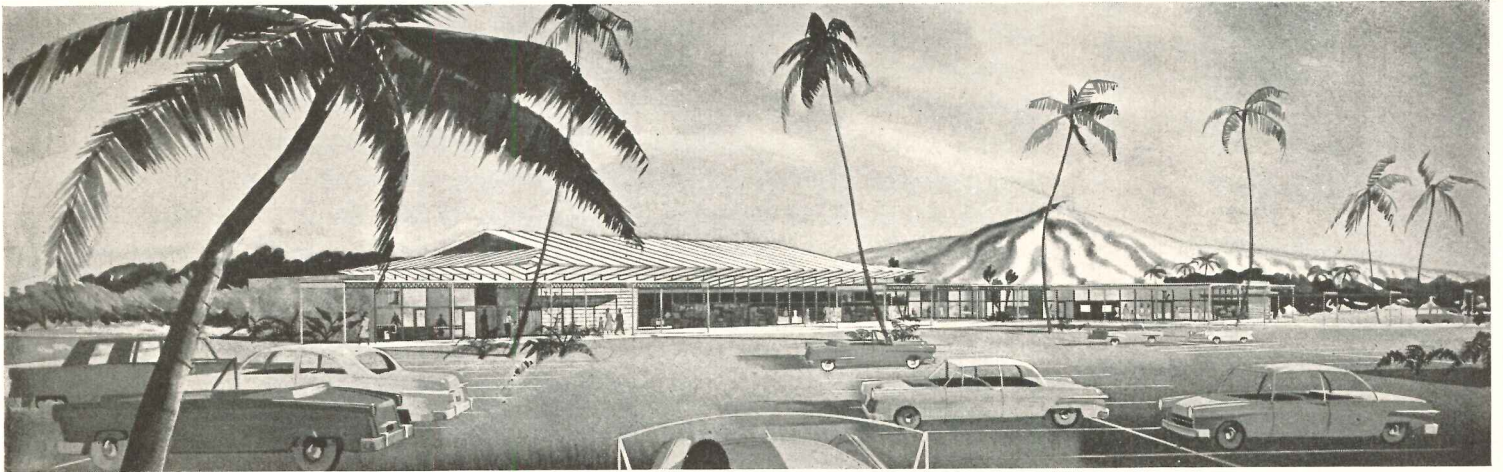
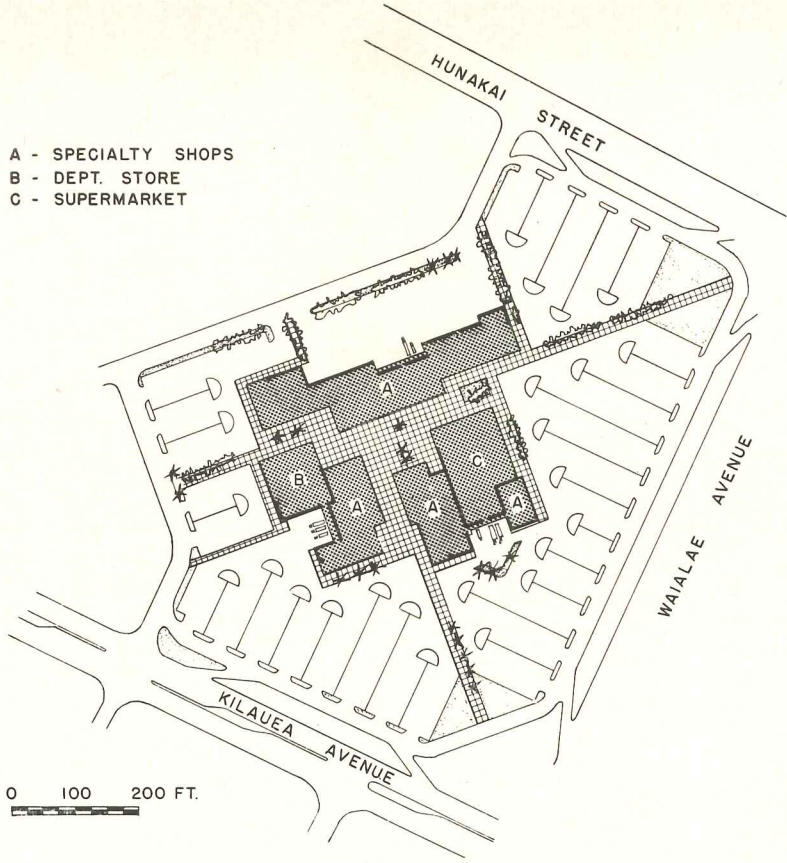



### arranging the space

The act of parking at a shopping center must be simple, trouble-free, and safe. The shopper should be able to find his way around without any previous study of the site. Complicated arrangements confuse the driver and often require directions from attendant (which is expensive for the owner).

*Shopping center parking is best a do-it-yourself procedure, because it is cheaper, smoother, entails no waiting, and is best for rapid turnover. The only case in which attendant parking is justified is for the center on expensive land (\$3 or more).*

As for general arrangement, Walter S. Schmidt says: "Spread the parking to distribute it equally on all sides of the center. People should not have to walk too far to reach the stores from their parking space. Try to limit the depth of parking to 300 or 350 ft each side of the store group."

Ease of circulation and safe movement for pedestrians and vehicles is of paramount importance. In addition, truck service traffic and consumer traffic should be segregated. The best arrangement is one that leads the shopper directly to the stores from his parked car.

*Several experts maintain that the main customer traffic should enter and deploy on a peripheral road which acts as a sort of traffic circle for the center, and that traffic near the stores should be discouraged in plan. A completely separated pedestrian walkway next to the stores is a good feature. It is advisable to limit vehicular access to the stores to a few selected key store entrances and a few passenger pickup points. A good scheme is for parking bins to have two-way aisles and open to the peripheral road; this plan keeps all traffic away from the area next the stores except for the few key stations mentioned above. Arcades which pierce through the stores at strategic locations provide a good means of pedestrian access from parking, provided they are spaced close enough to be convenient yet not so close as to create too much unproductive area.*

There are two preferred patterns for parking bin arrangements: angle or perpendicular. Perpendicular or 90 deg parking is generally favored because it combines economy of space with ease of circulation. It allows two-way movement, elimination of expensive curbing, better sight lines, and greater safety. When used, a width of 65 ft is required for two tiers of cars separated by a central two-way aisle.

Angle parking allows for easier entering of a stall and for one way traffic and also narrower bays. Where 45 deg parking is used, minimum width of bays can be 50 ft with one-way movement. With two-way movement, 60 ft is required. Angle or herringbone patterns are advisable only for areas where the space is restricted or where local preferences govern.

The width of the parking stall should be 9 ft, measured center to center of a 2-in. painted space-marker line. Mr. J. W. York says, "If you use an 8 ft width, you will lose more space from straddlers than if you mark the area at 9 ft."

### pedestrian strips

Raised walkways between rows of parked cars are not needed. Most people prefer to walk toward the shops on the wider car driveways. "Where you have plenty of cheap land," states Hugh Potter, "we should favor putting in a wide pedestrian strip. But where land is tight, we eliminate the strip but usually provide some bumper protection." If such strips are used, they have to be at least 7 ft wide to allow for bumper overhang and the passage of two people abreast. There is general doubt whether walkways are worth the cost and the space involved. Also, they are an obstacle to snow removal.

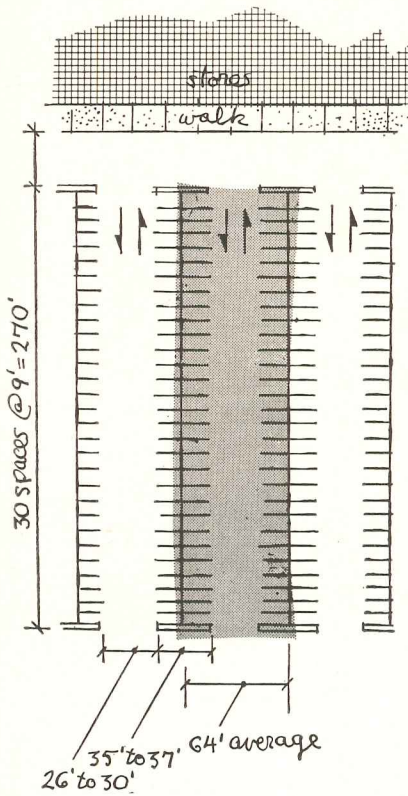

Two preferred parking patterns: "perpendicular" and "angular"

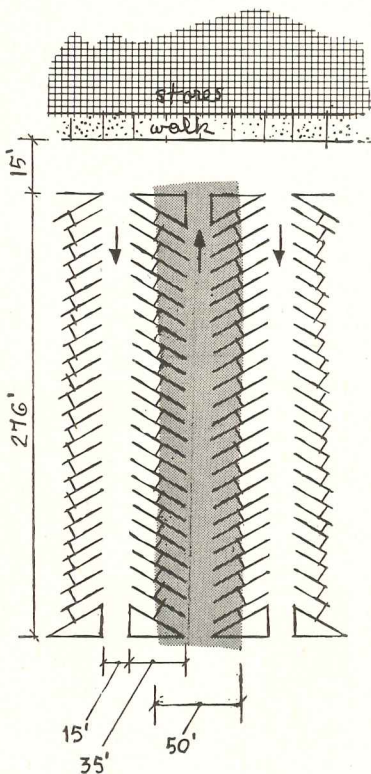

Drawings by Don Ervin



### pavement

Concrete surfacing is expensive, while black-top is satisfactory providing it is well drained. Where there are great expanses of pavement, trees and planted areas should be introduced to eliminate the otherwise barren and unsightly appearance. Best markers for the parking stalls are either painted lines or metal buttons.

### employee parking

Short-time and all-day parkers do not mix; and employees are all day parkers. If they are permitted to park indiscriminately, they will be using shoppers' space that

On a heart shaped plot having access from three main roads, Architects Tully & Hobbs have designed the Fairless Hills, Pa., center about an L shaped mall linked by covered walkways

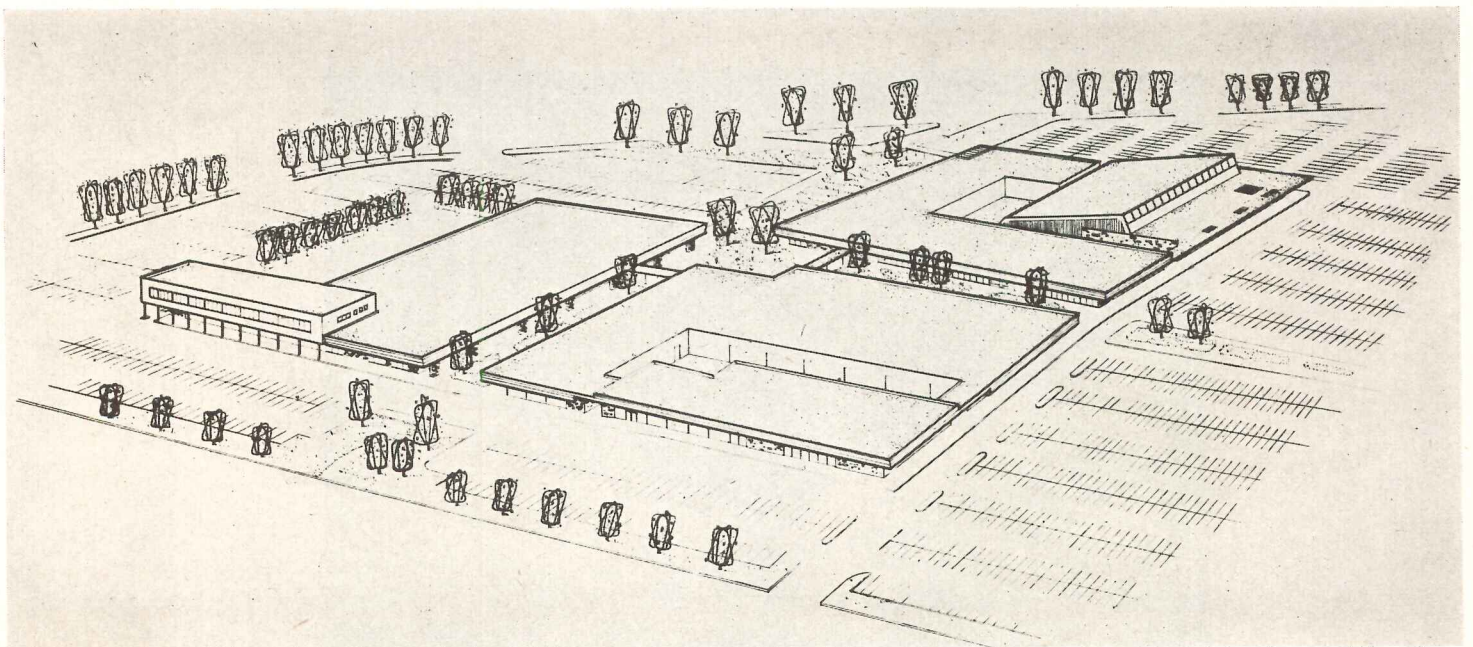
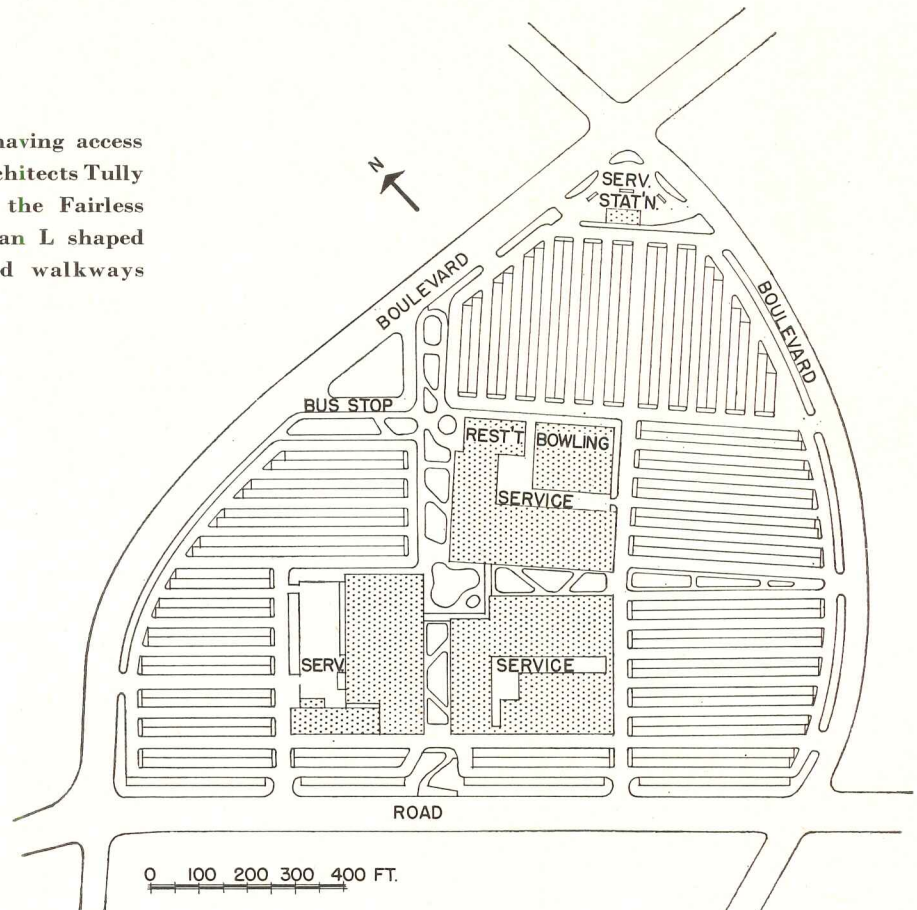



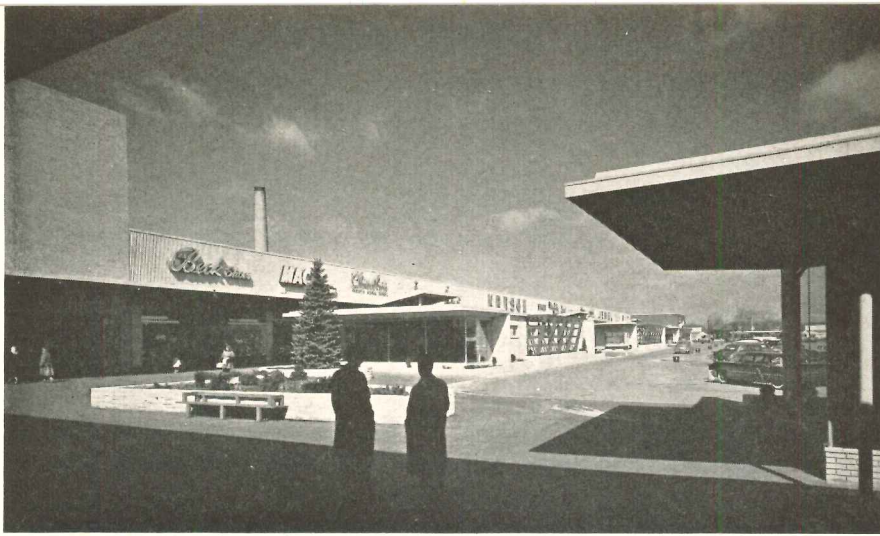

Bill Hedrich, Hedrich-Blessing — for Minneapolis Honeywell

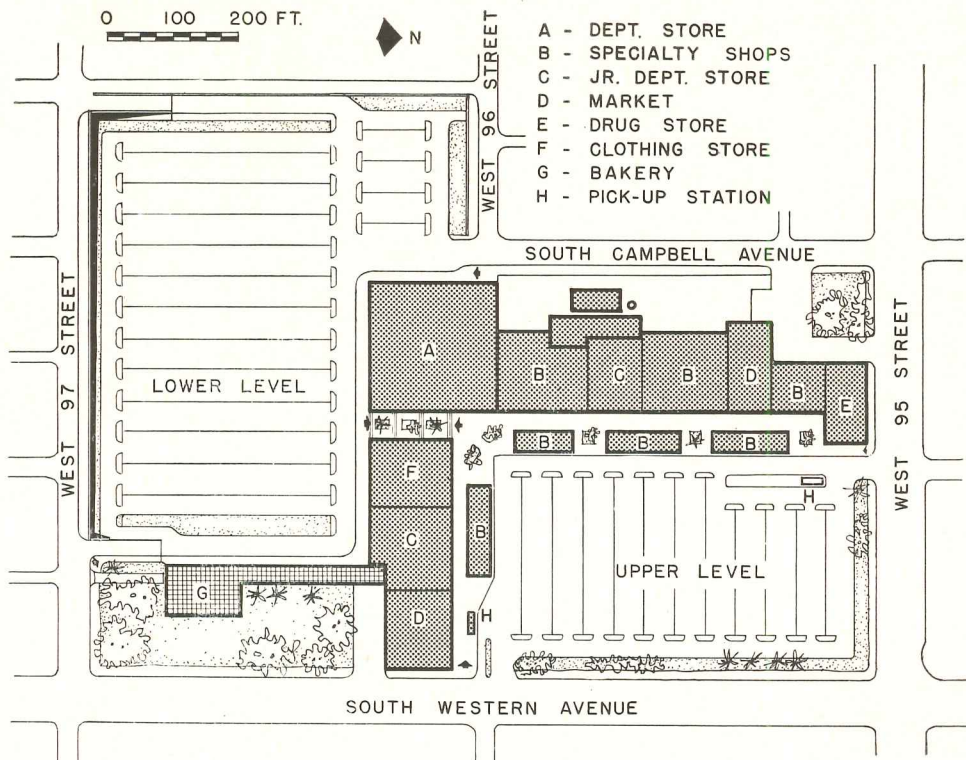

An L scheme served by two level parking which incorporates three main stores characterizes the plan for Evergreen Plaza, Chicago. Howard T. Fisher & Associates, Architects & Engineers; Holabird & Root & Burgee, Architect-Engineer; Arthur Rubloff, Developer

Chicago Aerial Survey Co.





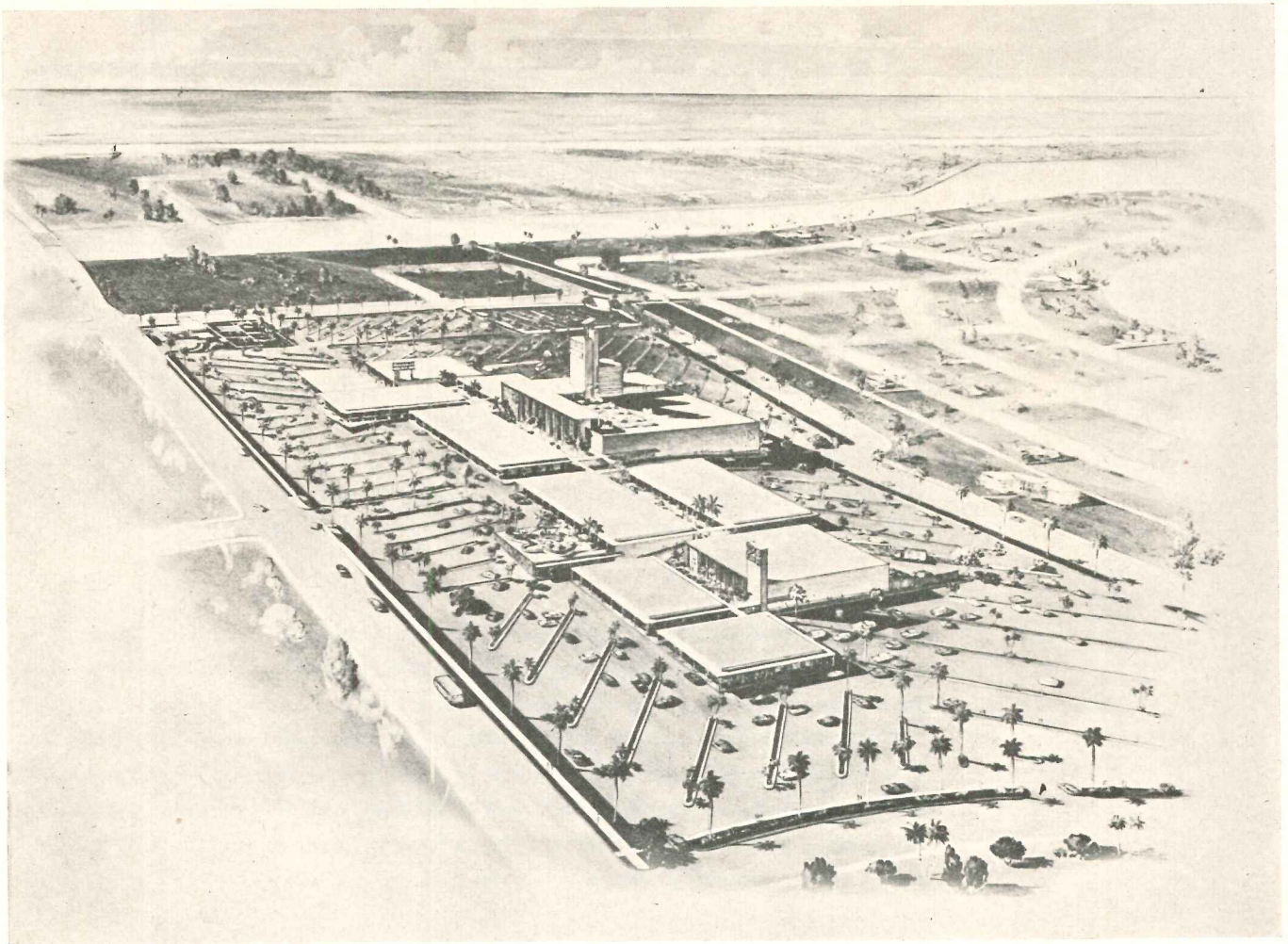

Adjacent to a 100-acre residential development, the Sunrise Shopping Center in Fort Lauderdale, Fla., is located in a rapidly expanding area. Gamble, Pownall & Gilroy, Architects & Engineers

should be turning over four or five times a day. A special area should be assigned to employee parking and violations sternly dealt with.

At J. W. York's Cameron Village we find an indication of the amount of employee parking: "There are 145 cars for 500 employees in a center of 234,000 sq ft gross building area. This means that there are 145 basic cars to contend with, or less than 1 car for each 3 employees."

## Services, Amenities

### service and the mall

The mall has many advantages for the larger center: it creates a pleasant, landscaped business street free of traffic hazard; it creates many strong locations; there is no "best side of the street"; by double-decking stores along the mall, building area can be doubled without increasing walking distance from parking.

Another point favoring the mall in a regional center is the possibility of the complete separation of truck service and pedestrian shoppers. This is accomplished by building a truck tunnel under the mall, as has been done at Northgate in Seattle, Stonestown in San Francisco, and planned for Northland in Detroit and Hillsdale in San Mateo. But, the truck service tunnel is expensive. "A truck tunnel will cost about \$800,000." When the truck service tunnel can be afforded, it offers the ideal solution to the problem of separating customers and deliveries.



Without a service tunnel, the mall scheme requires that service courts be provided. The problem then becomes one of screening the courts from view. Such courts must be large enough to permit truck maneuver within their area, and if not carefully handled, give a "backyard" appearance. The Shoppers' World at Framingham is a regional center with rear courts adjacent to the customer parking areas.

In the smaller center, the difficulty in separating pedestrians and service delivery can hardly ever be justifiably solved by either a mall or tunnel.

### **landscaping**

Planting and seasonal floral displays in appropriate places within the center add to its attractiveness and customer pull. The best advice of the Council is to have some, but since maintenance cost is high, to budget it. Where wide expanses of paved parking area occur, it is advisable to have trees and carefully placed planting. "Barren parking lots are terrific eyesores, and you have to break the expanse."

### **buffers**

When the center is near a residential area, it is necessary to insulate against any adverse effect of commercial use upon the adjacent residential development. A buffer strip at least 20 ft wide and preferably densely planted should be used. "Where such buffers are not possible, the use of walls, solid fences, or narrow but dense foliage should be provided. Failure to install permanent and effective physical separations between business and residential uses will detract greatly from the desirability and value of the latter." For a large regional center, the buffer should be extensive, and can in part be reserved for later expansion.

### **basements and storage**

The answer to the question, "When are basements best?" depends largely on site conditions, such as topography and sub-soil considerations.

Stores require storage space and the basement is good for that purpose. Also, the basement can later be converted to merchandising space should expansion occur. In lieu of basements, balconies are required (necessitating higher ceilings), or the store must be deeper. Another storage device, particularly where stores are shallow, is to provide (on a secondary plot location) a storage building which can be leased to individual tenants according to their needs. Examples are Town and Country in Sacramento and River Oaks in Houston.

Such stores as furniture and variety chains want basement areas for display and merchandising. But basements, like second floor areas, seldom bring an adequate rental, income generally running  $\frac{1}{4}$  to  $\frac{1}{3}$  of that from the first floor.

In the large regional center basements are a must, and can be scooped out at the same time the truck tunnel is excavated.

### **second stories**

Second floors do not necessarily increase earnings, particularly in neighborhood centers. Extra costs are involved in construction, plumbing, heating, lighting, and maintenance. A two-story center building does not too often pay. Second floor tenants are all-day parkers and their visitors are generally long-time parkers who are not shoppers. It is uneconomical to provide elevators for the second floor.

Doctors and dentists are not the best second floor tenants since the sick patients and healthy shoppers hardly mix well, and a trip to the dentist is seldom combined with a shopping spree.

Should second floor space be provided, the suitable kinds of tenants are those who



pull people to the center at regular and frequent intervals; who have visitors who do not park more than an hour or two; and who require no display space downstairs. Dance studios, bridge or language teachers and similar occupants are suitable second floor tenants.

**package pick-up stations**

Handling arriving goods at the center is a problem in itself, usually solved by planned arrangements of service courts, truck tunnels, or rear service roads; but the carrying home of their purchases by the customers is a separate problem. It is far more satisfactory for both seller and buyer if articles can be taken home at the time of purchase. But a bundle-laden female is unlikely to stroll past stores, even to do some window shopping.

An L plan centering on a pedestrian mall in an unusual shape characterizes Architects Weinberg & Teare's scheme for Lyndhurst, Ohio

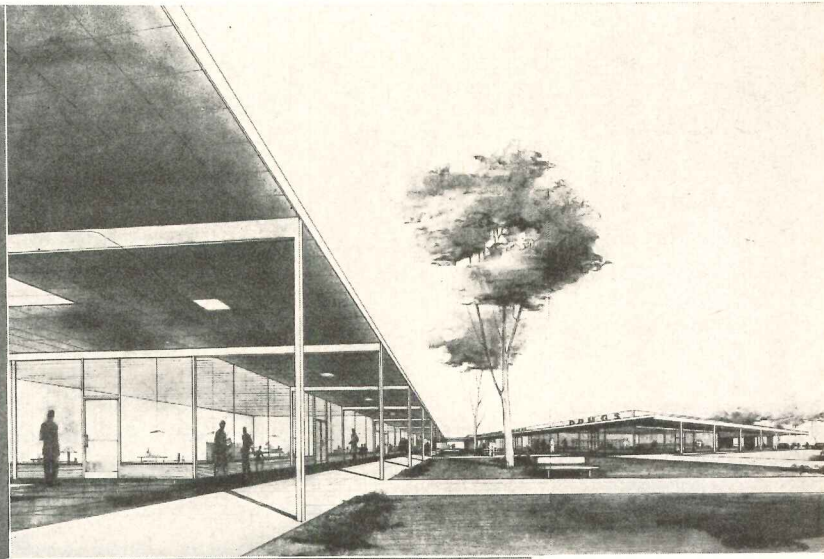
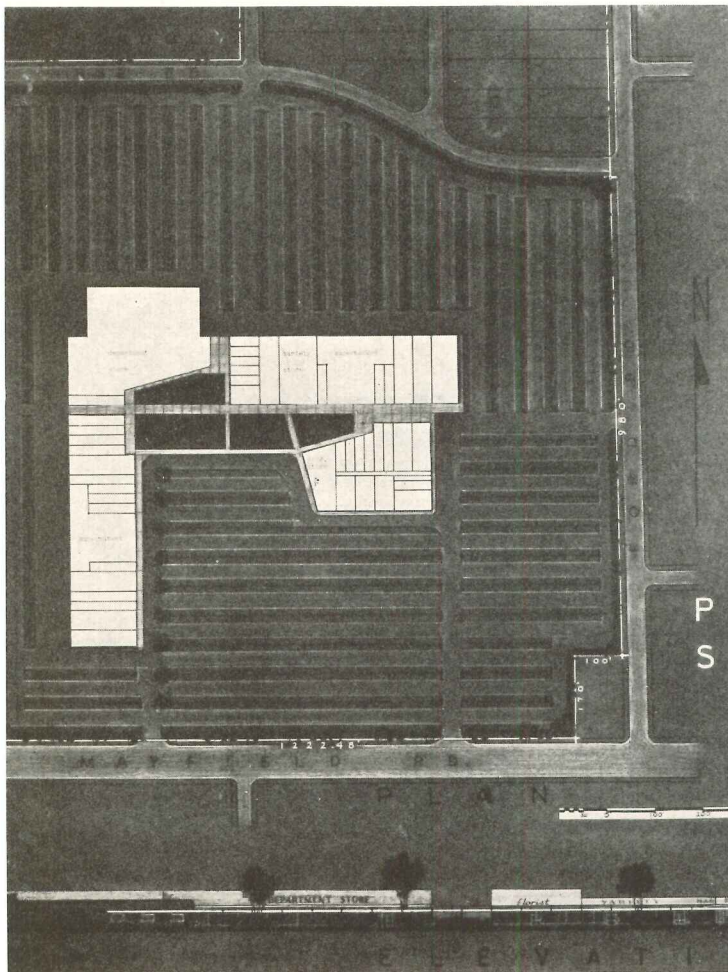
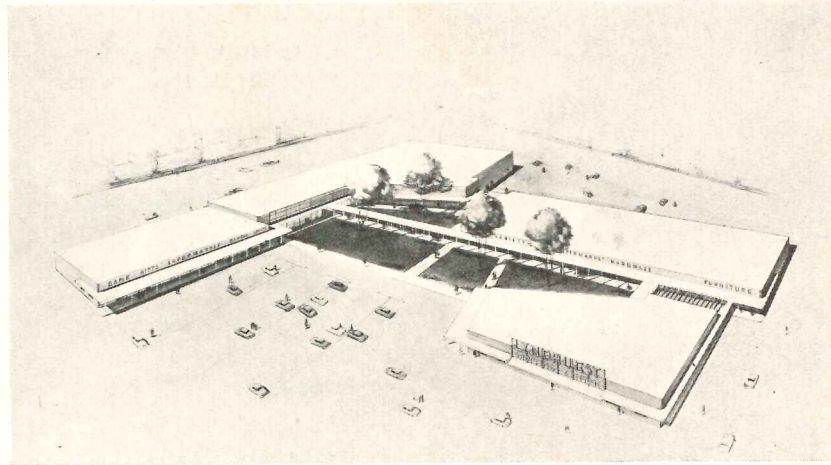

PROPOSED  
SHOPPING CENTER  
FOR LYN DHURST OHIO

LYNDHURST Shopping Center



Supermarkets have pioneered with carry-out service. But this is an expensive operation and the real answer must lie in some form of package pick-up station. In operation, the shopper checks her bundles, goes to her car, and then drives to the special station where, in return for a check, an attendant loads her car. The mechanics can vary, but a system can easily be worked out to solve the bundle-toting problem. A sound approach at the neighborhood center level is to have parking as close as possible to shopping.

## Variations

**service stations** in shopping centers are fitting and proper if their location does not interfere with parking lot circulation. They must occupy a prominent place.

We quote Hugh Potter, owner of River Oaks in Houston, which includes two service stations, who says, "You must segregate the filling station area from the customers' parking area. In order to put the filling station in a prominent place, you must have a good-looking structure; it must be kept clean and its traffic must be separated. There is no reason why a properly handled gas station cannot be attractive."

Mr. Bohannon adds: "If you are uncertain about the filling station, you can make a lease of 10 years or so. Lease the ground and take a percentage of sales (about 1¢ per gallon) and other revenues. If the station offers service, it should have an area for car storage."

**offices** can be better accommodated in a separate office building than in second floors over stores. Such a scheme allows special parking space, separated from the shoppers, which can be easily regulated.

Doctors prefer a one-story clinic type of building or one with elevator facilities. A separate building is best because their professional needs are special and for such they must pay higher rentals. Hugh Potter says: "Whatever you do, do not mix doctors and lawyers in the same building."

An office building brings people to the center, but must have its own parking area and be capable of handling all-day parkers. Provide sufficient site area to handle the special parking and traffic flow to this area.

**an automobile row** is not good in a shopping center.

**banks** in shopping centers are great conveniences. They generally pay a fixed rental at a high rate, although one developer reports that he gets  $\frac{1}{10}$ th of 1 per cent of all deposits as yearly rental. In lieu of a bank, a California development of interest serves as a "currency exchange," which cashes and issues checks. Such a business is good near a large population of factory or defense workers. The exchange takes a small area and pays a high rate — \$10 reported by one operator.

**bowling alleys** are suitable in a secondary location.

**church** sites should not be selected adjacent to a shopping center just to take advantage of the parking facilities. There is an overlapping in parking use. While churches may well be in the general neighborhood of the shopping center, do not make them a part of it.

**theaters**, due to television's influence on the economic picture, are hardly a sound tenant in a shopping center.



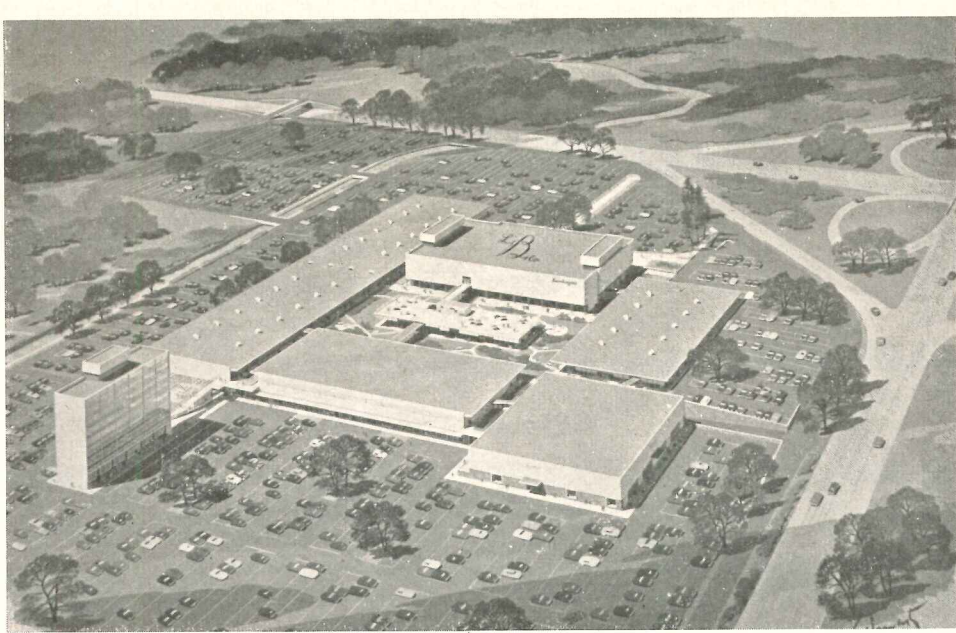

Above, perspective of the new Bamberger Center in Paramus, Bergen County, N. J., Abbott, Merkt & Co., Architects & Engineers. Below, perspective of River Park Regional Center, Philadelphia, Welton Becket & Associates, Architects & Engineers

Douglas M. Simmonds

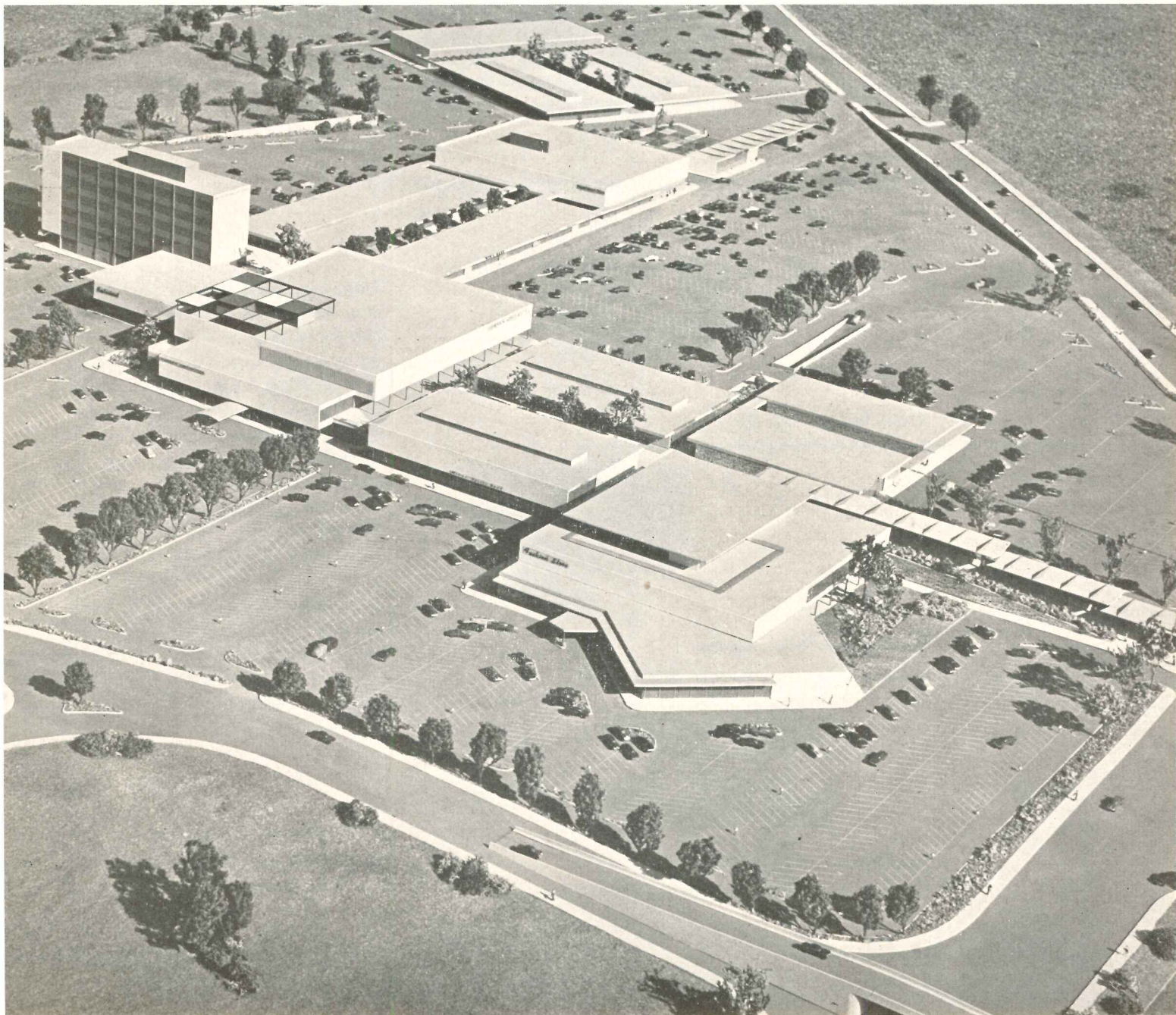



# ECONOMIES IN AIR CONDITIONING FOR

*A general discussion of the considerations involved in selecting the best system. Lowest annual cost is frequently the deciding factor*

By Francis A. Welch\*, Syska & Hennessy, Consulting Engineers

IN SUBURBS throughout the country, shopping centers are springing up in large numbers, attracting customers through new concepts of merchandising. First, spacious areas are provided for easy, convenient and assured parking, and now complete air conditioning is being planned to give a comfortable, clean atmosphere.

Shopping centers vary in size from small groups of stores to the more gigantic, ambitious plants, and the air conditioning systems vary accordingly in size and type. Therefore, each shopping center with its air conditioning system

\*Project manager and assistant to chief engineer

has to be considered individually, and the problems can be discussed here only in a general way. The following observations, however, are based on actual case studies.

### IS AIR CONDITIONING A NECESSITY?

Will shopping centers without air conditioning become obsolete? There are indications that they might. Take for example recent trends in modern office building design and their effect on existing buildings. Practically all of the new office buildings in New York City have complete air conditioning. Owners of older, but still excellent, office buildings are being forced to install air condition-

ing or face a loss of rental. It is not difficult to visualize a similar fate for shopping centers that are not comfort-cooled.

### TYPES OF SHOPPING CENTERS: EFFECT ON SYSTEM DESIGN

New shopping centers are of several types. The first type consists of a group of large buildings, each containing one or perhaps a number of tenants. These buildings are connected by walkways, malls, etc.

In some cases, passageways around and between buildings are enclosed for protection against inclement weather, and while not directly conditioned, are conditioned indirectly through the ex-filtration of treated air into the cov-

## Principal Types of Systems In Order of Lowest Annual Cost

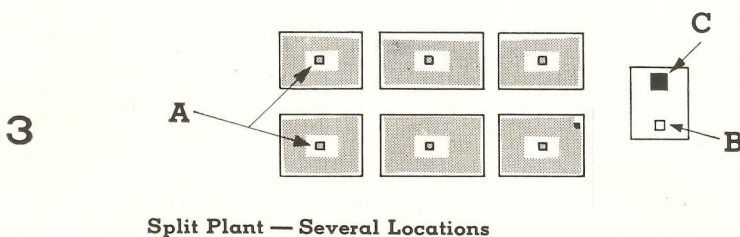
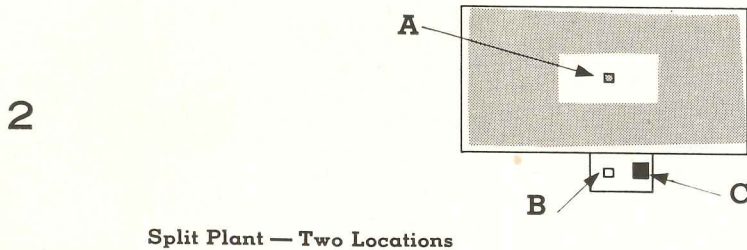
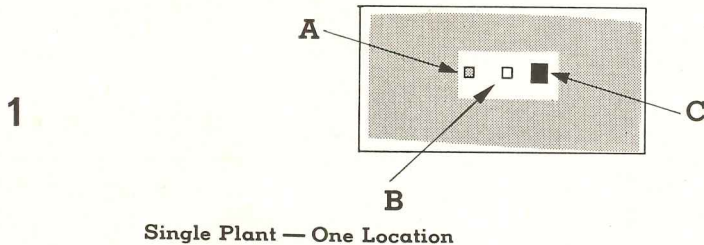

usually applies also to systems 4, 5 and 6 in table

One recent trend in shopping centers is to put all the buildings under one roof (1). Such an arrangement lends itself to a complete central air handling and refrigeration plant and an all-air, high velocity, high pressure distribution system. This gives the lowest annual cost of all. If, for esthetic reasons, the architect does not want the cooling tower and refrigeration apparatus on the roof, but in a separate plant (2) the cost is increased because of added piping. Sometimes it is not possible to group buildings closely enough to make air distribution from one source practical, and it is necessary to distribute chilled water to each building which has its own air handling plant (3)

A — Air Handling Equipment  
 B — Refrigeration Equipment  
 C — Cooling Tower



# SHOPPING CENTERS

ered passageways. This idea taken a step further, suggests that the entire shopping center be enclosed under one roof and completely air conditioned. This is the second and most advanced type. Also there is a compromise between the first two types, with some of the areas between buildings enclosed and conditioned, and other areas left open to the weather.

## Chilled Water Distribution

There are two types of air conditioning systems that seem to work out best for shopping centers. One system has a central refrigeration plant which distributes chilled water to strategically located air-handling equipment furnished by the owners or tenants of a number of buildings; each building generally has a central air handling plant.

## All-Air Distribution

The second system has a single, centrally located plant from which cooled,

conditioned air only is distributed to the completely roofed-in shopping center with its air conditioned streets, malls, gardens and plazas.

## Individual Air Conditioning

Architectural requirements of many of the larger, better shopping centers preclude the use of individual air conditioning systems (both cooling equipment fans). In some of the smaller shopping centers however, it may be practical to use them. This type of system in the large shopping center has many disadvantages such as multiplicity of maintenance, loss of rental space, and higher operating costs.

## CENTRAL SYSTEMS PROVE MOST ECONOMICAL

In large shopping centers, it has been found that the lowest annual cost (initial and operating) can be obtained from some form of central system. The type required would be indicated by the

architectural concept of the shopping center. Thus, with a multi-building layout it is out of the question to use a central air handling plant because of expensive duct runs, and, therefore, chilled water and steam distribution from a remote plant are necessary. In the entirely enclosed type of shopping center, the single central plant has the lowest total annual cost.

## FACTORS DETERMINING LOWEST ANNUAL COST

A comparison of central chilled water distribution to individual store air-handling units (fans, filters, dehumidifiers) versus a complete central station system from one point shows that, generally, and depending on the layout, the initial cost is less for the chilled water system. But more important is the fact that operating cost, especially when loss of rental space is taken into account, is higher with individual units.

Considering the disadvantages of (1)

Characteristics of Systems Indicated In Sketches

Type of System	Equipment Required	COSTS			Flexibility	Rentable Area Required	Limitations
		Initial	Operating	Maintenance			
1 One plant, single location	central high velocity, high pressure air handling  central refrigeration same location	lowest	lowest	lowest	maximum	none	not good for more than 500 equiv ft <sup>1</sup> duct runs
2 Split plant, several locations	central high velocity air handling one location  refrigeration plant separate location	low	low	low	maximum	none	not good for more than 500 equiv ft <sup>1</sup> duct runs
3 Split plant, several locations	central high velocity, high pressure each building  remote refrigeration plant	average	average	average	maximum	none <sup>2</sup>	increase in plant size increases distribution, initial and operating costs
4 Split plant, several locations	central low pressure conventional air handling each building  remote refrigeration plant	average to high	average to high	average	some	none <sup>2</sup>	not suitable to increases in load or changes in departments or tenants
5 Split plant, multi-locations	central low pressure conventional air handling each building and/or each tenant  remote refrigeration plant	average to high	average to high	average	some	none <sup>2</sup> and some	same as 4. Initial and operating costs higher than 4
6 Split plant, multi-locations	central refrigeration plant, distributed condenser water tenant units	high	high	high	none	yes	no advantage over distributed chilled water
7 Individual	refrigeration and air handling unit each tenant	highest	highest	highest	none	yes	not recommended

<sup>1</sup> 500 ft equiv means that the total friction loss in one duct run should not exceed that of 500 ft of straight duct, but this does not account for the extra loss of fittings, so duct runs naturally will total less than 500 ft in length

<sup>2</sup> Basement or other low-charge rental area commonly used for equipment space is considered "none" in this table



**ECONOMIES IN AIR CONDITIONING FOR SHOPPING CENTERS**

multiplicity of service points and servicing having to be done within the merchandising area, (2) loss of rental area, and (3) higher annual costs, the single central station system comes out ahead.

**ADVANTAGES OF  
HIGH VELOCITY AIR**

In the single central station system, the use of high velocity, high pressure air distribution has many advantages. Cooler supply air can be utilized (differential of 30 F between room and supply air temperatures) with its lower, more desirable relative humidity. This permits considerably less air to be handled for the same load, a reduction of one-third.

But to obtain the lower dew point a slightly larger refrigeration plant is required. Fan horsepowers are higher due to the higher static pressures developed. In actual operation, the high-velocity, high-pressure system provides control of air supply at diffusers through dampers, that cannot be achieved with the conventional low pressure system.

This is possible because the variation in static pressure necessary to produce the difference in volume required for the change in load is small in relation to the total static pressure of the system. The fan, and hence air-handling system, remains stable. The area covered by the high pressure diffuser is fairly uniform with not too much difference in coverage over its volume range.

In the low pressure system, the variation in the static pressure would be much larger, the fan and system performance more unstable, and the area covered by the diffuser much less uniform.

A study of initial costs shows the high velocity high pressure system to be low in comparison with all other systems, except the installation of a multiplicity of small air handling units receiving chilled water from a central plant.

An actual cost breakdown shows the following:

1. Sheet metal costs per unit length are the same for the high velocity, high pressure system and the conventional low pressure system. High pressure ducts, although smaller, must be sturdier and leak-proof.

2. High velocity, high pressure dif-

fusers with their sound boxes, baffles and controls are higher in cost than in the conventional low pressure outlets.

3. Due to the much smaller air volume handled, the high velocity, high pressure air handling apparatus cost will be less than for a conventional system due to the reduction in air volume (about one-third less) even though a more rugged fan and larger motor are required. Actual operating costs tend to be higher mainly due to the larger electric motors required to maintain the high static pressure in this type of system. However, considering all this, the single station high velocity, high pressure system will show the lowest total annual cost.

**Reason:** Mainly, no loss of rental can be charged against this system since all air conditioning apparatus can be located in one spot.

**Advantages:** 1. A flexible, modular system can be designed to meet varying loads and shifting department demands without any alterations in equipment. To accomplish this, the system is oversized. Thus, should any part of the system be taxed with a load greater than design load (because of a department being added, an increase of heating load due to more lighting, etc.) the automatic controls can draw on the surplus available. (*A big advantage to the tenant and owner.*)

2. Equipment location keeps maintenance separate from merchandising, and in a single location. (*A big advantage for servicing.*)

3. Small size duct work in furred ceilings. (*A big advantage for the architect if space is at a premium.*)

However, if cutting down the size of ducts is not essential, then it would pay to balance the savings in space that is possible through use of small, high velocity, high pressure ducts against the greater cost for fan motors — which are larger than required in conventional systems — and the additional power to run them.

To shave down costs, a system might be designed with the largest size ducts consistent with good engineering that would fit the space available, with static

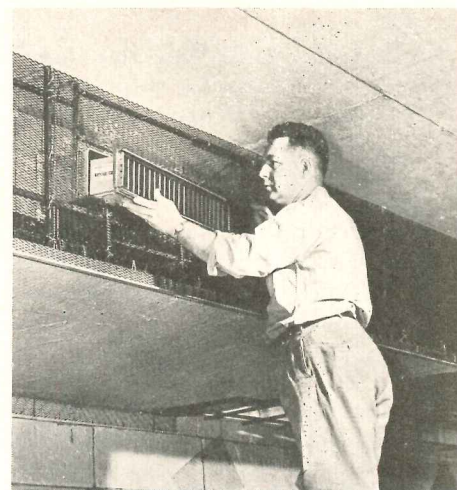

Barber-Colman Co.

**Sidewall diffuser with double-deflecting vanes has an air valve behind it to reduce high velocity air to normal flow**

pressure just high enough for the operation of high pressure diffusers. This system would have a fair amount of flexibility, permitting air quantities to be adjusted at the diffusers to meet changing operating conditions. But at the same time less expensive fans and fan motors could be employed because the static pressure would be lower than for the usual high velocity systems. Operating cost would come down too.

**ADVANTAGES OF  
CENTRAL REFRIGERATION**

No matter what type of system is used, it can be seen that in all instances, the central refrigeration plant offers economies. There are many reasons for this. Initial costs are lower. A comparison of the cost of cooling with individual air conditioners versus a single station system per ton of refrigeration has shown that the central plant of average design has a lower capital cost. A central plant of excellent design will show an even much lower capital cost.

**PROBLEM OF BILLING TENANTS**

Charging a tenant for cooling is a real problem. The most accurate and indisputable method is by therm meters. A therm meter measures and records the flow rate of chilled water and the temperature difference between supply and return in therms (therm = 100,000 Btu). This is an expensive means of



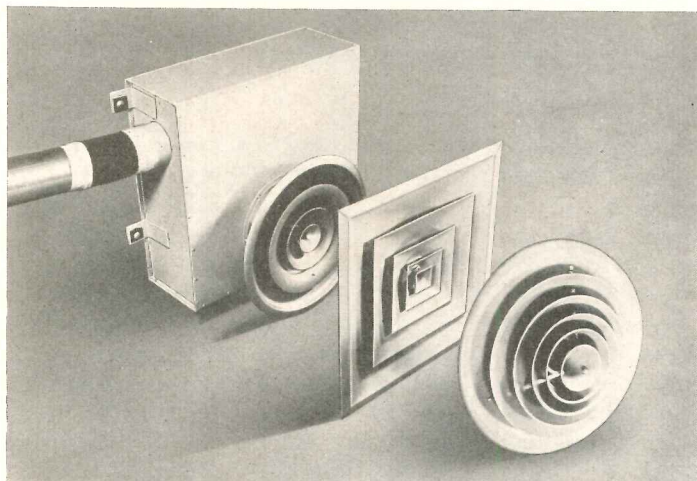

Anemostat

High velocity aspirating diffusers for both average and special conditions (use of cooler than normal air, for example). Square box at left is reducing valve and sound attenuator

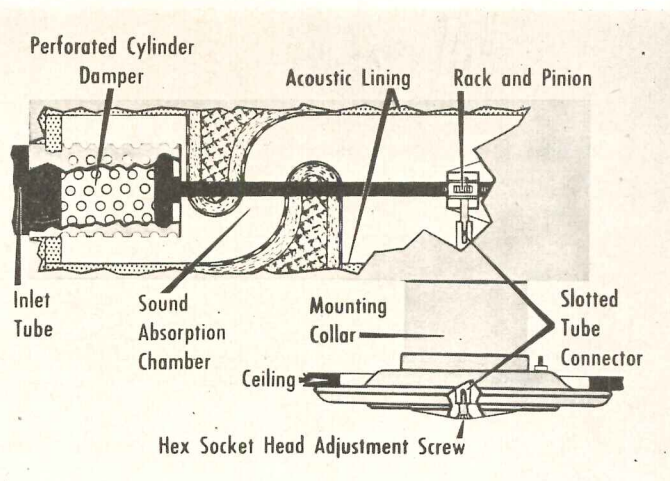

W. B. Connor Engr. Corp.

Cross section of another system. Air at high velocity and pressure is "braked" through a perforated cylinder and passes through acoustic chamber; piston regulates volume

metering and is not often used for that reason. A rental charge on a square foot basis over and above the usual rental charge is often resorted to. This also has its disadvantages. Tenant claims of unfairness due to differences in the amounts of cooling required for equal areas are common. However, equitable charges on a rental basis can be worked out, and since this is so much less expensive than the use of therm meters, it is the most popular method at the present time.

Charges to the tenant, including his proper share of the annual capitalization cost and operating cost, average approximately 50 cents per square foot of rental area, per year. Installation or capital costs range from between \$2 and \$3 or more per square foot of rental area depending upon the architectural concept of the shopping center.

#### COLLABORATION BETWEEN ARCHITECT AND ENGINEER

The architect can help the engineer in keeping duct runs, steam lines, chilled water lines, and condenser water lines as short as the esthetic values of the shopping center will permit, and by giving considerable thought to the location of apparatus rooms. If possible they should be placed on roofs, but if they must be within the building, the lowest-value rental area should be chosen.

Another item of major importance is

an accurate appraisal in the early planning stage of the amount of lighting needed because this is the largest single item of the cooling load and any variation can influence considerably system size, and therefore initial and operating costs.

Special attention should be given to the amount of storage area because of its very low illumination level. In calculating the amount of cooling load attributable to lighting, wattage per square foot should not be considered the same for merchandising and storage areas. Such an assumption would cause the cooling load to be overestimated and air conditioning oversized.

The engineer can contribute toward lower operating cost by making a study of the best drive for the refrigeration compressors and selecting cheapest power: (1) electricity, (2) steam from coal, oil or gas, or (3) steam through a combination of turbine and absorption units in series. In many cases the engineer can carefully evaluate the use of a high-velocity, high-pressure system. Here a word of caution. Fan motor horsepower requirements are high. This has a very important effect on refrigeration load since an increase in air volume is required due to the high sensible heat added to the cooling air by the fan motors. The author suggests that a careful study be made to determine a balance in design that would give the minimum fan

horsepower and minimum refrigeration load consistent with minimum duct size. This study should include the most efficient air handling fans on the market. Apparatus rooms located in non-rentable areas and in such way as to minimize duct runs should be included in this study to determine lowest operating cost.

The trend in design of large shopping centers seems to be toward precluding any individual tenant-installed air conditioning plants. Instead, the tenant is influenced to go along with the owner's air handling plant, obtaining chilled water from a central station, or to ride along as part of the complete central station refrigeration and air handling system. There are many reasons for this. Esthetics dictate a harmonious architectural design. This rules out unsightly individual tenant condenser water systems. A central condenser water system would comply with this requirement, but cost-wise, a central chilled water system is much more desirable.

Standards of air conditioning performance must be controlled throughout the shopping center. This is important because the customer has access to all selling areas, and naturally uniformity is desirable. The heavy investment necessary in the construction of a large plant such as a shopping center should be protected by creating and maintaining high standards.



# EMPLOYEE CAFETERIAS

*How to Plan for Seating  
and Service Requirements*

By Arthur W. Dana, Restaurant Consultant

**E**MPLOYEE food services, whether for office, industrial or department store workers, have usually justified their original installation in a number of ways. Among other things, such services help boost workers' morale by providing increased convenience and accessibility, reducing congestion during lunch periods, and making it unnecessary for them to leave the premises for lunch.

Now the trend among business and commercial organizations to relocate their headquarters in suburban areas has made the provision of employe food services a necessity for companies which formerly, perhaps, did not have to be concerned with such matters. In suburban locations, where normal facilities are fewer and more widely dispersed than in urban areas, the factors cited above become increasingly important.

Effective and efficient layouts of employe food services, as outlined in this article, will require much preliminary discussion with the client as to objectives and policies that affect the proposed food service and the accompanying employe morale goals. This article will review the basic elements in planning such installations, and will summarize special requirements for suburban commercial or business organizations. While these requirements are, on the whole, identical to those for employe facilities in urban installations, there are a few new elements which suburban relocation introduces. These will be suggested below.

## SEATING REQUIREMENTS

The determination of cafeteria seating requirements by the architect depends upon several considerations relative to the size of the organization, company policy and physical limitations. For example, company policy as to the exact use of facilities by employes (price of the food, restrictions against eating else-

where, or absence of such restrictions) helps determine the ratio of the total number of employes who can be expected to use the facilities. The proportion which will use the facilities at any one time is determined by such factors as (1) the number of "staggered" shifts which are provided; (2) the intervals between the start of each of these and the extent of their overlapping (by reason of seat occupancy time); (3) the length of the lunch period (each shift); and (4) the speed and efficiency of counter services. Determination of seating capacity which must be provided affects the total space requirements of the installation, both for the seats and tables themselves, aisle space, adequate counter facilities and space, and sufficient kitchen space.

## Ratio of Patronage

Where companies furnish meals to their employes at a nominally low (flat) price, a 90 to 95 per cent patronage ratio may be expected. Where employes must pay higher prices for the food, but are not permitted to eat elsewhere but in the company-provided facilities, seating for 90 to 95 per cent must be provided, although 20 to 25 per cent of these will probably bring their own lunches, supplementing them only with beverage and sometimes dessert from the counter. When no restrictions are placed on the employes in this respect, but the prices are not exceptionally lower than elsewhere, a range of 50 to 75 per cent patronage can be expected. This depends, however, on the length of the meal period, the existence or absence of long waiting lines, quality and price or value of the food, attractiveness of the facilities and the comfort of the seating. Remoteness of the store or offices from public restaurants and parking difficulties near public restaurants are other factors which can lower or raise the patronage ratio.

## Staggered Meal Periods and Effective Serving Times

The trend toward shorter luncheon periods appears to become stronger where employe food services are installed, with the minimum period frequently being 30 minutes, or in some instances 45 minutes. In a 30 minute period, the maximum available or effective time for serving patrons is within the first 7 to 8 minutes, leaving approximately 20 minutes for dining, etc. In the case of 60 minute periods the effective serving time is within the first 12 to 15 minutes. Wherever problems of management and interrelationship of departmental functions do not cause excessive complications, it is desirable to stagger employes' meal periods, preferably on a 10 minute minimum headway. Some companies are able to stagger periods on a 5 minute basis, but this may lead to excessive overlapping, because of delays in the use of washroom facilities and in traveling to and from the cafeteria.

The whole cycle may start at 11 A.M. or 11:30 A.M. and last until 1 P.M., providing as many as nine to twelve 10 minute periods. Department store employes are frequently served luncheon as late as 2:30 to 3 P.M. In very small operations serving 100 to 150 persons, a 10 to 15 minute break between each two shift periods may be of value. This will permit the cafeteria operator to replenish, clean up and prepare for the next group. In larger operations, this break may be unnecessary, especially if the patrons buss their own soiled dishes (see below).

## Elapsed Time of Seat Occupancy

In a 30 minute lunch period, the minimum time of seat occupancy is 12-13 minutes. Maximum for such a period would be 20 minutes, and this figure is allowable for part of the computation process. In longer periods, most office



Drawing by Don Ervin





In a later issue **ARCHITECTURAL ENGINEERING** will feature as a supplement to this article a graphical method for determining the number of seats required in an employe cafeteria on the basis of a number of variable conditions. This will furnish a shorthand method for figuring requirements

workers prefer to leave their tables after about 20 minutes to stretch and walk about. Department store workers, however, many of whom stand during much of their working day, are likely to remain seated for longer periods, unless other adequate lounge facilities are located nearby.

In a 45 minute luncheon period, the range of maximum seat occupancy is likely to be from 20 to 30 minutes, while in a 60 minute period, the range may be from 20 to 45 minutes.

#### Seating Requirements and Counter Speed

Suburban employe food services, particularly because of their usual location fairly far from public eating places, need to have effective counter speeds for optimum efficiency. Conventional cafeteria counters from 20 to 30 ft long have "speeds" of from 5 (sometimes less) to 6 persons a minute. This may be increased to a more satisfactory 7 or 8 a minute by introducing several modifications. "Free-flow" counters such as described below can accommodate from 10 to 30 per minute or more.

#### Additional Seating Functions

Planning of the cafeteria area is sometimes affected by the need to provide for seating functions other than the normal ones. The inclusion of private or executive dining areas is dependent upon management policy. Where there has been no previous food service, it is well to caution the client about certain "human relations hazards" in limiting the use of such areas. On the other hand, if the dining area has some flexibility, or if sufficient space is available, a small private dining area may be useful for entertaining special guests, officials and the like at conference luncheons.

Similarly, requirements for occasional banquets or multiple use for departmental meetings may affect table ar-

rangement or layout of the room. Public and community relations of the company in a suburban locale may also influence this phase if the area should be made available to civic groups at any time. Additional lounge facilities are usually desirable only where 45 to 60 minute luncheon periods exist, or where mid-morning or afternoon rest periods are customary.

#### SERVICE REQUIREMENTS

In planning for maximum efficiency and comfort in company cafeterias, the architect must be cognizant of a great many factors, including details of the actual management of the installation. Preliminary decisions on such matters can directly affect layout and spatial requirements. The manner in which foods are displayed and served, location of various categories of foods in relation to each other, decisions concerning the employment of pre-packaged sandwiches, etc., decisions as to whether or not patrons will be required to carry their own soiled dishes to service windows — all these have direct bearing on the size and nature of the facilities the architect must design.

#### Free-Flow Counters

Perhaps the most important of these considerations are the arrangement and location of serving counters. Frustrating delays in waiting lines at counters are an important factor in reducing both patronage ratios and employe morale benefits. The conventional counter is a series of cumulative bottlenecks — hot food serving station, made-to-order sandwich station, drinking water, condiments, coffee service, cashier station. These impede traffic flow and slow the line. When desserts are displayed above salads, for example, this arrangement can slow traffic. Serving speed can be increased, however, from 5 or 6 per minute to 7 or 8 per minute per cafe-

teria line by such devices as placing the hot food counter first in line, using ready-wrapped sandwiches, locating water and condiments at a stand in the dining area, and placing the cashier's stand about 12 ft from the coffee station, which should itself be last in the line. Since usually only  $\frac{1}{3}$  to  $\frac{1}{2}$  of the patrons will take coffee at noon, it is desirable to let those who prefer milk or iced tea by-pass this station.

Still greater increases in serving speed can be made by substituting a "free-flow" counter, such as that shown in Fig. 1, for the conventional serving counter. This arrangement permits those who wish cold food to by-pass queues at hot food or sandwich stations. Similarly, those who do not wish desserts can by-pass this station (only 65 to 75 per

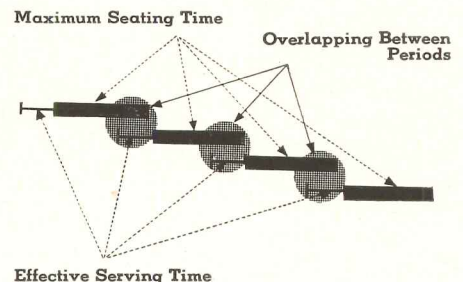

cent of the patrons usually buy desserts).

To expedite such by-passing, a traffic aisle 6 to 10 ft wide has to be provided. The free-flow counter with remote cashier stations can have a speed of 10, 20, 30 or more per minute, depending on the number of hot food stations provided and the linear display of quick-pick-up foods. Lengths of such counters may range from 40 to 70 ft or more. Advantages of the free-flow system include elimination of duplications in counter equipment (as in multiple counter lines) and reduction of the service staff. In actual practice no cross-traffic problems have been encountered in by-passing,

(Continued on page 208)



if the counter is properly designed. The free-flow counter depends for its success, however, on a fairly even flow of patrons into the cafeteria and a probable patronage distribution of *at least* 25 per cent for salads and ready-wrapped sandwiches. Separate snack bars or cold food lines are economically justified only in larger food service installations, but these can be incorporated in the free-flow design without duplication of dessert, beverage and cashiering facilities.

Besides the arrangement of the serving counters themselves, an important element in potential service delays is replenishment of foods at the counters, particularly at the hot food station. To reduce delays from this cause, it is desirable to plan pass-through facilities from the kitchen to storage cabinets for both hot and cold foods. Wherever possible, these should be designed so that there is a minimum number of steps from the hot food production facilities to the reserve warmer.

The location of the serving counters should afford some space for a waiting line-up. Screening or partially concealing both the serving counter and the line-up space from the view of the diners is sometimes done.

Still another factor which affects the architect's planning is the method by which soiled dishes are bussed. The increasing practice in employe cafeterias is for patrons to carry their own trays of soiled dishes to a pass-through window, conveyor belt or shelf. This procedure has the advantage of freeing tables

and seats as soon as the patron arises, thus reducing somewhat the total number required. The procedure also encourages diners to keep their plates on the trays while they eat, and this habit, in turn, makes the use of rectangular rather than square tables desirable, so that the trays (usually 18 by 14 in.) will fit on a table 30 in. wide and with a length of 2 ft per seat on each linear side. Other advantages to having patrons buss their own dishes are decreased labor costs (one bussing employe is needed for each 50 to 60 seats), decreased breakage of china and glassware, and elimination of scraping and stacking of dishes in trucks located in and around the dining area.

#### The Menu Pattern

The menu pattern, the approximate portion sizes to be served, and estimates of distribution of sales between salads, sandwiches and hot foods, are factors which the food service equipment specialist or consultant must transpose into equipment sizes or capacities and numbers of equipment items. The ratio of men and women patrons, and a considerable ratio of older people who must watch their diets, are among the factors that will influence the estimates of proportionate facilities for hot foods versus salads and sandwiches. The menu pattern that is limited to one, two or three hot plates will affect the maximum loads on roasting, frying, kettle or range top equipment.

To the extent that the menu pattern

avoids an excessive variety on any one day, the economic subsidy or burden inherent in employe feeding will be lessened and the quality of the food will be improved by faster turnover and opportunity for better supervision of preparation.

#### SPECIAL SUBURBAN PROBLEMS

Suburban locations may reduce the frequency of deliveries of meats and produce from a daily basis to two or three times a week and thus require slightly larger storage refrigeration and freezer space. Other perishables are usually on a daily basis. In suburban department stores the frequency of night operation is often greater than in the city, hence, the necessity to provide for two meals a day will increase refrigeration needs.

If the cafeteria is located near urban centers, meats may be made ready for cooking by the dealers, thus limiting the butchering or meat-cutting equipment which has to be provided for kitchen areas. Suburban department stores may require additional baking equipment, because of night operations, but would need very little more kitchen capacity; baked goods can be prepared in the morning for service at night, whereas most kitchen preparation would be freshly made for the evening meal.

Similarly, baking of pies and cakes may not be done, in favor of purchased products. However, it is safer to allow space for possible future baking, including that of rolls or biscuits. Bread is almost always purchased.

**FIG. 1**  
Free-Flow  
Serving Counter

A — HOT BEVERAGES  
B — MILK  
C — ICE CREAM  
D — DESSERTS  
E — SANDWICHES & SOUP  
F — SALAD  
G — BREAD  
H — HOT FOOD

I — FUTURE HOT FOOD COUNTER  
J — FUTURE TRAY & SILVER STAND  
K — PASS-THROUGH REFRIGERATOR  
L — PASS-THROUGH CABINET  
M — PASS-THROUGH WARMER  
N — TRAY & SILVER STAND  
O — SINK  
P — WORK TABLE

Q — TRAY SLIDE  
R — GUIDE RAIL  
S — CASHIER  
T — WATER & CONDIMENTS  
U — DISHWASHING AREA  
V — CONVEYOR  
W — DISH MACHINE  
X — DISH TRUCKS

0 5 10 FEET

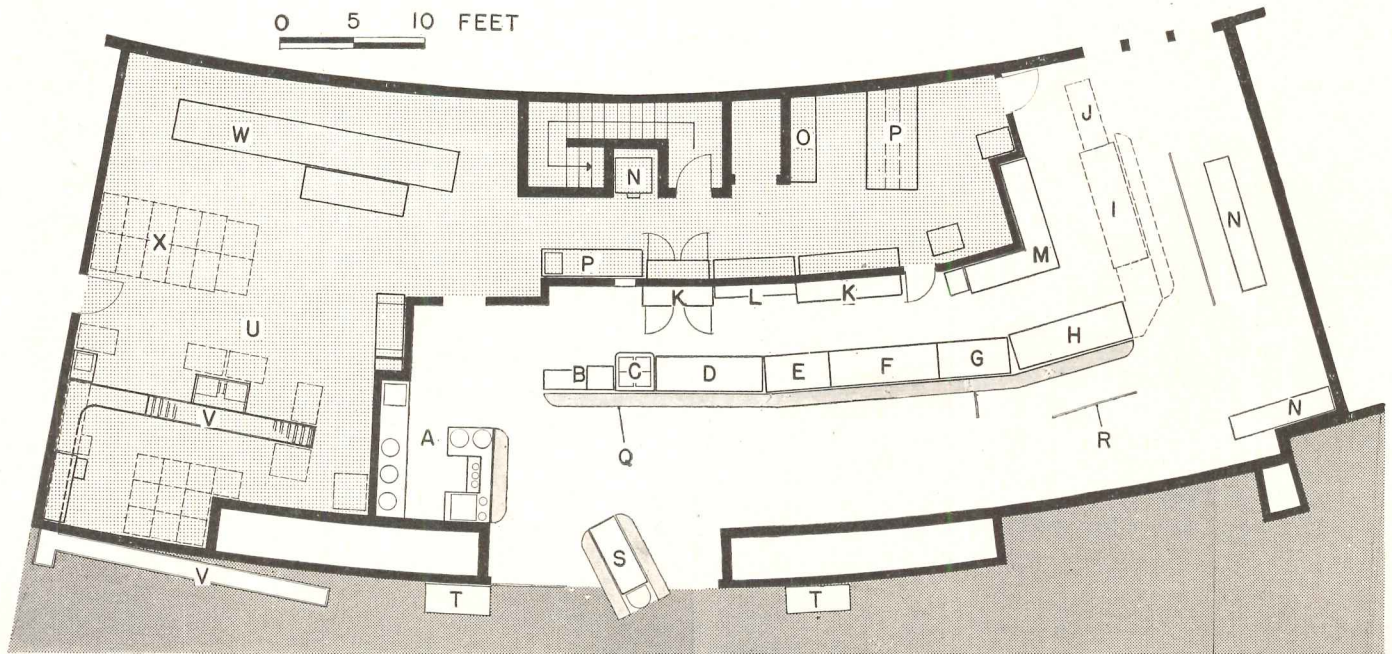



## PRODUCTS CHOSEN FOR 1953 GOOD DESIGN EXHIBITION

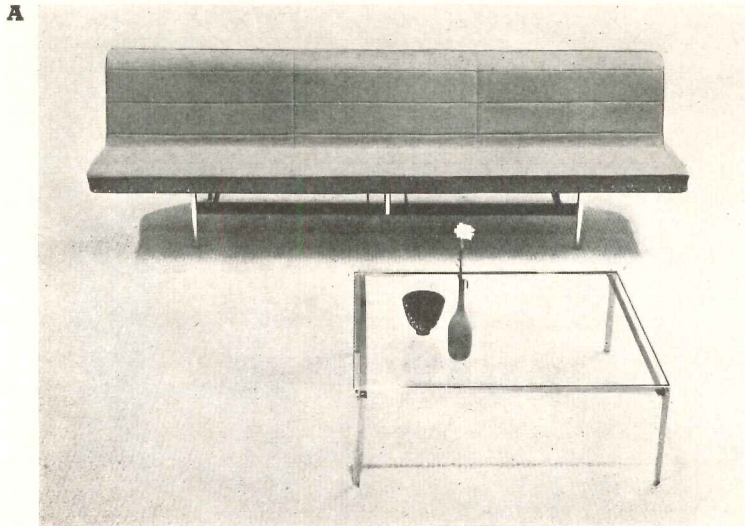

Shown on this page are a few of the items which have been chosen for the 1953 "Good Design" exhibition, sponsored jointly by the Museum of Modern Art in New York and the Merchandise Mart in Chicago. Included are, top to bottom, a foam rubber sofa with chromed legs and black enamel stretcher, and a coffee table with chrome base and plate glass top — both designed by Katavolos, Littell and Kelley of Laverne, Inc. (160 E. 57th St., New York, N. Y.); model "A" portable steel fireplace with glass fiber insulation — designed by George Kosmak for Kosmak Fireplaces (45 Castel St., San Francisco 11, Calif.); easy chair and ottoman with walnut frames and handprinted linen covering — designed by Folke Ohlsson for Dux Co. and distributed by George Tanier (521 Madison Ave., New York, N. Y.); dining table of white Carrara marble on brass plated steel legs, dining chairs with three chromed legs, black enamel stretchers and leather slings — Designed by Katavolos, Littell and Kelley of Laverne, Inc.

Exhibited during the summer furniture market at the Merchandise Mart, all of the illustrated items except the sofa will be on display at the Museum of Modern Art during October and November. Other items to be exhibited will include floor coverings, various types of fabrics, lamps, accessories, tableware, household appliances and many other miscellaneous products.

(Continued on page 220)

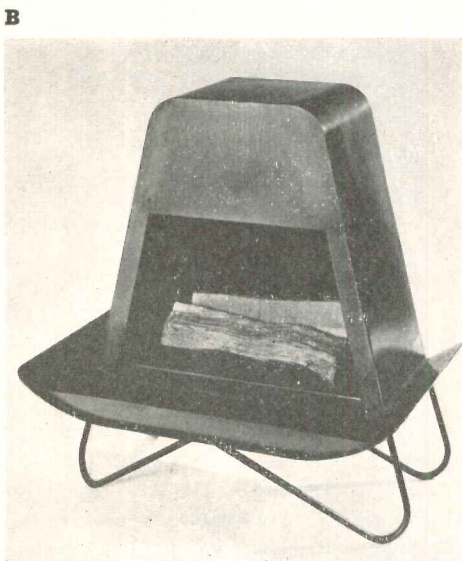

**A** Foam sofa and glass-topped coffee table both feature chrome legs

**B** Portable steel fireplace has grey-black finish, glass-fiber insulation

**C** Walnut framed easy chair and ottoman covered with handprinted linen

**D** White Carrara marble dining table on brass plated steel legs, leather sling, three leg chairs

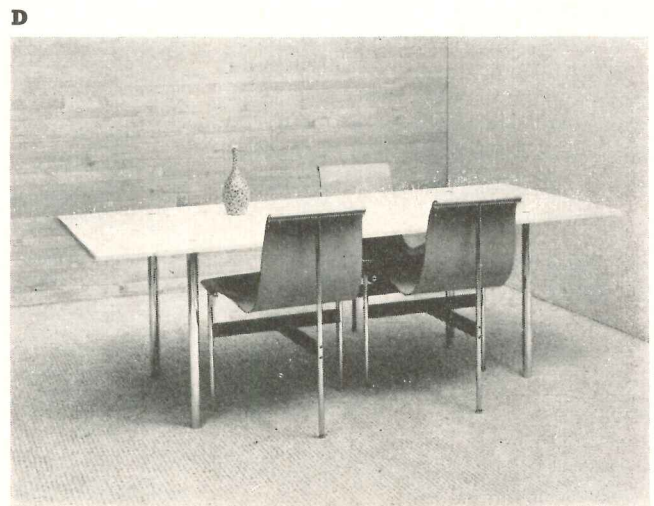



**BODY MEASUREMENTS OF SCHOOL AGE CHILDREN**

*Basic Body Measurements of School Age Children.* Prepared as a ready reference handbook for use by architects, school officials, design engineers, and others who need information on the basic body measurements of school age children, this book contains information on the means, the variability, and the range of 53 different body measurements for boys and for girls, for each age from 4 to 17 years. The measurements include the following: heights of different parts of the body from the floor, in standing and sitting positions; lengths of different segments of the trunk; lengths of the limbs and their component parts; depths, breadths, and diameters of different parts of the body as well as their arcs, girths, and circumferences. The measurements were selected on the basis of the responses to a questionnaire which was sent to architects, manufacturers, school business officials, specialists in school plant planning, and selected school officials and teachers. Only those measurements are included which are needed in building, furnishing, and equipping more functional school buildings for the youth of the nation.

The measurements taken alone, or in combination with others, can be used for computing the space requirements of children in carrying on the common learning tasks of the classroom and playgrounds; in planning school buildings and the facilities and services which go into them; and in designing, selecting, and purchasing the furniture and equipment which are needed for the different activities of children in the different grades. Single copies obtainable from the School Housing Section, Office of Education, U. S. Dept. of Health, Education and Welfare, Washington 25, D. C.

**DISHWASHERS FOR PUBLIC EATING PLACES**

*NSF Standard No. 3, Spray-Type Dishwashing Machines.* Booklet prepared by the Joint Committee on Food-Equipment Standards contains the Na-

*Other product information in Sweet's Architectural file, 1953*

**Right: Illustration from new government booklet shows frame proportions of a school age child**

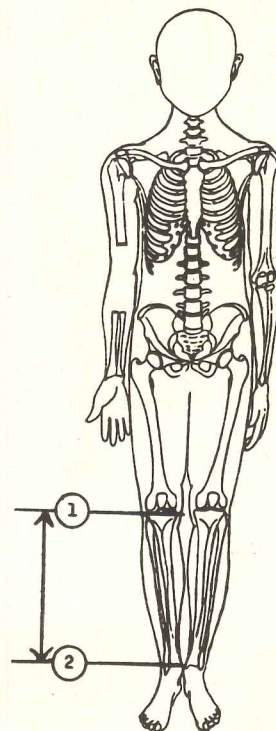

tional Sanitation Foundation Sanitary Standard for the construction of spray-type dishwashing machines, with recommendations covering installation. Complete information is included for various parts of the machines, such as water inlets, valves, temperature control, thermometers, pumps, etc. Wash and rinse cycles are discussed, and maintenance directions given, with suggested check list for sanitarians, applicable to spray-type machines. 46 pp., illus. The National Sanitation Foundation, University of Michigan School of Public Health, Ann Arbor, Mich.

**CLAY TILE INSTALLATION**

*ATCO Adhesives — Specifications and General Instructions for Thin-Setting of Real Clay Tile.* Booklet describes adhesives and other products and gives suitable base surfaces for the "thin-set" method of applying clay tile. General information includes proper storage temperatures, how to prevent damage from fire, and suggested solvents, thinners and tools. Thin-set methods of clay tile include base surfaces to receive tile, plastered partitions, layouts, leveling uneven surfaces, caulking, waterproofing, area to be tiled in one operation, and how to determine which method to use — a floating or a buttering method. Special instructions for shower stall construction, ceilings, bathroom accessories, grouting and finishing, and final cleaning

are also given. A short form specification for architects is provided. 10 pp., illus. ATCO Tile Sales Co., 101 Park Ave., New York 17, N. Y.

**HIGH VELOCITY AIR CONDITIONING**

*Anemostat Units for High Velocity Air Conditioning Systems.* Bulletin (HV Manual 48) contains engineering data on the selection, layout and installation of the manufacturer's units for high velocity air conditioning systems. Data is designed to help consulting engineers design high velocity air conditioning systems, and in combination with standard tables in the ASHVE Guide, it permits conversion of low velocity designs to high velocity. Useful tips on duct design, sizing of ducts, types of systems and balancing of units and information on how metal and space savings can be achieved are given. Anemostat Corp. of America, 16 E. 39th St., N. Y. 16.

**INDUSTRIAL FLOORING**

*Plastic Pellets.* Booklet explains advantages of plastic pellets in an asphalt-rock mixture for industrial flooring. Use in two types of flooring materials — "Immediate Set" and "Liggite" — is described, and characteristics of each type are cited. 8 pp., illus., Flash-Stone Co., Inc., 3723 Pulaski Ave., Philadelphia 40, Pa.

(Continued on page 271)



High  
Velocity

with

# Unlimited Capacity

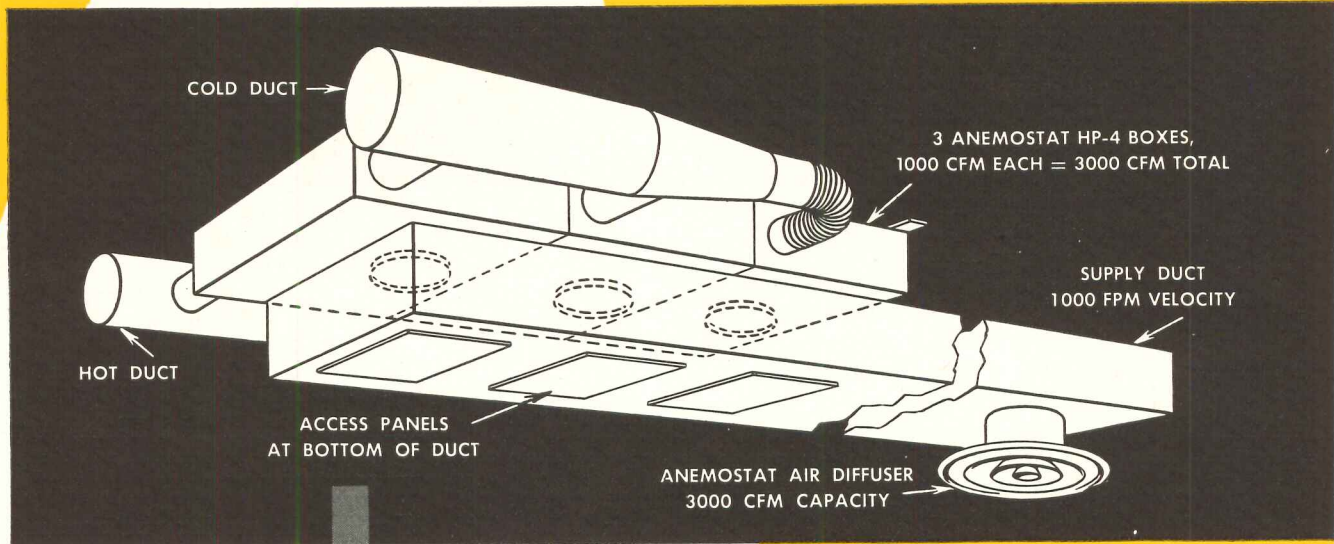

High Velocity air conditioning is constantly posing new problems. Here is one of many for which Anemostat has a practical solution.

**PROBLEM:**

How can you handle unlimited volumes of air from a single air diffuser on a High Velocity single or dual duct system?

**SOLUTION:**

Use 3 series HP-4 High Velocity Units in tandem connected to an Anemostat Air Diffuser.

*In High Velocity installations, too,  
"When Anemostat Air Diffusers are  
in sight the system is right."*

**ANEMOSTAT®**

**DRAFTLESS Aspirating AIR DIFFUSERS**

**ANEMOSTAT CORPORATION OF AMERICA**

10 EAST 39th STREET, NEW YORK 16, N. Y.

REPRESENTATIVES IN PRINCIPAL CITIES

*"No Air Conditioning System Is Better Than Its Air Distribution"*



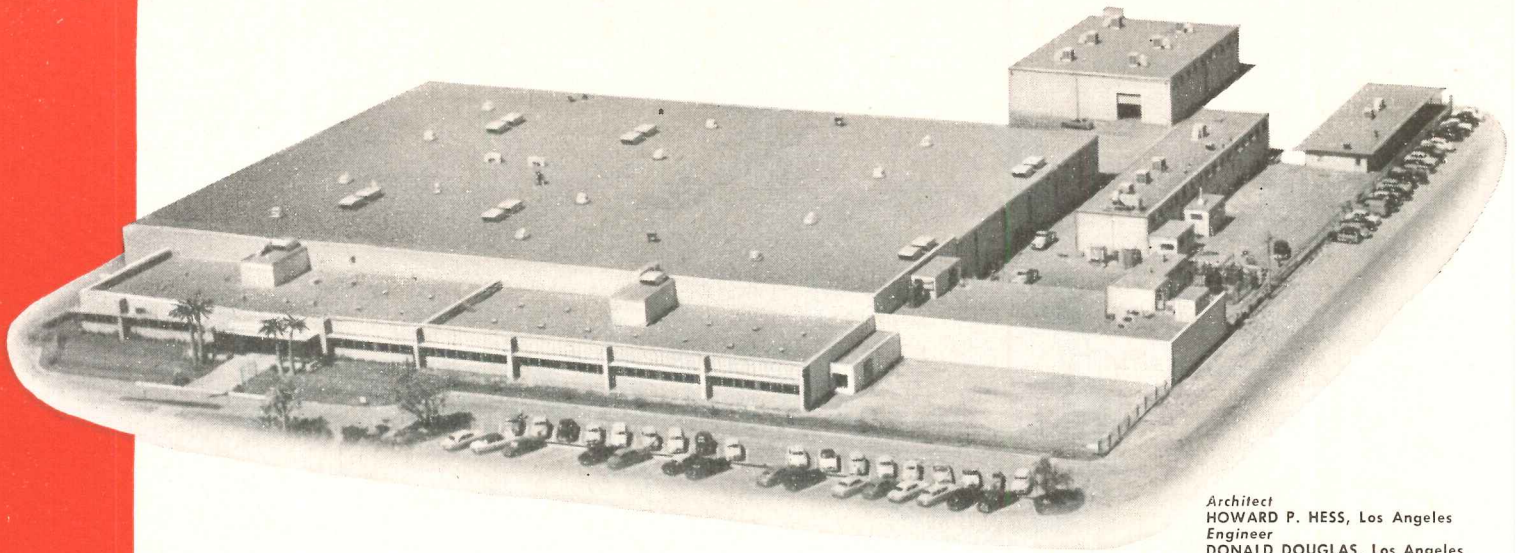

Architect  
HOWARD P. HESS, Los Angeles  
Engineer  
DONALD DOUGLAS, Los Angeles  
Builder  
PANELCRETE ENGINEERING CO.,  
Phoenix

**AiResearch Manufacturing Company of Arizona**  
builds for economy today, easy expansion tomorrow  
... installs **MILCOR** Steel Roof Deck

ALL materials selected for this new Phoenix plant were measured by three requirements: utility, speed of installation and easy integration with future construction. Milcor Steel Roof Deck qualified and was chosen.

*Horizontal expansion* of the new plant's 100,000 sq. ft. primary core was planned for in the design. Steel frame construction covered with Milcor Steel Roof Deck will permit future expansion to 750,000 sq. ft. *with no break in production.*

Many architects specify Milcor Steel Roof Deck for versatility like this — and for other advantages: Savings on structural supports. Ease and Speed of installation. High strength/weight ratio. Fire resistance. Low maintenance cost.

For help in planning efficient use of Milcor Steel Roof Deck on your jobs, see the Milcor Manual in Sweet's — or call on our engineering service.

\*Reg. U. S. Pat. Off.

**INLAND STEEL PRODUCTS COMPANY**

4035 WEST BURNHAM STREET • MILWAUKEE 1, WISCONSIN  
BALTIMORE 5, MD. — 5300 Pulaski Highway • BUFFALO 11, N. Y. — 64 Rapin St. •  
CHICAGO 9, ILL. — 4301 S. Western Blvd. • CINCINNATI 25, OHIO — 3240 Spring Grove Ave. •  
CLEVELAND 14, OHIO — 1541 E. 38th St. • DETROIT 2, MICH. — 690 Amsterdam Ave. •  
KANSAS CITY 41, MO. — P. O. Box 918 • LOS ANGELES 58, CALIF. — 4807 E. 49th St. •  
NEW YORK 17, N. Y. — 230 Park Ave. • ST. LOUIS 10, MO. — 4215 Clayton Ave.

M-116



Interlocking sides and overlapping ends (with ribs offset for easy nesting) speed installation of Milcor Steel Roof Deck. Sheets may be welded or anchored with clips. You get a perfect base for insulation and roof covering.

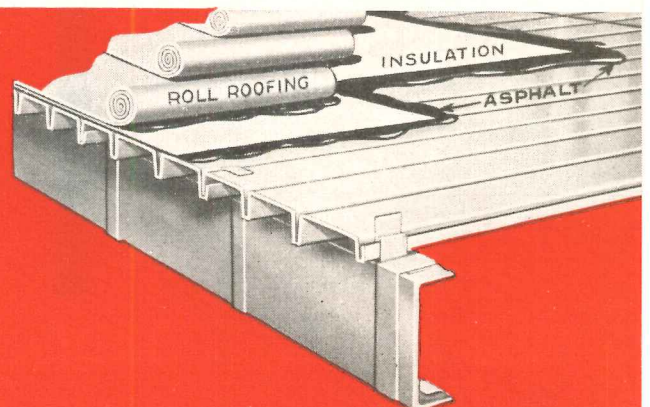



STRUCTURAL FORMS—25: THIN SHELLS OF REINFORCED CONCRETE

By Seymour Howard, Architect, Instructor at Pratt Institute

**B-3 ONE GROUP OF CENTERS OF CURVATURE BELOW THE SHELL AND ONE GROUP OF CENTERS OF CURVATURE ABOVE THE SHELL.**

(Anticlastic or saddle shaped surfaces also known as skew or ruled surfaces)

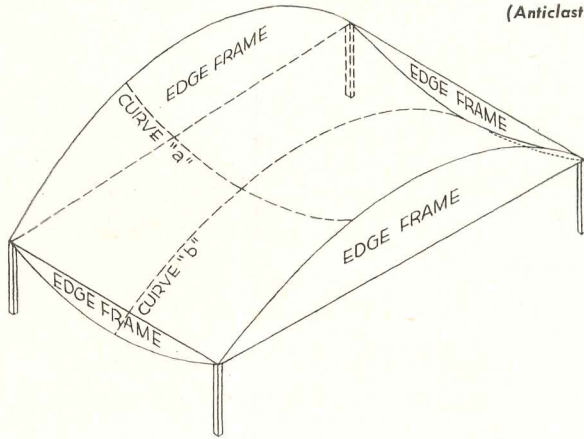

**General Case**

See Sheet 22

The difference between this type and B-1 & B-2 is that the centers of curvature of curve "a" are on the opposite side of the shell from the centers of curvature of curve "b"

This type of shell derives greater stiffness from its shape alone than any other type. In practice this form is used as either a hyperbolic paraboloid or as a conoid. (Hyperboloids of one sheet also have been used)

**B-3-a HYPERBOLIC PARABOLOIDS**

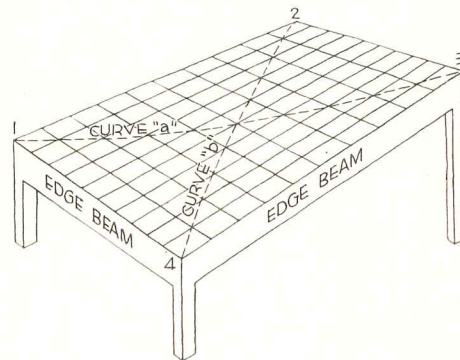
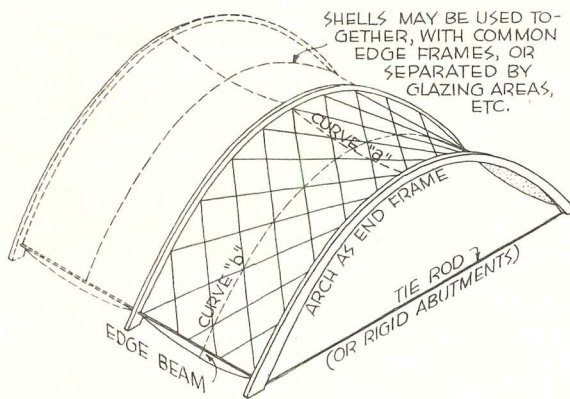

In a true hyperbolic paraboloid surface, both curves "a" and "b" are parabolas, while the traces of horizontal planes intersecting the surface are hyperbolas. In practice curve "b" may be any suitable curve. The surface is generated by connecting successive points on the two arches by straight lines, which lie in parallel planes. The fact that the warped surface is created from straight lines makes formwork relatively simple. The arches can be built first and straight beams hung on them to support the form boarding

**STRAIGHT EDGED FORM**

If one corner of a rectangle in plan is raised above the other three and straight lines lying in parallel planes are drawn connecting each pair of opposite sides, a hyperbolic paraboloid surface will be generated.

Corner 3 is higher than 1, 2 & 4; edges 1-2 and 3-4 are divided into equal spaces and the points are connected; similarly edges 1-4 and 2-3.

Corner 3 might also be located below instead of above the other three

**Example of anticlastic and synclastic shells used together to form continuous corrugated surface**

A shell of this type has been built of 330 ft span, 40 ft rise, spacing of corrugations (crest to crest) 32 ft, depth of corrugation 7 ft, shell thickness 2 3/8 in. (Marignane Airport, Marseilles, 1952)

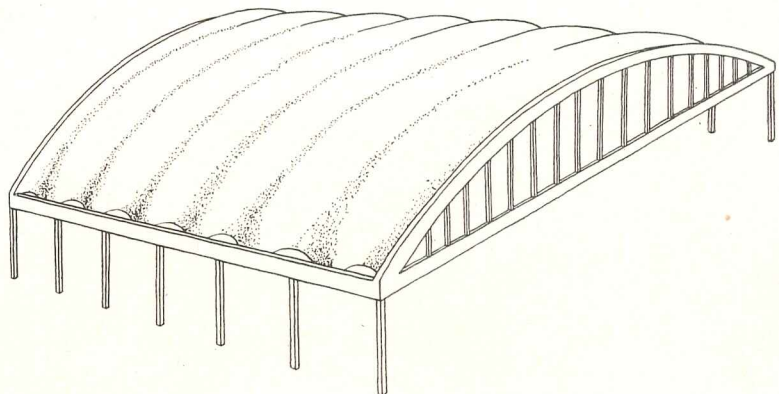



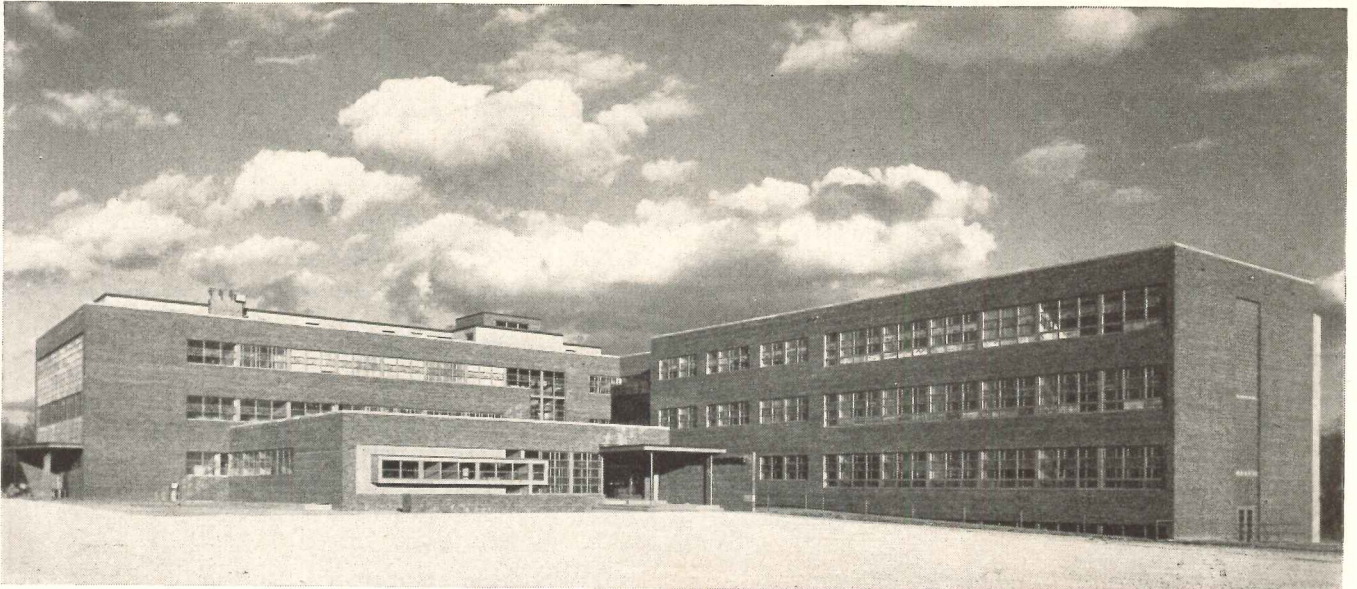

Ottumwa, Iowa, Hospital, built 1952. Architect: Morgan-Gelatt & Associates, Burlington, Iowa. Consulting Engineers: Beling Engineering Co. General Contractor: Ringland, Johnson, Inc., Des Moines, Iowa. Mechanical Contractor: Mechanical Constructors, Inc., Moline, Ill.

# WALL-to-WALL WARMTH

## For New 133-Bed Iowa Hospital

New Ottumwa Hospital, 28th hospital design completed by Architect Dane D. Morgan of Morgan-Gelatt & Associates, has wall-to-wall warmth assured by Tru-Perimeter hot water heating using Webster Walvector.

The new 133-bed Ottumwa, Iowa, Hospital, a community project built on a 40-acre tract, replaces a hospital group which for 60 years had struggled with space problems. The new hospital has 95,287 sq. ft. of floor space, 716 sq. ft. per bed, and was built at a cost of \$14.88 per sq. ft. or \$12,789.51 per bed. It has a maximum bed capacity of 175. Total cost of building and equipment was \$1,800,000.

Beling Engineering Co., Consulting Engineers, recognized the need for wall-to-wall warmth in every room. As a result, patients and personnel enjoy the comfort of a zone-controlled hot water system with "Tru-Perimeter" Heating by Webster Walvector. Water is heated by steam converters in penthouse.

Webster Walvector heats all exposed walls, gives gentle, even warmth. No cold spots, hot spots or



Operating Room. Webster Walvector offsets heat loss from large glass exposures here and in nursery and obstetric suite.

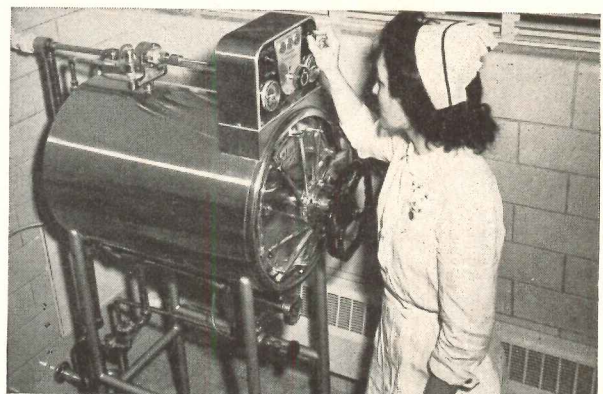

Where space is limited, as in this sterilizer room, Webster Walvector conserves floor space. Assures comfortable warmth, but is never in the way. Sterilizer is equipped with special Webster Process Steam Trap for fast heating-up . . . standard on all leading sterilizers.

drafts. Heating element and piping are concealed in attractive metal enclosures. Piping is simplified, fewer risers needed.

Whether you are considering new construction or modernization, investigate the advantages of Webster Walvector. For complete information, call the Webster Representative near you, or write us.

Address Dept. AR-10

**WARREN WEBSTER & COMPANY**  
Camden 5, N. J., Representatives in Principal U. S. Cities  
In Canada, Darling Brothers, Limited, Montreal

**Webster**  
**WALVECTOR**  
REG. U. S. PAT. OFF.  
**For Steam or Hot Water Heating**



STRUCTURAL FORMS—26: THIN SHELLS OF REINFORCED CONCRETE

By Seymour Howard, Architect, Instructor at Pratt Institute

B-3-a HYPERBOLIC PARABOLOIDS (Continued)

Combinations of straight edged form

NOTE: In addition to edge stiffeners, beams or thickenings of the slab are required along lines of gables or abrupt changes (knuckles) in the surface of the shell

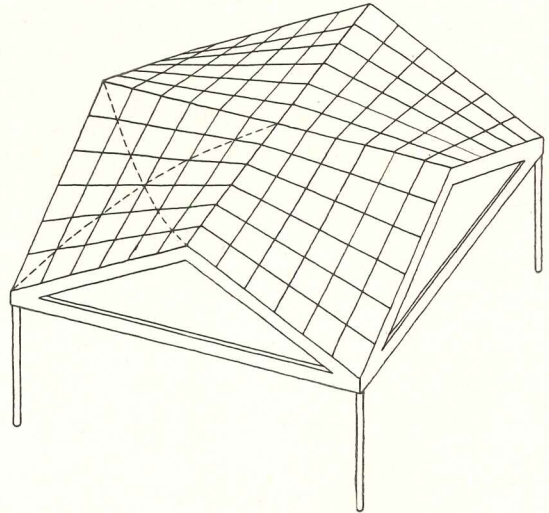
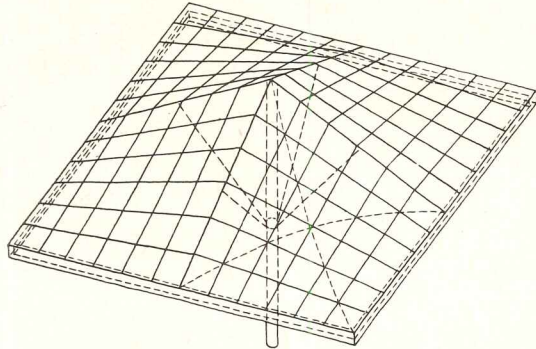

The Umbrella Form

Made by combining four hyperbolic paraboloid surfaces, each one having three low corners and one high corner. Diagonal struts may be required from column to ridges to take eccentric loading. This type would require column to be cantilevered up from wide footing if used alone. Stability can be achieved more easily by using minimum of four

The Four Gable Form

Made by combining four hyperbolic-paraboloid surfaces, each one having three high corners and one low corner. This type can stand alone or be combined: (downspouts can be provided in the columns)

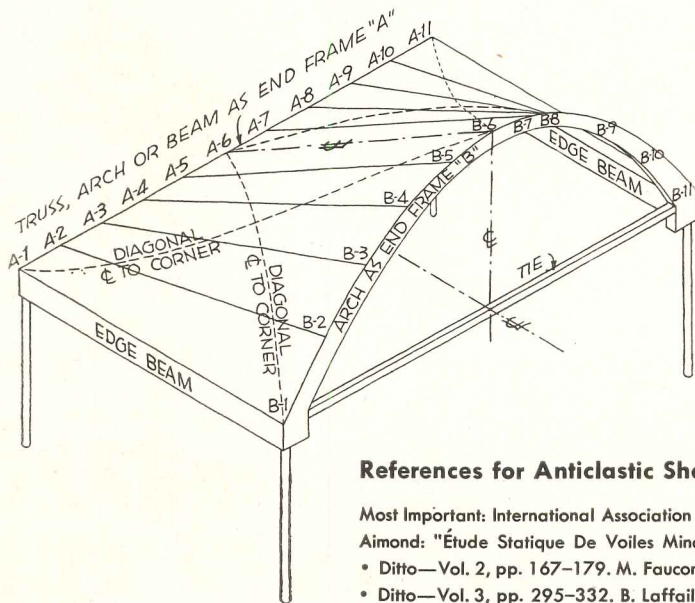
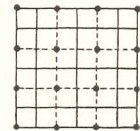

Surface generated by straight lines connecting corresponding points on opposite sides. Points are found by passing vertical planes parallel to vertical center line plane through both sides. Sides "A" and "B" may both be curved (of different curvatures), or one side may be straight and one curved (as shown).

Lines A-1 to B-1, A-2 to B-2, A-3 to B-3, etc., are all straight and all lie in planes parallel to center line plane through A-6 and B-6

References for Anticlastic Shells

- Most Important: International Association for Bridge & Structural Engineering, Zurich—Vol. 4, pp. 1-112 F.
- Aimond: "Étude Statique De Voiles Minces En Paraboloides Hyperboliques Travaillant Sans Flexion"
- Ditto—Vol. 2, pp. 167-179. M. Fauconnier "Essai De Rupture D'une Voute Mince Conoïde En Beton Armé"
- Ditto—Vol. 3, pp. 295-332. B. Laffaille—"Mémoire Sur L'Étude Générale Des Surfaces Gauches Minces"
- American Concrete Institute Journal, March 1953—F. Candela "Skew Shells Make Unusual House Roof."



**A MODERN, COMPLETELY  
AIR-CONDITIONED  
APARTMENT**



**WITH HEAT BY  
FITZGIBBONS  
STEEL BOILERS**

The new 200 East End Avenue Apartments in New York City. Heating contractor: Raisler Corp.; Owner-Contractor: Sol Atlas; Architect: Lathrop Douglass; Consulting engineers: Sears & Kopf

■ The “warmth” part of the year round comfort in this new and modern apartment building is capably and economically handled by two Fitzgibbons DM 425 steel boilers. These boilers are first choice among architects, heating engineers, building management and owners for dependable heat, minimum operating expense and trouble-free service life. For assured performance in apartments, schools, churches, commercial and institutional buildings, make it “heat by Fitzgibbons.”

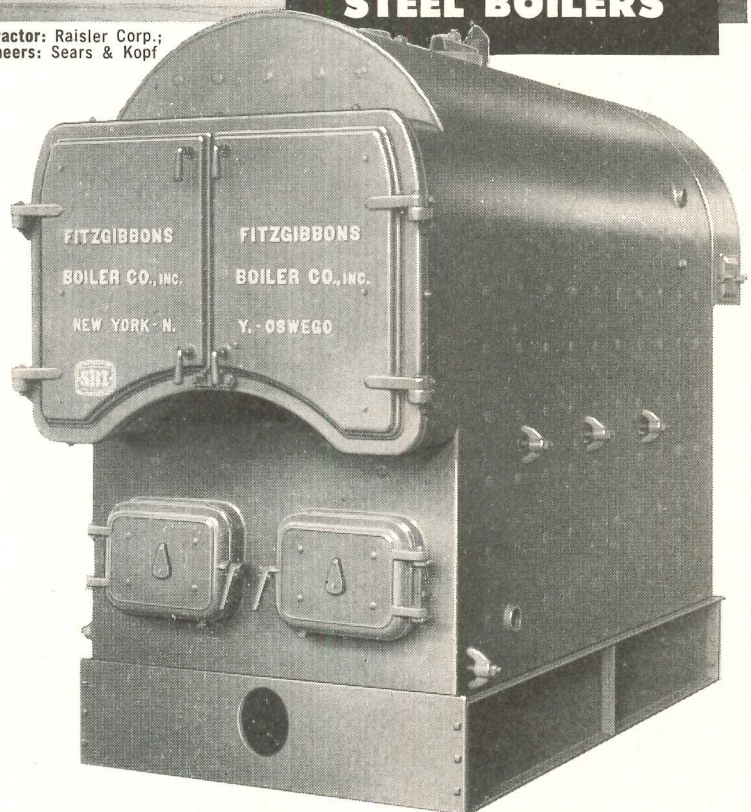

For full specifications and data write to the Fitzgibbons Boiler Company, Inc., 101 Park Avenue, New York 17, N. Y. Ask for catalog AR-10.



**THE FITZGIBBONS BOILER®**



STRUCTURAL FORMS—27: THIN SHELLS OF REINFORCED CONCRETE

By Seymour Howard, Architect, Instructor at Pratt Institute

B-3-b CONOIDS (Continued)

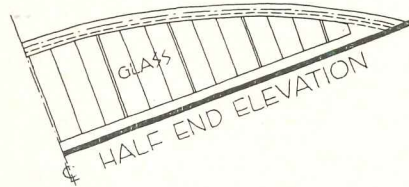
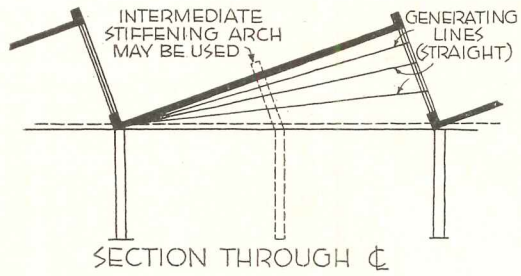

Used for north light:  
(compare with sheet 19, showing tilted conical & cylindrical shell solutions)

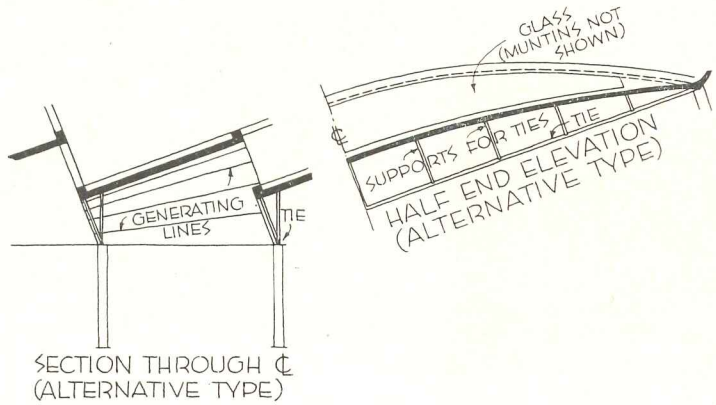
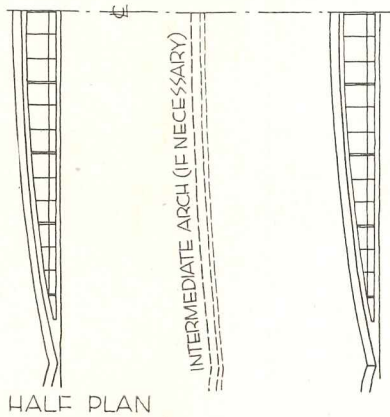

In addition to providing a simple solution to the north light problem, conoids can be effectively used as cantilevers over loading platforms or as double cantilevers for top lighting

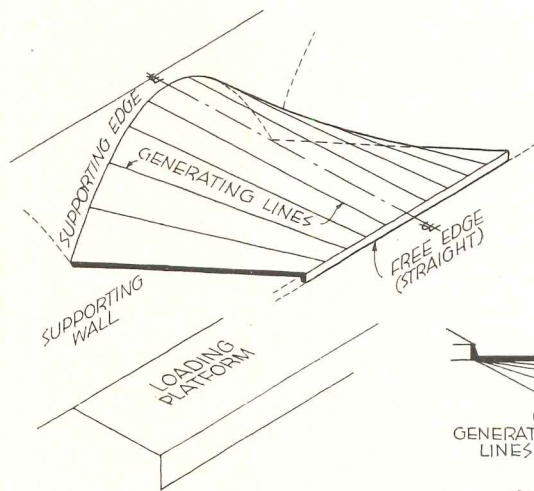

◀ Isometric of a conoid used as a canopy

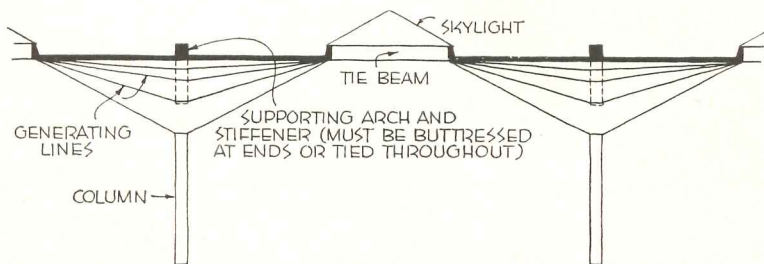

DOUBLE CONOIDS USED IN SERIES (MULTIPLE SHELLS) WITH OPENINGS BETWEEN SERIES FOR NATURAL LIGHTING



# Rotary Oildraulic

## THE MODERN ELEVATOR

### NORTHWESTERN MUTUAL FIRE ASS'N

Los Angeles, Calif.

Architect: Richard J. Neutra

Contractors: C. W. Driver, Inc.

Rotary Oildraulic Elevator (passenger)  
installed by Elevator Maintenance Co., Ltd.

*Photos by Julius Shulman*

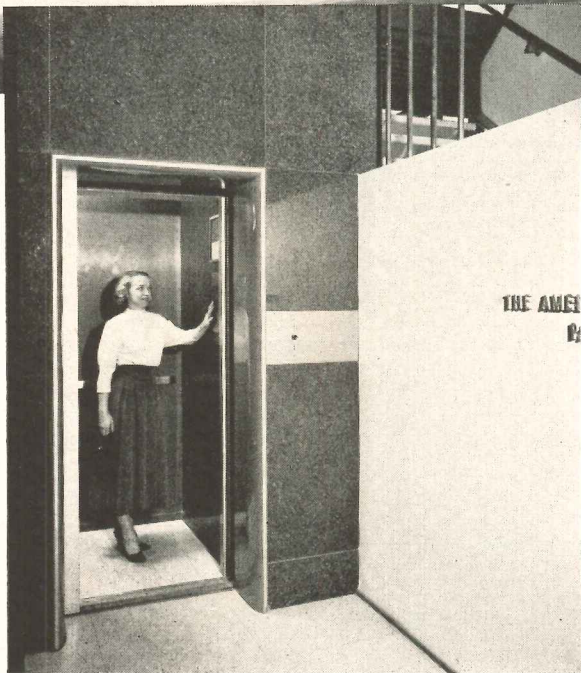
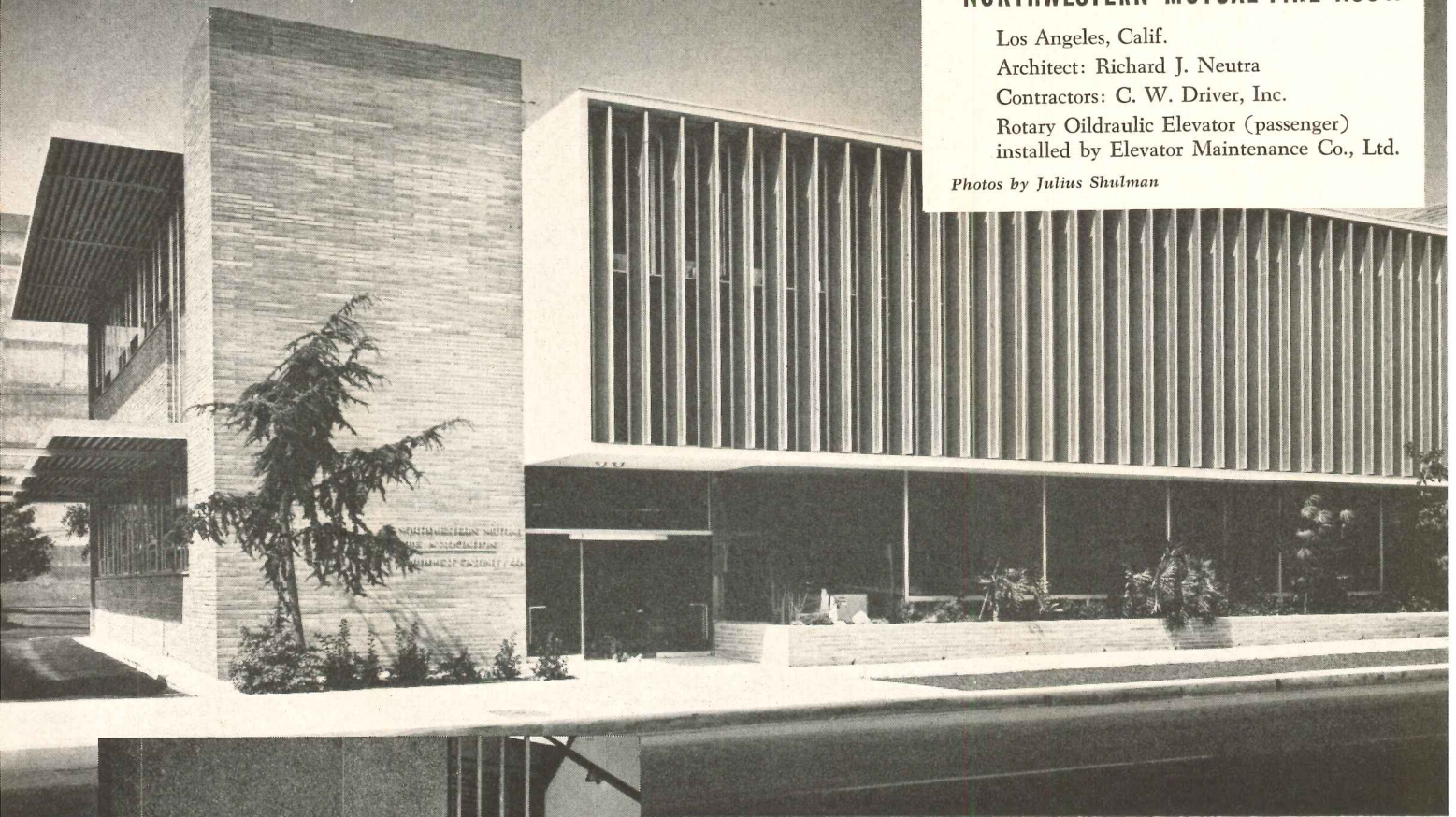

### Oildraulic Passenger Elevators

The velvet-smooth fluid operation of the Oildraulic system is ideal for passenger elevator service. You can depend on gentle starts, cushioned stops and accurate landings. Operation of elevator can be with or without attendant.

### No penthouse or heavy supporting sidewalls needed

The Rotary Oildraulic Elevator is moved and controlled by oil under pressure, the most powerful and practical of all methods of lifting heavy loads. The elevator car and its load are supported by the hydraulic system—not by the building structure. This makes possible a substantial lightening of the shaftway structure, with savings in construction costs. There's no need for heavy, load-bearing sidewalls, supporting columns and footings ordinarily required to carry the overhead machinery, the car and the load.

No penthouse is used with an Oildraulic Elevator and, in many cases, a machine room is unnecessary. Rotary's compact power unit can be located on any landing, on any side of the hatchway — anywhere within 50 feet of the elevator. This saves valuable space.

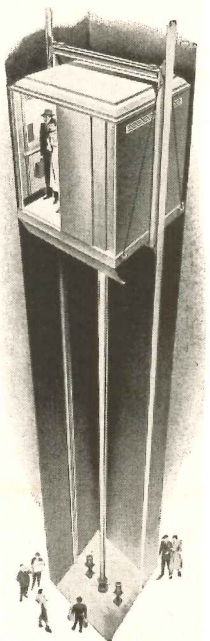



# OR PASSENGER OR FREIGHT SERVICE

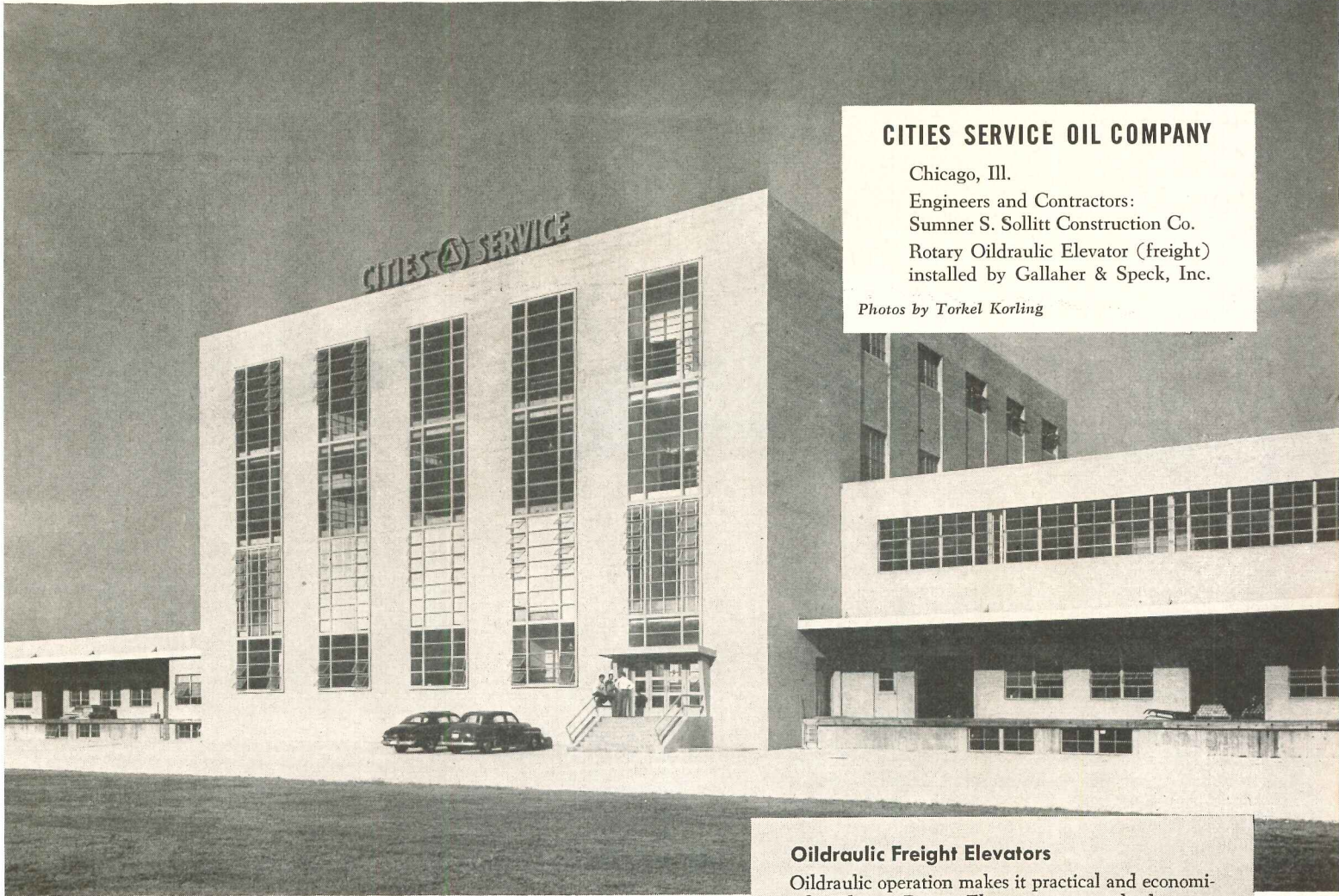

## CITIES SERVICE OIL COMPANY

Chicago, Ill.

Engineers and Contractors:

Sumner S. Sollitt Construction Co.

Rotary Oildraulic Elevator (freight)  
installed by Gallaher & Speck, Inc.

*Photos by Torkel Korling*

### Rota-Flow power system gives smooth, quiet, low-cost service

A revolutionary oil hydraulic power system moves Rotary Oildraulic Elevators on a smooth, continuous column of oil. Combined with the efficient Rota-Flow power unit to give perfect operation is the Oildraulic Controller. This engineering marvel handles the functions of seven separate control valves, simplifies adjustments and maintenance.

Smooth starts and stops are a feature of these modern elevators. Oildraulic automatic floor leveling positions the car to each landing with exactness— $\frac{1}{4}$ " accuracy is guaranteed!

Over 75,000 Rotary Oildraulic elevators and lifts are serving leading companies from coast to coast. Our Engineering Department will be glad to assist you. Write for catalog and complete architectural data.

**ROTARY LIFT COMPANY • 1011 KENTUCKY • MEMPHIS 2, TENN.**

**Rotary**<sup>®</sup>

## OILDRAULIC<sup>®</sup> ELEVATORS

Engineered and built by Rotary, the world's oldest and largest maker of oil hydraulic elevators

SEE OUR CATALOG IN SWEET'S FILES

### Oildraulic Freight Elevators

Oildraulic operation makes it practical and economical to design Rotary Elevators to carry loads up to 100,000 lbs. Oildraulic Freight Elevator cars have extra-rugged construction essential for rough, tough freight service and power truck loading.

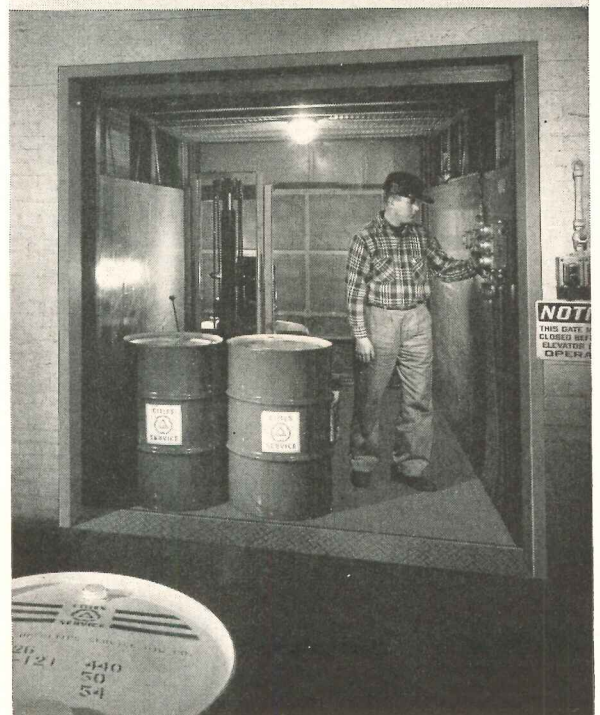



# How to pick the correct walls for the buildings you design



If you are designing a building, you can pick the correct wall by matching the function of the structure against the Robertson Q-Wall products shown here. These modern walls save construction time and money and give many extra years of maintenance-free service. They can be demounted and reused to keep pace with plant expansion. Q-Walls weigh less than 1/16th of the equivalent masonry wall.

**1. Galbestos.** Ideal for standard industrial plants. Galbestos has the highest resistance to corrosion and weather of any protected steel siding or roofing you can specify. For mill buildings, warehouses, or any other industrial structures that do not require full insulation.

**2. Insulated Galbestos.** Perfect for a dry-occupancy industrial building that must be heated. Non-combustible insulation is installed on the job by the Robertson *Top-Speed* fastening method, and Galbestos applied over. Its heat transmission factor (U-Value) is 0.16 BTU per sq. ft. per hr. per degree of temperature difference, F.

**3. G-Type Q-Panels.** This is a *field-assembled* wall made up of an interior steel vapor barrier, a layer of incombustible insulation, and an exterior of tough, long-lasting Galbestos. The proper combination for an industrial situation which requires both temperature and humidity control. U-Value—0.16 BTU.

**4. Q-Panels.** A quickly erected, *factory-assembled* panel combining strong, dry, lightweight construction with architectural beauty. Well adapted to air-conditioned buildings of all sizes, and obtainable with various exterior surfaces, either metal coated steel, stainless or aluminum. U-Value—0.16 BTU.

**5. H-Type Q-Panels.** Differ from standard Q-Panels essentially in that they contain twice as much insulation. Ideal for cold storage warehouses, refrigeration plants and structures subjected to Arctic conditions. U-Value is 0.08 BTU. Write for complete details.

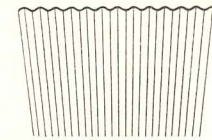

1

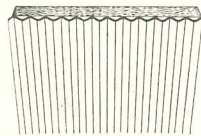

2

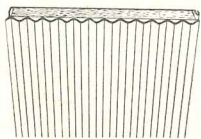

3

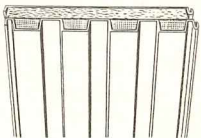

4

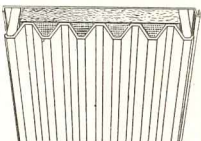

5

## Robertson Q-Walls

a product of **H. H. Robertson Company**  
2404 Farmers Bank Building • Pittsburgh 22, Pa.

Offices in All Principal Cities World-Wide Building Service



## A-E PRODUCTS

(Continued from page 209)

### UNIT VENTILATOR FOR CLASSROOMS

A new cooling, heating and ventilating unit for school classrooms in mild climate areas, the *Herman Nelson Amervent* incorporates a self-contained electronic temperature control with room thermostat. This control is installed and adjusted in each unit at the factory, and only steam or hot water piping plus an electrical connection is necessary on the

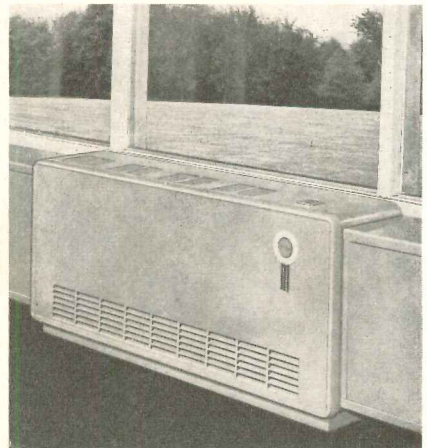

Unit ventilator features self-contained electronic temperature control with room thermostat

job. The resultant "package" unit is expected to reduce labor and installation costs on the job. Being designed specifically for design temperatures of plus 10 and above, the unit is also equipped with a "super-cooling" speed for comfort cooling in mild weather. It is available in three models, of which the "CC" model is a combination hot water and chilled water unit. Other models operate on steam or hot water and provide ventilation as well as heating. American Air Filter Co., Inc., 215 Central Ave., Louisville 8, Ky.

### RECESS LIGHTING

Low cost recess light for a wide range of applications is said to be provided by Guth "Loov-O-Lites," round incandescent fixtures recently developed. The units are built with aluminum reflectors for high efficiency and durability. The reflectors reportedly can be dropped without danger of breakage, and will not become brittle or tarnish from age or heat.