



BUILDING TYPES STUDY

COMMERCIAL BUILDINGS
SIGNS & SYMBOLS

238

PRUDENTIAL

INSURANCE COMPANY OF AMERICA



Left—Prudential Insurance Bldg., Jacksonville, Fla. Archt.—Kemp, Bunch & Jackson; Contr.—Daniel Construction Co. Pozzolith Ready-Mixed Concrete supplied by Capito Concrete Co.—all of Jacksonville.

Below—Prudential Office Building, Minneapolis, Minn. Archt. and Engr.—Magney, Tusler & Setter; Contr.—C. F. Haglin & Sons Co. Pozzolith Ready-Mixed Concrete supplied by Ready-Mixed Concrete Co.—all of Minneapolis.

Left—Prudential Building, Chicago, Illinois. Archt.—Eng.—Naess & Murphy; Contr.—Geo. A. Fuller Co.; Pozzolith Ready-Mixed Concrete supplied by Material Service Corp.—all of Chicago.

Right—Prudential Insurance Co., Los Angeles, Calif. Archts.—Walter Wurdeman and Welton Becket; Engr.—Murray Erick Associates; Gen. Contr.—Wm. Simpson Co.—all of Los Angeles. Pozzolith Ready-Mixed Concrete supplied by Transit Mixed Concrete Co., Pasadena.

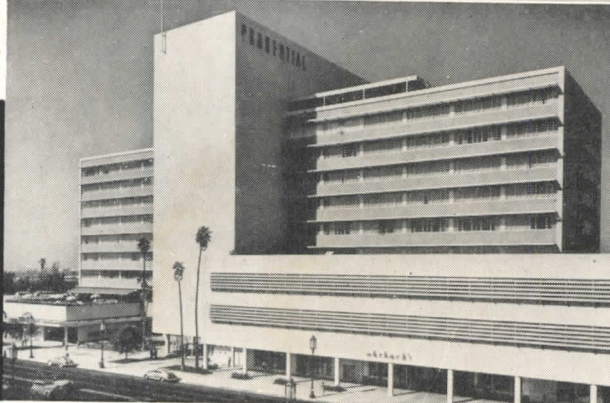

POZZOLITH employed for improved control of Concrete Quality...

“for the same owner time and time again”

These outstanding Prudential office buildings are representative of the many structures—often for the same owner time and time again—where Pozzolith has proved a valuable aid in economically obtaining concrete of desired properties. This is because Pozzolith provides the following three controls required for optimum concrete performance.

1. **Control of water content...** lowest possible unit water content for a given workability. Results in greatly improved concrete quality and economy.
2. **Control of entrained air...** for designed strength with required durability and low permeability.
3. **Control of rate of hardening...** for speed where needed, for retardation where required—in any event good uniform concrete.

Any of our more than 75 field technical men will be glad to demonstrate the full advantages of Pozzolith for your project.

COLORED MOTION PICTURE, "The Man With The Trowel", shows how Pozzolith and its adaptations—through control of water, air and rate of hardening—greatly improve your control of concrete quality. Film available for private showing to groups of any size.



the MASTER BUILDERS co.

Division of American-Marietta Company

Cleveland 3, Ohio — Toronto 9, Ontario

Cable Address, Mastmethod, N. Y.

ARCHITECTURAL RECORD

September 1956 Vol. 120 No. 3

Copyright 1956 by F. W. Dodge Corporation, with all rights reserved. Copyright not claimed by F. W. Dodge Corporation on color illustrations on pages 190 and 193. ARCHITECTURAL RECORD (combined with AMERICAN ARCHITECT and ARCHITECTURE) is published monthly, except May 1956 when semi-monthly, by F. W. Dodge Corporation, 10 Ferry Street, Concord, New Hampshire. Editorial and executive offices: 119 West 40th Street, New York 18, New York. Western editorial office, 2877 Shasta Road, Berkeley 8, California.

STAFF OF ARCHITECTURAL RECORD



F. W. DODGE CORPORATION H. Judd Payne, *Publishing Director*; Robert F. Marshall, *General Manager*; John Knox Shear, A.I.A., *Editor-in-Chief*; Marshall T. Ginn, *Circulation Manager*; Emerson Goble, *Managing Editor*; Frank G. Lopez, A.I.A., *Senior Editor*; James S. Hornbeck, A.I.A., *Senior Associate Editor*; Elisabeth Kendall Thompson, *Senior Associate Editor and Western Section Editor (Berkeley, California, Office)*; Robert E. Fischer, *Associate Editor (Engineering)*, Florence A. van Wyck, *Associate Editor*; Jeanne M. Davern, *Associate Editor (News)*; Daniel M. Kelley, *Associate Editor (Engineering Assistant)*; Herbert L. Smith, Jr., A.I.A., *Associate Editor*; Ernest Mickel, Dan Street (*Washington*), John Caulfield Smith, M.R.A.I.C. (*Canada*), *Contributing Editors*; Grace M. Anderson, *Assistant Editor*; Helen E. Cook, *Editorial Assistant (Production)*; Ruth Watson Martin, Dianne Thomas, *Editorial Assistants*; Eugene H. Hawley, *Design Director*; Thomas L. McArthur, Mildred F. Schmertz, Mary Ann Godfrey, *Design*; Sigman-Ward, *Drafting Consultant*; Thomas S. Holden, *Industry Relations Consultant*; Clyde Shute, *Statistical Consultant*; George Cline Smith, *Economics Consultant*; Clifford Dunnells, Jr., *Field Research Consultant*; Daniel J. Howe, Jr., *Public Relations Consultant*.

TABLE OF CONTENTS

The Record Reports

Perspectives	9
Buildings in the News	10
Economics the Subject as British Architects Meet at Norwich	16
Reviewing the Record — Another Look at the Works and Words of Louis Sullivan on his Centennial	18
Meetings and Miscellany	21
A Washington Report. GSA Reveals its Plan for Washington. <i>By Ernest Mickel</i>	32
News from Canada. <i>By John Caulfield Smith</i>	36
Washington Topics. <i>By Ernest Mickel</i>	48
Construction Cost Indexes	54
Required Reading	56
Calendar and Office Notes	392
Current Trends in Construction	476

Office Building with a Garden

A new attempt to alleviate the desert-like quality of the city by developing a garden in the interior court of a large office building; plus some new detailing of a curtain wall with increased protection against leakage. Lutheran Brotherhood Insurance Building, Minneapolis, Minnesota; Perkins & Will, Architects-Engineers

189

Beach Club Designed to Resist Hurricanes

Three previous club buildings had been lost to New England's hurricanes before this design encouraged them to try once more. Raised high on deep-driven piles, the building combines the principles of great strength with simple materials and minimum surface resistance to the winds and the waves.

Watch Hill Beach Club, Watch Hill, R. I.; Rockwell King DuMoulin, Architect

196

Tropical House Arcs to Open Panorama

Residence for Mr. and Mrs. Guy R. Daniel, Mulge, Mexico; F. J. Dennis Beatty, Architect

202

The Nature of the Site and the Nature of the School

An unusually happy use of the campus scheme to develop a large but difficult school site to avoid expensive excavation while realizing campus advantages.

Edgemont Junior-Senior High School, in the town of Greenburgh, Scarsdale, N. Y.; Warren H. Ashley, Architect

205



Cover: Tivoli Gardens, Copenhagen, Denmark; Holiday — Ewing Krainan photo

Continued on next page

New Approach to Roofs in Tension

Radial Steel cables covered by a skin of concrete form a prestressed inverted dome, suggesting a new answer to the hazard of "fluttering" in cable structures.

Shelter at Camp Columbia, Litchfield, Conn.; designed and constructed by the students at the Schools of Architecture and Engineering of Columbia University under the supervision of Bruno Funaro, A.I.A., Associate Professor of Architecture

211

An Outdoor Museum For Houses

The Homestyle Center, a new and permanent exhibition of houses in Grand Rapids, Michigan, will display designs of 50 architects from all parts of the United States. The first 15, soon to be built, are shown here. Homestyle Center, Grand Rapids, Michigan

217

Industrial Buildings

1. Engineering Building for an Oil Company

Office Building for Engineering Division, Imperial Oil, Limited, Sarnia, Ontario, Canada; John B. Parkin Associates, Architects-Engineers

225

2. Factory and Offices with Prestige Values

Plant for the Parker Pen Company, Janesville, Wisconsin; John J. Flad & Associates, Architects and Engineers

229

3. Office-Industrial Plant Becomes Showcase

The Plant Insulation Co., Los Angeles, Cal.; Smith & Williams, Architects

233

One Hundred Years of Significant Building

4. Schools

237

Building Types Sturdy Number 238 — Commercial Buildings: Signs and Symbols

A perpetual problem in architects' offices, signs and lettering with their symbolic values are terribly important to the client. The first major study in an architectural magazine devoted to principles and the means of graphic design.

Signs & Symbols in Commercial Architecture. By James S. Hornbeck, Senior Associate Editor

241

Architect Gruen States the Challenge That Graphic Design Presents. By Victor Gruen, Architect

244

How They Go About The Problem In Pei's Office. By Don Page, Head of Graphics Department, Office of I. M. Pei & Associates, Architects

248

A Conversation with Graphic Designer Lustig

254

The Woolworth Story. By Mildred Constantine

263

Corruption, Opportunity, and an Approach. By Robert Lepper

268

Architectural Engineering

Last Look at a Structural Landmark

Engineering significance of the former Wanamaker store is explored with after-fire photos and historical text. By Alan Burnham.

273

Technical Roundup

280

Product Reports

283

Literature

284

Time-Saver Standards: Useful Curves and Curved Surfaces

287

Index to Advertising

480

OFFICERS OF THE F. W. DODGE CORPORATION

James McV. Breed, Chairman of the Board; Paul Abbott and Thomas S. Holden, Vice Chairmen of the Board; Howard Barringer, President; Irving W. Hadsell, Chauncey L. Williams, Executive Vice Presidents; Howard M. Thompson, Vice President and Treasurer; Julius T. Little, Robert F. Marshall, T. Oliver Morgan, O. O. Paulsell, H. Judd Payne, George Cline Smith, Vice Presidents; Carl S. Bennett, Clinton C. Bennett, Ralph M. Hairston, Roy J. Hard, Richard H. Ray, John M. Williams, Regional Vice Presidents; Edwin H. Freed, Assistant Vice President and Comptroller; Walter F. DeSaix, Clifford G. Dunnells, Jr., Clyde Shute, Marc Wayne, Assistant Vice Presidents; Sanford D. Stockton, Jr., Secretary; William C. Breed, Jr., George W. Morgan, Jr., Assistant Secretaries; Irving B. Satin, Assistant Treasurer.

OTHER F. W. DODGE SERVICES

Dodge Reports — Dodge Statistical Research Services — Sweet's Catalog Services — Dodge Books — Dodge Mailing Service — Chicago Construction News — Daily Pacific Builder — Denver Daily Journal — Real Estate Record & Builders' Guide.

Members of Audit Bureau of Circulations and Associated Business Publications. Architectural Record is indexed in Art Index, Industrial Arts Index and Engineering Index.

Every effort will be made to return material submitted for possible publication (if accompanied by stamped, addressed envelope), but the editors and the corporation will not be responsible for loss or damage.

Subscription prices: Published monthly except May 1956 when semi-monthly. U. S., U. S. Possessions and Canada: \$5.50 per year; other Western Hemisphere countries, Philippines and Spain, to those who by title are architects and engineers, \$6.50 per year. Single copy price except Mid-May 1956 issue \$2.00; Mid-May 1956 issue \$2.95. Beyond Western Hemisphere, excluding Philippines and Spain, to those who by title are architects and engineers, \$9.00 per year for 12 monthly issues not including Mid-May 1956 issue. Subscriptions from all others outside U. S., U. S. Possessions and Canada for 12 monthly issues, not including Mid-May issue, \$24.00 per year. Change of address: subscribers are requested to furnish both old and new addresses, sending if possible stencil impression from magazine wrapper; allow four weeks for change.



THE RECORD REPORTS

P E R S P E C T I V E S

AN ARCHITECT'S IDEALS are all too apt to wither, if not die, in the hurly-burly of modern practice — or so it seemed to Howard L. Bouey and Kelly C. Stanley, honorary secretary and president respectively of the Architectural Association of Alberta. "The practice of architecture under present day technological influences, to any but the most dedicated, tends to produce an alienation within the architect from the ideals acquired during his academic years," they said. Accordingly, members of the association made an effort to recapture the idealistic days of their youth by planning "Session '56." With the Department of Extension at the University of Alberta as co-sponsors, the conference took place at Banff at the beginning of the year. The agenda carried such un-practical discussions as "Old Architecture and New Problems," "The Architect and Society" and "Architects' Training," all intended for stimulation rather than solution. Architect Richard Neutra was appointed director of the session and apparently dominated it, during and after "business" hours, like a true dean of architecture. Ideals revitalized, the architects are looking forward now to a "Session '57."

EDITORIAL HEADACHE: Bruno Zevi, editor of the recently-founded Italian journal *L'Architettura*, has been receiving letters from his readers with a complaint not unknown to other architectural editors; viz., too many "foolish constructions" are published, and too few "essays of profound and severe criticism." Following the arrival of a particularly "brutal" letter, Signor Zevi responded with an editorial describing the responsibilities of the magazine as he sees them: "The object of a daily paper, of a weekly journal or of a monthly magazine, is to report not only exceptional happenings — the assassination of Wilma Montesi, a coup d'etat in Brazil, the Pope's

visions or a declaration of war — but to follow up the facts of everyday life, announce births and deaths, give information on congressional laws and on the measures adopted by the town council — in short, to keep the public informed of anything of significance. . . . A periodical, whether it be a journal or a magazine, is of value because it reports on what happens day by day, allowing space to the many second-raters and to the very few luminaries; the whole presented in a uniform way — though some fail to notice this — derived from the collaboration of all men of good will. . . . We do want to publish artistic works in our review, but also other constructions which, though artistically imperfect, are of experimental interest. We mean to include works that may not be 'beautiful,' but that reveal strenuous effort, moral struggle, deeds of courage, and a commendable professional behavior. A review that will report on anything of significance in Italian architecture and embodying, not only art critique for everybody to participate in, but also a general account of the activities of a vast architectural community."

ARCHITECTURAL PLATFORM: once again (see AR, April 1956, p. 9), architecture wins at the polling place. In Madison, Wisconsin, Ivan A. Nestingen was elected mayor on a campaign promise to support the city's project for a Wright-designed center and auditorium.

THE ALLEGED USURPATION of the interior decorator's prerogative by architects overeager to do a complete job worries editor Harry Anderson of *Interior Design*. "The function of creating backgrounds for living and working within the interior space resulting from the shelter that the architect creates," he said in the June issue of the magazine, "is a highly specialized function, requiring spe-

cialized training and education totally different in concept from the education and training required by the architect." It is unprofessional behavior, Mr. Anderson charges, for the architect not to support his allied professions; no architect, he says, fails to hire competent masons, carpenters or electricians when they're needed, but few extend the same respect to specialists in interior decoration. The solution, he believes, may lie in a joint conference of the American Institute of Architects and the American Institute of Decorators "for the purpose of clarifying their respective professional functions and spheres of operations."

"TOTAL INTEGRATION" is the term Ulysses Floyd Rible, California architect, uses to denote a program for a professional organization stronger than the one American architects now have. The suggested "integration" would take place within the American Institute of Architects, but would demand a much broader scope in power than the institute now possesses. As outlined by Mr. Rible at a recent Orange County chapter meeting, the program is this: "The American Institute of Architects should prescribe student training; in cooperation with the schools of architecture it should prescribe curricula; it should accredit colleges; it should outline licensing requirements; it should advocate proper licensing laws and provide 'expert' help to the states; it should supervise the holding and grading of examinations, and provide for membership in itself for every architect, whether he practices or not, and in studied proper classifications to make provision in its membership for every draftsman and 'friend' of architecture. In these days of pressure politics, our profession with 250,000 members instead of 11,600 through the Institute would command significantly increased attention."

THE RECORD REPORTS
BUILDINGS IN THE NEWS

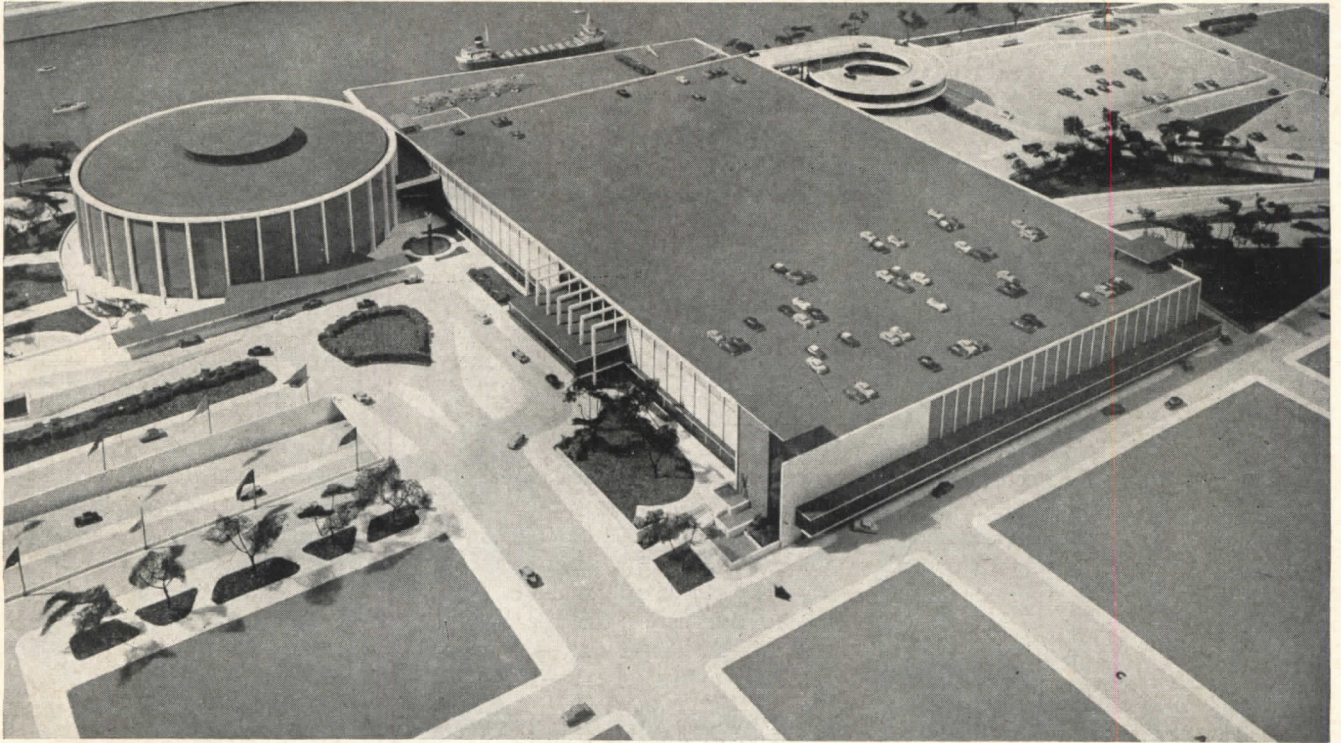

DETROIT MAKES ITS BID as a convention center with the latest addition to its Civic Center — a Convention and Exhibits Building designed by Giffels & Vallet, Inc., L. Rossetti, engineers and architects. The circular arena will seat 14,000 spectators for conventions, entertainments and

sports. The exhibits section will provide 1,600,000 sq ft of display space. Other facilities in the exhibitions unit will include a cafeteria for 1500, a coffee shop, and storage space. For motorists, more than 3000 parking spaces will be provided: on the roof, in a two-level garage in the

exhibits unit, in another garage underground near the arena and in a lot adjoining the project. Exterior of the exhibits unit will be marble, brick and glass; that of the arena will be green stone trimmed with white marble. Completion is scheduled for early 1959.

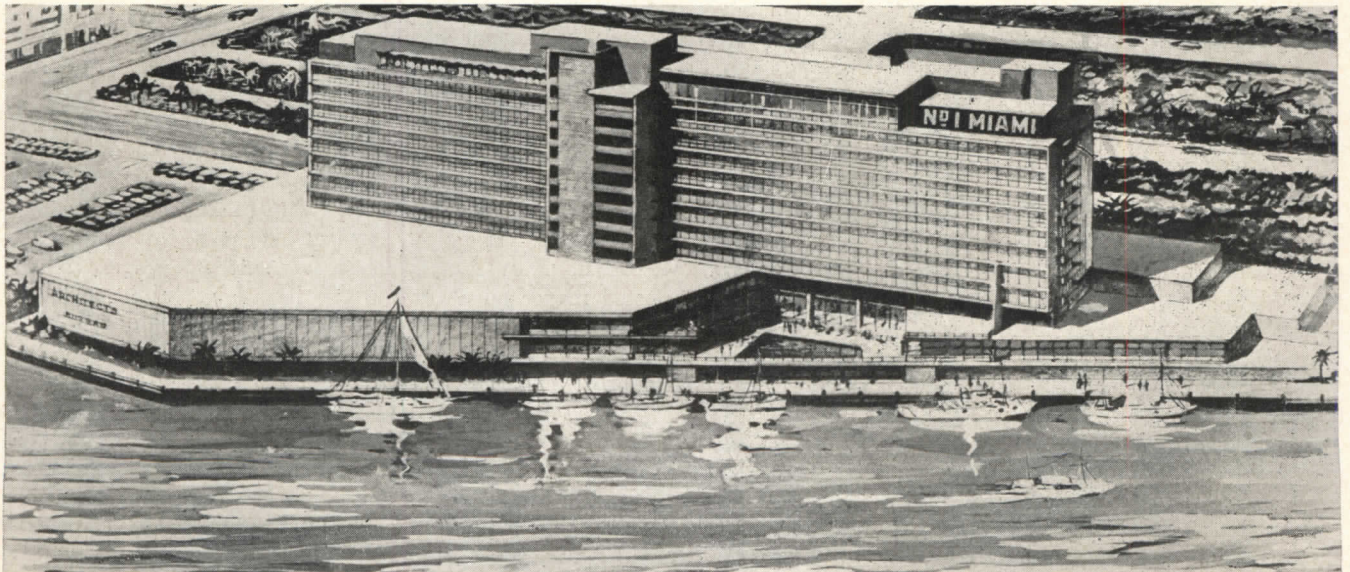

A "TRIPLE-SERVICE" BUILDING with the intriguing address of No. 1 Miami, Florida, will combine a 14-story office building, a 301-room hotel and a building products display center. In the

display center, offices will be reserved for the South Florida Chapter of the American Institute of Architects, the International Association of Architects and the Association of Interior Decorators. This section will also

contain an auditorium. All this plus a "monarch-sized" swimming pool and mooring facilities along the Biscayne Bay frontage. Frank H. Shufflin and John Edwin Peterson are the architects

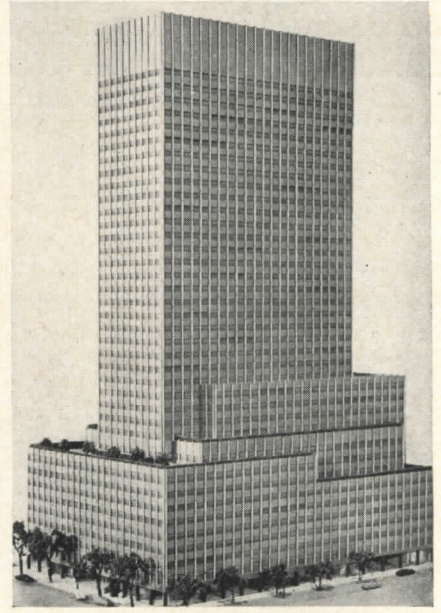

VARIATIONS ON A THEME: building (left) planned for 575 Lexington Avenue, New York, will use extruded aluminum panels of dull gold color; mullions will be brighter, gold-finished aluminum; architects are Sylvan Bien and Robert L. Bien. The projected Borg-Warner Building (center), to be built on the site of the old Pullman Building in Chicago, will have blue porcelain enamel spandrels and aluminum mullions; A. Epstein & Sons are the architects, with William Lescaze as consulting architect. And another New York building (right), designed by architects Carson & Lundin, will utilize aluminum panels embossed with small squares, while areas between the windows will be filled with 20-in. strips of white porcelain enamel in a three-in. aluminum frame; it is now under construction at 666 Fifth Avenue, near Rockefeller Center; sculptor Isamu Noguchi is designing the lobby and arcade

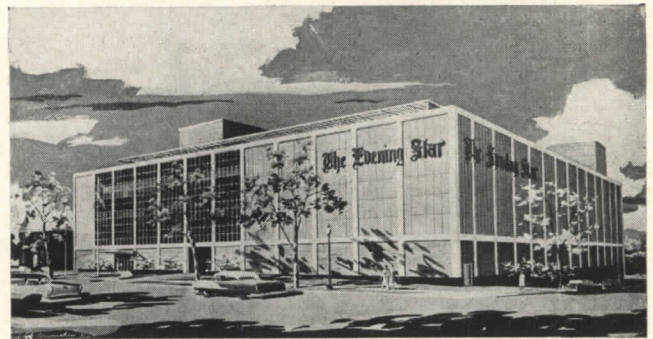

FOR THE PRESS: project for the Washington Evening Star puts editorial and business offices at one end of concrete and glass building, mechanical functions at the other. Architects are Faulkner, Kingsbury and Stenhouse of Washington

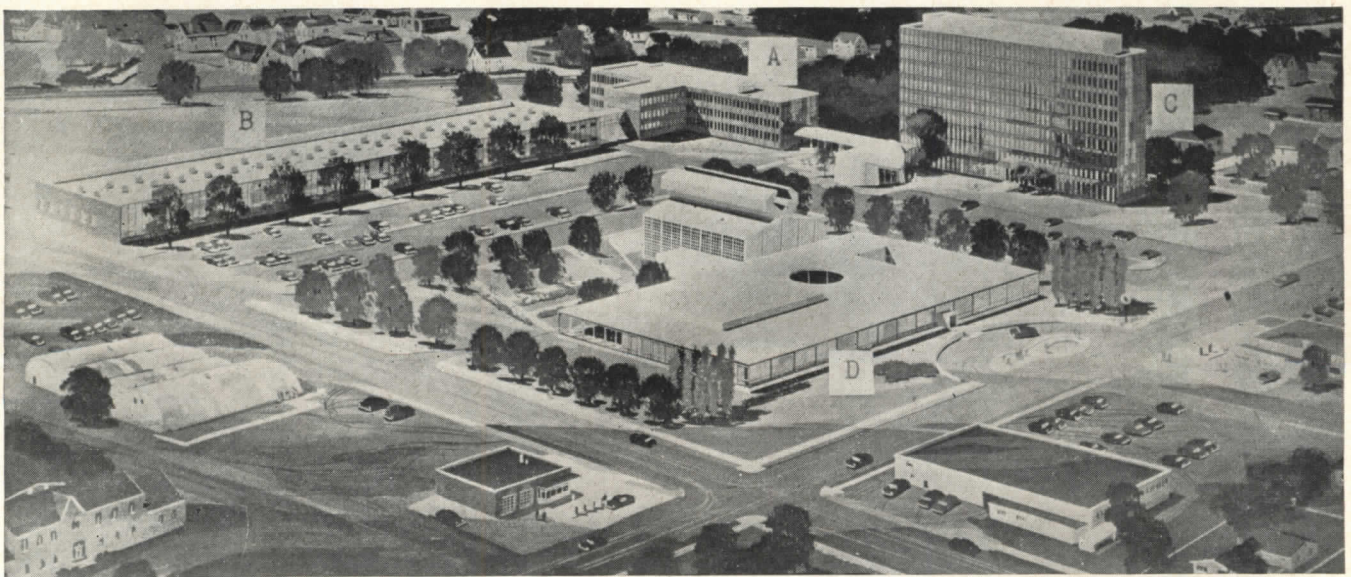

NEARING COMPLETION on a 17-acre site in Corning, New York, is the multi-million dollar research and administration center being built by the Corning Glass Works. Already opened to the

public, the Corning Glass Center (D) was completed in early 1951. Among the new buildings are a three-story research building (A); a single-story building (B) which will contain laboratories and development

shops; and a nine-story office building (C). The office building will have walls of black glass. Harrison & Abramowitz of New York are the architects for the center

(Continued on page 12)

THE RECORD REPORTS

BUILDINGS IN THE NEWS

(Continued from page 11)

CENTER FOR CLAY PRODUCTS RESEARCH OPENED IN ILLINOIS

Built to house the five-year-old research program of the Structural Clay Products Institute, the Structural Clay Products Research Foundation opened at the end of June with a two-day meeting at which members of the foundation discussed current research projects on lightweight clay products, mortar, facing tile, brick packaging, atomic blast resistance, thermal research and preassembled clay masonry

walls. The building, built at a cost of \$500,000 near Geneva, Illinois, is described as "two load-bearing masonry cubes placed side by side for maximum use of space, and symbolizing the familiar shape and pattern of structural clay products." Structural clay products figured largely too in interior finishes and at the entrance. Howard T. & Fisher Associates were the architects

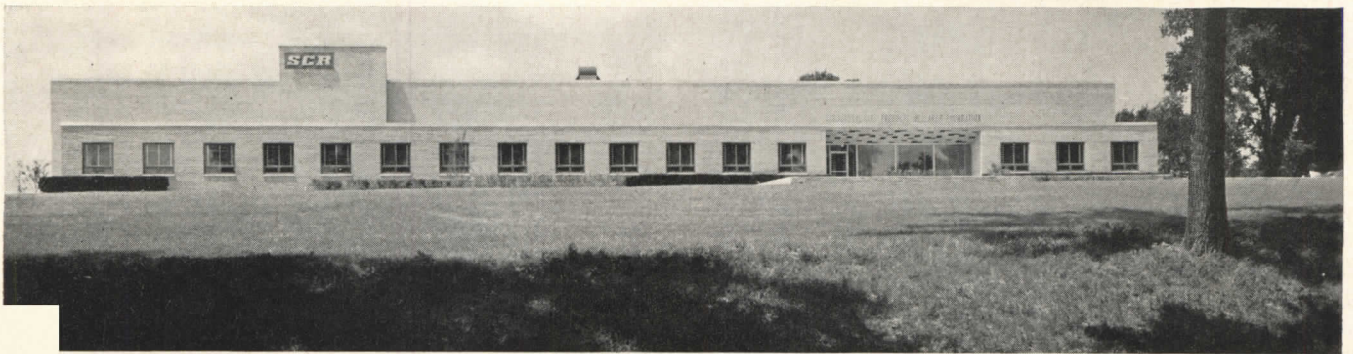

REHABILITATION CENTER PLANNED FOR OUTPATIENTS IN CONNECTICUT

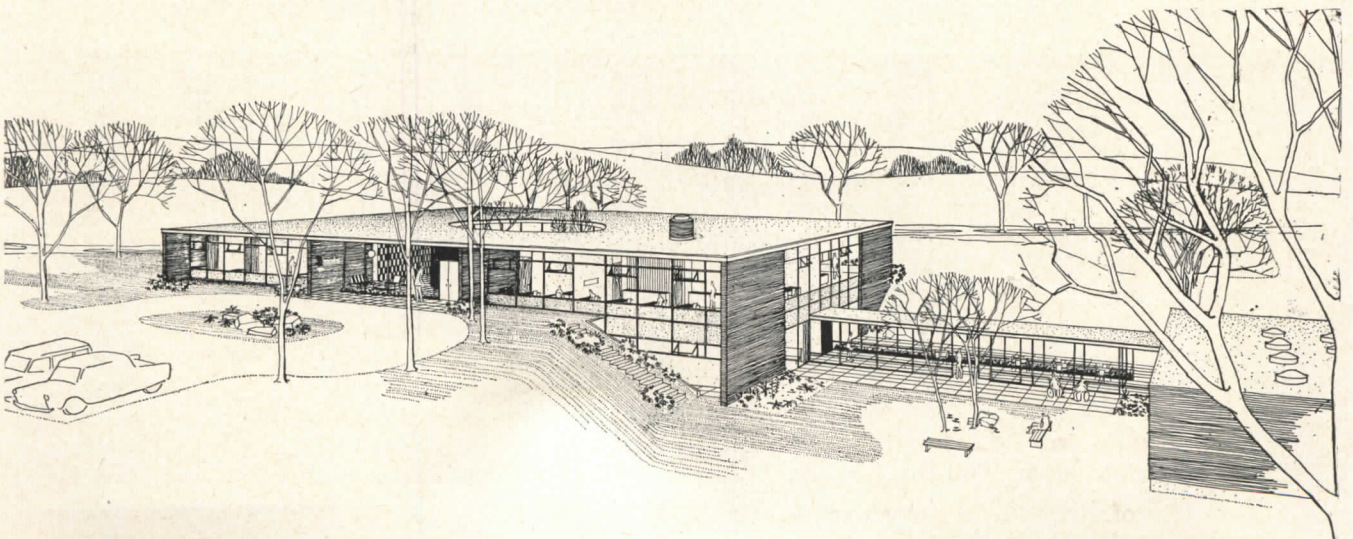

A rehabilitation center for the physically handicapped, to be built for the training and treatment of outpatients only, is now under construction at Stamford, Connecticut. Designed by Sherwood, Mills & Smith, Stamford architects, the center will have two buildings. In the main building

(see cut above), besides a court and waiting area, will be medical offices and space for occupational and physical therapy, vocational guidance, hydrotherapy, speech therapy, social service and pre-vocational testing. The smaller building will contain shops for vocational therapy, and a covered

walkway between the two buildings will shelter a lunchroom. In the main building, offices will be located at the front, therapeutic facilities will be placed at the rear of the building where they can be expanded easily if extra space should be required

(More news on page 16)



Y.M.C.A. BUILDING, PEORIA, ILLINOIS Architects: Gregg & Briggs General Contractor: Fred Harbers Sons, Inc.

➔ = Porcelain Enamel

For complete architectural porcelain service . . . depend

on

Erie's FULLY
INTEGRATED
OPERATION

When you are designing with architectural Porcelain Enamel, enjoy the benefits of ERIE's complete service . . . from detailing to final erection. These extra facilities of ERIE Enameling mean less drawing board hours, a guarantee of accurate, true color Porcelain Enamel,

and flawless erection that assures the success of your project.

There's a reason ERIE can offer this! ERIE has a fully integrated operation which includes experienced engineers, complete steel fabrication and porcelain enameling facilities and over 20 field crews to handle erection if desired.

For over 25 years ERIE has been a leading independent porcelain enamer recognized for top quality and progressive new design work, particularly on curtain wall panels. The architectural porcelain you specify today is a long term investment for the owner . . . insist on ERIE's quality and service.

THE
ERIE
ENAMELING
PLANT

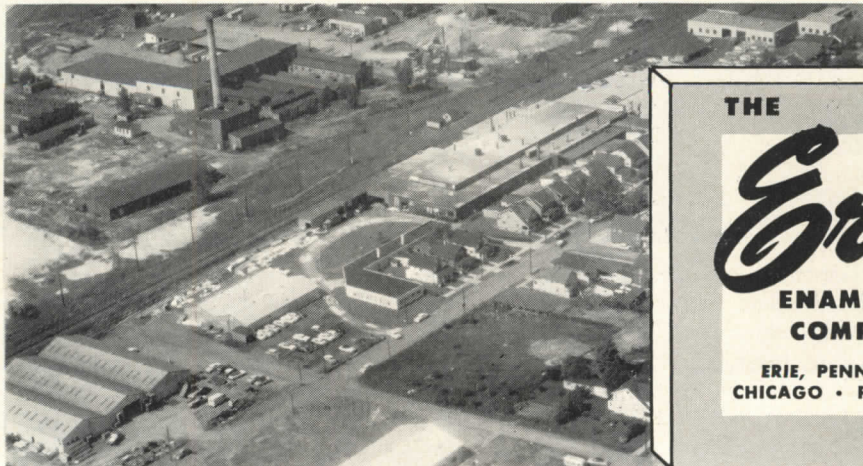

**SULLIVAN SEEN BY HIS CONTEMPORARIES:
IN HIS CENTENNIAL YEAR, ANOTHER LOOK**

"Man is not born in sin, but in glory," was Louis Sullivan's "modern affirmation."

In his centennial month,* the RECORD looks back at his views of architecture, and his contemporaries' views of him, as they appeared in earlier issues of the magazine.

It may be encouraging to observe in these views that the present is not always entirely blind to the talents of its time. Despite Sullivan's difficulty in obtaining commissions in his later years, he never wanted for critical praise. Few architects, surely, have ever had a better press. "There is no denying that a new work by Louis Sullivan is the most interesting event which can happen in

* Louis Henri Sullivan was born Sept. 3, 1856, and died April 14, 1924. Two of his buildings, the Wainwright Building in St. Louis and the Carson Pirie Scott store in Chicago, tied for first place in the RECORD's Significant Building series (May 1956, pp. 147-154).

the American architectural world today," wrote Montgomery Schuyler, a critic not ordinarily given to superlatives, in January 1912.

In the same article, Schuyler went on to say: "The architect who studies [Mr. Sullivan's work] with a view to getting from it any hints that may be available in his own practice will have to abandon it with the melancholy admission that there is nothing in it to steal. He has not, of course, nobody has, the pretension to rival its author as a master of decorative design. If an equal genius in that kind should haply arise, he would do something very different. But what is true of the decorative design is as true of the architectonic 'layout.' Every one of his buildings is the solution of a particular problem, and the result is a highly specialized organism, which is as suitable for its own purposes as it is inapplicable to any other. It is as inim-



itable in the mass as in the detail. Hence is the interest which architects continue to take in it disinterested, so to speak, their admiration free from any notion of direct appropriation. To go and do likewise would, in this case, mean to go and do something entirely different, as different as the conditions and purposes of the second building would, upon patient analysis, reveal themselves to be from those of the first. Nay, the author of the first shows an impossibility or an impatience of repeating his own design where the commonplace

(Continued on page 416)



Left: Prudential (Guaranty) Building, Buffalo, 1908, which Bragdon thought Sullivan's "finest." "[A skyscraper]," said Sullivan, "must be every inch a proud and soaring thing, rising in sheer exultation . . ." Center, top: Sullivan's sketch for a museum, shown in the Chicago

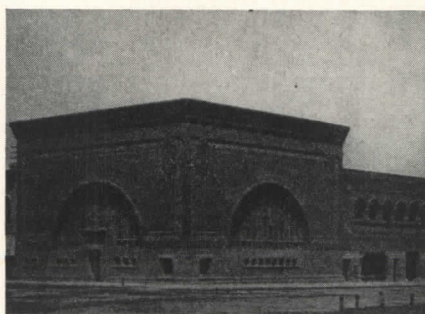
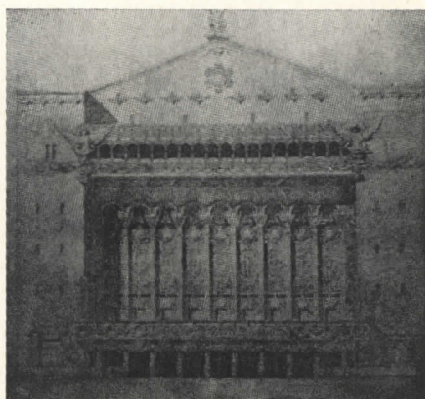

Architectural Club's Exhibition of 1913. Center, bottom: National Farmers' Bank, Owatonna, Minn.; Schuyler wrote that "at last report, 25 strangers a day were visiting Owatonna to see it." Right: the Bayard (Condil) Building, New York, 1898; agreeing with other critics that it

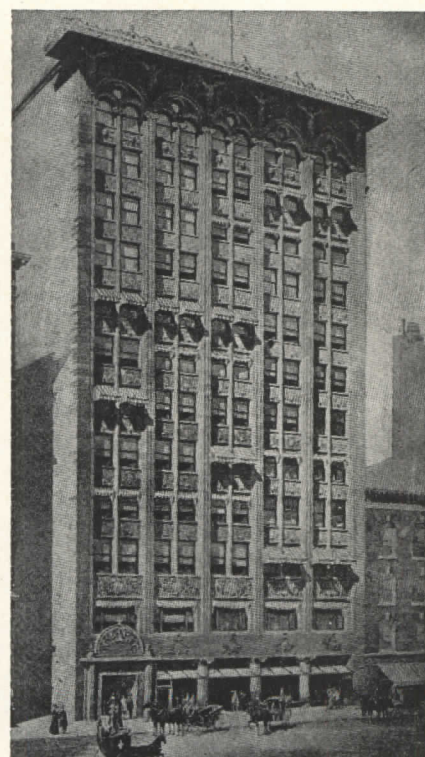

was not out of Sullivan's top drawer, Schuyler nonetheless thought that it was "the nearest approach yet made, in New York, at least, to solving the problem of the skyscraper." Lyndon P. Smith was listed as associate architect of the building with Sullivan

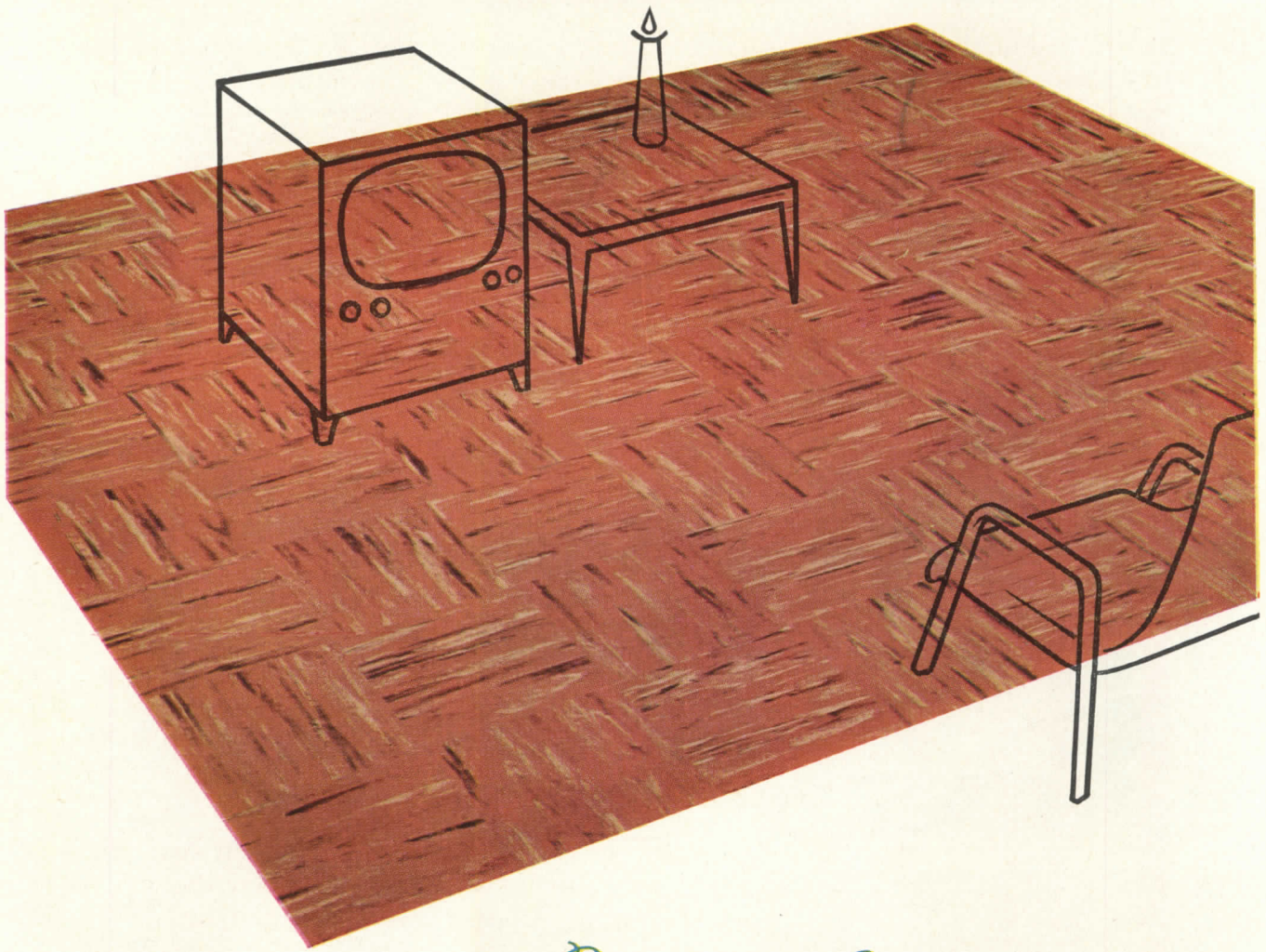

A *Vina-Lux*[®] FLOOR

makes life more enjoyable

Vina-Lux vinyl-asbestos tile gives a new approach to *living* . . . in beauty and in utility. It is designed to create new inspiration in setting the entire decorative theme of a room. It allows an imaginative approach to color, with its high-style, light, fresh combinations that lend themselves to unlimited design possibilities.

This resilient, unusually durable plastic tile has high resistance to greases, oils and household products. Its surface is so naturally sleek and smooth it never requires waxing to keep its "just-new" look. And Vina-Lux is made to create more leisure for *living* because it requires so little *keeping!* Discover the provocative ideas in Vina-Lux . . . write for complete information, samples and color chart.

Pattern shown: Coronado



AZROCK PRODUCTS DIVISION • UVALDE ROCK ASPHALT CO.

565 Frost Bank Building • San Antonio, Texas • Makers of Vina-Lux • Azrock • Duraco • Azphlex

ALBERTA ESTABLISHES FIRST TOWNS ACT ON CONTINENT

What is believed to be the first New Towns Act in North America has been established in the province of Alberta.

The law provides that up to a million dollars may be spent by the province to help a new town in its development. The money may either be in the form of a grant or a 40-year loan.

The Alberta act is based on the British New Towns Act and on the Province of Ontario's legislation dealing with town sites in unorganized territory.

Three communities have already applied for status as towns since the act was passed in March. One application to establish a town under the act has been received for a satellite to Edmonton, Alb. The other two applications come from communities in unsettled areas near the Pembina oil fields.

Under the act, all applications for new towns are sent to the Provincial Planning Advisory Board, which holds investigations and public hearings. The board then recommends whether or not the new town should be allowed to come into being. Planning must be done

by professional consultants, or the planning advisory board may require it to be done by its staff or by a district planning commission having jurisdiction in the area. The development cannot be undertaken until the board approves the plans.

ETHICS COMMITTEE READIES ONTARIO ARCHITECTS' CODE

The Committee on Professional Ethics, Ontario Association of Architects, is planning to prepare an O.A.A. code of

(Continued on page 40)

RECENT CANADIAN PROJECTS AND BUILDINGS OF NOTE

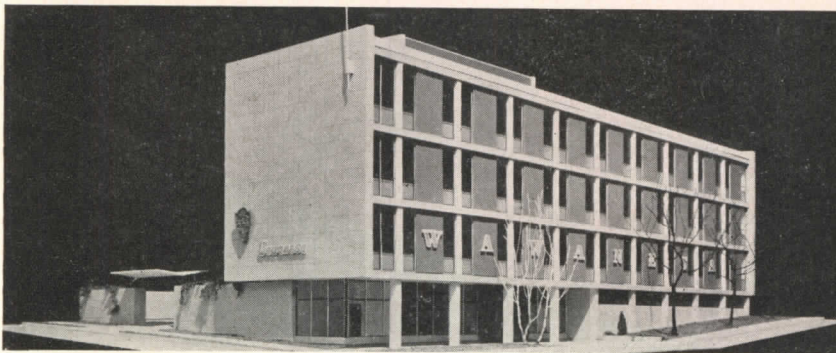

1

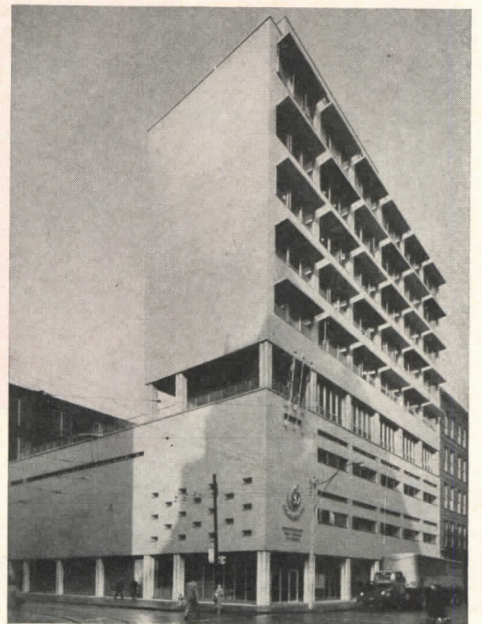

2

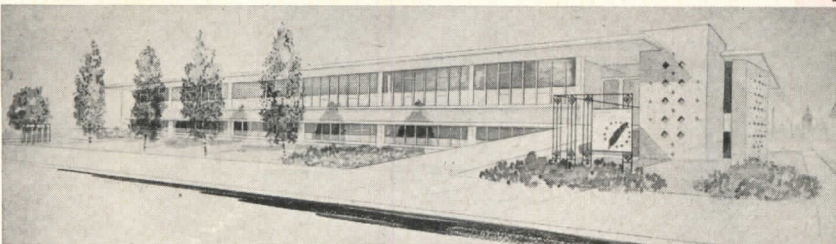

4



5



1. New office building for Wawanesa Mutual Insurance, Toronto, by architects Page & Steel of Toronto. 2. Headquarters building for Community Chest and Council of Greater Vancouver; William Henry Birmingham, architect, Prof. Fred La-

serre, architectural consultant, Fred T. Hollingsworth, design associate, all of Vancouver. 3. Salvation Army Offices, Toronto, John B. Parkin Associates, architects and engineers, Don Mills, Ont. 4. British Columbia Electric Office Build-

ing, Victoria, B.C., Sharp & Thompson, Berwick, Pratt, architects, Vancouver. 5. Hudson's Bay Oil & Gas Company Building, Calgary, Alta., J. Stevenson & Associates, architects, of Calgary. The building is nearing completion.



B.F. Goodrich

RUBBER

FLOOR TILE

... the one
 rubber floor tile that
cleans like a plate!

B. F. Goodrich rubber floor tile has a remarkable difference—a difference anyone can tell at a touch!

Super-density gives this tile a porcelain-smooth surface—free from dirt-catching pores, and so smooth that dirt glides right off it.

When you specify B. F. Goodrich rubber tile for its quiet and comfort, you're assuring the extra benefits of low maintenance costs during years and years of wear.

Available in 20 rich, glowing colors and in .80 gage, 1/8" and 3/16" thicknesses. No finer institutional or residential flooring anywhere for on or above grade installations.

Mail this coupon for further information and free sample:

B.F. Goodrich RUBBER TILE

B. F. Goodrich Co., Flooring Division, Dept. AR-9
 Watertown 72, Mass.



- Highest quality rubber!
- Super-dense surface!
- Natural resiliency!

Name _____

Address _____

City _____ Zone _____ State _____

NEW "AGATINE" TILE • KOROSEAL TILE • ASPHALT TILE • RUBBER COVE BASE • STAIR TREADS • ACCESSORIES

© 1956 The B. F. Goodrich Company

THE RECORD REPORTS NEWS FROM CANADA

(Continued from page 36)

ethics. Announcement came from N. H. McMurrich, chairman of the committee.

Decision to prepare the code was made on the basis of results of a questionnaire circulated by the committee.

The ethics questionnaire received the second largest response to surveys sponsored by the organization in the past 10 years, Mr. McMurrich said. Of a possi-



Dayton Building by Green, Blankstein, Russell & Associates, architects, was recently completed in Winnipeg

Service to Architects

the way they like it!

FOR generations it has been the privilege of Pratt & Lambert to work closely with leading architects, on every type of building, in every important city or town throughout the United States and the Dominion of Canada.

Out of this experience has come a keen appreciation of the architect's point of view—his aspirations and his problems. Out of this, also, has come proficiency in serving architects the way they like to be served with prompt, complete, reliable information; with authoritative painting specifications; with color counsel that is sound, distinctive and consistent with both form and function.

You are invited to make full use of Pratt & Lambert Architectural Service. It is available to you—the way you like it—without obligation.

Please write your nearest Pratt & Lambert Architectural Service Department: 3301 38th Avenue, Long Island City 1, New York; 326 West 26th Street, Chicago, Illinois; 75 Tonawanda Street, Buffalo 7, New York. In Canada: 254 Courtwright Street, Fort Erie, Ontario.

ble total of 765 replies, 264 were received by the committee.

The codes of ethics of the Royal Institute of British Architects and the American Institute of Architects will be used for reference purposes in drafting the code.

“The draft will be circulated to members before it is put in final form for submission to the Council and Registration Board,” said Mr. McMurrich. Questionnaire results showed 86.36 per cent of all responses in favor of a code of ethics.

CANADA ENGINEERS ELECT NEW OFFICERS AT MEETING

New officers of the Engineering Institute of Canada were elected at the 70th annual meeting of the group in Montreal.

V. A. McKillop of London, Ont., was named president; and H. R. Sills, Peterborough, Ont., G. M. Dick, Sherbrooke, Ont., and H. W. L. Coane, Halifax, N. S., were named vice-presidents. Twenty-six councillors were also chosen.

(Continued on page 44)



V. A. McKillop of London, Ont., new president of the Engineering Institute of Canada, receives congratulations from retiring president R. E. Hearlz of Montreal. Major General Howard Kennedy, center, of Ottawa, who was awarded the Julian C. Smith medal for outstanding engineering work in Canada

Wherever Architectural News is Being Made—

FORMICA[®]
Laminated Plastic

IS IN THE PICTURE



In the new and already famous St. Louis Air Terminal many thousands of feet of Formica are at work protecting the beauty of vertical and horizontal surfaces.

- ★ Ticket Counters and Fronts
- ★ Walls
- ★ Lunch Counter
- ★ Cocktail Bar
- ★ Partitions & Planters
- ★ Main Dining Room Tables
- ★ Booths & Fixtures

Now included in the Formica Sunrise Line of 70 patterns and colors are 14 new "Color Blended" patterns.

Ask your local Formica office for samples of the new Raymond Loewy designed colors and the new booklet on Formica vertical surfaces (Form 670) or write

FORMICA Corporation Subsidiary of
4632 Spring Grove Avenue, Cincinnati 32, Ohio
In Canada: Arnold Banfield & Co., Oakville, Ontario.

CYANAMID

ATTACHMENT OF A RETURN OF MONEY
Guaranteed by
Good Housekeeping
IF NOT AS ADVERTISED THEREIN

Beauty Bonded
FORMICA[®]
Laminated Plastic
Pays in Performance



THE RECORD REPORTS NEWS FROM CANADA

(Continued from page 44)

More than 1,000 engineers, including members of the institute from all the Canadian territories as well as representatives of the American Society of Mechanical Engineers, the American Rocket Society, and the engineering institutions of Britain and France, attended the three-day meeting held at the end of May.

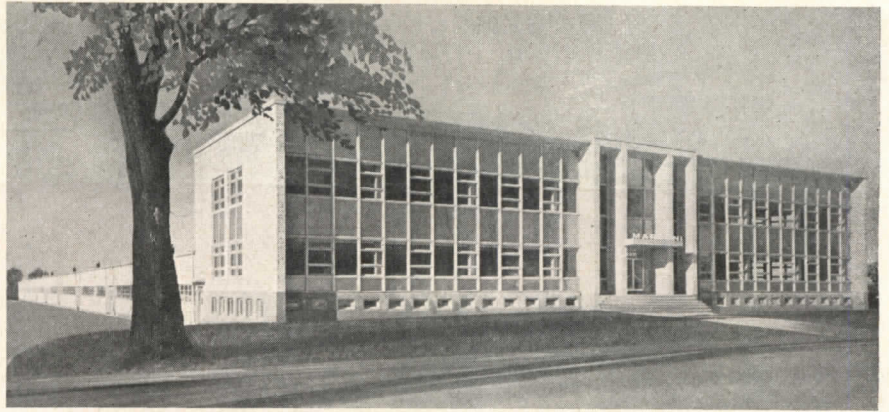

New plant for Canadian Marconi Company, Ville St. Laurent, Quebec, by Franco Consiglio, Montreal, architect. The building will provide two floors of air-conditioned office space and area for light manufacturing and warehousing purposes

COLUMBUS CASES
help make LANSBURGH'S
a merchandising

Masterpiece

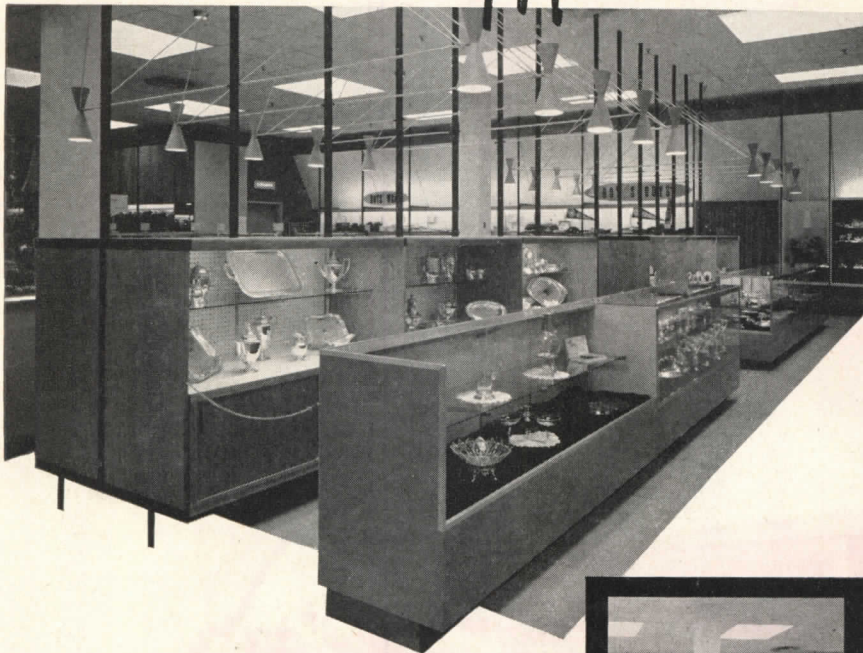

It's teamwork . . . store owner, architect and Columbus working together . . . that helped make Lansburgh's new Department Store a brilliant merchandising masterpiece. And it's this same teamwork that's produced so many of the nation's outstanding stores for over 60 years.

If you're modernizing, planning or considering a new store, we'd like to work with you and your client, provide helpful information and skilled assistance toward a common goal—an outstanding store.

- ☆ display cases
- ☆ counters
- ☆ wall cases
- ☆ merchandising tables
- ☆ service and self-service units
- ☆ special purpose and feature units



LANSBURGH'S
LANGLEY PARK, MARYLAND

DESIGNED BY THE OFFICE
OF MEYER KATZMAN,
A.I.A. ARCHITECT,
NEW YORK, N.Y.

Council Headquarters Mapped

The Dominion Council of Professional Engineers, meeting at Saskatoon, announced a decision to establish national headquarters in Ottawa. The Council represents 32,000 members in 10 provincial associations, including the Yukon.

The Council's Committee on Unity is studying, and may act upon, a proposed confederation of all engineering bodies in Canada.

New president of the Council is E. J. Durnin of Regina. Other officers are C. N. Murray, Sydney, vice-president; Prof. W. O. Richmond, Vancouver, councilor; and J. Murray Muir, Toronto, secretary-treasurer.

SIMPSON NAMED PRESIDENT OF MANITOBA ARCHITECTS

Earle G. Simpson, Architect, was elected president of the Manitoba Association of Architects recently at the group's annual meeting at the Marlborough Hotel.

Other officers chosen were Norman C. H. Russell, vice-president; Cecil N. Blankstein, Charles Faurer, H. H. G. Moody, R. Bryan Ross, Roy Sellors, George A. Stewart and Ralph I. Thompson, councillors. Mrs. Douglas Chevrier remains executive secretary.

A 100 per cent increase in membership of the organization over the past five years was reported by Cecil N. Blankstein, retiring president.

NEWS NOTES

A recommended salary schedule, intended as a guide for engineers and their employers, has been published

(Continued on page 46)

THE *Columbus* SHOW CASE COMPANY
866 West Fifth Avenue Columbus 8, Ohio

fusible power panelboard

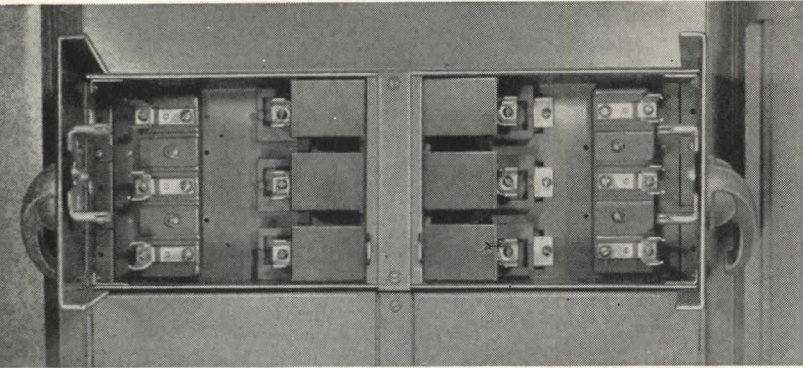

Increased protection and greater savings. Higher I.C. and horsepower ratings on low ampere G-E switches give you added protection on your equipment and save money at the same time. You get quick-make, quick-break switching plus the security of fuses—heavy-duty operation for the price of light-duty equipment. Fuses can be changed quickly because of obstruction-free compartments.

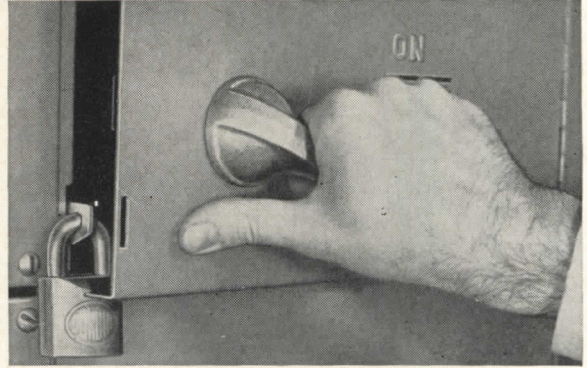

Extra safety features. Interlocked unit door cannot be opened when switch is in ON position. Switch unit door latch padlocks "closed" to prevent tampering, "open" to safeguard working electrician. New improved "swing-close" lock on panelboard door withstands rough handling and gives additional security.

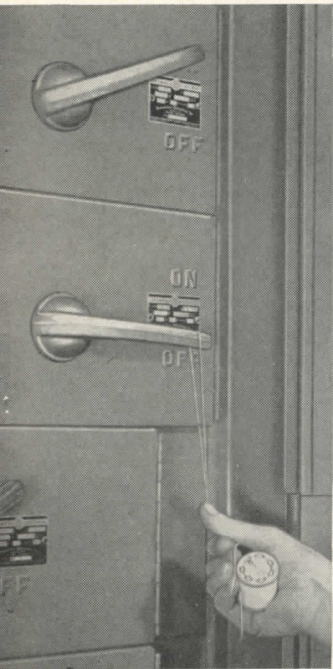

Easy Operation. A woman's touch—even with just the pull of a thread—can easily disconnect the circuit. Also, every QMR switch unit is calibrated for exact, uniform contact pressure—every switch unit!

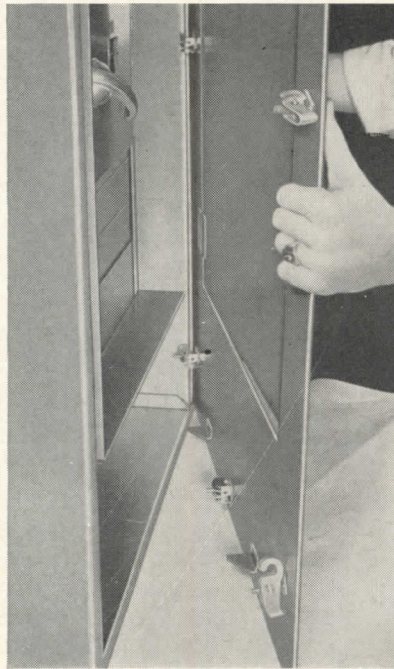

Quick, inexpensive installation. Solderless lugs, ample wiring gutters and removable box ends speed up installation. In fact, one man can do the wiring, put on the front and, with the rotating adjustable clamps, adjust it to compensate for any misalignment of the box mounting.

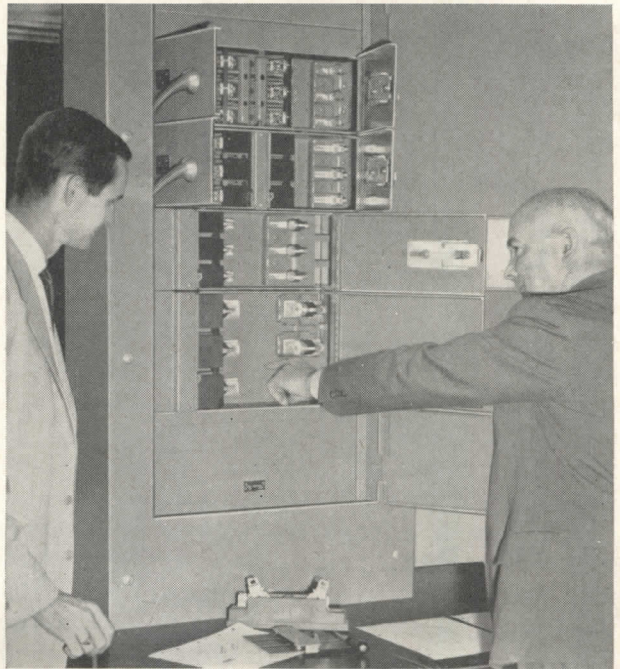

General Electric's full line of improved quick-make, quick-break switches are UL listed. They offer increased protection for a complete range of installation requirements . . . and with fillers and pre-drilled bus bars, the Type QMR panelboard allows for quick, inexpensive expansion in the future. For complete details on the new Type QMR panelboard, write *Distribution Assemblies Dept., General Electric Company, Plainville, Conn.*

Progress Is Our Most Important Product

GENERAL  **ELECTRIC**

NEUTRA SEES MAN AS NUCLEUS OF DESIGN

BY THADDEUS LONGSTRETH, A.I.A.

“— Before we can do the right and suitable thing for man — we have to know him as well as humanity itself — to observe all his functionings.”

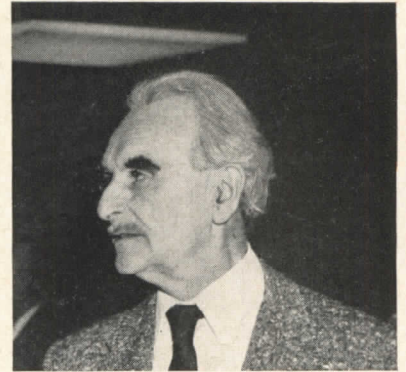

Life and Human Habitat. By Richard Neutra. Alexander Koch (Stuttgart, Germany) 1956. 318 pp, illus.

THE recent publishing of Richard J. Neutra's *Life and Human Habitat* by Alexander Koch of Stuttgart, Germany, has given the architect and the layman opportunity to study from their armchairs the thinking processes as well as photogenic results of those processes, in beautifully monographed form, of one of the world's leading architects and profound philosophers. It is far from a collection of magazine articles and photographs; it breathes the spirit of the artist in the text and opens windows to many hitherto unfamiliar ideas. It invites comparisons and gives endless opportunities for earnest scrutiny that crisp two dimensional expression can afford. This publication is a sensitive portrayal of a sensitive artist. Mr. Neutra's book of two years ago, *Survival Through Design*, a text of his philosophy which is really based on devoted practice, received wide acclaim here and abroad, and has been translated into numerous languages. In *Life and Human Habitat*, unlike *Survival*, one not only reads of some of this philosophy in a distilled form, but bears witness to the fruit. Since the text is of utmost importance, this reader, for one, is delighted that Mr. Koch decided to make an English version available to the American public which Mr. Neutra has served so faithfully.

Mr. Neutra has much to say about the design task. Humans are the most important and the most fragile element in any planning considerations, not the love of new shapes, forms and materials, or the gravity-defying structural design. The individual, (and the family) must be most sensitively examined. Considera-

tions for the physiological well-being of man is Neutra's first concern. He asks the fundamental question, "What is the science most deeply important to our life, the knowledge extending to the very depths of our humanity? It was said by the wise men of ancient Greece: 'Above all, know thyself.' Before we can do the right and suitable thing for man, in us and in others, we have to know him as well as humanity itself; we have to search closely to the last detail within him and observe all his functionings. Modern physiology does just that.

Too often the architect has become involved and enmeshed in construction, has fallen in love with materials. His big passion should, however, be the less advertised, the venerable human material under his hands that offers such wonderful organic reactivity. Nerves and brain with their inner strains and stresses, their responsiveness to all influences and stimuli." Neutra warns the architect who unknowingly through his design efforts, has created a trap in which his client will eventually, through daily subconscious irritations, find the breaking point in human relations, where cumulative effects prove fatal. Care and understanding of the human being, endowed with not just five senses, but thousands of sense receptors built into the tissues and neural network of the body and the innermost recesses of the brain, is paramount in any design considerations. The exploration which Neutra has undertaken in this field for almost three decades I believe is without precedent in the architectural realm. Certainly we have barely skimmed the surface in our efforts, and Neutra

(Continued on page 62)

National-U.S. Baseboard Hot Water Heating Systems



BEDROOMS: Comfort at sleeping time and at dressing time . . . control of temperatures to your choice.



BATHROOM: Comfort at bath-time . . . even temperature without sacrificing floor space.

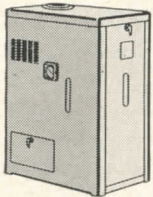

National-U.S.
Gas Boilers

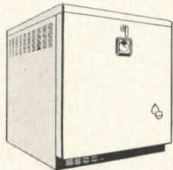

National-U.S. Packet
All-in-one, automatic
Home Heating Unit
For gas or oil firing

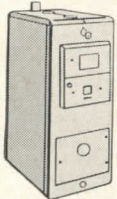

National-U.S.
Cast Iron Boilers
for Automatic Firing

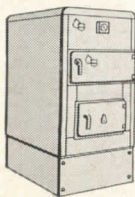

National-U.S.
Residential Steel Boilers,
Sizes to meet all needs



National-U.S. Baseboard Heating Systems work to highest efficiency when they are supplied by National-U.S. Hot Water and Steam Home Heating Boilers. There are styles and sizes for every residential requirement.

National-U.S. Systems also assure an ample automatic year 'round supply of domestic hot water for kitchen and bath—at no extra cost. They are also ideal for use with snow-melting systems in addition to temperature zoning and cooling.

Write for bulletins on National-U.S. Boilers and Heat Distributing Units.



National-U.S. Radiator
CORPORATION

HEATING AND AIR CONDITIONING DIVISION
Johnstown, Pennsylvania

an important new drafting technique

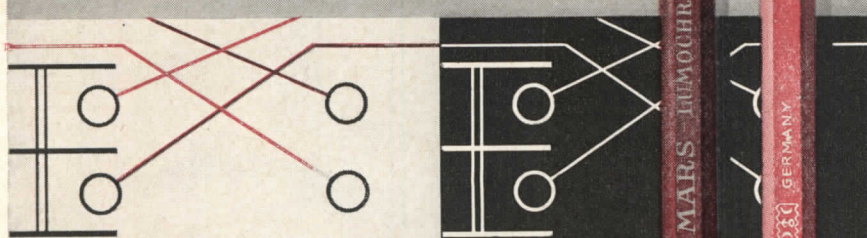

possible only with **MARS-LUMO CHROM**

All colors blueprint perfectly,
making color-drafting possible.

MARS-LUMOCHROM does not fade
... does not smear ... is waterproof
... erases perfectly ... keeps finest point

Send for free sample

STAEDTLER also proudly introduces the Mars-Pocket-Technico for field use, the Mars "Draftsman's" Pencil Sharpener with the adjustable point length feature, and the efficient, clean Mars lead sharpener. All available—along with the established standards: Mars-Lumograph black graphite drafting pencils, Mars-Technico lead holder and leads, and Tradition-Aquarell painting pencils—at all leading art material and drafting supply dealers.

J.S. STAEDTLER, INC. HACKENSACK, NEW JERSEY

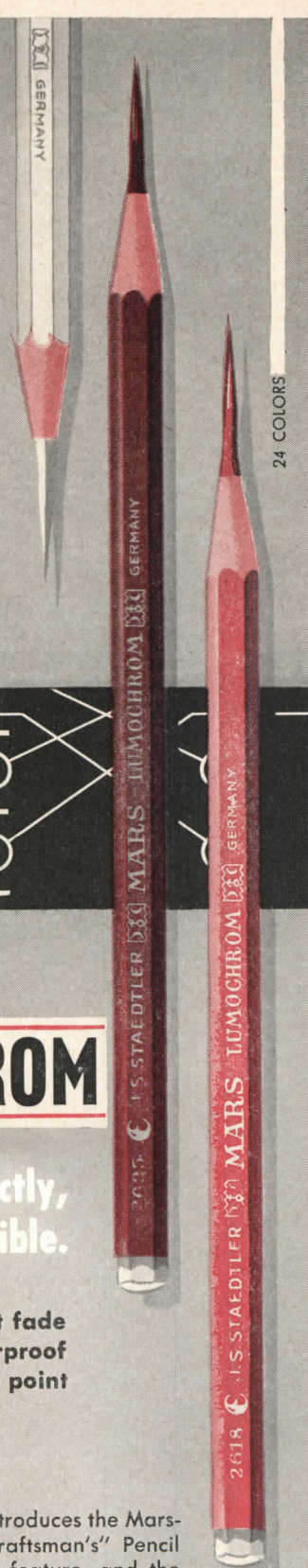

REQUIRED READING

(Continued from page 58)

holds out a brilliant future and a challenge to the young architect who will approach his task in this manner, the quality of empathy being characteristic of such service. "It must be followed by patient examination without readily giving way to reckless prejudices of the designer, for this would yield something much too short-lived to assure the lasting satisfaction hoped for by everyone who builds a home." This book is concerned with only the family home, the fundamental structural basis of human society. It is full of good advice both for the young practitioner and for the home owner, not only in regard to the mental attitude in approaching the problem, but excellent counsel is given on realistic mortgage considerations, storage problems, servant problems, feeding, sleeping, bathing, seclusion, the manifold ramifications of "what fits best in human existence and survival under technically prevailing circumstances."

Photogenic efforts of *Life and Human Habitat* form an essay on the quality of living for "wholesome survival." They are not a mere display of shapes and forms. Attempts have been made to describe what is loosely termed as "Neutra Style." His vigorous imagination is far too exploratory to become stylized. What may impress one as a "Neutra Style" is the result of infinite detailed refinement of the quality of space and the great care taken to avoid physiological barriers in the environment he creates. Professional critics have yet to learn to analyze design aesthetics generated from a physiological approach. At present they are relying on one sense perception, the visual sense, which by nature is complex and yet fragmentary, and often by circumstances second-handed. They should be employing all the human capacities with which they are endowed and to which the physiological design responds. For this reason perhaps Mr. Neutra's own clients are his most reliable and only true critics, and not journalists reviewing the visual arts.

Of particular interest are the portions of the book that deal with specific conditions under which the architect must work at times. Part Three, "Tradition made law and architecture restricted by decree" has an inspiring message of patience and of overcoming what seem like insurmountable handicaps. It is living

(Continued on page 66)

Products

Buildings modern

When you specify American-Standard plumbing, heating and cooling, you can be sure these products complement the modern design and serviceability of your building for years to come.

Why? Because these new products are simple and straightforward in design. Because they are easy to use. And because (like all American-Standard products) they are precision made with the most durable materials available.

For complete information on these products, write to American-Standard, Plumbing & Heating Div., 39 West 39th Street, New York 18, N. Y.

NEW LEDGEMOUTH CAST IRON DRINKING FOUNTAIN AND RECEPTOR—Offers improved sanitation and great utility. Ideal for school planning. This versatile fixture also has commercial, industrial, laboratory, club and church applications. Comes in 2 sizes—6 colors and white.

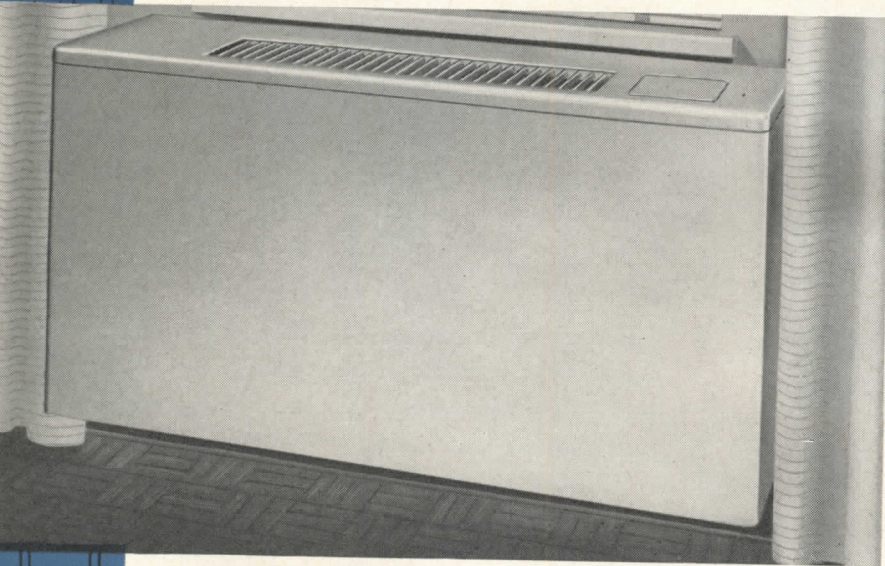

NEW NEO-HEALTH TOILET—First really new toilet in decades. A built-in cleansing spray, controlled with separate handle, affords the ultimate in personal hygiene. Water contained in special compartment is used for frequent and thorough personal cleansing. Harmonizes with other American-Standard bathroom fixtures in styling and wide choice of colors.

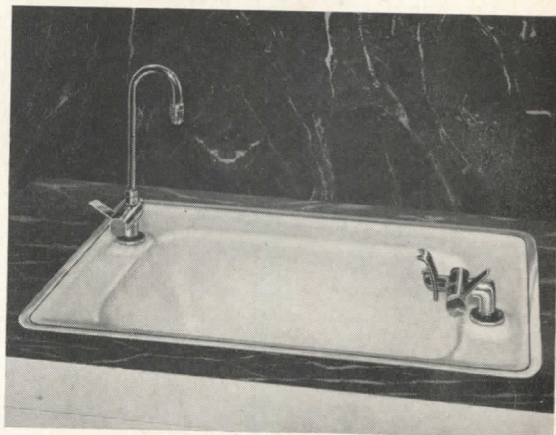

NEW SELF-CONTAINED REMOTAIRE YEAR 'ROUND AIR CONDITIONING—Complete flexibility gives new freedom of design. One unit may be heating, while another is cooling the adjacent room. Self-contained refrigeration circuit needs no water, central cooling plant or ductwork. Connects to two pipe steam or hot water for heating. One cabinet size for $\frac{3}{4}$ or 1 hp unit. The $\frac{3}{4}$ hp operates on 115, 208 or 230 volts; the 1 hp on 208 or 230. Available with top or front grille. Fits flush with outer wall.

American-Standard

PLUMBING AND HEATING DIVISION



REQUIRED READING

(Continued from page 62)

proof of the architect's duty never to falter in his task to seek the ultimate solution to every problem. Avoidance of such issues would retard man's understanding of himself, and work contrary to natural growth. The architect in this day of technological abundance has the opportunity for raising his sights on unlimited horizons. His ideas and instructions, as Mr. Neutra points out, can be represented almost instantly almost anywhere. The breadth of his imagination will control the radius of his activity and usefulness to man. "Architecture by remote control" is an interesting chapter of evidence on how carefully documented blueprints, and a thorough understanding of human beings and of climatic environment can sponsor the undertaking of projects, even of modest scale, many miles from the drawing board without loss of concept. It is further evidence of widespread acceptance of Neutra's philosophy on the budgetary plane of homebuilding. Vast governmental, industrial or institutional projects keep him air-borne much of the time. Yet the quality of a residence in Louisiana, or Connecticut, or Iowa reflects the care and attention that Neutra always gives.

Alexander Koch hopes that young architects will be inspired through *Life and Human Habitat* and "will recognize in Neutra's sincere words his respect and modesty before the great task." Of this inspiration the reader is assured.

SCHOOL GUIDE BOOK PANNED

How to Recognize a Good Elementary School. By a Committee of Connecticut Educators. Connecticut State Dept. of Education Bulletin No. 68. Jan., 1956. 28 pp, illus.

THIS PAMPHLET would not be worth reviewing if it were not a document prepared by an authorized state education agency as a guide for professional and lay citizens in evaluating public elementary schools. It is badly printed, unattractively presented, in spots downright ungrammatical (a direct quotation: "There are no classes of over thirty members and less is desirable."), and the cartoon illustrations liberally sprinkled through it, drawn by an 11-year-old elementary school pupil, are quite appropriate to say the least.

The subject-matter consists of a series of checklists divided into five general

areas: Climate (meaning school atmosphere), curriculum, physical facilities, personnel, community relations. Under each heading and subheading is a numbered series of positive statements, some of them highly debatable, which are evidently assumed to be the attributes of a "good" school. For instance, under "Curriculum" subheading A reads: "There is a satisfactory provision for the mastery of the skills necessary to live in our society"; and subheading B, "Active citizenship in a democratic society and an understanding of the inter-

dependence of peoples are major goals of the school." Subhead C emphasizes good health principles and D asserts that "foundations are prepared for enrichment of life." E refers to solving human problems. The section on physical facilities is equally penetrating, stressing functionalism, safety, code compliance, etc. In the entire pamphlet there is no reference to intellectual development except by haphazard indirection, nor any to the stimulus that a first-rate school plant can provide for its pupils.

(More reviews on page 468)

SOMETHING MISSING?

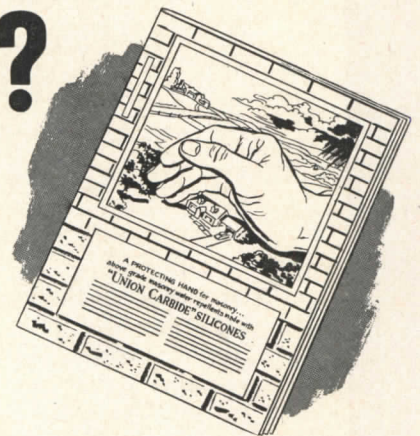

Are the next 32 pages of this copy of **ARCHITECTURAL RECORD** missing? They may well be, for they are intended for removal, study, and filing for frequent reference.

The pages comprise a unique and thorough reference file of information on the properties and application of Above-Grade Masonry Water Repellents made with **UNION CARBIDE Silicones**.

If the pages immediately following have been removed by a previous reader, or if you wish extra ones for your files, clients, or customers, write us on your business letterhead. We'll gladly send you copies while they last. Address Dept. SD-8.

SILICONES DIVISION

UNION CARBIDE
AND CARBON CORPORATION
30 EAST 42ND STREET **UCC** NEW YORK 17, N. Y.

In Canada: Linde Air Products Company, Division of Union Carbide Canada Limited
The term "Union Carbide" is a trade-mark of Union Carbide and Carbon Corporation.



LUTHERAN BROTHERHOOD

HOME OFFICE BUILDING, MINNEAPOLIS, MINN.
PERKINS & WILL, ARCHITECTS-ENGINEERS

SEPTEMBER 1956 ARCHITECTURAL RECORD

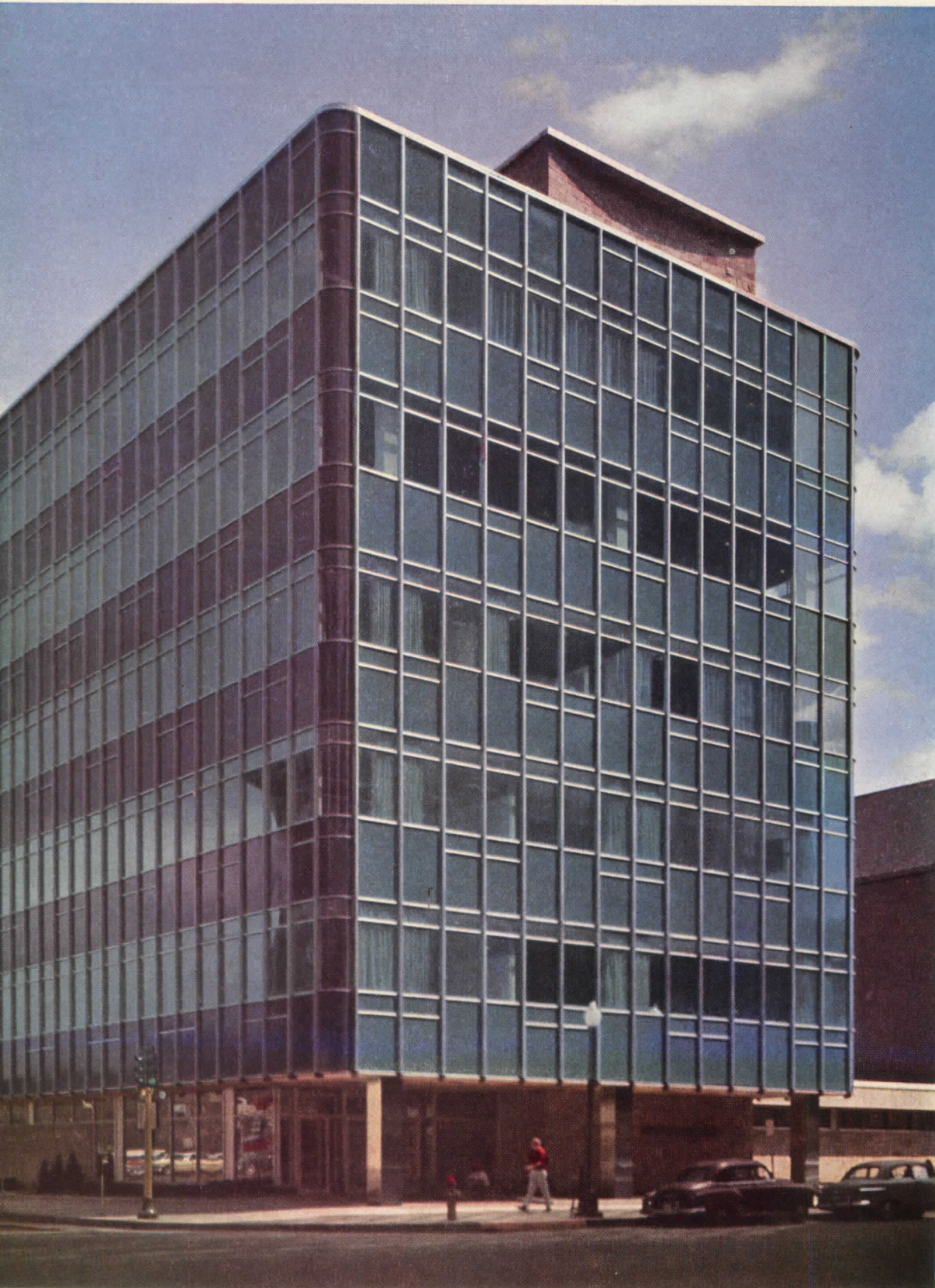

Entrance

LUTHERAN BROTHERHOOD



Main block contains home offices and rental space; low wing, right, local offices

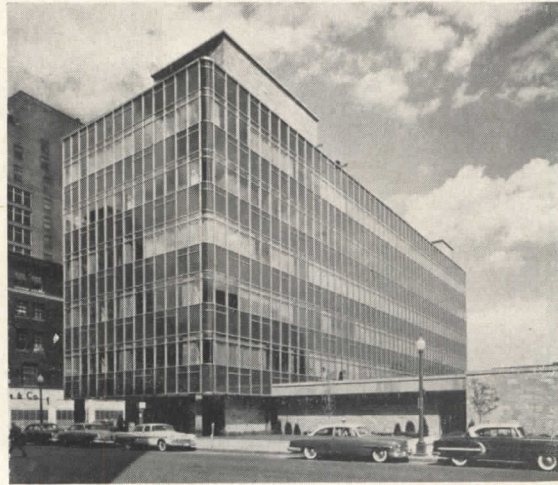

Hedrich-Blessing Studio

HOME OFFICE of a fast-growing fraternal life insurance and benevolent organization, Minneapolis' new Lutheran Brotherhood building was designed by **Perkins & Will**, Architects-Engineers (John E. Starrett, Resident Engineer); **E. R. Gritschke & Associates**, Mechanical Engineers. Its reinforced concrete structure is completely masked by the polished curtain walls of its main block, which are insulating glass and glass-insulated porcelain enamel, blue green, secured by snap-on stainless steel moldings without so much as a screwhead visible. In contrast, a low wing housing local branch offices is sheathed in New England granite in a mixture of rough surfacings showing some rust coloring. There are many refinements and design features: upper floors cantilevered; interior space laid out with perimeter corridors that act as air conditioned, enclosed sunshades; a sunken garden (see next page); complete air conditioning; passenger-operated elevators; a Martin Luther Library planned as a repository for historical documents relating to the Lutheran Church and graced with a stained glass screen (photo below) portraying church history, visible from the lobby side through a fluted glass wall (stained glass by Conrad Pickel Studios).

Lobby

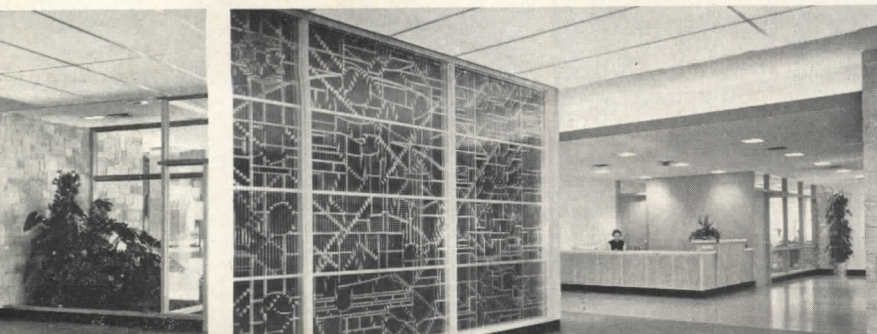

Martin Luther Library

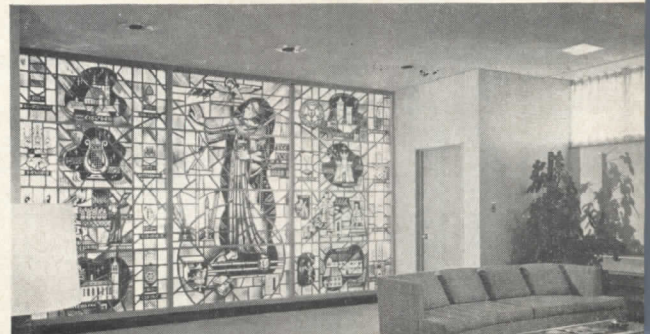

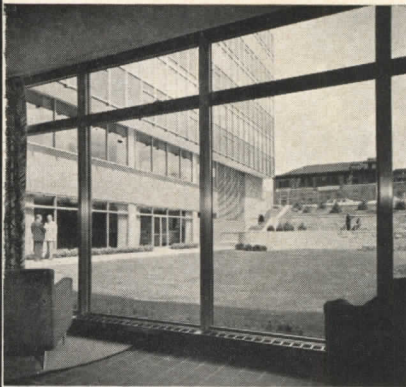

From the 300-seat auditorium one can look across the lounge to the sunken garden; auditorium's window wall can be darkened with drapes

Hedrich-Blessing Studio

Lutheran Brotherhood Court, a sunken garden screened from street traffic by the building's wings, adds a spot of green to downtown Minneapolis. Surrounding the Court is Lutheran Center, for use by employees; for meetings of the Brotherhood; by church groups, the community, visiting organizations

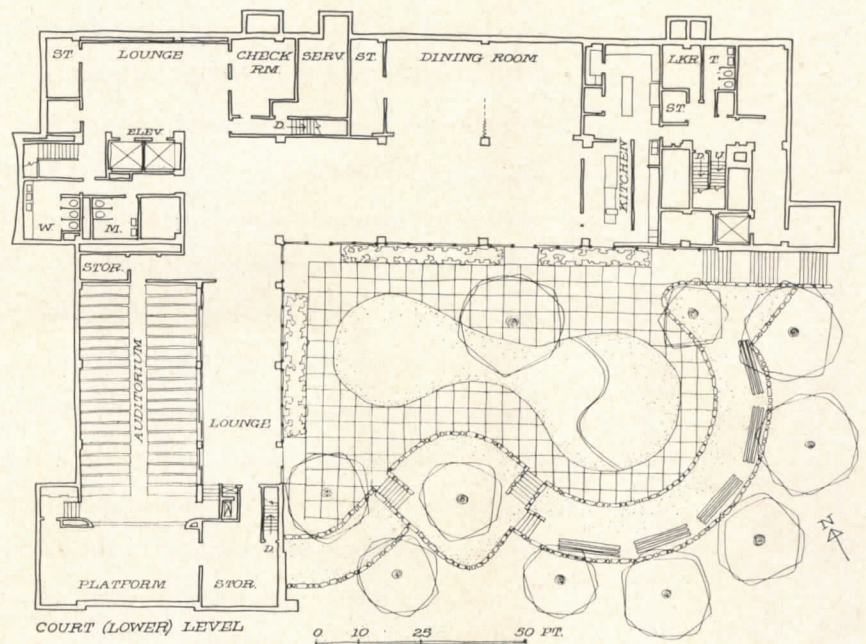

Executive offices on street floor (plan next page) also overlook the Court

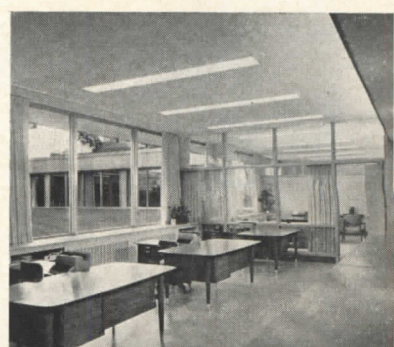
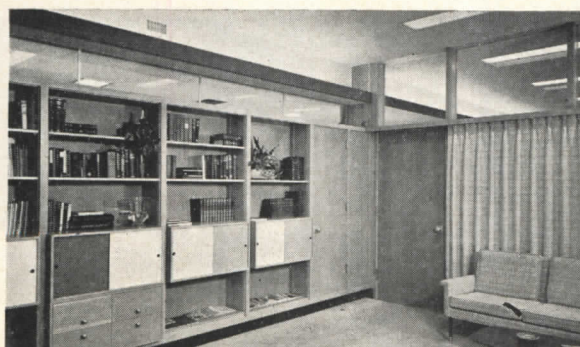

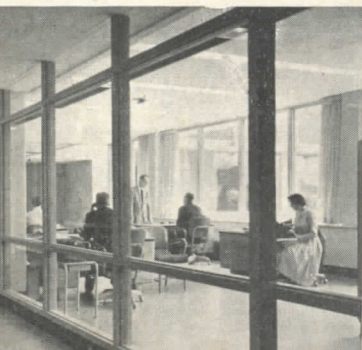

LUTHERAN BROTHERHOOD

Private and general office space, upper floor. Interior column bays are 25 ft square; lighting troffers, air conditioning outlets are recessed in acoustic ceiling

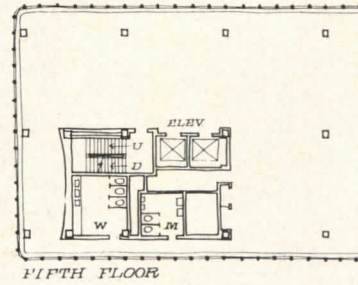
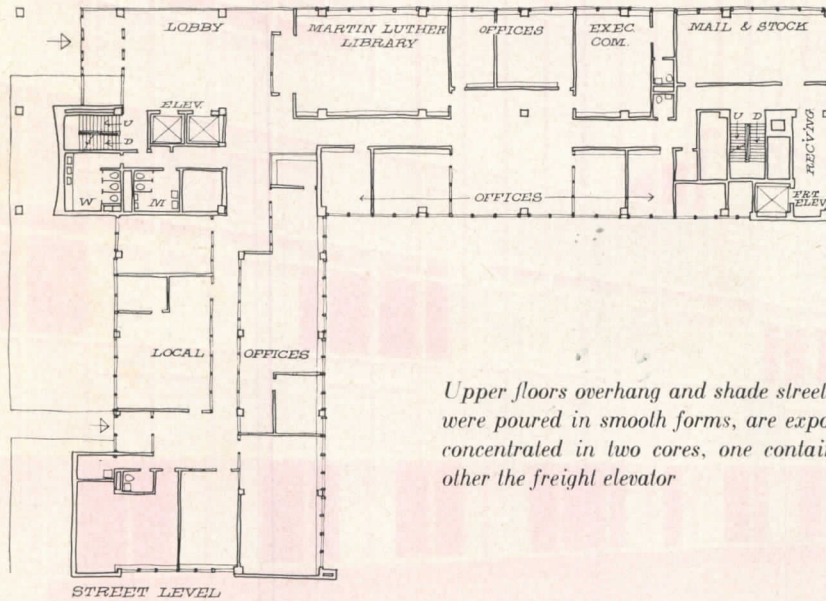

Upper floors overhang and shade street floor, on three sides. Concrete columns were poured in smooth forms, are exposed and painted. Vertical utilities are concentrated in two cores, one containing passenger-operated elevators, the other the freight elevator

CURTAIN WALLS:

Factory assembly



Hoisting into place

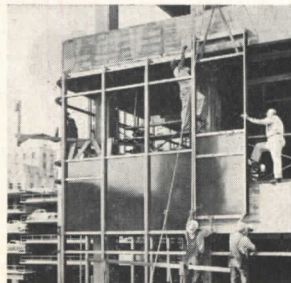

Guiding into exact position

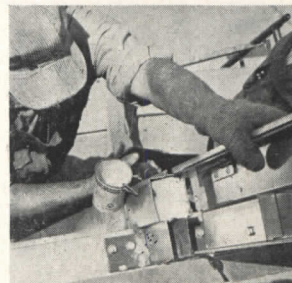

Bolting fast

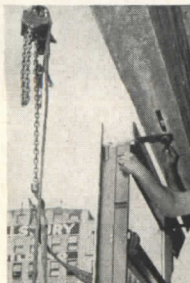

Corridors along outside walls, upper floors, act as sunshades. Beneath the exterior wall's insulating glass (outer pane heat resisting) are perimeter air conditioning units

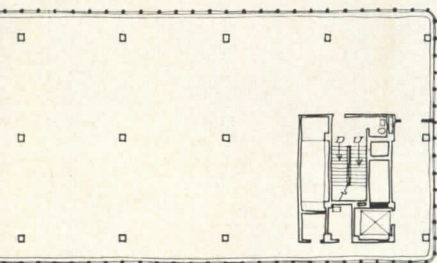

Perimeter air conditioning, a high-pressure conduit system, is locally controllable. Interior zones, a separate system, are automatically controlled



Finished wall; window washing trolley

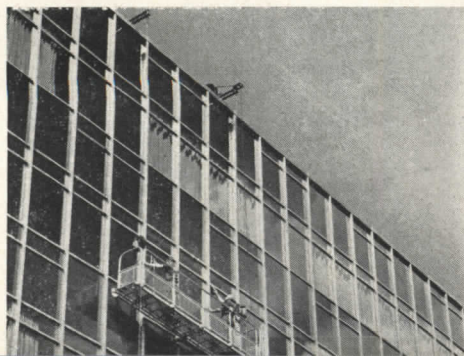

LUTHERAN BROTHERHOOD

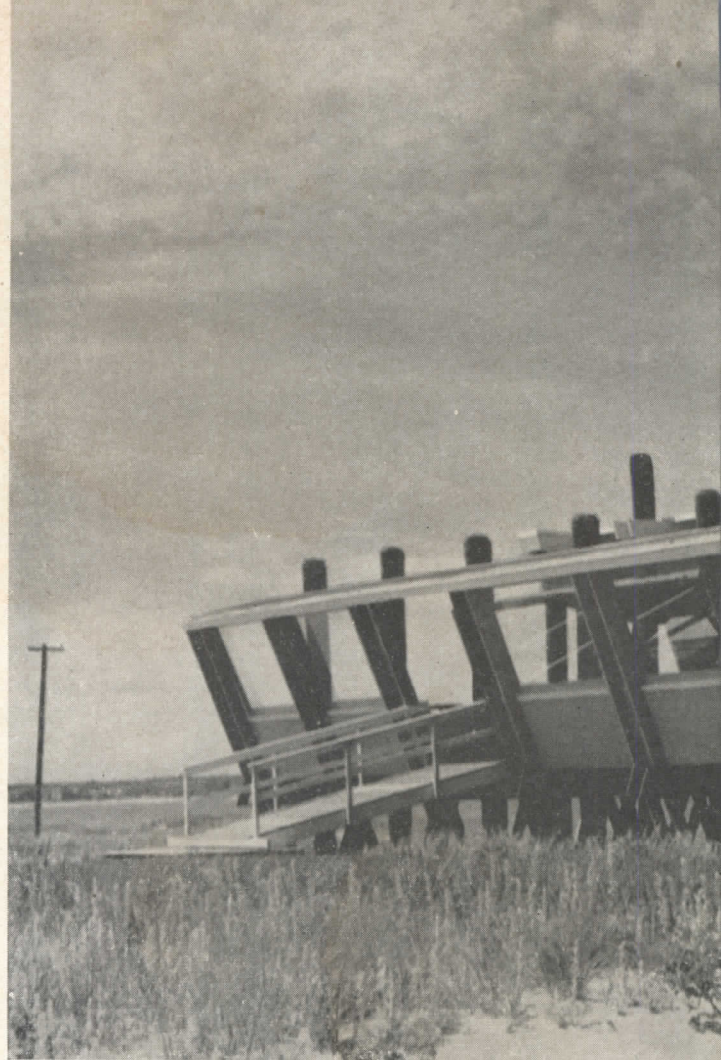

BEACH CLUB

Watch Hill Beach Club

Watch Hill, R. I.

Rockwell King DuMoulin, Architect

William J. LeMessurier, Engineer

Stuart Huckins, Consulting Engineer

Frank N. Gustafson and Sons, Inc., General Contractors

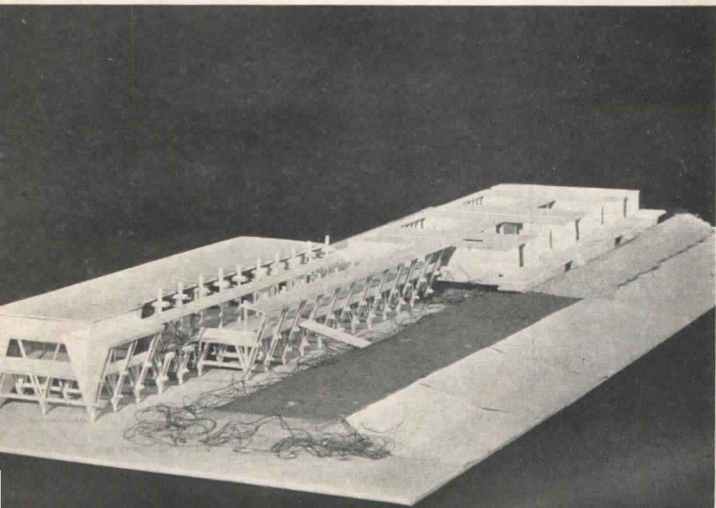

Model gives bird's-eye view of two-part beach club, with unique structural system calculated to withstand winds and waves of hurricane force. Buildings are raised on 40-ft poles driven half way into sand, heavily trussed together to form a mammoth rake. Model shows total original scheme, shortened somewhat in first stage

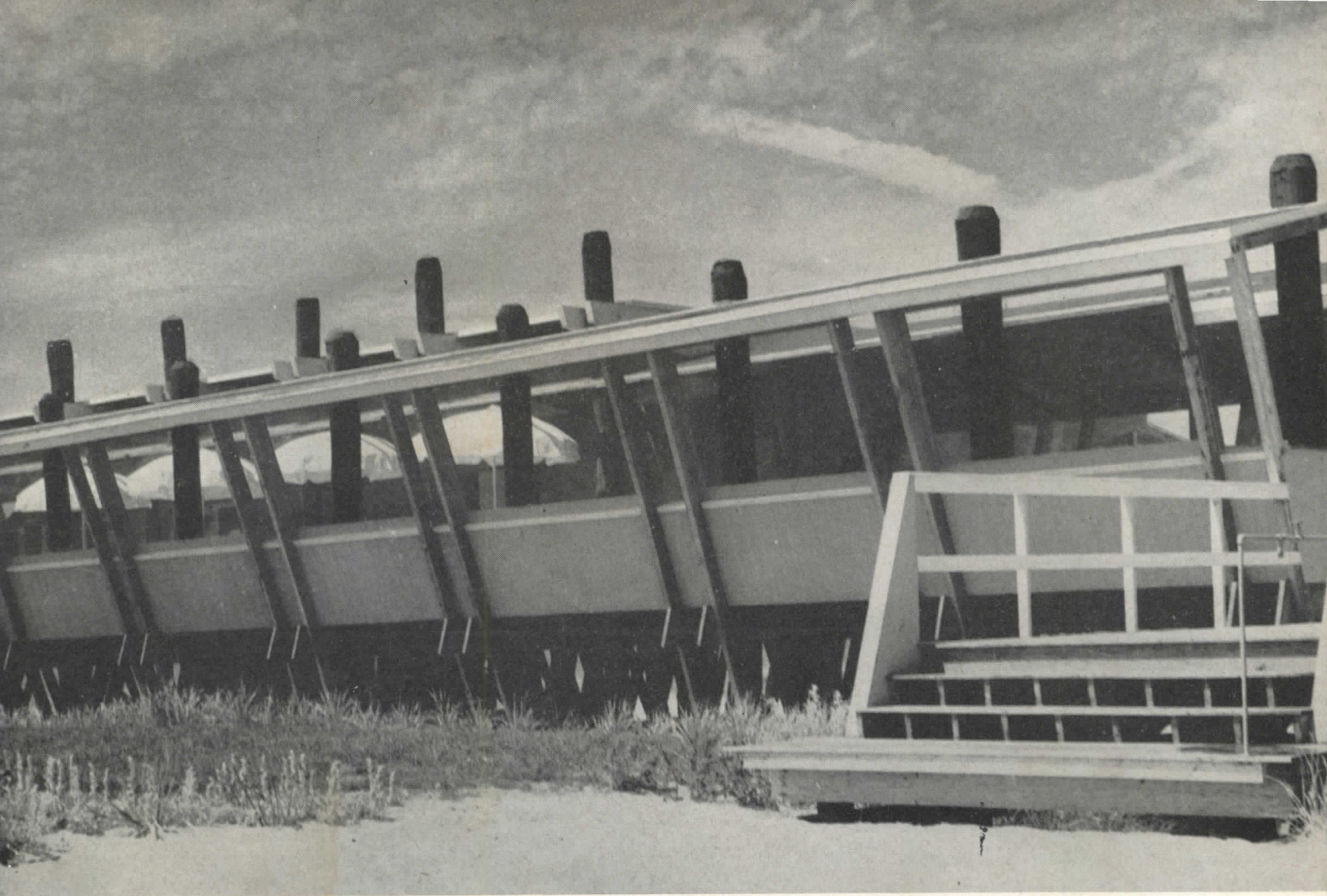

DESIGNED TO RESIST HURRICANES

HURRICANES HAD DESTROYED three club buildings on this site before the architect developed this design, on the basis of which the club — and the insurance company — was encouraged once again to stand against the fury of the winds.

The site is a low, sandy peninsula projecting into the Atlantic Ocean directly in the path of hurricanes that have devastated New England areas. Along with the three previous club buildings, substantial houses had all been washed away and their sites abandoned, and the government had given up trying to maintain a fort. The insurance company had said “no more.” But the club was loath to give up the excellent bathing beach and the views, and asked for new ideas.

The building committee considered and rejected

several alternatives. An expendable structure would be too costly in the long run, as it might be lost in any normal storm. A demountable building was considered too expensive on an annual basis and too slow to knock down, particularly in view of the numerous hurricane alarms. A massive structure of the Texas Tower type was impossible to finance.

The architect proposed the following:

1. Raise level of the building above “normal” hurricane tides.
2. Support it on piles driven deep into the sand.
3. Use the structure of the building itself to stabilize the poles.
4. Bulldoze a protective dune on the ocean side, plant it with grasses and shrubs to hold the sand.

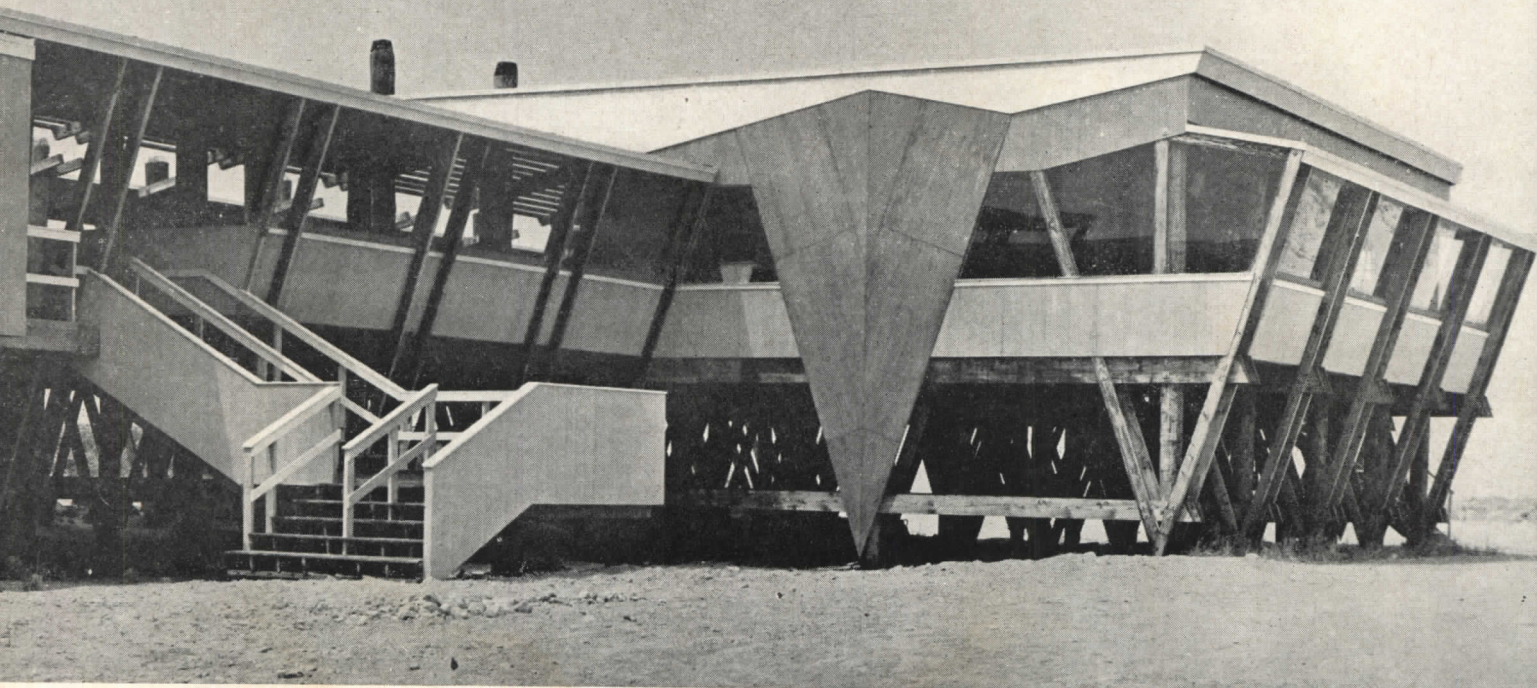

WATCH HILL BEACH CLUB

5. Some portions of the building to be demounted or folded away to reduce the area of surfaces subjected to hurricane winds. (This can be done in two hours by the staff regularly on duty.)

For the two portions — bath house and club house — the architect used two different types of plan and construction. The bath house was laid out so that small, cellular units would form long, rigid, honeycomb blocks running perpendicular to the ocean front. Passages between blocks are closed at each end by ports or baffles that can be folded back flat against the walls at hurricane warnings and in winter. Winds and waves can pass right through the building.

The club house portion required larger, more open spaces and could not so readily be opened for passage

of water through the building; hence the floor was carried at a higher level. The dune is widened here and kept well forward from the building, with a bridge from club house to terrace. Part of the club house is roofed over, part only by shadow bars, and some left open. Glass wind screens on the ocean side are for cool weather comfort, may be swung upward out of the way during a heavy blow. The angle of the eyebrow roof deflects wind upward. And projecting poles at the front are calculated to act as “spoilers” creating air turbulence above the roof to reduce the upward lift.

After studying plans and specifications, Lloyd's underwrote the entire risk at half the previous rate.

Costs were \$6 per sq ft for the bath house; \$11 for the club house, including grading but not equipment.

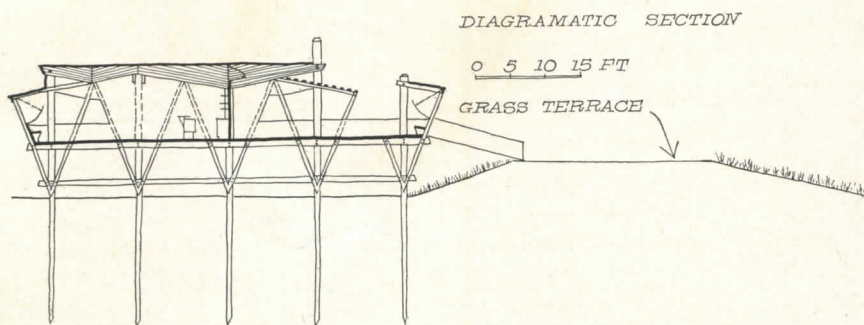
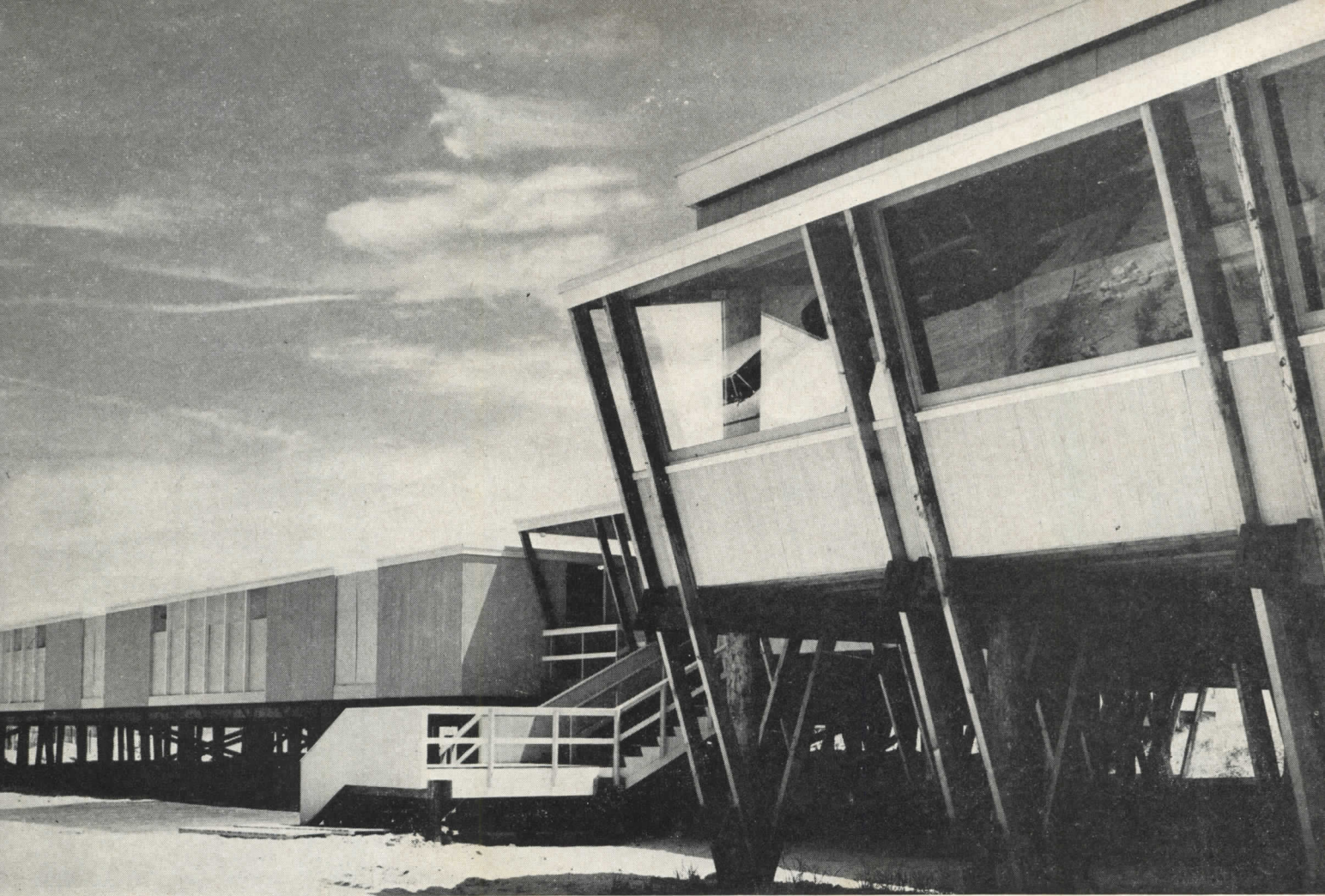

Short lines of poles, perpendicular to ocean, are heavily braced with open trusses below floor level. Wherever plan permits, these truss members go on up to join with roof trusses, forming unified trusses with total effective depth of 20 ft. Resulting trapezoidal shapes are covered with mahogany plywood, glazed or left open. Bulldozed sand dune, planted with grass, designed to break incoming waves, is considered expendable

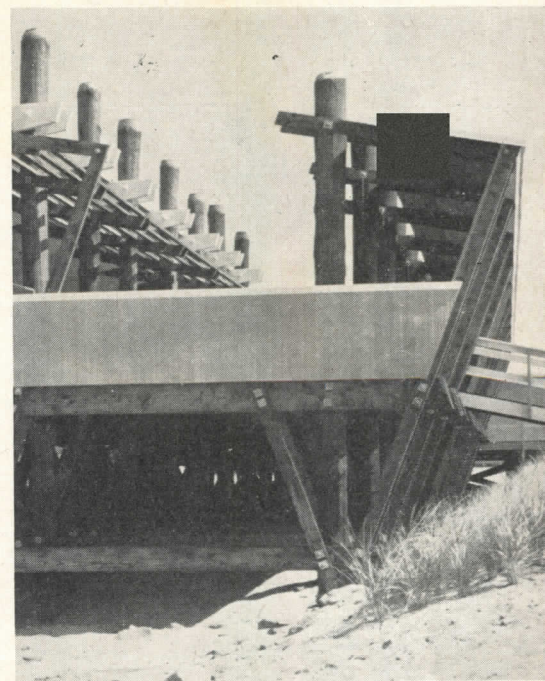

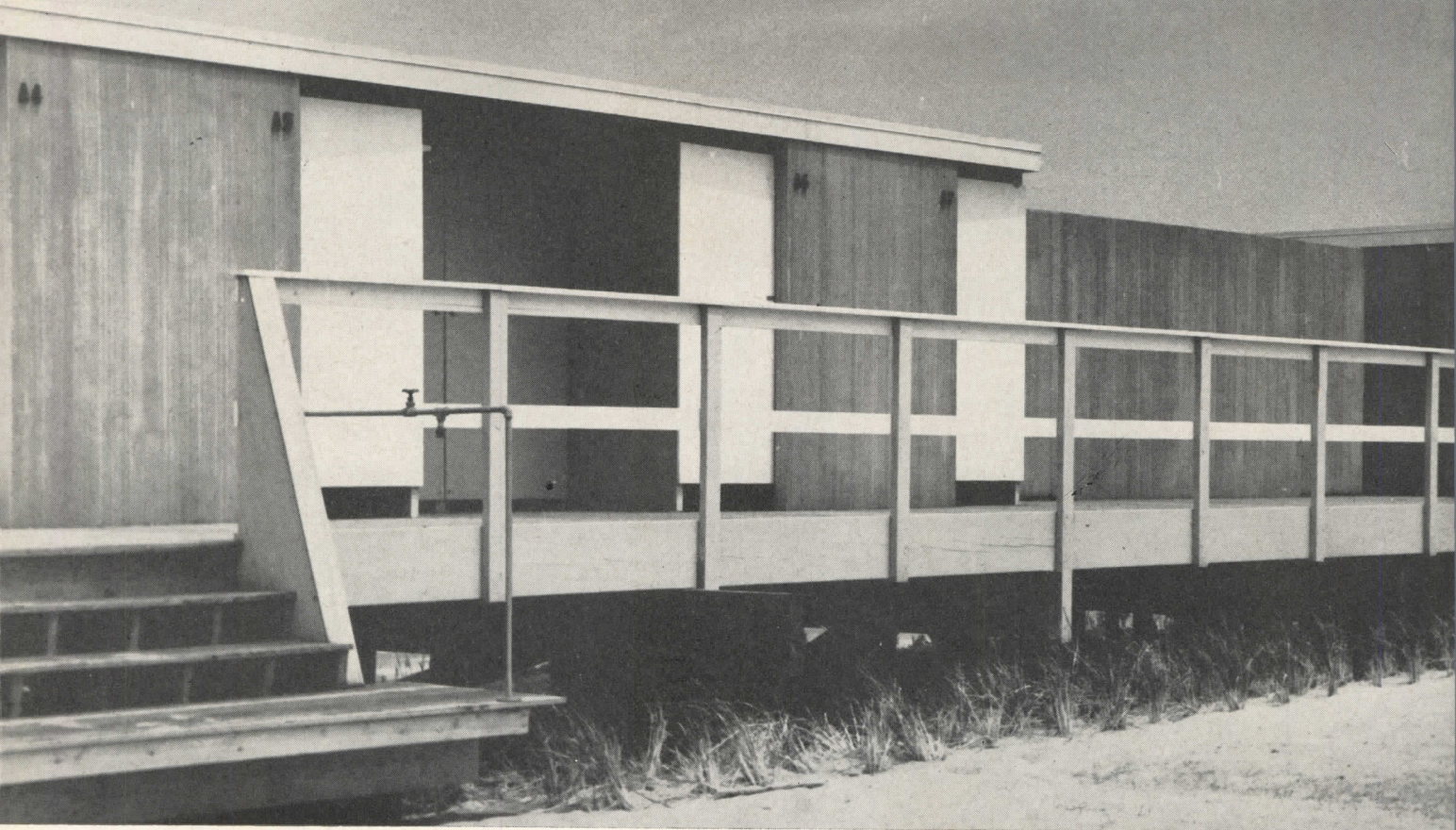

WATCH HILL BEACH CLUB

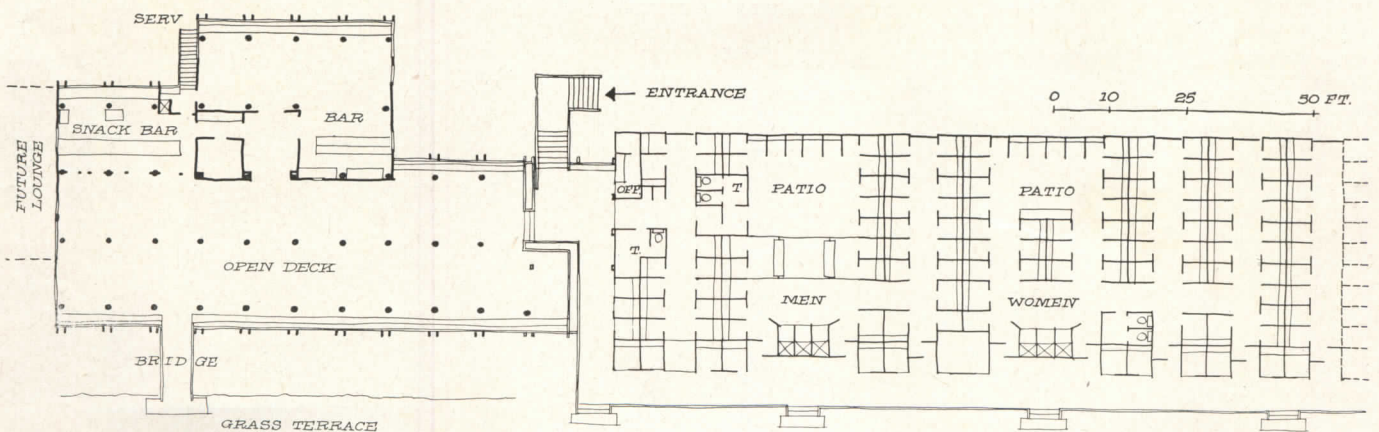

Bath house rows perpendicular to ocean, are designed as rigid honeycomb blocks for strength. Girders are bolted to tops of piles, joists are strapped to girders or attached with patented grips. Some of the wall panels run vertically, are lapped and

nailed to joists and rafters. Transverse partitions are of panels set horizontally running through two 5-ft bath houses to provide resistance to overturning. The system of tying everything together is calculated to resist the uprooting action of hurricanes



During heavy storms the bath house building is opened up to wind and waves to offer less resistance. Screen panels at ocean side are hinged, can be swung out of wind's path; panels at other side are simply lifted out and stacked in bath houses. The whole process takes only about two hours, is feasible even for false warnings

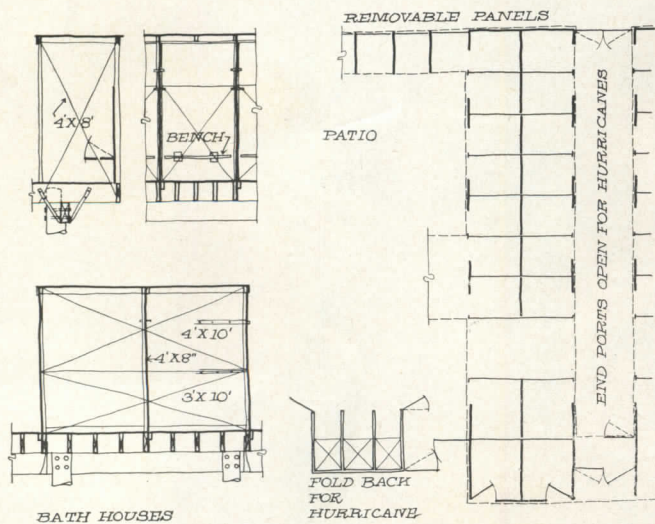
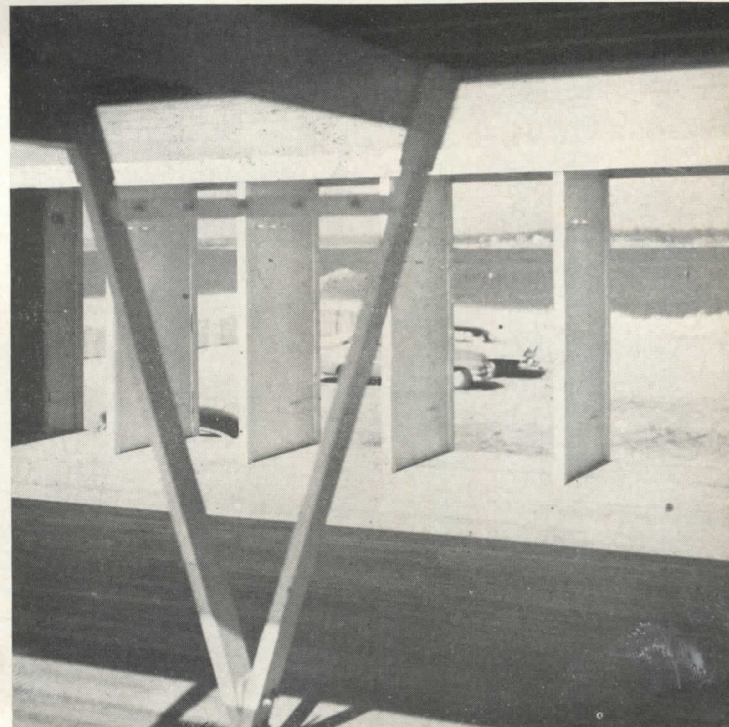
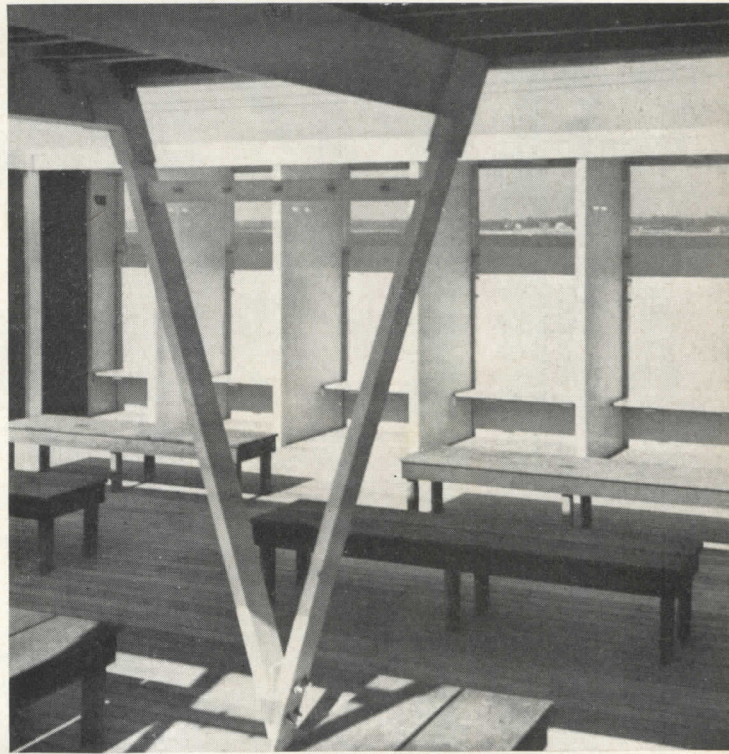



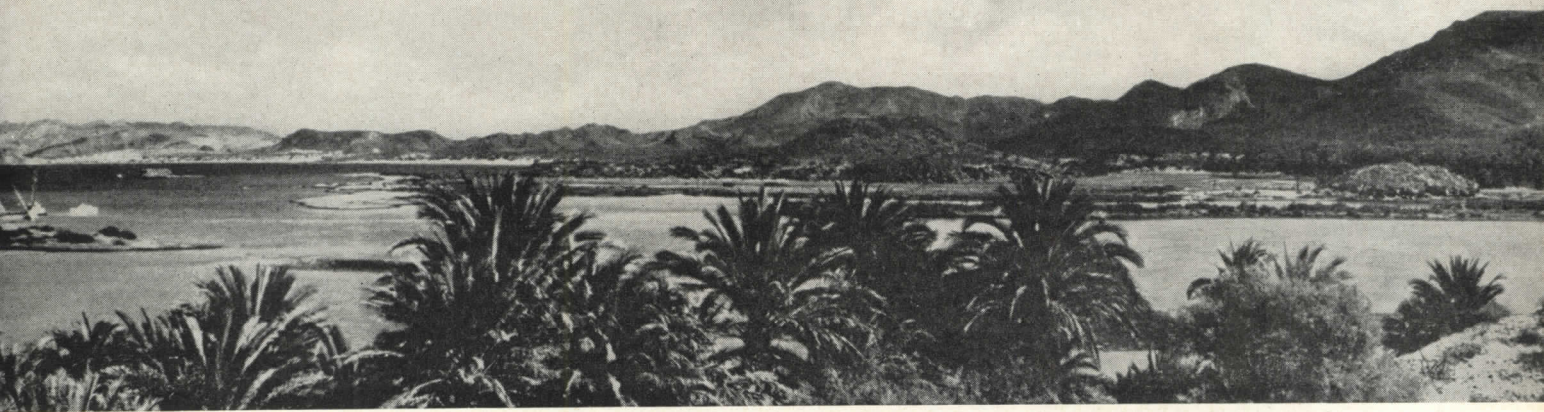

A curved plan focuses on a scenic sweep from the Gulf of Baja California to foothills of the Sierra Zacatecas

TROPICAL HOUSE ARCS TO OCEAN PANORAMA

Residence for Mr. and Mrs. Guy R. Daniel, Mulg , Mexico

F. J. Dennis Beatty, Architect

VIGOROUS REGIONALISM and a really spectacular setting highlight this retirement house, planned for the lower part of the Baja California peninsula in Mexico. The plan is oriented almost due east to take full advantage of prevailing winds and the scenic sweep. A dry, tropical climate makes possible generous use of outdoor living areas, including outdoor circulation.

Construction is entirely of local materials with the exception of glass, pipe, and electric wire, all to be shipped by boat from San Francisco.

The isolation of the site posed a number of special problems—particularly with utilities. Fresh water, originating from a lake in near-by Mulg , is available from an irrigation ditch at the foot of the property. Water will be pumped up the hillside-site to a pool-reservoir and storage tanks, to be used directly for washing, boiled for drinking. Continuous pool overflow assures clean water. A generator will supply electricity; hot water heater, stove and refrigerator will be run by bottled gas.

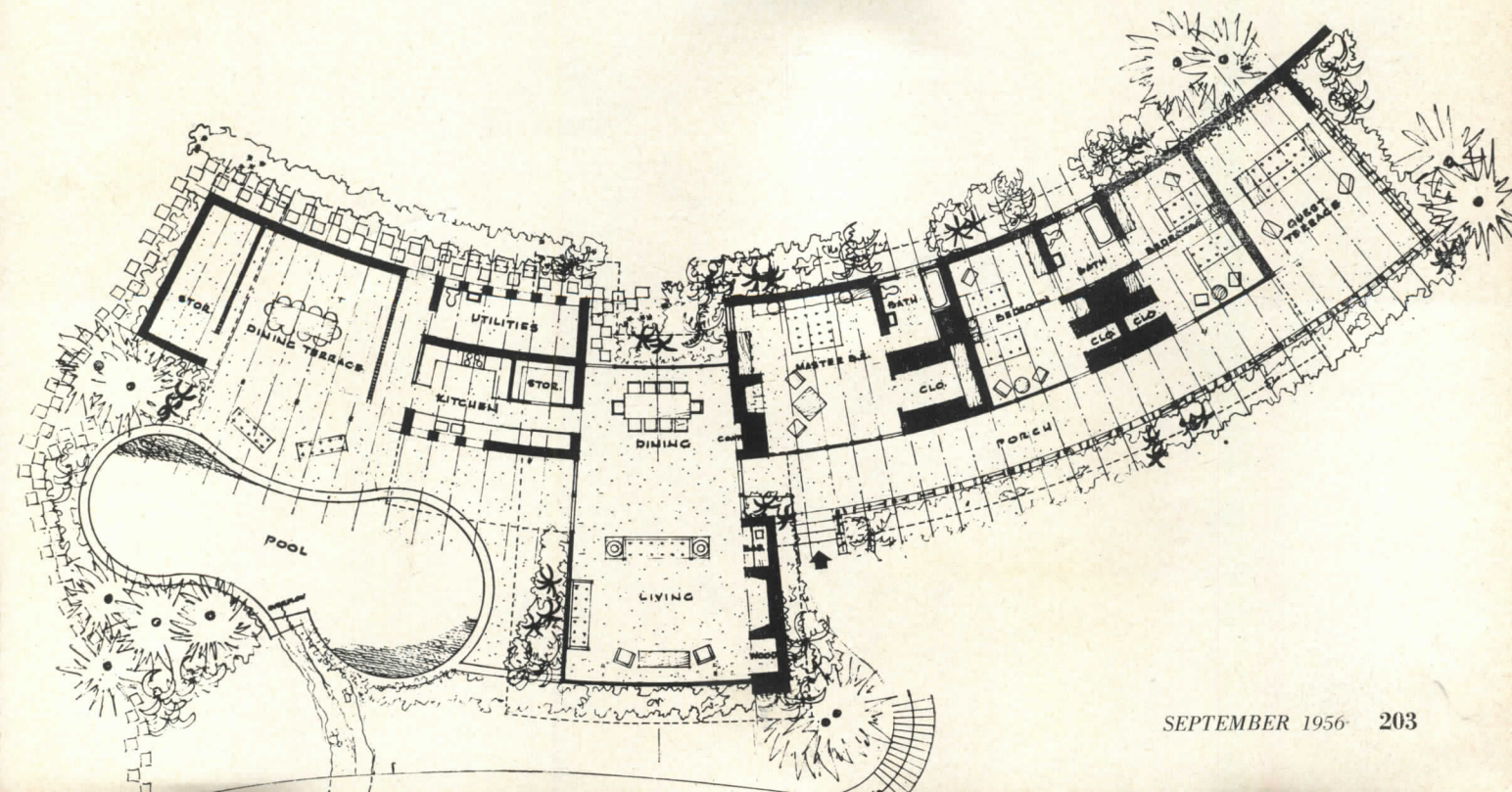

HOUSE IN BAJA CALIFORNIA

The house represents a fairly sophisticated use of local building techniques. A concrete slab, containing pipe and conduit, will be laid on a rock foundation. Two short walls and the pool will be of blackish-red volcanic rock; other walls will be white-plastered adobe. Roof beams radiate from the center of the plan arc. "Dowels" of Cordón cactus heartwood will be lashed across the beams, and covered with a 4-inch layer of palm thatch — which forms an excellent insulation

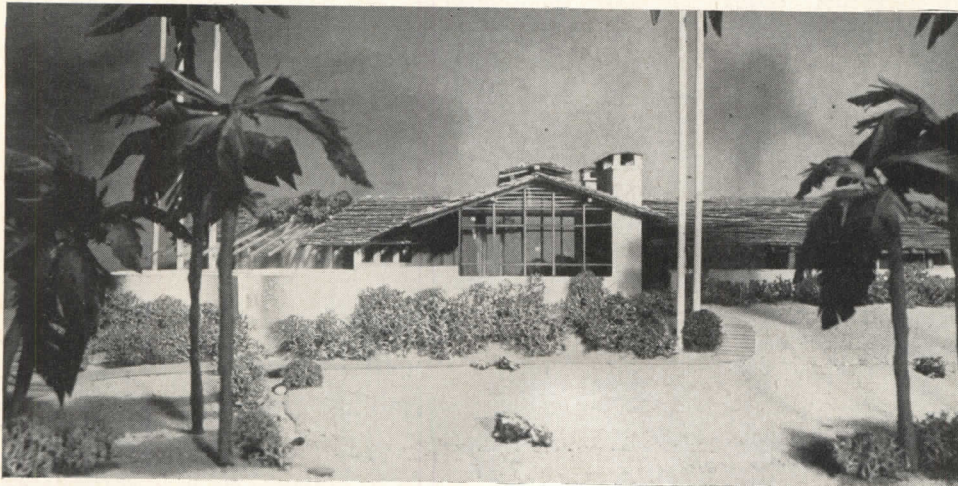
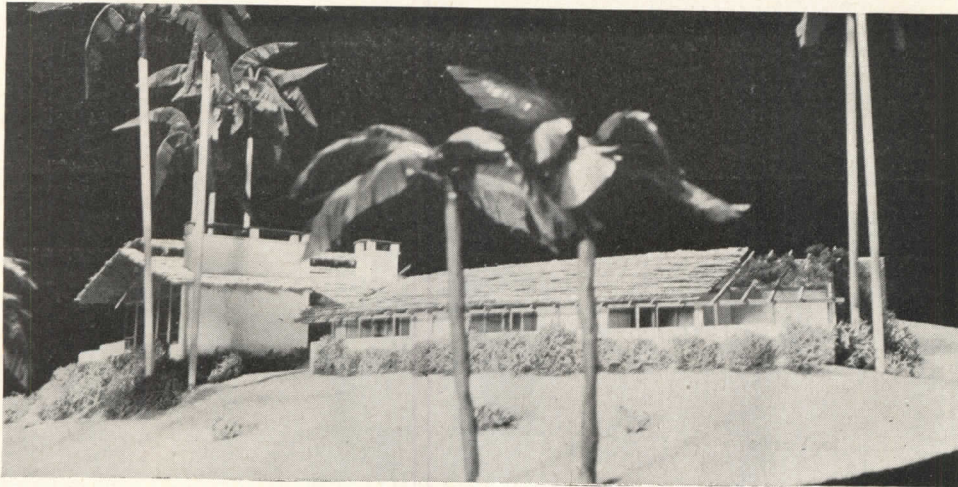

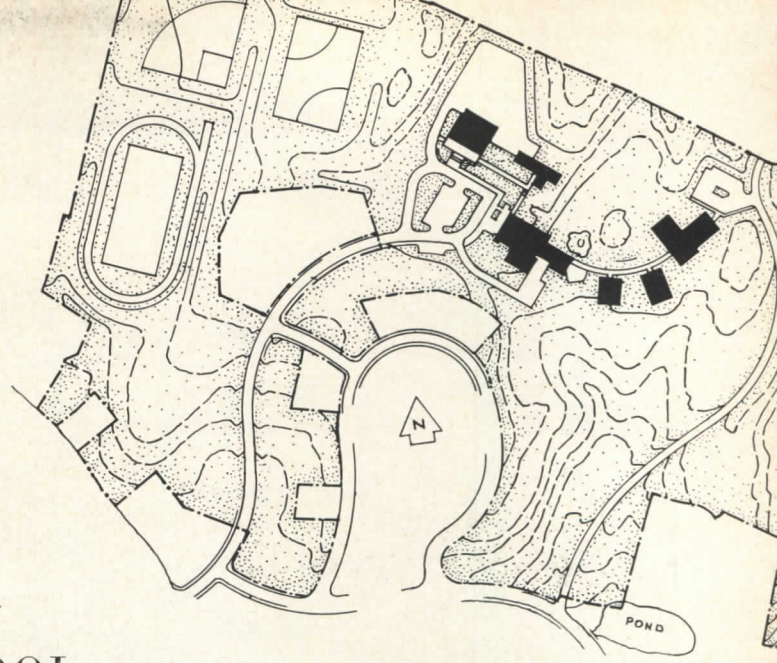

THE NATURE OF THE SITE

AND THE NATURE OF THE SCHOOL



NATURE OF SITE AND

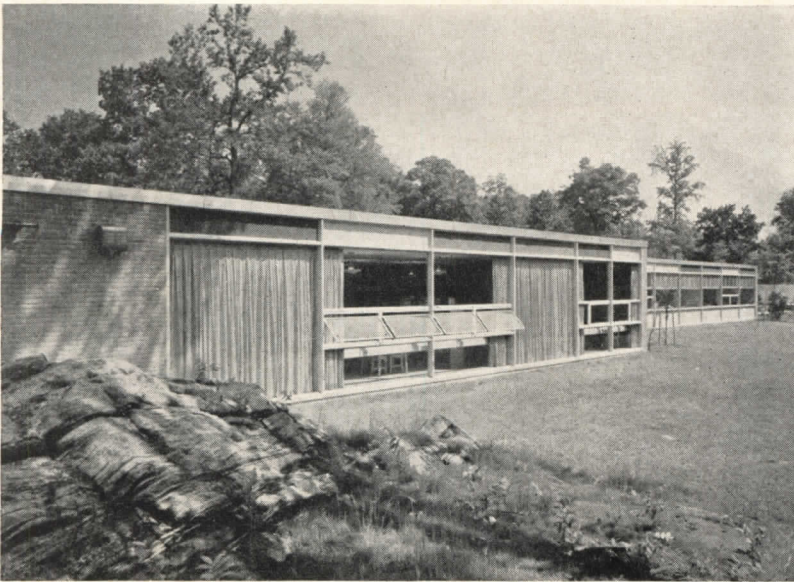

Joseph W. Molitor

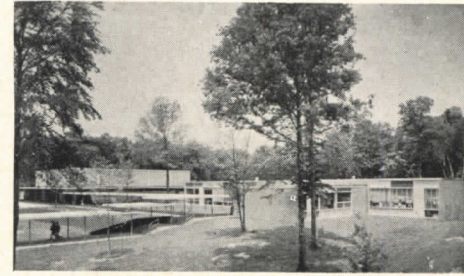

Left, Gymnasium;
right, Arts and Crafts

Edgemont Junior-Senior High School, in the town of Greenburgh, Scarsdale, N. Y., was designed for a college preparatory-general education curriculum and for a 70-acre site on which rock excavation would be prohibitively expensive. A campus plan, with walkways covered but not enclosed between buildings, was decided upon as offering the relatively advanced educational program the advantages of flexibility, simplicity of expansion, maximum use of the outdoors for study, social and community purposes, uncrowded corridors, etc. At the same time it permitted construction of small buildings on the several reasonably level spots with a minimum of excavation, thus keeping costs down and preserving the beauty of the site. Those responsible for the structure were: *Warren H. Ashley*, Architect; *H. E. Hollister*, Dist. Supt.; *W. D. Moyle*, Supervising Principal; *Engelhardt, Engelhardt & Leggett*, Educational Consultants; *C. A. Currier & Assoc.*, Site Planners; *Marchant & Minges*, Engineers.

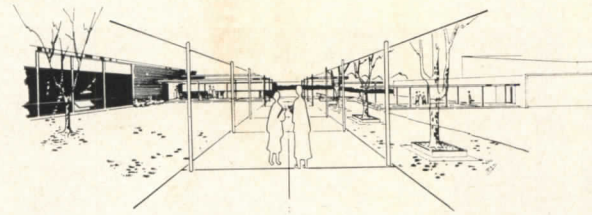

Library; Social Studies Classroom

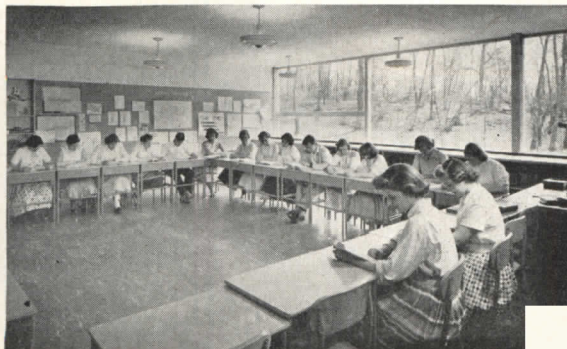

Auditorium Lobby



OF SCHOOL

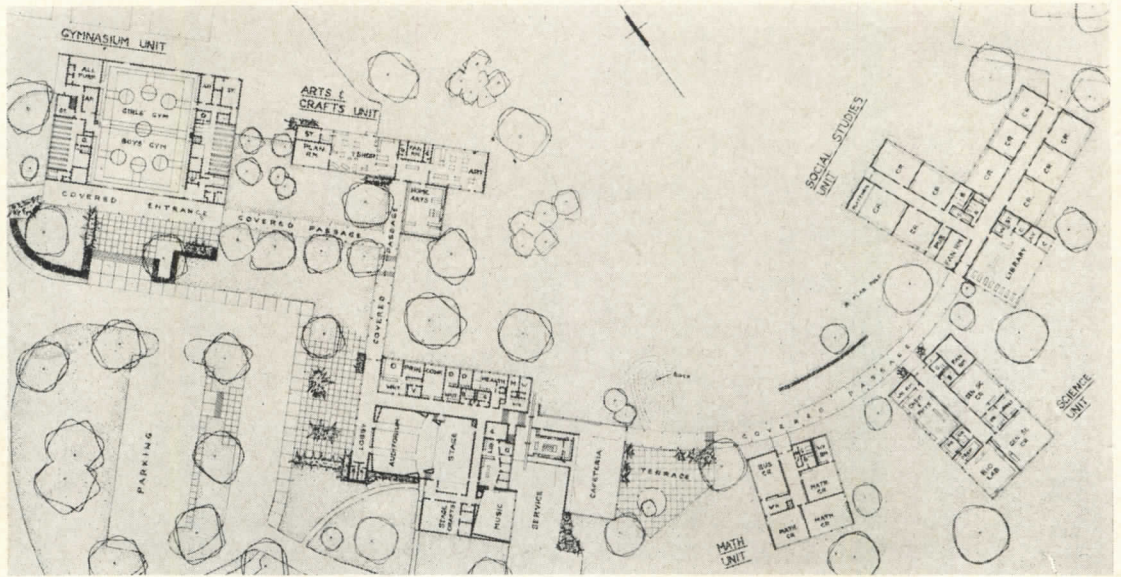

Entrance Terrace

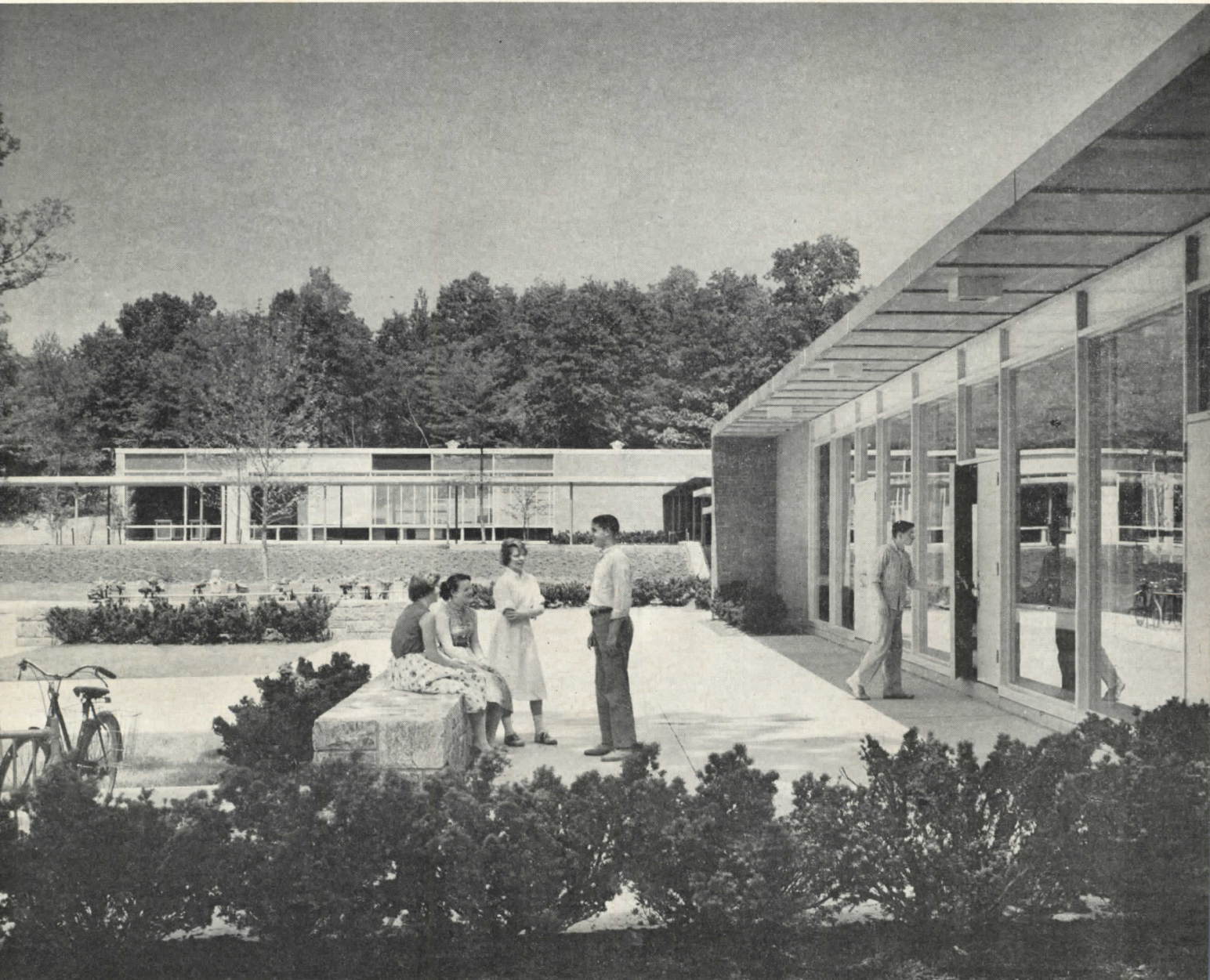



Designed for 550 pupils, with basic facilities to accommodate expansion to 800 by adding buildings, Edgemont Junior-Senior High has classrooms that vary in area from 700 to 1100 sq ft. Units such as the gym and auditorium, often used separately by the community, can be individually heated, thus reducing operating costs. Classroom units are grouped at one end of an arc; the indoor-outdoor cafeteria (200 seats) is centrally located; noisy shops and music room are separated from academic areas to minimize interference inexpensively. The flexible plant is estimated to provide educational facilities of high quality at about 10 per cent less than the initial cost of a large, multi-story structure.



Science Classroom

NATURE OF SITE AND

Left, Social Studies; right, Science

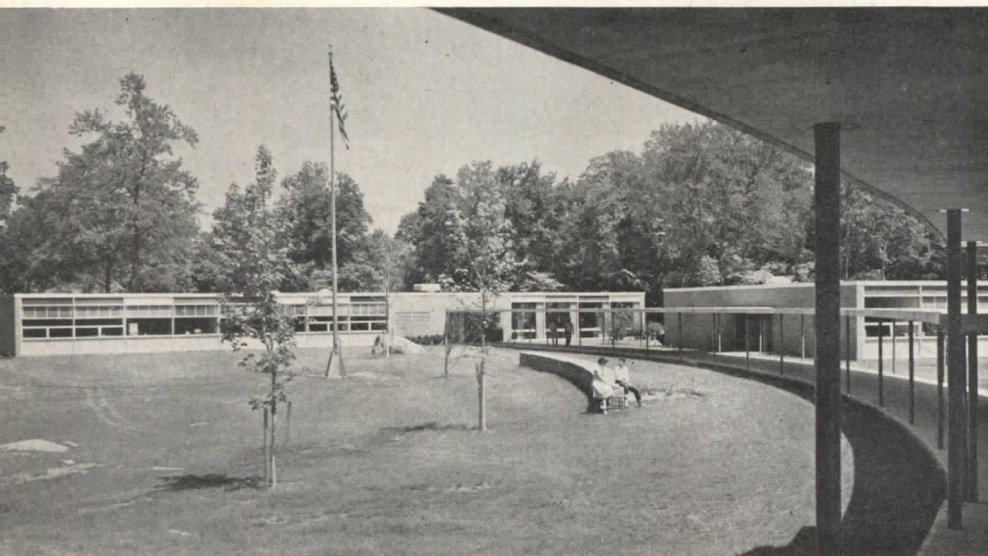

Home Making

Industrial Arts

Grades housed	7-12
Number of pupils	550
Total cost per pupil	\$3,281
Total sq ft per pupil	135
Building cost (at \$15.94 per sq ft)	\$1,285,672
Total cost (site, fees equipment)	\$1,804,986
Per cent educational area to total area	76%

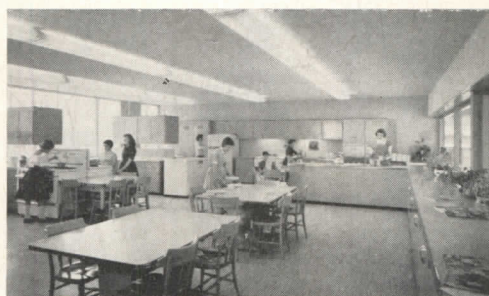

Joseph W. Molitor

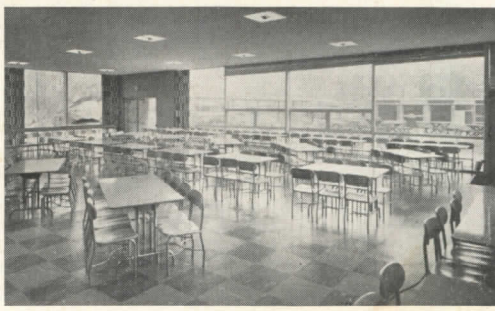
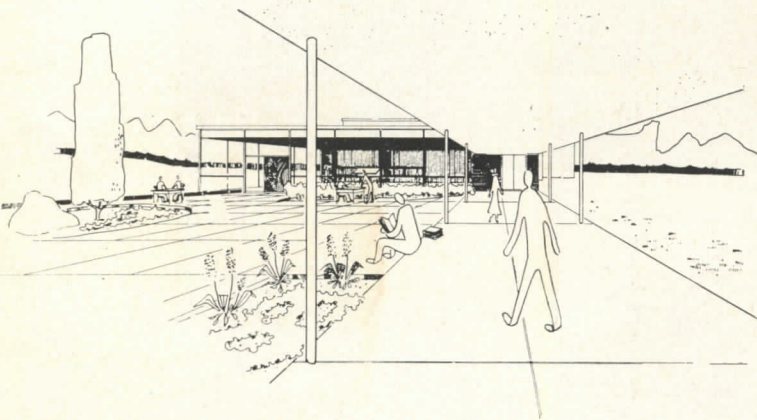

Cafeteria; sketch (left), dining and social terrace

OF SCHOOL

Cafeteria Corridor; Arts and Crafts visible through window



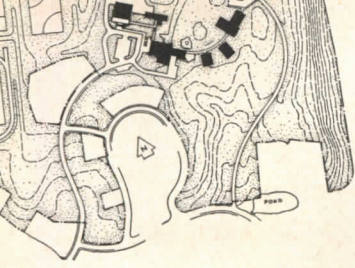

**NATURE OF SITE
AND OF SCHOOL**

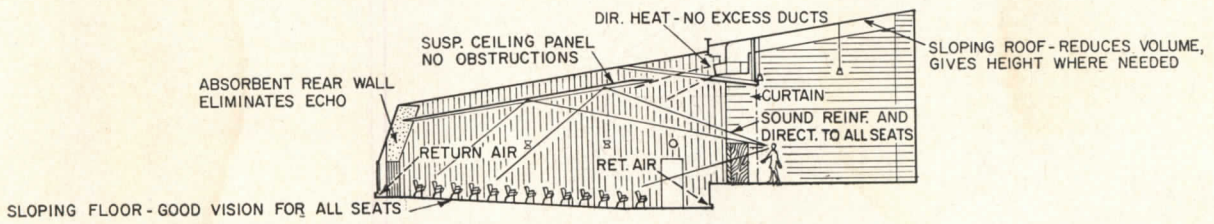

Auditorium (left rear), designed for doing, not just viewing, has 1700 sq ft stage, 2200 sq ft seating area (300 seats)

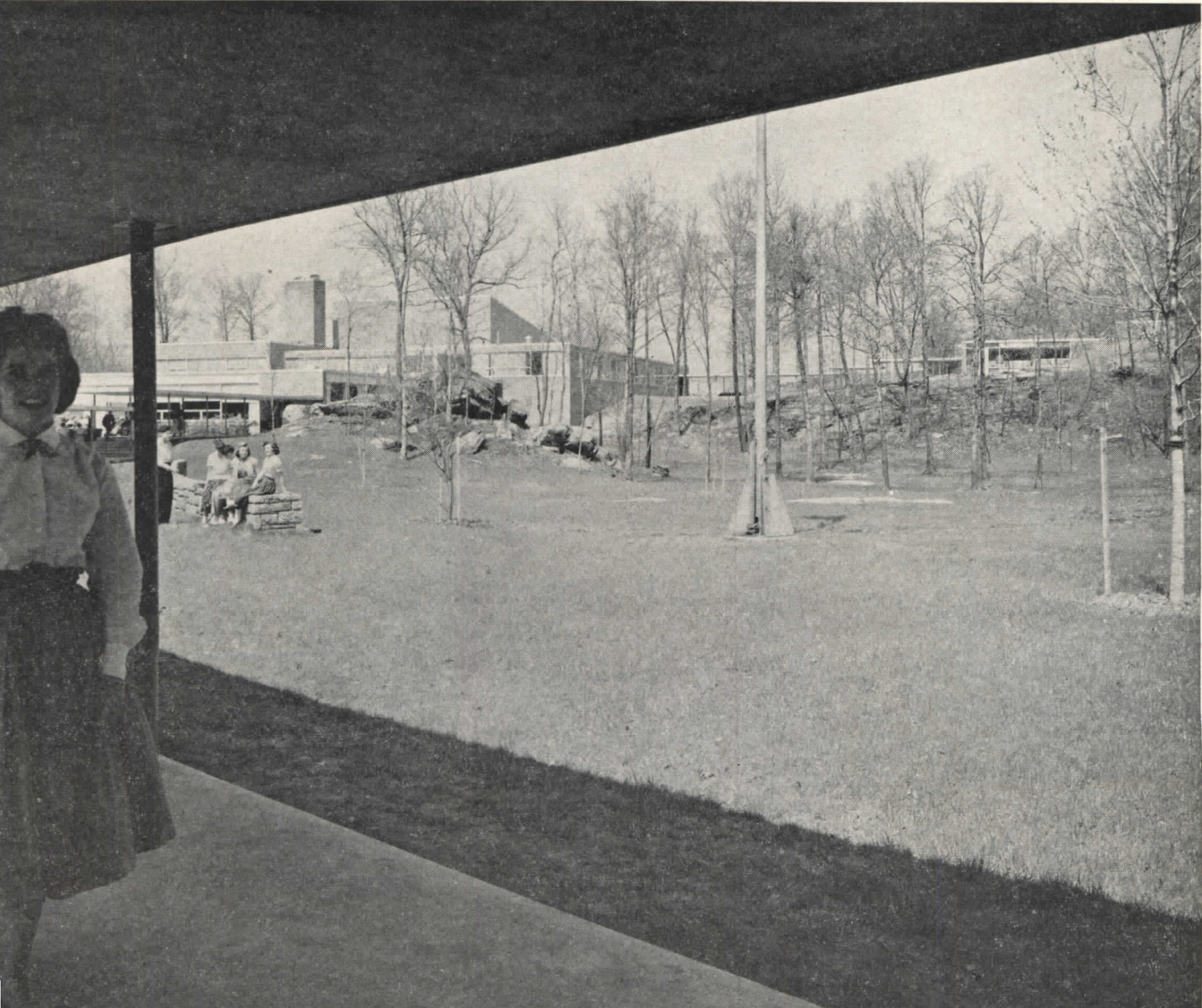



All photos by Charles Payne

NEW APPROACH TO ROOFS IN TENSION

Steel cables squeeze thin slabs to make a saucer cover for a shelter

RADIAL STEEL CABLES were laid in the form of a spider web and covered by a skin of wedge-shaped concrete slabs to form a prestressed inverted dome for a small shelter at Camp Columbia in Litchfield, Conn. It was patterned after a system devised by two Uruguayan engineers, Leonel Viera and Luis A. Mondino for a 300-ft circular arena* in Montevideo. Together these two structures suggest a new approach to the problem of long, unsupported spans which overcomes the hazard

*See Technical Roundup, ARCHITECTURAL RECORD, July, 1956.

of "flutter" which has kept many designers from going ahead with cable structures.

This extraordinary structure of wood, steel and concrete was built during the month of June by a group of students at the Schools of Architecture and Engineering of Columbia University under the supervision of Bruno Funaro, A.I.A., Associate Professor of Architecture. It had been designed during the spring term by the same team which did the actual building. The structural design was the main duty of the engineering students

NEW APPROACH TO ROOFS IN TENSION



A laminated wooden ring holds steel cables at the circumference of Camp Columbia shelter

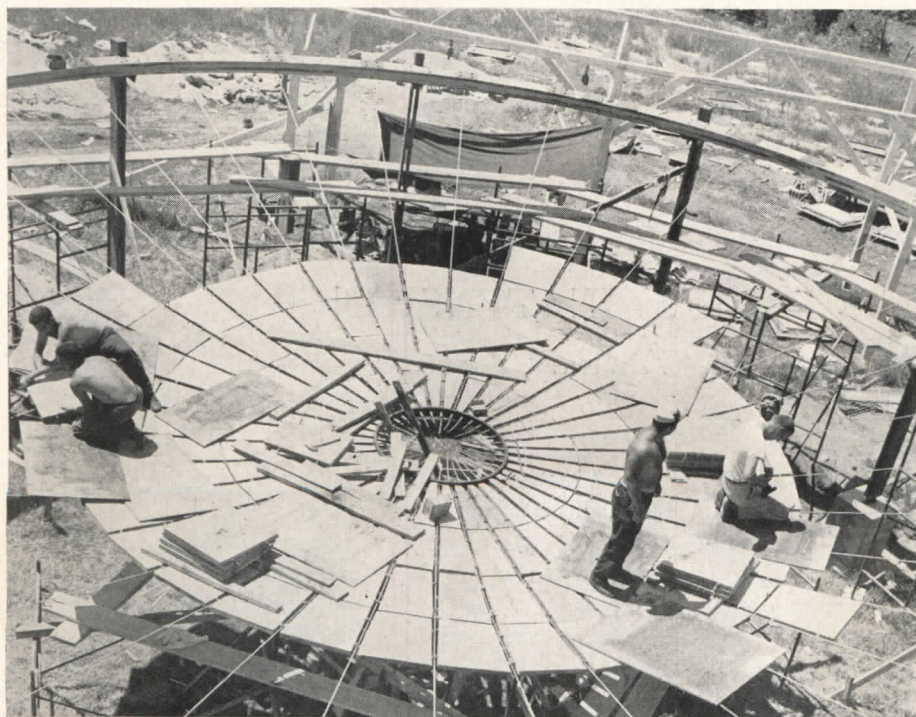

Looking down on the construction process as concrete slabs are being laid on top of cables

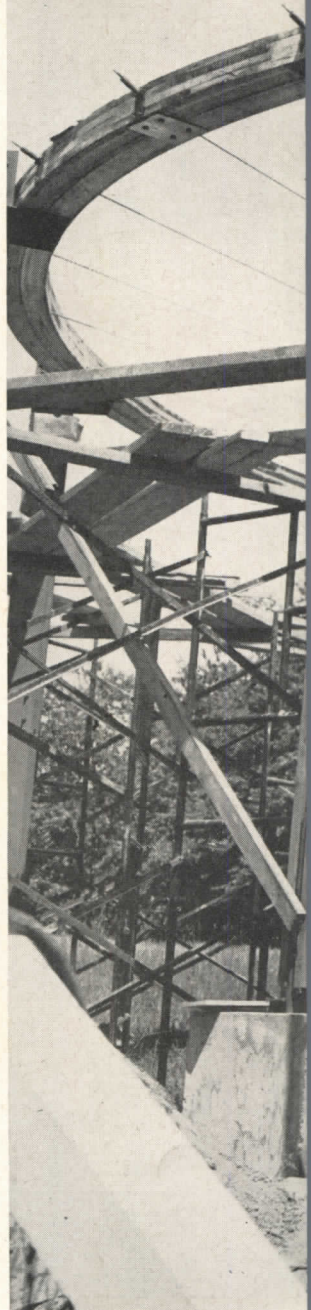

Overall view of the shelter

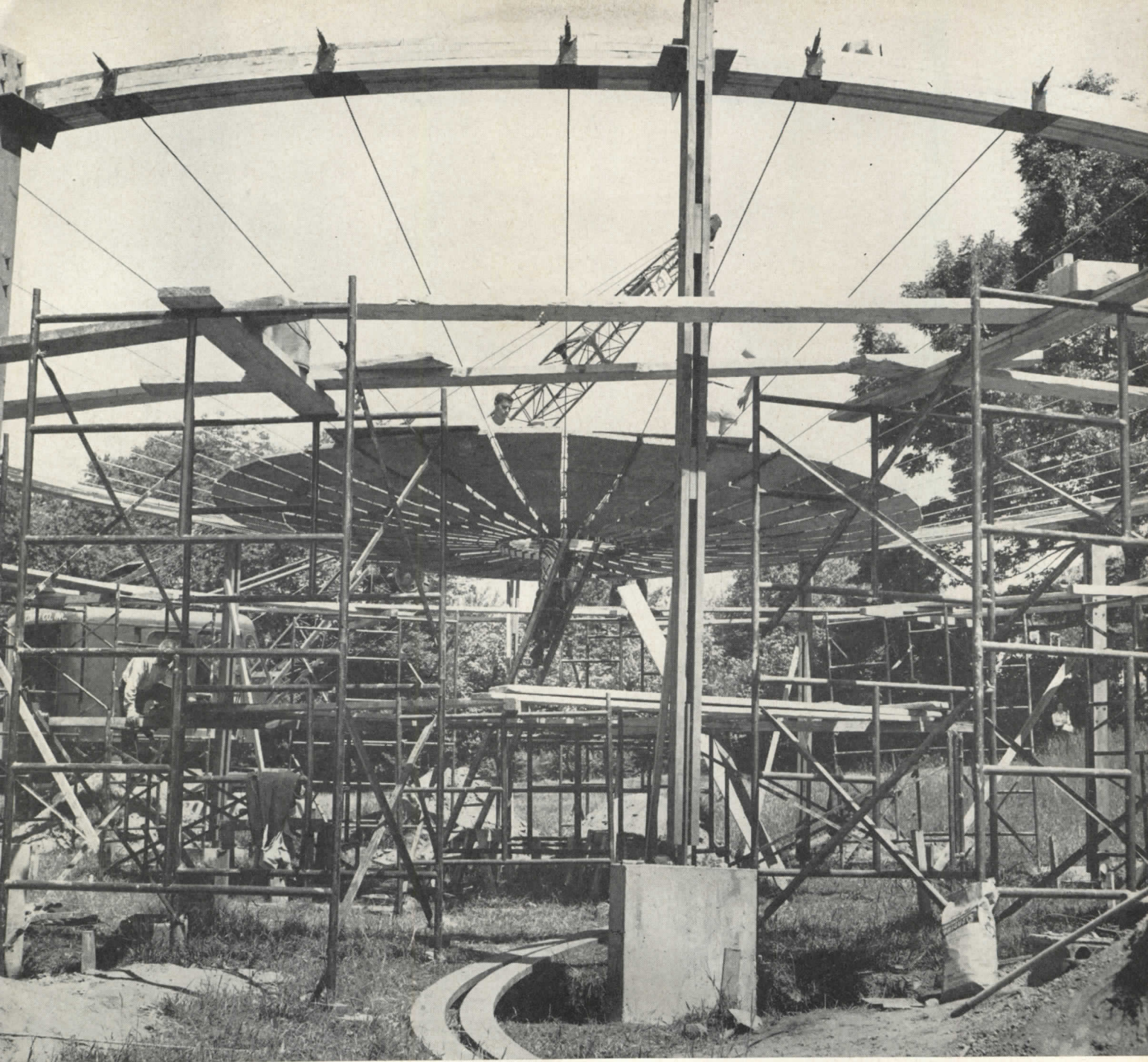

which has 12 wooden struts supporting an outer wooden ring from which steel cables are strung to an inner, 4-ft steel ring

under the supervision of Mario Salvadori, Professor Civil Engineering.

The Columbia students conceived a roof 50-ft in diameter, supported by 12 columns of wooden struts, evenly spaced, upon which sat a wooden ring made of prefabricated, laminated wood pieces. Thirty-six steel cables of $\frac{3}{8}$ -in. diameter stretch from the outside wooden ring to a central ring of steel, 4-ft in diameter. After the cables were in place, they were covered by 324, wedge-shaped, reinforced concrete slabs, only

$1\frac{3}{4}$ -in. thick, and varying in width from 4 ft to 2 in.

The unique feature of the structure is embodied in the next step which consists in first temporarily overloading the roof, in this case with 700, 50-lb sand bags to pretension the cables, and deflect the shell downward. The narrow gaps between the concrete slabs which run in both radial and circumferential directions are grout-filled with mortar while the roof is still loaded. After the grout has hardened the sand bags are removed. The roof tries to deflect upward, but it is pre-

NEW APPROACH TO ROOFS IN TENSION

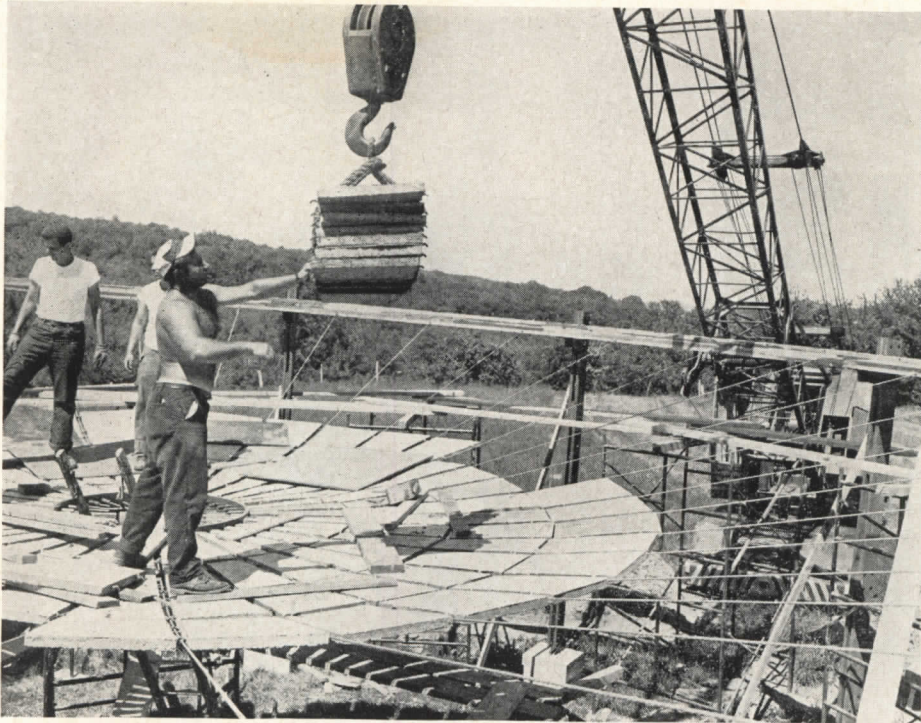

A small crane hoists the precast, concrete slabs to working position where they are laid on cables

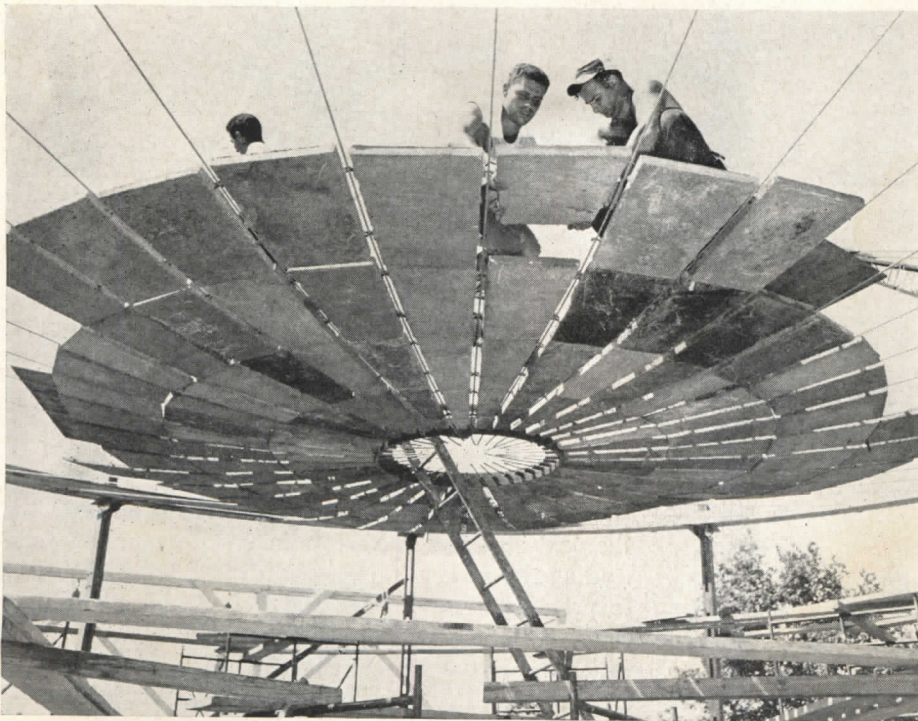

The 1¾-in. slabs are wedge-shaped to fit cables, have reinforcing "hooks" to hold them

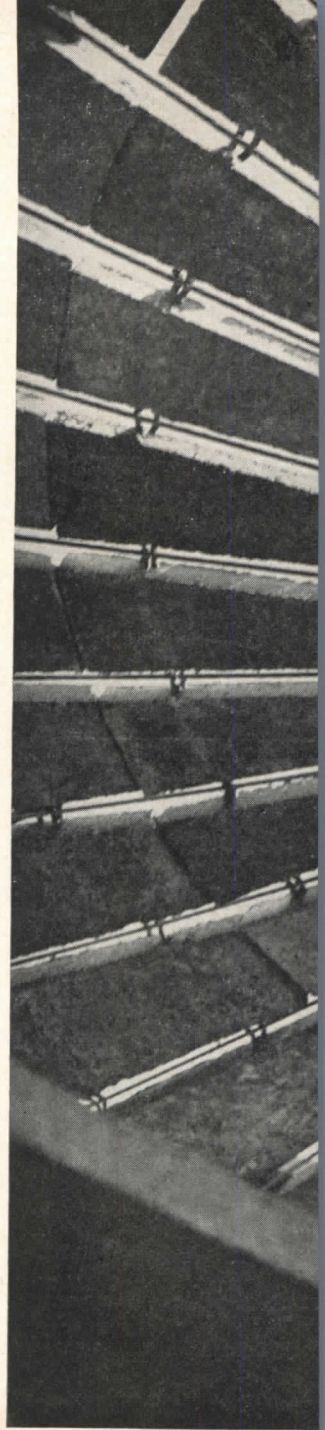

Pattern of precast slabs

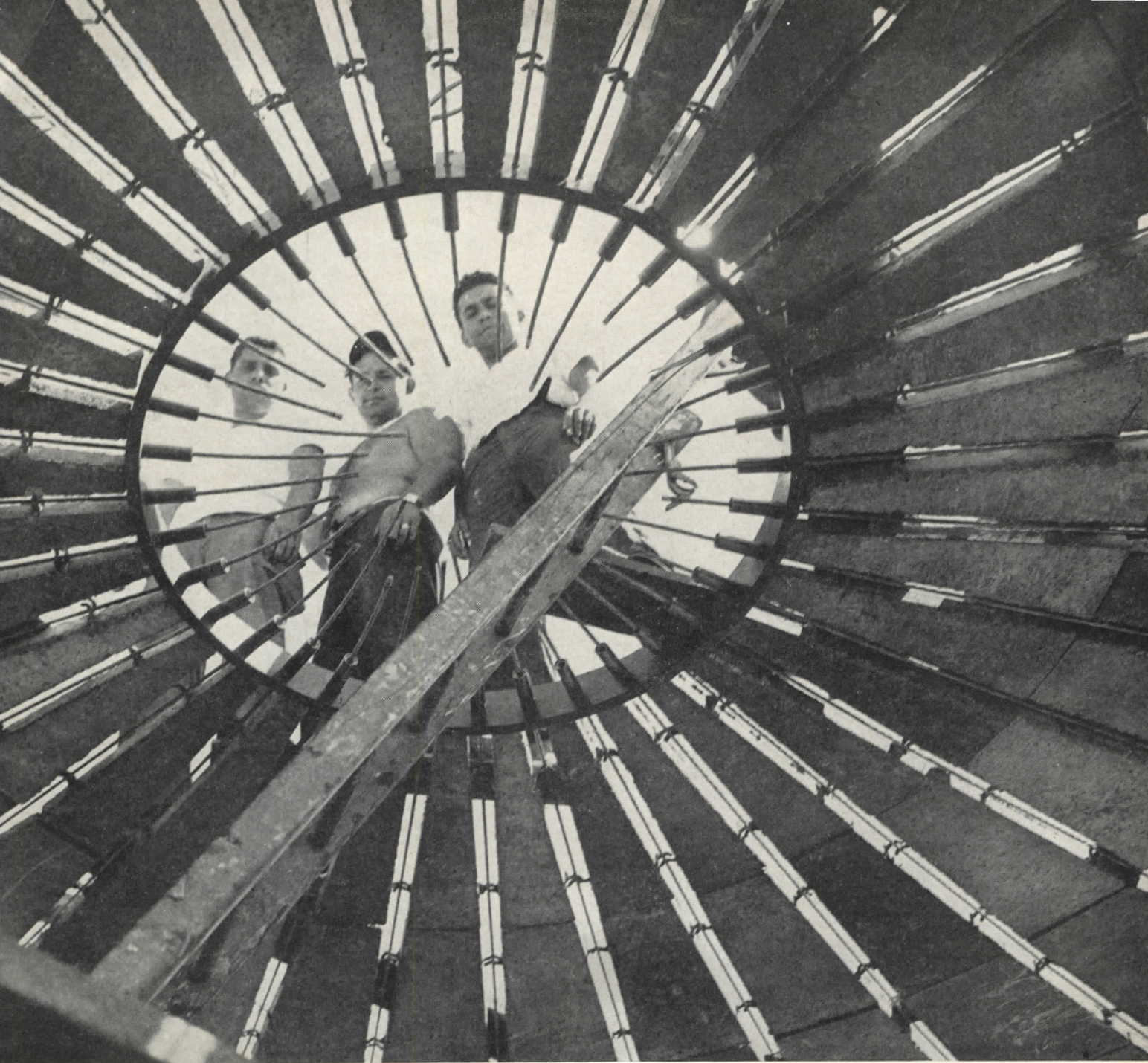

can be seen from view under roof. Notice the steel cables projecting through inner steel ring, held by wedge fittings

vented from doing so by its curved shape. The tension in the cables is frozen by the compression in the concrete slabs. The result is an inverted dome which provides an exciting spatial feeling and fully expresses the playfulness of the structural system.

The Camp Columbia shelter is not quite finished at this point, a month's time making an awfully tight schedule for a small group of students tackling a new construction. They were assisted by Jules Bonvicini, of the Bonvicini Construction Co., in Torrington, who

acted as construction consultant. The roof was "overloaded" and some joints poured. One kink that arose upon overloading was slight buckling of the laminated ring (a chance that the designers were willing to take). The ring will be reinforced on its faces by steel plates.

The shelter structure constitutes the "term paper" for a course in "Imaginative Building," proposed to the University by Dean Leopold Arnaud of the School of Architecture and Professor J. M. Garrelts, Executive Officer of the Department of Civil Engineering.

NEW APPROACH TO ROOFS IN TENSION

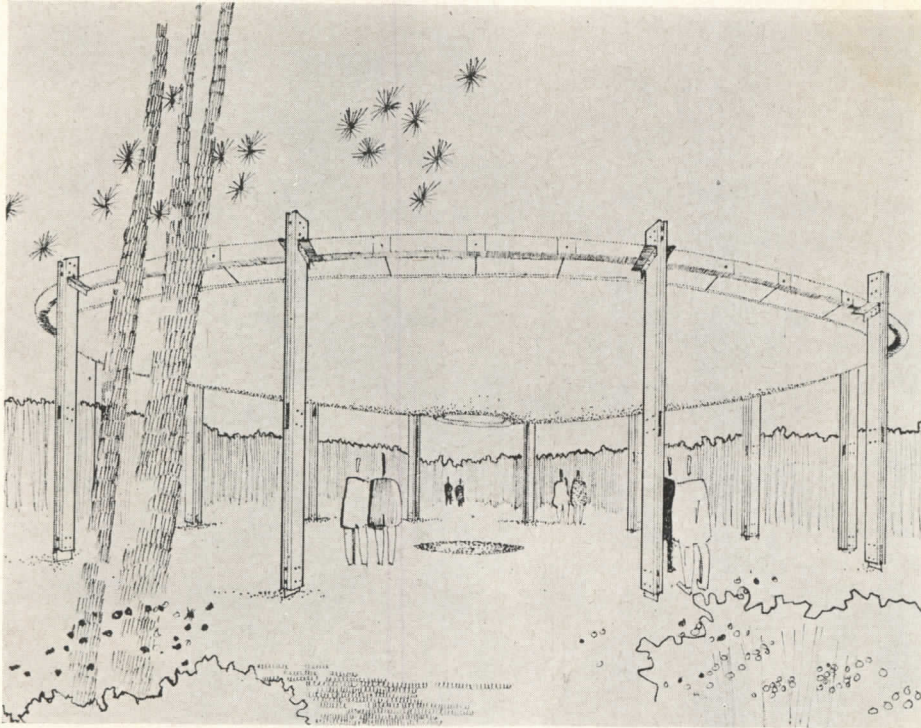

This is how Columbia Students expected the shelter at their camp to look when finished

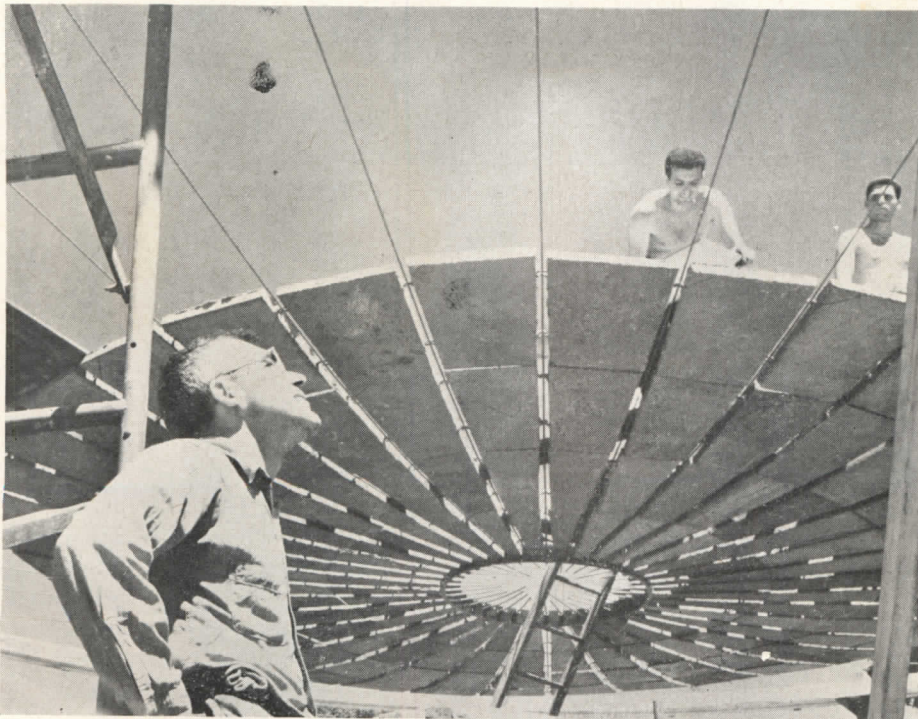

Supervising the project was Bruno Funaro, A.I.A. and Associate Professor of Architecture

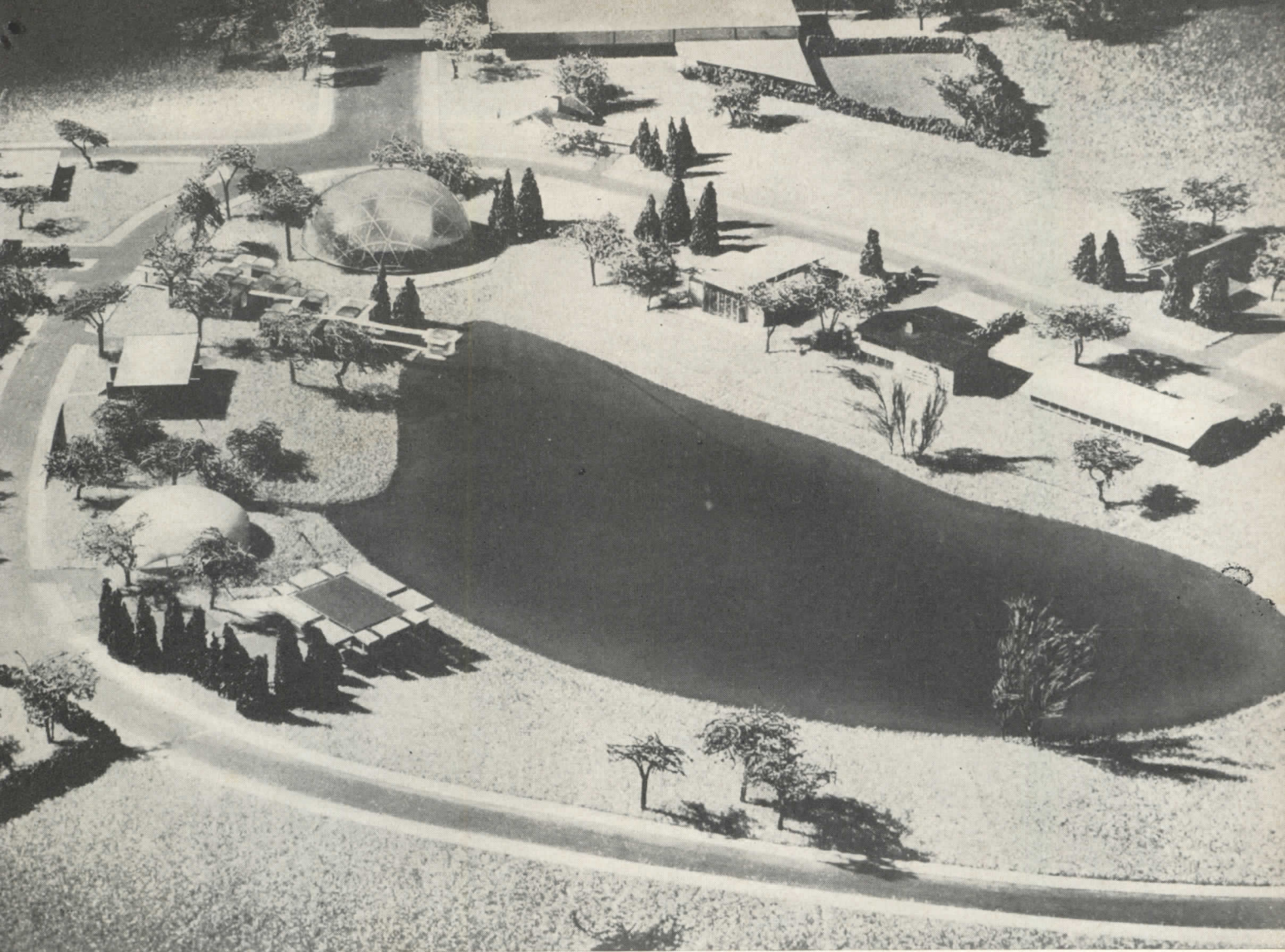

OUTDOOR MUSEUM FOR HOUSES

Homestyle Center

Grand Rapids, Michigan

ON THE OUTSKIRTS of Grand Rapids, a new project is taking shape that should be of great interest to all concerned in any way with houses. On an 80-acre site, a permanent display center for 50 homes is to be built by Home Research Foundation, Inc., described as an independent non-profit organization.

Perhaps the unique thing about the scheme, aside from the rather amazing list of architects selected, is that it will be "self-regenerating." Twenty-five of the homes are scheduled to be completed and on display by Spring 1957. The remaining 25 will be built, in approximately equal numbers, during the next three years. Thereafter, five will be razed and replaced by new ones each year. Interior decorations will be changed in each house every year. The idea, apparently, is to

keep completely abreast with house design, equipment, structure and furnishings.

Stated objectives include: to study how to better solve home living needs; to combine the talents of outstanding people in the varying professions; to show the best in available or experimental products; to serve as an information, reference and display center; to promote the consistent advancement of home living standards.

The houses are being assigned in several categories to assure a useful variety: locale (urban, farm, etc.); family size; price range; region; and design type. The Design and Standards Committee for the center has currently approved 15 of the houses, which are shown on the following pages.

Robert Little, Architect

The program for this house called for "a modern home demonstrating and emphasizing concrete lift-slab construction." It was to be planned for a Midwest suburban location, for a family of four, with three bedrooms and two baths. Approximate size — 2000 sq ft, cost \$50,000.

The approved design features space below the house for terrace, garage and storage; adjustable louvers for glare protection; and a mechanical core in the center. Garth Andrew is Interior Designer; Henry Pree, Landscape Architect

Eliot Noyes, Architect

Noyes was commissioned to devise a larger, two-story adaptation of his well known concrete bubble house. The thin shell has openings on all four sides, filled with glazed screens. The second floor is treated as a balcony, giving high ceilings over part of the living areas.

Hugh Smallens will do the interior design, and Even Harding will be Landscape Architect

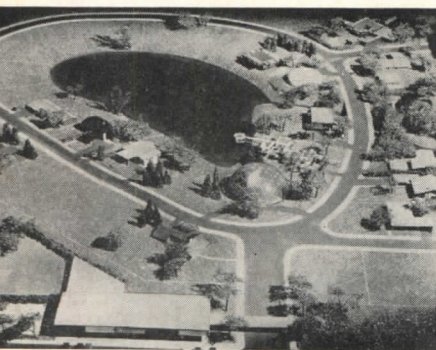
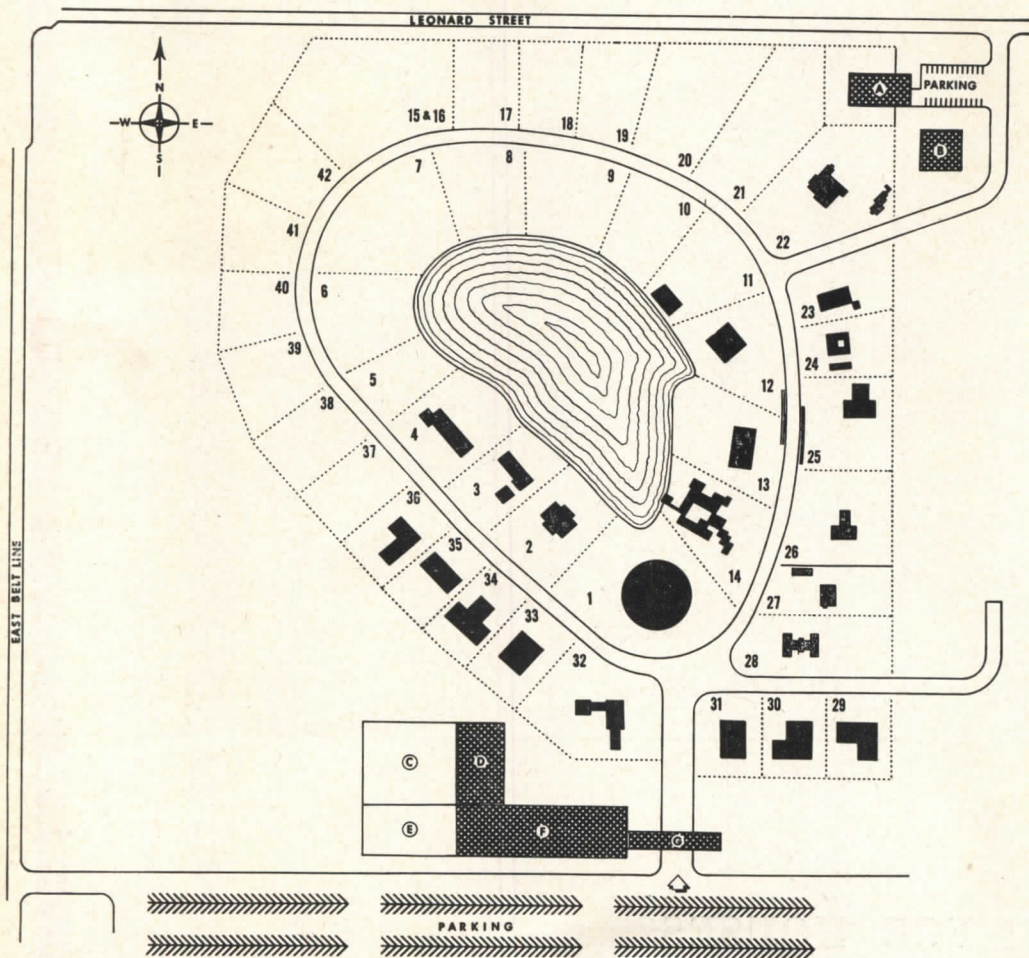

LOT ARCHITECTS' HOMES		AREA SERVICE BUILDINGS	
1	R. Buckminster Fuller	A	Relief Station
2	Alden Dow	B	Ground Maintenance & Service Buildings
3	Clifford Wright	C	Children's Supervised Play Area
4	John E. Dinwiddie	D	Administration Building
11	Paul Rudolph	E	Outdoor Patio
12	Eliot F. Noyes	F	Executive Offices, Restaurant & Auditorium
13	Robert A. Little	G	Main Entrance
14	George Nelson		
22	Harwell H. Harris		
23	Kazumi Adachi		
24	Ralph Rapson		
25	Painter, Weeks & McCarty		
26	Zema & Bumgardner		
27	Wurster, Bernardi & Emmons		
28	Jones & Emmons		
29	Rural Rehabilitation		
30	Urban Rehabilitation		
31	Import Home		
32	Royal Barry Wills		
33	Component House		
34	Prefabricated House		
35	Builder's House		
36-37	University of Illinois		

Harwell H. Harris, Architect

The assignment here was to create "a luxurious home for the Southwest, with due consideration to temperature and arid climate." The scheme is for a suburban plot, with three bedrooms and two baths — for a family of 3 to 5. Size — about 2000 sq ft; cost, \$75-85,000.

The plan centers around a glass-covered, air conditioned garden court, and features a formal motor entrance and separate play-house-cottage. Margaret Sedwick is Interior Designer; Richard Myrick, Landscape Architect

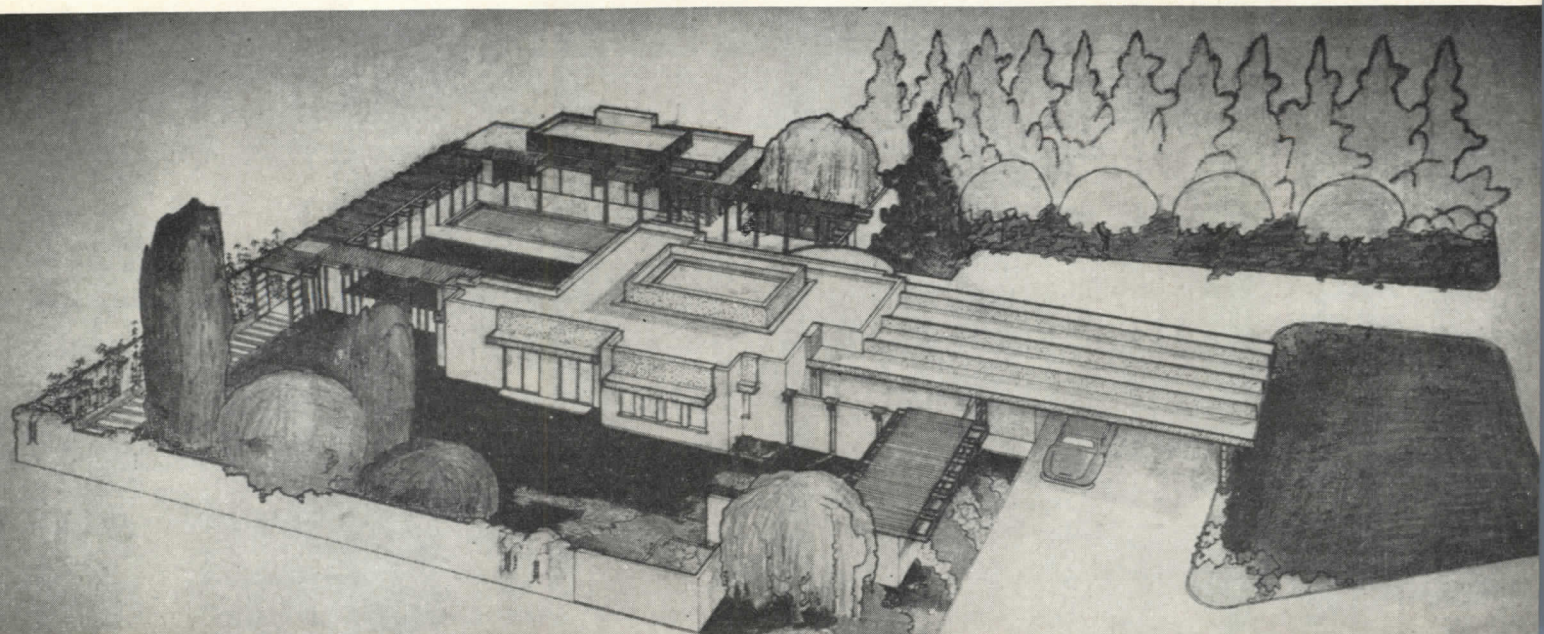
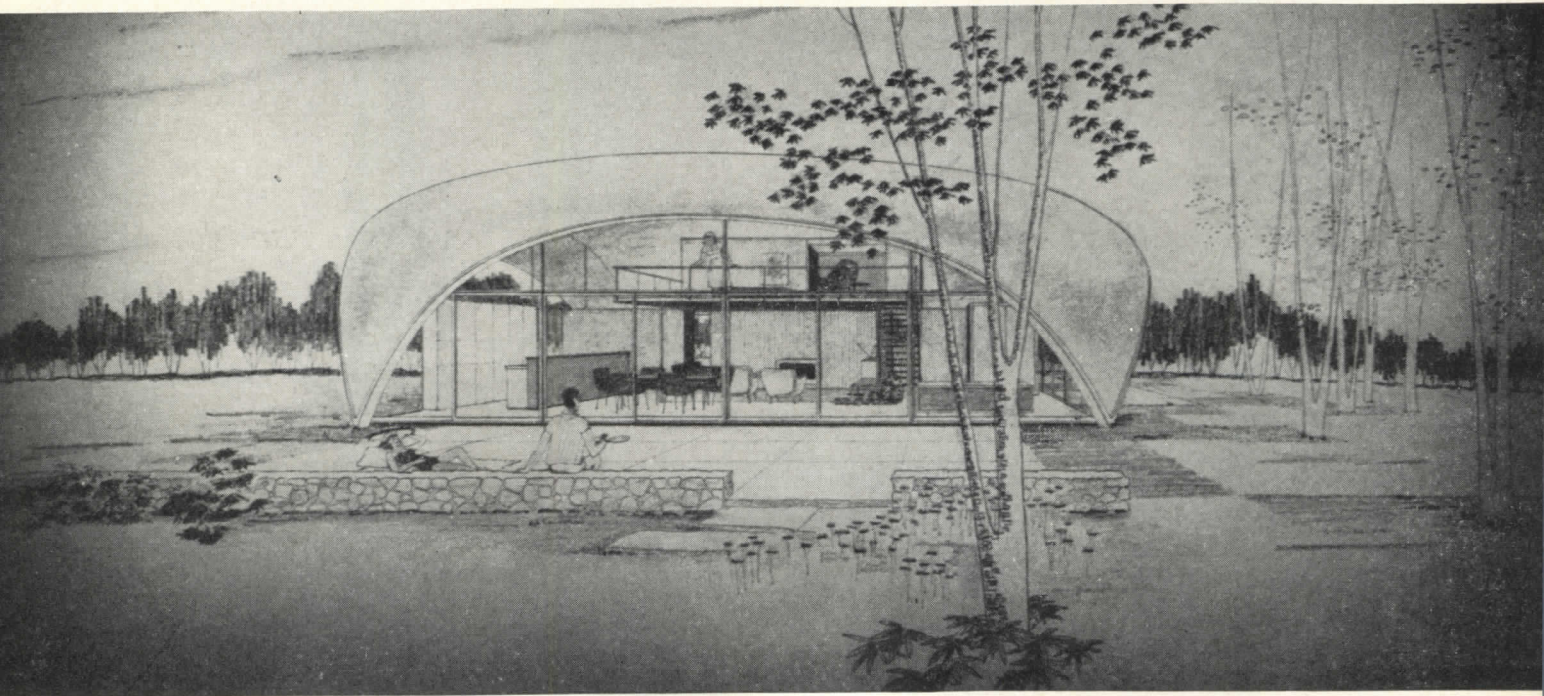
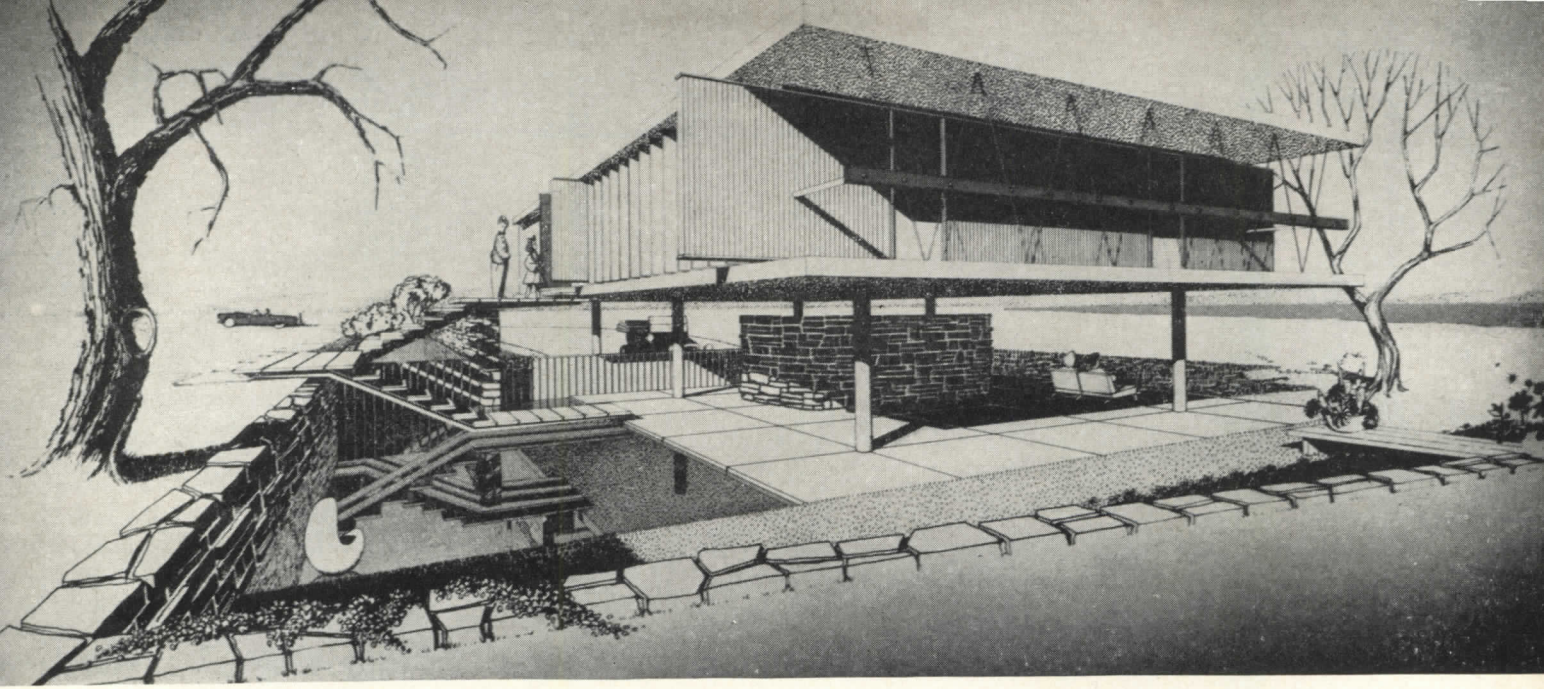

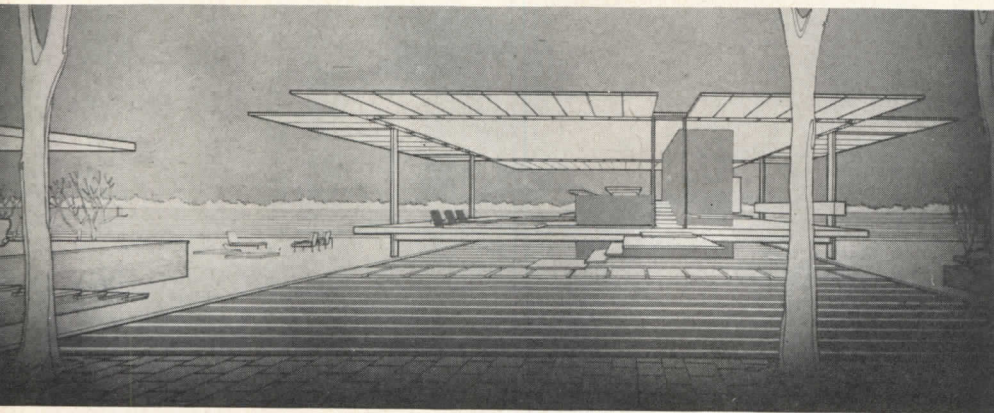
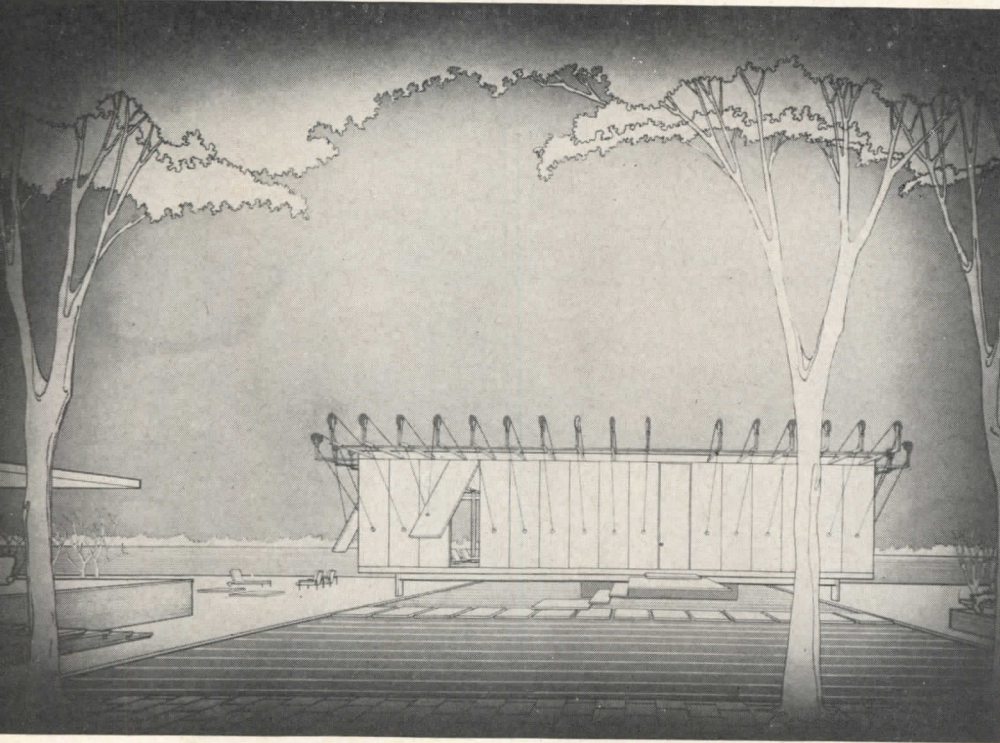

Paul Rudolph, Architect

This house was to be "an isolated suburban home reflecting the open living that may be enjoyed on the southwest Gulf Coast, completely flexible . . ." It was to have three bedrooms, two baths, for three to five people; contain about 1600 sq ft, and cost \$20,000. Rudolph used plastic panels, mechanically lifted, which convert the house into either a completely enclosed or open pavilion; natural light is by a peripheral skylight. The house straddles a lake inlet. Phillip Hall is Interior Designer; Frederic Stresau, Landscape Architect

Painter, Weeks & McCarty Architects

The use of precast concrete bents formed the main criteria for this house. It was also to be "a home for the south central region, reflecting some aspects of the design tradition and contemporary materials." Size about 1500 sq ft, with three bedrooms, one and a half baths, for three to five people. Cost — \$15,000. The house was to be suitable for urban or suburban location, and incorporate roof decking and other structural components that were adjustable to builder projects. James Cleveland is Interior Designer; John Scruggs, landscape

Wurster, Bernardi and Emmons, Architects

The program here required "a tract-built type home for the San Francisco Bay area — of moderate cost (\$16-18,000) — using mostly local materials; three bedrooms, two baths." Approximate size, 12-1400 sq ft.

The resulting scheme uses a compact two-story plan for economy, and to free as much of the site as possible for outdoor living. The structure combines plywood, wood framing. Interiors will be by Knorr Interior Planning, Inc. Landscaping will be by Lawrence Halprin

Kazumi Adachi, Architect

This retirement house for Southern California was to "demonstrate the Oriental influence becoming increasingly important in West Coast architecture." It was to have 1250 sq ft; two bedrooms, two baths; and cost about \$15,000. The house was to also minimize housekeeping requirements and emphasize facilities for intellectual and creative outlets.

The structural system has five equal 10-ft bays, laminated wood beams, arched shape for form and good drainage. Norman Hansen, Interior Designer; Francis Dean, Landscape Architect

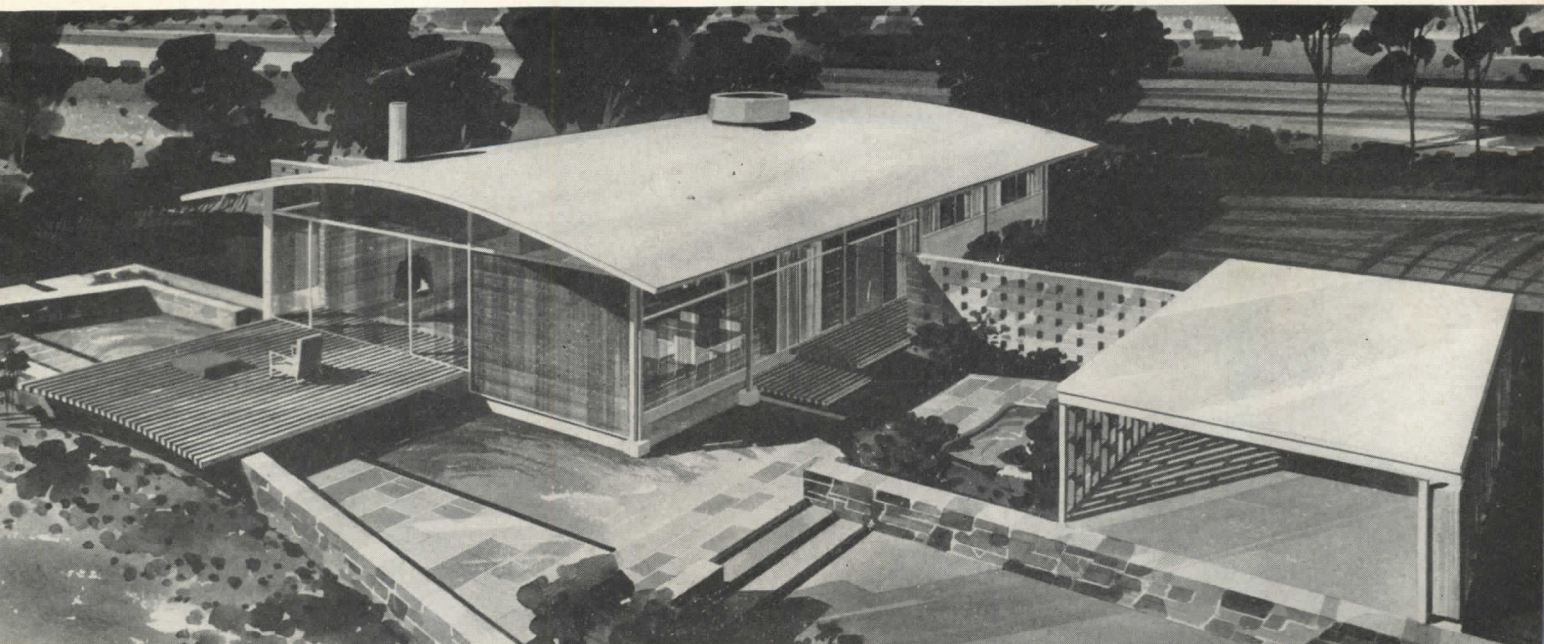
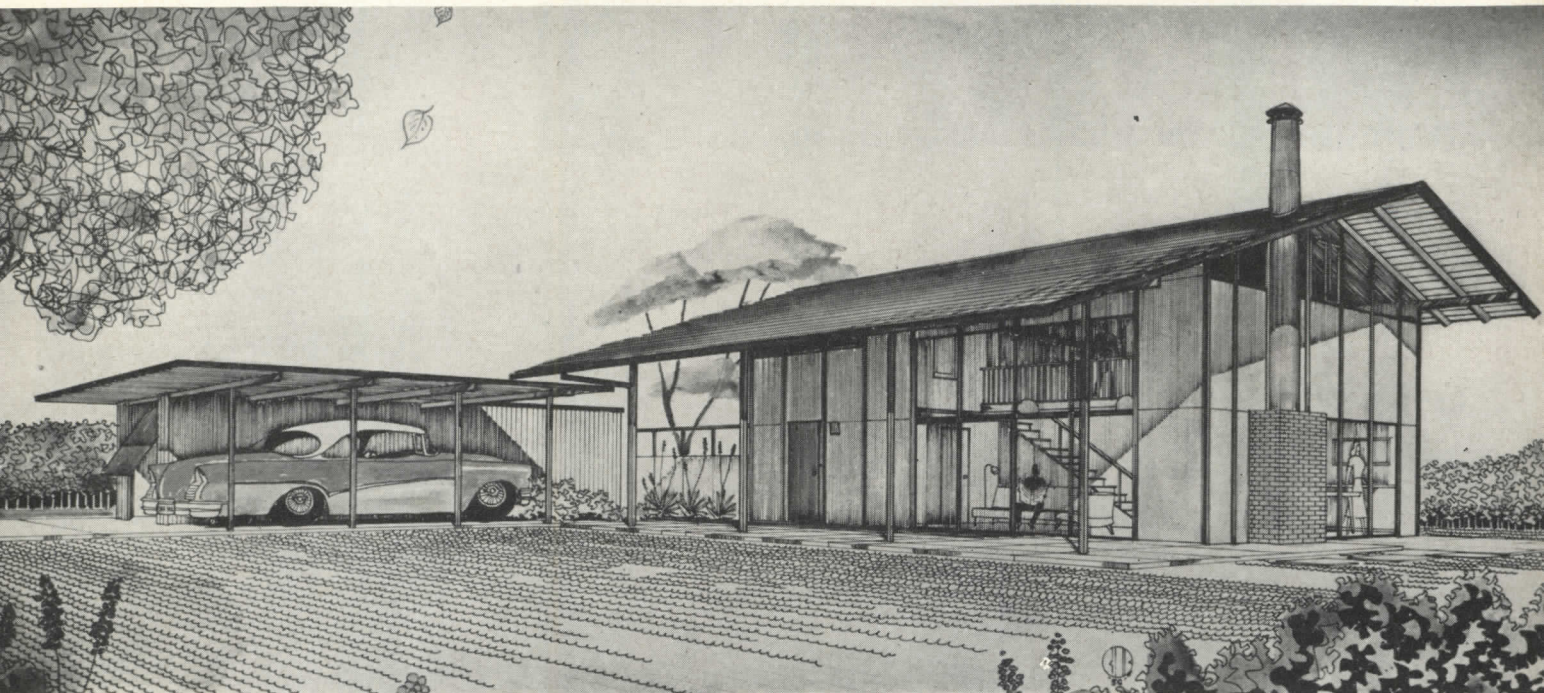
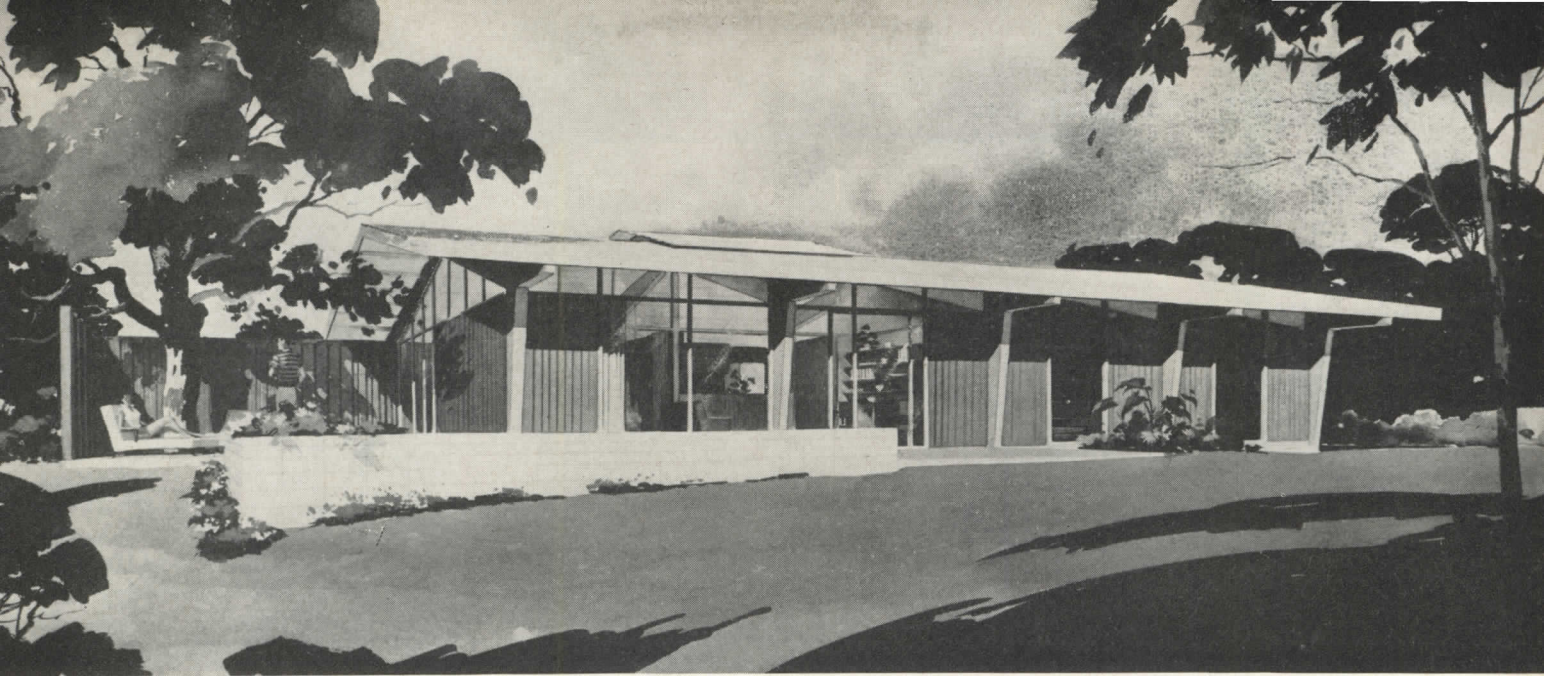

HOMESTYLE CENTER

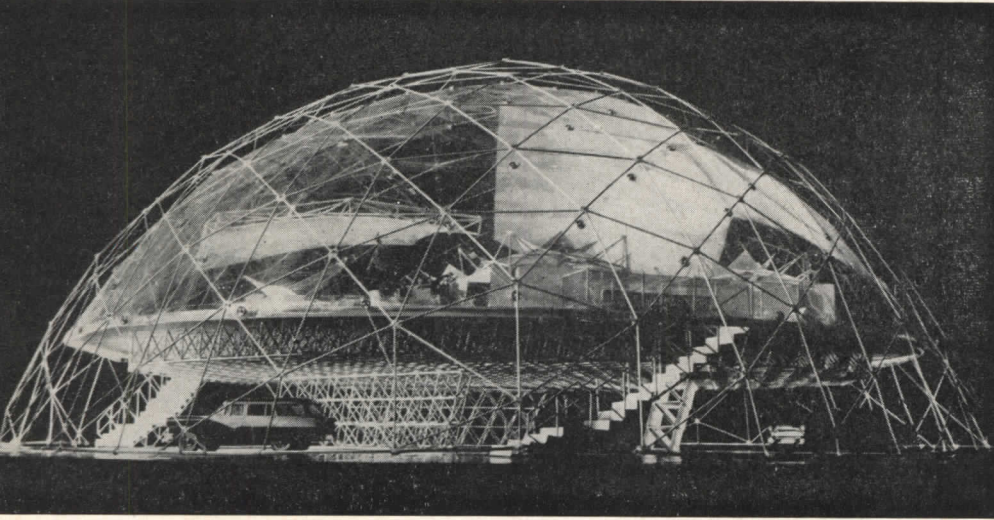

R. Buckminster Fuller, Architect

Fuller's famous dome has been evolved into a transparent "raised collage," with awning-like units to shade specific areas. As can be seen in the plot plan, this experimental house will form the focal point on entering the grounds of the Homestyle Center

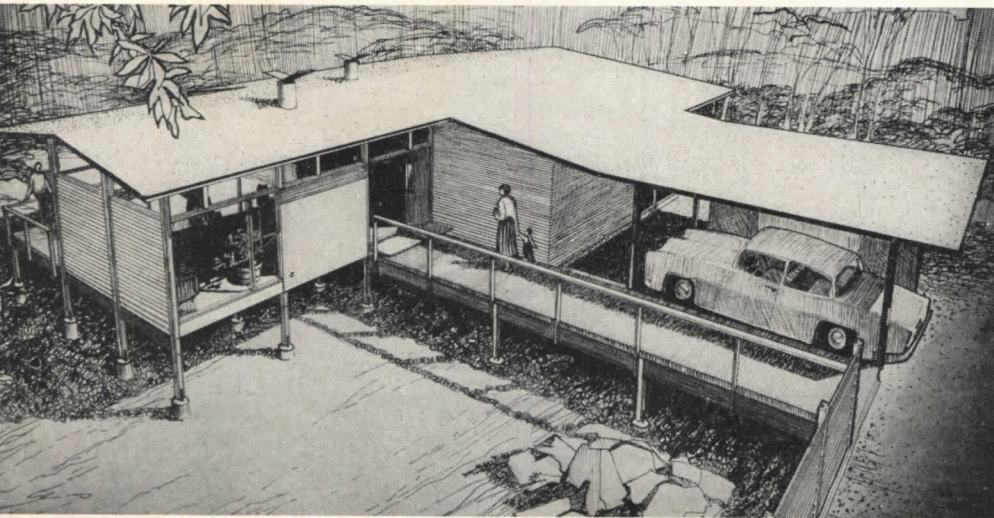

Zema and Bumgardner, Architects

The program for this budget house (\$12-15,000) required a plan "for a young, growing family of the Pacific Northwest utilizing . . . natural materials of the region; three bedrooms, two baths." Walt L. Kerr is Interior Designer; William G. Teufel is Landscape Architect

Alden Dow, Architect

A lakeside, suburban location was slated for this "home for the mid-west suited to a sloping lot, permitting entrance on two levels." Cost was to be about \$50,000, with 2000-2500 sq ft, four bedrooms, two baths.

The final plan is based on a sort of "great hall" scheme. One enters at balcony level in the two story living room. Bedrooms open on flanking balconies; low-ceilinged sitting and service areas are below. Eleanor Whaley, Interior Designer; Edward Laird, Landscape Architect

John E. Dinwiddie, Architect

Now located in New Orleans, Louisiana, Dinwiddie was commissioned to design this long, low-slung waterfront house, which gives all interior and exterior living areas a view of the water. Final plans are now being developed from this preliminary scheme.

Neither the Interior Designer, nor the builder has been selected. The Landscape Architect will be Robert Wreich

Jones and Emmons, Architects

The assignment here was for "a West Coast modern home providing the utmost in flexibility both in structure and special arrangement; three bedrooms, two baths." The house was to be suitable for tract and builder production, have about 1200-1500 sq ft, and cost about \$17,000.

The final design of the steel-framed house permits endless variation. Everything is modular and movable apart from the structural grid, even outside wall panels. Harry Saunders is Interior Designer; Garrett Eckbo, Landscape Architect

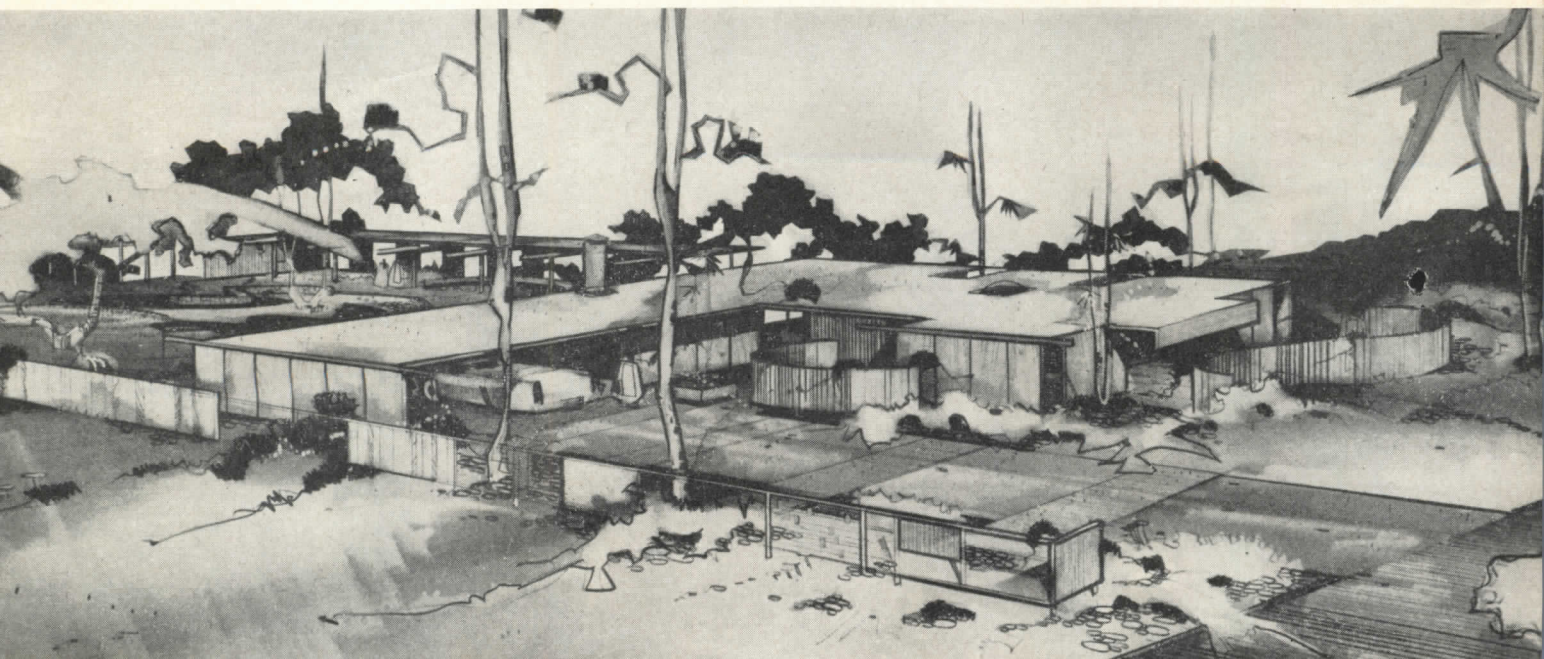
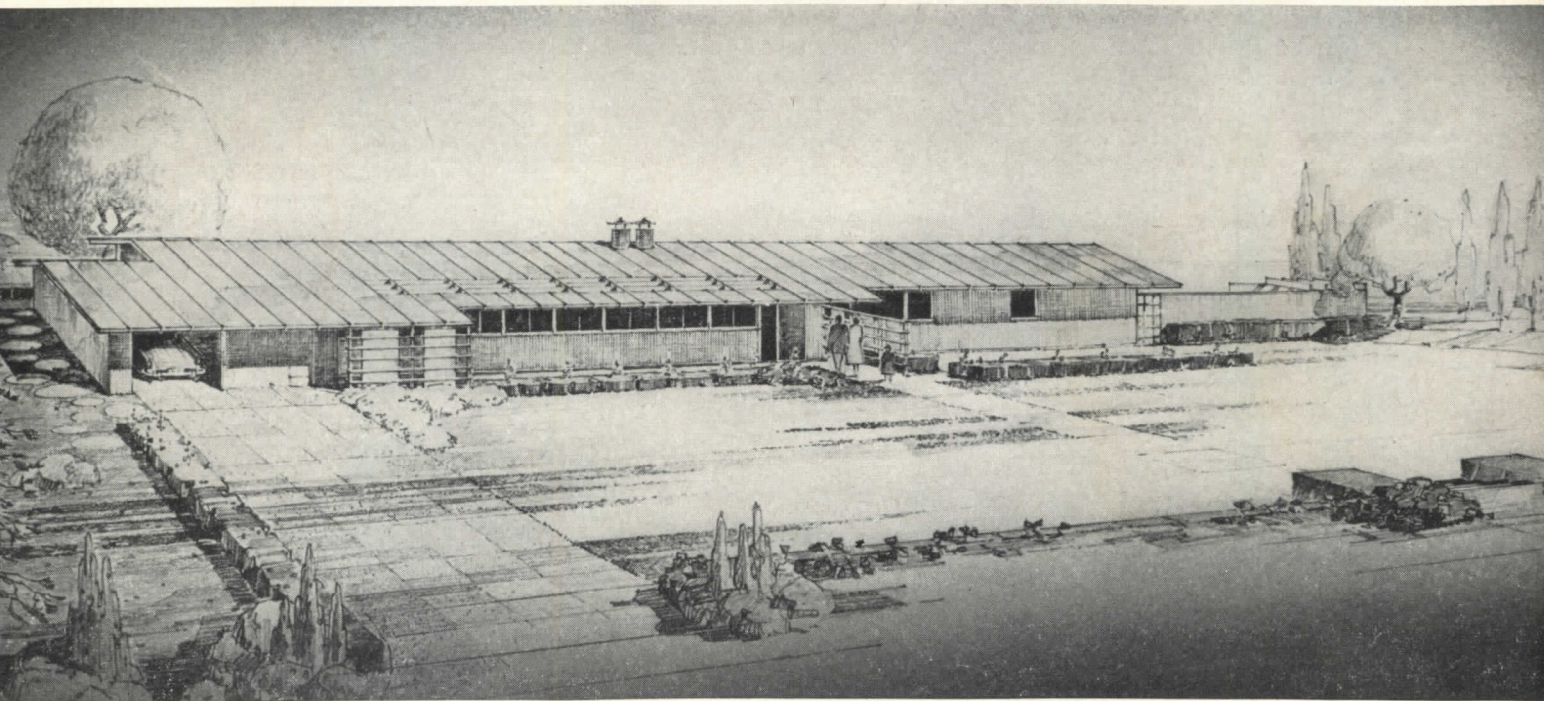
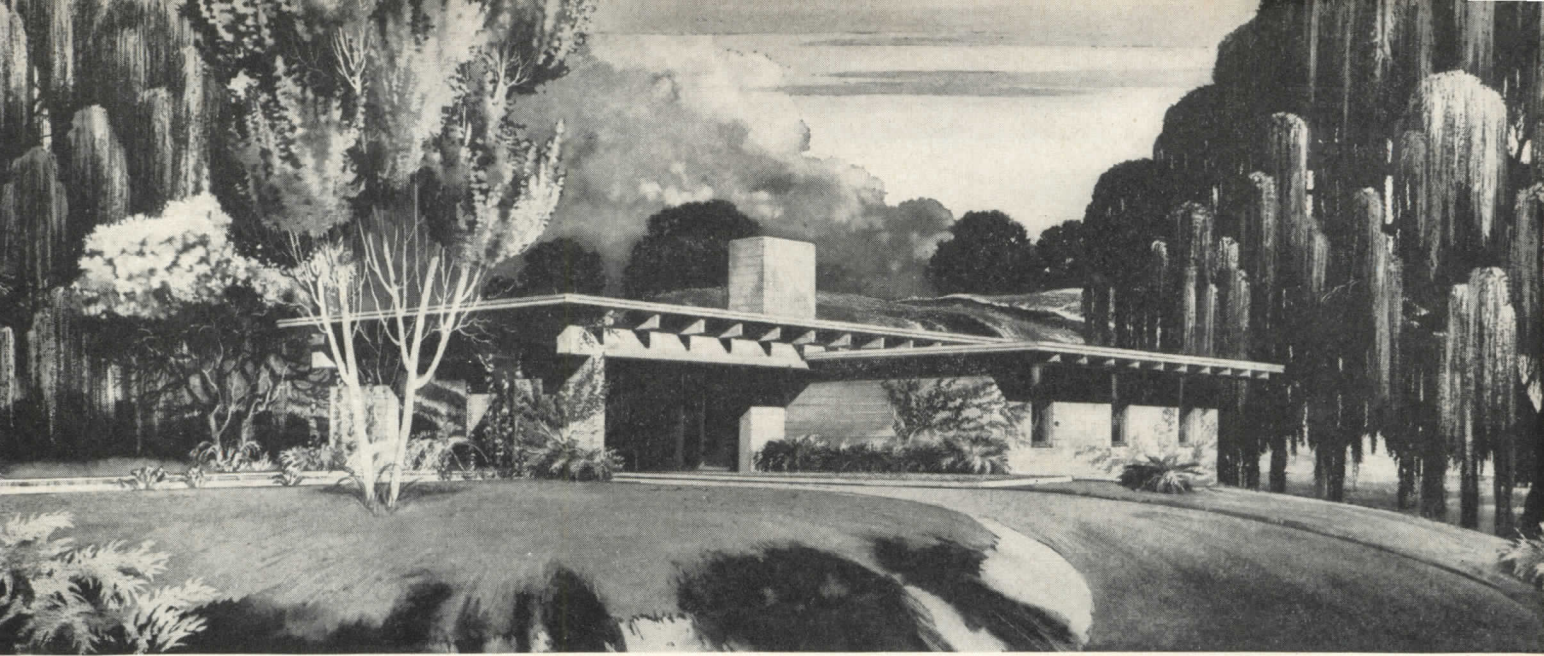

HOMESTYLE CENTER

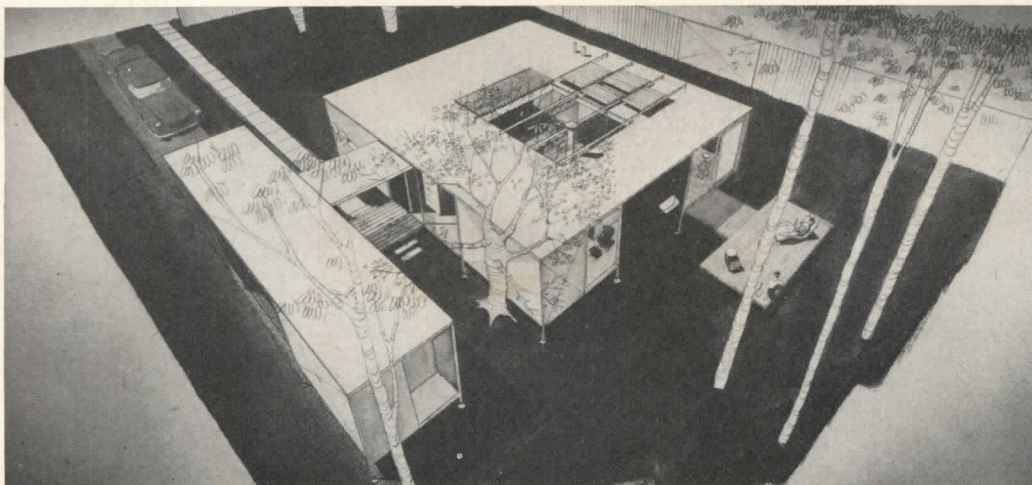

Ralph Rapson, Architect

This house offers a solution to the problem of planning for an interior urban site in the North Central part of the U. S. Size, 1250 sq ft; three bedrooms, two baths. Cost \$15,000. All rooms face a central court. Meg Torbell, Interior Designer; E. J. Phelps, landscape



Royal Barry Wills, Architect

This traditional house for the New England area incorporates open-plan features in the living areas. Size, 2000 sq ft; three bedrooms, two and a half baths. Cost, \$30,000. Benjamin Cook will be the Interior Designer; Olmsted Brothers will be Landscape Architects

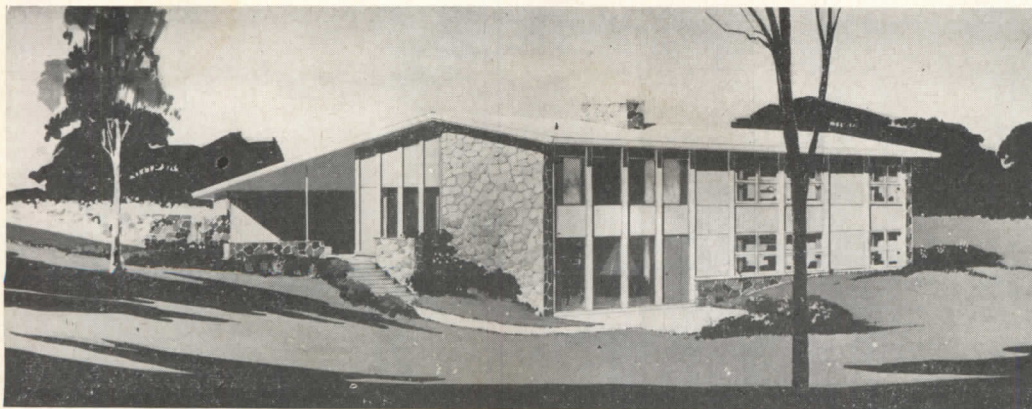

Clifford B. Wright, Architect

This house for the midwest was assigned to explore the possibilities for a sharply contoured site and the use of multiple levels. Size, 1600-1800 sq ft; four bedrooms, three baths. Cost, \$35,000. Henry Demant will be Interior Designer; H. F. Klein will be Landscape Architect

DESIGN AND STANDARDS COMMITTEE

Pietro Belluschi, F.A.I.A.

L. Morgan Yost, F.A.I.A.

Kenneth C. Welch, F.A.I.A.

Rodney M. Lockwood, Past President of NAHB

David C. Slipper, Chairman, NAHB Research Division

Martin L. Bartling, Member of NAHB Executive Committee

Sidney N. Shurcliff, Fellow and Past President of American Society of Landscape Architects

James P. Erdman, A.I.O., Coordinator Grand Rapids Furniture Makers Guild

Arleigh C. Hitchcock, Executive Director Home Research Foundation, Inc.

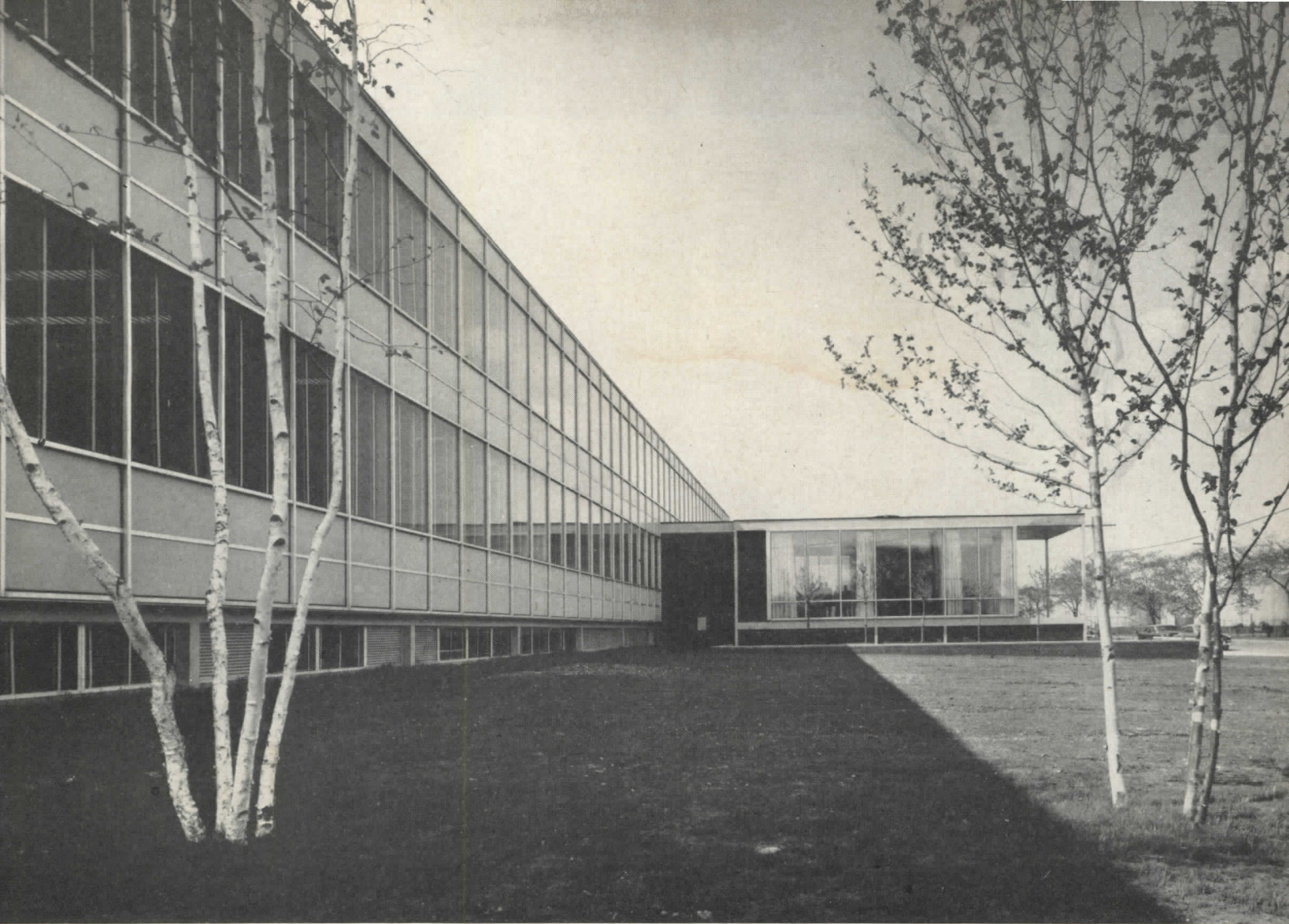

Panda

INDUSTRIAL BUILDINGS: 1

ENGINEERING BUILDING FOR AN OIL COMPANY

Office Building for Engineering Division, Imperial Oil, Limited, Sarnia, Ontario, Canada

John B. Parkin Associates, Architects and Engineers; John C. Parkin, Partner in Charge;

John E. Owen, Associate in Charge; J. E. Mews, Associate, Engineering;

V. L. Henderson, Consulting Engineer, Acoustics; Guy B. Panere, Consulting Engineer, Air Conditioning

SINCE THIS IS a building for the engineering division of a large oil company, the crisp efficiency of its exterior treatment seems particularly appropriate. It houses some 170 engineers, analysts and technicians, with offices, drafting rooms, conference rooms, graphic reproduction facilities and filing areas. There is a separate lecture hall at the front of the site, separate so that it may be used independently by the staff of the refinery across the street.

The building is enclosed with a skin of glass and porcelain-enamelled panels held in place by extruded, anodized aluminum sections. The skin is double: the windows are double-plate-glass sealed units; the metal-faced panels are backed by an air space and interior

panels of wood-chip aggregate concrete. The metal panels consist of two aluminum sheets with a rubber foam insulation filling, the outer sheet porcelain enameled and factory-sealed into aluminum frames. The same manufacturer supplied both wall panels and windows; the architects mention the factor of single responsibility for the whole skin covering.

For the lecture hall, the architects wanted the contrasting form of a roughly cylindrical building to set beside the rectangularity of the main office building, though the lecture hall is actually formed by fifteen flat panels of rich purplish brick. The clients wondered about the similarity to oil storage tanks across the street, finally decided they liked the symbolism.

Panda



INDUSTRIAL BUILDINGS: I
IMPERIAL OIL ENGINEERING

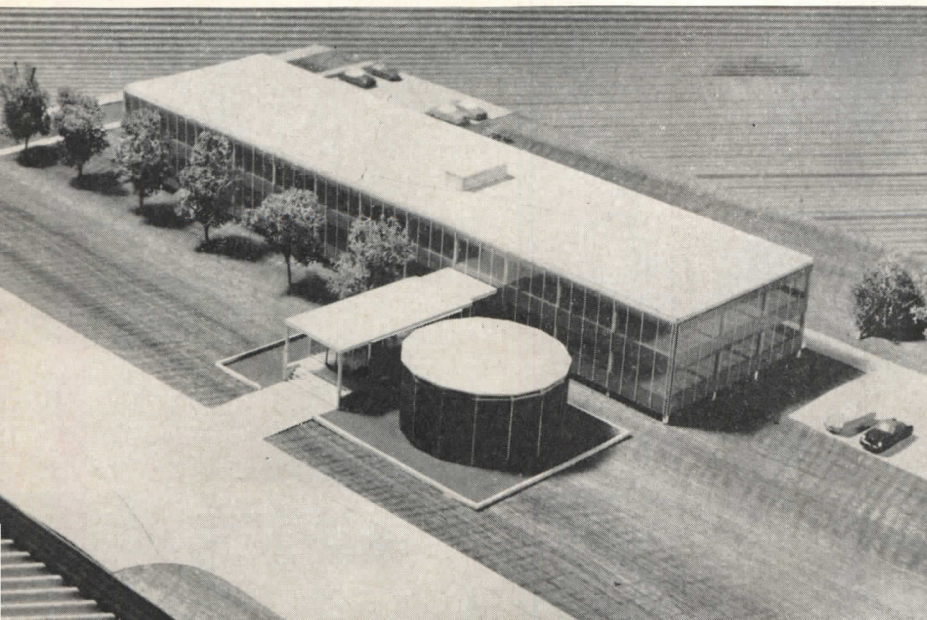

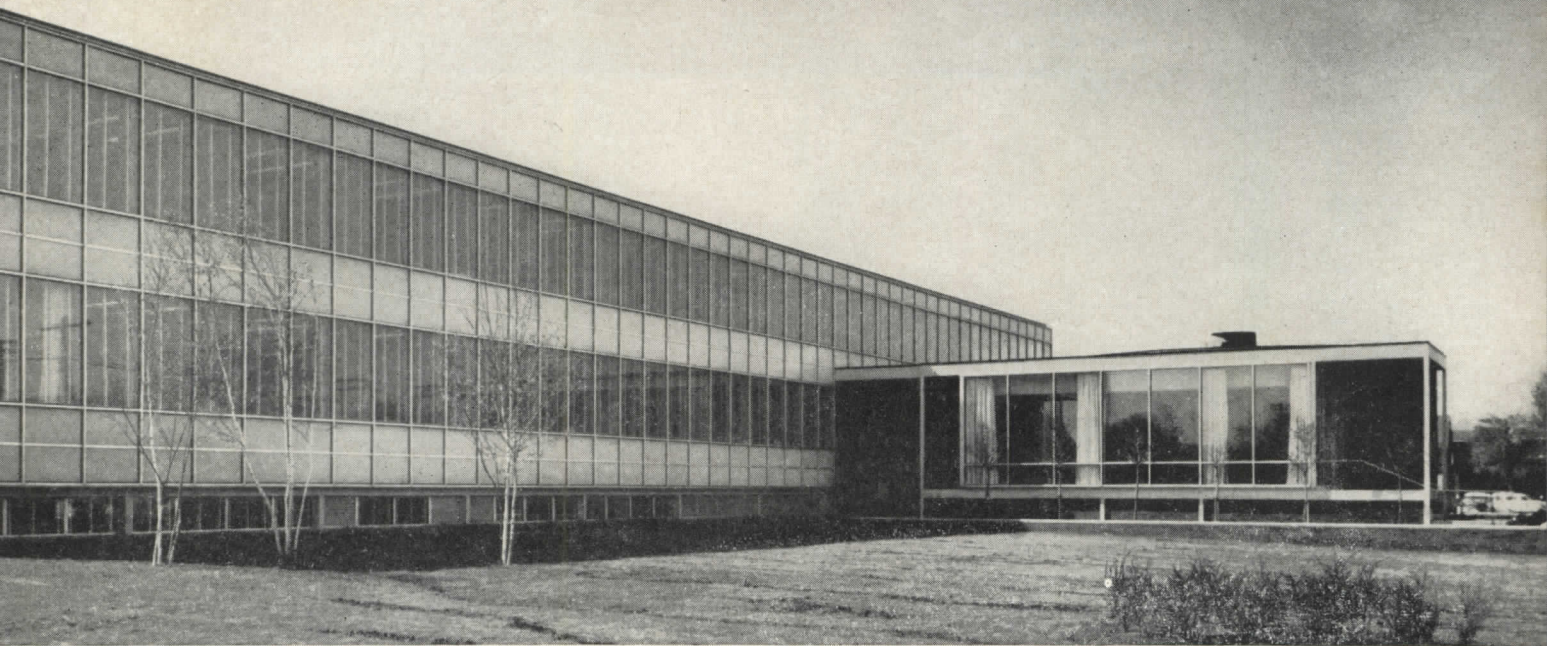

Module for office space is 5 ft. Both 4 and 5 feet were considered for this module, the alternatives being offices of from 12 to 24 ft as against 10 to 15 or 20 ft. Some study showed that considerations of economy and comfort would be well satisfied with the 5-ft unit. The double corridor scheme gives good natural light and outlook to all private offices; the inside space being used for wash-rooms, filing space, conference rooms and occasionally for stenographic pools. Main entrance foyer is so placed as to serve, separately, either the main building or the lecture hall

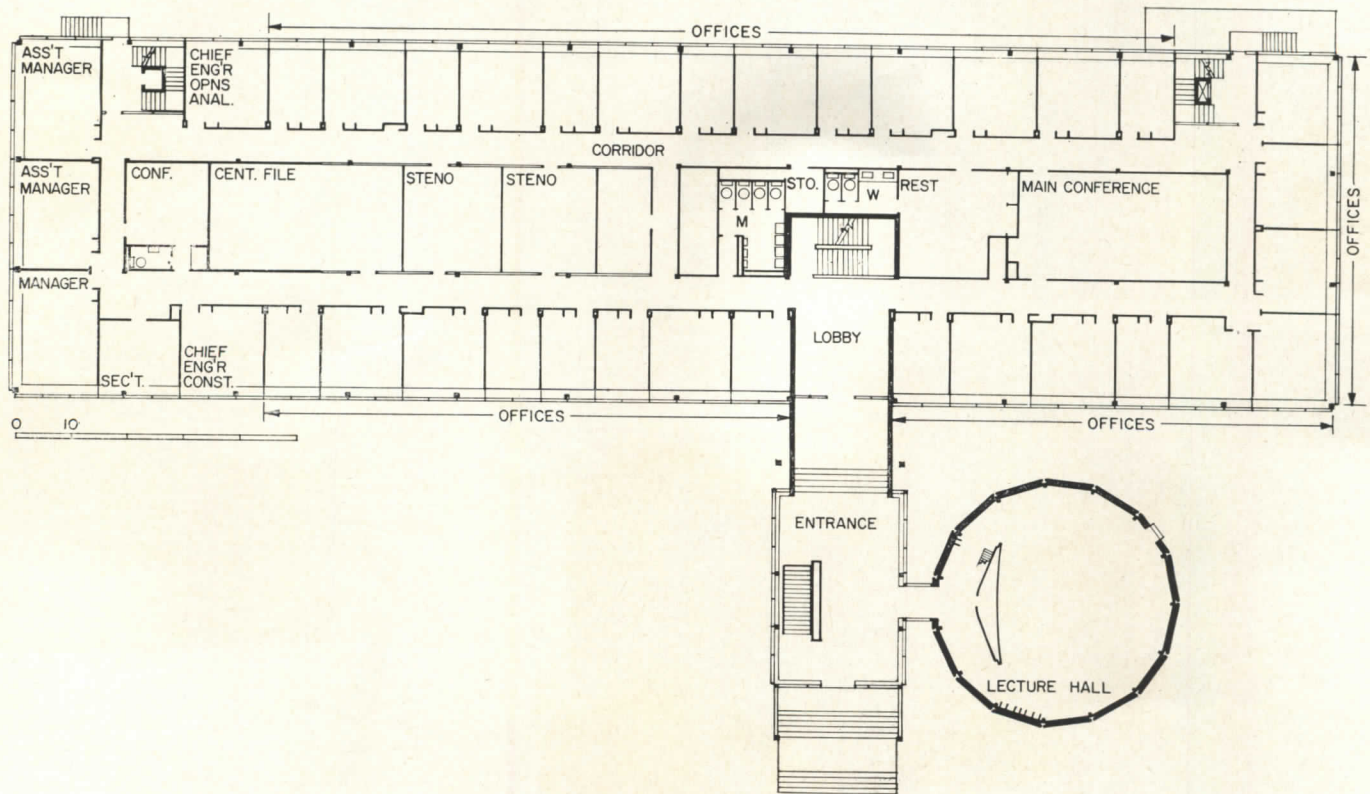

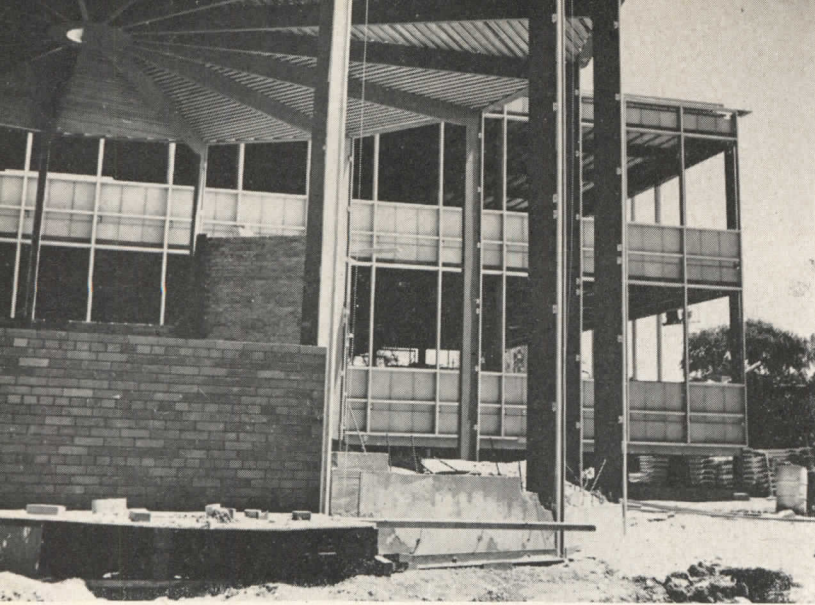

INDUSTRIAL BUILDINGS: 1. IMPERIAL OIL ENGINEERING

Building rests on a layer of good firm clay over a very soft stratum. Foundation and frame were designed to float the structure on this clay, using a raft-type reinforced concrete foundation. Excavation work had to be carefully checked, to avoid piercing the crust of the clay layer

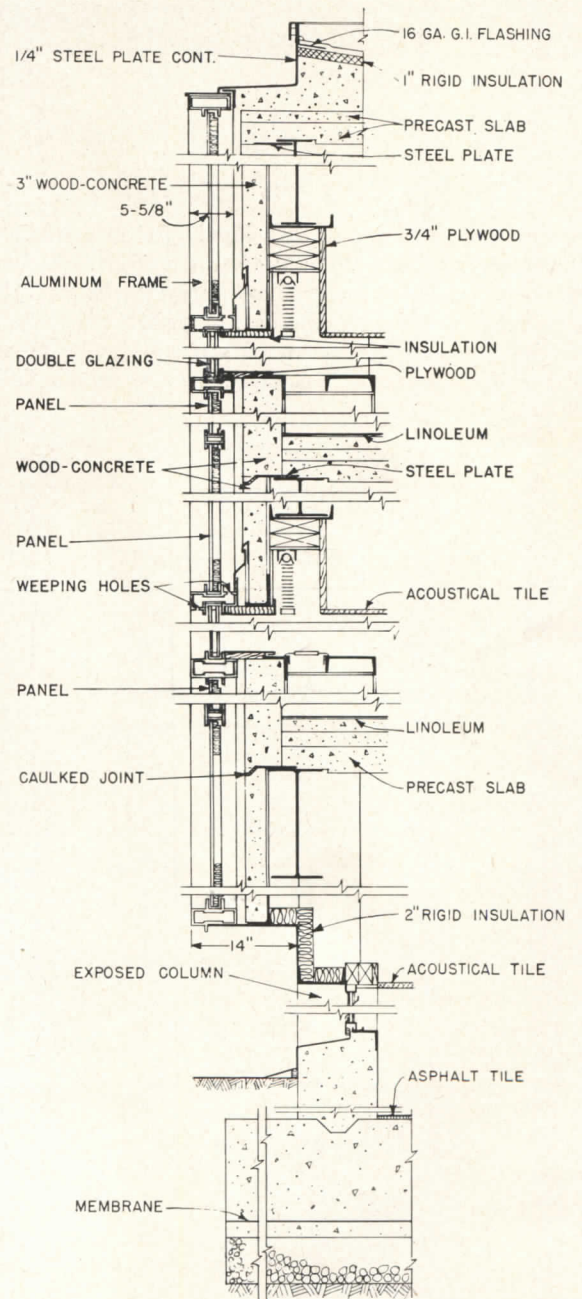

CURTAIN WALL DETAIL

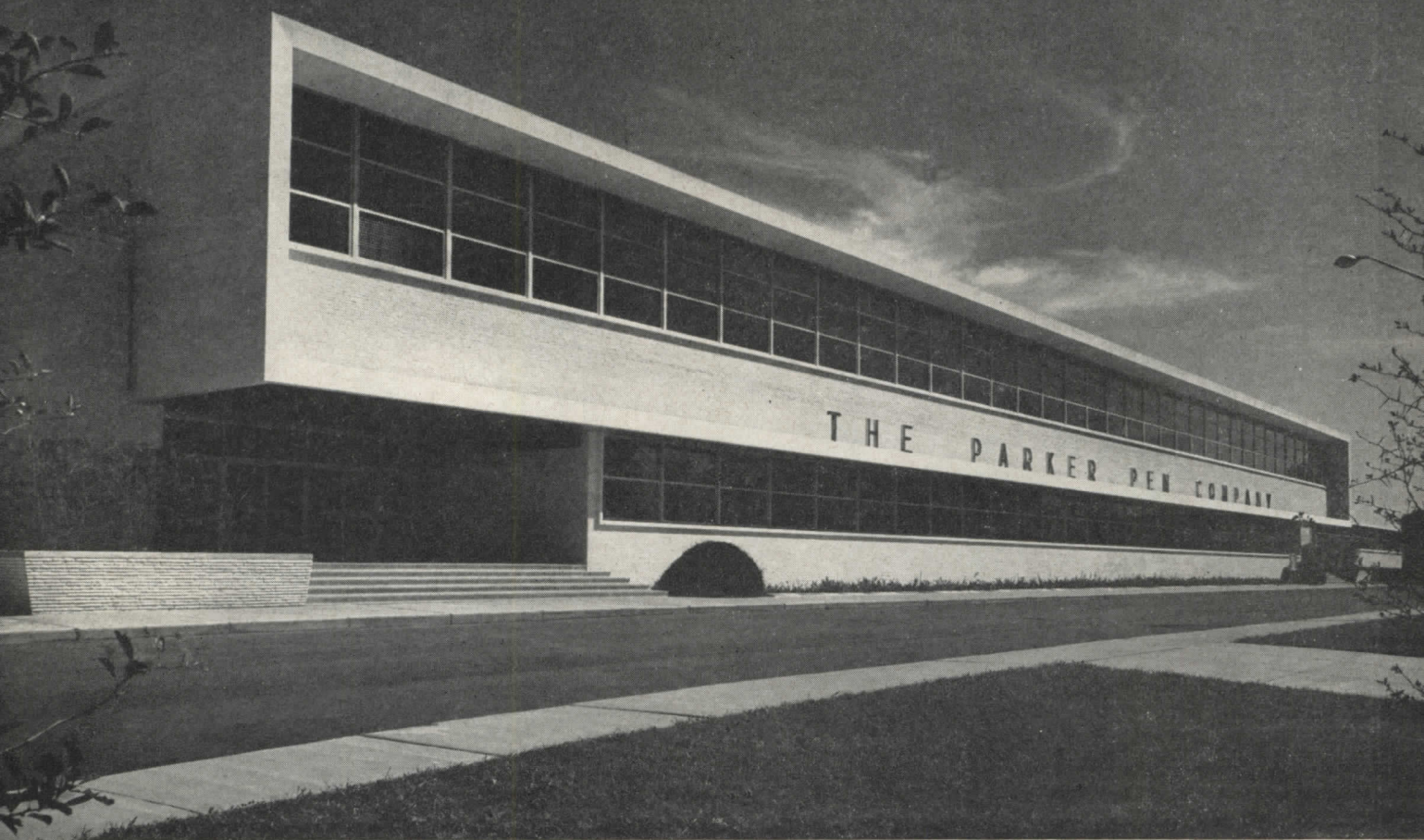

William Wollin

INDUSTRIAL BUILDINGS: 2

FACTORY AND OFFICES WITH PRESTIGE VALUES

Plant for the Parker Pen Company, Janesville, Wisconsin

John J. Flad & Associates, Architects and Engineers

THIS BUILDING was already under construction when the architects were called in. They were asked to keep what they could of materials already ordered, of footings already in place, but they were to give the whole building an assertive institutional quality. The project had changed from one of merely enclosing manufacturing and office space to that of developing prestige values. Happily, this latter concept was not merely shirt-front thinking; substantial improvements were possible pretty much throughout the whole plant.

The entire plant has all-year air conditioning; air supply is filtered by electrostatic precipitators in the

supply chamber. All exhaust air from polishing, buffing and grinding operations is filtered through separate precipitators and returned to the supply chamber.

The hand-faced white Roman brick (a dictated selection) is used on all exterior walls, in combination with white Texas limestone trim. All glazing is double thick, with heat absorbing plate on the exterior and diffusing glass on the interior. Ceilings throughout are of acoustical panels with glass insulation, with utilities plenum above the dropped ceiling.

The cost of the building — offices and plant — was \$4,500,000, exclusive of land, landscaping and fees.

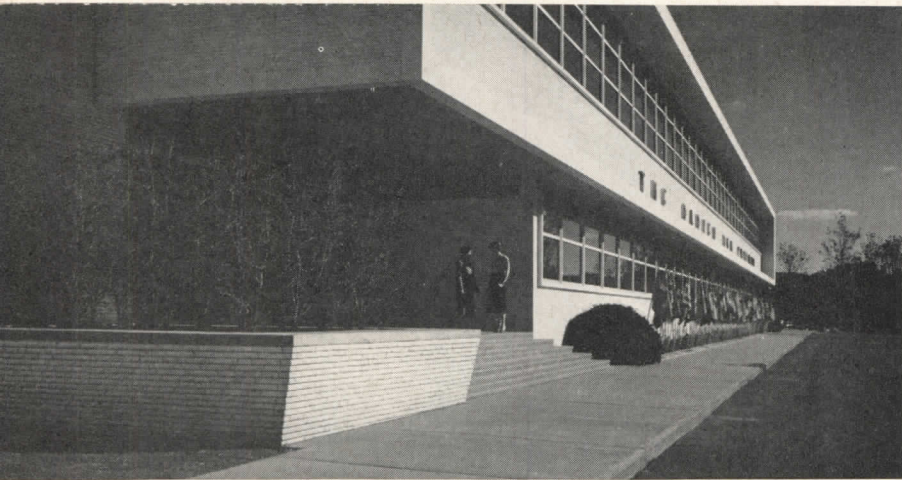
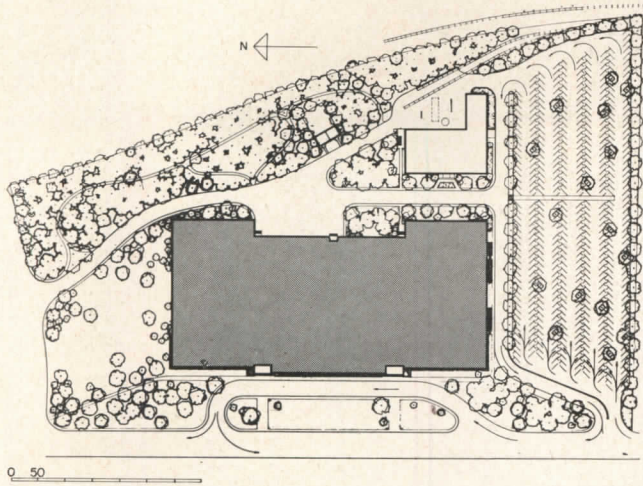

**INDUSTRIAL BUILDINGS: 2
PARKER PEN COMPANY**

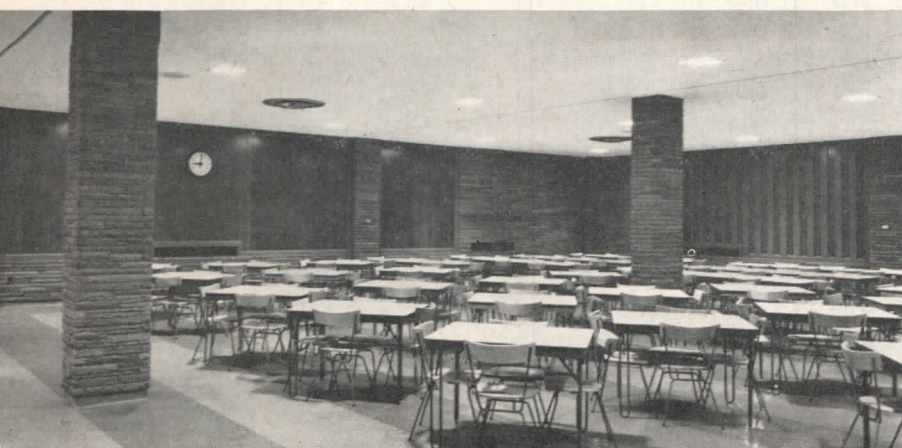
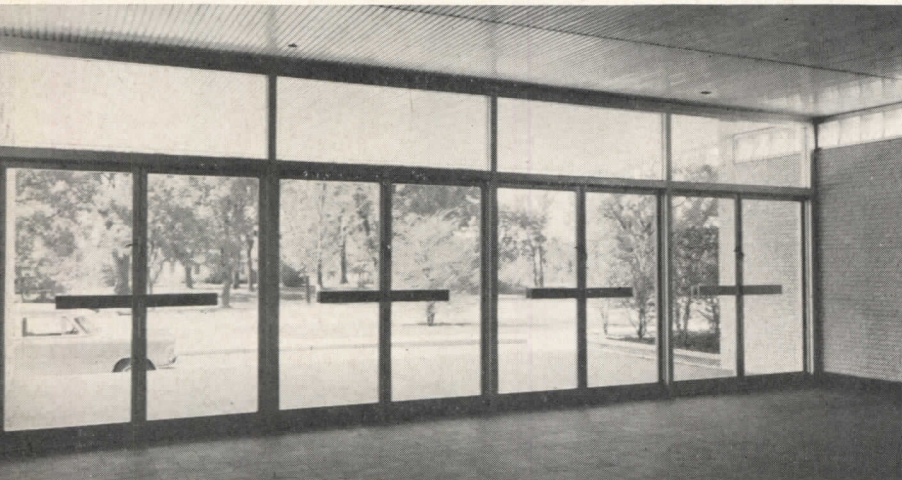

Service Building houses two 150 hp low-pressure boilers supplying steam for heating, air conditioning and processes; also one of three electrical sub-stations. Two smaller sub-stations (supply is at 12,470 volts) are located above the production floor in the plant itself. All lighting is recessed fluorescent. Flush mounted ceiling sprinklers protect the entire building from fire; there is a 150,000 gal underground reservoir to supplement the city water supply system



William Wollin

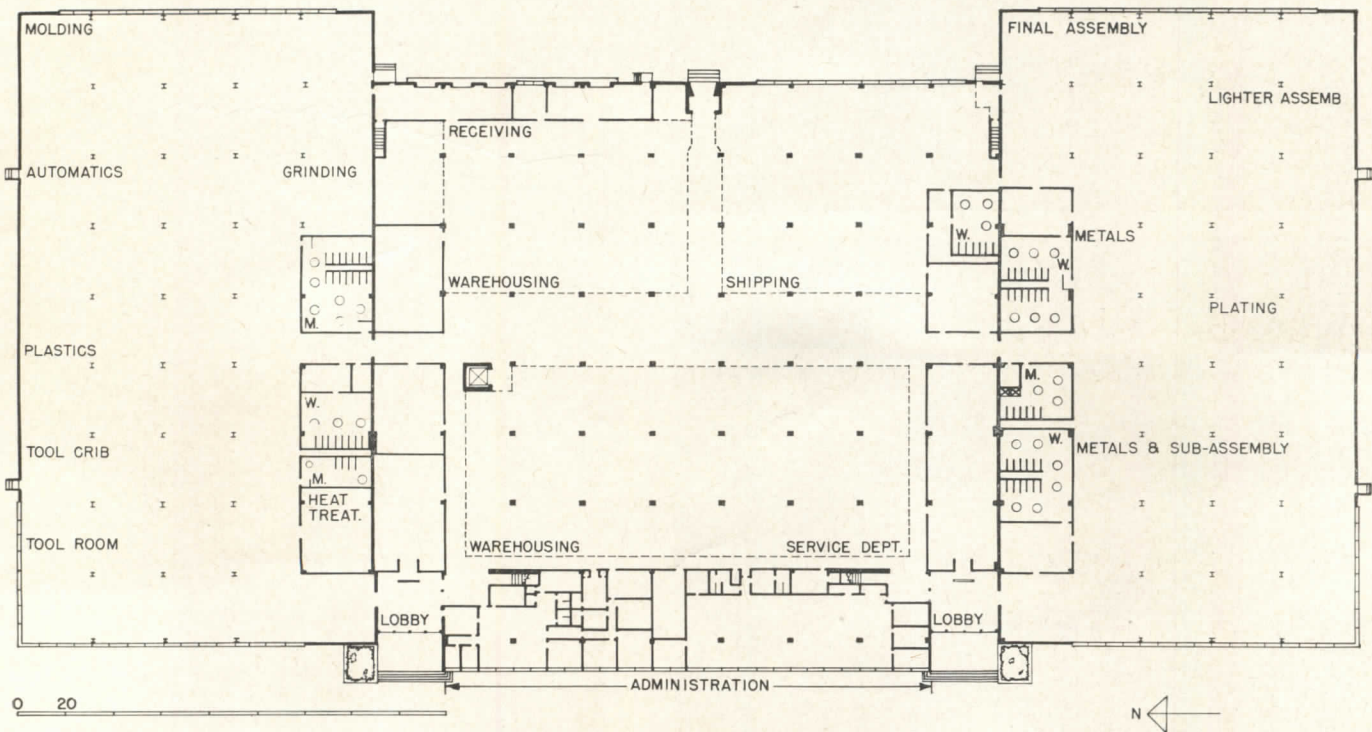
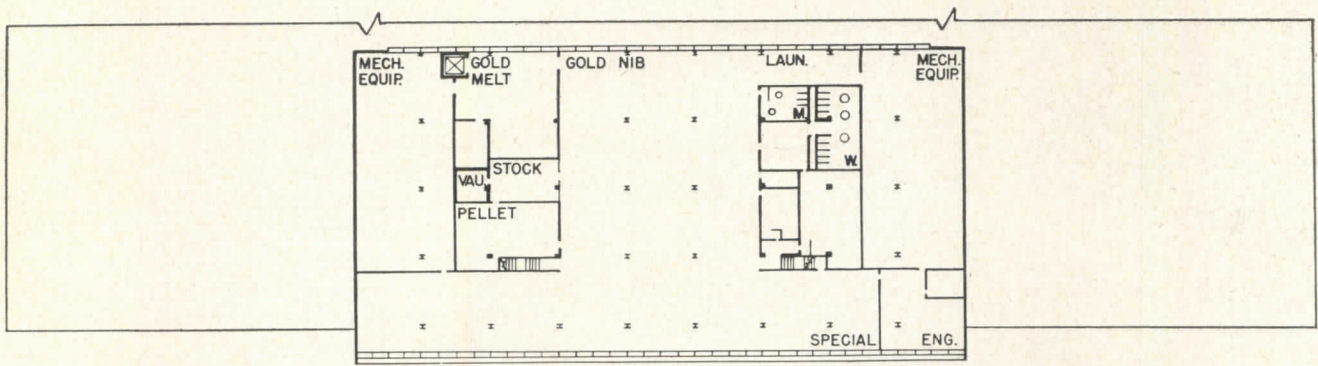

0 20



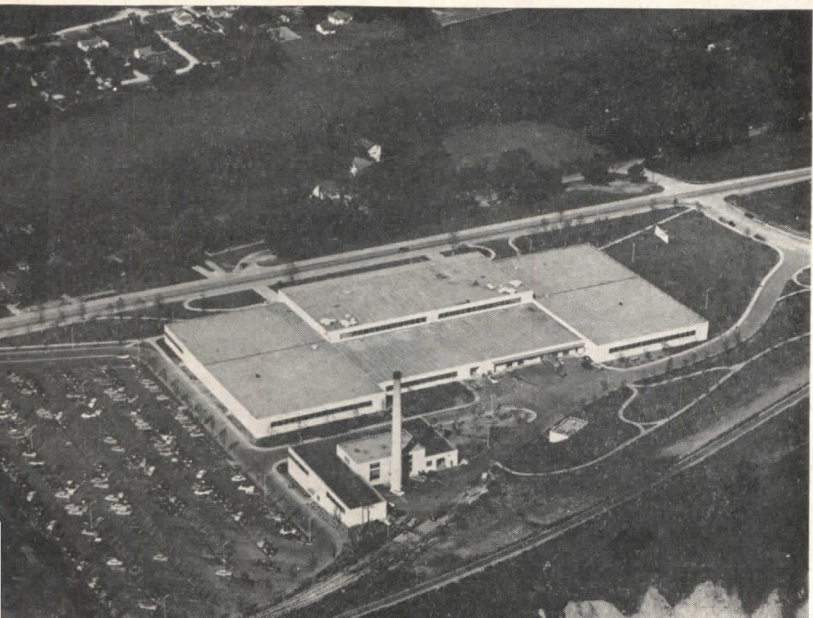

INDUSTRIAL BUILDINGS: 2
PARKER PEN COMPANY

The good-neighbor concept of industrial plant design extends to landscaping to the back as well as the front. The upper photograph shows the service road between main plant and service buildings, complete with trees, lawn and planting beds. Production areas are largely open; column spacing is 30 ft in both directions

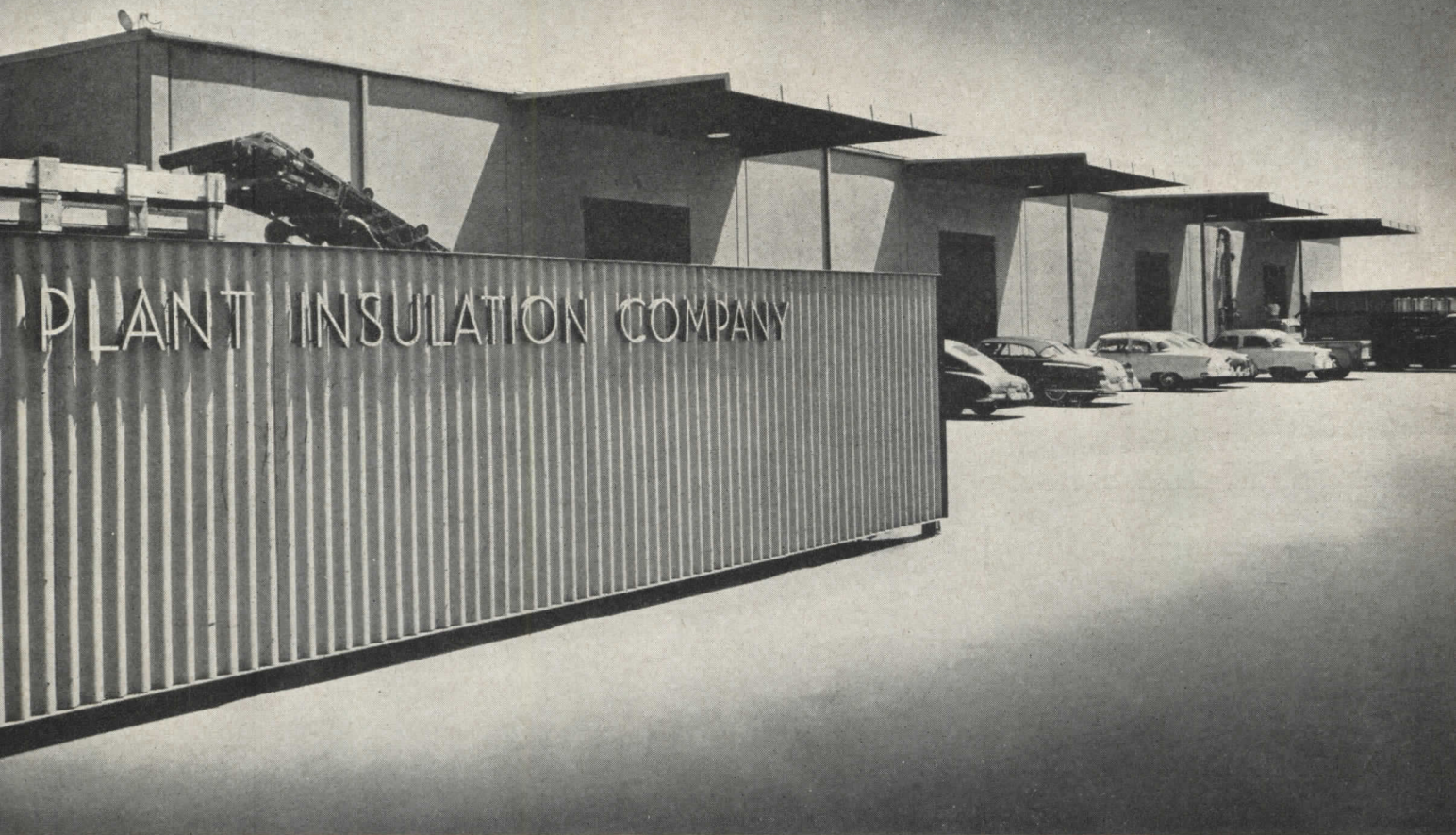

Julius Shulman

INDUSTRIAL BUILDINGS: 3

OFFICE-INDUSTRIAL PLANT BECOMES SHOWCASE

The Plant Insulation Co., Los Angeles, Cal.

Smith & Williams, Architects; Warren Jones, Landscape Architect; Mac Isaac & Menke, Contractors

THIS COMBINATION office-industrial building houses a rapidly growing, eight year old company devoted principally to the warehousing and distribution of insulating materials, and to the performance of contracting services over a four state area. Their new building comprises three main elements: an office wing, a warehouse building, and a small manufacturing plant. The three structures connect only as function requires, and their organization results in a clear expression of use, good visual screening to separate activities of different kinds, and a well organized traffic pattern.

Since the site is hot and dry, the entire office wing is air conditioned, and is insulated by a complete (floor,

walls, roof) sheath of glass foam 2 in. thick. The finish ceilings are of the company's insulating cork, and both flat and corrugated asbestos panels (also handled by the company) are used for exterior and interior finish. Thus the building becomes, in effect, a showcase for the display of the owner's products in use.

The structure is located in the Central Manufacturing District of Los Angeles, an area of 3400 acres which contains over 600 industrial buildings. The District — a planning story in itself — offers wide streets, adequate rail spurs, setback regulations, restrictions on the use of certain materials, etc., and is well placed for convenient access to the freeway system.

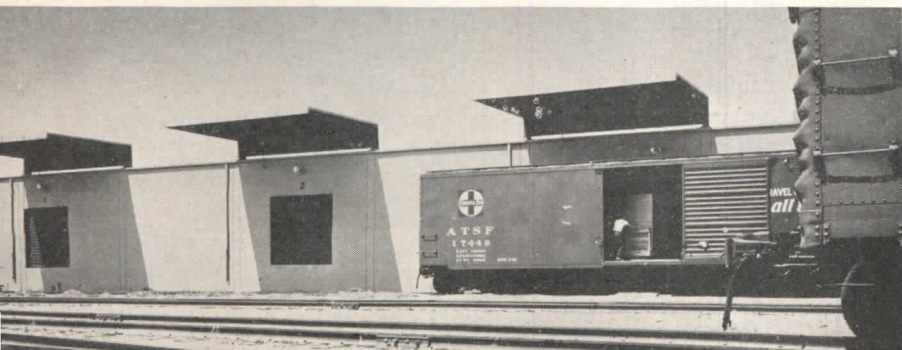
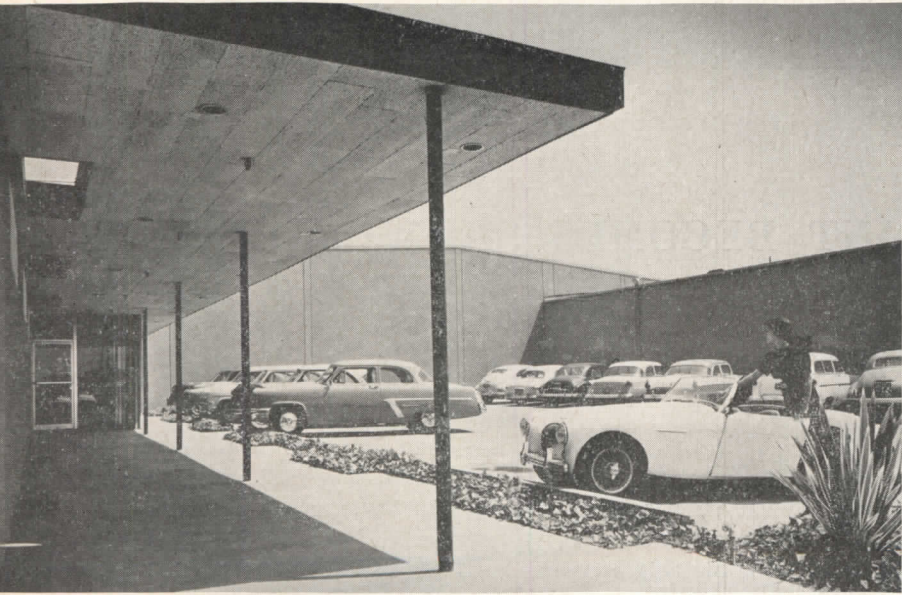
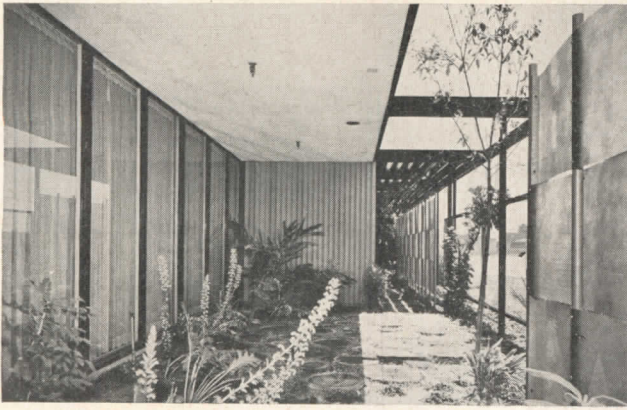

INDUSTRIAL BUILDINGS: 3
PLANT INSULATION COMPANY

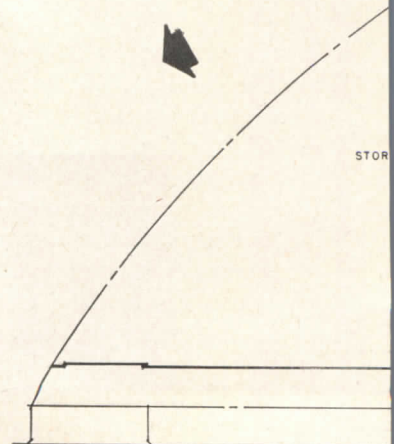

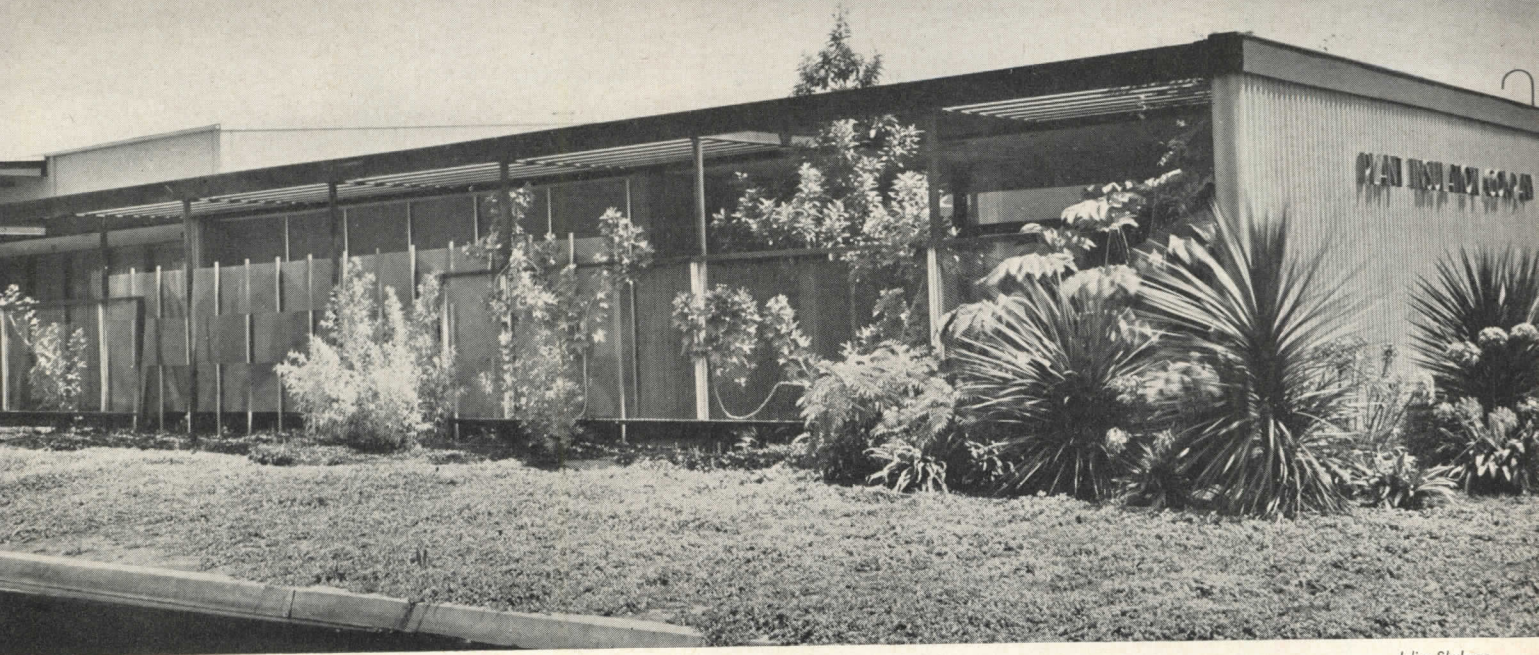

Julius Schulman

THE EXTERIORS are varied in aspect, as are the activities within the three main elements: the office wing and gardens; left, the parking area and entrance walk; bottom left, the series of canopies which are spaced to align with the standard openings in freight cars

THE PLAN clearly expresses the three part function of the building and shows the disposition of the three kinds of traffic serving those functions. All material arrives by rail and is unloaded in the warehouse area for straight-line handling to the truck docks opposite, where it is loaded for distribution. A portion may be processed (for contract work) in the manufacturing wing, which has its own truck dock. Automobile access and parking is carefully separated from the freight traffic

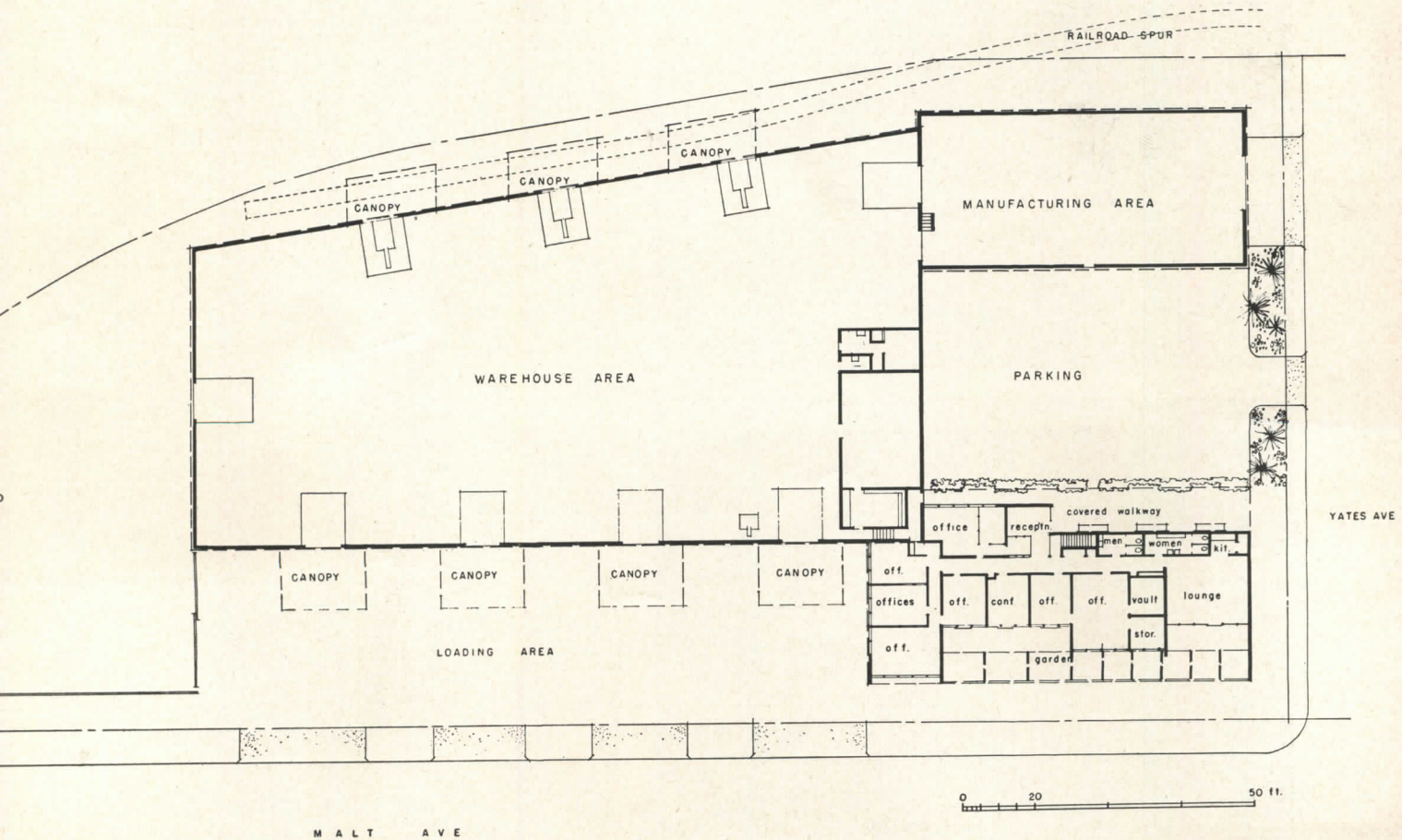



INDUSTRIAL BUILDINGS: 3

PLANT INSULATION COMPANY

THE INTERIORS are conceived both as a strong factor in building favorable employe morale and as a showcase for the company's acoustical products. Color, materials and furnishings have been carefully considered with these ends in mind.

From the parking area, visitors and office workers gain entrance by way of a shady covered walkway and attractive lobby, shown above. The colorful lounge, with adjoining kitchen and garden, center, is devoted principally to employes' activities; is used by executives only for occasional special functions. The bottom picture shows a typical executive office and adjacent garden

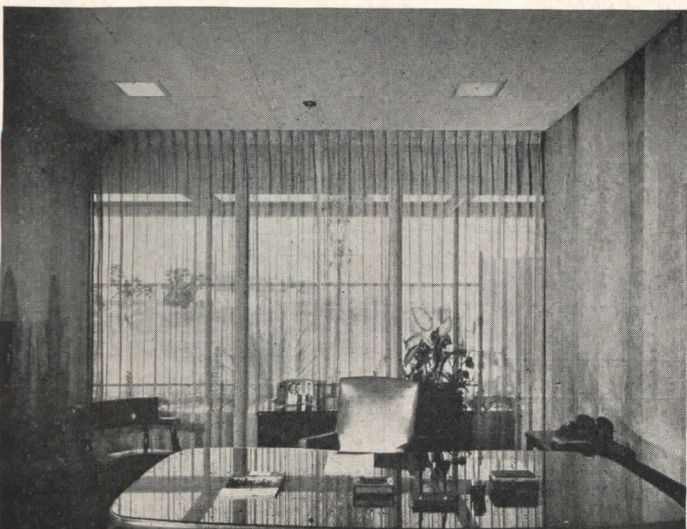

WRIGHT BUILDING, St. Louis
Louis Sullivan

ON PIRIE SCOTT STORE, Chicago
Louis Sullivan

EFELLER CENTER BUILDINGS, New York
Leinhard & Hofmeister; Corbett, Harrison
MacMurray, Hood & Foulhoux

R HOUSE, New York
Kidmore, Owings & Merrill

TY CHURCH, Boston
I. H. Richardson

DELPHIA SAVINGS FUND SOCIETY
UILDING, Philadelphia
Lowe & Lescaze

RAL MOTORS TECHNICAL CENTER, Detroit
Saarinen & Saarinen

SHORE DRIVE APARTMENTS, Chicago
Mies van der Rohe

JOHNSON & SON, INC., ADMIN. BLDG., Racine
Frank Lloyd Wright

ADNOCK BLOCK, Chicago
Burnham & Root

Y NEWS BUILDING, New York
Wood & Howells

NORRIS DAM & POWER HOUSE, Tennessee
Roland Wank, Architect-in-charge

ON PUBLIC LIBRARY, Boston
McKim, Mead & White

K PAVILION, Raleigh
Lowicki & Deitrick

STIAN SCIENCE CHURCH, Berkeley
Bernard Maybeck

LWORTH BUILDING, New York
Cass Gilbert

ISLAND SCHOOL, Illinois
Saarinen & Saarinen,
with Perkins, Wheeler & Will

UFACTURERS TRUST BUILDING, New York
Kidmore, Owings & Merrill

Y CHURCH, Oak Park
Frank Lloyd Wright

ASKA STATE CAPITOL, Lincoln
Bertram G. Goodhue

JOHNSON & SON, INC., LABORATORY, Racine
Frank Lloyd Wright

ED NATIONS SECRETARIAT, New York
Wallace K. Harrison & Consultants

OLN MEMORIAL, Washington
Henry Bacon

. AUDITORIUM, Cambridge
Eero Saarinen

TABLE BUILDING, Portland
Pietro Belluschi

IGHENY COUNTY BUILDINGS, Pittsburgh
H. H. Richardson

ERSITY CLUB, New York
McKim, Mead & White

BROOK SCHOOLS, Michigan
Eliel Saarinen

ERALS & METALS RESEARCH BLDG., I.I.T., Chicago
Mies van der Rohe

DA BUILDING, Pittsburgh
Harrison & Abramovitz

EUM OF MODERN ART, New York
Goodwin & Stone

ISYLVANIA STATION, New York
McKim, Mead & White

RIMENTAL SCHOOL, Los Angeles
Richard Neutra

GE TRUCK PLANT, Detroit
Albert Kahn

MEMORIAL DRIVE APARTMENTS, Cambridge
Kennedy, Koch, DeMars, Rapson & Brown

TRAL LUTHERAN CHURCH, Portland
Pietro Belluschi

U S E S

ROBIE, Chicago
Frank Lloyd Wright

KAUFMANN, Pennsylvania
Frank Lloyd Wright

CSIN WEST, Arizona
Frank Lloyd Wright

Y VILLARD, New York
McKim, Mead & White

S SHERMAN, Newport
I. H. Richardson

Y COONLEY, Illinois
Frank Lloyd Wright

WILLITTS, Illinois
Frank Lloyd Wright

GAMBLE, Pasadena
Greene and Greene

P JOHNSON, New Canaan
Philip Johnson

ER GUEST HOUSE, Florida
Paul Rudolph

N SCRIPPS, La Jolla
Erving Gill

ON HAVENS, Berkeley
Harwell Hamilton Harris

LL "HEALTH HOUSE", Los Angeles
Richard Neutra

H FARNSWORTH, Chicago
Mies van der Rohe

4: SCHOOLS

IN THE CLOSING YEARS of the 100-year period whose most significant buildings are being presented in this series, the design of our primary and secondary schools has constituted perhaps our outstanding architectural contribution. Both the number and quality of our school buildings have been enormously impressive.

Today good schools are the rule, and fine schools are so frequent that singling them out becomes virtually impossible. It is natural, then, that the schools most often nominated by ARCHITECTURAL RECORD's panel of architects and scholars were the pioneer achievements whose influence as well as intrinsic value cannot be doubted.

The three outstanding examples presented herewith were among the first in this country to acknowledge evolving educational objectives and educational methods as primary generators of architectural form. Here, too, the problem of designing in scale with the inhabitants was consistently and successfully addressed. Light, air, convenient materials, useful outdoor spaces and flexible indoor spaces characterize these buildings and the good schools which have been building since.

It may be said that in these examples we saw for the first time in this building type freedom from a preponderance of preconceptions about form. These are buildings in which the inner direction, born of design for specific purpose, is accorded at least equal place with the outer direction of generalized formal conception. It is from this confluence of particular and general forces that the forms of these buildings derive their exceptional strengths as physical entities.

The Cranbrook School was substantially completed in 1930, the Corona School in 1935 and Crow Island in 1940. Each is a milestone in the march to better design, and though the intervening years have been crowded with brilliant building events, these three schools set many lessons which we may — with profit — continue to study.

ONE HUNDRED YEARS OF SIGNIFICANT BUILDING

Crow Island School, Winnetka, Illinois, 1939-40, Saarinen & Saarinen, with Perkins, Wheeler & Will. (Tied for twelfth)

"The Crow Island School has emerged as a pivotal monument in American architecture. It symbolized the faith in public education which Americans have held with increasing enthusiasm for more than a century. It summed up the long search by Barnard, Wheelwright, Itner and the elder Perkins for practical and flexible functioning. And it translated into American terms Dudok's impatience with meretricious monumentality and his belief that a more humane conception of the formative power of fine architecture could facilitate and enrich the educational process itself. Finally because it opened the post war boom in school construction it served as a major source to inspire and express new generations of schools for American youth."

Turpin C. Bannister

"When I first saw the Crow Island School some twelve years ago the paramount impression was that here at last was a school designed to fit an enlightened educational philosophy and not one stuffed into a monument to the taxpayer. For

most U. S. schools prior to this early masterpiece by Perkins and Will and the Saarinens were primarily concerned with an architectural self-importance and were only casually disturbed by the young and their varied range of daily educational activities. Crow Island's studies actually started with the ideal design of a single classroom — with results yet to be surpassed — without even a thought of the building as a whole. This basic postulate of building, of proceeding from the client out, is one which we today are increasingly in danger of forgetting in our mad rush for the perfect façade or the novel and sensational in architecture. The past sixteen years have not changed the wonderful basic lesson of Crow Island."

G. E. Kidder Smith

"The Crow Island School is important for the profound influence it had on modern school buildings. Its human and friendly quality is today reflected in schools all over America. To me this influence makes it one of our important buildings."

Minoru Yamasaki

Hedrich-Blessing





Harvey Croze, Cranbrook Found. Photo Dept.

***Cranbrook School, Bloomfield Hills, Michigan, 1927-30,
Eliel Saarinen. (Tied for seventeenth)***

“A nordic and modern translation of classic purity and ideals, it was a culmination of current trends coordinated by the daring and clear thinking of individual genius. Like a clean wind, a breath of beauty, in its combination of form, color and materials — including earth, water and air — and as a setting for other revitalized arts, it seemed the dream of my own student-generation come true and, best of all, to have been created not with groans and theories but with ease and joy.”

Edward Steese

“Eliel Saarinen’s great contribution to our architecture was the instilling of the idea that architecture can be warm and delightful environment in contrast to the ever prevalent idea of building monuments which propound the grandeur of mankind. Cranbrook is exemplification of this idea and, therefore, important to the full understanding of the directions of our architecture.”

Minoru Yamasaki

ONE HUNDRED YEARS OF SIGNIFICANT BUILDING

Experimental School, Los Angeles, 1935, Richard Neutra. (Tied for twentieth)

"Twenty years ago the first publication of the Corona Experimental School came to a generation of architects and students whose elementary schooling had been too often in dim, airless, second-story rooms as stimulating evidence of what could be accomplished if the hands of the architect were unfettered by either school boards or his own imagination. Richard Neutra brought to this small school all the understanding and skill which has characterized his work both before and since its building, with the result that its single floor, clear distinction of parts — in plan and in three dimension — its open access corridor, bilateral clerestory lighting, orientation, ventilation, sliding walls, outdoor classrooms, and use of color are still as fresh in concept and in realization as they were long before they had helped us establish these goals which are becoming standard for school construction today." *John Knox Shear*



COMMERCIAL BUILDINGS

SIGNS
AND
SYMBOLS

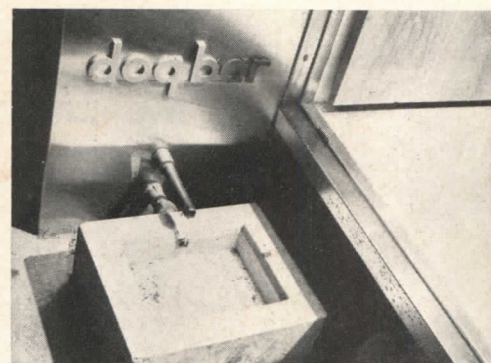
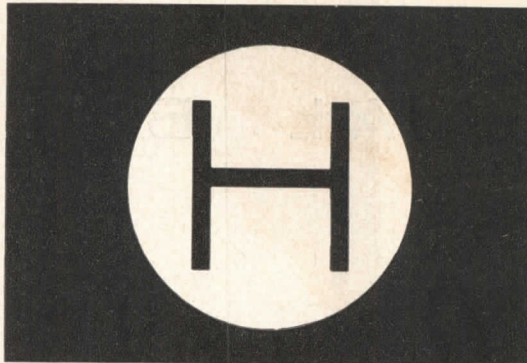
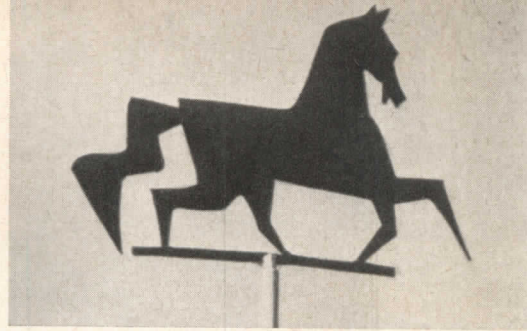

HUMBERTOWN

SHOPPING CENTER

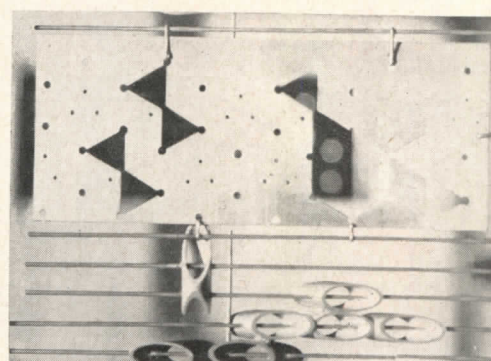

SIGNS & SYMBOLS IN COMMERCIAL ARCHITECTURE

By James S. Hornbeck, Senior Associate Editor

FEW ARCHITECTS will dispute the statement that the design of the lettering and symbolism so vital in today's commercial architecture presents a difficult problem to the average office. A project (we've heard it called a headache) which is usually: *a*, turned over to the junior draftsman; or *b*, given to a designer (probably a good architectural man) whose knowledge of letter forms and letter spacing is strictly intuitive; or *c*, in desperation handed over to a "sign man" for both design and fabrication. These alternatives can scarcely be expected to contribute greatly either to the elegance or distinction of commercial architecture. The sign man will most likely be a capable and conscientious craftsman and the architectural designer competent or even brilliant in his own field. But the missing ingredient will be first rate graphic design; the kind that can cause lettering or symbolism to complement and enhance architecture; can make of a sign or symbolic device more than a mere identifier — more than just another voice calling for attention in the market place.

In fulfilling the need to name or promote or locate or inform or direct, there exists a design opportunity too seldom realized; a fact easily verified by looking about almost any business section in almost any town. There is the chance for tasteful form, texture, color, material, play of light and shade — the possibility of enriching, through contrast, the flat severity and modular regularity of much contemporary work.

And how best go about it? In researching this subject, we have found that apparently increasing numbers of architects are consulting graphic design specialists for help in this phase of design, always maintaining over-all control, of course. Certain others, with organizations and commissions large enough to justify such a step, have built up graphic design departments within their own architectural offices. The guiding principle is the common-sense one that no architect can expect to be an expert in all of the specialized know-hows that go to make up today's architecture, although he obviously must possess a general knowledge of each. On the other

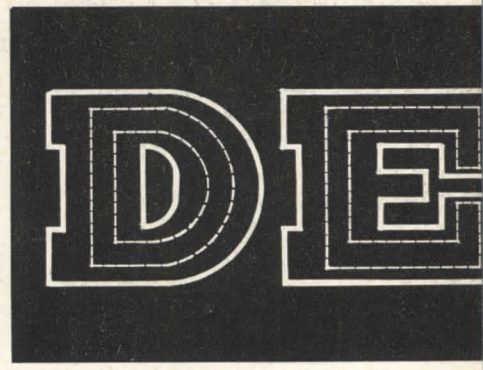
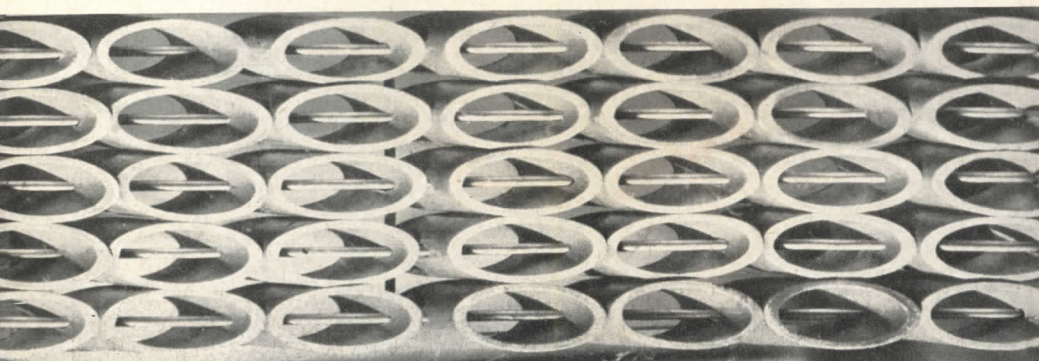

hand, it appears equally obvious that the architect — out of all those engaged in design — is the one best qualified to organize, coordinate, and direct all of the specialized know-hows involved. Only in a sympathetically conceived working together can the arts and sciences and architecture be brought to reach the degree of integration necessary for a valid and complete architectural expression for our times.

* * * * *

In presenting this, the first big (32 page) feature on signs and symbols to appear in the American architectural press, ARCHITECTURAL RECORD points up a challenge and suggests, by way of words and illustrations, an approach toward its solution. Included are many examples of good current work, as well as short articles in which an architect, the head of an architectural office graphics department, two graphic design specialists, and a teacher have their say on the subject. There is also the story of a familiar (and handsome) sign that is not being left "well enough alone."

Left page: Northland Shopping Center, Penn Fruit Market, Victor Gruen & Associates, Architects; Letter forms by Robert Lepper; GM Technical Center Sign by Elaine Lustig; Dog bar for Wallachs, Jamaica, L. I., Kelchum, Gina & Sharp, Architects; Sign by Victor Gruen & Associates; Design in metal by Robert Lepper

Above: Volkswagen Showroom, Kalz, Waisman, Blumenkranz, Stein, Weber, Associated Architects; GM Technical Center sign by Elaine Lustig; Maxwells store, Victor Gruen & Associates, Architects; Metal grill design by Robert Lepper; Carson, Pirie Scott store, Victor Gruen & Associates, Architects; 42nd Street signs; Lettering by Marcel Breuer, Architect

Photos: Gordon Sommers, Altwater & Brother, Lionel Freedman, Richard Jokel, Ben Schnall, Hedrich-Blessing



Morley Baer



Photograph House

All examples on these two pages are from Victor Gruen's offices: at left, roadside identification device for the Pala Shopping Center, San Jose, Cal.; the other three illustrations are of work for the Northland Center, near Detroit. Alvin Lustig was graphic consultant for the Northland work — some was drawn in his office; some in Gruen's graphics department in Detroit

ARCHITECT GRUEN STATES THE

By Victor Gruen, Architect

THE ARCHITECTURE of any time is an expression of the civilization of that era. The importance of business is a dominant in the civilization of our time. Thus, the architect is engaged, to a large degree, in the planning and design of buildings serving commercial and industrial functions. It is in the nature of such buildings that great attention is given to promotional considerations. This fact is expressed not only in the architectural elements themselves, but also in the quantity of signs and lettering their owners request.

In many cases the contemporary architect, secretly at loggerheads with the commercial nature of such tasks, adopts the policy of the ostrich and pretends that many of the problems do not exist; omits them from consideration. In so doing, he follows the same course so often taken in dealing with the contemporary necessities of air conditioning and mechanical equipment. The architect designs the building to the cornice line and lets the engineer take care of cooling towers, water towers, elevator penthouses, etc., which then

NORTHLAND CENTER

NORTHLAND CENTER

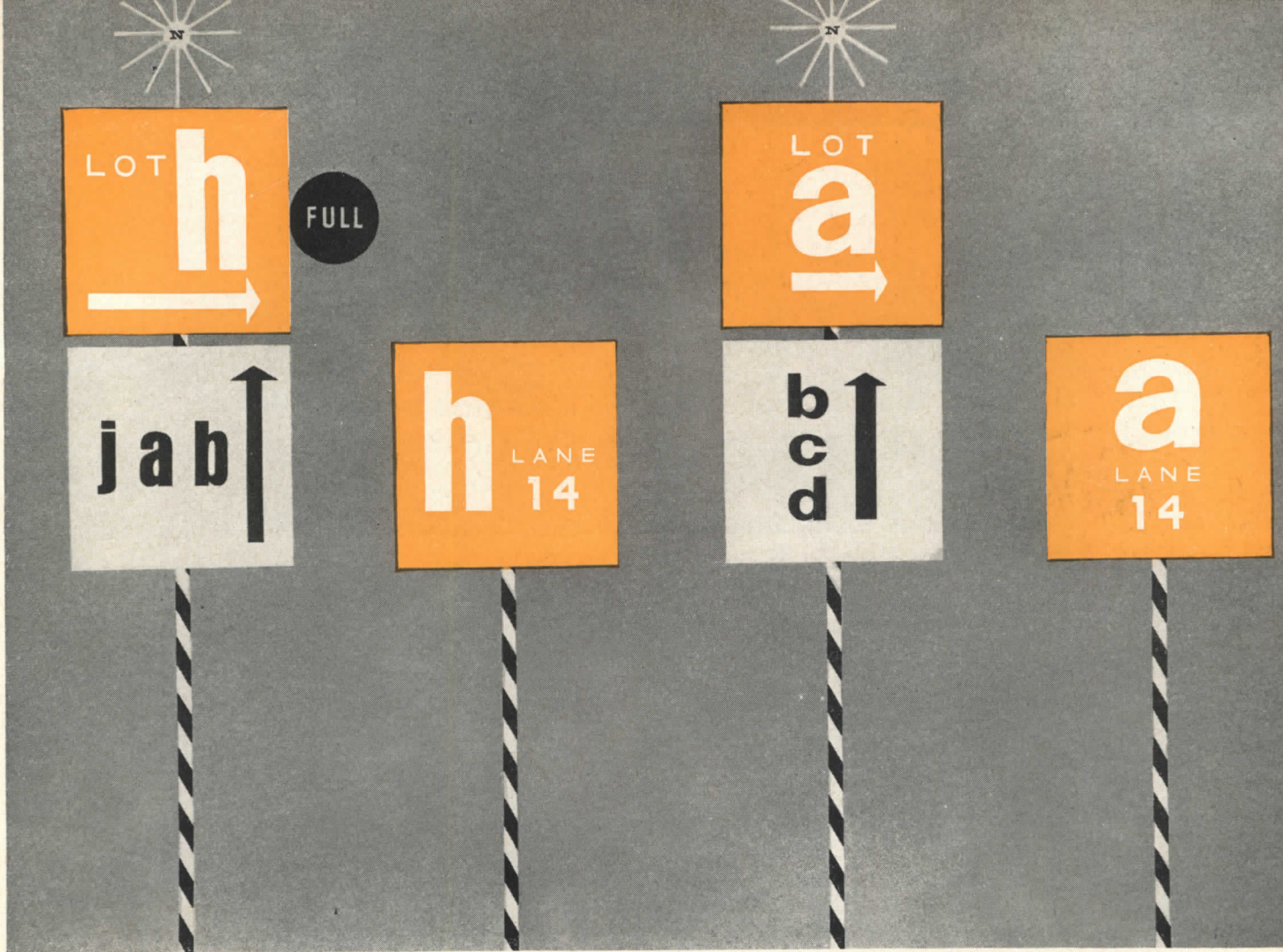

FULL

LOT h

LOT a

j a b

h LANE 14

b c d

a LANE 14

CHALLENGE THAT GRAPHIC DESIGN PRESENTS

form an engineering building atop the architect's.

It is obvious that such duplicity cannot possibly solve the problem of designing in the contemporary spirit. As long as architects do not make all of the mechanical necessities—and also all the commercial necessities such as signs and lettering—an integral part of their designs, we will fail to arrive at a truly expressive contemporary commercial architecture.

Such integration is not easy, and the owner's demands may exasperate the designer. If one is, for example, confronted with a sign such as the well known one of 58 letters naming a Welsh railroad station, it may be necessary to lengthen the station considerably just to accommodate it! Still, the initial discouragement evoked by the demands must give way to the determination to take care of the client's needs. The other alternative is for the client to take care of them when the architect is done. Esthetic chaos usually results.

There have been examples in which a building was designed in pristine cleanliness, photographed, pub-

lished, and then turned over to the client, who thereupon affixed the necessary and unnecessary signs and lettering in a manner that completely negated all the values the architect had tried so hard to create. The architect who wants to prevent such an occurrence must include all matters of graphic design in his scheme in such a way that they heighten and enliven it, instead of despoiling the effect intended. In order to be able to do so, he must acquire a basic knowledge of graphic design and must seek the consultation and cooperation of graphic artists in the same fashion that he calls on so many other specialists for aid in the structural, mechanical, and electrical fields.

Thus, it is obvious enough that it would be highly desirable if our architectural schools should pay more attention to the teaching of lettering and the graphic arts. In my opinion, a course in graphics should be a requirement in every architectural curriculum. As it stands, the ability of the average graduate to handle the simplest lettering problem is negligible.



Ben Schnell

1

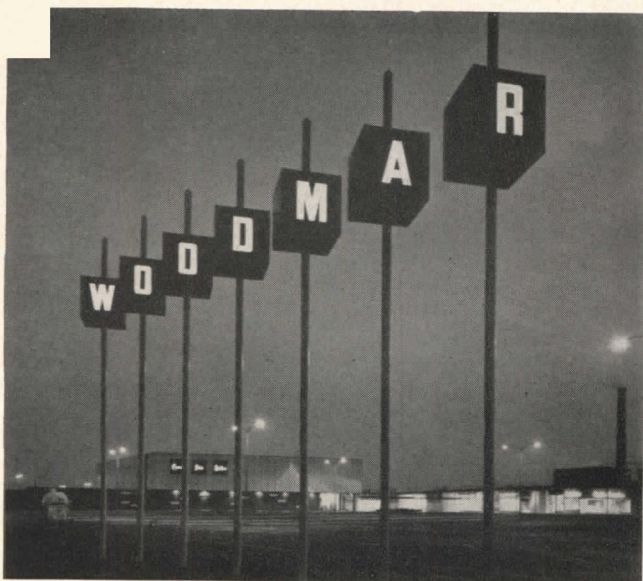

2

Hube Henry, Hedrich-Blessing

Victor Gruen:

The importance of graphic design in architecture extends beyond buildings proper. Signs which regulate traffic; signs which direct people towards buildings or other areas; signs which advertise; all of these influence structures and environments and therefore legitimately belong in the field of architectural design.

The architect will reach his greatest effectiveness not alone when he heeds and fulfills the demands of his client concerning signs, but also when he can *analyze the true needs of the owner and tastefully interpret them* — often by means other than signs; as by symbols, colors, shapes, etc. This must of course be done to the client's satisfaction and with an effect of elegance and of gaiety or dignity, as occasion requires.

When it is generally acknowledged that our architecture must be the total expression of all the facets and forces of our times; when we as architects do not shy away from those things we dislike, but try to improve them; then the way will be open to a better, more complete expression in commercial architecture.

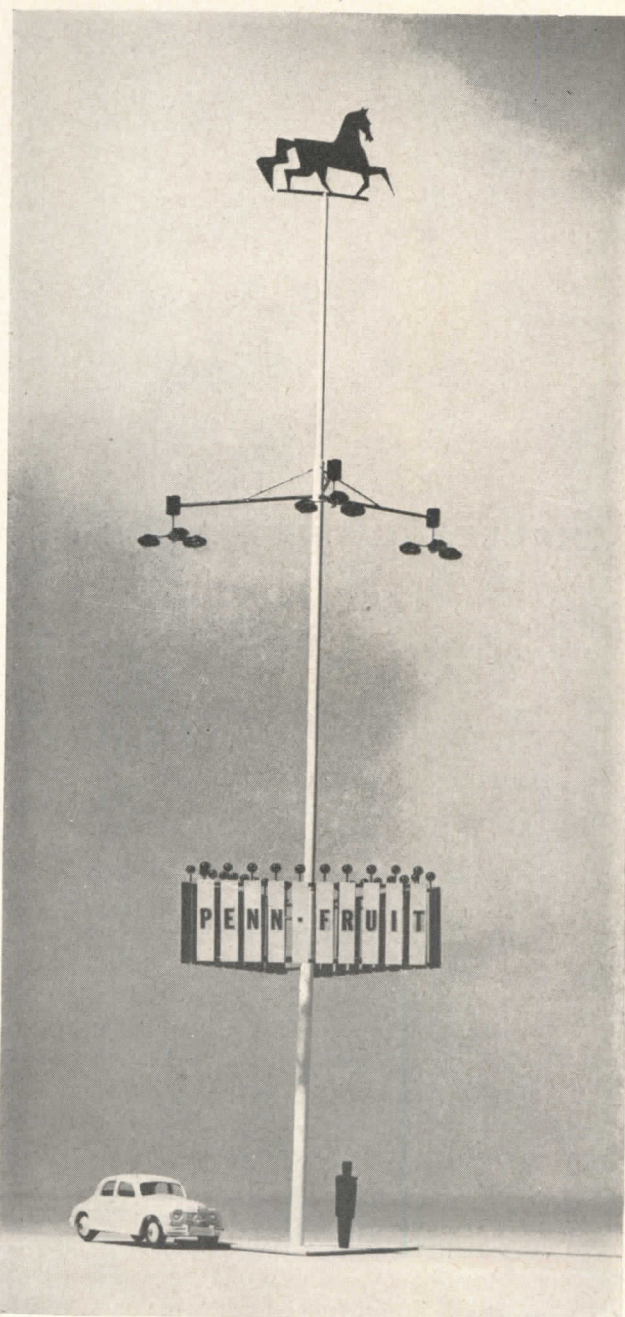

3

Gordon Sommer.

SIGNS & SYMBOLS



4

George E. Kawamoto Studios
Ben Schnall

More examples from the Victor Gruen organization: 1, Sign to identify parking lot, Northland Center, near Detroit; 2, Roadside marker for small shopping center near Woodmar, Indiana; 3, Device for Penn Fruit Market, New Jersey; 4, Symbolic "N" on water tower, Northland Center, near Detroit; 5, Maxwell's toy and sports shop in the Northland Center



5

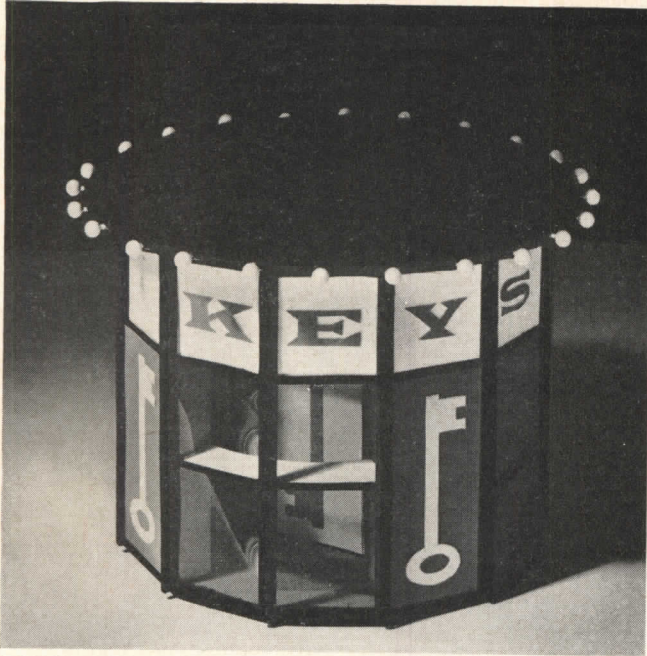
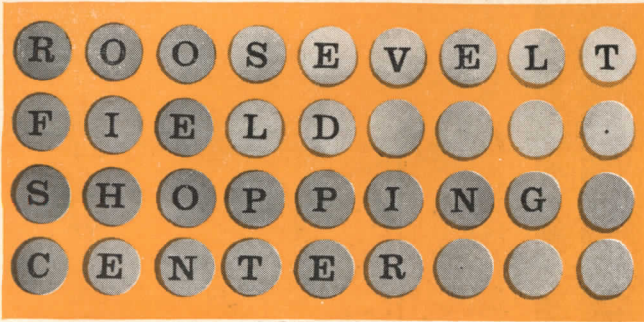

Louis R. Glessmann

Signs and symbols for the Roosevelt Field Shopping Center, Nassau Co., L. I., as developed by the graphics department of I. M. Pei & Associates, Architects, for Webb & Knapp, developers and owners of the project; top, sign for entrance mall, designed by George Pappas — plastic discs, interior lighted, strung on wires to vibrate with the wind; left, model of 9 ft. diameter key kiosk, designed by Philip Wood Swift; right page, study for sign showing future tenants, by Don Page and Martin Norman

HOW THEY GO ABOUT THE PROBLEM IN PEI'S OFFICE

By Don Page, Head of Graphics Department, Office of I. M. Pei & Associates, Architects

IN OUR WORK we include in graphics most of the things (except landscaping and site planning) that are not strictly concerned with building buildings as such. However, the fields overlap so that they work together and must be considered as essential parts of an entire picture. The expansion of the field of graphics from the two-dimensional to the three-dimensional seems reasonable, for the business of printing on paper gives another dimension-space to this simplest of operations. There are many examples of fine three-dimensional work which were done by graphics specialists.

Few architects would give themselves the task of designing the sculpture or the murals for a building. They would, as well, be wise to receive help where graphic problems are involved. It is not enough for architects to select a sans-serif alphabet (usually because it is considered "modern" and is perhaps the easiest to copy with T-square and compass) and attempt to fit the letters into a given space on the façade. The result is apt to exhibit questionable letter spacing, poor

legibility, and add little to the commercial message.

When the problems of letter size, letter versus space, proportion, materials to be used, readability, and atmosphere to be created are considered, the architect is somewhat out of his element. He needs help from the best graphics people available.

When signs are called for, an effort should be made to use well designed and well proportioned lettering and symbols. These give the extra interest and beauty that only good graphic design can supply. For good design creates an active interest in the beholder so he may be informed; not confused and bullied.

Of primary importance is the manner in which a sign or a symbol is to be read. For maximum effect, an entirely different kind of design is required for the motorist moving at high speeds along a highway than for the stroller in a shopping center. The time-distance of a sign is the basis for its size; the choice of letter, the color and form follow the development of the attitude to be presented; the controlling element being taste.

ROOSEVELT FIELD SHOPPING CENTER
 KITTY KELLY SHOES • HEMPSTEAD CHINA
 WOODS JEWELRY • FLORSHEIM SHOES
 GRAND UNION • EASTERN CAMERAS
 HARTFIELD STORES • MACYS
 WOLWORTH BROS. SHOES
 KRESGE
 MALLARY FURNITURE
 FARMER BUSTER BROWN
 THOM McAN
 FARMER BUSTER BROWN
 RIPLEY CLOTHES
 FOOD FAIR
 TEPEE TOWN BAKER SHOES



BEROTTI CANDIES



The model photographs show the scheme for typical modular storefronts for the Roosevelt Field Shopping Center in Nassau County, Long Island, which contain panels of white glazed brick. The signs and symbols illustrated were designed by Don Page and George Pappas of the graphics department, I. M. Pei & Associates, Architects for Webb & Knapp, owners and developers of the project. Detail photographs by Joseph W. Molitor

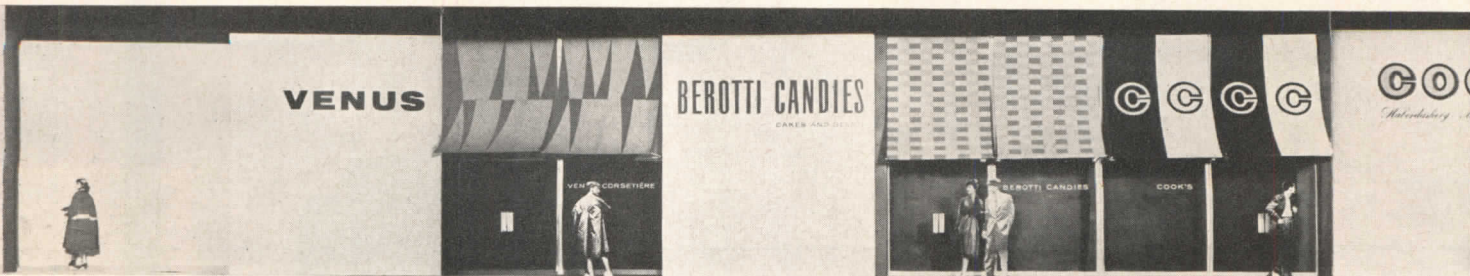

EMPIRE



Children's Center

VENUS

COOK'S

PERIN & COMPANY

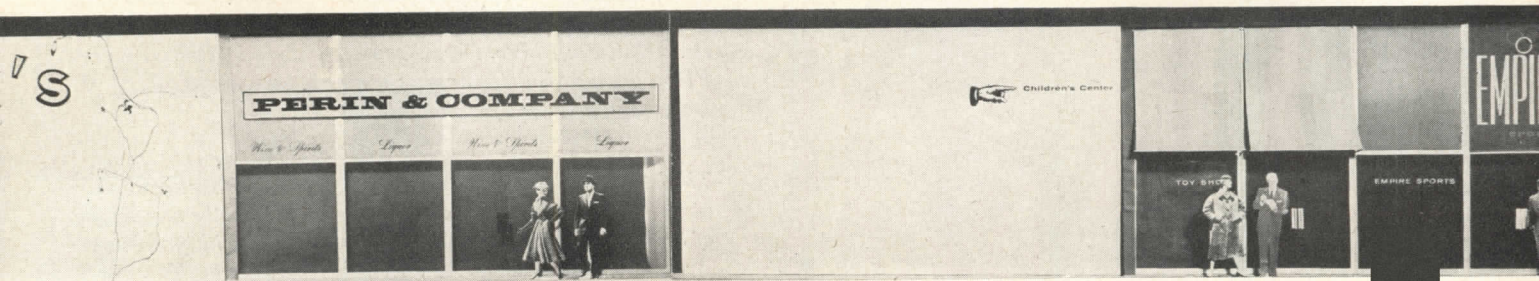

Louis R. Glusman

SIGNS & SYMBOLS

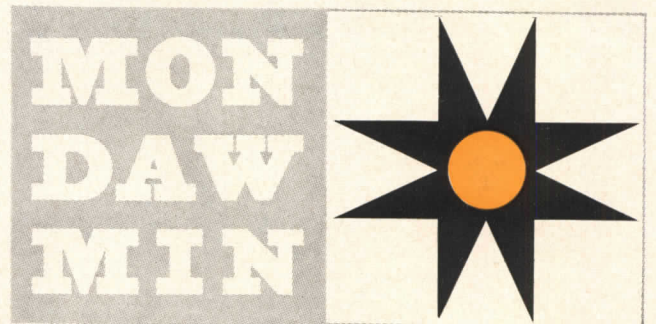

At left, symbolic tower for Mondawmin Shopping Center, Baltimore, Elaine Lustig, graphic designer, and above, the manner in which the symbol has been adapted for further use on stationery, etc. Architects: Fisher, Nes, Campbell & Associates; Dan Kiley, Pietro Belluschi & Kenneth C. Welch, Associated; J. & G. Daverman, architects for store front design

The letters on the right page have been selected from the display alphabet especially designed by Elaine Lustig for the new House of Seagrams, New York, Mies van der Rohe & Philip Johnson, Architects; Kahn & Jacobs, Associate Architects. The words "SIGNS AND SYMBOLS" on the title page (p. 237) are formed from this alphabet

Y

8

9

J

X

H

5

E

T

6

4

S

A

Q

K

R

N

GM

ADMINISTRATION

ENGINEERING

GENERAL

STYLING

RESEARCH

A CONVERSATION WITH GRAPHIC DESIGNER LUSTIG

IN GATHERING INFORMATION on the problem of lettering and symbolism in architecture, and the professional relationship between architect and graphic designer—editors John Knox Shear and James Hornbeck met with Elaine Lustig for a discussion on these subjects.

Mrs. Lustig conducts a graphic design studio and is experienced in working as a consultant to architects on lettering, symbols, etc. She is the widow and former partner of the late Alvin Lustig.

These were the principal questions discussed:

Q: What seems to be the most common difficulty architects have when they design lettering?

A: Most often, the difficulty seems to lie in the use of “neutral” letters, which lack character. These are probably chosen because they seem to “interfere” less with the architectural expression. I refer particularly to the widespread use of a thin-stem, sans-serif letter more or less on the order of Futura. This letter is innocuous — polite — but lacks the strength necessary

to complement architecture. In addition, such letters were a cliché as far back as the 30’s!

There is a great symbolic potential inherent in well designed, artfully spaced letters that possess a strength and character of their own. Naturally, they must be carefully related to the architecture, and conceived as playing their part in the “whole” effect.

Mockups are extremely helpful in studying sign and lettering design; often they are a must. In many cases the effect of lighting is not adequately considered, nor is the selection of materials and colors.

Q: Would you discuss the professional relationship between the architect and the graphic design consultant, and describe how they work together?

A: My collaborations with architects have been cooperative and pleasant; probably because the architects involved wanted help with graphic design.

I feel that the ultimate solution to integration — whether of sculpture, mural painting, graphic arts, or whatever — will result from the creative thinking and

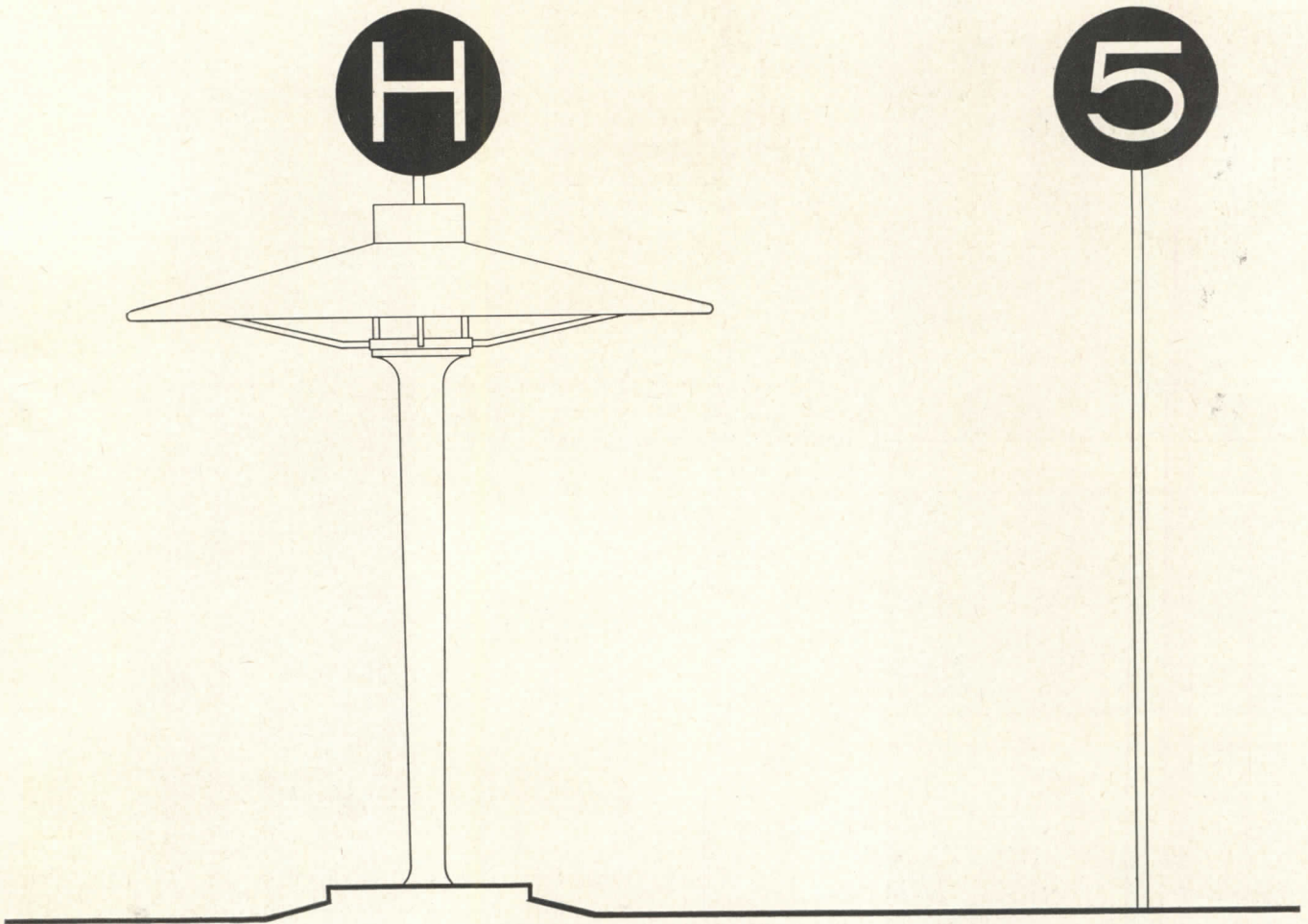

The signs for the General Motors Technical Center, Eero Saarinen & Associates, Architects, are shown above, right and left pages. Alvin and Elaine Lustig, graphic consultants, studied the alphabet to be used, considered the several variations shown, finally adopted that shown for "STYLING" and "ENGINEERING." The signs as fabricated consist of bright anodized aluminum letters on a gray aluminum background.

organizing ability of but one person; the architect.

Q: At what point during the architectural design process should the graphic designer be called in?

A: It is very important that the graphic designer be consulted early so that he can contribute most effectively in the development of a "whole" design, and so the lettering or symbolism is not an afterthought.

Q: What is your opinion regarding the best method for paying the graphic design consultant?

A: Fixed fee and time, I think, because then the client (owner) pays only for what he sees. There is, however, the drawback that it is sometimes hard to establish just how far the studies should be carried. A straight hourly rate usually scares the client since he is unable to judge how deeply he will become involved. Besides, it is difficult to charge "main design" on an hourly basis. The whole problem of payment is very similar to that confronting the architectural profession.

Q: In your work, who approves the scheme for a given project; the architect, the owner, or both?

A: We like to work closely with the architect and gain his approval first. Then, both of us can present a "united front" to the owner when his approval is sought. This procedure has proven effective in practice.

Q: Victor Gruen strongly recommends that a general course in graphics be required in the curriculum of every architectural school, as is common in Europe. What might be included in such a course? Also, would you suggest how it might be organized?

A: I agree heartily with Mr. Gruen, and might suggest collaboration problems, in which graphic design would be placed on the same plane as lighting, landscaping, etc. In addition, a series of illustrated lectures which would survey the historical development of letter forms, letter spacing, and possibly symbolism. In such a series, the stress might be on general knowledge and appreciation rather than on how to do it.

Q: How about knowledge of graphics for those architects who have finished school and are in practice?

A: I should think that educating them is your job!

Illek and Paul



K. Plicka J. Ehm

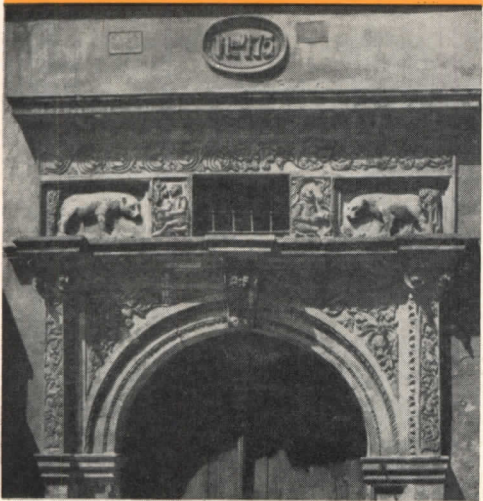

1, 2, 3

Symbols on medieval buildings — heraldic symbols of ownership. 1, Pernstejn castle gate, Bohemia, 1604. Identifiers of town houses; 2, House at the sign of "White Lion," and 3, House at the sign of "Two Golden Bruins," Prague, 15th & 16th century

Merchant symbols of past two centuries.

- 4, Tea kettle for Boston tea shop;
- 5, Haffenreffer collection of cigar store Indians;
- 6, Massachusetts butcher sign;
- 7, New York pawn broker symbol;
- 8 and 9, French locksmith and pharmacist symbols

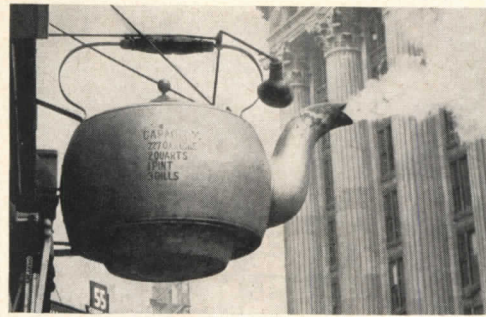

Merchandise display promotes the store's goods. 10, Hardware store, Indianapolis; 11, Marine supply store, N. Y.



10, 11



Ewing Galloway



Standard Oil Co. of N. J.

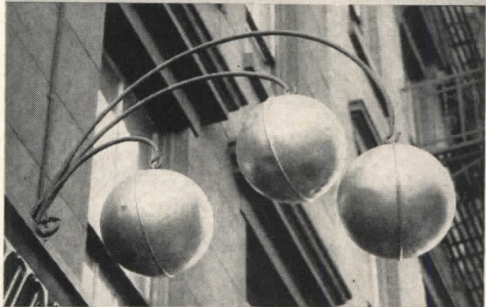
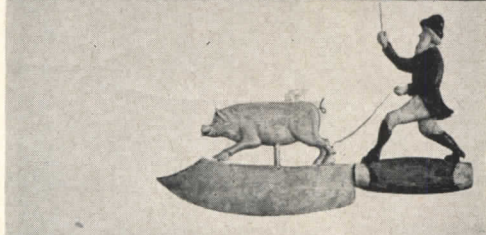

4, 5, 6, 7, 8, 9

Public Library

This Week - Werner - Wolff

N. Y. Public Library

Ewing Galloway

N. Y. Public Library

WE LIVE BY SYMBOLS. In the broader fields of human experience a symbol, as a potent instrument of identification, may bear the weight of vast human context. For good or ill, the visual symbol has expressed provincial attitudes, spanned time and continents with explosive ideologies. Yet, the visual object which becomes a symbol is actually nothing but itself—a simple object to the eye—until it acquires an accretion of information and associative values. The cross would be no more than a cross without the story of the crucifixion. Similarly, the visual symbolism of a trademark, which sometimes may consist of no more than a name or initials, can become meaningful only through advertising

and other means of sales promotion. At the immediate place where products are sold, the concept of symbols as point-of-sale devices involves nothing fundamentally new. Its roots extend deep into the past, into the activities of ancient market places. Simple and self-explanatory merchant symbols appealed directly to passers-by in the streets. What is relatively new today is the increasing complexity of the point of sale in all its aspects: the new selling methods, the increased competition, the quick multiplication of old and new product types. All this results in an increasing need for specific store design with quick identification and with direct product promotion on the building itself. Poorly designed

Opticians' signs sold to the trade; 12, Wedding ring sign, winking eye, illuminated spectacle sign (from American catalogs, c. 1906)

12

N. Y. Public Library



13

Holiday — Ewing Krainon



Kaleidoscope of traditional symbols of merchandise offered within the stores, 13, Tivoli Gardens, Copenhagen

COMMERCIAL SYMBOLS — Ladislav Sutnar

Today's symbols; goods and services promoted by trademarks on store front and window. Beer brands in a restaurant window; bell symbol for the Bell Telephone Co.; A & P trademark on Great Atlantic & Pacific Tea

Co. stores. The letters "a" and "e" as an identifier for the Arts and Ends jewelry shop in New York; designed by Katz, Waismann, Blumenkranz, Stein, Weber — Architects Associated

Ezra Stoller

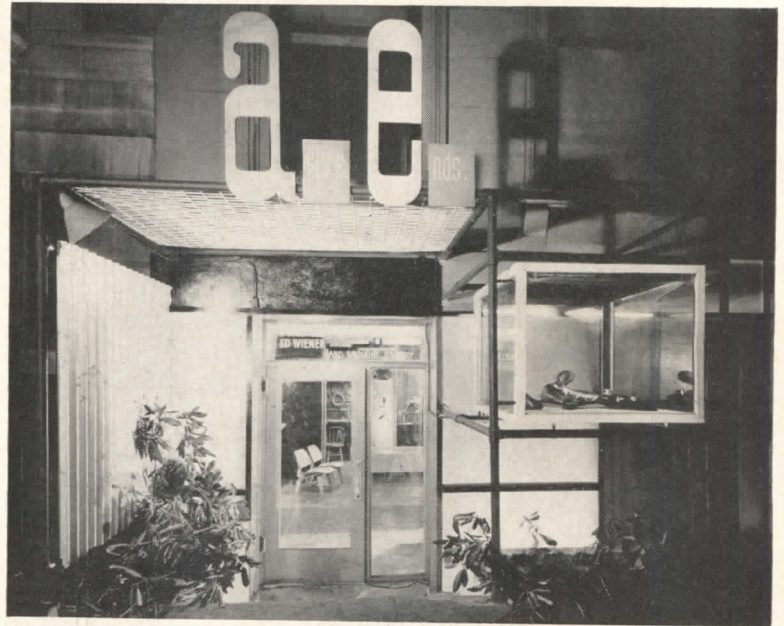

L. L. Rado

Visual symbol as an identifier for company activities; the Golden Griffin trademark imprinted on company stationery and publications, also applied to the bookstore itself in New York. Store design by Raymond and Rado, architects; Ladislav Sutnar, consultant for store design and designer for trademark and leaflet

Egyptian Art

Written by Florence Dunbar, Director General of the Department of Antiquities of the State Museum, with photographs by Eleanor Sedgwick. This magnificent book affords the student of Archaeology and Ancient History and the lover of art a fuller understanding and appreciation of the civilization and art of 12 successive dynasties of the Egypt, beginning with the Old Kingdom and the New Kingdom. From the Pyramid to the Ptolemaic period, the remarkable representations of the missing monuments and statues of ancient Egypt and the curious, penetrating analysis of their hidden meaning, give the reader a clear understanding of life as it was lived in the Land of the Pharaohs. She has unfolded the whole panorama of Egyptian art and culture, densely loaded as it was in the 19 figures, sculptures and other masterpieces of the golden age, with the Temple of Karnak, the great Temple of Luxor, the Temple of Amenhotep, the Temple of Amenhotep III, the Temple of Amenhotep IV, the Temple of Amenhotep V, the Temple of Amenhotep VI, the Temple of Amenhotep VII, the Temple of Amenhotep VIII, the Temple of Amenhotep IX, the Temple of Amenhotep X, the Temple of Amenhotep XI, the Temple of Amenhotep XII, the Temple of Amenhotep XIII, the Temple of Amenhotep XIV, the Temple of Amenhotep XV, the Temple of Amenhotep XVI, the Temple of Amenhotep XVII, the Temple of Amenhotep XVIII, the Temple of Amenhotep XIX, the Temple of Amenhotep XX, the Temple of Amenhotep XXI, the Temple of Amenhotep XXII, the Temple of Amenhotep XXIII, the Temple of Amenhotep XXIV, the Temple of Amenhotep XXV, the Temple of Amenhotep XXVI, the Temple of Amenhotep XXVII, the Temple of Amenhotep XXVIII, the Temple of Amenhotep XXIX, the Temple of Amenhotep XXX, the Temple of Amenhotep XXXI, the Temple of Amenhotep XXXII, the Temple of Amenhotep XXXIII, the Temple of Amenhotep XXXIV, the Temple of Amenhotep XXXV, the Temple of Amenhotep XXXVI, the Temple of Amenhotep XXXVII, the Temple of Amenhotep XXXVIII, the Temple of Amenhotep XXXIX, the Temple of Amenhotep XL, the Temple of Amenhotep XLI, the Temple of Amenhotep XLII, the Temple of Amenhotep XLIII, the Temple of Amenhotep XLIV, the Temple of Amenhotep XLV, the Temple of Amenhotep XLVI, the Temple of Amenhotep XLVII, the Temple of Amenhotep XLVIII, the Temple of Amenhotep XLIX, the Temple of Amenhotep L, the Temple of Amenhotep LI, the Temple of Amenhotep LII, the Temple of Amenhotep LIII, the Temple of Amenhotep LIV, the Temple of Amenhotep LV, the Temple of Amenhotep LVI, the Temple of Amenhotep LVII, the Temple of Amenhotep LVIII, the Temple of Amenhotep LIX, the Temple of Amenhotep LX, the Temple of Amenhotep LXI, the Temple of Amenhotep LXII, the Temple of Amenhotep LXIII, the Temple of Amenhotep LXIV, the Temple of Amenhotep LXV, the Temple of Amenhotep LXVI, the Temple of Amenhotep LXVII, the Temple of Amenhotep LXVIII, the Temple of Amenhotep LXIX, the Temple of Amenhotep LXX, the Temple of Amenhotep LXXI, the Temple of Amenhotep LXXII, the Temple of Amenhotep LXXIII, the Temple of Amenhotep LXXIV, the Temple of Amenhotep LXXV, the Temple of Amenhotep LXXVI, the Temple of Amenhotep LXXVII, the Temple of Amenhotep LXXVIII, the Temple of Amenhotep LXXIX, the Temple of Amenhotep LXXX, the Temple of Amenhotep LXXXI, the Temple of Amenhotep LXXXII, the Temple of Amenhotep LXXXIII, the Temple of Amenhotep LXXXIV, the Temple of Amenhotep LXXXV, the Temple of Amenhotep LXXXVI, the Temple of Amenhotep LXXXVII, the Temple of Amenhotep LXXXVIII, the Temple of Amenhotep LXXXIX, the Temple of Amenhotep LXXXX, the Temple of Amenhotep LXXXXI, the Temple of Amenhotep LXXXXII, the Temple of Amenhotep LXXXXIII, the Temple of Amenhotep LXXXXIV, the Temple of Amenhotep LXXXXV, the Temple of Amenhotep LXXXXVI, the Temple of Amenhotep LXXXXVII, the Temple of Amenhotep LXXXXVIII, the Temple of Amenhotep LXXXXIX, the Temple of Amenhotep LXXXXX.

1928 in the series of Golden Griffin Books published in Arts and Crafts, 728 Seventh Avenue, N.Y. 10

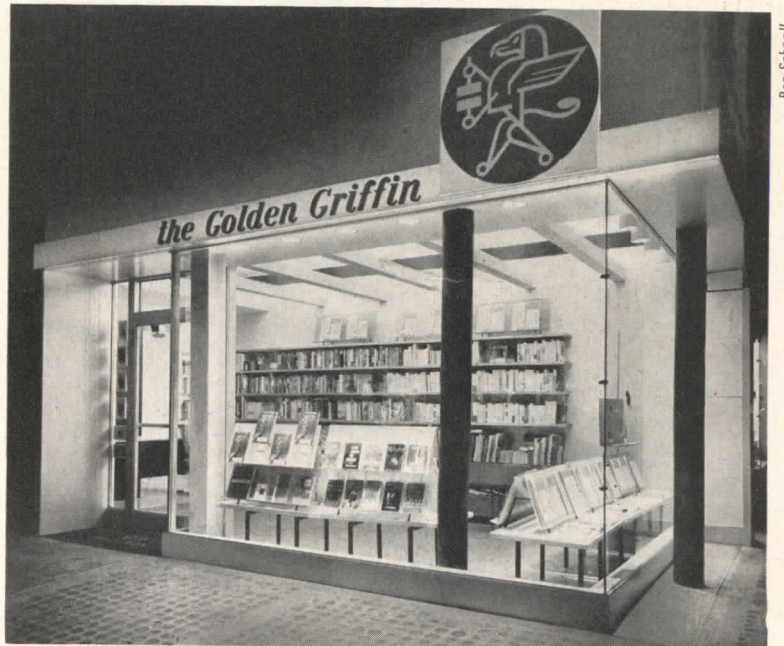

Ben Schaff

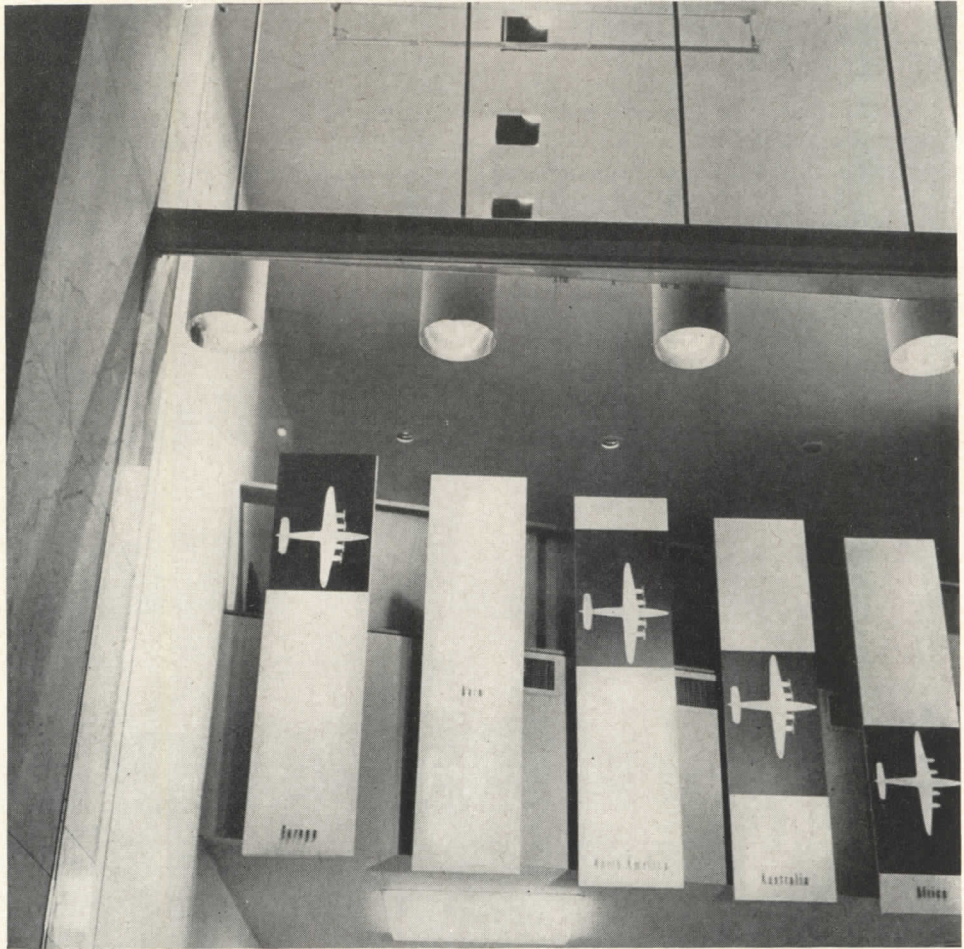

Ticket office display using symbols; KLM airlines intercontinental routes represented by panels indicating continents and by symbols of the fleet that connects them. Store design by Raymond & Rado, Architects; display design by Ladislav Sutnar

The visual symbol for the Roosevelt Field Shopping Center, a Webb & Knapp project which is now under construction on Long Island. 1, 50 ft diameter aluminum sphere at the entrance; 2, 3, 4, The same symbol applied to shopping bags, children's balloons, and wrapping paper. Symbol and applications designed by the graphics unit, office of I. M. Pei & Associates, Architects. Designers: Sphere-George Pappas; Bags and Wrapping Paper — Martin Norman; Balloons — Philip Swift

1
Louis R. Glassmann



2, 3, 4

Weiman & Lester





L. L. Rado



Shell Oil Co.

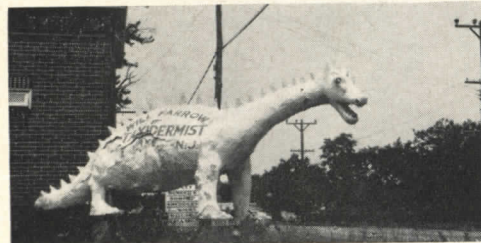

5, 6, 7



L. L. Rado



8, 9, 10

11
Hedrich-Blessing



Symbolic devices along the highway. 5, 6, 7, Animal symbols calculated to attract the motorist's eye; real estate office, dude ranch, and taxidermist's advertisement. 8, 9, 10, Service station identifiers; Texaco, Shell Oil, and Socony Vacuum. 11, Dealer Outlet identity; International Harvester trademark and branch designed by Raymond Loewy Associates

COMMERCIAL SYMBOLS — Ladislav Sutnar*

point of sale devices line America's streets, and their clutter and confusion extend to the open highway. Lacking the visual impact required for differentiation, the majority quickly lose the force of visual identification and message to the motorist. In this sense, it is increasingly recognized that the pressure of competition is a compelling force demanding better design. Individually or on a higher planning level, architecture today encompasses more and more. The architect is faced with the exciting challenge of inventing new avenues of approach. His scope of design includes exterior environmental factors and extends into store interiors, so that

merchandising potentials of sign and display may be incorporated and accentuated within an over-all harmonious design. Such a concept provides a well organized framework for various types of sales devices and controls their design. Thus, innumerable uses of symbols for sales promotion are at hand. When well designed, visual symbols can be attractive to look at, can tell a long story briefly, and can act as powerful magnets to draw customers into the store for further attention.

* Ladislav Sutnar, formerly director of the State School of Graphic Art, Prague, is a designer, Art Director for Sweet's Research Department, and author of "design for point of sale" and "package design: the force of visual selling."



Volkswagen Showroom, New York City; Katz, Waisman, Blumen ranz, Stein, Weber, Associate Architects

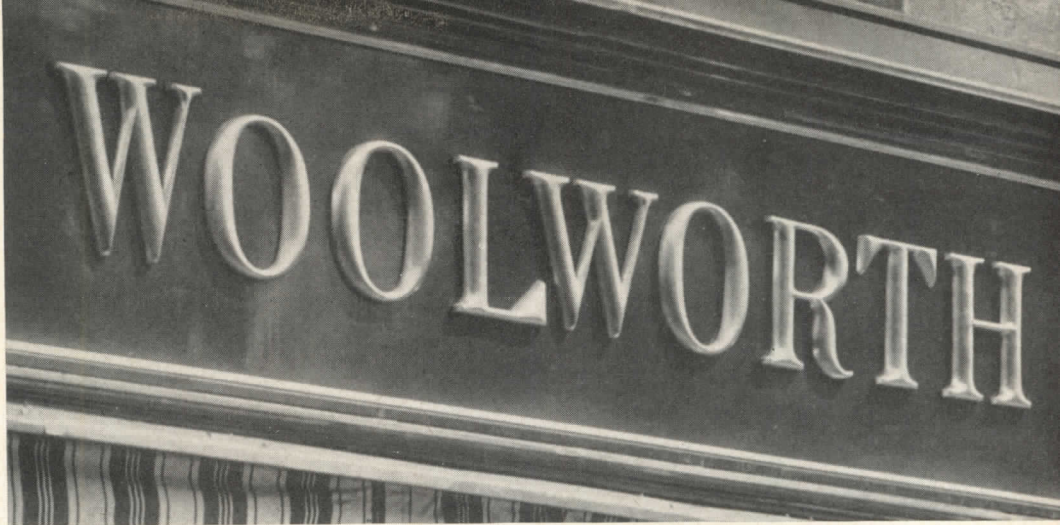

1



2



3

THE WOOLWORTH STORY

By Mildred Constantine*

PEOPLE MAKE WOOLWORTHS! The company proudly proclaims this in its brochure published in 1954 on the occasion of its 75th birthday. And they "enjoy the customers' preference in any given community to walk into the familiar variety store with the red-and-gold sign."

Yet, after seventy seven years, the company is abandoning its label; changing its identity! The first example for this article shows the letter — based on a classic Roman prototype — used in the familiar, traditional Woolworth signs in towns and cities all over the country. The second example shows the new letter. This writer would like to state immediately her unqualified preference for the first.

The three illustrations on this page (1, 2, 3) indicate the heritage of the Woolworth sign from three of the companies that were absorbed in creating the Wool-

* Mildred Constantine, Associate Curator of Graphic Design, Museum of Modern Art, has excerpted this article from a book she is preparing in collaboration with M. C. and Egbert Jacobson. Reinhold & Co., publishers, have scheduled the book for 1957.



4, 5, 6

THE WOOLWORTH STORY

worth empire. In the 1830's each of these stores was similarly identified. Their fascias carried a simple identification consisting, in each instance, of a light letter — generally Roman in character — used on a dark background as a decorative band. This perfectly respectable use of the fascia as a background for letters had its origin in Roman architecture.

In the 77 year period there has been very little change in the store front sign other than elimination of the words "5 and 10 cent store," consistent with the shift in merchandising policy. Of course, modifications in store sizes and fascias made it necessary to expand or condense the letter, but these variations did not detract from the beauty, function, or consistency of the sign (4, 5, 6). These changes in proportion of height to width, variation in stroke from thick to thin, the effective pattern made by the rounded, three-dimensional letter shapes, are characteristic of the Roman letter in its original forms. Note the section from a carved tablet (7) and the two-dimensional calligraphy of a manu-

script (8). In the latter, the brilliance of the heavy black ink lends style and sophistication, while in the tablet, the finely incised curves produce almost sculptural shadings. Thus the Woolworth signs retained their consistency and became synonymous with "5 and 10 cent store" even through changes in materials. In later examples, gold-leafed aluminum letters were substituted for wood; painted backgrounds were replaced with porcelain enamel for appearance and maintenance.

A spokesman at the executive offices of F. W. Woolworth Company states that two factors led to the development of a new sign to meet current requirements. First, imitation by other variety stores; and second, the growing use of illuminated signs for all retail establishments. Some maintain there is difficulty in illuminating the red-and-gold sign; others disagree on this point.

The cliché that imitation is a form of flattery brings two questions to mind. Is it sound economic policy to build up a symbol for 75 years and then abandon it to ones imitators and competitors? And, since the red-and-

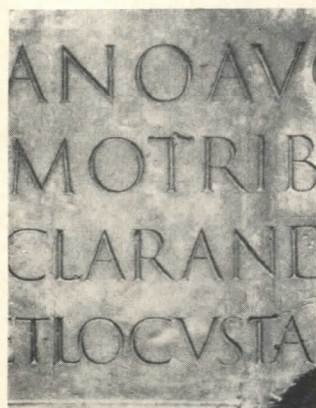

7

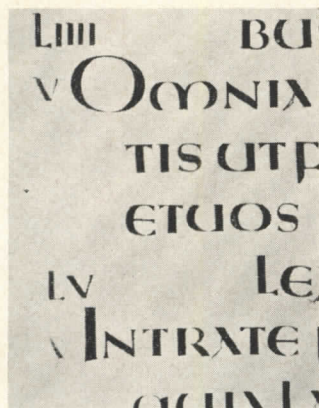

8

gold sign has for so long symbolized Woolworths, is it not conceivable that the customer in *any* variety store might think himself in Woolworths — so long as he had entered the store with the familiar red-and-gold sign?

For the sake of argument, let us grant the need for a change, in view of the supposed illumination difficulty, and look hastily at some of the in-between efforts. The reeded red plastic letter (9) placed directly on a brick wall, and the same letter (10) protruding above the canopy line but seen against a parapet containing a confused brick pattern. In both cases the letter form (11) is an unusually vulgar use of a new material, with nothing either decorative or legible to recommend it. A square-serif metal letter (12), massive in its proportions — note the squared-off O — set on a straight wall, a curved wall, and competing with the “chop suey” lettering on the vertical panels. Finally, the vacuous regularity of the sans-serif letter (13) on the fluted panel. Woolworth is to be congratulated on abandoning the latter two. But it is deplorable to think that the

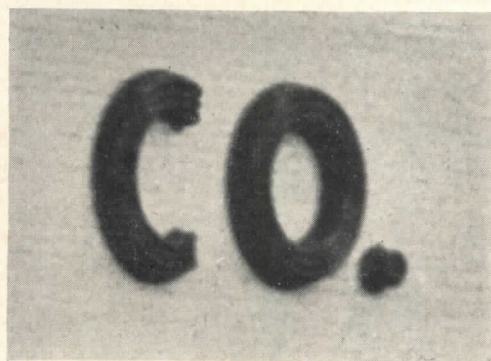

9

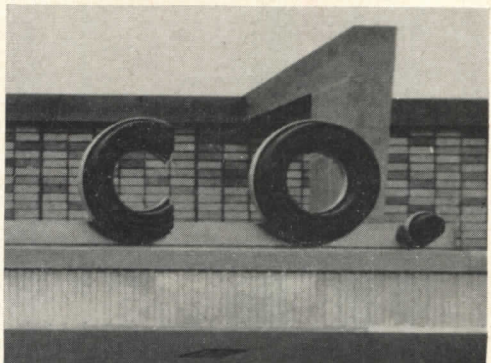

10

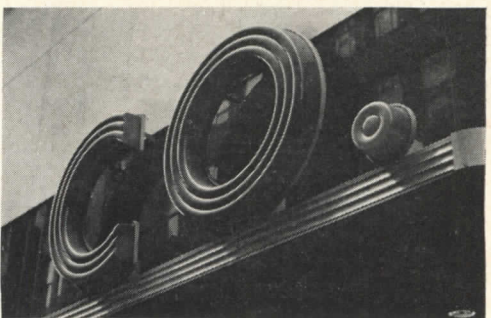

11



12

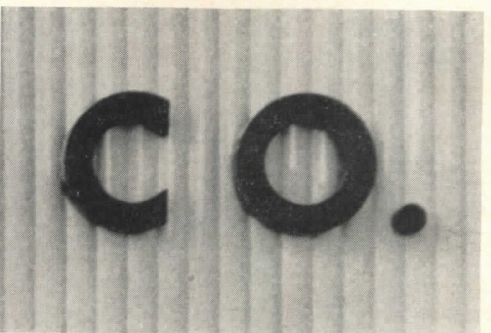

13

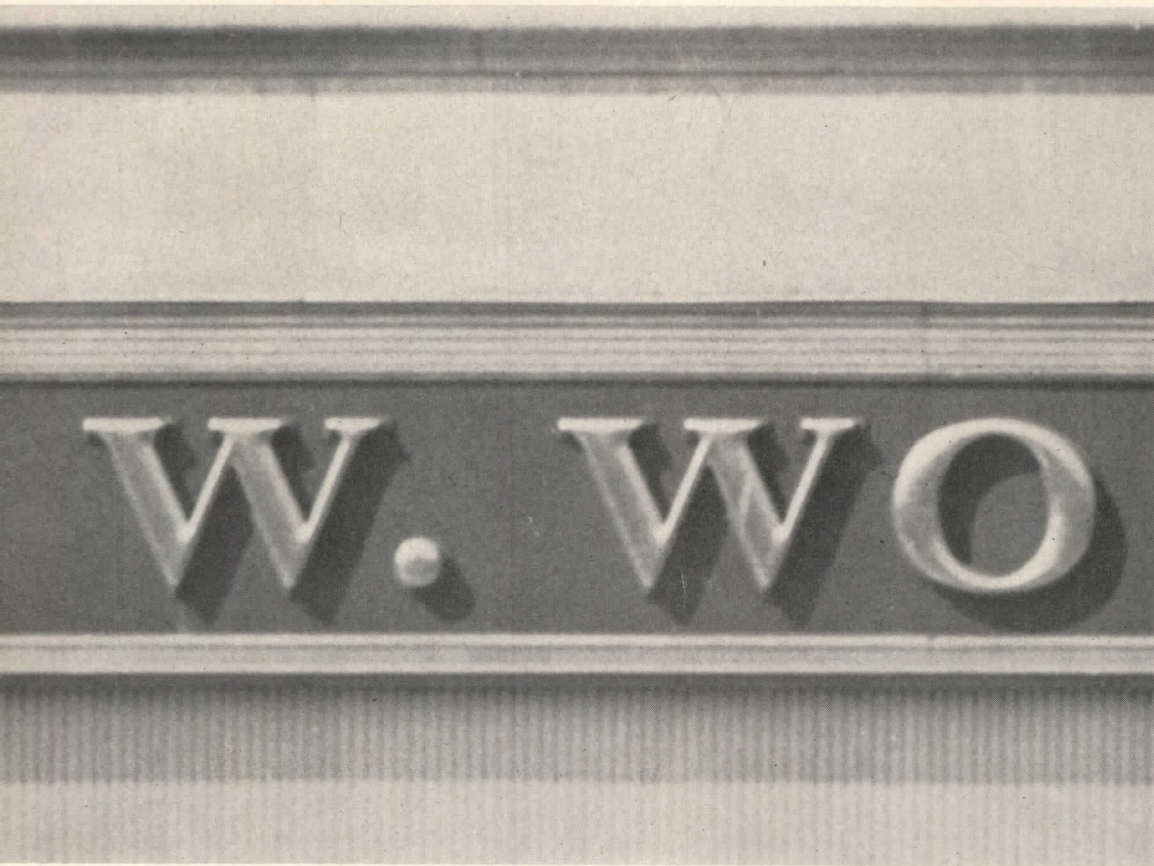

14

THE WOOLWORTH STORY

sculptural decoration on the facade is to be abandoned, and that the obsolescence factor of our economy rears its head at this point too.

Lighting experts say the red-and-gold sign can be illuminated — and anyone who passes one of the stores with the familiar sign can observe the effect of light on the modeled letters (14). On the other hand, with a need to observe uniformity — as in a shopping center where signs and symbols become a major visual problem — perhaps still another solution can be found.

To offset the stock letters offered to designers and buyers today (15, 16), efforts are being made by one plastics fabricator to supply the market with improved letter forms. In their laboratories the writer has seen the Roman Woolworth “O” executed in milky white plastic, which’s “up to date,” retains the sculptural qualities of the original letter, and can contain concealed lighting. Perhaps Woolworths can be persuaded to retain what is already excellent in their famous sign, even while making what may appear to be desirable adjustments.



15



16



Sign for bank in Columbus, Indiana, Eero Saarinen & Associates, Architects; Alvin Eisenman, Graphic Consultant

DE BUENKORF

Identification letters for store in Rotterdam, Marcel Breuer, Architect. Teakwood letters about 2 ft. high, free-standing against tan travertine wall

Night lighted signs at Shoppers' World, Framingham, Mass., Ketchum, Giná, & Sharp, Architects





Allwater & Brother

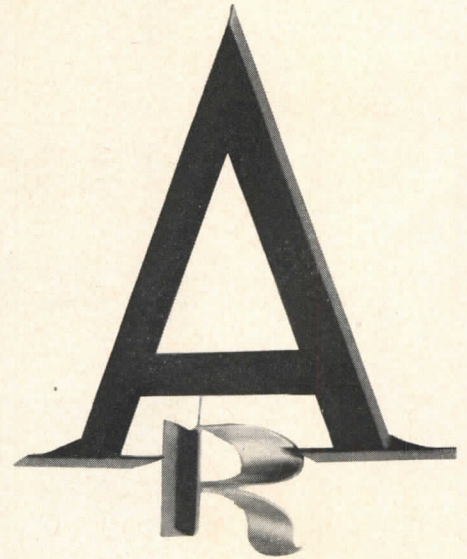

CORRUPTION, OPPORTUNITY, AND AN APPROACH

By Robert Lepper*

THE SIGN in contemporary architectural usage is a label. The specific purposes of the sign label appear to be:

To Inform: as: "EXIT"; "MEN"

To Name: to identify *Smith* lest he be confused with Jones. General Motors isn't General Electric isn't General Tire isn't General Dynamics.

To Express: to show that *Smith is Somebody*.

Information and identification orient; expression attempts to impress and influence. The first two are directly functional. The third is a basic characteristic of the human species.

The label appears to be here to stay. The Church, the State and a corporate giant may avoid it on rare occasions but *the Church*, *the State* and *the Monopoly* are loose mythical concepts. It is a practical necessity

*Robert Lepper is Professor of Design in the Department of Fine Arts, Carnegie Institute of Technology.

to differentiate sect from sect, postal sub-station from revenue office, Plant A from Plant B and Giant A from Giant B. The expressive label, in seeking to show that *Smith is Somebody*, naturally inspires the urge to showmanship. This sword is many edged. Its composite leads to Fifth Avenue, to Times Square, to Main Street, to Roadside Suburbia, and to the Shopping Center. Fifth Avenue and Times Square, despite their differences, share variety and fantasy; the sense of wonder and delight. Main Street aspires to both and usually arrives at messy chaos. Roadside Suburbia with its drive-in facilities is too often chaos squared. The Shopping Center seems to aspire to order, seldom achieves more than brutality. A very few of these stand out like good deeds in a naughty world.

Fifth Avenue, Main Street, Roadside Suburbia and the Shopping Center are consumer point-of-sale promotion. Times Square, like the circus, is in a class by itself. There remains that large class of label which usually stands aloof from enticement or exhortation. This

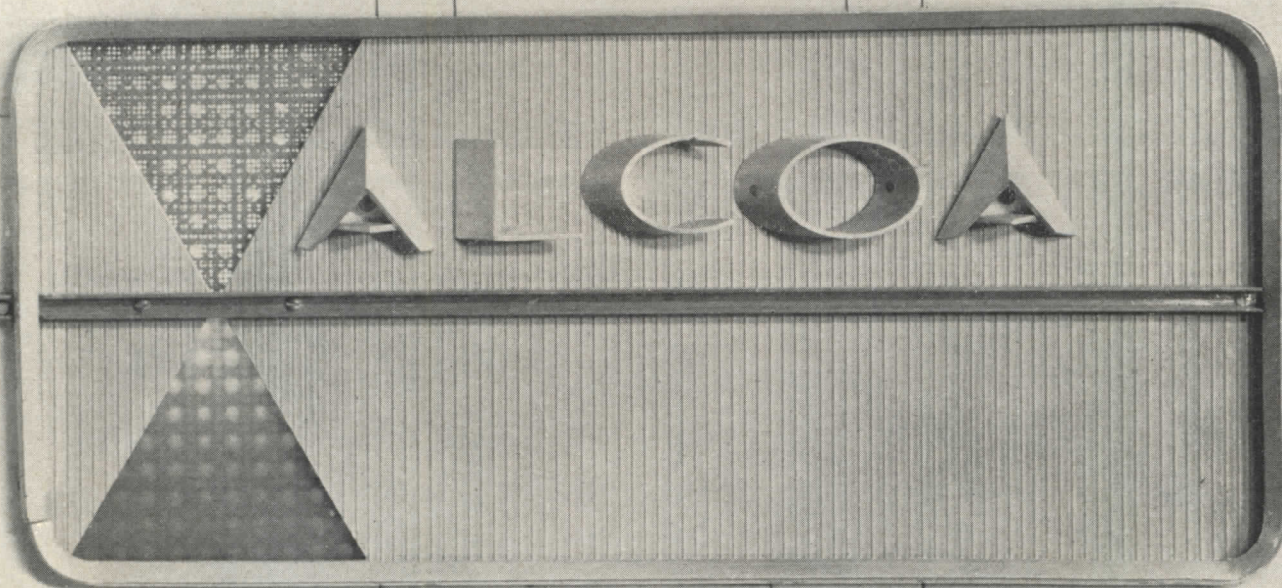

Allwater & Broder

Letter forms, above and left, developed from sheet aluminum. The shift of the positive-negative curve of the surface is a fresh mutation of the classic Roman and calligraphic thick and thin

type marks the bastion of the Home Office and the Plant and their territorial outposts. Whether the structure be on Park Avenue, in suburban "campus" or on the river banks or portsides of Heavy Industria, the problem of its relation to its label remains much as it always was — a matter of suitability to the structure, site and neighborhood. This classic trio must be expanded by the contemporary requirement that the label should identify to the passer-by at upwards of thirty mph. It is presumed that this latter requirement need not radically modify the desirability of the imaginative use of materials, of space, of light and of pigments, nor need it conflict with public decency.

The Sign seems to stimulate the impulse to the kind of showmanship which all too often *is* in conflict with public decency. This kind of showman's ambition for distinction starts and stops with the dream of *domination*. It is somehow supposed that one can achieve domination by the following means, singly or in any combination: NEWER, BIGGER, BRIGHTER, CONTRASTIER, COST-

LIER, OFTENER, and in a KEY LOCATION IN THE MARKET PLACE. The Urban Centers (Gateway in Pittsburgh, Mile High Tower in Denver, etc.) react to these vulgarities by treating orientation itself as a vulgarity. One is presumed to be a native with no need for signs.

It is obvious that the identity of a directory listing is no identity at all. The uniform listing falls short of the quite legitimate goal of expression of the inherent character of the individual enterprise. It must be less obvious that the urge to dominate as the sole objective of a sign is self-defeating. Otherwise Main Street and Roadside Suburbia would be both less offensive and more effective. There would be less cancelling out of stereotypes by stereotypes.

Fifth Avenue has the great virtue of foregoing the urge to dominate by crude power. If its composite is not pure enough for the puritans, it nonetheless has the variety, vitality and reserve that promises a pleasurable experience on a return visit. It is a continuous "natural" mural in relief. It has an infinite variety of *plastic* vari-

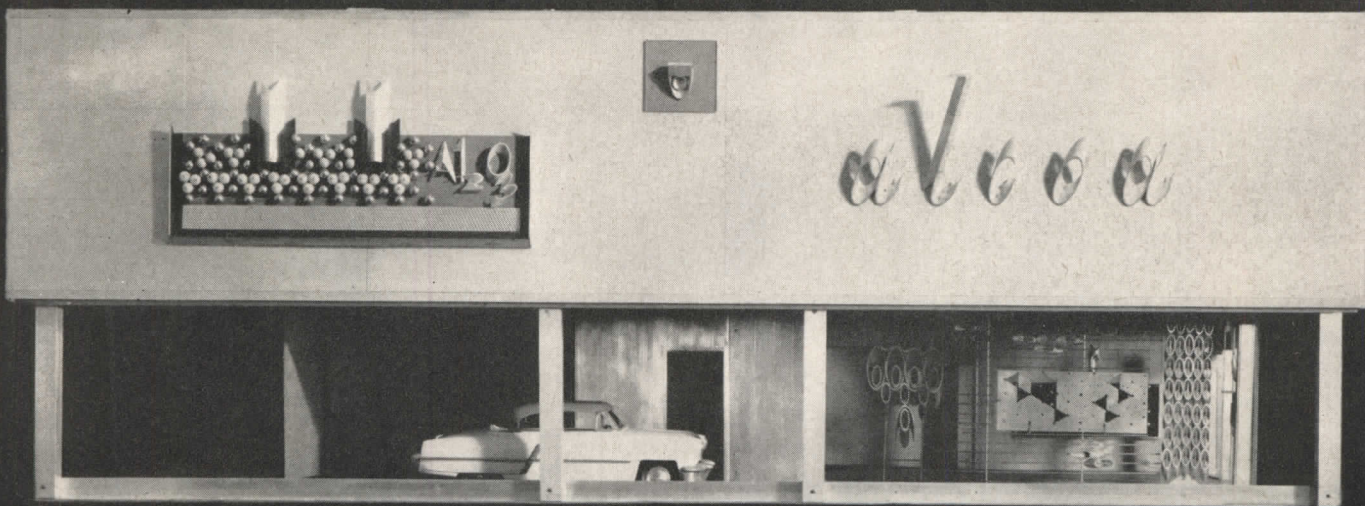
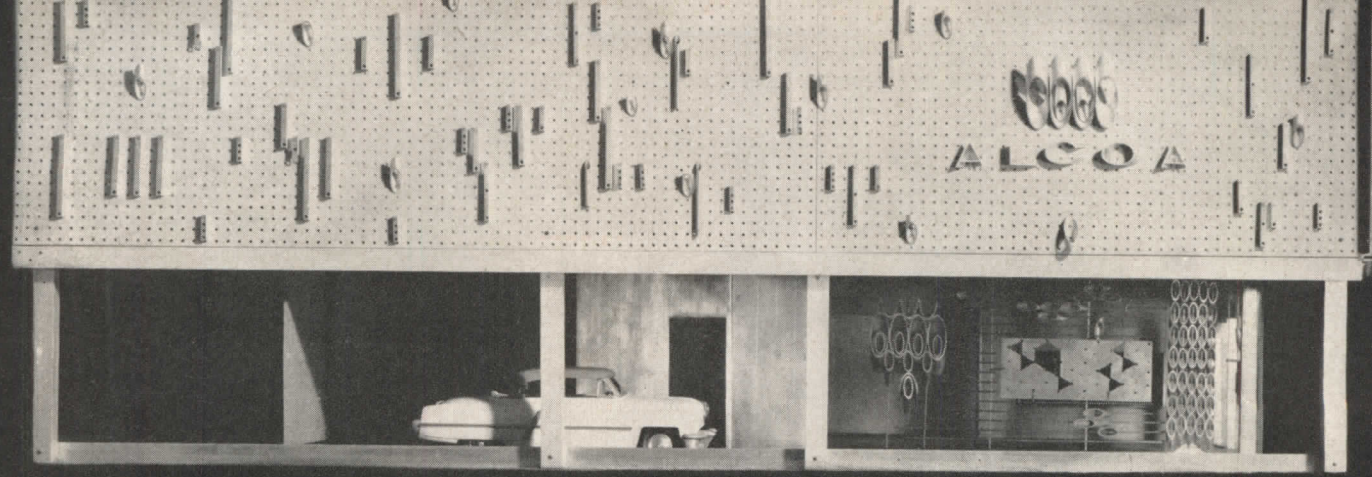

Altwater & Brothier

Studies for exterior mural walls and lettering by Robert Lepper; both welded extrusions in free pattern and scientific symbolism for the extraction of aluminum from alumina are design elements

Robert Lepper :

ables at a scale which entices the friendly participation of the pedestrian. If this were primarily a matter of the delights of merchandise display, then any Main Street would qualify as a provincial cousin. Unfortunately, it rarely does.

Corruption

The basic architectural structure is institutional and is a symbol. The House of Government, the Fortress, Factory or Cathedral remain even though they may change masters. The function or ownership of the institutional symbol may be misread, particularly in a competitive economy, so the symbol is labeled. While lettered labels presume the literacy of the passerby, they have other shortcomings. Lettered labels have little drama, limited tactile or sensory appeal and hence, little expressive differentiation. *They have little impact on the memory.* Consequently they are supplemented, and occasionally supplanted by a *device* or a "trademark." The British Lion and the Hammer-and-Sickle

have an impact on the eye and the memory that the letters LONDON TIMES or PRAVDA can never hope to match.

The architectural profession and its collaborators — the painter, the sculptor and the blacksmith, have monopolized this field of label making since the beginning of time — that is, until the advent of the professional advertising man. More recently, and without the benefit of architectural advice, the new Home Office or plant in many cases gets one of two label treatments: a blow-up of the letterhead or "signature" of the current advertising of the company, or a discrete Roman letter from the foundry catalogue. The former is in the interest of "family resemblance." The latter is a sensible if unimaginative hedge against future change of either the advertising or the management. It also gets a tough and interesting problem out of the way in dull fashion. The case for the blown-up signature derives from the weight of the repetition of the company name on millions of printed magazine pages, mailings and television screens.

Recognition is insured by repetition, so tie the sign into the advertising. What's wrong with that?

Well, first: the ad man works to the *scale* of the printer and the printed page. Second: his basic concerns are, generally, detailed information and promotion or exhortation in varying mixtures. The apparatus at the disposal of the ad man to dispense his detailed information is a superb array of mechanisms. The camera, photo-engraving, full-color printing and literally thousands of different type faces make it natural for him to be profligate with his graphic means. The more detailed the information, the weaker its expressive impact or its retention value. But the ad man need not be disturbed by this. He can rely on repeated exposure to compensate for lack of retention. His product is designed in full consciousness of short life expectancy. It is made to be thrown away. The scale of the printer and a short life expectancy are not in the tradition of architecture.

Opportunity and Approach

The current corruption of the sign is no reason for abandoning it as artistically hopeless or as socially unregenerate. It could do its bit toward reviving "ornament" as a legitimate element of architecture. Not only does the function of the sign justify some attention to its aesthetic delinquency, but the rapidly multiplying acreage of flat or fenestrated façade could well stand some imaginative relief.

That acreage is the price paid for sweeping away the clutter of "period" ornament. But, of course, there was a time when "period" was not "clutter," but rather was exploiting the infinite variables of sunlight and shadow — their play and change through time of day, of weather and of season. The smooth clean surface and the large structural or curtain unit have undeniable virtue but they too often fail to employ this cheap resource for sensual satisfaction. Since a sense of proportion is a classic asset of the designer, is it not proper for him to reconcile three conditions, namely: the size of the structure, its landmark power on the horizon, and some interest at close range? Since sunlight and its shadow play are not of any "period," sunlight can contribute to reconciliation. The sign, as part of the façade, in low relief, in dramatic projection, or as a free-standing island, is a natural device for exploiting it.

All these have been done, of course. The "better" ones have been done with V-section stock letters or with flat "gothics" with constant width of face, mounted parallel to the plane of the wall. The common fault of these latter is a static politeness (when they are not brutally out of scale) which stops so nearly at the function of identity that the observer has only a test of his literacy. His senses remain untouched.

The classic frieze of the stonemason was generally better. It derived its life from the continually changing plane of the *surface* of his material. His variables were form in light, shade, shadow and interval in the "field." These change further as the mobile pedestrian changes his viewpoint. The flat shape, even when projected from the wall, cannot match such variety and change.

Sheet metal and plastics are materials which have natural plasticity and the capacity for change of plane *within* the component shapes or letters of the "ornament." Color is limited for the plastics; has a considerable range for the metals in baked enamels and electrochemical treatments. Since change of plane within the material takes the sculptor's feel, development should be by model. The drafting board will only flatten.

Illumination

Whether king size or at more intimate pedestrian scale, it is probable that any sign which is interesting in daylight can look about as well at night under illumination. Lighting can be on the sign, within it, or behind it. The value of intermittent illumination is doubtful although there are always exceptions and the "spectacular" is a major one. Any cycle of change of intensity and source will give a complete show in a relatively short interval. The magic of the mechanical repeat — a jittery sequence of successive static images, quickly wears itself out to any one curious enough to stop and stare at it.

Translucent and perforated materials with artificial illumination have a potential for something new. Used together they are able to provide almost infinite variety and contrast in light intensity, color and movement under *constant* illumination. The element of movement in such derives not from the blatant flashes or mechanical devices but from the movement of the passerby. The sign can change subtly as *he* changes his position in relation to it. This movement can provide a kind of "magic" to intrigue the observer without its means getting in the way. Such a sign might appear as letters against a white field in daylight; a lively, glowing, mysteriously changing surface at night. This medium, related to painting, should be developed by direct experiment in model form.

If the sign were conceived and developed with the same care customarily lavished on the street-level entrance one might expect a result of equal merit. The logic of "fussing" with the materials, space and lighting of any area that leads from street to elevator seems to be generally accepted and understood. The entrance and the public lobby may be the last refuge of the senses in architectural space.

To summarize: The sign is an ancient piece of ornamental conceit and can be an honorable one. It is one of the few remaining opportunities for using plastic elements on the shell which encloses the plastic space of the well developed plan (or relates that space to all outdoors). The sign has a contemporary logic which should be less affected by the all too frequent self consciousness which of late accompanies "art" in buildings. Signs are so often dull when not offensive because conceived in anemic spirit by draftsmen who lack the sculptor's feel for materials and light. The sign will take a special kind of sculptor, to be sure — one sympathetic to the values and purposes of the parent building, one conscious of weight, weather, and maintenance as well as one sensitive to the manipulation (or design for fabrication) of his materials.

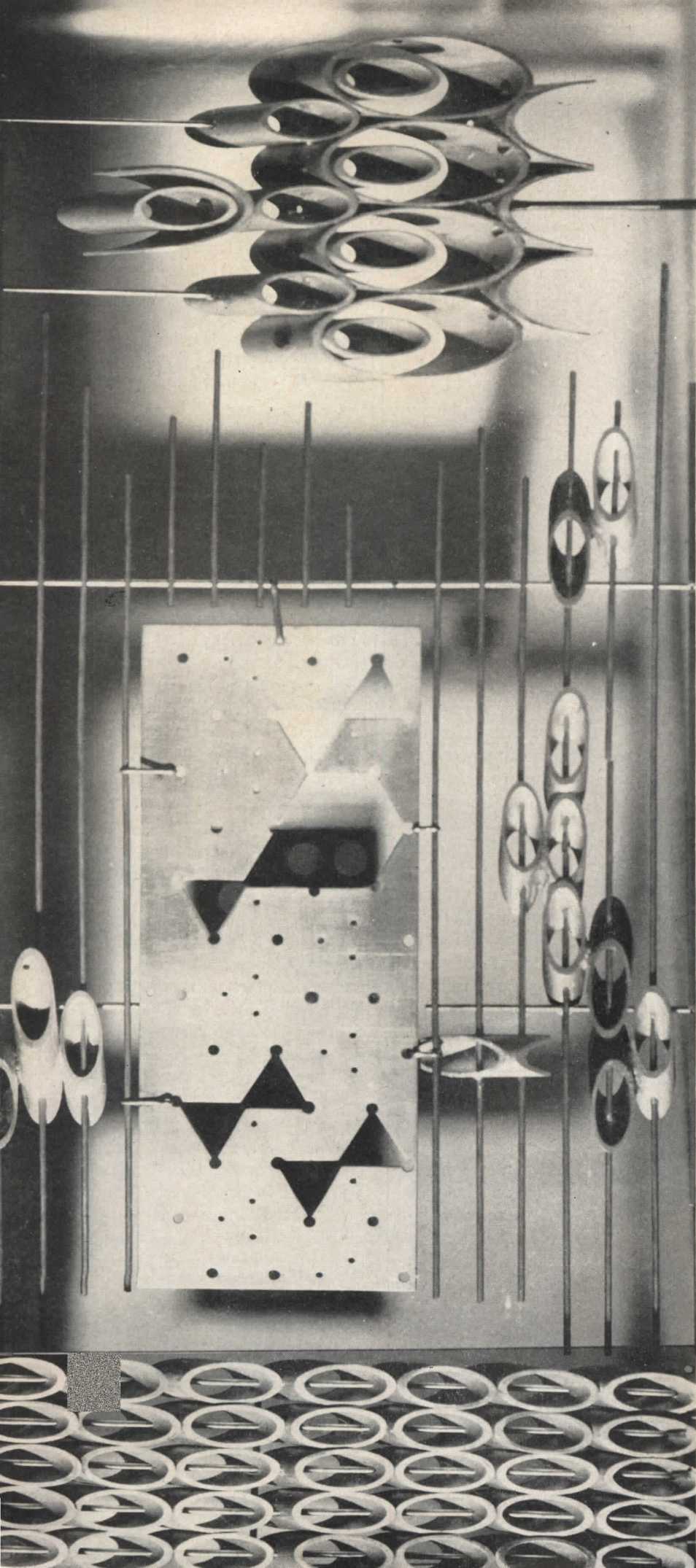

Altwater & Brothel

SIGNS AND SYMBOLS Grill element made up of standard aluminum geometric shapes — designed by Robert Lepper





LAST LOOK AT A STRUCTURAL LANDMARK

Charles Payne

What construction was like at the height of the cast iron period of architecture, precursor of prefabrication and skeleton framing, is portrayed by after-fire photographs of John Wanamaker's store together with an historical text by Alan Burnham

When the former John Wanamaker store building caught fire on July 14, popular interest was focused on the drama of the fire fighting, and probably few people realized that not only was the exterior facing cast iron, but so were the interior columns, and that the wrought iron beams were made in the famed Peter Cooper's foundry. Although the fire burned out of control for a day, the system of columns and girders remained straight, as did the

exterior. (The building was empty at the time, however, and the wooden floor system, comprised of 4- by 16-in. joists, supplied the main fuel for the fire, reaffirming early fears for such construction.) The following pages have a number of photographs taken after the fire which show, perhaps as never before, how inventors and architects, nearly a century ago, were making use of skeleton framing and prefabrication.

THE DEVELOPMENT of cast iron fronts in New York was inaugurated by James Bogardus' Laing stores of 1848 (Washington and Murray St., New York) where a simple post and lintel system in iron had been evolved logically from the earlier granite post and lintel type structure such as may have been seen on Water Street. Many merchants then were removing brick or granite piers and having them replaced by slender cast iron columns to provide larger show windows. Later on, first floors were built



While fire has destroyed the wood joists, cast iron columns and wrought iron beams stand straight and true



Skylight of the arcade which covered original court

Charles Poyne

LAST LOOK AT A STRUCTURAL LANDMARK

in this way with the upper floors of brick, sometimes faced with marble.

Bogardus introduced the first all-iron store front, a post and lintel type, which was later to be developed to perfection by 1861 when a store building was put up for a canny merchant of the time, A. T. Stewart (later Wanamaker's). The parts were bolted together in an integral manner so that the vertical forces were safely transmitted through continuous columns (usually pipe columns) to the foundation. Even before the emergence

of the first cast iron store front in 1848, the interiors of many buildings had been supported by a system of cast iron columns and wood girders which later were supplanted by wrought iron girders.

What were the causes leading to such a widespread acceptance of cast iron which began to take place in New York before the Civil War? Perhaps the most obvious ones were those qualities which best suited the merchants occupying the stores. One writer said that "... the new tenant likes to move into a seem-

View through arcade shows wrought iron girders, cast iron decoration and framing





Fire started before main demolition got under way; was worst in New York for 30 years.



Detail of the column and beam connections. Beams rest on shoulder; appear to be two I-sections bolted through stub of casting

Charles Payne

LAST LOOK AT A STRUCTURAL LANDMARK

ingly new building; and the whole metal front can be painted up afresh with the coming in of every fresh occupant."¹

Another much valued quality was that of economy, about which one contemporary author waxed enthusiastic when he said ". . . The interest on the difference in first cost, between a stone and iron front, will easily pay for one coat of paint a year. More than that: allow the difference in cost to accumu-

late with legal interest, less the expense of one coat of paint a year, and by the time the stone is ruined, the iron will not only have cleared itself, and stand on the balance sheet at a profit, but be in prime condition for continued service."² A further asset on the side of economy was the rapidity with which such a prefabricated structure might be assembled and bolted in place, leaving only the

¹History of Architecture and the Building Trades of Greater New York, N. Y., The Union History Company, 1899.

²"Iron Store Fronts," William J. Fryer Jr., The Architectural Review and American Builders' Journal, April, 1869.

Close-up of skeleton frame



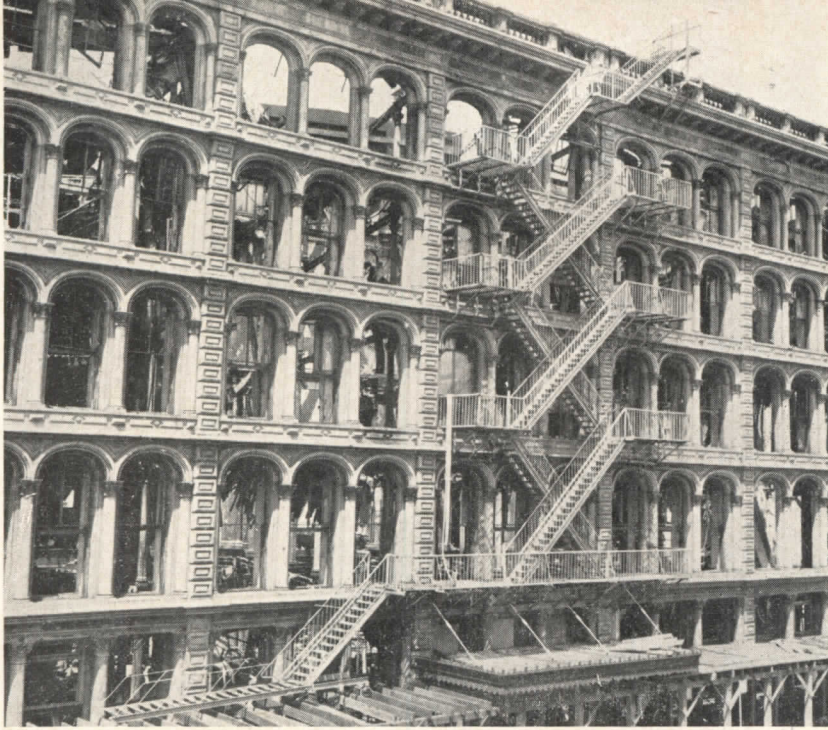

Cast-iron exterior still looks unravaged, but wood floors are completely gutted

LAST LOOK AT A STRUCTURAL LANDMARK

work of the carpenter laying his joists, to be laboriously done at the site

A. T. Stewart was "... an enthusiastic advocate of cast-iron fronts . . . believing that the material had in its favor unequalled advantages of lightness, durability, economy, incombustibility and ready renovation. . . . His uptown store gave the ample light that this merchant had learned was so valuable for his business. In its dress of white paint, Mr. Stewart used often to liken his iron front to puffs of white clouds, arch upon arch, rising eighty-five feet above the sidewalk."³

As to the strength of cast iron, much had been written on this subject before Stewart built his store. In compression, used for walls and columns, it was without peer at this date; but in tension, such as that exerted along the lower flanges of beams, it had been proven deficient. Consequently, cast iron gave way to wrought iron for beams, despite the fact that wrought iron was distorted more readily by heat.

One author writing in 1869 assured his readers that cast iron itself was resistant to fire when he said: "Events have proven, in the cases of the burning of store-houses, filled with combustible goods, that cast-iron fronts are absolutely fire-proof and will neither warp, nor crack, nor fall down."⁴

The public, suspicious of the seeming

lightness of the new construction, was quick to criticize, and did in fact hit upon the weakness of the system, namely the wood flooring: "... Continual attacks were made in the form of letters to the daily newspapers upon this way of building, for it appeared evident to all observing men who tramped daily past the rising structures that they were terrible 'firetraps' within their outer walls."⁵ Only Harpers' new building on Franklin Square had been built with brick floor arches resting on the lower flanges of "Cooper" wrought iron beams.

An early account of prefabricated cast iron components informs us that "... The process of manufacturing an iron front is interesting in every stage, from the time when the architect's small scale elevations are received until the finishing coat is put on the work set up in place. Large scale drawings are made, followed by full-size drawings of the principal parts. Then the patterns are prepared. In the foundry the pieces are moulded in sand and castings are made. Cleaning, chipping and filing next follow. The ends of the cast columns are cut off true and smooth in a double-ended rotary facing machine. In the fitting shop, the columns are laid on their backs, spaced the right distance apart, bolted together story upon story. The light castings, the arches, the soffits, the sill, the ornaments are all fitted in their place and bolted or

secured fast. Lying on the floor the iron front is thus put together in all its parts. A surface of oxide of iron paint is given to the work. The parts are then separated, care being taken to mark each piece so that it can be put back in its proper place."⁶

The type of materials used in the various castings was very important, placing a burden of responsibility on the iron founder. Columns cast directly from blast furnace iron were almost as brittle as glass, whereas pig iron possessed the desired qualities and was used in all the architectural foundries in New York, according to one source.⁷

Stewart's store on Broadway opened its doors in 1863, and such was its success that we learn from the annual report of the Superintendent of Buildings, for the year 1867, that Stewart proposed the construction of an addition which would more than double the size of the building: "... The superstructure to consist wholly of heavy cast-iron columns, wrought-iron girders and Cooper beams [from Peter Cooper's Foundry near Trenton, N. J.], well seasoned white pine floor-beams, headers and trimmers; the whole securely framed, bolted and screwed and strapped together."⁸

The Superintendent of Buildings apparently was as thorough as he was

³ "Men Who Have Assisted in the Development of Architectural Resources — John B. Cornell," ARCHITECTURAL RECORD, Vol. 1, No. 2, Oct.-Dec., 1891.

⁴ *op. cit.* "Iron Store Fronts," William J. Fryer.

⁵ *op. cit.* History of Architecture and the Building Trades of Greater New York.

⁶ *op. cit.* "Men Who Have Assisted in the Development of Architectural Resources — John B. Cornell," ARCHITECTURAL RECORD.

⁷ "Skeleton Construction," William J. Fryer Jr., ARCHITECTURAL RECORD, Vol. 1, No. 2, Oct.-Dec., 1891.

⁸ Annual Report of the Superintendent of Buildings for the Year 1867, p. 308.

How the cast-iron faced store appeared back in the early days of A. T. Stewart

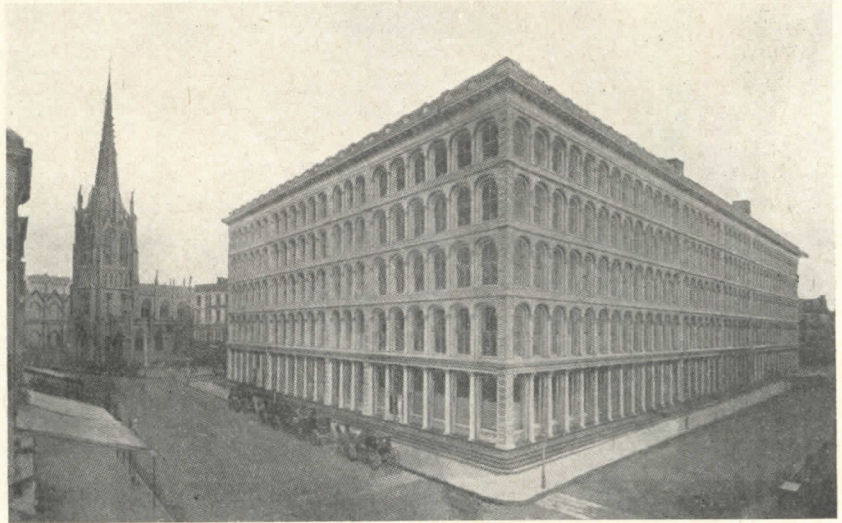

Architectural Record, Vol. 1, 1897

cautious, for he expressed anxiety in being called upon to pass judgment on such a novel structure: "I accordingly consulted, among others, Major General Newton, a well-known United States civil engineer of acknowledged ability. A thorough examination of the plans submitted proved them upon the whole, bold and good, every precaution having been taken by the architect, Mr. John Kellum, in the materials named and the manner they were put together, to insure strength and durability. Many suggestions were made to render assurance doubly sure."⁹

The architectural treatment of cast iron became a highly controversial subject with the attempts made by some architects to imitate masonry forms in this material. William J. Fryer Jr., writing in 1869, said that: ". . . Iron in this respect presents peculiar fitness. It wants proper treatment and asks not to be set up as a false jewel, colored and sanded in imitation of stone, or made flashy with over ornamentation. This material — emphatically an American building material — has peculiarities of its own and will preserve its own individuality. Let an observer stand on any of four corners of Stewart's immense drygoods store and take in with his eye the frontage on two streets. Those plain round columns and moulded arches and projecting cornices cannot be mistaken for stone. There is too much lightness and grace for anything but iron; and

both expansive elevations are beautiful too, being in iron."¹⁰ Only the rusticated quoins at the corners and piers, dividing the various sections of the building and balustrades at the top, might have been said to be reminiscent of stonework.

After Stewart's death, the store continued in business, becoming eventually Hilton, Hughes & Co. Many of the big department stores had already moved uptown and business had fallen off considerably when, in 1896, John Wanamaker bought the store, complete, for less than three million dollars. The Wanamaker store attracted so much business that it was necessary to open a 14-story addition across the street in 1907, connected by a "Bridge of Progress." This store was designed by Daniel Hudson Burnham of Chicago, and was admired in its day for the direct expression in masonry of the underlying steel skeleton.

Despite many years of flourishing business, Wanamaker's, placing a new emphasis on its suburban stores, regrettably closed its doors to business in December 1954. In 1956 it was announced that the north building (Stewart Store) was to be demolished to make way for apartment houses. Before operations got under way, one of the worst fires in New York's history broke out on the evening of Saturday, July 14. It was not until Sunday night that the fire was under control. When demolition was resumed, the actual structural system was fully

revealed behind the cast iron facades.

Watching the wrecker's big iron ball swing out into space and come rushing down with a loud "crack" against a window frame, we could now see revealed inside the broken "V" formed by two adjoining window heads, a continuation of the column between windows carried on up to become the column between the two windows above. The wrecking operation had proved that continuous vertical columns transmitted the loads from the topmost floor directly to the foundation, and it was in that verticality, hidden at first from view, that lay the seeds of the skyscraper.

In their lightness of structure, large glass areas, and prefabricated type of assembly, the great cast iron buildings of the '60's would seem to be the ancestral strain from which emerges our modern curtain wall of metal and glass; but such was not the case. A series of disastrous fires in wooden-floored, cast iron buildings discredited them, and although progress was made in the late '70's and '80's in introducing effective fireproofing for structural members, the architects reverted to massive exterior masonry bearing walls with adequately fireproofed interior floor and column systems. Later, when the steel skeleton system was devised, with steel columns actually supporting outer walls, architects continued to load tons of masonry on the outer framework, having turned their backs on the advanced thinking of the architects of the '60's.

Alan Burnham

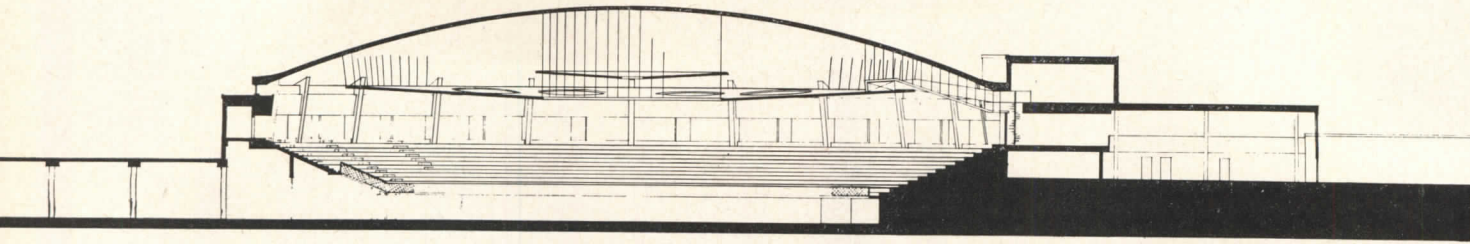

NATURAL HILL IS FORM FOR CONCRETE SHELL OF ALBUQUERQUE AUDITORIUM

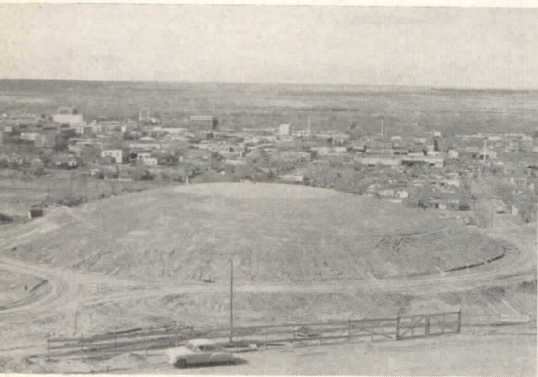

Albuquerque Journal

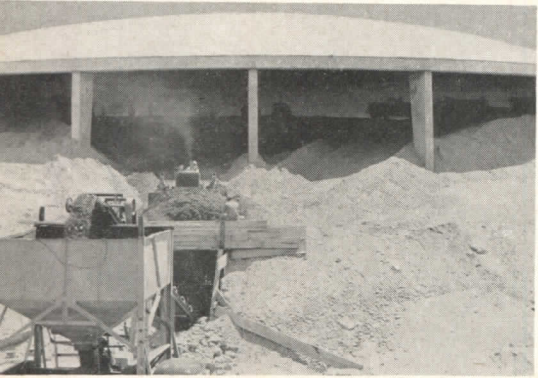

Steve Lowell



Steve Lowell

ONE OF THE MOST INEXPENSIVE FORMS ever devised—a natural sand and gravel hill—has been used for the concrete shell of the new Municipal Auditorium in Albuquerque, N. M. When the architects, Ferguson, Stevens & Associates, decided on a circular arena, (“to get as many people as close as possible to the center of attraction”), they considered a number of forming methods before finally arriving at what they thought would be the cheapest method: using a roughly rounded hill at the specified location, smoothing it off and pouring the concrete dome over it. This accounted for an estimated saving of \$50,000 over an alternative method of building up a hill of 90,000 cu yd of earth on a level site.

After the hill was shaped, it was covered with plywood, and over that was stretched reinforcing steel. Tapered concrete columns, 14 ft tall, were sunk into the ground before the shell was poured. In order to counteract the tremendous outward thrust of the 1850-ton dome, a tensioned steel collar with a cross section of 14 sq in. was stretched around the edge. The collar was made by winding 85 miles of $\frac{5}{32}$ -in. steel wire around the ring of the dome in a groove left for that purpose. A tractor was used to provide the necessary tension as the wire was

stretched around the ring. Estimated expansion of the ring is only about $\frac{1}{8}$ to $\frac{1}{4}$ in., which is absorbed easily by the massive supporting columns. Almost all the expansion of the shell itself is through vertical movement, and that is minimized by 2 in. of outside insulation topped with white marble chips to reflect heat. The dome is 5 in. thick at its peak; thickens to 2 ft toward the base.

After the 220-ft-diameter concrete shell had set, the sand and gravel mound was excavated from under the dome and the interior was finished. Basically the auditorium is a ring of 3500 upholstered, theater-type seats rising in tiers around a concrete-floored arena. This 140-ft-diameter arena can be covered with earth and sawdust for circuses, stock shows and similar events; it can be flooded over refrigeration coils laid in the concrete for ice shows; or it can be used for 2500 more temporary seats. The arena is reached through two tunnels from the main lobby at the same level. Two stairways lead from the lobby to the mezzanine and an 8-ft aisle circling the tiered seats at the upper edge. To minimize noise in the arena, an acoustical ceiling was suspended under the dome, as shown in the drawing above. Catwalks over the hung ceilings lead to lighting and air conditioning elements.

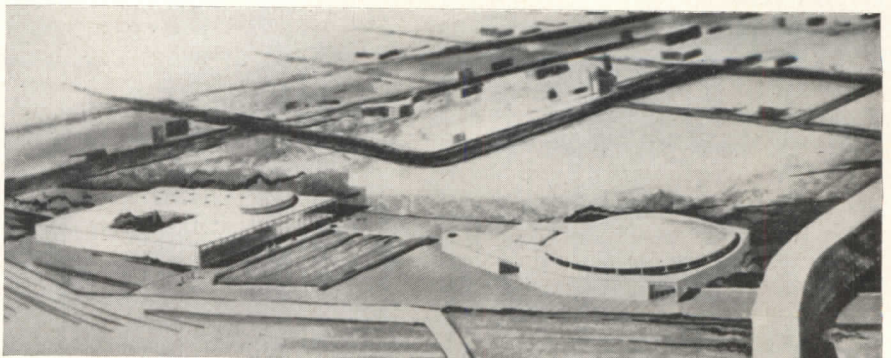

The hill was shaped as shown above, covered with plywood and reinforcing steel and then scooped out from under the shell after the concrete had set. Auditorium will be part of cultural center at right

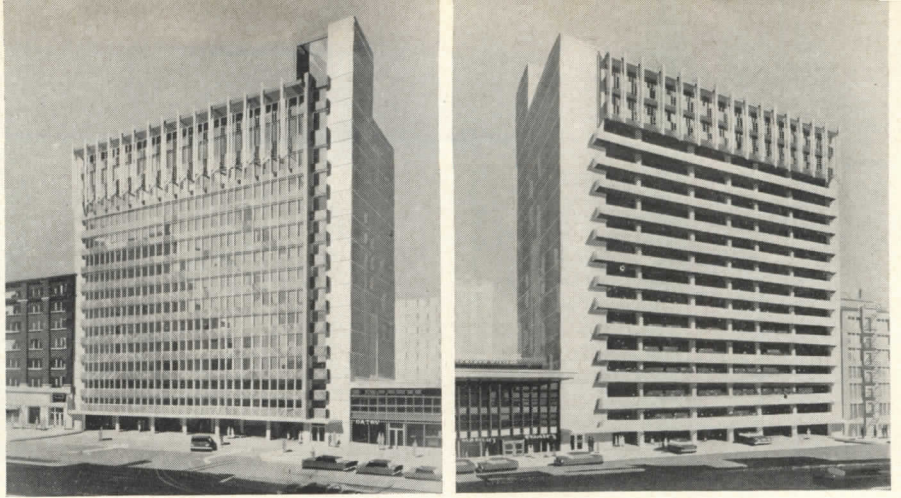
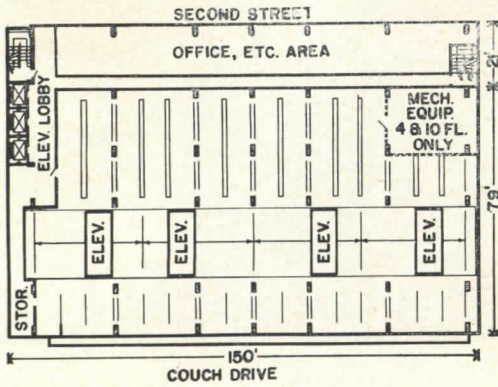

Petroleum Club Building: Second Street entrance (left), Couch Drive exit (right)

PARKING INTEGRATED WITH MULTI-STORY OFFICE BUILDING, HOTEL

"SKYSCRAPER PARKING," in which mechanical parking facilities have been integrated with the functional areas of both office buildings and a hotel, has introduced a new philosophical element into the handling of downtown parking. A new parking system utilizing elevators which move both vertically and horizontally has made it possible for office workers to drive right to their offices and for hotel guests to park right outside their upper story hotel rooms.

One of the first of these integrated-type buildings is the Petroleum Club Building in Oklahoma City, designed by Bailey, Bozalis and Associates, Architects. This 16-story office building utilizes approximately two-thirds of its 15,000 sq ft typical floor area for parking and elevator facilities and the balance for office space. An office worker drives into the Second Street entrance, surrenders his car to an attendant and rides on a passenger elevator to his floor. Meanwhile the car attendant drives the car into one of four storage elevators, presses a button indicator on a panelboard and takes the car directly to the stall indicated. When the office worker presents his car receipt to the cashier at the end of the day, he withdraws the stub from an electronic rack, thus making contact with a signal light on the elevator panelboard. When the attendant sees the light, he presses the button under it and the elevator takes him directly to the stall to pick up the car. The attendant takes it to the Couch Drive exit, which is one level below the Second Street entrance, and the worker drives off. The electrical signal system is the heart of the operation, showing on panels in both the elevators and the cashier's office the stalls which are empty and those which are occupied at all times.

As shown on the typical floor plan above, there are 46 stalls on each floor, each with 165 sq ft of area. There are no parking facilities on the 15th and 16th floors, which are given over entirely to the Petroleum Club. In addition, the Club has an open, balcony-covered veranda on the Couch Drive side of the 14th floor, which leaves only 30 parking stalls on that floor. On the second level, which is actually the Second Street entrance level, there are 40 receiving stalls and 16 parking stalls. These stalls are directly over the 14 exit driveways on the first level, which also has 9000 sq ft of service area that could be used for about 30 more stalls.

The Second Street facade of the Petroleum Club Building will feature continuous strip windows alternating with continuous blue aluminum panels covered with natural aluminum diamond mesh. The Couch Drive facade will be open balconies of painted concrete for all parking decks, with the top Club floors treated like the Second Street facade. Decorative aluminum fins project downward on both sides of the building on the Club floors.

"Beside parking" has been introduced in multi-story hotels in the new Astro Hotel in Mexico City. Here the hotel guest can drive into the receiving area of the garage, leave his car to be parked by the same system used in the Petroleum Club Building and go directly to the adjacent hotel lobby. The garage, with 366 parking stalls, accounts for approximately 94,000 sq ft in the structure, and the hotel area 70,000 sq ft. As shown on the typical floor plan, a lightwell rises from the third floor to the top of the structure, separating the parking area from the hotel area. There is a door between the hotel corridor and the garage area on each

floor, so that a bellboy can take baggage directly from the room to the car when a guest checks out. The hotel space and half of the garage area on the second floor is occupied by the upper part of the two-story lobby, dining rooms, etc.

The First National Bank Garage in Oklahoma City, designed by Sorey, Hill & Sorey, Architects, combines drive-in banking, an auditorium, a print shop and a cafeteria with parking facilities on 12 floors. Another office building in Miami will have six floors of garages and six floors of office space on top.

Originators of the Bowser Parking System in Des Moines, Iowa, feel that these buildings are just the beginning of a trend toward integration of parking facilities in buildings. They foresee its use in apartment houses, department stores and other building types, with the only limitation being a height of 12 or 14 floors.

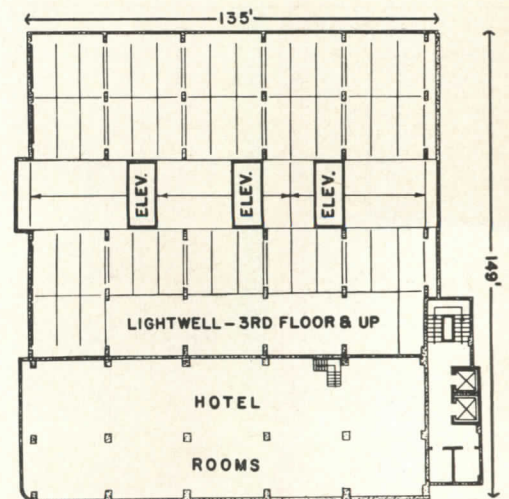

Typical floor plan of Astro Hotel and garage integrated in Mexico City

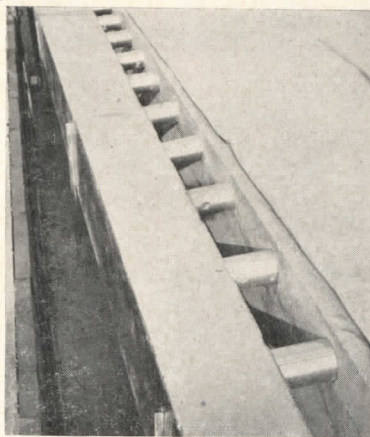
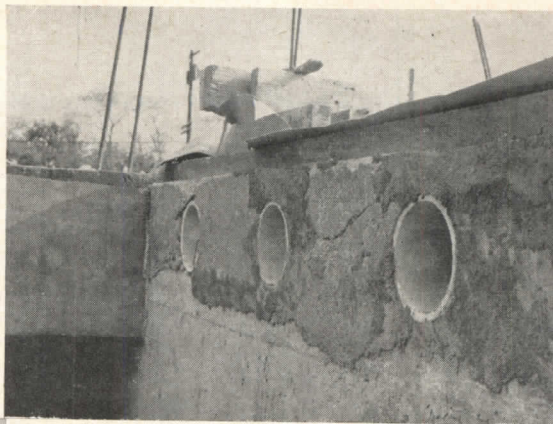
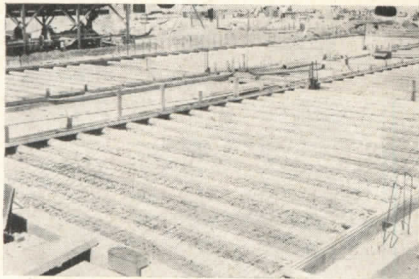

Supply line in utility tunnel (left) feeds into asbestos-cement warm air ducts at right angles. Ducts, shown ready for pour (above left) and after pour (above right) discharge into warm air trough along exterior wall, shown in right foreground of upper left photo (utility tunnel in center)

IN-SLAB DUCTS CIRCULATE WARM AIR THROUGH SCHOOL

ARCHITECTS JAGOW & HEIDELBERGER of Hempstead, N. Y., working with consulting engineer C. E. Langgaard of Mineola, N. Y., have designed into ten one-story, slab-on-grade schools a warm air circulation system which they believe to be both practical and economical. The system consists of a main supply line from the oil burner connecting with a separate supply duct to each classroom, which in turn feeds into a series of closely spaced *Transite* warm air ducts. The *Transite* ducts, 5 in. in di-

ameter, are spaced across each classroom 24 in. on center and discharge into an air trough along the outside of the room, from which the warm air rises into the room through grilles under the windows. After the air circulates through the room, it is exhausted into a corridor and pulled to a shaft above the heater room. Some of the air is exhausted to the outside and some returns to the heater room for combination with fresh air for re-conditioning and re-circulation.

The only excavation necessary is for

the heater room and the utility tunnel under the corridor for the supply ducts. The *Transite* ducts are laid on top of 5 in. of gravel, covered with wire reinforcing and then spread with a layer of 2 to 2½ in. of concrete. The pipe joins easily, is heavy enough to stay in place during the pour and isn't easily damaged during pouring and pre-pouring operations. Made of asbestos-cement, it provides radiant warmth upward to the concrete slab, eliminating cold spots in the floor without inducing hot spots

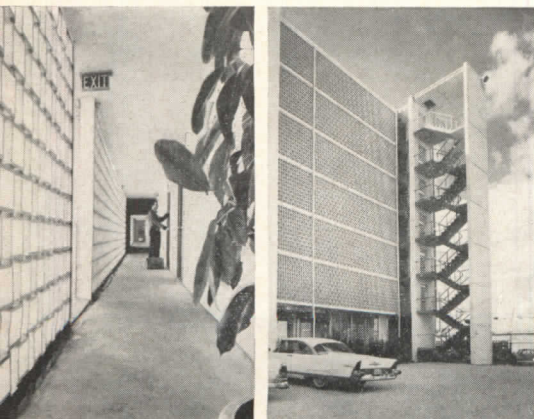

HONEYCOMB OF CLAY FLUES DECORATES MOTEL

THE NEW PAN AMERICAN MOTEL located on New Orleans' "Miracle Mile" features a six-story wall of 15,000 clay flues that gives the structure a feeling of openness. Said to have the structural strength of a solid 8-in.-thick brick wall, the honeycomb wall floods the long, narrow halls with light and fresh air, as can be seen in the interior photograph at left. Interior night lighting

shines through the apertures to produce a warm, translucent effect. The flue liners used in the wall were 8½ by 8½ in. and 6 in. deep. They were laid in a steel angle at the top and bottom of each floor in ½-in.-thick mortar. The building was designed by Curtis & Davis, Architects and Engineers, of New Orleans.

(More Roundup on page 294)

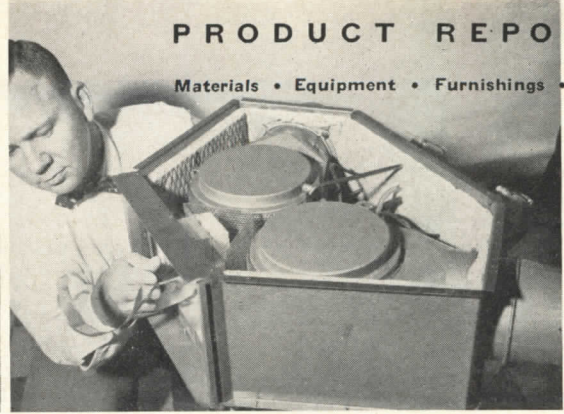
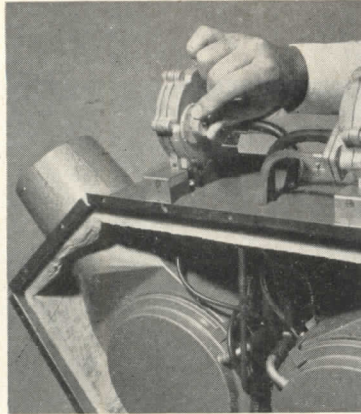
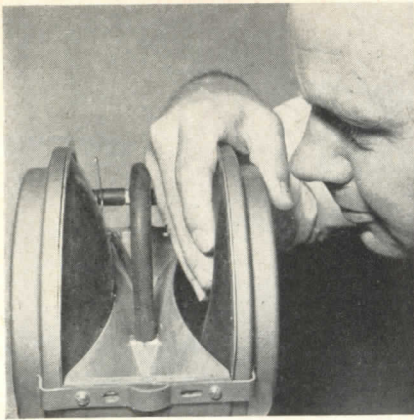

HIGH VELOCITY BLENDER VALVE CONTROLS AIR FLOW THERMOSTATICALLY

PRECISE INDIVIDUAL ROOM TEMPERATURE CONTROL of high pressure-high velocity air conditioning equipment is said to be possible with a unique new self-powered control system which permits "balancing" of air conditioning throughout a building by a simple dial adjustment. Key to the system is a blender valve which controls the amount of air passing through the duct, thus permitting thermostatic control over air volume rather than over a valve position as in conventional systems. Each valve consists of two balloon-like neoprene diaphragms which expand and contract against a metal weir to regulate the amount of air passing by them (see photo at left above). These diaphragms are the only moving parts of the system. No electrical wiring, separate motors, compressed air supply or other valves and linkage are needed.

Two valves are used in a "Y" arrangement at each outlet, one connected to the hot air supply and the other to the cold air supply. The rate of air flow desired for the area to be served is preset in cubic feet per minute on a dial mounted on a special flow regulator, as shown in the center photo. This regulates the hot air valve blender, which automatically controls the amount of heated air supplied according to demands from the thermostat. The cold air blender valve then adjusts the total air flow to maintain the pre-set cfm.

The system operates on the physical law that a drop in pressure is a measure of flow. When the thermostat calls for cooling, the flow regulator on the hot duct valve automatically reduces the amount of heated air entering the system by blowing up the neoprene diaphragms slightly and so decreasing the

space available for passage of air. This reduces the total flow of air into the blender and so changes the total pressure. The change is instantly detected by the flow regulator on the cold valve, which then deflates its diaphragms slightly to admit enough additional cold air to maintain the pre-set total air flow. As the addition of cold air brings the temperature below the thermostat setting, the flow regulators detect the change and automatically re-set the valves so that the rate of air flow is held at a constant level regardless of changes in the air pressure throughout the system. The system can be used with ceiling, side-wall or under-the-window air outlets, and in large work areas several blender units can be controlled from one thermostat. *Minneapolis Honeywell Regulator Co., 2753 Fourth Ave. South, Minneapolis 8, Minn.*

CONCRETE FLOORS HAVE ELECTRICAL RACEWAYS

OFFICE BUILDINGS can now be constructed with a precast structural concrete floor system which not only requires no fireproofing and permits clear spans of 20 ft without the use of intermediate beams but also incorporates underfloor electrical distribution. The system uses the hollow cells in *Flexicore* precast concrete floors as electric raceways and provides electrical floor outlet spacing as close as $5\frac{1}{3}$ in. As shown in the cutaway illustration at right, the floor is electrified by metal feeder ducts which are installed on top of the structural floor in a $1\frac{1}{2}$ -in. concrete fill. The ducts run at right angles to the floor slabs and attach easily to them, serving also as a level for screeding the floor fill. The wiring runs from panel box to feeder duct, then along the feeder to a hand-hole junction where it drops into a floor cell which is continuous from one end of

the building to the other. An outlet can be located at any point along the path of the cell and can be installed at any time during the life of the building. Any number of systems can be installed: electrical, telephone, intercom, etc.

Because of the fireproof qualities of the floor slabs (3-hr UL rating for 8- by 16-in. slabs with $1\frac{1}{2}$ -in. topping) no fireproof plaster ceiling is required, and so a suspended ceiling system can be planned which offers immediate relocation of lighting fixtures and ventilating outlets. Other savings are reported by the manufacturers because less steel is required with the long floor spans and so there is a weight reduction.

Floor cells are $4\frac{1}{8}$ or $6\frac{1}{8}$ in. in diameter depending on slab size. Feeder ducts are 4 in. wide, with depths ranging from $1\frac{1}{2}$ to 2 in. Handhole junctions between feeder and cell are $2\frac{3}{4}$ in. in diameter,

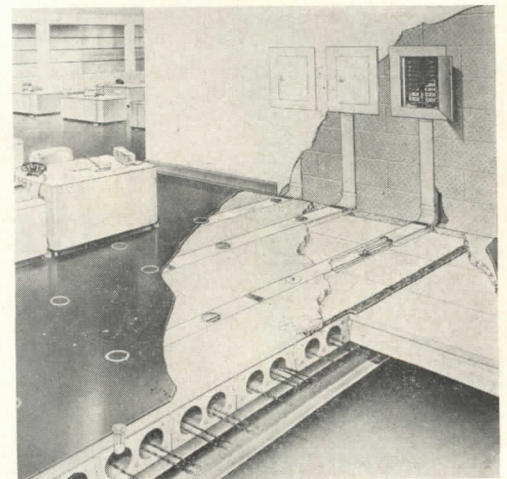

and the handhole in the finish floor is $3\frac{1}{2}$ in. Prefabricated fittings for the wiring system are manufactured by *The Condufflor Corp., Buffalo, N. Y.* The floor slabs are produced by *The Flexicore Co., Inc., 1932 E. Monument Ave., Dayton 1, Ohio.* (More Products on page 310)

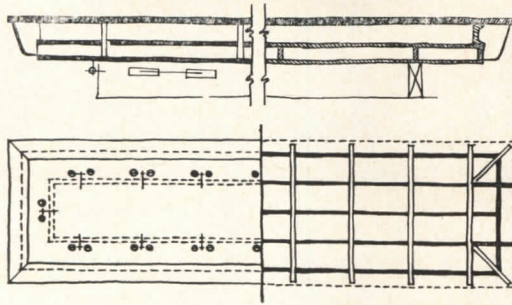

FIR PLYWOOD DESIGN IDEAS

In commemorating its 50th Anniversary, the Douglas Fir Plywood industry, through its Association, commissioned several leading architects to supply new design ideas using fir plywood. The only controlling factors were the imaginations of the architects and the natural limitations of fir plywood. This four-color loose-leaf portfolio (AIA 19-F) presents dramatic new design concepts of five of the architects: Chris Choate, Smith & Williams, Jones & Emmons, Anshen & Allen and Campbell & Wong. Each sheet presents a description, features, construction, a four-color photograph and a detail like the one shown at left of a garden reflecting pool. 30 pp. *Douglas Fir Plywood Assn., Tacoma 2, Wash.**

M-Floors (AIA 17-A)

Catalog M-57 presents load tables and other data on Mahon electrified Cel-Beam floor systems and long-span M-Decks. 24 pp. *The R. C. Mahon Co., Detroit 34.**

Lightweight Insulating Concrete

Circular 80 gives data and uses of *Poretherm*, a lightweight, fireproof cellular insulating concrete. 4 pp. *Porete Mfg. Co., North Arlington, N. J.**

Studlock Clip System (AIA 20-B-21)

Describes new system for the erection of non-combustible, non-bearing plastered partitions. 4 pp. *Penn Metal Co., Inc., 205 East 42nd St., New York 17.**

Electronic Air Cleaners (AIA 30-D-3)

Catalog E-90 presents the Trion HEV air cleaner, which the manufacturer claims will provide the cleanest air that is commercially available. 6 pp. *Trion, Inc., 1000 Island Ave., McKees Rocks, Pa.**

Wood Awning Windows

Catalog 16-L contains specifications, construction details, rough opening sizes and glazing information for Woodco E-Zee Loc awning windows. *Woodco Corp., Box 31, North Bergen, N. J.**

Pacific "LoSet" (AIA 30-C-1)

Catalog AP 279-B covers advantages of LoSet steel boilers for oil firing. 8 pp. *Pacific Steel Boiler Div., National-U. S. Radiator Corp., Johnstown, Pa.*

Facts about Grounding Electricity

Interprets and clarifies new and revised requirements of the 1953 National Electrical Code that pertain to the safe operation of tools and appliances. 12 pp. *The Arrow-Hart & Hegeman Electric Co., Hartford, Conn.*

Architectural Metal Letters

(AIA 15-R-1) Stresses importance of and illustrates architectural metal letters, signs and symbols in bronze, aluminum, brass, nickel-silver and stainless steel as integral parts of building design. 20 pp. "Letters, Signs and Symbols" kit also available from *A. J. Bayer Co., Architectural Metal Products Div., 2300 East Slauson Ave., Los Angeles 58.*

Electric Heaters

Catalog 83 describes radiant glass, tubular, infra-red, convection electric heaters, both permanent panel and portable. Engineering Bulletin 84, presenting heat requirement calculations, is also available from *Can-Arm Corp., P. O. Box 156, Champlain, N. Y.*

Continental Lighting by Globe

New hard-bound catalog in full color presents Continental lighting fixtures, which are said to be influenced by European designers. 38 pp. *Globe Lighting Products, Inc., 16 East 40th St., New York 16, N. Y.*

The Modern Hospital

... and Its Elevator Needs. Outlines the special problems and requirements of passenger and freight elevating and dumbwaiter service in hospitals, and describes the latest developments in vertical transportation to meet them. 24 pp. *Olis Elevator Co., Adv. Dept., 260 11th Ave., New York 1.**

Pumping and Sewage Equipment

Manual 1114 gives detailed information for determining capacities of and selection of vertical wet pit pumps and pneumatic ejectors. *Yeomans Brothers Co., 1999 No. Ruby St., Melrose Park, Ill.**

Grade-marked Lumber (AIA 19-A-1)

Southern Pine Architect's Bulletin 9 gives advice on quality control for lumber and offers grade-marking as a solution to many problems attendant to proper lumber specifications. 4 pp. *Southern Pine Assn., P. O. Box 1170, New Orleans 4.*

Ornamental Iron (AIA 15-C)

Catalog 8 presents a number of actual installations to show how ornamental iron can fit into individual home building. 16 pp. *Tennessee Fabricating Co., 1490 Grimes St., Memphis, Tenn.**

Transitubes

Catalog gives pictures, diagrams, layouts and engineering drawings of a pneumatic tube system designed to handle blueprints, large hospital case histories, complete files, tickets, etc. 36 pp. *The Grover Co., 25525 West Eight Mile Rd., Detroit 19.*

Selecting Lumber

Circular Series D7.0 gives essential facts about lumber and its use in home building. 8 pp. 10¢. *Small Homes Council, University of Illinois, Urbana, Ill.*

Sloan Act-O-Matic Shower Head

(AIA 29-H-3) Presents features and installation details of this automatically self-cleaning shower head. 10 pp. *Sloan Valve Co., 4300 West Lake St., Chicago 24, Ill.**

Go Modern with Weslock

Contains information and specifications on complete *Sunray* line of residential locksets and matching door handles and exterior trim. 4 pp. *Western Lock Mfg. Co., 211 N. Madison Ave., Los Angeles 4.*

* Other product information in *Sweet's Architectural File, 1956.*

(More Literature on page 374)

USEFUL CURVES AND CURVED SURFACES: 10 — Cycloid

By SEYMOUR HOWARD Assistant Professor, Pratt Institute, Architect associated with Huson Jackson and Harold Edelman

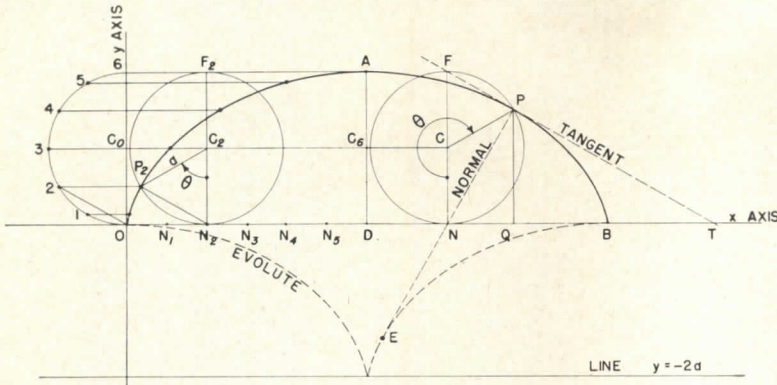

DEFINITION

The locus of a point P on the circumference of a circle which rolls along a straight line without slipping is called a cycloid. It has been used as a cross section of concrete shells (see TSS: Structural Forms, May 1955, p. 205)

PARAMETRIC EQUATION (most convenient)

$$\begin{aligned} x &= a(\theta - \sin \theta) \\ y &= a(1 - \cos \theta) \end{aligned} \quad (\theta \text{ in radians})$$

STANDARD FORM

$$x = a \arccos \left(\frac{a-y}{a} \right) - \sqrt{2ay - y^2}$$

METHODS OF DRAWING

1. Draw directly as a roulette (see definition, sheet 7) by rolling a circle of radius "a" along x axis. Take care that circle does not slip.

2. On y axis draw generating circle, radius = a, center at C (CO = a). Divide half circumference into whole number of arcs (here 6). On x axis lay out the lengths of these arcs ON₁, N₁N₂, N₂N₃, etc., by measuring directly or by measuring OD = πa and dividing into same number of parts. Draw a horizontal line through C and project points N₁, N₂, etc.

up to find successive positions of center of circle. At each center draw the radius vector, where θ is the corresponding multiple of

$$\frac{180^\circ}{\text{number of arcs}} \quad (C_2P_2 = a, \theta_2 = 2 \times \frac{180}{6} = 60^\circ)$$

for example). P₂ also lies on a horizontal line through point 2 on the generating circle as shown in initial position.

3. Proceed as directed in method 2, as far as measuring arc lengths along x axis. Then through points 1, 2, 3, etc. on circle in initial

position, draw horizontal lines. Measure on each line the corresponding length of arc and the corresponding point on the cycloid will be found. (For example, to find P₂, measure 2, P₂ = ON₂.)

4. Proceed as directed in method 2, as far as measuring arc lengths along x axis. To find P₂ shown, describe arc of radius 0, 2 from center N₂ and intersect horizontal line drawn through 2. Note that P₂N₂ is the normal to point P₂ and is half the length of the radius of curvature at P₂.

TANGENT to any point P passes through F at top of generating circle in corresponding position. Subtangent QT = a $\frac{(1 - \cos \theta)^2}{\sin \theta}$

NORMAL to any point P passes through N at bottom of generating circle. Normal PN = $\sqrt{2ay}$. Subnormal QN = a sin θ.

LENGTH OF CURVE for one arch = 8a. Centroid of this length is $\frac{4a}{3}$ above x axis.

LENGTH OF AN ARC of curve AP = 2 × PF (length of arc BP = 4a - 2 PF)

AREA UNDER ONE ARCH = 3πa². Centroid of this area is $\frac{5a}{6}$ above x axis.

RADIUS OF CURVATURE = EP = twice length of normal PN = 2 $\sqrt{2ay}$.

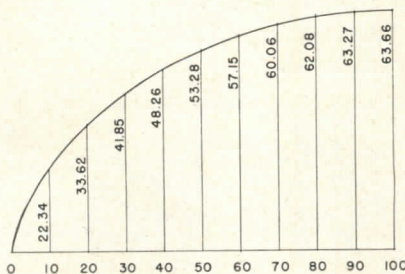

ORDINATES OF A CYCLOID expressed in terms of a half length of 100.

$$x = \frac{100}{\pi} (\theta - \sin \theta)$$

$$y = \frac{100}{\pi} (1 - \cos \theta)$$

$$\frac{100}{\pi} = 31.831$$

**NEW FIAT SHOWER FLOORS
IDEAL FOR TILE, MARBLE OR
STRUCTURAL GLASS SHOWERS**

A new, pre-cast terrazzo shower floor, the Monterey, has a threshold cast as an integral part of the floor. This new floor was recently introduced by Fiat Metal Manufacturing Company, long the leader in the packaged shower field. The threshold makes the floor an excellent base for showers of any material. This monolithic floor gives a high quality appearance at a lower cost than built-on-the-job floors. An added advantage is the fact that Fiat pre-cast shower floors are completely leakproof.



**ELIMINATES PILASTER
CONSTRUCTION**

Because of the smooth curb of the Monterey's threshold, a glass filler panel easily replaces pilaster construction. This filler panel rests directly upon the curb. Either hinged or sliding doors may be used as the solid threshold provides a convenient foundation for a track.

**AVAILABLE IN VARIOUS SIZES
AND COLORS**

The Monterey comes in six sizes and three different models. There are three square sizes for standard design shower applications: 32" x 32", 36" x 36" and 40" x 40". There is also a 48" x 32" rectangular model and two corner models: 36" x 36" and 40" x 40". The following color combinations are available: black and white marble chips in white cement; white marble chips in white cement; green marble chips in white cement; tan marble chips in white cement. A wrought brass drain body is cast integral with the floor as is the galvanized-bonderized steel tiling-in flange.

**COMPLETE INFORMATION AND
NEW LITERATURE AVAILABLE**

Fiat Metal Mfg. Company, 9301 Belmont Avenue, Franklin Park, Illinois will be glad to furnish full information on the Monterey shower floor as well as other style shower floors available. Write to them at the address given above.

MODERN LIVING

Requires modern bathing



The Corner Cadet is one of the three basic Fiat Cadet model showers. Whether square, built-on or corner, the versatile Cadet is excellent for any shower installation.

The pace of modern living is reflected in the design of modern homes . . . functional, labor-saving, yet completely comfortable. These modern homes, this modern living, require the modern way of bathing; the shower. You can satisfy this important requisite *economically* with FIAT, the *packaged* shower with the PreCast Receptor! The sleek corner Cadet model pictured above is one of the beautiful, permanent FIAT showers. It virtually tucks away in a corner . . . occupies minimum space while providing a roomy bath. A FIAT shower will enhance the value—improve the appearance of any home . . . satisfies the modern family's demand for bathing the modern way. In your specifications, include FIAT showers . . . the one single item that will upgrade your homes most for the money invested.

Send for new full color catalog—or see Sweets $\frac{25c}{F}$



AMERICA'S LEADING MANUFACTURER OF QUALITY SHOWERS. EST. 1922

FIAT METAL MANUFACTURING COMPANY

Three Complete Plants — Economy • Convenience • Service

LONG ISLAND CITY, N. Y. • FRANKLIN PARK, ILL. (CHICAGO SUBURB) • LOS ANGELES, CALIF.
IN CANADA: FIAT PRODUCTS ARE MADE BY PORCELAIN AND METAL PRODUCTS, LTD., ORILLIA, ONT.

USEFUL CURVES AND CURVED SURFACES: 11 — Trochoid

By SEYMOUR HOWARD Assistant Professor, Pratt Institute, Architect associated with Huson Jackson and Harold Edelman

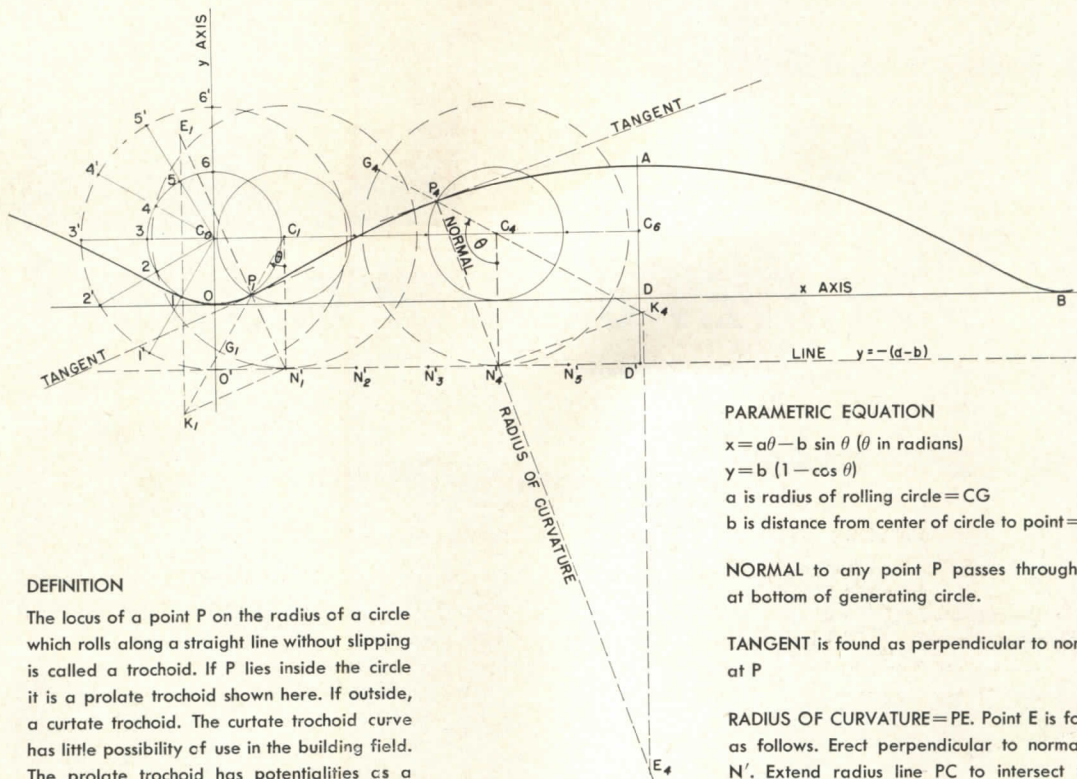

DEFINITION

The locus of a point P on the radius of a circle which rolls along a straight line without slipping is called a trochoid. If P lies inside the circle it is a prolate trochoid shown here. If outside, a curtate trochoid. The curtate trochoid curve has little possibility of use in the building field. The prolate trochoid has potentialities as a section for corrugated concrete shells (see TSS—Structural Forms, June 1953, p. 187). It is also used (upside down from position shown) as the curve of ocean waves for ship analysis, with a height (DA) equal to 20 times length (OB) and a length equal to length of shell.

METHODS OF DRAWING

The same methods as described for drawing a cycloid may be used. Note that the distance OB on the x axis is equal to $2\pi a$ and the height $AD=2b$. Lengths of arcs must be measured on the circumference of the outer circle, heights from the inner circle.

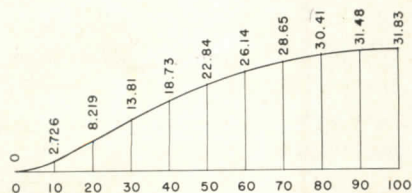

ORDINATES FOR A TROCHOID in which $a=2b$, expressed in terms of a half-length of 100. This might be used as the cross-section of a shell roof.

$$x = \frac{50}{\pi} (2\theta - \sin \theta)$$

$$y = \frac{50}{\pi} (1 - \cos \theta)$$

$$\left[\frac{50}{\pi} = 15.915 \right]$$

PARAMETRIC EQUATION

$$x = a\theta - b \sin \theta \ (\theta \text{ in radians})$$

$$y = b (1 - \cos \theta)$$

a is radius of rolling circle = CG

b is distance from center of circle to point = CP

NORMAL to any point P passes through N' at bottom of generating circle.

TANGENT is found as perpendicular to normal at P

RADIUS OF CURVATURE = PE. Point E is found as follows. Erect perpendicular to normal at N'. Extend radius line PC to intersect perpendicular at K. Draw vertical line through K to intersect PN' extended at E. E is center of curvature and PE is radius of curvature.

Equation:

$$PE = R = \frac{[a^2 - 2ab \cos \theta + b^2]^{3/2}}{2a^2 - ab(\cos \theta + 2) + b^2}$$

At point O, $\theta = 0$ and

$$R = \frac{(a-b)^3}{2a^2 - 3ab + b^2}$$

At point A, $\theta = 180^\circ = \pi$ and

$$R = \frac{(a+b)^3}{2a^2 - ab + b^2}$$

EVOLUTE for the prolate trochoid is in two parts, one on each side of the curve. The normal which makes the smallest angle with the x axis passes through the point of contraflexure and is asymptotic to each portion of the evolute.

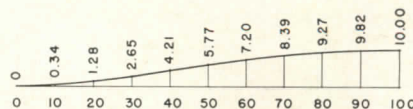

ORDINATES FOR A TROCHOID whose height is $1/20$ of its length, expressed in terms of a half-length of 100. This is the standard ocean wave, but upside down, i.e. the "0" ordinate is the crest, the "10" ordinate the hollow of the wave.

$$x = 5 \left(\frac{20}{\pi} \theta - \sin \theta \right)$$

$$\left[\frac{20}{\pi} = 6.366 \right]$$

$$y = 5 (1 - \cos \theta)$$

BUSH

TEAMED WITH

DUNHAM

FOR EVEN GREATER GROWTH

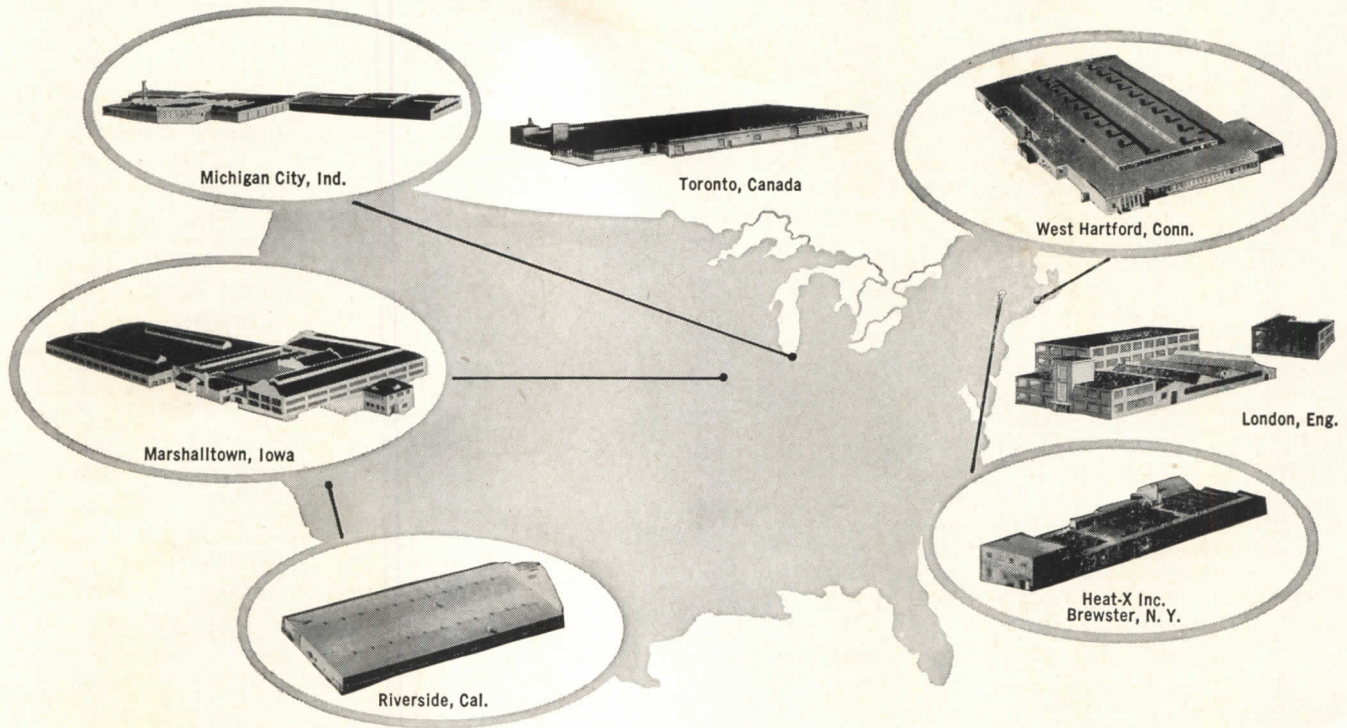

Heating, air conditioning and refrigeration products are flowing from the recently formed Dunham-Bush manufacturing facilities.

This "one-source" teaming of Dunham and Bush spells many advantages for architects, engineers, wholesalers and contractors.

A nationwide network of manufacturing plants and strategically located warehouses assures the "close-to-source" supply that permits faster delivery, lower freight costs. A substantially expanded force of sales engineers makes available on-the-spot engineering and application assistance. Greatly augmented resources and facilities permit continued research and development of new products to serve an expanding field.

Dunham-Bush . . . a single source, single responsibility for heating, air conditioning and refrigeration . . . teamed to serve an industry's growing needs.

Dunham-Bush, Inc.

WEST HARTFORD 10 • CONNECTICUT • U. S. A.

DUNHAM-BUSH

AIR CONDITIONING, REFRIGERATION, HEATING PRODUCTS AND ACCESSORIES

(To be continued in a later issue)

USEFUL CURVES AND CURVED SURFACES: 12 — Sine Curve; Geometrical Mean

By SEYMOUR HOWARD Assistant Professor, Pratt Institute, Architect associated with Huson Jackson and Harold Edelman

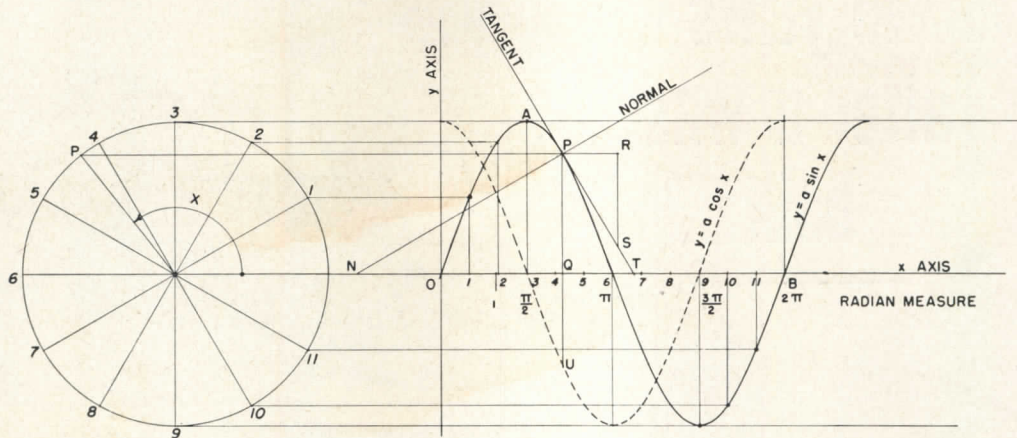

DEFINITION

The Sine Curve represents the vertical projection of a point P, moving with uniform velocity on the circumference of a circle, plotted against angular displacement. If a is the radius of the circle and b is the angular velocity of

point P on its circumference, and t is time; then $x = bt$ and $y = a \cos bt$. The amplitude = a and the period = 2π or $360^\circ = OB$. In building work this curve has been used as the centerline of the cross section of corrugated

concrete shells (See TSS: Structural Forms, June 1953, p. 187). It is also the elevation of a so-called spiral (helical) stair. And it is the projection of geodesic lines on a cylinder, such as plan projections of lamella arches.

EQUATION

$$y = a \sin x$$

METHODS OF DRAWING

1. Draw the generating circle with radius a and divide circumference into a whole number

of parts (here 12). Lay off the distance OB on the x axis and divide into the same number of parts. Erect a perpendicular at each point of division of the x axis. Draw horizontal lines through the corresponding points on the circumference of the circle and the intersections will be points on the curve. Note that distance

$OB = 2\pi$ radians and that $57^\circ 18' =$ one radian. To find the point at which $x = 1$ radian, divide OB into 2π or 6.283 parts and locate 1 on this scale.

2. Calculate and plot points using table of sines.

TANGENT

The slope of the tangent at any point = $a \cos x$. The curve $y = a \cos x$ has been drawn and has exactly the same shape but is displaced

$\pi/2$ radians or 90° to the left. To draw the tangent at P, draw a horizontal line through P and measure $PR = 1$ radian. Draw a vertical line through P intersecting x axis at Q and

extend to intersect cosine curve at U. Draw a vertical line RS through R of length $RS = QU$. The line PS is tangent to the sine curve at P, and can be extended to cut x axis at T.

NORMAL is drawn as perpendicular to tangent.

AREA under one arch (from origin to π or 180°) = $2a$. Centroid of this area is $\frac{\pi a}{8}$ above x axis.

RADIUS OF CURVATURE $R = \frac{(1 + a^2 \cos^2 x)^{3/2}}{a \sin x}$. At apex A, $R = \frac{1}{a}$

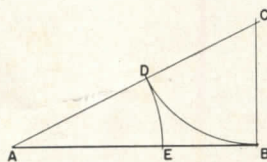

GOLDEN SECTION

Used by Greek artists and architects and often revived in theories of proportion. Basis of Modulor of Le Corbusier, using 2 m 26 (or 7 ft 5 in.) or 1 m 13 (or 3 ft 8 1/2 in.) as starting points for his two series. If

a line AB is divided so that $\frac{AB}{AE} = \frac{AE}{EB}$ it is in golden section. Or if g is

ratio such that $AE = gEB$,
 $g^2 = g + 1$ or $g - \frac{1}{g} = 1$ and $g = \frac{\sqrt{5} + 1}{2} = 1.6180$

To find graphically, erect perpendicular $CB = \frac{AB}{2}$ and swing arc $CD = CB$. Then swing arc AD to cut AB at E.

The angle which the diagonal of a rectangle whose sides are in the ratio $g:1$ makes with the short side = $\arctan 1.618 = 58^\circ 17'$.

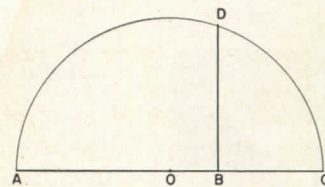

GEOMETRICAL MEAN

General case of which golden section is a particular case. To find distance BD which is geometrical mean or mean proportional between AB and BC, divide AC in half at O and with O as center and radius equal to $AO = OC$, draw semicircle. Draw perpendicular at B to intersect circle at D

Then $BD^2 = AB \times BC$ or $\frac{AB}{BD} = \frac{BD}{BC}$

15 years
after it was
built...



30 years
after it was
built...

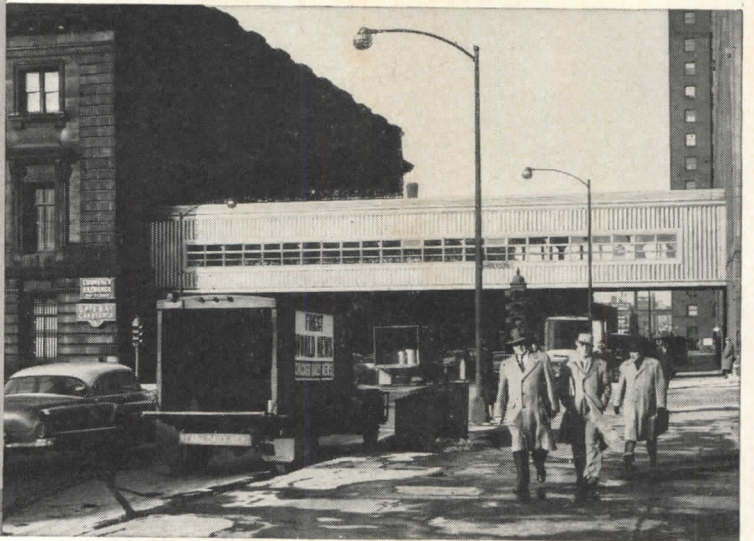

This STAINLESS "Covered Bridge" is *EVER-NEW*

"INFO" for Architects and Builders

- 1 "AL Structural Stainless Steels"—12 pages on stainless grades, properties, forms, finishes, standard "specs," uses and advantages.
- 2 "Stainless Steels for Store Fronts and Building Entrances"—40 pages of valuable data on examples and details. AIA File No. 26D.
- 3 "Stainless Steel Curtain Walls"—A 24-page progress report on methods. AIA File No. 15-H-1.

Write for Details

Address Dept. R-81

The top photograph of the AL Stainless Steel-surfaced concourse that connects the Chicago Daily News building with the North Western station was taken about 1939-40. The lower picture was made early in 1955. There's no discernible change.

Another 30 years—50 years—100 . . . the bridge's stainless shell will still be just as good as new. No one knows *how long* AL Stainless actually will last, but it could be for centuries, if required. And all the time it requires no particular maintenance,

no painting or refinishing—just occasional washing to remove the grime that isn't carried away naturally by wind and rain.

No other architectural metal can match stainless steel in these properties. Not one can last as long, cost as little to maintain, and prove as economical in the long run.

• Use AL Stainless in *your* projects, for maximum service and lasting beauty, both in exteriors and interiors. Ask us for any help you need. *Allegheny Ludlum Steel Corp., Oliver Bldg., Pittsburgh 22, Pa.*

For Stainless Steel in ALL Forms—call
Allegheny Ludlum

Warehouse stocks carried by all Ryerson Steel plants



W&D 5654

100,000 amps gets a new boss— the Westinghouse Tri-Pac breaker

The Westinghouse Tri-Pac breaker is the smallest protective device that can be used where 100,000 amps can be poured into faults. It combines the inherent advantages of both the molded case breaker and fusible current limiters to positively protect electrical circuits—throughout the range from overloads to fault currents that could build up to 100,000 amperes, if not stopped.

Co-ordinated triple circuit protection—thermal, magnetic, and current limiting—in one compact breaker. At much less cost than larger air circuit breakers of equivalent ratings and with more safety and convenience than switches combined with fusible elements. That's why Tri-Pac offers the most practical and economical solution to the constantly increasing interrupting requirements of network systems and those fed by large transformers.

The breaker trip portion of Tri-Pac handles overloads and moderate faults—eliminating fuse replacement headaches and costs. On higher currents, the current limiters in Tri-Pac trip faster, insuring the prompt protection required at those high currents. In Tri-Pac the current limiters and the breaker are co-ordinated so that the current limiter will trip at and above a point slightly under the interrupting capacity of the breaker. Below that point, the limiters remain undamaged, letting the breaker do the work.

Fault single phasing—a drawback of fuses—is averted by Tri-Pac breakers. The blowing of a current limiter actuates the breaker trip bar and all poles of the breaker open simultaneously. And when a high fault current is interrupted, indicating buttons on the current limiters clearly designate the troubled phase.

— NETWORK SYSTEM PROTECTION

With today's increased use of network systems, the possibilities of 100,000-amp fault currents are not uncommon. New Tri-Pac breakers insure positive protection against all system current faults—large or small—at a new and greater economy.

HERE'S MORE INFORMATION ON TRI-PAC

A Westinghouse sales engineer can show you additional reasons why the new Tri-Pac breaker is your best buy for powerful circuit system protection. Call him today.

J-30215

WATCH WESTINGHOUSE!

COVER THE PRESIDENTIAL CAMPAIGN ON CBS TV AND RADIO!

THE RECORD REPORTS

(Continued from page 428)

TOP DESIGN CONTEST ENTRY HONORS VIRGINIA WAR DEAD

The state war memorial in Richmond, Va., which honors Virginia's nearly 10,000 World War II and Korean War dead, is the culmination of an architectural competition sponsored by the Virginia General Assembly back in 1951.

The building was designed by Richard

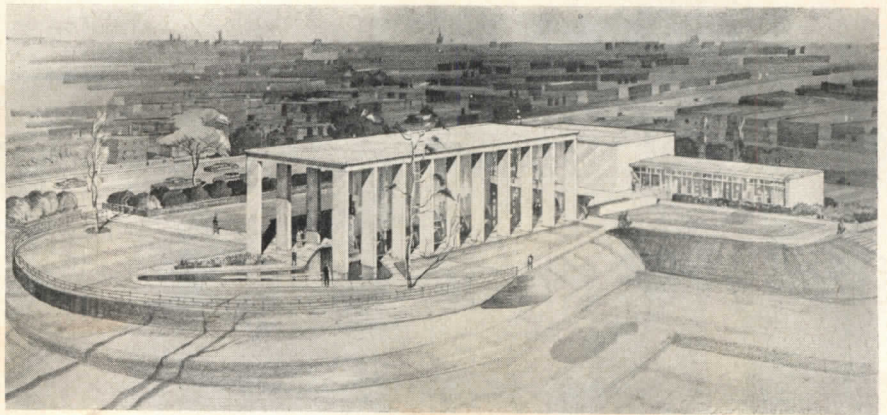

Virginia war memorial, a competition winning design by Richard E. Collins and the late Samuel J. Collins, Architects, was dedicated recently. The project cost about \$800,000

E. Collins, A.I.A., Silver Springs, Md., and his late uncle, Samuel J. Collins, who died shortly after the design competition was held.

The memorial, called "Hall of Memory," is a granite marble and glass-walled rectangular building open at both ends. It houses a 22-ft statue called "Memory," which was designed by sculptor Leo Friedlander of White Plains, N. Y. Mr. Friedlander won the commission through the design competition.

The building, 110 ft long and 35 ft wide, overlooks the James River at the north end of the Robert E. Lee Bridge on United States Route 1. Travelers are able to see the memorial and the statue from the highway.

A 22-seat auditorium and a small service wing are located in a separate building, just north of the Hall of Memory. Site for the two buildings is a seven-acre plot.



Heroic statue of "Memory" is central figure, lighted at night. Plaster model by sculptor Leo Friedlander was reproduced in an enlarged scale by carvers Joseph Campo, William Kapp

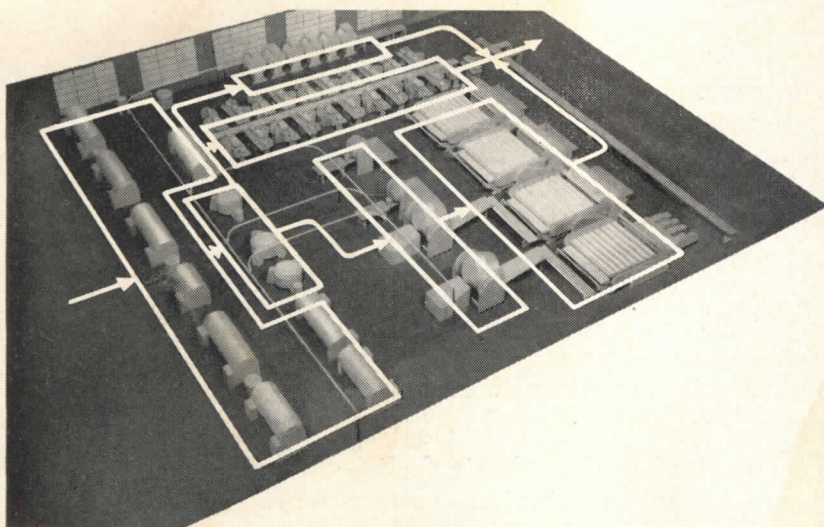

TROY SURVEY SERVICE insures efficient laundry work flow

Whatever the job — a laundry plan for a hospital, hotel, other institution or industrial plant — rely on Troy Survey Service to provide you with an experience-tested laundry layout based on direct work flow — plus modern labor-saving machinery. Your client will be assured the most efficient laundry possible in the least floor space, and will always enjoy prompt, reliable help on maintenance, supplied by Troy's strategically located sales and service offices.

Ask to see the Troy man. Or send for free literature and details on Troy laundry layout service.

Troy
LAUNDRY
MACHINERY

TROY LAUNDRY MACHINERY
Division of American Machine and Metals, Inc.
Dept. AR-956, East Moline, Illinois

- Have a Troy man call on me.
 Send free literature and details on Troy laundry layout service.
- Type of laundry Hotel Hospital
 Institution Other

FIRM NAME _____
ADDRESS _____
CITY _____ ZONE _____ STATE _____
ATTENTION MR. _____

"World's oldest builders of power laundry equipment"