

ARCHITECTURAL RECORD



BUILDING TYPES STUDY

SCHOOLS

239

AT GIMBELS

in the Southgate
Shopping Center...

unobtrusive,
dependable

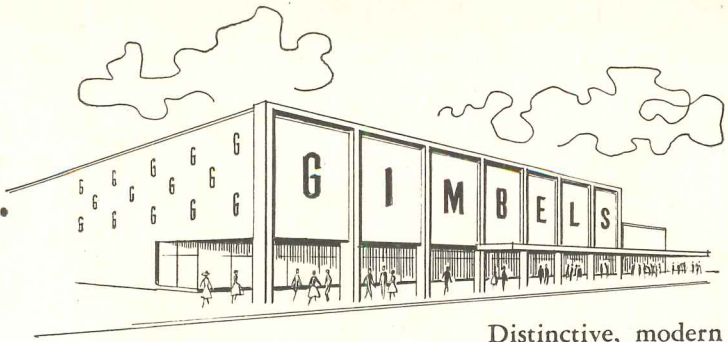

GRINNELL SPRINKLERS

Architects: GRASSOLD-JOHNSON ASSOCIATES
WELTON BECKET & ASSOCIATES



Grinnell
Ceiling-Type
Spray Sprinklers



Grinnell
Quartzoid Bulb
Spray Sprinklers

Distinctive, modern design, inside and out, plus effective store planning make Gimbel's Southgate an attractive addition to Milwaukee's first suburban shopping center. The spacious, uncluttered interior was designed for shopping ease and comfort . . . as well as to make the most effective use of merchandising areas.

The Grinnell Sprinkler System, specified by the architects at the planning stage, also has been made a functional part of interiors. Notice particularly how the Grinnell Ceiling-Type Sprinklers are almost invisible; extend but a scant inch and a quarter from the ceiling — not marring the interior decor. The end-result is an unobtrusive, smartly planned fire protection system that fits so well into the store design. Yet, should fire strike, Grinnell Sprinklers stand ready to operate quickly — effectively, day or night, to stop fire at its source.

Call in a Grinnell Fire Protection Engineer when you design your next project. He can advise you on the best system to suit your requirements. There is a Grinnell System for every type of fire hazard. Write for literature. Grinnell Company, Inc., 269 West Exchange Street, Providence, Rhode Island.

GRINNELL

PROTECTION AGAINST EVERY FIRE HAZARD

Manufacturing, Engineering, and Installation of Fire Protection Systems Since 1870



ARCHITECTURAL RECORD

October 1956 Vol. 120 No. 4

Copyright 1956 by F. W. Dodge Corporation, with all rights reserved. Copyright not claimed by F. W. Dodge Corporation on color illustrations on front cover and pages 174, 223 and 224. ARCHITECTURAL RECORD (combined with AMERICAN ARCHITECT and ARCHITECTURE) is published monthly, except May 1956 when semimonthly, by F. W. Dodge Corporation, 10 Ferry Street, Concord, New Hampshire. Editorial and executive offices: 119 West 40th Street, New York 18, New York. Western editorial office, 2877 Shasta Road, Berkeley 8, California.

STAFF OF ARCHITECTURAL RECORD



H. Judd Payne, *Publishing Director*; Robert F. Marshall, *General Manager*; John Knox Shear, A.I.A., *Editor-in-Chief*; Marshall T. Ginn, *Circulation Manager*; Emerson Goble, *Managing Editor*; Frank G. Lopez, A.I.A., *Senior Editor*; James S. Hornbeck, A.I.A., *Senior Associate Editor*; Elisabeth Kendall Thompson, *Senior Associate Editor and Western Section Editor (Berkeley, California, Office)*; Robert E. Fischer, *Associate Editor (Engineering)*; Florence A. van Wyck, *Associate Editor*; Jeanne M. Davern, *Associate Editor (News)*; Daniel M. Kelley, *Associate Editor (Engineering Assistant)*; Herbert L. Smith, Jr., A.I.A., *Associate Editor*; Ernest Mickel, Dan Street (*Washington*). John Caulfield Smith, M.R.A.I.C. (*Canada*), *Contributing Editors*; Grace M. Anderson, *Assistant Editor*; Helen E. Cook, *Editorial Assistant (Production)*; Dianne Thomas, *Editorial Assistant*; Eugene H. Hawley, *Design Director*; Thomas L. McArthur, Mary Ann Godfrey, *Design*; Sigman-Ward, *Drafting Consultant*; Thomas S. Holden, *Industry Relations Consultant*; Clyde Shute, *Statistical Consultant*; George Cline Smith, *Economics Consultant*; Clifford Dunnells, Jr., *Field Research Consultant*; Daniel J. Howe, Jr., *Public Relations Consultant*.

TABLE OF CONTENTS

The Record Reports

Perspectives	9
Buildings in the News	10
Trades Show Australia's Latest in Design	16
Review of Current Periodicals. Sources for Architects:	
School Publications	16B
Meetings and Miscellany	21
A Washington Special Report. Scheme to Extend East Front of the Capitol Raises a Controversy. <i>By Ernest Mickel</i>	32
News from Canada. <i>By John Caulfield Smith</i>	36
Washington Topics. <i>By Ernest Mickel</i>	48
Construction Cost Indexes	54
Required Reading	58
Calendar and Office Notes	384
Reviewing the Record	424
Current Trends in Construction	444

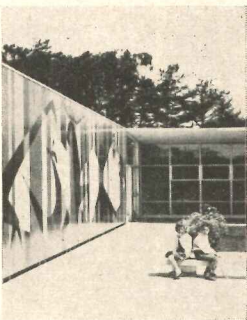

Cover: Olympia Primary School, Daly City, Calif., Mario J. Ciampi, Architect; Rondal Partridge photo

An Inspiring Place of Worship

Inspired by a really majestic site in one of the National Monuments, the architects designed a chapel which of itself has great power, and which solves problems of environment as few contemporary buildings do. Chapel of the Holy Cross, Sedona, Ariz.; Anshen & Allen, Architects 173

The Six Determinants of Architectural Form

The fashionable and the functional are not the only determinants of form in architectural design; throughout history architecture has found no less than six basic demands, some of which have lately been ignored. An article by Paul Rudolph 183

One Hundred Years of Significant Building

5. Houses Before 1907 191

Architecture AND Engineering

It has frequently been said of late that great engineering of itself rarely is great architecture, that innovative structure is but the means to an end. Here a well-known architect uses engineering in his own way. Memorial Hall for Japanese Steel Workers Yawata Arena, Kyushu, Japan; Raymond & Rado, Architects 195

Continued on next page

ARCHITECTURAL RECORD

Continued from page 5

Art, Artists and Architecture

Sand Sculpture by *Costantino Nivola* 201

Should a House Merge with the Ground

When the house has a beautiful rural setting there is always the problem of where the house leaves off and the country begins. Here are several examples of an idea used by one architect to define the house and its outdoor areas and to separate them from the rest of the countryside.

Platform Houses. Edward L. Barnes, Architect 205

Highly Functional Plant for Helicopters

Manufacturing Plant for Sikorsky Aircraft Division, United Aircraft Corporation, Stratford, Conn.; F. A. Fairbrother and Geo. H. Miehls, Architect and Engineer

213

Louis Sullivan Honored Again

On the hundredth anniversary of his birth The Art Institute of Chicago will present a major exhibition of his work, which will remind us again of the wholeness of his architecture, a quality constantly sought but rarely found. A preview of the exhibition, "Louis Sullivan and the Architecture of Free Enterprise"

217

Building Types Study Number 239 — Schools

The relationship of the school and community, both practical and intangible; and the ways the individual school design fulfills these better than repetitive designs

The Individual School and the Community. *By Frank G. Lopez, A.I.A.* 221

Westover Elementary School, Stamford, Conn.; William F. R. Ballard, Architect 222

Olympia Primary School, Daly City, Calif.; Mario J. Ciampi, Architect 229

Charlotte, N. C.: Fifty-one schools 235

Bellevue, Wash.: Three times as many classrooms as in 1952 249

Architectural Engineering

Ultimate Strength Design of Concrete; second article in a series — "A Change Ahead for Structural Design." *By Edward Cohen* 257

The New Developments in Masonry: 1-3: Brick, Limestone & Marble; 4: Silicone Waterproofing; 5, 6: Ceramic Curtain Walls 262

Technical Roundup 268

Product Reports 269

Literature 270

Time-Saver Standards: Fine Hardwoods for Architectural Uses — 10, 11 and 12 273

Index to Advertising

446

OFFICERS OF THE F. W. DODGE CORPORATION

James McV. Breed, *Chairman of the Board*; Paul Abbott and Thomas S. Holden; *Vice Chairmen of the Board*; Howard Barringer, *President*; Irving W. Hadsell, Chauncey L. Williams; *Executive Vice Presidents*; Howard M. Thompson, *Vice President and Treasurer*; Julius T. Little, Robert F. Marshall, T. Oliver Morgan, O. O. Paulsell, H. Judd Payne, George Cline Smith; *Vice Presidents*; Carl S. Bennett, Clinton C. Bennett, Ralph M. Hairston, Roy J. Hard, Richard H. Ray, John M. Williams; *Regional Vice Presidents*; Edwin H. Freed, *Assistant Vice President and Comptroller*; Walter F. DeSaix, Clifford G. Dunnells, Jr., Clyde Shute, Marc Wayne; *Assistant Vice Presidents*; Sanford D. Stockton, Jr., *Secretary*; William C. Breed, Jr., George W. Morgan, Jr.; *Assistant Secretaries*; Irving B. Satin, *Assistant Treasurer*.

OTHER F. W. DODGE SERVICES

Dodge Reports — Dodge Statistical Research Services — Sweet's Catalog Services — Dodge Books — Dodge Mailing Service — Chicago Construction News — Daily Pacific Builder — Denver Daily Journal — Real Estate Record & Builders' Guide.

Members of Audit Bureau of Circulations and Associated Business Publications. Architectural Record is indexed in Art Index, Industrial Arts Index and Engineering Index.

Every effort will be made to return material submitted for possible publication (if accompanied by stamped, addressed envelope), but the editors and the corporation will not be responsible for loss or damage.

Subscription prices: Published monthly except May 1956 when semi-monthly. U. S., U. S. Possessions and Canada: \$5.50 per year; other Western Hemisphere countries, Philippines and Spain, to those who by title are architects and engineers, \$9.00 per year. Single copy price except Mid-May 1956 issue \$2.00; Mid-May 1956 issue \$2.95. Beyond Western Hemisphere, excluding Philippines and Spain, to those who by title are architects and engineers, \$9.00 per year for 12 monthly issues not including Mid-May 1956 issue. Subscriptions from all others outside U. S., U. S. Possessions and Canada for 12 monthly issues, not including Mid-May issue, \$24.00 per year. Change of address: subscribers are requested to furnish both old and new addresses, sending if possible stencil impression from magazine wrapper; allow four weeks for change.



THE RECORD REPORTS

P E R S P E C T I V E S

WRIGHT THE UNPREDICTABLE, and the long-time enemy of skyscrapers, at least when they're in the wrong place (*i.e.*, the city), announced plans recently for a whopper, to be built in Chicago. The building, to house employes of Illinois, Cook County and Chicago, would be *one mile high* with *510 stories*. The Empire State Building is a mere 1250 ft.

THE HIGH ROAD: the fact that Congress passed the \$28 billion highway bill has caused a flurry of speculation and totting up of figures in circles likely to be affected by it — and that means practically everybody. The American Road Builders' Association cast a practiced eye over the supplies to be used in the 13-year program, and estimated that it will require, yearly, 113 million barrels of cement, 663 million tons of concrete aggregates, 9.2 million tons of bituminous products, 3.6 million tons of steel, 680 million bd ft of lumber for forms, 22 million linear ft for pilings. The current highway construction labor force of 250,000 will be increased by 130,000 by 1957, and will add still another 160,000 by 1960. And as if all this weren't enough, the Construction and Civic Development Department of the National Chamber of Commerce came up with a forecast of side effects fully as awesome as the program itself, including as they do ancillary construction for 40 thousand miles of road — filling stations, restaurants, motels, police stations — as well as suburban, shopping and industrial developments.

THE HOUSE OF SEAGRAM makes all sorts of news these days. The latest is the award of a plaque from the Committee for a Quiet City, grateful for the replacement of the rivet by the bolt in the erection of the building's steel frame. The technique has reduced construction noise by 50 per cent, the committee applauded.

TO SEE OURSELVES: Ian McCallum, executive editor of the British *Architectural Review*, played Baedeker for his countrymen upon returning home after a year spent in the U. S. as visiting lecturer at Yale. Recreating a flying trip from coast to coast for readers of *The Architects' Journal*, Mr. McCallum took New York as his point of embarkation. There, he said, "The boom alone . . . was insufficient to explain the chaos and inconvenience. One theory is that Americans have a guilt complex about not having been bombed and this is their way of experiencing at least the after-effects." He admired Lever House and the Seagram and Chase Manhattan projects, but deplored New York's zoning regulations which "result in buildings like enormous club sandwiches cut to the shape of a wedding cake." From New York Mr. McCallum made his way north, admiring on the way Herbert Matter's graphic design for the New Haven railroad, and stopping at New Canaan to see Philip Johnson's glass house, "*the most satisfactory 20th century building I know.*" Thence to New Haven, where he disapproved but nonetheless liked Yale's Gothic campus: "Such enclaves of historicism as Yale represents have a meaning to America that we may find it hard to understand, weighted down as we are by the responsibilities of our ancient and heavily built-up heritage. If we were to wipe these islands clear of buildings and start again, could you put your hand on your heart and say you would not hanker after a few old stones, even if they had to be faked a bit?" Next was Detroit, and the General Motors Technical Center, which in spite of some faults "is worth traveling 4000 miles to see." Chicago was a "Mies pilgrimage" to visit at the shrines of the Lakeshore Drive Apartments and Illinois Institute of Technology campus, and in Denver, I. M. Pei's Mile High

Center had a piazza which made up for the faults Mr. McCallum found in the building. From Denver, the traveler pressed on westward, over the Great Divide to San Francisco, where he "didn't find many interesting buildings. There is of course the Bay Region Style, and seven years ago this might have seemed more interesting. . . . But after the adventurous technical explorations of the eastern architects and the esthetic sophistication of a Mile High Center, the cozy redwood vernacular of the Bay Region, combined though it may be with the large sheets of plate-glass and pleasing concepts of indoor-outdoor living, does seem a little fusty and unadventurous. . . . I have the feeling that in *another* seven years this region will have broken with the more stultifying aspect of its vernacular tradition and will have some pretty interesting things to show." Los Angeles, the terminal point of his tour, Mr. McCallum termed "unerringly suburban." He concluded his observations with a bird's-eye view of the American architectural scene as a whole: "If there's one thing that a brief visit to America teaches you, it is that architecture is a live art there — money's thrown away on it, it makes news, it's kicked around, it's vulgar, refined, reckless, extravagant, cheeseparing, naive, sophisticated. . . . I suggest you thumb a ride and go have a look for yourself."

WORD COMES FROM PARIS, via *La Journée du Baliment*, that the cradle of modern art, and the haven for artists of all nations, will clear one of its slums for La Cité Internationale des Arts. The architecture of the new right-bank quarter will not be avant-garde, however, and will in fact avoid "aggressive modernism" by employing "a sort of Louis XIII style." *Chacun à son goût*, as they say.

UNIVERSITY OF CALIFORNIA CHOOSES

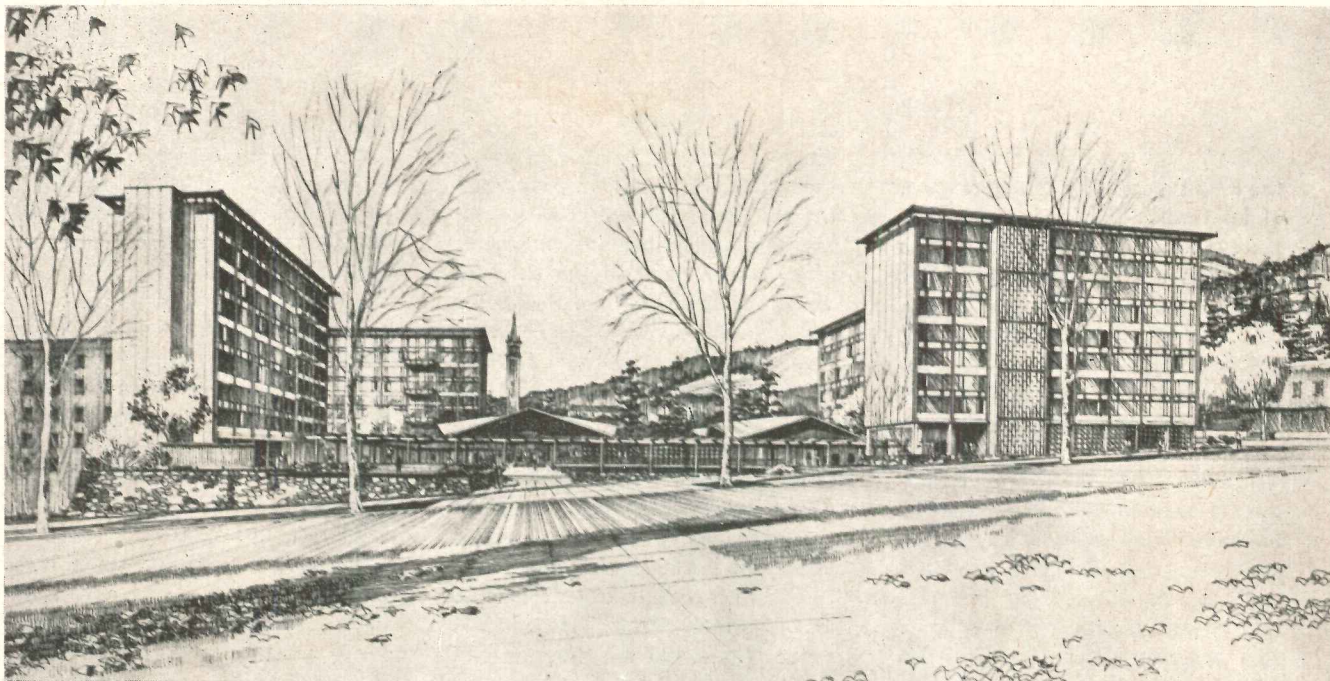

Design from Warnecke and Warnecke showed separate dormitory unit at each corner of the site, the four dining rooms and common recreation room at the center joined by covered walkways. The jury called it "an excellent solution of brilliant simplicity," commended it for its harmony with the surrounding buildings, and, in spite of some exceptions, generally liked the interior arrangements, particularly in the living quarters

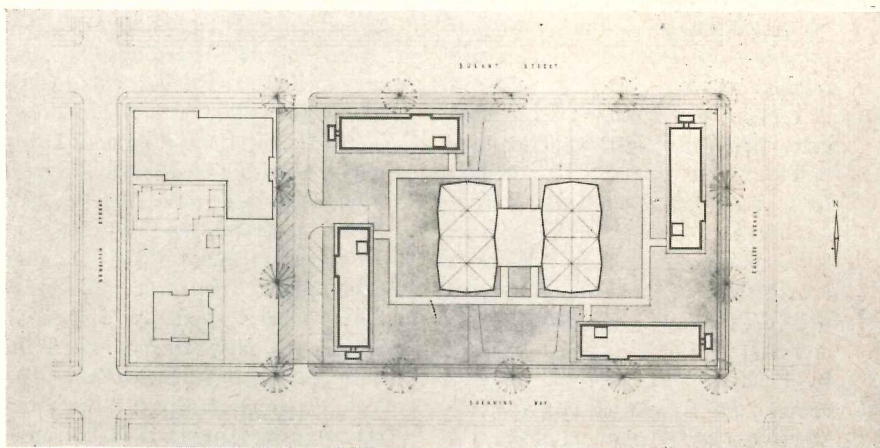

. . . AND IN MEMPHIS, THREE YOUNG ARCHITECTS WIN A SIMILAR CONTEST

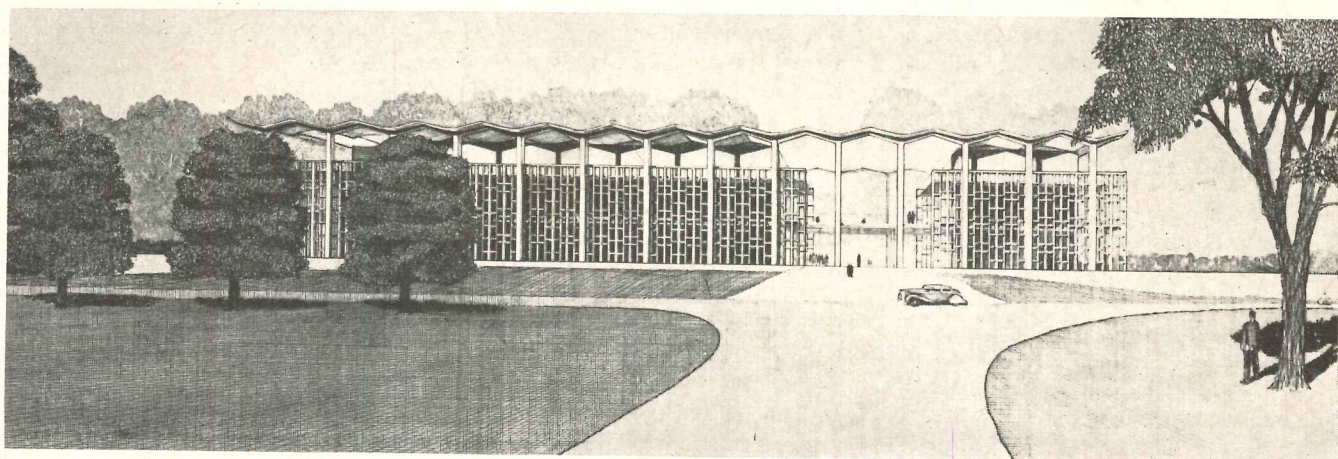

WARNECKE DORMITORY DESIGN IN INVITATIONAL COMPETITION . . .

In a competition open only to those architects invited to enter — Welton Becket Associates; Gardner Dailey; Vernon Demars, Joseph Esherick and Ernest Kump, in association; John Funk

and Kitchen and Hunt, in association; Pereira and Luckman; Warnecke and Warnecke; and Weihe, Frick and Kruse — the University of California at Berkeley selected the Warnecke design for

its new residence hall. The program called for a dormitory for 800, to be comprised of four self-contained units for 200 each, with a separate dining hall for each unit, but a common recreation

(Continued on page 12)

Honorable mentions were given to the entries of John Funk and Kitchen and Hunt (top) and Pereira and Luckman (bottom)

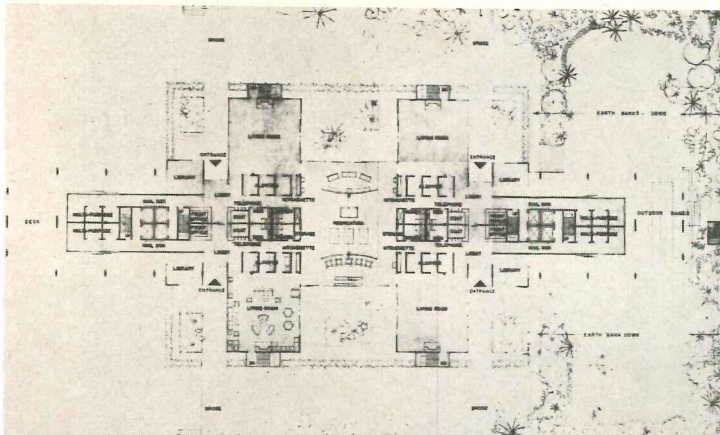
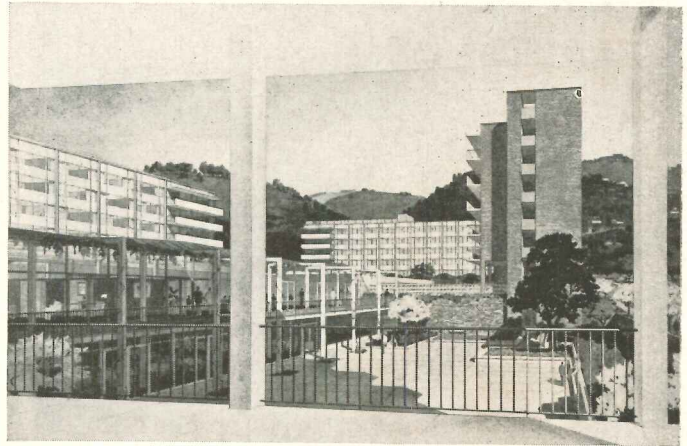
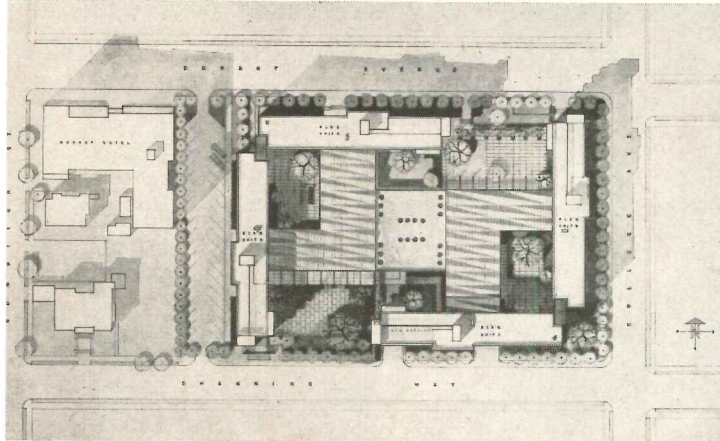

FOR A FINE ARTS CENTER

In another competition open only to local architects (though it was not invitational), Memphis awarded the commission for its new Fine Arts Center to architects William Mann and Roy Harrover, 33 and 28 years old respectively, with Leigh Williams, 28, as associate. The jury remarked of the winning design, which includes an art academy, theater and concert hall in the single building, that it "belongs in the park" where it will be built, and that "it should be beautiful from any aspect as one approaches it." Construction will

(Continued on page 12)

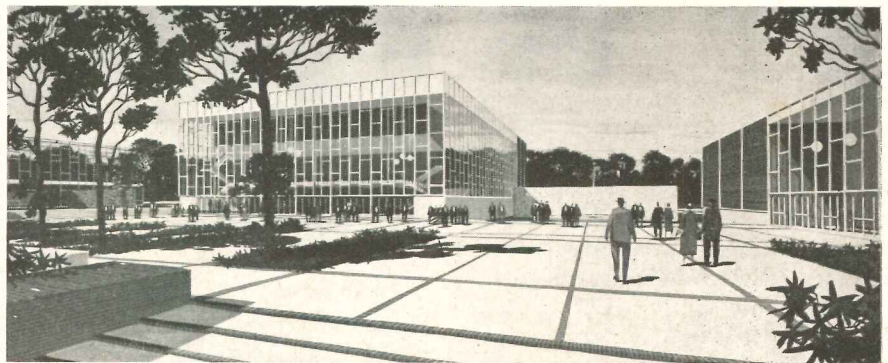

Second award went to architects A. L. Aydelott and Associates for "an excellent

solution" calling for a group of buildings planned around a plaza

THE RECORD REPORTS

BUILDINGS IN THE NEWS

(Continued from page 11)

California Competition

room. The program also emphasized that "the Berkeley climate and the Berkeley residential architecture provide a background which has a significance for this building." Besides the award of the

commission to the winning entry, other awards included \$3000 to each of the participants. Professional adviser was John Lyon Reid, F.A.I.A., and the jury was composed of Pietro Belluschi,

F.A.I.A., Cambridge, Mass.; John Ekin Dinwiddie, A.I.A., New Orleans; Paul Thiry, F.A.I.A., Seattle; Mrs. Dorothy B. Chandler, University regent; Barnham P. Griffiths, a former regent.

Top: left, Weihe, Frick and Kruse; right, Gardner Dailey; Bottom: left, DeMars, Esherick and Kump; right, Welton Beckel

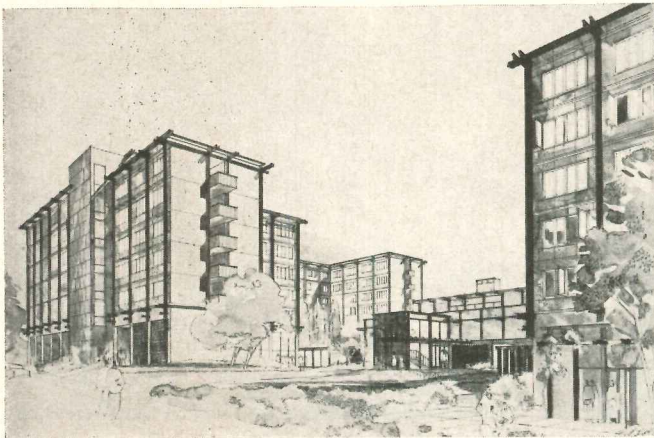
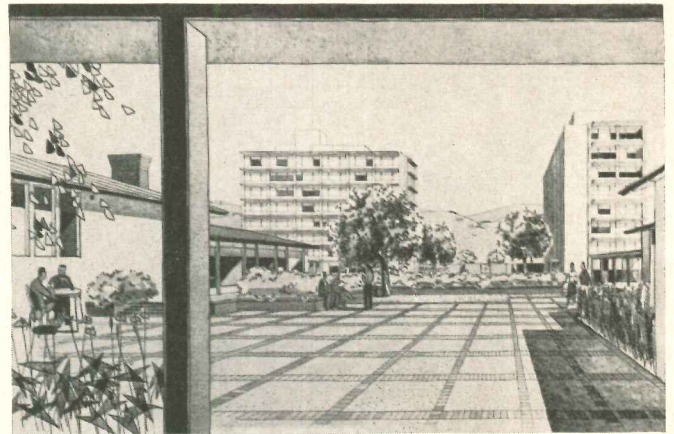
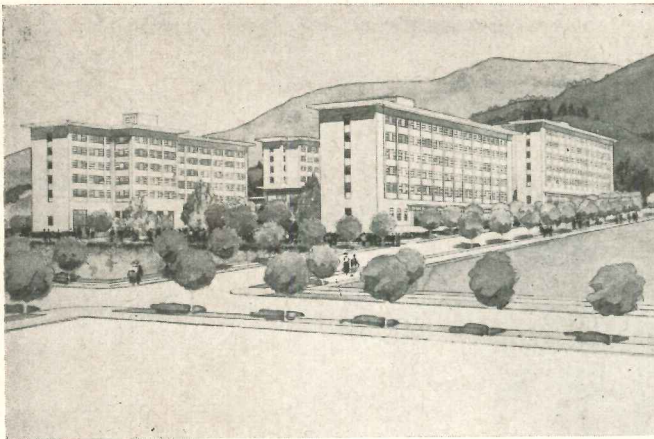

Memphis Competition

begin "as soon as possible." First prize was \$7000. The second prize, of \$1500, went to the entry of A. L. Aydelott and Associates, and the third prize, of \$750, was awarded to Thomas F. Faires and Associates. Paul Schweickher, head of the department of architecture at Carnegie Institute of Technology, served as professional adviser, and members of the jury included architects Philip C. Johnson, New Canaan, Conn.; Paul Rudolph, Sarasota, Fla.; and editor Thomas Creighton of *Progressive Architecture*.

(More news on page 16)

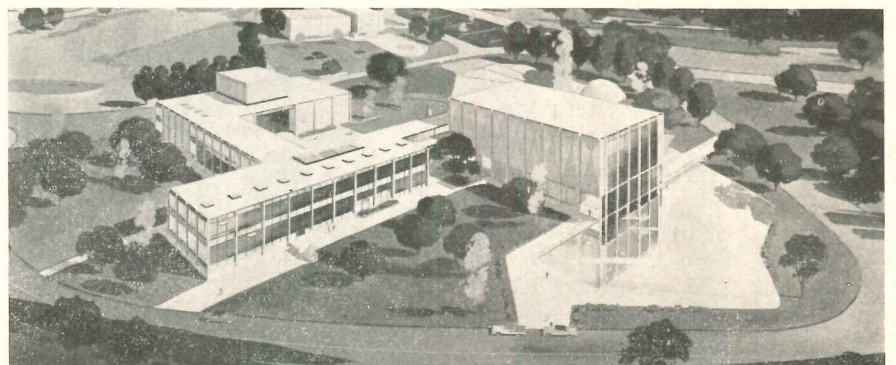

Third prize entry from Thomas F. Faires & Associates was commended by the jury

for its "pleasant cloister-like court" and "discipline in scale"

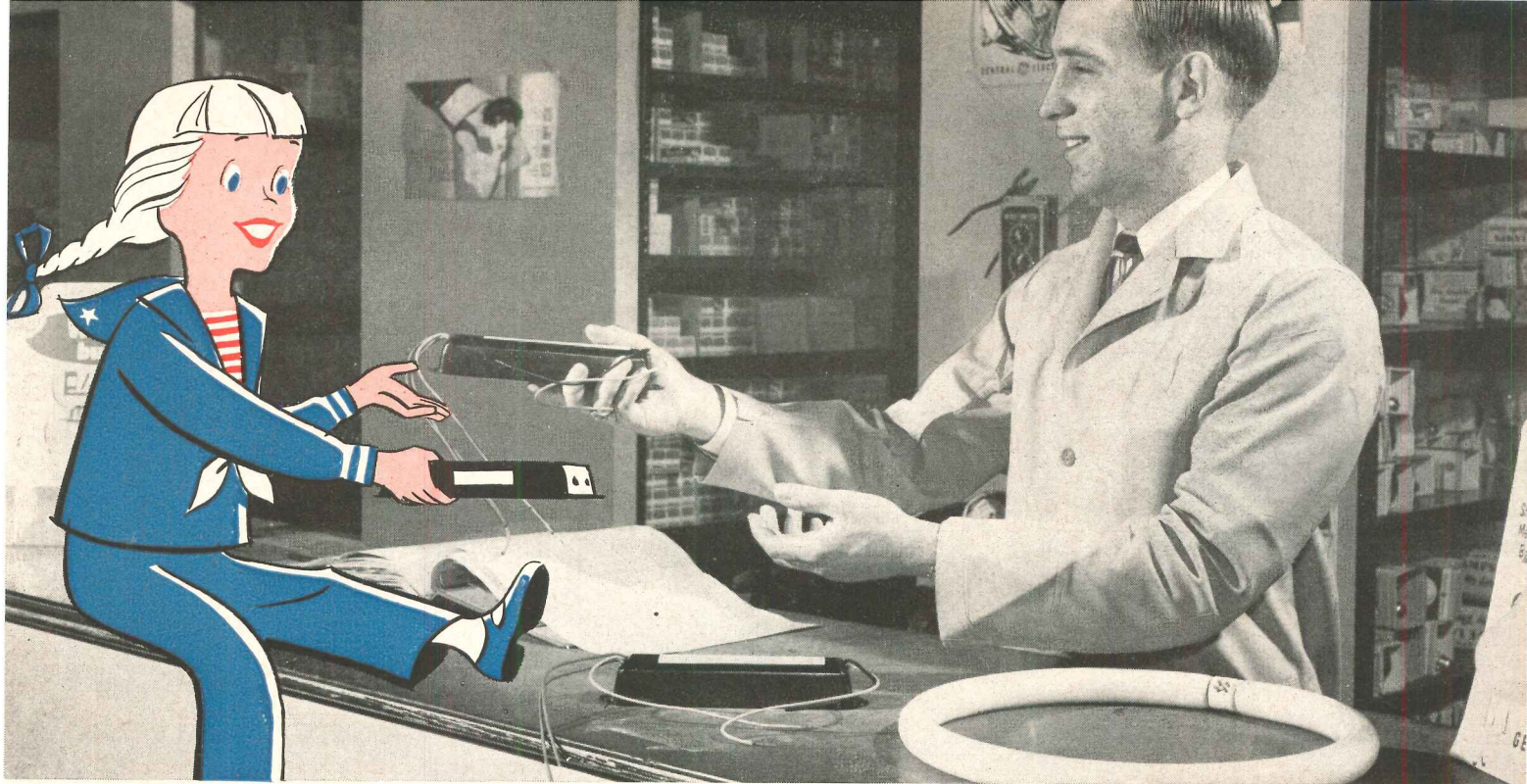

FLORA BALLAST* SHOWS how easy it is to make across-the-counter in-warranty replacement of G-E ballasts at no cost to you, from your

nearby G-E Ballast Service Center Distributor. They carry ample stocks of G-E ballasts from which you can select replacements for any make ballast.

Flora explains how . . .*

More Than 800 G-E Ballast Service Centers Help You Save Lighting Dollars

When it is necessary to obtain an immediate ballast replacement you'll get prompt service at the G-E Ballast Service Center Distributor located nearest you. The complete stocks and convenient location help you save time and money. There are G-E Ballast Service Centers in every major city—more than 800 of them in the United States. Here you can make NO CHARGE in-warranty replacements of G-E ballasts . . . and replace *any make*

ballast with a high quality G-E unit. And G.E. gives you top quality at low attractive prices too. Save time and money—solve your ballast replacement problems at your nearest G-E Ballast Service Center.

When you buy G-E ballasts you get other services too. G.E. maintains a network of national warehouses to speed volume orders. More than 150 trained sales engineers from G-E Apparatus Sales Offices are available to give you help in

applying G-E ballasts and in servicing G-E ballast installations.

A G-E ballast tag or sticker on your fixture is proof that it is equipped with the best in ballast value. It's the easy way to be certain. For a complete presentation on G-E ballasts, contact the G-E Apparatus Sales Office nearest you or write Section 401-16, General Electric Company, Schenectady 5, New York.

*Miss Fluorescent Ballast, G.E.'s Ballast Mascot
Copyright 1955, General Electric Company

Five more reasons why

GENERAL ELECTRIC IS YOUR BEST BALLAST VALUE

- EXCLUSIVE SOUND RATING SYSTEM
- SUPERIOR QUALITY CONTROL
- LONGER BALLAST LIFE
- PRECISE LAMP-MATCHED DESIGN
- PROVED PRODUCT LEADERSHIP



Progress Is Our Most Important Product

GENERAL  ELECTRIC



EXPERIENCED G-E BALLAST ENGINEERS are available to help you plan and service fluorescent lighting applications. For help, contact your nearest G-E Apparatus Sales Office.

THE RECORD REPORTS

(Continued from page 12)

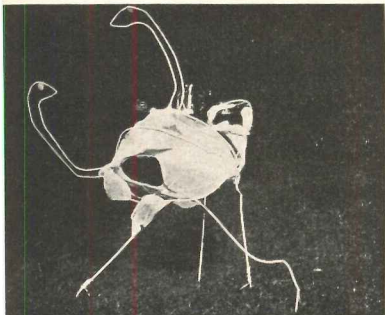

TRADES SHOW AUSTRALIANS LATEST IN DESIGN AT CONVENTION

New structural principles, new materials, and new forms of construction were exhibited to architects and public at the recent Sixth Australian Architectural convention in Adelaide, South Australia.

The exhibition, first of its kind in Australia, was composed of 14 buildings which housed trade exhibits. The buildings themselves were exhibits of advanced technique, materials, and design.

More than 100,000 persons visited the exhibition during a three-week period. Site for the exhibit was Botanic Park, located in the center of Adelaide, which provided a natural setting for the temporary buildings. The cost of materials and labor was paid for by the building industry and associated manufacturers and agents. A committee of Australian architects designed the exhibition buildings.

Integration of art and architecture at the exhibit was effected by use of sculpture and murals. Australian artists and

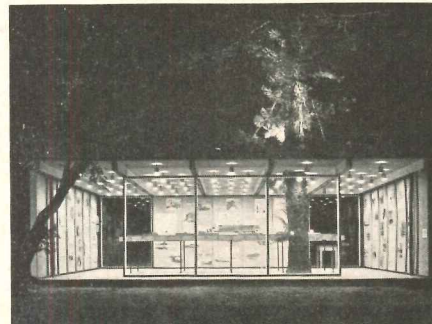
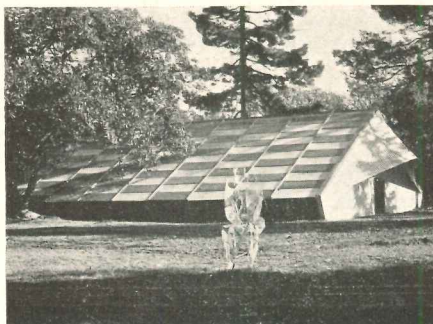

International Pavilion (top photo), at Australian exhibition, houses architectural exhibits from 12 countries. Constructed of wood and canvas, the five-pointed structure resembles a star. Lower photographs are of trades pavilion (left), formed from three pinned arches; and the government pavilion (right), made of glass and timber

sculptors contributing were Wladyslaw Dutkiewicz, S. Ostojka-Kotkowski, Wojta Marek, and Francis Roy Thompson. Dutkiewicz's steel rod and wire sculpture of emus is shown in photograph, above left. Keith Neighbor, architect, was chairman of the exhibition committee.

The convention of the Royal Aus-

tralian Institute of Architects had as its theme "Architecture and Man," and covered in symposiums such subjects as design for the nation, the community and the individual. Pietro Belluschi, Dean of the School of Architecture and Planning, Massachusetts Institute of Technology, was keynote speaker at the convention.

(More news on page 16B)



Timber house (left) at exhibition illustrates possible uses of timber in various forms, from beams to bathtub. Concrete



pavilion (center) is composed of six bays of 18 ft span prestressed periphery beams which carry a 3 ft grid of post-stressed

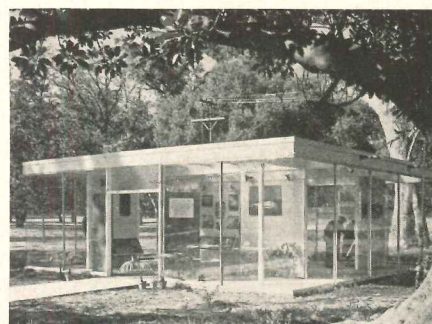

beams within them. Glass pavilion (right) is a glass cube with minimum of other structural materials



The spirit of youth in color and character

Virtually any color in the spectrum is yours to use dramatically — for plain surfaces, sculpture and polychrome panels—when you specify Architectural Terra Cotta. Whatever you create, Federal Seaboard can custom-make not only in form and color but in texture and size as well, for interiors or exteriors. This is why Architectural Terra Cotta can be combined so impressively with other materials...why it is utilized in so many outstanding buildings of all types. In addition to advantages of quality, appearance, permanence and price, it insures minimum maintenance. The original richness and beauty can be retained indefinitely by simple soap-and-water washings. Whatever the buildings now on your boards, write us for latest application data today.

Construction detail, data, color samples, estimates, advice on preliminary sketches, will be furnished promptly without charge on Architectural Terra Cotta and Ceramic Veneer.

JUNIOR HIGH SCHOOL

SOUTH ATTLEBORO, MASS.

Architects Collaborative—Architects
Vera Construction Inc.—Builders

Architectural Terra Cotta in units
12" x 12" x 1 1/4" comprise the colorful wall.



FEDERAL SEABOARD TERRA COTTA CORPORATION

10 East 40th St., New York 16, N. Y.
PLANT AT PERTH AMBOY, NEW JERSEY

THE RECORD REPORTS

MEETINGS AND MISCELLANY

(Continued from page 21)

lurgical and petroleum engineers, mechanical engineers and electrical engineers, as well as the chemical engineers who now have offices outside of the Engineering Societies Building. The fifteen-man task committee recommended that the societies remain at their present 39th street location, or, if rebuilding there seemed impractical, acquire another site in the Grand Central area. They rejected a suggestion that the engineering society center might be built in the Columbus Circle neighborhood. Offers from the other cities were tempting — Chicago, Philadelphia and Pittsburgh were each reported to have offered \$1.5 million toward a new building, and in Pittsburgh the Mellons added their offer of another \$500,000 for research grants. Other cities vying for the engineers' choice included St. Louis, Washington, Hoboken, N. J., Kansas City, Miami and Shreveport, La. New York is not known to have offered anything as concrete as a million dollars, but in choosing to remain in the city the engineers were heeding the advice of former President Herbert Hoover and the persuasions of Mayor Wagner and Governor Harriman.

Georgia Tech in Zagreb

"A Half Century of Architectural Education," an exhibit of the works of graduates of the 50-year-old architectural school at Georgia Institute of

Technology, was to be shown at the International Trade Fair held at Zagreb, Yugoslavia, September 7-20. The U. S. Department of Commerce chose this as one of the two entries from this country. Upon its return from Zagreb, the display will tour the U. S.

For Professional Coordination

The imminent opening of the Atlanta Building Industry Center has been announced by the Architects & Engineers Institute, Inc., a non-profit group backed by the Georgia Chapter of the American Institute of Architects and the Georgia Engineering Society. On November 1, the institute, which includes landscape architects, planners, contractors, surveyors and the Producers' Council as well as architects and engineers in its membership, will open the center in an 80,000 sq-ft building in downtown Atlanta. About half of the building will be given over to products display, described by institute vice president Bernard B. Rothschild as the "financial backbone" of the operation. Proceeds from the samples bureau will go into an educational and research fund. The rest of the building will house meeting rooms for the constituent organizations, a kitchen and a technical library.

The Modern Builder

To shed some light on the problems facing the construction industry in this technological age, the Armour Research Foundation of the Illinois Institute of Technology will sponsor a Modern

Builders Conference in Chicago on December 6 and 7. Up for discussion: research planning as the architect sees it; architect-builder coordination; research in structural clay, wood and concrete products; contractor-engineer and realtor-operator problems in material handling; prefabrication; interior surfacing and services. Information is obtainable from J. J. Kowal, Conference Secretary, Armour Research Foundation of I. I. T., 10 W. 35th St., Chicago 16.

Architectural Schools (Cont'd)

At the University of Florida, Dr. Turpin C. Bannister has been appointed Dean of the College of Architecture and Fine Arts, it has been announced. Dr. Bannister, who was professor of architecture at the University of Illinois, will succeed Dean Emeritus William T. Arnett.

The University of Michigan has named Charles H. Sawyer director of its Museum of Art, Professor of Art in the College of Architecture and Design and Professor of Fine Arts in the College of Literature, Science and Arts. Mr. Sawyer goes to Michigan from his position as Dean of the School of Architecture and Design at Yale University.

And at Yale, Boyd M. Smith, Associate Dean of the School of Architecture and Design, will serve as acting dean upon Mr. Sawyer's departure.

At the University of Pennsylvania, Professor Ian L. McHarg of the De-

(Continued on page 28)

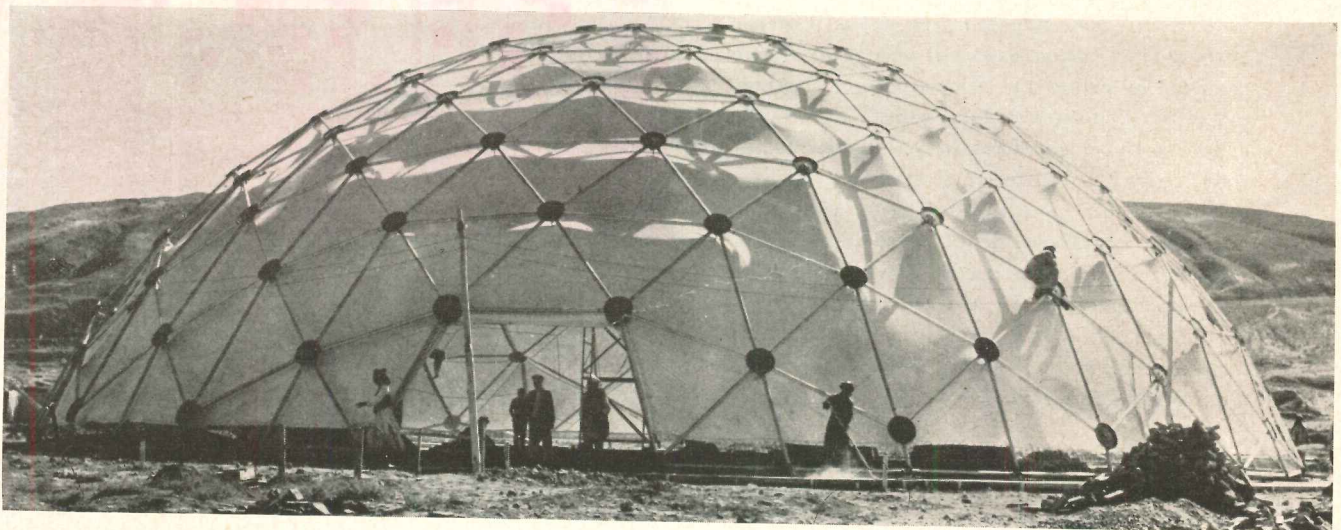

PICTURE OF THE TWAIN MEETING: Bucky Fuller's domes span the world. This one was built at the Jeshyn International Fair at Kabul, Afghanis-

tan, because the U. S. Department of Commerce detected a resemblance between a geodesic structure and the mobile yurts (tents) of Afghan tradition. According to

report, the Afghans loved it; the Commerce Department called it "unquestionably the most dramatic structure the United States has ever displayed in Southeast Asia"

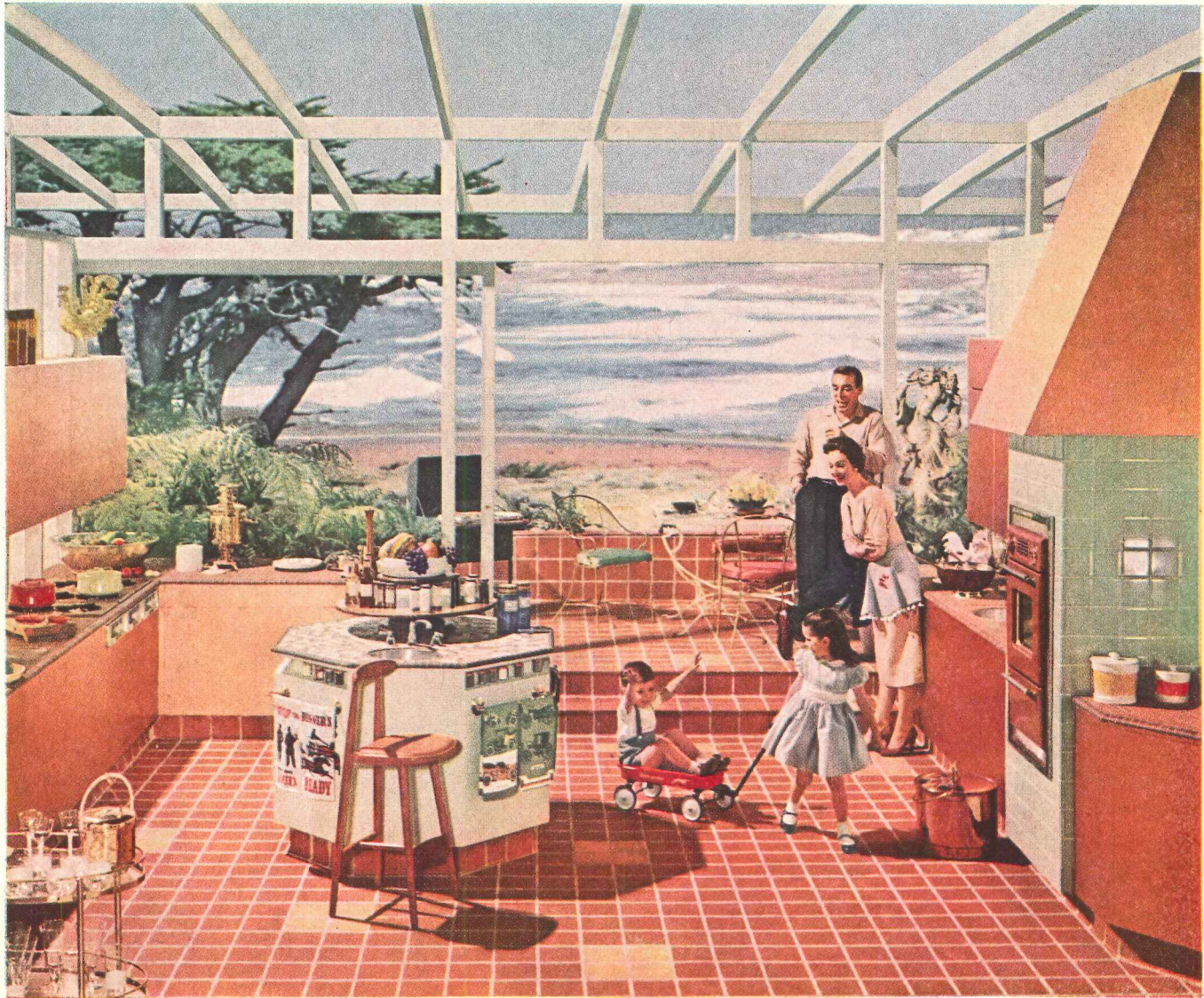

Lester Tichy, A.I.A., Architect.
 G. M. Crocetti, Inc., Tile Contractor.
 Accessories and costumes by Lord & Taylor.
 Cooking equipment by Magic Chef.
 Photo by Pagano, Inc. Plate No. 502.

Noted Architect's Indoor Patio of

MOSAIC Ceramic Tile

In this indoor patio, Architect Lester Tichy has brought summer fun and freedom indoors for year 'round enjoyment. Selecting his tile from America's only complete ceramic tile line, Mosaic, he found it easy to choose just the right colors and textures for floor, walls and counter tops.

You'll be pleased to learn how easy it is today to own Mosaic Ceramic Tile. It's as simple as visiting our showrooms (see phone book for addresses) or calling your Tile Contractor. His free estimate will show you that if you can own a home, you can own Mosaic Ceramic Tile.

Send today for details of this indoor patio and 38 other exciting tile ideas!

For Free Estimates
 on **MOSAIC** Tile,
 see your phone book
 for the name
 of Your Tile
 Contractor
 (Ceramic)



THE MOSAIC TILE COMPANY Zanesville, Ohio

I've enclosed 25¢ in coin. Please send 39 exciting Mosaic Tile ideas, including details of the Indoor Patio.

Name _____

Address _____

City _____ Zone _____ State _____

The Mosaic Tile Company, America's largest manufacturer of ceramic floor, wall and counter top tile

CANADA BUILDING BUSINESS SOARS WHILE PROFITS DROP

Competition, rising costs, and credit curbs are putting the pinch on Canada's construction industry despite a healthy increase in awards of construction contracts, latest statistical reports show.

The Bureau of Statistics forecasts that the increase in construction contracts granted this year will run as high as 19 per cent over last year's total. Already a new record of \$1.9 billion in contract awards has been set during the first seven months of this year. That is a 24 per cent increase over the same period in 1955 for contracts awarded.

In the face of accelerated construction activity, profits for the industry are dropping and company failures are rising. Despite the phenomenal total of work done in 1955 — \$5.3 billion worth — the number of industry failures rose to 358, or 111 percent above the 1954 figures. That represents 5 per cent of the estimated total of construction firms and, while few of them were major companies, a number were firms of long standing. There is every indication, evidenced by statistical reports, that the failure rate may be considerably higher this year.

One of the problems causing this good business-poor profits contradiction in Canada is intense competition. The Canadian Construction Association estimates that 25 per cent of all building companies have reported deficits over the past few years. In 1956 contractors are battling more intensely than ever to get jobs.

Much work is being taken on either at less than cost or so near the line that even slight variations in estimated time, labor and materials can cause a loss.

Costs Spiral Upward

In the background are spiraling wage rates and material prices. On the average, labor costs have climbed 7 per cent since 1954. During the same period, material prices have gone up about 10 per cent, though the rise in certain categories has been much steeper.

The tempo of increase is accelerating in 1956. So far this year, basic construction costs are 4 to 5 per cent higher, compared with hikes of 1 to 3 per cent in other recent years.

Union contracts signed in a dozen dif-

ferent building trades over the past few months represent an average increase of about 10 cents an hour, with another raise due next year.

Average material costs are running at an all-time high, with the Bureau of Statistics price index reading 127.5 for non-residential building items in June 1956 as against 121.2 in the same month in 1954, and 122.0 in June 1955. Residential building materials were 129.0 in June 1956 compared with 121.6 in the same month, 1954, and 124.3 in June 1955.

Credit Rates Rise

In August, the Bank of Canada raised the interest rate on its loans to chartered banks from 3 to 3½ per cent, the fifth increase in the past 12 months. The effect will probably be to stiffen credit and make lending more selective, putting added burden on Canada's construction industry.

1955 HOUSE CONSTRUCTION TOTALS \$1.5 BILLION

Residential construction in Canada including land costs, involved expenditures amounting to over \$1.5 billion during 1955. This was reported recently in a review of mortgage lending in Canada by the Central Mortgage & Housing Corporation.

Of the \$1.5 billion total, 53.4 per cent was financed by mortgage loans, mainly from lending institutions. Another 30.4 per cent represented the equity of owners in the form of down payments on dwellings for home ownership, and the equity investment of rental entrepreneurs. In addition 12.7 per cent was provided by owners who financed the construction of their dwellings without recourse to mortgage financing. The Federal government provided 3.5 per cent of total expenditures, mainly for the construction of quarters for married members of the armed services.

THORNCLIFFE PARK DEVELOPMENT

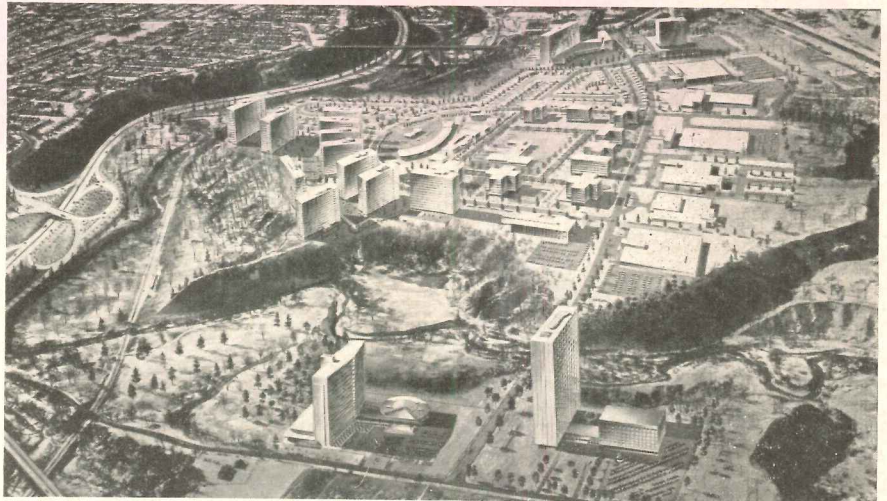

LUXURY HOUSING PROJECT BEING BUILT AT TORONTO

Construction began recently on a multi-million dollar housing development at the site of the Thorncliffe Race Track near Toronto. To be called Thorncliffe Park, the development will consist of a number of high-rise, 15-story luxury apartment blocks which will house some 12,000 persons. A shopping and community center, schools and churches will complete the development.

Situated on a 400-ft high plateau with an area of 388 acres, Thorncliffe

Park will be about ten minutes driving time from the heart of downtown Toronto. The site will be isolated from its surroundings by fully landscaped parkland which will include a sports center.

The new development is being built by F. H. McGraw of Ontario, Ltd., a subsidiary of the United States engineering and construction firm F. H. McGraw Co. Crang and Boake, Toronto, are associate architects along with F. H. McGraw.

(Continued on page 40)

Another sensational **Plextone** *first..*

A Full Year Guarantee

on multicolored textured paint

Plextone Standard Multicolors include These "COLOR LEADERS"



The most startling news since Plextone... A full year guarantee of this amazing color-flecked textured finish on walls! Only Plextone can give such a guarantee because of its unsurpassed durability. Plextone consists of two or more colors applied by a single spray application, from one container, forming a multicolor pattern of outstanding beauty and sales appeal. Be among the first to offer Plextone guaranteed painted walls.

Write for complete information and the new Plextone color palette.

PLEXTONE®

WORLD'S LARGEST PRODUCER OF MULTICOLORED PAINTS

MAAS & WALDSTEIN CO.

21 McCARTER HIGHWAY, NEWARK 4, NEW JERSEY

WEST DIVISION: 1658 Carroll Avenue, Chicago 12, Illinois

PACIFIC COAST DIV.: Smith-Davis Co., 10751 Venice Blvd., Los Angeles 34, Calif.

MAAS & WALDSTEIN CO.
Architectural Division
2129 McCarter Highway
Newark 4, New Jersey

Gentlemen: Please rush free new PLEXTONE color palette and application information.

our 80th year

Name _____

Title (or occupation) _____

Company _____

Address _____

City _____ Zone _____ State _____

THE RECORD REPORTS NEWS FROM CANADA

(Continued from page 36)

ONTARIO ARCHITECTS WANT MODULE, QUERY SHOWS

Ontario architects would like modular units to be made available, according to the results of a recent masonry survey.

A poll taken by a special committee of the Ontario Association of Architects showed 84 per cent of the architects responding were in favor of standard

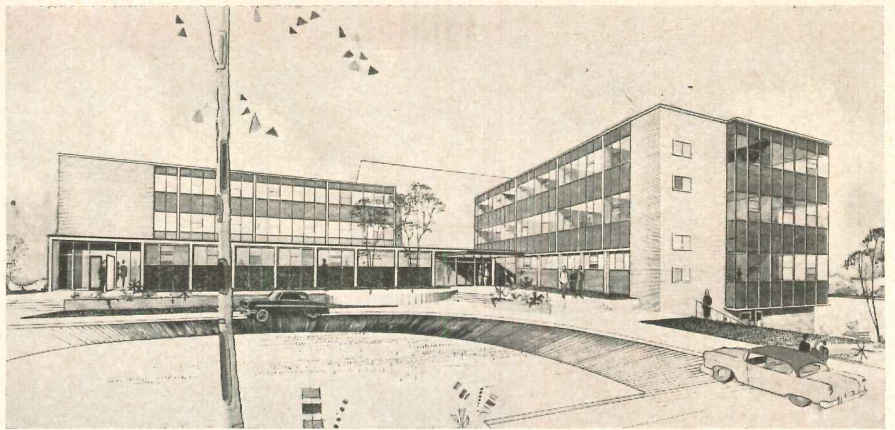

New 118-bed station hospital will be built at site of Camp Gagetown near Fredericton, N.B. The camp, which was begun three years ago, will ultimately cost about \$50 million and will include a town

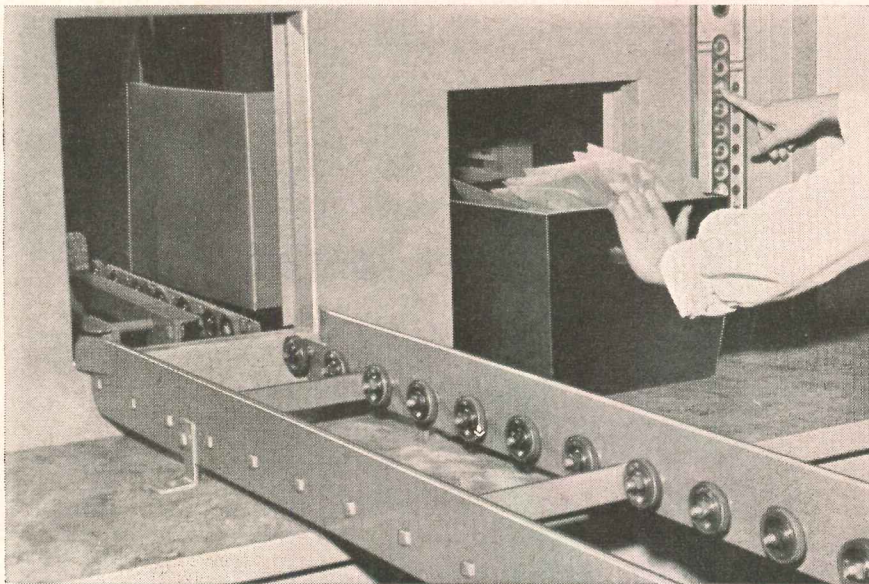

RECORDLIFT speeds important papers floor-to-floor automatically

*If you have an office building job
on the board — read this*

HERE'S the perfect answer to inter-floor handling problems in modern multi-story buildings. This STANDARD conveying system can distribute tons of mail, supplies and business papers every day—quickly and safely.

RECORDLIFT convenience and speed permit the uninterrupted coordination of related departments, regardless of their location. Containers can be sent to any floor in just a few minutes. And because of its simplicity and push-button control, the RECORDLIFT can be easily operated by anyone.

For complete details on cur-

rent RECORDLIFT installations, contact STANDARD CONVEYOR COMPANY, General Office: North St. Paul 9, Minnesota. Sales and Service in Principal Cities.

For details, see the Standard Engineer listed in your phone book or write for Bulletin S-150-00. Address Dept. AA-10.



brick and masonry units. Ninety-four per cent said existing brick sizes are not satisfactory.

The American module (8 in. by 2½ in. by 4 in.) was favorable to 74 per cent of those answering the poll. Some 150 replies were received to the questionnaire on measurements circulated among Ontario architects by the committee on brick sizes.

Twenty-two per cent of the architects replying wanted to change directly to modular sizes. Others felt that such a change would occur within the near future. Over one half of the 84 per cent replying in favor of modular brick said they would use the module in the majority of their work.

II COMMUNITY PLANNING FELLOWSHIPS ANNOUNCED

Eleven fellowships for post-graduate study in community planning have been awarded for the year 1956-57.

The fellowships, which amount to \$1200 each, were given by the Central Mortgage & Housing Corporation. Announcement of the awards came from Robert Winters, Federal Public Works Minister.

Winners are Claude Langlois, Montreal; L. A. Sullivan, Valleyfield, Que.; W. C. Bridcut, Ottawa; I. D. Macpherson, Toronto; L. F. Milne, Fredricton; H. D. Smith, Port Credit, Ont.; R. B. Truemner, Toronto; Edward Dolhun, Winnipeg; R. K. Jamieson, Montreal; P. D. McGovern, Vancouver; and J. R. Sharpe, Victoria.

Langlois and Sullivan will study at McGill University; Bridcut, Macpherson, Milne, Smith and Truemner at the

(Continued on page 44)

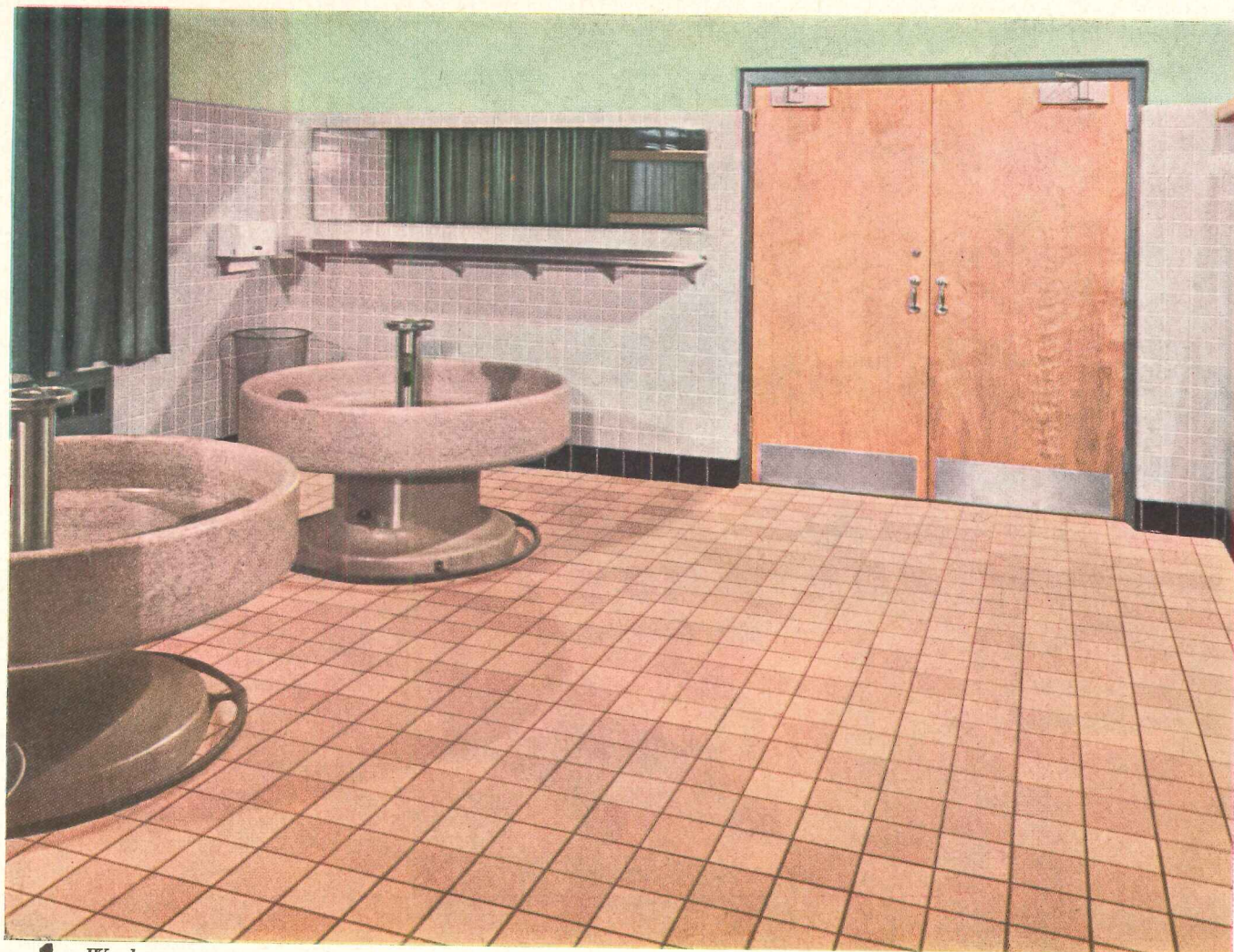

1. Washrooms

In schools... five key areas need tile

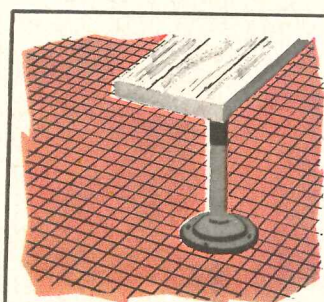

2. Locker Rooms

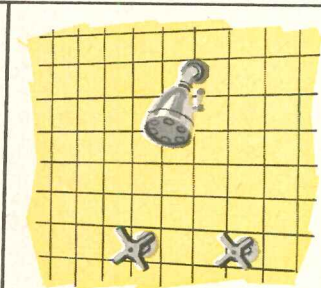

3. Shower Rooms

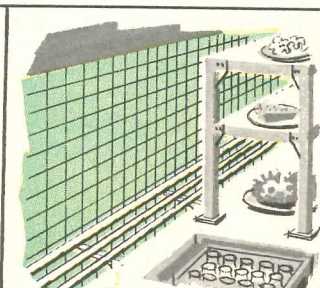

4. Kitchens and Cafeterias

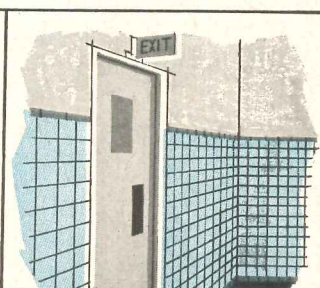

5. Corridors

The beauty and durability of American-Olean ceramic tile make it a sound choice for many areas in a school. But in every school there are five key areas where ceramic tile is not only wise, but essential.

In washrooms, locker rooms, and shower rooms, tile's resistance to water damage, its ease of cleaning, and its rugged permanence are deciding factors. In kitchens

and cafeterias, it cannot be harmed or stained by heat, grease, or spilled food, and it adds safety because it's fireproof. On corridor walls, pencil, ink and crayon marks wipe right off its smooth glazed surface.

Two free booklets. "Tile for Schools and Hospitals", and "Catalog of Tile Products", will be helpful in your planning. Won't you write for them today?

TILE SPECIFICATIONS FOR MAIN ILLUSTRATION

Color Plate 345, Washroom, Lake High School, Salisbury, Maryland. Architect, Edwin Wilson Booth. Walls: 28 Pearl Gray. Base: S-49 Gloss Black. Floor: Sand Buff Textone Pavers.

American-Olean Tile Company

Executive Offices: 1177 Cannon Avenue, Lansdale, Pennsylvania

Factories: Lansdale, Pennsylvania · Olean, New York · Member, Tile Council of America

THE RECORD REPORTS

NEWS FROM CANADA

(Continued from page 40)

University of Toronto; Dolhun and Jamieson will study community planning at the University of Manitoba; and McGovern and Sharpe will do advanced study in the field at the University of British Columbia.

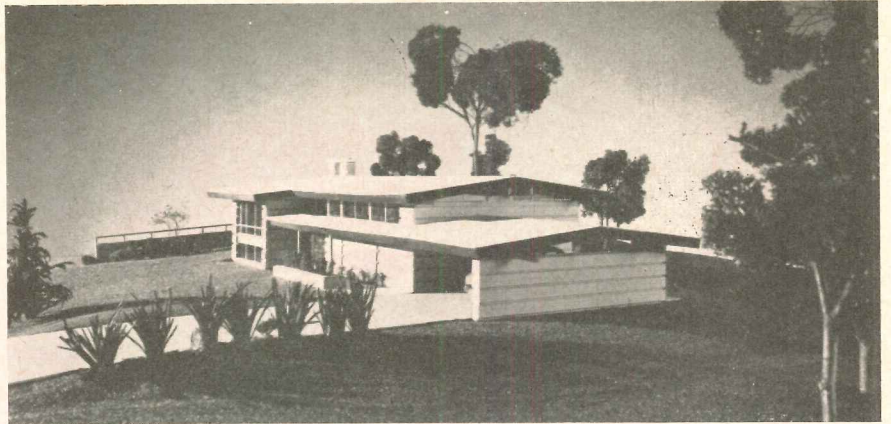

"HOUSE OF 1956" DESIGNED FOR CANADIAN MAGAZINE

The *Canadian Home Journal's* "House of '56" was opened to inspection by the public recently.

Designed by Fox and Stone, Toronto architects, the house is located at 101 Banbury Road, Don Mills, Ontario.

Plan for the house was based on the results of a survey by the *Journal* which queried a number of architects, builders, and typical families as to "what people really want in a home."

Requests for individual privacy; bedrooms "large enough to hold more than just a bed and chest;" a fireplace; room for such hobbies as music, photography, and sewing; "plenty of closets and storage space," and room for future electrical appliances, were incorporated into the house plan by the architects.

RECORD SET FOR CANADIAN HOUSING UNITS COMPLETED

A record 48,012 housing units were completed in Canada during the first six months of 1956, the Bureau of Statistics reports. The number of new units started — 59,645 — also represents an all-time high for a half year.

A 17 per cent drop in unit starts under the National Housing Act had been registered during the first quarter of 1956, as compared with the same period last year. Central Mortgage & Housing Corporation blamed the decline, which took place in Toronto and Vancouver, on lack of serviced land rather than on shortage of mortgage money.

PROF. LASSERRE COMPLETES TOUR OF EUROPEAN CITIES

Prof. Fred Lasserre, director of the School of Architecture, University of British Columbia, has just completed a tour of 52 cities in 12 European countries.

While on the tour, Prof. Lasserre
(Continued on page 46)

BRUNER INDUSTRIAL WATER SOFTENERS



ARE FREQUENTLY

Specified BY

LEADING ARCHITECTS
FOR IMPORTANT
INSTALLATIONS!

STATLER HILTON HOTEL, Dallas, Texas
Architect: William B. Tabler, New York, N. Y.
Consulting Engineers: Jaros, Baum and Bolles, New York, N. Y.
Plumbing Contractor: Brown and Olds Plumbing Co., Dallas, Texas

Many institutional, commercial and industrial buildings in all 48 states and seven foreign countries are serviced by Bruner water softeners and filters. Equipment is available from stock for most installations. Uses range from small laundries and schools to huge hospitals and atomic energy plants. Bruner is proud of its customer service — famous for product quality.

We solicit your inquiry.

BRUNER CORPORATION

America's most complete line of quality water softeners and filters

Executive Offices: 4763 N. 32nd St., Milwaukee 9, Wis.

Plants: Milwaukee, Wisconsin, and Santa Barbara, California
Sales and Engineering Offices in all principal cities.

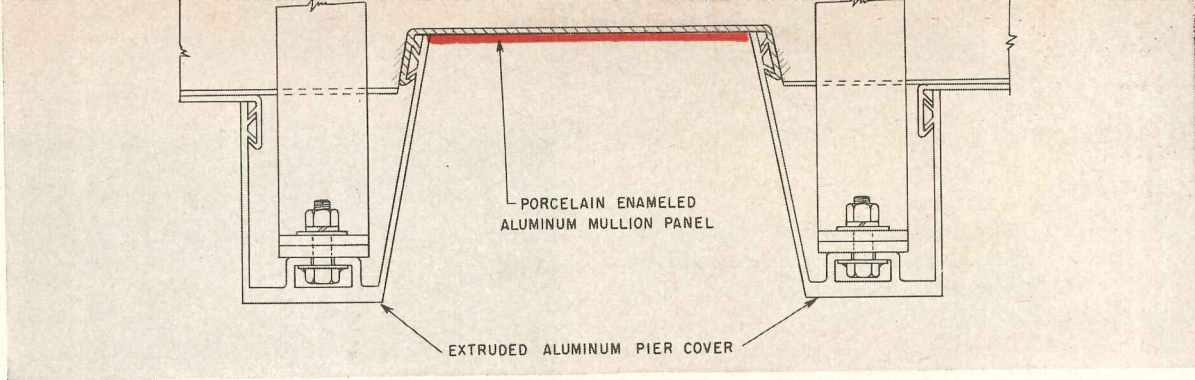

BANK OF THE SOUTHWEST—Trimmed with 6.2 miles of color-matched porcelain-enameled aluminum



Recently completed, the Bank of the Southwest stands as the tallest welded structure in Houston, Texas. One of the many interesting features of this building is the extensive use made of lightweight materials in the superstructure—especially in the vertical trim on the mullion panels. Here, 32,892 linear feet of aluminum, finished with Du Pont porcelain enamel, were used with color selection to harmonize with the red granite base.

Besides the savings in weight afforded by porcelain-enameled aluminum, it gives the added features of lasting beauty and durability. This material stays bright even in industrial atmospheres and under repeated exposure to strong detergents . . . is highly resistant to thermal shock, abrasion and flexing. In addition, aluminum finished in Du Pont porcelain enamels can endure a good deal of fabrication punishment—sawing, shearing, punching, drilling and welding—without exposure of metal or spalling.

Du Pont porcelain enamels for aluminum are available in an unlimited range of highly stable colors lending themselves to a variety of application possibilities.

May we send you detailed literature on these porcelain enamels for aluminum? We will be glad to put you in touch with an enameler who is thoroughly familiar with Du Pont porcelain enamels for aluminum and who can handle your requirements. The coupon below will bring a prompt reply.

ARCHITECT:

Kenneth Franzheim, Houston, Texas

GENERAL CONTRACTORS:

W. S. Bellows Construction Corporation
Houston, Texas

ORNAMENTAL CONTRACTOR:

General Bronze Corporation
Garden City, New York

ENAMELER:

Hamlin-Stevens, Inc., Fairfield, Conn.

DU PONT PORCELAIN ENAMELS for aluminum



BETTER THINGS FOR BETTER LIVING . . . THROUGH CHEMISTRY

E. I. du Pont de Nemours & Co. (Inc.)
Electrochemicals Dept., AR-10, Wilmington 98, Delaware

- Please send me Technical Bulletin CP 4-454 and illustrated folder on Porcelain Enamel for Aluminum.
- Have your technical representative call with further details.

Name _____ Position _____

Firm _____

City _____ State _____

"The great dams of the hydro-electric schemes are typical of the new elements which with vision can be forged into the landscape of the future . . ."

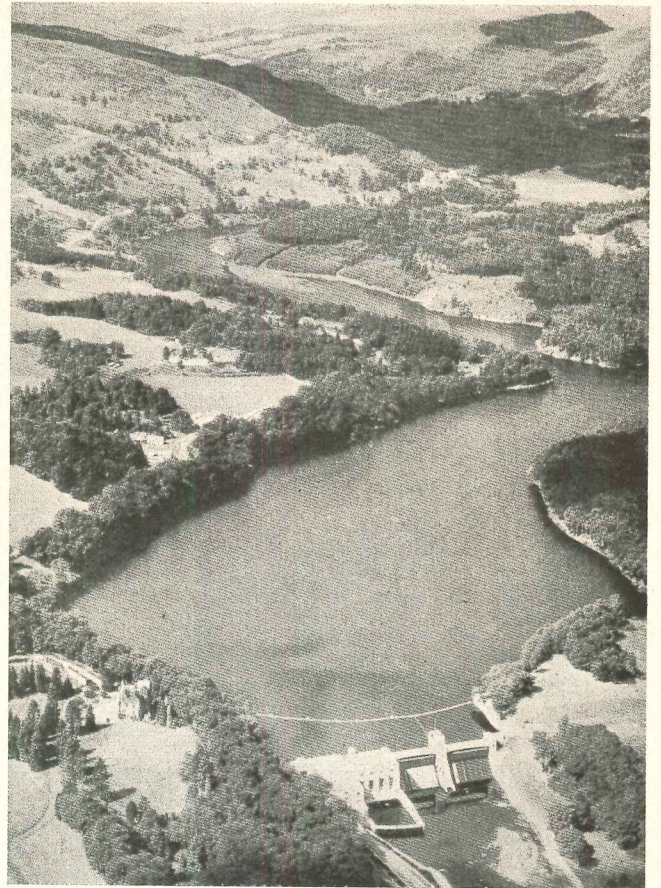

TAKING THE SUBTOPIAN BLIGHT OUT OF TOMORROW'S LANDSCAPE

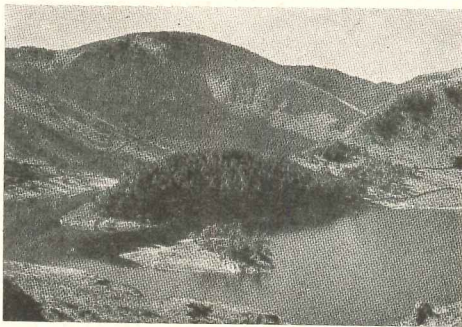

"A landscape which relies on its own proportion and soft atmospheric depth to create a scale of its own (above) can very easily be dwarfed by man-made intrusions (below) . . ."

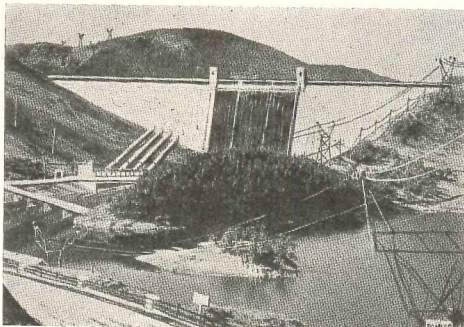

Tomorrow's Landscape. By Sylvia Crowe. The Architectural Press (9-13 Queen Anne's Gate, Westminster, S.W. 1, England) 1956. 20 pp, illus.

A LITTLE more than a year ago a book entitled *Outrage* was published in England by The Architectural Press (Reviewed in ARCHITECTURAL RECORD, November, 1955). The book decried the suburbia disease which has enveloped England and has plagued the rest of the industrial world in postwar years.

Outrage coined the word "Subtopia," formed from "suburb" and "utopia," to symbolize the outlandish destruction of the countryside by suburban developments. Subtopia was defined as "the annihilation of the site; the steam-rolling of all individuality of place to one uniform and mediocre pattern." This creeping blight, which leaves in its path neither town nor country but "mile upon mile of look-alike shacks, cute rusticities, wires and airdromes," supposedly threatens to engulf the whole English countryside.

Now a less biting, more constructive follow-up to *Outrage* has been published by The Architectural Press. *Tomorrow's Landscape*, by Sylvia Crowe, is a positive

(Continued on page 60)

PRESTRESSED CONCRETE 10th ANNIVERSARY

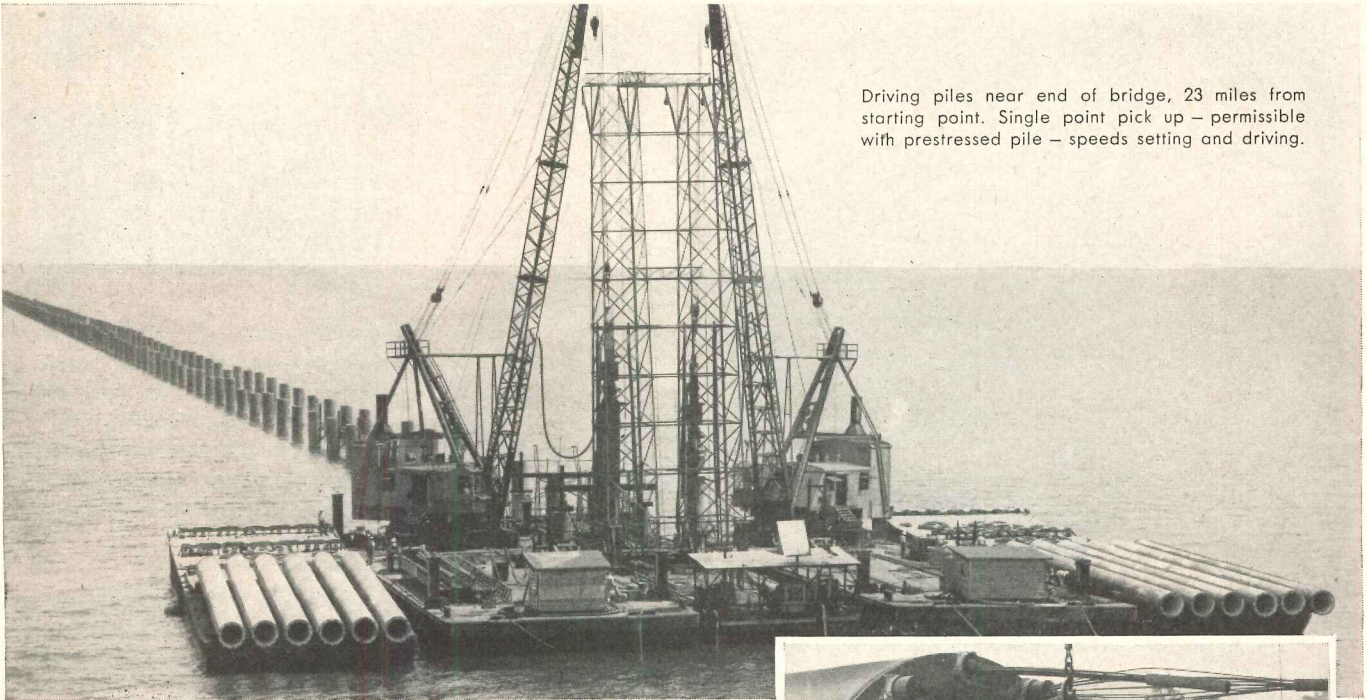

Driving piles near end of bridge, 23 miles from starting point. Single point pick up — permissible with prestressed pile — speeds setting and driving.

TEN YEARS AGO this month the first successful application of prestressed concrete in the U. S. was completed — the prestressed concrete portion of Roebling's Chicago Warehouse. Four years later the first prestressed concrete bridges in this country were completed — tensioned, of course, with Roebling materials. And during that interval we increased our knowledge through constant research plus the design and fabrication of prestressed concrete decks on several of our Central and South American suspension bridges.

As this new material has caught on with ever-increasing rapidity, engineers and fabricators have turned to us for information on materials and methods. This collaboration has not only helped *them* but has kept *us* constantly abreast of new developments and new requirements in tensioning elements.

An example of Roebling's position as America's foremost supplier of tensioning materials is the Lake Pontchartrain Bridge, utilizing 123,000 miles of .192" diameter Roebling wire for prestressing the piles supporting this 24 mile long structure.

When you need tensioning materials or have a problem in prestressed concrete, why not turn to headquarters for suggestions and advice on specific applications? Contact Construction Materials Division, John A. Roebling's Sons Corporation, Trenton 2, New Jersey.

Builders; Louisiana Bridge Co., Mandeville, La. (a joint venture of Brown & Root, Inc., Houston, Texas and T. L. James & Company, Inc., Ruston, La.). Designers, Palmer & Baker, Inc., Mobile, Alabama.

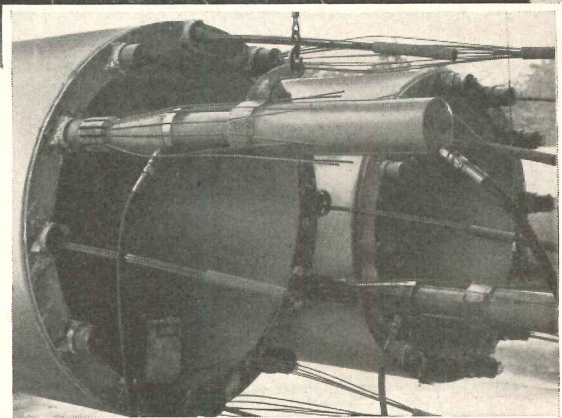

Post-tensioning the cables. Piles are 54" outside diameter, 80 and 96 feet long, and stressed with 12 cables each containing 12 wires, .192" in diameter.

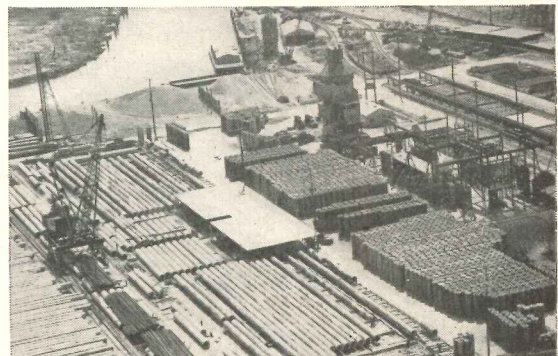

Louisiana Bridge Company casting yard where more than 900 feet of the Cen-Vi-Ro type piles were fabricated per day under special license agreement with Raymond Concrete Pile Company of New York.

ROEBLING



Subsidiary of The Colorado Fuel and Iron Corporation



You can see the difference!

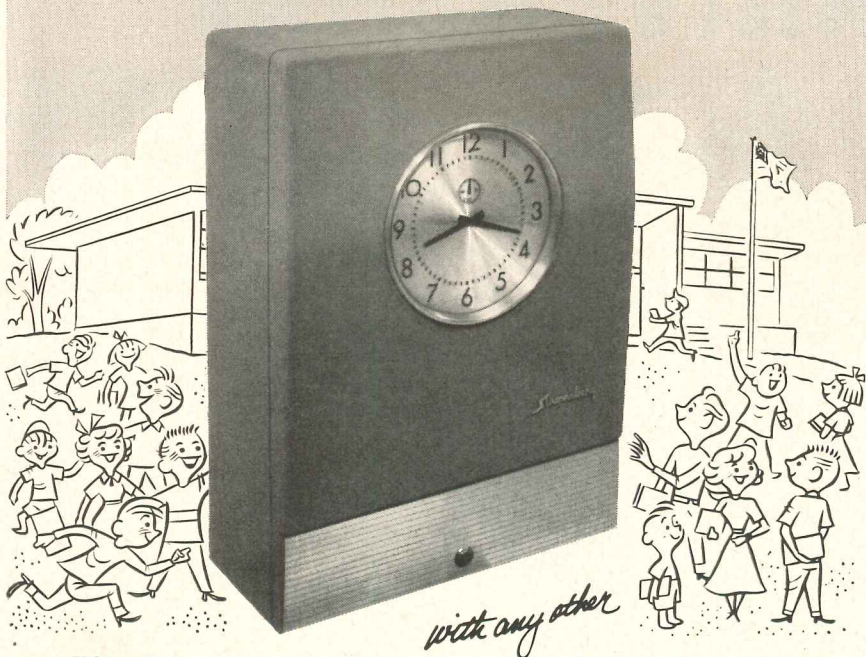

Just compare [^]the new Stromberg Electronic Time System . . .

*Here are some
(just a few)
of the many
PLUS features*

- Jewelled Master Clock movement with automatically wound 72-hour spring power reserve.
- Secondary Clocks standard with hourly and 12-hour supervision — correction cycles completed in 60 seconds.
- Program Unit, capable of 1440 signals daily on each circuit, immediately resets following power interruption.
- Manual signals sound instantly on depressing program key.
- Seven-channel transmitter — one for clock supervision, six for program signals.
- Installation and maintenance service available throughout U.S.A. and Canada.

A product of the laboratories of the largest clock manufacturer in the world—*YOUR GUARANTEE* of performance, quality and dependability.

For complete
details, write:

Stromberg

TIME CORPORATION
Thomaston,
Connecticut



SUBSIDIARY OF GENERAL TIME CORPORATION

REQUIRED READING

(Continued from page 58)

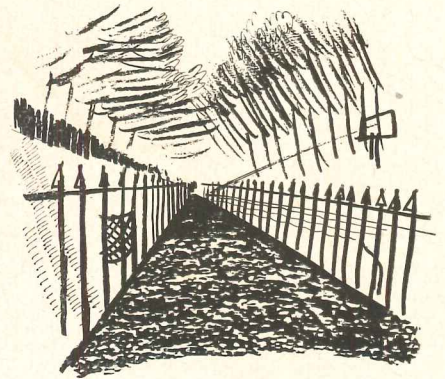

“Country paths, by the addition of concrete surfaces and iron fences, become urban paths carrying the worst element of town into the country. Paths treated in this barbarous way are simply a means of reaching a destination without pleasure in the going . . .”

attempt to show how that blight can be arrested by prompt, resolute, creative action. Miss Crowe, a practising landscape architect, has spent many years digging into the root causes of the suburban development problem. *Tomorrow's Landscape* is the culmination of this research presented along with her own practical prescriptions for a Subtopia cure.

Miss Crowe contends that the inevitable intrusion of industry and population can be absorbed, with proper planning, into a natural and beautiful landscape.

“Many of the forces which have made such tragic inroads into the English landscape during the last century cannot be reversed,” says Miss Crowe. “They cannot even be halted, but they can be guided if they are looked at with fresh eyes and used as elements of landscape composition.”

Her approach is to analyze current building and landscaping projects in England, showing their destructive or constructive effect on the natural environment, and to follow-up with ways destructive elements could be alleviated.

Her fluid style of writing is complemented by a profusion of photographs and sketches which illustrate and emphasize the points she makes so well.

Her book delivers a positive statement; in short, *Tomorrow's Landscape* shows how we can maintain beauty in the face of the ever-growing trend toward Subtopia.

D.T.

(More reviews on page 440)

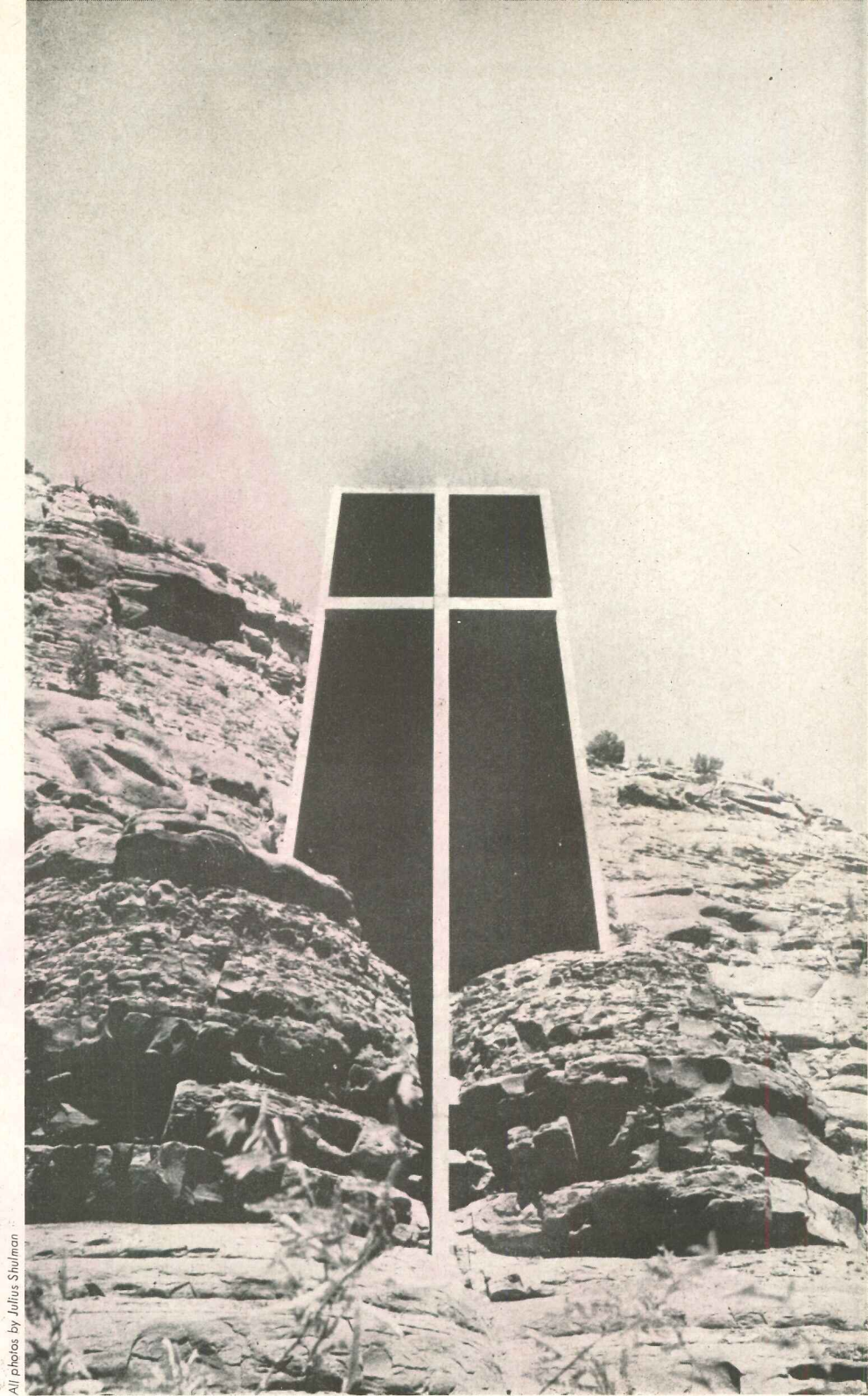

All photos by Julius Shulman

CHAPEL OF THE HOLY CROSS

Anshen & Allen, Architects; Robert D. Dewell, Civil and Structural Engineer; Earl & Gropp, Electrical and Mechanical Engineers; William Simpson Construction Co., General Contractors; Fred Coukos, Construction Superintendent; Bernard T. Espelage, O.F.M., D.D., Bishop of Gallup; John Driscoll, Pastor; Keith Monroe, Sculptor

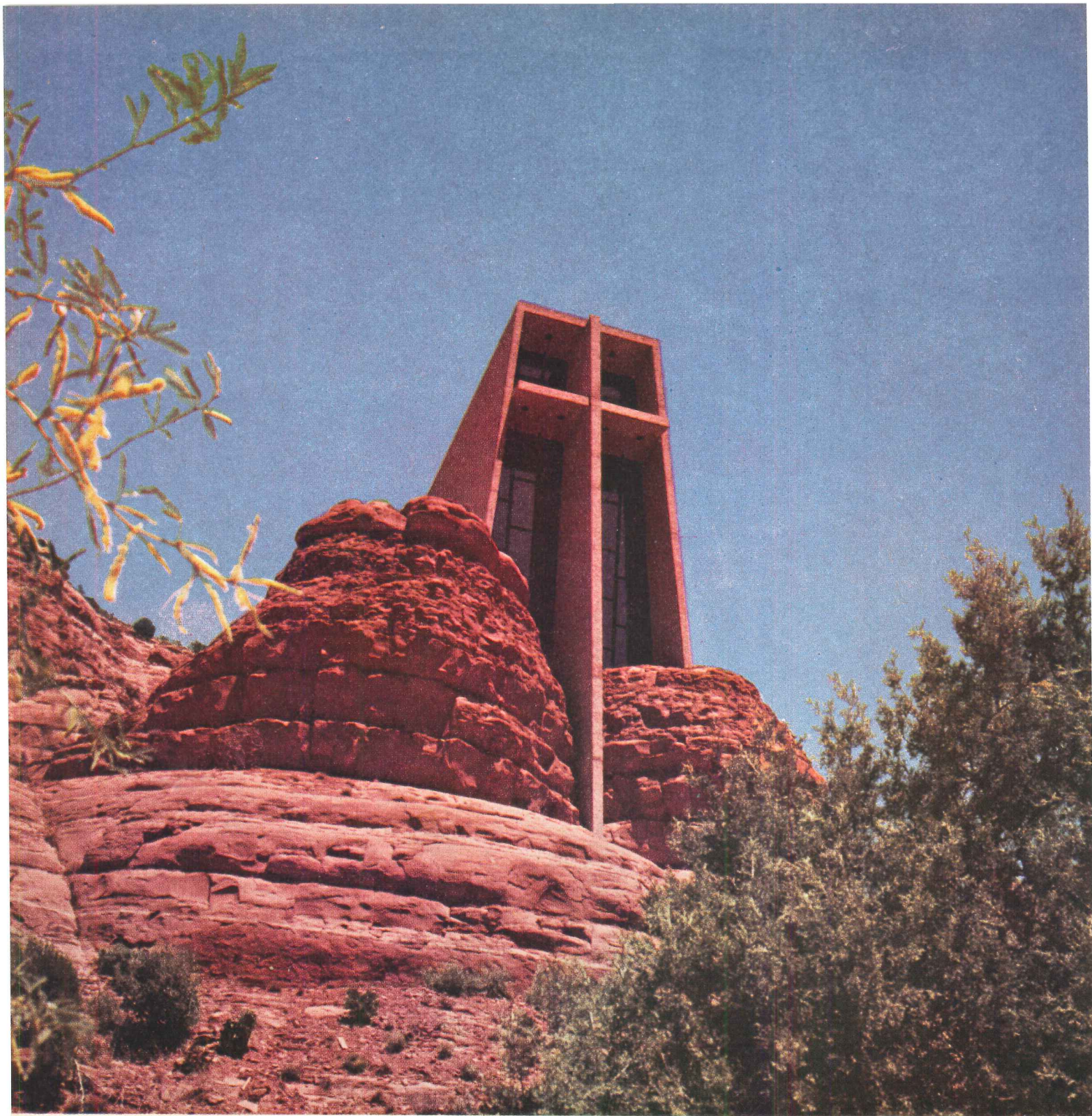

The Chapel of the Holy Cross at Sedona, Arizona is an arresting building. It is also fine architecture. It combines more than the usually requisite assortment of identifiable satisfactions in such a way that the total effect renders analysis of its particulars, though pleasurable, an academic process only partially instructive because it is incapable of completion.

Of course all fine architecture resists analysis. Here, for example, it is possible to identify the particular ingredient of an unparalleled site; to recognize in the shape and scale of the building and its parts, in the choice of surface, color

and texture the sensitive respect which the architects have expressed for the character of that site and at the same time for the particular functions and materials and processes involved.

These are causes and effects capable of sensible amplification. But beyond the ability of words to describe its achievement, this building can speak to the mind and spirit regarding place and time and purpose. Certainly it suits its site. It has the ability to suggest today, both yesterday and tomorrow, and it is an architecture appropriate for worship with power to impress its expressive image on the memory.

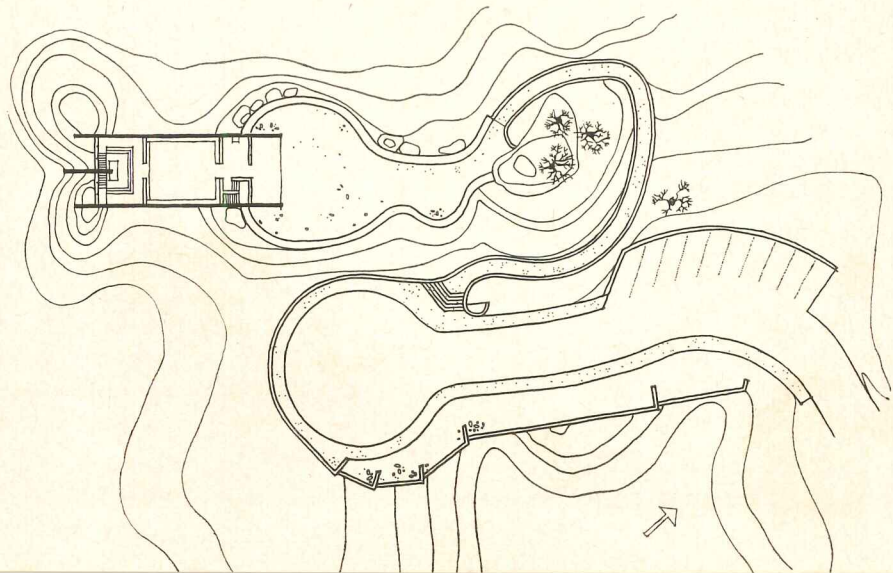
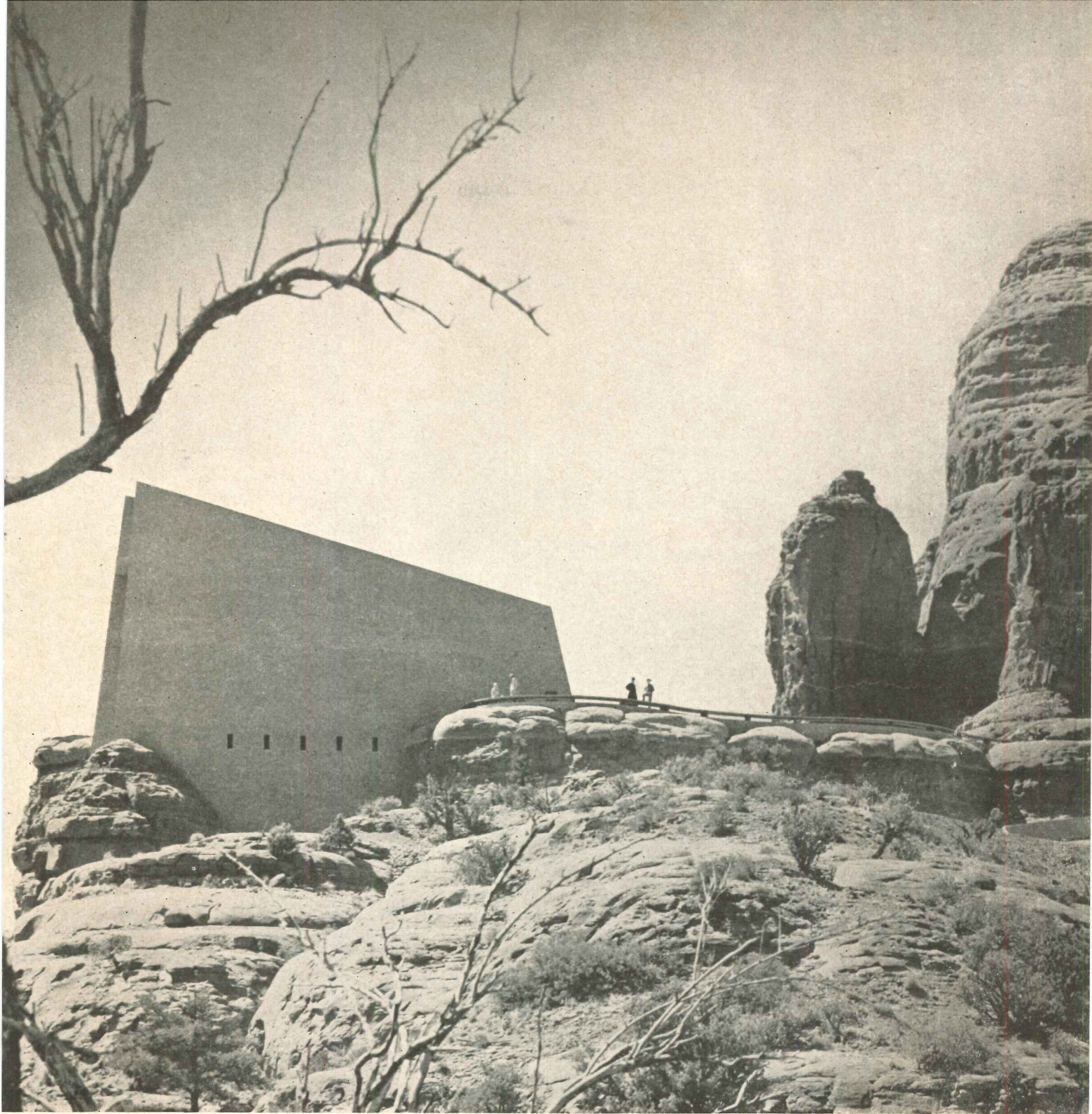



THREE MILES from Sedona, Arizona and one hundred fifty feet above the floor of the Verde River Valley, the chapel rises from a spur of deep red sandstone at the base of a fifteen hundred foot vertical cliff graduated in color from the red of the spur to a light cream top.

From the car turn around below and east of the chapel, steps lead to the textured concrete ramp, which curves up and around the cliff of the spur to the chapel entrance plaza.

The chapel itself, the gift of Marguerite Staude to the Roman Catholic Church in memory of her parents, is designed to seat approximately fifty people in the permanent pews along the side walls and across the rear. In the months when tourists may swell the size of the congregation, folding chairs will increase the capacity to one hundred fifty. In the basement are the confessional, office, two sacristies and services.

The building is a reinforced concrete shell, twelve

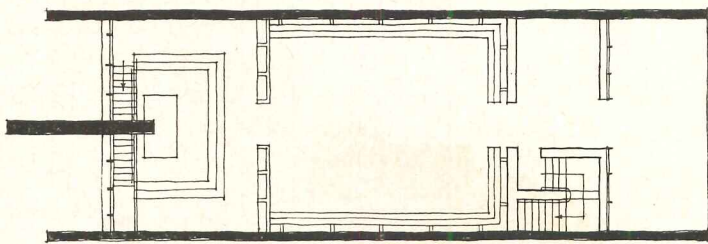
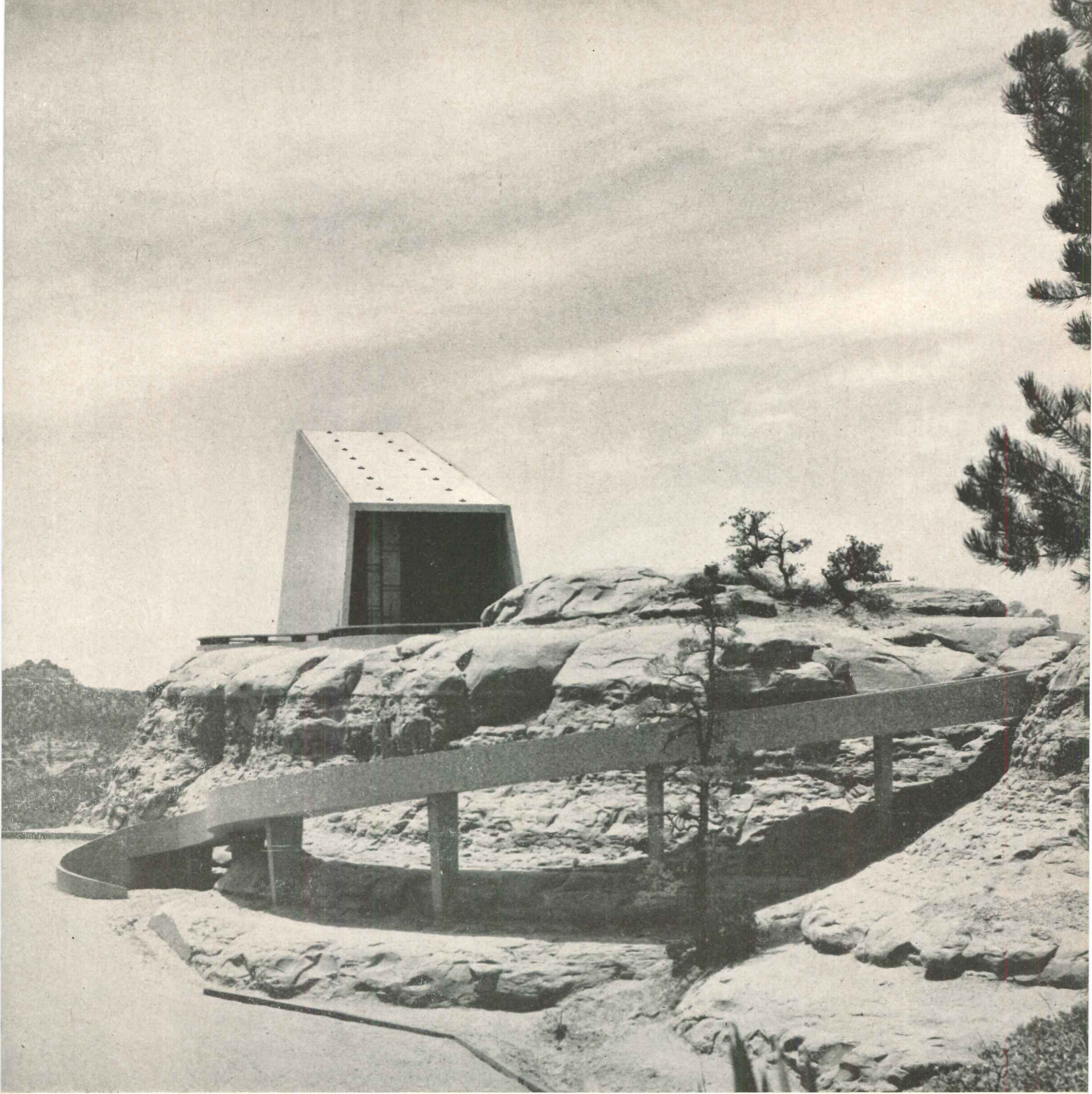

MAIN LEVEL

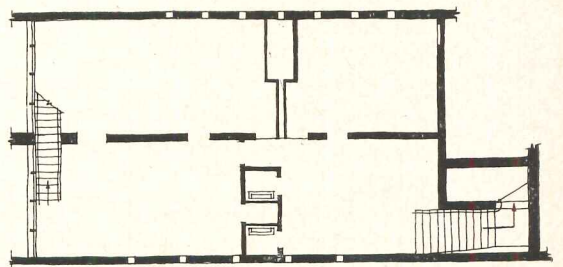

LOWER LEVEL

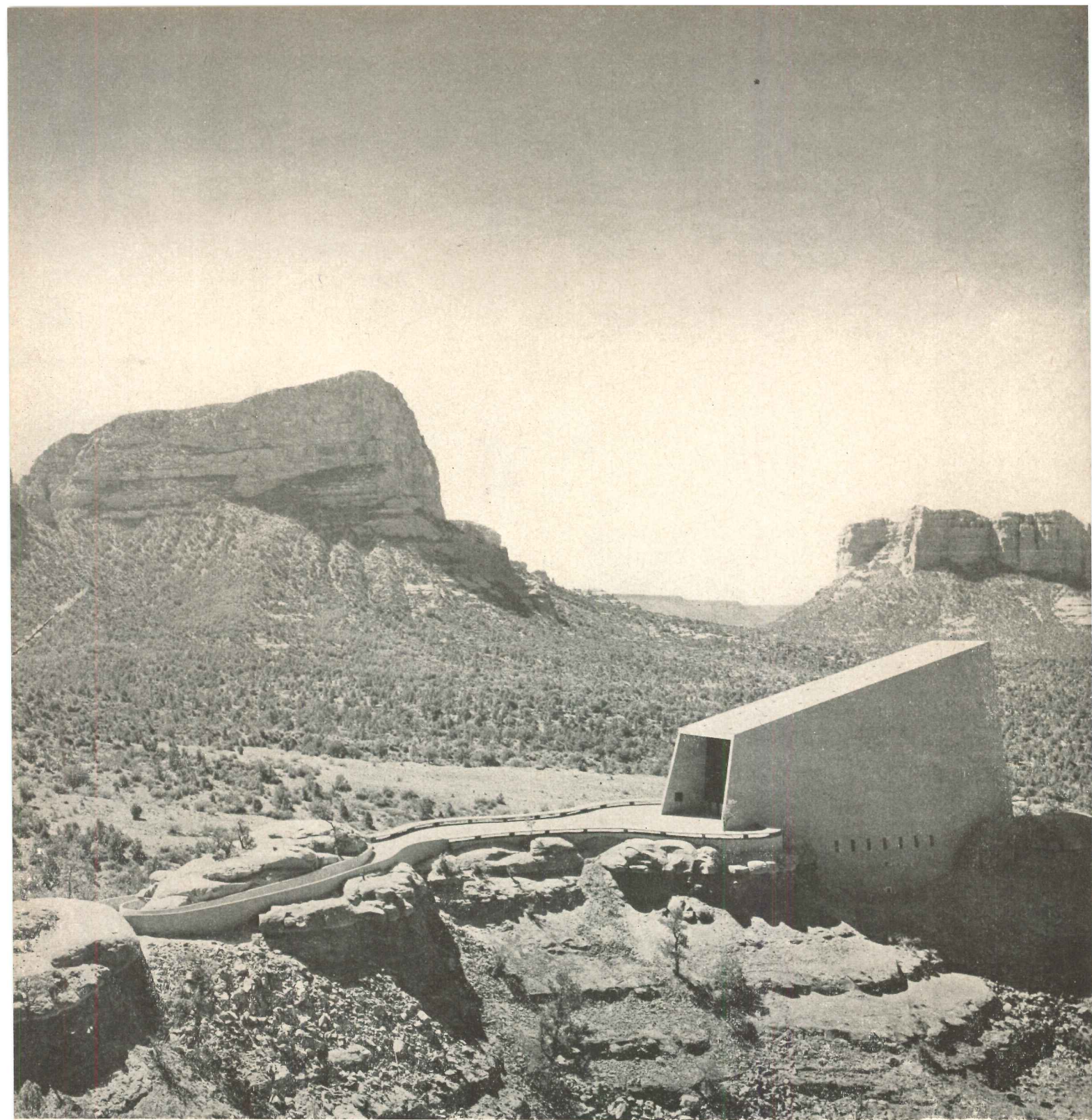

inches thick, integrally colored and sandblasted to expose a rich textured aggregate on both the interior and exterior surfaces. The walls were poured in sections, eight feet high. The two ends of the chapel are glazed with a smoke colored glass which eliminates glare while permitting a clear view of the magnificent panorama beyond the altar. The orientation to the southwest and the projecting side walls and cross act as a large louver in preventing direct sunlight from falling on the glass.

The floor surfaces are trowel-finished concrete. The tall, slim entrance doors are aluminum with specially detailed horn-shaped handles.

Construction was carried out under most difficult conditions and the architects are particularly grateful to the general contractor and his job superintendent for the high quality of the work. Interestingly the contractor as a young man had built the church which is the headquarters for the chapel pastor.

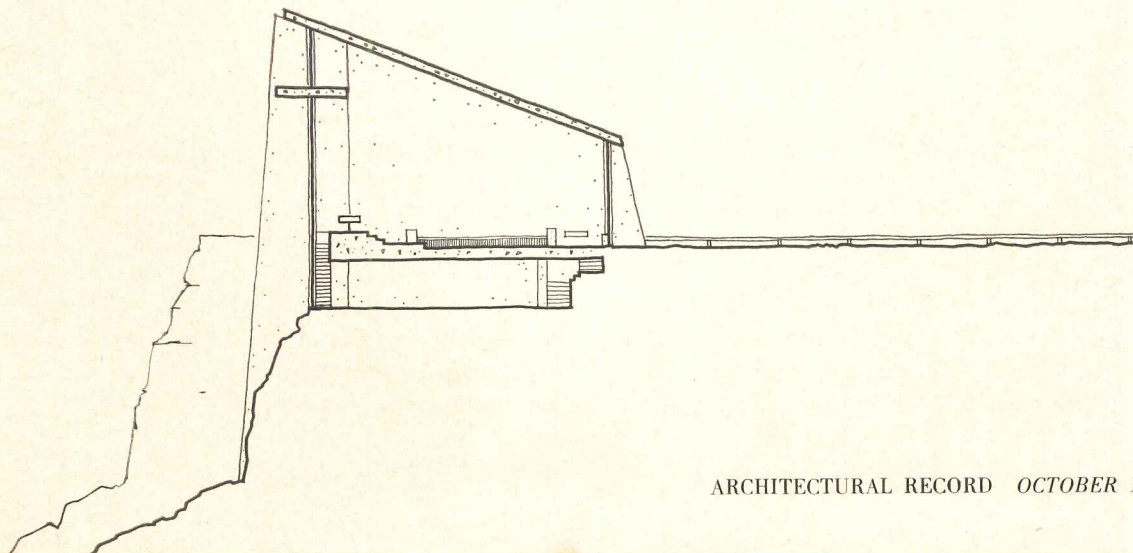

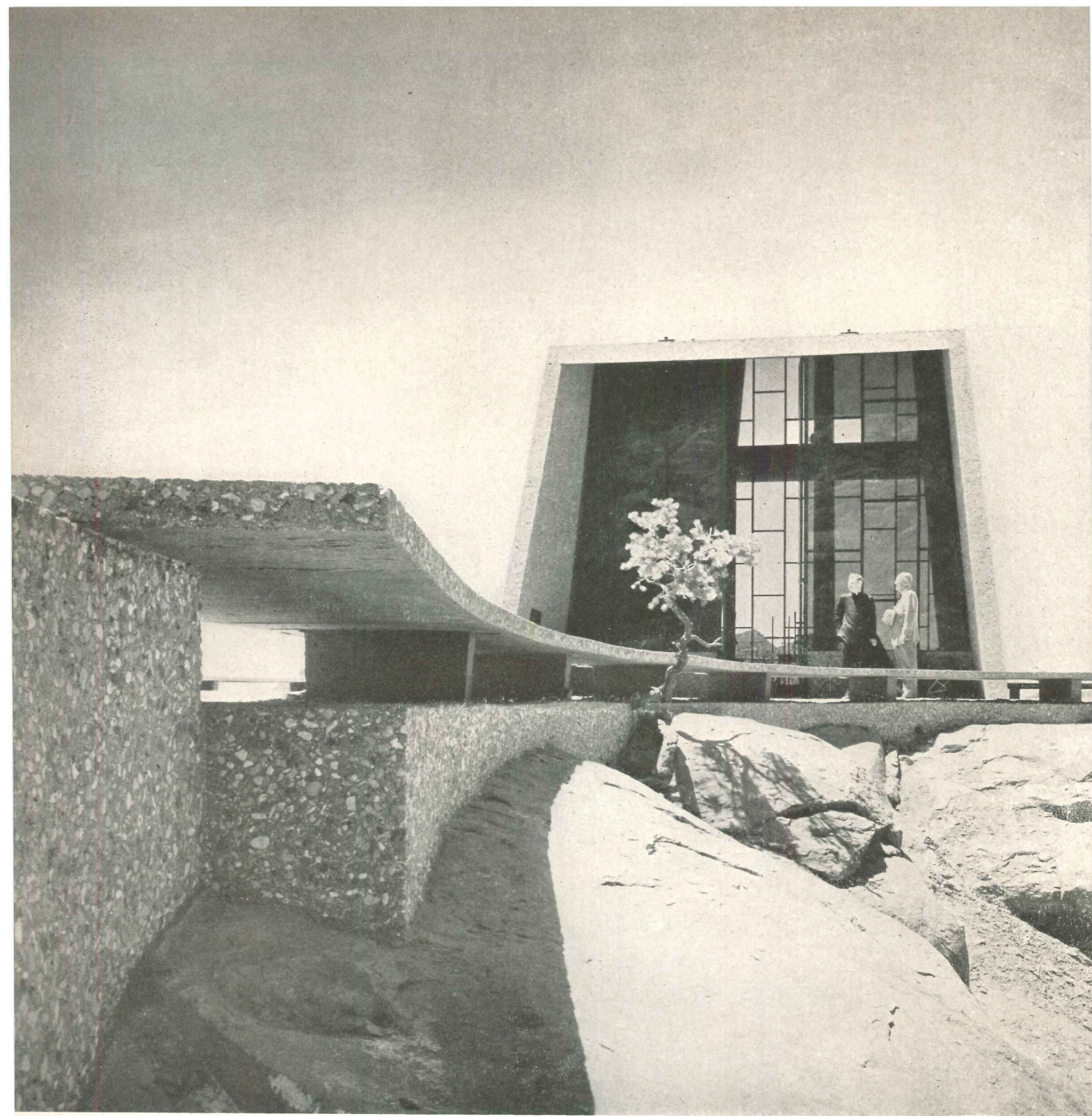

The great cross in the southwestern end wall is ninety feet high and carries on its interior face both the black marble altar and the Corpus. This fine piece is the work of Keith Monroe, San Francisco sculptor. It is wrought in iron and like the building as a whole strongly reflects the rugged environment. It is thirteen feet high and its rough highlighted shell surface is in strong contrast with its dark hollowed interior spaces.

Taken all together, this building is a transcendent

integration which seems to draw its strength from its location, from the simple freshness and suggestion of endurance in its profile, the rigorously restricted palette of materials, the recall of environmental elements without actual use of site materials, the skillful contrast of the curvilinear ramp and plaza with the crystalline contours of the building, and most importantly the precise organization of parts to achieve an impression of size which is in harmonious scale with the grand setting.

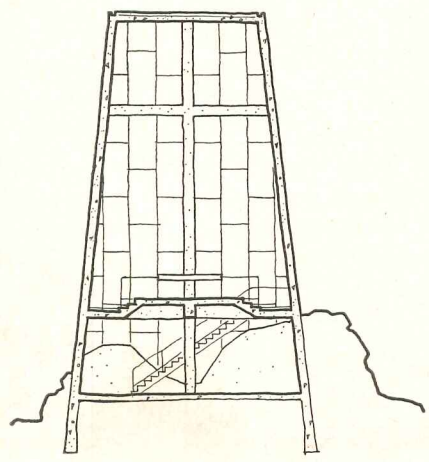



It may fall to the lot of other architects to work with sites of similar grandeur, if plans for the Mission 66 program of the National Park Service do lead, as planned, to a substantial building program in the national parks. NFS and its concessioners in the parks will be dangling before architects just such problems in scale, in awesome scenery, color, lighting conditions.

In an earlier day rusticity was the accepted answer, or chalet importations from another mountainous land. Contemporary architecture has not had much opportunity

to test its tenets in such terrain, or, too much success when it has had the chance.

The design of this chapel seems to suggest a better approach than we are used to in our national parks. The chapel does not seem bothered by the problem of scale. It does not seem to feel called upon to feign modesty, or to bow to the hills in feeble imitation. Nor does it try for self-assertiveness in the manner of a bantam rooster. It seems rather to appreciate its magnificent setting, and react like a well-mannered guest.

THE SIX DETERMINANTS OF ARCHITECTURAL FORM

By PAUL RUDOLPH

Illustrations from the author's collection, with his captions

THE EARLY THEORY of modern architecture focused on a very limited area. Many architectural problems were largely ignored, brushed aside as if they didn't even exist; disciplines gave way to worship of one god and then another. This limited approach, coupled with search for excitement, produced some very ungainly buildings, for surely mankind has never built such dry, timid, monotonous, modish structures as we do today. The general disorder has even been said by some to be "human," and anything else is termed pretentious, regimented, intellectual, dictatorial.

One of the most serious charges against modern architecture is its failure to produce understandable theories about the relationship of one building to another. The Ecole des Beaux Arts was actually very rich in this aspect while modern architects tend, even today, merely to admire some "human" square, preferably one located as remotely as possible, and proclaim that "we must make our squares more human." This plea is of course admirable, but it still leaves us with acres of cars and buildings casting shadows a quarter-of-a-mile long. The quickly moving vehicle and unprecedented requirements of sheer bulk have given us new dimensions of scale. Human scale must be coupled to the scale given by a quickly moving vehicle. The Ecole des Beaux Art created inhuman squares, boulevards, plazas, etc. when there were no automobiles. It is a paradox that our revolt against them has been so strong that we ignore the scale of vehicular traffic. One sees six-story high cottages on one hand and cottages utilizing skyscraper disciplines on the other. A flea is not designed like an elephant.

If we are concerned with new problems of scale and human response, we should also heed some older ones. Monumentality, symbolism, decoration, and so on — age-old human needs — are among the architectural challenges that modern theory has brushed aside. Possibly the extremes are illustrated by the so-called Bay Region style and Mies van der Rohe. The Bay Region style has validity in terms of cottages, but it has made little progress in showing us how to humanize buildings which involve large bulk.

Nikolaus Pevsner writing in the *Architectural Review* of April, 1954, explains that: "The qualities of the modern movement were not developed to please the eye, but because without them no workable, no functioning, no functional architecture is possible in our age." But surely he was reporting the attitudes of the thirties, not those of today. We no longer think that when the problems of function have been solved the exterior form will be found crystallized. As Matthew Nowicki warned us in his famous article "Function and Form," we cannot keep on pretending that we solve our problems without precedent in form.

Many of our difficulties stem from the concept of functionalism as the prime or only determinant of form. There are certainly as many as six determinants of architectural form, and though their relative importance varies with the individual problem, each is important, each must be heeded.

The first determinant is the environment of the building, its relationship to other buildings and the site. As stated above, modern architecture has been particularly weak in this respect and indeed even negative,



Identical units made palatable by manipulation of space between them

Relationship of a Building to its Neighbors

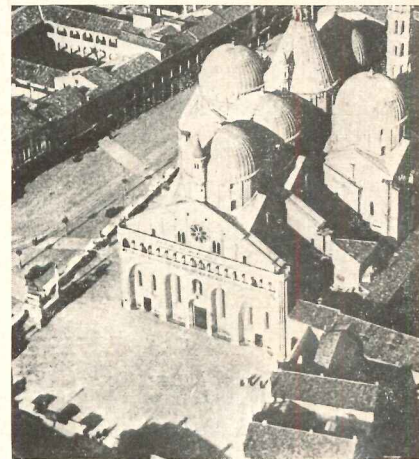

Church is given emphasis by coherent space around it, but in America our buildings are not well related



The Ecole des Beaux Arts was actually very rich in the handling of relationships between buildings

THE SIX DETERMINANTS OF ARCHITECTURAL FORM

ignoring especially the relationship of the building to the sky. We usually say that our buildings are related to others by contrast, but this excuse is adequate only occasionally. Of course, the danger in respecting too literally the earlier architecture, which is usually eclectic in character in this country, is that we may create a new eclecticism, i.e., one approach to creating harmony with Gothic, another to early New England, another to Georgian, etc.

A truly successful building must be related to its neighbors in terms of scale, proportions, and the space created between the buildings. Most important of all, it must define and render eloquent its role in the whole city scheme. Buildings such as governmental structures, religious buildings, palaces devoted to entertainment, gateways to the city, should serve as focal points in our cities and could undoubtedly indulge in certain excesses, while buildings for commerce, housing, finance, administration should not dominate our environment.

Just as the 19th century architects showed so little regard for construction, we 20th century architects tend to disregard our role in the city scape.

The second determinant of form is the functional aspects. I will not discuss this except to say that most of our buildings look like assemblages of workable parts from Sweet's Catalog, with little regard for the whole, the idea expressed, or the human response. This is not to say one is not passionately concerned with how the building works.

The third determinant of form is the particular region, climate, landscape and natural lighting conditions with which one is confronted. The great architectural movements of the past have been precisely formulated in a given area, then adapted and spread to other regions, suiting themselves more or less to the particular way of life of the new area.

We now face a period of such development. If adaptation, enlargement and enrichment of basic principles of 20th century architecture were carried out, related always to the main stream of architecture and the particular region, the world would again be able to create magnificent cities. Unfortunately, little progress has yet been seen. We continue to ignore the particular. Henry Russell Hitchcock has pointed out that "the utilitarian language of modern architecture as used throughout the world tends to have something of the thinness and lack of color of basic English. We do not want a uniformity of architecture which might tend to confuse a muddled traveler into attempting to enter a house identical to his own, not just in the wrong street, not even in the wrong city, but actually in the wrong country or the wrong hemisphere."

There are several conditions which tend to limit regional expression. First there is industrialization; second, ease of travel and communication; third, the rising cost of traditional materials and skilled labor; fourth, the influence of the architectural press; fifth, the worship of that which is popular and our desire to conform; sixth, the "do it yourself" "according to the manufacturer's instruction" movement; and seventh, the abstract qualities inherent in the new concept of space.

The fourth determinant of form is the particular materials which one uses. Each material has its own potential, and one seeks the most eloquent expression possible. We are currently going through a structural exhibitionism stage, but this will pass. The vitality of structural forms has beguiled architects into thinking that the dramatic use of structure could make great architecture. In fact there has been a very real misuse of structure and the formal qualities of architecture are still being ignored. Buckminster Fuller domes, the latest space frames, the newest plastics, etc., are only new kinds of bricks which broaden our means of expression.



One enjoys sensing the complete dimensions of a building from one point of view



The podium method



Another building as a base

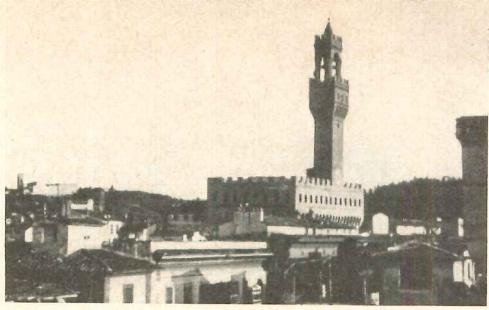

The role of the various buildings is clear, primarily because of the relationship to the sky

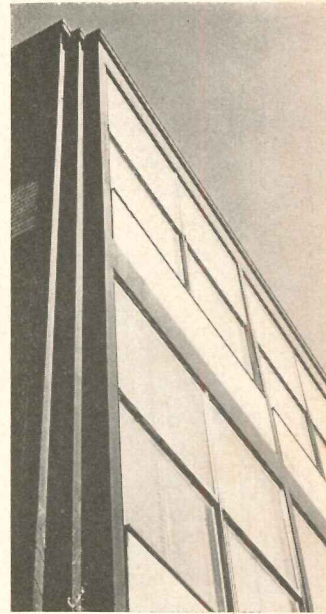

The corners are important

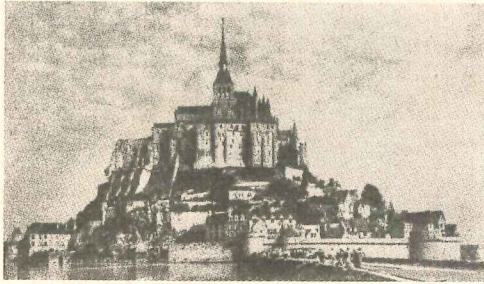

Relationship of Building to Sky

Relationship of Building to Ground



Water can be effective



The familiar pilotis



Walls adapted to the terrain



Platform supported by columns

The use of terraces



Only buildings which need great visual emphasis should utilize such devices, and structure should always remain merely a means to an end. Many younger architects fail to appreciate this basic principle. However, regular structural systems are usually a better method of organizing our designs than the axial arrangement of much traditional architecture.

The fifth determinant of form is the peculiar psychological demands of the building or place. Such necessities are met primarily through the manipulation of space and the use of symbols. We are particularly unsure in this aspect, partly because the revolution threw out much which still has validity. We must learn anew the meaning of monumentality. We must learn how to create a place of worship and inspiration; how to make quiet, enclosed, isolated spaces; spaces full of hustling, bustling activities pungent with vitality; dignified, vast, sumptuous, even awe-inspiring spaces; mysterious spaces; transition spaces which define, separate, and yet join juxtaposed spaces of contrasting character. We need sequences of space which arouse one's curiosity, give a sense of anticipation, beckon and impel us to rush forward to find that releasing space which dominates, which promises a climax and therefore gives direction.

The sixth and last determinant of form is concerned with the spirit of the times. This one is perhaps the most difficult of all; here is the call to genius. Sir Geoffrey Scott in *The Architecture of Humanism* says: "The men of the Renaissance evolved a certain architectural style because they liked certain forms of a certain kind. These forms, as such, they preferred, irrespective of their relation to the mechanical means by which they were produced, irrespective of the materials out of which they were constructed, irrespective sometimes even of the actual purposes they were to serve. They had an immediate preference for certain combinations of mass and void, of light and shade, and, compared with this, all other motives in the formation of their distinctive style were insignificant." We need not be ashamed of our own passion for certain forms today, although the layman does not always share our enthusiasm. Interestingly enough, the layman usually reacts favorably to that which is truly great.

These six determinants of architectural form might lead toward richer architectural expression. At the same time one cries for greater expressiveness one must also heed Rudolph Whitkower. He said, "When architects depend on their sensibility and imagination architecture has always gone downhill." There are few geniuses and most of us need guidance and discipline. Our architectural schools are more interested in appearing avant garde than making principles clear.

Isn't it true, however, that as younger architects acquire maturity they begin to feel the need for some of the disciplines they might have been given in school?

A few months ago there appeared in the *Architectural Review* a brilliant article by J. M. Richards entitled "In Defense of the Cliché." He said, "In the fine arts it may be necessary for each man to create his own revolution and thereby justify himself as having something personal to say. But in architecture what the architect has personally to say must, in most cases, be subservient to what the building has to do and the part it has to play in the larger prospect — for example, in the design of a town, which is the sum of many architects' buildings. In normal times that goes without saying. But at this moment architecture so sorely needs its plagiarists that the value of not being a genius needs stating afresh.

"Architecture cannot progress by the fits and starts that a succession of revolutionary ideas involves. Modern architecture brought release from the restrictions of an archaic ready-made style. But the freedom it also brought — freedom to plan in all three dimensions and to create new

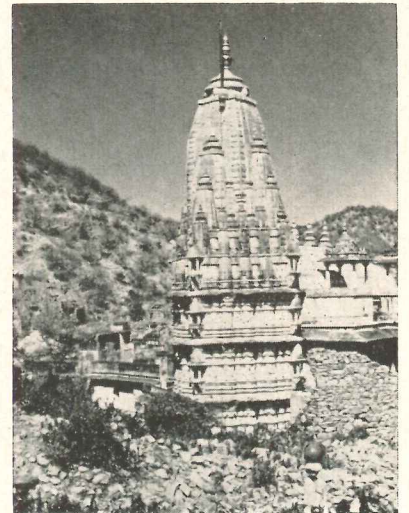

The monument



The awe-inspiring place

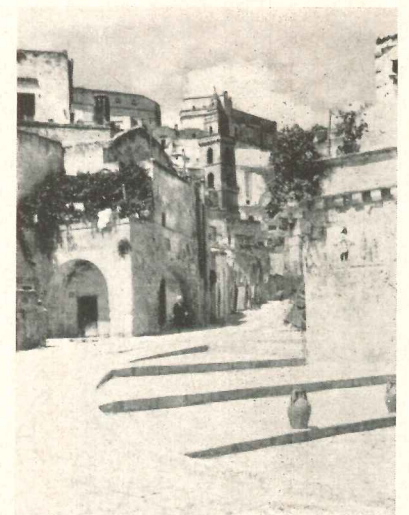

One is drawn forward



The place of worship



The sense of protection



Edward Ralcliffe, courtesy Rockefeller Center, Inc.

The interest of activity

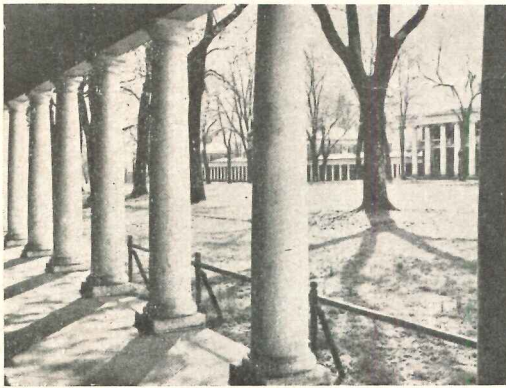

The sense of quiet repose

Psychological Demands

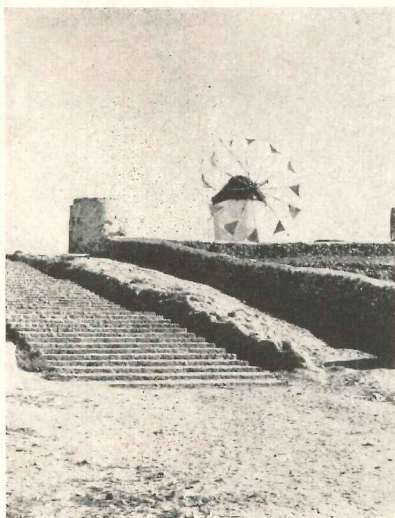

Anticipation

The haven



Wright was born knowing how to manipulate natural light (sometimes without full regard for the use to be made of it). Some other architects have been a long time learning

THE SIX DETERMINANTS OF ARCHITECTURAL FORM

esthetic values from the exploitation of new techniques — though a source of inspiration to the imaginative design, left most architects up in the air. Design of this kind looked easy to do; but just because of the absence of rules it was particularly difficult to do well. Suddenly, anything was possible; and quality in modern architecture suffered accordingly."

In one sense any classical building with its columns, capitols, porticoes and window architraves is a collection of clichés. The cantilever, the superstructure perched on pilotis, the glass enclosed staircase tower, the ribbon window, are legitimate expressions of our structural methods that in the last thirty years added so much to the architect's repertoire.

The clichés, in their proper role, are not merely a means of appearing up-to-date, but a means of insuring a civilized standard of design — even in the absence of genius — by providing the architect with a range of well-trying, culturally vital forms and motifs to convert the passive act of plagiarism into the creative act of building up and systematically enriching an architectural language appropriate to our times.

"Cliché" is perhaps not the right word for the enrichments we need. It has too much suggestion of contempt; there is a connotation of superficiality. To provide enrichment a form or motif needs something of real value in a common situation, some quality of lasting validity. Perhaps "standard" is a better term.

Last year I had occasion to analyze the 33 premiated designs from a broad awards program; I found them an interesting barometer to current preferences in forms, motifs, devices, or "esthetics."

If those designs are symptomatic of our present-day attitudes, then one concludes that a new tradition has indeed been established. There were striking similarities in spirit and intent in almost all the buildings selected. For example, 95 per cent utilized regularly spaced structural systems, thereby freeing the interior arrangement. The linear qualities inherent in such cage-like construction were usually emphasized, and were largely the means of organizing and disciplining the design.

It is worth noting that a recreation building, a residence and a war memorial were symmetrically organized; the remainder asymmetrically. One notes that the regular bay system seems more successful when the bay is wide enough to accommodate subsidiary divisions. No new light was shed on the problem of starting and stopping such bay-disciplined designs; they often resembled sliced loaves of bread with no beginning nor end.

Twenty-two per cent of the buildings were to be raised above the ground on pilotis, and another 25 per cent undertook to gain that effect by having the lower floor completely filled with glass enclosing walls. One-half were related to the ground by slab construction; only two were to rest on pedestals.

One of modern architecture's greatest failings has been its lack of interest in the relationship of the building to the sky. Ninety per cent utilized flat roofs; the remainder were to be pitched. Here is a slight cause for concern, for there are many design problems where the silhouette is of the utmost importance. One doubts that a poem was ever written to a flat-roofed building silhouetted against the setting sun. And what about its appearance on a misty, foggy day? The insistence on flat roofs also tends all too often to make modern architecture have the appearance of a dog-house, when juxtaposed against the high ceiling pitched roofs of much earlier architecture. With one exception water appeared to be mysteriously drained from all roofs. Traditional methods of water shedding created real drama, and one longs for the modern equivalents.

Rather surprisingly two-thirds of the architects turned the corners of their buildings by carrying the glass to the corners, with the return wall solid. This desire to reveal the essentially planar aspect of our construction reflected itself in almost all of the plans as well as in the elevations by

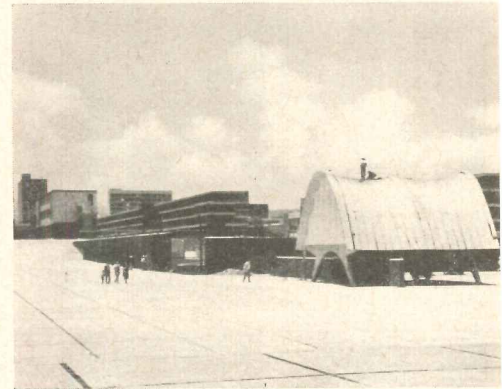

The cute and seductive building tends to dominate, even though it merely houses a machine



We should find ways of seeing our buildings above the automobiles

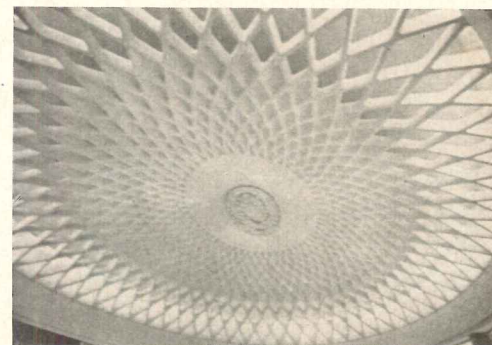

Elaborate form work is possible where labor costs are low. A hypothesis: labor-material ratios cause national differences, but true regionalism comes through form, not materials

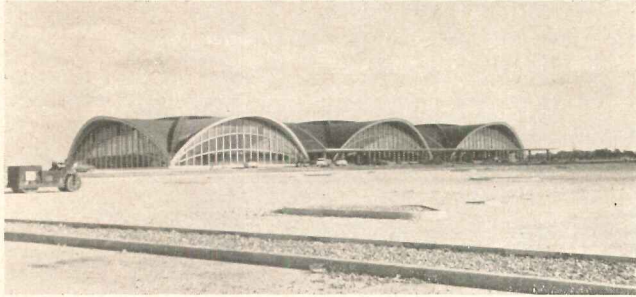
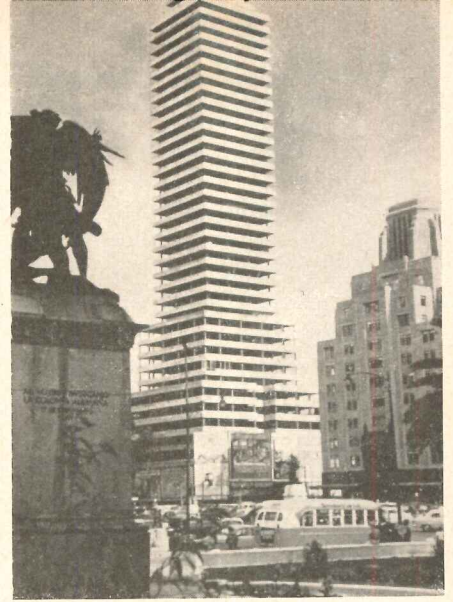

Hellmuth, Yamasaki
& Lemwebber, Architects

Plasticity should be reserved for "governmental structures, religious buildings, gateways to the city and palaces of entertainment." This gateway to the city (St. Louis airport) is properly plastic and its role in the city scape is thereby rendered eloquent. It is the only airport worthy of the name



The continual thinking in terms of individual buildings as unrelated gems is disastrous; buildings tend to brutalize rather than to refine

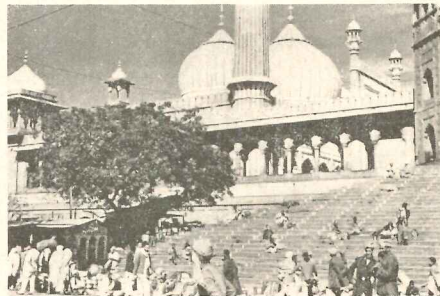

They did it better in Delhi than they did in San Francisco

Environmental Factors

Some Comments on Regionalism



Victorian architecture produced some fine regional examples such as this house at Veradero Beach, Cuba, with raised living quarters, precision in proportioning supporting members, and various light-catching details

Mies' apartments symbolize perhaps better than any other multi-storied structure America's industrialized techniques, and in that sense they are peculiarly American



This house design originated in Cambridge, but it moved to Australia without change

reducing all wall divisions to a series of rectangles. These modular constructions are undoubtedly expressions of industrialized component parts, although paradoxically most of them undoubtedly will actually be constructed by essentially handicraft methods.

Sixty-five per cent utilized uniform ceiling heights, 25 per cent allowed the ceilings to follow the slope of the pitched roof, while only 10 per cent varied the ceiling heights in any way. This self-imposed uniform ceiling height limitation is difficult to understand when one considers the importance of the psychological effect of varying ceiling heights. To a degree this spatial characteristic is compensated for by the courtyard completely within the building, a device to be utilized by 45 per cent. Twenty per cent of the designers created outer defined courtyards and patios by extending walls out into space.

However, the paucity and limitation of spatial concepts to be utilized are extremely disappointing. Laymen almost never demand that their structure be clearly expressed, but they often describe in eloquent terms architectural space and particular psychological implications desired. The laymen seem more knowing about those matters. This current architectural limitation is evidenced by the lack of interest in the handling of natural light. There are all too often interior spaces which are merely flooded with light without any consideration of psychological or physical effects.

We all recognize that strict functionalism does not satisfy the need for the "sense of symbolism, the lasting monument, the vital ideas and shared emotions that is part of architecture's historical function to perform." In the design awards one finds symbols used three times (it was always a cross) while two designs incorporated sculpture, and two painting. One understands the difficulties, but it is undoubtedly up to the architect to lead the way.

Perhaps the most important single aspect of those designs as a group is the apparent lack of interest in the environment in which the building is placed and the particular role it plays in the city as a whole. Only 15 per cent, as presented, indicated anything at all of the character of the surrounding structures. The continual thinking in terms of individual buildings as gems unrelated to earlier works is disastrous, creating cities whose buildings tend to brutalize, rather than refine.

The lack of interest in how our buildings actually appear is also indicated by the fact that only four of the thirty-three designs indicated any lettering or signs, and only about one-third indicated any comprehensive landscaping treatment.

Every building, no matter how large or small, is a part of a greater whole; and the architect perforce participates in planning. Park Avenue, like every corner cross-road in the land, is being rebuilt in a fragmented way. Indeed at least one intersection of Park Avenue will shortly have four unrelated buildings, one on each corner, with all-glass façades. It will be interesting to see glass buildings reflecting each other. Much of the esthetic enjoyment of a glass building is its mirroring of earlier and contrasting architecture.

In every cultural effort of each generation it is the very disciplines which we so anxiously want to cross out that help us find and determine our basic values. These of course change with each generation because society is dynamic. But for the clarity of its dynamic force it needs discipline. Otherwise it becomes chaotic.

Great architectural precepts — still valid — would surely suggest other determinants of form than the fashionable or the functional. Perhaps they would suggest also some disciplines, to keep us from being carried away by our new freedoms. Modern architects fought hard against the restraints of outworn styles; the day is won; but the visual disorder of our cities still abounds. Can we enlarge our vision sufficiently to meet this challenge? It is the architect's responsibility.

The Spirit of the Times



WAINWRIGHT BUILDING, St. Louis
Louis Sullivan

CARSON PIRIE SCOTT STORE, Chicago
Louis Sullivan

ROCKEFELLER CENTER BUILDINGS, New York
Reinhard & Hofmeister; Corbett, Harrison
& MacMurray; Hood & Foulhoux

LEVER HOUSE, New York
Skidmore, Owings & Merrill

TRINITY CHURCH, Boston
H. H. Richardson

PHILADELPHIA SAVINGS FUND SOCIETY
BUILDING, Philadelphia
Howe & Lescaze

GENERAL MOTORS TECHNICAL CENTER, Detroit
Saarinen & Saarinen

LAKE SHORE DRIVE APARTMENTS, Chicago
Mies van der Rohe

S. C. JOHNSON & SON, INC., ADMIN. BLDG., Racine
Frank Lloyd Wright

MONADNOCK BLOCK, Chicago
Burnham & Root

DAILY NEWS BUILDING, New York
Hood & Howells

TVA NORRIS DAM & POWER HOUSE, Tennessee
Roland Wank, Architect-in-charge

BOSTON PUBLIC LIBRARY, Boston
McKim, Mead & White

STOCK PAVILION, Raleigh
Nowicki & Deltrick

CHRISTIAN SCIENCE CHURCH, Berkeley
Bernard Maybeck

WOOLWORTH BUILDING, New York
Cass Gilbert

CROW ISLAND SCHOOL, Illinois
Saarinen & Saarinen,
with Perkins, Wheeler & Will

MANUFACTURERS TRUST BUILDING, New York
Skidmore, Owings & Merrill

UNITY CHURCH, Oak Park
Frank Lloyd Wright

NEBRASKA STATE CAPITOL, Lincoln
Bertram G. Goodhue

S. C. JOHNSON & SON, INC.; LABORATORY, Racine
Frank Lloyd Wright

UNITED NATIONS SECRETARIAT, New York
Wallace K. Harrison & Consultants

LINCOLN MEMORIAL, Washington
Henry Bacon

M.I.T. AUDITORIUM, Cambridge
Eero Saarinen

EQUITABLE BUILDING, Portland
Pietro Belluschi

ALLEGHENY COUNTY BUILDINGS, Pittsburgh
H. H. Richardson

UNIVERSITY CLUB, New York
McKim, Mead & White

CRANBROOK SCHOOLS, Michigan
Eliel Saarinen

MINERALS & METALS RESEARCH BLDG., I.I.T., Chicago
Mies van der Rohe

ALCOA BUILDING, Pittsburgh
Harrison & Abramovitz

MUSEUM OF MODERN ART, New York
Goodwin & Stone

PENNSYLVANIA STATION, New York
McKim, Mead & White

EXPERIMENTAL SCHOOL, Los Angeles
Richard Neutra

DODGE TRUCK PLANT, Detroit
Albert Kahn

100 MEMORIAL DRIVE APARTMENTS, Cambridge
Kennedy, Koch, DeMars, Rapson & Brown

CENTRAL LUTHERAN CHURCH, Portland
Pietro Belluschi

HOUSES

F. C. ROBIE, Chicago
Frank Lloyd Wright

E. J. KAUFMANN, Pennsylvania
Frank Lloyd Wright

TALIESIN WEST, Arizona
Frank Lloyd Wright

HENRY VILLARD, New York
McKim, Mead & White

WATTS SHERMAN, Newport
H. H. Richardson

AVERY COONLEY, Illinois
Frank Lloyd Wright

W. W. WILLITTS, Illinois
Frank Lloyd Wright

D. R. GAMBLE, Pasadena
Greens and Greens

PHILIP JOHNSON, New Canaan
Philip Johnson

WALKER GUEST HOUSE, Florida
Paul Rudolph

ELLEN SCRIPPS, La Jolla
Irving Gill

WESTON HAVENS, Berkeley
Harwell Hamilton Harris

LOVELL "HEALTH HOUSE", Los Angeles
Richard Neutra

EDITH FARNSWORTH, Chicago
Mies van der Rohe

ONE HUNDRED YEARS OF SIGNIFICANT BUILDING

5: HOUSES BEFORE 1907

ALTOGETHER FOURTEEN HOUSES were named by ARCHITECTURAL RECORD'S panel as belonging in the group of fifty buildings deemed most significant in the last one hundred years of architecture in America.

For convenience in presentation, these houses have been divided into two groups. Those completed in the first half of the period (before 1907) are shown in this installment of the series which began in June, 1956 and which will conclude in May, 1957 on the occasion of the 100th anniversary of the American Institute of Architects.

It is not surprising, though perhaps regrettable, that only three of the fourteen are products of the first half of the one hundred years under consideration. In many ways, they seem much more remote in time than the half to three-quarters of a century which separate them from our efforts today. Even the ones most frequently mentioned will demand from many a considerable objectivity if their significance in a developing architecture is to be understood and appreciated.

The Villard houses by McKim, Mead & White represent, of course, the academic tradition which informed the aspirations and activities of the majority of our best talents for over 50 years. The Low house, by the same architects, along with Hunt's Ochre Court and Biltmore received only slightly fewer nominations.

The Watts Sherman house, by Richardson, is an outstanding example of the rich, free and romantic reach for something beyond the academic and was rivalled in the nominations by the Stoughton and Glessner houses from the same man.

The Willitts house, by Wright, is more easily identified with the continuing development of the house as we have seen it in the last fifty years — in great part, no doubt, because of Wright's domination of that development which will be clearly seen in a subsequent installment of the houses built since 1907.

ONE HUNDRED YEARS OF SIGNIFICANT BUILDING

*Henry Villard Houses, New York, 1885,
McKim, Mead & White (Fourth)*

"Our historical interest today in 19th century forerunners of the modern movement, such as Richardson's work or the brown-shingled houses of McKim, Mead & White, often blinds us to the sheer esthetic quality of the best academic work. Authoritative in this field were the Villard Houses, adapted from the imposing Cancelleria Palace in Rome. Ordered, reticent, monumental, these houses introduced a new discipline of form after several decades of confused and picturesque romanticism. They set the mark for two generations of academic work based on the Renaissance and Classical traditions."

Hugh Morrison

"The first large-scale adaptation of the Italian Renaissance to our domestic architecture, it boldly combined several great houses into one "palazzo" surrounding a courtyard open to the street — a masterful innovation unfortunately unique.

The dignity of design, together with the employment of our best painters, sculptors and metal-workers in making the composition a sumptuous marriage of the arts, set a new standard of taste later exemplified by the Boston Public Library and the University Club by the same firm."

Edward Steese

Wayne Andrews

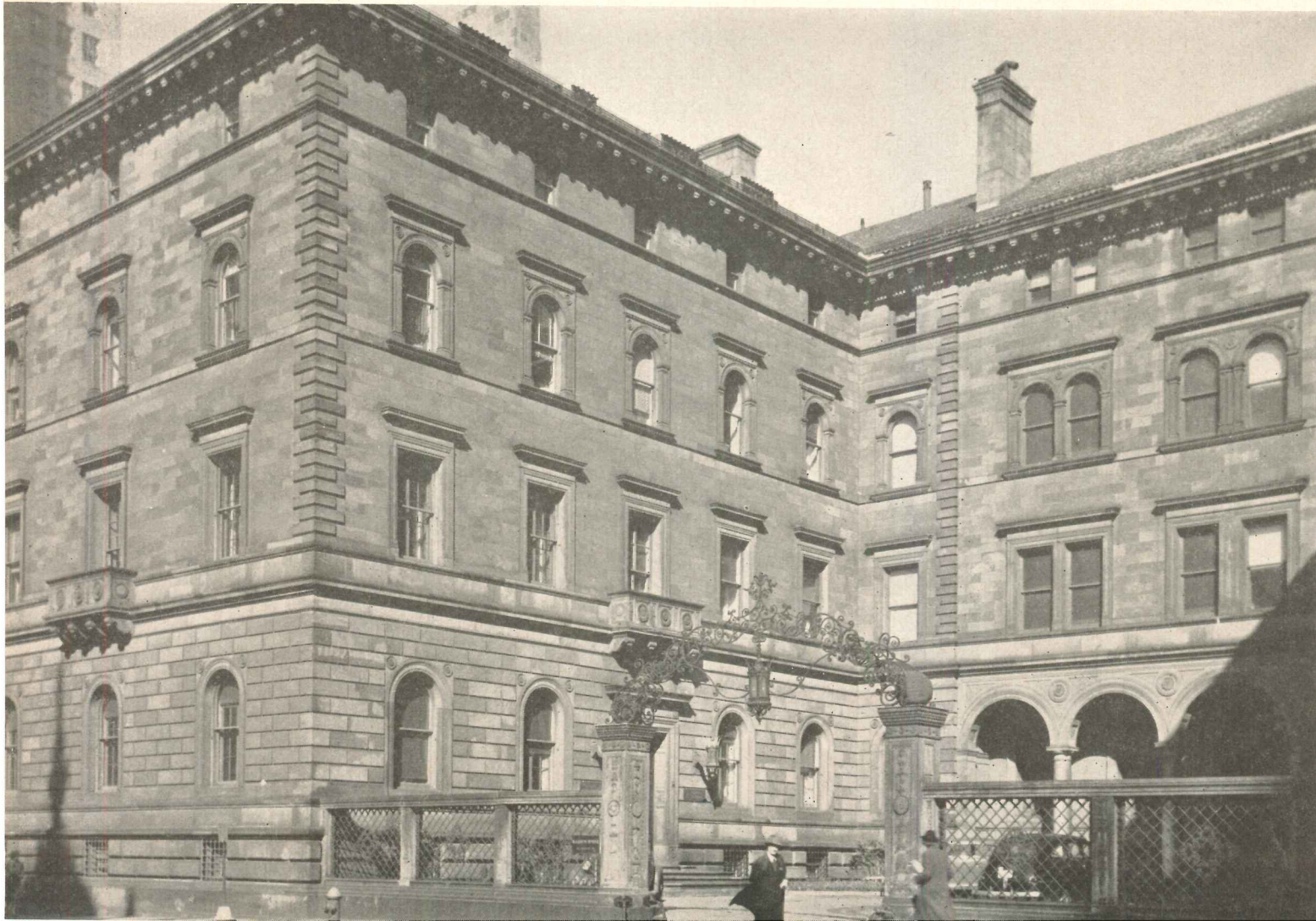



Wayne Andrews

***William Watts Sherman House, Newport,
1876, Henry Hobson Richardson (Fifth)***

"The Watts Sherman house is the Henry James novel of architecture; it civilized a straightforward yet romantic and adventuresome Yankee tradition aided, but not dominated, by Europe. What is more important, it restored to our domestic architecture a sense of organized space, light, texture and color. Perhaps some greater houses were built by Richardson and his followers afterwards, but who knows what they would have been without this sire?" **James Ackerman**

"Richardson's early essay in the eclectic style, miscalled 'Queen Anne,' it derives from all styles, yet copies none, and combines nearly all known materials and surfaces into a harmonious whole designed for *spacious* living.

Distinguished for boldness of plan and exterior design, with sweeping roof-slopes, massive chimneys and an inspired contrast of scale between sturdy structural members and meticulous details, it is an outstanding expression of individualism that set a comfortable mode for country estates and detached houses for many years." **Edward Steese**

ONE HUNDRED YEARS OF SIGNIFICANT BUILDING

*Ward W. Willitts House, Highland Park, Illinois, 1902,
Frank Lloyd Wright (Seventh)*

"This has been acclaimed the first of Wright's independent masterpieces. It stretches wide and rises high recalling broad terrains and slender trees; like the sky the unbroken roof planes reach over all. After half a century its energy is as palpable as its quiet, unpredictable entirety. It is a declaration of essentials not only sought but won.

Many features of the Willitts house were not new in its day — the central core of chimneys and circulation, the unbroken roof, the cross plan, dark timber framing with light stucco, the plinth, rain-catching urns. What makes this a masterpiece is the grand totality uniting details, the flow of space from the core outward through the farthest plant box, absorbing work areas, leaving no scraps, lifting its mass proudly against the unending horizon of the prairies, a house both new and whole."

Edgar Kaufmann

"When he designed the Willitts house Frank Lloyd Wright had been building houses for over ten years. But here for the first time his evolving Prairie Style reached sure maturity. In all the years since he has seldom surpassed the clear and gracious organization of space which he achieved in this cruciform plan with its skillful intersection of the cross arm volumes and the ordered grouping of openings under the broad reach of the simple hipped roof eaves. It is not difficult to understand why it became immediately an enduring model for his own and others subsequent work." *John Knox Shear*

Hedrich-Blessing



MEMORIAL HALL FOR JAPANESE STEEL WORKERS

Raymond & Rado, Architects

*Paul Weidlinger, Structural Engineer,
in collaboration with the Japanese staff
in Raymond & Rado's Tokyo office*

*Exterior and interior color
by Noemi P. Raymond*

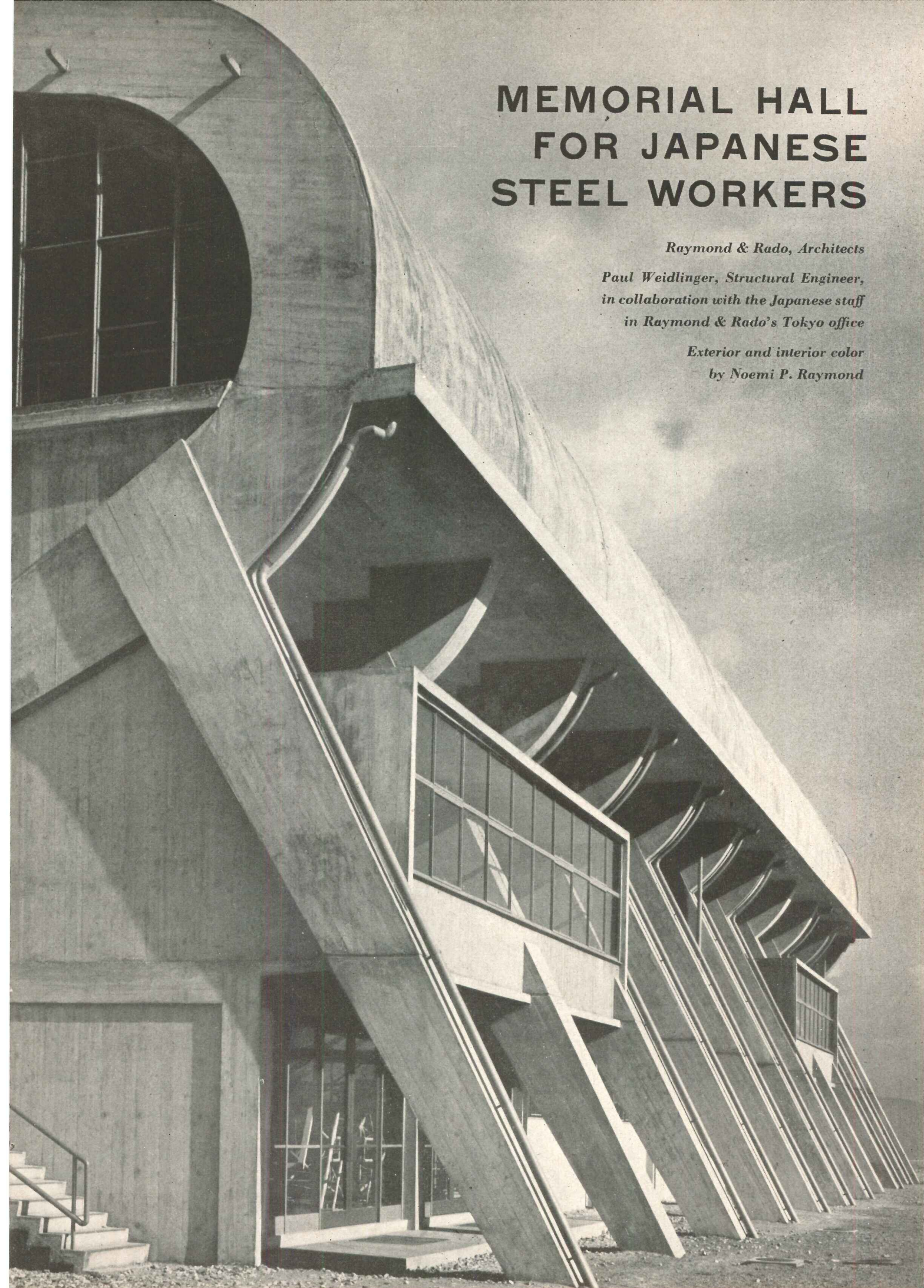

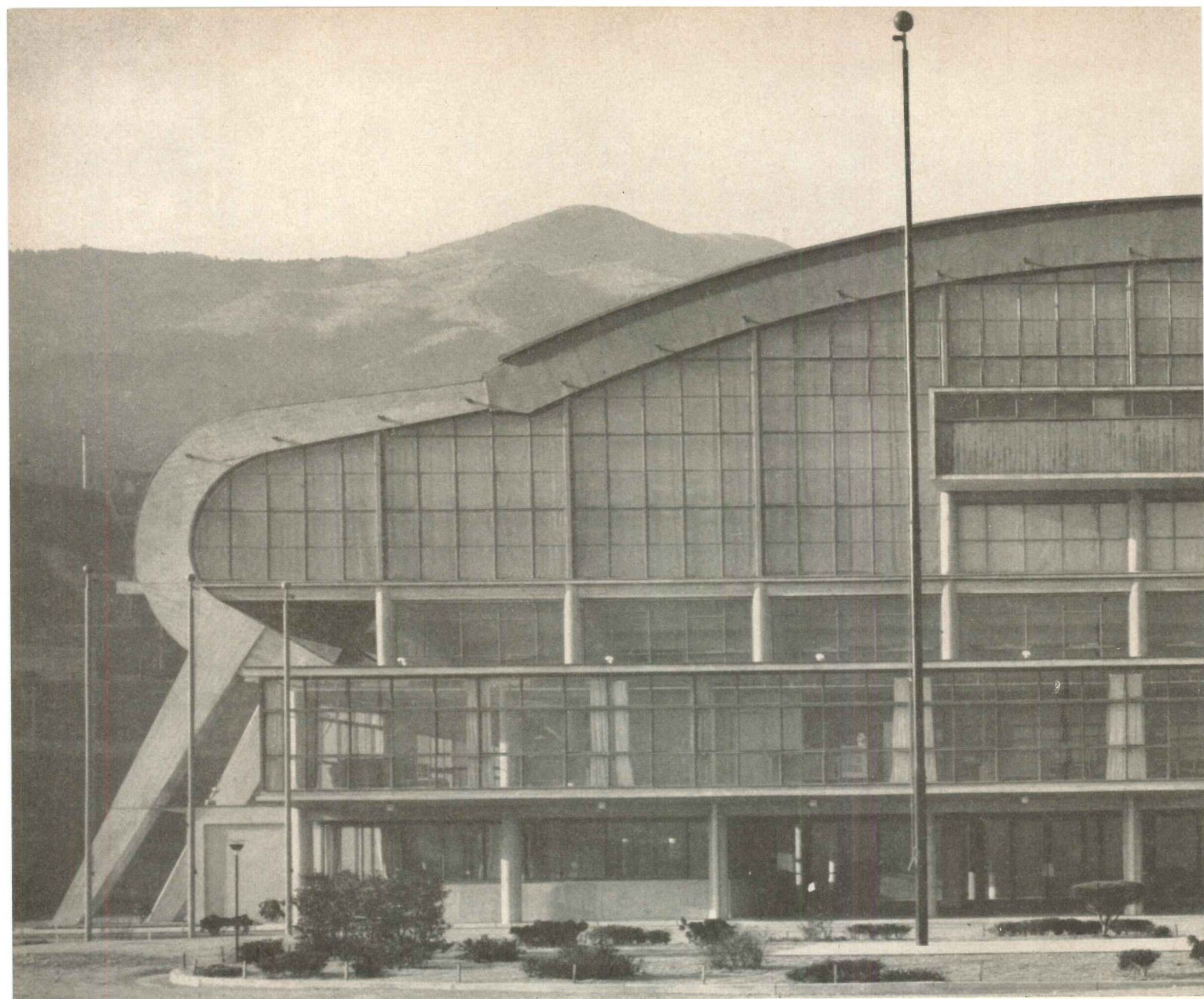

YAWATA ARENA

THE YAWATA STEEL MILL, largest in Japan, sprawls in the midst of a drab industrial area in northern Kyushu. A pall of smoke overhangs a setting which is dominated by the huge factories and dotted by small workers' huts of wood, paper, and light corrugated metal.

Following World War II, the first workers' union was organized — with American guidance — and the recently completed arena for sports, movies and plays was built under the joint sponsorship of the company and the union. The structure is located in a compound set aside for employe recreation. The performances it houses are extremely popular, and as a result the arena has assumed great importance in the lives of the workers.

The architectural problem was: first, to enclose — within a clear span — a large gymnasium floor and stage, together with appropriate seating; and second, to design that enclosure for maximum conditions of earthquake, typhoon and fire, since the structure lies within a hazardous belt subject to such disturbances.

The solution makes use of concrete reinforced by light structural steel sections — a technique widely used in Japan — to form a series of rigid, open U-shaped cantilever bents on two supports (see section at right) to which steel arches are hinged. The bents are regularly spaced at 5 meters (16.4 ft) and all footings are tied for earthquake and typhoon protection. The arch span is 125 ft and the total clear width to the bents is 180 ft. Overall inside height is 61 ft.

Engineer Paul Weidlinger explains that the idea behind the structural bents was “to balance vertical thrust against lateral thrust.” The resulting shape is an unusual one, appropriate to its use and setting, and is frankly expressed by the exterior of the building. Interestingly enough, the form of this arena has a peculiarly oriental flavor, despite its American technological origin, which suggests again that many of the “typically Japanese” forms have sprung from a studied consideration of structure and material.

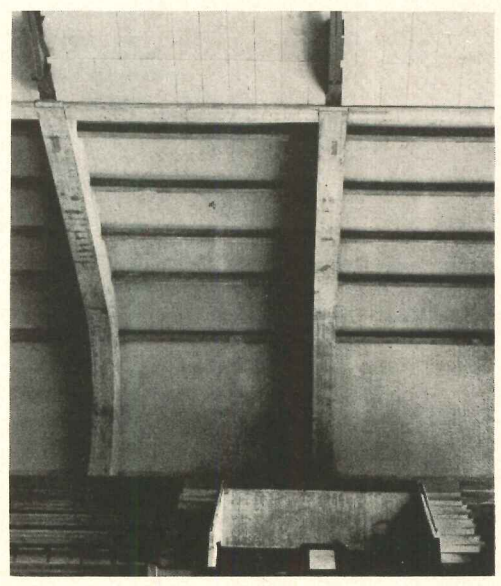
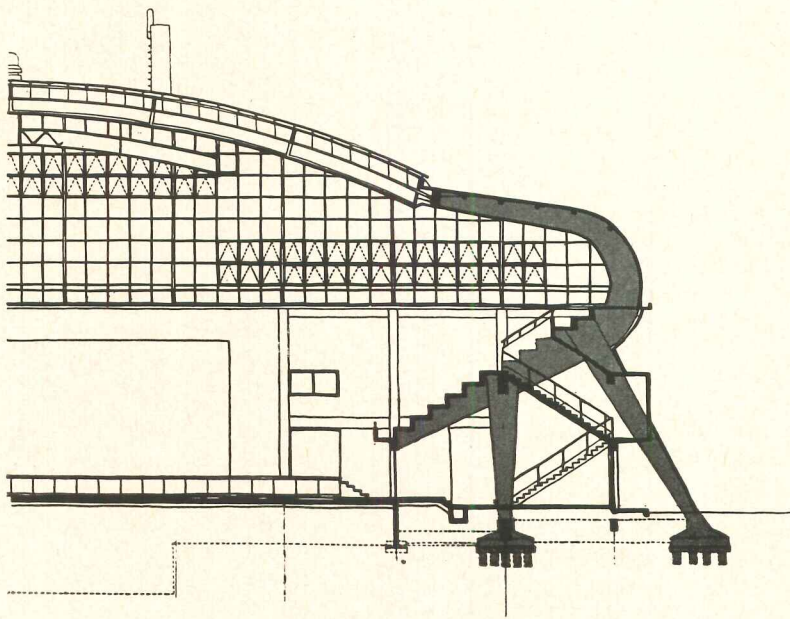
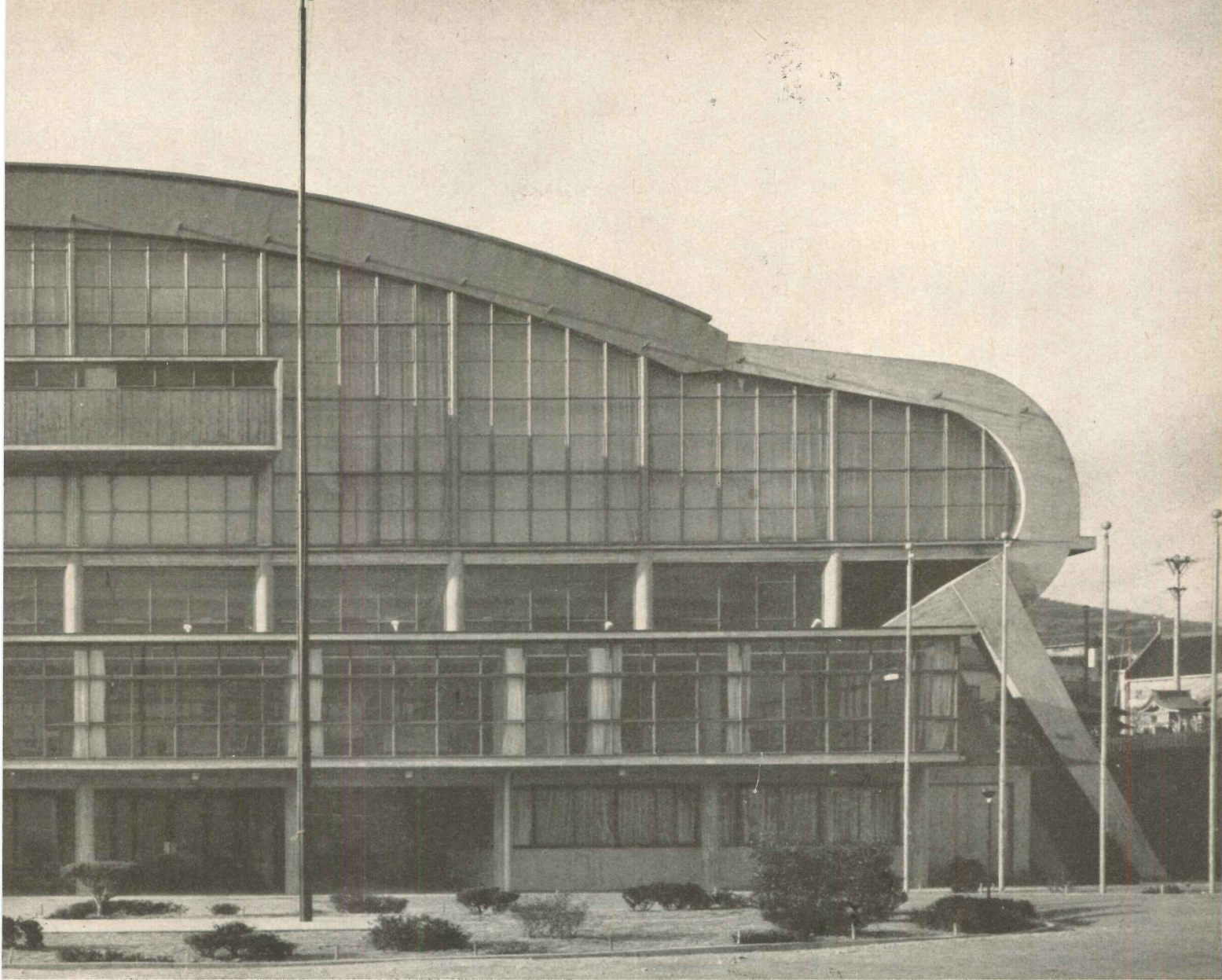

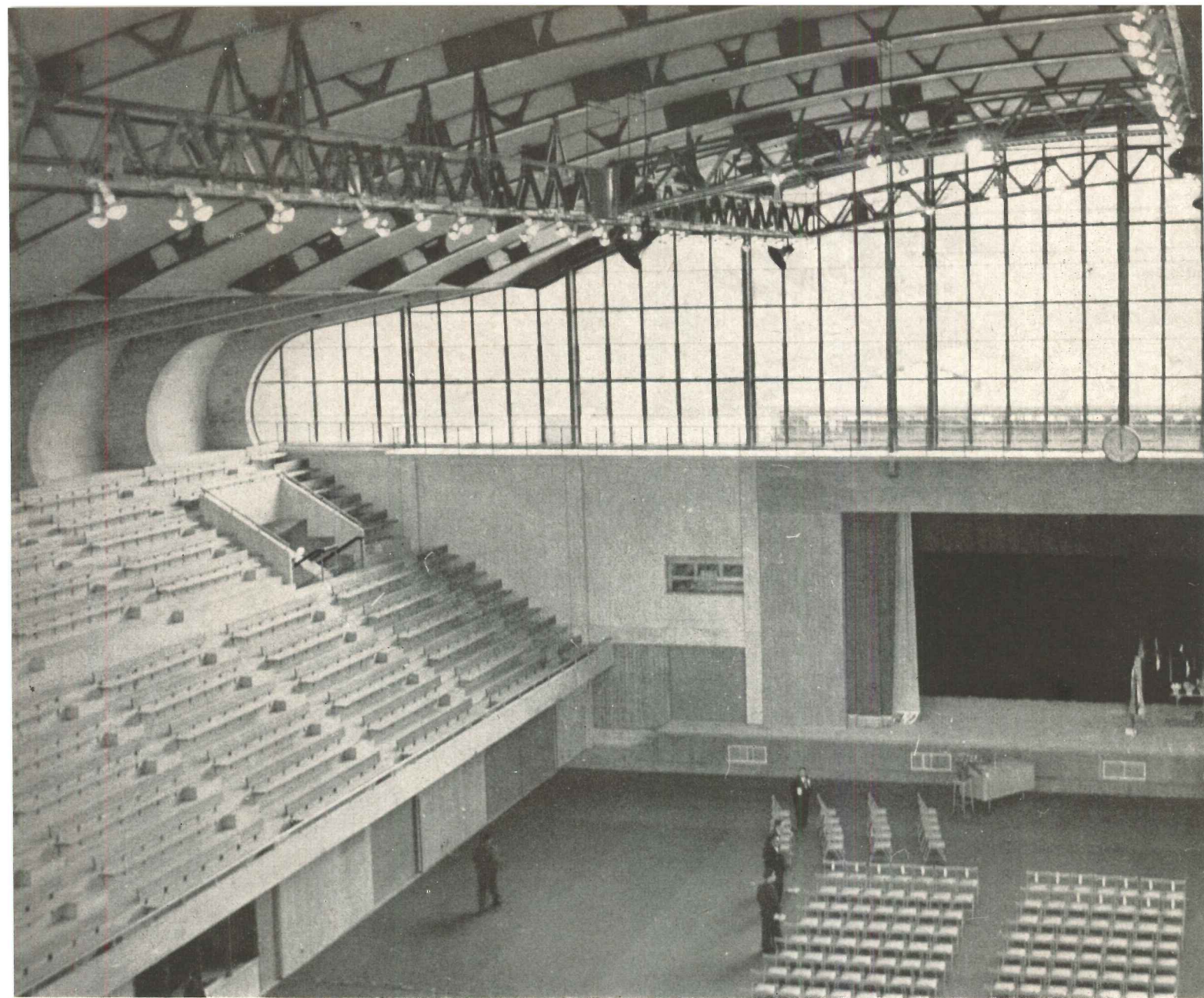

YAWATA ARENA



Although originally conceived as a building for indoor sports such as basketball, tennis, boxing, Judo, etc., the arena serves also for performances by choral groups and orchestras, also as a theater for drama and movies. The varied nature of such activities requires flexibility in seating and in arrangement. Normal seating capacity is 2500; but folding seats which are stored below the permanent benches (in the cross-hatched areas of the plan at right) can increase it to a total of 5000 places.

All materials are native and all components are of Japanese manufacture. The main floor is of maple; the structural frame is natural reinforced concrete which is — in part — color stained by means of an applied liquid plastic, much in the nature of a water color wash. The overhead steel is painted emerald green; the catwalk is turquoise; the panel infilling for walls and ceiling is the natural beige color of the lightweight concrete.

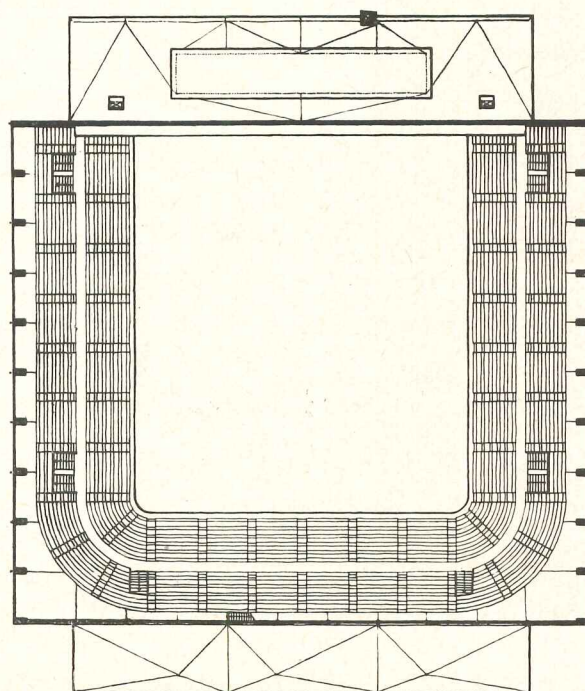
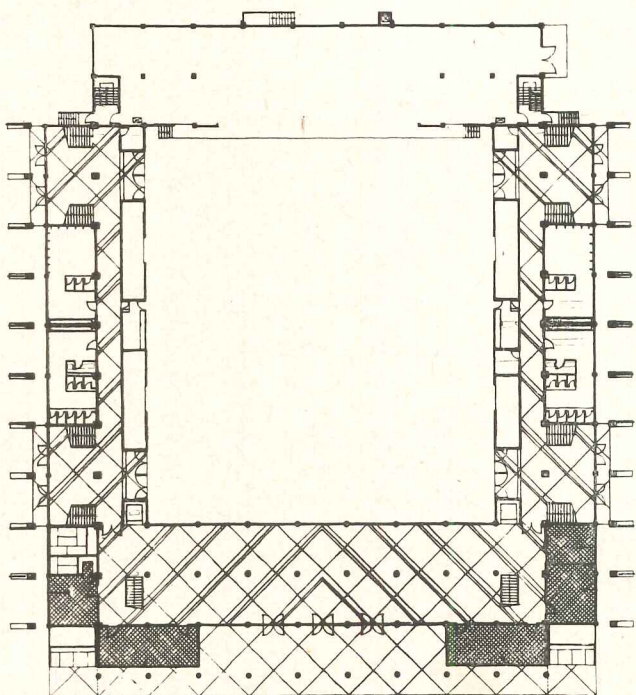
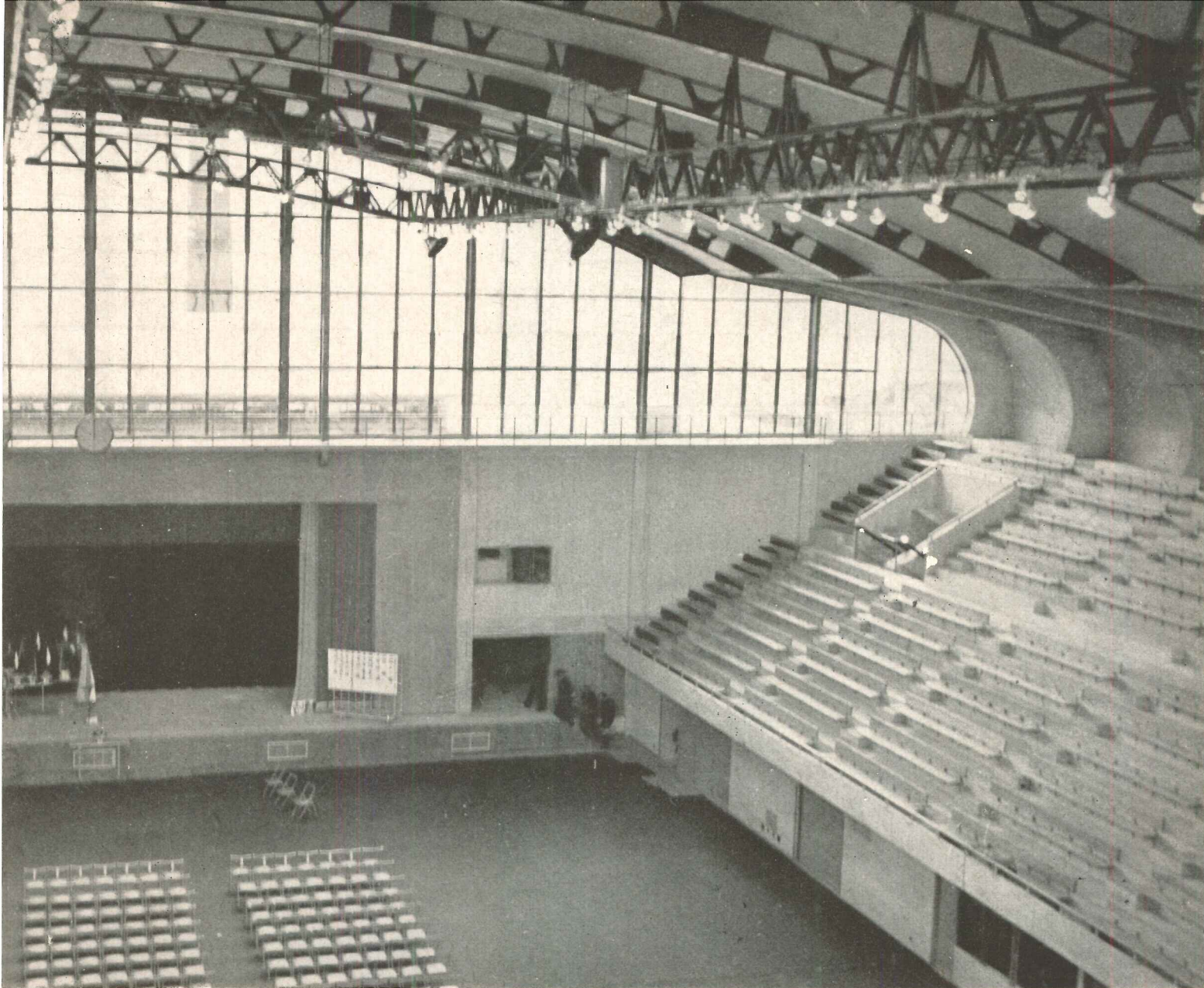



YAWATA ARENA

The main entrance lobby is pictured at left: the glass enclosure at second floor level houses offices for the managerial staff. The lobby floor is of black, gray and white terrazzo; the columns and sloping soffit are of natural concrete.

Architect Antonin Raymond explains that the combination of sand, cement and gravel widely used in Japan produces concrete of a pleasing warm gray color, unlike the rather cold, drab look usually associated with ordinary structural concrete. For this reason he uses the material extensively both for structure and finish. The forms — assembled with traditional Japanese wood-working skill — are lined with square-edged 4 in. boards, as first used by Mr. Raymond in the formwork for his own Bucks County, Pa. house in 1923.

After the forms are stripped, the only finishing of the concrete surface consists of cutting down the fins by carborundum. Sometimes the architect specifies a transparent stain for color, but its application in no wise alters either the texture or the character of the concrete surface

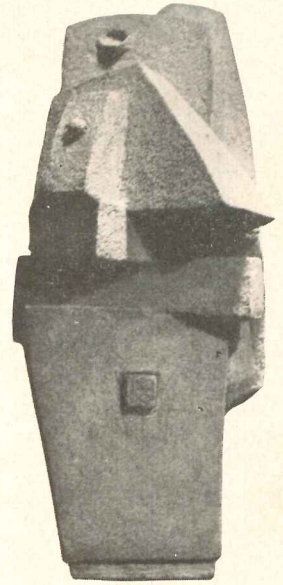
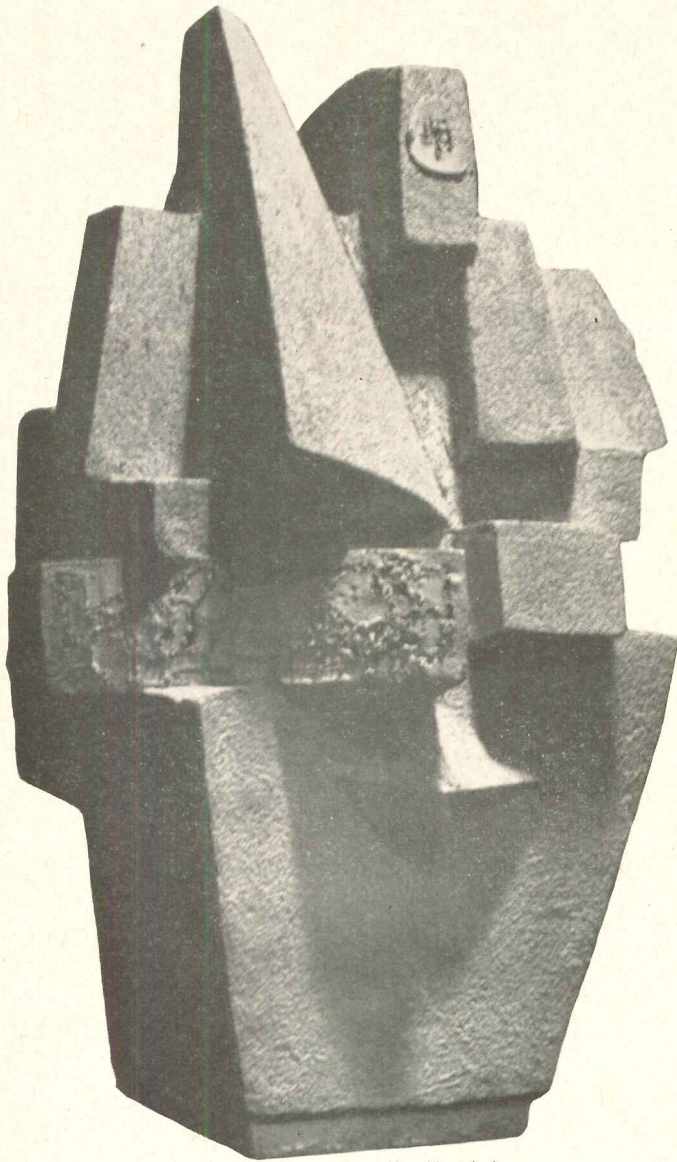
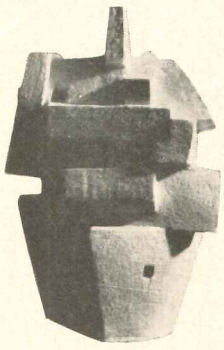

Hans Namuth photos

SAND SCULPTURE BY
COSTANTINO NIVOLA

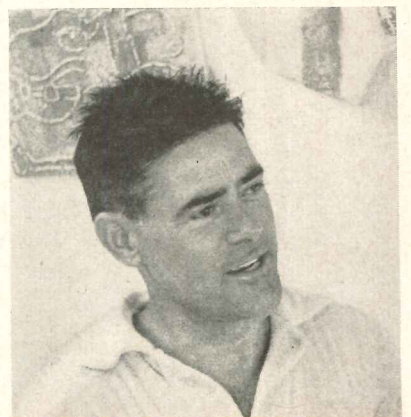

ART, ARTISTS AND ARCHITECTURE

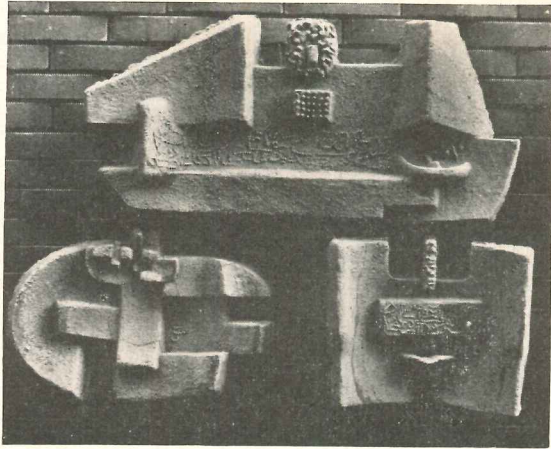

Norman Oberferst

Nivola's work ranges from the enormous, free-standing projects shown on the preceding page, to the more domestic scale of the plaques above from a New York apartment house. His wall for the Olivetti showroom in New York (far right) gives a simple, overall impact, but is filled with such intricate detail as that shown at near right. Below is a scheme for a projected fountain for an American embassy in the near east. Inset is a study for a free-standing monument or wall, made of many individual blocks

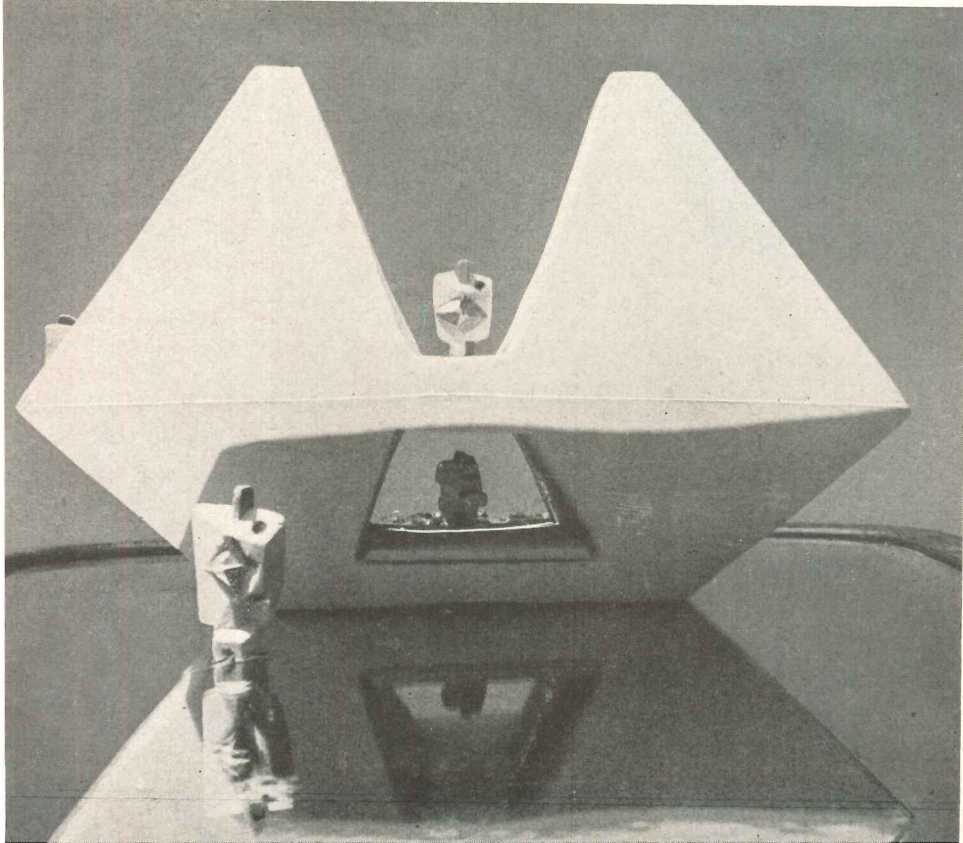
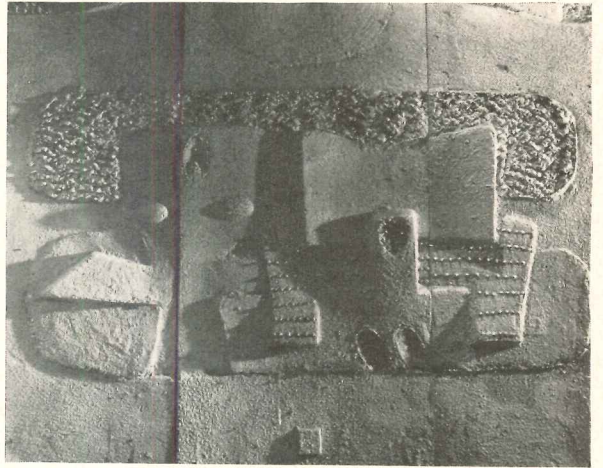
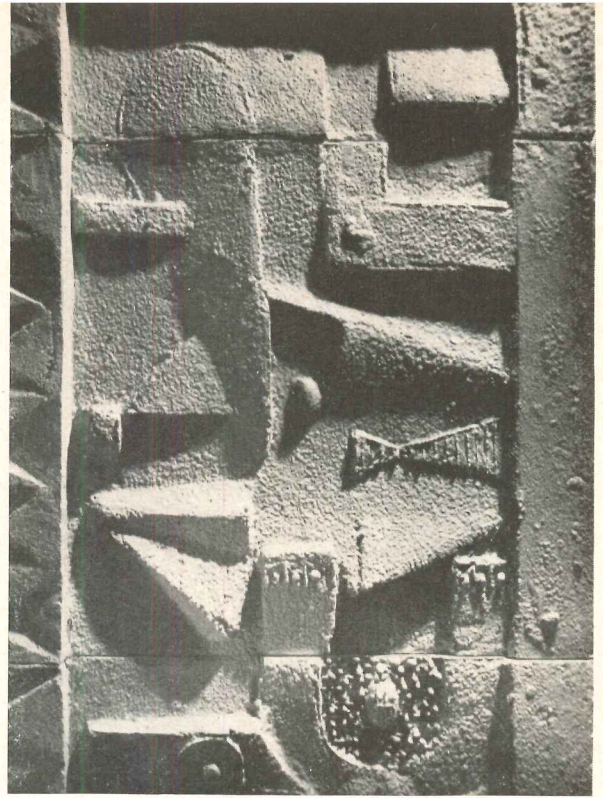

Hans Namuth



Hans Namuth

By Dore Ashton

AMONG THOSE currently striving for a vital integration of the arts, one of the most enthusiastic is the sculptor Costantino Nivola, who is perhaps best known for his sand sculpture wall in the New York Olivetti Showroom.

Nivola is overflowing with ideas on how the breach between architecture and the other arts can be closed — and he tends to split the blame equally. In order for sculpture to be related to architecture, he feels, there must be consistency in techniques. And for him, sculpture must always be related to environment; the scale of a piece of sculpture should suggest that it belongs somewhere.

“Sculpture ought to be made with the same building material, same technique, and same carpentry as the building in order to be consistent with the scale and design.” Furthermore, he adds, art should be incorporated in the plans at the same time as the plumbing as an equally important element in living. And

if an artist were to work truly in terms of today’s architecture, he would solve problems of time for installation, expense of materials, unions, and all the various considerations which discourage builders from incorporating art at this time.

Along with this goes a plea for a certain degree of artistic freedom. “The danger in being what they call a practical designer, is that you do things only to solve a problem. But there must be a background. An artist must do things independently of problems so that when he is given one, it is already partially solved. Art must be a disinterested act of inventing, explaining, revealing. Application is the second phase.”

Nivola has developed a highly personal technique. In the sands near his Long Island home, he scoops out generous forms, which are then cast in blocks of concrete. If such bas-reliefs are to be used in a large scale building, they are created in units which can be easily lifted and assembled by workmen. For three-dimensional

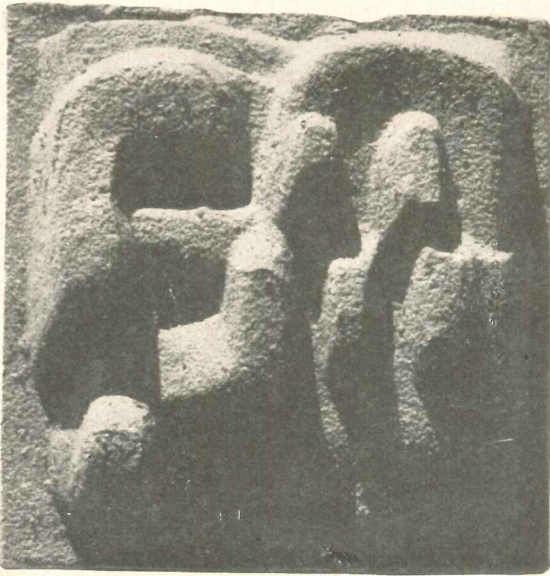

The use of sculptured inserts to provide shadow interest for a building façade is shown in this study for a school soon to be built. Each insert would be individually designed. A typical one is shown above

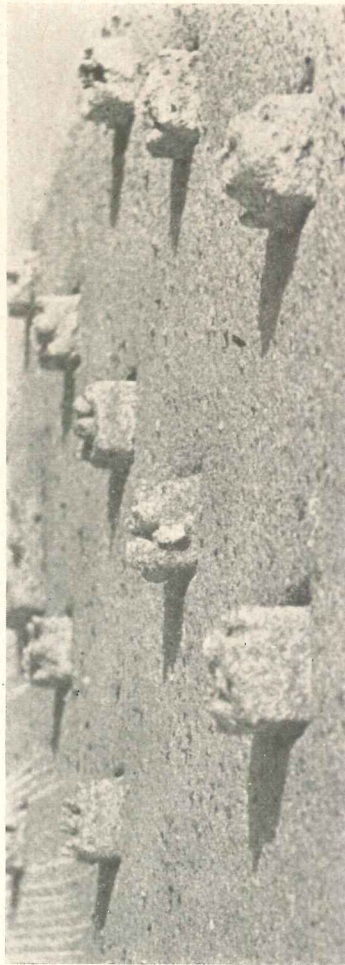

sculpture, blocks are molded separately and fitted together in monolithic, angular patterns.

In developing his style, Nivola has referred to two civilizations—he was born in the medieval village of Orani in Sardinia. His father was a master mason. “Working with my father,” Nivola recounts, “I learned how to use simple materials—lime, brick, clay and sand.” Later he augmented his craft by learning the art of stucco decoration. At fifteen, he was selected by a local painter as apprentice, and assisted in decorating the university in Sassari with Renaissance-derived designs. He next went to Monza, near Milan, where an advanced art school offered him a scholarship. Subsequent events brought him to America, and for a number of years he worked as a designer for publications.

His current sculptures strongly recall the great antique monuments of piled stone that punctuate the rise and fall of the Sardinian mountains, echoing their

imposing scale and simplicity of technique. He frequently adds the interplay of natural elements—wind, sun, shadow, water.

A project with architectural implications that he would like to do, is a labyrinth. It would have different levels, with views seen from narrowing or opening spaces. The accent would be on sensory experience, with surprises: a corner turned, and a splash of color on a wall, or a bridge over a pool.

Nivola is also fascinated with the idea of monuments, as tall as buildings, to “celebrate life.” One such idea is a huge, many-fired stove—a fireplace with several fires flickering against its sculptured flanks. Another is a project for his native town—a pergola that will cover the narrow streets until they converge on the large, open piazza. On the piazza would be a stone monolith and a wall—a big poster advertising nothing, but celebrating the piazza.



PLATFORM HOUSES

Edward L. Barnes, Architect

A NEW NOTE has been struck in the familiar debate on whether a country house should merge with its setting, stressing indoor-outdoor relationships — or be set crisply apart from the landscape. Edward Larrabee Barnes has developed a series of schemes which, in effect, achieve both qualities. Actual outdoor living areas and gardens are lifted above the surrounding terrain onto a podium or platform with the house; these areas are carefully cultivated, while the rest is left more or less as is. Thus the integrated gardens and house do stand apart. On the next few pages, we present several of these houses with Barnes' comments.

The house and nature: “the contrast between untouched nature and the area for living is dramatized in the platform plan. A house should never melt completely into the landscape — it should retain its identity as a habitation and have its own crisp organic form. To me ‘organic’ does not mean that the house sprouts out of nature like an over-fertilized plant.”

The house and garden: “in the platform plan, the garden is conceived as part of the house. Its wall is an extension of the house foundation; enclosed terraces complement inside spaces. Shade trees make a leafy outdoor ceiling.”

PLATFORM HOUSES

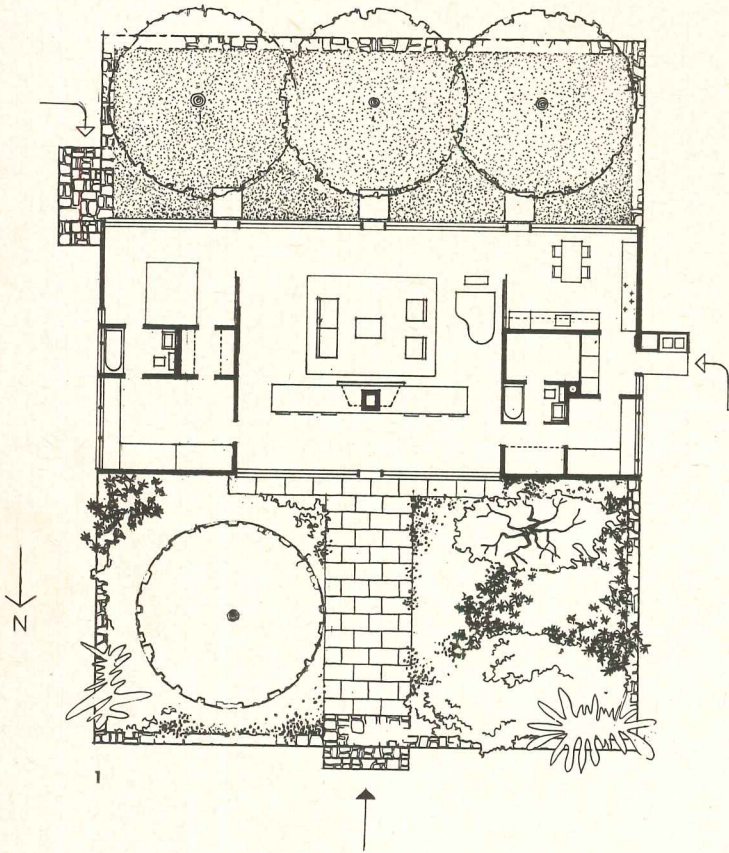

Edward Larrabee Barnes, Architect

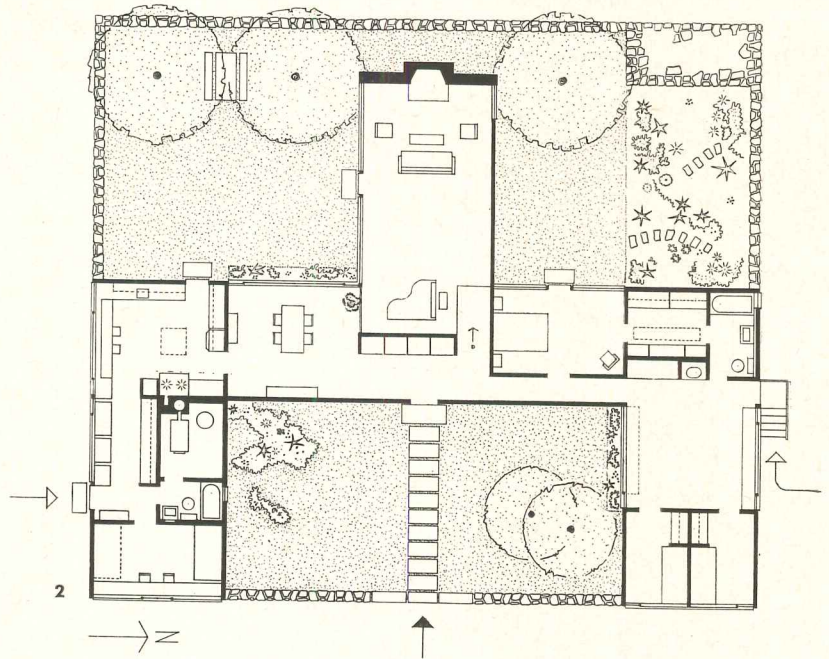

1. Edward Larrabee Barnes House
Mount Kisco, New York

"There is only one level in this hilltop house. The entrance garden, house interior and rear lawn are all flush with the top of the stone wall. Consequently, one is more conscious of looking *down* from the platform than in the other houses. Everything is conceived as one space; when in the house one feels the fireplace is not just the center of the living room, but of the whole platform. Open planning and wide vistas make one always aware of the whole house and garden — yet it is only a small house for a little family."

2. Robert Osborn House
Salisbury, Connecticut

"The outdoor spaces in this house are carefully integrated with the inside plan. The raised entrance court is level with the top of the stone wall and forms a classic entrance. The living-dining terrace is sunken to living room level, and one can sit on the surrounding stone wall. A stone table for outdoor dining is under the shade trees. The north court, with a garden and raised platform for sculpture, is a private area for the master bedroom. Staggered wings bring south light to all important rooms."

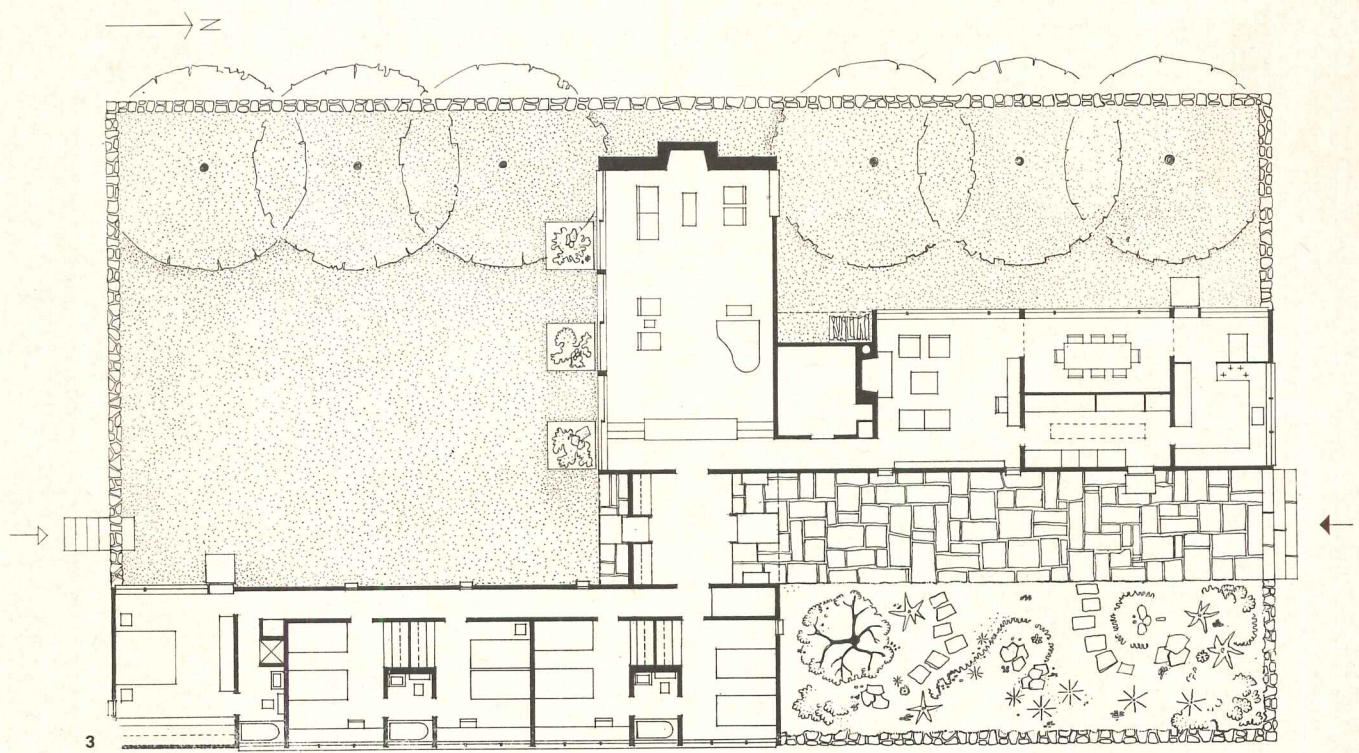
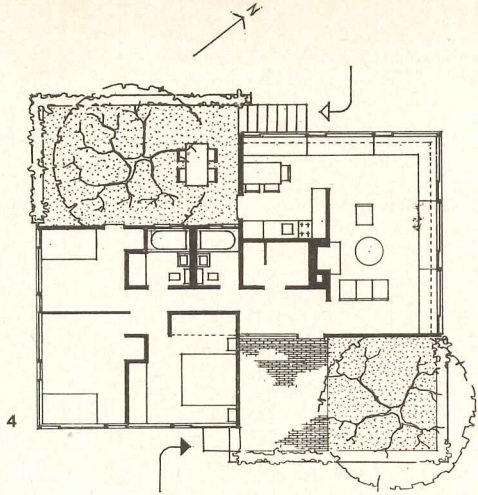

3. Theodore Marsters House
Litchfield, Connecticut

"This house sits on a bare hilltop with a sweeping west view — hence the line of shade trees. The living room faces a large square lawn enclosed by a low stone wall. Dining room, sitting room and breakfast alcove look west over a shallow dining terrace. Front and service doors open onto the entrance walk. This is not only handy, but it means that all functions including the service entrance are contained on the platform — and everything around can be left untouched. Somehow, this complete containment is very satisfying."

4. Allen Buck House
Salisbury, Connecticut

"Built within a very tight budget, this 1100 sq ft house, with its little terrace and flower boxes, is set on a three-foot high, painted concrete block foundation. The continuous window seat can sleep six guests, and makes large amounts of furniture unnecessary. The front terrace is kept neat and formal; the rear terrace, opening from kitchen and children's room, is for family living and outdoor dining. Each terrace has a shade tree, access to surrounding land. The house has been called a 'houseboat in the fields'."

PLATFORM HOUSES

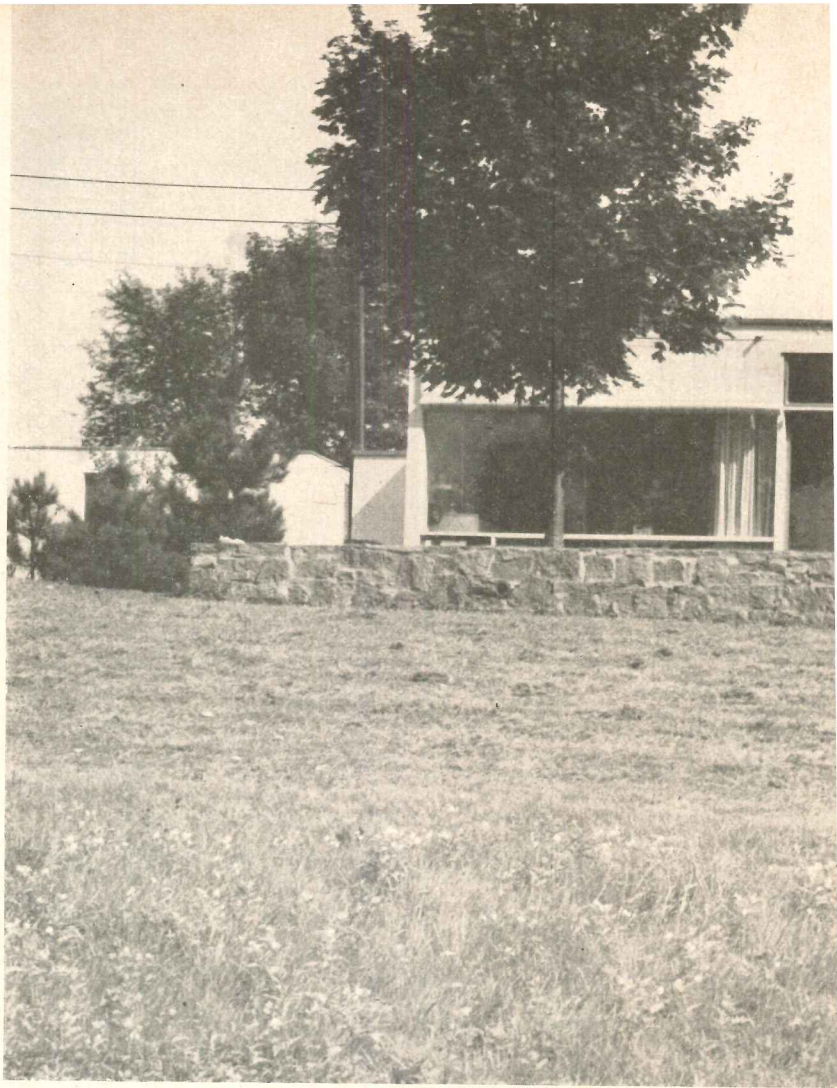
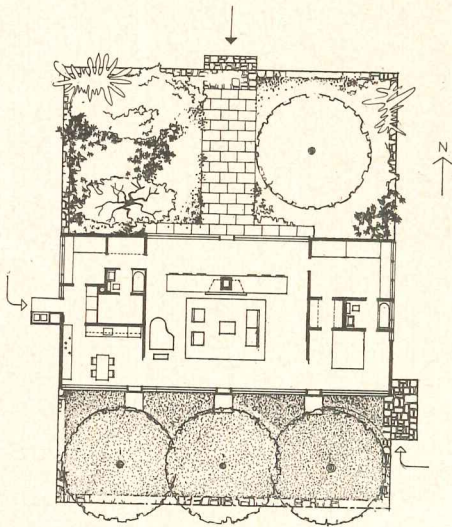

Edward Larrabee Barnes House

***The Plan:** bedroom and kitchen can be shut off by sliding doors, but partitions always screen the areas from view. A storage wall separates the living area from front hall — such a gallery makes coming into the house more of a pleasant ritual.*

***Landscaping:** maintenance is minimized. Only rough mowing is necessary for land off the platform. On the platform, the lawn can be mowed by hand in fifteen minutes; grass is flush with the stone, eliminating clipping. The raised entrance garden is planned to look well winter and summer — Myrtle and ivy are used as ground cover with flowers peeking through in season.*

***Shade trees:** three Norway maples cost a fraction of what a well detailed porch would. And trees let through winter sun, summer breezes. Later, bottom branches will be clipped to make a flat leafy ceiling.'*

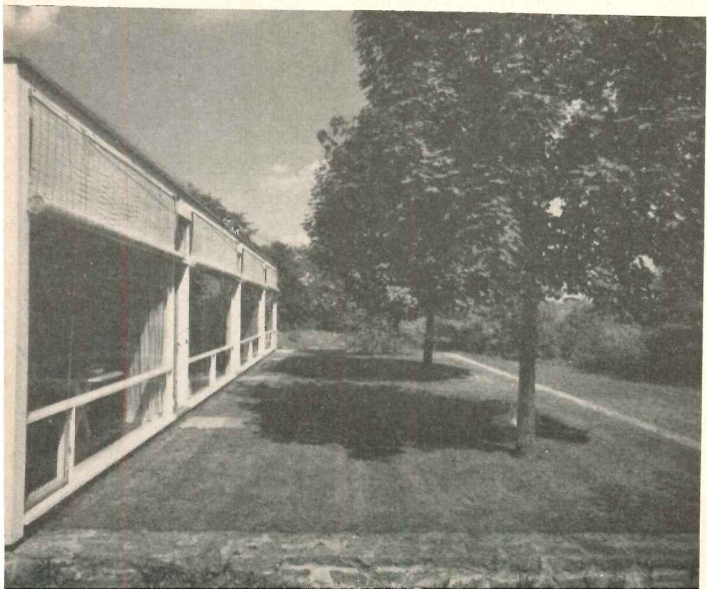
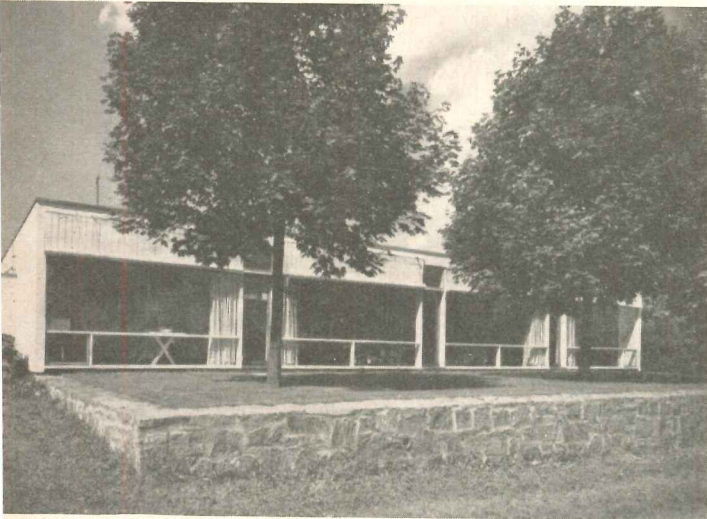

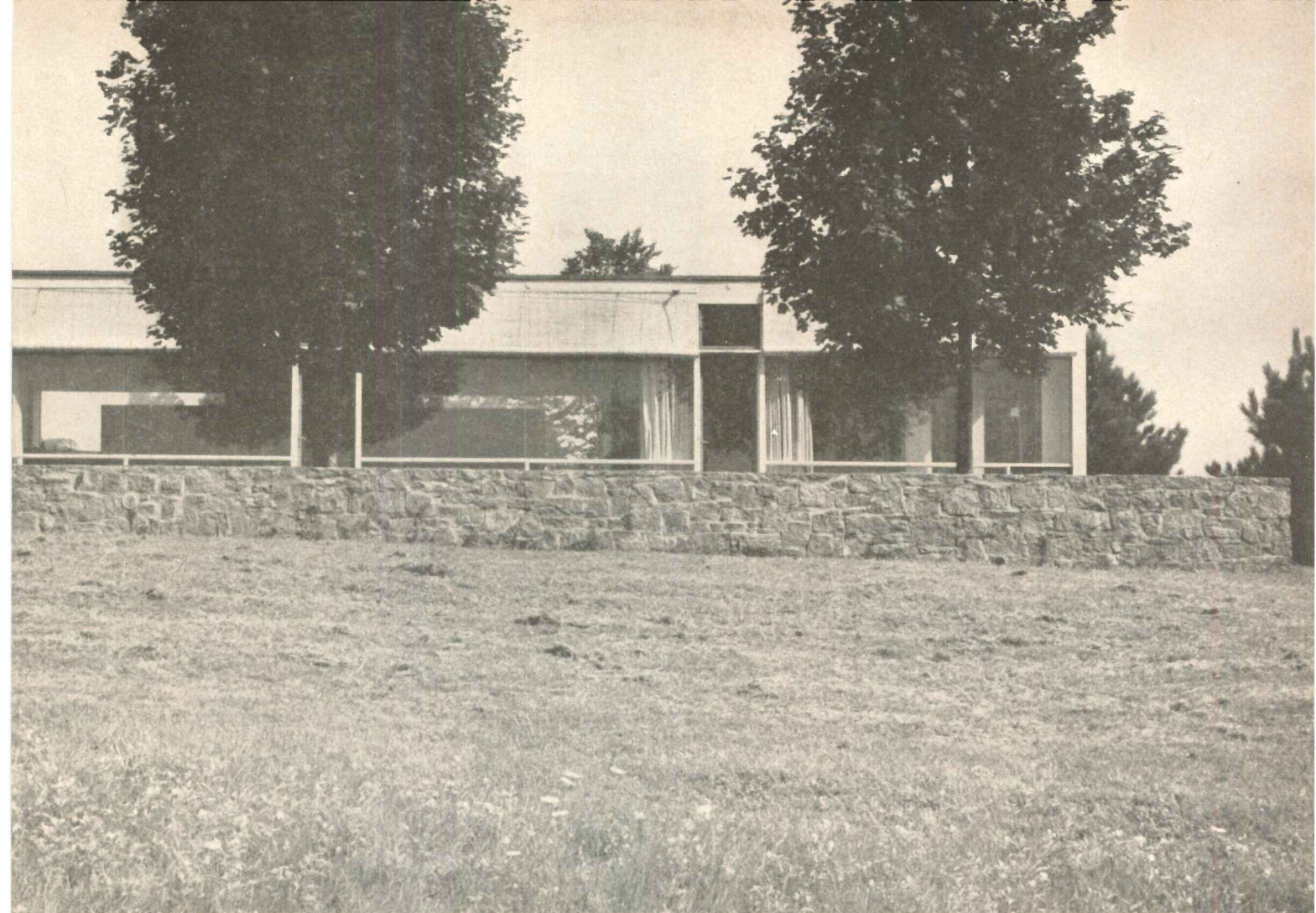

Ben Schnall

Edward Larrabee Barnes, Architect
James Fanning, Landscape Architect
Benjamin Spivak, Heating Engineer
August Nelson, Contractor

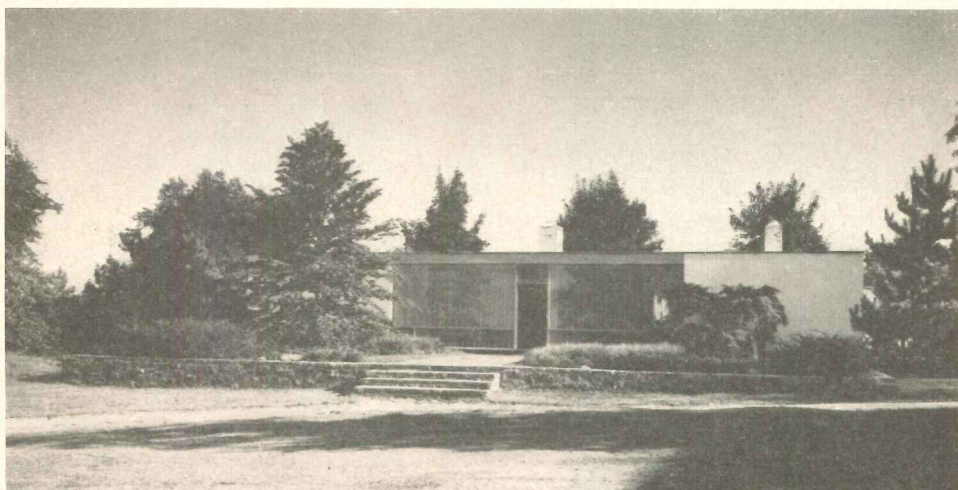

PLATFORM HOUSES

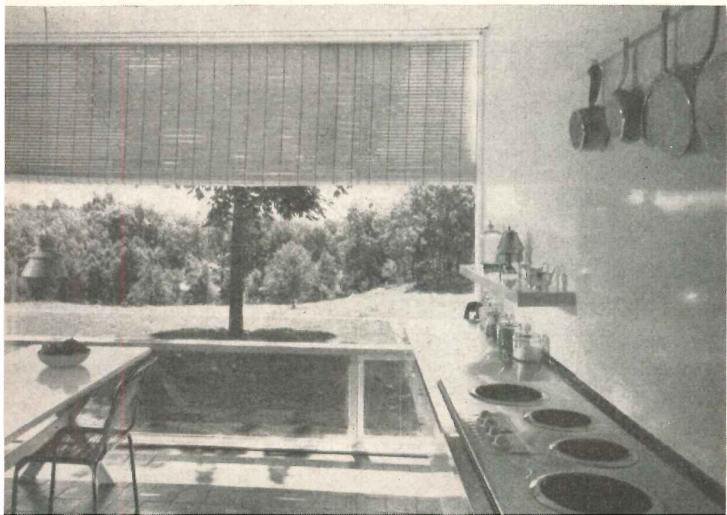
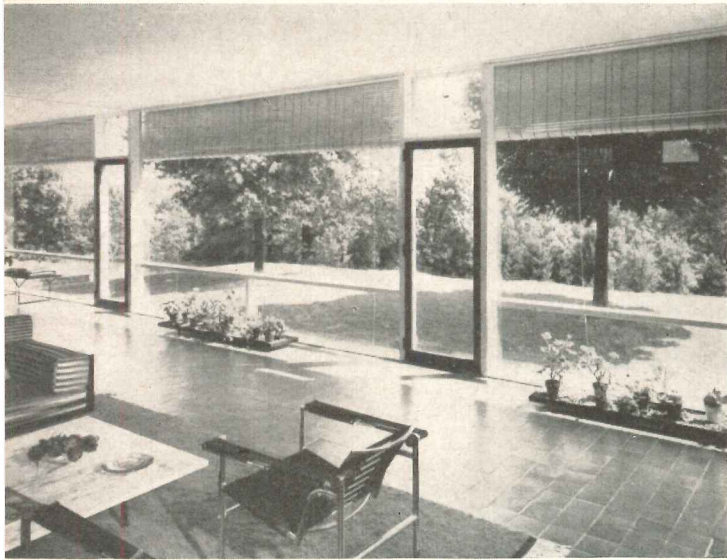
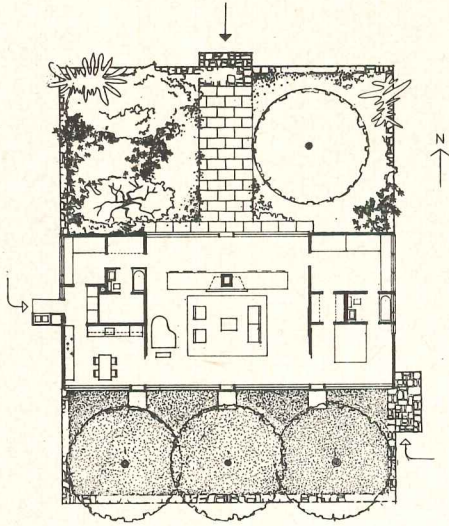

Edward Larrabee Barnes House

“The living area: ceilings are white acoustic tile, walls white plaster. Such an interior is always changing: it looks pink when lamps reflect off the reddish-brown tile floor, green when sun comes through the trees, and soft gray in a snowstorm. The floor is radiant heated.

The kitchen: we like to eat in the kitchen — only now the kitchen is not tucked off in a corner but faces the living terrace with full height windows and nice detailing. It is treated as a major room. Without a servant living in, such a solution is delightful.

Outside blinds: the glass is protected from sun on the outside. On hot days, the house can be closed in like a slat dwelling. When the trees are bigger, the blinds won't be needed in summer. Such blinds have long been used abroad; they have wind stays, and a locking device that eliminates the need for cleats.”



Ben Schnoll

Edward Larrabee Barnes, Architect

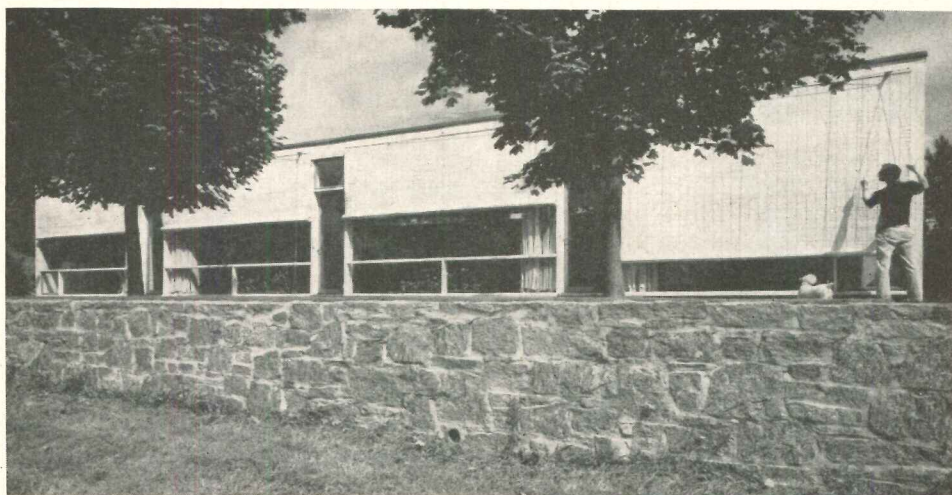

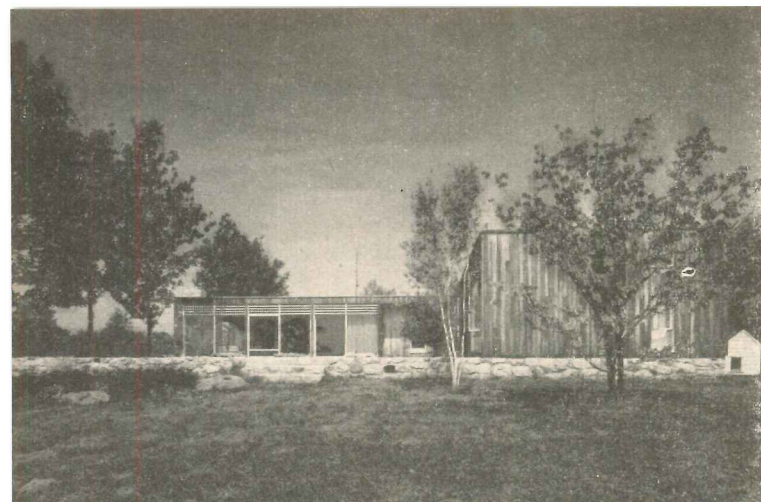

Joseph Moiror

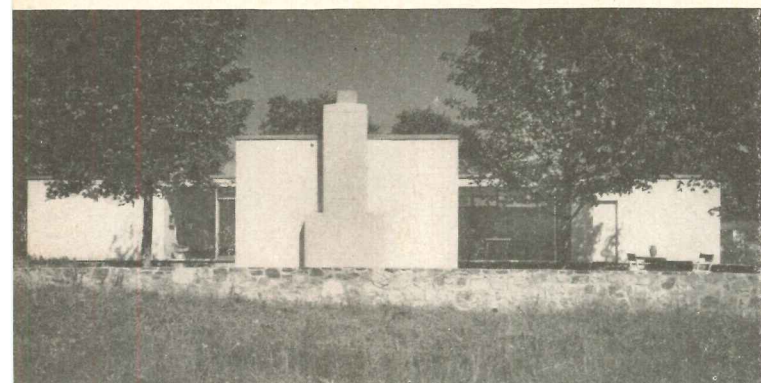
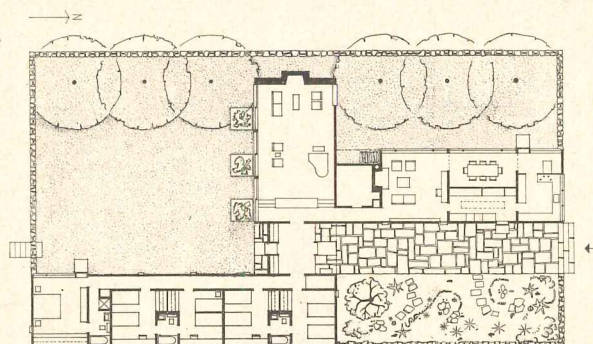

Ben Schnall

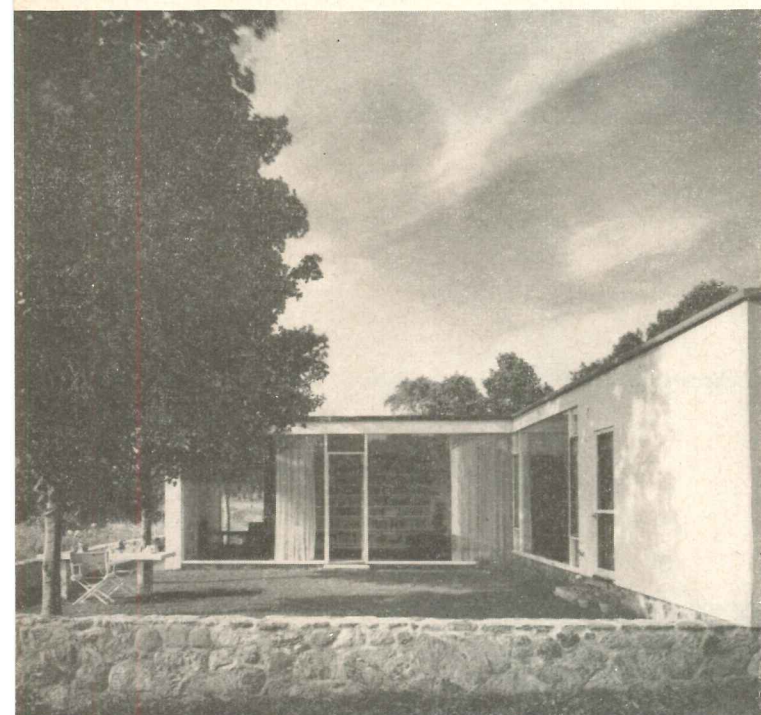
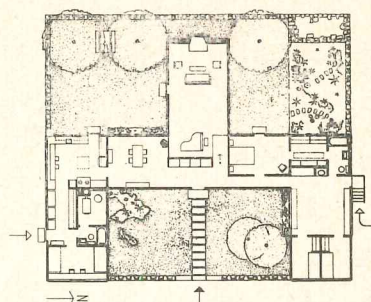

© Ezra Stoller

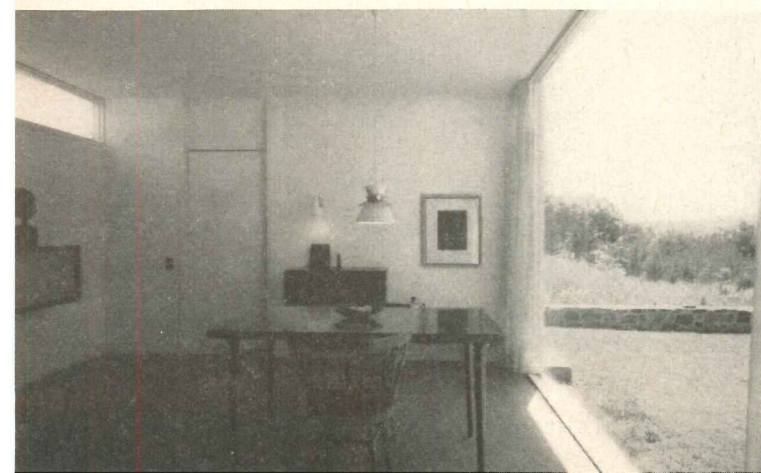

PLATFORM HOUSES

With larger, multi-wing platform houses, several courtyards are possible. Each of the schemes shown on this page have three. At top, the house for Theodore Marslers uses a zig-zag plan to achieve an informal arrangement of courtyards. Below, the house for Robert Osborn is quite symmetrical in layout.

Future platform houses: "on future houses, I would try to provide a service court on the platform so that functions don't 'spill off'. It would also be nice to be able to walk from one court to the next without stepping off the platform. I would like to see the shade trees clipped, and the gardens even more lush. On a large house, I would use overhangs and trellises to supplement the shade trees, and perhaps define the living platform at an upper level."

Edward Larrabee Barnes



Joseph W. Molitor

HIGHLY FUNCTIONAL PLANT FOR HELICOPTERS

*Manufacturing Plant for Sikorsky Aircraft Division, United Aircraft Corporation
Stratford, Connecticut*

*F. A. Fairbrother and Geo. H. Miehl, Architect and Engineer
Albert Kahn Associated Architects and Engineers, Consultants*

RARELY DOES functional building design involve so many different complications as the architects and engineers encountered in this manufacturing plant for helicopters. Though the plant is large (800,000 sq ft of floor space), mere size was less of a factor than the complications of helicopter manufacture. One section, for example, has a height of 36 ft and a clear span of 180 ft. Site preparation involved the moving of 1,450,000 cu yd of material. Then there were some highly special requirements for air conditioning and ventilation, for fire protection, and other special needs.

Comprehensive survey of many other areas throughout Connecticut and adjacent states preceded selection of the Stratford site as most closely meeting the requirements for the type of installations contemplated. Terrain of the acreage selected included farm land, sandy gravel knolls and hills, rocky and swampy back water areas. Final grades were set to provide a maximum of fill material to level and fill the greatest possible percentage of the site. Sizeable hillocks were cut down to provide fill in the swampy meadows adjacent to the Housatonic River and to bring the ground to the eleva-



Joseph W. MONTOR

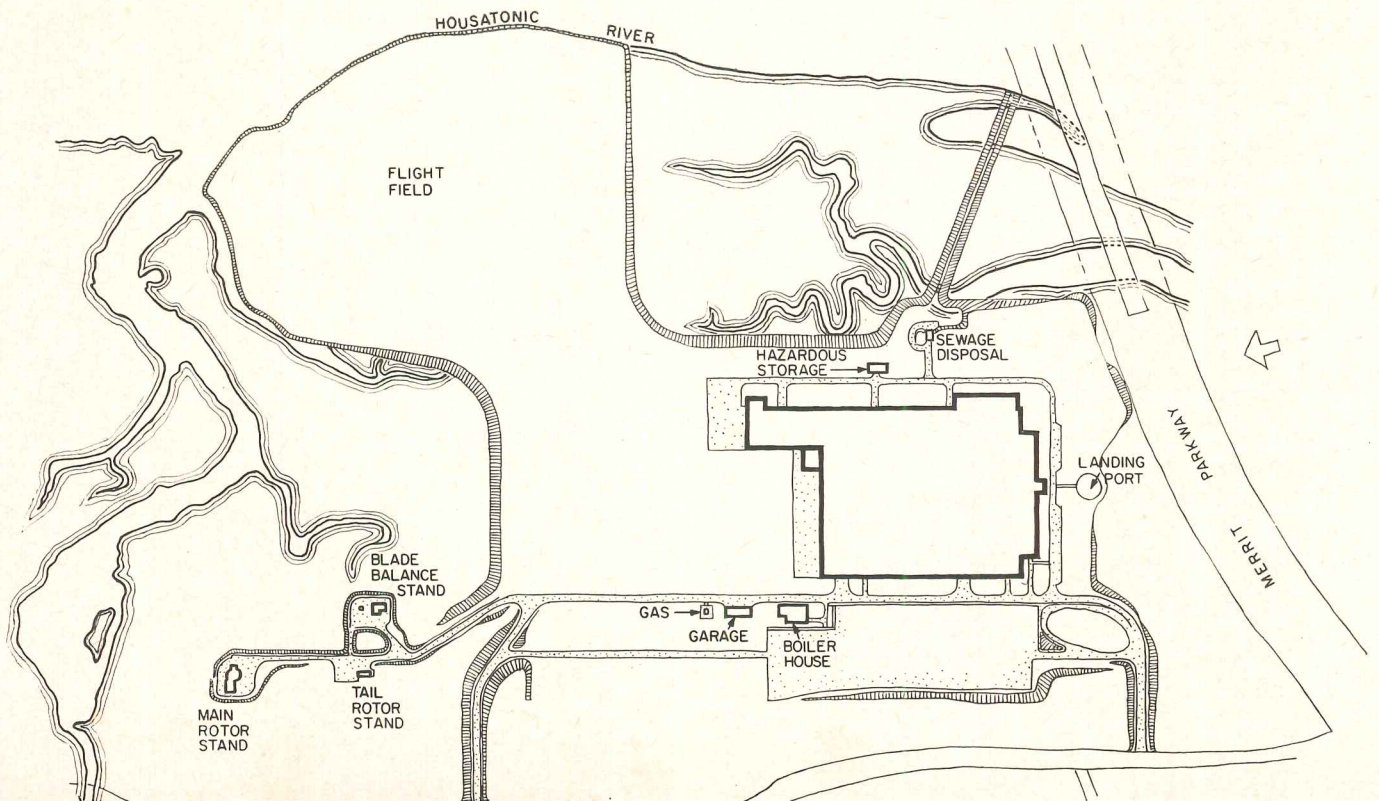

PLANT FOR HELICOPTERS

tions desired for the buildings, parking lot, roadways, possible future extensions to the North and East, flight field, and access roads to various test stands.

The main manufacturing building is 820 ft long by 700 ft wide, with an extension to the north of 180 ft by 300 ft which houses the hangar area. An attached office building along the south end of the plant is two stories high and has a basement area 60 ft wide by 520 ft long. At the northeast corner of the hangar is a two-story projection 80 ft long by 40 ft wide which is known as the pilots' ready area.

Construction consists, generally, of steel columns and trusses. Column spacing in the low bay area forms bays 40 ft by 60 ft and 40 ft by 70 ft with 16-ft clearance to the bottom chords of the trusses. The hangar and final assembly area, extending along the east side of the building, has a clear height of 36 ft under main roof carrying trusses and a clear span of 180 ft in width. Orville Wright could have made his epic first flight in the 180 ft clear span of this high bay — going across the bay, not down its length.

Exterior walls are of face brick backed up with concrete block to a sill height of 8 ft, aluminum projected sash, and insulated fluted aluminum siding. The roof, some 18 acres in area, is constructed of poured gypsum and composition roofing.

Toilet facilities are conveniently spaced throughout the first floor of the manufacturing area with foremen's offices located above. Locker rooms, plant protection headquarters, and employment facilities are located in the basement area near the manufacturing employees' entrance. The basement area and all the rooms off it are of extra heavy blast resistant construction. In all, it is an area about 120 ft by 200 ft overlaid with 12 in of reinforced concrete. One end of the administration building (about 60 ft by 180 ft) has received similar treatment. In an emergency the two areas could shelter approximately 5000 people.

The two-story area and the blade room in the factory section are completely air conditioned. The blade room

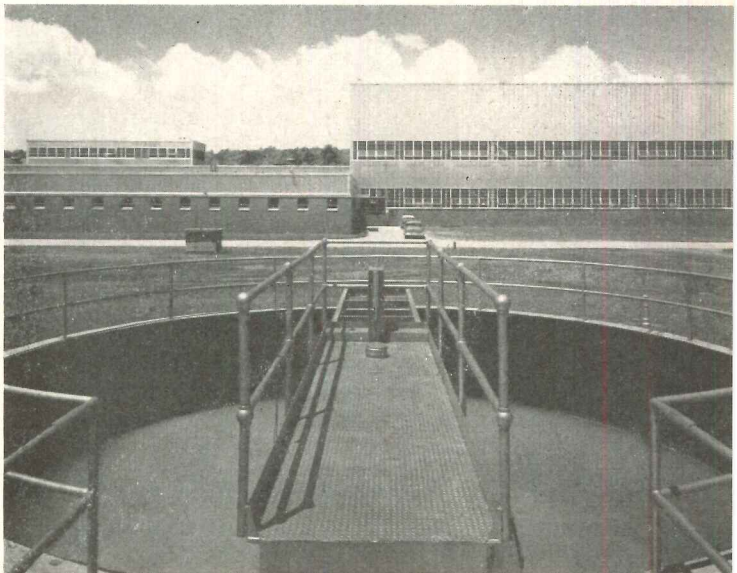
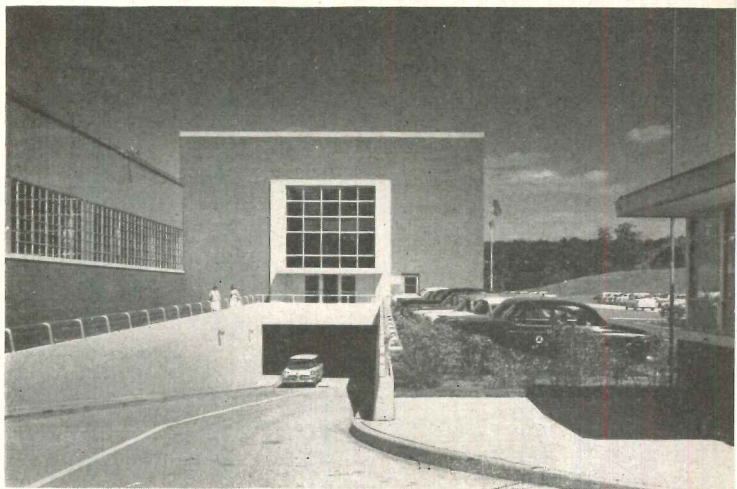

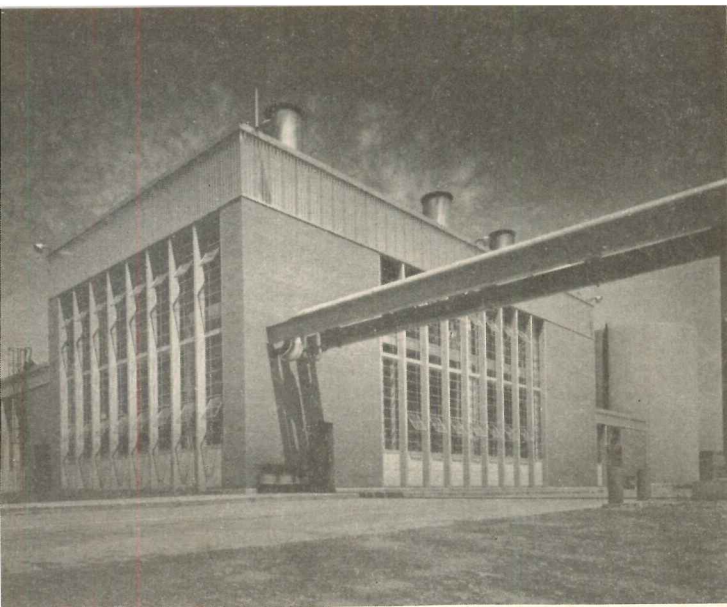

PLANT FOR HELICOPTERS

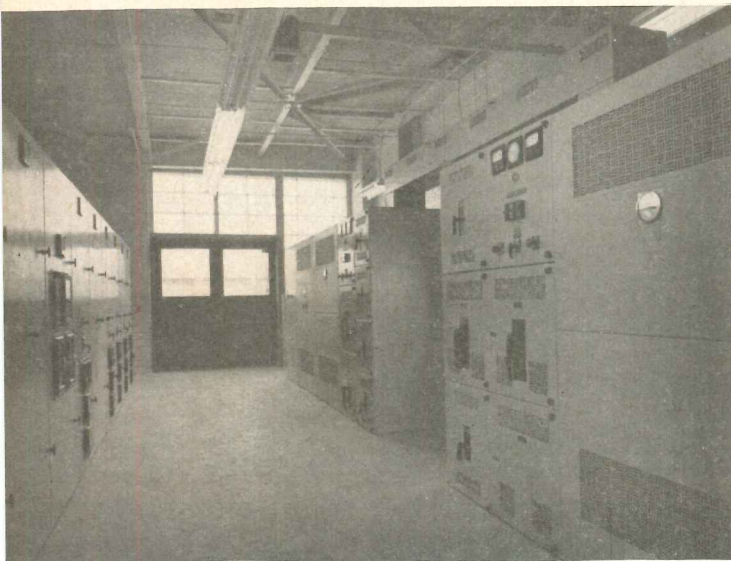

requirements are definitely fixed as to temperature and humidity throughout the entire year. In general, the air conditioning equipment for both the office area and the blade room are identical, the variations being in the control limits. The system consists of air filters, water cooling coils through which outdoor or recirculated air is drawn by a motor driven fan unit, and the fan unit which discharges the air through zone coils and ducts to various parts of the rooms. The requirements of the distribution system made it essential to provide different air temperatures around the outer zones near the exterior walls than are required for the interior areas where the heat gains and heat losses throughout the year are nearly constant.

Although the blade room is one completely enclosed area, separate zones are provided sectionalizing this room to permit different degrees of temperatures on the supply air system to balance the heat release given off by various pieces of equipment, thus making it possible to obtain the same room temperature throughout irrespective of the heat liberated by certain pieces of equipment.

The fire protection consists, generally, of complete wet pipe automatic sprinkler protection throughout the manufacturing building, with the exception of the transformer rooms, fan rooms and light hazard administration facilities.

Special hazard protection, consisting of automatic deluge systems of open type "water spray" sprinklers, are provided for the extinguishment of hazardous fires and the dispersion of flammable vapors or liquids within the aircraft hangar and the final assembly paint spray booths. Certain hazardous areas are protected by a complete wet pipe automatic sprinkler system, others are served by a "two-shot" high pressure, automatic carbon dioxide fire extinguishing system.

The exterior protection consists of underground fire mains enclosing the manufacturing building, with fire hydrants and roof standpipes provided at strategic locations.

LOUIS SULLIVAN

Authentic American masterpiece:

Louis Sullivan's distillation of color, precision and climactic glory in Merchant's National Bank, Grinnell, Iowa, 1914

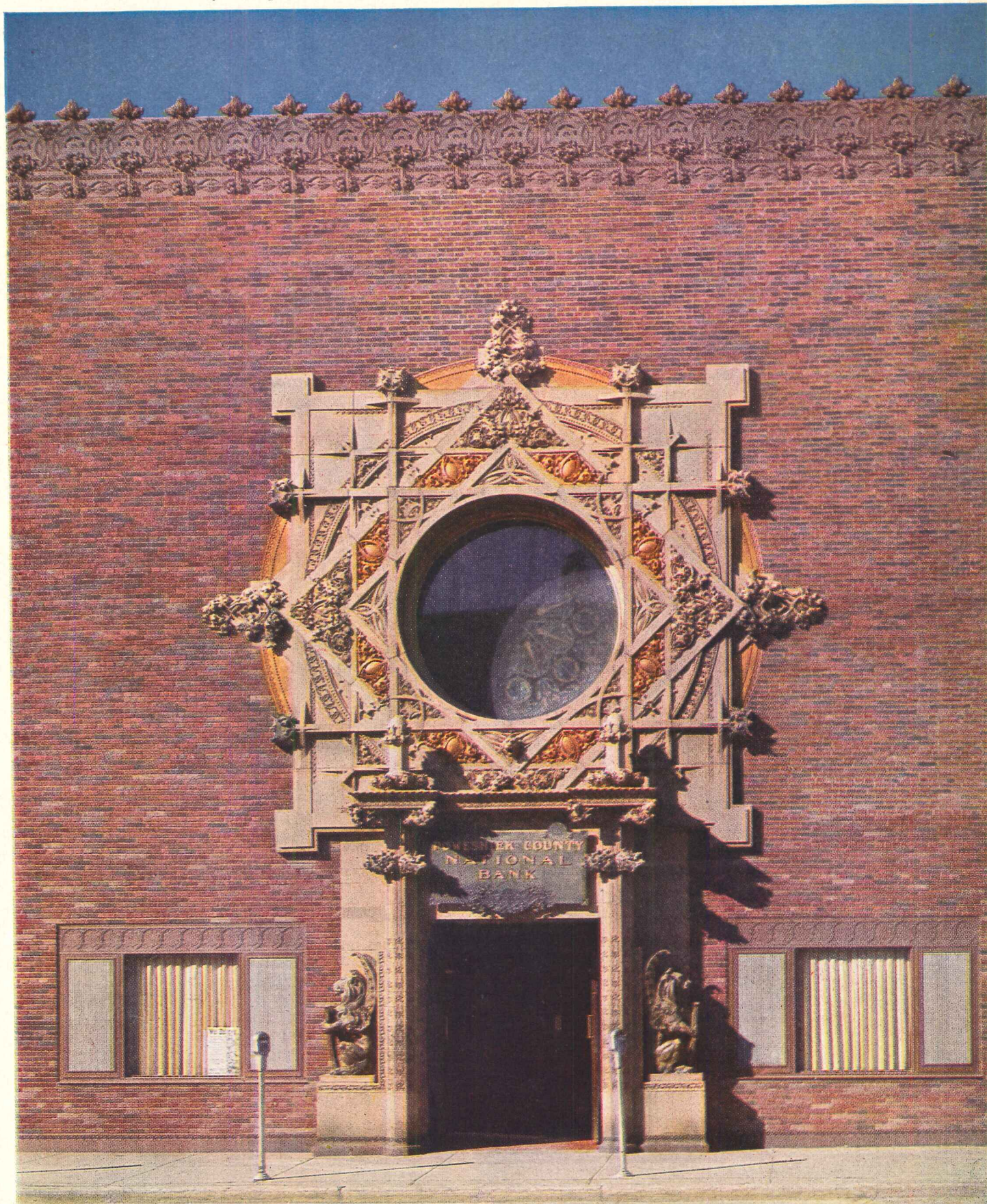

LOUIS SULLIVAN

The expression of a vital whole was to Sullivan's mind the real task of architecture — ornament came in only to clarify this expression. In these typical window walls Sullivan's deeper preoccupation with function and structure can be traced. From left to right: at the Auditorium, 1889, Adler and Sullivan (heeding their client's fondness for Richardson's Field Building) turned to the superimposed arcades of Roman aqueducts as the ordering theme of stone-clad façades; six years later the terra cotta arabesques on the Guaranty Building emphasized the soaring verticality and uniform office bays of steel cage structure; at the century's turn Sullivan stepped ahead again with a supremely balanced statement of cage structure individually framing in ceramic these ample apertures of Carson, Pirie, Scott and Co. above foaming iron ornament. Below: two 8-ft column bases from the Jewellers' Building, 1881, will be in the Chicago Art Institute exhibition.



Richard Nickel, Inst. of Design, I.I.T.



Paul B. Hassel, Inst. of Design, I.I.T.

IN CELEBRATION of the 100th anniversary of the great master of the "Chicago School," the Art Institute of Chicago will present a major exhibition, *Louis Sullivan and the Architecture of Free Enterprise*.

The first major architectural show at the Institute required special funds which were donated entirely by Chicago architects and builders, making it a truly civic demonstration. Though Sullivan's last years, like those of many geniuses, were spent in misery and neglect lightened by only a handful of faithful admirers, Chicago gave him opportunity that brought fame to both the architect and the city. Now it is the first U. S. city to celebrate in a centenary exhibition one of its own citizens as a great architect.

The exhibition will be held from October 25th to December 2nd and will show Louis Sullivan's architecture in five thematic sections: *Sullivan's Influence Today* will introduce the visitor to the big concepts, still guiding architecture, that Louis Sullivan so effectively realized in works and words; *Formative Years* will show what

Len Gittleman, Inst. of Design, I.I.T.

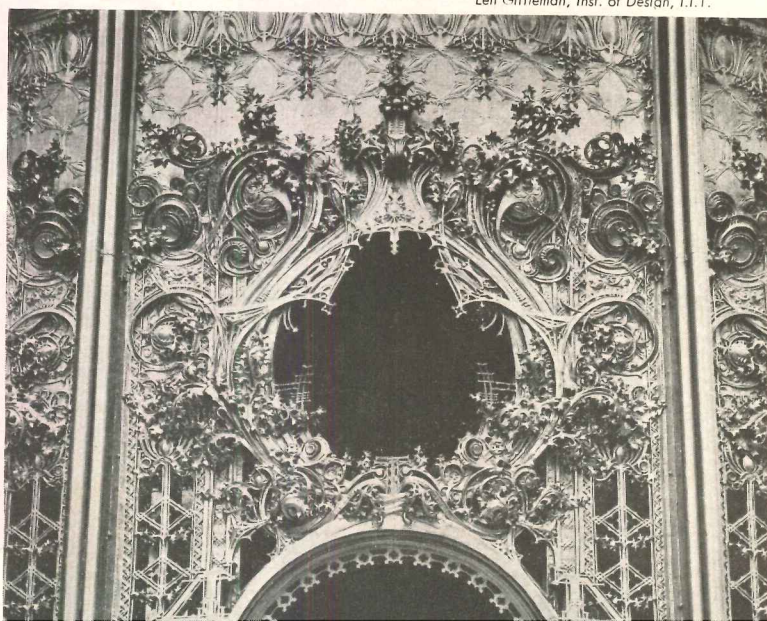
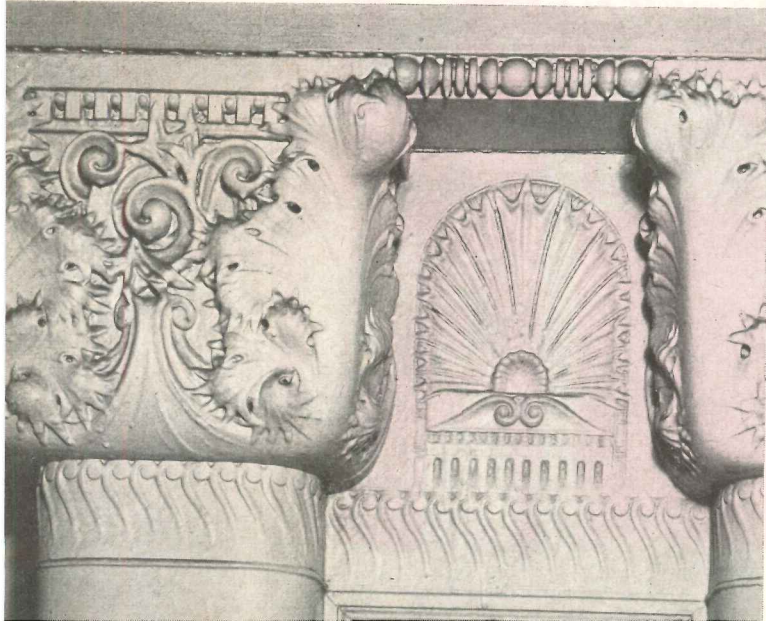

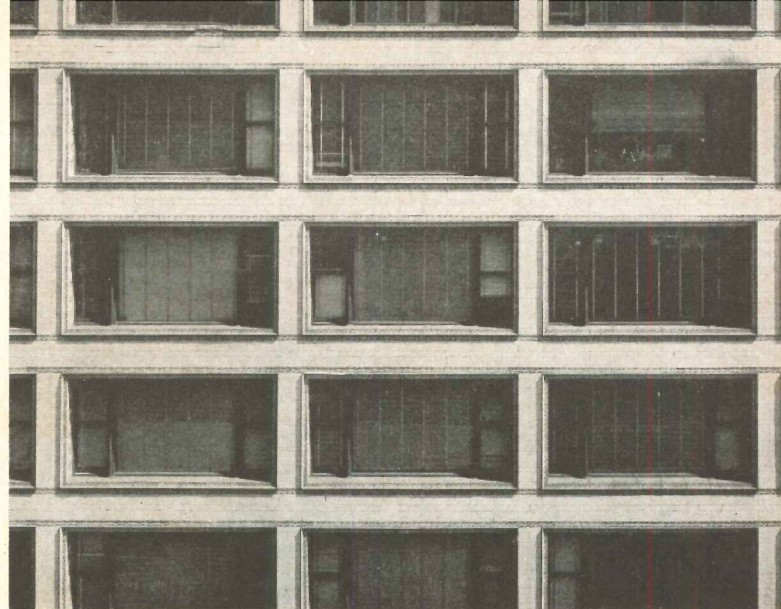
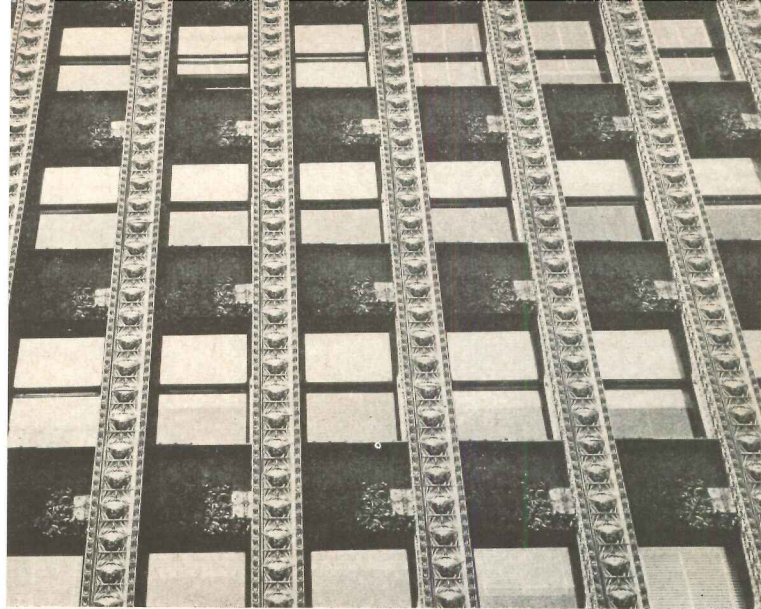

Photo by Len Gittleman, Inst. of Design, I.I.T.

led Sullivan toward these concepts, what nourished his art and what he as a beginner had to fight; *Adler and Sullivan* will be devoted to the great buildings designed in the partners' office, giving credit to the several collaborators involved — the architects Wright and Elmslie, the builder Mueller, etc. — this will, necessarily, be the largest section of the show; then follows *Sullivan Alone* with those few but brilliant expressions from the long years that led through neglect and bitterness to Sullivan's wretched, lonely death; a small section on Sullivan's greatest enthusiasm, *Ornament*, will compare his work in this field to that of his contemporaries, showing why Sullivan attached such importance to this element, and why this side of Sullivan's insight is of especial interest once again to the leading architects of our own day. Throughout, the exhibition will demonstrate Sullivan's architecture for commercial use.

Large color projections and black and white photographs will be accompanied by significant quotations from Sullivan's influential writings. Actual samples

of Sullivan's rich ornament will bring sculptural body and depth to appropriate sections throughout the show, and the whole will be approached through an entry where the spirit of Sullivanian ornament will be recreated in a total life-size surrounding. The photographic material has been drawn largely from the recent surveys conducted by John Szarkowski and from Richard S. Nickel and others under Aaron Siskind at Illinois Institute of Technology. Drawings will come from the Institute's Burnham Library and from Frank Lloyd Wright; Professor Hugh Morrison, Sullivan's distinguished biographer, is opening his files of notes and documents to the exhibition's organizers.

A special catalogue and a new publication of Sullivan's work in photographs by John Szarkowski from the University of Minnesota Press will be on sale.

The exhibition will be directed for The Art Institute of Chicago by Edgar Kaufmann; John Szarkowski is Photographic Supervisor; Daniel Brenner Installation architect; catalogue design by Mrs. Victor Zurcher.

Chicago Architectural Photo. Co.



Ornament, the flowering of Sullivan's art, was enriched by reference to earlier rare and elaborate skills. Details show such exotics mastered and reintegrated into everyday midwestern usage through the insight of a great architect. From left to right: in the lobby of the Auditorium Hotel, Chicago, 1889; on the corner entrance of Carson, Pirie, Scott and Co., Chicago, 1903; soffit of an arch inside the National Farmers' Bank, Owatonna, Minnesota, 1907. Byzantine, Gothic and Saracen artists would have welcomed their American compeer. His contemporaries of the corn-belt mightily admired in these buildings the proper opulence of a democratic society expressed with personal verve

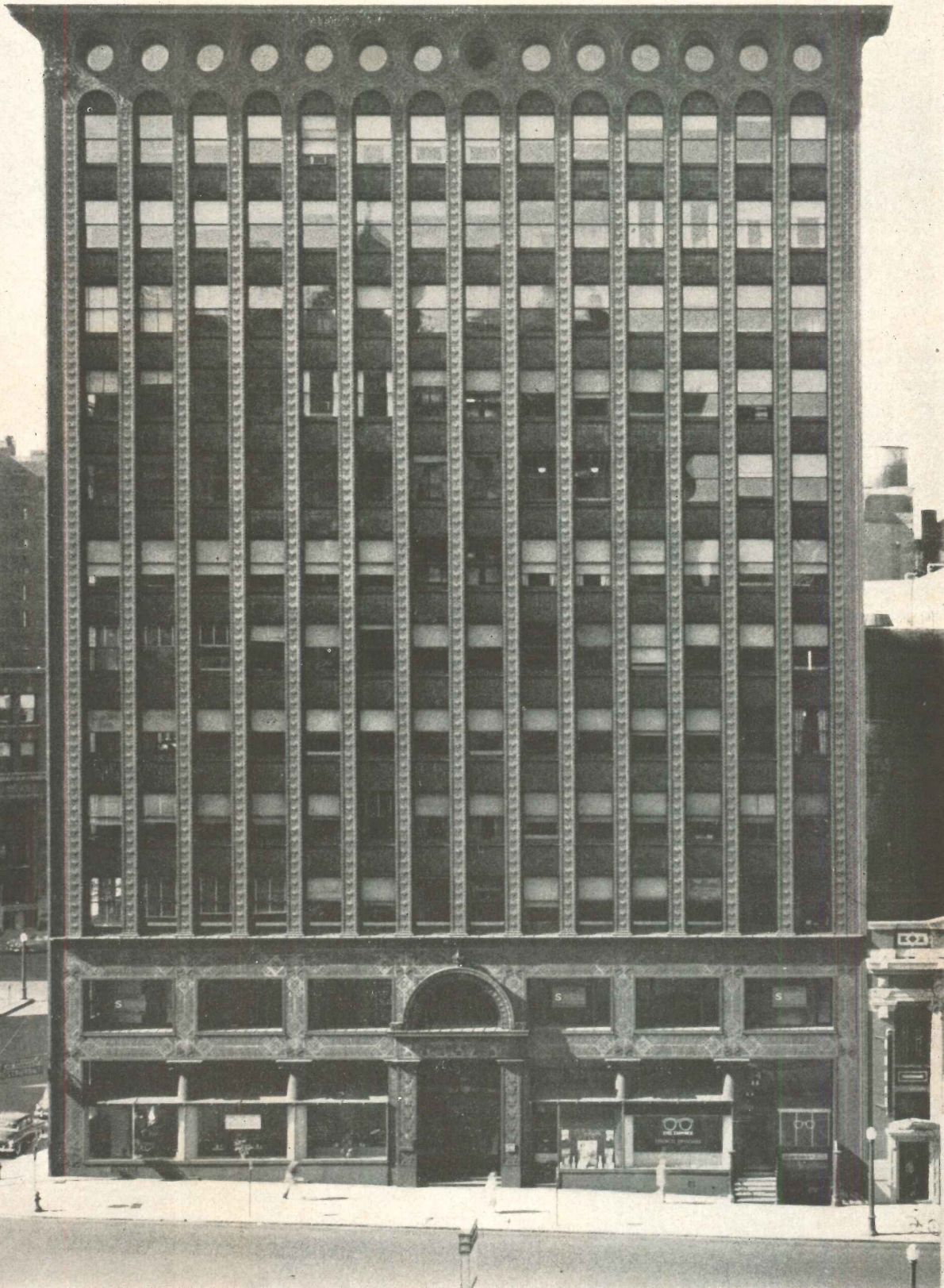

LOUIS SULLIVAN

Beauty rising new-born from Lake Erie: the Guaranty Building delivers suavely the powerful impact of modern business efficiency

The Individual School and the Community

by Frank G. Lopez, A.I.A.

SCHOOLS, it has long since been said, are first of all for children. So that this will not be forgotten in the discussion that follows we illustrate this short introduction with photographs of children creatively engaged at a California school which is more fully presented in later pages.

And schools are for adults too, even for those whose children are grown beyond school age or who have none. It is not just because we pay taxes that this is so. More than any other type of building except the houses people live in, its schools now serve to complete a community. In fact their importance has so increased in the past couple of years, our own surveys show, that schools have become the prime concern of the average American architect.

Why? There are any number of reasons. Increasing — almost formidably increasing — use of family automobiles today encourages household shopping, movie-going and the like at more distant, concentrated, efficient



centers than the local, usually more expensive shops where there is often less freedom of choice. Transportation by auto, rapid transit, long-distance bus or commuter train has contributed to the growth of our dormitory suburbs; the places where we work are seldom

within walking distance. On the other hand, schools — now so much a matter of public, political and professional concern — remain a local necessity. The preferred means of moving children are Shank's Mare or the short-run school bus. Again, the dominant factor in the school becomes evident: the child.

And again, the entire community is affected by the nature of its school plants. It has become common indeed for the school to function as a community center in many ways: as a facility for recreation indoor and outdoor, passive and active; as an adult education center; as, usually, the largest undertaking of its kind in the community and hence as a source of both pride and increased taxes. Besides these somewhat obvious impacts on its neighborhood the school has other effects intangible and tangible. To the rest of the world its schools mirror a community's taste and its concern for the education of its young. As housing continues to expand and the number of children born increases, more and more communities are being judged by their schools, a practice which contributes directly, as new householders select their dormitory homesites, to more houses, more children — and more schools. Maintaining high standards for schools might be considered to have its penalties, too; and in some cases this has been true. However, when one digs into a situation of this kind some other aspects of community structure are nearly always found wanting; there are really very few communities that literally and absolutely cannot finance their schools. Perhaps the tax structure is at fault, or zoning has been unwisely accomplished (if it exists), or there is too low a statutory debt limit, or other legal restrictions are too severe.

These, because changing them is a cumbersome, time-consuming process,

are too often considered fixed conditions. On the contrary, there is instance after instance of an aroused citizenry succeeding in changing them, by quiet action or after fierce activity. As the motive for action schools have thus been the means for improving the community's fiscal and legal position. Attempts by super-agencies — the state, for instance — to alleviate rather than cure such situations, for example by the paradoxical device of declaring a solvent



school district "insolvent," can be seriously questioned insofar as they substitute an easy "out" for the kind of positive action that will insure future civic health.

There are also matters of esthetics which are intensely personal to all the individuals in the community. How "Colonial" should today's school in New England be? How Southern Georgian in the Piedmont? How ranch-housy in California? Or should it look like a modern school in any setting? Another intimate concern is safety from traffic hazards, which relates not only to public highways but also to traffic within the school campus.

There may seem small items of secondary importance, but lack of attention to

any one of them can disrupt an entire program. Less likely to have this effect on a community because it is more difficult for the layman to grasp is the relation of school buildings to the physical and economic growth of the normal community. The school is a positive force in city planning. At best, the location and the nature of school plants can be employed to direct community growth; examples of this are many in the accompanying article on the Charlotte, N. C., school system. The least that is desirable is establishment or improvement of schools to alleviate civic faults; in some measure all schools serve this function. Sometimes the situation becomes a mad race to catch up; the story of the Bellevue, Wash., schools that closes this study might have been of that kind had not persistent, effective action been undertaken by Bellevue's growing population.

In between these extremes are all degrees of inter-action. Painstaking research corrected a difficult situation in Stamford, Conn.; and here the architect accomplished much more: his delightful conception has raised the tone of a neighborhood substantially. The transformation of a useless swamp into a beauty spot, the creation of a loved institution, are no mean achievements. So also has the California example lifted its community's sights. The child in the photograph below, completely absorbed in creating a masterpiece, is a far cry from the juvenile delinquent whose vandalism at other schools can be outrageous. The child is copying a huge, colorful, imaginative mural which the architect inspired, paid for, and gave to the school. There was no money in the state-determined budget for the mural, but the architect knew how badly it was needed.

Rondal Partridge

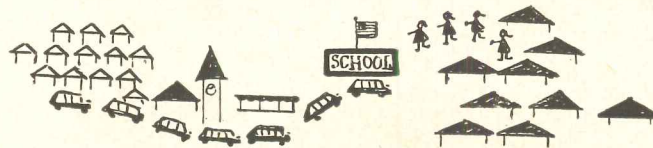
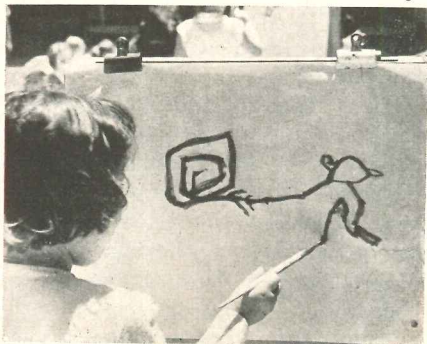

WESTOVER ELEMENTARY SCHOOL in Stamford, Conn., complements and virtually completes a small residential neighborhood created by a public housing development, Wm. C. Ward Homes, and a private development of one-family houses on small lots. It is colorful; it is advanced in many respects and entirely compatible both with its neighborhood and with the city's educational concepts: it is a school that shows when you visit it that the pupils, the staff and the community appreciate what they have.

It sits in a hollow between the two housing developments on 15 acres that were formerly a swamp — on what was called unbuildable land. All its pupils can walk to school. After much study the architect advised that there was one quadrant on which a building could be erected and that, considering the site's reasonable cost, drainage and fill would not be unduly expensive. The Connecticut Power Company agreed to supply fly-ash to fill under playfields. Footpaths connect directly with the children's homes. The good trees were preserved, including all the dogwoods.



Joseph W. Molitor

William F. R. Ballard, Architect; Lanier & Levy, Mechanical Engineers; Fraioli-Blum-Yesselman, Structural Engineers; Ralph Eberlin, Civil Engineer; Marianne Macmaster, Landscape Architect; Theresa Kilham, Color Consultant

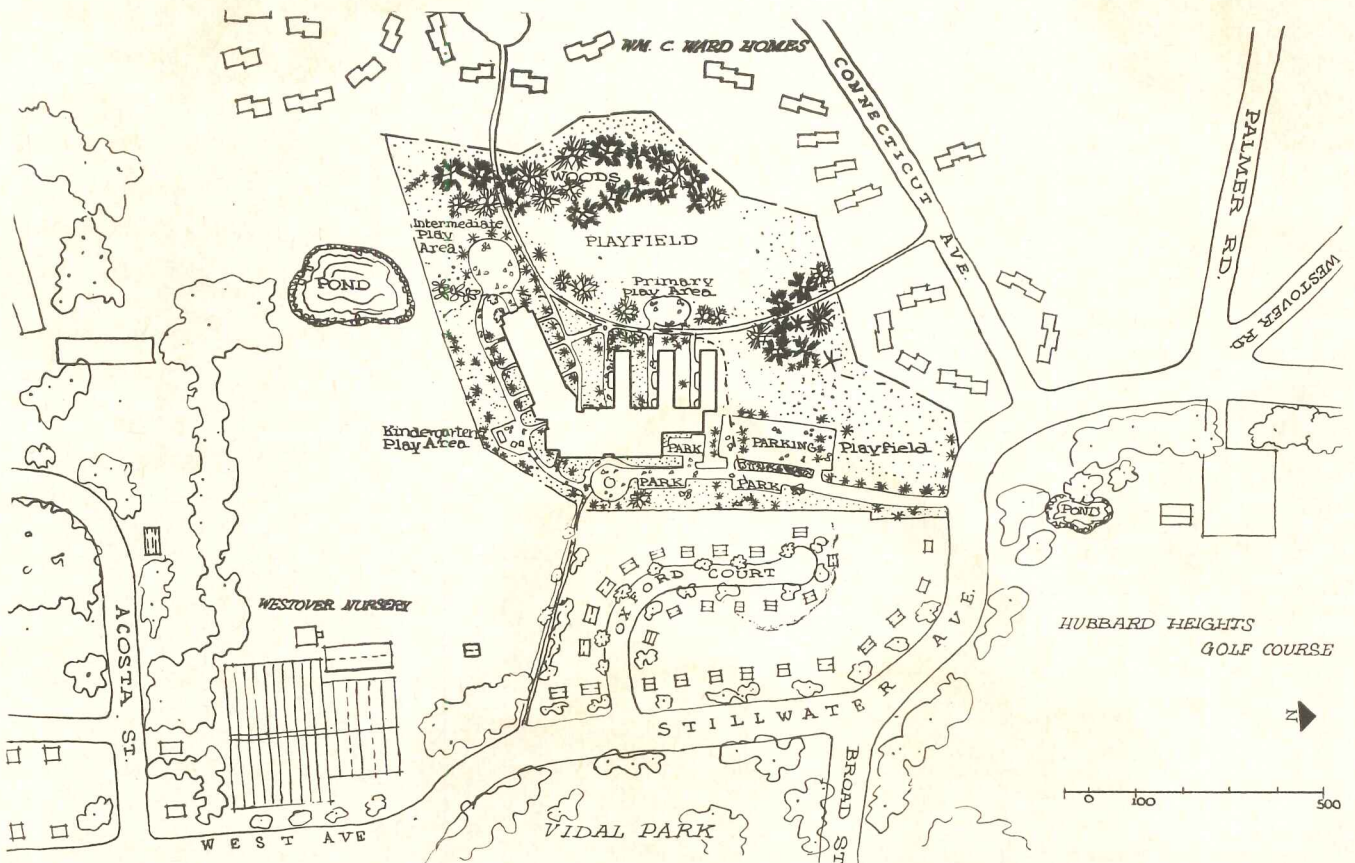

THE INDIVIDUAL SCHOOL AND THE COMMUNITY: STAMFORD, CONN.



Joseph W. Molitor

It should also be noted that Westover, built in 1954-55, cost \$13.32 per sq ft, \$925.47 per pupil, when average Connecticut costs for 1950-53 were \$15 to \$16 per sq ft, \$1200 to \$1250 per pupil. It has just under 70 sq ft per pupil (state average, 77-78). Of its total area, 68 percent is instructional; 15 per cent circulation; 6.4, service; 3.7, administration; 6.9, storage and boiler room — recognizably more efficient than the national average. Cost of construction was \$904,700; fees, equipment, land etc. added \$263,500; total, \$1,168,200 less than the budget.

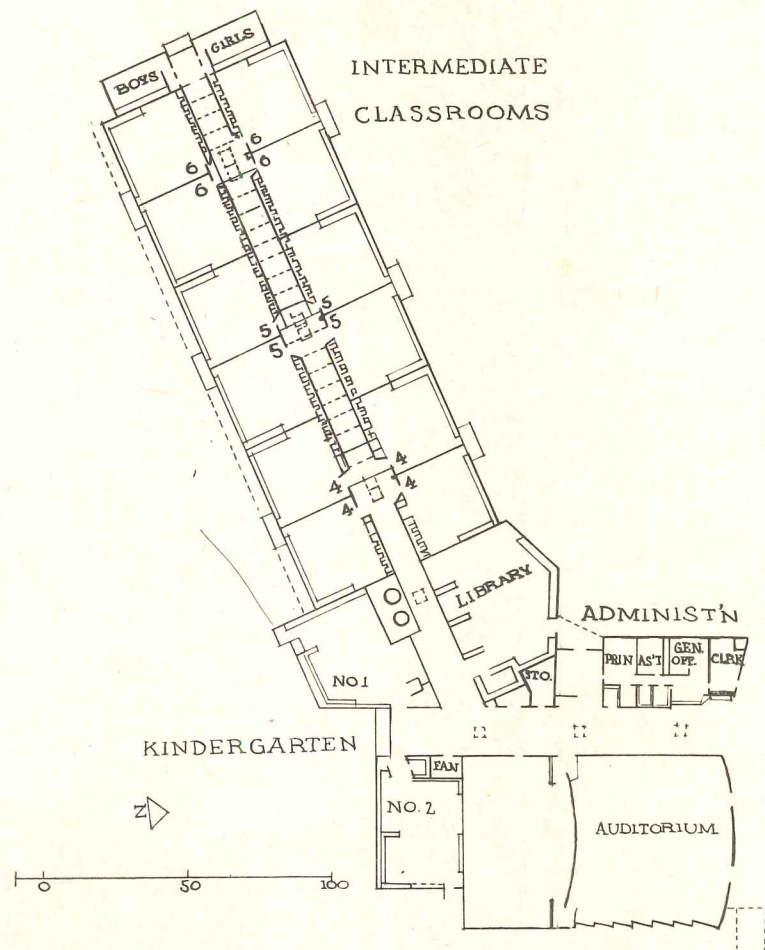

Westover Elementary was designed for 820 small children as an efficient educational plant, as moderate in cost as sound structure, easy maintenance and pleasant appearance would permit. This was the architect's first school. He studied the School Board's program, which had been carefully prepared; he visited many other schools and examined school building literature. The result is a buoyant, simple, one-story building of glass, brick and concrete block. Characteristic are the candy-stick-striped boiler and incinerator stacks covered with porcelain enamel. The library (opposite page) in the center of the building affords a view across grassed courts to and through all three primary wings. In these there is no wall separating corridors and classrooms. The intermediate wing has a double-loaded corridor; all rooms have outside doors. The playroom-cafeteria and the auditorium, both much used by adults, are easily accessible after school hours. Note in plan such refinements as the teacher's lounge, convenient yet remote from both office and classrooms.

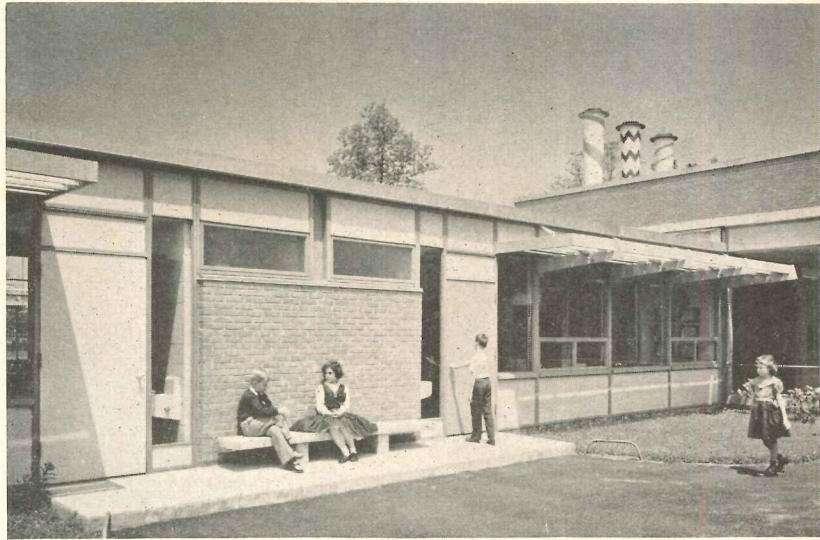

Above, second-grade wing

Joseph W. Molitor



Above, service areas; auditorium, playroom in distance
Below, first-grade wing

PRIMARY CLASSROOMS

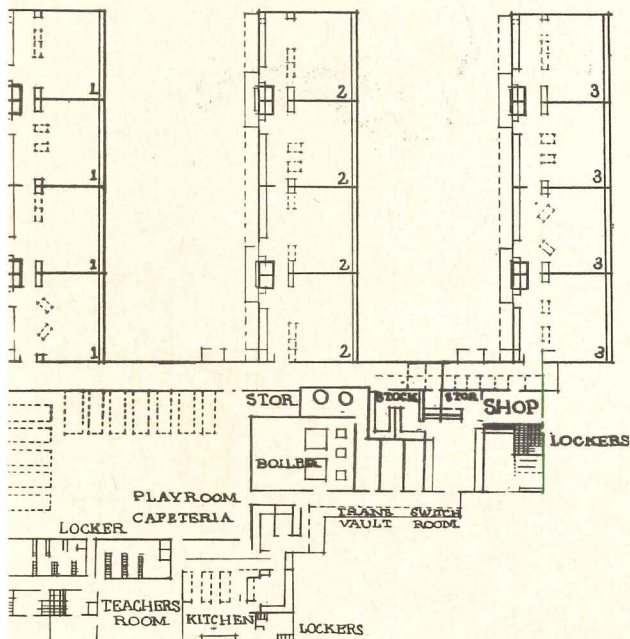

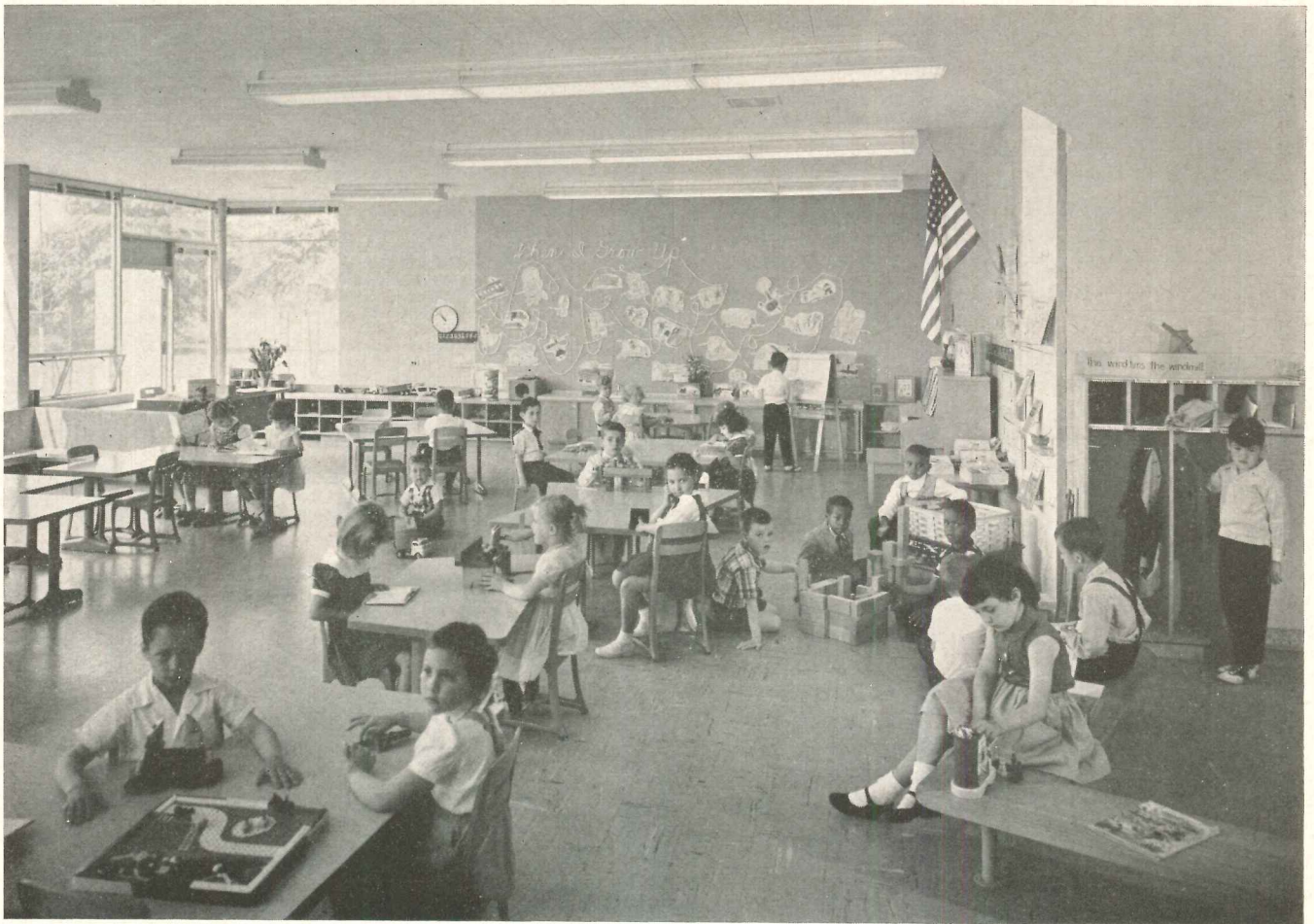

Joseph W. Malitor

Kindergarten; notice quality of children's work displays. Floor is radiant heated in both kindergartens

INDIVIDUAL SCHOOL AND COMMUNITY: STAMFORD, CONN.

Westover's classrooms all have two walls of floor-to-ceiling tackboard covered with washable fabric, exterior walls of steel windows (non-bearing) with cement-asbestos panels top and bottom; south window walls have slatted aluminum exterior sunshades and up-operating interior wood slat shades. Classrooms are supplied with fresh air by vents under windows; the regimented roof exhausts have porcelain enamel jackets in various bright colors. Most of the built-up roofing is surfaced with white gravel; the boiler-room roof is gray; auditorium and playroom roofs, red. Roof colors were carefully studied because the school sits in a hollow and the view from above is important. Structure is wall-bearing with precast roof plank on steel joists. Floors are vinyl tile with some hardwood and ceramic tile. Heating is hot water with finned classroom radiation.

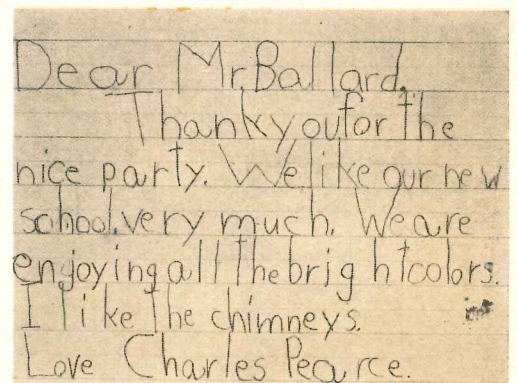

One of many "thank yous" for a party the architect gave when school opened

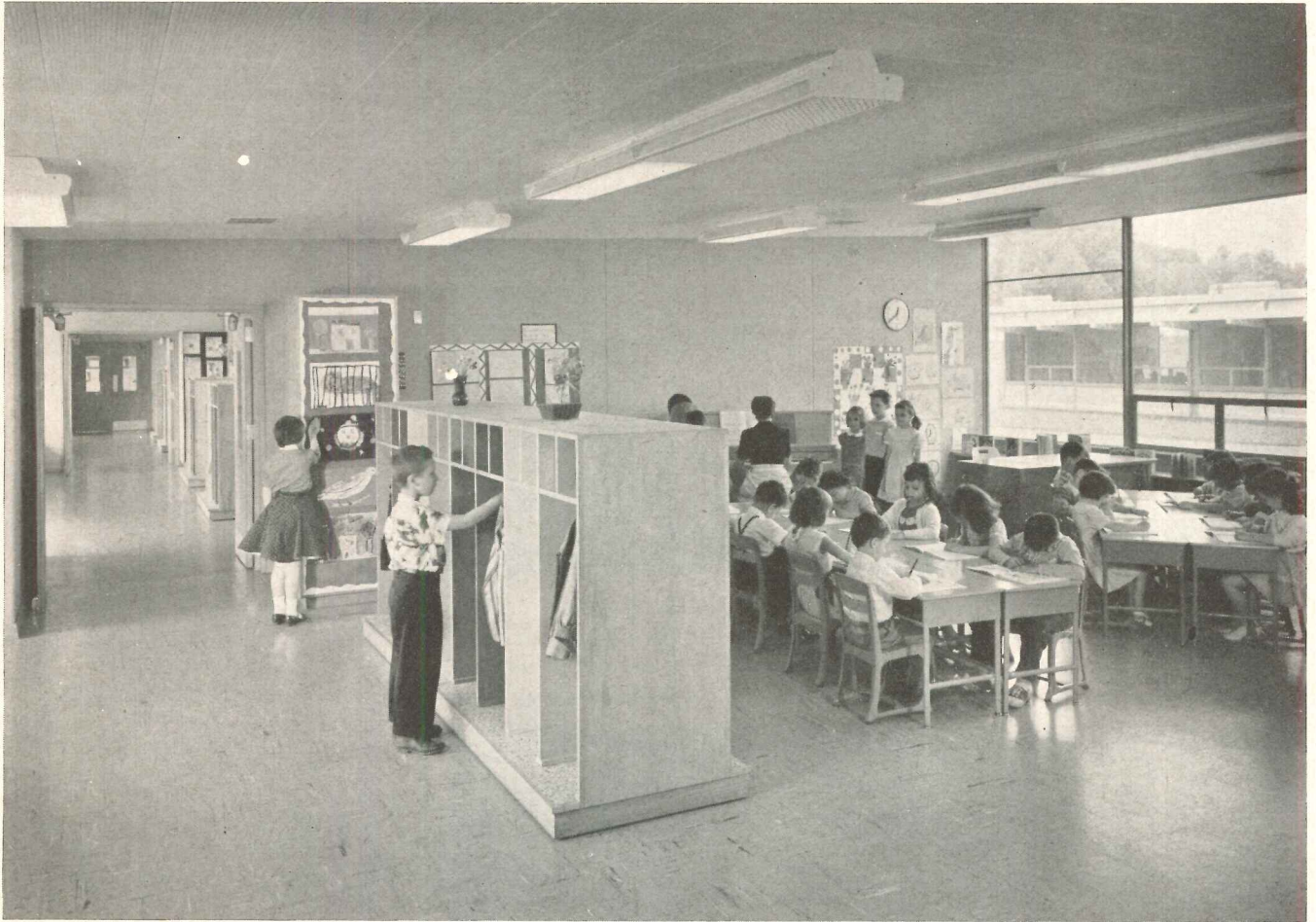

Corridorless primary wing; gay colored cubicles screen seating areas

Ben Schnall



Intermediate wing; corridors wide and skylighted at groups of room doors

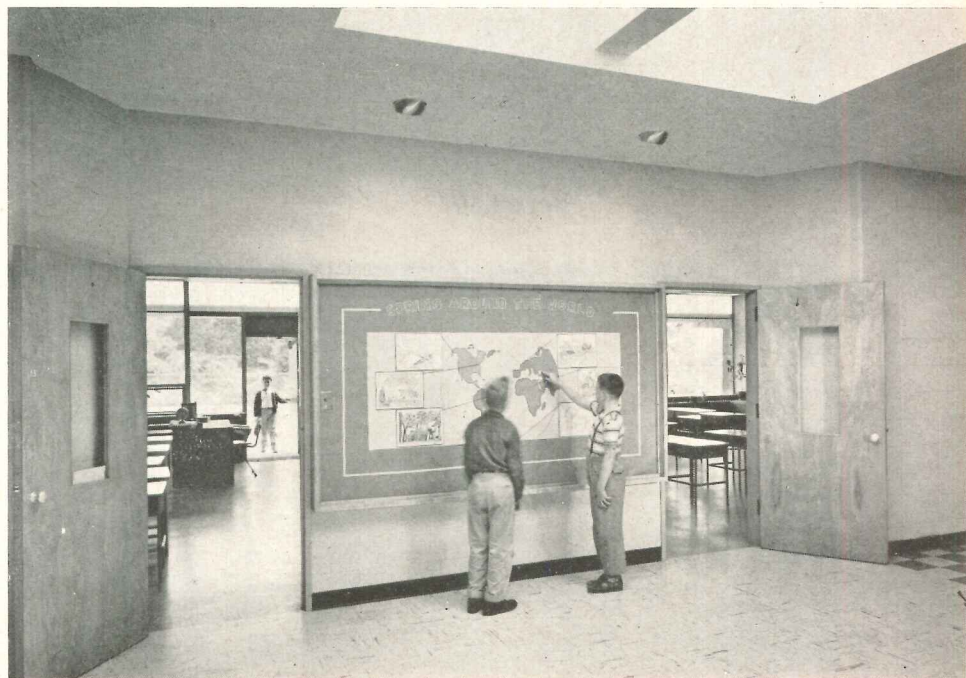

STAMFORD, CONN.

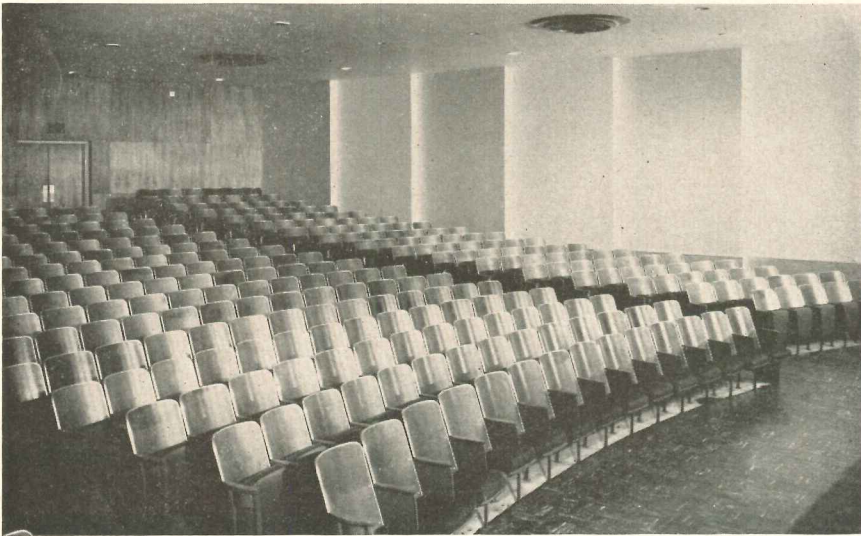

Ben Schnall

The Westover auditorium (446 seats), intended for and intensively used by both the school and the community, accommodates no other function. It has a sound-distributing plaster ceiling, sloped floor, angled walls to prevent reverberation and provide light recesses, a large stage. Below, library looking towards woods; court between primary wings

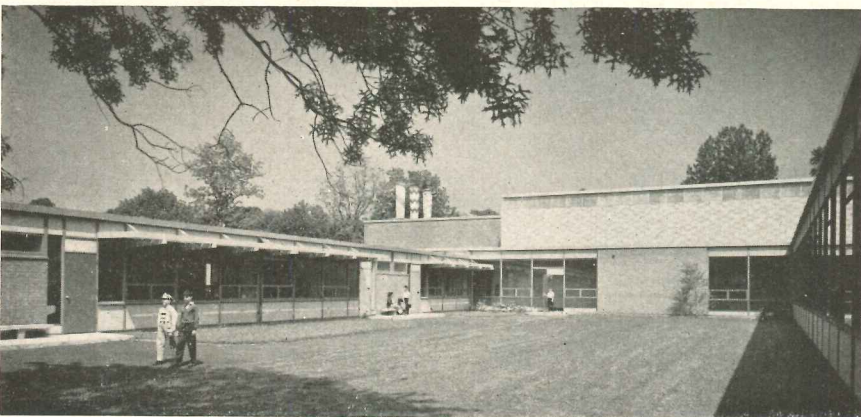
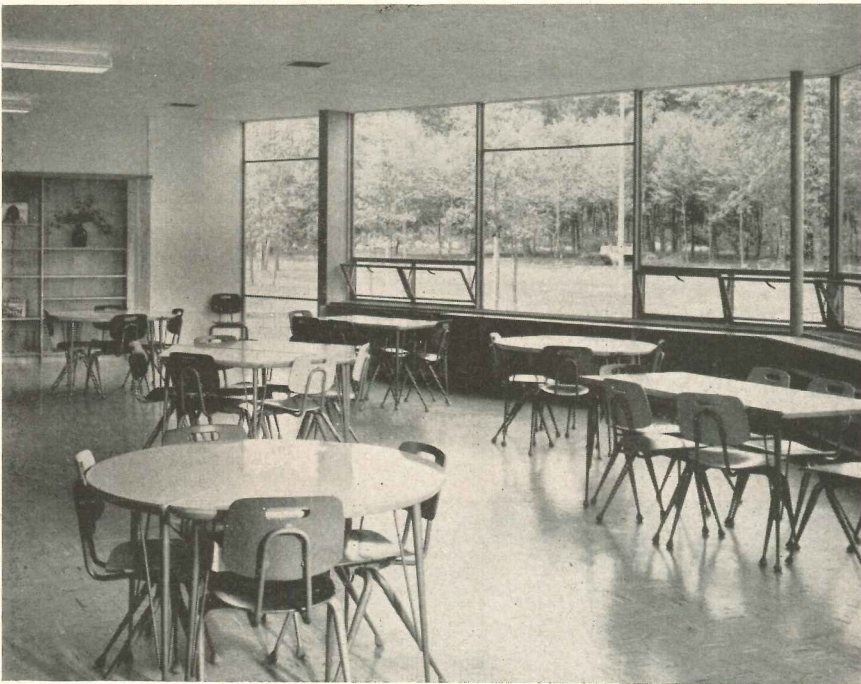

Joseph W. Mallitt



**THE INDIVIDUAL
SCHOOL AND
THE COMMUNITY**

**DALY CITY, CALIF.:
LOCAL NEEDS STIMULATE
DEPARTURE FROM THE ORTHODOX**

THE INDIVIDUAL SCHOOL
AND THE COMMUNITY:
DALY CITY, CALIF.



Olympia Primary School, recently completed for a San Francisco suburb, departs from the local norm in several ways, one of them a colorful mural which the architect gave to the school to emphasize the importance of art in education. Judging by class activity (below) and the inspiration it furnishes (above), the gift is amply justified

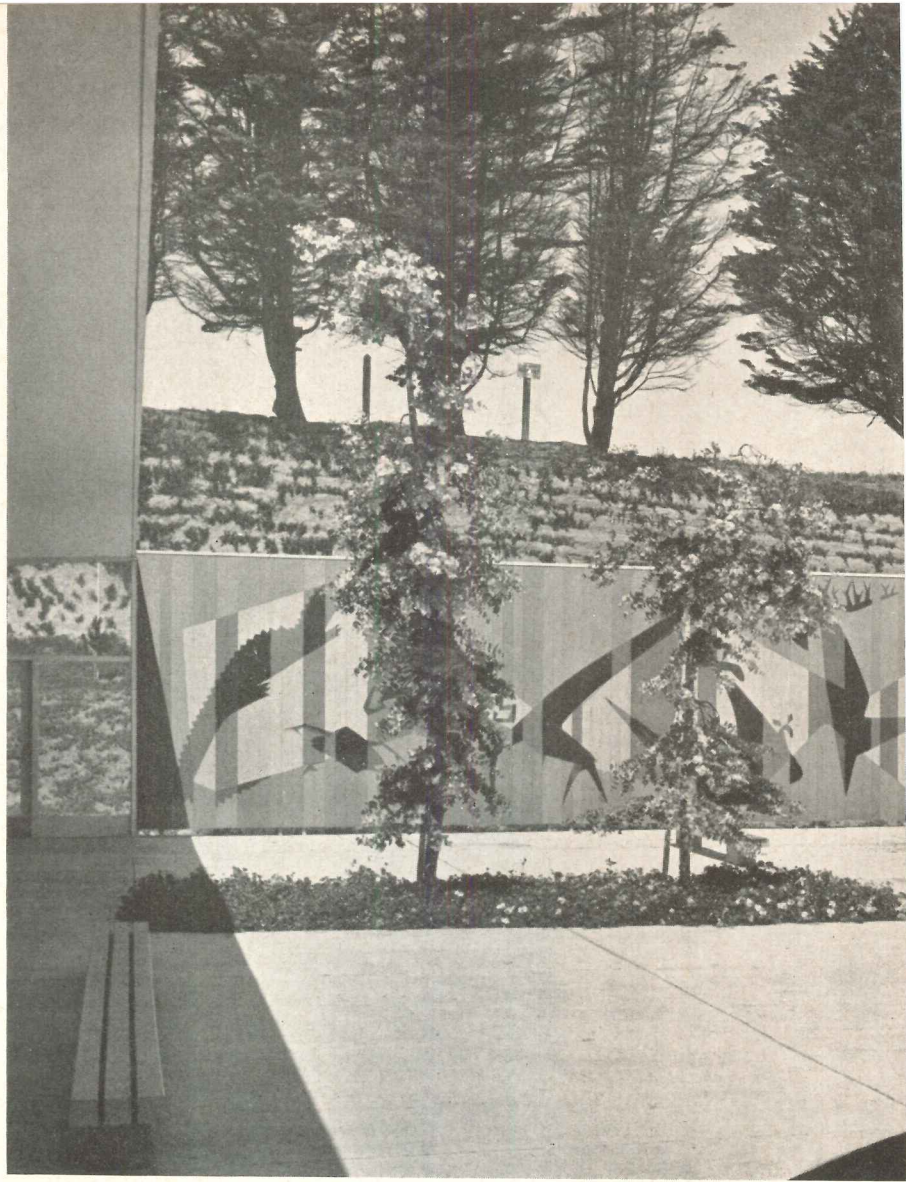

Rondal Partridge

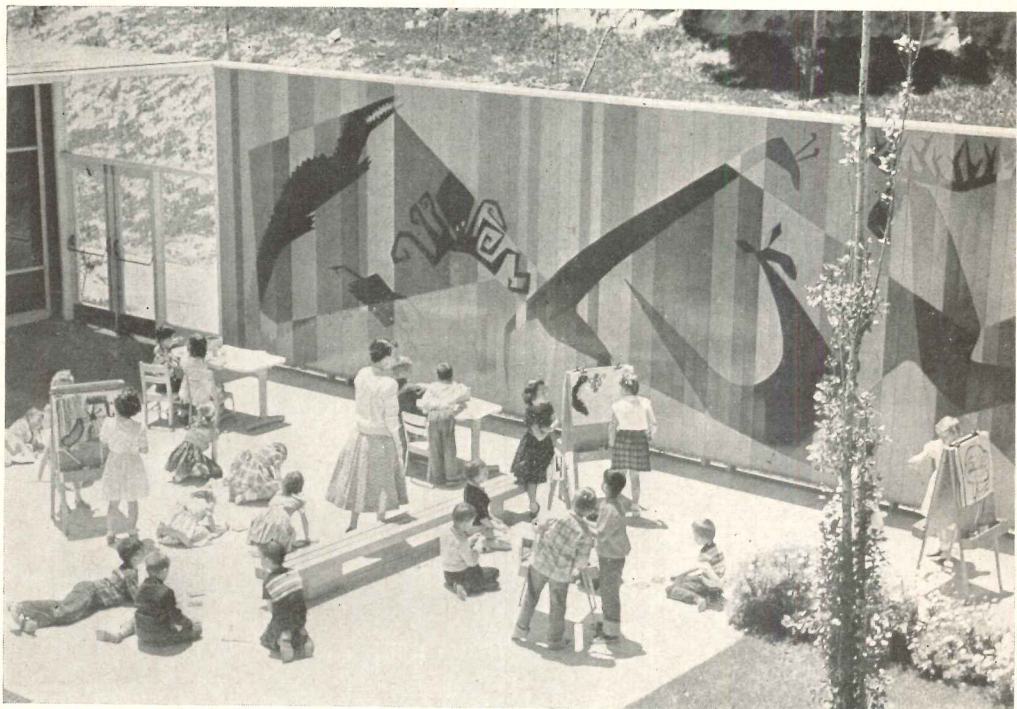

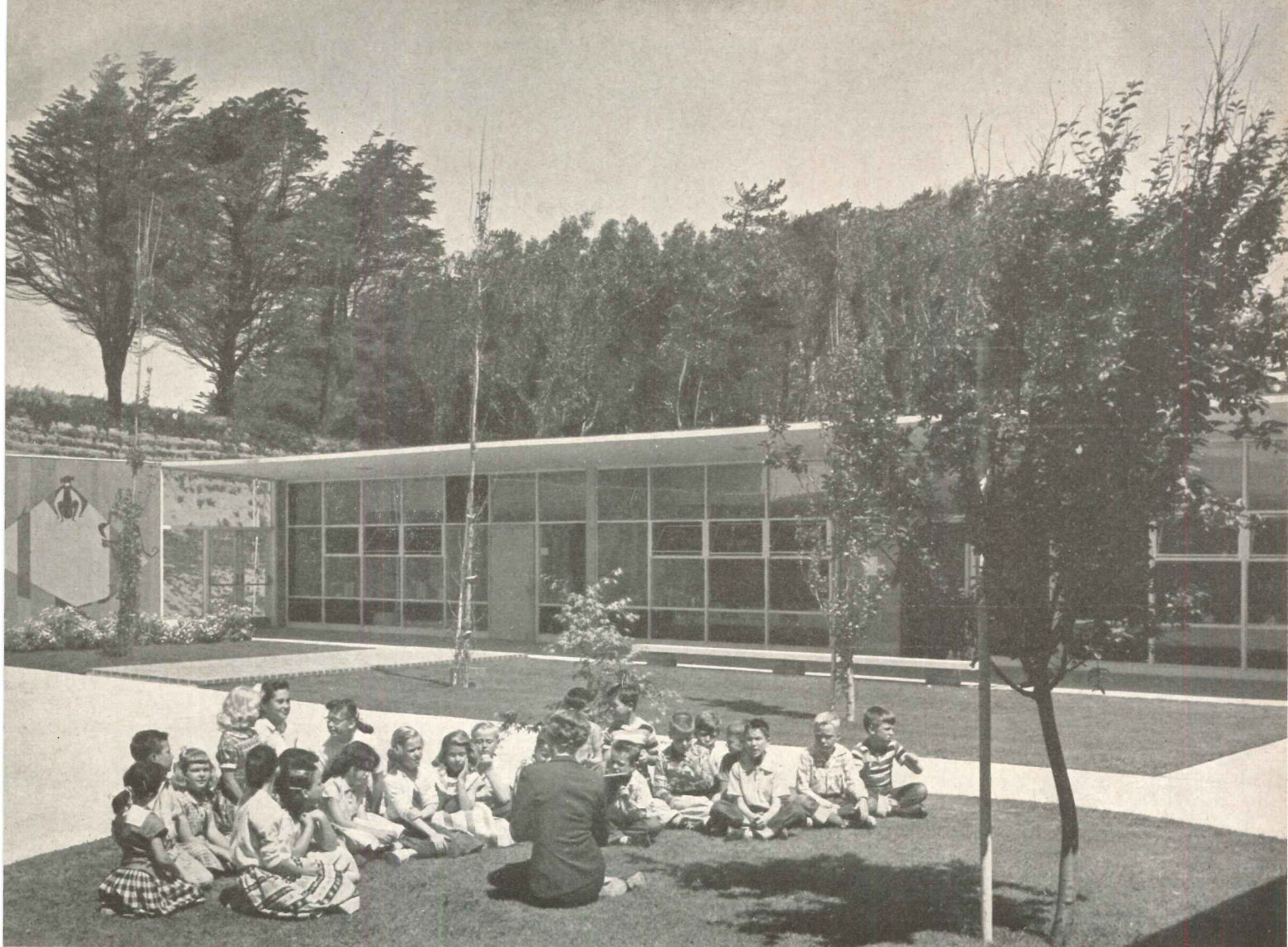

Architect:
 Mario J. Ciampi
Muralist:
 Ann Knorr
Landscape Architect:
 Lawrence Halprin

It is hard to believe from the photographs that the surrounding community is a typical densely populated series of subdivisions, but that is the case. Plan below indicates the extensive cut and fill that transformed the sloping site; dotted lines show original contours

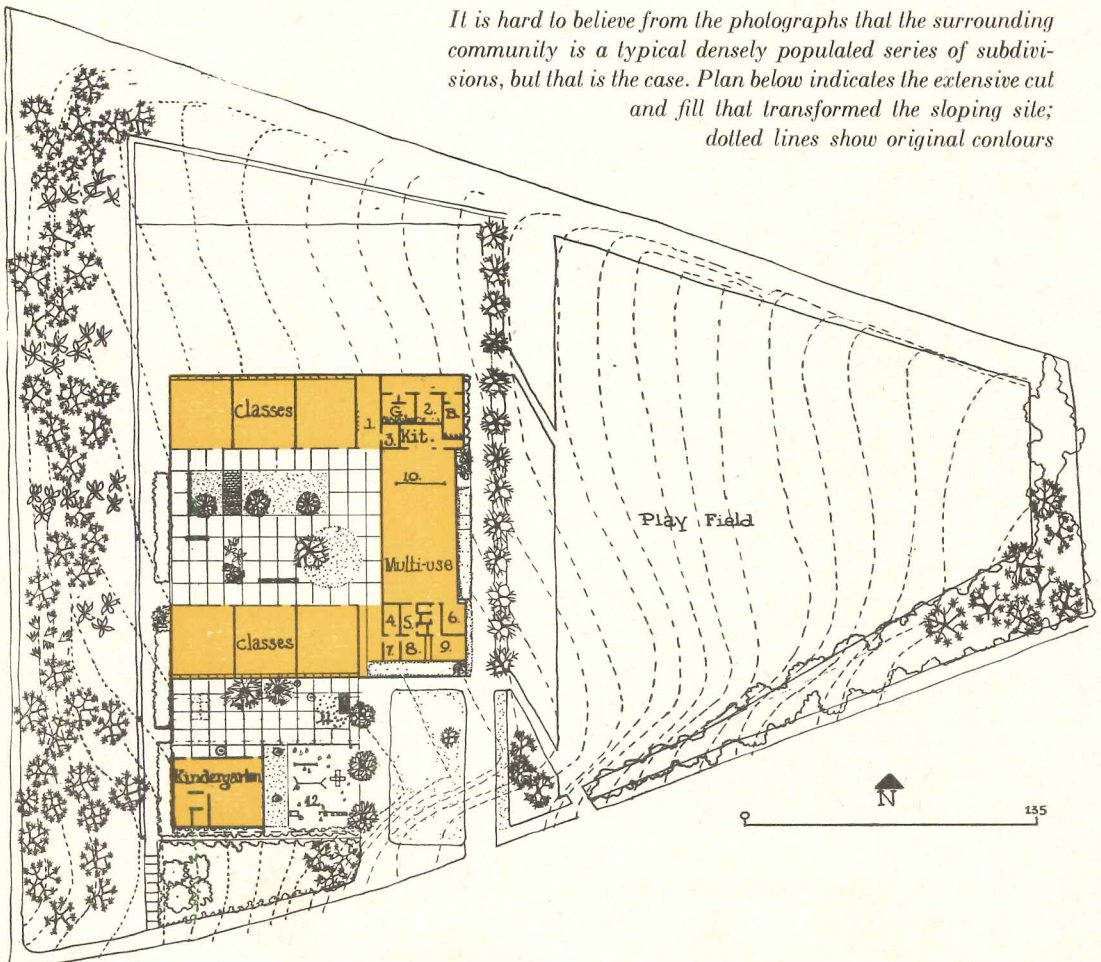



Above, another drawing inspired by the outdoor mural; right, children's art work of the same high order displayed on the multicolored, random-width board fence behind the all-purpose room's portable stage. Below, a typical classroom. At intervals in the window walls facing on the court are translucent colored panes

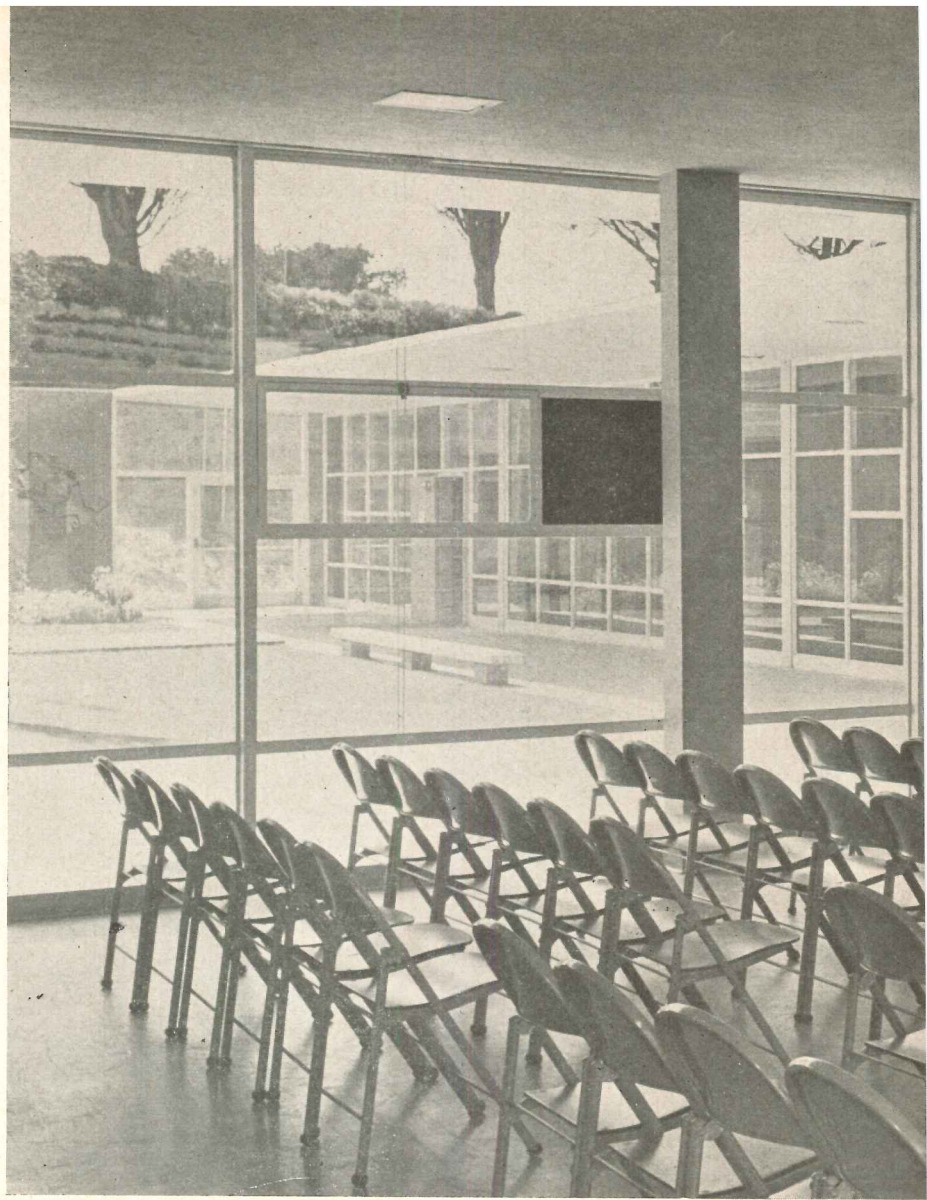

THE INDIVIDUAL SCHOOL AND THE COMMUNITY: DALY CITY, CALIF.





Rondal Partridge

OLYMPIA PRIMARY SCHOOL, though it is recognizably of a definite type, responds in several ways to the special needs of the community it serves. The architect had previously designed several rather orthodox schools for the district; out of that experience and a re-evaluation of the school building problems of Daly City's increasingly dense population came some fresh decisions, for which state approval had to be obtained.

Basically Olympia is a home school unit, kindergarten through third grade, a summer recreation facility and a center of community activity. In addition, the problems of maintenance, vandalism and exposure to winds and fog from the nearby Pacific Ocean became important design factors. The cost of maintaining wood and stucco

in the school district, the observation that classroom lights burned almost continuously despite careful design attention to daylighting, the need for a lively, joyous building in which the community could take pride — these were some more factors. Hence the building has a concrete roof deck erected by the lift-slab method; its exterior walls are of textured, reinforced concrete blocks painted a pleasing color; it turns inward to the surprise and delight of its central court, shutting out the monotone subdivisions that surround the site; its classrooms have entire luminous ceilings; it sparkles throughout with light and life and color that are a far cry from both the usual drab scientific interpretation of lighting requirements and the dead level of speculative housing.

THE INDIVIDUAL SCHOOL AND THE COMMUNITY: DALY CITY, CALIF.

Rondal Partridge

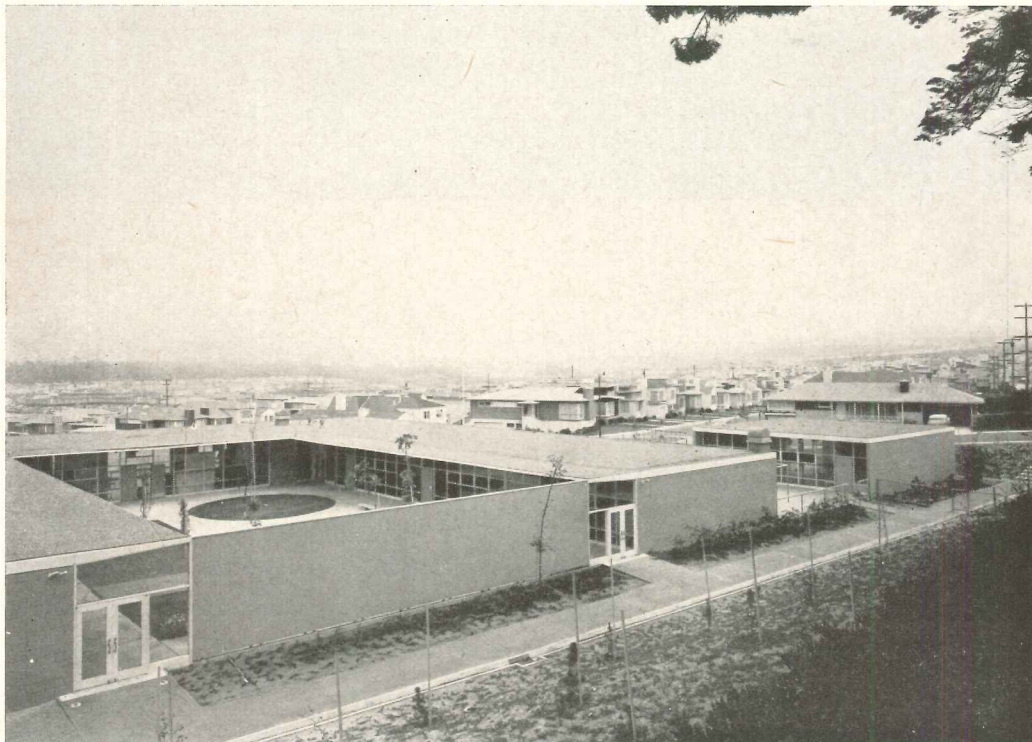
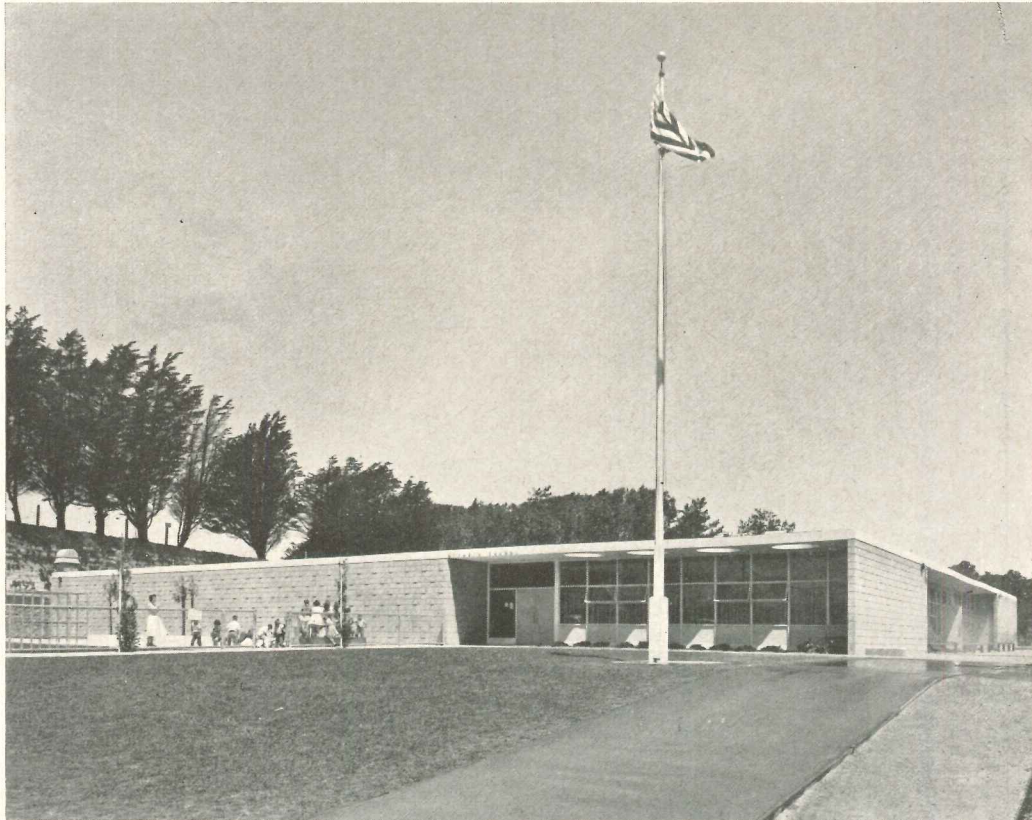

The upper picture shows the school as it is seen from Daly City; the multi-purpose unit is at the right. The lower view looks out over the courtyard and the school building and the enclosing sea of suburban dwellings. Olympia's cost, excluding fees, site work and mural, amounted to \$12.75 per sq ft — comparable to or less than the cost of some of the district's more conventional schools. Totals were: construction, \$176,950; site work, \$41,100. For this relatively modest outlay the community received a durable building easy to maintain, finished inside in natural woods and bright colors, one that stimulates a justifiable pride

CHARLOTTE, NORTH CAROLINA

CHARLOTTE, N. C., is a confident city, proud of its rich past, sure of its aims. It has grown steadily since its founding in 1766 at the crossroads — now Trade and Tryon Streets — where the county's log courthouse stood. Its schools have done more than keep pace with Charlotte's growth; until very recently the city had no professional planning agency, yet in its continuing expansion there has been an orderliness, a sense of direction to which the schools have at some times positively contributed and from which they have often received impulses. Educationally the city's goals are high, and as they are neared are constantly being raised; as a matter of course but not complacently education is granted its important position.

This happy educational climate is one reason Charlotte's school plants, by and large, are of a consistently high quality hard to match over the full width of any comparable city in the country. Another reason is advance educational planning of sufficiently long range, on bases sufficiently sound, so that seldom has the school administration been caught napping. Another is the talent displayed in the friendly yet stiff competition among the city's architects, virtually all of whom have been engaged in the school building program; still another, the cooperation between the school system and various other municipal agencies. Nor can Charlotte's excellent economic health be ignored as an underlying cause as well as, in part, an effect. To citizens of Charlotte, to become a member of the school board is quite literally an honor, carrying with it responsibilities for discharge regardless of politics; to Charlotte's architects, schools are satisfying commissions. How did this come to be? What is the present nature of the schools? What of the future? As Charlotte's metropolitan influence expands, inevitably the schools of surrounding Mecklenburg County are seriously affected; is this problem being solved to the satisfaction of both?

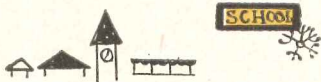
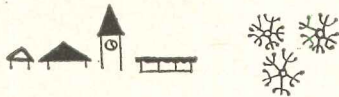

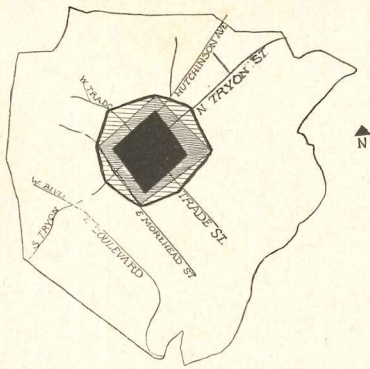

Year:	1855	1877	1885
Population:	1500	5000	8400

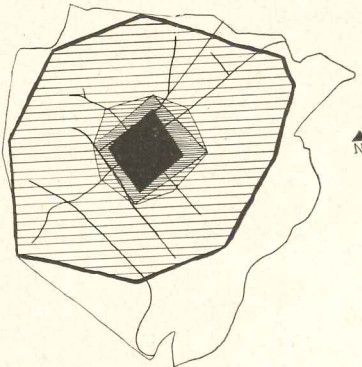

1907; population, 28,000

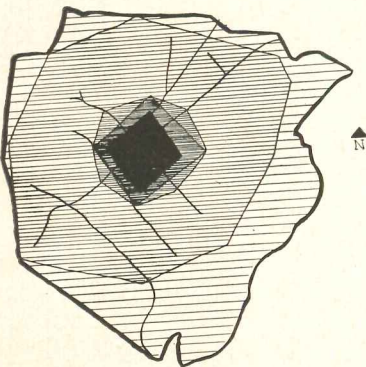

1928; population, 82,100

SCHOOL AND COMMUNITY: CHARLOTTE, N. C.

Charlotte's area and population (currently about 150,000) have heretofore grown fairly steadily; but now on the city perimeter there are 83 new, large developments totalling about 14,000 lots on which in mid-September stood roughly 4000 houses completed or under construction. In 1949-50 Charlotte had 30 school buildings (capacity, 17,610 pupils); following a program then formulated, 21 new schools have since been built (15 elementary, 4 junior high, 2 senior high; capacity, 11,560) and nearly every existing building has been added to or rehabilitated. The program in surrounding Mecklenburg County has been about two thirds as large. A new 5-year city-county program is just starting.

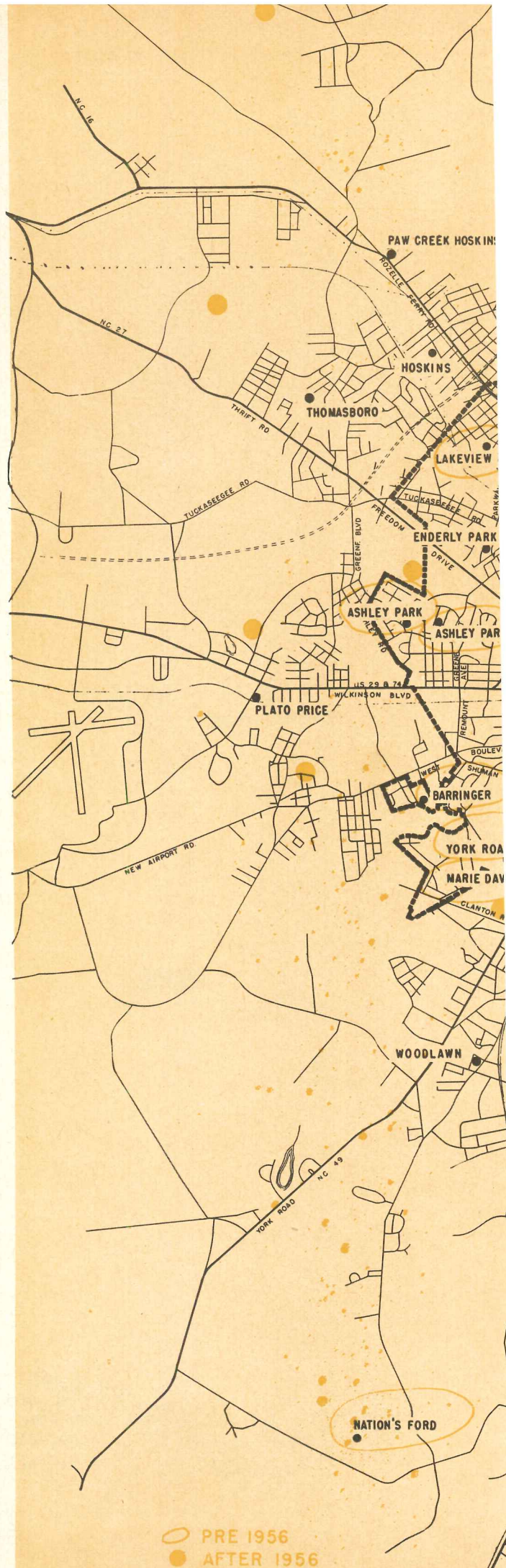

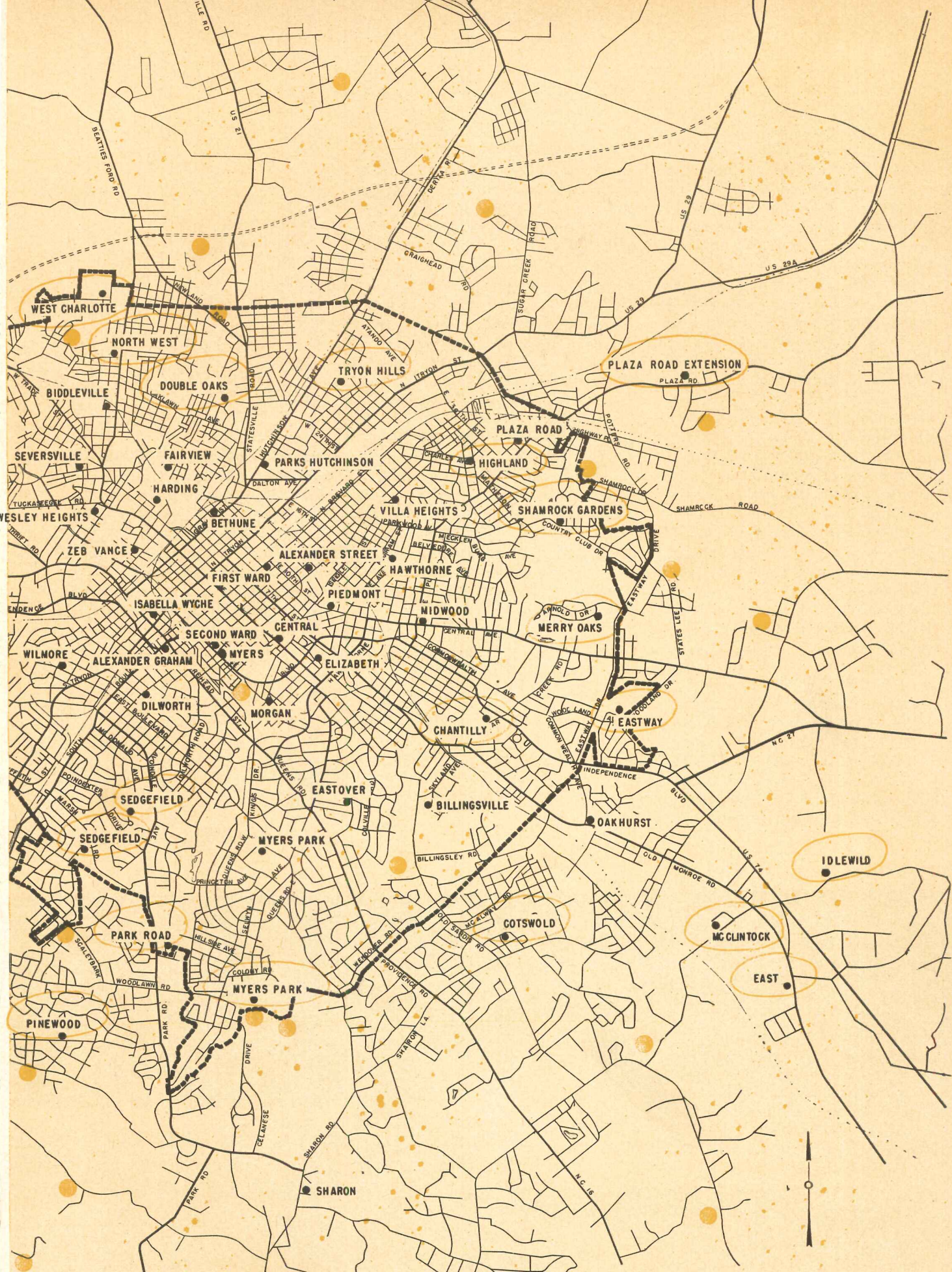

CHARLOTTE
NORTH CAROLINA
 AND
METROPOLITAN DISTRICT

PREPARED FOR THE SCHOOL BUILDING SURVEY 1956
 BY ENGELHARDT, ENGELHARDT AND LEGGETT, EDUCATIONAL CONSULTANTS



Charlotte embarked on its current school building program after World War II. The money for new buildings has come primarily from bonds issued by Mecklenburg County, with the proceeds prorated between the city and the County. Since 1946 a total of \$23,795,000 has been sold in four issues; no issue has been voted down at the polls; a fifth is in prospect this fall. As the amount issued has increased so have the County's assessed valuations. In 1952 there was a much-needed property revaluation. The statutory debt limit is 5 per cent, and (counting in debt service payments) all bond issues after 1946 have been close to the limit; in other words, the debt-to-limit ratio has been quite constant. Since 1946 the city has spent on construction nearly \$17 million. Most of this has come from bond issues, a small share is capital outlay and another portion, state grants. In addition, Charlotte has spent about \$1 million of capital outlay funds on modernizing, renovating, re-lighting, rewiring, etc., in old buildings.

Business of this magnitude might well have appalled the Charlotte schoolmen of earlier days, though judging from what they did accomplish one suspects they would nevertheless have tackled it. Charlotte was settled in the 1750's, mainly by Scotch-Irish Presbyterians, sturdy dissenters whose sincere interest in education is in all probability an underlying reason for the high order of its educational plant, administration and policies, and for the high local re-

gard for the teaching profession as well as for the architects. As in other states, North Carolina's early schools were private academies; in 1863 a bill to create grade schools was introduced in the legislature by Mr. Harris of Cabarrus County, near Charlotte. Politics and the Civil War interrupted; in 1875 the necessary tax bill was passed, but not until May, 1880, was it ratified by Charlotte's voters. A few weeks later the city's Board of School Commissioners was organized; in March, 1882 it picked its first Superintendent of Schools, T. J. Mitchell of Mt. Gilead, Ohio, who went to the best professional school he could find — Oswego, N. Y., Normal School — to get a core of well trained teachers. The following September two public schools opened: one in the barracks of the old Carolina Military Institute, and a school for Negro children in a tobacco barn on Fifth St. A teacher shortage existed in those days too, and one of Superintendent Mitchell's first acts was to bring Miss Eva Kellogg from Boston to head a teacher-training division.

Some of Charlotte's recent schools have helped accelerate sluggish though desirable community growth. Shamrock Gardens Elementary, started in 1950 and added to in 1952 at total cost of over \$350,000 (R. Edwin Wilson & Assoc., Archts.) is an example. The surrounding development had progressed very slowly; with the advent of the school it was rapidly built up.

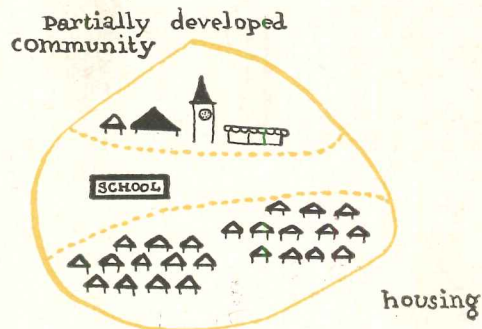

Shamrock Gardens Elementary

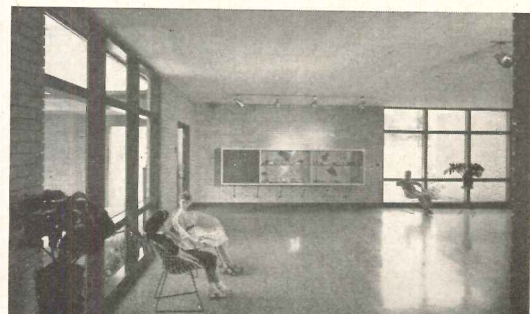
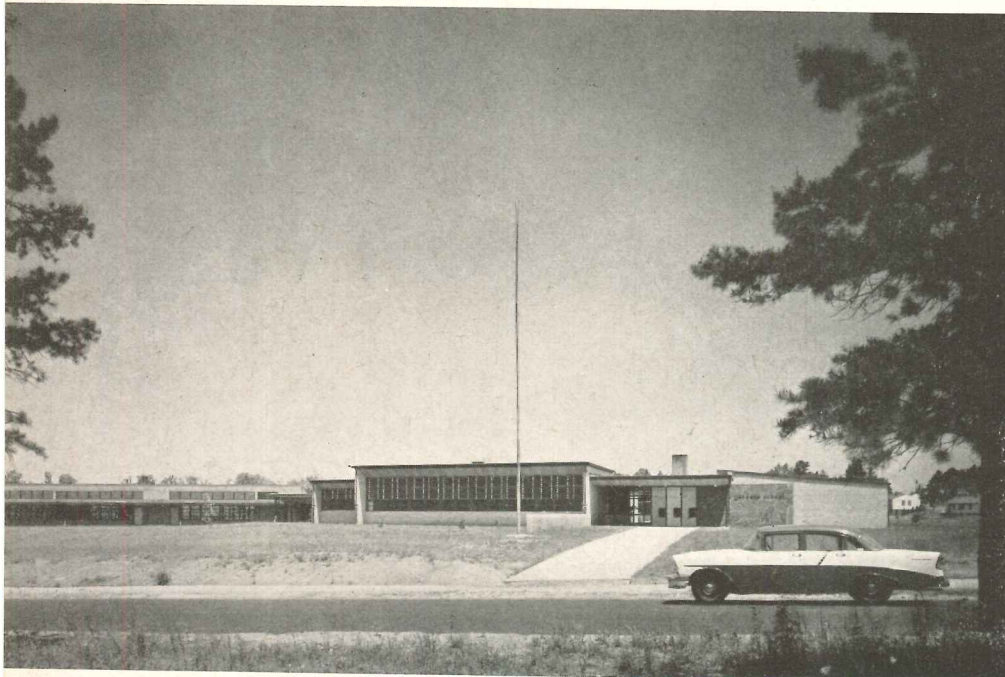

Joseph W. Molitor



**THE INDIVIDUAL SCHOOL
AND THE COMMUNITY:
CHARLOTTE, N. C.**

Central High



Myers Park High

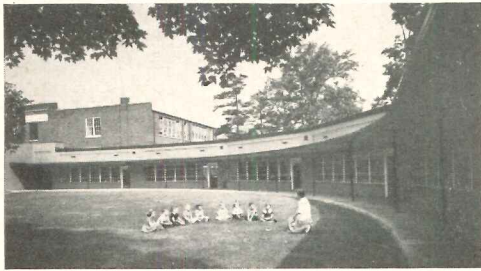

Elizabeth Elementary

TYPICAL PROBLEMS

To bring an entire school system up to date involves rehabilitation of and additions to existing structures as well as new buildings. In 1946 Central High got a \$17,400 field house (C. W. Connelly, Archt.); it has also been thoroughly rehabilitated. Myers Park High, designed at about the same time but built in stages (total cost well over \$1 million; J. N. Pease Co., Archts.) as one of the country's first campus-plan secondary schools, has attracted national attention. At Elizabeth Elementary a \$220,000 classroom addition (Biberstein, Bowles & Meacham, Architects) was accommodated on a small, difficult urban site. Ashley Park Elementary, started in 1950 and enlarged in 1952 (total, over \$375,000; D. M. Mackintosh, Archt.) was brand-new, on a large site; in it new educational ideas began to flower architecturally.

Ashley Park Elementary

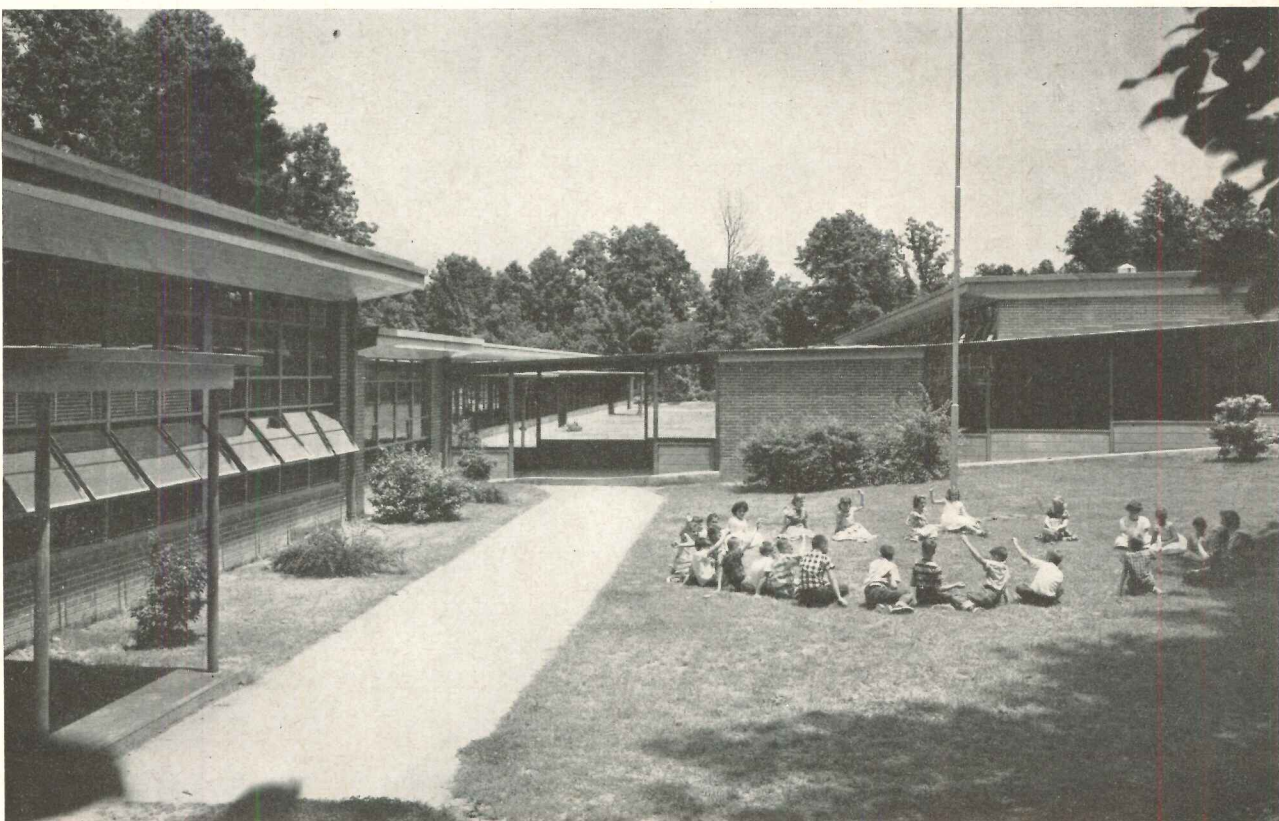

THE INDIVIDUAL SCHOOL AND THE COMMUNITY: CHARLOTTE, N. C.

In early days Charlotte's boys and girls were taught in separate classrooms; in the old South Graded School, the south side of the building was the boys', the north, the girls'. There were some great teachers in those days: Miss Sally Bethune, Miss Kate Shipp, Miss Lillie Long are recorded as being remembered with respect and affection. They stayed with the schools for a long time under a succession of superintendents. Supt. Mitchell became President of Alabama State Normal in 1886; J. T. Corlew, a former Charlotte school principal, was superintendent until 1888; and then came Dr. Alexander Graham, who had been superintendent at Fayetteville since those schools opened in 1878. Dr. Graham thus had a rich background of experience in public education, which was just getting under way in the state; the policies he initiated have of course been modified as educational theory has advanced; but to the strength and character he built into Charlotte's schools is due much of their present vitality.

Under his aegis the graded school system developed apace. His interest in manual training and mechanical drawing led him on a search for a promising teacher, whom he found in Mr. C. C. Hook of West Virginia, the father of the present Walter W. Hook, F.A.I.A., of Charlotte, one of whose schools appears in this collection. Drawing and music

came to be considered valuable features of the curriculum. By 1895, an increase in local school taxes was necessary and was approved at the polls. By 1900, the student body had outgrown its quarters and a new building, soon to be regarded as one of the most forward looking in the country, was erected: the First Ward School. On March 13, 1900, its cornerstone was laid before a crowd of 3000. At about that time Charlotte had 2700 pupils in its public schools, and 47 teachers. Today, in contrast, it has almost 30,000 pupils and approximately 1200 teachers.

Dr. Harry P. Harding followed Dr. Graham in 1913, and after a long, successful administration was followed in 1949 by the present superintendent, Dr. Elmer H. Garinger. Dr. Harding organized the upper grades into a departmentalized high school; and in 1923 the entire system was transformed into a 6-3-3 organization. The junior high schools then introduced were the first in the state.

Locations and design of many of Charlotte's new schools have been strongly influenced by housing projects; cooperation between the schools and both private developers and public authorities is standard practice. Double Oaks Elementary, which won national recognition (cost including addition, over \$600,000 in 1951-52; A. G. Odell & Assoc., Archts.), was erected on a part of a public housing site that was unusable for housing, between a public and private development

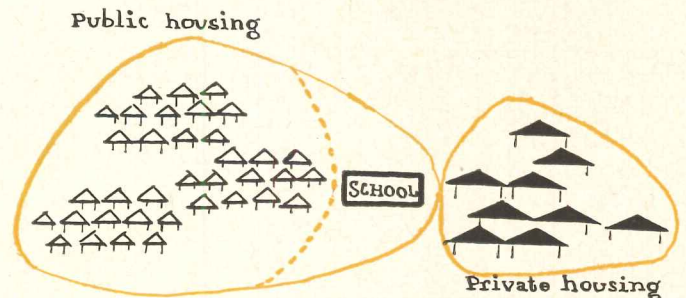

DOUBLE OAKS ELEMENTARY





LAKEVIEW ELEMENTARY

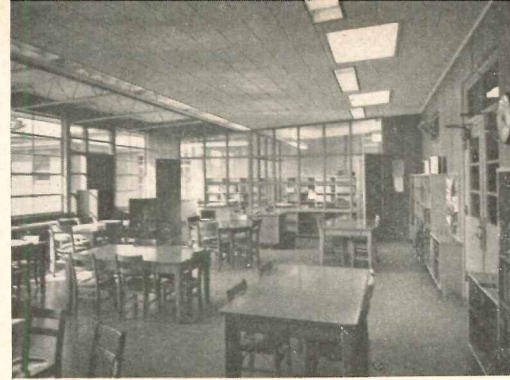

Joseph W. Molitor

School population increased more rapidly than had been expected though larger enrollments had been foreseen and schools planned for expansion. Lakeview, started in 1950, enlarged 1951, cost (total) over \$300,000; Charles W. Connelly & Assoc., Archts.

YORK ROAD JUNIOR HIGH

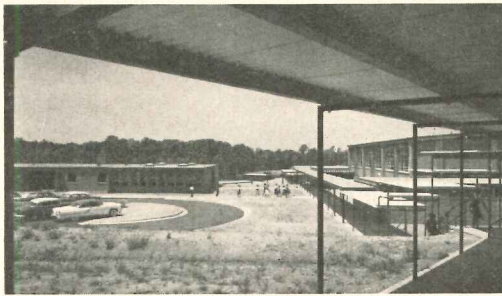

York Road Junior High, part of the 1952 program, cost over \$450,000 to build; Charles W. Connelly & Assoc., Archts. Its site, shared with Marie Davis (below), was acquired in unusual fashion

MARIE DAVIS ELEMENTARY

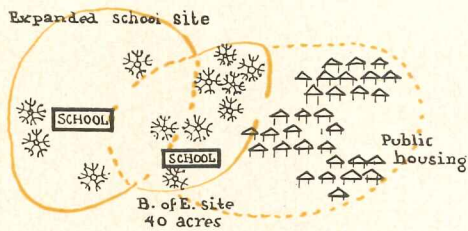
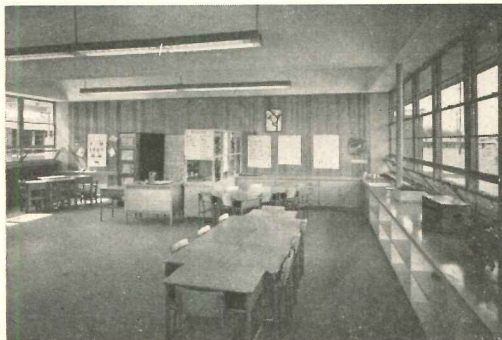

Marie Davis Elementary, another of the 1950 plants that was added to in 1952, occupies a large site part of which was turned over to the housing authority when that agency needed land. Later the school board expanded the site to provide room for York Road Junior High (above). Note: unless otherwise stated, dates given are those of allocation of funds, not of actual construction; cost figures are for construction only, not including sites, equipment, and similar factors

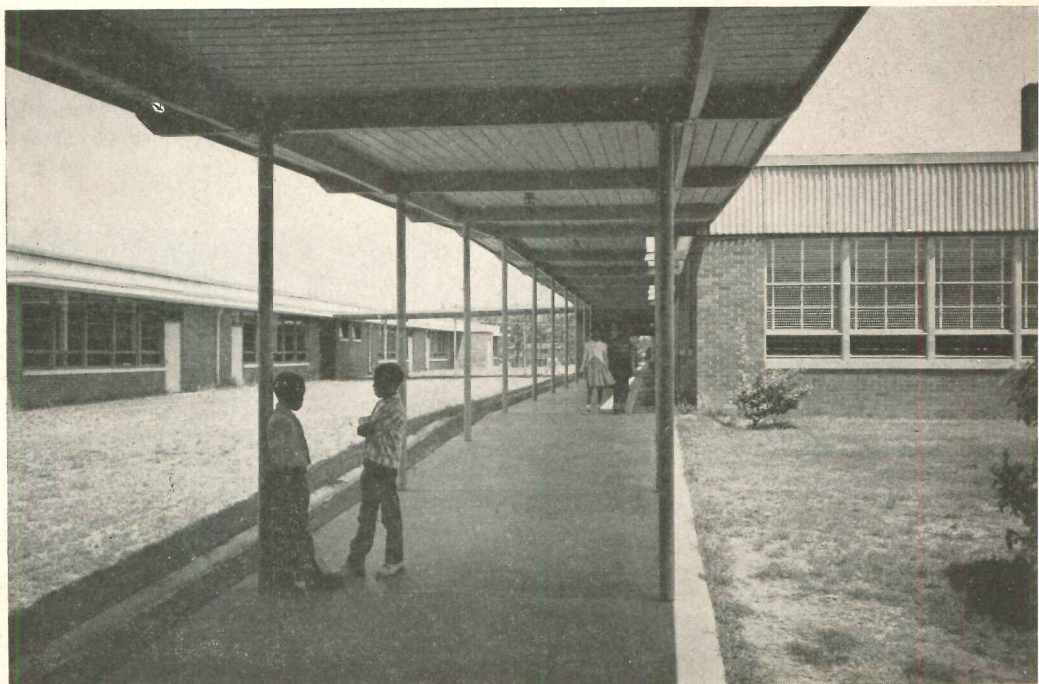

**THE INDIVIDUAL SCHOOL AND THE COMMUNITY:
CHARLOTTE, N. C.**

The wisdom with which Charlotte's school administration has progressed under its present leadership has raised its educational system to an enviable position. At the close of World War II a substantial school building program was inevitable. Recognizing that this was likely to be a task beyond their experience, the school authorities retained a firm of educational consultants (then Engelhardt, Engelhardt & Leggett, now Engelhardt, Engelhardt, Leggett & Cornell) to survey needs, make recommendations, and assist in detail in carrying them through. The survey and recommendations went far beyond forecasts of pupil loads, site selections and similar major practical responsibilities; they included consultation on such fundamentals as the nature of the educational program itself, and the possibilities inherent in sound school-community relationships. In effect the entire city became a vast education laboratory in which theory was evolved, tested, refined, and after thorough investigation put into practice. No problems were ignored. Educational needs were thoroughly discussed with teachers and staffs, and on occasion superintendents and specialists from all over the nation were called in for group consultations. The accuracy of the 1950 survey's predictions thus fulfilled is near perfection: first priority called for 17 elementary schools to be built between 1950 and '55; all but four additions have been completed and of these two were provided in a different manner, two are

Chantilly Elementary, started 1946, enlarged 1952 (cost, \$445,000; M. R. Marsh, Archt.); original classrooms are placed sawtooth-fashion, a precedent not followed in later buildings. Like West Charlotte High (below) it has a larger site than had earlier been considered necessary

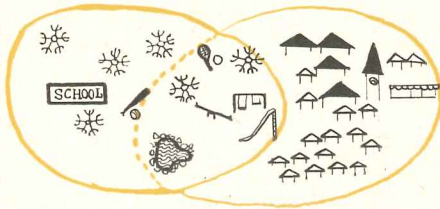
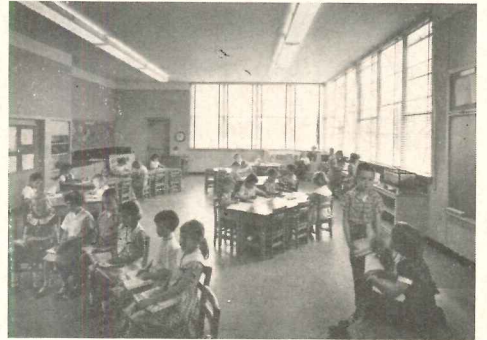
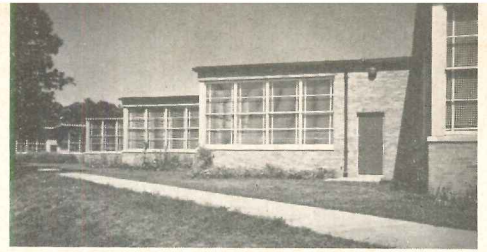

Chantilly Elementary School, one of the early postwar plants, was

West Charlotte Senior High School, another winner of national recognition, is just within the present city limits in the center of a high-quality Negro suburb that is building up on both sides of the county line. A new superhighway bisecting the development and cutting off access to school for many children led to cooperation with highway authorities to obtain a pedestrian overpass, and to relocation of a projected elementary school on the site

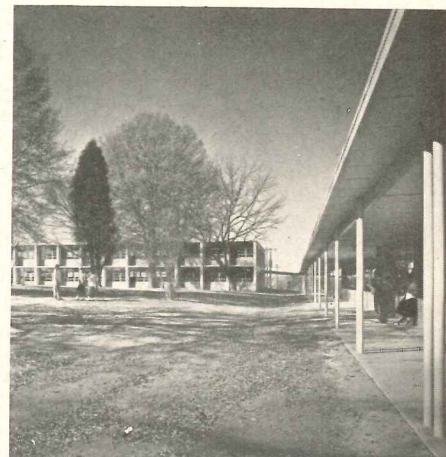
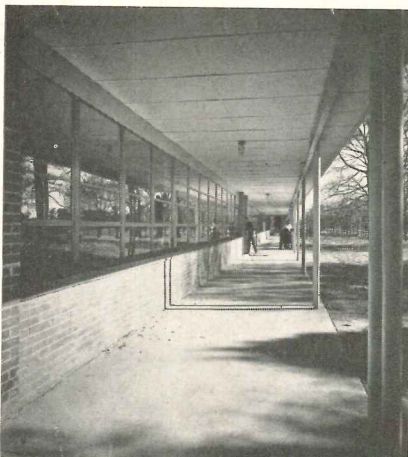



Joseph W. Molitor

carefully programmed educationally and designed to remain, as it has, an effective part of the learning process

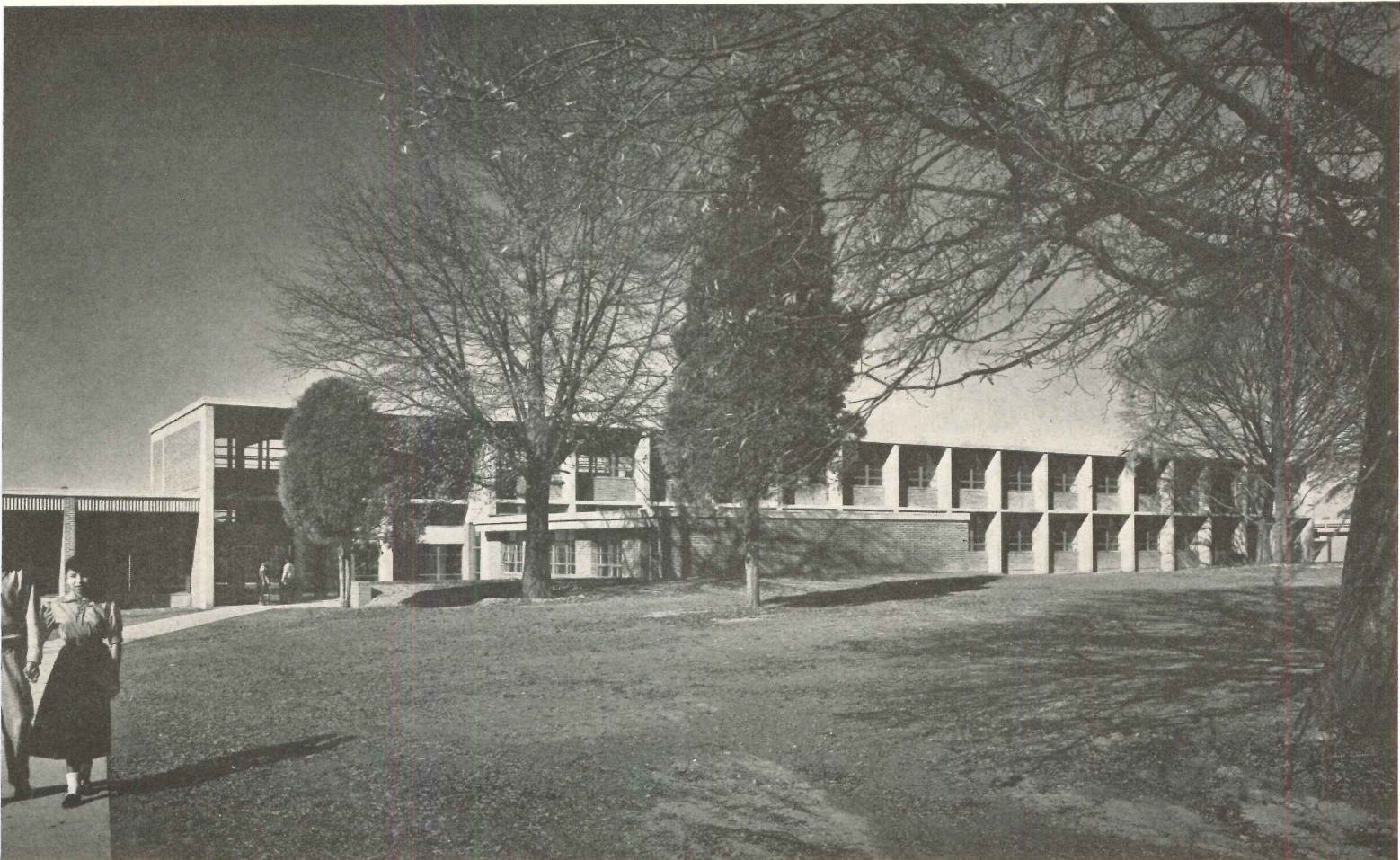

THE INDIVIDUAL SCHOOL AND THE COMMUNITY:
CHARLOTTE, N. C.



Joseph W. Molitor

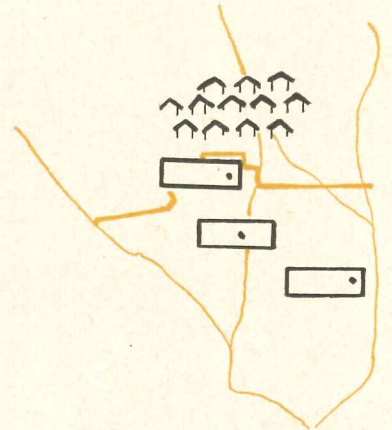

In Charlotte, construction of several excellent schools has led to development of high-class Negro suburbs — a rare phenomenon

now under consideration. All of four secondary plants or additions have been completed. Of lesser priority plants to be built 1955-60, three have been completed and several sites have been obtained.

The Charlotte school system — or any, for that matter — does not operate alone in its world. The city's school administration, it is evident, has cooperated extensively with the local housing authority, with benefits to both. The schools have at times followed, at times led private developers, always closely. There are the beginnings of similar close relations between highway authorities and the schools, between the Park and Recreation Commission and the schools. The large school sites recommended by the educational consultants, Engelhardt, Engelhardt, Leggett & Cornell — and almost uniformly acquired — make admirable beginnings for joint school and park development, a procedure which can be expected to increase. Provision of facilities of this kind, active acceptance of all these enlarging opportunities, is giving Charlotte good schools not only for all its children but also for all its citizens.

The spacious site of Eastway Junior High, above, a 1952 project (\$524,000; J. N. Pease & Co., Archts.), is one of many of the size recommended by the consultants. Below, modern shop in the old Central High School (Biberstein, Bowles and Meacham, Architects)

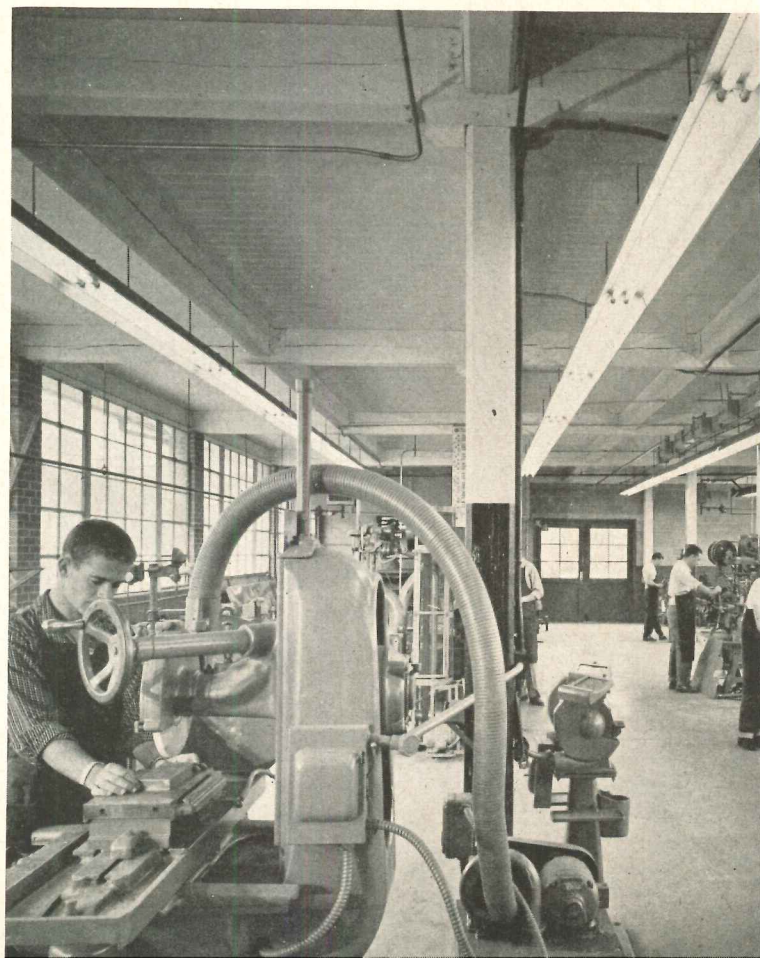



Above, Northwest Junior High (Charles W. Connelly, Archt.) is one example of the encouragement of substantial Negro suburbs. Below, children's art displayed in Sedgefield Elementary (Walter W. Hook, Archt.). Right, band room, Eastway; elementary classrooms, Sedgefield and Merry Oaks (Paul Snyder, Archt.)

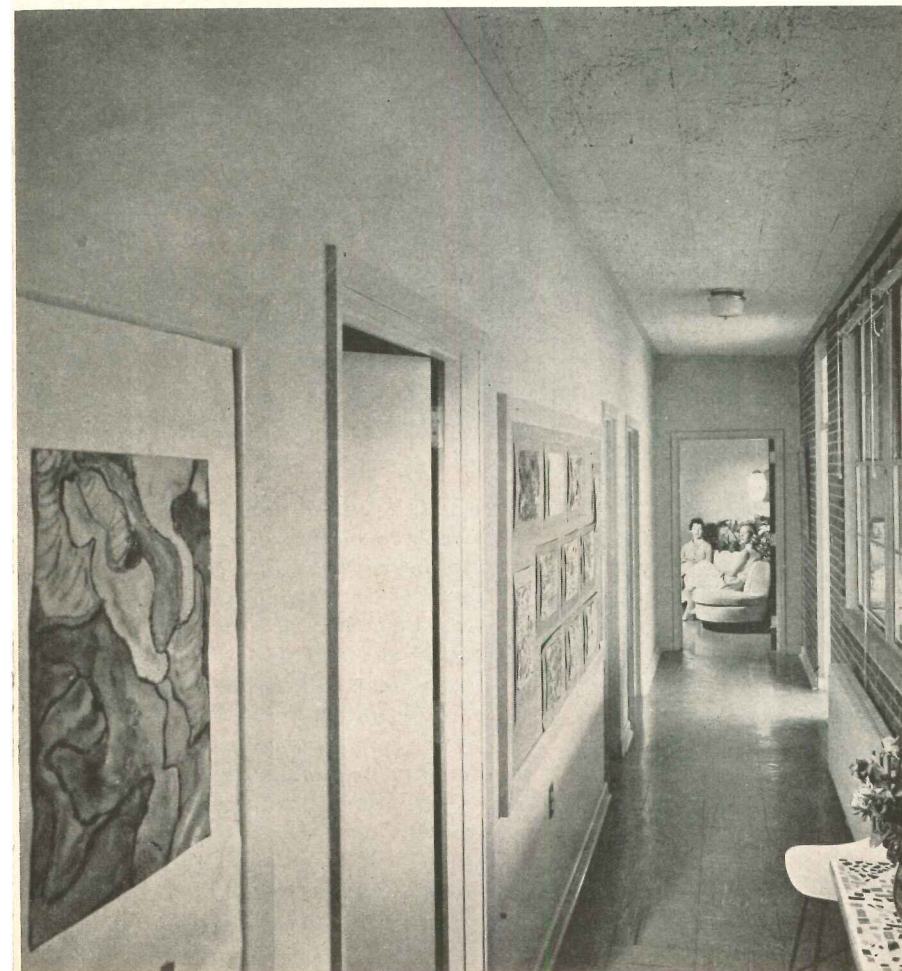
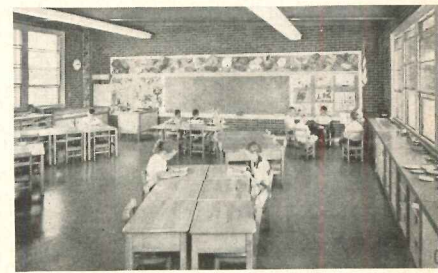

**THE INDIVIDUAL SCHOOL AND THE COMMUNITY:
CHARLOTTE, N. C.**

One postulate in the Charlotte school building program has been utilization of virtually all the city's architectural talent. Certain advantages have resulted, most of them foreseen. There has been no unethical practice, and yet stiff competition for jobs is the rule. This has meant that each architect is more than ever on his mettle when he works on one of Charlotte's schools, which of course means an increasingly high standard of architectural performance. It was also considered educationally essential that all buildings should fit their precise individual needs, and the repetitive details are few, the repetitive plan non-existent. A natural concomitant of the competitive architectural situation, this might be expected to produce over-expensive structures; in practice exactly the opposite has been true, chiefly because budgets were carefully estimated and seldom violated. One of the system's many visitors — hardly a week passes with-

out its quota of sincerely interested professional inquiries from far and near — was Dr. A. J. Stoddard, Consultant to the Fund for the Advancement of Education. Dr. Stoddard was quoted in local newspapers as being thoroughly impressed with the advanced design of all the schools, with the economy of land purchase and building construction, with the high quality; in any other city, he declared, they would have cost half again as much.

Among the city's architects schools are considered excellent commissions; while architectural fees are not high — indeed, one suspects that school jobs are often undertaken partly because they are civic duties and for the prestige they carry — rarely has a Charlotte architect actually lost money by doing one. No architect can be expected to get rich doing a superb custom job to a tight budget, and that is exactly what Charlotte requires.

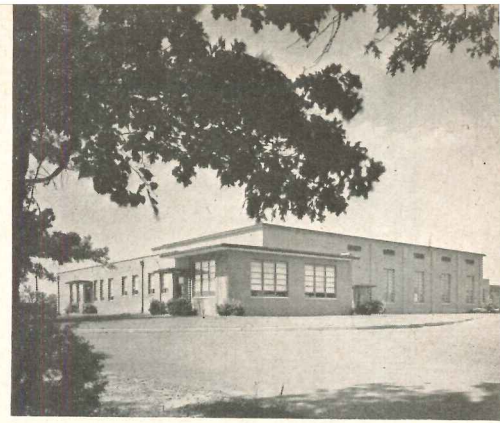

Charles W. Connelly, Archt.

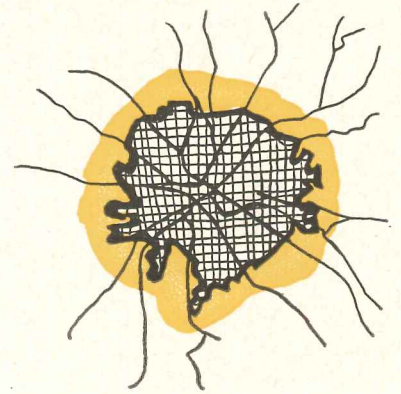

Architects: A. G. Odell & Assoc.

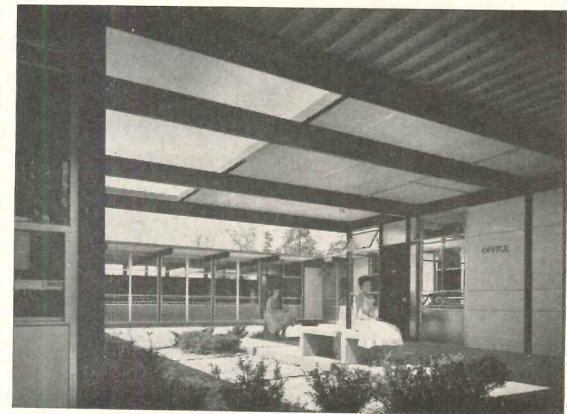
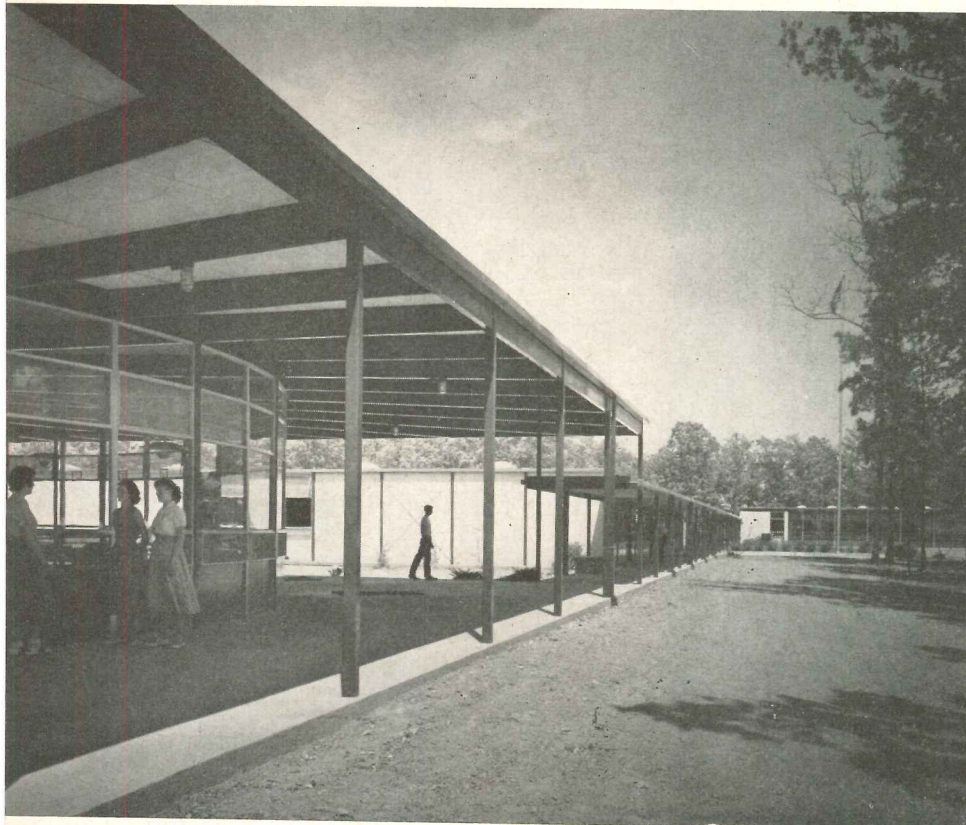

Most recent of Mecklenburg County's secondary schools is Wilson Junior High School, named in honor of the County Superintendent, Jim Wilson. The school, winner of awards in two national competitions, will eventually house 1200 pupils. It is of light steel frame with shop-fabricated wall panels and extensive glass areas, campus-planned as a series of buildings around several courts.

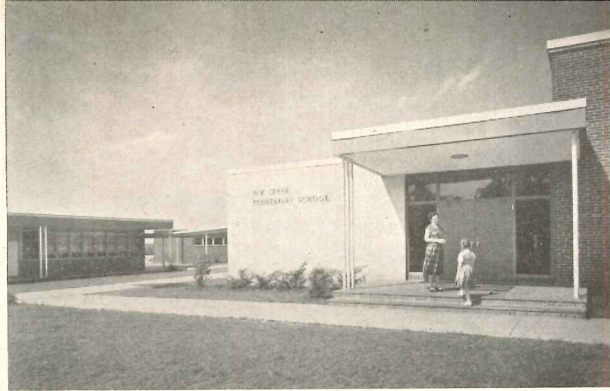

Graves & Toy, Archts. Photos: Malitor

Mecklenburg County surrounds Charlotte. School bonds for both County and city derive from the County. As the city's population has densified and its territory expanded there have inevitably been delicate situations; in fact, there has been danger that areas immediately outside city limits would become a sort of no-man's land. To avert this the two boards of education are now cooperating closely in a joint advance-planning program. Meanwhile the county has been solving its own building problems. Above, left to right, West Mecklenburg High; Hoskins Elementary; Paw Creek Elementary

Architect: R. E. Edwin Wilson & Assoc.

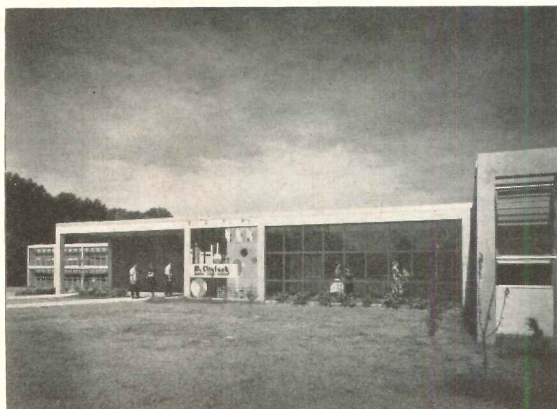

One county problem has been consolidation of numerous small, inefficient school buildings into fewer, larger, better functioning plants. There were many obstacles — the pride of the several individual rural communities, a diversity of opinions and loyalties, a tight budget. The county administration's patience has overcome most of these. Above, right, the new McClintock Junior High

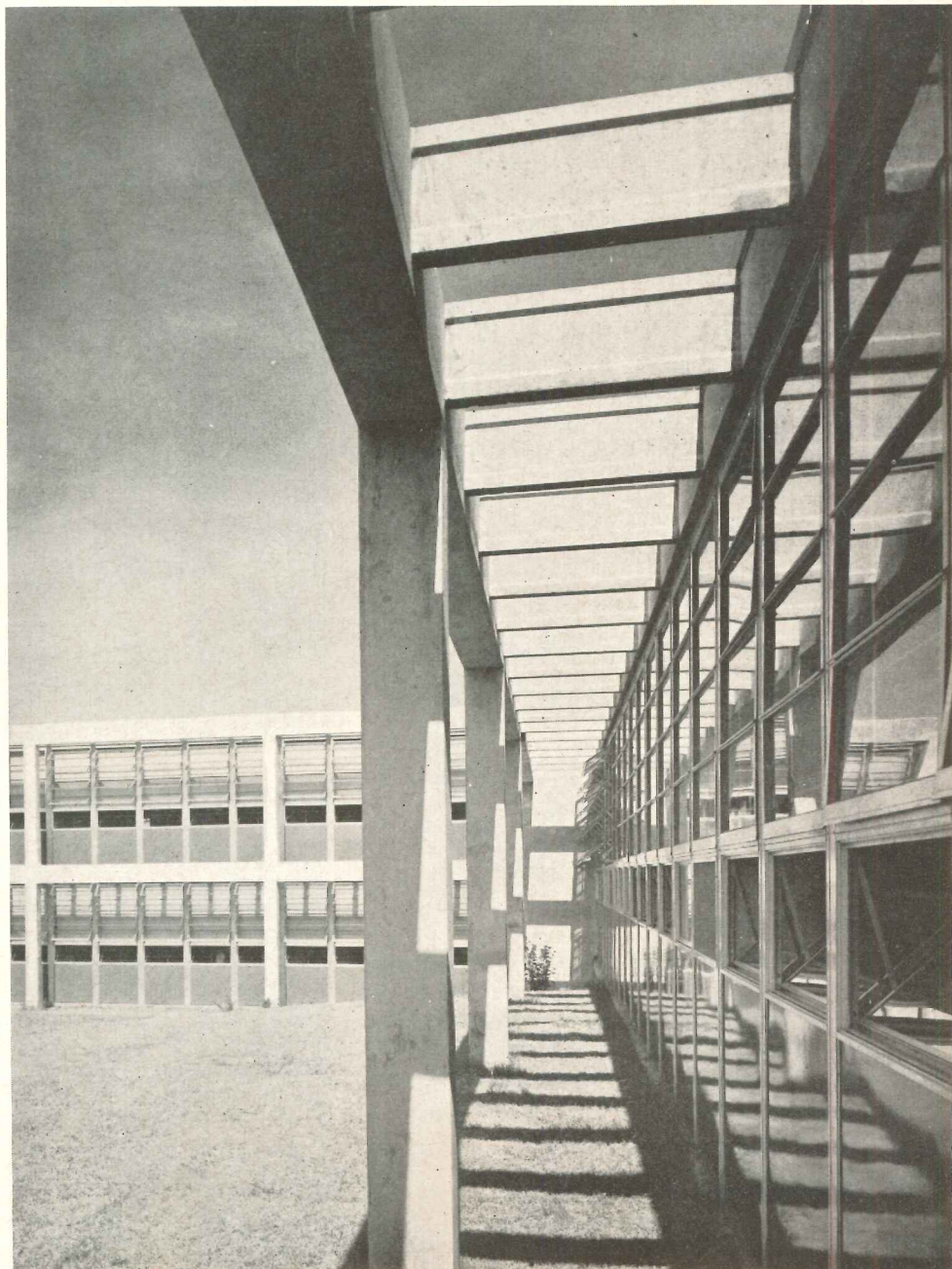

**THE INDIVIDUAL SCHOOL
AND THE COMMUNITY:
CHARLOTTE, N. C.**

Charlotte and Mecklenburg County were named in honor of Queen Charlotte of Mecklenburg-Strelitz, wife of George III of England. Nevertheless the famous Mecklenburg Declaration considerably antedated the colonies' Declaration of Independence. Self reliance still characterizes the people of the area. It is a good thing, then, to know that these two determined entities, the city and the county, have chosen to cooperate to solve their mutual school problems. As the county becomes suburban and the city pushes out into the countryside the question of who pays for what becomes important. To work things out equitably both boards have retained again the consultants who up to now have worked with them separately, and the first report of a five-year, continuing, joint survey of needs has been completed. Projects proposed for construction over the next five years are: Senior high schools, 4 new, 9 additions; junior highs, 7 new, 7 additions; elementary schools, 14 new, 16 additions; and an administration center to be the headquarters of both boards. The estimated cost of these 58 projects is \$23 to \$25 million at present prices. If past performance is a criterion, the new buildings will contain many advances over the old; and it is to be remembered that Charlotte's schools are noted for sensible pioneering in their campus plans, their schools-within-schools, their general education laboratories, and their concern for the development of the individual pupil as well as for the way they have helped their city to grow.

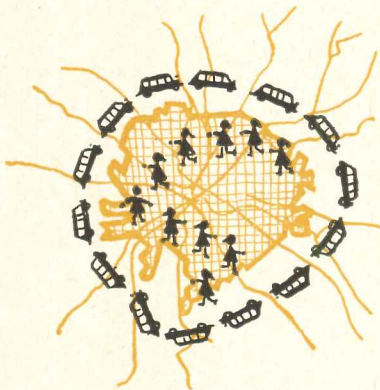

The city board provides no transportation for its pupils, but all modes are in use (photos, top to bottom: on foot, high school students' jalopies, lower-graders' bicycles, commercial bus lines). The county uses school buses driven by students

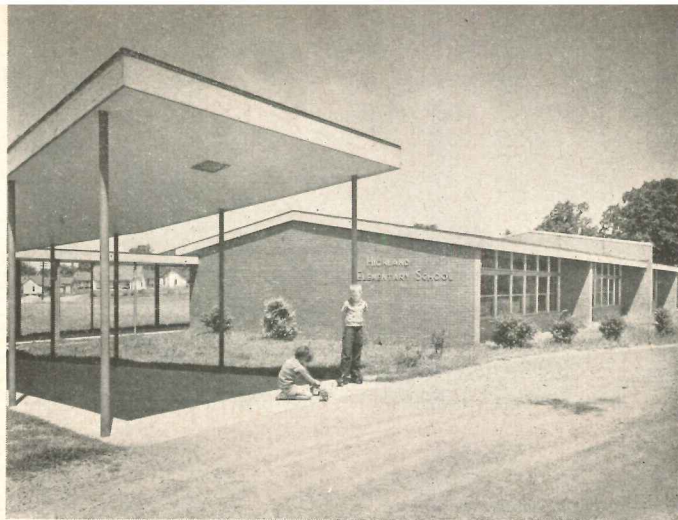

Joseph W. Mollitor

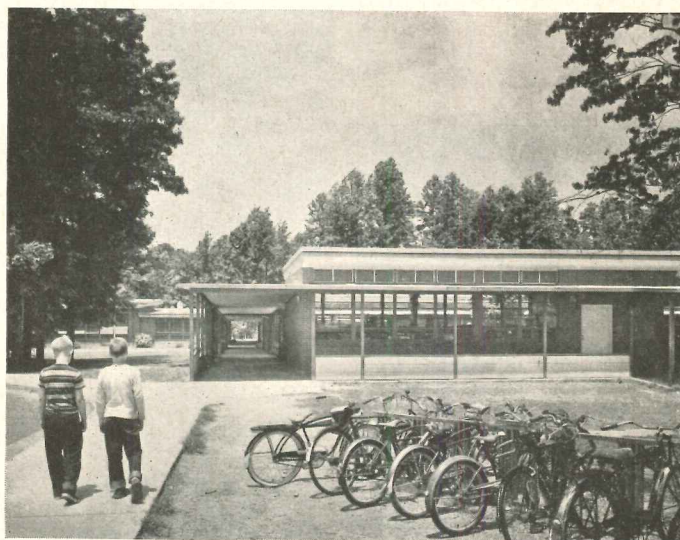



Dearborn-Massar

BELLEVUE, WASH., SCHOOL DISTRICT

Bellevue School District No. 405

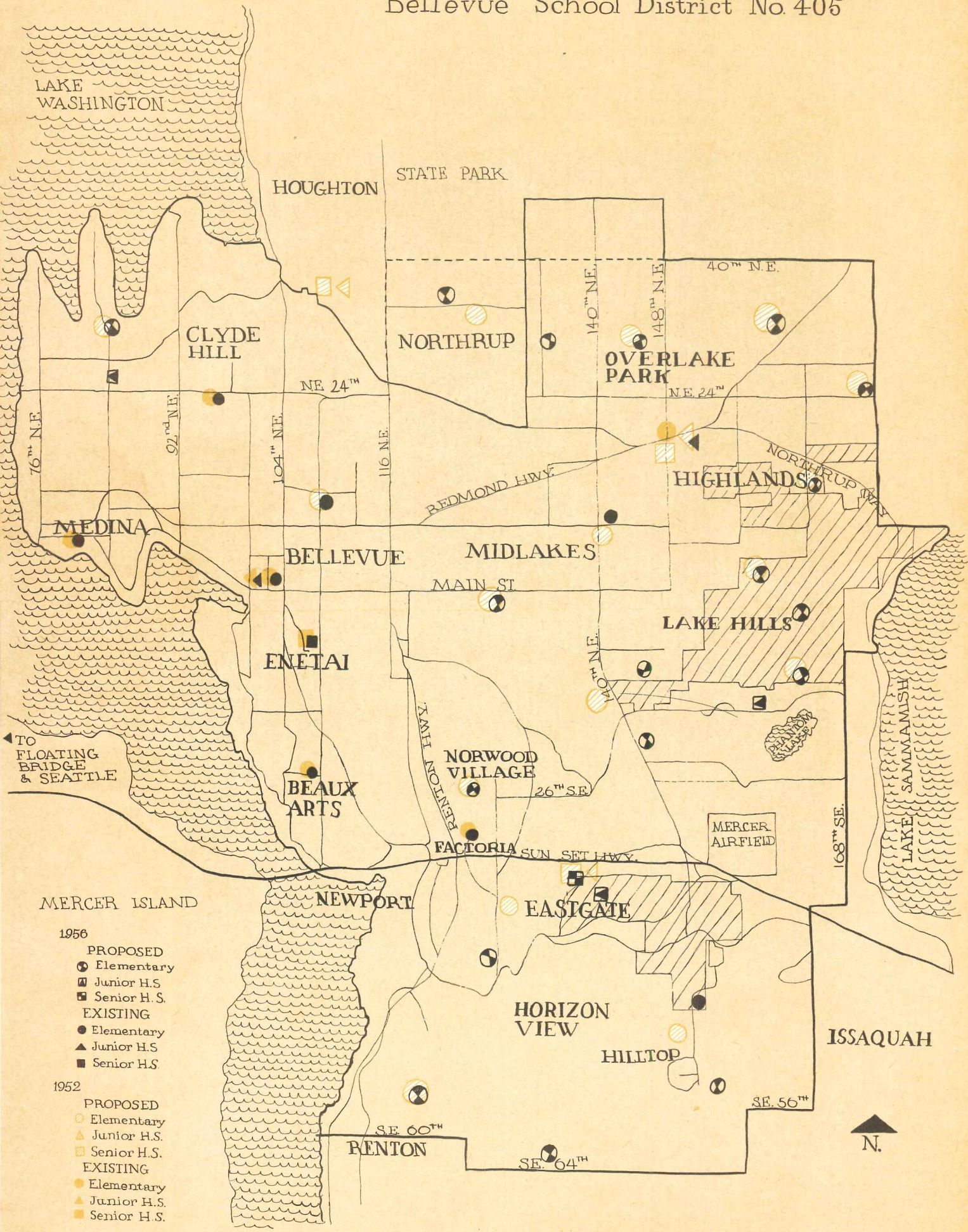

- 1956
- PROPOSED
 - Elementary
 - ▣ Junior H.S.
 - ▣ Senior H.S.
 - EXISTING
 - Elementary
 - ▲ Junior H.S.
 - Senior H.S.
- 1952
- PROPOSED
 - Elementary
 - △ Junior H.S.
 - ▣ Senior H.S.
 - EXISTING
 - Elementary
 - ▲ Junior H.S.
 - Senior H.S.



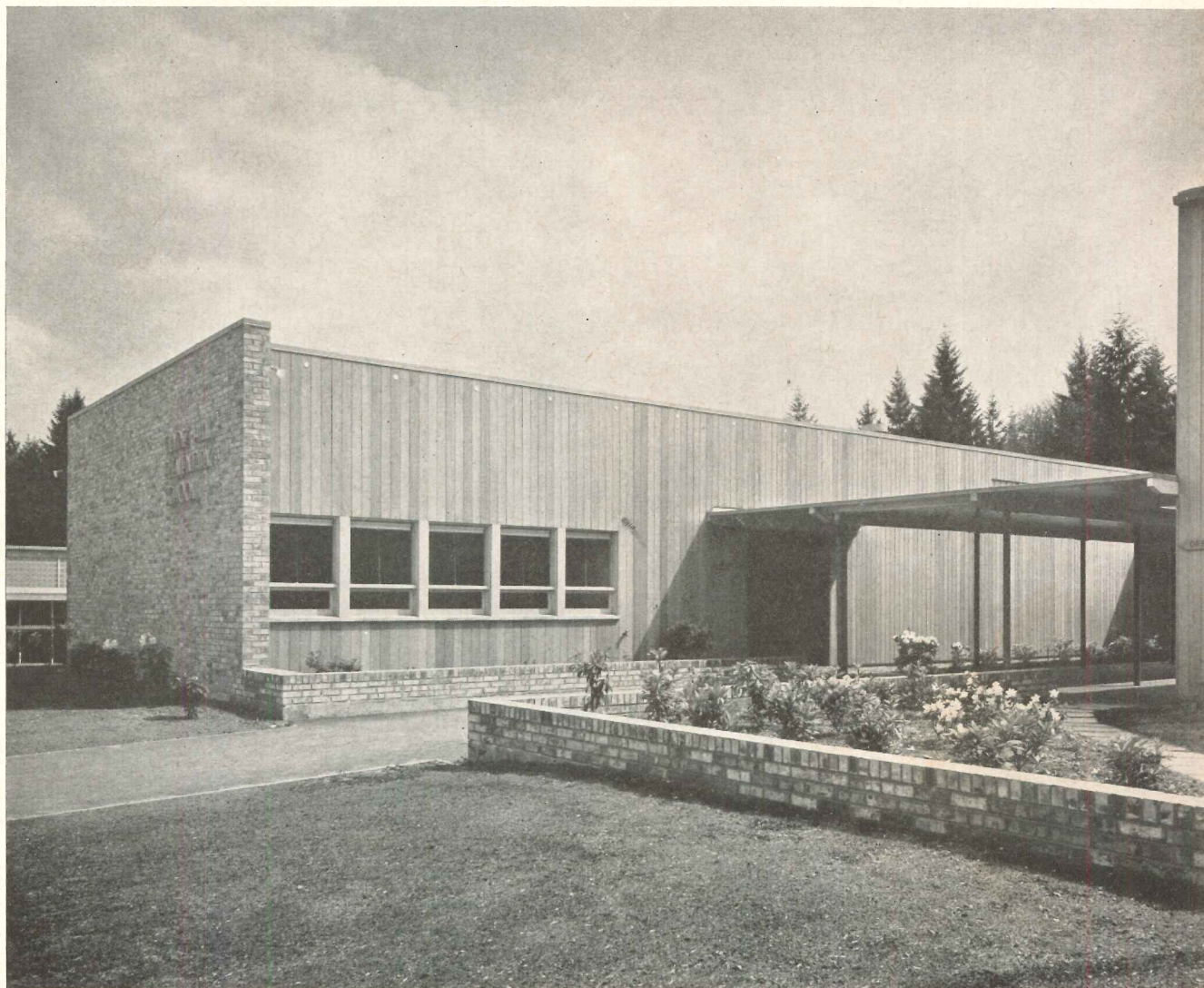

Dearborn-Massar

Distribution of Bellevue District schools proposed in 1952, based on reasonable development and population growth, compared with actuality and revised forecasts of 1956 after uncontrolled development had over-exploited some neighborhoods at expense of others. Yet school-developer relations have been fairly good; several developers have given or reserved school sites. Dotted line indicates recent enlargement of school district

THE BELLEVUE, WASH., SCHOOL DISTRICT did not exist in its present form until mid-World War II except as a high school district; however, soon the more articulate citizens of its several neighborhood communities realized it was a unit requiring an overall development plan if its school-building problems were to be met well at reasonable cost. One might expect an ideal result to come from such beginnings, but the citizens ran into circumstances which, for a time, they could not control. The school building program had to be adjusted to some of the very conditions the "plan" had been designed to avert. Now, however, the prospects are brighter.

Until 1940, Bellevue was a sleepy, rural, unincorporated community of

about 1000. Its business establishments were simple; its truck farmers grew berries and vegetables for the Seattle market. It had a few summer people, executives and professionals who owned scattered vacation places along Lake Washington's shore. It was a hilly pocket, partly cleared but much wooded, between Lake Sammamish on the east, Lake Washington on the west, and the established communities of Houghton and Renton north and south. In 1940 the floating bridge was built across Lake Washington and sleepy Bellevue found itself only a few minutes from downtown Seattle. That was the start of a residential development unparalleled in the Northwest.

Initially growth was slow; bridge tolls deterred many who might other-

**SCHOOL AND COMMUNITY:
BELLEVUE, WASHINGTON**

wise have moved to Bellevue. In 1946 tolls were eliminated, things began really to boom, by 1950 school housing was a very serious problem. In September 1951 the schools went to double shifts. Meanwhile the six separate elementary school districts in the area had consolidated with the one high school district, Union, to form what was first called Overlake (and is now Bellevue) School District. Consolidation took place in 1944; the present name was adopted in 1950, both upon local demand. This period also saw redevelopment of the local business district; substantial and still growing, this is now the hub of a prosperous shopping region and provides the business and professional services normal to such an area.

While the speculative land boom brought many problems—needs for doctors and lawyers, for streets and sewers and fire protection, for instance—it was most pressingly evident in the case of schools. Under the most fortunate kind of pressure, then, that applied by lay citizens who were their own constituents, the Board of Directors of the Bellevue School District employed Dr. Zeno B. Katterle, Dean of the School of Education at Washington State College, and Grant Venn, to develop a long-range plan which would encompass all these factors as well as regulate subdivision growth. More than 500 citizens actively participated in preparing the plan, whose essence was a reasonable and equitable distribution of potential population throughout the area, taking into account topography, highways and all the many other pertinent local factors, so that an eventual “saturation” population might enjoy what the area’s natives had always had and newcomers had come for: a semi-rural surrounding rather than built-up suburbia. By 1952 this community labor, in which the technical staff of the King County Planning Commission

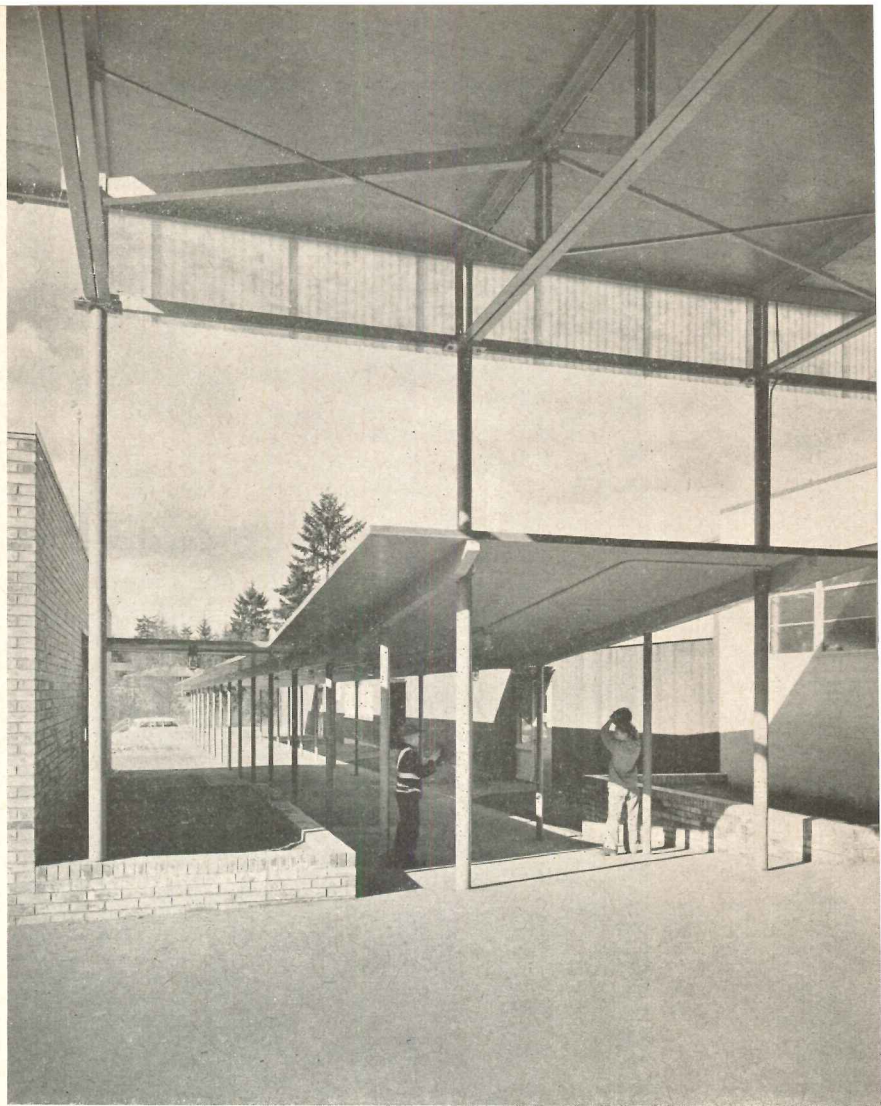

Dearborn



Two elementary schools undertaken early in the current Bellevue program: on this page, Enatai; facing page, Clyde Hill. Narramore, Bain, Brady & Johanson, Architects, here initiated in cooperation with school authorities certain flexible standards (see text) which have been improved in subsequent buildings

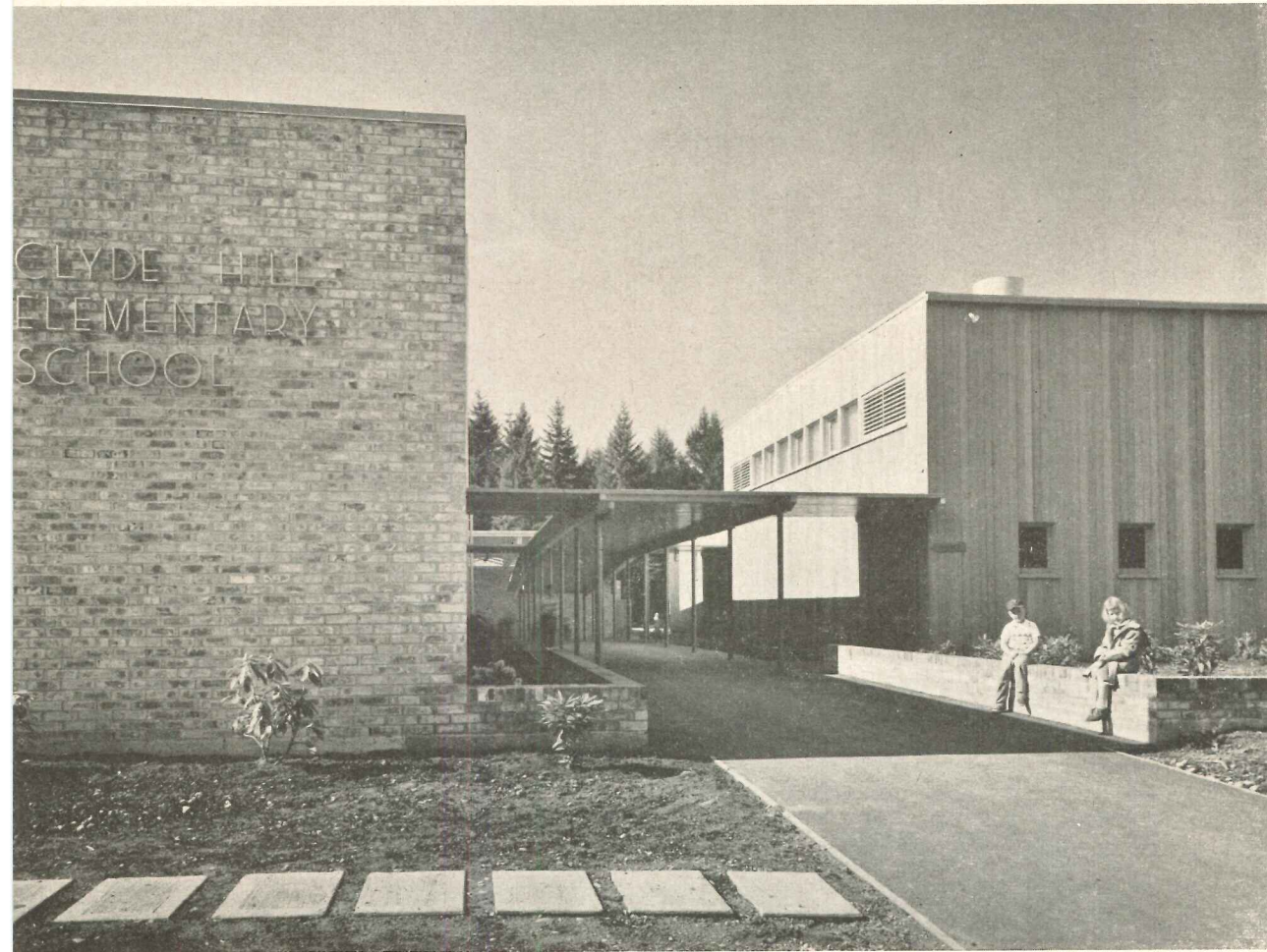

NE 24th St.

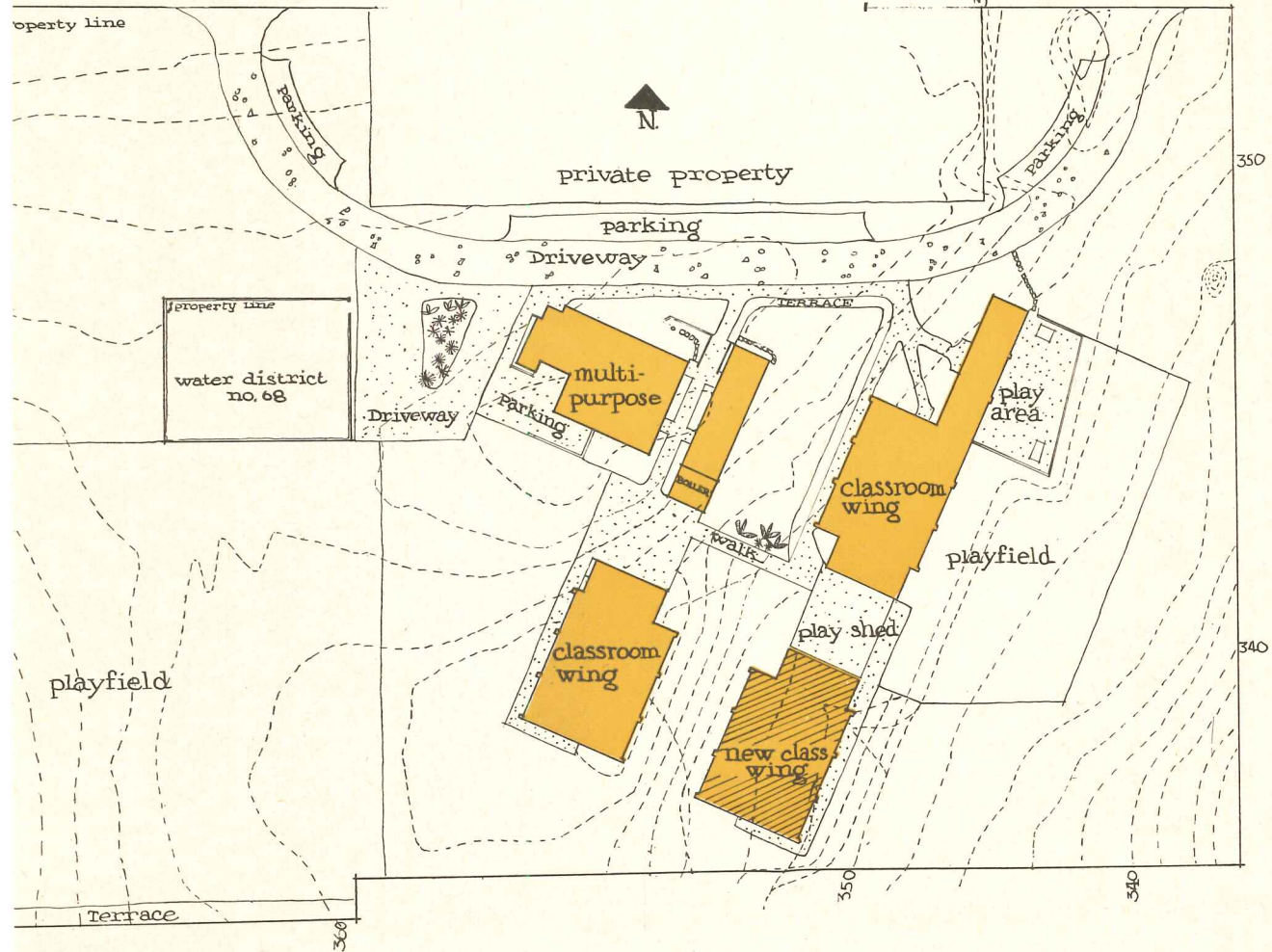



Darborn-Massar

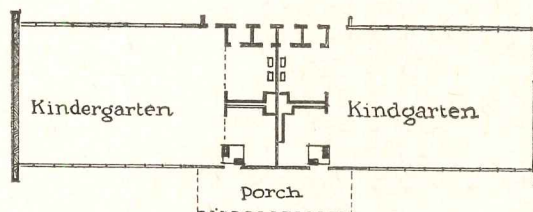

assisted, needed only ratification by the King County Board of Commissioners, who hold jurisdiction over unincorporated county communities.

The charges of politics, exploitation and interest as causes of the long delay in ratification would require more competent investigation than an architectural publication can undertake if they are to be proved or disproved. The fact is that ratification by the County Commissioners was delayed until the summer of 1956, and without official ratification the proposed plan had no teeth. In desperation, a few of the district's neighborhoods incorporated themselves and enacted zoning ordinances of their own, some requiring startlingly large lot sizes. Most of the land has been open to uncontrolled subdivision, and in certain areas — few of them reasonable for the purpose — population density is now so great that some planned school locations have been abandoned and others substituted

Standard units adapted to different needs: photo above, Enatai Elementary; below, kindergarten, Clyde Hill; opposite page, top, classroom unit with kindergarten element added, Clyde Hill; bottom, classroom, Enatai

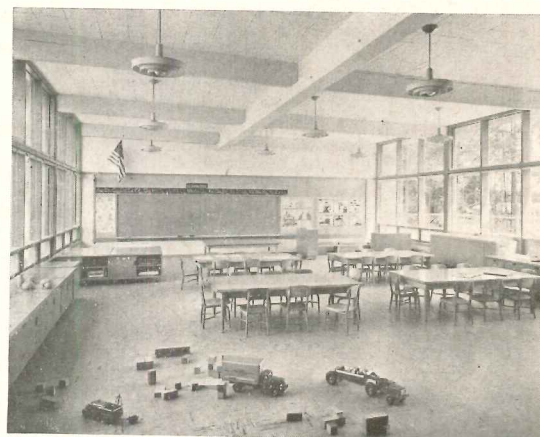

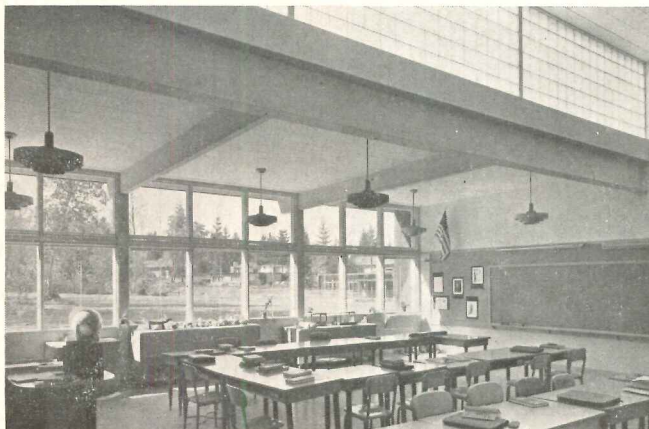
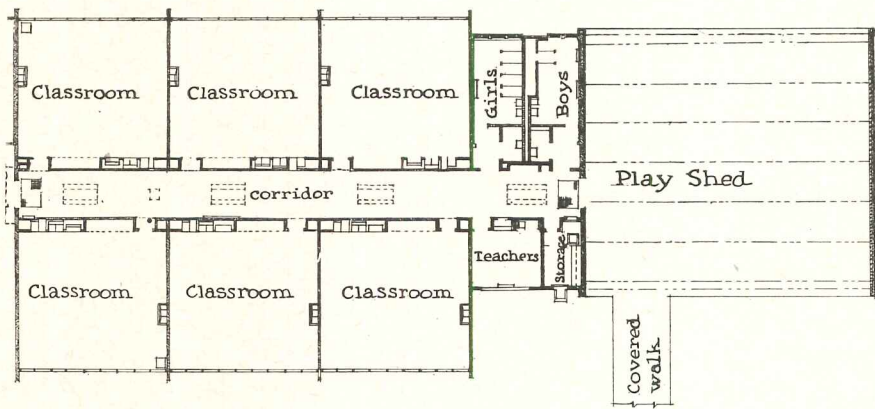
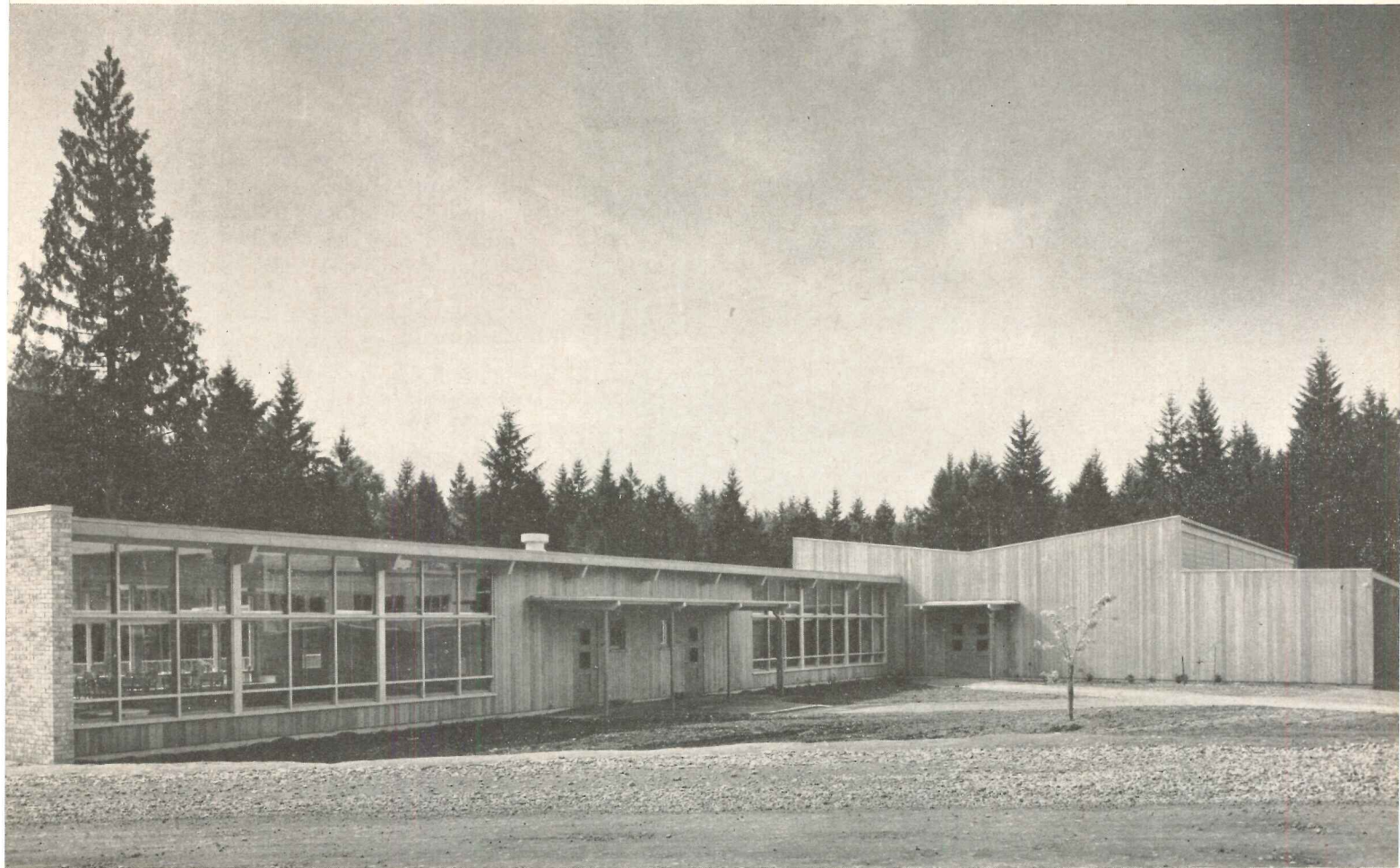

and proposed school building expansion has been shifted and accelerated.

Regarding the nature of their schools, the Bellevue Board and administration (first under the able Supt. T. R. Thor-darson and later under the equally competent Supt. George B. Brain) has been able to adhere to most of its earlier objectives, to progress toward others. Its difficulties are not chiefly financial although it must watch budgets carefully. At the time of its original plan-ning report, desirable maximum size for elementary schools was set at 20 rooms (18 classrooms, 2 kindergartens); of junior highs, 600 to 800 pupils; senior highs, 800 to 1200 pupils. There existed in 1952 six elementary schools, one junior and one senior high. Two of these, Clyde Hill and Enatai Elementar-ies (illustrated herewith), have each been enlarged to the 20-room maximum. One elementary building has been in-corporated in a new junior high now under construction and replaced with

**SCHOOL AND COMMUNITY:
BELLEVUE, WASHINGTON**

a new adjoining elementary plant. Others have been built or are building, or are in planning stages. Until recently one architectural firm, Narramore, Bain, Brady & Johanson of Seattle, has been retained for all school work; now other firms are coming into the picture.

The six-room building unit shown in the plans of Clyde Hill and Enatai was adopted as a flexible standard that could be modified as need and experience might indicate, as an economically sized building element suited to the rugged terrain, the climate, the educational program and community needs. The early structures are steel frame and masonry, enjoying good fire ratings and low insurance costs; recently the insurance differential has been so cut that high construction cost is no longer justifiable and the new Phantom Lake Elementary is to be of frame. Other developing ideas include changes in the size of the basic unit from 6 to 4 to 2 rooms each; thin paraboloid roofs of plastic for the unwallied playsheds of schools now being designed; and in the new junior high, a thin-shell concrete roof, luminous ceilings and interior walls all glass above the 5½ ft line. Where Clyde Hill had wood windows, newer schools have aluminum. In multipurpose rooms the stage has become less and less conventional.

Bellevue has other problems coming: a second floating bridge from Seattle will soon be reality — where will it enter Bellevue? The nature of the population is changing from mostly business and professional people to include others holding different viewpoints. Due to uncontrolled growth the unification of the District's people is more difficult to achieve. Incorporated Bellevue is growing; the school district is too. However, these are nothing compared to problems of the past which, though not perfectly solved, are in infinitely better shape than was thought possible a year ago. And action started in the schools.

Playsheds in Bellevue's elementary schools (top, Clyde Hill; center, Enatai) are large rooms without walls, serve well in the mild climate. Multipurpose rooms (bottom, Enatai) have been evolving to look less like gymnasiums in later schools

Dearborn/Massar

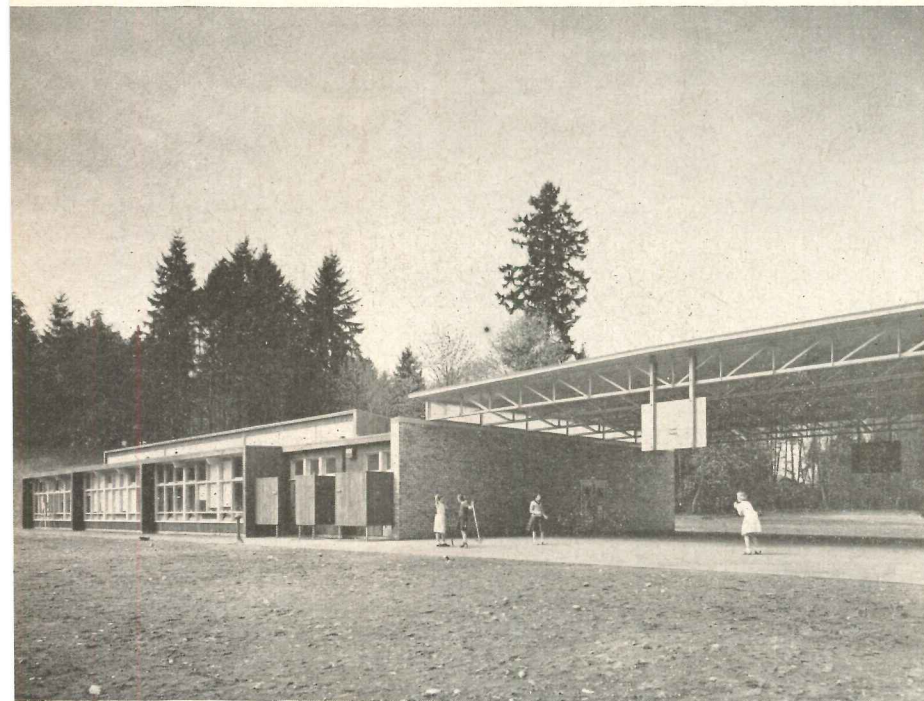
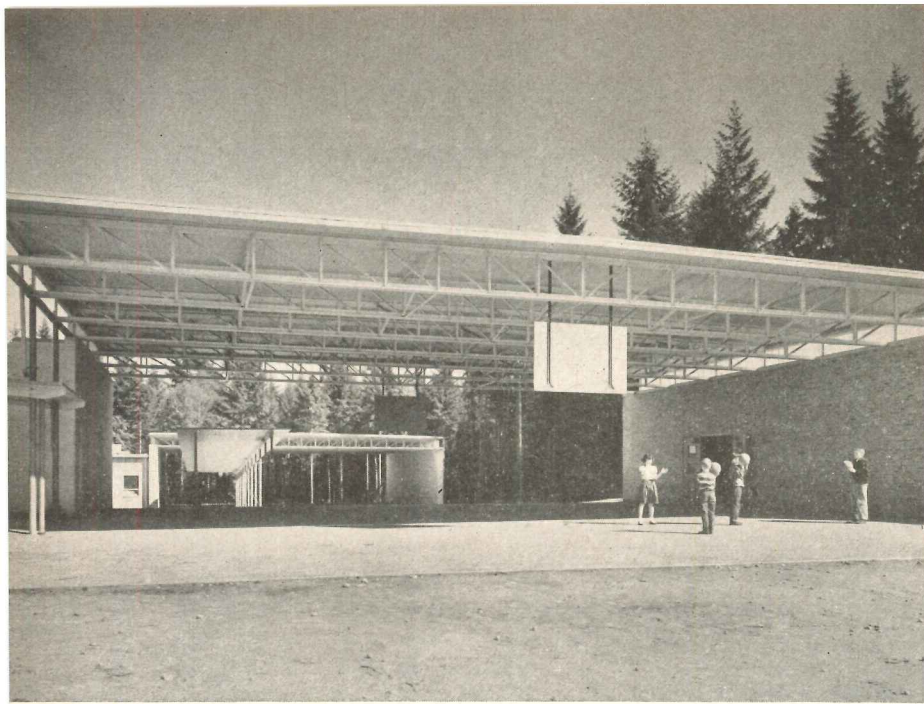

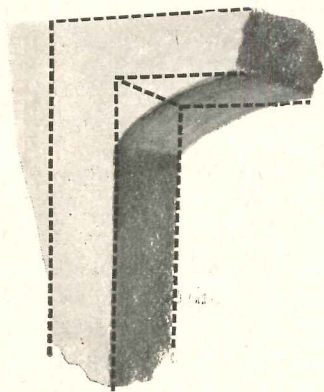

ARTICLE TWO IN A SERIES, "A CHANGE AHEAD FOR STRUCTURAL DESIGN"

ULTIMATE STRENGTH DESIGN OF CONCRETE

By Edward Cohen, Associate, Ammann & Whitney, Consulting Engineers, New York

AFTER FIFTY YEARS of progress in design, in construction and in the development of a true understanding of the structural mechanics of reinforced concrete, the basic American building code for concrete structures has undergone a fundamental revision. The American Concrete Institute Building Code Requirements of Reinforced Concrete (ACI 318-56) now states that "the ultimate strength method of design may be used for the design of reinforced concrete."

The basic innovations of the ultimate strength method of design consist of (1) using as design loads the actual working loads multiplied by the appropriate load factors or safety factors and (2) proportioning the sections for the resulting ultimate moments and thrusts by the use of a plastic stress distribution. Fundamentally this method affects only the design of column and beam sections for axial load, bending or bending plus axial load. The required strengths are determined from an elastic frame analysis for moments and thrusts and no allowance is made for redistribution of moments (limit design). Under the actual working loads the resulting structures will be primarily in the so-called "elastic range" and the stresses in the steel tension reinforcement will be only slightly higher than those which exist in most current designs for present commonly used grades of steel. However, allowance is made to utilize steels with higher yield points up to 60,000 psi.

Although some additional economy could be obtained, moment redistribution, or limit design, is unnecessary for the design of new structures of reinforced concrete because the reinforcement at each section can be readily proportioned in accordance with the variations of the elastic moment diagram. The use of limit design would involve the use of high stresses under working loads and unnecessary cracking. However, properly designed reinforced concrete has adequate ductility which may be utilized in analyzing existing structures for new overload conditions or in the design of structures for resistance to dynamic loads such as blast or earthquake. Ductility of reinforced concrete has been well demonstrated in the laboratory and in actual structures both under test and in normal use.

The present procedures for the design of reinforced concrete slabs make allowance for some redistribution of moments. In the Scandinavian countries full redistribution of moments has been used as the basic design method for slabs for several years. This method, the "yield line" method, is now gaining acceptance in the United States and laboratory studies are under way to refine its use and establish its limitations with respect to cracking and shear strength. Research is also being conducted on the application of plastic methods to the design of thin shells.

It is quite likely that a half century

ago engineers would have been as familiar with some of the general concepts discussed here as they are today. The design theories developed by the early pioneers Ritter 1899, Talbot 1904, Withey 1907, Mensch 1914, although limited in some respects, were based on good agreement with test results. Since then, starting with the first generally accepted code in 1910, design procedures for many years drifted into complete acceptance of the fictitious straight line or elastic stress distribution. However, many engineers were unsatisfied to proportion structures on the basis of methods with important limitations which could not be justified by tests. Starting with the papers by C. S. Whitney in 1937 and 1942 which presented a practical verified design procedure for ultimate strength design, new interest was rapidly developed in this concept.

In 1944 a joint ASCE-ACI Committee on Ultimate Strength Design was formed under the chairmanship of the late A. J. Boase. In 1955 this committee with L. H. Corning as chairman completed its assignment "to evaluate and correlate theories and data bearing on ultimate strength design procedures with a view to establishing them as accepted practice," with publication of its final report.

The 11 years which elapsed between the formation of the committee and its final report have been used to conduct extensive tests and to evaluate carefully

ULTIMATE STRENGTH VS. STRAIGHT LINE METHOD

Sketch shows how size of a reinforced concrete highway bridge can be reduced through use of the ultimate strength theory

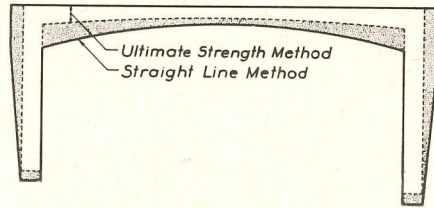

Dead loading
H-20 live load
Earth pressure
Temp = 30 F
Shrinkage 0.00013
Skew angle 45°-36'

Figure 1

the various design methods and load factors. The results of this report have been incorporated in the 1956 ACI Building Code as an acceptable method of design. Previous to this, ultimate strength methods could only be used for the investigation of special structures and for designs either outside the jurisdiction of building codes or with special permission from the supervising authorities. Now, after fifty years of progress, we return to design methods based on the true strength of reinforced concrete sections.

Effects of Ultimate Strength Design Methods

Although present practice already includes many empirical corrections which compensate for some of the more flagrant deviations of the straight line or

elastic methods for the design of sections, the application of the new code will give the structural designer new confidence and freedom in proportioning structures. The acknowledgment of the actual strength of flexural members as governed by the compressive strength of the concrete will allow the use of shallower beams and minimize the weight of required compressive reinforcement where the design is governed by the strength requirements. For any given set of load conditions the new provisions will generally result also in smaller columns in rigid frame structures. Additional economies and easier construction will be possible by the use of high strength reinforcement. The revised code now allows the use of steel with a yield point of 60,000 psi, which is equivalent to a maximum working stress

of 33,300 psi as compared with the previously allowed maximum of 20,000 psi, a 65 per cent increase when proper precautions are taken to limit deflections and cracking.

Although it is difficult to define the actual economies in dollars and cents, it is safe to assume that because the designs will be of more uniform strength, savings will be effected by the elimination of excess material from sections where it is not actually needed. Any analysis of savings should consider the savings in formwork, possible reductions of overall story height where beam depths are reduced or haunches eliminated, and savings in foundations where the total weight of materials is reduced.

Structures where obvious major economies are possible are those in which important forces are developed by volumetric changes such as temperature, shrinkage, creep, etc. By reducing the size of members and thus reducing the rigidity of the structure, the stresses caused by the volumetric changes are minimized. Thus, not only are economies possible by using the minimum required material for a given set of moments and thrusts, but the design moments and thrusts are themselves reduced.

Actual comparative studies of fixed concrete arches and rigid frame highway bridges as designed by standard procedures and by ultimate strength methods have indicated that the latter designs result in structures of substantially more slender proportions. The use of such structures has been found to result in (1) economy of concrete in the superstructure and the footings, (2) little if any increases in the total weight of reinforcing steel, (3) a decrease in the centering required for erection and (4) in the case of the bridges, a reduction in earthwork quantities and wingwall heights. For structures founded on piles, the reduction of the total reactions due to the reduced dead load and volumetric effects would mean even greater savings.

However, it is very important to note that the ultimate strength method will not always mean reductions. In some cases it may result in additional tensile reinforcing in order to provide a uniform factor of safety against overload rather than a given allowable stress under working load.

It should be noted that ultimate strength design is only a method of pro-

LOAD FACTORS

Effect of load factors and load combinations on the design of sections where the dead load effect is a concentric compression and the live load effect is a moment

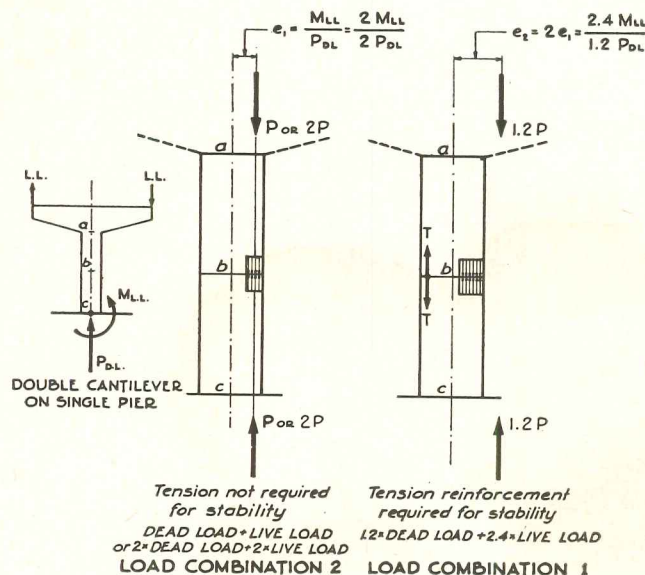

Figure 2

portioning sections based on their actual strength in direct stress, flexure, and combined flexure and direct stress as found by tests. When combined with load factors, it provides a method of obtaining a uniform factor of safety for flexure and thrust, if the field control is adequate to assure the required concrete strength in the structure.

Factors of Safety

The report of the Joint ASCE-ACI Committee on ultimate strength states that members should be proportioned so that:

- “(1) They should be capable of carrying without failure the critical load combinations which will insure an ample factor of safety against an increase in live load beyond that assumed in design;
- “(2) The strains under working loads should not be so large as to cause excessive cracking.”

In order to satisfy these conditions the following load factors are specified where the effects of wind and earthquake can be neglected.

Load Combination (1)

Design Load = $1.2 \times$ Basic Load (Dead Load and Volume Change Effects) plus $2.4 \times$ Live Load

Load Combination (2)

Design Load = $K \times$ Basic Load plus Live Load, where $K = 1.8$ for beams without axial load and 2.0 for columns and members with both bending and axial load.

Based on the above, the minimum factor of safety or load factor for working load (dead plus live) is 1.8. It also provides a factor of safety of almost $2\frac{1}{2}$ against live load. An allowance is made for a 20 per cent increase in dead load above that shown on the construction plans.

Similar formulas have been established where wind and earthquake effects must be considered.

Two conditions are required for the design of reinforced concrete because it is a non-homogeneous material, of which one constituent, the concrete, has adequate compressive strength but so little tensile capacity that it is normally disregarded. The first criterion controls the design when the dead load produces an essentially axial force on the section and

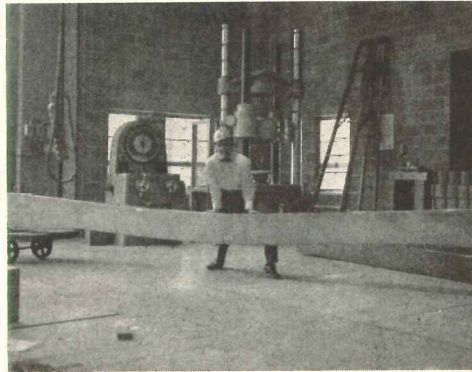

PLASTICITY

A 22-ft clear span concrete haunched beam with fixed ends as it appeared following load test. This member underwent a 7-in. permanent plastic deflection without loss of strength and with little damage

the live load effect has a large eccentricity. For such a case there may be no tensile stress nor requirement for tensile reinforcement under working load or any multiple of working load, but substantial tensile reinforcement may be required when the live load is increased disproportionately to the dead load.

For example, if a member subjected to dead load compression and live load flexure is designed for working loads on the basis of *Load Combination (2)* only or allowable stress, the factor of safety against an increase in live load may be far below the value assumed in selecting the allowable stress or the load factor because the dead load compression is fixed. The effect of increasing the live load moments without changing the dead load compression may be such as to move the resultant from inside the

section to some distance outside the section. If the member were originally designed for compression only, it might have little reserve for the tension stresses produced by the overload condition and failure would follow. The use of *Load Combination (1)* would prevent such failures.

The condition of dead load flexure plus live load tension would be similar.

The load factors recommended for ultimate strength design provide that the maximum internal forces acting on each section of a reinforced concrete structure will bear a uniform ratio to the ultimate strength of that section. It follows that the factors of safety used for the design of the individual sections will be the minimum factors of safety against collapse of the total structure and will be the actual factors

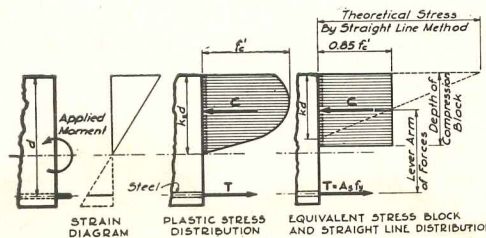

EQUIVALENT STRESS BLOCK

Formulas for proportioning sections to resist moments and thrusts are based on an equivalent rectangular stress block which, for simplicity, replaces the curved, actual stress block

Figure 3

ULTIMATE MOMENT CAPACITY

This sketch shows the magnitude of forces and resisting moment in an under-reinforced concrete beam at the point at which the tension steel is strained beyond the yield point

Figure 4

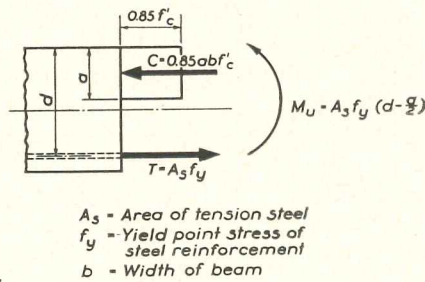

of safety against collapse only in those structures where moments cannot be redistributed under overload and where no self-relieving stresses are present such as simple beams or columns or rigid frames with single fixed positions of load and free of temperature and other stresses from volumetric changes.

For a rigid frame structure designed for pattern loading or moving loads, the collapse load will be higher than any of the given design loads multiplied by the load factors. This is so because with the present ultimate strength method the design moments and thrusts are computed from elastic frame analyses and generally only one or two sections of the structure are stressed fully by any one position of the design load. Therefore, as the load is increased these sections can yield without loss of strength,

and other sections not fully stressed will be brought to their full capacity. Only then, when plastic hinges are developed will failure take place. Although no allowance is made for such behavior by the ACI Code many tests have indicated that reinforced concrete structures have more than sufficient ductility to allow such redistribution under heavy overload. This characteristic has recently been verified by severe tests of structures subjected to blast pressures of atomic bombs.

An additional factor of safety against collapse due to overload is available in those structures where volumetric effects are present in the final design moments and thrusts. Because the basic design load includes volumetric effects which are self-relieving, that is, reduce and disappear as a result of yielding, and

do not affect the overload capacity, the factor of safety against collapse is increased.

Strength Calculations

The final phase of ultimate strength design involves the proportioning of sections to resist the computed moments and thrusts. For practical purposes the formulas based on an equivalent rectangular stress block given in the ACI Code may be used. (See Fig. 3.)

It should be noted that the depth of the equivalent stress block is not the same as, k_d , the actual distance to the neutral axis or kd , as computed by the straight line stress distribution method. The essential principles behind the rectangular stress block are that (1) the total compressive force is the same as that for the actual elasto-plastic distribution and (2) the center of the equivalent rectangle is at the same location as the resultant of the actual stress distribution.

In other words the actual irregular stress block is replaced for simplicity with a rectangular stress block of equal total force and an average compressive intensity of $0.85f'_c$ where f'_c is the crushing strength obtained from a standard test on a 6 x 12 inch plain concrete cylinder at an age of 28 days.

If the beam is under-reinforced so that primary failure will occur in the tensile steel, the concrete will crack as the steel is strained beyond yield and the equivalent depth of the beam in compression, "a", will decrease until the average effective concrete stress reaches the maximum of $0.85f'_c$. The resisting moment is given by the moment of the force in the tensile reinforcement about the centroid of the compression force. When the section is without compression steel:

$$M_u = A_s f_y \left(d - \frac{a}{2} \right)$$

The moment, M_u , must be equal to the sum of the dead and live load moments times their load factors. If the area of tensile steel is increased to $0.456 \frac{f'_c}{f_y}$ the moment capacity of the section will increase until failure occurs by crushing of the concrete at the same time that the stress in the reinforcing steel reaches yield point stress. Any further increases in the area of tension steel will not produce appreciable increases in the moment capacity.

BENDING AND AXIAL LOAD

This is an interaction curve for strength of a reinforced concrete column with both bending moment and axial load. Where strength is controlled by yield of tensile steel, moment capacity increases as axial load is added. Where strength is controlled by crushing of concrete, the moment capacity decreases as axial load is added.

Figure 5

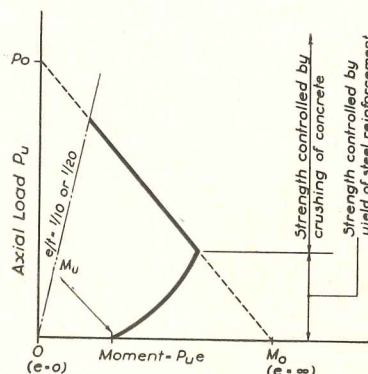

In order to eliminate the possibility of compression failures and maintain ductile sections the new ACI Code limits the maximum ratio of tensile steel for flexural members without compressive reinforcement to

$$\frac{A_s}{bd} = p = 0.40 \frac{f'_c}{f_y} \quad (2)$$

which is slightly less than the true ratio for balanced reinforcement but is about twice that allowed by the straight line method. The ultimate moment corresponding to balanced design by the revised code is

$$M_u = 0.306 bd^2 f'_c$$

For the case of a concentric axial load the ultimate capacity of a column is given by:

$$P_u = .85f'_c (A_g - A_{st}) + f_y A_{st}$$

A_g = Gross cross-sectional area
 A_{st} = Total steel area

the direct combination of the strength of the concrete and the reinforcing steel. However, since it is difficult to ensure that the actual loadings will ever be entirely concentric it is required that a minimum eccentricity of $\frac{1}{20}$ the total diameter for round spiral columns and $\frac{1}{10}$ the total thickness of rectangular columns be considered in the design.

The equation for members under combined bending and axial load where the strength is controlled by the tensile reinforcement is derived in a similar manner. Where the compressive strength controls, tests indicate an essentially straight line between the case of pure bending and the case of axial load. It is interesting to note that the moment capacity of a reinforced concrete section increases as axial load is added if it is controlled by yield of the tension reinforcement. Of course, if it is controlled by crushing of the concrete, the effect of axial load is to reduce the moment capacity. This is shown in Fig. 5.

Ultimate strength design of reinforced concrete thus provides one basic method for the design of beams and columns with any amount of eccentricity, from zero to infinity whereas conventional design requires different approaches for axial load, small eccentricity and large eccentricity or pure bending. Adoption of ultimate strength methods will result therefore in considerable simplification of the work of proportioning sections. Design charts are

available for flexure of rectangular sections, and for flexure and axial load of rectangular sections, round sections and square sections with round cores. It may be noted that the design formulas contained in the Joint Committee Report and the ACI Code are essentially the same as those proposed by C. S. Whitney 16 years ago.

The ultimate strength method of design requires that the actual concrete strengths and the steel strengths be at least equal to those assumed by the designer. The design formulas provide no factor of safety to cover shortcomings in the materials. For this reason the Code requires use of controlled concrete with not more than one 28-day cylinder test in 10 having an average strength less than that assumed in the design. It is also specified that the average of any three consecutive tests shall not fall below the design value. For the design of the reinforcement the minimum value of the yield stress of the steel is to be used in design. Since the strength of most of the steel and concrete will be higher than the minimum values used for design, most sections will therefore be designed on the safe side; seldom will the factor of safety be less than that intended.

Deflection of Beams and Slabs

Because the ultimate strength method of design will encourage the use of more slender members with steel working at higher stresses, the possibility of increased flexibility makes a careful consideration of deflections more important than ever before. Undesirable deflections have occurred in many structures designed by the straight line method and are not due to the method of design nor, in some cases, to stress conditions caused by dead or live load. It should be noted that the final long time deflections of reinforced concrete members may be 2.5 to 4.0 times those computed by elastic methods based on stress-strain curves which are conventionally used. As a result, the necessity of keeping the deflections within acceptable limits will often determine practical dimensions. With slender compressive members such as arches, the longtime change in shape of the member axis as a result of creep may add substantially to the design moments. The effect of shrinkage on the deflection of thin slabs reinforced on only one face are well known and

are best illustrated by the warping which has been reported for precast channel slabs with substantial bottom reinforcement in the stems and light reinforcement in the thin flange slab. Lack of rigidity in formwork supports during the setting period during construction may contribute additional slab deflections, particularly in multi-story buildings.

One of the important ways in which sagging can be limited is by addition of compression steel. This is useful in reducing the effects of creep because the effectiveness of the steel is increased as the effective modulus of elasticity of the concrete is reduced. Compression steel also reduces the effects of shrinkage by bridging and reducing the cracks. Of course, it is well known that the use of good concrete with adequate curing is of prime importance for reducing the effects of shrinkage. Creep is also greatly reduced by postponing the time for removal of forms and supports. Flexural members of minimum depth with heavy reinforcement should be used only where the resulting deflections will not be objectionable. However, it should not be inferred that flexibility properly considered by the designer is objectionable.

Conclusion

The present approved ultimate strength method for reinforced concrete applies primarily to the design of sections for combinations of moment and thrust. The ultimate strength method requires that the structure be detailed to have sufficient shear (diagonal tension) and bond strength to fully develop its moment-thrust capacity. It is also assumed that the control of the concrete production, placing and curing will be adequate to provide the required concrete strength. While designing members for strength the engineer must be careful not to overlook other factors such as deflection, crack resistance, and durability which greatly affect the usefulness and appearance of a structure for its intended purpose.

In designs based on ultimate strength, the engineer can prevent wasting construction material and design time and is allowed more freedom in the selection of sections. With the ultimate strength method as another powerful tool, he can more readily provide a structure which will meet the requirements of architectural design.

MASONRY IS MEETING THE DEMANDS OF MODERN CONSTRUCTION

Metal and glass buildings have been getting under the skin of the masonry industry. What they propose to do about it by developing new materials and techniques was revealed at a Building Research Institute meeting in Washington last month. On the following three pages and pp. 266-267 are reported the major advances announced. Discussion of masonry brings to mind the problems of waterproofing; so features of the relative newcomer in this field, silicone water repellent, are examined on page 265

BRICK

Research on brick and tile is moving in several directions in an effort to cut construction costs: (1) lighter weight — as much as 40 per cent — which will reduce the dead weight in buildings as well as save on freight costs; (2) changes in unit size to simplify wall construction; and (3) automation in the packaging of brick and in laying brick on the job.

It might also be said that this industry's search is being conducted in another direction which, paradoxically, is not aimed at making brick and tile lighter, but capitalizing on its mass. Eight test huts have been constructed of various materials including brick, tile, steel panels and wood siding in order to determine what benefits such as reduced size of heating and air conditioning plants as well as fuel bills, can result from the capacity of clay products to soak up heat or cold.

Lightweight Brick. By the end of the year, the Structural Clay Products Research Foundation, headed by Director Robert B. Taylor, hopes to be producing some 50,000 lightweight bricks in its pilot plant at Geneva, Ill. The brick is all clay, but is made light by mixing a lightweight aggregate, which consists of "exploded" clay particles, along with regular clay. This will make a 5 lb brick weigh 3 lb, an 8 lb brick, 5 lb.

Other advantages besides its light weight are: (1) greater uniformity of size; (2) can be cut more easily for precision grinding.

Prefabricated Brick Wall. Larger masonry units have become more popular recently — for example the SCR brick, introduced several years ago, which is $2\frac{1}{4}$ by $5\frac{1}{2}$ by $11\frac{1}{2}$ in. While originally developed for one-story houses as a single wythe wall, it has other potentialities including load-bearing walls for cellular, multi-story buildings up to 15 stories high. (See ARCHITECTURAL RECORD June 1952).

The trend to large panel sections has fostered a still different approach at the Research Foundation. A prefabricated brick wall section (see photo, far right) has been produced in sections of two bricks wide and 15 to 20 bricks high through the use of a fast-setting mortar — the panel can be poured and lifted the same day. For exterior use, the panels are $2\frac{1}{2}$ in thick and are reinforced to carry wind and structural loads.

One of the obvious ways to speed up laying a brick wall, according to the Research Foundation, is to provide scaffolding which keeps the mason's supply of brick and mortar at a convenient height and location behind him. Improvements in scaffolding techniques have demonstrated an increased productivity of between 20 and 25 per cent.

Packaged Brick. The matter of shipping and handling of bricks, while not affecting building design, does influence costs. So it's worth mentioning the development of a pilot-model machine at the Research Foundation which straps 20 bricks in a tight bundle. Packages are made up of three strapped bundles of 20 plus two spacer brick for handling by hand trucks or fork lifting equipment. The contractor can trim costs because of less breakage and less mess to be cleaned up after the building is finished.

Thermal Test Huts. Clarence B. Monk of the clay products research staff feels that clay masonry has a thermal property advantageous to the design and operation of heating and cooling systems which has not been exploited very much. The higher thermal capacity of clay units as compared with lightweight constructions, may make possible savings in initial cost, in fuel and in electricity. The reason for this is that the masonry can store heat from the sun in winter and cold from cool night air in the summer. It has been recognized for

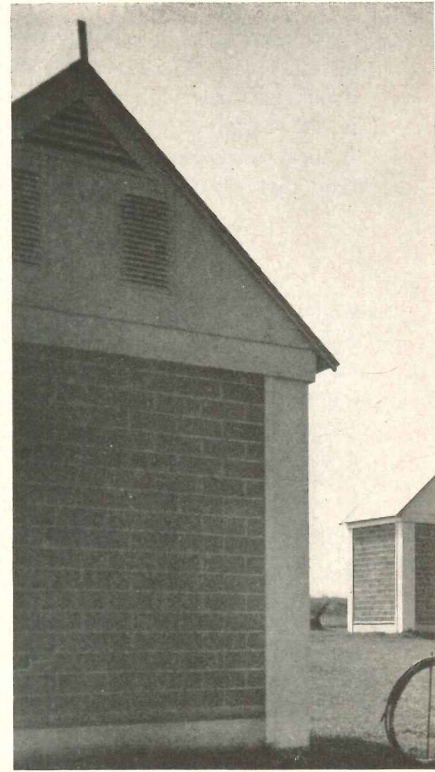

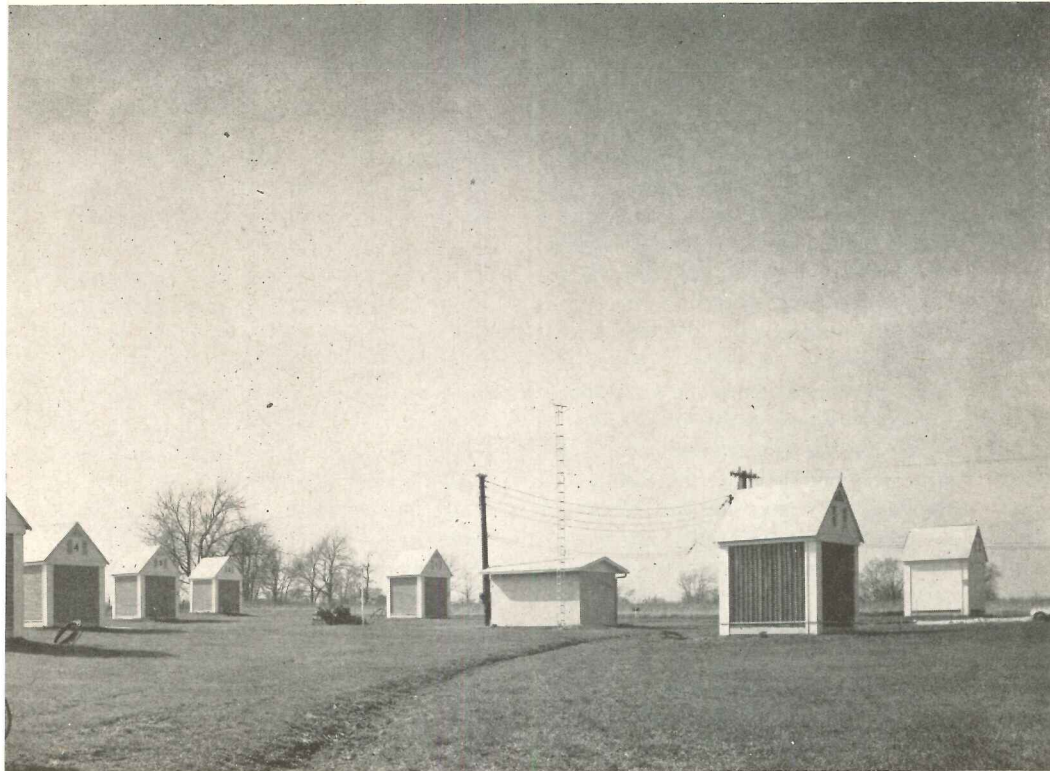

Hube Henry, Hedrich-Blessing

Eight test huts, six of masonry, one of wood frame, and one with metal panels were built at the Structural Clay Products Research Foundation to determine the beneficial effects of thermal lag

a long time that the "U" factor does not give a complete picture of the thermal properties of a wall or roof. The "U" factor gives heat loss or gain accurately only for the condition when heat flow is steady. With massive, dense materials, there is quite a lag between the time when the sunlight falls on a surface and when its effect is felt inside. At the other extreme, heat gain through glass is practically immediate. This phenomenon has been the subject of a good many excellent theoretical papers, but little has been done to give the engineer practical design data to use in the design of heating and air conditioning systems.

The eight test huts at the Structural Clay Products Research Foundation are instrumented to give empirical data on the thermal properties of constructions having a wide range response to temperature change.

LIMESTONE

Long a symbol of solidity and durability, limestone has gone modern too, in the sense that factory assembled units are available for complete and partial wall sections.

One through-wall unit consists of a 3-in. stone exterior, 2 in. of rigid insulation such as cellular glass and 3 in. of natural stone aggregate which serves as an interior and can be painted or plastered. The aggregate, made from natural stone waste, can be colored

at the time it is cast. For ease of handling the unit will be 5-in. high and 24-in. long, although it could be longer if necessary. This 8-in. thick unit has an average U factor of 0.12.

Another prefab unit is a window surround having a 1-in. smooth stone finish, 3 in. of insulating board core and a sprayed-on aggregate for the interior. The interior also could be painted or plastered.

Large-size curtain wall panels have been developed, according to J. T. McKnight, Executive Director of the Indiana Limestone Institute, with a 2-in. limestone outer face applied by mechanical fasteners to 2 in. of rigid insulation. One of the test samples had two pieces of stone for a panel 8-ft long and 3-ft high, but panels can be fabricated in larger sizes. The stone is fastened to masonry back-up with strap anchors or through use of shelf angles and dowels.

Waterproofing. Natural stones ordinarily do not have any inherent staining qualities; however staining can occur when water gets behind the wall and carries soluble salts or alkali to the surface. This can be prevented now through use of a new waterproofing material which takes advantage of the limestone chemistry itself. It has passed laboratory tests and will be on the market soon for application on Indiana Limestone.

Coloring. For those who would like a

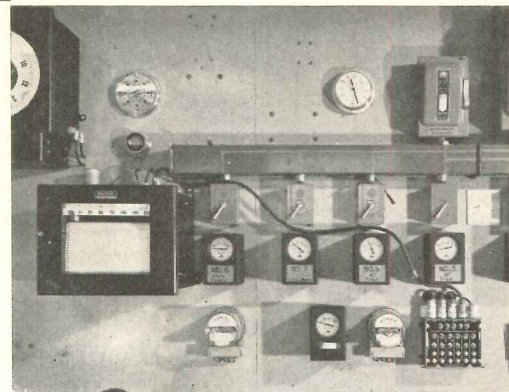

High strength mortar makes possible a prefabricated panel wall of brick, 15 to 20 high and two wide

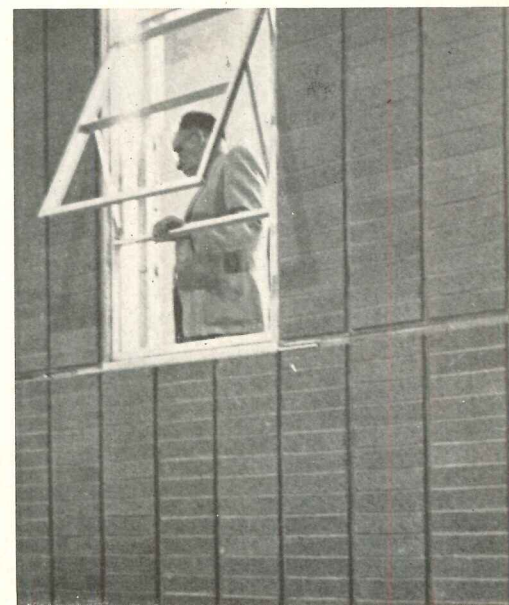

MASONRY MEETING DEMANDS OF MODERN CONSTRUCTION

variety of color for limestone walls, a penetrating stain has been developed in a series of basic hues which is sprayed on Indiana Limestone.

MARBLE

Back around 1930, marble was used extensively for its utility — in corridor walls, for example — as well as for decoration. More recently decorative uses have been prominent. Now it looks as though both features will be put to work, if current developments, as announced by A. T. Howe of the Marble Institute of America, are any sign. In addition to the popular veneer panels, there are a number of lightweight curtain wall constructions, using slabs of marble as thin as 1/2 in.

Curtain Wall Panels. The increasing

demand for thin, pre-assembled units has sparked the marble industry's efforts to produce a completed packaged wall in three possible forms: (1) marble plus insulation; (2) marble plus insulation in a marble frame on the back; and (3) marble plus insulation plus interior marble, or other backing. The first type of unit would be delivered to the job with only fitting into frames to be done in the field. In the second type, 2-in. wide marble strips are fastened to the back of the exterior slab, forming a recess into which the insulation is placed. The frame gives better bearing and wider marble to marble joining, and protects the insulation. An easily installed curtain wall panel, an example of the third type, has been fabricated by inserting marble, insulation and

backing in a metal frame which provides for snap-in connection (see photos below). The entire assembly weighs less than 9 lb per sq ft.

Another curtain wall panel is shown below in which the thin marble slab, in this case 1/8-in. thick, is set in place from inside the building, followed up by 3 in. of rigid insulation and 3/4 in. of plaster. An air space of 1/2 in. is left between marble and insulation, so that the total thickness is 5 1/8 in.

Marble can be cut as thin as its structural strength will allow, while retaining color, pattern and durability.

Future. Innovations to come include: (1) new finishes for exterior marble to enhance the natural markings, (2) new and improved methods of anchoring, and (3) better methods of shipment.

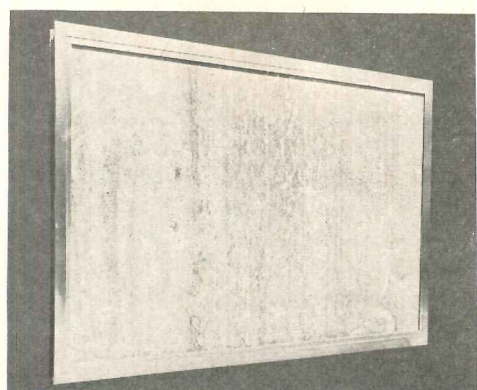
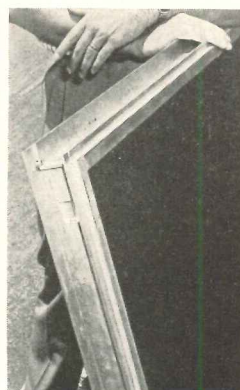
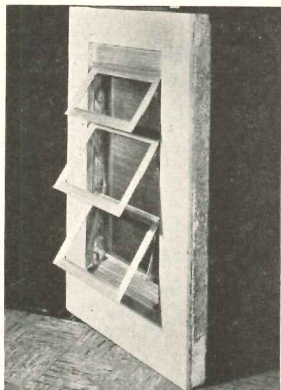
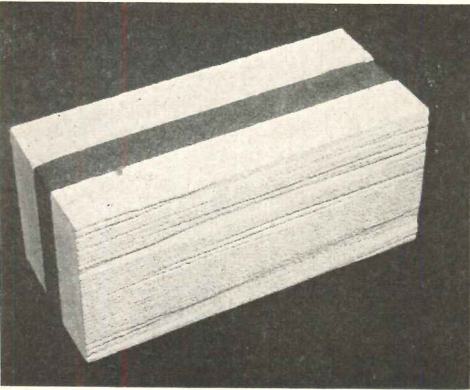

Prefabricated limestone: (1) a "thru-wall" unit with 3-in. limestone, 2-in. cellular glass, 3-in. waste stone; (2) window surround with 1-in. stone, 3-in. insulation and sprayed aggregate

Marble curtain wall panel uses 1/2-in. marble slab backed up by insulation and composition board, all held by an aluminum frame which interlocks with other frames. It weighs 9 lb per sq ft

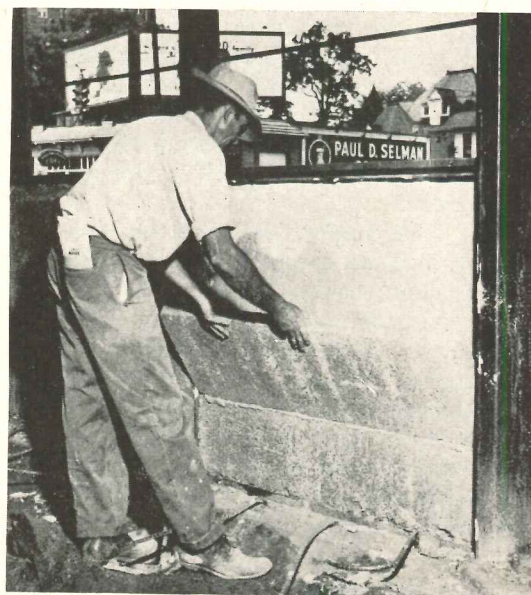
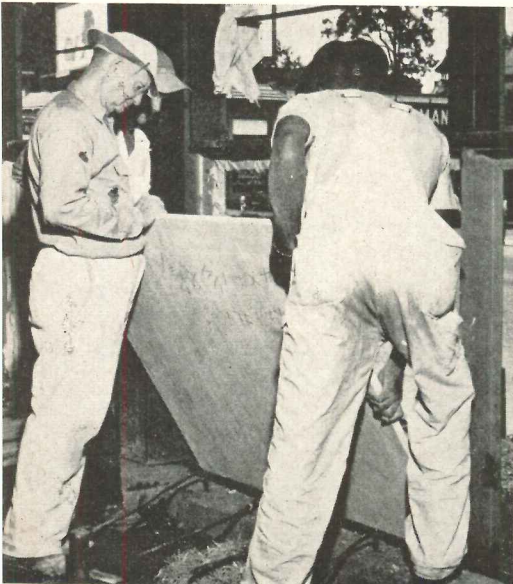

For another marble curtain wall, workmen first insert 1/8-in. slab in spandrel framework, followed by 3-in. rigid insulation; interior has 3/4-in. coat of plaster

SILICONES WATERPROOF MASONRY



AS TECHNOLOGY HAS MADE possible improved basic masonry and new units, so has it brought about a new concept in waterproofing. Experience is growing in the use of silicone chemicals which literally repel water and have been tested as even keeping out wind-driven rain, if the wall has been properly constructed. As a result, applications are increasing both in number and variety for this treatment which has been developed to prevent damp interiors, spalling and cracking, and annoying efflorescence. Silicone treatment is effective in preventing penetration of moisture through pores of masonry and hairline cracks in above-grade masonry, but does not offer protection against hydrostatic pressure.

Before silicones were available, the conventional way to give masonry a protective coating was to cover the surface with waxes or metal stearates. This amounted to sealing or varnishing the structure with a continuous film. Such a treatment had several disadvantages, the three principal ones being: (1) discoloration of the treated surface; (2) subsequent damage caused by moisture entrapped in the masonry at the time of application; and (3) relatively short period of useful service. In contrast, the silicones cause no change in appearance; they allow the masonry wall to breathe; (water vapor can pass through); and they have a life of from five up to as much as 10 years, based on accelerated laboratory tests.

Various types of masonry have different degrees of porosity, but in any case when moisture penetrates it, here are some of the things that can happen:

When water creeps into the masonry pores in cold weather and freezes, it causes spalling and deterioration.

And in above-freezing weather, water

comes in through the pores to the inside of a structure, causing paint to peel, woodwork to crack and warp, plaster to stain and fall apart.

Water also carries dirt into the pores where it lodges and defaces the outside walls, often in streaks.

If the masonry wall, the mortar joints, or the back-up contain soluble salts, and the water gets in, efflorescence with its tell-tale white or yellow blotches is likely to occur. Assuming that workmanship has been good on a wall, silicones can prevent efflorescence by coating the masonry pores and even hairline cracks with a water-repellent film.

Silicones are not a cure-all, nor can they be a cover-up for poor workmanship or detailing. In fact, authoritative sources, including national laboratories and formulators, stress the necessity of good construction when appreciable amounts of soluble salts are present in brick, and the exterior is coated with silicones. If moisture gets behind the masonry (through cracks caused by poor flashing, for example) and then later starts to move to the outside, the soluble salts will move as far as the silicone layer and will be deposited there, since silicones stop the passage of liquid water. This precipitate might result in slabbing of the brick.

Silicones can be used on all types of masonry including: brick, regular and lightweight concrete block, stucco, cement-asbestos siding, unglazed tile, cut and artificial stone, sandstone, some limestone (Indiana Limestone is an exception), and mortar joints.

Methods of Application. Spraying with a low pressure spray gives excellent results. Brushing with a good wall paint brush also does a good job. The surface actually should be flooded with liquid.

Silicones work in this fashion: The

solution penetrates the pores of the masonry. When the solvent evaporates, a film is deposited on the surface of the pores to a depth of from $\frac{1}{16}$ to $\frac{3}{16}$ in., depending on the material. A chemical reaction then takes place, resulting in a highly water repellent surface.

On new construction, application should be deferred for at least 30 days in summer and 60 days if the temperature has been close to freezing. On older buildings any loose mortar or stone fragments should be removed and all large cracks or holes pointed. Best results will be achieved if the wall is thoroughly dry before application. Temperature is of little importance, since silicone can be applied at temperatures as low as 15 F.

Only one application is needed except for the following materials: Tile mortar joints, cement asbestos board, concrete floors, marble and some cast concrete.

Silicone treated surfaces are paintable, too. If the wall is to be oil painted the silicone should dry for three or four days. If it is to be coated with a water-mixed cement paint, the silicone should be applied after the surface has been painted and is dry. With porous concrete products (pore size greater than $\frac{1}{32}$ in.) such as lightweight aggregate blocks, the surface should be given an initial coat of water-mixed cement paint or a plaster coat of cement, sand and lime.

Two coats of silicone treatment are said to protect concrete floors from dilute acids and alkalis, providing traffic is light.

On the average, the following coverages are possible with one gallon of silicone water repellent:

- Hand fired brick — 150 to 200 sq ft
- Soft brick — 100 to 125 sq ft
- Lightweight block — 70 to 75 sq ft.

Silicones are applied on large areas by means of a low pressure spray in a flooding action so as to insure thorough treatment

Photos courtesy Union Carbide and Carbon Corporation



CERAMIC BONDED TO CONCRETE FOR SPANDRELS

The first curtain wall panels made with a ceramic veneer facing and lightweight concrete back-up are installed in an Arcadia, Calif. hospital

BLUE-GRAY CERAMIC-VENEERED concrete wall panels which were cast in advance, then delivered to the site and attached in place by bolted connections, form the complete walls of the four-story Methodist Hospital in Arcadia, Calif. (Neptune & Thomas, Architects, Pasadena). Developed by the Architectural Terra Cotta Institute, the panels are only 3 in. thick and relatively light in weight, yet have good strength and thermal properties, weathertightness, flexibility, an easily maintained colored surface — and the obvious merit of reduced time and labor costs at the

site because of the elimination of a backup wall.

The CV (Ceramic Veneer) Panelwall (supplied for this job by Gladding, McBean & Co. of Los Angeles) is formed by placing in a form 1-in.-thick ceramic veneer (architectural terra cotta) facing units with a high-fired glazed finish and then casting a reinforced concrete backup 2 in. thick. The backup is a lightweight, expanded shale type aggregate, reinforced with galvanized welded steel mesh, which is vibrated in place for maximum density and good bond. The ceramic veneer is glazed,

fired (at 2200 F) and sized before it is placed in the casting mold. Here are some of the characteristics of the wall:

Weight: About 30 psf.

Weathertightness: The coefficient of expansion and contraction of the ceramic veneer and the concrete backing is about the same, and considerably less than metal, so there is a minimum of movement and therefore a watertight panel. A Koroseal gasket is used around the perimeter of the panel as a water seal. There is no through-the-wall joint in the panel itself, and so no other flashing is required.

(1) After being lifted into place by means of standard rigging equipment, the panels were stripped with Koroseal gaskets at the ends and placed in a cement mortar bed. (2) Panels were attached

to the backs of aluminum mullions by toggle bolts placed through holes in projecting strap anchors (which had been welded to reinforcing mesh and embedded in the concrete backing). (3)

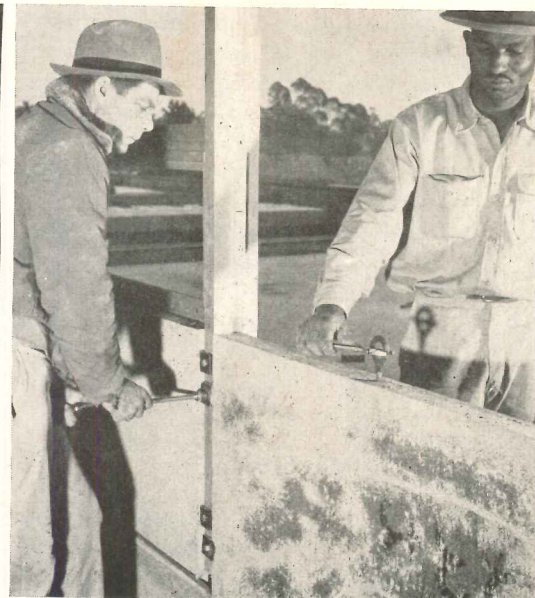
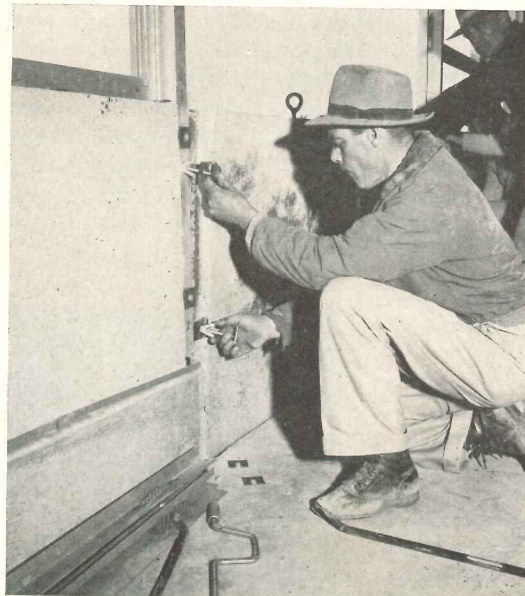
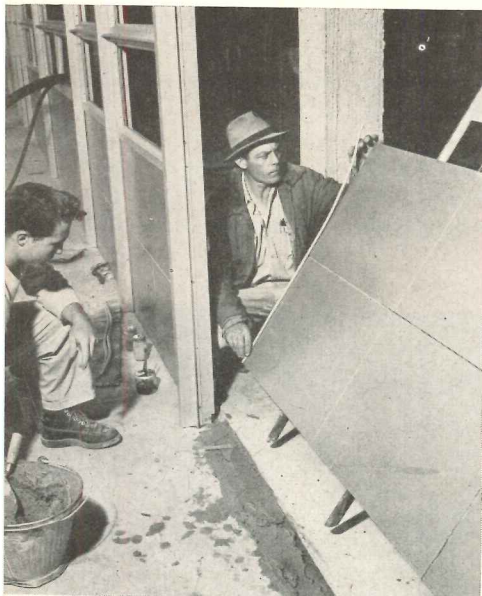

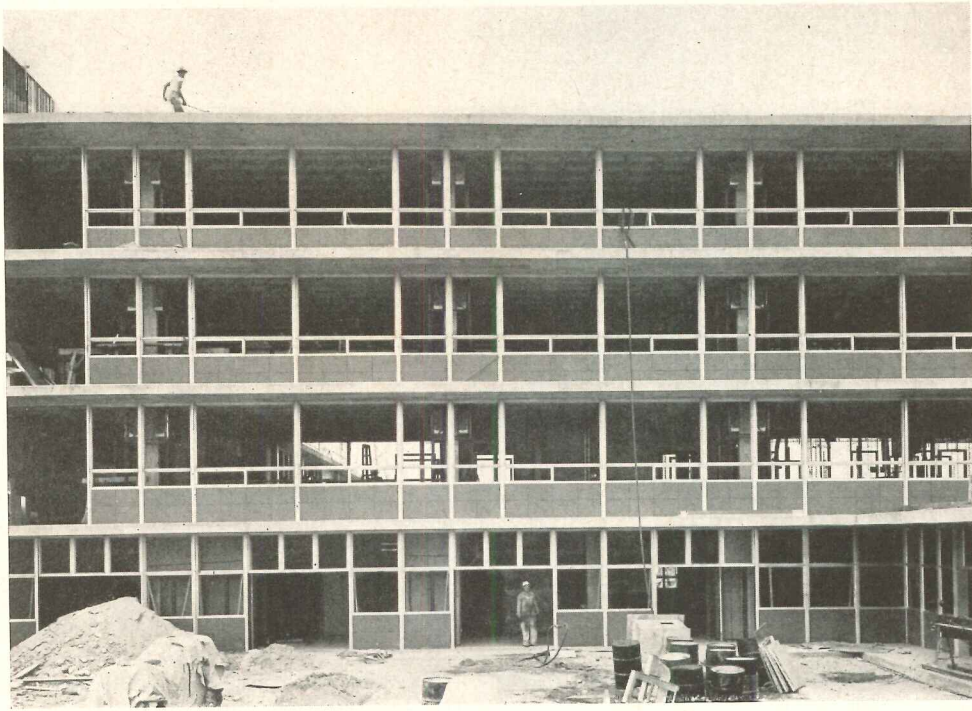

Rendering of Methodist Hospital and view of the ceramic-veneered panels in place during construction

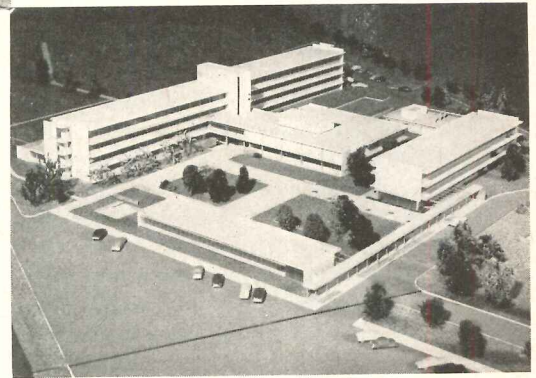

Thermal Characteristics: The U factor of the panel is between .5 and .6. However, with 1 in. of Zonilite plaster added to the back of the spandrel wall and covering the metal mullions, a U factor of about .27 was attained.

Fire Rating: The panel itself qualifies for a 1-hr fire rating.

The technique of installation of the panels is illustrated in the accompanying photographs. The Structural Clay Products Research Foundation is currently engaged in a research program to improve even further the panel construction and to assist in developing thinner and lighter panels.

After fiber gaskets (for insulation between steel and aluminum) and metal shims had been inserted for accurate adjustment, the bolts were tightened, and steel eye bolts used for lifting were unscrewed.

(4) Joint at concrete deck was caulked to 1/2 in. depth. (5) Base of mullion was sealed from rear by caulking. (6) Membrane strip covered back of mullions before application of interior plaster

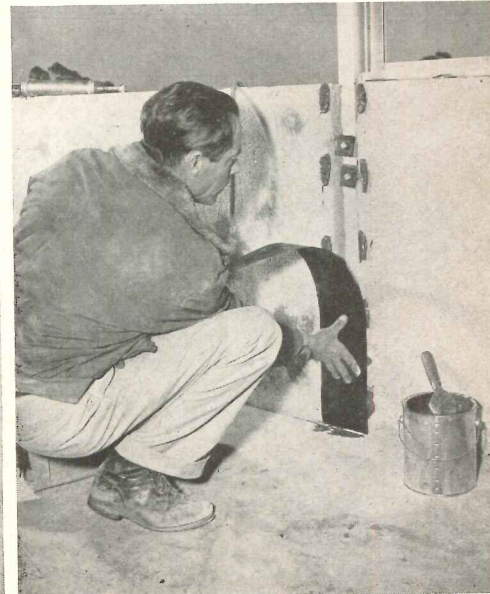
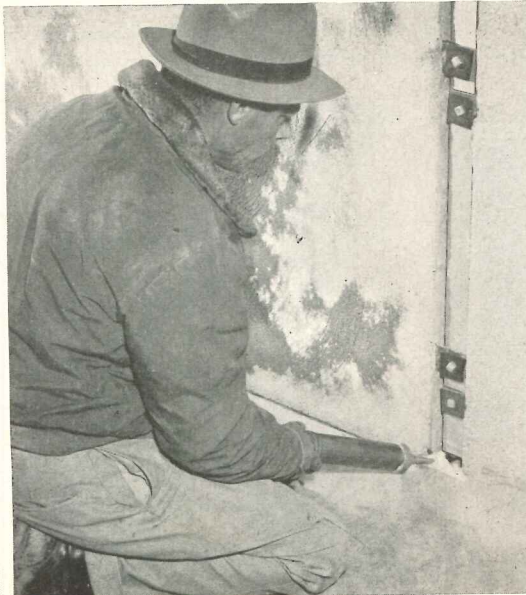
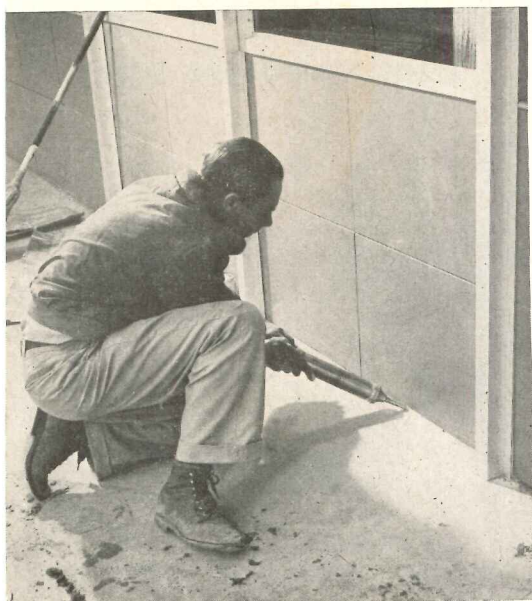

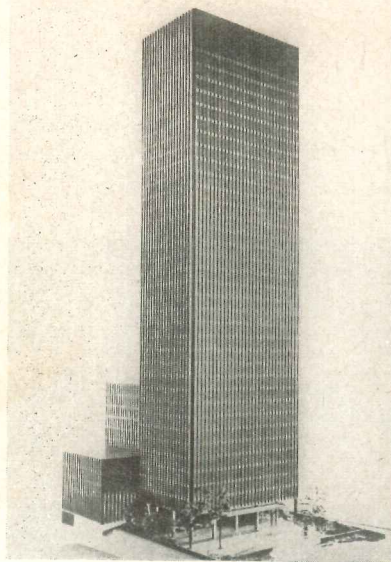

BRONZE CURTAIN WALL WITHSTANDS MINIATURE HURRICANE

THE NEW HOUSE OF SEAGRAM on New York's Park Avenue has withstood a hurricane—at least in miniature! A two-story mock-up of the building, which will be the first ever to be sheathed in bronze, was subjected to an intensive weathering test to determine the watertightness and durability of its window and curtain wall construction.

The components of the test are shown in the photograph below right: the two-story curtain wall and window replica, a propeller and overhead water pipes. The tri-blade propeller, driven by an airplane engine, provided wind velocities ranging from 50 to 120 mph, creating all conditions of nature's pressures against the skyscraper walls. Water falling from the overhead pipes at the rate of 4 in. per hr was driven against the wall by the wind, but failed, according to the test results, to dampen or damage the interior of the mock-up. For the higher wind pressures water was applied also from distribution rings aft of the airplane engine to assure torrential conditions at the faces of all windows.

The series of tests was staged at the

proving grounds of General Bronze Corp., which is fabricating the panels, and was designed to provide static and dynamic conditions of air pressure to permit measurement of unit infiltration of air and water from driving rains. The tests were observed by Mies van der Rohe and Phillip Johnson, the building's architects, among others.

The 38-story skyscraper, which is scheduled for completion late in 1957, will feature the first complete façade to be done in bronze. Architectural bronze was selected because of its non-rusting properties, its high resistance to corrosion, its workability and its permanency. After the bronze has been fabricated in the shop, it will be given a satin finish. Accelerated acid oxidation under ideal conditions will provide a good basis for the natural permanent patina. As it weathers, the bronze will take on a chocolate brown color and will require only periodic wiping to remove city dust and grit. Fixed windows (the building will be completely air-conditioned and so will need no operating windows) will be tinted pinkish gray to blend with the bronze as it ages and

also to eliminate glare.

The extruded bronze mullions, shown in the assembly below left, are shaped like lightweight steel columns and span from floor to floor to support the window and spandrel panel units. The I beams will also serve as guides for the mobile window equipment, which will travel vertically while maintaining the building façade. The mullions will be attached to the building structure by specially designed steel anchors which will permit perfect alignment in three directions. The window and spandrel units, 4 ft 7 in. wide and one story high, will be attached to the mullions in such a way as to allow for expansion and contraction within each unit, so there will be no accumulation of expansion or contraction over the entire façade. Window and spandrel frames will have completely welded corners with continuous gasketing material between them and the supporting mullions. Continuous copper flashing will protect the wall from condensation or other moisture at the window head level on each floor.

(More Roundup on page 280)

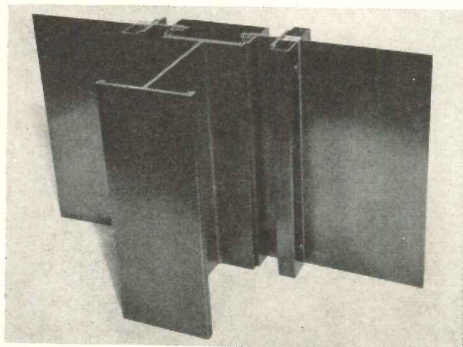

Positioning of exterior vertical I beams, spandrels and T bars at wall line



Propeller drives water from overhead pipes against building mock-up

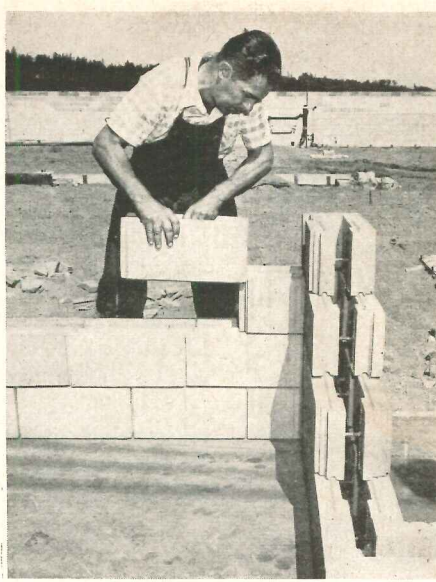
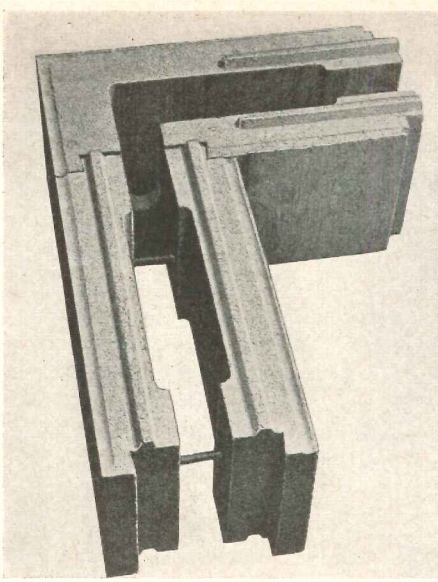

UNIQUE CONCRETE BLOCK FOR CAVITY WALL CONSTRUCTION

PRESTO BLOCK is a unique concrete building unit which is said to produce a true air-cavity wall with speed and economy. Each block is a miniature "twin-wall" in itself, comprised of two separate concrete units bound together by corrugated steel ties which are inserted into the units automatically by machine during the production cycle. The top, bottom and end surfaces are keyed to lock upon erection, as can be seen in the close-up photograph above,

thus permitting a wall to be laid so that at no point do the inner and outer walls have a through masonry bond. After the wall is erected, the keyed joints are pointed by hand or with a mortar gun to provide extra strength and a permanent moisture seal.

The "twin-wall" design simplifies the installation of electrical wiring and plumbing. No furring is needed, since the nature of the double wall construction creates a through air space.

No additional reinforcement is required because of the multiple strength of the steel ties which bind the individual units together. Mortar tubs and heavy construction scaffolding are eliminated.

The cavity wall construction makes a building cooler in summer and warmer in winter and combines also sound and moisture insulation qualities. *The Presto Block Machine Corp., Empire State Building, New York, N. Y.*

DUAL-FACE FIREPLACE

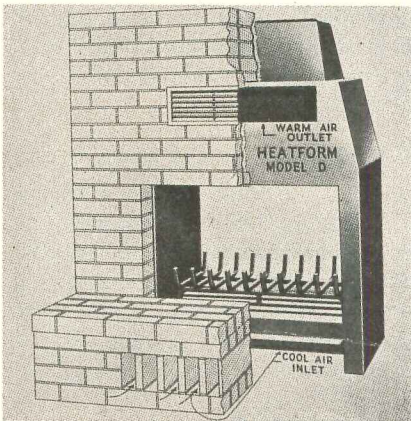

HEATFORM MODEL D is a fireplace unit serving two rooms, in which air chambers capture and circulate a large volume of the heat instead of losing it to the chimney. The unit has air heating chambers above and below the firebox, with connecting heating chambers leading from the lower to the upper heating chambers. It is shipped with a square end steel bar fuel grate made of $\frac{3}{4}$ -in. bars for wood burning only. *Superior Fireplace Co., 1708 East 15th St., Los Angeles 21.*

ELECTRIC HEATING FROM CEILING

ELECTRIC RADIANT HEATING which employs specially insulated heating wires hidden in the ceiling not only does away with the chimney, furnace, radiators, flues and pipes, according to GE engineers, but also frees the space that would be taken up by conventional fuel burners and storage tanks and adds to the flexibility of decorative planning. The entire heating plant consists of the heating wires, thermostats and connections to the electric power supply.

The wires are installed as shown in the illustrations below. First they are looped across the ceiling and stapled to it. Then they are covered with plaster or wallboard. The system heats by radiation, thus virtually eliminating drafts and air currents. According to GE engineers, the warmth is distributed evenly from ceiling to floor, with a variance of 4 deg or



less. Thermostats in each room permit separate selection of the temperature desired for that room. The wires can also be installed in concrete floors. *General Electric Co., Wiring Devices Dept., 95 Hathaway St., Providence 7, R. I.*

(More Products on page 289)

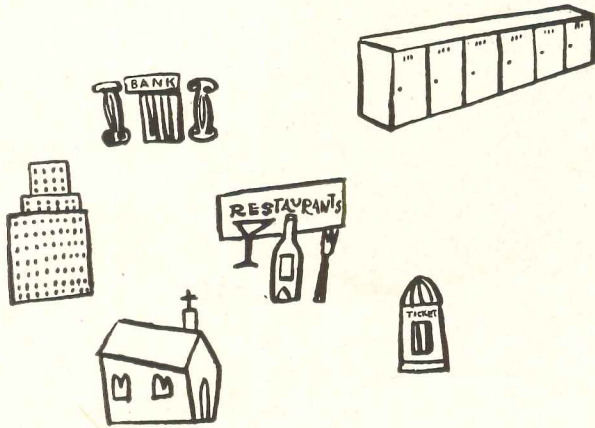

DESIGN BY MCPHILBEN (AIA 31-F-2)

Folio 56-6 presents engineering information for accomplishing successful interior lighting equipment applications. It offers a guide to levels of illumination in building types such as those shown in the sketches at left (taken from the brochure). It includes also sections on illumination calculations, lamp data, light distribution classifications and maximum spacing ratios, room indexes and tables of coefficients of utilization. 8 pp. *McPhilben Mfg. Co., Inc., 1329 Willoughby Ave., Brooklyn 37, N. Y.**

Religious Buildings (AIA 4-K)

Shows examples of how precast concrete slabs lend themselves to church buildings. 6 pp. *Flexicore Co., Inc., 1932 E. Monument Ave., Dayton 1, Ohio.**

Home Insulation

Form WHN-11 describes home insulation with reflective facing and shows suggested methods of application. 4 pp. *L. O. F. Glass Fibers Co., 1810 Madison Ave., Toledo 1, Ohio.**

Enameled Aluminum Siding

Two brochures describe *Koralum* interlocking enameled aluminum clapboard siding and *Lyfalum* nailable enameled aluminum clapboard siding. *Lyf-alum, Inc., Oconomowoc, Wis.*

Office Lighting

I.E.S. Recommended Practice for Office Lighting includes results of consultation over the past six years with representatives of the I.E.S. Committee on School Lighting, the A.I.A. and the National Council for Schoolhouse Construction. 32 pp. 50¢. *Publications Office, Illuminating Engineering Society, 1860 Broadway, New York 23, N. Y.*

Hi-Lo Fully Automatic Dockboards

(AIA 35-I-131) Bulletin D-160 explains and diagrams the Hi-Lo features for both the recess and package model automatic dockboards. 4 pp. *The Kelley Co., Inc., 316 East Silver Spring Drive, Milwaukee 17, Wis.*

Sectional Cafeteria Counters

Catalog shows various component parts of a sectional cafeteria counter and how they can be assembled in many different combinations to fit individual needs and requirements. 16 pp. *Southern Equipment Co., 4550 Gustine Ave., St. Louis 16, Mo.*

Physical Fitness Equipment

Catalog shows playground units of a new design embodying formed and welded sections instead of the standard friction joint assemblies. *Pioneer Wagon Works, Owosso, Mich.*

Sinks and Lavatories

Bound catalog presents diagrams with dimensions for each sink and lavatory fixture and also includes a price list section. *U. S. Porcelain Enamel Co., 4635 East 52nd Dr., Los Angeles.*

Tygon Protective Coatings

Bulletin 760 offers useful painting data in the form of charts, tables, diagrams and illustrations. *The U. S. Stoneware Co., Plastics and Synthetics Div., Akron 9, Ohio.*

High Fidelity Sound Reinforcement

Bulletin covers *Sonassist*, a hi-fi sound reinforcement system, available in console and table models, designed for meeting rooms in schools, hotels and churches. 4 pp. *Associated Consultants & Engineers, Inc., P. O. Box 7509, University Station, Austin, Tex.*

Progress Catalog 103

Describes a complete and expanded line of lighting fixture products, ventilating fans, range hoods and door chimes. 72 pp. *Progress Mfg. Co., Castor Ave. and Tulip St., Philadelphia 34, Pa.*

Storage Water Heaters

Catalog 19, tab-indexed for easy reference, presents all standard lines of Patterson-Kelley commercial and industrial storage water heaters and includes the latest provisions of the 1952 ASME Code for unfired pressure vessels. 48 pp. *The Patterson-Kelley Co., Inc., Storage Water Heater Div., 501 Fullon St., East Stroudsburg, Pa.**

Controlling Moisture

Design Techniques for Controlling Moisture in Building Structures is a manual prepared by a firm of technical engineering writers for *W. R. Meadows Inc., 7 Kimball St., Elgin, Ill.**

Sliding Glass Doors, Windows

Brochure presents photos applicable to new construction, a nomenclature of stock door sizes and a complete list of manufacturing members and associate members of the *Sliding Glass Door and Window Institute, 7421 Beverly Blvd., Los Angeles 36, Calif.*

Gilsulate

Describes *Gilsulate* insulation for hot underground pipes, with on-the-job photos and technical data. 4 pp. *American Gilsonite Co., 134 West Broadway, Salt Lake City 1, Utah.*

Mississippi Glass (AIA 26a-3, 5, 6)

... for Residential and Commercial Use. Catalog 56-R describes, with full-size and half-size photos, figured glass and glass types for non-structural and for structural decoration. 12 pp. *Mississippi Glass Co., 88 Angelica St., St. Louis 7, Mo.**

Lighting Catalog

Shows "dramatic, distinctive and decorative" residential lighting fixtures. 16 pp. *Estly Mfg. Co., 112 So. Sangamon, Chicago 7, Ill.*

Locksets and Accessories

Four-color catalog describes the "400" line of locksets and accessories in the Bel Air and Standard designs. 8 pp. *Kwikset Sales & Service Co., Anaheim, Calif.*

**Other product information in Sweet's Architectural File, 1956.*

(More Literature on page 346)

FINE HARDWOODS FOR ARCHITECTURAL USES—10

By *Burdett Green, Executive Vice President, Fine Hardwoods Association*
and *James Arkin, A.I.A., Consultant, Architectural Woodwork Institute*

LACEWOOD (*Cardwellia sublimis*)—Australian Silky Oak, Queensland Silky Oak, Selano, Silky Oak.

Source: Queensland, Australia

Color: Light pink with silvery sheen

Pattern: Small flaky grain due to large rays

Characteristics: Very attractive over-all pattern when used on small areas

Uses: Often as borders and limited, highly figured areas of fine furniture

Availability: Veneer (quartered) scarce

Price Range: Costly

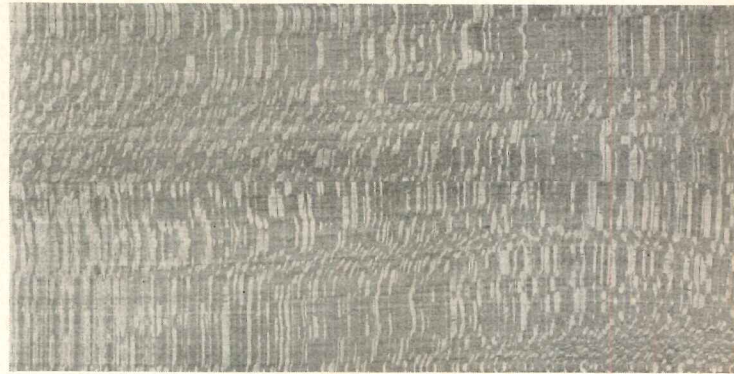

Lacewood, quartered (one piece)

LAUREL, EAST INDIAN (*Terminalia tomentosa*)—East Indian Walnut

This species is closely related to Ireme (note botanical name). However, the laurel principally imported into this country is a very important wood growing throughout India and Burma. It varies widely in color from a yellowish-brown through all stages to a rich, warm brown with dark streaks, handsomely marked, and many types of figure. Another type of Laurel produced in the United States, which is an entirely different species known as California Laurel or Oregon Myrtle, is usually produced in burl or clustered figure. This should not be confused with the Laurel from the Far East (*Terminalia*).

Source: India and Burma

Color: Gray or brown with black lines

Pattern: Striped; occasional block-mottle or fiddleback figure; indistinct rays

Characteristics: Coarse-grained; hard and brittle; pores not numerous

Uses: Fine cabinetry

Availability: Veneer (quartered) scarce. Lumber scarce

Price Range: Costly

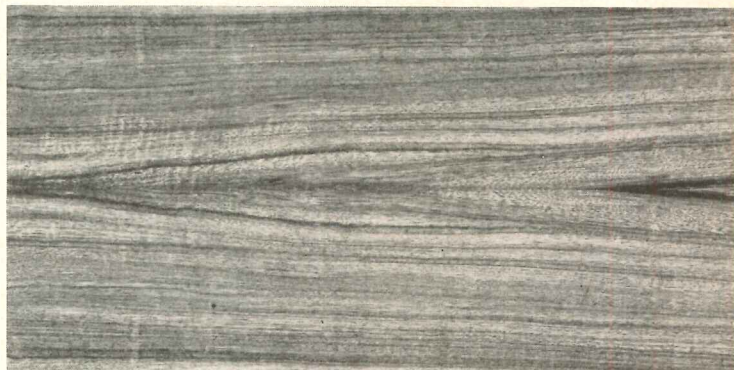

Laurel, East Indian, quartered (2 pieces, book-matched)

LIMBA (*Terminalia superba*) — "Korina," Afara, Frake, Offram

Another *Terminalia* which has been widely publicized under the trade-name of "Korina." In recent years this species has become one of the most popular naturally blond woods brought into this country. It has an especial appeal for architectural use in view of the fact that it is available in large sizes, as is Mahogany, and as both veneers (plywood) and lumber.

Source: West Africa

Color: Pale yellow to light brown

Pattern: Rays fine and irregular; pores scarce, but large enough to give an interesting grain character

Characteristics: Medium texture and hardness; a naturally blond wood of good working properties

Uses: Architectural paneling and woodwork; contemporary furniture

Availability: Veneer (quartered, sliced) plentiful. Lumber available

Price Range: Medium

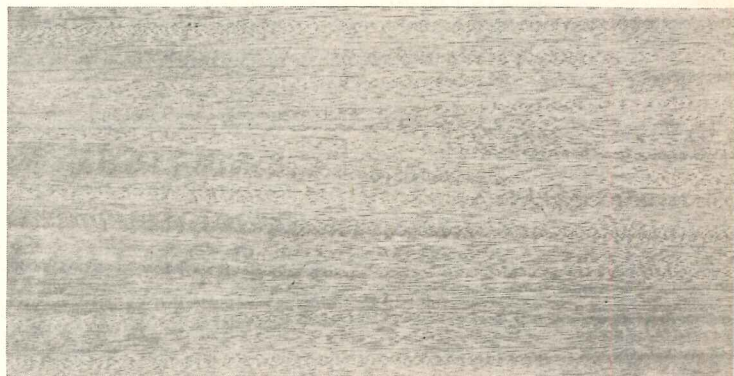

Limba ("Korina"), quartered (one piece)

MYRTLE (*Umbellularia californica*)—Acacia Burl, Baytree, California Laurel, Oregon Myrtle, Pepperwood (at times called Acacia but no relation)

Source: West Coast of United States, especially Southern Oregon and Northern California

Color: Golden-brown and yellowish-green. Wide range from light to dark

Pattern: Mixture of plain wood, mottle, cluster, blistered, stump and burl figure with a scattering of dark purple blotches

Characteristics: Hard, strong pores the size and distribution of Walnut; a magnificent, highly figured veneer

Uses: Decorative panels for architectural interiors, store fixtures and furniture; novelties; many fine turnings, trays and carvings

Availability: Veneers (half-round), lengths usually under 5 ft although up to 8 ft, rare to scarce. Lumber scarce

Price Range: Costly

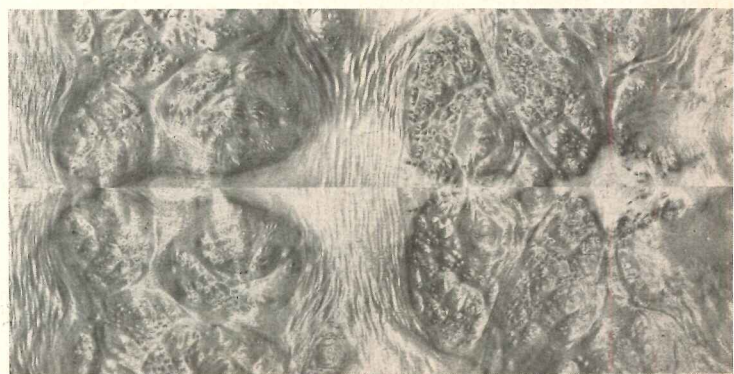

Myrtle Cluster, rotary (2 pieces, book-matched)



Beardsley Terrace Housing, Bridgeport, Conn. • Engineers: Frederick M. Hill and Paul D. Harrigan, New Haven.
Architects: Lindsay & Johnson, Bridgeport. • Heating Contractor: Bridgeport Pipe & Engineering Co., Bridgeport. • General Contractor: E & F Construction Co., Bridgeport.

Here's why Mechanical Engineer is enthusiastic about Sarcotherm in 1200-family 16-building project

AS Mechanical Engineer Paul D. Harrigan writes, "Sarcotherm steam heating controls in Beardsley Terrace Housing...working perfectly through extreme part of Winter as well as in Spring...sensitive, accurate and flexible...the Housing Authority, the architects and we ourselves are entirely satisfied."

Sixteen Sarcotherm Weather-Compensated Controls serve Beardsley Terrace. Of the continuous, modulated flow design, they provide individual zone control for the steam heating of each building. Precisely engineered orifice plates assure the proper steam flow to each heating unit.

COMPLETE SYSTEM — UNDIVIDED RESPONSIBILITY

Sarcotherm engineers cooperate in the preparation of working drawings and wiring diagrams for each job, and follow through with on-the-job help and supervision of installation.

Sarcotherm assumes undivided responsibility because the Sarcotherm System is **COMPLETE**—includes zone controls, panels, thermostats and steam specialties—traps, valves, and air eliminators.

Write for further details. Sarcotherm Controls, Inc., Empire State Building, New York 1, N. Y.

FEATURES OF SARCOTHERM CONTROL SYSTEMS

1. **Easy to install**—working drawings and wiring diagrams furnished for each job.
2. **Easy to maintain**—because of simplified construction, fewer parts.
3. **Easy to adjust**—to any desired setting.
4. **Engineered orificing**—assures even heat flow to all units from the start.
5. **Undivided responsibility**—by one maker, Sarcotherm, for the complete control system.

4003-D

Sarcotherm

An affiliate of SARCO COMPANY, INC.

WEATHER-COMPENSATED CONTROLS FOR STEAM, HOT WATER AND RADIANT HEATING

FINE HARDWOODS FOR ARCHITECTURAL USES—11

By Burdett Green, Executive Vice President, Fine Hardwoods Association
and James Arkin, A.I.A., Consultant, Architectural Woodwork Institute

OAK, ENGLISH BROWN (*Quercus robur*, L. Q.; *Quercus sessiliflora*, Salisb.)—European Oak, Pollard Oak

Source: England

Color: Light tan to deep brown

Pattern: Black spots, sometimes creating an effect much like tortoise shell

Characteristics: Noticeable figure and grain character; especially pronounced flakes due to the medullary rays showing on the quartered surface

Uses: Architectural woodwork; some fine furniture

Availability: Veneer (quartered, sliced) scarce. Lumber scarce

Price Range: Costly

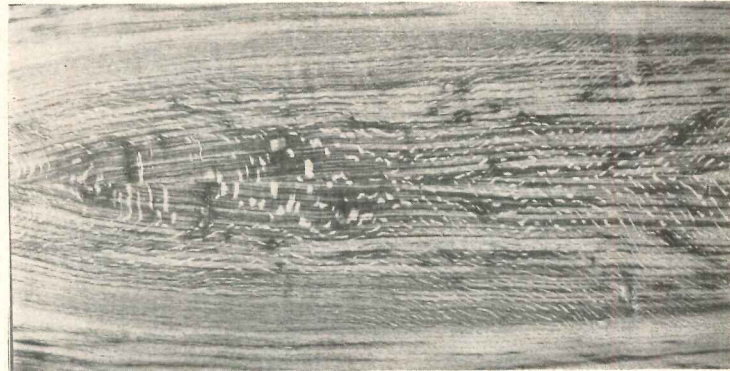

Oak, English Brown, sliced (2 pieces, book-matched)

PALDAO (*Dracontomelum dao*)—Dao

Source: Philippines, Indo-China and East Indies

Color: Gray to reddish brown

Pattern: Varied grain effects usually with irregular stripes, some occasionally very dark; occasional crotch or swirl

Characteristics: Pores are large, partially plugged; fairly hard; an exotic appearing wood

Uses: Architectural woodwork and furniture

Availability: Veneer (quartered, half-round) plentiful. Lumber available

Price Range: Medium

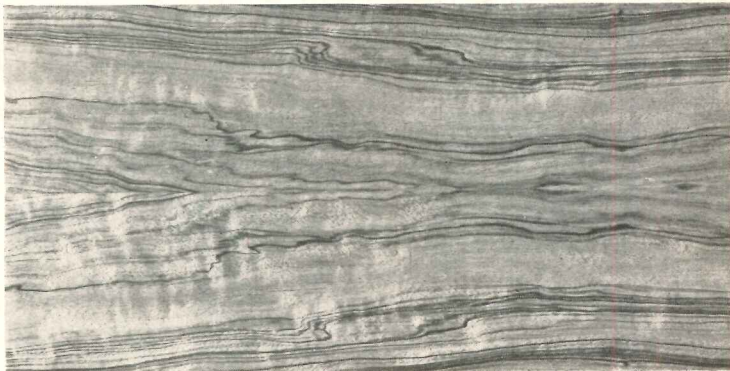

Paldao, quartered (2 pieces, book-matched)

PRIMA VERA (*Cybistax Donnell-smithii*)—Durango, Palo Blanco, San Juan (sometimes misnamed "White Mahogany")

Source: From Central Mexico, south through Guatemala and Honduras into Salvador (other species of *Tabebuia* found in northern South America)

Color: Yellow-white to yellow-brown

Pattern: Straight grain. Although often plain, it usually shows large mottle or diagonal block figure

Characteristics: Odorless and tasteless; medium to coarse textured; straight to somewhat striped grained; moderately light in weight

Uses: A fine, general-use cabinetwood

Availability: Veneer (quartered, sliced) scarce. Lumber available

Price Range: Costly

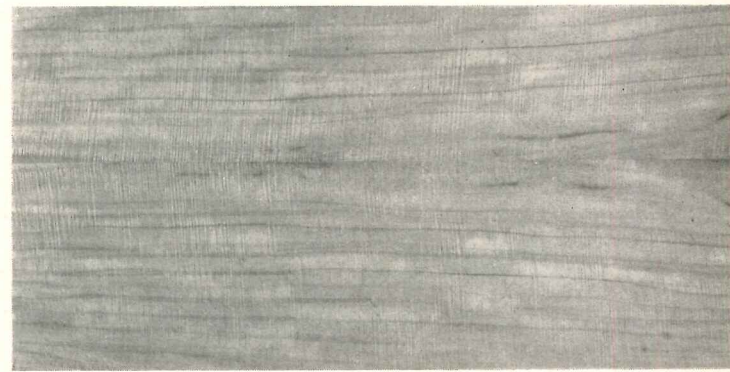

Prima Vera, quartered (2 pieces, book-matched)

SATINWOOD

There are several somewhat similar woods imported under this name. The two most important are:

SATINWOOD, CEYLON (*Chloroxylon swietenia*, D.C.)—East Indian Satinwood

Source: Ceylon and southern India

Color: Pale gold

Pattern: Ripples, straight stripes; bee's wing mottled

Characteristics: Hard; dense; interlocking grain; inclined to check

Uses: Furniture

Availability: Veneer (quartered, sliced, half-round) rare. Lumber rare

Price Range: Costly

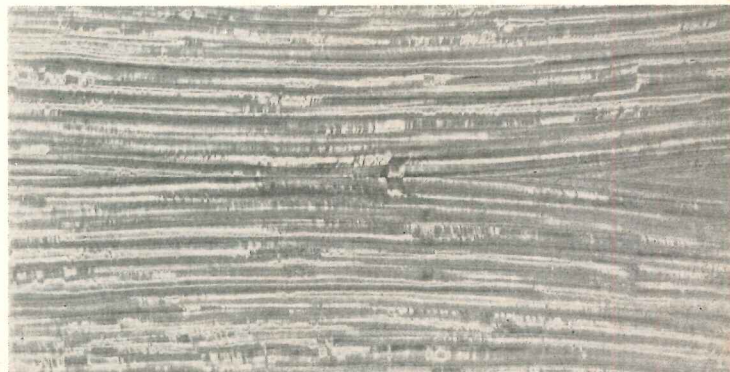

Satinwood, Ceylon, figured quartered (2 pieces, book-matched)

SATINWOOD, WEST INDIAN (*Zanthoxylum flavum*, Vahl.)—San Domingan Satinwood

Source: Puerto Rico, British Honduras

Color: Creamy golden yellow

Pattern: Wavy grain

Characteristics: Fine grained; hard and quite heavy; works well with most tools

Uses: Furniture; marquetry; inlaying; turnery

Availability: Veneer (sliced) scarce. Lumber available

Price Range: Costly

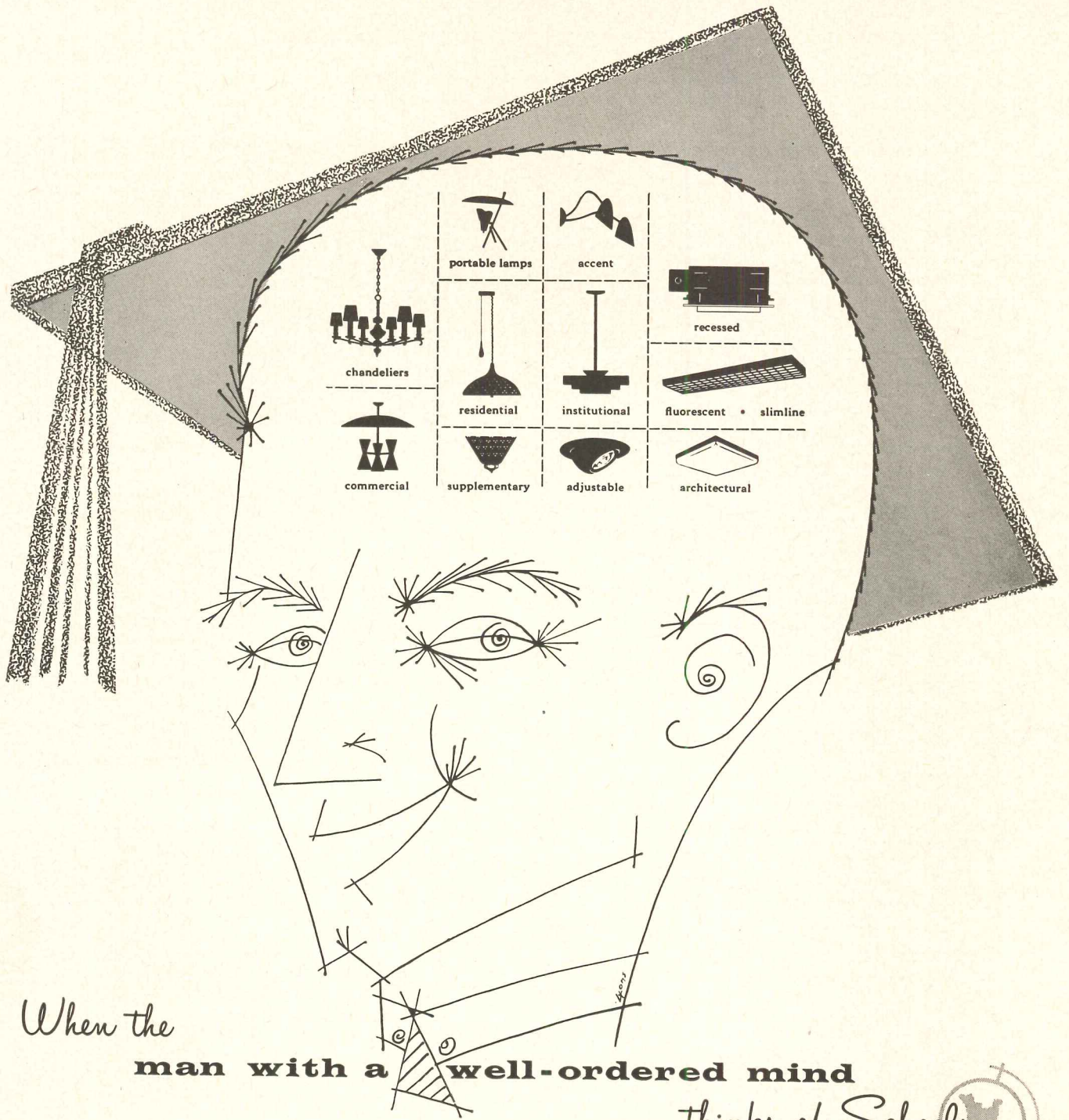

When the
man with a well-ordered mind
 thinks of Schools...



He fondly recalls the happy days at dear old alma mater. But when he thinks of school *lighting*, he calls LITECRAFT... to assure the comfort and happiness of students, and the satisfaction of clients. *Your* LITECRAFT Field Engineer, and your LITECRAFT Distributor's lighting specialists, are just waiting for the chance to help you work out an imaginative, efficient and economical solution to *your* school lighting problems. So call or write for a complete file of LITECRAFT lighting designs and specification data to enhance *your* next school project:

MR. JOHN A. OXFORD, *School Lighting Division*



LITECRAFT
 manufacturing corp | affiliates • FINLAND HOUSE Lighting
 8 EAST THIRTY SIXTH STREET • NEW YORK 16 NY | SALEM BROTHERS Inc.
 the lighting professional's supermarket

FINE HARDWOODS FOR ARCHITECTURAL USES—12

(To be continued in a later issue)

By Burdett Green, Executive Vice President, Fine Hardwoods Association
and James Arkin, A.I.A., Consultant, Architectural Woodwork Institute

SAPELE (*Entandrophragma cylindricum*)—Aboudikrou, Sipo, Tiama

Source: African Ivory Coast, Nigeria

Color: Dark red-brown

Pattern: Stripe and bee's wing

Characteristics: Considerable variation in grain; light portions of stripes lustrous; works fairly well with hand and machine tools; tough; harder and heavier than African Mahogany

Uses: Veneers for furniture; cabinetwork; interior decoration

Availability: Veneer (quartered) plentiful. Lumber available

Price Range: Medium

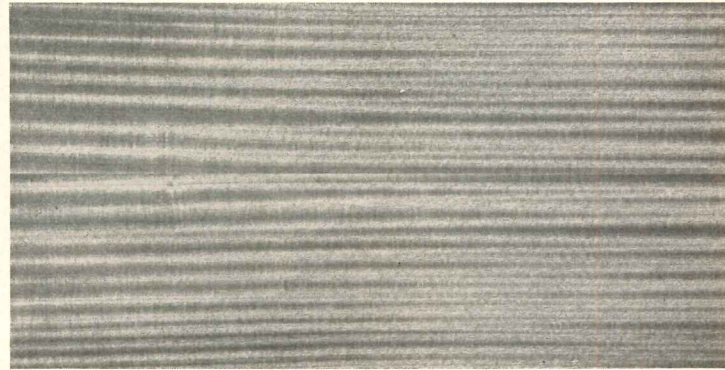

Sapele, quartered (2 pieces, book-matched)

TEAK (*Tectona grandis*)—Burma Teak, Rangoon Teak

Source: Burma, Java, East India, French Indo-China

Color: Tawny yellow to dark brown, often with lighter streaks, not black as many think

Pattern: A great deal like Walnut, sometimes mottled and fiddle-back

Characteristics: Strong; tough; oily. Like Walnut, except for oiliness, and is one of the finest cabinetwoods

Uses: Paneling; furniture; floors; ship decking

Availability: Veneer (quartered, sliced) plentiful. Lumber available

Price Range: Costly



Teak, flat cut, semi-figured (one piece)

TIGERWOOD (*Lovoa klaineana*)—Congowood (often misnamed African "Walnut," Benin Walnut and Nigerian Golden "Walnut")

Source: West Africa

Color: Gray-brown to gold with black streaks

Pattern: Pronounced ribbon stripe

Characteristics: Easily worked; transverse grain shows irregularly sized, scattered pores

Uses: Furniture; paneling

Availability: Veneer (quartered) plentiful. Lumber available

Price Range: Medium

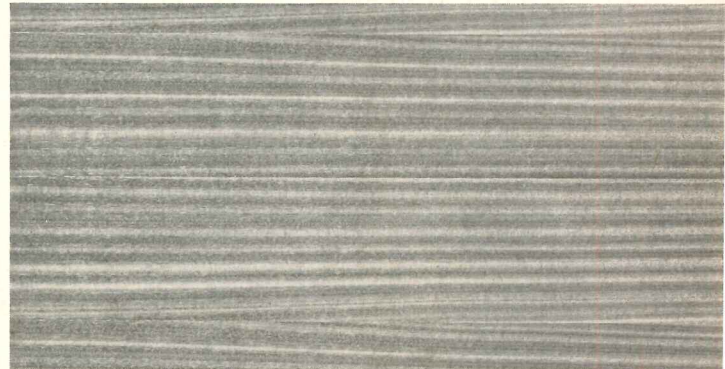

Tigerwood, quartered (4 pieces, book-matched)

YEW

Two species of genuine Yew are available:

YEW, AMERICAN (*Taxus spp.*)—Florida, Pacific or Western Yew

Source: Pacific Coast and Southwestern Canada

Color: Reddish-brown

Pattern: Close-grained; often highly grain figured

Characteristics: Heavy; hard; available in very small sizes

Uses: Veneers—decorative areas of fine furniture

Availability: Rare as both veneers and lumber

Price Range: Costly

YEW, ENGLISH (*Taxus, baccata*)

Source: England

Color: Pale red, somewhat like Cherrywood or Pencil Cedar

Pattern: Smooth, lustrous grain. Wild grain gives much character

Characteristics: Strong; elastic

Availability: In small sizes, individual pieces often being only 4 to 6 in. wide and 2 to 6 ft long

Price Range: Costly



Yew, sliced (2 pieces, book-matched)

It's Chase[®] copper for new

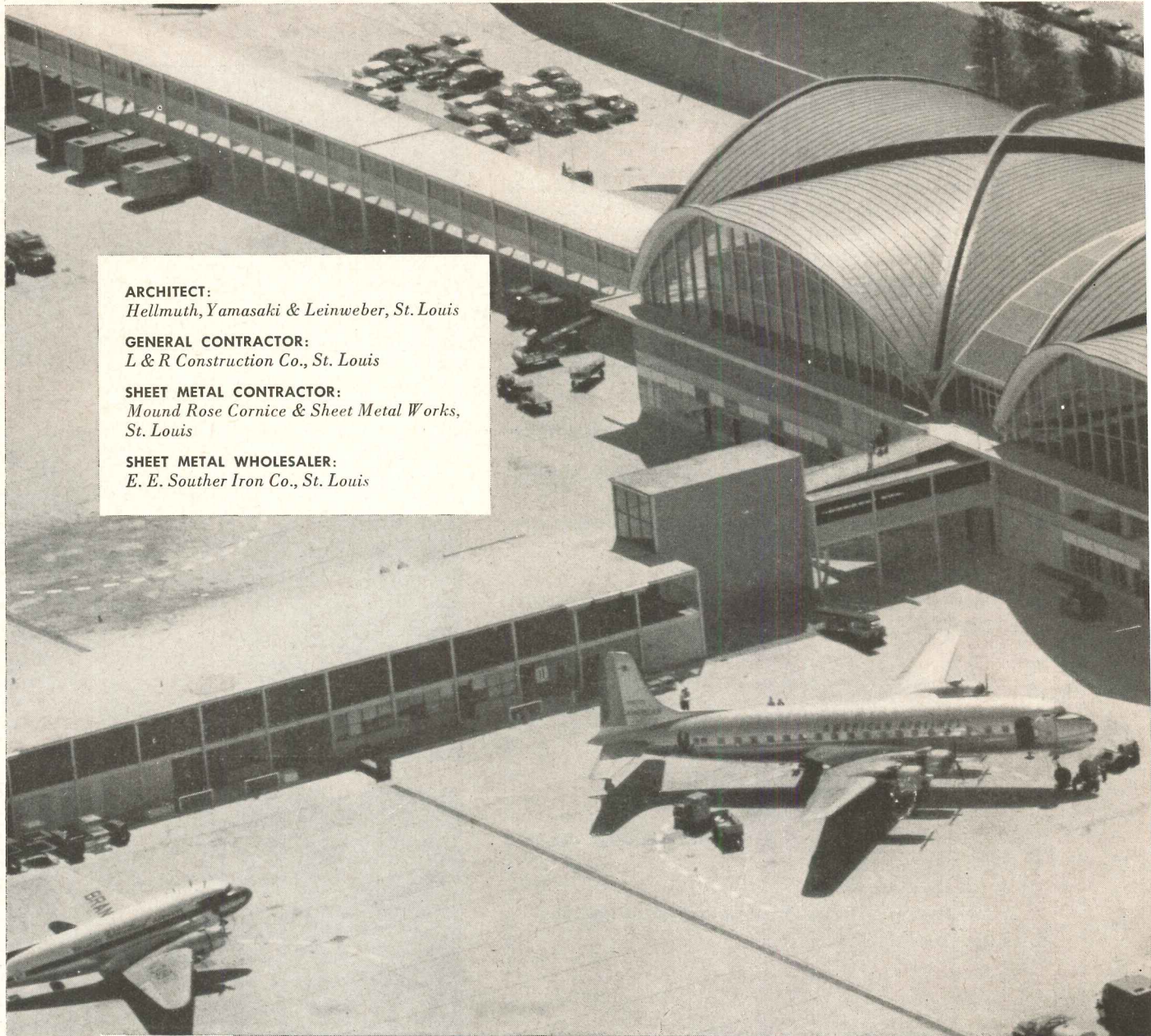

ARCHITECT:
Hellmuth, Yamasaki & Leinweber, St. Louis

GENERAL CONTRACTOR:
L & R Construction Co., St. Louis

SHEET METAL CONTRACTOR:
*Mound Rose Cornice & Sheet Metal Works,
St. Louis*

SHEET METAL WHOLESALER:
E. E. Souther Iron Co., St. Louis

Sweeping, curved roof on new \$4,500,000 Lambert-St. Louis Skyport uses 104,000 lbs. of Chase Sheet Copper

More than 50,000 square feet of surface! Three intersecting barrel-vaulted sections! This big roofing job called for flexible, long-lived 20 oz. and 24 oz. Chase Sheet Copper.

Using quality Chase copper really pays off! This versatile, malleable metal forms fast—fits the most complicated roof curves—helps you meet your

completion deadlines. It's durable—adds years of trouble-free service to your jobs. Chase Copper, properly installed, is without equal for *permanent* roofing. Then, too, it gives your jobs a rich appearance that improves with the passage of time.

For workability, durability, beauty, specify Chase Sheet Copper on your next job!

PITTSBURGH materials

its architectural appeal

... bring it practical advantages

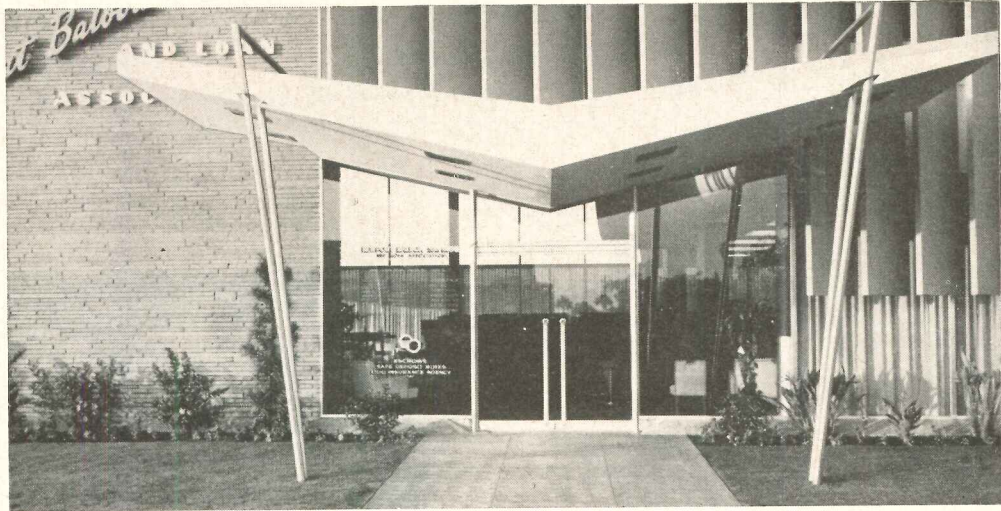

Pittsburgh's Pittcomatic® . . . "the nation's finest automatic door opener" . . . operates the Herculite® Doors at the entrance to the building, as well as on the side entrances. With the Pittcomatic Hinge, doors open automatically—at the lightest touch and with complete safety.

Here is a view of the employees' cafeteria, located on the second floor of the building, facing the harbor. This entire west wall is glazed with Solex, which makes it possible to take full advantage of the natural beauty of the outdoors while keeping room interiors cooler and glare at a minimum.

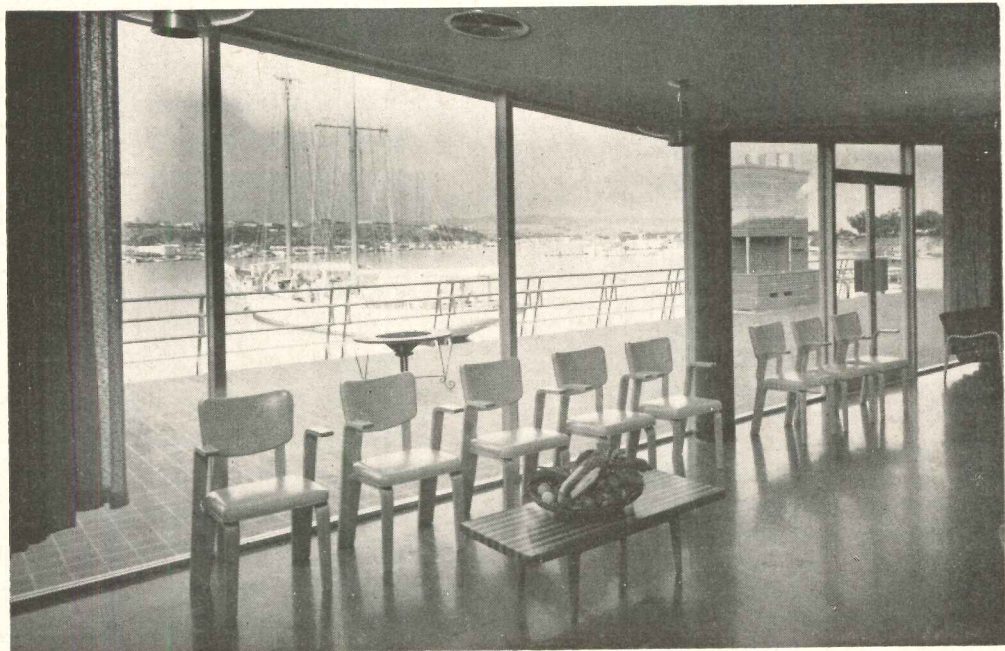

Your Sweet's Architectural File contains detailed information on all Pittsburgh Plate Glass Company products . . . Sections 6a, 15d, 20, 12e, 15a.



PAINTS · GLASS · CHEMICALS · BRUSHES · PLASTICS · FIBER GLASS

PITTSBURGH PLATE GLASS COMPANY

IN CANADA: CANADIAN PITTSBURGH INDUSTRIES LIMITED

TECHNICAL ROUNDUP

DRAMATIC MURAL USES EPOXY RESINS ON STAINLESS STEEL

A 9- by 34-ft mural in which epoxy resins have been used on stainless steel covers the entire east lobby wall of the new basic research laboratories of the National Carbon Company, which were dedicated last month at Parma, Ohio.

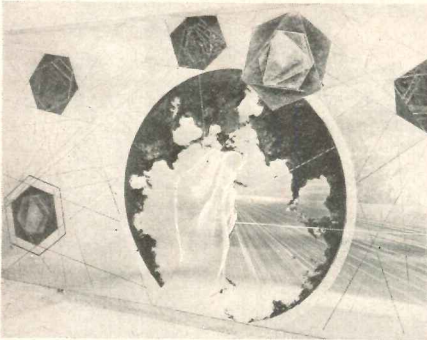

Designed and executed by artist Buell Mullen, famous for her pioneering work in steel, the mural features a hand symbolizing man's present grasp of scientific knowledge. Both controlled crystals, held by taut cords radiating from the hand, and uncontrolled crystals, indicating the many problems still to be solved, are formed of Bakelite epoxy resin paints, which can be supplied in endless layers to achieve a relief or sculptural effect and which are said to be compatible with stainless steel.

Noise Symposium

"Noise in Buildings" will be the theme of the Third Annual Meeting of the West Coast Noise Symposium on November 12th and 13th in Los Angeles. Some of the subjects that will be discussed are: Noise Control Criteria; Indoor and Outdoor Noise Sources; Design of Walls, Roofs and Windows; Noise Control Techniques for Heating and Ventilation, Plumbing, Appliances and Office Equipment; Noise Control Design in Homes, Apartments and Hotels, Schools, Offices, Hospitals and Churches, Conference Rooms, Auditoriums and Studios. Inquiries can be addressed to the Symposium at 610 South Main St. in Los Angeles.

New Trade Association

The Cold Cathode Association, Inc. has been formed, with headquarters at 515 Madison Ave. in New York, to promote the "technological advances of cold cathode lighting." One of the functions of the association will be to disseminate

educational material regarding proper cold cathode specifying procedures, applications and technical data among "architects, engineers, utility representatives and to all members of the consuming public either at cost, or, to the greatest extent possible, free of charge." Bert C. Pretzer, president of the Illuminating Engineering Co. in Detroit, was elected president of the new association.

Design Loads in Buildings

The American Standard Building Code Requirements for Minimum Design Loads

in Buildings and Other Structures, sponsored by the National Bureau of Standards and approved by the American Standards Association, is available in a 1955 revision. The Standard was revised to include the results of new research and experience and to allow for new construction practices, materials and techniques. The most significant changes are in the requirements for wind loads on buildings and signs and the inclusion of recommendations for wind loads on radio and TV towers. \$1.50. American Standards Association, 70 East 45th St., New York 17, N. Y.



You may remember this picture that illustrated an advertisement we ran back in early summer. When we photographed the kids, wide vistas of a long summer of unregimented fun danced in their eyes. You just couldn't see the Fall through the haze of swimming, fishing, camping, playing.

But time came around . . . swiftly, inexorably. The day came when the school bell shrilled its dirge. And classes, as they must to all kids, enveloped them in blackboards, potted plants and primers.

On the right are the same kids. We thought we'd better tell you. You'd never know it.



Diagram Shows Comparison of Conventional and Cofar Slab Sections

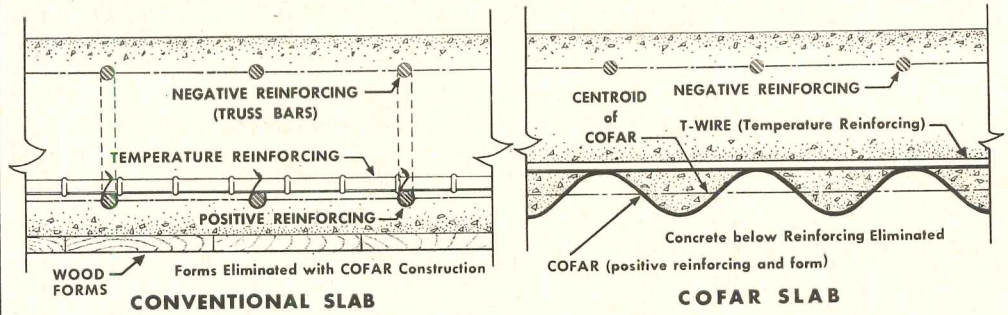

Read what members of the construction team say about Cofar:



GENERAL CONTRACTOR'S superintendent, Mike Kopko of W. E. Wood Company, says, "Speed is the essence of everything here and that's what Cofar gives us—speed! It covers a lot of area, provides a safe, solid, working platform. Trades come in and proceed with their jobs fast. We're getting nice level floors, too. With Cofar you haven't got the T-shores, forms, clean-up after pouring, loose concrete chipping away beneath and cement patching. This is the first Cofar job for all my men. They like it!"

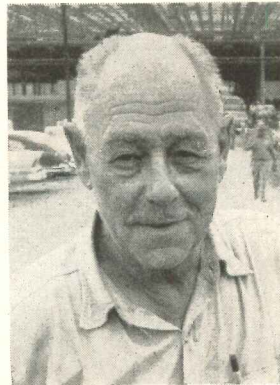

COFAR ERECTOR, Ray Ewer of Capitol Erection and Welding Company, says, "Ford is very happy with Cofar. Cofar was here in plenty of time. The sheets handle easily and placing is fast. Cofar 'cuts in' nicely and takes a lot of beating. I had visions of needing something to plug leaks but we've had no trouble with pour leaks or concrete finishing. We're going a little faster all the time."

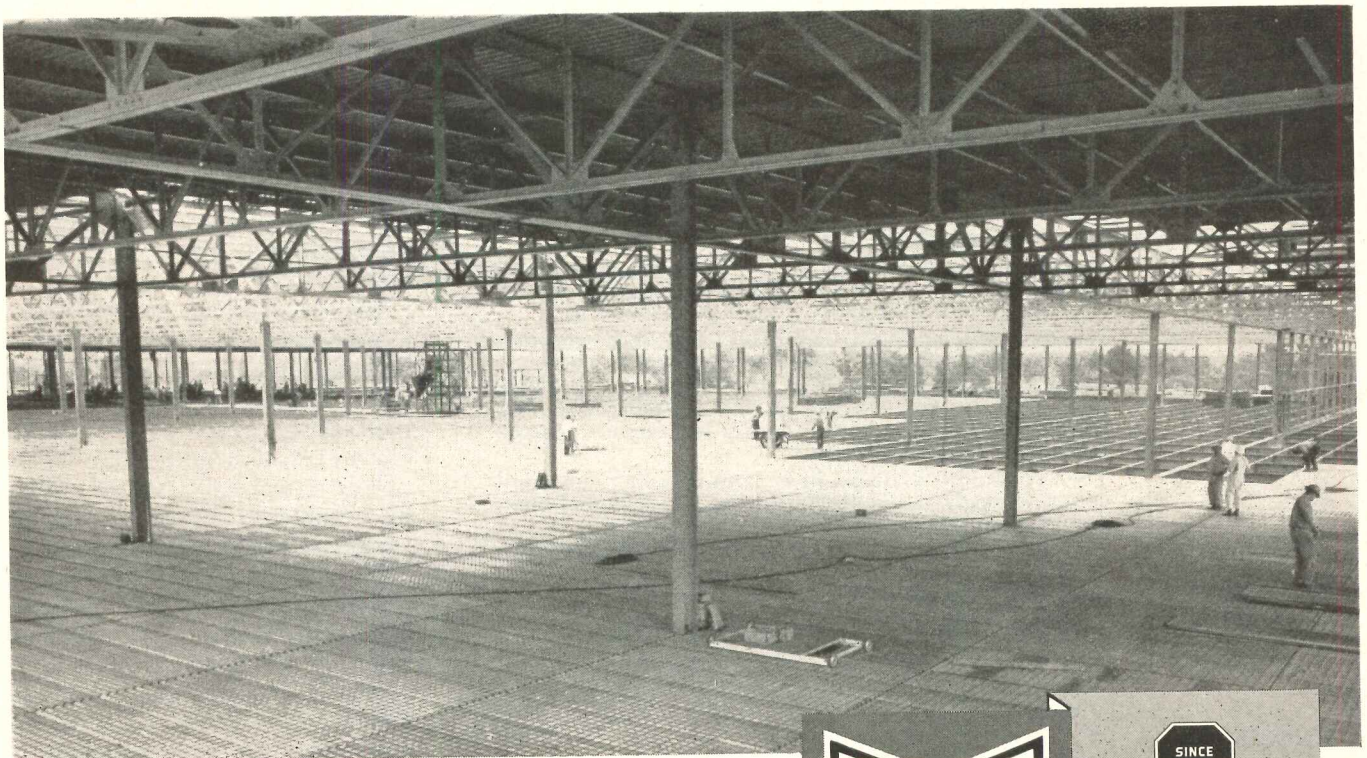

MORE THAN 318,000 SQ. FT. of 24-gage Cofar has been placed on the second floor and on fan and transformer rooms of the new Lincoln plant in Novi, Michigan. Cofar deep-corrugated steel units provide main reinforcement. T-wires, welded across corrugations, provide composite temperature reinforcement, mechanical anchorage and shear transfer from concrete to high-strength Cofar steel.



THE RECORD REPORTS

(Continued from page 396)

NEW B.B.C. TELEVISION CENTER PLANNED FOR LONDON SITE

A new TV center will be erected in London soon to house the British Broadcasting Corporation's television studios. The center is expected to be ready for occupancy in 1960.

Architect for the work is Graham Dawbarn, F.R.I.B.A., in association

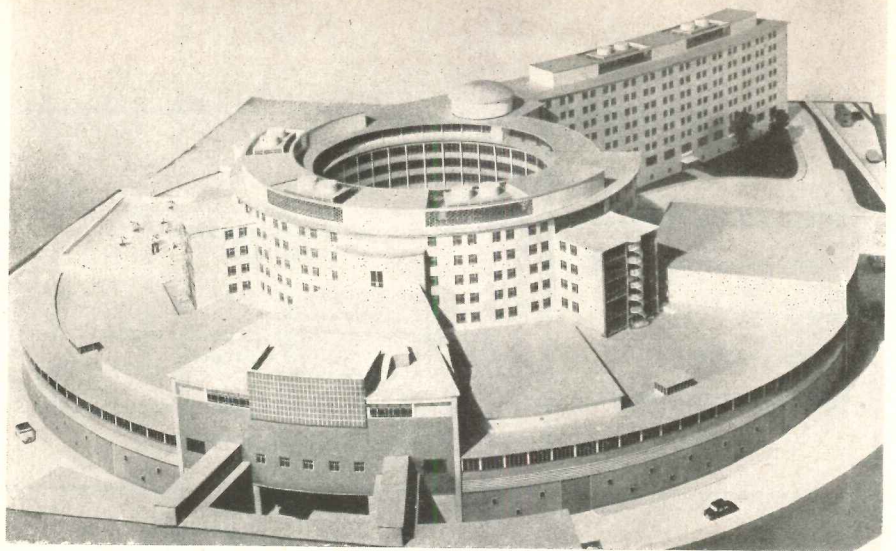

B.B.C. Television Center is under construction in London. Photo of model shows nine-story ring structure which is main block. Radiating from the ring will be studios, television and tele-recording facilities

light
ILLUSION

END-TO-END or

SIDE-BY-SIDE

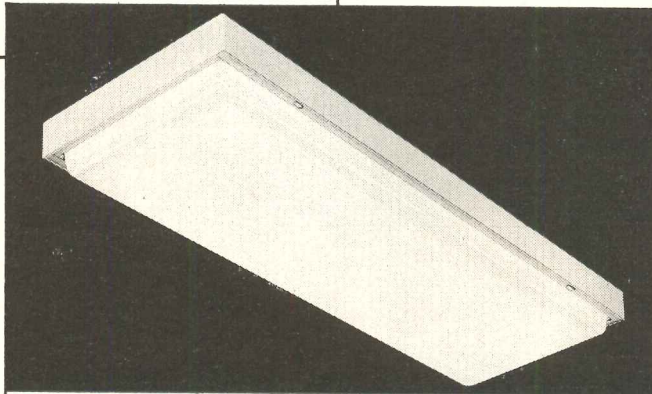

"The Cleveland"

A-15000 SERIES

2, 3 OR 4 LAMP
LUMINAIRE

- The Cleveland 15000 Series is a classically simple luminaire created especially for surface mounting. Its softly diffused lighting and low lines give it a built-in custom look.
- Flexible end-to-end, side-by-side and individual mounting make possible patterns and banks of unlimited variety.
- One-piece "dished" Acrylic or Polystyrene plastic is held in a rigidized steel channel closure equipped with full-length piano hinges. Spring latches are easy to operate, foolproof and inconspicuous.
- The Cleveland is available in 2, 3 and 4 lamp units wired complete, ready to install. Finished in all white, baked-on enamel. U. L. listed.

Write for Cleveland Specification Sheet.

PITTSBURGH REFLECTOR COMPANY

402 OLIVER BUILDING, PITTSBURGH 22, PA.

FLUORESCENT



INCANDESCENT

Lighting

IN CANADA

Pittsburgh Reflector of Canada, Ltd.
105 Tycos Drive, Toronto

REPRESENTATIVES IN PRINCIPAL CITIES

• WHOLESALERS EVERYWHERE

with M. T. Tudsbery, consulting civil engineer to the B.B.C.

A 13-acre site was chosen for the center, which itself will only cover about 3½ acres and involves planning of just over half of the entire site. The remainder of the site will be left unplanned until B.B.C. is in a position to judge how the site should be developed to best meet the demands of service.

The architectural conception of the half-site scheme had, however, to take into account the development of the site as a whole. A curvilinear "tail-piece" (see photo of model, above) was employed in the design to provide a measure of flexibility in the planning of the second half of the site. It is envisaged that the "tail-piece" will provide further studios, a large garage, rehearsal rooms, and possibly a roof heliport.

The main studio block will consist of a multi-story ring providing accommodation for dressing-rooms, wardrobe service, engineering, and offices. The ring encircles a garden of 150-ft diameter. Studios radiate from the ring. The periphery of the studios will be enclosed by a continuous runway for easy conveyance of scenery and props.

The scenery block itself covers approximately one acre, and is the first part of the project to be completed. Extensive workshops are provided for carpenters, property-makers, and scenic artists. There is a high (26 ft) setting-space where scenery is assembled, together with large storage areas for re-usable props. The scenery block building also contains 200 offices for the use of administrative staff, producers, etc.

(More news on page 402)



here's why
PAINÉ

REZO®

INSTITUTIONAL DOORS
with air-vented, all-wood grid core
are specified for America's finest
schools by leading architects:

- Proven dimensional stability . . . lightness . . . strength for the hardest possible use by active youngsters of all ages.
- Built for use with special hardware. Convenient to specify—no need to write detailed specifications.
- Backed by over 8,000,000 successful REZO installations including schools and public buildings coast to coast!

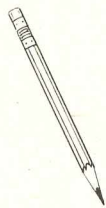
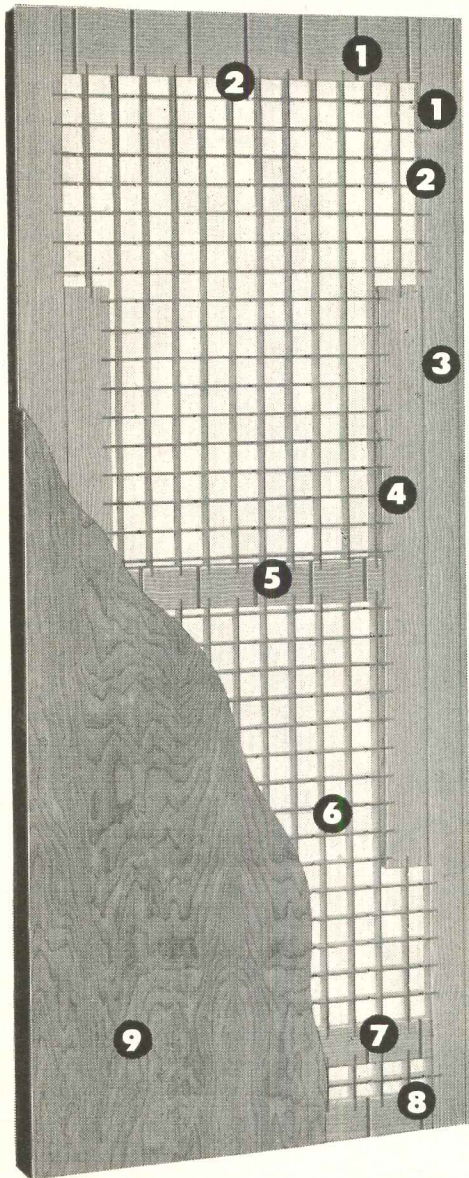

check these exclusive features

1. One rail is 5" wide and can be used as either top or bottom of the door. Stiles are 3" (nom).
2. Air-vented, all-wood gridwork is carefully mortised into the stiles and rails for greater strength.
3. Matching vertical edge strips can be furnished and finish not less than 1/2" wide after trimming.
4. Lock area is 6 3/4" wide and 21" from either end and varies in length proportionate to door height.
5. 3" rail for special hardware is 41" from bottom of door to top of rail unless otherwise specified.
6. Heavy duty 2" x 2" air cell all-wood gridwork interlocked for strength and dimensional stability.
7. 3" rail for kick plate located 10" from bottom of door to top of rail unless otherwise specified.
8. Vent grooves in top and bottom rails help keep moisture content in balance — prevent warpage.
9. Hand-matched hardwood face veneers, 3 ply, of any commercial species. Sanded to cabinetmaker's finish.



Lightweight — easy
one man installation

Resists Abuse — for
lifetime service

Convenient — easy
to open and close

Cost? Less expensive than solid core doors yet they're better in every respect! Architects who want America's finest Institutional Doors always specify REZO. For full details, see Sweet's Catalog or write:

PAINÉ
LUMBER COMPANY, LTD.
ESTABLISHED 1853 • OSHKOSH, WIS.

THE RECORD REPORTS

(Continued from page 400)

FASHION COLLEGE PLANNED FOR N. Y. GARMENT AREA

The Fashion Institute of Technology—a community college where students of the fashion industry can train for executive positions—will be constructed soon in the heart of New York City's garment district.

Designed by architects DeYoung, Moscovitz & Rosenberg, New York



Waterproofing approach walls Patapsco Tunnel between Baltimore and Brooklyn, Md. Waterproofing by Anchor Waterproofing Corp., New York City and Railroad Waterproofing Corp., Lynbrook, N. Y. joint venture.



"Karnak completely waterproof... never known to deteriorate."

That's what George Knight, superintendent of waterproofing for Patapsco Tunnel, says. He adds, "Karnak waterproofing mesh is one of the easiest-to-handle waterproofing materials... light-weight, durable and long-lasting... I've never known it to deteriorate, crack, or fail to do the job."

Karnak is the open-mesh, asphalt-saturated cotton cloth that's layered on the job with alternate moppings of highly refined, ductile asphalt. The open mesh allows the mopping asphalt to penetrate and interlock the layers, providing a firm membrane that maintains water proofing through the life of the structure. Karnak fabric is also available in tar and pitch saturation.

Karnak has met tough waterproofing requirements for over 30 years on dams, tunnels, bridges, swimming pools, viaducts and building foundations. Specify Karnak on your next waterproofing job. Manufactured by Lewis Asphalt Engineering Corp., 30 Church Street, New York 7, N. Y. Dept. 112.

© L.A.E. Corp.

Karnak®



Other Fine Karnak Products
Asphalt Roof Coatings and Cements
Calking Compounds • Asphalt Emulsions • Tile Cement • Asphalt Paint
Wood Block Mastic • Joint Filler
Aluminum Asphalt Coating



Two tones of blue aluminum will sheath new Fashion Institute of Technology planned for New York City. Auditorium and main building will be integrated, with passageway leading from second floor of main building to auditorium

City, the Institute will be sheathed in anodized aluminum. Two tones of blue will be used, accented with gold trim.

The nine-story structure will contain 35 academic units where 1250 full time students and 3000 part time students will be accommodated. In addition, it will provide 40 technical laboratories, a gymnasium, a fashion library, industrial seminar rooms for executives in the industry, and extensive exhibit areas. An 800-seat auditorium will stand adjacent to the main building.

The first, second, and ninth (top) floors of the main building will be set back ten feet from the building line. These three floors will be sheathed in glass and natural aluminum. The open areas of the roof will be landscaped, with trees and shrubbery. A courtyard and campus will complete the setting for the Institute.

The more rigid form of the main building will be relieved by the free-flowing lines of the auditorium. Though integrated with the main building, it is to be set forward to the building line.

First floor of the main building will be devoted largely to exhibit areas, including a glass enclosed room in which will be displayed the industry's latest fabric designs.

"Before setting one line on paper," said Benjamin Moscovitz of the architectural firm who designed the Institute, "we spent weeks watching the students and faculty at work. We were intrigued by the tremendous possibilities. The challenge before us was to create an atmosphere and background consistent with the good taste and atmosphere of the school itself."

(More news on page 406)

*Here's how
Latex Paints
are used . . .*

ON PLASTER SURFACES. This is the most common application of latex paints. Because they have excellent resistance to alkalinity, they can be safely applied right over fresh plaster. No need to wait days for the plaster to cure completely. If suction or over-gauging occurs in the plaster, latex paints still dry with a uniformity of appearance.

In most cases, two coats of latex paints are used on fresh plaster. The first acts as a sealer. Because latex paints dry rapidly the second coat can be applied the same day. From the application of plaster to completed paint job is days shorter with latex paints than with many other kinds of paint!

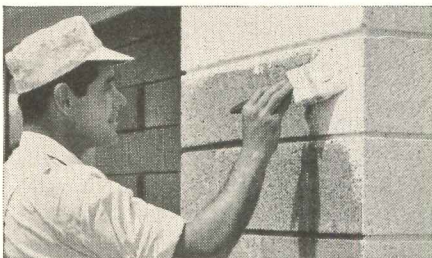
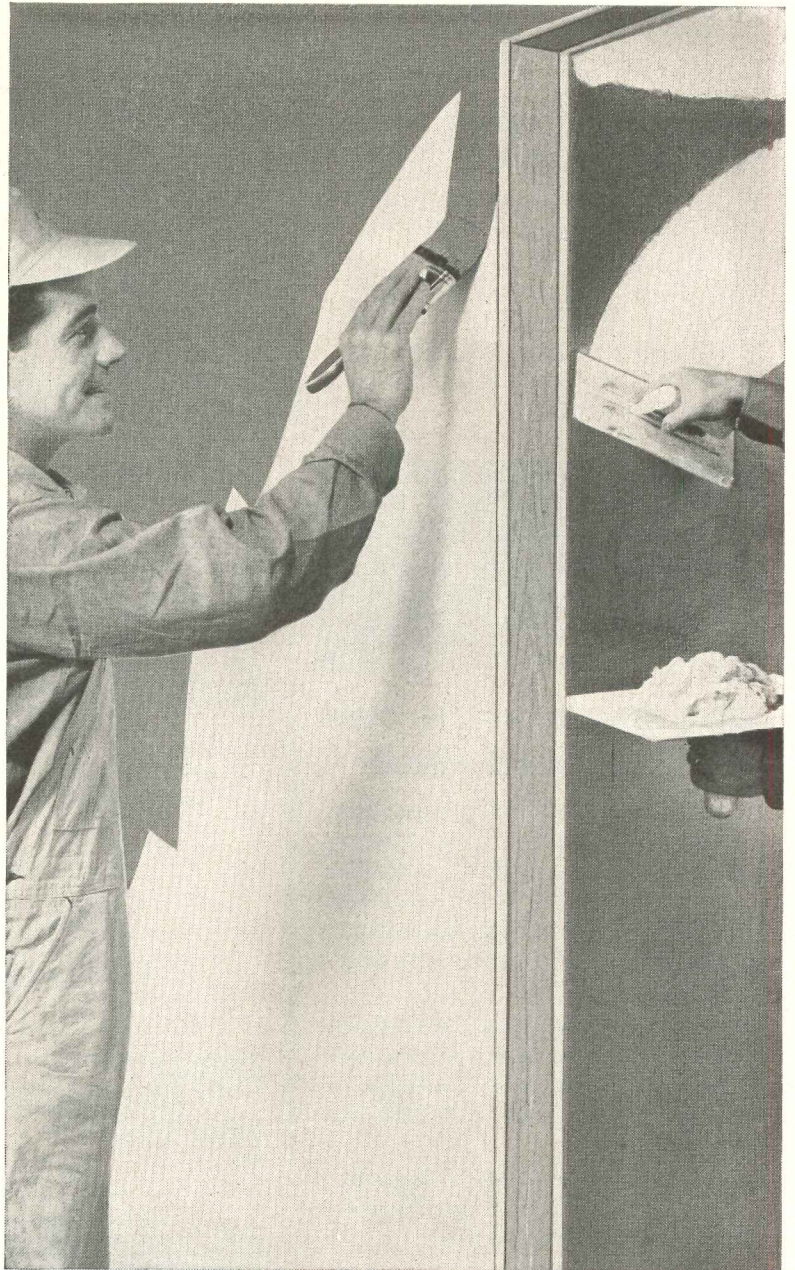

FOR EXTERIOR MASONRY. Exterior masonry paints are durable, self cleaning, resistant to alkali and stain. Used on cinder block, cement block, stucco and similar masonry surfaces.

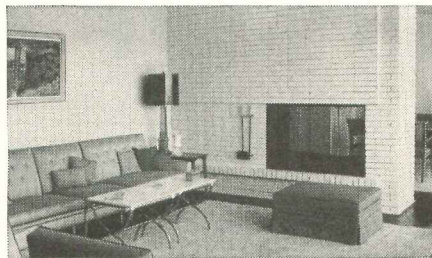

FOR INTERIOR BLOCK. Latex paints have excellent sealing properties over cinder block, concrete block, as well as many other porous surfaces.

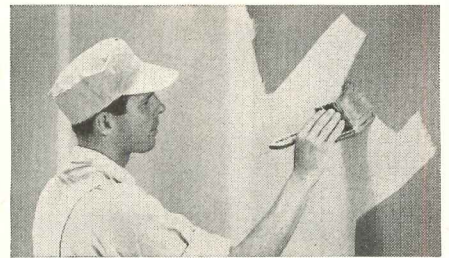

FOR DRY WALL CONSTRUCTION. Latex paints give the same excellent results—a smooth, colorful surface that's washable and has outstanding durability!

you can depend on DOW PLASTICS



THE RECORD REPORTS

(Continued from page 402)

DENVER PLANT FITS SCHEME FOR DECENTRALIZATION

A new electronics plant, designed by Pereira and Luckman, Architects, for the Ramo-Wooldridge Corporation, is under construction near Denver, Colo. Location of the production facility at Denver is in keeping with federal plans for industrial decentralization, a company spokesman said.

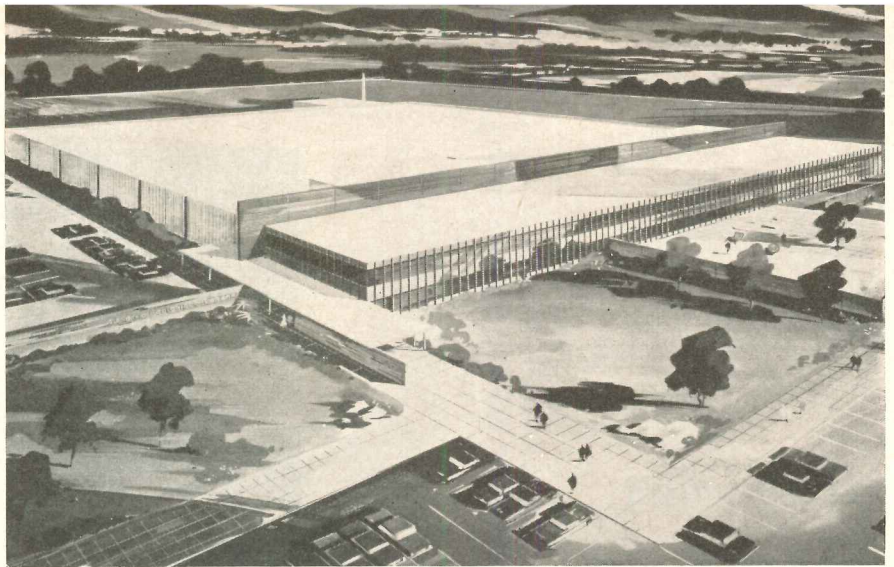

DESIGNED WITH THE FUTURE IN MIND

Selected for its distinctive appearance, long life, and minimum maintenance, Mo-Sai precast facing gives a decorative effect to the exterior of this new school building. The section of spandrels between the windows is green Mo-Sai with diagonal false joint scoring.

Unlimited in color range, available in standard or coarse surface texture, variable in size as required by the design — Mo-Sai fulfills the need of flexibility for the architect.

Consult your nearest Mo-Sai Associate Manufacturer for details, specifications, and samples of this versatile, economical facing material!

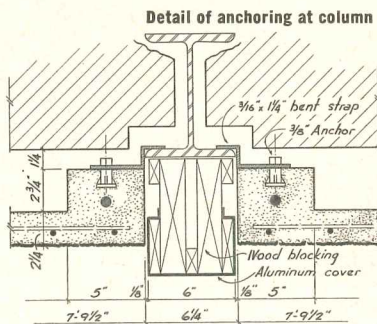

Detail of anchoring at vertical surround

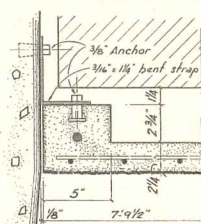

Northwest Classen High School,
Oklahoma City
Architect: Hudgins, Thompson-Ball &
Associates, Oklahoma City
Mo-Sai by Harter Marblecrete
Stone Co., Oklahoma
City

Ramo-Wooldridge electronics plant, under construction in Denver, will total 172,000 sq ft. The new plant is part of a building program recently initiated by the company. When complete, the program will give Ramo-Wooldridge over a million sq ft of occupied space

Scheduled for completion in 1957, the plant will be devoted to the production of fire-control systems for aircraft, radar systems, electronic computers, and communications equipment. The 172,000 sq ft plant was designed to allow for extensive future expansion. Later, the company expects to produce automation and data processing equipment for commercial clients.

Since its organization in 1953, Ramo-Wooldridge has worked in the research and development of guided missiles and electronic systems. The new Denver plant is the firm's first major venture in electronics manufacturing.

A 640-acre site located in Englewood, just south of Denver, was chosen "because of its proximity by air to Los Angeles and because of Denver's attractiveness to live in," according to Dr. Dean E. Wooldridge, president of the Los Angeles company. The Denver plant will ultimately employ around 1500 persons.

Ramo-Wooldridge now occupies eight buildings in the vicinity of the Los Angeles International Airport. The company is engaged in a building program which includes the Denver facility and a complex of nine research and development buildings totalling 900,000 sq ft near their present Los Angeles headquarters. Construction has recently been completed on a flight test facility on a seven-acre site at the Los Angeles airport. When completed, the building program will bring the total space occupied by the firm to a million and a half sq ft.

(More news on page 410)

MO-SAI ASSOCIATES, INC. Members, The Producers' Council

California
Connecticut
Massachusetts
New York
North Carolina
Ohio
Oklahoma
Texas
Utah
Virginia
Washington
Wisconsin
Canada

Los Angeles
South San Francisco
New Haven 3
Allston 34
Rochester 21
Greensboro
Cleveland 5
Oklahoma City
Houston 20
Salt Lake City 6
Richmond 7
Seattle 7
Oshkosh
Toronto 13

C. D. Wailes Co.
P. Grassi-American Terrazzo Co.
The Dextone Co.
Cambridge Cement Stone Co.
Goodstone Mfg. Co., Inc.
The Mabie-Bell Co.
George Rackle & Sons Co.
Harter Marblecrete Stone Co.
George Rackle & Sons Co.
Otto Buehner & Co.
Economy Cast Stone Co.
Olympian Stone Co.
Badger Concrete Co.
Toronto Cast Stone Co.





Steel Furniture for Contemporary Offices and Schools

All ASE products are of finest quality to complement your architectural talent. Take time to see the simple dignity of ASE design. Examine the fine craftsmanship . . . the deep luster of the finish . . . the good taste in modern colors. Specify ASE steel furniture for your new buildings. It has no equal.



As Modern as Today!

Executive Furniture Finishes—
Sea Gray, Bronze Tan, and
Ebony. Also available in
Dawn Gray, Stylite Tan,
Mist Green and Green.



CREDENZA



No. 6647

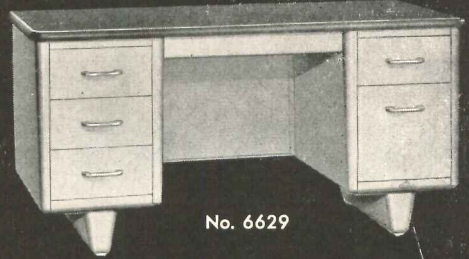

No. 6629



No. 810



No. 835

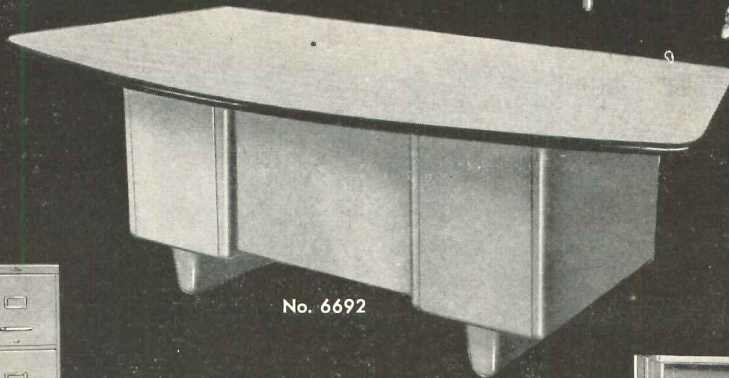

No. 6692

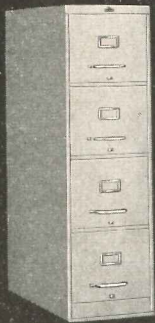

No. 5401

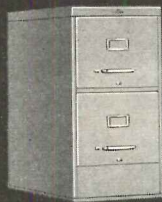

No. 5211

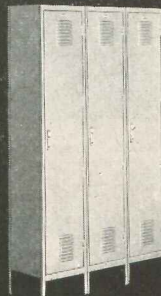

SINGLE-TIER



DOUBLE-TIER

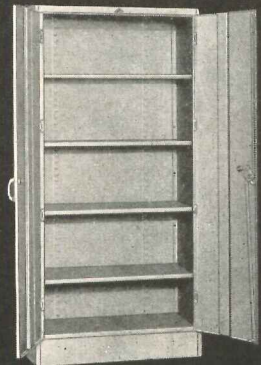

No. 3487

**Better Built for
Better Business**



ALL-STEEL EQUIPMENT INC., Aurora, Illinois

WRITE FOR COMPLETE INFORMATION, THERE'S AN ASE DEALER NEAR YOU

THE RECORD REPORTS

(Continued from page 406)

CURVED APARTMENT DESIGN ADDS MORE LAKE FRONTAGE

An apartment building with a completely curved shape and a convex façade facing Lake Michigan will soon be built in Chicago.

Designed by architects Hausner and Macsai, Chicago, the building will be located at 1150 Lake Shore Drive, and will house 250 apartments.

The 24-story building will be constructed of reinforced concrete and will have diaphragm walls to compensate for wind loads. In plan, the structure will be a quarter circle, erected on a trapezoid of land. Total lot area is 20,011 sq ft.

The circular design of the building was developed to afford more lake frontage than would be possible with a conventional square design. By curving across the corner of Lake Shore Drive

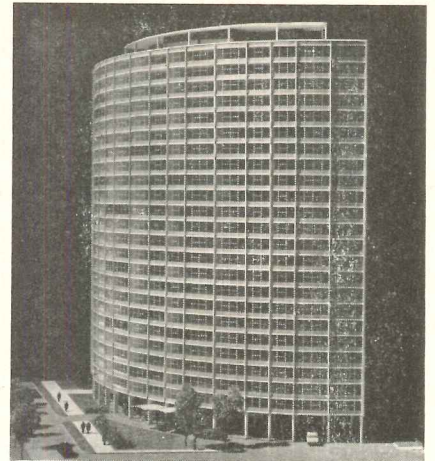

Curved design of apartment building on shores of Lake Michigan, Chicago, allows 76 ft more lake frontage than could be achieved by conventional square design. Approach to the 220 ft long sweeping arcade will be enhanced by a landscaped area.

and Division, 220 ft of building frontage will face the lake and parkway. A conventional square-shaped building would provide only a possible 144 ft of lake frontage. The curved effect also eliminates an obstructed view from the building to the north.

Curvature of the building will give an appearance of greater depth to the rooms, according to the architects. Forty-four of the apartments will have two bedrooms, 162 will have one bedroom, and 44 will be studio apartments. Some 184 apartments will face the lake.

Outside curtain walls will be of light grey brick. Blue spandrels will divide horizontally the glass windows in front.

Two high speed, electronically operated elevators and one freight elevator will serve the apartments. A three level garage will accommodate 128 cars.

Self-contained air conditioning units will be installed inside the walls of each apartment. Individual tenants will be able to control their own air conditioning at will. The separate unit method of air conditioning will mean that failure of one unit will not effect the operation of the rest of the units in the building. A tenants' laundry, a receiving room for deliveries, free utilities such as gas and electricity, and a free window-washing service will be provided.

The building will be completed in 1957 at a cost, including land, of over \$4,000,000. Prudential Insurance Company of America is financing the project.

Structural engineer for the building is Paul Rogers & Associates; mechanical engineer is William Goodman.

(More news on page 412)

MEADOWS BUILDING

Dallas, Texas

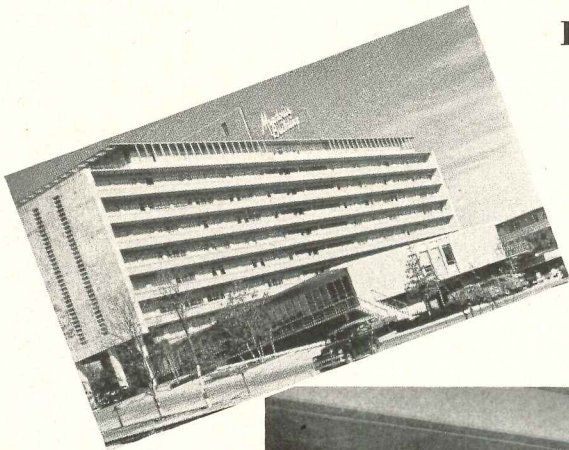

ARCHITECT

J. W. MacCannon

14 Balanced Doors
in the entrances
to the new Meadows
Building.



The Door that lets
TRAFFIC through QUICKLY

ELLISON BRONZE CO.

Jamestown, New York

representatives in 77 principal cities in the
United States, Canada and Puerto Rico

Ellison
the **BALANCED DOOR**

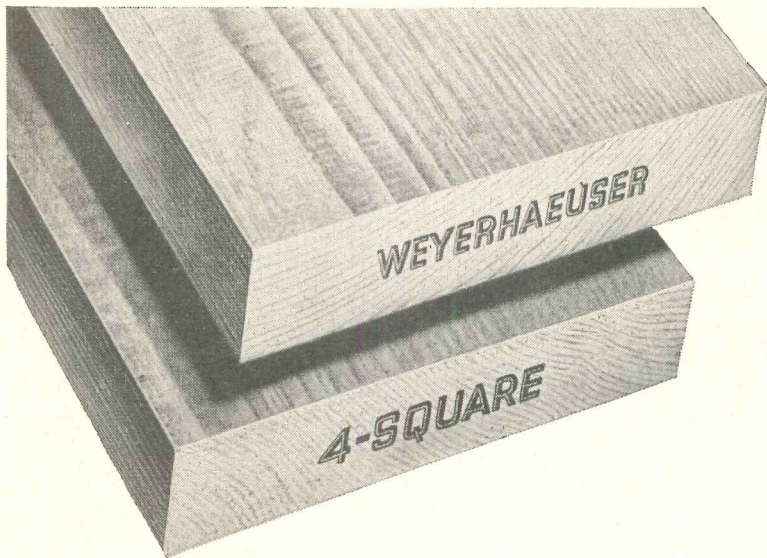

Announcing
an important
new development...

Water-Repellent

Treated Siding

Water-Repellent treating extends paint life—
improves siding stability

● Now, after extensive research, Weyerhaeuser presents a new, improved siding with all the beauty and durability of natural wood—plus a water-repellent treatment which results in better performance, and longer paint life.

The new Weyerhaeuser 4-Square water-repellent Treated Siding is the same as traditional siding in appearance. But a special treating process fills the walls of the surface cells of the wood with a water-repellent chemical.

Most important to your clients is the fact that paint lasts longer on Treated Siding. Water-repellent treatment helps prevent water entering behind siding, thus providing longer paint life. Treated Siding also resists the damaging effects of casual exposure to water during construction and prior to painting. Water-repellent treating adds stability to siding as it

retards moisture changes. The treatment also deposits chemicals which resist the development of mold and fungi.

Paint not only lasts longer, it is easier to apply on Treated Siding. The oils in the paint are absorbed slowly. The paint gives added protection because more of its oils are kept on the surface, where they are most valuable for resisting the damaging effects of weather.

Treated Western Red Cedar and West Coast Hemlock Bevel Sidings are now available in the standard widths and thicknesses.

Weyerhaeuser 4-Square water-repellent Treated Siding offers distinct advantages to home owners. For complete details about these fine products, talk to your Weyerhaeuser 4-Square Lumber Dealer—or write to our St. Paul office for full information.

Weyerhaeuser Sales Company

ST. PAUL 1, MINNESOTA



THE RECORD REPORTS

(Continued from page 410)

INTEGRATION OF INDUSTRY SOUGHT IN CENTER DESIGN

A center designed to integrate all the segments of the region's construction industry is being constructed this year in Los Angeles.

The new Construction Industry Center is keyed to meet the demands of the industry for some sort of centralization whereby the architect, builder, finan-

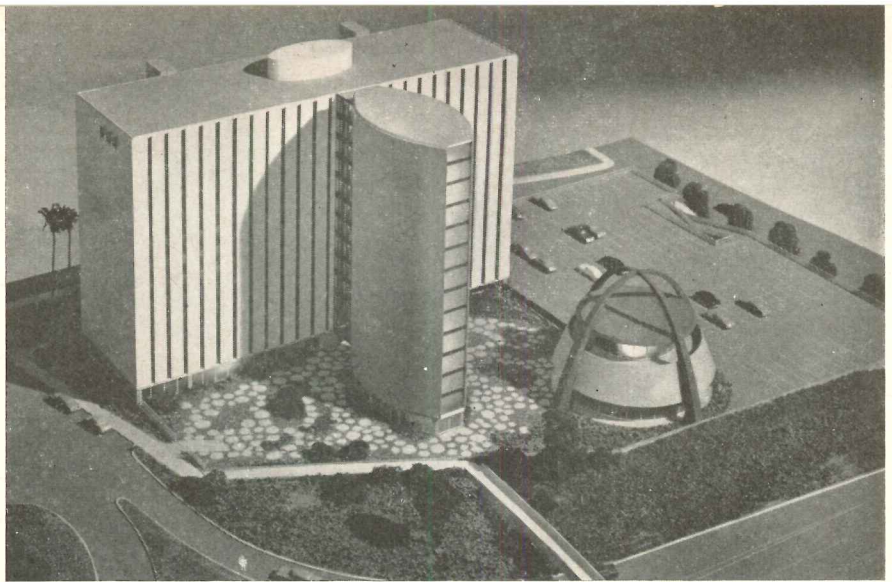

Construction Industry Center will have office, exhibition, promotion facilities. Surface and subsurface lots will handle traffic flow

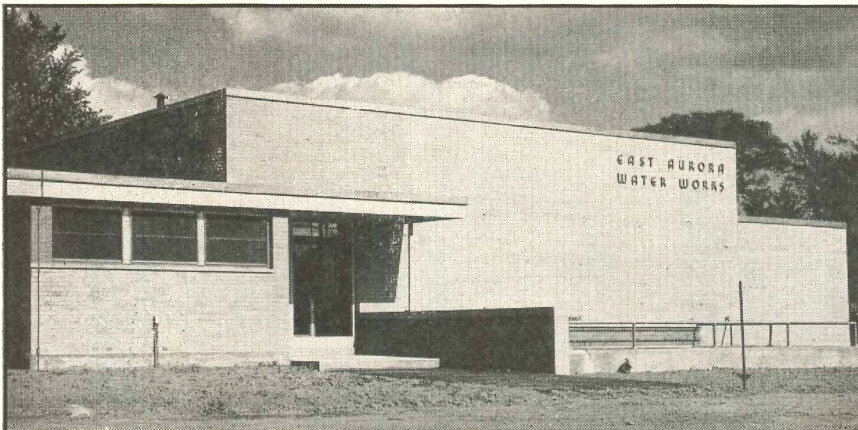

DEPENDABLE POWER PROTECTION

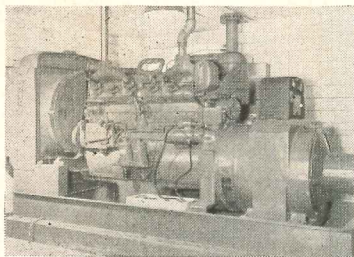

Standby electric plants assure the continuation of vital services when normal power fails. Pictured is a typical example of power protection in a municipal water plant. The Ready-Power standby unit assures an adequate supply of water for fire protection, sanitation, and other essentials during emergencies. A wide range of Ready-Power models up to 100 KW will meet your requirements. Write for information.

READY-POWER ELECTRIC PLANTS

The Ready-Power Company, 11231 Freud Ave., Detroit 14, Michigan
Gas and Diesel Engine Driven Generators and Air Conditioning Units; Gas and Diesel Electric Power Units for Industrial Trucks

ARCHITECTS: For complete information on electric plants, refer to Ready-Power Specification Pages in Sweet's Architectural File.
Write for Bulletin 279-2.

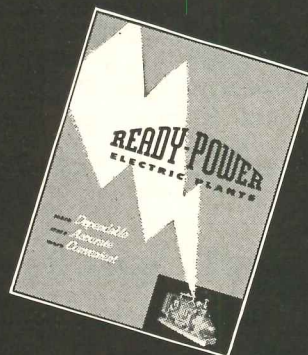

cial, decorator and product manufacturer can work together under one roof.

Architect John C. Lindsay, A.I.A., designed the center, to be built on a site chosen for its accessibility. Its location is at the hub of the Southern California Freeway network, less than a minute away from the giant superhighway cloverleaf which links all sections of Southern California.

The center will act as an all-industry clearing-house for promoting new business, for negotiating contracts, for showing new products and services, reviewing plans, arranging financial transactions, staging sales conferences, and holding meetings of industry groups.

Approximately 150,000 sq ft of sales and administrative offices in the main building will be rented to members of the industry.

The Tower of Exhibits, also 13 floors, is immediately adjacent to the office building. The two structures are connected by glass enclosed bridges at each of the 13 levels. Permanent displays of all new building products will be housed in the elliptical tower.

The center will maintain its own headquarters for promotion. The 3-story Graphic Arts Center, next door to the main building and tower, will serve as a central place of information about the construction industry. It will be made available to the press, TV, radio, and other publicity and public relations channels. A specially equipped press and information bureau with wire, phone and radio facilities for newsmen will serve as a base of operation.

The Building Contractors Association of California is sponsoring the center, which is expected to be ready for occupancy in September, 1957.

(More news on page 416)

ARCHITECTURAL RECORD?

The Fifteen Top
Monthly Magazines in the U. S.
In Advertising Page Volume
— 6 Months 1956 —

1. Electronics

2. Product Engineering

3. Chemical Engineering

4. Architectural Record

5. Purchasing

6. Modern Machine Shop

7. Electrical Manufacturing

8. Machinery

9. Building Supply News

10. Factory Management &
Maintenance

11. Aviation Age

12. Practical Builder

13. Petroleum Engineer

14. Machine & Tool Blue Book

15. House & Home

Note: Above rank is not affected by special issues
published by Electronics and Architectural Record.

1955

1956

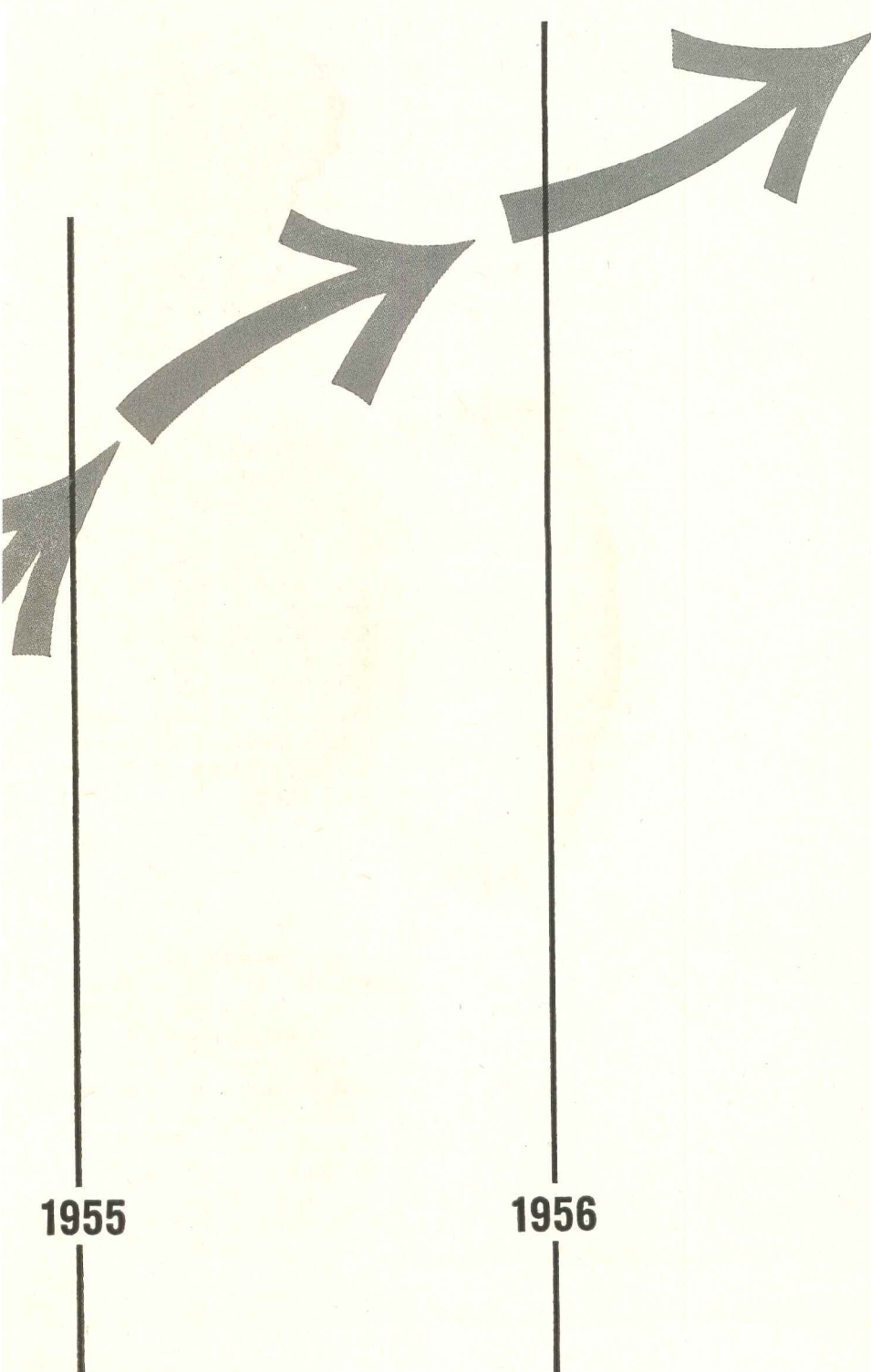

FOR

Fast

**DISCHARGE of AIR
at HIGH VELOCITY**

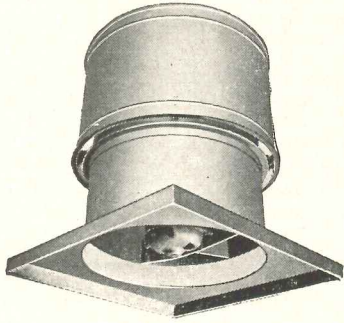

Allen

**VERTICAL
DISCHARGE FAN**

• *Keeps fumes from leaking back through building openings*

Whenever you face the problem of discharging fumes through a roof so that they will not short-circuit back through building openings, you'll find the solution in this Vertical Discharge Fan. It is designed especially for industrial applications that require the removal of a large volume at high velocity. It is fabricated of zinc-coated iron sheet with welded construction throughout. Automatic wing dampers open with air blast, close weather-tight when not operating. Available as "VD" direct drive with motor mounted inside air stream or as "VDR" with motor mounted outside throat of ventilator—both in a wide range of capacities and sizes.

See Sweet's Architectural File, Section 20b or write for catalog.



**ALLEN COOLER &
VENTILATOR INC.
ROCHESTER, MICH.**

Roof Ventilators for Every Industrial Need

FILL OUT AND SEND COUPON

**ALLEN COOLER & VENTILATOR INC.
ROCHESTER, MICHIGAN**

Please send me informative literature on your complete line of roof ventilators.

Firm _____

Name _____

Position _____

Address _____

City, State _____

THE RECORD REPORTS

(Continued from page 412)

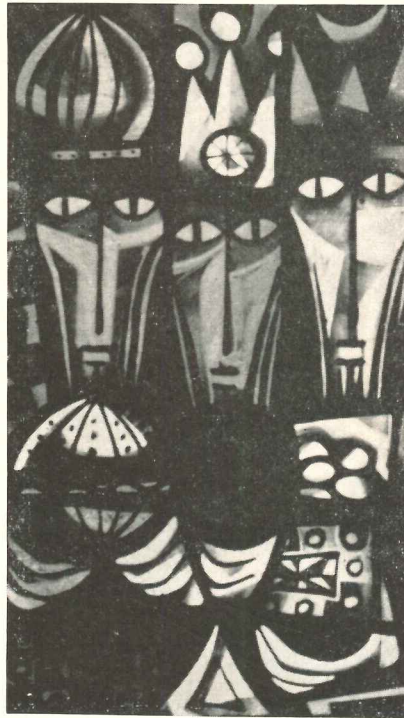

FIVE STAINED GLASS PANELS WIN COMPETITION AWARDS

Donald Erik Erikson, Cleveland, took first prize, and Alfred McArdle, Philadelphia, was awarded second prize in the 1956 Apprenticeship Competition sponsored by the Stained Glass Association of America. Mr. Erikson's stained glass panel is shown above; Mr. McArdle's slab glass in concrete panel is below.

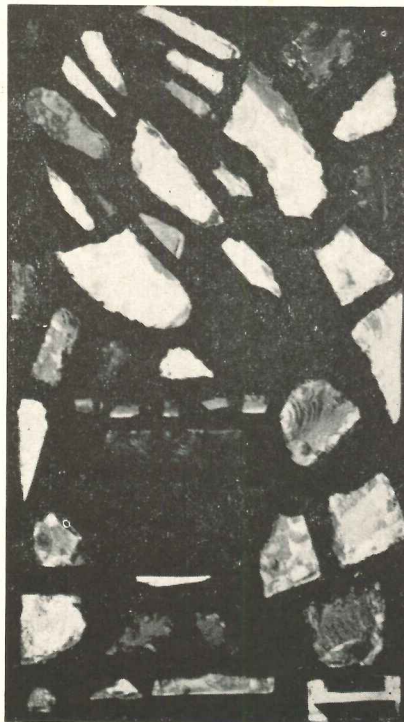

(Continued on page 420)

DESIGNERS

4 MAJOR JOB ADVANTAGES

now offered by
DU PONT

• Interesting, challenging, professional work assignments.

• Long-range company programs assuring stability.

• Promotion-from-within policy assuring opportunities for advancement.

• Varied technical and administrative training programs.

• IMMEDIATE OPENINGS FOR:

Architectural Designers

Apply today for a position that will allow you to realize your full potential as a designer. Your work will be in a wide range of increasingly important fields.

Please send complete resume, including details of education and experience, to:

Mr. T. J. Donovan
Engineering Department



Better Things for Better Living
...through Chemistry

E. I. du Pont de Nemours & Co., Inc.
Wilmington 98, Delaware

BLAKE

COMBINATION ADJUSTABLE "TY" FITTINGS AND CARRIERS

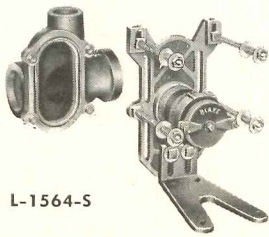

L-1564-S

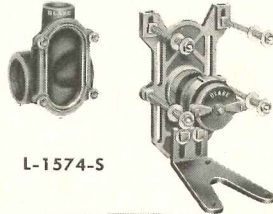

L-1574-S

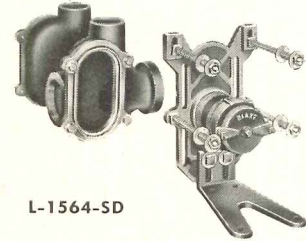

L-1564-SD

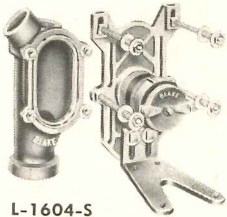

L-1604-S

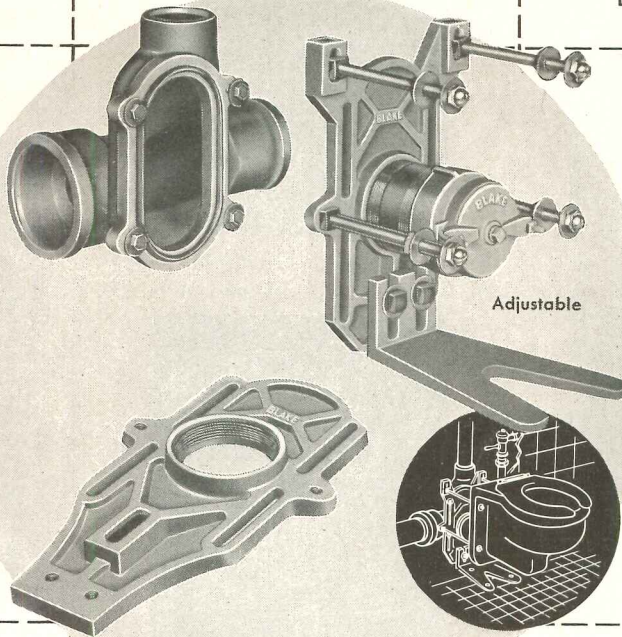

Adjustable

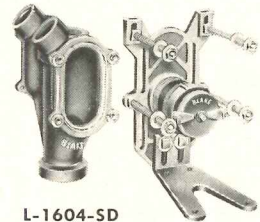

L-1604-SD

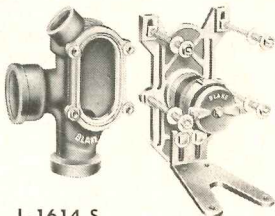

L-1614-S

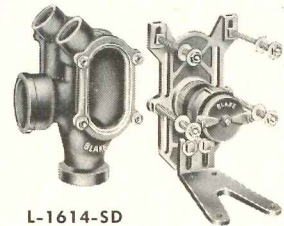

L-1614-SD

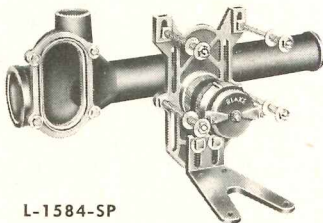

L-1584-SP

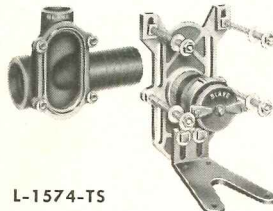

L-1574-TS

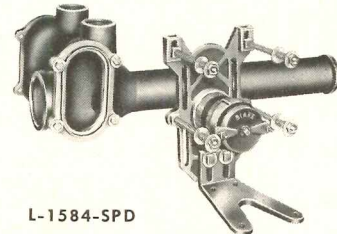

L-1584-SPD

KEEP THE FIXTURES OFF THE FLOOR!

Blake Carriers for Wall Type Fixtures Include:

- ✓ CLOSETS
- ✓ LAVATORIES
- ✓ URINALS
- ✓ SINKS
- ✓ HOSPITAL LAVATORIES
- ✓ HOSPITAL SINKS
- ✓ STERILIZERS

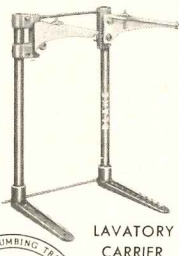

LAVATORY CARRIER

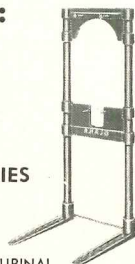

URINAL CARRIER

Blake engineered design "TY" fittings and carriers support wall type closets independent of the wall, providing sanitary and easily maintained rest rooms. A compact, efficient assembly of component parts requiring a minimum of space, Blake "TY" fittings conserve valuable building area and insure proper waste line pitch.

- Horizontal or vertical installations
- Single or double applications
- Screw pipe or soil pipe
- Syphon-jet or wall type closets
- Single installations or for batteries

For complete information on all Blake combination adjustable "TY" fittings and carriers, mail coupon.

HOFFMAN SPECIALTY MFG. CORP., 1700 W. 10th St.
Dept. AR-10, Indianapolis 7, Indiana

Please send me catalog No. 22 on Combination "TY" Fittings and Carriers.

Name _____

Firm _____

Address _____

City _____ Zone _____ State _____



Blake Division

HOFFMAN SPECIALTY MFG. CORP.

1700 WEST 10th STREET, INDIANAPOLIS 7, INDIANA

Reprinted
by Popular Demand

**"TYPICAL DESIGNS
of
TIMBER STRUCTURES"**

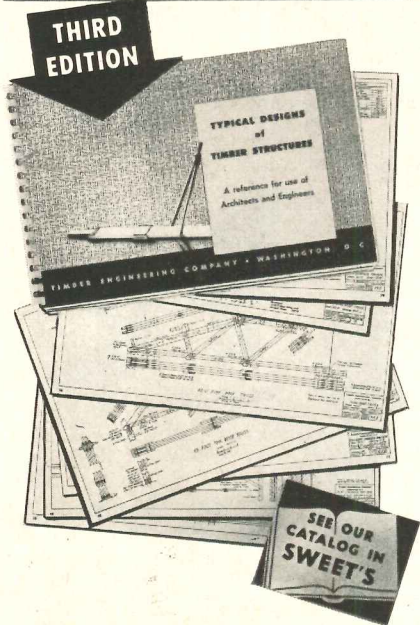

- 53** new typical designs of large and small timber roof trusses —
- 42** designs revised to reflect the latest developments in engineering and construction techniques —
- 7** special designs, unrevised.

TOTAL
102 dependable guides in planning efficient, economical structures in wood.

FREE
TO ARCHITECTS
AND ENGINEERS
USING THE COUPON
OR LETTERHEAD.

TIMBER ENGINEERING COMPANY
1319 18th St., N.W., Washington 6, D. C.
Please send **FREE** copy of "Typical Designs of Timber Structures."

NAME.....
FIRM.....
STREET.....
CITY.....ZONE.....STATE.....

THE RECORD REPORTS

(Continued from page 416)



Stained glass honorable mention (above) went to Robert W. Anderson, Milwaukee



"Nativity" (above) won honorable mention for Robert Johnson, Milwaukee

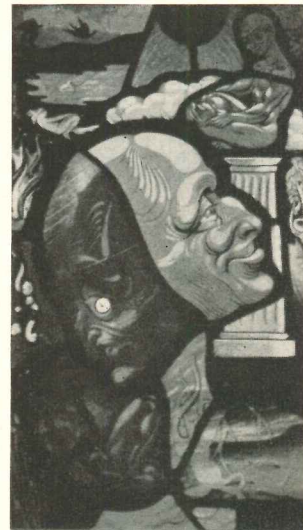

Richard Millard, New York City, also received honorable mention for panel (More news on page 424)

KOH-I-NOOR
The Choice
OF ARTISTS EVERYWHERE

Here are the Latest Products of **KOH-I-NOOR** Research...

The **KOH-I-NOOR ADAPTO-CLUTCH DRAFTING LEAD HOLDER No. 5617**
WITH THE NEW "Eye-Cue" INDICATOR

No more wondering what degree of lead you have in your holders... just dial the lead you have inserted! The indicator can be set to any one of the 17 degrees of Koh-I-Noor Drawing Leads.

The New KOH-I-NOOR Ejectomatic Lead Dispenser

All 17 degrees of No. 2200-I Koh-I-Noor (Imported) Drawing Leads are now packaged in this new automatic dispenser. This clever device permits the user to inject the lead into the holder *without touching the lead!* The transparent box permits visual control of remaining lead supply. Keeps hand and drawings clean, saving time and money.



The KOH-I-NOOR Rapidograph Non-Clogging "Technical" Fountain Pen

in four precision line widths
#0 Extra-Fine #2 Medium
#1 Fine #3 Broad

Almost easy as a pencil! Excellent for tracing, inking-in, lettering, and anything requiring reproduction. Uses either india ink or regular fountain pen inks.

Look on the drawing board of any successful artist and you will always find Koh-I-Noor represented... the choice of perfectionists in all professions.

KOH-I-NOOR PENCIL COMPANY
BLOOMSBURY, NEW JERSEY

KOHLER Electric Plants

for automatic stand-by protection in schools, hospitals, other buildings

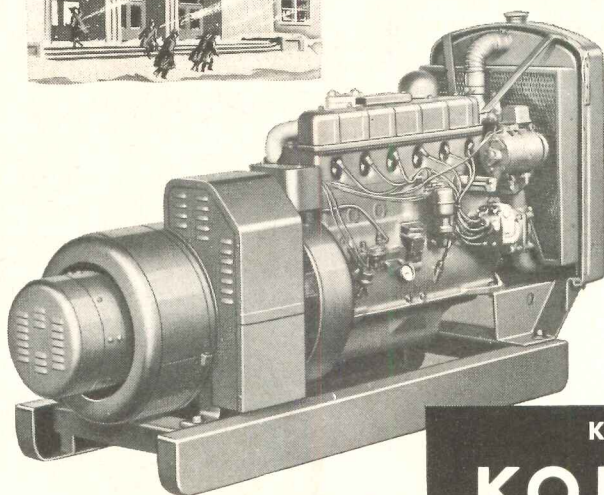

MODEL 35R81, 35 KW, 120/208 volt AC.
Remote starting.

When you include Kohler Electric Plants in building specifications, you insure vital protection before the emergency. Schools, stores, theatres, use Kohler stand-by plants to prevent panic in sudden darkness caused by central station power stoppage; homes, for automatic heat, refrigeration. In hospitals they maintain nurses' call bell systems, operating room lights, iron lungs, sterilizers. They prevent costly interruptions for hatcheries, greenhouses, motor courts, sewage treatment and filtration plants, refineries, communication systems, filling stations, bakeries. Complete Kohler Electric Plant specification sheets, ready to include in your plans, will be sent on request. Address Dept. L-15.

Kohler Co., Kohler, Wisconsin. Established 1873

KOHLER OF KOHLER

PLUMBING FIXTURES • HEATING EQUIPMENT • ELECTRIC PLANTS
AIR-COOLED ENGINES • PRECISION CONTROLS

WEATHERTITE

Positive SEAL for Masonry CONTROL JOINTS

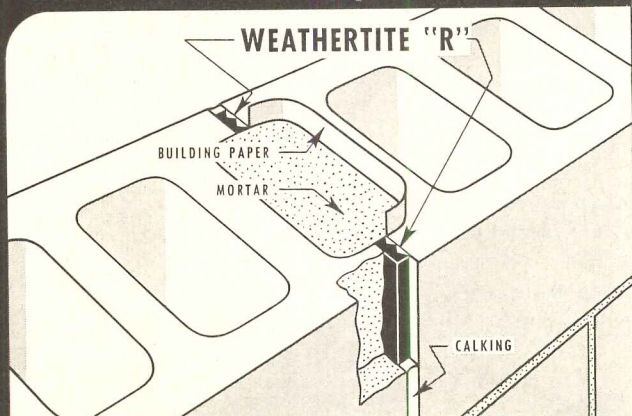

To guard against cracks in block-constructed masonry walls, caused by shrinkage, always use an approved Control Joint . . . to prevent water seepage through these very necessary control joints, always use WEATHERTITE for a permanent SEAL. This time-tested product is a continuous strip of expanded Polyvinyl Chloride . . . it is formed with serrations on one side to permit adequate compression when installed, and to provide the positive expansion which so effectively and permanently seals control joints in block constructed masonry walls. WEATHERTITE is available in three sizes which are designed to effectively seal any type of masonry control joint.

See Sweet's Architectural File, Section 9, or write for information.

WILLIAMS EQUIPMENT and SUPPLY COMPANY
16651 Baylis Avenue • Detroit 21, Michigan

planning a laboratory?

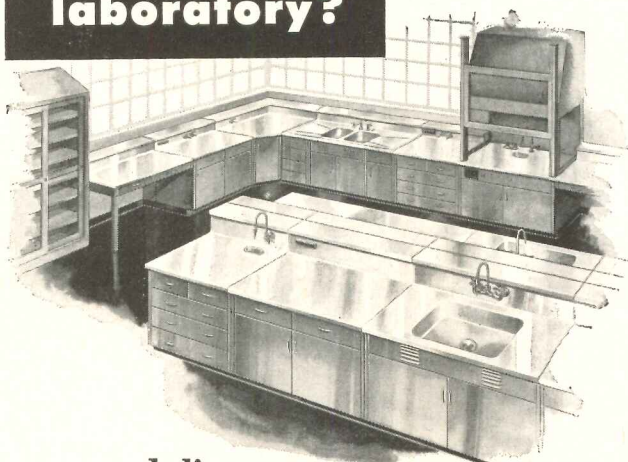

moduline simplifies the architect's layout and installation of cabinets and casework for laboratories and hospitals. Consists of sectional steel units of architecturally approved widths and depths; easy to adapt to any building layout. Fabricated of quality materials; stainless steel tops, or choice of wood, stone, Formica, etc.



A. S. Aloe Company AND SUBSIDIARIES
1831 Olive St., St. Louis 3, Mo.

Send your brochure: Moduline Unitized Laboratory Furniture.

Name _____
City _____
State _____

how you can get
the full benefits
of high-velocity
air conditioning

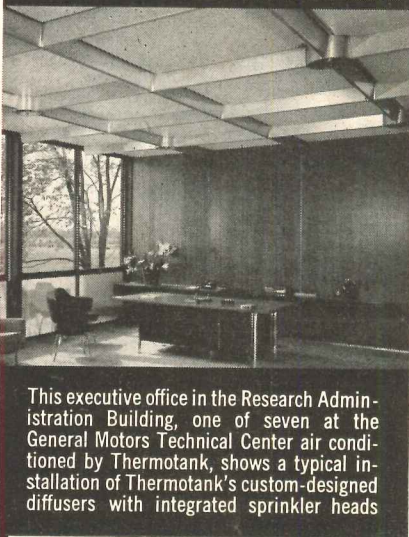

This executive office in the Research Administration Building, one of seven at the General Motors Technical Center air conditioned by Thermotank, shows a typical installation of Thermotank's custom-designed diffusers with integrated sprinkler heads

YOUR assurance of trouble-free performance, satisfactory temperature control with quiet, economical operation, is the practical background of our world-wide organization, pioneer in high-velocity air conditioning.

Since 1901, when Thermotank, Ltd., installed the first air conditioning in ships, we have engineered air handling systems for some of the world's foremost industries, including comfort air conditioning in offices and factories; humidity and temperature control for special processes.

During the five years of our operation in the United States, our services have been used by leading architects and engineers and by such companies as General Motors, Ford, Standard Oil, Michigan Bell and Borden's.

Our consulting engineering services may be used as extensively as desired—from preliminary surveys for utmost economy in first and annual costs through complete engineering design, specifications, and supervision during construction for satisfactory performance of the end result.

Write today, without obligation, for literature and details of our experience in solving diversified problems of heating, ventilating and air conditioning.

THERMOTANK
INCORPORATED

Air Conditioning Engineers & Consultants
Air Conditioning Products

11191 Lappin Ave. • Detroit 34, Mich.
In Canada: MONTREAL and TORONTO

REQUIRED READING

(Continued from page 60)

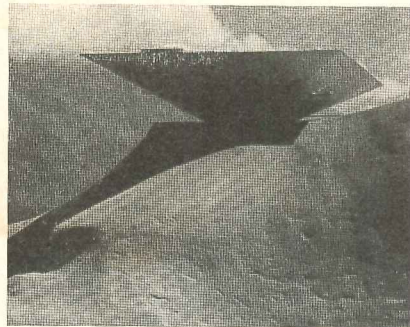

Niemeyer's final project for the Modern Art Museum of Caracas, Venezuela (1955), detaches itself clearly from the landscape and expresses "in the purity of its lines the forces of contemporary art."

LATEST NIEMEYER WORKS SHOWN IN NEW VOLUME

By RUTH WATSON MARTIN

Oscar Niemeyer: Works in Progress. By Stamo Papadaki. Reinhold Publishing Corporation (New York) 1956. 192 pp, illus., \$10.

Niemeyer's projects from 1950 to 1956 are shown and studied in Stamo Papadaki's second volume about the Brazilian architect, *Oscar Niemeyer: Works In Progress.*

Again, one is intrigued by the plastic and dramatic quality of Niemeyer's work and the spatial problems that he solves. Through excellent photographs, sketches, plans and working drawings, one can see a daring idea evolve into a completed building. There are 30 examples of 15 building types presented, including the Quintadilha pyramid (see photo, above) and a number of houses. In brief captions and many pictures and drawings the development of each building is explained.

HE'S "DUNN" IT AGAIN!

Alan Dunn, whose cartoons appear regularly in *ARCHITECTURAL RECORD* and *The New Yorker* magazine, has just had another volume of his work published by Simon and Schuster (N. Y., 1956, \$3.50). Entitled "Should it Gurgle?" the new book is a compilation of 152 cartoons, ranging in subject from architecture to communism, which have appeared in *The New Yorker* in the past ten years. He has had three previous volumes published. F. W. Dodge Corp. published Dunn's *The Last Lath* in 1947.

Schools for the Very Young

by HEINRICH H. WAECHTER, A.I.A.
and ELISABETH WAECHTER

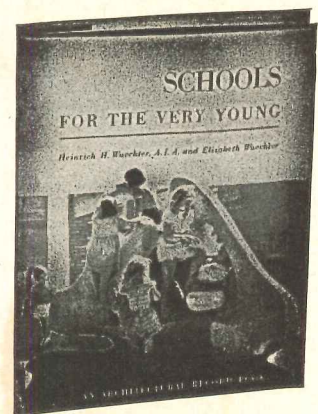

THOUGH many volumes have been written about school design, "Schools for the Very Young" is — so far as we know — the first in which an architect and a child educator have collaborated to provide an up-to-date treatise on the requirements of the particular type of school demanded for the proper training of the very young child.

Beginning with a brief yet adequate historical and philosophical background, in which the development of the theory and practice of child education is discussed, the book goes on to describe the pre-school in action, noting the events of the school day and the corresponding environmental needs of the children and their teachers. Examples of existing pre-schools are presented with the critical comment. Detailed information is given concerning the space apportionments and arrangements called for by the activities peculiar to such institutions. Since one of the authors is especially concerned with city planning, the relation of the pre-school to its neighborhood and community is analyzed, and the many different types of pre-schools that have developed to meet special conditions are enumerated and explained.

The outdoor space and its proper equipment are thoroughly covered from the standard of a capable architect who has given much thought to the problem. Technological problems of construction, lighting, ventilation, mechanical equipment, etc., are scrutinized in the light of the most recent practice. A wealth of illustrations add both interest and information, and a selective bibliography will aid further study. 208 pages, 7½ x 10, stiff binding. Price \$6.50.

Book Department, F. W. Dodge Corp.
119 West 40th Street, New York 18, N. Y.

Enclosed is \$..... for..... copy(s) of
"Schools for the Very Young" by Heinrich
H. and Elisabeth Waechter at \$6.50 per
copy. (Add 20¢ for N.Y.C. delivery —
\$6.70.)

Name.....

Address.....

City.....

Zone

State
935