

# ARCHITECTURAL RECORD

May 1961

5

*Building Types Study: Facilities for Retailing*

*Downtown Philadelphia: A Lesson in Design for Urban Growth*

*Office Interiors for Rockefeller Foundation*

*Full Contents on Pages 4 & 5*

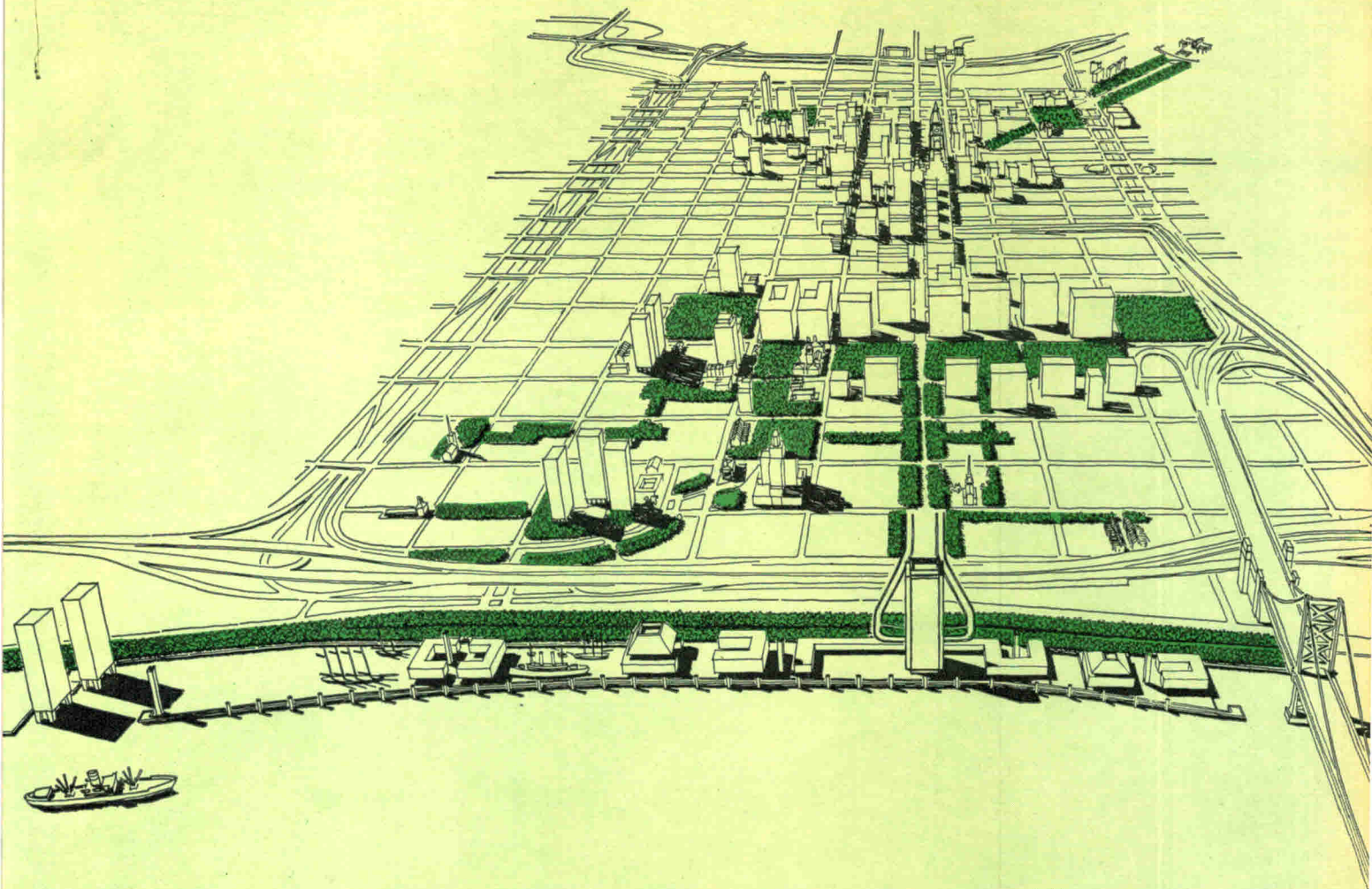



Right: Two Rotary Oildraulic passenger elevators serve "island" in center of Pan American World Airways Terminal Building.

Below: General freight in American Airlines hangar is moved between floors by 15,000 lb. capacity Rotary Oildraulic Elevator.



## serve New York's Idlewild Airport

Information on Rotary Oildraulic Elevators and Lifts is available through distributors listed in the phone book yellow pages. See our catalog in Sweet's Files or write for more information.

**DOVER** DOVER CORPORATION  
Rotary Lift Division

1003 Kentucky, Memphis 2, Tenn. • Chatham, Ontario

**Rotary Oildraulic equipment used in Idlewild buildings designed by these architectural and engineering firms**

AMMANN & WHITNEY  
BURNS & ROE

KAHN & JACOBS, Architects, ROY S. BENT, Associate

ANTONIN RAYMOND and L. L. RADO

EERO SAARINEN & ASSOCIATES

SKIDMORE, OWINGS & MERRILL

TIPPETTS-ABBETT-McCARTHY-STRATTON and

IVES, TURANO & GARDNER, Associates

Rotary Oildraulic equipment installed by  
BURLINGTON ELEVATORS, INC., NEW YORK



Rotary Levelator Lift (6,000 lb. capacity) raises freight to truck bed height for fast transfer to Pan American plane.



**Oildraulic® Elevators** • *Passenger and Freight*

# Architectural Engineering

AIR CONDITIONING DUCTS

BUILT INTO FLOOR AND ROOF STRUCTURES 190

A growing trend toward the integration of mechanical services and structure to conserve space is exemplified in a new building complex for Michigan Bell Telephone Co. Cellular steel flooring is used for air ducts and a concrete umbrella is shaped to provide duct space

A NEW LOOK AT FLAT PLATE CONSTRUCTION 193

by Seymour Howard, A.I.A., based on recent work by Lev Zetlin, Consulting Engineer

Architects and engineers can safely use flat plate concrete design to greater advantage—lengthening spans, omitting spandrel beams and even providing openings in slabs next to columns—once the structural behavior is understood and properly interpreted in the engineering details

TIME-SAVER STANDARDS 198

Store Fixtures: 1, 2, 3

A check list of merchandise categories is followed by dimensioned drawings of typical store equipment

BUILDING COMPONENTS 205

SELECTING FOOD SERVICE EQUIPMENT, PART 2

(Conclusion) 205

PRODUCT REPORTS 207

OFFICE LITERATURE 208

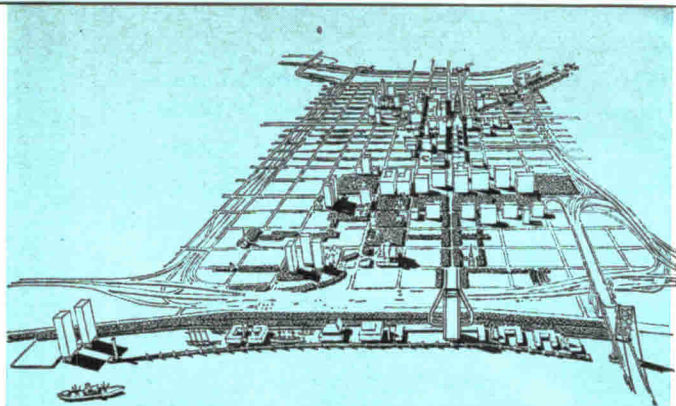

Cover:

Overall perspective of downtown Philadelphia. See "Downtown Philadelphia: A Lesson in Design for Urban Growth," by architect Edmund N. Bacon, page 131

Advertising Index 314

ARCHITECTURAL RECORD May 1961 Vol. 129, No. 5 © Published monthly, except May 1961, when semi-monthly, by F. W. Dodge Corporation, a McGraw-Hill Company.

Executive, editorial, circulation and advertising offices: 119 West 40th Street, New York 18, N. Y. Western Editorial Office: 2877 Shasta Road, Berkeley 8, Calif. Printed in Concord, N. H.; second-class mail postage paid at Concord, N. H.

Subscription rate for individuals in the field served \$5.50 per year in U. S., U. S. Possessions and Canada; single copies \$2.00, except Mid-May 1961 issue \$2.95. Further details on page 6. Postmaster: Please send Form 3579 to Circulation Manager, ARCHITECTURAL RECORD, 119 West 40th Street, New York 18, N. Y. (National Edition)

# ARCHITECTURAL

## Record Reports

BEHIND THE RECORD 9

"Conscious Design for Bad Taste?"  
by Emerson Goble

CURRENT TRENDS IN CONSTRUCTION 10

A monthly analysis prepared for the RECORD by George Cline Smith, vice president and chief economist, F. W. Dodge Corporation, a McGraw-Hill Company

BUILDINGS IN THE NEWS 12

Pei Wins Brunner Award for 1961 . . . Taliesin Associated Architects design new church in Scottsdale, Arizona . . . Two new temporary buildings for 7th I.U.A. Congress . . . Proposed World Trade Center in lower Manhattan

CONSTRUCTION COST INDEXES 18

MEETINGS AND MISCELLANY 23

A roundup of professional news

REQUIRED READING 50

CALENDAR AND OFFICE NOTES 260

## Architects and Buildings

ABBOTT, MERKT & CO. with Daniel Schwartzman, associate architect; The Hecht Company Store, Marlow Heights, Md. 181  
BACKSTROM & REINIUS. Nordiska Kompaniet Store, Stockholm, Sweden . . . . .174

CARSON, LUNDIN & SHAW. Offices for the Rockefeller Foundation, New York City . . . . .147

GEDDES, ROBERT L. Delaware River Scheme, Philadelphia 136

GRUEN, VICTOR, ASSOCIATES. Maryvale Shopping City, Phoenix, Ariz. . . . .177

HOLABIRD & ROOT. First National Bank of Minneapolis . .151

KLING, VINCENT. Municipal Services Building, Philadelphia . . . . .144

MASTON, CARL. Robert Addison House, Ventura, Cal. . . .161

PEI, I. M. Society Hill Redevelopment, Philadelphia . . . . .135

PERKINS & WILL AND GRASSOLD-JOHNSON ASSOCIATES. Mayfair Shopping Center, Wauwatosa, Wis. . . . .185

REDSTONE, LOUIS G., with Avner Naggar and Allan G. Agree, associate architects; Wonderland Regional Shopping Center, Livonia, Mich. . . . .165

YOST, L. MORGAN, AND D. CODER TAYLOR. Siebenthaler's Garden Center, Dayton, Ohio . . . . .188

## Authors and Articles

BACON, EDMUND N. "Downtown Philadelphia: A Lesson in Design for Urban Growth" . . . . .131

HOWARD, SEYMOUR. "A New Look at Flat Plate Construction" . . . . .193

REDSTONE, LOUIS G. "Festive Atmosphere Helps Sales" . .165  
AIR CONDITIONING DUCTS BUILT INTO FLOOR AND ROOF STRUCTURES . . . . .190

PROTOTYPE HOSPITAL—FALLOUT PROTECTED . . . . .155

SELECTING FOOD SERVICE EQUIPMENT, Part 2 . . . . .205

DOWNTOWN PHILADELPHIA: A LESSON IN DESIGN FOR URBAN GROWTH 131  
*Edmund N. Bacon, A.I.A., executive director of the Philadelphia City Planning Commission, describes Philadelphia's downtown urban renewal with emphasis on design*

ARCHITECTS' NOTABLE INTERIORS FOR ROCKEFELLER FOUNDATION 147 *Architects Carson, Lundin & Shaw provide appropriate headquarters for philanthropy in two floors of a New York skyscraper*

DESIGN FOR CONVENIENT BANKING 151 *Planned efficiency and convenience saves time and money in operation of Minneapolis bank and office building*

PROTOTYPE HOSPITAL—FALLOUT PROTECTED 155 *Standards for the protection of staff and patients from the dangers of nuclear fallout*

HILLSIDE POST AND BEAM HOUSE FOR \$21,650 161 *Carl Maston solves problems for an awkward site and low budget*

# RECORD

CONTENTS

May 1961

## *Building Types Study 294: Facilities For Retailing*

FESTIVE ATMOSPHERE HELPS SALES 165 *Architect Louis G. Redstone explains by text and pictures how art can complement architecture to create a lively, colorful shopping environment*

SMALL CENTER KNOWINGLY UNDERSTATED 171 *Architect Warnecke's "Sophisticated Rustic" for the Ladera Shopping Center in California*

SWEDISH STORE WITH NOTABLE INTERIORS 174 *Ketchum & Sharp collaborate with Swedish architects to introduce American merchandising—design ideas to Stockholm shoppers*

CENTER WITHIN A TOTAL SUBURBAN PLAN 177 *A handsome background for retailing in Arizona which is part of a larger complex by Victor Gruen*

TWO LEVEL STORE WITH TWO LEVEL PARKING 181 *A visually exciting branch department store in suburban Washington*

REGIONAL CENTER THAT LOOKS INWARD 185 *A large Wisconsin shopping center with notably attractive malls, outstandingly landscaped*

ATTRACTIVE ROADSIDE GARDEN CENTER 188 *Architects Yost & Taylor design a highway outlet that puts the average roadside facility to shame (architecturally)*

## Staff of Architectural Record

EDITOR  
Emerson Goble, A.I.A.

CONSULTING EDITOR  
John E. Burchard

SENIOR EDITORS  
James S. Hornbeck, A.I.A., *Features*  
William Dudley Hunt, Jr., A.I.A.  
Elisabeth Kendall Thompson, A.I.A., *West*

ASSOCIATE EDITORS  
Robert E. Fischer, *Engineering*  
Florence A. van Wyck, *Production*  
Jeanne M. Davern, *Assistant to the Editor*  
Herbert L. Smith, Jr., A.I.A., *Houses*  
Mildred F. Schmertz, *Design*  
Grace M. Anderson  
William B. Foxhall

CONTRIBUTING EDITOR  
Ernest Mickel, *Washington*

ASSISTANT EDITORS  
Kathryn Gallant  
Anne Kaffer

DESIGN  
Eugene H. Hawley, *Director*  
Alex H. Stillano, *Associate*

CONSULTANTS  
George Cline Smith, *Economics*  
Clyde Shute, *Statistical*  
Clifford G. Dunnells, Jr., *Field Research*  
Daniel J. Howe, Jr., *Public Relations*  
Edwin W. Magee, Jr., *Industry Relations*  
Sigman-Ward, *Drafting*

PUBLISHER  
Robert F. Marshall

EDITORIAL DIRECTOR  
Robert M. Cunningham, Jr.

PUBLISHING ADVISER  
H. Judd Payne

CIRCULATION MANAGER  
Marshall T. Ginn

## Officers of F. W. Dodge Corporation

HONORARY CHAIRMAN OF THE BOARD  
James McV. Breed

CHAIRMAN OF THE BOARD  
Paul Abbott

VICE CHAIRMAN OF THE BOARD  
Chauncey L. Williams

PRESIDENT  
Irving W. Hadsell

EXECUTIVE VICE PRESIDENTS  
Julius T. Little, Robert F. Marshall,  
T. Oliver Morgan, O. O. Paulsell

EXECUTIVE VICE PRESIDENT AND TREASURER  
Howard M. Thompson

VICE PRESIDENTS  
Robert M. Cunningham, Jr., William H.  
Hatch, Jr., H. Judd Payne, Richard H.  
Ray, George Cline Smith

REGIONAL VICE PRESIDENTS  
Miles W. Beatty, Carl S. Bennett, Robert G.  
Bingham, Clinton C. Bennett, Roy J. Hard,  
Alton W. Kitchens, Arthur D. Prior

ASSISTANT VICE PRESIDENT AND COMPTROLLER  
Edwin H. Freed

ASSISTANT VICE PRESIDENTS  
Walter F. DeSaix, Clifford G. Dunnells, Jr.,  
Gault Eastman, Clyde Shute

SECRETARY  
John S. Brittain

ASSISTANT SECRETARIES  
William C. Breed, Jr., George W. Morgan

ASSISTANT TREASURER  
Irving B. Satin

## Coming in the Record

### ARCHITECTURE AND CHURCHES

*Next month's Building Types Study will present remodeled as well as new churches. Additions are not the architect's favorite preoccupation, but if you doubt their potential for challenging architectural talent at the highest level, consider Pietro Belluschi's design for a chapel to be added to Boston's (and Richardson's) great old Trinity Church (or the Belluschi design for an addition to Trinity Episcopal Church in Concord, Mass.). The new churches to lead off the study are also led off with a Belluschi church — the now completed (and architecturally superlative) Priory Church and Monastery at Portsmouth, R. I.*

### SAARINEN DESIGNS FOR IBM RESEARCHERS

*For its researchers IBM provided a spacious and beautiful rural site in Kitchawan, N. Y.; Eero Saarinen, as architect for their new research center, has provided a dramatic curved building which offers the practicable possibility of a (one-story) "ivory tower" for each researcher within a plan of the most exemplary flexibility. The site and its panoramic outlook are both complemented and complimented in an adventurous design.*

ARCHITECTURAL RECORD (combined with AMERICAN ARCHITECT and ARCHITECTURE), title ® reg. in U. S. Patent Office, © copyright 1961 by F. W. Dodge Corporation, a McGraw-Hill Company. All rights reserved including the right to reproduce the contents of this publication either in whole or in part. Quotations on bulk reprints of articles available on request. Indexed in Reader's Guide to Periodical Literature, Art Index, Industrial Arts Index and Engineering Index.

Every effort will be made to return material submitted for possible publication (if accompanied by stamped, addressed envelope), but the editors and the corporation will not be responsible for loss or damage.

SUBSCRIPTIONS: Available only by paid subscription. Publisher reserves the right to refuse non-qualified subscriptions. Subscriptions to Architectural Record solicited only from architects and engineers. Position, firm connection, and type of firm must be indicated on subscription orders forwarded to Circulation Manager, Architectural Record, 119 West 40th Street, New York 18, N. Y. Subscription prices: U. S., U. S. Possessions and Canada: \$5.50 per year; other Western Hemisphere countries, to those who by title are architects and engineers, \$9.00 per year. Single copy price except Mid-May 1961 issue \$2.00; Mid-May 1961 issue \$2.95. Beyond Western Hemisphere, to those by title are architects and engineers, \$9.00 per year for 12 monthly issues not including Mid-May 1961 issue. Subscriptions from all others outside U. S., U. S. Possessions and Canada for 12 monthly issues, not including Mid-May issue, \$24.00 per year.

CHANGE OF ADDRESS: Subscribers are requested to furnish promptly both old and new address, sending, if possible, stencil impression from magazine wrapper; new postal zone number, if any, should be included. Allow one month for change.

UNCONDITIONAL GUARANTEE: The publisher, upon written request, agrees to refund the part of the subscription price applying to the remaining unfilled portion of the subscription if service is unsatisfactory.

OTHER F. W. DODGE SERVICES: Dodge Reports—Dodge Construction Statistics—Sweet's Catalog Services—Dodge Books—Dodge Mailing Service—The Modern Hospital—The Nation's Schools—College and University Business—Hospital Purchasing File—Chicago Construction News—Daily Pacific Builder (San Francisco)—The Daily Journal (Denver)—Real Estate Record & Builders Guide—Dow Building Cost Calculator.

Audit Bureau of Circulations



Associated Business Publications



## Conscious Design for Bad Taste?

Duty on an architectural jury is normally a pleasant surcease from your own creative endeavor. You give your mustache a figurative twirl, crank up your esthetic convictions another notch, and go forth on an artistic mission. Come the cocktail hour you are ready with a few Great Thoughts. Nothing wrong with that.

This observer learned to his sorrow recently that it doesn't always go so pleasantly. There have been several occasions on which, for one reason or another, there was some fear that the submissions would be too thin. Somebody would always remark, perhaps facetiously, that we didn't really *have* to come up with a winner. But on this particular tour of duty, for the first time in my experience, we did not premiate a single entry. Makes for a long day, and a trying one.

Detention homes for delinquent children was the subject. And the judging started on an enthusiastic note, as it was felt that this type of building was emerging from a dark age, promising enlightened dedication. Children were to be cared for, salvaged, encouraged. The A.I.A. responded cheerfully to an appeal to dignify years of forward-looking work with an architectural competition. Two ardent advocates of the new programs sat down with three defenders of the architectural faith, to pick two winners (large and small classes).

I say "defenders of the faith" only because that's where we ended up: it's not where we began. We listened patiently and with interest to a considerable lecture on program requirements and criteria. We agreed that these would have full weight; in fact they seemed likely to conduce to good architecture.

But it was soon apparent that they didn't, or hadn't. By lunch time all entries had had a pretty careful first inspection, and the disappointment of three of the jurors was pronounced. Distress showed more plainly during the afternoon, and the day ended on

the dismal note of no premiation.

It proved difficult to explain that the disappointment as to architectural achievement was of a negative, not positive, order: we were not saying that what we saw was bad; we were saying that it was not good. Actually there were two or three submissions which showed the creative touch we were seeking, but these proved to have violated the credo too badly to be accepted by the program element of the jury. So architectural criteria clashed with program criteria, and this was just what shouldn't have happened.

The why of it bothered me, and it still does. I confess to thinking, during the tension of the afternoon, that a program can be so finite as to stultify the creative efforts of the designer. It might be true, but I really doubted that it was in this instance. The whole trouble, architecturally speaking, was that creative effort seemed simply turned off, and a program could hardly do that. It might be, as was suggested, budget trouble, but that explanation also seemed inadequate. Or perhaps it was budget trouble as regards architectural fees; this was pure surmise, but it did seem to be getting closer.

The dead hand of government sponsorship finally appeared as the most likely generalization. Maybe government is too tight with its fee schedules, but you have to carry it farther than that. Low fees or not, you have to work hard to achieve that barracks or warehouse look that so generally characterizes our post offices, public housing, hospitals, office buildings, courthouses—name it yourself.

There was a time when a government commission called for the best efforts of top architects. But now—excepting the late embassy program—architectural creativity seems suspect, and building design has been beaten down to a conformist mediocrity. It's as if we were consciously designing for bad taste, as in TV programs. —Emerson Goble

## SIGNS THE RECESSION IS ENDING

THERE HAS BEEN a great deal of talk, to which we have contributed our share, on the enormous population growth expected in the United States during the Sixties. Our favorite analogy is that we are adding the equivalent of metropolitan Chicago, suburbs and all, every two years. Obviously, there is a good deal of significance in this for the construction business, because we must supply the equivalent of all the facilities of a Chicago, and then some, each biennium.

BUT TOTAL population is only a part of the story. Of equal importance (in fact, of much more importance to those whose interests are purely regional or local) is the question of where population growth will take place. There is food for a great deal of thought in the figures for the 1950's, recently compiled as part of the 1960 Census. It is apparent from the new data that widely divergent trends exist in different parts of the country, and more important, that the trends are shifting. The facts are pleasant or unpleasant, depending on one's attachment to a particular area; nonetheless, they are facts. Some examples: There has been very rapid growth on the East Coast, from Connecticut to Virginia; and the fastest-growing state in the nation is Florida. Northern New England and the Plains States, on the other hand, have been growing quite slowly. A few states actually lost population in the Fifties. Southern California gained greatly, but further north along the Pacific Coast the increases were not so notable.

THERE IS ROOM for considerable research and speculation as to the causes of these trends, and their future course. A glance at the map, however, seems to make a few things clear. Among them are these: a movement to the Southern climates; a movement toward water, on the Coasts and on the Great Lakes; and continued concentration around the government and business headquarters cities of Washington and New York. Complicating the picture, and not so readily apparent, has been a substantial race migration.

CONSTRUCTION ACTIVITY, despite the very bad weather this past winter, showed considerable promise in the opening months of 1961. Contract awards, as reported by Dodge for January and February, were running some six per cent ahead of the corresponding months of 1960. Single family homes continued to sag, but apartments were up; the result is that apartments accounted for more than a fourth of all the dwelling units put under contract, the highest proportion in many years. Office and bank building contracts were up, while stores declined a little. On the whole, the construction picture seemed to indicate that the recession was ending in the first quarter of 1961.

GEORGE CLINE SMITH  
*Vice president and chief economist*  
*F. W. Dodge Corporation*  
*A McGraw-Hill Company*

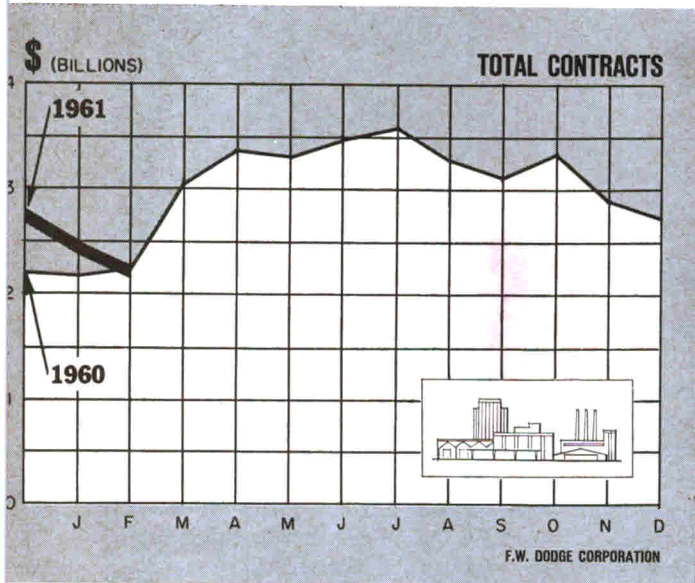

Total contracts include residential, nonresidential, heavy engineering contracts

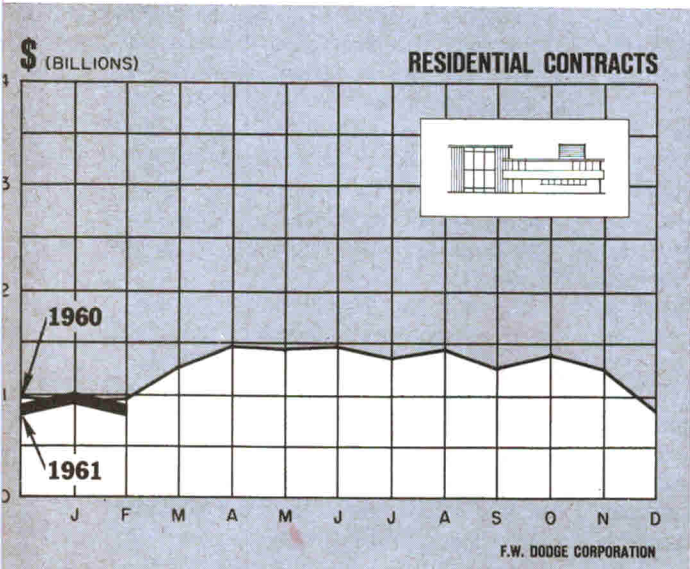
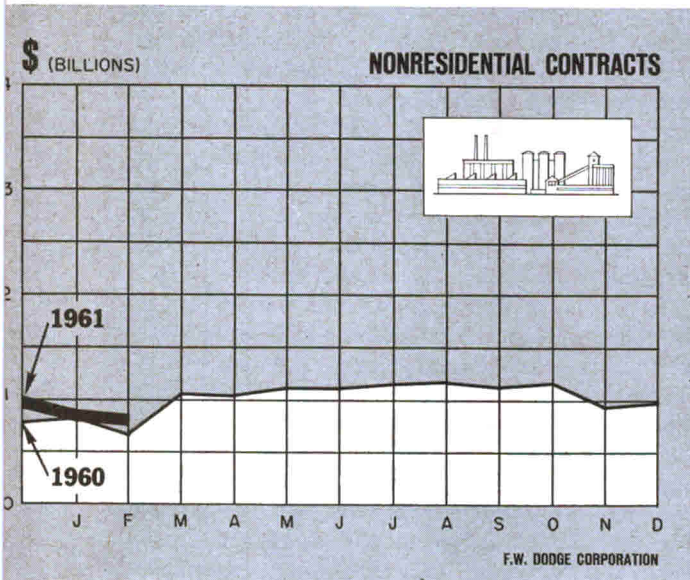



THE  
*Superiority*  
YOU  
EXPECT



• When the first astronaut is launched into space, it will have been only after years of exhaustive tests to prove that he was the fittest of all for the purpose. This is the type of superiority you have come to expect of Josam Products, since we "originate," not "duplicate."

Every Josam product — and there are thousands of them — each conceived for a different purpose, reached its destination only after it was endowed with superior features of design and construction, and subjected to exhaustive tests. You can therefore be assured that in Josam you do get the superiority you have a right to expect!

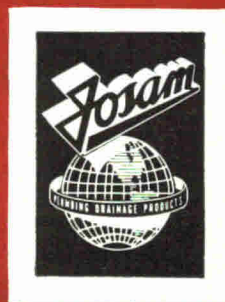

**JOSAM MANUFACTURING CO.**

General Offices and Manufacturing Division • Michigan City, Ind.

REPRESENTATIVES IN ALL PRINCIPAL CITIES

West Coast Distributors

**JOSAM PACIFIC CO.**

765 Folsom Street

San Francisco 7, Calif.

JOSAM PRODUCTS ARE SOLD THROUGH PLUMBING SUPPLY WHOLESALERS

Manufacturers and Representative in Mexico—HELVEX, S. A., Mexico City

## Buildings in the News



Town Center Plaza, Southwest Washington, D.C.: Town Center Towers East, twin nine-story apartment structures, comprise the first half of the development which will include four apartment buildings on a 20-acre site, an in-town shopping center with approximately 17 stores and a plaza with recreational facilities. The two completed buildings utilize an advanced reinforced-concrete construction method that produces a "stretched skin" effect. Contractors: Blake Construction Company



Kips Bay Plaza, New York City: the first of twin apartment towers in the \$22,000,000 10 acre apartment development is now ready for occupancy. Twin 21-story buildings will contain a total of 1120 apartments. Included in the development are an underground parking garage, landscaped plaza, shopping center, medical building. Contractors: Webb & Knapp Construction Corp.

Zeckendorf Plaza Development, Denver: view shows 1000-room Denver Hilton Hotel with its concrete and stone facade. On the other side of the tall slab are ballrooms and office facilities. In the foreground is the May Department Store and ice skating rink, part of the complex. Contractors: Webb & Knapp Construction Corp.

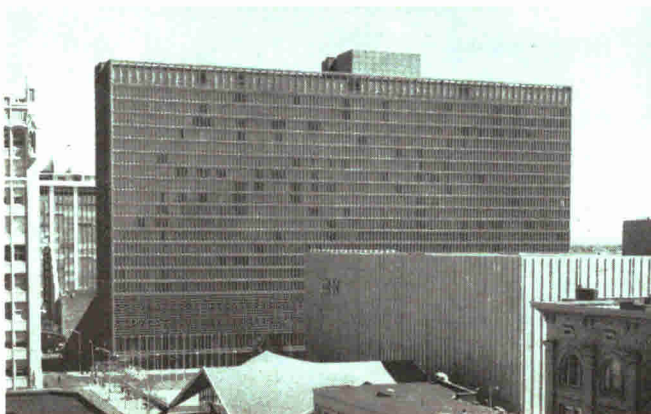

George Cserna

## I. M. PEI WINS BRUNNER AWARD FOR 1961

I. M. Pei has won the 1961 Brunner Award of \$1000 of the National Institute of Arts and Letters. He will receive the award, given annually since 1955 to an American architect who has made a contribution to architecture as an art, at the Joint Annual Ceremonial of the National Institute and the American Academy of Arts and Letters on May 24.

Shown on this page are some of his recent principal projects, each of them developed by Webb & Knapp, Inc. or Webb & Knapp affiliates.

Buildings of his design still uncompleted are: the Green Center for Earth Sciences, Massachusetts Institute of Technology; the Multi-Airline Terminal, New York International Airport; and the Metropolitan Tower, Honolulu, Hawaii.



Place Ville-Marie, Montreal: a 42-story anodized aluminum tower dominates the seven-acre commercial development now under construction and scheduled for completion in mid-1962. The tower, with 1,500,000 sq ft of office space, is surrounded by several smaller office buildings. The project includes two levels of underground parking for 1000 cars and an underground level of shops and arcades. Contractors: Foundation Company of Canada Limited

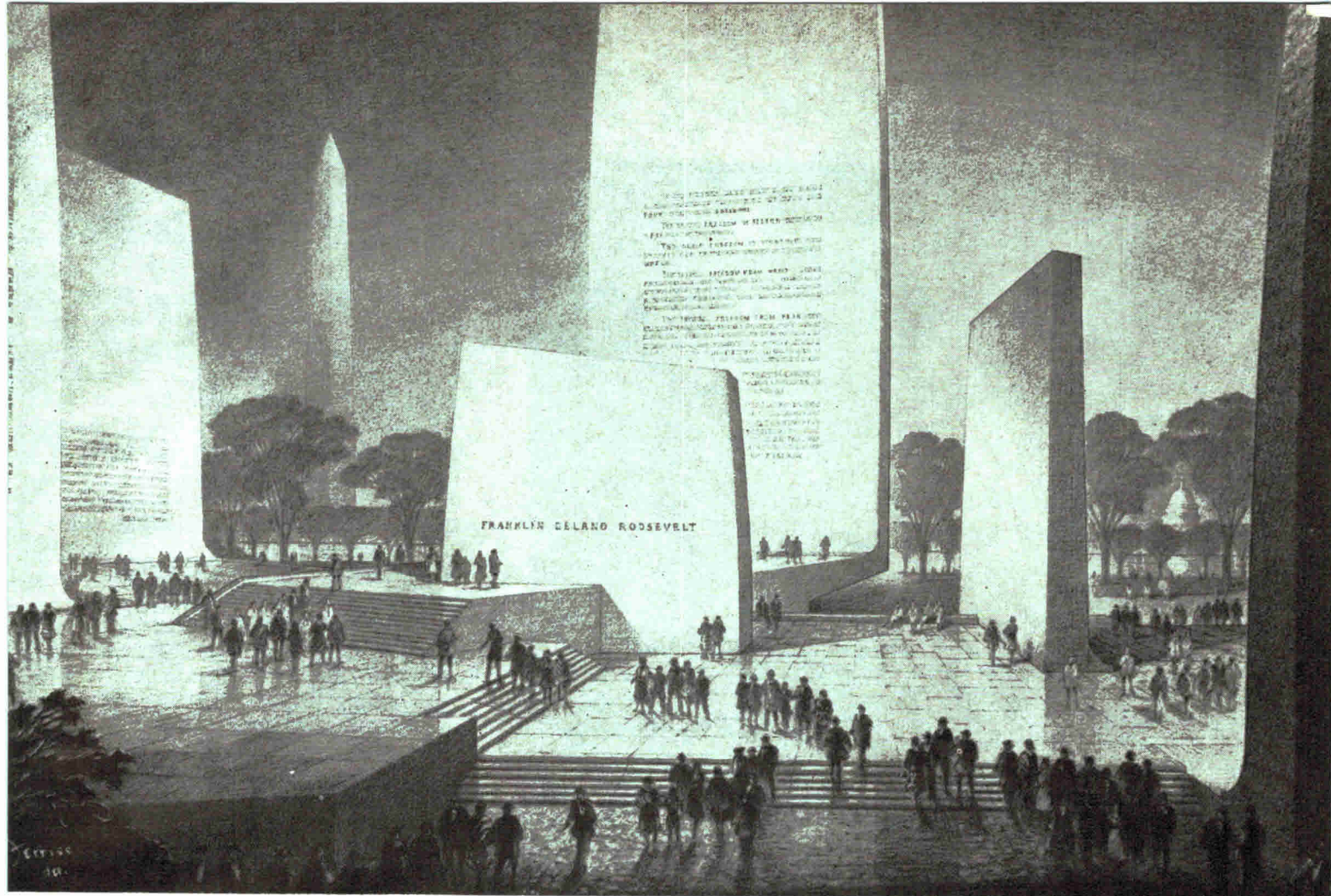

HUGH FERRISS RENDERING OF THE WINNING DESIGN in the Franklin Delano Roosevelt Memorial Competition: the entry of architects William F. Pederson and Bradford S. Tilney of New York, in association with Norman Hoberman, sculptor, Joseph Wasserman and David Beer, associates, and Ammann and Whitney, structural engineers. The Record regrets that a caption on page 177 of the March issue erroneously identified a model photograph as a photograph of the Ferriss rendering

Taliesin Associated Architects, an affiliate of the Frank Lloyd Wright Foundation, have created preliminary plans for a new Ascension Evangelical Lutheran Church to be located on a ten-acre site at the foot of Mummy Mountain in Scottsdale, Arizona.

The church will have a sanctuary to seat 750, Sunday school rooms and offices, assembly and other administrative quarters, a chapel and other spaces for related functions.

The initial phase of construction, expected to begin next fall, outlines expenditure of \$400,000. The projected completed cost was estimated at more than \$1,000,000, with Easter Sunday, 1962 as the completion target date.

The ceiling above the sanctuary will rise in a series of polygonal patterned domes graduating in length. The highest dome above the altar will be pierced to allow sunlight to fall on the worship center below, and will be surmounted by a slender gold metal spire.

Other features include a semi-circular wing for classrooms and offices; an earth bank to shield the central enclosed court from exterior parking areas; a parking area six ft below the general floor level; a central garden court; play areas; a pool with fountain jets; a social fireside room with provisions for serving 300 persons and an outside patio.

## TALIESIN ARCHITECTS DESIGN ARIZONA CHURCH

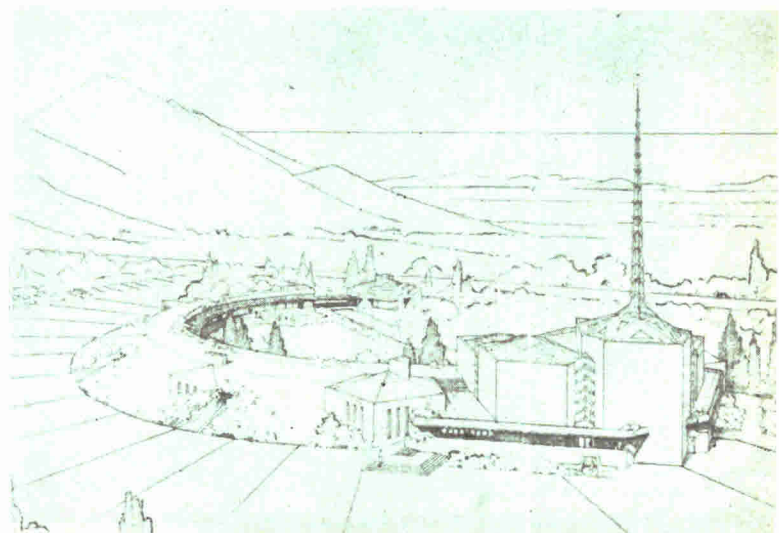

## TWO NEW BUILDINGS FOR I.U.A. CONGRESS

Two new temporary buildings designed by Theo Crosby, A.R.I.B., will house the meetings and exhibitions of the 6th International Union of Architects' Congress which will be held in London July 3-7. Located on the site of the old Dome of Discovery (one of the highlights of the 1951 South Bank exhibition) beside the River Thames, the Exhibition building and the Headquarters building are being erected free of charge by Taylor Woodrow Construction Ltd. of materials lent by manufacturers.

The Exhibition hall has no windows, but a roof of polythene sheeting. The structure consists of a galvanized steel space frame on galvanized tubular steel uprights, scaffold-board walls, a floor of concrete paving blocks.

Connected with the Exhibition hall by a paved area, the Headquarters building uses basic materials of glass, aluminum and asbestos insulation board. The roof, basically a rectangular grid, is composed of a mass of tetrahedrons each 8 ft sq on a base of aluminum sheet. Roof calculations were done by Dr. Z. S. Makowski, Imperial College of Science and Technology, London, in collaboration with the British Aluminium Company's research department and Frank Newby of F. J. Samuely & Partners.

The unity of the two contrasting structures is achieved by basing designs on a rigid dimensional system—multiples, divisions or repetitions of the 4 ft module Exhibition hall's space roof deck.

### A.I.A. Sends Delegates

More than 1500 architects from all over the world will attend the Congress organized by the Royal Institute of British Architects through the 1961 Congress Organizing Committee of I.U.A.

The five official delegates from the American Institute of Architects to the Congress are: Philip Will Jr., F.A.I.A., president of the Institute; Edmund R. Purves, F.A.I.A.; Samuel I. Cooper, F.A.I.A.; Henry Churchill, F.A.I.A.; and Ernest A. Grunsfeld Jr., F.A.I.A.

The theme of the Congress will be "New Techniques and Materials—Their Impact on Architecture." Three major papers will be delivered by Professor Henry Russell Hitchcock of Smith College, Professor Pier Luigi Nervi of the University of Rome, Italy and Professor Jerzy Hryniewiecki of Warsaw Polytechnic, Poland.

Model of I.U.A. Congress' identifying 42-ft tower designed by John Ernest. Erection by Scaffolding Ltd; engineer: T. W. Blackmore of S.G.B.

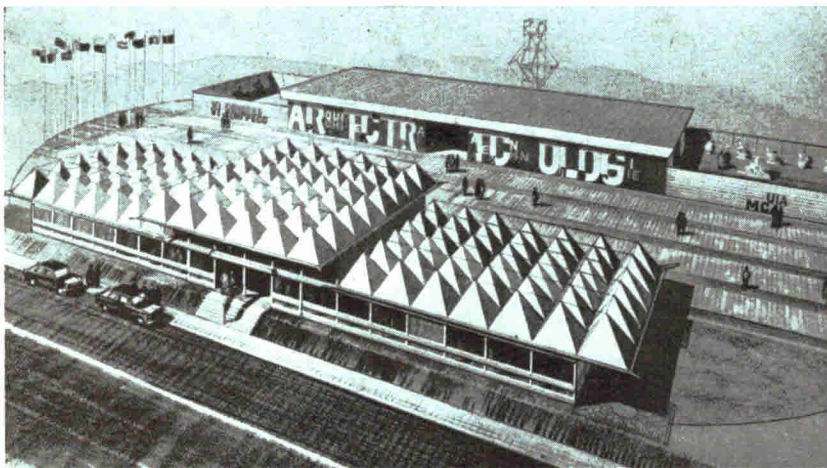
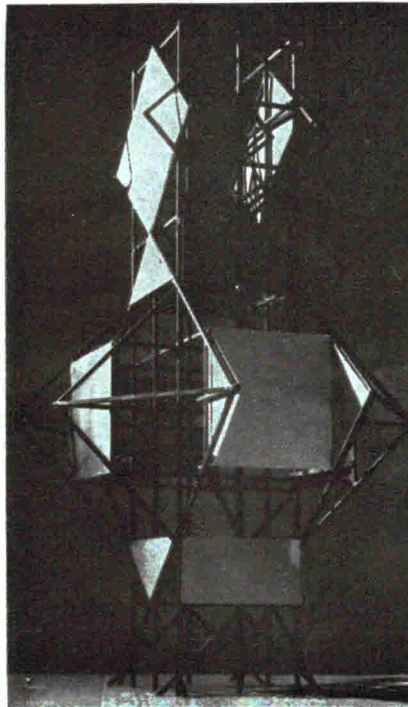

Drawing of the two temporary buildings being erected in London for the I.U.A. Congress. In the foreground, the Headquarters building; in the background, the Exhibition hall

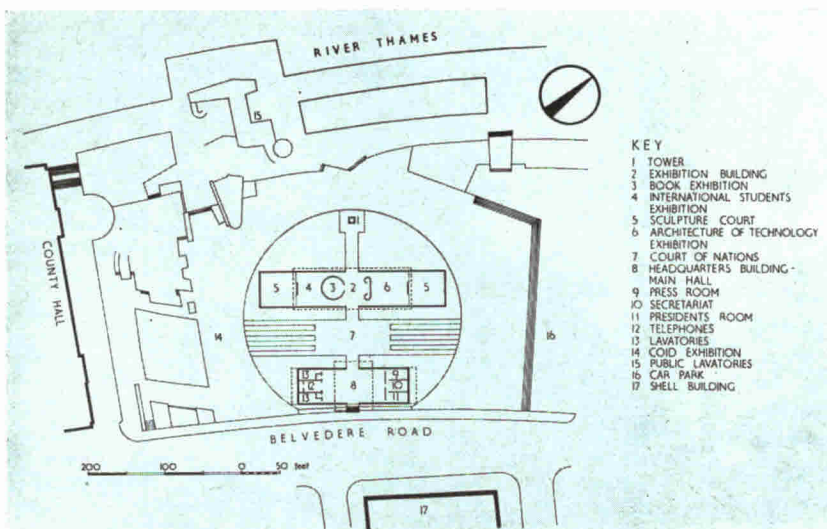

Ground plan of the two buildings and tower

- KEY
- 1 TOWER
  - 2 EXHIBITION BUILDING
  - 3 BOOK EXHIBITION
  - 4 INTERNATIONAL STUDENTS
  - 5 EXHIBITION SCULPTURE COURT
  - 6 ARCHITECTURE OF TECHNOLOGY EXHIBITION
  - 7 COURT OF NATIONS
  - 8 HEADQUARTERS BUILDING - MAIN HALL
  - 9 PRESS ROOM
  - 10 SECRETARIAT
  - 11 PRESIDENTS' ROOM
  - 12 TELEPHONES
  - 13 LAVATORIES
  - 14 COID EXHIBITION
  - 15 PUBLIC LAVATORIES
  - 16 CAR PARK
  - 17 SHELL BUILDING

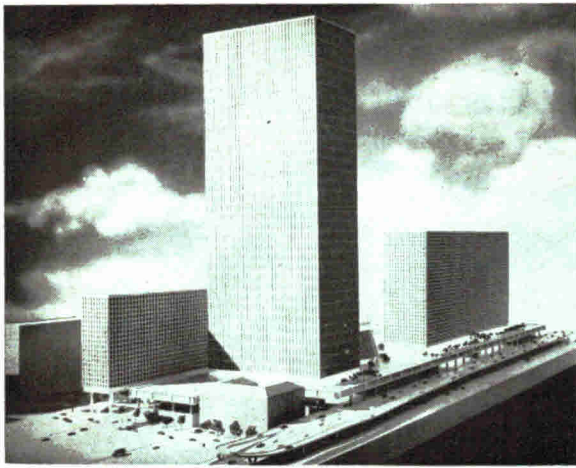

Esra Stoller Associates

(right) Artist's rendering of downtown Manhattan showing proposed World Trade Center on site. 1) 72-story World Trade Mart 2) circular 8-story Securities Exchange 3) 20-story Center Gateway 4) 30-story World Commerce Exchange 5) 6-level Concourse 6) heliport 7) housing 8) Battery Park. (above) Buildings rise from Concourse and Plaza. At right of Trade Mart tower is Commerce Exchange; at left, Trade Center Gateway, its first floor elevated 50-ft for colonnade over main entrance of Center

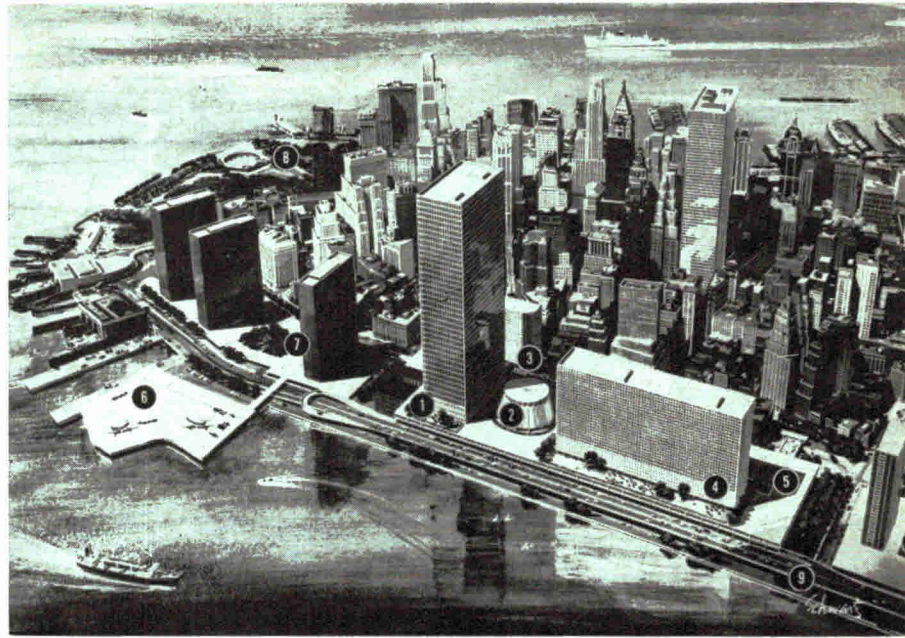

(above) A two-level 1400 ft long enclosed landscaped plaza on third and fourth levels of Concourse has glass-domed apertures. Shops, restaurants line both Plaza levels. (below) Three double-deck bridges such as one in foreground, equipped with motor stairs to both levels, are main pedestrian access to Center



## PROPOSED WORLD TRADE CENTER IN MANHATTAN

The establishment of a World Trade Center in the New York-New Jersey Port District has been recommended in a report by the Port of New York Authority to Governor Nelson A. Rockefeller of New York, Governor Robert B. Meyner of New Jersey and Mayor Robert F. Wagner of New York City.

Based on a year's study by the Authority following a recommendation by the Downtown-Lower Manhattan Association, the report proposes the redevelopment of 16 acres adjacent to the traditional core of world trade activity in lower Manhattan. The World Trade Center, to cost at least \$355,000,000, would comprise a multi-level Concourse; 72-story World Trade Mart; circular 8-story Securities Exchange; 30-story World Commerce Exchange; and 20-story Trade Center Gateway.

The planning of the architectural complex was done by architect Richard M. Adler of the firm of Brodsky, Hopf & Adler with the guidance of a Board of Architects composed of Gordon Bunshaft of Skidmore, Owings & Merrill; Wallace K. Harrison of Harrison and Abramovitz; and Edward Durell Stone.

The unifying element of the proposed center would be a 1600 by 400 ft enclosed five-level Concourse and landscaped Plaza above a single-story service area. This would house various world trade service activities and facilities essential to the operation of the Center.

FROM **MODINE** . . . THE FIRST NAME IN UNIT HEATING

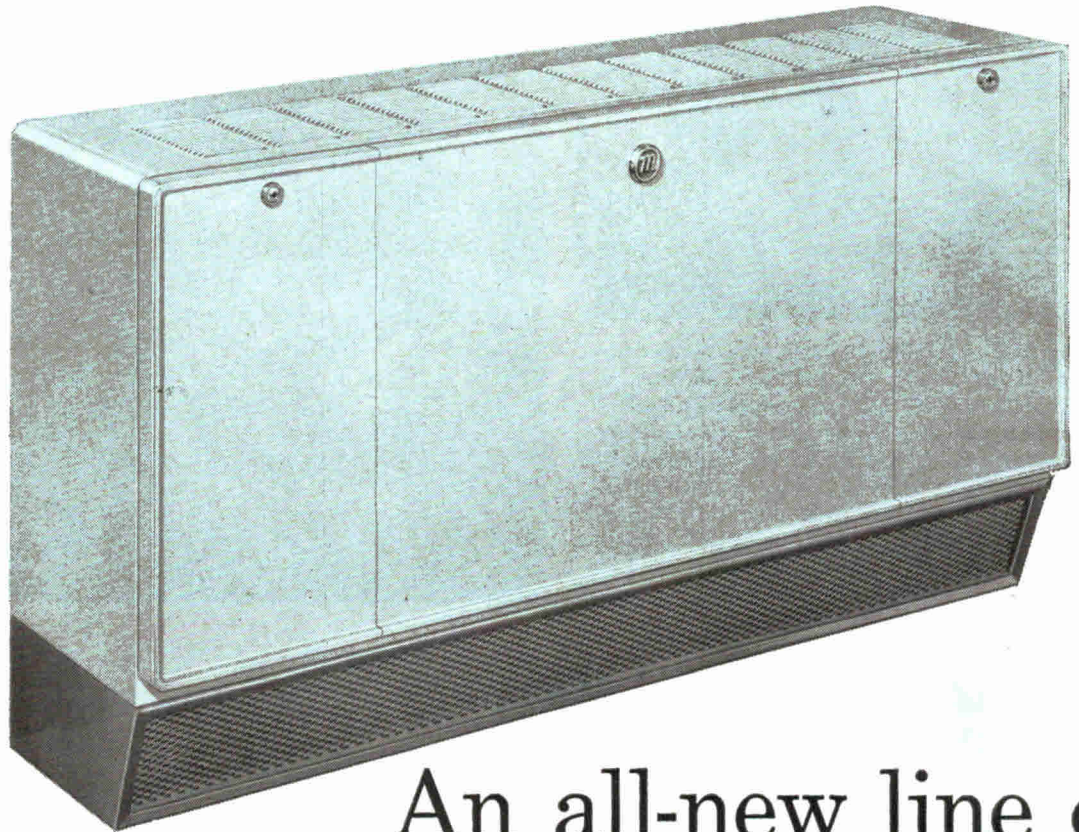

## An all-new line of cabinet unit heaters with

*NEW STYLING! NEW SIZES! 136 DIFFERENT MODELS FOR FLOOR, WALL OR CEILING MOUNTING*

Here's beauty, economy and just-right warmth for *any* commercial, institutional or public building. 17 types! Each in eight sizes! And *all* provide quick, positive, quiet distribution of heated air. No cold spots! No hot blasts! They can be installed with or without ductwork . . . operated manually or automatically on hot water or steam systems.

With smart, distinctive styling, Modine cabinet unit heaters are attractive additions to the decor

of today's most modern buildings. Most important, they install easily, economically . . . whether it's new construction or modernization.

Capacities range from 250 cfm to 2,000 cfm. The line includes free-standing units as well as types for use on walls or ceilings and for recessed installation. All exposed models are available in attractive light grey, tan beige, light green, coral red, light blue, cream yellow and dark grey.

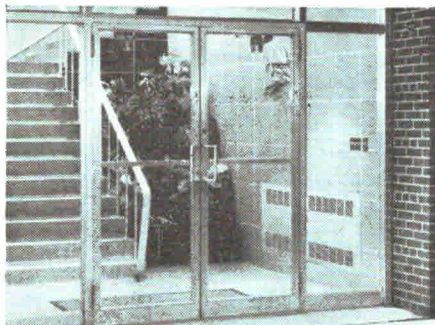

**UNIFORM WARMTH** is provided in this entrance by a Type FF-FB Modine cabinet unit heater. PERMA-LAP framing assures neat, permanent recessing.

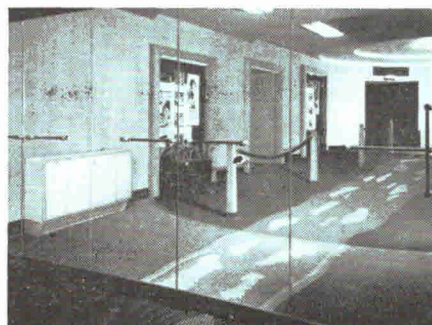

**CHILLING BLASTS** of winter pose no problem here. A Type FT free-standing Modine cabinet unit heater effectively blankets theater lobby with heated air.



**OVERHEAD AND OUT OF THE WAY**, a Type BT Modine unit helps keep shoppers warm. This ceiling unit is ideal where floor or wall space is limited.

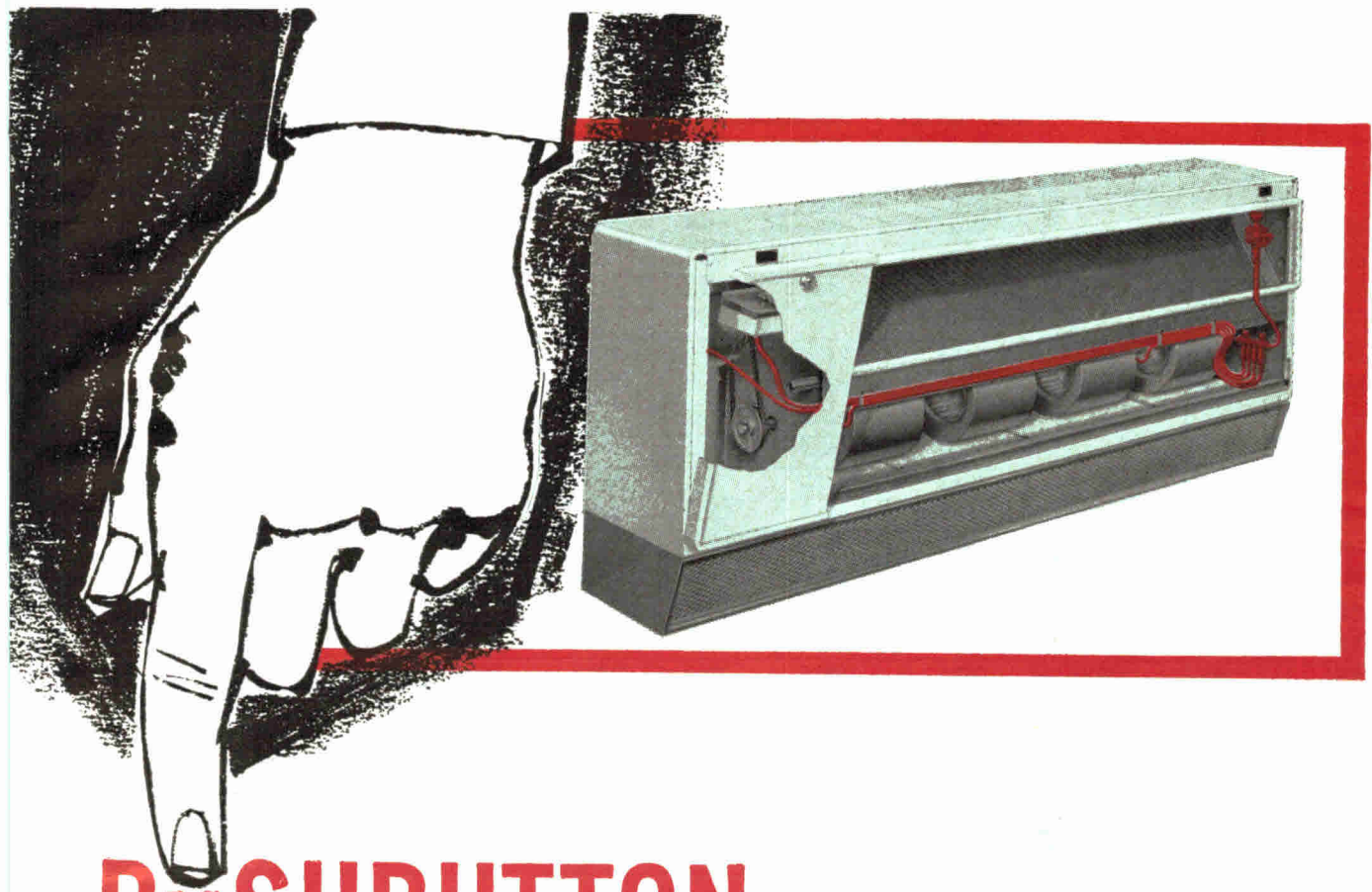

# PUSHBUTTON LUBRICATION

*saves the time, ends the grime of "oil-can" lubrication!*

Pushbutton lubrication is a Modine *exclusive!* An optional feature that soon pays for itself in maintenance man-hours saved. It ends the time-consuming, often messy, chore of "making the rounds" with an oil can. When Modine's new cabinet unit heaters need lubrication, all that needs to be done is to push a button. The automatic lubrication system does the rest . . . sends metered amounts of lubricant to every oiling point. Just *seconds* are spent with each unit!

## TWO MORE MAINTENANCE TIME-SAVERS

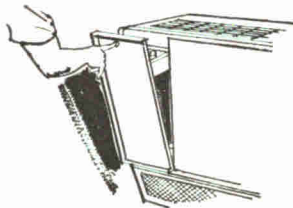

**EASY-ACCESS CONTROL PANELS** speed and simplify servicing. The hinged panels swing open at a turn of key-lock latches. No time-wasting screws to remove.

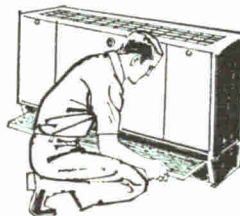

**FAST, SIMPLE FILTER REMOVAL!** No need to remove panels when the filter needs changing. It slides out fast and easy . . . like a drawer. Slide out the old, slide in the new!

**COMPLETE INFORMATION** on Modine's all-new cabinet unit heater line is contained in Catalog 561. For your copy, contact your Modine representative . . . listed in the yellow pages. Or write Modine Manufacturing Company, 1510 De-Koven Avenue, Racine, Wisconsin.

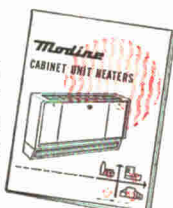

C-1428

# Construction Cost Indexes

Presented by Clyde Shute, Director of Statistical Policy, Construction News Div., F. W. Dodge Corp., from data compiled by E. H. Boeckh & Assoc. Inc.

Labor and Materials: U.S. average 1926-1929=100

## NEW YORK

## ATLANTA

PERIOD	RESIDENTIAL		APTS., HOTELS, OFFICE BLDGS. Brick and Concrete	COMMERCIAL AND FACTORY BLDGS. Brick and Concrete		Brick and Steel	RESIDENTIAL		APTS., HOTELS, OFFICE BLDGS. Brick and Concrete	COMMERCIAL AND FACTORY BLDGS. Brick and Concrete		Brick and Steel
	Brick	Frame		Brick	Steel		Brick	Frame		Brick	Steel	
1930	127.0	126.7	124.1	128.0	123.6		82.1	80.9	84.5	86.1	83.6	
1935	93.8	91.3	104.7	108.5	105.5		72.3	67.9	84.0	87.1	85.1	
1939	123.5	122.4	130.7	133.4	130.1		86.3	83.1	95.1	97.4	94.7	
1949	243.7	240.8	242.8	246.6	240.0		189.3	189.9	180.6	180.8	177.5	
1950	256.2	254.5	249.5	251.5	248.0		194.3	196.2	185.4	183.7	185.0	
1951	273.2	271.3	263.7	274.9	271.8		212.8	214.6	204.2	202.8	205.0	
1952	278.2	274.8	271.9	265.2	262.2		218.8	221.0	212.8	210.1	214.3	
1953	281.3	277.2	281.0	286.0	282.0		223.0	224.6	221.3	221.8	223.0	
1954	285.0	278.2	293.0	300.6	295.4		219.6	219.1	233.5	225.2	225.4	
1955	293.1	286.0	300.0	308.3	302.4		225.3	225.1	229.0	231.5	231.8	
1956	310.8	302.2	320.1	328.6	324.5		237.2	235.7	241.7	244.4	246.4	
1957	318.5	308.3	333.1	345.2	339.8		241.2	239.0	248.7	252.1	254.7	
1958	328.0	315.1	348.6	365.4	357.3		243.9	239.8	255.7	261.9	262.0	
1959	342.7	329.0	367.7	386.8	374.1		252.2	247.7	266.1	272.7	273.1	
1960	351.6	337.2	377.7	395.8	380.6		259.2	253.3	274.7	282.5	278.8	
Dec. 1960	354.0	338.9	381.0	399.5	381.3		259.8	252.9	276.6	285.2	278.9	
Jan. 1961	357.2	341.3	385.8	406.3	385.1		259.1	252.0	276.5	285.2	278.8	
Feb. 1961	357.9	341.7	386.9	407.9	386.4		259.1	252.0	276.5	285.2	278.8	
			% increase over 1939						% increase over 1939			
Feb. 1961	189.8	179.2	196.0	205.8	197.0		200.2	203.2	190.7	192.8	194.4	

## ST. LOUIS

## SAN FRANCISCO

1930	108.9	108.3	112.4	115.3	111.3	90.8	86.8	100.6	104.9	100.4	
1935	95.1	90.1	104.1	108.3	105.4	89.5	84.5	96.4	103.7	99.7	
1939	110.2	107.0	118.7	119.8	119.0	105.6	99.3	117.4	121.9	116.5	
1949	221.4	220.7	212.8	215.7	213.6	213.0	207.1	214.0	219.8	216.1	
1950	232.8	230.7	221.9	225.3	222.8	227.0	223.1	222.4	224.5	222.6	
1951	252.0	248.3	238.5	240.9	239.0	245.2	240.4	239.6	243.1	243.1	
1952	259.1	253.2	249.7	255.0	249.6	250.2	245.0	245.6	248.7	249.6	
1953	263.4	256.4	259.0	267.0	259.2	255.2	257.2	256.6	261.0	259.7	
1954	266.6	260.2	263.7	273.3	266.2	257.4	249.2	264.1	272.5	267.2	
1955	273.3	266.5	272.2	281.3	276.5	268.0	259.0	275.0	284.4	279.6	
1956	288.7	280.3	287.9	299.2	293.3	279.0	270.0	288.9	298.6	295.8	
1957	292.0	283.4	295.2	307.1	302.9	286.3	274.4	302.9	315.2	310.7	
1958	297.0	278.9	304.9	318.4	313.8	289.8	274.9	311.5	326.7	320.8	
1959	305.4	296.4	315.0	329.8	323.9	299.2	284.4	322.7	338.1	330.1	
1960	311.4	301.0	322.2	337.2	329.2	305.5	288.9	335.3	352.2	342.3	
Dec. 1960	312.8	301.9	324.6	339.6	329.6	302.0	283.6	337.1	355.3	343.5	
Jan. 1961	313.0	300.7	326.1	343.1	330.7	300.6	281.7	337.0	355.2	343.2	
Feb. 1961	313.0	300.7	326.1	343.1	330.7	300.6	281.7	337.0	355.2	343.2	
			% increase over 1939					% increase over 1939			
Feb. 1961	184.0	181.0	174.7	186.4	177.9	184.6	183.7	187.0	191.4	194.6	

Cost comparisons, as percentage differences, for any particular type of construction, are possible between localities, or periods of time within the same city, by dividing the difference between the two index numbers by one of them; i.e.:

index for city A = 110

index for city B = 95

(both indexes must be for the same type of construction).

Then: costs in A are approximately 16 per cent higher than in B.

$$\frac{110-95}{95} = 0.158$$

Conversely: costs in B are approximately 14 per cent lower than in A.

$$\frac{110-95}{110} = 0.136$$

Cost comparisons cannot be made between different types of construction because the index numbers for each type relate to a different U. S. average for 1926-29.

Material prices and wage rates used in the current indexes make no allowance for payments in excess of published list prices, thus indexes reflect minimum costs and not necessarily actual costs.



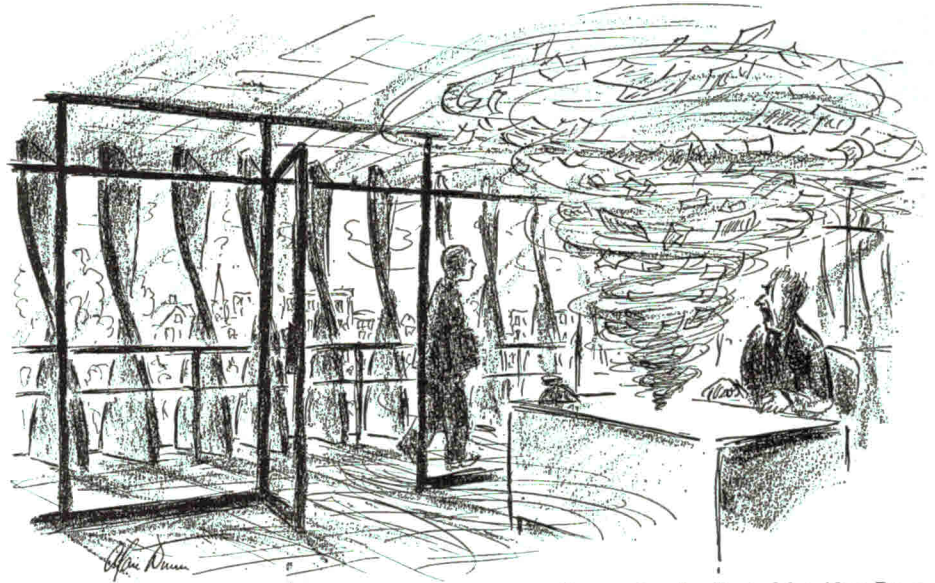

Drawn for the Record by Alan Dunn

"Close that door!"

## Rockwell Appointed Director, A.I.A. Public Affairs

Matthew L. Rockwell, practicing architect, planner and professional engineer of Winnetka, Ill., has been appointed Director of the Division of Public Affairs of the American Institute of Architects.

The division is one of three recently created under a reorganization of the A.I.A. headquarters staff. The other two are the Division of Member Services, headed by Theodore W. Dominick, A.I.A., and the Division of Staff Administration and Convention Management, headed by J. Winfield Rankin.

The Department of Public Affairs activities include government relations, public relations, and all A.I.A. publications, as well as all programs related to housing and community planning.

Among Mr. Rockwell's special assignments are the strengthening of A.I.A.'s services to its chapters and individual members, dealing with government agencies on all levels and developing effective programs to promote the "image of the architect" in the public mind across the nation.

Mr. Rockwell, who began his career as assistant planner of the Chicago Regional Planning Association in 1939, has worked with Boston's Urban Land Institute and the Chicago Plan Commission. A partner in the firm of Stanton and Rockwell, he is a past president of the Chicago Chapter of the American Institute of Planners and former lecturer in city planning at the Illinois Institute of Technology.

## 1961 Competition Announced: Massey Architecture Medals

In the fifth competition since its inauguration in 1950, the Royal Architectural Institute of Canada, with the concurrence of the Massey Foundation, invites the submission of entries for the 1961 Massey Medals for Architecture. One gold and nineteen silver medals will be awarded to the twenty outstanding buildings entered.

Eligible are buildings designed by architects registered and resident in Canada, although the buildings may be located anywhere in the world. They must have been completed and occupied for the first time since September 30, 1951.

The Jury of Selection will consist of Pietro Belluschi, F.A.I.A., Dean of the School of Architecture at Massachusetts Institute of Technology, Boston; John Bland, F.R.A.I.C., Director of the School of Architecture at McGill University, Montreal; and Peter Thornton, F.R.A.I.C., of the firm of Gardiner, Thornton, Gathe and Associates, Vancouver, B.C.

A preliminary judgment June 19-20 will select 100 outstanding buildings, final judgment being held Oct. 2-3 to select Medal winners. Announcement and medal presentation and opening of the exhibition at Ottawa's National Gallery will be Nov. 2, the exhibition on view through Nov. 23.

The entry form with registration fee of \$5.00 for each building must be sent to the Executive Offices of the Royal Institute, 88 Metcalfe St., Ottawa, Canada by May 15.

## Michigan Society of Architects 47th Annual Convention

About 600 architects, wives, exhibitors, and guests attended the 47th Annual Convention of the Michigan Society of Architects at the Sheraton-Cadillac Hotel April 5th to 7th.

The theme of the meeting was "Urban Renewal," which was discussed in three seminars. The first, entitled "Tools for Urban Renewal," was moderated by H. G. Sheltraw of Saginaw; the second, on "The Architect's Role in Urban Renewal," by William Rippatte of Kalamazoo; and the third, on "The City Renewed," by John Paul Jones of Grand Rapids. A group of distinguished architects and planners from various cities served as panelists. Architect Arthur O. Moran of Birmingham was general chairman.

Principal speakers for the luncheons and dinners included Philip Will Jr., A.I.A. President, Charles A. Blessing, A.I.A., Detroit Planning Director, and G. Herbert True, University of Notre Dame.

The Society's gold medal was presented to Joseph William Leinweber for "long and distinguished service to the architectural profession in the Detroit area, as well as for service to the American Institute of Architects and the Michigan Society of Architects."

An honorary membership was given to J. Gardner Martin, District Engineer for the Portland Cement Association, for his contribution in "improving human relationships within the profession and building industry." —James S. Hornbeck.

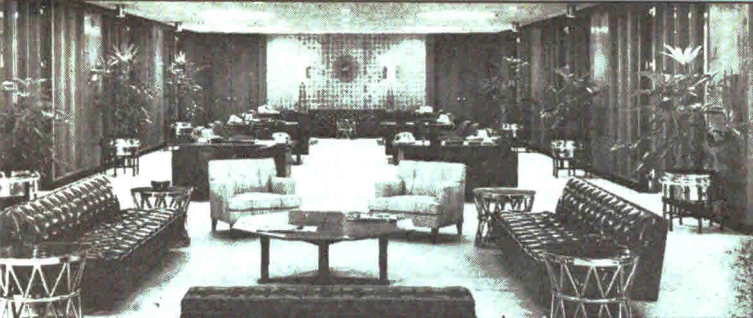

1

National Bank of Tulsa\*  
Specifies  
**EGGERS**  
Custom Matched  
Architectural Plywood

When the National Bank of Tulsa, Oklahoma, decided to remodel and extend their two areas of banking service, they chose Eggers Plywood Company to produce all the architectural plywood. They knew Eggers superior craftsmanship and experience in providing hardwood doors and paneling for over seventy-seven years was yet to be excelled.

That's because Eggers modern production facilities are geared to the careful selection, matching and cutting of flitch to insure continuous grain patterns and effects for walls and doors. For your next bank, school, church, hospital or other commercial project, be sure —specify Eggers. Flitch samples of face veneer submitted on request.

\*AIA Architect H. G. Barnard, Jr.

1. Ultramodern mezzanine features Eggers custom matched teak imported from Burma for walls, doors and louvered room dividers.

3. Eggers beautifully matched plywood is cut to angle of escalator and matched to side walls.

2. Perfect matching of teak flitch even around corners is found in executive suite.

4. Architectural plywood is used below counters and on back wall, providing a continuous grain effect.

**EGGERS PLYWOOD COMPANY** Two Rivers, Wisconsin • phone 378  
Quality Manufacturers since 1884 See Sweet's Arch. File-16/E9.

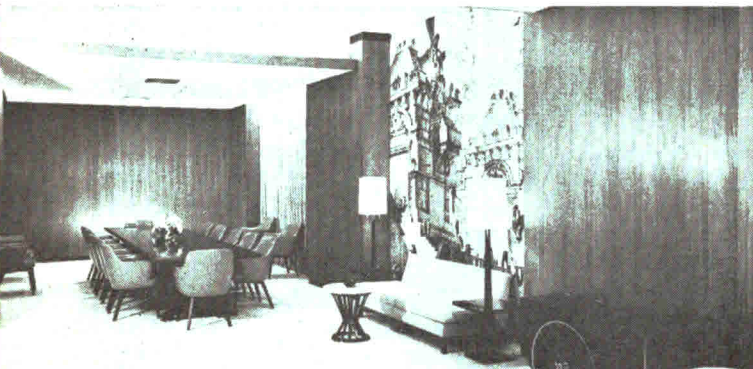

2

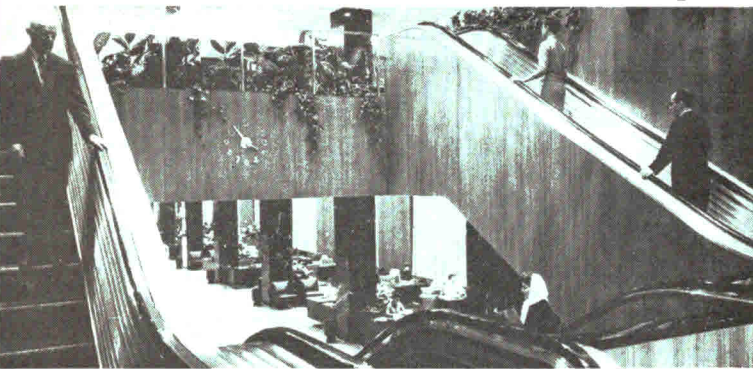

3 ▲ ▼ 4



## ARCHITECTS • INTERIOR DESIGNERS!

For more than three decades, **SCALAMANDRÉ** has been called upon to furnish Fabrics, Trimmings and Wall Coverings for America's leading Historical Shrines, Restorations, Reproductions and Modern Interiors; Commercial, Institutional and Residential. Our experience is vast, unlimited and diversified. Avail yourself of our newly established Courtesy Consultation Service. Call or write:

**Gino Scalamandr , Vice President**  
Architectural Contract Division  
37-24 24th Street — Long Island City 1, N.Y. — ST 4-0794

**OR VISIT OUR SHOWROOMS LISTED BELOW**  
Fabric and Wallpaper coordinations; Jacquard and Hand Printed on finest Silks, Cottons and Imported Linens; selected synthetic fibres. 20,000 patterns to choose from.

**WHEN IN NEW YORK BE SURE TO VISIT OUR MILL. NO ORDER TOO LARGE OR TOO SMALL. SAMPLE CUTTINGS AVAILABLE.**

*Scalamandr *

Main Showroom: 63 East 52nd St., N. Y. C.

ATLANTA • BOSTON • CHICAGO

LOS ANGELES • PHILADELPHIA • SAN FRANCISCO

## Designing a Swimming Pool?...You'll need **PADDOCK'S DESIGN MANUAL** (A.I.A. File No. 35-2)

All the information you'll need in designing a pool of any size is contained in our indexed, clearly written Design Manual. You'll find typical examples of pool design, the National Swimming Pool Institute's minimum standards for public pools, information on computing by hydraulics, and other pertinent data.

**WRITE for your copy today—available to designers at no charge.**

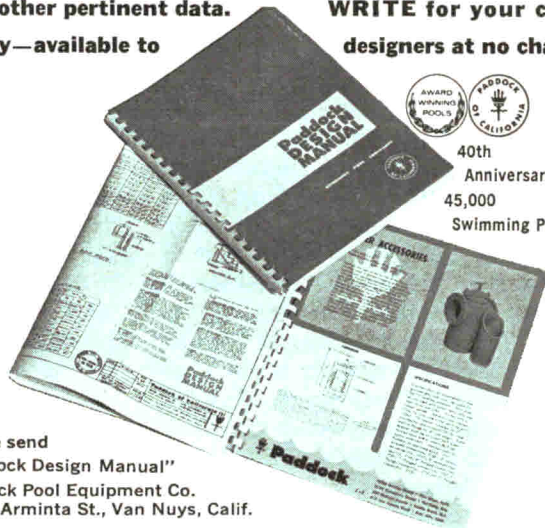

Please send  
"Paddock Design Manual"  
Paddock Pool Equipment Co.  
14600 Arminta St., Van Nuys, Calif.

NAME \_\_\_\_\_

STREET \_\_\_\_\_

CITY \_\_\_\_\_ STATE \_\_\_\_\_

## How Armstrong Acoustical Fire Guard can save you up to two months' construction time

The large ceiling of the airline terminal on the left features the new Armstrong Acoustical Fire Guard *lay-in* system. This revolutionary ceiling system combines, for the first time, the economy and fast installation advantages of an exposed grid system with the protection of a time-design-rated ceiling.

The smaller lounge ceiling which you see just below the mezzanine is of Acoustical Fire Guard *tile*. Millions of feet of this tile have been installed since it was first introduced two years ago.

In either form, Armstrong Acoustical Fire Guard can save up to *two months'* construction time. Here's why.

Since Armstrong Acoustical Fire Guard is fully approved by the Underwriters' Laboratories, Inc., there's no need to install intermediate protection between the acoustical ceiling and the steel structural members.

Installation is a completely *dry* operation that does not require an extensive cleanup.

There are none of the other inconveniences and delays of a wet operation. Carpenters, painters, and flooring contractors can be on the job at the same time as the acoustical contractor. This alone can save weeks.

The Armstrong Acoustical Fire Guard lay-in units are available in both the Classic and Fissured designs. There are two nominal sizes: 24" x 24" x 5/8" and 24" x 48" x 5/8".

For information about either Acoustical Fire Guard tile or lay-in units, call your Armstrong Acoustical Contractor (he's in the Yellow Pages under "Acoustical Ceilings") or your nearest Armstrong District Office. Or write to Armstrong Cork Company, 4205 Rock Street, Lancaster, Pennsylvania.

**Armstrong ACOUSTICAL CEILINGS**

*First in fire-retardant acoustical ceilings*

Architectural design and  
rendering by Helmut Jacoby

OFFICE OF THE YEAR  
AWARDS FOR 1960  
HONOR  
SIX BUILDINGS

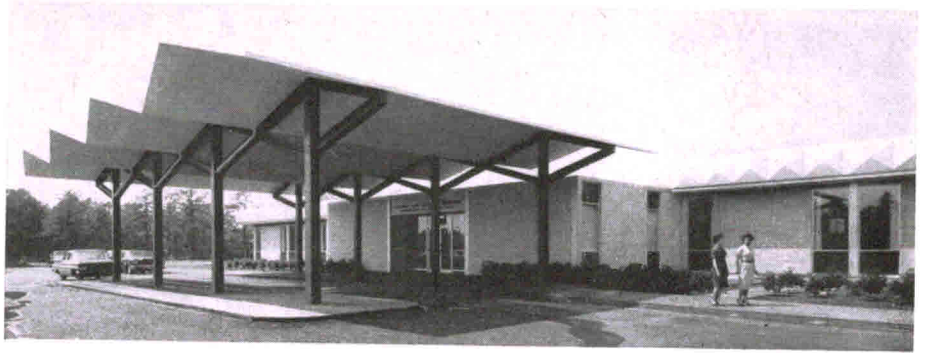

Office of the Year (up to 300 employees): Atlantic City Electric Co., Atlantic City

# Planning a laundry for a

- HOSPITAL?**
- HOTEL?**
- COMMERCIAL LAUNDRY?**
- MOTEL?**
- INDUSTRY?**
- SCHOOL?**
- INSTITUTION?**

## Then here's time-saving help

TROY offers you *complete laundry planning service* to help you design the most efficient laundry in the *least* floor space for your client. TROY will prepare floor plans and specifications to your instructions. Or send for complimentary 100-page data book containing machine dimensions, suggested floor plans and other helpful information printed on separate, loose-leaf pages. Just attach coupon below to your business letterhead.



**Troy**®

TROY LAUNDRY MACHINERY DIVISION OF  
American Machine and Metals, Inc.  
EAST MOLINE, ILLINOIS

**TROY LAUNDRY MACHINERY**

Division of American Machine and Metals, Inc.  
Dept. AR-561, EAST MOLINE, ILLINOIS

- Please send me the name of the nearest TROY representative.
- Please send me architect's data sheets.
- Or both.

NAME & TITLE \_\_\_\_\_  
FIRM \_\_\_\_\_  
ADDRESS \_\_\_\_\_  
CITY & ZONE \_\_\_\_\_ STATE \_\_\_\_\_

Six buildings have been selected as the leading office buildings erected in 1960 by the editors of *Office Management and American Business Magazine*. Photographs of the two top winners are shown on this page.

The Union Carbide Corporation Building was designed by the New York office of Skidmore, Owings & Merrill; the Atlantic City Electric Company Building, by Frank Grad & Sons, Newark, New Jersey.

The awards, now in their 11th year, honor "American business's



Office of the Year (300 or more employees): Union Carbide Corp., N. Y.

successful quest for functional esthetically pleasing space to house its administrative operations." The winning buildings are divided into two categories: those designed for 300 or more employees; and those designed for up to 300 employees.

In addition to the two top winners, four Awards of Merit were made.

*continued on page 72*

35 YEARS LATER, AND AGAIN  
**NEW YORK LIFE INSURANCE CO.**  
 SELECTS ***GENERAL BRONZE***

... for its new  
 home office building

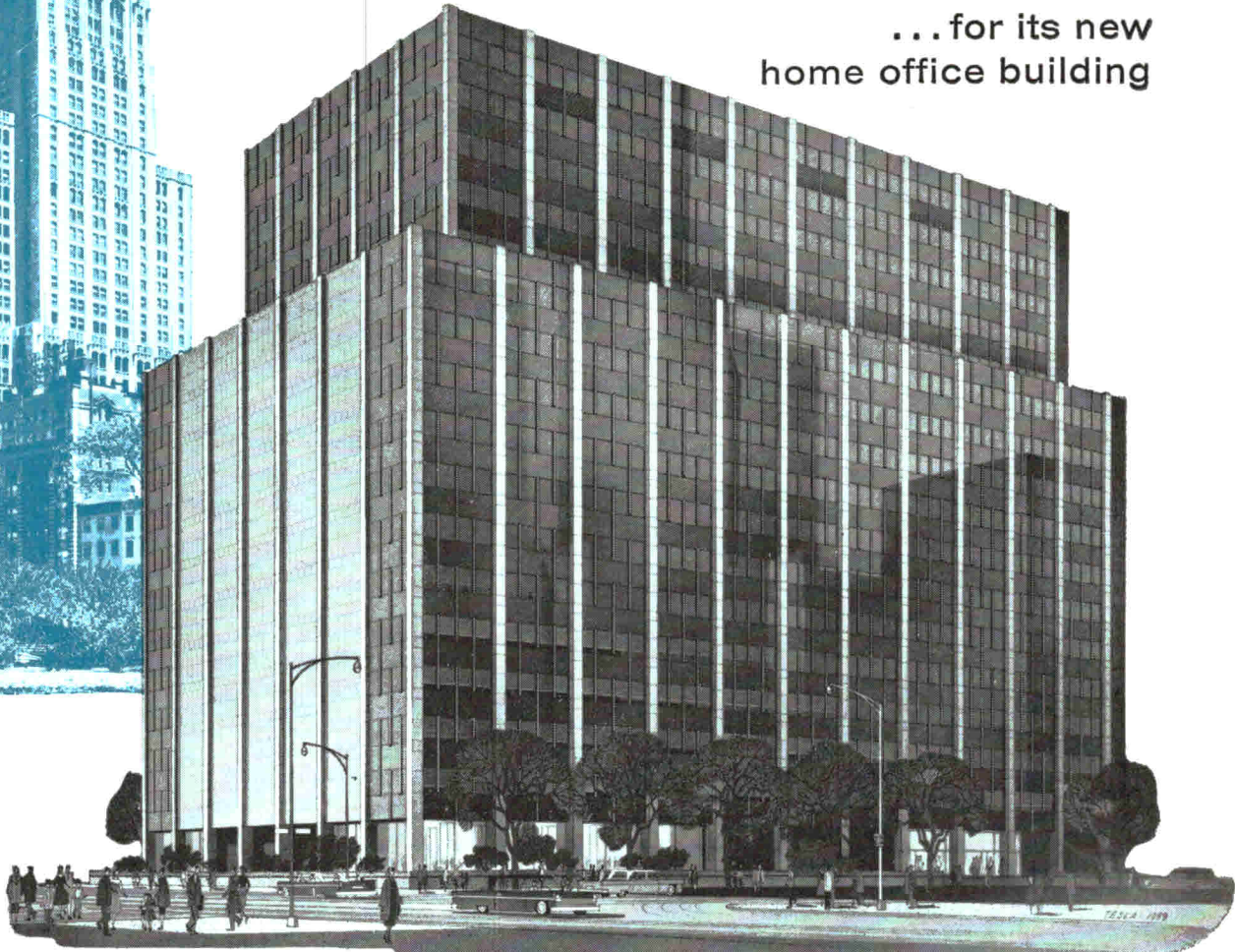

26  
 New York Life Insurance Co.  
 Home Office, New York, N. Y.  
 Architect: Cass Gilbert

1  
 Office Building, New York, N. Y.  
 Architects: Carson & Lundin  
 Contractor: Turner Construction Co.

There's no better endorsement of a product or service than to have it repeatedly specified by satisfied architects and owners.

In 1926, the renowned architect, Cass Gilbert, designed a new Home Office Building for the New York Life Insurance Co. and specified Permatite windows "by General Bronze." Now, 35 years later, the New York Life plans a new, modern curtain wall building to house its ever expanding operations and, once again, "General Bronze" has been specified. This time by the architects, Carson & Lundin.

Reflecting the modern trend in architectural design, the new building will feature a glass and aluminum grid curtain wall system set in 21 ft. bays between full height stone piers. Horizontal mullions of dark gray anodized finish give emphasis to the staggered vertical mullions which are finished in natural color anodized aluminum. All details were designed to permit setting the glass in pre-moulded channels with pressure glazing stops. Aluminum track guides for window cleaning equipment are designed into the jambs.

As the country's foremost producer of curtain walls, windows and architectural metalwork in either aluminum, bronze or stainless steel, General Bronze is anxious and ready to serve you, too. Call us in on your next job. Our Catalogs are filed in Sweet's.

**GENERAL BRONZE**  
 CORPORATION • GARDEN CITY, N. Y.  
 SALES OFFICE: 100 PARK AVE., NEW YORK 17, N. Y.

- PERMATITE DIVISION—Windows, Curtain Walls, Architectural Metal Work.
- ALWINTITE DIVISION—Stock-size Aluminum Windows and Doors.
- BRACH MFG. CO. DIVISION—Radio, Television and Electronic Equipment.
- STEEL WELDMENTS, INC. DIVISION—Custom fabrication in Steel and Iron.
- GB ELECTRONICS DIVISION—Telemetry and Tracking Antenna Systems.





—from *Le Corbusier 1910-1960*

## Collected Works of Corbu

LE CORBUSIER 1910-1960. *Edited by Boesiger & Girsberger. George Wittenborn, Inc., 1018 Madison Ave., New York 21, 329 pp., illus. \$15.*

This compendium of Le Corbusier's work over the last 50 years covers buildings from his very early house at La Chaux-de-Fonds, built when he was 18 years old, to the Dominican convent called La Tourette, finished last year. After a brief biographical introduction, the material is divided into five main categories: private houses; large buildings, including offices, apartments and public buildings; museums, exhibitions and religious buildings; painting, sculpture and tapestries; and town planning. Except for the urban planning section, the editors have concentrated mostly on completed buildings.

The editors have also concentrated on showing the material graphically, with photographs, plans and sketches from the hand of Le Corbusier. Captions accompanying the illustrations are sometimes disappointingly short, but always adequate; in any case, the decision to sacrifice text space in order to accommodate a great many illustrations seems a wise one. The only genuine objection to the presentation is that plans and sketches have sometimes been reduced in size past the point where legends can be read without a magnifying glass.

All text and captions are printed in French, English and German.

It seems unlikely that one will find another single volume containing a more comprehensive collection of Corbu's work.

## Architectural Journals Indexed

THE ARCHITECTURAL INDEX FOR 1960. *Compiled and edited by Ervin J. Bell. The Architectural Index, 517 Bridge-way, Sausalito, Calif. 61 pp. \$5.*

For the 11th year, *The Architectural Index* has issued its very helpful coverage of the major American magazines in the field: *Arts and Architecture*, *Architectural Forum*, *ARCHITECTURAL RECORD*, *House & Home*, *Interiors*, *Progressive Architecture*, and the *Journal of the American Institute of Architects*. Entries are categorized by building types, by architects and by location.

## Iberian Baroque

BAROQUE IN SPAIN AND PORTUGAL. *By James Lees-Milne. B. T. Batsford, Ltd., London; distributed in U.S.A. by the Macmillan Co., 60 Fifth Ave., New York 11. 224 pp., illus. \$7.*

As a sequel to his earlier *Baroque in Italy*, the author here explores the rather different Baroque of Spain

and Portugal—different from Italy's, and different from each other's. In a relatively limited space, the author has had little chance to do more than introduce the reader to the varieties of Baroque architecture in Iberia: the section on Portugal, on which there have been very few recent writings in English, is on this ground the most helpful. He has concentrated on the architecture of the period, but has not ignored the fine arts, nor the cultural, religious and political background.

## Architectural Anthology

ARCHITECTURE IN AMERICA: A BATTLE OF STYLES. *Edited by William A. Coles and Henry Hope Reed Jr. Appleton-Century-Crofts, Inc., 35 W. 52nd St., New York 1. 472 pp., illus. \$2.40 (paperbound).*

Intended primarily for college writing courses, this collection of brief excerpts from architectural writings perhaps too casually "presupposes no prior knowledge of architectural history." The unprepared liberal arts student is likely to be confused by an unannotated body of opinion ranging in time from Vitruvius to Albert Bush-Brown and in mood from Louis Sullivan to Le Corbusier. Some interesting by-ways of architectural criticism are recalled, but the general

*continued on page 56*

## Franchised Distributors of SoundLock Products

**ALABAMA**—Birmingham—Acousti Engineering Co. of Alabama, Inc.  
**ARIZONA**—Phoenix—Arizona Acoustics  
**CALIFORNIA**—Los Angeles—The Harold E. Shugart Co., Inc. (Glendale)  
 San Diego—Hackett Ceiling & Lighting, Inc.  
 San Francisco—F. K. Pinney Co.  
**DISTRICT OF COLUMBIA**—Washington—The Hampshire Corp. (Bladensburg, Md.)  
**FLORIDA**—Jacksonville—Acousti Engineering Co. of Florida  
 Branches in Fort Myers Villas, Orlando, Tallahassee and Tampa  
 Miami—Rowell-Van Atta Acoustics, Inc. Branch in Fort Lauderdale  
 West Palm Beach—Benson Acoustical & Insulation, Inc.  
**GEORGIA**—Atlanta—Acousti Engineering Co.  
**ILLINOIS**—Chicago—Fisher, Albright & Masters  
 Chicago—Anning-Johnson Co. (Melrose Park)  
**INDIANA**—Evansville—General Insulation Co.  
 Indianapolis—Anning-Johnson Co.  
**IOWA**—Des Moines—Allied Construction Services, Inc. Branches in Davenport and Waterloo  
**KANSAS**—Wichita—Henges Co., Inc.  
**KENTUCKY**—Louisville—Pochel-Chowning Co.  
**MAINE**—Auburn—The Bader Co., Inc.  
**MARYLAND**—Baltimore—The Hampshire Corp.  
**MASSACHUSETTS**—Boston—Pitcher & Co., Inc. (Cambridge)  
 Pittsfield—Acoustical Ceilings, Inc.  
 Worcester—Pitcher & Co., Inc.  
**MICHIGAN**—Detroit—Nichols Co.  
 Grand Rapids—Leggette-Michaels Co.  
**MINNESOTA**—Minneapolis—Hauenstein & Burmeister, Inc.  
 Minneapolis—Insulation Sales Co.  
**MISSOURI**—Kansas City—Henges Co., Inc.  
 St. Louis—Henges Co., Inc.  
**NEW HAMPSHIRE**—Concord—The Bader Co., Inc.  
**NEW JERSEY**—Elizabeth—Jacobson & Co., Inc.  
**NEW YORK**—Buffalo—Buffalo Acoustical Corp.  
 New York—Jacobson & Co., Inc. Branch in Westbury (L.I.)  
**NORTH CAROLINA**—Charlotte—Associate Structures, Inc.  
**OHIO**—Cincinnati—Cincinnati Floor Co.  
 Cleveland—Anning-Johnson Co.  
**OREGON**—Portland—Johnson Acoustical & Supply Co.  
**PENNSYLVANIA**—Harrisburg—Jacobson & Co., Inc.  
 Philadelphia—Jacobson & Co., Inc.  
 Pittsburgh—Standard Floor Co.  
**RHODE ISLAND**—East Providence—Pitcher & Co., Inc.  
**SOUTH CAROLINA**—Charleston—Associate Structures, Inc.  
 Greenville—Associate Structures, Inc.  
**TENNESSEE**—Chattanooga—Wallace Tile, Inc.  
**VERMONT**—Burlington—The Bader Co., Inc.  
**VIRGINIA**—Richmond—The Hampshire Corp. Branches in Norfolk and Roanoke  
**WASHINGTON**—Seattle—Noise Control of Seattle, Inc.  
**WEST VIRGINIA**—Charleston—The Hampshire Corp. (St. Albans)  
**WISCONSIN**—Milwaukee—Building Service, Inc.  
**CANADA**—Montreal—Dominion Sound Equipments Ltd.  
 Branches in Calgary, Edmonton, Halifax, Hamilton, London, North Bay (Ont.), Ottawa, Regina,  
 St. John, Saskatoon, Toronto, Vancouver and Winnipeg.

and many other new and remodeled buildings across the country.

For more information about SoundLock, check Sweet's Catalog, call the franchised distributor near you, or write the pioneer in sound transmission control . . . The Kemp Corporation, Dept. C-5, 124 South Woodward, Birmingham, Michigan.

quiet conversation

allow easy access to the plenum chamber. These fire-safe panels have a textured baked-enamel finish. Built to last the life of the building, SoundLock usually costs less than conventional metal ceilings. You'll find fire-safe SoundLock in New York's IBM building (designed by Eero Saarinen), St. John's Hospital in Springfield, Ill., Ohio's Heidelberg College,

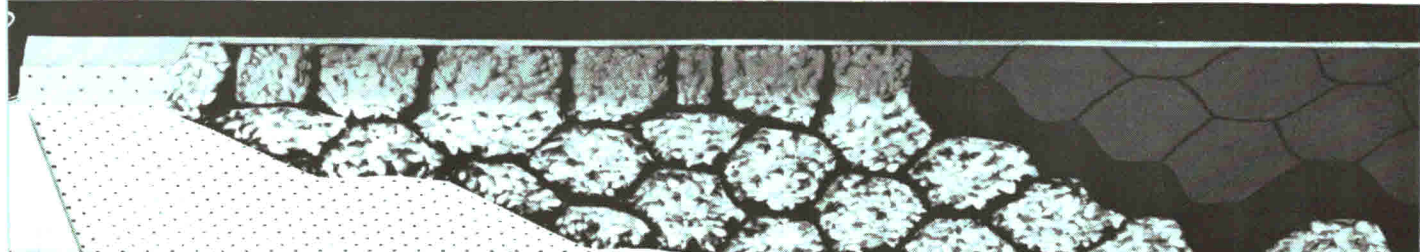

# 29 Years of Heavy Foot Traffic ...but still **NON-SLIP** Wet or Dry

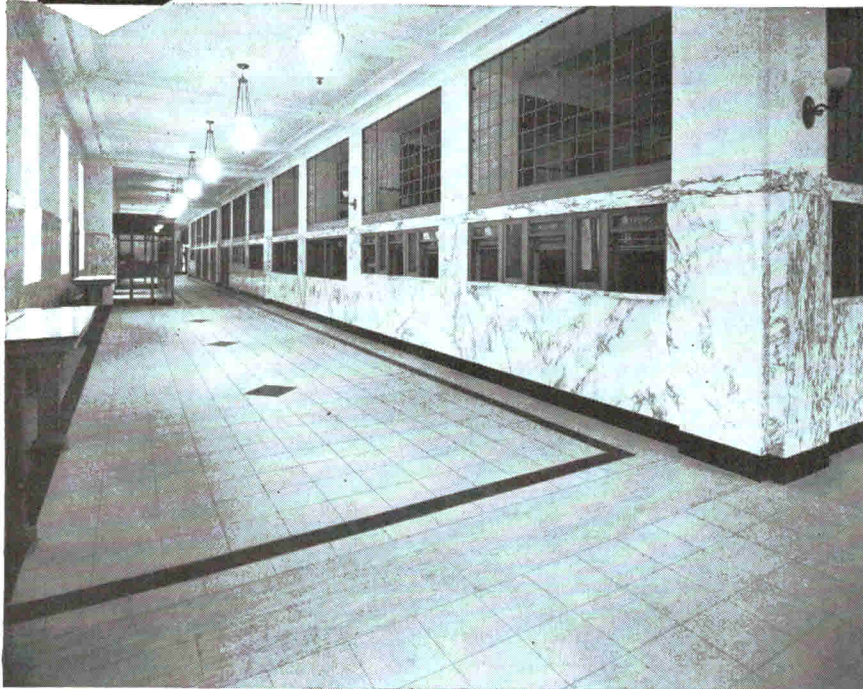

## **ALUNDUM TERRAZZO** provides permanent walking safety — year after year!

In 1932, when the new United States Post Office in Worcester, Massachusetts, was built, floors of Norton ALUNDUM Terrazzo were installed to provide **walking safety** for the countless thousands who were to use its main floor areas.

Today, after 29 years of the heaviest kind of foot traffic, these same floors of Norton ALUNDUM Terrazzo are still non-slip, wet or dry, and retain their initial beauty. Even in the vestibules where traffic is concentrated, the floor shows only the faintest trace of wear.

For floors, ramps and stairways in all types of buildings, both public and commercial, Norton ALUNDUM Aggregate in the **proper proportion** furnishes a terrazzo surface which is permanently non-slip and exceptionally resistant to wear.

Full specifications in Norton Pages in SWEET'S or on request from us or from the National Terrazzo and Mosaic Association, Washington, D. C.



By specifying Norton ALUNDUM Terrazzo for the approaches to the newly built United States Post Office in St. Petersburg, Florida, the architect provided the public with permanent walking safety in all kinds of weather.



**NORTON COMPANY**  
WORCESTER 6, MASS.

**NON-SLIP FLOORS**

ALUNDUM AGGREGATE for Terrazzo and Cement • ALUNDUM STAIR and FLOOR TILE  
ALUNDUM and CRYSTOLON Non-slip Abrasives

## *Required Reading*

*continued from page 50*

### Architectural . . .

architectural reader will have seen much of the material elsewhere.

### The Archaeologist's Rome

THE GOLDEN HOUSE OF NERO. *By Axel Boëthius. The University of Michigan Press, Ann Arbor. 195 pp., illus. \$15.*

Despite the title, only one of the book's four chapters devotes itself to the Golden House; the others are titled "From Earliest Roman Villages to Etruscan Urbanization," "The Hellenized Italic Town and Its Legacy to Imperial Rome," and "The Domestic Architecture of the Imperial Age and Its Importance for Medieval Town Building." Relying largely on information disinterred by archaeologists (of whom he is one), the author definitely does not address himself to the beginning, or even the intermediate, student. Advanced students will have, in addition to the content, the pleasure of a handsomely designed and printed volume.

### Two Approaches to Gothic

THE GOTHIC. *Sources and Interpretations through Eight Centuries. By Paul Frankl. Princeton University Press, Princeton, N.J. 916 pp., plus illus. \$17.50.*

A work of staggering scope and scholarship, this survey of documents and criticism of Gothic buildings will, unfortunately but undoubtedly, leave the casually interested reader feeling, to paraphrase one little girl's comment on another book, that "it tells me more about Gothic than I want to know." Historians of architectural criticism as well as of the Gothic will find it more rewarding.

MONT-SAINT-MICHEL AND CHARTRES. *By Henry Adams; introduction by*

*continued on page 64*



FOR OR AGAINST...  
*you cannot now  
ignore this*  
BUILDING SYSTEM

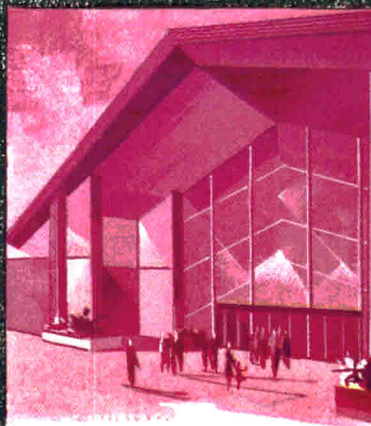
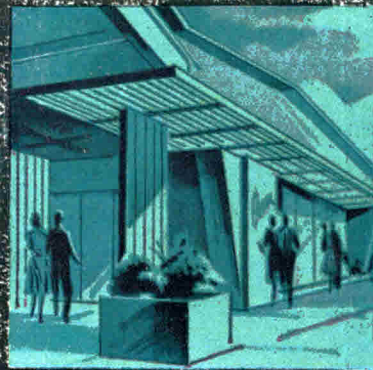

## THE BUTLER BUILDING SYSTEM

*...as a new opportunity for architects*

As the craftsman disappears, and labor takes a different view of work . . . as the financing, ownership, and even promotion and sale of structures change . . . as fundamental concepts of the functions and useful life of buildings alter, the role of the architect loses its classic outline. Today he needs the economy and efficiency of pre-engineering. He needs the quality control that factory fabrication guarantees. He needs simplification and even identification of responsibility at the job site. Sometimes, too, he can find financial resources

useful. All these advantages the Butler Building System and the new kind of contractor that has evolved with it—are prepared to offer. Why not adopt an aggressive skepticism to this system? Call your nearby Butler Builder. Ask him to show you the new color film, "Facing the Public"—a document of the work of 31 architects using the Butler Building System.

Or write direct to Butler Manufacturing Company, 7427 East 13th Street, Kansas City 26, Mo., and we will arrange a showing in your offices.

# Now...a complete NEW line of Halsey Taylor fixtures ✨



You are looking at the very newest in face-mounted wall fountains... exciting new designs dramatically created in stainless steel by Halsey Taylor. They're just some of the many fountains and coolers in the complete new Halsey Taylor line!

The Halsey W. Taylor Co.  
Warren, Ohio

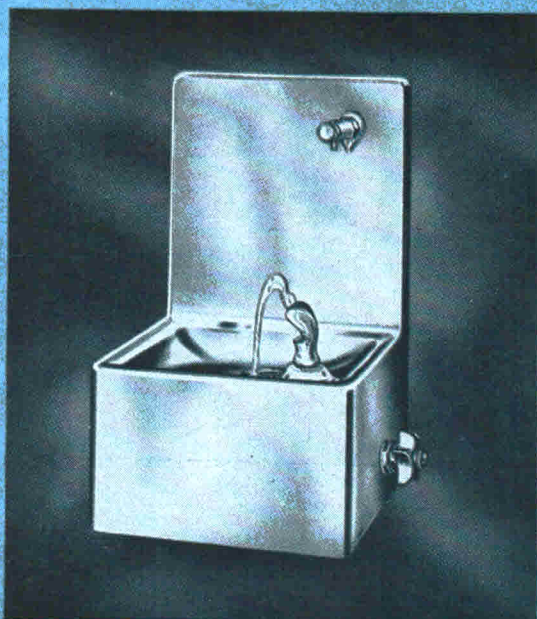

## in glamorous stainless steel

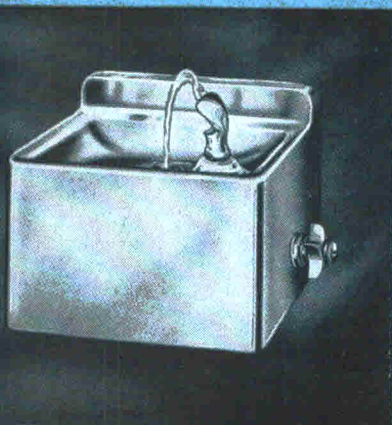

In addition to these, you can obtain recess and semi-recess wall types, coolers for all purposes, class-room fixtures and wall brackets...all in lustrous stainless steel.

And you also get all the extra Halsey Taylor features, such as dependable performance, health-safety, maintenance-free service.

### Fountains illustrated:

Top View...13" back  
Centre...1 3/4" back  
At right...6" back

Write for latest catalog, or see  
Sweet's or the Yellow Pages



THIS MARK OF LEADERSHIP IDENTIFIES THE MOST  
COMPLETE LINE OF MODERN DRINKING FIXTURES

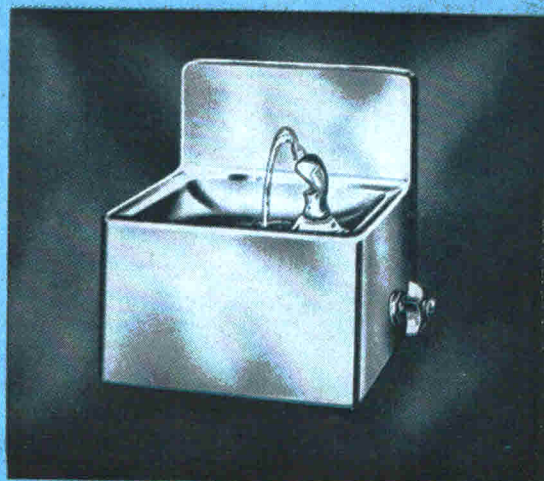

## Required Reading

continued from page 56

### Two Approaches . . .

*Ernest Samuels. New American Library, 501 Madison Ave., New York 22. 388 pp., illus. 75¢ (paperbound).*

Adams' guide for "tourists" who, as he says, prefer not dates but poetry, receives more testimony, if it needs it, of its place as a standard by this widely distributed "Mentor Classic" paperbound.

### Technical Books

*SPECIFICATIONS. By H. Griffith Edwards, D. Van Nostrand Company, Inc., 120 Alexander St., Princeton, N.J. 372 pp., illus. \$8.*

The second edition, considerably revised, of an introduction to specifications writing. The early chapters present the general aspects of specifying, with emphasis on clarity and organization. Later chapters take up specific points relating to the various building trades, and entirely new material deals with asphalt paving and lawns and planting.

*FLUORESCENT LIGHTING MANUAL. By Charles L. Amick. McGraw-Hill Book Company, 327 W. 41st St., New York 36. 416 pp., illus. \$12.50.*

The third edition, with revisions, of a guide to the design, installation, maintenance and repair of fluorescent lighting systems.

*OSCAR FABER'S REINFORCED CONCRETE. Rewritten by John Faber and Frank Mead. D. Van Nostrand Company, Inc., 120 Alexander St., Princeton, N.J. 532 pp., illus. \$14.75.*

The second edition of this British book for consulting engineers and advanced students has been revised and expanded in the areas, among others, of slabs, retaining walls, roads, shell-concrete roofs, and pre-stressed concrete.

*BOILERS: Types, Characteristics and Functions. By Carl D. Shields. F. W. Dodge Corporation, 119 W. 40th St., New York 18. 559 pp., illus. \$15.*

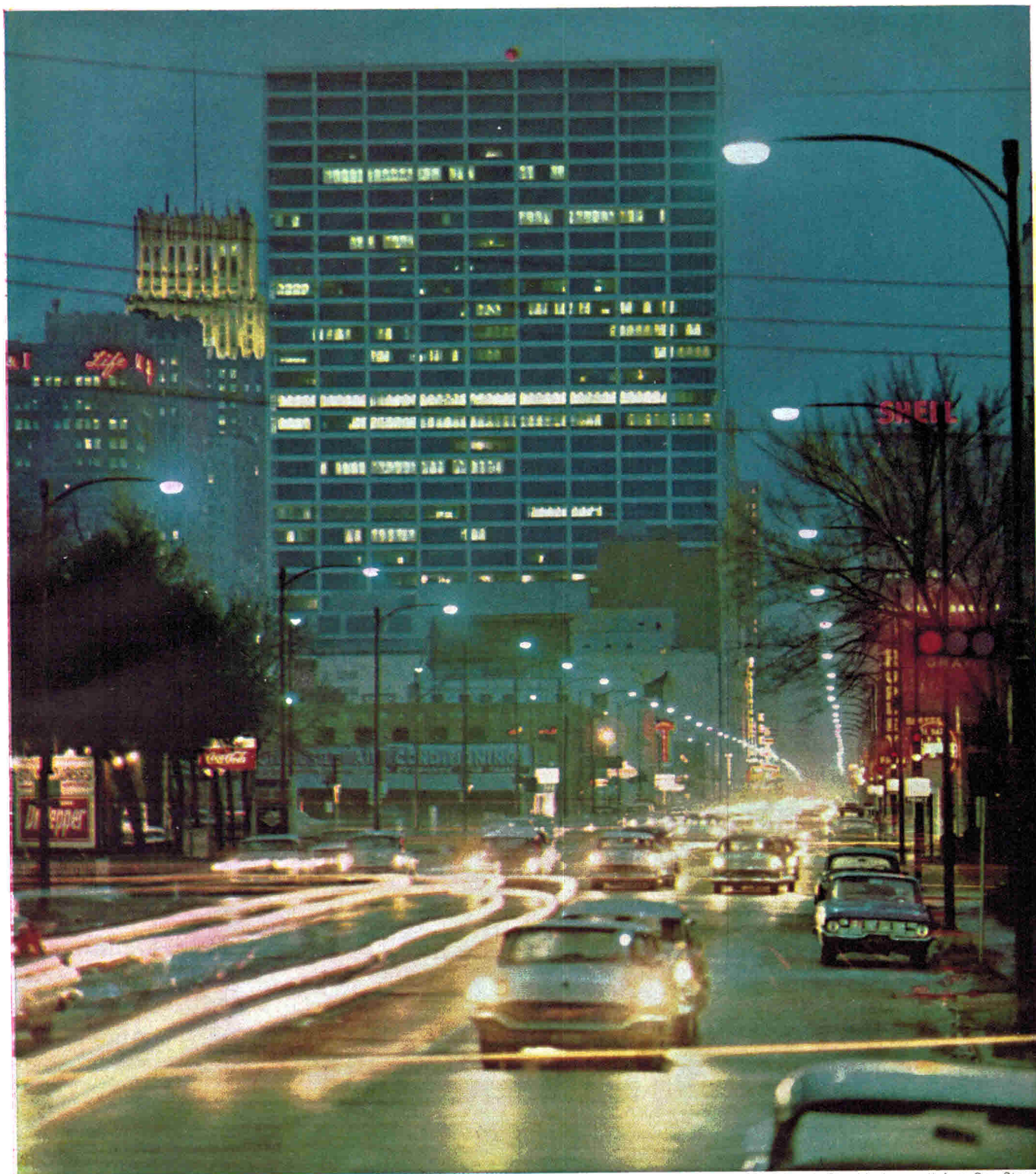

Fannin Street looking north from Gray Street

**HOUSTON DISCOVERS** that traffic congestion either ends at curbside or extends into building lobbies—depending upon the kind of elevating used. Why? Because there is more to completely automatic elevating than simply leaving the operator out of the car! Any elevator installation that fails to provide complete automation for all of the constantly changing, widely varying traffic patterns that occur throughout the day and night—invites curtailed service, long waits and traffic congestion. This applies in a like degree to the greatest skyscraper and the smallest commercial or institutional building. How do tenants and visitors react? After all, they are people. They react in a like manner to elevator service. And a building's reputation soon reflects their reactions. The mark of a CLASS "A" building—large or small—is completely automatic AUTOTRONIC® elevating. It accurately predicts and delivers a magnificent performance. Since 1950, more than 1,100 new and modernized buildings across the United States and Canada have contracted for AUTOTRONIC elevating by OTIS—the world's finest!



**OTIS  
ELEVATOR  
COMPANY**

260 11th Avenue, New York 1, N. Y.  
Offices in 448 cities around the world



AUTOTRONIC® OR ATTENDANT-OPERATED PASSENGER ELEVATORS • ESCALATORS • TRAV-O-LATORS • FREIGHT ELEVATORS • DUMBWAITERS  
ELEVATOR MODERNIZATION & MAINTENANCE • MILITARY ELECTRONIC SYSTEMS • GAS & ELECTRIC TRUCKS BY BAKER INDUSTRIAL TRUCK DIVISION

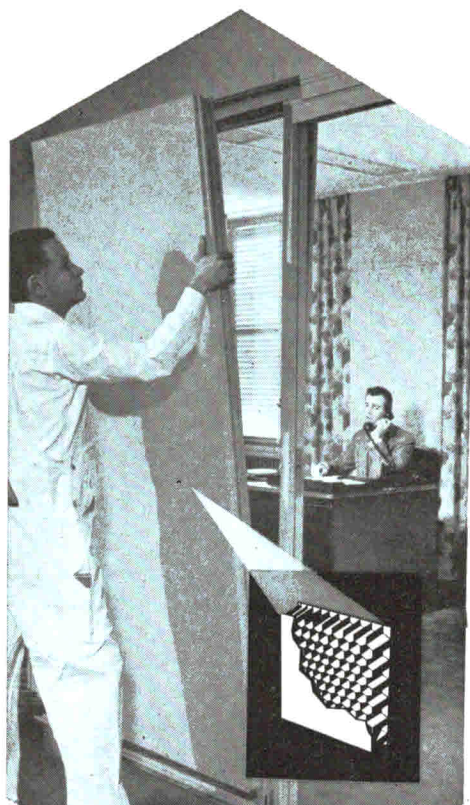

**UNION  
HONEYCOMB**  
in  
**OFFICE  
PARTITIONS**

Simplify partition construction with kraft paper HONEYCOMB sandwich cores. And save money! Improved design cuts finishing operations . . . assures fast, easy installation. Light weight lowers freight charges . . . speeds handling. Durable HONEYCOMB cores also minimize maintenance costs. And they can be bonded to almost any facing material.

Write for free booklet and names of partition manufacturers who are now using UNION HONEYCOMB.

**UNION-CAMP  
HONEYCOMB**

Union Bag-Camp Paper Corporation  
233 Broadway, N. Y. 7, N. Y., Dept. B2

*The Record Reports*

Office of the Year Awards

*continued from page 44*

Those receiving Merit Awards in the smaller building category are shown on this page. The Standard Rate & Data Service, Inc. Building was designed by Maher & McGrew of Chicago; the Parke, Davis & Company Building, designed by the Chicago office of Skidmore, Owings & Merrill.

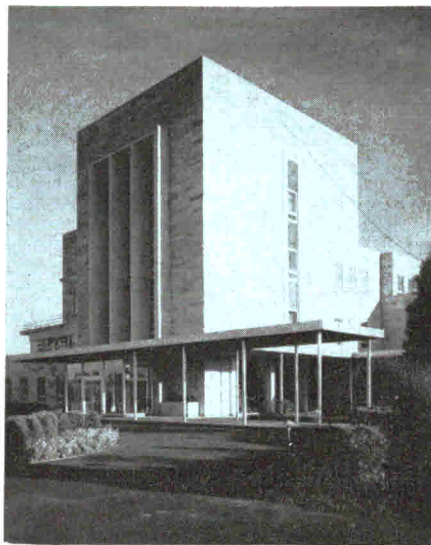

Awards of Merit (up to 300 employees); (above) Standard Rate & Data Service, Inc., Skokie, Ill. (below) Parke, Davis & Company, Ann Arbor, Mich.



Office buildings which received Merit Awards in the category of buildings designed for 300 or more employees were: the Blue Cross-Blue Shield Headquarters, Boston, designed by Paul Rudolph and Anderson, Beckwith and Haible, associated architects; and Kaiser Industries, Inc., Oakland, California, whose architects were Welton Becket and As-

*continued on page 82*

*other*

**GLIDE-GRIDWALL**  
*architectural aluminum*  
**PRODUCTS**

*glide*  
**SLIDING WINDOW**

Monumental stock and custom types. All sash operate and bypass for window cleaning from interior. Strength of section allows height to 6'6". The leader in the field for weather-tight performance and beauty of sight lines.

*glide*  
**SLIDING DOORS**

Monumental stock and custom types. Glazed with 3/8" to 1" thick glass. Double sill, flush with floor, leak-proof even in complex multiple track and wall pocket units. Stainless steel rollers and track. Transom units available as integral part of door framing. Screens may be used on interior or exterior as required.



**SLIDING DOORS**

PANAVIEW stock door units employ the finest construction features of the GLIDE door series at competitive prices. Double weather-stripped, aluminited, and available in panels with single or 3/8" insulated glass.



**WINDOWS AND WINDOW WALLS**

The most economical window wall available. Infinite variety is achieved by mulling and stacking PANASEAL windows in any combination. Ideal for schools and commercial buildings. PANASEAL windows also available for residential use.



**ENTRANCES**

Engineered for greater strength by integrating 1" narrow stiles with 1/2" plate glass, GRIDWALL offers the most appealing entrance door on the market. Cylinder lock, housed in push and pull plates of charcoal bronze finish, simultaneously throws a concealed bolt into threshold and head of door frame for maximum security. A complete line of mullion framing for flush glazing is available.

*write for brochures and details:*  
**GLIDE-GRIDWALL • 7463 Varna Avenue  
North Hollywood, California • TR. 7-3213**

or Mothers' rooms . . . to and from chapels and sanctuaries.

Executone implements these functions, at low cost, by simple input switching through the main power booster—for bridging and separating individual sound channels. Small, conveniently placed, transistorized line amplifiers serve as secondary controls. Executone's zero-level transmission eliminates distortion and noise problems.

#### 4. Maintain quality reproduction from moving sources.

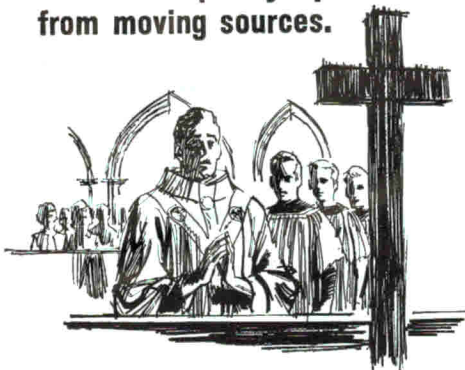

Church and synagogue services illustrate a problem that arises frequently in large-room design. That is: the need for multiple sound pickups capable of evenly reinforcing speech or music from roving participants. System planning based on the complete Executone line finds ready solutions. For example, the wide variety of specialized microphone pickup patterns helps the church designer provide sensitive coverage of altar, pulpit, organ, choir, Stations of the Cross, and all other points from which services are conducted. Placement of controls in the

congregation—as explained in (2), above—assures maintenance of proper volume and balance.

#### 5. Link separated functions with intercom.

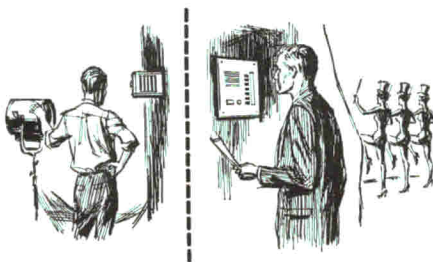

Executone communications are invaluable in rooms where a number of separate functions have to be coordinated. In theaters or auditoriums, for example, stage management, lighting and other functions mesh smoothly when instant contact is available—via Executone.

#### 6. Apply system planning to acoustics, aesthetics and performance.

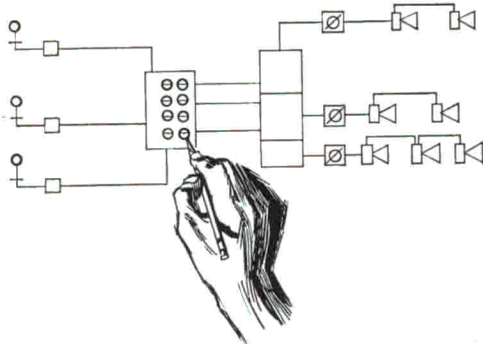

The importance of a coordinated sound system goes far beyond the savings

available through single-source specification. Matched electronic characteristics are essential for clear, life-like reproduction. System planning minimizes the architect's aesthetic problems, too. The compactness and smart detailing of Executone components . . . the wide choice of units and unobtrusive mountings . . . flexibility of placement . . . all contribute to good appearance.

The broad line of reproducers meets the special acoustic demands of any interior. Low-level coverage is available through a wide selection of multiple ceiling reproducers . . . high-level coverage through carefully designed theater type systems.

With an integrated Executone system, you also have the assurance of full installation responsibility, and *on-the-spot* maintenance for any contingency—by factory-trained technicians. There are no field assemblies. Each system is manufactured and tested—in its entirety—at the Executone factory. All units are engineered to stringent transportation terminal standards—for operation 24 hours a day, 365 days a year. Every component is guaranteed by the factory for a full year.

Use the coupon below for complete data including wiring plans and specifications on Executone sound systems for places of assembly.



# Executone

Executone, Inc., Dept. B-4  
415 Lexington Avenue, New York 17, N. Y.

SOUND and COMMUNICATION SYSTEMS

- |                                   |                                   |                                    |   |  |                                      |
|-----------------------------------|-----------------------------------|------------------------------------|---|--|--------------------------------------|
| <input type="checkbox"/> theaters | <input type="checkbox"/> schools  | <input type="checkbox"/> hospitals | <input type="checkbox"/> transportation | <input type="checkbox"/> offices       | <input type="checkbox"/> other _____ |
| <input type="checkbox"/> churches | <input type="checkbox"/> stadiums | <input type="checkbox"/> plants    | <input type="checkbox"/> terminals      | <input type="checkbox"/> retail stores | _____                                |

Please send me your Architect's File on Sound Systems for Places of Assembly.

I am specifically interested in the following building types:

Name \_\_\_\_\_

Firm \_\_\_\_\_

Address \_\_\_\_\_

City \_\_\_\_\_ Zone \_\_\_\_\_ State \_\_\_\_\_

In Canada: 331 Bartlett Avenue, Toronto

Office of the Year Awards

continued from page 72

sociates of Los Angeles, California.

More than 60 nominations for the awards were made by members of the American Institute of Architects and members of the Association of Consulting Management Engineers. Thirty buildings were in active contention. The jury consisted of the editors of *Office Management and*

*American Business Magazine.*

Silver plaques will be awarded the two "Office of the Year" top winners; bronze plaques will go to the Merit Award winners.

In the past ten years, winners of the awards have included: the John Hancock Mutual Life Insurance Building, Boston; the United Na-

tions Secretariat Building, New York; Lever House, New York; Aluminum Company of America, Pittsburgh; General Foods Corporation, White Plains, New York; Mid-American Home Office, Prudential Insurance Company of America, Chicago; Seagram's, New York, Southland Life Insurance, Dallas.

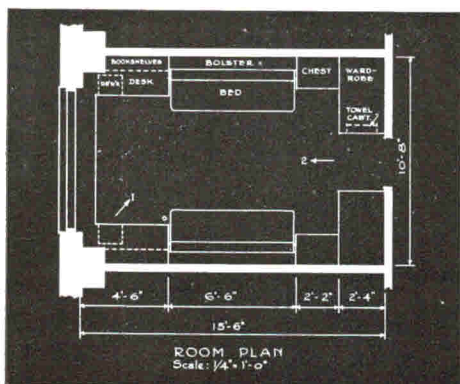

Chances are **1000** to **1** that this plan **WON'T** fit your requirements!

Out of over a thousand dormitory furniture plans on which we have worked there has been only one case where two institutions adopted exactly the same student room furniture layouts and designs. This is why Sligh-Lowry Contract Furniture Company has no stock plans or furniture units but is constantly called in to consult with the architect and the college administrators and residence halls directors to assist in developing room layouts and designs and specifications for pre-built, pre-finished, built-in and free-standing furniture for dormitory rooms to best suit each individual institution's needs, wishes and budget. The above illustrated plan exactly met the requirements of a leading mid-western university. Let us help to develop one that will completely meet yours. Send for our comprehensive Dormitory Furniture Planning Manual at no cost to college and university officials or architects.

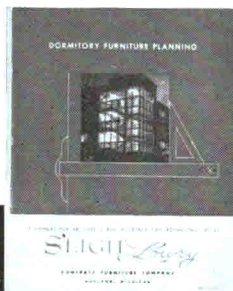

**SLIGH** *Lowry*

CONTRACT FURNITURE COMPANY HOLLAND, MICHIGAN



Awards of Merit (300 or more employees): (above) Blue Cross-Blue Shield Headquarters, New York (below) Kaiser Industries, Inc., Oakland, Calif.

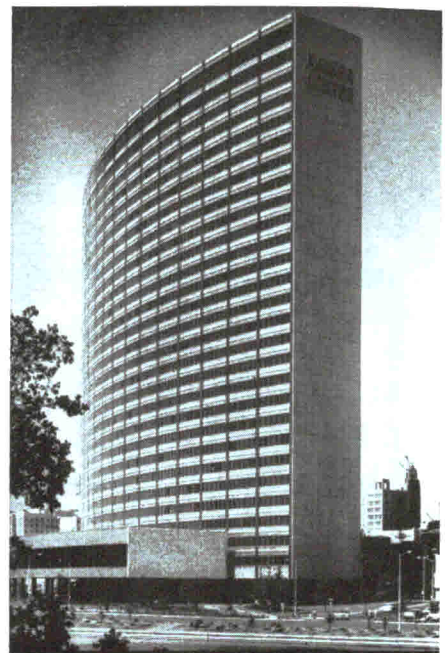

more news on page 260

# DOWNTOWN PHILADELPHIA: A LESSON IN DESIGN FOR URBAN GROWTH

by Edmund N. Bacon, A.I.A.

"A great urban aesthetic arises not from a cluster of architectural *chefs-d'oeuvre* but from a sensitivity on the part of each successive builder to the amenities that are already there. No good architect would dream of destroying the beautiful natural terrain of an isolated site but would instead, try to marry his building to the land and vegetation, and the water, and the sky. It is easier to forget and it is common to forget that there is also an urban terrain and that this too, is entitled to respect, even to love. Urban aesthetics are not to be made over as lightly as ladies clothes."\*

When William Penn laid out Philadelphia between the Delaware and the Schuylkill Rivers, he established its first amenities in the form of a clearly defined cross axial pattern of major streets with five squares, one in the center and one in each quadrant. Penn's design can now be discerned as the shadow of the substance of the city's downtown redevelopment program. Architect Edmund N. Bacon, executive director of the Philadelphia City Planning Commission, describes the major urban renewal projects of his city in a new context which emphasizes an urban aesthetic, based upon a design structure growing organically from what has gone before, which looks toward the future without obliterating the past.

—EDITORS

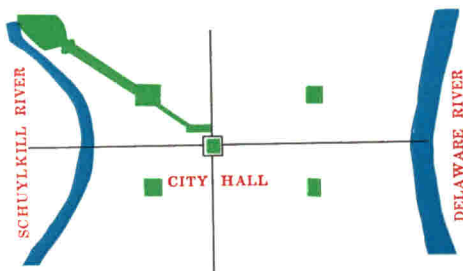

Note: in these plans and the others which follow, North is assumed at the top of the page.

The power of a design idea to influence the subsequent growth of a city is brilliantly demonstrated in the center of Philadelphia by the Penn plan of 1683 shown at left. Not only did it result, 200 years after its formulation, in the construction of City Hall at the intersection of two main axes, just as Penn planned it, but architecturally the design idea extended vertically in the 547 ft high City Hall tower, now dominant in the city's skyline, and always to be dominant because of an unwritten rule that no other building shall be as high.

This same centrality, in the following century, drew the green open spaces of Fairmount Park in the form of the 1909 Greber Parkway, cut diagonally through the developed center city, right to the 1683 William Penn focal spot, at the intersection of the two major streets.

Today Philadelphia's planners continue to develop design principles in a form capable of influencing future action. We do not try to design each new building ourselves, but we have endeavored to establish a design idea of such potency that it welds the work of individual architects, designing in fragmented areas, into some kind of coherent whole. The production of this design idea is a creative act. It must not expire with the promulgation of regulations. It can be done only by designers of the highest possible skills. How this design idea was evolved in Philadelphia over the past fifteen years by many designers, in government and out, and how it influenced the work of subsequent designers and was, in turn, influenced by them, is the subject of the pages that follow.

\*Excerpt from "The Urban Aesthetic," by John Ely Burchard, *The Annals Of the American Academy of Political and Social Science*, November 1957.

## 1944-HISTORICAL PARKS

*Philadelphia's planners create new open spaces for old buildings of historic importance*

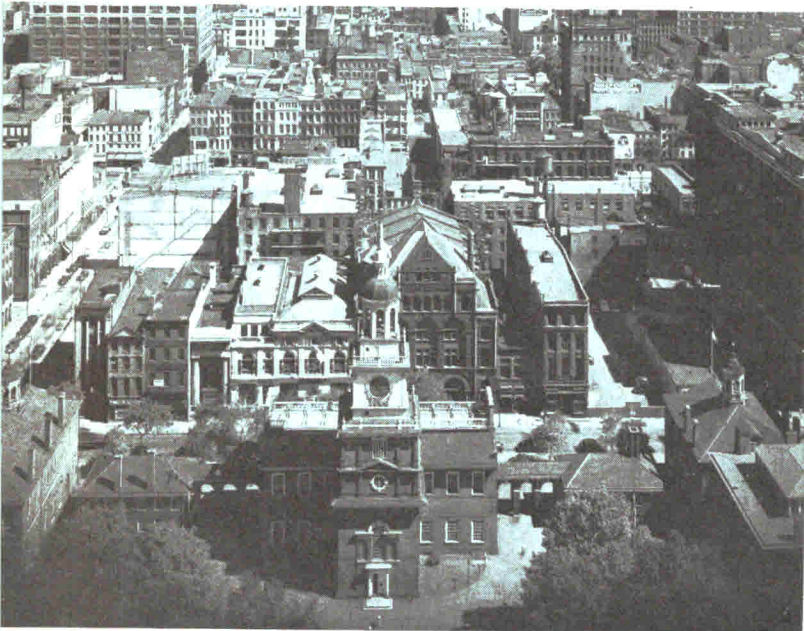
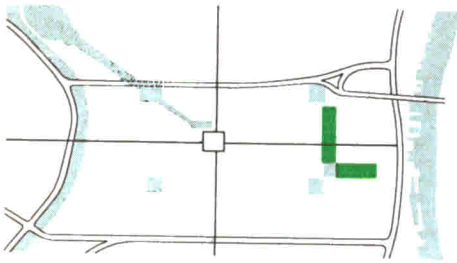

The publication in 1944 by the Fairmount Park Art Association of architect Roy F. Larson's designs for a setting for Independence Hall leads six years later to the first major surgical operation in downtown Philadelphia since the 1909 Greber Parkway. Independence Mall, now being completed by the Commonwealth of Pennsylvania from designs that Larson prepared for the city, extends north from Independence Hall, providing a formal foreground for this historic shrine, a practical link with the downtown expressway loop and a transition from automobile to pedestrian scale.

Larson's proposal for a modest interior block extension to the east of Independence Hall, linking it with three important and several minor historical buildings (shown along with the original Mall plan on the first plan development drawing facing page 136), was adopted and extended by the National Park Service to include the destruction of all non-historic buildings in the three block area.

The simple L shaped open space plan, with Independence Hall in the pivotal position, provided the design framework from which grew all of the later designs for this part of center city.

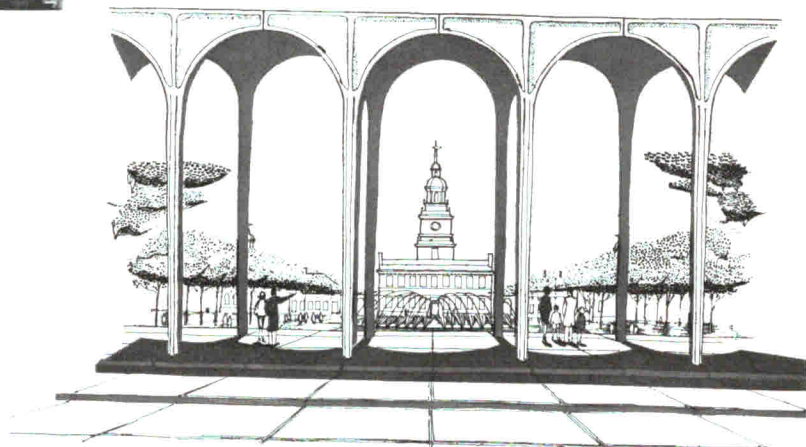



## 1947-GREENWAYS

*Small parks and footpaths link interesting buildings, provide recreation spaces and vistas*

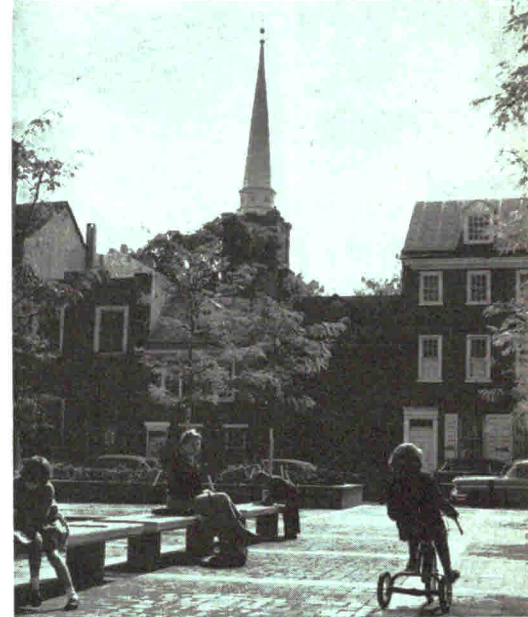
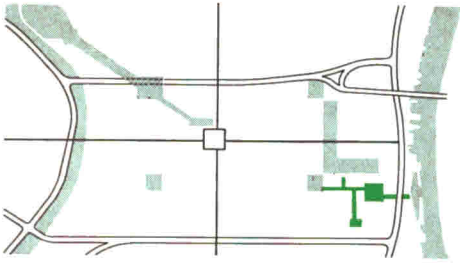

Lewis-Claire Studio

Included in the Philadelphia City Planning Commission's proposals displayed at the better Philadelphia Exhibition of 1947 was my scheme for a series of inner-block park and footpath extensions (see key plan above) centering upon and connecting together the principal historic structures scattered through the venerable but blighted Society Hill area. (See the first plan development drawing facing page 136). Deliberately joggled to be in scale with pedestrian movement, this open space or greenway system pulled vistas of church spires deep into residential blocks, and later became the determinant for the placing of the new apartment towers which were to follow.

The first leg of our proposed system, the connection between Strickland's Second Bank of the United States and the historic houses on Locust Street, was adopted by the National Park Service, and is now under construction.



# 1957-SOCIETY HILL

*A decaying area in downtown Philadelphia becomes a redevelopment project*

Despite valiant individual efforts, the idea begun in our greenway proposal of revitalizing the area known as Society Hill languished for ten years. The destruction of historic houses continued until Richardson Dilworth, upon becoming mayor of Philadelphia, adopted the redevelopment of Society Hill as one of the key points in his program and referred it to Albert M. Greenfield, then chairman of the City Planning Commission, for action.

The first step was the restudy by architects Vincent Kling, Roy F. Larson and Oskar Stonorov of our 1947 greenway design. Their 1957 study is shown in the photograph of the model at left. They adopted the main premise of the earlier greenway plan but enlarged and extended it from the Delaware River to Broad Street, giving it firm connections with Washington Square (shown in green on model photograph), and the waterfront.

Business leaders formed and gave financial support to the Old Philadelphia Development Corporation, organized for the explicit purpose of seeing that the plan is carried out. Encouraged by the business group, by the unique characteristics of the site, and by the architectural elegance of Preston Andrade's reinterpretation, done under a contract with the Redevelopment Authority, of the 1957 plan, four major developers went into action. Each spent approximately \$40,000 in preparation of separate competitive design proposals.

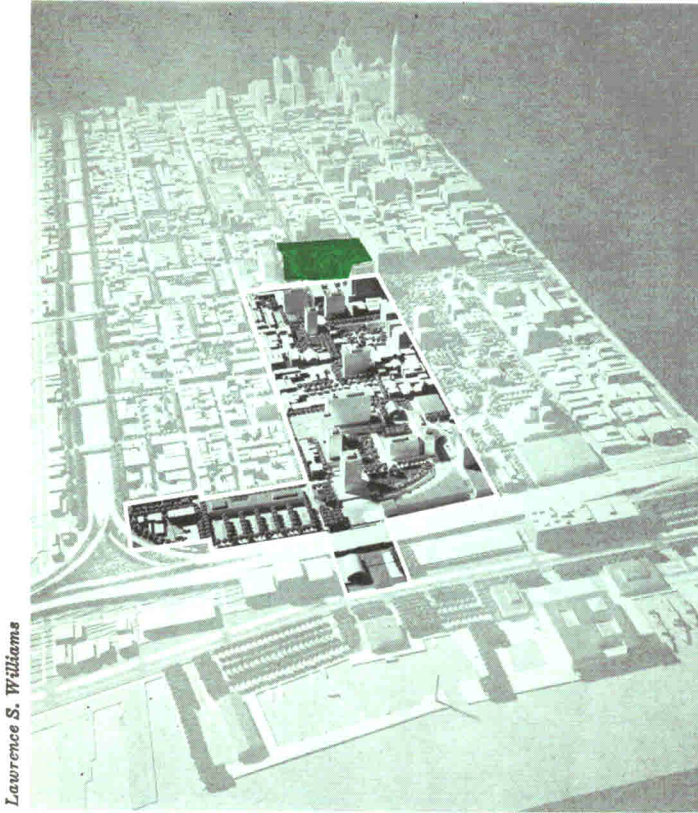

Lawrence S. Williams

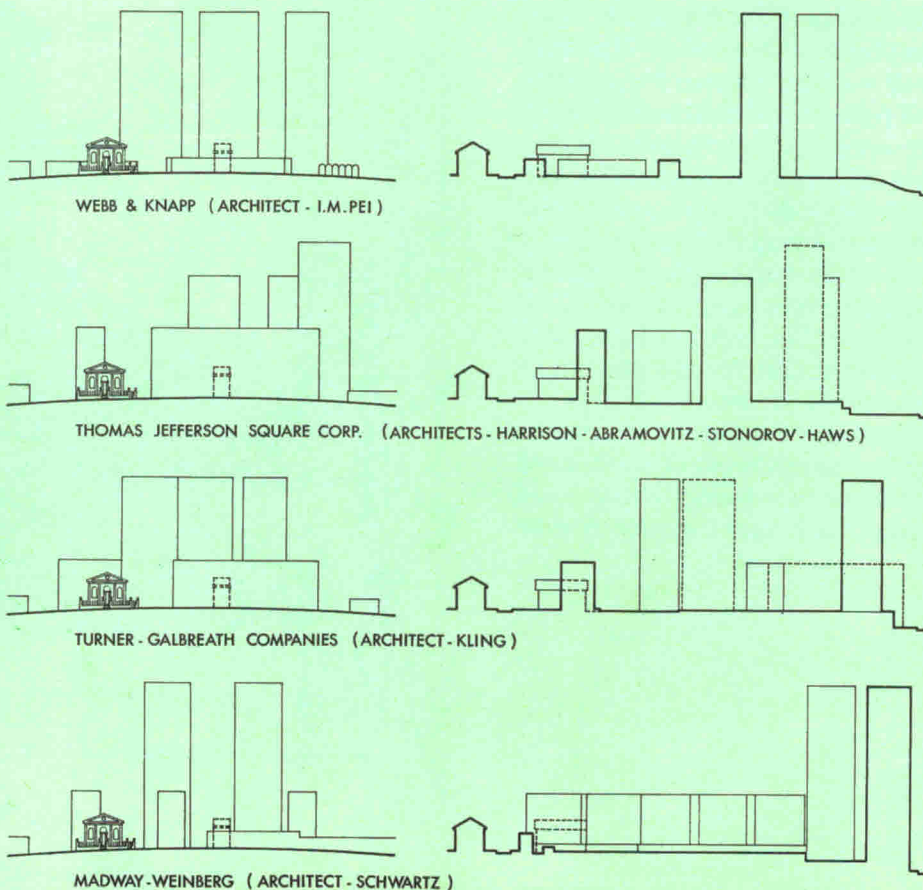



A



B

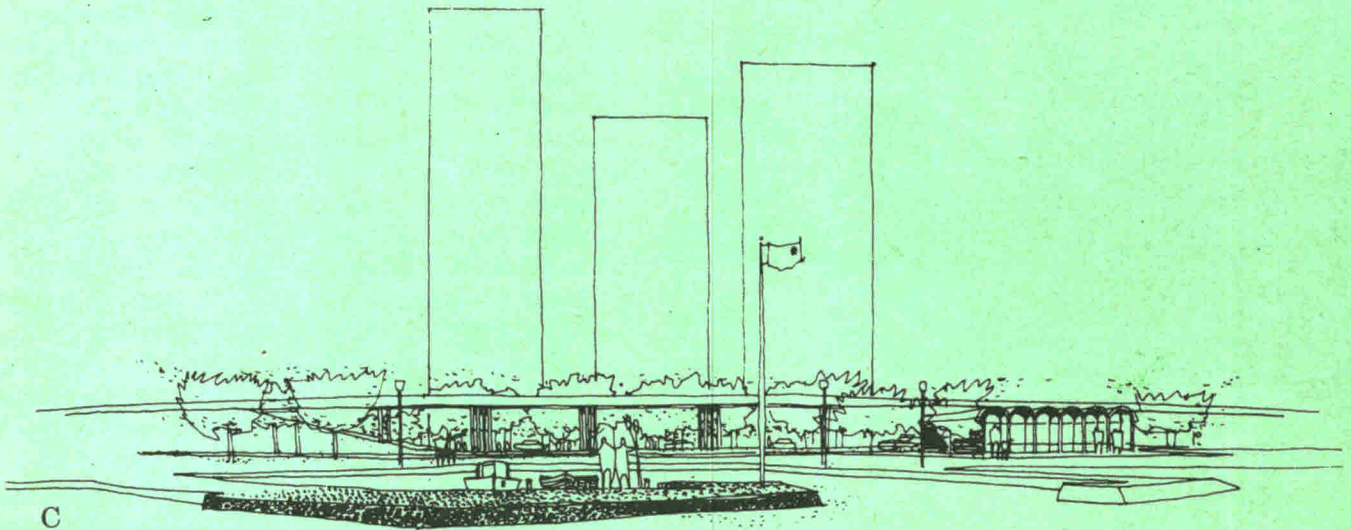

C

## 1958-THE COMPETITION

### *I.M. Pei's Society Hill project wins*

The Society Hill redevelopment project presented a particularly complex design problem because of the need to respect the scale and character of the modest 18th century buildings which were to remain. The brilliant solution worked out by I. M. Pei for the Webb and Knapp submission, shown in diagrammatic section and elevation on the opposite page, placed three-story town houses opposite and adjacent to the historic church and houses, and concentrated all the new apartment construction in three simple towers well removed from the historic buildings. This scheme was immediately adopted as the basis for construction. Pei's sensitivity to the design structure of the larger area is shown by the perspective sketch (D) which he included in his submission. The positioning of each of his three towers is precisely determined by a series of influences impinging on this site from the outside, one centering on the greenway alongside Saint Paul's Church (B), one on the axis of the Market Head House (A), and one on the town house court which is part of his scheme. From the river they have a vigor consistent with the scale of the topography and the expressway movement (C).

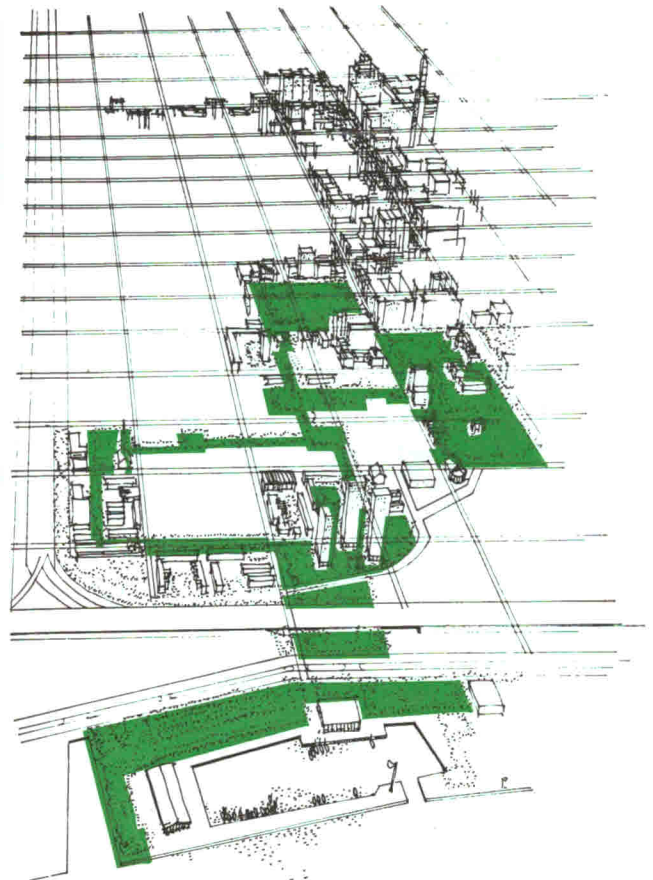

D

## 1960-THE WATERFRONT

*The Delaware River bank becomes part of the design structure*

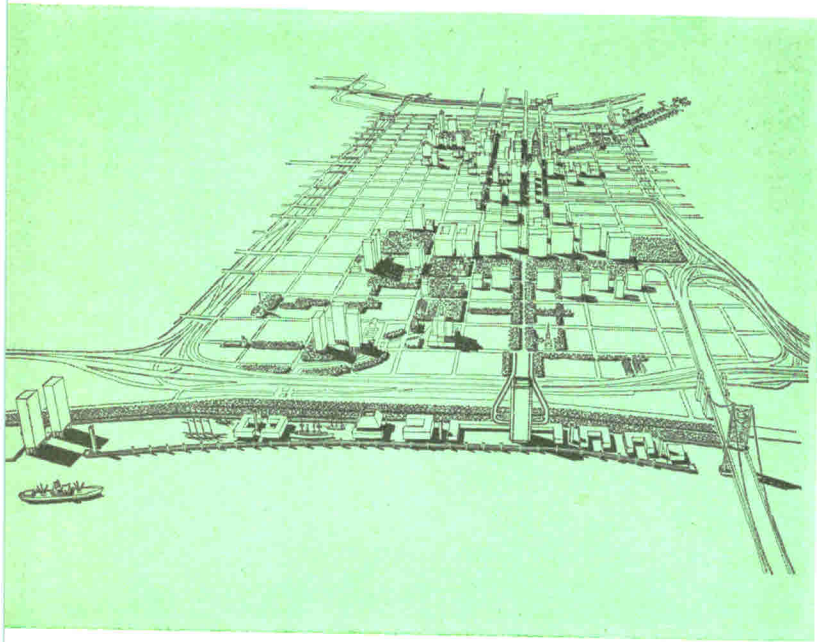
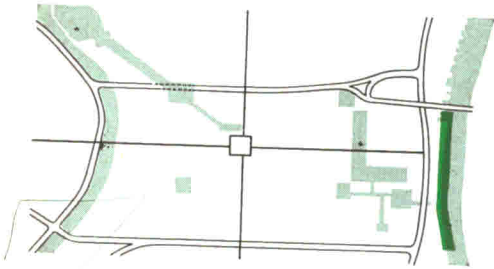

The two bordering riverbanks, essential elements in William Penn's original plan, have changed over the years from aesthetic assets to eyesores. It was architect Robert L. Geddes's job, working with the Ballinger Company engineers under a contract with the Commerce Department, to recreate the Delaware River edge as a design element and to join it with the Penn Market Street axis (horizontal line on key plan above). The waterfront scheme receives the thrust of the Society Hill greenway system, deflecting it northward to join with the greenway extension planned by Larson to complete the circle above Market Street. The manner in which Geddes achieved this integration is shown in the perspective at left and on the third in the series of three plan development drawings which follow.

Geddes conceived his plan in terms of the design structure of the whole center city area. By basing his design on a few simple, underlying forms set in a firm relationship to each other, he demonstrated the important principle that a strong overall scheme will permit highly individualized design of a few key, carefully positioned buildings by different architects without destroying the unity of the whole composition.

The overall plan for central Philadelphia also includes a scheme for the redevelopment of the Schuylkill waterfront to the west.

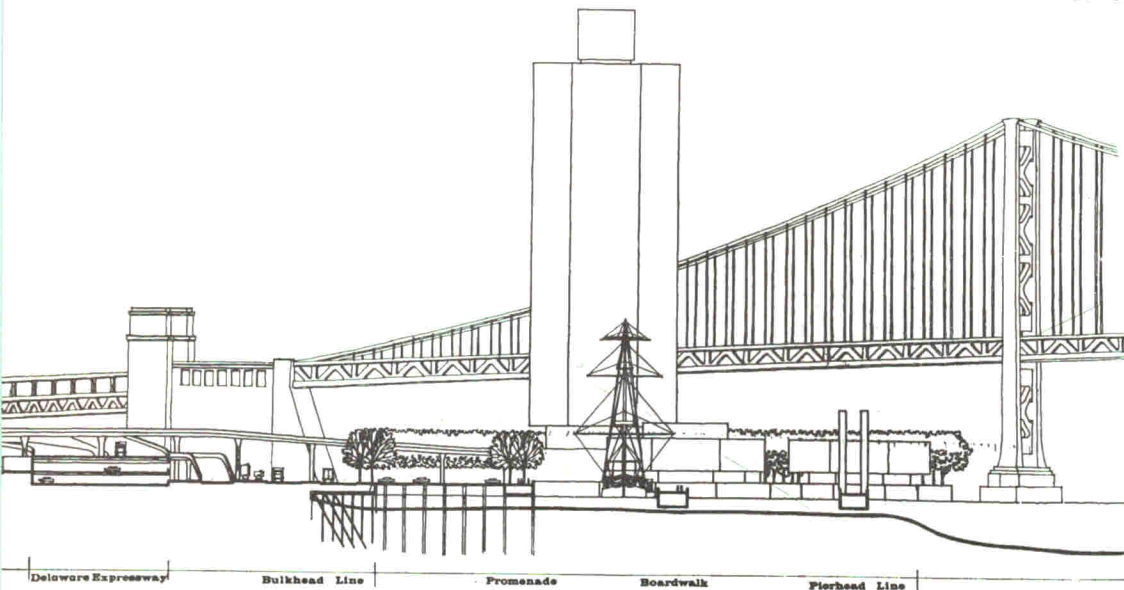

The three following pages portray the evolution of the basic design structure for the eastern third of downtown Philadelphia from 1944 to the present, illustrating the progressive clarification of its elements resulting from the interaction of planners, architects, developers, civic leaders and politicians

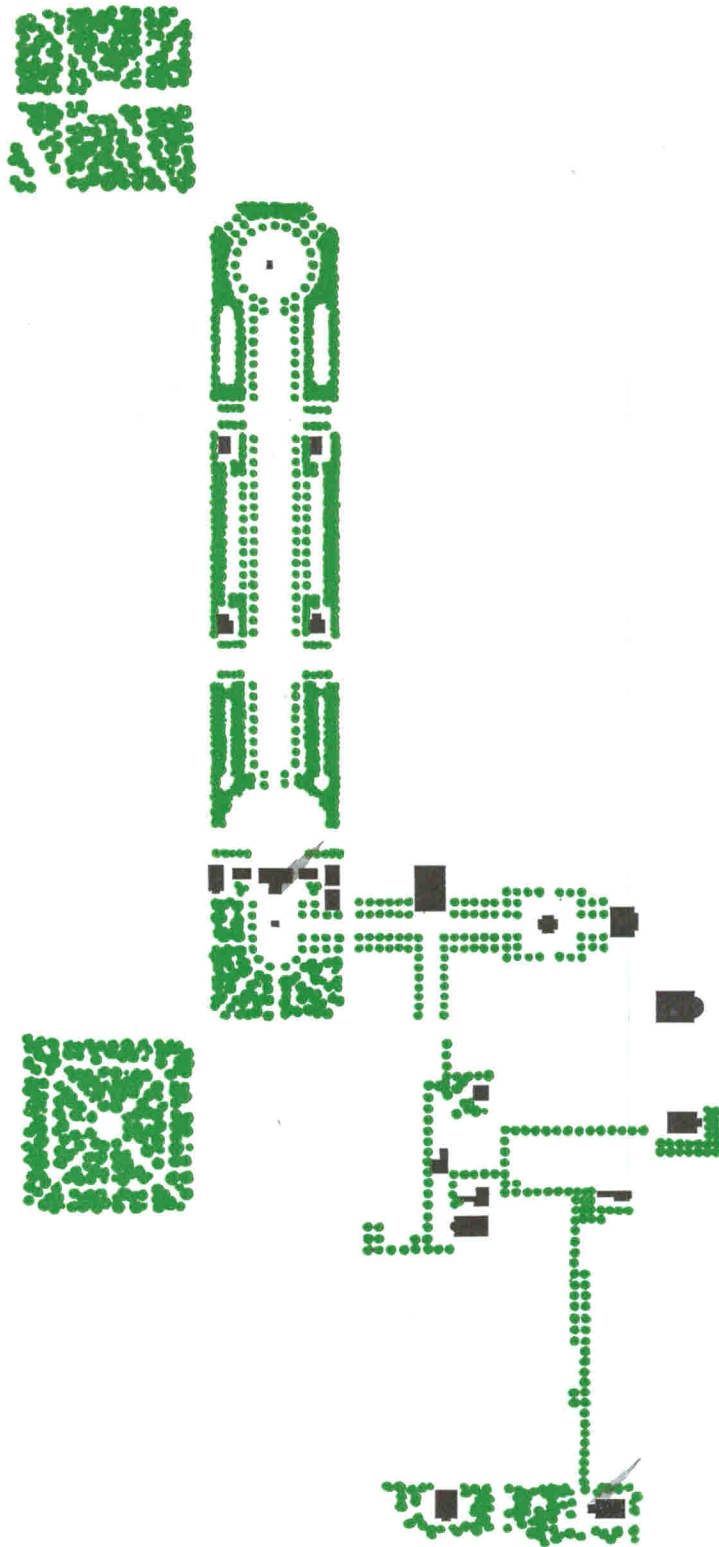

Original plan for Independence Mall to the north of Independence Hall, and the first scheme for a park linking historic buildings to the east (1944). The initial Society Hill greenway proposal (1947) is shown to the southeast. Washington Square, one of William Penn's five original squares, appears to the west and south of Independence Hall; another is situated to the north beyond Independence Mall

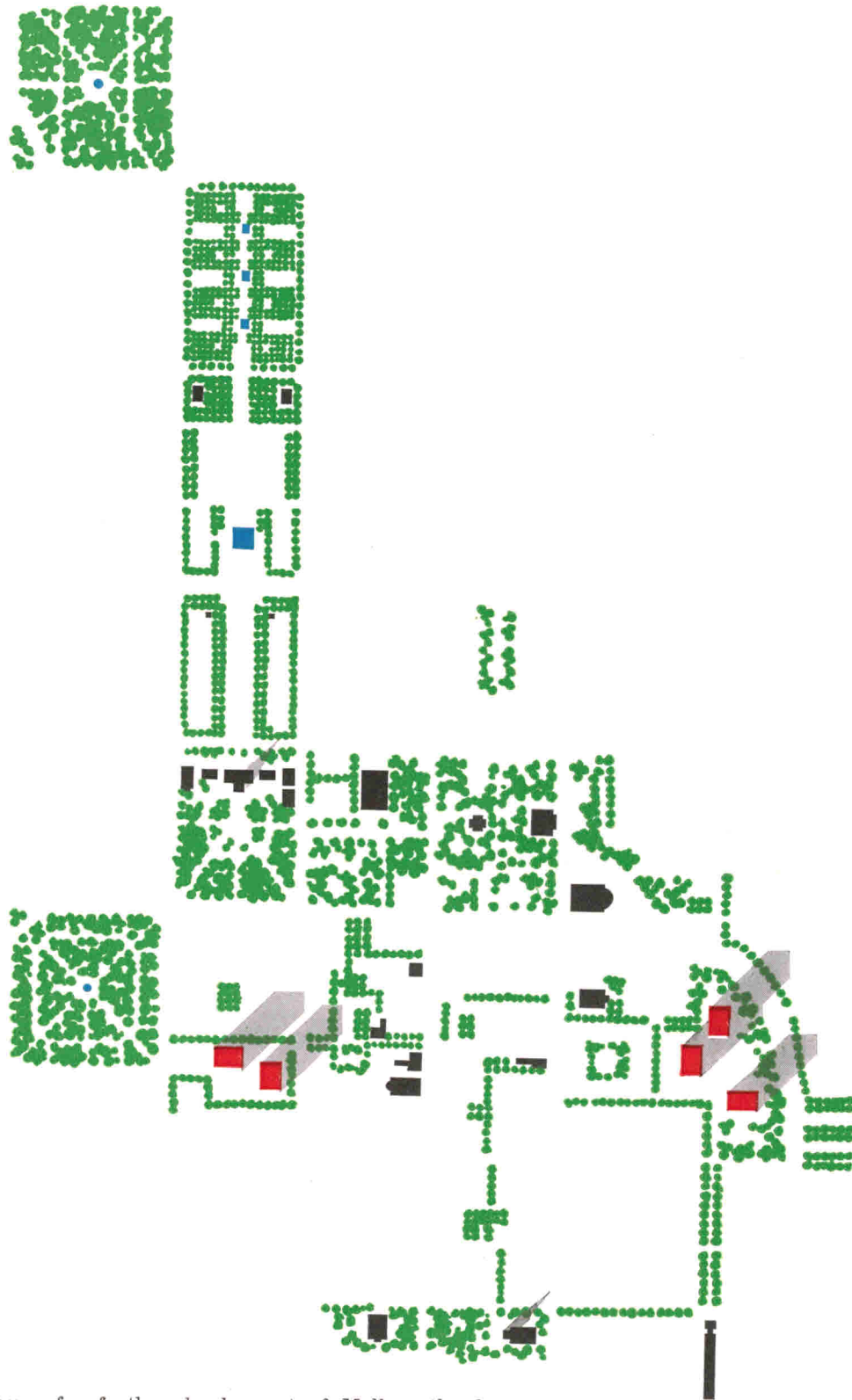

Present scheme for further development of Mall north of Independence Hall and historic park to the east. Plan shows further development of Society Hill area to the southeast, showing I.M. Pei's three towers proposed in the 1958 competition and two more towers later planned by Pei adjacent to Washington Square. Historic buildings are shown in black, Pei's towers in red. *Opposite page:* plan includes Delaware River waterfront development proposed in 1960, and the projected greenway extension to the north

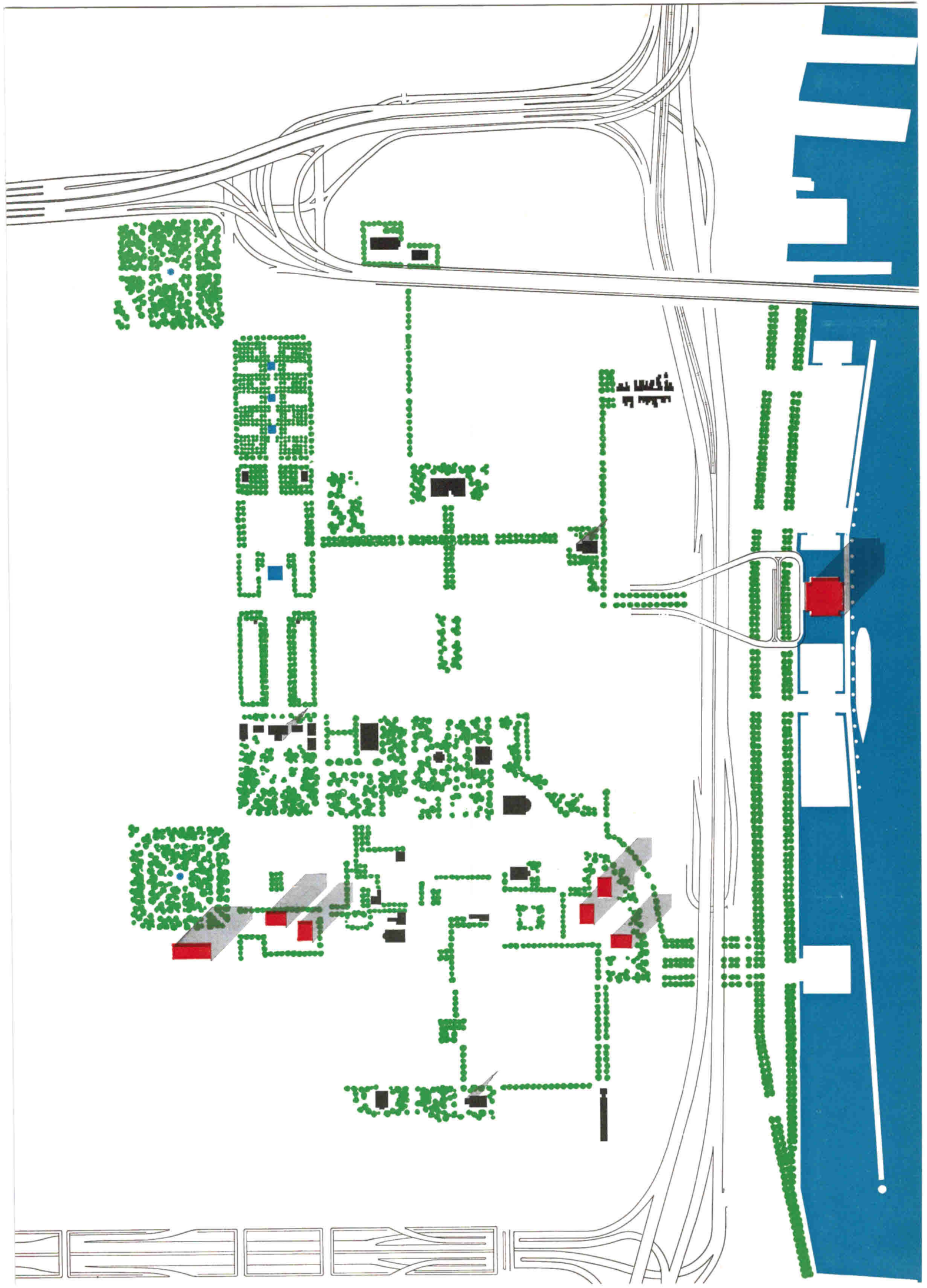

# DOWNTOWN PHILADELPHIA: THE OVERALL PLAN

Although several of its elements had been sketched out long before, the mature form of the center city plan was arrived at only after fourteen years of design and development involving many people. The structure is now very clear in both a functional and architectural sense.

The decision was made not to try to fight the automobile, a losing battle at best, but to treat it as an honored guest and cater to its needs. The separation of the pedestrian from it, accomplished in Society Hill two-dimensionally by the footpaths in the middle of blocks, was achieved in the more crowded central areas by developing for foot circulation continuous areas above and below level. Only on Chestnut Street are the automobiles to be removed and replaced by light electric trolleys moving directly into terminal parking garages (indicated in plan by cross hatched pattern) where Chestnut Street meets the two expressways.

The green area shows the planned extension to the south of the lower level pedestrian superblock already built in Penn Center to the west. The exten-

sion will connect with the underground parking garage adjacent to the crosstown expressway, and east into the main shopping area. Here it lies between and connects the underground commuter railroad loop (indicated in plan by a wide dashed line), and the rebuilt Market Street subway stations. These will open into the courts and gardens created in the lower level superblock. (Subway lines are shown in plan by a narrow dashed line.) The white area shows the shopping promenade, an elevated sidewalk connecting directly with second floors of the five great department stores. Adjacent to the shopping promenade is the local and long haul bus terminal above which is a parking garage, both served by ramps which connect directly with the regional expressways. The plans of the various levels are shown on pages 142 and 143.

The sectional drawings on the opposite page show Market East as a transportation mechanism, tying all the modes together, and, more important, providing a decent entrance to center city for those who use them.

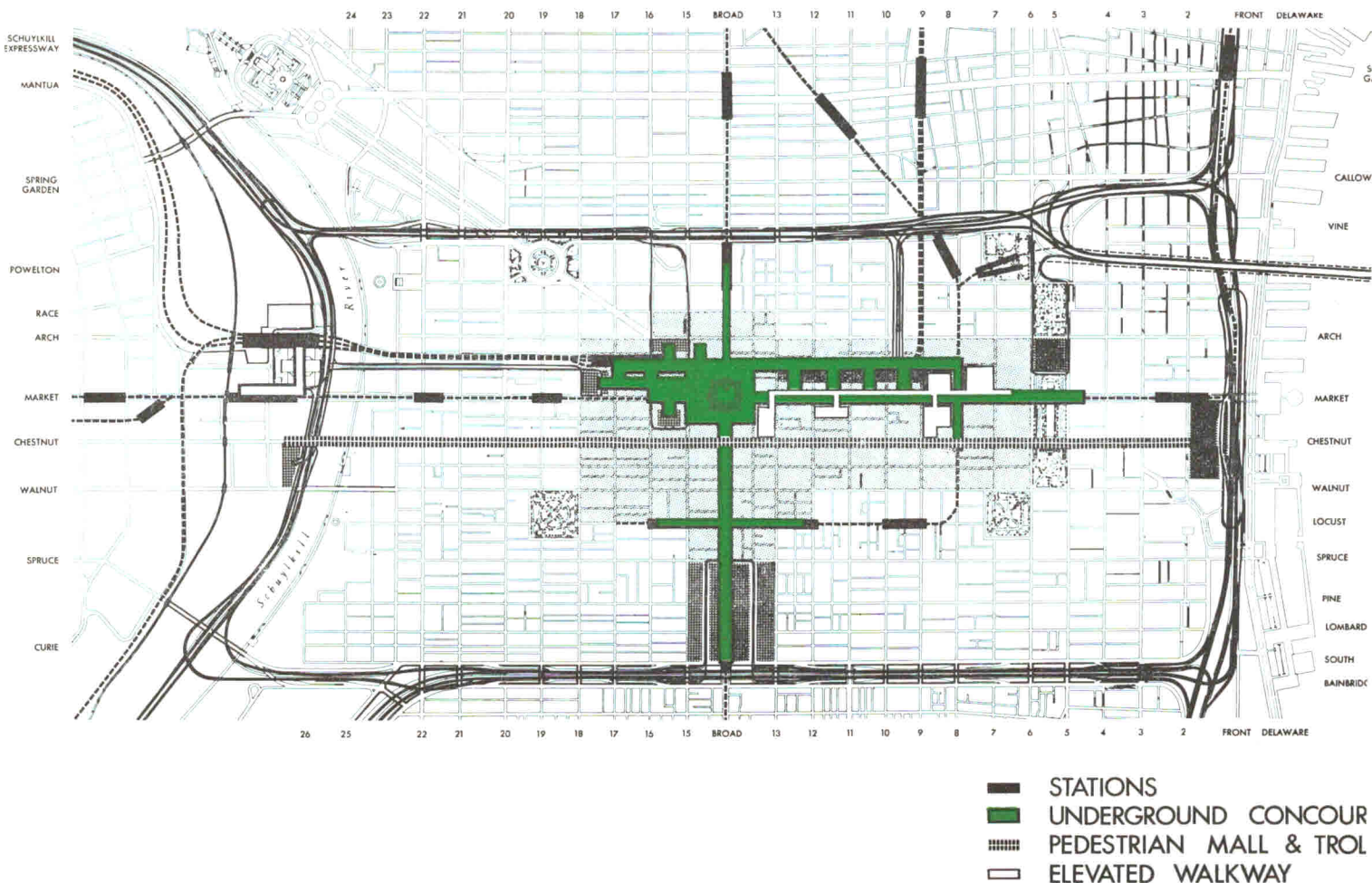



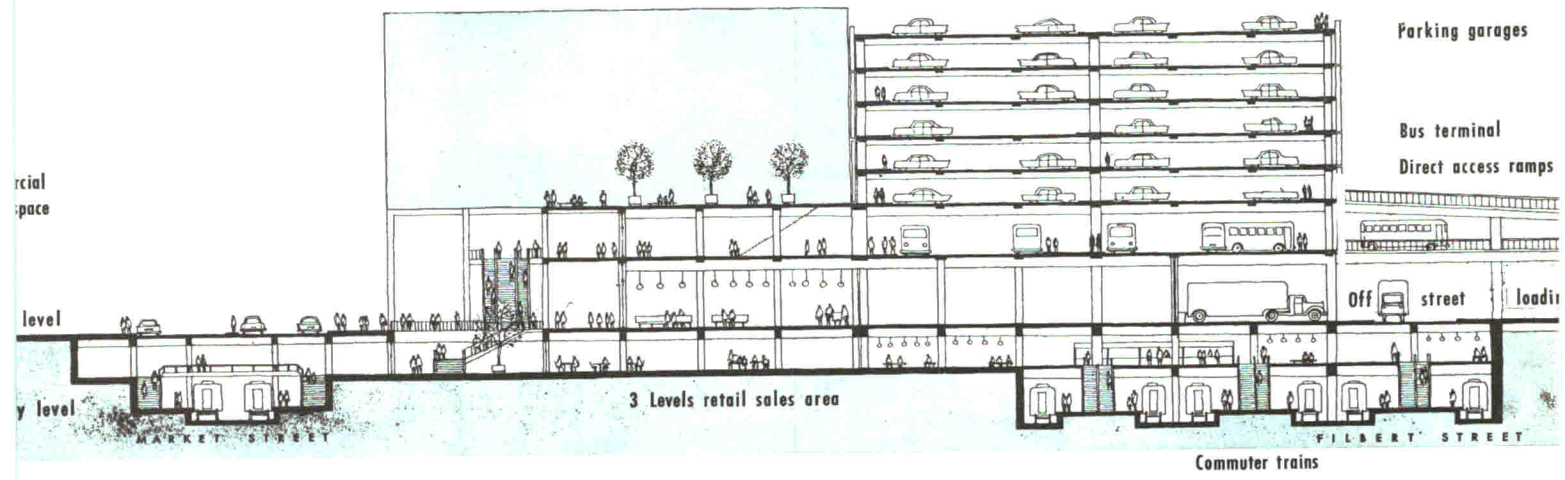
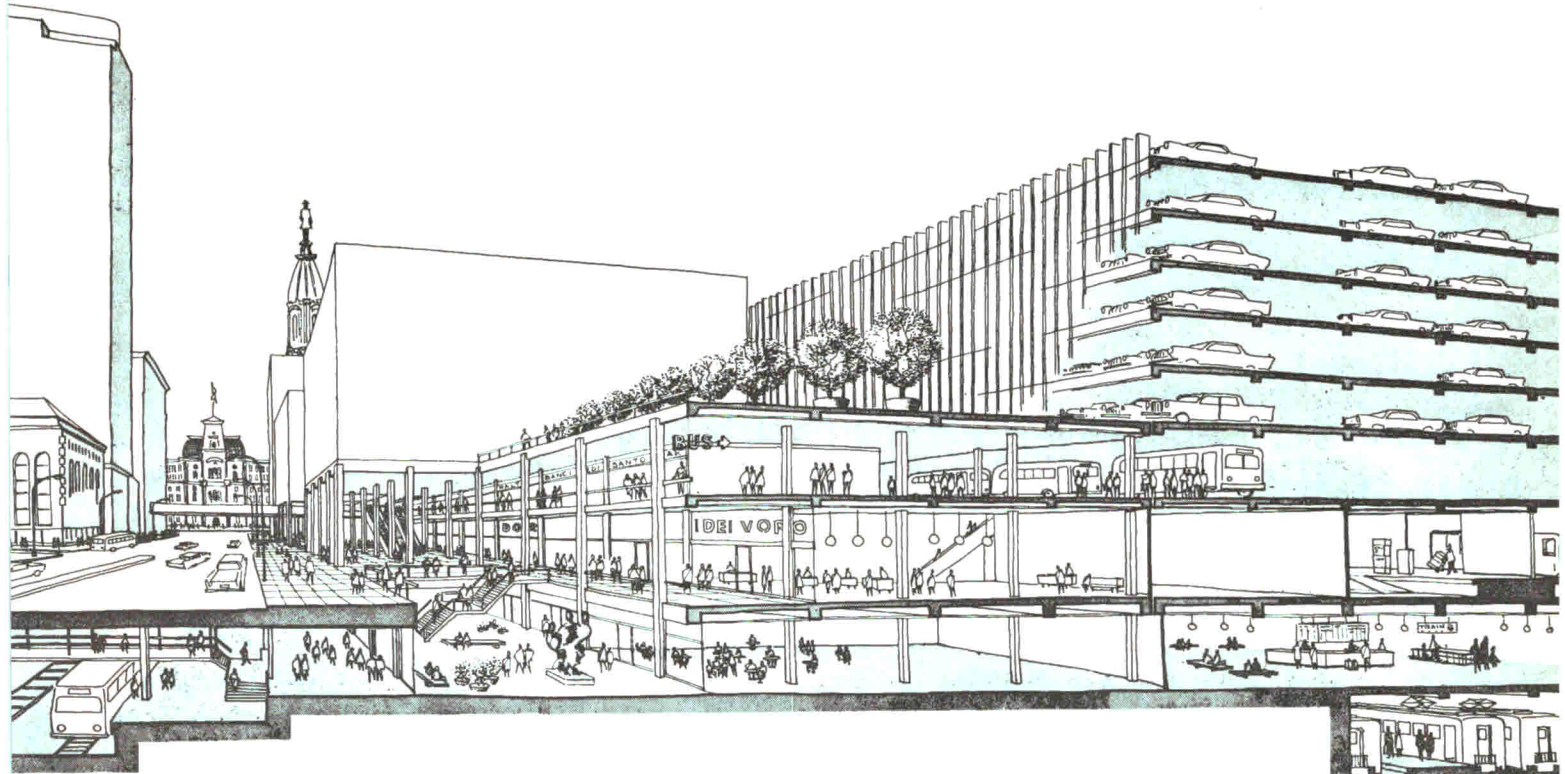

# DOWNTOWN PHILADELPHIA: MARKET EAST

## ELEVATION

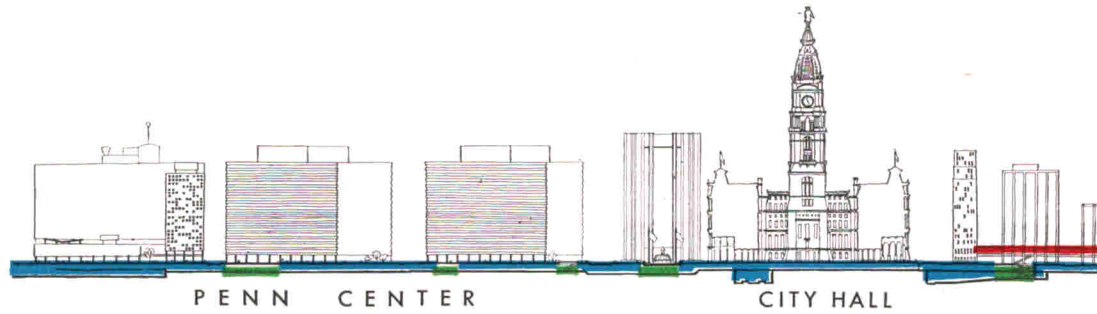

## UPPER LEVEL AND STREET LEVEL

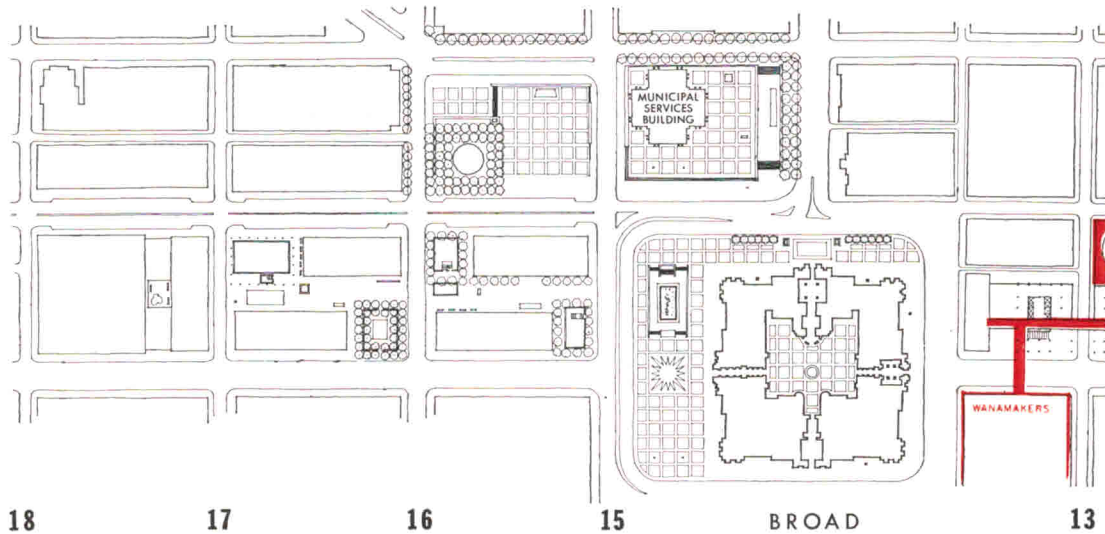

## LOWER LEVEL

- ELEVATED WALKWAYS
- LOWER LEVEL CONCOURSES
- OPEN GARDEN COURTS
- RAIL TRANSIT LINES

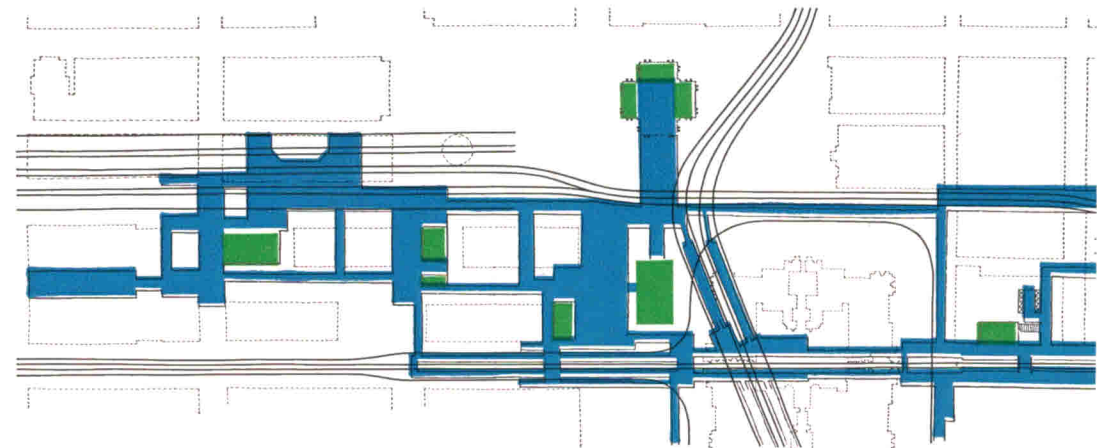

The completing element of the center city plan is Market East shown between the now finished Penn Center to the west and Independence Mall to the east. This comparatively small but intense project binds all parts of the plan into a cohesive whole. It represents a resolution of regional forces into a three dimensional system of space organization. This is not architecture as customarily practiced, nor planning as it is usually done. It is a statement of a program to achieve planning objectives and a frame of reference within which the architect will function.

I must add that although the staff of the Philadelphia Planning Commission has worked with consultants on many other parts of the plan for downtown Philadelphia, Market East is entirely our work.

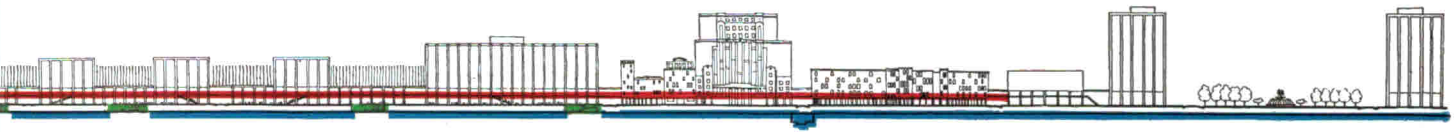

MARKET EAST

INDEPENDENCE MALL

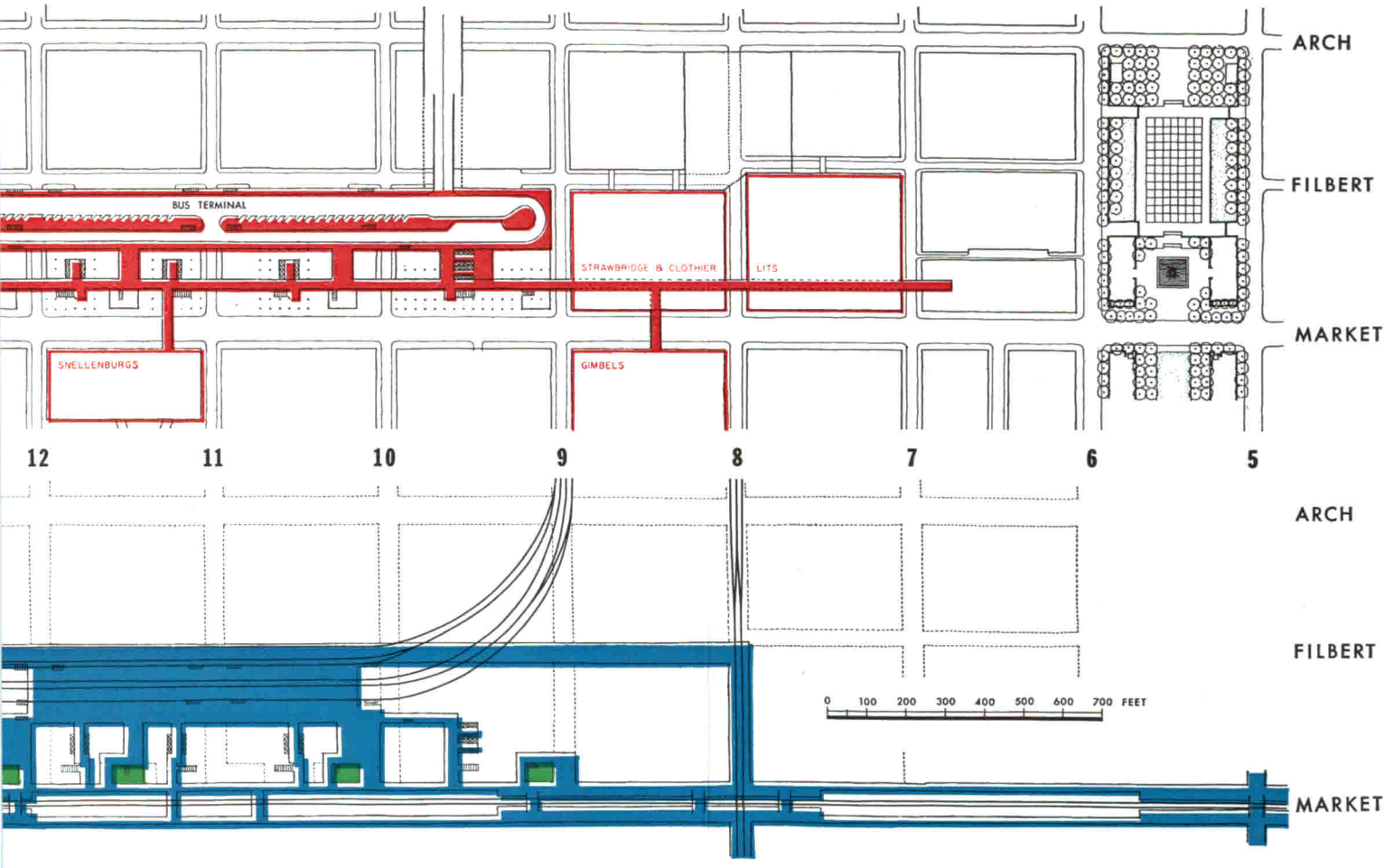

## DOWNTOWN PHILADELPHIA: MUNICIPAL SERVICES BUILDING

This projected building by Vincent Kling expresses in its basic design the upper-lower level relationship established as one of the design determinants of Market East and Penn Center (see plans and elevation on preceding spread and Penn Center photographs on page 146). These design determinants have proved to be remarkably fertile and seem to extend themselves almost of their own volition. The upper-lower level relationship of Penn Center, now complete thanks to the vision and energy of the Pennsylvania Railroad, was originally conceived around a single, central open space esplanade extending west from City Hall at the core of Penn's original cross axial plan. Now a cross element has grown out of it, bound to the esplanade by the proposed fountain in West City Hall Plaza and terminating at the northern end in Vincent Kling's projected Municipal Services Building. Here the need for tying the lower and street levels together received a new expression in the three handsome two-story glass enclosed lobbies of the building (shown in green on plot plan), and in the lower court in Reyburn Plaza, immediately to the east of the proposed building. Kling has succeeded in expressing architecturally the visual dominance of City Hall by the carefully controlled spatial relationships in his design.

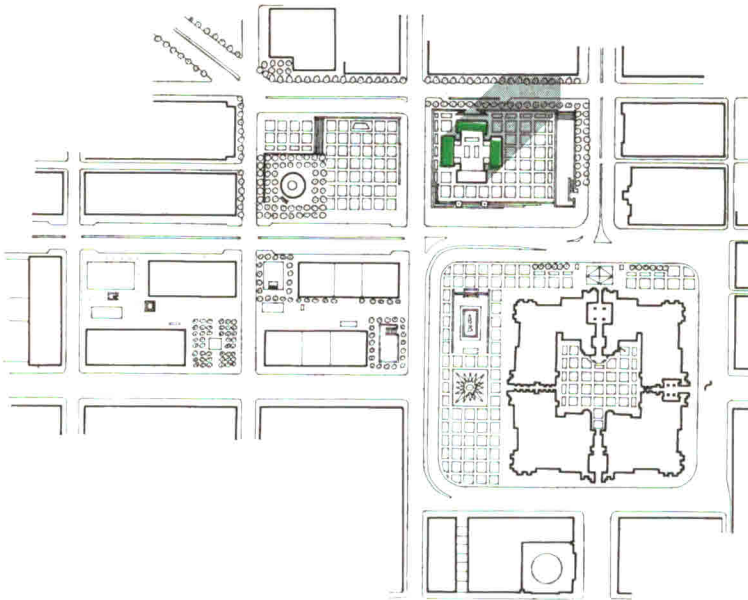

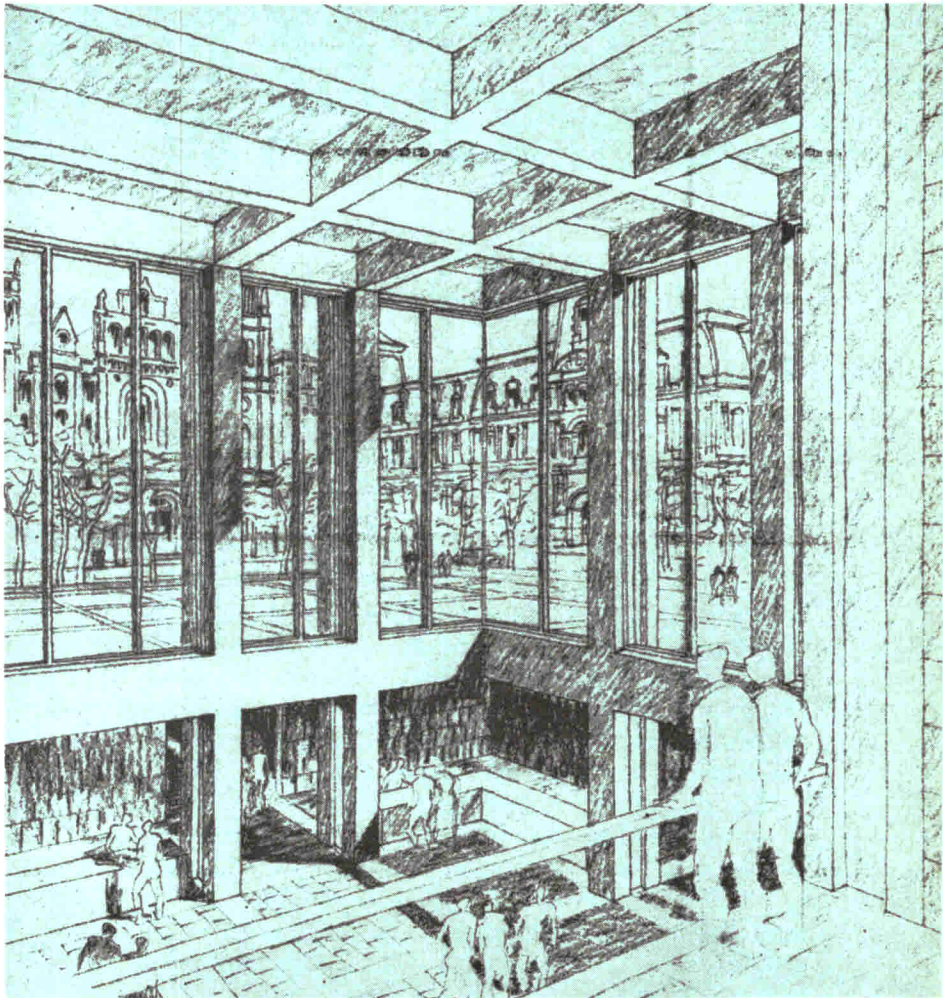
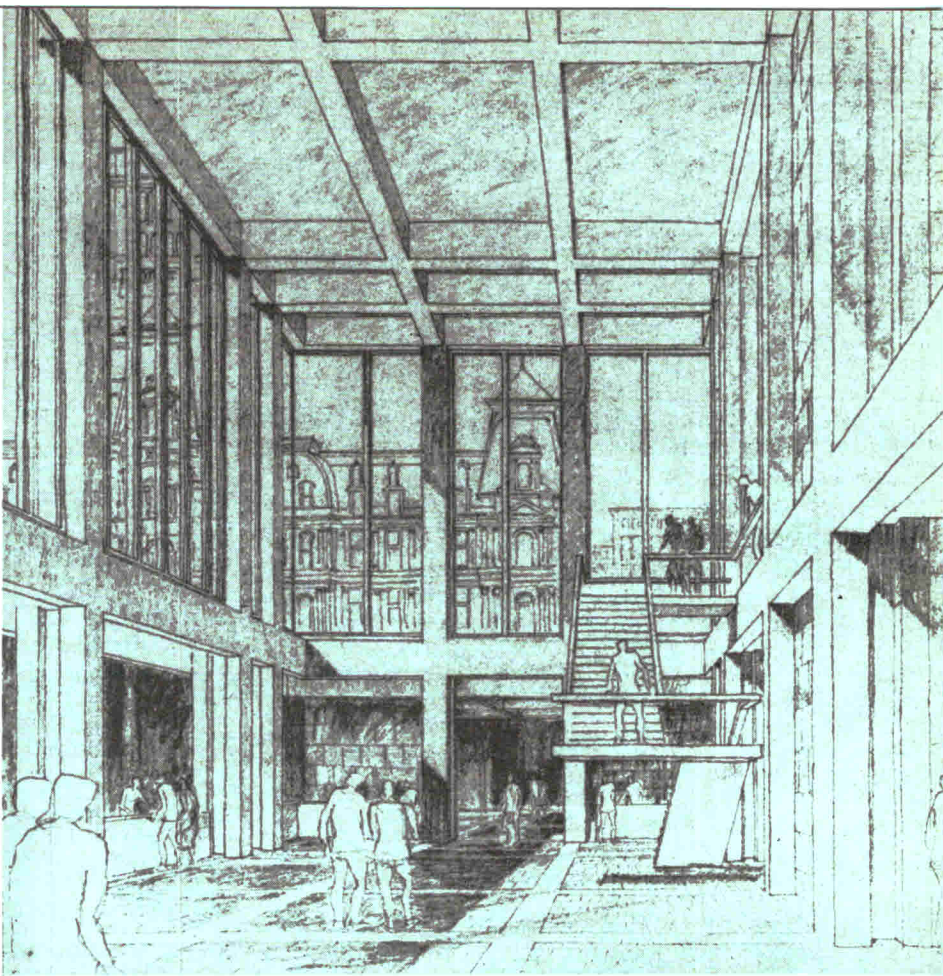
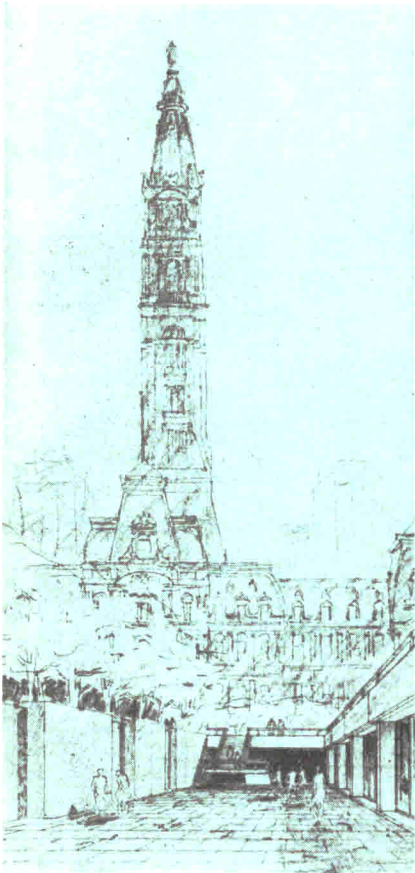

# TODAY: PENN CENTER COMPLETED

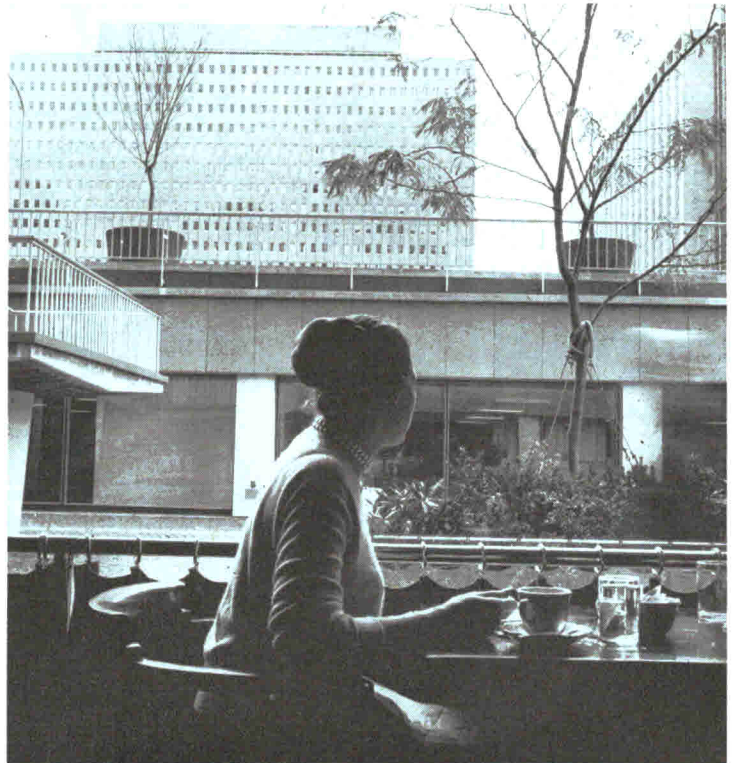

*Lewis-Claire Studio*

And so parts of the plan are getting built. This is the essential ingredient lacking in so many of the grandiose plans that are stillborn. The planner must learn from the architect and the client, the architect from the demonstrated scope of vision of the planner, the developer from the work of other developers, and the government officials, the newspapers and the community at large from what they see rising about them, the whole brought to life by the heat of the tensions of construction.

But all this is foredoomed to failure unless there is an underlying design structure of a force and clarity capable of influencing action, and the skill and will in government to produce, modify and extend this structure so that it is continually alive, and to support and protect it when support and protection are needed.

**AUTHOR'S NOTE:** Because of space limitation many important people, organizations and facts had to be left out. To those concerned, my apologies.

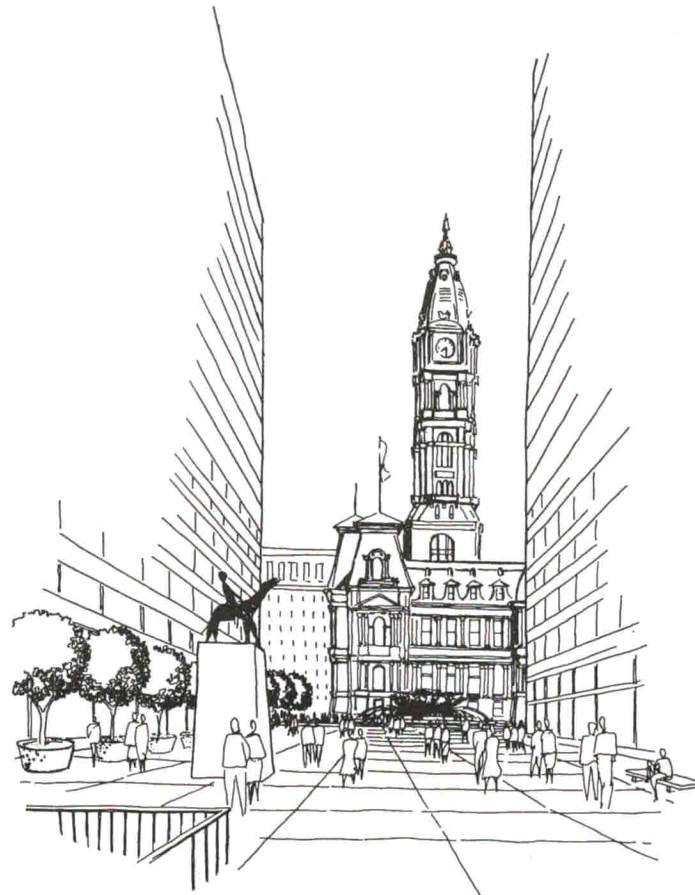

All photos by Ben Schnall



## ARCHITECT'S NOTABLE INTERIORS FOR PHILANTHROPIC ORGANIZATION

*The Rockefeller Foundation  
New York City*

ARCHITECTS:  
*Carson, Lundin & Shaw*

MECHANICAL ENGINEERS:  
*Syska & Hennessy*

STRUCTURAL ENGINEERS:  
*Edwards & Hjorth*

CONTRACTOR:  
*George A. Fuller Co.*

The well-planned and attractive spaces that make up the Rockefeller Foundation headquarters offer further convincing testimony that architects can be counted on to do a job of this kind exceedingly well. The problem was to design and furnish two floors in the newest of the Rockefeller Center buildings; one floor to serve as executive and secretarial quarters, the other as accompanying service area (treasurer, purchasing, shipping, travel, personnel, library, publications, lunch room, switchboard, etc.).

After arriving at a plan that works, the real trick in successfully designing a project such as this is to come up with interior treatments that create a character appropriate to the client. In this case the effect is properly restrained but not austere; dignified yet interestingly varied. Teakwood, white marble, travertine, off-white hangings, and muted floor coverings set the general tone—which is enlivened here and there by carefully placed accents of bold color. Details have been carefully studied to give spaces a simple, clean, uncluttered look.

The Rockefeller Foundation was chartered in 1913, and endowed by John D. Rockefeller. Its broad objective is to promote the well-being of mankind through the advancement of knowledge and its effective application. Shown above: the president's office as one enters.



Main reception area has a mineral tile ceiling with inset teak strips; white marble floor; blue carpet; tobacco brown vinyl wall covering; teak desk, table, and chairs; off-white hangings; natural white sofa; green upholstered lounge chairs

### Architect's Interiors: The Rockefeller Foundation



Committee room has a mineral tile ceiling; walls of teak, travertine, or bottle green burlap; beige carpeting; teak table



Committee room lounge has built-in TV and Hi-Fi; adjoining meeting room has concealed blackboard and projection screen



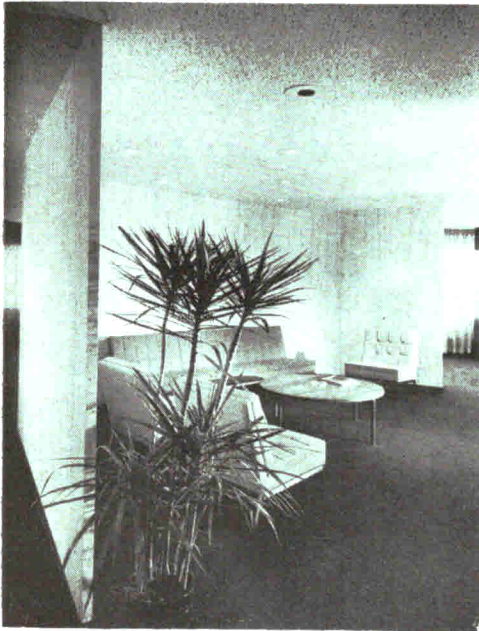

The executive reception area is defined by a floor to ceiling curved travertine screen; the sofa is vivid red; lounge chairs white

The plan of the executive floor at right shows how offices for the five major divisions (administration, medical and natural sciences, social sciences, and humanities) occupy the perimeter of the floor; while the committee (and board) meeting room and lounge are at the center of the plan; the main reception room adjoins the elevators; and the executive reception area is located near the bottom (eastern end) of the plan to serve the administrative offices, which overlook nearby Rockefeller Plaza.

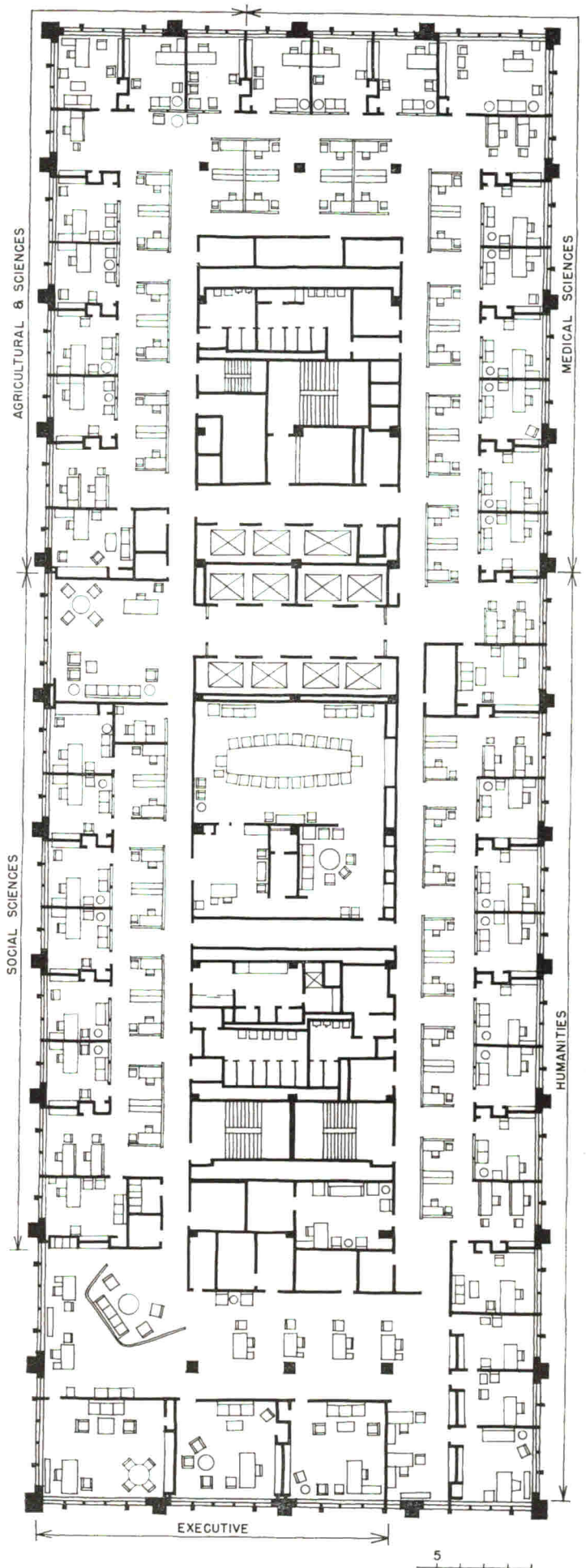

resident's office has green carpeting; teak desk, cabinets and table; red leather lounge chairs; white conference chairs

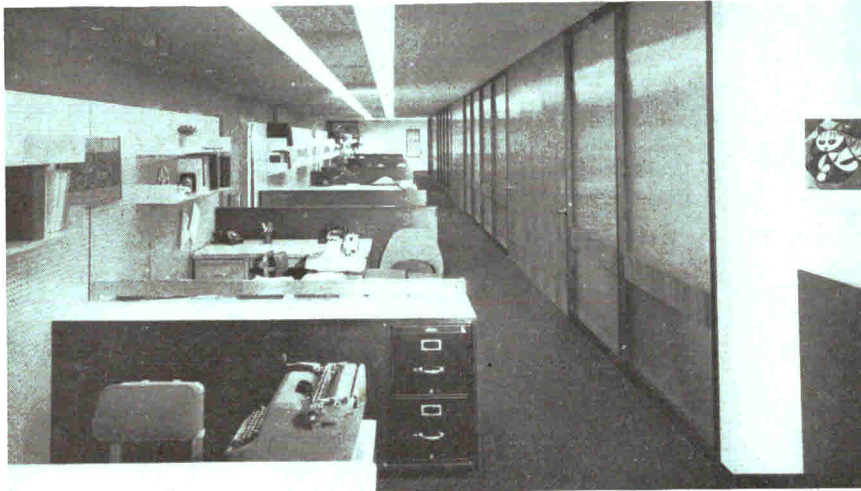

## Architect's Interiors: The Rockefeller Foundation

The secretaries are located adjacent to the officers, in L-shaped galleries which extend out to window walls. Obscure glass and teak walls separate private offices.

Each secretary occupies a space equivalent to a small office, the details of which are shown on this page. Pandanus covered screens, 5 ft 6 in. high, define two such units; each secretary has a desk, visitor's chair, book shelves, 2-drawer file, storage cabinet, and a counter-top work space for collation, etc.

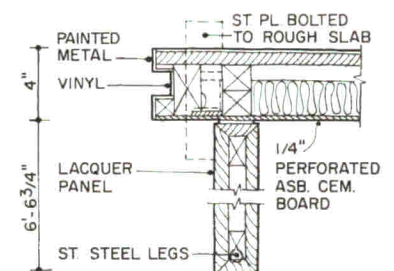
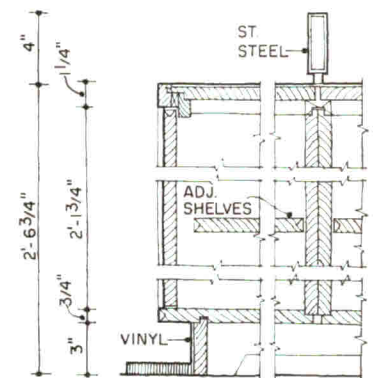
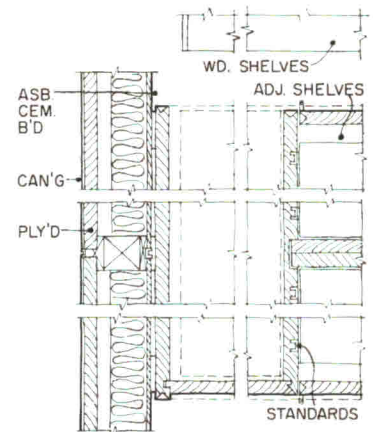
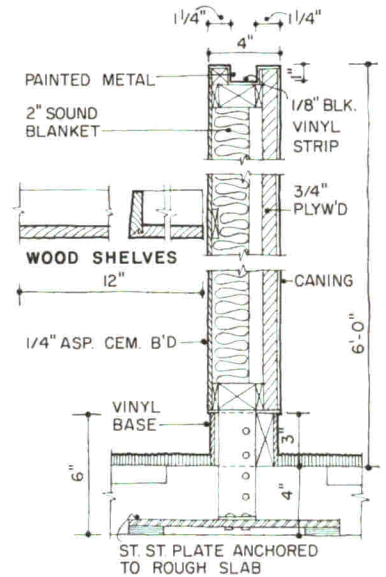
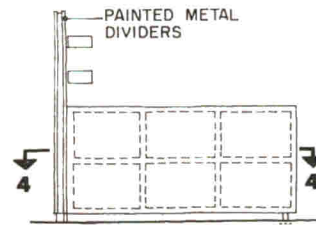
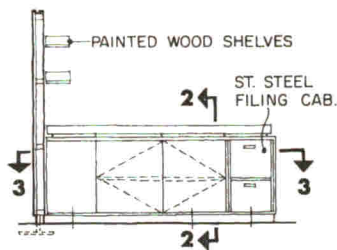
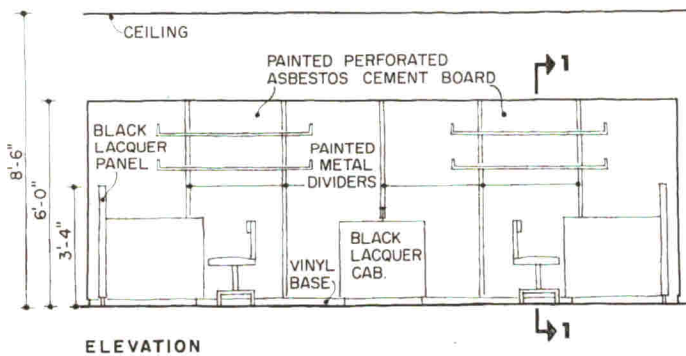
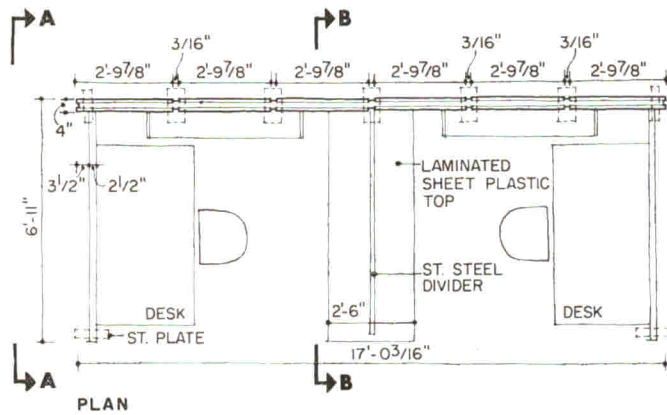

DESIGN FOR  
CONVENIENT  
BANKING

*First National Bank of Minneapolis*

ARCHITECTS: Holabird & Root

ASSOCIATE ARCHITECTS: Thorshov & Cerny, Inc.

CONTRACTORS: Naugle-Leck, Inc.



*Warren Reynolds, Infinity, Inc. photos*

## *Bank—planned efficiency and convenience saves time*

The officials of this bank say that the most important single factor in attracting customers to a commercial bank is convenience.

The architects of the building have managed to provide a high degree of convenience for the bank's customers and, in addition, provide for employe convenience and efficiency of operations. In the five story banking wing, 92 per cent of all customers complete their business on the ground floor. For those who prefer drive-in banking, there is a below grade parking garage, with tellers' windows. All of the bank departments are functionally related to each other. Those on the upper floors are in close proximity to the elevators. The elevators themselves are centrally located for convenience.

The bank officials say that efficient planning saves the bank more than \$100,000 a year in operating costs, in addition to the incalculable savings in time and effort. Part of this is due to the careful study of departmental relationships in the design. Other important factors are the efficient vertical transportation for securities, cash, and the like and the separate elevators for employe use. All employe circulation is separated from that of customers and the tenants of the office tower.

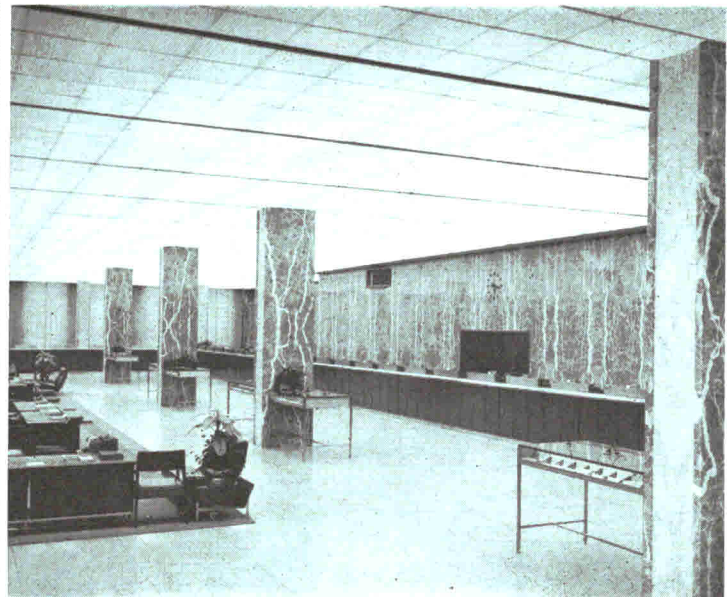
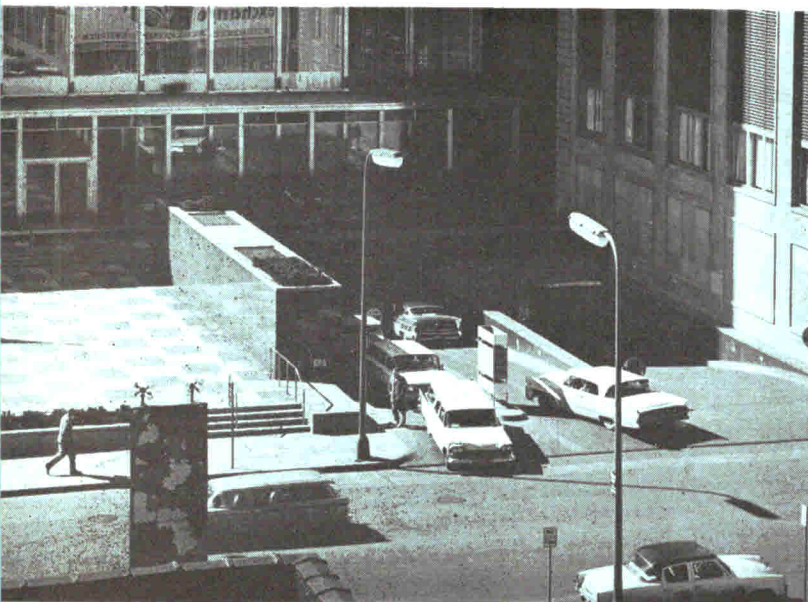

and money in operation



## Minneapolis Bank

At the left is a view of the open and spacious plaza located at the main entrance to the building. At the right, in this view, is the entrance to the below grade parking garage and drive-in facilities. The adjacent view shows the treatment of the main banking floors with the tellers' counters in the background and the officers' area at the extreme left. This entire floor has been kept uncluttered and open for free-flowing circulation of customers between the various departments. The view above shows a typical banking area on an upper floor.

In the plans may be seen the relationships between the first two bank floors and typical office tower floors. The third floor of the bank is devoted mainly to units of the trust department, the fourth entirely to space for machine processing operations, the fifth to ancillary spaces such as a 300 seat auditorium, an employe cafeteria, and the like

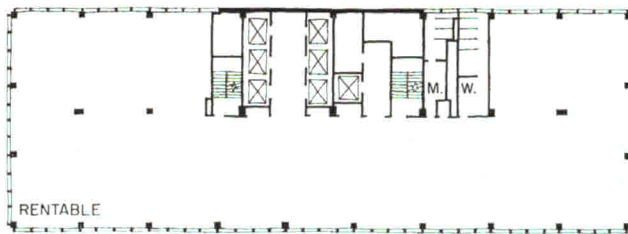

15th THROUGH 24th FLOORS

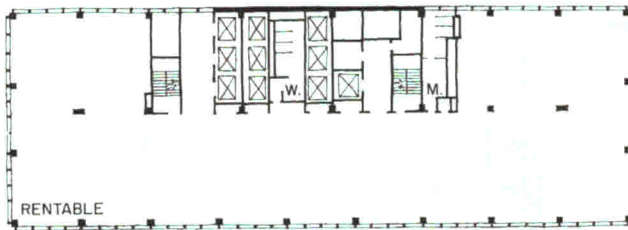

8th THROUGH 10th FLOORS

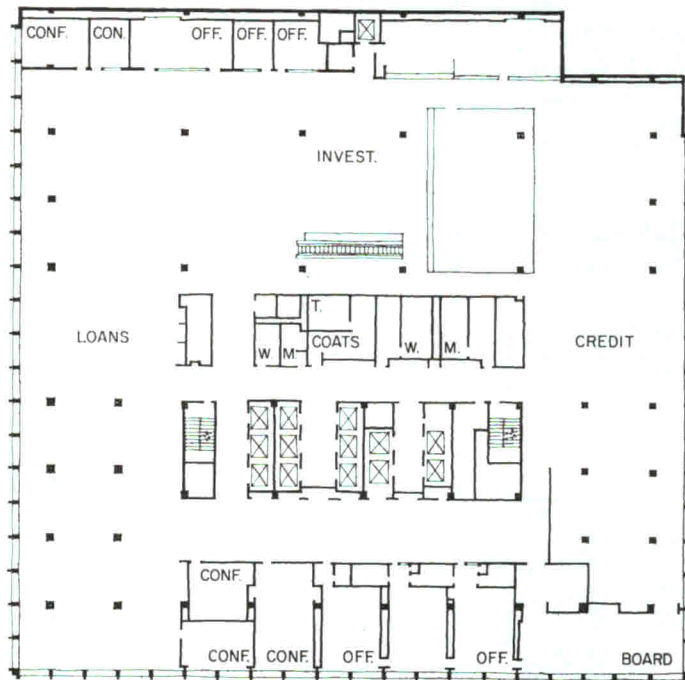

SECOND FLOOR



FIRST FLOOR

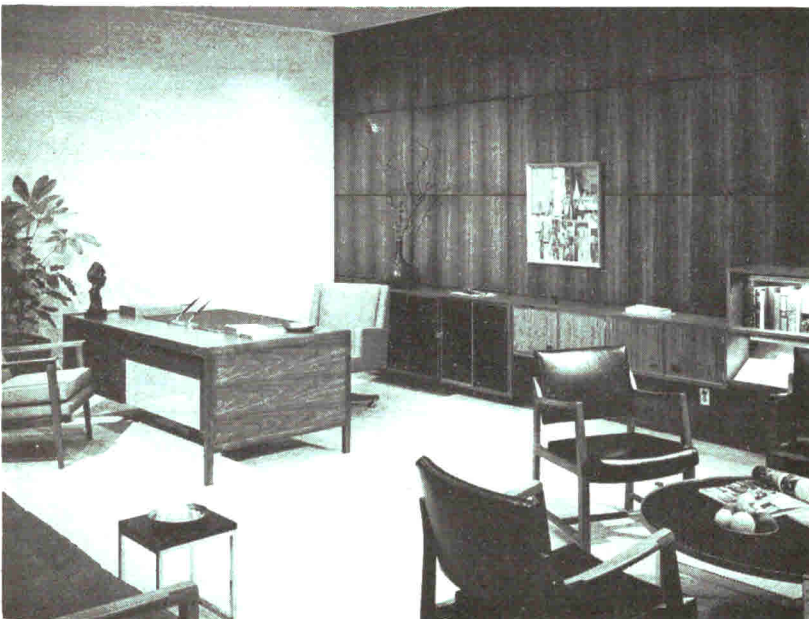
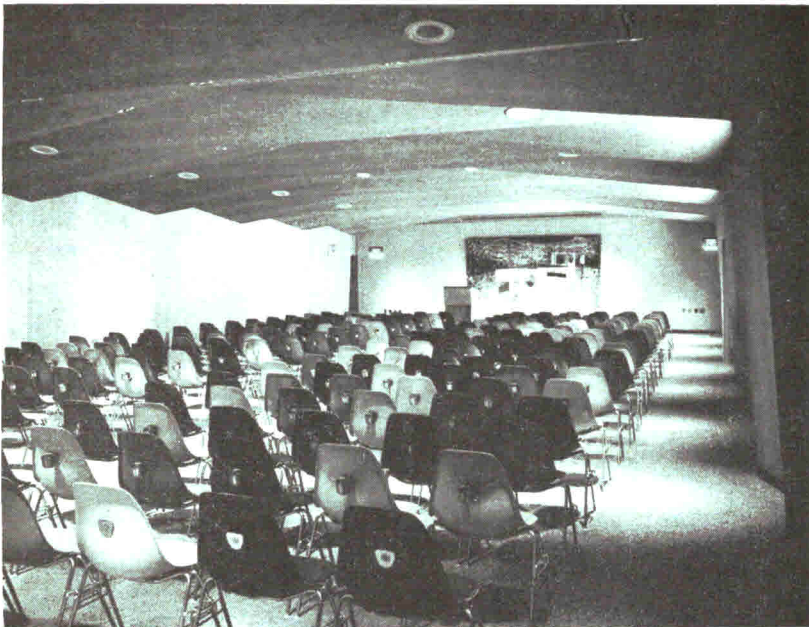

## Minneapolis Bank

At the top is shown the entrance to the bank vault area. The vault, located on a lower level, is directly connected with all banking departments requiring access to it by a special elevator and a conveyor system. Below the vault is shown a view of the auditorium, used for meetings, forums, and the like. At the lower left is a typical bank official's office. Directly above is a view of the board room. The building structure is steel frame with cellular steel-concrete fill floors, except service core which has reinforced concrete floors. The exterior walls on the bank wing, aluminum and plate glass in the office tower. Floors are terrazzo, or asphalt tile, ceramic or quarry tile, marble, or carpeting over concrete. Ceilings are acoustically treated with metal pans or mineral fiber board. Many interior partitions are movable

# PROTOTYPE HOSPITAL— FALLOUT PROTECTED

*Prepared By*

*Architectural and Engineering Branch,  
Division of Hospital and Medical Facilities,  
Public Health Service, in collaboration with  
Office of Civil and Defense Mobilization*

*Associated on the project were:*

*Robert W. Hegardt, Architectural Consultant  
Peter W. Bruder, Engineering Consultant  
Armour Research Foundation, Blast Consultant*

The National Shelter Policy, announced by the Office of Civil and Defense Administration in 1958, states as follows, "The Administration has conducted exhaustive studies and tests with respect to protective measures to safeguard our citizens against the effects of nuclear weapons. These several analyses have indicated that there is a great potential for the saving of life by fallout shelters. In the event of nuclear attack on this country, fallout shelters offer the best single nonmilitary defense measure for the protection of the greatest number of our people."

"The Administration's national civil defense policy, which now includes planning for the movement of people from target areas if time permits, will now also include the use of shelters to provide protection from radioactive fallout."

To implement this established policy, the Public Health Service has collaborated with Office of Civil and Defense Mobilization to develop criteria and standards for protective measures in hospitals.

## PROTECTION PLANNING

A prototype hospital of 150 beds was selected as a basis of design because it is typical of the size likely to be built in the periphery of an urban community or in the distant suburbs of a potential target area. Because of its location, the hospital would be spared the destructive effect of blast and heat but could be subject to some fallout radiation. It was also felt that the 150 bed hospital would be the optimum size for presenting the complex normal problems of department relationships, traffic, and communications in conjunction with the essential features of shelter without obscuring the obvious characteristics of either. A fundamental requirement was that the protective measures must in no way impair the normal functional aspects of the hospital design. Therefore, the resulting design would be useful as a guide for planning a hospital with varying degrees of protection, from maximum to minimum, depending upon the determination of the community's civil defense program.

## FUNCTIONAL ASPECTS

This project presents a sound basic hospital of 150 beds designed to serve the needs of an average American community. It demonstrates that protective measures against fallout can be incorporated in the planning and construction of hospital buildings at reasonable cost without sacrifice of functional or operational requirements.

The hospital is basically composed of a protected unit and an unprotected unit joined by a circulation unit containing connecting corridors and elevators.

The protected unit contains only those elements whose function or use would not be jeopardized, in any manner, by being located in a windowless environment. For example, the concept of placing clinical and diagnostic areas in a windowless structure is already widely accepted as an efficient planning arrangement. Similarly, the service facilities, central sterilizing and supply, stores, laundry, and dietary are located on the lower floor of the protected unit in a manner consistent with normal practice. These areas provide ample space for the maximum population of the hospital and, in fact, will permit limited shelter capability for others commensurate with the requirements of the community civil defense plans.

Since the administrative areas are closely interrelated with the main entrance and lobbies which are generally

*Louis Checkman*



Model: Theodore Conrad

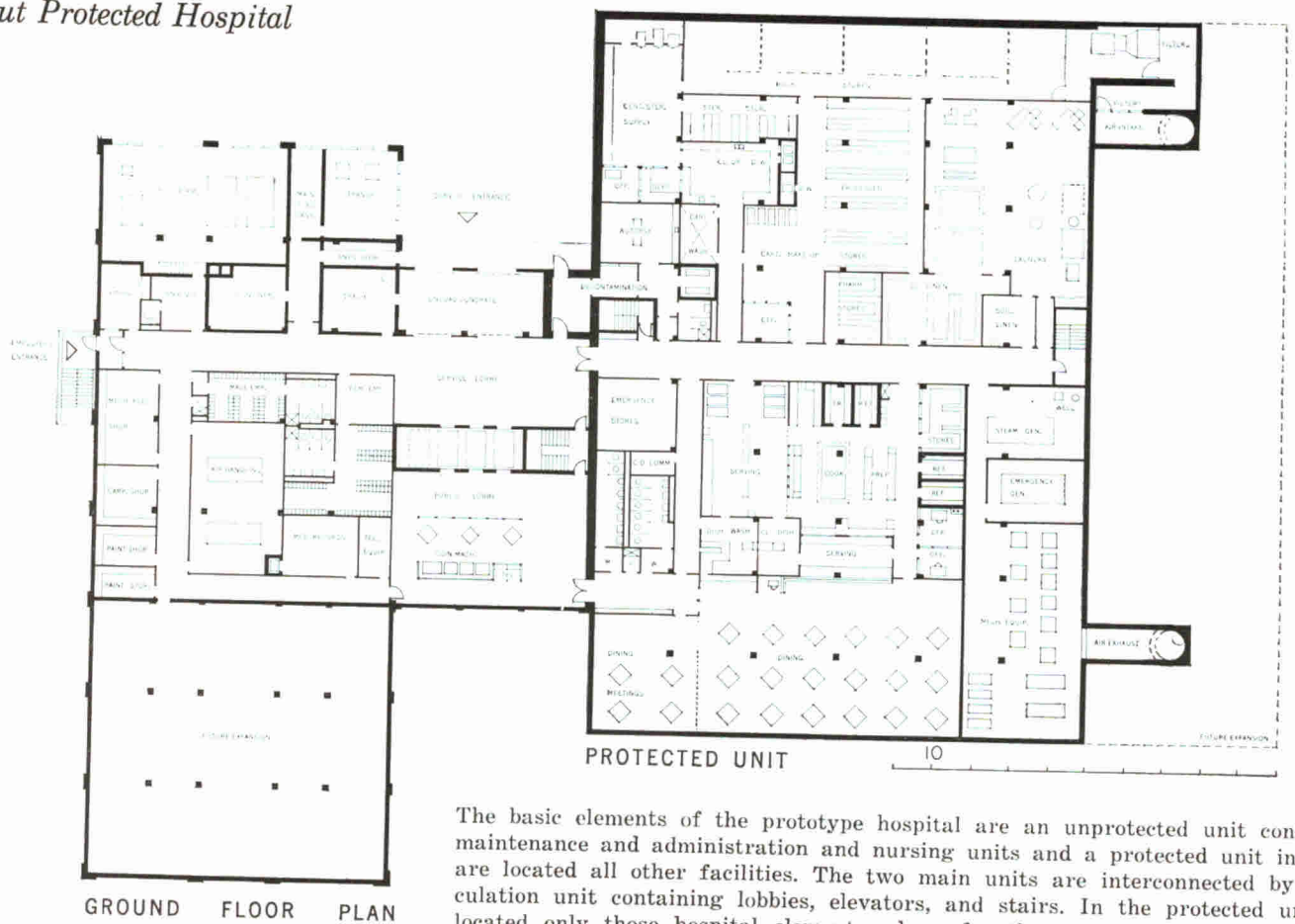

The basic elements of the prototype hospital are an unprotected unit containing maintenance and administration and nursing units and a protected unit in which are located all other facilities. The two main units are interconnected by a circulation unit containing lobbies, elevators, and stairs. In the protected unit are located only those hospital elements whose functions are not adversely affected by the absence of windows. Entries to the protected unit are kept to a minimum

arranged for easy access from the street, these areas are placed in the unprotected unit of conventional construction. The nursing units are similarly located because of present building code requirements as well as widespread public prejudice against windowless patient rooms.

For shielding purposes, access openings into the protected unit are limited to the minimum necessary for functional use. On the first floor, the outpatient department has ready access to x-ray, pharmacy, laboratory and physical therapy. The other entrance is limited to staff and inpatients and leads to surgery, obstetrics and the clinical services common to the outpatients. In like manner, the lower floor has a public entrance to the dining facilities and a separate door for service and housekeeping functions.

During the period of fallout emergency, all main doors to the protected unit will be closed and access to and egress from this structure, if necessary, will be via the autopsy and morgue. This is arranged with air locks and suitable washing facilities to permit the decontamination of individuals who may have been subjected to the fallout environment.

The site plan is designed to separate service traffic from staff, employees, and visitors. Convenient parking is provided for visitors near the main entrance and the overflow, if any, can be accommodated in the main employee and staff parking area at the side. The judicious use of landscaping and tree plantings serve to minimize street noise and dust as well as improve the view of the hospital occupants.

Flexibility to permit expansion was seriously considered in this plan. The dotted lines on the plans of the protected unit indicate logical directions for increasing the clinical and service departments, and this construction

may be protected or unprotected as deemed necessary. The surgery department could be expanded into the obstetrics area which could be placed on the second floor of the protected unit along with a future maternity and nursery department. Additional medical and surgical nursing units could be constructed over the new obstetrics unit as well as over the existing nursing units.

### SHELTER SPACE

In the event of nuclear attack, under normal weather conditions, significant amounts of fallout do not arrive outside the blast area earlier than about one-half hour after the explosion. It is reasonable, therefore, to assume that a hospital (if located outside the blast area) would have some time to prepare for the fallout emergency if promptly notified of a nuclear attack.

Upon such warning, all patients, staff, and others in the unprotected wing of the hospital would be evacuated to the protected area. The door closures, consisting of loose keyed masonry blocks, would be arranged to seal the door openings. The mechanical and electrical systems would be switched on to the predesigned civil defense emergency operating condition, and sufficient cots would be set up to accommodate the number of persons to be sheltered. Based on civil defense criteria, it is assumed that the fallout emergency situation may last as long as two weeks and sufficient food, fuel and other supplies should be stored for this time interval.

Since an attack may occur at any time, the hospital should be prepared to act without undue delay and be able to provide, at least, shelter accommodations for all individuals within the hospital at the time of the alert. The peak population of a 150 bed general hospital is estimated to be 363 and this would serve as an indica-



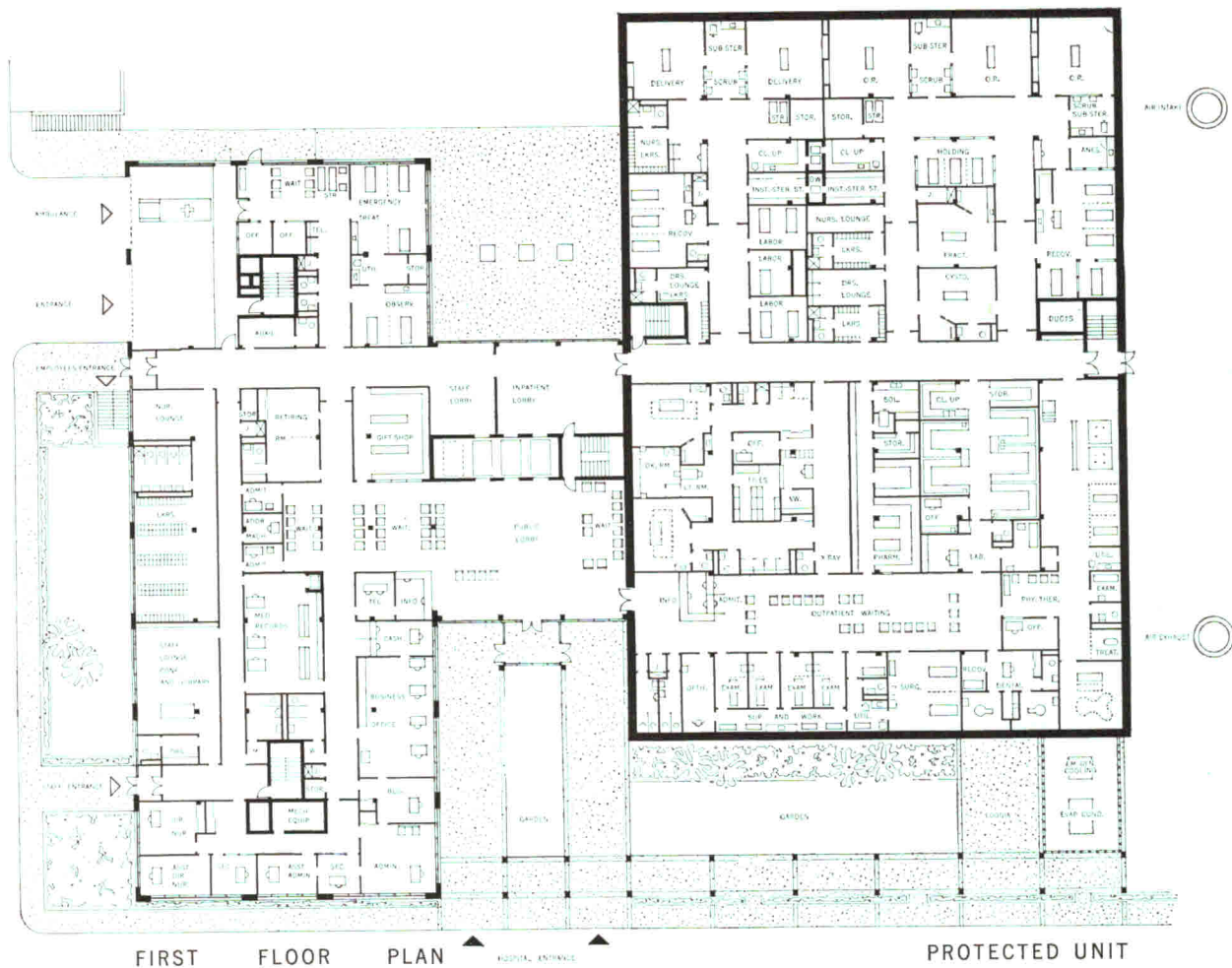

tion of the minimum arrangements that should be provided. The hospital plan selected would also influence the extent of the protected area. On this project, for example, it is possible to protect the entire clinical-diagnostic-service unit and to accommodate a total of about 750 people at little additional cost over the amount required to provide protection for the bare minimum population. This additional capacity could be an important adjunct to the community civil defense program by providing the capability for sheltering additional hospital and medical personnel and the public.

### SHIELDING

Utilizing the principles outlined in this project, any degree of protection from fallout radiation commensurate with the community civil defense plan can be incorporated in the hospital design. The specific shielding requirements for a particular hospital should be evaluated by the local authorities on the basis of its location with respect to probable target areas, direction of prevailing winds, potential for evacuation, and other civil defense oriented factors.

For this study project, a radiation protection factor of 1000 was adopted for the protected unit. This means that radiation intensity within the building is reduced to 1/1000 of the radiation level outside. This would be adequate for the heaviest fallout areas. As a result, the exposed wall construction is equivalent to a mass thickness of 315 pounds per square foot (about 20 inches of concrete). If a lesser shielding value is selected, a lesser thickness of wall and roof construction would then be required. Since the requirements other than shielding (i.e., mechanical, electrical, and architectural) will be the same for all degrees of fallout protection; it is readily apparent that

the protection capability is controlled by the amount of shielding provided. Because small increases in mass thicknesses produce large increases in shielding and are comparatively inexpensive, the ultimate cost of better protection from fallout is insignificant.

A vital factor in obtaining a reasonably uniform shielding value throughout the protected unit is to plan it with as few openings to the outside as possible. It is difficult to protect doors, windows, stair towers, elevator shafts and similarly large openings with any efficiency. A circuitous entrance pattern or maze will reduce radiation penetration (although not to the same extent as a direct closure) but does impose the problem of hindering traffic flow. Direct closures of exterior wall openings by temporary baffle walls or massive doors, on the other hand, can be made as effective as the basic wall construction without affecting traffic in any way.

Since efficient traffic patterns are a functional requirement in hospital planning, it is recommended that the direct closures of exterior wall openings be used. Temporary baffle walls are more practical from an economic point of view when a high degree of shielding is specified, and were, therefore, used in this study project. Heavy doors would be more suitable when the specified radiation reduction factor is of a low order.

The elevator and stair shafts were removed from the protected unit without sacrificing hospital function, thereby eliminating the need for any protective measures in connection with these elements.

### SLEEPING

Single cots are provided for the critically ill patients whose medical condition indicates the need for intensive nursing care. The remaining patients would be assigned

to double-deck cots near the intensive care patients.

The administrative staff of the hospital would be on call around the clock during the shelter emergency, and it is recommended that they be assigned permanent spaces in double deck cots. All other non-patients would be organized on a three-shift per day program of work-rest-sleep and three persons would be assigned to each double-deck bunk unit for sleeping purposes. This would tend to eliminate the 'hot bunk' problem without requiring excessive sleeping accommodations. Bedding (a sheet or unlined sleeping bag) would be furnished each occupant in a kit that would also contain a number of indispensable hygiene items.

### FOOD

Since the dietary department including food stores is in the protected unit, all food reserves in the hospital at the beginning of the alert would be available for use during the civil defense emergency. Under an average hospital's normal purchasing policy, this stock of food supplies, when rationed to the shelter occupants at subsistence levels, might last as long as a week. This means that pre-packed food rations, strictly for emergency use, would then have to be furnished for only another week. Cooking would be kept to a minimum, being limited to soups and beverages warmed on the electric cooking appliances.

For maximum utilization of working personnel and facilities within a normal three meals per day schedule, food can be served every six hours around the clock as indicated on the shelter operational chart. Except for bed-ridden patients, cafeteria style serving lines using single service paper plates and cups are recommended if sufficient water is not available for washing dishes.

### ELECTRIC POWER

Electric service for a protected hospital of the type described herein operates in the same manner as for an ordinary nonprotected hospital. Occasional interruption of the utility service is expected for any hospital during the normal course of time and events. An emergency electric service, usually of limited capacity, is required for all hospitals to assure continuity of critical functions within the hospital. Many public utility service facilities will not be protected against fallout radiation; hence it must be assumed that such services will not be available during such an emergency. Accordingly, emergency electric generating facilities must be installed in the protected sections of the hospital and must be of sufficient capacity and have the correct electrical characteristics for operation of the selected lighting, pumps, fans and other essential motorized equipment, and for cooking or warming food. A supply of fuel and lubricants for operation of the generating unit at full load continuously for not less than two weeks should be provided.

This hospital is divided into two principal sections, one section protected against fallout radiation, the other an unprotected section. During an ordinary interruption of the utility service, the emergency service would be connected in both the protected and the unprotected sections. During fallout conditions, the emergency service would be disconnected from the unprotected section. The emergency electric capacity thus saved could then be applied in the protected section to operate additional equipment not emergency operated during an ordinary short time interruption of the normal utility service. It is expected

that the emergency power capacity required for operation of the protected section alone, under fallout conditions, would be approximately equal to the total required for operating both protected and unprotected sections during ordinary short-time interruptions of utility service.

In both the protected and the unprotected sections of the hospital, the selected lighting circuits should be automatically connected to the emergency service when the normal service is interrupted, but motors, except fractional horsepower motors, should be arranged for manual starting in such a sequential manner as not to overload the generator. Overload protection of feeders should be so provided that an internal fault in one section of the hospital will not cause an interruption of service in any of the other sections.

It is recommended that consideration be given to providing circuitry to permit convenience of alternately operating certain equipment and also for possible future connection of additional generating capacity.

### AIR

The normal air components for physical comfort and well being with which we are primarily concerned are oxygen, carbon dioxide and water vapor. However, not to be overlooked in the overall planning are such toxic, noxious, and pathogenic constituents as: chemical, biological and radiological warfare agents, carbon monoxide, combustible gases and odorous substance.

The capacity of the air conditioning system provided for the average modern hospital will usually exceed the requirements for shelters. However, certain modifications are required to adapt the system for shelter use. Air purity, temperature and humidity must be kept at suitable levels during the emergency. The totally enclosed nature of the shelter spaces and their comparatively high occupancy during the emergency means that air conditioning including cooling will be a requirement in most areas of the United States.

Temperature and humidity must be maintained within reasonable comfort levels, particularly for the benefit of hospital patients. Effective temperature, which is an arbitrary index representing the effect of warmth or cold felt by the human body is the best available index of ambient atmospheric conditions in relation to the physiological response of man. An effective temperature not to exceed 75° is recommended for hospital shelter areas. This provides a range of temperatures and humidities somewhat above normal design practice for comfort but well within tolerable limits.

Although the broad emphasis has been placed upon fallout protection, it is strongly recommended that sufficient space should be provided and the design of the ventilation system should permit the installation of a combined chemical, biological and radiological (CBR) filter unit. The system should be designed to permit the bypassing of all outdoor air through the CBR filter unit during the emergency to provide additional protection by removing gas and bacteriological warfare elements.

In view of the space requirements of the CBR filter units, it may be desirable to hold the introduction of outdoor ventilation air to a minimum.

Oxygen and carbon dioxide must be maintained at suitable levels. This may be accomplished by the introduction of outdoor air. Oxygen replenishment from normally stored supplies is not recommended for emergency periods,

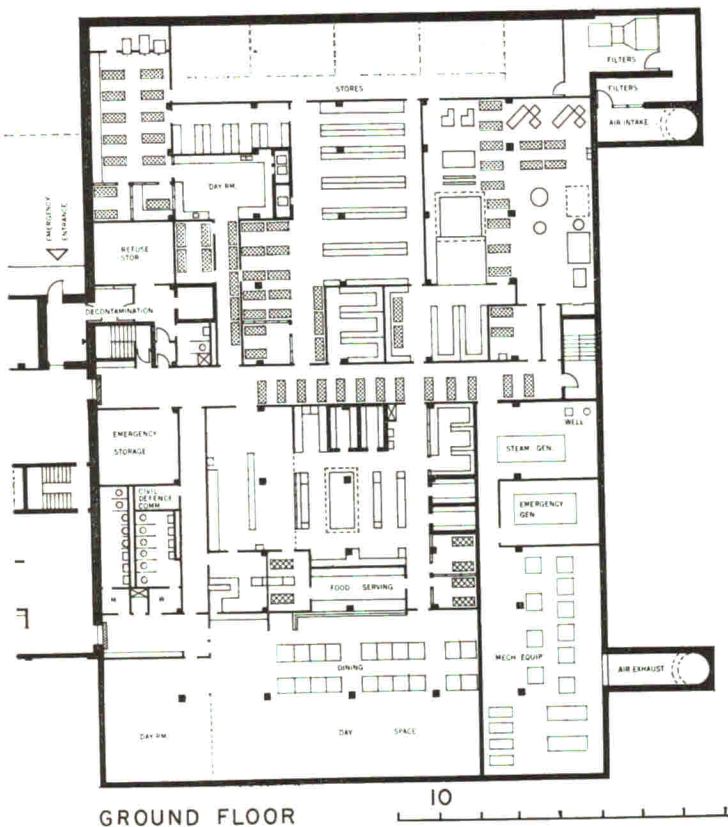

In the event of a nuclear attack, all patients and others in unprotected wing would be evacuated to the protected unit. Loosely keyed masonry would be used to seal the door openings. The plans indicate projected arrangement of cots for sleeping

although if available, should not be overlooked as a reserve resource. Absorption or closed regenerative systems are not recommended for maintenance of oxygen and carbon dioxide levels when outdoor air is available.

Minimum outdoor air ventilation rates to maintain suitable levels of oxygen and carbon dioxide are dependent upon the per capita space allotment of the shelter area. The accepted rate for mass public shelters is 3 cfm per occupant, for normally healthy persons. However, because of the physical condition of many of the occupants of the hospital shelter and because of the specific ventilation requirements of certain clinical areas, which may be active during the emergency, a minimum of 5 cfm per person of outdoor air is recommended for hospital shelters. Higher ventilation rates are desirable to provide greater flexibility in controlling the air pressurization of the shelter area which is necessary as a protection against the infiltration of contaminants. Higher ventilation rates will also contribute to odor control. Where the air supply is limited to the minimum, activated charcoal filters installed in the ventilation system are recommended for odor control.

Good hospital design assumes good filters in the normal outdoor air intake ventilation systems. Filters with a minimum of 80 per cent efficiency according to the National Bureau of Standards "Dust Spot Method" of testing offer ample protection against radiological fallout particles. An abrupt change of direction of air flow after entering the intake and prior to the filters will materially aid in deposition of large contaminated particles, thus reducing the filter load. As the deposition chamber and the filters may become highly contaminated with radiological particles, it is mandatory that a protective barrier be interposed between them and the shelter area.

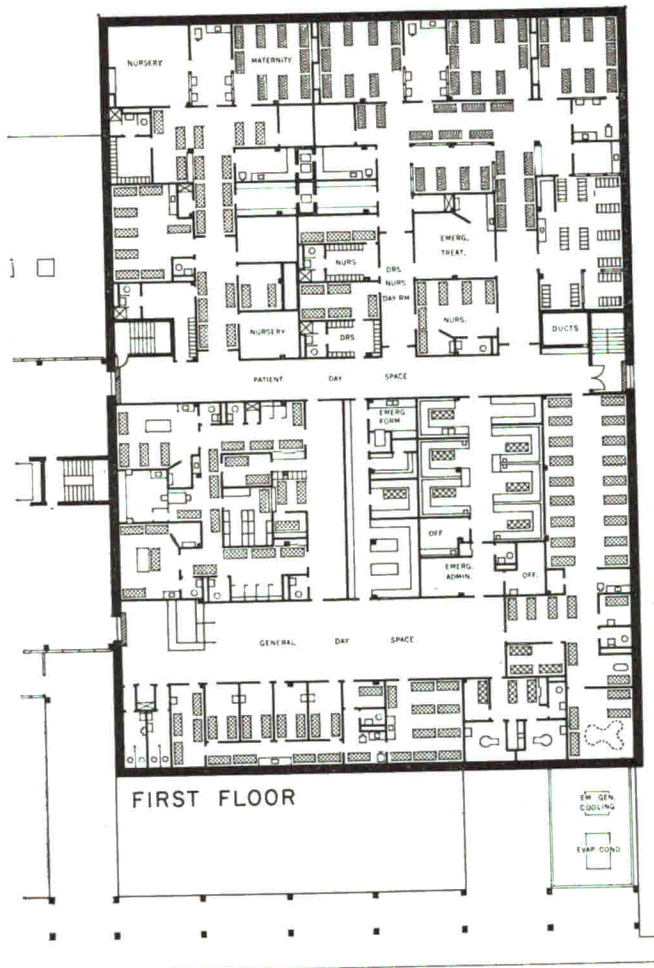

To maintain the boiler and electric generator rooms uncontaminated for the operating and maintenance personnel while supplying combustion air for this equipment, normal exhaust air from selected areas within the shelter may be bypassed through these rooms.

As no filters have been devised which will remove carbon monoxide, it is important that outdoor air inlets be remotely located from any possible source of fire such as adjacent combustible buildings.

Evaporative condensers are recommended for the discharge of heat from the shelter air conditioning system to eliminate any possibility of carrying radioactive contaminants into the shelter through the cooling system.

#### WATER SUPPLY

Because of the possibility of radiological contamination of public sources of water supply such as impounded reservoirs, rivers and water sheds, and because of the possible destruction or contamination of community distribution lines, it is essential that a reliable source of water be provided for the emergency. Ground water, which is available in a large part of the country, offers a ready solution to the problem, in that wells can be developed within the shelter area.

A well, in addition to providing safe water may eliminate the need for restricting water usage for domestic purposes. Where the water from a well source is not potable, consideration should be given to its use for sanitary purposes such as cleaning, toilet flushing, etc. In this case, storage must be provided for a minimum of 1 gallon of potable water per occupant per day. This storage must be placed in series in the regular distribution lines to insure continuous turnover of the water so that it will be fresh at the beginning of the emergency.

## HEATING

Boiler rooms are usually designed with large windows and other openings to provide light and ventilation. These openings make the boiler room a particularly hazardous and untenable area in case of radioactive fallout. Proper operation and maintenance of this vital equipment may be impossible under certain fallout conditions. (Unprotected public utility services may suffer from similar circumstances.) For this reason, an emergency source of heat must be provided. There are two methods of providing this heat which merit investigation: (1) diesel engine electric generator heat loss recovery and, (2) a small emergency boiler. Of the two heat sources, the boiler is more adaptable to hospital operation. Under usual conditions it is recommended a small high pressure boiler be installed within the protected area for use during the emergency period. Some designs may lend themselves to a normal usage of this boiler, but for economy in design and operation, under most circumstances, this boiler would serve only for the emergency period. The capacity of the boiler should be kept to a minimum to serve only those vital functions required during the emergency, such as: space heating, water heating, and operating a sterilizer.

Because of the high density population and the confined nature of the shelter area, space heating regardless of the season will be a minimal load. Heating requirements will usually be supplied through the ventilation system. The hot water load will depend upon the availability of a water supply and may therefore vary in different areas of the country. Where water supply is dependent upon hospital storage facilities, austerity will be invoked and the boiler load will probably be considerably less than where a well water supply is available. During the period of confinement, it is anticipated that sterilization needs will be taken care of by one pressure sterilizer.

Oil is recommended as the emergency period fuel because of the ease of storage of an ample supply for the emergency period and because it eliminates dependence upon an outside source of supply. Where a boiler is installed solely for use during the emergency, consideration should be given to combining the storage of boiler and the emergency electric generator fuel oils. This would provide some turnover of the stored oil and place it under more constant supervision.

## SANITATION

Provision for the disposal of rubbish and human waste must be carefully planned. A certain amount of rubbish in the form of garbage, heavy cartons, bottles and cans will pose the greatest problem. The use of garbage grinders for the disposal of food waste and the use of incinerators for the disposal of food waste and rubbish should be explored. However, garbage grinders are dependent upon an ample supply of water and incineration is not effective for bottles and cans. A rubbish storage room located within or adjacent to the decontamination area offers a solution to the problem. In this plan, the autopsy room has been selected for this purpose. This area will not be a part of the general circulation area for the population, and storage there would not be objectionable. It is anticipated that as outdoor levels of radiation intensity decrease, it will be possible to periodically remove the accumulation of waste materials to the outdoors.

## PLUMBING

The plumbing system for the hospital shelter area poses no particular design problems. Where the shelter area is a part of the normal hospital, water, sewer, gas, oxygen and other service distribution systems will serve both the shelter and the non-protected portions of the hospital. In such cases, in so far as possible, a grouping of these systems at one point of entry to the shelter area with cut-off valves within the shelter, will facilitate shutting off these services to the unused portion of the hospital, if necessary at the time of the emergency. Where a well is available, the normal water distribution system will be cross-connected with the well system.

Where well sources are available, the use of flushing type fixtures is recommended for human waste. Chemical type toilets will usually be required in situations where no well source is available and it is necessary to store potable water.

Toilet facilities for hospital shelters are recommended as follows: Water Closets—1 for each 25 patients and 1 for each 35 non-patients, Lavatories—1 for each 35 persons, Shower Baths—1 for each 60 patients and 1 for each 120 non-patients.

Because local sewage disposal facilities may not be protected against radiation and therefore may not be staffed or in operation during the emergency, it is necessary to provide a means for removal of sewage. For this purpose, it is recommended that a bypass from the normal building drain be made to a sewage sump within the shelter from which sewage may be pumped to the outside. Where chemical toilets are required, their contents may be periodically disposed of through the sewage sump.

Leaders for conducting rain water from roof surfaces should not pass through the shelter area because of the danger of creating hot spots in the conductor system in case of rain during the emergency.

## COST

A major objective of this study is to demonstrate that protective measures against fallout can be incorporated in the planning and construction of hospital buildings at reasonable cost. Although true cost figures are singularly elusive under normal circumstances, they tend to be particularly so in a study where comparative costs must be determined without benefit of definitive contract prices. However, preliminary construction cost estimates, based on mid-1960 costs in the New York City area, have been completed and indicate that the cost of constructing the prototype hospital incorporating protective measures as described herein would probably be in the range of three to five percent more than the cost of a similarly planned hospital of conventional construction that would be completely air conditioned.

The low cost can be attributed to a number of factors:

1. Little additional space is required solely for protective purposes. Only space for the storage of emergency supplies (food, cots, etc.), civil defense communications, emergency boiler, air intake and filter, and air exhaust is in excess of normal hospital requirements.
2. Little additional equipment is required solely for protective purposes because a hospital is well supplied with mechanical and electrical equipment that is readily convertible for shelter use.
3. The hospital areas involved permit a high degree of efficiency in providing maximum shelter capability.



*Julius Shulman*

# HILLSIDE POST AND BEAM HOUSE FOR \$21,650

OWNERS: *Mr. and Mrs. Robert Addison*

LOCATION: *Ventura, California*

ARCHITECT: *Carl Maston*

CONTRACTOR: *H. N. Weeks*



*Julius Shulman*

## Addison House

This extremely pleasant and economical house was faced with the restricting requirement, for a small hillside lot, of avoiding any steps between garage, and the inside or outside living areas. Other program needs included a desire for very informal living with a maximum of convenience and freedom from maintenance cares; independent and outside access for a room for two college-age sons; and an outside living area on the leeward side of the house.

All this was deftly incorporated in the plan for the relatively modest cost of \$21,650 for a house of 1950 sq ft. The structure is a simple, and regular, Douglas Fir post and beam system, which becomes a dominant design element of the house, and serves to integrate the inner courtyard and the living room balcony unusually well with the house. This is also true of the carport.

The framing system employs 3 by 12 in. beams on 6-ft centers; these support 2 by 4 joists and plaster ceilings inside, and transite roof panels over the garage. The outside posts or "vertical returns" of the beams allows for installation of slatted blinds between them for sun control on the West.

Foundation and garden walls are concrete block. Exteriors are redwood with an oil finish. Inside, most walls and ceilings are plaster, and floors cork tile on plywood. Exceptions are lacquered walnut walls in living area and vinyl tile bath floors.

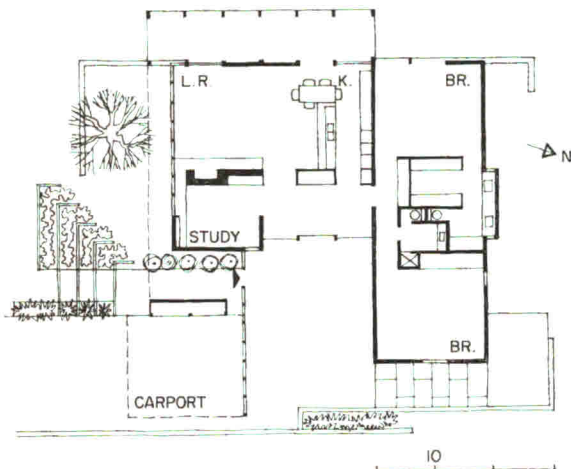
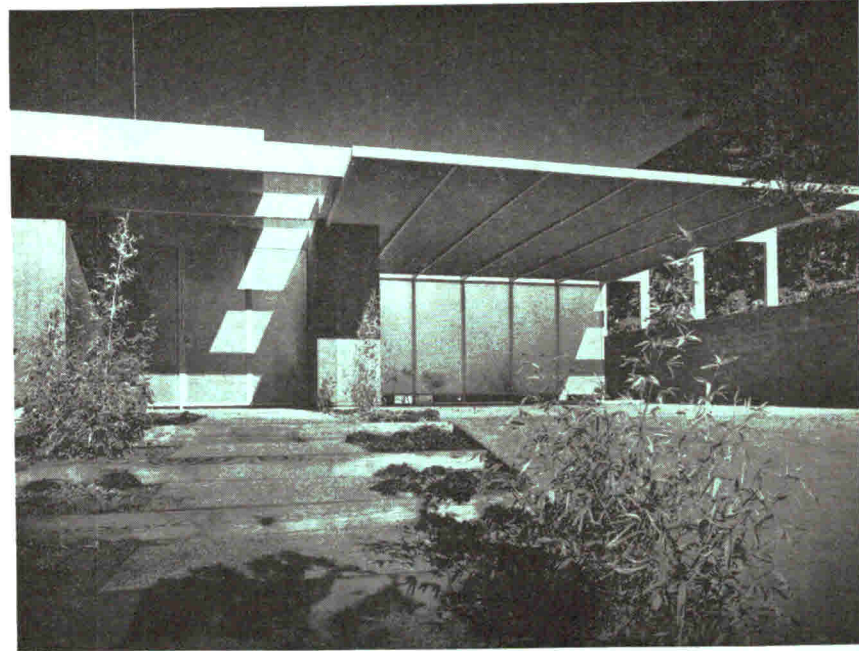



Addison House

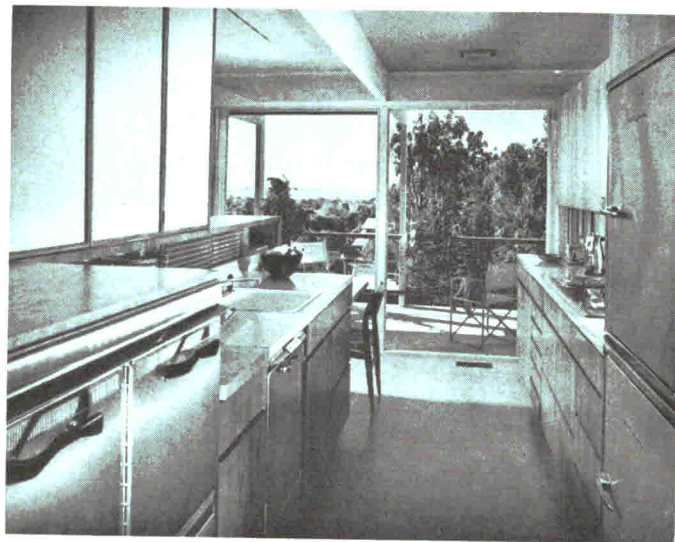

The openness of the interior living areas, and their close relationship with the inner courtyard make the house seem unusually spacious. The handling of the study (below left) and the kitchen (above and top right) also add to this effect. In the study, a sliding wall joins it with the entrance and living areas, and the same brick floor of the terrace and entry is continued here (see large photo on preceding page). The kitchen opens directly to the living area over a furniture-like counter; the area above the counter can be closed by a folding half-partition. The glass walls overlook the Pacific Ocean and the Channel Islands. The sash in living area and kitchen are sliding. Heating is by a forced warm air system.

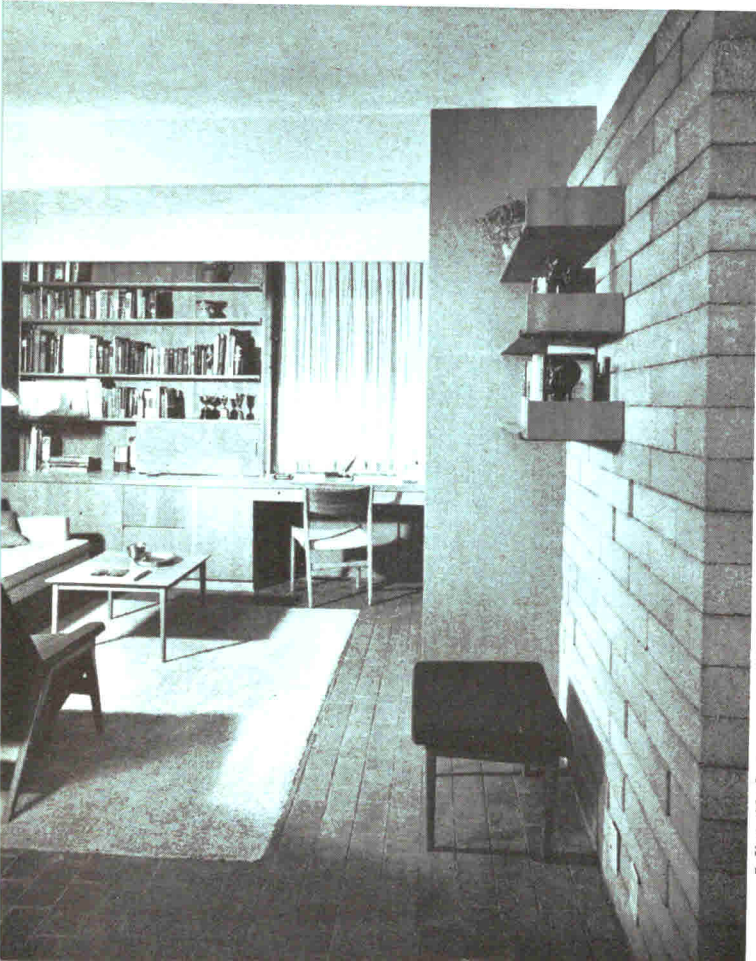



# FACILITIES FOR RETAILING

BUILDING TYPES STUDY 294

®

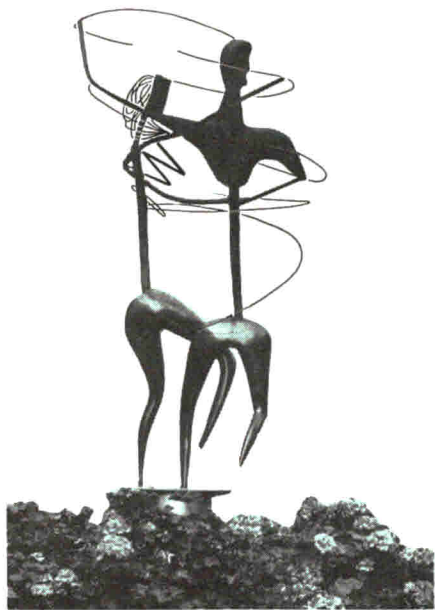

Above: Whirling Dervishes—6-ft metal sculpture by Nathaniel Kaz. At right: mall next to the Federal department store; glazed brick mural by Richard Jennings



## FESTIVE ATMOSPHERE HELPS SALES

*In discussing Wonderland—  
one of the seven retailing facilities  
presented in this study—  
architect Redstone explains how  
mall design and related arts  
create a sprightly and  
colorful shopping environment*

WONDERLAND REGIONAL SHOPPING CENTER  
LIVONIA, MICHIGAN

by Louis G. Redstone, A.I.A.

A basic design goal for this center was to bring about a festive and colorful environment; to create a marketplace that would make shopping a gayer, more interesting experience set in sprightly, good-natured, attractive surroundings. Merchandising experts tell us that dollars come out of womens' purses more readily in such an atmosphere; and return visits will of course be more frequent when the center has the power to amuse or attract both children and grownups. In carrying out this concept, two factors played a large role: the proportions, scale, and character of the malls and sheltered crosswalks; and the extensive use of the related arts, i.e., mural decoration, sculpture, planting, fountains, graphics, etc. The fact that many people visit the center for browsing as well as shopping—even on Sundays, when stores are closed—proves the validity of the idea. Wonderland may well emerge as the center for a wide variety of social and recreational activities in the area, and may soon become an important hub of the city. A recreational center and professional offices for the center are now in preliminary design.

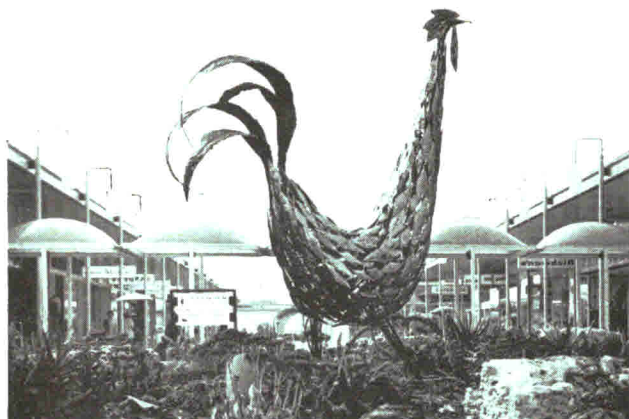

The Rooster—6-ft metal sculpture by Donald Buby

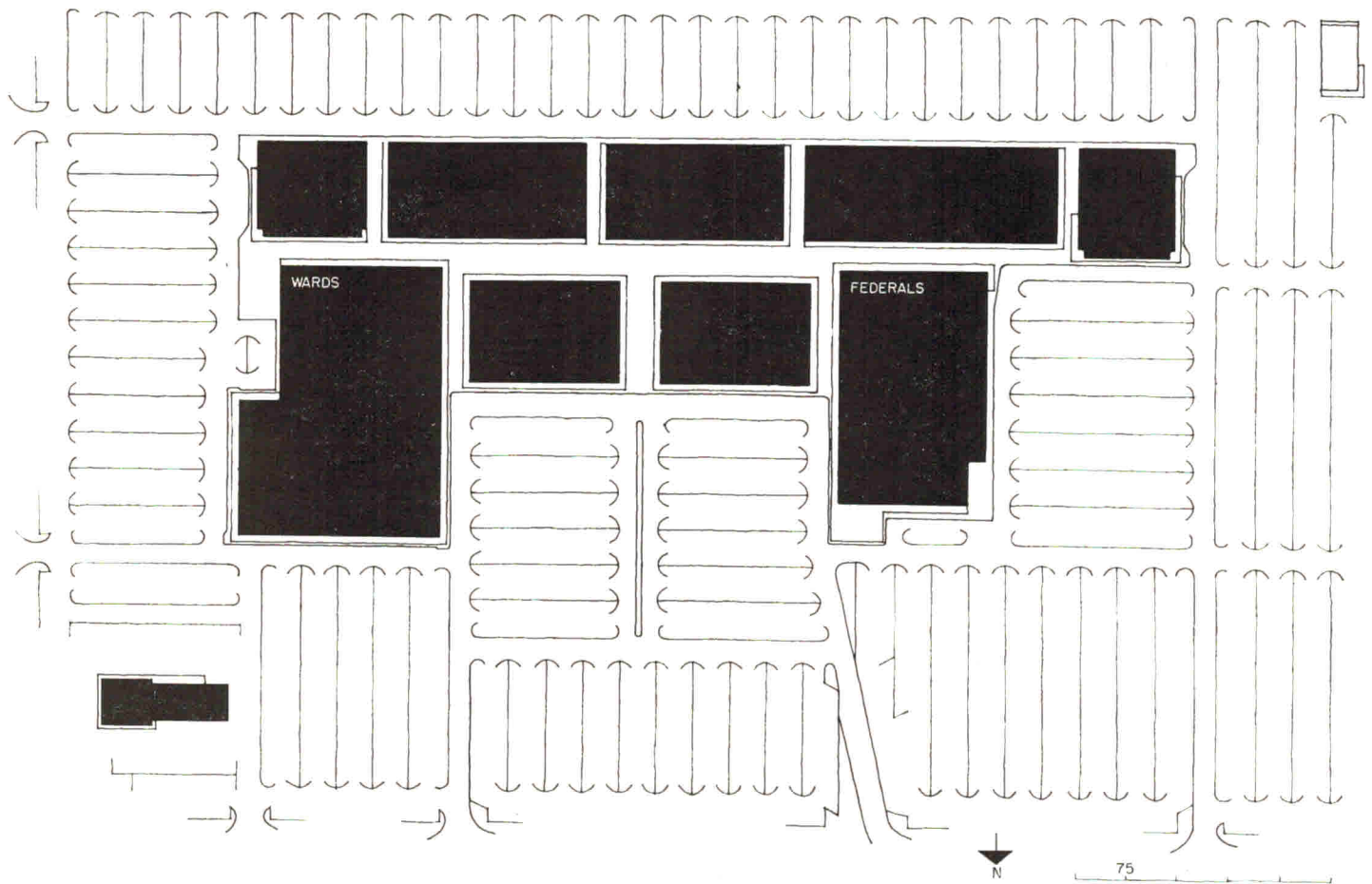
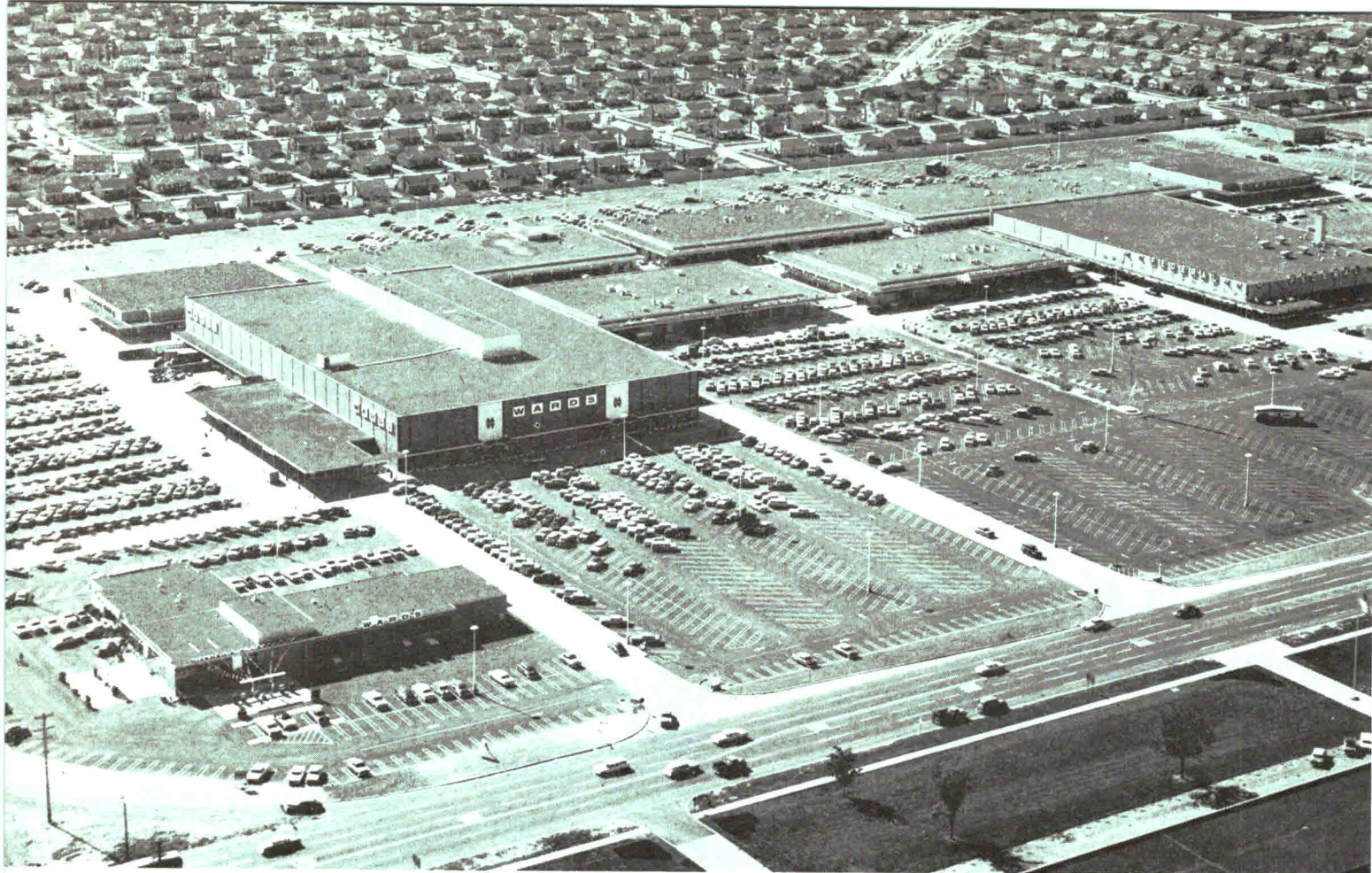

ARCHITECTS: *Louis G. Redstone; Avner Naggar, Associate Architect; The late Allan G. Agree, Associate Architect*  
 Participating Staff: *Bernard W. Colton, Coordinator; Samuel Hack, Mechanical; Albert E. Lawrence, Structural*  
 LANDSCAPE ARCHITECTS: *Eichstedt-Johnson Associates*  
 CONTRACTORS: *Walter L. Couse & Co., General Work; Perron Construction Co., Montgomery Ward store*

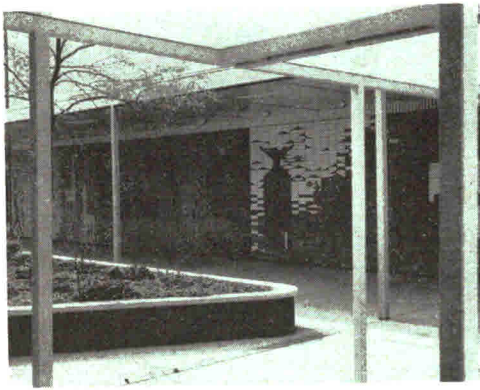

Mall near Federal department store

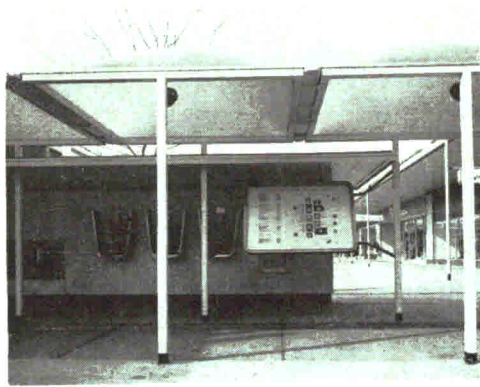

The Orientation Center

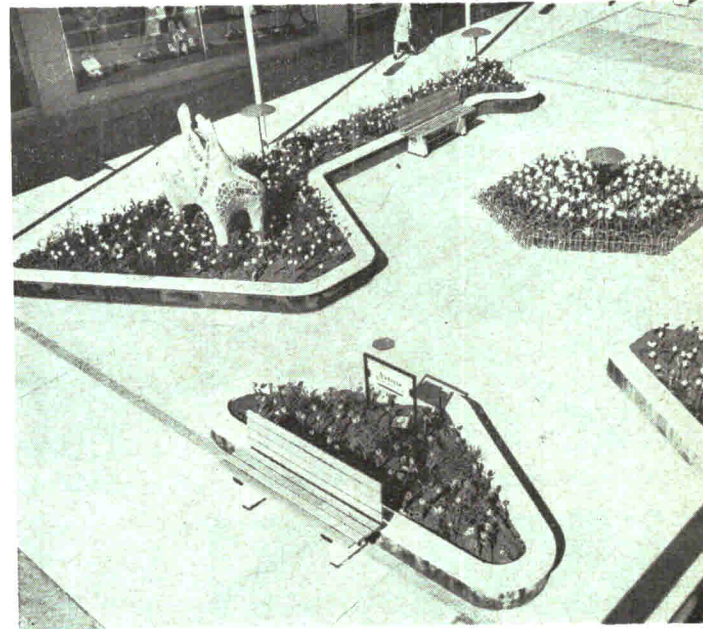

Shaped landscaped areas in main mall

### The Plan

The plan is based on the idea of a magnet, or anchor, at each end of the complex. The two principal tenants, Montgomery Ward and the Federal Department Store, occupy the anchor positions. Added interest and strength is given to the Federal portion of the plan by the introduction of an arcade building, which provides space for various service and specialty stores such as barber, beauty shop, shoe repair, flower shop, etc. This building also houses the auditorium and the center's offices.

In order to attract the shopper to other tenants, a "T" shaped main mall was introduced leading the shopper past these stores, before proceeding to either of the major department stores. This "T" mall is visually extended into the main parking area through a covered landscaped walk. Added directional incentive was gained by reversing the parking pattern perpendicular to the walk. This walk originates at the "Spike", a 75 ft steel landmark dominating the main approach.

### Shopping Environment: The Malls

In the search for proper scale and a comfortable shopping environment in the malls, the open spaces between buildings were very carefully studied. The width of 64 ft for the main "T" mall gives the shop-

per the proper feeling of intimacy, not so large that he loses identity, yet wide enough for effective commercial displays. The narrower 30 and 40 ft malls opposed to the interplay of solid walls versus canopied fronts creates effective visual contrasts. The proportions of the malls were studied in relation to building heights; spatial divisions were defined by cross-overs, orientation shelters and landscaped area. The result is a changing series of visual experiences, in size, in shape, in color, in material, in texture, etc., adding up to an exciting shopping atmosphere.

The cross-overs, built of steel and plexiglass domes, accent with different colors the various mall locations, helping the shopper to orient himself. The colorful glow of the domes at night harmonizes with the soft lighting from the column lanterns. During the day the rhythmic pattern of the white lanterns is reflected against the curved polished shapes of the domes.

The interest of the shopper is also subtly carried to the pattern of the mall walks. The paving patterns are done in black and light grey concrete with linear accents of black terrazzo-like asphalt paving blocks.

Colorful landscaped areas and fountains soften all malls and complement the organized paving pat-



Main mall looking west toward Federal store. Fountain by Richard Jennings



Concrete and ceramic Laughing Horse, by Rosemary Zwick



Main entrance mall next to parking

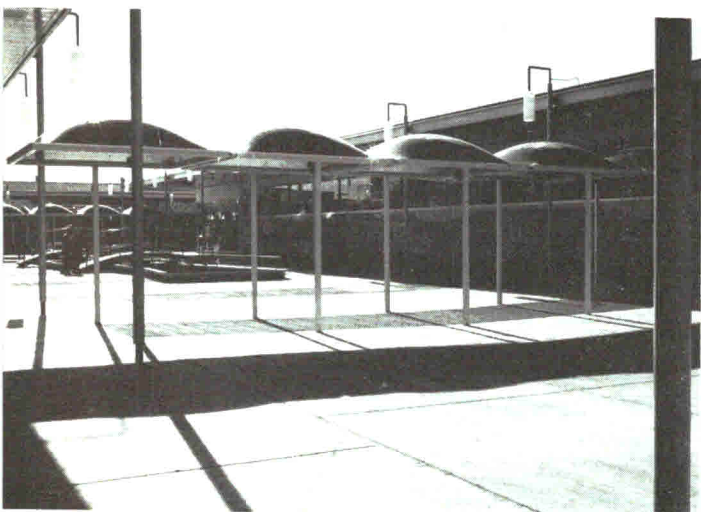

42 ft mall at Montgomery Ward store



Whirling Dervishes by Nathan Kaz in mall location

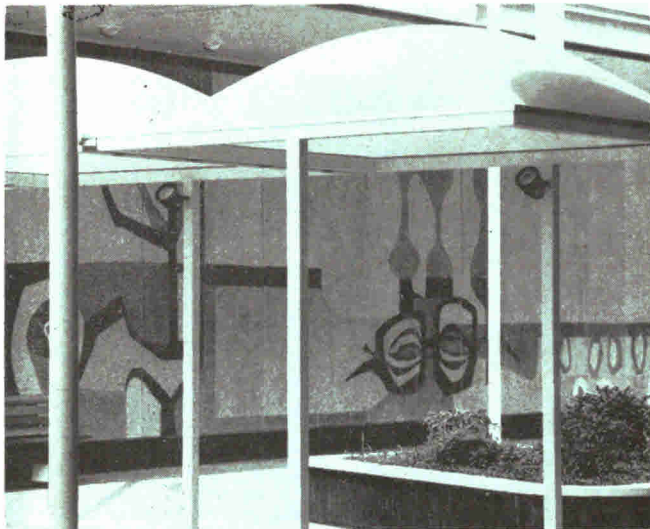

Precast concrete mural, Marjorie Kreilick, sculptress

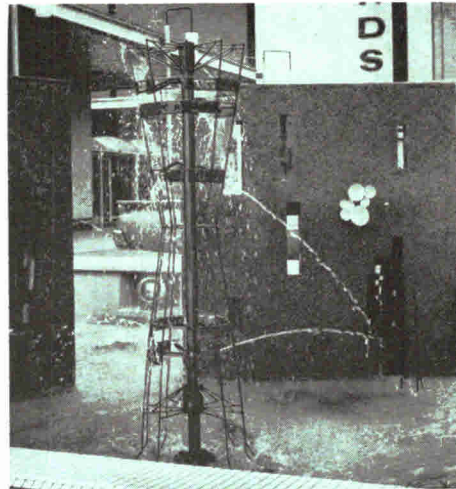

Fountain by Richard Jennings



Family of Bugs,  
by Betty Conn

tern; their impact is heightened by the variation in size, shape and height.

#### Shopping Environment: Art

An important factor contributing to the festive and interesting environment is the introduction of extensive art work. Two large murals were executed in vivid colors of standard size glazed bricks: one 80 ft long by 10 ft high, designed by Richard Jennings, depicting animal and plant forms derived from temperate and tropic zones. The intricate pattern includes elephants, snakes, giraffes, an octopus, etc. The other brick mural, by Gerry Kavanaugh, depicts a colorful landscape of flowers and foliage. The bricklayers followed the pattern to the minutest detail, proving that brick has many uses. This skilled brickwork also brings together the artisan, artist and architect and belies the opinion that there are no dedicated craftsmen in this country. Another abstract mural 120 ft long, designed by Marjorie Kreilick, was executed in precast concrete panels and chipped aggregates; each panel 3 ft by 12 ft was prefabricated in the shop from full size patterns by the artist.

In the walks through the malls there are many other pleasurable and amusing experiences for the shopper: the "Whirling Dervishes", designed by

Nathan Kaz, a pair of 6 ft figures rotating slowly on their base; three fountains, each having its own unique character, designed by Samuel Cashwan, Richard Jennings and Betty Conn; two whimsical figures—"The Laughing Horse" and the "Cat"—by Rosemary Zwick, made of concrete with inlaid ceramics; and a 6 ft "Rooster" by Donald Buby, with colorful enameled metal feathers and tail.

Color and visual interest is also carried into the parking area through the use of graphics. Parking areas are identified by signs mounted on lighting poles. These signs graphically illustrate various animals, flowers and other geometric figures, their colors and shapes making it easy for the shopper to locate his parked car.

#### Service

Of vital importance to the Center is ease and convenience of merchandise delivery, especially for the smaller stores with limited sales staff. Three main types of servicing were considered: the full underground service, the courtyard service, and direct surface service.

The underground service system was discarded because of its prohibitive construction and maintenance costs and its doubtful maximum utilization

PHOTOS on pages 165-170 are by David R. Kicz, John Gaffield Studio, Baltazar Korab, Aurora Photographic and Richard Jennings

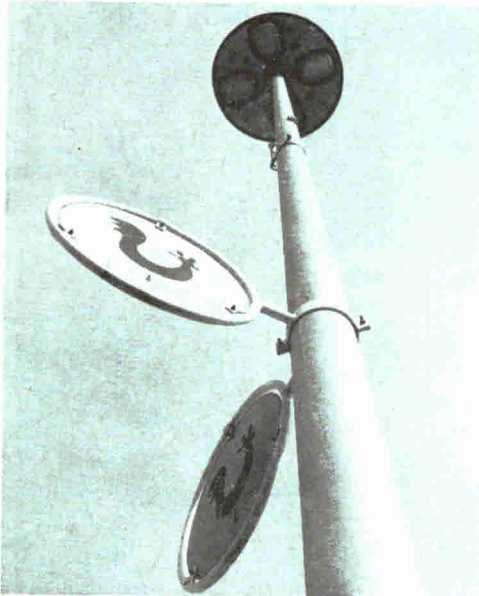

Enameled steel parking signs

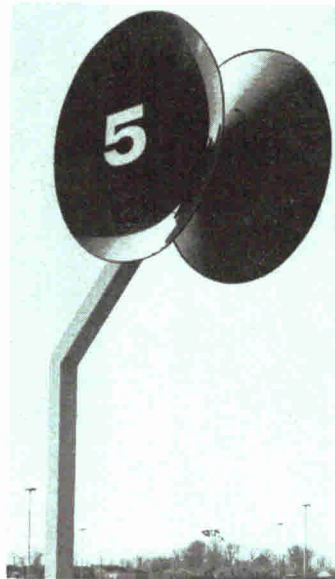

Entrance drive identification



The Cat, by Rosemary Zwick

by the tenants. The enclosed service court arrangement, with each court serving a group of stores, was quite adaptable, but occupied excessive valuable space and eliminated store frontage.

The introduction of a limited tunnel originating at a central service point, leading to the front and branching out underground to serve the two North buildings, proved very successful. This tunnel is served by an elevator and an inclined conveyor belt. Electric cars within the tunnel carry merchandise to individual tenants.

#### Structural

Based on economical spans, an orderly gridiron structural steel system was established for the entire Center, with the exception of the Montgomery Ward Store. This was designed in an effort to anticipate the needs of future tenants. To allow for freedom in store front design in unassigned areas, columns were eliminated from all store fronts by setting the columns back 10 ft from the building line. The structural system itself is based on the cantilever beam principle, which lightens the steel sections considerably.

An entirely different solution was used for the structural system of the Montgomery Ward Store. Here the first floor construction was of reinforced

concrete, caisson foundation, and concrete waffle ceiling; while the second floor was designed for structural steel framing.

#### Dual Ownership

The dual ownership of the Center provided a challenge which appeared in the very preliminary stages of development. While the major department store—Montgomery Ward & Co.—owned its land and building, the balance of the Center was built by a developer for leasing to individual merchants. This factor required initiative and firm control on the part of the architects in the establishment of project requirements which would be binding for all tenants.

The ultimate goal was to create continuity of architectural design and a unified character for the entire complex. However, the tenants' individual identity was retained and expressed within the overall pattern. Heights of buildings and canopies, use of materials, location of services, size and placement of signs and an overall color scheme, all contributed to the unification of the Center.

Serving more than a dozen communities, Wonderland occupies 60 acres, with an additional 20 acres set aside for expansion. The center is located midway between Detroit and Ann Arbor, Michigan.

## SMALL CENTER KNOWINGLY UNDERSTATED

*Ladera Shopping Center  
near Palo Alto, Cal.*

**ARCHITECT:**

*John Carl Warnecke*

**LANDSCAPE ARCHITECT:**

*Lawrence Halprin*

**STRUCTURAL ENGINEERS:**

*Wildman & Morris*

**MECHANICAL & ELECTRICAL ENGINEERS:**

*G. L. Gendler & Associates*

The Ladera shopping center skillfully echoes the character of its environment; a high-class residential section which will undoubtedly strive to maintain its pleasantly rural quality as it develops. The center's wide-spreading, wood shingled roofs, its informal grouping of three low buildings, and its almost rustic character—expressed by exposed wood construction with either glass or redwood board-and-batten infilling—all contribute to the effect. The deep shade of the low-hung, sheltering arcades adds an inviting coolness for hot days, as does the fountain (photo next page). All signs were under the control of the architect—except for those stickers supermarket operators insist upon plastering on most of the glass available, and at an angle!

The plan is based on the idea that the shopper is a pedestrian. The three buildings that form the center are grouped in L shape and linked together by covered walks; are oriented to face upon an open, landscaped courtyard that can be reached directly from the parking area.

*All photos by Roger Sturtevant*



# Ladera Shopping Center

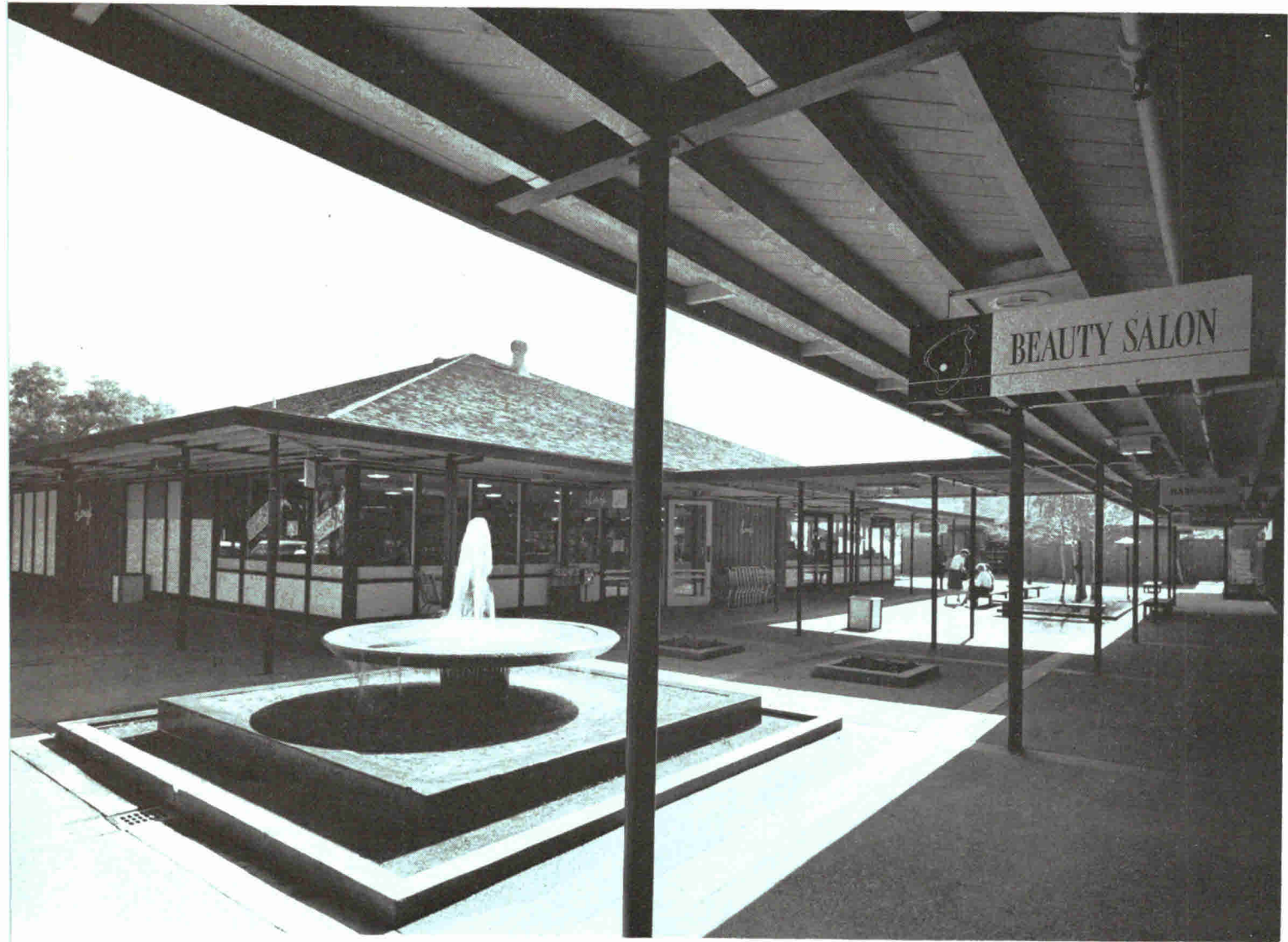

Fountain in courtyard between market and building of shops provides a welcome cooling note

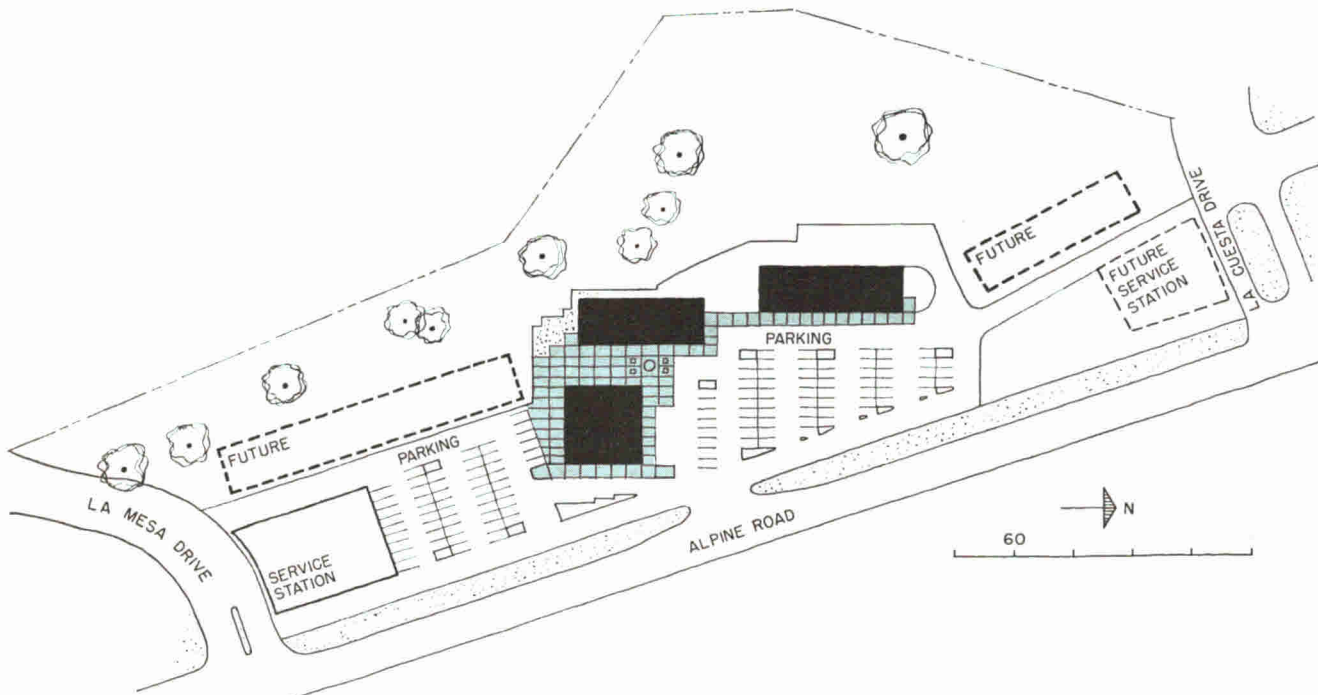

Site plan shows arrangement of the three buildings and parking area on the five-acre plot



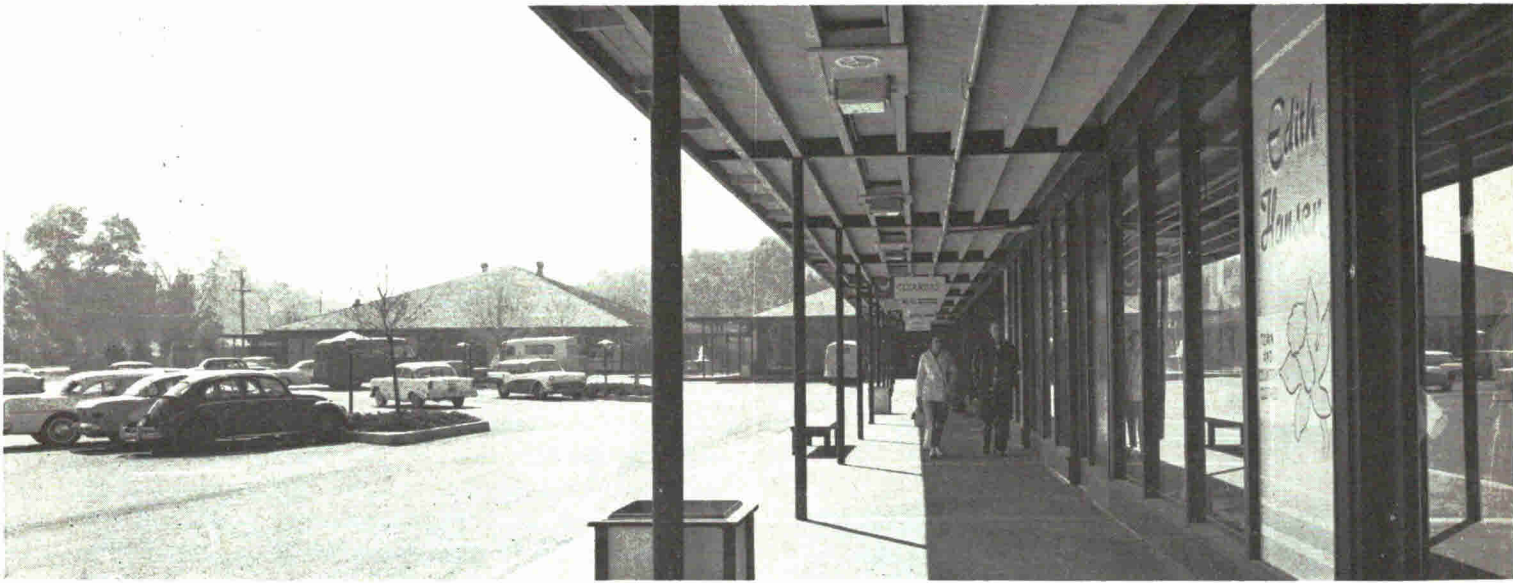

View showing the three buildings and their relationship to parking



Looking along the court towards the parking area

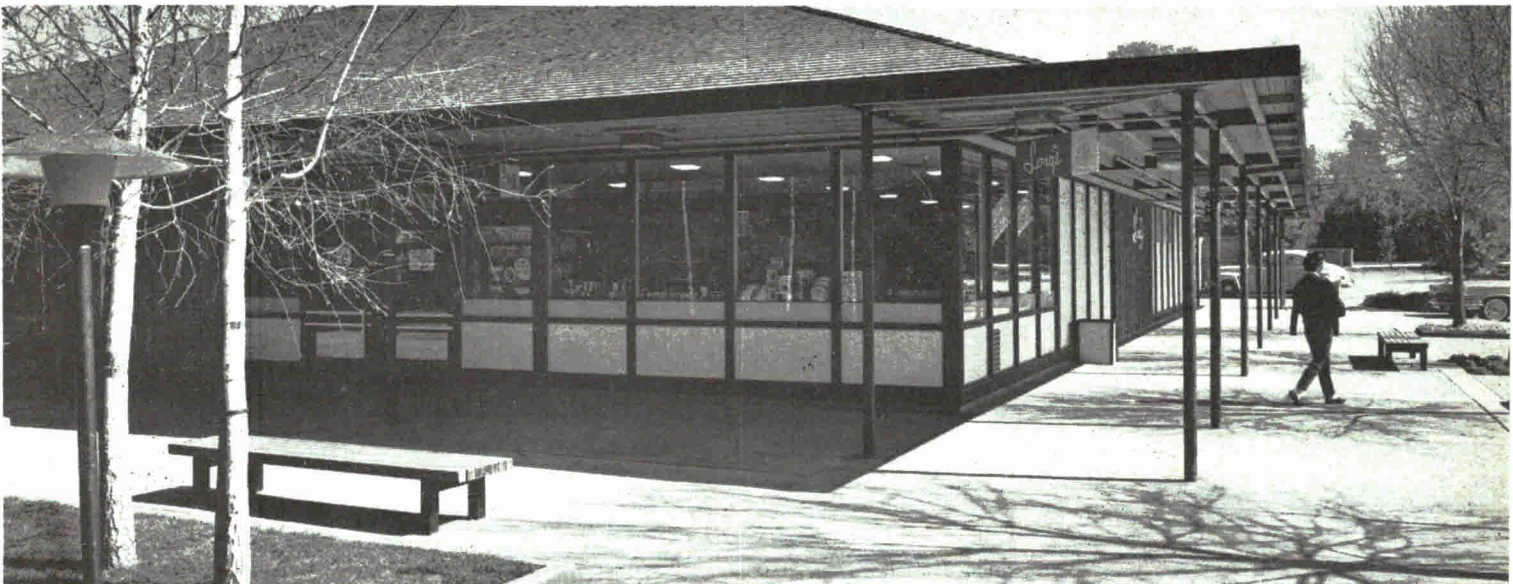

Photo showing supermarket in the foreground; parking at the right

# SWEDISH STORE WITH NOTABLE INTERIORS

*Nordiska Kompaniet Store  
Farsta Center, Stockholm, Sweden*

ARCHITECTS: *Backstrom & Reinius*

INTERIOR ARCHITECT: *Hans Harald Molander*

CONSULTING ARCHITECTS: *Ketchum & Sharp*



*All photos by Alexandre Georges*

This air-conditioned department store—which serves a market of 235,000 in suburban Stockholm—was designed by a team of Swedish and American architects working in close collaboration. The result is that American store planning methods and merchandising concepts have shaped the building and determined its interiors, while Swedish design has given the whole its visual character. Unlike most Swedish stores, which combine natural and artificial light, Nordiska Kompaniet has blank upper walls and artificial light only, in accordance with American practice. Interiors are typically Swedish in character, with color sparingly used, and with white and natural wood serving as predominant tones.

At left, the façade on the center's main pedestrian mall. The upper walls and pierced balustrade are of textured gray Swedish granite; the store front glazing members are bronze; the exposed columns at ground level are clad in polished gray granite.



Ground floor sales area. White marble floor; natural walnut and white plastic sales fixtures



China and glassware department



China department



Lamp department

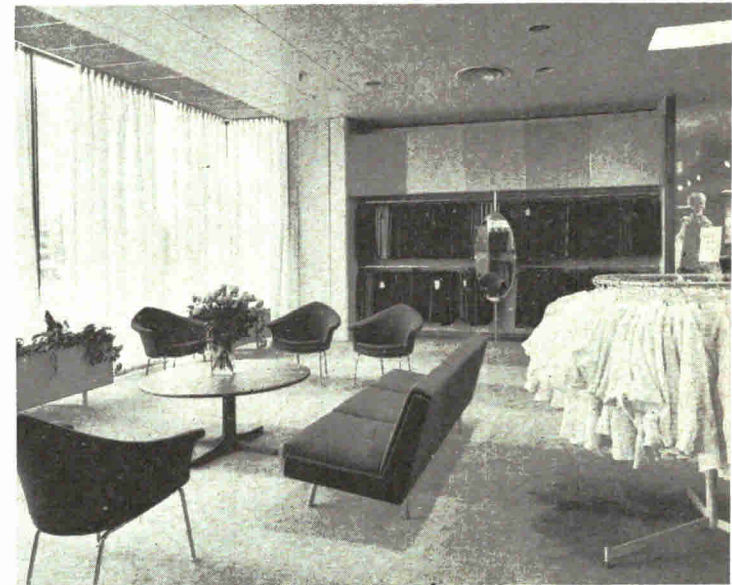

Women's sportswear section



Women's shoe department



Tearoom on the upper floor

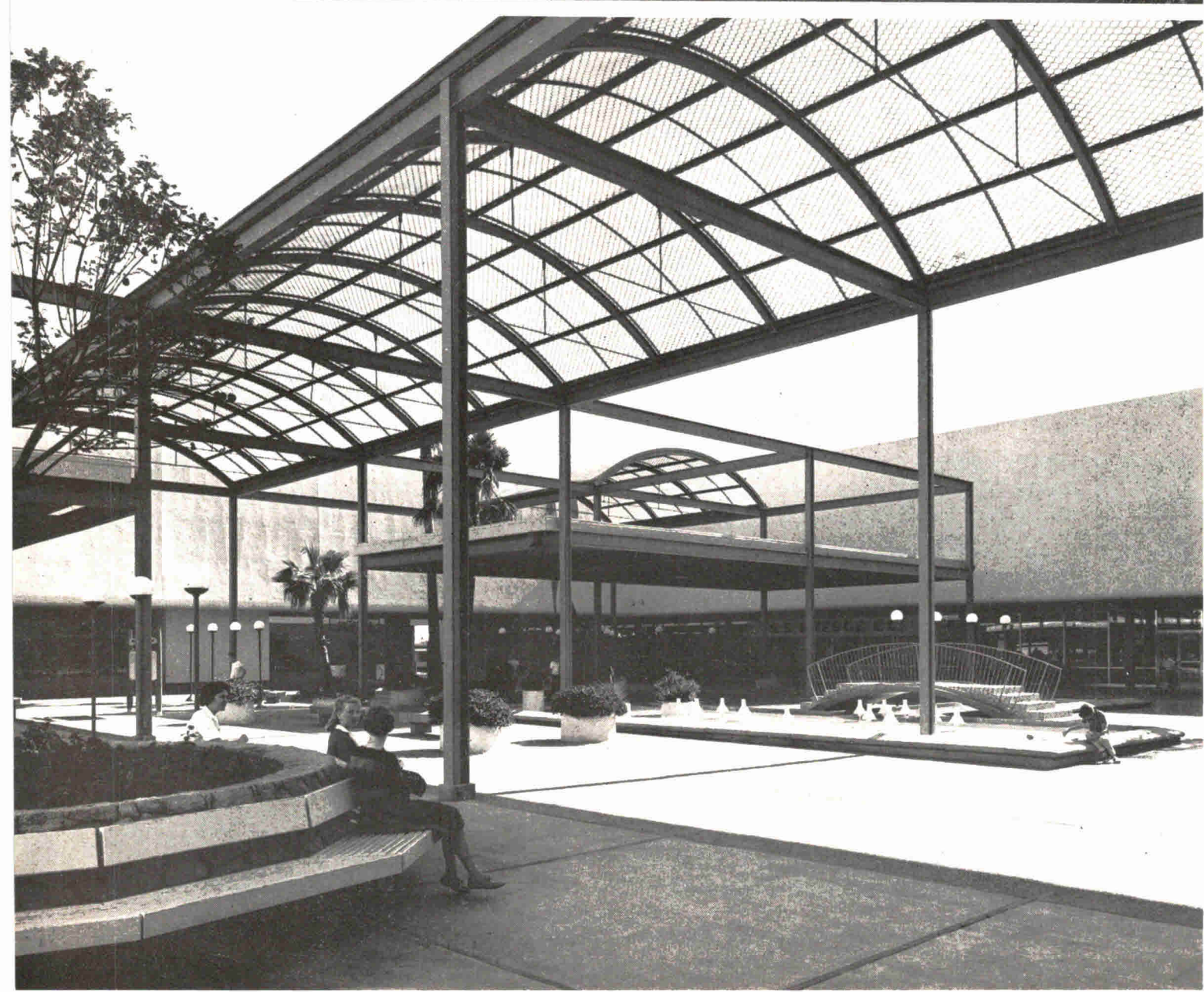

## CENTER WITHIN A TOTAL SUBURBAN PLAN

*Maryvale Shopping City*  
Phoenix, Arizona

ARCHITECTS:  
*Victor Gruen Associates*

GENERAL CONTRACTOR:  
*John F. Long Home Builder, Inc.*

This handsome shopping center—crisp in form, colorful, and full of visual interest—is actually part of a 6,000-acre total suburban plan (also by Gruen) for the development of a self-contained community of 60,000, located 12 miles northwest of the Phoenix central business district. A notable effort directed against uncontrolled suburban sprawl, the community will eventually include a hospital and medical center, a park, a golf course and club, schools, an industrial park for research and light industry, and housing.

The shopping center consists of five buildings clustered about an interestingly handled garden courtyard, shown in the photo at lower left. The courtyard canopies provide relief from the intense desert sun; some have flat, solid roofs—others are barrel vaulted with special patterned paper embedded in translucent plastic. An arched bridge with tile steps and walk spans a central, T-shaped, dark blue pool which contains groupings of lighting fixtures. The court is variously paved with tile, exposed aggregate concrete with redwood strips, and brick.

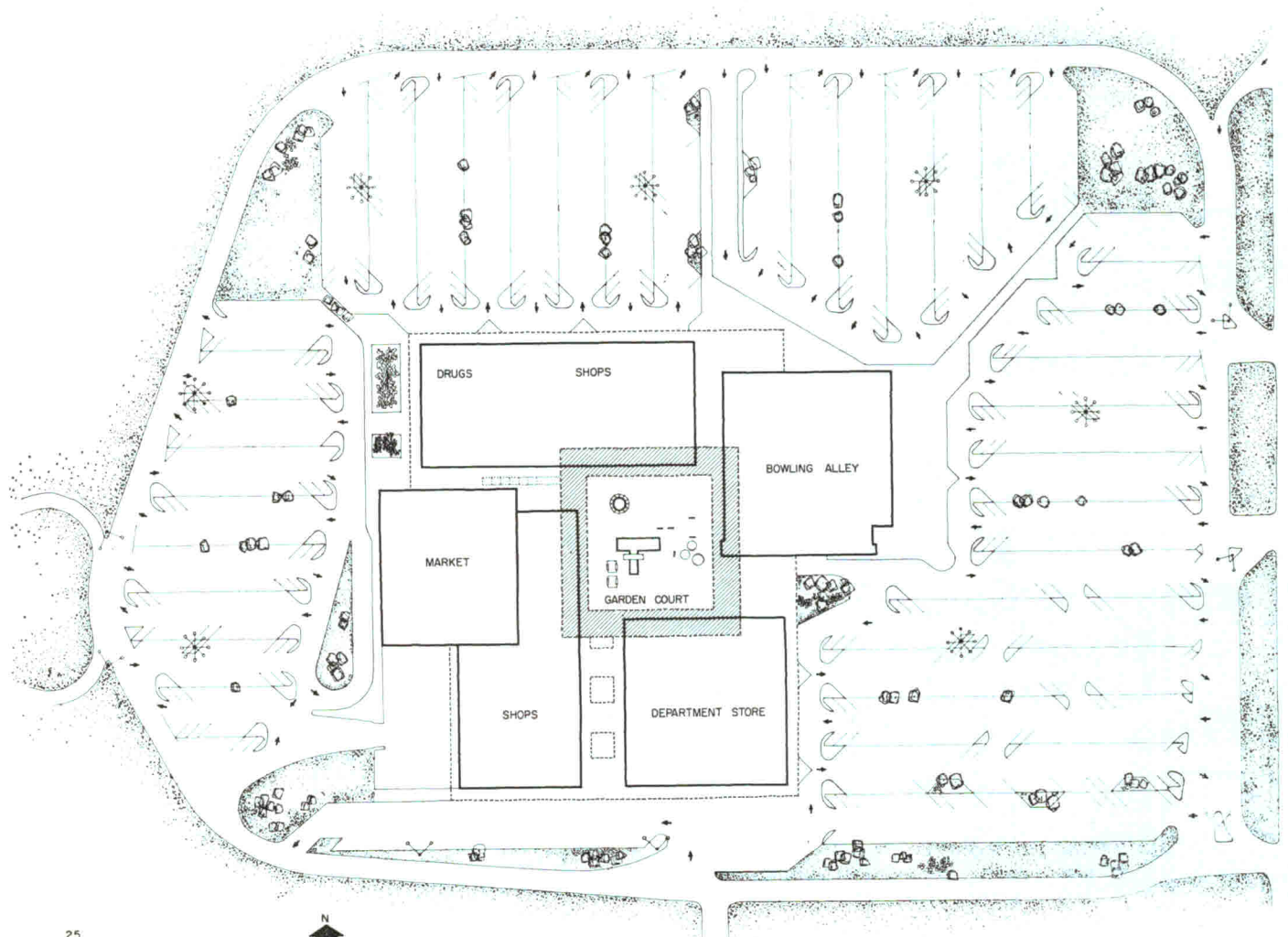

## Maryvale Shopping City



Canvas banners with Maryvale symbol mark arcade entrance. Black and white awnings shade a row of shops



Montgomery Ward store has concrete block walls, plaster fascia, metal canopy. Exterior lights make pattern on wall



Bowling alley has block walls painted deep rust color, white plaster canopy with yellow tile panels between beams

All photos (including page 176) by Marvin Rand

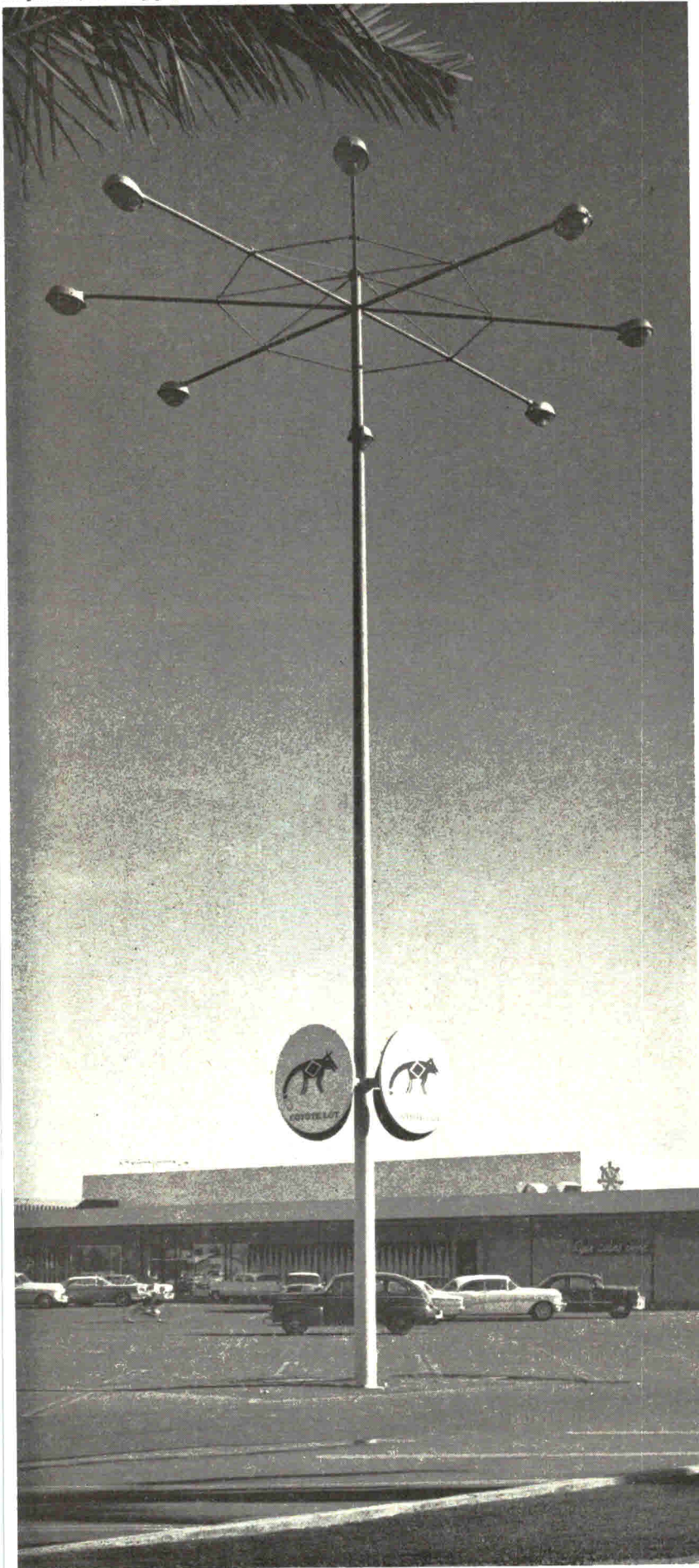

Circular signs with desert animal motif identify parking lots

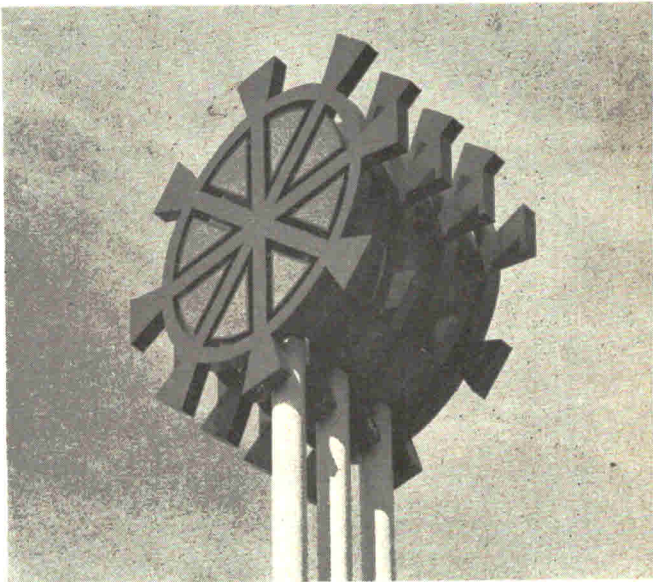

Center symbol, derived from Indian symbolism

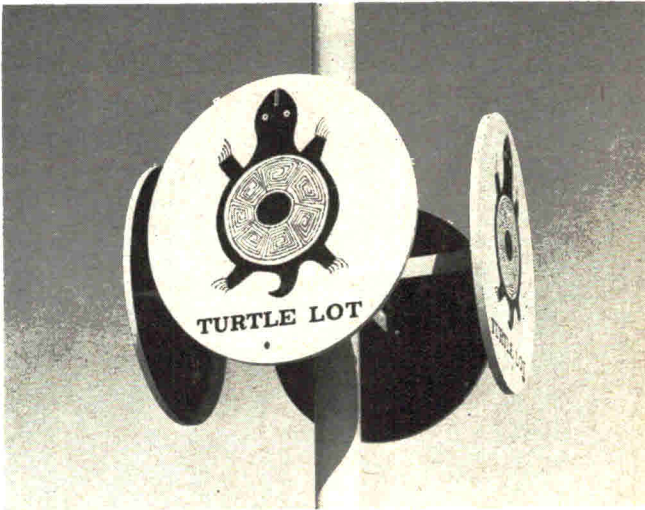

Parking lot identification markers

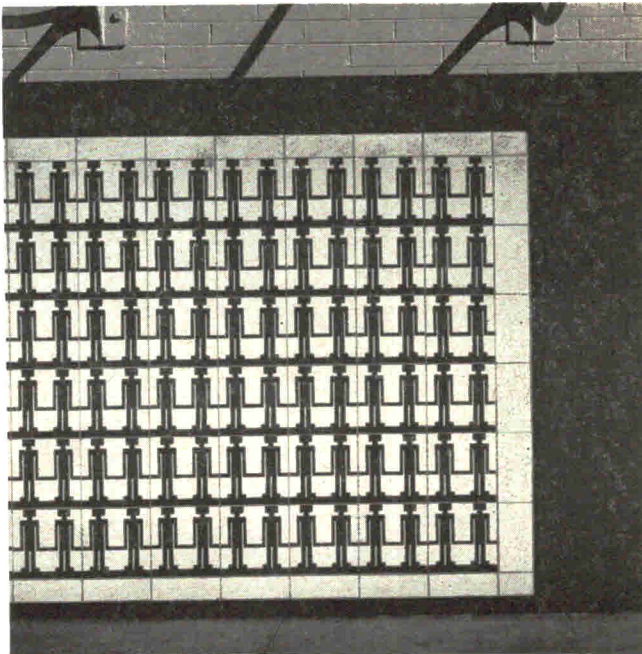

Decorative tile pattern at market entrance

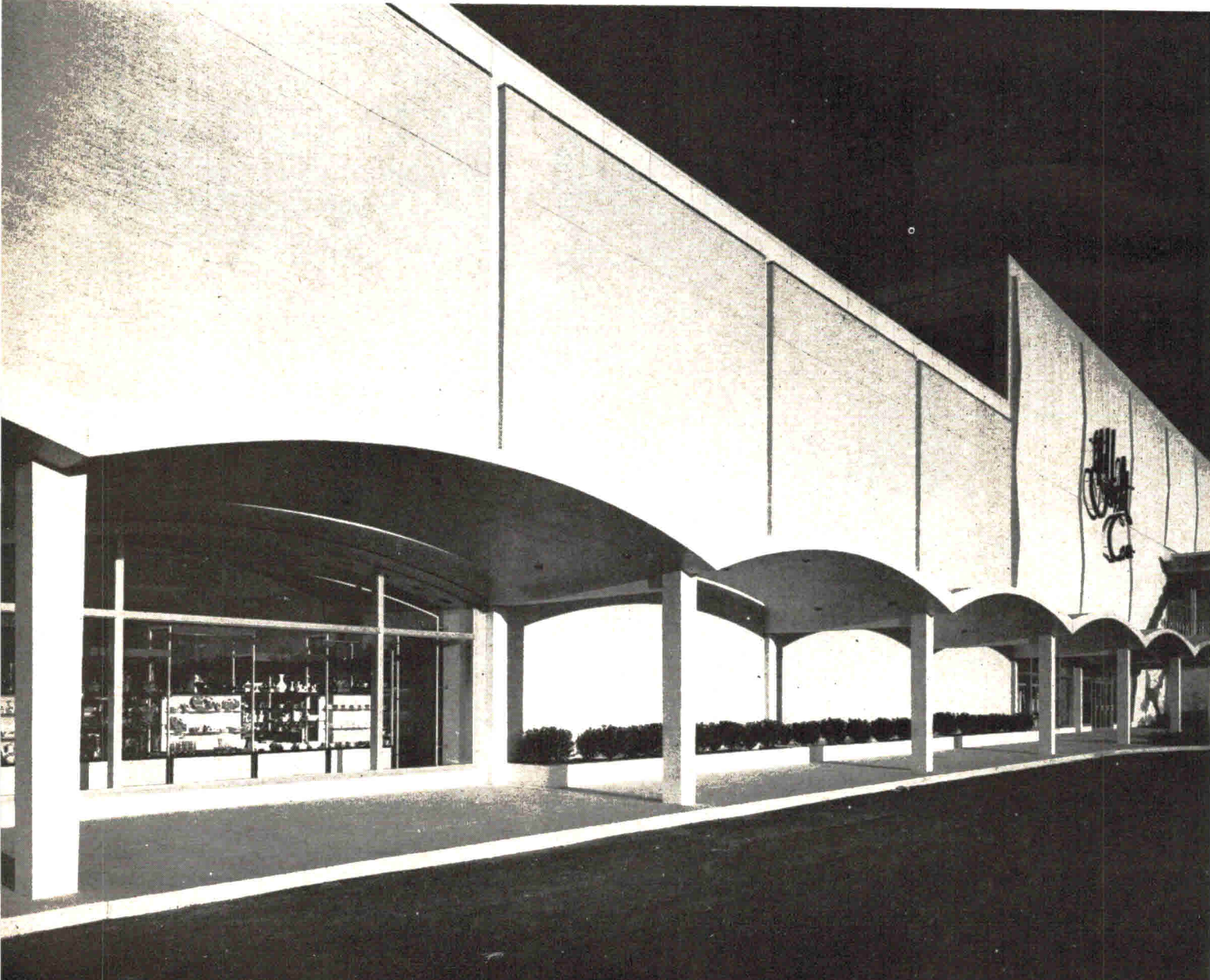
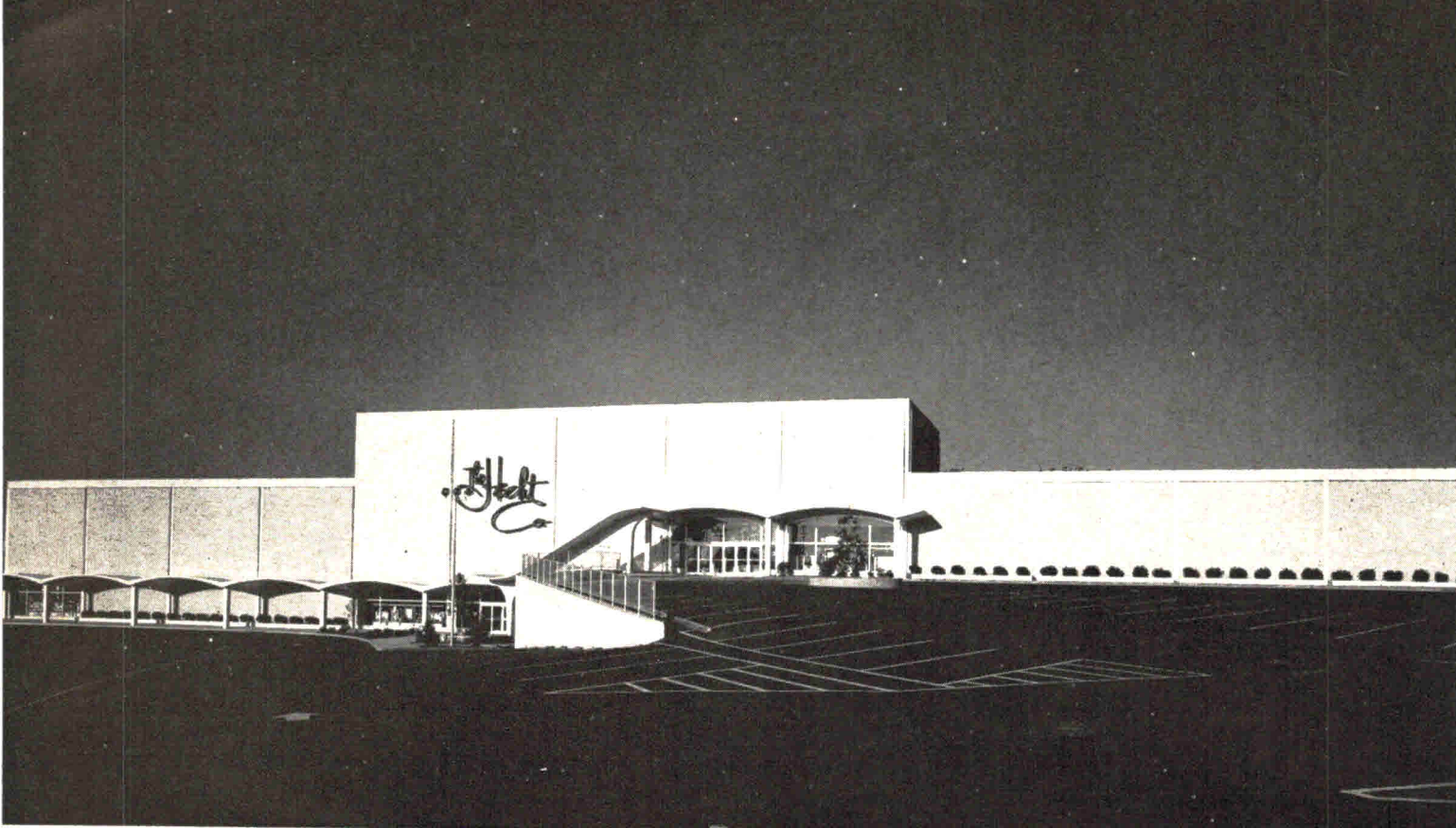



## TWO LEVEL STORE: TWO LEVEL PARKING

*The Hecht Company*  
*Marlow Heights, Maryland*

ARCHITECTS & ENGINEERS:  
*Abbott, Merkt & Co.*

ASSOCIATE ARCHITECT:  
*Daniel Schwartzman*

GENERAL CONTRACTOR:  
*Prescott Construction Co.*

Regarding the design of this visually exciting branch department store in suburban Washington, architect Daniel Schwartzman says, "The lower level has direct access to the shopping center mall on one side; while the upper level has access to a secondary mall to be built later. This split level arrangement provides direct access to parking on both levels. One of the design problems was to solve, as gracefully as possible, the relationship between the two entrances at different levels. Our solution was an open reinforced concrete stairway with a curved canopy, connecting the two arched canopies which shelter, respectively, the lower walkway and the upper entrance.

"The structure is of reinforced concrete, and where it remained exposed it was given a liquid tile finish in off-white. Major exterior walls were faced with split-face, exposed quartz aggregate concrete brick, also off-white. Large panels of precast, exposed quartz aggregate concrete in sculptured form—large in scale—were used for the panels over the entrances (shown in the photograph below). The simple and rather elegant quality achieved by the single color of the building, together with its arched and sculptured forms, gives it a distinctive character expression of the merchandising philosophy of the store."

All photos by Ben Schnall



The Hecht Company, Marlow Heights

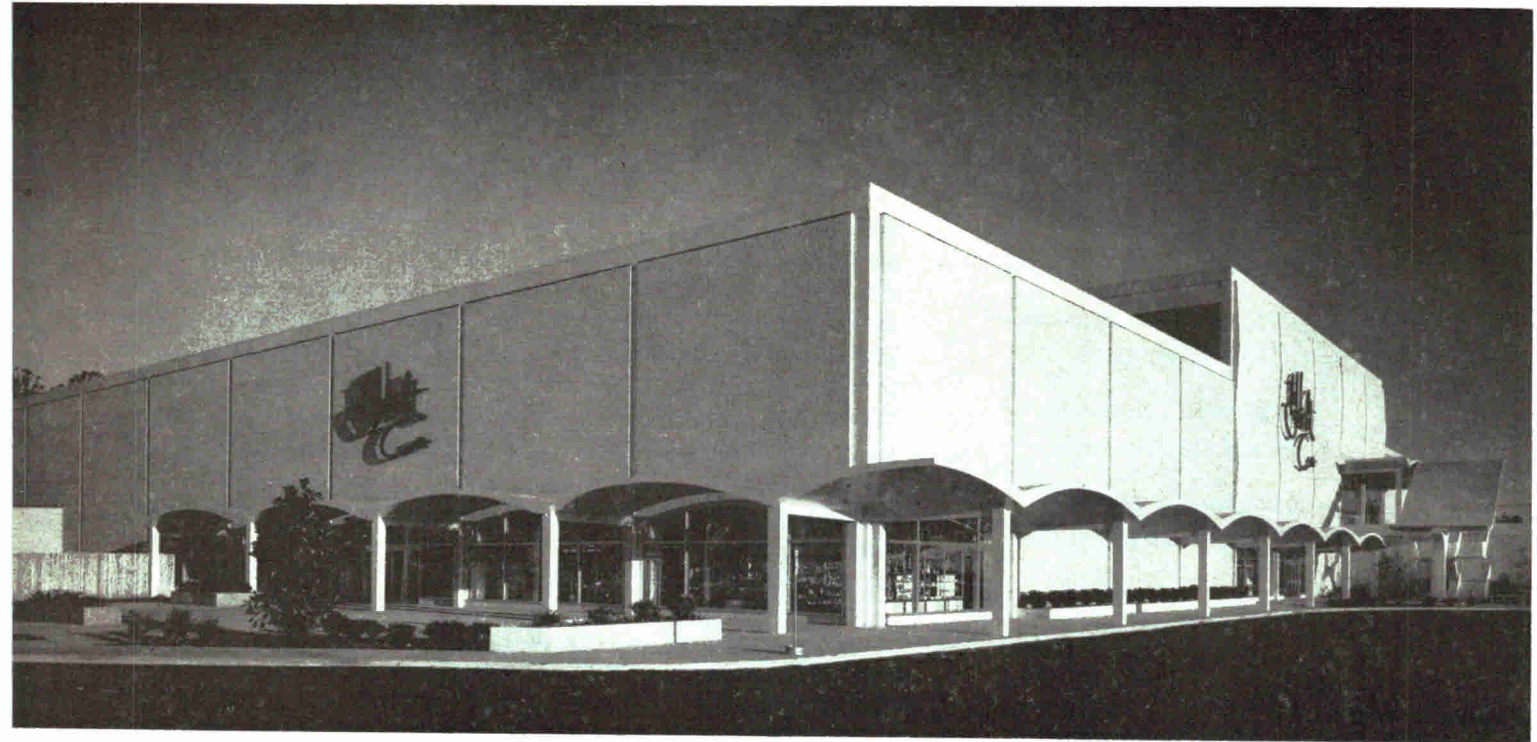

View at lower level corner, showing arched display windows and open stairs to upper level



China and glassware department has interesting see-through character, due to coordination of fixtures and building



Exterior view of the china and glassware department, located at the lower level corner shown at left



A decorative metal grill separates and defines the Hi-Fi and television department as a small shop

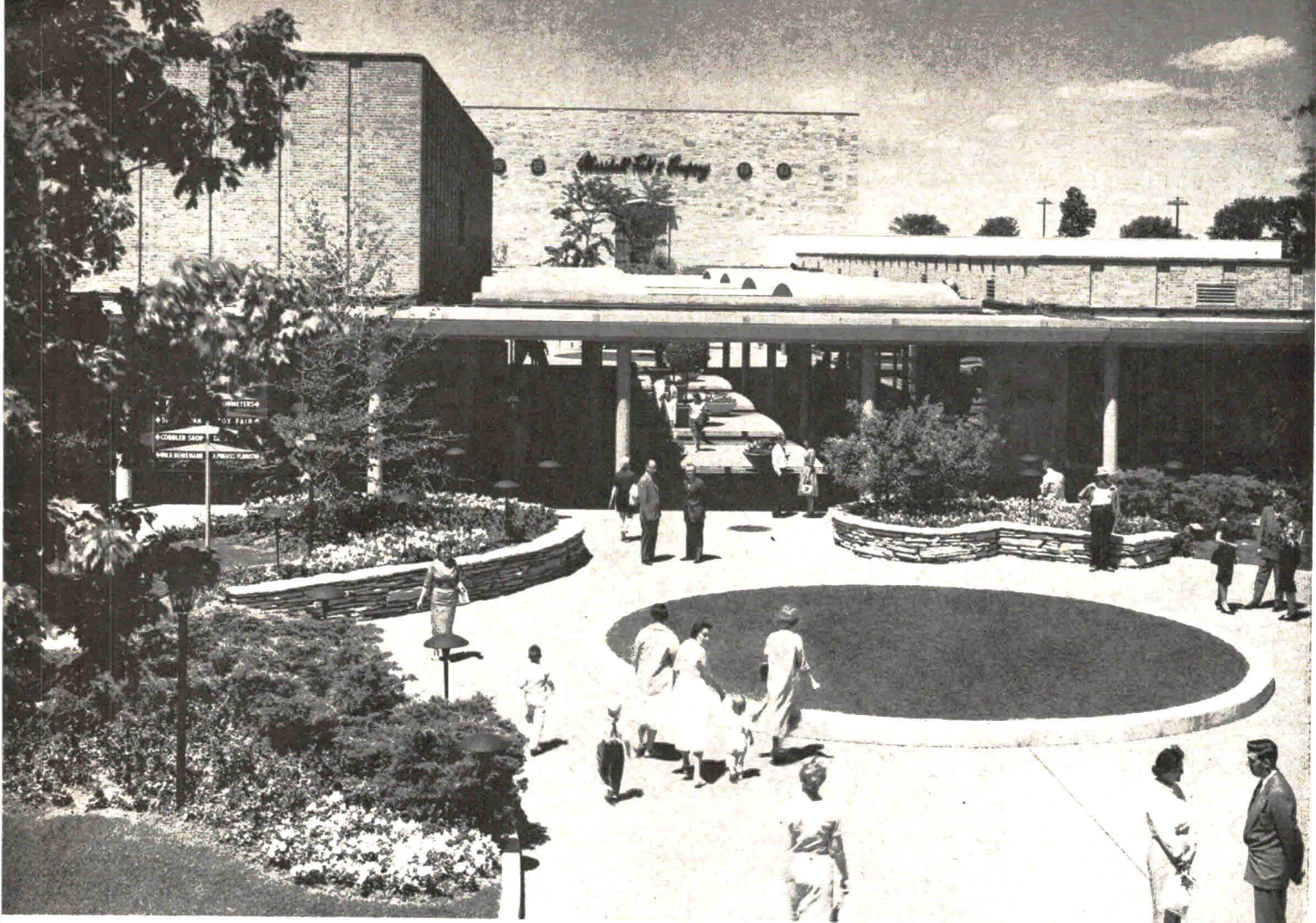

All photos by Hedrich-Blessing

## INWARD DIRECTED REGIONAL CENTER

*Mayfair Shopping Center*

*Wauwatosa, Wisconsin*

**ARCHITECTS:**

*Perkins & Will and Grassold-Johnson Associates*

*Marshall Field Store: Loeb, Schlossman & Bennett*

*Gimbel's Store: Welton Becket & Associates*

**LANDSCAPE ARCHITECT:** *Franz Lipp*

**CONTRACTOR:** *Hunzinger Co.*

This 20 million dollar shopping center—built on a 150-acre plot in a Milwaukee suburb—is designed with its 70 shops having their main fronts and business entrances opening to an attractive interior mall. The two exceptions to this general principle are the “anchor” department stores, Marshall Field & Co. and Gimbel’s which close the plan at the ends. The 960 ft mall is tastefully handled, and with its canopied side-walks, rest areas, and landscaping, creates an unusually appealing environment for shopping. Fieldstone, white palos verdes stone, concrete, tile, and a wide range of brick and woods are used in various combinations to make a variety of texture, color, and form for visual interest.

The six-story professional office building adds a vertical element to the composition and offers a contrast to the wood and stone of the shops. Its two end walls are of white concrete, while the long façades are curtain walls of aluminum with panels of light blue procelain enamel on steel alternating with the glass in checkerboard pattern.

The center is serviced by a two-lane underground tunnel in loop shape, which can be entered from either of two entrances. The tunnel serves also to carry heat, light, power, and air-conditioning runs for the various stores.

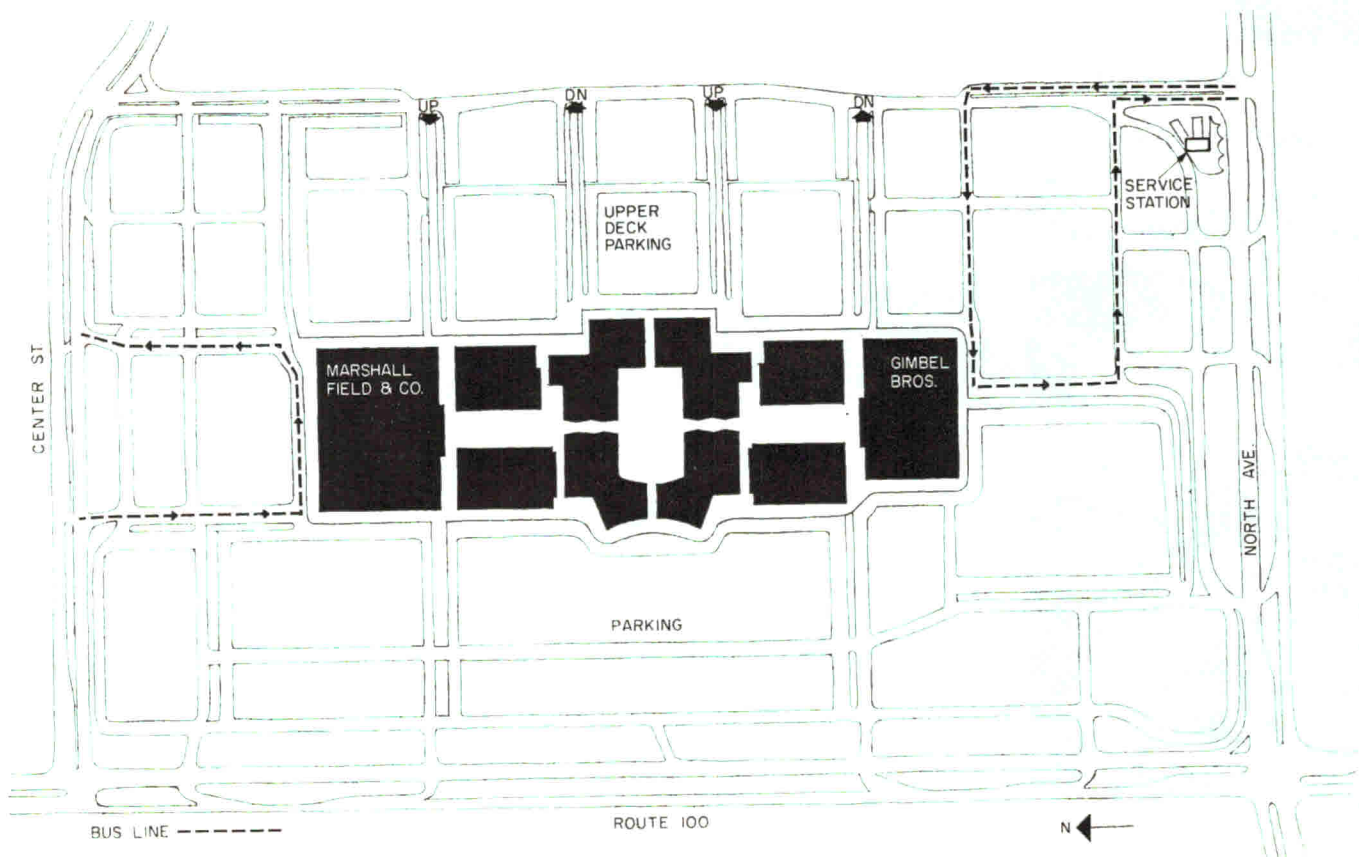

Mayfair Shopping Center

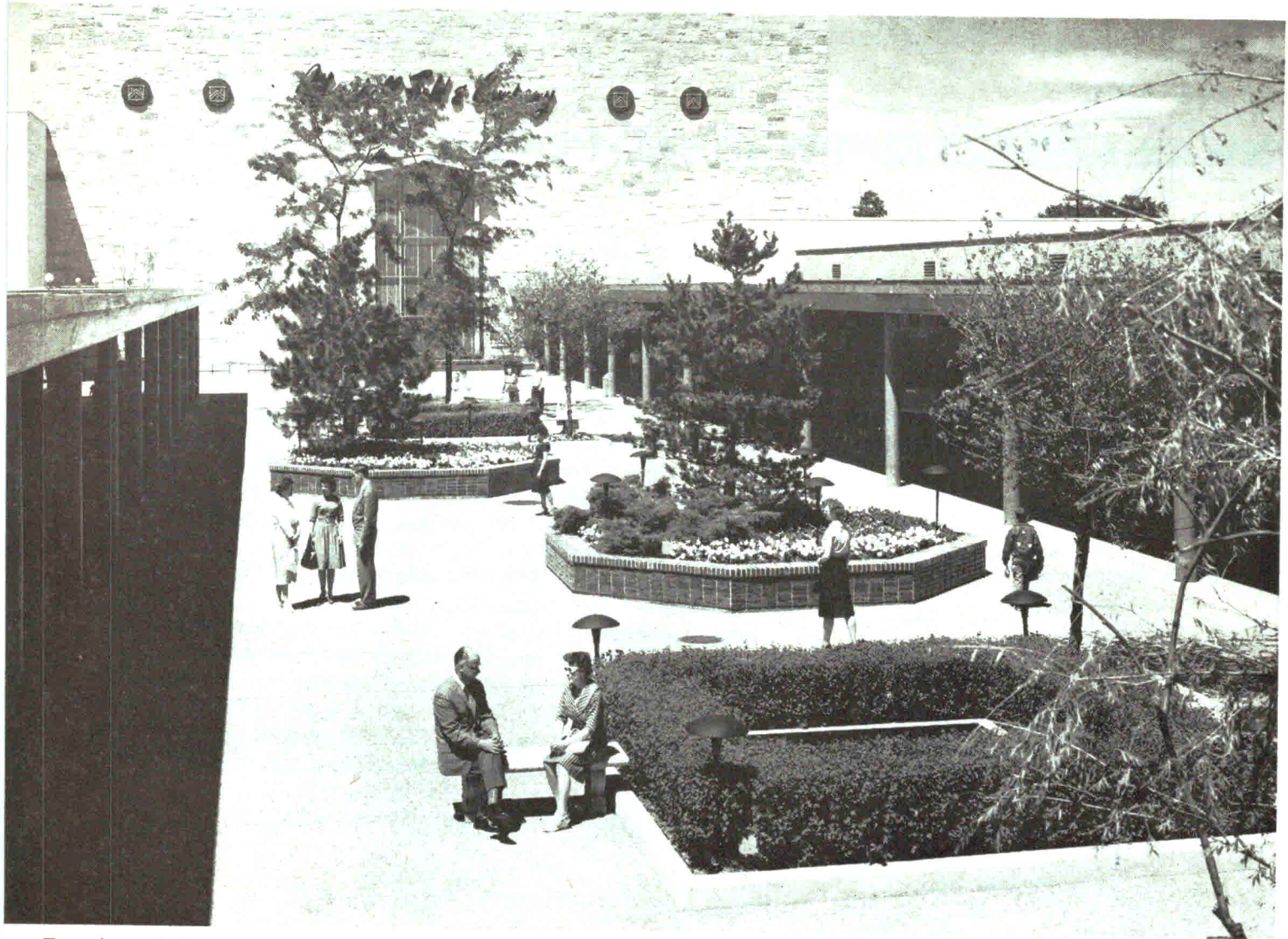

Two views of the attractively landscaped central mall

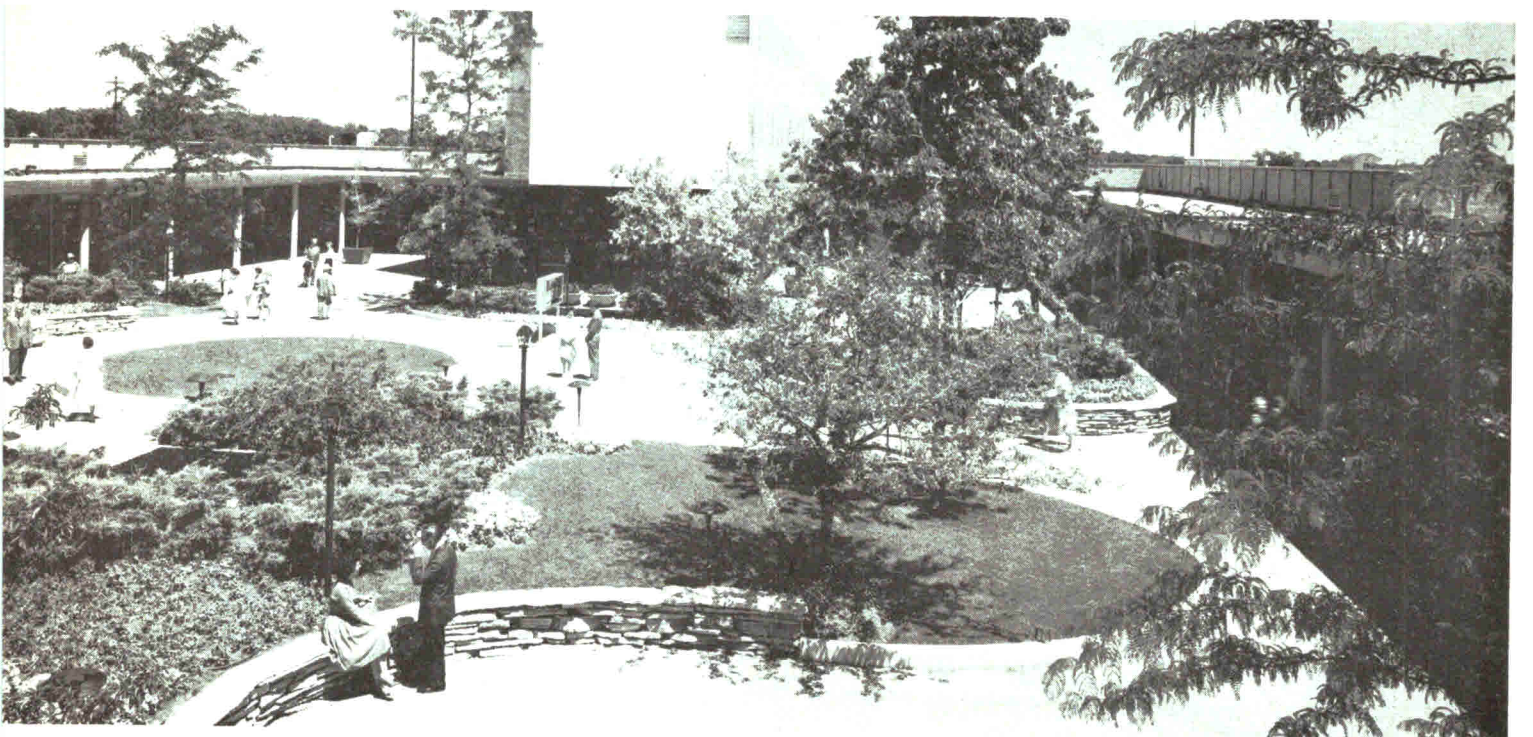

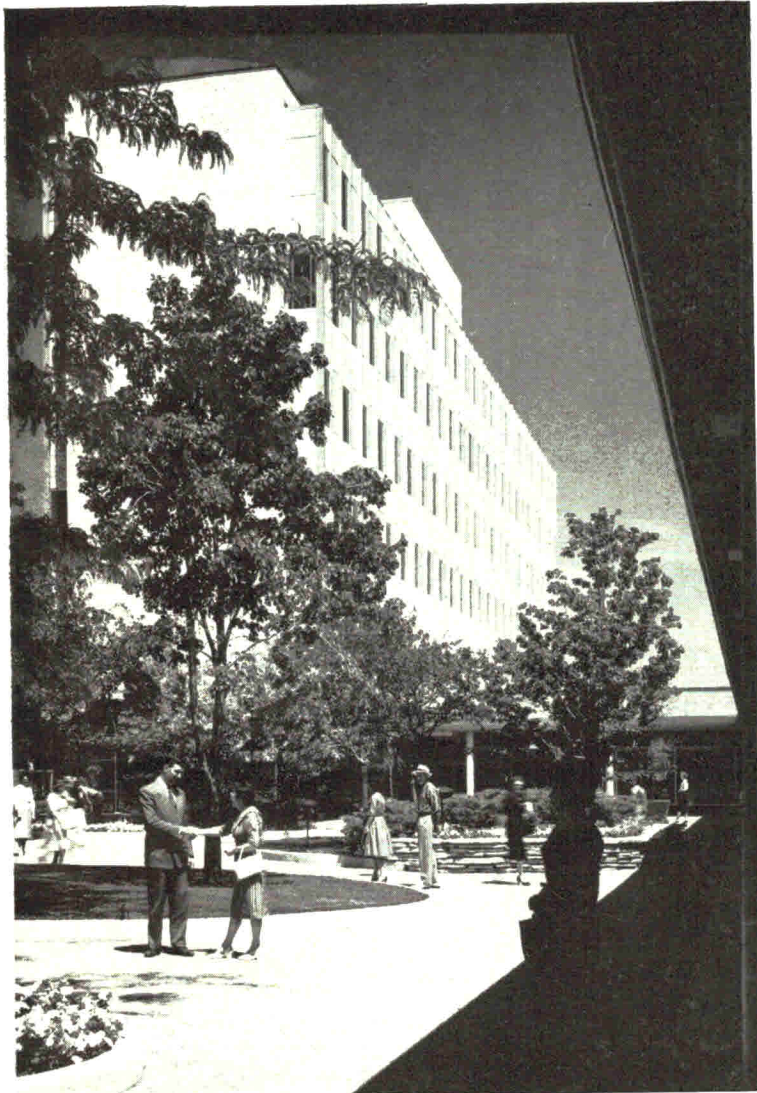

The office building strikes a vertical note in the group



Arcaded walks with interesting light and shade



Parking entrance to the Marshall Field store

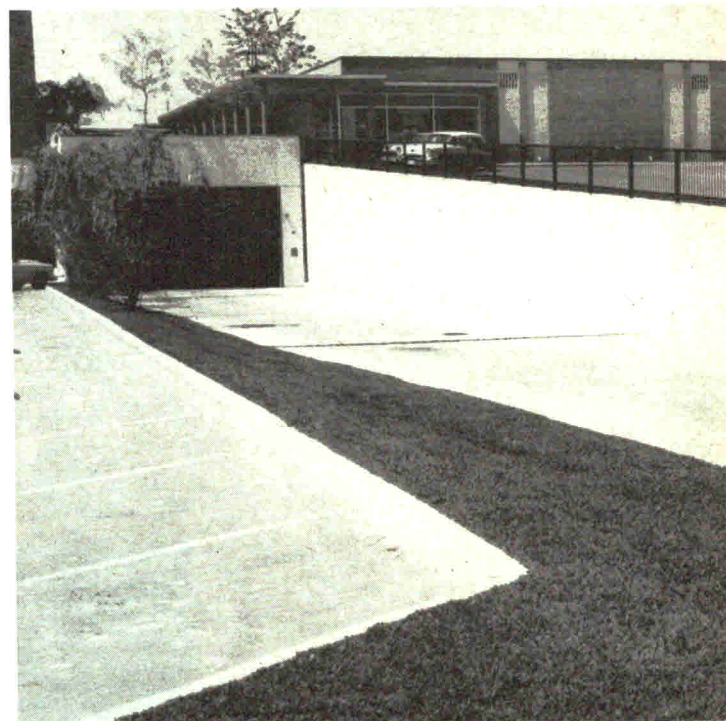

Lower level entrance to the service tunnel

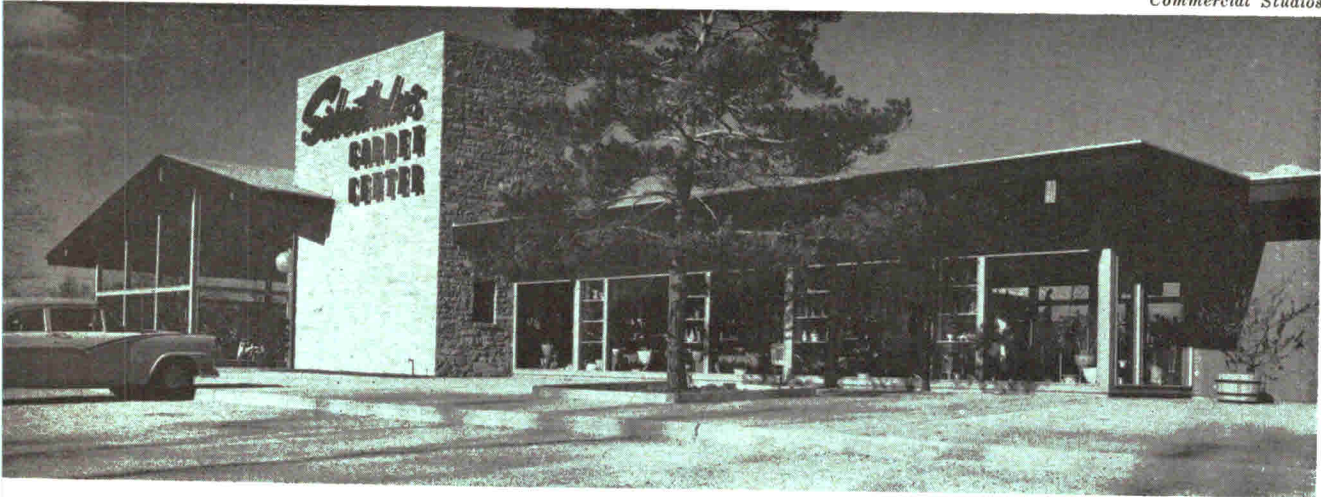

## ATTRACTIVE ROADSIDE GARDEN CENTER

*Siebenthaler's Garden Center*  
Dayton, Ohio

ARCHITECTS:

*L. Morgan Yost & D. Coder Taylor*

LANDSCAPE ARCHITECT:

*George Siebenthaler*

CONTRACTOR:

*Dwain Pansing*

This suburban nursery and outlet for garden supplies is located at the intersection of two highways—hence is designed for customers on wheels. In the development of the plot, gardens, and buildings, sight lines for traffic from four directions were carefully studied, as were the locations of parking areas and access. The post and beam building is of fir timbers and planks, while the siding is rough-sawn cedar. The cream-colored stone was obtained from an old barn existing on the property.

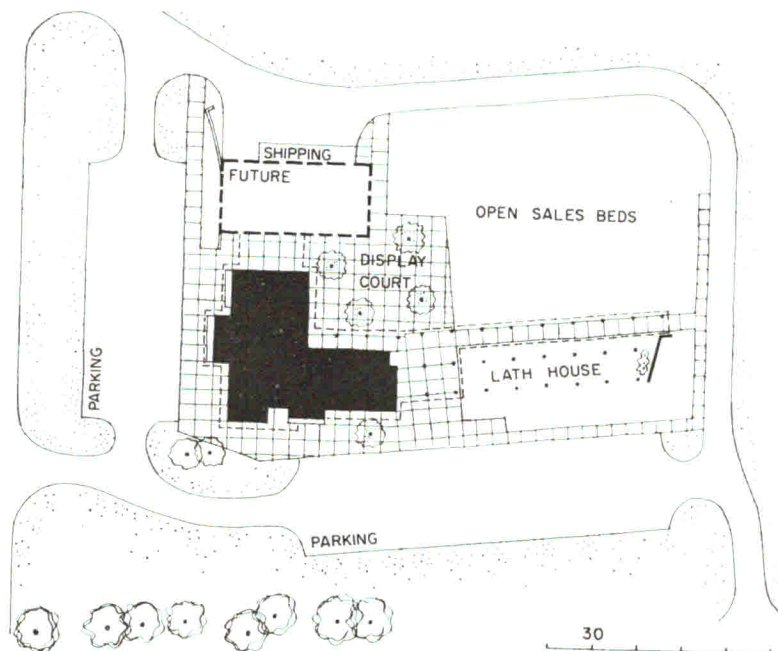



# Architectural Engineering

## The Economics of Insulation

The economics of thermal insulation has suddenly become a highly topical subject in building construction and for industrial piping and process equipment. Several insulation manufacturers, for example, have developed short-cut methods for determining savings in heating and cooling costs through use of insulated walls and roofs. Beyond this, two recently published treatises give methods for determining economically the optimum amount of insulation. The first of these is an 8-page monograph, "How Much Building Insulation is Economically Justified," by C. C. Thomas in the March 1961 Reference Section of *Air Conditioning Heating and Ventilating*. Essentially, this article gives an equation for optimum insulation thickness (for a given insulator and a given design temperature) based on cost of insulation, cost of heating plant and the present value of future fuel costs. The other work is a 182-page manual, "Economic Thickness of Insulation for Flat Surface and Pipes," prepared by the Engineering Experiment Station of West Virginia University in cooperation with Union Carbide Chemicals Co. Although a classic equation of L. B. McMillan published in 1926 gave optimum thicknesses for pipe insulation, it proved to be too tedious and time-consuming to be practical. In the new manual some 54 billion possible combinations involving heat costs, insulation costs, insulation conductivity, temperature differences, pipe sizes and flat shapes have been set up in a series of graphs and tables (360 on pipe insulation thickness). The data was determined by 83 hours' use of electronic computer time. As it stands, the manual is set up for determining insulation thickness for piping and process vessels and for boilers and piping in building heating systems. It will be available after June 15 from the National Insulation Manufacturers Association, 441 Lexington Ave., New York 17, N. Y. for \$10 per copy.

## Instant Shells

Texas A & M College professor James H. Marsh III has developed a rapid method for building thin shells in which the reinforcement is laid out on the ground, popped up into three-dimensional shape through tension applied to cables, and finally covered by lightweight concrete, plastic or other surfacing material.

## More Russian Concrete

The rapid rate of urbanization now taking place in Russia has been made possible largely through the assembly-line production of precast concrete building units, according to Dr. A. Allan Bates, Vice-President for Research and Development of the Portland Cement Association, who headed a U. S. delegation of concrete and construction experts that toured the Soviet Union last summer. The concrete products are factory produced after development by Soviet central research institutes. There are several of these which control every activity in concrete work from geological search for raw materials to design of finished structures. Applied research and development are performed on a wide scale, and, because of the powerful position of the research institutes, results are put into practice quickly.

## Status of Plastics in Building

What are the hurdles in the way of plastics making greater headway in the building field? This was the subject of an investigation by a team of second-year students at the Harvard Graduate School of Business which has now been published in a 129-page book titled *Plastics as Building Construction Materials*. Factors considered were: the applicability of plastics to building construction; terminology and standards problems; building codes; trends affecting the acceptance of plastics as building materials; action taken by special interest groups; manufacturing and construction problems; and cost problems. It may be obtained from Structural Plastics Associates, P.O. Box 13, Belmont 13, Mass. \$18.50.

## This Month's AE Section

*AIR CONDITIONING DUCTS BUILT INTO FLOOR AND ROOF STRUCTURES*, p. 190. *A NEW LOOK AT FLAT PLATES*, p. 193. *TIME-SAVER STANDARDS*, Store Fixtures, pp. 198, 199, 200. *BUILDING COMPONENTS: Food Service Equipment*, p. 205. *Product Reports*, p. 207. *Office Literature*, p. 208.

# AIR CONDITIONING DUCTS BUILT INTO FLOOR AND ROOF STRUCTURES

1. Steel sub-floor in two office buildings provides cells for dual-duct air distribution
2. Edges of concrete umbrellas shaped to form supply air plenums for a cafeteria

*Northwest Staff Center  
Michigan Bell Telephone Co., Detroit, Michigan  
Architects and Engineers: Smith, Hinchman & Grylls Associates, Inc.*

Mechanical services for buildings used to be treated more as appendages than as integral parts of them. But as air conditioning loads have zoomed upwards, architects and engineers have had to take a closer look at ways to minimize the space required for these services, particularly ductwork. In addition the public is growing more sophisticated about the quality of thermal control, and systems are being designed to provide much greater flexibility.

Illustrating these two trends is a new building complex in Detroit, the Northwest Staff Center of the Michigan Bell Telephone Co., designed by Smith, Hinchman & Grylls Associates, Inc., Architects and Engineers.

There are two examples of the use

of structural elements for ducting conditioned air: In one case the cellular steel floors of two office buildings now under construction have large cells to serve as branch air ducts, as well as the smaller conventional cells for electrical distribution. This system is a development of the H. H. Robertson Co., Pittsburgh, Pa. In the other case, edges of the concrete umbrellas for the Service Building roof form supply plenums which blanket the cafeteria with conditioned air.

## Cellular Floor System

Main supply ducts for cold and hot air run the length of the office buildings feeding the air cells which are perpendicular to the main ducts.

Interior areas always require cooling. Perimeter areas may require either heating or cooling, depending on the season; cooling also will be necessary on winter days when the solar load is large enough.

For perimeter areas, pairs of air cells extend from the main supply ducts to mixing boxes. From the mixing boxes the air is fed back into the cells which are connected to continuous sill units. Individual control is provided on an 8-ft module.

For interior offices, which have individual control also, air from the mixing boxes is ducted to ceiling diffusers.

The floor system distributing the air is a high velocity, high pressure system. There are two main supply

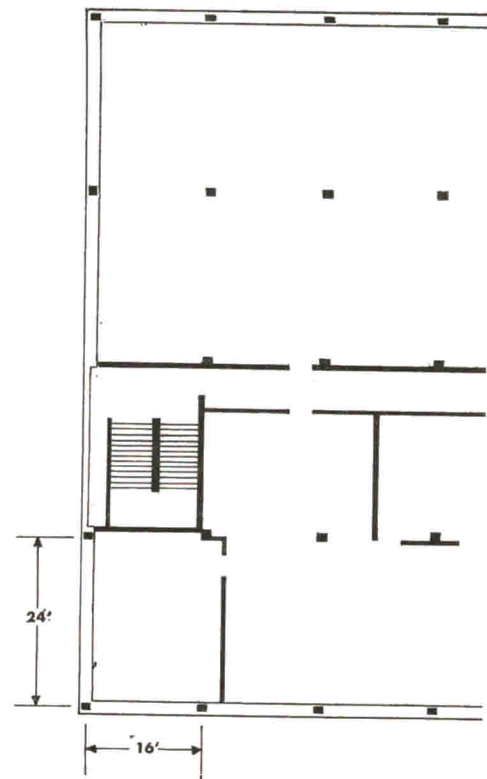
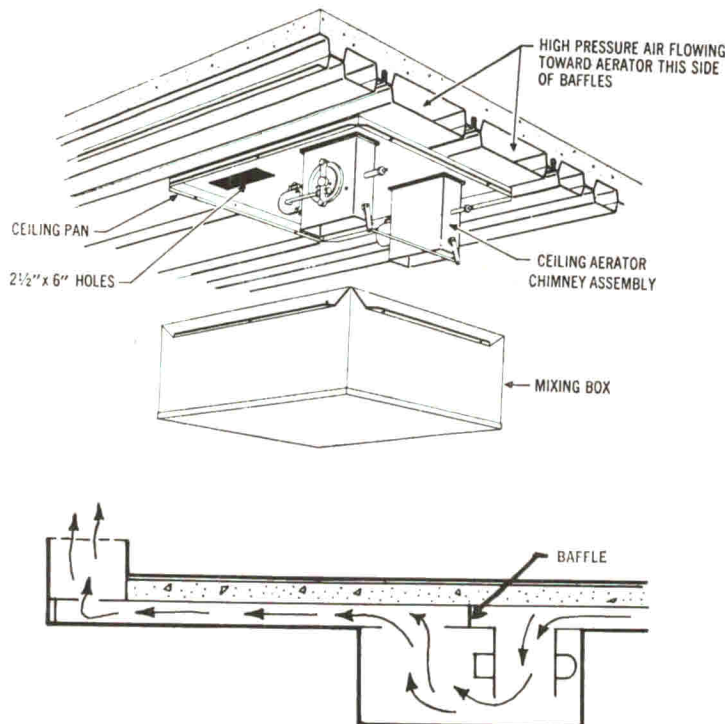

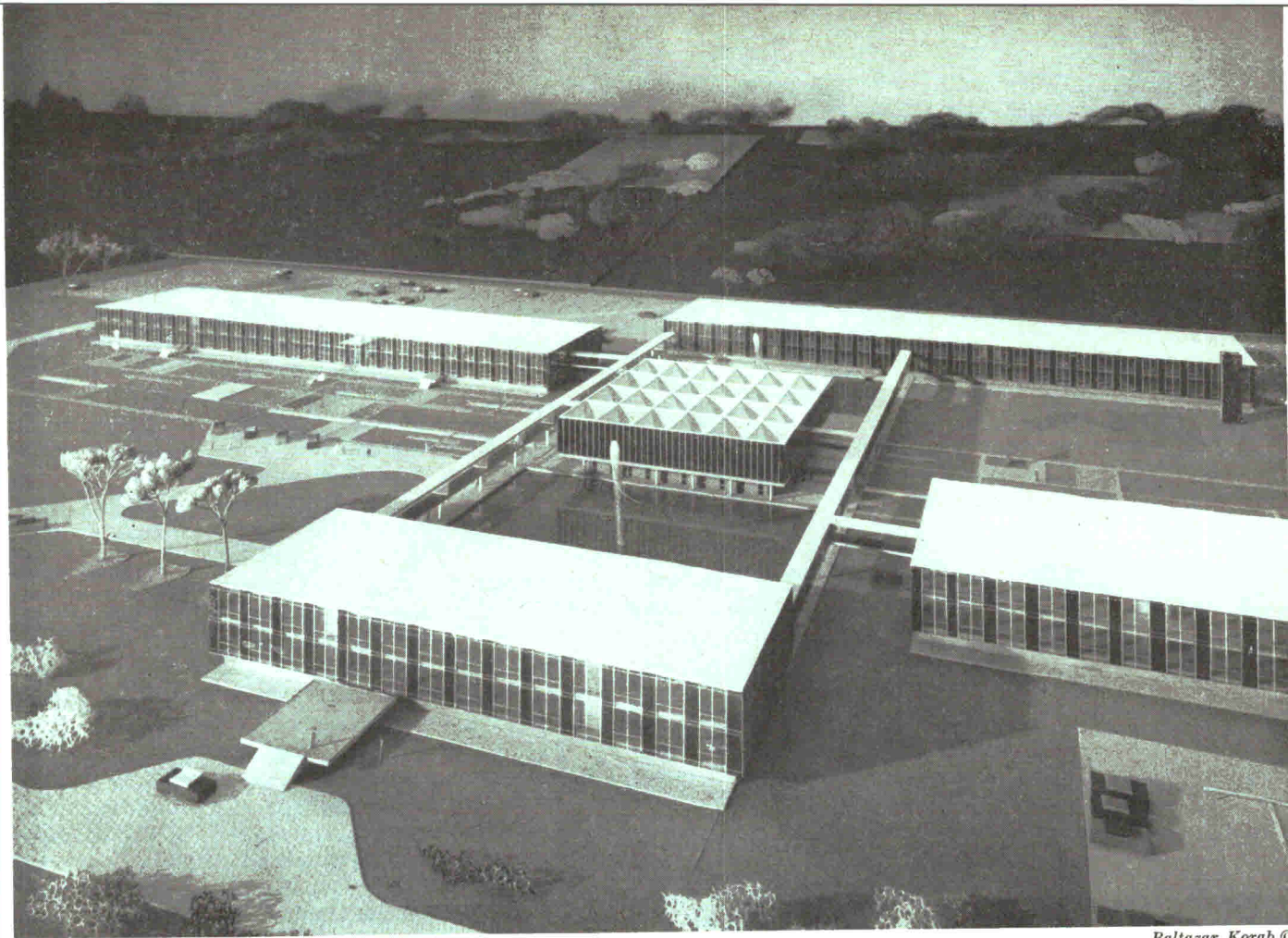

Baltazar Korab ©

In this five-building complex, two office buildings, the Engineering Building (background, left) and the Woodward Building (foreground) use cellular steel flooring for air distribution. The office buildings are enclosed in glass and, at columns, porcelain enamel panels; the long sides face north and south. The air cells, which are perpendicular to the main supply ducts, feed cold and hot air to mixing boxes attached to the underside of the steel flooring, and from there to continuous sill diffuser units. For interior areas, the air is ducted from mixing boxes to ceiling diffusers. Air is returned

through ceiling registers. When full cooling is required, the hot supply duct is switched to a cold duct so that all cells supply cold air to diffusers. On the heating cycle, hot (up to 120 F) and cold air is mixed to provide a constant volume of air at the required temperature. On the cooling cycle, the volume of air (at 55 F) is varied by dampers to satisfy cooling demands. Two sets of main supply ducts are used. This was necessary because mechanical rooms and elevator shafts south of the corridor interrupt the air cells; this also permits the ducts to be shallower.

Floor Plan (One-Quarter, Engineering Building)

Mechanical Plan

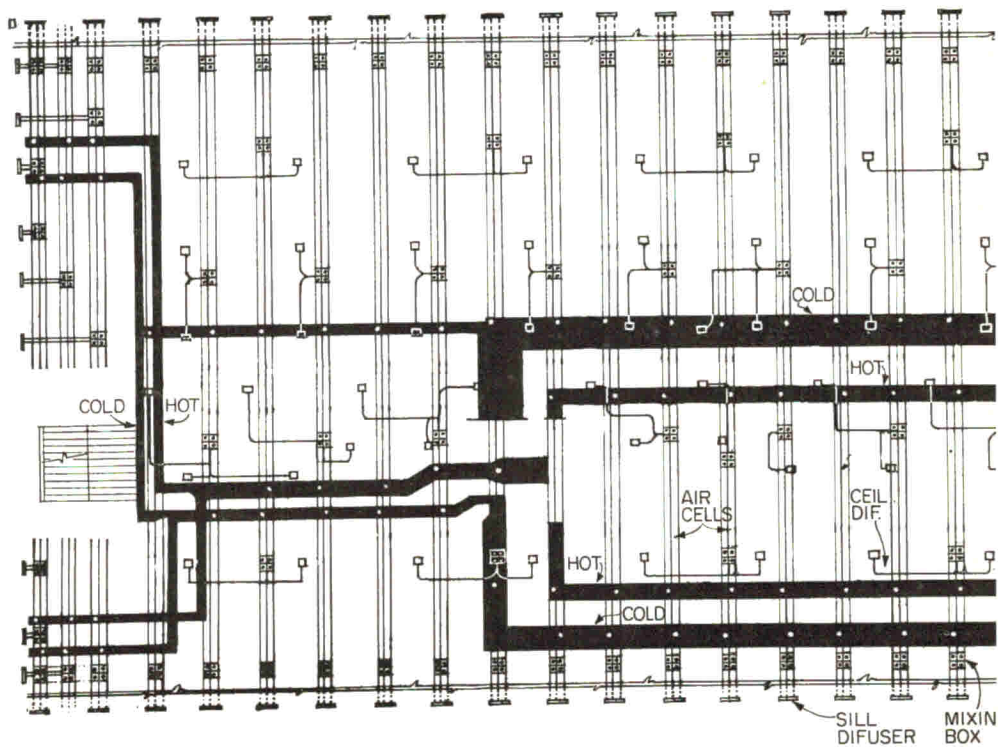
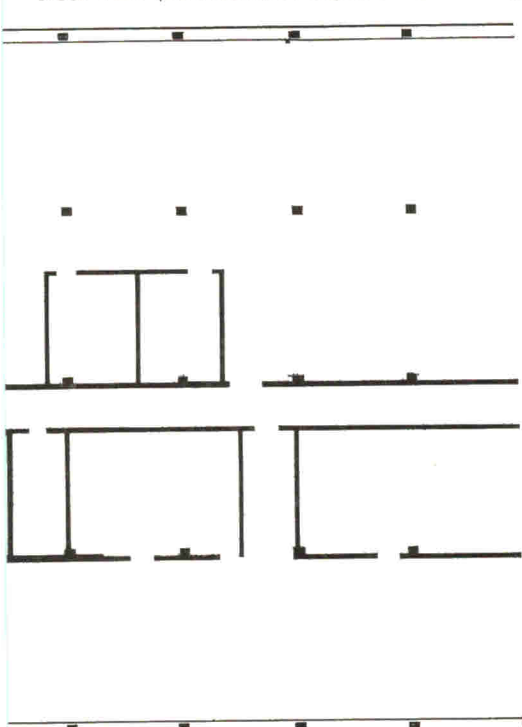

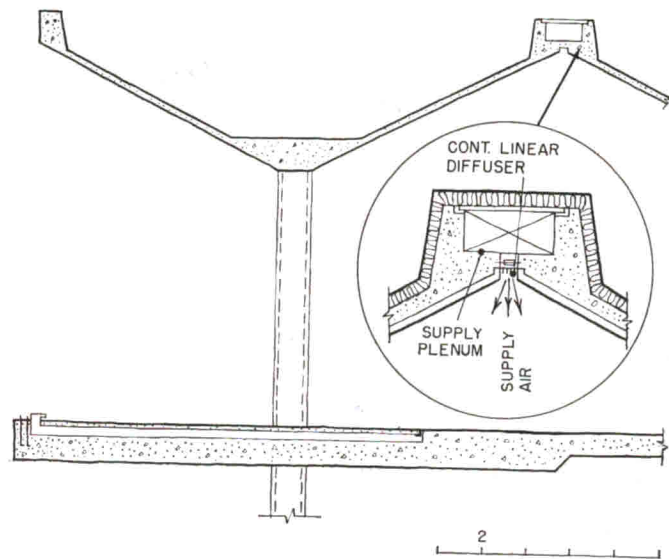

Above: Top floor of the Service Building (center in photo previous page) has a roof of inverted concrete umbrellas which cover the cafeteria and kitchen. Air supply for the cafeteria comes from plenums up to 68-ft long formed by the top edges of the umbrellas. Air supply for the corridor around the perimeter of the building is delivered through a plenum provided in the top of the floor slab.

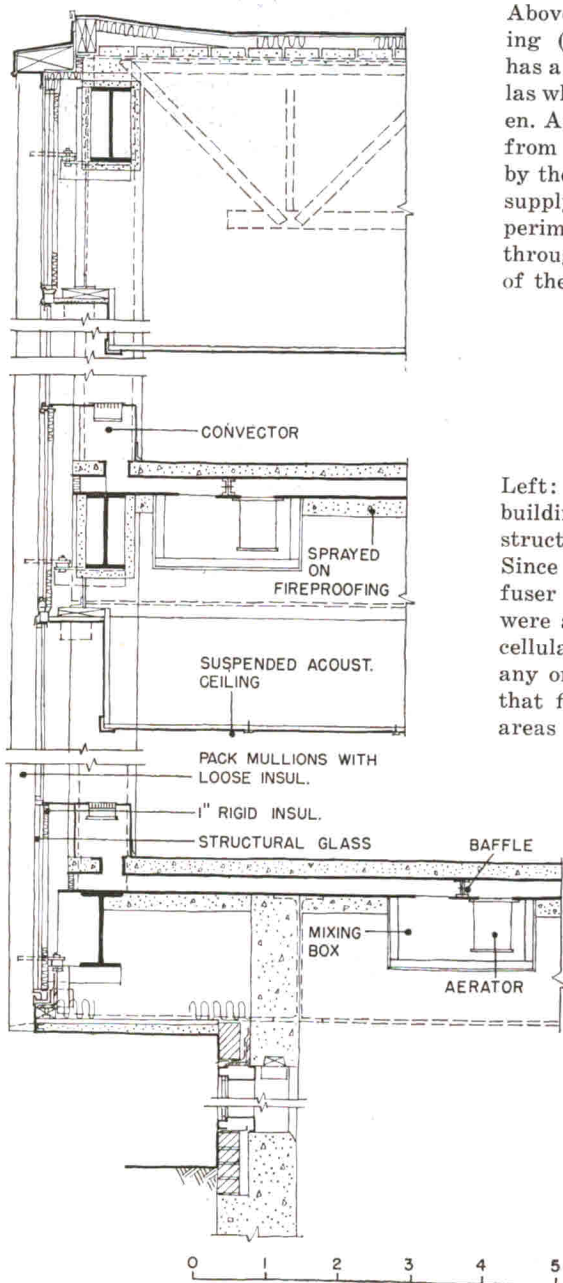

Left: Wall section through the office building shows the relationship of structure and air distribution system. Since a low silhouette perimeter diffuser was desired, the mixing boxes were attached to the underside of the cellular steel flooring. The air cells at any one floor supply the perimeter of that floor and the ceiling of interior areas on the floor below.

ducts feeding each side of the building, one cold and one changeover.

During heating periods, one main supply duct carries cold air and the changeover supply duct, hot air. When the whole building requires cooling the changeover duct is switched to cold air. The changeover duct is converted to a hot duct through use of a reheat coil in the equipment room.

Economies in both operating and initial costs were achieved by the control of air volumes during the heating and cooling cycles. Air volumes, and thus temperatures for the various spaces, are established by dampers in devices called Aerators. There are two Aerators for each mixing box.

On the heating cycle, a constant volume of air is supplied. Dampers in the Aerators operate at right angles to each other to admit proportional amounts of warm and cool air. As the hot damper opens, the cold damper closes and vice versa. (The minimum amount of air is supplied during this cycle.)

On the cooling cycle both air cells to each mixing box are furnishing cold air and the dampers in the Aerators are operating in unison to vary the quantity of air in proportion to the cooling load. The quantity of air supplied to the perimeter of the building is thus dependent upon the instantaneous load rather than the sum of individual peak loads as would be the case in a system delivering a constant volume of air at all times.

Variation in air volume is dependent on the heat gain at a particular time. Without solar load, the volume of air delivered on the south side could be reduced by 45 per cent.

With the building operating normally, the fluctuation of load is due mainly to change in solar and conduction load. In the morning (and with a relatively small east exposure) the quantity of air could be 15 per cent less than at 4:00 P. M.

As a result the fans and other equipment can be smaller than that required if the cooling also was designed for constant volume air supply.

The engineers specified fan capacity control with inlet vanes to maintain constant duct pressure, thus taking advantage of reduction in fan motor operating cost through use of throttling control for cooling and reduced air capacity for heating.

# A NEW LOOK AT FLAT PLATE CONSTRUCTION

by Seymour Howard, A.I.A., Associate Professor, Pratt Institute

A discussion of recent work by Lev Zetlin,  
Consulting Engineer, New York

*Although flat plate construction—reinforced concrete slabs supported directly on columns without beams—has been on the building scene for some time, its design potential has remained largely unexploited. As reported here, however, structural engineer Lev Zetlin has demonstrated the new architectural possibilities that flat plates offer when their structural advantages are correctly understood and their structural behavior correctly analyzed. Dr. Zetlin has designed economical flat plates with longer-than-customary spans, with openings next to the column, and without spandrel beams.*

A "flat plate" is defined as a reinforced concrete floor slab supported directly by columns without beams. Unlike "flat slabs," flat plates have neither capitals nor drop panels over the supporting columns, but rest directly on top of columns which have constant cross section from floor to ceiling.

The expanding practice of using flat plates in multi-story apartment, office and hospital buildings has been brought about largely by the obvious economy effected by the absence of beams: cheaper formwork; elimination of furring and other finishes common to projecting members; flexibility in ductwork and other mechanical fittings; and, finally, reduction of total story height since the entire space between floor and ceiling is utilized. Although flat plate floor slabs are usually thicker than slabs supported by beam grids, the total quantity of concrete in a flat plate is comparable to, or smaller than, that in a beam-and-slab floor.

Flat plates are also gaining favor for their speed and simplicity of erection. Time and again bid prices for flat plates have come in lower than other conventional structural systems. Until recently, a flat plate would prove economical for buildings up to only twelve stories high, but flat plate office buildings and apartment houses are now becoming economical up to 24 stories high due to the longer modern cranes.

One of the other commonly mentioned advantages of flat plates is the flexibility in locating columns in plan, but while this is an advantage for architectural planning, it is not beneficial economically. The design of flat plates with regular column spacing is covered by the ACI building code, but irregular column spacing requires an elaborate design which sometimes results in over-design. Also, irregular bays necessitate variations in size and length of bars, which increases the cost of reinforcement. Regular bay sizes may be monotonous architecturally, but they are more economical.

However, flat plates have a number of other inherent possibilities that do offer further flexibility in architectural design and economy—particularly in mechanical installations, architectural planning and finishing. On the whole, these potentialities of flat plate design have not been explored sufficiently, but Dr. Lev Zetlin's recent practice shows that architects can safely use flat plates to greater advantage, lengthening spans, omitting spandrel beams, and even introducing openings in the slabs next to the columns.

Before discussing these possibilities, however, there is a general question that should be considered.

## What is a "Correct Structure"?

This question has preoccupied many architects in recent years as they

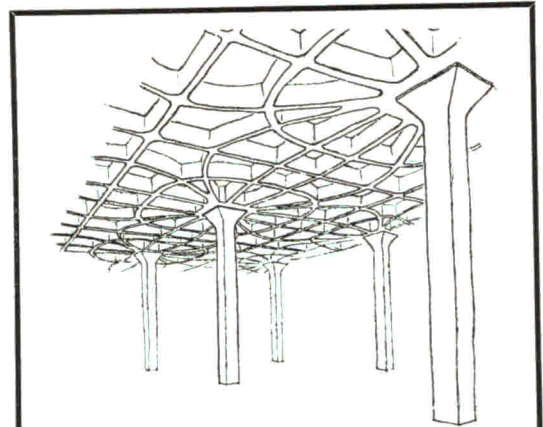

Figure 1

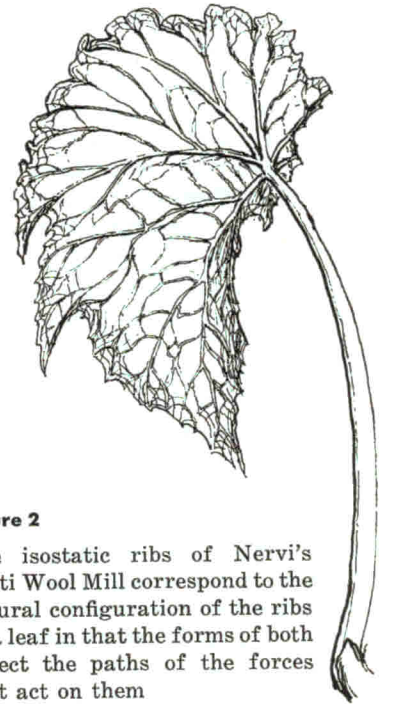

Figure 2

The isostatic ribs of Nervi's Gatti Wool Mill correspond to the natural configuration of the ribs of a leaf in that the forms of both reflect the paths of the forces that act on them

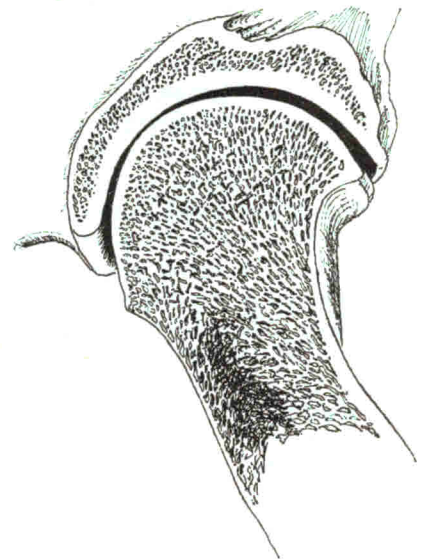

Figure 3. Other natural structures respond to forces with changes in material. In a bone, the wall thickens at the joint, the interior is hollowed out like a sponge

have sought logical shapes for their buildings. The poet-engineers like Maillart and Nervi have been admired for the consistent way they have designed their structures so that the form reflects the path of forces. This might be called the "form follows force" theory and can be substantiated by many examples in nature, particularly in plants.

An esthetic system could be developed as an extension of this theory, using the following argument: From earliest childhood our structural intuition is built up slowly from continually feeling the action of forces on our bodies and from repeatedly seeing natural forms which have received their shape from the forces acting on them. Then, when we are confronted with the isostatic ribs of the Gatti Wool Mill, for example, we are intuitively and consciously aware of the correspondence with the ribs of a leaf. (Figures 1 and 2.) We recognise a principle of design which has general validity. This may be the reason for the almost universal acclaim accorded to the great civil engineering monuments such as bridges and dams whose visible shape is determined by the analysis of forces.

However, we can easily find in nature thousands of examples which are less familiar as structural solutions but which indicate that there are many other aspects to the problem of form and many other answers to our question. Instead of changing the external shape, the material itself may be varied. A section through a bone shows how the solid wall is thickened at the joint and how the structurally less necessary interior is hollowed out like a sponge. The visible shape is determined mainly by mechanical considerations. (See Figure 3.) This might be called the "material follows force" theory of structural design, to distinguish it from the one we have named "form follows force."

Actually the very awkwardness of this terminology reveals the limitations of the theories. The reason is that "structure" by itself is only a concept which is meaningless without reference to some more primary purpose. The objective underlying the form of the leaf is to expose the

maximum number of cells to the sunlight. Its flat shape solves this best and the structure must conform to it, even though ribs subject to bending moments are less efficient than structural elements loaded purely in tension or compression. Even these ribs are given their form as much from their function as food arteries as from structural requirements. An animal must walk or fly or swim. The complicated structure of bones and ligaments and muscles must conform to the mechanical requirements. Similarly the primary forms of ships and airplanes are derived from the requirements of stability and propulsion.

The design of buildings should follow the same principle. The primary form should be given by the need for certain spaces for human activities. In the past we have accepted many limitations on these spaces because of inadequate construction techniques. In fact beauty has been created out of these very limitations. Now that it is technically possible to do almost anything imaginable, we are at a loss. The great architectural problem of our time is to define in human and esthetic terms what the nature of our buildings and cities should be. Every development in technique which frees us from arbitrary limitations should be welcomed, however much it may disorient us when it first appears.

#### **Flat Plates in Reinforced Concrete**

An example, though not new, of such a development is the flat plate concrete slab. This consists only of columns and slabs, without drop panels and without capitals for the columns. Here the external form does not follow the distribution of forces as they vary through the slab or column. The building as a whole is primary, with its requirements for mechanical equipment, for the free placement of partitions and for economy. A structurally sensitive design is still possible, however, by varying the nature of the material: the pattern of the steel reinforcement is evidence of this variation.

Flat plate design has been used with increasing frequency in the United States over the past 20 years.

While flat slabs with capitals and drop panels were developed as appropriate for warehouses and factories, flat plates have been found advantageous for the lighter live loads of multi-story apartment houses, offices and hospitals.

The absence of beams and drops simplifies the formwork, permits ductwork and piping to be run without obstructions and usually reduces floor to floor heights. Although flat plate slabs are typically thicker than those supported on beams (usually about  $\frac{1}{36}$  of the span), the total quantity of concrete may be less than in a beam and slab floor. The amount of steel is likely to be somewhat greater.

One of the often mentioned advantages of flat plates is the freedom in column location, known by the descriptive term of "spatter column" design. This may help to squeeze low-cost housing plans so that there is no "extravagance" and every room is the exact legal minimum, but it does not save money. Irregular column spacing requires more complicated and hence more expensive structural calculations than regular spacing. Also, irregular bays necessitate variations in sizes and lengths of bars, increasing the cost of reinforcement. Regular bay sizes are definitely more economical and of course can help establish an architectonic rhythm.

Although in general the architect does not personally design the pattern of the reinforcement, it is desirable for him to be aware of the general behavior of a flat plate. A concrete flat slab acts differently from a steel plate of similar span because the stiffness and the strength of the concrete vary with the amount of reinforcement. Given spans, slab thickness and column dimensions, it is mathematically possible and not impractical to calculate accurately the deflections and hence the moments at any point of a steel plate under a given loading, because the material is uniform throughout. The deflections depend on Young's Modulus (E) and on Poisson's ratio, which relates strain in the direction of normal stresses to those at right angles. With steel both of these are constant. For reinforced concrete,

both of these vary with the mix of concrete, with the amount and distribution of reinforcement, with the age of the concrete and with the duration of loading.

An interesting illustration of this variation was given by J. Bar of Haifa in the English periodical "Concrete and Constructional Engineering" of November, 1953. A 4-in. slab, freely supported on six 12 by 12-in. columns and loaded only by its own weight, gave four different "contour maps" of deflections merely by varying the steel. These are shown in Figure 4.

It was from studies of this type that Aldo Arcangeli in the office of Nervi and Bartoli devised the concept of isostatic ribs shown in Figure 1, arranging the ribs to intersect each contour line at right angles. Of course, once the ribs are provided, they are bound to carry the maximum share of bending because of their great stiffness. Sensitive structural design is thus a creative act. The magnitude of the stresses will be determined by the variations in form or in material provided by the designer.

Although the most economical spans for flat plates are in the 16 to 24 ft range, Dr. Lev Zetlin, consulting engineer of New York, has recently designed 11-in. thick flat plates spanning 36 ft for the East Branch Public Library in Yonkers, New York (Eli Rabineau, architect). He has also developed an ingenious method for preventing excessive deflections in long spans without using such great thicknesses. For example, a thin slab with a span of 30 ft is calculated with the four corner columns providing necessary moment connections as well as support. Since this will give considerable deflection at the center, another column is introduced as a prop to remove the deflection. This center column can be somewhat slenderer than the corner columns. As far as plan obstructions are concerned, the total number of columns is only doubled, while with the conventional solution of cutting all the spans in half, the number of columns would be quadrupled. This is shown in Figure 5, with the central prop columns unshaded.

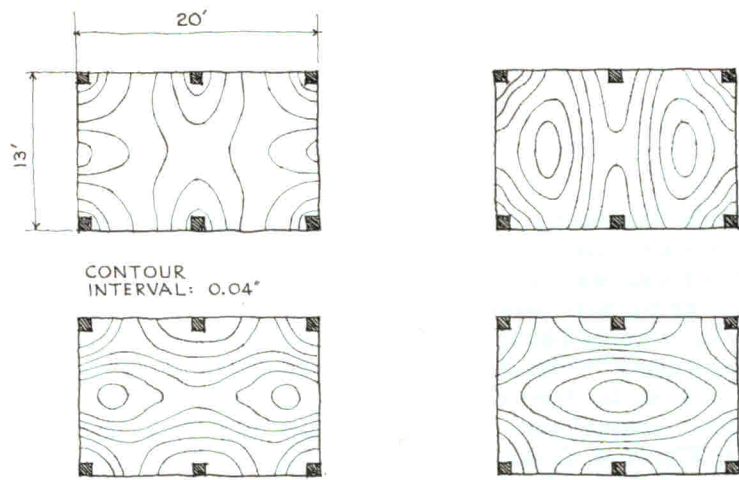

Figure 4. "Contour maps" of the deflections in a flat plate slab show the variations caused by varying the reinforcing steel

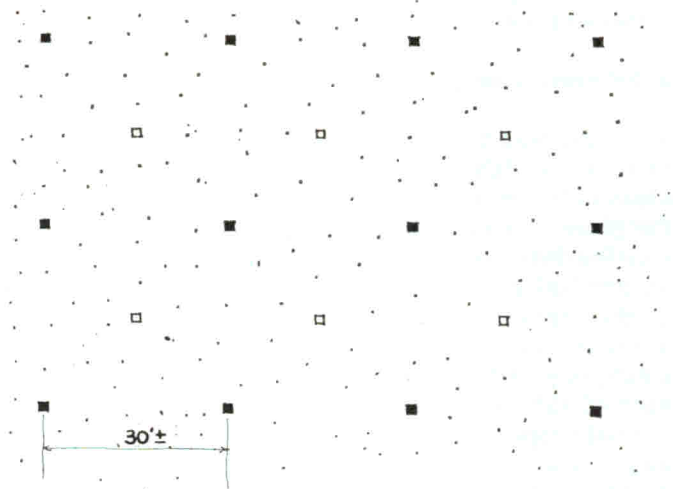

Figure 5. Introducing center "prop" columns prevents excessive deflections in long spans without increasing the thickness of the slab

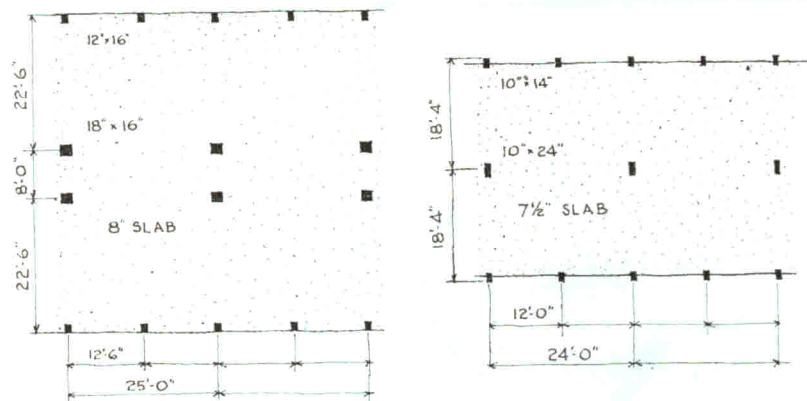

Figure 6. "Half-bay" spacing of exterior columns reduces torsional moments on them, cuts deflection along the edge of the slab

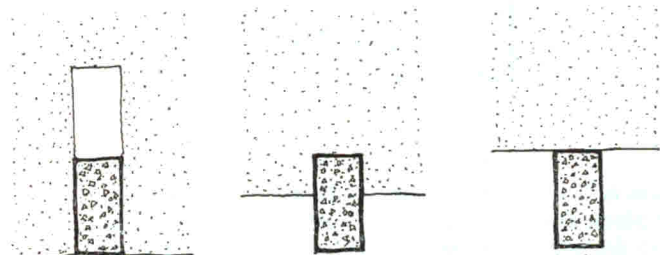

Figure 7. Careful analysis and detailing makes it possible to take advantage of the design implications of column connections like these

Dr. Zetlin has used a somewhat similar device to reduce deflections along the outside edge of a slab and to reduce the torsional moments on the exterior columns. The spacing of the columns along the façade is half that of those on the interior, again minimizing obstructions to free planning. Figure 6 shows two examples, the first for the Cornwall (N.Y.) Hospital, Helge Westermann, architect, and the second for the Sarah Lawrence College Dormitory, Philip Johnson, architect.

### Connection between Slab and Column

Much more critical than the general reinforcement of the slab, which is covered adequately by the A.C.I. Code, or the placement of columns is the connection between the slab and column, particularly if the columns are at the edge of the slab.

Many architects are still reluctant to use flat plate design because of the danger of failure when this connection is not properly designed. Unfortunately such failures have occurred. Some engineers refuse to use flat plate design because they

do not believe sufficient stiffness can be provided in the column-slab connection to resist horizontal forces such as wind or earthquake.

This problem has generally been overcome by using spandrel beams, which stiffen the edges of the slab as well as provide an increased area of contact between slab and column. Openings in the slab near the column have been avoided.

Under the pressure of mechanical engineers for duct, pipe and conduit space, and in view of the evident money-saving advantages of simpler formwork, however, Dr. Zetlin has found that the spandrel beam can be omitted and that openings of considerable size can be provided next to the columns. To do this, advantage must be taken of the true shearing strength of concrete and of the great increase in stress resistance achieved by confining the concrete with additional reinforcing around the edges of the section.

The problem can be considered in terms of three possible failures, first imagining the concrete to be unreinforced. Taking the worst possible case, with a large opening next to

the column, Figure 8 indicates the familiar "diagonal tension" failure. Although concrete is strong in shear (about half as strong as in compression), it is weak in tension and cannot resist the tensile stresses which occur along a plane at 45 degrees to the planes of maximum shear. This is easily prevented by diagonal bars or by vertical stirrups.

Figure 9 shows failure in tension due to negative bending. As usual, top steel will prevent this. The region of negative bending will typically extend out about  $\frac{1}{5}$  of the span from the column.

In Figure 10 we see the most dangerous possibility and the one most likely to occur—torsion of the slab, which is twisted away from its connection to the column. Just as vertical shear results in a tension failure in concrete, so shearing stresses due to torsion cause tensile stresses to occur along a surface lying at 45 degrees to the surface of maximum shear.

A similar type of failure, with tension along a helicoid surface, can be seen by twisting a piece of

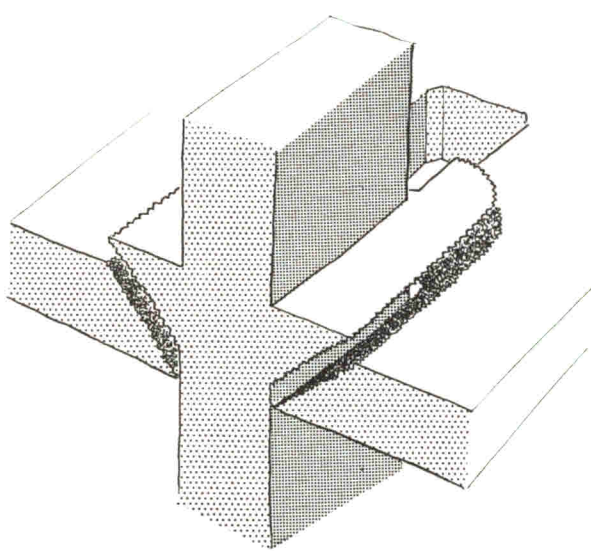

**Figure 8.** The familiar "diagonal Tension" failure of a flat plate, failure due to tensile stresses along a plane at 45 degrees to the planes of maximum shear, can be prevented by using diagonal reinforcing bars or vertical stirrups

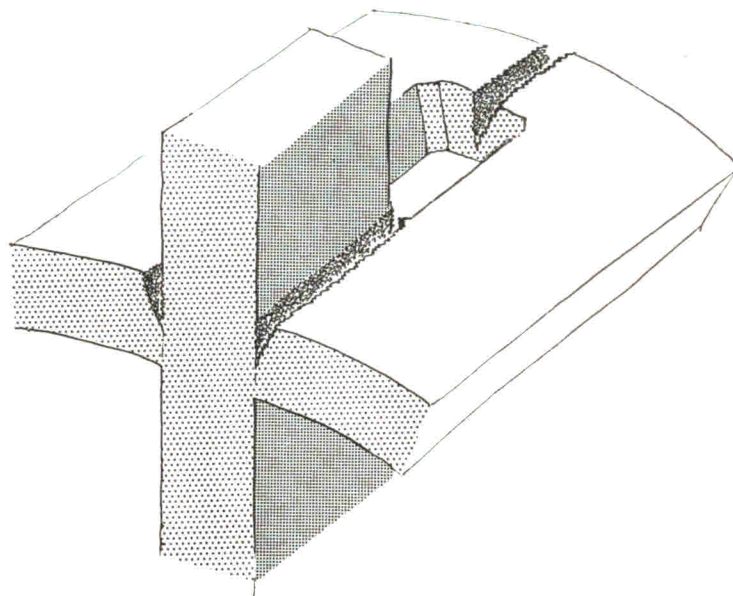

**Figure 9.** Failure in tension due to negative bending, usually occurring in a region that extends out about two-fifths of the span from the column, can be prevented by careful design and placing of the top reinforcing steel



ordinary chalk or a square eraser until it breaks. The source of the torsion of the slab is found in the rotation of the slab edge as the flat plate is bent or in the bending of the column as it resists the wind.

Analysis of stresses due to torsion arose chiefly in the design of machinery shafting. The French mathematician and physicist Barré de St. Venant published the first complete study of this in 1853. With a circular shaft, the maximum shearing stresses occur along the surface and diminish linearly along radial lines to zero at the center. With non-circular sections, however, warping of the cross-sections occurs. The maximum shearing stresses for a rectangular section will be found at the middle of the long sides, with no shearing stress at the corners.

The column to slab connection shown here is somewhat different because the warping cannot occur immediately adjacent to the face of the column and a greater resistance to torsion is provided. It can also be seen that the tensile stresses due to vertical shear and those due to tor-

sion will tend to cancel out, except when torsion occurs in the opposite direction due to the bending of the column under wind loads.

Figure 11 shows a schematic arrangement of the reinforcement as it might be placed to prevent all of these failures. To simplify the drawing, the general reinforcement of the slab is not shown, although it is of course provided.

Analysis by Dr. Zetlin and the engineers in his office have shown theoretically that the stresses in the concrete in such a detail are within the capacities of the material, and experience with constructed buildings has proved the detail to be safe practically. As a result, the architect can add to his vocabulary flat plate floors without spandrel beams and without edge beams around large openings, and can take advantage of the implications for plan and elevation of column connections like those shown in Figure 7.

Of course, it is possible to lay out the floor plan with square bays, and with the columns set in about  $\frac{2}{3}$  of the bay spacing from the exterior walls, the need for these relatively

expensive torsion-resistant connections will be eliminated. The structural solution will be simpler, less expensive and, therefore, "better." However, if this causes awkward planning, the more complicated solution is justified.

#### References and Credits:

D'Arcy W. Thompson: *On Growth and Form* 2nd edition, Cambridge, 1948

S. P. Timoshenko and S. Woinowsky-Krieger: *Theory of Plates and Shells* 2nd edition, McGraw-Hill, 1959

S. P. Timoshenko: *History of Strength of Materials*, McGraw-Hill, 1953

J. DiStasio and M. P. van Buren: *Flat Plate Floors Designed as Continuous Frames*, Portland Cement Assoc., 1947

American Concrete Institute: *Building Code Requirements for Reinforced Concrete* (ACI 318-56), 1956

Figure 1 redrawn from photograph in: P. L. Nervi, *Structures*, F. W. Dodge, 1956

Figure 3 redrawn from photograph in: Andreas Feininger, *The Anatomy of Nature*, Crown, 1956

Figure 4 redrawn from diagrams in: J. Bar, "A Method of Designing Slabs", *Concrete and Constructional Engineering*, Nov., 1953

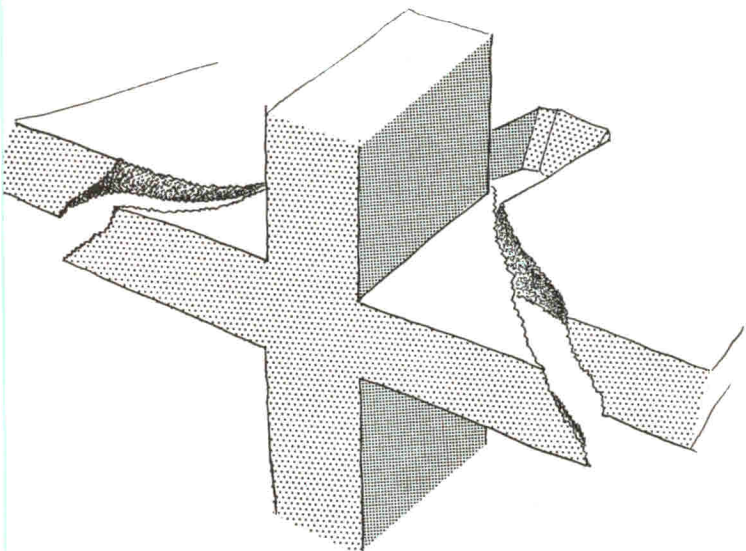

**Figure 10.** Another common type of tension failure is caused by shearing stresses due to torsion of the slab. However, warping cannot occur adjacent to the column face, which helps the resistance to shear

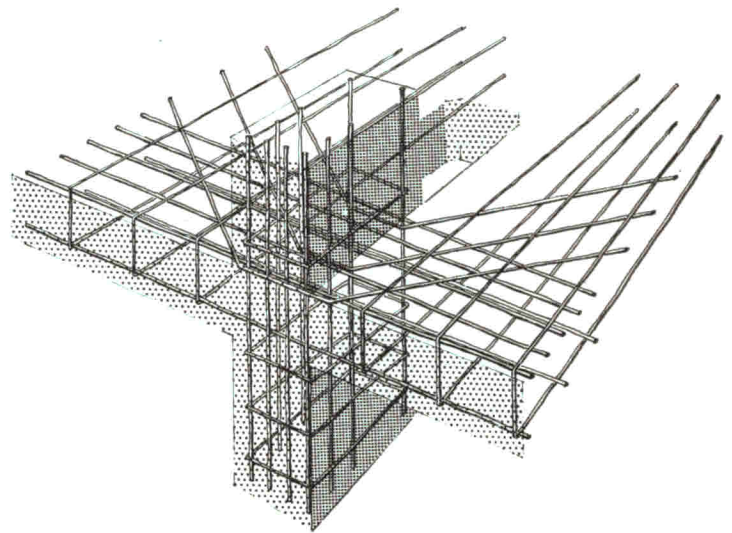

**Figure 11.** This schematic diagram indicates how reinforcement might be arranged to prevent the failures shown by keeping stresses within the capacity of the concrete. To simplify the drawing, general reinforcement of the slab is not shown

®

**STORE FIXTURES: 1 — Merchandise List**

by Daniel Schwartzman, F.A.I.A., Architect

MERCHANDISE CATEGORY LIST

1•PIECE GOODS	Dress fabrics Patterns Sewing machines		Misses Sportswear including Blouses Womens Sportswear including Blouses Budget Sportswear Street floor Sportswear Junior Sportswear Junior Suits & Coats Junior Dresses	12•DRAPERY	Curtains and Draperies Upholstery Blinds and Awnings Bedspreads & Borders
2•DRY GOODS	Linens and Towels Domestics Blankets			13•FASHION HOME FURNISHINGS	Silverware China and Glass Giftware Pictures and Mirrors Lamps
3•SMALLVARES	Notions, including Sewing accessories Closet Shop Drugs Cosmetics Stationery and Greeting cards Books	7•CHILDREN'S WEAR	Infants Wear, includes Layette Infants Furniture Boys 3-6x and 7-14 Girls 3-6x and 7-14 Hosiery Millinery Accessories Shoes Girl and Boy Scouts Sub-Teens Wear Sub-Teens Accessories Teens Wear Teens Accessories	14•HOUSEVARES	Bath Shop Laundry & Cleaning Oilcloth and Paper Kitchen Gadgets Cutlery Bts. and Fans Pantryware Kitchen and unpainted furniture, cabinets Hardware & Paints Small Electrics
4•WOMENS' FASHION ACCESSORIES	Umbrellas, Neckwear and Handkerchiefs Handbags Small leather goods Costume and Better Jewelry Hosiery Gloves Belts Millinery, including Hat Box Shoes, including Casual & Slipper box	8•MENS WEAR	Clothing Sportswear Furnishings Hats Shoes	15•MAJOR APPLIANCES	Refrigerators Ranges Dishwashers Washing Machines Air Conditioners Vacuum Cleaners
5•INTIMATE WEAR	Underwear Corsets and Bras Ribes and Negligees	9•MISCELLANEOUS	Cameras Luggage Sporting Goods Toys	16•MUSIC	Radios, TV, Hi-Fi Records Musical Instruments
6•WOMENS' READY TO WEAR	Misses Better Suits and Coats Womens' Better Suits and Coats Furs Budget Suits and Coats Misses Better Dresses Womens Better Dresses Formal and Bridal Budget Dresses Maternity Aprons and Uniforms Cotton Dresses	10•FURNITURE	Upholstered Furniture Living Room Furniture Dining Room Furniture Terrace Furniture Occasional Furniture Outdoor Furniture Bedding	17•MISCELLANEOUS and CUSTOMER SERVICES	Fet Shop Candy Bakery Groceries Liquor Shop Beauty Salon Photo Studio Optical Shoe Shop Garden Shop Restaurant, Coffee Shop Auto Shop Fur Repair & Storage Shoe Repair Jewelry Repair Appliance Repair Gift Wrap
		11•FLOOR COVERINGS	Broadloom Carpets Summer Rugs Orientals Resilient Flooring Small rugs and Mats		

**STORE FIXTURES: 2 - Typical Fixture Layout; Fitting Rooms**

by Daniel Schwartzman, F.A.I.A., Architect

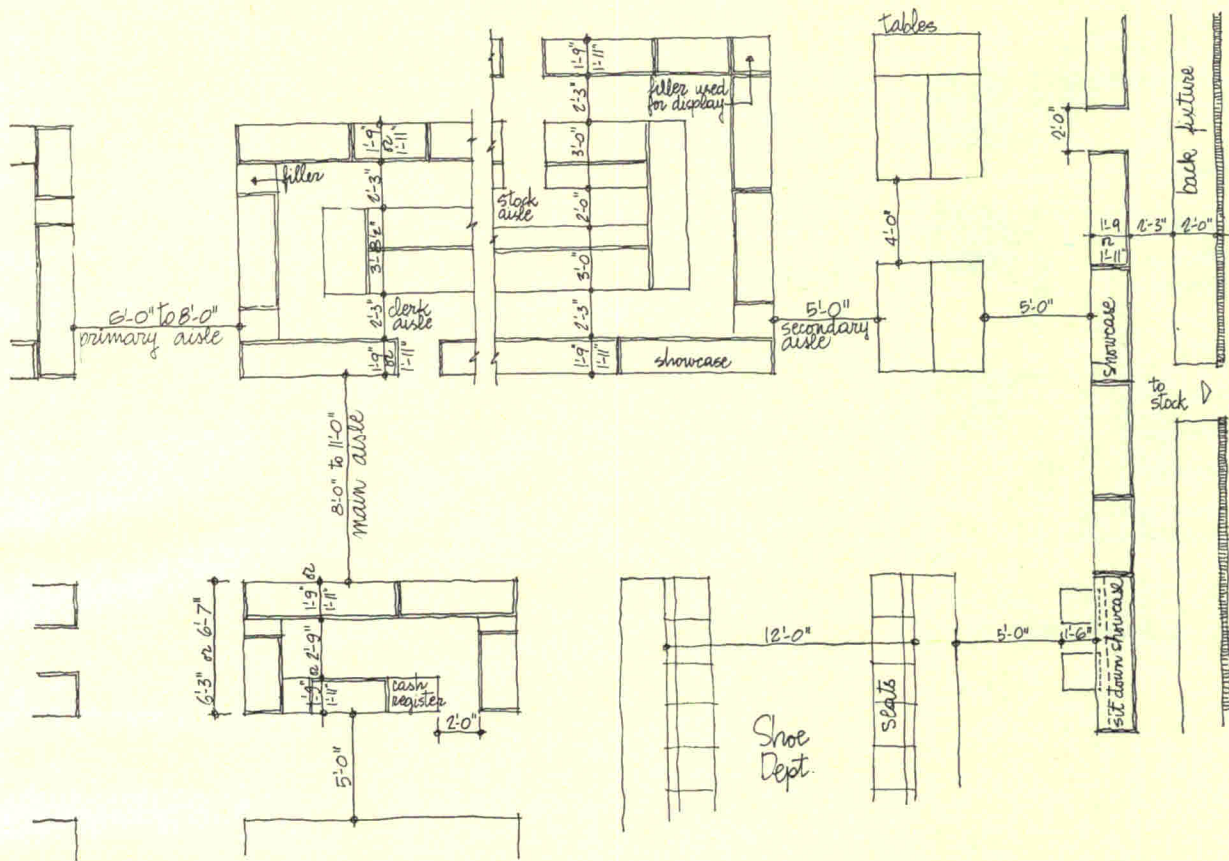

TYPICAL FIXTURE LAYOUT and STANDARD AISLE WIDTHS. scale 1/8" = 1'-0"

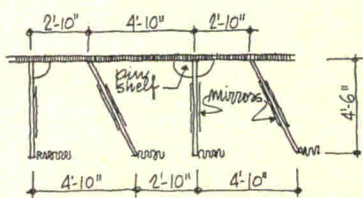

TYPICAL FITTING ROOM

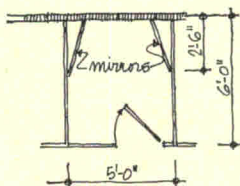

BETTER DRESSES FITTING ROOM

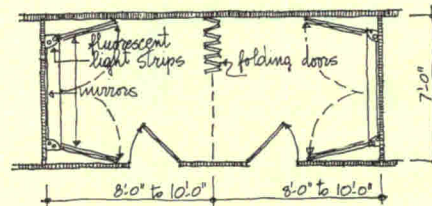

BRIDAL FITTING ROOMS



**STORE FIXTURES: 3 - Back Fixtures; Show cases**

by Daniel Schwartzman, F.A.I.A., Architect

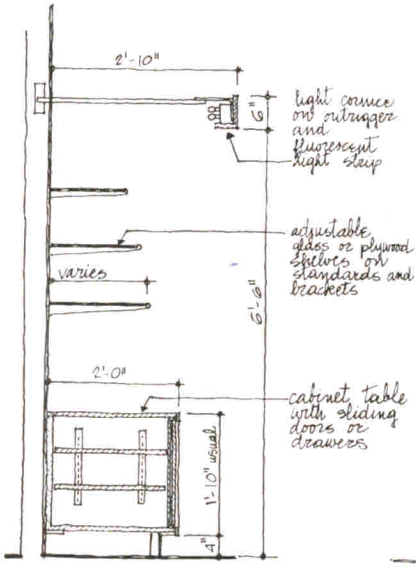

BACK FIXTURE with SHELVES and CABINET UNIT BELOW

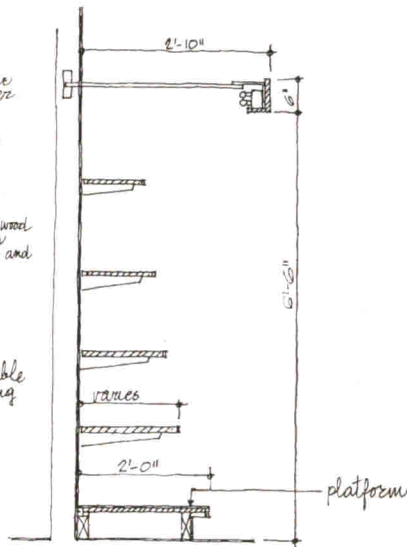

BACK FIXTURE with SHELVES only

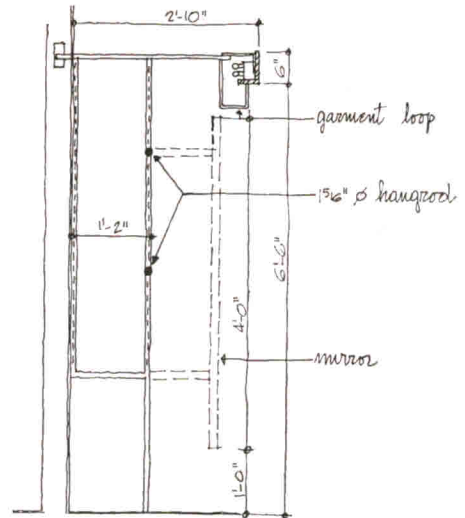

BACK FIXTURE with SINGLE or DOUBLE HANGING

can be converted to shelving

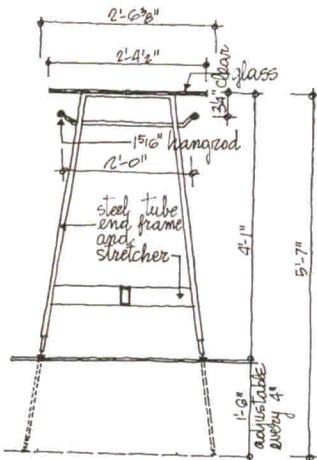

FREE STANDING HANGING RACK

1. length of hanging rack: 5'-0"

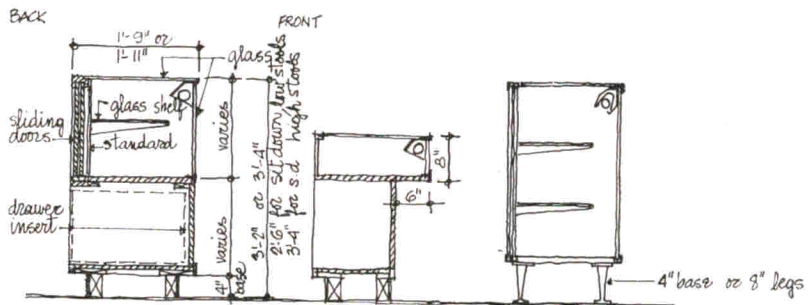

SHOWCASE - wood frame

SHOWCASE - metal frame

1 depth of glass front, 1'-0" to full height  
 2 length of showcase is determined by lamp size and is 2'-4", 3'-9", 5'-7"  
 3 showcase ends, either glass or plywood

1 frame can be stainless steel or extruded nickel silver or bronze

(Continued in June issue)

## SELECTING FOOD SERVICE EQUIPMENT

### Part 2 of 2

Last month's article outlined principles of food service planning such as space and layout requirements and basic criteria for equipment selection. Details and characteristics of several types of equipment were given. Part 2 covers several more types.

NOTE: All details from National Sanitation Foundation Standard 2, Ann Arbor, Michigan

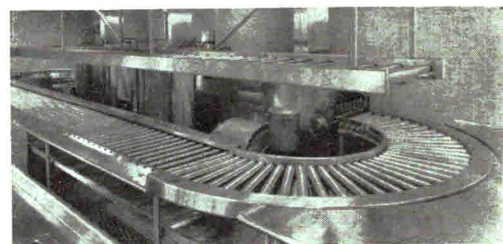

**CONVEYORS** have proved successful in reducing the time involved in moving dishes and food from one place to another in food service operations of all types. They are particularly useful in handling dirty dishes. Almost any conveyor scheme desired can be designed using custom or stock components or a combination of both. Types commonly used include live rollers or belt powered conveyors for moving materials long distances; gravity rollers which are efficient up to 12 feet; vertical conveyors which handle floor to floor movement; and overhead monorails for meat and heavy or bulky materials. Above: Addition, Hotel Fontainebleau, Miami Beach, Fla. A. Herbert Mathes, Architect; Irving Semel, Food Consultant; Straus-Duparquet, Fabricator

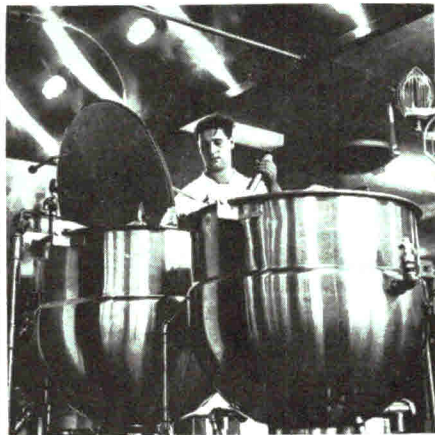
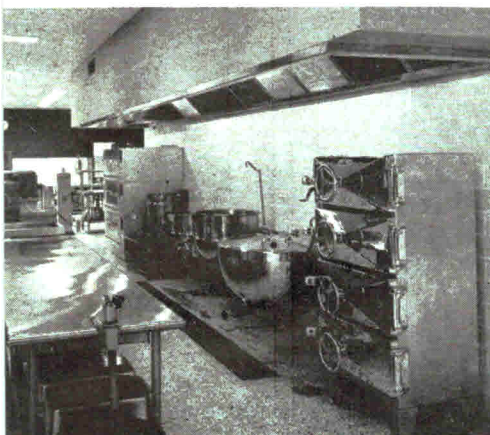

**STEAM COOKERY.** Steam kettles and cookers are fast and economical in the preparation of large quantities of food. Where possible, equipment should be kept off the floor for easy cleaning. Kettles should be set lower than counter height for convenience in loading and unloading. Water and steam facilities should be conveniently arranged for use in cooking and cleaning. Drainage devices and facilities should be planned to eliminate hazards such as curbs, slick or uneven floors and the long flow of hot liquid which might splash on employees. Adequate ventilation for steam vapors should be provided. Left: Warren Township H.S., Indianapolis; Everitt I. Brown & Co., Architects; G. V. Aikman, Food Service Designer; steam kettles, Groen Mfg. Co.; steam cooker, Market Forge Co.; Right: Phelps Memorial Hospital, Kiff, Colean, Voss & Souder, The Office of York & Sawyer, Architect; B. H. Hubbert & Son, Inc., Kettle manufacturer

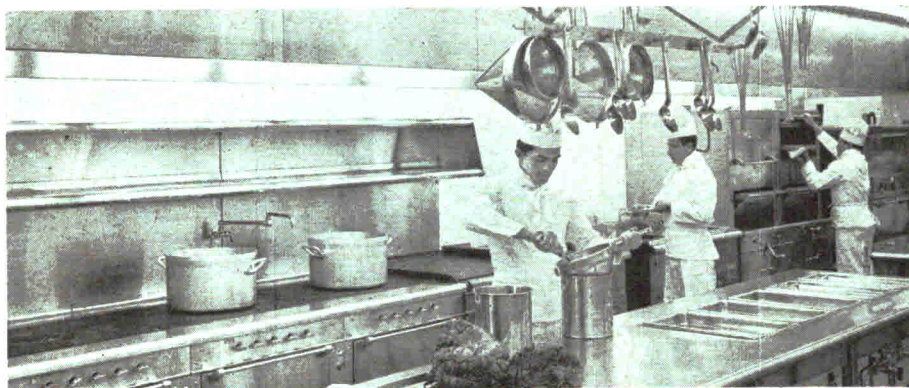

**RANGES, BROILERS AND OVENS.** Qualities to consider are: 1) speed of operation, 2) flexibility, 3) controllability, 4) economy of operation, 5) sanitation, 6) durability. Provision should be made for hoods or canopies which can be cleaned easily. Heavily insulated equipment minimizes kitchen heat and energy consumption. Interior linings of porcelain and exteriors of stainless steel allow easy cleaning. Service facilities must be considered in advance of installation as well as accessibility of equipment for repair. Union Carbide Building, Skidmore, Owings & Merrill, Architects; Howard L. Post, Consultant; Vulcan-Hart Corp., ranges, broilers, ovens; Hotpoint Co., electric fryer

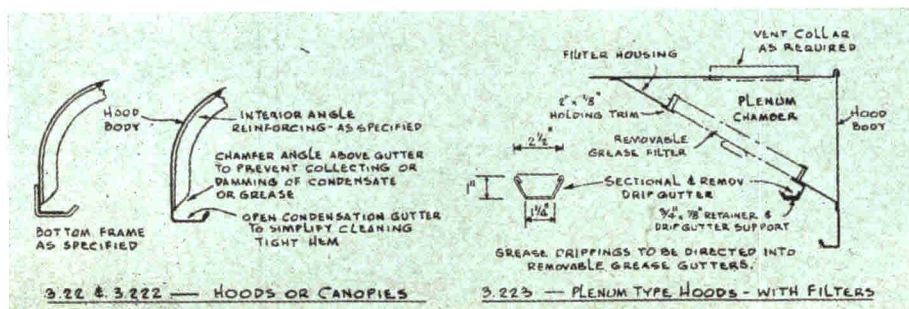



3.282 — INSULATED DOORS

NOTE: PIPE SLEEVE FOR REFRIG. LINES MUST EXTEND ABOVE BOTTOM

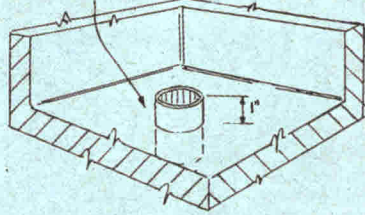

3.057 — FOOD COMPTS. OF REFRIGERATED UNITS

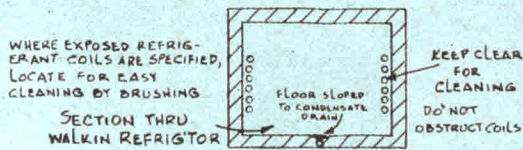

3.231 — REFRIGERATION COILS

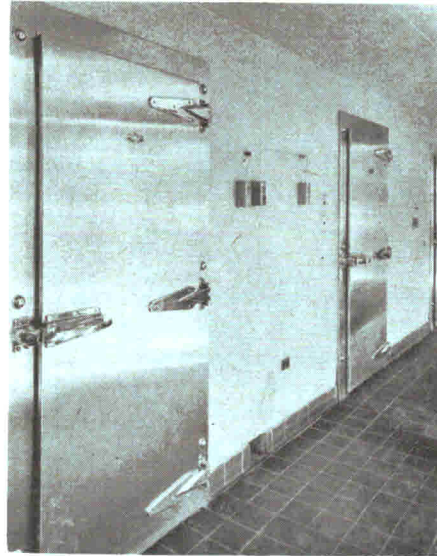

**REFRIGERATORS** should be laid out to allow a minimum amount of food handling and cross traffic. Walk-in type cold storage units for bulk foods, meat and other perishables should be located near the receiving area with preparation areas nearby. Floors should slope to a drain for condensate removal. Refrigerators for salads, beverages, ice cream, etc. are usually placed next to the serving line. For sanitation, the following must be considered: a) gasketing must be cleanable and replaceable; b) exposed refrigerator coils must be located for easy cleaning; c) shelving should be of closed tube or open angle construction. Above, right: *New York Foundling Hospital, New York City; S. Blickman, Inc., Fabricator*

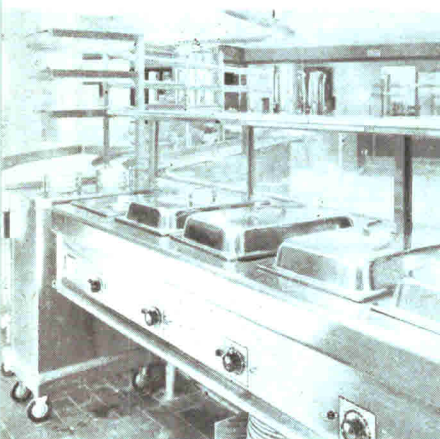

**HOT TABLES** may be either custom designed or assembled from standard units. Warming cabinets should be well insulated to maintain the proper temperature. Electrical, steam, water and drainage facilities should be provided. Wall outlets should be provided in appropriate locations for portable units. Left: *Cafeteria at Columbia University; S. Blickman, Inc., Fabricator*. Electric hot food section in foreground is mounted on carriers to allow easy cleaning and to leave space underneath for portable carriers

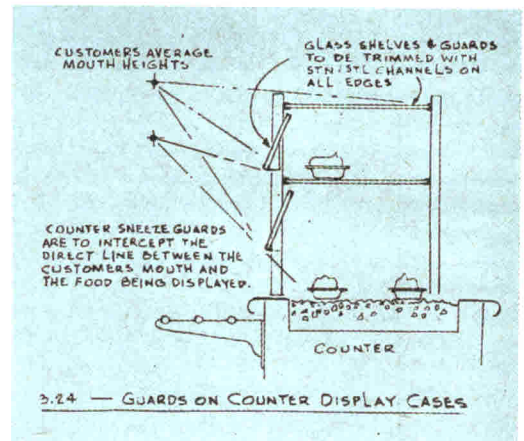

3.24 — GUARDS ON COUNTER DISPLAY CASES

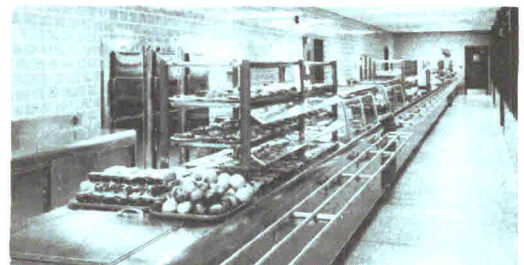

**CAFETERIA LINES** may be custom designed or assembled from standard units. Equipment should be constructed in accordance with National Sanitation Foundation Standards prepared by the Committee on Food Equipment Standards. Electrical, water and drainage facilities should be provided to the line. Be sure that materials and methods of construction are adequately shown and described in the drawings and specifications. *Warren Township High School, Indianapolis; The Bastian-Blessing Co., Fabricator*

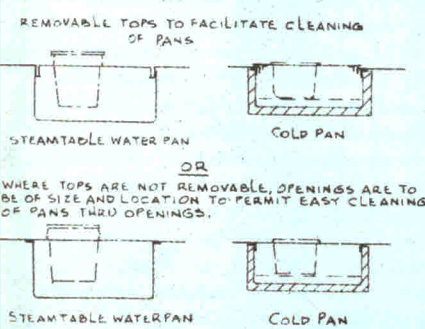

3.57 — TOPS OF STEAMTABLES WITH WATER PANS AND TABLES WITH COLD PANS.

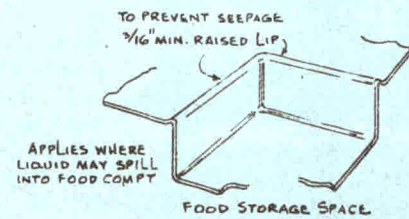

3.055 — TOP OPENING OR RIM

## Aluminum and Plastic Components for Screens and Railings

*Curtainscreen* is a system of standard components in aluminum and plastic designed for exterior and interior screens and railings. The components are a coordinated group of interlocking, slip-fit extrusions—mullions, panels, spacers and glass stops.

Aluminum components are furnished in a variety of finishes, including plain (for anodizing or enameling), anodized, etched decorative designs, or laminated wood veneers. Plastic components are black, will be made available in colors later.

These standard components can be used either alone or in combination with other materials, such as panels of wood, glass, sheet plastic, or laminated glass fiber sheet. A special feature of the system is that its components can be used to form single or dual plane screens, for three-dimensional effects or for free-standing

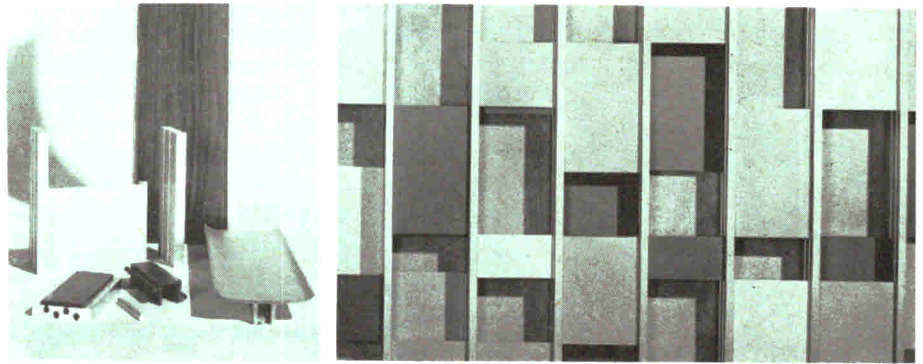

screens which must be finished on both sides. The aluminum panels are available in 4-, 6-, and 8-in. widths, and lengths up to 20 ft. Panels can be placed side by side for appearance of even greater width, and can also be placed end to end for greater length.

In exterior applications, *Curtainscreen* can be used to form solar screens, protective screens for walk-

ways and arcades, and screens for cooling towers or mechanical equipment. Typical interior applications include divider partitions, facing screens for walls and ceilings, and display partitions. A booklet describing and illustrating the complete *Curtainscreen* system in greater detail is available. *Julius Blum & Co., Inc., Carlstadt, N. J.*

## Factory-Fabricated Wall is Sealed by a "Zipper" Gasket

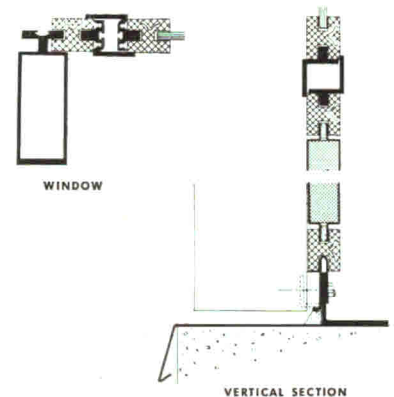
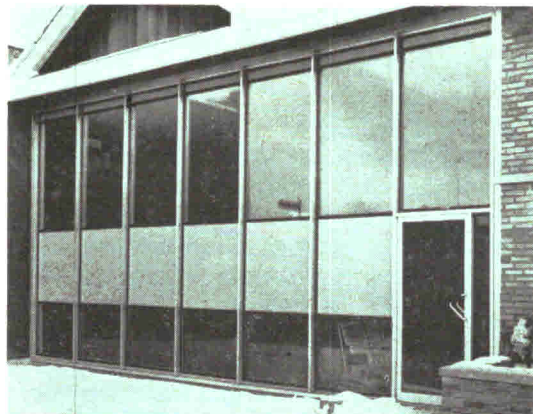
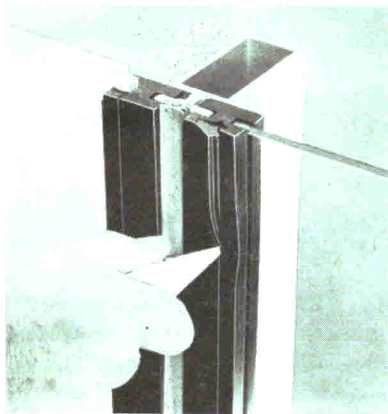

*Zipperwall* is a new wall system featuring a structural neoprene gasket and factory fabricated aluminum mullions, panels and windows. The "H" shaped neoprene gasket serves as the connector of most structural components. The gaskets are used as horizontal members, becoming an actual part of the wall framing. The gaskets transmit loads from glass and panels, and live loads imposed upon them, to the mullions.

Basic aluminum parts of the system are the mullions, sill and head runners and adapter angles. Only two clips and screws, at the top and

bottom of each mullion, are used in assembly.

All parts, except for the slim mullions, are cut to size from stock lengths at job site. Mullions are delivered in factory fabricated lengths according to the architect's plans.

Infill components of glass, panel, sash or combinations, are "zipped" into the exposed opening of the weatherstrip with a special tool.

Joint sealing problems are obviated by the neoprene's ability to absorb expansion of infill components. Runners and mullions with matching flanges on the same plane leave no

corner crevices which can become seepage problems.

This system is suited for either 1/4-in. glass or flanged 1-in. panels, although a larger gasket will be made available for thick glass. The 1-in. panels are formed from pre-coated steel insulated with an expanded perlite core.

The *Zipperwall* system accommodates Kawneer doors, concealed overhead closers or other Kawneer closers of the surface applied or overhead type anywhere in the grid. *Kawneer Co., 1105 Front St., Niles, Mich.*

*more products on page 214*

**Axial-Flow Fans**

Axial-flow fans for heating, cooling, ventilating, fume removal, and drying systems, are described in a new 16-page illustrated bulletin. Fans with direct-connected motors and designs with V-belt drive are covered. Construction details, optional equipment, specifications, tables of capacities and dimensions are included in the new bulletin AFF-61. *L. J. Wing Mfg. Co., Linden, N. J.*

**Built-Up Roofing Manual**

The 52-page 1961 Barrett Built-Up Roofing Manual covers specifications for both pitch and asphalt applications on all types of roof deck. Emphasis has been given to the advantages of fiberboard roof insulation. The new manual also depicts many flashing details together with drainage and vent flashing systems and appropriate materials. Included are simplified illustrations and tables which enable architects to select materials appropriate to the type of bond required. Included are new roofing specifications which require a coated base sheet over all forms of roof insulation. Recommendations are offered for temporary roofing to protect new roof decks. *Product News Section, Barrett Division, Allied Chemical Corp., 75 West St., New York 6, N. Y.\**

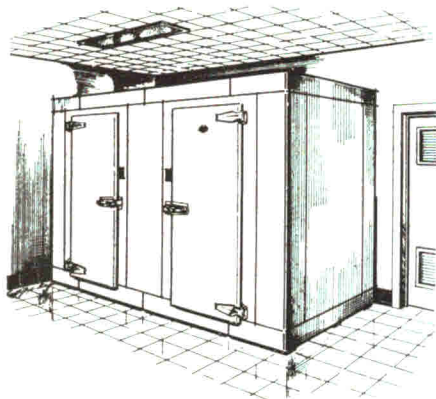

**Walk-In Coolers and Freezers**

Portfolio give 48 different installations in hospitals, laboratories, universities, schools and industrial plants. Plans, sections and perspectives are given along with a condensed specification list. Catalogs are available for detailed technical information on sectional, all-metal walk-in refrigerators. Information is included on interior accessories and refrigeration apparatus. A comprehensive specification guide also is available. *Bally Case and Cooler, Inc., Bally, Pa.*

**Steel Tubing**

Describes both seamless and electric welded steel tubing up to 7-1/2 in. o. d. by .375 in. wall in mechanical and pressure grades. Seamless carbon and alloy steel tubing is listed up to 7-in. o.d. in mechanical, pressure, aircraft mechanical and airframe grades. Additional material covers square, rectangular and other special shapes and fabricating and forgoing of tubing into finished or semi-finished tubular parts. Catalog CS-61, 8 pp. *Ohio Seamless Tube Division of Copperweld Steel Co., Shelby, Ohio.*

**Metal Partitions, Compartments**

Henry Weis Mfg. Co. has brought out three new catalogs featuring cabinet showers, toilet compartments and movable office partitions. Six new cabinet shower models, glass and vinyl shower doors, glass shower enclosures and receptors are described in the cabinet shower catalog. The toilet compartment catalog illustrates a line of plastic laminated toilet compartments as well as baked

enamel and porcelain enamel compartments. Movable office partitions are featured in a third catalog. *Henry Weis Mfg. Co., 226 West High St., P. O. Box 724, Elkhart, Ind.\**

**Steel Windows and Screens**

Complete line of steel windows available for commercial, monumental and industrial buildings is shown in a 40-page *Ceco* catalog, No. 1001-Q. Contains technical data on 1 1/2-in. heavy-intermediate windows, sub-frame construction, classroom windows, 1 1/4-in. intermediate windows, architectural projected windows and industrial windows. In addition, mechanical operators and screens are illustrated. Window sections and recommended installation details are given, supplemented by photographs of finished buildings. *Department A, Ceco Steel Products Corp., 5601 West 26 St., Chicago 50, Ill.\**

**Ballasts for Fluorescent Lamps**

Contains revised tables of prices and data for General Electric's full line of fluorescent lamp ballasts. Has sections on new Bonus Line and totally weatherproof ballasts, as well as applications and operating data on other indoor and outdoor ballasts. Cross-section dimensions, wiring diagrams, obsolete ballast replacement table, and installation instructions are included. 4 pp. *General Electric Co., Schenectady 5, N. Y.*

**Condulets**

Condulets for hazardous locations and pertinent sections of the National Electrical Code are discussed in Bulletin 2722, a 60-page publication by Crouse-Hinds Co. Code articles are quoted, along with recommendations for meeting their requirements. *Crouse-Hinds Co., Syracuse 1, N. Y.*

**Air Distribution**

Condensed catalog of air distribution allows designers to survey the wide range of equipment designs, sizes, finishes, and applications available from Barber-Colman. Included in this 8-page catalog (F-4417-8) is information on new continuous line extruded aluminum ceiling diffusers and modifications to continuous line diffusers. *Barber-Colman Co., 1300 Rock St., Rockford, Ill.\**

*\*Additional product information in Sweets Architectural File more literature on page 248*





and beauty to new medical center!

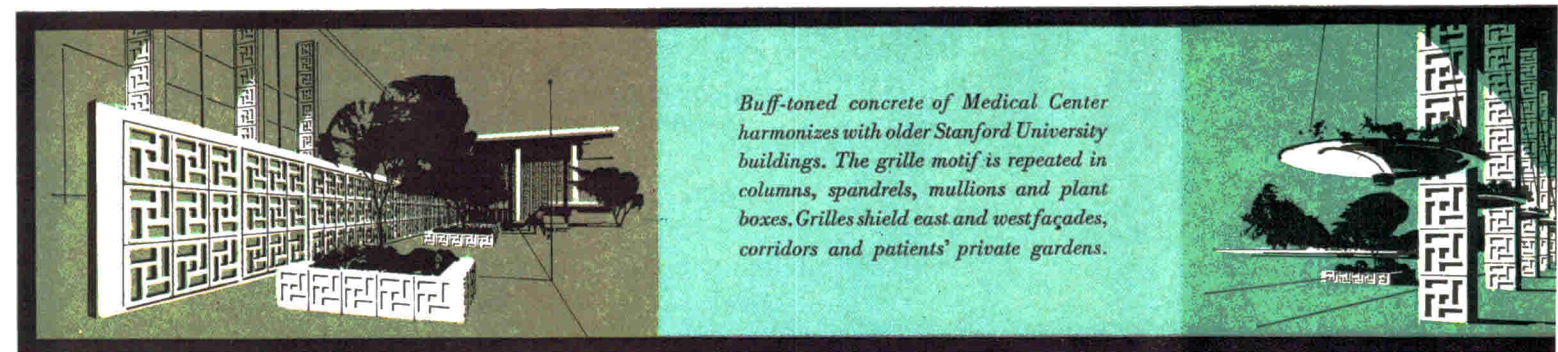

*Buff-toned concrete of Medical Center harmonizes with older Stanford University buildings. The grille motif is repeated in columns, spandrels, mullions and plant boxes. Grilles shield east and west façades, corridors and patients' private gardens.*

## Product Reports

continued from page 207

### New School Unit Ventilator

*School-Vent* utilizes a novel, full-damper system to provide positive, constant room temperature control for heating, ventilating and cooling: 1) a face-an-bypass insulated damper directs air through and around the heating coil according to comfort requirements; 2) an insulated anti-wipe damper permits complete isolation of the coil to eliminate heat pick-up from the coil; 3) indoor and outdoor dampers blend fresh and recirculated air. This full-damper system is designed to insure accurate temperature control with no delay between comfort demand and delivery. *Modine's School-Vent* heat with steam or hot water and cools with central-source chilled water. Five sizes up to 1500 cfm heating and cooling are available. The unit can be ceiling or wall mounted, partially and fully recessed or fully exposed. *Modine Manufacturing Co., 1500 DeKoven Ave., Racine, Wisconsin.*

### Automatic Light Switching

Photo-electric control has been combined with time switching in a new automatic on/off control for lighting by *Tork Time Controls*. The photo-sensitive time control turns lights on whenever natural light drops to 2 to 4 footcandles. Momentary darkness, however, will not affect the switch. Automatic off switching means lights do not have to remain on overnight as with ordinary photo electric controls. Capacities go up to 4000 watts. *Tork Time Controls, Inc., Mount Vernon, New York.*

### Prefabricated Shower Compartment

*Showerpack* is a packaged<sup>®</sup> shower unit which includes a precast terrazzo receptor, shower door and enclosure pieces of Napoleon Grey Marble. *Carthage Marble Corp., Carthage, Mo.*

### Honeycomb Ceiling Panel

*Metalcel* is a steel honeycomb panel designed for illuminated ceilings with  $\frac{3}{8}$ -in. hexagonal cells and in sizes 2 by 4 ft, 2 by 3 ft, 2 by 2 ft, 2 by 1 ft, 1 by 3 ft and 1 by 1 ft. It is painted with two coats of baked white enamel or copper brazed finished and weighs 0.98 lb per sq ft. *Metalcel Division, Fannon Products, 3000 East Woodbridge, Detroit 7, Mich.*

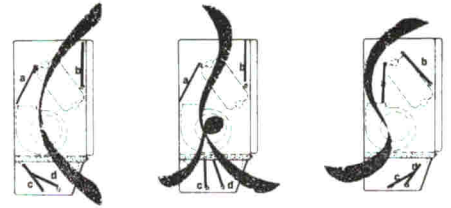
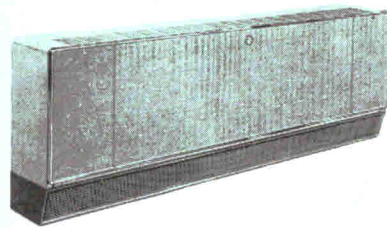

Left: Nighttime operation; full recirculation. Center: Room air, outside air mixed. Right: Full outside air

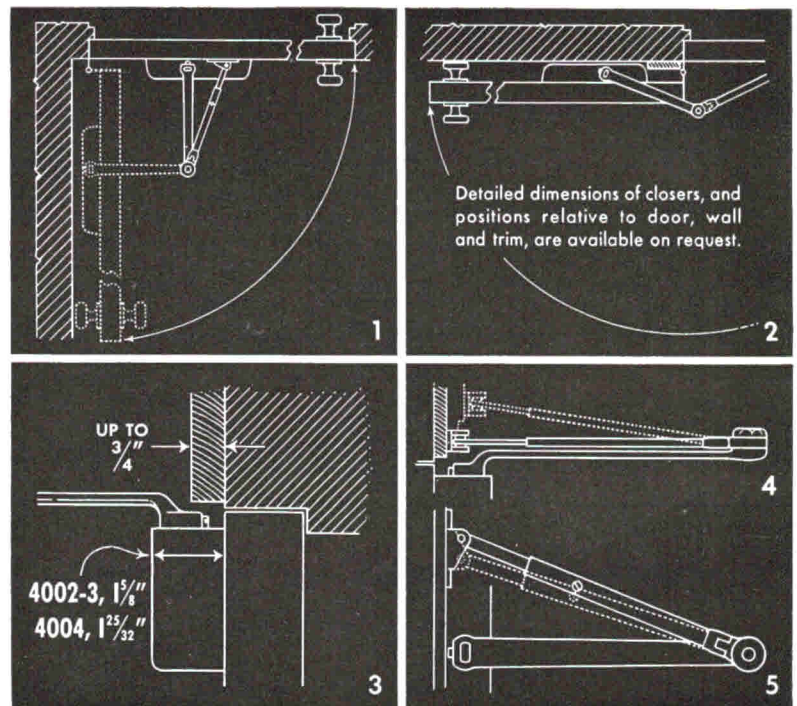

### APPLICATION DETAILS

for the Modern LCN "Smoother" Exposed Door Closer  
Shown on Opposite Page

As Demonstrated in Drawings Above:

1. The LCN "Smoother" takes less space than most doorknobs between door and wall.
2. Degree of door opening possible depends mostly on type of trim and size of butt used.
3. Arm of LCN "Smoother" is curved to avoid conflict with almost any conventional trim.
4. Joints in arm and shoe make it easy to vary the height of shoe as needed for beveled trim.
5. Power of closer is increased or decreased by simply reversing position of shoe.

Complete Catalog on Request—No Obligation  
or See Sweet's 1961, Sec. 18e/Lc

**LCN CLOSERS, INC., PRINCETON, ILLINOIS**

Canada: LCN Closers of Canada, Ltd., P. O. Box 100, Port Credit, Ontario

more products on page 218



“**d**esign flexibility  
plus the appropriate  
natural appearance”—*architect*

“Rilco laminated wood arches and beams gave us design flexibility plus the appropriate natural appearance,” state the architects. “They blended in perfectly to create a warm, colorful and informal atmosphere.”

■ ■ ■ Rilco laminated wood structural members are easily adapted to any design—church, school, residential or commercial. They gracefully span large areas—provide the warm, friendly feeling of wood without extra cost. Rilco field sales engineers will be happy to consult with you ■ ■ ■ Write Weyerhaeuser Company, Rilco Engineered Wood Products Division, W818 First National Bank Building, St. Paul 1, Minnesota. District offices: Linden, New Jersey; Fort Wayne, Indiana; Tacoma, Washington.

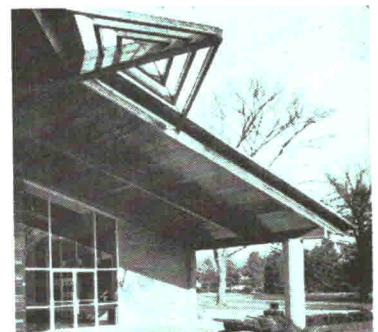

The Holden Museum of Living Reptiles, Detroit Zoological Park, Detroit, Mich. Architects: Charles N. Agree, Inc., Detroit. Rilco laminated wood arches and beams erected by Laco, Inc., Fraser, Mich.



**Weyerhaeuser**  
**RILCO ARCHES**

# DUKANE

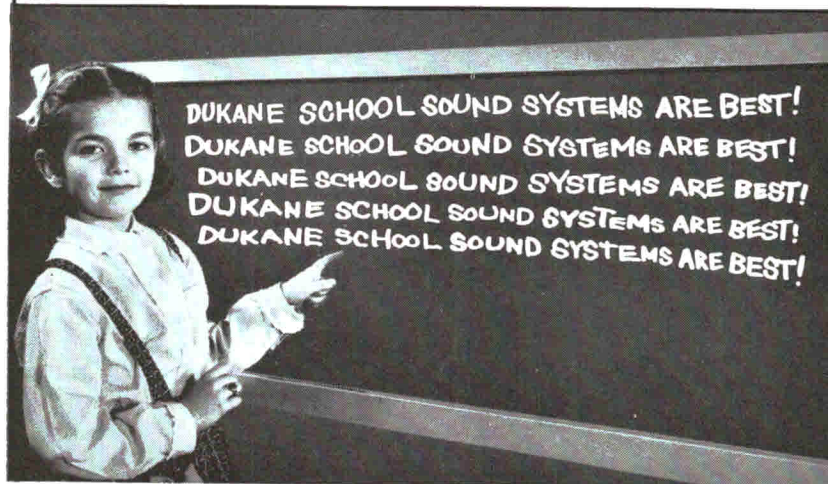
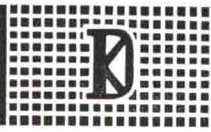

## MORE THAN 300 REASONS WHY DUKANE SCHOOL SOUND SYSTEMS ASSURE QUALITY SOUND PERFORMANCE

**REPUTATION**—DUKANE engineering "know-how" in the field of school sound systems is widely recognized. Each school sound system is built with all the scientific quality control that modern industry commands. Perfection in quality sound reproduction and maximum functional utility are integral design features of every system. **FLEXIBILITY**—DUKANE modular construction provides for future expansion. Advanced electronic design eliminates costly custom design time and modification. There is a DUKANE School Sound System to meet every size school requirement. **INSTALLATION AND SERVICE**—Over 300 DUKANE Sales-Engineering Distributors across the nation assure customer satisfaction beyond the sale. From tailoring a school sound system to meet needs and budget, supervising installation, instructing personnel in operation to assuming the responsibility for satisfaction during the years of usage, DUKANE Sales-Engineering Distributors provide the final link between manufacturer and ultimate user that assures quality sound performance.



Three Channel System, Four microphone inputs, many deluxe extras. Serves up to 150 classrooms or areas.

### JUST A FEW OF THE COMPLETE LINE OF DUKANE SCHOOL SOUND SYSTEMS



Two Channel System, Three microphone inputs. For schools with up to 48 classrooms or areas.

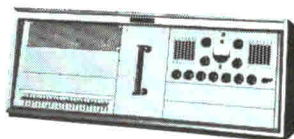

Dual Channel System, Four microphone inputs. For schools with up to 75 classrooms or areas.

# DUKANE CORPORATION

Dept. AR-51, St. Charles, Illinois

Write for Bulletin



## Product Reports

### Epoxy Fastens Anchor Bolts

*Sika Epoxy Bonding Compound* has been used in a new technique for positioning anchor bolts for the posts of railings on concrete structures, eliminating the necessity for placing these bolts within the formwork prior to pouring of concrete. First application was on the Oneida Lake Bridge at Brewerton, New York. The epoxy compound was applied both to a small portion of the concrete beam and to the steel plate to which the anchor bolts had been welded. When the epoxy became tacky, the plate was placed on the beam; no pressure was required. *Sika Chemical Corp., Passaic, New Jersey.*

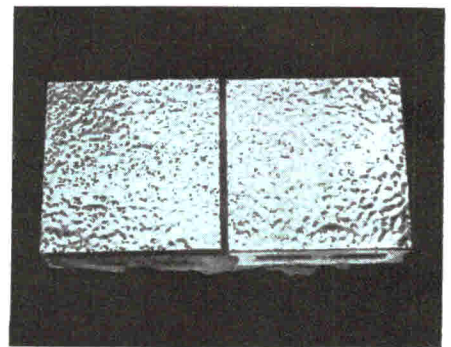

### Bright Gold Coatings

*Hanovia* gold (23 k) coatings are being applied with increasing frequency for office buildings, bank fronts, stores and similar structures. The gold coating can be applied to porcelain enameled metals, stainless steel, tile glazed brick, structural glass, terra cotta. Coatings may be applied by brush, roller or spray, and decorative patterns are achieved by silk screening, rubber stamping or by rollers. The gold is suspended in an organic liquid; when this carrier is burned off, it leaves the gold film. *Hanovia Liquid Gold Division, Engelhard Industries, Inc., 1 West Central Ave., East Newark, N. J.*

### Stipple Architectural Glass

A new translucent rough-textured plate glass with a stipple pattern surface is being produced in a  $\frac{3}{32}$ -in. thickness for use in interior partitions. The stipple pattern is the second product to be added to the Pittsburgh Plate Glass line for interior partitions; the other product is a swirl pattern, rough plate glass. *Pittsburgh Plate Glass Co., 632 Fort Duquesne Boulevard, Pittsburgh 22, Pa.*

more products on page 222

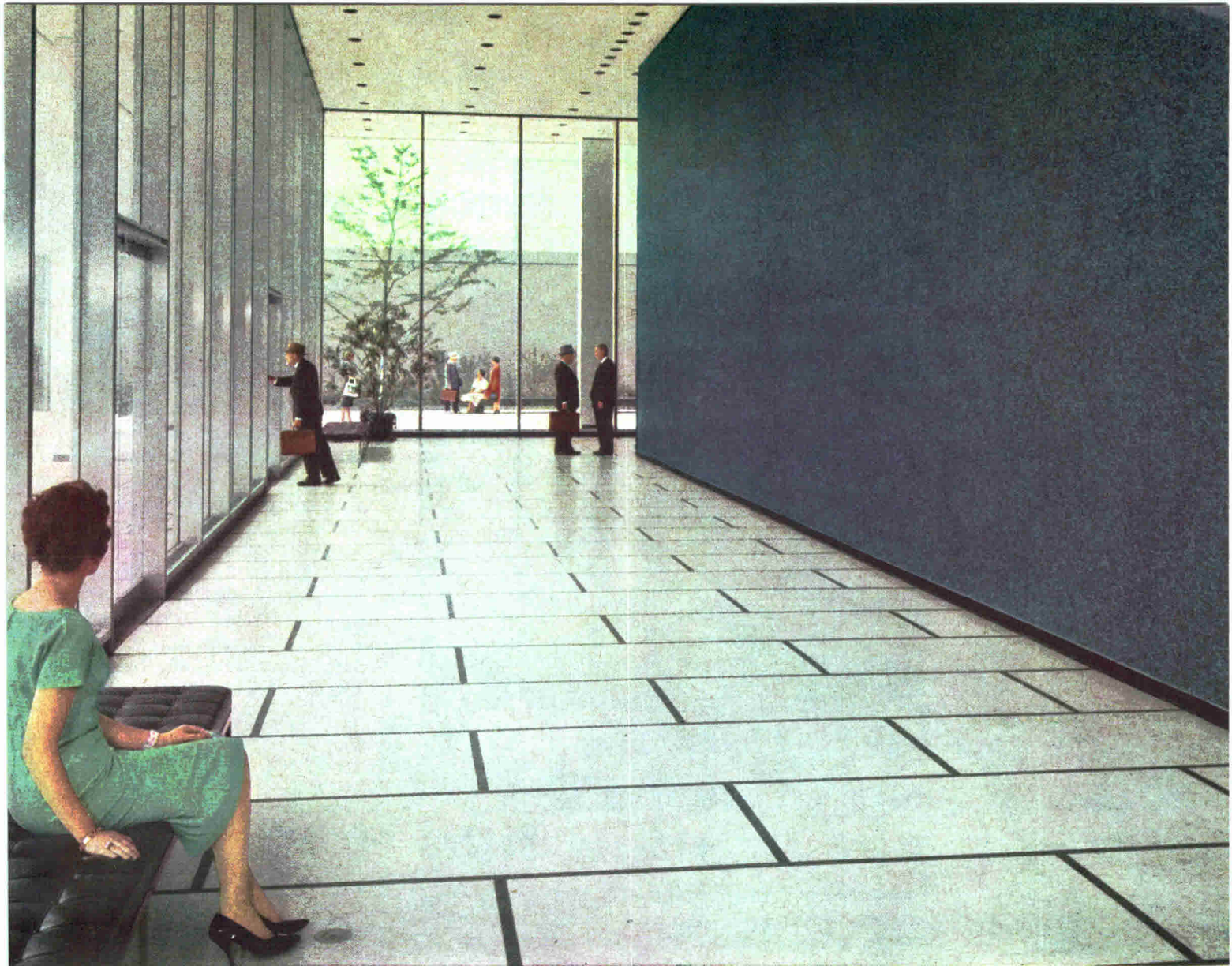

LIBBEY-OWENS-FORD BUILDING, TOLEDO. ARCHITECTS: SKIDMORE, OWINGS & MERRILL. PHOTOS: HEDRICH-BLESSING STUDIO, CHICAGO.

## *Indoors and Out, Terrazzo Paves the Way to Contemporary, Ageless Beauty*

Trim, simple and clean, the L-O-F office building in Toledo offers the look of brisk efficiency associated with modern design. Yet its Terrazzo floor is ageless. Covering radiant coils (used for snow melting) outdoors, and basement area, as well as the entire lobby, 60,000 square feet of decorative Terrazzo offer a marble-hard, jointless surface that is virtually impossible to wear out. The pattern is a basic 6 x 3' rectangle, outlined with black dividing strips. Slip-proof-treated, requiring only wet cleaning (*no refinishing, no*

buffing needed), Terrazzo meets practical as well as aesthetic needs.

Co-starred is the lobby's mosaic wall—four million pieces of specially made blue tesserae individually placed in two 25 x 62 x 20' sections. Not only visually delightful, the mosaics are *permanently* easy to clean.

No pattern or situation is too difficult for Terrazzo. Specify any design you wish, in virtually any combination of colors. Free AIA kit upon request. Catalogued in Sweet's.

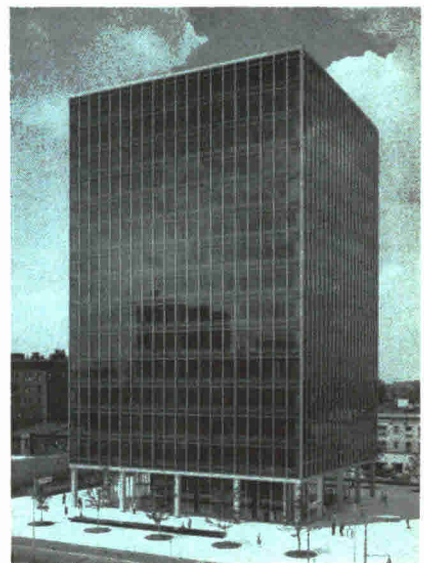

# HOW TO

## SET A SIGNAL PROGRAM SCHEDULE

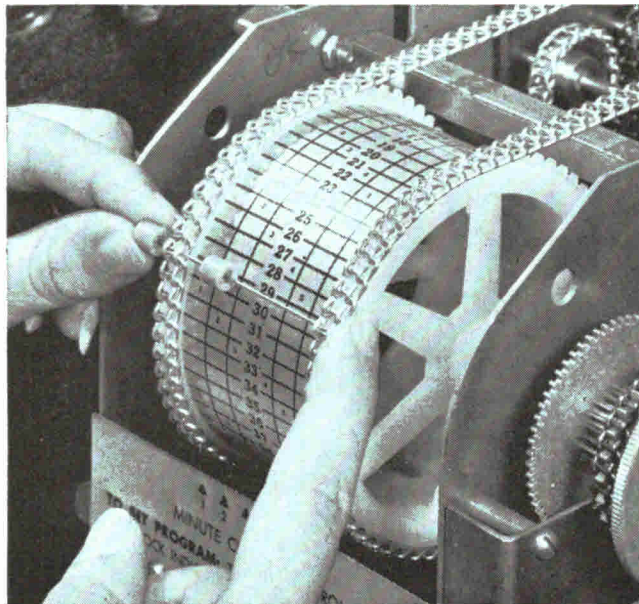

### THE EASY WAY WITH A **Cincinnati** CLOCK AND PROGRAM SYSTEM

Push a roller on a pin—Your signal is set. It's that simple with a Cincinnati System! Anyone can set a signal program schedule in minutes. No tools are required. And, pins and rollers are re-usable.

Contrast this simple procedure with any other system.

You'll also find features like wall or flush mounting and the exclusive swing-out construction make a Cincinnati System simple to install and maintain. There's also an automatic 12 hour reset correction and spring reserve to help overcome power failure and assure continuous, accurate signal and clock operation.

Get the complete story by contacting your nearby Cincinnati representative; or, send for your free copy of the "Time Systems Handbook" covering "Clock and Program" and "Fire Alarm" systems.

**IF IT'S ABOUT TIME . . . CALL FOR . . .**

**THE Cincinnati TIME RECORDER CO.**  
1740 Central Avenue  
CINCINNATI 14, OHIO  
SINCE 1896

Gentlemen:

Without charge or obligation, please send my new "Time Systems Handbook."—A basic guide to clock and program systems.

Name \_\_\_\_\_

Address \_\_\_\_\_

City \_\_\_\_\_ State \_\_\_\_\_

Organization \_\_\_\_\_ Position \_\_\_\_\_

## Product Reports

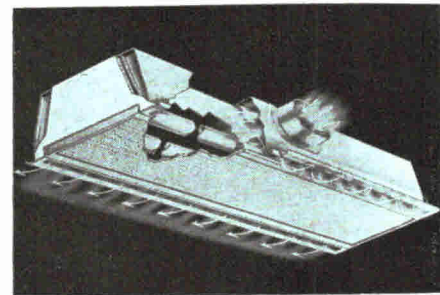

### Combination Fixture

*Curtis Allbrite Ventro-Lux* combines a lighting troffer with a high capacity Anemostat air diffuser. The troffer uses a CALux lens to conceal lamps as well as provide light diffusion. The air diffuser distributes air horizontally along the ceiling to eliminate drafts and uncomfortable temperature changes. Silhouette of the fixture is 6 in. or less. The two units are installed separately to eliminate trade conflicts. *Curtis Allbrite Lighting, Inc., 6135 W. 65th St., Chicago 38, Illinois.*

### New Line of Fan Coil Units

*AIRditioner* fan coil units are available in 11 different types up to 1500 cfm capacity for mounting on floor, wall or concealment in the wall. One of the new features, offered as optional equipment, is an automatic push-button lubrication system. Quiet operation is insured through rubber-pad mounting of motors, low-speed fans with shock-absorbing bearings, and insulation and mastic to deaden noise. *Modine Manufacturing Co., 1500 DeKoven Ave., Racine, Wisconsin.*

### Commercial Refrigerators

The *Raetone* line of commercial reach-in refrigerators, freezers, under-counter refrigerators, beverage coolers and water stations has been redesigned to be in full compliance with the National Sanitation Foundation standards and to provide a number of features improving operation and maintenance. These include: 1) four inches of insulation in cabinets, 2) larger, rounded interior corners, 3) heavy-duty pan slide and shelf supports, 4) tubular-type, 6-in. adjustable legs, 5) electric condensate vaporizer to eliminate need for floor drains, 6) self-closing hinges and magnetic catches. *Raetone Commercial Refrigerator Corp., Plymouth Meeting, Pa.*

*more products on page 226*

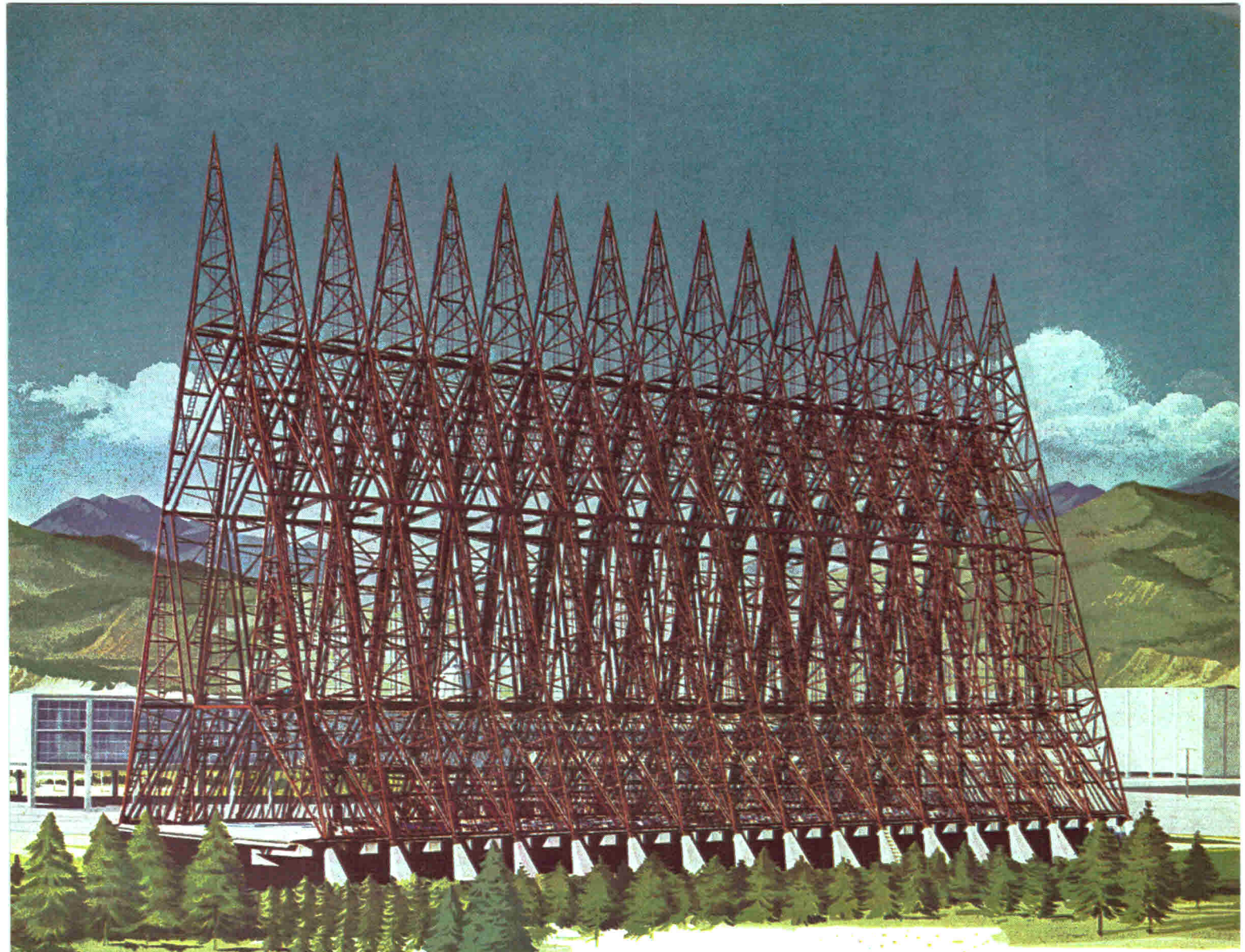

MVSS developed special equipment for guiding torches, special jigs for holding and turning 100 4½-ton tetrahedrons while mitering and welding the tubular steel at vertices of 7 components — at uncommon angles.

*Architect —*  
Skidmore, Owings & Merrill  
Chicago

*General Contractor —*  
Robert E. McKee  
General Contractor, Inc.,  
Santa Fe

## SPAN-POWER\*

U. S. AIR FORCE ACADEMY, COLORADO: Aesthetics and Engineered strength are combined in sloping “roof” and “walls” to give a structural design that echoes the individuality of surrounding Colorado Rocky Mountain Peaks. 100 tubular steel tetrahedrons rise sharply in varied planes from the floor of the new Air Force Academy chapel, to converge 150 feet above in 17 spiry peaks. 100 of these massif-like modules, each 75 feet long and weighing 4½-ton, were fabricated to exacting government specifications by MVSS in 20 weeks.

\***MVSS HAS IT** 1100 men and their manpower . . .  
six completely equipped fabricating plants . . .  
three erection companies . . . generate MVSS span-power.

Steel tetrahedrons surfaced with aluminum panels are the architectural essence of the chapel—which Air Force officials term “the commanding structure on the campus”. Upon completion, 1500 cadets . . . Protestant, Catholic and Jewish, will worship within its three sanctuaries.

**MISSISSIPPI VALLEY**

**STRUCTURAL STEEL COMPANY**



Six Strategic Plants • Chicago (Melrose Park) • St. Louis, Mo.  
Flint, Michigan • Lansing, Michigan • Decatur, Illinois • Chattanooga, Tenn.

© 1961 MVSS CO., Decatur, Illinois

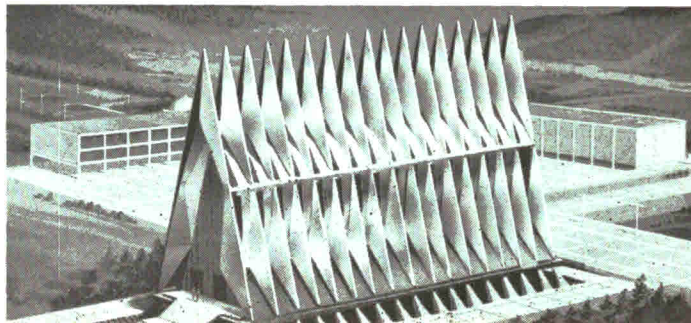

# GRIFFIN

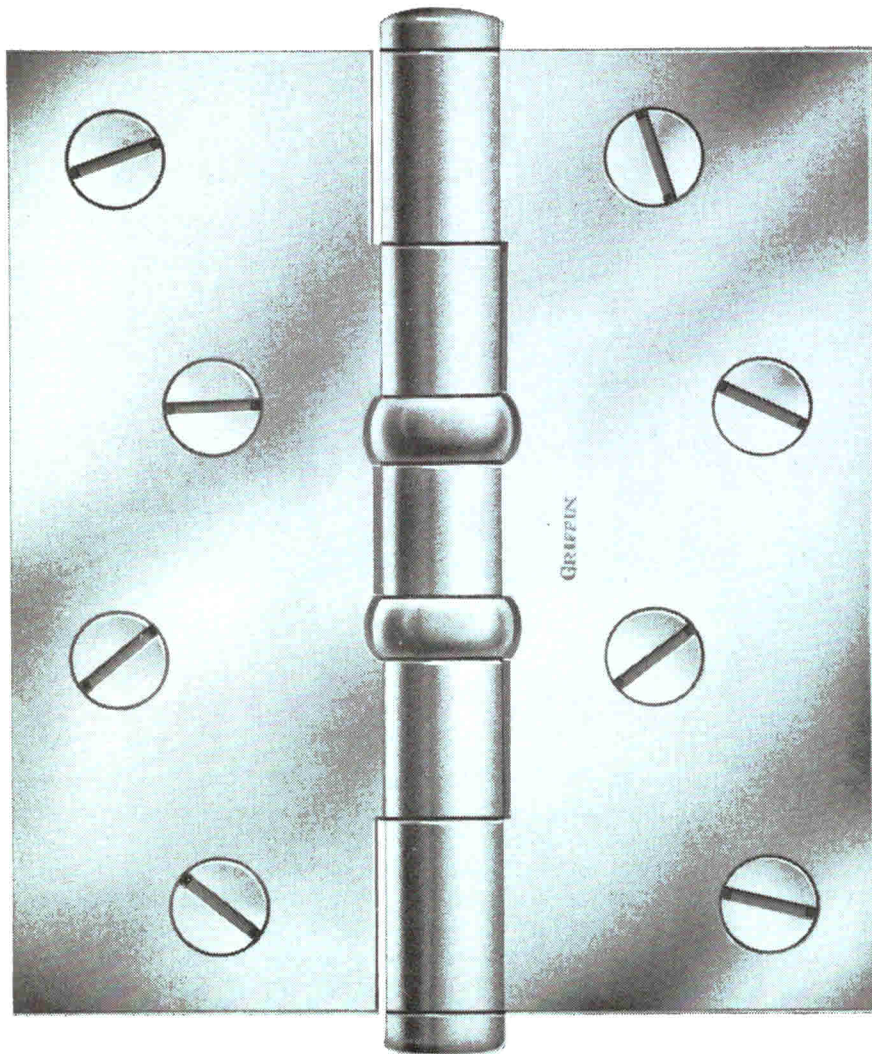

## HINGES for DOORS of AVERAGE FREQUENCY USE

Full mortise, ball bearing, template hinge with non-rising pins for medium weight interior or exterior doors of average frequency use. Made of wrought steel, planished and plated or bonderized and primed for painting. Also available in solid brass, bronze or stainless steel with stainless steel pins. Wide throw steel hinges available when clearance is required. All hinges conform to Federal specifications.

**GRIFFIN MANUFACTURING COMPANY • ERIE, PA.**

## Product Reports

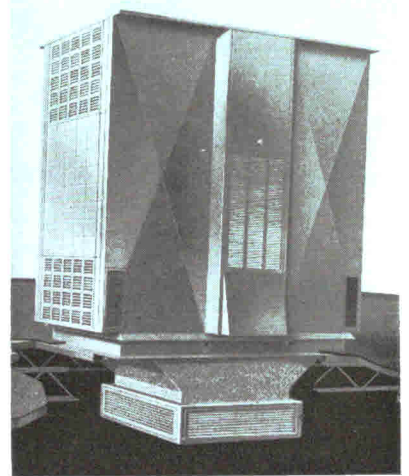

**Roof-Top Air Conditioning Unit**  
A new roof-mounted heating, ventilating and air conditioning unit for stores, office buildings and other commercial structures delivers either 7½ or 10 tons of cooling combined with heating capacity from 204,000 to 340,000 Btuh. Conditioned air may be ducted or distributed through a specially designed diffusing head which projects below the ceiling surface. The unit employs a remote compressor-condenser. *Lennox Industries, Inc., Marshalltown, Iowa.*

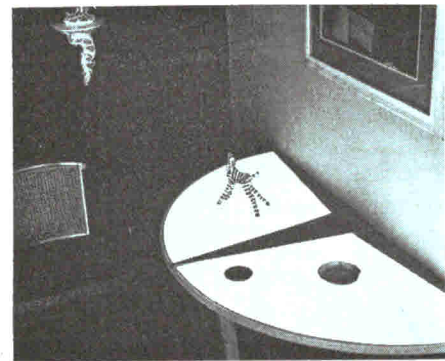

**Electroluminescent Lamps**  
Westinghouse has announced the availability of *Rayescent* lamps in sizes up to 30-in. square in a variety of colors including green, orange, blue and yellow. Individual lamps may be multicolored and in practically any two-dimensional shape. Lightweight aluminum fixtures are available for mounting. Intensity of the light may be varied by means of a simple dimming device. Surface brightness is approximately 10 foot-lamberts at 600 volts, 60 cycles. *Westinghouse Electric Corporation, Lamp Division, Bloomfield, New Jersey.*

*more products on page 236*



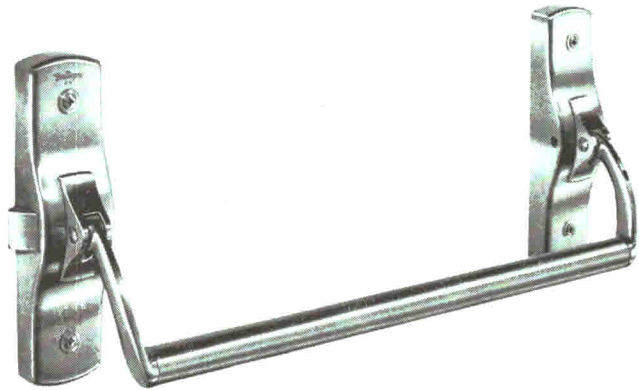
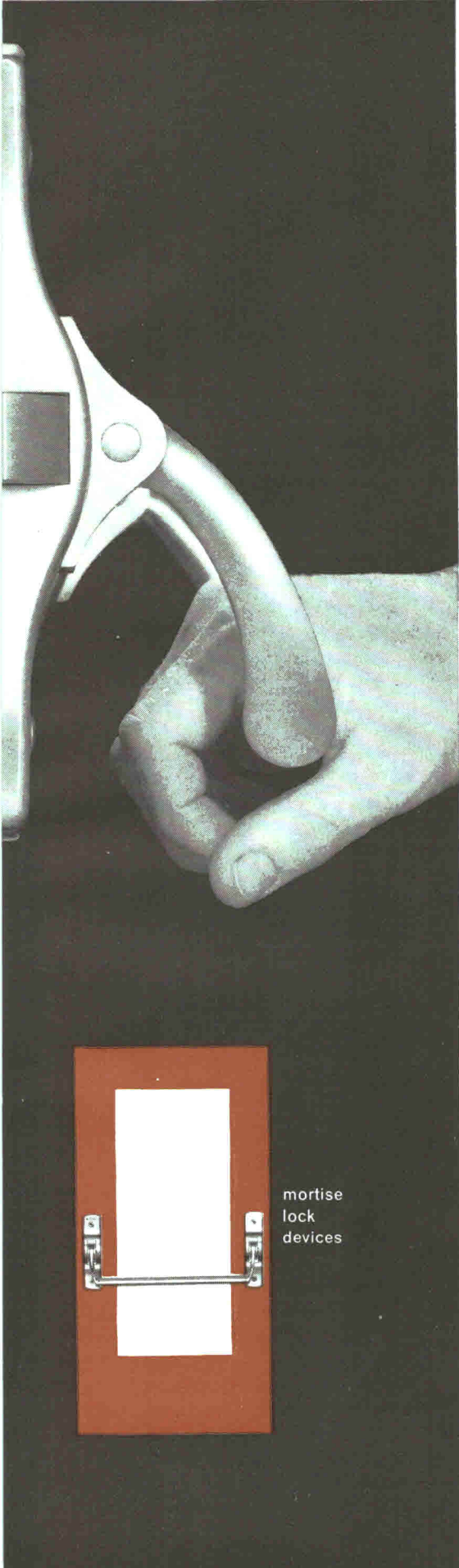

# Von Duprin 66

● Quality engineered . . . quality appearance . . . quality operation. That's the Von Duprin 66.

For enduring beauty and lasting service, the job calls for Von Duprin 66 in stainless steel. You quickly sense the excellent quality of this device . . . its clean, tasteful appearance will harmonize with your finest buildings.

Rim, mortise lock and vertical rod models are furnished with a smart new series of matching outside trims. Type 66 devices are also available in bronze.

Write for your copy of Bulletin 581 . . . full details on construction, function and accessory items.

mortise  
lock  
devices



VONNEGUT HARDWARE CO. • VON DUPRIN DIVISION  
402 West Maryland Street • Indianapolis 25, Indiana



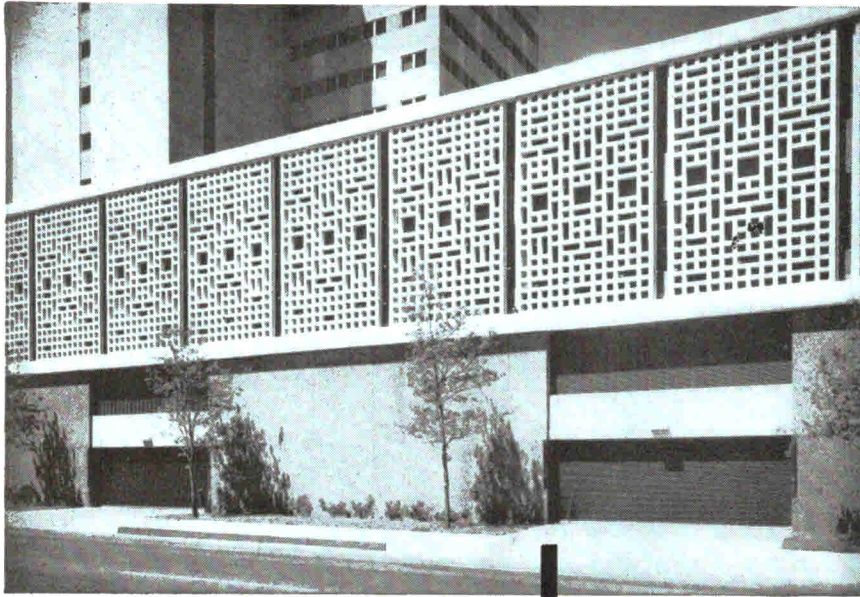

*Upward-acting, all-metal grilles that block intrusion when closed, without cutting off light, air or vision . . . coil quickly out of the way above the opening whenever desirable . . . and complement the beauty of today's most distinguished buildings and architectural designs*

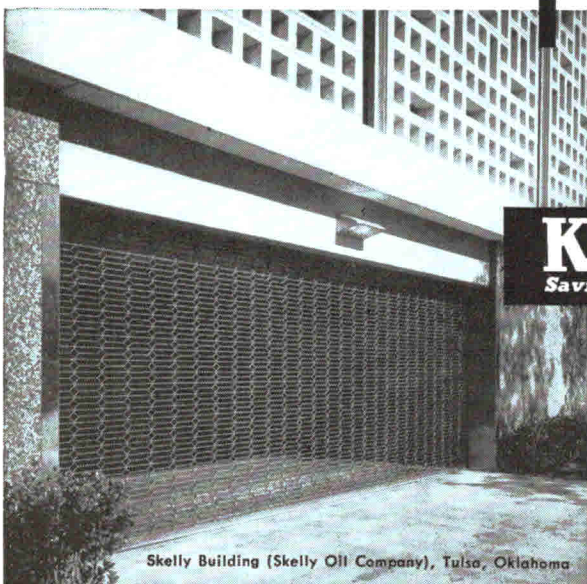

Skelly Building (Skelly Oil Company), Tulsa, Oklahoma

# Kinnear Steel Rolling Grilles

Built of steel, aluminum or bronze, to fit any doorway or other opening — with motor or manual control — for face-of-wall or under-lintel installation — made by the makers of . . .

**KINNEAR**  
ROLLING DOORS  
Saving Ways in Doorways

## The KINNEAR Mfg. Co.

FACTORIES:  
1860-80 Fields Avenue  
Columbus 16, Ohio  
1742 Yosemite Avenue  
San Francisco 24, Calif.  
Offices and Agents in  
All Principal Cities

## Product Reports

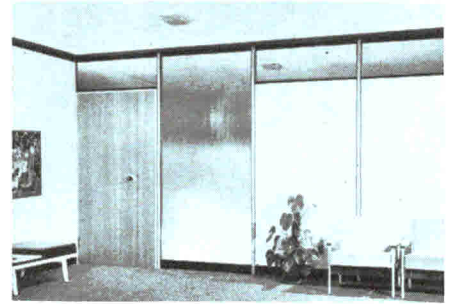

### Movable Wall System

In the new *Forecast Series* movable wall system each element of the partition is clearly defined by change in plane and contrast in color. (Conventional movable walls often have unwanted visual lines dictated by the manufacturing processes. Two types of panel are used— unit type and removable face type. Universal posts provide for rearrangement of panels without disturbing adjacent units. Both series are 2¼ in. thick. Seven standard post design variations are available and the base and ceiling trim can be recessed, flush, or projected. Perimeter sound seals, fully cushioned door frames, sound tight posts, and packaged panels are provided. Mills Co., 965 Wayside Road, Cleveland 10, Ohio.

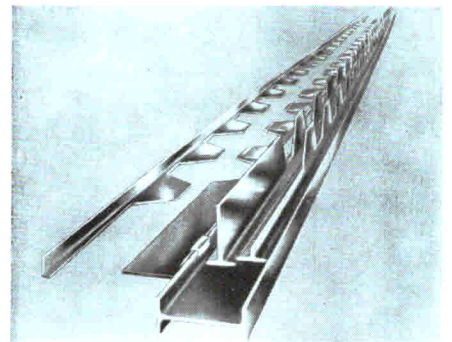

### Machine for Castellated Beams

Automated machinery has been developed by Waller International Corp. for the production of castellated (open-web) structural beams of steel or aluminum. Production involves two steps: cutting of the castellated profile by acetylene or other gas and assembly by welding, with or without height-extending spacers. Up to three beams can be cut at one time with only one operator. Cutting speed is from 16-20 in. per minute for three beams. Waller International Corp., Dept. F., Industrial Center, Crystal Lake, Ill.

*more products on page 244*

Here's another  
colorful innovation

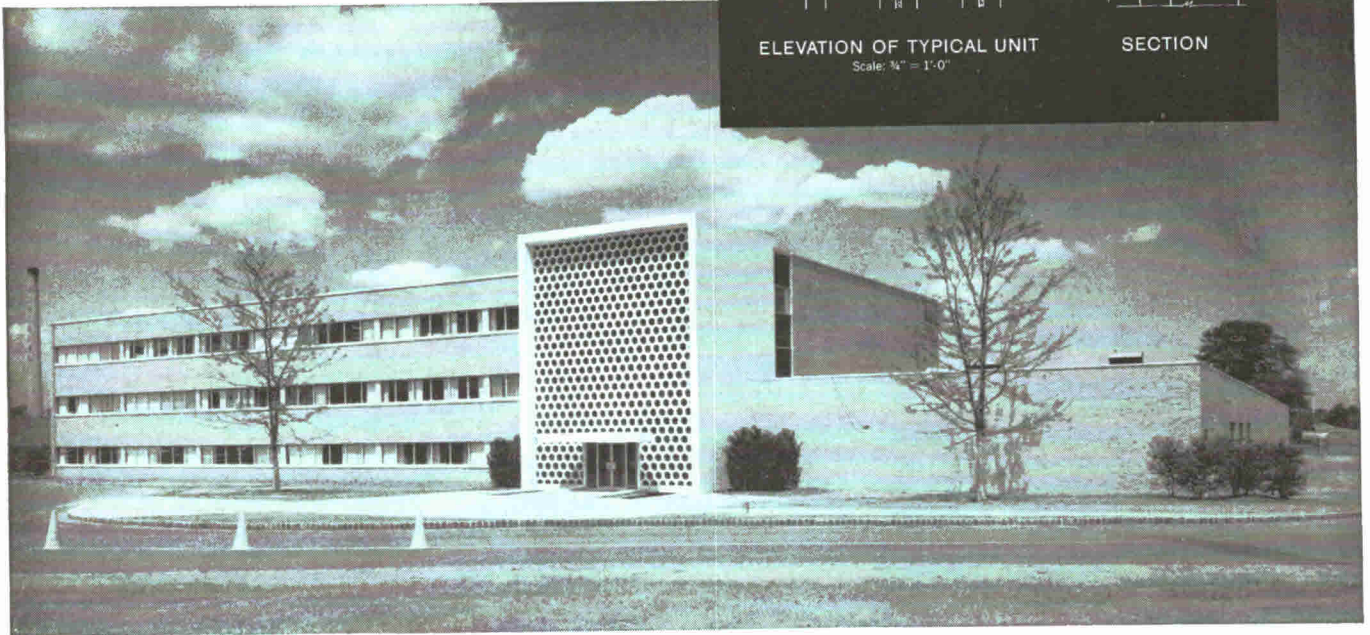
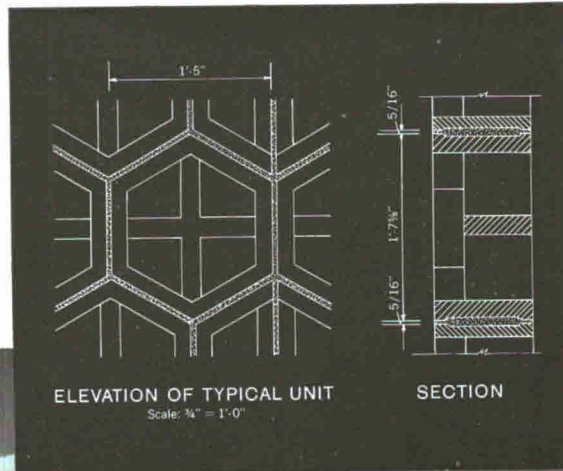

## created with Ceramic Veneer through-wall grilles

With perforated facades of Ceramic Veneer, you can create functional beauty in buildings of all types. You are not limited in your selection of colors: you have many smart designs from which to choose... and Federal Seaboard will custom-make grille units of your own design. Through the use of color, form and lustrous ceramic finish, the perforated facades and solar screens you design can be as distinctive as they are practical. Visibility with the right amount of privacy, sunlight with sun control, beauty that's within your budget—all this you can achieve with through-wall grilles of versatile Ceramic Veneer. Write today for solar screen and color guide brochures. Without charge we will gladly furnish construction detail, data, advice and estimates on preliminary sketches involving Ceramic Veneer—grilles, plain surfaces or polychrome panels.

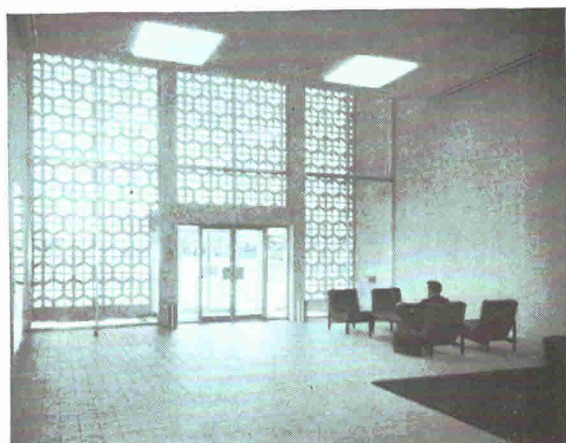

*Schering Corporation's Union, N. J. Plant Administration Building, designed and built by Walter Kidde Constructors, Inc. Ceramic Veneer through-wall units are Federal Seaboard design FS-E custom-made with cross-members added to back of grille. Exterior is a lustrous pure white with base and sides of cross-members a dark brown. For the interior, Ceramic Veneer grilles and cross-members are pure white.*



**FEDERAL SEABOARD TERRA COTTA CORPORATION**

10 EAST 40TH STREET, NEW YORK 16, N. Y.  
PLANT AT PERTH AMBOY, NEW JERSEY

## MR. ARCHITECT:

Add a Valuable Man to Your Staff . . .

Your Raynor Distributor . . .

Offers You NATIONWIDE

## Consultation... Installation... Service

### CONSULTATION

Your Raynor Distributor will help you in writing specifications, providing complete details for closing any opening, as well as assisting in any design, mechanical or construction problem.



### INSTALLATION

Factory trained installation men . . . craftsmen who are specialists in the installation of overhead type doors, assuring lasting satisfaction to you and your client.



### SERVICE

A nationwide organization that works together . . . your guarantee of fast, dependable service, no matter where the location may be.

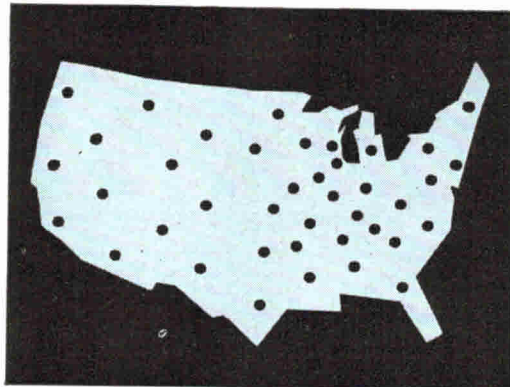

. . . Of utmost importance, with RAYNOR DOORS, you have a quality product that will provide a lifetime of continuous dependability.

RAYNOR SECTIONAL OVERHEAD TYPE DOORS  
Wood • Aluminum • Steel • Electronic Operators

## RAYNOR MFG. CO.

Dixon, Illinois    Hammonton, New Jersey

Builders of A Complete Line of Residential,  
Commercial and Industrial Type Doors

## Product Reports

### Patterns for Prestressed Beams

Prestressed concrete beams are being cast in reinforced fiber glass plastic forms to give a surface texture and design in a technique that insures exact dimensions and smooth surfaces. A recent example is a series of 28-ft beams for a suburban Minneapolis high school designed by Matson and Wegleitner, Architects. Plastic forms developed by Archer-Daniels-Midland Co. eliminated a number of problems experienced heretofore with reinforced plastics. One of these problems—the plastic's tendency to shrink and warp due to steam curing plus heat given off by concrete—was solved by a complex method of bracing the mold and through the use of an ADM polyester resin. To assure a smooth, trouble-free mold face, a special gel coat was applied. *Archer-Daniels-Midland, 700 Investors Building, Minneapolis 2, Minnesota.*

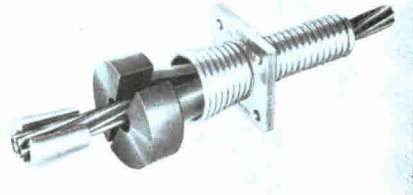

### Prestressing Anchorage

A new, simple system for post-tensioning concrete eliminates several time-consuming steps: Instead of special bolts, the *Atlas System* uses nails to hold the coil anchor and plate firmly in position. In addition, pockets for shims or nuts are eliminated through reusable rubber thimbles. The anchorage uses standard 7-wire strand of  $\frac{3}{8}$ - $\frac{7}{16}$ - or  $\frac{1}{2}$ -in. diameter. Its small size allows very thin members to be post-tensioned without the necessity of unsightly thickened edges or ends. *Atlas Service Corp., 14809 Calvert St., Van Nuys, California.*

### Air-Cooled Condensers

High capacity air cooled condensing units for split system installations are being made available by *Chrysler Airtemp* in 10- and 15-hp sizes. Both condensing units use a 5-cylinder compressor. All safety controls are reset at the thermostat. Both units are designed for simple field modification to serve as heat pumps. *Chrysler Airtemp, P.O. Box 1037, Dayton 1, Ohio.*



# INLAND CELLUFLOOR

Quick, inexpensive openings for electrification!

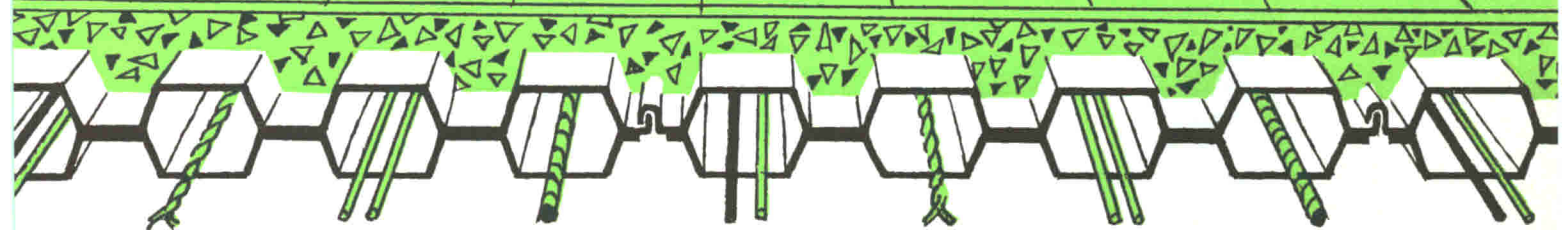

*... whenever you want them, wherever  
you want them — with Cellufloor*

The typical office interior today is streamlined to the nth degree. Big open work areas — a bare minimum of walls.

Where, then do you put the miles upon miles of wire a modern office building needs now — and the additional miles it's sure to need tomorrow? More and more architects are reaching this logical conclusion: *In Cellufloor*.

Since Cellufloor provides wiring raceways 6" o.c. under every square foot of floor area, no worker need ever be more than inches away from electrical, telephone, and dictation service outlets. Whenever a tenant needs a new connection, he has an electrician drill through the floor and pull up the wires — anywhere in the room! Circuits can be changed — new service outlets installed or relocated — without costly alterations.

Many buildings with a future use this floor with a future — including Union Carbide office building, New York City, and Kaiser Center office building, Oakland, California.

There are other advantages of Cellufloor — savings of steel, footings, construction time, and overhead. See Sweet's — or write for Catalog 270.

member  
of the  
**INLAND**<sup>®</sup>  
steel  
family

ENGINEERED PRODUCTS DIVISION

**INLAND STEEL  
PRODUCTS COMPANY**

Dept. E, 4033 West Burnham Street  
Milwaukee 1, Wisconsin

EP-3

# Burt

## ROOF VENTILATORS WALL LOUVERS

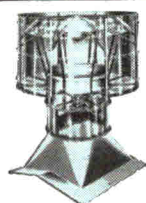

FREE-FLOW FAN

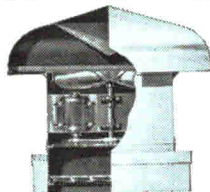

LOW TYPE

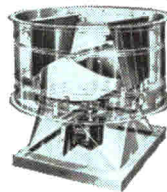

FREE EXHAUST FAN

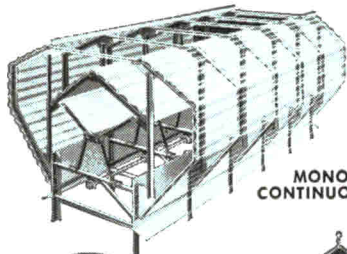

MONOVENT  
CONTINUOUS RIDGE

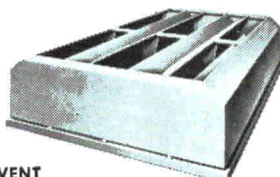

THERMOVENT



CENTRIFLOW



STANDARD  
GRAVITY



FREE-FLOW GRAVITY



LOUVERS



MONITOR TYPE

### SEND FOR FREE DATA BOOK

BURT'S complete ventilator line includes a type and size to put air to work most efficiently and economically for your specialized needs. BURT'S engineering skill and know-how from more than half a century designing and building ventilators is your assurance of satisfaction. Your inquiry will receive prompt and qualified attention.



FAN & GRAVITY VENTILATORS LOUVERS  
SHEET METAL SPECIALTIES

## The Burt Manufacturing Company

48 E. South St., Akron 11, Ohio

MEMBER AIR MOVING & CONDITIONING ASSOCIATION, INC.

## Office Literature

### Air Conditioning Controls

Describes General Electric's complete line of definite purpose contactors and starters for air conditioning and refrigeration. New 30- and 40-amp contactors are pictured and discussed along with 50- and 60-amp starters and contactors. Another section describes overload relays, custom control panels, and a step starting accessory available for air conditioning applications. Load data, coil data, outline numbers, wiring diagrams, and weights of devices are included. Bulletin GEA-7316, 8 pp. General Electric Co., Schenectady 5, N. Y.\*

### Extruded Aluminum Railing

Econo-Rail aluminum tubular railing for office buildings, institutions, hospitals, industry and schools is covered in details, mechanical drawings and illustrations. The double wall construction tubing is installed with non-ferrous fittings and fasteners. Railings are completely factory assembled with all necessary fastenings, ready to erect. Newman Brothers, Inc., 670 West Fourth St., Cincinnati 3, Ohio.\*

### Precast Concrete Data Sheets

File folder of Gemset Technical Data Sheets (A.I.A. File 4-K-1) is an aid for architects in detailing applications for exposed aggregate precast concrete. A series of transparent velum tracing sheets provide scaled details for a number of applications, including panels, spandrels, window surrounds, copings, soffits, lintels, steps and stringers. Other similar sheets illustrate details relevant to hoisting erection, anchoring, joining, and paving. Indiana Limestone Co., Inc., Bedford, Ind.\*

### Metal Ties for Masonry Walls

Investigation of Continuous Metal Ties as a Replacement for Brick Ties in Masonry Walls is a study prepared by Armour Research Foundation which compares the relative merits of the brick header course in wall construction with continuous wire reinforcement. Studies were made of flexural strength vertically, compressive strength and water permeability. 44 pp. Cedar Rapids Block Co., Cedar Rapids, Iowa.

more literature on page 256

# Welded Wire Fabric

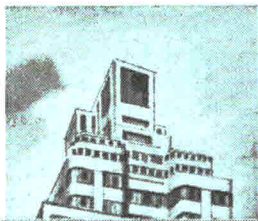
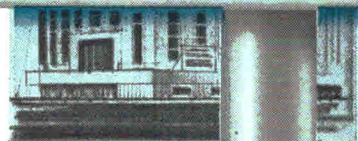
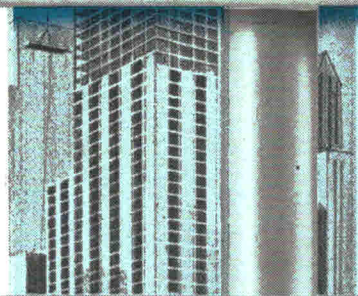
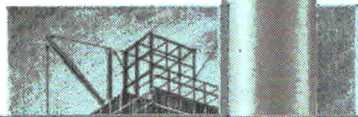

2"

1/2"

2"

Nothing is more gentle  
than smoke—  
*nothing more frightful!*

(Victor Hugo, 1802-1885)

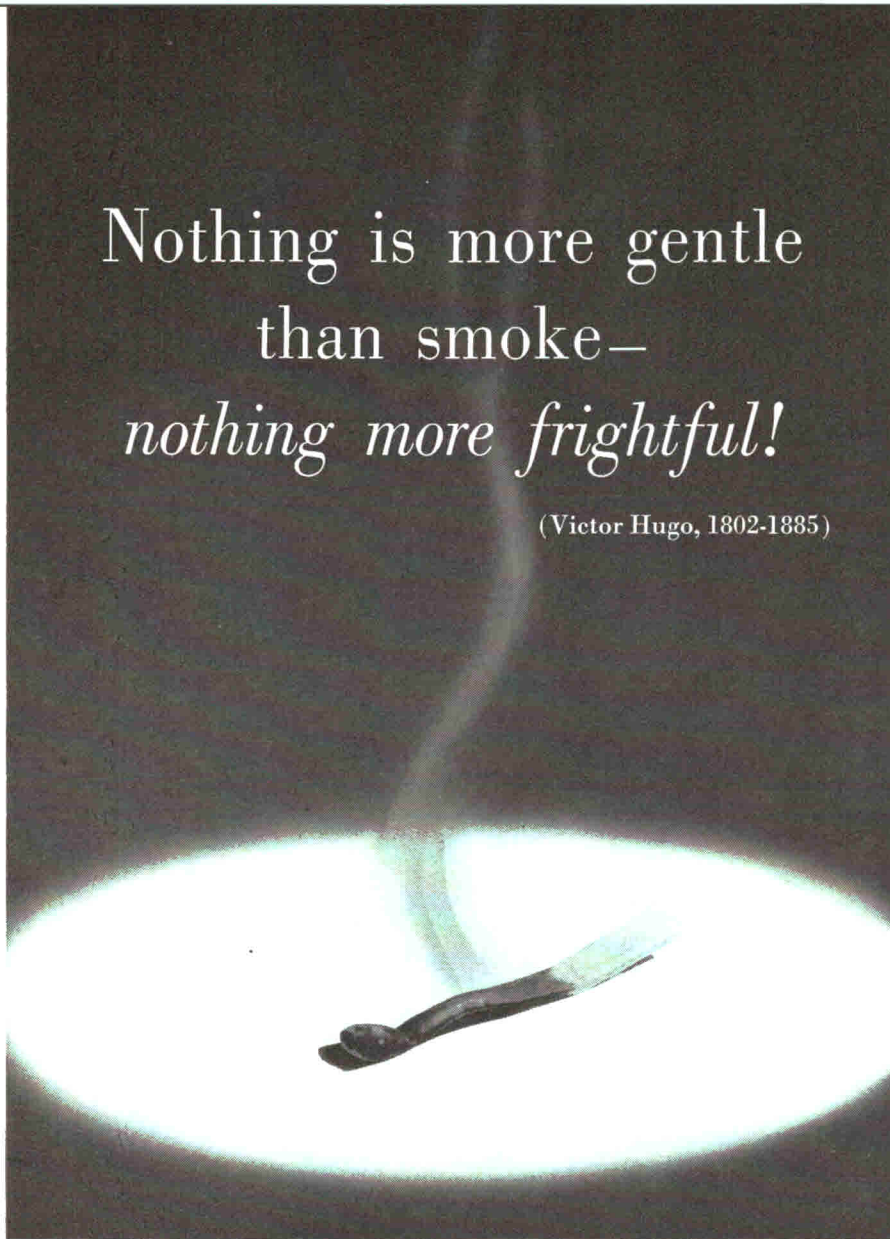

The smoke that heralds an unfriendly fire is indeed frightful. But it may also be useful! There are many places where the smoke itself can be utilized to give an automatic signal so swiftly that fire can be smothered while still in its smoldering stages.

ADT automatic smoke detection and alarm service goes into action at the first tell-tale puff of smoke, and by being faster than the flames, can save untold damage in areas such as:

- Record-storage vaults
- Computer and electronic data processing rooms and electrical switching centers
- Fur vaults
- Heating, ventilating or air conditioning ducts
- Bins containing seasonal stock such as hops or tobacco

The system operates automatically to call emergency forces and to sound a local alarm. In duct systems it will also act automatically and simultaneously to shut off air-circulation fans and close dampers.

For information on the full line of ADT Protection Services, write Dept. J for free booklet (Canada and U.S. only). Or call an ADT security specialist, listed in your phone book under *Fire Alarms* and *Burglar Alarms*.

**AMERICAN DISTRICT TELEGRAPH COMPANY**  
Executive Office: 155 Sixth Avenue, New York 13, N. Y.  
A N A T I O N W I D E O R G A N I Z A T I O N



## Office Literature

### Hollow Metal Doors

Hollow metal doors with matching frames and hardware are described in a 32-page catalog No. 2040-I. Featured is a new welded door with no seams on either face or edges. Other styles are shown in flush and panel designs, as well as louvered doors. In addition, transom frames, side-lights, and hardware are described and construction details given. *Ceco Steel Products Corp., Department A, 5601 West 26 St., Chicago 50, Ill.\**

### Specifications for Insulated Decks

Recommended product and application specifications for structural insulating roof deck have been released by the Insulation Board Institute. Chapters cover product description, methods of testing, minimum physical requirements and application instructions for use in open-beam-ceiling roof construction. When used with customary roof coverings, both 2- and 3-in. insulating roof deck units meet the FHA requirement of 0.15 U value for ceilings. *Robert A. LaCosse, Technical Director, Insulation Board Institute, 111 W. Washington St., Chicago 2, Ill.*

### Double Duct Air Blender

Catalog 1100-B107 describes a new twin-duct air blender for high velocity, double duct air conditioning systems. How the new ceiling and under-window air blenders operate without the use of motors, piston operators, or mechanical linkage is explained with their design features. The catalog gives detailed engineering information on specifications and noise levels as well as selection and performance data with dimensional drawings. *Worthington Corp., Air Conditioning Division, Technical Publications Section, Ampere Station, East Orange, N. J.\**

### Packaged Steam Generators

Bulletin O. AA-2760 is a simple, easy-to-read presentation of the new AA line of packaged steam generators ranging in horsepower from 20 to 600. Model AA features a newly-designed low pressure air atomizing oil burner, new multi-orifice ring type gas burner and other engineering improvements. *Ames Iron Works, Inc., Oswego, N. Y.*

\* Additional product information in *Sweet's Architectural File*



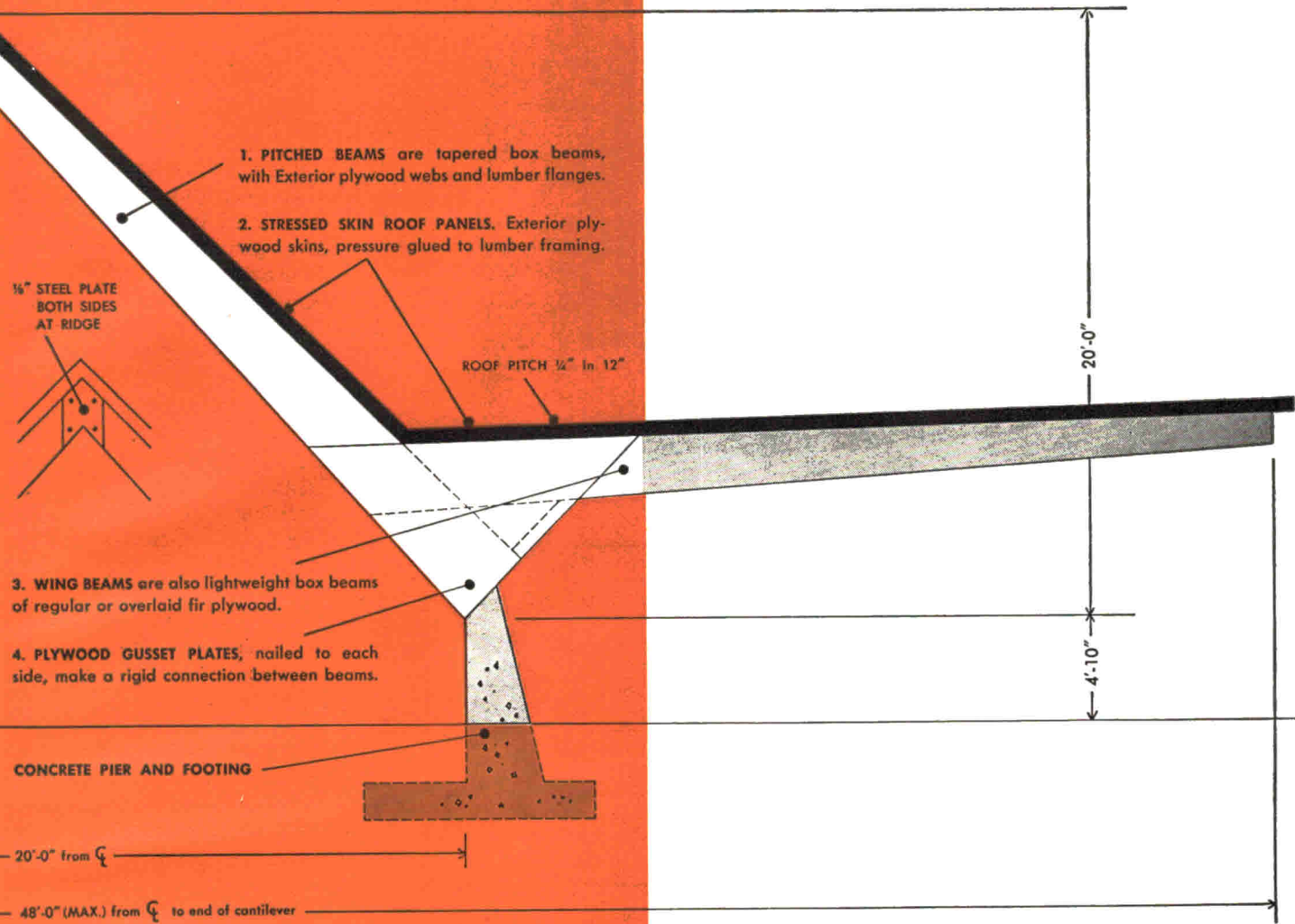

**THE DELTA SYSTEM PERMITS LIMITLESS DESIGN VARIATIONS**

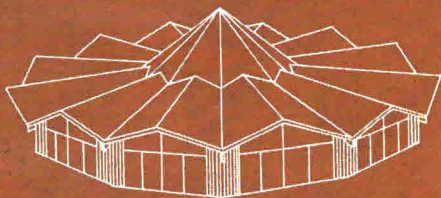

Supermarket has circular folded roof; wings radiate from center.

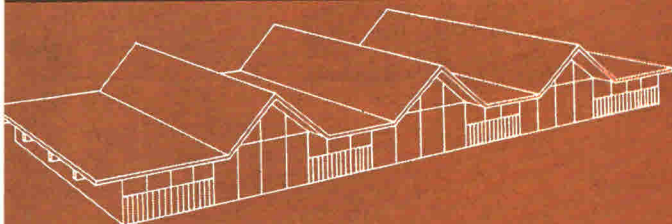

School is a series of Delta units with cantilevered wings joined.

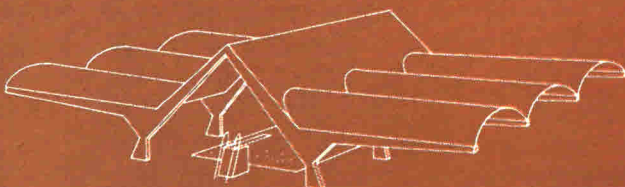

Pool, under Delta section, is flanked by plywood-vaulted cabanas.

DELTA STRUCTURES—based on a revolutionary new building system keyed to engineered plywood components—combine distinctive appearance, speed and ease of construction and remarkable design flexibility. They also offer important cost advantages.

Named for its dominant triangular profile, the Delta System was developed and engineered by Douglas Fir Plywood Association to meet the need for an attractive, versatile and low-cost commercial-industrial building with large clear floor area and non-load bearing walls. Several Delta structures have been built to date, besides the one shown at left.

The simplicity of the structural scheme, which depends on only four basic plywood components, permits almost limitless design variations. Length and width may be varied by changing the size and number of basic Delta frames or the length of wing beams. DFPA has prepared design recommendations for 608 structural variations.

For more information on Delta System and other plywood components, and name of fabricator nearest you, write Plywood Fabricator Service, Inc., Chicago 17, Ill. Delta components are made and sold only by PFS licensees, and are available in most parts of the country. For basic plywood design data, write (USA only) Douglas Fir Plywood Association, Tacoma 2, Washington.



ALWAYS SPECIFY BY  
DFPA TRADEMARKS

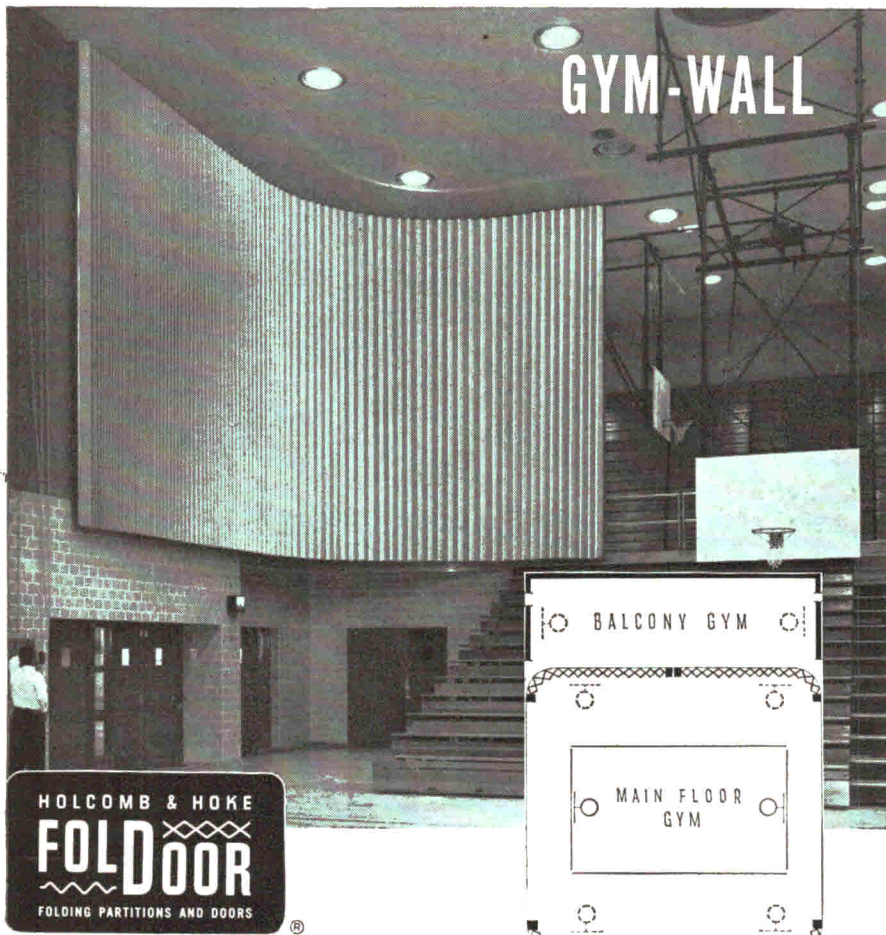

## NEW PROVEN PARTITION handsome, rugged, economical

Shown above is the *largest, curved, power-operated GYM-WALL* folding partition ever installed. It consists of two pairs of partitions, each partition measuring 127' wide and 20' high when extended! When the gym is not in use for major athletic events, the press of a button quickly converts it into three separate areas for girls' and boys' gym classes, band practice, speech and drama rehearsals or other group activities.

Not only does GYM-WALL make efficient use of floor space, but it's built to take the slams and buffets of indoor sports. Under GYM-WALL's colorful vinyl covering, the rugged steel frame is supported with extra rows of hinges and is covered with building board panels and steel plates. Here is one of the most rugged, and economical, folding partitions available for multiple activity areas.

Warren Central High School, Indianapolis  
Architect: Everett I. Brown Company

A NEW WARRANTY, the strongest ever issued on folding partitions, backs GYM-WALL and all other models in the complete Foldoor line. In addition to the standard one-year warranty on the entire unit, hinges, trolleys and trolley pins are guaranteed for an *additional 9 years*, while the track is guaranteed for the life of the installation.

For decorative, see-through space dividers, ask for information on FiliGrille, Holcomb & Hoke's new styrene grillework for interior or exterior use.

HOLCOMB & HOKE MFG. CO., INC.  
1545 Van Buren St., Indianapolis 7, Ind. Dept. B34

Please send complete data on:

GYM-WALL Foldoor     FiliGrille grillework

Have job in planning; please call

NAME \_\_\_\_\_

FIRM \_\_\_\_\_

ADDRESS \_\_\_\_\_

CITY \_\_\_\_\_ STATE \_\_\_\_\_

## The Record Reports

### On the Calendar

#### May

- 7-10 International Conference and Office Equipment Exposition, sponsored by National Office Management Association—Sheraton-Jefferson Hotel and Kiel Auditorium, St. Louis
- 12-14 South Atlantic A.I.A. Regional Conference; theme, "Continuing Education"—Winston-Salem, N.C.
- 14-18 Annual meeting, National Fire Protection Association—Detroit
- 16-18 Building Research Institute Spring Conferences—Shoreham Hotel, Washington, D.C.
- 17-20 Annual convention, Royal Architectural Institute of Canada; theme, "The Building Community"—Chateau Frontenac, Quebec City, Canada
- 22-24 Fifth annual convention, Construction Specifications Institute—Commodore Hotel, New York City
- 22-26 41st International Conference and Office Exposition of the National Office Management Association—Queen Elizabeth Hotel and Show Mart, Montreal
- 23-25 1961 Conference on Church Architecture, sponsored by the Church Architectural Guild of America and the Department of Church Building and Architecture of the National Council of the Churches of Christ with cooperation of the Pittsburgh Chapter, A.I.A., and the Pittsburgh Architectural Club—Penn-Sheraton Hotel, Pittsburgh

#### June

- 5-7 First Inter-governmental Symposium on Urban Renewal, organized by the United Nations Economic Commission for Europe's Housing Committee—Palais des Nations, Geneva, Switzerland.
- 5-9 Ninth National Plastics Exposition, sponsored by the Society of the Plastics Industry, Inc.—The Coliseum, New York City
- 25-30 Annual meeting, American

*continued on page 268*



**Acousti-CELOTEX**  
REGISTERED U.S. PAT. OFF.  
SOUND CONDITIONING PRODUCTS

The Celotex Corporation, 120 S. La Salle St., Chicago 3, Ill.  
In Canada: Dominion Sound Equipments, Limited, Montreal, Que.

#### OTHER FIRE-RATED PROTECTONE PRODUCTS

1. SERENE for UL 2-hr. concrete deck assembly. 2. PLAID, 3. STRIPATED, both for 1-hr. fire-rated wood deck assembly.

For samples, specifications, expert Ceiling Consultation Service, call your Acousti-Celotex distributor. He's in the Yellow Pages.

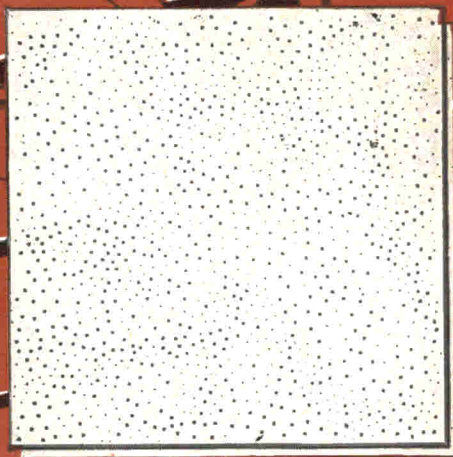

①

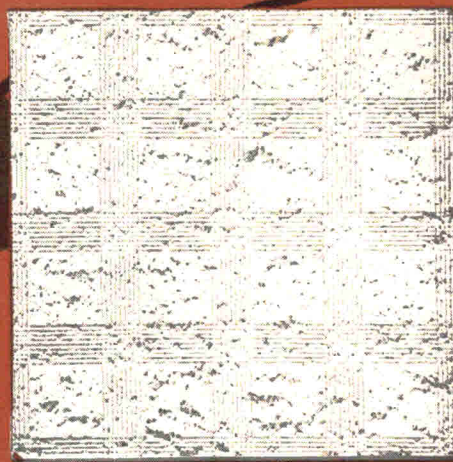

②

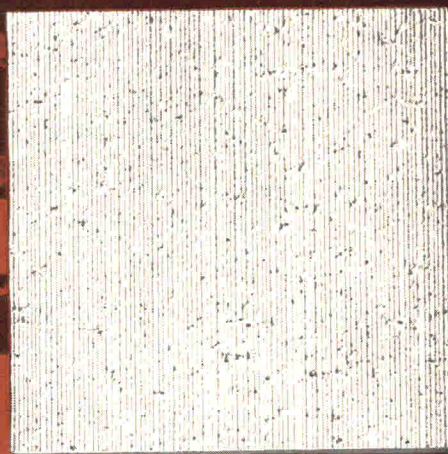

③

DREYFUSS DESIGNED FOR  
TODAY'S OFFICE INTERIORS

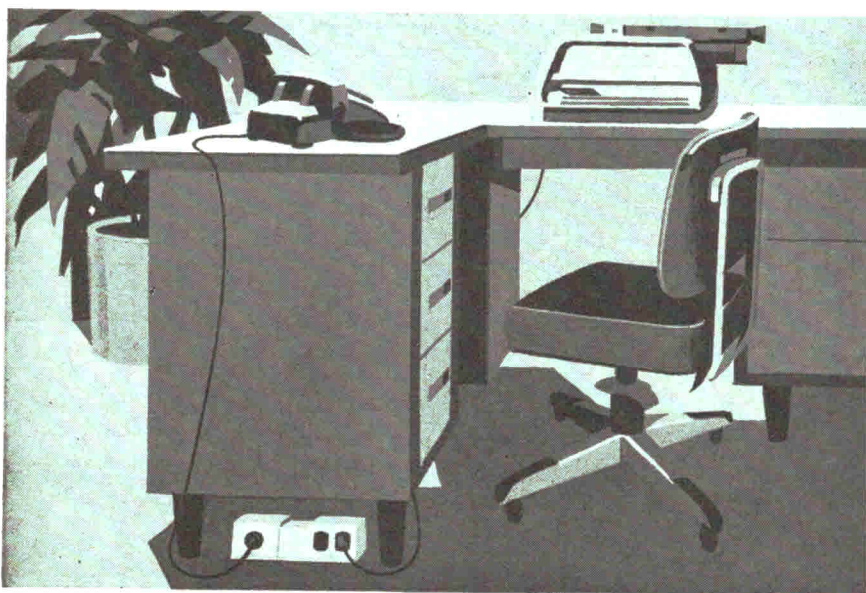

## MODERN COPE POWER AND TELEPHONE SERVICE FITTINGS FOR UNDERFLOOR SYSTEMS

An outstanding designer and T. J. Cope now give you the clean, functional styling plus the utility you look for in fittings for modern underfloor distribution systems.

Consider the Cope telephone service fitting:

The tapered shape and low silhouette fit inconspicuously against the side of a floor-flush desk . . . or under a desk.

Securely, too—because Cope's unique method of coupling the fitting to the duct insert ensures a really flush fit, prevents twisting or wobbling.

Easy removal of the front and back plates exposes the entire inside area—speeds and simplifies installation, maintenance, future circuit changes.

And, like all Cope Service Fittings, it can be furnished in attractive brushed aluminum or satin brass finish to complement every building interior.

Cope Service Fittings cost no more. The complete line is available for use with the new, shallower Cope Underfloor Duct and Headerduct Systems . . . or for adaptation to other underfloor systems. For more information on service fittings designed with your client in mind, talk to a qualified Cope representative—or write direct. FORMERLY SPANG—NOW MADE BY COPE, THE LEADING MANUFACTURERS OF CABLE SUPPORTING SYSTEMS.

**TJ COPE** DIVISION ROME CABLE CORPORATION  
Collegeville, Pennsylvania Dept. O

A CHOICE OF WIRE AND CABLE SUPPORTING SYSTEMS

## The Record Reports

continued from page 260

Society for Testing Materials  
—Chalfonte-Haddon Hall, Atlantic City

26-28 Annual meeting, American Society of Heating, Refrigerating and Air-Conditioning Engineers—Denver

### July

3-10 Sixth Congress of the International Union of Architects; theme: "New Techniques and Materials—Their Impact on Architecture"—Royal Festival Hall, South Bank, London, S.E.1.

9-21 First of three seminars on atomic shelter and survival in the nuclear age; theme: "Planning Aspects of Atomic Shelter"—Pennsylvania State University, University Park, Pa.

10-12 62nd annual meeting, American Society of Landscape Architects—Harvest House, Boulder, Colo.

17-28 23rd Massachusetts Institute of Technology Special Summer Program on City and Regional Planning—M.I.T., Cambridge, Mass.

23ff Second seminar (of three) on atomic shelter and survival in the nuclear age; theme: "Structural Engineering Aspects of Atomic Shelter"; through Aug. 4—Pennsylvania State University, University Park, Pa.

### Office Notes

#### Offices Opened

Robert V. Buck, architect, and Thomas L. McKittrick, associate, announce the opening of an office for the practice of architecture. Their address is 202 First National Bank Building, McAllen, Tex.

Harland Bartholomew and Associates, City Planners, Civil Engineers, Landscape Architects, have opened a new office at 412 Transportation Building, Washington 6, D.C.

A new office has been opened in Philadelphia at 138 South 20th St. by Fred S. Dubin Associates, Consulting Engineers. Mr. Desreal Puterman is in charge.

continued on page 277

## The Record Reports

continued from page 268

Robert E. Langdon Jr., A.I.A., and Ernest C. Wilson Jr., A.I.A., have opened new offices at 3324 Wilshire Blvd., Los Angeles 5, Calif. under the firm name of Langdon & Wilson, Architects.

### New Firms, Firm Changes —

Scruggs and Hammond, Landscape Architects and Planning Consultants, have announced that D. Lyle Aten and John C. Lawrence, landscape architects, have been named to associate membership in the firm and that L. Donald Luebbe, city planner, has joined the staff. The firm's offices are in Peoria, Ill. and Lexington, Ky.

Carl F. Burmeister Jr. and Thomas B. Bealle Jr. have formed a partnership for the general practice of architecture under the firm name of Burmeister and Bealle-Architects. The address is 1914½ Grant St., Mobile, Ala.

Albert A. Kaufmann, formerly of 252 N. Broad St., Elizabeth, N.J., and Howard L. McMurray, formerly of McMurray and Associates, 983 Stuyvesant Ave., Union, N.J., have opened a new office at 430 Morris Ave., Elizabeth, N.J. under the name of Kaufmann & McMurray, Architects.

The partnership of Goldberg, LeMessurier & Associates has been dissolved and two new firms for the practice of consulting and structural engineering have been formed. They are: Albert Goldberg and Associates, Inc., 669 Boylston St., Boston 16, Mass.; and Wm. J. LeMessurier & Associates, Inc., 711 Boylston St., Boston 16, Mass.

John R. Olmstead, A.I.A., is now a partner with F. A. Evans Jr., A.I.A., and John T. Davis, A.S.C.E., the firm name having been changed to Evans, Davis & Olmstead, Architects-Engineers. Offices are still at 403 Fulton St., Troy, N.Y.

Alexander Hale, A.I.A., has joined the Chicago architectural and engineering firm of Friedman, Alschuler & Sincere. He will act as Project Manager.

J. Franklin Clark Jr., A.I.A., and McCall and Leach, A.I.A. have formed a partnership under the firm name of Clark, McCall and Leach, A.I.A., with offices at 1808 Carolina

continued on page 284

## BEAUTY WITH MUSCLES OF STEEL!

When you think of steel, you think of strength. Strength to stand the test of time and stress. But in the hands of today's designers steel can also be a thing of beauty. And the beauty of steel is that it endures. Plan with steel . . . then for skill, versatility, and economy . . . specify Ingalls for the fabrication and erection. The Ingalls Iron Works Company / Birmingham, Alabama



# INGALLS



# SILANEAL Reduces Water

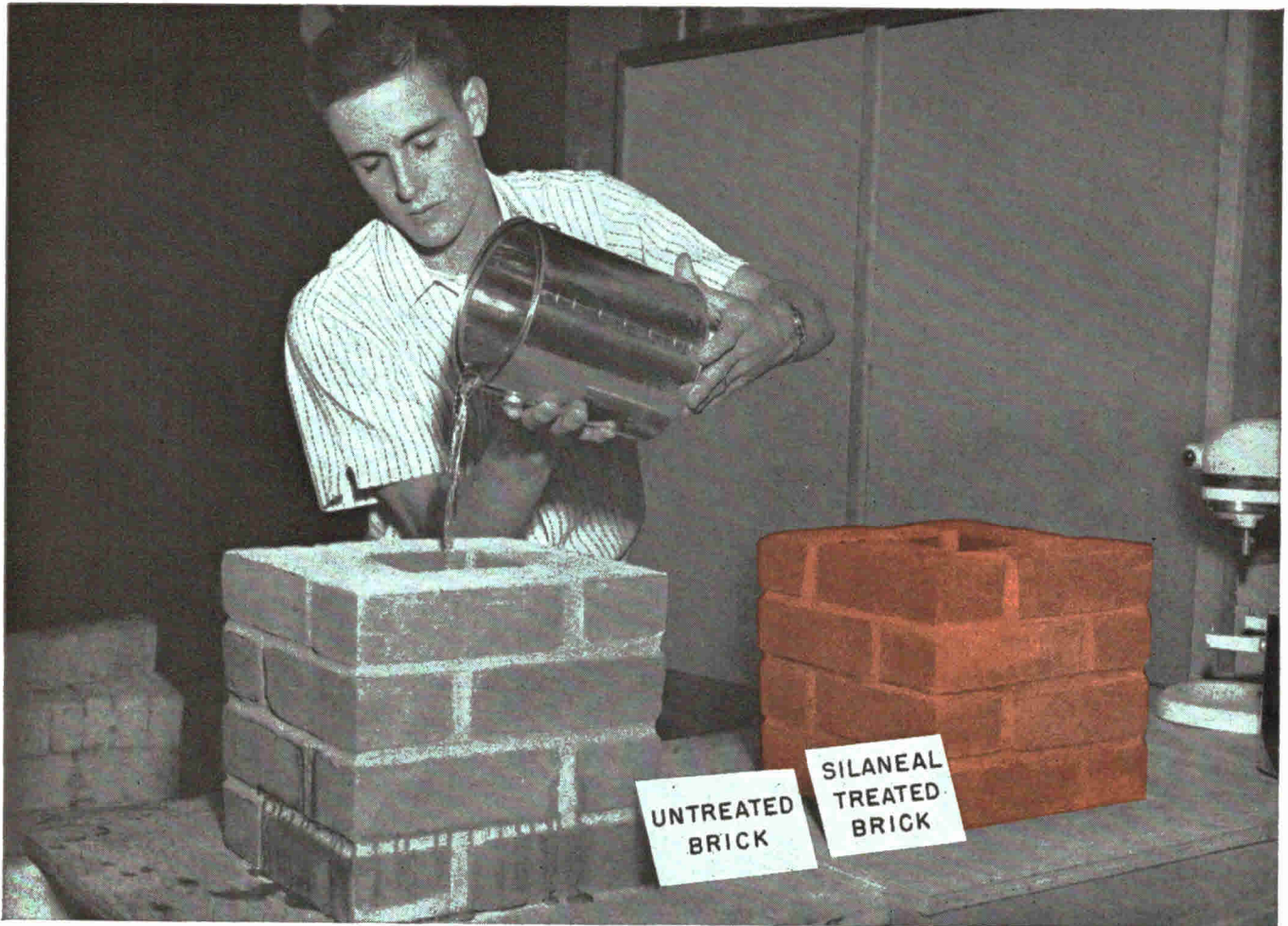

## Tests Prove: SILANEAL Helps Prevent Leaks and Improve Bond Of High Suction Brick

Both brick test tanks above were built by the same mason, using full head and bed joints from the same batch of mortar and the same type of *high suction rate* brick. The only difference: tank at right was built of brick which were *treated at the brick plant with Silaneal®*. Just before the photo was snapped, this tank was filled with 8 inches of water. No leakage occurred. The other tank developed leaks even as it was being filled.

Now, look at the photo at right. It shows the same two tanks five minutes later. Note how the one built of brick treated with *Silaneal* still shows no sign of water penetration. The one built of *untreated* brick shows severe leakage at the mortar-brick interface.

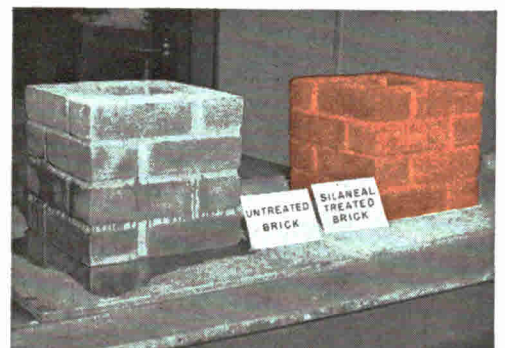

Specify



**Dow Corning**

# Variable Volume Reheat

unit by

# TITUS<sup>®</sup>

\* developed in conjunction with Minoru Yamasaki... Smith, Hinchman & Grylls, Associated Architects and Engineers

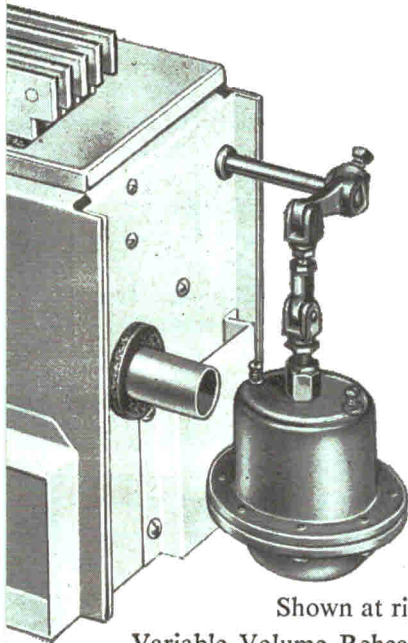

PATENT PENDING

Shown at right is actual photo of new Titus Variable Volume Reheat units installed in mock-up of Michigan Consolidated Gas Company Office Building. The units were installed under the floor with a 3-inch pre-cast concrete sill containing Titus extruded aluminum Linear Grilles as outlets. *The new Titus VVR units fully met all requirements of the variable volume reheat system.* They proved capable of maintaining room temperature within 1 F—with varying heating and cooling loads.

**TESTED AND PROVED** in a 2-story mock-up of the new Michigan Consolidated Gas Company Office Building in Detroit

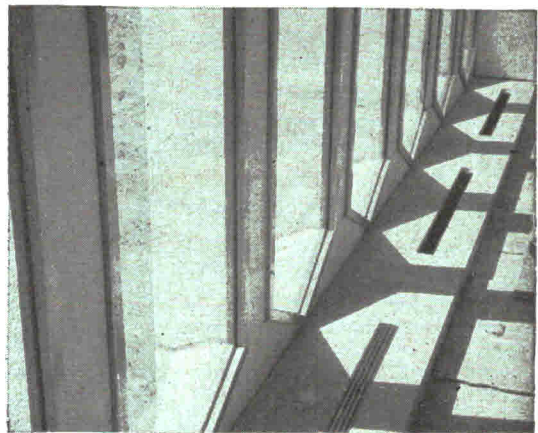

**MAIL  
COUPON  
FOR  
COMPLETE  
INFORMATION**

**TITUS MFG. CORP., WATERLOO, IOWA**

Please rush new CATALOG giving complete details on the new Titus Variable Volume Reheat unit.

NAME \_\_\_\_\_

COMPANY \_\_\_\_\_

ADDRESS \_\_\_\_\_

CITY \_\_\_\_\_ ZONE \_\_\_\_\_ STATE \_\_\_\_\_

"...highest degree of sound proofness possible in a movable wall"

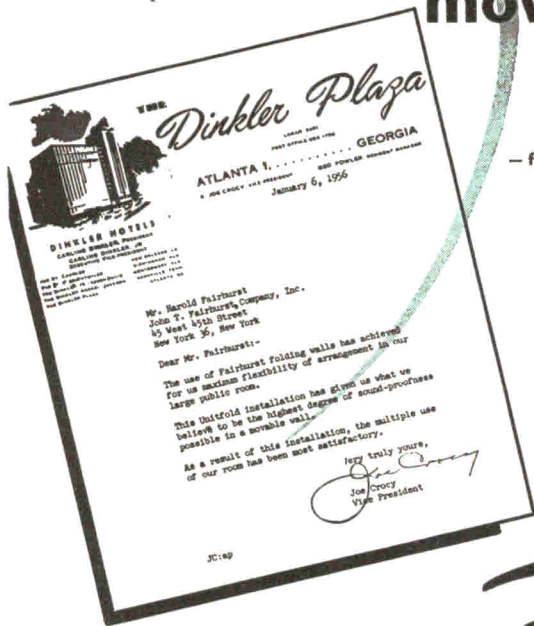

— from a letter by A. Joe Crocy, Vice-President, The DINKLER-PLAZA, Atlanta. Alexander & Rothschild, Arch.

*Fairhurst*

**UNITFOLD® FOLDING WALLS**

In the Dinkler-Plaza banquet room, Unitfold Walls are used to create as many as six separate areas. Sound between these rooms is blocked with the efficiency of a 10" to 12" plaster-coated SOLID BRICK WALL. This is done through double-run wall sections, lined with acoustical material and separated by sound retarding dead-air space.

All Fairhurst Walls are solid, rigid, with virtually unlimited choice of decor. Write Dept. AR for free illustrated booklet describing Fairhurst solutions to perplexing space problems.

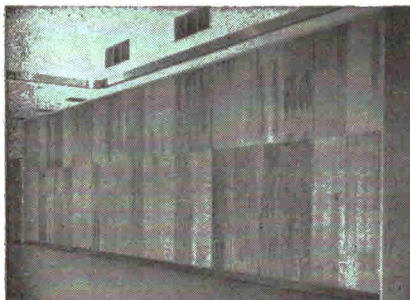
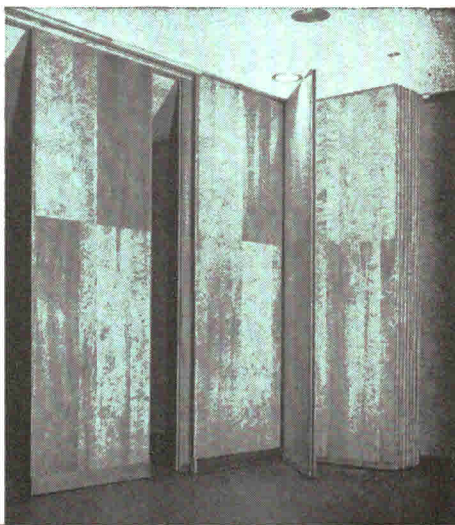

Units fold compactly to one side at the Dinkler-Plaza. Possible variations allow complete concealment of wall in special pockets.

Handsome grained veneers give the appearance of a permanent wall.

**John T. Fairhurst Co., Inc.**

45 West 45th Street

New York 36, N. Y.

FAIRHURST . . . First Name in Folding Walls

*The Record Reports*

continued from page 277

Ave., Hartsville, S.C. and 107 Mill St., Kingstree, S.C.

Gerald Germanson, architect of Sioux City, Ia., and Foss and Company, Architects and Engineers of Moorhead, Minn., announce the formation of a new architectural and engineering office in Sioux City, Ia. The new firm of Germanson-Foss & Co., Architects and Engineers, has offices at 1308 Pierce St.

The firm name of Monahan, Meikle and Johnson has been changed to Johnson and Haynes, Architects. The address remains the same: 255 Main St., Pawtucket, R.I.

Slocum & Fuller, New York City mechanical and electrical consulting engineering firm, has opened a branch office in Sydney, Australia in association with Rankine and Hill, Australian civil and structural engineering firm. The office is located at 40 Miller St., North Sydney, New South Wales, Australia. The combined firm of Rankine & Hill-Slocum & Fuller will undertake either complete structural, mechanical and electrical design work or any combination of these design services for all types of commercial and industrial buildings. Technical liaison is being maintained between the two offices. Daniel Barton, senior associate member of Slocum & Fuller is in charge of mechanical and electrical design in the Australian organization.

Elected to partnership in the Chicago office of the architectural firm of Perkins & Will are F. Philip Brotherton, an associate of the Royal Institute of British Architecture, and Jack D. Train, who is second vice president of the Chicago chapter of the American Institute of Architects.

The partnership of Mayer, Whittlesey & Glass having been dissolved, M. Milton Glass, A.I.A. has opened new offices for the continuation of his practice of architecture and urban planning at 630 Third Ave., New York 17.

Sherman Morss has become a member of Shepley Bulfinch Richardson & Abbott. New associates with the Boston firm are Robert T. Holloran, Richard M. Potter and Hugh Shepley.

Julian Hill Whittlesey, F.A.I.A., William J. Conklin, A.I.A., and Edward G. Echeverria, A.I.P. announce the establishment of offices for the

continued on page 288



# LAPIDOLITH hardened concrete floors can take the grind of day in and day out traffic.

Here are some additional facts about LAPIDOLITH:

**1. ONLY LAPIDOLITH CONTAINS DYNEX®.** Because of Dynex, LAPIDOLITH not only chemically hardens the surface, but *penetrates deeply* into the sub-surface pores and capillaries giving *greater HARDNESS IN DEPTH*. Proof of hardening in greater depth is shown in chart below. These radioactive tracer tests, were conducted by FOSTER D. SNELL, INC.

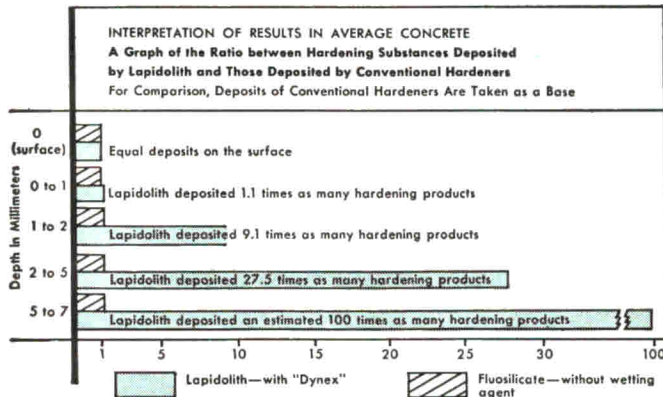

**2. RESISTS INSTANTANEOUS ACID ATTACK.** LAPIDOLITH protection permits enough time to flush off acids before the concrete is harmed. (Proof of acid test available on request.)

**3. GUARANTEED.** LAPIDOLIZED concrete floors are fully bonded and guaranteed for 5 years against concrete dusting as a result of abrasion and wear, when applied under contract by Sonneborn—America's foremost manufacturers of liquid chemical concrete floor hardeners.

**4. PROVEN SUCCESS.** LAPIDOLITH is the *original* chemical floor hardener and has been distinguished by having received the famous "Brand-Names-Award." Over

half a billion square feet of concrete floors have been successfully LAPIDOLIZED in the past 57 years.

**5. EASY TO APPLY.** LAPIDOLITH is a laboratory controlled, factory prepared, stabilized colorless solution and very simple to apply.

## "CUSTOM DESIGNED" LAPIDOLITH CONCRETE FLOOR SYSTEM

There is no one product or system that can perform all the functions required for all concrete floors. Floors are individually designed for different purposes, and every one product or system may be either under-designed or over-designed for the specific requirement. Only Sonneborn offers you a "custom designed" LAPIDOLITH Concrete Floor System to help *you* with your *specific* floor problem. Sonneborn is the one company you can come to with *all* your concrete floor treatment requirements.

At no obligation to you, we will have one of our qualified floor specialists make an expert inspection and recommendation for you.

Replacing worn-out concrete floors will cost you many times more than a simple, low cost, application of LAPIDOLITH. WRITE TODAY FOR FREE INSPECTION.

All photos are *actual* and *unretouched* and are of tests made by FOSTER D. SNELL, INC., with their facilities and under their supervision.

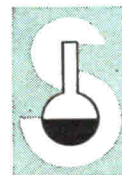

## SONNEBORN CHEMICAL AND REFINING CORPORATION

Building Products Division Dept. AF-50  
404 Park Avenue South, New York 16, N. Y.

HOUSTON, CHICAGO, LOS ANGELES, TORONTO

*Always Consult Your Architect or Engineer*



HERE YOU SEE THE LAPIDOLITH treated concrete after 500 strokes. Note that even under six magnifications the surface appears unbroken, with total wear being measured at only 0.0003 inch! The equivalent of 1/3 of 1 mil! Particles of metal may be seen imbedded in surface of the concrete.

practice of architecture and city planning in the United States under the firm name of Whittlesey & Conklin and offices for consultation on projects in other countries under the firm name of Whittlesey Conklin & Echeverria. New associates are James S. Rossant, R.A., and Jonas Vizbaras, R.A. The address of the firm is 31 Union Square, New York 3.

William Bailey Smith, A.I.A., formerly a partner in the Baton Rouge, La. firm of Bodman & Murrell &

Smith, Architects and Engineers, is now assistant to Edward D. Stone, F.A.I.A. The name of his former firm has been changed to Bodman, Murrell, Landry & Webb. Mr. Smith is past president of the Baton Rouge chapter of the A.I.A., former secretary-treasurer of the A.I.A. Regional Council and a past vice president and past president of the Louisiana Architects' Association.

Harold K. Pratt, P.E., has been appointed to the staff of Stanley En-

gineering Company. He is chief civil and hydraulic engineer with the firm's headquarters in Muscatine, Ia. Registered in New York and California, Mr. Pratt is a Fellow, American Society of Civil Engineers; chairman, A.S.C.E. Committee on Hydraulic Structures; and immediate past chairman, Hydraulics Division, San Francisco Section, A.S.C.E.

The partnership of Francis B. Jacobberger, F.A.I.A., Everett B. Franks, A.I.A., and Richard W. Norman, A.I.A., has been formed under the firm name of Jacobberger-Franks-and-Norman, Architects. The address is 512 McKay Building, Portland 4, Ore.

A. J. Nelson, State Architect, Department of Administration, St. Paul, Minn., announces the appointment of Mr. Max Fowler as Architect II to the staff. Prior to his appointment, he was employed in the Department of Plant Services of the University of Minnesota.

The firm of Morris Lapidus, Kornblath, Harle & Liebman has been dissolved and the new firm of Leo Kornblath Associates formed for the practice of architecture, planning and interiors. The new firm is located at 18 E. 41st St., New York 17.

Two new directors have been elected to the firm of F. H. McGraw & Company, Engineers and Constructors, New York City. They are both vice presidents of the company, Maurice Knopf of Hartford and Joel Morris of New York.

*New Addresses*

Richardson, Severns, Scheeler & Associates, Architects, 606 South Neil St., Champaign, Ill.

Craig Ellwood Associates, 8322 Beverly Blvd., Los Angeles 48, Calif.

**Elections**

Frank L. Hope, a principal in the San Diego architectural firm of Frank L. Hope & Associates, has been elected 1961 president of the California Council of the American Institute of Architects. He is a past president of the Institute's San Diego chapter and a member of the San Diego Planning Commission and the American Society of Military Engineers.

Other officers elected were: William Stephen Allen, San Francisco,

*continued on page 292*



Cement-asbestos formed into stone hard panels by hydraulic pressure.

Rust-proofed steel permanently laminated for shock-proof permanence.

Litegreen magnetic face of built-up slating coats for life-long service.

**INDESTRUCTIBLE  
ECONOMICAL  
MAGNETIC  
CHALKBOARD**

*Another Beckley-Cardy Original*

STEELBESTOS® withstands every schoolroom test. Cement-asbestos backing is permanently bonded to smooth, rust-proof steel surface to give uniform, indestructible writing face . . . and it's simple to install.



AT YOUR  
DEALERS  
—EVERYWHERE

1900 N. Narragansett  
Chicago 39, Illinois

# Big, wide, wonderful open space!

There's a light, airy look about buildings that have roofs of Tensiform and light-weight aggregate fill.

That's because exceptionally strong Wheeling Tensiform permits fewer, lighter roof supports . . . and Wheeling's *all-new* design provides excellent lateral stability for all types of structures.

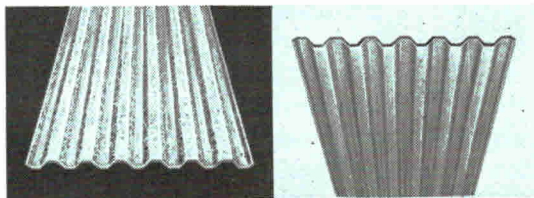

**USE TENSIFORM AS A CEILING, TOO!** The long, angular lines of Tensiform make nearly any building look more expansive.

More than that, galvanized Wheeling Tensiform, combined with either conventional or light aggregate concrete, gives you roofs with:

Excellent "U" factors at low initial costs.

Lower fire and extended coverage ratings.

Earlier occupancy because shoring isn't needed . . . and Tensiform can be installed even in freezing weather.

Cleaner construction because precision-formed Tensiform cuts cement seepage at *both* lateral and end joints.

Get the full story on Wheeling Tensiform for roof and floor slabs from our catalog in Sweet's. Or write to the Wheeling Corrugating Company, Wheeling, W. Va.



## WHEELING CORRUGATING COMPANY • IT'S WHEELING STEEL!

Immediate delivery on all stocked items from these warehouses: *Boston, Buffalo, Chicago, Columbus, Detroit, Kansas City, Louisville, Minneapolis, New York, Philadelphia, Richmond, St. Louis.* Sales Offices: *Atlanta, Houston, New Orleans.*

### WHEELING PRODUCTS INCLUDE:

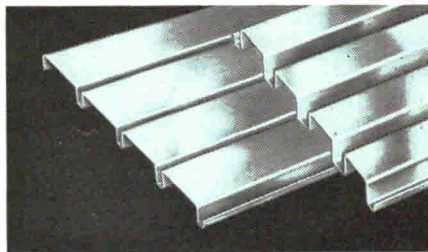

**STEEL ROOF DECK** — For use with conventional built-up roofs. Like Tensiform, Wheeling Steel Roof Deck goes on fast in all weather . . . can be field-painted the color you specify. Made of Cop-R-Loy® steel for extra-long life.

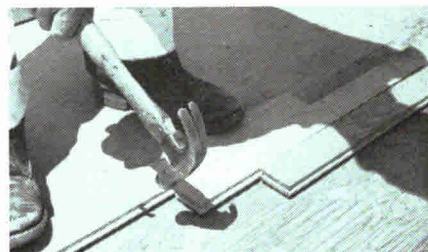

### LABELLE CUT FLOORING NAILS

— Unexcelled for laying tight, quiet hardwood floors because the nail corners cut wood fibers . . . make them work like fish-hook barbs.



**METAL LATH** — A complete line of expanded metal laths and lath accessories for all plaster applications.

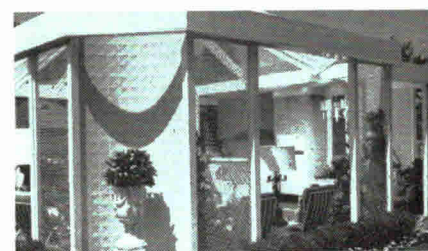

**EXPANDED METAL** — Stronger than the steel from which it's made, Wheeling Expanded Metal is widely used as a decorative material . . . and wherever free passage of light, air, heat or liquids is required.

vice president; Donald E. Neptune, Pasadena, secretary; Joseph J. Jozens, Sacramento, treasurer; and C. Day Woodford, Los Angeles, member-at-large.

New officers of the Oregon Chapter, Inc. of the A.I.A. are: Everett B. Franks, president; Robert B. Martin, vice president; John W. Foster, secretary; Neil Farnham, treasurer; G. Murlin Drury, director; and Frederick Rudat, director.

**Lasker Trust Creates Program for City Planning Scholarships**

At the annual meeting of the National Housing Conference held in March, a national program of scholarships and fellowships for training in housing and city planning was announced. The scholarships will be financed by a trust fund of \$300,000 established by Miss Loula B. Lasker of New York City. Miss Lasker, who

died on January 28th, devoted her life to housing, slum clearance and other welfare activities, was a founder and member of the Board of Governors of the Conference and a member of the New York Citizens Housing and Planning Council.

The trust will provide for the training of 100 to 200 experts in housing, urban renewal and city planning over the next 15 years. Miss Lasker recognized that in these comparatively new activities, a shortage of adequately trained professional leadership is a major impediment to local and national programs which have grown rapidly during the post war years.

Trustees for the Loula Lasker Scholarship Trust include: Dr. Robert Weaver, recently appointed Housing and Home Finance Administrator; Mr. Charles Abrams, attorney and author of New York City; Dr. William Wheaton, director of the Institute for Urban Studies, University of Pennsylvania; Mrs. Catherine Bauer Wurster, author and professor of city planning at the University of California; and Mr. Lee Johnson, director of the Denver Housing Authority. They are all officers of the National Housing Conference. In addition, Mr. Phillip W. Haberman, New York attorney, will serve as a Trustee. Dr. Charles Ascher, professor of political science at Brooklyn College, is an alternate.

Commenting on the establishment of the Trust, president of the N.H.C. Nathaniel S. Keith said the Lasker Fellowships emphasize Miss Lasker's "lifelong conviction that the goals of housing and urban renewal are the improvement of human welfare, and that only through the leadership of dedicated individuals will our goals in housing be recognized."

Dr. Wheaton termed the Lasker Fellowships "the first national recognition of the growing importance of training in this field." He said, "They will make a major contribution to the expansion of graduate training and professional leadership now needed so badly."

Mr. Abrams expressed the hope that the Trust would be able to announce its program in detail before September, 1961.

more news on page 296

ANOTHER  
**HAWS**  
PROJECTION  
OF STYLE

**HAWS MODEL 71**



The essence of modern styling is simplicity... clean lines, completely functional—with a unity of form that says, "For this object, this shape is right." Fiberglass construction, color selection (at no extra cost!) and HAWS Craftsmanship are also "right." Your Sweet's File can give you more details. Or write to HAWS for the comprehensive catalog.

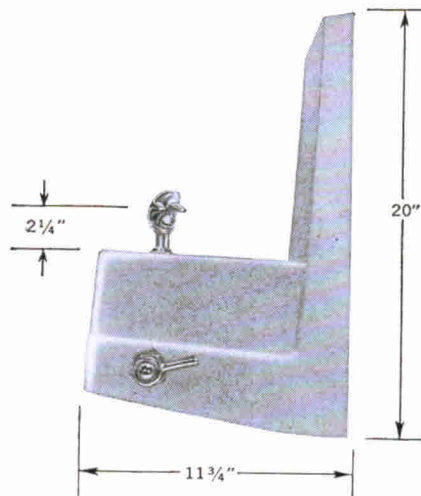
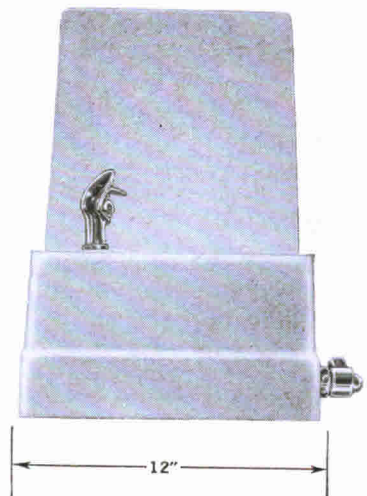

Since 1909  
products of  
**HAWS DRINKING FAUCET COMPANY**  
1441 Fourth Street • Berkeley 10, California  
Export Dept.: 19 Columbus Ave., San Francisco 11, California

Architect: Justement, Elam, Callmer and Kidd, Washington, D.C.

# STYROFOAM<sup>®</sup> saves on new hospital insulating costs

... reduces heat loss through wall by 35%

In specifying Styrofoam insulation board for the 350-bed Sibley Memorial Hospital, the Architects provided a three-fold advantage. First, Styrofoam insulation acts as its own vapor barrier, an important factor in areas where high humidity levels must be maintained, such as nurseries and operating rooms. Second, its permanently high insulating efficiency assures keeping even temperatures throughout hospital rooms, thus helping to assure maximum patient comfort.

The third reason was economic. Styrofoam permits savings in construction costs. For example, Styrofoam insulation was used as a "plasterbase," eliminating furring and lathing. In this method, Styrofoam insulation is bonded to the masonry walls using portland cement mortar; plaster is then applied directly to the Styrofoam. This technique often results in a wall insulated at a lower cost than conventionally insulated masonry walls and in some cases at a cost equal to or lower than uninsulated masonry walls.

Construction costs were drastically reduced in building air intake plenums. Because Styrofoam insulation board provides its own horizontal support, external supporting members were done away with. In this application, Styrofoam reduced construction costs by almost half.

At Sibley Memorial Hospital, Styrofoam insulates all external walls of the main structure and of an adjacent dormitory-classroom building. In addition, multiple layers of Styrofoam insulate the hospital's meat freezer and many coolers and refrigerators.

Styrofoam insulation board contains millions of tiny non-interconnecting air cells. It provides a low "K" factor that stays low, permanently,

because Styrofoam doesn't absorb water. Nor does this chemically engineered insulation rot or mildew. It has no food value to attract vermin. And lightweight Styrofoam is so easy to handle and install—for both heavy wall construction and solid masonry—that installation costs are reduced to a minimum. For more information write to THE DOW CHEMICAL COMPANY, Midland, Michigan, Plastics Sales Department 1500N5.

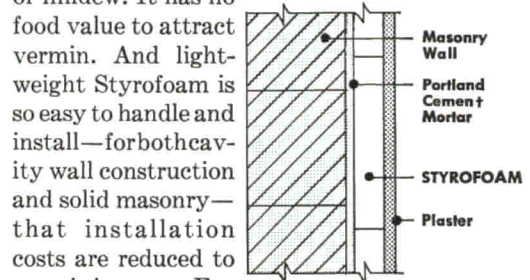

*Styrofoam is a registered trademark of The Dow Chemical Company. It is applied only to the homogeneous expanded polystyrene made according to an exclusive Dow process. Styrofoam brand insulation board is available only from Dow and its authorized representatives.*

## Other Dow Building Products

**ROOFMATE\*** lightweight insulation for built-up roofs that serves as its own vapor barrier. It provides permanent high resistance to water vapor. Light weight and ease of handling reduce installation time.

\*TRADEMARK

**SARALOY<sup>®</sup> 400** flexible roof flashing. Accommodates expansion and contraction. Can be bonded quickly, permanently to most construction materials. Easily conformed to fit building contours.

**SARALOY<sup>®</sup> 200** flexible through-wall flashing and membrane waterproofing. Won't crack or become brittle. Makes long-lasting, waterproof liners for shower pans.

**SCORBORD<sup>®</sup>** (Patent applied for) permanent insulation for foundations and perimeters. Pre-scored for easy use. Excellent moisture barrier.

THE DOW CHEMICAL COMPANY

**DOW**

Midland, Michigan

**Proven in actual use in over \$1,000,000,000 of construction**

**INSTALL in MINUTES**

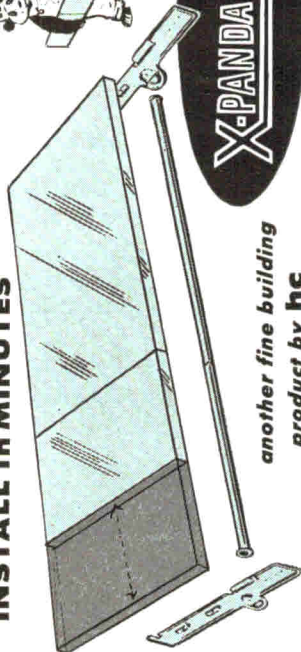
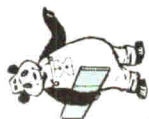

**another fine building product by hc**

X-Panda is the complete answer to all your shelving problems! All-Steel, completely fabricated and packaged, cuts labor costs 85%, all sizes have 13" length adjustment, installs in less than 10 minutes, choice of greytone or linen finish.

**TYPICAL INSTALLATIONS**

- Bearing Terrace Apartments Washington, D.C.
- Washington U. Medical Students' Dorm, St. Louis, Mo.
- Women's Dormitory University of Missouri Peoria, Illinois
- Wilshire Garden Apartments Baltimore, Maryland
- Cocoa Beach Motel Cocoa Beach, Florida

\* Reg. U. S. Trade Mark

**hc** products co.

**home comfort**

Princetonville, Illinois

**H-C PRODUCTS COMPANY** PRINCETONVILLE, ILL.

AR200

Please send additional literature on X-Panda shelves.

Name \_\_\_\_\_

Address \_\_\_\_\_

City \_\_\_\_\_ State \_\_\_\_\_

**The Record Reports**

*continued from page 292*

**Architects' Tour of Japan Planned**

The 1961 annual Architecture and Gardens Tour of Japan will leave from Los Angeles on October 6 for Tokyo, according to tour director Kenneth M. Nishimoto, A.I.A. The 24-day tour will give architects and allied professionals a comprehensive look at buildings of architectural importance and at old and new gardens.

By request a special 9-day post-tour extension (October 30-November 7) to western Japan is being added to introduce tour members to less well known parts of the country.

Since the tour membership is limited to 25 persons, early registration is advised. For further information, write Kenneth Nishimoto, A.I.A., 263 South Los Robles Avenue, Pasadena, Calif.

**Architects Join Planning Team: New York North River Study**

The architectural firm of Eggers and Higgins is one of three firms to make up a planning team whose purpose is the study of a six-mile long North River waterfront between the Battery and 72nd Street and its relation to the Port of New York for the years 1960 through 2000. Other members of the team are: Ebasco Services, Inc., Management Consultants, Engineers and Constructors; and Moran, Proctor, Mueser and Rutledge, Consulting Engineers. The three firms will retain Dr. Herbert B. Dorau, a specialist in land use, professor of economics at New York University and chairman of the University's Public Utilities and Transportation Department, as consultant.

The team will work in collaboration with engineers of the New York City Department of Marine and Aviation headed by Rear Admiral Roy T. Cowdrey, consulting engineer, and Captain Lewis H. Rabbage, chief engineer.

The (estimated) \$300,000 economic, engineering and architectural planning study has been approved by Mayor Robert F. Wagner and the Board of Estimate. Accord-

*continued on page 304*

**IRCLGRID**

**a NEW product for the ARCHITECT**

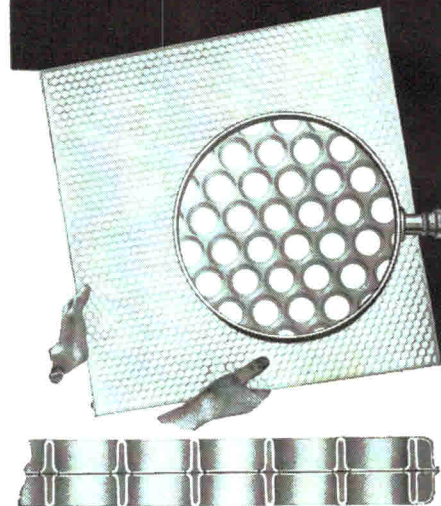

**Cross Section through Circlgrid Louver**

Nominal Sizes — 2' x 2' x 1/2"  
" " — 2' x 4' x 1/2"

Translucencies — 300-150-75 FC

**More than a Luminous Louver**

- ▶ It's **UL listed-20** (non-combustible)
- ▶ It's both **RIGID** and **LIGHTWEIGHT**
- ▶ Outstanding **BRIGHTNESS CONTROL**

As lighting specialists we developed Circlgrid to meet building lighting codes—it will not support combustion and is safely applied under sprinklers. Circlgrid is thermo-formed from two sheets of vinyl and fused electronically to a center vinyl membrane for structural strength and rigidity—yet weighs only 3 1/2 oz./sq. ft. Many leading lighting equipment manufacturers are licensed to sell and distribute Circlgrid in USA, Canada and other countries.

The moment you see and inspect a Circlgrid sample you'll think of many applications in modern lighting.



Write for sample and technical data.

**c i r v a c**  
**p l a s t i c s**

**BOX 655-AR • ERIE, PA.**  
**Illuminating Engineers and Specialists in Vacuum Forming and Electronic Welding**

Building material because it's **waterproof**.  
 It's cellular glass

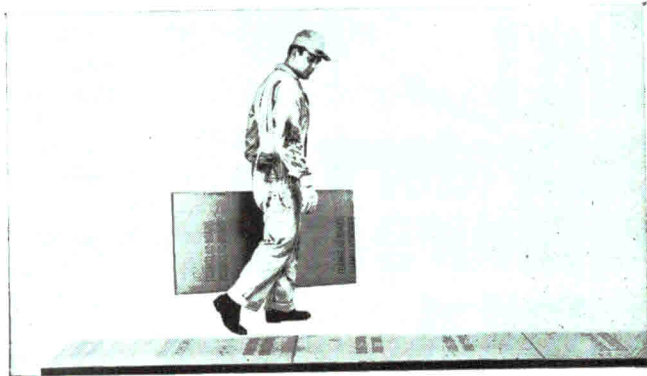
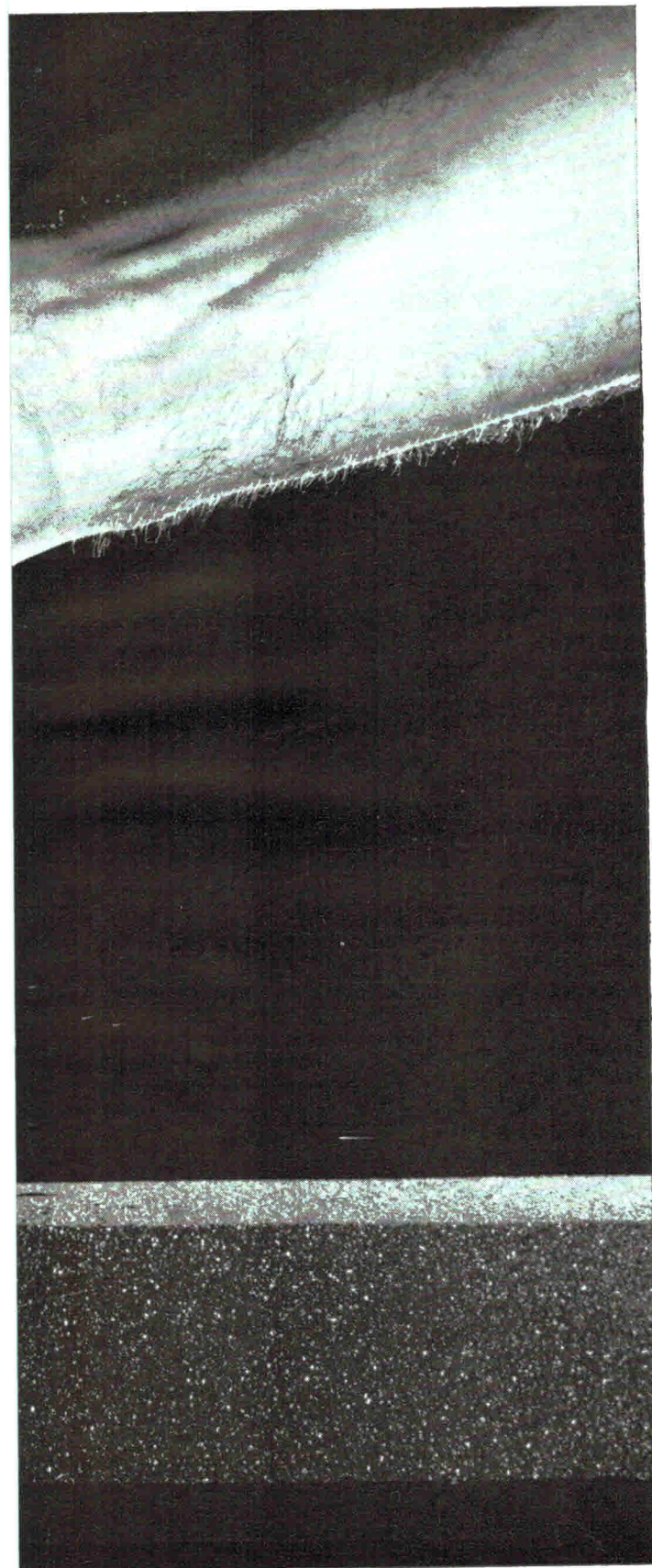

**New FOAMGLAS-BOARD** presents the quality of FOAMGLAS in an easy-to-handle new size, 2' x 4', for fast, economical, trouble-free roof installation. 1½" FOAMGLAS is sandwiched between specially laminated sheets of kraft paper, reducing the number of insulation joints.

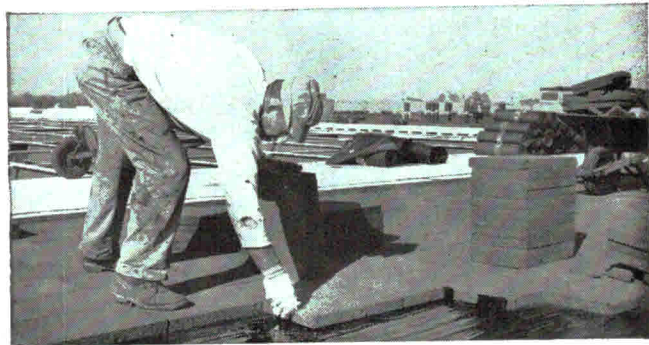

**FOAMGLAS Insulation** clears the air beneath this roof. Cold outside temperatures contrasting with a hot, humid interior atmosphere, had caused a fog-like condensation. FOAMGLAS roof insulation eliminated the problem. And the incombustibility of FOAMGLAS was an important extra-benefit here.

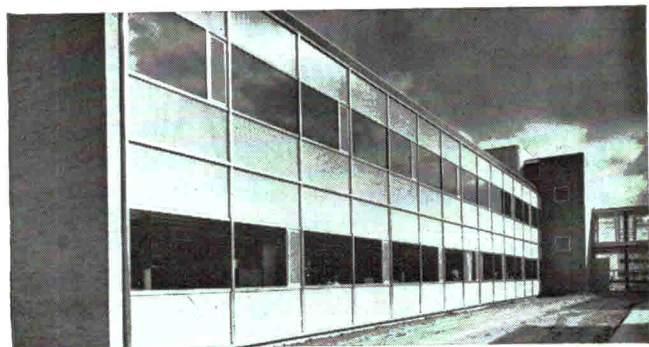

**RCA selected FOAMGLAS** to insulate porcelain enamel panels for vast curtain wall areas at their Cherry Hill Project, Camden, N.J. FOAMGLAS remains moistureproof in all kinds of weather and contributes important rigidity to the panels.

◀ **The sealed glass cell** composition of FOAMGLAS makes it completely impervious to any form of moisture. On roofs, it remains dry even if the roof leaks.

See how these important FOAMGLAS benefits can work for you. Write for our Building Insulation Catalog. Pittsburgh Corning Corporation, Dept. B-51, One Gateway Center, Pittsburgh 22, Pa. In Canada: 3333 Cavendish Blvd., Montreal, Quebec.

**PITTSBURGH**

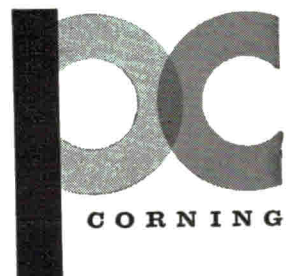

**specify**  
**BLICKMAN-**  
**BUILT**  
**laboratory**  
**furniture and**  
**hospital**  
**casework!**

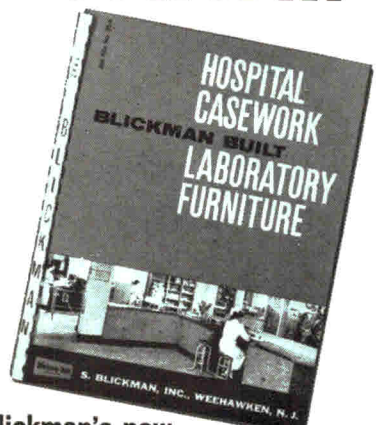

**Blickman's new 40-page catalog provides a quick-reference implement for basic planning of laboratory and hospital installations.**

It includes specifications for **standard and specialized laboratory furniture, and fixtures**... PLUS details of Blickman's exclusive **CONFLEX** construction. This new concept achieves maximum flexibility of door and drawer arrangements, without the use of tools... and without loss of rigidity or structural soundness!

More than 75 years of manufacturing experience stand behind the famed Blickman-Built symbol. It identifies the finest in stainless and enameled steel equipment!

**SEND FOR YOUR COPY TODAY!**

**S. BLICKMAN, INC.**  
 7005 GREGORY AVE., WEEHAWKEN, N. J.

Gentlemen:  
 Please rush my copy of your Hospital Casework and Laboratory Furniture catalog.

company \_\_\_\_\_  
 name \_\_\_\_\_  
 address \_\_\_\_\_  
 city \_\_\_\_\_ state \_\_\_\_\_

*The Record Reports*

*continued from page 296*

ing to Vincent A. G. O'Connor, Department of Marine and Aviation, who feels that this study is "basically important to the continued redevelopment of the City's waterfront and to the future economic strength of its port," "One of the immediate objectives will be an inquiry into passenger ship terminal requirements." He said, "In advance of the 1964 World's Fair and consistent with President Kennedy's program of encouraging tourism, we expect to attack the problems of the physical requirements of ship berthing, modern facilities for customs . . . and the relief of traffic congestion in the area of the passenger ship piers . . . we expect either to develop new or redevelop existing passenger ship terminals to make New York, America's greatest port, a most happy gateway for the traveling public."

Within one year the consultants are to submit a preliminary report, including studies, drawings and preliminary cost estimates. In 90 days following review by the Department, the consultants will deliver a final report.

Eggers and Higgins will be particularly concerned with digesting the information accumulated in the studies of what land will be available and to what use it can best be put. They will recommend alternate and multiple uses of waterfront and adjacent properties for parking facilities, housing, commercial, industrial and other possible uses for public and semi-public facilities. These would include apartments, motels, boatels and a heliport.

The North River study is the third survey to be undertaken by the Department of Marine and Aviation to determine the potential and plan the redevelopment of important areas of New York City's waterfront. It is the only one which uses an architectural firm as an integral part of the study team.

The first was the survey, at a cost of more than \$100,000, of the one and three-quarter miles of lower Manhattan's East River commercial waterfront. Made by consulting engineers, Tippetts-Abbett-McCarthy-Stratton in collaboration with the Department of Marine and Aviation

*continued on page 308*



**WEIGHT**



**REYNOLDS ALUMINUM RIGID CONDUIT**

- ★ Easy to Cut
- ★ Easy to Thread
- ★ Easy to Handle
- ★ Easy to Bend
- ★ Less Voltage Drop
- ★ Locally Stocked

For complete information and names of Reynolds Aluminum Rigid Conduit Distributors, call your Reynolds Sales Office, or write: *Reynolds Metals Company, Box 2346-EM, Richmond 18, Virginia.*



# with Koppers building products

stories show how Koppers products can also give you greater design flexibility because they protect the basic construction materials. And this greater flexibility and permanence are frequently possible with lower initial costs and lower maintenance cost.

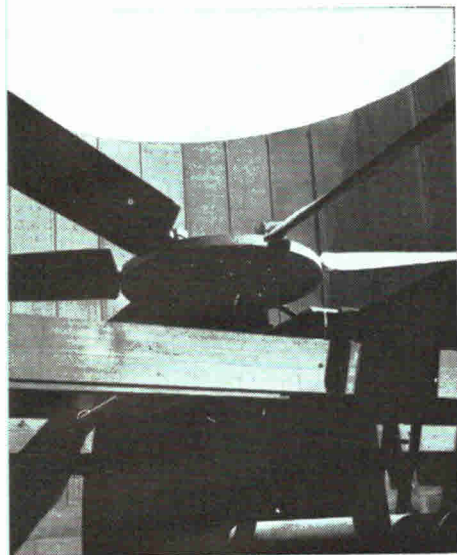

## No decay problem in wood cooling tower

This 22-foot diameter, six-bladed aerodynamic fan is one of four built by Koppers Metal Products Division for the water cooling tower installation at the atomic reactor testing station near Idaho Falls, Idaho. These exceedingly efficient fans help the redwood tower cool 24,000 gallons of water per minute. And in spite of the heat and moisture, the wood has lasting protection from fungus and decay because it was pressure-treated with ERDALITH® salts, an *insoluble* Koppers preservative, driven under heat and pressure deep into the cells of the wood. Check the coupon for information on pressure-treated wood and vibration-free AEROMASTER fans.

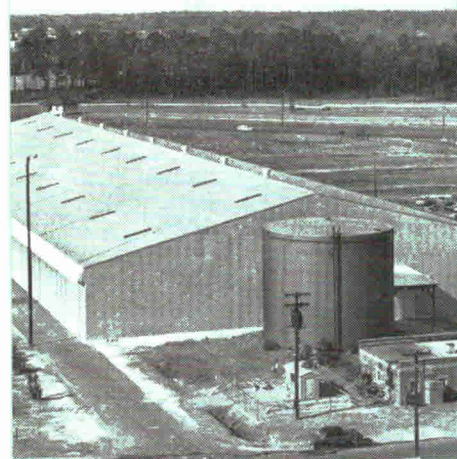

## Warehouses: 2 for the price of 1

Paper manufacturers usually store paperboard outdoors and absorb a 10% weather spoilage rather than invest in a warehouse. But WEST VIRGINIA PULP AND PAPER COMPANY decided to investigate the economy of pressure-treated pole construction. They found that their savings in paper spoilage would pay for a pole-type building in only 24 months! In fact, pole construction proved so economical that they built this 2-acre building at the cost of a 1-acre warehouse of ordinary construction. Interested in saving money on permanent warehouse construction? Check the coupon.

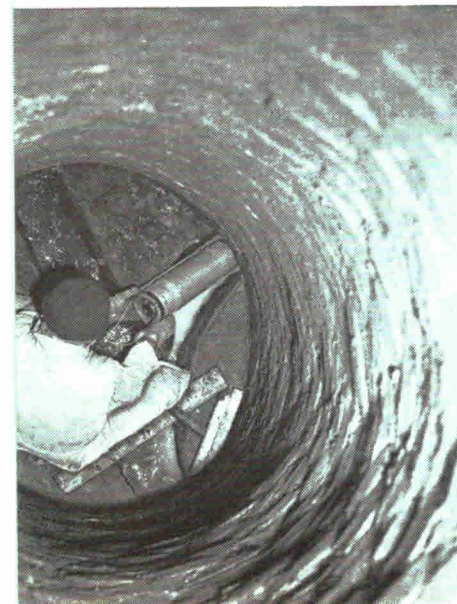

## Pipeline coating stays "picture perfect"

Engineers used a specially designed waterproof camera to check the interior of this combination sanitary-storm sewer pipe in Jersey City. Six years ago the 24" diameter concrete pipe was lined with BITUMASTIC® Super Service Black, one of the protective coal tar coatings produced by Koppers. In spite of the daily flow of 500,000 gallons of raw sewage and abrasive washings from storm sewer interceptors, the BITUMASTIC coating was still in excellent condition; no cracks, breaks or peels. For more information about Koppers *tough* coal-tar coatings, check the coupon.

## KOPPERS PRODUCTS FOR BUILDING AND CONSTRUCTION INDUSTRY

BITUMASTIC® PROTECTIVE COATINGS FOR STEEL, CONCRETE AND MASONRY

COLOR ON ALUMINUM

CREOSOTE FOR PRESSURE TREATMENT OF WOOD

DYLITE® BUILDING PANELS

NON-COM FIRE PROTECTED LUMBER

PAVEMENT SEALERS AND ROAD TARS

PENACOLITE® WATERPROOF ADHESIVES

PRESSURE-TREATED WOOD PRODUCTS

Bridge Timbers

Fence and Guard Rail Posts

Foundation Piling

Poles for Pole-type Buildings

Utility Poles and Cross Arms

WOLMANIZED® Lumber

Wood Decking

ROOFING, WATERPROOFING, AND DAMPPROOFING

Coal-Tar Emulsions

Coal-Tar Pitch Built-Up Roofing

Polyethylene Film

Waterproofing Pitch

SOUND CONTROL

AIRCOUSTAT®—Sound Traps

Industrial Sound Control

Soundproof Rooms

To: Earl F. Bennett, Mgr.-Architectural Sales  
Koppers Company, Inc., Room 1322  
Koppers Building, Pittsburgh 19, Pa.

Please send additional information about:

- NON-COM Fire Protected Wood
- Pole-type Construction
- BITUMASTIC® Coatings
- Cooling Tower Lumber
- AEROMASTER Fans

2-2

Name \_\_\_\_\_  
Job Title \_\_\_\_\_  
Company \_\_\_\_\_  
Address \_\_\_\_\_  
City \_\_\_\_\_ Zone \_\_\_\_\_  
State \_\_\_\_\_

# KOPPERS



**Divisions:**  
Chemicals & Dyestuffs  
Engineering & Construction  
Gas & Coke • Metal Products  
Plastics • Tar Products  
Wood Preserving  
International

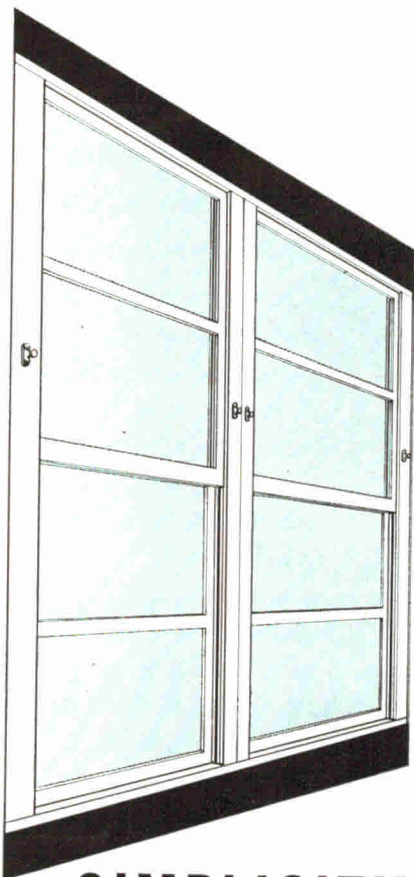

## SIMPLICITY

Superb in its simplicity... bold in its quality... dramatically down-to-earth in concept and design. Here is the sparkling new Series A730... double-hung aluminum window by the master craftsmen of Albro.

Some features of interest:

- easily installed in single or multiple units
- adaptable to curtain wall systems
- economically priced
- in all commercial sizes
- mechanical and electro-chemical finishes
- for use in apartment, office, institutional structures
- backed by rigid laboratory tests and...
- more than thirty years of creativity in metals...

See it in Sweets or write

**ALBRO METAL PRODUCTS CORP.**  
944 Longfellow Avenue  
New York 59, New York

## The Record Reports

*continued from page 304*

engineers, the study resulted in the Board of Estimate's approval of a \$40,000,000 project to redevelop the area.

The second of the port studies, at a cost of \$67,000, was conducted by the Department in collaboration with the consulting engineers, Parsons, Brinckerhoff, Quade and Douglas. This study, now in progress, involves the mile of City-owned piers on Staten Island.

### Brunner Scholarship Awarded Architects Miller and Connell

The annual Arnold W. Brunner Scholarship of the New York Chapter of the American Institute of Architects has been presented to architects Richard A. Miller and Arnall T. Connell for their study of visual perception as it is related to design. The winners were chosen from a total of 36 applicants from throughout the country.

Mr. Miller, visiting lecturer, and Mr. Connell, assistant professor, both at Ohio State University, will receive \$3000 to complete their study relating the psychological and physiological concepts and principles of visual perception to environmental design. According to the Brunner Awards Committee, the subject is of vital importance at this time. The materials which evolve from their research will be useful in the practice, teaching and learning of designing buildings and cities. At present there is no existing literature applicable to the architectural field on this topic.

In addition to the Scholarship award, two grant-in-aids of \$2000 each were made by the committee. The recipients of one were Harold Edelman and Stanley Salzman, associate professors of architecture at Pratt Institute, for completion of their book on principles of architectural composition. Mr. Edelman and Mr. Salzman were given a Brunner grant of \$1000 in 1960 to start their project.

The other \$2000 grant-in-aid went to G. E. Kidder Smith to finish his work "A Guide to Contemporary Architecture in Europe." Mr. Smith received the 1959 Brunner Scholarship which he used to launch his work.

*continued on page 312*

## SPECIFY

# Rauland

## Sound Systems



available for every requirement

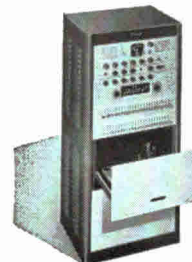

SCHOOL  
INDUSTRIAL  
INSTITUTIONAL  
EVACUATION  
PAGING  
INTERCOM

designed and built so you can  
SPECIFY WITH CONFIDENCE

Engineered and built by pioneers in communications, RAULAND Sound Systems are available for unlimited applications. There is a complete choice of program facilities and features, including multiple microphone use, emergency or evacuation announce, remote control, etc.

Also available are RAULAND'S famous Amplicall intercom systems in a wide choice of models for every desired function.

School, Industrial and Institutional systems can be designed to your exact requirements from standard panels, to RAULAND'S traditional high engineering standards.

RAULAND distributors are located everywhere.

### ENGINEERING HELP

Our new Manual of School System Specifications is available to consulting engineers. Includes general and typical specs; covers classroom speaker assemblies, call switches, microphones, auditorium systems, etc.



**Rauland** Ask on your letterhead for this unique engineering help.

**RAULAND-BORG CORPORATION**  
3535-R Addison St., Chicago 18, Ill.

# readership and confidence ... for more resultful advertising!

*"The reader reads because he finds information that helps him in his job. If this information is useful... he comes in time to associate a feeling of trust and confidence in the magazine and this feeling may carry over to the advertisements..."*

*... "if a magazine delivers both readership and confidence it is furnishing about the most valuable commodities an advertiser can buy."*

William Schink, Media Director, G. M. Basford Co., Inc.  
From McGraw-Hill's "Industrial Advertising Handbook"

## Architectural Record



119 West 40 th Street  
New York 18, N. Y.  
OXford 5-3000

"stimulus to creative architectural and engineering design"

*Kaiser Center  
Oakland, Calif.  
Architects:  
Welton Becket, FAIA  
and Associates*

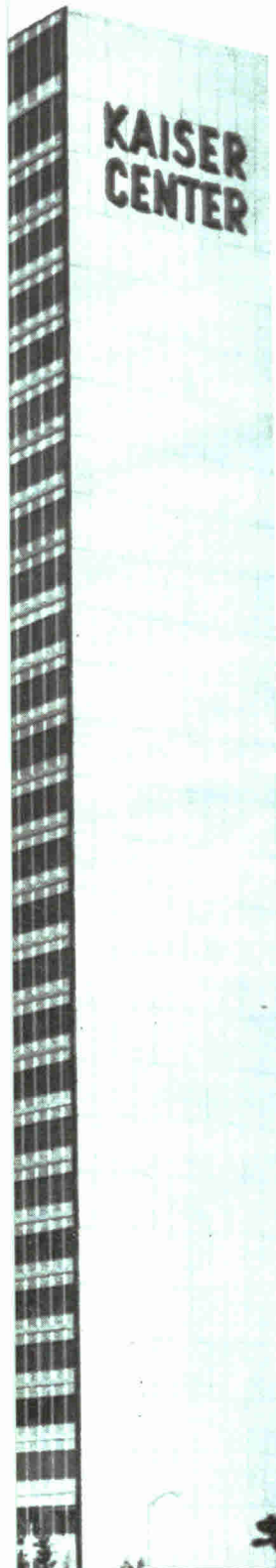

**Adulterate!**  
**Never!**

*Adulterate:  
To make impure  
by admixture of other  
or baser ingredients;  
corrupt.*

Sta-Crete doesn't — Sta-Crete ships unadulterated epoxy formulations for your concrete job. Always specify Sta-Crete to solve concrete bonding problems.

**Sta-Crete —**

- Bonds concrete to concrete
- Waterproofs
- Resurfaces
- Decorates



Start dating now —  
the Sta-Crete datebook  
is reserved for you.

-----  
STA-CRETE Inc.,  
115 New Montgomery,  
San Francisco 5, California

Name \_\_\_\_\_  
Address \_\_\_\_\_  
City \_\_\_\_\_  
State \_\_\_\_\_  
Position \_\_\_\_\_  
Company \_\_\_\_\_  
Phone \_\_\_\_\_

*Dealer Inquiries Invited.*

## The Record Reports

*continued from page 308*

### Three Architects Win Rome Prize Fellowships

Three architects are among eleven artists and scholars to receive Rome Prize Fellowships for one year each, beginning October 1, 1961. The fellowships carry \$3000, free residence and studio at the American Academy in Rome.

The architects are Robert M. Goldner of Philadelphia, Pa., who received his Bachelor in Architecture in 1960 from the University of Pennsylvania and expects his Master in Architecture in 1961; Bernard N. Steinberg, New York, N.Y., who has a Master in Architecture from the University of California; and Charles T. Stifter, Birmingham, Mich., who has a Master in Architecture from Massachusetts Institute of Technology and is with Eero Saarinen & Associates.

Founded in 1894, the American Academy in Rome is devoted to furthering the development of fine arts and classical studies in the U.S.

### Architect Sprague Wins Ford Foundation Fellowship

Architect Chester Sprague of Boston, Mass., was among eleven recipients of Ford Foundations Fellowship awards ranging from \$4500 to \$7500 for studies in the creative arts.

The fellowships are designed primarily to assist persons not regularly associated with academic institutions to undertake studies of potential significance to others interested in the creative arts.

Mr. Sprague's subject of research is pre-historic, historic and contemporary architecture of the pueblo-dwelling Indians of the southwestern United States.

### Institute of Puerto Rico Honors Jose Fernandez

José A. Fernandez, A.I.A., vice president of the Architects League of New York, has received the "Citizen of the Year 1960" award from the Institute of Puerto Rico. At present Mr. Fernandez is working on blueprints for the El Plaza Hotel which will be constructed in Santurce, Puerto Rico.



**weather-proof  
everlasting  
protected  
lighting**

**82-84**  
square round

lines

**by mc Philben**

Exterior and interior ceiling surface applications under CANOPIES, MARQUES, in SHOWER ROOMS, CORRIDORS, VESTIBULES, ALL PURPOSE ROOMS, LOBBIES, SHOPPING CENTERS. Absolute security application in PSYCHIATRIC HOSPITALS, PRISON CELLS, CHILDREN SHELTERS.

82 and 84 lines feature:

- ALL CAST ALUMINUM, sturdy, 2 piece construction in both guarded and non guarded units with integral cast hinge. Extra heavy .156 inch wall thickness.

- VAPORTIGHT (enclosed and gasketed), BUGTIGHT, WEATHERPROOF performance.

- mcPhilben's EVERLASTING ANODIZED satin aluminum finish, for permanent protection against corrosive elements.

- CHOICE of diffusers: Holophane prismatic Controlens,® tempered Fresnel Lens, heavy molded Carrara glass, or Herculite (for high security applications)

Complete specification data sheets on request Section A pages 9-10/9a-10a

**mc Philben**

LIGHTING

1329 Willoughby Ave., Brooklyn 37, N. Y.