

CIVIC CENTER, THOUSAND OAKS, CALIFORNIA BY ROBERT MASON HOUVENER
TWO REMODELED BARNS BY STANLEY TIGERMAN & ASSOCIATES
JOHN S. LEHMANN BUILDING, ST. LOUIS, MISSOURI, BY HELLMUTH, OBATA & KASSABAUM
BUILDING TYPES STUDY: PUBLIC ADMINISTRATION BUILDINGS
SEMI-ANNUAL INDEX ON PAGES 223-226
FULL CONTENTS ON PAGES 10 AND 11

ARCHITECTURAL RECORD

JUNE 1974

6

A MCGRAW-HILL PUBLICATION THREE DOLLARS PER COPY





There's a lot more to Quiet Zone than meets the eye—or the ear. When you first see it, Armstrong Quiet Zone looks like a modern, attractive Armstrong Vinyl Corlon® floor. But when you walk on it, and feel its comfort, and listen to your footsteps, you might think it's carpet.

Because underneath, Quiet Zone is unlike any floor you've probably ever seen. A thick backing of Cushioncord® vinyl foam muffles footsteps and the clatter of dropped objects. It also cushions feet, for more walking and standing comfort.

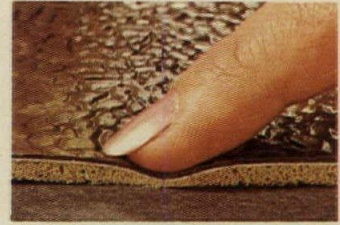

You know how important quietness and comfort are. You know how important good design is. And you know how important practicality is.

Quiet Zone is all of that. Its rugged, heavy-duty vinyl surface resists scuffs and stains. Maintenance is simple and economical. And Quiet Zone is available in two handsome patterns, which are richly textured to help disguise traffic marks and subfloor irregularities.

Shh. Install Quiet Zone. Listen to it work. More information? Please mail the coupon.

Quiet Zone™ at work. You know it's vinyl, but you might think it's carpet.



83020 Brown



83021 White



83022 Beige



83023 Gold



83024 Green



83025 Gray-Beige

The Quiet Zone pattern illustrated here is called Grand Central.

For more information, send this coupon to Armstrong, 307 Rock St., Lancaster, Pa. 17604.

Name _____

Company _____

Address _____

City _____ State _____ Zip _____

FROM THE  INDOOR WORLD® OF
Armstrong
For more data, circle 1 on inquiry card



Three models of fully recessed water coolers in 8 to 12 gallon per hour capacities. In satin finish stainless steel or in bronze-tone finish. Model shown EFR-8A.

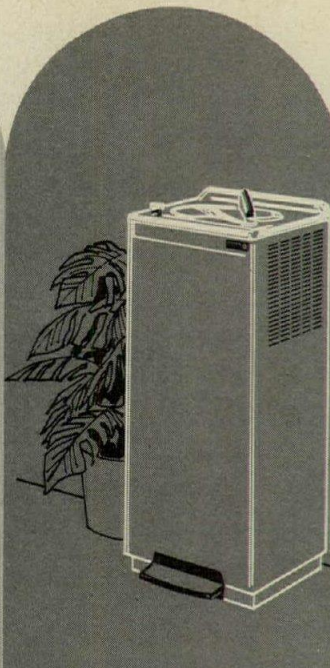

Self contained floor models in 4 to 20 gallon per hour capacities. Panels available in stainless steel, 9 vinyl decorator colors and two in baked enamel. Model shown EF-8.

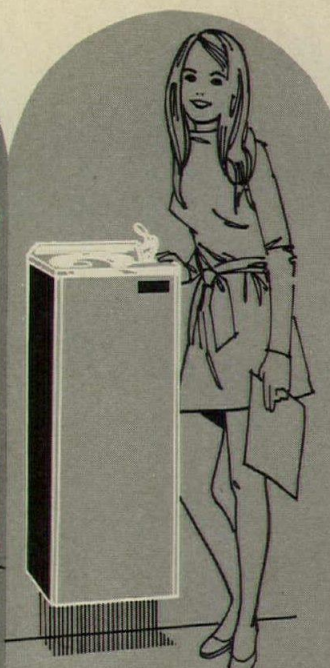

Space-ette series. The ideal water cooler where space is limited. Capacities are 3, 5 or 8 gallons per hour. Also in floor models. Model shown W-701-5.

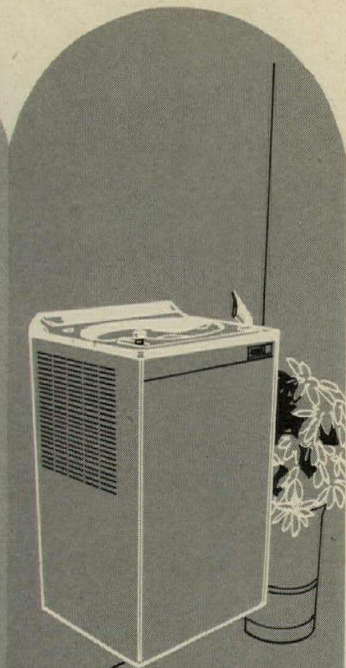

Wall mounted models in regular and compact sizes with Elkay's exclusive Cascade Basin. Full range of colored panels. Regular size 4 to 20 gallons. Compact in 4 to 14. Model shown EW-8.



Wall-mounted, simulated semi-recessed coolers, ESW series. Require no wall cut-out or mounting box. Model shown ESW-13.

Elkay reinvented the water cooler and here's why

Water coolers needed to be redesigned to permit simple, fast and economic installation. Elkay did that with sectional construction to keep mechanical systems away from the plumbing connection area. Water coolers needed a basin that is vandal-proof, minimizes splashing, looks better. And Elkay has created water coolers to fit every need: corner models, free standing, multiple basin models, two-level models. All of them with contemporary styling and finishes and colors to complement any decor.

Write for Catalog DFC-4 for more information.

ELKAY® Manufacturing Company, 2700 S. 17th Avenue, Broadview, Illinois 60153

For more data, circle 2 on inquiry card

Armstrong introduces
the bold textured lay-in
ceiling panel.

Boldface™

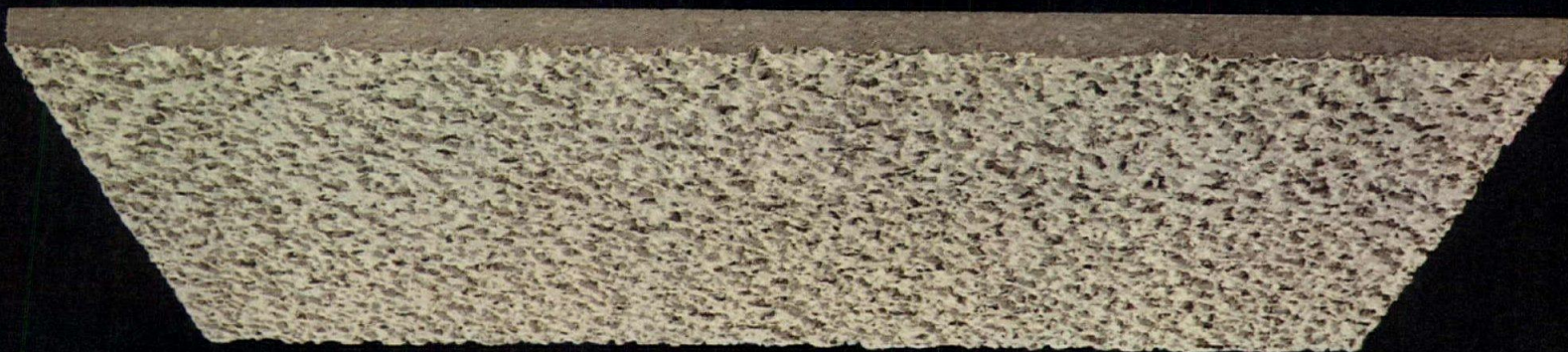

Easy-to-install, economical, and, above all, good-looking—those were the criteria that the Armstrong designers had to meet for our latest lay-in ceiling panel.

What they gave us was a panel with an exciting, bold, rough texture. We called it Boldface, and we think it's a beauty.

Its design is nondirectional with a white paint finish, making Boldface the ideal ceiling for any interior space.

Boldface is available in 24" x 24" or 24" x 48" lay-in panels and 24" x 48" Tegular lay-in panels which rest on a standard exposed-grid suspension system. Installation is simple and economical.

Its specifications rank Boldface well. It has an NRC of .60-.70; flame-spread rating of Class 25; good light reflectance—70-74%. And it has an average C factor of .52 at 3/4".

Boldface. It met all of our specifications and more. We're sure it will exceed yours, too.

For more information, write Armstrong, 4201-3 Rock Street, Lancaster, Pa. 17604.

FROM THE  INDOOR WORLD® OF

Armstrong

For more data, circle 3 on inquiry card

Letter to the publisher

This is to thank you for the very excellent editorial on "What can we do about housing the world urban poor?" which appeared in your April 1974 issue. Having been Chief of Housing for the United Nations for nine years before transferring to the UN Environment Programme, I appreciated especially the thoughtful and constructive viewpoints you presented in the editorial. It certainly serves as a major lead-in to the announcement of the formation of the International Architectural Foundation and the International Design Competition for the urban environment in developing countries.

For me, your two quotations from the late Charles Abrams, were also evocative, especially where he stated that "the solution to the problems of urbanization may be the key to an international rapprochement—and even to a lasting peace."

Sir, you have performed a very notable national and international public service with the publication of this editorial and I am sure that it cannot but help involve architects and planners around the world to achieve a sense of greater commitment, participation and dedication to the solution of real problems, with housing and a sense of community as the basic human needs which must be fulfilled.

Eric Carlson
UNEP

HABITAT
The UN Conference
on Human Settlements

Letters to the editor

The article "Prior approval: architect's answer to the or-equal spec" by H. Maynard Blumer, in the January, 1974 issue, describes a method we believe is the only way to avoid trouble with substitutions. In public work however, it must have the firm support of the legal department of the public body involved so that the contractor cannot claim restriction of choice where a single product is specified to establish a criterion. Public work is a haven for contractors who use devious methods and are consequently rejected by architects from bidding lists on private work, even though they may be financially sound. What I am saying is that nothing is foolproof and the architect and owner must use utmost care.

We have been using Mr. Blumer's method for some years with modifications to suit conditions. When a

product is approved, we promptly issue an addendum that is sent to all known bidders before bids are received so that all are informed. The original bidder who made the application for the substitution sometimes objects to this. What is Mr. Blumer's reaction to this point?

W. Henry Neubeck, A.I.A.
Neubeck & Tatler, Architects P. A.

Truly the Architect can only do a good job when the Owner supports him. We have experienced excellent support from public agencies which find it difficult to adapt their self-imposed regulations to new ideas. Hopefully, publication of the system by RECORD will aid those agencies in updating their regulations. The key to your problem of objections from "original bidder who made the application" can be found in Point 2 of the "Prior Approval Processing" which states "Submissions will be received by the Architect from any supplier, etc." When Submittals are received only from the prime bidder, there is a natural feeling of ownership of the idea. However, this is overcome when submittals originate from manufacturers, sales representatives, or other interested parties. All approvals are issued in the form of an addendum as was explained in the article. In this form, all approvals are logically open to use by all prime bidders.

The unchallenged success of the system is obtained in the unwritten law of the processing procedure which is "treat all submitters alike on a cold, hard fact basis with no special considerations and no exceptions." The system is only defensible when it is applied equally to all. Know and understand the 11 points of the Prior Approval Processing procedures. Apply them consistently and uniformly and the system will be upheld as reasonable, fair, and just.

H. Maynard Blumer, AIA-FCSI
Guirey, Srnka, Arnold & Sprinkle

Haven't we heard more than enough about the New York Five? Andy Warhol stated that in the future everyone will be a hero for five minutes. He must have had the Five in mind because there is as much substance to their work as is deserving of that time allotment.

The last time New York was involved in an architectural movement, its revival style destroyed the great Chicago School of Richardson and Sullivan. This "New" New York revival style would quickly wither

away if your very interesting magazine and others like it would devote less space to it.

Why don't you provide more exposure to the more meaningful work of architects of greater substance?

Martin Price, AIA

I have just read the article by Paul Goldberger of The New York Times in your February issue, and I would like to salute the Record for publishing what I think is the best piece of architectural criticism I have read in a long time.

"Should anyone care about the 'New York Five'? . . . or about their critics, the 'Five on Five'?"

No!—none of us who care about architecture *should* care about architecture which, in Mr. Goldberger's words, "chooses to cut itself off from much of what architecture is about."

How about some articles on the philosophies of architects who ARE dealing with the tough, painful, complex problems which ARE what architecture is about? Not forgetting, please, that elevation of the human experience *beyond* the ordinary, *above* the-best-the-system-allows, has ALWAYS been one of the great responsibilities of architecture, and its most significant achievement.

Jeanne M. Davern
New York City

Calendar

JUNE

14-15 Seminar on How the Architect and Engineer Can Profit as Builder-Developer, Houston. Sponsored by Architectural Record. Contact MCI, 505 Park Avenue, New York, New York 10022. Phone (212) 759-5830.

14-16 Fourth Annual Maine Preservation Conference, Westbrook College, Portland, Maine. Contact Mrs. Susan T. Sewall at the above address.

16-21 International Design Conference on the theme, "Interaction between the self and the system," Aspen, Colorado. Contact Aspen '74 Office, Room 10-411, MIT, Cambridge, Massachusetts 02139.

17-20 Conference of the American Society for Engineering Education, Rensselaer Polytechnic Institute, Troy, New York. Contact C. A. Eckert at the Society, Suite 400, One Dupont Circle, Washington, D.C. 20036.

17-21 Course in Energy: Resources, Conversion and Utilization, University of California at Berkeley. Contact Continuing Education in Engineering, University of California Extension, Berkeley, California 94720.

ARCHITECTURAL RECORD (Combined with AMERICAN ARCHITECT, ARCHITECTURE and WESTERN ARCHITECT AND ENGINEER)

June 1974, Vol. 155, No. 7, Title® reg. in U.S. Patent Office copyright© 1974 by McGraw-Hill, Inc. All rights reserved. Copyright not claimed on front cover and editorial four-color separations. Indexed in Reader's Guide to Periodical Literature, Art Index, Applied Science and Technology Index, Engineering Index, and The Architectural Index. Published monthly except May, August, and October when semi-monthly, by McGraw-Hill, Inc. Quotations on reprints of articles available. Every possible effort will be made to return material submitted by possible publication (if accompanied by stamped, addressed envelope), but the editors and the corporation will not be responsible for loss or damage.

EXECUTIVE, EDITORIAL, CIRCULATION AND ADVERTISING OFFICES: 1221 Avenue of the Americas, New York, New York 10020. Other Editorial Offices: 425 Battery Street, San Francisco, Cal. 94111; 1249 National Press Building, Washington, D.C. 20004.

PUBLICATION OFFICE: 1221 Avenue of the Americas, New York, New York 10020. Second class postage paid at New York, New York 10001 and at additional mailing offices.

OFFICERS OF McGRAW-HILL PUBLICATIONS COMPANY: John R. Emery, president; J. Elton Tuohig, executive vice president-administration; David J. McGrath, group publisher-vice president; senior vice presidents: Ralph Blackburn, circulation; John B. Hoglund, controller; David G. Jensen, manufacturing; Gordon L. Jones, marketing; Jerome D. Luntz, planning & development; Walter A. Stanbury, editorial.

CORPORATION OFFICERS: Shelton Fisher, president and chief executive officer; Wallace F. Traendly, group president—McGraw-Hill Publications Company and McGraw-Hill Information Systems Company; Robert N. Landes, senior vice president and secretary; Ralph S. Webb, treasurer.

SUBSCRIPTIONS: Subscriptions solicited only from architects and engineers. Position, firm connection, and type of firm must be indicated on subscription orders. CHANGE OF ADDRESS or subscription service letters should be forwarded to Fulfillment Manager, ARCHITECTURAL RECORD, P.O. Box 430, Hightstown, N.J. 08520. Provide old and new addresses, zip code or postal zone number, if possible, attach issue address label. Annual subscription prices: U.S., U.S. possessions and Canada: \$10.00 for architects, engineers and other individuals in the fields served, all others \$22.00. Other countries: \$25.00 to architects, engineers; others \$35.00. Single copies \$3.00. GUARANTEE: Publisher agrees to refund that part of subscription price applying to unfulfilled part of subscription if service is unsatisfactory.

ASSOCIATED SERVICES / McGraw-Hill Information Systems Co.: Sweet's Catalog Files (Architectural, Light Construction, Interior Design, Industrial Construction, Plant Engineering, Canadian Construction), Dodge Building Cost Services, Dodge Reports and Bulletins, Dodge/SCAN Microfilm Systems, Dodge Management Control Service, Dodge Construction Statistics, Dodge regional construction newspapers (Chicago, Denver, Los Angeles, San Francisco).

THIS ISSUE is published in national and separate editions. Additional pages of separate edition numbered or allowed for as follows: Western Section 32-1 through 32-2. POSTMASTER: Please send form 3579 to Fulfillment Manager, ARCHITECTURAL RECORD, P.O. Box 430, Hightstown, N.J. 08520.

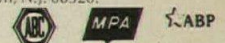

Take a second look.
Those ceiling tiles are really
lay-in panels.

Introducing the Second Look™ ceilings by Armstrong.

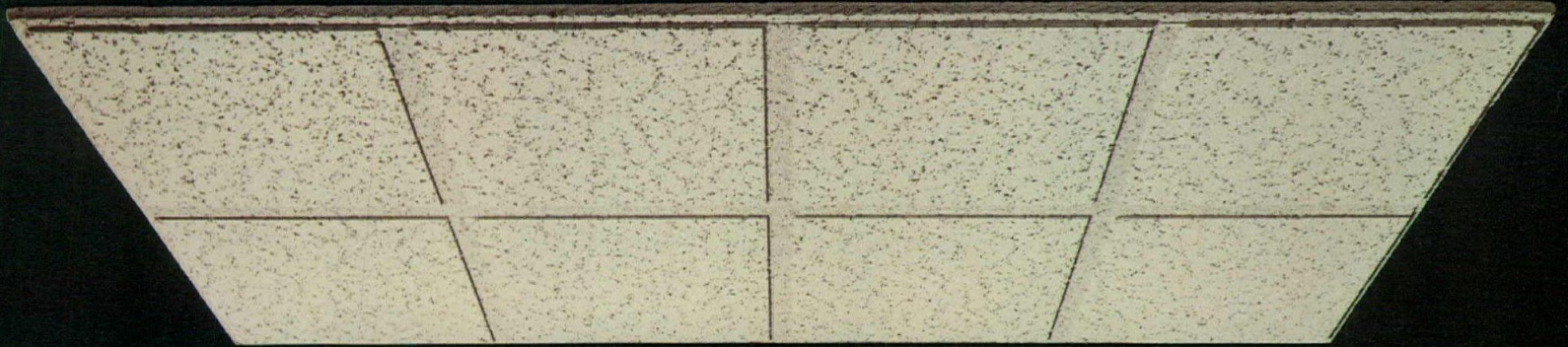

Second Look II ceiling panel

You really have to look twice. These are not 12" x 12" or 24" x 24" ceiling tiles, they are 2' x 4' lay-in panels.

That's why we call our new lay-in panels Second Look. They're designed to give ceilings the look of tile but with the economy of lay-in panels. What your client gets is a good-looking bargain. And the ceiling gets a lot of second looks.

We created this effect by scoring the panels to simulate 12" x 12" or 24" x 24" tiles—and we matched the exposed grid to the board finish in a speckled or low-gloss design.

Installation is the standard, economical suspended grid system. Just as soon as the panels are suspended, the total effect is achieved, because the grid and

the ceiling panels visually blend to give an overall appearance of more expensive tile.

Find out more about these unique Second Look lay-in ceiling panels. Write Armstrong, 4201-4 Rock Street, Lancaster, Pa. 17604.

Then you can take a good long second look at our Second Look.

©Second Look Ceiling Systems I and II patent pending

FROM THE  INDOOR WORLD® OF

Armstrong

For more data, circle 7 on inquiry card



Cover: Civic Center,
Thousand Oaks, California
Architect: Robert Mason Houvener
Photographer: Gary Joiner

EDITOR

WALTER F. WAGNER, JR., AIA

MANAGING EDITOR

HERBERT L. SMITH, JR., AIA

SENIOR EDITORS

ROBERT E. FISCHER
WILLIAM B. FOXHALL
MILDRED F. SCHMERTZ, AIA
ELISABETH KENDALL THOMPSON, FAIA

WASHINGTON EDITOR

ERNEST MICKEL, Hon. AIA

ASSOCIATE EDITORS

GERALD ALLEN
BARCLAY F. GORDON
CHARLES E. HAMLIN
CHARLES K. HOYT, AIA

EDITORIAL ASSISTANT

JANET NAIRN

PRODUCTION EDITOR

ANNETTE K. NETBURN

DESIGN

ALEX H. STILLANO, Director
ALBERTO BUCCHIANERI, Associate
ANNA-MARIA EGGER, Assistant
MURIEL CUTTRELL, Illustration
J. DYCK FLEDDERUS, Illustration
JAN WHITE, Consultant

EDITORIAL CONSULTANTS

EDWARD LARRABEE BARNES, FAIA
JONATHAN BARNETT, AIA, Urban design
GEORGE A. CHRISTIE, JR., Economics
PAUL RUDOLPH, FAIA
Foreign architecture:
L'Architecture d'Aujourd'hui, Paris

McGRAW-HILL WORLD NEWS

RALPH R. SCHULZ, Director
10 domestic and 8
international news bureaus:
Bonn, Brussels, Buenos Aires,
London, Milan, Moscow, Paris,
Tokyo.

SALES MANAGER

LOUIS F. KUTSCHER

CIRCULATION MANAGER

HUGH S. DONLAN

PUBLISHER

BLAKE HUGHES

THE RECORD REPORTS

13 Editorial

Those Guiding Principles gonna rise again! And let's hope soon!

4 Letters/Calendar

33 News in brief

Short items of major national interest.

34 News reports

AIA convention draws architects to Washington, D. C. to discuss humane architecture. For a report on convention news, see page 37.

40 Buildings in the news

Cleveland Hopkins International Airport extension, Cleveland. Robin Hood Dell theater, Philadelphia. Downtown renewal, Denver. Judicial/Heritage Center (below), Denver.

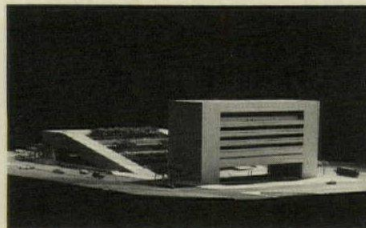

Ed Morrison

43 Human Settlements: World News

45 Required reading

56 Office notes

ARCHITECTURAL BUSINESS

65 Business plans record spending for plants and equipment

The 27th annual McGraw-Hill survey of the spending expectations of U.S. business for plants and equipment shows a projected gain of 19 per cent in 1974 to \$119.1 billion, of which 20 per cent will be for buildings. Preliminary plans show an expected average of about \$129 billion per year will be spent over the following three years.

67 Construction management

A new estimating service developed by Dodge Building Cost Services will be an annual guide to systems and materials costs for architects and engineers to evaluate design options during preliminary phases. Computerized data are applied to categories of assemblies comprising whole buildings of various types and are tabulated to show costs per gross square foot of building for each system.

71 Building costs

Costs per square foot for building renovation get John Farley's attention as gasoline shortages generate a population return from suburbs to older urban buildings.

73 Building activity

How real are building materials shortages, now that Phase IV price controls are eased? Jim Carlson sees considerable relief in, for example, rebar supplies, as the constraints of steel pricing structure shift with demand.



FEATURES

- 95 **Buildings for recreation**
Four buildings that reflect the diversity of recreational activity in today's increased leisure.
- 95 **Airpark Lodge, Reelfoot Lake State Park**
Tiptonville, Tennessee
Gassner/Nathan/Browne, architects
- 98 **Bedford-Stuyvestant Community Pool**
Brooklyn, New York
Morris Lapidus Associates, architects
- 100 **Lake Cochiti Recreation Center**
Cochiti, New Mexico
Frank O. Gehry and Associates, architects
- 104 **Jewish Community Center**
Portland, Oregon
Wolff Zimmer Gunsul Frasca, architects
- 105 **Church Park Apartments**
Boston, Massachusetts
Popular concepts in housing the urban poor are based on some assumptions that may not always be valid. This Boston project by The Architects Collaborative tries a new sociological approach which does not rely on building form and which may produce the most successful results to date.
- 111 **John S. Lehmann Building**
St. Louis, Missouri
Hellmuth, Obata & Kassabaum, Inc.
Inside, it contains a superb collection of botanical specimens that make it a mecca for browsers and scholars alike. Outside, it achieves an unusual harmony with its surroundings that make it a welcome addition to one of the most handsome urban parks anywhere in the Midwest.
- 117 **Down on the farm, barns are still being upgraded for people**
Although the remodeling of barns for residential use is a fairly commonplace event, the results only rarely have architectural interest. Some exceptions are two barns by Stanley Tigerman & Associates, each of which has a strong contemporary image, while remaining unmistakably a barn.

BUILDING TYPES STUDY 462

- 123 **Public administration buildings**
A collection of recent buildings from many different parts of the United States illustrate some problems and successes in the collaboration between architects and public clients.
- 123 **Thousand Oaks Civic Center**
Thousand Oaks, California
Robert Mason Houvener, architect
- 130 **Greensboro Governmental Center**
Greensboro, North Carolina
Eduardo Catalano, architect
- 134 **Police precinct station**
Queens, New York
Holden/Yang/Raemsch/Terjesen, architects
- 136 **Police Headquarters**
Schenectady, New York
Feibes & Schmitt, architects
- 138 **Firehouse**
San Francisco, California
Braccia/De Brer/Heglund, architects



Gary Joiner

ARCHITECTURAL ENGINEERING

- 141 **Prefabricated space trusses that are both rational and form-giving: Part 2 (conclusion)**
Last month's article described Hirsch & Gray's basic approach to off-site fabrication of space truss elements, and showed their application in a horizontal truss roof. This month different geometries are shown for two roofs with more complex shapes.
- 151 **Product Reports**
- 153 **Office Literature**
- 192 **A/E Update**
- 223 **Semi-annual Index**
- 228 **Advertising Index**
- 230 **Classified Advertising**
- 231 **Reader Service Inquiry Card**

NEXT MONTH IN RECORD

Scarborough Civic Center
Designed by Ramond Moriyama, this complex is the hub of the Scarborough town center in metropolitan Toronto. The center includes a large enclosed shopping mall, and will eventually have office buildings, a hotel and high-density apartments. RECORD will feature the Civic Center in the context of Moriyama's long-range plan for the town center.

Building Types Study

Community colleges are an increasingly important segment in today's educational cycle. As diverse as the curricula they offer are their locations—downtown, suburban, rural—and their architectural expression. Five new campuses, designed to give the college a clear identity in the community and enhance the community's own interest will be shown.

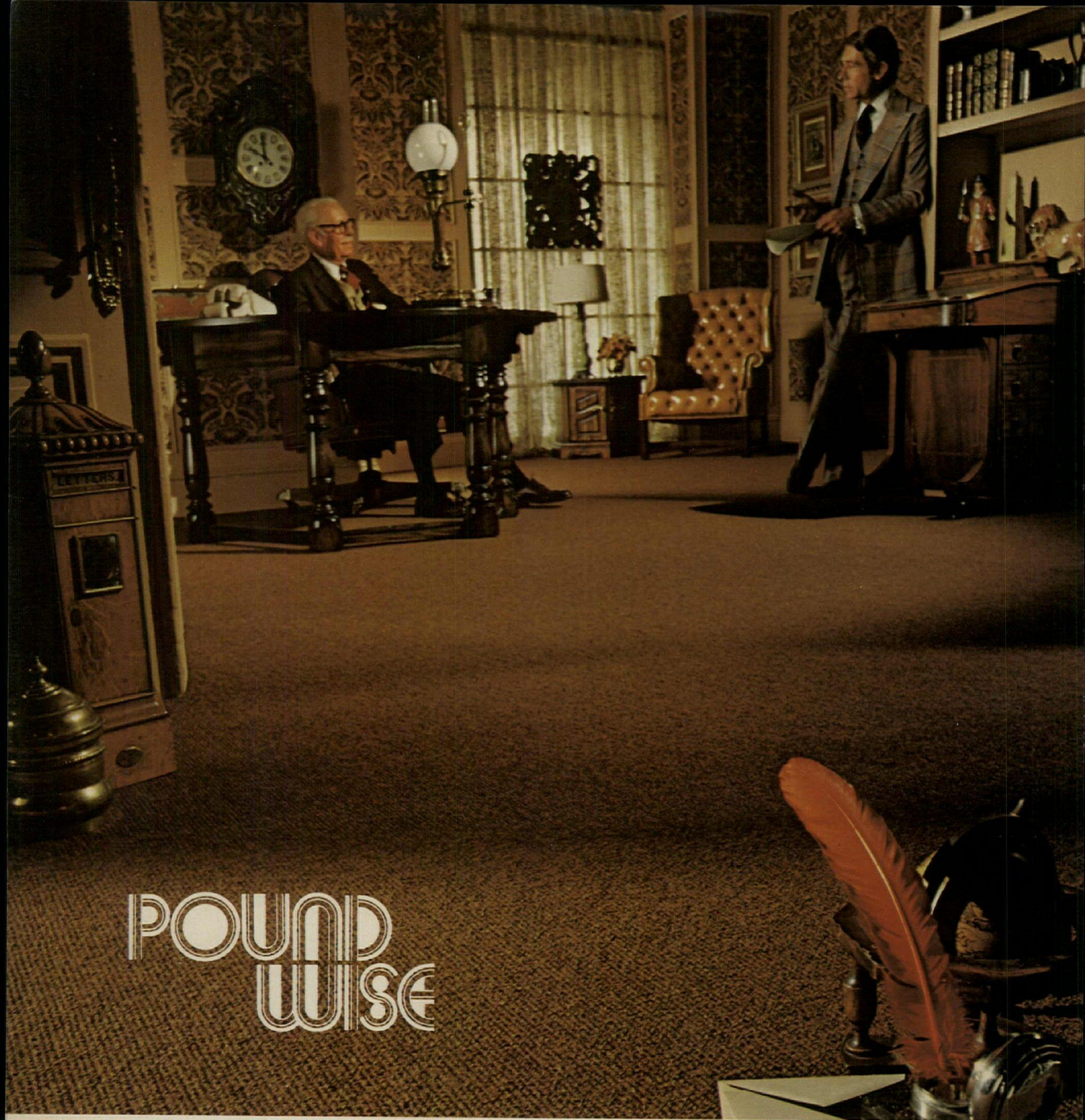

POUND WISE

Because a good businessman isn't penny foolish. He expects business-like performance from his carpet. And Pound Wise gives him the rugged durability of 6-ply Celanese PCP Fortrel polyester yarn. Plus the assurance of a 5-year wear guarantee. But there's another plus. Pound Wise has the comfortable, congenial good looks he doesn't expect in a business carpet. Textural, extra-

gant sized rows of quarter-gauge nubby loops. Available in 12 natural colors. This carpet is a wise choice for the man who sets an appreciable value on appearance. For only a few pennies more. Pound Wise is one of five Capital Assets carpets. Rugged commercial carpets for big business. Each different in appearance, for places where appearance is an asset to

business. Capital Assets completes a line of commercial carpets for every installation from the ground floor to the executive suite. Available in every commercial fiber, construction and price range. And all commercial quality, because we make nothing else. Write or call for catalogs.

Fortrel® and Fortrel PCP are trademarks of Fiber Industries, Inc., a subsidiary of Celanese Corporation.

CELANESE FORTREL

Because we're committed to commercial quality and nothing else.
wellocarpetcorporation



WELCO CARPET CORPORATION □ P. O. BOX 281 □ CALHOUN, GEORGIA 30701 □ TELEPHONE: 404/629-9276 □ A WHOLLY OWNED SUBSIDIARY OF MANNINGTON MILLS, INC. SALEM, N. J.

Those Guiding Principles gonna rise again! And let's hope soon!

The news is that last month the National Endowment for the Arts released a document entitled "Federal Architecture: A Framework for Debate." Let me say at once that I think the debate ought to be very short indeed because the proposals are very good indeed and ought to be adopted forthwith by our government—preferably by the same kind of strong Presidential order that, back in 1962, revolutionized the quality of Federal building with the original Guiding Principles.

In addition to an ad hoc task force of professionals on which I had the honor to serve, there has been major input of information and judgment from a committee of designees representing 20 Federal agencies with construction responsibilities, and the major credit for the excellence of the report goes straight to the National Endowment's Nancy Hanks and Bill Lacy and an Endowment-sponsored staff headed by Lois Craig. So though I kibbitzed, I intend to be shameless in praising (and quoting at length) aforesaid report, for the reasons stated before.

For those too young, or for those who have forgotten, it all began in 1962. . .

. . . when a committee on Federal office space issued a report that was primarily concerned with Federal space in Washington and the redevelopment of Pennsylvania Avenue, but which—on one page—listed some "Guiding Principles for Federal Architecture." The major points of those Principles, first enumerated in a speech by Daniel Patrick Moynihan a few months earlier, were: "The policy shall be to provide facilities in an architectural style and form which is distinguished and which will reflect the dignity, enterprise, vigor, and stability of the American national government. Major emphasis should be placed on the choice of designs that embody the finest contemporary American architectural thought. . . . Where appropriate, fine art should be incorporated in the designs, with emphasis on the work of living American artists. . . . The development of an official style must be avoided. Design must flow from the profession to the government, and not vice versa. The Government should be willing to pay some additional cost to avoid excessive uniformity in design. . . . The advice of distinguished architects ought to, as a rule, be sought prior to the award of important design contracts (and) special attention should be paid to the general ensemble of streets and public places of which Federal buildings will play a part. . . ."

Well, Miss Hanks said from the start that the starting point for the study which has now resulted in the new report would be those Principles. Indeed it was, but there is a great broadening of concept, some new insights, some fresh and appropriate ideas, and most importantly, reading through every line, a conviction that we must do something. Under "Intervention for Quality," in the early pages, the report states the all-important premise that "as the nation's largest single building client, the Federal government has a special obligation to seek quality in its buildings", and makes clear that "Our focus [in writing the Report] has not been on architectural style but on expanding the principles to include the present scope of Federal architecture and a broadened view of architectural excellence more suited to our times." Here are what seem to me—out of the 43-page double-spaced draft of the document—the most important parts of that expansion:

The report faces right up to "The Cost of Quality . . ."

. . . and minces no words by stating that "Costs in the design of public buildings are usually related to the perception of initial costs. The result is a weighting toward banality. . . ."

"Banality is not necessarily cheap. Not only can banal buildings cost staggering amounts of money initially; but poorly designed, cheaply built buildings can be exorbitant in cost in the long run."

Correctly, the Report argues that the concept of life-cycle costing (initiated and strongly supported by GSA Administrator Arthur Sampson) puts into perspective "those costs of good design that relate to quantifiable building value received." But, equally correctly, the point is made that that is not enough; that "in addition to long-term costs of the building itself, the ultimate judgment about costs cannot be made without an evaluation of community benefits . . . and these benefits are calculated beyond the four walls of a structure."

"There is no ready formula for 'costing' the social benefits of good design. This kind of 'cost-accounting' is related to overriding public purposes and requires judgment based on imprecise measurements. The demand for precise economic evidence can become a distraction behind which environmental abuse takes place long after it is obvious to even inexpert eyes."

Says the Report, realistically: "In a pluralistic democratic society, we cannot mandate

This Alan Dunn cartoon is, I am very sorry to tell you, the last that he drew. He finished it just a few days before he died on May 20th.

And so ends a relationship between RECORD and Mr. Dunn that began on page 7 of the June 1937 issue of this magazine—exactly 37 years ago.

We've often asked ourselves what we would do when there were no more Alan Dunn drawings. Now we must face that question, and the answer seems clear. There can be no replacement for Alan Dunn.

For Alan Dunn was not a cartoonist, he was an architectural critic of great importance—a fact recognized by the AIA last year when Mr. Dunn was given the Architectural Critic's Citation.

New month, we'll do a small retrospective of some of our favorite Alan Dunn drawings. And perhaps in each December issue we'll give you (and us) a Christmas present by publishing more of our favorites.

But there cannot, and will not, be a replacement. For us who worked with him, for you who enjoyed his work, and for architecture—which for so many years profited from his insight, an era that lasted 36 years is just plain over.

—W. W.

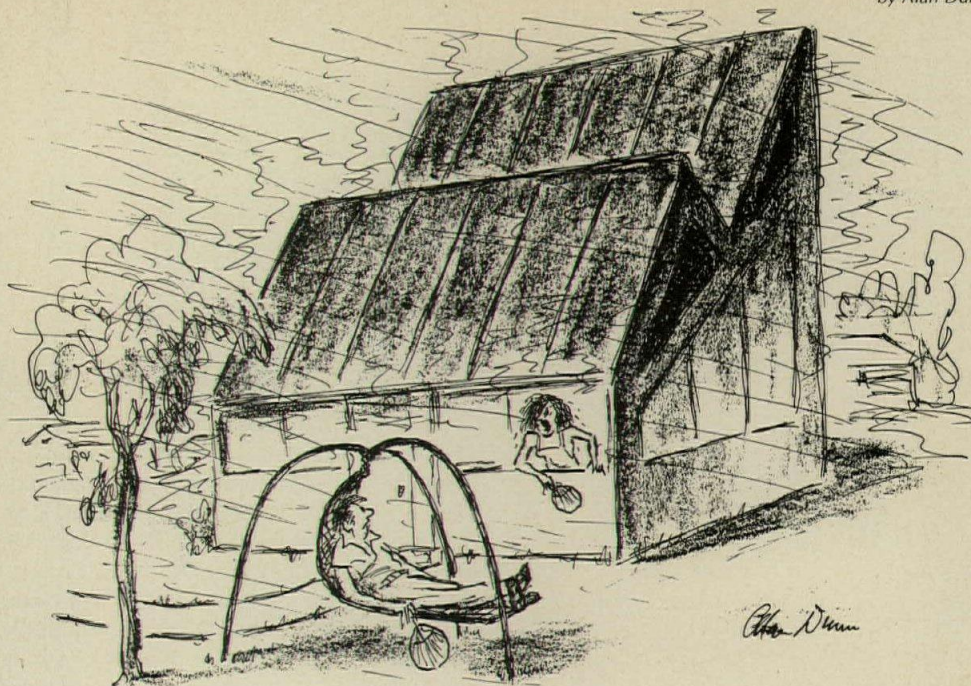

"How do I turn off the solar energy?"

good public design by fiat. But we can mandate the public policy climate in which it can flourish."

The "interim recommendations" of the Report suggest a framework for this policy

... and I quote them here at length because I believe they form the basis for a whole new relationship among client agencies, the GSA and its people, architects and engineers, and finally and most importantly the people who, as taxpayers, pay all the bills and who, as citizens of the United States, deserve in their public buildings not a minimum acceptable quality of architecture but the very best that we can accomplish with sound relationships between the best qualified people.

On people in government and selection of architects, the Report recommends that

■ "Government administrators, professional societies, and educators should address the special training needs and incentives for attracting and keeping talented design professionals in public service. Consideration should be given to placing [more] design professionals at policy levels in design and construction agencies."

■ "In selection of architects and engineers for major public building contracts, the ranking, selection process, and rationale for the final selection should be documented. In all transactions regarding selection it would be desirable to devise procedures for making all contracts from outside the agency a matter of public record." Oh, wow, would it ever. This is a fairly calm statement for a subject that needs drastic attention—and it should be noted that a GSA task force on architect-engineer selection is soon to complete a major study of problems and possible solutions.

■ Noting, with great politeness, that "preference in the selection of consulting profes-

sionals for public projects tends to be given to established firms", the Report argues that "selection . . . should be based solely on professional qualifications with no undue attention to seniority or political influence" and that "newer and smaller as well as minority firms" should be encouraged to apply for work.

■ Further on selection, the Report supports (and this will stir up controversy!) "Design competitions, properly financed . . . to encourage public design concern and demonstrate government receptivity to new ideas and people." Wisely, it supports this "selection alternative" for a limited number of projects not just "of national significance or high public interest" but "small projects particularly appropriate to attracting new talent."

On quality, there are important new ideas . . .

The National Endowment's Report urges that "Federal buildings used by the general public in urban locations should enhance as well as protect the environment by encouraging street vitality and a lively pedestrian setting in and around these buildings . . ."

How do you accomplish that "vitality and lively setting?" There are bold new suggestions here:

■ One is mixed use: "Federal buildings should provide the widest possible range of uses along with the Federal use . . . including other levels of government, commercial, educational, institutional, civic, cultural and recreation uses." This makes such good sense from the point of view of vitality—and why shouldn't government lead the way?

■ Another recommendation for "vitality" and enhancing the environment is "priority consideration to adapting existing structures—particularly structures of architectural or historic significance—for Federal use . . . This alternative should include consideration of satisfying space needs by adapting a cluster of smaller

buildings as well as adapting single large buildings."

And from these basic ideas develop others . . .

There's not room here to even try to summarize 44 thoughtful pages, but a few other basic ideas include: careful attention to approaches, landscaping, appropriate scale and design of even those buildings planned for minimum public contact; setting up "non-deductible" budgets for art and the design and costs of appropriate interiors, furnishings, and landscaping; more thoughtful programming by client agencies; post-occupancy evaluation of buildings; a government-wide design awards program to "encourage a broadened view of architectural excellence"; and—most important—"to give continuity to periodic initiatives [like this one] for Federal design achievement, government concern for the design quality of Federal facilities should be formalized. An over-all design advisory office should monitor all Federal building activities with periodic reports measuring government progress and recommending changes in Federal policies to raise the level of design achievement."

And that's a goal worth support

The Interim Report is now being circulated by the National Endowment to government agencies, interested state and local government officials, and professionals who have been actively involved in the Report and the considerations leading up to it. Here's my comment, National Endowment. I think the Report and its recommendations deserve support by every professional, because I think they point to a clear way to encourage better public architecture—and we sure need that.

As I said at the start: may the debate over this Interim Report be brief; and then let's push for strong support and implementation of the new "Guiding Principles."—Walter Wagner Jr.

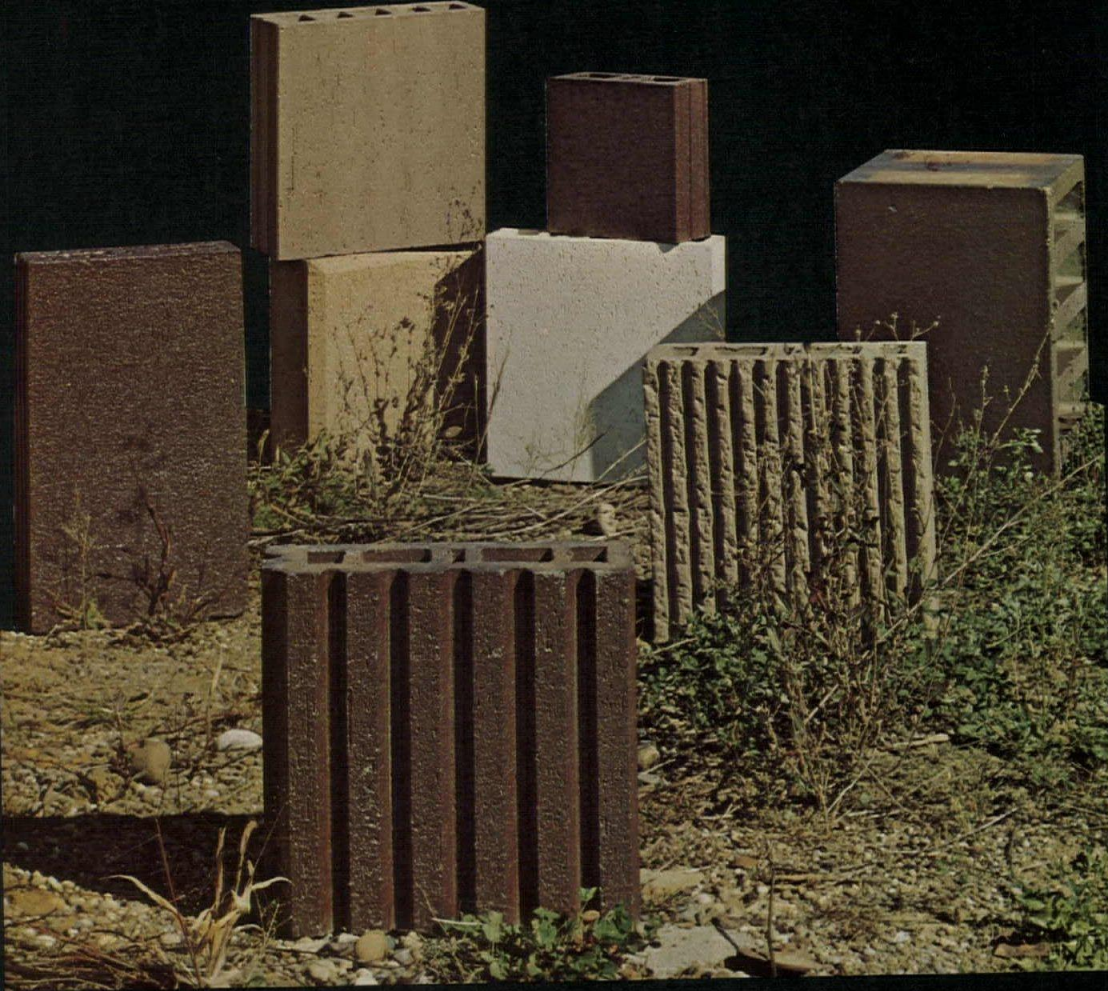

Panelbrik™

A contemporary answer in masonry, blending with the total environment. And like other genuine fired-clay building units, Panelbrik meets the challenge of costs. Write for full information.



 **Glen-Gery**
CORPORATION
READING, PA 19607

POOL/BRIARWOOD REGIONAL RETAIL DEVELOPMENT, Ann Arbor, Michigan
 21800 Southfield, Michigan. Owner-developer: The Taubman Company, Inc., Southfield, Mich.

For more data, circle 9 on inquiry card



Bradglas for plant washrooms. Tough. Bradley style.

Bradglas® reinforced polyester Washfountains are tough to take the wear and tear of plant washroom use. Resistant to abrasion, acid and corrosion. Won't chip, peel or flake.

Won't shrink, warp or crack. And they complement today's design treatments, with clean, contemporary lines in five decorator colors. Serve up to eight with one set of

connections. See your Bradley representative and write for literature. Or Call (414) 251-6000. Telex 2-6751. Bradley Corporation, Fountain Blvd., Menomonee Falls, WI 53051.

Another bright idea from  **Bradley**

For more data, circle 10 on inquiry card

Come Hail or High Water Tapered FOAMGLAS® Insulation Gives Positive Drainage



The best way to get proper slope for positive water drainage is with Tapered FOAMGLAS Insulation. The blocks come pre-tapered $\frac{1}{8}$ inch per foot to provide proper water drainage and an excellent base for built-up roofing.

Pittsburgh Corning guarantees that Tapered FOAMGLAS Roof Insulation will not absorb moisture, will retain its original insulating efficiency and compressive strength and will remain incombustible for 20 years when applied in accordance with the written guarantee.

Tapered FOAMGLAS Insulation, which is available for prompt delivery, provides one-contractor responsibility for the roofing insulation and built-up roofing. And, the new Tapered II system cuts

installation time and material waste.

Learn more about the Pittsburgh Corning guarantee and the unique inorganic closed-cell construction of FOAMGLAS Insulation.

Send in the coupon below.



MAIL TO: Pittsburgh Corning Corporation
 Department AR-64
 800 Presque Isle Drive
 Pittsburgh, Pennsylvania 15239

Yes, I'd like to know more about Tapered FOAMGLAS® Insulation and its guarantee
 I would like to see a Sales Representative

Name _____
 Title _____
 Company _____
 Address _____
 Telephone _____

For more data, circle 11 on inquiry card

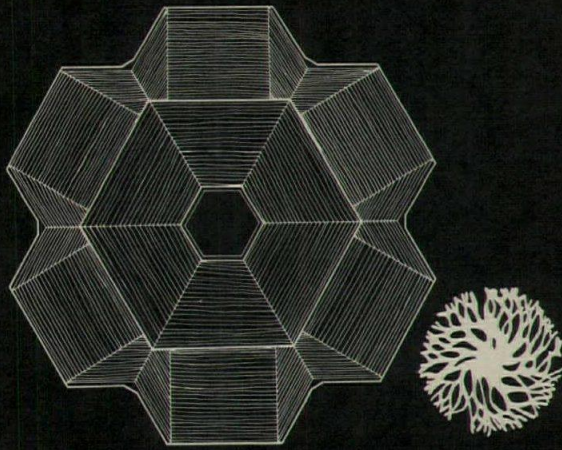

Red cedar makes a school a home.

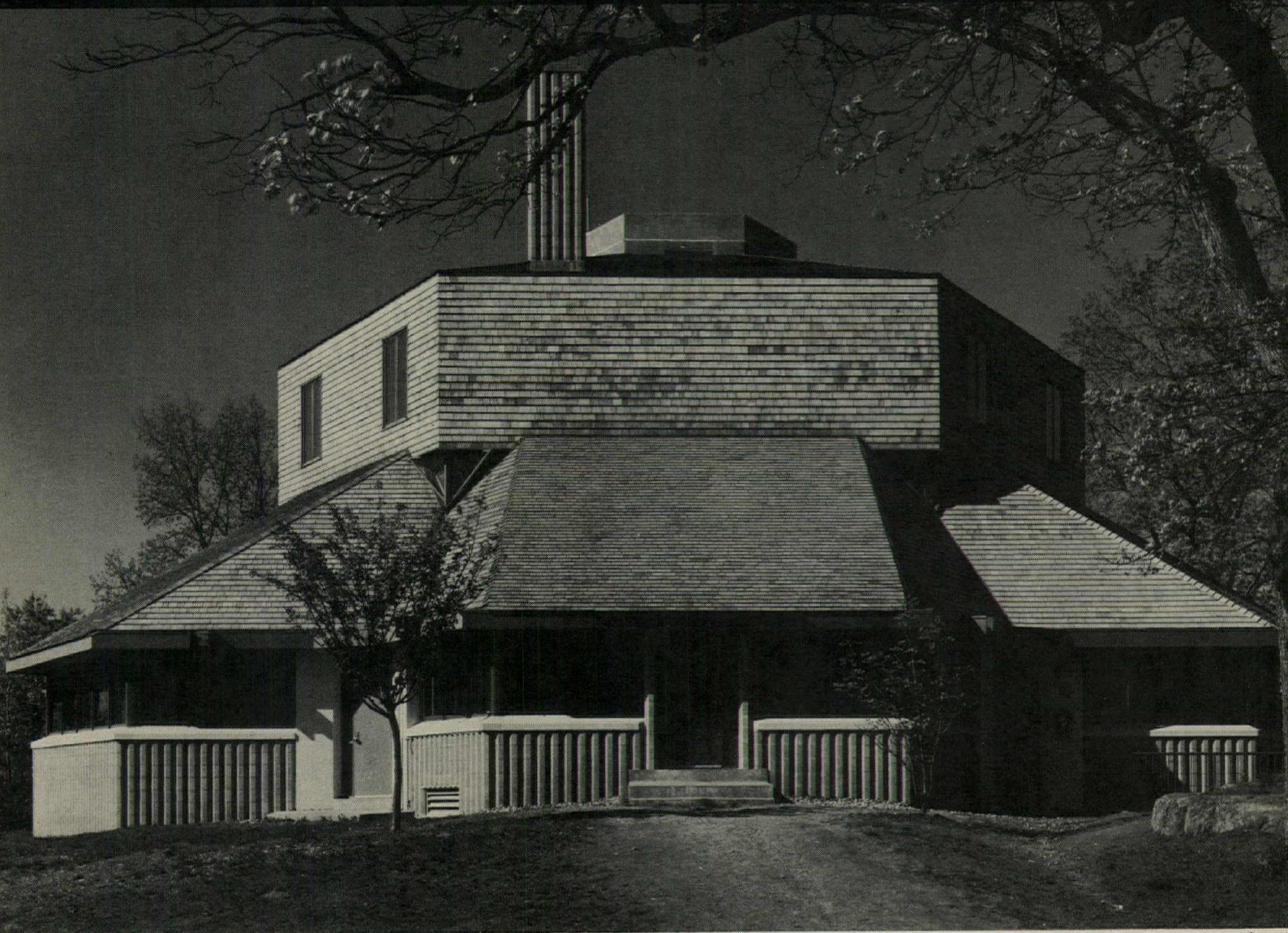

The Walker School, Needham, Massachusetts. Architect: Henry Hardings Menzies, Boston. General Contractor: J. M. Construction Co., Needham, Massachusetts.

The Walker School in Needham, Massachusetts, is a special school for youngsters with emotional and educational difficulties.

Its design answers the problem of giving an institutional structure warmth and humanity. While employing dramatic lines, the architect has retained an inviting, comforting atmosphere.

Red cedar shingles are part of the solution. Their texture and organic feeling moderate the structure's upward motion,

blending it with the New England landscape. Making it a home.

Red cedar shingles' unique durability and insulative properties will help keep the school warm and heating costs down during the hard Massachusetts winters.

Next time you have a design problem, consider Red Cedar Certigrade Shingles and Certi-Split Shakes, the distinctive materials that help make a New England school a home.

For more details, write: Red Cedar Shingle & Handsplit Shake Bureau, 5510 White Building, Seattle, Washington 98101, (In Canada: 1055 West Hastings Street, Vancouver 1, B.C.)



These labels on bundles of red cedar shingles or handsplit shakes are your guarantee of Bureau-graded quality. Insist on them.

Red Cedar Shingle & Handsplit Shake Bureau

One of a series presented by members of the American Wood Council.

For more data, circle 12 on inquiry card

PROGRAM WITH PLEXIGLAS®

... the problem solving plastic for glazing

You name the glazing need. Plexiglas brand acrylic plastic will provide the answer. Answers made possible through the unique combination of advantages that only the complete line of Plexiglas formulations offers.

Plexiglas offers properties like breakage resistance, weatherability, safety, optical clarity, light weight, formability.

Advantages that include availability in a wide assortment of sizes, colors and thicknesses . . . in clear form, in transparent tints and patterned sheets.

Right now Plexiglas is hard at work in a broad range of glazing areas—everything from hockey rinks to storm doors . . . from energy-conserving solar control windows to security partitions in banks and offices . . . from vandal-resistant school windows to a variety of beautiful architectural forms.

Look at the keys below for your specific glazing needs. Then write for literature and advice on how we can help you.

For more data, circle 13 on inquiry card

Plexiglas acrylic plastic is a combustible thermoplastic. Observe fire precautions appropriate for comparable forms of wood. For building uses, check code approvals. Impact resistance a factor of thickness. Avoid exposure to heat or aromatic solvents. Clean with soap and water. Avoid abrasives.

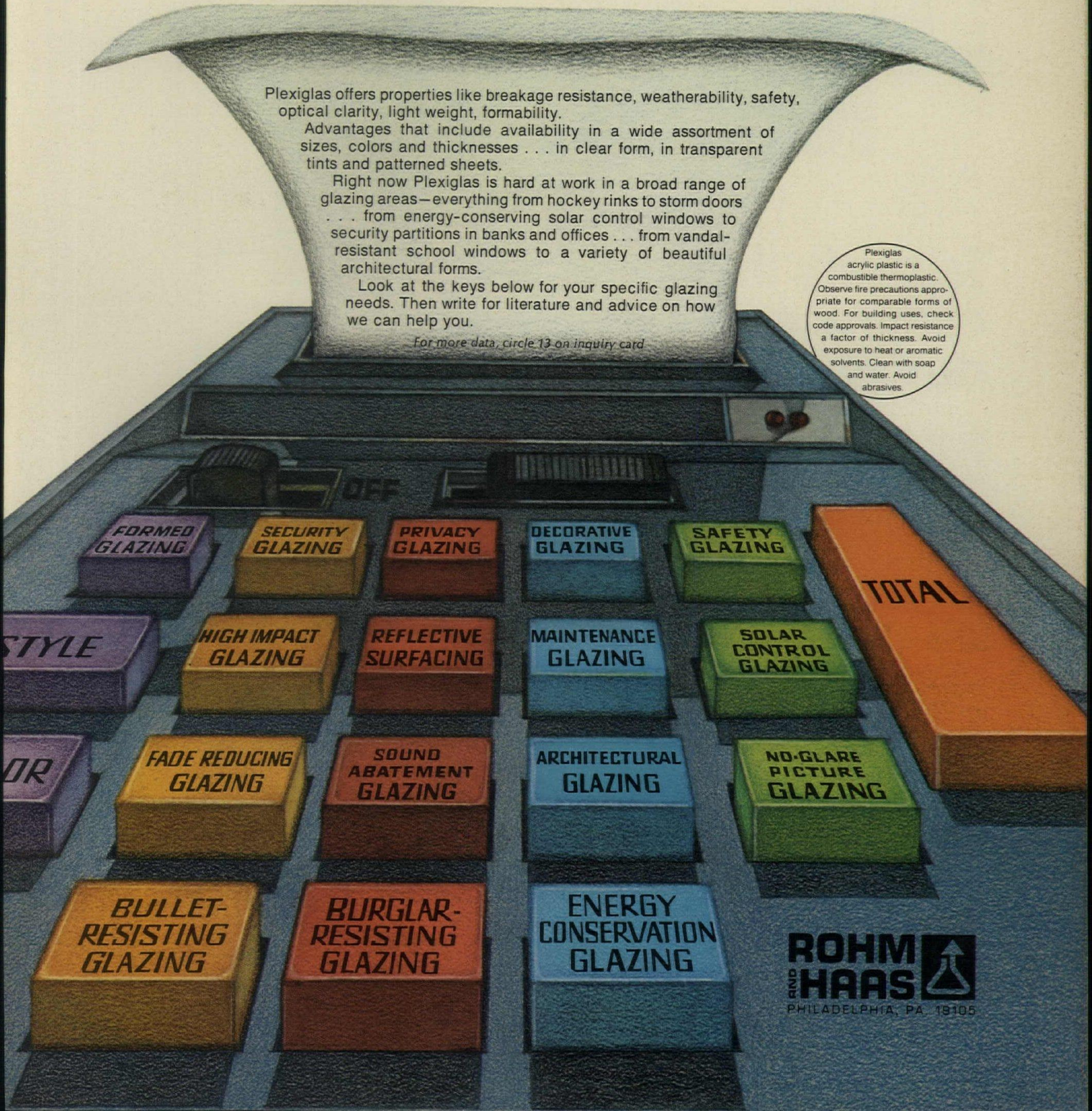

FORMED
GLAZING

SECURITY
GLAZING

PRIVACY
GLAZING

DECORATIVE
GLAZING

SAFETY
GLAZING

TOTAL

STYLE

HIGH IMPACT
GLAZING

REFLECTIVE
SURFACING

MAINTENANCE
GLAZING

SOLAR
CONTROL
GLAZING

OR

FADE REDUCING
GLAZING

SOUND
ABATEMENT
GLAZING

ARCHITECTURAL
GLAZING

NO-GLARE
PICTURE
GLAZING

BULLET-
RESISTING
GLAZING

BURGLAR-
RESISTING
GLAZING

ENERGY
CONSERVATION
GLAZING

**ROHM
AND
HAAS** 
PHILADELPHIA, PA. 19105

Check these ideas.

Tall walls that eliminate clutter.

Inryco® Longspan walls look as good inside as out. Inside they're clean and flush from floor to roof. No dirt-catching horizontal girts. Tough, off-white Duoprimer™ finish. Outside, Longspan walls offer a wide variety of colors and profiles. Milcor® steel studs in the wall carry structural loads, need no heavy girts. Composite wall design resists wind loads. Erection is fast, economical, minimizes field labor. Costs are low from installation through maintenance.

For more data, circle 14 on inquiry card

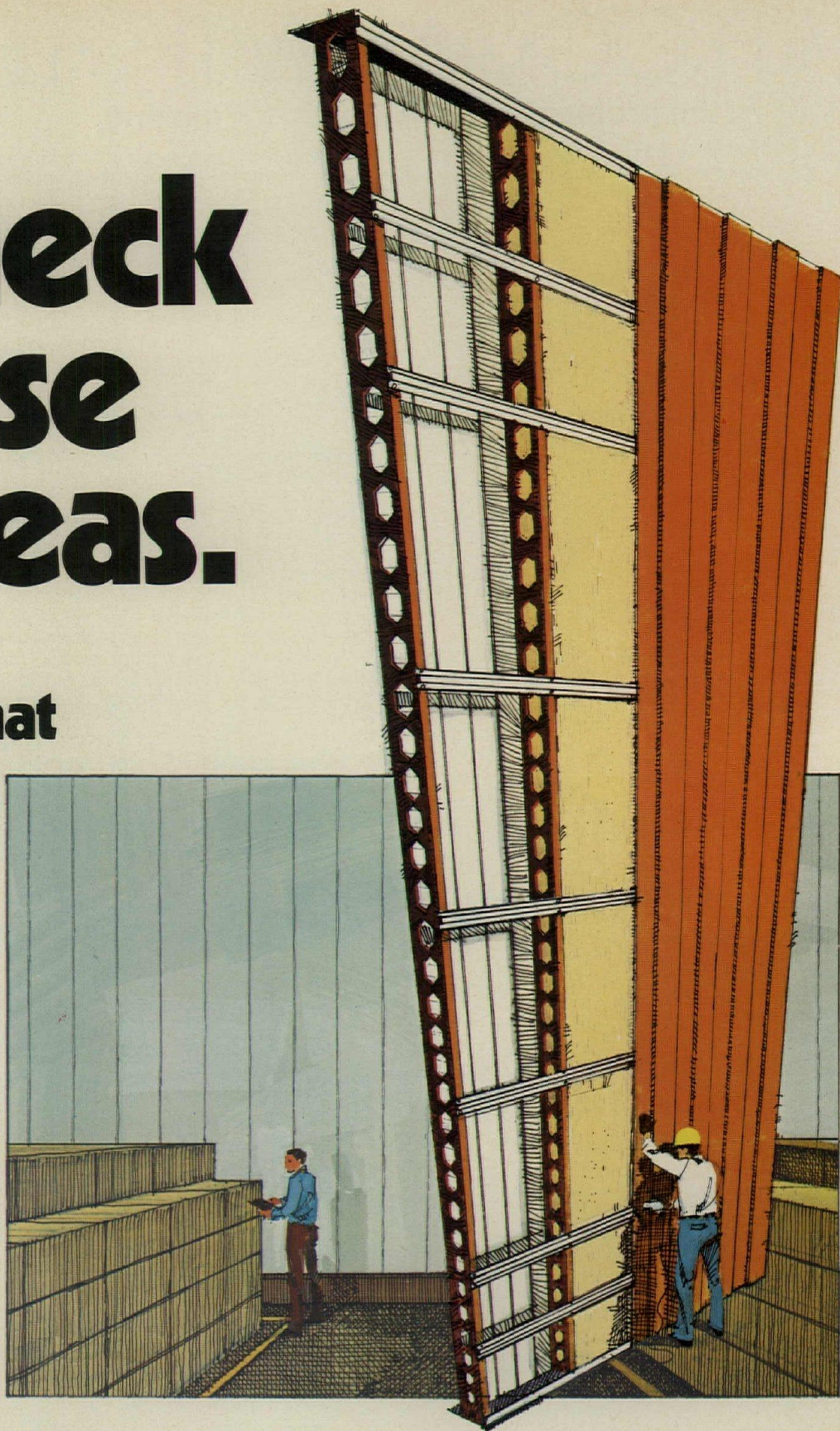

Ideas from Inryco help you design

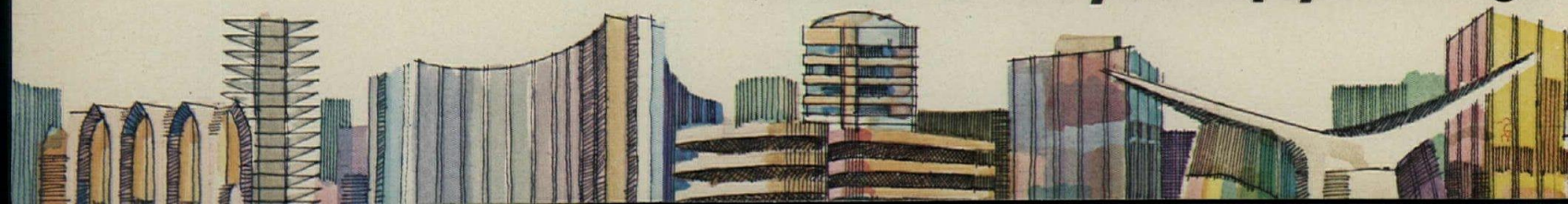

Deck and walls that soak up noise.

Inryco Acoustideck® serves as both a structural steel roof deck and an exposed acoustical ceiling. And Acoustiwall® provides the same combination for walls. Both greatly reduce noise and reverberation without the need for costly separate acoustical treatment. Ideal for schools, churches, auditoriums, hospitals, laboratories and offices, as well as factories where OSHA regulations have stimulated new interest in noise control.

For more data, circle 16 on inquiry card

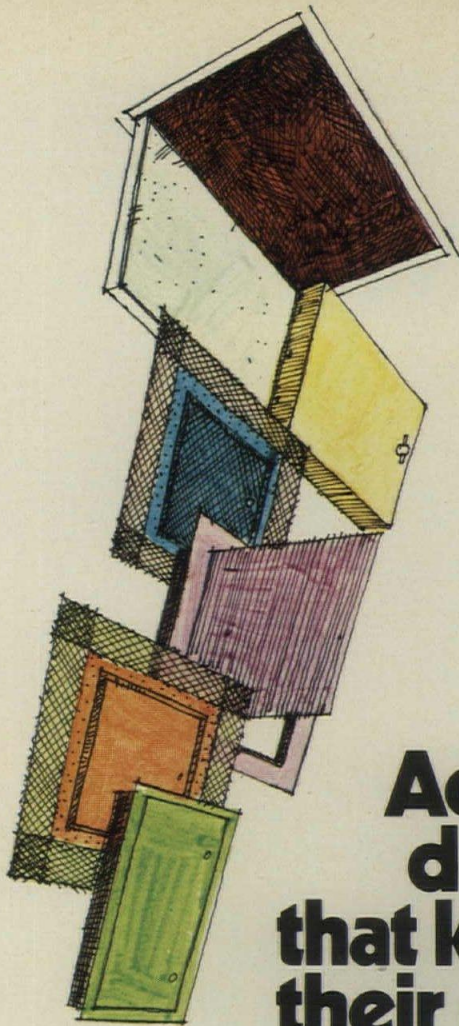

Access doors that keep their cool.

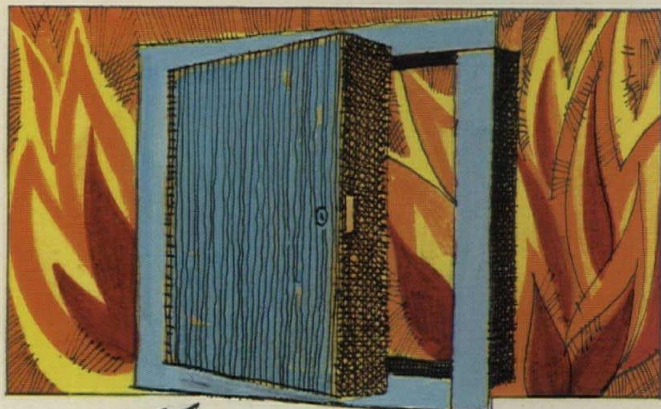

Milcor® Fire Rated Access Doors carry the Underwriters Laboratories' 1½-hr. "B" label (250°-rating). They maintain continuity of the fire barrier when service access to utilities is required in fire rated construction. Easily installed. Sizes up to 48" x 48". And there are seven other styles of Milcor metal access doors for the specific needs of other wall and ceiling conditions. Prime painted a neutral color... easily finished to match your color scheme.

For more data, circle 15 on inquiry card

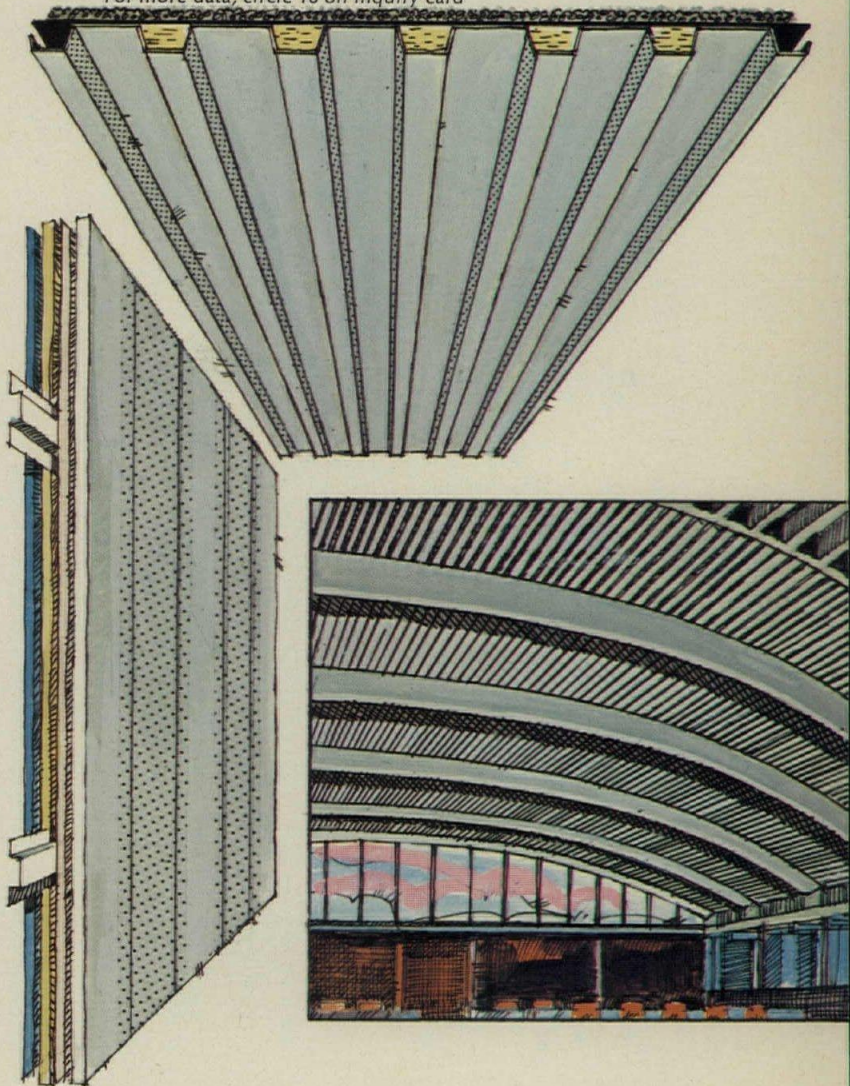

better buildings

See our catalogs in Sweet's 

INLAND RYERSON

A member of the  steel family
Inland-Ryerson Construction Products Co.
Dept. F, 4033 West Burnham Street
Milwaukee, WI 53201

Send me more Inryco ideas, as checked:

- On Inryco Longspan wall systems. On Acoustiwall and Acoustideck. On Milcor access doors.

Name _____

Title _____

Company _____

Address _____

City _____ State _____ Zip _____

MR. BARWICK IS IN CONFERENCE NOW.



Combining business with pleasurable surroundings is a Barwick specialty.

And that's to be expected, since we make the most extensive selection of contract carpet and tufted wall coverings for every design imaginable.

This is just one of them: Explorer[®] II, a 70% Creslan[®] acrylic/30% P.V.A. heavy-traffic carpet in 20 colors, ranging from natural tone-on-tone heathers to bright, crisp tweeds.

For more information on the carpet that meets the requirements of the job you're working on, call Bob Alpert collect at 404/451-4761, or write: Barwick Contract Carpet Systems, Chamblee, Ga. 30341.

BARWICK CONTRACT CARPET SYSTEMS™

A Division of E.T. Barwick Mills™
World's leading maker of tufted carpets.

For more data, circle 17 on inquiry card

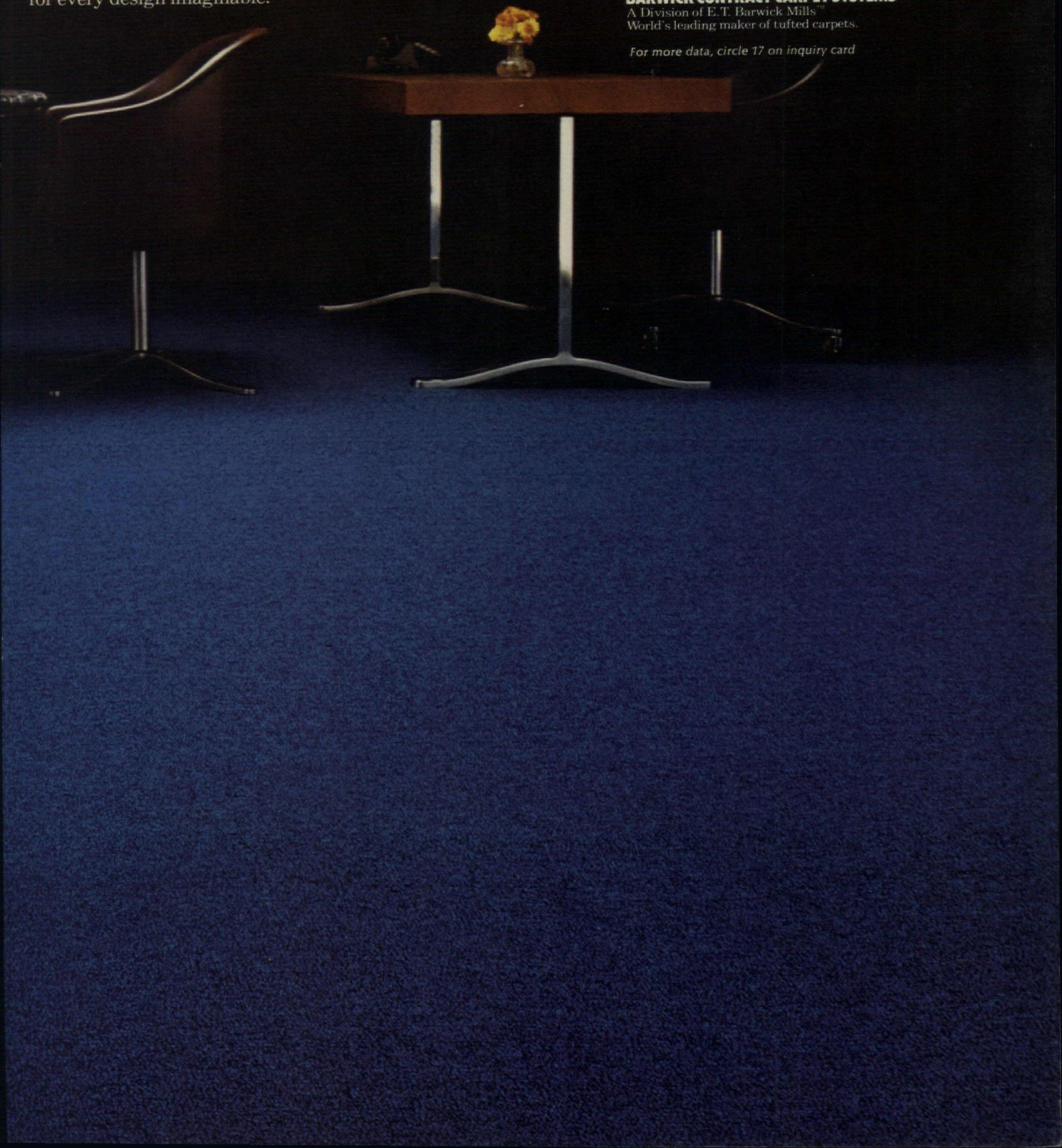

ASL

Architectural Site Light by Holophane.

Suddenly the sphere becomes efficient as well as beautiful.

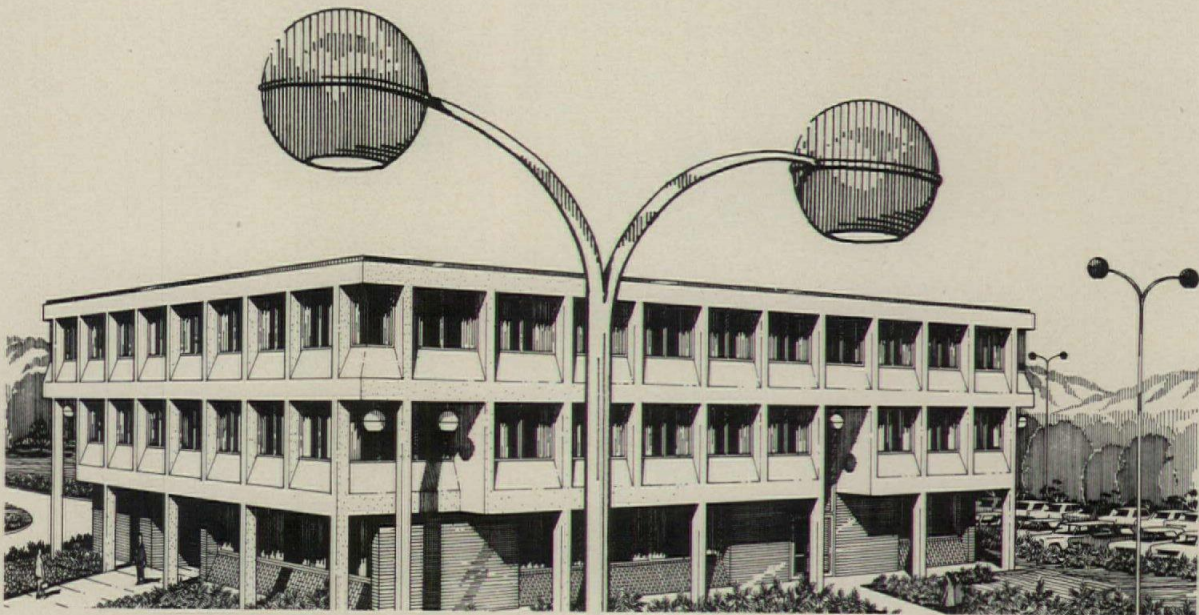

Until now, when you specified large-area H.I.D. lighting, you had to decide whether the emphasis should be on attractive appearance or optimum efficiency.

Until now.

Now Holophane has designed a classic sphere-shaped luminaire with advanced optics. To direct pleasing light exactly where it's needed.

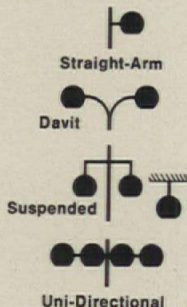

Choice of mounting and lamps: 400W sodium, metal halide or mercury; 1000W metal halide or mercury.

EFFICIENCY WITHOUT GLARE. The ASL luminaire provides soft, comfortable, glare-free light.

This is accomplished by means of a prismatic glass reflector that spreads the lamp image uniformly, and a unique low-brightness baffle trim that cuts off high-angle light.

FEWER POLES NEEDED. You can achieve a spacious, uncluttered look by specifying ASL with wide area distribu-

tion. This gives excellent uniformity with distance-to-mounting height ratios of 5:1 or more, and substantially reduces installation, maintenance and power costs. If you require higher light levels, you can specify medium or concentrated distributions.

EXTENSIVE APPLICATIONS. ASL is an excellent choice for shopping malls, airports, car lots, gas stations, campuses, parks and many other applications.

In fact, ASL is the logical choice whenever you don't want to choose between beauty and efficiency in an H.I.D. outdoor luminaire.

Your local Holophane sales engineer has all the details on ASL and our other outdoor, commercial, industrial and emergency lighting products. Call him. Or write Dept. AR-6, Holophane, A Johns-Manville Div., Greenwood Plaza, Denver, Col. 80217.

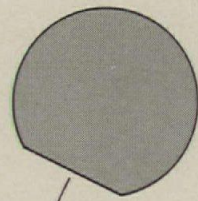

25° tilt

Versatility for perimeter lighting or increased vertical illumination is provided through a range of 6 tilting angles, from 0° to 25°, in 5° increments.

Holophane®

A Johns-Manville Division

For more data, circle 18 on inquiry card

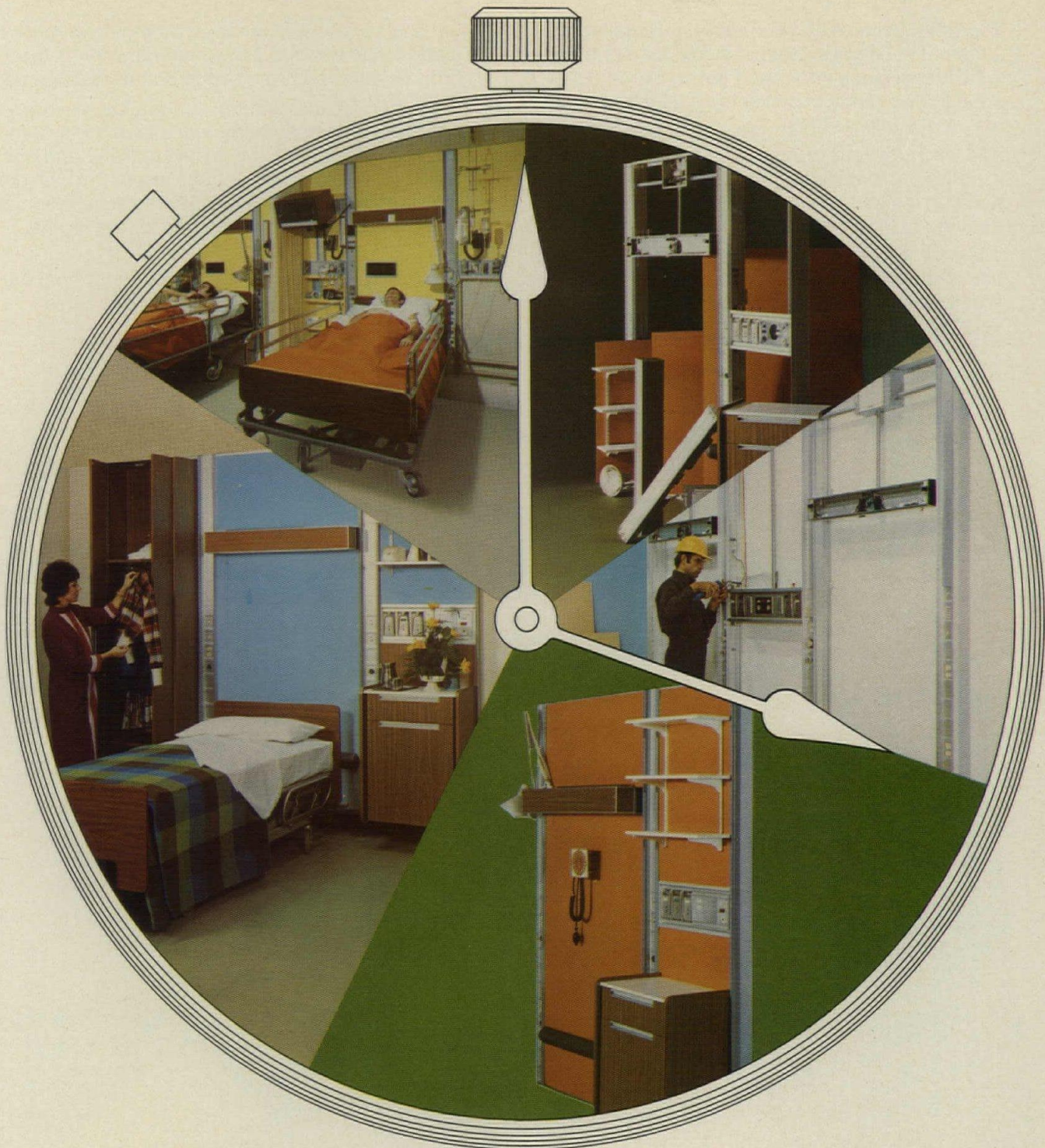

Ours In Hours.

With AMSCO's Patient-Service Wall System, you can erect a complete general-patient, ICU, CCU or special care environment in hours. Not days, but hours. And all you need are ordinary hand tools.

Viewed in the long run, the same wall system can be modified, modernized, upgraded, expanded, or completely dismantled and reassembled elsewhere. Also in hours.

Timely features? You bet. And these are just for starters. You'll also discover new ideas in function, safety, and a beauty that lends a hand-

some, contemporary appeal to the entire room. See why our new Patient-Service Wall Systems are all we say they are. Request our highly informative, well-illustrated brochure. It's an education in advanced patient-room service technology.



AMSCO

American Sterilizer Company

ERIE • PENNSYLVANIA

For more data, circle 19 on inquiry card

If we tried to solve all your material-handling problems with a single system, it would be like trying to fit square pegs into round holes. So we developed a wide range of systems, to fill the needs of virtually any hospital.

And we back our products with expertise that helps us tailor our material-handling equipment to your building instead of requiring that you plan your building to fit our systems.

We work with you to determine the best system or combination of systems for the job you want done. We gather facts and figures on costs and cost-savings. We design the system down to the last

nut and bolt — and can even employ computer simulation to prove that our plans will work as well in actuality as they promised to on the drawing board.

We supervise installation . . . train hospital personnel in proper and efficient use of the system . . . and remain on hand during start-up and operation to make sure all the bugs are out. To assure that they stay out, AMSCO offers you a nationwide network of service technicians for preventive maintenance or repair.

When it comes to material handling for hospitals, we may not have all the answers. But we're working on them.

in material handling... we fit round pegs

*AMSCOMATIC Module Transport System, the overhead rail system that employs new techniques developed exclusively for the health-care field.



*AMSCAR System for automated transport of virtually all hospital supplies.

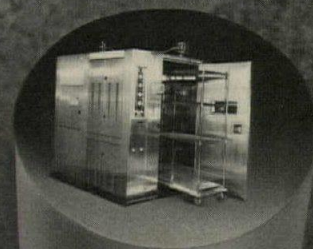
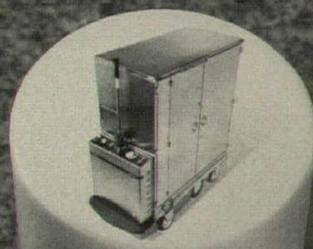

Carts and Cart Washers designed to mate with virtually any manual or automated material-handling system.

STO/TRA, the flexible, containerized STOrage and TRAnspOrtation system that organizes material management in every department of your hospital.



Cargomaster® / CARTveyor for semi-automated vertical and limited horizontal distribution.



Pneumatic Transport Systems, for safe and economical delivery of everything from a single message or medical record to pharmaceuticals . . . linen . . . trash . . . even blood samples.

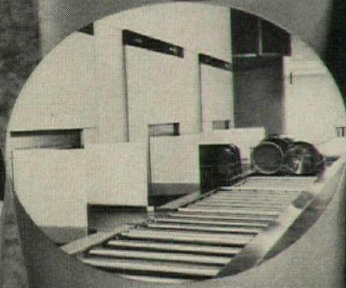

Central Processing Department, featuring AMSCOMATIC washing and sterilizing equipment and Rotary Sorting Tables . . . plus centralized responsibility for decontamination.

*Manufactured by Control Engineering Company, affiliate of Jervis B. Webb Company, Detroit, Michigan 48204.

Today's **AMSCAR System** is generations advanced over original models. But even then the System was generations ahead of its time, as proved in almost a score of hospitals throughout the country. Battery-powered electronically-guided **AMSCARs** in those hospitals deliver virtually all supplies, including patient food trays, without human assistance. Even up and down their own elevators. Besides saving time and money, **AMSCAR** automated distribution frees hospital personnel for their most important job: improved patient care.

talk with us. we can help.



**AMSCO
SYSTEMS**

Division of American Sterilizer Company

For more data, circle 20 on inquiry card

to round holes

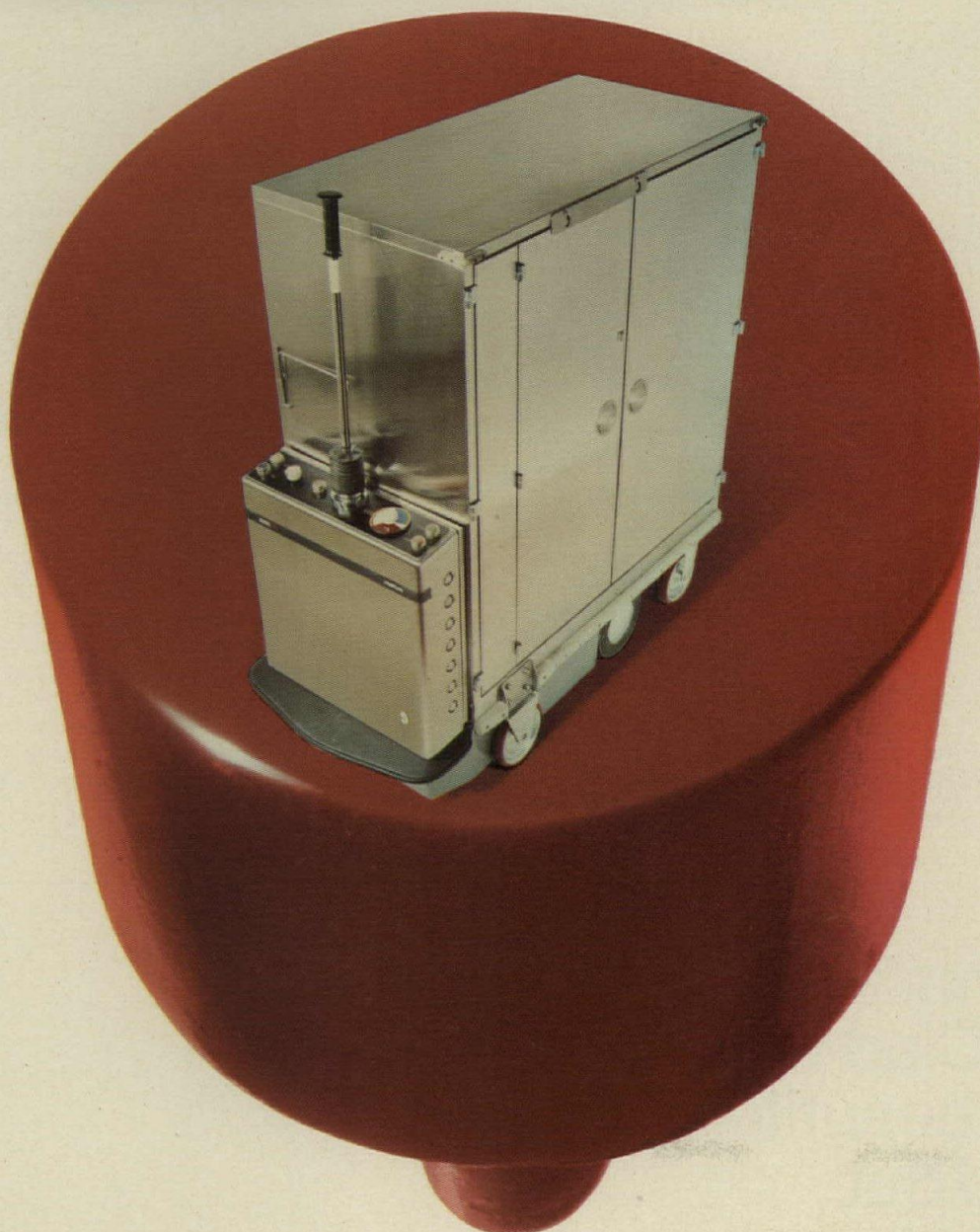



Outside, a low maintenance, acrylic coated aluminum exterior in one of 11 colors available.

In a Pella Clad Wood Window, all exterior wood surfaces are covered with an acrylic coated aluminum skin. An outside finish that is known for its durable, low maintenance qualities. Equally important, however, is the fact that our clad exterior lets you select colors, shapes and sizes that complement your plans. Naturally. Pella Clad Wood Windows. Available in three standard (a) and eight special colors. On our Casement, Awning, Double Hung, Fixed and Trapezoidal Windows.



(a)

Inside, the natural warmth and beauty you expect to find in a quality wood window.

While we recognize the need for a low maintenance exterior, we are also well aware of the natural warmth and beauty that a wood window contributes to a building's interior. So we were very careful to preserve these two qualities when we designed the Pella Clad Wood Window. For example, the exterior aluminum skin never penetrates the frame or sash (b). Leaving the natural insulating value of the wood intact. And the natural beauty of the interior wood surfaces completely undisturbed.



(b)

**At Fingerhut's new headquarters,
this Pella Clad window system
blends in beautifully,
inside and out.**

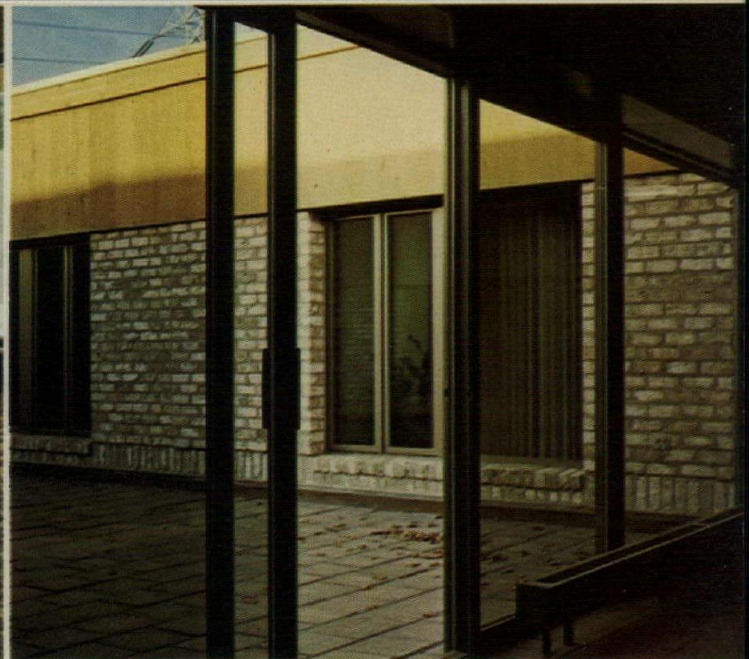
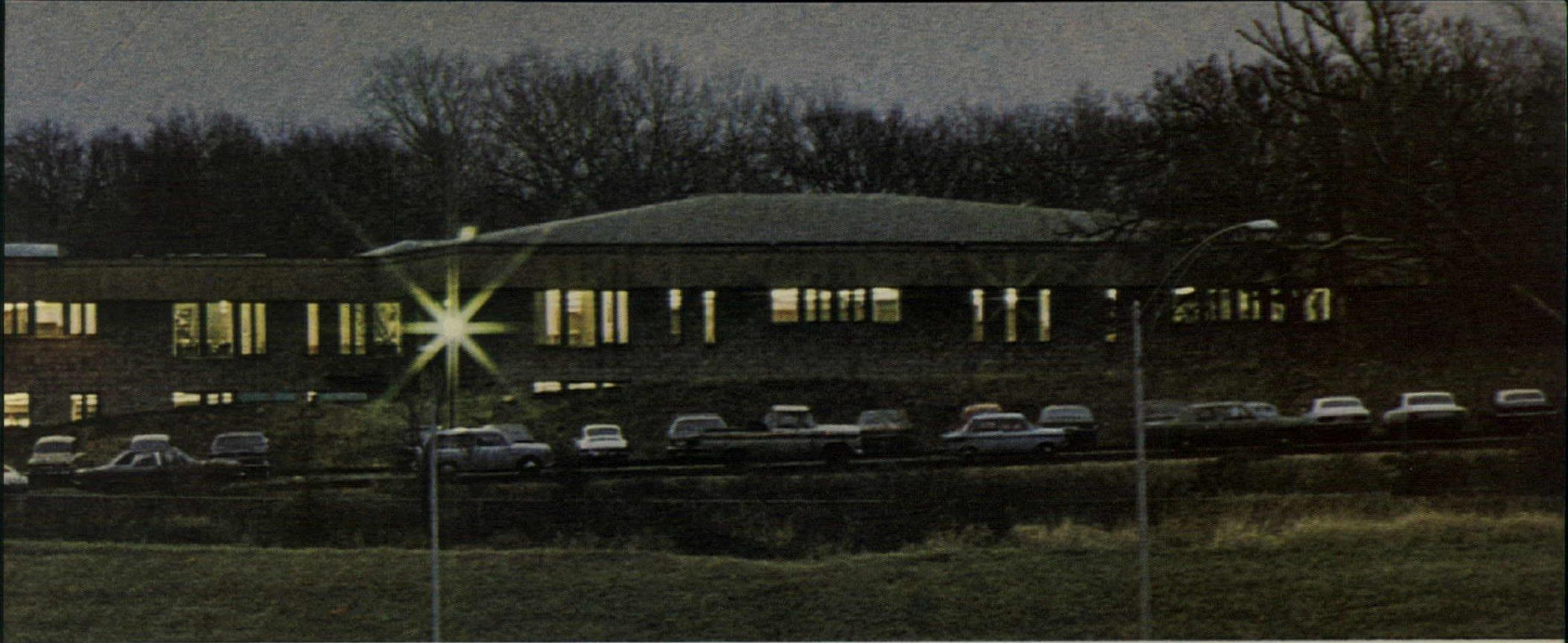

Architect: Ackerberg and Associates Inc. Architects Builder: Nystrom Constructors Inc. Windows: Pella Clad Casement and Fixed Units

Afterward, the convenience of maintaining a center-opening Pella Clad Casement Window.

Routine maintenance is a factor to be considered. Because, in a lot of ways, it has a lot to do with your clients' ongoing satisfaction with their new structure. Our clad casement windows have a unique hinging system which allows the sash to rotate a full 90°, to the center of the frame (c). So the outside glass can be easily reached, and washed, from inside the building. And this same kind of built-in satisfaction is also found in our Awning, Double Hung and Horizontal Pivot Windows.



(c)

Pella Clad Sliding Glass Doors are as solid, as beautiful and as maintenance-free as a Pella Window.

Pella Clad Sliding Glass Doors combine the natural beauty and insulating value of wood with an exceptionally solid framing system. Welded steel T-sections (d) frame the glass in the slender wood panels. This prevents warping and keeps the panels aligned for smooth, easy operation. Pella Clad Sliding

Glass Doors let you extend the view, without having to sacrifice inside appearance or comfort. They are weathertight, even under severe weather conditions. Available in all 11 colors.



(d)



For more detailed information, send for your free copy of our 24-page, full-color brochure on Pella Clad Windows & Sliding Glass Doors. See us in Sweet's Architectural File. Or look in the Yellow Pages, under "windows", for the phone number of your Pella Distributor.

**CLAD WINDOWS
SLIDING GLASS DOORS**



Please send me your 24-page brochure on Pella Clad Windows & Sliding Glass Doors. I am specifically interested in: Double-Hung Windows, Casement Windows, Awning Windows, Sliding Glass Doors, Wood Folding Doors.

Name _____
 Firm _____
 Address _____
 City _____ State _____ ZIP _____
 Telephone _____

Mail to: Pella Windows & Doors, 100 Main St., Pella, Iowa 50219 Dept. T31F

Also Available Throughout Canada

Introducing pure wool knit fabrics...an exclusive on TCI furniture.

Built for comfort, beauty, and long wear under the most exacting conditions...these natural finish, solid oak seating pieces are covered in 100% virgin wool. The natural, undyed wool yarns are knitted by a unique process and are selected by TCI to provide the ultimate in luxurious texture and superb durability. TCI contract furniture designed by Milo Baughman can be seen at Space 1173 Merchandise Mart, Chicago.

TCI

THAYER COGGIN INSTITUTIONAL, INC.

South Road, High Point, North Carolina 27262, (919) 883-0111

ADDITIONAL SHOWROOMS: Atlanta 876-5823, Chicago 828-0310,
Cincinnati 681-1101, Dallas 239-7227, Los Angeles 659-5050,
San Francisco 863-4442, Seattle 323-1416.



"The Woolmark label is your assurance of quality-tested upholstery fabrics made of the world's best...Pure Wool."

For more data, circle 22 on inquiry card



Subtle carved textures and patterns in wood for the new look in today's architecture. Also benches and planters in laminated redwood and oak scaled for large architectural spaces.

Forms & Surfaces Box 5215 Santa Barbara, California 93108 (805) 969-4767

FORMS + SURFACES



Model 1070



Model 1400



Model 1405

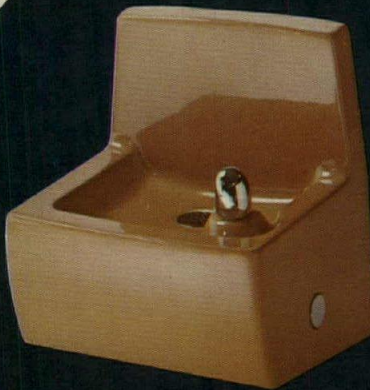

Model 1205

Haws polymarble fountains meet very demanding requirements at a cost comparable to ordinary fountains. They are durable, attractive, highly resistant to impact and abrasion, and available in six colors at no extra cost. The color runs throughout the material, so it won't chalk or fade. Flush-mounted, patented, push-button valves and new heavy-duty bubblers provide excellent vandal resistance.

■ Today, many polymarble models are excelling in practical application. For more information and product test results, contact Haws Drinking Faucet Co., 1441 Fourth Street, Berkeley, CA 94710.

Haws offers the world's best drink
For more data, circle 24 on inquiry card

THE BEAUTY OF
polymarble
Haws

NEWS REPORTS
BUILDINGS IN THE NEWS
HUMAN SETTLEMENTS
REQUIRED READING

Approximately 4500 persons attended the 1974 AIA convention in Washington, D.C., May 19-23. A report of convention activities—professional and social—begins on page 37.

In an unprecedented action, the AIA Board voted to form a committee to investigate misconduct charges. If investigation of such allegations warranted, the appointed committee could bring charges of unprofessional conduct before AIA's National Judicial Board, the appropriate state registration board, and/or appropriate legal authorities. Details on page 37.

A two-part resolution on political contributions (ethical standards) was passed by the convention. Submitted by the New York Chapter, AIA, it directs every architect making a contribution to political parties and candidates for public office to do so publicly in his own name. The resolution further states that the AIA and its components will work for appropriate public disclosure laws in every area, and that the Institute will support the concept of public funding of political campaigns.

Revision of ethical standards to include employee concerns will be studied for the 1975 AIA convention. Among the 19 resolutions presented to the convention last month was a controversial one regarding employer-employee relations. After lengthy discussion, the convention voted to have the AIA board study the resolution, submitted by the New York Chapter, and report to the 1975 convention. Copies of the resolution are available from AIA headquarters.

Among bylaw changes adopted at the AIA convention is one that will change the dues structure. Under the change, a higher proportion of total dues income will derive from supplemental dues in lieu of regular dues, structured so that all members pay on an equitable basis. Further, an effort will be made to reduce and maintain regular dues at the lowest possible level. The AIA budgeting of expenditures from dues income in each future year will be limited to the amount collected in 1974, with a reflection of the cumulative Consumer Price Index and membership increases.

Support of the 27th Amendment to the Constitution on equal rights, was resolved by the AIA convention. Specifically, the amendment would bar discrimination on the basis of sex, so AIA support would bolster efforts to encourage female participation in the profession and the Institute which will urge state legislatures to ratify the Amendment.

Louis de Moll, FAIA, was elected first vice president of the AIA, for the year 1975, meaning he will assume the AIA presidency in 1976. Other newly elected officers of the Institute are: Elmer E. Botsai, Carl L. Bradley and John M. McGinty, vice presidents; Hilliard T. Smith, secretary.

A report draft on national housing policy was presented to the AIA convention by David Todd, chairman of the AIA Housing Committee. Among the ten points mentioned was a need to identify housing as a major national resource to be protected. Todd further explained that the AIA report addresses special needs of people which call for a pluralistic approach, relying on local standards and Federal financing. The final report is expected to be released soon.

Architects are urged by the AIA to contact their Representatives in support of the Land Use Planning Act of 1974. The land use measure is to be debated in the House this month, and opposition is expected. The AIA has supported the concept of land use planning and has worked with the Interior Committee for legislation in this area.

The convention report on minority/disadvantaged scholarships shows many regions lag in quotas. Only Texas, New York and the Mid-Atlantic regions have come close to meeting their quotas in the AIA program, a successor to the Ford Foundation program begun with AIA two years ago. The goal of the program is \$600,000 by 1976.

Bechtel Corporation and Welton Becket Associates have contracted for the new Moscow Trade Center. Announcement of the signing of an \$8 million design contract was made in Moscow by the over-all coordinator of the \$110 million project, Occidental Petroleum. The center is due for completion in two years and design will begin shortly.

Congress failed to pass legislation that would provide the U.S. conversion to the metric system. On a vote of 240 to 153, the House rejected the AIA-supported measure and probably killed its chances in the current session. It should be pointed out that conversion would be voluntary, but opponents feel pressures to perform the costly conversion would force it on companies.

Associated General Contractors of America have called for an embargo on steel scrap exports, to alleviate shortages of reinforcing steel. Approximately half the steel raw material used in producing reinforcing steel is scrap, according to AGC, which claims \$10 billion in construction could be affected in 1974 by a severe shortage of reinforcing steel.

Louis I. Kahn honored by Columbia University

Louis I. Kahn was awarded the Doctor of Humane Letters degree posthumously at Columbia University's 220th commencement exercises on May 15. The honorary degree was accepted by his widow.

On January 17, Columbia president William J. McGill had written to Mr. Kahn inviting him to accept an honorary degree. Mr. Kahn replied affirmatively on January 21 in a letter to Dr. McGill, remarking, "It will be great to be with the teachers and students of the University on May 15th."

After Mr. Kahn's death on March 17, President McGill invited Mrs. Kahn to accept the degree in his name. She responded in part: "I would indeed be proud to receive the degree. I would have been with him on the 15th in the normal course of events, so now he will be with me in spirit."

Saving landmarks: the Chicago Plan

James Biddle, president of the National Trust for Historic Preservation, announced the publication of a plan to help save urban landmarks by removing the economic pressures that often cause their demolition. An aspect of the scheme, known as the Chicago Plan, is developed in a book by Professor John J. Costonis of the University of Illinois Law School, *Space Adrift: Saving Urban Landmarks Through The Chicago Plan*.

The book is an analysis of the legal, economic and design effects of the sale and transfer of development rights unused by landmarks that cannot take advantage of the full height potential of their sites as now zoned.

Recognizing that in many dense urban areas there are enormous forces working against the preservation of landmark buildings, Professor Costonis proposes transferring development rights elsewhere.

For instance, if the owner of an eight-story landmark is not realizing the full value of his investment and wishes to demolish the building and replace it with a 40-story high-rise, he has under the Costonis plan the alternative of selling the development rights to the 32 floors above his landmark at market value. This space could be sold and used by developers who wish to go higher on their lots than present zoning allows. The higher real estate taxes for these expanded building projects would proportionately offset taxes paid on the landmark properties.

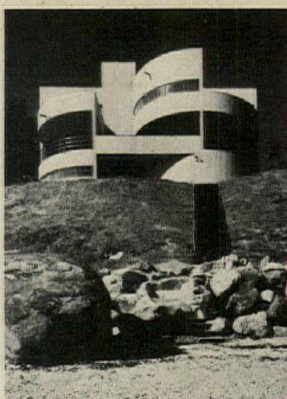

Annual Homes for Better Living Awards announced

House & Home's annual Homes for Better Living Awards program has announced that 16 architect-designed homes and multi-family housing projects have won awards for 1974.

The winners, their awards and categories are: Awards of Merit for custom-designed houses to Booth & Nagle, Chicago; Freedman/Clements/Rumpel, Jacksonville, Florida; Myron Goldfinger (house shown left), New York City; Huygens and Tappé Inc., Boston; William Kessler & Associates Inc., Grosse Pointe, Michigan; Stanley Tigerman & Associates, Chicago; and Robert Whitton, Coconut Grove, Florida.

First Honor Awards for



multi-family housing: Anderson Natter Associates Inc., Boston; Donald Sandy Jr., AIA and James A. Babcock (building shown right), San Francisco.

Awards of Merit for multi-family housing: Design Five Maine Inc., Cambridge, Massachusetts; Louis Sauer Associates, Philadelphia; Kaplan and McLaughlin, San Francisco; Schleicher-Soper Architects, AIA, Syracuse, N.Y.; Werner Seligmann & Associates, Cortland, N.Y. and Daniel Solomon, AIA, San Francisco.

Award of Merit in the built-for-sale house category was won by Robert E. Jones and Edwin K. Hom of La Jolla, Cal.

Contractors group calls for "sanity" in wages

The national president of the Associated General Contractors is urging both management and the building and construction trade unions to use "sanity" and "self restraint" in their upcoming wage negotiations now that controls have ended.

Saul Horowitz, Jr., who is chairman of HRH Construction Corporation in New York City, said AGC reports indicate that wage demands in the first quarter of the year were beginning to "creep" up, in some cases as high as 30 per cent. And, Mr. Horowitz continued, many local unions with con-

tracts expiring before April 30 refused to begin negotiations until they saw whether controls would be continued. He said of the 1500 agreements which have expired since January 1, only 400 agreements have been settled. More than 4000 contracts expire this year.

Mr. Horowitz said that construction accounts for about 11 per cent of the nation's annual GNP. "A sudden inflationary push in this industry could trigger still greater inflation throughout the economy and a return to further government intervention," he added.

HUD asks new rules on handicapped and housing

A new effort to make dwelling units more usable and convenient for the physically handicapped has been launched by the Department of Housing and Urban Development.

Responding to a request from the President's Committee on Employment of the Handicapped and the National Easter Seal Society for Crippled Children and Adults, HUD's Office of Policy Development and Research has just issued a Request for Proposals (RFP) for a study to develop and test new standards for making both the interiors and exteriors of single- and multi-family housing and mo-

bile homes more liveable for the physically handicapped.

The new standard will be submitted to the American National Standards Institute (ANSI) for adoption. The existing ANSI standard in this field (A117.1) applies principally to public buildings and does not treat the problem of making residential space such as kitchens, bedrooms and private bathrooms usable by some 30 million Americans whose physical disabilities restrict their ability to live independently unless their environment is shaped to meet their needs, according to HUD spokesmen.

Fire Research Center created in new legislation

The fire safety factors in building design will undergo intensified research under terms of a House bill passed last month creating a new Fire Research Center in the National Bureau of Standards.

The Senate passed its version of the Fire Prevention and Control Act last November and the two bills are headed for a conference committee resolution of differences. Both measures place responsibility for carrying out provisions of the proposed law in the Department of Commerce.

As passed by the House, the measure would authorize \$3.5 million for the fire research program in the next fiscal period but funds "as necessary" were authorized for implementing provisions between enactment and the end of the fiscal year.

Under FRC activities, the Bureau would carry on its current basic and applied research on the phenomenon of fire,

looking toward development of new technology and, eventually, better fire codes.

The center would be charged with studying the design of buildings and other structures to generate design concepts enabling architects, engineers and builders to incorporate fire safety into buildings that are comfortable, beautiful and economical.

While the FRC would be expected to make its findings known to the U.S. Fire Academy (also established by this legislation), to other Federal agencies, to industry and to state and local governments, the principal means of applying the research results would be through codes, standards and test methods.

Much of the substance in both bills stems from findings and recommendations of the National Commission on Fire Prevention which made its report, "America Burning," last July.

Kennedy Memorial Library undergoes redesign

Revised plans for the John F. Kennedy Memorial Library are complete.

This was announced by Stephen Smith of New York, president of The Library Corporation and brother-in-law of the late President, following a closed meeting Smith attended at Cambridge City Hall last month with about 20 persons involved in a controversy over the location and planning of the proposed library-museum com-

plex near busy Harvard Square.

He declined to disclose how the new plans by architect I. M. Pei will differ from those unveiled a year ago, but other sources indicated that the new building will be smaller.

The memorial project, long delayed by opposition from environmentalists and others, was first proposed nearly 10 years ago. A private firm is now conducting an impact study to be completed this summer.



Architect noted for his wit and song honored

The Pittsburgh Chapter of the American Institute of Architects recently conferred a special architectural critic's citation on Robert Watson Schmetz, FAIA, (shown) in honor of his songs about architects and architecture.

The occasion was the Chapter's spring meeting and John Pekruhn, FAIA, read the ci-

tation, quoted in part:

"His ballads have illuminated the foibles and the reality of architecture, taught us to care about history and recognize our own pretensions, reminded us that architecture is for people and that architects are people too, encouraged us to do architecture, enjoy architecture and love each other."

Report covers architect employment

Employment opportunities for architects are expected to be favorable through the mid-1980's the Federal government says in its new Occupational Outlook Handbook.

(This 842-page volume can be ordered from the U.S. Government Printing Office, Washington, D.C. 20402, at \$6.85 per copy.)

Department of Labor's Bureau of Labor Statistics, which issued the 1974-75 edition, anticipates that several thousand openings for architects will occur annually because of the very rapid growth of the profession and to replace those who die, retire or transfer to other fields of work.

The largest opportunity expansion is expected in new areas of work because of expanded need in business and government for people with professional design training, the book states. Openings for positions with established architectural firms and opportunities for starting a private practice will grow more slowly, the government experts predict.

New job opportunities for architects are also expected to be generated by increasing public concern about the quality of physical environments, the government believes. Urban redevelopment, city and community environmental planning projects were mentioned as constituting a wider range of fields for design activity than in the past. Beyond this, more manpower will be needed in research to develop new tools, materials, and systems for the construction industry. Still other architects should find employment in manufacturing and construction companies in design, sales, and administration. Government agencies will be hiring more architects as they become more involved in environmental design and planning, the Labor Department said. The handbook gives this information on earnings:

- Private industry starting salaries for new graduates were between \$125 and \$175 per week in 1972. Draftsmen with two or more years experience received \$160 to \$260 per week and job captains, specification writers and other senior employees from \$245 to \$330 per week.

Bachelor degree holders without experience start in the Federal government at \$150 to \$185 a week, those with master degrees at \$225, and the PH.D.'s at \$320.

The publication places at "about 37,000" the number of

licensed architects employed in 1972 and indicates that fewer than five per cent of these were women. About two-fifths of all architects are said to be self-employed, either practicing individually or as partners. Most of the rest work for firms. About 1,400 are employed by the Federal government, working mainly in the Departments of Defense, HUD and GSA.

Deaf taught architectural skills

A concept in education of the deaf in architectural technology and drafting is being developed at the National Technical Institute for the Deaf in Rochester, New York.

Through NTID's Division of Technical Education, deaf students gain the technical skills needed for successful job entry and mobility in areas such as business, science, applied art and photography, printing technology and engineering technology. In the engineering field, NTID offers diploma programs in architectural and industrial drafting, electronics, machine tool operation and numerical control; associate degree programs in architectural civil, and electro-mechanical technology.

In the architectural drafting program, for example, students gain enough background in the field to provide them with skills for entry into a drafting job in architecture or other construction-related fields.

For more information on hiring NTID graduates please contact: Victor Maguran, Office for Occupational Liaison and Research, NTID, Rochester Institute of Technology, One Lomb Drive, Rochester, N.Y. 14632.

Urban neighborhoods: new HUD program

The Housing and Urban Development Department has launched still another program aimed at rescuing deteriorating neighborhoods. This is a pilot test to be run in about 20 cities—including Chicago—to learn more about the potentials of a plan such as that carried out successfully in Pittsburgh over the past six years.

HUD will put \$750,000 into the research and demonstration project this fiscal year and has budgeted \$2 million for the year starting July 1. An urban reinvestment task force is being formed to aid local communities in mounting programs based on the Neighborhood Housing Services of Pittsburgh. The task force staff director is William A. Whiteside, who

helped develop the Pittsburgh project as a model.

HUD said the task force would encourage local communities to form partnerships of local interests involving lending institutions, local governments, community residents, and philanthropic groups.

A typical neighborhood for application of such a Neighborhood Housing Services treatment is described as one in an early stage of deterioration but containing basically sound housing structures. It is a neighborhood where home improvement loans may be difficult to obtain.

An important part of the new approach will be the revolving loan fund through which assistance is extended to residents of target communities who normally are ineligible for other loans due to age, credit status, or some other reason.

Codes group to vote on plastics

New regulations that would severely restrict the use of plastics in the interior of buildings will be voted on by the International Conference of Building Officials (ICBO) at that organization's annual meeting in Fort Worth, Texas, in October.

The major change affecting plastics is a proposed new section for the uniform building code, Section 1717, which would forbid the use of all plastic foams unless they are covered by a thermal barrier (for example, foam insulation enclosed by masonry). The regulation would apply to all classes of buildings. At present, the Universal building code has no rules covering plastic foams.

The proposals were approved by ICBO's code exchanges committee at a meeting in San Diego, California, in April. About a week later, on April 25, code consultant John G. Degenkolb warned a society of plastics engineers symposium on plastics in building construction that "A lot of panels currently being manufactured just aren't going to make it" under the new regulations.

He noted that Nevada and Utah had recently passed laws similar to the ICBO proposal for regulation of plastic foams in construction. He added that the proposed UBC Section 1717 calls for flame spread of 75 or less under the tunnel test for foam insulation to be used between masonry walls. The test is done on 4-in.-thick material, but foam up to 10 in. thick would be permitted in an actual installation.

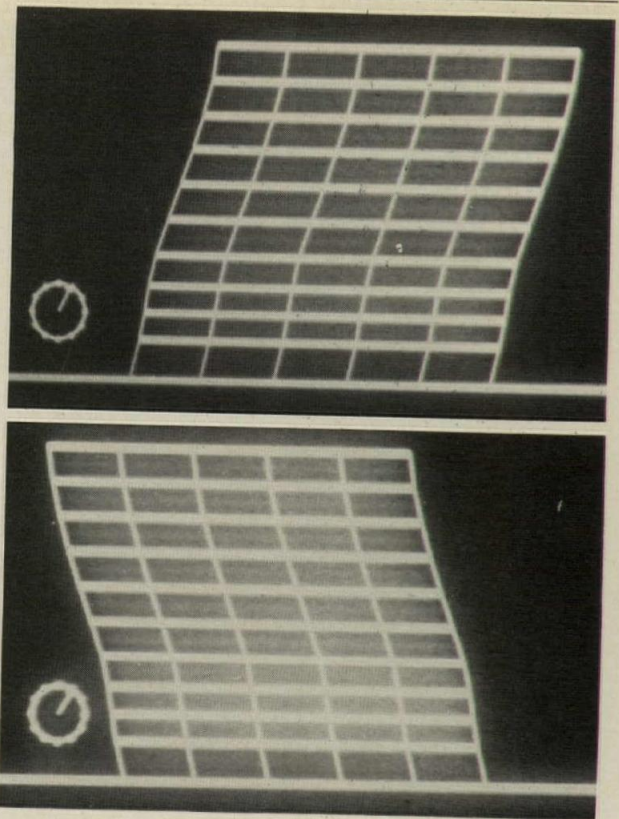

Technique may aid in designing for earthquakes

Newly-developed techniques make it possible to analyze the magnitude of a probable earthquake at various distances from a building, plus the structural characteristics of the building, to determine what the results of the quake would be.

That is the conclusion of researchers at Systems, Science & Software (S-cubed), La Jolla, California, who have just completed a detailed new earthquake study to analyze the effects of ground motion and building movement. The scientists made use of special computer techniques developed by the firm for such studies, and utilized a Las Vegas structure as a test case.

"The use of a computer-generated earthquake gives us the freedom to place the building at any distance from the epicenter, rather than rely on the few available measured earthquake records," according to Dr. Joel Sweet, principal investigator at S-cubed and a registered professional engineer. "The precise data generated by the computer is an important part of the study program, but the film provides a far more visual and dramatic presentation of the information," he noted.

San Diego awards design contract for rapid transit

The San Diego Comprehensive Planning Organization has awarded the contract for design of a rapid transit system covering San Diego County to a joint venture of VTN Consolidated, Incorporated, Irvine, California and Parsons, Brinckerhoff,

"Engineers are already capable of designing buildings which have a high probability of surviving a strong quake," Dr. Sweet said. "But the problem is a complex one, particularly with high-rise structures, and it is virtually impossible to predict with any accuracy just how a proposed structure will react to a given quake, unless highly sophisticated techniques like these computer programs are utilized.

"Other researchers have also developed techniques for analyzing the effects of building motion," Dr. Sweet explained. "But unless you also have a way of analyzing ground movement, you can't predict what a quake some distance away will do to a given building. The combination of the S-cubed earth movement and the structural computer programs thus makes it possible to do these analyses for the first time."

Assistance with the structural design of buildings to improve their earthquake resistance is currently being offered by S-cubed to architects and structural engineering firms in California and other earthquake-prone areas, the scientist said.

Quade and Douglas of San Francisco.

A first-stage plan must be ready by July, according to terms of the \$300,000 contract, so the proposal can be placed on the November ballot.

more news on page 37

The more sophisticated your theater design, the more you need Dover Stage Lifts.

Dover's wide-ranging stage lift experience includes installations in some of the most sophisticated theaters in the world.

Architects and theater consultants have learned that Dover's superior engineering and construc-

tion techniques produce stage lifts of outstanding dependability.

If you're building a complex multiple-use theater—or a single-purpose high school auditorium—call the foremost designer and builder of stage lifts.

For more information, see our catalog in Sweet's Files, or write Dover Corporation, Elevator Division, P. O. Box 2177, Memphis, Tennessee 38101. In Canada: Dover/Turnbull.

DOVER Stage Lifts

For more data, circle 27 on inquiry card

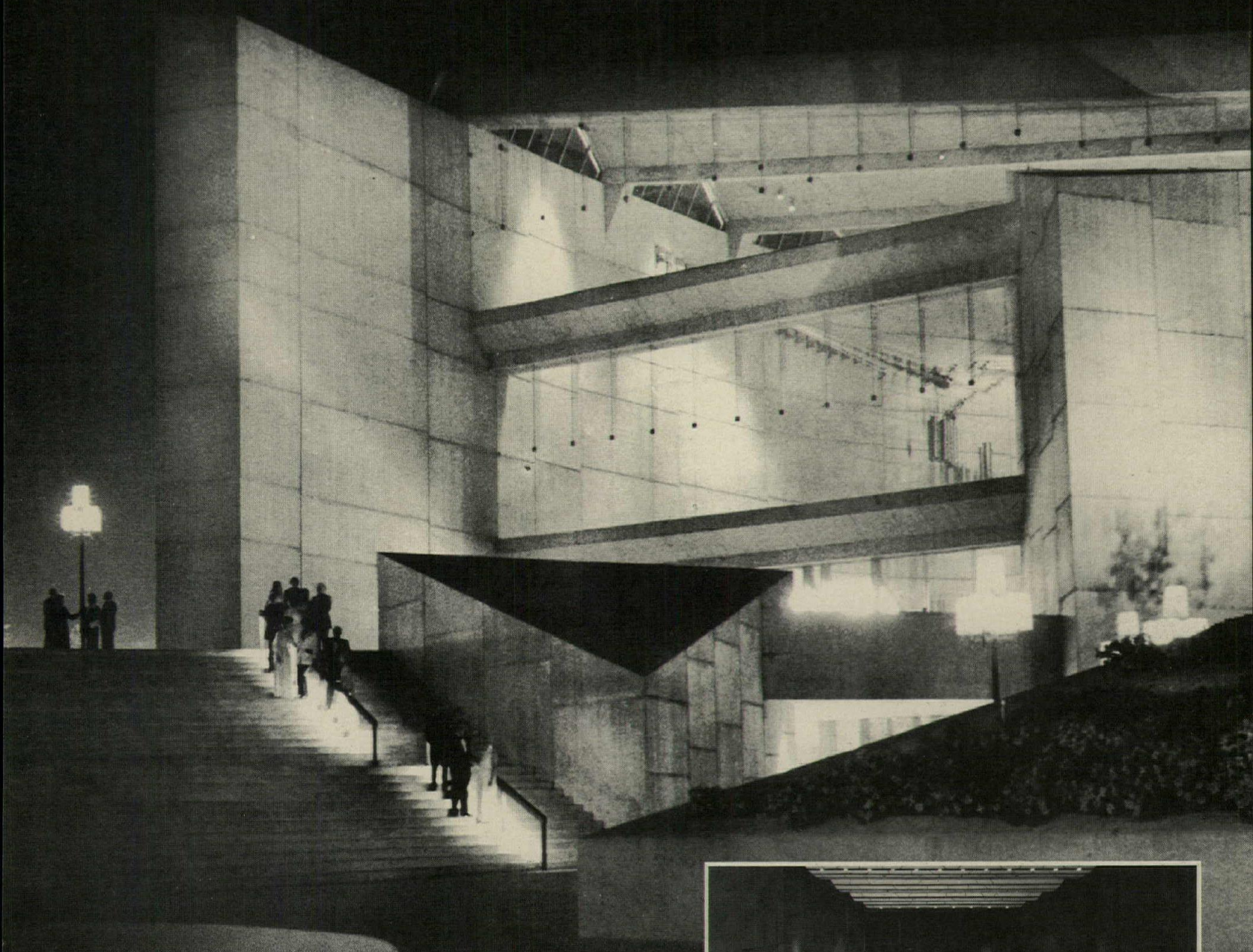

Edwin J. Thomas Performing Arts Hall
University of Akron

Architects: Caudill Rowlett Scott
Dalton, van Dijk, Johnson & Partners
Carl E. Bentz

Theater Consultant: George C. Izenour

General Contractor: Mosser Construction, Inc.

Stage lifts installed by Dover Elevator Co., Cleveland, Ohio

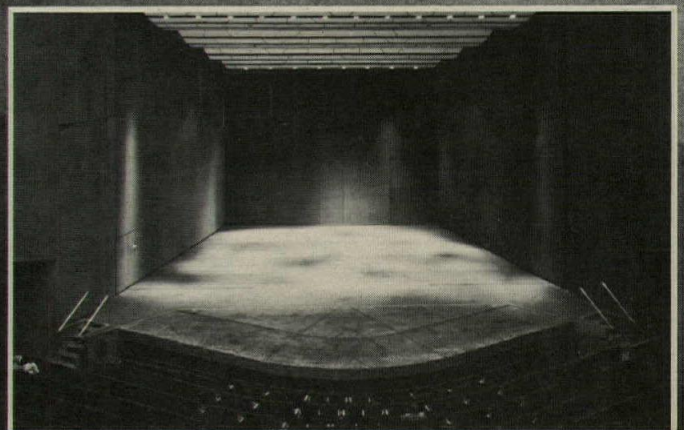



Twenty-five year award to FLLW

For the second time in a row, a project designed by Frank Lloyd Wright received The American Institute of Architects' 25-Year Award. The building is the Administration Building for S. C. Johnson & Son Incorporated, in Racine, Wisconsin. The award was presented during the Institute's annual convention in Washington, D.C., May 20-23.

The award is given for architectural design of enduring significance and is restricted to structures at least 25 years old. The Johnson's Wax Administration Building, opened in 1939, joins a small but distinguished list of buildings that have been honored with the award: Rockefeller Center, New York City (1969); Crow Island School, Winnetka, Ill. (1971); Baldwin Hills Village, Los Angeles (1972); and Taliesin West, Scottsdale, Ariz., the other Wright design (1973).

AIA board votes inquiry committee

In an unprecedented action, the board of directors of The American Institute of Architects voted May 18 to establish within the Institute a national committee to investigate allegations of misconduct by architects. If investigation of such allegations warranted, the committee could bring charges of unprofessional conduct before AIA's National Judicial Board, the appropriate state registration board, and/or appropriate legal authorities.

The national inquiry committee, which will consist of 10 to 50 members appointed by the Institute's board of directors, will provide a pool from which a panel of three to five members will be selected to investigate specific charges on an ad hoc basis.

The inquiry committee will be charged with investigating matters brought to its attention (whether by complaint or otherwise) that appear to involve unprofessional conduct or violations of AIA's Standards of Ethical Practice involving a major public interest, such as recent allegations of illegal political contributions and kickbacks by architects seeking public contracts. Cases involving failure to conform to registration laws, or violations of criminal statutes committed in relation to the practice of architecture, will also be handled by the committee.

In each case, the panel would be charged with determining whether the matter should be referred to the Insti-

tute for consideration under its disciplinary procedures, to the appropriate state registration board, or to legal authorities. If the panel determines that grounds for complaint exist, the inquiry committee would act as complainant in instituting proceedings against the alleged offender.

While the AIA may terminate membership of Institute members found guilty of violating its Standards of Ethical Practice, suspension or revocation of licenses to practice is reserved to the appropriate architectural registration board. In some jurisdictions, registration boards have been hesitant to undertake investigative activities in cases of alleged wrongdoing, because of uncertainty about statutory authority.

Honorary Fellows elected by AIA

Elected Honorary Fellows of the Institute by the AIA Board of Directors were: Luis Barragán, Mexico; Henryk Buszko, Poland; Juan José Casal Rocco, Uruguay; Allan F. Duffus, Canada; Alex Gordon, England; Colin Laird, Trinidad; Dr. Hans Bernard Reichow, West Germany; André Remondet, France; Dr. German Samper Gnecco, Colombia; Peter Shephard, England, and Michel Weill, France.

The title of Honorary Fellow is reserved exclusively for architects of esteemed character and distinguished achievement who are not U.S. citizens and do not practice in this country or its possessions. The 1974 recipients were invested during the annual convention of the Institute.

Industrial Arts Medal: Olivetti

The American Institute of Architects awarded the world-wide manufacturing and sales organization, Ing. C. Olivetti & Company, S.p.A., the 1974 Industrial Arts Medal, presented on May 20 at the convention.

The medal is awarded annually by the Institute for excellence in design for execution by machine in such fields as furniture, textiles, typography, etc.

In citing the company for its achievement, the Design Committee recognized Olivetti's long innovative history of coordinating all the manifestations by which an organization is known by the public. These include the appearance of its products, the language of its communications, and the public and social events it presents and participates in.

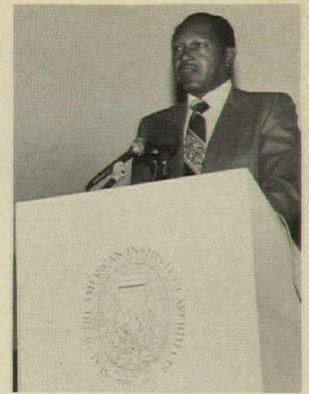

Los Angeles mayor addresses AIA

Los Angeles Mayor Tom Bradley warned last month that "cities cannot wait for the Federal government to deliver" a national growth policy "on its own." He called for a Federally-guided policy for "the orderly, balanced, and reasoned growth of urban and rural areas" within which "local policies can be implemented.

Bradley was keynote speaker at the formal opening of The American Institute of Architects convention May 20, in Washington, D.C.

Bradley said, "No decision is a decision. De facto national urban policy exists in highway, income tax, mortgage financing, and other Federal policies which may meet specific goals but which have secondary effects which combine to "constitute an inadvertent national urban policy."

However, Bradley said "a national growth policy which ignores local governments is not serious about succeeding. He said his views are also those of the National League of Cities (NLC), the national organization of city officials of which he is current president. Bradley praised the AIA for taking an early stance on national land use policy (the AIA first presented recommendations on the issue in 1972, after a three-year study).

Jack D. Train honored for service

Jack D. Train, FAIA, of Chicago, has been selected as the recipient of the 1974 Edward C. Kemper Award given in recognition of significant contributions to the Institute and the profession.

Train, who has served as commissioner of Professional Practice and chairman of the AIA's task force on the Study of Standards of Professional Practice, was recently appointed by Maryland Governor Marvin Mandel to a public commission studying procurement.

more news on page 39

I.M. Pei firm winner of Reynolds Memorial Award

An urban office building praised for its uncommon design has won for its designer the 1974 international R.S. Reynolds Memorial Award for distinguished architecture using aluminum.

An American Institute of Architects jury has conferred the honor on James Ingo Freed, AIA, associate partner of I.M.

Pei & Partners, New York, for his "demonstration of excellence" in the design of 88 Pine Street, New York, owned by Orient Overseas Associates. (The building is shown above in the center.)

I.M. Pei & Partners received a \$25,000 honorarium and an original sculpture.

German architect honored by aluminum company



The "joyous environment" of Munich's revitalized center city—and the hope it offers communities faced with similar problems—has been cited by an American Institute of Architects' jury for one of the Western world's highest awards in new urban design.

For planning of the Fussgängerbereich (pedestrian zone) in the Altstadt (old town) of Munich, architect Bernard Winkler (shown center, with Archibald Rogers, left, and an official of Reynolds), in association with architect Siegfried Merschederu, received the third international R. S. Reynolds Memorial Award for Community

Architecture. The award, presented at the AIA convention in Washington, D.C., confers a \$25,000 honorarium.

The Altstadt has a typical medieval plan, with irregular and narrow streets, enriched by the buildings of successive periods—medieval, renaissance, baroque, rococo, revival, Victorian and modern. The wider main streets, Neuhauserstrasse and Kaufingerstrasse, and the main Marienplatz square, on which the town hall faces, are aligned, creating an identifiable space 2,800 feet long. This space, plus many side streets and arcades, is the new pedestrian zone.

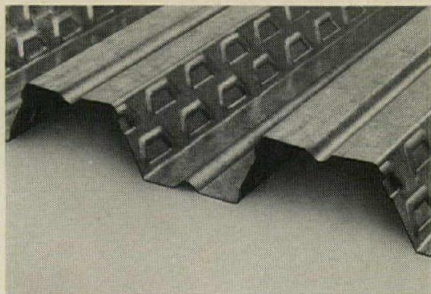

The unique double embossing technique used on new COMDEK sheets is the key to the strong composite action that makes construction move fast.

Efficient construction savings is what Granco's new COMDEK is all about. You save time because COMDEK's wide 36" coverage means fewer welds, less labor. You save again because no positive reinforcing steel is added. And you save concrete because the deep, double embossed rib indentations provide super positive composite action. Thus your pouring form becomes an integrated structural unit as concrete sets.

And, for greater economies, COMDEK is available in both 2" and 3" depths. Lengths to 45'.

Like to get down to specifics? Send for the new Granco COMDEK Catalog. Complete specs, fire ratings, and load tables. Write Granco, P. O. Box 40526, Houston, Texas 77040.

For more data, circle 28 on inquiry card

Granco[®]
Building products that perform

 Granco Steel Products Co.
Subsidiary of
National Steel Corporation

New COMDEK[™] by Granco may simply be the simplest, most efficient composite deck system available today.

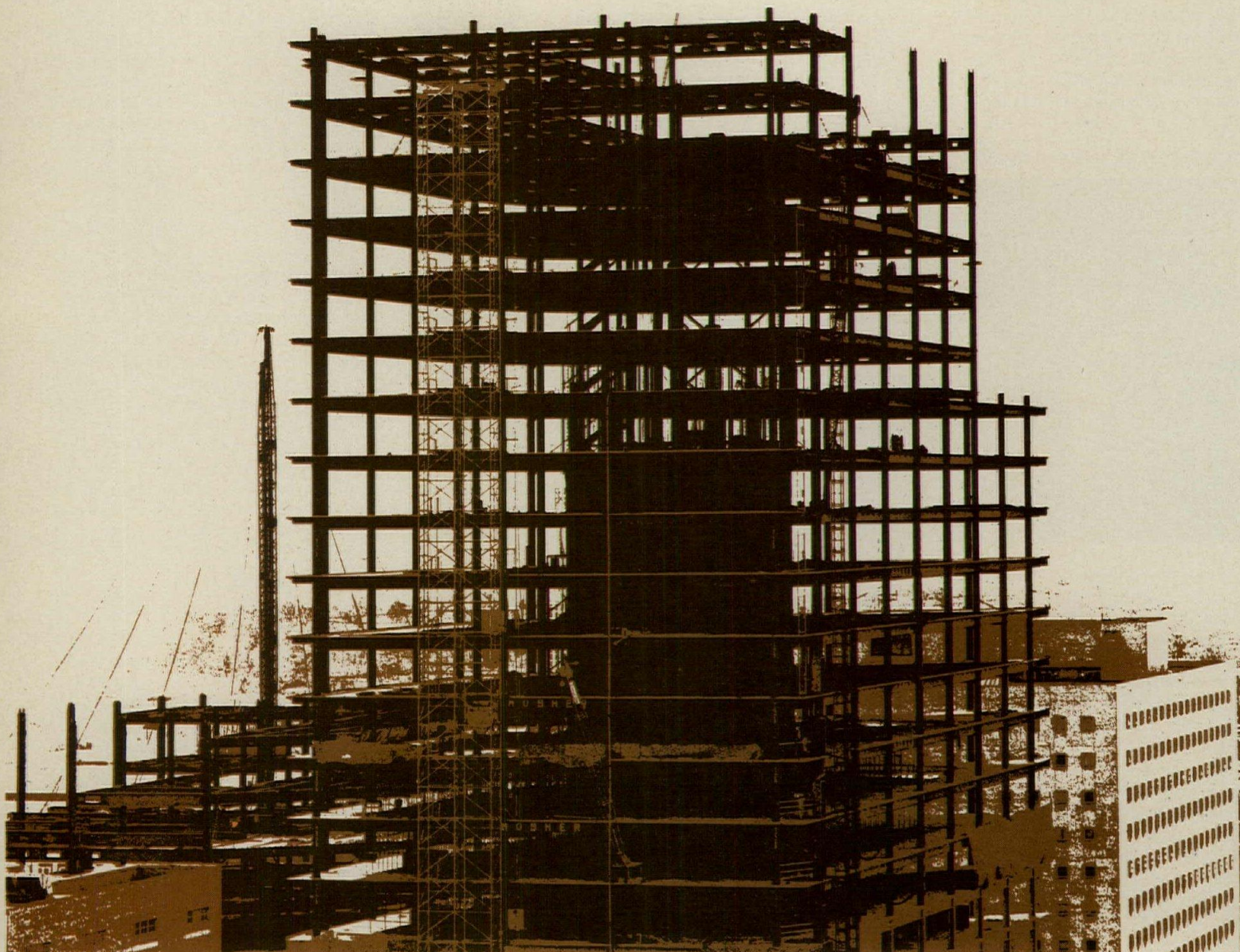

Awards presentations open convention

The Institute gave a number of medals and citations to artists and craftsmen, critics, and other individuals who through their professional achievements have contributed significantly to the profession of architecture and presented 1974 Honor Awards (RECORD, May 1974) to owners and architects of eight architectural projects.

Honorary members: R. Mayne Albright, attorney for the North Carolina Chapter, AIA; Alan C. Green, secretary-treasurer of the Educational Facilities Laboratories Inc.; The Honorable Ernest F. Hollings, Senator from South Carolina; Ada Louise Huxtable (shown top left with Archibald Rogers), architectural critic for *The New York Times*; John B. Johnson, chairman of the Dormitory authority of the state of New York; Fotis N. Karousatos, executive director of the Florida Association, AIA; James W. Rouse, developer and builder; Philip D. Stitt, editor of *Arizona Architect* magazine; Russell E. Train, administrator of the Environmental Protection Agency; William C. Wolverton, controller, AIA.

Medalists: Allied Professions Medal—Kevin Andrew Lynch, Watertown, Mass.; Fine Arts Medal—Ruth Asawa Lanier, San Francisco, Cal.; Craftsmanship Medal—Sheila Hicks, Paris, France; Industrial Arts Medal—Ing. C. Olivetti & C., S.p.A.; Architectural Photography Medal—David L. Hirsch (shown second from top), New York, N.Y.; AIA Medal for Research—Professor Ralph Lewis Knowles, Los Angeles, Calif.; Citation of an Organization—New York State Urban Development Corporation; Architectural Firm Award—Kevin Roche John Dinkeloo (shown third from top) and Associates, Hamden, Conn.; Architecture Critics' Medal—Walter McQuade (shown bottom left), FAIA, New York, N.Y.; Architecture Critics' Citation—Regional Plan Association, New York, N.Y.; Edward C. Kemper Award—Jack D. Train, FAIA, Chicago, Ill.; Whitney M. Young Jr. Citation—Stephen Van Daalen Cram (posthumously); R. S. Reynolds Memorial Award for Community Architecture—Pedestrian Way, Munich, Germany (see page 37). Twenty-five year award: S. C. Johnson & Son Administration Building, Racine, Wisc., designed by Frank Lloyd Wright.

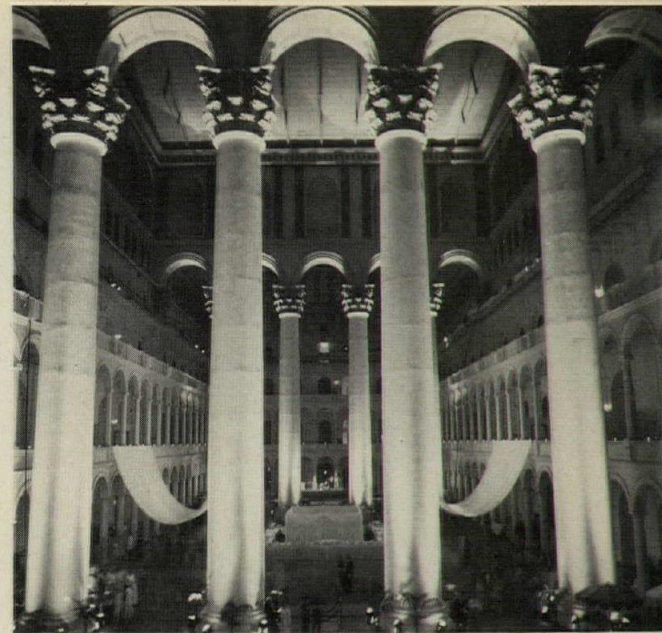
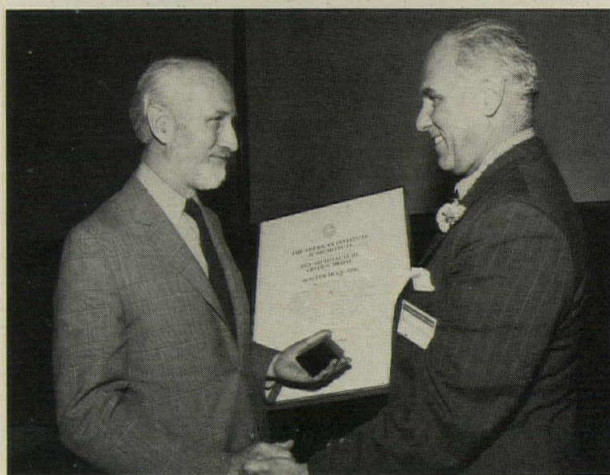
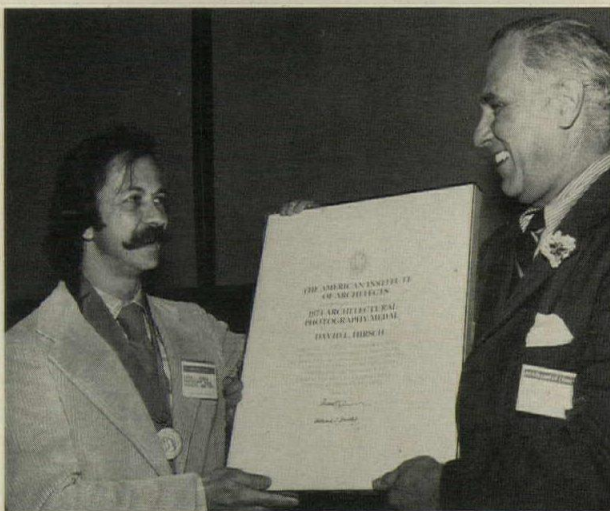

Convention host chapter event: Pension Building Ball

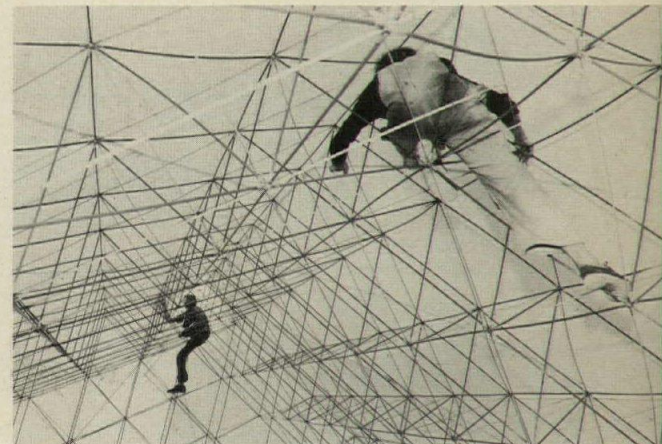

Students construct pavilion on Mall in Washington, D.C.



Host chapter party in Baltimore: Garrett-Jacobs Mansion



Students hold forth on the Mall

Cleveland airport will begin renovation

The passenger terminal at Cleveland Hopkins International Airport will undergo extensive renovation beginning this summer, with construction phased over the next four years. When completed, the terminal will meet passenger needs through 1985, with expansion potential through the year 2000. The renovation is being designed by Richard L. Bowen and Associates, with Pietro Belluschi serving as design consultant. According to the architects, the long flat roof creates a unifying lid over the reorganized airport spaces inside.

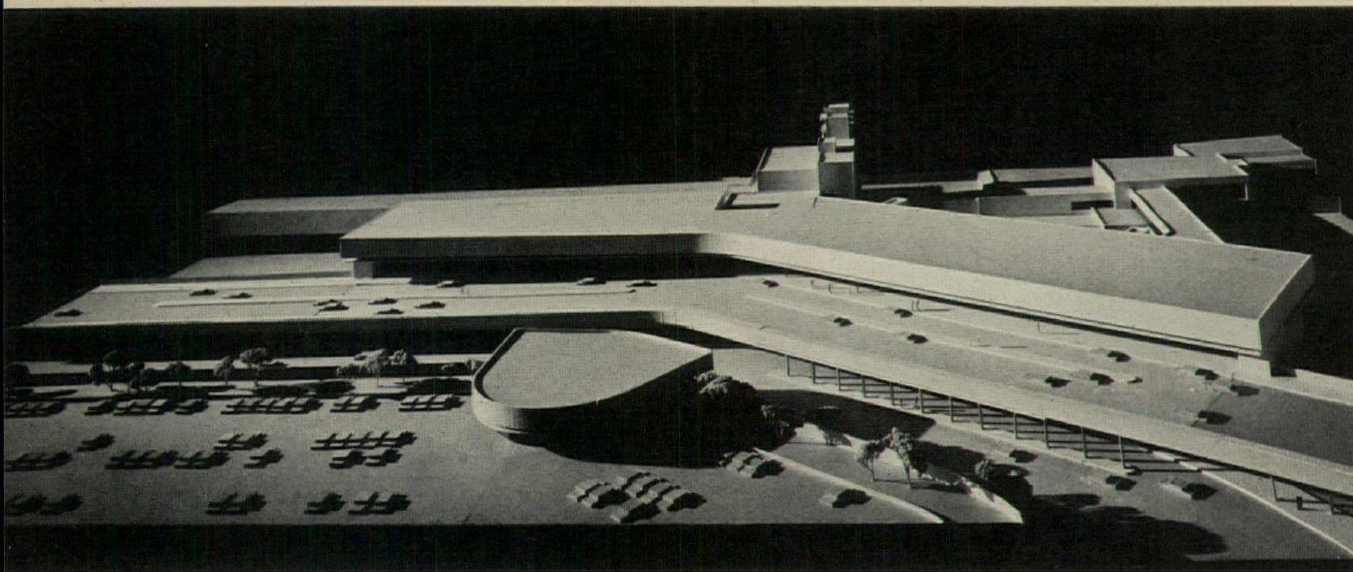

Erol Akyaras

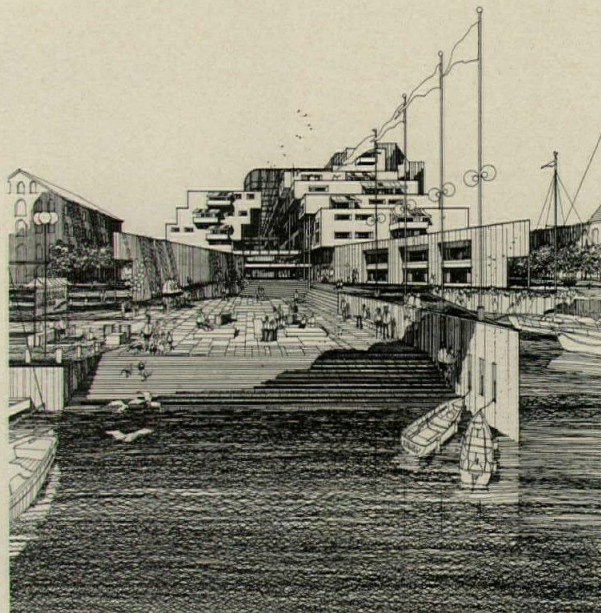
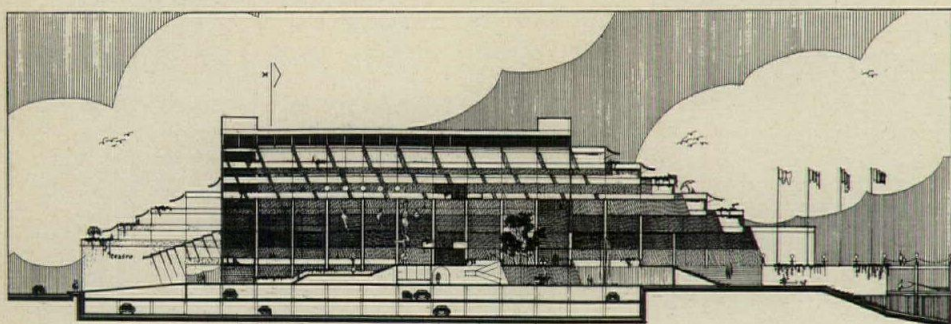

Architect and local businessmen propose Boston waterfront development

In conjunction with the North End Businessmen's Development Corporation—a group of Italian-American businessmen—architect Gerard R. Cugini has designed this multi-use facility to be located on Sargent's Wharf, on the Boston waterfront. The plan is part of the local business community's at-

tempt to grow with the emerging new waterfront and Faneuil Hall-Quincy Markets developments of Boston's North End. Mr. Cugini, who lives nearby, feels his concept carries out the traditional "finger-tip" development of the area. The Boston Redevelopment Authority, which controls the property,

will not give preference to the scheme, hoping to receive other submissions in competition. One such submission could come from architect Carl Koch, who has designed a rehabilitation now occupying much of the Sargent site. BRA will call for designs of new or rehabilitated buildings, or both.



Denver Center for Performing Arts announced

Four blocks in downtown Denver will become a mix of theaters, concert hall, covered walks, shops, and restaurants in a unique plan that calls for integration of new construction with renovations of existing buildings. The complex has

been designed by Kevin Roche John Dinkeloo. Its focal point is a cruxiform glass-covered gallery 60-feet-wide and 76-feet-high linking all the facilities, intersecting at the new concert hall by Hardy, Holzman and Pfeffer.



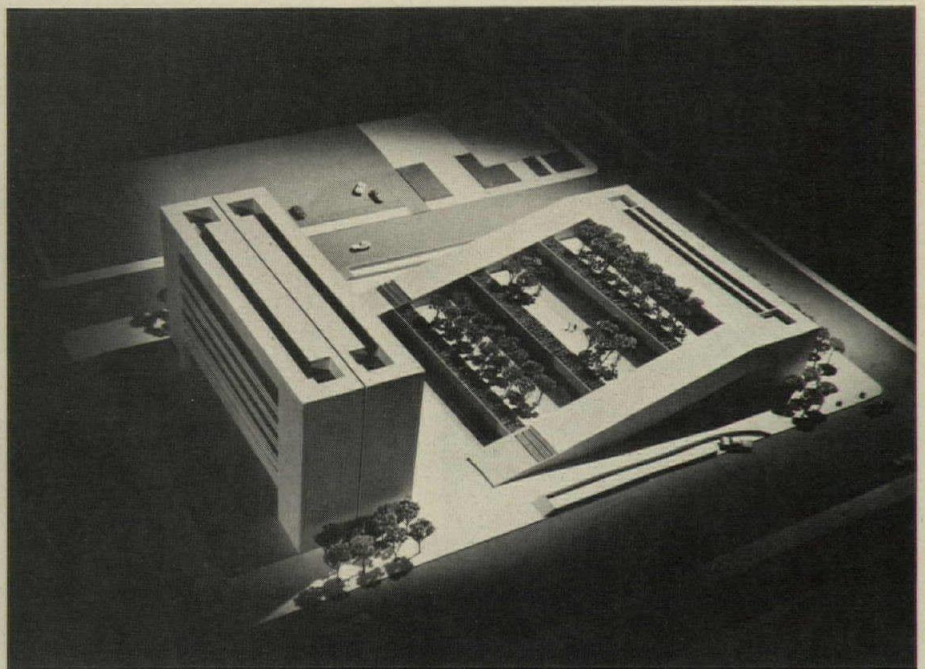
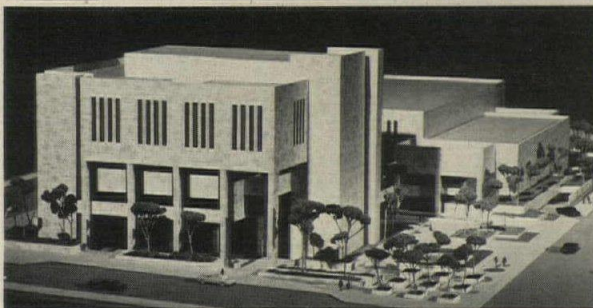
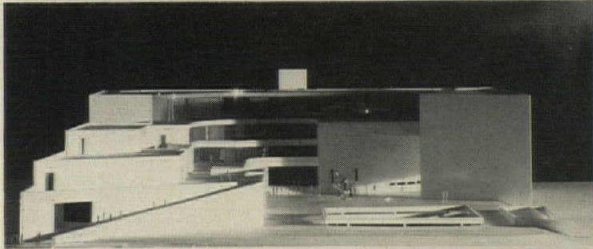
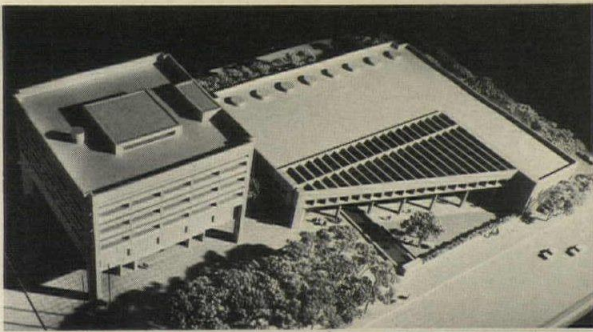

Ed Morrison

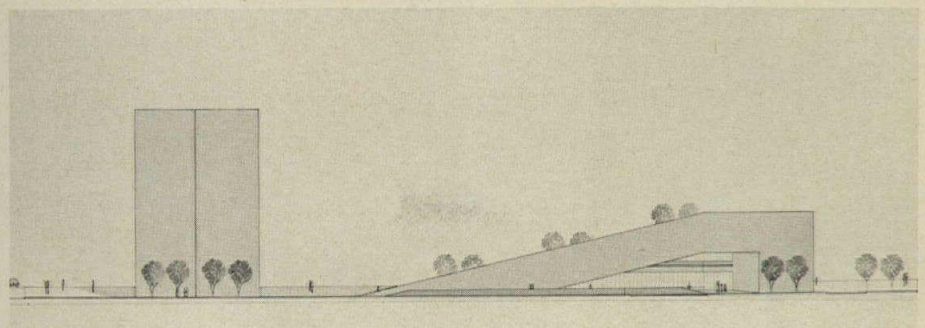

Colorado state project selected in AIA-conducted design competition

In the state's first competition for a public building, the firm of Rogers-Nagel-Langhart (RNL, Inc.) was the unanimous choice to build the Colorado Judicial/Heritage Center complex in Denver. All Colorado architects were invited to present qualifications, and six finalists were asked to prepare specific design

proposals. The jury, chaired by Pietro Belluschi, declared the RNL entry (above) an architectural composition of high quality, original and restrained—with the greatest promise. Construction is expected to begin next October, with completion in 1976. Other entries (left, from top to bottom)

were by: Lusk & Wallace Associates and Johnson-Hopson Associates (first runner-up); Marvin Hatami and Associates and The Ken R. White Company (second runner-up); The ABR Partnership; James Sudler Associates; and Haller & Larsen, Ltd. and Fisher, Reece and Johnson.

Open-air theater planned for Philadelphia

MacFadyen/De Vido are the architects for this open-air theater, for Robin Hood Dell in Philadelphia. The roofed area of the project will cover 5000 seats and 10,000 additional seats are to be provided outside. The facility is designed primarily for orchestral use during the summer by the Philadelphia Orchestra, as well as visiting musical attractions. The budget is \$3 million and completion is anticipated for the summer of 1976. Structural engineers are Lev Zetlin Associates.



MAKING MASONRY WALLS MORE EFFICIENT

NO. 4 IN A SERIES

The loose-fill cavity wall insulation that outperforms all other mineral fills!

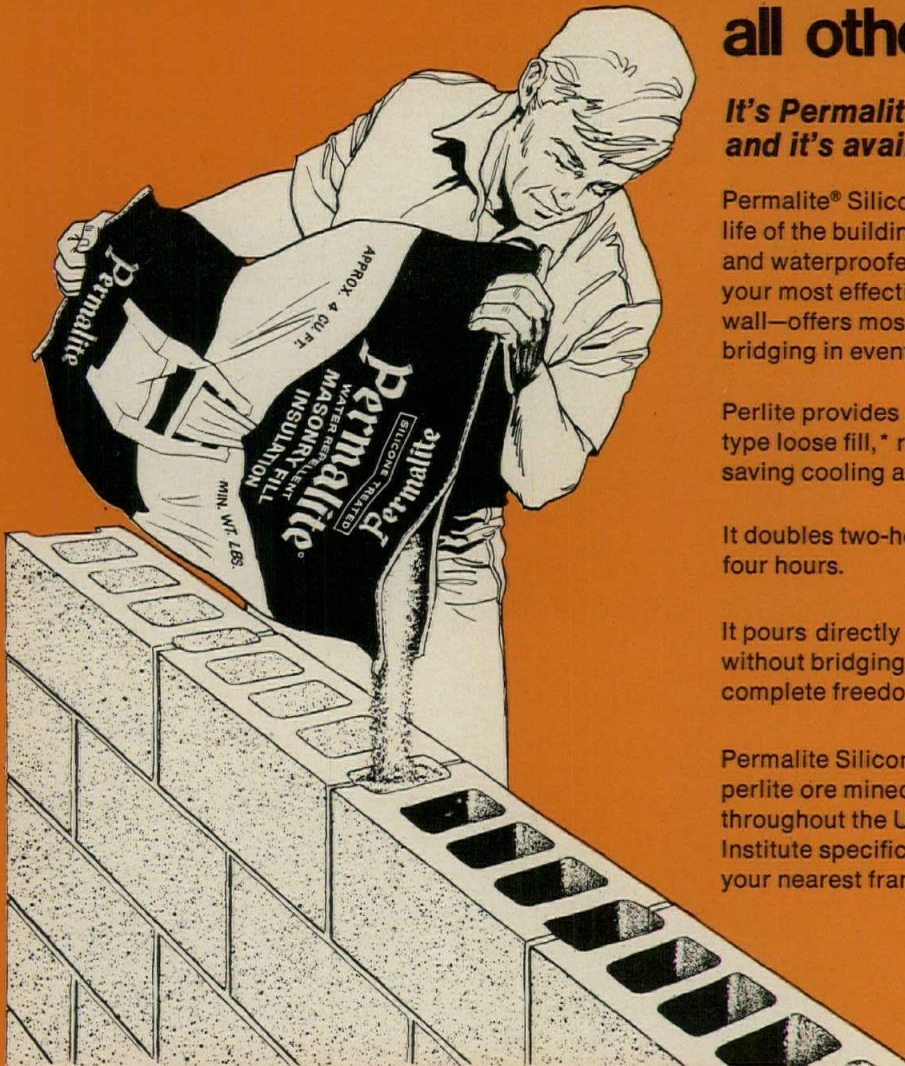

It's Permalite® Silicone-Treated Perlite Masonry Fill, and it's available now!

Permalite® Silicone-Treated Perlite Masonry Fill stays bone dry for the life of the building because the inorganic perlite particles are coated and waterproofed with non-flammable silicone water repellent. It is your most effective barrier against penetration of moisture across the wall—offers most protection against moisture soak-up and water bridging in event of leaking walls.

Perlite provides 20% better insulation than any other popular mineral-type loose fill,* reducing heat transmission by 54% or more and saving cooling and heating dollars that soon exceed its cost.

It doubles two-hour fire rated concrete masonry unit construction to four hours.

It pours directly from the bag and is so free-flowing it fills all voids without bridging. It is self-leveling—won't settle or pack, and offers complete freedom from rot, termites and vermin.

Permalite Silicone-Treated Perlite Masonry Fill is manufactured from perlite ore mined by GREFCO, Inc., by licensed Permalite franchisees throughout the United States and Canada in conformance to Perlite Institute specifications. Write for specification data and the name of your nearest franchisee who can supply your needs NOW.

*k factor of 0.38 as published in ASHRAE Handbook of Fundamentals.

*Permalite Silicone-Treated Perlite Masonry Fill is ideal:
For Concrete Masonry Unit Construction*

For Veneer Wall Systems

For Cavity Wall Systems

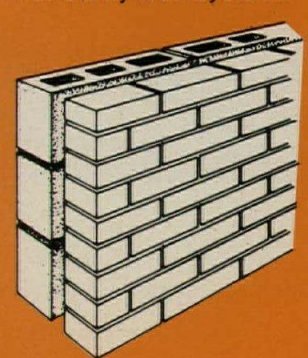
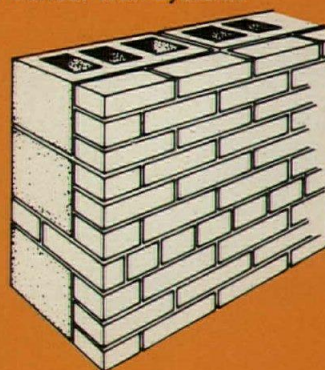

MAKE YOUR OWN INSULATION TEST

Put some Silicone-Treated Perlite Masonry Fill in a jar with water. (Your Permalite franchisee will gladly supply it.) Let it stand 6 hours, 6 days or 6 years.

Shake it as hard as you can. The Perlite Masonry Fill stays dry! Laboratory tests prove perlite is five times more water-repellent than the next best mineral fill material!

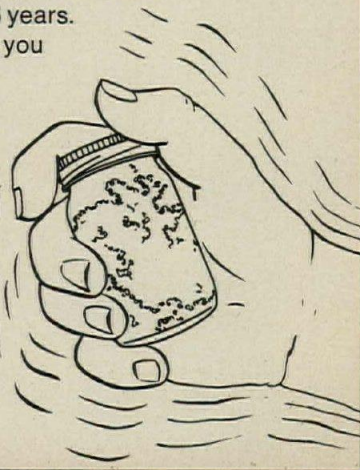

PERMALITE SILICONE-TREATED Perlite Masonry Fill

THINK OF IT AS AN ENERGY SAVER!

Permalite
—the world's leading perlite.

GREFCO, Inc./Building Products Division
3450 Wilshire Blvd., Los Angeles, CA. 90010



A subsidiary of General Refractories Company

For more data, circle 29 on inquiry card

U.S. engineer sees Middle East market

An American engineer with long exposure to Mideastern affairs says that area represents a wide open market for a variety of American consulting services, and, moreover, the countries there are predisposed to "Buy American."

Clarence R. Jones, president and board chairman of Jones and Fellers Architects, Engineers & Planners, Augusta, Georgia, recently returned from his third trade mission to the area. Jones' knowledge of the Mideast comes from his earlier trade missions there over the past eight years and work that his firm has performed in the region. In addition, his brother, who has served as a director of the World Bank was the first head of the planning board of Saudi Arabia.

The most recent trade mission, April 1-17, visited Kuwait, Qatar, Saudi Arabia, and Jordan, and was directed primarily at water resources development. The 11 representatives of American firms involved in the mission paid their own expenses, which permitted them to try to sell the services of their own firms as well as the general expertise of the American design profession.

Jones, who went on to Beirut for three days after the end of the trade mission, put his estimate of future contracts on a 36-month basis. Discounting the possibilities by 90 per cent, Jones says he still comes up with an estimate of \$10 million in fees that his firm may realize over the next three years provided follow-up trips are made in the first 24 months. The \$10 million figure represents construction volume of about \$160 million.

He also brought back with him a strong concern that American consulting engineers may not be pursuing aggressively enough the market emerging for their services in the Mideast. To let foreign firms grab the lion's share of the Mideastern market, he believes, is not only to the short term detriment of the design profession, but in the long-run a danger for the American

industrial community and international trade position.

Only recently, he says, have the State and Commerce Departments recognized that the sale of American services must precede the sale of American products.

U.S. officials have told him that they are working on programs to get American consultants involved in the overseas market to a much greater degree than they have been. Jones feels that some government incentive programs may be necessary to induce the professions, especially smaller firms, to enter the market.

Entry into the market at this stage is important for the long-term national interests, Jones points out, because standards, specifications, and codes are only now being adopted in many of these states which, as has been publicized, have vast amounts of capital to spend on improvements.

The Arabs are still channeling their money into chemical and industrial plants, some of which are dubious investments, that will revolve around their petroleum resources. But Jones also sees a growing sophistication among the Arab leaders, many of whom are second generation executives in their late 30's and early 40's who were educated in the West, and are striving for balanced economic development.

Saudi Arabia, for example, has undertaken a program of exploration for other resources development as a step toward strengthening the area's agricultural base to support further economic development.

Internal development seems to be the number one priority for the use of the oil revenues now flowing into many of the Arab states, says Jones. As a general policy, any surplus above and beyond that needed for internal development is destined for investment in other Arab countries, with African states, especially those that are pro-Arab, third in line for excess capital.

Of the four countries on the itinerary of the trade mission, Saudi Arabia appears to have the most potential for American

consulting firms, Jones says, with a "tremendous volume of work" planned that may run as high as \$4 billion. Moreover, the Saudis are the most favorably disposed toward the U.S. of any of the Arab countries. One of the projects being discussed for Saudi Arabia is a rapid transit system to run between Jidda and Mecca, to accommodate Moslem pilgrims.

Kuwait, Jones figures, has heavy construction planned for the next two to three years that will total approximately \$850 million, exclusive of projects such as housing, hotels, and irrigation. The Kuwaitis also have a sophisticated process for screening design and construction firms and unlike other countries prohibit the use of agents or ties to contractors, manufacturers or distributors.

Projects planned in Kuwait include a power system and desalination plant, an oil refinery, a steel mill, and a liquified natural gas plant. There are also plans afoot to develop the Arabian gulf area as a resort.

Construction in Qatar will probably total \$300 million over the next 24 months, and includes a new international airport and a 6000-bed hospital.

Jones, who has worked extensively with the arms of professional societies concerned with international engineering, says that the greatest problem to penetration of the overseas design market lies with the profession itself.

After overcoming professional inertia, Jones ranks the financial resources of consultants as the second problem. While it will cost a consultant \$150,000 or so to open a full-service office in another city in the U.S., Jones says it will cost \$300,000 or more to open a comparable office in the Mideast. The expense involved in such an operation is one reason Jones feels there is a great need for a government program to provide incentives to small, medium, even large firms.

"If we don't," he says, "our competition is going to take over," particularly the Japanese who, in Jones' opinion, see a large market for their products and services.

Student energy designs announced

Five energy-conserving designs, ranging from a day care center to a complete residential community, have received awards in an energy conservation competition sponsored by Owens-Corning Fiberglas Corporation and the Association of Student Chapters of The American Institute of Architects.

The purpose of the competition, which was open to any student enrolled in a school of architecture, was to encourage awareness of energy use in the built environment. Award winning projects are: a residential community designed by Bob Evans, a student at the Southern California Institute of Architecture, Santa Monica; a solar energy system design for community energy use, submitted by Douglas Bancel, Nicholas Carnevale, Jack Crocker, John Davis, Peter Nelson, Robert Pritchard, and Forest Sheldon, all fourth year students at the University of Colorado, Boulder; and a "prototypical single-family farming complex," designed by Rex James Hall, Oklahoma State University, Stillwater.

An energy-conserving day care center "with sun and wind in mind," was designed by William F. Rogers and Kim Wong of Cornell University, Ithaca, N.Y.

"Eco-Unity" was designed by Peter Clegg and Richard Loope of Yale University, and featured a comprehensive analysis of the natural environment while using technological advances to achieve an energy-conserving architectural expression.

The jury, chaired by Caren Yglesias, a student at Virginia Polytechnic Institute included: Larry Degelman, engineer and faculty member at the School of Architecture, University of Maryland; John P. Eberhard, AIA, president of the AIA Research Corporation; Frank Powell, chief, Thermal Engineering Section, National Bureau of Standards; Richard Stein, FAIA, New York architect, and Kevin Weiler, student at University of Maryland. AIA is exhibiting the projects.

There is only **ONE TJ and it's number **ONE** in every way.**

Any way you look at it, test or measure, TRUS JOIST has the highest quality, most dependable series of light-weight roof and floor joists available anywhere.

TRUS JOIST quality means level floors and straight ceilings that stay that way, consistent uniformity in every joist. It means that no TRUS JOIST will take a large permanent set which could cause roof or floor damage, sticking doors, cracks in walls, water ponding on roofs, or other serious problems. It means dependability and economy—plus peace of mind.

TJ quality has been proven in thousands of buildings of every size and type throughout the United States and Western Canada. That quality has built TRUS JOIST Corporation into a multi-million dollar company with 15 manufacturing plants, 87 sales offices and a staff of over 200 highly-trained technical representatives.

Naturally that kind of success breeds imitators. All over the country dozens of them are attempting to produce roof and floor joists which will compete with TRUS JOIST. But the difference between most of these low cost imitations and the highly-engineered custom-manufactured TRUS JOIST is as great as the difference between day and night.

For instance, every patented TRUS JOIST is computer designed for accuracy and safety. It is then manufactured in our own plants with sophisticated machinery under strict standards of quality control supervised by professional engineers and checked by third-party inspectors. The process is so precise that TRUS JOISTS are made to tolerances closer than any other structural system, be it wood, metal or concrete. It's this kind of precision which allows us to guarantee the performance of every TRUS JOIST in writing.

Next time you're tempted to specify or buy on price alone, consider the price you put on your reputation as an architect or builder.

Is it worth the gamble?

trus Joist[®]

Creative Engineering In Structural Wood

For more data, circle 30 on inquiry card

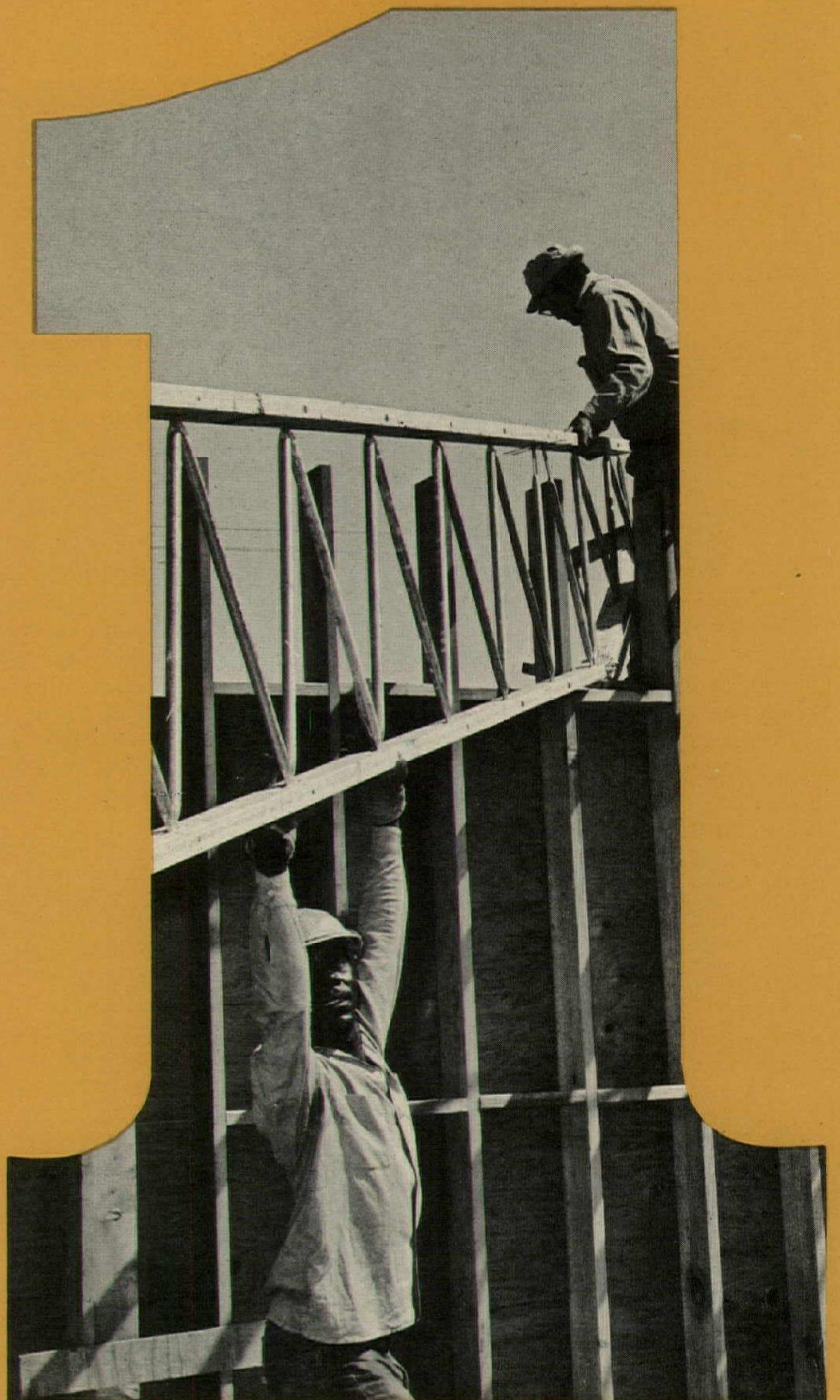

Opening the black box

THE UNIVERSAL TRAVELER, by Don Koberg and Jim Bagnell; William Kaufmann, Inc., Los Altos, California, 1974, paperback, 128 pages, illus., \$3.95.

In schools of architecture across the country a number of publications arise which are edited essays, class notes or workbooks designed for specific courses. Usually these products remain part of the "underground" press and do not surface for general use outside the schools. Recent works of this kind include an *Introduction to Architectural Programming*, by Edward White at the University of Arizona, a graphics workbook by Michael Utzey at the University of Oregon, and a half-dozen publications from the University of California at Berkeley, on topics ranging from basic design and graphics to housing.

The fact that these books remain underground (and therefore under-read) could change with more communication between schools stimulated by the newsletters and conferences of the Associated Collegiate Schools of Architecture. Once in a while, too, a commercial publisher finds one of these works and offers it to a greater audience. Fortunately, William Kaufmann, Inc. found *The Universal Traveler* by Don Koberg and Jim Bagnell, of California State University at San Luis Obispo.

What Dr. Rubin did for sex *The Universal Traveler* does for the design process. After years of lofty mystique, of invasions by scientists and mathematicians, and of various other black box techniques, the act of designing has come to seem an ability savored by the few—who have benefited from making it mysterious and academic by placing themselves in the position of being experts. While *The Universal Traveler* does not slight new philosophies of design, neither does it elevate them above the natural problem-solving skills that laypeople and beginning students already have. As the authors say, "it is perfectly ok to be intuitive"—and bubble diagrams have the same legitimacy as "pattern language" and syntectics. And the book has many bibliographical references for those who want to explore various methodologies in depth.

It is the affirmative spirit of the *Traveler*, not just its content, that makes it a valuable book, particularly for the student and the instructor. It is useful for the student because it legitimizes his own "baggage," his natural ability to solve problems, and because it provides a way to order these abilities into a useful format.

There are also many suggestions to help him define and question a design problem. For those with traditional educational back-

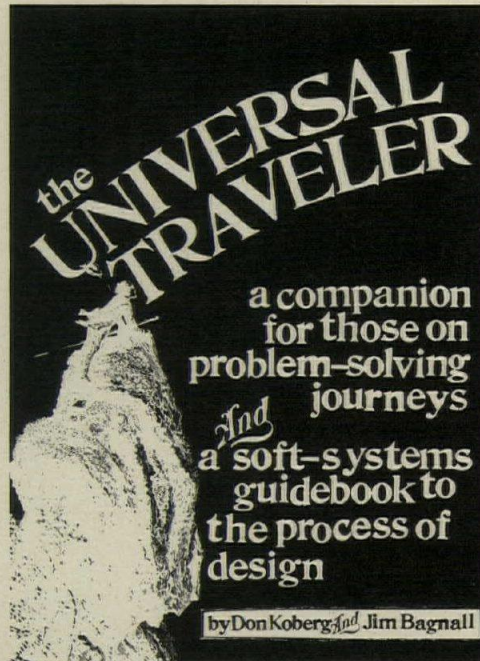

grounds, independence in formulating problems—or even believing that such independence is appropriate—is difficult, because they are used to having a problem presented and then finding the appropriate answer. Since there are no set answers in design, defining and analyzing the problem are important skills to be developed.

Once problems are formulated, the *Traveler* suggests ways for stimulating ideas. For beginning designers (and also for many experienced ones) there is an incredible security in an idea; there is always the pressure of time and the pressure for approval, and so designers may be reluctant to give up an idea, even if it is mediocre. But this book states over and over again that "ideas are a dime a dozen," "don't fall in love with an idea, there are many of them," and the authors describe such things as syntectics and "brainstorming" to overcome this pitfall.

In an attempt not to be intimidating like many academic publications on the same subject, the authors have used the format of a travel guide with cartoon illustrations throughout. The analogy is fun, successful and only occasionally tedious as it relates abstract concepts to a concrete and familiar activity. In order to explain, for instance, that you should choose an appropriate method for a particular problem, the authors state that you don't use a moving van to bring home groceries, or that you fly or drive or walk or take public transportation, depending on where you are going and what you want to experience on the way.

Throughout these trips and side trips many proverb-like utterances are woven into the

text, like so many quotes from Chairman Mao (or Confucius) for designers:

"the design process is a process of fulfilling a prophecy"

"everyone is a problem solver"

"creativity is a learnable state of behavior patterns"

"creativity is not magic"

"ego strength is not an ego trip"

"we are kept from creativity by our own pride, fear, jealousy and contemplativeness"

"creativity is blocked by fear of making mistakes"

"inventions are easy, it is the job of making them work which is hard"

"if you want to learn about something, try teaching it to someone else"

"don't expect to operate without sleep"

One problem with the book and with its myriad of short comments is that it tends to blur, so you remember the particular parts less than you remember that you like how it all sounds, and that you needn't fear the process of design. But for a serious student, and for a teacher, that is a lot.

—Sam Davis

Mr. Davis is an architect who teaches at the University of California at Berkeley.

Also received

TIME-SAVER STANDARDS FOR ARCHITECTURAL DESIGN DATA, fifth edition, edited by John Hancock Callender; McGraw-Hill, New York, 1974, 1040 pages, illus., \$32.50.

Information on structural design, building materials, components and techniques, and environmental control make up this new edition of *Time-Saver Standards*. Expanded and revised coverage of many topics, including modular coordination, design loads, waterproofing, termite control, elevators and roof drainage has been incorporated into this familiar reference book. Sections on wood walls, architectural metals, gas appliances and heating and cooling systems for houses have also undergone extensive revision.

Because of the recent air pollution legislation, former sections on incinerators have been dropped completely from this edition and have been replaced by new material on solid waste handling systems. The flexible format allows for numerous drawings and tables, which are supplemented with explanatory texts.

SECURITY, by Walter M. Strobl; Industrial Press, New York, 1973, 280 pages, illus., \$17.50.

A practical guide to procedures and devices for maintaining security in buildings.



Job site service.

Your clients get it when you specify General Electric Zoneline™ air conditioners.

When you specify packaged terminal air conditioners to your clients, it's a major investment for them.

So if anything should go wrong later on, we believe they're entitled to have repairs made conveniently and expertly. And if it's at all possible, repairs should be made right at the job site.

This is exactly what happens with General Electric's Customer Care... Service Everywhere.™ Which means that wherever your project is in the continental U.S.A., there'll be a qualified GE serviceman nearby.



GE has a network of Factory Service Centers in over 100 major cities plus 5,000 franchised servicers throughout the country.

Our service trucks and experienced servicemen can take care of most problems right at the site. Should a major component such as the compressor be involved, however, we remove it, repair it, replace it, and, during the warranty period we pay for it. GE Zoneline Air Conditioners carry a one year parts and service-labor repair warranty against failure due to manufacturing defects with an additional four year parts and service-labor repair warranty on the sealed refrigerating system.

So when you specify packaged terminal air conditioners, remember General Electric provides what you want—job site service, everywhere in the continental U.S.A.

For more information call your GE Contract Sales Representative or write to: Air Conditioning Contract Products Operation, General Electric Company, Building 53, Louisville, Kentucky 40225.

GENERAL  **ELECTRIC**

For more data, circle 31 on inquiry card

Visit Sao Paulo, Rio, Brasilia—and meet the designers of some of the world's most innovative buildings and places.

The First International Seminar to Brazil...
October 23 through 31st, sponsored by
ARCHITECTURAL RECORD

The three cities are varied — but all are showcases of architecture and planning

We chose Brazil because the proliferation of architecture in this booming country is so astonishing as to be of singular significance to the architect or engineer of any nation.

For example, Sao Paulo is the fastest growing city in the world. With a population of over eight-and-a-half million people, it presents a living model of the myriad problems facing the urban developer, architect, or engineer.

Rio de Janeiro, containing four-and-a-half million people between miles of coastline on one side and confining mountains on the other, offers a totally different planning and design challenge.

Then there is the staggering accomplishment of Brasilia — an entire capital city planned and built in the Brazilian jungle — currently housing 700,000 people and showing, after a difficult start, the vitality that was anticipated at the time of its monumental conception.

You'll meet and exchange ideas with the architects and planners of the best work



Niemeyer

In Rio de Janeiro, Oscar Niemeyer has graciously agreed to meet with us at his home. The great landscape architect Burle Marx, and Sergio Bernardes — whose work has become famous for its environmental and human concern—will also meet with us.

In Sao Paulo there is Joao Vilanova Artigas, Jorge Wilhelm, Alberto Botti, and John Gian Carlo Gasperini, all of whose efforts are transforming the face of the world's sixth largest city.

Besides meeting with these renowned professionals in formal seminar sessions, you will meet members of the Institute of Architects of both Rio and Sao Paulo—your counterparts in these important South American cities—and establish the informal one-to-one dialogue that makes a trip like this so invaluable.



Marx

... visit public buildings and parks, houses and housing, office towers and stadiums ...

You will visit sites selected by *Architectural Record* as representing the most important examples of the many architectural genres under discussion.

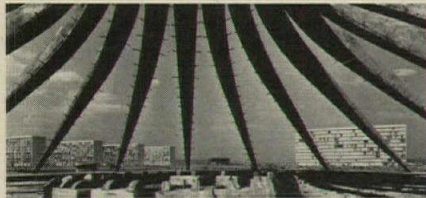

Brasilia

In Sao Paulo our three-day stay will include visits to Morumbi, the site of the world's largest sports stadium; Casa do Bandeirante, the two sumptuous homes by Paulo Mendes da Rocha; Cidade Universitaria; Ibirapuera Park, an astonishing complex of public buildings; Downtown, where new commercial and residential buildings are marking both the city's remarkable growth and new horizons in design; and other significant sites.

In Rio, where you will spend four days and four nights, you can visit the Ministry of Education, Museum of Art, South American Hospital, Rio Airport, Coastal Boat Station and Seaplane Station, Municipal Church, Flamengo Park, University of Rio, Pedregulho Housing Project, and much more — illustrating in all the broadest possible variety of purpose, problem, and solution.

... and see Brasilia, experiment without parallel in the world of architecture

As a living example of what can be done in terms of total city planning when starting literally from *nothing*, Brasilia is of course unique.

An entire day has been set aside for an on-site inspection of this remarkable new capital, planned by Lucio Costa and designed by Oscar Niemeyer.

Particular attention will be given to the Palaces of the Senate and Congress, Palace of Arches, President's Palace, Square of Three Powers, the stunning Cathedral, residential blocks, and new government buildings in progress.

The successful experiment of Brasilia—and the new era it launches—will have a dramatic and lasting influence on any professional who experiences it first-hand.

The cost* is exceptionally low — and your wife (or husband) can go for a fraction more

During your four days and four nights in Rio, you will live at the Hotel-Nacional Rio—Brazil's largest and most beautiful hotel, nestled between white sands and green mountains, and designed by Oscar Niemeyer.

In Sao Paulo, your comfort and convenience will be provided for at the lovely San Rafael Hotel.

Total land and air cost of \$895 per person includes:

Roundtrip airfare from JFK (New York) • deluxe hotel accommodations 7 nights • full-course breakfasts and dinners • all transfers

between hotels and airports • baggage handling • all gratuities • all ground transportation to and from seminar events • city sightseeing in each city • everything except personal purchases and lunches.

The all-inclusive travel price is less than the cost of economy airfare alone. Your professional seminar registration fee of \$395, added to the \$895, brings the total cost to you to only \$1290*. For an additional \$895—your wife can accompany you on this marvelous week in Brazil.

Ample free time is provided for enjoying together all the advantages of a South American trip. And these Brazilian cities offer so much to the visitor that, if your wife does not care to attend the seminar sessions, she will be totally and enjoyably occupied.

Plan now. Don't delay — registration and attendance are limited.

To establish a group size that makes the professional and cultural dialogue most stimulating and rewarding, it is necessary to limit the size of the group. Registrations will be accepted in the order in which they are received. To assure your attendance at this inaugural *Architectural Record* international seminar, return the coupon below today.

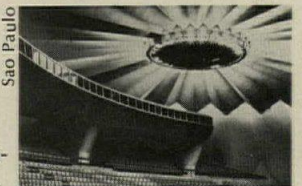

Sao Paulo

*Tax Deduction of Expenses:

Income tax deductions are allowed for expenses of education (including registration fees, travel, meals, lodging) undertaken to maintain and improve professional skills (see Treas. Reg. 1.162-5) (Coughlin vs. Commissioner, 203 F. 2d 307).

Seminar management by Professional Seminars International; all travel arrangements by their affiliate, American International Travel Service.

Mail to:

Professional Seminars International
516 Fifth Avenue, New York, N.Y. 10036

Please register me for the *Architectural Record* International Seminar, October 23-31, 1974, departing and returning JFK New York. My \$100 deposit per person is enclosed. I understand deposits are totally refundable if I cancel my registration any time up to 45 days prior to departure and that I will be charged \$100 per person for any cancellations after that. I also understand that the balance of the payment(s) are due 35 days prior to departure.

Name _____ Spouse _____

Address _____

City _____ State _____ Zip _____

Phone _____

Enclosed is \$ _____ as deposit as full payment for _____ people.

(Rates are based on double occupancy. Single supplement is \$60 additional. Please make checks or money orders payable to: Professional Seminars International, Inc.)

Sponsor reserves the right to adjust prices in the event of rate and tariff changes over which it has no control.

When its 95 outside,
 this brick cavity wall gains heat
 at the rate of only .72 Btu/h
 a square foot.



10" brick cavity wall. 4" brick units
 with 2" polyurethane insulation.

A highly efficient glass
 wall admits 60 times more heat;
 a top-quality metal sandwich panel
 admits nine times more; a concrete
 sandwich panel admits three times more.

And, from a
 design point-of-view, it's also a
 more interesting square foot.

With a U value of only .06, brick
 cavity walls provide the most efficient
 barrier against solar heat gain in
 buildings. A 10,000-square-foot brick
 cavity wall gains only 7,200 Btu/h
 under summer design conditions,
 compared to 440,000 Btu/h for a
 double-glazed reflective glass wall.
 Brick solves energy conservation

problems inexpensively. In most areas,
 a brick cavity wall can be installed
 for \$4.50 to \$7.50 a square foot. Price
 includes finished interior walls.

If the cavity wall doesn't meet
 your design needs, other brick walls
 will. All offer similar energy
 conservation and none will shatter
 your project's budget.

Brick Institute of America, 1750 Old Meadow Road, McLean, Virginia 22101

For informative booklet comparing energy conservation
 characteristics of brick with competing systems, please
 fill out and mail coupon to:

Brick Institute of America, Dept. EC AR
 1750 Old Meadow Road, McLean, Virginia 22101

Name _____

Title _____

Firm Name _____

Street _____

City _____

State _____ Zip _____



For more data, circle 32 on inquiry card

INSULATION SEE THROUGH

Salt Lake City residence. Architect: Dee Wilson.



IN YOU CAN H, FROM LOF.

HOW TO UTILIZE NATURAL LIGHT AND SAVE ENERGY DOLLARS, TOO.

Economic and energy crises shouldn't keep you from designing attractively open structures. Because LOF makes high-performance glass with insulative properties that can mean year-round occupant comfort, enhanced by the use of natural light.

Thermopane® insulating units help prevent heat loss in winter; Vari-Tran® reflective glass insulates against solar heat gain in hot weather. In combination, energy costs for heating and cooling can be cut the year round.

HIGH-PERFORMANCE GLASS LOWERS BUILDING OPERATING COSTS.

In Jacksonville's Independent Square building, when completed and operating, use of this LOF high-performance duo is projected to cut building energy consumption for heating and cooling by 28% as compared to ordinary glass. This would be a savings of 3 million kilowatts a year, or 186,000 gallons of fuel oil.

A total energy concept of design must take into account, of course, all construction materials. One of our highly qualified architectural representatives will be glad to help you save energy dollars with the right glass.

Call Dan Hall at (419) 242-5781. Libbey-Owens-Ford Company, 811 Madison Avenue, Toledo, Ohio 43695.

For more data, circle 33 on inquiry card

LOF

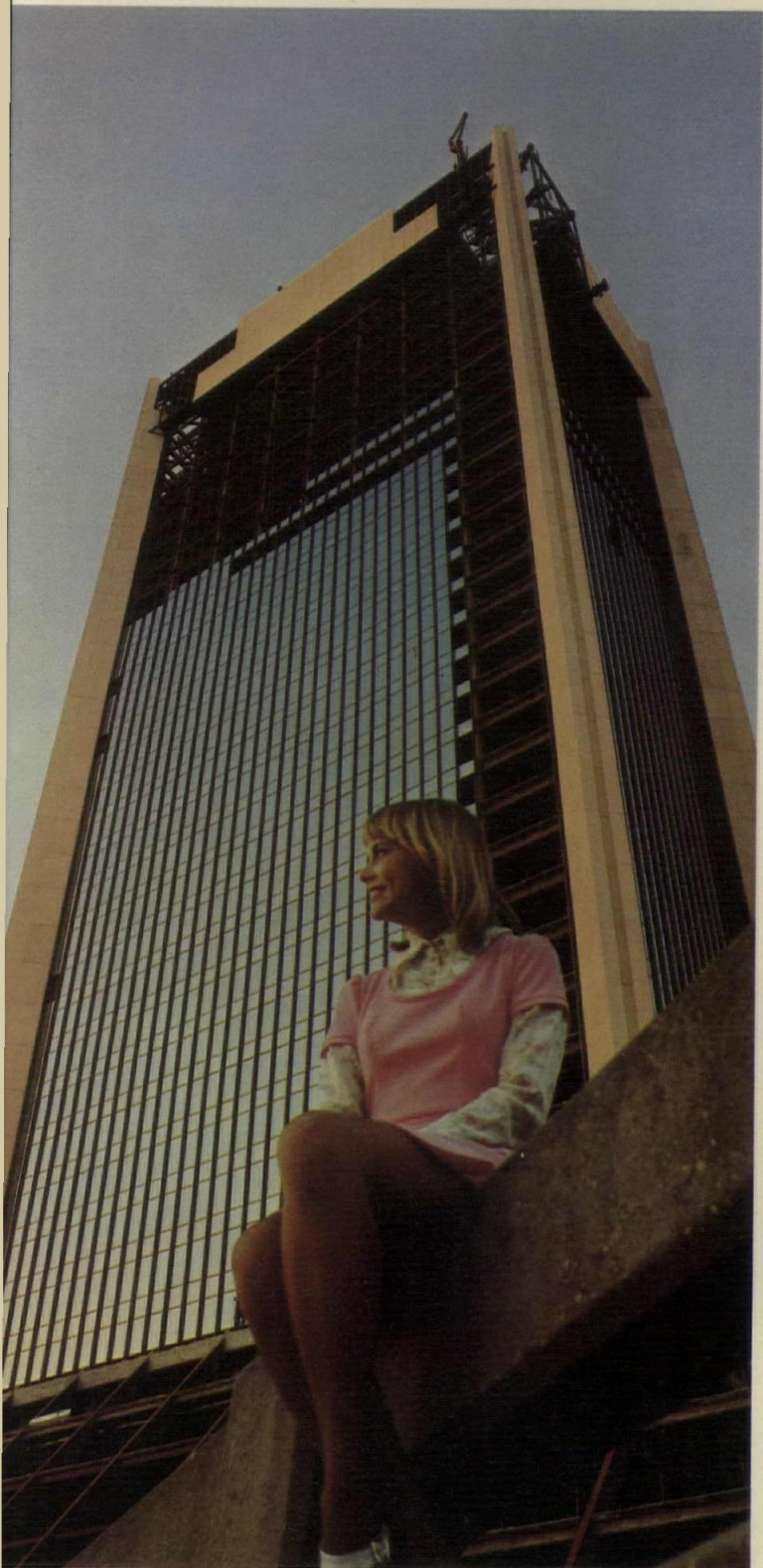

Independent Square, Jacksonville, Fla., to be completed February, 1975.
Architect: Kemp, Bunch & Jackson. Project Architect: Warren C. Hendry, Jr.
Owner: Independent Life Insurance Co.



Andersen™ Perma-Shield® Windows help an Alaska hospital fight the common cold.

When winter comes to Fairbanks, temperatures drop. Often as low as 40° below zero.

So it's no wonder the architect was concerned about cold weather when he designed the new Fairbanks Memorial Hospital.

That's why he specified Andersen™ Perma-Shield® Casement Windows.

Fighting cold weather and sealing out drafts are second nature for Andersen Windows—even at 40° below.

For one reason, Perma-Shield Windows have a weatherproof sheath of rigid vinyl over a wood core (one of nature's best insulators).

For another, Andersen weatherstripping is two times tighter than industry standards require.

And double-pane insulating glass cuts conducted heat loss by 35% (compared to single glazing).

These same fuel-saving Andersen features also help seal in the high relative humidity levels necessary to patient comfort and hospital safety.

Perma-Shield Windows cut maintenance costs, too. They won't rust, pit or corrode like metal. Won't need painting.

And double-pane insulating glass eliminates storm window bother. Cuts cleaning chores in half.

So, if fighting cold weather and sealing in an environment are important to your hospital design, specify low maintenance, fuel-saving Andersen Perma-Shield Windows.

For more information, contact your local Andersen dealer or distributor. He's in the Yellow Pages under "Windows, Wood." Or write us direct.

The beautiful, carefree way to save fuel.

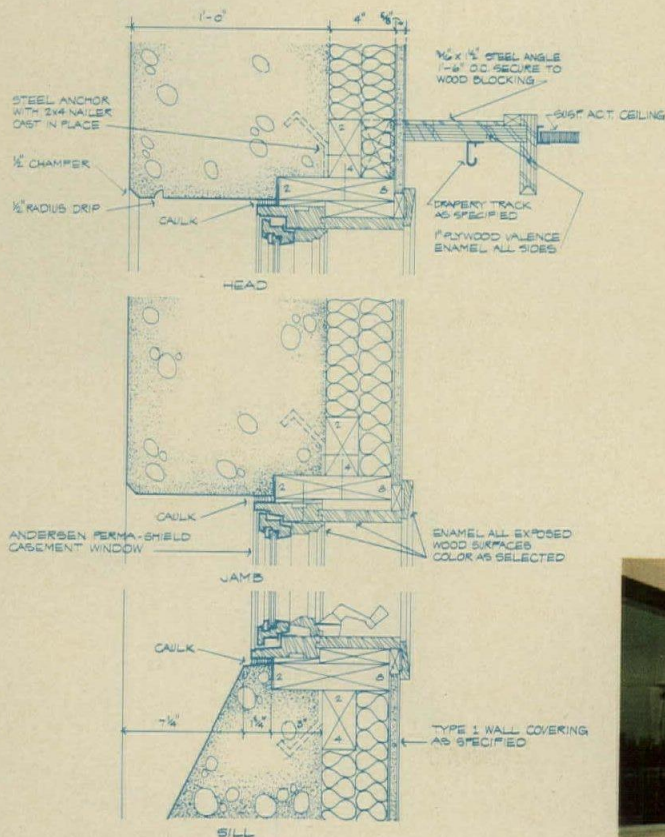

Fairbanks Memorial Hospital,
Fairbanks, Alaska.
Architect: Maloney, Herrington,
Freesz & Lund, Seattle, Wash.



Copyright © Andersen Corp.,
Bayport, Minn. 1974.

Andersen Windowalls®
ANDERSEN CORPORATION BAYPORT, MINNESOTA 55003



For more data, circle 34 on inquiry card

From U.S.G.



More sound control concepts.

RC-1 SHEETROCK* Resilient Channels put walls on rails to stop noise in its tracks.

Today's builders know well the selling value of effective sound control. But, until U.S.G. research showed the way, many builders found the cost of silence too golden. The solution was a strip of springlike steel that made sound control economical for every party wall and ceiling in all wood frame buildings, from motels to offices and apartments. This strip, RC-1 Resilient Channel, is attached to the wood framing. Then drywall panels are attached to the channel which decouples them from the framing. Sound waves are derailed between the partitions, then absorbed and dissipated in the insulation. RC-1 is so unique it's patented.† And it's so obviously effective and economical that builders have already made it the most popular sound control system in the industry.

A. ACOUSTONE* Space Units absorb sound on all six surfaces; install against walls or ceilings to control reverberation, enhance acoustics in music studios and other rooms with sound absorption problems.

B. Versatile THERMAFIBER* Mineral Fiber Blankets have millions of tiny dead air spaces to trap sound waves; improve the sound rating to 52 STC in this typical RC-1 residential partition system.

C. Beautiful AURATONE* Acoustical Ceiling Panels are perforated to provide absorption of up to .80 NRC of noise within a room.

For details on any of these systems, write to Dept. AR-64, 101 S. Wacker Drive, Chicago, Ill. 60606.

For more data, circle 35 on inquiry card

*Reg. U.S. Pat. Off.
†U.S. Pat. No. 3,090,164

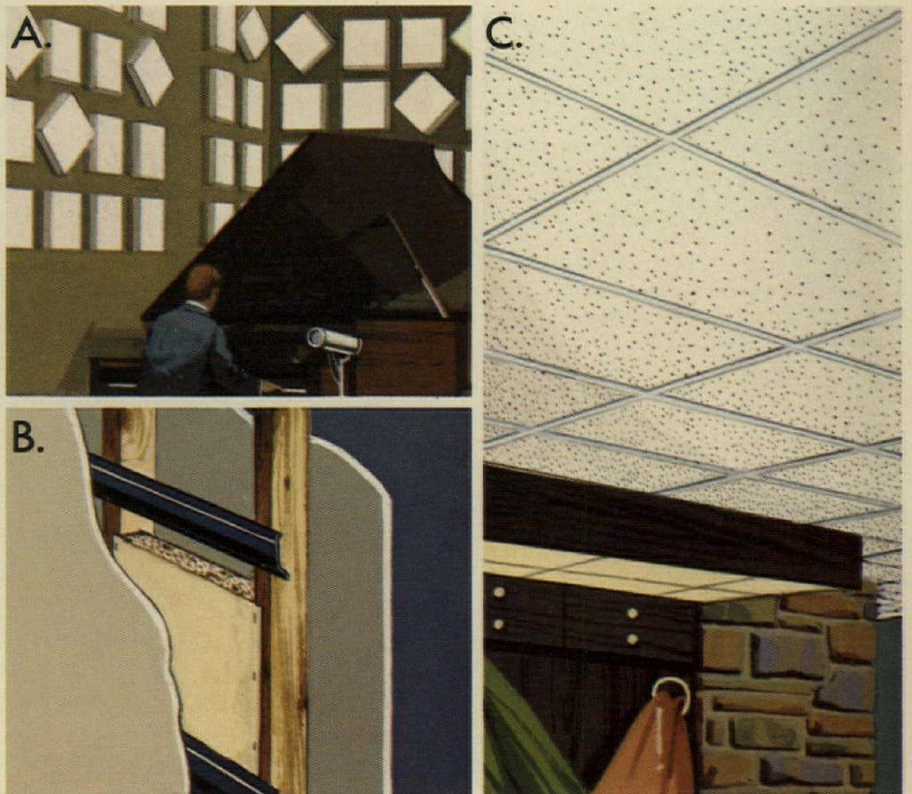

UNITED STATES GYPSUM 
BUILDING AMERICA

Pleasant under glass.



Bring the great outdoors indoors with Lord & Burnham glass enclosures.

There's something special about the pleasant living or working environment created by the addition of a glass enclosure. Whatever it's used for, solarium, skylight, greenhouse, living room, working or recreation area, Lord & Burnham glass enclosures add an extra, functional dimension to any design, any building application.

Lord & Burnham has been involved in the greening of American architecture for more than 117 years, so we speak your language when it comes to cost control or custom designs. And while a glass enclosure is pleasant for your clients, we go all out to make your planning pleasant by providing complete architectural consultation services at no extra cost.

If you'd like to see some recent examples of our work, just look us up in Sweet's (13.7/Lo) or for complete information or consultation, at no obligation, write or call your nearest district office listed below.

Lord & Burnham
Irvington-on-Hudson, N.Y. 10533



CALIFORNIA *Hayward* 94545 / (415) 782-6236
CONNECTICUT *Cheshire* 06410 / (203) 272-5321
ILLINOIS *Des Plaines* 60016 / (312) 824-2181
MASSACHUSETTS *Belmont* 02178 / (617) 484-2716
NEW JERSEY *Cherry Hill* 08034 / (609) 795-3434
NEW YORK *Irvington-on-Hudson* 10533 / (914) 591-8800
NORTH CAROLINA *Saluda* 28773 / (704) 749-3091
OHIO *North Ridgeville* 44039 / (216) 327-5622
CANADA *St. Catharines, Ontario* / (416) 685-6573

For more data, circle 36 on inquiry card

OFFICE NOTES

New firms, firm changes

Parsons Brinckerhoff Quade Douglas are now located at One Penn Plaza, 250 West 34th Street, New York City.

Mr. Arthur C. Metcalf of Wright & Metcalf has retired from practice. Mr. Wright will continue the practice under the name of **J. Warren Wright Architect AIA**, 2323 E Street, P.O. Box 2344, Bakersfield, California.

Neski Associates/Architects have moved to new offices located at 18 East 53rd Street, New York City.

Don Knorr, FAIA, formerly senior partner in the San Francisco firm of Knorr-Elliott & Associates, recently announced the formation of his new organization, **Don Knorr and Associates**, 950 Battery Street, San Francisco. The firm name of the Alaska office will be changed to **Lane-Knorr and Associates**, 505 West Northern Lights, Anchorage.

Porter and Ripa Associates of Morristown, New Jersey, has opened new offices in Atlanta, located at 230 Peach Tree Street.

The architectural firm of Carson, Lundin & Shaw, 425 Park Avenue, New York City, has announced that the name of the firm has been changed to **Carson, Lundin & Thorson**.

John Pat Guthrie, AIA, architect has opened his new office at 3444 East Mountain View Road, Phoenix.

RTKL Associates Inc. have been relocated in new offices at the Village Square, Village of Cross Keys, Baltimore.

Eugene Lew, AIA recently opened his new office for the practice of architecture and planning. The new firm, **Eugene Lew & Associates**, is located at 1844 Union Street, San Francisco.

Hellmuth, Obata & Kassabaum, Architects have moved to new offices at 915 Front Street, San Francisco.

Sanford Hirshen and Partners, Architects, is now known as **Hirshen, Gammill, Trumbo and Cook**, Architects, located at 2150 Dwight Way, Berkeley, California.

Perkins & Will have been relocated in larger quarters at 488 Madison Avenue, 17th floor, New York City.

Lowell Brody, architect, AIA, formerly with the firm of Abbott, Merkt & Co., Inc., New York, has formed his own architectural firm with offices at 164 Winthrop Place, Englewood, New Jersey.

New Partners, Associates

Max O. Urbahn, FAIA, president and chief executive officer, and Philip F. Moyer, PE, AIA, executive vice president, have announced the appointments of **A.J. McArthur, AIA** as vice president/general manager, and of **Peter Randall Stark** as vice president/development of Max O. Urbahn Associates, Inc./Architecture and Planning, 521 Fifth Avenue, New York, New York 10017. Mr. McArthur was previously executive vice president for eastern operations of Charles Luckman Associates, Architects, of Los Angeles; and Mr. Stark was a vice-president, based in New York, of Curtis and Davis, Architects.

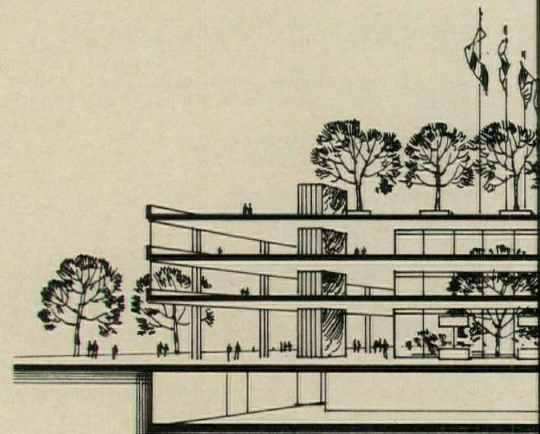

call the



For total design

Bell System when preplanning.

Efficient buildings provide facilities to install today's sophisticated communications systems. Since these facilities should be integrated with your design, we want you to know about our Building Industry Consulting Service.

A Bell System consultant can advise you on local building codes which affect communications, and suggest a system that offers maximum efficiency and makes optimum use of space. And there's no extra charge for this service.

Calling us early can eliminate the need for expensive alteration, or exposed cables and wires.

Our insert in Sweet's Catalogue has basic information. For questions on current or future projects call a Building Industry Consultant at your Bell Company or send in our coupon. At AT&T and your Bell Company, we want to help you produce an efficient end product.

We hear you.



Building Industry Consulting Service K
American Telephone and Telegraph Company
 Room 2238D, 195 Broadway
 New York, New York 10007

I am interested in the Building Industry Consulting Service.

- Please send me additional information.
- Please have a representative contact me.

Name _____

Title _____ Tel. _____

Company _____

Street _____

City _____ State _____ Zip _____

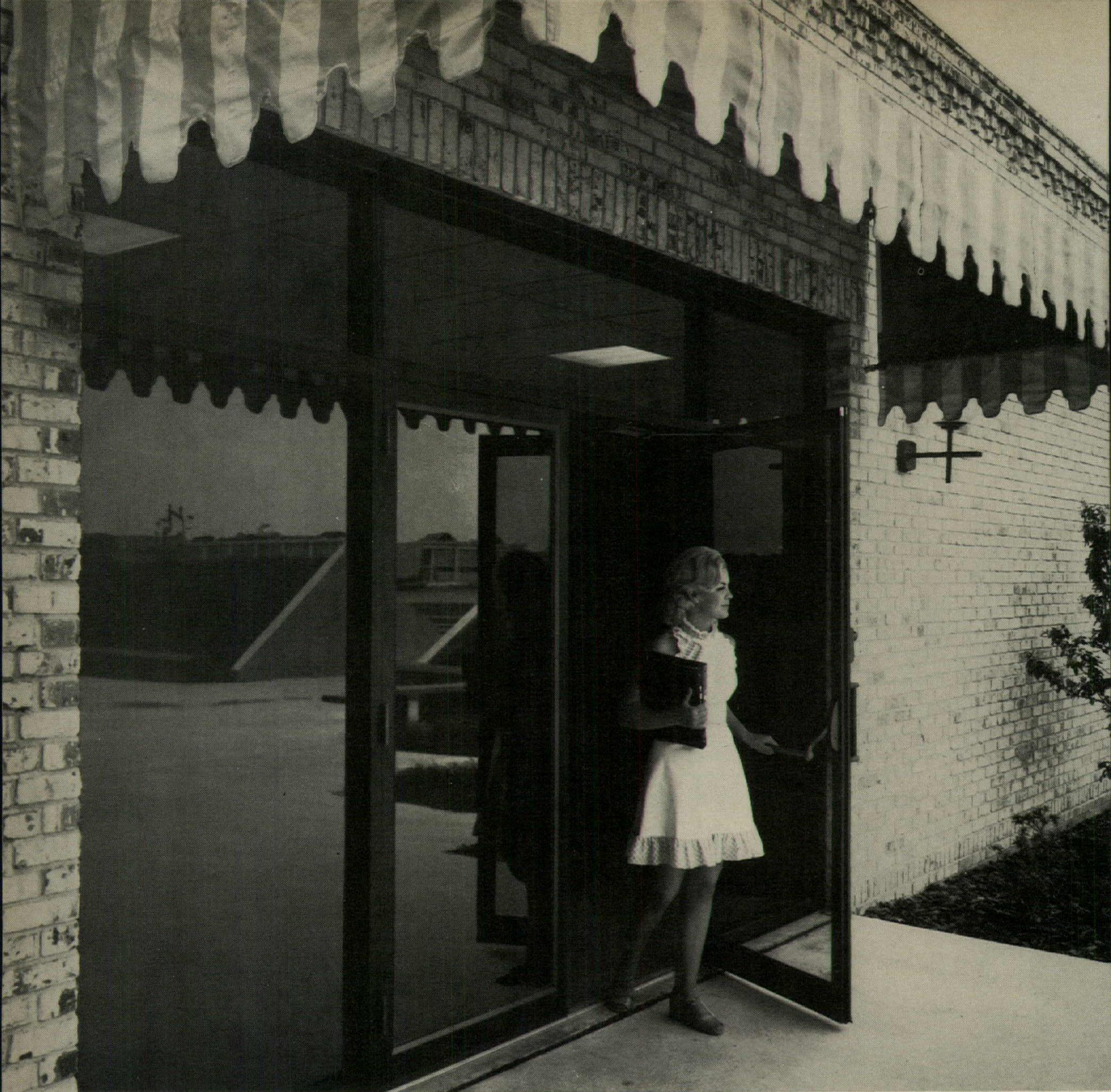

DOORWAY NOTES

HIGH FREQUENCY USAGE OF THESE EXTERIOR DOORS DEMANDS HEAVY DUTY FULL RACK AND PINION OPERATION. ADJUSTABLE HYDRAULIC BACKCHECK CUSHIONS OPENING SWING WITH TWO RANGE ADJUSTABLE CONTROL OF CLOSING. ALL THIS AND AN ADJUSTABLE RESERVE OF POWER WERE SPECIFIED IN THE 4020 SERIES SMOOTHIE® CLOSER. THE 4020 SMOOTHIE® SURFACE MOUNTED ON THE HEAD FRAME, HAS AN LCN PAINTED FINISH TO BLEND WITH DARK ANODIZED ALUMINUM DOOR AND FRAME MEMBERS. SEE SWEET'S (830/LC) OR WRITE FOR CATALOG I7C.

Louisiana State University, New Orleans
 Food Service Building
 Architect: Nolan, Norman & Nolan, New Orleans



LCN CLOSERS, Princeton, Illinois 61356

For more data, circle 37 on inquiry card

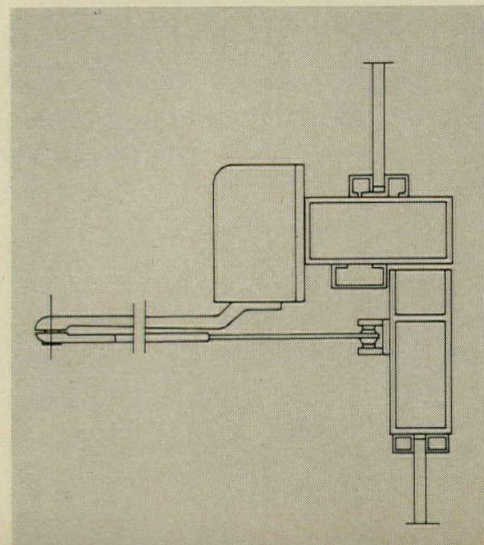

All of the reasons to use an Acoustiwal system aren't sound.



ACOUSTIWAL

Absorbing 85% of the sound is just one of many advantages.

The unique construction of an Acoustiwal screen disperses and absorbs 85% of the sound in an office. That goes a long way towards cutting down ear pollution, and providing a pleasant, work-inducing atmosphere.

But that's hardly the only reason to specify Acoustiwal.

Astonishing Flexibility

Acoustiwal's straight and curved screens, in many different heights and widths; its 360 degree rotating base legs; let you change offices and work areas in minutes. That goes for the simplest clerical stations to the most formal executive areas. Adding to that flexibility is our Dynatex flame resistant outer fabric, available in 16 colors, all of them coordinated to other

InterRoyal products. So you get maximum value and minimum maintenance from each square foot.

Two Kinds of Integrity

Last, but not least, there are a couple of things you can always rely on with Acoustiwal. First, its structural integrity; assured by its all-welded construction of square tubing. It resists the kind of warping you can get with wood framing. The second is InterRoyal's name. It doesn't go on anything, from an Acoustiwal screen to a hospital bed, that isn't the best of its kind.

So if you're about to make a change in your office, talk to InterRoyal. We'll show you how Acoustiwal will be easy on your eyes, your ears, and your budget.

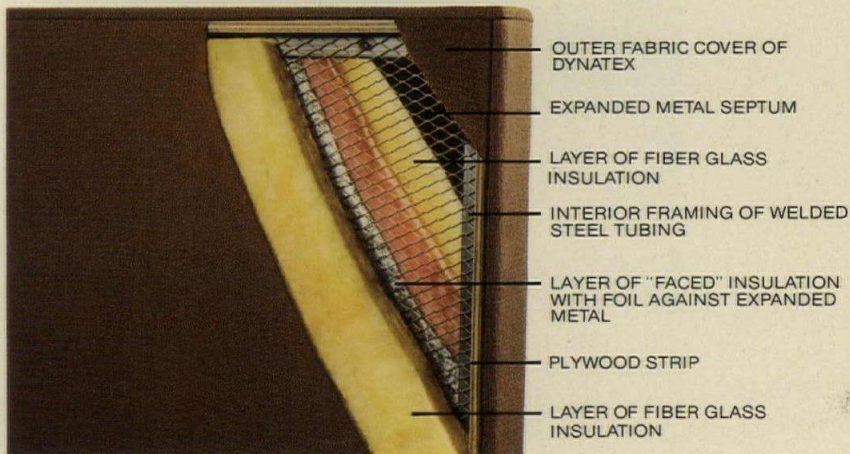

ACOUSTIWAL. A sound investment for efficient offices.



One Park Avenue, New York, N.Y. 10016

For more data, circle 38 on inquiry card

**PINE KNOB MUSIC THEATRE,
Independence Township, Michigan**
Jurors' Comment: "Here is a well designed structure that uses exposed structural steel to create a gay and light environment appropriate to the function of the theatre. It is straightforward, honest, and very nice."

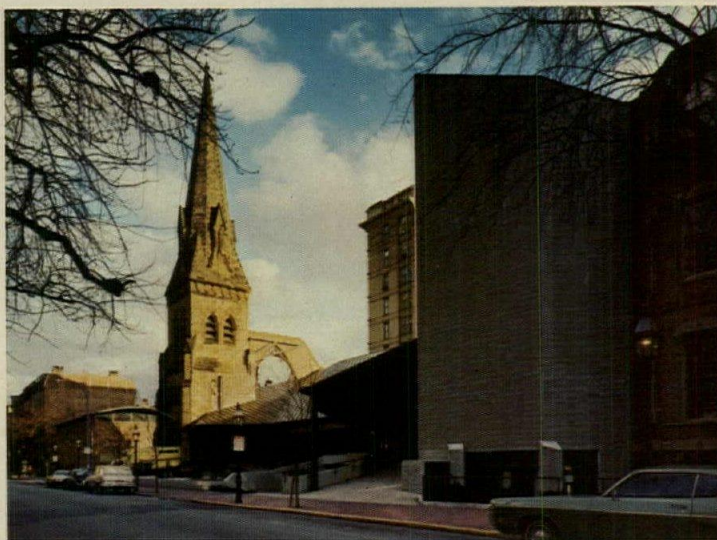
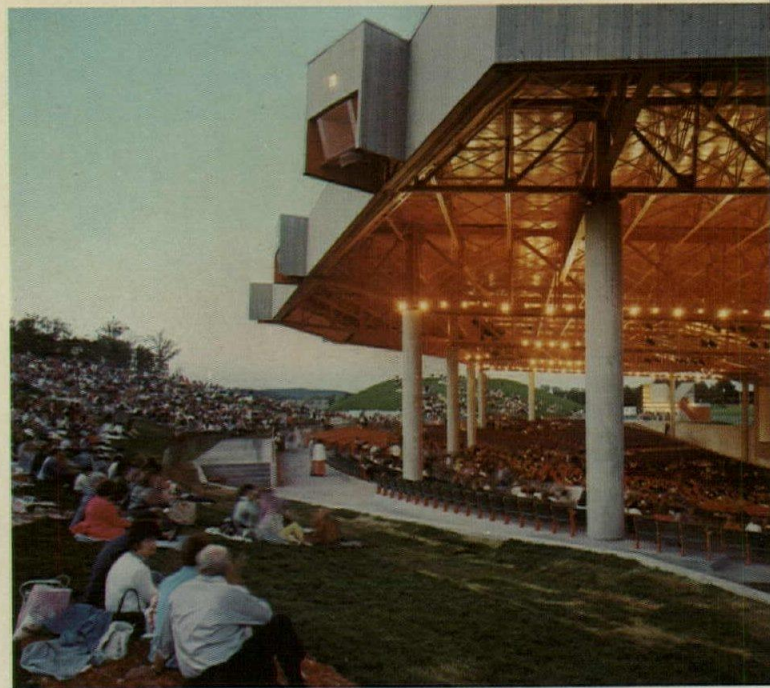

FIRST and SECOND CHURCH, Boston, Massachusetts
Jurors' Comment: "This addition of contemporary space to the remains of an old church very successfully weds the old and the new without compromising either the contemporary flavor of the new or the Victorian and eclectic flavor of the old. An important symbol has been restored and a functional area for community use has been added. The jury was impressed with the handling of steel as an essential material for constructing the new addition and relating it to the remaining parts of the old church."



FOURTH DISTRICT HEADQUARTERS, METROPOLITAN POLICE DEPARTMENT, Washington, D.C.
Jurors' Comment: "The jury regards this dignified design for a government agency as having considerable importance. It represents a trend toward simplicity and direction that should be recognized and encouraged."

ARCHITECTURAL AWARDS OF EXCELLENCE-1973

American Institute of Steel Construction

These buildings represent four of the twelve award-winning structures selected from 121 entries in the Fourteenth Annual Competition for steel-framed buildings sponsored by the AISC. As these examples demonstrate, steel-framed buildings can be designed to express almost any geometrical shape desired. Bethlehem furnished structural steel for the buildings illustrated.

NATIONAL JURY OF AWARDS Pietro Belluschi, FAIA, AIA 1972 Gold Medalist, Former Dean, School of Architecture & Planning Massachusetts Institute of Technology, Boston, Massachusetts

William W. Caudill, FAIA
Caudill Rowlett Scott
Houston, Texas

Victor O. Gray, M. ASCE
Vice President, Consulting Engineering Council
Victor O. Gray & Company
Seattle, Washington

Ambrose M. Richardson, FAIA
Chairman, Department of Architecture
University of Notre Dame
Notre Dame, Indiana

Archibald C. Rogers, FAIA
President AIA
Chairman, RTKL Inc.
Baltimore, Maryland



OXFORD VALLEY MALL, Bucks County, Pennsylvania
Jurors' Comment: "Here is a fine example of the internal common space which is restoring a very important sense of community to the urban areas of our cities. Steel is a most important material for creating the crystal palace effect that envelops these malls."



CREDITS:

Pine Knob Music Theatre *Owner:* Indusco Corporation, Clarkston, Michigan; *Architect:* Rossen/Neumann Associates, Southfield, Michigan; *Structural Engineer:* McClurg & Associates, Inc., Bloomfield, Michigan; *General Contractor:* Indusco Corporation, Clarkston, Michigan; *Steel Fabricator and Erector:* Structural Steel, Inc., Mt. Clemens, Michigan.

Fourth District Headquarters, Metropolitan Police Department *Owner:* Government of the District of Columbia, Department of General Services, Washington, D.C.; *Architect:* McLaughan & Johnson, Washington, D.C.; *Structural Engineer:* The A. B. Engineering Company, Bethesda, Maryland; *General Contractor:* Lormack Corporation, Upper Marlboro, Maryland; *Steel Fabricator:* Dietrich Brothers, Inc., Baltimore, Maryland; *Steel Erector:* Janco Enterprises, Inc., Clinton, Maryland.

First and Second Church *Owner:* First and Second Church, Boston, Massachusetts; *Architect:* Paul Rudolph, New York, N.Y.; *Structural Engineer:* Nichols, Norton and Zaldastani, Inc., Boston, Massachusetts; *General Contractor:* George B. H. Macomber Company, Boston, Massachusetts; *Steel Fabricator and Erector:* A. O. Wilson Structural Co., Inc., Cambridge, Massachusetts.

Oxford Valley Mall *Owner:* Kravco, Inc., King of Prussia, Pennsylvania; *Architect:* Cope Linder Walmsley, Philadelphia, Pennsylvania; *Structural Engineer:* Meridian Engineering Inc., Philadelphia, Pennsylvania; *General Contractor:* McCloskey & Co. Inc., Philadelphia, Pennsylvania; *Steel Fabricators:* Unistrut Corporation, Philadelphia, Pennsylvania; Delco Steel Fabricators, Inc., Cornwells Heights, Pennsylvania; *Steel Erector:* Thomas Lindstrom & Co., Cinnaminson, New Jersey.

Bethlehem 

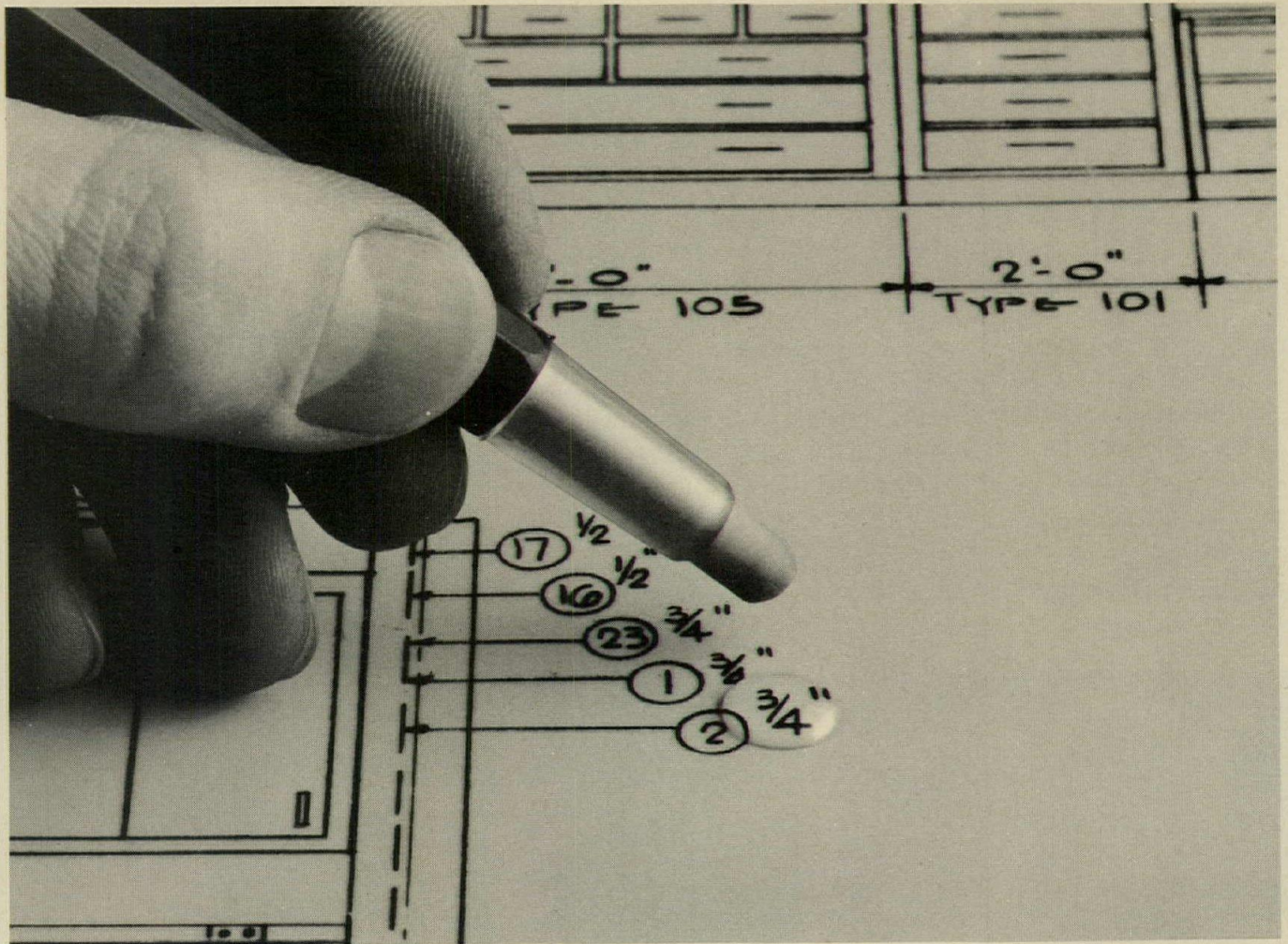

Get the drop on redrawing drudgery.

Shortcuts with Kodagraph materials can turn drafting hours into minutes.

Nobody likes to retrace a whole drawing just because a few revisions are necessary. You don't have to if you make a second original on Kodagraph wash-off film. Simply wet-erase what you don't want—using plain water and a soft eraser—draw in the new details and the job is done.

If on the other hand, you're faced with repetitive details, draw them once. And then order as many Kodagraph film or paper reproductions as you need. Cut them out,

tape down on drawing form, rephotograph and you have a new original.

When you need to restore a battered, old drawing, have a reproduction made on Kodagraph film. Stains virtually disappear. Weak lines come back strong. And you end up with a crisp, legible black-on-white print.

Get the details.

Write for information on how you can reduce drafting time with photoreproduction techniques. Eastman Kodak Company, Business Systems Markets Division, Dept. DP768, Rochester, N.Y. 14650

Kodak products for drawing reproduction.



For more data, circle 39 on inquiry card



Lock-Deck[®] has a special feeling for townhouses.

More and more townhouse projects are capitalizing on the economy and sales appeal of laminated wood decking.

Developers find that Lock-Deck decking imparts a look of quality—a look that means quicker sales and higher profits per unit.

Contractors endorse the use of Lock-Deck in townhouses because it works quickly and easily, with minimum waste.

And designers know that laminated wood decking lets them achieve distinctive effects with real economy. Lock-Deck from Potlatch is wood ideally suited for townhouse roof and floor decking. It provides the natural warmth of wood while economically forming integral ceilings and floors for townhouses.

The strength and beauty of Lock-Deck is achieved by laminating three or more kiln-dried boards under heat and pressure, to make wood stronger than nature could.

Lock-Deck is available in smooth-surfaced, saw-textured or wire-brushed textures, providing maximum design opportunities. Lock-Deck applications reduce construction time and costs, while producing a more attractive, faster-selling townhouse.

Write for more information today.

We know our way in the woods.

Potlatch

Potlatch Corporation
Wood Products, Western Division
P.O. Box 5414
Spokane, Washington 99205
(509) 326-3653

For more data, circle 40 on inquiry card

SHOPPING CENTER, SCHOOL, FACTORY, ROOF DECK CONSIDERATIONS: *

cost and durability

2-hour UL fire ratings

fast all-weather installation

OSHA noise control standards

resistance to seismic shock
and hurricane-force winds

thermal insulation

low insurance rates

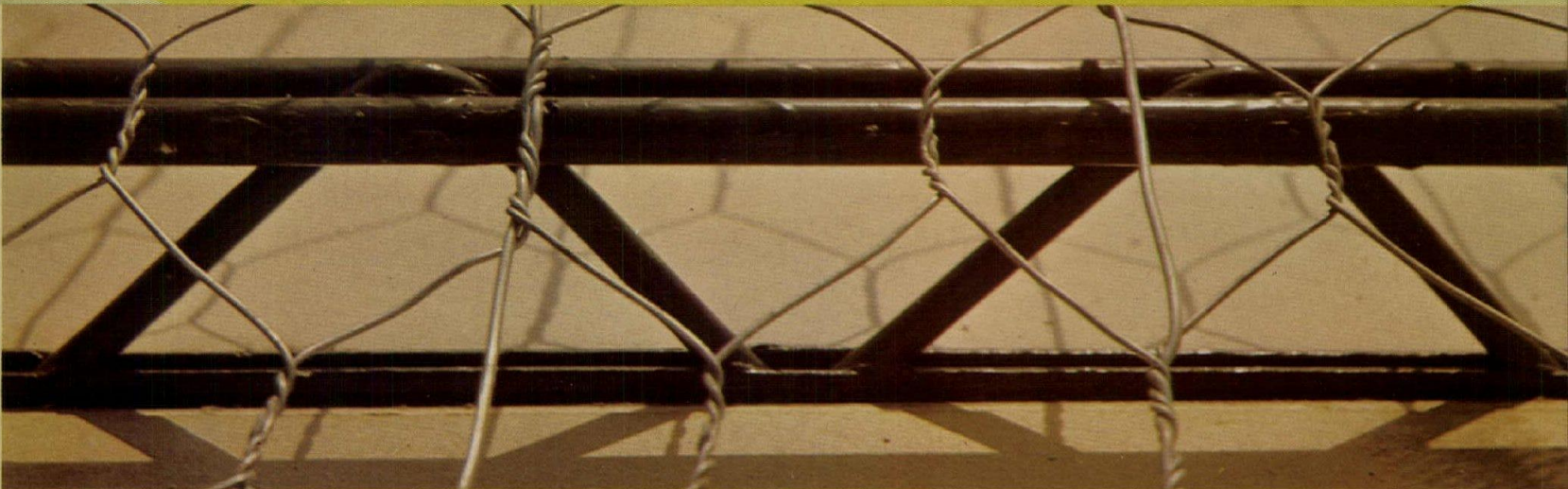

(actual size, KEYDECK subpurlin style 000-3-14-2-1/2)

* KEYDECK subpurlins have an open-web truss design that permits complete embedment of chord and truss members into poured decks. The materials unite into a monolithic slab and work compositely. This results in greater load carrying capacity and minimizes deflection with less weight of steel.

KEYDECK reinforcing distributes temperature and stress strains over large areas quickly, adding strength and reducing cracks.

Your choice of form boards and poured deck materials in combination with KEYDECK subpurlins and reinforcing will provide the desired fire ratings, insulation and acoustical values.

For detailed specification and design information, refer to our catalog in Sweet's Architectural File, Sec. 3.4, write or call Construction Products Division, (309) 697-0200. Keystone Steel & Wire, Peoria, Illinois 61607 Division of Keystone Consolidated Industries, Inc.

KEYSTONE STEEL AND WIRE FOR CONSTRUCTION
STUCCO, CONCRETE, MASONRY, ROOF AND FLOOR REINFORCING, TRUSS AND BULB TEE SUBPURLINS

For more data, circle 41 on inquiry card

CONSTRUCTION MANAGEMENT
BUILDING COSTS
BUILDING ACTIVITY

Business plans record spending for plants and equipment

"Business is looking ahead to a spectacular investment year, with spending plans for new facilities now reaching \$119.1 billion. The \$19.4 billion rise in U.S. business' plans for 1974 is larger than any previous rise and represents an increase of more than 19.4 per cent over 1973. This is the highest percentage gain planned since our 1956 spring survey when business investment was expected to climb 30 per cent." So says Douglas Greenwald, chief economist, reporting on the 27th Annual Survey of Business' Plans for New Plants and Equipment, made by the McGraw-Hill Publications Company's Department of Economics.

"Much has happened to 1974 investment plans since our fall survey, taken in October, indicated a 14 per cent increase in capital spending. Our recheck, taken in mid January-February, showed plans for 1974 capital spending were up more than 18 per cent. And this survey, taken in March and early April, indicates a solid 19 per cent rise in 1974 business investment plans. Our survey reflects a continuation of rising appropriations, new orders for capital goods, new contracts for industrial and commercial construction, as well as significantly higher capital goods prices.

"Our survey is not a forecast, but a report of what companies are planning now. Plans may be changed in light of future developments. Amounts actually spent will be affected by the pace of inflation, the trend of interest rates, and by the ability of capital goods suppliers to meet anticipated delivery schedules.

"Current capital spending plans for 1974 are so large as to suggest some difficulty in getting the labor, materials and capacity needed to carry out these plans. But whatever is postponed until 1975 will add to the total in that year and help business prospects for next year."

Thus, American business' 1974 investment program is giving a shot in the arm to the economy. This year's planned investment, if it is carried out, will account for nearly 8.5 per cent of an estimated \$1,405 billion Gross National Product. It will be the first time in nearly two decades that capital spending will account for 8.5 per cent of the GNP.

The spending pattern emerging from the survey suggests strong gains right across the industrial board. Twenty-five of the 26 major industries for which we report capital spending data now plan increases for this year. Manufacturers expect a healthy rise in their capital spending this year, more than two and a half

times the expected rise in the nonmanufacturing sector. Plans of manufacturers are now up 32 per cent, on the average, compared with an actual increase of 21 per cent last year. Non-manufacturers' plans are up 12 per cent compared with an 8 per cent increase in 1973.

Durables versus nondurables

Durable goods producers, as a group, plan a 29 per cent increase in 1974 capital spending. The leading durable goods industry gainer, in percentage terms, is nonferrous metals, which now expects to raise its spending 71 per cent this year to \$2.86 billion. The nonelectrical machinery industry plans a 41 per cent hike in its 1974 capital investment to \$4.83 billion. The transportation equipment industry, excluding automobiles and aerospace, and the steel industry both look for 35 per cent growth in expenditures this year. The automobile industry, hard hit by the tremendous drop-off in demand for large cars due to the gasoline shortage, expects to increase its 1974 capital investment by only 12 per cent over last year. And the catch-all "other" durables group—consisting of furniture, lumber and miscellaneous durables—looks for the smallest percentage rise (7 per cent) in 1974 spending.

Nondurable industries, as a whole, plan to spend 35% more than last year. Within this group, petroleum, the leading capital investor among manufacturing industries, expects a 52% rise, the biggest percentage gain, to \$8.28 billion. 1974 plans of the paper industry are up 49%. The chemical industry expects to boost its capital spending 36%, up to \$6.07 billion this year. At the other extreme, the rubber industry plans to increase its capital spending this year by only 14%. And the catch-all "other" nondurables group—consisting of apparel, leather products, tobacco and printing and publishing—plans the smallest percentage rise (4%) among manufacturing industries.

In the nonmanufacturing area, seven of the eight major industries plan to increase their investment this year. The mining industry, up 41% from 1973, expects to spend \$3.85 billion. Railroads, stimulated by the energy crisis, will spend \$2.53 billion, 29% above last year. Gas utilities plan a 26% increase in capital expenditures in 1974. The smallest increase, 5%, is now scheduled by commercial business.

The need for new capacity

Manufacturers' needs for new and efficient capacity weigh heavily in the final results of the survey. Manufacturers as a whole, plan to de-

vote 53% of their capital spending to expansion and the remaining 47% to replacement and modernization, which includes pollution control and safety and health. Last year, expansion's share was 50%. For the three years ahead a whopping 56% of the investment dollar will be allotted to expansionary purposes.

The modernization versus expansion pattern varies among individual industries. With the exception of steel (30%), textiles (31%), other nondurables (32%), paper (33%), "other" transportation equipment (37%) and aerospace (38%), no industry expects to devote less than 43% of its 1974 investment to expansion this year.

PLANS FOR CAPITAL SPENDING
(Billions of Dollars)

INDUSTRY	1973		1973-4		% of 1974 for Build-ings	Prelim. 1975
	Actual*	Planned	% Change	%		
Iron & Steel	\$ 1.76	\$ 2.38	35%	9%	\$ 2.81	
Nonferrous Metals	1.67	2.86	71	14	3.32	
Electrical Machinery	2.84	3.29	16	15	3.36	
Machinery	3.42	4.83	41	25	4.75	
Autos, Trucks & Parts	2.28	2.55	12	21	2.04	
Aerospace	.53	.70	32	15	.72	
Other Transport. Equip.	.31	.42	35	22	.30	
Fabricated Metals & Instruments	2.94	3.73	27	50	3.72	
Stone, Clay & Glass	1.49	1.96	32	23	2.03	
Other Durables	2.01	2.16	7	25	2.09	
TOTAL DURABLES	19.25	24.88	29	20	25.14	
Chemicals	4.46	6.07	36	15	6.74	
Paper & Pulp	1.86	2.77	49	16	2.85	
Rubber	1.56	1.78	14	22	1.67	
Petroleum	5.45	8.28	52	8	9.36	
Food & Beverages	3.11	3.93	26	21	3.87	
Textiles	.77	.89	16	14	.84	
Other Nondurables	1.55	1.61	4	21	1.32	
TOTAL NON-DURABLES	18.76	25.33	35	15	26.65	
ALL MANUFACTURING	38.01	50.21	32	17	51.79	
Mining	2.74	3.85	41	5	4.15	
Railroads	1.96	2.53	29	22	3.09	
Airlines	2.41	2.27	-6	8	1.77	
Other Transportation	1.66	1.79	8	13	1.86	
Communications	12.85	13.88	8	10	14.85	
Electric Utilities	15.95	18.66	17	8	21.27	
Gas Utilities	2.76	3.48	26	19	3.62	
Commercial (1)	21.40	22.47	5	45	22.02	
ALL NONMANUFACTURING	61.73	68.93	12		72.63	
ALL BUSINESS	99.74	119.14	19	20	124.42	

* Source: U.S. Department of Commerce; Securities and Exchange Commission.

(1) Figures based on large chain, mail order and department stores, insurance companies, banks and other commercial business.

The Tudor Regency desk caused a stir when introduced 400 years ago. The full-to-the-floor pedestals were a totally new concept in writing tables.

Tudor Regency styling is making heads turn again—in All-Steel's new 1500 Series cube.

We haven't changed the style. It's classic. We've just adopted a good idea to complement today's contemporary office environment.



Floor length pedestals mean more storage. Up to 30% more. And the clean, crisp lines go uncluttered with built-in raceways designed to conceal communication and electrical wiring.

Specify the 1500 Series from All-Steel. Selection of desk models, tables, L-units and credenzas.

For more information write, All-Steel Inc., Aurora, Illinois 60507.

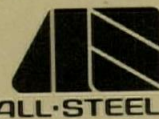

For more data, circle 42 on inquiry card

A classic design for today's office environment.



ALL-STEEL

Showrooms in New York, Los Angeles, Chicago, Aurora. In Canada, All-Steel Canada, Ltd., Montreal, Toronto. One of the **CIT** Companies.

Dodge issues new cost control guide for preliminary design analysis

A new Dodge annual called *Dodge Construction Systems Costs* will provide a ready guide to the cost consequences of early design decisions about building materials, systems and assemblies. It is based on detailed analysis of material and labor costs in all the component systems in a wide variety of building types. It makes use of an immense bank of actual case-history data (a Dodge resource for many years) now computerized and analyzed for this specific application. Joseph A. D'Amelio, vice president for development of the Sweet's Division, McGraw-Hill Information Systems Company, describes the rationale and format of the new manual, scheduled for publication this fall, in the following article.

In the early stages of a project—during the programming, schematic and preliminary stages—crucial design decisions are made that dictate the economics of the project. The cost saving potential is greatest during these early stages, so there has been a growing need, in these times of rising costs and fixed budgets, for easy-to-use guides to help the architect understand and make rapid cost analyses of his alternatives during design development.

Parts of some publications provide costs per square foot for different building types, and several books annually provide unit costs and labor costs for the detailed materials and equipment that go into a structure. But these are cumbersome at best when an architect is trying to understand quickly the cost implications of different structural systems and bay sizes, or when he is comparing various exterior walls, partitions or roofing methods.

Value engineering of construction assemblies

The well-known term "value engineering," is valid here. We are talking about the ability to look at each functional part of a building and study the alternative solutions. Available alternatives vary because of material composition and construction methods or different configurations. The quality and performance factors of components such as partitions, exterior walls and structural systems are generally known to the architect, or reference information is available. What has been lacking is easy-to-use and up-to-date printed data on the cost of alternative solutions.

Market research conducted by the Dodge Building Cost Services Division of McGraw-Hill Information Systems Company revealed this need and major informational void. This need forms the basis of a new annual cost/de-

sign-analysis guide, the first edition of which will be available from Dodge this Fall.

Functional parts of a building

In the preliminary stages of a project, the architect and engineer both think and design in terms of the functional parts that enclose, shape and support the building. Therefore, cost analysis of the total building, or of individual parts, is best done in terms of those parts. To provide a consistent method of data compilation and comparison, cost factors of the entire building are divided into the 17 categories listed in the tabulation of average systems costs and in the print-out illustrations.

Cost of systems and assemblies

One help in preliminary estimating is to have cost information on different building types organized in this manner. From this the architect could learn the average cost impact of each part of the particular building type he is developing and compare this to the equivalent part of his project. The table of average building systems costs is a sample of the format (not necessarily real cost figures) of this new guide which will similarly cover several different building types. There will also be tabulations of actual cost histories upon which these averages are based.

Cost analysis of systems and assemblies

Of all the assemblies and systems listed in the

table, the architect primarily designs and selects solutions to certain parts. These include: superstructure (structural frame, floor and roof construction), floors on grade, exterior walls, roofing, partitions, wall finishes, floor finishes and ceiling finishes.

Therefore, the most useful information is the cost of all important alternates in each of the assembly/system categories. When considering partitions, for example, the architect might be interested in quickly comparing costs of certain drywall partitions with certain plaster or block partitions. If he is initially considering a metal curtain wall, but heat load factors dictate less fenestration and more insulating materials, then he would be interested in comparing different masonry exterior walls. Data on costs per square foot of different exterior walls, each with different amounts of glass, would expedite such an analysis.

The new cost guide will provide this kind of data on the categories listed in the illustrated "Table of Contents." Each category will include all the common as well as some uncommon solutions. As an example, under drywall partitions there will be some 18 methods or assemblies.

The illustrated sample page shows how drywall partitions will be presented.

Building up cost estimates for your project

The figures show costs as dollars per square foot of the actual assembly or element. Of fur-

AVERAGE BUILDING SYSTEMS COSTS
PER GROSS SQUARE FOOT

BUILDING TYPE: OFFICE (PRIVATE)-HIGH RISE

BUILDING SYSTEM	LOW AVERAGE		AVERAGE		HIGH AVERAGE	
	\$/SF	% TOT	\$/SF	% TOT	\$/SF	% TOT
SITE IMPROVEMENT	\$ 1.50	6%	\$ 2.50	7%	\$ 3.50	7%
FOUNDATIONS	.50	2	1.50	4	2.50	5
FLOORS ON GRADE	.20	1	.30	1	.40	1
SUPERSTRUCTURE	4.60	18	5.90	16	6.70	14
ROOFING	.30	1	.50	1	.80	2
EXTERIOR WALLS	3.50	14	4.60	12	5.60	12
PARTITIONS	2.50	10	3.30	9	3.80	8
WALL FINISHES	.50	2	.70	2	.90	2
FLOOR FINISHES	.40	2	.60	2	.75	2
CEILING FINISHES	.60	2	.75	2	.85	2
CONVEYING SYSTEMS	1.50	6	2.50	7	4.00	8
SPECIALTIES	.30	1	.60	2	.80	2
FIXED EQUIPMENT	.30	1	.50	1	.80	2
HVAC	4.20	17	5.80	16	7.50	16
PLUMBING	.80	3	1.20	3	1.70	4
ELECTRICAL	2.50	10	4.00	11	5.25	11
GENERAL CONDITIONS	1.20	5	1.75	5	2.25	5
CONSTRUCTION TOTAL	\$25.40	100%	\$37.00	100%	\$48.10	100%

NEW! One thousand and one vinyl wallcoverings!

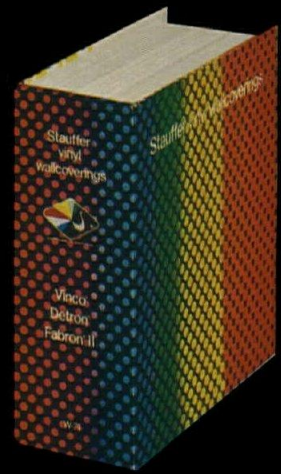

QUO VADIS



SEQUANA II



ASTEROID



SCULPTA



STONE



GLACIER

Never has there been such choice in a commercial collection! Striking new designs, vibrant colors in every imaginable hue... all bound into the largest manufacturer's pattern book available anywhere.

Best of all, this vast new collection is brought to you by Stauffer,

S SEE OUR CATALOG IN SWEET'S

producer of premier quality vinyl wallcoverings for the finest commercial and institutional interiors. Every wallcovering conforms to Federal Specification CCC-W-408A. All materials are "fire hazard classified."

See the big, new Stauffer line soon.

For more information write to Stauffer Chemical Company, Plastics Division, Dept. W.C., Westport, CT 06880.



For more data, circle 43 on inquiry card

ther use would be cost data on an assembly—e.g. a drywall partition—in terms of dollars per gross square foot of the total area of particular building types. This would say that in typical classroom buildings using drywall partitions their cost would be \$1.09 per gross square foot of the building. Naturally, this would have to be qualified as to whether stairs, corridors and other features are enclosed by such partitions. Such data would allow the architect to plug his assembly and system costs into the comprehensive average costs of each building type. This process would provide guideline costs for all the other parts of the building, e.g., HVAC, plumbing and electrical and many comparisons and cost/value analyses are possible. Therefore, these data on different systems and assemblies—stated in terms of dollars per gross square foot of the total building—allow the architect to build a complete cost profile of his particular project. Also trade-off considerations are facilitated because the cost savings or increases between alternates of different building parts are easily understood and manipulated.

Structural systems costs depend upon materials and bay sizes

When considering different structural solutions, the designer generally deals with two variables: 1) the construction method (i.e. steel or concrete) and 2) the size of structural bays. Decisions could be vastly facilitated if up-to-date cost data on alternate solutions at different bay sizes were readily available. Here the cost is best expressed as dollars per gross square foot of the total building. Here again alternative structural solutions can be plugged into the average cost for the given building type. Thus, the project's customized cost profile and numerous quick cost analyses are possible. This new publication will provide cost data on all the standard structural systems and floor construction methods. Also, instruction will be provided to facilitate comparisons and expedite the design process.

Planning guidelines for each building type will include gross/net ratios

Besides the above data, the new manual will provide guidelines for efficient planning of useable space. Data for each building type will indicate the average gross area to net area ratios for that type. In certain building types, data will include gross area per unit of functional use, such as hospital beds, school classrooms and parking garage space per car.

This new service has been developed by the Dodge Building Cost Services and Sweet's Division of McGraw-Hill Information Systems Company with the assistance of Wood and Tower, Inc., of Princeton, New Jersey. Cost information will be collected and developed by these sources and all data are being updated and processed through Wood and Tower, Inc., of Princeton, New Jersey. Cost information will be collected and developed by these sources and all data are being updated and processed through the firm's computer facilities.

TABLE OF CONTENTS

EXTERIOR WALLS	CEILINGS
Wood	Gypsum Board
Stucco	Lath & Plaster
Masonry	Acoustical
Concrete	Metal
Precast	Applied Finishes
Metal	
Curtain	
Windows	
Doors	
PARTITIONS	ROOFING
Drywall	Wood Shingle
Lath & Plaster	Asphalt Shingle
Masonry	Composition Shingle
Plaster on Masonry	Concrete Tile
Gypsum Block	Tile Shingle
Structural Glazed Tile	Slate
Concrete	Metal Pitched
Windows	Built-Up
Doors	
INTERIOR WALL FINISHES	FLOORS ON GRADE
Drywall-Plaster	Concrete
Wood	
Plywood	
Thin Covering	
Tile	
Masonry Veneer	
FLOOR FINISHES	SUPERSTRUCTURE
Resilient	Vertical Members
Tile	Framing Members
Wood	Decking
Masonry	
Terrazzo	
Carpet	
Special	
Concrete Topping	

PARTITIONS
DRYWALL

	LABOR	MATERIAL	TOTAL
121101			
WOOD STUD & 1/2" GYPSUM BOARD			
1/2" GYPSUM BOARD	0.12	0.11	0.23
2"x4" WOOD STUDS 16" OC	0.11	0.15	0.26
1/2" GYPSUM BOARD	0.12	0.11	0.23
TAPING & SPACKLING	0.14	0.03	0.17
TOTAL PER SQ FT	0.49	0.40	0.89
121102			
STEEL STUD & 1/2" GYPSUM BOARD			
1/2" GYPSUM BOARD	0.12	0.11	0.23
3" STEEL STUDS 16" OC	0.19	0.20	0.39
1/2" GYPSUM BOARD	0.12	0.11	0.23
TAPING & SPACKLING	0.14	0.03	0.17
TOTAL PER SQ FT	0.57	0.45	1.02
121103			
STEEL STUD & 1/2" GYPSUM BOARD INSULATED			
1/2" GYPSUM BOARD	0.12	0.11	0.23
3" STEEL STUDS 16" OC	0.19	0.20	0.39
2 1/2" BATT INSULATION	0.09	0.05	0.14
1/2" GYPSUM BOARD	0.12	0.11	0.23
TAPING & SPACKLING	0.14	0.03	0.17
TOTAL PER SQ FT	0.66	0.50	1.16
121104			
STEEL STUD & 1/2" LAMINATED GYPSUM BOARD			
TWO-1/2" GYPSUM BOARD	0.24	0.22	0.46
3" STEEL STUDS 16" OC	0.19	0.20	0.39
TWO-1/2" GYPSUM BOARD	0.24	0.22	0.46
ADHESIVE	0.12	0.06	0.18
TAPING & SPACKLING	0.14	0.03	0.17
TOTAL PER SQ FT	0.93	0.73	1.66

PlanScape® Screens

choice of people who care!



PlanScape Installation at Ethan Allen, Inc., Danbury, Conn.

You believe that anything worth doing is worth doing right, and that the time you spend being selective is time well spent. You don't want something that's second best; you appreciate real quality and won't settle for less. You're the kind of person we had in mind when we designed our system of acoustical office screens. We think you'll like what you see when you take a close look at our PlanScape Screens. Please write for our full color brochure.

VOGEL · PETERSON CO.

DEPT. 515, ELMHURST, ILLINOIS 60126 • Telephone: 312/279-7123

THE MERCHANDISE MART, SPACE 1689, CHICAGO

NEW YORK SHOWROOM, 205 LEXINGTON AVENUE

For more data, circle 44 on inquiry card

Renovation of urban buildings surges

The recent gasoline crisis, spiraling construction costs, and soaring tax rates in the suburbs have combined to reverse the outward flow of families from the urban areas of this country. In many of the older cities, homes with distinctive architectural features are attracting renewed interest on the part of buyers. Municipal authorities, aware of this resurgence, are actively encouraging the rehabilitation of existing structures to conform to the architectural design of a certain era. Federal low-interest funds are generally available to home owners for the expressed purpose of rehabilitating their homes to conform to criteria set by local architectural review committees.

Rehabilitation of these structures usually involves the preservation of the exterior walls and the complete rebuilding of the interiors. New plumbing, heating, floors, walls, electrical service and ceilings may have to be installed. The exteriors are either painted or sandblasted. To coincide with the property owners' investment, the municipality will often add sidewalks and lighting to conform with the architectural designs.

Rehabilitation costs vary somewhat due to the quality of materials used, availability of working space and geographical location. The following, however, are costs based on a national average:

Residential: \$20 to \$26 per sq ft

Commercial/industrial: \$15-\$19 per sq ft

*John H. Farley, senior editor
Dodge Building Cost Service*

INDEXES: May 1974		Current Indexes				% change last 12 months
Metropolitan area	Cost differential	non-res.	residential	masonry	steel	
U.S. Average	8.3	457.7	429.8	448.2	437.5	+11.37
Atlanta	7.5	563.4	531.2	551.3	539.3	+ 7.50
Baltimore	8.6	526.6	495.1	513.8	500.2	+16.82
Birmingham	7.1	412.2	383.4	397.7	393.3	+ 9.10
Boston	8.9	462.5	437.0	458.7	445.6	+ 9.90
Buffalo	9.0	506.6	475.7	498.6	483.8	+10.00
Chicago	8.3	523.0	497.2	504.7	498.0	+10.49
Cincinnati	8.6	492.3	463.2	478.1	467.4	+12.54
Cleveland	9.0	498.7	469.2	488.4	475.9	+12.24
Columbus, Ohio	8.1	476.1	447.1	465.4	455.0	+10.37
Dallas	7.7	459.2	444.7	447.8	439.6	+11.36
Denver	7.9	482.8	454.2	473.6	460.4	+10.82
Detroit	9.7	525.7	501.8	534.1	512.8	+12.08
Houston	7.1	417.4	391.9	404.7	398.7	+ 9.16
Indianapolis	7.6	411.5	386.4	401.6	393.5	+ 9.57
Kansas City	8.3	442.7	418.3	433.4	421.9	+12.32
Los Angeles	8.4	527.1	481.9	511.7	501.0	+13.43
Louisville	7.6	457.9	429.9	446.0	437.3	+12.30
Memphis	8.1	463.7	436.0	447.0	439.7	+20.97
Miami	7.8	474.7	452.2	461.1	451.8	+11.57
Milwaukee	8.2	510.3	479.7	500.7	486.5	+11.89
Minneapolis	8.5	476.3	448.2	467.0	457.4	+ 9.06
Newark	8.5	436.6	409.1	427.3	419.1	+ 7.62
New Orleans	7.4	444.6	419.7	437.7	428.4	+14.46
New York	10.0	510.3	474.5	497.9	486.0	+ 9.66
Philadelphia	8.9	502.6	478.9	497.5	484.0	+ 7.91
Phoenix (1947 = 100)	7.9	264.7	248.6	255.6	251.3	+11.36
Pittsburgh	8.7	450.0	423.4	444.3	431.1	+ 9.18
St. Louis	8.4	466.1	440.0	458.9	449.3	+ 7.21
San Antonio (1960 = 100)	7.4	174.8	164.2	169.8	165.9	+15.80
San Diego (1960 = 100)	8.4	193.2	181.5	189.1	185.3	+16.67
San Francisco	9.2	663.0	606.0	657.0	636.0	+ 6.70
Seattle	8.5	450.6	403.3	444.2	428.1	+12.69
Washington, D.C.	7.9	437.2	410.6	425.7	415.4	+12.30

1941=100.00 (except as noted)

Cost differentials compare current local costs, not indexes.

Tables compiled by Dodge Building Cost Services, McGraw-Hill Information Systems Company

HISTORICAL BUILDING COST INDEXES—AVERAGE OF ALL NON-RESIDENTIAL BUILDING TYPES, 21 CITIES

1941 average for each city = 100.00

Metropolitan area	1964	1965	1966	1967	1968	1969	1970	1971	1972	1973 (Quarterly)				1974 (Quarterly)			
										1st	2nd	3rd	4th	1st	2nd	3rd	4th
Atlanta	313.7	321.5	329.8	335.7	353.1	384.0	422.4	459.2	497.7	516.4	518.0	543.8	544.8	555.2			
Baltimore	280.6	285.7	280.9	295.8	308.7	322.8	348.8	381.7	420.4	441.8	443.6	474.5	475.5	516.3			
Birmingham	260.9	265.9	270.7	274.7	284.3	303.4	309.3	331.6	358.3	371.7	373.2	401.1	402.1	405.5			
Boston	252.1	257.8	262.0	265.7	277.1	295.0	328.6	362.0	394.4	414.0	415.6	436.8	437.8	455.1			
Chicago	306.6	311.7	320.4	328.4	339.5	356.1	386.1	418.8	444.3	465.3	466.9	507.6	508.6	514.2			
Cincinnati	269.5	274.0	278.3	288.2	302.6	325.8	348.5	386.1	410.7	430.4	432.0	461.4	462.4	484.5			
Cleveland	283.0	292.3	300.7	303.7	331.5	358.3	380.1	415.6	429.3	436.7	438.3	461.2	462.2	490.3			
Dallas	256.4	260.8	266.9	270.4	281.7	308.6	327.1	357.9	386.6	407.3	408.9	435.4	436.4	453.7			
Denver	287.3	294.0	297.5	305.1	312.5	339.0	368.1	392.9	415.4	429.5	431.1	460.0	461.0	476.1			
Detroit	277.7	284.7	296.9	301.2	316.4	352.9	377.4	409.7	433.1	463.4	465.0	500.0	501.0	519.5			
Kansas City	250.5	256.4	261.0	264.3	278.0	295.5	315.3	344.7	367.0	387.7	389.3	404.8	405.8	435.6			
Los Angeles	288.2	297.1	302.7	310.1	320.1	344.1	361.9	400.9	424.5	453.3	454.9	503.2	504.2	514.3			
Miami	274.4	277.5	284.0	286.1	305.3	392.3	353.2	384.7	406.4	419.0	420.6	446.2	447.2	467.6			
Minneapolis	282.4	285.0	289.4	300.2	309.4	331.2	361.1	417.1	412.9	430.6	432.2	455.1	456.1	469.7			
New Orleans	240.9	256.3	259.8	267.6	274.2	297.5	318.9	341.8	369.7	382.1	383.7	419.5	420.5	437.5			
New York	289.4	297.1	304.0	313.6	321.4	344.5	366.0	395.6	423.1	453.5	455.1	484.3	485.3	497.4			
Philadelphia	275.2	280.8	286.6	293.7	301.7	321.0	346.5	374.9	419.5	459.3	460.9	484.1	485.1	495.7			
Pittsburgh	263.8	267.0	271.1	275.0	293.8	311.0	327.2	362.1	380.3	406.3	407.9	423.4	424.4	443.7			
St. Louis	272.1	280.9	288.3	293.2	304.4	324.7	344.4	375.5	402.5	427.8	429.4	443.2	444.2	458.7			
San Francisco	365.4	368.6	386.0	390.8	402.9	441.1	465.1	512.3	561.0	606.4	608.0	631.3	632.3	647.1			
Seattle	266.6	268.9	275.0	283.5	292.2	317.8	341.8	358.4	371.5	388.4	390.0	423.4	424.4	437.8			

Costs in a given city for a certain period may be compared with costs in another period by dividing one index into the other; if the index for a city for one period (200.0) divided by the index for a second period (150.0) equals 133%, the costs in the one period are 33% higher than the costs in the other. Also, second period costs are 75% of those in the first period (150.0 ÷ 200.0 = 75%) or they are 25% lower in the second period.

TEXTURED DOORS FROM KAWNEER

All the exciting I-Line 4000 Series entrance options are covered in a new brochure available from Kawneer Product Information, 1105 N. Front Street, Dept. C, Niles, Michigan 49120



I-LINE
4000
SERIES

Building materials: how severe are the shortages?

With the big construction months of 1974 just ahead of them, and the initial round of post Phase four price increases just behind them, building contractors are watching intently to see if the higher prices they're paying for materials are really the necessary evil that will insure a freer flow of these materials when they really need them the most.

Clearly, it's been no picnic up until now. Between the fourth quarter of 1972, when private nonresidential building began adding its momentum to the still-buoyant housing component, and this year's opening quarter, the backlog of unfilled orders for construction materials surged more than 50 per cent. The current delivery period for heavy construction equipment is roughly three times what it was a year ago. And, some plastics building materials are unavailable at any price in certain areas.

While any attempt to predict just when the turning point of an economic series will come is a risky business at best, a number of factors indicate that the materials shortages problem will be easing significantly in the months ahead. Some of these factors are directly linked to the ending of controls, while others are completely unrelated to that issue.

A direct beneficiary of the demise of Phase four controls is iron and steel. Shortages of such items as steel reinforcing bars can be traced, in large part, to the way the steel pricing structure worked under the controls program. Under the controls system, manufacturers of steel products, unable to restructure prices in accordance with shifting supply and demand conditions, simply shifted their production into those products that would yield the most profit. Under this arrangement, some construction steel products—steel reinforcing bars, for instance—were discriminated against in favor of product lines with higher margins.

A similar case existed in the cement industry, where shortages were a persistent complaint until controls were lifted back in January. Although cement prices are significantly higher now, the problem of shortages has been reduced considerably because several high-cost facilities were able to reopen on a profit-making basis.

In the case of petroleum-based products, and products like plastics, that contain a large proportion of petroleum derivatives, existing shortages are the direct result of the oil embargo. To the extent that this is no longer with us, these shortages should soon be easing.

The problem with lumber and plywood

bottlenecks has pretty much evaporated. But there, the source of the relief was not necessarily the most desirable one. In constant dollar terms, new residential construction being put in place is currently 25 per cent below year-ago levels. Housing's decline will affect not only lumber, but all other products that go into this segment of construction. And, those products that go into both residential and nonresidential building, will be generally more available for nonresidential use.

In this regard, too, it's significant that the latest industrial operating rate survey taken by McGraw-Hill's Publications Division Economics Department shows that the operating rates for the three major building products industry classifications, lumber, stone, clay and glass, and iron and steel are all below last year's.

Although this won't be of much help in 1974, the higher prices building materials manufacturers are getting for their products will serve as a stimulus to new capital investment and plant expansion. Overall, manufacturers plan to spend some 30 per cent more this year than last to increase capacity. And, of the industries directly linked to construction, iron and steel plans a 35 per cent gain, and stone, clay and glass plans a 28 per cent increase in outlays.

Higher prices, of course, are nothing unusual in an industry where inflationary conditions are generally accepted as a way of life. In

fact, they're probably easier to live with when the problem is so widely entrenched in the economy generally, like today, than when the construction industry can be pointed to as one of the few problem areas. But, in an industry faced with the prospect of a slower rate of growth during the next five years than it experienced during the past five—and, that's what construction is faced with—excessive cost pressure can become a severe burden. This is especially true when the opportunities for relief through gains in productivity appear to be limited.

To a certain extent, existing competitive forces will serve to mitigate these cost pressures somewhat. But all facets of construction are not equally sensitive to the forces of competition. Pockets of monopoly power are scattered throughout the industry, and will serve to aggravate conditions if left unchecked. This will be disruptive not only as far as the internal processes of design, bidding, scheduling, and the actual building processes are concerned, but it will also affect the overall demand for construction. In certain parts of the economy it could be relatively easy to "make do" with existing structures for a while rather than build new ones if costs get too severe. All it takes is for someone to get the idea and the process could well become habit-forming.

*James E. Carlson, Manager, economic research
McGraw-Hill Information Systems Company*

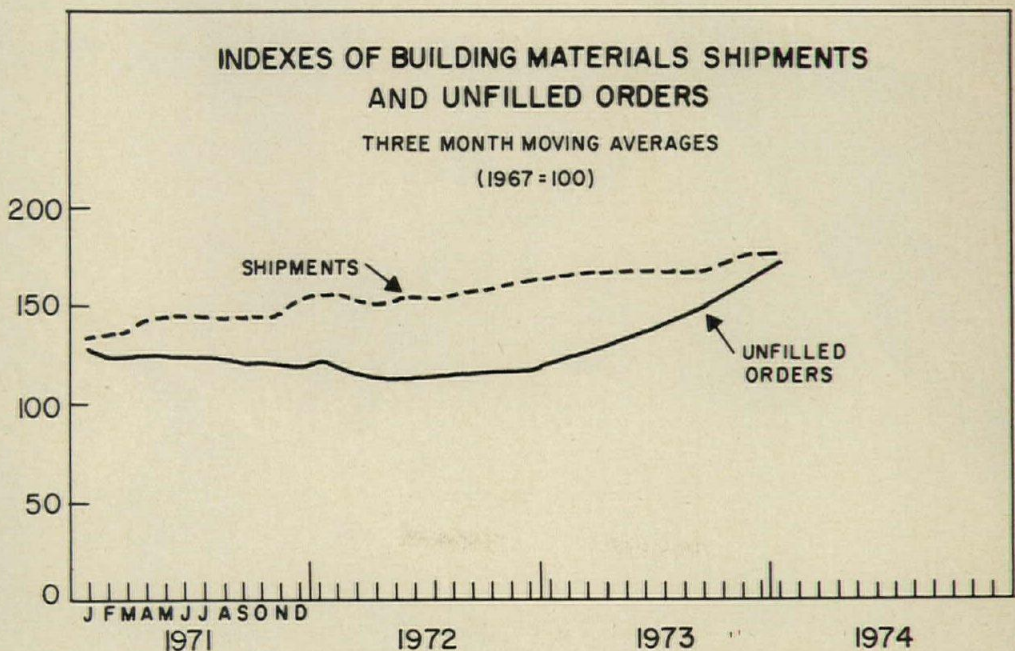

SOURCE: U.S. DEPARTMENT OF COMMERCE

Brunslon® and Brunsmet® are the Number One static-control system in carpet.

It didn't happen overnight, 'cause it doesn't happen overnight.

It takes years to develop a fully effective static-control system. Years of pioneering research, followed by day-in, day-out on the job performance. This kind of performance has made Brunslon and Brunsmet the sales leader in static control. The World's Number One system.

Brunslon and Brunsmet are on the job today in over 90 million sq. yds. of carpet. And used by over 80 major carpet manufacturers in over 360 lines of carpet. No other system gives you better sales performance, technical superiority, flexibility. Brunslon and Brunsmet are easily incorporated into carpet of every fiber, construction, color, design.

Our proven system created the demand, and we've got the supply to meet it. In fact, we've recently opened another new plant — in Westborough, Massachusetts — that will keep carpet manufacturers fully supplied.

Insist on the Number One static-control system. The one that has earned its success with dealers, distributors, and manufacturers.

The Number One System is available right now.



**TECHNICAL
PRODUCTS
division**

BC
BRUNSWICK

BRUNSWICK CORPORATION
One Brunswick Plaza, Skokie, Illinois 60076, U.S.A.

For more data, circle 46 on inquiry card



52" x 52" domes form exposed ceilings fast, economically

Economy is the important key to Ceco's 5' module system for concrete floors and ceilings. These 52" x 52" fiberglass domes are used floor by floor to save on time and money. And architect-engineers like this simplicity.

You too can get design freedom and versatile floor treatments with Ceco's standardized waffle-slab or one-way rib floor forming systems. With Ceco fiberglass forms or steel forms you can choose either small or large modules and design for either exposed or suspended ceilings.

Ceco's concrete forming services are backed up by 60 years of experience in formwork specialization. Please see Sweet's files or consult your nearest Ceco district office.

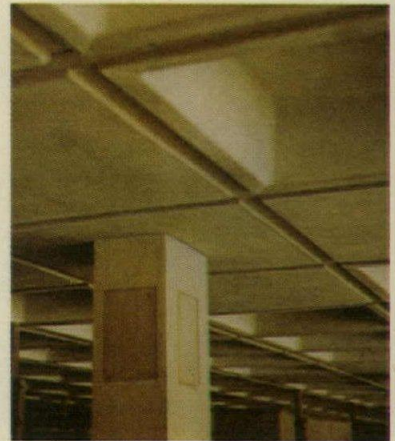

*U of Tennessee Library, Chattanooga
Architects:
D. Derthick and Henley, Architects
Contractor:
H. E. Collins Contracting Co.*

CECO concrete forming services

The Ceco Corporation • General Offices
5601 West 26th Street • Chicago, Illinois 60650

For more data, circle 47 on inquiry card

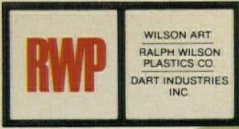

**With Wilson Art...
design control and cost ratios
work beautifully together.**



Specify the Wilson Art look. It makes color and design coordination perfectly easy.

Aesthetic choice? More than 150 woodgrains, solid colors and patterns give you almost limitless latitude to match, to contrast, to coordinate walls, doors and casework.

Cost? You won't find a better ratio of initial-to-ultimate cost.

Service? All your Wilson Art surfaces come with famous Wilson Art service. Find out for yourself: contact your Wilson Art Architectural Design Representative today.

Walls

◀ WILSONWALL PANELING SYSTEMS

System 310, shown here, is one of four distinctive **Wilsonwall** systems you can specify. All are available in the full range of **Wilson Art** woodgrains and solids that coordinate perfectly with **Wilson Art** laminated plastic and **Dor-Surf** door facing. In addition to **System 310** with its hidden aluminum moldings you can realize your designs in a standard V-groove system, a reveal system, and a Class-1A fire-hazard system.

Whatever your design concept, **Wilsonwall** works with it.

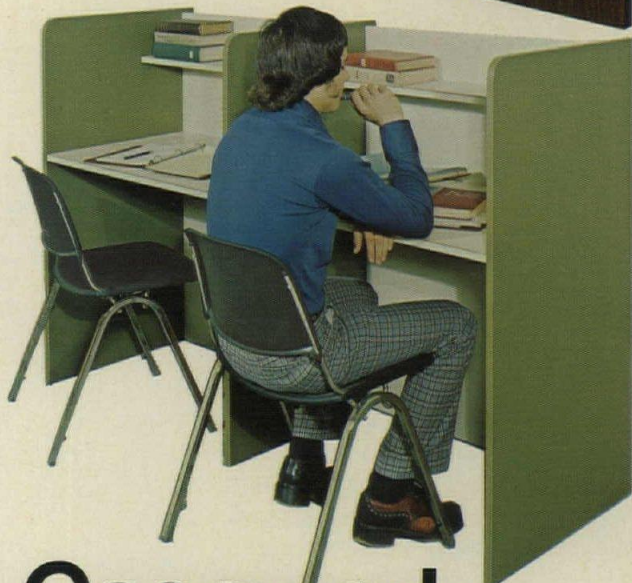

Casework

WILSON ART LAMINATED PLASTIC

Casework, furniture and fixtures surfaced with **Wilson Art** laminated plastic help you maintain complete design control. **Wilson Art** variety—in solids, in woodgrains, in surfaces that include true dimensionals — gives you the choice, the widest possible choice, of aesthetic effect—with ideal cost ratios.

Whatever your idea, our idea works with it!

Doors

DOR-SURF® DOOR FACING

Doors that work beautifully with your ideas in **Wilsonwall** are surfaced with **Dor-Surf**—1/8-inch-thick **Wilson Art** laminated plastic with exceptional resistance to impact and abrasion. Easy to specify, easy to come by, easy to match or contrast with your choice of **Wilsonwall** paneling systems, easy to maintain during their long and beautiful life.

Whatever **Wilsonwall** system you specify, **Dor-Surf** works beautifully with it.

When the chips are down,
you can depend on **Wilson Art**.



WILSON ART . . . TEMPLE, TEXAS

For more data, circle 48 on inquiry card

ATLANTA
(404) 377-0731

BOSTON
(617) 662-9700
or (617) 664-5230

CHICAGO
(312) 437-1500
or (312) 625-7590

DENVER
(303) 388-3686

LOS ANGELES
(213) 771-8141
or (213) 921-7426

MIAMI
(305) 822-5140

NEW JERSEY
(609) 662-4747
or (215) 923-5542

NEW YORK
(914) 268-6892
or (212) 933-1035

SAN FRANCISCO
(415) 782-6055

SEATTLE
(206) 228-1300

TEMPLE, TEXAS
(817) 778-2711



Lens installations for swing doors

Door frames, hinges and mechanical latches for recessed lighting never have done much to enhance esthetics. So American Louver eliminated them.

Our Frameless Customlens[®] is injection molded in one piece with integral hinge pins and raised edges that eliminate the need for mechanical locking, hinging or framing devices. Lighting can be truly integrated with ceiling planes.

Injection molding means dimension stability and precision-formed prisms of highest quality that conceal lamps and provide uniform illumination of the entire lens surface.

1 x 4, 2 x 2 and 2 x 4 panel sizes fit most commonly used fixtures. Frameless lenses are optically designed for general commercial lighting applications.

Send for Bulletin #201. It just might be able to swing you over.



AMERICAN LOUVER COMPANY
7700 AUSTIN AVENUE • SKOKIE, ILLINOIS 60076 • (312) 966-0300

For more data, circle 49 on inquiry card

Goodyear Speedramp.[®] Clearly the way to move people to move merchandise.



The new Speedramp[®] passenger conveyor system with glass balustrade (shown here in exact scale model) is a logical part of the new light, airy concept of interior design and merchandising.

The glass balustrade Speedramp is supported by an opaque enclosure less than 2 feet thick for a slim, attractive profile. Conventional escalator systems—even those using glass balustrade—require a heavier opaque enclosure, nearly 4 feet thick.

Speedramp offers passengers a clearer view of displays. And it offers you more opportunities to catch the shopper's gaze and turn it into sales.

Your customers also enjoy the convenience of cart shopping. A special Cart-Lock[®] feature allows the grooved cart

wheels to grip the belt and then release automatically at ramp end.

If you're planning to move lots of people—and lots of merchandise—you'd be wise to include a Speedramp system in your plans. For complete information, write to Goodyear, Transport Systems, Box 52, Akron, Ohio 44309.

The glass balustrade Speedramp.
A moving idea that's perfectly clear.

GOODYEAR
TRANSPORT SYSTEMS

For more data, circle 50 on inquiry card

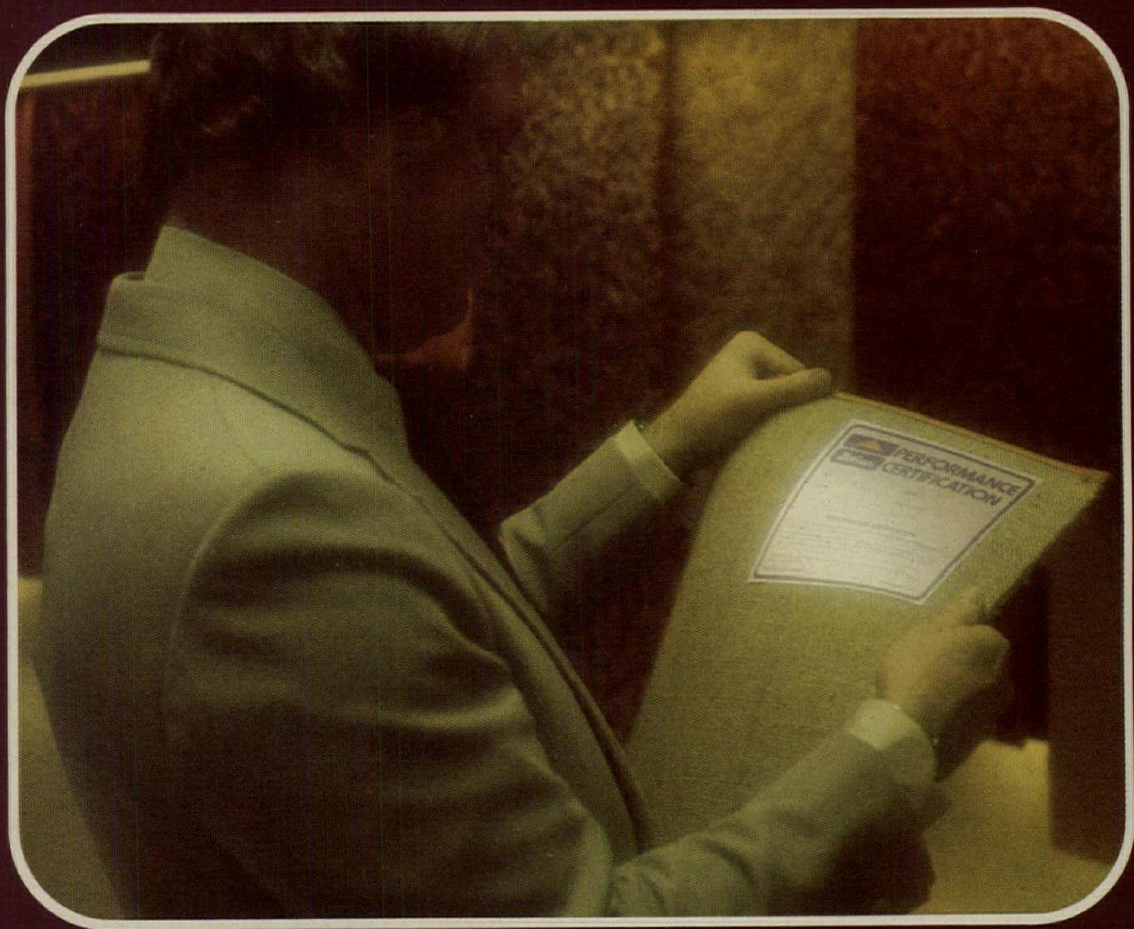

Confidence Man

At Dow Badische when he puts our "Performance Certification" label on a carpet you can be sure it will live up to its promises.

Promises, promises. Every fiber producer or carpet manufacturer is full of them every time you specify contract carpet. But at Dow Badische we base our performance promises on facts.

Whenever you see our Performance Certification label on a carpet made of Dow Badische specially engineered fibers and yarns, it means that (1) the actual carpet construction has also been specially engineered to meet our high performance standards and (2) the carpet has been rigorously tested to prove it.

Our "confidence men" don't take their jobs lightly. They know that if the carpet you specify doesn't live up to its promises, you'll never specify another one made of our products. That's why they make doubly sure that any carpet bearing our label gives satisfaction. To you and your client.

Look for our Performance Certification label on carpets next time you have an installation job. At Dow Badische we back our promises with facts. After all, we have a reputation for confidence-building to protect.



Dow Badische Company
Williamsburg, Va. 23185
(804) 887-6573

For more data, circle 51 on inquiry card

Efficient building idea: Use this much more Fiberglas roof insulation and save up to \$27,000 every 60,000 sq.ft.

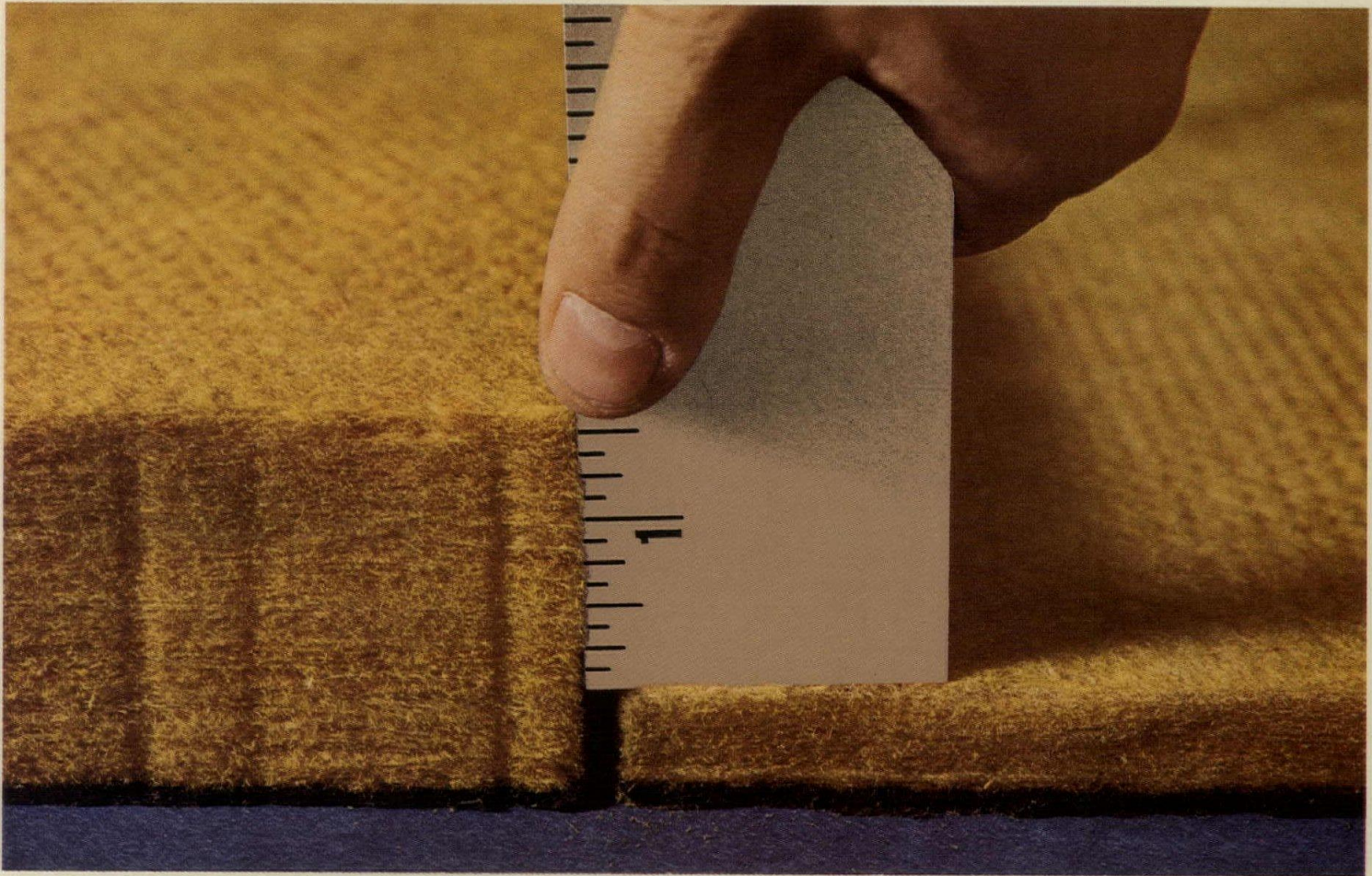

Those are the potential savings you could realize on the initial cost of heating and cooling equipment. Your client could also save an additional \$2500 a year on fuel.

Simply by using 2 1/4" instead of 3/4" of Fiberglas* roof insulation.

These particular savings were figured for a suburban office plaza in the northern climates (zone 1). Factors taken into account were: the normal temperature range of

the region, size and type of roof deck, the "U" improvement due to thicker insulation. And the added cost of the thicker insulation.

How much can you and your client save by using 2 1/4" insulation?

Send for our free booklet "Raising the Roof." It'll show you how to figure your own savings for your section of the country for common types of roof decks.

Write Mr. G. Z. Meeks, Architectural Products Division, Owens-

Corning Fiberglas Corp., Fiberglas Tower, Toledo, Ohio 43659.

Energy Conservation Award

Owens-Corning is offering awards to stimulate new designs and ideas for conserving energy. Special Steuben sculptures will go to the three architects or engineers who—according to a panel of independent judges—do the best job of designing buildings that don't waste fuel. For details, write to Mr. Meeks at the above address.

Owens-Corning is Fiberglas

OWENS/CORNING
FIBERGLAS
TRADEMARK ®

*T.M. Reg. O.-C.F. Corp.

For more data, circle 52 on inquiry card

If granite is so hard to install, why didn't someone tell First Federal Savings and Loan, Detroit?

Sure. They'd heard the myth about granite posing costly installation problems. But they also knew you can't plan buildings on myths, so they went over the facts about Cold Spring granite with their architect. And they liked what they found: the natural beauty of Cold Spring's polished granite resists weather, stains and all types of traffic as no other building material can; it won't fade or deteriorate; it requires virtually no maintenance; it comes in a wide spectrum of colors; and . . . *it's economical to install, thanks to Cold Spring's development of new fabrication techniques that include improvements*

like steel-backed granite panels.

In fact, they liked the idea well enough to use granite inside as well. In heavy traffic, high wear areas like check writing tables, teller's counters, and the wall facing that encloses the elevators.

How expensive is granite? Talk to our Customer Service Department about that. Tell them what you want to do and they'll tell you how it can be done. Step by step. And likely as not you'll find that granite fits your plans well on a cost-in-place basis. Refer to Sweet's Catalog No. 4.1/Co. Or call us.

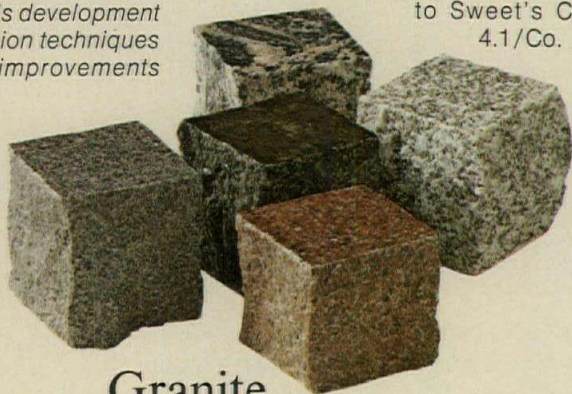

Granite
can color
your thinking.

First Federal Savings & Loan,
Main Office, Detroit, Michigan
Architect:
Smith, Hinchman and Grylls
Contractor:
Fuller Construction Co.
Granite:
Dark Pearl



COLD SPRING GRANITE COMPANY / COLD SPRING, MINN.

For more data, circle 53 on inquiry card

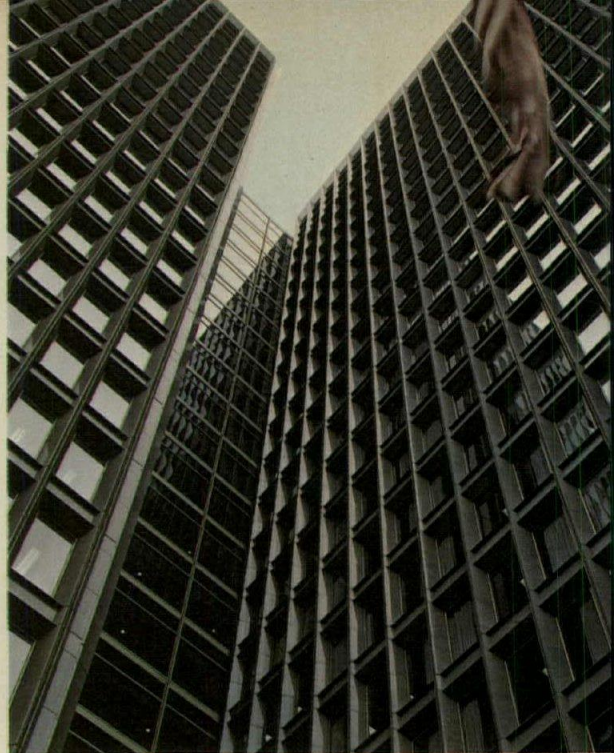



And introducing a new dimension to soft seating. Rounded forms from every angle and enveloping comfort for any seating posture are the essence of the Wilkes collection.

In each piece, for every posture, the resilient seat yields to the angles, contours and pressures of the body. The high resiliency molded foam shapes are covered with two-way stretch upholstery that is both durable and comfort-insuring, since the porosity of the knitted fabric allows "breathing." And, a draw-string securing the cover underneath the seat may be released to replace the cover if necessary.

presenting a new chair man: ray wilkes



Repeating the soft-edge image in the five-point base, the molded radius "pods" enclose the casters so that they become an integral part of the base structure. There is an impression of the base hovering just above the floor, perceptibly adding to the sense of buoyancy in the total look of the chairs.

The more familiar four-point and sled base choices have softened edges in keeping with the profile of the chairs. Contained within the radius bases is an optional pneumatic lift that provides instant seat height adjustment.

The four shapes of the collection . . . high back, medium back, square and angle arm chairs all express a generous scale, soft surface concept indicative of supreme comfort.

Any choice of the three seat shapes clustered in whatever groupings desired, is eminently suitable for multiple seating in lobbies or reception areas.

See your local Herman Miller dealer for further information on specifications, colors, deliveries, etc. Or, write us for the Herman Miller dealer directory, Herman Miller Inc., Zeeland, Michigan 49464.

☐ herman miller

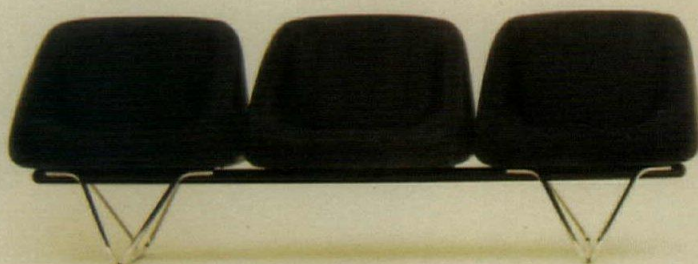

For more data, circle 54 on inquiry card

**Owens-Corning announces
its third annual
Energy Conservation Awards Program
for architects and engineers**

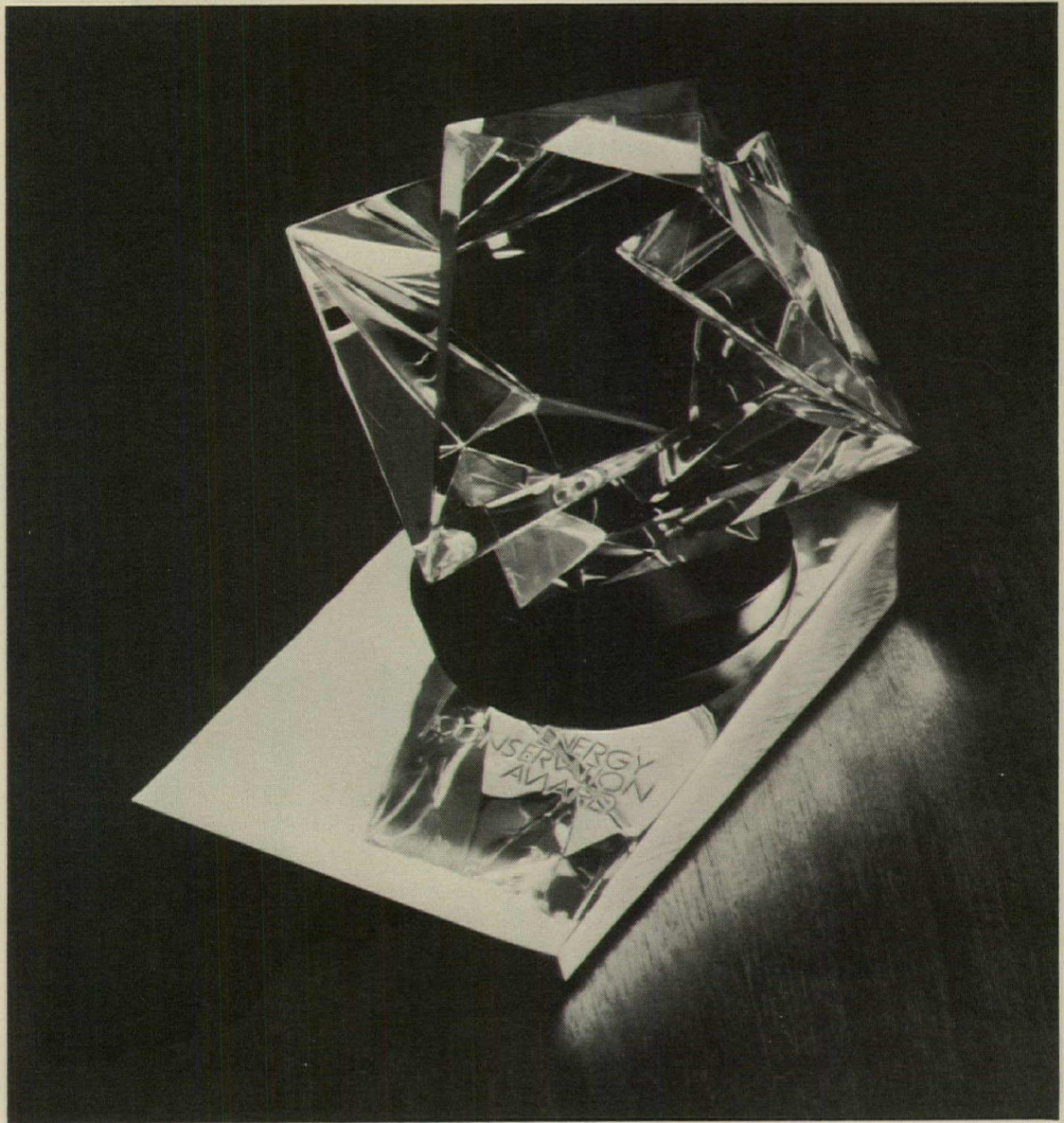

The Owens-Corning 1974 Energy Conservation Award.
"Triangles," a Steuben Crystal sculpture that captures and refracts light from multiple triangular planes.

This year, the whole world is watching.

Show our Awards Jury a building design that doesn't waste energy—and you could win one of the Energy Conservation Awards Owens-Corning will present for 1974.

The Awards Jury will be looking for three things: Creativity. Originality. And most important of all—designs that save energy.

Too many buildings waste fuel and contribute to environmental pollution.

By continuing the Energy Conservation Awards Program we initiated in 1972, Owens-Corning hopes to stimulate even more new ways to conserve energy. And it will let us honor the architects and engineers who do the best job of designing buildings and mechanical systems that conserve fuel.

Who can enter

Any registered architect or professional engineer practicing in the U.S. is eligible. As an individual. Or in a team. But to qualify, your entry must be a commissioned building project—in the design process, under construction, or a completed structure.

Although Fiberglas* products are an excellent way to conserve energy, their use is not a requirement.

Four entry categories

A winner will be selected in each of these categories:

Institutional—schools and hospitals, for example.

Commercial—office buildings, shopping centers, retail stores, and similar structures.

Industrial — including manufacturing plants, research centers, warehouses.

Governmental—post offices, administrative buildings, and military structures to name a few.

The Awards

Winning architects and/or engineers will receive the Steuben Crystal sculpture "Triangles." Owners or clients associated with winning entries will receive other Steuben Crystal awards.

The Awards Jury for 1974

Eight outstanding professionals in architecture and engineering will serve as the Awards Jury to select the winners.

H. Fred Campbell, H. F. Campbell Company, Detroit, Mich.; Walter H. Costa, Skidmore Owings & Merrill, San Francisco, Calif.; Sital Daryanani, Syska & Hennessy Inc., Engineers, N.Y., N.Y.; Dr. Donald P. Greenberg, Prof., Cornell Univ., Ithaca, N.Y.; George T. Heery, Heery & Heery, Atlanta, Ga.; Philip J. Meathe, Smith Hinchman & Grylls, Detroit, Mich.; Richard L. Mullin, Symes Maini & McKee, Cambridge, Mass.; Thomas A. Stokes, Cary B. Gamble & Associates, Inc., New Orleans, La.

Send for entry details now

Completed entries must be submitted by August 31, 1974. Winners will be selected and notified in early September.

For a brochure giving complete details, contact your local Owens-Corning representative. Or write N. E. Meeks, Owens-Corning Fiberglas Corporation, Architectural Products Division, Fiberglas Tower, Toledo, Ohio 43659.

*T.M. Reg. O.-C.F.

Owens-Corning is Fiberglas

OWENS/CORNING
FIBERGLAS
TRADEMARK ®

For more data, circle 55 on inquiry card

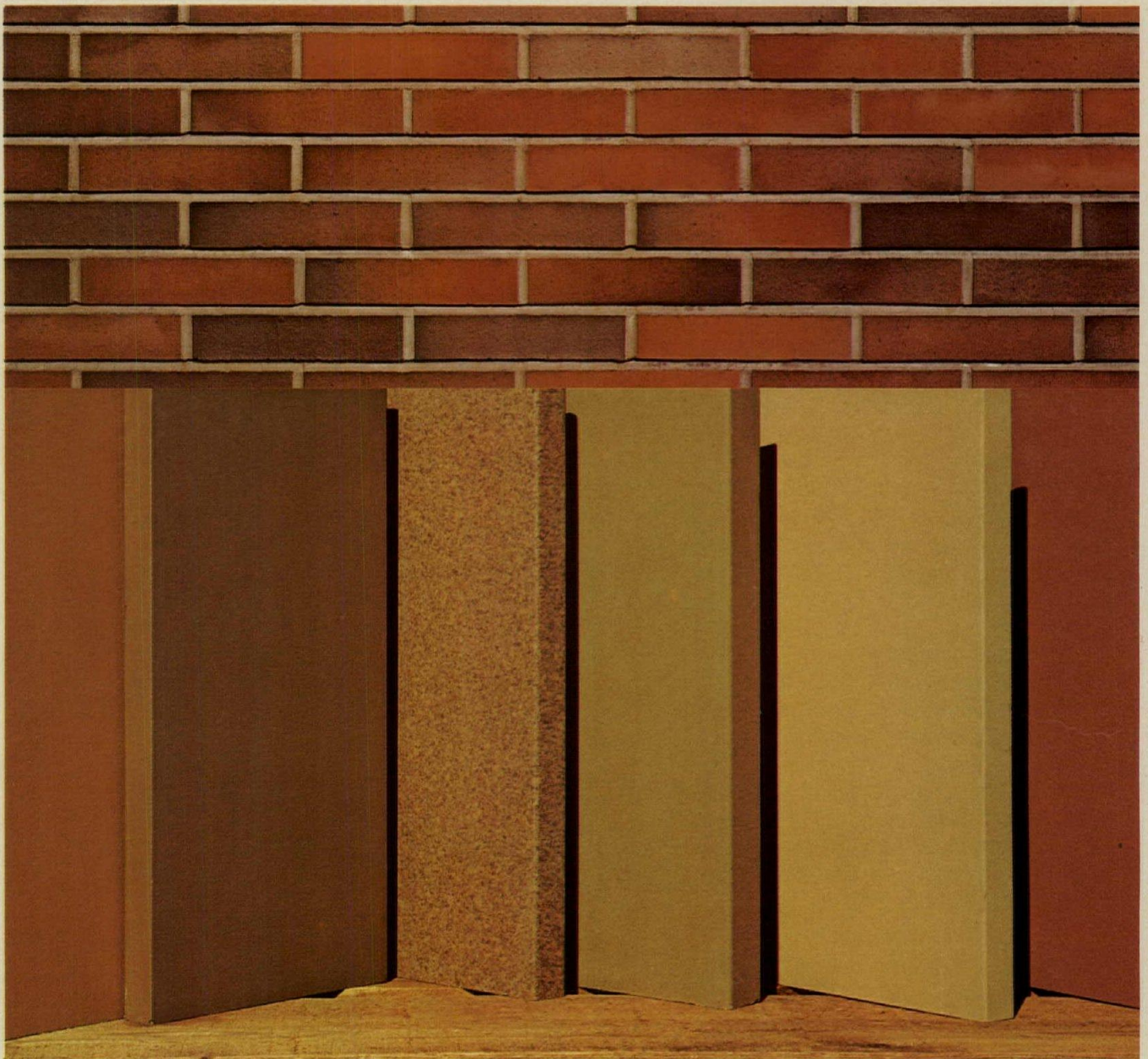

PICK A BRICK...ANY BRICK AND MATCH THE COLOR IN TERRA COTTA COPING

Terra Cotta Coping offers the opportunity to design the finishing touch for exterior brick walls by extending the warm, earthy look of the brick to the top with a color-matching ceramic coping. These units not only offer an aesthetic advantage, but also the maintenance advantage of a ceramic surface which is easy to clean and will not stain, fade or deteriorate.

Terra Cotta Coping is available in a wide variety of sizes and shapes. Colors are made to individual job requirements. Send for a brochure today.



2901 Los Feliz Boulevard
Los Angeles, California 90039

260 Cherry Hill Road
Parsippany, New Jersey 07054

For more data, circle 56 on inquiry card

At GAF we have an informer in our midst. It's our newsletter. And six times a year, it will tell you everything we're doing.

For instance, you'll know about drops before they happen. And about new Federal Specifications as they happen.

The Informer also includes a special number you can call if you need additional specifying information. Or some help in

choosing what's just right for your needs.

If you have not been receiving The Informer, write to GAF Corporation, Floor Products Division, Dept. F64, Box 1121, Radio City Station, New York, N.Y. 10019. After all, it's very important. Because The Informer will give you the answers before you can even think of the questions.

For more data, circle 57 on inquiry card

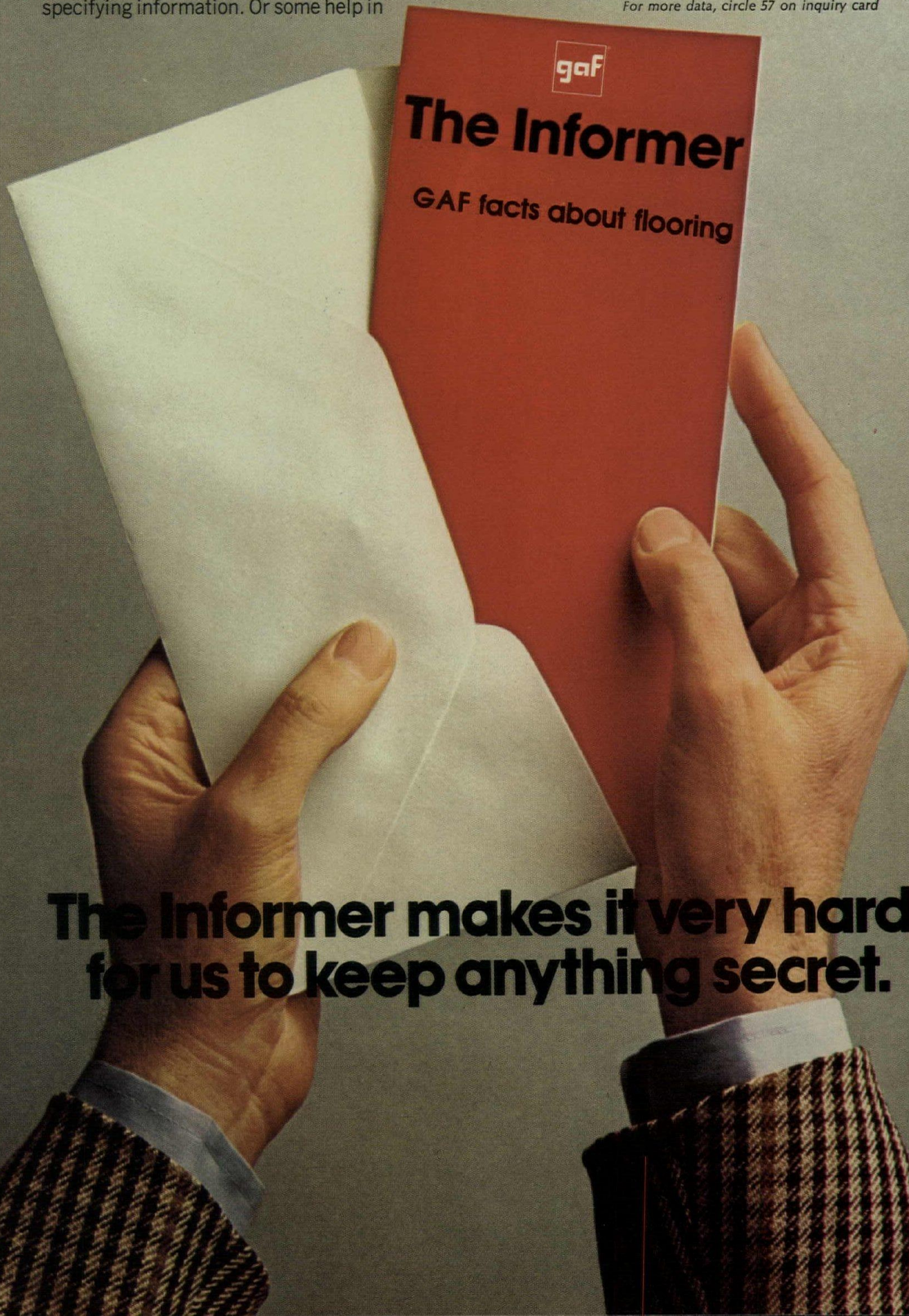

**The Informer makes it very hard
for us to keep anything secret.**

Gold Bond Metaledge Corewall.

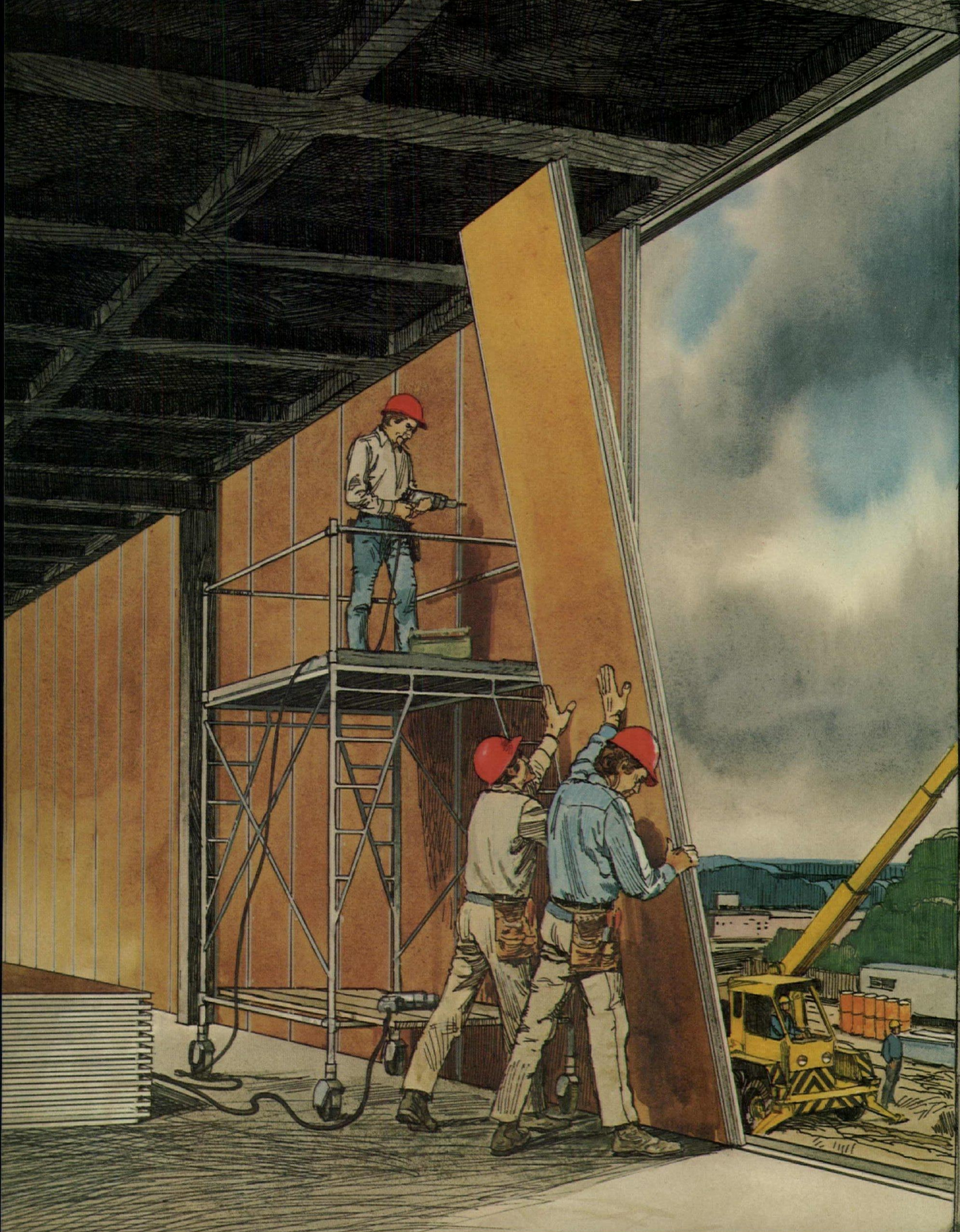

Instead.

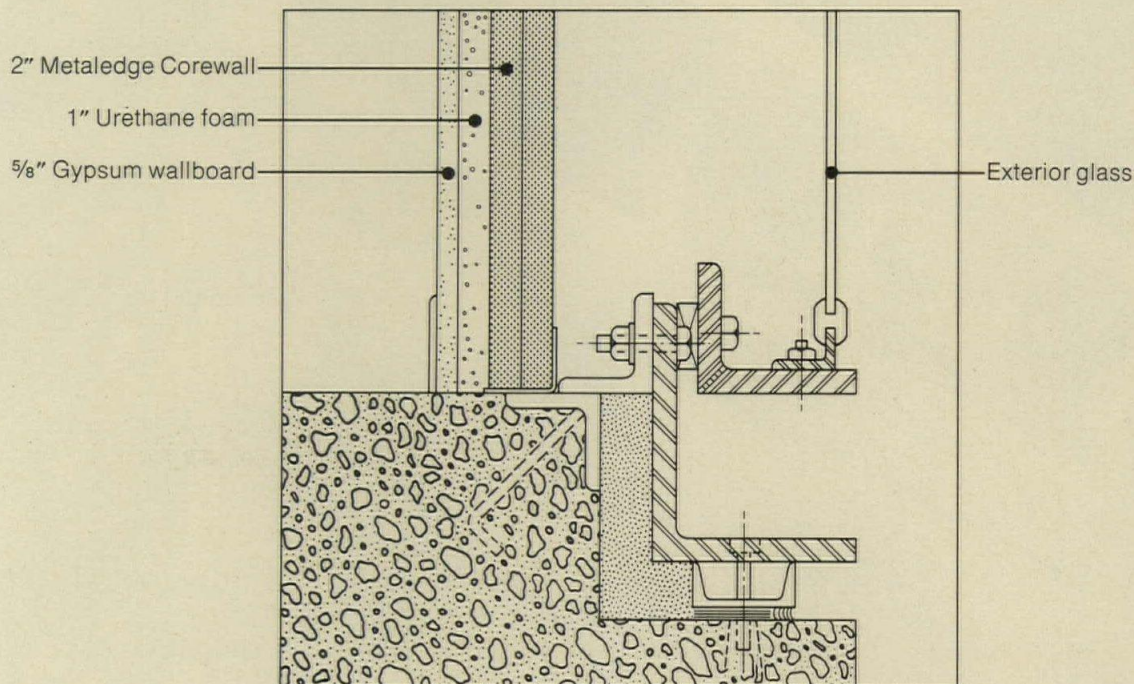

Looking for a way to make a windowless wall look good? An innovative curtainwall is Gold Bond® Metaledge Corewall®, under glass. Instead of conventional material. We created Metaledge Corewall as a more economical solution to enclosing elevator shafts in high-rise buildings. Or for vertical chases, or stairwells.

We made it just two inches thin to save space. And light enough for just two men to install in 7 to 16-foot lengths. So it not only cuts construction time and cost, but saves weight.

We created Metaledge Corewall for one use. Now, architects are finding new ways to use it.

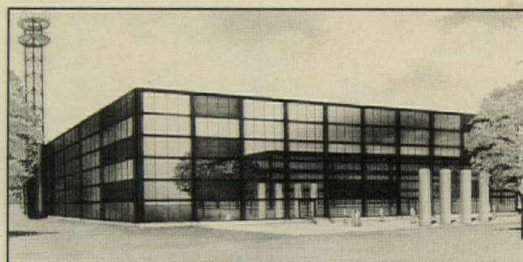

For example, the perimeter wall system of this Illinois Bell Telephone equipment building designed by Chicago architects Holabird & Root. In it, 24,000 square feet of Metaledge Corewall replaced conventional nonload-bearing construction in perimeter walls as well as elevator shafts. Because Metaledge Corewall goes up fast, the building would be enclosed rapidly to protect massive electronic equipment which had to

be installed before the walls were completed. And with a minimum of dust and dirt which could damage sensitive equipment.

For tight humidity and temperature control, a special wall

system was designed. Our Metaledge Corewall was insulated with urethane foam and finished with our Sta-Smooth® gypsum wallboard. This wall system was also designed to be removable for planned expansion.

For more details, contact your Gold Bond representative. Or write Gold Bond Building Products, Division of National Gypsum Company, Dept. AR-64G, Buffalo, N.Y. 14225.

**We're gypsum,
and then some.**



DIVISION OF NATIONAL GYPSUM COMPANY

For more data, circle 58 on inquiry card



Sonic Boon

Guests of St. Louis' new Marriott Motor Hotel can watch the jets come and go at Lambert St. Louis International Airport across the road. They don't have to listen.

Because all 435 guest rooms are protected from noise by C-E Polarpane Sound Control Units: A real sonic boon that shuts out as much sound as a 6-inch concrete block wall.

Basic Polarpane is built with a 3/16-inch and a 3/8-inch lite . . . with an acoustical, resilient 2-inch thick edge separator and 2-inch air space. Glass edges are hermetically sealed with two separate all-weather sealants, and protected with an aluminum edge-band.

Basic Polarpane meets the requirements of STC42 in accordance with ASTM E90-66 and RM14-2. And, C-E Glass can develop units with higher STC ratings, if required.

Polarpane Sound Control provides excellent insulating capabilities with a "U" value of .48. And the product is protected by a 10-year warranty against vision obstruction from inside dust, film or moisture collection.

To learn more about C-E Polarpane Sound Control Units, see the C-E catalog in Sweets: 8.26/CE. For additional information, contact your local C-E Glass representative or write C-E Glass, 825 Hylton Road, Pennsauken, N.J. 08110, (609) 662-0400.

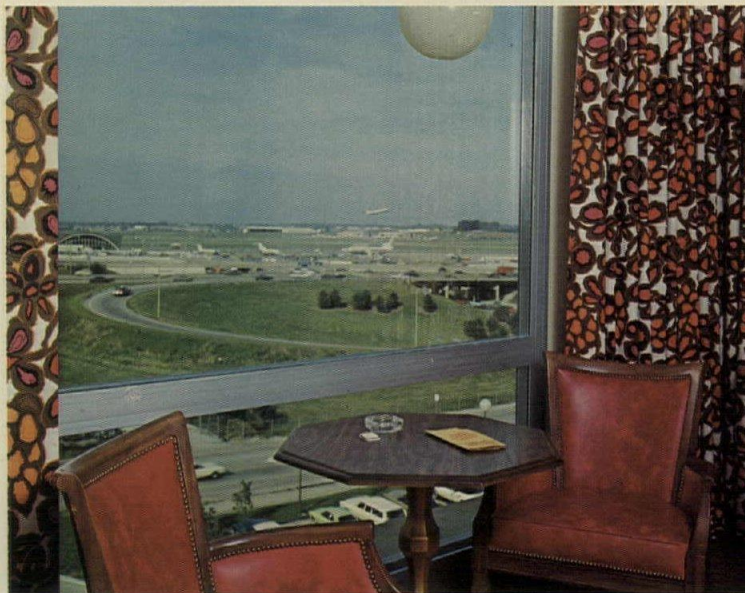

Architect: Marriott Corp., Washington, D.C.
Glazing Contractor: Starline, Inc., Carencro, La.

C-E Polarpane Sound Control Units also installed at Marriott Motor Hotels at Chicago O'Hare, Dulles, Miami and Kansas City International Airports.

CE GLASS
COMBUSTION ENGINEERING, INC.

For more data, circle 59 on inquiry card

Series 9000. A 2001 idea in 1974 from Steelcase.

Unlike any furniture you've experienced before. A desk, a credenza, a work station and a space divider system.

A totally new direction in office furniture for the private office as well as the open area. For every department of the 2001 company.

A system of furniture that grows with you. Changes with you. Supports your every work need.

Series 9000—a new idea that will influence your office planning for years to come. Now in full production.

Write Department G for literature. Your Steelcase Dealer and Regional Office have complete information. They're in the Yellow Pages.

Steelcase Inc., Gd. Rapids, Mi 49501; Tustin, Ca 92680; Toronto, Ontario; Steelcase (Far East) Ltd., Tokyo.

For more data, circle 60 on inquiry card

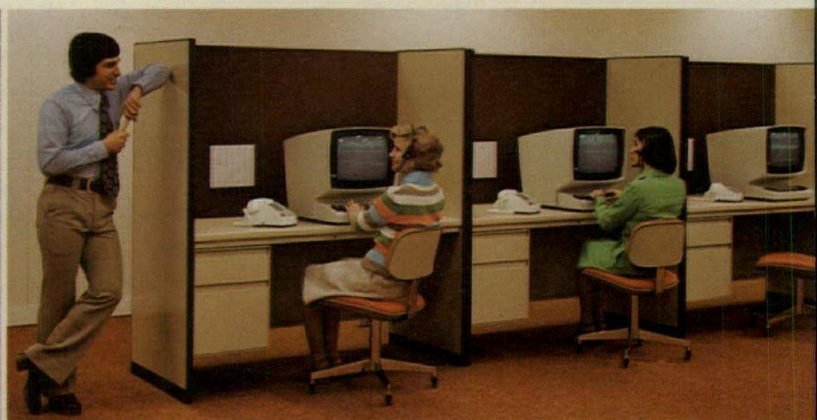
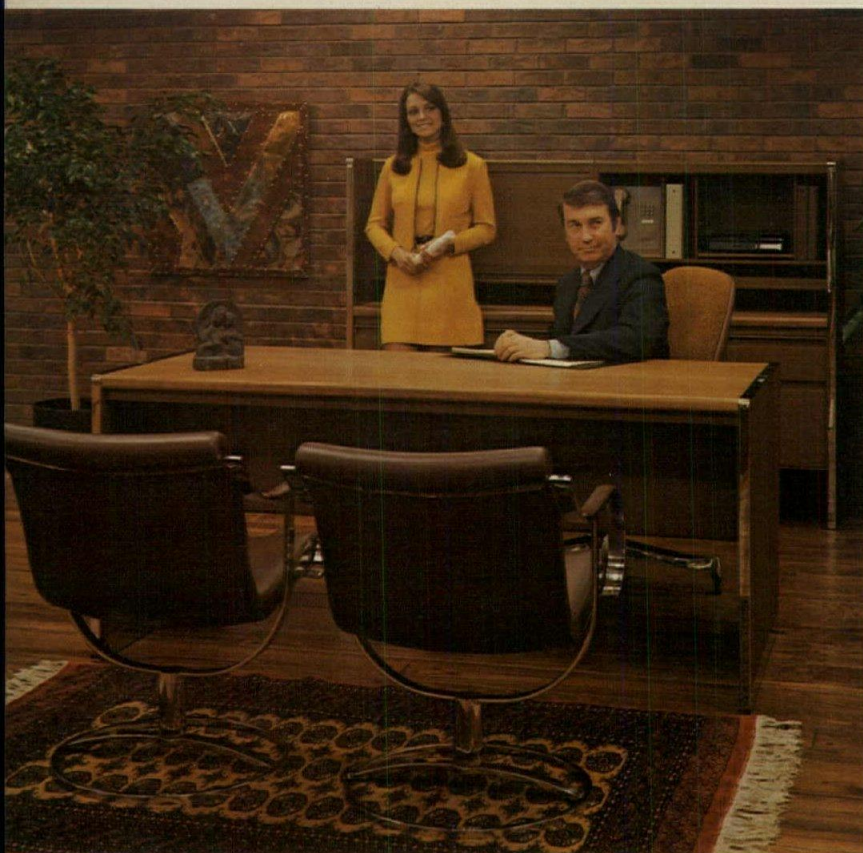

BUILDINGS FOR RECREATION

Airpark Lodge at Reelfoot Lake

Otto Baitz photos

The master plan for development of Reelfoot Lake State Park recognized the great fragility of this swampy wilderness lake and the importance of preserving it undisturbed, and it set up a number of basic design premises for implementation of the plan. When the architects for the master plan were commissioned to design the first phase of the development, it was this aspect—the relating of the project to the natural surroundings, with minimal disturbance to the flora and fauna of the area—that they found to be the most challenging part of the job. That they were successful is obvious.

Reelfoot Lake was formed in 1811-12 as a result of the great New Madrid Earthquake which caused the Mississippi River to flood extensively on either side of its channel. After the river resumed its natural course, what had been a vast sunken cypress forest remained flooded, and became Reelfoot Lake. Located in the northwest corner of Tennessee, the lake has an area of some 18,000 acres at normal level. Although it has been for many years a paradise for hunters and fishermen, much of it is still wilderness. Making it possible for many people to enjoy the very special beauty of this unique place was the goal of the state's master plan. Airpark Lodge—so called from the existing airstrip for fly-in campers—and the development around it is the first step toward the implementing of this goal.

The swampy nature of the site made the use of piers particularly appropriate, since they could extend through the swamp without disturbing either trees or water plants and would allow the development to spread out, minimizing its impact and at the same time maximizing the visitor's experience of the place.

The Lodge complex consists of several buildings set on pilings over the water and connected to the main pier by short walks. At the entrance to the pier is the park office with a supply shop and a boat rental dock adjacent. Beyond the office, astride the pier, is the restaurant/lounge building with decks for outdoor dining, and farther along are clusters of motel units among the trees, each of the 20 units with a balcony for fishing or for looking at this almost-wilderness. At the lake end of the 600-foot pier is a public fishing deck. The interiors and the engaging graphics, bold against simple rough sawn cypress boards, were designed by the architects.

 AIRPARK LODGE, REELFOOT LAKE STATE PARK, Tiptonville, Tennessee. Architects: *Gassner/Nathan/Browne*. Engineers: *Wooten, Smith & Weiss* (structural); *Pickering Engineering* (foundation, soils, mechanical/electrical). General contractor: *McAdoo Contractors, Inc.*

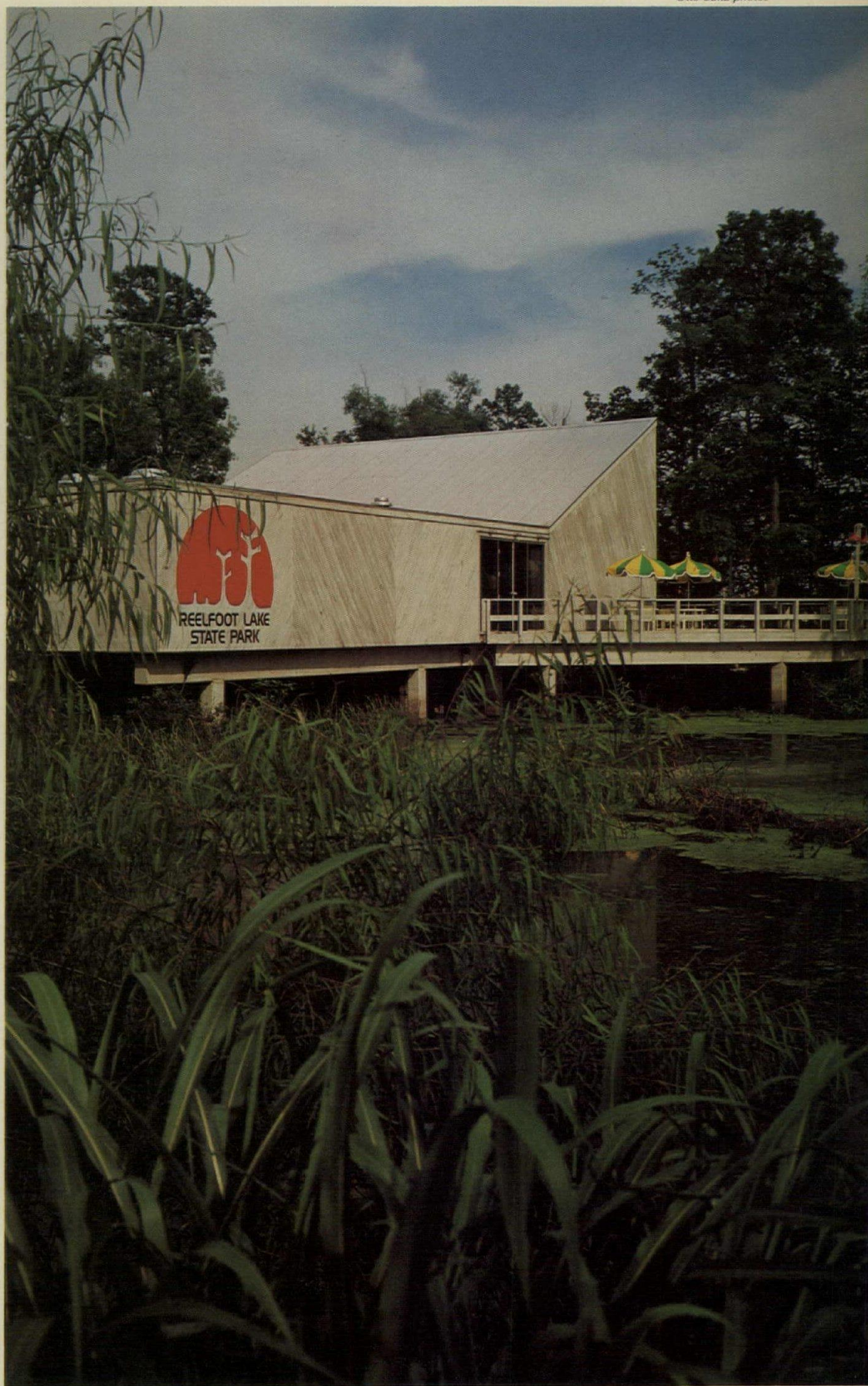

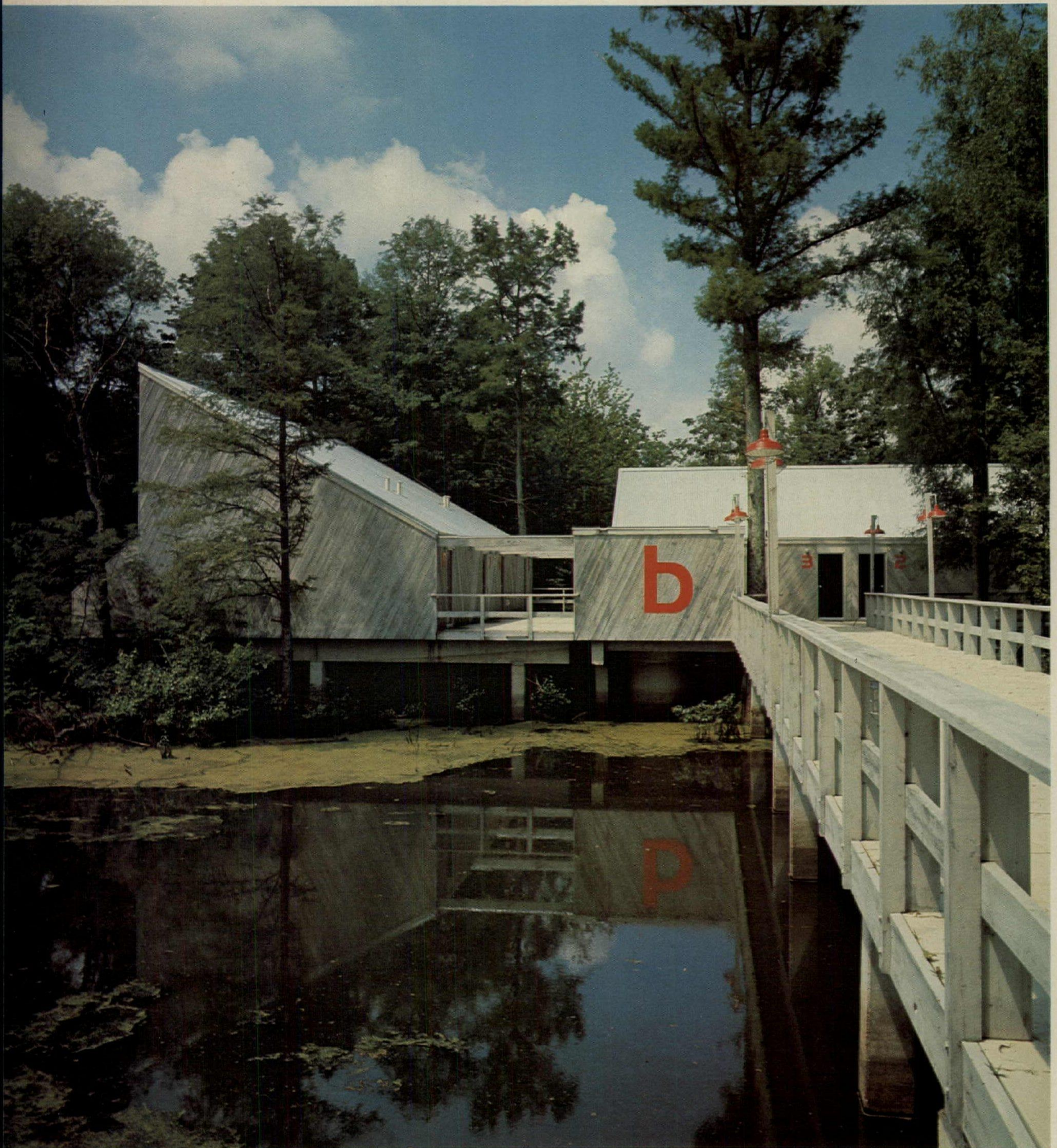

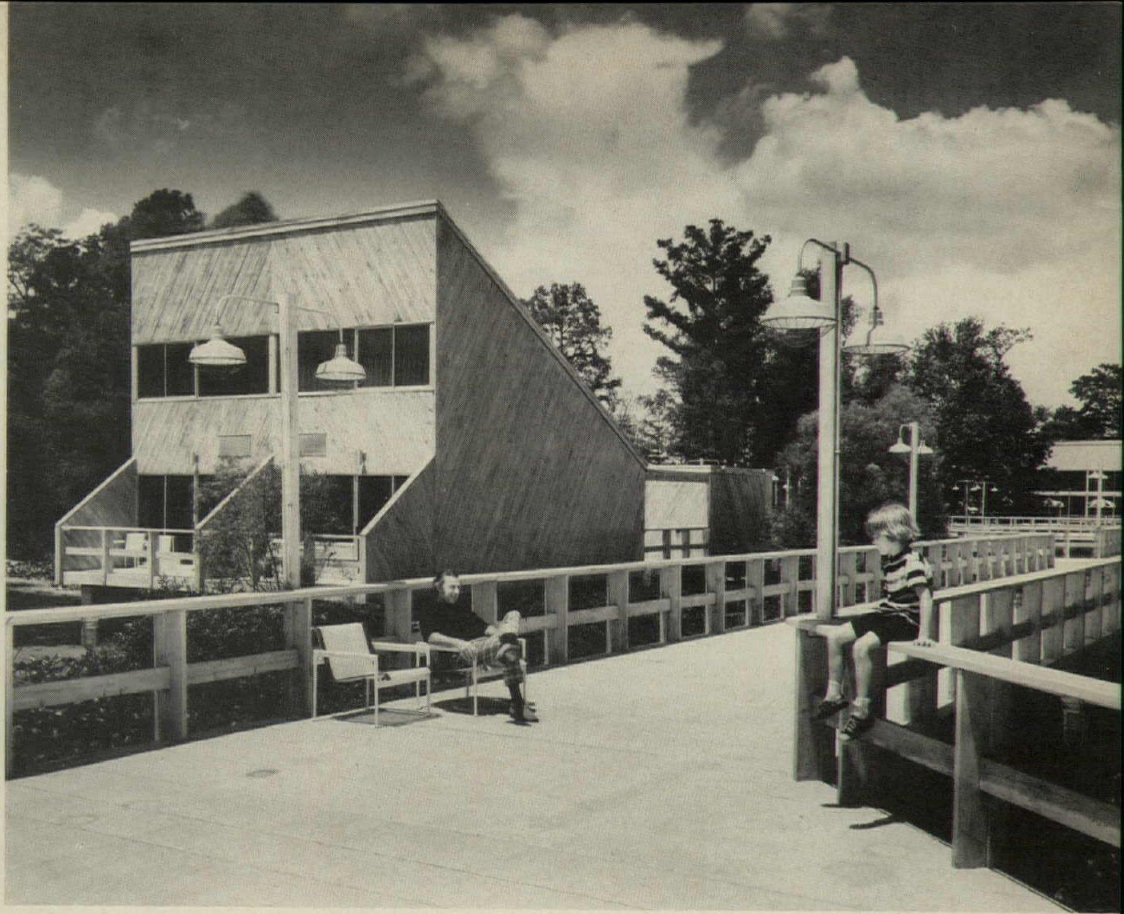

The very pleasant motel units are an important part of the changed image of Reelfoot Park, making it attractive to families as well as to sportsmen, as is provision of restaurant/lounge (left top and center) for day and overnight visitors. Public fishing deck terminates the 600-foot-long main pier.

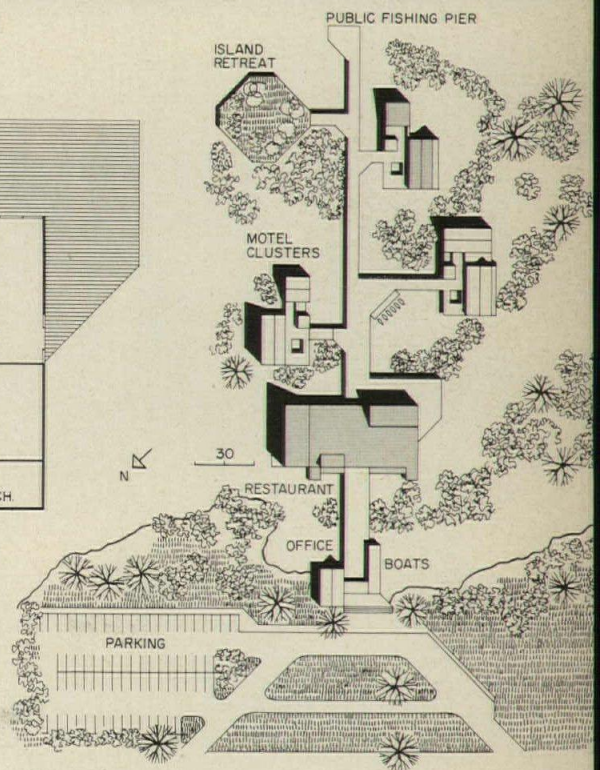
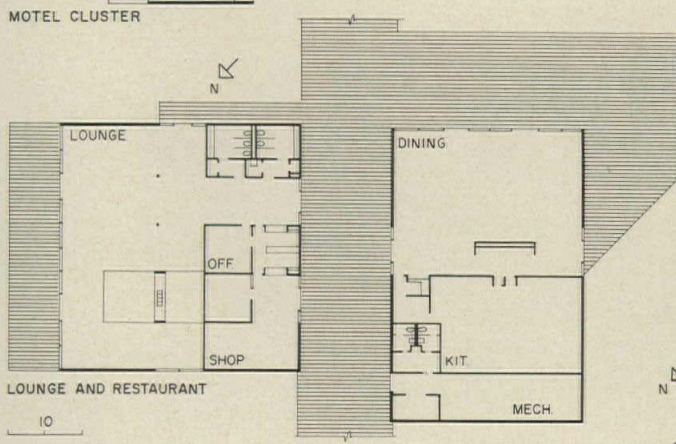
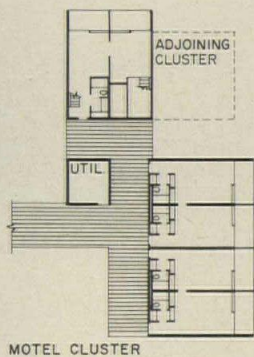
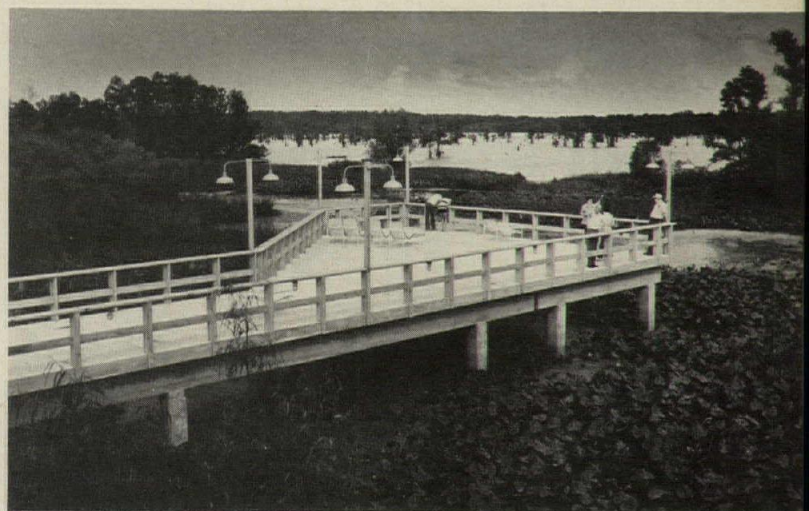

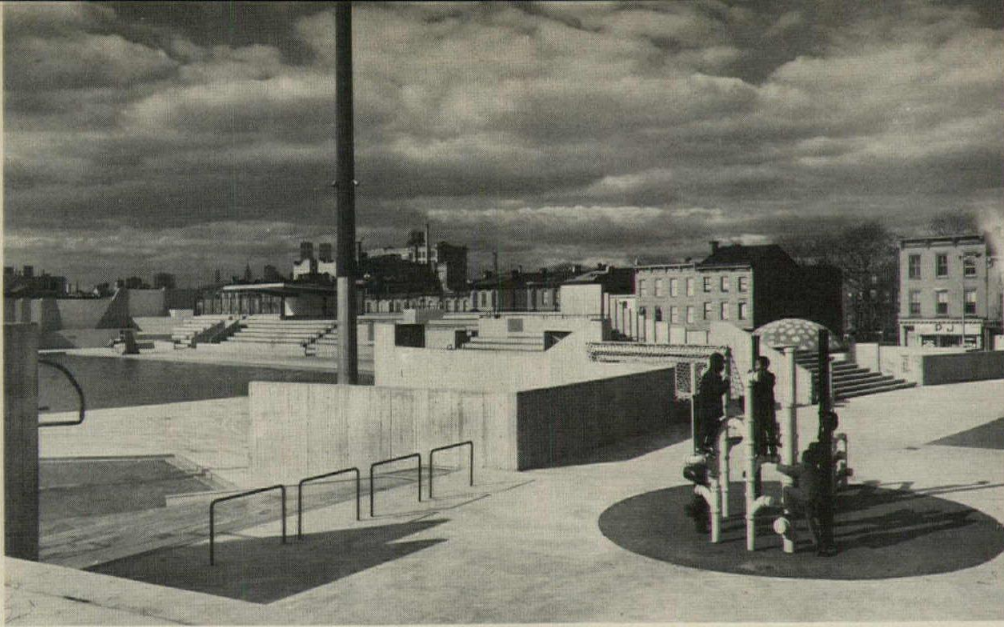

Bedford Stuyvesant Community Pool

More than just a pool, although that was what the program called for, this lively outdoor recreation center is the focal point—and largest open space—for a crowded ghetto neighborhood. “The People’s Pool” is the name given it by the people of the neighborhood, but its formal name locates it in a high-density area of Brooklyn, Bedford Stuyvesant. Despite a small site—three-quarters of a city block—this center provides a competition-sized pool, a diving pool, spectator seats along one side, dressing rooms and lockers and, for smaller athletes, a wading pool with fountain and imaginatively equipped play areas. The means for getting so much onto the site and at the same time maintaining exceptional openness—more welcome in Bedford Stuyvesant than in most city districts—was the architect’s decision to sink the bathhouse facilities one half level below grade in order to use their rooftop as a playground for small children. Broad steps, which double as places to sit and form an amphitheater for various kinds of neighborhood performances, make the transition between the rooftop playground and the main deck. Protrusions of mechanical equipment are put to use as part of the play equipment: ventilating fans are inside a pyramid for slides, and vent stacks would never be recognized in the maze of plumbing pipes which are interlocked to make a jungle gym. To be as vandalproof as possible, play equipment is built of concrete, painted cast iron pipe, or cargo nets. The wading pool (left, center) is connected to the upper level of the playground by a flight of steps which is also a water cascade, and by two water slides.

The structure is poured-in-place concrete throughout, with various textures at different points. All of the pools are of aluminum, and the fountain spray sculpture is also aluminum. Light poles are of weathering steel with narrow-beam targeting luminaires. The total cost of the center was \$4,413,278.

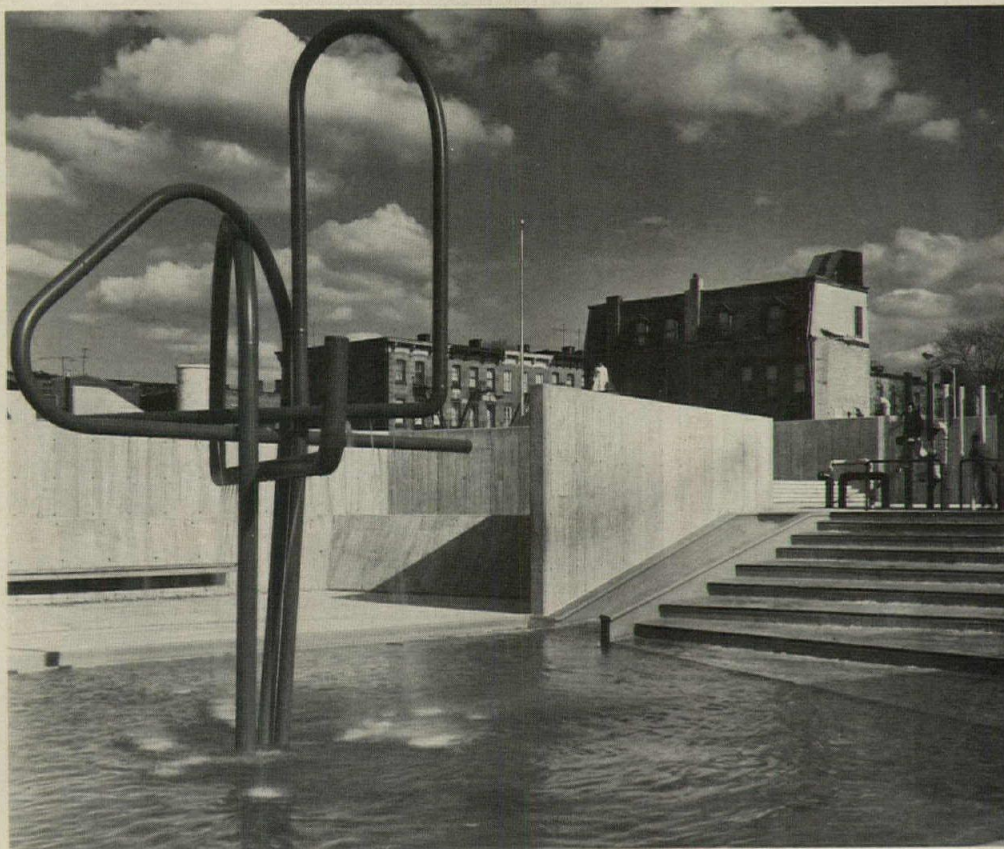

BEDFORD STUYVESANT COMMUNITY POOL, Brooklyn, New York, Architects: *Morris Lapidus Associates—Morris Lapidus, Alan Lapidus, John Bowstead, designers.* Engineers: *Ralph Dell’Abate, James McCosker and Associates, (structural); Herman Scherr Associates (mechanical); Meyers & Locker (electrical).* Lighting consultant: *Abe Feder.* General contractor: *Tern Construction.*

Ezra Stoller © ESTO photos

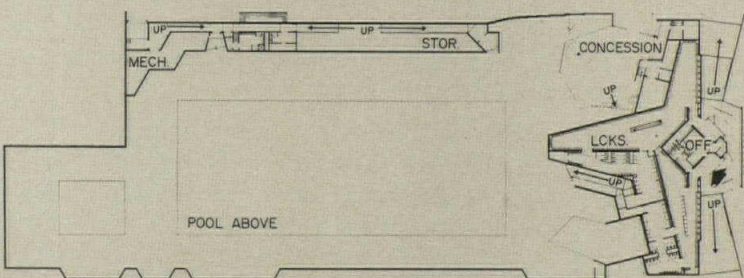

LOWER LEVEL

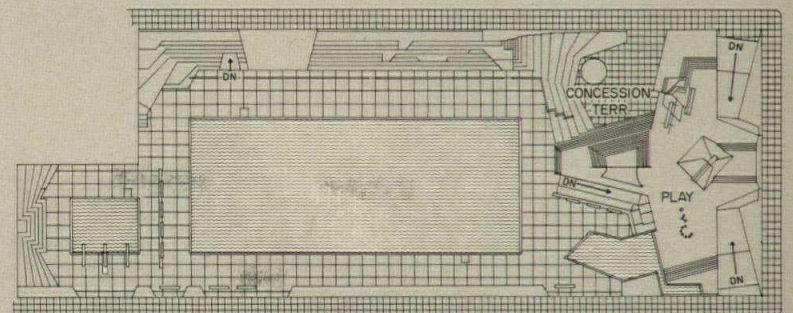

UPPER LEVEL

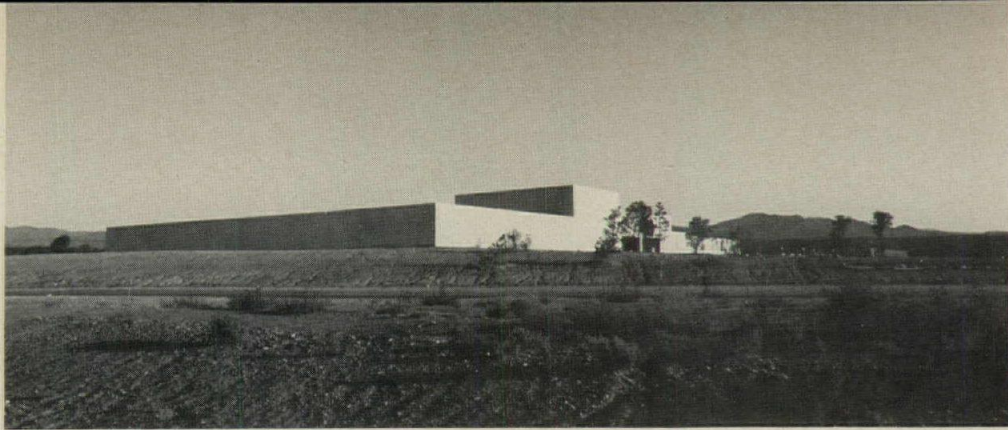

Cochiti Lake Recreation Center

Cochiti is a new town being developed in the high desert country north of Albuquerque, New Mexico, on an Indian reservation. To serve both the new residents and the long-time pueblo residents, a Town Center, with shops, offices, restaurant, crafts studios and apartments, is being built.

Cochiti Lake Recreation Center is the first building to be completed in the Center. It provides for both indoor activities and outdoor sports—its indoor facilities including a large game and assembly room which can be divided into smaller spaces, a kitchen, offices, and locker rooms to serve the two outdoor pools and two tennis courts.

This first building of the Center has been designed with the harsh character of the surrounding countryside as the determinant. The climate is hot, dry and windy, the earth dusty, vegetation sparse, and relief from the heat is welcome. The architectural solution derives from the intent to provide a building which would "temper the formidable elements of the place and employ its more amiable features. It was, accordingly, designed to be a hospitable, inviting place which pueblo children and Cochiti residents can adapt to their wishes." Thus, on the south and west there are no windows; light comes from the north and east, and even from these sources is controlled. Clerestory windows in step-backed walls admit an even amount of light to the assembly room at all times. Entrances are sheltered from direct sun and from winds.

Despite its harsh qualities, the setting for this building is spectacular, with mountains rising behind it, open sky above it and, as yet, nothing to disturb the great openness around it. The form of the building is simple but bold, horizontal planes responding to the land, the high central element reminiscent of Southwestern mesas. The exterior walls are a cool sky blue in color, physically and psychologically effective, as they reflect the sun's intense heat and also at the same time suggest coolness. The stucco is rough textured, and wood where used and exposed, is rough sawn—appropriate to the simple details designed to make the building's execution, under less than usual conditions, feasible. Completed in December 1973, the building and outdoor sports areas cost \$380,000, or a total of \$18 per square foot.

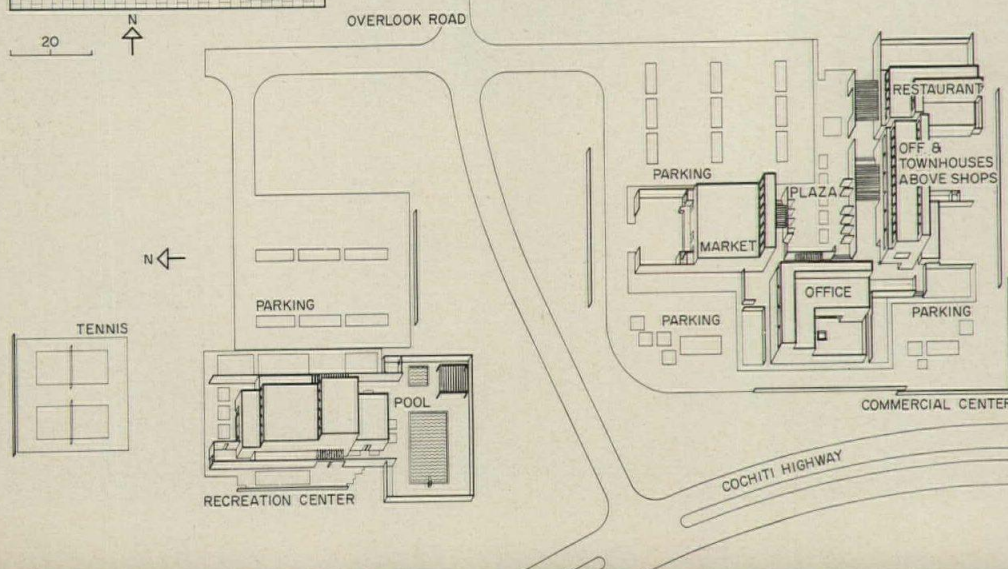
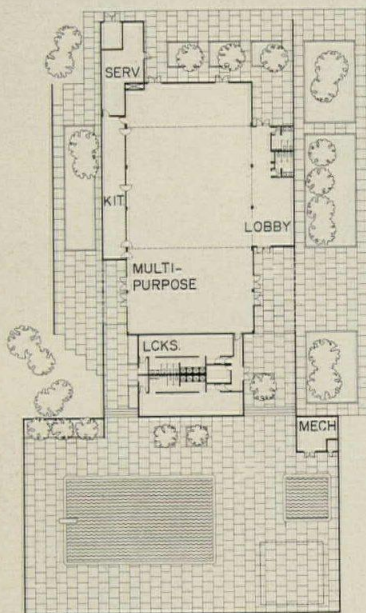

COCHITI LAKE RECREATION CENTER, Cochiti, New Mexico. Architects: *Frank O. Gehry and Associates*. Engineers: *Joseph Kinoshita & Associates* (structural). Landscape architects: *Sasaki Walker & Associates, Inc.* Contractor: *Great Western Cities Corporation, Inc.*

Jayne Odgers photos

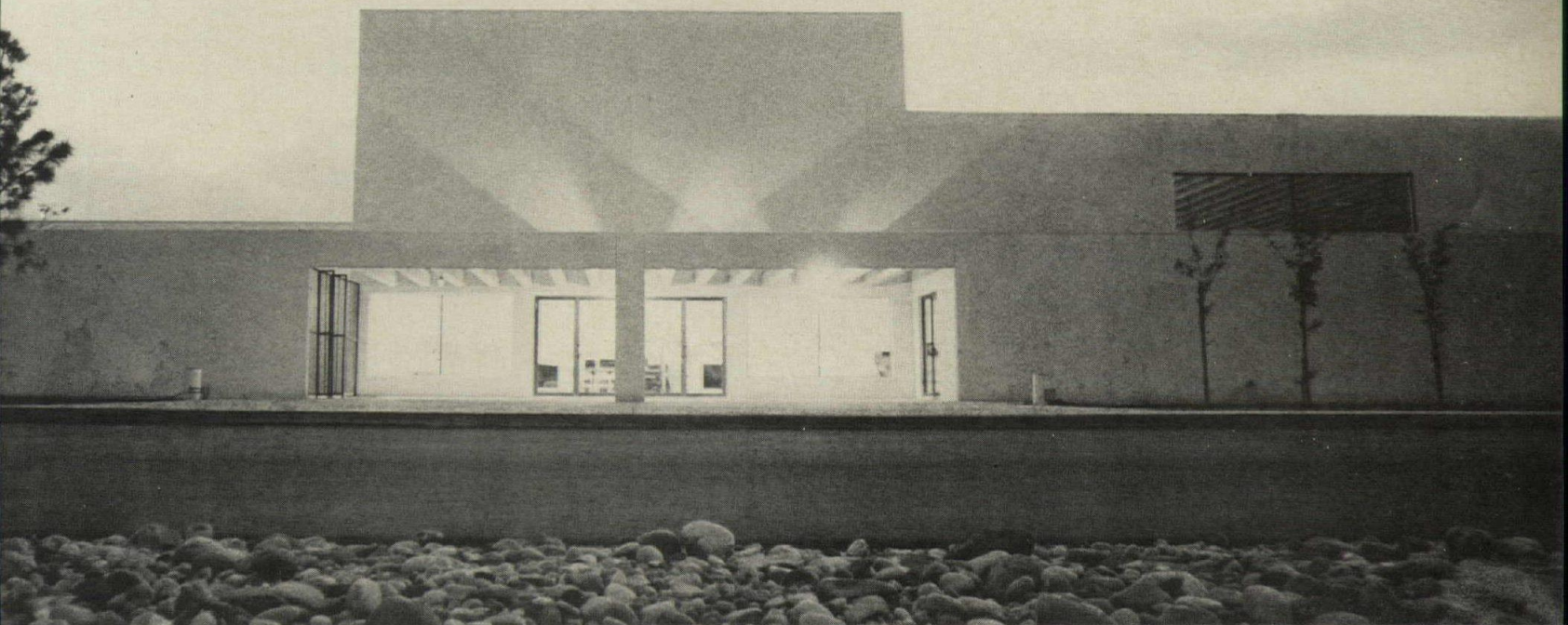
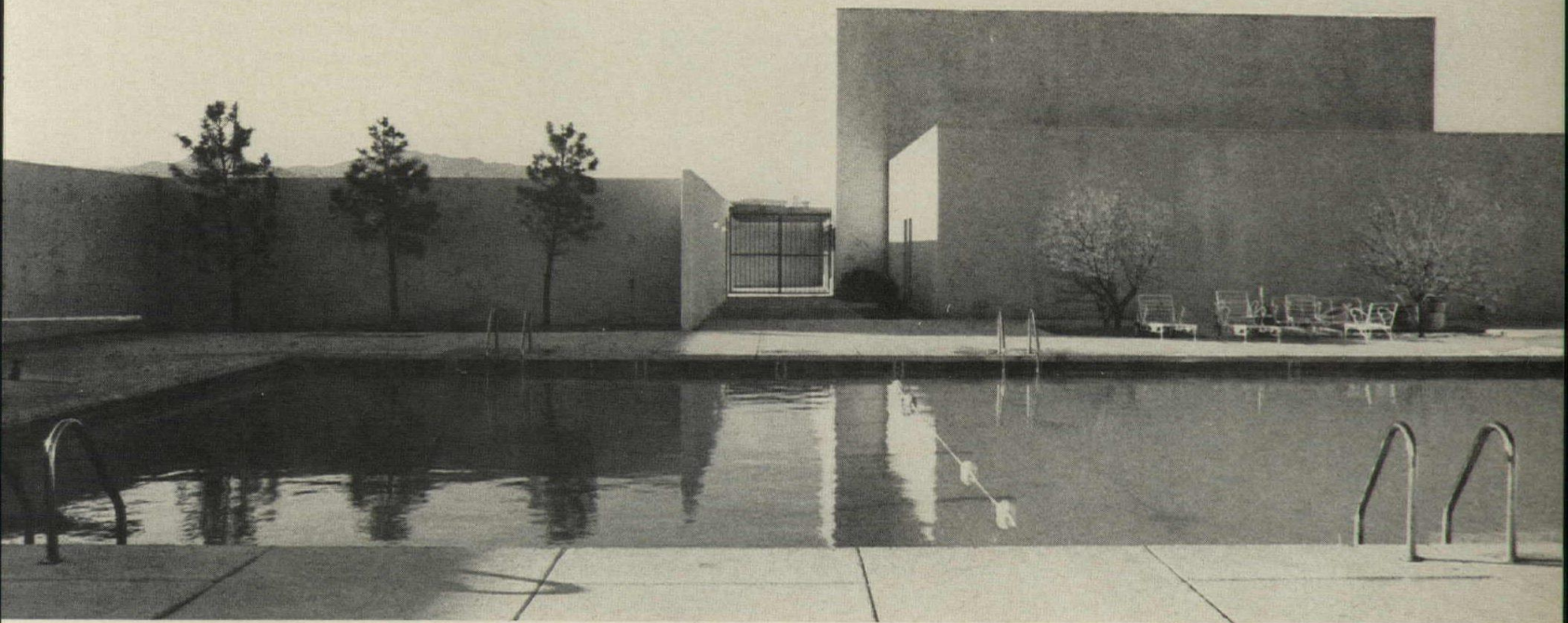

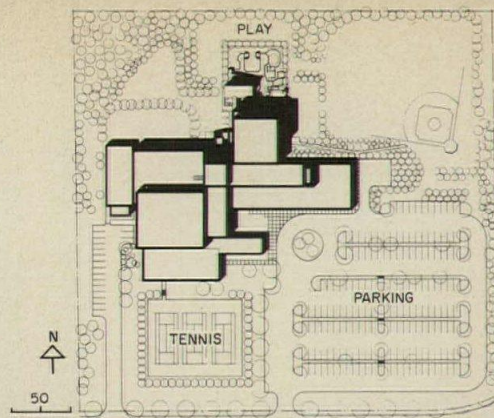

Jewish Community Center

A center for social, cultural and athletic activities is an important part of the program of a Jewish community. Sometimes such a center is part of a religious building complex, but it need not be so connected. The Portland (Oregon) Jewish Community Center is not part of a complex, but is instead located in a suburban part of the city, on a 10-acre tract surrounded by residences, apartments and a tree nursery. From this location it serves the whole Jewish community of Portland, and because of a long tradition of opening its swimming pool for therapy to any handicapped persons, it also serves others of the city as well as its own membership. The new building includes both a regulation-sized pool for general use and a smaller pool with separate entrance and lockers especially for therapy patients.

Since the building serves a full range of age groups, the program for the new building required provision of both specific areas for each group's activity and places of general assembly where all could come together for events of interest. As the plans show, a wide variety of special places, from pre-school to teenage to senior rooms, are provided in ways that preclude conflicts in use.

The building is two stories high, with the main entrance on the upper level (at grade because of a sloping site). Secondary entrances, serving the therapy pool and the preschool, are on the lower level. The lobby, off the main entrance, is central to all principal activity areas, and has direct spectator access to the gym, pool and multi-purpose room, all of which, because of the grade change, are at somewhat lower levels. The open balcony above the lobby (page 104) is a small reading room.

With a stringently limited budget, the provision of such a diversity of spaces was no simple accomplishment. To achieve both the kind of building that the clients wanted and the economy necessary, the architects devised a vernacular for the building based on the use of optimum (and different, but compatible) structural, mechanical and material systems. Reinforced concrete is used for foundations, floors, and columns. Where exterior walls appear as extensions of the foundations, they are of concrete, board-formed; where they are otherwise supported, they are of prepainted steel panels. The roof structure is wood frame.

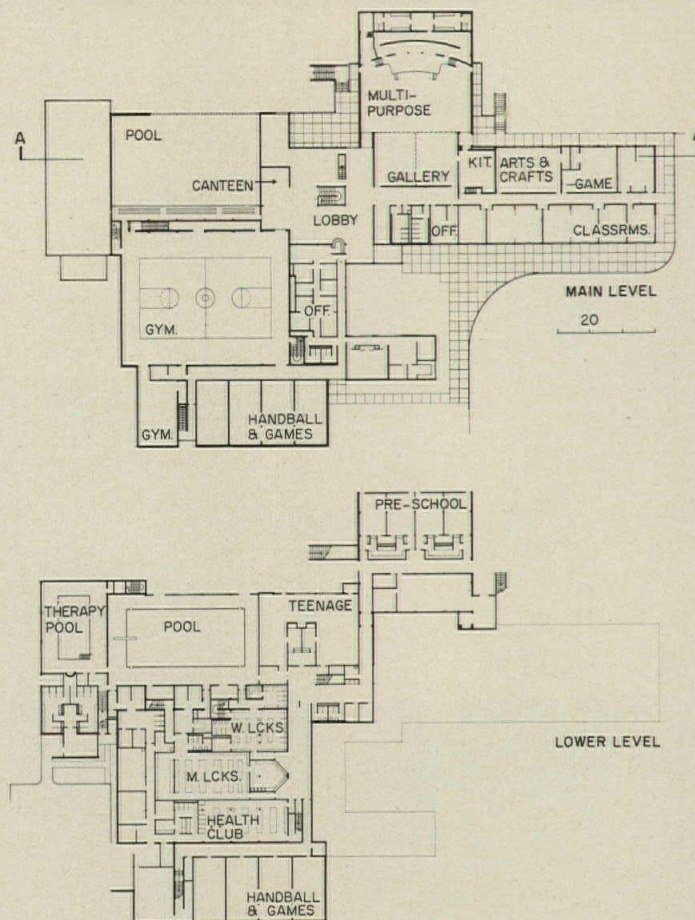

PORTLAND JEWISH COMMUNITY CENTER, Portland, Oregon. Architects: *Wolff Zimmer Gunsul Frasca*—Robert Frasca, partner-in-charge; Prescott Coleman, project architect; Wallace Roeder, job captain; John Williams, interior design. Engineers: Nortec Engineers, Inc. (structural, mechanical, electrical). Landscape architect: Robert Perrin. Contractor: Minden Construction Company.

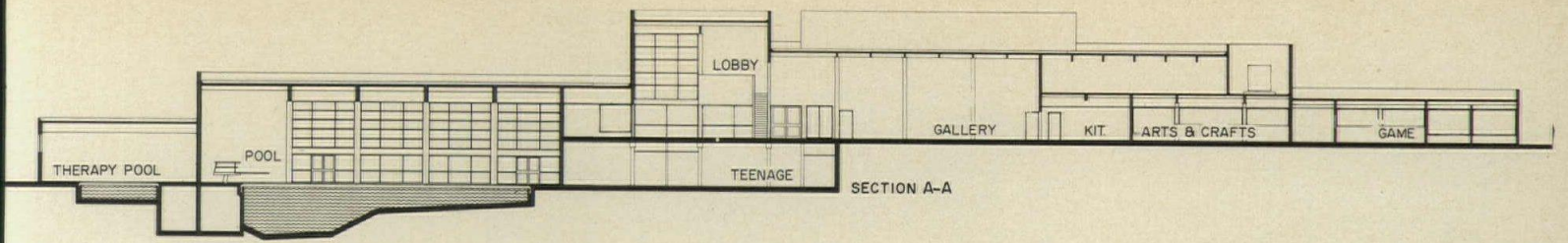

Ed Hirschberger photos

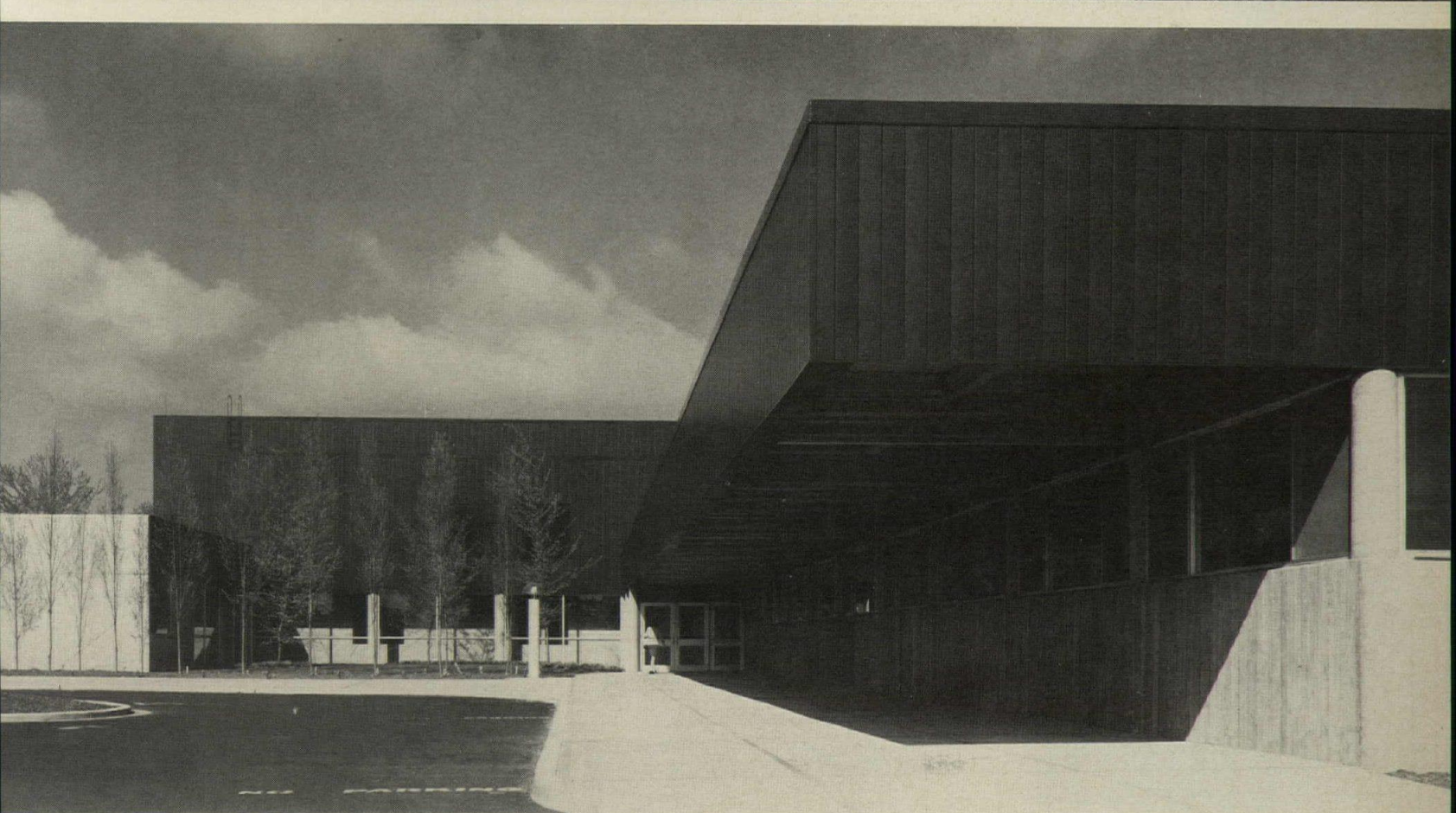
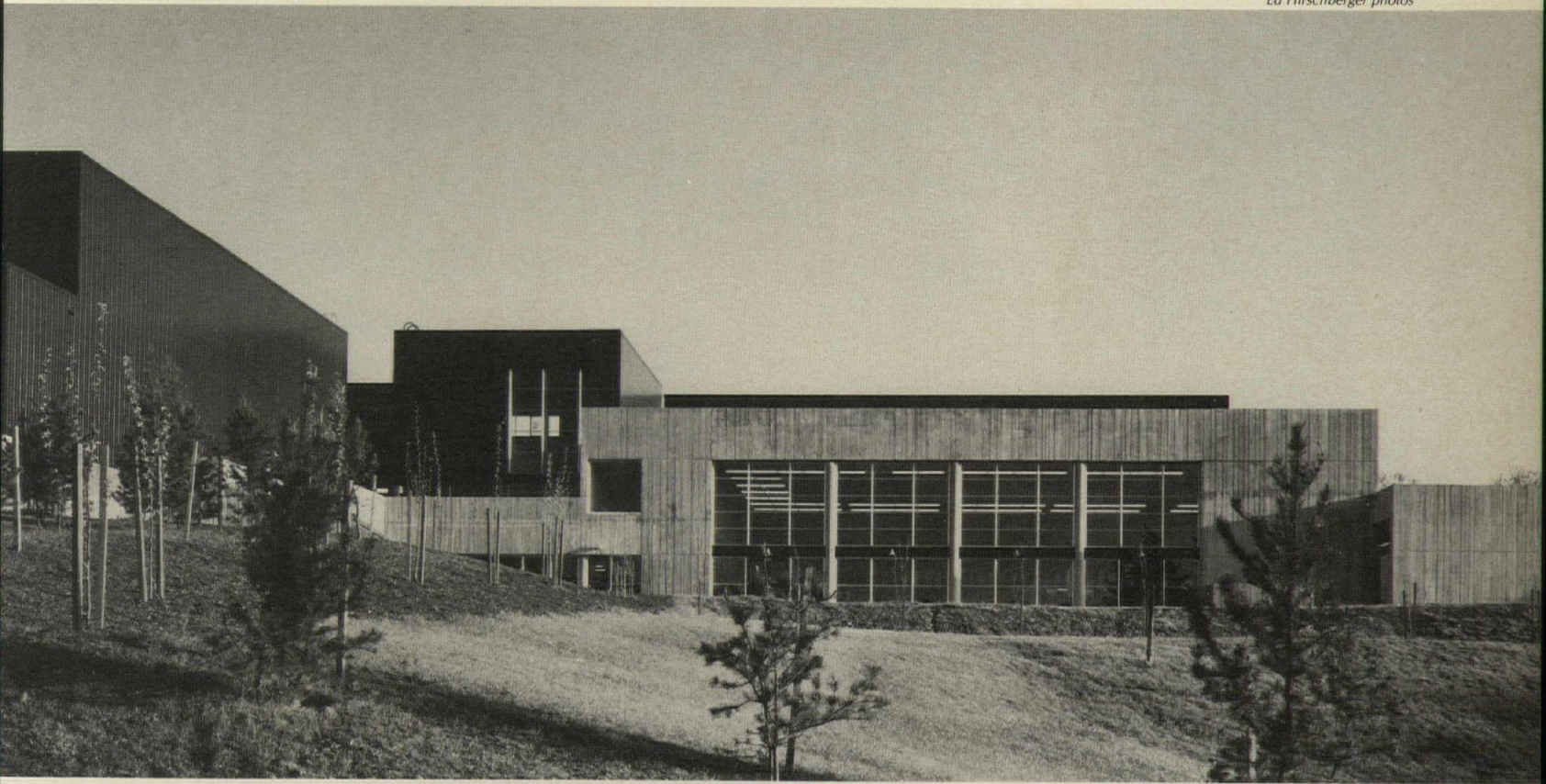

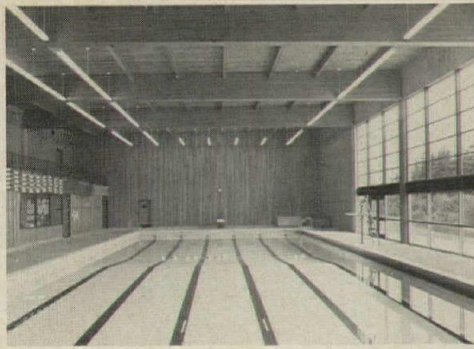

The multi-purpose room (left, top), is a place of general assembly, used for events of interest to the whole community. The lobby (above) is a dramatic place, by day and at night, with its two-story concrete columns which support, midway, balcony spaces. The large pool (top photo) is regulation size and is used by the membership. A smaller pool, with separate entrance and its own lockers, is used by therapy patients from all parts of Portland, a long-time tradition of the Jewish community of the city.

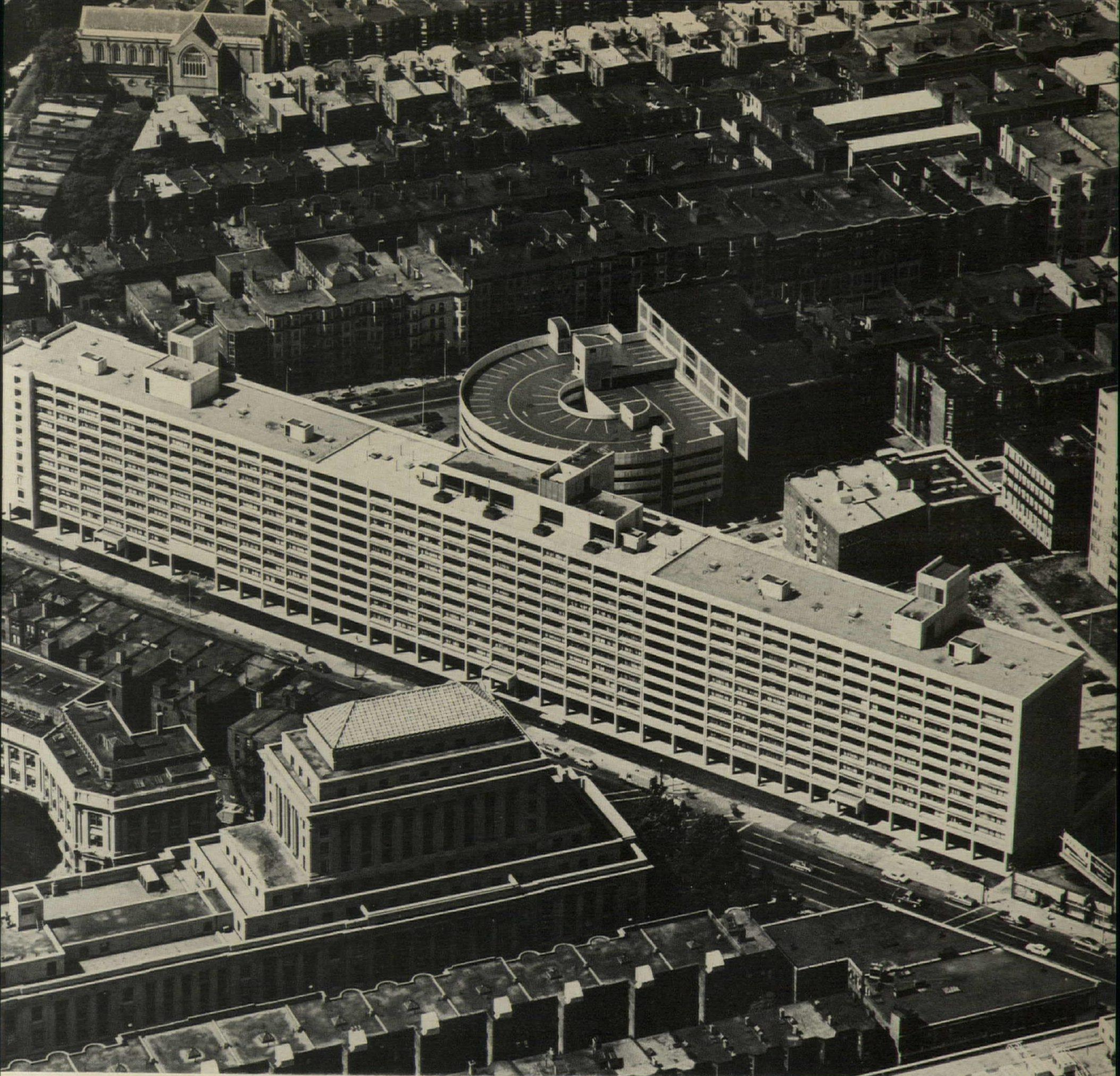

Wayne Soverns photos

CHURCH PARK APARTMENTS

A large scale building to fit a larger scale concept

At a time of increasing discussion among architects about the best ways to produce viable living situations in multi-family housing, several concepts are gaining popularity: usable open space near the units, groupings of small numbers of residents to encourage mutual concern, and respect for the surrounding-building scale to reinforce existing neighborhood resources. But these concepts are based on assumptions about the way in which buildings will be used which are not as relevant in this case as the building's role within a large scale urban plan, and The Architects Collaborative has not been afraid to express that role in a decisive manner. Partner-in-charge Alex Cvijanovic states that residential buildings can fulfill their most important function, provision of the maximum amenities for living, without being forced into house-like envelopes—and that massing is not necessarily relatable to what goes on inside.

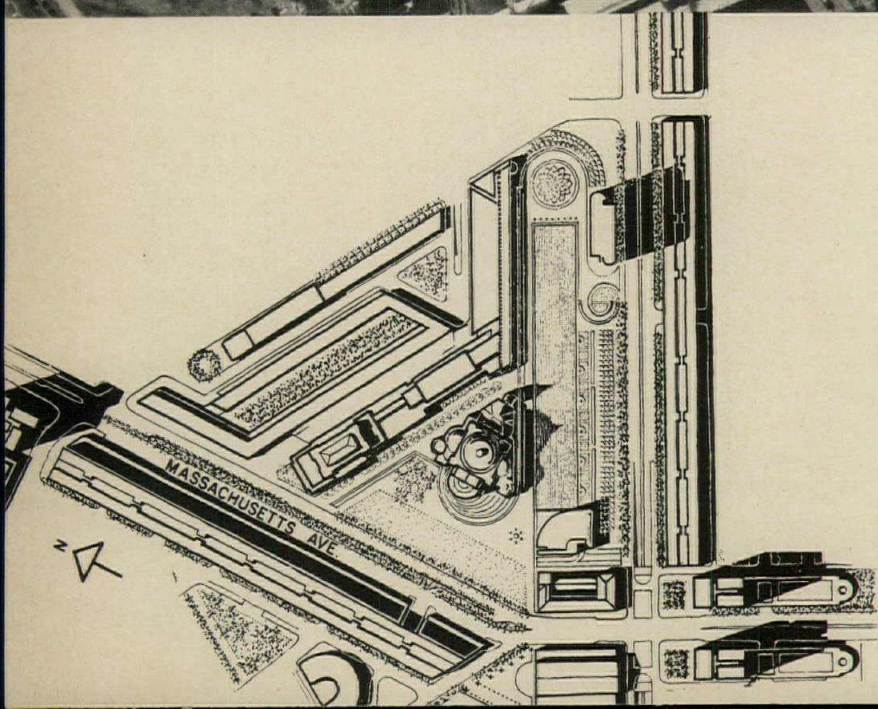
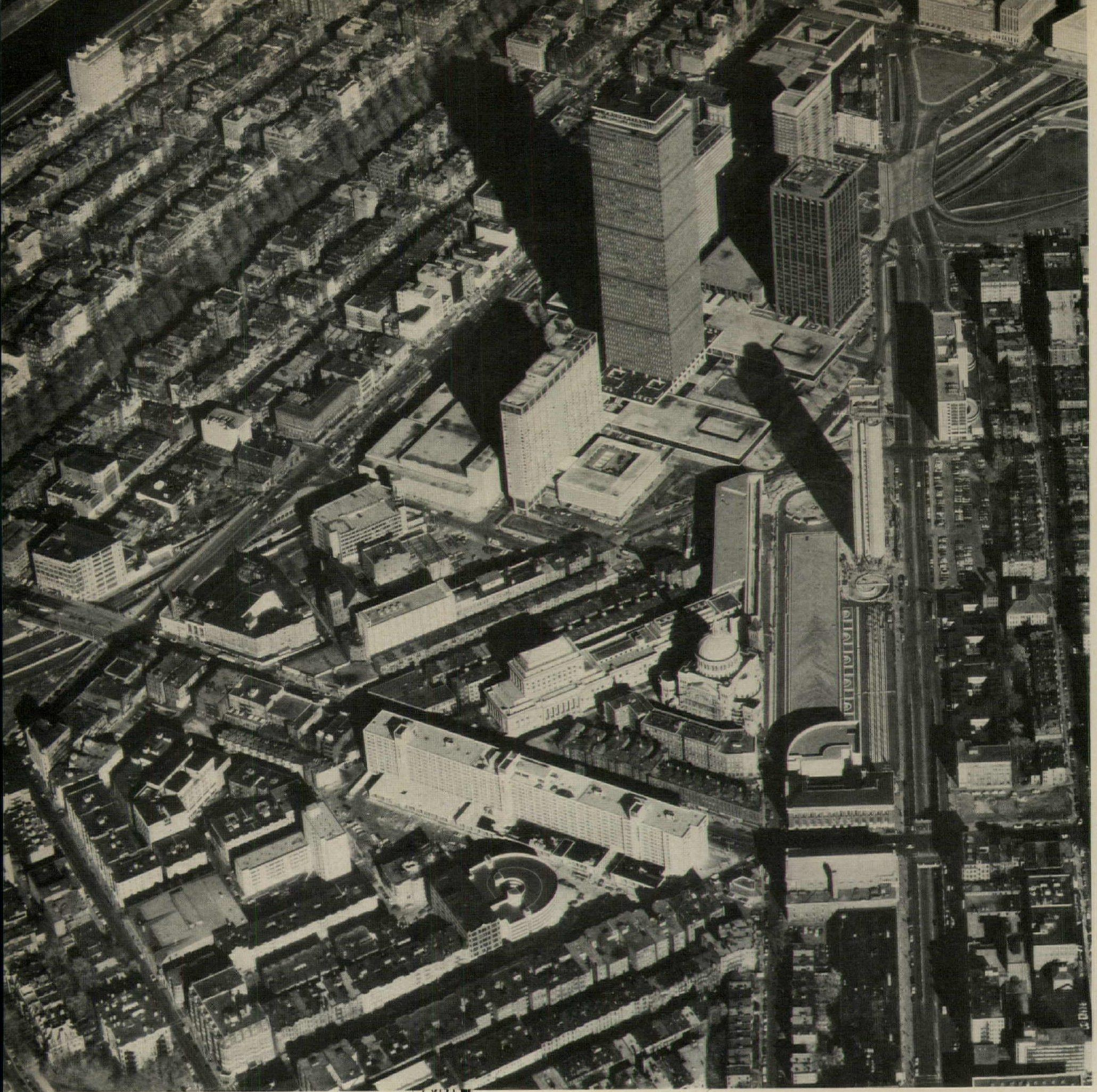

Church Park is an integral part of the Christian Science Center whose master plan (left) was prepared in 1964 by I. M. Pei and Partners and Araldo Cossutta, Associated Architects with Vincent Ponte as consultant. The scheme was devised to block a bevy of high-rise projects planned by developers around Prudential Center (top) and threatening to obscure the domed Mother Church while disrupting the residential neighborhoods to the west and south (see plan). The new apartment building partially completes two intentions of the master plan. Housing was programmed for the west and south boundaries to provide a stimulus to adjacent residents in doubt about their continued social and physical well-being and to supply a maximum number of facilities for the tenants displaced by the demolition required to carry through the Church's plan. The eventual financing methods were to be particularly appropriate to both parts of this goal (more later). The second intention was the formation of a visual boundary for a new forecourt



to the Church presently being created by demolition between that building and the apartments (the present condition can be seen in the photo, near right). A height requirement for most of the new buildings in the master plan was set at 104 feet which is the height of the bottom of the drum under the Church dome (higher towers will identify the three corners of the area). Accordingly, this new building has ten stories of apartments and a ground floor of commercial space. TAC's Cvijanovic states that another reason for this limitation is the enforcement of predominant heights, along the great length of Massachusetts Avenue, including those of the historic Horticultural and Symphony Halls directly southward. He also feels that a horizontal visual quality is appropriate to a heavily trafficked artery, which will contain a landscaped center divider in front of Church Park's 700-foot length. A street has been routed under the building (photo, far right) to avoid breaking the continuity of massing.

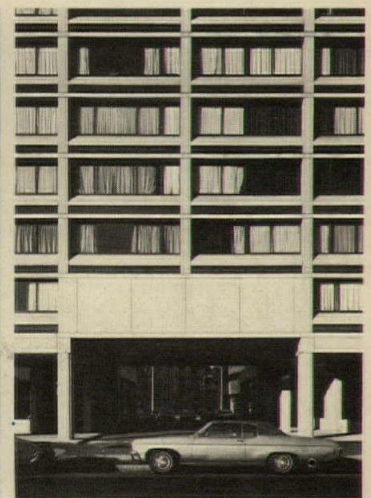

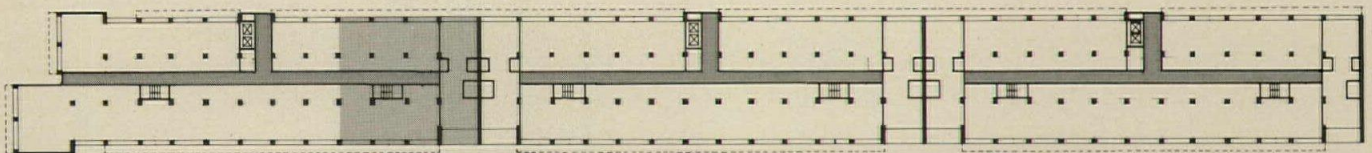

TYPICAL FLOOR

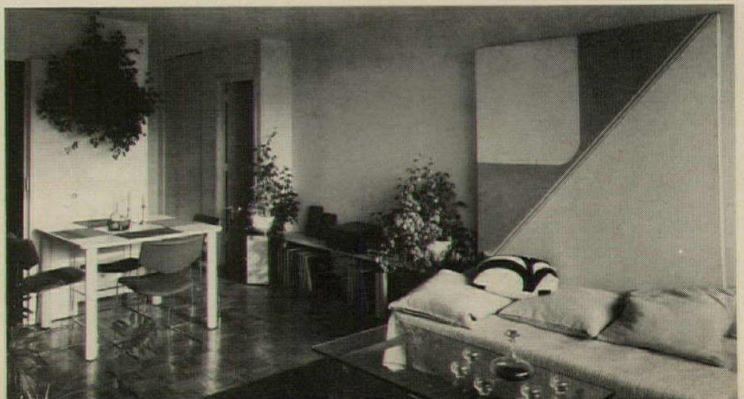
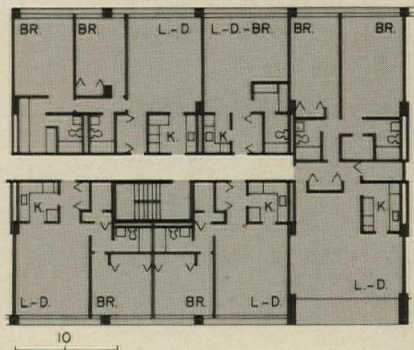

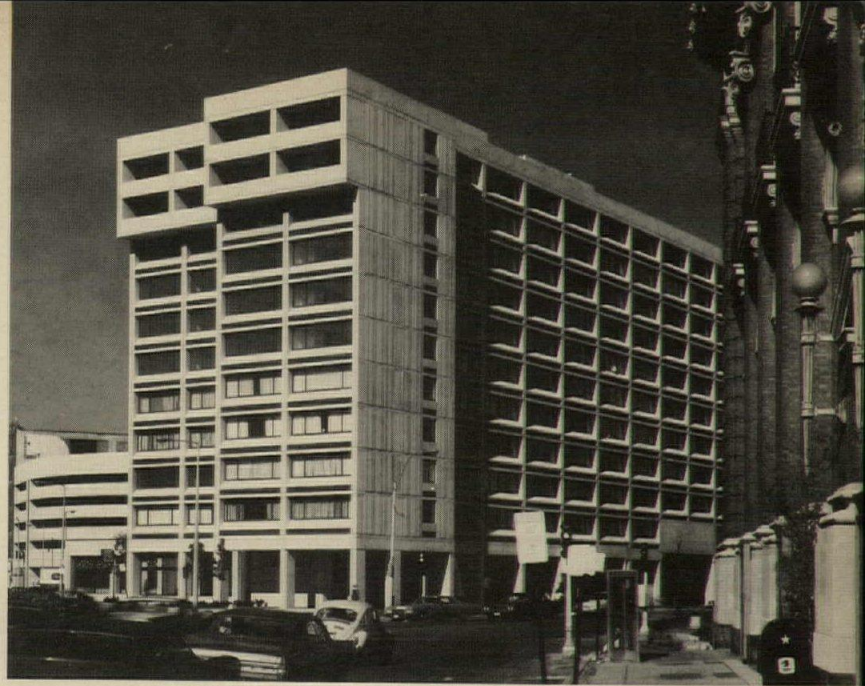

The various contexts of the facades are expressed by different treatments. The side of the building toward the smaller scaled-existing neighborhood is interrupted by projecting stair towers and ground-floor commercial space (left). The southern end of the building (above) recognizes the monumental character of the Horticultural and Symphony Halls in the foreground.

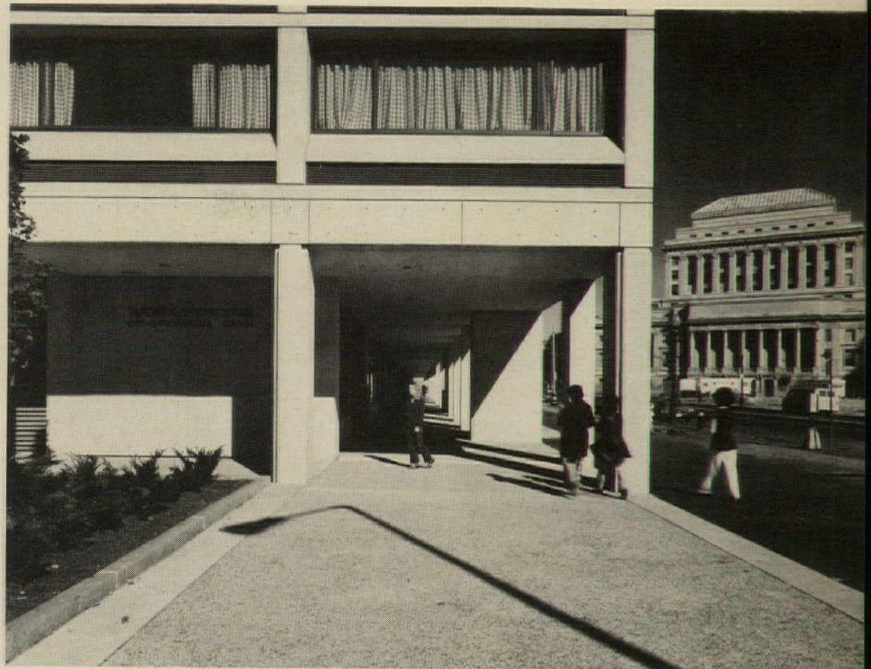

The master planner's urban-design concepts closely agreed with those of Cvijanovic, who now ponders the visual problems related to a possible 500-foot extension of the present building. Early proposals to stagger the building's plan were dropped as they were thought inappropriate, and such future digressions are not anticipated in the extension. The designers preferred to rely on subdued variations in the facade instead of pronounced articulation. On the Massachusetts Avenue side (above, right) the building is meant to be viewed from a speeding car or from the distance of the Church's forecourt. Pedestrians walk within an arcade.

Despite a great concern for fulfilling a "master" plan, Church Park does not turn its back on the neighborhood or relegate its inhabitants to life within an arbitrary form. There has been a determined effort to change visual scale on the face away from the Avenue (above). And the placement of the building directly on Massachusetts

Avenue leaves a maximum amount of land as a buffer between the 11-story structure and the existing neighborhood. The length of the building is interrupted by the projection of the elevator lobbies. A five-story parking garage with shops on the first floor forms a transition to the adjacent houses.

A look at the plan reveals that there are three distinct divisions within the one building, and the potential length of public corridors is greatly reduced. A maximum of 18 apartments on any floor share common facilities. The possibility for the mutual interest of residents previously discussed does exist, but Cvijanovic believes that such sociological aspects may not be that important in a building designed to function as free market buildings for small families. Another benefit of the divisions is the ability to provide apartments with two exposures at the corridor ends. Common outdoor space, community rooms and laundries are provided on the roof.

Church Park will be the first urban test of mixed income housing under the new concepts of the Massachusetts Housing Finance Agency which lends low-interest construction monies obtained from tax exempt bonds and requires that buildings in its programs be competitive on the free market while providing 25 per cent of the living units for the poor. The idea is to assure that high standards of construction, space, amenities and management are obtained for residents of all income levels whose undifferentiated apartments are mixed throughout the developments. MHFA had an early hope that rent skewing would pay for deficits caused by the lower-income units, but the Agency has had to become aggressive in obtaining public subsidies—including those under the FHA 236 program which are now largely attached to its work with Operation Breakthrough. The resulting tenant mix is particularly appropriate to Church Park, because it promises to fulfill the aim of providing stable housing for the various groups currently represented in the neighborhood.

Church Park has 22 efficiency apartments, 416 one-bedroom apartments and 70 two-bedroom apartments. Accordingly, many of the tenants are single persons or small families. Of the total 508 apartments, 127 are leased to the Boston Housing Authority for predominantly elderly tenants whose rents are set at one quarter of their annual income (which can not exceed \$5,400). Another 50 apartments are designated for subsidy under the FHA 236 program, and many of these house persons dislocated by new construction in the area and unable to pay free-market rents. The remaining units rent for amounts up to more than \$400 for a two-bedroom apartment.

To obtain the higher rents, the building has had to be designed to standards of amenity that are above average. Two-bedroom units have varying floor areas which can exceed 1,300 square feet. Parking for 544 cars is supplied on one level below the building and in the separate semi-circular garage. Fifty-nine thousand square feet of commercial space on the ground floor include provision for convenience shopping. On-going meetings between the tenants and the management, and the monitoring influence of the MHFA, assure high maintenance standards.

The Christian Science Center is located on land fill in what was Back Bay less than a hundred years ago. Piles of 80 to 90 feet are not uncommon in the area, but the developers of Church Park were fortunate in the discovery that their site is located over a level of bearing strata less than 10 feet below the ground level. It was the desire not to pierce this strata that caused excavation to be limited to the one level of parking and the separate parking structure to be built. The discovery was particularly fortunate because the construction costs limitations for this project were \$19.65 per square foot, and complicated foundations would have been built at the expense of above-

grade amenities. In calculating the allowance, such areas as garages are assigned a full-square-foot value, and a more traditional method of reckoning costs would have produced a figure closer to \$24 per square foot—still very low.

There are no "revolutionary" construction systems here. The structural frame is "flat-plate" concrete slab on poured-in-place-concrete columns. The concrete is exposed on the exterior in conformity with the materials of the Church Center. Window sills are pre-cast inserts and are separated from the floor by five-inch-high louvered grilles for individual heating and air-conditioning units in each room (the heat source is Boston's central steam plant).

To assure that this building and the other new construction around the Center would fulfill the intentions of the 1964 master plan, the Church purchased that part of the 32 acres which was included in its study but not directly controlled. Fifteen of those acres on the west and south boundaries, which were designated for residential construction by private developers, were to carry a programmed density of about 170 dwelling units per acre. In the case of Church Park's three acres, the MHFA required that the land be purchased by the developer, but design controls and a right of future repurchase were retained by the seller. The Boston Redevelopment Authority had the site designated as part of the Fenway Urban Renewal area in 1967 at which time it adopted the entire Pei-Cossuta plan as its own. The BRA continues to be active in the Area and has been instrumental in initiating the imminent construction of the two apartment towers in the south-west corner of the master plan. Construction of the intended extension of the Church Park building to the north along Massachusetts Avenue is not so certain. The Authority is looking for a developer who would choose his own architect. Alternately the possibility of rehabilitating existing buildings exists.

MHFA construction allowances are dependent on the "bottom line" in the total development costs. Higher allowances would certainly be required to reproduce this building today. The Agency makes no minimum standards such as the FHA, because "minimum standards become all that you get," according to an agency spokesman. Instead, there is an individual project review of plans with an emphasis on free-marketability. Director William J. White feels that quality of design will be important in making the mixed-income-resident concept work and is delighted with the results.

—Charles Hoyt

CHURCH PARK, Boston, Massachusetts. Owner: *The United Company*. Architects: *The Architects Collaborative, Inc.*—partner-in-charge: Alex Cvijanovic—associate-in-charge: Royston T. Daley; job captains: Richard Brimley and Edward Matick. Engineers: *Souza & True* (structural); *Haley & Aldrich, Inc.* (soils); *Joseph Schneider Engineers* (mechanical/electrical). General contractor: Volpe and URH (joint venture).

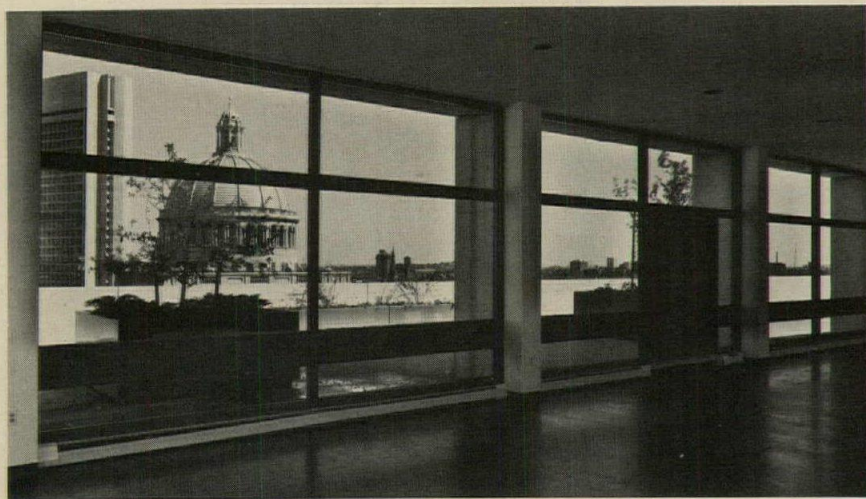

New Reflections in Shaw's Garden

Its mirror glass walls reflecting the verdant images of Shaw's Garden, the John S. Lehmann Building, by Hellmuth, Obata & Kassabaum, is the latest addition to the Missouri Botanical Garden. Its architects strove to make the low-profile exterior recede into its surroundings—to make it a backdrop against which the changing seasons could play out their annual drama. Behind the glass walls, the Lehmann Building contains a superb collection of more than 2 million botanical specimens, some collected more than a century ago by Charles Darwin and John C. Freemont. In addition, the building provides public reading, work and support spaces that must surely make it the envy of scientific institutions everywhere.—*Barclay F. Gordon*

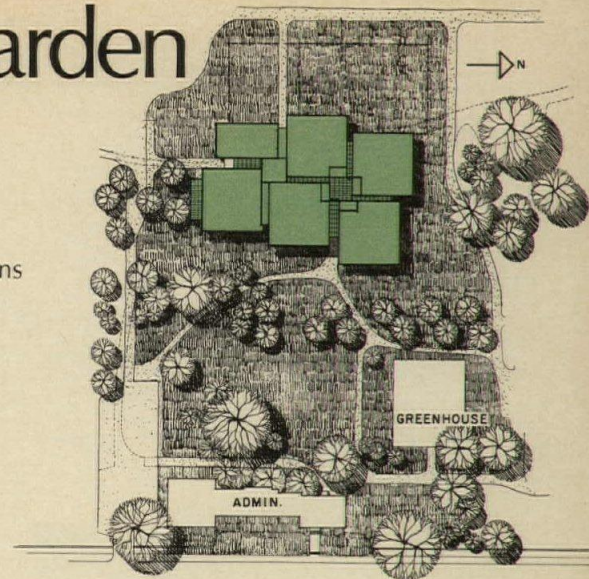

At the heart of the John S. Lehmann Building is the herbarium and, forming its nucleus, is a new storage system of "compactors"—bright orange metal cabinets containing dried plant specimens and mounted in tandem on steel tracks. By pushing a coded button, a researcher sets the compaction system in motion and it keeps moving until an aisle is opened up alongside the desired unit. The research staff estimates that the system nearly doubles the capacity of the storage area while requiring only slightly more floor space than more traditional storage systems. Because the compactors produce a substantial load, they are kept on the lower level which is depressed

half a level below grade. The floor above is occupied by a reading room, shelving for 125,000 volumes, rare book room, bindery, cataloging and office space. The half level between (see plan) is used by the public as an Education Department and has its own auditorium and entrance on grade.

These several functions are housed in 65-by 65-foot modules arranged in a pinwheel shape and spaced out by skylights wherever possible. These skylights break up the mass of the building, introduce daylight deep into the interiors and exert a strong linear pull, guiding visitors along principal avenues of circulation (photos right and below).

The building's exteriors make more than ample use of mirror glass, but at the interrupted parapet and on wall surfaces where glass was inappropriate, the architects have used concrete, finished to match the color and texture of Henry Shaw's historic Tower Grove House which stands nearby.

The compelling interiors speak eloquently in their own behalf.

JOHN S. LEHMANN BUILDING, St. Louis Botanical Garden, Missouri. Architects: *Hellmuth, Obata & Kassabaum, Inc.*—Gyo Obata, principal-in-charge; Charles Danna, project architect; L. Dean Smith, interior design. Contractor: *Hercules Construction Co.*

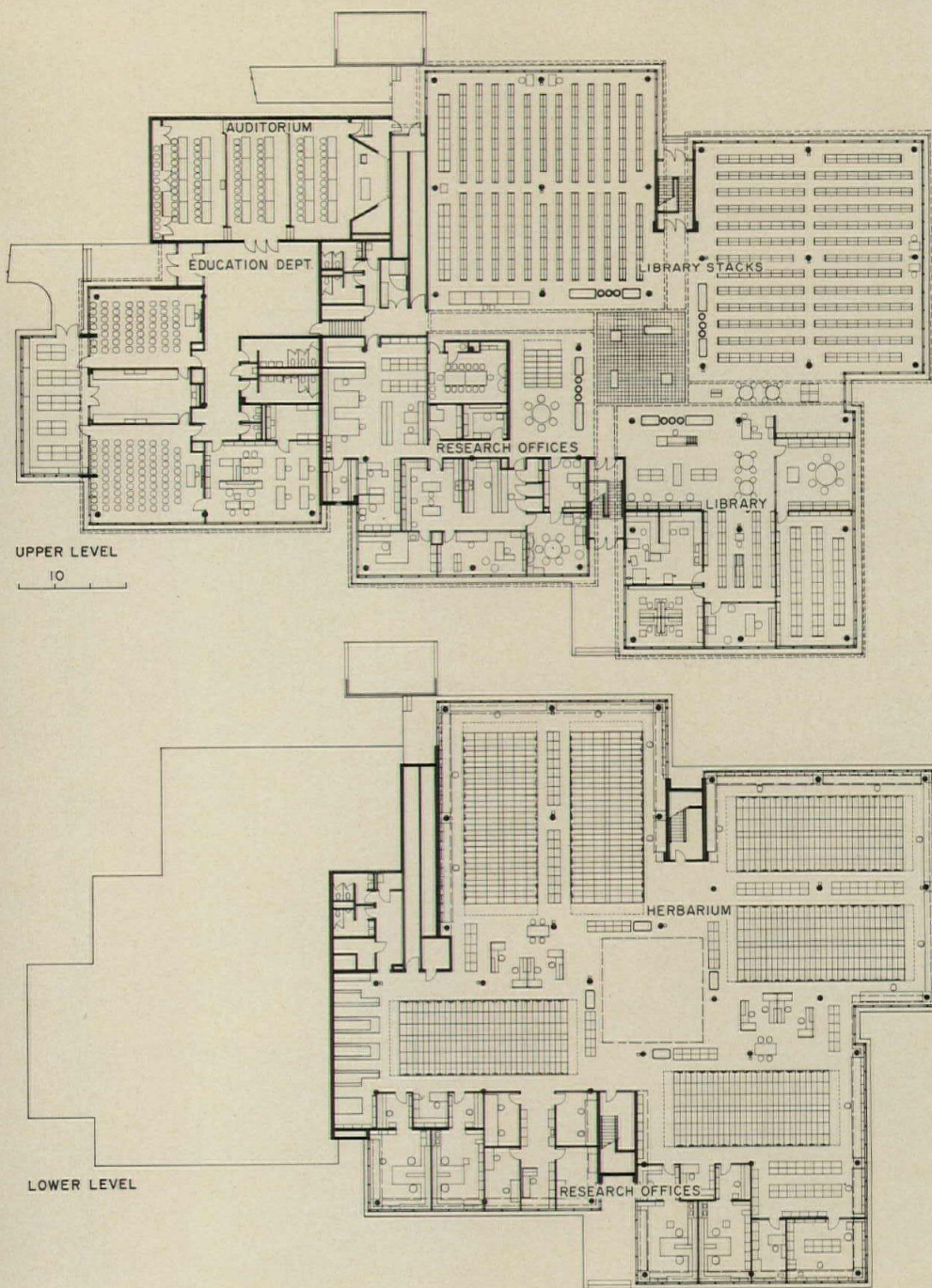

The 65- by 65-foot modules show up clearly in the plans. Ranged around a skylighted reception area, the modules pinwheel out in functional divisions and are spaced apart by narrow skylights. Provision has been made for later expansion of the Lehmann Building by repeating the modules as more space becomes necessary.



Alexandre Georges photos



Construction costs for the three-level, 50,000 square-foot building was approximately \$1.8 million of which \$600,000 was obtained in a grant from the National Science Foundation. The balance came from private donations—mostly from local citizens. The citizens, with substantial assistance from Henry

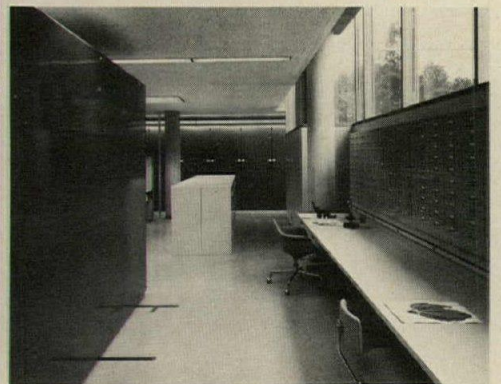

Shaw's estate, also maintain the facility and most of its programs. The herbarium includes what is probably the most extensive collection of plant specimens from tropical Africa to be found anywhere in the United States.

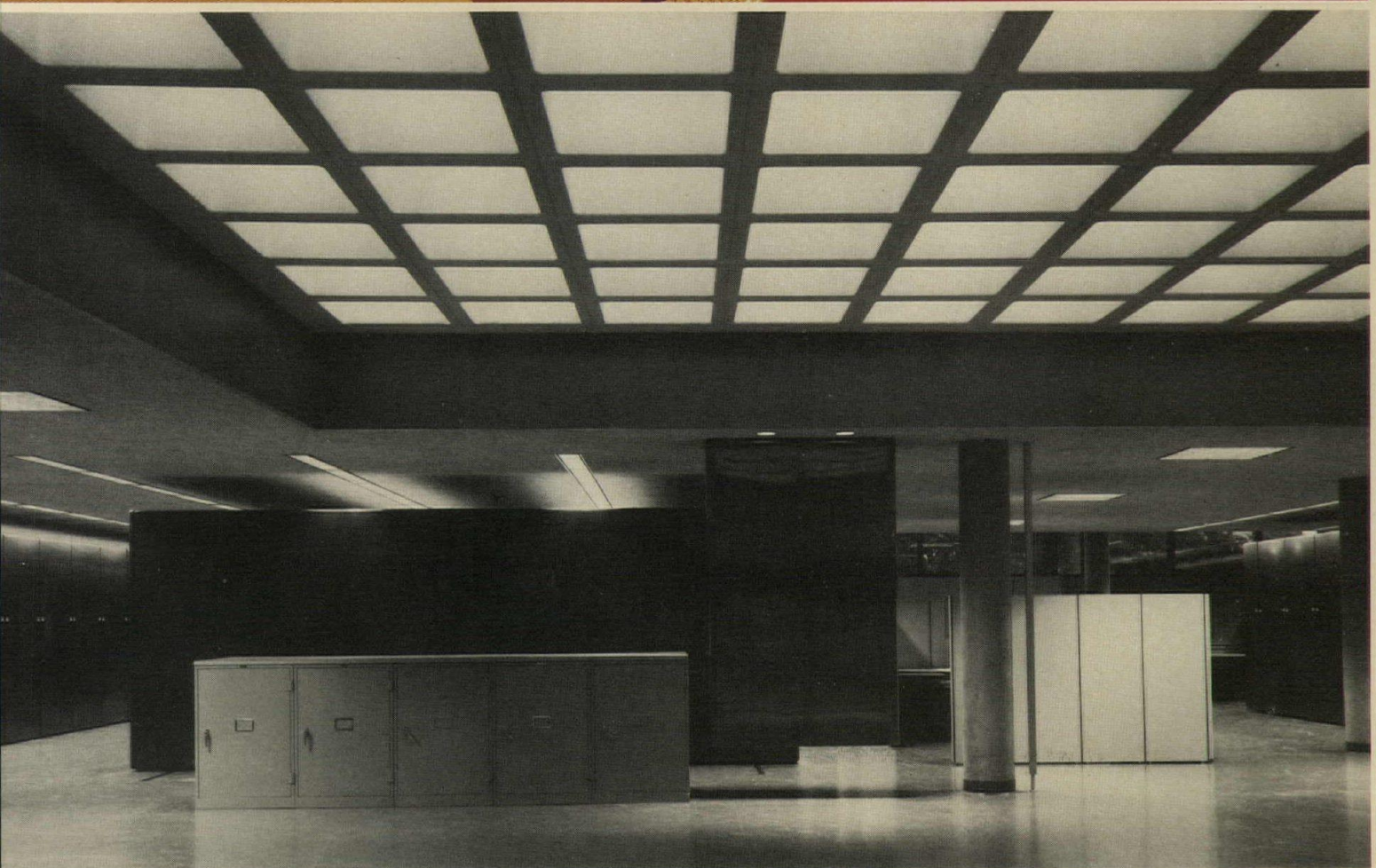



Silver reflective glass was a natural choice for the window walls because it acts as a mirror from outside and a transparent sheet from within (photo below). Its reflective quality and thermal properties are affecting significant savings in heating and air-conditioning costs.

The 275-seat auditorium (below) serves both staff and

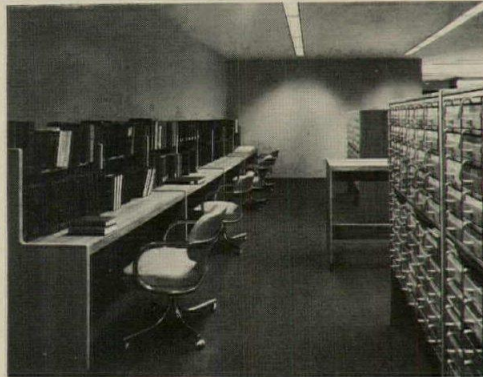

the general public who enroll in botanical and horticultural classes and programs offered on a regular basis by the institution.

In addition to the auditorium, the education department includes a greenhouse, two classrooms, an office and a workroom, giving the institution a strong public service component.

Upgrading barns to be inhabited by people

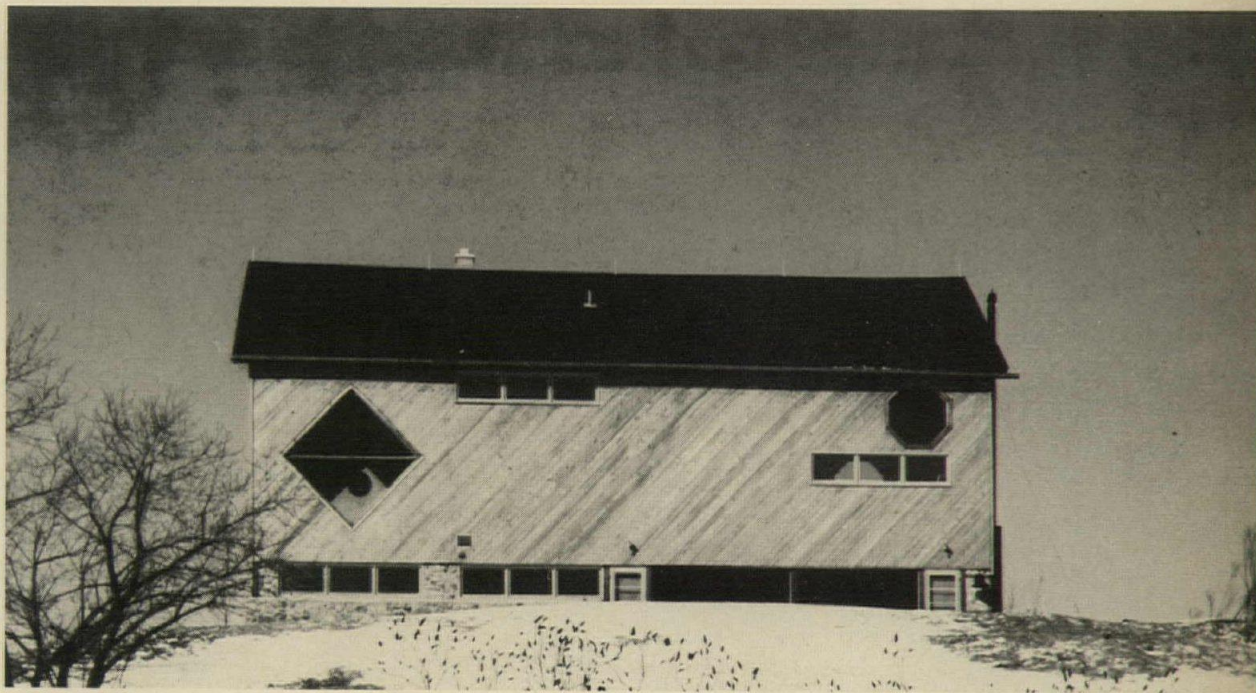
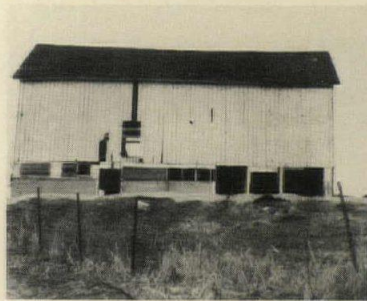

Cows and horses are still moving out of landmark barns and city folks are moving in. Ever ready to facilitate this particular ebb and flow is architect Stanley Tigerman who has remodeled the two barns shown on these pages and would like to do more. Once the hay and livestock are gone, an old barn becomes a challenging place. When set upon by spirited clients and a knowing architect, it ceases to be intact as an expression of its original function. Transformed by windows and doors located and shaped with deliberate esthetic intent, it proclaims the existence and nature of its new inhabitants and is a barn no more. A Tigerman barn becomes an anomalous hybrid, its form still visibly the unconscious artistry of a turn-of-the-century farmer, but its expression the product of the conscious artistry of one of this country's most sophisticated architects. Such juxtapositions are always arresting and often even pleasing—as we believe these two barns to be.—*Mildred F. Schmertz*



Philip Turner photos



A unique family house with a fine old barn for a skeleton

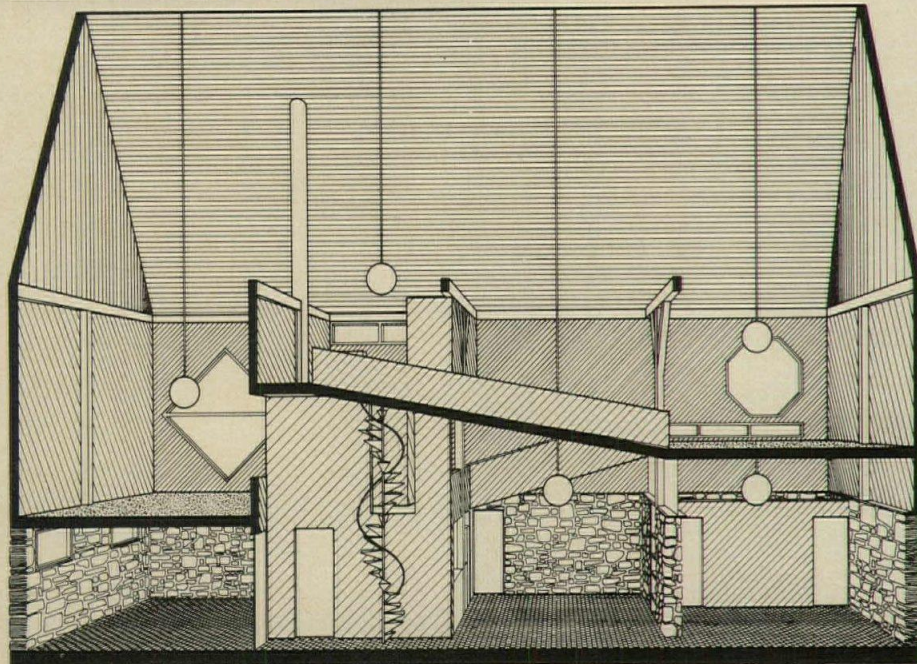
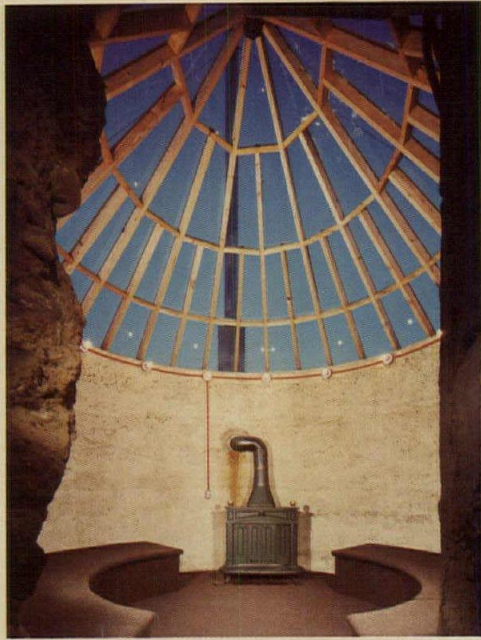

When a client buys an old barn, he usually gets only a rough-hewn timber skeleton (top right) on a stone foundation. The threshing floor, exterior siding and roof are usually in such poor repair to at best provide only firewood. After the barn floor is removed, new levels, ramps and staircases are added to make the most of the interior volume. Early in the construction process, a new roof is installed and the timber skeleton is wrapped in new siding perforated by strategically placed windows and doors. A kitchen and bathrooms are added and the barn becomes a spatially complex house.

Architect Tigerman's clients chose a barn located on a large farm which they are turning into a natural game preserve. The family consists of four children from primary school to college age. The construction budget was quite low, but cannot be divulged at the client's request. The 30- by 60-foot barn had been burned out, but the whole foundation was there and its structure and knee braces were in good shape. A local carpenter was hired to put it all together again. He completely remade the exterior envelope, after which the electrical work was put in, exposing all conduit, switch plates and duplex receptacles, which were color-coded. The plumbing and ductwork is also exposed and color-coded. The silo foundation (top left) has been converted into what the architect calls a "womb room."

THE VOLLEN BARN, southern Wisconsin. Owners: Mr. and Mrs. Harry Vollen. Architects: Stanley Tigerman & Associates; associates—Anthony Saifuku and John Haley. Engineers: Wallace & Migdal (mechanical and electrical). Interior design consultants: Stanley Tigerman & Associates. General contractor: Lee Whitmore.



Philip Turner photos

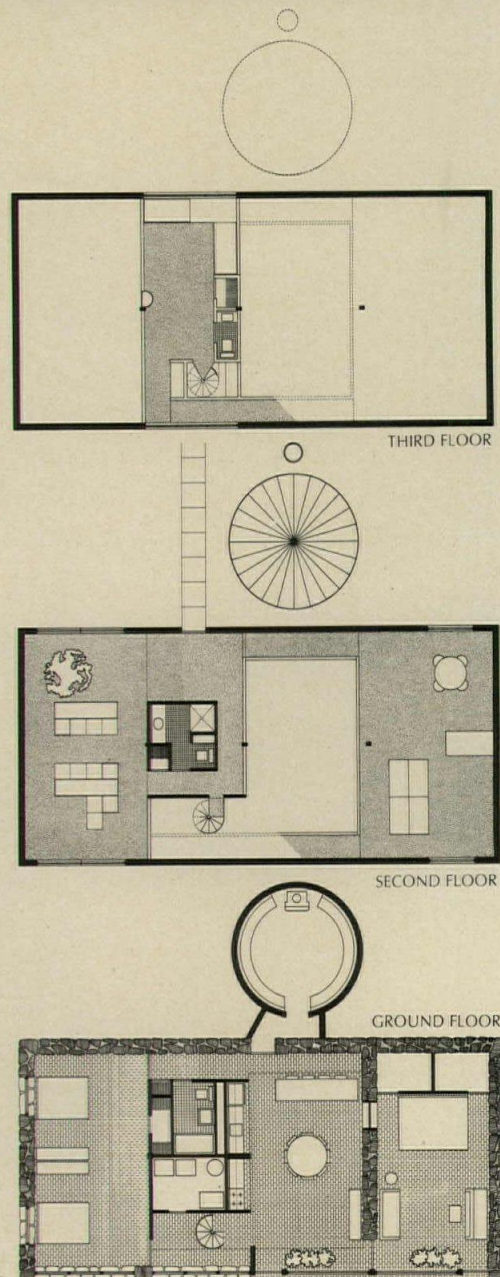
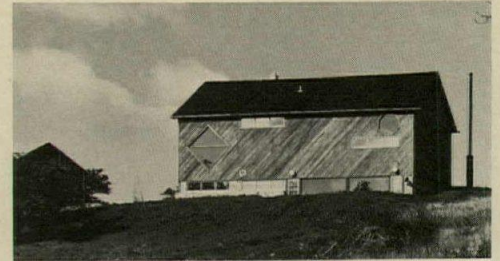



Part pumpkin, part lunchbox—it was once a barn

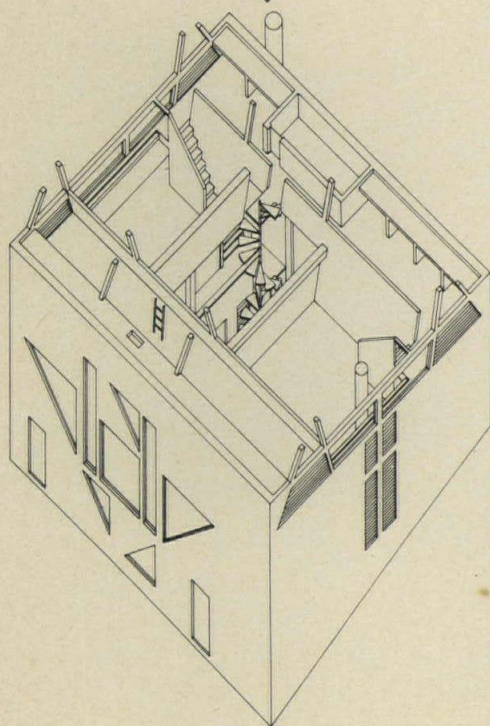
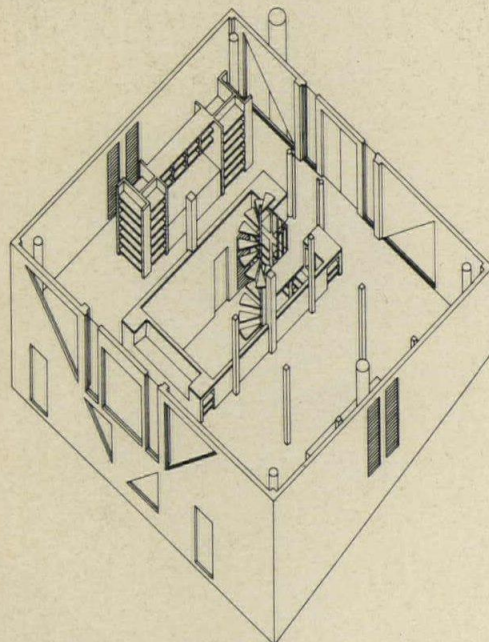
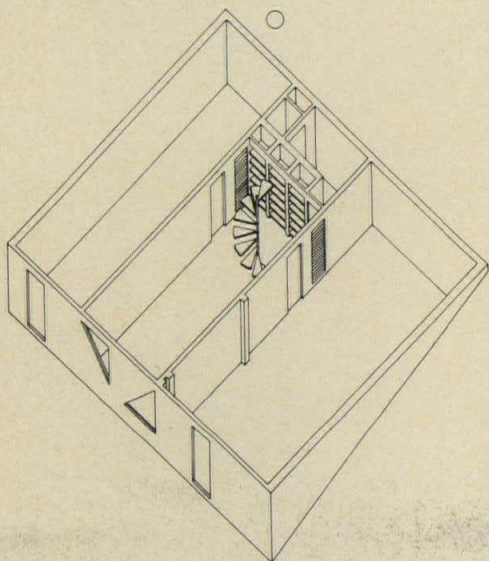

Take a gambrel roofed, Pennsylvania Dutch type barn, insert windows which make it smile like a Halloween pumpkin and wrap the whole thing in black asphalt shingles and what do you get? A form without precedent certainly, which some may consider a bit spooky. Others may feel it has a humorous presence rather like a figure in a Klee drawing. It is certain that the humble beasts which once inhabited this barn would never recognize their old home, but its present occupants—a veterinarian who is also an organist, his painter wife and their three children find that it suits them perfectly.

The plan includes a studio for the wife and accommodations for an organ. The scored plywood siding makes a handsome interior finish and provides a diaphragm structure which stiffens the 100-year-old barn. As in the Vollen Barn, all conduit, heating ducts and plumbing are exposed and color-coded blue, red and yellow respectively. All glazing is gray-tinted plate. Like Tigerman's other barn, costs were quite low, but again the client does not wish to reveal them.

FROG HOLLOW, southern Michigan. Owners: *Dr. and Mrs. James Christiansen*. Architects: *Stanley Tigerman & Associates*; associates—*Anthony Saifuku and John Haley*. Engineers: *Raymond B. Beebe & Associates* (structural); *Wallace & Migdal* (mechanical and electrical). Interior design consultant: *Stanley Tigerman & Associates*. General contractor: *Lester & David Krumerie*. Principal subcontractors: *F. H. Klugh & Son* (mechanical); *Mead & White Electric* (electrical); *Ace Plumbing Co.* (plumbing).

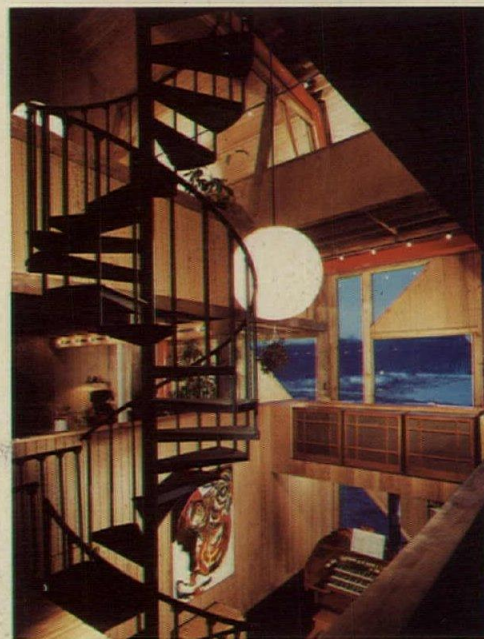
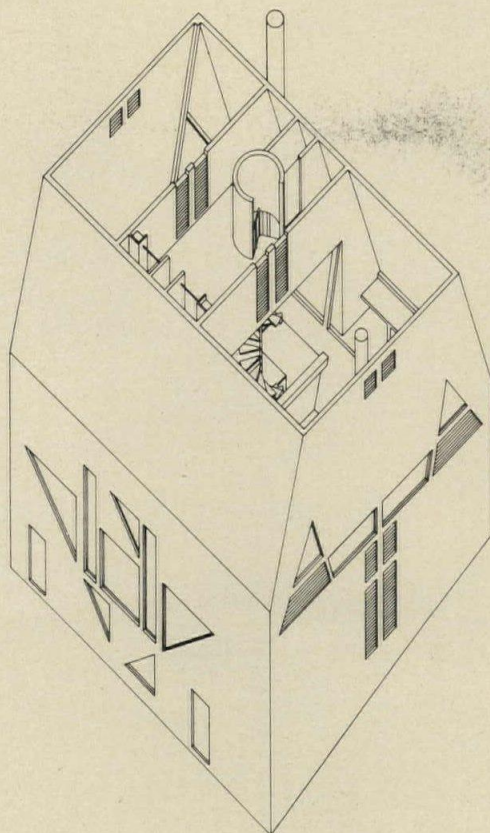

Philip Turner photos

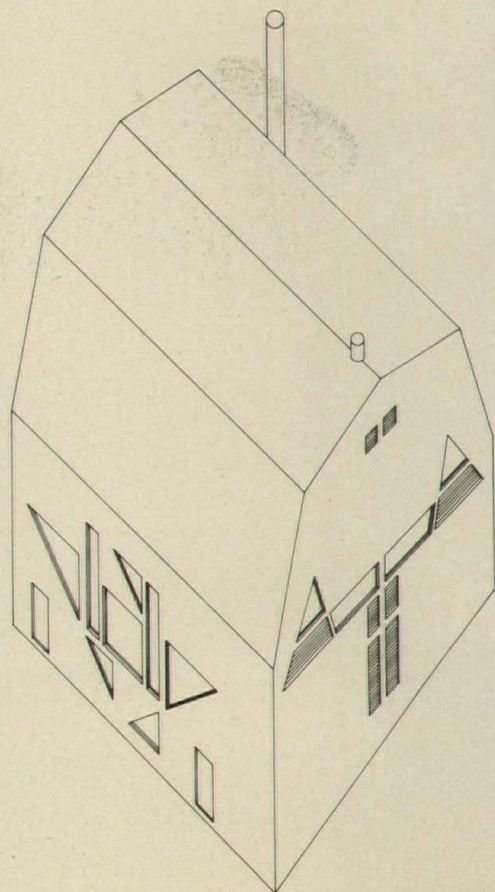

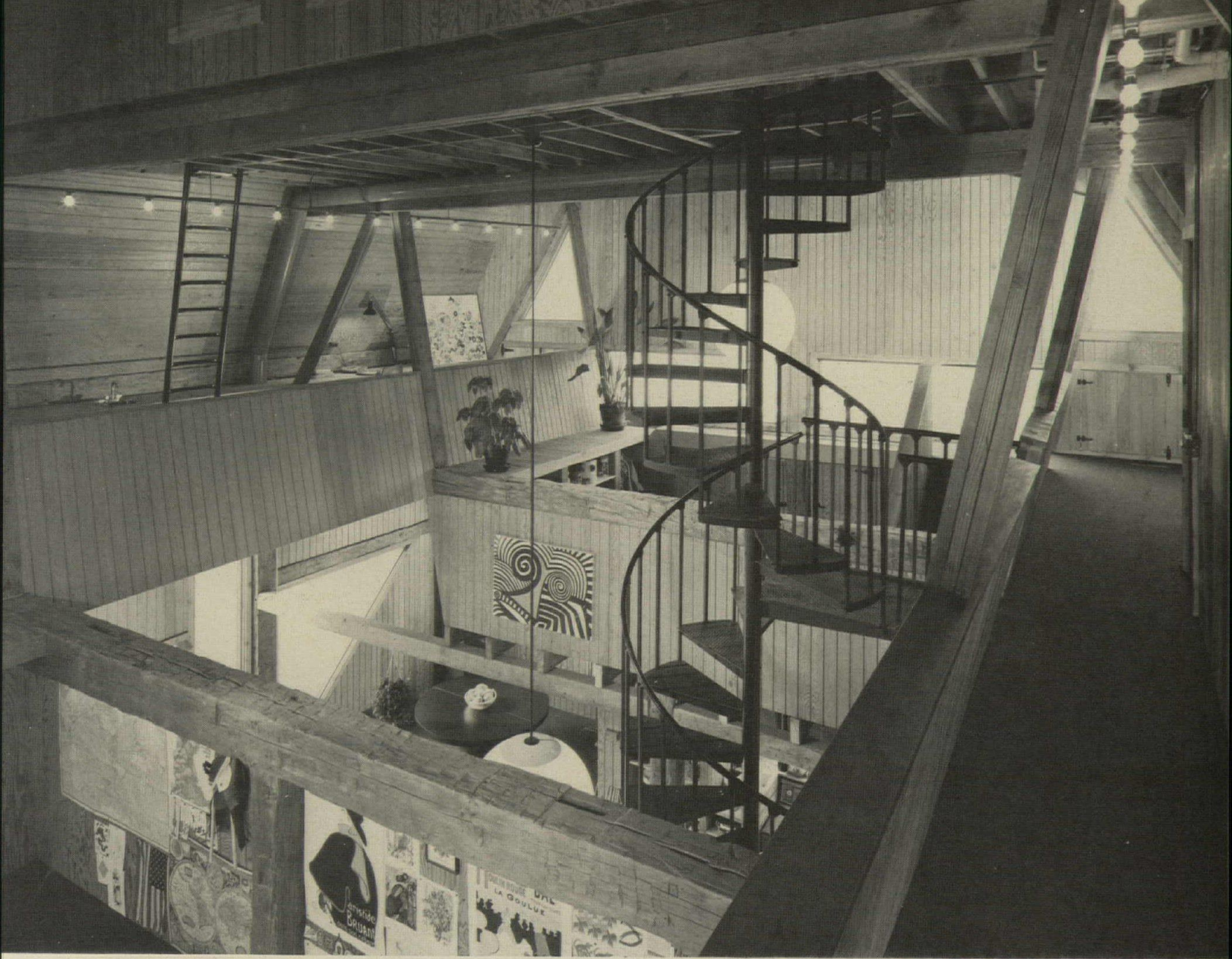

The freestanding circular metal stair connects all levels serving as the dominant sculptural element





John Yang



Jim Boorn

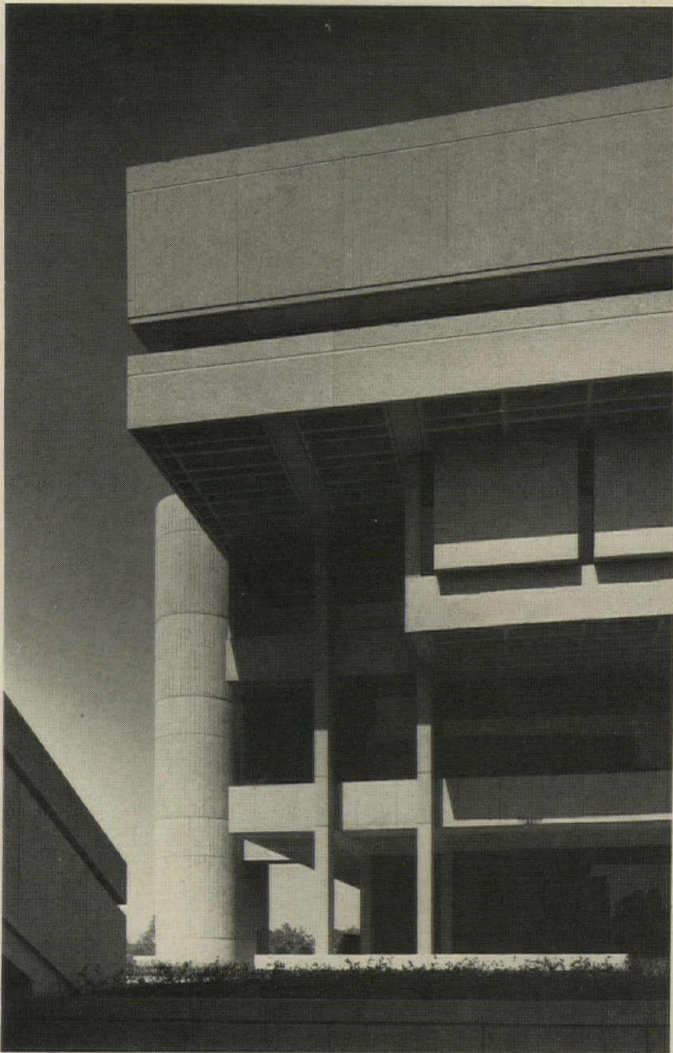

Gordon H. Schenck

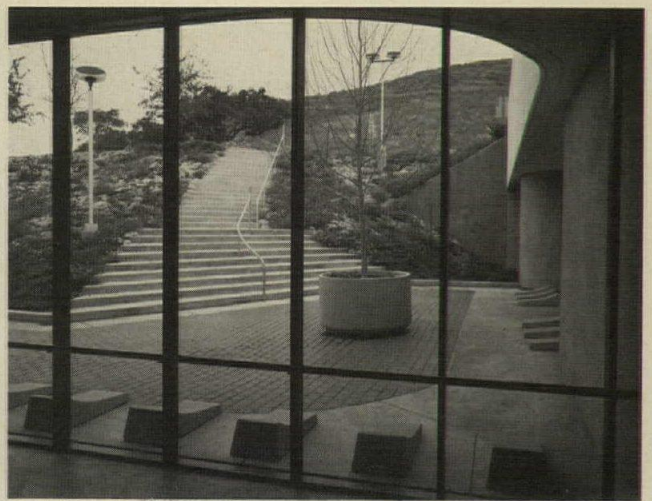

Gary Joiner

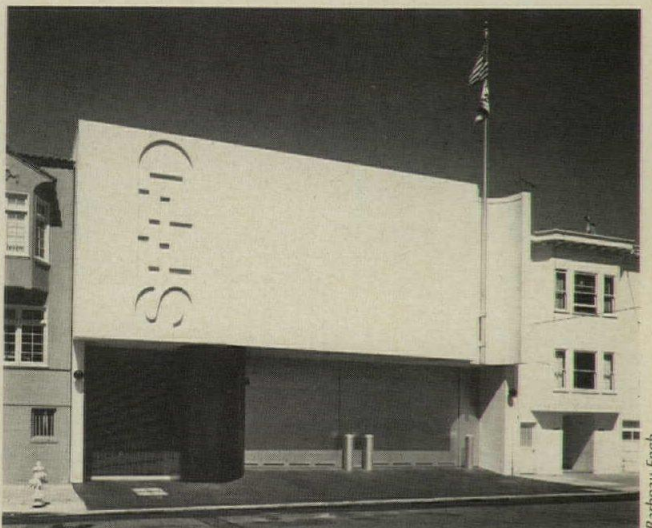

Barbeau Engh

PUBLIC ADMINISTRATION BUILDINGS

The designs for the buildings shown on the following pages were achieved in a number of different ways—by competitions, by selection committees, and by one-to-one consultation between architects and public officials. The buildings themselves—at different scales and in different places—offer some indication of the current level of design excellence in the public realm.

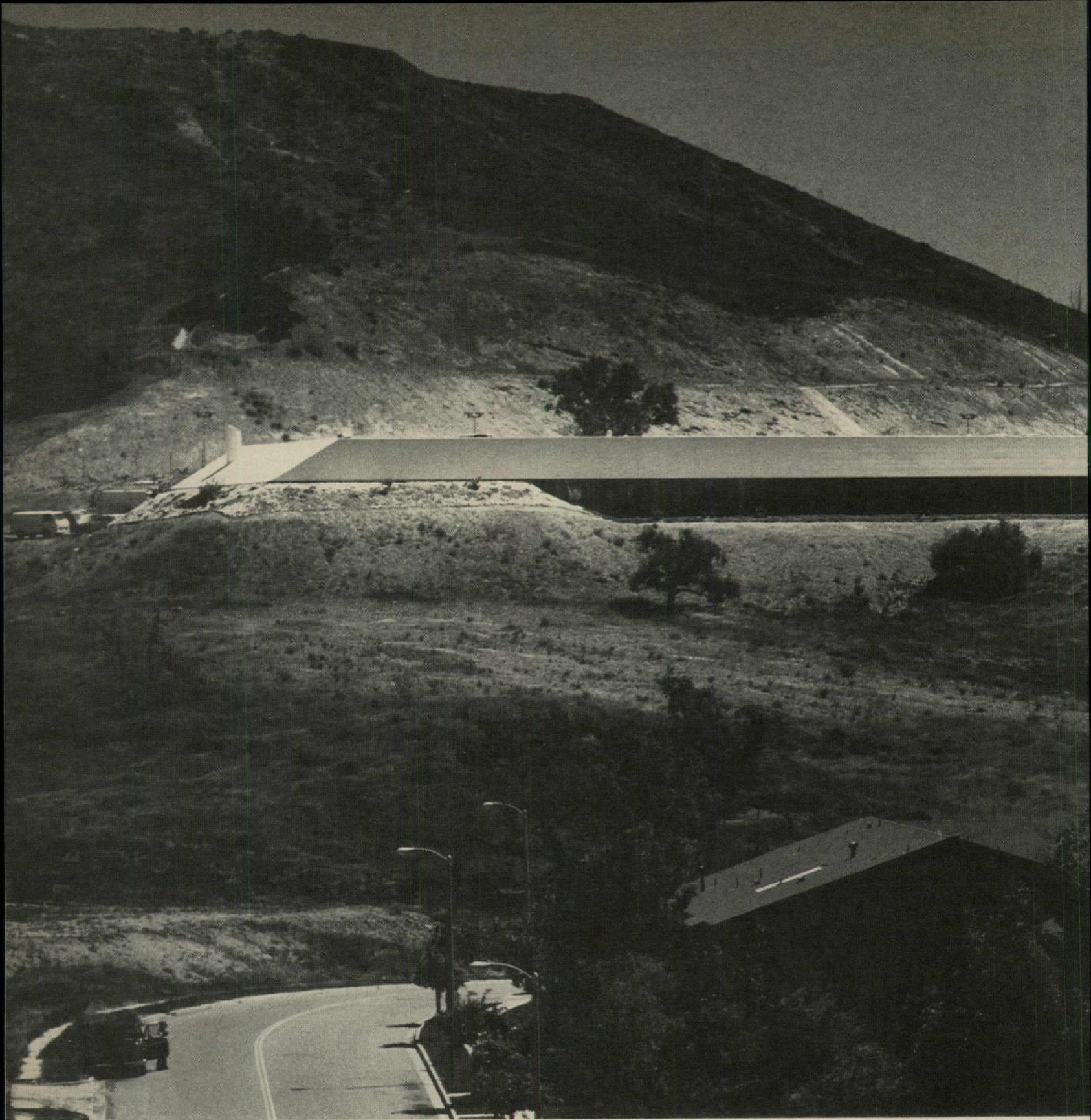

THOUSAND OAKS CIVIC CENTER

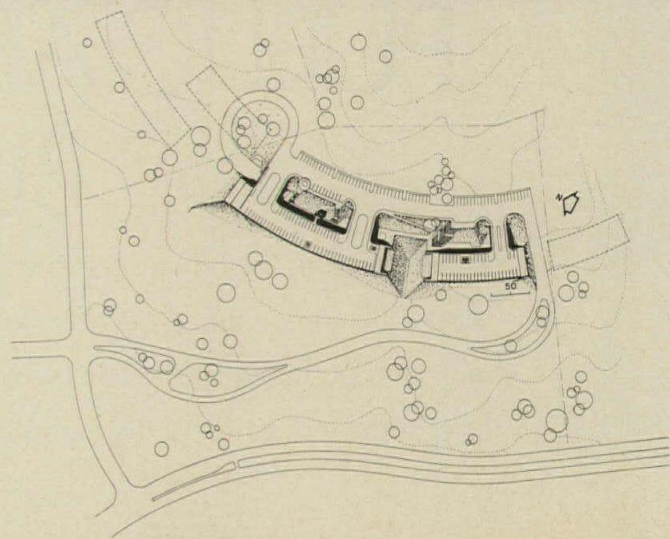

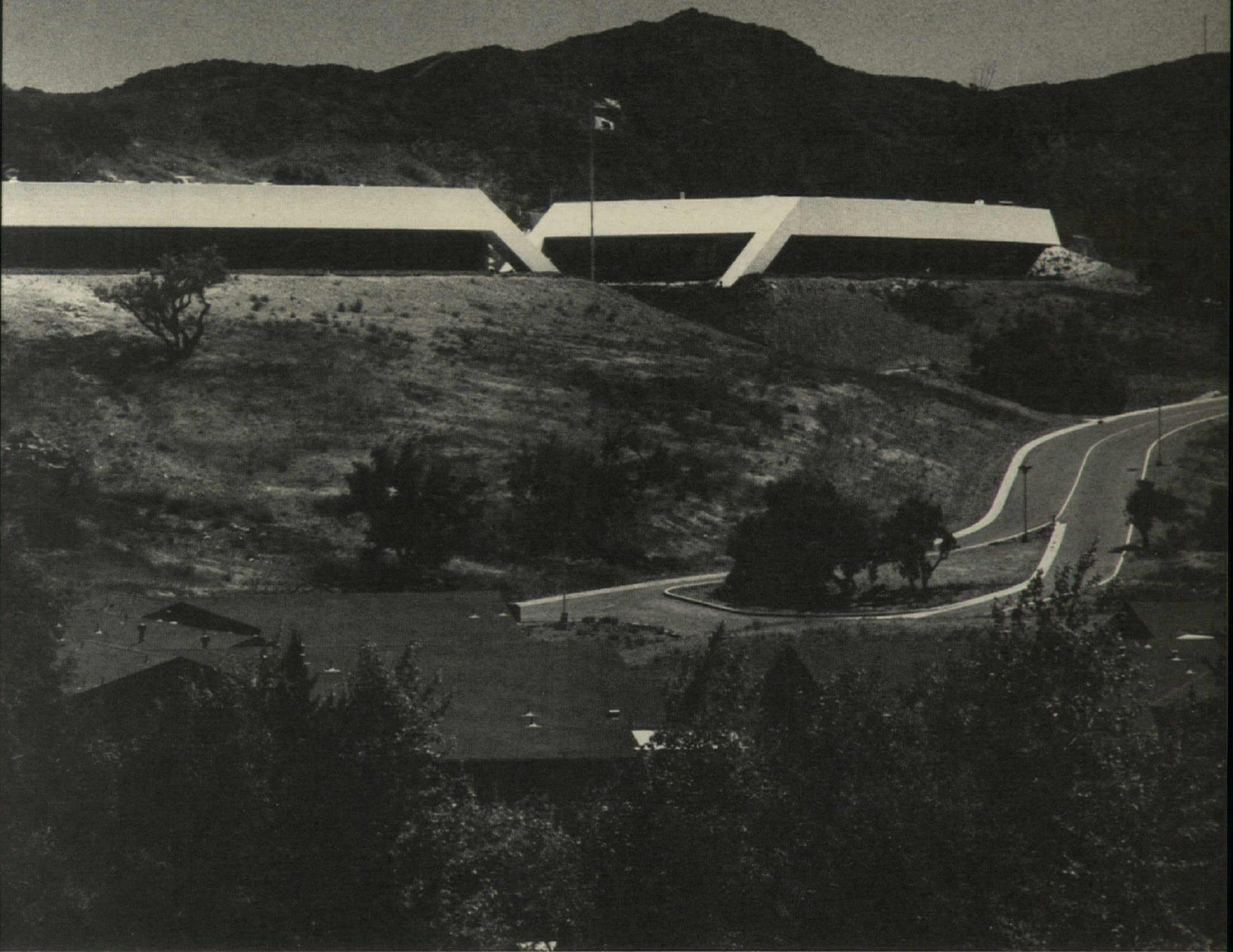

Gary Joiner

In April, 1969, the City of Thousand Oaks, California, announced a competition for the design of its new civic center. The site for the new building was a 30-acre parcel of land overlooking the town and adjacent to a major freeway; in spite of its fairly central location, it had an almost rural quality, and was made up of gently rolling hills dotted with oak trees. Architects were invited to submit a masterplan for the entire site, a conceptual design for the ultimate phase of the civic center, and detailed designs for the first two buildings—a city hall and facilities for a chamber of commerce. The challenge of the competition was to make something on a difficult site (and within a fairly tight budget) that would be identifiable as a

structure of civic importance, and that would also be in concert with its environment—not just with the physical surroundings, but with the spirit of this growing southern California town.

By September of 1969, 155 architects had responded to the invitation (a response that represented \$1.5 million worth of labor, according to one estimate), and their boards were presented to the jury, which included Charles Moore, then dean of the Yale Architecture School, and Cesar Pelli, then a partner of Victor Gruen Associates. The winner was a newcomer, Robert Mason Houvener, who was at the time a project design engineer for the Navy. His building is shown above.

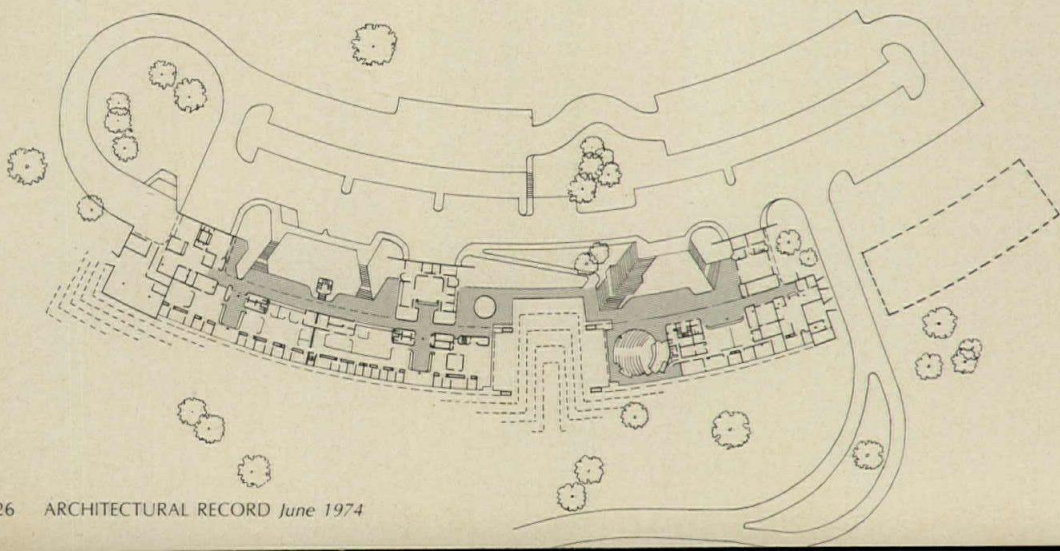



Gary Joiner

In their general comments the jury for the Thousand Oaks Civic Center competition pointed out that while many of the entries were fine, many more were without concept, a lack that was "camouflaged by highly complex and often, in detail, quite pleasant solutions." They went on to conclude that such entries "managed to miss the point of the simplicity and clarity that this building needed in order to work and in order to perform its symbolic function. That is what made the First Prize get the First Prize—sticking to a very simple and strong idea."

Robert Mason Houvener's winning scheme is indeed very simple, a range of one-story buildings in a broad arc high on the hill-

side. From the freeway below it is seen as a long white band curving across the land (photo on previous page); parking is on the roof of the buildings and on grade on the uphill side. Inside the buildings (plan left) individual offices tend to face the view, while larger interior spaces open onto landscaped courtyards with stairways leading up to the on-grade parking. It is hard to imagine a more direct approach to the problem. The buildings make a clear image for themselves as they accommodate the required functions inside. They make it clear how you arrive and how you enter. They show that this is a public place, but one which nevertheless respects the natural site. They look like they ought to be there.



Gary Joiner

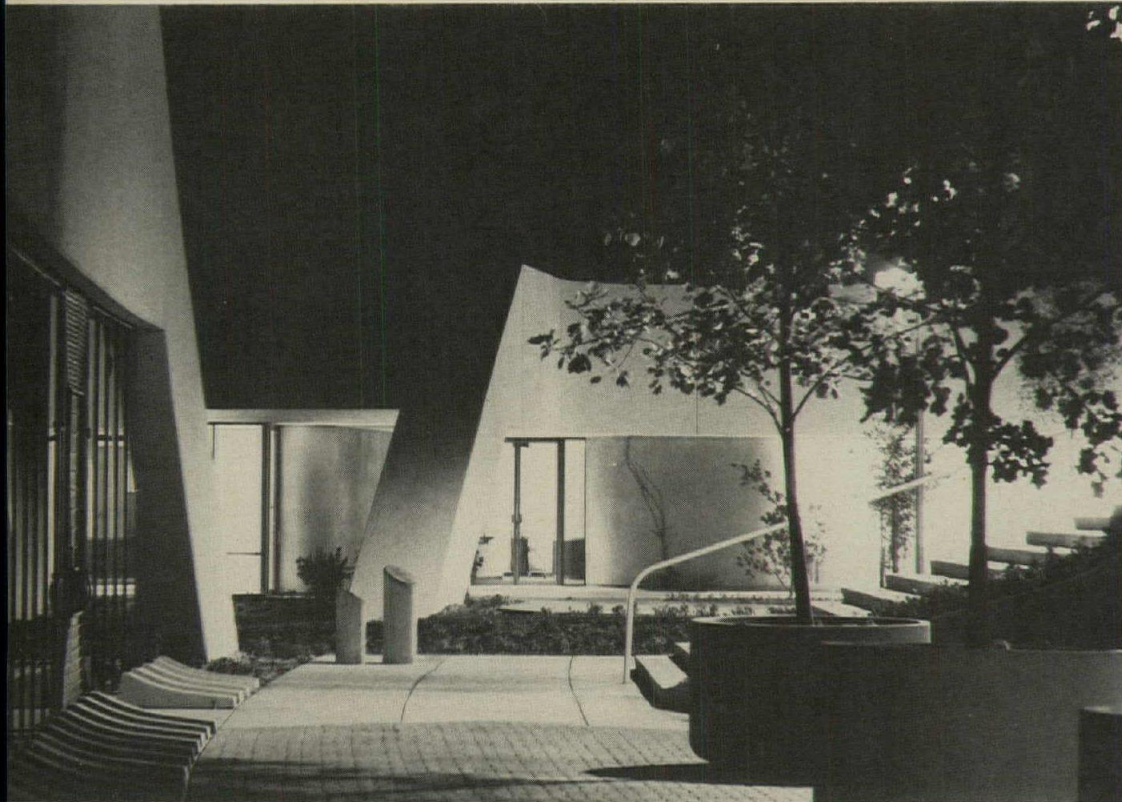

J. Spencer Lake



Buildings designed around a strong, simple and consistent concept are often unsatisfactory in some of their details—where what seems ideal in one particular part may not fit the format of the whole. In the case of the Thousand Oaks Civic Center what is required to make the bold image shown on the previous pages is not automatically suited, for instance, to the desirable scale for pedestrians who, after they have parked their cars, approach and enter. But the architect has gone to considerable effort here to soften the feeling of the uphill side of the building without actually changing its over-all concept. The plan and photograph on the previous two pages show how, on this side, the continuous sweep of the façade is

broken up into a series of small outdoor spaces by the bridges that lead from the approach road to the roof parking. These spaces are populated by stairs, ramps, small trees and plants that make this side of the building as inviting as the other side is imposing. The photographs above show one of these spaces from three different vantages; it is the entrance to the council chamber used for ceremony.

THOUSAND OAKS CIVIC CENTER, Thousand Oaks, California. Architect: *Robert Mason Houvener*. Engineers: *A. J. Blaylock & Associates* (structural, mechanical and electrical); *Moore & Taber* (foundations). Consultants: *James Dean & Associates* (landscape); *Albert R. Vallin* (cost). General contractor: *Ralph T. Viola Co.*



James Wheat

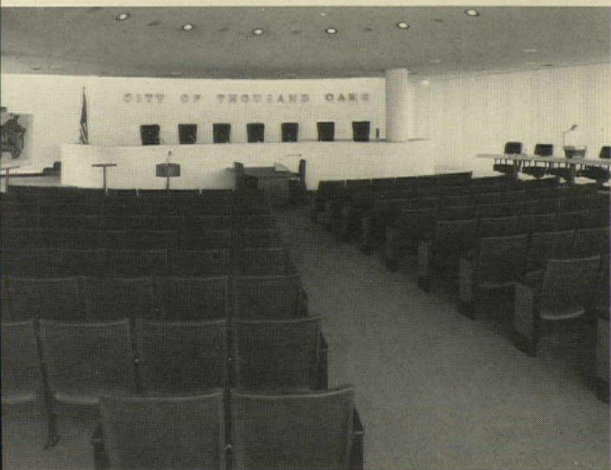

Gary Joiner



GREENSBORO GOVERNMENTAL CENTER

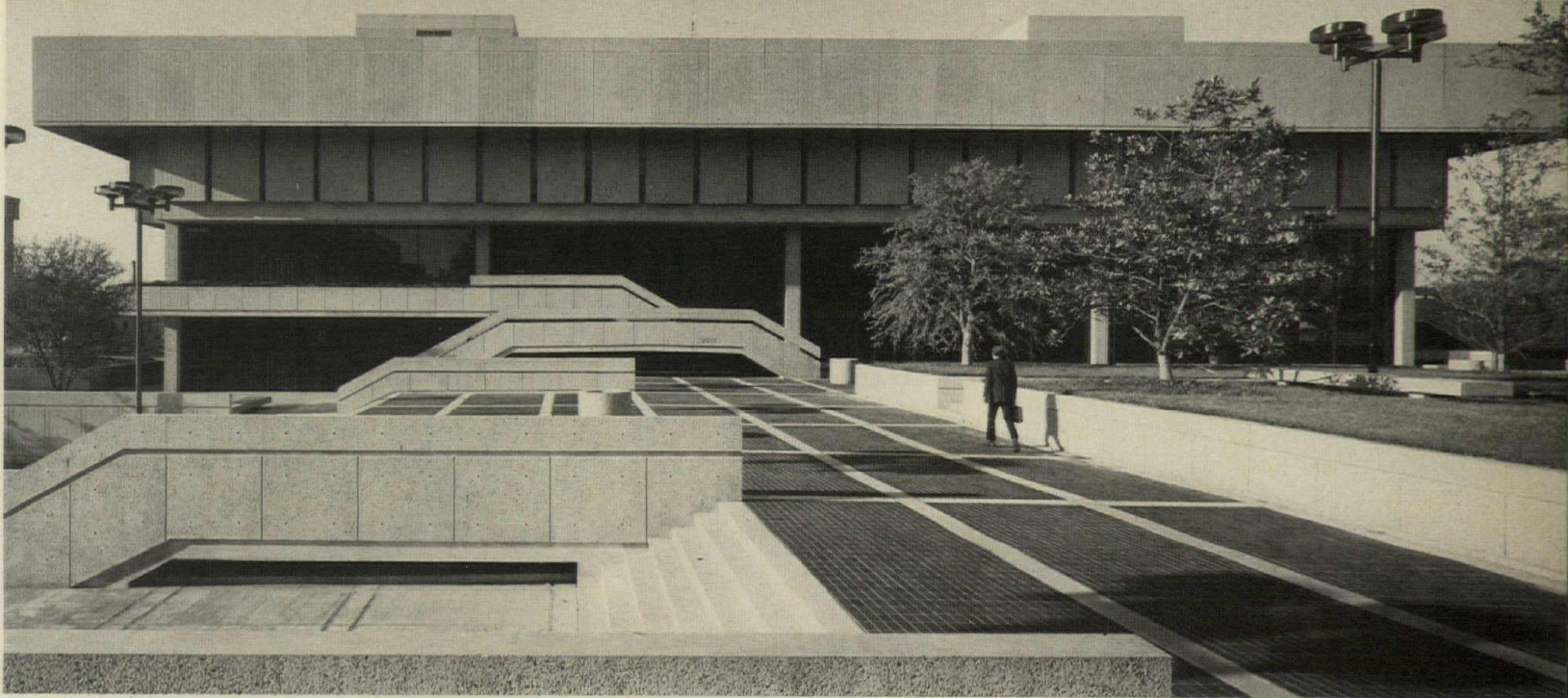

Gordon H. Schenck photos

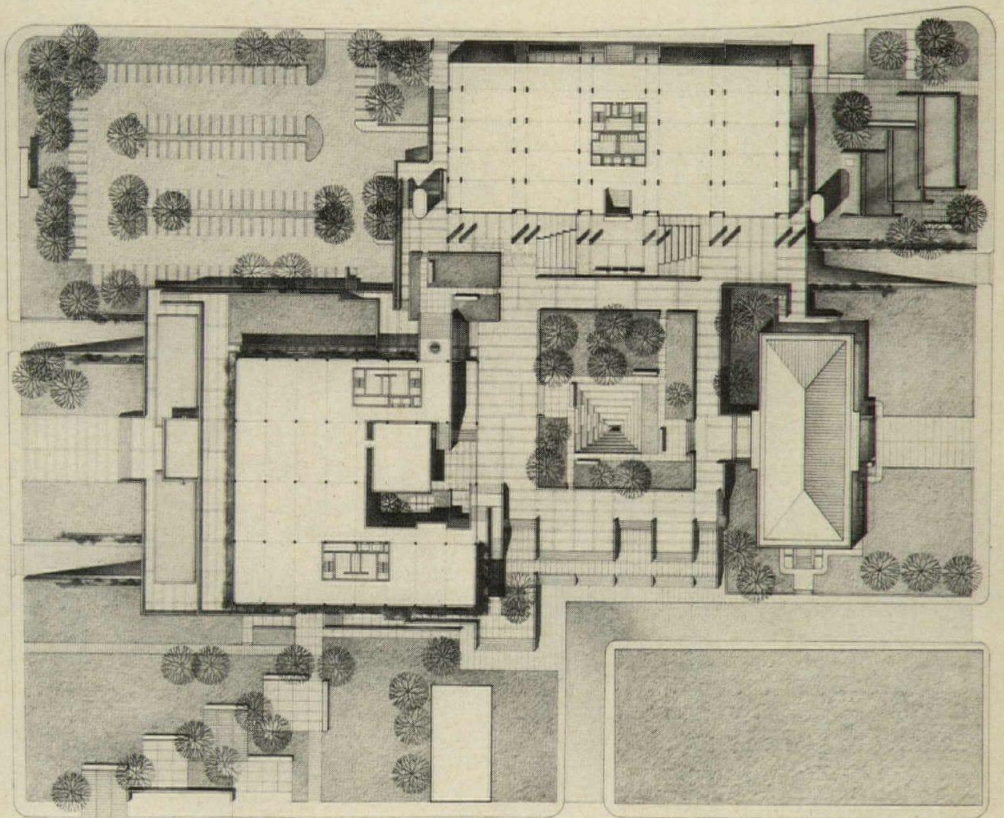

The Governmental Center in Greensboro, North Carolina, is one example of the benefits that can be derived from unified planning policies between city and county governments. Here the city and Guilford County have combined forces to create a complex of buildings in downtown Greensboro on the site of an existing court house (right in the photo opposite). The center is composed of a municipal building (left in the opposite photo and top photo above), a new county court house and office building, the old court house, and a 400-car two-level underground parking garage. The center covers a ten-acre site which slopes about 20 feet, providing the opportunity to open the main levels of the three above-

ground buildings to a central plaza, while other levels can be approached directly from the surrounding streets at a lower elevation.

The central plaza has a 90- by 120-foot planter with live oaks, magnolias and junipers; at its center a pyramidal sunken garden leads to a stair and to the parking garage below. The major structural components of the building are precast, with only retaining walls, low parapets, beams and columns cast in place. The structure is lineal in character, with beams and columns on a 24-foot span, and four-foot wide precast double tees with a maximum span of 48 feet. The tees are prestressed in areas with suspended ceilings, but where they are exposed normal reinforcing steel is used.



The municipal building is square in plan, five stories high, and designed for a sixth floor expansion. Below the plaza level there are two floors for the police department, parking for 85 police cars, and general services. The three levels above the plaza are used for administrative and technical offices. An open court (photos above and right) three stories high contains a landscaped area, an exhibition room, and a freestanding council chamber (photo far right). The court was made possible by a provision in the North Carolina building code which allows buildings for office use to have spaces of up to three stories high completely open, as long as the spaces are simply designed, and unobstructed.

The county building is a six-story structure in which the court rooms depart from tradition in the placement of judges and witnesses (photo right); the judge's bench is located at the corner of each room. As a whole the building contains most of the county administration offices on the plaza level, and the second and third floors contain all of the courtroom facilities. The top floor of the building has been built for future expansion.

GOVERNMENTAL CENTER, Greensboro, North Carolina. Architects: *Eduardo Catalano—associate, Peter C. Sugar*. Associate architects: *McMinn, Norfleet & Wicker*. Engineers: *Deborah Forsman* (structural); *Francis Associates* (mechanical/electrical). General contractor: *Weaver Construction Co.*

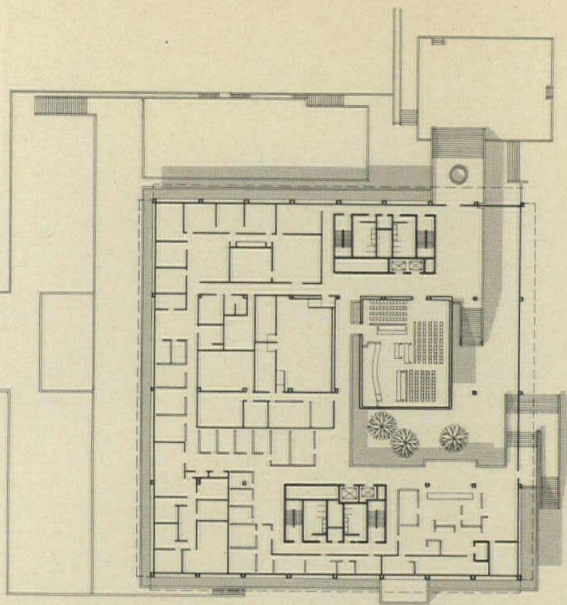

MUNICIPAL BUILDING

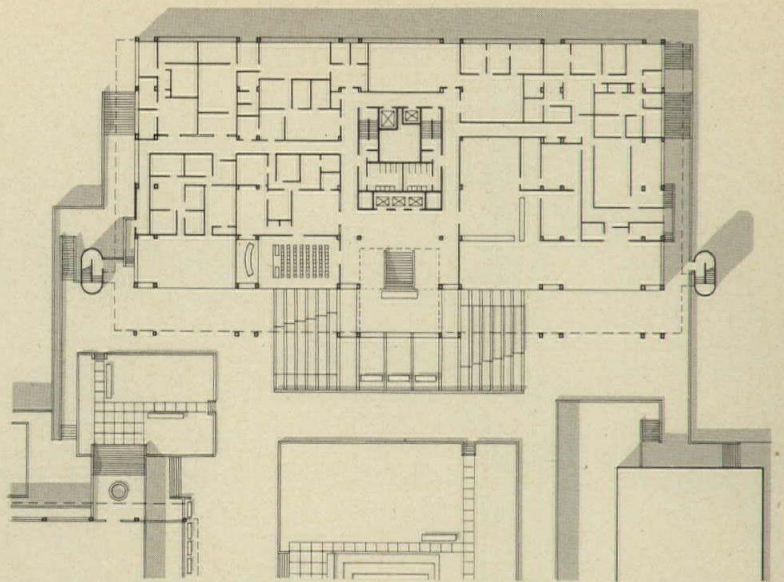

COUNTY COURTHOUSE



Gordon H. Schenck photos

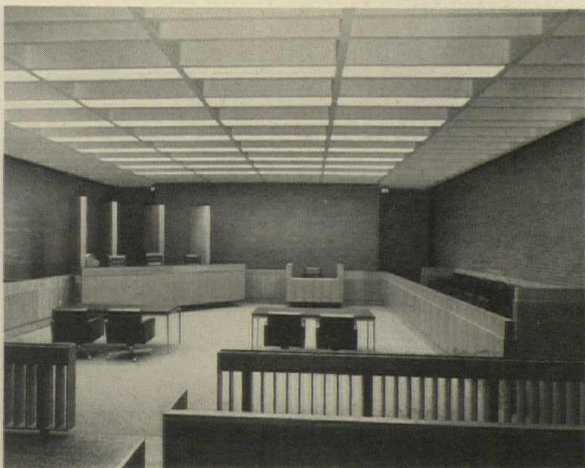
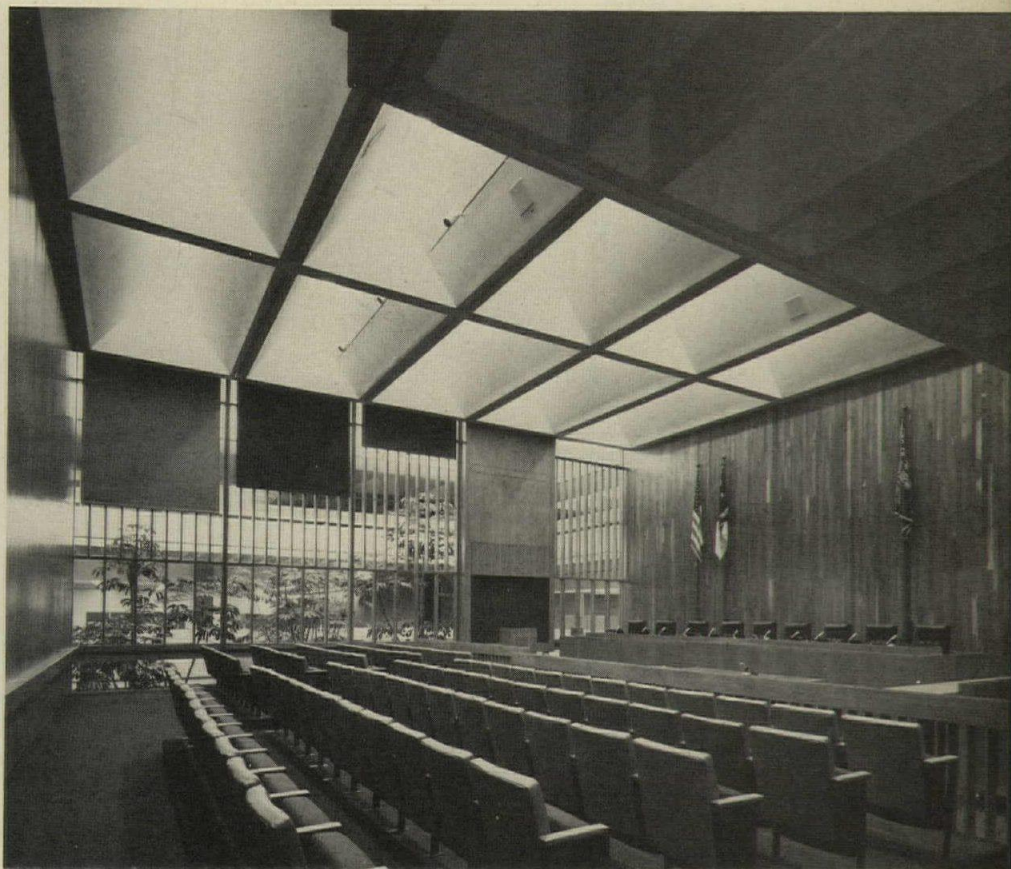



114th PRECINCT STATION

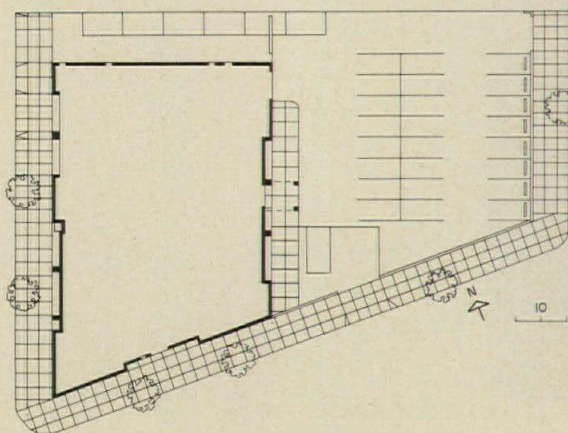

This building, a well studied design in the classic manner of the New Brutalism of the late 40's and 50's, makes a dignified appearance in a haphazard environment along a freeway in Queens, New York (photo above right), and adapts itself without rancor to the residential scale of the adjacent side streets (photos right). It is a police station which houses district as well as precinct level functions on a trapezoidal lot (site plan left). Placing the building on the street line gave a maximum area for police parking and for the temporary storage of abandoned vehicles. The building itself and the low wall that surrounds the parking lot occupy the entire site, thus providing both security and screening for the parking area, and maintain-

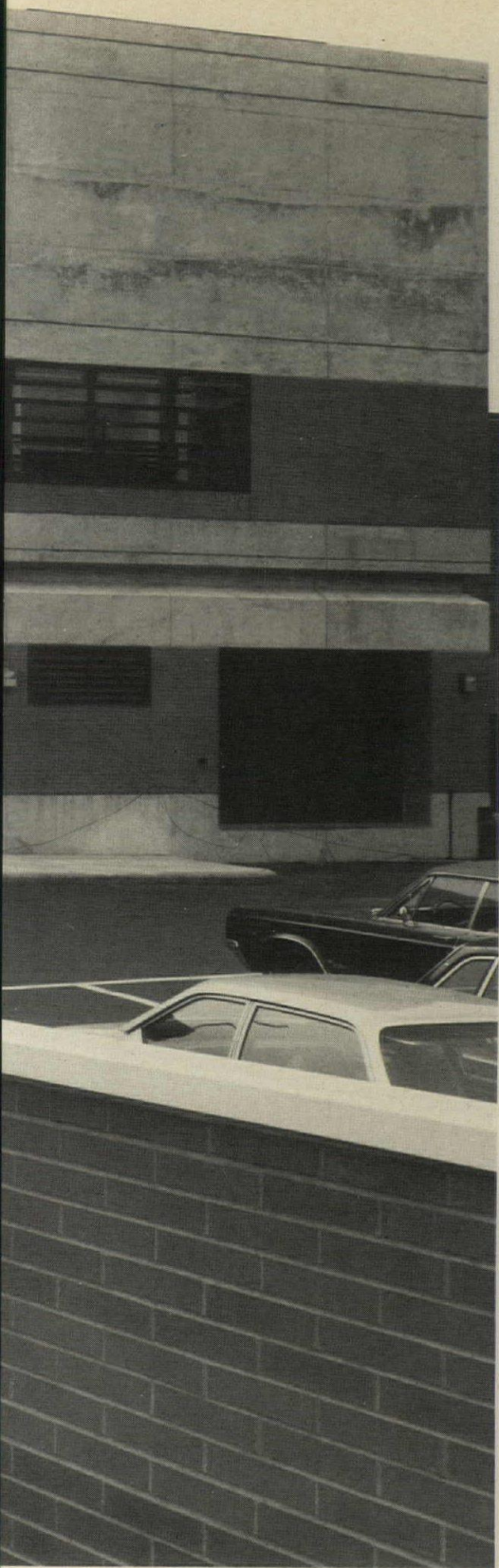

John Yang

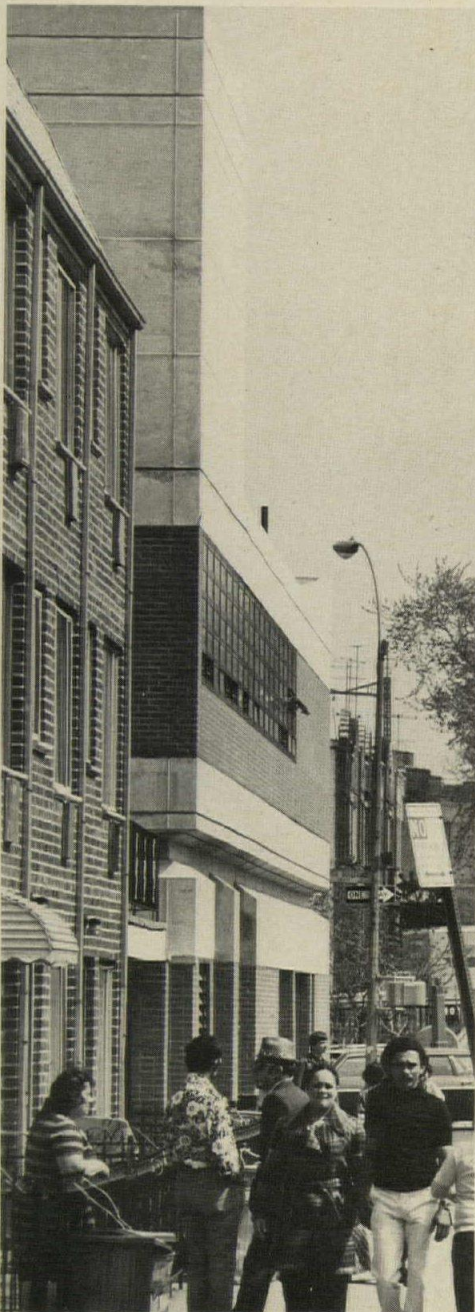

ing the traditional format of this residential area—street, sidewalk and building.

The exterior walls are brick and concrete; security windows and the entrances are of black anodized aluminum. All of the materials were chosen for their durability, their economy and their promise of lasting good appearance. The demarkation between the floors is emphasized by the recessed edge of the floor slab.

114th PRECINCT STATION, Queens, New York. Architects: Holden/Yang/Raemisch/Terjesen—partner-in-charge, John Yang; project architect, James D. Crabb. Engineers: Throop & Feiden (structural); Kal-len & Lamelson (mechanical/electrical). Consultant: H. A. Sloane Associates (cost). General contractor: Renel Construction Incorporated.



SCHENECTADY POLICE HEADQUARTERS

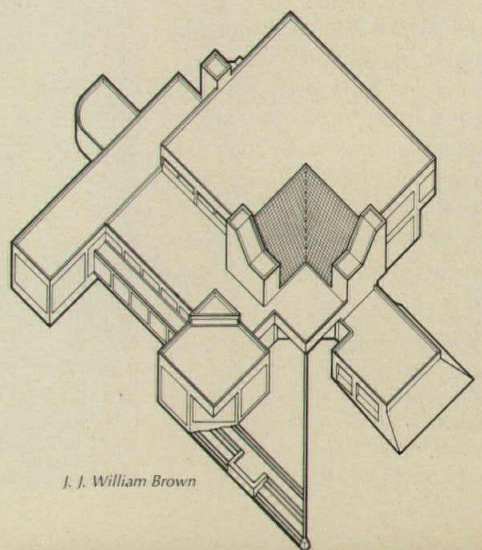

J. J. William Brown

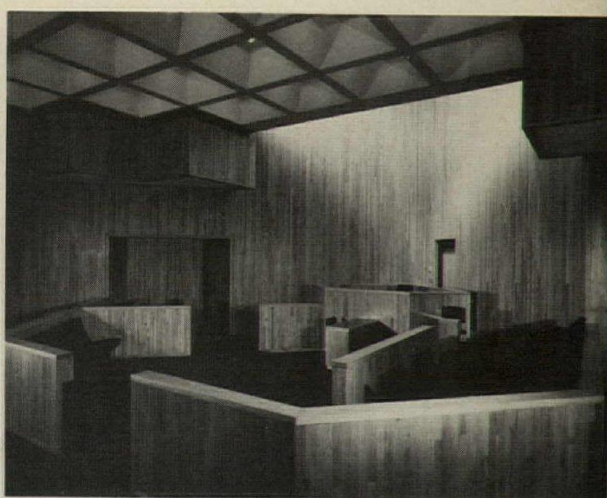
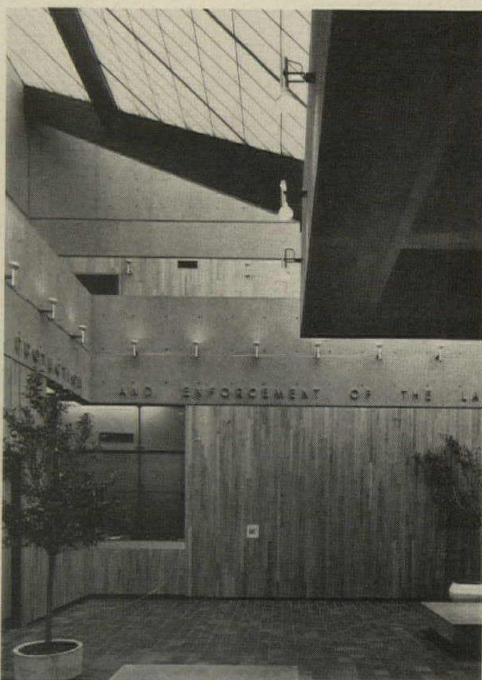
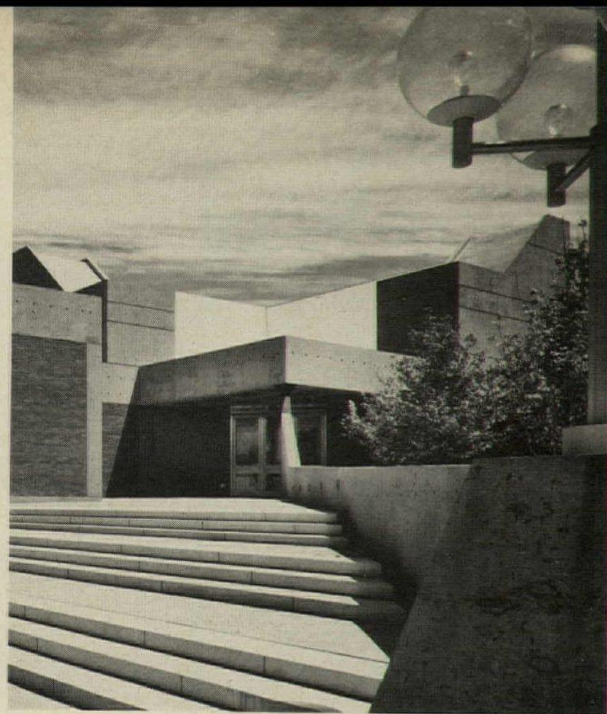
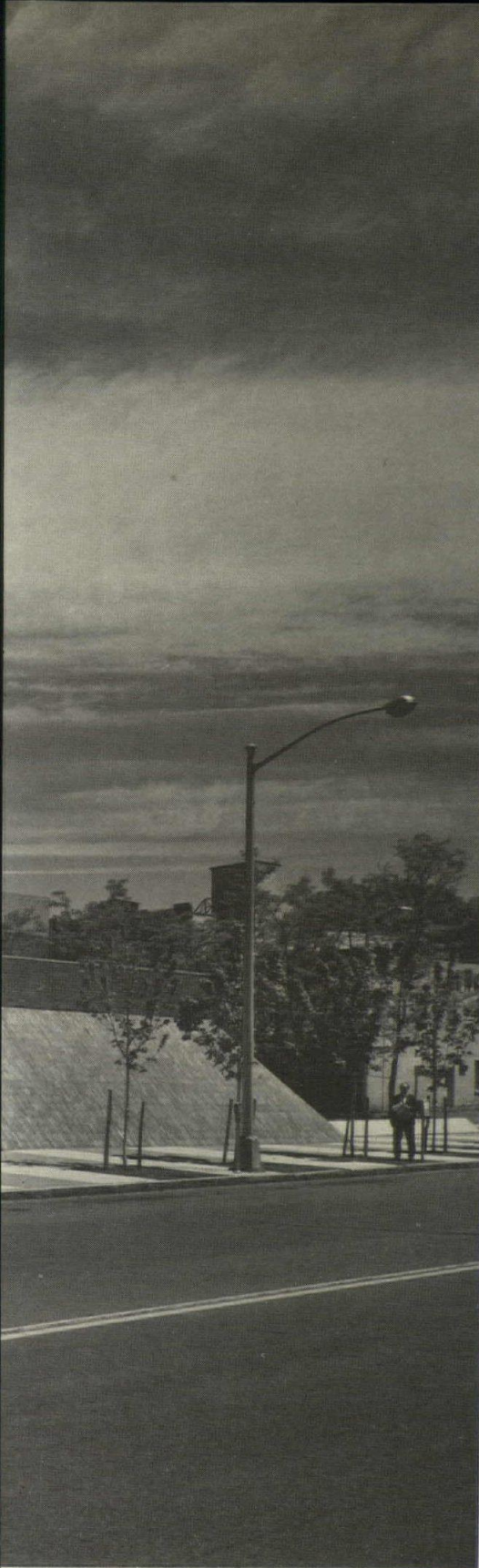

Joseph W. Molitor photos

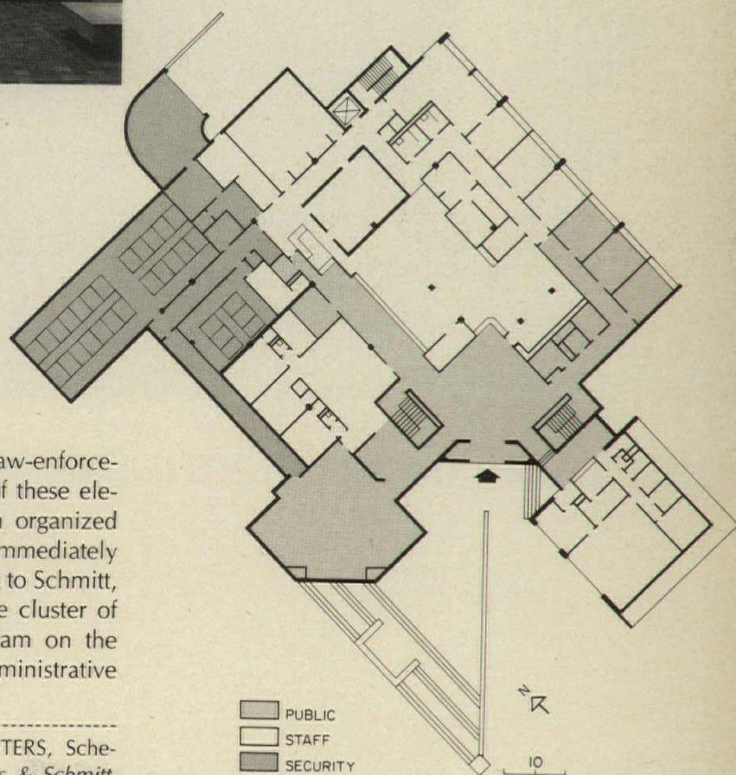

This police headquarters building—designed by architects Werner Feibes and James Schmitt—was built to accommodate the activities of a 150-man police force, and also to create a handsome and visible image for the law enforcement profession in this upstate New York town of 81,000 people. The site is adjacent to the Schenectady County Public Library and close by the central business district, city hall and post office, since it was thought that such contiguity with the everyday public life and affairs of the community would aid the morale of the police force even as it indicated to the public the force's role.

The form of the building, according to the architects, resulted from the complexity of ac-

tivities that make up a modern law-enforcement facility; they allowed each of these elements proper expression and then organized them all in their most natural and immediately identifiable way, so that, according to Schmitt, the building "emerged as a village cluster of interconnected forms." The diagram on the right shows how security areas, administrative areas and public areas are related.

SCHENECTADY POLICE HEADQUARTERS, Schenectady, New York. Architects: *Feibes & Schmitt*. Engineers: *John T. Percy and Associates* (structural); *Robert D. Krouner Consulting Engineer* (mechanical/electrical); *Thomsen Associates* (soils). Consultant: *Bristol, Hiser & Leaver* (landscape). General contractor: *Hanson Construction Corporation*.



SAN FRANCISCO FIREHOUSE

This building was one of four prize winners in a field of 130 designs submitted in a municipal competition held in San Francisco in 1967. The competition was unusual in that the jury was charged with selecting four designs for premiation and then selecting the architect of one as the candidate for appointment by the city to be the architect for the first in a series of new firehouses. The authors of the other premiated schemes would, by implication, be commissioned for later firehouses. The jury pointed out that the principle of selecting an architect, rather than a design, for such a program had great merit, because of the complexity of the problem and the likelihood that no competition solution would be completely ad-

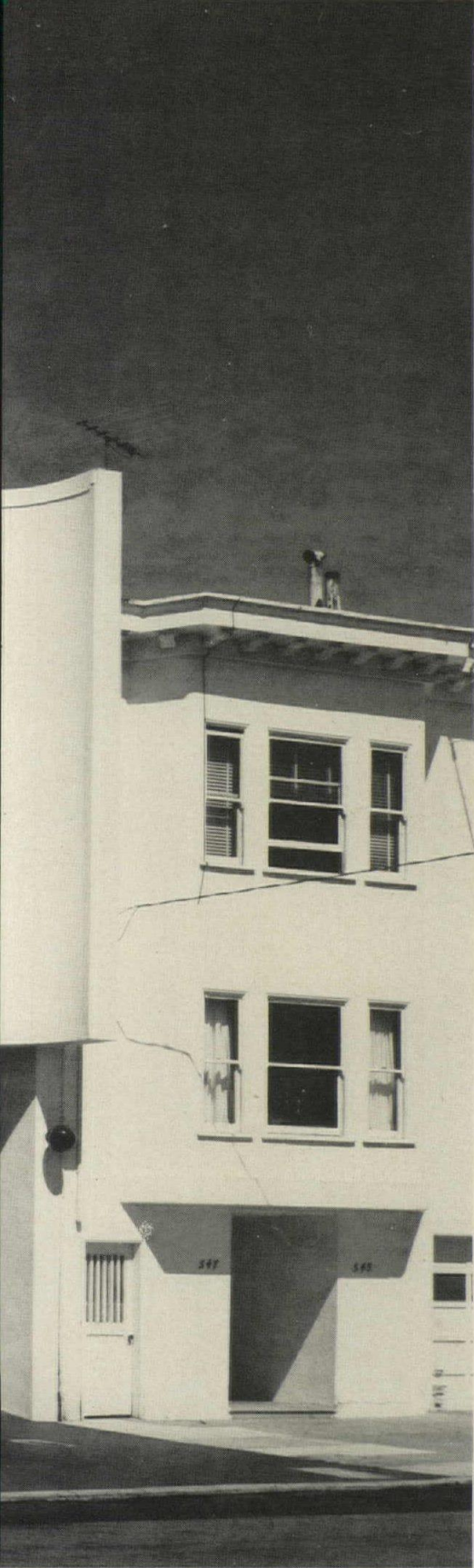

Barbeau Engh photos

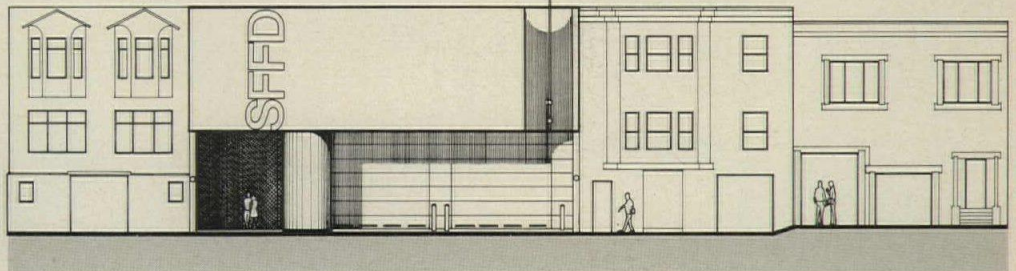
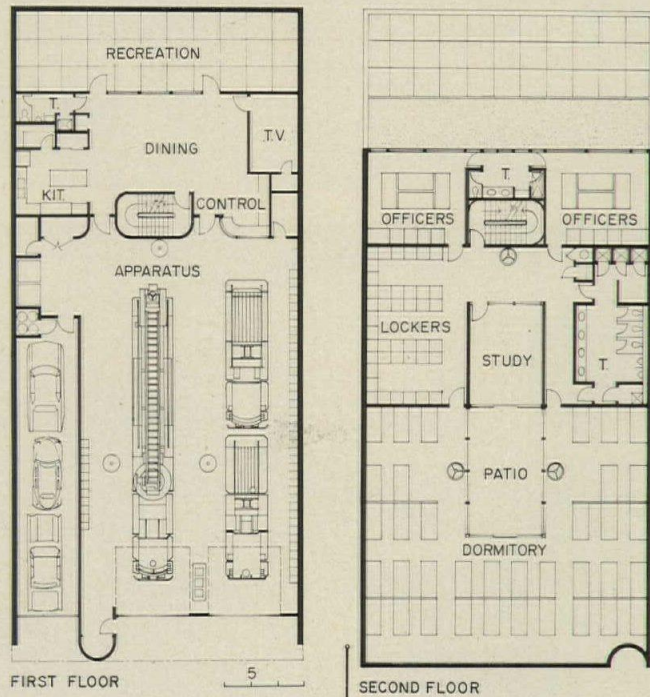

ELEVATION

equate without additional, highly technical modification. The building shown here, by the firm of Braccia/De Brer/Heglund, is thus somewhat different from the design which was originally submitted, though its formal outlines are the same. A remarkably simple facade fronts the street between two row houses, and from it the fire engines can emerge at a moment's notice. The lower floor of the building contains, in addition, communal facilities.

SAN FRANCISCO ENGINE COMPANY #14, San Francisco, California. Architects: *Braccia/De Brer/Heglund*—Jacques De Brer, partner in charge of design. Engineers: *Harding-Lawson Associates* (soils), *Yanow & Bauer* (mechanical/electrical). General contractor: *Dunn & Gaulke Construction Co.*

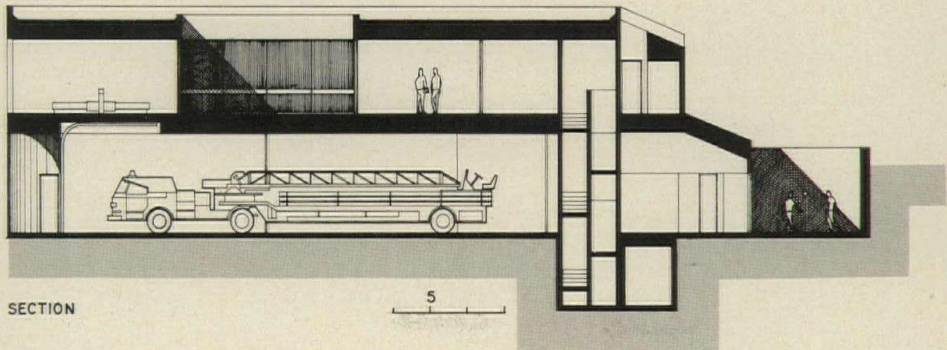

SECTION



Barbeau Engh photos

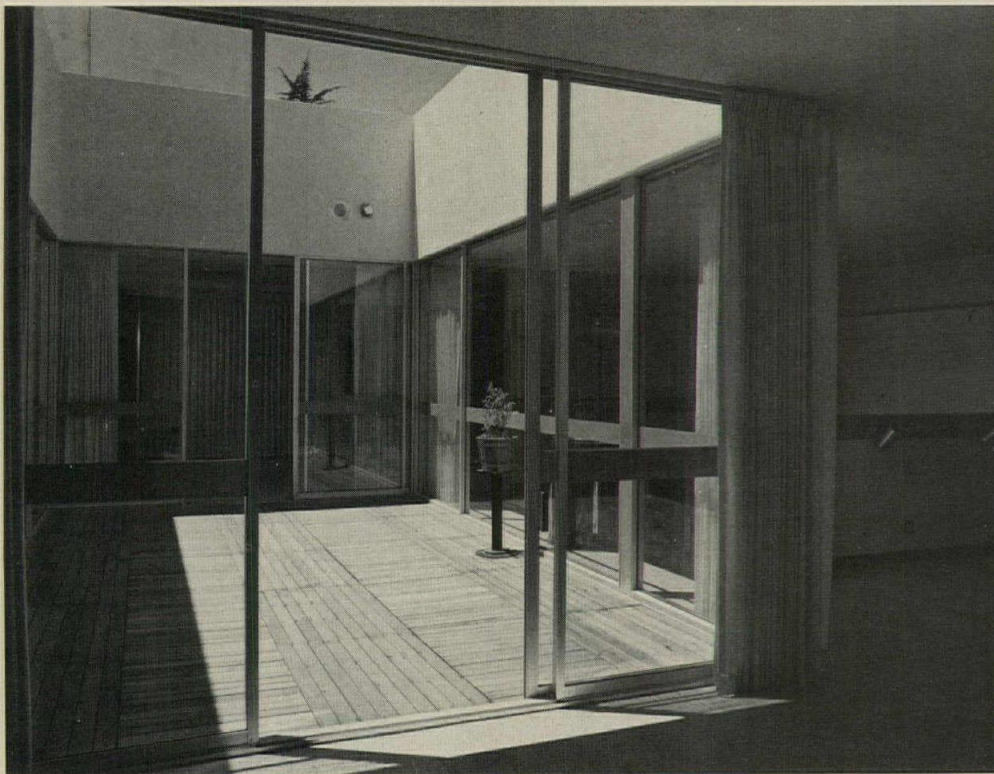

A ground-floor control room is shown in the top photograph above. The other photograph shows the interior court on the second floor of the firehouse; it is surrounded by the dormitory for firemen.

Prefabricated space trusses shape the roofs of two libraries

Conclusion of a two-part article on structural designs by Hirsch & Gray that exemplify a varied response to architectural requirements in a practical space-truss context

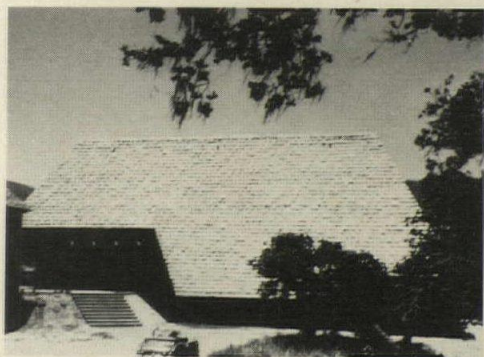

The library for York School in Monterey, California is basically one large mansard roof that touches the ground only along portions of three of the four edges. And to support the roof, rhomboidal-cross-section truss units were stacked on top of each other, at a 60-degree angle, as many as seven-tiers high. Similar truss units were used to close in the top. The units, composed of regular tetrahedra, were shop welded from small angles and tees.

Structural analysis, even by computer, posed a problem at the time because of the vast number of joints and members involved. The other problem facing engineers Hirsch & Gray was how to get an appropriate mating pattern between the truss units. They evolved a design that gave continuous and flat match surfaces, minimizing chance of field interference and misfit. Care in detailing and choosing member configurations, the engineers state, was the key to success in construction of the truss system.

The truss units were trucked some 120 miles to the site, and the entire erection took just seven days. Field connections between the truss units were made with two high-strength bolts at each of the panel points; a stitch bolt was used between panel points to connect webs of adjoining members and to prevent local buckling.

The building is 68-ft by 86-ft in plan, and 31-ft high. The front of the structure cantilevers some 27 ft beyond the side edge supports. In total, the space-truss units took about 40 tons of steel. They were 4 ft 6 in. on edge and ranged from 22 to 81 ft in length.

The library, designed by Smith/Barker/Hansen, architects, makes a feature of the exposed space-truss system. It was a recent winner of an Architectural Award of Excellence from the American Institute of Steel Construction.

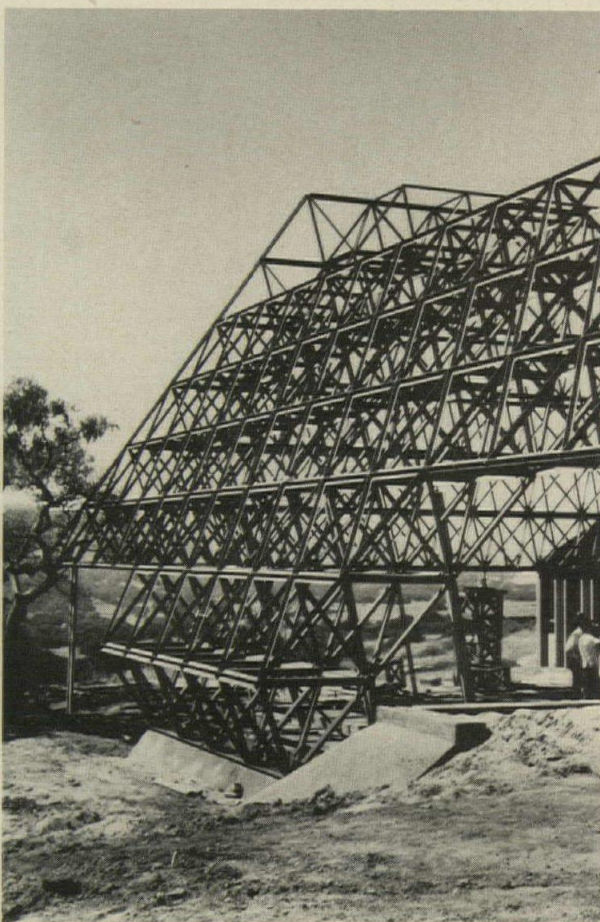
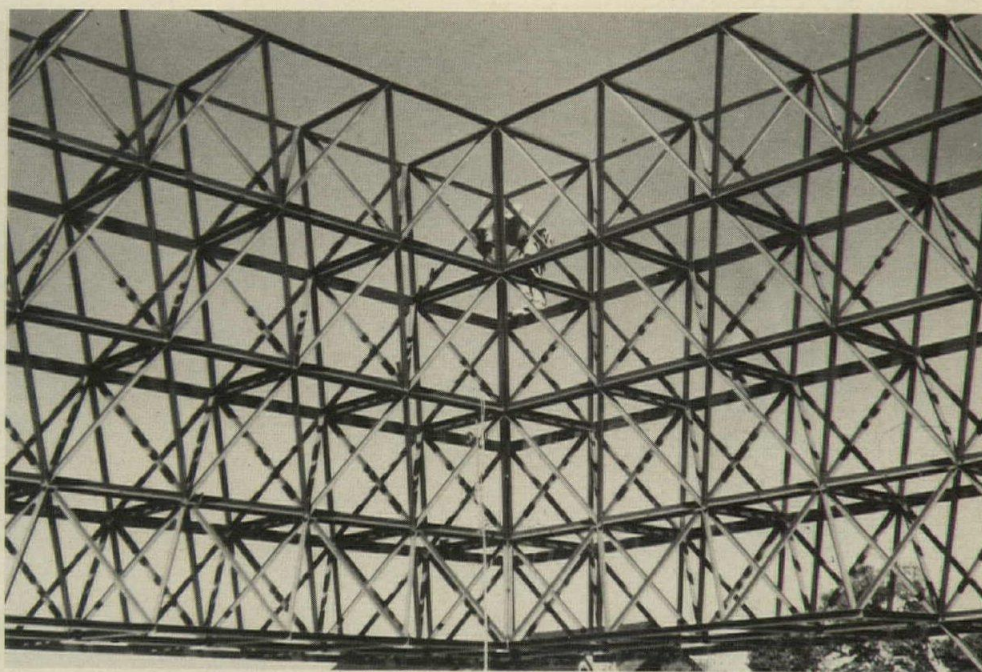

Rhomboidal cross-section space trusses were stacked up like "steel masonry" to form the structural support for the huge roof of York School library. At the top of the building the units form a closed frame, but lower down there are cutouts to provide openings for entrances and windows. Field connections between truss units were made with high-strength bolts. The units were transported by truck 120 miles to the site where they were erected in seven-days' time. The engineers say that successful erection of the frame, with a minimum of field problems, could be attributed to careful study of details and member configurations.

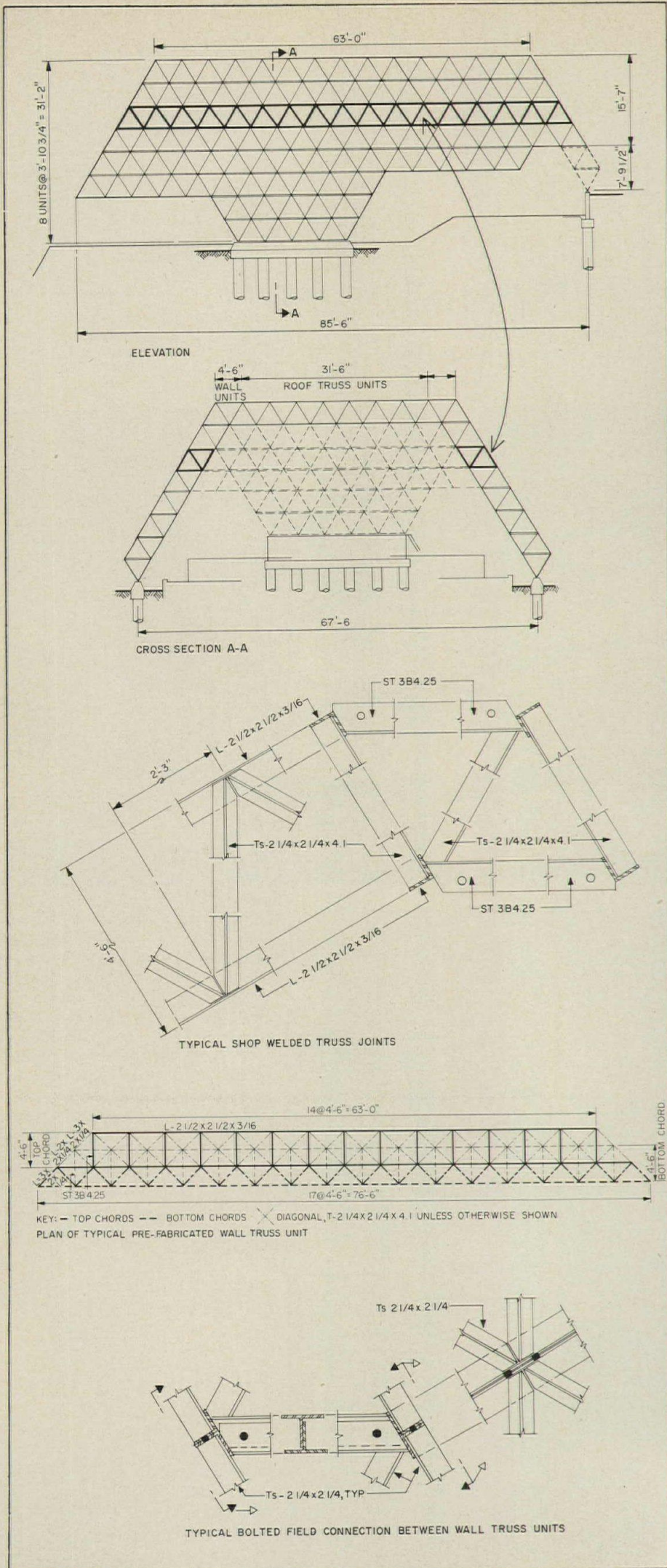

Truss units vary in length from 22 to 81 ft to produce the irregular facades of the mansard-shaped building. About 40 tons of steel were used for the rhomboidal cross-section units. Field connections between units were made with two high-strength bolts at each of the panel points and with a stitch bolt midway between panel points to connect webs of adjoining members and to prevent local buckling. The space truss is painted and left exposed for visual interest.

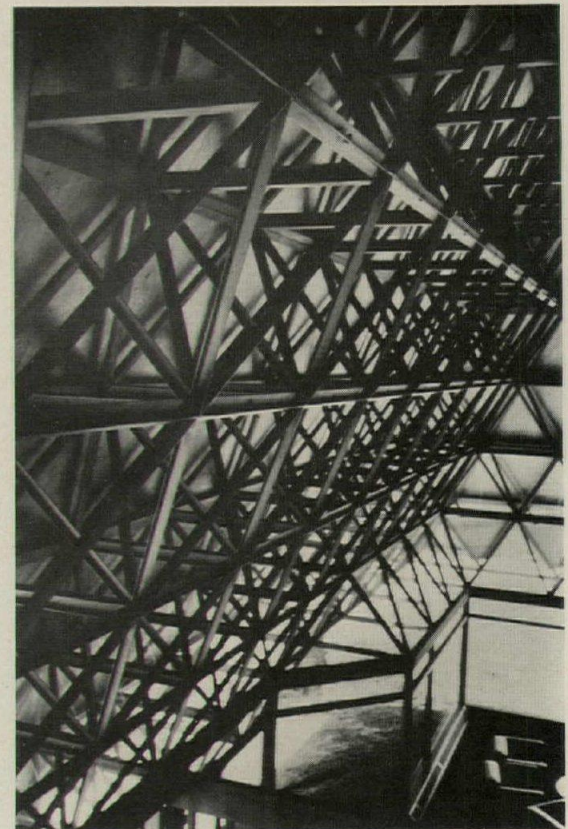
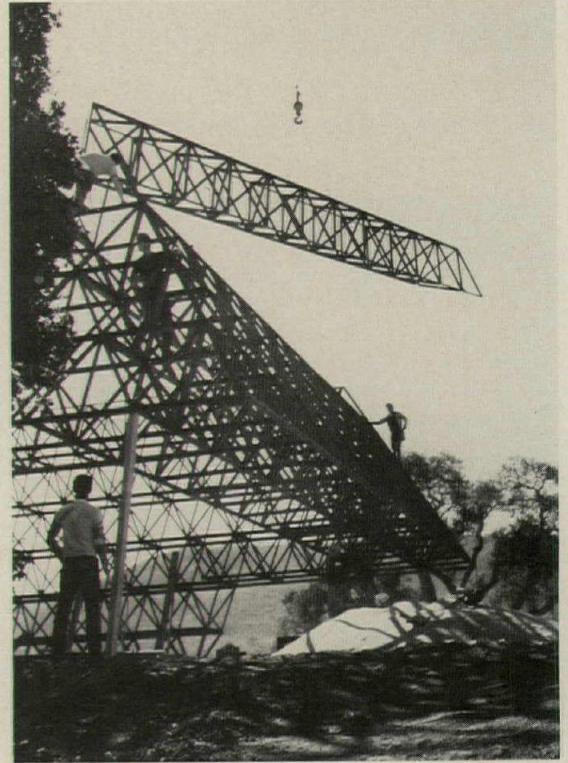

Ephraim Hirsch photos except where noted

Kurt E. Oswald

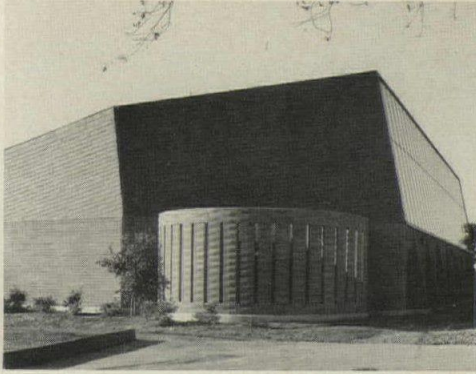

The space-truss configuration for San Lorenzo, California Branch Library reflects a number of architectural requirements and conditions, among which were: 1) the architects' desire for a design statement for the main reading room; 2) a room shape that is an irregular hexagon; 3) a sloping roof line that allows a large clerestory on the building's east face. The one-story building was designed by architects Oswald & Kelly.

The pattern is one of intersecting, elongated diamonds, the bottom-chord system being offset from the top-chord system by one-half module. The truss structure was painted yellow to make it stand out as an architectural element, and it serves as a "lighting fixture" as well, with fluorescent lamps installed in the longitudinal "V" formed by the bottom angle chord.

A number of practical factors also influenced the design by structural engineers Hirsch & Gray. They had to spend many hours developing details to provide the very narrow intersection angles. But they report that this effort was rewarded with rapid fabrication and erection—almost routine in its simplicity. The truss elements were shipped and erected within five days.

The structure was subdivided into 11-ft-wide by 80-ft-long units to meet the limitation of maximum-width unit that could be transported by highway. They were fabricated from angle and wide-flange sections. Despite the geometric complexity, only 48 field connections were required between the 10 truss units, themselves, and between units and Y-shaped columns. The first two modules were bolted together on the ground prior to lifting to form a stable unit; subsequent modules were erected singly, being stabilized by the one that went before.



Kurt E. Oswald

Geometry of the space-truss roof system reflects the plan shape itself—an irregular hexagon. The pattern is of elongated, connecting diamonds. The sloping units span from a wall at the back to Y-shaped columns in the front, the upper halves of the columns showing through the tall clerestory. Fluorescent lamps were installed within the bottom chords for indirect lighting.

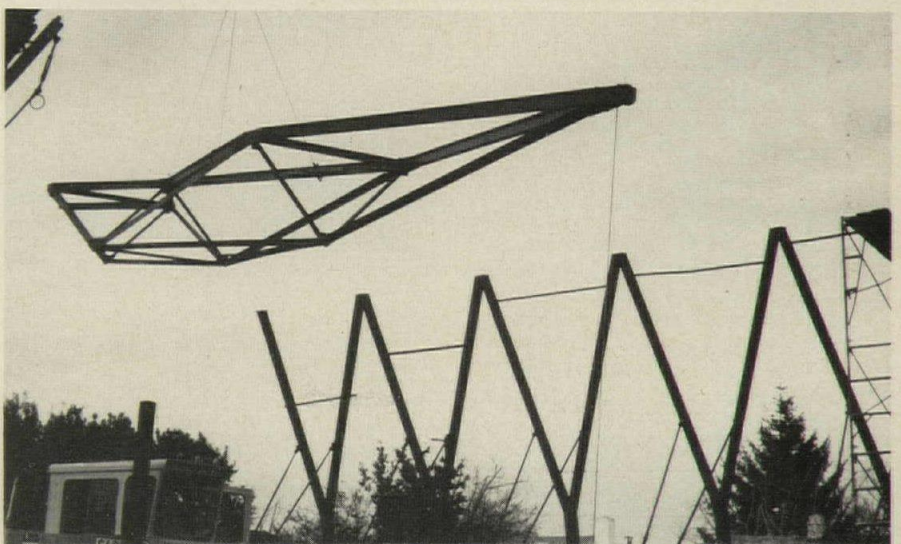
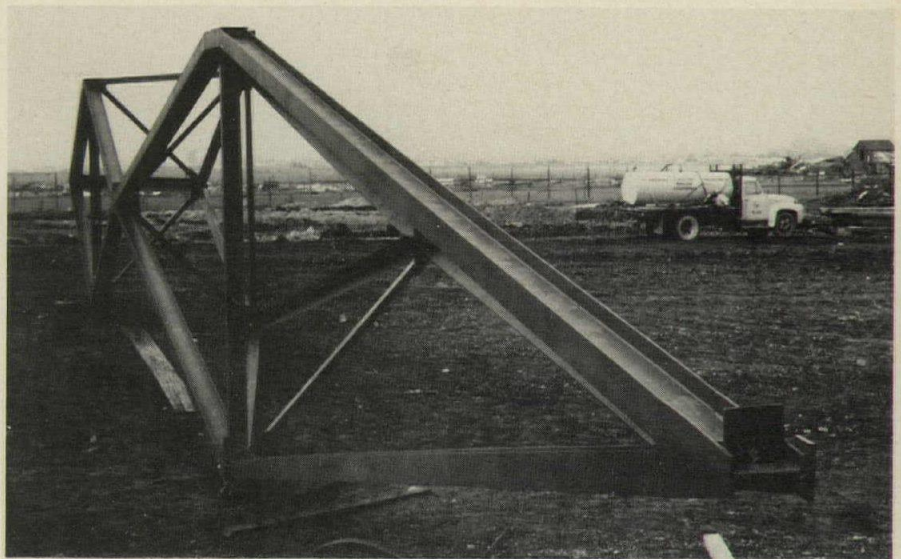

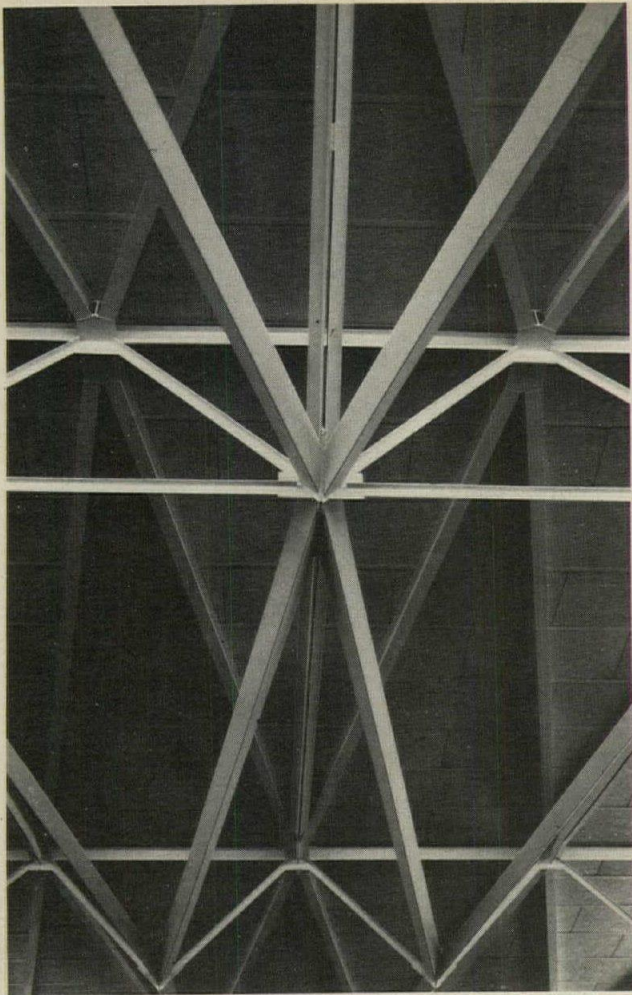

The 80-ft-long truss units were fabricated from angle and wide-flange sections. Altogether only 48 field connections were required between the truss units and trusses and Y-columns. The 11-ft-wide truss units were bolted as shown in the drawing below. First step was bolting together of two units on the ground to form a stable assembly. Transportation and erection of the roof structure took only five days. One of the shop-welded connections is shown in the photo below. The intricate pattern of the final assembly is displayed in the photo at left.

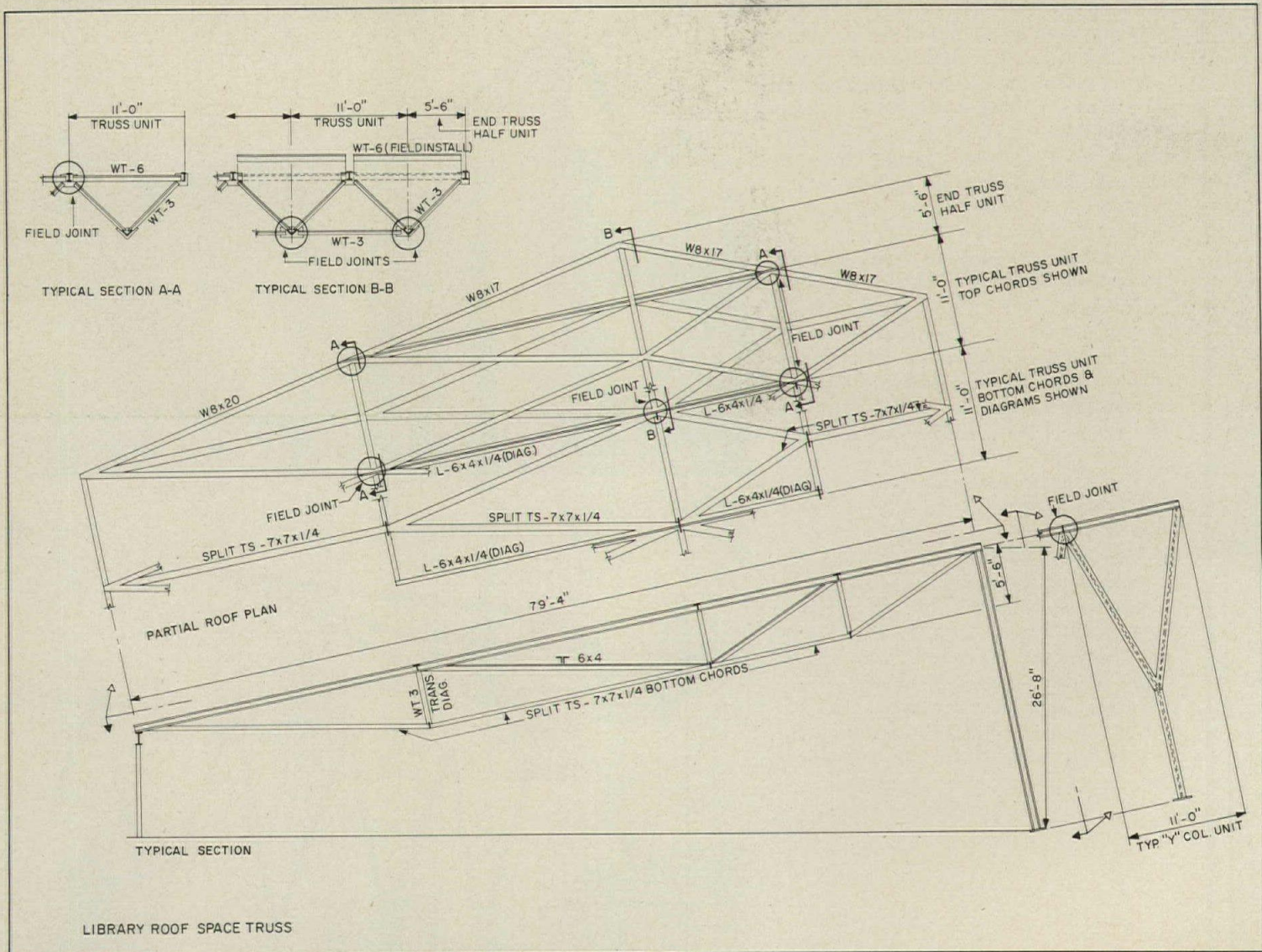
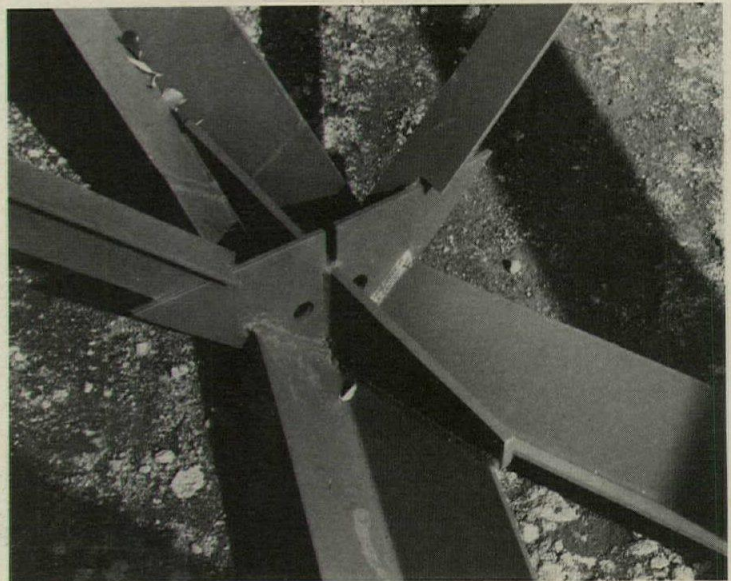

For more information, circle item numbers on Readers Service Inquiry Card, pages 231-232.



Standard elevator cabs that look special

The company has introduced a line of elevator cabs that look "special" but cost about the same as standard units. A basic steel shell economically accommodates cabs in 20 designs that can be combined for many interiors. The designs come in four series for apartment buildings, service use, hospitals and office buildings. A variety of materials and special finishes are available. ■ Otis Elevator Co., New York City.

Circle 300 on inquiry card

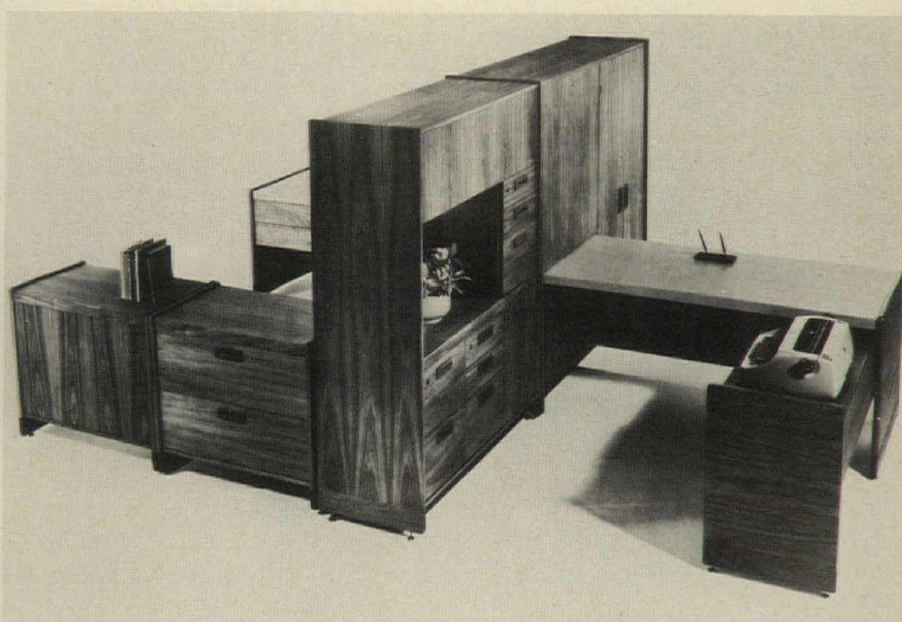

Open plan group with bi-directional capability

The flexibility of this open plan group is rooted in the high cabinet-dividers engineered to accommodate components functioning on both sides. The secretarial area shown features two vertical units with a work surface, box and file drawers, storage areas, wardrobe and lateral files in low cabinets. The

other side features an executive work set-up. The standard Group 5 woods, oak and walnut, are available in many finishes, and desk tops may be covered in plastic laminate or one of 75 vinyls. There are four desk styles. ■ Jens Risom Design, Inc., New York City.

Circle 303 on inquiry card

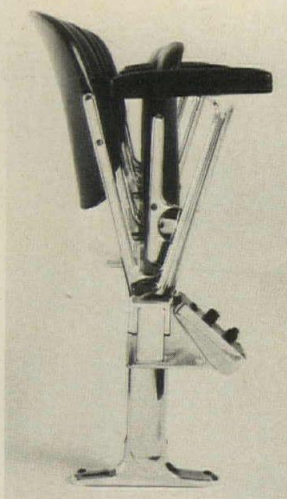

Multiple seating with options

Axis 4000 is said to have a unique folding seat that returns noiselessly, with a patented mechanism. Options include lighted row markers, ash trays, writing arms, and audio equipment. Color and material choices are numerous. ■ Castelli Furniture, Inc., New York City.

Circle 302 on inquiry card

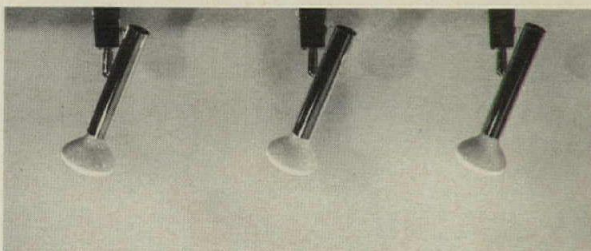
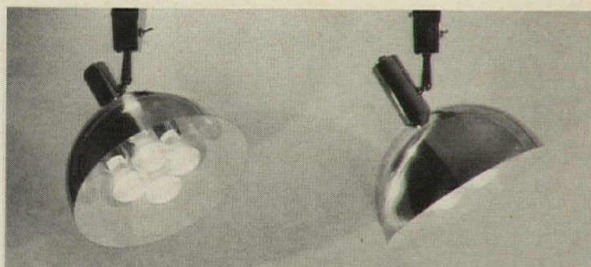

Extensive line offered in track lighting

Shown are two of the company's architectural track lights; all are also available for direct mounting to 4-in. outlet boxes. Multi-lamp units, plus pendants, are included in the line, with numerous finishes in colors or polished metal. The

model shown top features a chrome finish and measures 12 in. in diameter. The chrome-finished model shown bottom measures 9 in. long. ■ TSAO Designs, New Canaan, Conn.

Circle 304 on inquiry card
More products on page 155

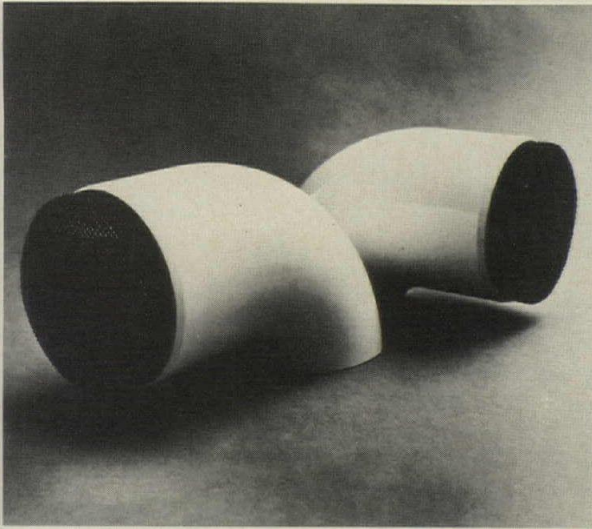

Clean, compact styling in high fidelity speakers

Imported from Sweden, this stereo loudspeaker system is being marketed exclusively for contract interior applications. A full-range high fidelity sound response is claimed for the units, measuring 1 ft deep, 6 1/4 in. in diameter, and standing

7 1/4 in. high. The speakers can be placed on walls, ceilings or on shelve-tops. The enclosure is high-impact plastic in white, black or red. ■ Intercontinental Enterprises, Co., Eastchester, N.Y.

Circle 301 on inquiry card

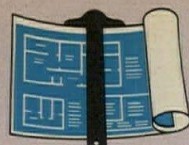

Georgia-Pacific Eternawall:TM * Resists fire. Looks great. Made to last!

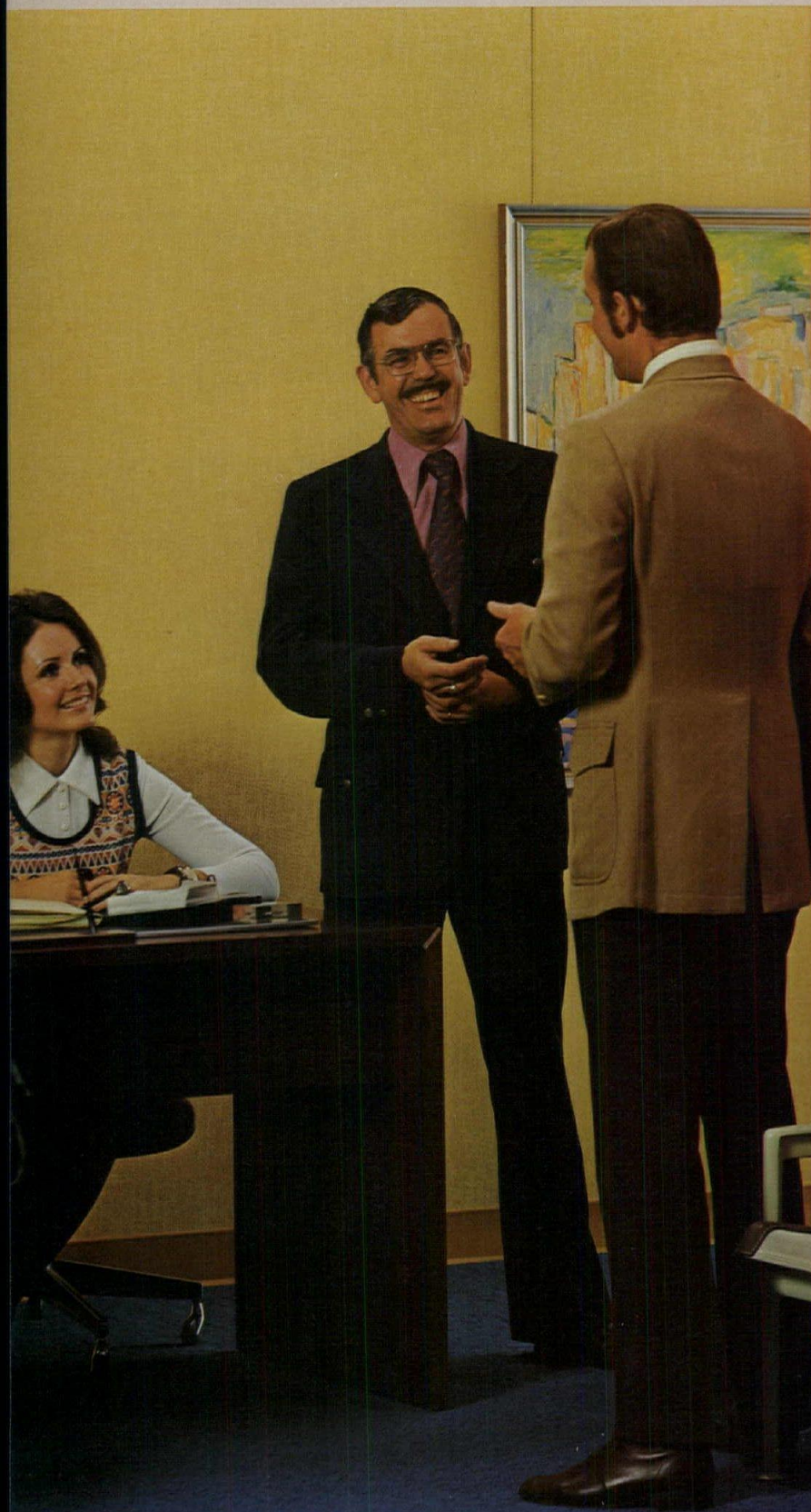

Eternawall:TM
The only vinyl-surfaced
gypsumboard with a
UL Class A Flame
Spread Rating of 25.**

And that's just the beginning!

Specify EternawallTM over G-P Sound Deadening Board, and you'll get a UL Class A flame spread rating of 25, plus a one-hour fire rating and, with insulation, an STC of 50!

You'll get a wall that lasts, too. EternawallTM resists most bumps, scratches and stains. And with 30 styles to choose from, you can use it almost anywhere!

Write for our free EternawallTM color swatch brochure. And check your Sweet's catalog. Or give your G-P man a call.

Then, make beautiful things happen. With Eternawall!

*Vinyl-surfaced gypsumboard.

**This flame spread rating available only with Eternawall's 15 standard colors.

Georgia-Pacific

The Growth Company

For more data, circle 66 on inquiry card



For more information, circle item numbers on
Readers Service Inquiry Card, pages 231-232.

You can do beautiful things with our holes

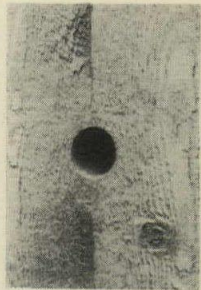

Those nice round holes left in exposed concrete when you specify Dayton Sure-Grip® form ties with cones. Combine the holes with a plain or textured surface for

added beauty. If you don't like holes, we can supply ties that leave a small hole that's grouted quickly.

For positive protection against rust stains, specify Sure-Grip stainless steel ties ... and rebar supports.

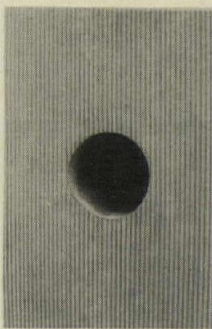

*Designing a
Stadium
or Gym?*

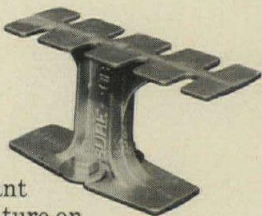

You'll want our literature on ductile iron and aluminum seat brackets. It describes the **most complete line** of architecturally styled seat brackets available.

Check the reader service card now for free literature on Sure-Grip accessories for architectural concrete.

THE DAYTON SURE-GRIP & SHORE COMPANY



721 Richard St.
Miamisburg, Ohio 45342
Phone 513-866-0711

Additional offices and plants in
Birmingham, Al.; Hialeah Gardens, Fl.;
Folcroft, Pa.; Torrance, Ca.

For more data, circle 67 on inquiry card

MULTI-CABLE TRANSIT / A 12-page, full color brochure is now available describing the *Multi-Cable Transit* penetration device. The product can be used in making vertical or horizontal penetrations with cable, conduit or pipe through walls, floors or ceilings. It can also be used as a cable support in vertical shaft cable runs. *MCT* is a firestop device. It has been tested to withstand temperatures in excess of 2000 degrees F. ■ Nelson Electric Div., Sola Basic Industries, Tulsa, Okla.

Circle 400 on inquiry card

RESILIENT FLOORING / The 32-page catalog shows both residential and commercial tile including self-adhesive backed tile, and a new concept in reinforced vinyl tile. Full-color photographs of actual installations are included. ■ The Flintkote Co., East Rutherford, N.J.

Circle 401 on inquiry card

GENERATOR SETS / Water-cooled engine generator sets in the 10KW through 1000KW range are described in new literature that covers diesel, gasoline, LP-gas and natural gas sets; complete specifications on all 15 models in the gas-driven category and 30 models in the diesel-driven category are included. ■ Dynamics Corp. of America, Bridgeport, Conn.

Circle 402 on inquiry card

PAINT COLORS / A color card has been developed for alkyd industrial enamel, a synthetic high-gloss coating designed for interior and exterior maintenance of commercial and industrial structures, machinery, and equipment. Forty-two tints and intermixed colors are shown on the card, plus six safety colors. Environmental earthtone colors have been added. Safety colors meet OSHA and ANSI specifications and can be recommended for use in areas requiring these standards. ■ Glidden Maintenance Coatings, Cleveland, Ohio.

Circle 403 on inquiry card

SOUND ABSORPTION FOAM / A lightweight, self-supporting, flexible polyurethane foam for middle- and high-frequency acoustical control of walls, curtains, etc., is detailed in a new four-page bulletin that includes complete product description, application, performance characteristics, physical properties, installation tips, and ordering data. ■ Ferro Corp., Norwalk, Conn.

Circle 404 on inquiry card

CLOSET SYSTEMS / An eight-page catalog and an architectural specification brochure describe the *Float-Away* line of closet systems. The illustrated catalog outlines design and construction features and architectural specifications of steel bi-fold doors and adjustable closet shelving. Seven door styles are offered. Specifications are designed to allow selection of styles, sizes and optional accessories. ■ United States Gypsum Co., Chicago, Ill.

Circle 405 on inquiry card

GROUPED METERING / An eight-page bulletin describing indoor grouped metering includes installation details and construction features. *EZ METER-PAK* indoor grouped metering is suited for high-rise applications. ■ Square D Co., Lexington, Ky.

Circle 406 on inquiry card

PRE-ENGINEERED PLENUMS / Acoustic/thermal plenums are available for any system either as a completely pre-engineered job, or as a "do-it-yourself" modular package. Either way, use of the standardized plenum components—accurately rated for

acoustic and thermal performance—cuts down on drafting time and field installation costs, according to the company. Specifications of the *Quiet-FLOW Moduline* plenums as well as a partial listing of satisfied customers are contained in the bulletin. ■ Industrial Acoustics Co., Inc., Bronx, N.Y.

Circle 407 on inquiry card

PHASE LOSS PROTECTION / An application guide to aid in the installation of phase loss, low voltage, and phase reversal protection in 3-phase power systems contains several application notes, schematics and charts. ■ Time Mark Corp., Tulsa, Okla.

Circle 408 on inquiry card

LAMP HOLDERS / This catalog features lampholders for all floodlamps from a 75W PAR-38 to the 1000W QPAR-64 (Quartz). Featured, too, is the extension principle which is said to prevent many lampholder changeovers should lighting specifications be revised at any time during the life of the installation. Among the associated accessories included along with the lampholders are cast aluminum cluster covers, lighting troughs, fittings, boxes, spikes, illuminators, and a full selection of automatic, dawn-to-dusk photo-electric switches. ■ Bell Electric Co., Chicago, Ill.

Circle 409 on inquiry card

LABORATORY EQUIPMENT / This edition lists over 40,000 different products for the laboratory: instruments, apparatus, appliances, furniture, and supplies. Users will also find the catalog has included quick reference charts to compare products, and full-color illustrations. ■ Fisher Scientific Co., Pittsburgh, Pa.

Circle 410 on inquiry card

FIRE DAMPERS / This information sheet describes the correct design and use of primary and secondary fire dampers, their differences, applications and design. The bulletin is said to dispel some common misconceptions. ■ Airstream Products, Inc., Philadelphia, Pa.

Circle 411 on inquiry card

FLOOR COVERINGS / A brochure to be used as a reference source for both commercial and residential installation floor-covering design contains a swatch sampling of custom carpeting as well as readily available broadloom lines. A pocket, attached to the rear inside cover, offers an installation brochure in full color, a design folio of patterns, color plates of the running broadloom lines and an oriental rug and broadloom collection for commercial planning. ■ Couristan, Inc., New York City.

Circle 412 on inquiry card

WALLCOVERINGS / A wallcovering samplebook designed for architects and builders contains a wide assortment of popular designs and colors in laminated vinyl fabrics. ■ United-Desoto Inc., Chicago.

Circle 413 on inquiry card

CONTEMPORARY FURNISHINGS / Included are armchairs, side chairs and executive chairs, as well as lounge chairs, sofas, barstools and reception-area tandem and multiple seating. Also shown, a wide selection of glass and wood top tables. The complete 52-page catalog, with price list and sample swatches of all currently available fabrics, is available for \$3.00 (postpaid). ■ Jansko, Inc., P.O. Box 1751, Ft. Lauderdale, Fla. 33302.

Circle 414 on inquiry card
more literature on page 161

Bally Walk-Ins belong where the first toast is to fine food and fashionable dining

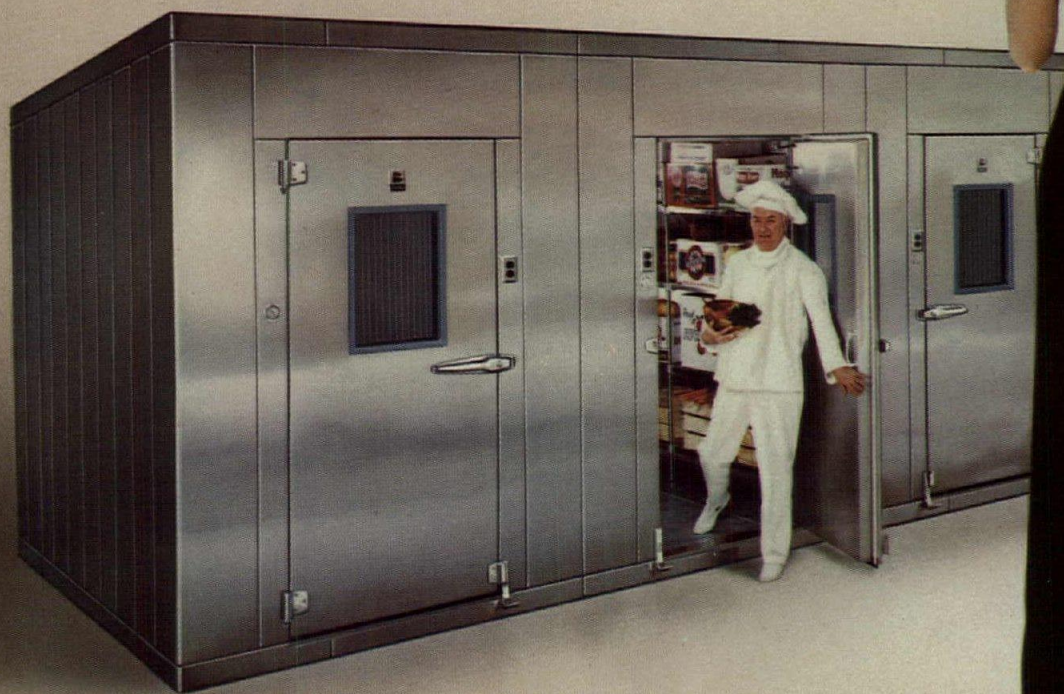

Bally Walk-In Coolers and Freezers belong everywhere mass feeding takes place. They can be assembled in any size for indoor or outdoor use from standard panels insulated with four inches of foamed-in-place urethane, UL 25 low flame spread rated and Factory Mutual research approved. Choice of stainless steel, aluminum or galvanized. Easy to enlarge . . . easy to relocate. Refrigeration systems from 35°F. cooling to minus 40°F. freezing. Subject to fast depreciation and investment tax credit. (Ask your accountant.) Write for 28-page book and urethane wall sample. **Bally Case & Cooler, Inc., Bally, Pennsylvania 19503.**



© 1973. ALL RIGHTS RESERVED.

ADDRESS ALL CORRESPONDENCE TO DEPT. AR-6

For more data, circle 68 on inquiry card

EXIT SIGN / The compact, easy-to-install *EXqulsiTe*



exit sign is said to meet all safety requirements in OSHA, the Life Safety Code and the National Electric Code. It includes diecast construction; a radius stencil seal to prevent light leaks; reflectors to eliminate hot spots and aid in the distribution of light; and metal snapout orifices enabling the owner to focus and adjust the amount of downlight. The *EXqulsiTe* comes in a precision cast aluminum housing, offered in either black or white. ■ Dual-Lite Co., Newtown, Conn.

Circle 305 on inquiry card

HEAVY-DUTY FLOOD / This NEMA heavy duty

flood is constructed of cast aluminum alloy for lightweight ease of handling, according to the company. Hinged upper housing opens for access to electrical components and the complete unit is gasketed. ■ ITT Landmark Lighting, Southaven, Miss.



Circle 306 on inquiry card

DUCT TAPE / An economy-grade duct tape is built

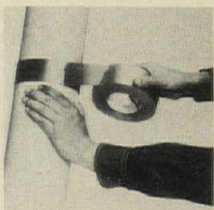

on a rubberized fiber substrate rather than the traditional woven cloth. It consists of a silver-colored polyethylene film laminated to a fiber substrate and a high-track adhesive. The tape forms an effective water barrier, so it maintains its grip even when moisture condenses on cool ducts, according to the company. ■ Tuck Industries, Inc., New Rochelle, N.Y.

Circle 307 on inquiry card

PACKAGED AIR CONDITIONERS / A new line of

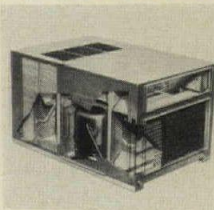

packaged air conditioners ranges in size from two to five tons and has been designed with major consideration for the residential replacement market. Cooling capacities begin at 24,000 Btuh and go up

to 58,000 Btuh in the largest five-ton unit. They are UL listed and ARI certified. All components, including optional electric heat, are housed in one compact cabinet of heavy gauge galvanized steel, with a durable bonded baked-on enamel, weatherproof finish. ■ Lennox Industries Inc., Marshalltown, Iowa.

Circle 308 on inquiry card

PUSH BUTTON STATIONS / A line of rubber-

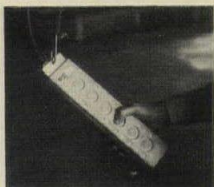

enclosed pendant push button stations for safe controlling of cranes, hoists, machine tools, etc., is said to meet OSHA standards. The shock-proof design features a compact steel reinforced high visibility yellow rubber NEMA 4 enclosure case with a choice of two-, four-, six- or eight-button operation. The push button stations are UL listed, with switches rated at 20 amps., 250 V.A.C. ■ Duct-O-Wire Co., Waukesha, Wis.

Circle 309 on inquiry card

more products on page 157

T-100

JG Furniture Company Inc. 121 Park Avenue
Quakertown, Pa. 18951

Auditorium seat designed by Dave Woods. Installed at the Guggenheim Auditorium, The Institute of Man and Science, Rensselaerville, New York. Architects: Prentice & Chan, Ohlhausen.



JG

Carrier rooftop cooling sits on a curb and hides.

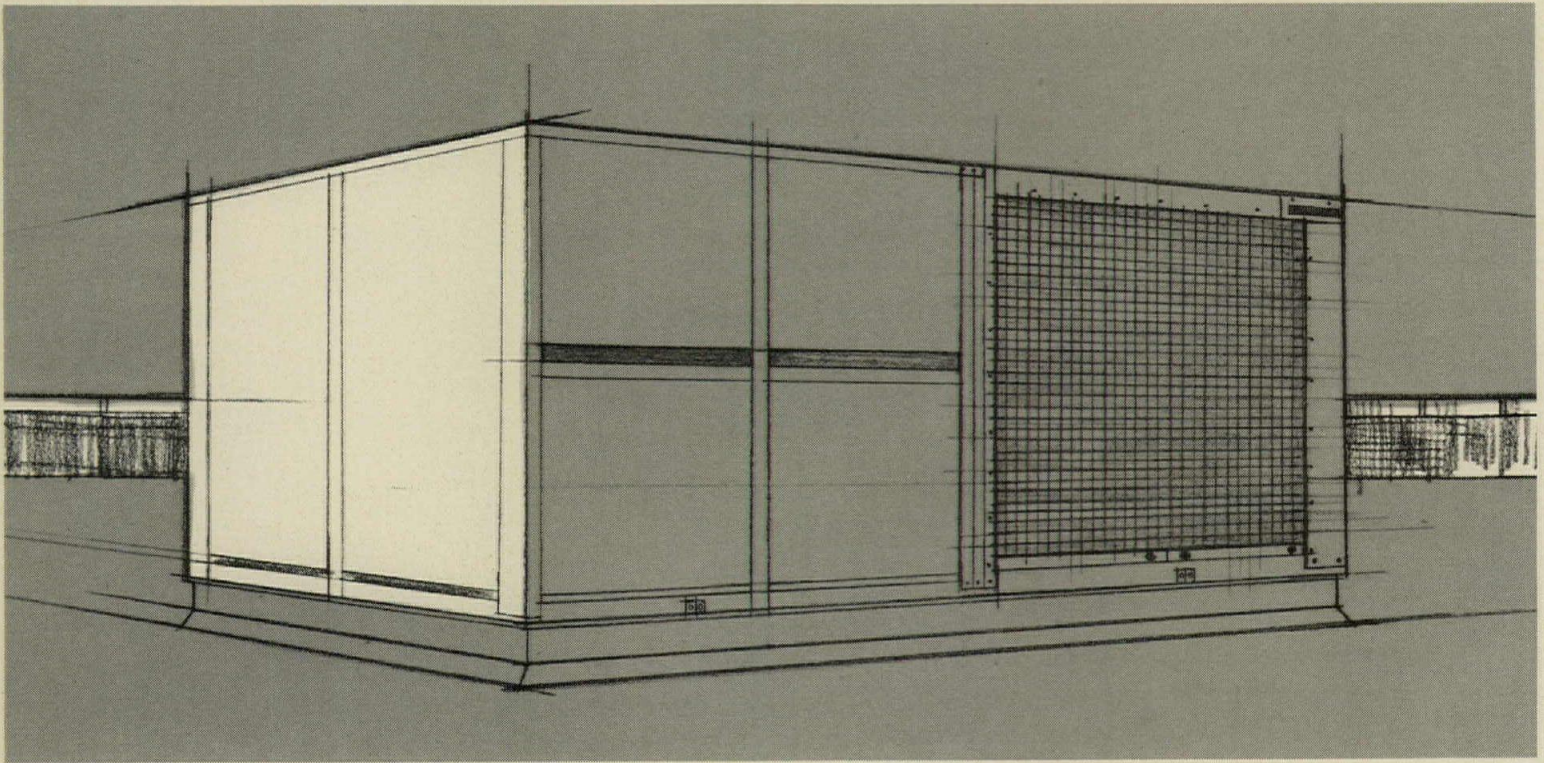

Our rooftop units won't spoil your roof line. Won't take a lot of extra roof support. Won't waste your client's energy. And won't use up indoor space.

To begin with, they sit on a factory-supplied NRCA-approved curb. They're down low, so they can hide on the roof.

In all their 10 through 50 ton cooling sizes, they're easy to handle to cut on-site labor costs.

And you can plan on our factory-installed economizer option to save energy by giving your client free cooling on mild days. Without unsightly sheet metal contraptions.

Gas or electric Carrier rooftop units for cooling (and heating). All UL or AGA approved. Your Carrier representative has the details. Carrier Air Conditioning Division, Syracuse, N.Y. 13201.

Number One
Air Conditioning
Maker



Division of Carrier Corporation

Carrier

For Maximum Rolling Door Efficiency -

be sure to ask for YOUR copy of this latest CATALOG!



KINNEAIR®

ROLLING DOORS

Saving Ways in Doorways Since 1895

KINNEAIR CORPORATION

A SUBSIDIARY OF **Harsco**

1860 Fields Ave., Columbus, Ohio 43216

FACTORIES:

Columbus, Ohio 43216 • San Francisco, Calif. 94124
 Centralia, Wash. 98531 • Toronto, Ont., Canada.

Offices & Representatives in All Principal Cities
 Listed in Yellow Pages under "Doors." Also see Sweet's!

For more data, circle 70 on inquiry card

ALARM ANNUNCIATORS / A series of new remote fire annunciators for use with the company's early warning fire and smoke detection systems provide remote fire indication for up to 48 individual zones by use of a back-lighted, translucent panel. The panels, measuring approximately 15 in. high, 13 in. wide, and 5 in. deep, come with a hinged black and blue face plate framed in aluminum. ■ Pyrotronics, Cedar Knolls, N.J.



Circle 310 on inquiry card

WATER CLOSET TANK / Called *Thermo-Tank*, the new closet tank is made of injection molded ABS plastic and contains a special thermal liner making it condensation-free even under conditions of high humidity. The traditional flush lever has been replaced by a corner flush tab, located just above the spot where traditional flush levers are mounted. Corrosion-free materials are used almost throughout the inner workings of the tank to guard against liming and other results of corrosive elements in water. Weight is 8 lbs. ■ Universal-Rundel Corp., New Castle, Pa.



Circle 311 on inquiry card

PLASTIC COOLING TOWERS / *RCT Series* forced draft cooling towers featuring non-corrosive all plastic construction are available in nominal capacities of 10 through 750 tons and can be used in a variety of industrial and commercial applications. High impact polyethylene is used for the one-piece casing. The deck and eliminators are made from self extinguishing ABS resin spirally wound into an easy-to-remove one-piece unit with PVC hand straps. The sump is integral with the cooling tower shell and equipped with an automatic make-up valve and adjustable float. ■ Rheem Mfg. Co., Jackson, Mich.

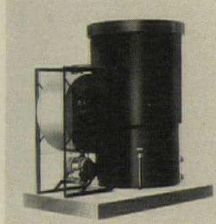

Circle 312 on inquiry card

SQUARE LUMINAIRE/POST / For strength, the luminaire is constructed from an aluminum extrusion, notched and bent to form the clean square architectural corners. The one-piece injection-molded clear prismatic acrylic lens is in a specially extruded aluminum door frame. All exposed hardware is stainless steel. A vandalproof injection-molded lens is available on request. Standard finish is brushed aluminum with clear anodized coating. All duranodic finishes also available. Modalities are: 150-watt incandescent; 100-watt and 175-watt mercuries. ■ Street Lighting Equipment Corp., Hackettstown, N.J.

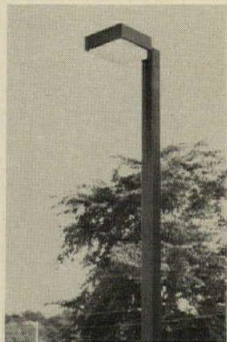

Circle 313 on inquiry card
 more products on page 159

High Rise/Life Safety Code Requirements

If you will be designing a multi-story building which must comply with the ICBO, BOCA or Southern Building Codes, Wasco Products can help you. Having worked very closely with the professionals in developing the smoke control provisions, Wasco is now able to provide the hardware that can meet them. For instance, we have completed or are now installing exterior wall smoke vents with remote release devices, similar to the drawing below, in eight multi-story buildings.

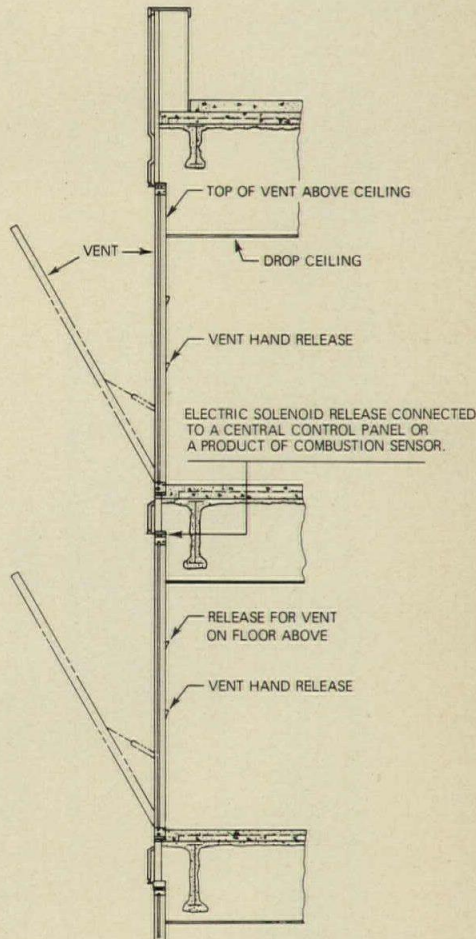

WASCO EXTERIOR WALL SMOKE CONTROL VENT

These vents not only meet code requirements but allow the architect a wide range of choice of both exterior and interior panels or glazing.

Because Wasco has been so close to this life safety effort, we can also offer extensive design assistance.

For copies of the various code sections pertaining to life safety or for specific help on individual jobs, write Richard L. Swan, Wasco Products, Inc., Box 351, Sanford, Maine 04073, or call 207-324-8060.

For more data, circle 71 on inquiry card



The last word in environmental ceilings

Striking good looks, excellent performance, superb engineering, and quality craftsmanship are all brought together in the new "Project EC" environmental ceiling system — a simple, easily-installed four-component system that advances the concept to its ultimate refinement.

The 5-by-5 modules with perforated metal coffers are available with a wide range of options to allow unprecedented design flexibility.

The whole story is told in GUTH LIGHTING's "Project EC" Catalog. Write or call for a copy — it's good reading.

GUTH LIGHTING



P. O. BOX 7079 • ST. LOUIS, MO. 63177 • (314) 533-3200

SOLA BASIC DIVISIONS: ANCHOR ELECTRIC • BISHOP ELECTRIC • DIELECTRIC COMMUNICATIONS • DOWZER ELECTRIC • GUTH LIGHTING
HEVI-DUTY ELECTRIC • LINDBERG • NELSON ELECTRIC • SIERRA ELECTRIC • SOLA ELECTRIC • TEMPRESS • WARREN G-V COMMUNICATIONS

For more data, circle 72 on inquiry card

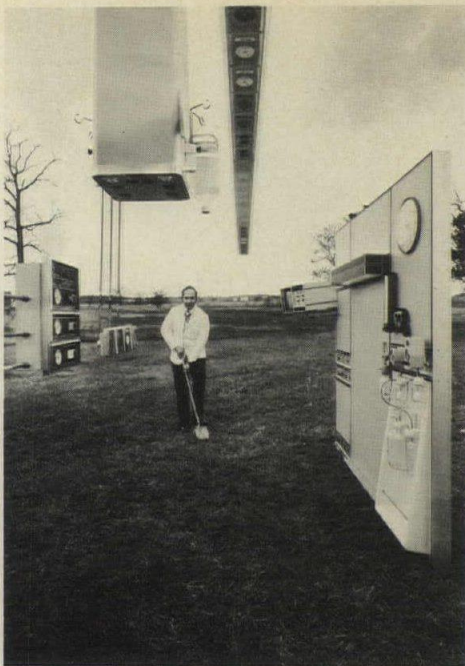

When you start to plan, coordinate, or install medical service walls and piping systems... start with Ohio®

If you're planning hospital construction or renovation, call on Ohio's exclusive full service planning department. For information and assistance on the most comprehensive medical gases, vacuum piping and Multi-Wall® modular medical service systems in the industry.

Our specialists will assist architects and engineers in planning the most efficient systems for your specific project.

Our design staff reviews over 800 hospital projects each year. This keeps us current on all aspects of hospital planning and design. And our 60 years of experience enables us to recommend the right medical life support system to meet your needs.

Look to Ohio for help in developing a coordinated, compatible system which offers maximum efficiency for the hospital staff.

Call your nearest Ohio representative. Or write for a packet of literature.

Ohio Medical Products

P.O. Box 1319 Dept. AR
3030 Airco Drive
Madison, Wisconsin



For more data, circle 73 on inquiry card

HAZARD-AREA LIGHTING FIXTURES /

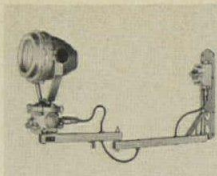

Two special explosion-proof lighting fixtures, for use where hazardous conditions are encountered, include Docklite Model DL-300D-EXB (shown). Designed for class 1—gaseous atmospheres, it uses medium screw base PAR 38 or R-40 type "sealed beam" lamps up to 300 watts.

Model DL-300-EX2B is for class 2—explosive dust atmospheres. It uses PS-30 type lamps to 300 watt maximum. Both cast aluminum fixtures are mounted on dual swing arms. Mounting brackets, arms, and all hardware are galvanized or plated.

▪ Phoenix Products Co., Inc., Milwaukee, Wis.

Circle 314 on inquiry card

NURSE CALL SYSTEM /

A centralized nurse call system is said to permit all of a hospital's patient calls to be answered from a single console. This contrasts with the answering of calls from individually-manned master stations on each floor. The system is called *Graphic-Call* for its architecturally-oriented display of all patient and nurse duty stations on the console turret. When a call is placed by a patient, illumination of a switch/lamp and the sounding of a tone at the console alerts the attendant to the call. Pressing the switch/lamp identified with the patient establishes two-way voice communication. ▪ Dukane Corp., St. Charles, Ill.

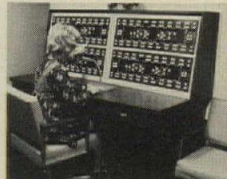

Circle 315 on inquiry card

NON-SYMMETRICAL BEAM PATTERNS /

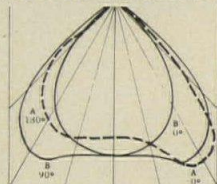

According to the company, designers are often forced to specify more luminaires than are actually needed for a job because of "aisle-spacing." Now asymmetric and bisymmetric beam patterns can be used to allow only the minimum number of fixtures to be specified yet spread light throughout the room's area as desired. With "aisle-spacing," light can be directed onto displays for good in-shelf illumination and at the same time minimize floor-reflected glare. Full information on conventional, asymmetric or bisymmetric units is offered. ▪ Wide-Lite Corp., Houston, Tex.

Circle 316 on inquiry card

PEDESTAL FOUNTAIN /

A new outdoor pedestal drinking fountain, for use by the general public and persons in wheelchairs, has a sculptured receptor that is mounted on a 19¼ in. extension with two lever handle valves for right- or left-hand operation. The waste strainer is integral with the receptor and features a patented vent for quick drainage. A vandal-resistant bottom plate is included. The fountain, of hard anodized aluminum, is finished to a dark bronze tone. ▪ Haws Drinking Faucet Co., Berkeley, Cal.



Circle 317 on inquiry card



Stop noise from leaping over sound-rated walls with ACOUSTILEAD®

Even sound-rated walls won't keep an office quiet unless you plug the leak in the plenum barrier—the space between a hung ceiling and the slab above. All it takes is a curtain of Acoustilead—¼" thick sheet lead.

Nothing else stifles noise so effectively with so little weight or thickness. Acoustilead doesn't just strain noise like porous materials. It stops noise effectively because it's limp and dense.

Acoustilead is easy to install. Cuts with scissors or knife. Crimps around ducts and vents for an airtight seal.

For our how-to booklet on plenum barriers, or the name of an Acoustilead distributor near you, write Sound Attenuation Department, Asarco, 120 Broadway, New York, New York 10005.

75 Years of Progress in Metals

ASARCO⁷⁵

American Smelting and Refining Company
FEDERATED METALS DIVISION

For more data, circle 74 on inquiry card



Dynaglide. The energy-conscious elevator drive.

Dynaglide delivers unmatched elevator performance on less energy—at far less operating cost—than any other drive. And brownouts don't bother it.

Armor's unique solid-state Dynaglide does away with field regulators and bulky motor generators in applications with speeds of 150 to 400 fpm. It's so efficient, it cuts waste heat sharply, and uses 10% to 35% less power than other drives. So it not only conserves energy, it saves owners money, too.

Which is what we designed it to do.

But that's not all we designed it to do.

In brownouts, Dynaglide just goes on about its business of providing the fastest, smoothest acceleration, the most efficient dispatching there is. And it's compact; fits in any standard controller cabinet.

Dynaglide solid state drive is typical of the bright new ideas coming out of Armor research. Ideas that cut costs. Conserve energy. And improve elevator service. Which is one reason we're growing faster than ever in vertical transportation.

Armor Elevator Company, Inc., Louisville, Ky. 40214.

Armor Elevator Canada Limited, Pickering, Ontario.



Subsidiary of **ASmith** Corporation

73-03R1

PRECAST CONCRETE DECKS / This fully illustrated booklet shows the benefits of using precast concrete decks in floor or roof construction, and also discusses load-span requirements and camber characteristics, as well as the adaptability of the company's decks with other precast components, or with more traditional masonry and cast-in-place walls. ■ The Flexicore Co., Inc., Dayton, Ohio.

Circle 415 on inquiry card

LIGHTING CATALOG / A 104-page catalog, featuring nearly 300 full-color photographs of lighting fixtures, including a customized chandelier for each major line grouping, features specifications on each page for the fixtures shown. ■ The Feldman Lighting Co., Los Angeles, Cal.

Circle 416 on inquiry card

DECORATIVE FABRICS / The Marimekko® Fall '74 collection will be available in late August and a brochure picturing the collection is offered now. ■ Design Research Inc., Braintree, Mass.

Circle 417 on inquiry card

VERTICAL FILING / This illustrated brochure is said to simplify selection of vertical filing systems for large or small applications. One binder, interchangeable in all units, is used in portable, open or closed cabinets designed to blend with most offices. ■ Viking Metal Cabinet Co., Inc., Chicago, Ill.

Circle 418 on inquiry card

CARPET YARN / To help the commercial carpet specifier and to be sure of the right product for each specified area, the company has put together a series of pocket-size brochures on all its Zefran acrylic and nylon products. All of these offer specifiers an explanation of traffic classifications as they relate to end-use requirements and also supply useful information on carpet maintenance and cleaning. ■ Dow Badische Co., Williamsburg, Va.

Circle 419 on inquiry card

INSULATED PANELS / A new architectural panel construction, featuring interlocking tongue and groove aluminum extrusions on the panel edges, has been introduced and is offered in a choice of porcelain enamel, aluminum, or aggregate facings in a variety of colors and textures. Panels are available single- or double-faced for combination exterior-interior walls or for interior use as relocatable wall partitions. Panels come with standard cores of UL-approved non-combustible moisture-resistant expanded perlite, or polyurethane (ASTM D-1692). Product Literature is available. ■ Kaiser Mirwal, Port Carbon, Pa.

Circle 420 on inquiry card

WASHROOM ACCESSORIES / A 36-page catalog and price schedule covering over 300 soap dispensers and other washroom accessories describes a range of individual wall-mounted, basin-type and recessed soap dispensers, as well as a line of multi-functional units. ■ American Dispenser Co., Inc. Carlstadt, N.J.

Circle 421 on inquiry card

HOSPITAL FURNITURE / A 36-page catalog illustrating a complete line of hospital furniture and equipment features the FRED hospital bed. In addition to its many options, the bed's 12 nursing positions are detailed. The catalog also describes the *Newmatic* hand control which allows patients to start the bed's motors with air instead of electricity. Other hospital beds are included. Also covered are a complete line of coordinated cabinets and chests, overbed tables and chairs for lounge, visitor and geriatric use. ■ InterRoyal Corp., New York City.

Circle 422 on inquiry card

We Guarantee . . .

All Vicrtex materials, when adhered to a sound surface with the manufacturer's recommended procedures and adhesive, are guaranteed for a period of five years from the date of sale against manufacturing defects only.

Said materials are further guaranteed against permanent surface staining attributable to mildew and/or bleed-through of foreign impurities embedded in the backing as well as separation of the vinyl from its backing.

If defects are claimed during this period, and proper documentation is presented to the manufacturer with regard to date of sale plus adhesive used and surface applied to, the manufacturer will replace the vinyl and assume installation costs.

The foregoing Guarantee is in lieu of all other Guarantees or Warranties, express or implied, written or oral.

Guarantees are not all the same,
any more than vinyl wallcoverings
are all the same!

No other manufacturer offers a
guarantee this broad,
this comprehensive

-only Vicrtex[®]
is guaranteed for a
full five years!

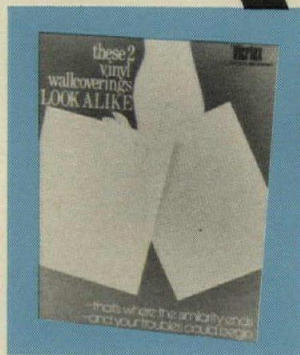

New Vicrtex GUIDE

"VINYL WALLCOVERINGS—
QUESTIONS & ANSWERS"

Write for your complimentary
copy, or call your Vicrtex man!

There are but four other written guarantees in the contract vinyl wallcovering field—and they are only one-year guarantees. None is as extensive as ours. Our superior product allows us to provide a five-year guarantee. Learn more about vinyl wallcoverings, and what causes tearing, staining and mildew. Get the facts. Ask for the new Vicrtex guide,

"VINYL WALLCOVERINGS—
QUESTIONS & ANSWERS"

L. E. CARPENTER

AND COMPANY

964 Third Ave., New York, N.Y. 10022 (212) 355-3080



A DAYCO
COMPANY

For more data, circle 76 on inquiry card

DISTRIBUTED BY: VICRTEX SALES DIVISION,

New York, Atlanta, Chicago, Dallas, Los Angeles, San Francisco, Boston, Minneapolis, Toronto/HOWELLS, INC., Salt Lake City/PAUL RASMUSSEN, INC., Honolulu.

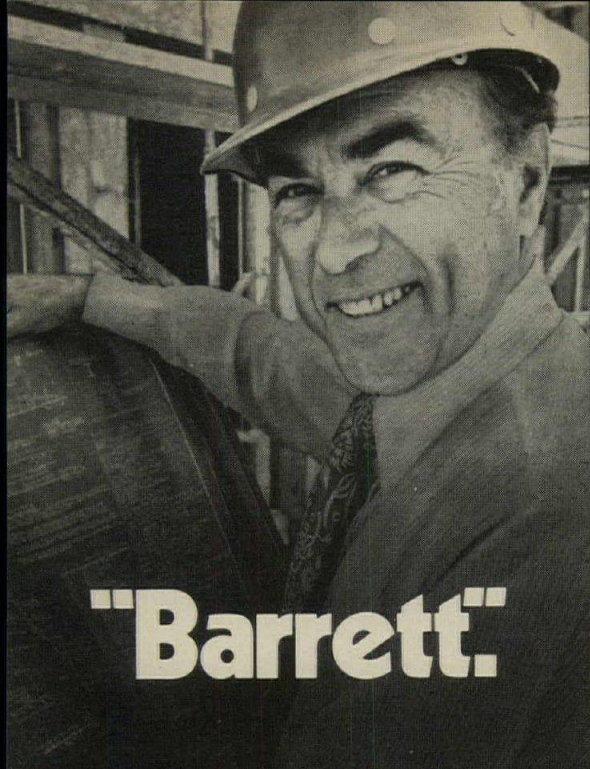

"Barrett."

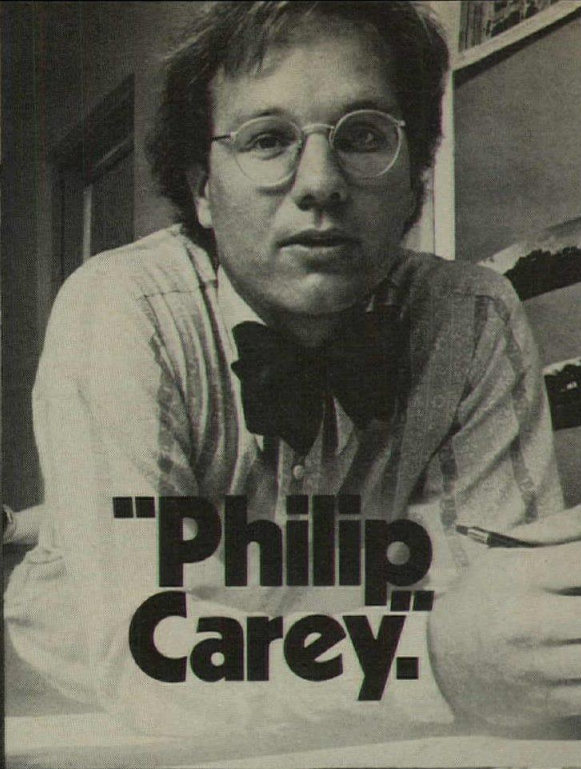

**"Philip
Carey."**

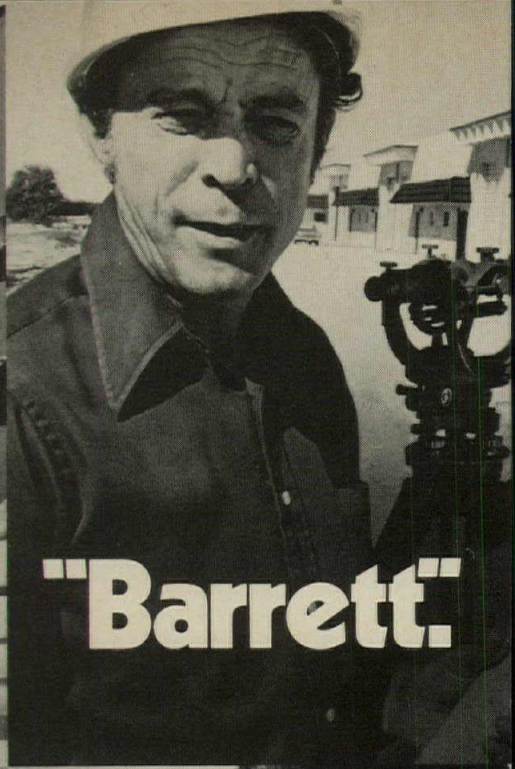

"Barrett."

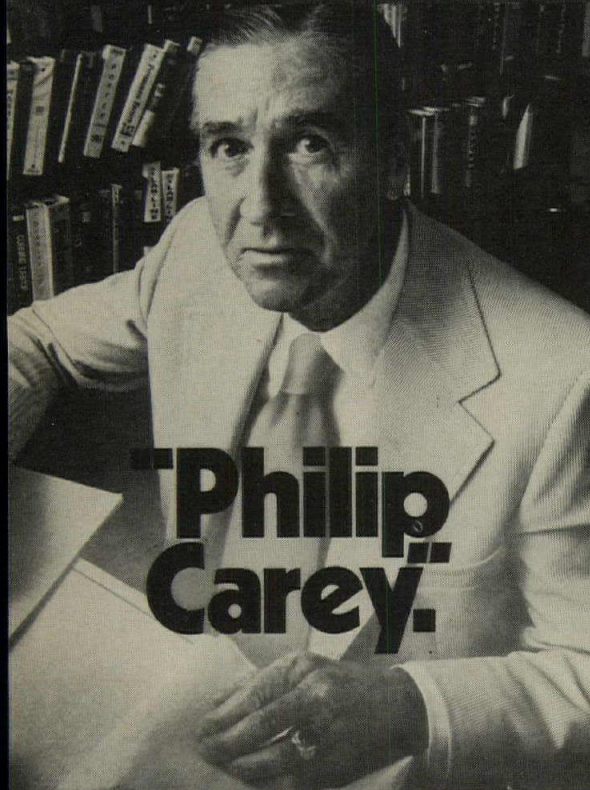

**"Philip
Carey."**

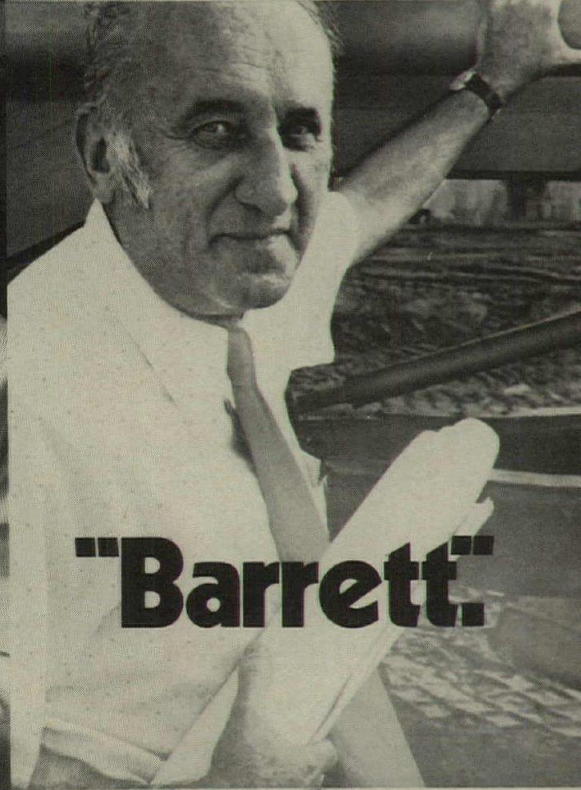

"Barrett."

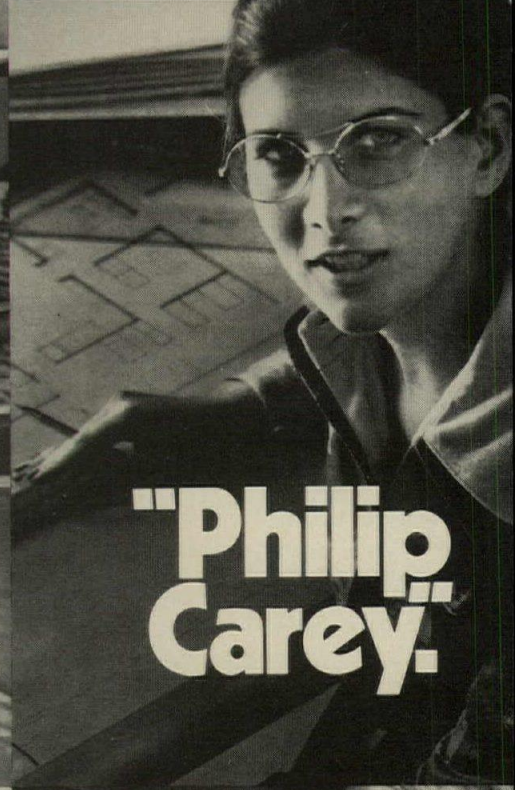

**"Philip
Carey."**

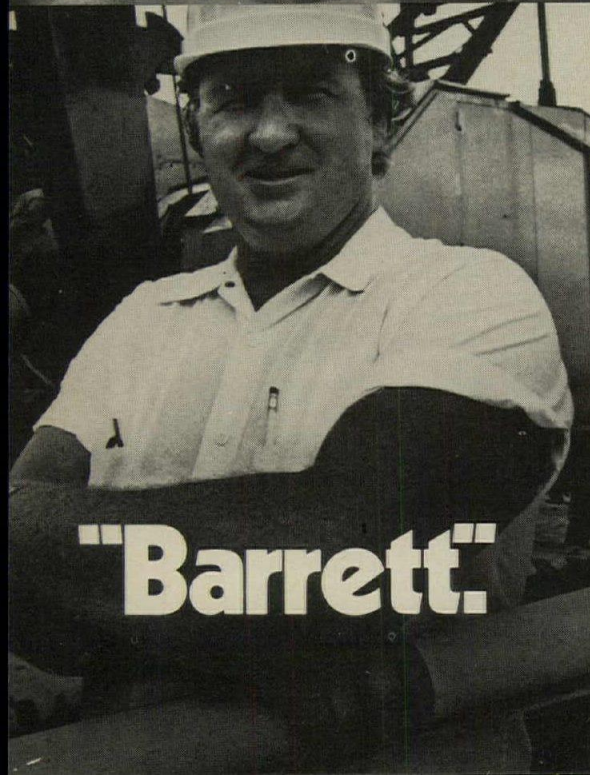

"Barrett."

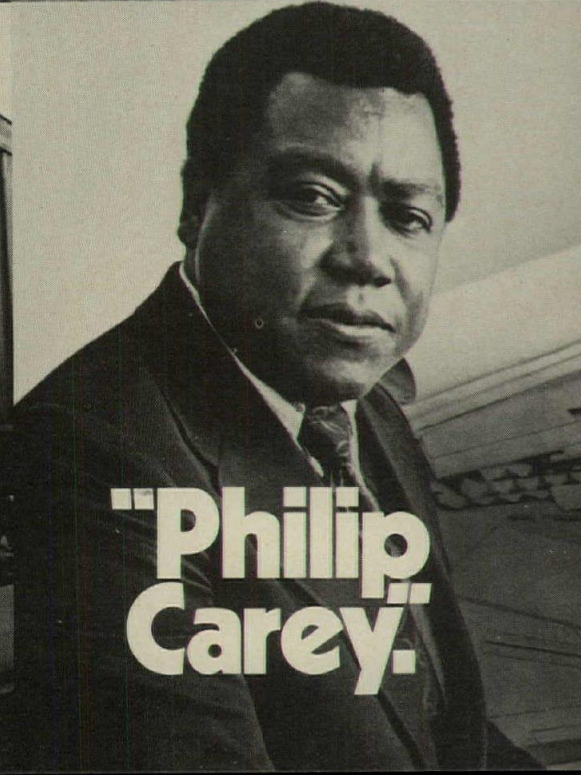

**"Philip
Carey."**

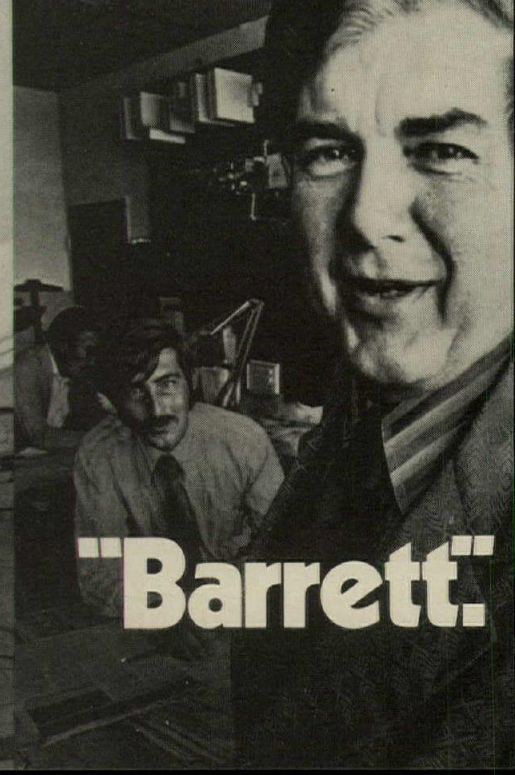

"Barrett."

People in roofing have been calling us other names.

We'd like you to call us Celotex.

For quite some time now, people involved in roofing have been saying, specifying, and installing, what they thought of as either Philip Carey or Barrett brands of roofing products.

And they were right.

The products were...still are...Philip Carey and Barrett. But now they're all called by one family name. Celotex.

This means that now, when you say Celotex, you're naming the finest working combination of built-up roofing products available.

And you're naming a manufacturer with one of the broadest lines of materials and systems to choose from. With a strong team of product researchers, marketing specialists, and manufacturing experts. And with a matchless plant and distribution network.

Celotex can also offer additional services in pre-spec roof design assistance; technical support, and a Celotex Roof Inspection & Service Contract.

If you're going to call us a name, make it Celotex.

Philip Carey and Barrett will both understand. They're part of the family.

Celotex™

BUILDING PRODUCTS

The Celotex Corporation, Tampa, Florida 33622

a **JIM Walter** company

For more data, circle 77 on inquiry card

Something **New** from Smith

...A CHOICE IN LONG-SPANNING WALLS

1 DYNA SPAN ...a New Dimension in Metal Wall Panels

- **MASSIVE PROFILE**
Bold profile casts strong shadows ... gives an aesthetic appearance to massive buildings.
- **SAVE STRUCTURAL GIRT COSTS**
Long span strength reduces number of girts required ... saves on structural material costs.
- **SPANS LONGER DISTANCES**
DYNA SPAN is super strong ... spans greater distances between structural supports.
- **SAVES ON ERECTION COSTS**
Reducing number of structural girts reduces erection costs.

HOW IT COMPARES ...

Compare DYNA SPAN with industry-standard V-Beam. Based on 22 gauge galvanized steel at 20 psf loading, DYNA SPAN will span 20'9" in a single span. V-BEAM, same gauge and wind loading, will only span 12'0".

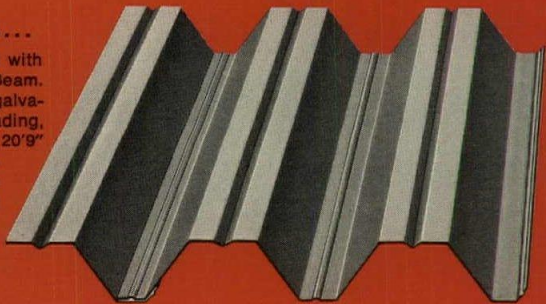

2 VARISPAN PANEL SYSTEM... for longer spans, greater strength

- **SPAN COLUMN TO COLUMN**
VARISPAN can be installed horizontally on columns to eliminate unsightly structural girts.
- **PROFILE SELECTION**
Choose from 23 exterior profiles.
- **THERMAL VALUE**
Choice of insulation thicknesses from 1½" to 7½".
- **SAVE MONEY**
Installed vertically or horizontally ... the super strength spanning qualities of VARISPAN save structural steel material and erection costs.

SMITH VARISPAN Panel System provides a new dimension in super strength, longer spanning ability and versatility. Variable depths are available, permitting single spans in excess of 30'0". Various insulation thicknesses, as shown below, are available. Write for full details.

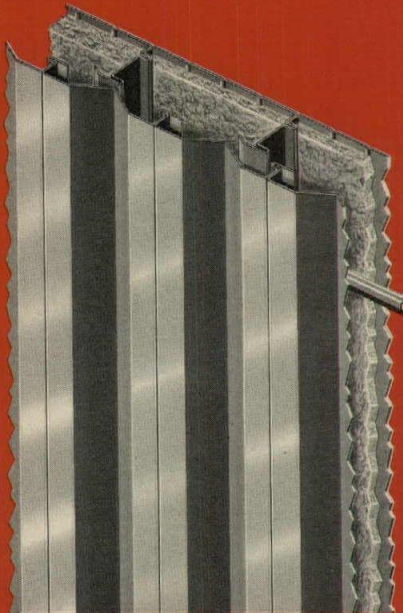

4 VARISPAN Panels for wide selection of spanning distance



ELWIN G. SMITH DIVISION

100 WALLS STREET, PITTSBURGH, PENNSYLVANIA 15202

EGS 114

For more data, circle 78 on inquiry card



Incandescent, Fluorescent Dimmer Switches from Ideal.

14 models of incandescent and fluorescent dimmer switches to handle virtually every requirement. Voltage compensated, solid-state circuitry. Complete, self-contained units. From economy units to attractive Decorator Styled designs. Send for your FREE dimmer switch reference file.

IDEAL INDUSTRIES, INC., 1328-F Becker Pl., Sycamore, Ill. 60178
In Canada: IDI Electric (Canada) Ltd., Ontario



For more data, circle 79 on inquiry card

Specify Nord

Architectural spindles.
Turned from clear kiln-dried Western hemlock. In 9 styles. Lengths from 7½ inches to 8 feet. With 2-, 3-, and 4-inch widths.

They make into handsome dividers, classic banisters, elegantly patterned walls and grilles.

For full-color literature, write "spindles" on your letterhead and mail it to E. A. Nord Company, Dept. AR, Everett, WA 98206.

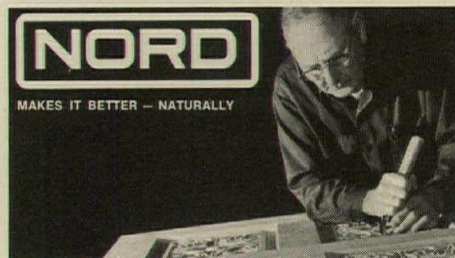

For more data, circle 80 on inquiry card

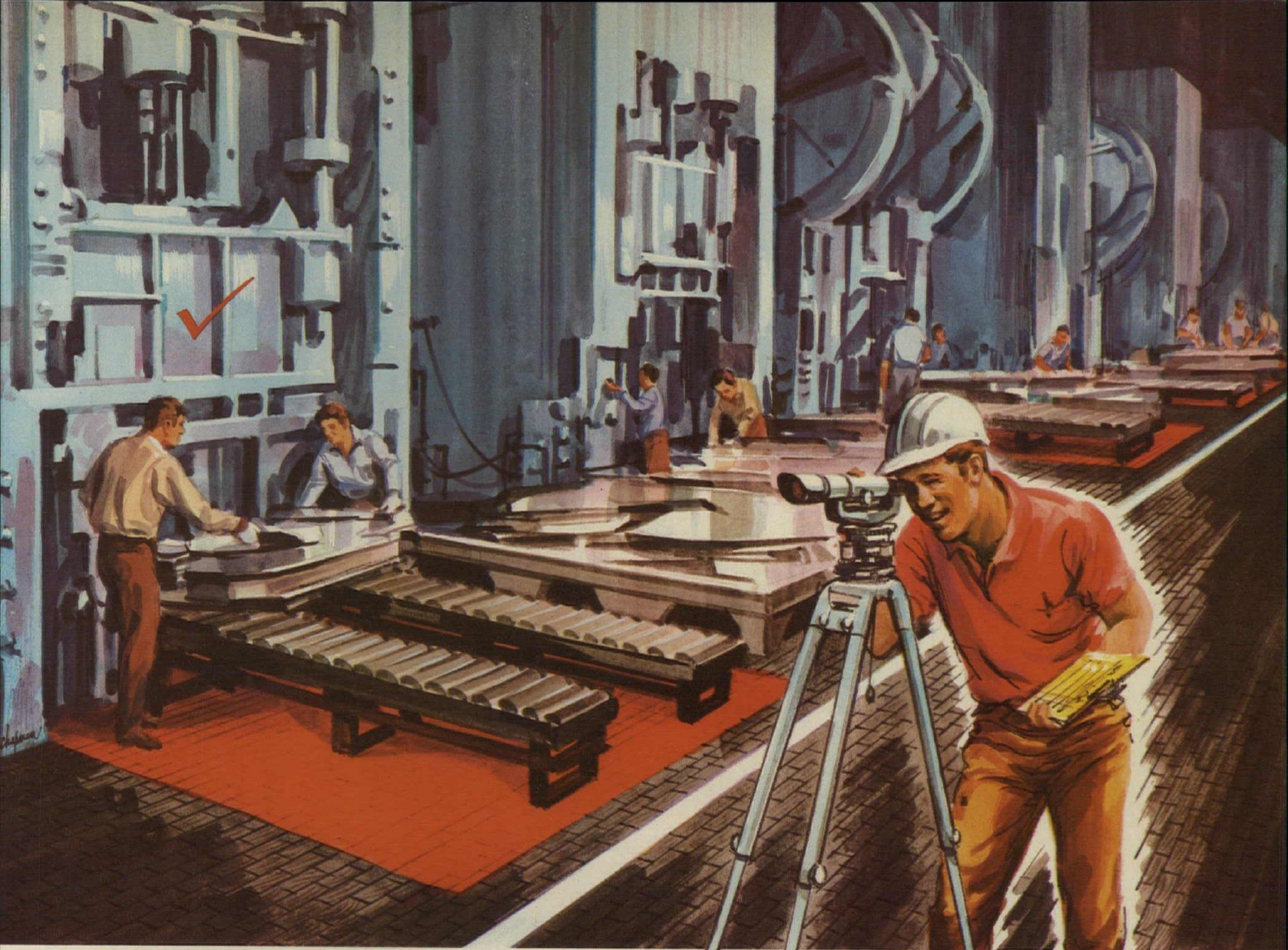

Engineered

FACTORY FLOORS

by Jennison-Wright

ADVANTAGES OF KREOLITE® FLOORS:

1. Easy relocation and concealment of service lines to machinery.
2. Speed and economy of replacement in aisles and other heavy wear areas.
3. Special finishes for absolutely dust-free surfaces.
4. Versatility in providing for in-floor conveyor systems, tow-lines, etc.
- ✓ 5. Measurable contributions to noise abatement.
6. Easy installation of oil dispersal and/or recovery systems.
7. Traditional properties of comfort through insulation.
8. Non-sparking surface in volatile areas.
9. Reduction of damage to dropped tools and products.
10. Priced for profitable production.

At first glance, wood blocks don't look sophisticated. It would be easy to assume that their installation requires a minimum of preplanning, but this is not so in most cases. Your flooring should be engineered to your requirements just as your factory was. Jennison-Wright Kreolite® End Grain Wood Block Floors have many advantages (see panel at left), but to take full advantage of their features, preplanning is most desirable. Our Design Engineers will gladly perform this service at no charge.

The Jennison-Wright Corp., P. O. Box 691, Toledo, Ohio 43694

... you'll find us in Sweet's Catalog and in the Yellow Pages

For more data, circle 81 on inquiry card



Miami International Airport:
Cosa/Tron, in the F.A.A.
Tacon (Traffic Control) Room,
clears the air of jet fumes and
tobacco smoke, protects the
electronic equipment as well as the
controllers. Engineer-architects:
Berry & Ellis Associates.

CLEAR THE AIR BETTER ...SAVE ENERGY, TOO

Unique Cosa/Tron delivers air so clean that up to 95% of the conditioned room air can be recirculated. Since 1964, Cosa/Tron has been proving itself to be the *only* truly effective way to control the induced as well as internally generated, suspended submicron particles in the conditioned room air — smoke, odor and other contaminants.

Cosa/Tron works with all high efficiency filters, from 55% efficiency (NBS Dust Spot) to HEPA. Just mail the coupon for free illustrated literature explaining how Cosa/Tron not only clears the air, but can affect major savings on original refrigeration equipment requirements, monthly operating costs, and cleaning expenses.

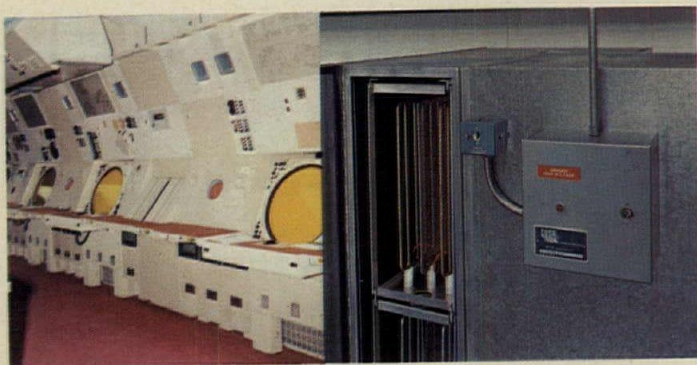

Tacon Control Room (above, left) relies on Cosa/Tron to guard equipment and personnel against contaminants. Cosa/Tron components (above, right) are: 1) electrodes, in air conditioning duct, change the electrical characteristics of air; 2) power generator feeds the electrodes with the system's unique power characteristics.

COSA/TRON®

Makes air conditioning work better for less.

To: CRS Industries Inc.
5405 W. Crenshaw Street
Tampa, Florida 33614

AR-2

Without obligation, please send me illustrated literature explaining the functioning and benefits of Cosa/Tron contamination control system.

Name _____ Title _____
Company _____
Street _____
City _____ State _____
Zip _____ Phone _____

CRS INDUSTRIES INC.

Contamination Reduction Systems
5405 W. Crenshaw Street/Tampa, Florida 33614
Phone: 813/886-1717

"Commit thy works unto the Lord, and thy thoughts shall be established." Proverbs 16:3

For more data, circle 82 on inquiry card

The most convenient, economical ground fault protection for everyone

You've heard a lot lately about ground faults—mostly in connection with equipment protection in heavy industry. But danger from ground faults also exists with a worn or damaged toaster, power tool or business machine. Or in electrical service to swimming pools and all outdoor receptacles. And a ground fault of only .05 amperes (50 ma), which is only a fraction of the current required to open a circuit protected by a standard 15 ampere circuit breaker or fuse, can be fatal. The National Electrical Code recognizes dangers from ground faults and requires ground fault protection in many electrical service applications.

QWIK-GARD® circuit breakers, now available from Square D Company with 10,000 ampere interrupting capacity, offer a practical and economic means of providing protection from ground faults for people and equipment. And they provide the same branch circuit wiring protection as the standard QO® circuit breaker available only from Square D.

Designed to automatically disconnect a circuit when a ground fault current is .005 amperes (5 ma) or more, UL listed QWIK-GARD breakers occupy the same space as a standard QO breaker and may be permanently installed in any QO circuit breaker load center.

QWIK-GARD circuit breakers also offer individual branch circuit wiring protection. Should a ground fault condition trip a breaker, power to other circuits will not be interrupted.

On your next job, give your customers the maximum in electrical protection at a minimum price—QWIK-GARD circuit breakers. For specific data, contact your nearby Square D field office or distributor. Or write, Square D Company, Dept. SA, Lexington, Kentucky 40505.



SQUARE D COMPANY

Wherever Electricity is Distributed and Controlled

For more data, circle 83 on inquiry card

MOUSETRAPS, METALS AND MARKETING

Consider for a moment that old New England adage to the effect that if a man make a better mousetrap than his neighbor, "tho' he build his house in the woods, the world will make a beaten path to his door." How little relevant these words seem at a time when merchandising can often be more important than the product merchandised. And rather unhappily so from our own standpoint, for in TCS (Terne-Coated Stainless Steel), Follansbee has a nearly perfect example of the proverbial better mousetrap.

Here — quite simply — is a roofing and weather-sealing metal which has literally no peer when measured by the major criteria of corrosion resistance, freedom from maintenance, durability and amortized cost.

We can, of course, prove this statement, but in an era considerably more McLuhanesque than Emersonian, we are still confronted with the formidable task of bringing such proof to the attention of most architects and engineers, professionals who, as a group, are notably product-wary and slogan-shy.

As one step toward that goal, may we at least make the TCS data available to you?

FOLLANSBEE

FOLLANSBEE STEEL CORPORATION • FOLLANSBEE, WEST VIRGINIA



*rare beauty.
rarer economy.*

Beauty is in the eye of the beholder. It is usually subjective. Rarely universal. But economy is another thing. It is difficult to be subjective about economy in the face of facts that prove it. Even after hearing charge and countercharge concerning overall costs of various flooring materials. Consider terrazzo vs. carpet. A recent study showed clearly that the total annual cost of nylon carpet is at least twice that of terrazzo—126% higher, to be exact. Considering cost of material based on average life, maintenance labor, capital equipment and supplies, the total annual flooring cost per 1,000 square feet for nylon carpet came to \$541.81. For terrazzo—only \$245.45. Economy that's beautifully rare in these times. We'll be happy to send you details of the study, and the results. Write **terrazzo** 716 Church St., Alexandria, VA 22314. Or call (703) 836-6765.

terr
a
z
z
o

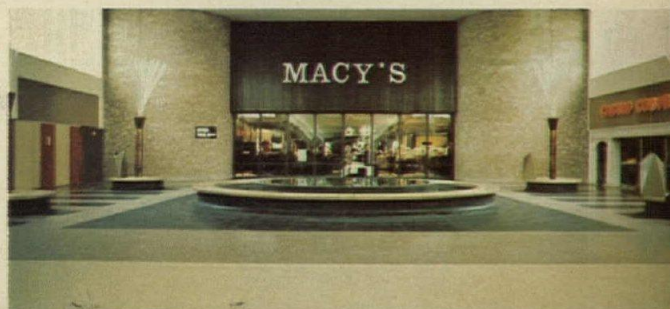
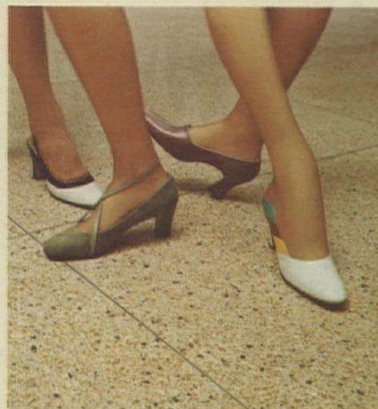

For more data, circle 85 on inquiry card

Negotiating Contracts?



Get a
big lift
from the
best drink
in the house.

When you get together a team of building owners, architect, contractors, and engineers, you've got a lot of smarts in one place. But no one man or one team can be expected to know every detail of every product and system going into a building.

We can give you a lift.

When you get around to talking water coolers, call in your Halsey Taylor Water Systems Engineer.

Why, specifically, the Halsey Taylor man?

Because he has the engineering capability to analyze the chilled water requirements of any building and to help meet those requirements at the lowest possible cost.

Because Halsey Taylor has more drinking water experts, nationally, than any other manufacturer.

Because your Halsey Taylor man is nearby, ready to assist you on a moment's notice.

And because he's backed up by the most extensive field inventory in the business — for prompt delivery.

A product you can depend on

For pure product excellence and dependability, Halsey Taylor water coolers have the best reputation in the business. This means lower life cycle cost, due to extra features like heavy duty regulating valves, start capacitors, cast iron fan motors, and spot welded, unitized

cabinet construction.

And with Halsey Taylor, installation cost is minimal because we assemble every cooler at the factory. No panels to assemble, no bubbler to install.

Let your Halsey Taylor Water Systems Engineer help you iron out specification details. Then let the performance of Halsey Taylor water coolers protect your good name and keep your client satisfied — for a long time to come.

Get in touch with your local Halsey Taylor man. Or write for more information to: Chuck Thompson, Sales Manager, Halsey Taylor Division, 1554 Thomas Rd., Warren, Ohio 44481.



Halsey Taylor
KING-SEELEY **KST** THERMOS CO.

For more data, circle 86 on inquiry card

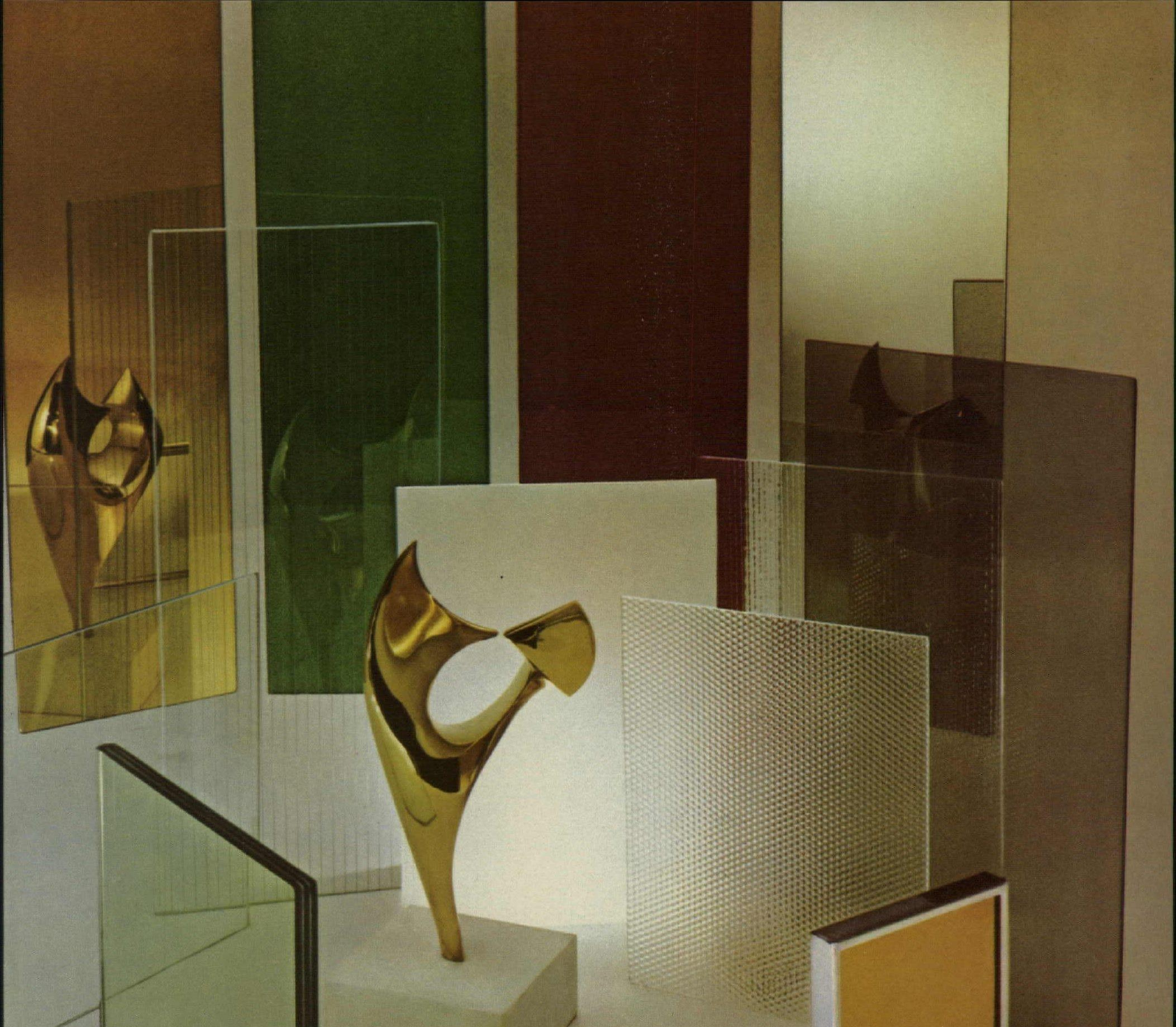

ASG

Our name says the Glass Company,
and that's saying a lot.

Over the years, ASG has come to stand for both pioneering and innovation. And ASG is constantly working to bring you new and better products in everything from float, plate and window glasses to insulating, reflective, tempered, wired, laminated, patterned and lighting glasses. We're always on the lookout for new developments to help you perform your job better and more easily. And ASG backs what it sells with service that

makes a difference. Service that includes the willingness and expertise to work with you on special projects and problems. ASG service also means things like delivery where and when you want it, along with the most advanced package designs in the industry. Just a few of the things that make ASG, the Glass Company, the only name to look to for versatility plus quality in both product and service. Write us for complete information.



ASG Industries Inc.

The Glass Company, P.O. BOX 929, KINGSPORT, TENN. 37662

For more data, circle 91 on inquiry card

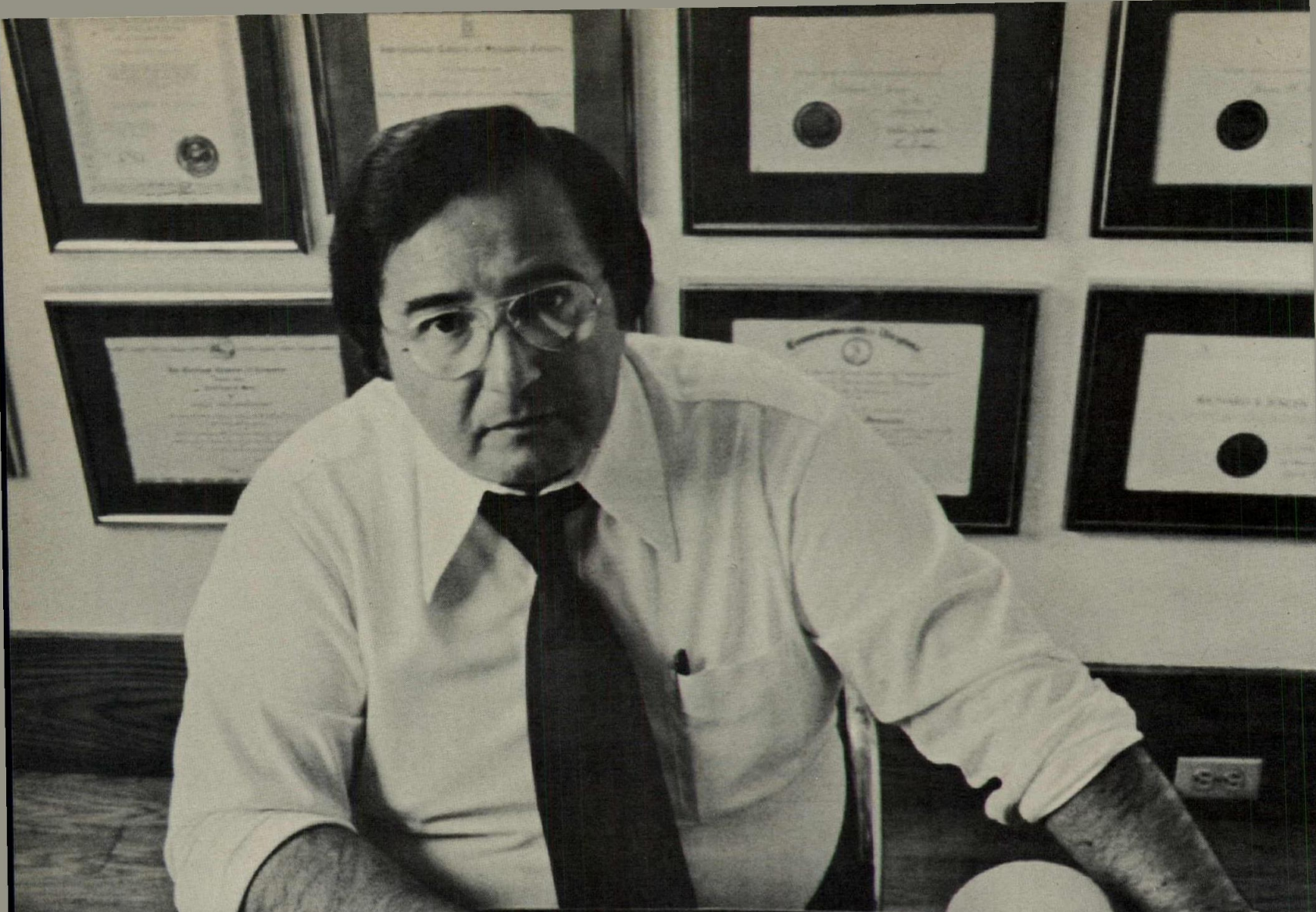

“General Electric HID lighting systems are easy to install, easy to maintain and there’s no ballast audibility problem.”

Richard R. Jencen — Richard R. Jencen Associates, architects and interior designers for the Marianne, Stuarts and Petrie chains

Architects, consultants, electrical contractors and building owners demand a lot of an indoor lighting system. And they’re finding that General Electric’s energy-efficient HID lighting systems meet their most exacting requirements.

Richard Jencen was concerned about ballast noise. He says, “We’ve encountered audibility problems with some HID systems, but the General Electric Panelglow® system solved all of our problems. It’s easy to install, easy to maintain and there’s no ballast audibility problem.”

If you’d like to know more about GE’s HID solutions for commercial lighting applications, contact your local GE representative or write:

GE Lighting Systems Business
Department, Section 460-99 A,
Hendersonville, N. C. 28739

**GE lighting
makes the
difference**



GENERAL  ELECTRIC

For more data, circle 92 on inquiry card

Copper was first choice for roofing community buildings at Eastman, a 3500-acre recreational home development rising in the hills of Grantham, New Hampshire.

Planner Emil Hanslin knew he wanted copper's warm, natural look right from the start. But he had some doubts about first cost.

New light gauge "Tough 12" high-strength copper sheet was the answer. The high yield strength of "Tough 12"

meant that copper weight per square foot could be cut 25% without affecting performance.

Copper's easy workability with hand tools helped keep on-site costs to a minimum. Bends, locks, and seams could be easily formed and there was no need to pre-punch holes for nails in cleats and edgings.

Durability and freedom from maintenance tipped the scales firmly in copper's favor. Once costs of repairing and

maintaining alternate materials were factored in, "Tough 12" copper sheet was clearly competitive.

Copper comes out on top in the long run. For Emil Hanslin. And for all the people who will work and play under the beautiful, practical standing-seam copper roofs of Eastman.

For an informative brochure on new "Tough 12" copper sheet, write

Copper Development Association Inc.
405 Lexington Avenue, New York, N.Y. 10017

Planner Emil Hanslin couldn't believe new "Tough 12" copper roofing was competitive. Now he's a believer.

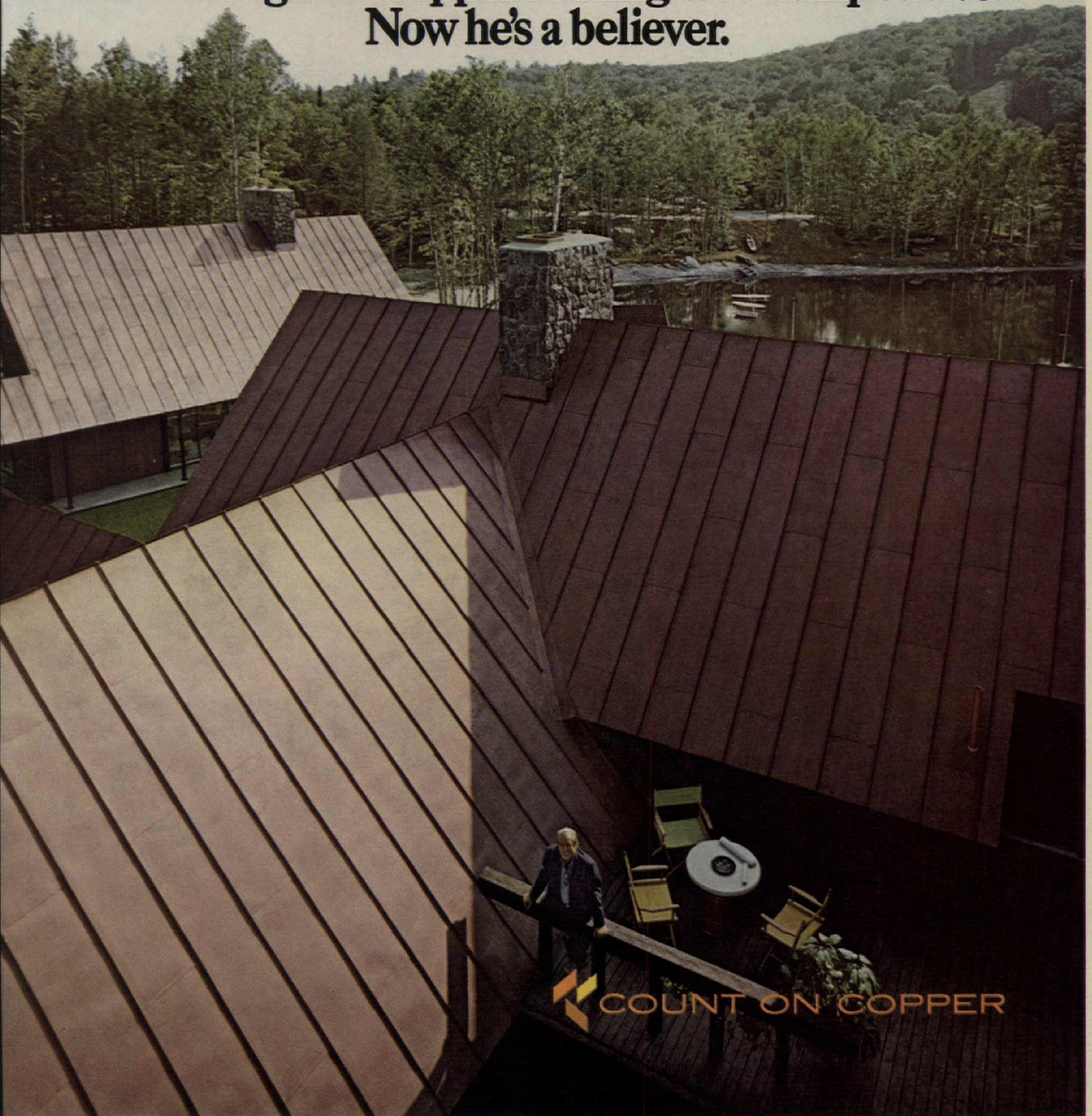

 **COUNT ON COPPER**

ARCHITECTURAL RECORD

PRESENTS

HOW TO MARKET PROFESSIONAL DESIGN SERVICES

A series of two-day PROFESSIONAL MARKETING WORKSHOPS[®] produced for ARCHITECTURAL RECORD by the Continuing Education Division of Building Industry Development Services, Washington, D.C.

- Understanding marketing fundamentals
- Organizing for a productive, professional business development program
- Where and how to attract new clients—while retaining the old ones
- Planning for change, expansion and professional growth
- Evaluating existing and potential markets
- Using business development tools—from job histories to preparation of Standard Form 251
- Specialized intelligence gathering and investigation of leads
- Effective selling preparations—what to do before, during and after the interview
- Successful strategies for getting the job
- Political action
- Associations and joint ventures

"Up to now, the design professional traditionally has had to learn selling techniques essentially by experience, through trial and error, and with no real standards against which to measure the degree of his successes and failures."
from HOW TO MARKET PROFESSIONAL DESIGN SERVICES
a McGraw-Hill book by Gerre L. Jones

These workshops are *not* for the design professional who believes that his client acquisition activities have reached a stage of perfection—or for the firm that, for whatever reasons, is satisfied that it has more clients and contracts than it can comfortably handle over the next 3 to 6 years.

Nor are the workshops geared to firms whose principals are convinced they have achieved the ultimate in

- organization and staff participation in business development
- practice and client mix
- productive, customized, *selling* presentations
- public relations
- all of the tools of job search and acquisition

If you have never attended a professional workshop or seminar on business development, be assured that ARCHITECTURAL RECORD and Building Industry Development Services have assembled the faculty from among the most experienced, knowledgeable people in the field. Discussion leaders will include successful, sales oriented directors of business development from small-to-large firms and client representatives of both public and private sectors. For the first time, participants in ARCHITECTURAL RECORD's Professional Marketing Workshops[®] will have the opportunity to hear it like it is—from both sides of the marketing fence.

Senior coordinator for the workshops is Gerre L. Jones, executive vice president of Building Industry Development Services, and author of the authoritative McGraw-Hill book, HOW TO MARKET PROFESSIONAL DESIGN SERVICES.

Each participant will receive a set of invaluable course materials for his continuing use. The specially produced course handbook contains ideas, suggestions and sample materials available from no other source.

A unique periodic follow-up program to the workshops assures every participant of continuing interest and advice for up to six months beyond the concentrated two-day workshop session itself.

b.i.d.s. Building Industry Development Services • 202/785-2133
1301 20th St., N.W., Suite 104, Washington, D.C. 20036

Please enter ___ reservations in my name for the Professional Marketing Workshop[®] checked at the right of this form and rush complete details about the workshop.

Name _____
Title _____
Firm Name _____
Address _____
City _____ State _____ Zip _____
Telephone _____
Architect Engineer Planner Designer
Other _____

Check for \$350, payable to Architectural Record-PMW Enclosed.

1974-1975 Professional Marketing Workshops[®] are planned for the following cities:

1974		
September	5- 6	Newark, New Jersey
October	7- 8	San Francisco, California
November	4- 5	Houston, Texas
December	5- 6	Phoenix, Arizona
1975		
January	9-10	New Orleans, Louisiana
February	6- 7	Miami, Florida
March	6- 7	New York, New York
April	3- 4	St. Louis, Missouri
May	1- 2	Dallas, Texas
June	5- 6	Seattle, Washington

Dates and locations of workshops in other areas for 1975-1976 will be announced.

Build a 10 story building with loadbearing masonry and get the 11th story free.

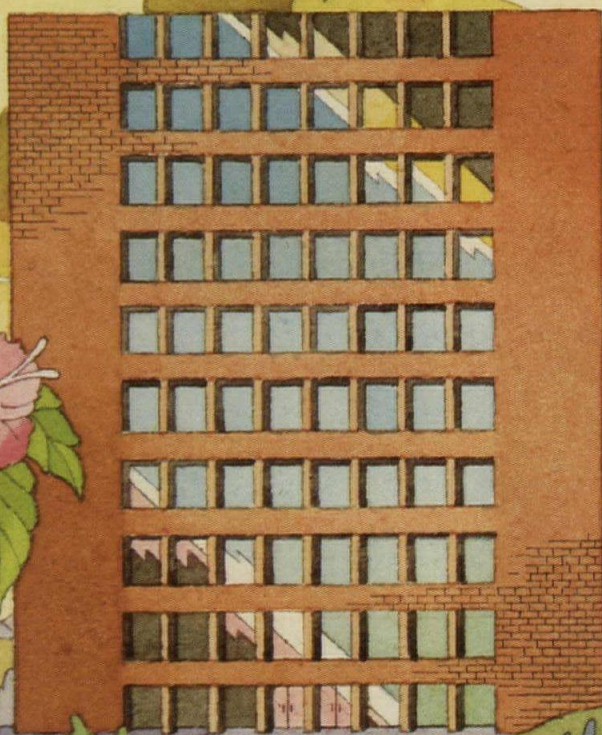
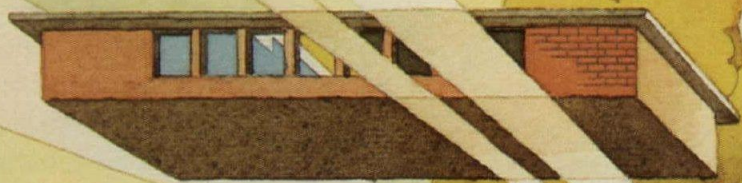

When you build with a modern loadbearing masonry system, you can save as much as 10% on construction costs.

Because masonry lets you save on the two biggest expenses of building. Time and materials.

Instead of building separate structural systems and enclosure walls, you can have them both in one step. Masonry walls work together with roof and floor systems to create one solid structural shell. Complete with enclosure walls and inside partitions.

And you can begin finish work on each floor as soon as the masons begin erecting the floor above it. So your building is finished faster. And you can stop paying interim interest and start charging rent.

You save on maintenance costs too. Because masonry doesn't warp, dent, bend, buckle or rot. It gives superior fireproofing and sound control. And with its inherent beauty, it never needs painting.

When you add all these savings up, you can save enough money to add that eleventh story. If that sounds like an interesting prospect to you, mail this coupon. We'll send you the complete story.



International Masonry Institute
Suite 1001 823 15th Street, N. W.
Washington, D. C. 20005 AR

Send me information on the modern
loadbearing masonry building system.

Name _____

Title _____

Company _____

Address _____

City _____

State _____

Zip _____

Nature of Business _____

THE Super Pro GETS IT STARTED!



A Hillyard Super Pro makes things happen. He's a quick starter, and quick to adapt to change. He's a representative who knows when and how to pass the baton to the Super Team back home — innovative chemists, imaginative researchers and veteran floor specialists.

When Hillyard Super Pros in the field called for a floor stripper that could handle new cross links and copolymers as well as waxes — without the objectionable odor of ammonia — Hillyard Research and Development came through with Power-Strip. Ammonia-free and without phosphates, Power-Strip breaks waxes and copolymers easily and completely.

Power-Strip. Another example of how Hillyard came up with the answer because the Super Pros got it all started. One of them can get things started for you, too.

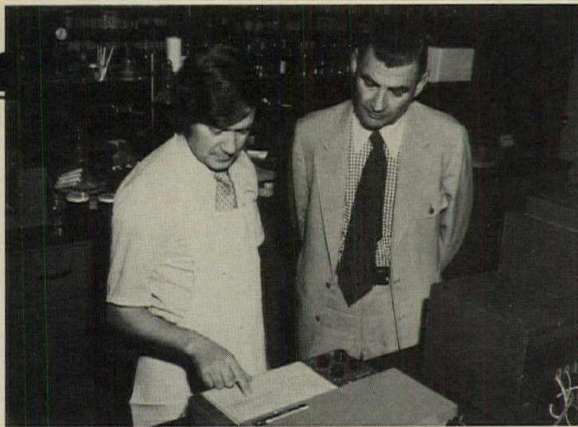

SUPER PRODUCTS FROM HILLYARD

TROPHY
Slip-resistant, glare-free, wood floor seal and finish.

CEM-SEAL II
Non-yellowing, single-coat; provides a quick seal and a slow cure for concrete floors.

ONEX-SEAL II
Penetrating finish and seal for terrazzo floors; prevents efflorescence and discoloring stains.



HILLYARD CHEMICAL COMPANY
302 North Fourth Street
St. Joseph, Missouri 64502
(816) 233-1321
Keeper of the floors world-wide

For more data, circle 95 on inquiry card

Movable Kwik-Wall creates a beautiful look of permanency

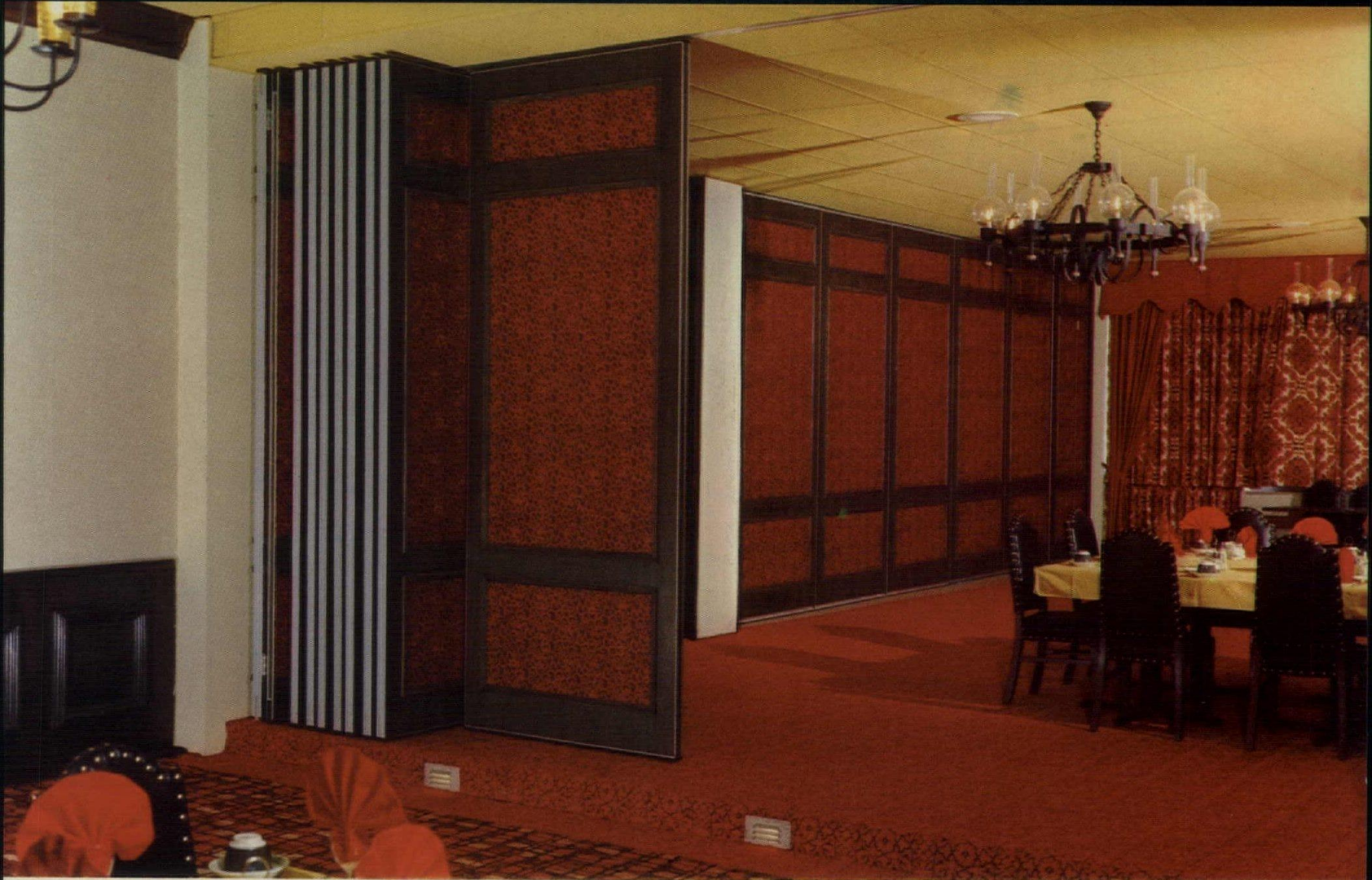

Add flexibility and usability to your room space with Kwik-Wall, the movable wall partitions featuring qualities of a permanent wall... attractiveness, durability, sound control. The solid construction of Kwik-Wall makes each area it divides a separate room in the strictest sense of the word. Impressively designed, Kwik-Wall adapts to blend with any design motif, beautifully.



Portable Kwik-Wall (left) requires no tracks on ceilings or floors. Free-standing panels can be stored anywhere, easily rolled into position on optional retractable wheels. Select 1-3/4" standard or 2-1/4" deluxe Kwik-Wall.

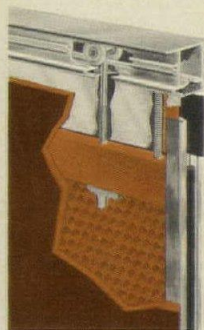

Track-Mounted Kwik-Wall glides with ease on inconspicuous ceiling tracks; needs no floor guides or rollers. Pocket doors provide complete, coordinated concealment of panel storage. 2-1/4" deluxe or 3" master thickness.



Over 1500 Decorator Facings to select from to give your decor the look of permanence. Chalkboard, chalk trays, corkboard finishes available, in addition to pass-doors with cylinder locks.

One-Hand Locking Operation, insert crank and give a half-turn; spring-loaded top rail expands firmly against ceiling, forming effective sound seals around each panel perimeter.



the permanent look in movable walls



Send for Free Color Brochure

Kwik-Wall® Company, Dept. 32
P.O. Box 3267, Springfield, Illinois 62708

Name _____
Title _____
Firm _____
Address _____
City/State _____ Zip _____



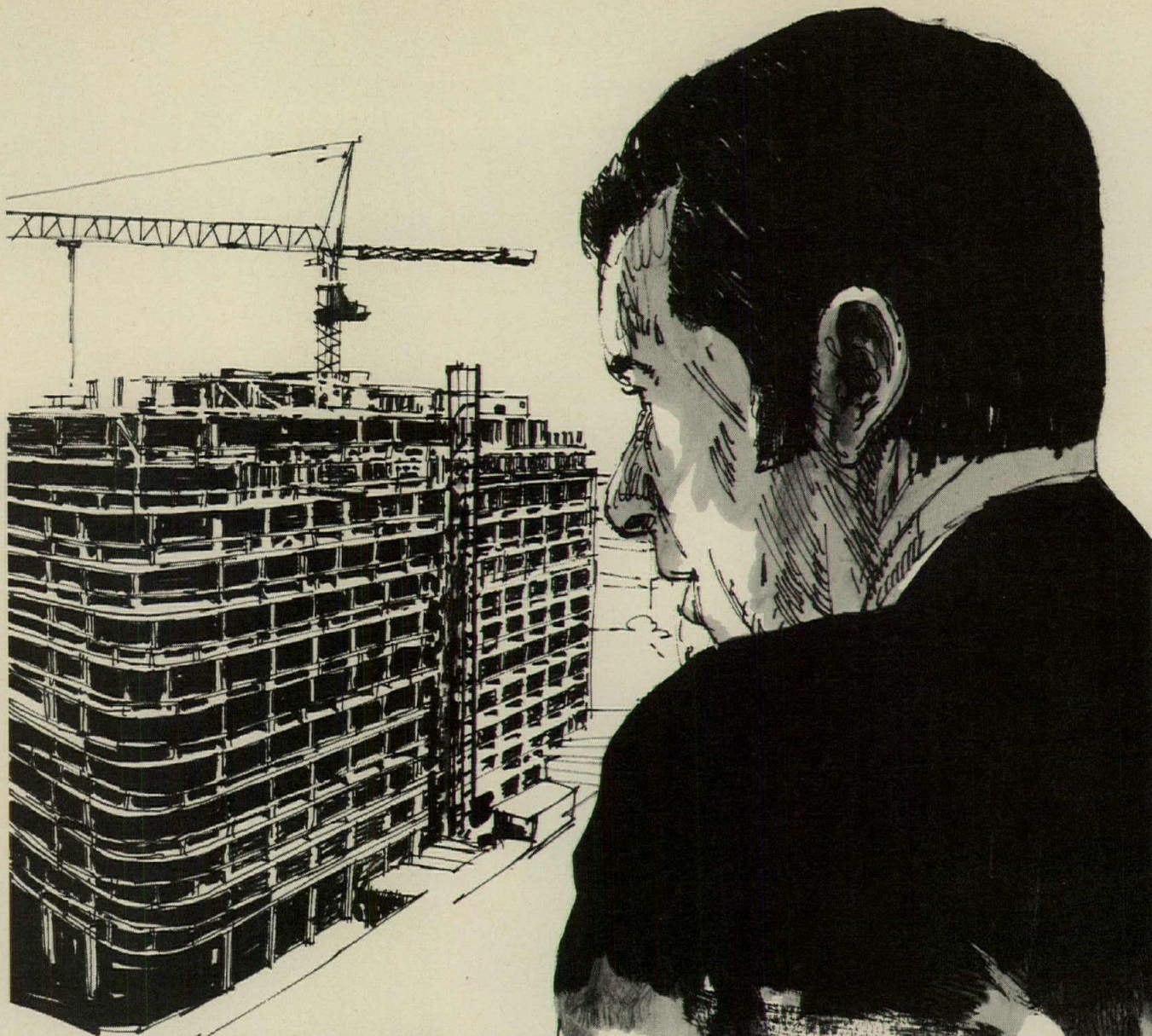

How do you select an electrical contractor?

NECA study reveals opinions of design professionals.

NECA, the National Electrical Contractors Association, recently completed a study among key decision makers on the building team to determine what characteristics they look for in selecting or recommending electrical contractors for new construction and modernization projects.

Most participants agreed: Competence is the single most important characteristic looked for in professional electrical contractors. Closely related qualifications include integrity, reliability, efficiency, quality of work, financial

position, caliber of work force and equipment, and ability to coordinate with other construction craft groups. All these qualities are found in professional electrical contractors. Advantages?

Work well done, when and where it is needed. Economically, accurately, efficiently. Handled by

a flexible, well managed work force of electrical craftsmen. Competent in everything electrical—from power line construction and power distribution wiring to interior and exterior lighting, communications, security alarms, motors and controls, space conditioning, etc., etc., etc.



National Electrical
Contractors Association, Inc.
Washington, D.C. 20014

**If electricity makes it possible,
electrical contractors make it practical.**



The Mansards, Griffith, Indiana

"The whole idea of "The Mansards" is to provide gracious living accommodations in a natural setting of trees and water. The convenience of city living is combined with the graciousness of country living here.

We have put top quality into "The Mansards" and that extends to our coin-operated laundry equipment.

We chose Speed Queen for one simple over-riding reason—it's the best we could get."

Duane J. Hicks, Jr., General Manager

Lake Point Tower, Chicago, Illinois

"Lake Point Tower represents a new kind of urban life—a completely self-contained city at the edge of Lake Michigan. We appeal to individuals and families of middle and upper income. They expect and get the best at Lake Point Tower. That's why we chose Speed Queen equipment for our laundry facility. Speed Queen represents quality which will be on the job—not out of order.

And I understand the Stainless Steel feature is a real plus when laundering durable press fabrics."

Robert E. DeCelles, Building Manager

"We chose Speed Queen laundry equipment for one simple reason—it's the best we could get."

Let SPEED QUEEN and your SPEED QUEEN COMMERCIAL ROUTE OPERATOR help you plan coin-operated laundry facilities



SPEED QUEEN®

Ripon, Wisconsin 54971



a McGraw-Edison Company Division

For more data, circle 97 on inquiry card

FORM NO. 5541C

AR-6

Mr. E. W. Jess,
Manager, Commercial Department
Speed Queen, Ripon, Wisconsin 54971

Gene, please forward your laundry room design brochure.

- Please send me name of the Speed Queen Route Operator nearest me.
- I would like a Speed Queen representative to call.

Name and title _____

Firm name _____

Address _____

City _____ State _____ Zip _____



Pajaro Dunes, California. George Cody, A.I.A.

Simpson Ruf-Sawn Redwood Plywood. A natural for going back to nature.

More and more prospective homeowners today are looking for designs and materials that fit in more harmoniously with nature. A natural reason for using Simpson Ruf-Sawn Redwood Plywood siding.

No other commercially available wood surpasses Redwood for beauty in any setting. Left natural, it weathers to a soft driftwood gray. And Redwood is exceptionally resistant to surface checking, making it outstanding for durability and maintenance economy in any climate.

Simpson Ruf-Sawn, with its rustic rough-sawn surface,

enhances Redwood's natural charm. And because it's plywood, you get all the advantages of plywood, too. High strength-to-weight ratio. Easy handling. Excellent workability. Plus economy when compared with solid lumber.

Simpson Ruf-Sawn Redwood Plywood. A beautiful way to get back to nature.

For full information on grades, patterns and sizes, contact Simpson Timber Company, 2000 Washington Building, Seattle, Washington 98101, 206-682-2828.

Simpson

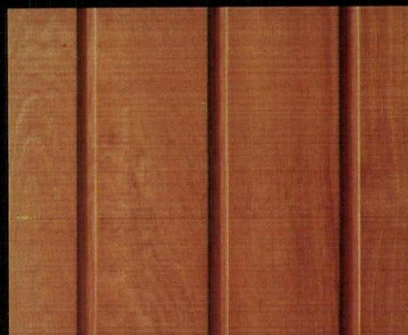

For more data, circle 98 on inquiry card



XEROX® is a trademark of XEROX CORPORATION.

One thing they don't teach you in drafting class is how to use a drawer.

1. Open the drawer.
2. Take out whatever standard details you need.
3. Use the Xerox duplicator to copy them onto adhesive-backed Mylar.
4. Place the imaged Mylar onto the new working drawings.
5. Put the standard details back in the drawer until the next time you need them.
6. Close the drawer.

For a firsthand lesson, have our Architecture/Construction/Engineering specialists show you all the ways a Xerox duplicator can help you turn repetitive time into creative time.

And then instead of going back to the drawing board, maybe you'll start going back to the drawer.

XEROX

For more data, circle 99 on inquiry card

MYLAR® is a trademark of DuPONT CORPORATION.

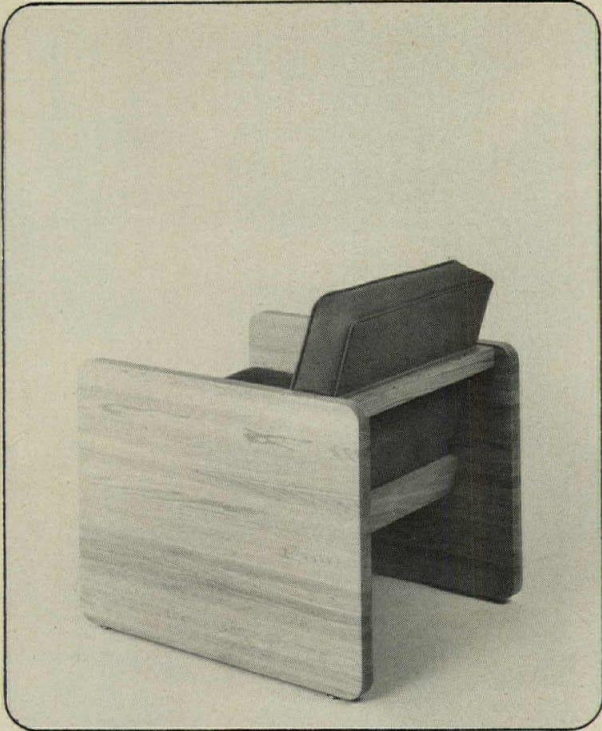

INNOVATORS IN OAK SINCE 1850

by buckstaff

oshkosh, wisconsin

showrooms: chicago, merchandise mart; dallas, oak lawn plaza

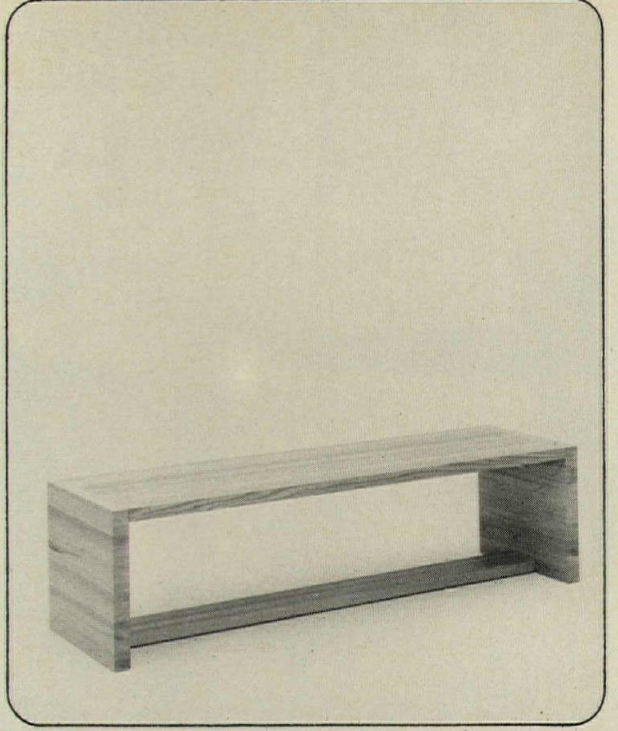

INNOVATORS IN OAK SINCE 1850

by buckstaff

oshkosh, wisconsin

showrooms: chicago, merchandise mart; dallas, oak lawn plaza

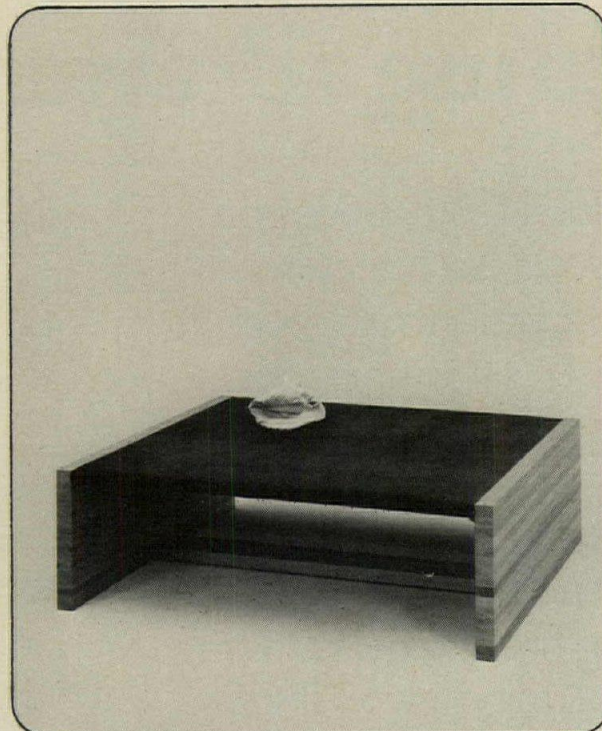

INNOVATORS IN OAK SINCE 1850

by buckstaff

oshkosh, wisconsin

showrooms: chicago, merchandise mart; dallas, oak lawn plaza

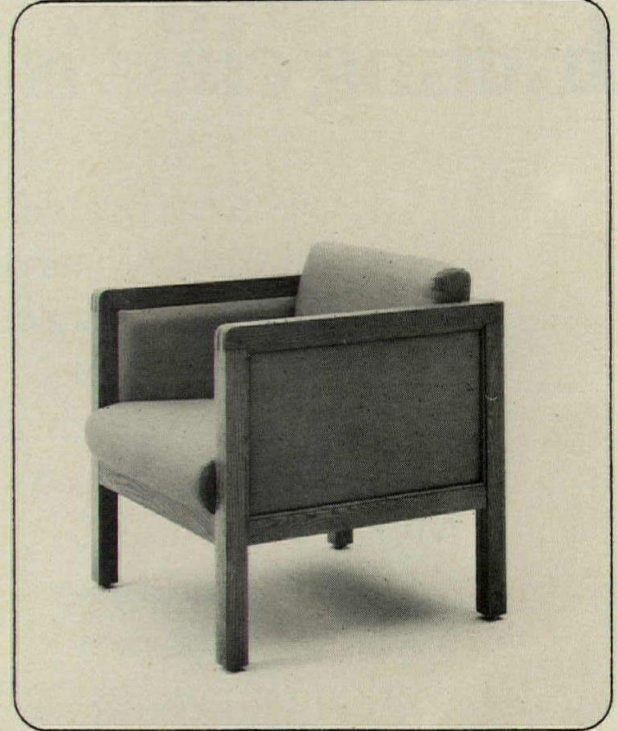

INNOVATORS IN OAK SINCE 1850

by buckstaff

oshkosh, wisconsin

showrooms: chicago, merchandise mart; dallas, oak lawn plaza

For more data, circle 100 on inquiry card

Now! Two great products bring you one great metal roof deck system.

- 2-hour fire rating
- Lowest U-value
- Slope to drains!

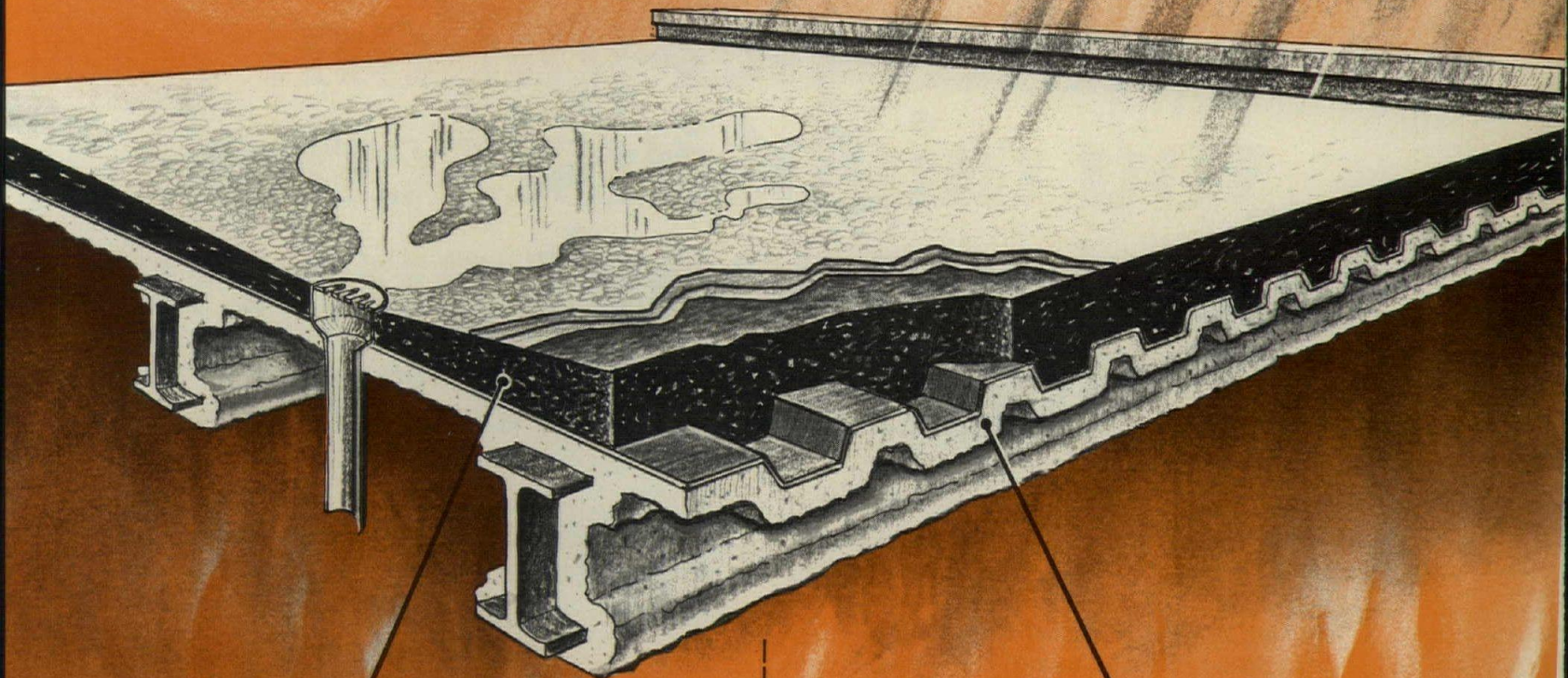

All-weather Crete[®]

ROOF DECK INSULATION



DECK-SHIELD C/F
CAFCOTE V
SPRAY FIRE PROOFING

ENERGY SAVER! The excellent insulating properties of All-weather Crete insulation provide this system with a completely dry, seamless installation having a better k factor than any other poured roof deck insulation (.40 k factor). It is applied hot to the metal deck, sloped to drains, and compacted to any desired thickness from 1½" to 5". Energy saving capabilities of this fine system offer life/cost economies that are unsurpassed by similar systems. Get the facts. For complete literature and specifications contact Silbrico Corporation, 6300 River Road, Hodgkins, Illinois 60525, (312) 735-3322.

 **SILBRICO**
CORPORATION

FIRE PROTECTOR - Protecting and insulating the lower half of the system is CAFCO direct-to-steel spray fireproofing. CAFCO products are factory blends of non-crystalline refractory materials containing no asbestos. They have excellent fire resistive qualities, are usually applied in one coat, and harden quickly. CAFCO dependability has been proven in many of the world's finest buildings. Complete specifications for 1, 1½ and 2 hour systems can be found in the UL Fire Resistance Index (Design Nos. P-802, P-804, P-705 and P-706), or contact United States Mineral Products Company, Stanhope, New Jersey 07874, (201) 347-1200.

UNITED STATES MINERAL[®]
USM
PRODUCTS COMPANY

For more data, circle 101 on inquiry card

If you understood lumens-per-watt the way you understand miles-per-gallon, you might just scrap your company's present lighting system.

The "lumen" and the "watt" may not be as familiar to you as the "mile" and the "gallon." But the principle is exactly the same.

And if more American businessmen realized that, more American businesses would be saving money on lighting.

The lumen-per-watt. It's simpler than it sounds.

A lumen is nothing more than a unit of light. A lamp that gives 100 lumens is giving twice as much light as a lamp that gives 50 lumens.

A watt is a unit of electrical power. How much electricity it takes a fan or a toaster or a light bulb to do its job. Something that uses 100 watts is using twice as much electricity as something that uses 50 watts.

Now, it doesn't take a degree in engineering to figure out that the lamp that gives the most lumens-per-watt is the most efficient lamp. Just like the car that gives the most miles-per-gallon is the most efficient car.

And that's about all the fancy, technical language you're going to need to start evaluating your company's lighting system.

Some light bulbs you've heard of... and some we're pretty sure you haven't.

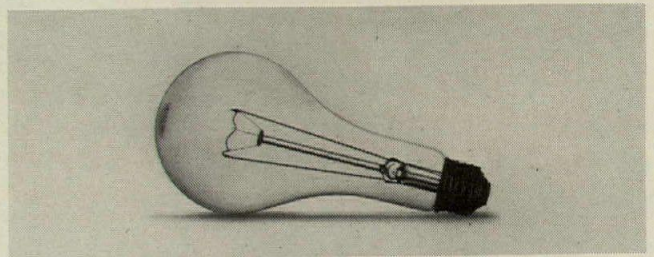

The incandescent light bulb.
About 10 to 23 lumens-per-watt.

The incandescent light bulb. A very flexible lamp that can be used almost anywhere. Nevertheless, an incandescent bulb is usually the least efficient lamp you can buy. Only 10 to 23 lumens-per-watt. (Efficiency increases as wattage goes up.)

The mercury lamp. A definite improvement. On the average, one 100-watt mercury lamp gives as much light as two 100-watt incandescent light bulbs. (Higher wattage mercury lamps are even more efficient.)

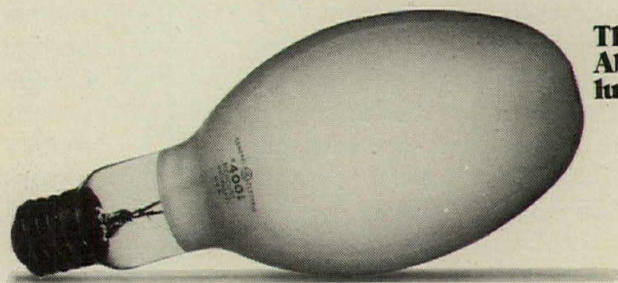

The mercury lamp.
About 42 to 63 lumens-per-watt.

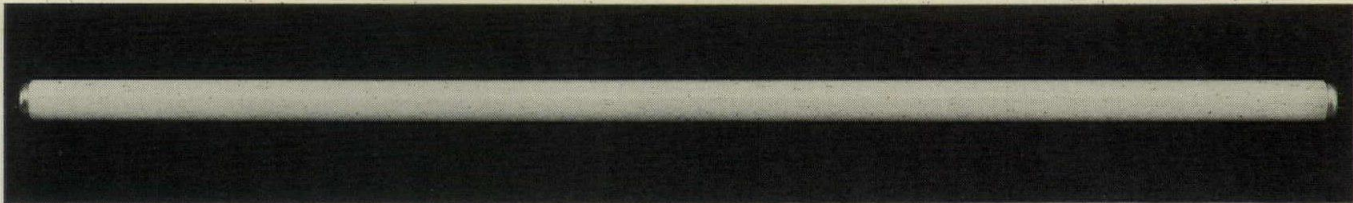

The fluorescent lamp.
About 55 to 83 lumens-per-watt.

The fluorescent lamp. It's used a lot. It could be used a lot more, especially in place of incandescent bulbs. Typically, one four-foot, 40-watt fluorescent lamp gives as much light as a 150-watt incandescent light bulb... for about 1/3 the electricity.

three 1,000-watt mercury lamps. Or, six 1,000-watt incandescent light bulbs.

So what's our point?
Simply this.

Your company can probably get the light it needs more efficiently.

Right now, your company may be using too many lamps near the top of this list and not enough near the bottom.

If you were using some of the newer, more efficient lamp types, you might be able to get the same amount of light you're getting now for substantially less electricity.

It won't be free.

Updating your company's lighting system to make it more efficient will cost you money. Usually, it requires new fixtures and ballasts. And, generally speaking, the more efficient lamp types are also more expensive. But before you let this discourage you, remember this. When you save electricity, you're not only saving energy. You're also saving money. In fact, the money you save in the first couple of years of operation can often pay for the cost of a new Lucalox lighting system.

Something that is free.

One thing we can give you for free is more information.

If this ad has even partly interested you in updating your company's lighting system, we ask you to take one small, but important next step. Find out more. Call your local GE lamp representative.

Or write us. General Electric Lamp Business Division, Dept. C-406, Nela Park, Cleveland, Ohio 44112.

**We can help
make every watt count.**

GENERAL  ELECTRIC

For more data, circle 102 on inquiry card

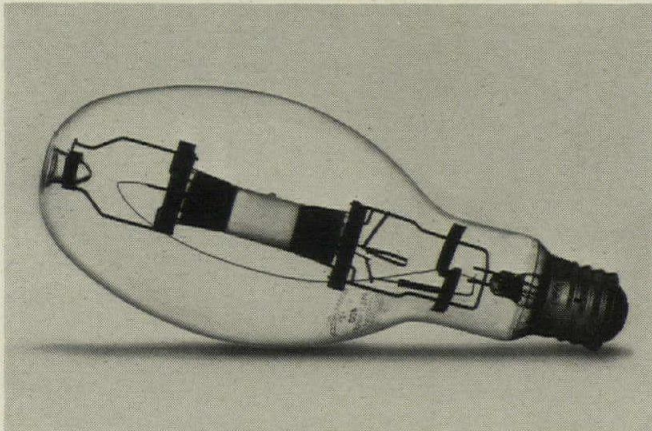

The Multi-Vapor® lamp.
About 85 to 100 lumens-per-watt.

The Multi-Vapor® lamp. Often used to light glamorous places like baseball and football stadiums. Also used in slightly less glamorous places like parking lots, factory buildings and warehouses. It's the second most efficient lamp we make. A single 1,000-watt Multi-Vapor lamp gives nearly as much light as four 1,000-watt incandescent lamps. (In other words, the same light for about 1/4 the electricity.)

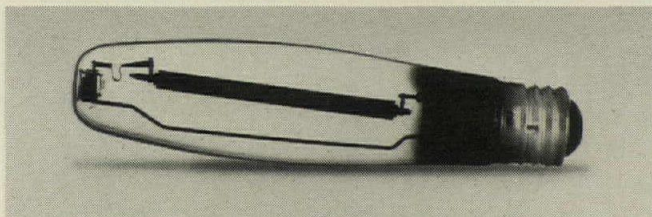

The Lucalox® lamp.
About 102 to 140 lumens-per-watt.

The Lucalox® lamp. The high-pressure sodium vapor lamp is the most efficient lamp we make. To equal the light of one 1,000-watt Lucalox lamp, it would take

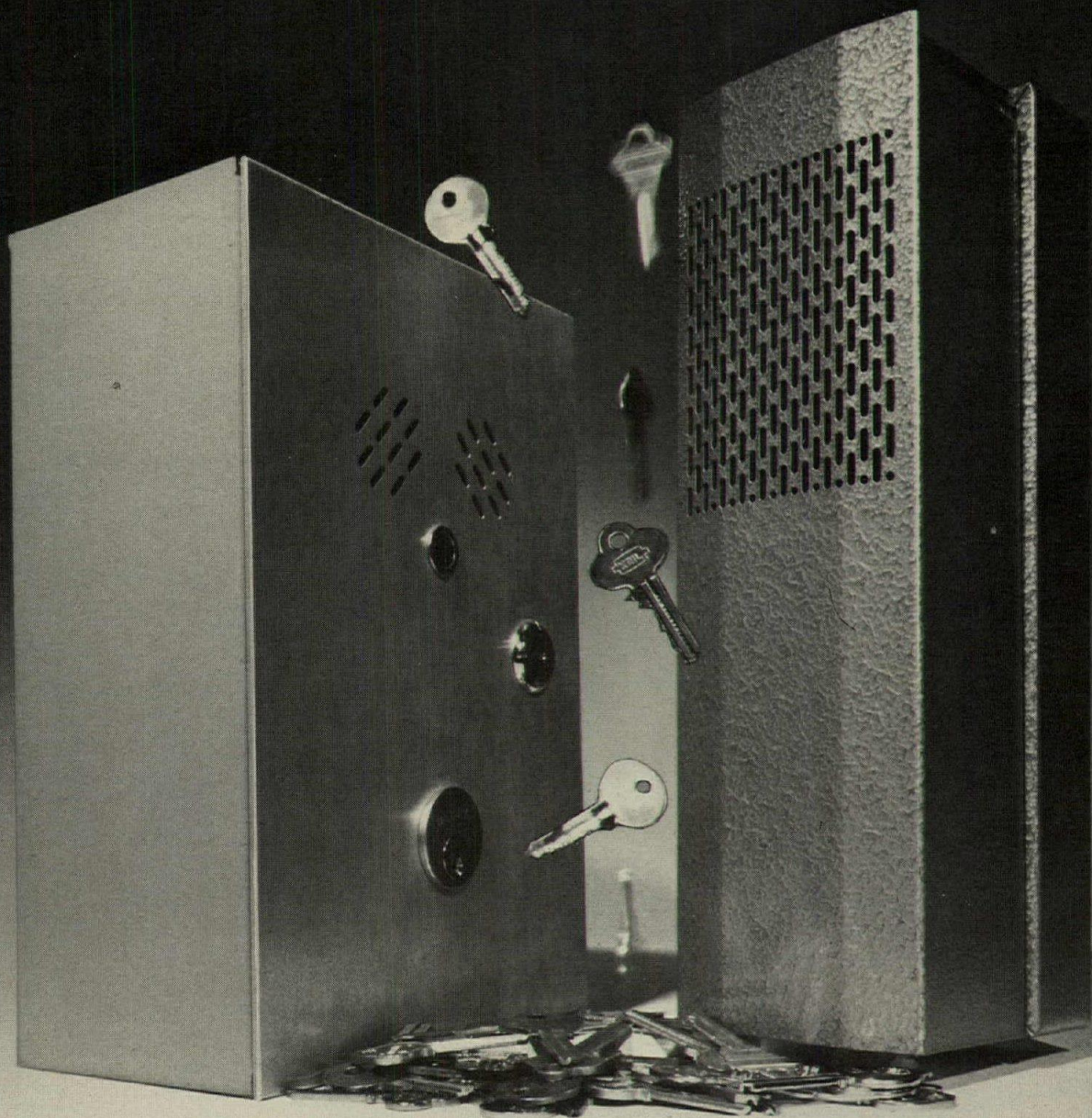

Only the right key can keep your Detex exit alarm from sounding off. It's a loud deterrent to non-emergency exit and inside-assisted, unauthorized entrance. Choose surface or flush

mount, 115V AC or low voltage rechargeable battery models from the biggest selection under one name. Two strident horns announce unauthorized comings or goings. Nickel cadmium battery operated units are kept charged by low voltage AC transformers. These units comply



with National Electrical Code, Class II, when used with approved transformer. After disarming by authorized key, security is automatically restored upon closure. Many applications individually or in systems. Send now for full information. Detex Corporation, 4147 N. Ravenswood Avenue, Chicago, Illinois 60613, (312) 348-3377

DETTEX

For more data, circle 103 on inquiry card

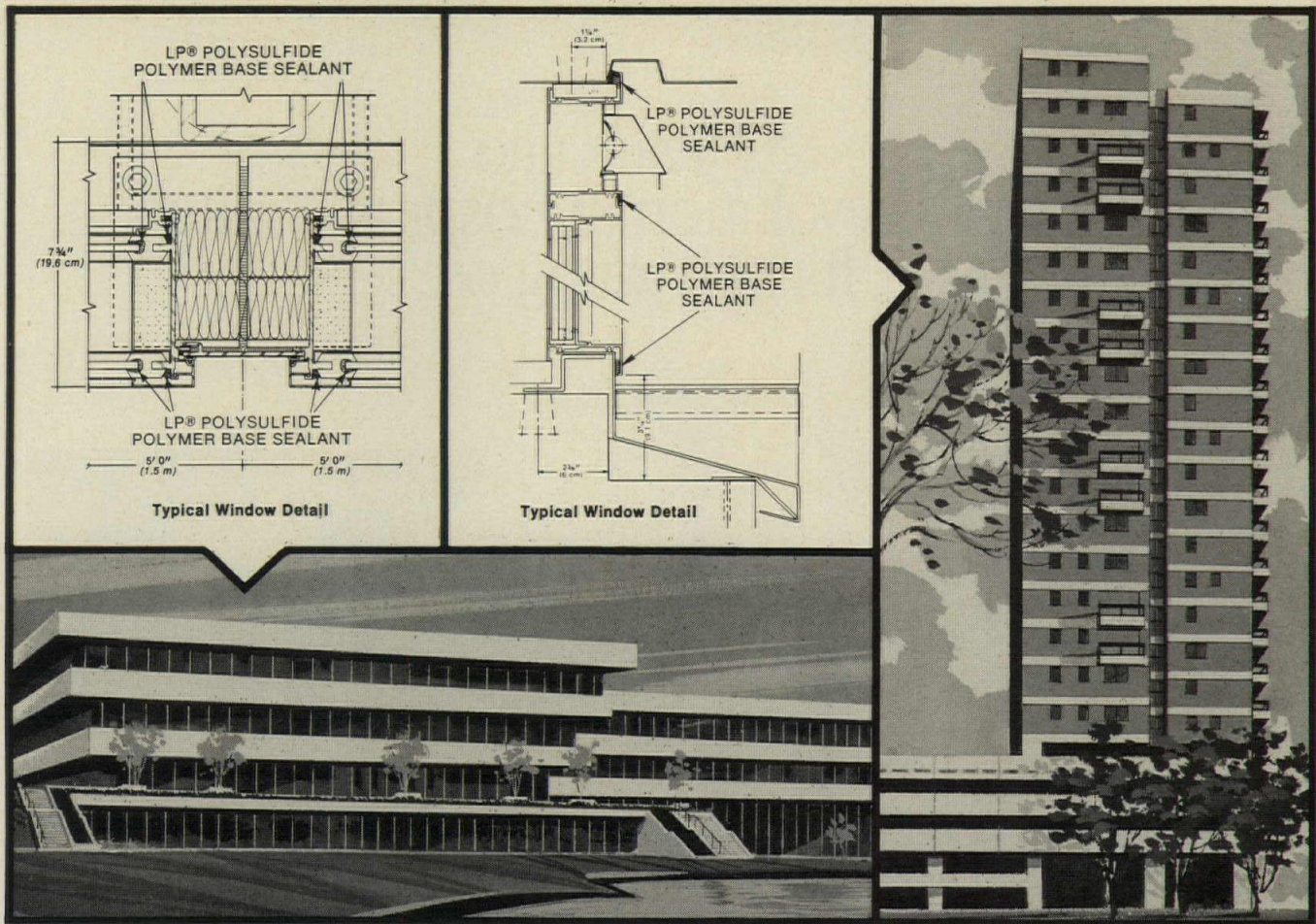

Two glass panes can live cheaper than one

Saving energy saves money. Energy sources cost more and are in shorter supply than ever before. The high 1.09 heat transfer coefficient (U value) of single pane window, door and storefront glass places expensive extra work load and energy demands on heating and air conditioning systems.

Two glass panes—in a framed and sealed double-hung insulating unit—provide a cost-cutting air vacuum as insulation to reduce this heat transmission factor. The U value factor drops by about 41 percent down to 0.64. Furthermore, if the insulating glass unit has one pane of metalized-coated glass, glare is reduced and this factor is cut by 15 percent to 0.50.

LP® polysulfide base sealants, used for many years by leading insulating glass manufacturers, expand and con-

tract while providing the necessary strong, long-lasting airtight bond between the glass and metal frame. Documented success in LP polysulfide base joint sealants goes back more than 25 years—and more than 15 years in insulating glass. Other sealants—with no such record—are available, but will they perform trouble-free over the life of your building?

The key to reliable insulating glass performance is the sealant. Window units with LP—polysulfide base sealants have been cutting costs and saving energy for building owners for a long time. These insulating glass units give consistent trouble-free performance year after year in every climate situation—hot, cold, wet or dry. For more information contact Thiokol/Chemical Division, P.O. Box 1296, Trenton, N.J. 08607, or phone 609-396-4001.

Thiokol

Specialty Polymers • Off-Road Tracked Vehicles • Synthetic Fibers & Fabrics • Sprayers • Propulsion • Educational Services
Disc Brake Pads • Ski Lifts • Pyrotechnic Devices • Closures • Rubber and Rubber Chemicals • Medical Electronics Equipment

For more data, circle 104 on inquiry card

52 years ago
we started a revolution in hospital sanitation.
It's still going on.

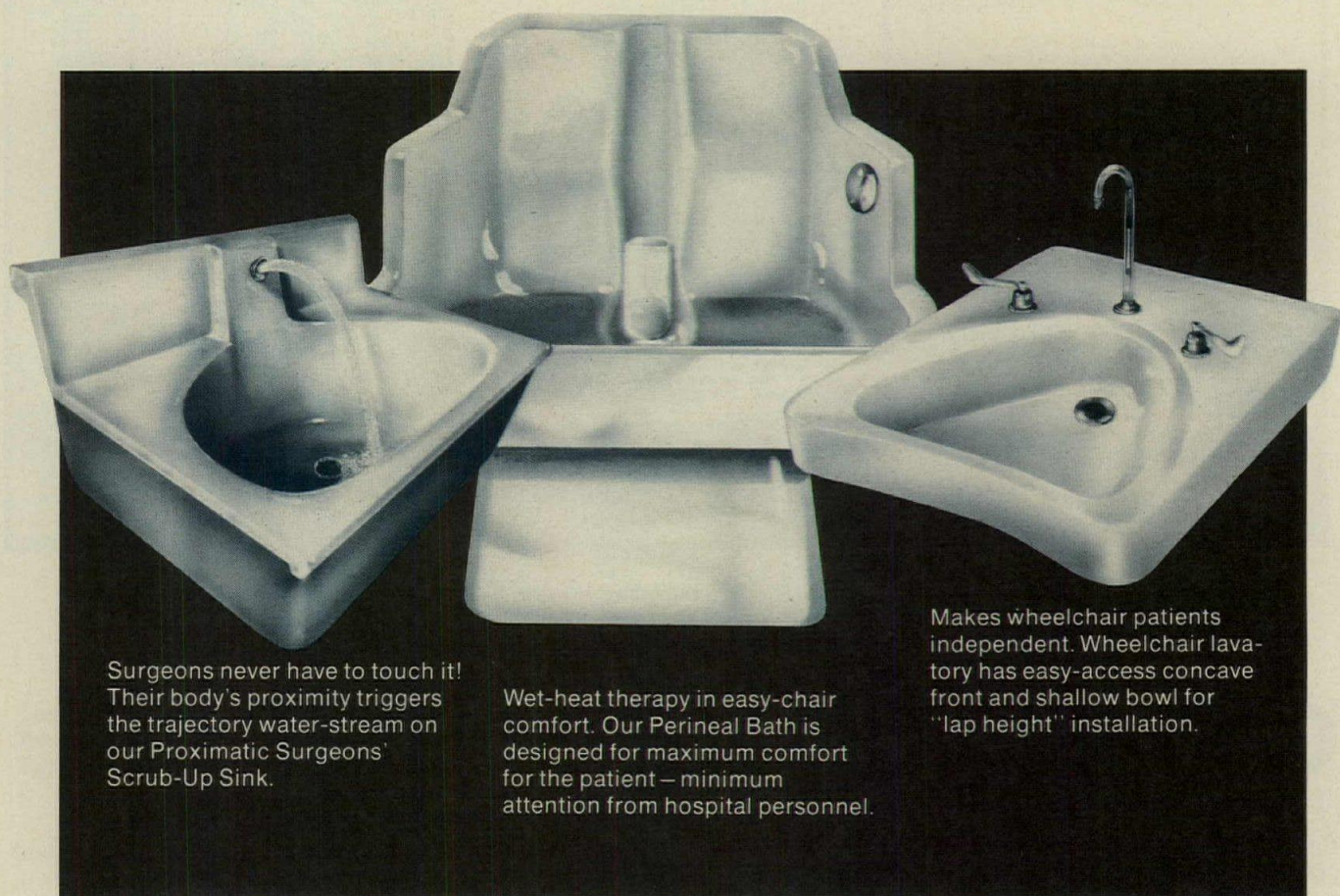

Surgeons never have to touch it! Their body's proximity triggers the trajectory water-stream on our Proximate Surgeons' Scrub-Up Sink.

Wet-heat therapy in easy-chair comfort. Our Perineal Bath is designed for maximum comfort for the patient – minimum attention from hospital personnel.

Makes wheelchair patients independent. Wheelchair lavatory has easy-access concave front and shallow bowl for "lap height" installation.

All product names are trademarks of American Standard, Inc.

American-Standard leads the way.
Again. And again. And again.



For more data, circle 105 on inquiry card

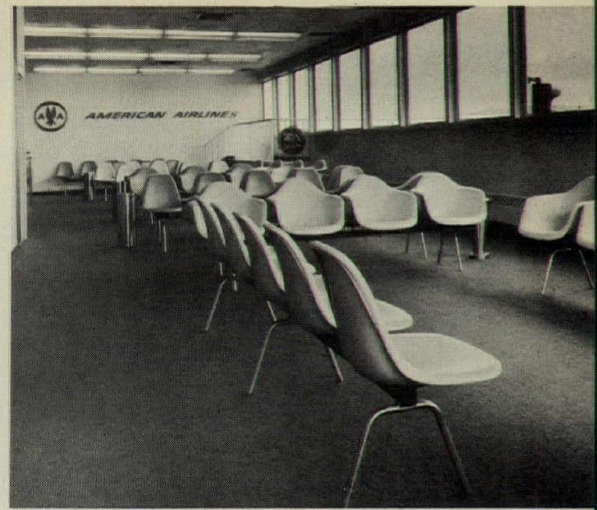

P assenger after passenger after passenger travels on proven carpet by Bigelow.

If you're doing a public transportation job, terminal, passenger train, even a ship interior, you can create your own specifications for the carpet you want. And we can make it for you.

However, Bigelow has another practical suggestion: specify carpeting that has already proven it can take the hard use (not to mention abuse) passengers, guests and staff deal out. Carpet that has repeatedly demonstrated it can take a beating year after year after year.

Bigelow has that kind of proven in actual use carpeting ready for you in a wide selection of carpet styles and patterns. Carpet that is the result of research and development combined with the realistic experience gained in hundreds of transportation installations.

And Bigelow will do more than just sell you proven carpet. We'll give you expert counselling in installation and through our Karpet Kare® Division, we'll give you the best advice available on maintenance. It's a total package designed to assure you that you can specify Bigelow with total confidence.

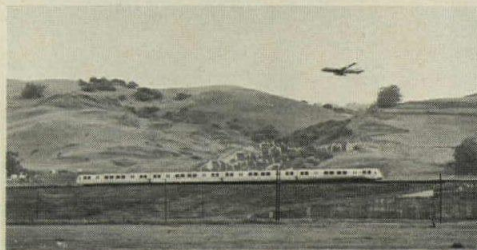

Bigelow[®]
RUGS & CARPETS SINCE 1825

AMERICA'S MOST EXPERIENCED CARPET MAKER

For more data, circle 106 on inquiry card

Bigelow-Sanford, Inc., Dept. A
140 Madison Avenue, New York, N.Y. 10016

I'd like to hear the proof on Bigelow's proven carpets for public transportation.

NAME _____ Print Clearly

TITLE _____

ADDRESS _____

CITY _____

STATE _____ ZIP _____

"COME IN"

**TO SPEED
TRAFFIC FLOW**

**"STAY
OUT"**

TO AID SECURITY

Richards-Wilcox Industrial Doors have been delivering these messages for 94 years. And, while "Life Cycle Costing" is new terminology, the idea of high quality construction for easy operation and long, maintenance-free life dates back to 1880 at Richards-Wilcox.

■ Wide choice of door sizes custom built for swinging, sliding, folding, overhead or vertical lift operation ■ Specify wood, steel clad, sheet steel, corrugated sheet steel or aluminum ■ Full selection of industrial door hardware and electric operators (for faster traffic flow) ■ FM approved and UL listed fire doors available.

Contact us for assistance in specifying industrial doors that speak your language.



Richards-Wilcox
MANUFACTURING COMPANY

116 Third Street, Aurora, Illinois 60507

Phone: (312) 897-6951

One of the White Consolidated Industries

WCI

AE/UPDATE A classified advertising section devoted to helping architects and engineers keep up to date on building product manufacturers.

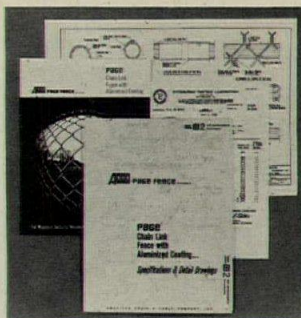

FREE FENCE SPEC KIT saves time, trouble. Invaluable for planning chain link fencing. Kit includes drawings on styles, wire gauges, gates, fittings, framework. Also includes lab reports, work sheets and specifications. Page® aluminized fabric lasts 3-5 times longer than the best of galvanized. Send for your kit today. Page Fence Division of Acco. P.O. Box 430, Bridgeport, Conn. 06602.

For more data, circle 108 on inquiry card

For snow-melting concrete or asphalt surfaces, specify Easy-Heat Series G fiber mesh electric heating mats. Completely pre-assembled with fully grounded resistance heating cable bonded to fiberglass mesh, the G mat is applicable for walks, drives, and parking areas. U.L. listed for 208, 240, 277 and 480 V. A.C. A wide selection of watt densities provides a choice of heating mats to meet climate requirements. Write for Literature—Easy Heat-Wirekraft, 555 Michigan, Lakeville, IN 46536.



For more data, circle 109 on inquiry card

1,344 STANDARD SIZE WALK-INS

When you need a walk-in cooler, we'll go to great lengths to meet your needs. Anything from 5 by 5 by 6½ ft. up to 20 by 18 by 10 ft., with 1,342 sizes in between. Nor-Lake walk-ins are fast to erect and enlarge. Simple to relocate. Underwriters' Laboratories approved.

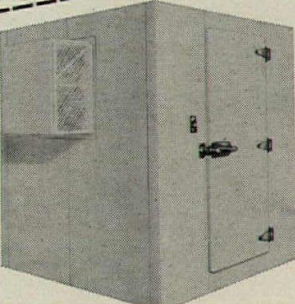

PLEASE SEND ME MORE INFORMATION ON NOR-LAKE WALK-IN COOLERS.
My temperature requirements are: _____

Name

Address

City

State

ZIP

MAIL TO:
 **NOR-LAKE INC.**
Second and Elm, Hudson, Wisconsin 54016 Dept. 3173

For more data, circle 110 on inquiry card

◆ *For more data, circle 107 on inquiry card*



To
copy
is human.



To Create is Thonet.

We don't blame anyone else for copying Thonet. It's only human. But if someone else tells you they introduced the classics . . . well, that's where we'd like to draw the line. We were the first and only company that produced the Bauhaus Classics in the late twenties and early thirties. We introduced them. And we've been offering these chairs longer than anyone else. You can still see them in our old catalogs. The Mart Stam chair. The Mies van der Rohe chair. The Lorenz chair. Even Marcel Breuer's famous "Wassily" chair was first produced by Thonet. Thonet's been first for a long time now. So if anyone else tries to tell you he's got the real thing. Call him a copy cat. Or just smile and call Thonet.



THONET

Thonet Centers of Design
New York, Chicago, Los Angeles, Dallas
Thonet Industries Inc., 491 East Princess Street, York, Pa. 17405 Telephone (717) 845-6666
Circle 111 on inquiry card

When movement attacks your roof edge, what's going to defend it?

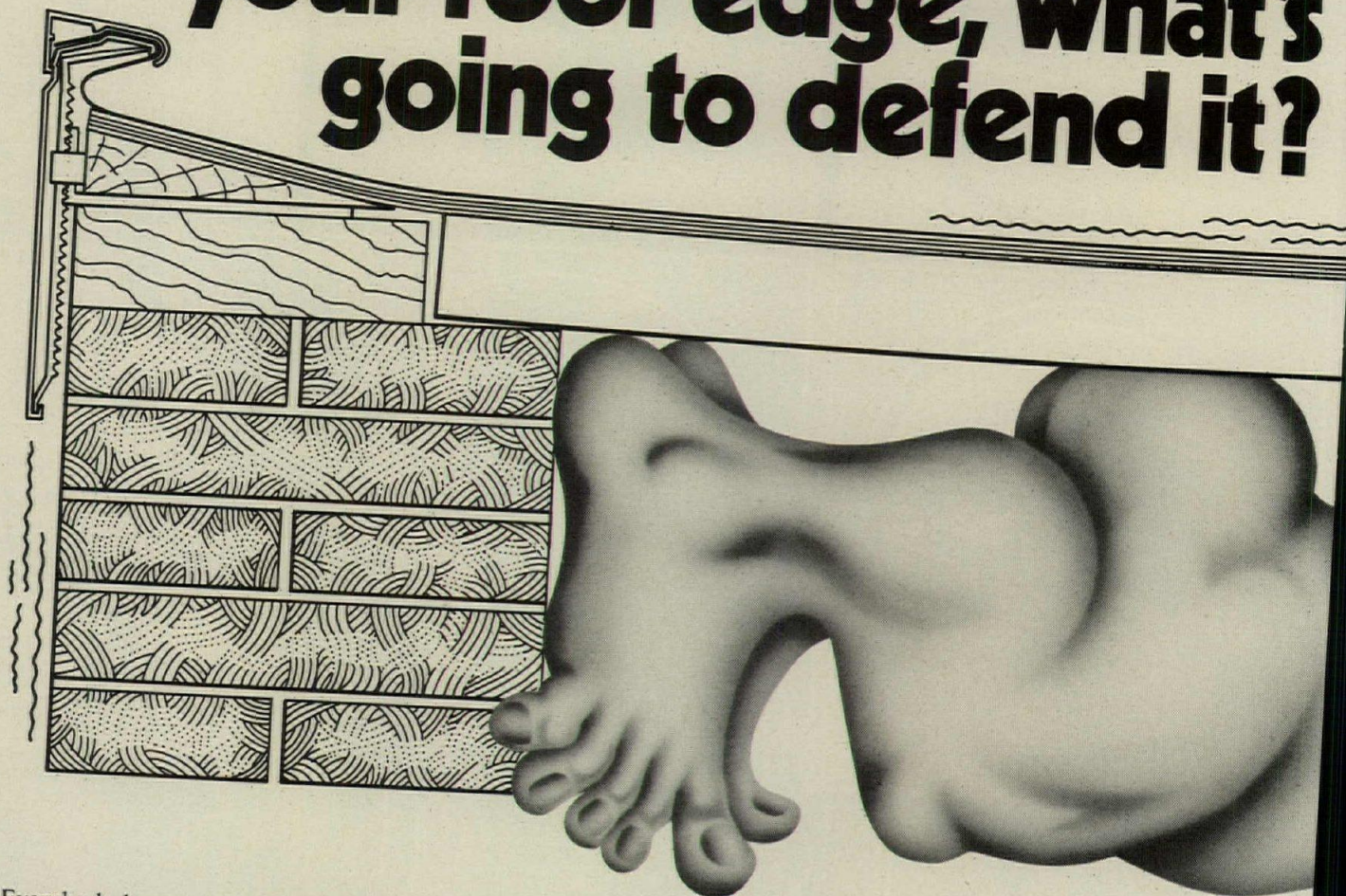

Everybody knows you can't stop the attack. For wherever you find two adjoining structural planes, you'll also find movement. Movement in different directions, at different rates, that makes nails pop, nail holes enlarge, joints open, etc. Any of which can cause leakage.

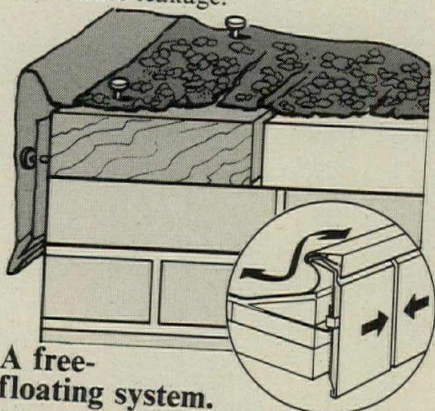

A free-floating system.

But now there's a beautiful defense against movement: Tremline®, a unique free-floating fascia system that takes movement in stride like no other roof edging system can.

For other systems are static and have very little give. But the components in Tremline are free to move independently, without exerting strain on each other. So Tremline can absorb movement between the roof and wall. And keep absorbing it for years and years. There are no exposed fasteners so these potential leak spots are eliminated.

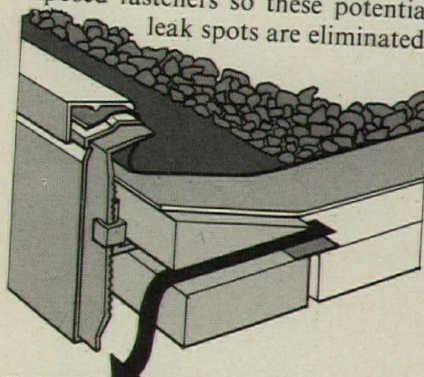

Built-in venting, too.

Tremline also allows perimeter venting of the roof insulation. Other edgings provide only partial venting, if any. And with the neoprene mem-

brane in position, you have an unbroken weatherproof seal around the entire building edge. The membrane also acts as an expansion joint which absorbs roof movement.

A complete modular system.

Tremline is also versatile and adaptable. With its modular design, it can easily be installed on concrete, lightweight concrete and steel decks. And there's also a

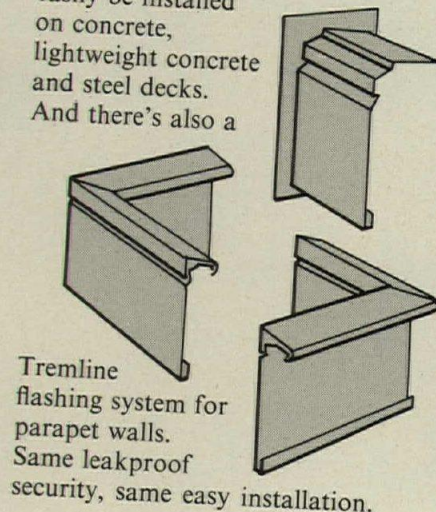

Tremline flashing system for parapet walls. Same leakproof security, same easy installation.

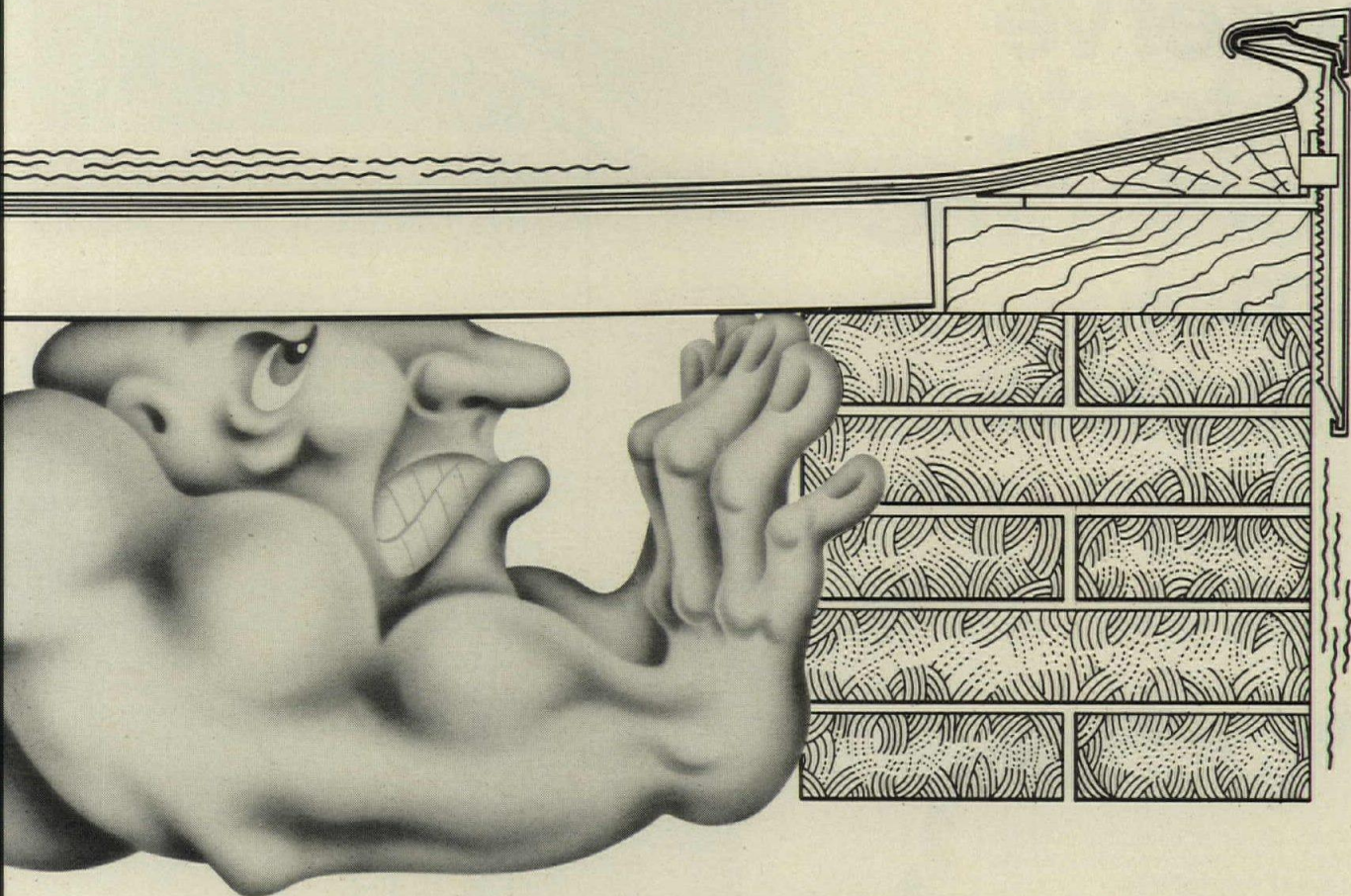

And with Tremline, you get the complete system, from one responsible supplier. All necessary components are preassembled to meet conditions at corners, ends and transition points. So there's little to be detailed on drawings or fabricated on the job. Fascia is packaged in 15' lengths, 6" or 8" facings.

Architecturally beautiful.

Tremline is uniquely beautiful, too.

Gives a clean-line appearance to the roof edge. The extruded aluminum fascia comes in mill, anodized or custom-painted finishes, with slip joints every 15 feet. No ugly exposed fasteners. No oil canning.

Your contractor will appreciate another beautiful feature: its easy installation. It snaps together and self-locks, adjusts up or down in 1/16" increments. Which also makes for easy alignment and compensates

for most roof irregularities.

The Tremline/Alwitra Edging System is a patented product that has been proven in performance for more than seven years. It meets insurance wind requirements and is approved by Factory Mutual System. For more details, see your Tremco man.

And if you have any caulking, glazing or waterproofing problems, he can help too. For over 40 years, our business has been solving these problems and providing top-quality leak proof systems and products, such as our job-proven sealants MONO®, DYmeric® and Lasto-Meric®, and liquid polymer Tremproof waterproofing. Tremco, Cleveland, Ohio 44104. Toronto, Ontario M4H 1G7.

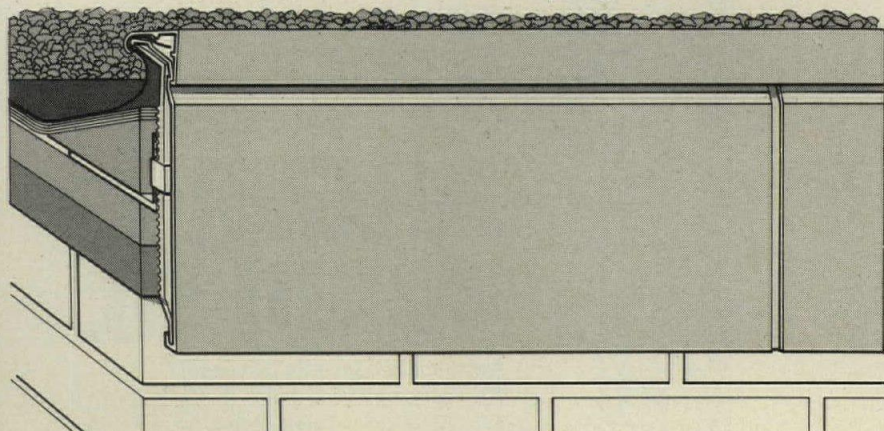

THE ALWITRA EDGING SYSTEMS FROM:

TREMCO®

For more data, circle 112 on inquiry card

Seven reasons why your investments deserve Pyrotector photoelectric smoke detectors.

1. They provide earlier detection of incipient (smoldering) fire than ionization detectors. We'll prove this by demonstration.
2. They detect smoke of required density regardless of distance smoke particles have travelled.
3. They have none of the safety problems possible with radioactive devices.
4. They are not "threshold" alarm devices and thus have no threshold-related false alarm or desensitization problems.
5. They are nearly maintenance-free in normal environments.
6. They can be installed in or adjacent to air ducts or entries.
7. They carry all required listings and approvals.

Send the coupon to us at 333 Lincoln St., Hingham, Mass. 02043. We'll send you our brochure with even more reasons why you should protect your investments with Pyrotector photoelectric smoke detectors.

Name, Title _____

Firm _____

Address _____

City, State, Zip _____

PYROTECTOR

The photoelectric way.

For more data, circle 113 on inquiry card

It writes your language

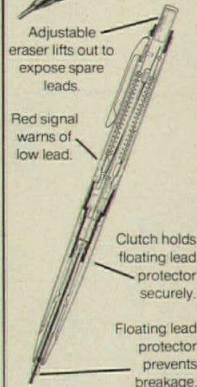

In your line of work, odds are you need a pencil that writes with a super thin line. A line so thin that it can show a lot of detail in a limited space. Or crowd a lot of information on one small line. That pencil is the new improved Ultra-FINELINE from Sheaffer. Available in 0.3mm and 0.5mm models.

It's a mechanical pencil you can get technical with. The exclusive Floating Lead Protector won't wobble or allow the lead to rotate... or break off. If it ever gets jammed with broken lead, you simply replace the Protector. You never need to repoint a lead or adjust the amount of lead exposed. And the Ultra-FINELINE even signals you when it's getting low on lead.

The Ultra-FINELINE. It makes designing and technical drawing so much easier, we sometimes wonder how we designed it... without it. 0.3mm and 0.5mm models. Just \$2.98 to \$5.98. (How's that for talking your language?)

Floating Lead Protector replacements now available... 6 for \$1.

ultra
fine
line
SHEAFFER
WORLD-WIDE. A **textron** COMPANY

For more data, circle 114 on inquiry card

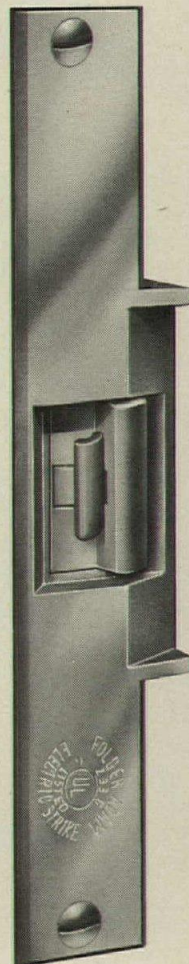

TOTAL DOOR SECURITY

- ▶ **CONTROL** — lock and/or unlock from a remote location
- ▶ **MONITOR** — from a central control panel
- ▶ **RELEASE** — automatically in a power failure emergency

SPECIFY RELIABLE ELECTRIC STRIKES
ENGINEERED AND MANUFACTURED BY

 LISTED

FOLGER ADAM CO.

Architectural Security Division
700 Railroad Street, Joliet, Ill. 60436
815/723-3438 Telex 72-340

For more data, circle 115 on inquiry card

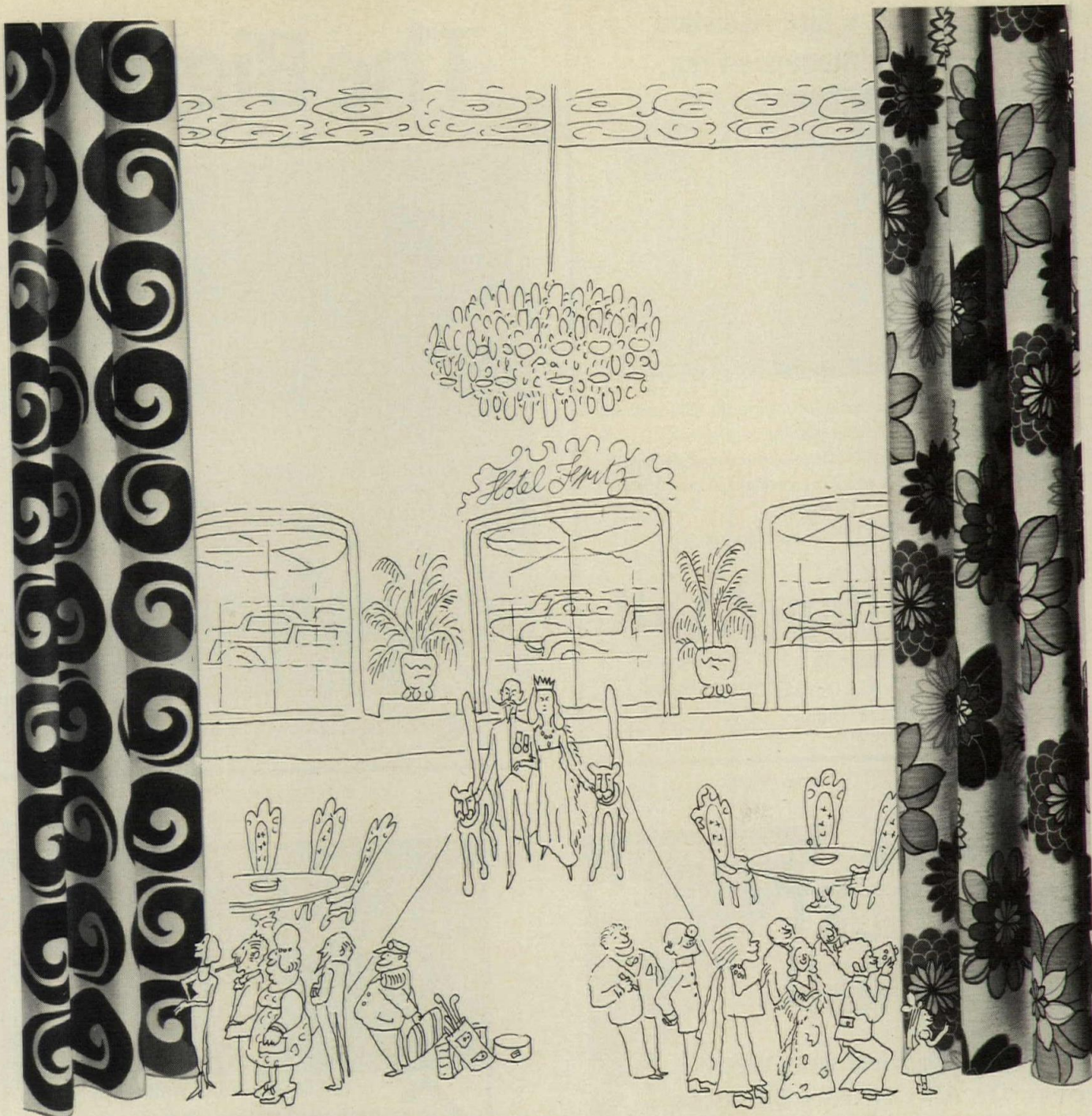

The SEF® Print Collection from Lazarus: in a hotel, it'll upstage the celebrities.

Next time you specify contract drapery fabrics for a hotel, set the scene with posh SEF prints from Lazarus. They're not only sophisticated, they offer the superior flame retardancy needed to pass the California Fire Marshall Test.

SEF is the new modacrylic fiber from Monsanto. It produces drapery fabrics with all the rich aesthetics of an acrylic—plus all the performing talents of a modacrylic. Colors and print patterns are clear,

fast and sun-resistant. Texture variety offers wide decorating scope. Hands are soft, drapeable. And, superior soil release and flame retardant properties are built right in.

For hotels that want to put on the ritz, or offices, high-rises and restaurants, too, specify SEF prints from the oldest, most reliable firm in the business. The one that guarantees delivery dates! Lazarus, 516 West 34th Street, New York, N.Y. (212) 736-6200.



For more data, circle 116 on inquiry card

NOW! School Walls and Ceilings That Are Fire-Resistant, Vandal-Proof and Maintenance-Free.



Laminated to Type X fire-coded gypsumboard, AllianceWall porcelain-on-steel panels create a fire-resistant barrier with a "0" rating for Flame Combustion, Smoke Development and Fuel contribution. No painting or expensive maintenance is ever required. Interior panels are guaranteed for 50 years.

AllianceWall porcelain comes in 112 standard colors.

For further information write:

AllianceWall[®]
CORPORATION
BOX 247
ALLIANCE, OHIO 44601

Plants in Alliance, Ohio; Okmulgee, Okla.; Genk, Belgium and Odense, Denmark

For more data, circle 117 on inquiry card

The Big Sit-In



astrolounger

Massey has the solution to your deep-seated problems — a big, luxurious oversized lounger featuring three-pillar back support, with full depth foam cushion and back. You can always rest assured that the Massey Astro-Lounger will answer your seating questions most comfortably. Also available as the Astro-Rocker.

You're always sitting pretty with
Massey Seating Co.
NASHVILLE, TENNESSEE 37208

S FOR REFERENCE SEE SWEET'S ARCHITECTURAL CATALOG FILE 12.5 MA.

For more data, circle 118 on inquiry card

TOUGH... RESILIENT... LONG LASTING

TENNIS COURT COLOR FINISH

44 Years Weather and Wear Proven On All Concrete Surfaces

Wherever you find recreational, industrial, public utility or commercial concrete construction, you'll likely find Kemiko Col-r-tone.

Col-r-tone's unique chemical composition defies sun, wear, moisture or alkalis for years and years. Won't chip, crack or peel. Non-skid, glare-free in beautiful flat and matte finish. Easily and quickly applied by brush or roller it seeps right in. 8 basic colors that may be intermixed to provide over 50 contemporary colors.

Write today for free illustrated brochure and color chips.

KEMIKO INC.
DEPT. AR-64
2443 N. Naomi St.
Burbank, Calif. 91504

For more data, circle 119 on inquiry card

STOP VANDALS AND THIEVES

15-YEAR FACTORY WARRANTY

OLORBOND[®] II FENCE SYSTEM
Vinyl Bonded to Pre-galvanized Steel

America's strongest, most durable chain link fence (100,000 PSI steel wire) is a real vandal stopper & sound investment. The only chain-link fence with a 15-year factory warranty against rust & corrosion. Never needs maintenance because all components — framework, fabric & fittings — are vinyl bonded to pre-galvanized steel. Available in green or black, in all standard gauges, meshes and heights. Colorbond Maximum Security Fence (photos) has 3/8" diamond mesh that cannot be climbed. American made to U.S. Gov't specs. Send for free catalog today.

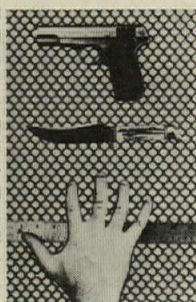

Dept. AR-3

OLORGUARD
CORPORATION

World's Largest Mfr. of Vinyl Bonded Galv. Steel Fences

1 JOHNSON DRIVE
RARITAN, N.J. 08869
(201) 526-0255

For more data, circle 120 on inquiry card



Anso[®] nylon's five year carpet guarantee. It puts the odds on your side.

When it comes to carpet, the Sahara Hotel in Las Vegas doesn't believe in gambling.

So they put their money on "Years Ahead," by Berven of California. And got Guarantesth—the guarantee with teeth. Allied Chemical's assurance that any carpet made of either ANSO nylon, or ANSO-X anti-static nylon, will not wear more than 10% in 5 years, or we'll replace it, installation included.

Now when you specify "Years Ahead," you will get the benefits of ANSO-X, the most advanced anti-static system on the market. The anti-static protection is built right

into the fiber. That means uniform protection over the entire carpet and it means permanent anti-static protection that's guaranteed for the life of the carpet.

So when you're looking for carpet, look for the label with the little animal who symbolizes Allied Chemical's Guarantesth—the strongest carpet fiber guarantee that you can get. For your free copy of our contract carpet manual, write to: Allied Chemical, Home Furnishings Merchandising, Dept. AR, 1 Times Sq., N.Y. 10036. (212) 736-7000, ext. 7766.

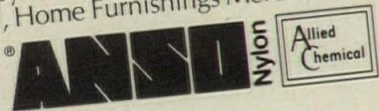

Guarantesth. The guarantee with teeth.

Hotel Sahara, Las Vegas.

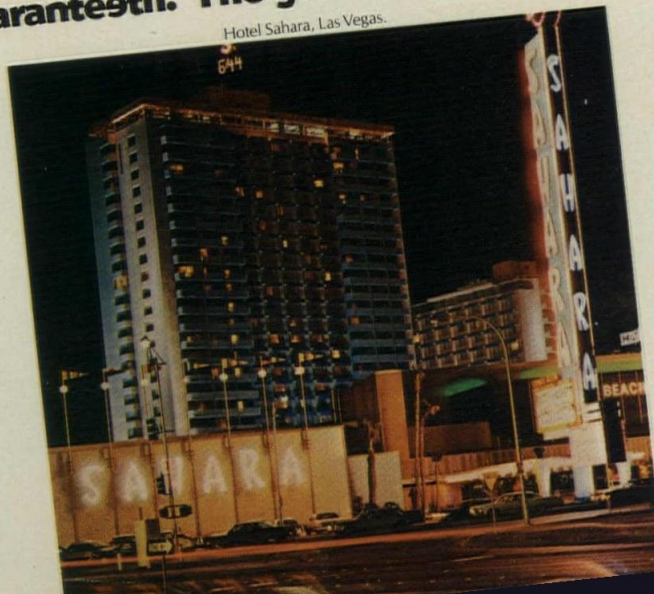

For more data, circle 121 on inquiry card

ARCHITECTURAL
RECORD
REPEATS
ITS HIGHLY
SUCCESSFUL
CONFERENCE

PRESENTS

**... a special two-day
conference
examining the
exciting profit
opportunities
available in this
new vista**

How the Architect and Engineer can Profit as a Builder/Developer

All over the United States, pioneering architects and engineers are starting to capitalize on their expanding opportunities in development building. In doing so, they are entering new areas of profitability. These opportunities bring with them involvement in a whole range of problems with which the professional practitioner has had little or no previous experience. Now, for the first time, Architectural Record has developed a special conference designed to help cope with these problems and to take full advantage of emerging opportunities.

The faculty for these conferences includes not only successful architect/engineers-developers but attorneys, CPA's, mortgage bankers, contractors, marketing experts and brokers as well.

MAY 9-10 — ATLANTA / MAY 13-14 — LOS ANGELES / JUNE 14-15 — HOUSTON

Conference Highlights

- Feasibility Studies—how to determine the potential marketability and profitability of a project
 - Land acquisition—how to choose the right land—how to secure favorable zoning
 - Project financing—an evaluation of the alternative methods of real estate financing—how to find the money
 - Legal and ethical implications of the architects involvement in development building
 - Professional liability
 - How to organize for success and choose the kinds of partners you need
- Case studies in various building opportunities

MC² Management Concepts International, Inc.
505 Park Avenue, New York, N. Y. 10022 • 212 759-5830

Please rush additional registration information on How the Architect and Engineer Can Profit as a Builder/Developer.

Name _____

Company _____

Address _____

City _____ State _____ Zip _____

Phone (A/C) _____ Number _____ Ext. _____



Minnesota Ore Operations Administration Building, Mountain Iron, Minnesota. *Owner:* United States Steel Corporation, Pittsburgh, Pennsylvania. *Architect:* Architectural Resources, Inc. Hibbing & Duluth, Minnesota. *Engineer:* R. O. Jacobson, Jr., Hibbing, Minnesota. *Fabricator:* American Bridge Division, United States Steel Corporation, Chicago, Illinois.

No invisible means of support!

U.S. Steel builds first load-bearing exposed steel plate-wall building.

Sitting among the ore fields of Northern Minnesota, at Mountain Iron, is a structure that breaks new ground in building design.

Serving as the administration headquarters of U.S. Steel's Minnesota Ore Operations, its most unique feature is a load-bearing, exposed A36 steel plate-wall. Floor and roof loads are directly supported by the wall.

To our knowledge, this is the first building in which exposed, painted steel plate *on the outside* supports loads *on the inside*. The steel plate wall actually holds up the building!

This advance in building design is functionally efficient and can help cut construction costs.

The rolled wide-flange shapes welded to the plate wall, apart from serving as an architectural element, perform two key functions: they stiffen the plate-wall and support the floor

loads. The wall itself was fabricated in modules with window openings cut into the plate.

A 3-coat paint system was used—a primer and 2 field coats, having a total thickness of 3.5 mils.

Considerable research and experimentation went into the construction of this new building at Mountain Iron. The result is a clean, crisp structural wall in steel that serves the additional purpose of enclosing the building.

This system, pioneered and developed by U.S. Steel, marks another step forward in the uses of exposed steel for modern building exteriors.

For more information, contact a USS Construction Marketing Representative through the nearest USS Sales Office or write: United States Steel, (Room C189), 600 Grant Street, Pittsburgh, Pa. 15230.

United States Steel



For more data, circle 122 on inquiry card

IT FITS

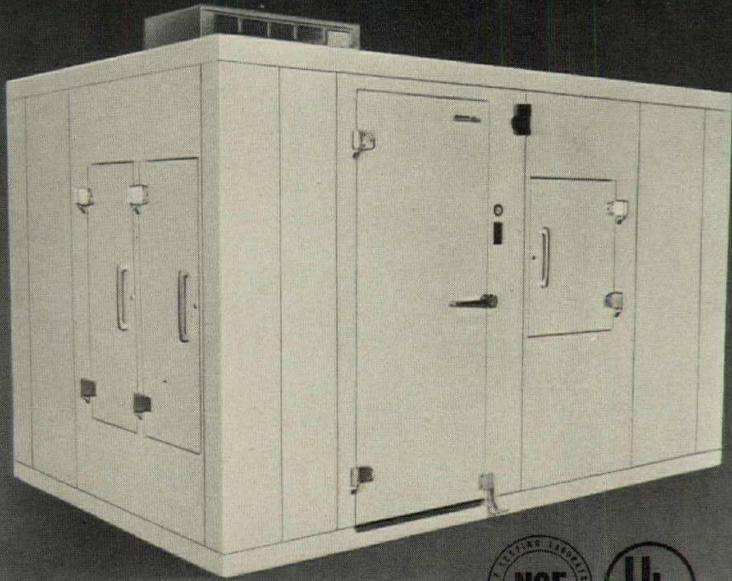

VOLLRATH WALK-IN COOLER/FREEZER

Name your dimensions and we'll provide a modular walk-in that fits . . . exactly. We use true, full-size dimensions, not nominals, making your specification work easier. Means more storage space, too. To insure a perfect fit, all components are factory tested. Vollrath walk-ins are fabricated in accordance with N.S.F. and U.L. standards, using the latest technology: foamed-in-place urethane insulation, posi-loc assembly, fully covered floors and ceilings, tight energy-saving joints and doors. Wide choice of options, finishes, self-contained or remote refrigeration systems to fit your needs and requirements.

Ask your Vollrath equipment specialist for details, or send for our comprehensive design/specification manual.



Vollrath SINCE 1874
THE VOLLRATH COMPANY - SHEBOYGAN, WIS.

For more data, circle 123 on inquiry card

If you "go by the book," make it this one

When you specify or buy carpets, you need to know about backings

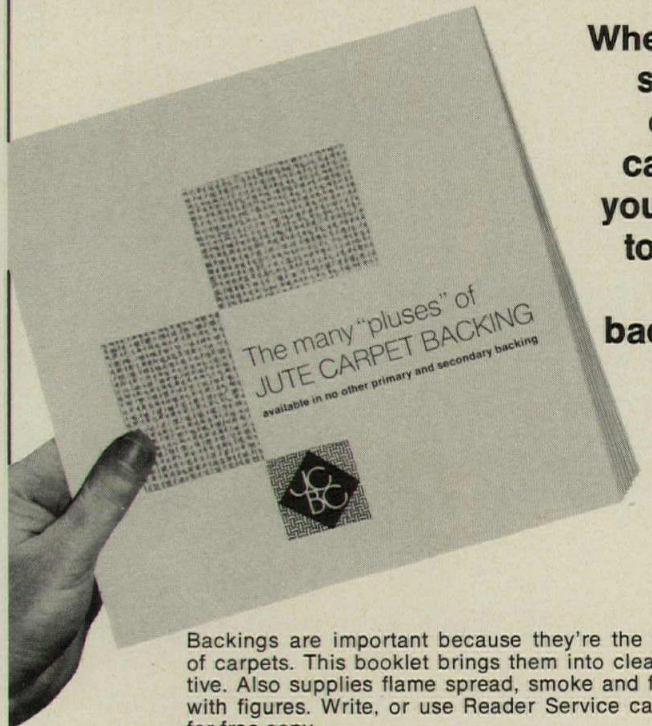

Backings are important because they're the foundation of carpets. This booklet brings them into clear perspective. Also supplies flame spread, smoke and fumes data with figures. Write, or use Reader Service card in back for free copy.

JUTE CARPET BACKING COUNCIL, INC.
30 Rockefeller Plaza • New York, NY 10020

For more data, circle 124 on inquiry card



Strand Century lighting also conserves energy. Has been for a long time.

Before energy conservation became a way of life, Strand Century was doing just that—for 40 years. Conserving energy while enhancing architectural lighting is a basic policy of the company that knows light. Among our notable environmental systems are:

- General Motors Building, New York
- Federal Reserve Bank, Minneapolis
- Xerox Educational Center, Leesburg
- Miami Beach Convention Center
- Bell Laboratories, New Jersey
- Pepsico International, Purchase
- Alcoa Building, Pittsburgh
- Eastman Kodak Co., Rochester

And now, Environ[®], the first modular, low-cost, all-electronic environmental lighting system. Ask us for further information.

STRAND CENTURY INC.
A COMPANY WITHIN THE RANK ORGANISATION
20 Bushes Lane, Elmwood Park, N.J. 07407 / (201) 791-7000

• Environ is a registered trade mark of Strand Century Inc.

For more data, circle 125 on inquiry card



INDUSTRIES

For nearly two decades we at Paragon have been designing, engineering and perfecting our Para-flye deck equipment which today is universally recognized as the industry standard, widely acclaimed by leading coaches, swimmers and divers everywhere.

With our exclusive ability to interchange materials, lengths, superstructure and accessories, specifications can be made to meet any and all individual requirements.

To you, the creative Architect or Engineer, this means custom fabrication and total design flexibility without compromise.

We at Paragon know the problems. We also know the answers.

Precision engineering; variable design capability; and proven service to your needs. That's why Paragon is consistently specified when building or re-equipping a school, club, municipal or residential pool.

See our catalog in Sweets File or write Paragon.



We build the best deck equipment so you can design a better pool.

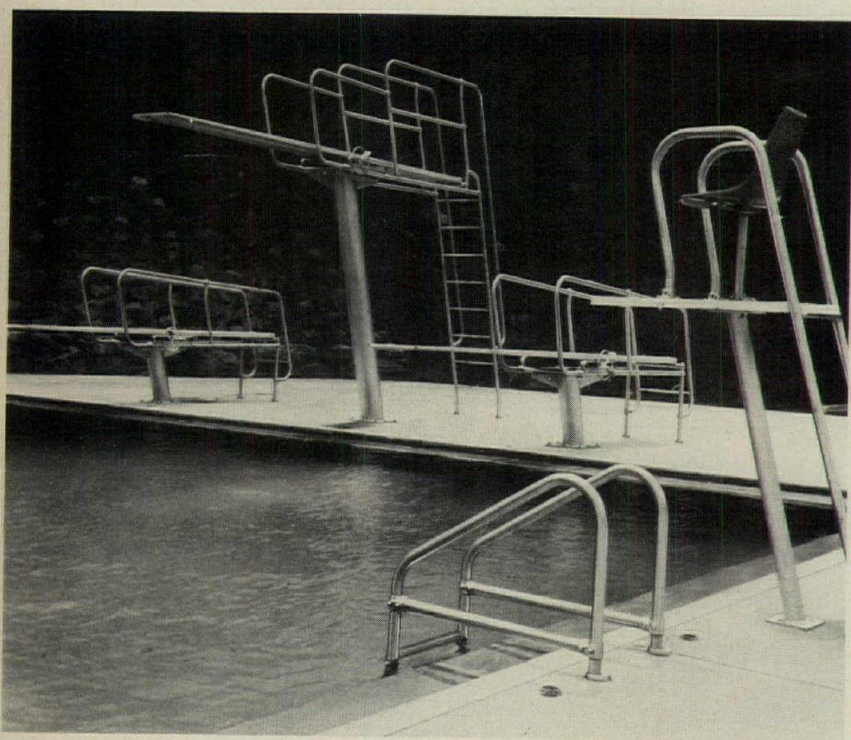

KDI Paragon Inc. The Architect's Friend.



KDI Paragon Inc.
Manufacturers of Quality
Deck/Underwater Equipment
12 Paulding Street
Pleasantville, N. Y. 10570
914-769-6221

West Coast Rep:
Corrick International
206 Locust Street
Santa Cruz, Ca. 95060
408-426-9010

For more data, circle 128 on inquiry card

This John Chipman Bench was planted 500 years before Columbus sailed for America.

John Chipman works in Redwood. The Heartwood of the Redwood. Redwood over 1,000 years old. Tough. Resilient. Almost weatherproof.

Wood like this makes a bench that resists termites, warping, fire and decay, and looks good doing it...for generations.

But John Chipman and Landscape Forms not only offer you the beauty and durability of Redwood, their Woodforms Series turns this remarkable wood into fine mall and street furniture.

When you have a site furnishing job to do, think about Chipman in 1,000-year-old Redwood. Even if your benches only have to last another 100 years.

Landscape Forms, Inc.

Route #3, Kalamazoo, Michigan 49001
(616) 381-0396

See our complete listing in
Sweet's Architectural
File, 2.16/La



For more data, circle 129 on inquiry card

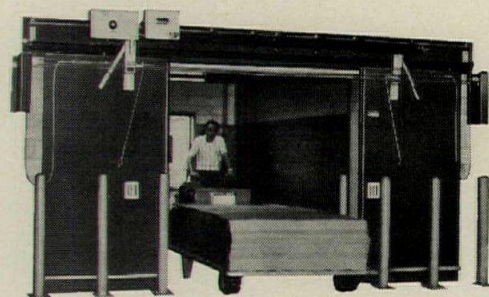

At last — a fast acting double-slide industrial door that's also a UL-listed, Class A fire door.

Our new Fire Chief™ is the first double horizontal slide Class A, 3-hour endurance rated, UL and FM labeled door that's fast enough for the busiest doorway.

The Fire Chief's complete pre-assembled, pre-wired package installs easily and inexpensively. Provides equal or greater protection than much heavier conventional doors through years of dependable, maintenance-free service.

Before you invest in a fire door *and* an industrial door, see the one that does both jobs. Available in double or single slide. Write for free literature or find us in the Yellow Pages.

69 Myrtle Street, Cranford, N.J. 07016
(201) 272-5100 Telex 13-8268



For more data, circle 130 on inquiry card

For more data, circle 131 on inquiry card

Mother Earth



The good earth now comes in six colors and six shapes . . . Earthstone. Its warm rustic charm comes from handmolding in primitive wooden forms. And as nature demands, when Earthstone's natural colors are fired deep into its redburning shale, the hues vary ever so subtly tile by tile. This somewhat antique quality endows Earthstone with a warm mellowness found in no other tile.

Sure we planned this 1/2-inch thick tile carefully, in six interesting shapes and colors, but nature gave it originality. Naturally, what you do with all this to add new dimension, new texture, new durability to floors and walls. . . well, that's a whole new art form isn't it. You can specify any of Earthstone's six shapes and colors now, or if you ask we'll provide custom shapes as well. Samples, too.

florida tile



DIVISION OF SIKES CORPORATION
FLORIDA TILE • P. O. BOX 447 • LAKELAND, FLORIDA 33802

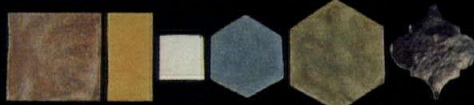

Earthstone is a trademark of Florida Tile, Division of Sikes Corporation.

Product catalog in Sweets architectural file.

THE BEST WAY TO PREPARE FOR THE 1974 ARCHITECTURAL REGISTRATION EXAM

**"THE CLOSEST YOU
CAN COME TO
ACTUALLY TAKING
THE EXAM"**

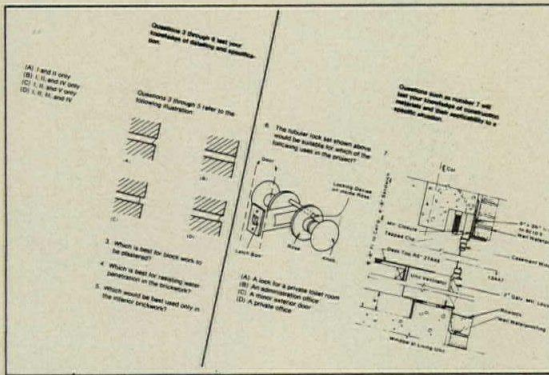
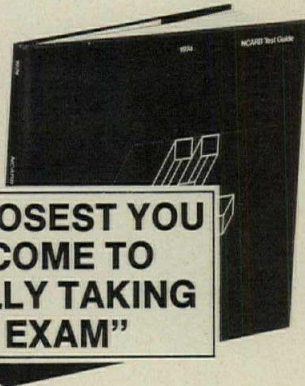

Here—within the pages of a single book—you'll find the information and help you need to prepare for the December, 1974 Architectural Registration Exam. This 186-page Test Guide is the only one sponsored and recognized by the NCARB, the organization that prepares the examination.

New—and expanded—this edition draws its material directly from the December 1973 exam. The questions are the same ones confronted by the candidates who actually took the exam—all the test information for all four parts is reproduced in the Guide.

EXCLUSIVELY THIS TEST GUIDE FEATURES:

- INSTRUCTIONS AND QUALIFICATIONS for applying for the new professional Examination as well as the equivalency examination.
- The 1973 EXAM—with questions and answers from the actual examination which tested candidates knowledge and judgment in environmental analysis, architectural programming, design and technology, and construction administration.
- RESULTS OF THE 1973 EXAM—how the candidates did nationally, by region and state . . . what the candidates thought of the exam . . . what they thought of their education/training.
- WHAT THE NEW EXAM WILL BE LIKE—with answers to such questions as: How is the new examination structured? . . . graded? . . . scored? . . . Is guessing a good idea? . . . Is there a predetermined pass/fail point? . . . What scores will be reported and to whom? . . . Will credit be given for passing individual parts?
- A GLOSSARY OF TERMS AND IDEAS with which candidates must be familiar with to deal effectively with each problem area.
- A BIBLIOGRAPHY OF RECOMMENDED READING AND REFERENCES encompassing the periodicals and books of special relevance to candidates for the Professional Examination.
- INDISPENSABLE INFORMATION FOR ALL CANDIDATES, describing the philosophy of the new Professional Exam, the new exam and the law, and how the NCARB intends to help the professional after registration.
- REQUIRED READING FOR ALL PRACTITIONERS by shedding light on the whole institution of registration and licensing as a professional prerequisite. Architects already in practice, both here and abroad, can benefit professionally from having their own copy.

RECOMMENDED BY LAST YEAR'S CANDIDATES

Candidates who bought the first edition in preparation for the 1973 exam readily endorsed the Test Guide as a practical and useful tool in their studies. The expanded 1974 edition is of the *utmost* importance to anyone taking the Professional Exam and will be of professional interest to all educators and practitioners.

The first edition of the Test Guide was completely sold out and paper and printing commitments will also limit the second edition. To ensure that you'll receive your own copy, send your order and payment to:

ARCHITECTURAL RECORD BOOK • BOX 682 • HIGHTSTOWN, N.J. 08520

**ORDER
NOW!
USE THIS
HANDY
COUPON**

ARCHITECTURAL RECORD BOOK • BOX 682 • HIGHTSTOWN, N.J. 08520

Please send _____ copies of the Architectural Registration Handbook

Name _____

Address _____ City _____

State _____ Zip _____

Full payment of \$21.00 per copy (plus 50¢ postage) must accompany your order

It makes you look good, too.

We put beauty, elegance and reliable operation into the Delta faucet.

We left the washer out. And all the problems worn washers cause.

That's why when you specify Delta, you are specifying one of the most efficient, trouble-free faucets made.

One of the safest, too. Because of the Delta pressure balance bath valve.

When flushed toilets or clotheswashers suddenly decrease the pressure on water lines, the valve automatically compensates to maintain the same hot or cold water mix.

So the shower temperature stays constant. And no one gets scalded or hurt.

There are Delta washerless faucets for kitchens and bathrooms. For sinks and showers. Both single-handle and double-handle models. In beautiful new decorator designs.

They're styled to look good and to work better. And to make the specifier look as good as they do.

For illustrated literature, write Delta Faucet Company, A Division of Masco Corporation, Greensburg, Indiana 47240, and Rexdale, Ontario.

Delta Faucets.

Washerless. To work as good as they look.

For more data, circle 132 on inquiry card



**Our cities can
work better today
...and tomorrow.**

Modern ways to transport people.

Cities are having a rebirth, largely because developers are taking a new look at the tremendous investments in urban property. And modern mass transit ideas are helping make this rebirth happen. The automated, computer-controlled vehicles that have helped move people safely and conveniently through airports, are now being applied to the needs of downtown areas, colleges, industrial complexes and recreation centers. Westinghouse is helping make it happen.

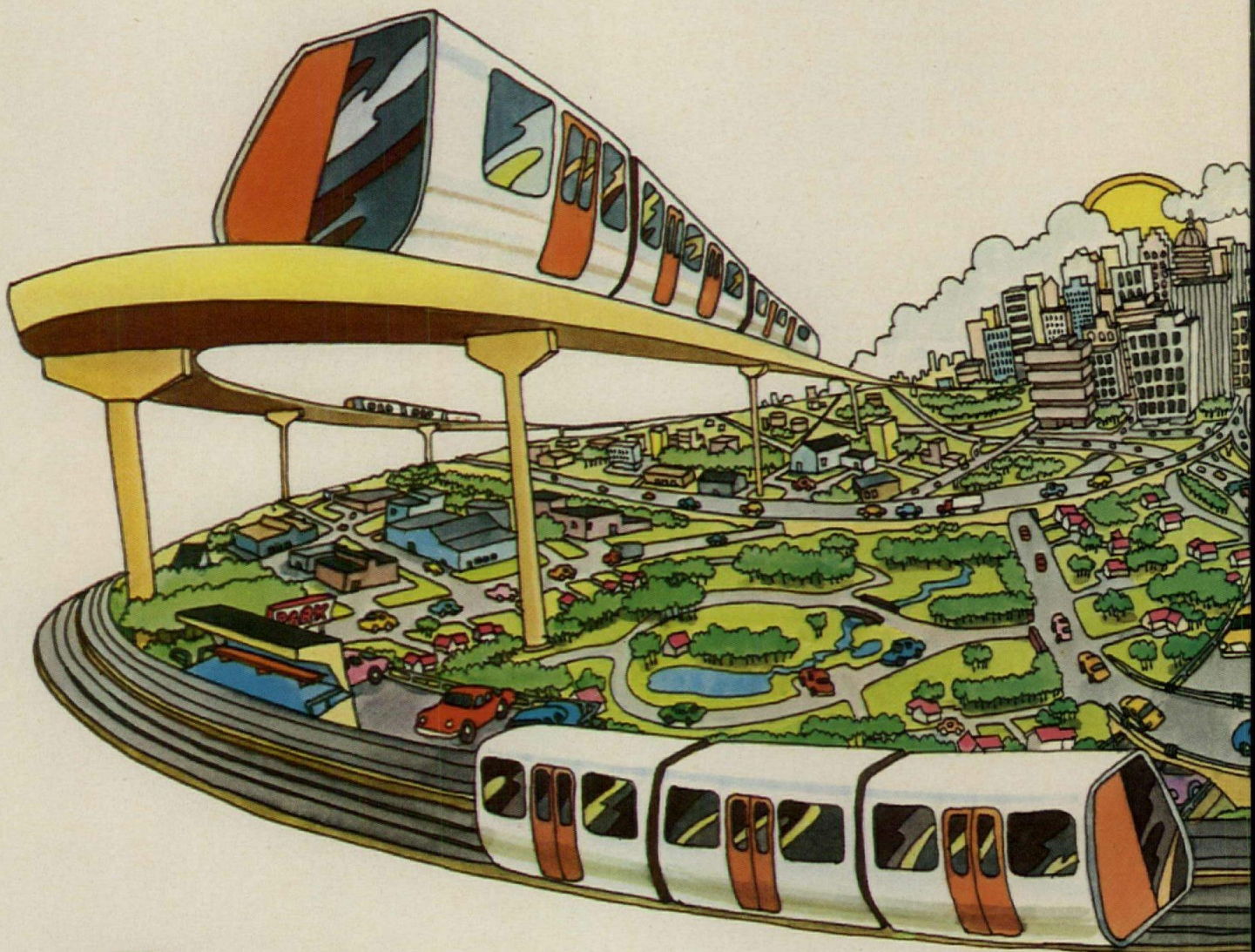

Westinghouse

Buildings designed to use less energy.

New buildings are saving energy these days by using existing heat . . . from the lighting systems . . . to cut heating loads. Circulating water or air picks up the lighting heat and redistributes it throughout the building. In summer, the same system carries the heat out of the building to cut air conditioning needs. Total energy savings can amount to 10% or 15%.

Better lighting for better safety.

New Westinghouse Ceramalux™ high-pressure sodium lamps for residential streets deliver twice the light of ordinary mercury vapor lamps for 10% less power, helps discourage street crime. Ceramalux systems are being installed now in New York City, Washington, D.C., and dozens of other cities.

Westinghouse Electric Corporation
Pittsburgh, Pa. 15222

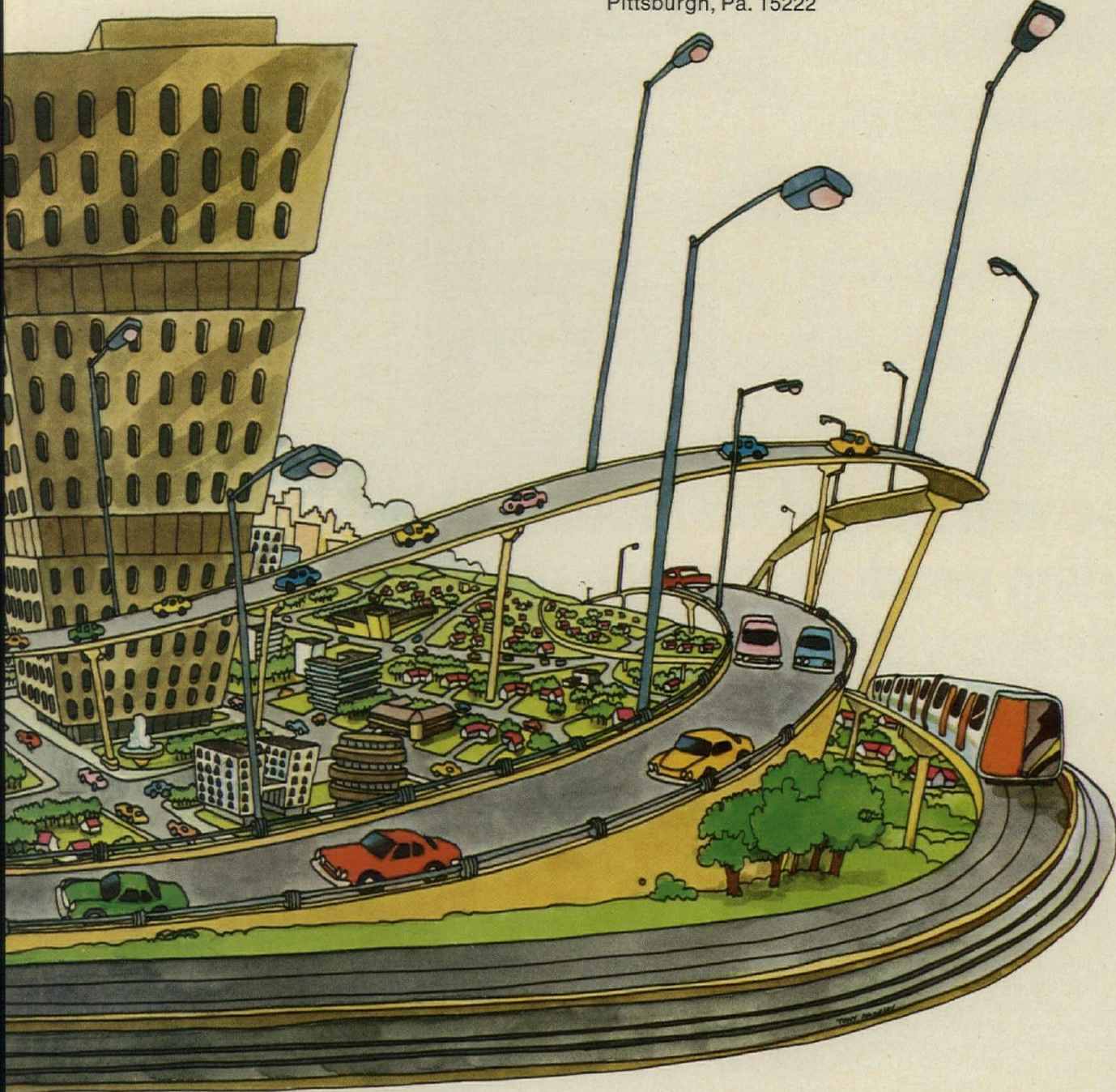

helps make it happen

For more data, circle 133 on inquiry card

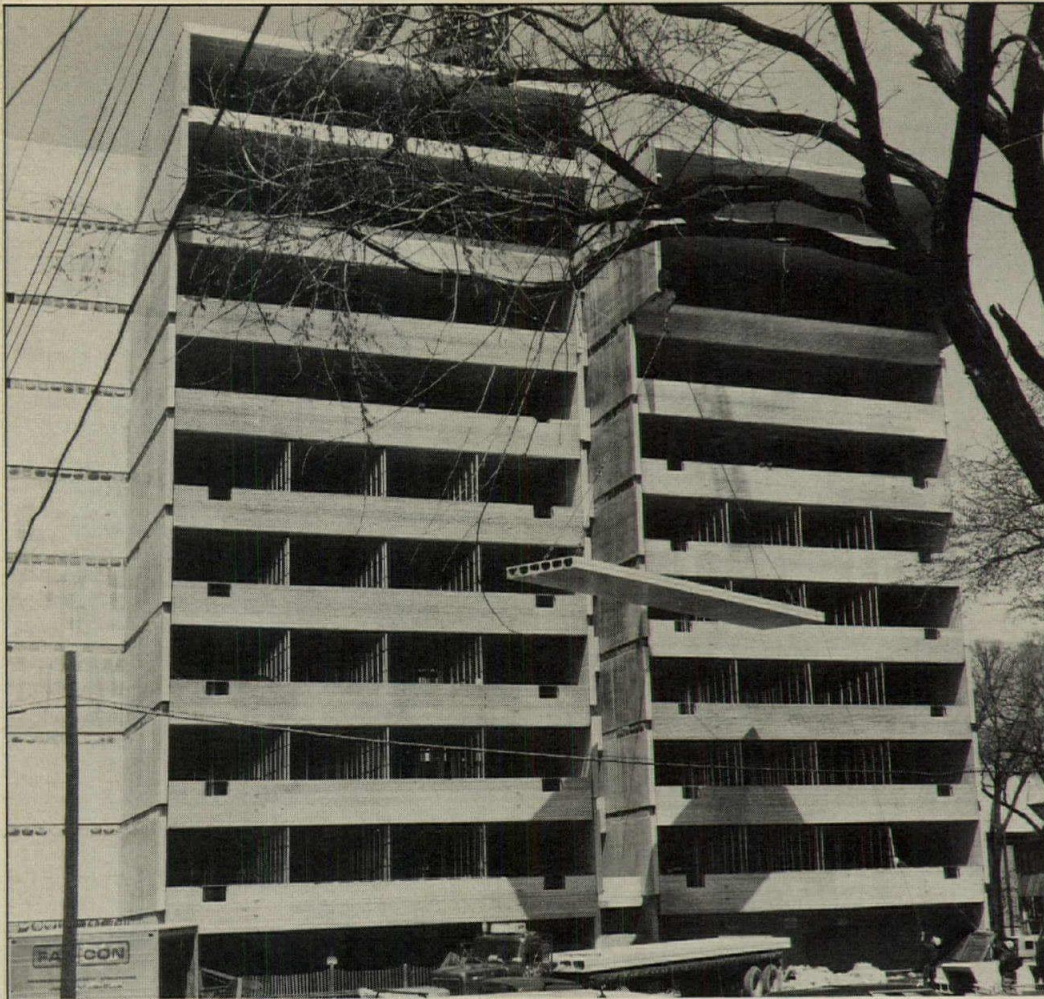

SPAN-DECK® MANUFACTURERS

- ARIZONA**
Tanner Prestressed & Architectural Concrete Co.
T. E. Blizard
P.O. Box 13309
Phoenix, Arizona 85002
(602) 254-5823
- CONNECTICUT**
C. W. Blakeslee & Sons, Inc.
Joseph Gold
P.O. Box 1844
New Haven, Conn. 06507
(203) 772-2500
- FLORIDA**
Stresscon International, Inc.
Waldemar E. Lee
P.O. Box 1480
Hialeah, Florida 33011
(305) 823-8950
Stresscon International, Inc.
Lakeland Plant
Ben C. Scales
P.O. Box J.
Eaton Park, Florida 33840
(813) 688-7717
- ILLINOIS**
Midwest Prestressed Concrete Co.
H. D. Rubbel
P.O. Box 1389
Springfield, Illinois 62705
(217) 528-0471
- INDIANA**
American Precast Concrete Inc.
C. T. Corbin
1030 So. Kitley Ave.
Indianapolis, Indiana 46203
(317) 353-2118
- IOWA**
Prestressed Concrete of Iowa
4003 J. St. S.W.
Cedar Rapids, Iowa 52404
(319) 366-2751
Prestressed Concrete of Iowa
J. H. Boehmle
P.O. Box 822
Iowa Falls, Iowa 50126
(515) 648-2579
- KENTUCKY**
Breeko Industries
Louisville, Ky.
(Contact Nashville Office)
- LOUISIANA**
Belden Concrete Products
R. L. Couret
P.O. Box 607
Metairie, Louisiana 70004
(504) 833-5593
- MAINE**
Bancroft & Martin, Inc.
Richard I. Davies
27 Main Street
South Portland, Maine 04106
(207) 799-8571
- MARYLAND**
Strescon Industries, Inc.
Wayne C. Hart
3501 Sinclair Lane
Baltimore, Maryland 21213
(301) 327-7703
- MINNESOTA**
Fabcon, Inc.
David W. Hanson
700 W. Highway 13
Savage, Minnesota 55378
(612) 890-4444
- MISSISSIPPI**
Jackson Ready Mix Concrete
John Lishamer
P.O. Drawer 1292
Jackson, Mississippi 39205
(601) 362-1646
- MISSOURI**
Wilson Concrete Company
Charles Wilson
P.O. Box 10305
St. Louis, Missouri 63145
(314) 739-3232
- NEBRASKA**
Wilson Concrete Co.
Larry LaFollette
P.O. Box 7208, So.
Omaha Station
Omaha, Nebraska 68107
(402) 733-3611
- NEW YORK**
Lockport Prestress, Inc.
George G. Switzer
5550 Hinman Road
Lockport, New York 14094
(716) 434-6113
- NORTH CAROLINA**
Arnold Stone Company
Gerd H. Marohn
P.O. Box 3346
Greensboro, N. C. 27402
(919) 668-2742
Gifford-Hill & Co., Inc.
Dennis Foster
P.O. Box 5247
Charlotte, N. C. 28205
(704) 372-1080
- OHIO**
SPAN-DECK Div.
Permacrete Products Corp.
Joe Kelleher
P.O. Box 62
Grove City, Ohio 43123
(614) 875-8601
Cleveland Builders Supply Co.
Jack French
5161 Warner Road
Cleveland, Ohio 44125
(216) 621-4300
- PENNSYLVANIA**
Dickerson Structural Concrete Corp.
Earle Butts
P.O. Box 160
Youngwood, Pa. 15697
(412) 925-3585
Nitterhouse Concrete Products, Inc.
Richard F. Maffett
P.O. Box N
Chambersburg, Pa. 17201
(717) 264-6154
Strescon Industries, Inc.
Walter L. Hoggard
P.O. Box 57
Morrisville, Pa. 19067
(215) 295-8144
- TENNESSEE**
Breeko Industries
C. M. Blackburn
P.O. Box 1247
Nashville, Tenn. 37202
(615) 255-3171
Featherlite Precast Corp.
Roy Wright
P.O. Box 13202
Memphis, Tenn. 38113
(901) 942-4473
Southern Cast Stone Co., Inc.
William A. Ayres
P.O. Box 1669
Knoxville, Tenn. 37901
(615) 524-3615
- TEXAS**
Texas Industries, Inc.
Clyde C. Spraggins
P.O. Box 400
Arlington, Texas 76010
(214) 637-3100
- WASHINGTON**
Central Pre-Mix Concrete Co.
J. Gordon Fenton
P.O. Box 510
Kent, Washington 98031
(206) 852-7874
Central Pre-Mix Concrete Co.
W. W. Wasterman
Box 3366, Terminal Annex
Spokane, Washington 99220
(509) 535-2941
- AUSTRALIA**
E.P.M. Concrete Pty Limited
Athol Gudgeon
P.O. Box 196
Blacktown, Australia 2148
Phone: 622-7111
- CANADA**
Con-Force Limited
E. J. Ottewill
P.O. Box 398
Calgary 2, Alberta, Canada
(403) 265-6550
Con-Force Limited
John S. Ink
13072 - 125th Ave.
Edmonton, Alberta, Canada
(403) 455-2131
Con-Force Limited
R. W. Stark
P.O. Box 9520
Vancouver 5, B.C.
Canada
(604) 278-9766
Pyramid Structural Concrete
Gerald Brennan
Bedford Industrial Park
Bedford, Nova Scotia
Canada
(902) 835-8337
Stanley Structures Limited
John Fowler
P.O. Box 1311
Brampton, Ontario, Canada
(416) 454-1311
- INDONESIA**
P.T. Beton
c/o P.T. MABA
Fred Haradiran
Dji. Sutan Sjahrir I.C.
Jakarta, Indonesia
- PUERTO RICO**
Relbec Corporation
Edgar Navas
1717 Hato Rey
Puerto Rico 00919
(809) 765-4370
- VENEZUELA**
Creamer & Denis, S.A.
Ivan Denis
Quinta MAREMI, Calle Madrid
Urb. Las Mercedes
Caracas, Venezuela
Phone: 91.42.07

Maybe you should be looking at a building product that can meet your delivery schedule...and your cost control requirements.

In today's scramble to save time and dollars, you need quick delivery from your suppliers so you can get buildings erected fast and economically. SPAN-DECK precast-prestressed hollow core concrete planks can help you in two ways.

First, SPAN-DECK manufacturers all across the United States and parts of Canada are meeting critical delivery deadlines. The product is there when you need it. But getting SPAN-DECK planks is only half the fun. The other half is seeing how quickly they go into place. Buildings erected with SPAN-DECK go up significantly faster than those built with other materials. And the sooner the building is completed, the lower overhead costs tend to be. Owners start realizing a return sooner too.

The second way building with the SPAN-DECK system can help you is in cost control. Prices of major building supplies have skyrocketed over the past few months. The cost of building with SPAN-DECK products hasn't. With rising materials costs, you look for savings anywhere you can get them.

Compare the cost of SPAN-DECK versus building with other materials.

SPAN-DECK planks are more economical for you several ways. And you don't sacrifice structural soundness for economy. Call a SPAN-DECK manufacturer. He'd be glad to review your building plans and then show you how and where you can save money using the SPAN-DECK system.

SPAN-DECK planks are available in 4' and 8' widths with lengths varying according to application. See our catalog in Sweet's Architectural File and Sweet's Canadian Construction File.

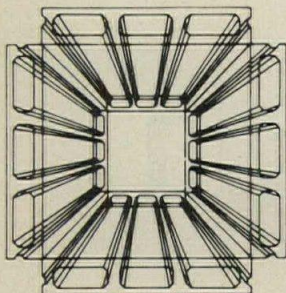

SPAN-DECK®
Prestressed Hollow Core Concrete Planks

For more data, circle 134 on inquiry card

Sanspray, the beautiful alternative.

Sure, concrete and masonry are OK. But you know what they cost. Not to mention how much trouble they are.

You have a beautiful alternative. Sanspray®. A plywood siding with decorative stones bonded onto it.

So you can forget about cement trucks or heavy pre-cast panels. Sanspray is light and easy for men to handle and install on the job site. Sanspray panels cut readily with a power saw and they go up easily with

a glue gun or a hammer and nails.



Sanspray is durable. The substrate is 3/8" exterior grade plywood. (Sanspray Shadowline™ is bonded to 5/8" plywood.) In fact, it meets the requirements of FHA/HUD and the major codes for single-wall applications.

Sanspray doesn't need finishing and is virtually maintenance-free. (We're sure. We



industrial complexes.

Medical centers and hospitals. Schools and universities.

Use it outside. As a siding, skirting or facade. Or use it

tested it in all kinds of climates for ten years.)

Sanspray comes in Regular, Large and Jumbo size aggregates. And Sanspray Shadowline, which is a regular aggregate panel with vertical grooves spaced eight inches on center.

It comes in eight rich colors. Like Salt and Pepper, Gaelic Green, Monterey Sand and Tangerine.

So it gives you a lot of ways to make a lot of things beautiful.

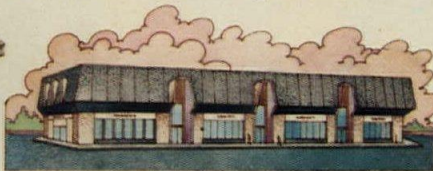

Homes for instance. (It's a natural for a Tudor.) Townhouses and condominiums. Stores and shopping centers. Factories and

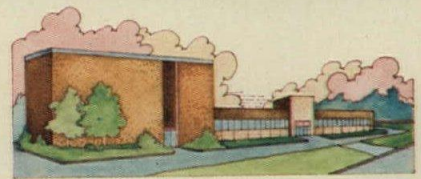
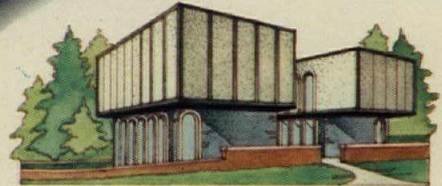

inside. In lobbies, waiting rooms and public rooms.

In fact, for just about anything you want to make beautiful, you should use Sanspray, the beautiful alternative.

Find out more about it at your U.S. Plywood Branch Office.



EXTERIOR
CLADDING BY

U.S. Plywood

777 Third Avenue, New York, N.Y. 10017

 **U.S. Plywood**
Division of Champion International

For more data, circle 139 on inquiry card

People come in different sizes. So should chairs.

Small
Work Chair



Work Stool



Medium
Work Chair



Medium Chair



to be Antron[®] nylon. look to last.

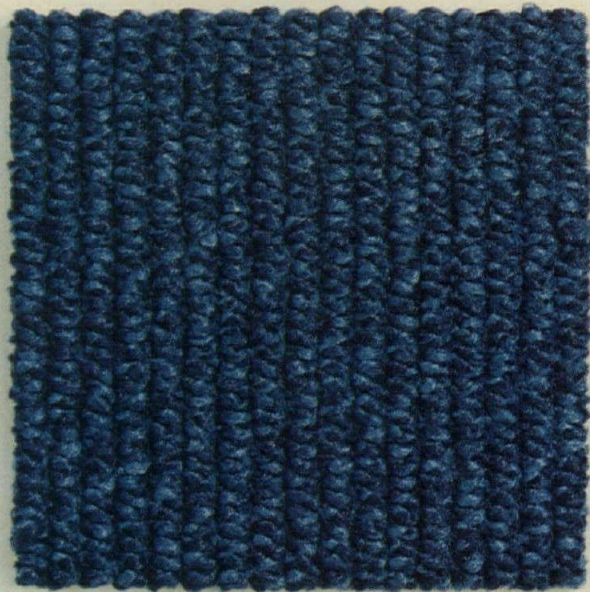

What you see is what you'll get for a long time. "Antron" is a soil-hiding carpet fiber. It is the leading commercial carpet fiber brand with more than twice the available styles in "Antron" than those made of the next brand. Its ability to diffuse light helps blend soil concentrations into the overall look of the carpet (normally they would show up as spots). Also, being nylon, "Antron" gives carpet exceptional durability and crush resistance.

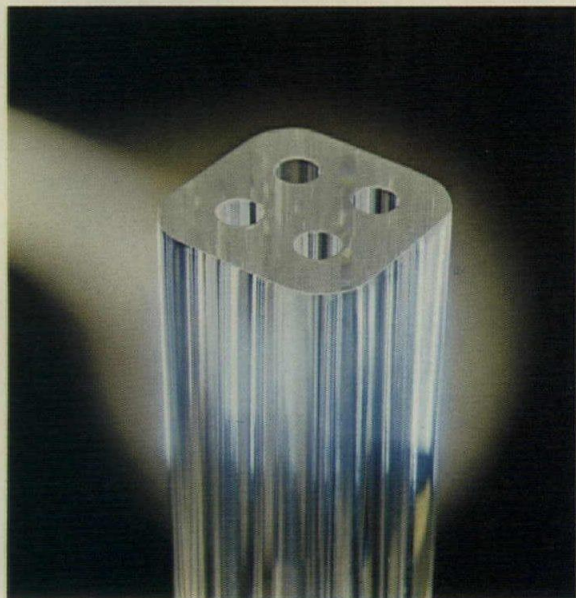

How "Antron" keeps carpet looking fresh. Its filament structure is remarkable, as simulated in this greatly enlarged model. The four microscopic holes scatter light to minimize rather than magnify the dulling effects of soil, while maintaining an attractive, subdued luster. This property of the fiber, together with its outstanding wearability, helps the look of the carpet to last.



For more data, circle 137 on inquiry card

General Telephone & Electronics Corporation wanted commercial carpet that didn't look commercial, a style to complement the distinctive architecture of their new world headquarters in Stamford, Conn. At the same time GTE wanted to take full advantage of the long-term appearance retention inherent in carpet with pile of Antron* nylon. From the wide variety of styles now available in "Antron" they specified this ribbed-texture construction in four custom colors for a total of 35,000 sq. yds.

NEW: "Antron" III nylon for static control is now available in selected styles.

*Du Pont registered trademark. Du Pont makes fibers, not carpets.

Alcoa EZ Wall. A vertically textured facing that adds zest to wall surfaces.

The basic unit is a 12-in. striated aluminum extrusion. But there's no stereotype, no standard effect of these ribbed planks. Do you want a random effect? Alcoa® EZ Wall achieves it for you on fascia, interior wall decor, spandrels, column covers, or as curtainwall facing. If you seek a highly disciplined pattern, EZ Wall can achieve that, too, depending on the modular mix of components and colors chosen by the designer.

The point is, it's individual. Re-

strained or free. A modular surface that goes with you. Complements surrounding architecture. Enhances the vertical dimension of the building. Available in Alumilite* finish, Duranodic* bronze tones, or the brighter palette of Super Alunalure® colors. And, surprisingly low in installed cost.

For detailed information, send for our EZ Wall brochure. Write to Aluminum Company of America, 1035-F Alcoa Building, Pittsburgh, PA 15219.

*Trade Name

For more data, circle 138 on inquiry card



Change for the better with
Alcoa Aluminum

 **ALCOA**

INTERIOR SPACES DESIGNED BY ARCHITECTS

The First Comprehensive Collection of Living and Working Interior Environments Created by Architects.

Gathered from the pages of Architectural Record, this book contains outstanding interiors for a full range of residential and non-residential buildings. Included are:

- Interiors for Civic and Community Use
- Interiors for Teaching
- Interiors for Worship
- Interiors for Business
- Interiors for Selling and Display
- Interiors for the Performing Arts
- Interiors for Living

Just Published

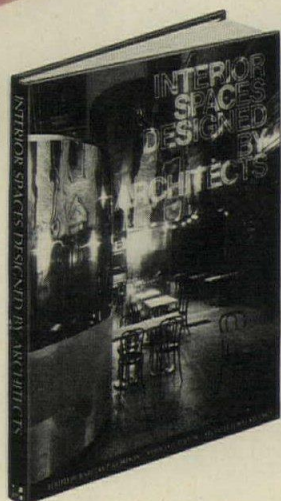

With more and more architects involved in interior design, this one volume contains some of the best, most recent examples of interior architectural design. Together, they constitute a visual and analytical definition of interiors . . . presenting fresh, striking, and imaginative ideas for both new and renovative construction . . . for the creative use of both old and new materials.

With 240 pages of text and photographs (many in four-color), this new and exciting book will be an important addition to the libraries of all professionals interested in "both sides of the wall."

To order your copy, use the handy coupon below or mail your request to Architectural Record Books, Box 682, Hightstown, New Jersey 08520.

Please send me _____ copy(ies) of INTERIOR SPACES DESIGNED BY ARCHITECTS @ \$22.50.

Name _____

Address _____

City _____ State _____ Zip _____

Architectural Record Books • 1221 Avenue of the Americas • New York, New York 10020

Lennox announces a major breakthrough in energy utilization.

Introducing the Lennox DMS4 multizone rooftop system, with exclusive Outside Air Discriminator.™

Here is one of the most versatile problem-solving machines in space heating and cooling... its efficiency and energy-conserving superiority challenge all other HVAC systems available today.

Feature 1: Exclusive Outside Air Discriminator™ automatically determines heating/cooling modes.

Which is more efficient: Cooling with outside air and heating with primary energy... or, cooling with mechanical refrigeration and reclaiming condenser heat for heating? The DMS4 makes the decision for you automatically. It trades Btu's available within the multizone system for maximum economy... and it reacts promptly when the efficiency of cooling with outdoor air is greater than the energy savings of condenser heat reclaim.

Feature 2: The DMS4 conserves energy.

The DMS4 continually monitors the ratio of heating input to cooling requirement, in order to operate at the lowest energy level.

Lennox DMS4 Multizone vs. Other Units.
RELATIVE POWER INPUT @ 45° OUTSIDE TEMP.
(4 zones, 2,000 cfm each. Typical supply air temperature requirements.)

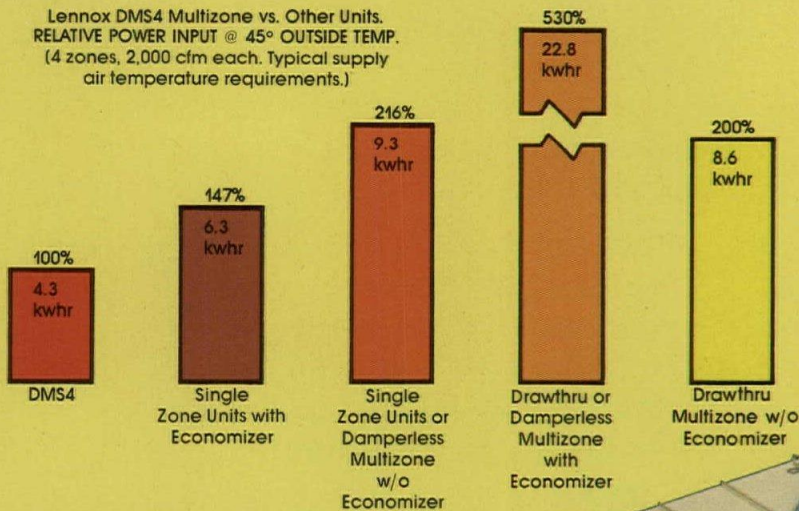

The DMS4 will show similar performance efficiencies at other typical outdoor air temperatures.

Discharge sensors are placed in zone heads for quick zone response. And the DMS4 solid-state electronic control system is designed for maximum dependability.

Feature 3: The DMS4 saves money.

This exceptional energy-conserving sensitivity is achieved without adding significantly to the unit cost, and results in lower operating costs.

Application Versatility.

Lennox DMS4 offers gas, electric, hot water, or steam heat. Seven models range from 16 to 45 tons cooling capacity.

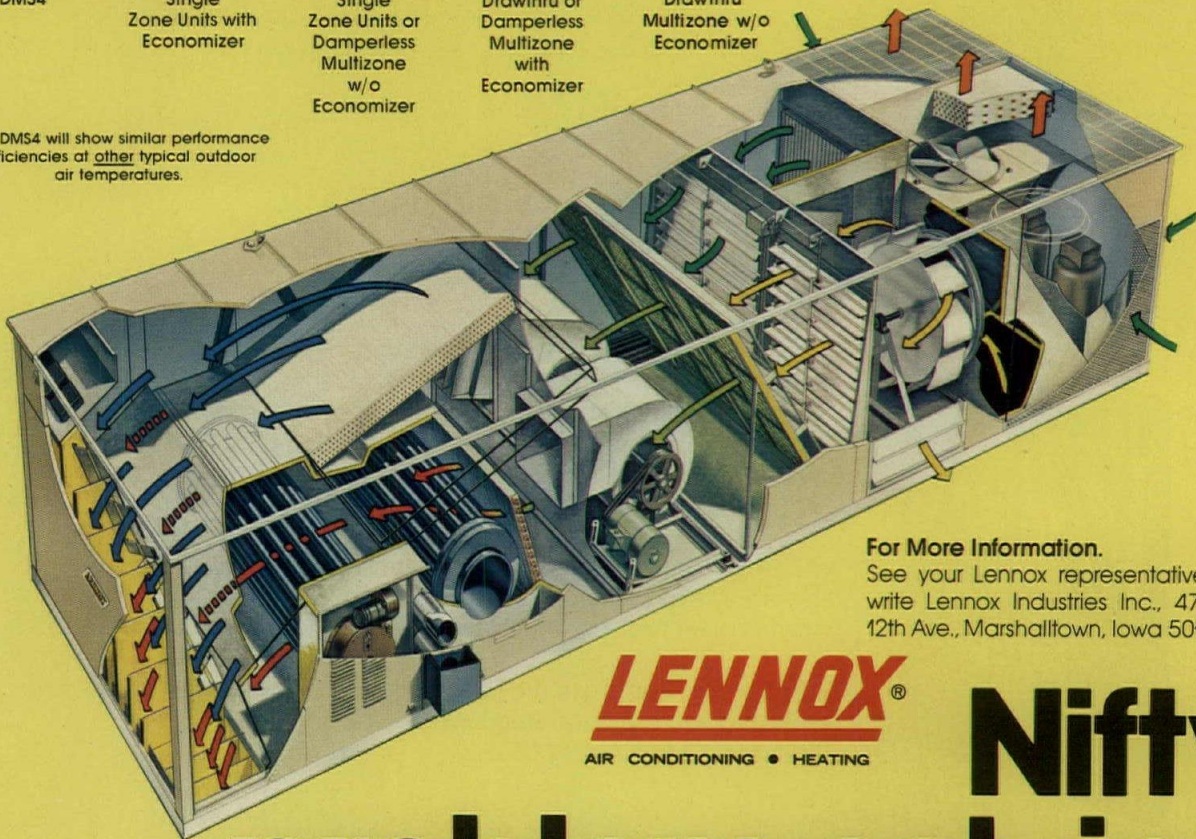

For More Information.

See your Lennox representative, or write Lennox Industries Inc., 471 S. 12th Ave., Marshalltown, Iowa 50158.

LENNOX[®]
AIR CONDITIONING • HEATING

Nifty problem-solving ideas from Lennox.

ARCHITECTURAL RECORD. Published by McGraw-Hill, Inc., 1221 Avenue of the Americas, New York, New York 10020. © 1974. All rights reserved.

Readers using the index will find buildings entered in three ways: by architect's name, by building or owner's name, and by building type (apartments, hospitals, schools, etc.). Other categories cover subjects in the engineering section (concrete, lighting, prefabrication, etc.). ABBREVIATIONS: AB—Architectural Business; AE—Architectural Engineering; BA—Building Activity; BTS—Building Types Study; CM—Construction Management.

A

- Adams, William residence, Roseau, Minn.; Thomas N. Larson, archt.—Mid-May 1974, BTS, pp. 76-77.
- Airpark Lodge, Reelfoot Lake State Park, Tiptonville, Tenn.; Gassner Nathan Browne, archts.—June 1974, pp. 95-97.
- Allegheny Commons, Pittsburgh, Pa.; Tasso G. Katselas, archt.—Mid-May 1974, BTS, p. 126.
- American University in Cairo library, Cairo, Egypt; Hugh Newell Jacobsen, archt.—May 1974, p. 120.
- Anatolia College "Gymnasium," Thessaloniki, Greece; Hugh Newell Jacobsen, archt.—May 1974, p. 121.
- Apartments. See Housing & Apartments.
- Architects Collaborative, Inc., (The) archts.; Church Park Apartments, Boston, Mass.—June 1974, pp. 105-110.
- Architectural Business. "Environmental impact analysis: tool for better design?," by Paul Buckhurst & Bradford Perkins—Feb. 1974, pp. 65-66. "The guaranteed maximum price: a sampling of views"—Apr. 1974, pp. 65-76. "Industry's plans for new plants and equipment"—June 1974, p. 65. "Job satisfaction: key to reduced A/E employee turnover" by H. Maynard Blumer—May 1974, pp. 65-67. "National growth policy: the AIA builds a strong new framework for action," Editorial by Walter F. Wagner, Jr.—Mar. 1974, pp. 13-14. "1974: Maybe this is a year that we find time to stop and think," Editorial by Walter F. Wagner, Jr.—Jan. 1974, pp. 13-14. "Organization for professional business development"—review-extract of the book *How to Market Professional Design Services*, by Gerre L. Jones—Mar. 1974, pp. 65-66. "Prior approval: architect's answer to the or-equal spec," by H. Maynard Blumer—Jan. 1974, pp. 73-77. Architectural Business. See also Building Activity, Construction Management.
- Architectural Education. "Pedagogical analogy: or, How beginning students at Berkeley learn the principles of design by redesigning familiar household objects"—May 1974, pp. 141-144.
- Architectural Engineering. "Designing and engineering computer controlled acoustic flexibility for a multiple-use theater," by George C. Izenour—Mar. 1974, pp. 143-148. "Engineers tailor structure's wind resistance to cut costs"—Feb. 1974, pp. 141-144. "Flexible electrical distribution for changing spaces"—Apr. 1974, pp. 153-156. "Floodlights in an open-plan school yield low-energy illumination"—Jan. 1974, pp. 157-160. "Prefabricated space trusses that are both rational and form-giving," Pt. 1—May 1974, pp. 161-164, Pt. 2—June 1974, pp. 141-144.
- Autheman, Michel and Nichole, archts.; La Colle-sur-Loup, France—Mar. 1974, pp. 98-99.
- Babcock, James & Donald Sandy, archts.; University Park,

- Ithaca, N.Y.—Mid-May 1974, BTS, pp. 124-125.
- Banks. Blaine Bank of Montana, Chinook, Mont.; Davidson & Kuhr, archts.—Jan. 1974, p. 110. Southern Bank of Ohio, Cincinnati, Ohio; RTKL Assocs., Inc., archts.—Jan. 1974, p. 116.
- Barnes, Edward Larrabee, archt.; Crown Center retail complex, Kansas City, Mo.—Apr. 1974, BTS, pp. 144-145.
- Baystate West Shopping Mall, Springfield, Mass.; Eduardo Catalano with Pietro Belluschi, archts.—Apr. 1974, BTS, pp. 142-143.
- Baywood, Newport Beach, Cal.; Fisher-Friedman Assocs., archts.—Mid-May 1974, BTS, pp. 114-117.
- Bedford Stuyvesant Community Pool, Brooklyn, N.Y.; Morris Lapidus, Assocs., archts.—June 1974, pp. 98-99.
- Belluschi, Pietro with Eduardo Catalano, archts.; Baystate West Shopping Mall, Springfield, Mass.—Apr. 1974, BTS, pp. 142-143.
- Betts, Hobart, archt.; Private residence, West Hampton, L.I., N.Y.—Mid-May 1974, BTS, pp. 94-97.
- Blaine Bank of Montana, Chinook, Mont.; Davidson & Kuhr, archts.—Jan. 1974, p. 110.
- Booth & Nagle, archts.; Private residence, Des Moines, Ia.—Mid-May 1974, BTS, pp. 50-51.
- Bower & Fradley, archts.; Market Street East Transportation Mall Center, Philadelphia, Pa.—Apr. 1974, BTS, pp. 146-149.
- Braccia, De Brer, Heglund, archts.; San Francisco Firehouse, San Francisco, Cal.—June 1974, BTS, pp. 138-140.
- Brixen & Christopher, archts.; Lodge at Snowbird, Snowbird, Utah—Mar. 1974, p. 123. Snowbird Base Tram Terminal, Village Plaza and Skiers' Bridge, Snowbird, Utah—Mar. 1974, p. 122.
- Broadway Plaza, Los Angeles, Cal.; Charles Luckman Assocs., archts.—Apr. 1974, BTS, pp. 138-141.
- Bromley, R. Scott, archt.; Western Union message center, New York, N.Y.—Jan. 1974, p. 120.
- Buckman Laboratories, Inc., Phase One, Memphis, Tenn.; Walk Jones + Francis Mah, Inc., archts.—Feb. 1974, BTS, p. 140.
- Building Activity. "Building materials: how severe are the shortages"—June 1974, p. 73. "Construction labor in 1974: the end of peaceful relations?"—May 1974, p. 73. "Construction outlook 1974: first update"—Apr. 1974, p. 79. "Energy and construction: where the troublespots lie"—Jan. 1974, p. 81. "Where we've been: 1973 in review"—Feb. 1974, p. 75. "Where we've been: regional roundup"—Mar. 1974, p. 75.
- Bull Field Volkmann Stockwell, archts.; Kirkwood Meadows Lodge, Lake Kirkwood, Cal.—Jan. 1974, BTS, pp. 148-149. Northstar-At-Tahoe, Cal.—Jan. 1974, BTS, pp. 142-147.

C

- Campbell, Aldrich & Nulty, archts.; Murdough Center, Dartmouth College, Hanover, N.H.—Feb. 1974, pp. 109-112.
- Campbell, Yost & Grube & Partners, archts.; Warn Industries plant, Milwaukee, Ore.—Feb. 1974, BTS, p. 130.
- Canada. Hamilton Place, Hamilton, Ontario, Canada; Trever P. Garwood-Jones, archts.—May 1974, pp. 111-116.
- Cap-d'Agde, France; Jean Le Couteur, archt.—Mar. 1974, p. 110.
- Catalano, Eduardo, archt.; Greensboro North Carolina Government Center, Greensboro, N.C.—June 1974, BTS, pp. 130-133.
- Catalano, Eduardo with Pietro Belluschi, archts.; Baystate West Shopping Mall, Springfield, Mass.—Apr. 1974, BTS, pp. 142-143.
- Caudill Rowlett Scott, archts.; Edwin Thomas Performing Arts Hall, University of Akron, Akron, Ohio—Mar. 1974, AE, pp. 143-148.

- Caudill Rowlett Scott, Koetter, Tharp & Cowell, Neuhaus + Taylor, archts.; JVIII, a joint venture; Hyatt Regency Hotel, Houston, Tex.—May 1974, BTS, pp. 152-160.
- Chipper Machines & Engineering Co., Portland, Ore.; John Thodos, archt.—Feb. 1974, BTS, p. 131.
- Christie Village Condominiums, Beech Mountain, Banner Elk, N.C.; Frank Schlesinger, archt.—Mid-May 1974, BTS, pp. 110-113.
- Chubb Building, 100 William Street, New York, N.Y.; Davis Brody & Assocs., archts.—Mar. 1974, BTS, pp. 138-139.
- Church Park Apartments, Boston, Mass.; The Architects Collaborative, Inc., archts.—June 1974, pp. 105-110.
- Churches. See Religious Buildings.
- Cité Marine de Port La Galère, Riviera, France; Jacques Couelle, archt.—Mar. 1974, p. 105.
- City Planning. See Planning.
- Cochiti Lake Recreation Center, Cochiti, N.M.; Frank O. Gehry & Assocs., archts.—June 1974, pp. 100-101.
- La Colle-sur-Loup, France; Michel and Nichole Autheman, archts.—Mar. 1974, pp. 98-99.
- College Buildings. See University & College Buildings.
- Construction Management. "An architect's notes on construction management," by J. Karl Justin—Jan. 1974, pp. 75-77. "Budgeting method: key to top building value," by Corwin P. Vansant, series from CM Assocs.—Feb. 1974, pp. 69-70. "Dodge issues new cost control guide"—June 1974, pp. 67-69. "Let's define construction management," by George T. Heery—Mar. 1974, pp. 69-71. "Project purchasing strategy: CM tool for cost control," by Charles B. Thomsen, series from CM Assocs.—May 1974, CM, pp. 69-70, 192.
- Corbett, Harrison & MacMurray, archts.; Rockefeller Center, First Campaign, New York, N.Y.—Mar. 1974, BTS, pp. 128-133.
- Couelle, Jacques, archt.; Cité Marine de Port La Galère, Riviera, France—Mar. 1974, p. 105.
- Crites & McConnell, archts.; Len Walworth residence, Burlington, Ia.—Mid-May 1974, BTS, pp. 62-63.
- Crown Center retail complex, Kansas City, Mo.; Edward Larrabee Barnes, archt.—Apr. 1974, BTS, pp. 144-145.
- Cuetara, Edward, archt.; Wollner residence, Chilmark, Mass.—Mid-May 1974, BTS, pp. 104-105.
- Cullman Courts, Yale University, New Haven, Conn.; Herbert S. Newman Assocs., archts.—Jan. 1974, p. 111.

D

- Dartmouth College, Murdough Center, Hanover, N.H.; Campbell, Aldrich & Nulty, archts.—Feb. 1974, pp. 109-112.
- Davidson & Kuhr, archts.; Blaine Bank of Montana, Chinook, Mont.—Jan. 1974, p. 110.
- Davis, Brody & Assocs., archts.; Lambert Houses, Bronx Park Urban Renewal Area, Bronx, N.Y.—Jan. 1974, pp. 133-140. 100 William Street (Chubb Building), New York, N.Y.—Mar. 1974, BTS, pp. 138-139.
- Detti, Eduardo, archt.; "The new architecture of Florence"—Feb. 1974, pp. 95-108.
- Dimitrijevic, Jean, archt.; Marines de Cogolin, France—Mar. 1974, pp. 108-109.
- Dow Chemical Co's Midland Div., Mich.; HOK Assocs., archts.—Feb. 1974, BTS, pp. 128-129.

E

- Ebert, archt.; Student housing, University of Munich, Germany—Mar. 1974, p. 102.
- Editorials. "Energy conservation standards: too much, too fast?," by Walter F. Wagner, Jr.—May 1974, pp. 13-14. "The more we know about housing shortages, the worse it gets," by Walter F. Wagner, Jr.—Feb. 1974, p. 13. "National growth policy: the AIA builds a strong new frame-

work for action," by Walter F. Wagner, Jr.—Mar. 1974, pp. 13-14. "1974: Maybe this is a year that we find time to stop and think," by Walter F. Wagner, Jr.—Jan. 1974, pp. 13-14. "Those Guiding Principles gonna rise again! And let's hope soon," by Walter F. Wagner, Jr.—June 1974, pp. 13-14. "What can we do about housing the world's urban poor? we can try. And here's one way," by Blake Hughes—Apr. 1974, pp. 13-14.

Educational Facilities. See Schools, University & College Buildings.

Eggers Partnership, archts.; Schaefer's Lehigh Valley Brewery, Allentown, Pa.—Feb. 1974, BTS, pp. 138-139.

Egypt. Library for the American University in Cairo, Cairo, Egypt; Hugh Newell Jacobsen, archt.—May 1974, p. 120.

Eisenman, Peter, archt.; "Should anyone care about the 'New York Five'? . . . or about their critics, the 'Five on Five'?" by Paul Goldberger—Feb. 1974, pp. 113-116.

El Zoghby, Gamal, archt.; Private apartment, New York, N.Y.—Jan. 1974, pp. 108-109.

Elkhorn at Sun Valley, Sun Valley, Idaho; Killingsworth, Brady & Assocs., archts.—Jan. 1974, BTS, pp. 150-156.

Energy Conservation. "Energy and construction: where the trouble-spots lie"—Jan. 1974, BA, p. 81. "Energy conservation standards: too much, too fast?," Editorial by Walter F. Wagner, Jr.—May 1974, pp. 13-14.

Engle residence, Boxboro, Mass.; Robert Whitton, archt.—Mid-May 1974, BTS, pp. 88-89

Enteleki Architecture, Planning, Research, archts.; Cliff Lodge at Snowbird, Snowbird, Utah—Mar. 1974, p. 124. Mid Gad Valley Restaurant, Snowbird, Utah—Mar. 1974, p. 125. Snowbird Lodges IV and V, Snowbird, Utah—Mar. 1974, p. 126.

F

Faller, Peter & Helmut Schröder, archts.; Neugereut, Stuttgart, Germany—Mar. 1974, p. 101. Wohnanlage Tapachstrasse, Stuttgart, Germany—Mar. 1974, p. 100.

Feibes & Schmitt, archts.; Police Headquarters, Schenectady, N.Y.—June 1974, BTS, pp. 136-137.

Fisher-Friedman Assocs., archts.; Baywood, Newport Beach, Cal.—Mid-May 1974, BTS, pp. 114-117.

Foreign Architecture. See individual country.

Fowler, John, archt.; Harold's Restaurant, New Haven, Conn.—Jan. 1974, pp. 118-119.

Fraga & Assocs. of Miami, archts.; One Biscayne Tower, Miami, Fla.—Feb. 1974, AE, pp. 141-144.

France, Cap-d'Agde; Jean Le Couteur, archt.—Mar. 1974, p. 110. Cité Marine de Port La Galère, Riviera; Jacques Couelle, archt.—Mar. 1974, p. 105. La Colle-sur-Loup; Michel and Nichole Autheman, archts.—Mar. 1974, pp. 98-99. Marina Baie des Anges, Riviera; André Minangoy, archt.—Mar. 1974, p. 104. Marines de Cogolin; Jean Dimitrijovic, archt.—Mar. 1974, pp. 108-109. Port Grimaud; François Spoerry, archt.—Mar. 1974, pp. 106-107.

Frog Hollow barn remodeling, southern Mich.; Stanely Tigerman & Assocs., archts.—June 1974, pp. 120-122.

G

Garwood-Jones, Trevor P., archts.; Hamilton Place, Hamilton, Ontario, Canada—May 1974, pp. 111-116.

Gassner Nathan Browne, archts.; Airpark Lodge, Reelfoot Lake State Park, Tiptonville, Tenn.—June 1974, pp. 95-97.

Gehry, Frank O. & Assocs., archts.; Cochiti Lake Recreation Center, Cochiti, N.M.—June 1974, pp. 100-101.

Germany. Neugereut, Stuttgart; Peter Faller & Helmut Schröder, archts.—Mar. 1974, p. 101. Olympic Village, Munich; Heinle, Wischer & Partner, archts.—Mar. 1974, p. 103. Student housing, University of Munich, Germany; Ebert, archt.—Mar. 1974, p. 102. Wohnanlage Tapachstrasse, Stuttgart; Peter Faller & Helmut Schroder, archts.—Mar. 1974, p. 100.

Goldfinger, Myron, archt.; Private residence, Bedford, N.Y.—Mid-May 1974, BTS, pp. 68-70.

Graham, Bruce Campbell, archt.; Harvey Hubbell Corporate Headquarters, Orange, Conn.—Apr. 1974, pp. 122-126.

Graves, Michael, archt.; "Should anyone care about the 'New York Five'? . . . or about their critics, the 'Five on Five'?" by Paul Goldberger—Feb. 1974, pp. 113-116.

Greece. "Gymnasium" for Anatolia College, Thessaloniki, Greece; Hugh Newell Jacobsen, archt.—May 1974, p. 121. Library for Pierce College, Athens, Greece; Hugh Newell Jacobsen, archt.—May 1974, p. 121.

Greensboro North Carolina Government Center, Greens-

boro, N.C.; Eduardo Catalano, archt.—June 1974, BTS, pp. 130-133.

Gwathmey-Siegel, archts.; Barn renovation, Greenwich, Conn.—Jan. 1974, pp. 114-115. Meadow Mall, Simsbury, Conn.—Apr. 1974, BTS, pp. 150-152. "Should anyone care about the 'New York Five'? . . . or about their critics, the 'Five on Five'?" by Paul Goldberger—Feb. 1974, pp. 113-116.

H

HOK Assocs., archts.; Dow Chemical Co.'s Midland Div., Mich.—Feb. 1974, BTS, pp. 128-129. Hospital Linen Services, Inc., Central Laundry, Kansas City, Kan.—Feb. 1974, BTS, p. 127. John S. Lehmann Building, Shaw's Garden, St. Louis, Mo.—June 1974, pp. 111-116.

Half Moon Bay Hotel Golf Club, St. Johns, Antigua, West Indies; Hugh Newell Jacobsen, archt.—May 1974, p. 122.

Hamilton Place, Hamilton, Ontario, Canada; Trevor P. Garwood-Jones, archts.—May 1974, pp. 111-116.

Harold's Restaurant, New Haven, Conn.; John Fowler, archt.—Jan. 1974, pp. 118-119.

Harper & Row office, New York, N.Y.; Smotrich & Platt, archts.—Jan. 1974, pp. 105-107.

Harrison, Abramovitz & Harris, archts.; Rockefeller Center: Second Campaign—Exxon Building, McGraw-Hill Building, Celanese Building, New York, N.Y.—Mar. 1974, BTS, pp. 134-137.

Harvard University, Undergraduate Science Center and Chilled Water Plant, Cambridge, Mass.; Sert Jackson & Assocs., Inc., archts.—Mar. 1974, pp. 111-118.

Hedjuk, John, archt.; "Should anyone care about the 'New York Five'? . . . or about their critics, the 'Five on Five'?" by Paul Goldberger—Feb. 1974, pp. 113-116.

Heinle, Wischer & Partner, archts.; Olympic Village, Munich, Germany—Mar. 1974, p. 103.

Hellmuth, Obata & Kassabaum, archts. See HOK Assocs, archts.

Heublein Corporate Headquarters, Farmington, Conn.; Russell Gibson von Dohlen Inc., archts.—May 1974, pp. 136-140.

Holden Yang Raemsch Terjesen, archts.; Police Station, Queens, N.Y.—June 1974, BTS, pp. 134-135.

Hollis Middle School, New Hampshire; Michael B. Ingram, archt.—Jan. 1974, AE, pp. 157-160.

Hood & Foulhoux, archts.; Rockefeller Center: First Campaign, New York, N.Y.—Mar. 1974, BTS, pp. 128-133.

Hoover, George with Muchow Assocs., archts.; Park Central, Denver, Colo.—Apr. 1974, pp. 107-112.

Horton residence, Greenwich, Conn.; Eliot Noyes, archt.—Mid-May 1974, BTS, pp. 82-85.

Hospital Linen Services, Inc., Central Laundry, Kansas City, Kan.; HOK Assocs., archts.—Feb. 1974, BTS, p. 127.

Hotels & Motels. "New directions for downtown and suburban shopping centers," Building Types Study 459—Apr. 1974, pp. 137-152. "Convention hotels: an American hybrid in hotel design," Building Types Study 460—May 1974, pp. 145-160. Cliff Lodge at Snowbird, Snowbird, Utah; Enteleki Architecture, Planning, Research, archts.—Mar. 1974, p. 124. "Developing a hotel: clients and finances have changed," by William B. Tabler—May 1974, BTS, pp. 146-147. Half Moon Bay Hotel & Golf Club, St. Johns, Antigua, West Indies; Hugh Newell Jacobsen, archt.—May 1974, p. 122. Hyatt Regency Hotel, Houston, Tex.; JVIII, a joint venture of: Koetter, Tharp & Cowell, Caudill Rowlett Scott, Neuhaus + Taylor, archts.—May 1974, BTS, pp. 152-160. Lodge at Snowbird, Snowbird, Utah; Brixen & Christopher, archts.—Mar. 1974, p. 123. "Planning a hotel: segregate and contain functions"—May 1974, BTS, pp. 148-151. Snowbird Lodges IV and V, Snowbird, Utah; Enteleki Architecture, Planning, Research, archts.—Mar. 1974, p. 126.

Houses. "Record Houses of 1974," Building Types Study 461—Mid-May 1974, pp. 49-126. Adams, William residence, Roseau, Minn.; Thomas N. Larson, archt.—Mid-May 1974, BTS, pp. 76-77. Barn remodeling: Vollen barn, southern Wisc., Frog Hollow barn, southern Mich.; Stanley Tigerman & Assocs., archts.—June 1974, pp. 117-122. Barn renovation, Greenwich, Conn.; Gwathmey-Siegel, archts.—Jan. 1974, pp. 114-115. Cité Marine de Port La Galère, Riviera, France; Jacques Couelle, archt.—Mar. 1974, p. 105. La Colle-sur-Loup, France; Michel and Nichole Autheman, archts.—Mar. 1974, pp. 98-99. Engle residence, Boxboro, Mass.; Robert Whitton, archt.—Mid-May 1974, BTS, pp. 88-89. Four houses in the Hamptons, Long Island, N.Y.; Robert L. Rotner, archt.—May 1974, pp. 123-132. Horton residence, Greenwich, Conn.; Eliot Noyes, archt.—Mid-May 1974, BTS, pp. 82-85. Lovett

residence, Crane Island, Wash.; Wendell Lovett, archt.—Mid-May 1974, BTS, pp. 86-87. Moore, J. Hiram residence, Austin, Tex.; Robert Nichols, archt.—Mid-May 1974, BTS, pp. 76-77. Morgan residence, Atlantic Beach, Fla.; William Morgan, archt.—Mid-May 1974, BTS, pp. 64-67. "The new architecture of Florence"—Feb. 1974, pp. 95-108. Poliak, Saul residence, West Redding, Conn.; Joseph Salerno, archt.—Mid-May 1974, BTS, pp. 98-99. Port Grimaud, France; François Spoerry, archt.—Mar. 1974, pp. 106-107. Private residence, Armonk, N.Y.; Mayers & Schiff, archts.—Mid-May 1974, BTS, pp. 54-55. Private residence, Bedford, N.Y.; Myron Goldfinger, archt.—Mid-May 1974, BTS, pp. 68-70. Private residence, Darien, Conn.; Huygens & Tappé, Inc., archts.—Mid-May 1974, BTS, pp. 72-75. Private residence, Des Moines, Ia.; Booth & Nagle, archts.—Mid-May 1974, BTS, pp. 50-51. Private residence, upstate N.Y.; Twitchell & Miao, archts.—Mid-May 1974, BTS, pp. 56-59. Private residence, West Hampton, L.I., N.Y.; Hobart Betts, archt.—Mid-May 1974, BTS, pp. 94-97. Residence for Glen Nimnicht, Sea Ranch, Cal.; Fred L. Osmon, archt.—Apr. 1974, pp. 132-133. Residence for Mr. & Mrs. Henry O. Whiteside, Sea Ranch, Cal.; Donald Jacobs, archt.—Apr. 1974, pp. 134-136. Rovida residence, Pittsburgh, Pa.; Tasso G. Katselas, archt.—Mid-May 1974, BTS, pp. 90-91. Scores, Dr. Robert residence, Woodside, Cal.; Knorr-Elliott & Assocs., archts.—Mid-May 1974, BTS, pp. 92-93. Sobel residence, Houston, Tex.; Robert Sobel, archt.—Mid-May 1974, BTS, pp. 100-103. "Some housing in Europe—and some thoughts about options"—Mar. 1974, pp. 97-110. Walworth, Len residence, Burlington, Ia.; Crites & McConnell, archts.—Mid-May 1974, BTS, pp. 62-63. Whisnant residence, Charlotte, N. C.; Murray Whisnant, archt.—Mid-May 1974, BTS, pp. 60-61. Winston house, Lyme, N.H.; Donald Metz, archt.—Mid-May 1974, BTS, pp. 52-53. Woolner residence, Chilmark, Mass.; Edward Cuetara, archt.—Mid-May 1974, BTS, pp. 104-105.

Housing & Apartments. "Record Houses of 1974," Building Types Study 461—Mid-May 1974, p. 49-126. Allegheny Commons, Pittsburgh, Pa.; Tasso G. Katselas, archt.—Mid-May 1974, BTS, p. 126. Baywood, Newport Beach, Cal.; Fisher-Friedman Assocs., archts.—Mid-May 1974, BTS, pp. 114-117. Cap-d'Agde, France; Jean Le Couteur, archt.—Mar. 1974, p. 110. Christie Village Condominiums, Beech Mountain, Banner Elk, N.C.—Mid-May 1974, BTS, pp. 110-113. Church Park Apartments, Boston, Mass.; The Architects Collaborative, Inc., archts.—June 1974, pp. 105-110. La Colle-sur-Loup, France; Michel and Nichole Autheman, archts.—Mar. 1974, pp. 98-99. Indian Woods Apartments, East Lyme, Conn.; Rosenfeld, Harvey & Morse, archts.—Mid-May 1974, BTS, pp. 122-123. Lambert Houses, Bronx Park Urban Renewal Area, Bronx, N.Y.; Davis, Brody & Assocs., archts.—Jan. 1974, pp. 133-140. Marina Baie des Anges, Riviera, France; André Minangoy, archt.—Mar. 1974, p. 104. Marines de Cogolin, France; Jean Dimitrijovic, archt.—Mar. 1974, pp. 108-109. "The more we know about housing shortages, the worse it gets," Editorial by Walter F. Wagner, Jr.—Feb. 1974, p. 13. Neugereut, Stuttgart, Germany; Peter Faller & Helmut Schröder, archts.—Mar. 1974, p. 101. "The new architecture of Florence"—Feb. 1974, pp. 95-108. Olivetti dormitory building, Tarrytown, N.Y.; Richard Meier & Assocs., archts.—Feb. 1974, pp. 117-124. Olympic Village, Munich, Germany; Heinle, Wischer & Partner, archts.—Mar. 1974, p. 103. Orindawoods Apartments, Orinda, Cal.; Mackinlay, Winnacker, McNeil & Assocs., archts.—Mid-May 1974, BTS, pp. 108-109. Pennsylvania Avenue Housing, Washington, D.C.; Hugh Newell Jacobsen, archt.—May 1974, pp. 118-119. Private apartment, New York, N.Y.; Gamal El Zoghby, archt.—Jan. 1974, pp. 108-109. Raleigh Boardwalk Apartments, Portland, Ore.; Martin, Soderstrom, Matteson, archts.—Mid-May 1974, BTS, pp. 118-119. Sahalee Village, Redmond, Wash.; Mithun & Assocs., archts.—Mid-May 1974, BTS, pp. 120-121. "Some housing in Europe—and some thoughts about options"—Mar. 1974, pp. 97-110. Student housing, University of Munich, Germany; Ebert, archt.—Mar. 1974, p. 102. University Park, Ithaca, N.Y.; Donald Sandy & James Babcock, archts.—Mid-May 1974, BTS, pp. 124-125. "What can we do about housing the world's urban poor? We can try. And here's one way," Editorial by Blake Hughes—Apr. 1974, pp. 13-14. Wohnanlage Tapachstrasse, Stuttgart, Germany; Peter Faller & Helmut Schroder, archts.—Mar. 1974, p. 100.

Houvenier, Robert Mason, archt.; Thousand Oaks Civic Center, Thousand Oaks, Cal.—June 1974, BTS, pp. 123-129.

Hubbell, Harvey Corporate Headquarters, Orange, Conn.; Bruce Campbell Graham, archt.—Apr. 1974, pp. 122-126.
Huygens & Tappé, Inc., archts.; Private residence, Darien, Conn.—Mid-May 1974, BTS, pp. 72-75.
Hyatt Regency Hotel, Houston, Tex.; JVIII, a joint venture of: Koetter, Sharp & Cowell, Caudill Rowlett Scott, Neuhau + Taylor, archts.—May 1974, BTS, pp. 152-160.

I

Indian Woods Apartments, East Lyme, Conn.; Rosenfeld, Harvey & Morse, archts.—Mid-May 1974, BTS, pp. 122-123.
Industrial Buildings. "Industrial buildings: Good neighbors and good places to work as good business," Building Types Study 457—Feb. 1974, pp. 125-140. Buckman Laboratories—Phase One, Memphis, Tenn.; Walk Jones + Francis Mah, Inc., archts.—Feb. 1974, BTS, p. 140. Chipper Machines & Engineering Co., Portland, Ore.; John Thodos, archt.—Feb. 1974, BTS, p. 131. Dow Chemical Co.'s Midland Div., Mich.; HOK Assocs., archts.—Feb. 1974, BTS, pp. 128-129. Ford Motor Co., plant renewal; Smith, Hinchman & Grylls Inc., archts.—Feb. 1974, BTS, p. 126. Hospital Linen Services, Inc., Central Laundry, Kansas City, Kan.; HOK Assocs., archts.—Feb. 1974, BTS, p. 127. IBM production facility, Boulder, Colo.; Smith, Hinchman & Grylls Inc., archts.—Feb. 1974, BTS, p. 126. Roure Bertrand Dupont, Inc. offices, Teaneck, N.J.; Kahn & Jacobs, archts.—Jan. 1974, pp. 112-113. Roure, Bertrand Dupont, Inc., perfumery, Teaneck, N.J.; Kahn & Jacobs, archts.—Feb. 1974, BTS, pp. 134-135. Schaefer's Lehigh Valley Brewery, Allentown, Pa.; Eggers Partnership, archts.—Feb. 1974, BTS, pp. 138-139. Seiko Instruments, Inc., U.S. headquarters, Torrance, Cal.; Kajima Assocs., archts.—Feb. 1974, BTS, pp. 132-133. Warn Industries plant, Milwaukee, Ore.; Campell, Yost & Grube & Partners, archts.—Feb. 1974, BTS, p. 130. Westinghouse underground distribution transformer plant, Jefferson City, Mo.; Kivett & Myers, archts.—Feb. 1974, BTS, pp. 136-137.
Ingram, Michael B., archt.; Hollis Middle School, New Hampshire—Jan. 1974, AE, pp. 157-160.
Interiors. Barn renovation, Greenwich, Conn.; Gwathmey-Siegel, archts.—Jan. 1974, pp. 114-115. Blaine Bank of Montana, Chinook, Mont.; Davidson & Kuhr, archts.—Jan. 1974, p. 110. Cullman Courts, Yale University, New Haven, Conn.; Herbert S. Newman Assocs., archts.—Jan. 1974, p. 111. Harold's Restaurant, New Haven, Conn.; John Fowler, archt.—Jan. 1974, pp. 118-119. Harper & Row office, New York, N.Y.; Smotrich & Platt, archts.—Jan. 1974, pp. 105-107. Heublein Corporate Headquarters, Farmington, Conn.; Russell Gibson von Dohlen Inc., archts.—May 1974, pp. 136-140. Private apartment, New York, N.Y.; Gamal El Zoghby, archt.—Jan. 1974, pp. 108-109. "Record interiors of 1974"—Jan. 1974, pp. 105-120. Roure Bertrand Dupont, Inc., Teaneck, N.J.; Kahn & Jacobs, archts.—Jan. 1974, pp. 112-113. Seagram, Joseph E. offices, New York, N.Y.; Giovanni Pasanella Assocs., archts.—Jan. 1974, p. 117. Southern Bank of Ohio, Cincinnati, Ohio; RTKL Assocs., Inc., archts.—Jan. 1974, p. 116. Western Union message center, New York, N.Y.; R. Scott Bromley, archt.—Jan. 1974, p. 120.
Italy. "The new architecture of Florence"—Feb. 1974, pp. 95-108.

J

Jacobs, Donald, archt.; Residence for Mr. & Mrs. Henry O. Whiteside, Sea Ranch, Cal.—Apr. 1974, pp. 134-136.
Jacobsen, Hugh Newell, archt.; "Gymnasium" for Anatolia College, Thessaloniki, Greece—May 1974, p. 121. Half Moon Bay Hotel & Golf Club, St. Johns, Antigua, West Indies—May 1974, p. 122. Library for the American University in Cairo, Cairo, Egypt—May 1974, p. 120. Library for Pierce College, Athens, Greece—May 1974, p. 121. Pennsylvania Avenue Housing, Washington, D.C.—May 1974, pp. 118-119.
Jones, Walk + Francis Mah, Inc., archts.; Buckman Laboratories—Phase One, Memphis, Tenn.—Feb. 1974, BTS, p. 140.

K

Kahn & Jacobs, archts.; Roure Bertrand Dupont, Inc. offices, Teaneck, N.J.—Jan. 1974, pp. 112-113. Roure, Bertrand Dupont, Inc. perfumery, Teaneck, N.J.—Feb. 1974, BTS,

pp. 134-135.
Kajima Assocs., archts.; Seiko Instruments, Inc., U.S. headquarters, Torrance, Cal.—Feb. 1974, BTS, pp. 132-133.
Katselas, Tasso G., archt.; Allegheny Commons, Pittsburgh, Pa.—Mid-May 1974, BTS, p. 126. Rovida residence, Pittsburgh, Pa.—Mid-May 1974, BTS, pp. 90-91.
Killingsworth, Brady & Assocs., archts.; Elkhorn at Sun Valley, Sun Valley, Idaho—Jan. 1974, BTS, pp. 150-156.
Kirkwood Meadows Lodge, Lake Kirkwood, Cal.; Bull Field Volkmann Stockwell, archts.—Jan. 1974, BTS, pp. 148-149.
Kivett & Myers, archts.; Westinghouse underground distribution transformer plant, Jefferson City, Mo.—Feb. 1974, BTS, pp. 136-137.
Knorr-Elliott & Assocs., archts.; Dr. Robert Scoren residence, Woodside, Cal.—Mid-May 1974, BTS, pp. 92-93.
Koetter, Sharp & Cowell, Caudill Rowlett Scott, Neuhau + Taylor, archts.; JVIII, a joint venture; Hyatt Regency Hotel, Houston, Tex.—May 1974, BTS, pp. 152-160.

L

Lambert Houses, Bronx Park Urban Renewal Area, Bronx, N.Y.; Davis, Brody & Assocs., archts.—Jan. 1974, pp. 133-140.
Lapidus, Morris, Assocs., archts.; Bedford Stuyvesant Community Pool, Brooklyn, N.Y.—June 1974, pp. 98-99.
Larson, Thomas N., archt.; Adams, William residence, Roseau, Minn.—Mid-May 1974, BTS, pp. 76-77.
Le Couteur, Jean, archt.; Cap-d'Agde, France—Mar. 1974, p. 110.
Lovett, Wendell, archt.; Lovett residence, Crane Island, Wash.—Mid-May 1974, BTS, pp. 86-87.
Luckman, Charles Assocs., archts., Broadway Plaza, Los Angeles, Cal.—Apr. 1974, BTS, pp. 138-141.

M

Mackinlay, Winnacker, McNeil & Assocs., archts.; Orindawoods Apartments, Orinda, Cal.—Mid-May 1974, BTS, pp. 108-109.
Mah, Francis, Inc. + Walk Jones, archts.; Buckman Laboratories—Phase One, Memphis, Tenn.—Feb. 1974, BTS, p. 140.
Marines de Cogolin, France; Jean Dimitrijovic, archt.—Mar. 1974, pp. 108-109.
Market Street East Transportation Mall Center, Philadelphia, Pa.; Bower & Fradley, archts.—Apr. 1974, BTS, pp. 146-149.
Martin, Soderstrom, Matteson, archts.; Raleigh Boardwalk Apartments, Portland, Ore.—Mid-May 1974, BTS, pp. 118-119.
Mayers & Schiff, archts.; Private residence, Armonk, N.Y.—Mid-May 1974, BTS, pp. 54-55.
Meadow Mall, Simsbury, Conn.; Gwathmey-Siegel, archts.—Apr. 1974, BTS, pp. 150-152.
Meier, Richard & Assocs., archts.; Olivetti branch office, Washington, D.C., branch office prototype "A", branch office prototype "B", dormitory building, Tarrytown, N.Y.—Feb. 1974, pp. 117-124. "Should anyone care about the 'New York Five'? . . . or about their critics, the 'Five on Five'?" by Paul Goldberger—Feb. 1974, pp. 113-116.
Metz, Donald, archt.; Winston house, Lyme, N.H.—Mid-May 1974, BTS, pp. 52-53.
Mithun & Assocs., archts.; Sahalee Village, Redmond, Wash.—Mid-May 1974, BTS, pp. 120-121.
Moore, J. Hiram residence, Austin, Tex.; Robert Nichols, archt.—Mid-May 1974, BTS, pp. 76-77.
Morgan, William, archt.; Morgan residence, Atlantic Beach, Fla.—Mid-May 1974, BTS, pp. 64-67.
Motels. See Hotels & Motels.
Muchow Assocs. with George Hoover, archts.; Park Central, Denver, Colo.—Apr. 1974, pp. 107-112.
Murdough Center, Dartmouth College, Hanover, N.H.; Campbell, Aldrich & Nulty, archts.—Feb. 1974, pp. 109-112.

N

Neugereut, Stuttgart, Germany; Peter Faller & Helmut Schröder, archts.—Mar. 1974, p. 101.
Neuhau + Taylor, Koetter, Sharp & Cowell, Caudill Rowlett Scott, archts.; JVIII, a joint venture; Hyatt Regency Hotel, Houston, Tex.—May 1974, BTS, pp. 152-160.
Newman, Herbert S. Assocs., archts.; Cullman Courts, Yale University, New Haven, Conn.—Jan. 1974, p. 111.

Nichols, Robert, archt.; J. Hiram Moore residence, Austin, Tex.—Mid-May 1974, BTS, pp. 76-77.
North Carolina Blue Cross and Blue Shield Headquarters, Durham, N.C.; Odell Assocs., Inc., archts.—May 1974, pp. 134-135.
Northstar-At-Tahoe, Cal.; Bull Field Volkmann Stockwell, archts.—Jan. 1974, BTS, pp. 142-147.
Noyes, Eliot, archt.; Horton residence, Greenwich, Conn.—Mid-May 1974, BTS, pp. 82-85.

O

Odell Assocs., Inc., archts.; North Carolina Blue Cross and Blue Shield Headquarters, Durham, N.C.—May 1974, pp. 134-135.
Office Buildings. "High-rise office buildings—the public spaces they make," Building Types Study 458—Mar. 1974, pp. 127-142. "New directions for downtown and suburban shopping centers," Building Types Study 459—Apr. 1974, pp. 137-152. "The future of the office building," by Jonathan Barnett—Apr. 1974, pp. 127-130. Heublein Corporate Headquarters, Farmington Conn.; Russell Gibson von Dohlen Inc., archts.—May 1974, pp. 136-140. Hubbell, Harvey Corporate Headquarters, Orange, Conn.; Bruce Campbell Graham, archt.—Apr. 1974, pp. 122-126. "The new architecture of Florence"—Feb. 1974, pp. 95-108. North Carolina Blue Cross and Blue Shield Headquarters Building, Durham, N.C.; Odell Assocs., Inc., archts.—May 1974, pp. 134-135. Olivetti branch office, Washington, D.C., branch office prototype "A", branch office prototype "B", Tarrytown, N.Y.; Richard Meier & Assocs., archts.—Feb. 1974, pp. 117-124. One Biscayne Tower, Miami, Fla.; Fraga & Assocs. of Miami, archts.—Feb. 1974, AE, pp. 141-144. 100 William Street (Chubb Building), New York, N.Y.; Davis, Brody & Assocs., archts.—Mar. 1974, BTS, pp. 138-139. Park Central, Denver, Colo.; Muchow Assocs. with George Hoover, archts.—Apr. 1974, pp. 107-112. Rockefeller Center: First Campaign, New York, N.Y.; Reinhard & Hofmeister; Corbett, Harrison & MacMurray; and Hood & Foulhoux, archts.—Mar. 1974, BTS, pp. 128-133. Rockefeller Center: Second Campaign—Exxon Building, McGraw-Hill Building, Celanese Building, New York, N.Y.; Harrison & Abramovitz & Harris, archts.—Mar. 1974, BTS, pp. 134-137. Smith, Hinchman & Grylls headquarters, Detroit, Mich.; Smith, Hinchman & Grylls Inc., archts.—Apr. 1974, pp. 120-121. World Trade Center, New York, N.Y.; Minoru Yamasaki & Emery Roth & Sons, archts.—Mar. 1974, BTS, pp. 140-142.
Office Practice. See Architectural Business.
Offices. Harper & Row, New York, N.Y.; Smotrich & Platt, archts.—Jan. 1974, pp. 105-107. Roure Bertrand Dupont, Inc., Teaneck, N.J.; Kahn & Jacobs, archts.—Jan. 1974, pp. 112-113. Seagram, Joseph E. offices, New York, N.Y.; Giovanni Pasanella Assocs., archts.—Jan. 1974, p. 117. Smith, Hinchman & Grylls headquarters, Detroit, Mich.; Smith, Hinchman & Grylls Inc., archts.—Apr. 1974, pp. 120-121. Western Union message center, New York, N.Y.; R. Scott Bromley, archt.—Jan. 1974, p. 120. Olivetti branch office, Washington, D.C., branch office prototype "A", branch office prototype "B", dormitory building, Tarrytown, N.Y.; Richard Meier & Assocs., archts.—Feb. 1974, pp. 117-124.
Olympic Village, Munich, Germany; Heinle, Wischer & Partner, archts.—Mar. 1974, p. 103.
Orindawoods Apartments, Orinda, Cal.; Mackinlay, Winnacker, McNeil & Assocs., archt.—Mid-May 1974, BTS, pp. 108-109.
Osmon, Fred L., archt.; Residence for Glen Nimnicht, Sea Ranch, Cal.—Apr. 1974, pp. 132-133.

P

Park Central, Denver, Colo.; Muchow Assocs. with George Hoover, archts.—Apr. 1974, pp. 107-112.
Pasanella, Giovanni Assocs., archts.; Joseph E. Seagram offices, New York, N.Y.—Jan. 1974, p. 117.
Pennsylvania Avenue Housing, Washington, D.C.; Hugh Newell Jacobsen, archt.—May 1974, pp. 118-119.
Performing Arts Buildings. Hamilton Place, Hamilton, Ontario, Canada; Trevor P. Garwood-Jones, archts.—May 1974, pp. 111-116. Thomas, Edwin Performing Arts Hall, University of Akron, Akron, Ohio; Caudill Rowlett Scott, archts.—Mar. 1974, AE, pp. 143-148.
Pierce College Library, Athens, Greece; Hugh Newell Jacobsen, archt.—May 1974, p. 121.
Planning. "Land use planning and design for ski resorts," Building Types Study 456—Jan. 1974, pp. 141-156. Elkhorn at Sun Valley, Sun Valley, Idaho; Killingsworth,

- Brady & Assocs., archts.—Jan. 1974, BTS, pp. 150-156. "Helping downtown compete with the suburbs," by Jonathan Barnett—Jan. 1974, pp. 127-132. Lambert Houses, Bronx Park Urban Renewal Area, Bronx, N.Y.; Davis, Brody & Assocs., archts.—Jan. 1974, pp. 133-140. "National growth policy: the AIA builds a strong new framework for action," Editorial by Walter F. Wagner, Jr.—Mar. 1974, pp. 13-14. "The new architecture of Florence"—Feb. 1974, pp. 95-108. Northstar-At-Tahoe, Calif.; Bull Field Volkman Stockwell, archts.—Jan. 1974, BTS, pp. 142-147. "Snowbird: in scale with the mountains"—Mar. 1974, pp. 119-126.
- Poliak, Saul residence, West Redding, Conn.; Joseph Salerno, archt.—Mid-May 1974, BTS, pp. 98-99.
- Police Headquarters, Schenectady, N.Y.; Feibes & Schmitt, archts.—June 1974, BTS, pp. 136-137.
- Police Station, Queens, N.Y.; Holden Yang Raemisch Terjesen, archts.—June 1974, BTS, pp. 134-135.
- Port Grimaud, France; François Spoerry, archt.—Mar. 1974, pp. 106-107.
- Portland Jewish Center, Portland, Ore.; Wolff Zimmer Gunsul Ritter Frasca, archts.—June 1974, pp. 102-104.
- Public Buildings. "Public Buildings," Building Types Study 462, June 1974, pp. 123-140. Greensboro North Carolina Government Center, Greensboro, N.C.; Eduardo Catalano, archt.—June 1974, BTS, pp. 130-133. Police Headquarters, Schenectady, N.Y.; Feibes & Schmitt, archts.—June 1974, BTS, pp. 136-137. Police Station, Queens, N.Y.; Holden Yang Raemisch Terjesen, archts.—June 1974, BTS, pp. 134-135. San Francisco Firehouse, San Francisco, Cal.; Braccia, De Brer, Heglund, archts.—June 1974, BTS, pp. 138-140. Thousand Oaks Civic Center, Thousand Oaks, Cal.; Robert Mason Houvener, archt.—June 1974, BTS, pp. 123-129.
- Public Buildings. See also Hospitals, Housing & Apartments, Schools, University & College Buildings.
- R**
- RTKL Assocs., Inc., archts.; Southern Bank of Ohio, Cincinnati, Ohio—Jan. 1974, p. 116.
- Raleigh Boardwalk Apartments, Portland, Ore.; Martin, Soderstrom, Matteson, archts.—Mid-May 1974, BTS, pp. 118-119.
- Recreational Facilities. Airpark Lodge, Reelfoot Lake State Park, Tiptonville, Tenn.; Gassner Nathan Browne, archts.—June 1974, pp. 95-97. Bedford Stuyvesant Community Pool, Brooklyn, N.Y.; Morris Lapidus Assocs., archts.—June 1974, pp. 98-99. Cochiti Lake Recreation Center, Cochiti, N.M.; Frank O. Gehry & Assocs., archts.—June 1974, pp. 100-101. Cullman Courts, Yale University, New Haven, Conn.; Herbert S. Newman Assocs., archts.—Jan. 1974, p. 111. Portland Jewish Center, Portland, Ore.; Wolff Zimmer Gunsul Ritter Frasca, archts.—June 1974, pp. 102-104.
- Recreational Facilities. See also Ski Resorts.
- Reinhard & Hofmeister, archts.; Rockefeller Center: First Campaign, New York, N.Y.—Mar. 1974, BTS, pp. 128-133.
- Religious Buildings. St. Thomas Church, New York, N.Y.; Cram, Goodhue & Ferguson, archts.—Apr. 1974, pp. 113-118.
- Renovations & Restorations. Barn remodeling: Vollen barn, southern Wisc.; Frog Hollow barn, southern Mich.; Stanley Tigerman & Assocs., archts.—June 1974, pp. 117-122. Barn renovation, Greenwich, Conn.; Gwathmey-Siegel, archts.—Jan. 1974, pp. 114-115. Harvey Hubbell Corporate Headquarters, Orange, Conn.; Bruce Campbell Graham, archt.—Apr. 1974, pp. 122-126. Smith, Hinchman & Grylls headquarters, Detroit, Mich.; Smith, Hinchman & Grylls Inc., archts.—Apr. 1974, pp. 120-121.
- Research Buildings. Lehmann, John S. Building, Shaw's Garden, St. Louis, Mo.; HOK Assocs., archts.—June 1974, pp. 111-116.
- Research Buildings. See also University & College Buildings.
- Restaurants. Harold's Restaurant, New Haven, Conn.; John Fowler, archt.—Jan. 1974, pp. 118-119. Mid Gad Valley Restaurant, Snowbird, Utah; Enteleki Architecture, Planning, Research, archts.—Mar. 1974, p. 125.
- Restorations. See Renovations & Restorations.
- Riani, Paolo, archt.: "The new architecture of Florence"—Feb. 1974, pp. 95-108.
- Ricci, archt.: "The new architecture of Florence"—Feb. 1974, pp. 95-108.
- Rockefeller Center: First Campaign, New York, N.Y.; Reinhard & Hofmeister; Corbett, Harrison & MacMurray; and Hood & Foulhoux, archts.—Mar. 1974, BTS, pp. 128-133. Second Campaign—Exxon Building, McGraw-Hill Building, Celanese Building, New York, N.Y.; Harrison & Abramovitz & Harris, archts.—Mar. 1974, BTS, pp. 134-137.
- Rosenfield, Harvey & Morse, archts.; Indian Woods Apartments, East Lyme, Conn.—Mid-May 1974, BTS, pp. 122-123.
- Roth, Emery & Sons & Minoru Yamasaki, archts.; World Trade Center, New York, N.Y.—Mar. 1974, BTS, pp. 140-142.
- Rotner, Robert L., archt.: Four houses in the Hamptons, Long Island, N.Y.—May 1974, pp. 123-132.
- Roure Bertrand Dupont, Inc. offices, Teaneck, N.J.; Kahn & Jacobs, archts.—Jan. 1974, pp. 112-113.
- Roure Bertrand Dupont, Inc., perfumery, Teaneck, N.J.; Kahn & Jacobs, archts.—Feb. 1974, BTS, pp. 134-135.
- Rovida residence, Pittsburgh, Pa.; Tasso G. Katselas, archt.—Mid-May 1974, BTS, pp. 90-91.
- S**
- Sahalee Village, Redmond, Wash.; Mithun & Assocs., archts.—Mid-May 1974, BTS, pp. 120-121.
- St. Thomas Church, New York, N.Y.; Cram, Goodhue & Ferguson, archts.—Apr. 1974, pp. 113-118.
- Salerno, Joseph, archt.: Saul Poliak residence, West Redding, Conn.—Mid-May 1974, BTS, pp. 98-99.
- San Francisco Firehouse, San Francisco, Calif.; Braccia, DeBrer, Heglund, archts.—June 1974, BTS, pp. 138-140.
- Sandy, Donald & James Babcock, archts.; University Park, Ithaca, N.Y.—Mid-May 1974, BTS, pp. 124-125.
- Schaefer, F & M Brewing Co., Lehigh Valley Brewery, Allentown, Pa.; Eggers Partnership, archts.—Feb. 1974, BTS, pp. 138-139.
- Schleisinger, Frank, archt.; Christie Village Condominiums, Beech Mountain, Banner Elk, N.C.—Mid-May 1974, BTS, pp. 110-113.
- Schools. Hollis Middle School, New Hampshire; Michael B. Ingram, archt.—Jan. 1974, AE, pp. 157-160.
- Schröder, Helmut & Peter Faller, archts.; Neugereut, Stuttgart, Germany—Mar. 1974, p. 101. Wohnanlage Tapachstrasse, Stuttgart, Germany—Mar. 1974, p. 100.
- Scoren, Dr. Robert residence, Woodside, Cal.; Knorr-Elliott & Assocs., archts.—Mid-May 1974, BTS, pp. 92-93.
- Sea Ranch, Cal., two houses: Residence for Glen Nimnicht; Fred L. Osmon, archt.—Apr. 1974, pp. 132-133. Residence for Mr. & Mrs. Henry O. Whiteside; Donald Jacobs, archt.—Apr. 1974, pp. 134-136.
- Seagram, Joseph E. & Sons, Inc. offices, New York, N.Y.; Giovanni Pisanella Assocs., archts.—Jan. 1974, p. 117.
- Seiko Instruments, Inc., U.S. headquarters, Torrance, Cal.; Kajima Assocs., archts.—Feb. 1974, BTS, pp. 132-133.
- Sert, Jackson & Assocs., Inc., archts.; Undergraduate Science Center and Chilled Water Plant, Harvard University, Cambridge, Mass.—Mar. 1974, pp. 111-118.
- Shopping Centers. "New directions for downtown and suburban shopping centers," Building Types Study 459—Apr. 1974, pp. 137-152. Baystate West Shopping Mall, Springfield, Mass.; Eduardo Catalano with Pietro Belluschi, archts.—Apr. 1974, BTS, pp. 142-143. Broadway Plaza, Los Angeles, Calif.; Charles Luckman Assocs., archts.—Apr. 1974, BTS, pp. 138-141. Crown Center retail complex, Kansas City, Mo.; Edward Larrabee Barnes, archt.—Apr. 1974, BTS, pp. 144-145. Market Street East Transportation Mall Center, Philadelphia, Pa.; Bower & Fradley, archts.—Apr. 1974, BTS, pp. 146-149. Meadow Mall, Simsbury, Conn.; Gwathmey-Siegel, archts.—Apr. 1974, BTS, pp. 150-152.
- Ski Resorts. "Land use planning and design for ski resorts," Building Types Study 456—Jan. 1974, pp. 141-156. Elkhorn at Sun Valley, Sun Valley, Idaho; Killingsworth, Brady & Assocs., archts.—Jan. 1974, BTS, pp. 150-156. Kirkwood Meadows Lodge, Lake Kirkwood, Calif.; Bull Field Volkman Stockwell, archts.—Jan. 1974, BTS, pp. 148-149. Northstar-At-Tahoe, Calif.; Bull Field Volkman Stockwell, archts.—Jan. 1974, BTS, pp. 142-147. "Snowbird: in scale with the mountains"—Mar. 1974, pp. 119-126.
- Smith, Hinchman & Grylls Inc., archts.; Ford Motor Co., plant renewal, IBM, Boulder Colorado Mfg. Facility—Feb. 1974, BTS, p. 126. Smith, Hinchman & Grylls headquarters, Detroit, Mich.—Apr. 1974, pp. 120-121.
- Smotrich & Platt, archts.; Harper & Row office, New York, N.Y.—Jan. 1974, pp. 105-107.
- Sobel, Robert, archt.: Sobel residence, Houston, Tex.—Mid-May 1974, BTS, pp. 100-103.
- Southern Bank of Ohio, Cincinnati, Ohio; RTKL Assocs., Inc., archts.—Jan. 1974, p. 116.
- Spoerry, François, archt.; Port Grimaud, France—Mar. 1974, pp. 106-107.
- Superstudio, archts.: "The new architecture of Florence"—Feb. 1974, pp. 95-108.
- T**
- Theaters. See Performing Arts Buildings.
- Thodos, John, archt.; Chipper Machines & Engineering Co., Portland, Ore.—Feb. 1974, BTS, p. 131.
- Thomas, Edwin Performing Arts Hall, University of Akron, Akron, Ohio; Caudill Rowlett Scott, archts.—Mar. 1974, AE, pp. 143-148.
- Thousand Oaks Civic Center, Thousand Oaks, Calif.; Robert Mason Houvener, archt.—June 1974, BTS, pp. 123-129.
- Tigerman, Stanley & Assocs., archts.; Barn remodeling: Vollen barn, southern Wisc.; Frog Hollow barn, southern Mich.—June 1974, pp. 117-122.
- Twitchell & Miao, archts.; Private residence, upstate New York—Mid-May 1974, BTS, pp. 56-59.
- U**
- University & College Buildings. College of Business Administration, University of Hawaii, Manoa Campus, Honolulu, Hawaii; Leo S. Wou & Assocs., archts.—Jan. 1974, pp. 121-126. Cullman Courts, Yale University, New Haven, Conn.; Herbert S. Newman Assocs., archts.—Jan. 1974, p. 111. "Gymnasium" for Anatolia College, Thessaloniki, Greece; Hugh Newell Jacobsen, archt.—May 1974, p. 121. Library for the American University in Cairo, Cairo, Egypt; Hugh Newell Jacobsen, archt.—May 1974, p. 120. Library for Pierce College, Athens, Greece; Hugh Newell Jacobsen, archt.—May 1974, p. 121. Murdough Center, Dartmouth College, Hanover, N.H.; Campbell, Aldrich & Nulty, archts.—Feb. 1974, pp. 109-112. Student housing, University of Munich, Germany; Ebert, archt.—Mar. 1974, p. 102. Thomas, Edwin Performing Arts Hall, University of Akron, Akron, Ohio; Caudill Rowlett Scott, archts.—Mar. 1974, AE, pp. 143-148. Undergraduate Science Center and Chilled Water Plant, Harvard University, Cambridge, Mass.; Sert, Jackson & Assocs., Inc., archts.—Mar. 1974, pp. 111-118.
- V**
- Vollen barn remodeling, southern Wisc.; Stanley Tigerman & Assocs., archts.—June 1974, pp. 117-119.
- von Dohlen, Russell Gibson Inc., archts.; Heublein Corporate Headquarters, Farmington, Conn.—May 1974, pp. 136-140.
- W**
- Walworth, Len residence, Burlington, Ia.; Crites & McConnell, archts.—Mid-May 1974, BTS, pp. 62-63.
- Warn Industries plant, Milwaukee, Ore.; Campbell, Yost & Grube & Partners, archts.—Feb. 1974, BTS, p. 130.
- Western Union message center, New York, N.Y.; R. Scott Bromley, archt.—Jan. 1974, p. 120.
- Westinghouse underground distribution transformer plant, Jefferson City, Mo.; Kivett & Myers, archts.—Feb. 1974, BTS, pp. 136-137.
- Whisnant, Murray, archt.; Whisnant residence, Charlotte, N.C.—Mid-May 1974, BTS, pp. 60-61.
- Whitton, Robert, archt.; Engle residence, Boxboro, Mass.—Mid-May 1974, BTS, pp. 88-89.
- Winston house, Lyme, N.H.; Donald Metz, archt.—Mid-May 1974, BTS, pp. 52-53.
- Wohnanlage Tapachstrasse, Stuttgart, Germany; Peter Faller & Helmut Schröder, archts.—Mar. 1974, p. 100.
- Wolff Zimmer Gunsul Ritter Frasca, archts.; Portland Jewish Center, Portland, Ore.—June 1974, pp. 102-104.
- Woolner residence, Chilmark, Mass.; Edward Cuetara, archt.—Mid-May 1974, BTS, pp. 104-105.
- World Trade Center, New York, N.Y.; Minoru Yamasaki & Emery Roth & Sons, archts.—Mar. 1974, BTS, pp. 140-142.
- Wou, Leo S. & Assocs., archts.; College of Business Administration, University of Hawaii, Manoa Campus, Honolulu, Hawaii—Jan. 1974, pp. 121-126.
- Y**
- Yale University's Cullman Courts, New Haven, Conn.; Herbert S. Newman Assocs., archts.—Jan. 1974, p. 111.
- Yamasaki, Minoru & Emery Roth & Sons, archts.; World Trade Center, New York, N.Y.—Mar. 1974, BTS, pp. 140-142.

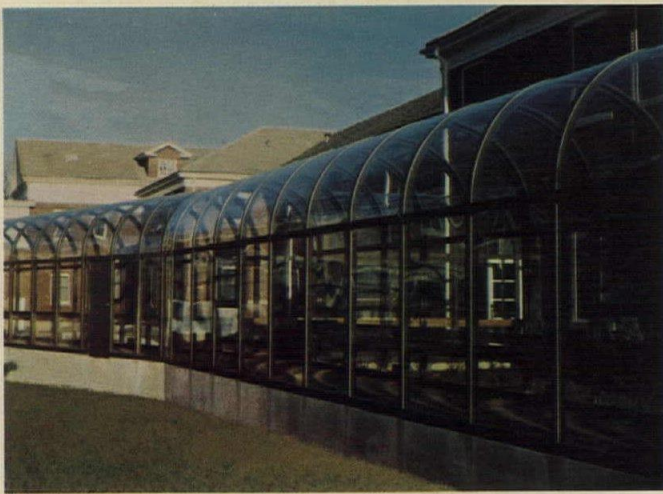

Enclosed passageway—
Installation: Westminister Village, Indianapolis, Indiana
Architect: Woolen Associates
Materials: Aluminum and Acrylic

Write for Complete details and specifications.

o. o. McKINLEY co., inc.

Box 55265, Indianapolis, In 46205

SPECIALISTS IN METAL FABRICATION • METAL FINISHING • PLASTICS FORMING



For more data, circle 141 on inquiry card

ADVERTISING INDEX

Prefiled catalogs of the manufacturers listed below are available in the 1974 Sweet's Catalog File as follows.

- A Architectural File (green)
- I Industrial Construction File (blue)
- L Light Construction File (yellow)
- D Interior Design File (black)

A

Acco, Page Fence Division	192
A AllianceWall Corporation	198
D Allied Chemical Corp., Fibers Div.	199
All-Steel Inc.	66
A-I-L Aluminum Co. of	
America	198A to 198D, 220
Amarlite Products Div.	145-146
American Louver Co.	78
A-I American Smelting & Refining Co.	159
A-I American Standard, Plumbing & Heating Div.	190
A American Sterilizer Co.	25 to 27
A-I American Telephone & Telegraph Co.	56-57
A-L Andersen Corp.	52-53
Architectural Record Books	208, 221
Armstrong Elevator Co. Inc.	160
A-I-L Armstrong Cork Co.	2nd cover—1, 3, 5, 7, 9
A-I-L ASG Industries Inc.	173
A-L Azrock Floor Products	3rd cover

B

A Bally Case & Cooler, Inc.	154
E.T. Barwick Industries Inc.	22-23
A-I Bell Telephone System	56-57
Bethlehem Steel Corp.	60-61
A Bigelow-Sanford Inc.	191
A-I-L Bilco Co.	172
A-I Bradley Corporation	16
A-L Brick Institute of America	49
A Brunswick Corporation	74
Buckstaff Company	184

C

A Carpenter & Co., L.E.	161
A-I-L Carrier Air Conditioning Co.	156
A-I Ceco Corp.	75
A-I Celotex Corp.	162-163
A Chester Products Inc.	147
A-I Clark Door Co., Inc.	206
A Cold Spring Granite Co.	82-83
A-I Colorguard Corp.	198
A Combustion Engineering—C-E Glass Division	92-93
A Copper Development Association, Inc.	175
CRS Industries Inc.	166

D

Dayton Sure-Grip & Shore Co.	153
A-L Delta Faucet Company	209
DeSoto, Inc.	203
Detex Corp.	188
A Dover Corp., Elevator Div.	36
D Dow Badsche Co.	80
A-D DuPont De Nemours & Co., Inc.	218-219

E

Eastman Kodak Co.	62
Easy-Heat-Wirekraft Div.—MSP Industries	192
A-I Elkay Mfg. Company	2

F

A Florida Tile, Div. of Sikes Corp.	207
Folger Adam Co.	196
A Follansbee Steel Corp.	168
Forms & Surfaces	31

G

A-I-L GAF Corp., Floor Products Division	89
General Electric Co.—Lamp Marketing Dept.	186-187
General Electric Co.—Lighting Systems Business Dept.	174
A-I-L General Electric Co.—Zoneline	46-47
A-I Georgia-Pacific Corporation	152
Glen-Gery Corp.	15
A Goodyear Tire & Rubber Co.	79
A Granco Steel Products Co.	38
A-I Greco Inc., Building Products Division	42
Guth Lighting—Div. Sola Basic Industries	158

H

A Haws Drinking Faucet Company	32
Herman Miller Inc.	84-85
A-I Hillyard Chemical Co.	178
A Holophane, A Johns-Manville Division	24

I

Ideal Industries Inc.	164
A-I Inland-Ryerson Construction Products Co.	20-21
International Masonry Institute	177
A Interpace Corp.	88
A InterRoyal	59

J

A-I Jennison-Wright Corp.	165
J.G. Furniture Company, Inc.	155
Jute Carpet Backing Council, Inc.	202

K

Kawneer Co.	72
A KDI Paragon	206
Kemiko Inc.	198
A-I Keystone Steel & Wire Co.	64
A Kim Lighting Inc.	213
A-I Kinneer Corp.	157
A-D Kwik-Wall Company	179

L

A Landscape Forms, Inc.	206
A LCN Closers, Inc.	58
A-I-L Lennox Industries, Inc.	222
A-I-L Libbey-Owens-Ford Co.	50-51
A Lord & Burnham Div. of Burnham Corp.	56

M

The Magee Carpet Co.	6
A Massey Seating Co.	198
A Matthews & Co., J.H.	166A to 166F
Maytag Co.	150
O.O. McKinley Co., Inc.	227
Metalphoto Corp.	8
A Monsanto Company, Textiles Div.	197

N

National Electrical Contractors Association	176
A-I-L-D National Gypsum Co.	90-91
A-D National Terrazzo	169

A-I-L Neenah Foundry Co.	172
A-L-D Nord Co., E.A.	164
A Nor-Lake, Inc.	192

O

Ohio Medical Products Div. of Airco Inc.	159
A Osmose Wood Preserving Co.	172
Ottawa Silica Co.	229
A-I-L-D Owens-Corning Fiberglas Corp.	81, 86-87

P

Page Fence Division of ACCO	192
A-L Pella Rolscreen Co.	28-29
A-I Pittsburgh Corning Corp.	17
A-L-D Potlatch Corp.	63
A-L PPG Industries, Inc., Commercial Glass	204-205
Pyrotector Inc.	196

R

A-L Red Cedar Shingle & Handsplit Shake Bureau	18
A-I Richards-Wilcox Mfg. Co.	192
A-L Rohm & Haas Company	19
Russwin, Div. Emhart Corp.	171

S

St. Joe Minerals Corporation	214
Sheaffer World-Wide	196
A-I Silbrico Corp.	185
A-I Simpson Timber Co.	182
Sloan Valve Company	4th cover
A Smith, Elwin G. Div. Cyclops Corp.	164
Solite Corp.	182A to 182D
Southern California Gas Company	32-2
A Span Deck Inc.	212
A-L Speed Queen, Div. of McGraw-Edison Co.	181
Square D Company	167
A-L Stauffer Chemical Co., Plastics Div.	68
Steelcase Inc.	94
Strand Century Inc.	202
Stretch Forming Corp.	32-1

T

A-I Taylor Co., The Halsey W.	170
Thayer Coggin Institutional Inc.	30
A-I Thiokol Chemical Corp.	189
Thonet American Chair Company	193
A-I Tremco Mfg. Co.	194-195
Trus Joist Corp.	44

U

A-I-L-D United States Gypsum Co.	54-55
A-I United States Mineral Products Co.	185
A-I-L-D U.S. Plywood Corp.	215
A-I United States Steel Corp.	201
A-L Uvalde Rock Asphalt Co.	3rd cover

V

A Vogel-Peterson Co.	70
A Vollrath Co.	202

W

A Wasco Products, Inc.	157
Wellco Carpet	12
Westinghouse Electric Corp.—Architectural Systems	216-217
Westinghouse Electric—Corporate	210-211
Wide-Lite Corporation	148-149
Wilson Art	76-77

X

Xerox Corp.	183
-------------	-----

Mystic White®

A multi-purpose quartz aggregate.
— Architectural and landscape stone,
and architectural sand.

It's a lively white!

ARCHITECTURAL RECORD

McGraw-Hill, Inc., 1221 Avenue of the Americas, New York
New York 10020
Advertising Sales Mgr.: Louis F. Kutscher (212) 997-2838
Eastern Sales Mgr.: Robert G. Kliesch (215) 568-6161
Western Sales Mgr.: James A. Anderson (312) 751-3770
Advertising Services Mgr.: Joseph R. Wunk (212) 997-2793
Marketing Services Mgr.: Elizabeth Hayman (212) 997-2858
Research Mgr.: Camille Padula (212) 997-2814
Classified Advertising: (212) 997-2557

District Offices:

Atlanta 30309

Edward G. Graves, 100 Colony Square, 1175 Peachtree St., N.E.
(404) 892-2868

Boston 02116

Robert L. Tagen, 607 Boylston St., (617) 262-1160

Chicago 60611

James A. Anderson, Robert T. Franden, Edward R. Novak,
645 N. Michigan Ave. (312) 751-3770

Cleveland 44113

Willis W. Ingersoll, 55 Public Square, (216) 781-7000

Denver 80202

Harry B. Doyle, 1700 Broadway (303) 266-3863

Detroit 48202

1400 Fisher Bldg., (313) 873-7410

Los Angeles 90010

Richard R. Butera, 3200 Wilshire Blvd.-South Tower (213) 487-1160

New York 10020

Blair McClenachan (212) 997-3584

Philadelphia 19102

Robert G. Kliesch, George T. Broskey, Three Parkway
(215) 568-6161

Pittsburgh 15222

Edward C. Weil, III, 4 Gateway Center, (412) 391-1314

St. Louis 63011

Richard Grater, Manchester Rd., (314) 227-1600

San Francisco 94111

Richard R. Butera, 425 Battery Street (415) 362-4600

Overseas Offices:

Brussels

Galerie Porte de Namur, 22-26, Chaussée de Wavre
1050 Brussels, Belgium

Frankfurt/Main

Elsa-Brandstroem Str. 2, Frankfurt/Main, Germany

London

34 Dover Street, London W.1, England

Milan

Via Baracchini No. 1, Milan, Italy

Paris

17, rue Georges Bizet, 75 Paris 16e, France

Tokyo

2-5, 3-chome, Kasumigaseki, Chiyoda-ku, Tokyo, Japan



Mystic White® is the distinctive name given to this family of lively white aggregates and architectural sand: Architectural Stone, in 1/4" to 1 1/2" sizes, for architectural concrete, and ornamental and landscape applications—decorative planters and ground cover. Architectural Sand, the whitest available, provides the "white-look" when using gray or white cement. For specialty concrete products, architectural finishes. It's beautiful and lasts, and lasts, and lasts. Write for brochure and become acquainted with Mystic White.



OTTAWA SILICA COMPANY

Connecticut Silica Division
RSD #7, Box 855, 577AR
Ledyard, Connecticut 06339

For more data, circle 142 on inquiry card

CLASSIFIED SECTION

POSITIONS VACANT

ARCHITECTS

Detroit based A/E/P firm has positions for architectural designers with minimum 5 years experience. Must be capable of leading design team for major projects, of developing building programs, of conducting client meetings, of following projects through construction documents and construction.

Write in confidence to:

James M. Leefe, AIA
Giffels Associates, Inc.
243 W. Congress
Detroit, MI 48226
or call collect (313) 961-2084

An Equal Opportunity Employer, M/F.

ARCHITECTS—PEACE CORPS/VISTA ACTION. Volunteer overseas and U.S....Low-income housing projects, design of schools, hospitals, community centers, etc. Most openings: singles, some couples. Information: Bruce Mazzie

ACTION

OCP Box A-1, Washington, D.C. 20525.

Architectural Specialist—The National Clearinghouse for Criminal Justice Planning and Architecture provides technical assistance services to criminal justice agencies throughout the United States. Requirements include a professional degree in Architecture with a minimum of 2 years experience, a good command of the English language, and good communication skills. Salary ranges from \$12,000 to \$16,500, commensurate with experience and qualifications. Send resume to: Frederic D. Moyer, AIA, Director—National Clearinghouse for Criminal Justice Planning and Architecture—505 E. Green, Suite 200, Champaign, IL 61820—The University of Illinois is an Affirmative Action—Equal Opportunity Employer and encourages applications from minorities and women.

Director, Campus Planning and Facilities Development—Director, Campus Planning and Facilities Development is responsible for the direction and coordination of the activities of new facilities and the development of long-term space needs for the University. The preparation and updating of the University's long-term development plan is also a function of the position. Qualifications include graduation from a five year college or university with major course work in Architecture, Engineering or a Graduate degree in Planning or Public Administration. Considerable experience in Physical Planning is also necessary. Please respond by resume only. Responses must include salary history or expectations. Personnel Office, Wayne State University, Detroit, Michigan 48202. An Equal Opportunity Employer.

Architects—for positions in working drawings, project management and design. Many challenging projects in an office with highly qualified personnel in architecture and engineering. Location excellent in community of 300,000. Send resume or call Greg Slaybaugh, Daverman Associates, Architects and Engineers, 200 Monroe N.W., Grand Rapids, Michigan 49502 (616) 451-3525.

Responsible Project Architect—with design background and 5 years experience needed by small diversified firm with design and production orientation in small western city. Salary beginning at \$15,000. Send resume, references and work examples with application. Reply to: P-5250, Architectural Record.

Structural Designers/Draftsmen—Career opportunities currently exist in the Washington, D.C.-Baltimore area for experienced structural designers and draftsmen. Designers must have a minimum of 3-5 years experience with registration a plus. Draftsmen should have 2-4 years experience. Salaries range from \$12K to \$22K with all relocation expenses paid. To apply please contact Dennis Burstein, Construction/Engineering Division, 5530 Wisconsin Avenue, Suite 1452, Chevy Chase, Maryland 20015. 301-652-4540.

Project Managers—Architectural—Large progressive total service-oriented Architectural/Engineering firm, Northeastern United States, seeking qualified Project Managers—Architectural, proven ability, leadership, management; thorough knowledge of design, construction processes. Educational requirements include Architectural registration. Salary range upon request; benefits competitive. An equal opportunity employer. Send confidential resume to: P-5254, Architectural Record.

Architects—We have many career openings for architects to serve as project architects for large designer-builder of medical and institutional facilities. Excellent companies. Good salary, bonus and car compensation packages. Send resume. Management Recruiters of Green Bay, 115 S. Jefferson St., Green Bay, Wis., 54301. Or direct dial 414/437-4353.

Specification Writer—This position involves preparing architectural specifications using CSI and government formats and working with a computer master spec. An architectural degree and a minimum of 5 years experience is required, including some in hospitals and educational facilities. Excellent career potential and benefits. Send replies to Perkins & Will, 1828 L Street, N.W., Washington, D.C. 20036. EOE/MF.

Project Architect—An architect with at least 5 years experience, some of which should be in medical facilities planning and design. This position requires the capability to demonstrate positive management responsibilities for a variety of projects. Excellent career potential and benefits. Send replies to Perkins & Will, 1828 L Street, N.W., Washington, D.C. 20036. EOE/MF.

Site Planner/Landscape Architect—A design oriented site planner/landscape architect to be a part of the A/E project development team. A degree and 3-5 years experience desired. Excellent career potential and benefits. Send replies to Perkins & Will, 1828 L Street, N.W., Washington, D.C. 20036. EOE/MF.

Architect—registered in New York State, to manage 10 man Architectural-Engineering Office. 10 years of progressively responsible experience in planning, designing, and construction of large scale projects—schools preferred. Salary \$17,903-\$23,759. Closing date for applications, June 30, 1974. Equal Opportunity Employer. Send resume: Mrs. Ruth Radford, City School District, 13 Fitzhugh Street South, Rochester, New York 14614. 716-325-4560.

Project Architect—Outstanding opportunity for right individual. Key position. Young, multi-disciplined, growing, St. Louis firm. Exciting, diverse, architectural practice. Must excel in design and working drawings. Commitment to better environment and modern design essential. Individual with initiative and capability to assume substantial responsibility. P-5247, Architectural Record.

Architectural-Engineering-Construction firm located in Central Maine seeks design oriented architect registered in State of Maine to participate in all phases of design and construction. Scope of work involves residential, commercial and industrial buildings. Send complete resume, references and salary requirements to P.O. Box 1126, Bangor, Maine.

POSITIONS WANTED

Architect, A.I.A., NCARB, 38 registered in several states, seventeen years experience including five years in Europe. Strong architectural/engineering/construction/financial management background; interested in organization, client relations, consulting, coordination and of complex projects. Seeks affiliation or position with architect/engineer/developer. Prefer New York, New Jersey or Pennsylvania area but will also relocate for the right opportunity. Write to PW-5172, Architectural Record.

Architect, urban design and design oriented, NCARB, AIA, licensed in four states. Formerly principal in two small-to-medium-sized firms. Eighteen years experience in educational, institutional, governmental, religious, commercial and residential projects. Design awards. Additional skills and interest in urban transportation, solar energy, graphics and photography. M. Arch., A.B., Harvard. Seeking responsible position with firm offering full range of environmental design services. Location open. Opportunity for advancement prime. Reply to PW-5282, Architectural Record.

Architect, NCARB, seeking challenging position in the western U.S. Background in Commercial, Multi-Family Housing, Shopping Centers, Resort type projects and Project Management. Licensed in Colorado and Texas, A.I.A. Managed Colorado Branch office for one year and presently in private practice. Seeking challenging opportunity. PW-5354, Architectural Record.

Architect seeks challenging position with Florida firm utilizing valuable combination of experience—10 years comprehensive Architectural experience all phases professional practice plus 5 years Construction/Project Management experience with multi-family developers. Licensed 4 states, NCARB. PW-5253, Architectural Record.

Architect-Facilities Planner—with heavy experience in programming judicial, academic and municipal facilities. Some corporate and office buildings. Available on long or short term project basis. Free to travel. Resume and references on request. Reply to PW-5355, Architectural Record.

EMPLOYMENT SERVICE

Edwards and Shepard Agency: An architectural and interior placement service for professionals seeking knowledge, guidance, confidentiality and informed representation. Bill Shepard, a Pratt graduate, offers effective results to: Architects, Planners, Production Specialists and Industrial Designers. Interviews by appointment—(212) 725-1280, 1170 Broadway, New York, N.Y. 10001.

BUSINESS OPPORTUNITIES

Architect: Established east coast architectural-engineering firm with annual construction volume of \$60 million in quality commercial industrial practice seeks design partner. Unusual opportunity. Reply: BO-5366, Architectural Record.

EQUIPMENT FOR SALE

MOVE UP A BETTER IDEA



MOORE OVERHEAD CLOTHES STORAGE SYSTEMS

Clothing stored overhead, where it should be. A complete standardized system—overhead grid supports, elevating Lockerbaskets, bench units. Thrifty, attractive, sanitary.

Write for free catalogue.

THE MOORE COMPANY
1329 Quarrier St., Charleston, W. Va.
516 Fifth Ave., New York, N. Y.