



A CORPORATE HEADQUARTERS FOR IBM DESIGNED BY EDWARD LARRABEE BARNES  
BUILDING TYPES STUDY: RECORD INTERIORS OF 1977  
ROBIN HOOD DELL WEST, BY MACFADYEN/DE VIDO  
SMALL WEEKEND HOUSE AT THE SEA RANCH BY DONALD JACOBS  
"AN ARCHITECTURE FOR PEOPLE AND NOT FOR THINGS," BY JOHN PORTMAN  
FULL CONTENTS ON PAGES 10 AND 11

# ARCHITECTURAL RECORD

JANUARY 1977 **1** A MCGRAW-HILL PUBLICATION FIVE DOLLARS PER COPY



This pendant fixture, movable to many points in the room, provides both quality task lighting and substantial energy savings.

## The Synercon<sup>TM</sup> 60 Ceiling System from Armstrong. A new standard of design flexibility produces a new high in energy savings.

The Synercon 60 Ceiling System from Armstrong is all new from the grid to the board, from the lighting options to the air handling. More important than even its newness, however, is its innovation. Innovation that serves to increase design flexibility, decrease energy consumption, and enhance lighting quality.

**The new lighting** starts with a pendant fixture designed to provide highly efficient task lighting that can save as much as 65% in electrical costs when compared to conventional-type recessed troffers. It accommodates two 40-W lamps which result in 70 or

more footcandles at the work surface and is offered with a special double lens that controls brightness and effectively beams the light exactly where it's needed. What's more, with the fixture suspended, the ceiling is 100% acoustical material.

With the Synercon 60 Ceiling System, however, that's only the start. Because there are two other lighting options as well. The newly designed recessed troffer you see above that also saves energy because it normally requires fewer fixtures than competitive systems. And the energy-efficient sodium fixture has been



## Listed, tested, accepted.

# ERA-1™ puts UniGroup™ in a class all by itself.

What's made open plan so popular? In a word, flexibility. Flexibility in design. Flexibility for change. Flexibility to accommodate all kinds of people with all kinds of needs.

Yet until a few short months ago, panel/component systems showed a glaring lack of flexibility when it came to power distribution. And let's face it. Today's office is nowhere without abundant plug-ins.

No wonder ERA-1 created such a stir. Here was the first comprehensive panel system ever pre-wired for power. And suddenly, there was no other open plan office system quite like our UniGroup.

**An innovation that made sense.** The ERA-1 addition to UniGroup made power as

flexible as open plan itself. And everyone wanted a closer look.

They looked. They tested. And today, ERA-1 is at work in offices, banks, institutions—wherever it made sense to plan spaces around people, not around fixed wiring.

Acceptance has been gratifying, but not at all sur-

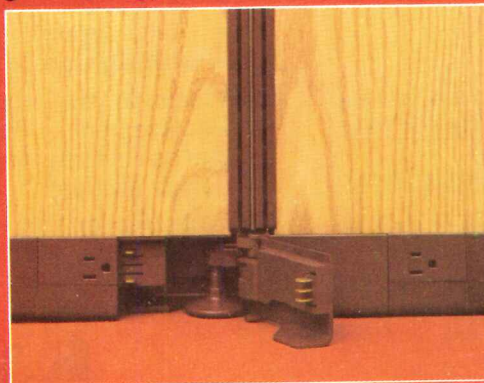

prising. Designed in compliance with the National Electrical Code, ERA-1's electrical system has earned Listing by Underwriters Laboratories. And power is only part of ERA-1's story.

**Closest thing yet to the perfect panel system.** Panel-to-panel power distribution, generous communications handling, superior strength, Class A fire rating, excellent acoustics. ERA-1 puts UniGroup in a class all by itself. It's an accepted, Listed fact.

Ask your Haworth representative for detailed literature, or write Haworth Inc., Holland, Michigan 49423.

**HAWORTH™**



## ARCHITECTURAL RECORD

McGraw-Hill, Inc., 1221 Avenue of the Americas, New York  
New York 10020

Advertising Sales Mgr.: Louis F. Kutscher (212) 997-2838  
Eastern Sales Mgr.: Robert G. Kliesch (215) 568-6161  
Western Sales Mgr.: James A. Anderson (312) 751-3770  
Assistant Business Mgr.: Joseph R. Wunk (212) 997-2793  
Sales Promotion Mgr.: Richard M. Gross (212) 997-2815  
Research Mgr.: Camille Padula (212) 997-2814  
Classified Advertising: (212) 997-2557

### District Offices:

Atlanta 30309

J. L. Moran, 100 Colony Square, (404) 892-2868

Boston 02116

Robert L. Tagen, 607 Boylston St., (617) 262-1160

Chicago 60611

James A. Anderson, Robert T. Franden, Edward R. Novak,  
645 N. Michigan Ave. (312) 751-3770

Cleveland 44113

Edward C. Weil, III, 55 Public Square, (216) 781-7000

Denver 80203

David M. Watson, 123 Speer Blvd., #400 (303) 837-1010

Detroit 48202

John W. Maisel, 1400 Fisher Bldg., (313) 873-7410

Los Angeles 90010

Donald O. Hanson, 3200 Wilshire Blvd.-South Tower (213) 487-1160

New York 10020

Blair McClenachan, 1221 Avenue of the Americas (212) 997-3584

Philadelphia 19102

Robert G. Kliesch, George T. Broskey, Three Parkway  
(215) 568-6161

Pittsburgh 15222

Edward C. Weil, III, 2 Gateway Center, (412) 391-1314

St. Louis 63011

Richard Grater, Manchester Rd., (314) 227-1600

San Francisco 94111

Richard R. Butera, 425 Battery Street (415) 362-4600

### Overseas Offices:

Brussels

Galerie Porte de Namur, 22-26, Chaussée de Wavre  
1050 Brussels, Belgium

Frankfurt/Main

Elsa-Brandstroen Str. 2, Frankfurt/Main, Germany

London

34 Dover Street, London W.1, England

Milan

Via Baracchini No. 1, Milan, Italy

Paris

17, rue Georges Bizet, 75 Paris 16e, France

Tokyo

2-5, 3-chome, Kasumigaseki, Chiyoda-ku, Tokyo, Japan

For more data, circle 132 on inquiry card



Aslesen & Herman, Architects

# KALWALL® SYSTEMS

A Kalwall System can be a ROOF — or a  
WALL — or a WINDOW REPLACEMENT!



Stockley & Leahy, Architects

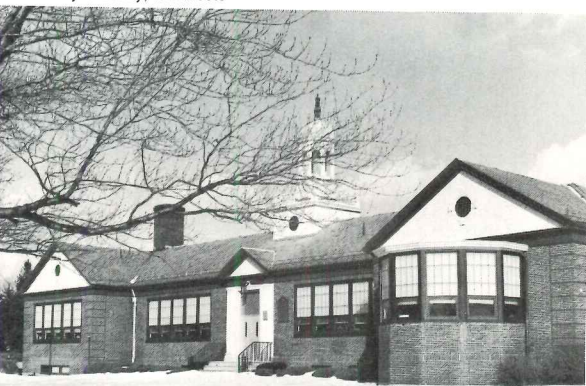

*Kalwall is a complete, translucent, insulating building panel system.*

We know how much energy Kalwall saves as a Window Replacement — owners have reported savings over 30% in heating and 15% in lighting. Imagine what the savings can be for a new building when Kalwall is used instead of any of the other natural light transmitting materials!

For optimizing the buildings energy efficiency, Kalwall offers a choice from these Key Factors:

- "U" Factors between .06 and .40!
- Light transmitting values between 3% and 75%!
- Shading Coefficients from .85 to less than .06!

Whatever your project — Wall, Roof, Window Replacement — Kalwall has a complete System that can cut total energy consumption; and still win design awards!\*

Write or phone for technical and design data, plus a copy of our 1976 full color catalog.

**KALWALL**  
CORPORATION

1111 Candia Road, Manchester, N. H. 03103  
Phone 603-627-3861

\*Documentation available on request.

Patented

FOR ENERGY SAVING BUILDINGS!

# ADVERTISING INDEX

Prefiled catalogs of the manufacturers listed below are available in the 1977 Sweet's Catalog File as follows:

- G General Building (green)
- E Engineering (brown)
- I Industrial Construction and Renovation (blue)
- L Light Residential Construction (yellow)
- D Interiors (white)

## A

G	Alliance Wall Corp.	97
	Allied Chemical Corp.	201
	All-Steel Inc.	80
E-G-I	Aluminum Co. of America	28, 197
	American Buildings Co.	9
G	American Olean Tile Company	93
G-L	Andersen Corp.	86-87
G	Appleton Electric Co.	192
	Architectural Record	216
	Architectural Record Books	34-1, 66A, 66D, 165, 178, 198, 200, 214
D-G-L	ARCO/Polymers Inc.	67
D-G-I-L	Armstrong Cork Co.	Ilcov-1, 2-3, 5
E-G	ASG Industries Inc.	185
G-L	Azrock Floor Products	168

## B

G	Bally Case & Cooler, Inc.	166
	Bethlehem Steel Corp.	60-61
G	Bobrick Corporation, The	29
G-I	Bradley Corporation	212
	Bruning Division-Addressograph Multigraph Corporation	96
	Buckstaff	175
G-I	Burns & Russell Co.	161

## C

G	Carpenter & Co., L.E.	21
	Carson Pirie Scott & Co.	190
G-I	Ceco Corp.	50
D-E-G	Celanese Fibers Marketing Co.	72-73
G	Cem-Fil Corp.	98
	Chester B. Stem Inc.	163
G	Chevron Asphalt Co.	204
G-E-I	Clark Door Co. Inc.	96
	Clearprint Paper Co.	172
E-G	Construction Specialties	220
G-I	The Cookson Company	32
G	Crown Metal Mfg. Co.	184
	Cy/Ro Industries	71

## D

	Delta Airlines	163
	Detex Corp.	204
	A.B. Dick Co.	20
G	Dover Corp., Elevator Div.	196
D-G	Dow Badische Co.	215
D-E-G-L	DuPont de Nemours & Co.; Inc., E.I., Antron	58-59
D-E-G-L	DuPont de Nemours & Co., Inc., E.I., Iastomers	155 to 158
D-E-G-L	DuPont de Nemours & Co., Inc., E.I., Zepel	16

## E

EG-I	Ebco Mfg. Co.	64
------	---------------	----

## F

G	Flexiwall-Systems Div. of Wall & Floor Treatments Inc.	211
G	Follansbee Steel Corp.	3rd cover
G	Formica Corp.	176-177
	Fraser Laundry Systems, A Division of Economics Laboratory Inc.	162

## G

D-G-I-L	GAF Corp., Floor Products Division	44
	General Electric Co.—Video Display Eqpt. Operation	92
	General Portland Inc., Trinity Division	213
	GF Business Equipment Inc.	207
G	Glasweld International	225
	Glidden Durkee Div. of SCM Corp.	174
D-E-G-I-L	Goodrich General Products Co., B.F.	52-53
G-I-L	Grace & Co., W.R., Construction Products	22-23
E-G-I	Grinnell Fire Protection Systems Co. Inc.	8

## H

	Hager Hinge Company	186-187
E-G	Halsey Taylor Div., King Seeley Thermos Inc.	209
G	Hauserman Inc.	38
	Haworth Inc.	230
G	Haws Drinking Faucet Company	171
	Herman Miller Inc.	90-91
	Holmsten Ice Rinks, Inc.	227
	Hume Snow Melting Systems Inc.	206

## I

D-G-I	Identification Systems Inc.	92
G-I-L	INRYCO, Inc.	6-7
E-G	International Masonry Institute	217
	International Products Corp.	34-1

## J

G	Jamison Door Co.	173
D-G-I	Jennison-Wright Corp.	224
D-E-G-I-L	Johns-Manville Building Systems Division Holophane Division	202-203 179, 218-219

## K

E-G	Kalwall Corp.	229
G	Kawneer Company, Inc.	194-195
G	KDI Paragon	19
G-I	Kelley Co., Inc.	96
I	Kemlite Corp.	206
G-I	Kinnear Corp.	66

## L

D-E-G-I-L	Libbey-Owens-Ford Co.	46
	Lundia, Myers Industries, Inc.	164

## M

G	Maple Hardwood Flooring Mfg. Assn.	184
I-L	Marlite, Division of Masonite Corp.	191
	Marvin Windows	99
D-G-I-L	Masonite Corp.	56-57
G	Jas. H. Matthews & Co.	210
	McPhilben Lighting	184
E-G-I	Mobay Chemical Corp.	74
	Moldcast Ltg.	34
D-G	Monsanto Company, Textiles Div.	100
	Morrison Molded Fiber Glass Co.	205
	Mutschler—A Triangle Pacific Co.	12

## N

	National Electrical Contractors Association	70
G-I-L	National Gypsum Co.	14-15
G	Nucor Corp., Vulcraft Div.	88-89
G-L	Nutone Division of Scovill Mfg. Co.	17-18

## O

E-G	Olympic Stain Company	79
D-E-G-I-L	Owens-Corning Fiberglas Corp.	40-41, 47 to 49, 54-55

## P

	Pahlavi National Library Project Internation Architectural Competition	188
D-G-L	Pella Rolscreen Co.	68-69
	Phillips, Eindhoven	66B-66C
D-G-L	Potlatch Corp.	189
	Power Strut Div. of Van Huffel Tube Corp.	169
G-I	PPG Industries Inc.—Coatings & Resins	62-63
	Provident Mutual Life Insurance Co.	84

## R

	Rally Inc.	204
G-I-L	Raynor Mfg. Co.	24
E-G-I	Robertson Co., H.H.	34-2
D-E-G	Rohm & Haas Co.	30-31
	R-Way Furniture Co.	199

## S

	Scalamandre Silks	220
E-G-L	Schlage Lock Co.	221
G	Sedgwick Machine Works Inc.	165
G	Sico Inc.	160
E-G-I	Silbrico Corp.	220
E	Sloan Valve Company	4th cover
G	Soss Mfg. Co.	92
	Sperry Univac, Office Equipment	33
E-G-I	Stanley Works	85
G	Stark Ceramics Inc.	170
	Steel Joist Institute	193
E	J.P. Stevens & Co., Inc.	208
G	Summitville Tiles Inc.	180-181

## T

	Terry Hinge & Hardware Co.	34-1
	Tiffany Industries	25-26
	Trinity Division, General Portland, Inc.	213

## U

E-G-I-L	United States Gypsum Co.	51
E-G-I	United States Steel Corp.	94-95, 222-223

## V

G	Vinyl Plastics Inc.	27
G	Vulcraft Div. of Nucor Corp.	88-89

## W

	Walker/Parkersburg Div. of Textron Inc.	183
G	Wasco Products, Inc.	167
E-G-I-L	Westinghouse Electric Corp.— Architectural Systems Dept.	182
	Wide-Lite Corporation	65
	Wilson Art	82

## SPECIAL SERVICES

We specialize in  
**PROFESSIONAL  
 LIABILITY INSURANCE**  
**Luftig-Frank & Assoc. Inc.**  
 330 Greenwich St., Hempstead, NY 11550  
 516-481-7810  
 — Our 45th Year —

**Vitruvius Designs Corp.**—artistic renderings & scale models for a better image. Regular drafting services available. Box 1316 Dept. AR, Radio City Sta., New York, NY 10019. (212) 697-5499.

**Architectural Illustration guides, tree stamps, transfer sheets**—free catalog. Instant Landscape—20 Whaleship Plaza, San Francisco, CA 94111.

**6 Ft. wooden cigar store Indian, carved from solid log.** \$325.00 F.O.B. Phoenix. Pictures \$1.00. Wood Carver will do any figure from your picture or sketch. Clyde Davis, P.O. Box 264 AR, Apache Junction, Arizona 85220.

## EQUIPMENT FOR SALE

**Charrette/Corbu Stencils:** The original French lettering and numbering stencils as used by LeCorbusier. Available in fourteen sizes. Made to last a lifetime. Ideal gift for architect. Available at our New York and Cambridge stores. Mail orders and information: Charrette Corporation, 2000 Massachusetts Avenue, Cambridge, Massachusetts 02140.

## Classified Section Non-Display Order Form

To place a non-display advertisement, fill out this form, including your name, street address, city & state with ZIP code, attach it to a separate sheet containing your advertising copy, and mail it to:

ARCHITECTURAL RECORD/  
 P.O. BOX 900  
 NEW YORK, N.Y./10020

Rates: \$5.25 per line, minimum insertion three lines, six words to a line, box number counts as one additional line. Display rates on request.

Payment Enclosed \$ . . . . .  Bill me

Use Name & Address  Use Box No.

Advertisement to appear . . . . . time(s)

.....  
 Signature

The firm of Hartrampf, Powell & Associates has moved to larger offices at 180 Allen Road, Northeast, Atlanta, Georgia, and will change its name to **Hartrampf/Powell, Inc.**

### New associates, promotions

**Reyner Banham** has joined the faculty of the State University of New York at Buffalo School of Architecture and Environmental Design.

**Barbara Gray** has rejoined William L. Pereira Associates as a vice president.

**Wallace J. Toscano**, architect, has joined the firm of Karlsberger and Associates of Columbus, Ohio as director of design.

Sverdrup & Parcel and Associates, Inc. announces the appointment of **Frederick W. Lyman** as manager of landscape architecture.

**Ernest R. McCamman** has been appointed executive vice president of Giffels Associates, Inc.

**Chancy M. Lott**, AIA of William L. Pereira Associates has been named assistant managing director.

Psomas & Associates has announced the appointment of **Joel C. Silverman** and **Don P. Jones** to the positions of vice president.

Sverdrup & Parcel and Associates, Inc. announces the appointment of **N. Bradley Susman** as manager of economics and marketing research.

Day & Zimmerman, Inc. announces the following promotions: **John P. Follman** to vice-president-administration; **Charles Graves** to vice-president-marketing; **Marvin Nadel** to additional post of vice-president-corporate development; **Darryl W. Copeland** to the presidency of Cole-Layer-Trumble Company, subsidiary; **John B. Handlan** to the presidency of the firm's H. L. Yoh Company Division.

Cole Associates announces the following promotions: **Louis J. Polman** to vice-president for operations; **William Moe** to vice-president for marketing; **Donald Appenzeller** to vice-president for architecture; **Gary Reeder** to vice-president for engineering; **William Andrews** to vice-president at the Chesterton office; **James Burkart** to vice-president at the Indianapolis office; and **Paula Jones** to assistant secretary for administration.

### Errata

In the mid-October issue, Product Reports 77, item 143 on page 47 is manufactured by the William L. Marshall Division of Balfour, MacLaine International Ltd., at 450 Park Avenue South, New York, New York 10016. We regret that William L. Marshall Division did not receive proper credit.

In our story on the Basking Ridge Complex of the American Telephone and Telegraph Company, page 16 of the Mid-October 1976 issue, we failed to credit ISD Incorporated as part of the team responsible for design integration of the interior systems.

In the November 1976 issue, on page 151, we erroneously stated the light transmittance of the Rohm and Haas Company product, *Tuffak-Twinwal*. The correct light transmittance is about 80 per cent, according to the company.

# Thinking about an ice rink?

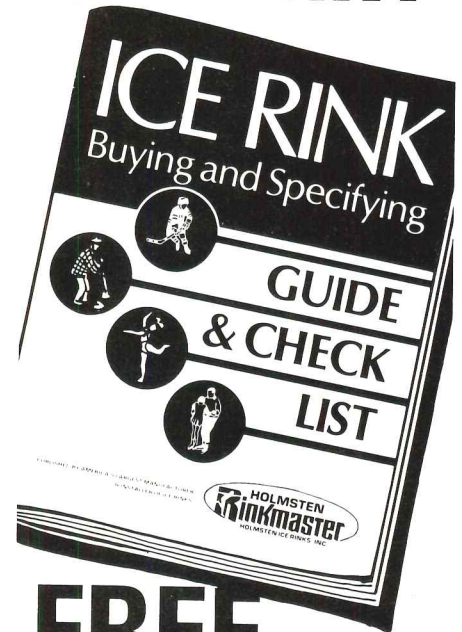

**FREE** FROM  
**HOLMSTEN**  
 AMERICA'S LARGEST  
 MANUFACTURER &  
 INSTALLER OF ICE RINKS.

This 28 page guide explains the different kinds of ice rink refrigeration systems with cost and feature comparisons.

For your free copy, just write or call us.

If you are planning a new rink . . . or modernizing a present ice skating facility . . . **this guide will save you time and money.**

Whatever your ice rink needs . . . from planning to the finished rink . . . call on the Holmsten Ice Rink organization . . . by far the most experienced team of ice rink engineers and installers.

*SINGLE SOURCE . . .  
 TOTAL RESPONSIBILITY . . .  
 from the rough grade to the  
 finished rink in operation.*

**HOLMSTEN ICE RINKS, INC.**  
 2301 Como Avenue  
 St. Paul, Minnesota 55108  
 612-646-8625

For more data, circle 131 on inquiry card

# CLASSIFIED SECTION

POSITIONS VACANT

POSITIONS VACANT

POSITION WANTED

## Director Of Inspection & Permits (CODE SUPERINTENDENT)

Modern City in Central Illinois "A Pleasant Place To Live" is seeking an experienced individual with previous background in administration of building, plumbing, HVAC, and electrical codes. Degree in Architecture or Engineering helpful but equivalent in experience could qualify. Salary in High Teens to Lower 20's commensurate with experience. Outstanding benefit program. Send resume with salary history to Director of Personnel:

### City of Champaign

102 N. Neil St., Champaign, IL 61820

we are an affirmative action equal opportunity employer m/f

### VOLUNTEER PEACE CORPS/VISTA

Architects/planners needed for Peace Corps projects in Latin America, Africa, Asia; VISTA projects in U.S. Housing projects, design of schools, hospitals, community centers, rehab., university teaching, regional planning, etc. Expenses paid: travel, medical, vacation and living. U.S. citizens, singles or couples only. Information: Cynthia Poindexter, ACTION, Box A-1, Washington, D.C. 20525.

**University of Petroleum and Minerals—Dhahran, Saudi Arabia**—The Department of Architectural Engineering, University of Petroleum and Minerals, Dhahran, Saudi Arabia, will have faculty positions open for the Academic Year 1977-78 starting 1 September 1977. Qualification includes Master's degree plus teaching and/or practical experience. Candidates with PhD degree in Architectural Engineering are desirable. English used for instruction. Minimum regular contract for two years, renewable. Competitive salaries and allowances, free air conditioned and furnished housing, free air transportation to and from Dhahran each two year tour. Attractive educational assistance grants for schoolage children. Local transportation allowance in cash each month. All earned income without Saudi taxes. Ten-month duty each year with two-month vacation paid and possibility of participation in University's ongoing Summer Programs with adequate additional compensation. Apply with complete resume on academic and professional background, list of references, publications and research details, and with copies of degrees/testimonials, including personal data, such as, home and office addresses, telephone numbers, family status (names of children, age and sex) to: University of Petroleum and Minerals, c/o Saudi Arabian Educational Mission, 2223 West Loop South, Suite 400, Houston, Texas 77027.

**Architect Designer: Position available with a multi-disciplined nationally known design oriented AE firm.** Must have a minimum of five years experience and be a lead designer with demonstrable skills in conceptualization of a broad range of architectural projects. Should be capable of functioning individually and as a member of project oriented design teams. Duties require developing and managing projects from pre-design client contact through design and contract documentation to job completion. Professional Registration required. Send resumes to: Lorenz Williams Lively Likens and Partners, 2600 Winters Bank Building, Dayton, OH 45402.

### Exhibit Designer

GS-1084-11, Visual Information Specialist  
\$17,056. per annum

Air Force exhibit organization is accepting applications for position as Visual Information Specialist. Candidate must be able to handle all phases from concept through detailing. Bachelors/Industrial Design preferred, plus three years related experience. Application forms (SF-171) may be obtained from any Federal Job Information Center or Federal agency. Applications must be postmarked no later than January 24, 1977.

Submit applications to: 2750TH ABW/DPCEE, Wright-Patterson AFB, OH 45433. Qualified candidates will be required to submit portfolios and supplemental information. For additional information call collect for Mr. Dixon or Mrs. Gropper. AC 513/257-6363, 9 a.m. - 3:30 p.m. EST

AN EQUAL OPPORTUNITY EMPLOYER

**California State Polytechnic University, Pomona** announces a vacancy in the position of Dean of the School of Environmental Design. The Dean is the harmonizing force and projects the philosophical leadership in the School for the three disciplines of Architecture, Landscape Architecture, and Urban Planning. The School offers both bachelor's and master's degrees in these disciplines. Candidates must have a professional master's degree and possess teaching and professional experience in one of the disciplines, preferably in more than one. Three years responsible administrative experience is also required. Full membership in at least one professional society is desirable. Send resume and application or letter of intent, in confidence, before January 31, 1977, to Dr. Kenneth H. Anderson, University Dean for Academic Affairs, California State Polytechnic University, Pomona, 3801 W. Temple Ave., Pomona, CA 91768, Attention: Charlotte Bray. An equal opportunity/affirmative action employer.

### POSITION WANTED

**Financial Executive—Heavyweight—Listed co. V.P., Contoller—CPA (Big 8 exp.)—Attorney—Acquisitions, financial controls, taxes, Exp'd. real estate, construction industries.** Combines technical skills with imagination. \$28-32,000 required. For resume: PW

**Architect/Planner: 36, family, multiple degrees, NCARB, principal of firm.** Comprehensive experience in top-level management, marketing, conceptual design, financing & client relations for large-scale hospital & Fortune 500 clients. Interested in partnership/equity position with architectural, consulting, or real estate firm. Consider part-time consulting arrangement. Reply Box: PW-3698, Architectural Record.

**Designer/Draftsman—B. Arch, Assoc. Arch Eng, 9 yrs experience** all phases architectural drafting seeks design/drafting position. Southern Rockies region preferred but will consider other locations. Resume' available upon request. PW-3941, Architectural Record.

### SELLING OPPORTUNITIES AVAILABLE

**MFG. REPS. Wanted. Several territories now open for Spec. oriented individuals & unique patented Plaster in a Roll™ by Flexi-Wall.** See our ad in Architectural Record. Flexi-Wall Systems, P.O. Box 477, Liberty, S.C. 29657.

### PROFESSIONAL SERVICES

#### MATERIALS HANDLING CONSULTANT

**DISTRIBUTION CENTERS**  
Warehousing and Storage Arrangement  
Equipment Design and Specifications

Twenty Years of Successful Practice  
Metropolitan New York  
Fee or Per Diem

**PETER GONDELL**  
19 Crest Drive · White Plains, N.Y. 10607

**EXTERIOR MAINTENANCE  
CONSULTANTS**  
for High Rise Buildings  
"Investigate the benefits of a new concept in consulting!"

**VERTA CORPORATION**  
8120 Penn Avenue South, Suite 548  
Minneapolis, Minnesota 55431  
(612) 884-8822

### BOOKS

**Europe: Architectural Guide 1860-Today** by Jeryll Habegger. 13 countries-500 Bldgs. with address, architect + date. 150 Illus. \$4.50  
Order from: Architectural Guidebook, 421 West Belden, Chicago, Illinois 60614.

### OVERSEAS JOBS GUIDE

**Job Hunters Guide & Directory of 600 firms.** \$6.00 + \$.50 P&H (US \$ check or MO only). Foreign-add \$2.00. Friar Books, Dept. AR, 8956 E Ardenale, San Gabriel, CA 91775.

When Answering

## BOX NUMBERS

to expedite the handling of your correspondence and avoid confusion, please do not address a single reply to more than one individual box number. Be sure to address separate replies for each advertisement.

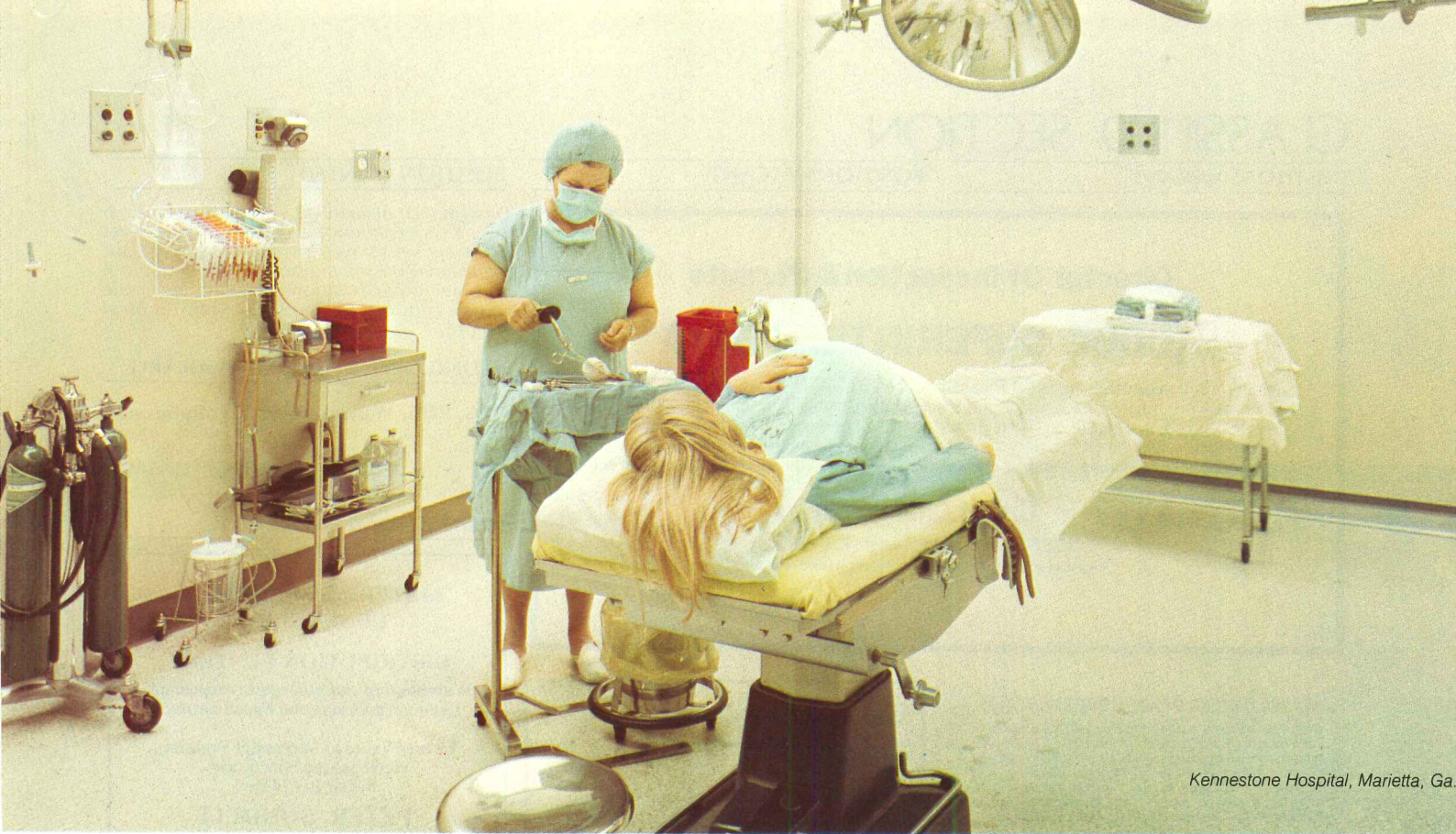

*Kennestone Hospital, Marietta, Ga.*

**For high-use interior walls... If cost is no object, consider mud-set tile. If it is, specify Glasweld.**



*Kennestone Hospital, Marietta, Ga.*



*New School for Social Research, New York, N.Y.*



*Castillo Jr. H.S., San Jose, Calif.*

Glasweld International, one of the world's largest producers of mineral fiber cement products, has adapted its well-established line of exterior cladding materials to an entirely new spectrum of interior building and design applications.

If your wall requirements include:

- Abrasion resistance and surface hardness
- Color fastness and optical

flatness  FDA-approved surfaces (to inhibit dust or bacteria build-up)  Incombustibility (0-0-0)  Chemical, stain and graffiti resistance.

Glasweld can prove an outstanding value in both performance and economy. Check the alternatives. You'll find that competitive materials (tile, porcelain enamel, gypsum, etc.) vary in their ability to satisfy the most demanding requirements. Glasweld meets them all. The same standards of excellence that have popularized Glasweld's exterior wall facings on scores of commercial, institutional and high-rise residential structures have been applied to the new interior line. Before you detail your next building or remodeling project, take a hard look at the durability, aesthetic appeal, economy and performance characteristics of Glasweld. For our latest catalog, write:

**G Glasweld International**  
 One Embarcadero Center  
 Suite 611  
 San Francisco, California 94111  
 (415) 981-3385

*For more data, circle 5 on inquiry card*



*Mobil Oil drilling rig living quarters, Gulf of Mexico*



*Coca-Cola plant, Pembroke Pines, Fla.*



*Corpus Christi Bank & Trust Tower, Corpus Christi, Tex.*



**Jennison-Wright Kreolite Wood Block Floors** are adding new life to all sorts of establishments. The naturally beautiful effects of wood, and particularly end grain wood, have captured the imagination of eclectic owners, architects and designers. Though end grain wood blocks were originally created for industrial floors and have served that purpose long and well (for over 60 years) our new process using a clear, transparent

preservative has opened up many new fields for this handsome product. (Developers of shopping centers, book stores, restaurants, etc., please take notice) It not only enhances

**blocks blend beautifully** at Abercrombie and Fitch, too!

its environment with mellow warmth and charm, but it also offers extreme durability and relaxing "softness" for tired feet—and jangled nerves. This is truly a luxury floor that deserves the acclaim it is receiving. We'll welcome your expression of interest. Please write us .

The Abercrombie & Fitch Store, Oak Brook Plaza in Oak Brook, Illinois

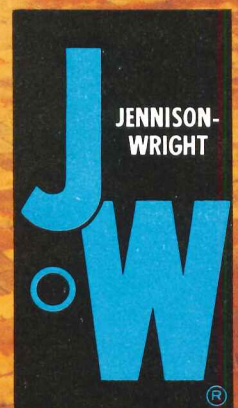

**The Jennison-Wright Corporation**, P.O. Box 691, Toledo, Ohio 43694 . . . you'll find us in Sweet's Catalog and in the Yellow Pages

*For more data, circle 133 on inquiry card*

# Super-C Steel Framing can cut your in-place costs.



Super-C Steel Joists and Studs, developed by U.S. Steel, are pre-engineered to install faster, with less labor cost and virtually no waste. So your in-place costs can be lower than with other framing systems.

Steel is strong, so you can use fewer members than wood—and spacings can be wider (usually 24" O.C.). Wall sections can be prefabricated, on or off site, and set in place as a unit.

And Super-C framing is dimensionally stable. Members won't warp, swell, shrink, or rot—even in bad

weather. You should never have to replace a joist or stud—with all the costly re-wiring and plumbing that involves. Super-C Steel Framing assemblies can have 1-hour and 2-hour fire resistance ratings.

Super-C Joists and Studs come pre-cut to specified lengths. Virtually no waste time or material in the field. And they're pre-punched to speed wiring and plumbing.

They work well with any form of construction. Use them separately—or as a complete framing system. Fast delivery and technical service are available from an independent licensed fabricator serving your area.

For more information, see our catalog in Sweet's Architectural File (5.3/Uni). Or mail this coupon for a detailed booklet on both Super-C Steel Joists and Steel Studs.

**United States Steel**



*For more data, circle 128 on inquiry card*

**Super-C  
Steel Joists  
and Studs**

United States Steel, P.O. Box 86 (C546-2)  
Pittsburgh, Pa. 15230.

Please send me information on Super-C Steel Joists and Studs.

Name \_\_\_\_\_

Title \_\_\_\_\_ Firm \_\_\_\_\_

Address \_\_\_\_\_

City \_\_\_\_\_ State \_\_\_\_\_ Zip \_\_\_\_\_

Phone (include area code) \_\_\_\_\_



# Quality Endures

In 1600 it took a German craftsman more than a year to create this unique five-bolt castle lock.\*

Schlage's Double Security "G" Lock is built in the same tradition of quality and craftsmanship that has enabled the master locksmith's art to endure.



## SCHLAGE.

The World's Most Respected Name in Locks!

For a set of Antique Lock Posters write: Schlage Lock Company, P.O. Box 34186, San Francisco, CA 94134  
Use Reader Service Card for product literature.

# WILTONS

BY

## Scalamandré

### BRITANNIA COLLECTION

27" WIDE, 80% WOOL, 20% NYLON

EXCLUSIVE PATTERN  
"DOMINO"

950 Third Avenue (10th Floor) New York 10022

Atlanta • Boston • Chicago • Dallas • Los Angeles  
Houston • Philadelphia • San Francisco

To the trade only

For more data, circle 106 on inquiry card

# recycle roof decks!

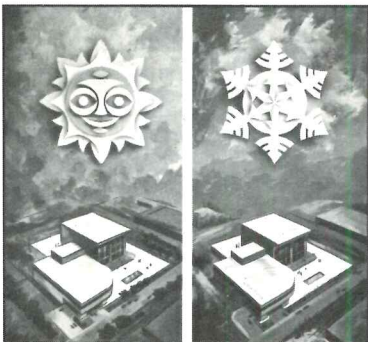

**All-weather Crete**  
re-roof insulation

7  
MULTI-PURPOSE  
INSULATION  
1976

**add slope to drains and insulation  
with one material...All-weather Crete.**

Get the facts in this free re-roof guide describing how All-weather Crete insulation helps you solve re-roof problems once and for all...and in most cases without a tearoff! Save costs, save energy, save roofs!



**SILBRICO CORPORATION**  
6300 RIVER ROAD • HODGKINS, ILLINOIS 60525  
CHICAGO PHONE (312) 735-3322

For more data, circle 105 on inquiry card

## Eliminate leakage at butt joints.

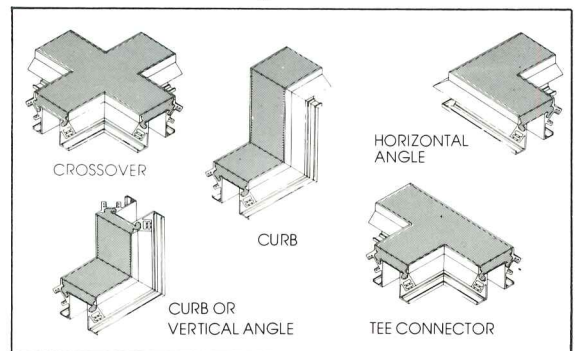

## Make the transition to Elastalum expansion joint seals.



Elastalum, the first and only engineered expansion joint system, makes joint covers obsolete. Our 360° omni-directional elastomeric seal completely encloses the joint. Exclusive, factory-formed transition pieces eliminate old-style leak-prone butt joint covers. Handsome, economical and easy to install.

Accessories available include: Tees, Y's, cross-overs, curbs, and vertical or horizontal angles.

Write or call today for free 16-page Elastalum Catalog.



**CONSTRUCTION SPECIALTIES, INC.**

P.O. Box 380, Route 405, Muncy, PA. 17756 (717) 546-5941  
725 Twin Oaks Valley Rd., San Marcos, CA. 92069 (714) 744-0300

For more data, circle 107 on inquiry card



Open-Plan SpanAcoustic®  
Fiber Glass Panels

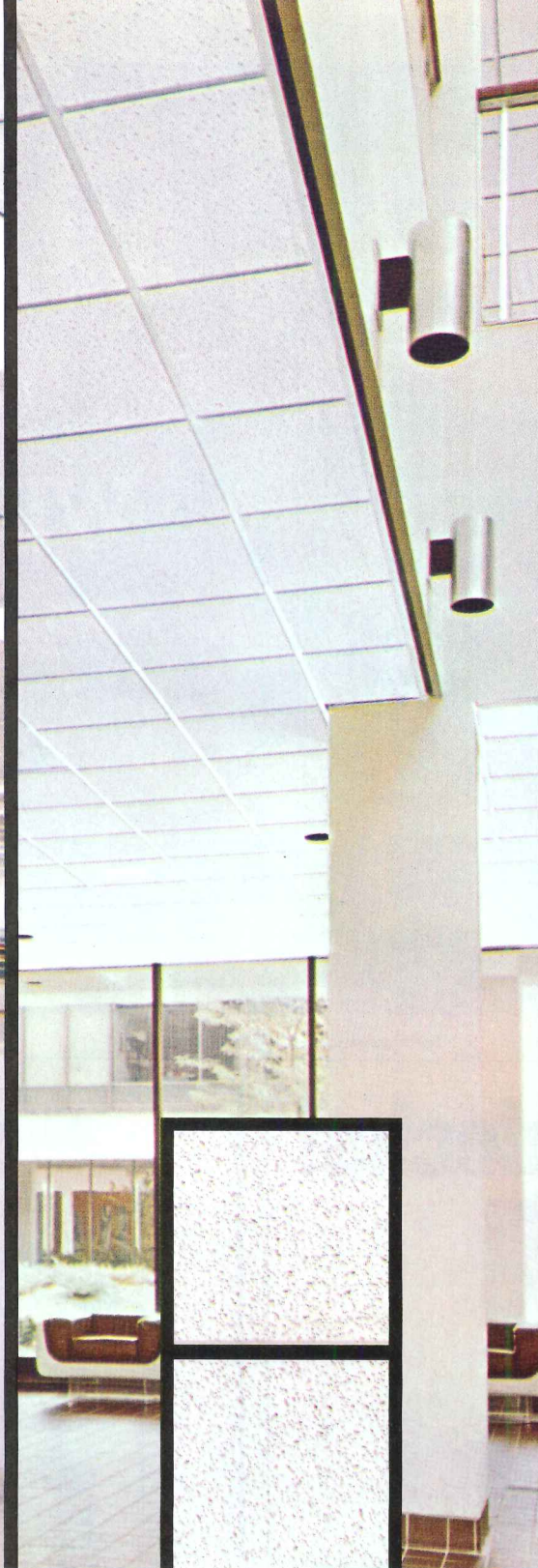

Quadrette®  
Reveal Edge Panels



Spintone® and Firedike®  
Felted Mineral Panels:  
360, Concord, DCF

J-M offers a selection of acoustical materials in almost unlimited sizes, textures and patterns to expand your design possibilities. Even in the face of tight budget restrictions.

Choose felted mineral tiles and panels for durability and dimensional stability. Or sculptured fiber glass panels to emphasize ceilings in large open areas like shopping malls and auditoriums. Or fiber glass panels that meet GSA speech

privacy requirements in open plan office landscaping.

We also have special purpose tiles and panels for clean rooms, high humidity areas, access ceilings, ventilating ceilings, for ease of maintenance and for fire safety. All feature excellent acoustical properties.

For information, write Johns-Manville Sales Corp., Holophane Division, Greenwood Plaza, Denver, Colo. 80217.



**Johns-Manville**

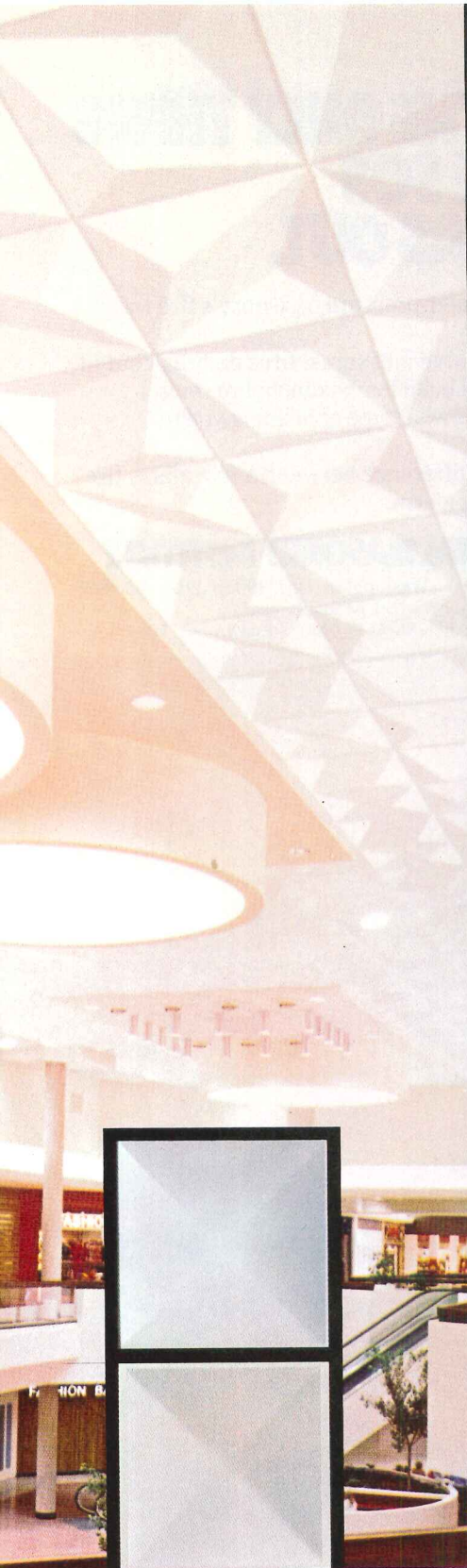

Sculptured Fiber Glass Panels:  
Prismatic®, Profile®, Acousti-Shell®



Acousti-Clad® Aluminum-Faced Tile:  
Delta, Random, Diagonal



Temper-Tone® Felted Mineral Tile:  
360, 720, DCF

# Ceilings Unlimited from Johns-Manville.

A choice of acoustical ceilings that look great  
and perform even better.

# BECAUSE OF MASONRY FIRE WALLS, THE ONLY THING THAT SPREAD FROM SUITE 503 WAS NEWS THAT THE FIRE WAS OUT.

When fire breaks out in a building, the critical concern is control. Smoke detectors and sprinklers may help. But a sure way to prevent the spread of fire and protect lives and property is with masonry fire walls, designed and built between rooms, suites and apartments for just that reason.

Masonry fire walls insure that fire will stop where it starts. And assure a flame-free exit for occupants and approach for firemen. There are no "working parts" to malfunction; yet masonry fire walls are always working to provide sound barriers and structural support even when they aren't needed to stop a blaze cold. And because they

stand up to extreme water pressure, masonry's fire rating is waterproof, too.

Despite all preventive measures, fires do break out in buildings. So design and build for maximum fire control with masonry. No matter what type of building you're designing or erecting.

It could mean the difference between a five alarm fire and very little cause for alarm.

 **INTERNATIONAL MASONRY INSTITUTE**

Suite 1001, 823 15th Street, N.W., Washington, D.C. 20005 (202) 783-3908

*For more data, circle 125 on inquiry card*

THE MASON CONTRACTORS AND BRICKLAYERS UNION OF CANADA & THE U.S.A.





Architectural Record presents...

**fifteen  
issues  
a year  
for  
architects  
& engineers** | **one  
each  
month...  
and three  
spotlight  
issues**

The editors of Architectural Record regularly throughout the year present a wide variety of editorial content specifically geared to the known interests of architects and engineers.

In addition, responding to the need of architects and engineers for in-depth presentations of significant trends and developments in major areas of interest, the editors of Architectural Record each year publish three Spotlight issues. Each is an expansion of a continuing feature in the regular issues of the Record.



**RECORD HOUSES  
AND APARTMENTS**

The annual mid-May issue devoted to the year's best architect-designed houses and apartments. More than 45,000 architect and engineer subscribers . . . plus distribution to 20,000 Sweet's-qualified builders and 4,000 Sweet's-qualified interior design offices.



**ENGINEERING  
FOR ARCHITECTURE**

The annual mid-August issue, devoted to a comprehensive survey and analysis for architects and engineers of the most significant current developments in engineering for buildings. Bonus coverage of newly active building engineers.



**PRODUCT REPORTS**

The annual mid-October round-up of the most interesting new and improved building products. Organized by the Uniform Construction Index, this "product file on the drawing board" provides a quick up date of out-of-date catalogs and literature.





# The Beaten Path

**Contract carpets that pass our tough wear tests can handle most any traffic problem.**

That's because we simulate actual high traffic conditions in our lab before we allow carpets made of Dow Badische fibers and yarns to carry our Performance Certification Label.

First, we put the unpadded sample carpet through many electronically-recorded "walk-ons." This Stair Tread Wear Test shows us if the carpet has a high degree of resistance to matting and soiling.

Then we put it through our Tetrapod Test, which simulates the kind of severe abrasion conditions a carpet would receive in year-in and year-out use.

These are just two of many critical performance and appearance retention tests a carpet must pass in order to be a Dow Badische Performance Certified product.

Next time you specify contract carpet, make sure it bears the Performance Certification label. Then you know it can take the daily grind in stride. For further help with your carpet specifying problems, contact our Contract Carpet Consultants Service and ask for our Contract Carpet Selection and Specifications Guide.

Dow Badische Company, Create Center  
Williamsburg, Va. 23185  
(804) 887-6573

**PERFORMANCE  
CERTIFICATION**



Dow Badische produces acrylic and nylon fibers and yarns especially engineered for carpets of beauty and performance.



Today, more and more architects are involved in interior design. Here, in this one volume, are some of the best, most recent examples of interior architectural design as presented in photographs, drawings, specifications and descriptions as shown in *Architectural Record*. All together, they constitute a visual and analytical definition of interiors, 1968-1973, and present fresh, striking imaginative ideas for both new and renovative construction—ideas on how to...

- ... Create interiors that express new trends and outlooks in life style
- ... Handle traditional problems in new, non-traditional ways
- ... Transform old buildings so they serve modern needs in modern ways
- ... Plan interiors for multi- and varying uses
- ... Use new materials and products creatively and functionally
- ... Make space flexible—expandable or contractable as need dictates
- ... Use graphics to both inform the viewer and please the eye
- ... Allow for both openness and privacy and to ease communication among occupants of the space
- ... House today's technological apparatus in yesterday's structures
- ... Blend "office landscapes" with "office towers"
- ... Design retail interiors to both attract and sell customers
- ... Use flexible, demountable, and portable elements
- ... Suit lighting and acoustics to purpose and desired effects
- ... Answer the needs of the experimental theater
- ... Solve the problems of the multi-use music facility.
- ... Design religious facilities to conform to new trends in religious services
- ... Adapt the home to its location and its occupants.

**All this and so much more!**

# INTERIOR SPACES DESIGNED BY ARCHITECTS

An Architectural Record Book

Edited by Barclay F. Gordon, Associate Editor, Architectural Record

- Interiors for Civic and Community Use
- Interiors for Teaching
- Interiors for Worship
- Interiors for Business
- Interiors for Selling and Display
- Interiors for Dining and Drinking
- Interiors for the Performing Arts
- Interiors for Living

256 PAGES ■ 9" x 12" ■ 800 ILLUSTRATIONS

Mail Coupon Below for 10-Day Free Examination

AR-1-77

ARCHITECTURAL RECORD  
1221 Avenue of the Americas  
New York, N.Y. 10020

Please send me *Interior Spaces Designed by Architects* (002220-8) for 10 days' free examination. At the end of that time I will remit \$27.50, plus local tax, postage, and handling, or return the volume without obligation. *This offer good only in the U.S. and subject to acceptance by McGraw-Hill.*

Print Name \_\_\_\_\_

Street Address \_\_\_\_\_

City \_\_\_\_\_

State \_\_\_\_\_

Zip \_\_\_\_\_

**PAY NOW AND SAVE MONEY!**

Remit in full with this order, plus local tax, and McGraw-Hill pays postage and handling costs. Return book in 10 days for full refund if not completely satisfied.

23K-149-4005-3





Architect: The Shaver Partnership, Michigan City, Indiana  
Design Architect: Lawrence C. Olson, Michigan City, Indiana  
Concrete Consultant: Architectural Concrete Consultants, Dallas, Texas  
Contractor: Tonn & Blank, Inc., Michigan City, Indiana  
Precast Supplier: Precast/Schokbeton, Inc., Kalamazoo, Michigan  
Ready-Mix Supplier: Russell & Feldhaus Ready-Mix Concrete Inc., Michigan City, IN

## Hospitality. Warmth. Solidarity.

The architects for the new main office of Citizens Bank of Michigan City, Indiana achieved this result for their client by using people-oriented concrete made attractive by the use of Trinity WARMTONE® cement.

The blending of precast and cast-in-place components creates a natural expression of color,

texture and strength in the midst of a beautiful park-like setting.

That's the beauty of Trinity WARMTONE. Its natural tan color is derived from the manufacturing process. There's no pigment, cement color consistency is guaranteed.

Please write for free planning guides.

trinity  
warmtone®

P. O. Box 47524 • Dallas, Texas 75247

The new cement for Creativity in Concrete. From the people who make TRINITY WHITE™.

Offices: Dallas • Houston • Tampa • Miami • Chattanooga • Fort Wayne • Oklahoma City • Lake Charles, La. • Los Angeles



General Portland Inc.

For more data, circle 123 on inquiry card



# Construction costs. The Battle of the Bulge.

Time. Labor. Materials. The high cost diet that'll bulge a construction budget. Trimming that costly bulge in washroom construction is the beginning of Bradley Washfountain savings.

Bradley Washfountains save time with rapid delivery for remodeling and fast track schedules. Only 3 plumbing connections to provide washing capacity for 2 to 8 people. Uncomplicated, fast installation that cuts the high cost of labor. And a Bradley equipped washroom has lower component and material costs than a lav-equipped washroom with the same capacity. It all adds up to a total savings of 46% to 73% on construction costs. Plus reducing the amount of space needed for washing facilities by an average of 25%.

Increasing washroom efficiency and decreasing washroom construction costs. That's a Bradley Washfountain. And that's how you can trim your construction costs. By contacting your local Bradley representative. Or write for more information on the complete Bradley line. Bradley Corporation, 9107 Fountain Blvd., Menomonee Falls, Wisconsin 53051.

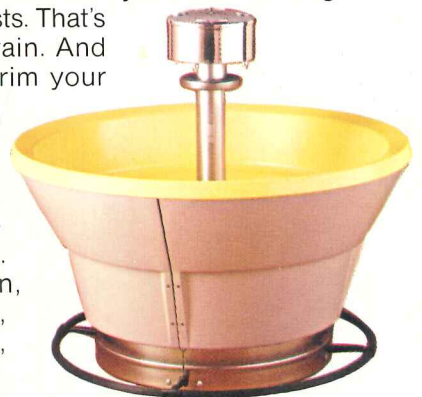

**Bradley**  **Cuts down on costs.**

*For more data, circle 122 on inquiry card*

# Plaster in a Roll™ the no problem heavy-duty wallcover that covers problem walls

Plaster in a Roll™ goes up like wall paper over every conceivable surface including *poured masonry, concrete block, plaster, gypsum board, expanded foam, metal, glass, wood and plastic.*

Easily installed by any wall covering applicator, this unique *gypsum impregnated jute* product bridges small voids, hides blemishes and bumps. An optional *anti-graffiti* protective coating provides a tough, clear, low-gloss finish, highly resistant to most common stains.

If you're involved in renovation or construction in *hospitals, hotels, motels, schools, apartments, public buildings* or any *high traffic area*...if you're looking for *lead paint hazard elimination* or want a one-step process that takes you from a problem to a finished wall...take a look at *Flexi-Wall* covering systems.

We're a one-step time and money saver which can turn your problem walls into a decorator's dream. Specify Flexi-Wall Plaster in a Roll™ where ever you would use Type III heavy duty vinyl wall-covering.

**FLEXI-WALL®**  
Plaster in a Roll™

- Comes in a roll
- A one-step process to cover problem walls
- Cost competitive
- Class A flame spread
- Lead paint hazard elimination
- Exceptionally durable
- Easy installation
- Nine million square feet in use
- Saves time and money
- Decorator look with colors and patterns
- Optional anti-graffiti protection
- Goes up fast... lasts long
- Marine approved
- Needs little or no surface preparation
- Bridges small voids
- Hides minor blemishes and bumps

(Sweet's Architectural and Interior Design Files #9.13/F1, Spec/Data File, Section 9/Wall Coverings. Means Building Construction Cost Data/Wall Covering Gypsum.)

**Call  
(803) 855-0500**

For complete architectural data and swatch book, write Flexi-Wall Systems, P.O. Box 477, Liberty, South Carolina 29657.

*For more data, circle 121 on inquiry card*

Holiday Gold #0005

Heather White #0002

New-Edinburgh Blue #0001

Glasgow Green #0004

Loch Green #0006

Lanark Yellow #0003

Rajah Blue #0008

Delhi Orange #0007

Fern Green #0018

Assam Brown #0010

Calcutta Red #0009

Talk To Us For Total Signage Systems

**800-245-6574**

We found another way to add to our total signage service. We've always done our best to offer you the very best in signage. Signage that's integrated into the building plan as a subsystem and coordinated to maximize building efficiency. Signage that's compatible enough to enhance and blend with the building's esthetics and yet remain functional.

Working with you, our Architectural Division can develop the entire signage system, fabricate it, install it, whatever it takes. Interior or exterior. And, we'll take full responsibility for the finished product.

Now, how have we added to that kind of service? With a toll-free phone number. We do a great deal of business with you by telephone, so

we decided that the one thing we could do to improve our total signage service was to make it easier for you to talk to us. All you have to do is pick up the phone and talk to us. Toll-free: 800/245-6574 (Pennsylvania calls: 412/561-3456). And you should have no trouble getting through. So talk to us. For whatever you need in signage systems—interior or exterior.

**800-245-6574**

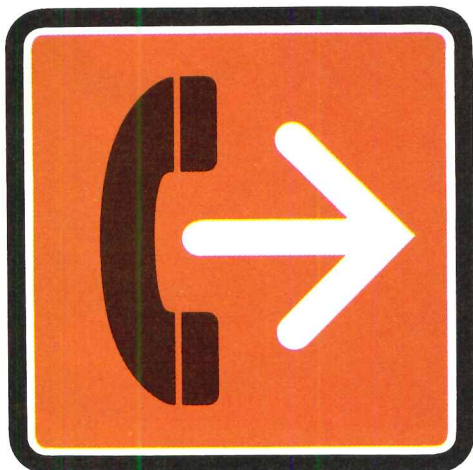

**800-245-6574**



**MATTHEWS  
Architectural Division**

1315 West Liberty Avenue, Pittsburgh, PA 15226

# Without a little soft soap,

## Halsey Taylor never would have made it.

Just about 62 years ago, a man named Halsey Taylor called on the U.S. Surgeon General with sketches for an altogether new type of water fountain projector. When the Surgeon General insisted on an actual model, Halsey Taylor bought a bar of soap, sat down on a Washington park bench and carved out the first—and now famous—twin-stream projector.

Thus, the Halsey Taylor Company was launched—on a bar of soap.

Today, we manufacture the widest selection of water coolers in the industry. And every one of them is built with high quality, heavy-duty components to deliver years of service with minimum maintenance. For example, we use corrosion-resistant regulator valves, positive start capacitors, long-life fan motors, dual temperature controls that counteract freeze-up, and overload protectors that prevent overheating.

Each of our welded unitized cabinets is topped by a polished stainless steel receptor. And most cabinets can be finished in any of eight different Polychrome colors or your choice of our vinyl clad steels. Stainless steel and PATINA bronze-tone stainless are available on selected models.

Halsey Taylor water coolers. Products you can honestly rely on. And that's no soft soap. Write for a copy of our catalog to Halsey Taylor Division, King-Seely Thermos Co., Route 75, Freeport, Illinois 61032.

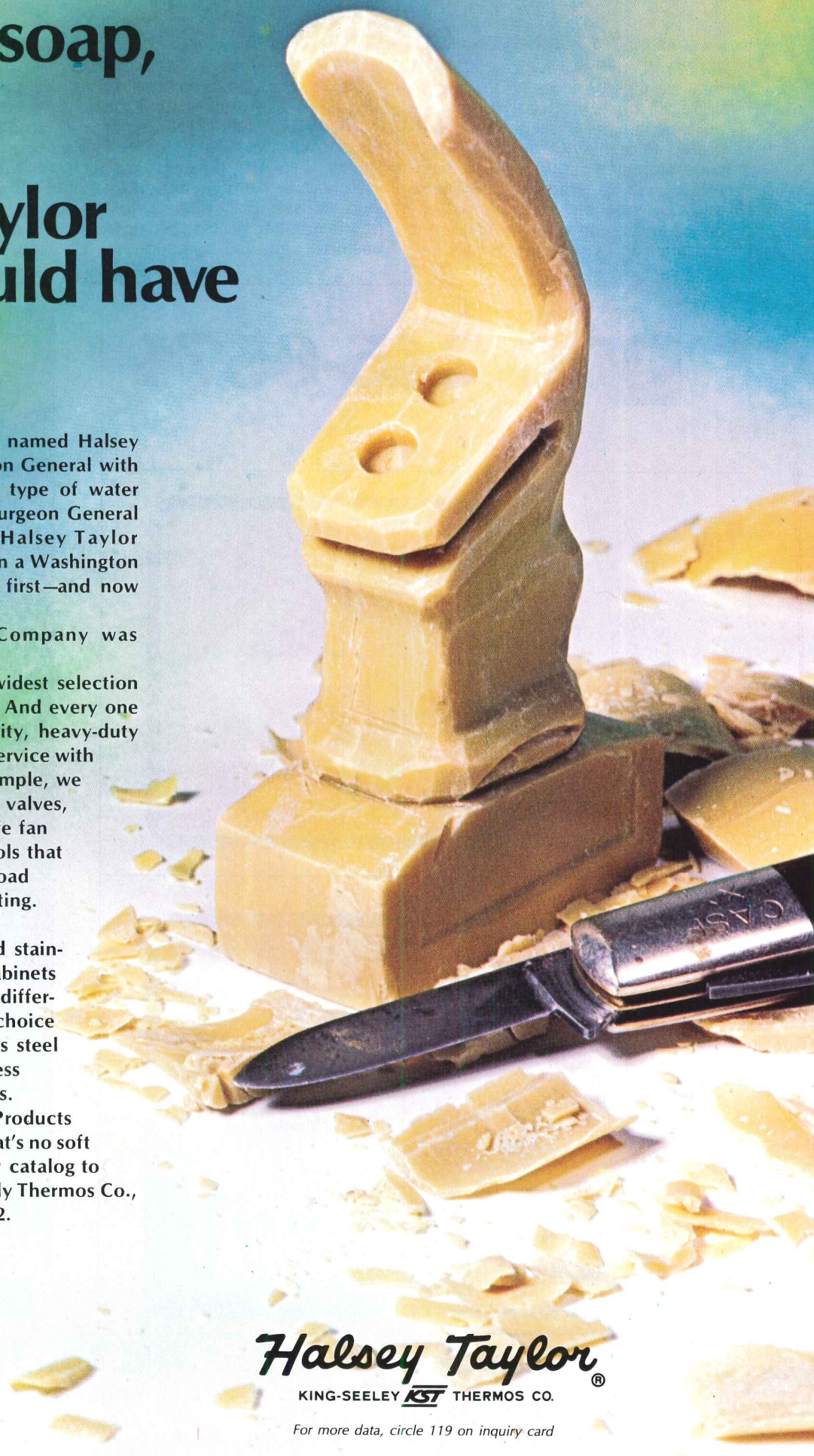

### Halsey Taylor®

KING-SEELEY **KST** THERMOS CO.

For more data, circle 119 on inquiry card



The end of boring flooring!

# The Systemic Collection

Gulistan pioneers a totally new system in contract carpeting that opens up new creative possibilities for architects, designers and space planners.

The Systemic Collection designed by Jack Lenor Larsen allows the juxtaposition of patterns and solids to actually landscape floors, define and identify areas in ways that put a definitive end to the monotony of floors.

A system in which color and fiber are common denom-

inators; with pattern, the variant.

The Collection comes in four pattern designs. In three colorways (sapphire, russet and mushroom) that coordinate with selected colorations in the Gulistan contract line. And it's made of Anso<sup>®</sup> nylon for rugged performance and soil-resistance demanded in commercial use.

**For immediate information, call us toll free 24 hours a day, (even Sunday): 800-243-5676. (In Conn.: 1-800-882-6500.)**

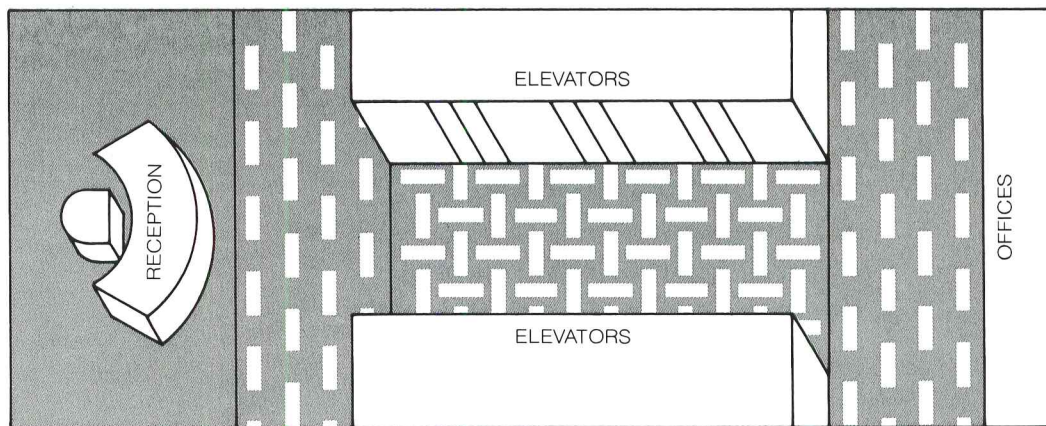

**Gulistan<sup>®</sup>**  
by J.P.Stevens

**Value right down the line.**

J.P.Stevens & Co., Inc. 1185 Avenue of the Americas, New York, N.Y. 10036

For more data, circle 118 on inquiry card

# The GF Cube. It doubles your thinking power.



The new GF Cube offers twice as many desk and console configurations as our best competitors.

That has to start you thinking. Because, this great variety of configu-

rations allows you to make better use of very expensive floor space.

The open office shown here gives you just a glimpse of the possibilities.

Ask your GF repre-

sentative to put the complete GF Cube story together for you. Or write us for literature. GF Business Equipment, Inc., Youngstown, Ohio 44501. In Canada: Toronto, Ontario.

 **Office  
Furniture  
Systems**  
GF Business Equipment

*For more data, circle 117 on inquiry card*

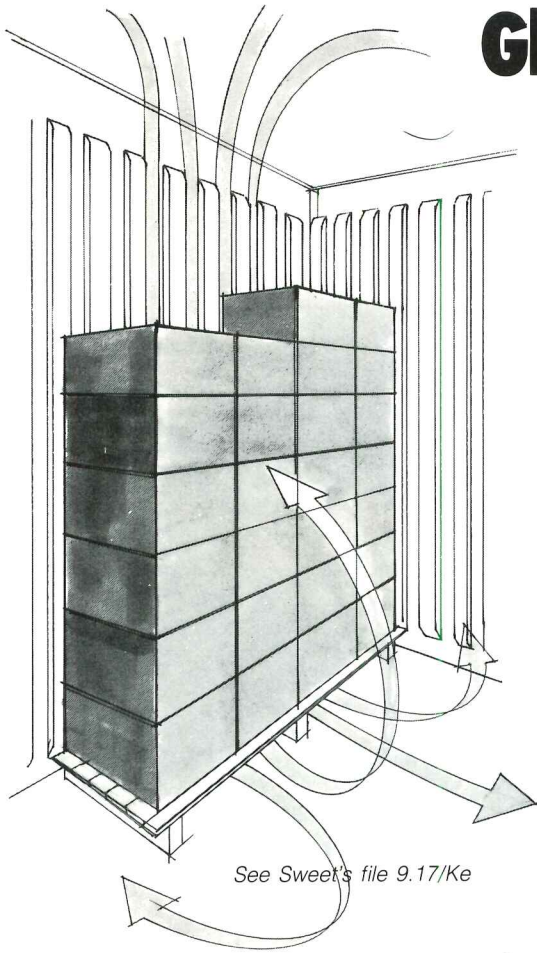

# Glasbord<sup>®</sup> ribbed panels help your refrigerators refrigerate.

## ...foodstuffs stay fresher

Glasbord ribbed panels on your cooler walls allow free flow of cold air around tightly stacked boxes, bins, and cartons. Foodstuffs stay fresher, spoilage is reduced, profits go up.

Glasbord ribbed panels are a tough, durable fiber glass reinforced plastic (frp) lining material, compression molded with protruding ribs to assure maximum air circulation at wall areas. "Hot spots" that encourage spoilage are eliminated. Panels are nonporous, stain resistant, USDA accepted.

Learn how Glasbord ribbed panels can help your refrigerators refrigerate. Get the full story today.



**KEMLITE CORPORATION**  
P. O. Box 429, Joliet, Illinois 60434

For more data, circle 114 on inquiry card

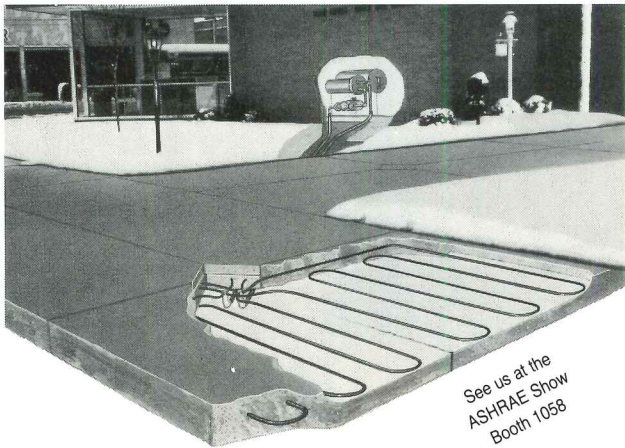

## AUTOMATIC SNOW CONTROL with GUARANTEED Reliability

The patented Hume system sets state-of-the-art performance standards for in-ground automatic snow melting. So reliable, it's backed by a full five-year pipe system warranty. Our latest illustrated brochure contains full details and system specifications. Send for your copy today.

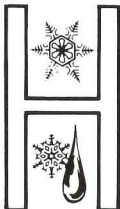

**HUME SNOW MELTING SYSTEMS, INC.**  
4405 FERNLEE AVENUE • ROYAL OAK, MICHIGAN 48073  
(313) 549-2830

For more data, circle 115 on inquiry card

## This Publication is Available in MICROFORM

from...

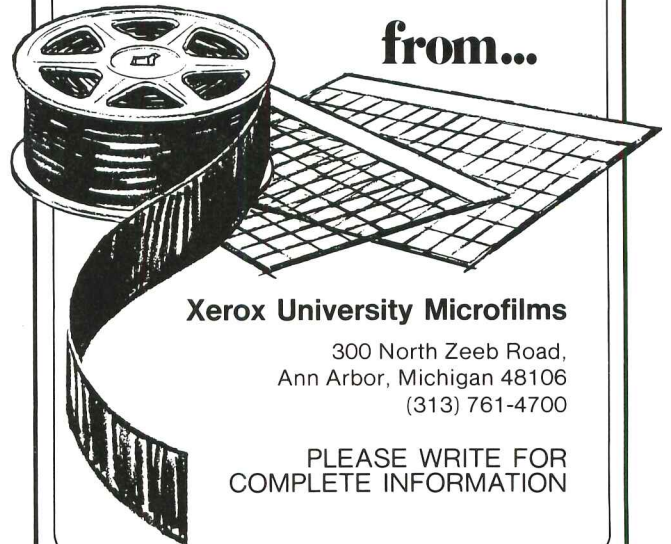

**Xerox University Microfilms**

300 North Zeeb Road,  
Ann Arbor, Michigan 48106  
(313) 761-4700

PLEASE WRITE FOR COMPLETE INFORMATION

# A new species

## MFG FRP Extren® Pultrusions

From the Blue Ridge Mountains of Virginia, a new species of basic design material has come of age for architectural use. Half fiberglass-half polyester resins. Continuously molded, FRP (fiberglass reinforced plastic) pultrusions offer new design parameters - with unique properties and construction possibilities. Pultrusions are stronger than steel pound-for-pound, lighter than aluminum, resilient as wood and dent-free. Pultrusions provide good dielectric and thermal insulation . . . and are non-corrodable to most chemicals and gases. Good weathering characteristics and permanently molded-in colors reduce outdoor maintenance needs. You'll be pleasantly surprised how easy it is to design and work with MFG Extren pultrusions. Many standard shape I-beams, angles, channels, round and square tubing, carried in stock by nationwide distributors. Ninety-nine standard shapes. Fire-resistant Series 525 also available. Color pultrusions available in mill-run quantities. Write or call for current availabilities and specifications.



**MFG**  
MORRISON MOLDED FIBER GLASS CO.  
P.O. Box 508AR  
Bristol, Virginia 24201  
Phone: 703-669-1181

# How to specify a

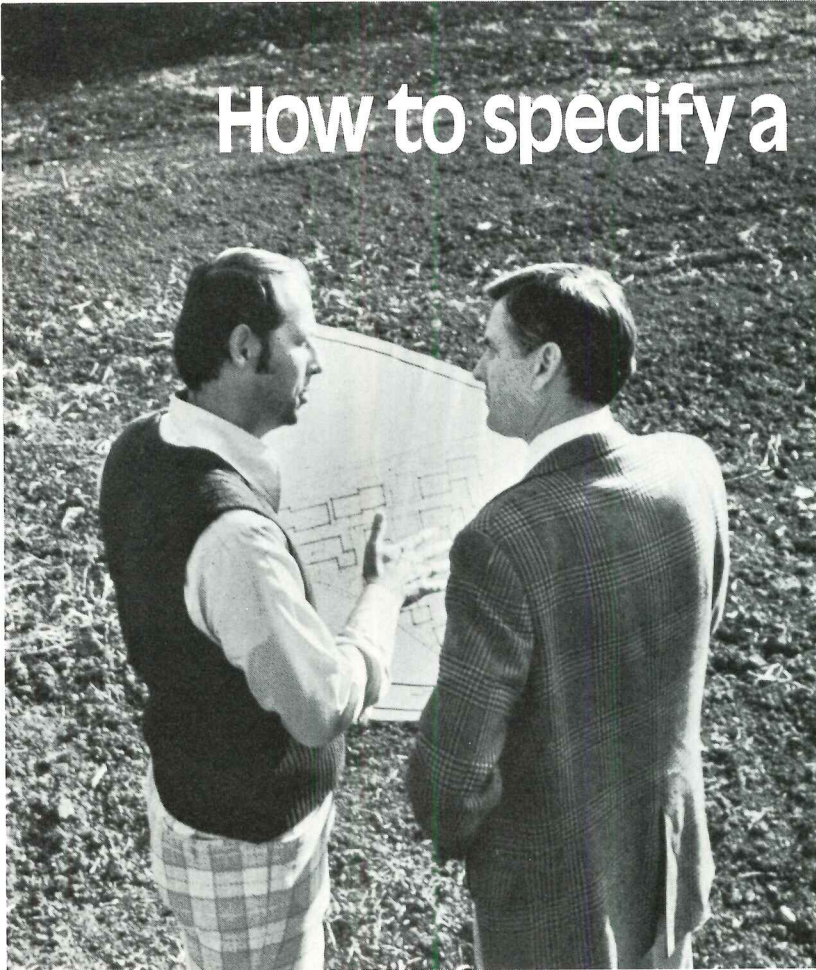

# Tennis Court.

If you're an architect or anyone who specifies tennis courts, you need the best source material available.

That's where we come in.

We've put together a brochure that provides complete information for the preparation of detailed construction specifications, and gives you facts on a variety of surfacing products.

For example, do you know what surface is best for tournament play? Or for heavy public use? What are the specs for slope, subgrade and base requirements? What you need to know about resurfacing is all there.

You can find this indispensable information in your Sweets catalog, or Spec Data, or just drop us a line. We'll send you a copy at no cost . . . and promptly, too.



**Chevron U.S.A. Inc.**

**Asphalt Division**

Mr. Jack Goldschmidt, Dept. 0 194  
P.O. Box 7643, San Francisco, CA 94120  
(415) 894-4682

For more data, circle 110 on inquiry card

**most bikeracks  
are a waste  
of money.**

**"we've  
never  
lost a  
bike"**



**Rally Racks®**  
the leading secure  
bicycle system

- Economical
- Vandal proof
- Maintenance free. No moving parts.
- Architecturally designed flexibility
- Accepts all bicycles and locking devices recommended for bicycle safety.
- Five models available that secure both frame and wheels.

A Division of:  
**Rally Inc.,** Box 779  
Mill Valley, CA 94941

For more data, circle 111 on inquiry card

**The cost of security is  
getting to be a crime**

If the growing cost of security equipment seems like highway robbery — let Detex help satisfy your specs and your client's budget limits. Here's how:

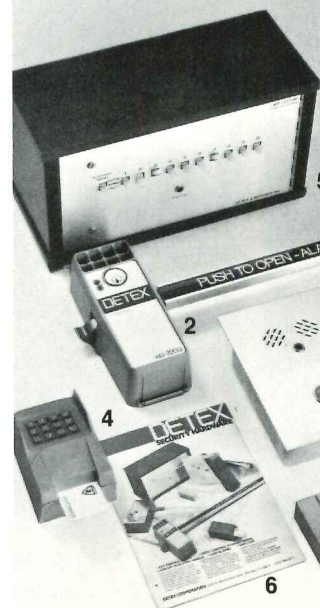

1. Locksets to lock doors electrically.
2. Exit control locks to secure emergency exits.
3. Alarms that make a fuss about unauthorized door usage.
4. Dentco Access Units using cards, pushbuttons or both.
5. Remote Indicating Panels that monitor up to 50 doors at once.
6. Our new Detex Security Catalog. We've saved you a free copy.

**DETEX**



4147 Ravenswood Ave., Chicago, Ill. 60613

For more data, circle 112 on inquiry card

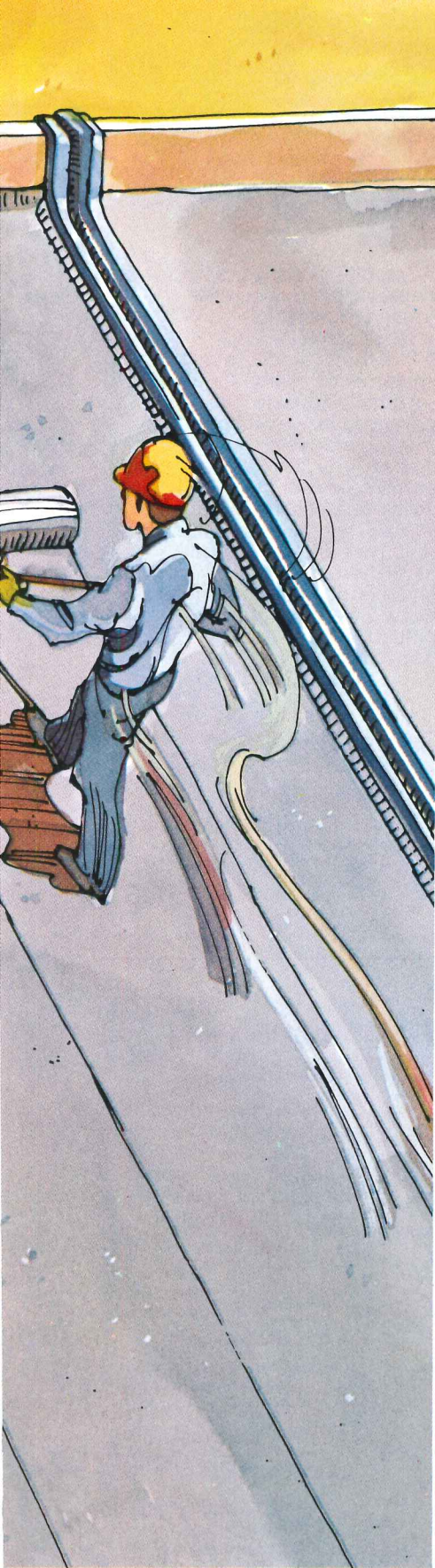

J-M Asbestos Finishing Felt.



J-M Expand-O-Flash<sup>®</sup>  
Expansion Joint Covers.



J-M Asbestile<sup>®</sup> Flashings.

Because Johns-Manville makes everything that goes into a built-up roof, you have J-M quality all the way—from the deck up.

And when those materials are applied using J-M specifications, the result is “from-the-deck-up” dependability.

Plus clear-cut responsibility for

the performance of all J-M materials in the finished assembly when a J-M Guarantee is issued.

That's why a J-M built-up roof really makes sense. And saves a lot of dollars in the long run.

Need help with roofing problems? Write Johns-Manville, Box 5108, Denver, Colorado 80217.

*For more data, circle 109 on inquiry card*



**For single-source  
built-up roofing systems.**

**JM Johns-Manville**



J-M Asbestogard™ Vapor Barrier.

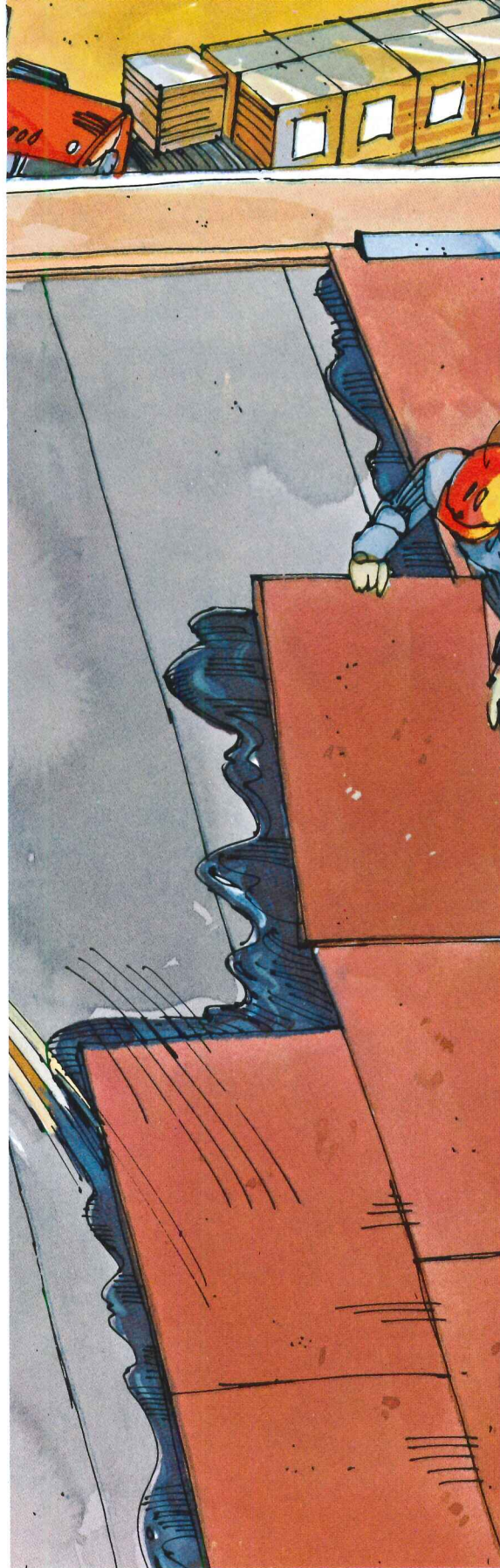

J-M Fesco® Board or  
Fesco-Foam™ Roof Insulation.



J-M Centurian® Asbestos Base Fel

**When J-M covers a roof,  
J-M really covers a roof.  
It's called one-source  
material responsibility.**

**These platform wedgies have traipsed through the aisles of the Huntington Mall for the past 2 years.**

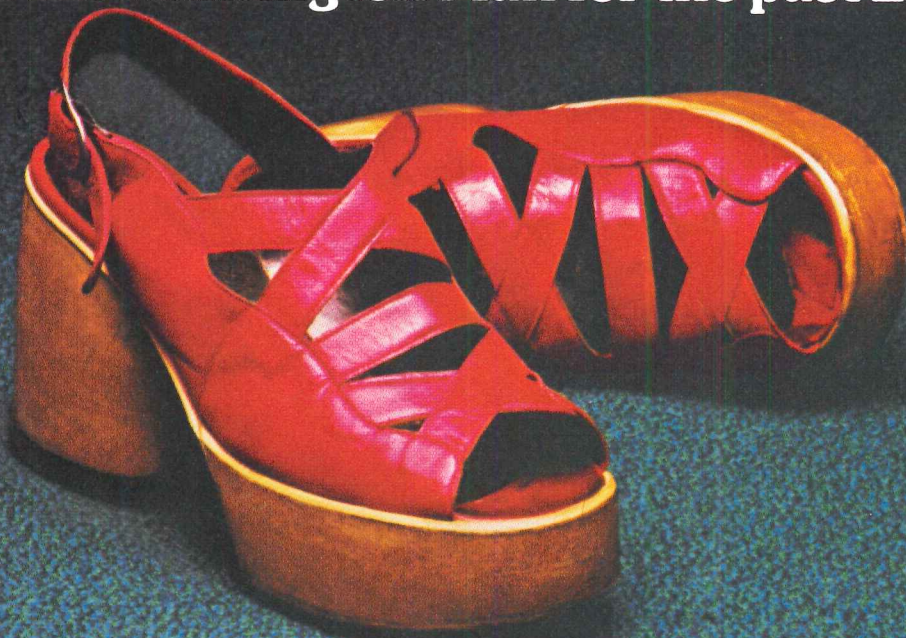

**Good thing the floors are carpeted with Anso® Nylon. It's guaranteed for 5 years.**

What a pair of funky feet can do to a carpet is enough to make a designer wince. Soil it. Stain it. Even stomp to some rock tune on it.

That's why the designers of the Huntington Mall in Melville, New York chose to carpet the 75,000 foot expanse with carpet of Anso nylon. It's the second-generation, anti-soil nylon that resists dirt and stains and is easily maintained.

Only carpet of Anso has the Guarantesth®: the guarantee with teeth. Your assurance that if any portion of the carpet wears more than 10% in five years, Allied Chemical will replace it—free.

The Guarantesth also applies to Anso-X, the anti-shock version of Anso nylon. Carpets of Anso-X are also guaranteed anti-static for the useful life of the carpet.

All types of shoes pass through the aisles here. But carpet of Anso nylon is tough enough to withstand the traffic. Discover why more and more specifiers prefer it to all other nylon fibers. For more information write or phone: Allied Chemical Corporation, Fibers Division, Contract Department, 1411 Broadway, New York, New York 10018. (212) 391-5069.







# TEN BY WARREN PLATNER

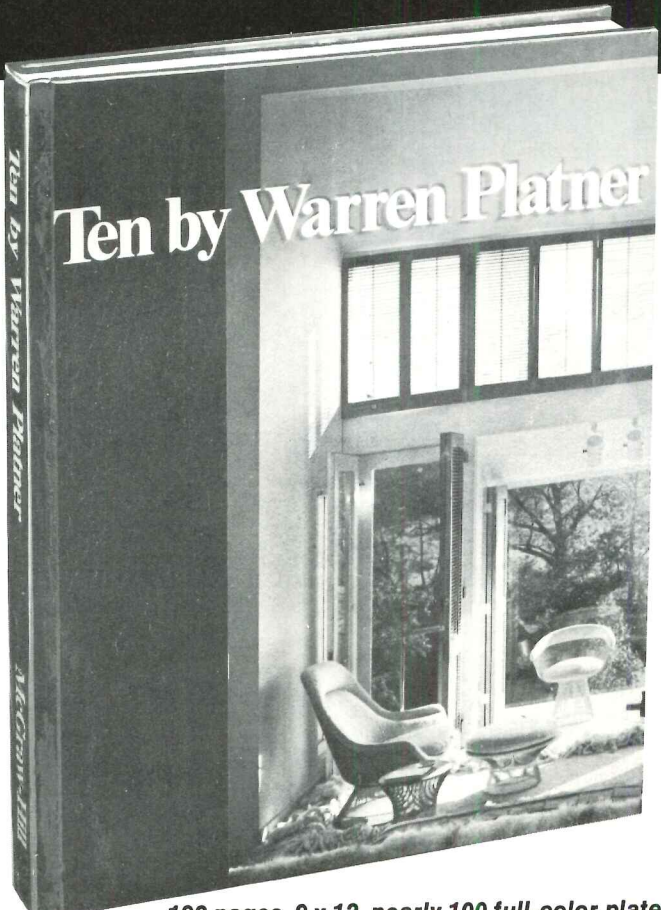

193 pages, 9 x 12, nearly 100 full-color plates

## See how 10 ordinary assignments are turned into small masterpieces of architecture.

Warren Platner. One of America's most honored architects, interior designers and designers of furniture, lighting, and other architectural elements. His buildings have been described in many languages. Furniture of his design is in use the world over. And his views of architecture and related fields are widely sought after.

**TEN BY WARREN PLATNER.** Now, in this impressive 193-page pictorial volume, Platner provides an intimate view of ten of his most superbly beautiful creations. A restaurant. Office building. Library. Private home. Design center. Showroom. And others.

You'll see how Platner, with a sure eye and an impeccable sense of style, creates dazzling architectural effects while balancing textures, shapes, light, proportions, colors, materials, and all the other elements of an architect's palette.

**Brilliant full-color photography illuminates the work.** Platner's creations speak for themselves through the magnificent artistry of leading architectural photographers. Vivid full-color photographs enable you to get the full impact of Platner's gifted imagination.

TEN BY WARREN PLATNER . . . a book so dramatic, so outstanding in content and design, that it may well influence the ideas and thinking of contemporary masters in its field. Get your copy now. Available in bookstores. Or return the coupon below for a free 10-day examination.

AR-1-77

**ARCHITECTURAL RECORD**

1221 Avenue of the Americas  
New York, N.Y. 10020

Please send me Ten by Warren Platner (050285-4) for 10 days' free examination. At the end of that time I will remit \$24.50, plus local tax, postage, and handling, or return the volume without obligation. This offer good only in the U.S. and subject to acceptance by McGraw-Hill.

Name \_\_\_\_\_  
Address \_\_\_\_\_  
City \_\_\_\_\_  
State \_\_\_\_\_ Zip \_\_\_\_\_

**PAY NOW AND SAVE MONEY!**  
Remit in full with this order, plus local tax, and McGraw-Hill pays all postage and handling costs. Return book in 10 days for full refund if not completely satisfied. **23K201-4005-3**

# cambay



## R-WAY

R-WAY FURNITURE COMPANY • Sheboygan, Wisconsin 53081 • Phone Area 414-457-4833

SHOWROOMS • CHICAGO NEW YORK DALLAS MINNEAPOLIS SAN FRANCISCO SEATTLE

*For more data, circle 104 on inquiry card*

# Copies Still Available for Purchase!

# HUMAN SETTLEMENTS

## The May 1976 Issue of Architectural Record

Featuring the winning designs in the International Design Competition for the urban environment of developing countries—focused on Manila

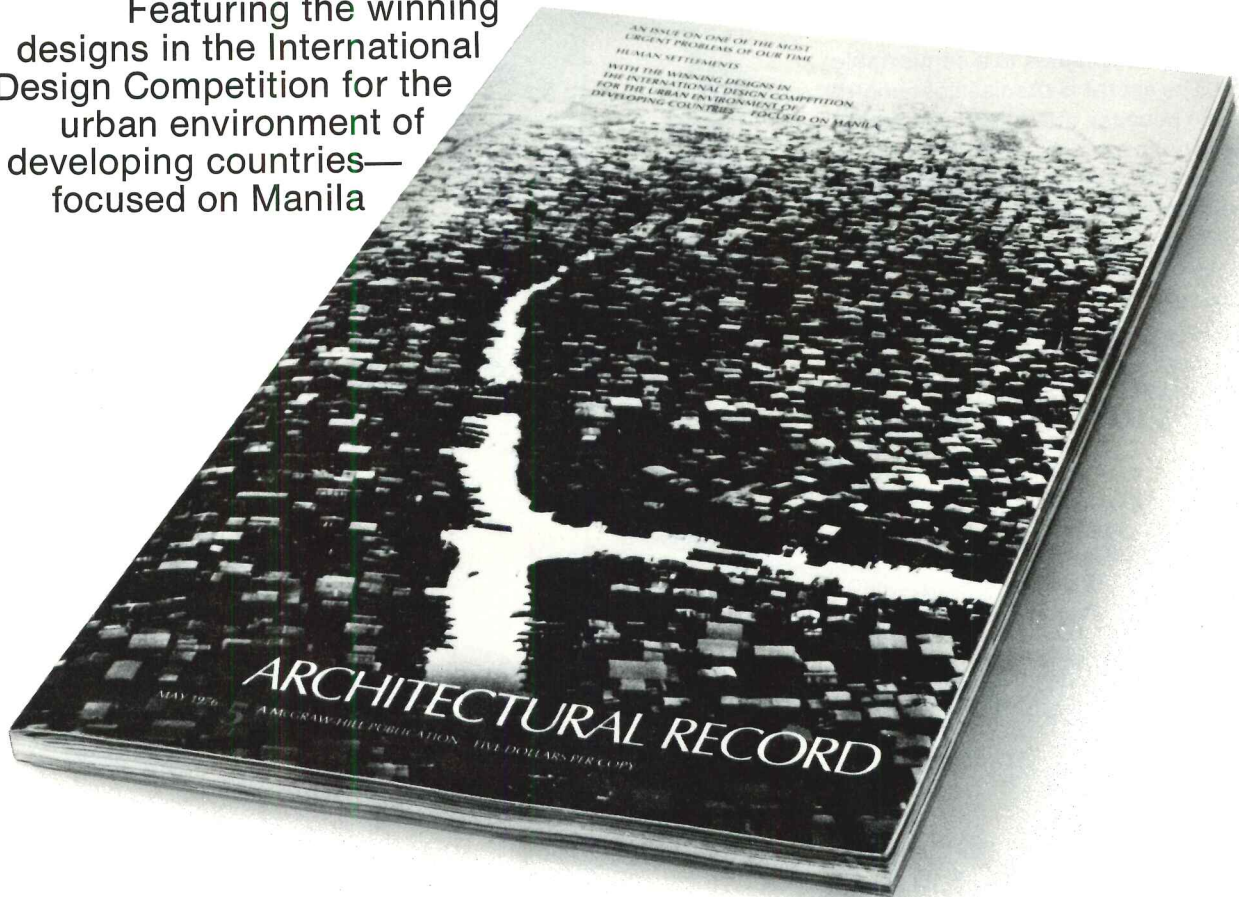

### Here's what People Around the World are Saying About It!

"An essential document for all who still think the world can be made a better place."  
—William Houseman, Editor, *Environmental Monthly*

"Truly remarkable...this kind of magazine issue is a reflection of a proud profession stating goals of great import."  
—John D. Bloodgood, AIA, Des Moines, Iowa

"Most striking about the solutions...is the fact that the architects stuck with local building products available, and included huge elements of self-help..."  
—Richard W. O'Neil, Housing Advisory Council, Ltd., Lakeville, Conn.

"Ian Athfield's design is innovative in its concept, creative in its solution, timely in its message, and sensitive in its response to human needs and human aspirations."  
—Robert Spillman, AIA, Bethlehem, Pennsylvania

Thousands of architects, engineers, planners, government officers around the world are studying the design solutions featured in this important issue. Thousands of designs were submitted—and you can see the top prize winners and the honorable mentions, plus an entire section devoted to innovative and useful design ideas from the non-premiated entries.

Beyond the firms that entered and succeeded in this important competition, the real winners are the people from the site in Manila who will occupy the new development that First Prize winner Ian Athfield will create from a grant from the Philippine government. The other winners are the architects, engineers, and planners who will read this outstanding May issue filled with bright, new ideas—not just for urban settlements, but for all forms of architecture.

You can still obtain copies of this May issue. Just send \$5.00 for surface mail, or \$10.00 for air mail, to Architectural Record, May Issue, 1221 Avenue of the Americas, New York, New York 10020

**Architectural Record, May Issue**  
1221 Avenue of the Americas  
New York, NY 10020

Please send me \_\_\_\_\_ copies of the May, 1976 issue on Human Settlements. Please send them via surface mail (@ \$5.00 each) \_\_\_\_\_; by airmail (\$10.00 each) \_\_\_\_\_.  
add sales tax where applicable.

Name \_\_\_\_\_

Address \_\_\_\_\_

City \_\_\_\_\_

State \_\_\_\_\_ Zip \_\_\_\_\_

# The beauty of Alcoa Coilzak in parabolic luminaires is the beautiful way it controls light.

Parabolic luminaires are esthetically pleasing, in the design of the fixture and in the type of light they dispel. This is particularly important where people work, read or shop, where low visual brightness contributes to a comfortable atmosphere. The secret is precise light control, made possible because the reflective material in quality parabolic systems is Alcoa\* Coilzak lighting sheet. Note that we said *lighting sheet*. In a properly designed luminaire, reflectivity is only part of the story. Controlled image clarity and reflective diffusion are just as important. Alcoa Coilzak sheet is an Alzak®-finished reflector material that meets precise reflectivity and gloss standards.

Operating costs of a parabolic lighting system can be low. Because of its efficient light

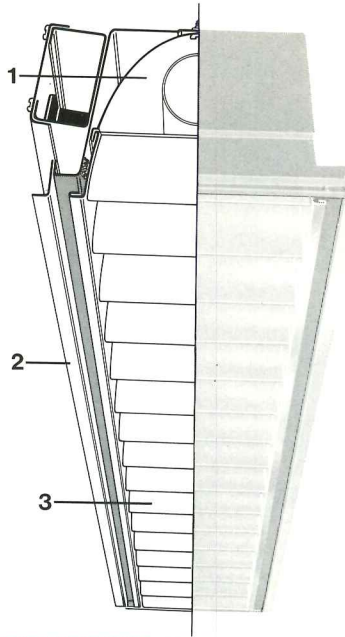

distribution, a properly planned system may require fewer luminaires, resulting in low electrical loadings. Savings in cleaning maintenance are possible also. Parabolic luminaires do not require a lens and the unique design, plus the static-free Coilzak louvers, resists soil and dust accumulation.

For more information on the many advantages of Coilzak lighting sheet in parabolic luminaires, write Aluminum Company of America, 310-A Alcoa Building, Pittsburgh, PA 15219, or see us in Sweets under 16.10a/AL.

\*Registered Trademarks of Aluminum Company of America

1. One-piece constructed Coilzak reflector with accurately controlled parabolic shape.
2. Extruded aluminum trim.
3. Coilzak parabolic baffle assembly.

Photo courtesy of Columbia Lighting, Inc.

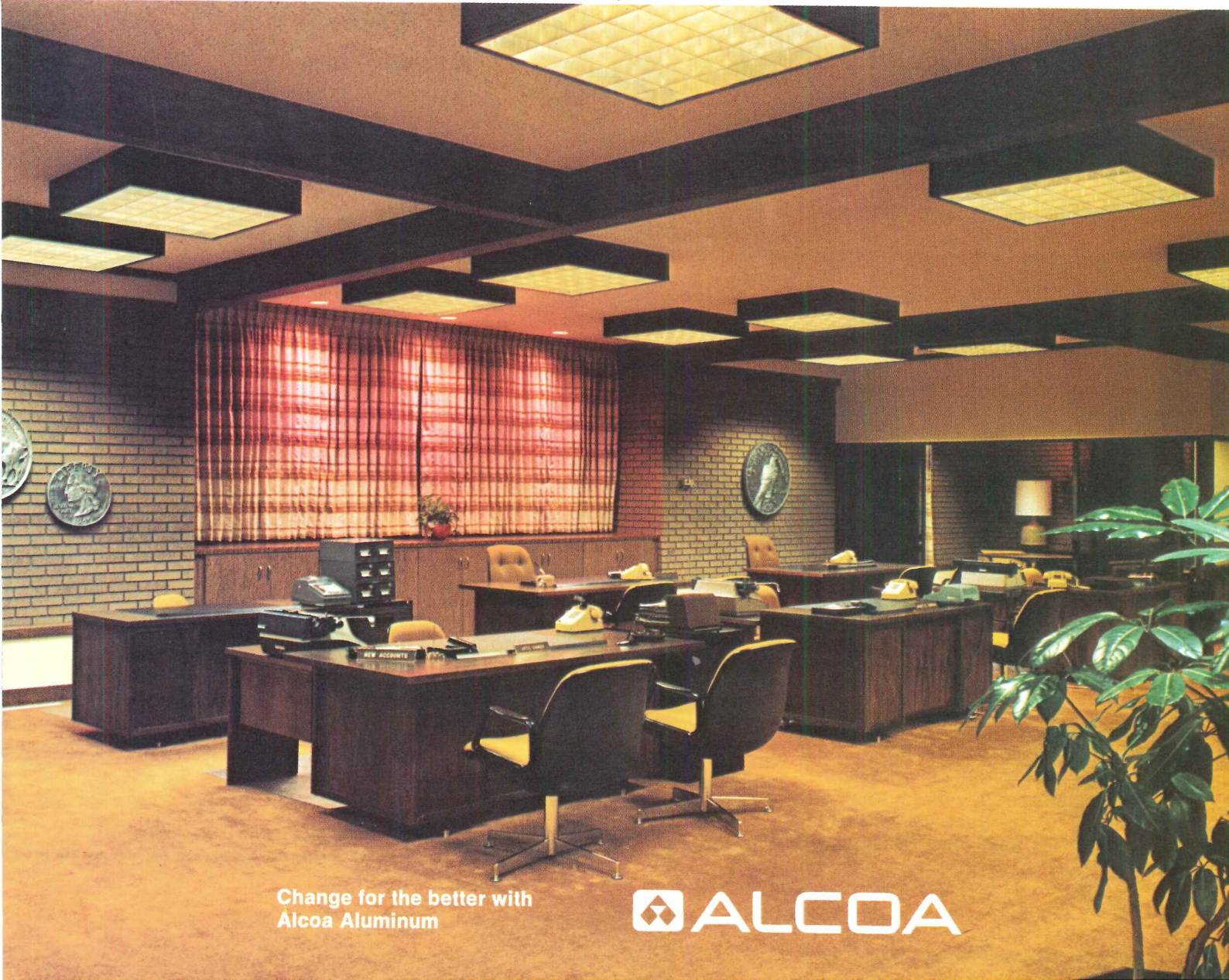

Change for the better with  
Alcoa Aluminum

 **ALCOA**

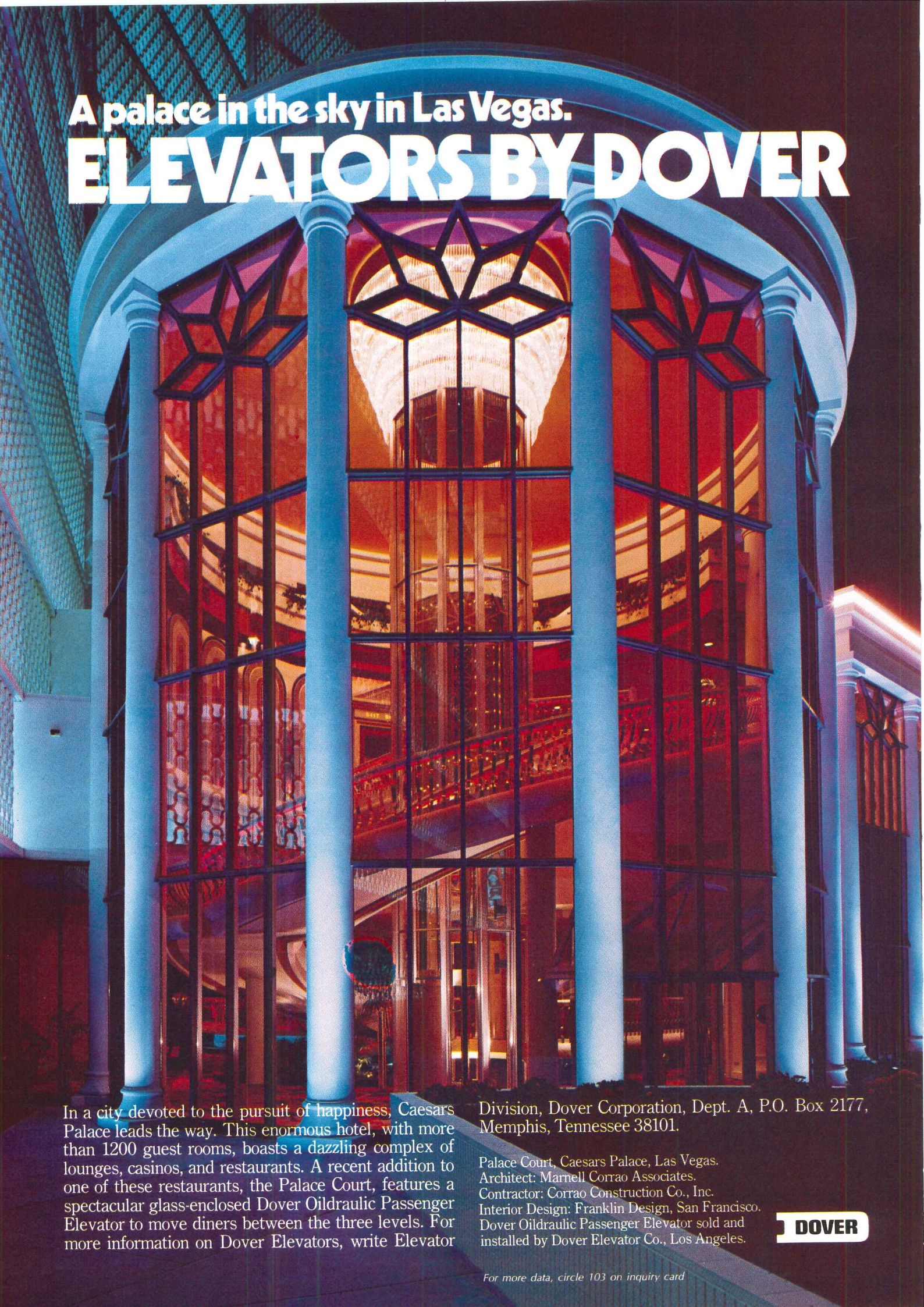

A palace in the sky in Las Vegas.

# ELEVATORS BY DOVER

In a city devoted to the pursuit of happiness, Caesars Palace leads the way. This enormous hotel, with more than 1200 guest rooms, boasts a dazzling complex of lounges, casinos, and restaurants. A recent addition to one of these restaurants, the Palace Court, features a spectacular glass-enclosed Dover Oilraulic Passenger Elevator to move diners between the three levels. For more information on Dover Elevators, write Elevator

Division, Dover Corporation, Dept. A, P.O. Box 2177, Memphis, Tennessee 38101.

Palace Court, Caesars Palace, Las Vegas.  
Architect: Marnell Corrao Associates.  
Contractor: Corrao Construction Co., Inc.  
Interior Design: Franklin Design, San Francisco.  
Dover Oilraulic Passenger Elevator sold and installed by Dover Elevator Co., Los Angeles.

**DOVER**

For more data, circle 103 on inquiry card

Kawneer architectural aluminum products are found in installations all over the world. Following are a few examples from hundreds of buildings where Kawneer products are used.

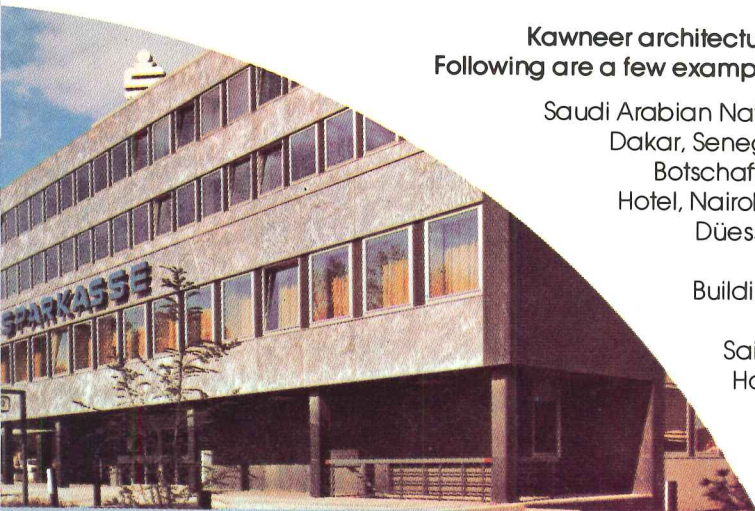

Saudi Arabian National Guard Complex, Jidda, Saudi Arabia / U.S. Embassy Building  
Dakar, Senegal / Intercontinental Hotel, Dubai, United Arab Emirates / Deutsche  
Botschaft, Kabul, Afghanistan / U.S. Embassy, Brasilia, Brazil / Intercontinental  
Hotel, Nairobi, Kenya / U.S.S.R. Embassy, Quito, Ecuador / Hotel Intercontinental,  
Düsseldorf, W. Germany / Accra Hotel, Accra, Ghana / Life of Jamaica  
Building, Kingston, Jamaica / U.S. Embassy, Tokyo, Japan / Armuli 1  
Building, Reykjavik, Iceland / Hotel Colon, Quito, Ecuador / Hotel Holiday  
Inn, München Gladbach, W. Germany / Holiday Inn, London, U.K.  
Saipan Continental, Saipan / National Theater Project, Lagos, Nigeria  
Hotel Intercontinental, Bucharest, Romania / University of Libya, Tripoli,  
Libya / Chase Manhattan Bank Building, San Juan, Puerto Rico  
Holiday Inn, Strand, U.K. / Managua Airport, Managua, Nicaragua  
Jahn Center, Düsseldorf, W. Germany / Canadian Embassy,  
Pakistan / Hippodromo Nacional, Caracas, Venezuela  
French Embassy, Lagos, Nigeria / Hotel Intercontinental,  
Frankfurt, W. Germany / Enlisted Mens Bachelor Qtrs.,  
Agana, Guam / Italian Embassy, Kabul, Afghanistan  
University of Libya, Benghazi, Libya / Tunis International  
Airport, Carthage, Tunisia / Saipan International Airport,  
Saipan / University of Addis Ababa, Addis Ababa,  
Ethiopia / Santo Domingo International Airport, Santo  
Domingo / Enlisted Men's Service Club, Agana,  
Guam / Hotel & Tourist, Inc. Rhodes Palace, Rhodes,  
Greece / Esso Motor Hotel, Bremen, W. Germany  
American Pacific Life, Agana, Guam / Secretariat,  
Port Harcourt, Nigeria / Public Safety Headquarters  
Saint Croix, U.S. Virgin Islands / Bank of Uganda, Kam-  
pala, Uganda / Park Central, Caracas, Venezuela  
Montego Bay International Airport, Montego Bay,  
Jamaica / VIP Lounge, Lagos International Airport,  
Lagos, Nigeria / Black Arts Festival Village, Lagos,  
Nigeria / Hotel Intercontinental, Cologne, W. Germany  
Curaçao International Airport, Curaçao / Hotel Holiday  
Inn, Ingolstadt, W. Germany / International Trade  
Center, Agana, Guam / Canadian External Affairs  
Building, Islamabad, Pakistan / U.S. Embassy, Jakarta,  
Indonesia / Sonatrach LPG Plant, Algeria / Moscow  
World Trade Center, Moscow, USSR / Addition to Health  
Center Dhahran Dental Clinic, Dhahran, Saudi Arabia  
Al Hasa Medical Clinic, Hofuf Al Hasa, Saudi Arabia

**when you  
specify Kawneer,  
anywhere in the world**

# Nothing is lost in translation...

Today's architects are meeting new challenges in the international market. They need architectural building components from a company that knows that market.

Because experience counts.

And Kawneer has vast experience in the international market. Look over the partial list of world installations in this ad to get an idea of how much experience we have.

In fact, wherever you go in the world, you will find Kawneer curtain wall systems, entrances, windows and facings.

And for good reason. At Kawneer, we've had over 70 years of experience designing and manufacturing architectural products. So we've refined and improved our products to achieve an unparalleled level of standardization. That means standardized components, plans and materials wherever in the world you're building. That's what it takes to meet international specifications. For maximum ease of installation and operation without unnecessary complications.

Each of Kawneer's worldwide manufacturing plants — not offices — is a fully integrated operation with extrusion, anodizing and fabricating capabilities.

We employ 3500 people in our 10 worldwide manufacturing plants, with 2,500,000 square feet (23,000 sq. meters) of manufacturing and warehouse space to process 80,000,000 lbs. (36,287,761 Kilograms) of aluminum every year. So Kawneer can provide on-time delivery of all components to the job site.

When you're building anywhere in the world, don't let little details become big headaches.

CALL ON KAWNEER. WE'VE BEEN THERE.



Our capabilities brochure has full details.  
Call your Kawneer representative or contact:  
KAWNEER ARCHITECTURAL PRODUCTS, 1105 N. Front Street,  
Dept. C, Niles, Michigan 49120.

**KAWNEER**  
ARCHITECTURAL PRODUCTS



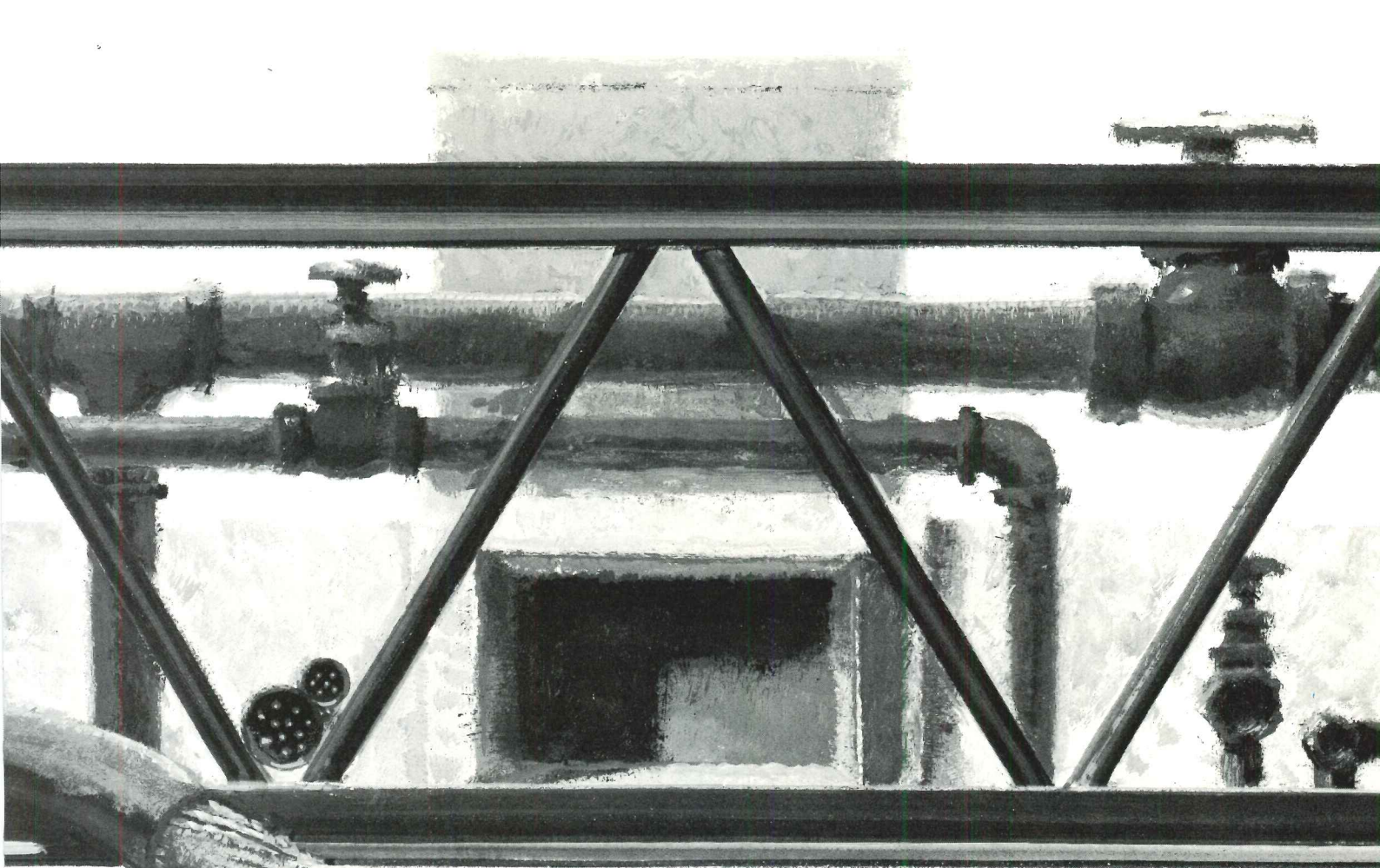

# The beauty of steel joists.

What this illustration demonstrates so aptly is that joists can accommodate your mechanical designs—the way you create them.

Unlike poured floors, open web steel joists let you install ducts, wiring, pipes . . . and do it efficiently.

Speed and economy are just several of the advantages you enjoy due to the flexibility of open web steel joists. To make it easier for you to use steel joists on your next job, we'd like to send you our latest edition of Specifications and Load Tables. It gives the facts on Open-Web, Longspan and Deep Longspan Joists. It's free. Just mail the coupon.

76-006

## STEEL JOIST INSTITUTE

Room 204, 1703 Parham Road  
Richmond, VA 23229

Please send me your latest copy of Specifications  
and Load Tables.

NAME \_\_\_\_\_

TITLE \_\_\_\_\_

FIRM \_\_\_\_\_

ADDRESS \_\_\_\_\_

CITY \_\_\_\_\_ STATE \_\_\_\_\_ ZIP \_\_\_\_\_





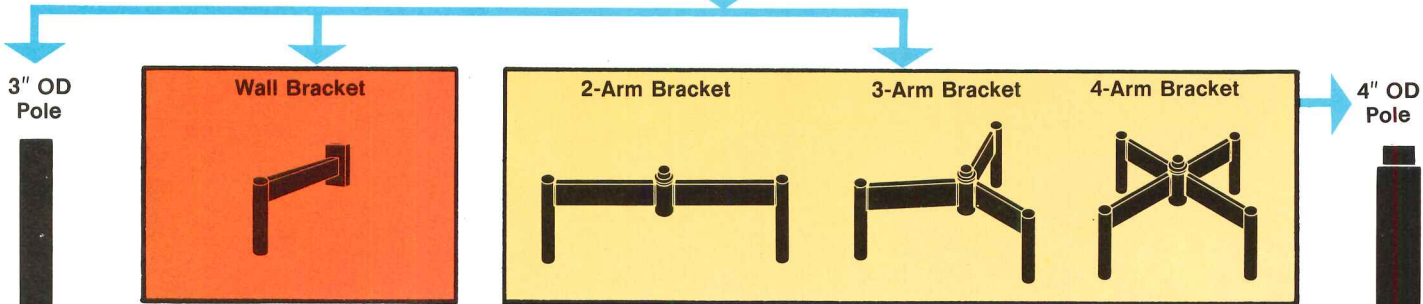

**Ten Glo-Metrics diffuser designs.** Offers unlimited architectural lighting design flexibility. Most shapes in choice of opal-white, transparent clear or tinted diffusers, with or without refractors where appropriate. Diffusers accommodate incandescent, mercury, or high-pressure-sodium lamps in a wide range of wattages.

**Pre-wired brackets.** Stems hold "in-pole" ballasts for

mercury units. Rugged aluminum construction, with all stainless steel hardware and gaskets.

**Matching poles with base.** Glo-Metrics 3" OD straight-shaft round aluminum poles mount single luminaire diffusers to 14' Ht. For cluster luminaires, 4" OD poles (3" tenon) allow mounting to 20' Ht. Poles have attractive cast aluminum bolt cover.

## Appleton **GLO-METRICS**™ system.

**You already know how beautiful it is.  
Now see how practical it is.**

Appleton Glo-Metrics outdoor luminaires are beautiful *and practical*. Diffusers are formed of ultra-violet resistant acrylic, with smooth, precision-made diffuser ring and fitter assemblies. Diffuser installs with a simple 1/4-turn twist-locking motion, secured by cam-action spring-loaded locking lugs plus a set screw. Two weatherproof gaskets seal out dirt and moisture. Diffuser fitters lock to pole-top or mounting bracket stems by means of a single-bolt toggle-action locking assembly. Luminaire, bracket,

and pole design presents smooth, crisp, unbroken lines. For full information, write for our 28-page, full-color Glo-Metrics catalog. Appleton Electric Company, 1701 Wellington Ave., Chicago, Illinois 60657.

(In Canada, Appleton Electric Limited, 750 Lawrence St., Cambridge, Ont. N3H 2N1)



**APPLETON**®

# The Door.

It should look like it was  
part of the plans.

There's a lot to be said for Marlite Brand Doors and Door Frame Systems. They're fast and easy to install. A total opening concept. Pre-hung. Pre-finished. The aluminum and steel frames adjust to most wall thicknesses. And that reduces labor cost. But best of all, they look like they're part of your plans. You can coordinate them with any design, specifying high pressure laminates, designer colors, or textures by Marlite Division. Like Marble. Leather. Or roughsawn wood. Add a window. Maybe a louver. Marlite Brand Doors can take on just about any appearance, size and configuration. You write them into the plans. They'll look the part. For colorful details, write Marlite Division Commercial Sales, Dover, Ohio 44622. Phone (216) 364-8854.

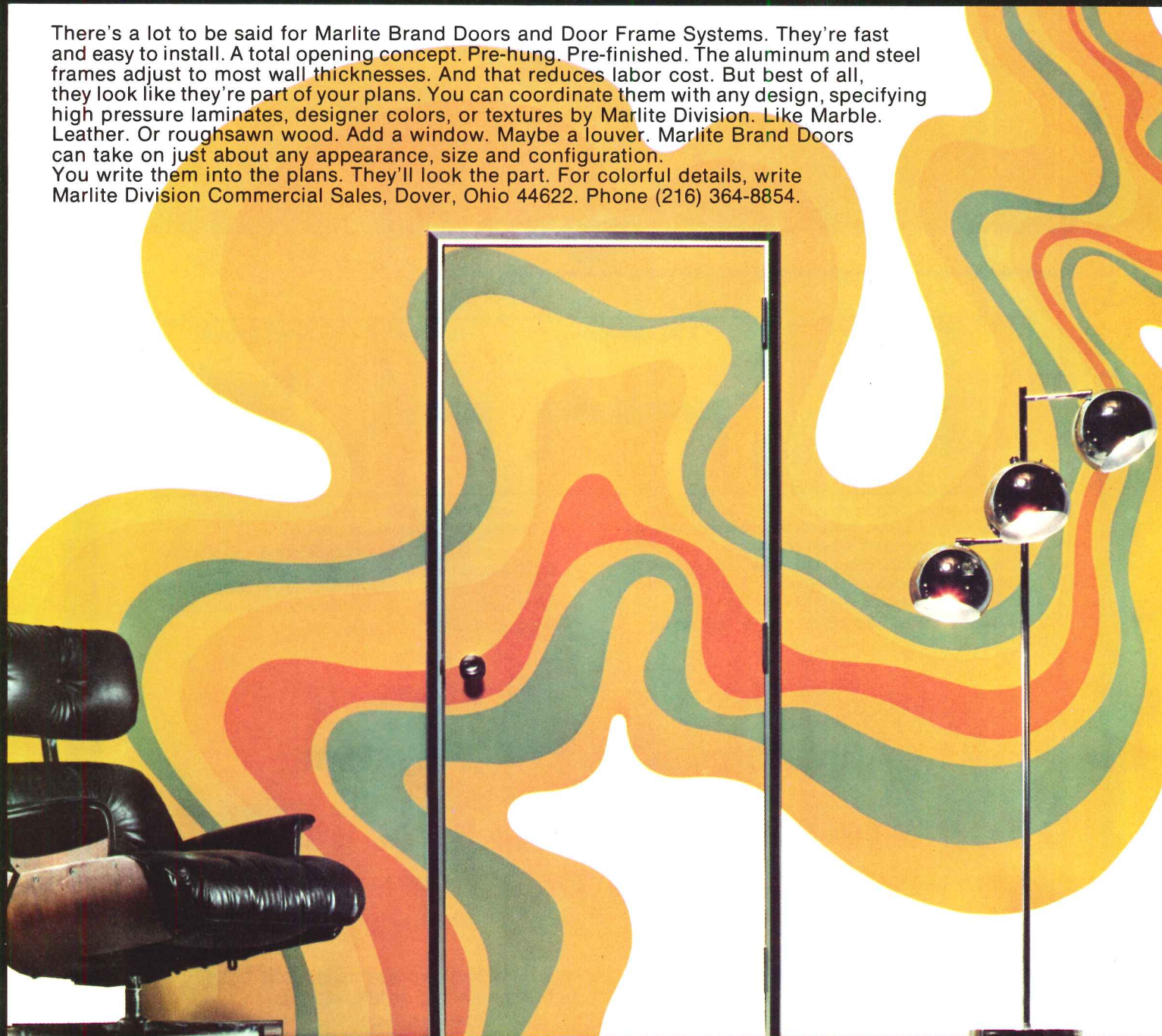

**Marlite**<sup>®</sup>

MASONITE  
CORPORATION

DIVISION OF MASONITE CORPORATION  
DOVER, OHIO 44622

MEETING THE CHALLENGE OF CHANGE

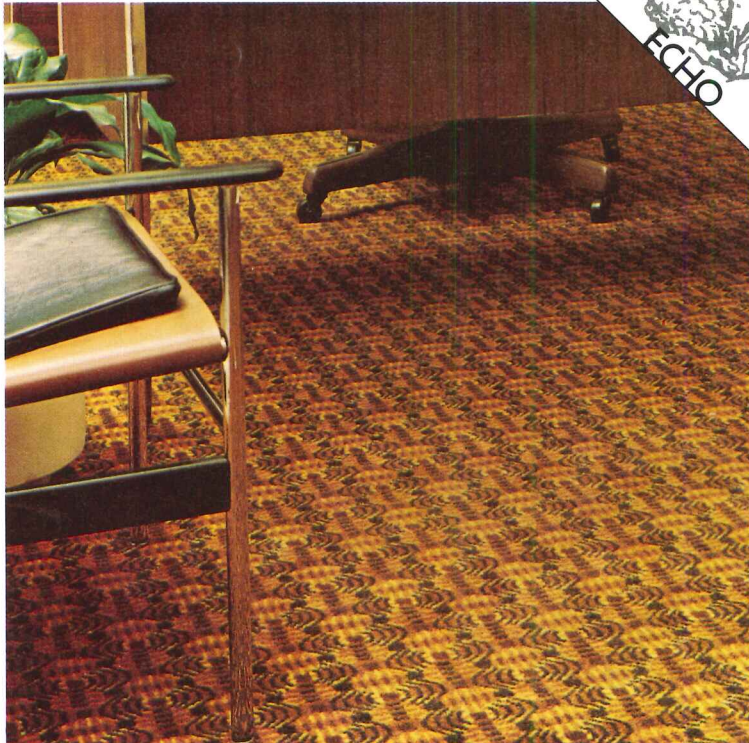
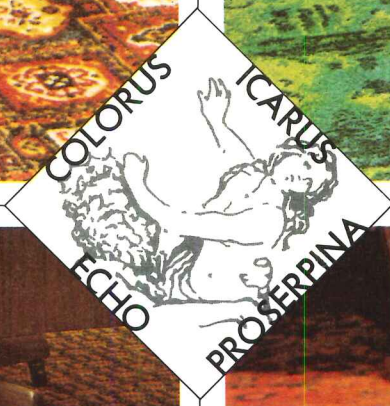

# THE GRAND VOYAGER COLLECTION

Patterns inspired by Mythology transformed into Carpet meeting the demands of Reality

Carpet that can satisfy your strictest commercial specifications:

- Anso® soil hiding nylon
- Static control. Dense, cut pile
- Super-high twist, autoclave heat-set yarns
- 5-year commercial wear warrantee
- ASTM E-84 - FS-70, SD-85, FC-40
- Four patterns and 18 colorways
- Recommended usage — anywhere! Hotels, airports, restaurants, department stores, schools . . .
- Moderately priced at under \$13. per sq. yd. installed

When your next installation demands carpet with brilliant colorations and unique patterns, specify: THE GRAND VOYAGER COLLECTION.

another ROYAL SCOT Carpet from



13-127 MERCHANDISE MART • CHICAGO, IL

Distribution Centers: Chicago • Cincinnati • Cleveland • Columbus, OH • Elmwood Park, NJ • Ft. Wayne • Indianapolis • Miami • Milwaukee • Minneapolis • Pittsburgh

# Potlatch

## Lock-Deck®



### Space Beautiful

...for homes, churches, commercial and institutional structures.

Lock-Deck is a superior laminated decking designed by Potlatch to free the outer limits of your imagination and work with you to make space beautiful in a variety of ways.

The warmth, charm, and natural elegance of wood: Inland Red Cedar, Idaho White Pine, Southern Pine, Douglas Fir/Larch, and White Fir.

The textural qualities and subtle color tones allow the designer to uniquely personalize his plan. A broad range of



Architect: Cavender/Kordys Associates, Inc., East Point, Georgia

acrylic stains on wire brush, smooth, or saw textured surfaces are available for your selection.

And, Lock-Deck's strength to weight ratio offers the kind of structural freedom that allows the designer to create imaginative structures as diverse as church and home.

So if you're interested in making space beautiful through free play of the design imagination, contact the Western Wood Products division now.

**Potlatch Corporation**  
**Wood Products, Western Division**  
**P.O. Box 5414, Spokane, WA 99205**  
**(509) 455-4260**

*For more data, circle 97 on inquiry card*

# Pahlavi National Library Project

## Tehran, Iran

### GOVERNMENT OF IRAN ANNOUNCES INTERNATIONAL ARCHITECTURAL COMPETITION FOR DESIGN OF NATIONAL LIBRARY

An Important International Architectural competition for the design of a 100,000 square meter national library building to be constructed in Tehran, has been announced by the Government of Iran. Conducted under the rules of the International Union of Architects, this will be a single-stage competition, open to any registered architect, to any architect entitled to practice architecture in his own country, or to any team led by such an architect. Two-hundred thousand dollars in prizes will be distributed as follows:

**\$50,000—FIRST PRIZE**

**\$25,000—SECOND PRIZE**

**\$25,000—THIRD PRIZE**

**\$10,000—EACH, FOR NEXT TEN**

**DESIGNS SELECTED BY  
THE JURY**

The first prize winner will receive a commission to design the project.

By decree of His Imperial Majesty, the Shahshah of Iran, the proposed new library has been officially designated The Pahlavi National Library.

The new library will be prominently located in Shahestan Pahlavi, the future city center of Tehran, now in an advanced stage of planning.

The Pahlavi National Library, planned by a group of national and international experts and consultants as a model national library, is expected to be one of the most advanced national libraries in the world. The planning which has gone into the preparation of the

building program, together with the importance of the site in the Shahestan Pahlavi, combine to make this an architectural competition of outstanding importance and significance.

Architects who meet the qualifications outlined above may register for the competition and request the competition documents by forwarding a registration fee of \$70.00 (U.S.) together with a certificate attesting that they are registered architects, or are entitled to practice architecture in their own country.

The registration fee may be paid as follows:

1. **By check drawn to the order of the Pahlavi National Library Project, International Architectural Competition, or**
2. **By bank transfer to: Account No. 1126, Pahlavi National Library Project, International Architectural Competition, Bank Melli Iran, Aryamehr Square Branch, Tehran, Iran.**

The check, or a copy of the bank transfer slip, should be sent with the registration request to the Pahlavi National Library Project, Committee for the International Architectural Competition, Aryamehr Square, 9 Bisotun Avenue, Tehran, Iran.

The registration period extends from January 22 to April 19, 1977. Program documents will be mailed to registrants between April 4 and May 1, 1977. Deadline for receipt of all entries is January 20, 1978. The program for the competition will be available in both Persian and English. All entries must be in English.

Hager has a hinge for any opening. Commercial, industrial and residential. You name the application, and Hager has a special hinge for it. Hager hinges come in a wide variety of popular decorator finishes. And you can add a beautiful decorator touch with a fine selection of distinctive hinge tips.

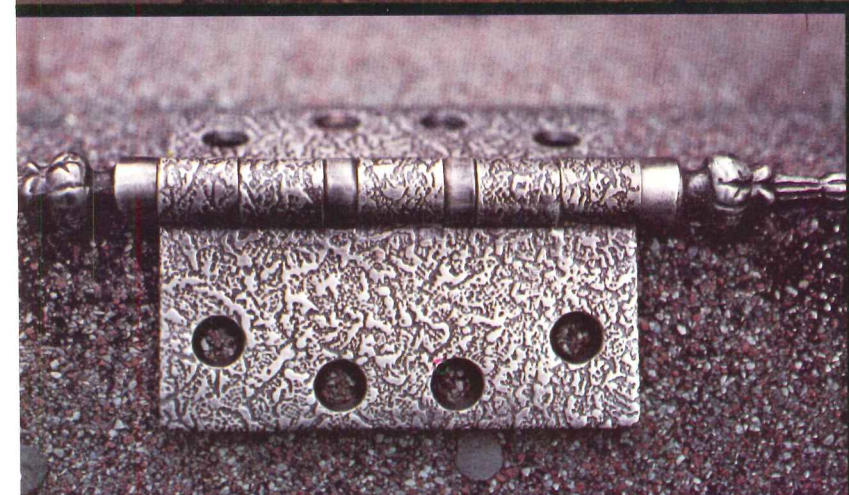
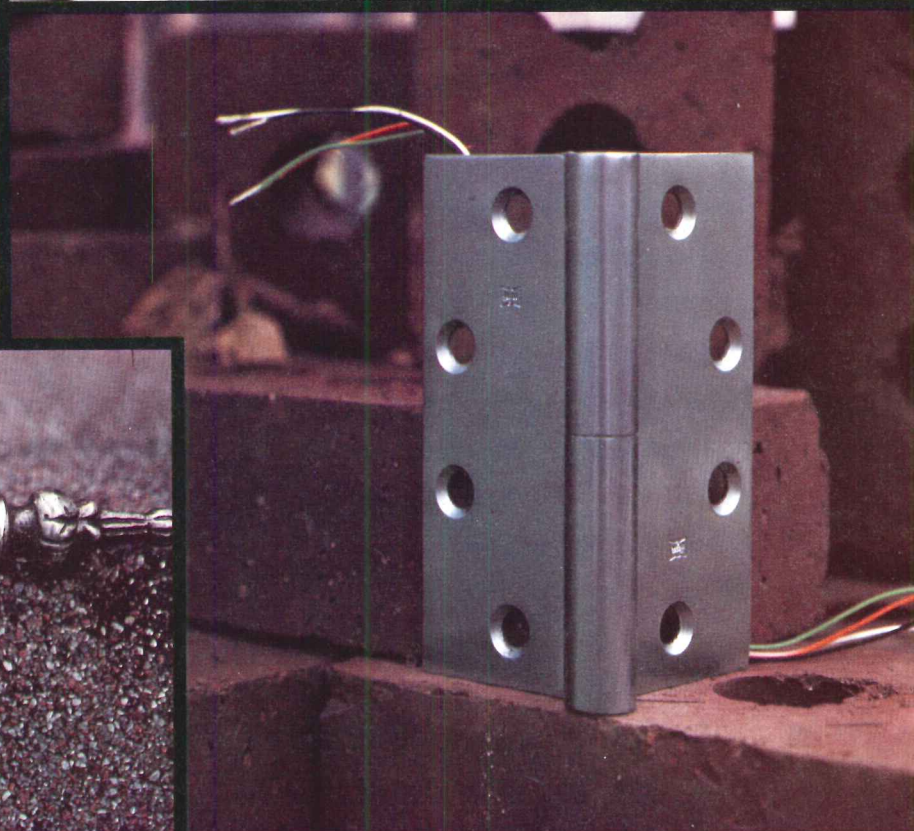
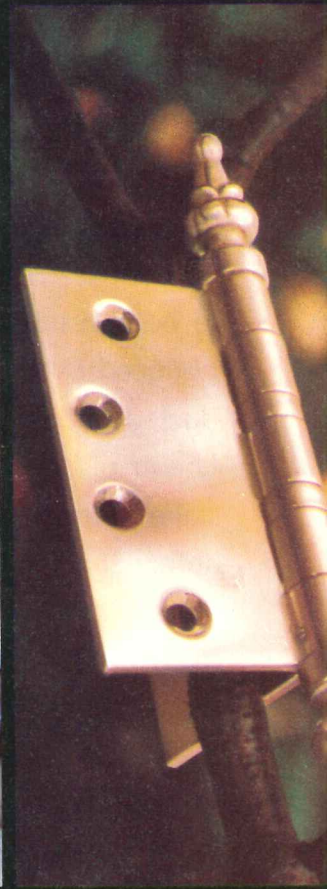

Ask your architectural hardware consultant for an interesting look at Hager's complete selection of fine quality door hardware. Or, write Hager Hinge Company, 139 Victor Street, St. Louis, Mo. 63104.

*For more data, circle 96 on inquiry card*



**Anyone can make hinges,  
Hager creates concepts.**

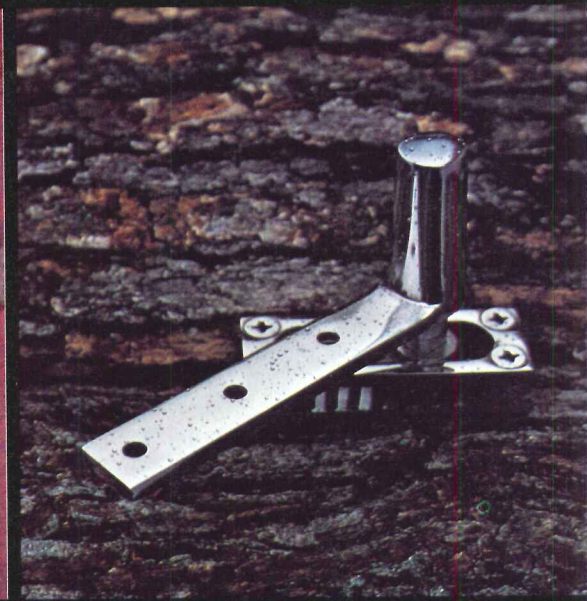

Cuyahoga County Justice Center, Cleveland, Ohio.  
Exterior: ASG Bronze. Interior: ASG Penal-Gard and Bullet Resisting glass.



*Since ASG went to jail,  
things are looking better.*

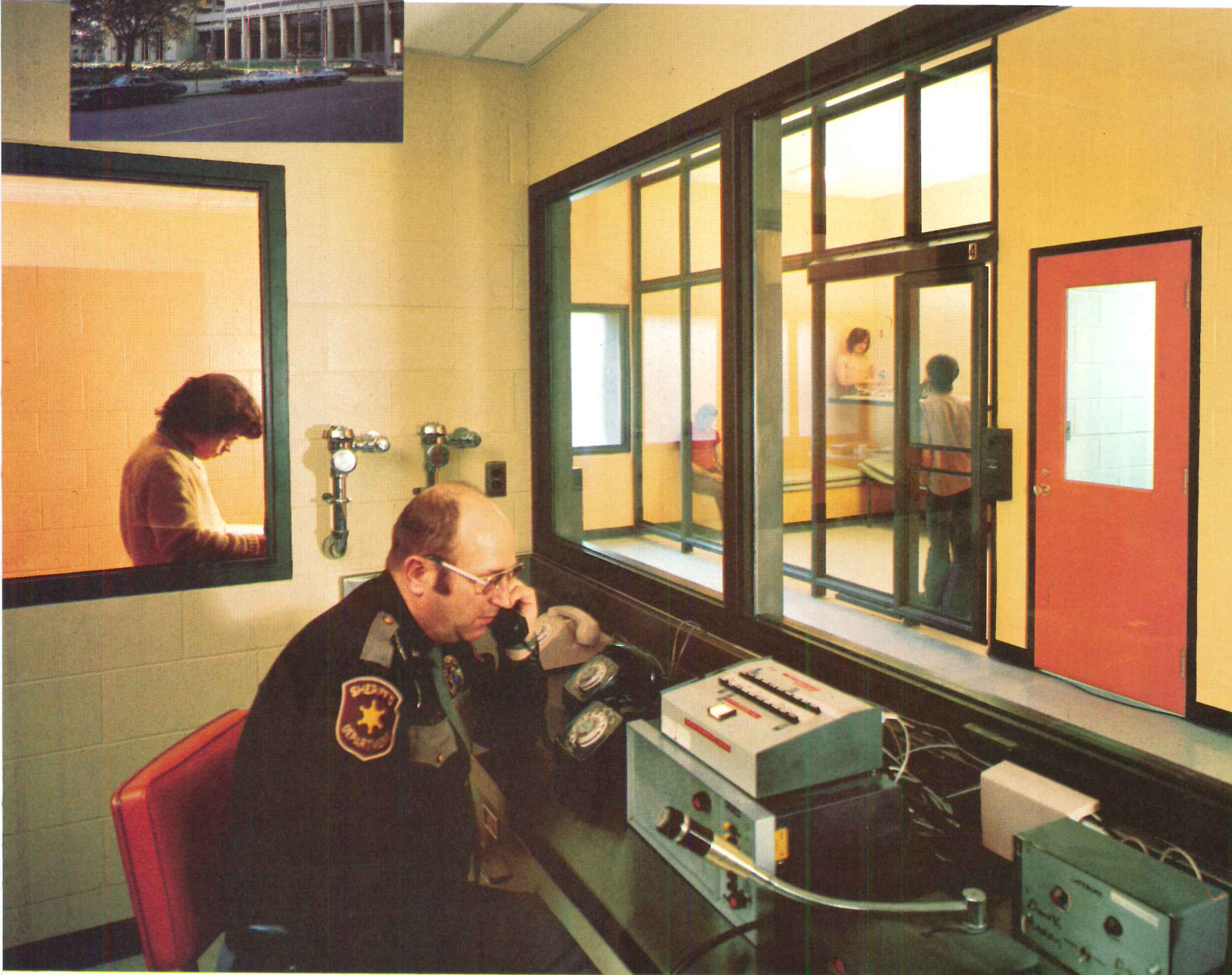

From the inside. Or outside. A jail with ASG Penal-Gard® Security Glass instead of bars seems less like a jail. In fact, at Michigan's Montmorency County Police Building, the prison area is called a lock-up instead. A more humane environment, with improved safety on both sides of the glass is certainly a step toward reform.

Penal-Gard also makes it easier to maintain security. A single guard can watch an entire cell block from his station. Noise is greatly reduced. And house cleaning much simpler. Penal-Gard looks better to the taxpayer too; costs are generally less, delivery and installation faster.

See for yourself. Write for our catalog which includes present installations along with pertinent test information.

Penal-Gard is available in clear, tinted and as a one-way mirror (Duovue Penal-Gard). From the Glass Specialists.

ASG Industries Inc., Dept. 21  
P. O. Box 929, Kingsport, Tenn. 37662.  
Or phone 615/245-0211.

Montmorency County Police Building, Atlanta, Mich

security  
glass

ASG

THE GLASS SPECIALISTS



SEE OUR CATALOG IN SWEET'S 

For more data, circle 95 on inquiry card



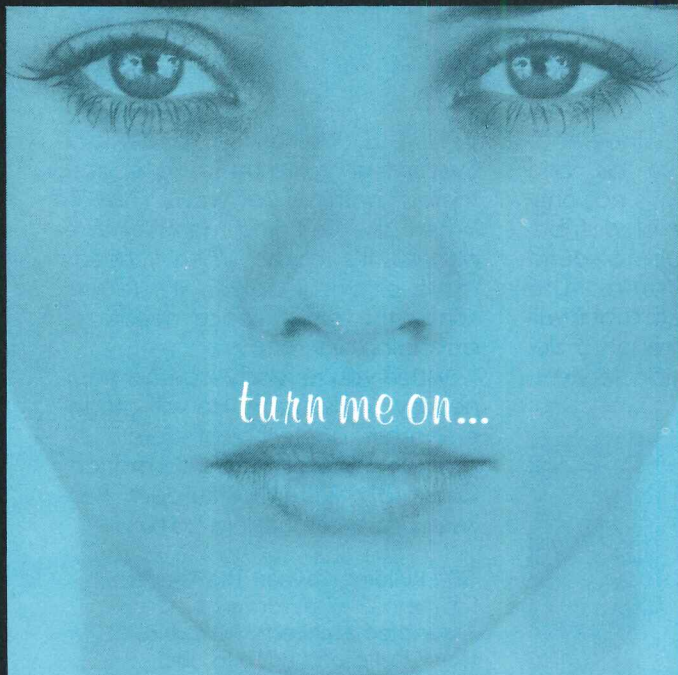

turn me on...

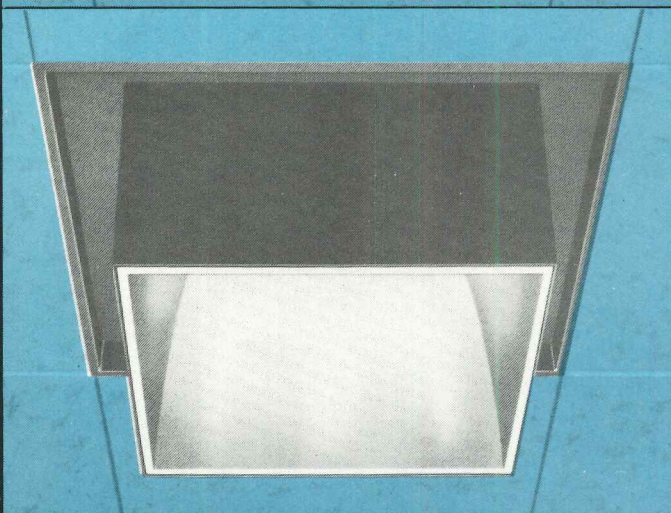
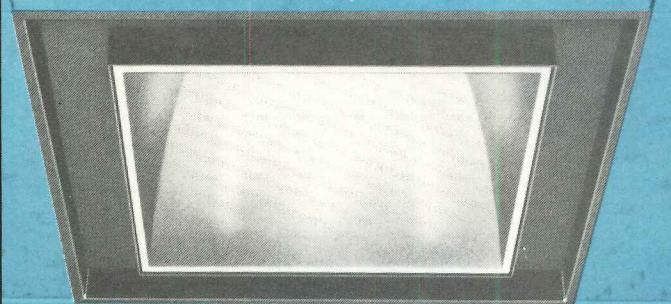

purely beautiful: recessed, semi-recessed low brightness parabolic cell downlights

"AURA" by **OMEGA** LIGHTING

EMERSON ELECTRIC CO.

270 LONG ISLAND EXPRESSWAY/MELVILLE, NEW YORK 11746  
516-293-8500

In Canada: EMERSON ELECTRIC CANADA LTD., P.O. Box 150, Markham, Ontario, Canada, 416-297-2330

For more data, circle 92 on inquiry card

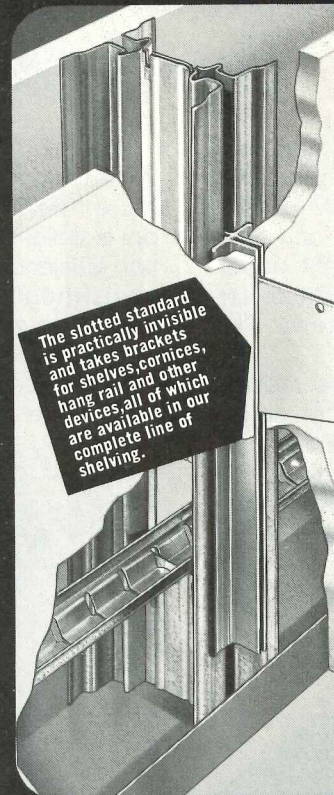

FOR VIRTUALLY INVISIBLE  
SLOTTED STANDARD INSTALLATION  
SPECIFY

**YOCA**™  
STUD WALL SYSTEM

Patent No. 3562970

Manufactured only by

**Crown Metal**

The slotted standard is practically invisible and takes brackets, for shelves, cornices, hang rail and other devices, all of which are available in our complete line of shelving.

Combining slotted standard and metal stud in ONE sturdy unit used in conjunction with standard metal studs for installing dry wall.

YOCA™ studs offer the perfect solution for in-store merchandise display or off-the-floor storage for commerce, industry, institution or school.

Standard USG metal stud at necessary spacing.  
3 3/8"

For complete specifications, please write, and we'll send you our complete catalog of other display hardware too.

**Crown Metal** MANUFACTURING CO

312/873-3833

Dept. AR 75

5925 South Lowe Avenue, Chicago, Illinois 60621

For more data, circle 93 on inquiry card

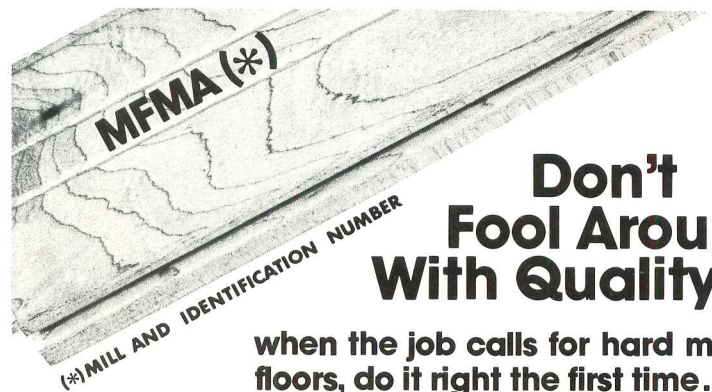

**Don't Fool Around With Quality**

when the job calls for hard maple floors, do it right the first time... with MFMA flooring

Specify MFMA and be done with it...MFMA certified flooring installed with skill and experience by an MFMA Associate Member. The MFMA trademark assures that the flooring on which it appears is...

- True to Species...genuine hard maple with no unspecified species intermixed.
- True to Grade and Dimension...uniform appearance and performance characteristics.
- Inspected and Warranted...every single shipment is inspected and accompanied by the MFMA certificate—your assurance of excellence.

Write for the complete, new "MFMA GAME MARKINGS MANUAL." Limited quantities available.



Maple Flooring Manufacturers Association, Inc.  
424 Washington Ave., Suite 104 -Dept. AR-17  
Oshkosh, Wisconsin 54901  
Telephone 414/233-1920

For more data, circle 94 on inquiry card

# "A Walkerduct underfloor system or nothing. The choice was easy."

While the 580 Building in Cincinnati was still on the drawing board, the firm of O. W. Motz and W. B. Motz had to decide whether or not to recommend a permanent underfloor telephone and electrical services distribution system. The decision was easy.

They saw several good reasons to justify the higher cost of an underfloor system. It permitted changing phones and adding new equipment effortlessly. (A good economy.) It contributed to the esthetics by providing clutter-free wide open spaces. And it was much safer than the alternative.

With a Walkerduct Underfloor System, they got all of this, and more. The 580 Building is not only an excellent example of distribution efficiency, but it's also a sound investment for the future. The owners have no problem that it will outlive its usefulness through a deficiency in communication services. And neither will you.

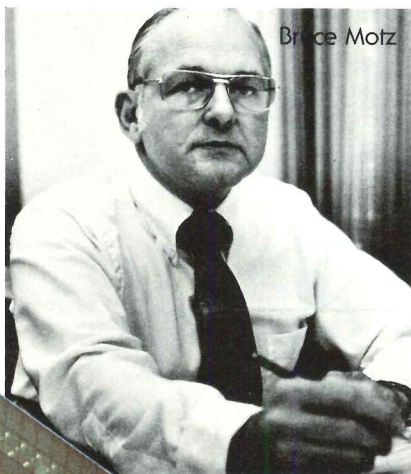

Bruce Motz

With a Walkerduct Underfloor System in your building specs, there's nothing to worry about. When the building needs more phones, it's ready. When it needs more electrical power, it's ready. When the office space needs re-arranging, it's ready.

When you're ready, contact your nearby Walkerman. He will gladly elaborate on technical details or provide more product information. Or simply write: Walkerduct, Parkersburg, West Virginia 26101.

580 Building Owner: The Western-Southern Life Insurance Co.  
Associated Architects: RTKL, Inc., Harry Hake and Partners, Inc.  
Consulting Engineers: O. W. Motz & W. B. Motz

## WALKERDUCT® PRODUCTS

*For more data, circle 88 on inquiry card*

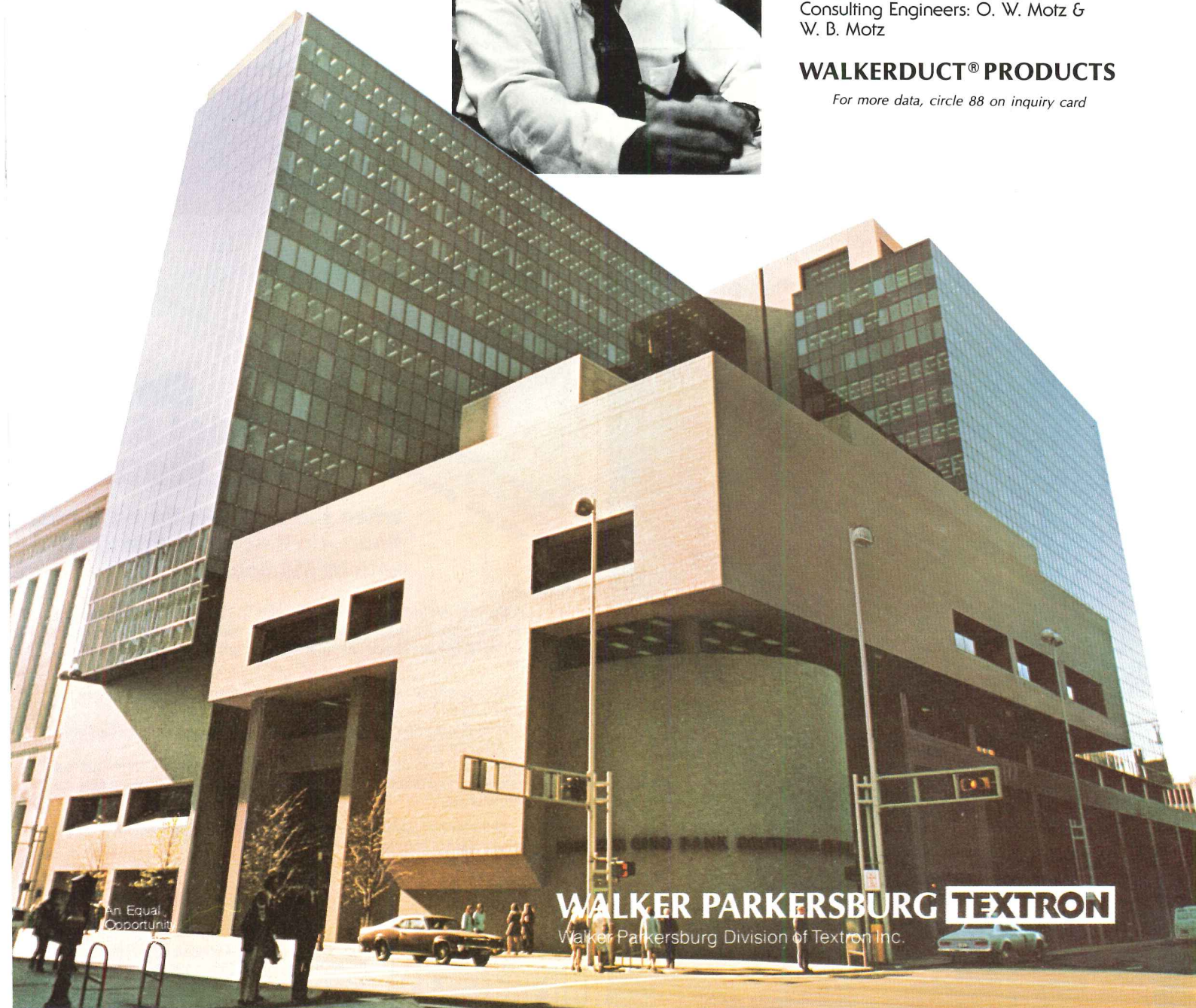

**WALKER PARKERSBURG TEXTRON**

Walker Parkersburg Division of Textron Inc.

# The All-New 1977 Calendar of Historic Architectural Events



Baiton City Hall, Baiton, Massachusetts. 1956. Norman Marvin & Associates architects. Photo by G. E. Kidder Smith.

## MARCH

SUNDAY	MONDAY	TUESDAY	WEDNESDAY	THURSDAY	FRIDAY	SATURDAY
		<b>1</b>	<b>2</b>	<b>3</b>	<b>4</b>	<b>5</b>
		1948 Public works program authorized by Congress. (1948)	1876 Charles L. Bulfinch's design for the Massachusetts State House completed.	1928 American architect Frank Lloyd Wright's design for the Guggenheim Museum in New York City.	1861 Architect Thomas Jefferson's design for the University of Virginia completed.	1975 American architect Frank Lloyd Wright's design for the Guggenheim Museum in New York City.
<b>6</b>	<b>7</b>	<b>8</b>	<b>9</b>	<b>10</b>	<b>11</b>	<b>12</b>
1938 American architect Frank Lloyd Wright's design for the Guggenheim Museum in New York City.	1876 Charles L. Bulfinch's design for the Massachusetts State House completed.	1948 Public works program authorized by Congress. (1948)	1876 Charles L. Bulfinch's design for the Massachusetts State House completed.	1928 American architect Frank Lloyd Wright's design for the Guggenheim Museum in New York City.	1861 Architect Thomas Jefferson's design for the University of Virginia completed.	1975 American architect Frank Lloyd Wright's design for the Guggenheim Museum in New York City.
<b>13</b>	<b>14</b>	<b>15</b>	<b>16</b>	<b>17</b>	<b>18</b>	<b>19</b>
1938 American architect Frank Lloyd Wright's design for the Guggenheim Museum in New York City.	1876 Charles L. Bulfinch's design for the Massachusetts State House completed.	1948 Public works program authorized by Congress. (1948)	1876 Charles L. Bulfinch's design for the Massachusetts State House completed.	1928 American architect Frank Lloyd Wright's design for the Guggenheim Museum in New York City.	1861 Architect Thomas Jefferson's design for the University of Virginia completed.	1975 American architect Frank Lloyd Wright's design for the Guggenheim Museum in New York City.
<b>20</b>	<b>21</b>	<b>22</b>	<b>23</b>	<b>24</b>	<b>25</b>	<b>26</b>
1938 American architect Frank Lloyd Wright's design for the Guggenheim Museum in New York City.	1876 Charles L. Bulfinch's design for the Massachusetts State House completed.	1948 Public works program authorized by Congress. (1948)	1876 Charles L. Bulfinch's design for the Massachusetts State House completed.	1928 American architect Frank Lloyd Wright's design for the Guggenheim Museum in New York City.	1861 Architect Thomas Jefferson's design for the University of Virginia completed.	1975 American architect Frank Lloyd Wright's design for the Guggenheim Museum in New York City.
<b>27</b>	<b>28</b>	<b>29</b>	<b>30</b>	<b>31</b>		
1938 American architect Frank Lloyd Wright's design for the Guggenheim Museum in New York City.	1876 Charles L. Bulfinch's design for the Massachusetts State House completed.	1948 Public works program authorized by Congress. (1948)	1876 Charles L. Bulfinch's design for the Massachusetts State House completed.	1928 American architect Frank Lloyd Wright's design for the Guggenheim Museum in New York City.	1861 Architect Thomas Jefferson's design for the University of Virginia completed.	1975 American architect Frank Lloyd Wright's design for the Guggenheim Museum in New York City.

The 1977 Architectural Calendar is better than ever! It is all new—365 more historic events in architectural history and 13 more stunning architectural photographs by award-winning architect-photographer G. E. Kidder Smith, FAIA. And, for the first time, this year's calendar is designed to be used as a write-in desk calendar as well as a wall calendar! They said it couldn't be done, but the 1977 Architectural Calendar continues its daily commemoration of memorable architectural events . . . famous firsts in architecture and engineering . . . births and deaths of the world's greatest architects and engineers . . . significant, amusing and little-known facts that inform and surprise even the most knowledgeable . . .

- The day Palladio was fined for absenteeism from the construction site
- The day the Parthenon was "rediscovered" during the Renaissance
- The day that Latrobe complained that architecture wasn't a "fit profession for a gentleman"
- The day Michelangelo began painting the Sistine Chapel
- The day Thomas Jefferson insured Monticello—for \$6300
- The day Inigo Jones loaned his client (and King) £500
- The day the Congressional Medal of Honor was awarded to a famous American architect
- The day Disneyland opened

. . . these and hundreds of other bits of history make the 1977 Architectural Calendar a valuable source of architectural knowledge and a true collector's item.

Illustrated with 13 beautiful, full-color photographs illustrating the architectural heritage of the United States, this calendar will make a handsome and decorative addition to your home or office, and would make a much-appreciated (and inexpensive) gift. This strikingly designed calendar is printed on luxurious enamel stock in an oversized, 9x12" format. Only a limited number of calendars are being printed this year, so in order to avoid disappointment, order today! Send your payment for \$5.00 to Architectural Record Books, 1221 Avenue of the Americas, 41st Floor, New York, N.Y. 10020, or use the handy order blank below.

## Architectural Record Books

1221 Avenue of the Americas, 41st Fl.  
New York, New York 10020

AR-1-77

Please send me \_\_\_\_\_ copies of The 1977 Architectural Calendar @ \$5.00 each. add sales tax where applicable.

Name \_\_\_\_\_

Address \_\_\_\_\_

City \_\_\_\_\_

State \_\_\_\_\_ Zip \_\_\_\_\_

Payment must accompany your order

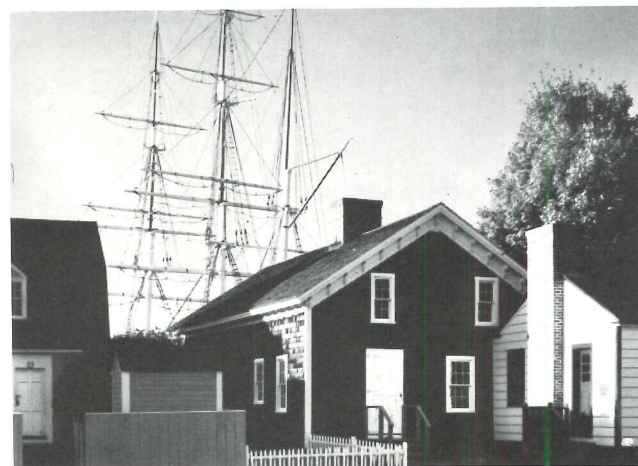

Philadelphia, 1820s. Philadelphia, Pennsylvania. c. 1811. 1810. Queen Anne. Architect: Richard Wilson. Photo by G. E. Kidder Smith.

## JUNE

SUNDAY	MONDAY	TUESDAY	WEDNESDAY	THURSDAY	FRIDAY	SATURDAY
		<b>1</b>	<b>2</b>	<b>3</b>	<b>4</b>	
		1948 Public works program authorized by Congress. (1948)	1876 Charles L. Bulfinch's design for the Massachusetts State House completed.	1928 American architect Frank Lloyd Wright's design for the Guggenheim Museum in New York City.	1861 Architect Thomas Jefferson's design for the University of Virginia completed.	1975 American architect Frank Lloyd Wright's design for the Guggenheim Museum in New York City.
<b>5</b>	<b>6</b>	<b>7</b>	<b>8</b>	<b>9</b>	<b>10</b>	<b>11</b>
1938 American architect Frank Lloyd Wright's design for the Guggenheim Museum in New York City.	1876 Charles L. Bulfinch's design for the Massachusetts State House completed.	1948 Public works program authorized by Congress. (1948)	1876 Charles L. Bulfinch's design for the Massachusetts State House completed.	1928 American architect Frank Lloyd Wright's design for the Guggenheim Museum in New York City.	1861 Architect Thomas Jefferson's design for the University of Virginia completed.	1975 American architect Frank Lloyd Wright's design for the Guggenheim Museum in New York City.
<b>12</b>	<b>13</b>	<b>14</b>	<b>15</b>	<b>16</b>	<b>17</b>	<b>18</b>
1938 American architect Frank Lloyd Wright's design for the Guggenheim Museum in New York City.	1876 Charles L. Bulfinch's design for the Massachusetts State House completed.	1948 Public works program authorized by Congress. (1948)	1876 Charles L. Bulfinch's design for the Massachusetts State House completed.	1928 American architect Frank Lloyd Wright's design for the Guggenheim Museum in New York City.	1861 Architect Thomas Jefferson's design for the University of Virginia completed.	1975 American architect Frank Lloyd Wright's design for the Guggenheim Museum in New York City.
<b>19</b>	<b>20</b>	<b>21</b>	<b>22</b>	<b>23</b>	<b>24</b>	<b>25</b>
1938 American architect Frank Lloyd Wright's design for the Guggenheim Museum in New York City.	1876 Charles L. Bulfinch's design for the Massachusetts State House completed.	1948 Public works program authorized by Congress. (1948)	1876 Charles L. Bulfinch's design for the Massachusetts State House completed.	1928 American architect Frank Lloyd Wright's design for the Guggenheim Museum in New York City.	1861 Architect Thomas Jefferson's design for the University of Virginia completed.	1975 American architect Frank Lloyd Wright's design for the Guggenheim Museum in New York City.
<b>26</b>	<b>27</b>	<b>28</b>	<b>29</b>	<b>30</b>		
1938 American architect Frank Lloyd Wright's design for the Guggenheim Museum in New York City.	1876 Charles L. Bulfinch's design for the Massachusetts State House completed.	1948 Public works program authorized by Congress. (1948)	1876 Charles L. Bulfinch's design for the Massachusetts State House completed.	1928 American architect Frank Lloyd Wright's design for the Guggenheim Museum in New York City.	1861 Architect Thomas Jefferson's design for the University of Virginia completed.	1975 American architect Frank Lloyd Wright's design for the Guggenheim Museum in New York City.

FORMICA PRESENTS  
**SPECTRUM**

15 new clear, honest colors added to the broadest line in the laminate industry.

Now, Formica gives you solid colors in the breadth and scope you need! Each color family has been rounded out to beautifully broaden your options.

Formica's Design Center—unique in the laminate industry—has worked closely with fabricators, architects, designers and

the Color Marketing Group to ensure that each color will fill a need. Not just today, but tomorrow as well.

See this spectrum of solids . . . part of the broadest line in the laminate industry. Contact your Formica Distributor now!





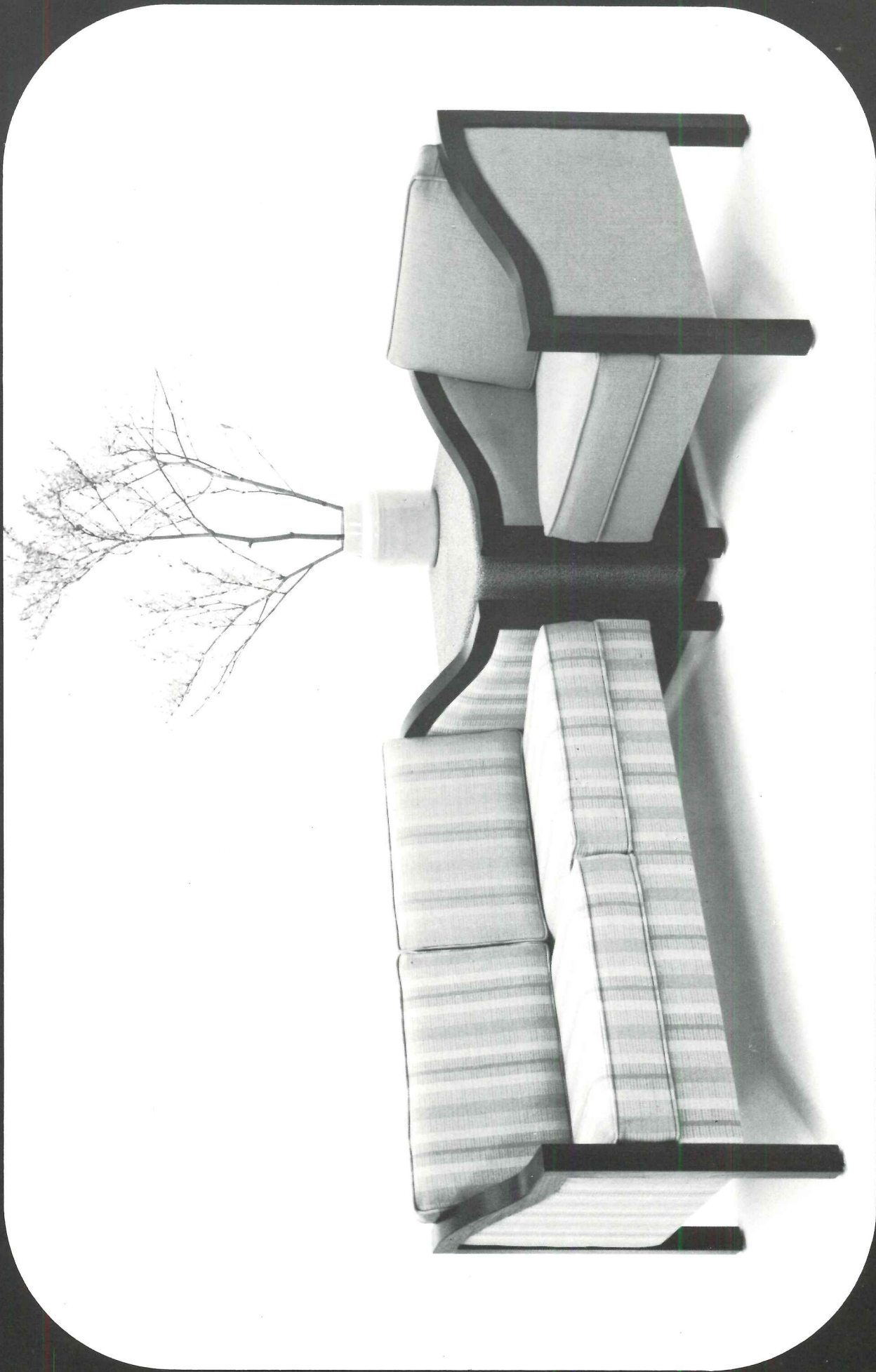

**fine furniture since 1850**

**buckstaff®**

oshkosh, wi 54901  
414-235-5890

showrooms...chicago 312-944-6958 dallas 214-651-1387 new york 212-675-7030 san francisco 415-621-0159 atlanta 404-876-4448 tampa 813-251-3701 miami 305-757-0659

# Active worlds need Glidden.



## Our epoxies, urethanes, latexes, and alkyds are trained to be tough.

Because we make them to go where the action is.  
And stay there.

On floors and walls and equipment. On wood and masonry and metal. In schools, sports arenas, factories, laboratories, hospitals, and entertainment centers. Everywhere in the world of hard knocks.

Thirty-one of Glidden's maintenance coatings are rated "excellent" protection against abrasion, and six of these stand up to *intense* abrasion.

When you've got an active world to tame, come to Glidden. Because Glidden has put a team of services and products together to help you do it profitably:

- Single source convenience. Big jobs demand specialized coatings. One source, Glidden, has them all. And gets them to you at the right time

and right price to save you dollars and hours.

- Technical service backup. When you run into problems you haven't faced before, call on Glidden technicians who have faced and solved them.
- Free color styling and decorator help. From professionals of the Glidden Color Studio. Puts the "icing" on your bid to help sell the job.

Tell us about the job you're after. We'll tell you how we can help you get it.



**SCM**® **GLIDDEN COATINGS & RESINS**  
**ARCHITECTURAL & MAINTENANCE**  
SCM CORPORATION, CLEVELAND, OHIO 44115

For more data, circle 85 on inquiry card

Name changes, new firms

**Daniel, Mann, Johnson & Mendenhall** has opened an office in St. Louis. The office will be under the management of Richard C. Brown, Jr. professional engineer.

**Gensler and Associates** has moved to 248 Battery Street, San Francisco, California.

**Hellmuth, Obata & Kassabaum** announces the removal of its offices to 100 North Broadway, St. Louis, Missouri.

**David Jay Feinberg, AIA** is pleased to announce the relocation of his office to Suite 210, Cutler Ridge 1, 10700 Caribbean Boulevard, Miami, Florida.

**Donald R. Simpson, AIA** has established a new practice at 26 Champlin Street, Newport, Rhode Island.

**Harold Bloom P.E.** has opened an office at 101 Park Avenue, Room 402, South Wing, New York, New York.

R. W. Booker & Associates and Robert D. Field & Associates have formed an association called **Booker/Field**, located at 724 St. Louis Road, Collinsville, Illinois.

**John Roger Johansen, AIA** has opened an office at 100 Portage, Houghton, Michigan.

**David Gura** has opened a new firm located at 15 East 48th Street, Suite 301, New York, New York.

Diversified Design Disciplines/3D announces the formation of **3D/Engineering** located at 2000 South Post Oak, Suite 1300, Houston, Texas.

RWA announces their new name to be **The Hawkweed Group, Ltd.** located at 4643 North Clark Street, Chicago, Illinois.

**Carson, Lundin & Thorson PC** has recently moved its headquarters to 880 Third Avenue, New York, New York.

Warren H. Smith, Edward G. Lunz, William A. Romberger and James G. Whildin, Jr. announce the formation of **Smith Architectural Group, Incorporated** located at 402 South Kentucky Avenue, Suite 570, Lakeland, Florida and 315 Golf View Drive, Suite 213, Boca Raton, Florida.

Lee Radziwill has taken offices with the architectural firm of John Carl Warnecke & Associates at 745 Fifth Avenue, New York, New York. Her firm is to be called **Lee Radziwill, Inc.**

**Anthony E. Oliver** and **John Glidden** announce the opening of their architectural practice at 204 Brazilian Avenue, Palm Beach, Florida.

Shavey & Schmidt, AIA, Architects is expanding its partnership and changing the firm name to **Shavey Schmidt DeGrasse Shavey.**

Francis V. Biskup and Golden J. Zenon, Jr. have formed an architectural partnership, **Zenon Biskup and Associates** with offices in Omaha.

**Allen & Hoshall, Inc.** announce the opening of an engineering planning and design office at 612 North State Street, Jackson, Mississippi.

**Richard W. Campbell** has returned to consulting engineering practice at 135 South Maryland Avenue, Glendale, California.

more office notes on page 227

# Introducing... Specialized technology in doors for engineered environments

- Pressure
- Blast Load
- Noise
- Temperature
- Atmosphere
- Chemical Reaction

**Jamison can help you . . . now.**

We can't guess what kinds of unusual door problems you're already into, or will be facing in the near future.

But we can say that more and more architects, designers, constructors, and owners are asking us to engineer and build specialized doors for specialized applications.

High intensity sound isolation for example. And virology laboratory atmospheric security . . . protection from arctic temperatures, searing heat and flood threats . . . controlled recreational environments . . . and many more.

Jamison has 70 years' experience in dealing with the complexities of door technology . . . from cold storage to blast load.

We understand door construction, gasketing, sealing, insulation, hardware, cladding materials, and power operation. We know how to put them all together to meet a wide range of critical requirements.

You should have two informative new booklets describing our capabilities. Ask for them today . . . send our coupon or use the reader service card.

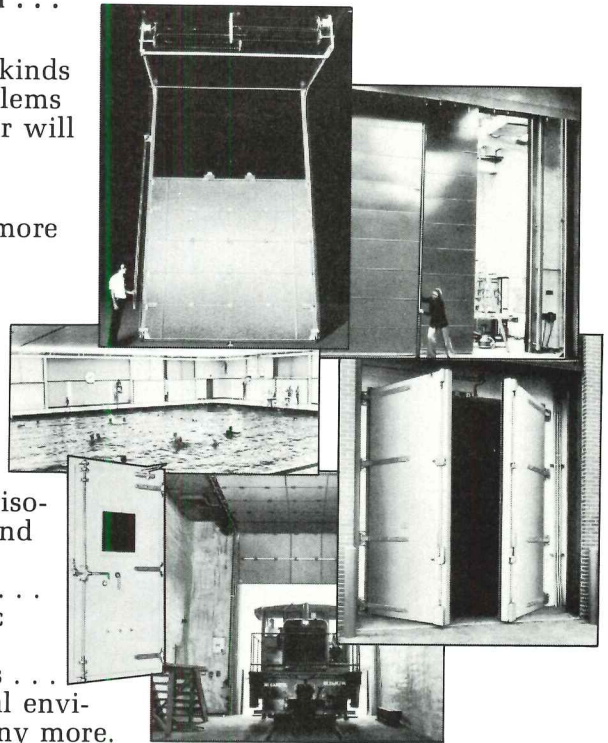

Please rush me copies of Jamison's new literature on specialized door technology.

Please have engineering representative contact me.

## JAMISON

JAMISON DOOR COMPANY  
P.O. BOX 70  
HAGERSTOWN, MD 21740

NAME \_\_\_\_\_

TITLE \_\_\_\_\_

COMPANY \_\_\_\_\_

STREET \_\_\_\_\_ TELEPHONE \_\_\_\_\_

CITY \_\_\_\_\_ STATE \_\_\_\_\_ ZIP \_\_\_\_\_

For more data, circle 84 on inquiry card



# TEST THEIRS.

And "theirs" can be any drafting paper you choose.

Draw a line, erase and redraw it. Then, look for ghosts. On any paper, other than Clearprint, they're almost sure to be there.

That would be the perfect moment to fill out our coupon and send for your free catalog. Then, try the same test on our paper. You won't get any ghosting. Forty years and more from now you won't see any cracking or yellowing either.

Send for your catalog today. Of course, there's no obligation — except to yourself and your company.

**We perfected paper in 1933**

# TEST OURS.

## •Free Catalog•

Please send us your catalog of samples and suggested price lists. We use drafting paper

for: \_\_\_\_\_

\_\_\_\_\_

Name \_\_\_\_\_

Title \_\_\_\_\_

Firm Name \_\_\_\_\_

Address \_\_\_\_\_

City \_\_\_\_\_

State \_\_\_\_\_ Zip \_\_\_\_\_



CLEARPRINT PAPER CO., 1482-67th STREET  
EMERYVILLE, CALIFORNIA 94608

AR500

**1.** Lay down a line on your drafting paper.

**2.** Erase and redraw the same line in the same place several times.

**3.** If you see a ghost, the paper isn't Clearprint.

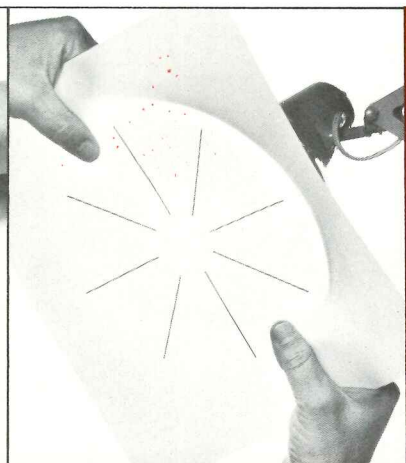
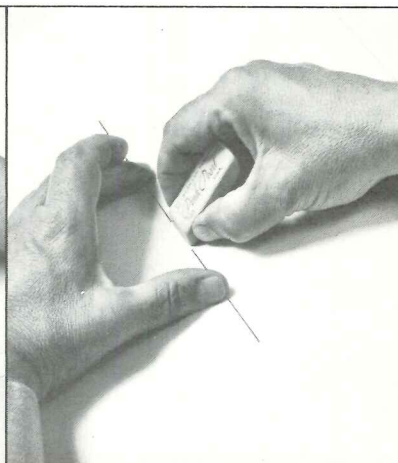
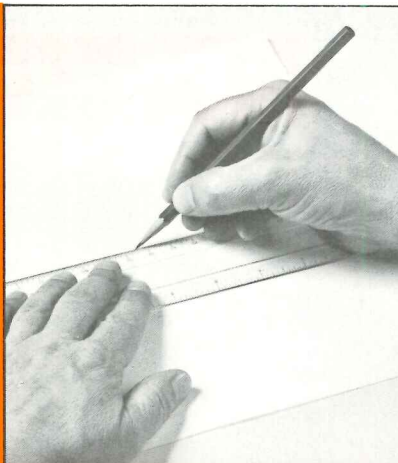

# Haws makes it an

# EASY REACH!

This Haws electric water cooler beckons to those in wheelchairs and the general public alike. It promises the satisfaction of cool water for all, fulfilling the requirements of Public Law 90-480 and most state codes.

Dual, self-closing operating lever valves offer greatest possible accessibility. All-stainless steel exterior eases maintenance, assures permanent brilliance. Electric water chiller with 5-year warranty is packaged in a metal enclosure; easily installs behind louvered panel.

Model HWCD-8 wall-mounted electric water cooler is the ideal unit to specify for schools, hospitals, office complexes, or any other projects where building construction, leasing or financing involves federal funds. Get full facts on Model HWCD-8 from your nearest Haws Representative or Haws Drinking Faucet Co., 1441 Fourth Street, Berkeley, CA 94710.



**Haws**  
WATER COOLERS

Model HWCD-8

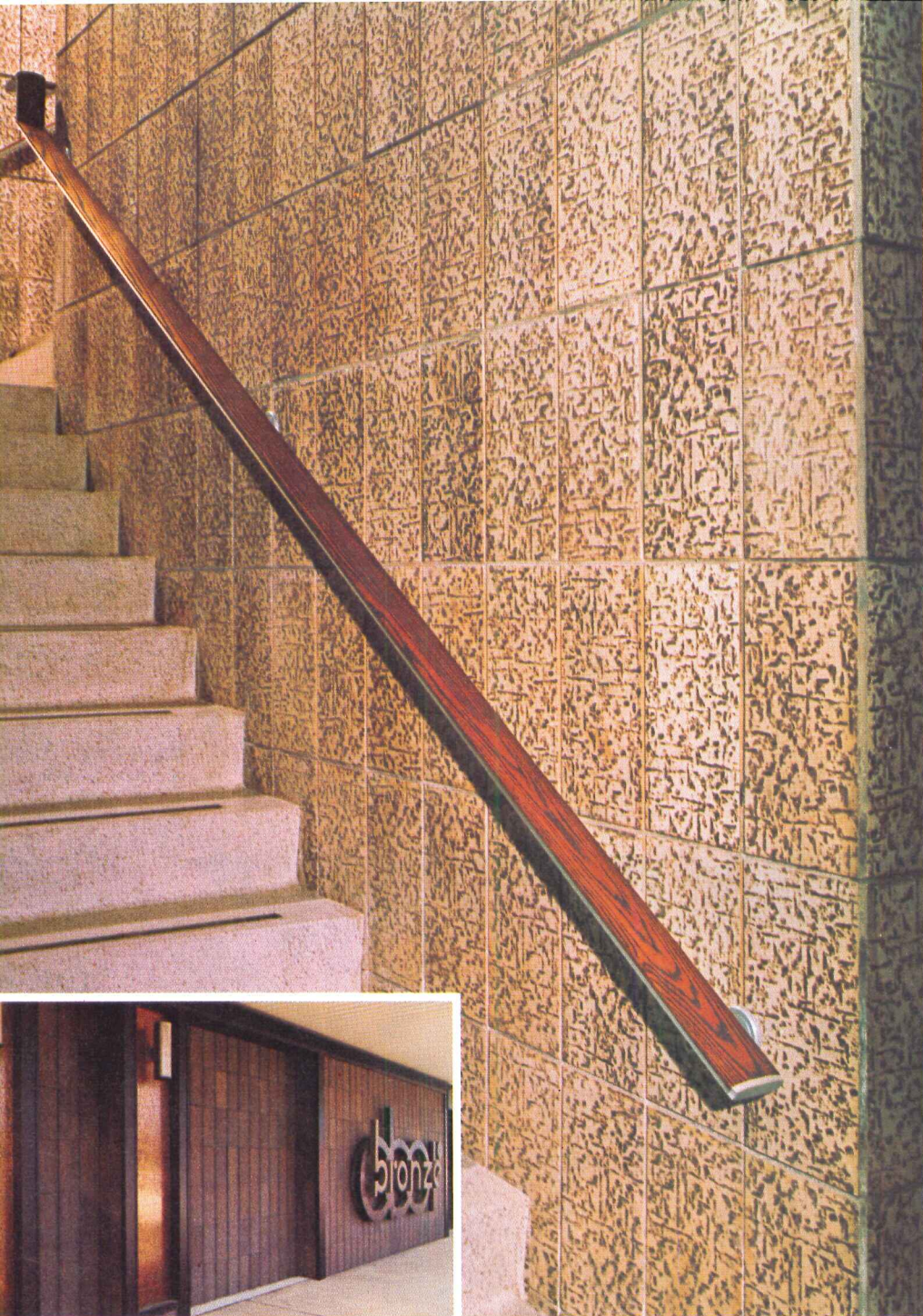

Interior and exterior installations of Stark textured tile.

## Textured Structural Tile...

the quality  
look that lasts

Consider the colors and textures now available in structural clay tile from Stark. They offer new design possibilities with the functional benefits found only in load-bearing clay masonry walls.

Energy is conserved ("U" factor for a 10" insulated cavity wall is only 0.072 BTU/hr./sq. ft./degree F). Wall colors are permanent and non-fading for the life of the building. The ceramic coating simplifies cleaning, provides abrasion and impact resistance . . . just as with structural glazed facing tile.

Zero flame spread, a minimum compressive structural strength of 1,500 PSI, and sound transmission coefficient (STC) rating of 45 are additional benefits.

Investigate the *ultimate* cost and value of a Stark textured structural tile wall system for high abuse and minimum maintenance areas as well as for pure beauty and endurance inside or out.

For further information, refer to our catalog in SWEET'S 4.4/St, or call TOLL FREE 800-321-0662. In Ohio, call collect (216) 488-1211. **Stark Ceramics, Inc.**, P.O. Box 8880, Canton, OH 44711.

**stark**

**PLYWOOD SIDING** / Fully illustrated with end-use photos and detail drawings, a 16-page publication discusses the design flexibility, strength, impact resistance, durability, acoustical and thermal value, and economy of plywood siding. There is also a section on the use of plywood in shear wall construction. ■ American Plywood Assn., Tacoma, Wash.

*Circle 416 on inquiry card*

**GARAGE DOORS** / A full line of garage doors for residential, industrial and commercial applications is described in two illustrated catalogs. Included are steel, wood, fiber glass, and aluminum doors; there is a track selection guide for special installation requirements. Information is given on electric operators and other accessories. ■ Raynor Mfg. Co., Dixon, Ill.

*Circle 417 on inquiry card*

**REFLECTIVE GLASS** / A technical booklet presents the advantages of residential glazing with *Solarcool* reflective glass, said to transmit 60 per cent less solar energy than clear glass. One suggested application is the use of add-on *Solarcool* panels during warm months to lower air-conditioning loads. ■ PPG Industries, Inc., Pittsburgh, Pa.

*Circle 418 on inquiry card*

**SPECIALTY TIMBERS** / Custom posts and beams of Douglas fir or Western hemlock are available in widths up to 24 in., and in lengths of up to 28 ft. A specialty timber brochure contains photos of such end-use applications as architectural posts and beams, industrial members, marine lattices and playground equipment. ■ Simpson Timber Co., Seattle, Wash.

*Circle 419 on inquiry card*

**PLYWOOD MANUFACTURERS** / A directory, "Where to Buy Hardwood Plywood and Veneer," is designed to help specifiers and purchasers of hardwood plywood, veneer, adhesives, finishes, and machinery find the manufacturer they need quickly and easily. The book is available from the Hardwood Plywood Manufacturers Association at no charge. ■ HPMA, Arlington, Va.

*Circle 420 on inquiry card*

**STRUCTURAL CLAY PRODUCTS** / A 12-page full color catalog features a complete line of structural glazed facing tile, structural textured and acoustical tile, High Brick and utility brick. A matched-color spread shows all of the colors available for each product; "U" values, sound- and fire-resistance ratings are also given. ■ Stark Ceramics, Inc., Canton, Ohio.

*Circle 421 on inquiry card*

**COMPOSITE FLOOR SYSTEM** / Featured in a new illustrated brochure on the *Epicore* composite floor are the system's heavy loading capacity, material savings of the beam system, and flexible lifetime hangers. Also given are revised engineering tables, fire ratings, and data on use in hospitals, electric power facilities, and telephone equipment buildings. ■ Epic Metals Corp., Rankin, Pa.

*Circle 422 on inquiry card*

**PRECAST DECKS** / An illustrated brochure shows how precast concrete decks combine with precast and masonry-bearing walls to provide fire-resistive nursing home structures. Other advantages of precast construction in the design of six different projects are given in the booklet. ■ The Flexicore Co., Inc., Dayton, Ohio.

*Circle 423 on inquiry card  
For more data, circle 82 on inquiry card*



**COMMERCIAL LIGHTING** / This line of light bulbs has been specifically designed for hotels, motels, restaurants and cocktail lounges. Longer life filaments are said to lower maintenance charges by reducing lamp replacements. This "job-tailored" lamp series includes 150- and 250-W Krypton PAR spot and flood lamps; three 2500-hr "Bug-A-Way" yellow bulbs; and eight 4000-hr decorative lamps for special effects. ■ Westinghouse Electric Corp., Lamp Commercial Div., Bloomfield, N.J.

Circle 318 on inquiry card

**AGGREGATE BONDING MATRIX** / *HydrEpoxy*



*104*, a two-part water-based epoxy matrix designed for on-site bonding of exposed aggregate to vertical surfaces, is now available in 15 new colors. *HydrEpoxy 104* will bond to a variety of surfaces, both damp and dry, and is said to be odorless, non-flammable, and virtually non-toxic. The epoxy should be extended with an equal volume of sand or Portland cement; when cement is used, the matrix will cure to temperatures as low as 32 F. ■ Acme Chemicals & Insulation Co., New Haven, Conn.

Circle 319 on inquiry card

**ROOF DRAIN PUMP** / This pump system automatically removes ponded roof water as it collects, preventing damage to the roof membrane. The self-priming pump is placed in the lowest area of the pond, and flexible pipe is run to the nearest roof drain or over the side of the building. A separate power unit inside the building provides 12 volts DC to the pump, which automatically operates when roof water depth reaches 1/2-in. No manifold is necessary; the roof drain system comes complete with all parts needed for installation. ■ Sentonics, Inc., Cleveland, Ohio.



Circle 320 on inquiry card

**WOOD PROTECTIVE FINISH** / "CWF Clear Wood Finish" penetrates exterior wood surfaces to provide a durable seal against water and weathering. The high solids finish can be used on any exterior wood, from cedar shakes to redwood decks, and is said to work equally well on old, new, rough sawn, planed or pressure-treated wood. "CWF" reacts with the wood itself to produce a uniform honey to brown color, with a matte appearance. ■ The Flood Co., Hudson, Ohio.



Circle 321 on inquiry card

**ROOFING/WATERPROOFING MEMBRANE** / *KMM*



membrane is a prefabricated five-layer sheet of modified bitumen, with an outer coating of either polyethylene film (for waterproofing use, flat roofs or decks); or embossed aluminum foil (for steep roofs and flashing application). *KMM* membrane is spread directly over the substrate, with each row overlapped 4 in. The joints between overlapping sheets are heated to fuse and seal the bitumen layers. On standard *KMM*, a second seal is made by heating the top of the joint and smoothing the melted bitumen with a trowel (pictured). ■ Koppers Co., Inc., Pittsburgh, Pa.

Circle 322 on inquiry card

**WALL COVERING** / The *Acrovyn* (vinyl/acrylic alloy) wall covering system has been granted a Class I Fire Rating; after being tested in accordance with UL's Tunnel Test, ASTM E84, and NFPA standard 255. The .028-in.-thick wall surface comes in 12 colors, with a matte pebble grain; *Acrovyn* is said to offer superior resistance to marring, stains, chemicals and commercial solvents. The wall system itself includes coordinated or contrasting moldings; contact or mastic adhesive; installation tools; and complete working drawings. ■ Construction Specialties, Muncy, Pa.



Circle 323 on inquiry card

*design flexibility* **The Key to Power-Strut's Grid Ceiling Support System**

Easily moved internal partitions allow for seasonal expansion or contraction

Adjustable track lighting fixtures hidden by baffles, spotlight merchandise

Hanging baffles hide open ceiling, electrical and mechanical equipment

A criss-cross grid of Power-Strut continuous slot channel is hung from unfinished ceiling or building's steel structure

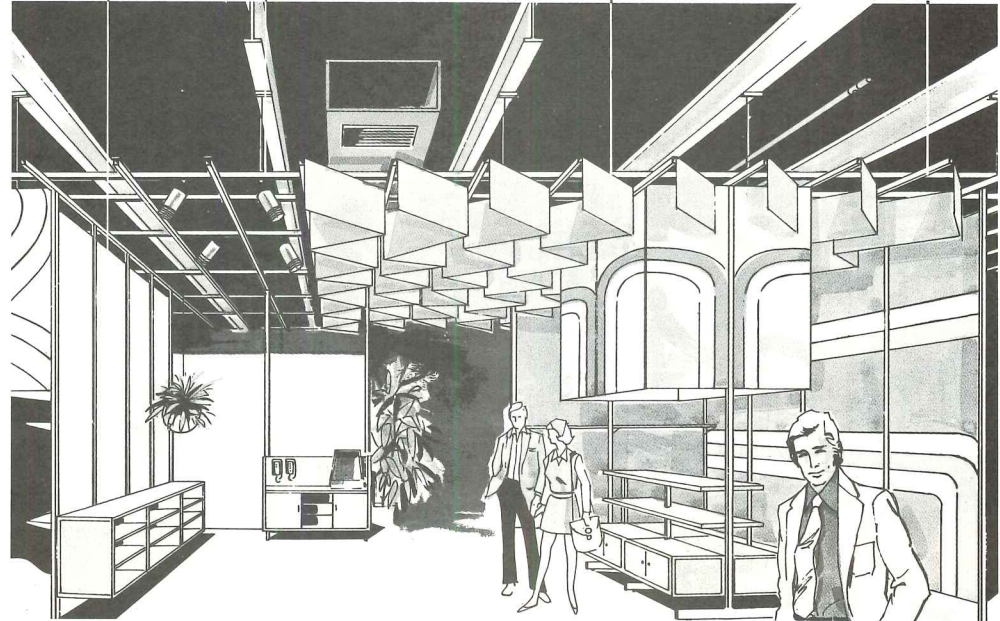

**A unique concept in functional esthetic effects . . .**

The Power-Strut Modular Grid Ceiling Support System is simple in design and easily installed. A criss-cross grid of Power-Strut continuous slot metal framing is hung from the rough unfinished ceiling or the building's steel structure.

Decorative baffles or fins are hung vertically from this grid. The decorative baffles hide all mechanical, heating and cooling ducts, sprinkler systems, etc.

Adjustable "track" lighting spotlights merchandise displays.

Since walls and divider panels are easily attached to the grid, seasonal or department expansion or contraction can be reduced to an overnight project.



For more information write . . .  
**VAN HUFFEL TUBE CORP.**  
WARREN, OHIO 44481

For more data, circle 80 on inquiry card

# Strength in Numbers.

Numbers? Azrock has them. The largest, most comprehensive selection of contract colors and styles available in vinyl asbestos tile. These are just a few of the over 130 Azrock contract patterns you can choose from to express your creativity. In 1/8" and 3/32" gauge through-chip, solid, and embossed designs for heavy and medium traffic areas. In through-chip 1/16" stylings—exclusive with Azrock—for lighter traffic and residential use. All in big 12" x 12" tiles.

Strength? Azrock tiles are made to give years of durable, long-lasting service. Time-tested floors that people have been walking on for over 40 years. With a money-saving no-wax maintenance system, Azrock has it all—styling, economy, dependability—in the floor that won't let you down.

But one picture isn't worth 130 in-the-hand samples. So call your Azrock flooring contractor. Or write Azrock Floor Products, Dept. 536A, P.O. Box 531, San Antonio, Texas 78292 for samples of the entire line. Free, of course, from Azrock.

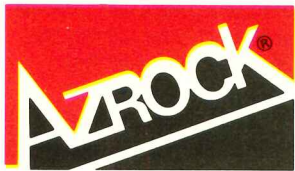

**The vinyl asbestos  
floor tile specialists.**





**FIRE RESISTANT PARTICLEBOARD** / This hospital nursing station was constructed using *Duraflake FR* particleboard as the core element in laminated cabinets, counters and panels. (Cedars-Sinai Medical Center, West Los Angeles, Calif.; A.C. Martin and Charles Luckman, architects.) With a UL and ICBO Class I fire rating, *Duraflake FR* board can be used extensively in installations requiring fire preventive materials. Thicknesses of from 3/8- to 1 1/4-in. are available. The graduated-layered particleboard is designed for the application of a variety of laminates and veneers. ■ Duraflake Div., Willamette Industries, Inc., Albany, Ore.

Circle 313 on inquiry card

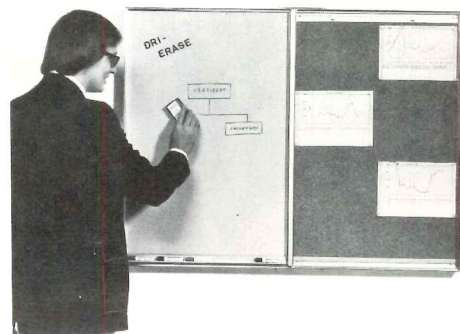

**VISUAL COMMUNICATION PANELS** / The "Visual Idea Center" provides everything needed for effective visual communication: a dry eraseboard for markers; chalkboards; cork tack panels; writing/charting tablets; storage tray; and, on two larger models, a pull-down projection screen. Cabinets are available in wood grains or plastic laminates, framed in either natural, matte black, or bronze-toned aluminum. ■ Omni, Grand Rapids, Mich.

Circle 314 on inquiry card



**LEATHER-UPHOLSTERED SEATING** / This series of lounge seating was created specifically for the covering, full *Toro* bull hides of 5mm-thick un-split leather, available in five aniline-dyed colors. The "Crusader" line, designed by Urs Felber and Ernst Luthy, consists of a club chair, a two-seat sofa, and a larger, three-seat sofa. All have hardwood frames and *Dacron* and foam upholstery on a sleigh base. ■ Stendig Inc., New York City.

Circle 315 on inquiry card



**OFFICE FURNITURE** / The "Contemporary Collection in Wood" consists of chairs, tables and file carts, plus desks, credenzas and bookcases: all intended to be flexibly arranged in open office installations. The line, designed by Alvin E. Palmer, is constructed of wood with natural oiled oak as the standard finish. Coordinating acoustical screens are available. ■ Rose Mfg. Co., Grand Rapids, Mich.

Circle 316 on inquiry card

**CARPET BACKING** / The *Certilok* backing system for direct glue-down carpet installations has a 20-lb tuft-bind strength, said to virtually eliminate the problem of tufts being pulled or accidentally snagged from the carpet surface. ASTM Tuft Bind Test (D 1335) is shown in the photograph. The co-polymer latex backing is easy to cut, with ravel-resistant edges; single-back construction prevents delamination. *Certilok* backing can "breathe;" adhesive moisture can escape through the carpet. Three lines of commercial-grade nylon or acrylic fiber carpets are currently available with the *Certilok* backing system. ■ Armstrong Cork Co., Lancaster, Pa.

Circle 317 on inquiry card  
more products on page 169



# A View That Can Save Energy

When you look up at the ceiling and see the sky or the leaves on a tree or snow flakes, your spirits are lifted. When you see a room lit by sunlight, you see it at its best.

The National Bureau of Standards has issued a publication titled "Windows and People" that discusses the psychological benefits of contact with the outdoors to people living or working indoors. Now, Wasco, the leading supplier of skylighting, has compiled significant data on the gains and losses of energy attributed to skylights. It is quite fascinating to see how, under the right conditions, skylights can actually save energy in most areas of the United States. Naturally, there are many variables, including unit design, positioning on the building, building usage, percent of roof coverage and geographical location. If you would like a copy of Wasco's summary of current information, it's yours for the asking.

Please send me Wasco's free summary of current information relating to the effect of skylighting on the energy balance.

NAME \_\_\_\_\_

ADDRESS \_\_\_\_\_ CITY \_\_\_\_\_

STATE \_\_\_\_\_ ZIP \_\_\_\_\_



**WASCO PRODUCTS, INC.**

P.O. BOX 351 / SANFORD, MAINE 04073 / TEL: 207-324-8060

For more data, circle 78 on inquiry card

**Bally** where all our energies  
are aimed at reducing  
your energy cost.

**ALL-WEATHER**

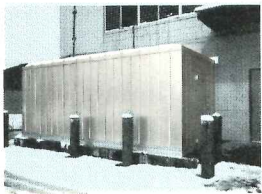
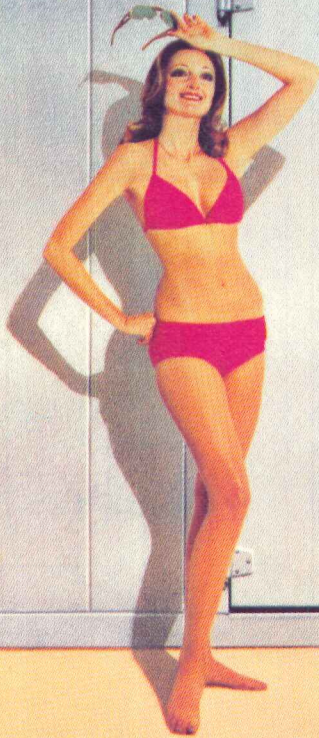

More and more . . . mass feeding establishments and retailers everywhere . . . are installing walk-ins outdoors. They're placing them on loading docks and parking lots to gain these important advantages.

- Increased refrigerated storage space.
- The use of additional indoor space for other critical needs.
- Vendor deliveries during night time hours made easy.

Many planners beat high building costs by installing walk-ins outdoors and reducing building size.

**When the lack of space indoors sends you outdoors for refrigerated storage, it's critically important to select a walk-in that will withstand punishing weather and still save energy.**

Burning sun . . . driving rain and sleet . . . heavy snow loads . . . hurricane winds . . . demand much more from an outdoor walk-in than is required for normal indoor use . . . and it takes more than an average walk-in to do the job.

Bally Walk-Ins have what it takes. Four inch thick urethane insulation . . . heavy gauge metal skins . . . patented joining device that locks panels together tightly with perimeter steel bands . . . all-weather aluminum roof . . . all combine to ignore weather and time.

**It's one more reason why you should buy Bally.**

Bally is the world's leading producer of walk-in coolers/freezers. They can be assembled in any size for indoor or outdoor use . . . easy to enlarge or relocate. Refrigeration systems

from 50°F. cooling down to minus 30°F. freezing. Subject to fast depreciation and investment tax credit. (Ask your accountant.) Write for free 28-page book and urethane sample.

**Bally Case & Cooler, Inc., Bally, Pennsylvania 19503.**

Address All Correspondence to Dept. AR-1 Phone: (215) 845-2311



©1976 All rights reserved.

For more data, circle 77 on inquiry card

# IN THE CAUSE OF ARCHITECTURE FRANK LLOYD WRIGHT

## WRIGHT'S HISTORIC ESSAYS FOR THE FIRST TIME IN ONE VOLUME

### Essays for *Architectural Record* 1908-1952

With a symposium on architecture  
EDITED BY  
FREDERICK GUTHEIM

Now for the first time ever, the seventeen historic essays Frank Lloyd Wright wrote for *Architectural Record* are collected in one definitive volume. *In the Cause of Architecture*, Wright's major statement of his architectural philosophy, is an essential key to understanding this creative giant.

Reproduced in their entirety and in their original format as they appeared in the pages of the *Record*, these essays give penetrating insights into the mind of an architectural genius at the time he was creating his most significant works.

This handsome, 256-page volume is illustrated with hundreds of photos, drawings, plans and perspectives of F.L.L.W.'s greatest buildings as well as a fascinating photo-essay of never-before-published pictures of Wright taken shortly before his death.

Edited by noted Wright authority Frederick Gutheim, the book also includes a symposium of eight essays by Wright's associates that take a new look at the life and work of America's greatest architect.

*In the Cause of Architecture* will be of lasting interest to architects, students, and all those interested in Wright—a basic reference for school, home and office libraries. Beautifully designed, it will be a treasured gift for years to come.

Architectural Record Books AR-1-77  
1221 Avenue of the Americas, 41st Fl.  
New York, New York 10020  
*add sales tax where applicable.*

Please send me \_\_\_\_\_ copies of  
*In the Cause of Architecture: Frank  
Lloyd Wright* @ \$17.50 each.  
*add sales tax where applicable.*

Name \_\_\_\_\_

Address \_\_\_\_\_

City \_\_\_\_\_

State \_\_\_\_\_

Zip \_\_\_\_\_

Payment must accompany order

**LAY-IN CEILING PANEL** / An embossed pattern simulating rough cast exposed aggregate concrete, the *Safetone Marquis* ceiling tile is said to provide a textured appearance without a directional effect. The suspension system acts as a reveal edge for the 24- by 24-in. lay-in panels. *Safetone Marquis* panels have an NRC in the .65-.75 range; light reflectance of .72; and meet FS SS-S-118A and ASTM E 84 requirements. ■ The Celotex Corp., Tampa, Fla.

Circle 308 on inquiry card

**ROOF INSULATION** / The top and bottom layers of this sandwich-type roof insulation are fire-resistant perlite; the core material is warp- and stress-free urethane. Asphalt can be applied at normal application temperatures to the top perlite layer. Four nominal thicknesses consistent with standard lumber sizes, and facia dimensions with "C" values ranging from .10 to .06 are offered. ■ Grefco, Inc., Building Products Div., Oak Brook, Ill.

Circle 309 on inquiry card

**HOSPITAL DRAPERIES** / This line of coordinated bedspreads, draperies, and cubicle curtains is specially produced for use in healthcare institutions. All fabrics are said to be inherently flameproof as well as easy to maintain, and are available in a wide variety of colors, materials and patterns. Cubicle curtains have non-rusting aluminum eyelets, and may be ordered with *Velcro* self-tiebacks. Draperies may be installed using a track system requiring neither pins nor hooks, as well as standard traverse rods. ■ Tami Products Co., Shaker Heights, Ohio.

Circle 310 on inquiry card

**APARTMENT DOOR OPENER/INTERCOM** / Up to 256 individual apartments can be serviced by a single "300 Series" entry directory unit. This intercom/security system utilizes existing AC wiring; only the handset/directory panel, entrance door control and door strike require installation. The individual apartment intercom units need only be plugged into a standard 110-120 volt AC outlet; no additional wiring is necessary from the control to each apartment. ■ Technicom, Inc., Kirkland, Wash.

Circle 311 on inquiry card

**EXECUTIVE CHAIR** / Compact and slightly scaled down in size, "220" desk chairs take minimal space in office landscape applications. The chair is available in either low- (shown), medium-, or high-back versions, and a choice of vinyl or fabric upholstery. Different base and pedestal options are offered, including either glides or casters. ■ Hiebert, Inc., Torrance, Calif.

Circle 312 on inquiry card

more products on page 167

## Half an elevator is better than one.

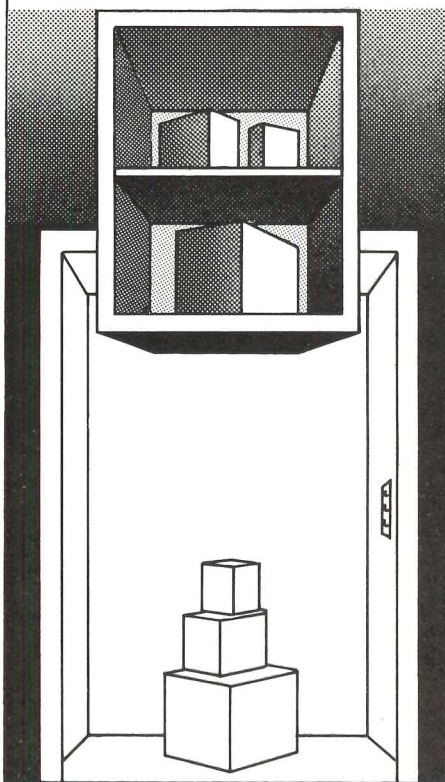

Many commercial buildings that don't really need a whole elevator get one anyway. Or they get an extra one. For freight. This is expensive. It's sort of like buying a first class ticket for a package.

There is an alternative. Several in fact. Sedgwick Dumbwaiters and Parcel Lifts. They come in a variety of shapes, sizes and capacities. From small, efficient Correspondence Lifts to big powerful Rotowaiters, rated up to 500 lbs. (with a safe operating overload margin of 50%).

What are the advantages? Cost and efficiency to name two. For the price of one full size elevator, several Sedgwick Dumbwaiters could be installed in convenient locations.

Don't send freight first class. Send it by a Sedgwick Dumbwaiter or Parcel Lift.

For a complete catalog, write to Sedgwick Machine Works.

**sedgwick machine works**  
box 630 AR  
poughkeepsie, ny 12602  
(914) 454-5400



For more data, circle 76 on inquiry card



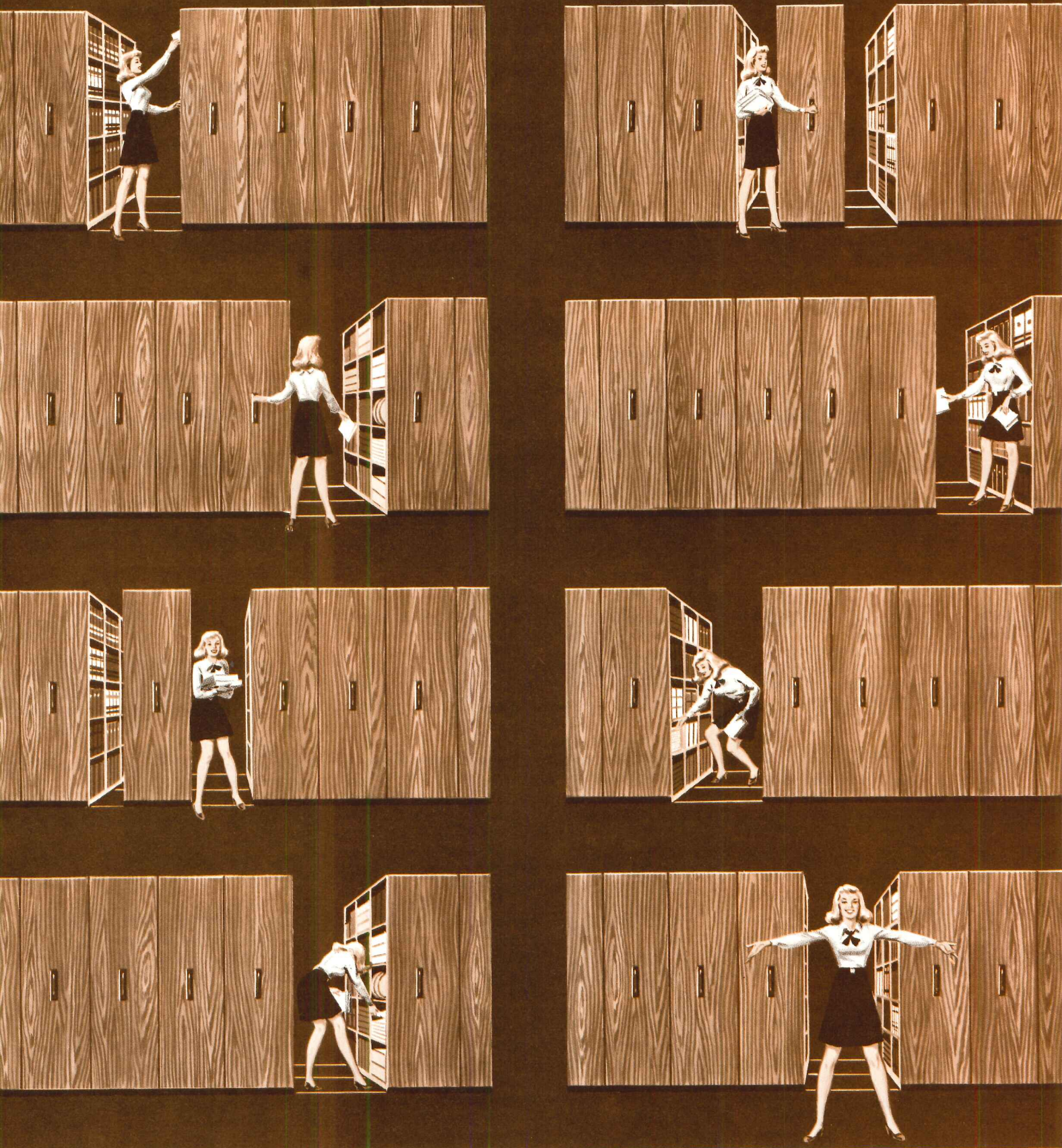

## FULLSPACE...the file with the movable aisle!

If you tried to provide your clients with this much storage or file space using ordinary files or shelves, you'd need 6 aisles and up to 4 times the floorspace. FULLSPACE does it with just one aisle that opens where it's needed. Furthermore, when the aisle is opened, all the space on both sides is exposed, greatly reducing access time.

But there's more to FULLSPACE than space-saving and efficiency. High quality finishes in handsome wood grains or colored laminates create handsome furniture that complements any decor.

*Want more information? Write today, or call us collect.*



**LUNDIA**  
The World's Record Holders®

LUNDIA, MYERS INDUSTRIES INC.  
600 Capitol Way  
Jacksonville, IL 62650  
217/243-8585

General Services Administration  
FSC Group 71, Part V, Section C

**When you want a small package delivered fast, it's in the bag.**



Delta's DASH guarantees delivery on the flight or routing you specify between all Delta cities and most cities served by other airlines through interline agreements. Packages accepted up to 50 lbs. with length plus width plus height not to exceed 90."

Call Delta for an expedited pick-up, or bring your package to Delta's passenger counter at least 30 minutes before scheduled departure time (or to the air cargo terminal at the airport 60 minutes before schedule departure time). The package can be picked up at the DASH Claim Area next to the airport baggage claim area 30 minutes after flight arrival at destination. Or we deliver it at an additional charge.

Delta reservations can give actual DASH charges between specific points. You may pay by cash, company check, most general-purpose credit cards, special credit arrangement or, on government shipments, by GBL.



Rate examples	(Tax included)
Atlanta-Washington. . . . .	\$21.00
Boston-Miami. . . . .	26.25
Los Angeles-New Orleans. . .	31.50
Dallas/Ft. Worth-	
Los Angeles . . . . .	26.25
San Francisco-Atlanta . . . . .	31.50
Philadelphia-Houston. . . . .	26.25
New York-Tampa . . . . .	26.25
Chicago-Orlando. . . . .	26.25
Detroit-Memphis . . . . .	21.00

For full details, call Delta reservations.

For expedited pick-up and delivery at extra charge, call 1-800-424-1092 toll free anywhere in the Delta system. In Washington, D.C. call 466-3131.

**Delta is ready when you are.®**

For more data, circle 74 on inquiry card

**STEEL ROOFING /** The SR 100 standing seam roof

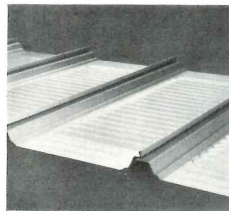

features a factory-applied weather seal 2½-in. above the drainage surface, said to ensure a weathertight roof seam. Structural cross ribs in the roof panel provide additional rigidity. The roof system can accommodate a slope of ¼- on 12-in., and was designed especially for the manufacturer's Horizon Series of metal buildings. ■ National Steel Products Co., Houston, Texas.

Circle 303 on inquiry card

**WATER COOLER /** The Model HFS-14 floor-



mounted water cooler is 33-in.-high, making it readily accessible to a child's reach. Water, drain and electrical connections are made through the back of the compact unit. The welded steel cabinet has a gray hammertone finish with a charcoal vinyl removable front panel. Five other vinyl finishes are also available at no extra cost. The unit may be bolted to the floor to prevent vandalism. ■ Haws Drinking Faucet Co., Berkeley, Calif.

Circle 304 on inquiry card

**ROOFING PANEL /** Formac roofing panels come



preassembled with sheathing, felt, and red cedar shakes in 8-ft units. The panels require two nails per rafter, and can be cut easily on the roof to fit construction requirements. Formac panels produce a solid plywood sheathing with horizontal and vertical overlaps for strength. ■ Foremost-McKesson Building Products Inc., San Jose, Calif.

Circle 305 on inquiry card

**ELECTRONIC SCOREBOARD /** New "Series 6000"



scoreboards are said to have a virtually unlimited operating life because there are no moving parts; all units carry a five-year warranty. An operator's console provides a complete back-up timing and scoring system; switches show information simultaneously as it appears on the scoreboard. A two-wire control system incorporates single pin connectors for easier installation. Attachments and various captions make the solid-state "Series 6000" board convertible to many different sports. ■ Fair-Play Scoreboards, Des Moines, Iowa.

Circle 306 on inquiry card

**STEEL CONSTRUCTION FRAMING /** New products



and sizes have been added to this line of steel framing for load-bearing bearing and non-load-bearing applications. Wide-flange studs, "C"- and screw-type studs, deep leg track and construction accessories are available in several galvanized steel gauges; studs come in widths from 2½- to 6-in. All units conform to AISI specifications, and meet virtually all wind loads up to 140 mph. ■ The Ceco Corp., Chicago, Ill.

Circle 307 on inquiry card

more products on page 165

**THE Stemwinder**

NEWS AND VIEWS ON HARDWOODS AND VENEERS



Richard K. Stem  
President  
Chester B. Stem  
Incorporated

**IS THERE ANY EXCUSE FOR ORDINARY WALL PANELING?**

Not much, because Stem's inventory of exotic hardwood veneers from every corner of the world offers an almost unlimited opportunity for creative expression. Perhaps you have the perfect installation in mind for PEANUT SHELL TAMO from the Orient. Or, how about the beautiful and unusual FIDDLEBACK MAPLE?

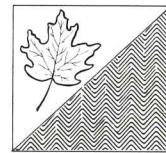
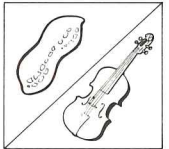

Or, you might want to consider LEAFY BUTTERNUT, which combines the natural buttery warmth of the wood with an unusual leaf-pattern graining. Or, there's the light and lively HERRINGBONE AVIDORE, the African wood with a distinctive grain pattern that lives up to its name.



The point is, you don't have to settle for ordinary wall paneling.



**FLITCH SPECIFICATION.** There may be times when simply specifying stock wall paneling is inadequate—times when you wish to more precisely express your own individual taste. The flitch specification process—plus Stem's bold inventory of woods—allows you to do just that. You handpick the veneer that best meets your aesthetic criteria for color and grain patterns. We welcome your inquiry.



Chester B. Stem, Inc., 2704 Grant Line Road, New Albany, Ind. 47150. Manufacturers and importers, sliced wood and lumber. Fifteen minutes from Louisville, Ky. airport. Telephone (812) 945-6646.



**STEM**  
EMINENCE IN WOOD

**Let's face it: only wood is wood.®**

# Question: Should an architect have to do the laundry?

Answer: No way. Instead, feel free to call on Econ Systems for everything your client needs in a well-planned, on-premise laundry. You could come out a hero. Because we can often help you point to a 30 to 40 percent cost saving, compared to a contract laundry situation. This represents a continuing operational saving for your client.

We can help you right from the design stage. Or, subject to your wishes, we can do everything:

feasibility survey, overall cost and projected savings, preliminary planning, sizing of installation to your available design space, schematic layout, supplying of equipment, and specialty detergents. After the laundry is installed, we back it up with factory-direct service and regular preventive maintenance from our 750 specialists.

So you see—having Econ Systems do your laundry could be just the ticket. Next time, give

us a call at our toll free number: 800-238-5557. For a free copy of Econ Systems *Engineering and Architectural Specification Manual*, write Econ Systems, a division of Economics Laboratory, Inc., 4 Corporate Park Drive, White Plains, New York 10604.



For more data, circle 73 on inquiry card 1



For more information, circle item numbers on Reader-Service Inquiry card, pages 231-232.

**STORAGE CONTAINERS** / A 20-page catalog describes the *Totem* line of plastic industrial containers. Included are tote boxes, trays, security containers and lids. The tote boxes can be nested, stacked, and divided, and provide color-coded, organized storage for schools, health care facilities, etc. ■ BQP Industries, Inc., Denver, Col.

Circle 400 on inquiry card

**HARDWOOD DOORS** / Both architectural and residential hardwood flush doors are covered in a 1977 catalog. Included are descriptions, specifications and illustrations for each type door. There is also a section on *Rezolute* vinyl-veneer doors. ■ Paine Lumber Co., Inc., Oshkosh, Wis.

Circle 401 on inquiry card

**PNEUMATIC TUBE CONTROL CENTER** / The *Trans-Logic* computerized pneumatic tube system consists of a computer console, video display (cathode ray tube/keyboard), and supervisory panel, which provides a digital display of all transactions. A four-page bulletin briefly outlines features of the various system components. ■ Powers Regulator Co., Skokie, Ill.

Circle 402 on inquiry card

**ARCHITECTURAL SKYLIGHTS** / A full-color brochure presents photos of recent monumental skylight installations, as well as technical details and drawings of the structural and glazing systems used. These extruded aluminum skylights are guaranteed by the manufacturer for ten years against leakage or construction defects. ■ Super Sky Products, Inc., Thiensville, Wis.

Circle 403 on inquiry card

**PAVING TILE** / A four-color brochure contains on-site photos of "Carolina Colony" quarry paver installations. Tile shapes, colors, and trim, as well as pattern possibilities, are shown. ■ Mid-State Tile Co., Lexington, N.C.

Circle 404 on inquiry card

**WOOD TREATMENT** / An illustrated 1977 catalog contains in-use photos and test data for *K-33* pressure-treated wood products and *Flame Proof* fire-retardant wood. Separate data sheets give more detailed information on the characteristics, qualities and various applications of each product. ■ Osmose Wood Preserving Co., Buffalo, N.Y.

Circle 405 on inquiry card

**ELECTROSTATIC PLOTTING** / A four-page newsletter reports on new electrostatic output systems for *PERT* (Project Evaluation and Review Technique) applications. Software described includes plotters with special features such as shading, toned patterns and variable line widths. New *PERT* hardware offerings include extra-wide electrostatic printer/plotters and a CRT hard copy system. ■ Versatec, Santa Clara, Calif.

Circle 406 on inquiry card

**SITE WORK** / An illustrated brochure gives details on recently-completed construction projects using *Reinforced Earth* structures for retaining walls, retention dikes, abutments, and other earth-retention and load-supporting uses. Facts are given on the economic advantages and construction flexibility of the method, which uses planar metallic reinforcements to produce a coherent gravity mass with good seismic integrity. ■ The Reinforced Earth Co., Washington, D.C.

Circle 407 on inquiry card

**DRAFTING EQUIPMENT** / A color brochure presents all models of the *Dial-A-Torque* drafting table, with details on individual features of each table. ■ Hamilton Industries, Two Rivers, Wis.

Circle 408 on inquiry card

**ARMORED FLOOR SURFACE** / *Masterplate 200* floor hardener is said to provide an economical method of increasing the thickness, impact resistance, and wear properties of industrial concrete floors. A fact sheet gives the benefits, recommended applications and necessary precautions for the metallic aggregate compound. ■ Master Builders, Cleveland, Ohio.

Circle 409 on inquiry card

**INSTITUTIONAL FURNITURE** / A six-page brochure contains drawings and dimensional data on the "076 Caseloads Group" of storage, desk, and bed units, as well as such accessories as locks, mirrors, lights, etc. Most pieces are available in Class 1 fire-resistant construction. The furniture features *Tho-Tech* polyester edging and tamper resistant screws. ■ Thonet Industries, Inc., York, Pa.

Circle 410 on inquiry card

**INSULATED WINDOWS** / A fully-illustrated booklet shows several types of commercial applications of *Perma-Shield* vinyl-coated wood windows and sliding doors. Photographs illustrate casement, awning, gliding and double-hung windows, as well as doors, in offices, schools, health care facilities, etc. Included in the brochure are data on glazing options, such as environmental and decorative glass, available in some *Perma-Shield* units. ■ Andersen Corp., Bayport, Minn.

Circle 411 on inquiry card

**ARCHITECTURAL GLASS** / An attractive catalog gives fabrication and performance data on a full line of custom architectural glazing products. Included are both laminated and tempered safety glass, and glass for special security, sound control and institutional purposes. Most of the special purpose glass is available in insulated glazing units. ■ Viracon, Inc., Owatonna, Minn.

Circle 412 on inquiry card

**URETHANE FOAM** / A 14-page booklet presents case reports on *Isofoam* rigid urethane foam used in such applications as: thermal insulation, roofing and reroofing, structural reinforcement, commercial construction, pipe and tank insulation, and in prefabricated panels. Tables show the physical properties and insulating efficiency of rigid foam; fire safety guidelines are also included. ■ Witco Chemical Corp., Isocyanate Products Div., New Castle, Del.

Circle 413 on inquiry card

**ANIMAL CARE EQUIPMENT** / Factors affecting equipment selection for animal care facilities are reviewed in a six-page brochure. Information is given on surgical and necropsy tables, surgical lights, feeder bottle washing and filling stations, cage and rack washers, and sterilizers. ■ AMSCO/American Sterilizer Co., Erie, Pa.

Circle 414 on inquiry card

**MASONRY REINFORCING SYSTEMS** / Reinforcing data for all types of masonry wall—single- and two-wythe cavity; faced and veneer masonry walls; composite walls and others—is given in a 12-page selection guide. ■ AA Wire Products Co., Chicago, Ill.

Circle 415 on inquiry card  
more literature on page 170



(actual size)

the NEW

**Spectra-Glaze**

GLAZED MASONRY UNITS

**VARI-TONE  
SERIES**

**A NEW & UNIQUE SPECTRA-GLAZE®** blend of ceramic particles in a soft satin texture of 24 enduring earth-tone colors. **VARI-TONE PROVIDES** a completely new range of variegated interior and exterior masonry wall finishes with choice of scale and pattern in Scored & Sculptured faces too.

**ALL THE ADVANTAGES** of traditional SPECTRA-GLAZE® block-thru-wall loadbearing construction, great insulation, permanent sanitary finish, fire ratings. **MEETS** Federal Specifications, OSHA & USDA requirements for glazed surfaces. Excellent weathering and ultra-violet resistance.



©Reg. U.S. Pat. Off.,  
Canada & other countries  
by THE BURNS & RUSSELL CO.,  
Box 6063, Baltimore, MD 21231.  
301/837-0720. © 4.4/Bu in SWEET'S.

**Now you can have  
new color and  
texture in glazed  
masonry walls!**

For more data, circle 72 on inquiry card

**Imagine how much  
extra, usable floor space  
there would be in the world**

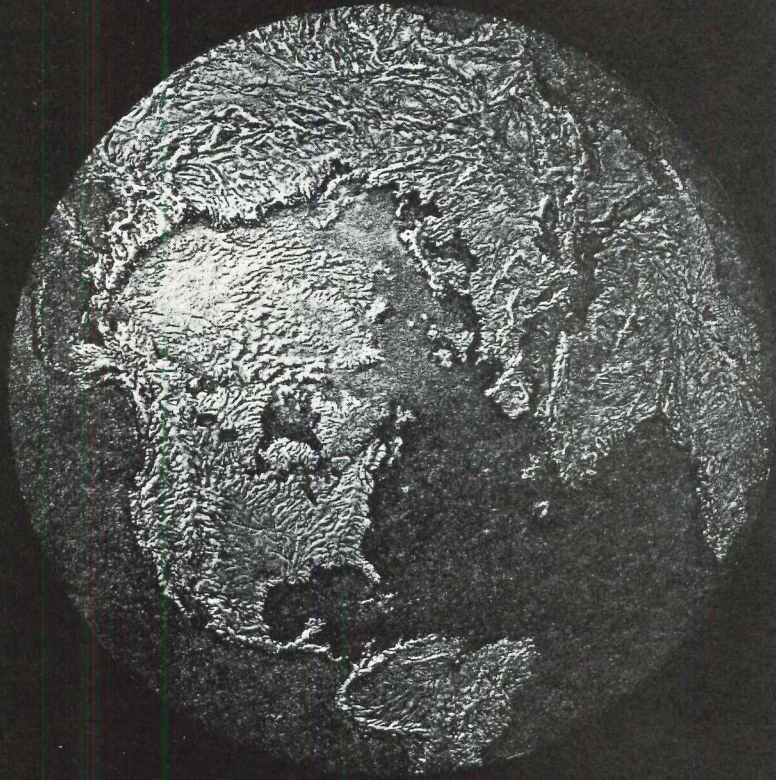

**if all the beds  
got up in the morning  
like you do.**

SICO® Wall Beds—when floor space that is used at night for sleeping, is needed for better things by day.

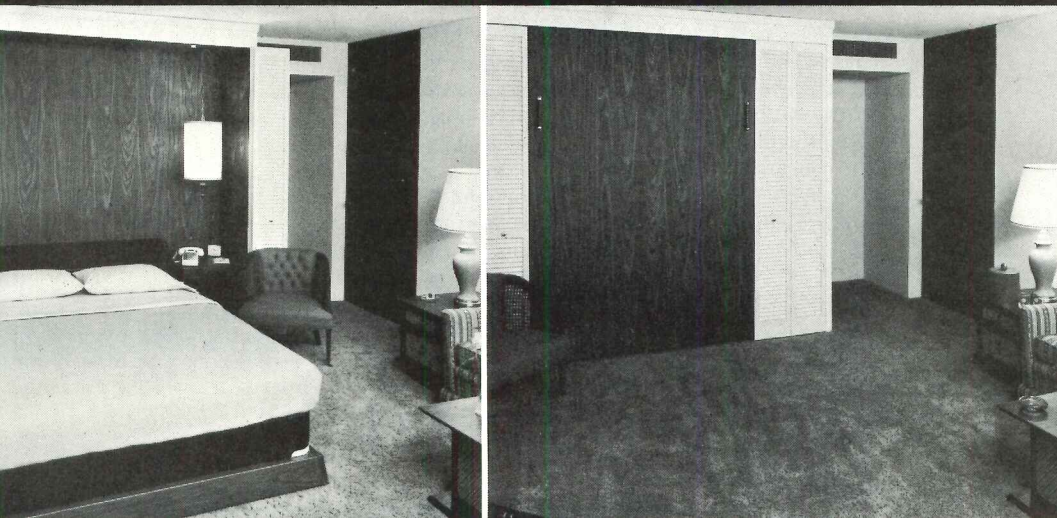

**FREE CATALOG!** For complete information on the bed that gets up in the morning like you do, fill in the coupon and mail today!

NAME \_\_\_\_\_

COMPANY \_\_\_\_\_ TITLE \_\_\_\_\_

STREET \_\_\_\_\_

CITY \_\_\_\_\_ STATE \_\_\_\_\_ ZIP \_\_\_\_\_

PHONE \_\_\_\_\_  
(Your inquiry answered within 24 hours.)

**Mail to:**  
SICO Incorporated  
Special Markets Division,  
AR-1 P.O. Box 1169,  
Minneapolis, MN 55440



For more information, circle item numbers on Reader Service Inquiry Card, pages 231-232.

**Painted murals are obtained from photos**

Anything that can be photographed—including art or printed matter—can become a mural-size, four-color graphic through a new process that images with pigmented paints. The technique, illustrated by the background panel (right) in this recent exhibition, is based on computer scanning of a conventional color transparency, and transmission of the color information to micro paint spray guns. Cloth, paper or other substrate material can be used. The process is said to provide original graphics at a price competitive with conventional large-scale photography, lithography or silkscreening. Delivery time is estimated at four weeks or less, and murals are installed by wallpaper contractors. The enlarging process produces finished "paintings" to any desired size. The Renwick Gallery exhibition shown here was designed by Venturi & Rauch. ■ 3M Co., St. Paul, Minn.

Circle 300 on inquiry card



**Power pack converts fluorescent fixtures to emergency use**

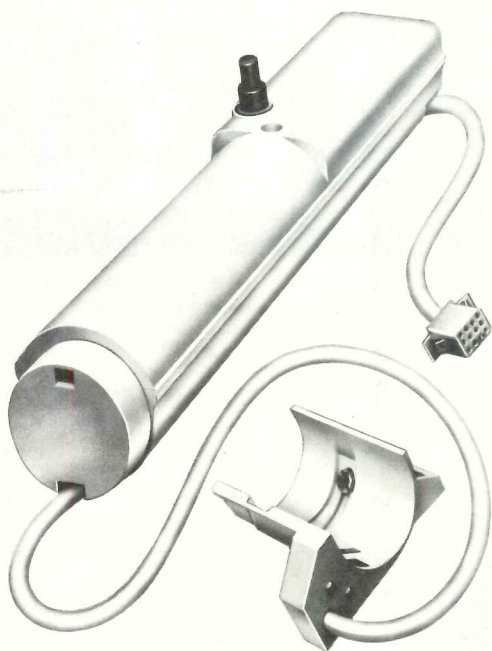

LAMPAK, a power pack designed to mount inside the fixture but outside the ballast, converts fluorescent units to emergency use in the field—an advantage over the usual procedure of equipping such fixtures in the factory. Recommended for retrofitting, LAMPAK can be placed by the contractor between or alongside the 40-watt tubes of a typical fixture; this method, unlike the ballast-type packs, removes the unit from ballast heat, which reduces battery life. The UL-approved LAMPAK unit will operate lamps for 90 minutes in 120- or 277-volt situations. ■ Dual-Lite, Newtown, Conn.

Circle 301 on inquiry card

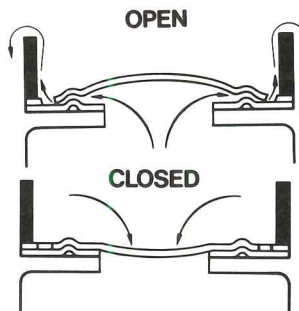

**Solar-operated one-way vent for built-up roofs**

A roof vent designed to release sealed-in moisture-laden air is recommended for installation in new or existing built-up roofing systems. The unit is activated when the sun's heat causes trapped moist air to expand. A one-way valve releases the moisture into the atmosphere, and closes when the roof cools. It operates in a range of -65 F to 450 F. ■ Johns-Manville, Denver, Colo.

Circle 302 on inquiry card  
more products on page 163

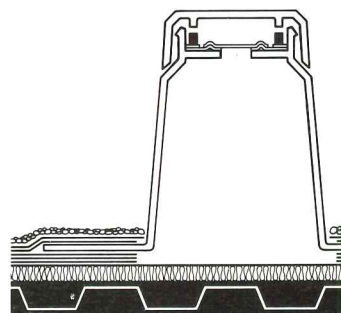



Applied Photography Ltd.

## UNUSUAL HYPAR ROOF SHELTERS ZOO ANIMALS

The architectural and hence structural solutions for the enclosure of the Africa and Indo-malayan Pavilions at the Metropolitan Toronto Zoo strongly reflect the philosophy that animals should be perceived in as natural a context as possible. Both of the pavilions were designed to be jungle "landscapes," with irregular viewing pathways. Furthermore, a variety of spaces was required of different scale and character, having areas with both light and shade.

To meet these requirements, the structural engineers suggested a roof structure of interconnected hyperbolic paraboloids. The actual geometry of the forms was determined through the use of models. In plan, two basic hypars were used, one a square, and the other a diamond. By tilting them at different angles, a variety of spaces was created.

The hypars were framed of latticed tubular members joined by Triodetic connectors. A wooden deck was installed over the tubes. Edge members of the hypars are structural steel tubes. These members were supported by concrete buttresses, which were positioned as required by roof thrusts.

The roof structure was prebid, including the glazing, not only to ensure the economic viability of the concept, but also to reduce over-all construction time. Architects for the project were The Thom Partnership, Clifford & Lawrie, Crank & Boake. Structural engineers were M. S. Yolles & Associates Ltd.

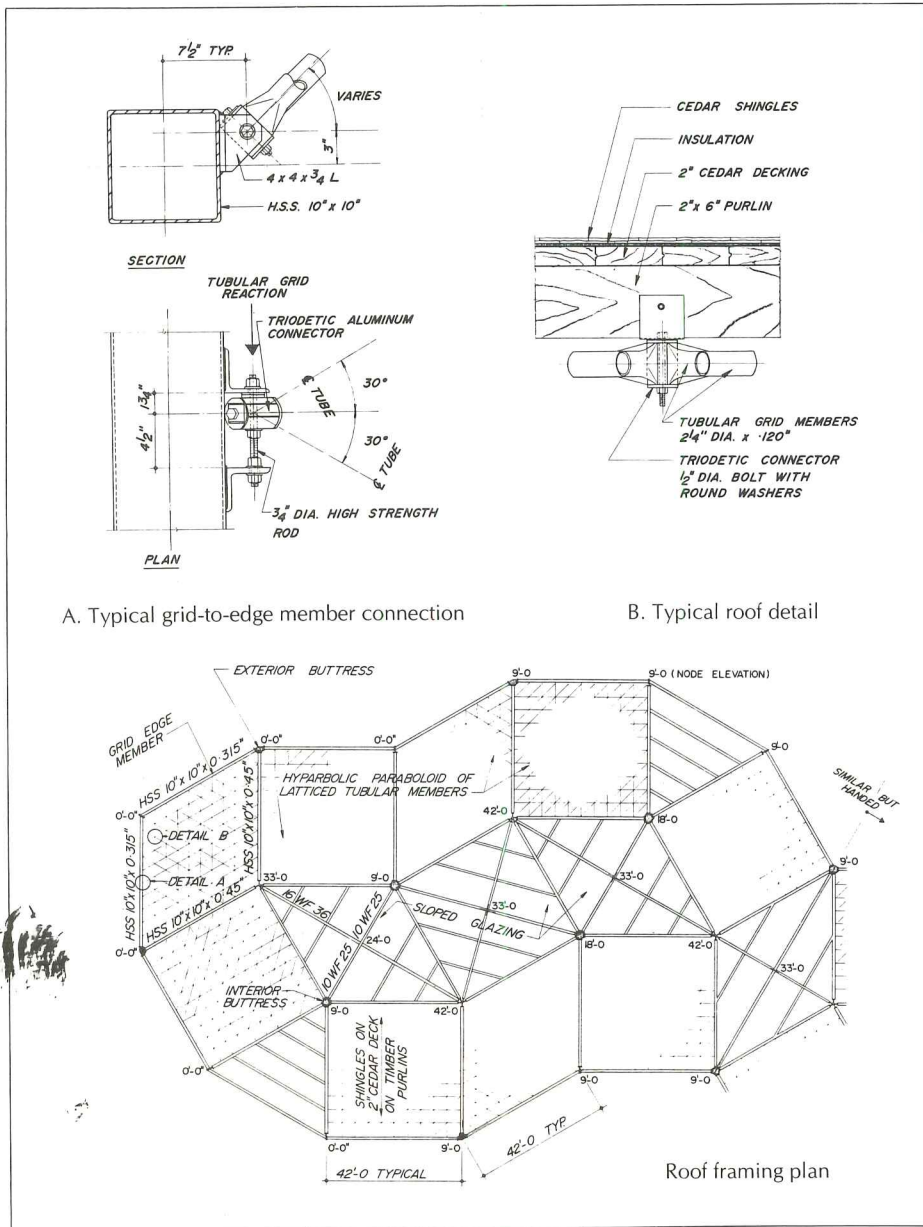

A. Typical grid-to-edge member connection

B. Typical roof detail

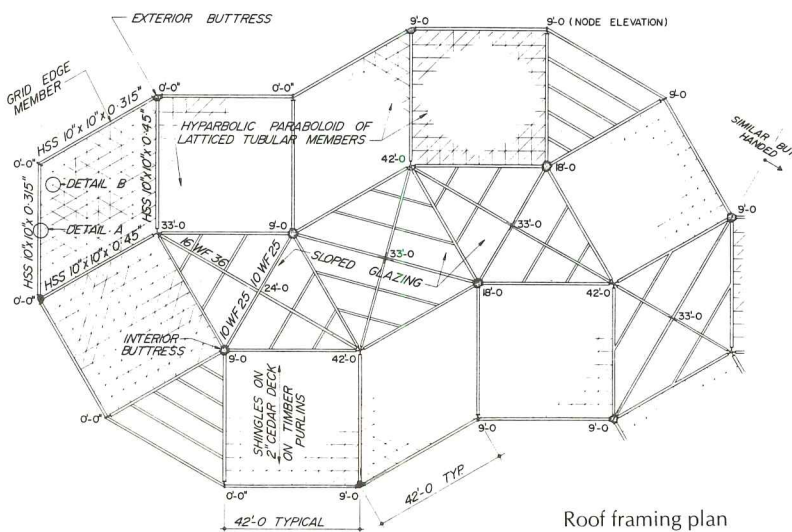

Roof framing plan

Applied Photography, Ltd.



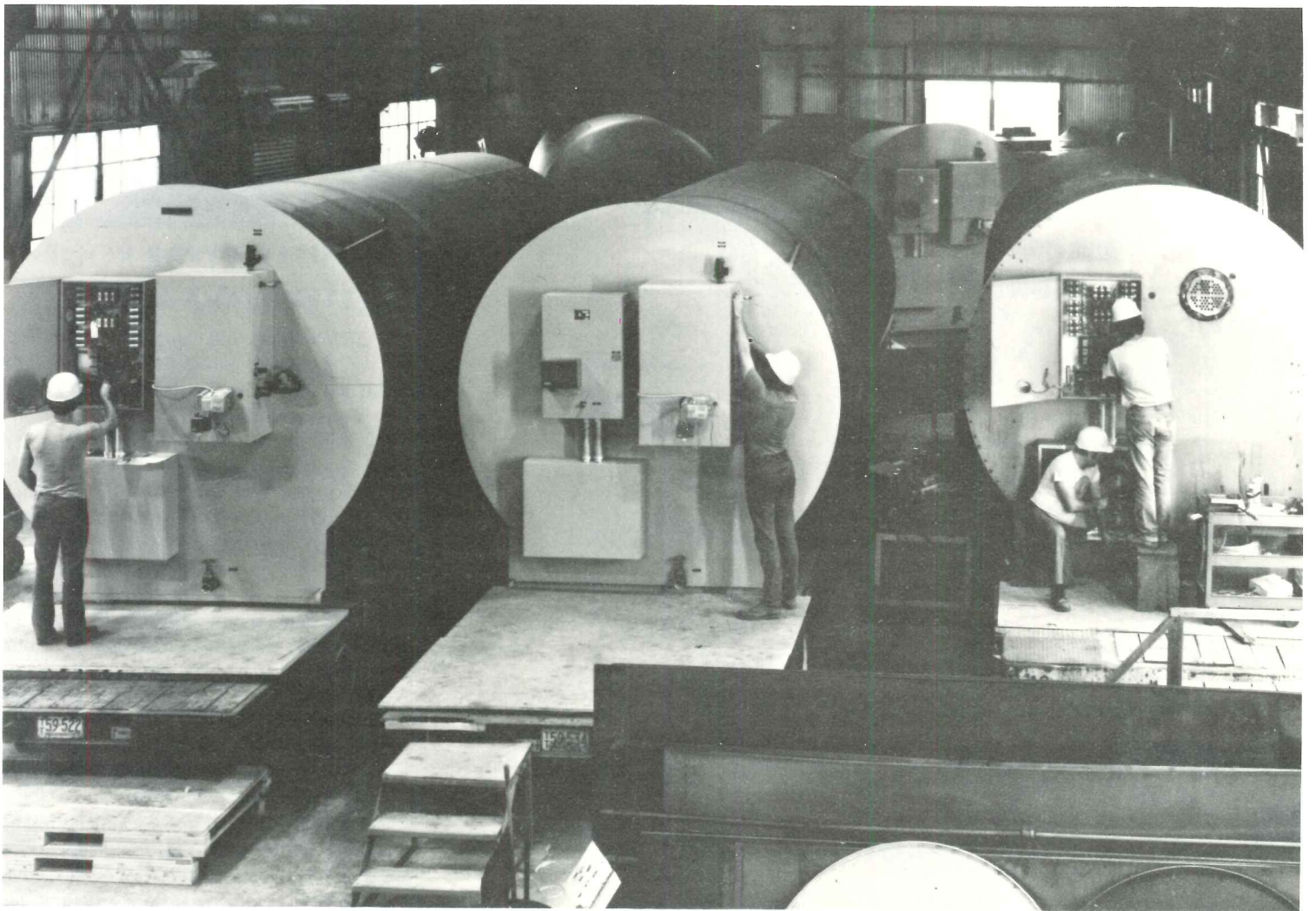

## ALL OF HOSPITAL'S HEAT IS FROM OFF-PEAK POWER

Catholic Medical Center in Manchester, New Hampshire, a 250,000-sq-ft hospital formed by the merger of two existing institutions, will have all of its heating requirements supplied by a thermal storage system that heats water by electricity during off-peak hours from 8 p.m. to 7 a.m. The heating system will serve 70,000 sq ft of an existing building and a new 181,000-sq-ft building designed by architects Huygens and Tappé Inc. Consulting mechanical and electrical engineers are Cosentini and Associates. Associate architects are Isaak and Isaak, and structural engineers are Weidlinger Associates.

Because Public Service Company of New Hampshire is a winter-peaking utility, the company is encouraging off-peak consumption during the winter to help bring its load into better balance. Similar, but smaller, installations are in use in 15 other buildings in the state. The inducement is that, effectively, there is no demand charge for the off-peak usage. Also the electric rate is lower.

The storage system comprises eleven 11,000-gallon tanks—eight for space heating, two for domestic hot water, and one for spare capacity. The tanks are filled with water, to a predetermined level, and this water, which remains in the tanks, becomes the heating source. Electric immersion elements heat this water to from 160 F to 280 F. Water for space heating, or for domestic hot water, is circulated through a heat exchanger to extract heat from

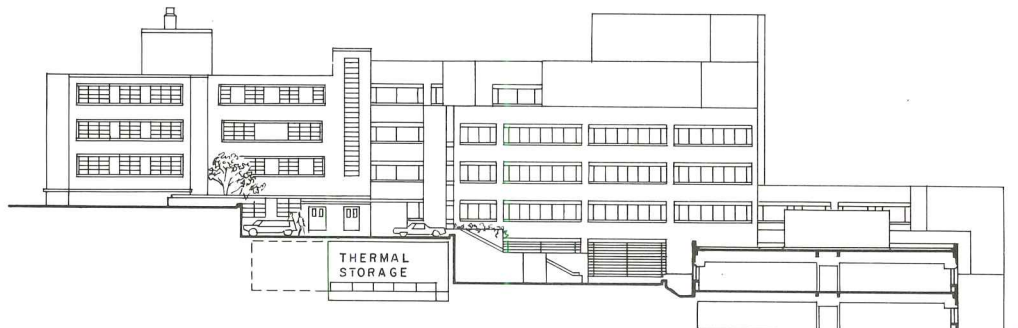
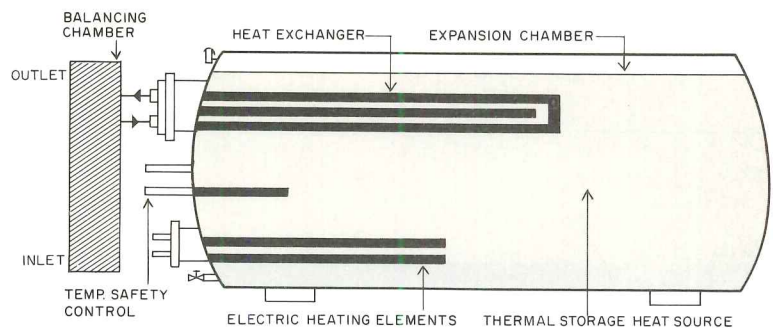

the water stored in the tank. In the system, developed by Megatherm of East Providence, Rhode Island, the water to be heated first passes through a tempering condenser. Control of tank temperature, or capacity, is achieved by pressure controllers.

Only in severe cold weather will all units need to be in operation at the start of the off-peak period. Furthermore, a sensing system

has been included to allow part of the heating tanks to come on during peak hours when the demand by the hospital for other purposes is below peak.

For steam, electric steam generators have been provided. Make-up water for these generators is supplied from the thermal storage system; thus, the cost of steam is reduced by using water preheated at off-peak rates.





## MODIFIED LIGHT-GAGE STEEL UNITS FRAME HOSPITAL'S INTERSTITIAL FLOORS

Nearly half the area of the \$130-million Erie County Medical Center in Buffalo has an interstitial floor system of light-gage steel framing, described by its developers as, "the most flexible system at the lowest square-foot cost on the market today." Two inventive, though simple, modifications were made to standard light-gage C-shape studs and joists to allow the deck system to be easily installed—or removed—and to impart slip resistance to the walking surface. The 852-bed hospital was designed by the Buffalo-based architectural firm, Foit, Maharan, Sloan and Schneider.

The interstitial space of 455,000 sq ft is in the spread-out first two stories of the hospital, while the balance of the structure, which is high-rise, has conventional story heights. Main framing of the interstitial floors is 9-ft-deep trusses spaced 10 ft on center. Joist saddles welded to the trusses support 5½-in., 16-gage joists on 4-ft centers. These joists, in turn, support 3½-in.-wide deck units on 5½-in. centers.

The deck units (normally used as studs in light construction) are held in place by means of a friction-fit connection (see detail). The upper flanges of the joists have light-gage angles welded to them that project into slits cut into the flanges of the deck members. To minimize impact-noise transmission from footsteps, and further restrain deck movement, neoprene pads are placed between deck members and joists.

The other modification is the slotted surface of deck units. The punched-out webs provide slip resistance. Furthermore, together with the gaps between units, the slotted surface provides the 50 per cent free-air opening in the deck required by local code for ventilation in case of fire.

The removable deck system was chosen by the architects from 15 designs, including catwalks. It was built with Super-C steel members developed by U.S. Steel, and the modifications for this application were developed by the fabricator, Syracuse Tank and Manufacturing Co. Computer documentation of load-carrying capacity of the system was available to the fabricator. Cost was under \$9 per sq ft.

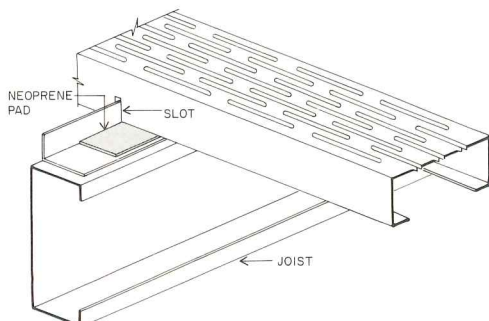



An excitement is generated in the interior spaces by the architect's positioning of a skylight and windows and the exposed structural cross-bracing, focused in the dining room (below). Views from the front of the house are shielded from the parking area by a six-foot-high fence and few low windows (center, page 148), but light flows through the skylight (left) and two clerestory windows on that southern side; these placed so light "moves around the space," says Jacobs, spotlighting the dining room in the morning. Subtleties of design play an important role in the small interior—the openness is modulated and the rooms defined by the columns, and a window seat expands the living room (bottom left). A feeling of intimacy is achieved by the house's proximity and views to the trees. A study (separated from the living room by two sliding wood barn doors) and a loft add variety. The interior wallboards and columns are of Douglas fir.





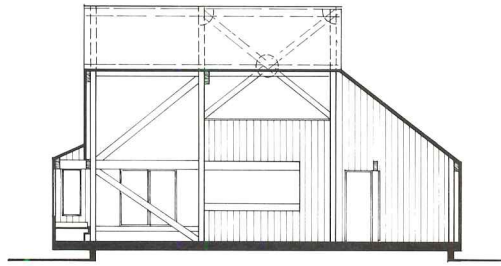

Merg Ross photos



Unlike many houses at The Sea Ranch, a private housing development 100 miles north of San Francisco along the coast, this house is quite small—approximately 900 square feet—and is situated in the wooded hill range set back from the coast. Used as a vacation/week-end house by the owner, its form is reminiscent of the barns frequently seen in the area (a form often reflected in residential design at The Sea Ranch).

The house was sited sensitively for the conditions: on a linear lot with a predetermined driveway entrance to the west, the house was nestled into a large stand of trees to the north, taking advantage of the only view to the Pacific Ocean—a glimpse, seen through the trees, to the west. This orientation also capitalizes on southern light exposure; the entrance, a skylight and clerestory windows open to the meadow. An appropriately scaled barn-like form with a high, sloping roof has a dual purpose of acting as a transition from the tall trees to the flat meadow, while producing a high-ceilinged interior.

Standard wall construction was used as the most economical (the total cost of the house was \$33 per square foot), but to provide extra structural support for earthquake resistance, diagonal beams were used and exposed throughout, most noticeably at the corner of the dining room where the cross-bracing is the focal point of the interior spaces. Seen from the exterior (from the roadway and driveway, top right) these diagonal beams provide strong visual interest—an unusual, unexpected, intriguing effect. The L-shaped deck is most usable, for the site is little affected by the strong, prevalent coastal winds. The exterior is redwood boards with a redwood shingle roof.

THE GOECKER RESIDENCE, The Sea Ranch, California. Architect: *Donald Jacobs*. Structural engineer: *Fook Z. Lee*. General contractor: *Jay Baker*.



UPPER LEVEL

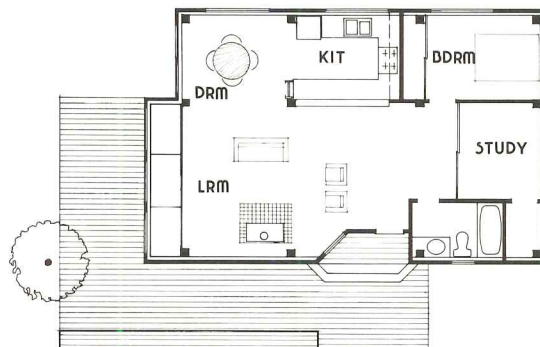

FLOOR PLAN

0 5 10



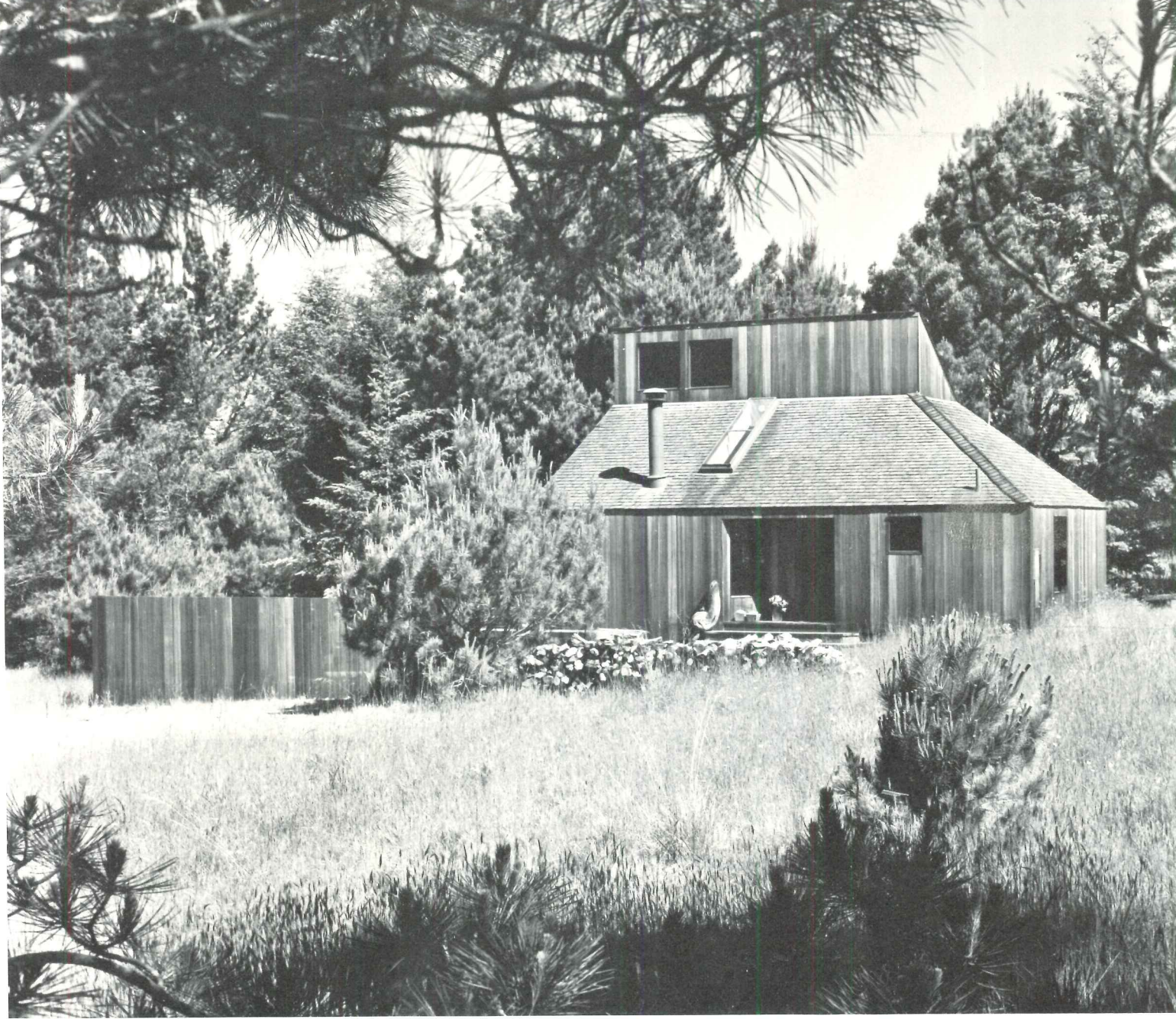

## DELIGHTFUL WEEKEND RETREAT AT THE SEA RANCH

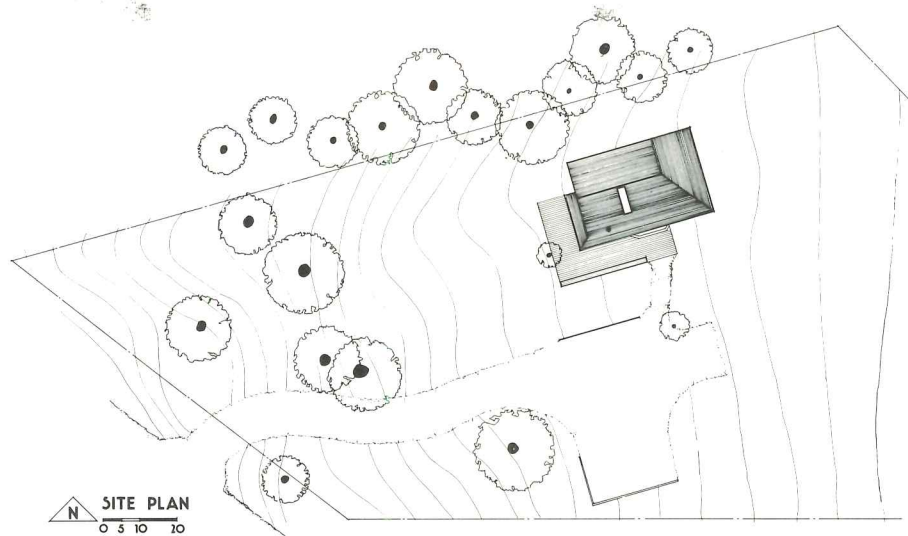

Donald Jacobs' design for this California house is unassuming but totally functional, with an obvious concern for spatial arrangement, and characteristic of the architect's work in the manipulation of light to create an exciting interior within an essentially simple but carefully designed form.



The typical office floor (left) has a quality of spaciousness inherent in its office landscaping system. The cafeteria (left bottom) overlooks the moat and surrounding meadows. Shown below are a landscape detail in the parking lot, a graphic directional system incorporated in the ceiling and a detail of one of the many collages specially designed for the building by the graphic design firm of Chermayeff and Geismar.

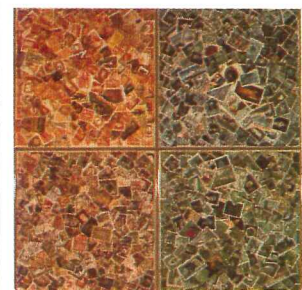

Each wing of each of the three floors has an administrative service station that combines mail distribution points with self-service office supply stations and copying machines. The mail distribution itself has been automated with a system that carries mail on tracks, concealed between the ceiling and the floor above, to and from a central mailroom and the various service stations located throughout the building.

The building has a total of 383,000 square feet and accommodates about 1,000 people. It was built at a cost of \$38 per square foot.

IBM WORLD TRADE AMERICAS/FAR EAST CORPORATION HEADQUARTERS, Mt. Pleasant, New York. Architects: *Edward Larrabee Barnes—associates-in-charge: Bruce S. Fowle and Martin E. Rich; space planning: Thomas Czarnowski; interior design: Mary Barnes.* Engineers: *Severud, Perrone, Sturm, Bandel* (structural/foundation); *Joseph R. Loring & Associates* (mechanical/electrical); *Martin O'Grady and Associates* (civil). Consultants: *Bolt Beranek and Newman, Inc.* (acoustical); *Donald Bliss* (lighting); *Peter G. Rolland and Associates* (landscape); *Chermayeff and Geismar* (graphics); *Wolf and Company* (costs). General contractor: *Pollera Building Corporation.*

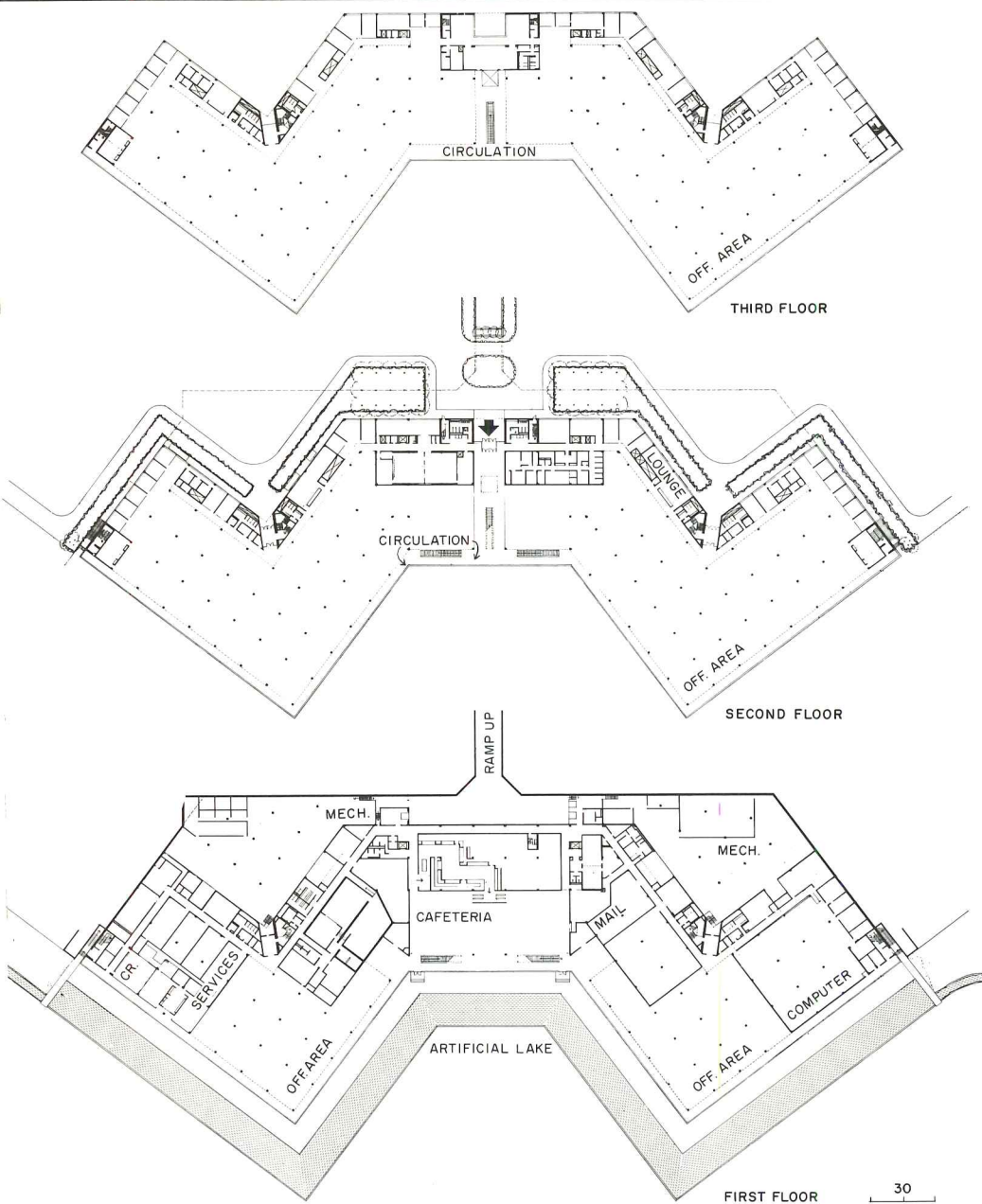

TYPICAL PLAN SECTION AT SPANDREL CORNER & JOINT

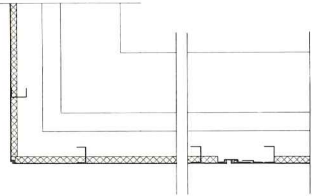

TYPICAL PLAN SECTION AT GLASS CORNER & JOINT

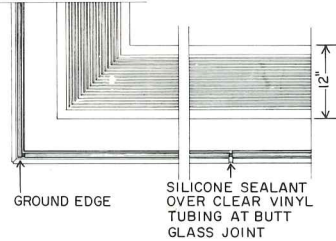

The spandrel panels are flush  $\frac{3}{16}$ -inch aluminum with a hard anodic coating in dark green. The glass has siliconed butt joints set almost flush with the spandrels. The glass is set on Teflon-coated setting blocks to allow uniform thermal movement coordinated with the panel movement. All the glazing pockets are weeped and all the panel joints are backed by a drainage system that weeps out at the head of the window below to assure against water damage.

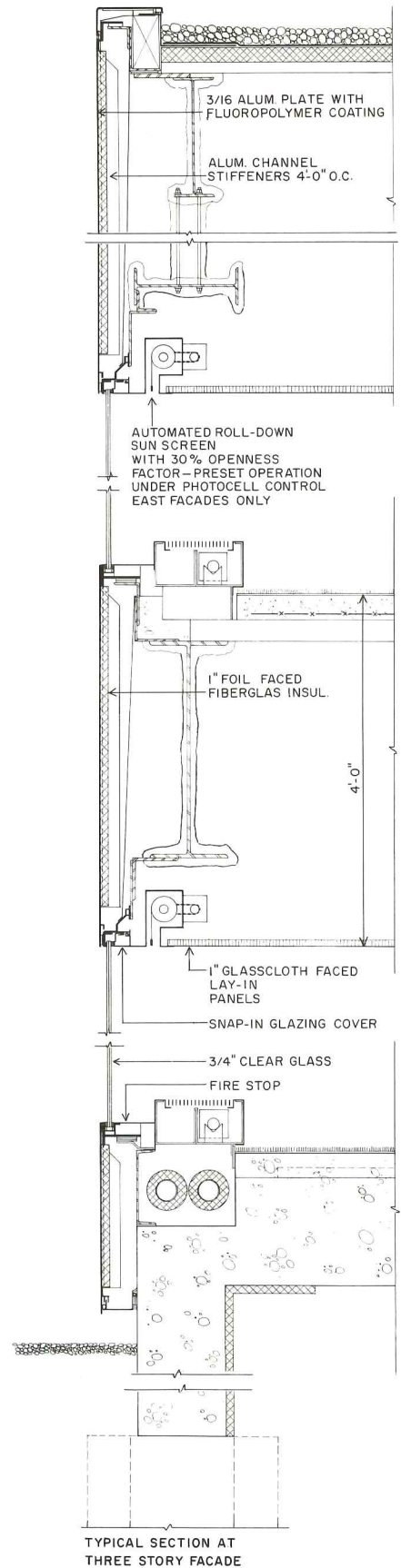

entrance doors when employees insert magnetically-coded badges into "card readers," and to permit limited access to special areas. The other computer is designed for eventual control of the building's interior environment, including the monitoring of lights, fans, heating pumps and air conditioning. This system is expected to make substantial savings in the use of energy.

Many areas in the building are decorated large acrylic-enclosed cases containing collages of every-day objects from 130 countries. These have been assembled by the graphic de-

sign firm of Chermayeff & Geismar Associates and include collections of stamps, seeds, coffee beans, dolls and flags. The largest collection—stamps—is displayed in the main lobby. It is 30 feet in length and contains thousands of stamps from many nations of the world—appropriate to the international nature of the division's work.

An employee dining room is located on the first floor, facing the curtain of glass and the meadow beyond. The dining room's rear wall is paneled with mirrors, increasing the feeling of spaciousness.

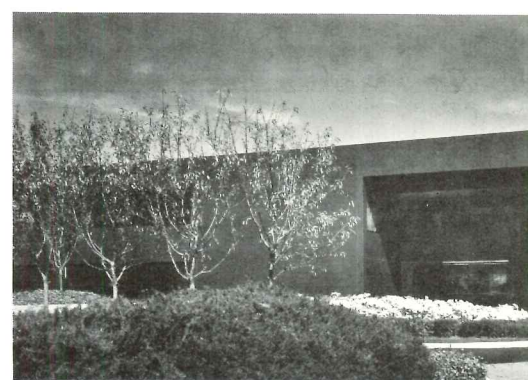



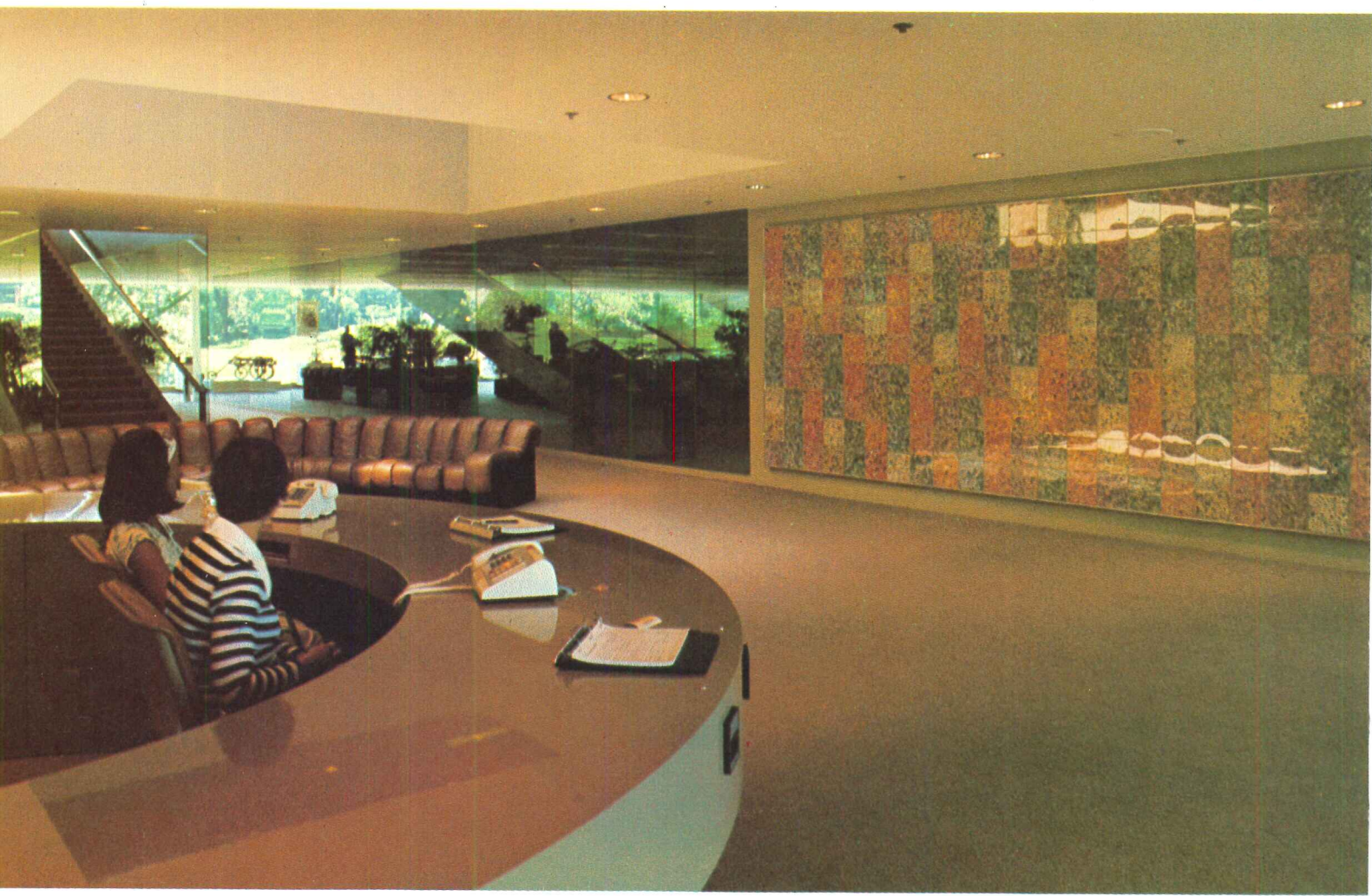

through the glass curtain wall as compared to about five per cent had the interior been laid out with conventional enclosed offices. An open corridor on the perimeter of each floor on the meadow side brings the outdoors to the direct perception of the employee during his routine walks about the floor.

In addition to the acoustically treated panels, the wall-to-wall carpeting has sound absorbing qualities. The ceiling is covered with removable fiber glass panels that provide maximum ambient noise absorption. Speakers for masking sound have been located above this

ceiling, which has been designed to provide for the penetration of this sound that helps to mask the audibility of conversations and machine noises, thus contributing to the sense of privacy.

The quality of openness achieved in the interior spaces was further enhanced by the use of floor to ceiling butt-jointed glass partitioning in the lobby, computer space, the classrooms, cafeteria, principal stairways and everywhere else that physical separation was required for climatic, acoustical, fire control or other purposes. This glass is recessed in a flush

ceiling pocket and a channel base at a minimum of four inches high. Reflective glass is used where partial visual separation is desired and mirrored glass is used on certain opaque walls opposite windows to reflect the uninterrupted view. Tempered glass is used where smoke barriers are required for fire protection.

The computer center has two large computing systems that are accessible from more than 75 communications terminals within the building. Two other computers help control the building's security and environment. The former is programmed to unlock the various



served on the site. From the inside the glass appears non-existent, affording an unimpeded view of the magnificent old estate. The sheet aluminum spandrels have a hard anodic coating in dark green, which help the facades to become more a part of the landscape. The building actually does recede, amazingly, and in all seasons.

Open office landscaping is used for all except a few executive offices, classrooms, medical facilities and executive briefing centers. The movable panels are 60 inches high with perforated linen cloth over fiber glass insula-

tion for acoustic absorption. The furniture is oak veneer. Approximately 800 planter boxes filled with live plants have been designed within the furniture module and are used throughout to enhance the environment and to act as visual screens. Everything—panels, plants and furniture—is movable and can be rearranged to reflect future organizational or functional changes.

The open landscape office plan contributes to the merging of the interior with the out-of-doors. IBM points out that over 95 per cent of the office personnel share an outdoor view



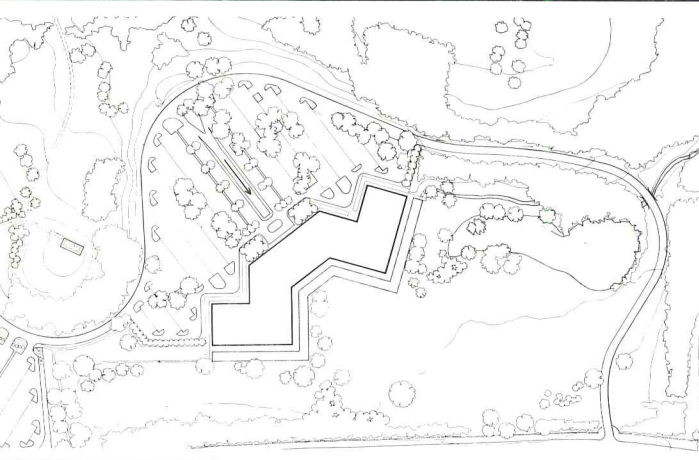

Not only is the IBM building itself unobtrusive, but so are its own mechanical and electrical systems. According to Jack Beech, corporate vice-president of the Joseph R. Loring & Associates mechanical and electrical engineering firm, his directive from Barnes was to keep all hvac equipment off the roof of the building and not to litter the landscape with a visible cooling tower or pumping station. The hvac equipment rooms are inserted at the first floor level directly beneath the parking lot (see plans page 145). The air intakes and the exhausts are in the parking lots concealed by planting beds and trees. The cooling tower has been located high on the site, but it has been completely hidden by a natural stand of trees. The only portion of the site upon which the building could be constructed to remain invisible to the neighbors was soggy. The site water was diverted into the moat shown on the site plan and in the photos. It is connected by a sluice gate to a stream and duck pond. The moat is a second source for fire water and is connected to a diesel-driven fire pump. The moat water is heated electrically at the inlet to prevent freezing at this point. By this means the level of water is kept constant, for fire protection.



IBM's Mt. Pleasant headquarters was designed to be almost invisible. It is sited within a meadow and woodland estate, which originally belonged to the Rockefellers and was sold by them to IBM. According to the terms of the sale, the structure IBM was to build was not to spoil the views from the windows, terraces and gardens of the various Rockefeller mansions in nearby Pocantico Hills. The charge to architect Edward Larrabee Barnes was to create a quiet building, with a low profile, upon the relatively small portion of the 79-acre site within which the headquarters would be

completely hidden from the Rockefellers' gaze and awareness.

Barnes decided to limit the building's height to three stories and to contain its space within a W-shaped plan. By the latter means, he reduced its apparent length as indicated in the site plan (above) and the aerial photo (opposite page right). Because the site slopes, Barnes was able to locate the main and secondary entrances on the second floor directly off the main drive and parking lot. Thus employees need climb or descend only one level on their way to or from work. The continuous

glass windows of the three-story side overlook a broad meadow. This facade is rimmed by a handsome moat (visible in all the photos above), which in combination with a duck pond and stream doubles as an emergency water supply in case of fire.

Barnes and his associates made every effort to establish a close relationship between the building and the outdoors as perceived from inside and out. On the exterior, the mullion-free butt-jointed glass window walls reflect the decades-old sycamore, silver maple, oak and hickory trees which have been pre-

# A LOW PROFILE FOR IBM

Joseph W. Molitor photos



Architect Edward Larrabee Barnes was instructed by IBM to design a headquarters building that would become one with its environment—a beautiful old estate in Mt. Pleasant, New York. The neighbors were “not to know it was there.” As it turned out, the neighbors don’t know what they are missing, for Barnes has created an elegant building that gives an esthetic pleasure which is almost Japanese in its refinement. Although it is doubtful that IBM’s employees have the time or inclination for Zen-like contemplation during the working day, the building’s quiet spirit would seem to invite it, because for this suburban office, as for the Katsura Palace, the landscape is everything. —*Mildred F. Schmertz*

## Light, color, and materials

I use color very sparingly and always deliberately as an integral part of an environmental entity. Sometimes it is used in a sculptural form that complements a space, as it is in the tubular sculpture of Japanese kites that I designed for the Chicago hotel. I also use color as large-scale curvilinear graphics on banners and walls and sequences of fabric hangings to add softness to constructed space and to define important places.

A building wants to be all one thing in the

end and, in its most idealized form, would be an entity created from a single material. The many factors involved in construction seldom permit such a solution, but it is important to remember that greater dignity and integrity lie in using the smallest number of different materials.

The structure and materials form space, and light reveals it; but both should be subordinate to it. Everything that has a role in the environment of a space must be orchestrated to produce its character and evoke a sense of well-being in the individual.



## Nature

Plants and trees can be used as an important way of forming space and modifying light in buildings. As the sun comes through foliage, it makes patterns. The light in the Shopping Gallery at Peachtree Center is filtered through hanging plants; it makes a pattern in the café like shadows on the floor of a forest. The plants also lower the ceiling, giving a sense of enclosure without blocking out a sense of the larger space.

Rows of trees can modify space, create and define separate areas. They can also pro-

vide places of solitude and privacy in the midst of the city's crowds and confusion.

I have at times put cages of birds into large spaces. They are another element of nature that gives life and movement. In the Embarcadero hotel in San Francisco, I have also introduced a "sound sculpture" by Bernhard Leitner that creates the impression of a flock of birds flying in, alighting on the trees, and bursting into song. I use elements of nature to make a connection between the built environment and the human psyche. They are human environmental connections.



## Shared space

The whole concept of shared space is based on the human desire for a release from confinement. If more than one thing is happening in a space, if you can look out from one area and be conscious of other activities going on, it gives you a sense of spiritual freedom.

I recall very vividly the first time I went into the Guggenheim Museum in New York. About halfway down the ramp, I began analyzing why this experience felt so good and

worked so well. I would look at a few paintings, and then I'd walk over to the rail, look around and see people, look down into the space, and then go back and look at more paintings. I also observed that other people were doing the same thing.

The principle of design that makes the Guggenheim work so well is the concept of shared space.

When you design a space, that's not the end of it. You have to articulate it for human involvement. A ceiling at around seven feet can create a strong sense of enclosure; as you

raise the ceiling, this feeling of protection diminishes. That is why I projected a trellis structure out from the balcony-corridors of the Regency hotel in Atlanta at a height of about seven feet. It gives you a sense of shelter as you look out, as well as softening the impact of looking directly down, because you see the lobby through the trellises below you.



## People watching people

People enjoy watching a changing scene. This is very obvious. I learned from visiting the Tivoli Gardens in Copenhagen that one of its main attractions is the opportunity for people to watch other people. That is the attraction of the sidewalk café. Everybody who goes to Paris has to walk the Champs-Élysées, and here are all the sidewalk cafés. There is some magic about it, whether you are sitting in a café watching other people or walking up and down the sidewalk yourself. Some people enjoy watching other people more than they enjoy having other people watch them; others

like to be on the stage, part of the passing parade.

We don't have a tradition of sitting in similar public places in the United States; everyone runs up and down the sidewalks like rats. But when Americans go to Europe, they gravitate to the sidewalk cafés. I don't believe in mimicking the historic European cities (or anything else for that matter), but I think we can create opportunities for the same kinds of experiences.





## Water

---

Water can be used in architecture to evoke memories of the natural environment: a brook, a fountain, a waterfall, or a lake. People respond to water. They put their hands into a sheet of water to see what will happen; they watch reflections, movement. Water is kinetic, active; water also makes sounds, provides a background. It is one of the elements that can transform a building from a static object to a dynamic environment.



## Movement

When people move through a building, their journey should be orchestrated. Architects should articulate the journey into a sequence of spaces, ranging from tight enclosures to large volumes. There should also be places that produce a neutral emotional effect, in the same way that a piece of bread cleanses the palate between two wines. What I call "people scoops" are designed to be such places of tran-

sition, from outdoors to indoors or from one kind of space to another.

Riding an escalator is also a transitional experience, and it can be used in such a way that the space you are entering is gradually revealed. That is why, in the hotel in San Francisco, I had the escalators bring people up facing away from the main space. I wanted a more gradual realization than you get in the Regency hotel in Atlanta, where you walk through a low entranceway, a people scoop, directly into the central atrium.

Riding in an elevator is another important

transitional experience, and there is no reason why you must ride in a closed-in box. Pulling the elevator out of its shaft and opening it up with walls of glass makes it another way of experiencing architectural space. The elevator is like a seat in a theater, but one in which your vantage point is moving continuously.

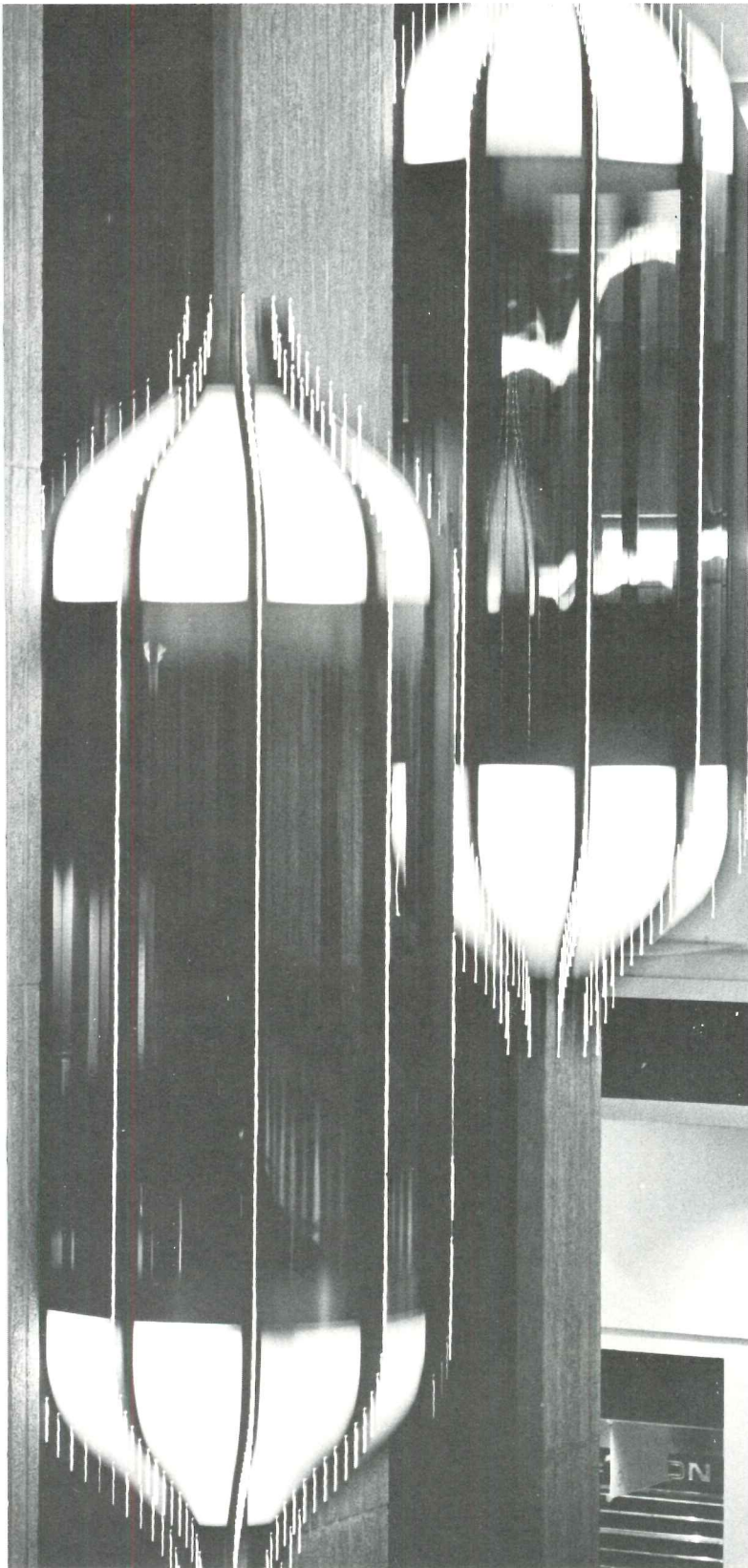

*Jerry Spearman photos*

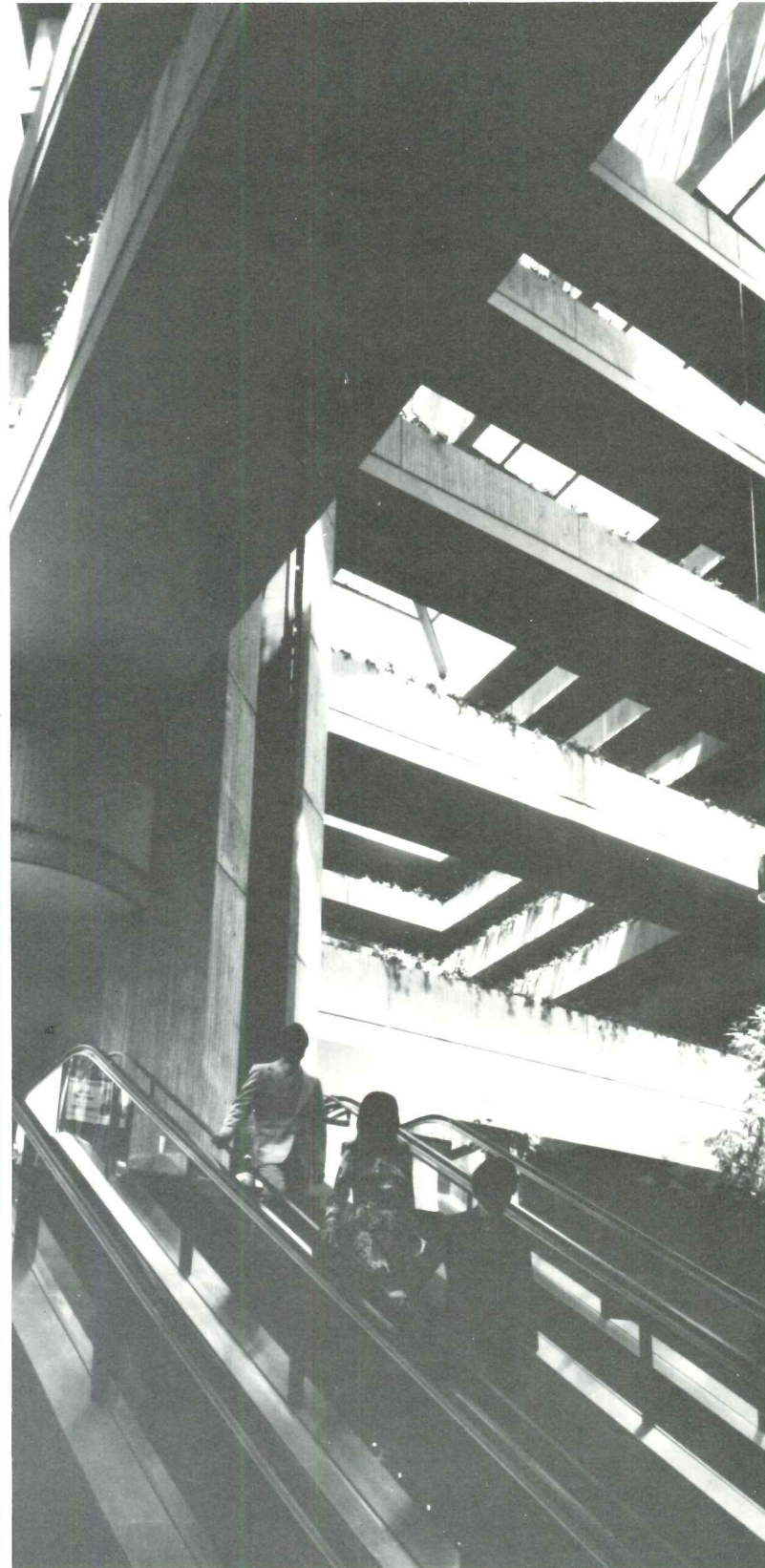

## Order and variety simultaneously achieved

In drama, the play is the thing; the stage, the scenery, and the lighting are important, but they serve a subordinate purpose. In architecture, space is the thing, and architects must be careful not to overemphasize elements that should be subordinate to space, such as structure, materials, light, or color. But space has no existence except as it is defined, and order is a necessary element of spatial definition. Inately, human beings, because they are capable of reason, require an order to things.

Order creates a sense of comfort and well being. But the mind craves variety at the same time that it requires order. At Brasília, too much order becomes something the mind abhors. What is needed is an order strong enough to permit variety and informality without losing the integrity that creates a harmonious environment: order and variety simultaneously achieved.

The wooden, treelike columns at the Midnight Sun restaurant in Peachtree Center (below) are used to define a strong, orderly system of spatial organization. They even extend

beyond the glass line into the courtyard to help integrate indoors and outdoors. At the same time, there is a system of niches and pockets of space that give individual tables their own private environment. You are aware of your intimate immediate surroundings and the whole restaurant, simultaneously. Space is allowed to flow in such a way that you can see from the cocktail lounge in the front all the way to the opposite end of the restaurant; yet you are always in your own intimate area.



# AN ARCHITECTURE FOR PEOPLE AND NOT FOR THINGS

by John Portman

A design philosophy is the rudder for the boat; it makes possible a continuing course in a meaningful direction.

I first began thinking seriously about such guiding principles of architecture and design when I made a trip to South America for the dedication ceremonies at Brasília in 1960. I was very excited about the prospect of seeing a new city completely designed by architects, but it was not long before the excitement turned to disappointment. What an inhuman place! Nothing but great blocks of buildings arranged in military order. Some of the architecture is actually quite interesting, but the buildings seen together become objects arranged in a sterile, two-dimensional pattern that shows no understanding of human scale or the need of people to become involved in their surroundings. I found that after one look there was no desire to walk down the street, turn the corner and suddenly discover something, because I already knew what was there.

This trip to Brasília made me realize that many of the design concepts that had come to be accepted by the architectural profession did not work very well at the scale of an entire city. Older cities, no matter how badly their designs had evolved, were still better at providing for human needs than Brasília, whatever the virtues of the architecture. I came to the conclusion that what we needed to do in the United States was to restructure our existing cities, not build new ones.

I returned to Atlanta resolved to improve my abilities as an architect in two ways: first, to learn how to design at the scale of the city; and, second, to find ways of making buildings more responsive to human values.

We had just finished the largest building in Atlanta, the Merchandise Mart, at one of the major intersections, and I felt that we could not allow just anything to happen up and down the block and across the street. Why not take the first steps toward creating a larger-scale environment? So we started assembling land. We gained control of the plots next door to the Mart and parcels in other key locations, with the specific aim of creating a new environment that followed a master development plan, would grow step by step, and would add to, not obliterate, the life, the vitality, and the interest of the existing city.

If a building is to meet the needs of all the people, the

This article is excerpted from the second of a three-part book, *The Architect as Developer*, by John Portman and Jonathan Barnett (McGraw-Hill Book Company, \$22.95). This part, written by Portman, describes his design philosophy; the other parts, written by Barnett, describe Portman's design development process.

architect must look for some common ground of understanding and experience. The need for this common ground led me back to people as creatures of nature, perceiving their environment through the five senses. I decided that if I learned to weave elements of sensory appeal into the design, I would be reaching those innate responses that govern how a human being reacts to the environment. In that way I could create environments that all people would instinctively find harmonious.

The definition of the design problem comes from understanding the essence of the variables, but the solution evolves through the application of constants, principles of design that hold true in every case. The resulting design should be a marriage of the constants and the variables.

Another way to understand this opposition of principles and practical obstacles is to speak of statics and dynamics. Architects in the past have tended to concentrate their attention on the building as a static object. I believe dynamics are more important: the dynamics of people, their interaction with spaces and environmental conditions. Architects must learn to understand humanity better so that they can create an environment that is more beneficial to people, more rewarding, more pleasant to experience. I'm naturally interested in the latest structural techniques, in innovative building materials and the technology of my craft; but I am more interested in people. Buildings should serve people, not the other way around.

If you go back and analyze the history of architecture, most buildings that historians consider important are objects built to the greater glory of God, or an individual, or a political system; they are not environments for people to live in. One purpose of the pyramids was to express political domination. The cathedrals dominated the towns in which they were built. The great Haussmann plan for Paris, which has given such pleasure to so many people, was carried out to assist Napoleon III in keeping control of the city: great boulevards, wonderful trees, but the motive of domination is also there. Most office buildings are built to serve only narrow corporate objectives. They are saying: "I'm Mr. Big; look how powerful I am, what strength I have, what security."

When you analyze the buildings you see every day and the motives behind them, you find that most are not created with any comprehensive view of what people need. What I wanted to do as an architect was to create buildings and environments that really are for people, not a particular class of people, but all people.

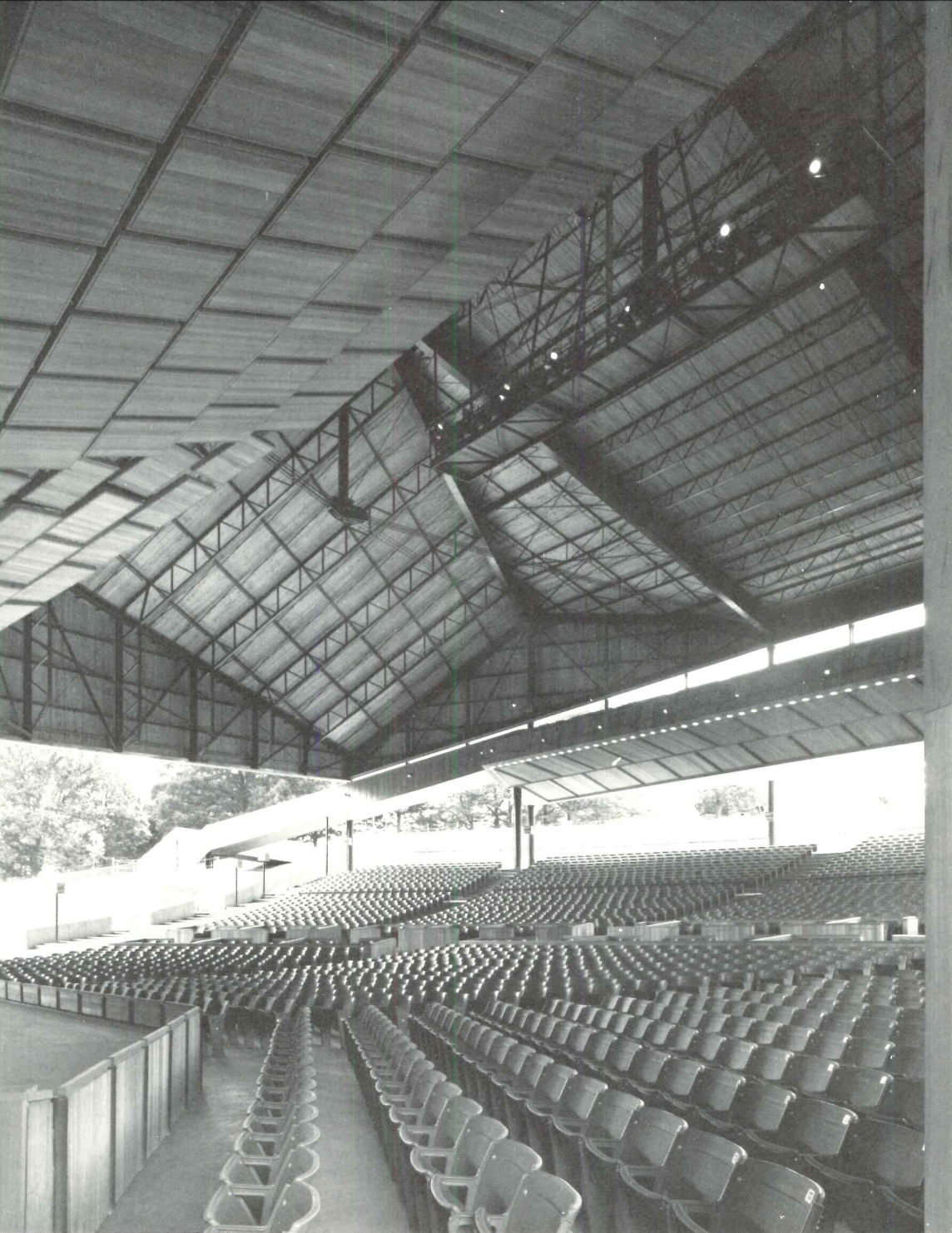

The generous dimensions of the enclosure are evident in the photos at left. The distance from the stage to the farthest balcony seat is 170 feet. The proscenium opening is approximately 72 feet wide, 34 feet high and the gross stage area is a monumental 14,000 square feet. The rigging dimension, equally impressive, is 70 feet from stage floor to grid and a loading bridge, for the system of counterweights, is located eight feet under the grid.

Under this large stage and stage-house are a Green Room, various dressing rooms, administrative offices and other support spaces.



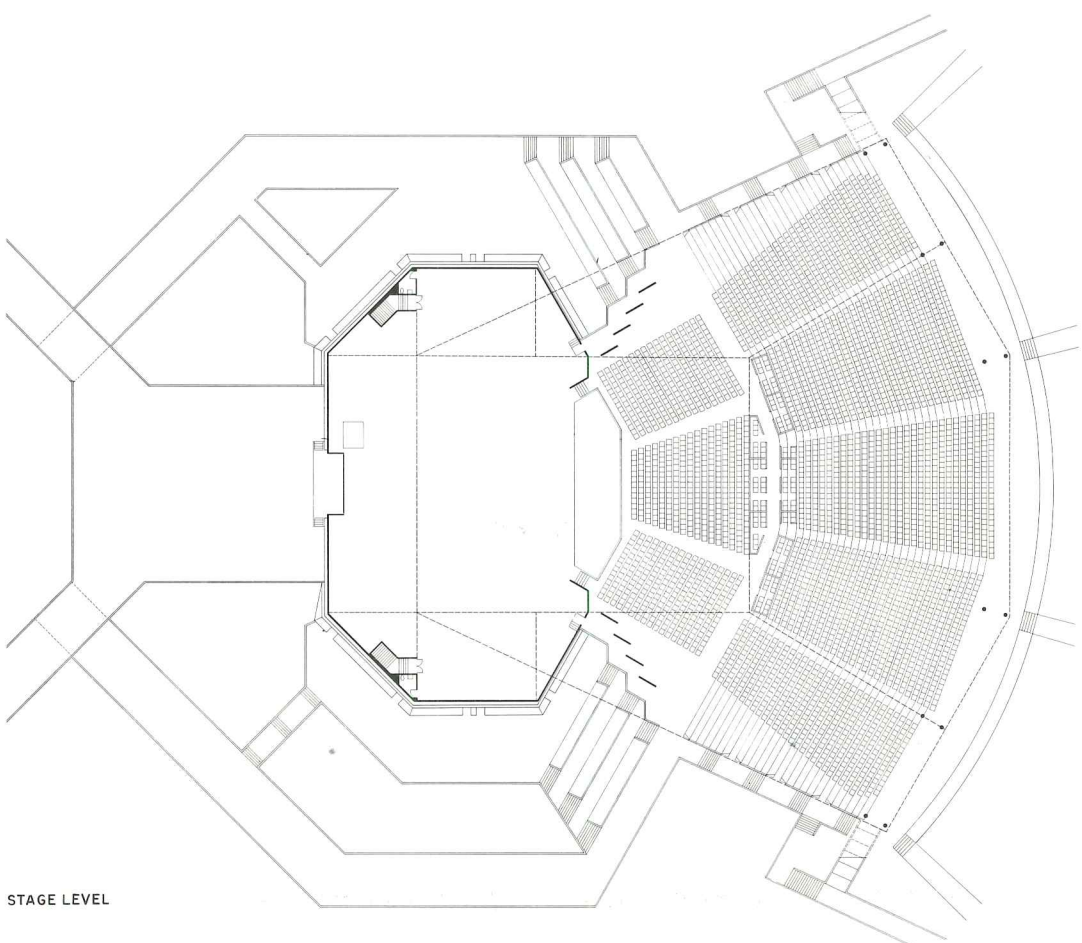

STAGE LEVEL

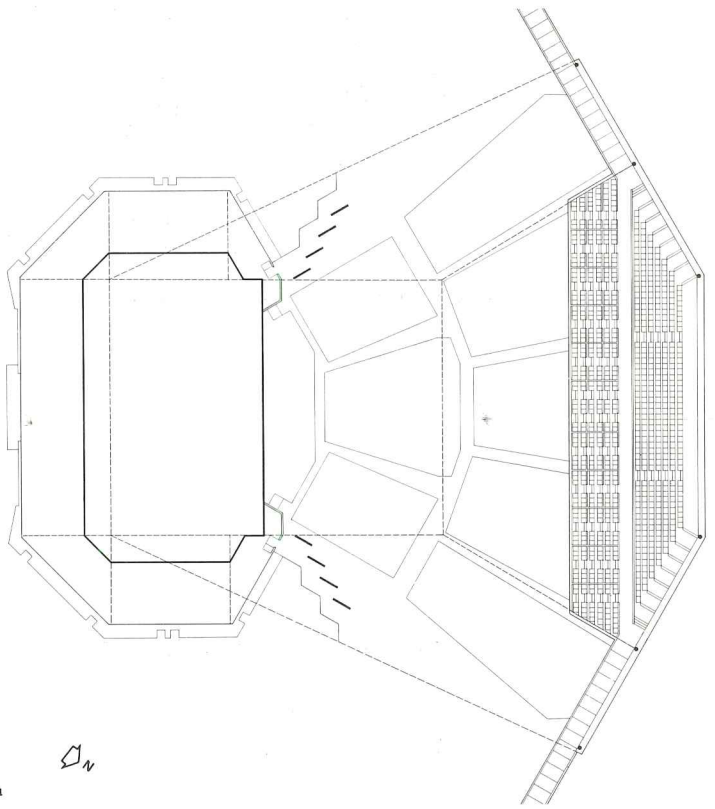

BALCONY LEVEL

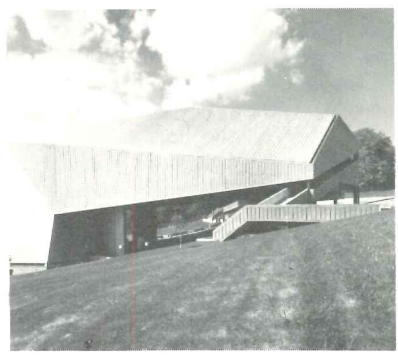
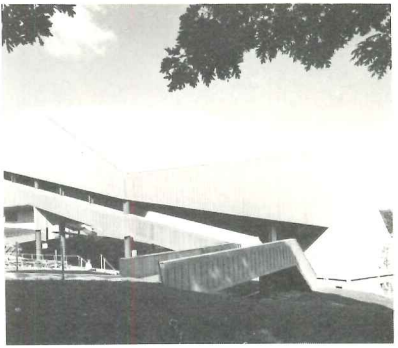
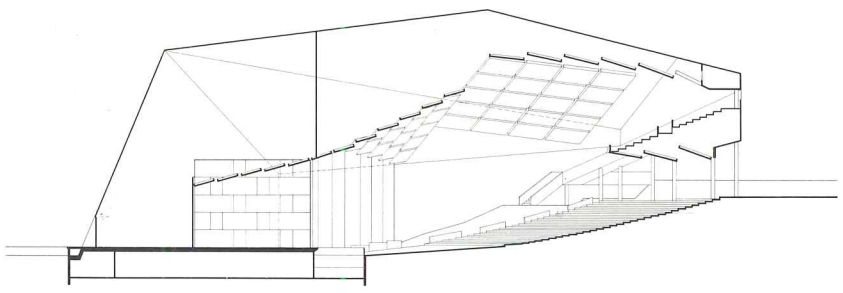
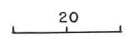

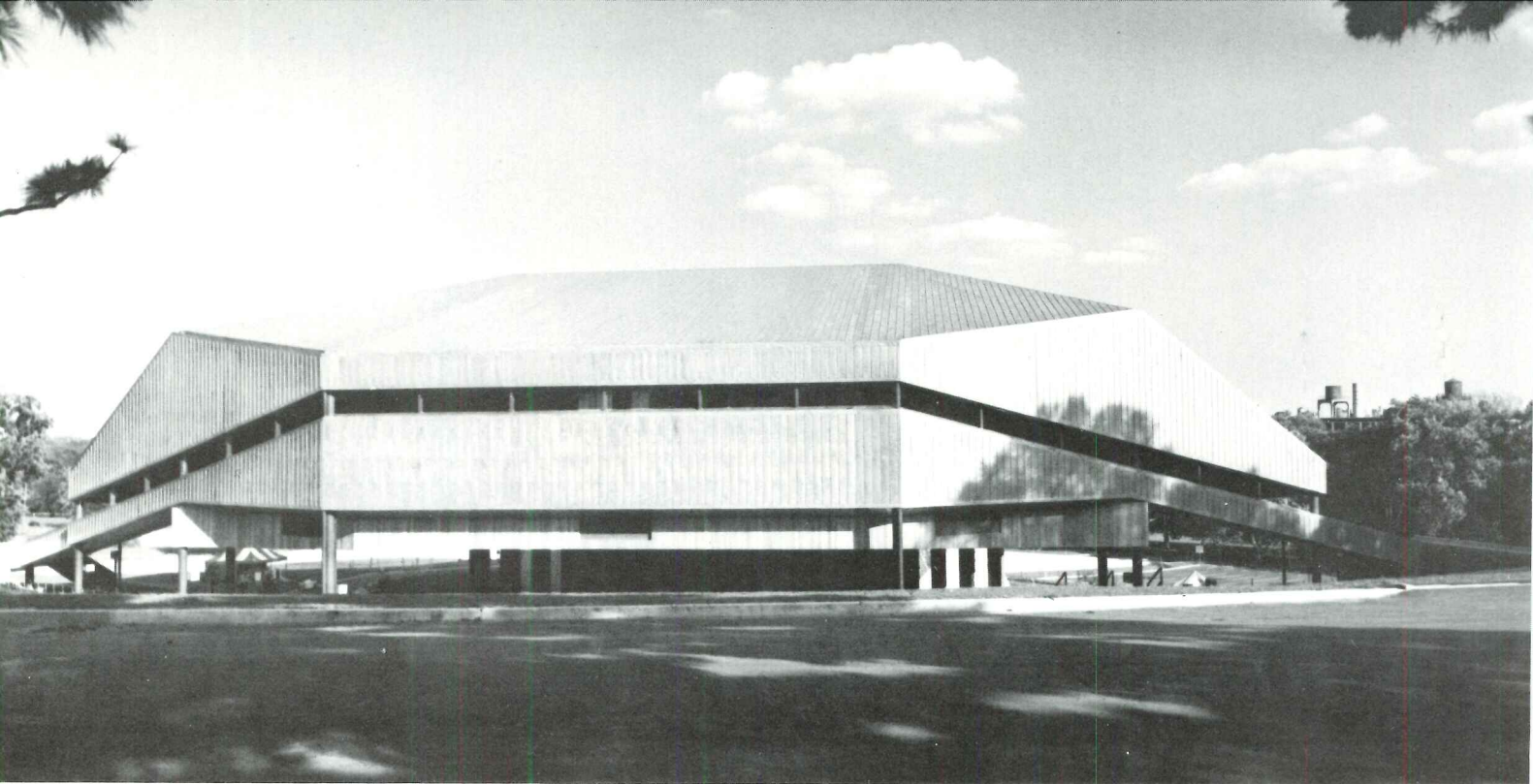

Outdoor music "tents" are an American phenomena and the number of such facilities built in recent years seems to suggest a continuing public appetite for summer music in surroundings less rigorous and more relaxed than the concert hall. The most recent, and largest, of this new group—and one of the few designed for full-scale operatic productions—is the Robin Hood Dell West, built in a rolling, parkland setting only a few minutes from downtown Philadelphia. The new structure rests rather lightly on its softly-contoured hillside site and the complex geometry of its roof form is not easily assimilated. Its multi-faceted surfaces, finished in terne-coated stainless steel, respond to acoustical needs in their design and provide a fairly complete sense of enclosure except at the sides where large openings frame pleasant twilight views of the park. When night has fallen, outdoor lighting plays off the metal

surfaces in lustrous, opalescent patterns that change in phantom patterns with each new point of vantage.

Inside, the spatial volume is very ample. Open web steel joists support the wood plank ceiling in a lightweight but muscular display. Adjustable wood baffles over the front of the orchestra furnish acoustical controls but also act to focus the space downward toward the stage and shell.

The enclosure seats almost 5,000 with space for nearly 10,000 more outside, but there is little sense of crowding. Circulation routes in the form of elevated ramps and outdoor stairs are clearly defined and generously proportioned so that even during arrival and departure, the processional experience is surprisingly smooth.

Sound reinforcement is, of course, a practical necessity. At the Dell there are two elec-

tro-acoustical amplifying systems—one for outside, one for inside. Both are controlled from a console in the balcony. To this writer's not overly critical ear, the aural picture seemed clean and the voices of the various instruments pleasantly free from distortion. And minor re-landscaping around the area of the parking lot, now underway, will do much to dampen the trivial nuisance of ambient sound, most of it created by latecomers or parking attendants going about their duties in ways that are noisier than necessary.

ROBIN HOOD DELL WEST, Philadelphia, Pennsylvania. Architects: *John H. MacFadyen and Alfredo De Vido*.—Hans-Jeorg Baehler, job captain. Associate architect: *Israel Demchick*. Engineers: *Charles H. Thornton, The Office of Lev Zetlin Associates, Inc.* (structural); *M. Michael Garber & Associates* (mechanical); *Heinrich Keilholz* (acoustical). Contractor: *McCloskey & Company, Builders*.





Ezra Stoller © ESTO photos

## **ROBIN HOOD DELL WEST: A NEW SUMMER CAPITAL FOR PHILADELPHIA'S MUSIC LOVERS**

*For many years Philadelphia's justly famous symphony orchestra has had no really adequate summer home. Philanthropic industrialist Frederic R. Mann set out to change that. With financial help from sources both public and private, Mann provided the impetus and organizational skills that were required for so complex a project. New York architects MacFadyen/De Vido provided the Fairmount Park site with its architectural centerpiece.*





David Franzen



David Franzen

The remaining element of the original apartment, a former north-facing greenhouse next to the library, is now Franzen's office for work at home. All of the rest of the rooftop structure was almost totally rebuilt within the existing structure. The surrounding higher buildings form an enormous room in which the "house on top of a building" gains a sense of containment that is unusual for a penthouse.

Norman McGrath



# OPEN SPACES FROM ENCLOSED ROOMS: AN ARCHITECT'S NEW YORK PENTHOUSE

Norman McGrath photos

Once a dark "rabbit warren" of rooms that were a haunt of colorful Mayor Jimmy Walker, architect Ulrich Franzen's penthouse apartment is today spacious and filled with natural light. According to Franzen, the obvious advantage of a penthouse is that it can be designed almost independently from the rest of the building, like a "house in the sky." Accordingly, many of the original walls were replaced by low partitions. Overhead glazing, which admits the brightest south light, was introduced in the darkest room. Small exterior doors onto the north terrace were greatly widened to provide an eye-level view of a nearby church's dome, which becomes a strong decorative element. The raised library area is used for ordinary living-room functions, and overlooks what Franzen refers to as the "parlor" (foreground, photo at left) used for entertaining. But as opposed to parlors of the past, the room is furnished *less* conventionally than the rest of the apartment and most clearly satisfies friends' and clients' expectations of a noted designer's lifestyle. Chromed metal covers the one visible column.

FRANZEN APARTMENT, New York, New York. Architect: *Ulrich Franzen*. Engineers: *Andrew Eliot* (structural); *Aaron Zichman* (mechanical). General contractor: *Van Hyning Construction Company*.

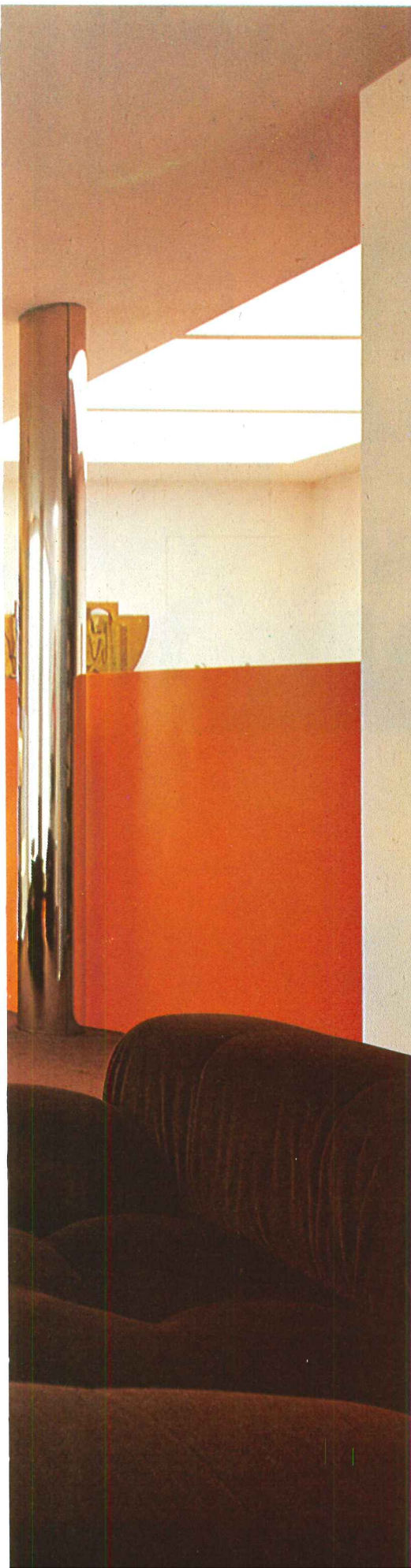



Jeremiah O. Bragstad photos

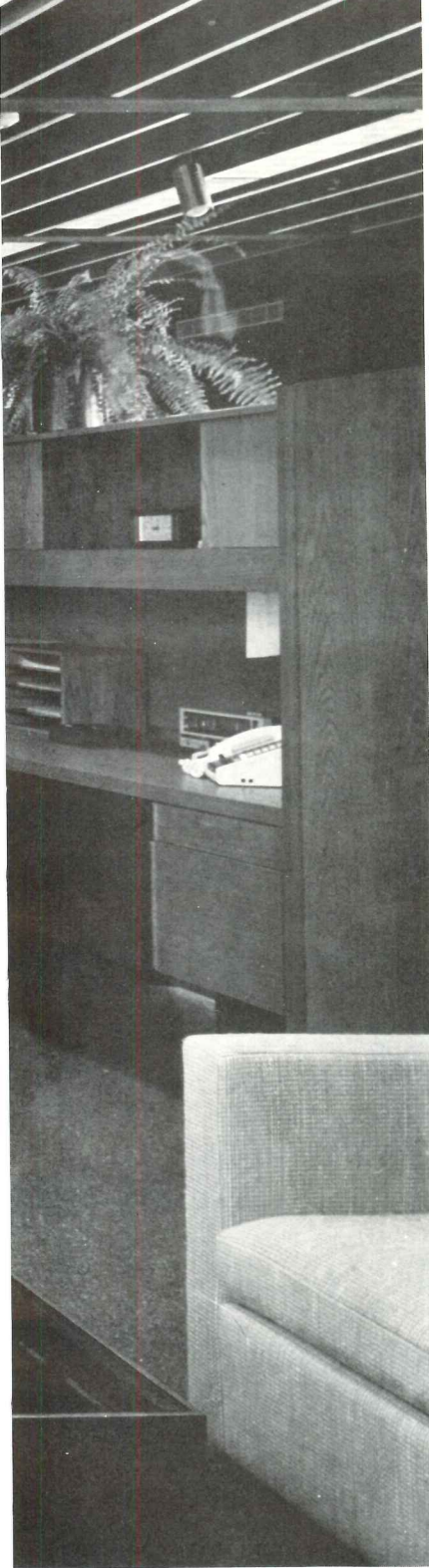

In this office remodeling, the retention of the original brick walls and the addition of an oak furniture system, office landscaping of color highlights of orange and yellow express the natural, casual atmosphere the client sought. The open wood ceiling system (a direct result of exposing the air-conditioning ducts and light fixtures) establishes an interesting ceiling pattern (top left) and contributes to this atmosphere. Public spaces such as the reception area (far left) and lounge (top right) are conservatively contemporary in design. The only glass-enclosed work areas are conference rooms with the remaining space open planned.





## REMODELED STEAMSHIP OFFICES WERE DESIGNED TO REFLECT THE CLIENT'S CONTEMPORARY IMAGE

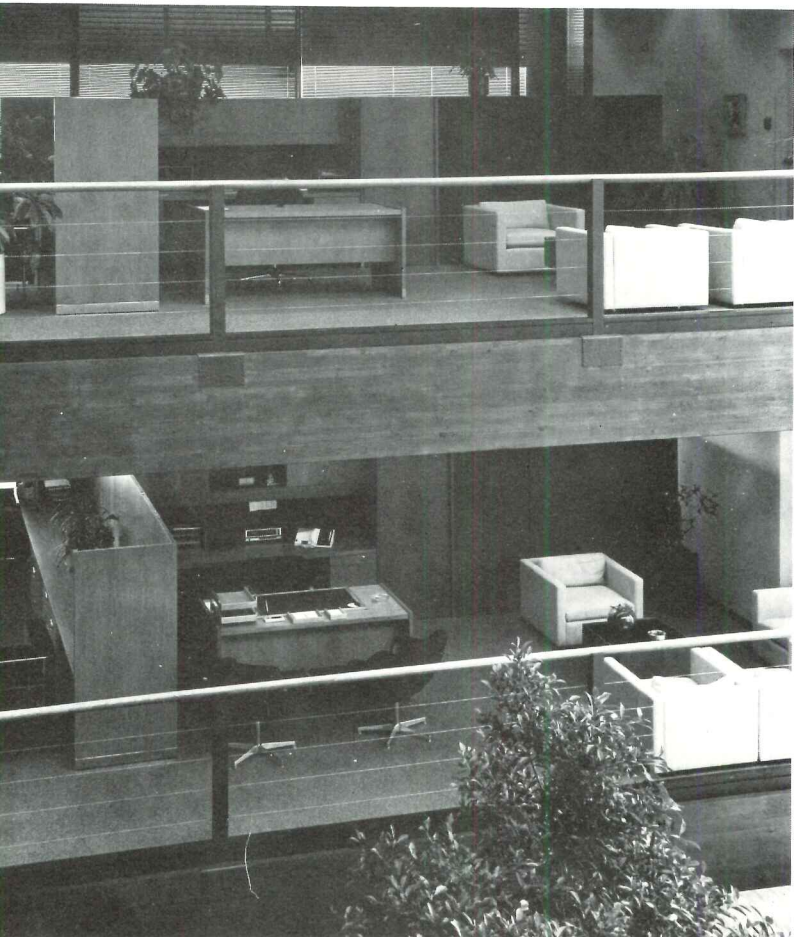

In a waterfront area zoned for maritime-related business, these headquarter offices for a steamship company are in a newly remodeled building, formerly used as an oceanographic research laboratory. Located at the end of a pier in the Long Beach port, the thrust of the remodeling was the addition of two floors (necessitating major structural changes) and the opening up of the interior to light and views.

The focal point of the office is an open, three-story, column-free space used as an employee lounge and bordered on one side by a glass window wall. A series of skylights covering 2,000 square feet encloses the area. The influx of natural light, lush office landscaping and a fountain contribute to the over-all casual, natural atmosphere. By utilizing an open space plan with low partitions, each work area has a view to nearby shipping activity. This also permits flexibility in office arrangement.

The client's need for a large amount of office space required the addition of two floors, but the 32-ft roof height did not accommodate mechanical systems to be regularly installed between the floors. Therefore, the air-conditioning ducts were exposed and lighting fixtures were interlaced between a wood grille system attached to the joists and beams at ceiling height. Sound absorption material was placed between the grille slots.

RELTA STEAMSHIP COMPANY OFFICES, Long Beach, California. Space planners/interior designers: *Hugh Gibbs & Donald Gibbs Architects and SLS-Environetics*. Structural engineer: *Donald Erb*. General contractor: *Collins McPherson Chapman*.





The Evening Bulletin  
Abortion issue  
of party clash  
may be cause  
Contest pits lawyer  
against communist  
Hello, rain hurt crops





use of reflective material to enlarge and enliven the space is contrasted with an unusual and sensitive use of granite. "Rather than use stone like wallpaper," Platner used it in individual blocks only at the points where its protection was needed: as a wainscot in the entrance stair, as corner blocks set into the plaster at each of the arches, around all door openings, and in the walls opening to the elevator cabs. Everywhere, the stone is expressed as individual stones—"the way to best show its character and make the greatest visual impact."

THE PROVIDENCE JOURNAL PUBLISHING COMPANY, Providence, Rhode Island. Architects: *Warren Platner Associates*; architect-engineer: *Chas. T. Main, Inc.* Contractor: *O. Ahlberg & Sons, Inc.*



The 10,000-square-foot news room is lighted by the top section of the building's tall arched windows; is divided only by glass partitions so that everyone shares the light and the space is open for communication in the news-room tradition. The advertising-department space below is identical except for the windows and furniture placement. Because of the heavy use of electronic equipment, anti-static lay-in carpeting was used over the concrete, heavily ducted subfloor. Photo above is of the editor's round desk in the newsroom with his glassed-in conference area at the left.

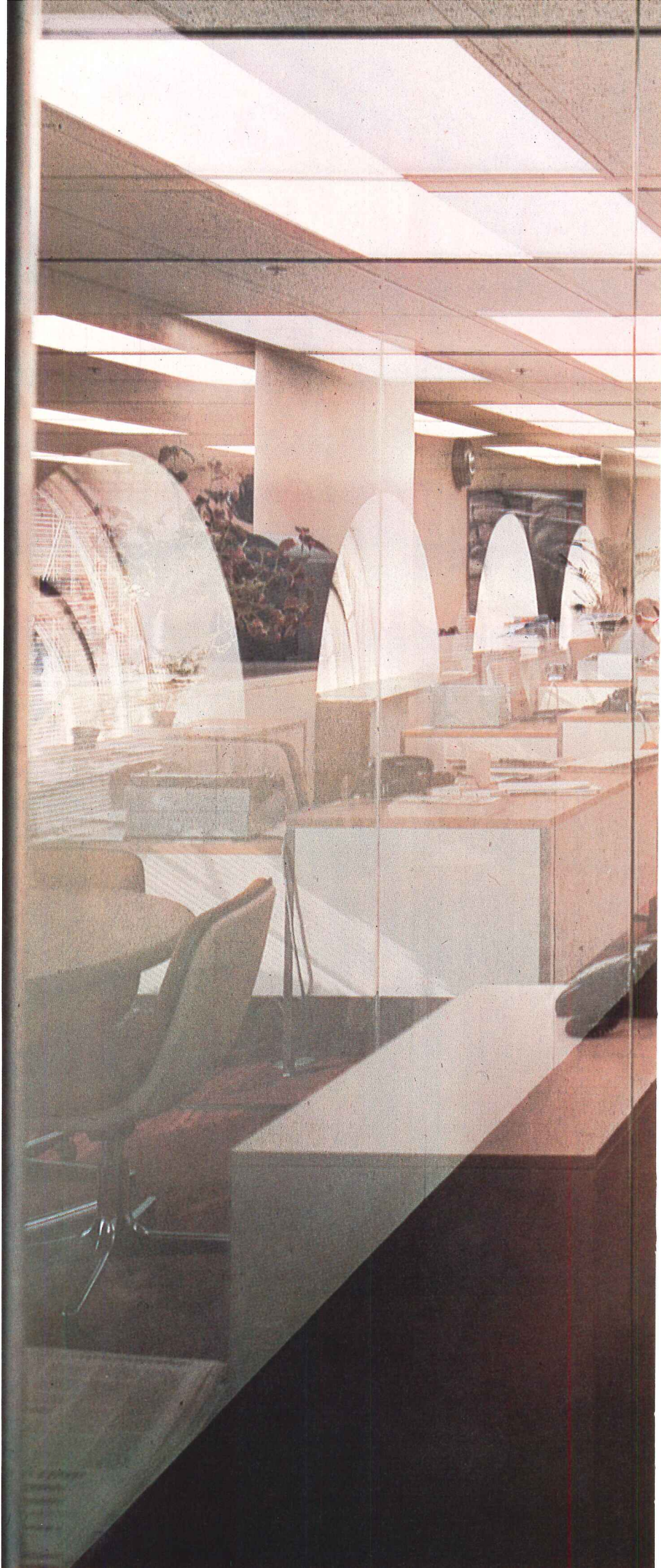



## NEW SPACE AND NEW CHARACTER ARE ADDED IN THIS OFFICE REHAB



Faced with a need for new editorial and advertising space—and no place to put it—The Providence Journal Publishing Company employed architect Warren Platner to study the problem. The existing “front-office” space of the 1933 “rather ordinary but still graceful” building had 20-foot ceilings—a 12,000-square-foot space lighted by large windows (photo left). Platner’s solution was simply to divide the space into two ten-foot floors, doubling the space; and to create modest but typically elegant interiors (see photos overleaf). While this solved one problem, it created another: the already cramped and rather decrepit lobby lost its height where the new floor went through—and with it any sense of being a suitable “arrival place” for a major newspaper office. Platner’s redesign involved carrying back the arched form of the front-door fanlight into the lobby space. This arched space continues back through an all-glass “vestibule” entrance to the point where the new second floor cuts through. There, polished brass in the top 3/5ths of the arch terminates the tall space, but reflects back the image of the fan light (photo below). Brass is also used on the ceiling of the elevator lobby and on its rear wall (where it is protected against marks by a glass wall set off four inches). This

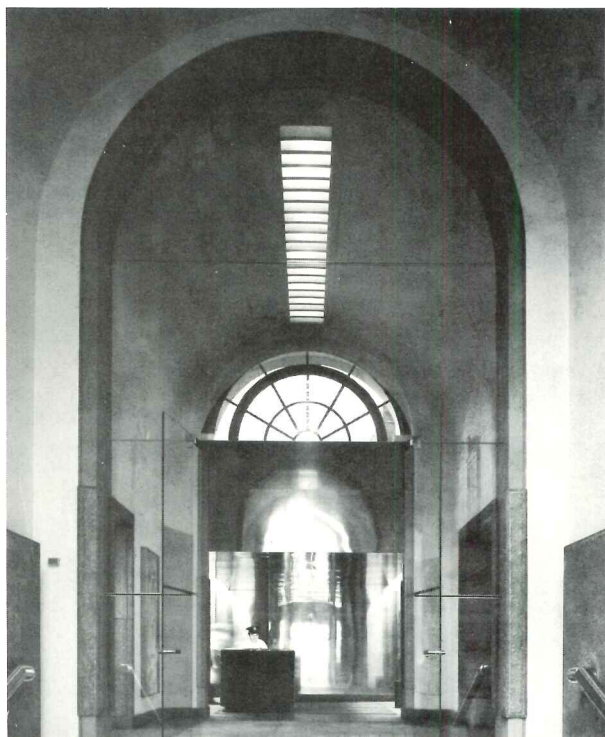
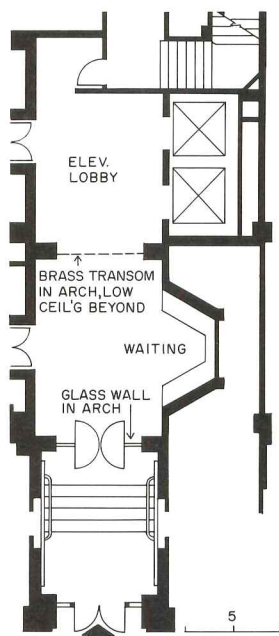

© Ezra Stoller photographs

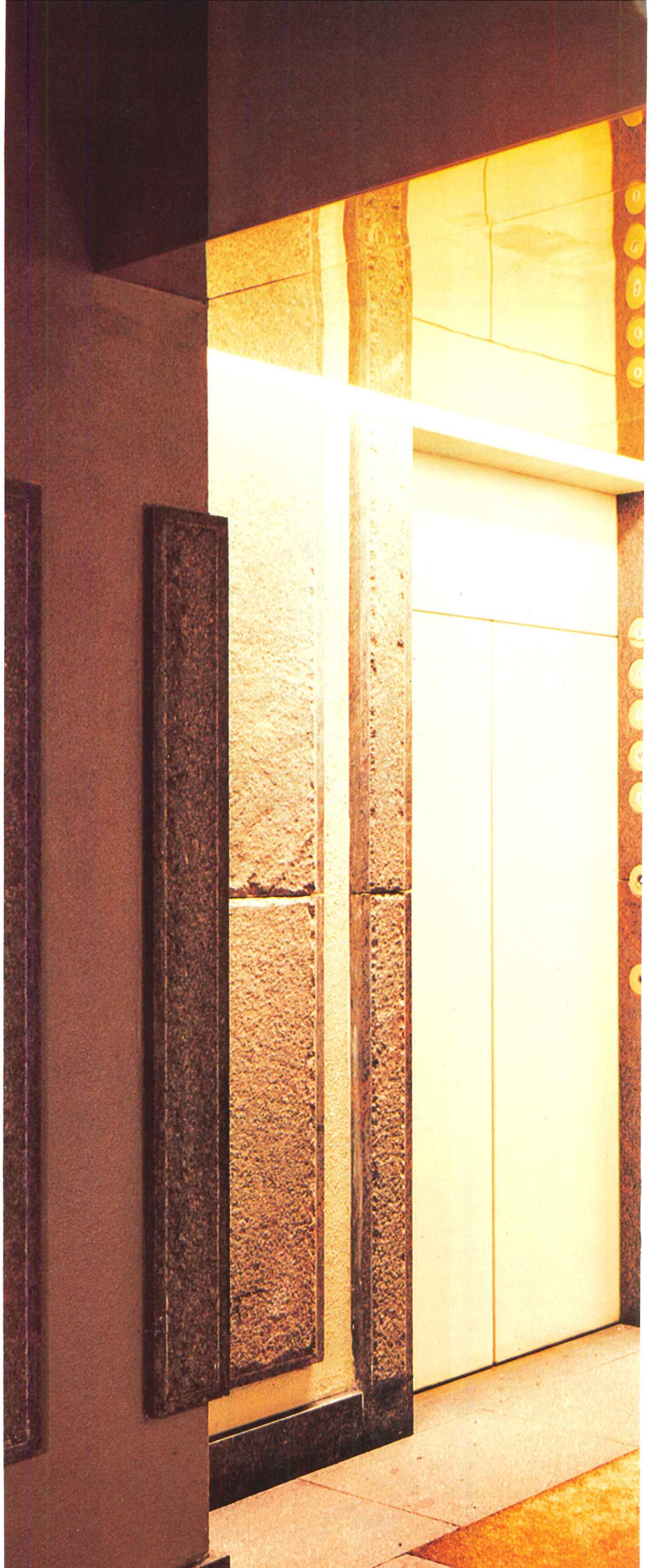

FROM CHAOS TO CLARITY:  
A RETAIL RENOVATION  
BY ARCHITECT JACK FLEIG

What could more eloquently express the extent of the transformation that has happened here than a comparison of the two photos at left? Below, before renovation: a visual blitz, a shopper's nightmare, a complete roll call of merchandising "don'ts." Above, after renovation: a really inviting interior with selective display and with functional separations expressed by spatial modulations. Quarry tile and carpeting replace the old asbestos flooring. Pipe columns have been furred out, finished in drywall, and integrated into the over-all system of counters and cabinets. Fluorescent lighting fixtures have been replaced by incandescent track lights and recessed cans. A new dropped ceiling of pine siding conceals the older ceiling of metal pan. Handrails, countertops and trim are finished in red oak and sealed with polyurethane.

The result is a retail space through which shoppers move in orderly patterns and can comprehend what they look at. For its owners, the renovation provides a pleasant working environment with reduced problems of inventory, display and security.

LEISURE WORLD ELECTRONICS,  
Baraboo, Wisconsin. Architect: Jack  
Fleig. Contractor: Ralph Tuttle, Inc.

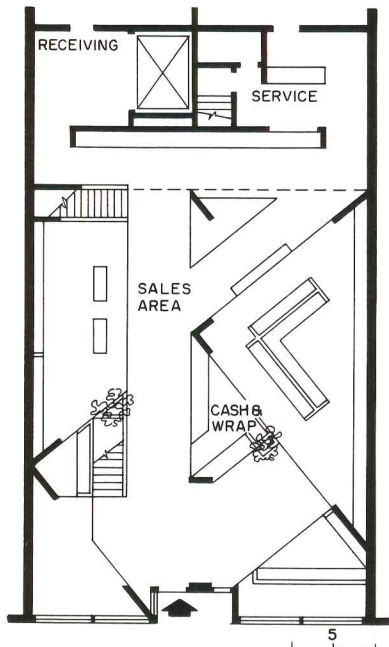

Mike McGinnis photos

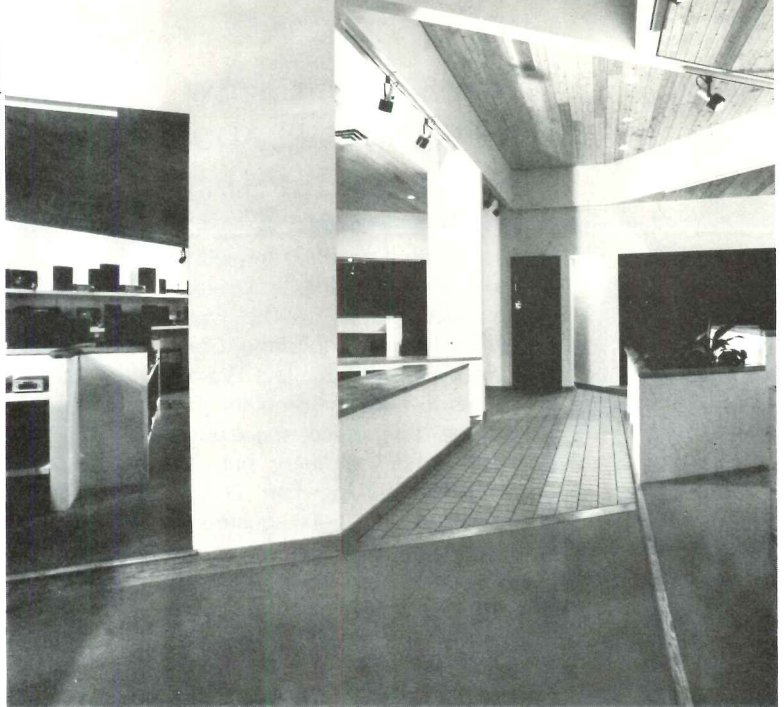





CAST-OFF INDUSTRIAL SPACE  
SALVAGED AND REJUVENATED  
BY MINNEAPOLIS ARCHITECTS



In what had been a machine shop along an industrial/commercial strip in Minneapolis, four architects have fashioned an office for their new firm that generates considerable visual excitement with the simplest of means. The thoughtful solution that emerges—full of plants, light and character—is a lesson for renovators.

The existing stairs, bathroom and windows were retained, as was the existing entry adjacent to parking. The remaining space, unaffected by these constraints, was playfully manipulated to achieve intriguing volumetric associations without sacrifice to functional need. The main level was zoned into work area and reception with partitions to define individual work stations. Dropped soffits also help define these stations as well as main circulation routes.

The lower level is used for conference, display and storage. Renovated for under \$20 psf, using modest materials but using them well, the Design Consortium Offices were owner-designed, and owner-built.

ARCHITECT'S OFFICES, Minneapolis, Minnesota. Architects: *Design Consortium/Zuber, Incorporated.*

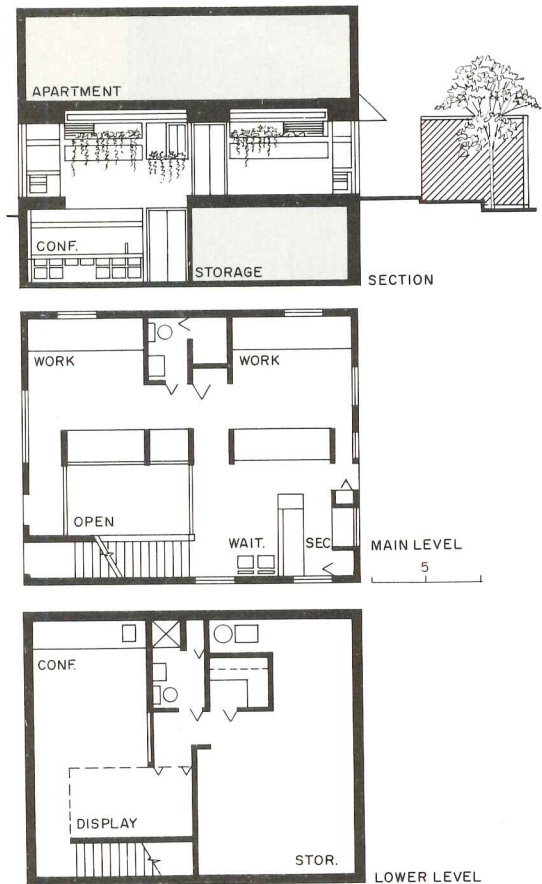

Philip James photos

© Edmund H. Stoecklein photos

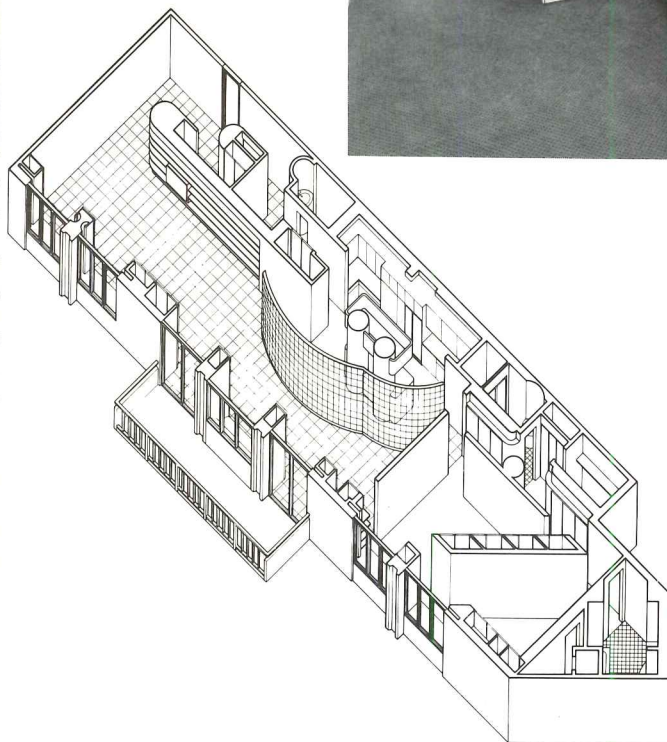
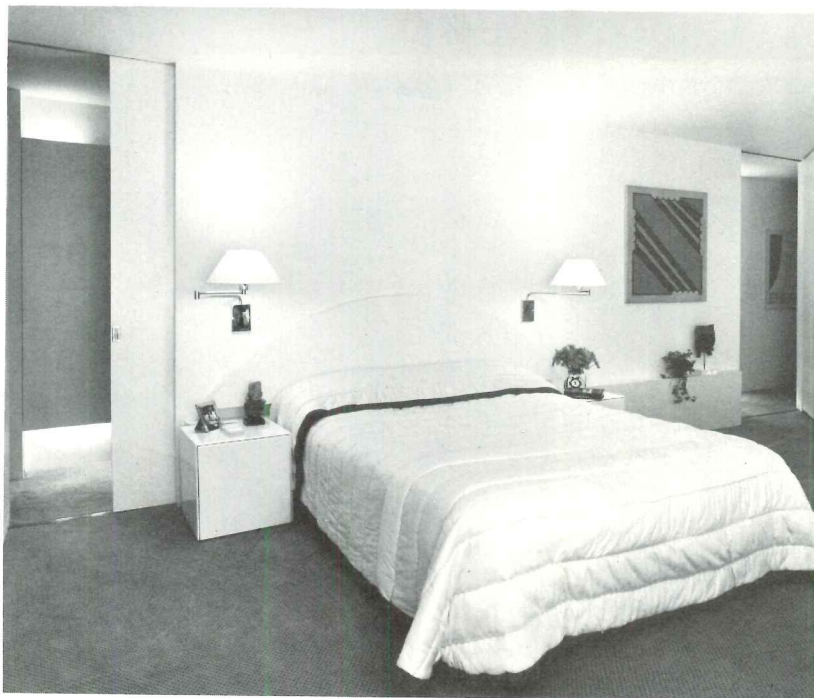
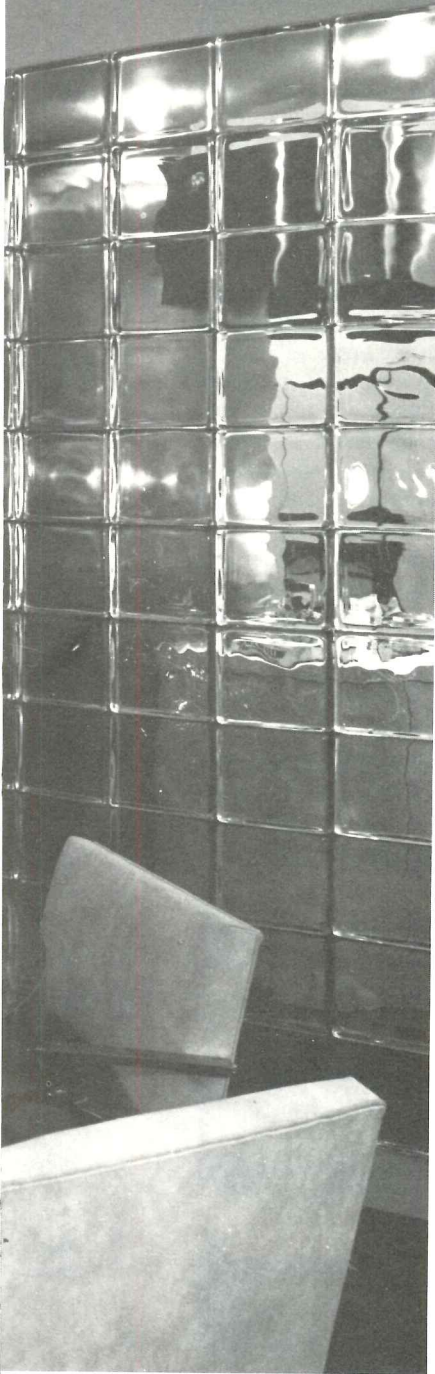

Functionally many small low rooms, the apartment's presence is that of spatial grandeur. Within the current standard of smaller over-all space this is achieved by immediate visual contact with every extremity of an above-average area (a 15-foot bay was added from the next apartment at the living-room end). Doors that reveal the full length of the window wall can close off the bedrooms at night (photos, right). Projecting air-handling units were covered by a new inside "wall" into which cabinets are recessed.

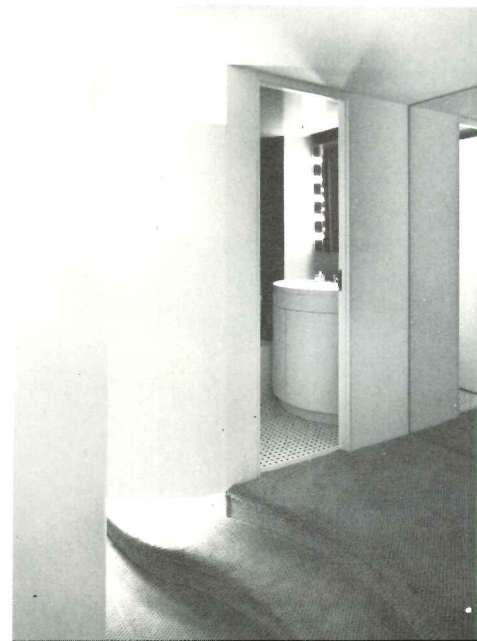







LEGANT PRIVATE APARTMENT  
IN A STANDARD BUILDING,  
BY ROBERT STERN & JOHN HAGMANN

In a new speculatively built suburban apartment building, the client-couple (she is an antique dealer) purchased unpartitioned floor space, and asked the architects to design something more than the builder's suggested plan, a series of box-like rooms. The result is an enormous (2500-square-foot) and gracious space that defies the restrictions of "standard" ceiling heights and of the anticipated compartmented uses. The kitchen, normally on the outside wall, was located in the center of the apartment, and its curved solid-glass-block (epoxy jointed) wall was used to modulate the living space undulating around it—and to provide a sparkling transfer of light back and forth (see overleaf). The effect on the living room side is heightened by multiple small lights on the kitchen ceiling. The doors of the bedrooms can be opened to visually extend the main space during the day. Like many of the partitions, those in the entrance hall (photo, below) are built by cabinet-makers and lacquered. The small hall opposite the entrance leads to the coat closet. The floors are rough-cut, "thin-set" slate that had to be ground in place to make an even surface. Many antiques from the owner's collection blend well with the contemporary furniture recommended by the architects, and contributing to the spacious and luxurious ambiance.

PRIVATE APARTMENT, Elkins Park, Pennsylvania. Architects: Robert Stern & John Hagmann—assistants: Joan Won Yee Chan and Ronnie Fisher. Engineers: Robert Silman & Associates (structural).

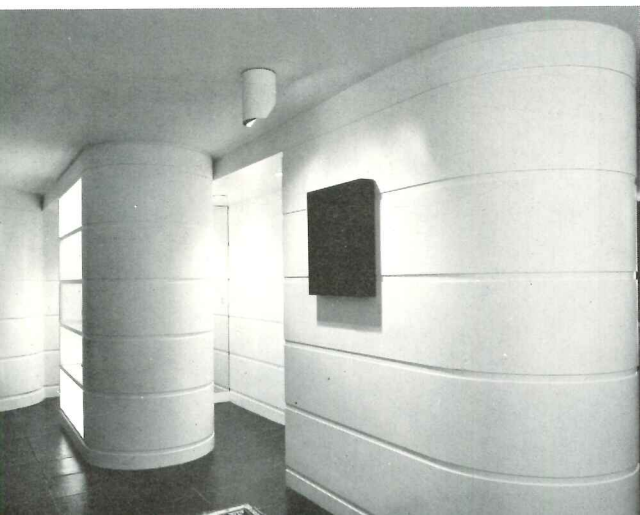
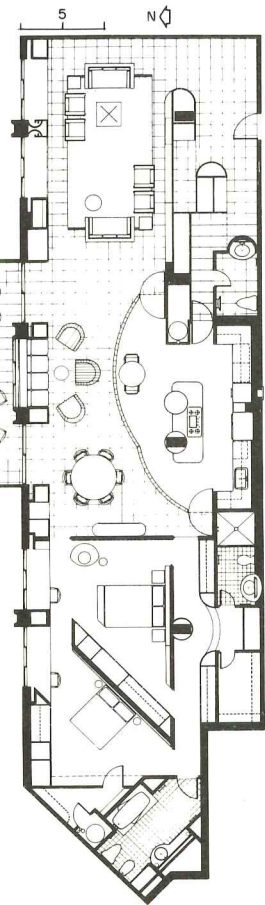

## SQUASH/1: FOR PLAYERS AND SPECTATORS AN ELEGANT SPORTS ENVIRONMENT

Racquet clubs of various sorts are springing up in city and suburb across the country. Squash/1, a response to the sport's fast growth, was fashioned from an existing structure built as an ironworks (with 27-foot ceilings) and used more recently as an appliance and trucking depot. Within the framework of this existing structure, the architects provided five singles courts, three with glass rear walls facing the lounge, a device that brings spectators virtually into the play. The ½-inch thickness of tempered glass is fitted with special hardware and stiffened with fins also of glass. New court floors of maple were installed and the court walls were constructed using a fiberglass-reinforced plaster over conventional block and finished smooth. The existing corrugated metal ceilings were painted off-white, the ductwork a bright yellow. A building type too often characterized by neglect is here treated as a serious design problem with handsome and altogether satisfying results.

SQUASH/1, Mamaroneck, New York.  
Architects: *Gordon/Spencer*. Engineers: *Arne Thune* (structural); *Michael Dalton Associates* (mechanical/electrical). Graphics consultant: *Margorie Katz Design*. Contractor: *Spencer Construction Corp.*

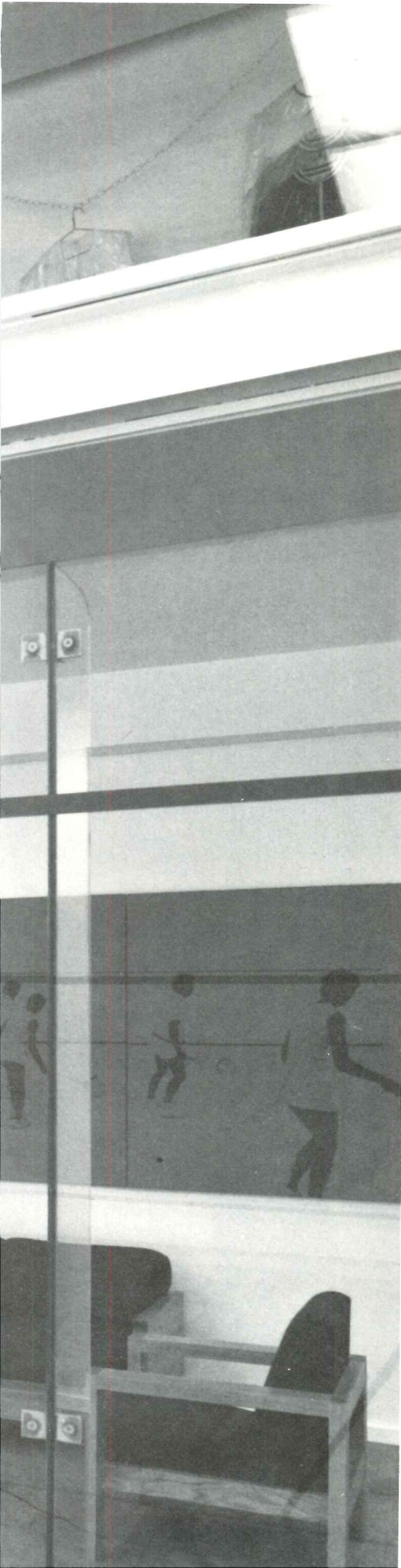
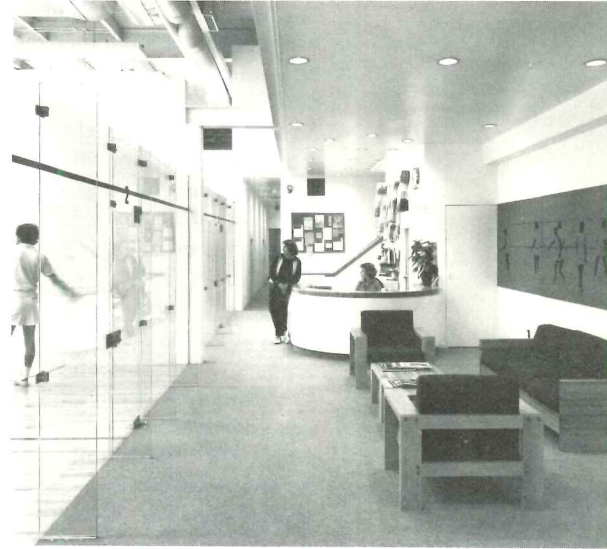



OLD AND NEW  
ARE BEAUTIFULLY MIXED  
IN THIS ARCHITECT'S OFFICE  
OUTSIDE BOSTON

Converted from an old Stanley Steamer factory—a structure reputed to be the first reinforced concrete building in New England—this office by and for architects Crissman & Solomon stands in Watertown, Massachusetts on a site overlooking the Charles River. In the large drafting room, the original system of columns and beams remains, looking none the worse under a new coat of paint, and the original wood floor, sanded and refinished, adds a note of warmth throughout the office. The small offices along the south wall open through clerestories to the public corridor and admit daylight from the outside wall. The individual drafting stations, carefully detailed, are particularized but partitioned only to half height so that from a standing posture the entire space is visible.

As with all good renovations, the design hand here was sensitive to what was worth saving and knew how to introduce new elements—ductwork, lighting, cabinetwork—in ways that are sympathetic and integrant.

OFFICES OF CRISSMAN & SOLOMON, Watertown, Massachusetts Architects: *Crissman & Solomon*. Contractor: *Costa J. Limberakis, Inc.*

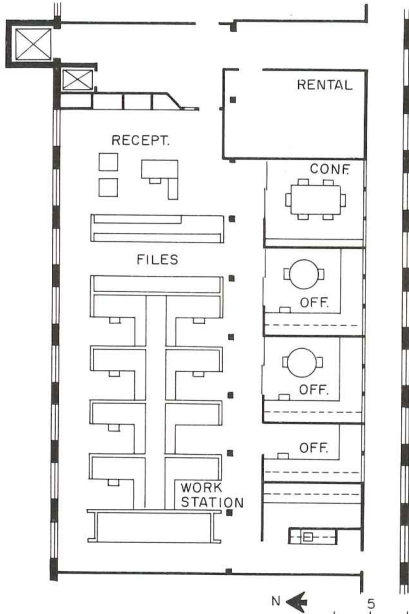



© Steve Rosenthal photos



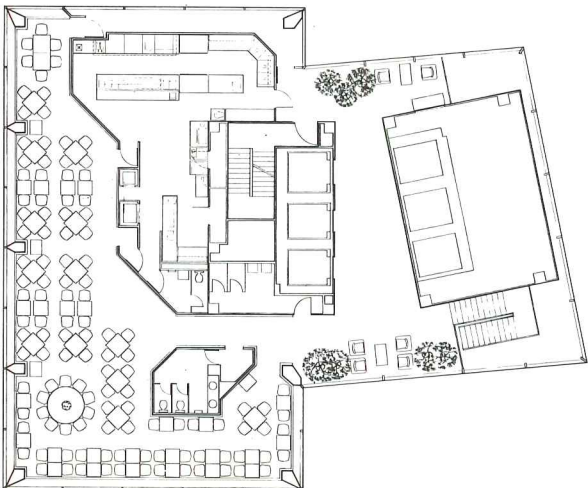



## SIMPLE ELEGANCE IN THE MIDDLE OF MASSACHUSETTS

Worcester Plaza, designed by Roche Dinkeloo and Associates, engages the streetscape of this old Yankee town, and grabs a wide slice of an undulating, colorful horizon. In the Plaza Club, located on the top two floors of the 24-story, twin-tower structure, people are grabbing, soup to nuts, one of the architects' most sumptuous interiors—sumptuous in the unadorned elegance of basic ingredients brought to light. Light, in fact, is the most basic, and its gradations of intensity and color, most dramatic along the horizon at sunset, are literally absorbed by the mirrored or stainless steel surfaces, latched onto by the texture of wood trim and fabric. The sharply angled ceiling of the Club's two-story lobby is ebulliently lit, its reflective planes setting up a kaleidoscopic effect, framing views to the outside as one passes into the restaurant or, farther, into the bar or private dining rooms. Continuous soffits of stainless steel, with recessed lighting, run below the restaurant ceiling, softening the juncture with the walls, and creating a floating spatial sensation. Down to the last glint in the stemware, it is a place to sink one's teeth into.

PLAZA CLUB, WORCESTER COUNTY NATIONAL BANK, WORCESTER PLAZA, Worcester, Massachusetts. Owner: Worcester County National Bank. Architects: Roche Dinkeloo and Associates. Contractor: Blount-Fontaine.

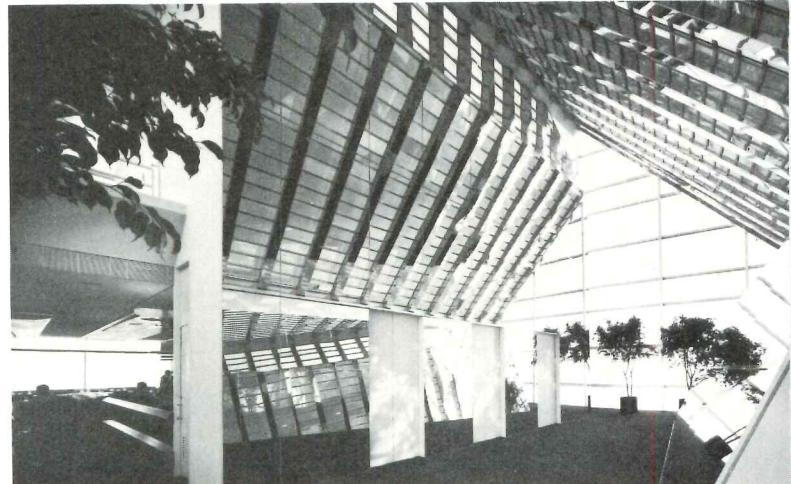
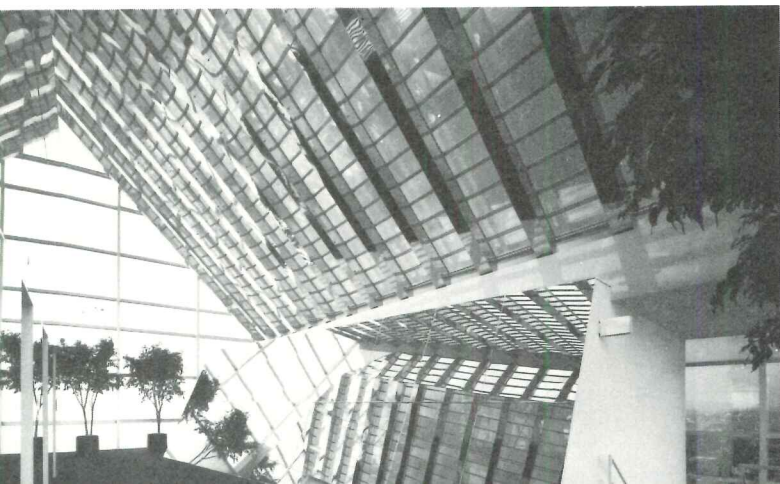



Exit  
5th Street

Independence

5

5

## MORE THAN NEW SURFACES: SIGNS OF A NEW COMMITMENT TO MASS TRANSIT UNDER HISTORIC PHILADELPHIA

All the vexing problems associated with underground mass transit were present before renovation of this station in an historic district of downtown Philadelphia. Most have now been eased. Drabness is gone, replaced by sparkling, easily maintained new wall surfaces—many enriched with patriotic themes rendered in abstract supergraphic patterns. Ventilation and lighting have been substantially upgraded. Security has been improved by eliminating niches and hidden areas, by placing the toll booths at the center of a platform splayed in plan and, finally, by the installation of a closed-circuit television system. New column cladding and new benches complement the new aluminum ceiling, which unifies the whole station and improves its scale.

The project was conceived to demonstrate that subway stations can be made attractive to users without extraordinary expense. Architects Ueland and Junker have done that—and much more—with new finishes and fresh, exciting images.

5th STREET SUBWAY STATION, Philadelphia, Pennsylvania. Architects: *Ueland and Junker—Burkart Stelzer, project architect, Joanne Thiede, graphic design.* Engineers: *Howard, Needles, Tammen & Bergendorff.* General contractor: *Backman Construction, Incorporated.*

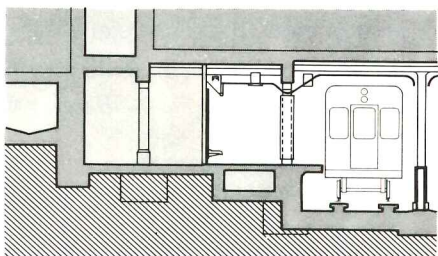
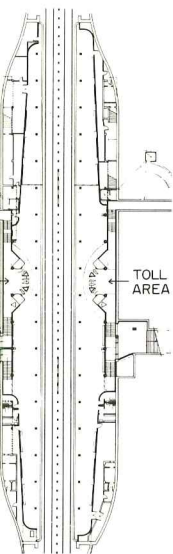



# RECORD INTERIORS OF 1977

Eight of this year's ten Record Interiors are renovations. This high proportion of projects in which architects worked within the constraints of existing spaces is neither accidental nor entirely unexpected. It reflects the broader economic circumstances of current practice and seems to lend support to Warren Platner's remark that "today all architects are in the interiors business—whether they like it or not." And like it they must, for the architects whose work is shown here and in the pages that follow have created interiors with exceptional skill and with a keen sensitivity to color and texture, to finish and detail. Though united by a common excellence and, to some extent, by a shared point of view, the ten projects are diverse in character and forthright in their search for individual expression and thoughtful solutions.

—Barclay Gordon

ARCHITECTURAL RECORD JANUARY 1977  
BUILDING TYPES STUDY® 497

MONSANTO INTRODUCES

# ULTRON<sup>®</sup>

THE LAST WORD IN ADVANCED GENERATION NYLON  
CARPET FIBER

Once you've said Ultron<sup>®</sup> nylon, there's nothing else to say. Because Ultron is a product of the finest carpet technology presently known. In Ultron, Monsanto has achieved an outstanding degree of abrasion-resistance, static-control, and soil-hiding...the practical performance properties that an advanced generation nylon should have. Yet, Ultron doesn't sacrifice the aesthetic benefits of bulk, luster, color clarity and resilience. So if you're looking for the brightest new idea for solving carpeting's worst problems, just say the word. Ultron.

Static build-up in carpeting is a problem for people, equipment, and the carpeting itself. So Monsanto engineers developed Ultron to have highly effective control of static. With its polymer system and with a conductive element added to the yarn bundle, Ultron is able to keep static build-up to a minimum. In fact, as confirmed through extensive testing, carpets with pile of 100% Ultron nylon, when constructed in accordance with Monsanto recommendations, will effectively keep static build-up well below the 3,000 volt human shock level, at a relative humidity as low as 20%.

In the areas of abrasion-resistance and soil-hiding, Ultron performance is equally outstanding. Because of its special properties, this durable fiber offers excellent resistance to abrasion and a high degree of resilience. It also features effective resistance against soiling and staining, and does a superior job of hiding the soiling that does occur. We've got a lot more to say about our proud new fiber and we'll gladly tell you everything. Just contact the Contract Carpet Department at Monsanto Textiles Company, 320 Interstate North Parkway, Atlanta, Georgia, 30339, Telephone (404) 955-4000.

ULTRON HAS IT ALL. SOIL-HIDING. ABRASION-RESISTANCE.  
**STATIC-CONTROL.**

**Monsanto**  
the science  
company.

For more data, circle 69 on inquiry card

# When you want the windows to look custom-built, start by looking at some classic standard units

A window like this bow isn't just a window, it's an architectural asset. You won't find many bows and bays in stock at the local lumber yard, but that doesn't mean they're hard to get: Marvin makes them in many shapes, sizes, and styles. They come from the factory set up, complete with head and seatboards, or without them if you prefer. The material, the workmanship, and the design of these beautiful windows has made them the choice in many of America's finest homes, large and small. Write for the facts on our standard bows, bays, and picture windows. Marvin Windows, Warroad, MN 56763. Phone: 218-386-1430.

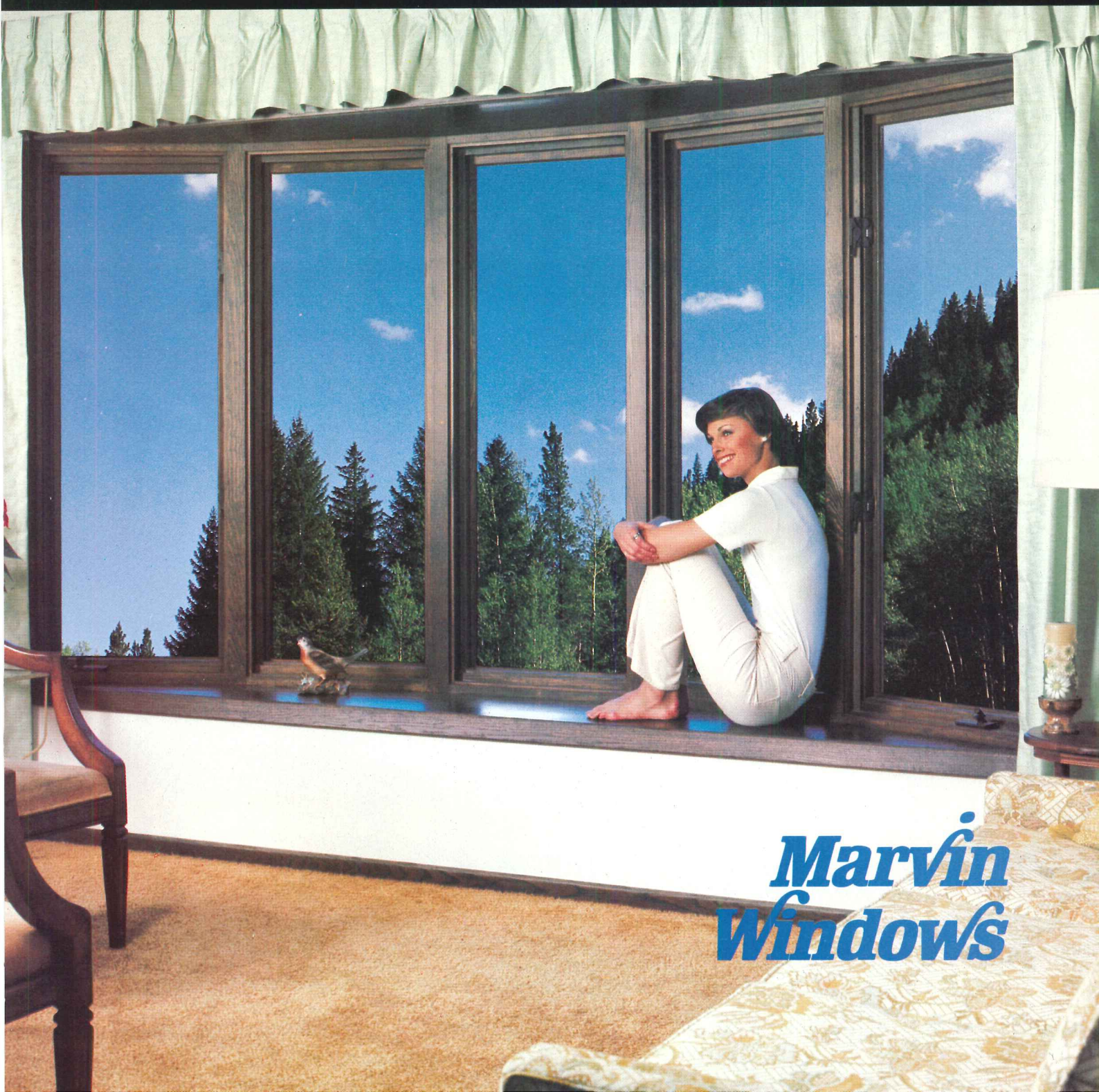

**Marvin  
Windows**

# TAKE A GOOD CLOSE LOOK AT Cem-FIL® AR GLASS FIBER, GLASS REINFORCED CEMENT...

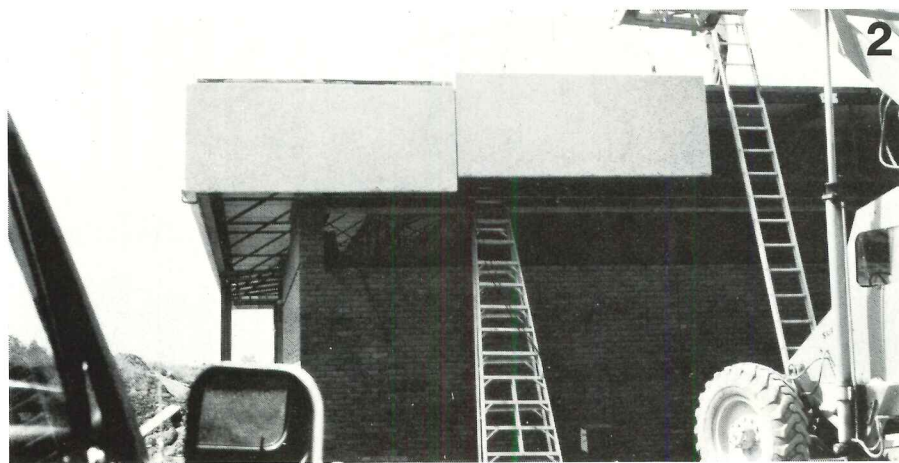
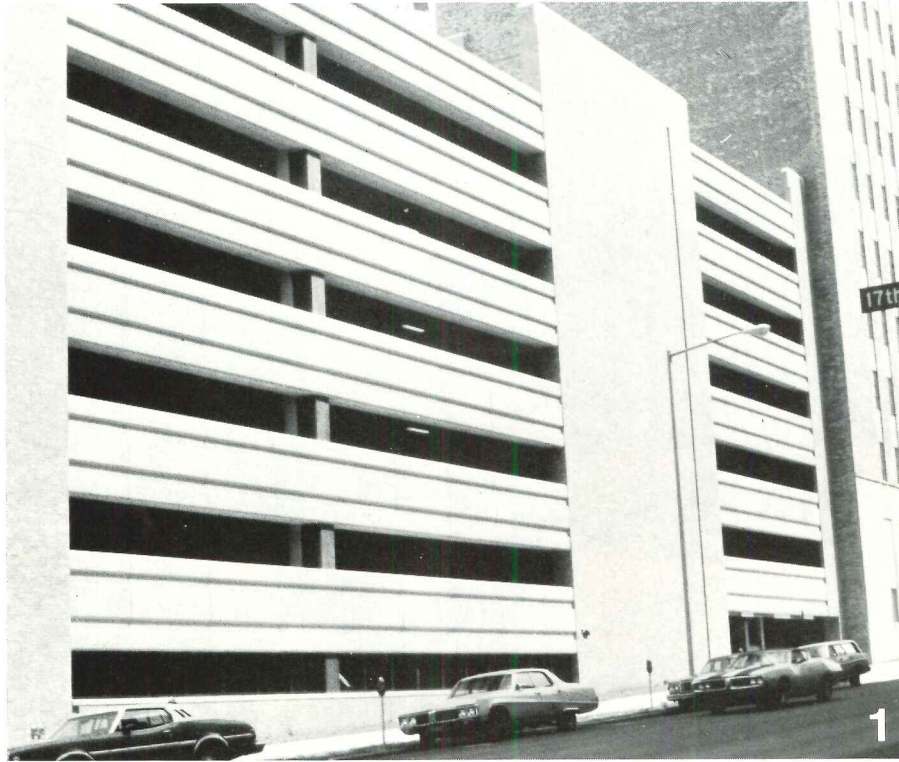

## It's More Than A Pretty Face.

Glass Reinforced Cement (GRC) begins and ends with Cem-FIL AR Glass Fiber. This is the fiber that made GRC a reality. The first and only fiber extensively field tested and proven alkali resistant. When combined with cement, the result is a strong, relatively lightweight and exceedingly versatile building material.

This label is your guarantee of GRC integrity.

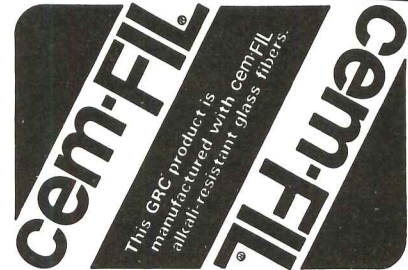

It assures that Cem-FIL AR Glass Fiber has been used as the reinforcing agent in the end product that bears it. It also implies the highest degree of GRC technology and quality control in the manufacturing process. This label is found only on GRC products incorporating Cem-FIL AR Glass Fiber, available from a growing list of licensed GRC producers.

A few new GRC applications in the U.S.A.:

**NO. 1** — Single skin panels on the Alabama Power Company Car Park, Birmingham, Alabama. Architect: Warren, Knight & Davis. Manufacturer: GRC Incorporated, Birmingham, Alabama.

**NO. 2** — Aggregate-faced, single skin, 10' x 6' fascia panels on the Educational Center Building at Hagerstown, Maryland. Architect: Nes, Campbell and Associates. Manufacturer: Cem-FIL Corporation.

**NO. 3** — Single skin panels in buff cement on the Countryside Shopping Mall, Tampa, Florida. Architect: Mudano Associate Architects, Inc., Clearwater, Florida. Manufacturer: Lake Manufacturing Company, Tampa, Florida.

**Cem-FIL®**  
CORPORATION

Two International Plaza Drive  
Nashville, Tenn. 37217  
(615) 361-4664  
Telex 55-5120

**When you specify GRC products, specify  
GRC reinforced with Cem-FIL® AR Glass  
Fiber. There is no equal.**

See Sweets General Building (Architectural File)  
7.5/Cem

# Transportation Control Center of L&N Railroad

... a magnetic marvel of efficiency.

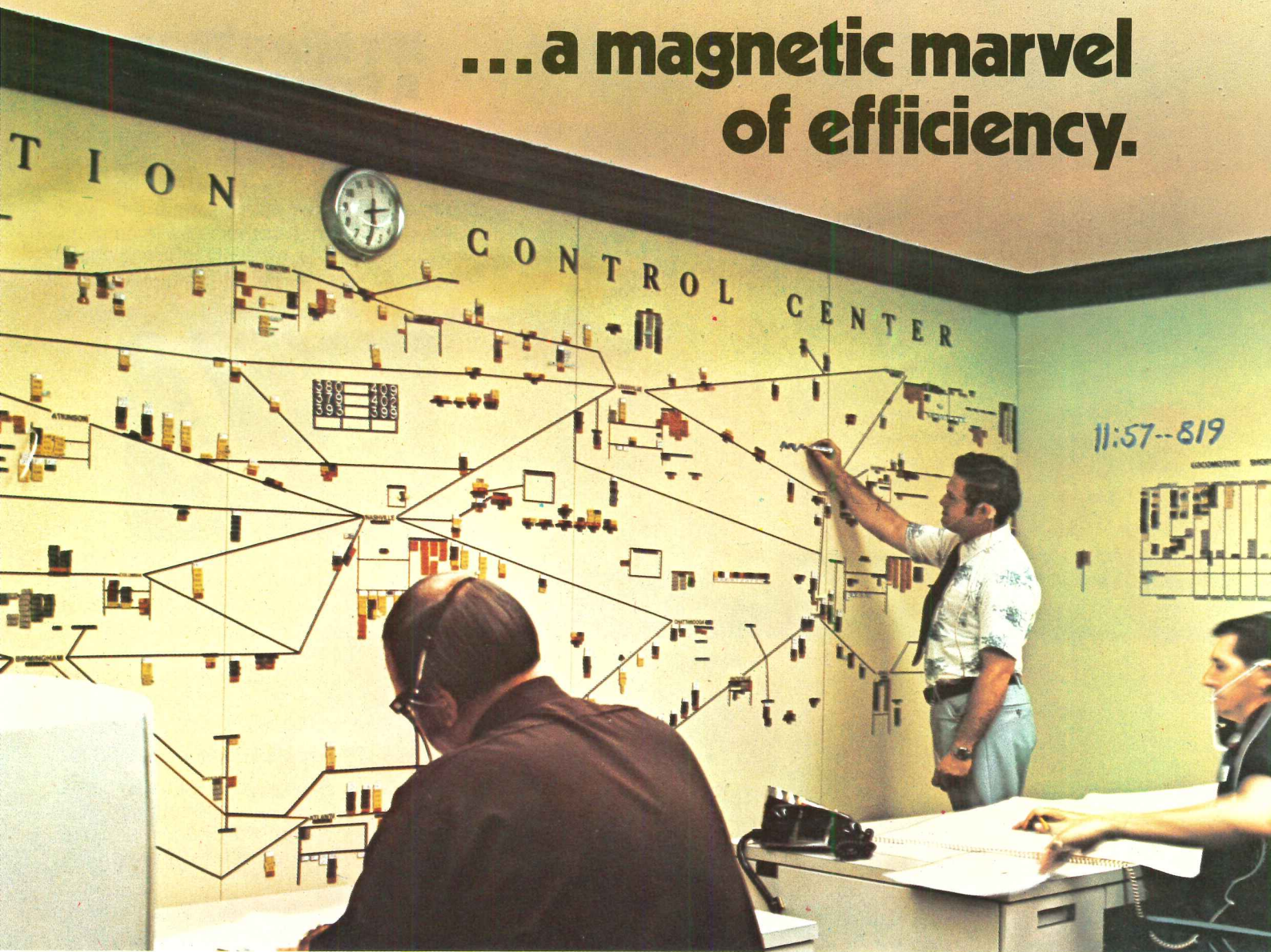

**Combines AllianceWall porcelain-on-steel WhyteBoard<sup>\*</sup> magnetic symbols and dust-free writing system.**

How do you keep tabs on thousands of different railroad cars? The Louisville & Nashville Control Center does it with AllianceWall porcelain-on-steel WhyteBoard walls and an ingenious system of magnetic symbols used to plot the movements of trains.

These same porcelain-on-steel WhyteBoard walls, combined with special dry-wipe Rite-On, Wipe-Off markers, form a dust-free writing system. Markers write clear and clean. Erase clean with swipe of dry cloth. WhyteBoard walls double as projection screen. The writing surface, virtually indestructible, is guaranteed for 50 years.

AllianceWall WhyteBoard is an ideal wall system for all types

of business offices, sales and conference rooms, schools... anywhere people meet to communicate.

Write AllianceWall Corporation, Box 247, Alliance, Ohio 44601.

**AllianceWall<sup>®</sup>** Corporation

Manufacturing plants in Alliance, Ohio; Okmulgee, Oklahoma; Genk, Belgium and Odense, Denmark.

\*formerly known as Rite-On, Wipe-Off panels.

*For more data, circle 66 on inquiry card*



# Don't Let Your Clients Accept Substitute Docklevelers

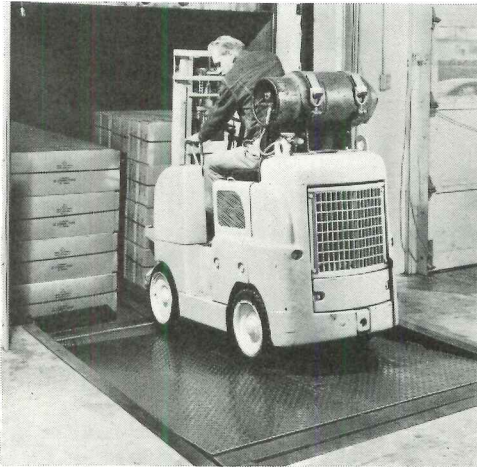

With today's high labor costs and safety emphasis you design loading docks to include permanent docklevelers. Facts prove they can easily pay for themselves in one year.

However, to assure maximum return on investment, specify genuine Kelley Docklevelers of the right type, size and capacity.

Docklevelers with patented automatic safety features and a predictable life span to stand-up

to high volume use year-after-year. Choose hydraulic or mechanical, standard heavy duty or extra-heavy duty models. Kelley Docklevelers cost about the same, or even less. So there's no reason to accept substitutes. Get the complete facts from your Kelley Representative or contact:

**Kelley Company, Inc.**  
6768 North Teutonia Avenue  
Milwaukee, Wisconsin 53209  
Phone: (414) 352-1000



For more data, circle 63 on inquiry card

55-767

## The Original Odorless.

Bruning's PD80 introduced the ventless, odorless PD® development process. It worked so well, the PD80 became today's most popular convenience copier.

Energy-saving, instant on-off, 110-volt—it delivers dry prints of engineering drawings in



WHAT'S THAT I DON'T SMELL?

seconds. And it's nice to be next to, because there's no ammonia.

Ask your Bruning man to demonstrate the PD80 or one of the other "fresh as a daisy" machines. Or write Bruning, 1834 Walden Office Square, Schaumburg, Illinois 60196.



**BRUNING**  
DIVISION OF  
ADDRESSOGRAPH MULTIGRAPH



For more data, circle 64 on inquiry card

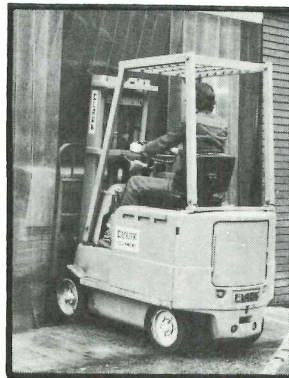

Low cost Clearstrip — the flexible, see-through vinyl curtain — helps stop loss of cooled or heated air and reduces transmission of noise, smoke, dirt and fumes. Fast, safe passage for vehicles and pedestrians. Available for openings up to 14' high with unlimited width. Suitable for temperatures down to -20° F. Write or call today for free catalog.

### Clark's see-through Clearstrip<sup>TM</sup> curtain reduces air flow and noise.

### Clearly—an energy saver.

Clark Door Company, Inc.  
69 Myrtle Street,  
Cranford, N.J. 07016  
Tel. (201) 272-5100; Telex: 13-8268



For more data, circle 65 on inquiry card

Nature set the scene for the creation of what has been called the world's most acoustically perfect amphitheater—the new 4.5 million dollar Concord Pavilion, located in Contra Costa County, 28 miles northeast of San Francisco.

Built in a natural bowl in the foothills of Mt. Diablo, it can seat 3,500 people under the roof, while 4,500 more can enjoy the sights and sounds from a grassy, gently sloping hill.

The 40,000 square foot, exposed steel roof deck is supported by two main trusses, each 200 feet long and 13 feet deep, weighing 50 tons each. Six intermediate roof trusses are 200 feet long, varying in weight from 15 to 25 tons. Both high-strength bolts and field welding were used for connections. The roof is supported by four columns of 14-inch wide flange structural steel shapes encased in concrete.

Three hundred fifty tons of structural steel went into the Concord Pavilion. Seventy per cent

of the steel is U.S. Steel's USS EX-TEN (A572) high-strength low alloy steel; the remainder is A36. Fabrication and erection were completed in only 15 weeks.

Spectacular by day or night, the new Concord Pavilion represents an expression of contemporary architecture that blends to perfection with the environment. It is one more beautiful example of the imaginative use of exposed steel.

For further information, and for advice on the many uses of architectural steel, contact a USS Construction Representative through your nearest U.S. Steel Sales Office, or write: United States Steel, P.O. Box 86, (C575), Pittsburgh, Pa. 15230.

USS and EX-TEN are registered trademarks.



**United States Steel**



# ***Exposed steel performs beautifully in new outdoor theater.***



**Owner:** Concord Performing Arts Center Authority.  
**Architect:** Frank O. Gehry & Associates,  
Santa Monica, Calif.  
**Structural Engineer:** Garfinkel & Kurily  
Santa Monica, Calif.  
**Theater and Acoustic Designer:** Jaffe Acoustics, Inc.,  
Norwalk, Conn.

**General Contractor:** F.P. Lathrop Construction Co.,  
Emeryville, Calif.  
**Fabricator and Erector:** National Iron Works  
Subsidiary of Allied Engineering & Production Company,  
Alameda, Calif.

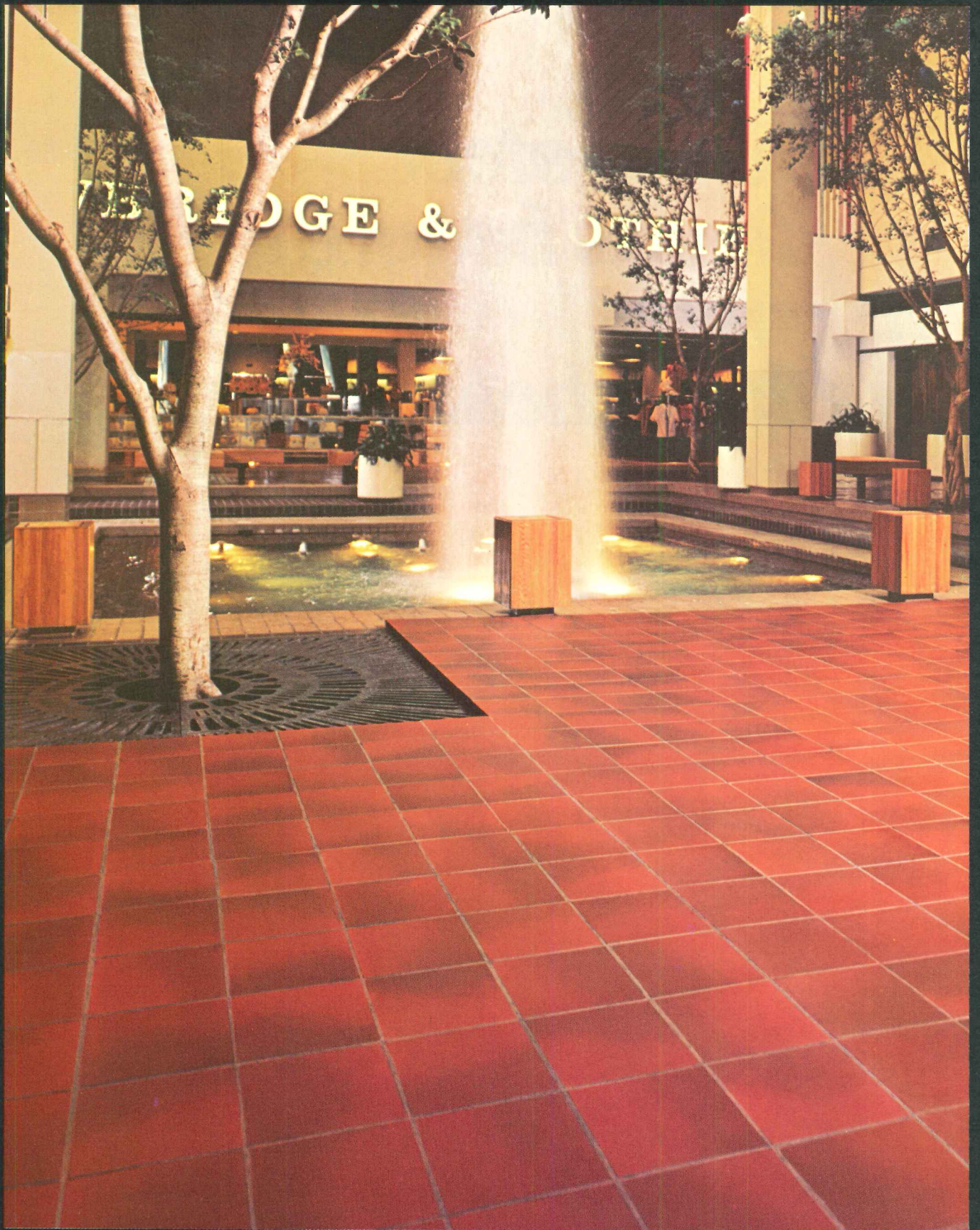

*Ember Flash—Plate No. 689*

**The floor? Murray® quarry tile available only from**

CERAMIC TILE  
**American  
Olean**

American Olean Tile Company  
2375 Cannon Avenue, Lansdale, Pa. 19446

A Division of National Gypsum Company

# For a group of 50 or 5000 GE large screen TV projection

GENERAL  ELECTRIC

GE large screen television projectors are at work, today, presenting video information to audiences in Education, Business and the Arts.

At Universities, lectures, science demonstrations and off-campus programs are being presented in bright, color video, on screens up to 20 feet wide. At live seminars, overflow attendance is being accommodated in nearby facilities with large screen television projection.

At medical schools, surgical techniques and medical procedures are projected in images larger than life, with clarity and impact which facilitates subject retention and learning.

In addition to use at stockholder's meetings, seminars and training programs, business management also employs GE large screen television projection to present computer bank data. Coupled to computer facilities through interface equipment, it projects alpha numeric data, graphic displays and computer generated images in real time.

The GE Solid-state PJ5000 is reliable and designed to deliver projected pictures with high contrast, brightness and resolution, with simple remote control operation. Here's why:

- GE's exclusive single gun, simple optical path system generates the complete range of colors simultaneously.

No fussy alignment of three separate images.

- Single optical path provides the same color picture to everyone in the audience, regardless of his angle of view.
- Variable picture size from two to 20' wide for both large and small groups.
- Simple image changeover for front or rear screen projection, with sweep reversal switches.
- For easy set-up, internal sync and RGB Color Bar generators are provided.
- Convenient remote control unit allows picture set-up adjustments and operating control, at the projector or up to 200 feet away with the addition of an accessory control cable.
- Only power required is standard 120V/20 amp appliance outlet.
- No radiation hazard. Highest voltage used is 7,200V.
- High efficiency power conditioning circuits permit operation over a range of line voltages without affecting picture.
- Versatile projector mounting on table top or accessory rolling base. Easy to transport from one location to another.
- Compact in size and weight; projector and tilt mechanism weigh 130 pounds.

For more information call (315) 456-2562 or 456-2533 today, or write to: Video Display Equipment Operation General Electric Company Electronics Park—6-206 Syracuse, New York 13201

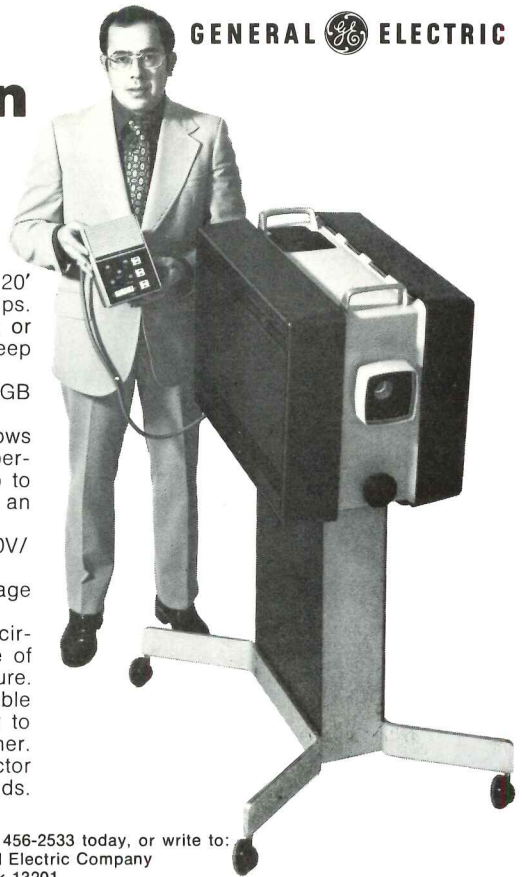

## GE large screen color TV projector... PJ5000

For more data, circle 59 on inquiry card

# fibrex

... a fiber reinforced polyester (FRP) that offers the designer of signs unusual flexibility in size, shape, and color while providing the quality and versatility of screen printed graphics.



providing a lifetime of excellent legibility and color fidelity.

FIBREX material is remarkably vandal and weather resistant due to its high impact strength and moisture resistance.

FIBREX surfaces, defaced by aerosol paints, marking pens, or inks, may easily be wiped clean with solvents without affecting the surface of the material or the legibility of the graphics.

For more information on our complete sign and support systems and samples of FIBREX, write or call us today.



FIBREX is manufactured of thermo setting polyester resin, reinforced with chopped glass fiber mat. The graphic message is actually embedded within the polyester, assuring that the design, graphic message and colors are completely protected by the resin and glass fiber.

FIBREX contains ultra-violet inhibitors to provide maximum color stability and resistance to fading, thus

**ID** Identification Systems, Inc.  
P.O. Box 707 Industrial Park, Shelbyville, TN 37160  
Phone (615) 684-3555

For more data, circle 60 on inquiry card

# The hinge that hides

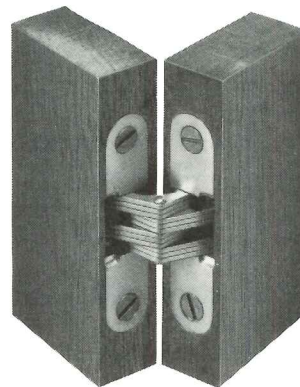

NOW YOU SEE IT



NOW YOU DON'T

The Soss Invisibles—for a custom look for any room! These amazing hinges hide when closed, eliminating unsightly gaps, hinges, and door jambs. They're the perfect hidden touch for doors, doorwalls, storage cabinets, built-in bars, stereos, and TV's. Specify the Soss Invisibles wherever looks matter. See listing in Sweet's or write for catalog: Soss Manufacturing Co., Division of SOS Consolidated, Inc., P.O. Box 8200, Detroit, Mich. 48213.



For more data, circle 61 on inquiry card

# Herman Miller made them superlative bargains.



Charles Eames didn't design this chair to sit in a museum. It was designed for people to sit in it. Not just people who visit, own or work for wealthy companies. It is priced competitively with lesser chairs.

Yes, this is a real Eames Chair by Herman Miller. No, it is not expensive. The fads will come and go but great design endures. As does that which is made well. You know that. But there may be things about these chairs which you do not know. Did you know that you have the option to vary these chairs 5,000 ways? Do you know how moderate the prices really are? Have you thought about the infinite number of places and functions where you could use these chairs?

When was the last time you sat in one of these chairs by Herman Miller and studied the design that remains so fresh, so new and functional? The genius of Charles Eames is recognized and appreciated all over the world. Yet the surprise at the low cost for these pure Eames Chairs is near universal.

Surprise yourself at your local Herman Miller dealer. For the location of one nearest you, contact Herman Miller, Inc., Zeeland, Michigan, 49464; Telephone (616) 772-3442.

 **herman miller**

For more data, circle 58 on inquiry card

**Charles Eames made these chairs timeless classics.**





*Use of 100' long span joists and 30' joist girders created a large clear span area in the center section of this enclosed shopping mall.*



*Wide spacing of deep steel joists (6'8" in floors and 7'6" in roofs) resulted in stiffer floor system and saving in the cost of joists.*



*Vulcraft steel joists and joist girders allowed for simple and fast column connections.*



*Joist girder design flexibility provided for a wide range of load support, from normal roof loads to heavy mechanical equipment loads.*

# VULCRAFT

A Division of Nucor Corporation

*Owner: Penn-Can Shopping Mall General Contractor: Pankow Construction Company, Altadena and San Francisco, California, Seattle and Honolulu Architect: Welton Becket & Assoc., Los Angeles Structural Engineer: Johnson & Neilsen, Los Angeles Steel Framing System: McLean Steel, Hayward, California Steel Fabricator and Erector: Rebco Steel Corp., Niagara Falls, New York*



# WHEN PANKOW NEEDED TO SAVE MONTHS, VULCRAFT SAVED THE DAY.

In June 1974, Pankow Construction Company needed to begin erection of the structural steel framing for the Penn-Can Shopping Mall in Cicero, New York.

The plans called for both steel joists and wide flange beams.

Pankow had no problem getting the joists. But then they got some bad news about the beams. Steel mills were back ordered, and could not supply them before the first quarter of 1975.

A costly delay stared Pankow right in the face.

So Pankow and the design team including McLean Steel of Hayward, California, redesigned the structural framing to use Vulcraft open web joist girders, for both floor and roof, to replace wide flange beams.

Vulcraft joist girders were chosen for a number of reasons.

They could be quickly and easily designed to take the place of beams.

Vulcraft could deliver them fast.

And Vulcraft joist girders were competitively priced.

The change to Vulcraft joist girders enabled Pankow to finish the structural framing right on schedule.

Vulcraft joists and joist girders had saved the day.

And they can do the same for you.

For more information, just contact your local Vulcraft representative. Or write Vulcraft, P.O. Box 17656, Charlotte, North Carolina 28211 for your Joist & Joist Girder Guide. (See Sweets 5.2/Vu.) Or call (704) 366-7000.

It could make your day.

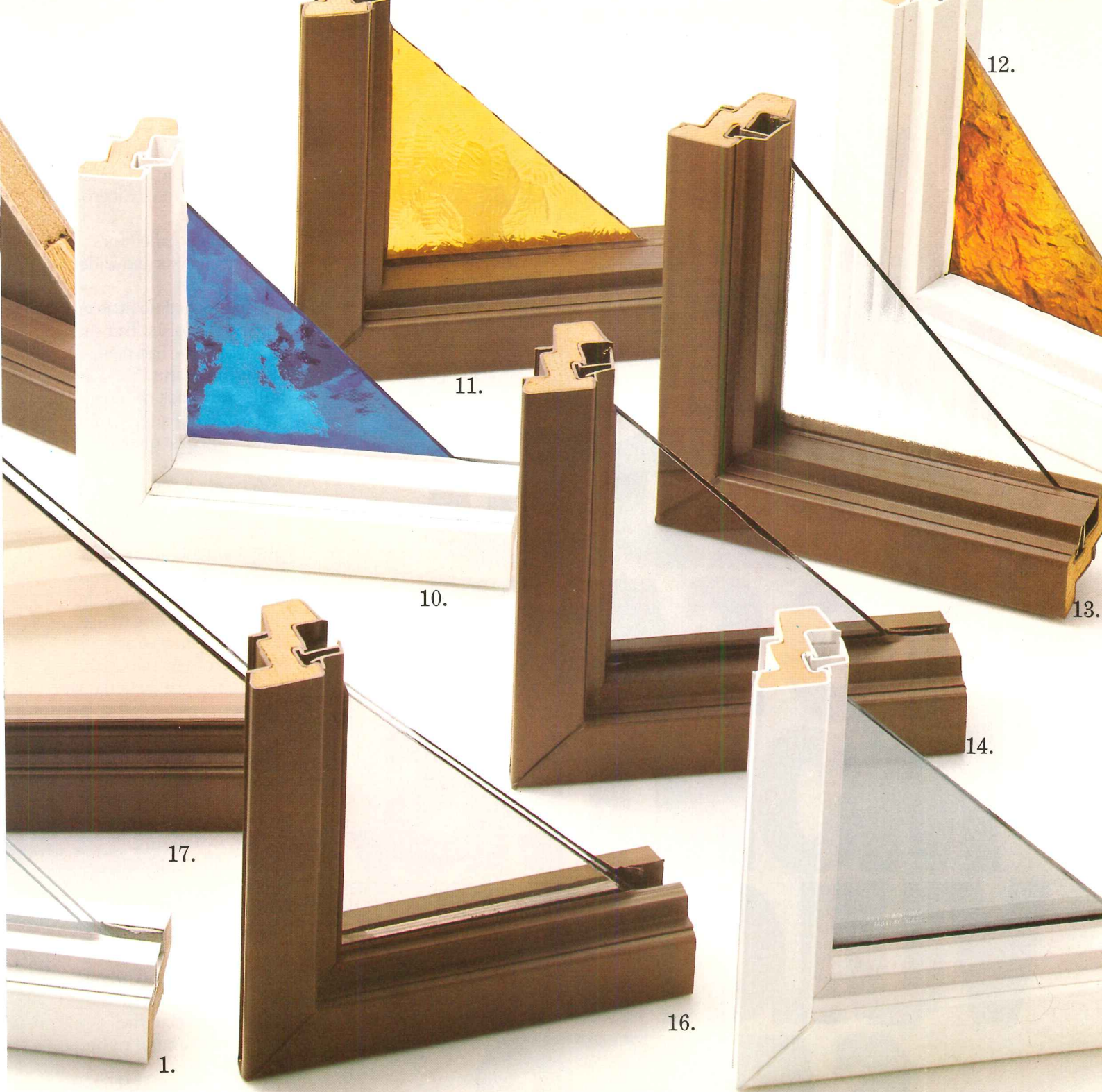

# well enough alone.

fit into your plans. Clear, tinted, environmental, spandrel, safety glazing . . . whatever your design demands, Andersen Windows and Gliding Doors are an excellent choice.

While these glazing options are available in most Andersen

windows, there may be limitations in certain sizes and types. For specific availabilities, call your Andersen Distributor. He's in the Yellow Pages under "Windows." Or write us. Andersen Corporation, Box 12, Bayport, MN 55003.

12. Krinkglas® decorative panels by Dimensional Plastics Corporation. Translucent or opaque acrylic polyester fiber glass reinforced. Gives colorful, decorative effect. 324 options.

13. Other Pattern Glass by Combustion Engineering. 8 other patterns and textures. Distorts image. Glare reducing finish available. Tempered or untempered.

**Environmental Glazing**  
14. Grey tinted glass from LOF, PPG and Cardinal. Available tempered or untempered. Single-pane or double-pane insulating glass.  
15. Vari-Tran® coated reflective glass by LOF. Environmental mirror effect. Tempered or untempered. Reduces glare and heat gain. 4 colors.

16. Solarcool® reflective glass by PPG. Reduces solar heat gain and glare while providing tinted, mirror-like exterior effect. Tempered or untempered. 3 colors.

17. Bronze tinted glass from LOF, PPG and Cardinal. Available tempered or untempered. Single-pane or double-pane insulating glass.

The beautiful way to save fuel.™

**Andersen® Windowalls®**  
ANDERSEN CORPORATION BAYPORT, MINNESOTA 55003



For more data, circle 56 on inquiry card



# We just can't leave

1,060 Andersen® Window glazing options say you can't either.

Single glazing or double-pane insulating glass in Andersen Windows and Gliding Doors have clearly been the beautiful way to complement any design. And they still are. But, they're only two of 1,060 optional glazings you can

1. Clear glass available single-pane or double-pane insulating glass.

#### Safety Glazing

2. Tempered Safety Glass. Hard to break safety glass. When broken, granular pieces lessen the chance of serious injury. Single-pane or double-pane insulating glass.

3. Lexan® Sheet safety glazing by General Electric and Plexiglas® acrylic sheet by Rohm and Haas. Extremely hard to break. Mar resistant. Lightweight. Transparent.

4. Mississippi Wire Glass by Combustion Engineering. Six patterns of clear, obscure or pattern safety glass with solid wire reinforcement.

#### Spandrel Panels

5 & 9. Mirawal® panels by Kaiser Aluminum. Spandrel glazing of porcelain enamel on steel with cement asbestos core. 46 colors. Insulated panel shown in illustration 9.

6. Vitrolux® spandrel glass by LOF. Spandrel panels of opaque glass, heat strengthened, fused ceramic color. 10 colors.

7. Glasweld® panels distributed by PPG. Opaque spandrel reinforced mineral panels. Mineral color surface. 31 colors.

8. Spandrelite® Glass panels by PPG. Heat strengthened opaque glass. Ceramic color fused to surface. 10 colors.

#### Decorative Glazing

10. Plexiglas decorative acrylic sheet by Rohm & Haas. High impact resistance. In translucent, transparent and semi-opaque colors.

11. Amberlite Pattern Glass by Combustion Engineering. Decorative effect in hammered amber patterns. Tempered or untempered.

# Your long life needs are answered!



Stanley's LifeSpan™ hinges are the slimmest, longest life, concealed bearing hinges on the market. Concerned with life cycle costs? They're guaranteed for the life of the building!

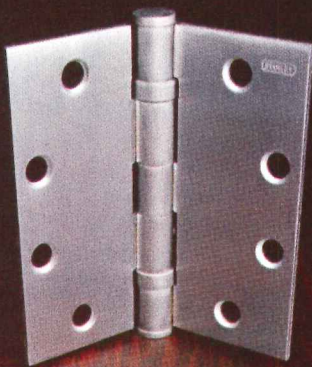

Stanley's FBB179 line of five knuckle hinges is the standard of the industry. Substantial and time proven!

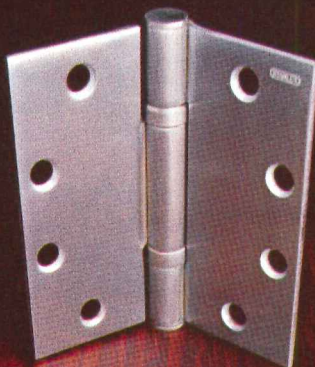

Stanley's BB600 was the first three-knuckle ball bearing hinge line ever made. Still a favorite for beautiful buildings meant to last.

Stop worrying about long life performance. With Stanley you get the quality you respect, the beauty you hoped for, and the service that makes your job easier. Stanley Hardware, Division of The Stanley Works, New Britain, Conn. 06050. In Canada: The Stanley Works of Canada, Ltd.

*See our catalog in Sweet's Architectural File.*

**STANLEY**  
helps you  
do things right

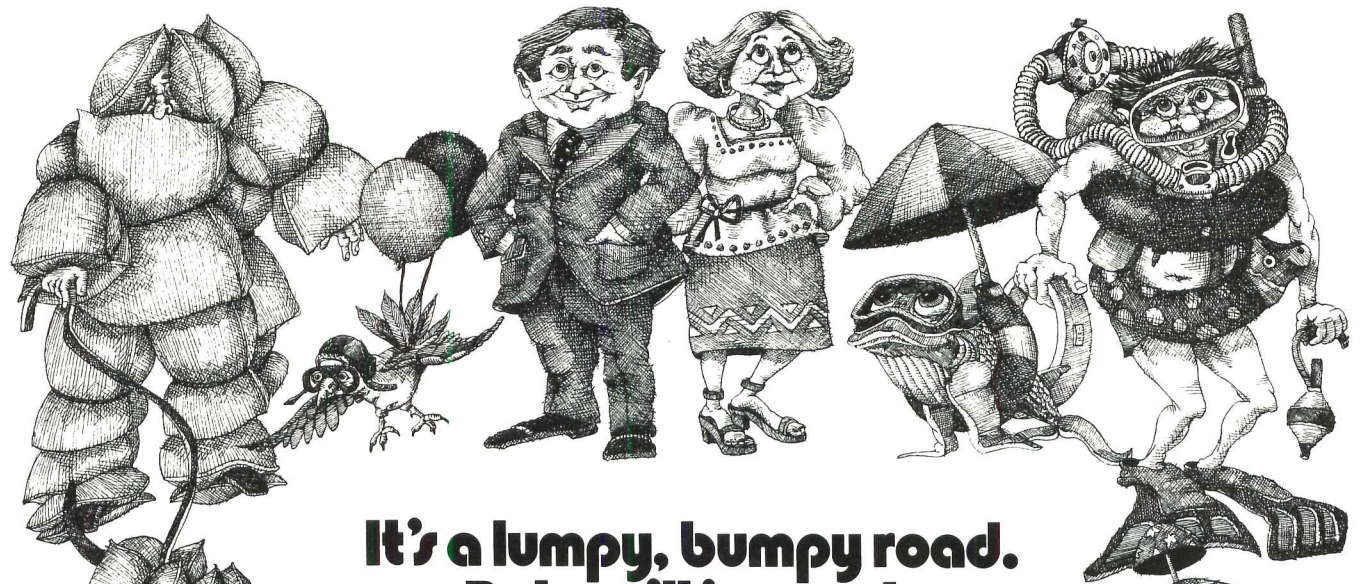

## It's a lumpy, bumpy road. But we'll iron out the wrinkles.

A fashion forecast from Provident Mutual:

What will the style of your future be? Naturally, you'll want it to be sleek, comfy, snug, and, most of all, protective. Yet there are a lot of contingencies down the road and you'll want to be . . . covered.

There's one knowledgeable designer you can count on to smooth out the rough spots: your Provident Mutual representative. Together, you'll fashion a flexible life insurance program providing much-needed protection now. Plus regular savings for your financial future. To shield the family from unforeseen costs and still have a reserve for the later years. For traveling. For fun and games. Hobbies. A mountain hideaway. Even insurance gifts for your children or grandchildren. Anything.

Discretionary income: it's a flexible suit of armor, tailored expressly for you with Provident Mutual life insurance. Slip into some today. And be well-fitted when you take to the road.

**Provident Mutual.**  
*Tailored expressly for you.*

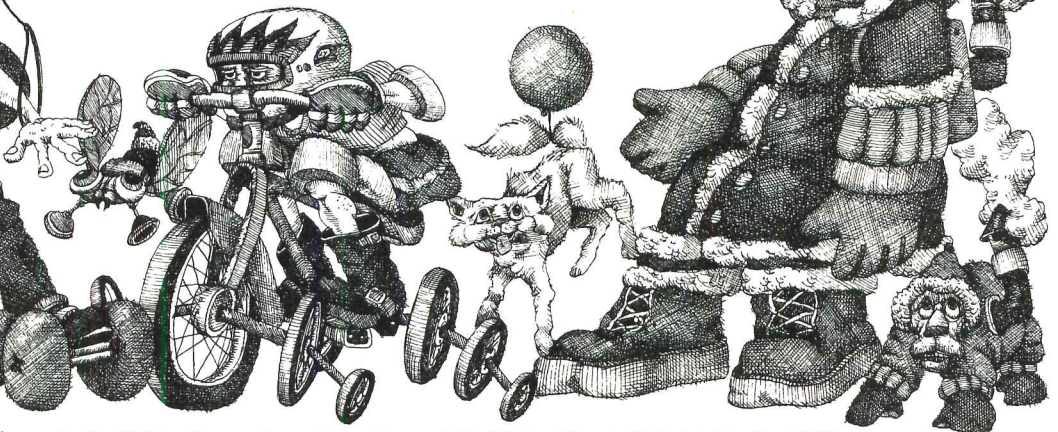
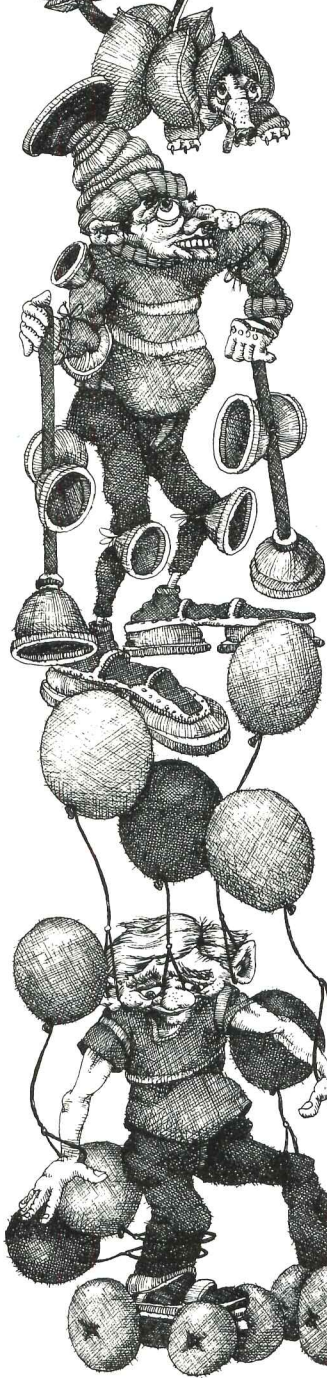
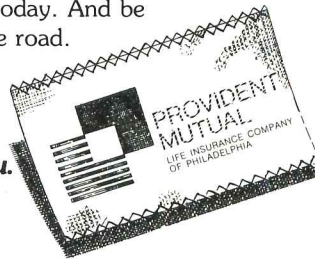

Look for us in the Yellow Pages. Or write us direct. 4601 Market Street, Philadelphia, Pa. 19101

For more data, circle 54 on inquiry card

## Tax cuts and Federal spending needed to revive economic recovery in 1977

There's a "Catch 22" to the business cycle, and it goes something like this. A recovery is a fragile thing, especially in its early stages. It will go just so far on its own and then needs to be reinforced. At some point that reinforcement has to involve a surge of investment in plant and equipment (otherwise known as business capital spending). Without this added support, a recovery might—probably would—abort. Now here comes the catch. If the early stage of a recovery is relatively weak and fails to bring most of the economy's idle productive capacity into use, it fails to create the incentive for business to invest in additional plant and equipment. In other words, the more the economic system needs a burst of capital spending to lift it out of a recession, the less likely it is to get it.

That's part of the problem in the current business cycle. After what looked like an unusually strong recovery in the making during the early months of 1976, the so-called summer "pause" set in. By fall that pause had become a "lull" (in official Washingtonese, that is), with two direct consequences. One was that the expected surge of self-generated capital spending failed to materialize (Catch 22 in operation). The other: dissatisfaction with the "hands off" economic strategy of the Ford Administration. In its place has developed the urge for someone to "do something . . . anything" to break the 1976 pattern of stagnation before it becomes the recession of 1977.

### The capital spending gap

At this time last year all the right things were happening. Industrial production was making its way back, and unemployment was edging down. Even inflation was receding. Under those happier circumstances the industrial operating rate rebounded from its recession low of only 70 per cent of capacity in use to 78 per cent, approaching the magic 80 per cent rate, which is the traditional threshold between too much capacity and not enough. The outlook for business capital spending in the spring of 1976 seemed to be firming up nicely.

Unfortunately, the operating rate never did get any higher than 78 per cent. Once the recovery lost its momentum, the gains of the previous 12 months quickly reversed themselves. Industrial production stopped rising in August and slipped back during September

and October. And without a sufficient volume of production to absorb the steadily growing labor force, unemployment quickly climbed back to 8 per cent. Against these odds the industrial operating rate could do no better than hold steady at 78 per cent of capacity in use from February through August, and then slipped two percentage points in as many months. These developments did not exactly cause a stampede of capital spending.

The recently-published McGraw-Hill Survey of Business Plans for Capital Spending is evidence of how industry is reacting to the economic slowdown. The strategy, not surprisingly, is one of playing it close to the vest. Industry actually spent \$4 billion less than intended for plant and equipment in 1976, but rather than cut these projects out of their budgets altogether, they shifted them forward into 1977. This "carryover" spending is now the basis for most of 1977's anticipated gain of 13 per cent. However, last year's heavy deferral of intended capital spending is a good indication of what could happen to 1977 plans in the event of prolonged economic stagnation. And unless these 1977 capital spending plans are realized, the current "pause" might become the prelude to something worse.

### Stimulation: not whether, but how

Six months ago the hottest economic policy issue was whether or not the system needed some kind of stimulus to break the stagnation deadlock. Since then, the drooping economic indicators and the election results have at least clarified matters on this point. It's no longer a question of whether, but when, and what form of stimulation will be most effective and produce the least undesirable side effects.

There are several routes Mr. Carter can take to recovery, and there's no rule that says he can't take all of them if he wants to. Congress already exercised one of the available options last October when it forced through a \$3.7 billion appropriation to fund the Public Works Employment Act of 1976. These funds began flowing into the economy late last year, and will have their major impact during the first half of 1977. Roughly \$2 billion of the total is slated for construction—mostly roads and sewers, plus a smattering of public buildings like schools, hospitals, and libraries. The basis for allocating this money has less to do

with where construction is in greatest demand than where unemployment is highest. Jobs have a clear priority over construction needs in this program, and some influential legislators—Representative Reuss, Chairman of the House Banking Committee, and Senator Long, Chairman of the Senate Finance Committee, for example—contend that increased spending through job programs like this should be the main thrust of government's efforts to support economic growth.

Monetary ease offers another option. Even though there's no dire shortage of credit in today's slack economy, the extremely high level of interest rates is a deterrent to borrowing. Both business capital spending and housing would respond favorably to lower rates.

Here Mr. Carter must confront Federal Reserve Board Chairman Burns on the basic issue of economic priorities. Burns' ultra-conservative monetary policy, aimed almost exclusively at the control of inflation, is part of the explanation for the weak recovery of 1976. And Mr. Burns' intimation that restrictive monetary policy might be used to offset budgetary activism in 1977 illustrates the limit of an incoming President's ability to change.

Finally, there's the option of a tax cut. It worked well for Mr. Ford back in 1975, and could be equally effective for Mr. Carter in 1977. A tax cut—or more likely a tax *rebate*—of \$10 to \$15 billion stands high on the probability list. Its main advantage is speed, and quick action is one thing this shaky economy needs. There are disadvantages to going the tax route (just as there are drawbacks to spending programs and to monetary activism). The biggest problem is that since a fairly large slice of any tax rebate winds up being saved, it takes a significantly bigger tax cut to generate the equivalent stimulus that could be created through direct spending. Besides that, a tax cut is general in its approach, while a jobs program can be more specific in dealing with the critical problem of high unemployment.

Chances are very good that we'll be getting some much-needed stimulus through *both* channels in the months ahead. Hopefully it will arrive in time to let 1977 live up to its potential for recovery and growth.

George A. Christie  
vice president and chief economist  
McGraw-Hill Information Systems Company



Subdued . . .

dominant . . .

and anything  
in between.

**Wilson Art**  
DESIGN GROUP I

**Solid colors**

Wilson Art brand Design Group I offers you an exceptionally wide range of solid color options - including new Camel selected by many designers as the ideal retail store fixture color.

Soft and quiet to loud and strong, the new Wilson Art brand solid colors in Design Group I were carefully selected for your contemporary needs. Write for the Wilson Art brand Solid Colors brochure - the designer's own collection from the new design leader.

*Tomorrow's design innovations . . .  
available for the way we live today.*



**1977 Dodge manual offers remodeling costs**

Up-to-date remodeling and renovation costs are highlighted in the *1977 Dodge Manual for Building Construction Pricing and Scheduling*, which includes a new section devoted to unit costs for small-scale projects based on man-hours. Cost data in this section are designed for use primarily by home improvement contractors and home owners.

This 12th annual reference, expanded by 36 pages over its previous edition, is now available from Dodge Building Cost Services. Its primary use is on large building projects of all types. Among items the Manual has added to the 10,000 units it now lists for the general construction field are bathtubs, shower systems, cedar beams, simulated beams, prefinished moldings, vertical wood siding, and fiber glass insulation board.

For each unit, the Manual's cost data include material, equipment, labor, size of work crew, its productivity rate, and required time for installation. Large project costs are based on unit installations per day, not the manhours calculated for remodeling and renovation work. The Manual also includes 120 U.S. and Canadian cities and 22 major and minor trade groups in its local cost adjustment index.

Price of the Dodge Manual is \$22.80 prepaid plus the appropriate state sales tax. Purchasers may send mail orders to Dodge Building Cost Services, McGraw-Hill Information Systems Company, Room 2051, 1221 Avenue of the Americas, New York, N.Y. 10020.

Metropolitan area	Cost differential	Current Indexes					% change last 12 months
		1941=100.00 (except as noted)					
		non-res.	residential	masonry	steel		
U.S. Average	8.5	562.7	528.3	555.1	541.3	+08.3	
Atlanta	7.5	665.6	627.5	655.5	642.3	+09.7	
Baltimore	8.5	595.5	559.9	579.4	567.7	+00.6	
Birmingham	7.3	559.6	520.5	549.8	538.3	+22.9	
Boston	9.0	563.6	532.6	565.5	548.3	+08.3	
Buffalo	9.1	594.9	558.6	585.5	568.8	+02.7	
Chicago	8.3	644.7	606.7	636.1	620.0	+13.4	
Cincinnati	8.8	618.3	581.8	603.7	590.7	+10.7	
Cleveland	9.0	642.4	604.5	631.1	616.0	+19.1	
Columbus, Ohio	8.2	565.7	531.3	563.0	546.2	+06.5	
Dallas	7.9	543.9	526.7	540.4	526.0	+07.7	
Denver	8.4	623.4	586.5	617.2	604.0	+11.2	
Detroit	9.8	624.6	595.0	622.0	605.5	+03.2	
Houston	7.4	522.3	490.5	510.9	501.9	+06.5	
Indianapolis	7.8	523.5	491.6	515.3	504.5	+13.2	
Kansas City	8.7	554.9	524.4	545.9	533.7	+07.5	
Los Angeles	8.5	688.5	629.4	671.6	653.7	+13.2	
Louisville	7.6	558.7	524.7	550.2	537.5	+11.0	
Memphis	8.4	541.4	508.4	526.5	513.8	-00.7	
Miami	7.9	600.2	571.8	596.4	583.5	+06.0	
Milwaukee	8.7	685.3	643.5	680.9	657.9	+12.6	
Minneapolis	8.9	570.9	537.1	565.9	550.1	+04.8	
Newark	9.0	516.6	485.1	514.0	500.9	+04.2	
New Orleans	7.5	542.3	511.9	532.8	523.8	+08.1	
New York	10.0	594.7	553.0	581.5	571.4	+08.8	
Philadelphia	9.1	586.1	558.4	579.2	567.2	+02.0	
Phoenix (1947 = 100)	8.2	319.5	300.1	315.9	307.6	+05.7	
Pittsburgh	8.9	532.6	501.1	522.6	511.6	+03.2	
St. Louis	8.7	544.6	514.1	540.3	528.5	+01.5	
San Antonio (1960 = 100)	7.6	222.1	208.6	217.2	213.1	+10.1	
San Diego (1960 = 100)	8.7	256.0	240.4	252.8	246.5	+15.5	
San Francisco	9.6	839.6	767.5	833.7	803.9	+08.9	
Seattle	8.6	585.9	524.4	571.3	552.4	+10.7	
Washington, D.C.	8.4	549.4	515.9	542.6	527.0	+04.7	

Cost differentials compare current local costs, not indexes, on a scale of 10 based on New York

Tables compiled by Dodge Building Cost Services, McGraw-Hill Information Systems Company

Metropolitan area	HISTORICAL BUILDING COST INDEXES—AVERAGE OF ALL NON-RESIDENTIAL BUILDING TYPES, 21 CITIES																
	1941 average for each city = 100.00																
	1966	1967	1968	1969	1970	1971	1972	1973	1974	1975 (Quarterly)				1976 (Quarterly)			
										1st	2nd	3rd	4th	1st	2nd	3rd	4th
Atlanta	329.8	335.7	353.1	384.0	422.4	459.2	497.7	544.8	575.0	583.8	585.3	597.2	598.7	602.6	604.1	655.6	657.1
Baltimore	280.9	295.8	308.7	322.8	348.8	381.7	420.4	475.5	534.3	538.7	540.2	579.6	581.1	609.7	611.2	583.5	585.0
Birmingham	270.7	274.7	284.3	303.4	309.3	331.6	358.3	402.1	421.2	438.6	440.1	447.4	448.9	469.0	469.5	550.4	551.9
Boston	262.0	265.7	277.1	295.0	328.6	362.0	394.4	437.8	462.5	484.1	485.6	511.7	513.2	535.7	537.2	554.4	555.9
Chicago	320.4	328.4	339.5	356.1	386.1	418.8	444.3	508.6	529.6	539.2	540.7	558.6	560.1	560.3	561.8	633.7	635.2
Cincinnati	278.3	288.2	302.6	325.8	348.5	386.1	410.7	462.4	500.1	518.0	519.5	549.1	550.6	602.9	604.4	608.3	609.8
Cleveland	300.7	303.7	331.5	358.3	380.1	415.6	429.3	462.2	509.5	516.6	518.1	529.5	531.0	578.7	580.2	631.4	632.9
Dallas	266.9	270.4	281.7	308.6	327.1	357.9	386.6	436.4	477.9	488.3	489.8	498.1	499.6	506.1	507.6	537.0	538.5
Denver	297.5	305.1	312.5	339.0	368.1	392.9	415.4	461.0	510.0	530.4	531.9	552.1	553.6	580.3	581.8	614.5	616.0
Detroit	296.9	301.2	316.4	352.9	377.4	409.7	433.1	501.0	538.7	554.4	555.9	596.0	597.5	615.1	616.6	615.7	617.2
Kansas City	261.0	264.3	278.0	295.5	315.3	344.7	367.0	405.8	444.9	481.1	482.5	507.6	509.1	523.8	525.3	545.8	547.3
Los Angeles	302.7	310.1	320.1	344.1	361.9	400.9	424.5	504.2	531.8	546.7	548.2	592.6	594.1	599.1	600.6	671.6	673.1
Miami	284.0	286.1	305.3	392.3	353.2	384.7	406.4	447.2	485.5	499.5	501.0	557.4	558.9	588.1	589.6	591.0	592.5
Minneapolis	289.4	300.2	309.4	331.2	361.1	417.1	412.9	456.1	488.6	513.9	515.4	536.5	538.0	548.3	549.8	562.6	564.1
New Orleans	259.8	267.6	274.2	297.5	318.9	341.8	369.7	420.5	442.1	463.5	465.0	493.2	494.7	522.8	524.3	533.3	534.8
New York	304.0	313.6	321.4	344.5	366.0	395.6	423.1	485.3	515.3	524.1	525.5	532.0	533.5	539.4	540.9	579.3	580.8
Philadelphia	286.6	293.7	301.7	321.0	346.5	374.9	419.5	485.1	518.5	531.5	533.0	566.0	567.5	581.8	583.3	577.7	579.2
Pittsburgh	271.1	275.0	293.8	311.0	327.2	362.1	380.3	424.4	465.6	475.2	476.7	508.0	509.5	508.5	510.0	524.8	526.3
St. Louis	288.3	293.2	304.4	324.7	344.4	375.5	402.5	444.2	476.7	497.5	499.0	527.4	528.9	542.7	544.2	535.6	537.1
San Francisco	386.0	390.8	402.9	441.1	465.1	512.3	561.0	632.3	672.5	716.0	717.5	751.8	753.3	790.1	791.6	819.3	820.8
Seattle	275.0	283.5	292.2	317.8	341.8	358.4	371.5	424.4	450.2	472.5	474.0	513.6	515.1	525.9	527.4	569.0	570.5

Costs in a given city for a certain period may be compared with costs in another period by dividing one index into the other; if the index for a city for one period (200.0) divided by the index for a second period (150.0) equals 133%, the costs in the one period are 33% higher than the costs in the other. Also, second period costs are 75% of those in the first period (150.0 ÷ 200.0 = 75%) or they are 25% lower in the second period.





Scaled to today's emerging office environment, the new 500 Series from All-Steel offers uncompromising comfort... unsurpassed All-Steel quality. 28 models; a full selection of fabrics, vinyls, shell colors and base options. Write for information. All-Steel Inc. Aurora, Illinois 60507.



Olympic Stain  
isn't the answer  
for everything.



**That's why we make Olympic Overcoat.**

You won't find a more beautiful acrylic latex exterior finish for hardboard, stucco, concrete, masonry, galvanized metal or previously painted wood. Overcoat's durable beauty is the perfect protection for any surface that needs paint instead of stain. And you can specify Overcoat in 25 distinctive colors. Just consult Sweet's catalogs, or write us: Olympic, Dept. O, 1148 N.W. Leary Way Seattle, WA 98107 (206) 789-1000



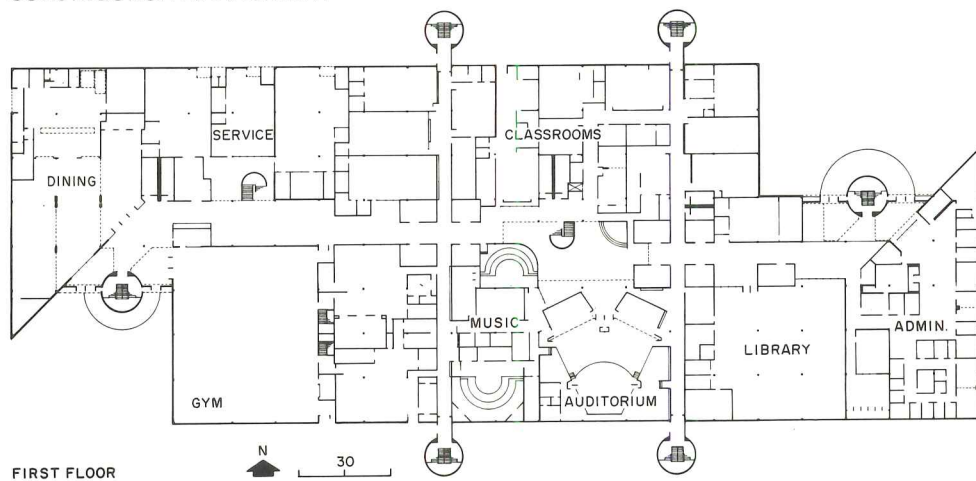

FIRST FLOOR

The high school was designed for an academic and vocational program for 2600 students, and after-hours community programs. The client imperative for a vandal-resistant building necessitated a windowless building, lighted by skylights above a central, two-story mall (photo, page 75). The emphasis is on separating daytime and nighttime areas. Noisy areas (shops, physical educational and food service areas) are separated from areas needing acoustical isolation (library, classrooms and administration), with the acoustical zoning functioning both horizontally and vertically. Painted plaster is used over metal studs.



mind is whether the slab on grade should be on the grade beam with the exterior wall on top, or the exterior wall placed directly on top of the beam with the slab poured to it. The answer, of course, is to put the exterior wall on the foundation (with rebar tie backs in the slab). Both solutions can be acceptable to the engineer and architect. The outward appearance is not different; however, the second condition would allow the exterior wall to be erected prior to slab on grade and thus enclose the building weeks or months earlier."

The suggestion to slope the roof to the outside of the building, and drain it at the perimeter also advanced the schedule of interior finish work. Since interior work depends on a permanent roof that depends on an operable drainage system, the roof design permitted temporary drainage at the outside of the build-

ing without affecting inside construction. While the necessary soakage pits—which require two months of construction—were being prepared, the porous soil absorbed the roof run-off. The temporary drain was the permanent system with a "gooseneck" above ground.

The subject of time and cost savings in a project cannot be discussed without bringing up the subject of quality. All participants in this project, including the owner, feel that if anything, the way in which this project was designed and managed increased the quality of the building, particularly in maintenance and operation features. Satisfied that the CRS-CM prototype meets the school district's needs, Dade County is proceeding with its construction for a second time.

The District will spend \$102 million in the

next five years to upgrade its school facilities. Asked about client problems arising from construction-managed projects, the District's representative, John Pennington, said that clients should be prepared for greater exposure to the construction process because of multiple contracting. This, of course, can have an impact on the client's own management processes and staff. However, with the fresh success of a completed construction-managed high school, it is not surprising that the Dade County School District has joined the other public clients increasingly recommending construction management techniques.

DADE COUNTY HIGH SCHOOL, Miami, Florida. Architects: *Caudill Rowlett Scott*. Associate architects: *The Smith, Korach, Hayet, Haynie Partnership*. Consultant: *David McCandless* (acoustical). Construction manager: *CM Associates, Inc.*

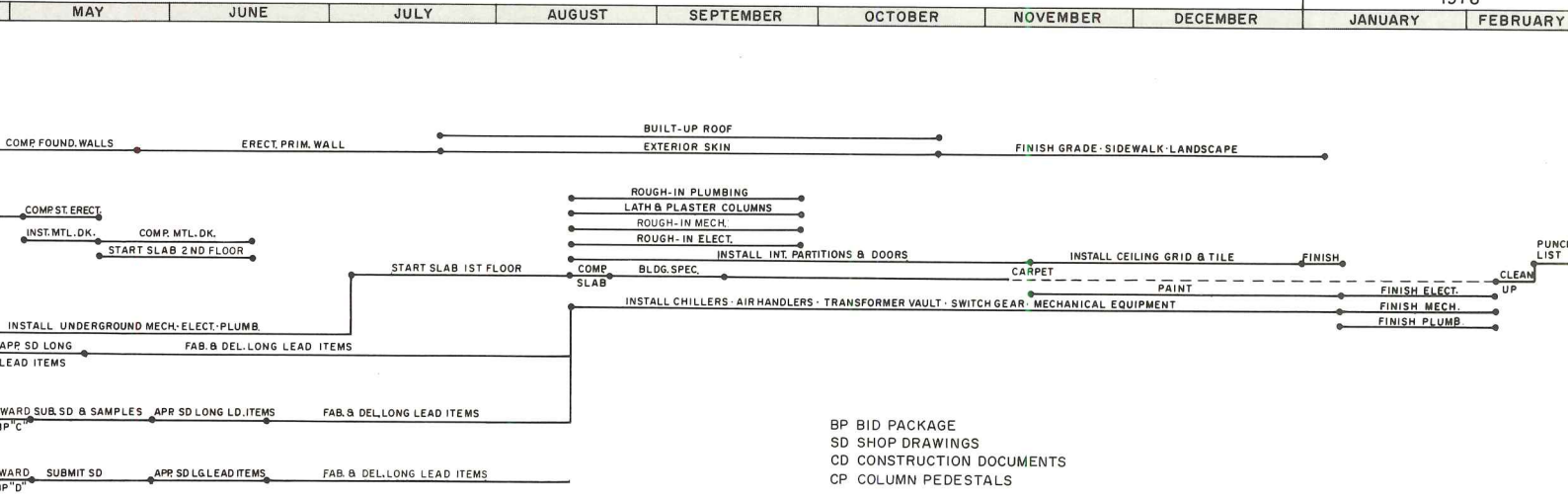

Otto Baitz photos

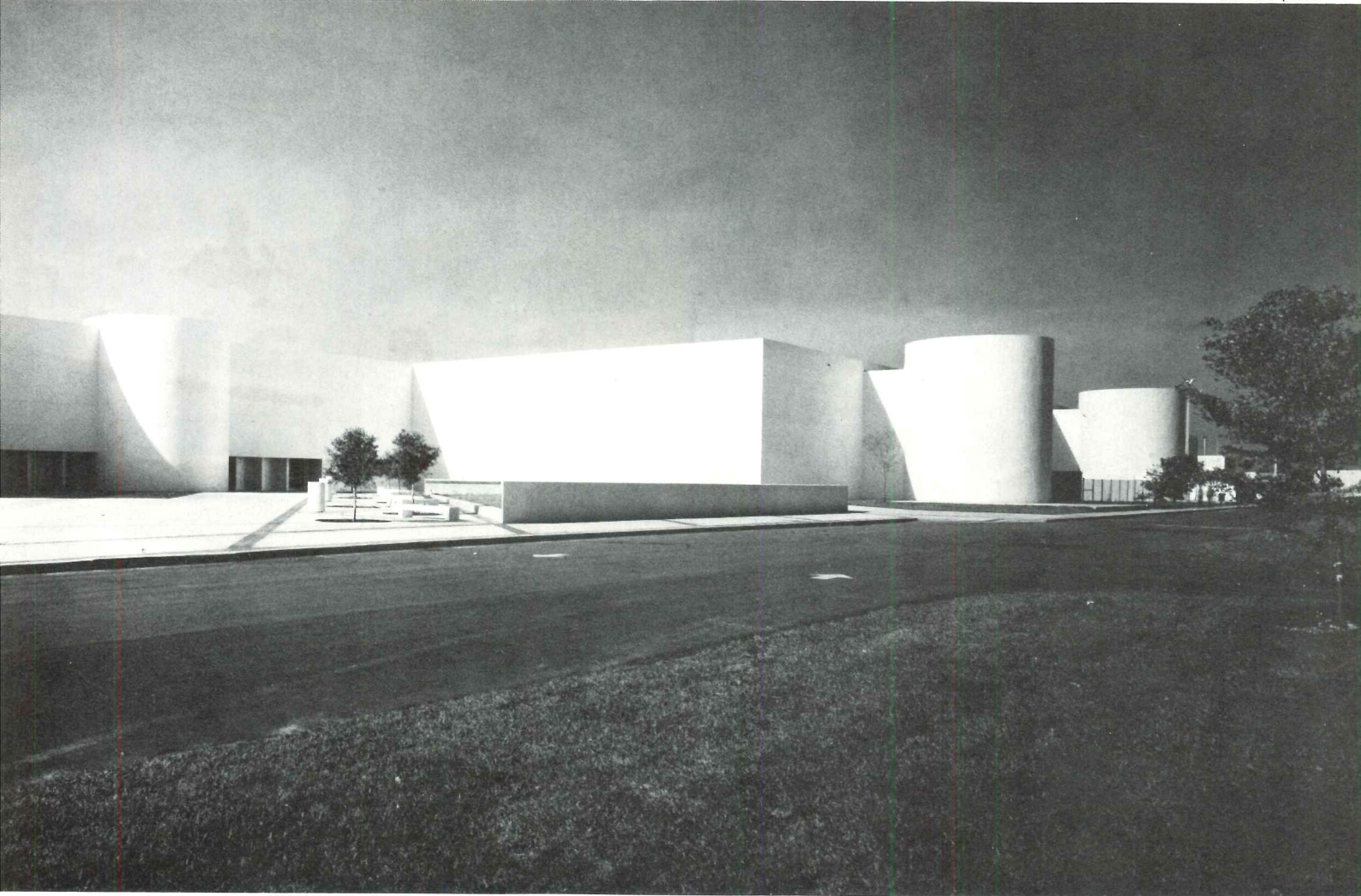

building; design roof drainage so that drain lines run on the edge of the building to the outside (not inside building).

2. Exterior walls: should be independent of structural system. Interface details to other systems should be checked. Shop drawing/fabrication delivery time should be minimized.

3. Roof: slope the drain to edge. Specify temporary roof and drainage systems complete with maintenance and sediment trenches. Require hvac contractor to expedite roof shop drawings. Specify that the plumber must rough-in stacks first, then run system.

4. Interior walls: review ceiling/wall interface. Walls which are constructed to structure above will expedite construction; if two-story (or three-), specify one system (one contractor) for one floor and another system (another contractor) for the other floor. Specify

separate crews on each floor.

5. Equipment: do not allow A/E to require "field dimensions." Allow filler pieces on cabinet work.

6. Finish: use demountable partitions. Use spray or roll-on paint. Minimize brush use. Use paint that does not require perfectly "dried-in" conditions.

7. General: sequence project in orderly fashion. Structure should be erected in the same direction as the plumbing underground will run (i.e., east to west, north to south; whichever direction is "uphill" for the sanitary sewer lines). Or specify particular plan for plumber.

To minimize the interfacing between contractors, CM recommended a structural system (systems steel) that could be erected entirely by one contractor and exterior walls (concrete

block) that were independent of the structural system.

CM investigated three types of structural systems: steel, pre-cast concrete, and poured-in-place. Concrete block with tie beams and tie columns was not considered because of design time and shoring delays. For similar reasons, waffle slabs were eliminated. The study indicated total cost per bay for steel would be \$8,037; for pre-cast, \$9,585; and for poured-in-place, \$15,975. Further, a schedule analysis indicated 28 weeks design and erection time for steel, 39 for precast, and 49 for poured-in-place (plus shoring).

According to Mo Appleton, CM Associates project manager, "erection of structure is half the problem; the other half is checking the interface details with other systems to minimize conflicts. The example that comes to

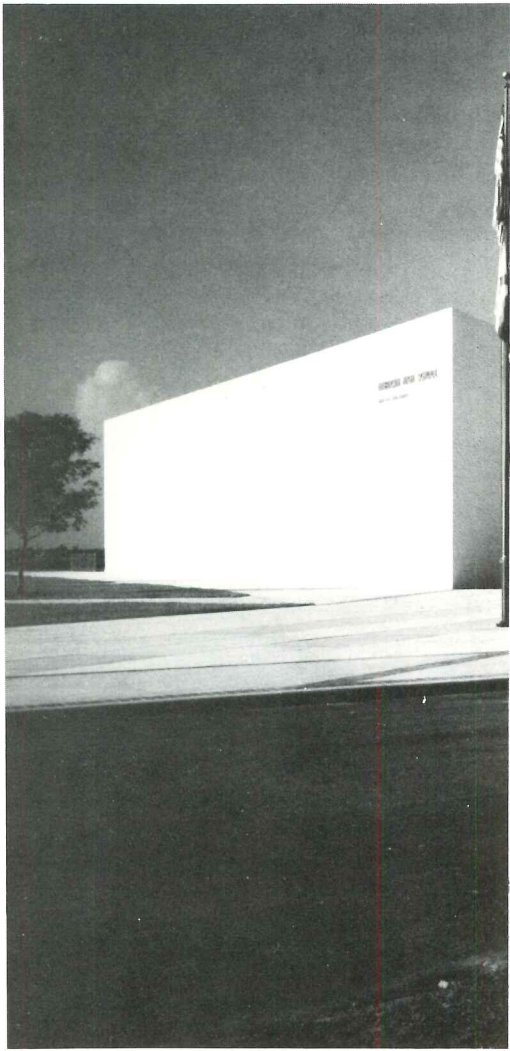
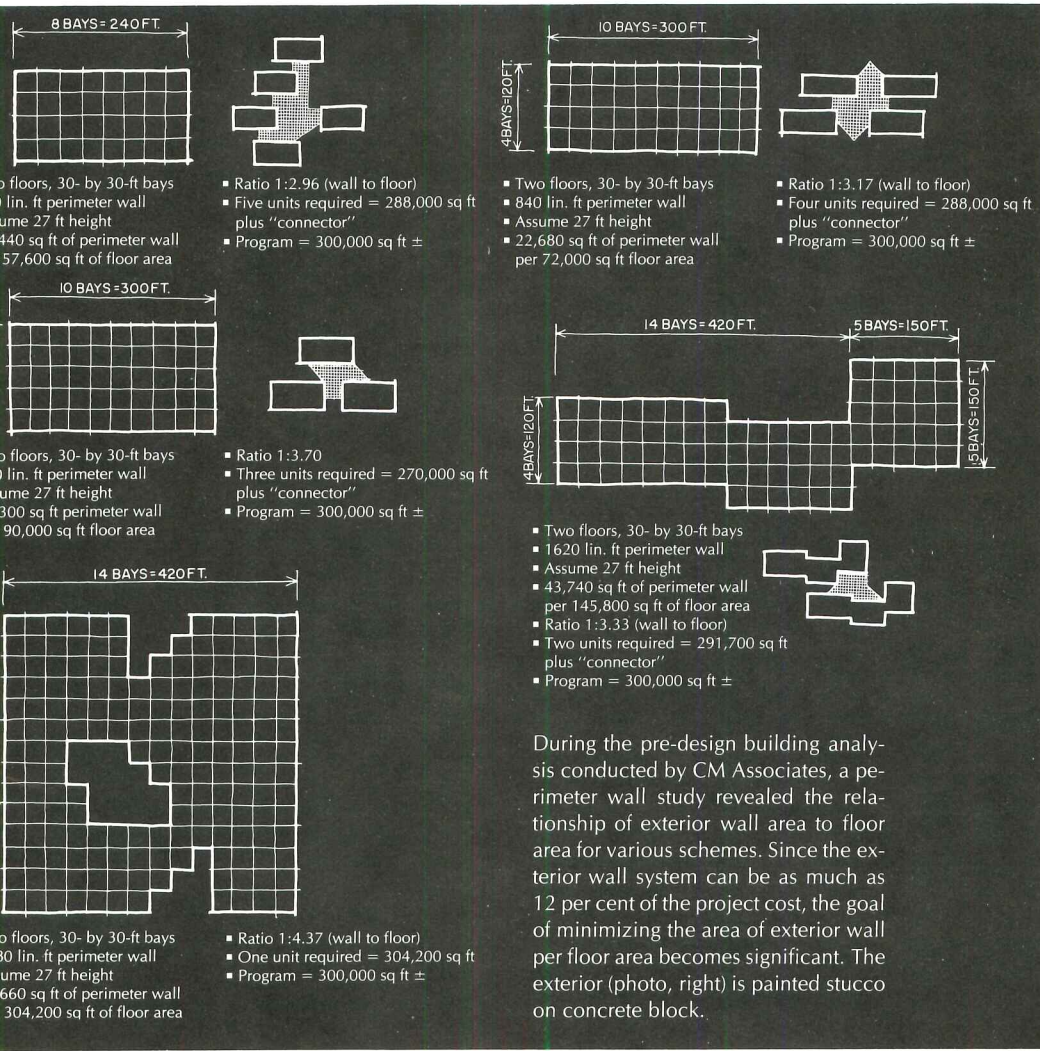
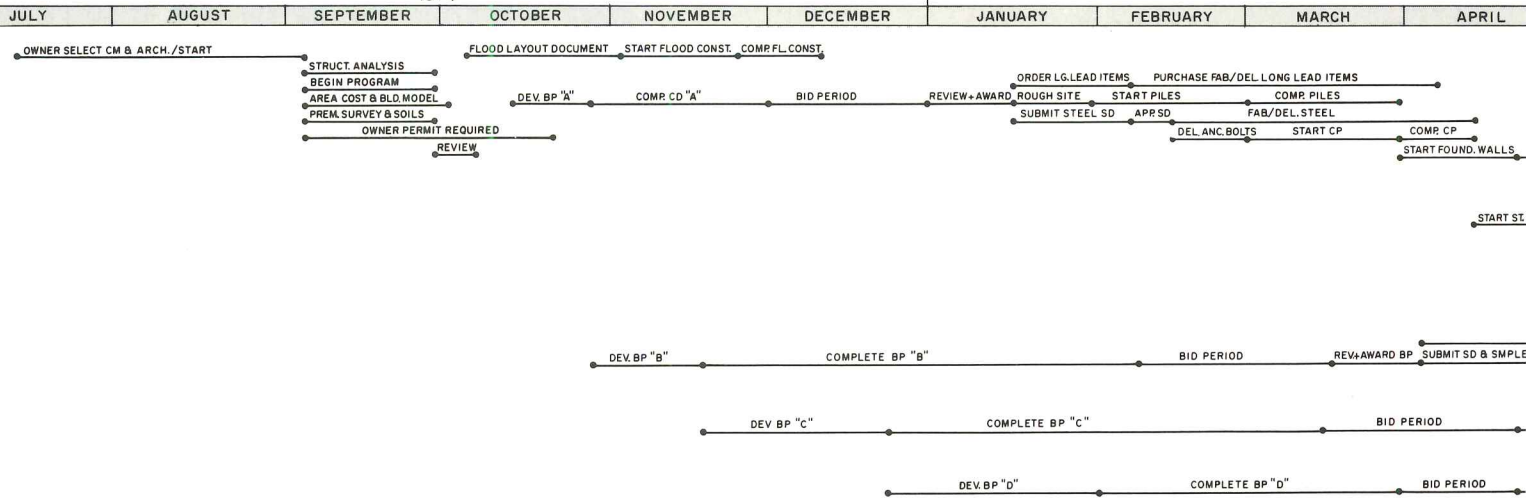

During the pre-design building analysis conducted by CM Associates, a perimeter wall study revealed the relationship of exterior wall area to floor area for various schemes. Since the exterior wall system can be as much as 12 per cent of the project cost, the goal of minimizing the area of exterior wall per floor area becomes significant. The exterior (photo, right) is painted stucco on concrete block.

of the savings was attributed to market factors, but \$750,000 was due, according to the client, to the construction management process. The cost includes the CM fee (3 per cent plus reimbursable expenses), negotiated with the owner. The "design re-use" school, using a general contracting approach and a linear schedule, cost \$41.60 per square foot, or \$9.6 million for 238,000 square feet. Total delivery time for the design re-use school was 31 months. Total design and construction time on the construction-managed project was 21 months.

The schedule reduction resulted primarily from fast-tracking the project. CM Associates actually began site work three months into design, and construction one month after that. Construction on the re-use project did not begin until design adaptation was complete—nine months after the project began. In project-

ing a future schedule for re-use of the CRS design, CM Associates estimates that this 21-month schedule can be reduced to 16, largely through reduction of design time (three to four months maximum for site adaptation).

But fast-tracking was only part of the strategy. Before design began, CM Associates investigated long-term costs as well as first costs of major building components and systems: structural, exterior, hvac, foundation, ceiling/lighting, and roof.

During a pre-design building analysis conducted by CM Associates, certain assumptions had to be made. The least flexible assumption was the owner's requirement of 300,000 square feet in two stories. Bay sizes were assumed to be 30 by 30 feet in the first level and 30 by 60 feet in the second level.

Two sources of information were used to

compile data. One was the CM Associates data bank of more than \$2 billion worth of construction history over the past ten years. This system is broken into building components, factored for local areas, and provides early-on cost estimates and budgets.

The second data source was a survey conducted by CM in the Miami area. Contractors, suppliers and local authorities were interviewed to evaluate market conditions, material availability, and costs.

Many of the design recommendations made to the architects by CM were of a general nature, all designed to complement the fast-track schedule (above) and minimize interdependence of contractors:

1. Slab-on-grade: reduce underground plumbing, mechanical, tanks, etc; place all grease traps, dilution tanks, etc., outside the

## Construction management, in a Miami test, saves \$1.5 million

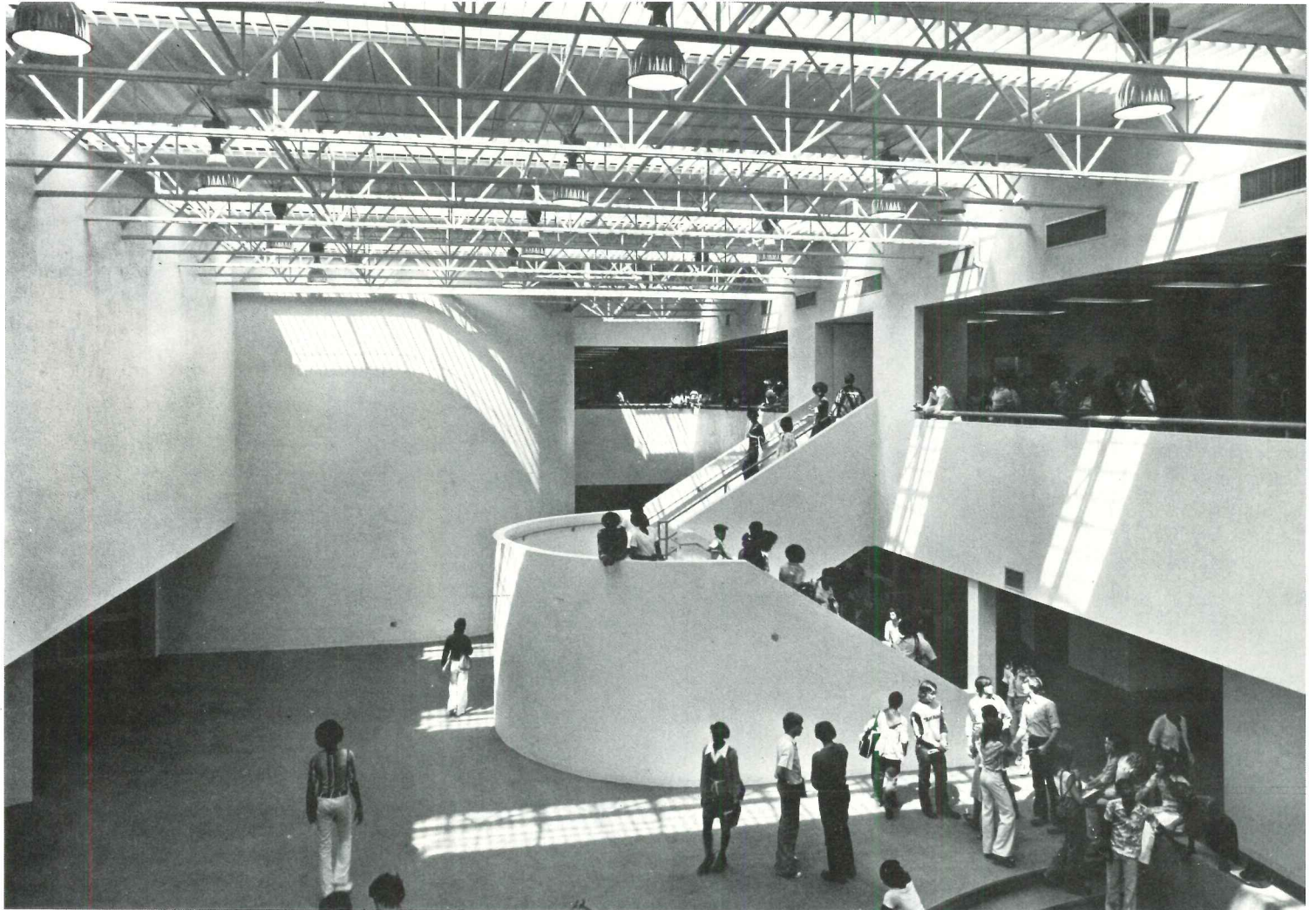

Having just saved \$1.5 million on a new high school designed and built according to construction management techniques, the nation's fifth largest secondary school district has a compelling reason to feel that construction management provides a realistic approach to public building.

Up until the early 1970s, the Dade County (Miami) School District building program followed the traditional construction method of awarding a single building contract to a general contractor. A 1968 attempt by the district to streamline building delivery established a prototype high school design, the re-use of which saved time and fees; but construction management of the projects was not tested until 1974, when added encouragement to improve school building delivery in Dade County came in the form of state legislation known as

the Educational Facilities Construction Act. The lawmakers directed Florida school districts to innovate in design, financing and construction methods, not only to save money but to get it into circulation faster, for Florida was then heading into its construction slump.

A test situation comparing construction management with conventional project delivery arose in Dade County early in 1974 with the need for two new high schools. One of the schools was to be the third re-use of the prototype plans, adapted by an architect, and built by a general contractor.

CM Associates, Inc., the Houston-based construction management subsidiary of CRS Design Associates, Inc., advised the District to consider an entirely new design for the second school. In the firm's opinion, the District could build a more economical and adaptable proto-

type than the previous one, and do it in a much shorter period of time, in spite of the new design effort. The District accepted the idea, and retained CM Associates to manage the project, and the architectural firms of Caudill Rowlett Scott and The Smith, Korach, Hayet, Haynie Partnership to design it.

CRS was responsible for architectural programming, design, and design development. SKHHP was responsible for engineering, working drawings, and construction administration. CM Associates was responsible for scheduling, cost control, evaluation of design in terms of time and costs, and managing the procurement and construction.

Occupied last fall, the construction-managed high school (above), with 250,000 square feet, cost \$35.41 per square foot, or \$8.6 million—\$1.5 million below the budget. One half

# ENERGY SAVERS

## Today's way to build is with urethane-insulated panels.

When Burriss Foods, Inc. decided to expand a gigantic frozen food warehouse by another 1.58 million cu ft, just about every decision they made added up to savings for today or the future.

The big question was how to keep their full (3.04 million cu ft) facility at a constant  $-12^{\circ}\text{F}$  with minimum energy input. The big answer was a super-efficient new urethane foam insulation system developed by Bally Case & Cooler, Inc., a traditional leader in frozen food storage facility design.

The new insulated system is based on factory-made wall panels with a 4" core of rigid urethane foamed in place between galvanized steel interior and exterior skins. Urethane foam-Perlite board composition was used to insulate the built-up roofing over metal decks.

**Saves time.** Weighing only  $3\frac{1}{2}$  psf (about 90% lighter than cinder block) the panels are fabricated as a single module, are easy to handle, go up fast, need only to be interlocked at the job site. The Burriss job saved about 25% in construction time over conventional masonry methods.

**Saves energy.** With urethane foam's  $k$  factor of 0.14, the panels have a thermal resistance of R-28.5 (about twice as efficient as an equal thickness of glass fiber). This allows Burriss to hold a constant frigid temperature with 20-25% less energy input.

**Saves money.** With their unique design and efficiency, the new panel modules mean savings in shipping and handling, field labor, every step of the way. And, if urethane-core panels can produce savings like this in a frozen food warehouse, think of what they can do for a project where you only have to keep people comfortable!

For the full story on how urethane foam insulation can save you time, energy and money, ask for our fact-filled manual: "How to Conserve Energy in Commercial, Institutional and Industrial Construction." It's from the Mobay People who wrote the book on polyurethane chemistry.

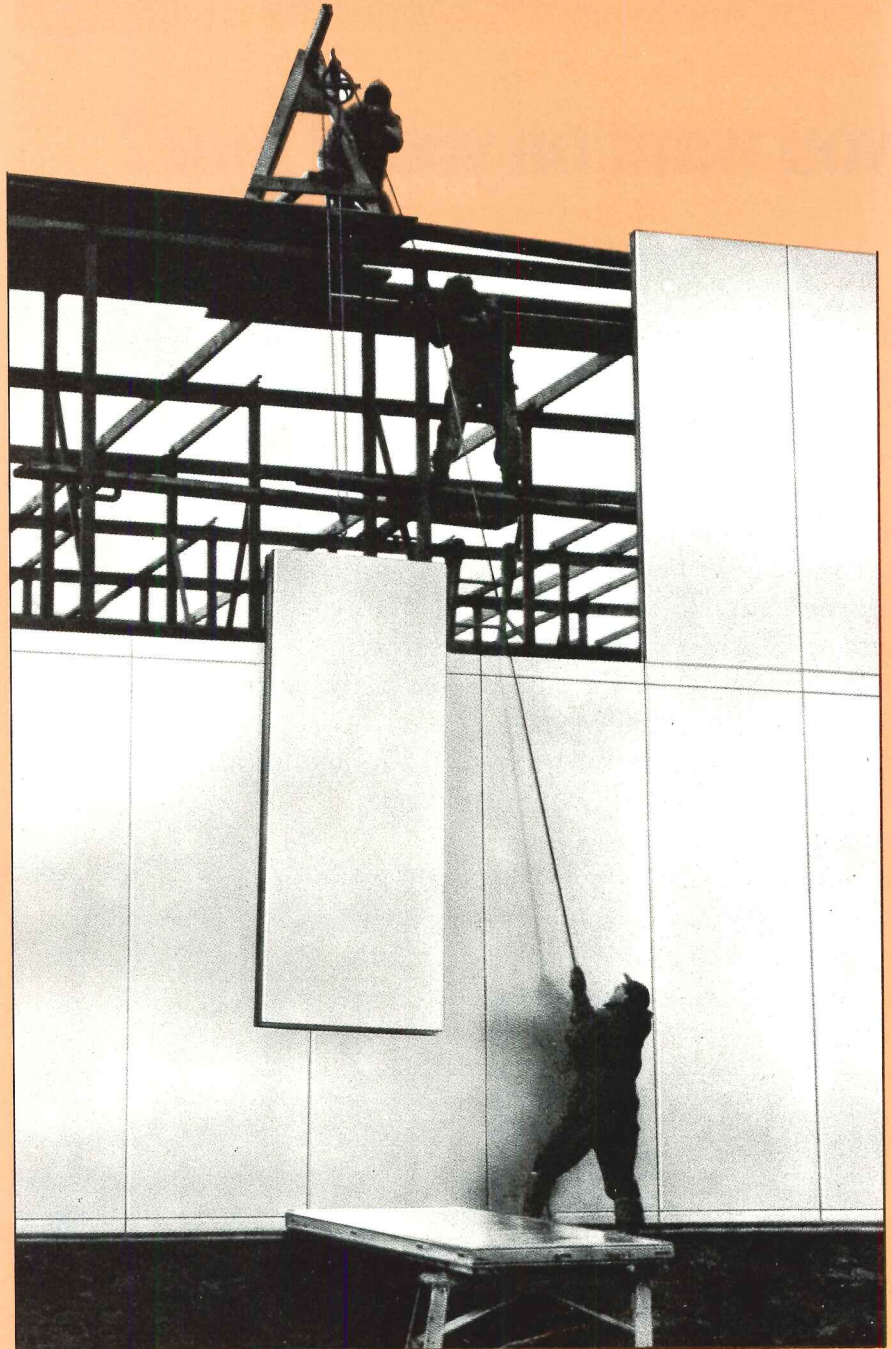
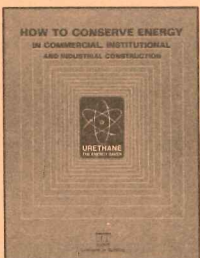

Refer to Sweets  
Architectural File  
15.20/Mo

**Mobay**  
Chemical Corporation

Polyurethane Division, Code AR-17, Pittsburgh, Pa. 15205

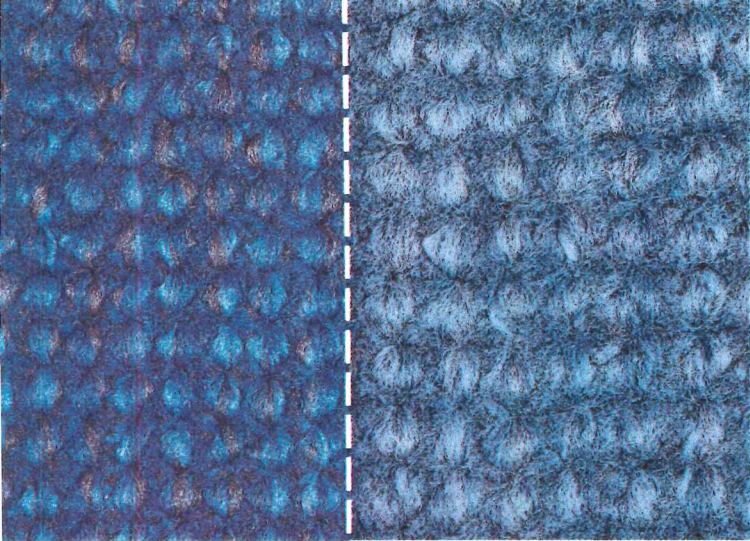

*Nylon before & after exposure to 1500 hrs. of Xenon-Arc lamps.*

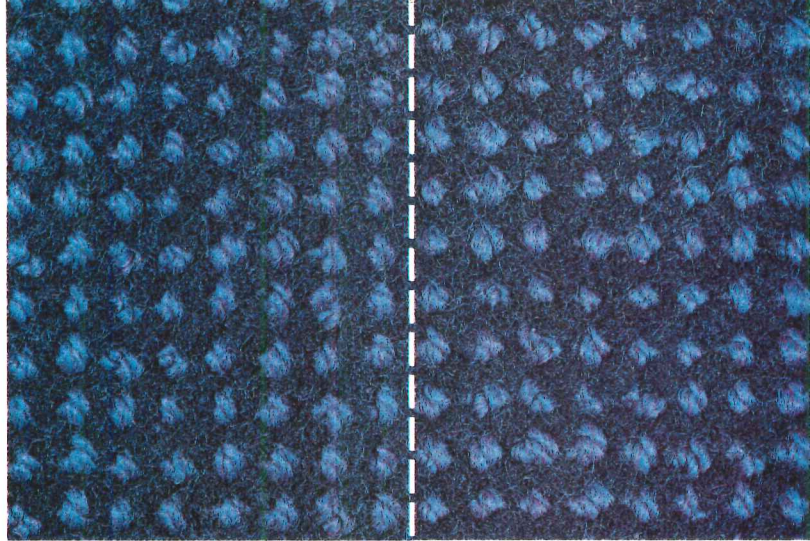

*Fortrel PCP before & after exposure to 1500 hrs. of Xenon-Arc lamps.*

## do you want on your floor?

1500 hours of exposure to Xenon-Arc lamps. (That's 18 times the industry standard.) The carpet of nylon had faded substantially well before 1500 hours.

### **Wear Guaranteed.**

These are only three of twelve exacting standards that every carpet of Fortrel PCP polyester must meet before it is awarded our five-year wear guarantee. It's the *only* wear guarantee available anywhere on contract grade polyester carpeting and it guarantees that "if the surface pile of the carpet wears more than 10% within five years from the date of initial installation, Celanese will replace the affected area with equivalent carpeting at absolutely no cost to you."

Now you can be sure which carpet you want on your floor. The one that resists static, fading, wearing, staining, soiling, and mold. And has the only five-year guarantee around.

### **Fortrel PCP.**



*The back of most carpeting.*

*The back of carpeting of Fortrel PCP polyester.*



If your new carpeting is made from 100% Fortrel PCP polyester, commercial-grade, and has been properly installed and maintained, Celanese Fibers Marketing Company guarantees it. Here is how.

If the surface pile of the carpet wears more than 10% within five years from date of initial installation, Celanese will replace the affected area with equivalent carpeting at absolutely no cost to you.

Note that the guarantee is non-transferable and applies only to carpeting (stairs excluded) for which wear, if any, is not attributable to negligence or burns, casualties, cuts, pulls, and the use of improper cleaning methods or other causes beyond the control of Celanese.

This guarantee applies only to commercial-grade carpet as defined in Fortrel Polyester Carpet Performance FT-207.



Fortrel PCP is a trademark of Fiber Industries Inc., a subsidiary of Celanese Corporation. Celanese Fibers Marketing Company is a division of Celanese Corporation.

**Your next five years are guaranteed with:  
FORTREL PCP**

# This time do it right.

Floor Coverings Department, Celanese Fibers Marketing Co., 1211 Avenue of the Americas, New York, N.Y. 10036, (212) 764-7640.

For more data, circle 49 on inquiry card



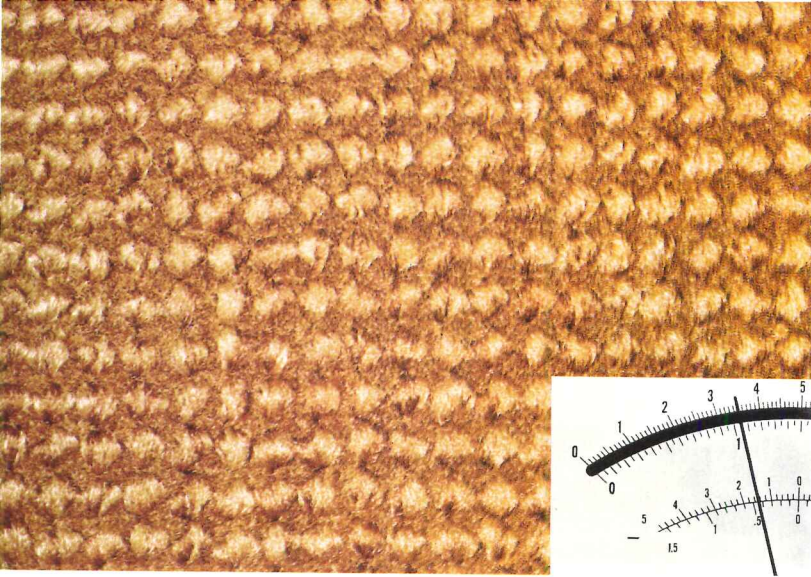

*Static generated by nylon.*

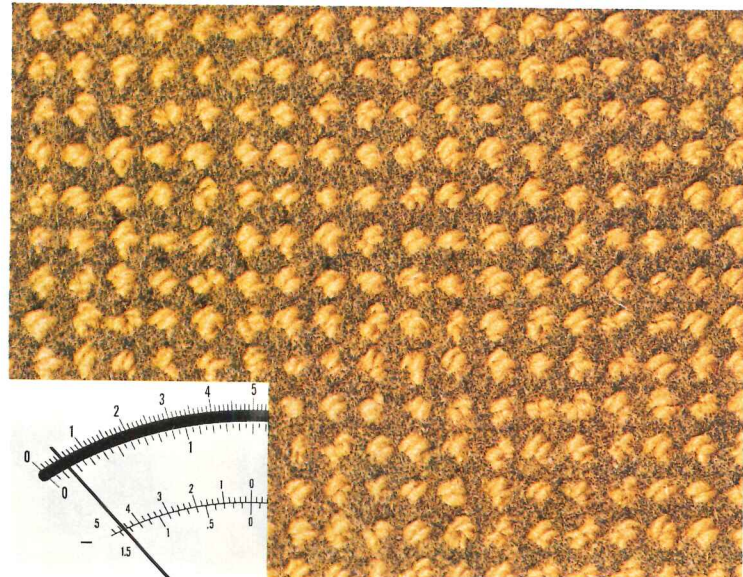

*Static generated by Fortrel PCP*

## Which carpet

You're looking at photos of the actual results of three tests conducted by Certified Testing Laboratories, Inc. on carpets of Celanese Fortrel PCP producer colored polyester, and commercially available carpets of similar construction in different fibers.

Fortrel PCP outperforms them all.

### **More Durable.**

After only 1,800 cycles on a taber abrader (taber abrasion test ASTM D-1175), the carpet of acrylic fiber reached the breaking point (abraded to the backing) and registered a pile weight loss of 11.6%. The carpet of Fortrel PCP polyester didn't reach the breaking point until 22,000 cycles! And didn't lose 11.6% of its pile weight until 29,900 cycles!

### **Less Static.**

In checking static generation, the AATCC Walk Test with Neolite Soles (134-1969) was conducted. Carpet of Fortrel PCP polyester generated a mere .5 kilovolt, well below the threshold of human sensitivity.

(Even below the level necessary for such delicate applications as computer rooms and hospitals.) The carpet of Antron II, even with metallic protection, generated seven times as much static—3.5 kilovolts.

### **No Fading.**

In the AATCC Colorfastness to Light Test (Test Method 16E), the carpet of Fortrel PCP polyester showed no evidence of fading or color change after

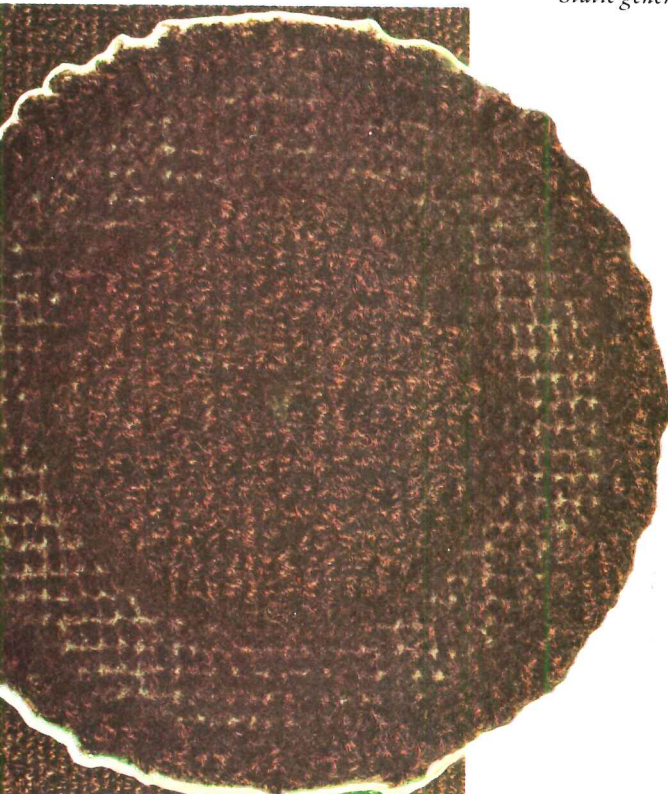

*Acrylic after 1,800 cycles on a Taber Abrader.  
Fortrel PCP after 1,800 cycles on a Taber Abrader.*

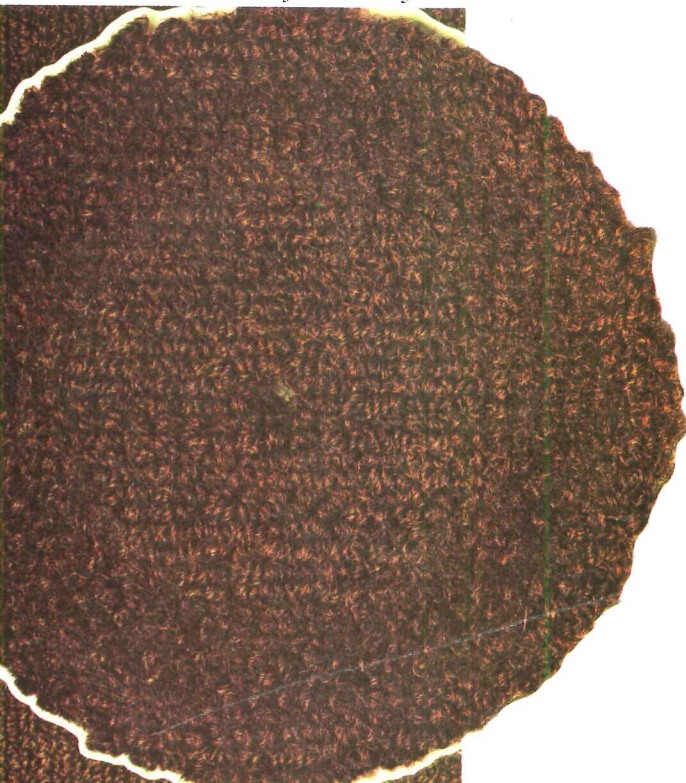

# CY/RO is the newest in transparent plastics.

And CY/RO has news for you. By now, you probably know CY/RO as a new name in the transparent plastics industry.

A new company committed to innovation, and building on the combined experience and expertise of American Cyanamid Company and Rohm GmbH...in research and invention...technology...production...marketing...distribution...service. You'll want to watch our messages in the coming months for news of exciting new products, offering new properties, new property balances. *Designed* transparent plastics... created to fit the particular demands of specific situations. New energy conserving double-skinned sheet for glazing and architectural use in acrylic and polycarbonate versions—whites and solar tints, too.

Transparent and translucent fire retardant ACRYLITE® acrylic sheet.

We'll be bringing you news of these and more CY/RO inventions and innovations in transparent plastic—new products from CY/RO to help you design the future. CY/RO Industries, Wayne, New Jersey 07470.



A Partnership of Cyanamid Plastics, Inc.  
and Rohacryl, Inc.

For more data, circle 48 on inquiry card

# WATTS ENERGY

## ENERGY MANAGEMENT VIEWS FROM THE NATIONAL ELECTRICAL CONTRACTORS ASSOCIATION Vol. 1 No. 3

### ENERGINEERS\* REDUCE UTILITY COSTS WITH DEMAND CONTROLLERS

After many years of steadily declining electric charges, utilities now are finding it necessary to raise rates to cover higher fuel, operating, and construction costs. Utility bills, once routinely paid, are now being scrutinized for ways to save and obtain more efficient use of purchased power. Automatic demand controllers provide a practical solution. Enginengineers should know what they can do.

Large users of power sometimes are billed on a combination of two or more rate bases. One is the overall amount of power used (like gallons of water) and another is the rate of use (like gallons per minute). These bases translate roughly into kilowatt-hours and kilowatts. The rate of use factor is called the demand rate as compared to the overall amount used which is called the total energy usage. Since electric utilities must, by law, provide the capacity for maximum user demands they must have ready to go sufficient generating equipment, transmission and distribution facilities for the projected demand at peak operating periods. Reasoning concludes that the larger users should pay a proportional share of providing the needed operating plant. Hence the demand charge. Automatic demand controllers produce savings by limiting the demand charge since they reduce the peak needs that must be supplied by the utility.

Here is how it works. The need for demand metering was recognized long ago so techniques now are highly refined. Both analog and digital devices are in use. Two basic approaches are integrating demand and lagged or thermal demand. The integrating approach uses a wathour meter with a timing clock added. This type sums up the amount of energy used in a specific time

interval—usually 15 or 30 minutes and thus indicates average power for a specific block of time. The lagged demand approach uses a wattmeter that heats up as current passes through. The demand interval is determined by how fast it takes for a temperature sensitive device to register 90 percent of full response under a steady load. Many variations and readout methods are used. Both methods result in computation of demand based on a specific time interval. Ideally, the energy user should try to keep his peak demand level below some established threshold for each interval. That's what automatic demand controllers can do.

Figures 1 and 2 show comparison of a typical demand chart before and after load control.

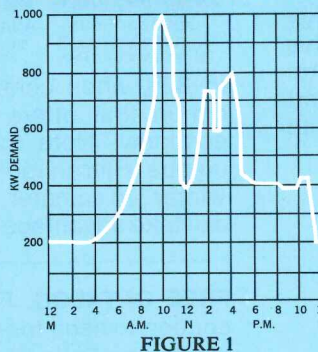

FIGURE 1

Each line represents a demand interval. As the automatic controller senses that established peak thresholds will be exceeded, it sheds certain loads by turning off pre-selected electrical equipment. Thus, demand controllers are basically automatic comparators, constantly comparing actual usage with an ideal precomputed maximum to minimize charges while maintaining satisfactory facility operations. The user determines which loads can be shed in which order or priority. Load shedding usually takes place only in the last few minutes of each demand interval so lengthy disruption of service is avoided. Equipment turned off

is selected so that tenants and operators are hardly aware of loads being shed. Typical electric loads that can be shed without harming operations are furnaces, boilers, air conditioners, space heaters, snow melters, water heaters, and compressors.

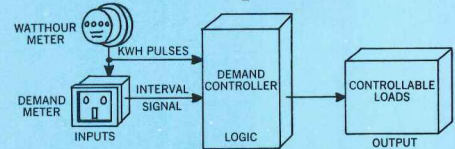

FIGURE 3—BLOCK DIAGRAM OF DEMAND CONTROL SYSTEM

Figure 3 shows a typical demand control system. Every system includes input, logic, and output control signals. The input comes from utility billing meters, logic basically is a two directional counter and difference encoder, output acts on decisions to activate

relays, contactors, motor controls, etc.

Energy savings and equipment return on investment is fairly easy to compute for a qualified supplier or electrical contractor. Data needed is a copy of the demand printout for one

billing period, copy of the utility rate structure, and a recent electric bill. Savings of 10 percent are easy to achieve with up to 30 percent not unusual. Remember automatic demand control, an energy management innovation. Consult a local qualified electrical contractor on matters of application and installation.



WHEN YOU PLAN  
FOR ELECTRICITY, PLAN  
WITH A PROFESSIONAL.

\*Enginengineers . . . designers, specifiers, users and installers of energy efficient building systems.

In addition to conduction losses, buildings also lose heat due to infiltration . . . cold air entering through cracks around doors and windows. This is where weatherstripping and precision manufacture to exacting tolerances become important. In this chart we compare 20 windows meeting two different industry standards (Class B and A) with 20 Pella Double-Hung and Casement Windows. Each group of 20 windows has 280 lineal ft. of crack. Heat loss through infiltration for one OX-34 Pella Sliding Glass Door is also included. Test was calculated at 0° with a 25 mph wind.

### Heat Loss Due To Air Infiltration

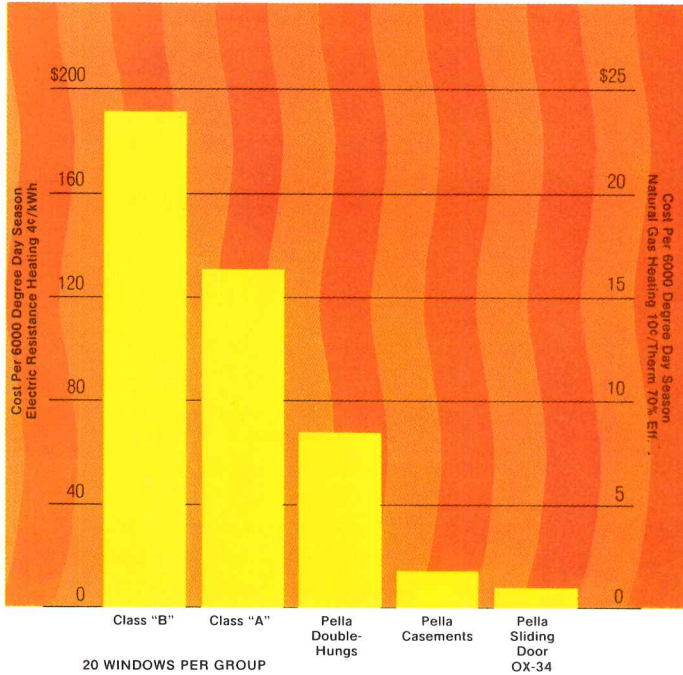

Another way Pella Wood Windows can help save energy and money is by helping control solar heat gain. This reduces the amount of work air conditioners must perform and can produce a reduction in electric bills. The chart below compares cooling costs between windows with different glazing and shading provisions.

### Cooling Cost Comparisons

For 90 days of 5 hour Exposure (75°inside - 90°outside)

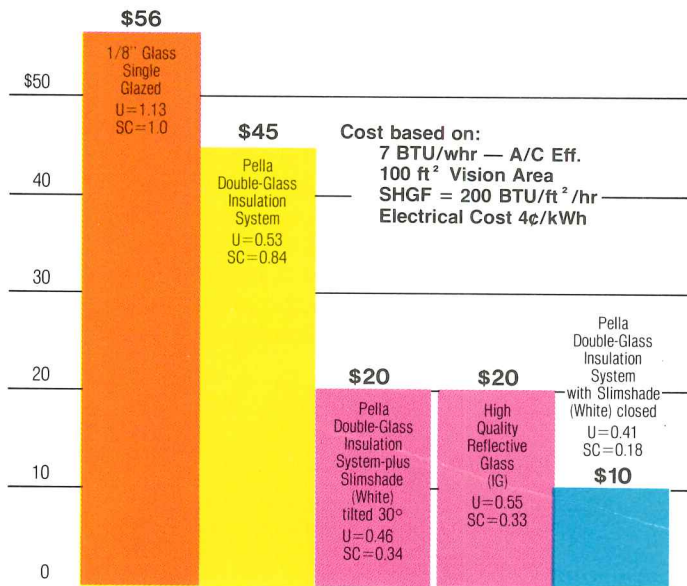

Pella's exclusive Double Glass Insulation System and optional Slimshade® (shown below) greatly improve the energy efficiency of Pella Windows.

### More Insulation for Less Money

Only Pella makes a double glass window with a full 13/16" dead air space between the panes. And the greater the space between panes (up to about 1"), the greater the insulation value. As a result, Pella's Double Glass Insulation System actually outperforms ordinary insulating glass and costs less per window. Add this fact to Pella's many other "Energy-Tight" features and you have a truly superior energy saver.

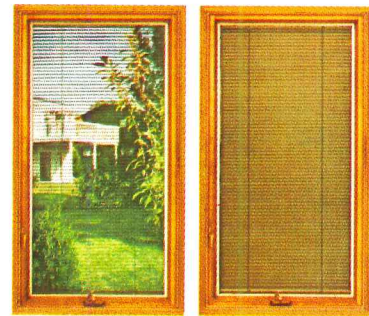
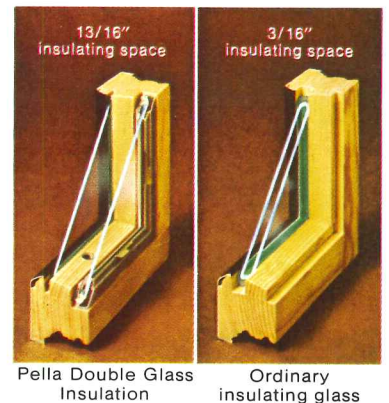

Optional Pella Slimshade® open to let in the view  
Adjusts at the touch of a dial to control heat and light

Only Pella makes the Slimshade®. It fits in the 13/16" dust-free, dead air space between the panes of the Pella Double Glass Insulation System and provides privacy at the touch of a dial. But even more important, the Slimshade®, when completely closed, can reduce heat loss by as much as 62% and solar heat gain up to 82% when compared with single unshaded glass. An option that offers real savings in today's energy-short economy. Note that a variable system such as Pella's unique Slimshade® is an advantage both summer and winter. In summer, heat gain is reduced, but in winter you can take advantage of solar heat with the Slimshade® open.

**FREE CATALOG.** For more detailed information, use this coupon to send for your free copy of our 28-page, full color catalog on Pella Clad Windows & Sliding Glass Doors. See us in Sweet's General Building File. Call Sweet's BUYLINE number or look in the Yellow Pages, under "windows", for the phone number of your Pella Distributor.

Name \_\_\_\_\_

Firm \_\_\_\_\_

Address \_\_\_\_\_

City \_\_\_\_\_

State \_\_\_\_\_ ZIP \_\_\_\_\_

Telephone \_\_\_\_\_

Mail to: Pella Windows & Doors, Dept.T31A7, 100 Main Street, Pella, Iowa 50219.  
Also available throughout Canada.  
This coupon answered within 24 hours.

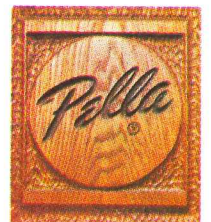

For more data, circle 46 on inquiry card



# What Pella "Energy Tight" Windows can mean to you

Pella is concerned with helping to conserve that part of America's energy that goes into heating and cooling our residential and commercial buildings. The right windows in these buildings, the "Energy Tight" kind that Pella manufactures, can help cut energy losses. And when you save energy, you're saving money, of course. The following charts and graphs demonstrate how, but first, a quick refresher course in the "language of energy".

## British Thermal Unit (BTU)

A BTU is a unit of heat energy — the amount needed to raise the temperature of one lb. of water one degree Fahrenheit.

## R Values

R Values refer to the resistance a material has to heat flow. Higher numbers indicate greater insulating capability.

## U Values

U Values refer to the total heat flow through the complete heat barrier from room air to outside air. Lower numbers indicate greater insulating capability.

## SC — Shading Coefficient

The amount of solar energy (expressed as a ratio) which passes through a specified material.

## SHGF — Solar Heat Gain Factor

The amount of solar energy impinging on a material (expressed in BTU/sq. ft./hr.).

## Degree Day

The number of days in the heating season times the difference between an inside temperature of 65° and the average outside temperature.

An example of how the R Value of certain materials relates to the U Value is contained in the following chart of typical building materials and materials used in the manufacture of windows.

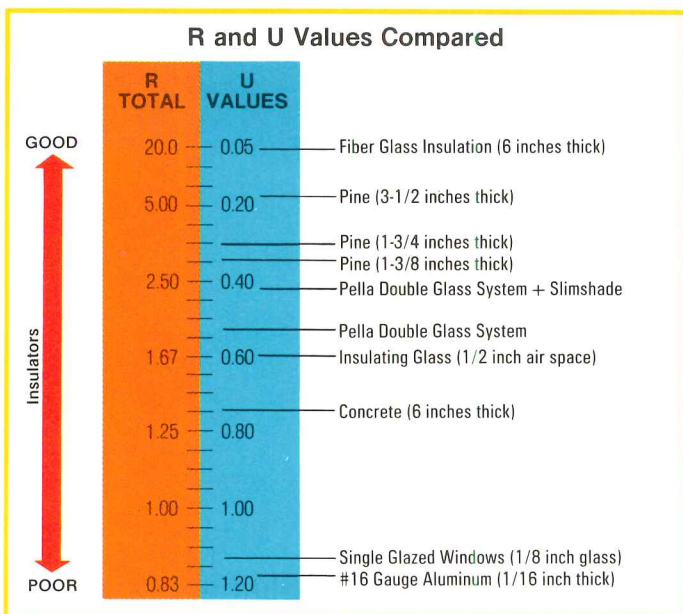

## Heat Loss by Conduction

Heat may be conducted out of buildings during winter through walls, ceiling, doors and windows.

Heat loss may be reduced by improving insulation in ceiling and walls. Choosing wood windows glazed with a low heat transfer system will reduce losses still further.

The following graphs illustrate the differences in heat loss in dollars per season for each 100 sq. ft. of window area. U Values used in calculations are based on winter conditions.

### Heat Loss By Conduction — Natural Gas Heating

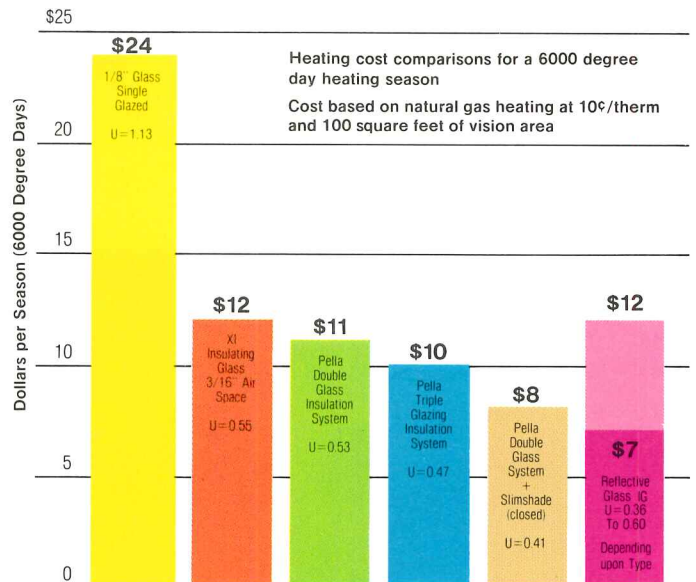

### Heat Loss By Conduction — Electric Resistance Heating





let it rain  
let it rain  
let it rain

Students and faculty of New Jersey's Stanhope Elementary School no longer mind. Their roof is now covered with pre-tapered insulating planks molded from expandable polystyrene—topped by a PVC membrane.

So they're getting the benefits of positive drainage from existing drains without any need for structural alteration.

Boards molded from Dylite® expandable polystyrene are rigid, easy to install and lightweight. They are also resistant to moisture and hold their insulating properties for years and years. Thermal conductivity (k) is 0.22 at 0°F, resulting

in substantial saving in heating and cooling costs.

Pre-tapered roof panels fabricated from Dylite billets provide an effective, cost-cutting way to insulate and to achieve positive drainage. They meet or exceed the requirements of USA Federal Specification HH-I-524B.

For more information, write ARCO Polymers, Inc., Dept. 1037, 1500 Market Street, Philadelphia, PA 19101.

*CAUTION: The foamed polystyrene described in this advertisement is combustible and should not be exposed to open flame or other ignition sources.*

**ARCO/Polymers, inc.**   
Subsidiary of  
AtlanticRichfieldCompany

*Contractor: Rainbow Roofing, Inc., Elmwood Park, N.J., Molder: Toyad Corporation, Latrobe, Pa.*

*For more data, circle 45 on inquiry card*

# up front or out back....



## there's a **KINNEAR** Rolling Door & Grille to do the job!

There are Kinnear closures that let you secure a loading dock, block a fire or turn an entire store or lobby into an intrusion-proof 24 hour-a-day showcase.

Kinnear Rolling Grilles provide an impenetrable barrier to people and even very small objects. There is no hindrance to the passage of air or blockage of sight. In sheltered areas, such as shopping malls, the grilles may be used in place of regular store-front walls or display windows. In exterior installations they provide unrestricted vision as well as protection when installed outside regular windows. (For fullest protection possible, Kinnear Rolling Doors may be used in conjunction with the grilles.)

When not in use, Kinnear Grilles, like Kinnear Doors, retract out of sight above the opening.

Available in three attractive designs, Kinnear Rolling Grilles also are ideal for restricting entry into "off-limit" areas in commercial buildings, or anywhere it

might be desirable to screen off selected areas from time to time. They do not hamper airflow or lighting.

**Meanwhile** . . . back on the loading dock, time-tested and proven Kinnear Rolling Doors provide the most efficient closure available. Tough, rugged, designed for constant commercial-level use, they operate vertically, requiring no valuable floor space to allow for swing. And they can handle an opening of practically any width and height.

Both grilles and doors are available for manual or power operation. Power units may be remote-controlled.



**Write today** for up-to-date catalogs on Kinnear Rolling Grilles and Doors.



Saving Ways in Doorways Since 1895

A DIVISION OF **Harsco**

1860 Fields Avenue, Columbus OH 43216

Factories: Columbus OH 43216 • San Francisco CA 94124  
Centralia WA 98531 • Toronto, Ontario, Canada

# One of today's smart new creations can save this store \$12,000 in lighting.



Automatic Energy Control from Wide-Lite is one beautiful example.

With a typical HID lighting system\* AEC can save over 400,000 kilowatt hours and \$12,000 for each and every relamp interval. This means savings from 15% to 25% for most commercial installations.

Why? Because AEC maintains constant level illumination — so you won't have to pay for higher initial footcandles to meet the specified minimum as lamps age.

And how does Automatic Energy Control work?

It all starts with a photocell sensor which simply reads illumination levels.

Then the AEC system converts this reading into a signal which alters power input. Thanks to our special dimming ballasts which continuously and automatically adjust lamp lumen output to maintain a predetermined value.

So, as lamp lumen depreciation lowers illumination, AEC automatically compensates by increasing lamp power.

Or if ambient daylight increases total room illumination, AEC automatically compensates by reducing lamp power.

The result is that you get only the amount of light you need. And pay for only the amount of light you need.

Of course, we recommend you use our dustproof luminaires as part of your AEC system to keep maintenance costs at a minimum.

We also recommend you write for our brochure that details how AEC can save on any indoor lighting project you may have.

It shows how fantastic you can look with our smart new creation.

Spectra V Regressed  
Luminaire

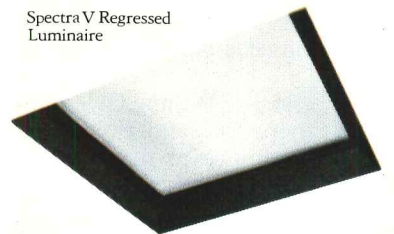

## WideLite

POST OFFICE BOX 191, HOUSTON, TEXAS 77001  
WIDE-LITE® PRODUCTS ALSO MANUFACTURED IN AUSTRALIA,  
BELGIUM (FOR EUROPE), CANADA, MEXICO AND GREAT BRITAIN.  
A COMPANY OF THE ESQUIRE LIGHTING GROUP

\*150 1000-WATT FIXTURES WITH MERCURY VAPOR DX LAMPS,  
BURNING 12-HOURS PER DAY, FOR A TOTAL OF 16,000  
HOURS BEFORE RELAMPING, AT 3¢ PER KWH.

For more data, circle 42 on inquiry card



# New Oasis "Soft Touch" cooler makes it easy for the handicapped to get a drink.

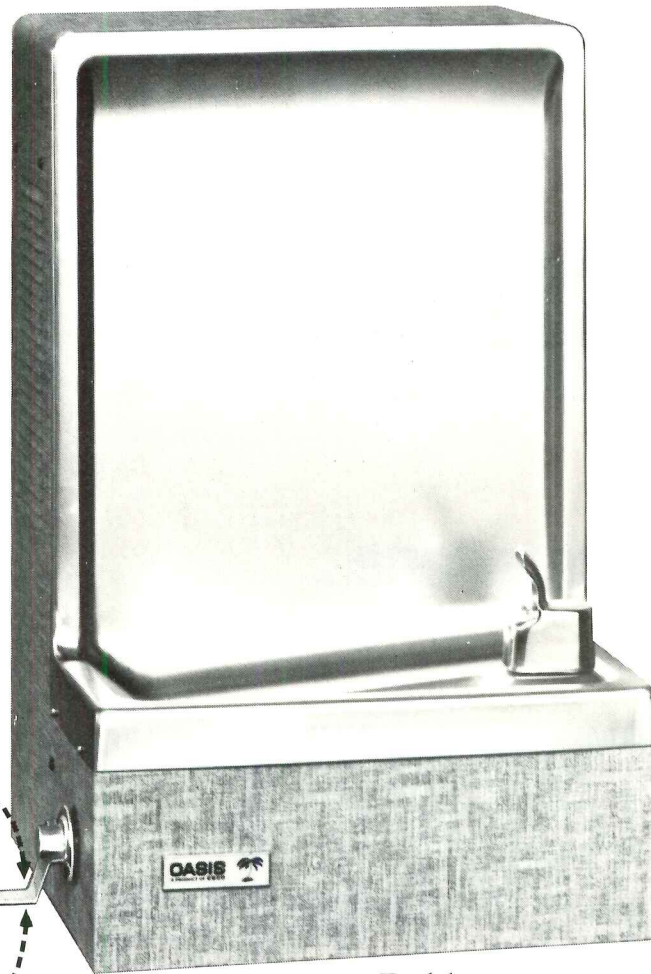

This new wall-mounted cooler is designed for people whose physical handicaps make it hard for them to get a drink from conventional water coolers. Wheelchair users, for example, will find it much handier.

Two "Soft Touch" levers—one on each side of the cooler—operate up or down at the slightest pressure. Either one of them will activate the bubbler, and there are no hard-to-use knobs or buttons. The levers can be positioned or re-positioned any place in a 360° circle, and their unique no-linkage mechanism needs no adjustment.

A metal plate on the bottom of the cabinet protects against injury or torn clothing. All the other famous OASIS

water cooler features are there, too, and it serves seven gallons of cold water per hour. It also conforms to A.N.S.I. Standard A117.1 Section 5.7.2 and

Public Law 90-480.

Call or write for a demonstration of our new "Soft Touch" Model ODP7WM-D. See for yourself how much better it is. And how it makes it easy to get a drink when it's hard to get a drink.

## OASIS®

The word for water coolers.

OASIS  Ebco Manufacturing Co., Columbus, Ohio 43213

For more data, circle 41 on inquiry card

# Acrylic-epoxy

**EXCLUSIVE  
NEW CHEMISTRY-  
PATENT PENDING**

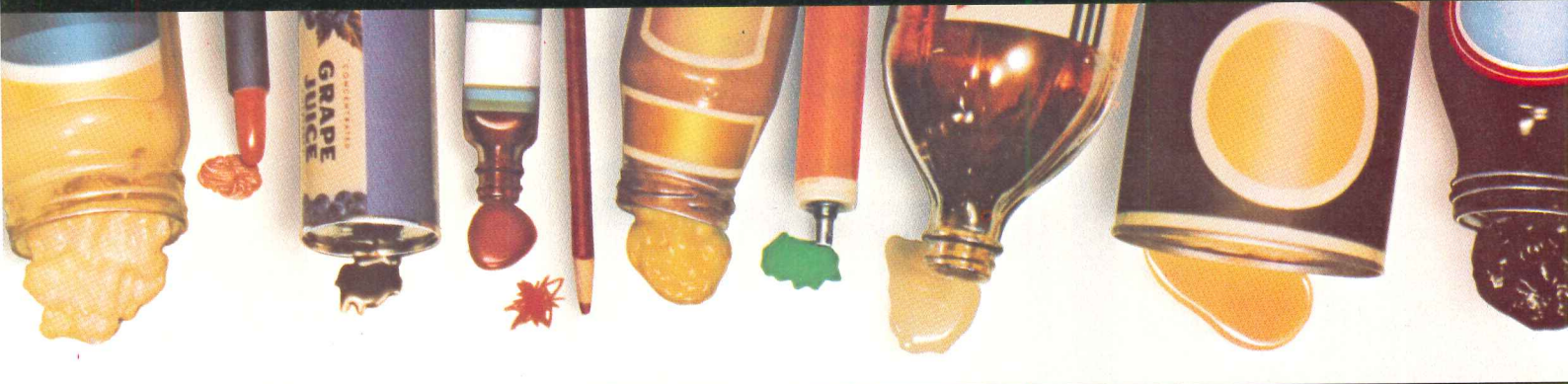

saving high-build coverage...

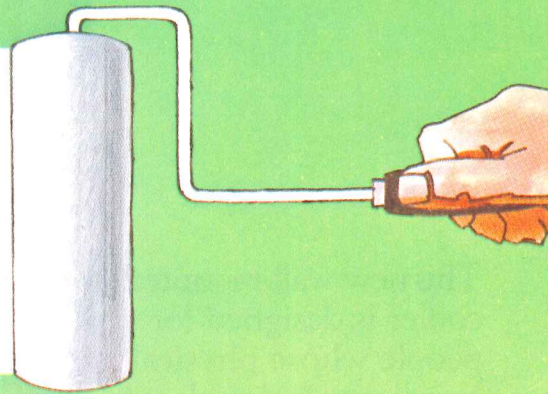

## PITTSBURGH® PAINTS

EASY EQUIPMENT  
CLEAN-UP  
IN WARM  
SOAPY WATER.

HUNDREDS OF  
PASTEL COLORS  
AND WHITE  
COMPLEMENT ANY  
DECOR.

GLOSS AND  
SEMI-GLOSS  
FINISHES, TOO.

Pittsburgh Paints  
C & R Advertising Dept.  
One Gateway Center  
Pittsburgh, Pa. 15222



- Please send your new catalog No. 83A on Pitt-Glaze Coatings.
- Have a representative call.

NAME \_\_\_\_\_

TITLE \_\_\_\_\_

COMPANY \_\_\_\_\_

ADDRESS \_\_\_\_\_

CITY \_\_\_\_\_

STATE \_\_\_\_\_

ZIP \_\_\_\_\_

AR \_\_\_\_\_

For more data, circle 40 on inquiry card

# **NEW** High Solids *Pitt-Glaze*<sup>®</sup>

It can take  
just about everything  
people splash on it —  
and come back again  
for more!



**A WATER BASE HIPAC\* coating featuring money**

**PLUS**  
all these  
features

APPLY BY  
ROLLER,  
SPRAY  
OR BRUSH.

LOW ODOR  
DURING  
APPLICATION.  
YOU CAN WORK  
WHILE PAINTING.

TOUGH, DURABLE—  
RESISTS SCUFFING.  
VERY ABRASION  
AND CHEMICAL  
RESISTANT.

MEETS  
FEDERAL SPECS.  
TT-C-001979  
(GSA FSS)

\* High Performance  
Architectural Coating

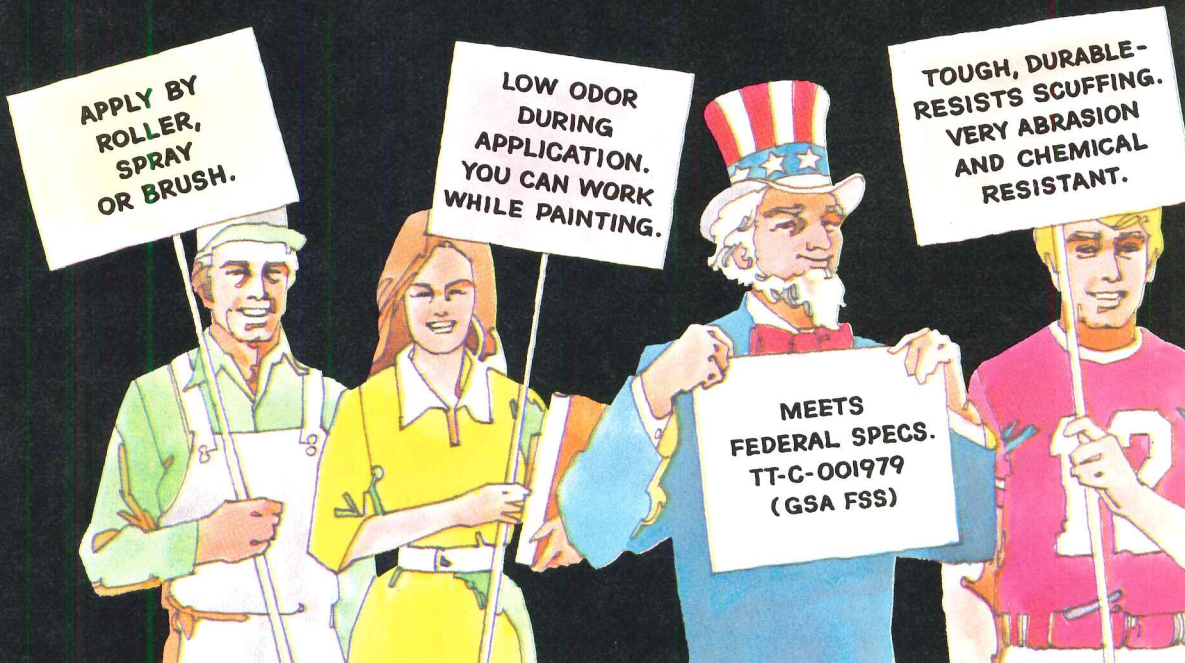

# depend on Bethlehem

A state road-widening project through Grundy, Va., eliminated many of the town's Main Street parking spaces. And because of the area's steep terrain, no alternative off-street parking sites were available.

**Solution:** build a three-level, 144-car parking structure into the side of a mountain to replace the spaces eliminated by the construction.

The difficult nature of the site immediately suggested the use of structural steel framing. It could provide the required column-free long spans. And it could be erected rapidly.

**Sales Engineering service valuable.** "Bethlehem Sales Engineering personnel were very helpful in furnishing us with technical publications and advice," reports Mr. Gerry E. Higgs, president, Higgs & Higgs, Inc., designers of the structure. "Two slide presentations, featuring steel-framed parking structures and the use of Weathering Steel in construction, were given to our engineering staff. It was also on the advice of Bethlehem's Sales Engineer that we considered Weathering Steel for the interior, as well as the exterior framing of the structure."

**Why Weathering Steel?** The designers decided on ASTM A588 Weathering Steel for both the exterior and interior framing for two reasons: (1) it provides a very rustic appearance which, when fully matured, will blend well with the surroundings of this rural coal mining community; and (2) its low maintenance cost will minimize future financial burdens on the town.

Several special design details are employed to minimize staining during the weathering process. Open slots are placed in the concrete slabs around all columns to avoid runoff from the columns onto the slabs. At grade level, gravel pockets surround all the column bases.

**Architectural considerations.** A low-profile parking structure was desired in order to avoid overpowering the neighboring one- and two-story buildings. The design features an open structure with exposed steel framing, partially faced with sand-blasted precast panels.

A set of ramps at the south end provides entrance and exit to the parking levels. One of the ramps also serves as the entrance and exit right-of-way for the property on the mountainside above the parking garage. The system of circular and straight ramps allows one-way traffic to be maintained on all parking levels. Stair towers, located at each end of the structure, control pedestrian flow.

**Technical and advisory services available.** Bethlehem's Sales Engineering Division offers a wide variety of services to help make it easier for you to design in steel. Our Preliminary Framing Analysis can provide you with budget cost information for the total "systems package" of a structure under study . . . and our advanced engineering group can assist you with technical evaluations. For more information, just call the Bethlehem Sales Engineer at the Bethlehem sales office nearest you. His number is listed below.

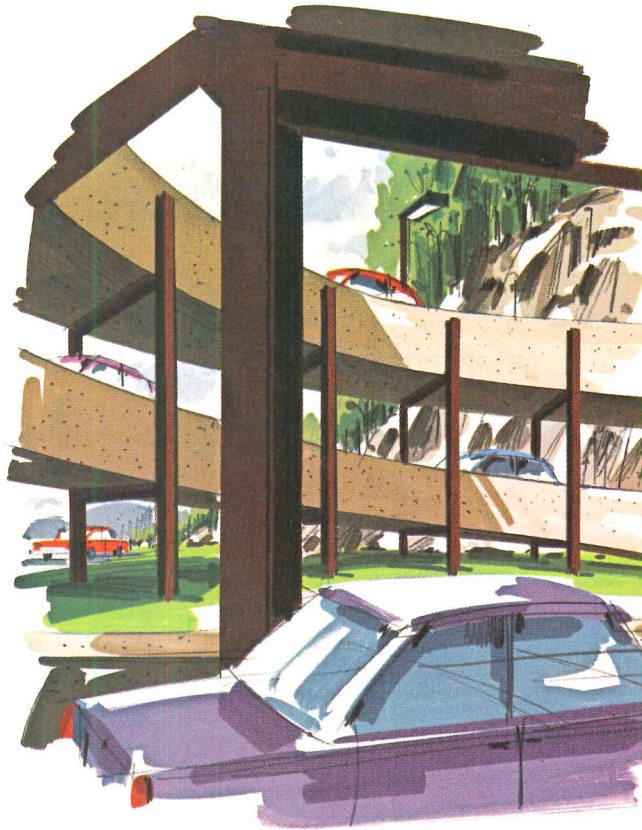

A circular ramp at the north end permits traffic flow from the level below to the one above.

## Bethlehem



### Phone:

Atlanta (404) 522-4918	Los Angeles (213) 726-0611
Baltimore (301) 685-5700	Milwaukee (414) 272-0835
Boston (617) 267-2111	New Haven (203) 865-0833
Buffalo (716) 856-2400	New York (212) 688-5522
Chicago (312) 664-5422	Philadelphia (215) 561-1100
Cincinnati (513) 381-6440	Pittsburgh (412) 281-5900
Cleveland (216) 696-1881	St. Louis (314) 726-4500
Detroit (313) 336-5500	San Francisco (415) 981-2121
Houston (713) 659-8060	Seattle (206) 285-2200

*Ask for Sales Engineer*

Slide presentations, as well as numerous Bethlehem publications and design aids, provided valuable assistance to Higgs & Higgs, the project's designer.



# Technical service and practical design aids ease design of this Weathering Steel parking structure.

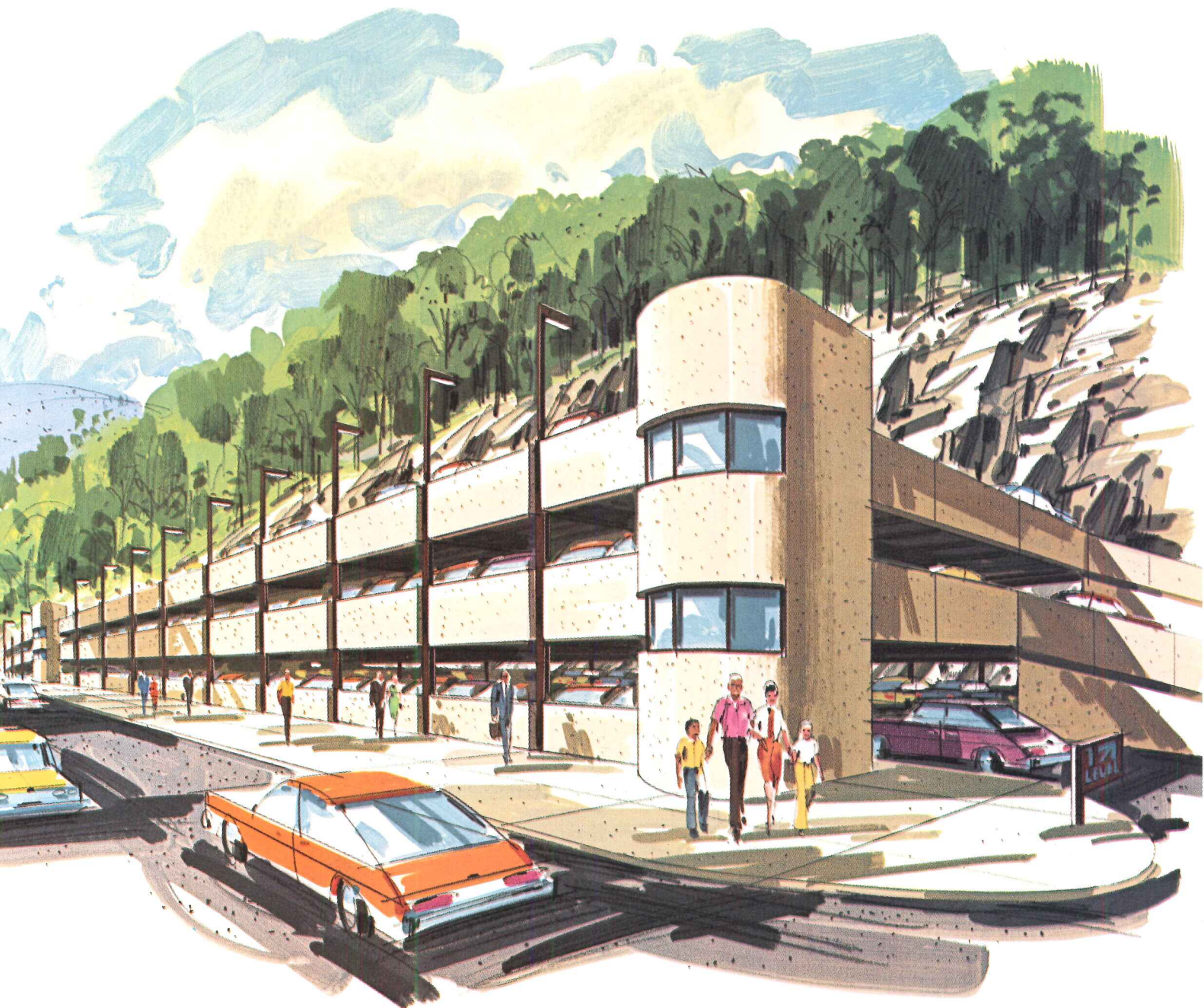

*Client:* Virginia Department of Highways & Transportation; *Owner:* Town of Grundy, Va.; *Designers:* Higgs & Higgs, Inc., Vienna, Va.; *Consultant Architect:* James W. Ritter, Springfield, Va.; *Contractor:* Wiley N. Jackson Company, Roanoke, Va.; *Fabricator:* Structural Steel Company, Inc., Roanoke, Va.; Structural steel furnished by Bethlehem Steel Corporation.

The depth of the mountainside excavation, which greatly influenced the cost of the project, dictated the need for a long (240 ft), narrow (63 ft) structure.

# DuPont carpet fiber good looks. At A.T.&T.

The new A. T. & T. Administration Building,  
Basking Ridge, New Jersey.



The carpet—all 150,000 square yards—is a special woven construction with pile of Antron\* II nylon. "Antron" II was selected for its outstanding long-term appearance-retention qualities.

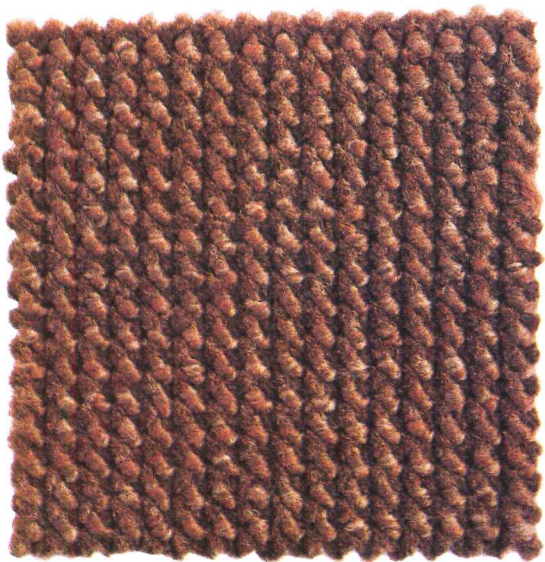

**Why "Antron" II?** "Antron" II nylon is designed to mask the presence of soil. And, because it is

a nylon, it's the most abrasion-resistant of all carpet fibers. In addition, "Antron" II has a pleasant, subdued luster, unlike bright or sparkle-luster fibers that can dull rapidly in contained high-traffic areas. Cleanability and texture retention are excellent.

These are the properties most specifiers expect from "Antron" II, the fiber known for its lasting good looks. And they are among the reasons why it is the leading contract carpet fiber brand.

**How "Antron" II masks soil.** Here in this 250X electron micrograph, you can see the remarkable four-hole fibers of "Antron" II. The four microscopic voids scatter light to mask soil and help blend soil concentrations into the overall carpet look. The smooth exterior shape minimizes soil entrapments, making cleaning more effective than irregularly shaped fibers.

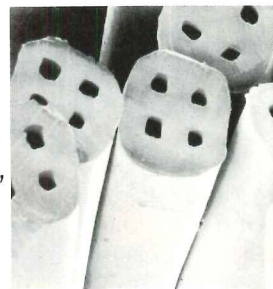

**"Antron" III nylon** for durable, effective static control is available in most styles in "Antron" II.

**Specifier's Information Kit.** For more information—a carpet manufacturers' resource list, a specification guide for commercial office buildings, and a maintenance manual—write: Du Pont Contract Carpet Fibers, Centre Road Building, Room AR, Wilmington, DE 19898.

\*Du Pont registered trademark. Du Pont makes fibers, not carpets.

## Antron® II.

### The leading contract carpet fiber brand.



For more data, circle 39 on inquiry card

# Antron® II nylon. The known for its lasting

Architect: Vincent G. Kling & Partners, Philadelphia, Pennsylvania.  
Flooring Contractor: B. Shehadi & Sons, Livingston, New Jersey



## No Other Door Looks or Feels Like It



Most hardboard door faces are like Tweedledee and Tweedledum: it's hard to tell one from another. But you'll know Legacy when you see it. Because Legacy's wood grain isn't just lines on the surface; its pattern is deeply embossed. You see a grain rich in natural highlights and you can feel the texture as well. So Legacy faced doors are more than doors. They're a dramatic accent piece for every room.

## Not To Mention Durability

Some door facings seem as fragile as Humpty Dumpty. Not Legacy. Fifty percent denser than wood, hardboard Legacy is finished with an equally tough stain and mar resistant coating. The result is a door face highly likely to remain blemish free through installation manhandling and years of rugged use.

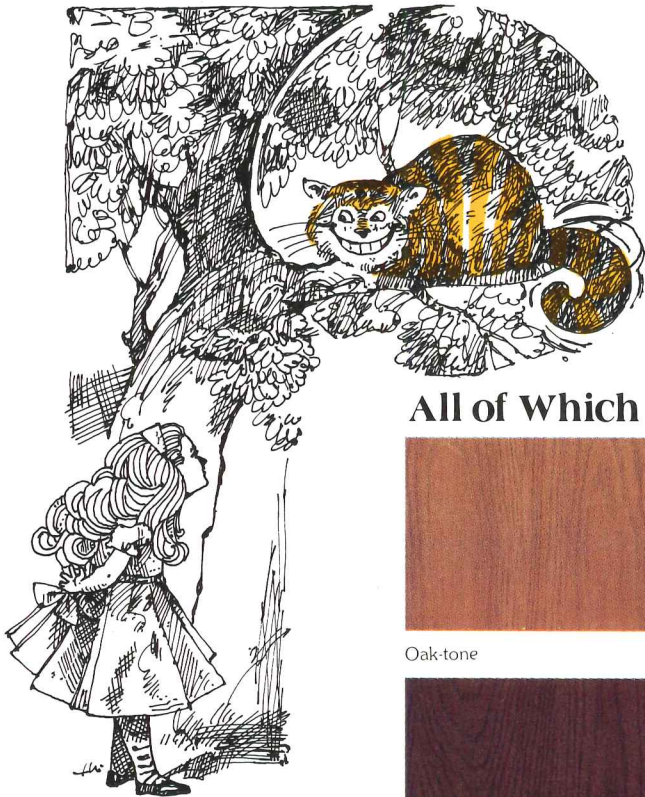

## And Low Cost

Legacy's high card trump is low cost. Priced well below solid real wood doors and just a bit above lauan and unfinished birch, every penny spent on Legacy faced doors buys more beauty and performance than money spent on any other door. So, go ahead. Smile like a Cheshire Cat. Your Legacy purchase will be a very clever buy.

## All of Which Means Legacy Stands Alone



Oak-tone



Walnut-tone

Masonite and Legacy are Registered Trademarks of Masonite Corporation.

Through past fluctuations in building starts, Legacy sales have moved ever upward. It takes a product without equal to generate such continually growing demand and Legacy is that kind of product. But then, it's what you'd expect from us. Hardboard's first name is Masonite.

For the names of quality door manufacturers using Legacy write: Masonite Corporation, 29 North Wacker Drive, Chicago, Illinois 60606.







# Legacy<sup>®</sup> is Trump

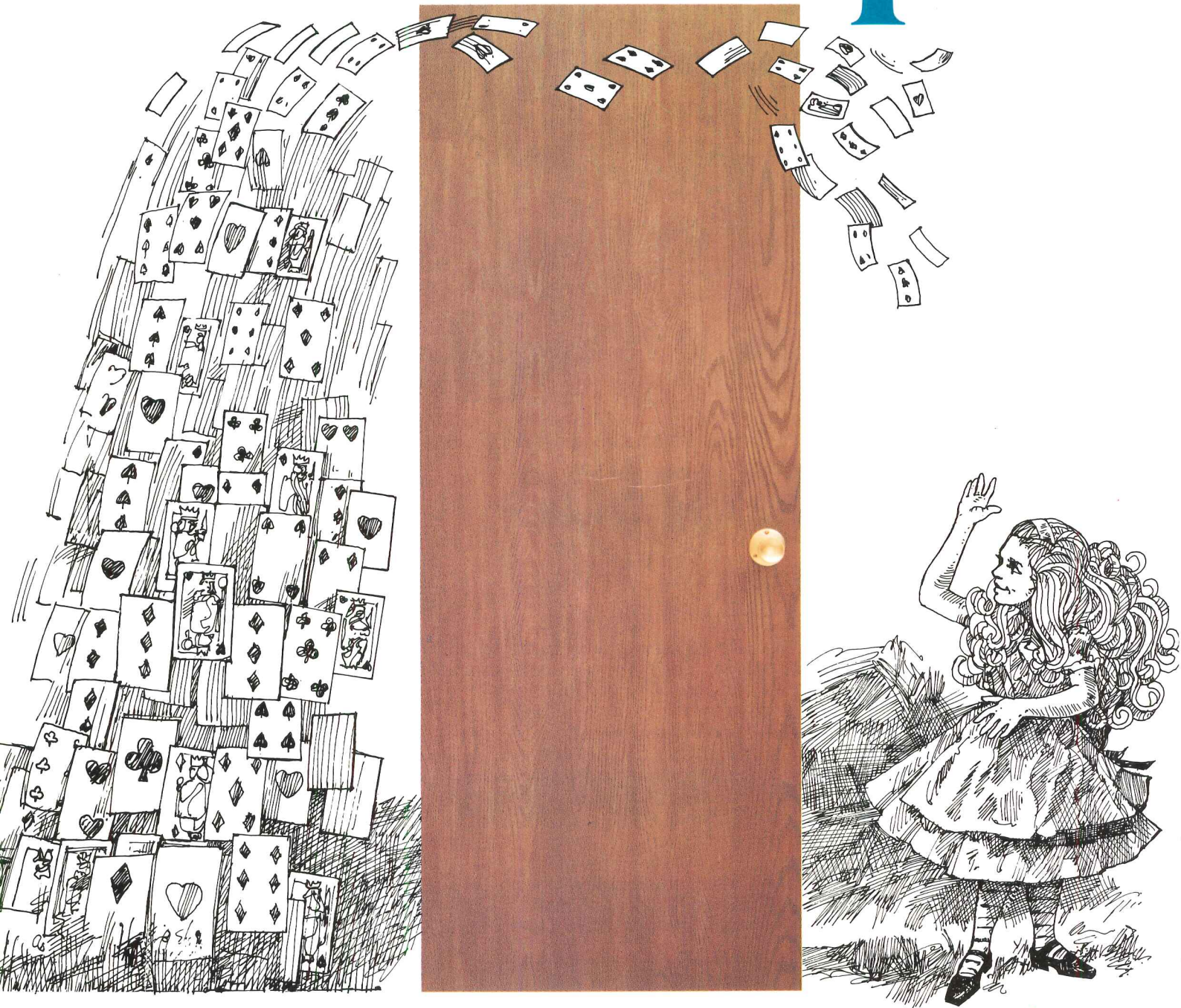

Other Doors Only Follow Suit

# cheaper than oil

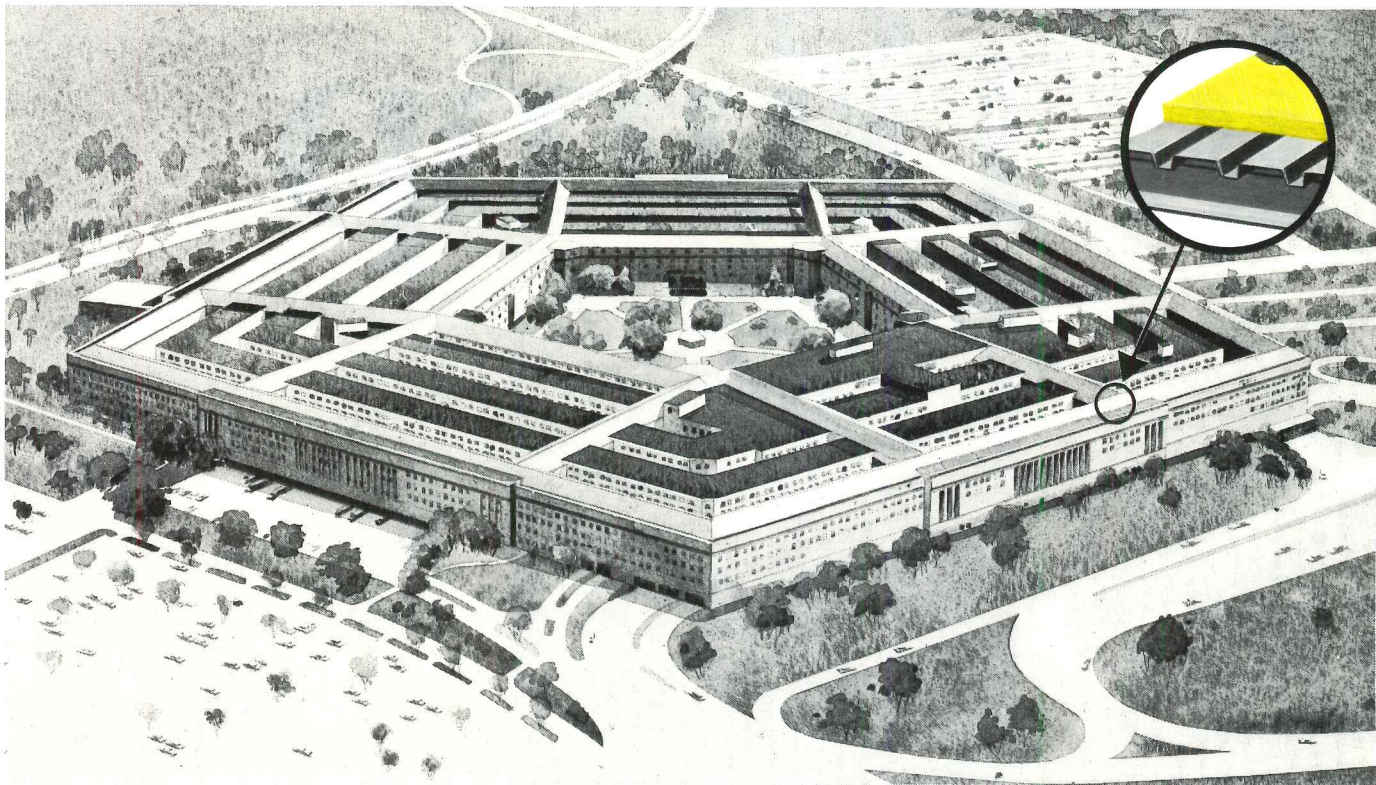

Projected cost to heat and cool the Pentagon for the next 20 years, if it were built today using thicker 2¼-inch Fiberglas roof insulation (after allowing for the cost of thicker insulation!):

## \$1,207,500

roof insulation saves money two different ways:

### A saving of \$1,333,954

1. It saves on energy costs. Estimated savings per year, based on gas heat and electric cooling in the Washington area, with a projected increase in energy costs at 7% per year and estimated future savings discounted at 10% per year: \$66,697 — or \$1,333,954 every 20 years.

2. It saves on construction costs. The estimated first cost of this en-

ergy-tight Pentagon would be *lower* than if the less efficient version were built! Reason: the improved thermal performance of the roof would permit use of smaller-capacity, *less costly* heating and cooling equipment. Amazingly, the estimated savings would be large enough to cover the added cost of the thicker roof insulation *twice* over.

**Important:** Thicker Fiberglas roof insulation also makes sense when it's time to re-roof *existing* buildings. It should pay for itself in a few

years, then go on saving thousands in fuel bills for years to come.

### Ask our "talking" computer

Our EMS II (Energy Management System) computer can give you savings figures on your next roofing job — by phone! You'll get projected energy *and* equipment savings, plus *payback* period. (Actual savings may vary.) For details, call your local O.-C.F. rep, or write: M.C. Meeks, Owens-Corning Fiberglas Corp., Fiberglas Tower, Toledo, Ohio 43659.

Owens-Corning is Fiberglas

OWENS/CORNING  
**FIBERGLAS**  
TRADEMARK®

For more data, circle 37 on inquiry card

# Insulation is

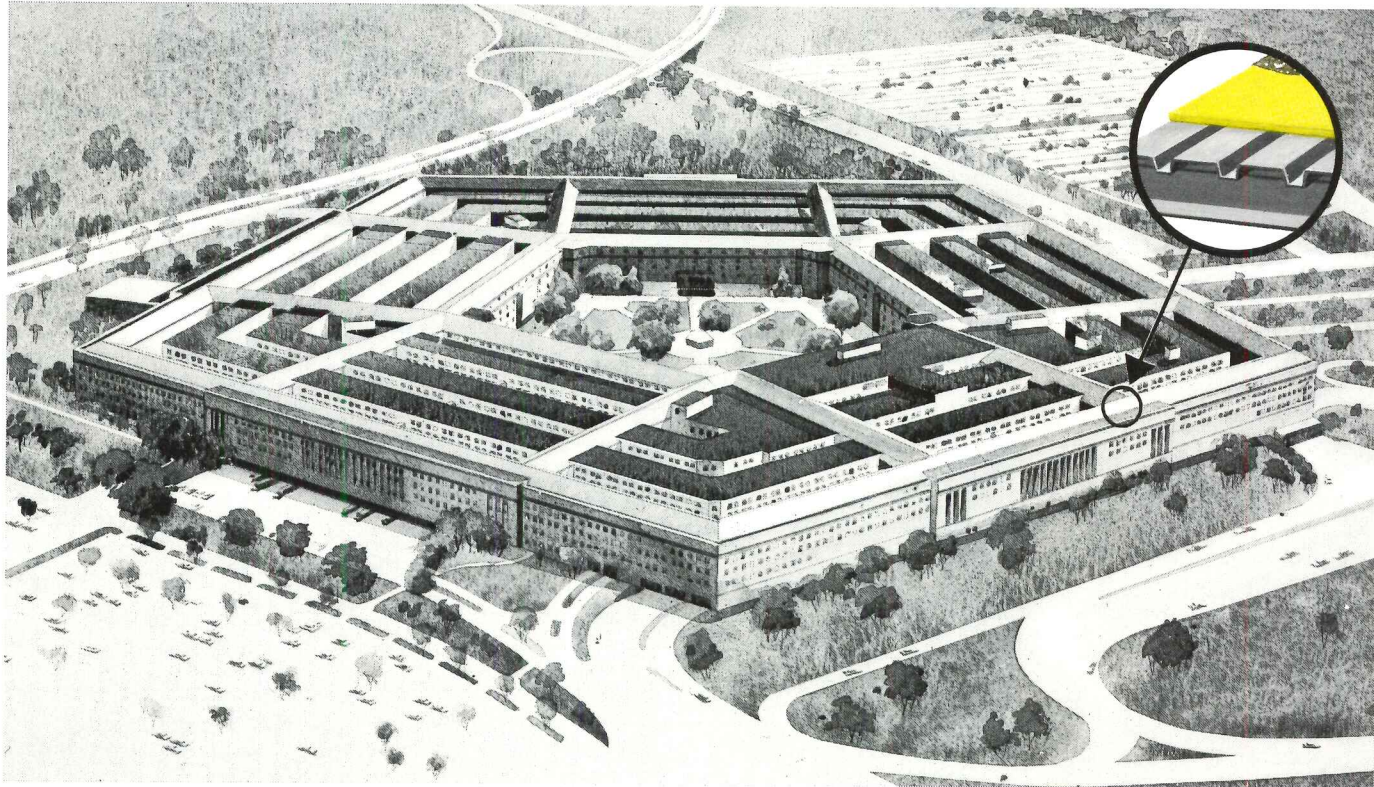

Projected cost to heat and cool the Pentagon for the next 20 years, if it were built today using only 15/16-inch Fiberglas roof insulation:

## \$2,541,454

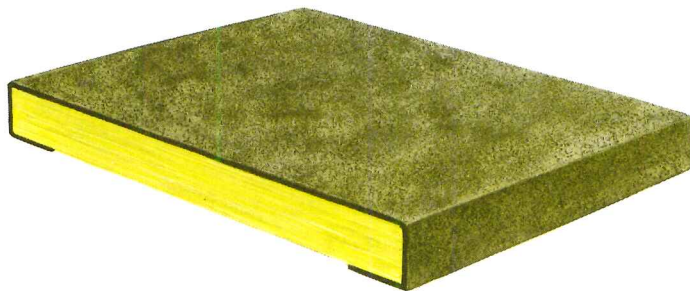

**Owens-Corning Fiberglas roof insulation—the only glass fiber roof insulation on the market.** Dimensionally stable. Retains thermal value. Easier to apply than organic/mineral boards. For over 30 years, the *best* base for built-up roof decks.

**T**he Pentagon—world's largest office building.

If it were being designed by *today's* architects for *today's* soaring heating and cooling costs, we trust it would have the specifications of the version on the right.

This version has a full 2¼-inch layer of roof insulation, instead of the thinner layer that has been usual for offices, schools, stores and other commercial buildings for the past 20 or 30 years.

Using thicker 2¼-inch Fiberglas

\*T.M. Reg. O.-C.F.

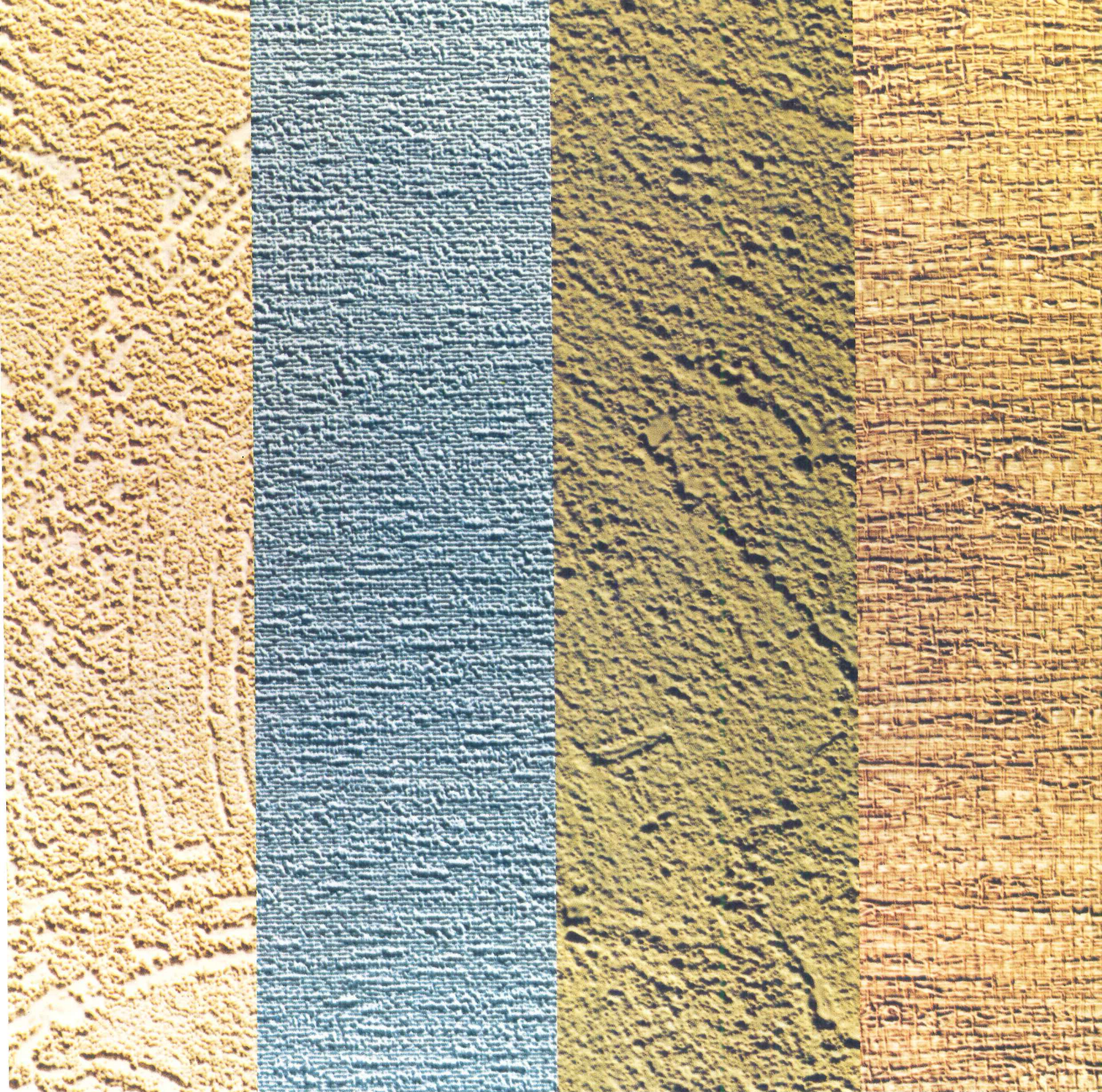

But we can make red walls, green walls, or gold walls. Barnboard walls. And grasscloth walls. Walls that have a look of leather. Full rich vinyl textured walls of all kinds.

And the B.F. Goodrich name is your assurance that they're quality vinyl wallcoverings. The very best we can manufacture.

Each pattern and design stands out because we've added a bit more to the textures. They're thick. Deep.

And because our wallcoverings are made of fabric backed vinyl, they're strong. And tough too. So the beauty never fades.

B.F. Goodrich vinyl textures can take a lot

more wear and tear than paint can. And you won't face the cost and hassle of regular repainting.

Think about it. And when it's time to cover your walls, specify B.F. Goodrich.

Get a hold of our Koroseal® swatch book. Check Sweets for your nearest BFG distributor or call Sweets Buyline (800) 255-6880.

B.F. Goodrich. Our name says it's the best.

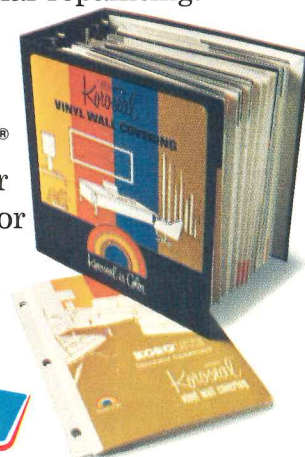



**And you thought that  
B.F. Goodrich  
only made whitewalls.**

# If you want all the latest answers,

Versatility? Assembly speed? Sound control?

Thermal insulation? Fire resistance? Weight savings? Component products?

Adaptability? Weather resistance?

curtain wall design manual

with Product and Construction Standards

UNITED STATES GYPSUM

## just ask.

This new STEEL-FRAMED CURTAIN WALL design manual is yours for the asking. U.S.G. covers everything for you in this handy reference guide, from bed-rock basics to the latest information regarding Problems and Remedies, Physical Test Data and Applications for Stucco, Brick or Panel Facings. Mail the coupon now and update your knowledge of the many advantages of USG® Curtain Wall Systems . . . the low cost way to enclose concrete and steel frame structures.

United States Gypsum, 101 S. Wacker Drive,  
Chicago, Illinois 60606, Dept. AR-17

I'm asking . . . so please send your new answer book,  
The Curtain Wall Design Manual, to:

Name \_\_\_\_\_

Firm \_\_\_\_\_ Title \_\_\_\_\_

Address \_\_\_\_\_

City \_\_\_\_\_ State \_\_\_\_\_ Zip \_\_\_\_\_

**UNITED STATES GYPSUM**  
BUILDING AMERICA

For more data, circle 35 on inquiry card



In Norfolk's Skyline:

## A decade of Ceco formwork

Contractors and owners coast to coast save on forming costs with Ceco services

Impressive architecture in concrete is adding excitement to Norfolk's modern, growing skyline. These four projects are typical of Ceco's concrete formwork in Norfolk over the past decade.

With Ceco services you get simplicity, speed and reliability.

— And a firm contract price that represents cost savings to contractors and project owners.

— And performance by formwork specialists who take pride in getting the job done right.

Ceco offers economical and time-saving formwork for rib-slabs, waffle-slabs, flat-slabs, columns and beams. Services are nationwide on a local basis. For more facts, please see Sweet's or contact your nearest Ceco office.

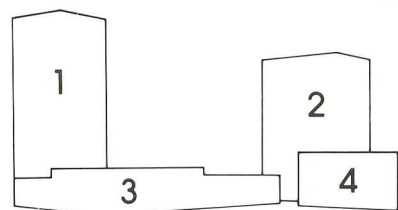

1. Virginia National Bank Building (1965)  
Skidmore, Owings & Merrill, *architects*  
Williams and Tazewell & Associates, *architects*  
Weiskopf & Pickworth, *structural engineers*  
Basic Construction Co., *contractors*
2. United Virginia-Seaboard Bank Building (1968)  
Vlastimil Koubek, *architect*  
Baskam & Chester, *structural engineers*  
Thorington Construction Co., *contractors*  
L. J. Martone and Associates, *concrete contractors*
3. I.C.C. Office Building (1975)  
Toombs, Amisano & Wells, *architects*  
Harald Nielsen & Associates, Inc.,  
*structural engineers*  
Batson-Cook Co., *contractors*
4. First Virginia Bank Building (1975)  
Dudley, Morrisette, Cederquist & Associates,  
*architects & engineers*  
Basic Construction Co., *contractors*



**CECO**

concrete  
forming  
services

The Ceco Corporation • General Offices  
5601 West 26th Street • Chicago, Illinois 60650

For more data, circle 34 on inquiry card

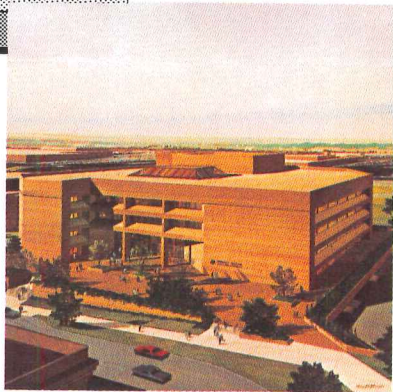
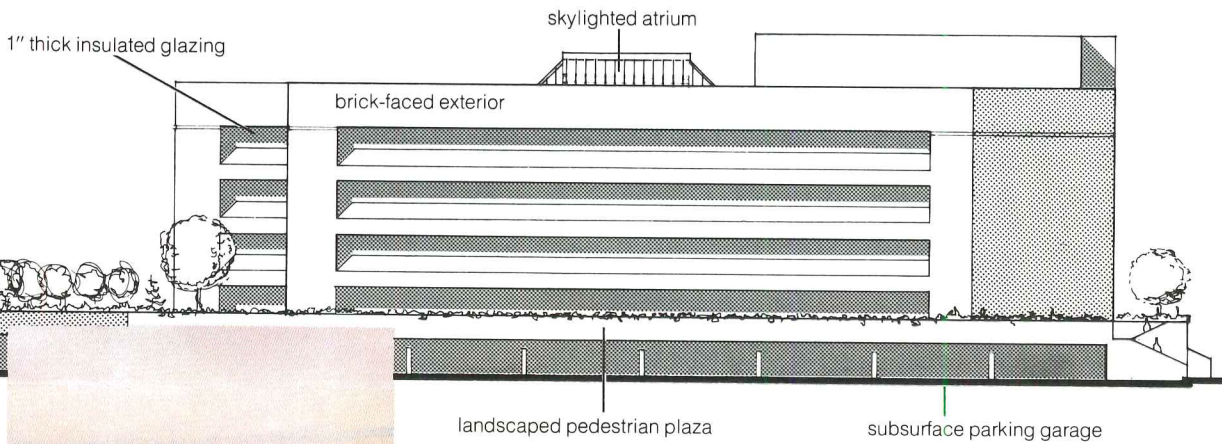

**Federal Office Building, Topeka, Kansas.** Uses mass plus heavy insulation in walls and roof to create an energy-conserving envelope. Open, skylighted interior atrium allows minimum exterior glazing. Windows comprise only 17% of exterior wall area. Glazing is recessed or shaded to reduce heat gain in summer. Lighting is 2.3 watts/sq. ft. Estimated saving on heating costs: \$2,600/year.

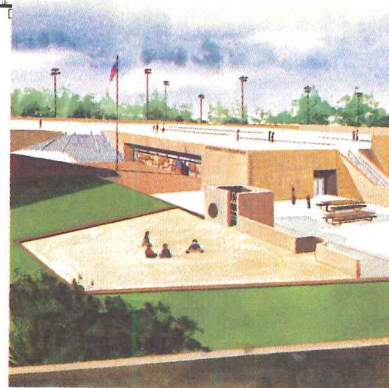
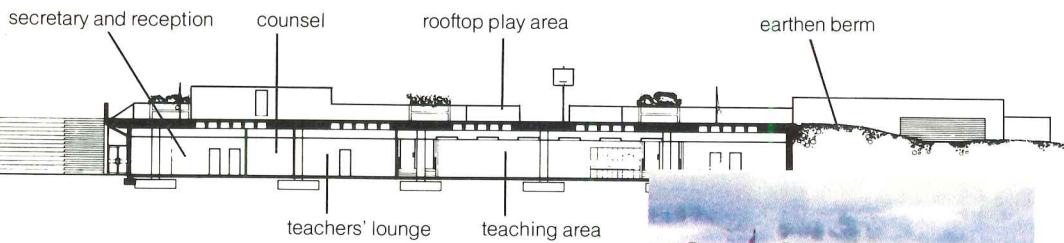

**Fremont Elementary School, Santa Ana, California.** Poured-in-place concrete construction stores heat in the structure, causes a lag in heat transfer to occupied spaces. Subsurface design and earthen berms reduce heat gain and loss through walls. Total cooling load is cut 20%, electrical consumption is cut by 42.5 kw/hr for annual savings of \$2,142.

Owens-Corning is Fiberglas **OWENS/CORNING FIBERGLAS** TRADEMARK (S)

For more data, circle 33 on inquiry card



## Three winning designs, and why they won

These buildings won top honors in the Owens-Corning Energy Conservation Awards Program for 1976. Look them over. They show how new and not-so-new thinking can produce outstanding energy-saving designs. For more information about all the 1976 winners, write to K.T. Meeks, Owens-Corning Fiberglas Corporation, Fiberglas Tower, Toledo, Ohio 43659.

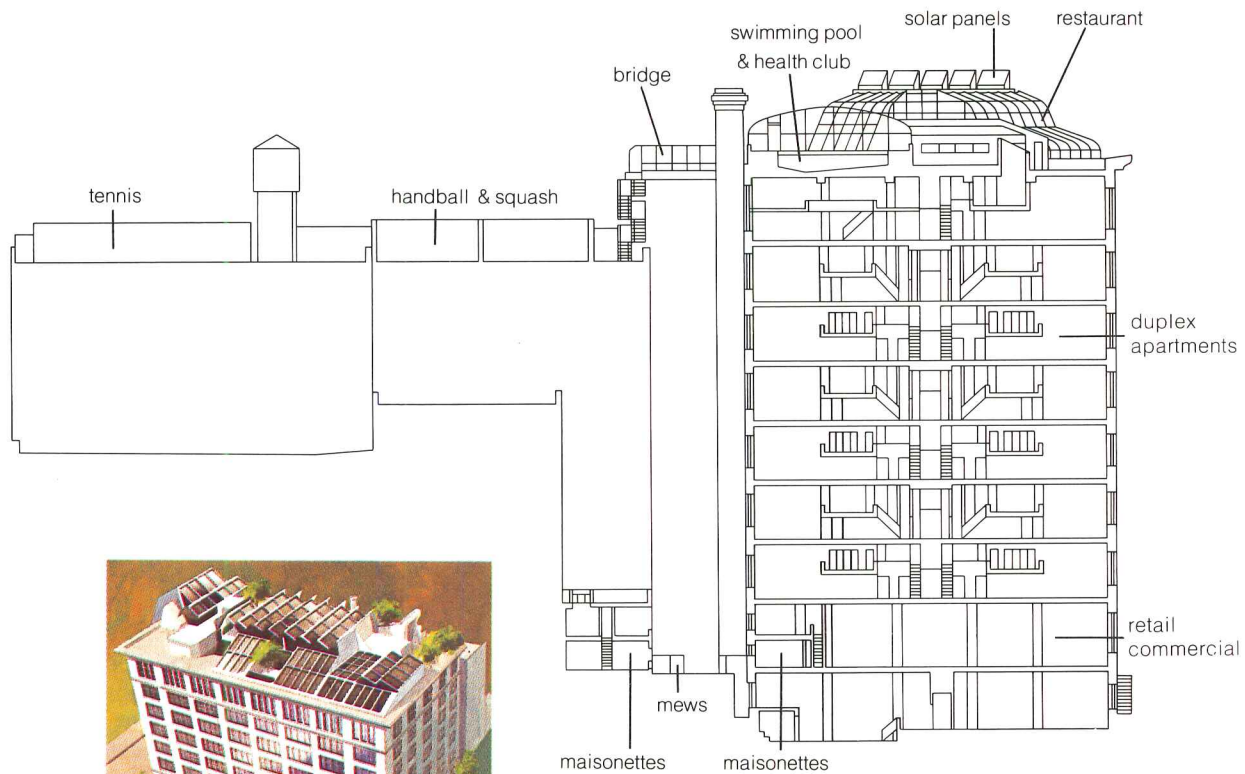

**Printing House, New York City.** Recycles an obsolete industrial building to create unique urban style housing. A vertical heat pump provides heating and cooling. Solar panels provide energy for domestic hot water. All insulation standards are upgraded. All windows are  $\frac{5}{8}$ -inch insulating glass.

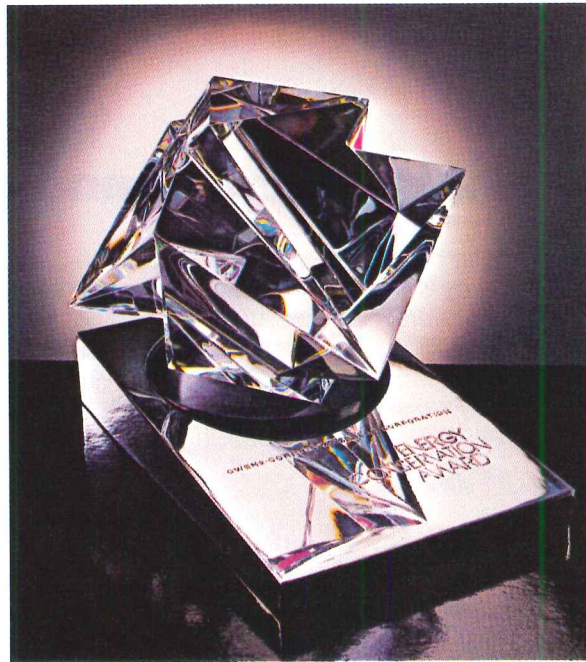

"Triangles" — a multi-faceted Steuben Crystal sculpture

## Announcing the 1976 winners of the Owens-Corning Energy Conservation Awards

### Winner, Institutional category

Allen and Miller, Architects, Santa Ana, California, for the Fremont Elementary School, Santa Ana, California

### Winner, Special category

Stephen B. Jacobs & Associates, New York, N.Y., for the Printing House, a former loft building in New York City

### Winner, Governmental category

Kansas Architects and Planners Associated, Lawrence, Kansas, for the Federal Office Building, Topeka, Kansas

### Honorable Mention, Governmental category

Unthank Seder Poticha Architects, Eugene, Oregon, and Marquess Engineering Company, Springfield, Oregon, for the Lane County Public Service Building, Eugene, Oregon

### Honorable Mention, Commercial category

Taylor and Collum, Architects, Atlanta, Georgia, for the Shenandoah Solar Community Center, Shenandoah, Georgia

### Honorable Mention, Institutional category

Arthur Cotton Moore/Associates Architects, Washington, D.C., for the Science Classroom at Madeira School, Greenway, Va.

### The 1976 Energy Conservation Awards Jury

This year's winners were selected by: John Street, chief architect, John Portman Associates, Atlanta, Ga.

William C. Louie, vice-president, Smith Hinchman and Grylls, Detroit, Mich.

Charles Schaffner, senior vice-president, Syska & Hennessy, Inc., N.Y.C.

Nathaniel Curtis, partner, Curtis & Davis Architects and Planners, New Orleans, La.

C. Herbert Wheeler, professor of Architectural Engineering, Pennsylvania State University, University Park, Pa.

Samuel Hack, director of facilities and construction management, U.S. Energy Research and Development Administration, Washington, D.C.

For a look at three of the winning designs, turn the page.

# Vari-Tran<sup>®</sup> is saving at Houston's Champions Bank.

## A glance at the chart will tell you how much.

When it comes to saving money, you can't fool a banker. The owners of the Champions Bank Building had their architects take a careful look around before they decided on LOF's Vari-Tran<sup>®</sup> 1-108 coated glass.

When the owners compared 1/4" Vari-Tran coated glass to 1/4" grey glass, they found they'd save \$111,363 right away—on heating, cooling and distribution equipment. And, they'd save all year long when it came to operating costs.

After that, the decision was easy.

What can LOF high-performance glass mean to your clients? Check the chart—then, contact one of our architectural representatives. He'll put our computers to work on a spec sheet for a building you have in the works.

For more details on LOF glass products, see our Sweet's Catalog—"Glass for Construction". Or, write Marty Wenzler at Libbey-Owens-Ford Company, 811 Madison Avenue, Toledo, Ohio 43695.

	1/4" Grey Glass	1/4" Vari-Tran 1-108	Savings
<b>Glass</b>	\$ 36,486	\$ 69,380	\$-32,894
<b>Heating, Cooling and Distribution Equipment</b>	184,020	72,657	111,363
<b>Comparative Initial Construction Costs</b>	220,507	142,047	78,460
<b>Annual Heating Costs</b>	2,208	1,613	595
<b>Annual Air Conditioning Costs</b>	36,776	13,503	23,273
<b>Annual Insurance Premium</b>	1,103	710	393
<b>Annual Property Taxes</b>	8,820	5,682	3,138

Owners—Champions Bank & Joe A. McDermott, Inc.  
Architect—McCleary Associates, Inc., Houston  
Mechanical Engineer—Jochen & Henderson, Inc., Houston

# LOF

## The flowering of Art Nouveau

*ART NOUVEAU BELGIUM FRANCE: Catalogue of an exhibition organized by the Institute for the Arts, Rice University, and the Art Institute of Chicago by Yvonne Brunhammer et al.; Institute for the Arts, Rice University, Houston, 1976, 512 pages, illus., \$20.00.*

In its brief life span of about twenty years (from approximately 1889 to 1909), the Art Nouveau style was widely diffused. It was to be found in varying degrees of intensity in Scotland, England, France, Belgium, Italy, Spain, Austria, Hungary and Bohemia (Czechoslovakia). This superbly illustrated book originally served as the catalog for the most comprehensive exhibition of Art Nouveau ever held in the United States. It was organized by Dominique de Menil, Director, Institute for the Arts, Rice University. In the book the focus is narrowed, as it was in the exhibition, to include only this efflorescent period as it glowed in Belgium and France. Within this judiciously limited scheme, however, the book's range is exhaustive. It examines and interrelates the style in all its aspects—those of painting and graphic arts including posters, sculpture, the decorative arts and architecture—displaying the work in hundreds of beautifully printed plates, including unusually fine color reproductions.

Art Nouveau was the last great style in every form of two- and three-dimensional expression. Their goal was a synthesis of the arts and, for a short time, they brilliantly succeeded. Theirs was the last era where mastery in all handicrafts was available to the designer, encouraging architects like the Belgian Henry van de Velde and the French Hector Guimard to work in all available mediums. Van de Velde, as shown in the book's sumptuous section on sculpture and the decorative arts, designed wall paper, chairs, appliquéd and embroidered hems, cuffs and collars for women's gowns, belt buckles, candelabras, canes, cufflinks, dinner services, flatware, wine glasses, stoves, door handles and other hardware. The painting and graphic arts chapter displays a Cézanne-like pastel on paper study of a garden by van de Velde, and a wood engraving by him for the cover of the magazine *Van Nu en Straks*. The section on architecture includes drawings and photographs of no fewer than seven projects designed by van de Velde including the *Kunstschule* in Weimar, which later, under Gropius, was to become the birthplace of the Bauhaus.

Guimard, like van de Velde, designed in ceramic, stained glass, wood, fabric and wall-paper. He drew covers for books, designed dress ornaments, created furniture, picture

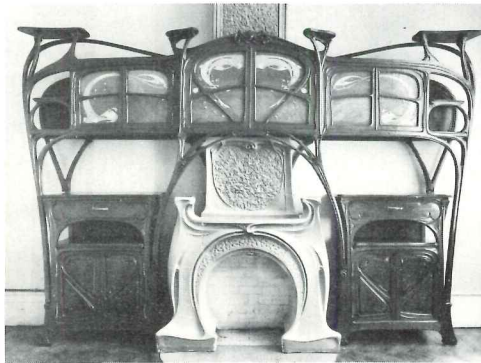

*Fireplace and buffet (c. 1899-1900) designed by Hector Guimard. The buffet is in fruitwood with panels of enameled glass. The fireplace is of glazed lava. It is in the Maison Coilliot, Lille.*

frames, canes and clocks. The book includes examples of all this work in its selection of sculpture and the decorative arts, and acknowledges Guimard's unique greatness by including a separate chapter on his architecture and ornamental cast iron.

The Belgian architect, Victor Horta, did not attempt to master as wide a range of the arts and crafts as did van de Velde and Guimard, limiting his work for the most part to the design of buildings and their ornamentation. The book includes rarely seen drawings and photographs of his marvelous turn-of-the-century houses for which structural iron was cast or bent in the shape of trees and plants upholding wonderful stained glass domes like great flowers.

Many lesser known architects have been included in the exhibition and book: the Belgians Joseph Bascourt, Ernest Blérot, Jules Brunfaut, Paul Cauchie, Alban Chambon, Paul Hankar, Antoine Pompe, Albert Roosenboom, Paul Saintenoy, F. Smet-Verhas, Gustave Strauven, Emile van Averbeke and Paul Vizzavona; the French Jules Lavirotte, Emile André, Henri Sauvage, Charles Plumet, Louis Sorel, Du Bois d'Auberville, Léon Binet, Anatole de Baudot and Frantz Jourdain.

Each category of Art Nouveau in the book is introduced by historical and critical texts and the architectural section has three: *Art Nouveau Architecture in Belgium: Red Steel and Blue Aesthetic*, by Maurice Culot; *Art Nouveau Architecture in France*, by François Loyer; and *Ornamental Cast Iron in Guimard's Architecture*, by Alain Blondel and Yves Plantin. Maurice Culot puts Belgian Art Nouveau in a social and political context with particular emphasis on the fact that the style was favored by the socialist Belgian Workers Party because of friendship between the party's young intellectual leaders and the avant-garde artists. Victor Horta designed the *Maison du Peuple*

(1895-1899) in Brussels for the Belgian Workers Party and in his memoirs (1940) described the commission with a hint of nostalgia for the enthusiasms of his youth:

"... I could see immediately that the work would be interesting: to build a palace, which wouldn't be a palace but a 'house' where air and light, too long excluded for workers' hovels, would be the luxuries. The house would lodge the administrative offices, cooperative offices, political and professional meeting rooms, and a cafe where the price of drinks would be in keeping with the director's desire to combat alcoholism, still a great problem among the people. There would be conference rooms for instruction and to crown it all, an immense auditorium for political meetings and the party's congress, as well as for the musical programs and theatrical events the members would produce."

Culot points out that from the beginning, Art Nouveau in Belgium was a means by which clients expressed their ideology. The liberals, socialists and freethinkers of the day chose Art Nouveau, just as their successors of the present day tend to select the more far-out of contemporary trends. In turn-of-the-century Brussels, engineers, lawyers and artists were more receptive than ordinary citizens to vanguard design for their own houses as they are today in late-20th-century New York. Culot adds that the Belgian Catholics of the time chose to build in Gothic Revival or Flemish Renaissance. Says he: "They condemned Art Nouveau on the ground that its sinuous curves appeared to be the mark of a totally pagan lubriciousness, and forbade its teaching in the architectural schools of St. Luc."

François Loyer focuses upon Art Nouveau architecture in terms of space as well as ornamentation, demonstrating its roots in academicism, eclecticism and particularly the Gothic Revival. He traces the effect of the work of Viollet-le-Duc upon Guimard and indicates how such other mid-nineteenth century architects as Henri Labrousse and J.A.E. Vaudremer helped lay the groundwork for the great artistic resurgence soon to come.

The last article by Alain Blondel and Yves Plantin is devoted appropriately to Guimard alone. After about 1909, when Art Nouveau with amazing suddenness became passé, this great architect did not, as Horta and many others eventually were to do, misrepresent and repudiate his early work in an attempt to appear as a pioneer of functionalism. His last building, constructed in Paris in 1928, was boldly cast in the by then thoroughly discredited Art Nouveau style. As the authors point out: "He was the last Art Nouveau architect, as he had been, in France, the first."

—Mildred F. Schmertz

Finally, GAF® introduces the first truly

color coordinated Architectural Floor Tiles.



So now, when you decide on  or 

you can match with   and  or

blend with   or highlight with 

 or  or decide on   or 

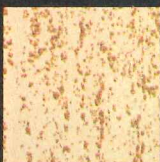
and match with   or contrast with

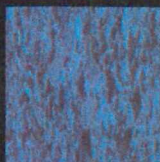
  or even . Whatever. You can

create it with the first Architectural Floor  
Tile Line made to go beautifully with itself.

In 45 colors, 26 of them new for 1976.

Beautiful.  Architectural Floor Tiles

**In Tehran: a private developer plans condominiums for the suburbs**

For private developer Deyhuk Co. Ltd. in Tehran, Martin Holub, a New York City architect who also practices in Iran, designed the 15-unit Ghey-tarieh condominium for one of the city's rapidly growing suburbs. Mr. Holub attributes the acceptance of his design at least partially to American experience in efficient floor planning—local architects, with expansive notions of interior space, were unable to achieve more than an uneconomical 12 units on the site—as well as to American experience in nego-

tiating code variances—the zoning code here was varied to accommodate a penthouse on the fifth floor, a height normally permitted only if the entire building were raised on piloti. The stepped duplex apartments (each floor plan is different from the others) pass through the building to provide cross-ventilation and to command views both northward toward the mountains and southward, from private terraces, toward the city. The building, to be faced with local stone, will overlook a landscaped garden at the back.

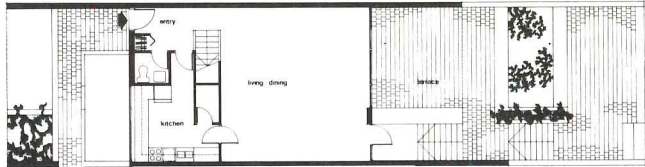
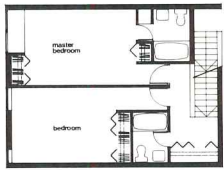
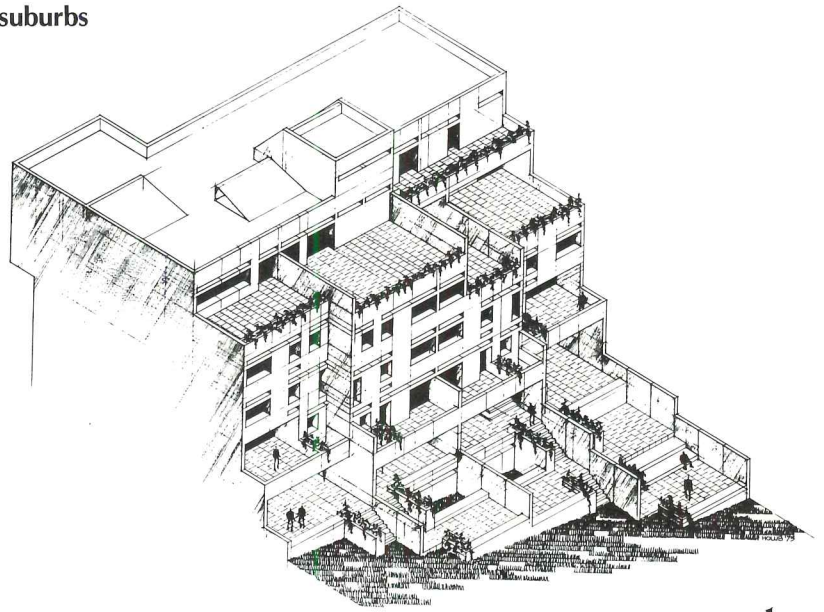

apartment 1

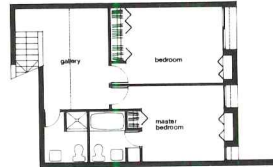
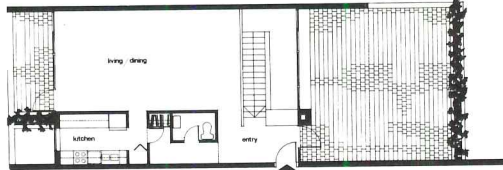

apartment 9



apartment 15

**In Salalah: a 167-shop *souk* will occupy the new town center**

In the town of Salalah, Oman, the government plans to build a new *souk*, or market place. Both *souk* and the new town center of which it will be part were designed by architects McGaughey, Marshall & McMillan of Norfolk, Virginia, for Ashaykh Braik Ben Hamoudi Alghafiry, the Wali of Dhofar. (Salalah, on the Arabian Sea, is the chief government center of Oman's southern Dhofar Province.) The 200,000-sq-ft facility will encompass 167 shops of various sizes and a large meat and fish market, all interconnected by a network of shaded pedestrian walkways leading into small tiled courts with fountains. Service vehicles and customer parking will be accommodated at the periphery. The *souk* will cost an estimated \$19 million.

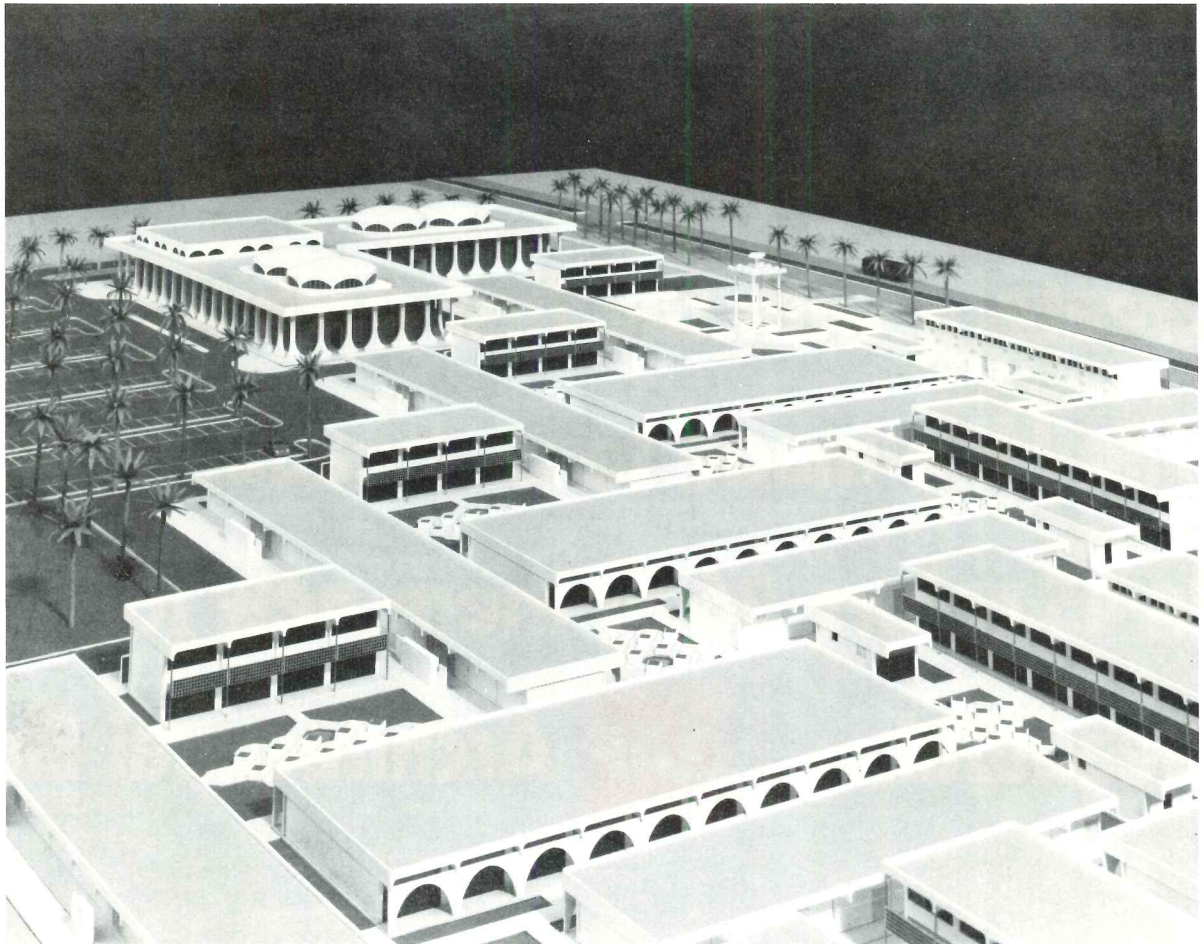

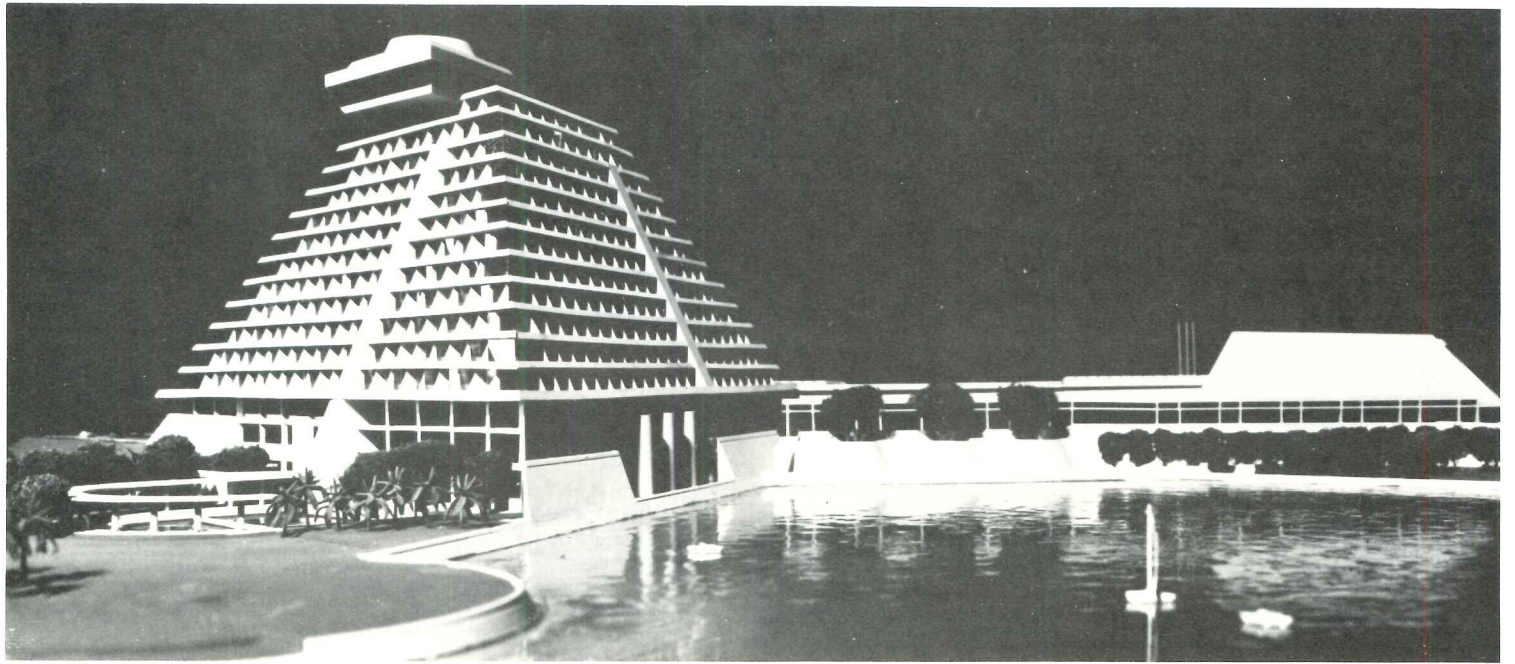
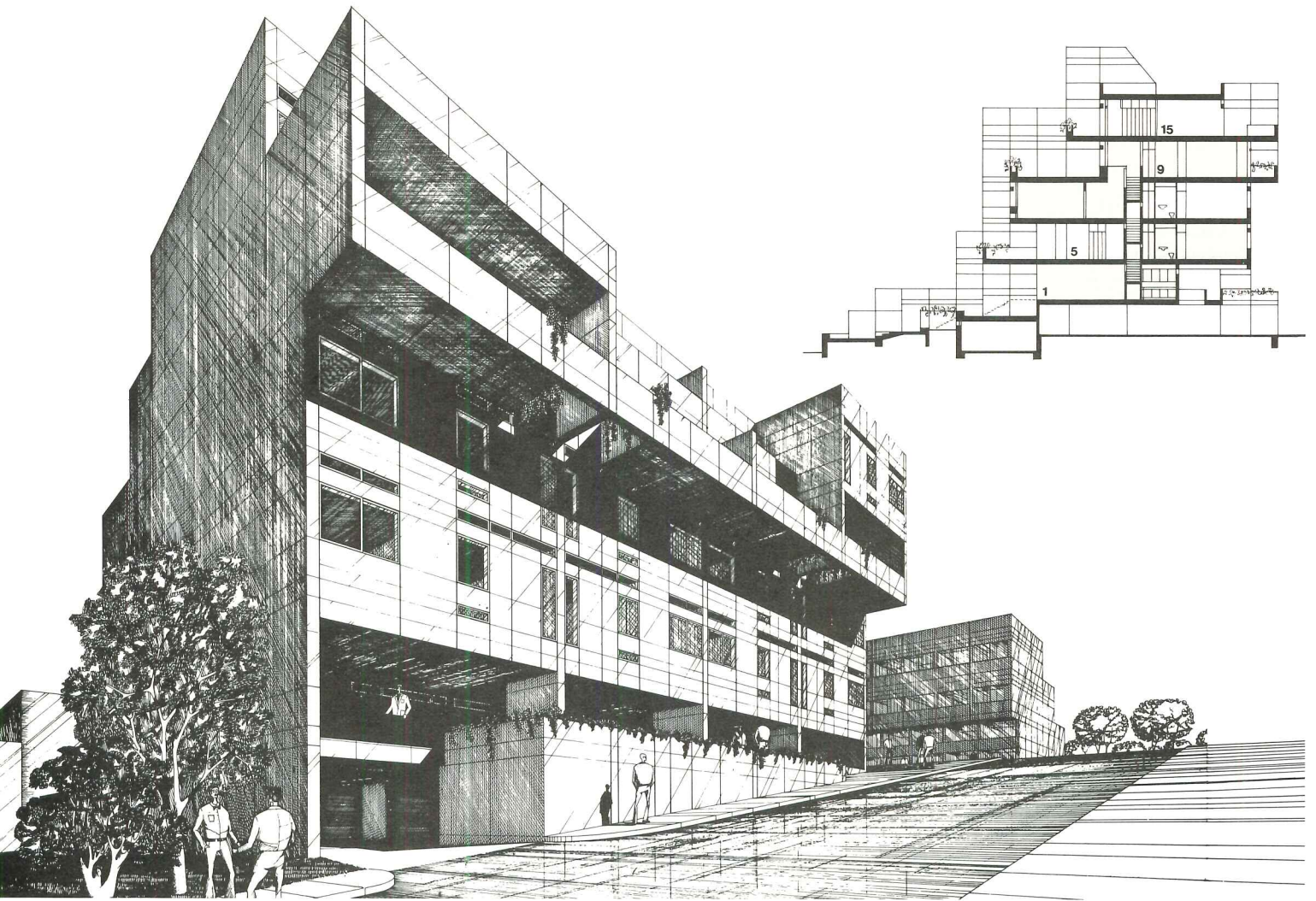

**In Doha: the Sheik builds a luxury hotel with convention center**

A triangular pyramid, which will house a luxury hotel and a conference center, is presently under construction on a point overlooking the Persian Gulf at Doha, Qatar. Designed by William L. Pereira Associates for Sheikh Khalifa bin Hamad al-Thani, the Emir of Qatar, the profile of the 16-story tower, at

the northern edge of Doha's harbor, will echo a proposed tower at the harbor's southern edge in New Doha, now being planned by WLPA. In addition to 430 terraced guest rooms and a 750-seat auditorium in the conference center, facilities will include restaurants, a motion picture theater, a ballroom and

*souk* (shopping Galleria). A 13-story atrium will provide what the architects term a "man-made oasis," and continuous sunshades on the exterior will shield guest-room balconies. The steel-frame, precast building, scheduled for completion late next year, will cost an estimated \$90 million.

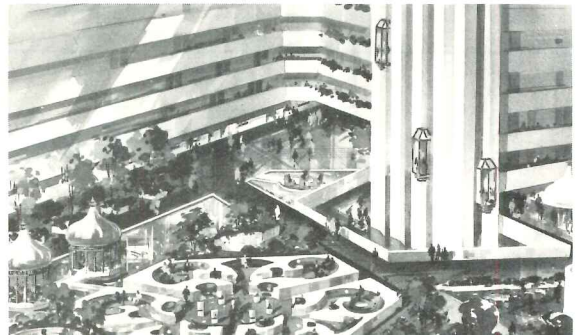

**T**he results are in.

Grueling, independent tests by Bowser-Morner Testing Laboratories—using National Bureau of Standards performance criteria for built-up roofing systems—have proven what we've been saying all along:

When it comes to thermal shock performance, our Fiberglas\* Perma Ply-R built-up roofing system is superior to conventional systems.

As defined by the National Bureau of Standards, "The Thermal Shock Factor (TSF) is an indicator of the roof membrane's ability to withstand the normal temperature changes of its environment. Values of the coefficient of expansion, tensile strength, and load-strain modulus can be used to calculate the TSF."

The heart of our system is the unique, inorganic Perma Ply-R felt. It works two ways to give the system its strength.

First, when daily temperature changes cause a roof to expand and contract, Perma Ply-R is the best reinforcement it can have. That's because the Perma Ply-R felt is made of strong,

continuous strand glass fibers. So its physical strength characteristics are similar, both longitudinally and transversely.

Second, Perma Ply-R helps create a monolithic roofing system. The strongest kind of system there is. The reason: Perma Ply-R is a porous felt. So it meshes totally with the bitumen.

What does all this mean to anyone who's faced with specifying a built-up roofing system?

Simple.

Properly installed, our Perma Ply-R system minimizes the possibility of splitting, blistering, and internal deterioration of membranes. It has the potential to outlast any other BUR system money can buy.

If you want to see the "Thermal Shock Performance Comparisons," please contact your local Owens-Corning representative or write: M.H. Meeks, Owens-Corning Fiberglas Corp., Fiberglas Tower, Toledo, Ohio 43659.

They've got the test results that prove every word.

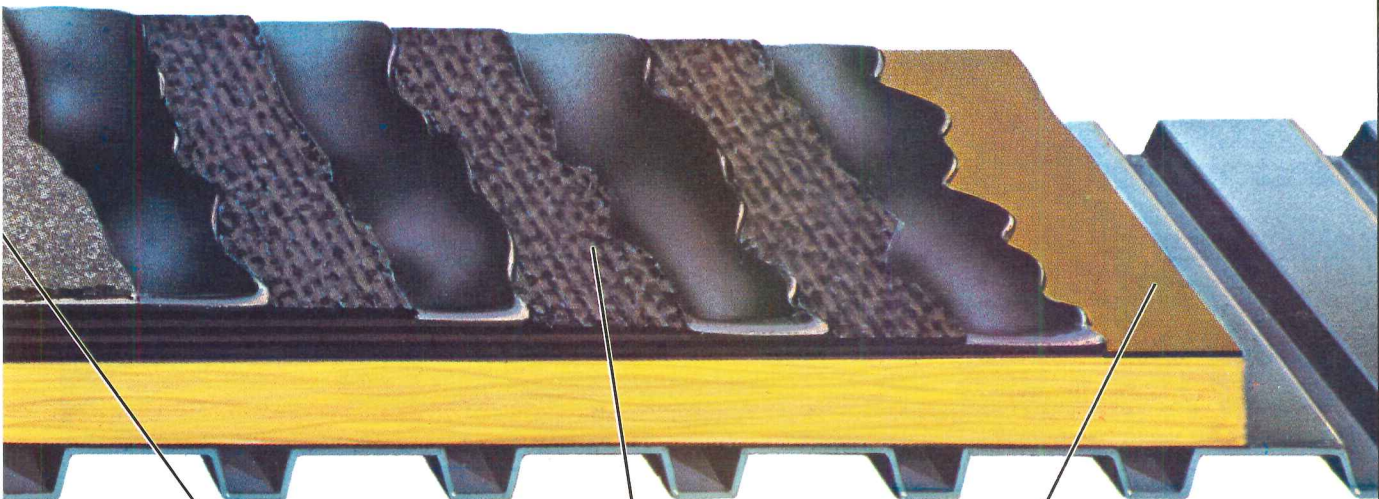

Our Perma Cap surfacing sheet combines two materials: Fiberglas—so it's tough, won't warp or rot. And inert, non-combustible white ceramic granules that reflect sunlight and help minimize thermal shock.

Our Fiberglas Perma Ply-R is a porous felt. So it can mesh with the bitumen, creating a monolithic roofing system that minimizes interply blistering and adds to the roof's outstanding thermal shock performance.

Our Fiberglas roof insulation has its own Fiberglas reinforced asphalt cover. So the bitumen can be applied directly to it, making the insulation an integral part of the membrane.

**Owens-Corning is Fiberglas**



For more data, circle 30 on inquiry card



**TESTS PROVE:**

**Of the leading roofing systems,  
Fiberglas Perma Ply-R withstands thermal shock  
better than any other**



## Colombia will build shell housing with unfinished interiors at a Bogotá condominium

struction and Building Materials Program in Commerce's Domestic and International Business Administration.

The new committee will be chaired by Under Secretary Edward O. Vetter, who personally delivered Mr. Richardson's letter to Mr. Abrams. The letter says that the committee "should provide an immediate forum for the construction industry within the Department of Commerce." However, it says, the involvement of an Under Secretary assures ready access to all units of Commerce and the "department's top policy echelon, and, when needed, between the department and other Federal agencies."

The committee will have representatives from Commerce's Bureau of Domestic Commerce, the Bureau of International Commerce, the National Bureau of Standards, the Economic Development Administration, the Office of Minority Enterprise, the Bureau of the Census, and the Office of Energy Programs.

Construction groups began clamoring for an Office of Construction—perhaps at the Cabinet level—after a 1974 housing and construction conference on inflation was held in Atlanta. It appeared at that time that the Administration was unaware that nonresidential construction considered as a whole has problems far different from those of homebuilders considered alone.

Mr. Richardson and other top officials turned down the industry's initial requests which "involved an elaborate organization with a wide scope of operations."

"To be frank," Mr. Richardson said, "while we are very sympathetic to the purpose behind your proposal [for an Office of Construction], we must also be able to reconcile any major organizational move for construction with other proposals for strengthening Commerce's industry programs in general."

He said Commerce could not create the office "at this time," but added that his committee proposal "is appropriate and responsive to your request."

The NCIC also voted to reconsider its historic bar of discussions and positions on labor relations matters. It instructed its by-laws committee to prepare a proposal for consideration at a special meeting in January, making it clear that the 30-member council can discuss and take positions on any subject affecting the industry.

This, presumably, opens the way for the Council to engage in the fight against situs picketing legislation and against repeal of Section 14(b) of the Taft-Hartley Act—both of which are expected to come up when Congress convenes this month.

In other action, the council appropriated \$2,500 to pay Samuel J. Dennis, a retired Bureau of Census official, to develop a construction statistics program.—*William Hickman, World News, Washington.*

For a 1,200-unit mass housing condominium planned for Bogotá, the Colombian firm Cuellar Serrano Gomez will combine a Mexican precast structural system with unfinished interiors to achieve a low-cost building that will also encourage the participatory engagement of owner/occupants in the construction process.

For the basic structure, the Colombian builders will use the Cortina System, a system of walls and floor slabs precast on site in layers so that the walls unfold as the slabs are successively jack-lifted into position (see RECORD, mid-August 1975, page 124). Masonry units for exterior infill and interior walls are carried on the slabs as they are raised.

At Bogotá, the system will be cast in a configuration called by its designers "type H." The 50 square meters in each apartment are interrupted by two walls enclosing the bathroom, while the U-shaped interior bearing panels, after the structure unfolds, provide columns to anchor occupant-built parti-

tions—curtains or plywood can be installed to yield one, two or three bedrooms. The project management will provide building materials at reasonable prices, as well as advice on construction techniques and bimonthly inspections for safety.

The developers see two key advantages in the design of the project—one social, the other economic.

First, they see a built-in defense against the alienation and resentment that are common problems in "project" housing programs. Because occupants of such mass housing do not understand what goes into them, they are often antagonistic toward what seems like a giveaway program. Says Gonzalo Cortina of Eledifica, S.A., owner of the Cortina System, "The typical case is the man who discovers his walls are hollow, then angrily punches holes in them. That won't happen if he builds them himself." Instead, it is hoped, owners will take pride in their own work. Ideally, social status will be conferred on the

owner of the best-finished apartment, and his neighbors will copy his work.

The economic advantages of the project include both the low-cost basic structure and the use of "auto-construction" techniques by the project's users—that is, the utilization of construction experience that the project occupants have acquired in building the shanty towns replaced by the new housing units.

I. C. Construcciones, S.A., parent company to Eledifica, has also proposed a similar undertaking for Mexico's housing agency INFONAVIT (see RECORD, June 1976, page 37). The proposed Mexican type H units would include both sink and gas stove in each kitchen. (At Bogotá, occupants will furnish their own petroleum stoves.) I. C. Construcciones estimates that the Mexican proposal could reduce construction costs by 28 per cent, allowing 39 per cent more units to be built within the available housing budget.—*Timothy Berry, World News, Mexico City.*

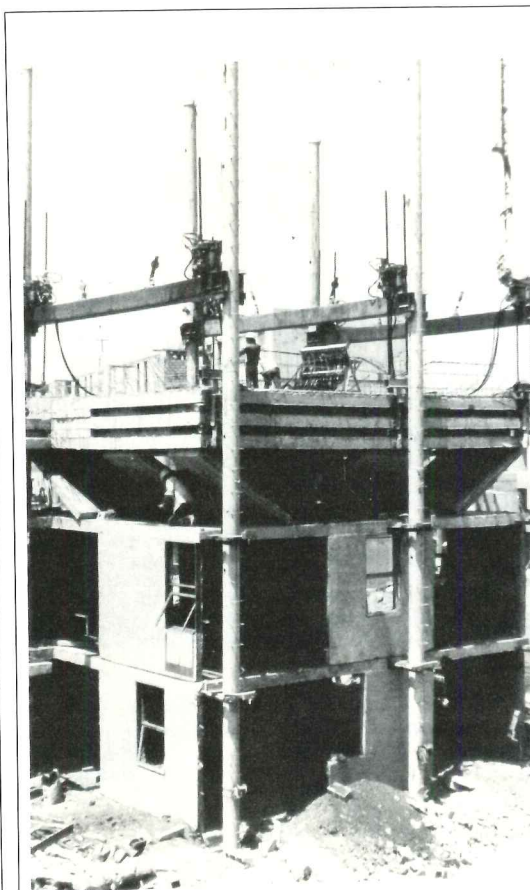

Above: Cortina System in erection

Top right: entrance facade

Center right: typical floor plan, unpartitioned

Bottom right: lateral facade

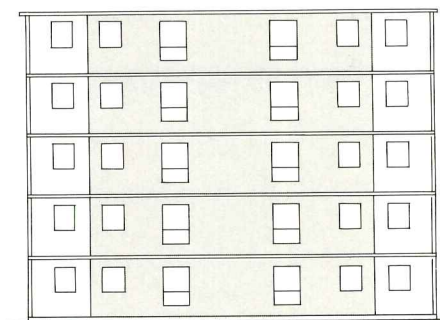
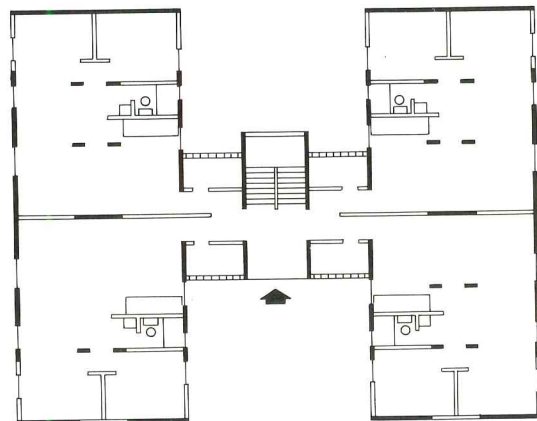
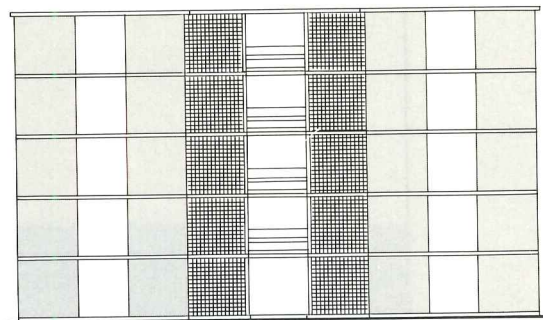

HAUSERMAN  
CLEVELAND / TORONTO

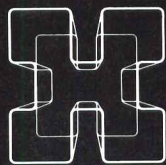

Today's office will not be right for tomorrow.  
The system you select now should be right for both. The  
Hauserman Office System is completely adaptable to your requirements . . .  
today and tomorrow . . . space division, files and storage components,  
desks and work surfaces, power distribution and lighting,  
accessories and a new breed of graphics.



Hauserman, Inc., 5711 Grant Avenue / Cleveland, Ohio 44105 / (216) 883-1400  
Hauserman Ltd, 125 Bethridge Rd. / Rexdale, Ontario, Canada / (416) 743-3211

## Proposed Museum of the Building Arts gets \$85,000 earnest money from HUD, the National Endowment and L.A.W. Fund

An institution to celebrate and enhance architecture and the other building arts through a museum, archives, library and study center is now being planned—probably as an expansion of the Smithsonian complex in Washington.

A committee of planners, headed by architectural historian Cynthia R. Field, has determined that the 1885 Pension Building—not too far from Capitol Hill—should be the home for the new complex, which they are calling The National Museum of the Building Arts.

Dr. Field and her committee are now striving to interest architects, building engineers, urbanists, business and labor leaders in helping refine a proposal that may lead to the museum's establishment. The emphasis will be on the entire built environment.

The committee has received \$85,000 in grants. The National Endowment for the Arts and the Department of Housing and Urban Development have both provided \$40,000, and \$5,000 came from the L. A. W. Fund, a New York foundation. The museum committee has also signed on Wolf von Eckardt, *Washington Post* architecture critic, for a year of effort in developing the proposal.

Dr. Field, who operates out of the third-floor loft of a Dupont Circle townhouse, hopes to attract a wide range of business and industry interests to participate in the program. In her view, it may be possible to attract

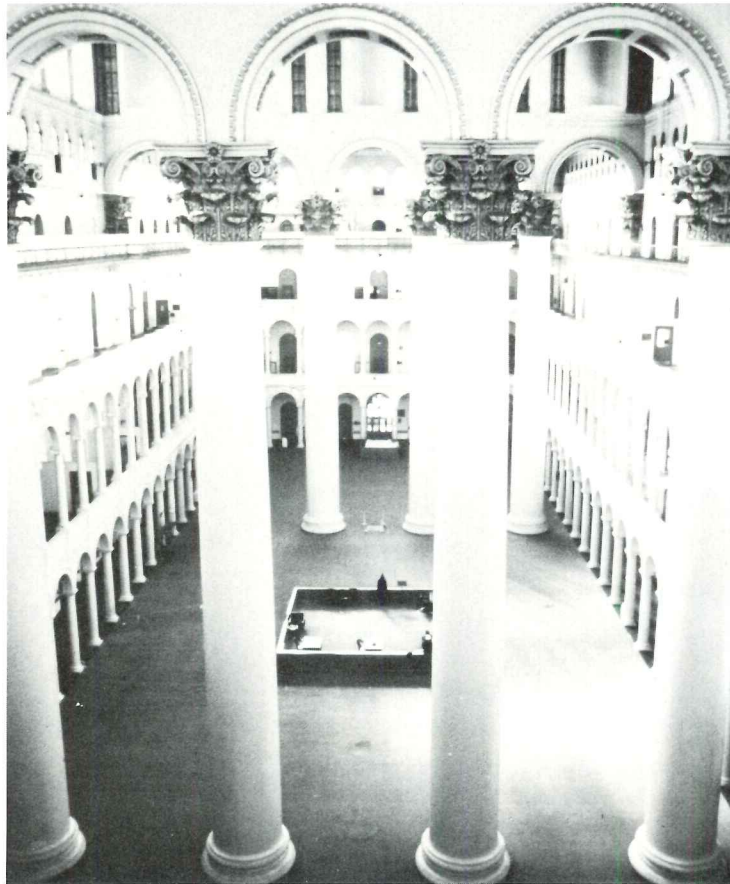

participation by the Library of Congress, the National Archives, historical preservationists, and perhaps even the National Institute of Building Sciences.

The Pension Building, which is owned by the Federal General Serv-

ices Administration, is now occupied by courtrooms of the District of Columbia Superior Court. A new building now under construction will house the Superior Court in about two years.

The building, built at 5th and G

Streets N.W. more than 90 years ago, was designed by Montgomery C. Meigs, a general in the Corps of Engineers. It has a grand court enclosed by a gallery roof supported by eight massive 75-foot Corinthian columns. A guidebook published by the American Institute of Architects calls it the "most astonishing room in Washington."

Before the renovation work gets underway, it will be necessary to win several forms of approval. Dr. Field is trying to attract aid from all construction interests. If the ball gets rolling, she and her committee hope to publish the first draft of their formal proposal by June. If acceptances follow, the committee will go to Capitol Hill to round up legislative support and authority to spend renovation and operational money.

Early planning is pointing toward an institution with four distinct functions:

- A museum presenting man's architectural and environmental heritage with changing exhibits.
- An archives for collecting and preserving papers and designs of American architects, planners, engineers, builders and landscape architects.
- A library that will specialize in books and journals related to American building and design.
- A study center to encourage the National and International exchange of scholarly studies to "increase knowledge of American accomplishments in the building arts."—*William Hickman, World News, Washington.*

## NIBS issues a wide-ranging Missions Paper to define its strategies and operations

The National Institute of Building Sciences (NIBS), now being organized by its board of directors, is carving out a large role for itself. The 21 board members feel the Institute should be preeminent in all areas involving building technology.

That is probably what Congress had in mind, too, when it went along with the construction industry's request that the Institute be established in the first place. The fact that the board—composed of business, labor, government, consumer and public members—agrees so closely with the legislation's intent bodes well for the NIBS' future.

A charter, which is in its sixth revision, says the organization would deal with all problems associated with the development of construction technology and speed its adoption in a somewhat standardized form. In its preamble, the NIBS Missions Paper says the organization will stimulate development of "needed scientific and technical knowledge" and ensure "that existing and yet-to-be-formulated construction technologies are rapidly introduced into and accepted by the building community."

The Missions Paper, prepared by a subcommittee headed by architect Herbert H. Swinburne of Philadelphia,

establishes "strategies" to be followed by the organization:

- Establish the Institute as the authoritative national source of information on building science and technology, performance criteria and standards, and the building process.
- Identify research areas, develop building research agenda, define issues related to innovation, and encourage research by public, private and educational institutions.
- Develop a system for recognizing building performance criteria and standards.
- Create a national system for the evaluation and requalification of existing and new building technologies.
- Establish a building regulation information program by assembling data on existing codes and standards.
- Demonstrate how the building code process can be coordinated to become a system that consolidates the building community.
- Develop methods for introducing scientific and technological innovations and performance criteria.
- Develop a system for making the Institute financially self-supporting.

While the strategies are being pulled together by Mr. Swinburne's group, another panel headed by Joseph H. Newman of Tishman is begin-

ning to sort through more than 80 résumés of candidates for the NIBS presidency, the chief permanent staff position. Mr. Newman says the committee will offer a recommendation early this year. His subcommittee will also suggest a salary for the president that will be competitive with private industry compensation rather than with civil service pay.

Nicholas A. Panuzio, Commissioner of the Public Building Service in the General Services Administration, acknowledged that he is an applicant for the top job. Mr. Panuzio is a Republican and former mayor of Bridgeport, Connecticut. He assumes the Carter Administration will replace him at PBS.

Many other names are being circulated, including one from a top architect who has offered to dissolve his firm if selected for NIBS' top slot.

NIBS was authorized by Congress in 1974 as a nongovernmental, non-profit organization. The 21 board members were nominated this year. The chairman is Otis M. Mader, an executive with the Aluminum Company of America. Robert A. Georgine, president of the Building and Construction Trades Department, AFL-CIO, is the secretary-treasurer—*William Hickman, World News, Washington.*

## Commerce Department moves toward Office of Construction

On-again, off-again signals from Federal officials considering an Office of Construction are presently on. As a first step, the Commerce Department has agreed to create a Construction Program and Policy Coordination Committee (CPPCC) with an executive director. The committee will serve as the focal point for construction industry contact with the Federal establishment.

Announcement of the committee's creation came at a recent meeting of the National Construction Industry Council in Washington. NCIC has been in the forefront of a two-year battle to win Federal government recognition of the nonresidential construction industry.

Commerce officials said they would encourage President-elect Jimmy Carter's transition team to continue the construction committee into the new administration.

Outgoing Commerce Secretary Elliot L. Richardson said in a letter to NCIC chairman Philip Abrams that he was naming Aaron Sabghir, a 34-year veteran of government service, as the committee's executive director. Mr. Sabghir, who regularly attends NCIC meetings, is director of the Con-

*continued on page 39*

## Urban unions reduce wages to stimulate housing rehab

What may be a major breakthrough in rehabilitating inner-city housing—both single-family units and apartments—has been launched by the outgoing Republican Administration and the leadership of the building trades unions of the AFL-CIO.

Housing Secretary Carla M. Hills, building trades leader Robert A. George, and the contractors in the National Housing Rehabilitation Association have pushed through agreements in a number of cities whereby the major building trades unions accept lower wage rates—usually 75 per cent of their regular scale—for rehab work. For their part, city officials, the Department of Housing and Urban Development, and rehab contractors have to commit themselves to financing enough rehab work to produce enough jobs to make the program attractive to the building trades locals.

Thus far such agreements have been signed in Philadelphia, Atlanta, and New York City—with the expectation that they will be signed soon in a number of other cities, such as Boston, Cincinnati, Pittsburgh, Kansas City, and Oakland, California.

The Philadelphia agreement, signed last summer, covered rehab work to be done there on several hundred HUD-owned row houses. After they have been rehabbed, these single-family units are to be put on the market at HUD-specified prices.

For the apartment rehab program, HUD is providing the back-up financing to make the multifamily units eligible for subsidies to low-income families under the Section 8 program—and thus far has committed funds to rehabilitate an estimated 17,000 such units.

HUD is offering to increase a city's Section 8 housing subsidy allocation on a one-for-one basis—providing the additional subsidy funds for one unit to match each unit that the

city agrees to rehabilitate under other programs.

Thomas Appleby, New York City Housing Administrator, has asked HUD for 4,000 so-called "bonus units" under the program, which would mean that at least 8,000 units would be rehabilitated in New York City. Mr. Appleby says, "I happen to think rehab's time has come. This is one approach to wholesaling rehabilitation instead of retailing it—which has always been the problem."

By the November 30 deadline, HUD officials had received applications from 46 cities, including Delray Beach, Florida; East Chester, New York; Lowell, Massachusetts; Newark and a handful of other cities in New Jersey.

The program was launched under a tight deadline, with cities having to certify that a rehab wage agreement had been signed by January 10. If that deadline is not met, a city's application will be rejected and its allocation will then be turned over to other applicants.

Interested developers must "pre-qualify" with local HUD officials by showing their capacity to carry out large-scale rehabilitation and by showing that they can offer a large number of units in neighborhoods that qualify for the program.

When all the pieces fit together, the city advertises for bids giving developers only until January 15 to submit their proposals.

Contractors promoting the program are Carlton Dukes, of Continental Wingate, who is president of the Rehabilitation Contractors Association; Ranbir Sahni, American Development Corp., Los Angeles; Melvin Weintraub, of Morelite Construction Corp., Bronx, New York; and Preston Moore, Urban Home Ownership, New York City.—*Donald Loomis, World News, Washington.*

## Laymen will outnumber pros on California licensing board

Some of California State's licensing boards may be shaken up in 1977 when their make-up will become predominantly nonprofessional members in conformance with new legislation (California SB 2116). In some cases, cuts will be made in the number of professional members that will serve on the boards.

"The intent of the new law," the Governor's office said, "is to ensure that the primary concern of these boards and commissions is the protection of the public interest."

One change will occur on the Board of Architectural Examiners—and it is a significant change, considering that California examines and licenses more architects than any other state—requiring the board to be composed of five public members, one building designer and three architects.

William Hawley, president of the California Council of the American Institute of Architects—a state organization representing AIA members and professional views to the state legislature—said, "CCAIA does not basically disagree with the Governor's belief that the Board of Architectural Examiners be oriented to consumer needs, but the existing board had been responsive to both the profession and the consumer. We don't understand how loading up the Board with more people and more public members will help further the Governor's goals. The real difficulty lies in the examining and reviewing processes that must be done by the technically knowledgeable Architectural Board members."

What some consider an alarming trend is the decrease in architects serving on the architectural board—a cut from nine members in 1963 to three in 1977.

Robert Marquis, Western regional director of the AIA, feels that "architects should recognize this new legislation as symptomatic of our society's

becoming more consumer-oriented and should look on it as a way to have a more constructive impact on the environment. In my experience, lay members have become strong vocal proponents of the profession, but the danger is clear: non-architect members do not have the training to review the licensing of architects."

Concern over the increased work that will fall on the remaining architect members of the board was expressed by Robert Duncan, executive secretary of the Board of Architectural Examiners: "The new board is scheduled to have only three architects, and this number is not adequate for the work load. Therefore, I have discussed with the Department of Consumer Affairs the possibility of adding at least one more member from the architectural profession."

Another board whose membership will be altered is the Board of Registration for Professional Engineers, to be composed of six public and five professional members. Donald Wright, executive secretary of the engineering board, believes that it will take until June 1978 before the non-professional majority will swing into full action, since new public members are expected to be appointed only as the terms of the present professional members expire. "I think we should question why the composition of certain boards was changed, for there are some other professions that were not affected by the legislation—for example, accountants and attorneys."

There may also be an impact on the work load carried by the boards' support staffs. Other boards will be affected, including the Contractors State License Board (seven public and six professional members) and the Board of Landscape Architects (four public and two professional members).—*Janet Nairn, Architectural Record, San Francisco.*

## Britain's economic travails leave a quarter of its architects unemployed and put a third of its private firms out of business

Britain's economic miseries have thrown a quarter of its 25,000 registered architects out of work. Some 6,000 are presently jobless and a third of the country's architectural practices have closed their doors in the past year, leaving the remaining 2,500 firms facing a bleak future that promises little but continued decline in available work.

One London architect sums up the plight of many: "When the project I have now finishes in a couple of months, I'll be out of a job." With little work on the home front, a number of the larger firms maintain their previous levels by going overseas, especially to the Middle East. Ian Fraser, John Roberts and Partners—which has a 20-man team working on the giant \$350 million tent-roof stadium for the Saudi Arabian capital, Riyadh—estimates its overseas workload could rise to 80 per cent of the total by the end of next

year. Five years ago the foreign total was only 10 per cent.

And as these firms shed staff, many individual architects are going abroad on their own, finding work either as part of on-site design teams or at colleges and universities. Many recent graduate architects are entering volunteer overseas service. They work in underdeveloped countries at local pay scales. Those who stay in Britain and cannot find work in architecture leave the profession, sometimes for jobs as remote as farming.

A series of government public spending cuts to reduce inflation and stabilize the sagging pound has hit British architects and all construction-related industries especially hard because of the high percentage of public participation in the sector. Even in housing, where private enterprise usually thrives, the government now dominates. This year the private sector will

build 160,000 homes, compared to 170,000 public housing units. Just four years ago, the private sector built 228,000—nearly double the public housing figure.

Proposed legislation by the Labor government to permit local authorities to compete for work in the private sector could add to the woes of architects. Raymond Moxley, chairman of the Association of Consultant Architects, says such a law could result in unfair competition, with local authorities operating with hidden subsidies or tax advantages.

Last month members of the construction-related industries met with the Labor government's Minister of Housing and Construction Reg Fresson to plead for help in maintaining the industry's capacity so it could play a strong role in the eventual economic recovery. The government is expected to respond next month, but with the

International Monetary Fund placing further major public spending cuts as a condition to its vital \$3.9-billion loan, architects do not hold out much hope.

If nothing else, the current crisis has brought together the design and building industry in their fight for survival. Although there exists no strong political lobby for construction interests in Britain, pressure groups have recently been formed for this purpose. Patrick Harrison, secretary of the Royal Institute of British Architects, says, "The extreme seriousness of the situation has made it possible to galvanize the construction industry into a united front. Architecture's employment base, recruitment, training and investment are threatened to an extent which now jeopardizes the capacity to meet even substantially lower levels of demand."—*Molly Burns/Ty Marshall, World News, London.*

NEWS REPORTS  
BUILDINGS IN THE NEWS  
HUMAN SETTLEMENTS  
REQUIRED READING

**October construction rose 31 per cent over last year's monthly figure**, sparked by five large utility contracts and an 18 per cent increase in residential building, according to the F. W. Dodge Division of McGraw-Hill Information Systems Company. Dodge economist George A. Christie sees both good and bad news in these facts: "... housing starts will bring an immediate payoff in jobs and building materials sales," but "utility projects offer little in the way of immediate stimulation. . . ." In the building sector, residential contracts, which totaled \$6,792,158,000, included a 72 per cent increase in multi-family housing. Nonresidential contracts rose six per cent to \$2,728,449,000, with gains in stores, offices and hospitals and declines in schools, public buildings and recreation.

**Hourly wage rates for the building trades rose only 0.5 per cent in the third quarter of 1976**, according to the Department of Labor. This figure represents the lowest third-quarter increase in the last 10 years. Over the 12 months ending October 1, wages rose 6.1 per cent, against 8.3 per cent for the previous year. Wages reported for seven major trades averaged \$9.52 an hour, up 54.4 cents from October 1, 1975.

**HUD, the building trades and contractors have agreed to wage reductions to stimulate housing rehabilitation** in Philadelphia, Atlanta and New York, and hope to complete similar agreements elsewhere. Details on page 36.

**Architects Muldawer & Patterson Associates have designed stands for Jimmy Carter's Presidential inauguration.** The Atlanta firm reports that the design took its form from Mr. Carter's declared principles of governmental simplicity and accessibility: the swearing-in stand will be small and low, with glass panels to increase visibility, and it will be set at a 45-degree angle from Pennsylvania Avenue to open a vista toward the White House and so affirm the preeminence of the office over the man. The architects also considered the use of resources in their design, concerning themselves with economy of construction and demounting and the re-use of materials. The inaugural stand will be warmed by a solar heating unit lent by the Georgia Institute of Technology.

**A National Museum of the Building Arts is planned as an extension of the Smithsonian Institution.** The committee has hired architectural critic Wolf von Eckhardt to develop a proposal. Details on page 37.

**California will alter its architectural registration board to favor a preponderance of laymen over professionals** in response to consumerism pressures and despite misgivings on the part of the profession. Details on page 36.

**The National Organization of Minority Architects has elected Robert J. Nash, FAIA, its president.** Other new officers of NOMA include Charles F. McAfee, first vice president, and Norcell Haywood, secretary. Mr. Haywood will continue to serve as editor of NOMA's newsletter, and Robert T. Coles will continue as treasurer.

**As a possible first step toward a Federal Office of Construction,** the Department of Commerce will establish a Construction Program and Policy Coordination Committee. Details on page 37.

**About a quarter of Britain's architects are out of work, and a third of its architectural firms have closed,** with little promise of early relief in the face of the nation's persistent economic difficulties. Details on page 36.

**Walter H. Annenberg has pledged \$20 million toward a new visual arts center for the Metropolitan Museum of Art.** The proposed Fine Arts Center of the Annenberg School of Communications will be quartered in the museum's Southwest Wing, now being designed by Kevin Roche/John Dinkeloo and Associates, and will be headed by Thomas Hoving, who retires next year as the museum's director. Mr. Annenberg is president of Triangle Publications, Inc., and was formerly the American ambassador to Great Britain.

**Sir Basil Spence, architect of Coventry Cathedral, died in England November 20 at the age of 69.** His contemporary design for the Cathedral Church of Saint Michael, which replaced the 14th-century church destroyed by bombs in World War II, initially drew criticism from modernists and traditionalists alike. But, Lewis Mumford wrote after its dedication in 1962, "Its originality consists in its indifference to originality, and in its respect not for the letter of modernism but for the spirit that giveth life."

**The National Institute for Architectural Education offers two traveling fellowships and cash prizes** to architectural students. The Lloyd Warren Fellowship (64th Paris Prize) and the William Van Alen Memorial Fellowship each carry a \$6,000 first prize and a \$1,000 second prize. Additionally, the Hiron design competition will grant \$3,000 in prize money. Contact: NIAE, 139 East 52nd Street, New York, New York 10022.

**The Rotch Traveling Scholarship will award a stipend of \$11,000 in its 1977 competition,** which is open to American citizens under 35 who have either taken architectural degrees at Massachusetts schools or completed one year of practice in Massachusetts. Contact, before February 25: Hugh Stubbins, Secretary, Rotch Traveling Scholarship, 1033 Massachusetts Avenue, Cambridge, Massachusetts 02138.

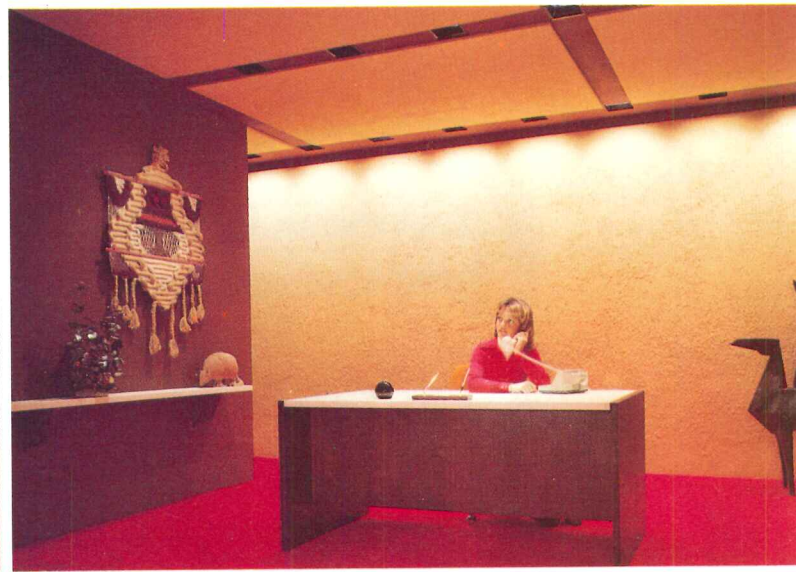
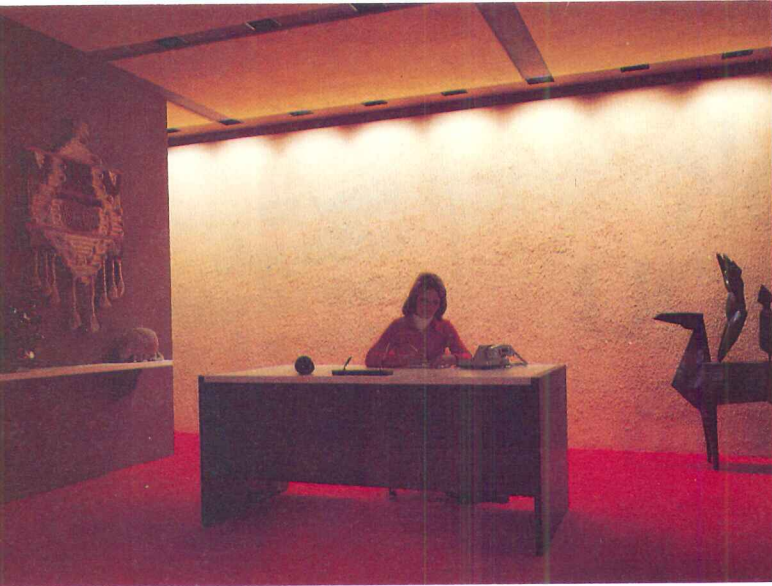

## PUT THE LIGHT WHERE YOU WANT IT

## the flexible CONTROLUX CONE DOWNLIGHT

In the above interiors, only the lighting effects are different. The hidden light source fixtures in the ceiling are the patented Controlux Cone Downlight by Moldcast®. Varying lighting effects are created by adjusting the directions and widths of the beams of light.

The top left photograph illustrates the directional beam adjustment to produce wall washing. To the right, the dramatic effect of accenting is produced by aiming selected Controlux Downlights. The lower left view demonstrates illumination of a horizontal surface by concentrating the light from a number of fixtures. The fourth photograph shows the sum of all effects, plus general illumination — All using the same fixture type to produce hidden-source illumination from an architecturally coordinated ceiling.

The heart of the Controlux Cone Downlight is an efficient, variable focus reflector that eliminates distracting glare. The unique, stepped contour of the optical system has a far smaller aperture than parabolic cone downlights — making it even less noticeable.

Variations in both width and direction of the light pattern are easily produced on the job. Only the Controlux Cone has the ability to provide this range of control efficiently and without glare. In addition to lighting effects, increased beam width can allow as much as 40% greater spacing between fixtures where 45° cutoff is not required. This means up to 40% fewer fixtures and lamps.

Freedom to adjust the pattern of light solves many problems such as varying ceiling heights, sloped ceilings, or fixture positions not directly over the subject area. If changes are to be made in the layout of the interior or if corrections in lighting design are required after installation, the Controlux Cone's flexibility will adapt to meet the new situation.

The Controlux Cone Downlight is offered in a wide, coordinated selection that uses incandescent and HID lamps. Indoor and outdoor models are available in round and square, recessed, semi-recessed and surface versions with a variety of finishes.

For your next new project or restoration, consider the first truly versatile, hidden-source lighting tool . . . The CONTROLUX CONE DOWNLIGHT.

For further information, write Moldcast Lighting, Interstate 80 at Maple Avenue, Pine Brook, N.J. 07058  
In Canada: Varco Industries, Ltd., Dorval, Que. H9P 2N4

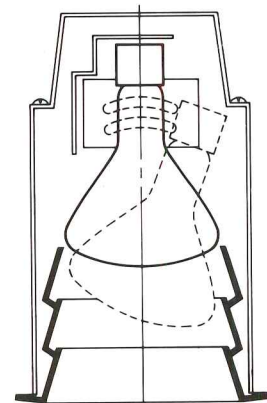

**MOLDCAST**  
LIGHTING

A Division of Wylain, Inc.



# This book can save you time, space, and money.

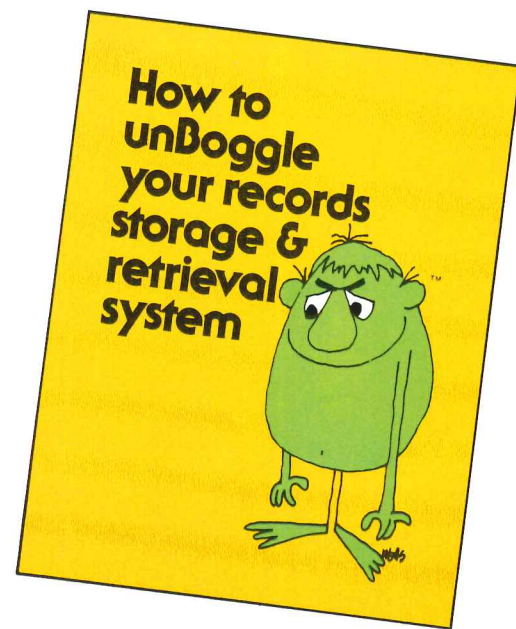

## How do we know? We wrote the book.

Our book can solve a lot of big problems for you. Solve them by helping you identify them. That's what the Remington Systems Approach to records storage and retrieval is all about. It can help you discover where your record-keeping system is getting Boggled down. And it will show you how to get the Boggles out. Find out how our Systems Approach can streamline your operation and cut your costs at the same time. Write us today for our book. It's the last word on the subject!

**SPERRY UNIVAC**  
OFFICE EQUIPMENT  
SPERRY UNIVAC IS A DIVISION OF SPERRY RAND CORPORATION

SPERRY-UNIVAC  
P.O. Box 500 (Dept. 100-P4) Blue Bell, PA 19422

### SEND ME THE BOOK!

NAME \_\_\_\_\_  
 POSITION \_\_\_\_\_  
 COMPANY \_\_\_\_\_  
 STREET \_\_\_\_\_  
 CITY \_\_\_\_\_  
 STATE, ZIP \_\_\_\_\_  
 TYPE OF RECORD KEEPING PROBLEM \_\_\_\_\_





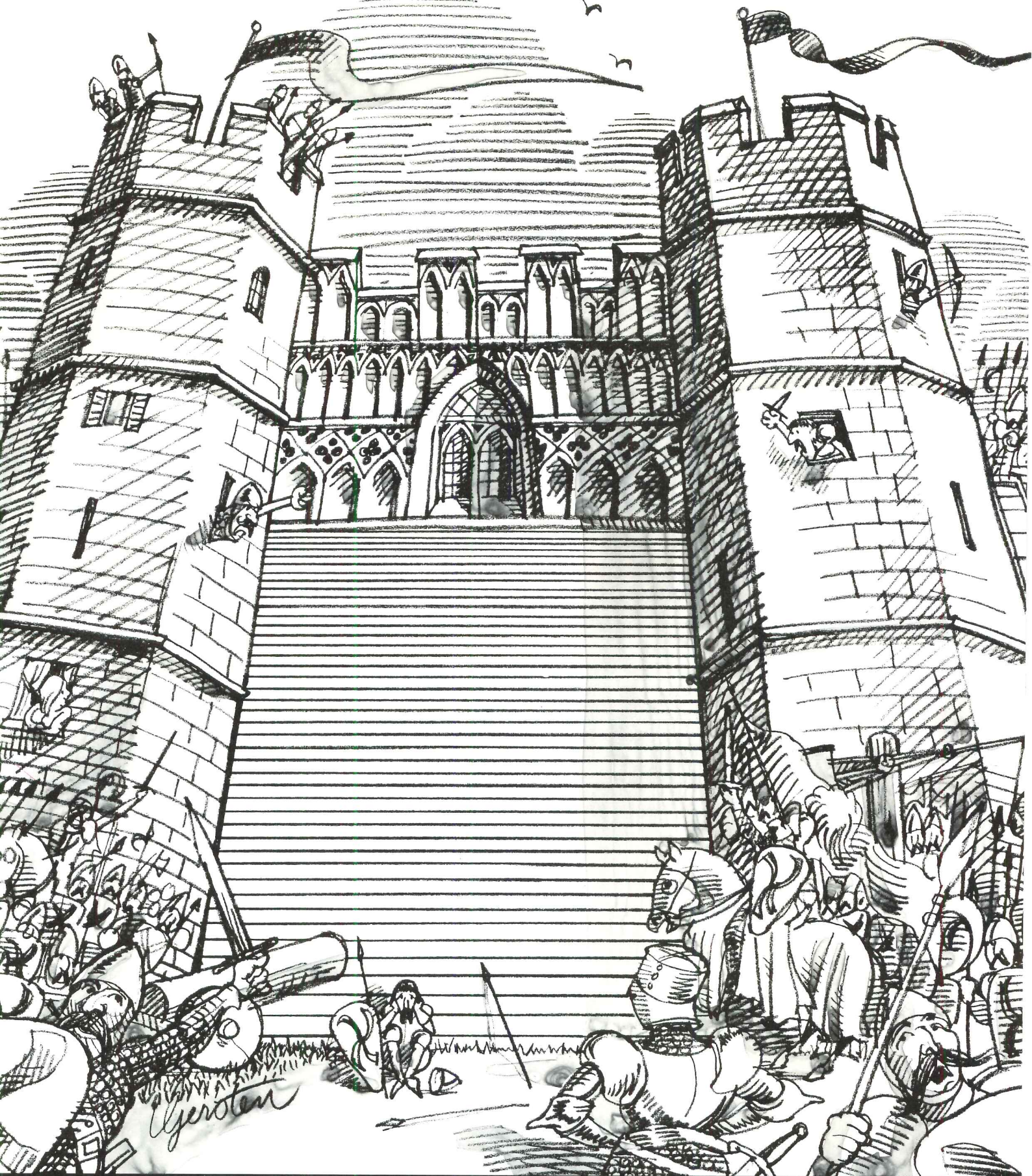

## **Cookson Rolling Doors. The best way to close an opening.**

Specified nationwide by architects who demand dependability, superior craftsmanship and outstanding performance. For information on our custom-engineered rolling doors, grilles and counter doors, consult our catalog in Sweet's (8.7/Co) or send for your own copy. The Cookson Company, 700 Pennsylvania Avenue, San Francisco, CA 94107.



# PLEXIGLAS®

today,  
more than ever...  
it makes such  
beautiful  
sense.

Flat or formed. Clear or color.  
Strong. Light weight. Beautiful.  
Plexiglas brand acrylic plastic.  
Making sense, solving problems  
... any way you look at it.  
In banks where it provides  
transparency, security and  
crystal-clear beauty. In school  
skylights and windows where  
it resists breakage, controls  
glare and conserves energy.  
In homes where its formability  
makes small worlds larger.

Find out more about Plexiglas  
by writing for our brochures and  
engineering data. For on-the-  
spot answers to specific  
questions write or call our  
Architectural Coordinator (215)  
592-6799. See our catalog in  
Sweet's—8.26/Roh

*Building codes limit areas of plastic  
glazing. Approvals for large-area Plexiglas  
enclosures must be applied for on a special  
permit basis. Fire safety design  
considerations must take into account  
the combustibility of Plexiglas.*

Martin Luther King Elementary School  
Pittsburgh, Pa. (above)  
Architects: Liff, Justh and Chetlin  
Pittsburgh

Suffolk Franklin Savings Bank  
Boston, Mass. (left)  
Architects: Bastille-Neiley  
Boston

Beach Cottage, Harvey Cedars, N.J. (right)  
Architects: Murphy Levy Wurman  
Philadelphia, Pa.

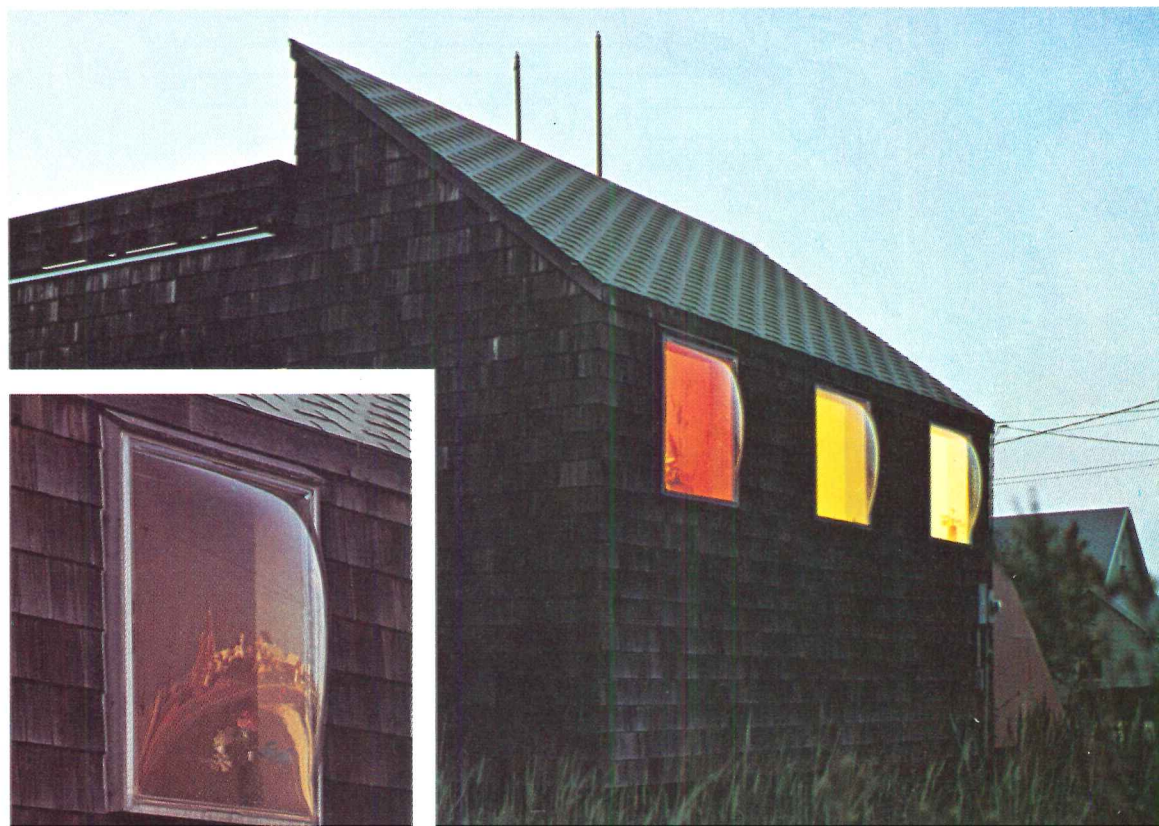

the trademark  
**PLEXIGLAS**

the company

**ROHM  
AND  
HAAS**  
PHILADELPHIA, PA. 19105

# CONDITION WITH



Plexiglas acrylic plastic is a combustible thermoplastic. Observe fire precautions appropriate for comparable forms of wood. For building uses, check code approvals. Impact resistance a factor of thickness. Avoid exposure to heat or aromatic solvents. Clean with soap and water. Avoid abrasives.

# the new color coordinated washroom



Now, add color to the washroom with a new design concept. Coordinate the colors of Washroom Accessories with Toilet Compartments, Countertops and Wall Paneling . . . all in laminated plastic . . . all from one source, Bobrick. Bobrick's new "Designer" Series Accessories include dispensers for soap, paper towels and toilet seat covers; feminine napkin vendors and disposals; waste receptacles and wall urn ash trays. They feature doors of solid laminated plastic on lifetime stainless steel recessed cabinets. They add accents of color to the washroom. The doors defy graffiti, resist scratches and rust, and are most easy to clean and maintain.

Colors of Bobrick's "flush front" Toilet Compartments can be mixed or matched with "Designer" Series Accessories. Along with Bobrick Countertops and Bobrick's "Inter-Lock" Wall Paneling System, an economical substitute for tile . . . you achieve a total design concept for the new washroom . . . in bold or subtle colors and rich, warm wood grains.

Bobrick's Planning Guide for the Color Coordinated Washroom shows how you can create added color interest. Request your copy now. Write to Bobrick Architectural Service Dept., 101 Park Ave., New York 10017. Bobrick products are available internationally.

**bobrick** 

*For more data, circle 21 on inquiry card*

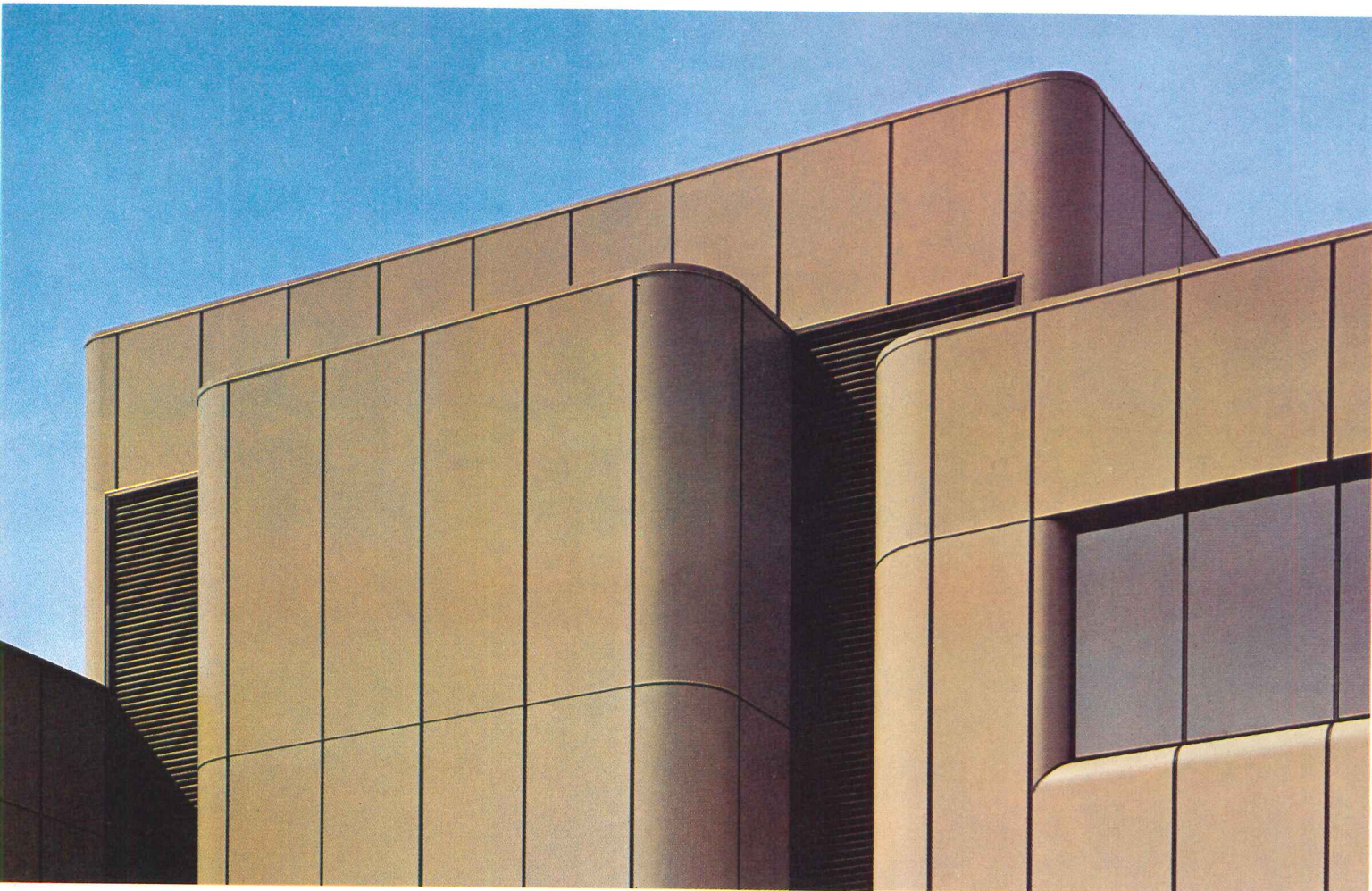

Project: Keen College Academic Building, Union, N. J. Architect: Robert Hillier, Princeton, N. J. Curtain Wall Erector: Whelan Mfg. Co., Trenton, N. J.

## Alcoa Alply Insulated Panels offer you custom design flexibility.

### Why settle for less?

If aesthetic freedom and energy conservation are important to you and your client, then we suggest you contact us for your nearest Alcoa Alply\* panel regional distributor, who offers you single-source responsibility — everything from engineering to the completed wall system, in place, with integral fenestration, interior and exterior finish and thermal insulation.

No other insulated modular wall offers all these choices for low- to middle-rise buildings:

Exterior and interior skins: aluminum, stainless steel, hardboard, plywood, cement-asbestos — you name it.

Finishes: four standard finishes and 18 colors, including Super Alumalure\* baked-on, factory-applied fluoropolymer enamels . . . Alumalure baked-on synthetic resin enamels . . . Alumilite† electrolytic coatings in natural aluminum . . . Duranodic‡ hard-coat finishes in three integral bronze shades and three new integral gray shades.

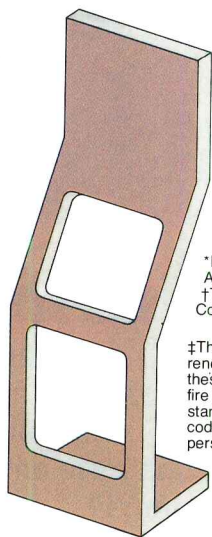

\*Registered Trademark of Aluminum Company of America  
†Trade Name of Aluminum Company of America

‡The use of polyurethane, polystyrene and isocyanurate cores in these applications may present a fire hazard under certain circumstances. Consultation with building code officials and insurance company personnel is recommended.

Panel cores: polystyrene, polyurethane, isocyanurate‡ or other materials, depending upon project requirements.

Wide range of panel sizes: up to 5 feet wide, 18 feet long.

Variety of shapes: panels can be shop-formed to almost any three-dimensional shape desired.

Choice of joining systems: Alcoa's patented Snug Seam\* caulking, splines, battens or frames.

Variety of cutouts possible: to accommodate windows, doors, sloping grade lines, walkways, difficult contours, parapets.

Whatever you're designing, let our regional Alcoa Alply panel distributors help. They know a great deal about wall systems, finishes, industrial roofing and siding and other low- and middle-rise construction problems. For further information, write: The Stolle Corporation, Aluminum Company of America, 1075-A Alcoa Building, Pittsburgh, PA 15219.

**The Stolle Corporation** A Subsidiary of Aluminum Company of America



## First we made it safe. Then we made it seamless.

Conductile static-conductive vinyl flooring offers the hygienic advantages of seamless installation—no joints, gaps or edges to catch dirt or bacteria. Its 36" x 36" sections are permanently heat-welded and flash-coved into a totally continuous surface.

Conductile is also offered in 12" x 12" tiles, Micro-squared™ so joints all but disappear. Both types have static-conductive material distributed evenly through the entire surface and thickness to last indefinitely.

Ideal for new or existing construction, Conductile is UL listed and meets NFPA stan-

dards. Applied with VPI Conductive Epoxy Adhesive, it affords protection even where non-flammable anesthetics are used. And Conductile embodies the quality you expect from VPI.

For your new free catalog, write VPI, 3123 S. 9th Street, P.O. Box 451, Sheboygan, WI 53081. Phone 414-458-4664. Or see our catalog in Sweet's.

**CONDUCTILE®**

**VPI**



# modulo<sup>3</sup>

**Agnoli.** A comfortable chair of polished chrome and genuine leather. Model 2601 available in Red, Black, Brown or White leather.

**Modulo 3 Inc.**

A subsidiary of Tiffany Industries, Inc.  
145 Weldon Parkway  
Maryland Heights, Missouri 63043  
(314) 878-4222

*For more data, circle 19 on inquiry card*

A woman with dark curly hair, wearing a white turtleneck and a red skirt, is seated in a modern office chair at a light-colored desk. She is looking towards the right. A white and brown cat is perched on the desk to her right. The background consists of light-colored vertical blinds. The overall scene is brightly lit, suggesting a window with blinds.

# modulo<sup>3</sup>

**Free standing furniture.** Available in White and Putty laminate. Wood veneers are of natural oak or walnut. Brushed aluminum or dark bronze metal accents.

**Modulo 3 Inc.**

A subsidiary of Tiffany Industries, Inc.  
145 Weldon Parkway  
Maryland Heights, Missouri 63043  
(314) 878-4222

For more data, circle 130 on inquiry card



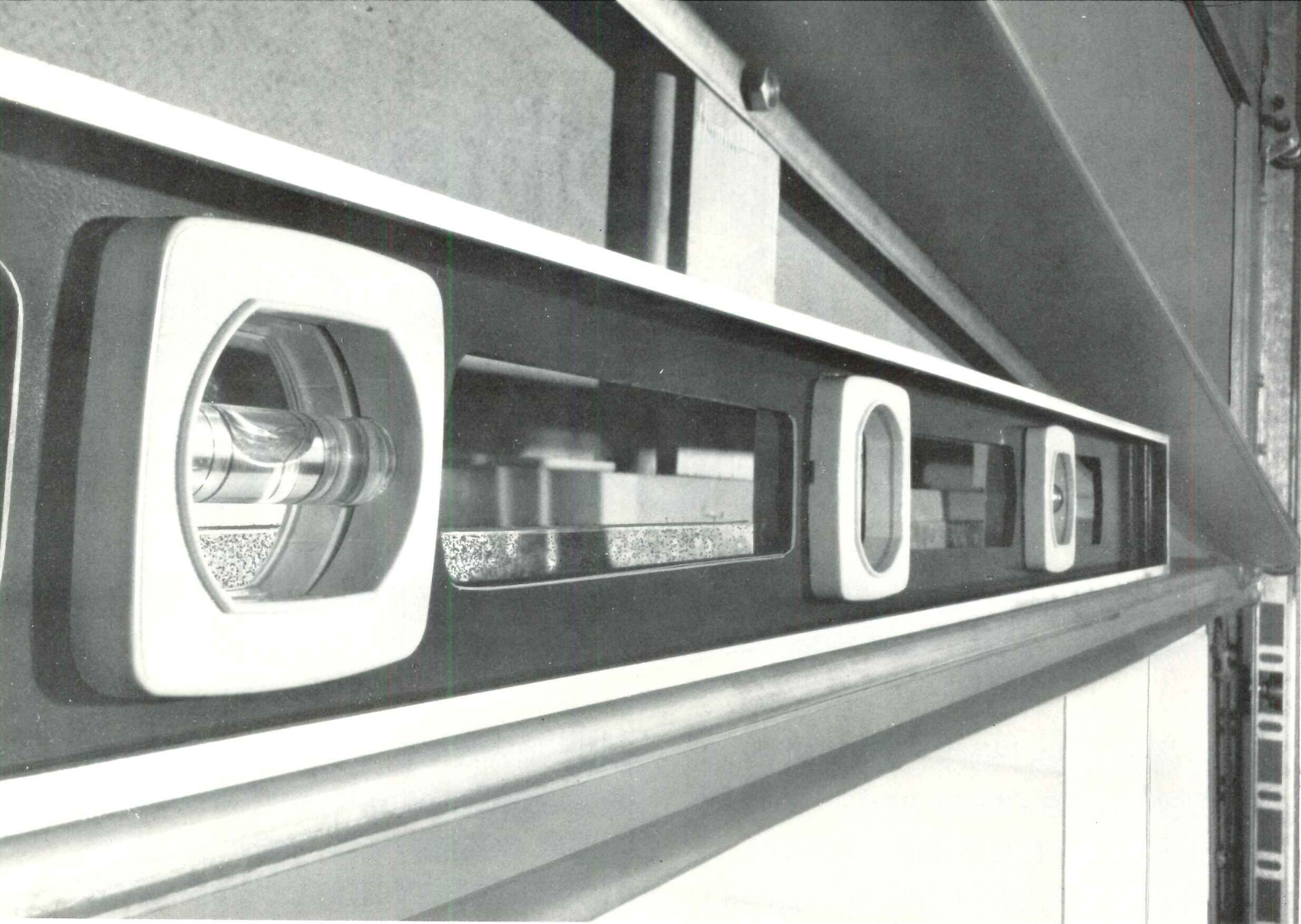

## At Raynor we give it to you straight ...and that's the way it stays!

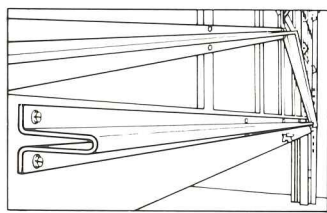

Most overhead type doors look great when they're first installed. But given some time and

plenty of ups and downs they begin to sag in the middle.

Raynor doors won't sag . . . and for a very good reason: U-Bar reinforcement. We engineer and fabricate this special reinforcement in our own plant for all extra-wide doors.

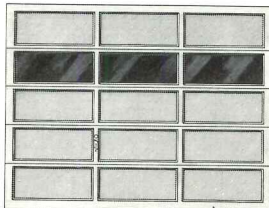

It's this extra concern for quality that's made Raynor a brand you can depend on for residential, commercial and industrial doors made of wood, aluminum, fiberglass or steel.

Call us for more specifics.  
815/288-1431.

Or write Raynor Manufacturing Company, Dept. AR, Dixon, IL 61021 for the name of the Raynor factory-trained distributor/installer near you.



**RAYNOR™**

Raynor Manufacturing Company, Dixon, Illinois 61021

# Zonolite<sup>®</sup> Roof Decks are covered by a 10-year warranty.

The Zonolite Roof Deck is more than a mere assembly of roofing components. It is an engineered system, designed to be the ideal base for the built-up roof, insure maximum insulation values, provide protection against wind or fire damage, and prevent problems which cause premature failures.

With Zonolite Roof Decks you are always assured top

performance, superior strength, fast application and lower installation costs. And, now you get the added bonus of a ten-year performance warranty.

Ask your Zonolite representative to give you all the facts. Or write W. R. Grace & Co., 62 Whittemore Avenue, Cambridge, Mass. 02140. In Canada, 66 Hymus Road, Scarborough, Ontario M1L 2C8.

# GRACE

# Zonolite<sup>®</sup> Roof Deck Performance 10 year Warranty

**GRACE**

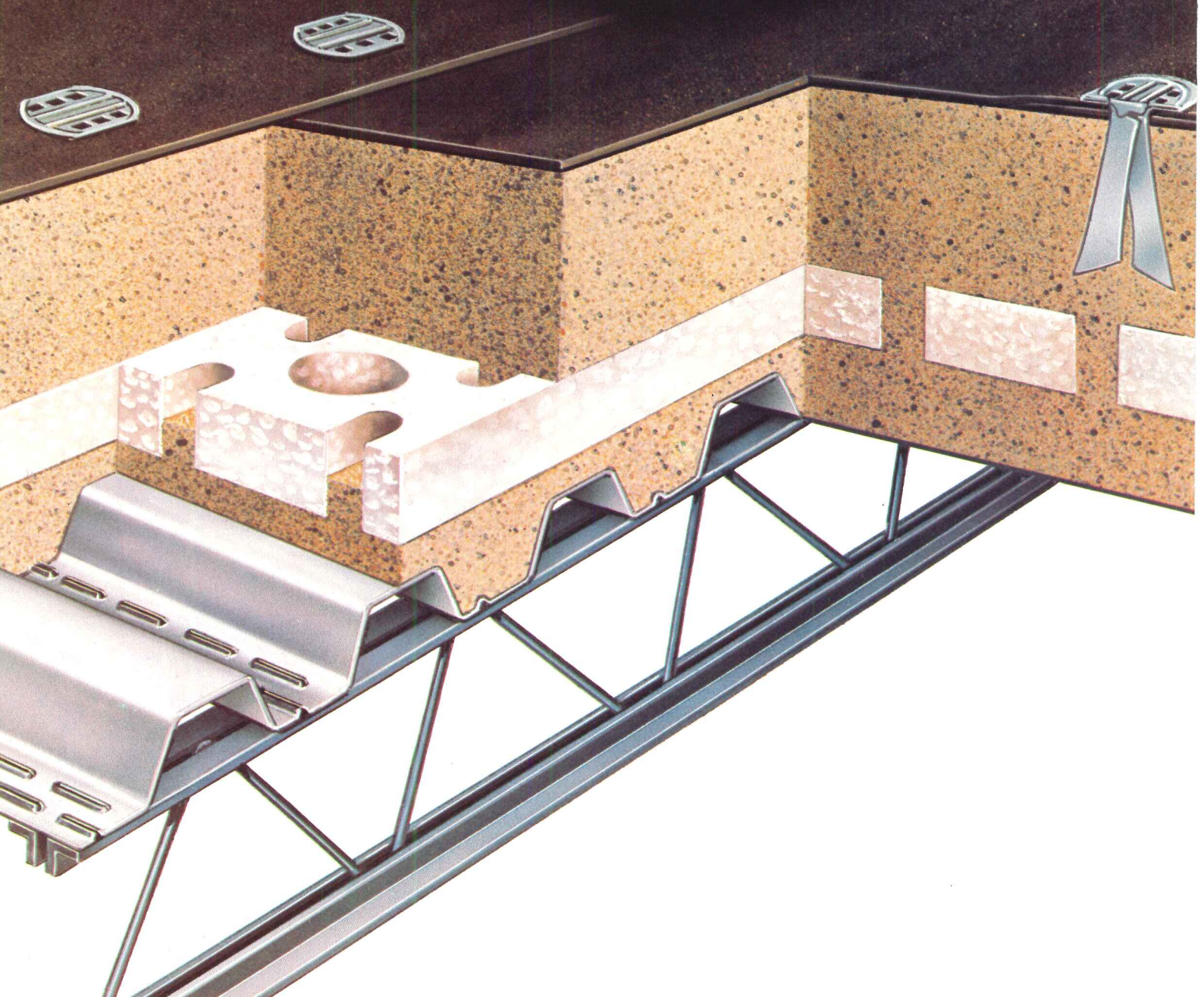

Mass. Mutual specified  
**VICRTEX®** and **VICRACOUSTIC®**  
 to give long life, health  
 and beauty to  
 important wall areas.



Vicracoustic Panels



Vicrtex installed by Allstate Vinyl Wallcovering, Brighton, Mass.

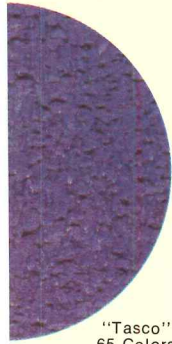

"Tasco"  
65 Colors



"Rivera"  
20 Colors



"Kona"  
18 Colors

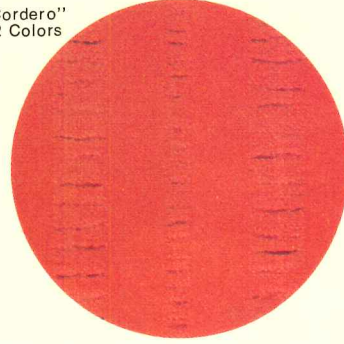

"Cordero"  
12 Colors



"Mesa"  
21 Colors

Sound coverage, a basic principle of most insurance companies, motivated Mass. Mutual's architects to design office walls with

VICRACOUSTIC® sound-absorbing panels—  
to achieve maximum sound control,

VICRTEX® vinyl wallcoverings—for unique decorative effects.

Massachusetts Mutual chose from over 70 original Vicrtex® patterns, thousands of colors, to cover walls as well as sound-controlling Vicracoustic® panels with Vicrtex®. They also enjoy "double indemnity" against possible liabilities of scuffs, marks and stains thanks to the guaranteed durability of Vicrtex®.

*Interiors of Massachusetts Mutual Insurance Company, Springfield, Mass. feature interesting free-form arrangements of Vicracoustic® panels. Architect: Hoyle, Doran & Berry, Boston. In addition to custom-cut panels, Vicracoustic® systems are offered in 5 resilient constructions, including monolithic.*

**L. E. CARPENTER**

AND COMPANY



A DAYCO  
COMPANY

170 North Main Street, Wharton, New Jersey 07885  
 (201) 366-2020

NYC: (212) 355-3080

**DISTRIBUTED BY: VICRTEX SALES DIVISION**, New York, Atlanta, Chicago, Dallas, Los Angeles, San Francisco, Boston, Minneapolis, Toronto, Montreal / **HOWELLS, INC.**, Salt Lake City / **PAUL RASMUSSEN, INC.**, Honolulu.

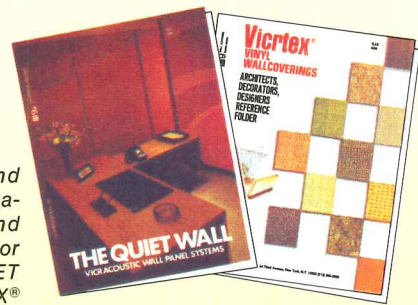

*Look into this sound and beautiful combination of Vicrtex® and Vicracoustic®. Write or phone for "THE QUIET WALL" and VICRTEX® catalogs—today!*

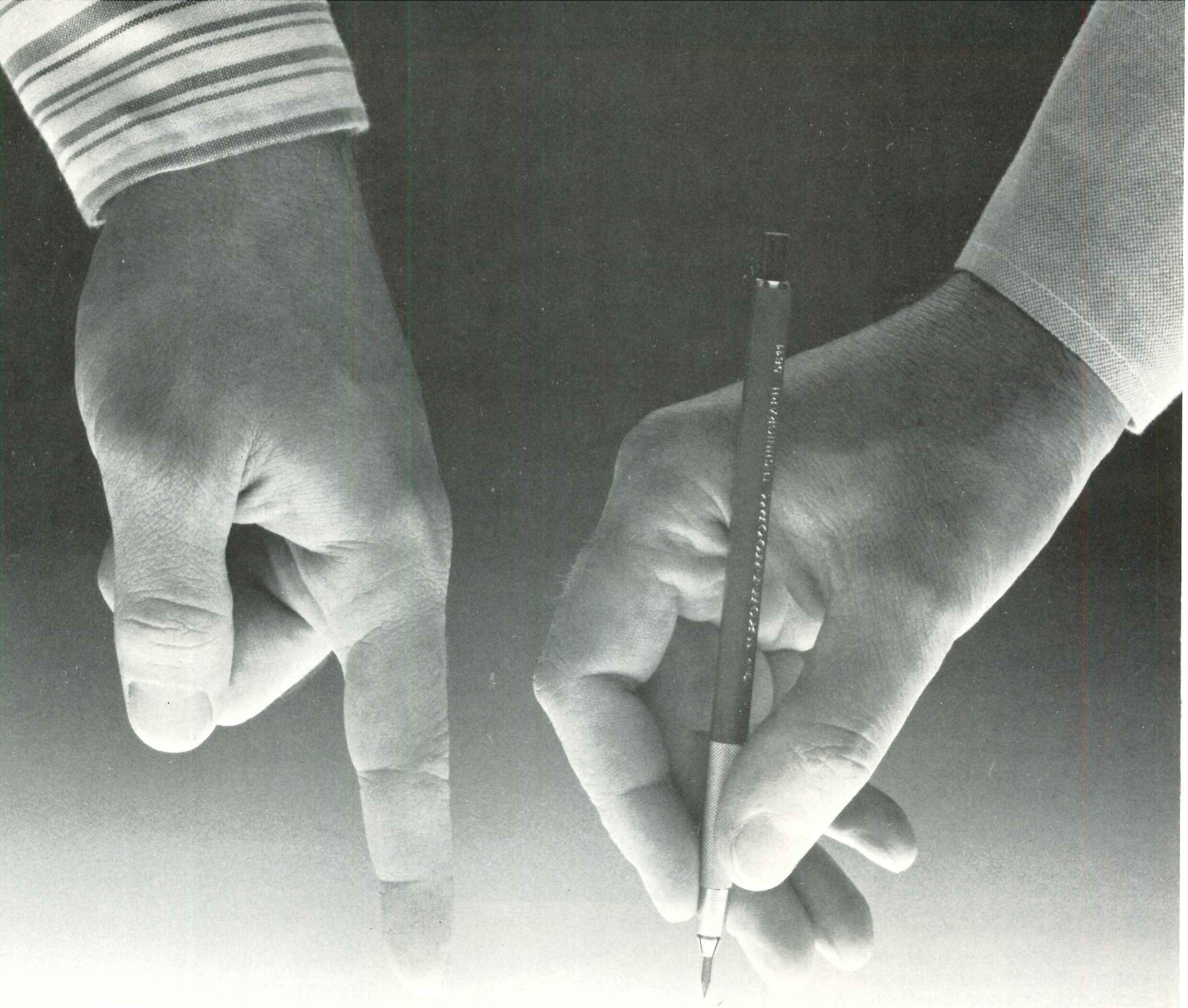

## Pushing a button costs 30% less than pushing a pencil.

As much as 20% to 30% of the typical architectural drafting job can be repetitive. Repeated floor plans. Repeated columns. Repeated elevation details. Cut your production costs by doing repetitive drafting at the push of a button with the A. B. Dick Design Master™ camera, and you'll put far fewer draftsman hours into each completed project.

### It's a drafting tool anyone can use.

No need for a special operator. Or a special darkroom.

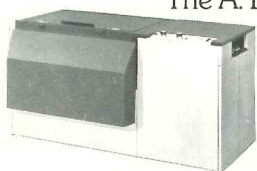

The A. B. Dick Design Master camera takes little more space than a drafting table. And it can cost only about \$200 a month—roughly one-third as much as conventional photo-drafting equipment.

### Change drawing scale with the turn of a dial.

You can make an exact one-to-one copy. Enlarge a drawing up to 120%. Or reduce it as much as 45%. So

it's easy to make scaled-down site plan worksheets from your original building floor plans.

### See how much repetitive jobs are costing you.

# ABDICK

Just mail this coupon to:  
A. B. Dick Company  
5700 West Touhy Avenue  
Chicago, IL 60648

- Send me your free bulletin on reprodrafting techniques.
- Tell me more about the Cutting Production Costs laboratories sponsored by the Continuing Education Department of the AIA.

Name \_\_\_\_\_ Title \_\_\_\_\_

Company \_\_\_\_\_

Address \_\_\_\_\_

City \_\_\_\_\_ State \_\_\_\_\_ Zip \_\_\_\_\_

# INTRODUCING THE PASSWALL® AUTOMATIC STAINLESS STEEL POOL SYSTEM!

**P**aragon is proud to introduce the PassWall® system, embodying the latest in swimming pool technology.

**PassWall®** is an unsurpassed, complete system comprising an automatic, recirculating overflow gutter combined with a stainless steel wall. Backed up by steel buttresses, it forms a structurally stable pool wall section containing a complete, pipe-less hydraulic system - eliminating all perimeter piping.

**PassWall®** is suitable for installation in any climate! It will not crack, spall, bulge, or leak. Fabricated entirely of 12-gauge, polished stainless steel, it requires neither coating for protection nor any annual maintenance other than wiping. It is shop fabricated and delivered to the job site in long sections. Erection and welding are by factory-trained crews. The installation is completed quickly and accurately.

A recirculating overflow gutter is the preferred system for competitive pools. (It is a requirement for pools in which national meets are to be held.) The absorption of turbulence by the gutter makes such pools quieter and results in faster swimming times. And with our recirculation duct removed from the gutter - an exclusive feature - we offer greater surge storage capacity than all other systems.

**PassWall®** is an economical system, offering the latest in pool technology. You can now obtain all the components for your pool from one source, with a single responsibility; the pool wall with recirculating overflow gutter, a superior line of deck equipment, complete filtration systems, chlorination and mechanical equipment, moveable bulkheads.

We've been manufacturing quality equipment for institutional and commercial pools for the past twenty years. When you specify Paragon, you'll be getting quality and reliability from a firm dedicated to excellence in design and manufacturing.

For further information, see us in Sweet's Architectural File 13.22, or contact us. Area representatives who can offer advice or assistance are located throughout the country.

**KDI Paragon Inc.,  
The People Who Care.  
12 Paulding Street  
Pleasantville, New York 10570  
914-769-6221  
TWX 710 572 2202**

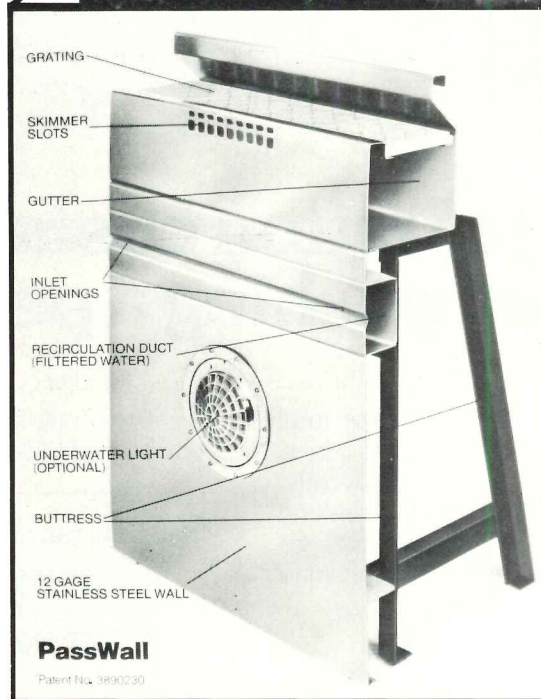
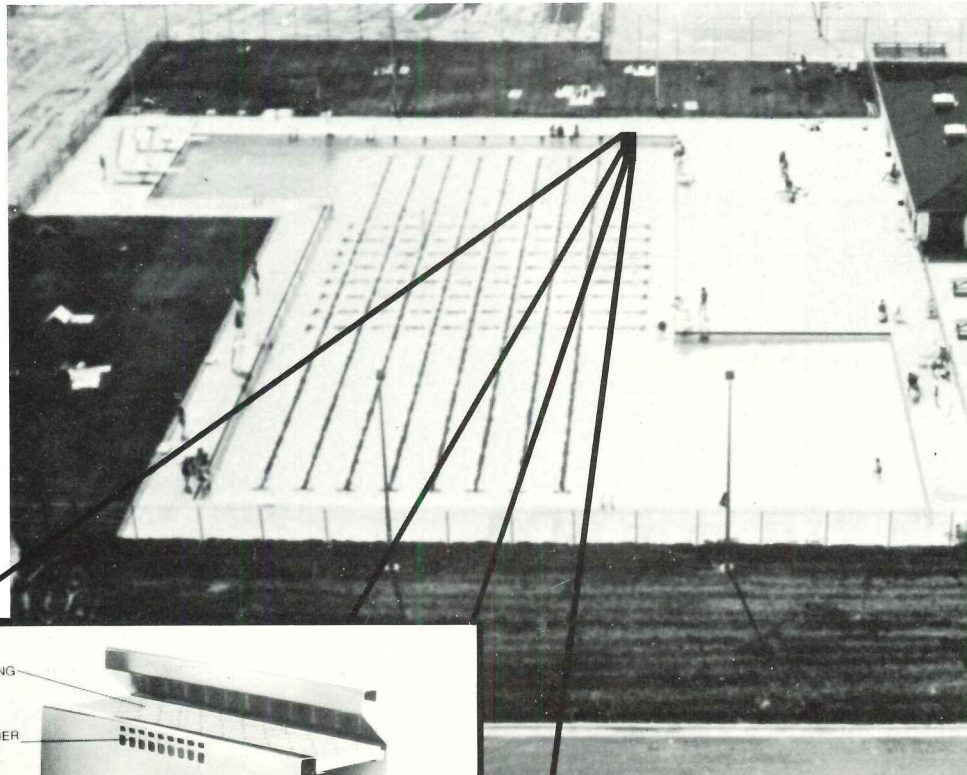

**Colonial Park Pool  
640 Lin. Ft. of PassWall  
16,400 Sq. Ft. of Pool Area**

**PassWall  
Wall and Gutter Section.**

## FROM PARAGON: 20 YEARS OF MANUFACTURING THE BEST IN SWIMMING POOL EQUIPMENT.

# PATCRAFT



ZEFRAN® is a registered trademark of Dow Badische Co.

## ARCHIVES ...

**PATCRAFT'S** "CLASS A" textured loop of 100% ZEFRAN® acrylic berber by Dow Badische. (Pictured above with COURT HOUSE, a match-mate heavy duty cut pile plush.) Both in the same 6 earthtones and available with

**DU PONT  
ZEPEL**  
REG. U.S. PAT. OFF.  
CARPET PROTECTOR

ARCHIVES and COURT HOUSE are the stand up and take it carpets from ...



MILLS INC.  
Box 1087 • Dalton, Ga. 30720

For more data, circle 12 on inquiry card

demountable partition systems. A smooth wall with no visible fasteners or battens is provided by specially-designed spring steel clips that hold the Durasan panels snugly against metal H-studs. Contempo-Wall partitions can range from bank-rail height to ceiling height, and assure the flexibility needed in any office for future change or expansion.

*In permanent wall systems* which must meet a variety of sound and fire ratings, 1/2" or 5/8" Durasan gypsum panels provide the ideal face layer. Choice of 24," 30" and 48" panel widths allow for design versatility.

**LET DURASAN TURN YOUR IMAGINATION INTO REALITY**

Durasan combines beauty, texture and color with the time-proven characteristics of gypsum wallboard...strength, fire-resistance and ease of installation. Its use reflects your creativity, good taste and professionalism.

For all the facts on Durasan, ask your Gold Bond salesman...see Sweet's Architectural Catalog File 9-6/Go...

or write Gold Bond Building Products Division, Dept. AR1, National Gypsum Company, Buffalo, New York 14202.

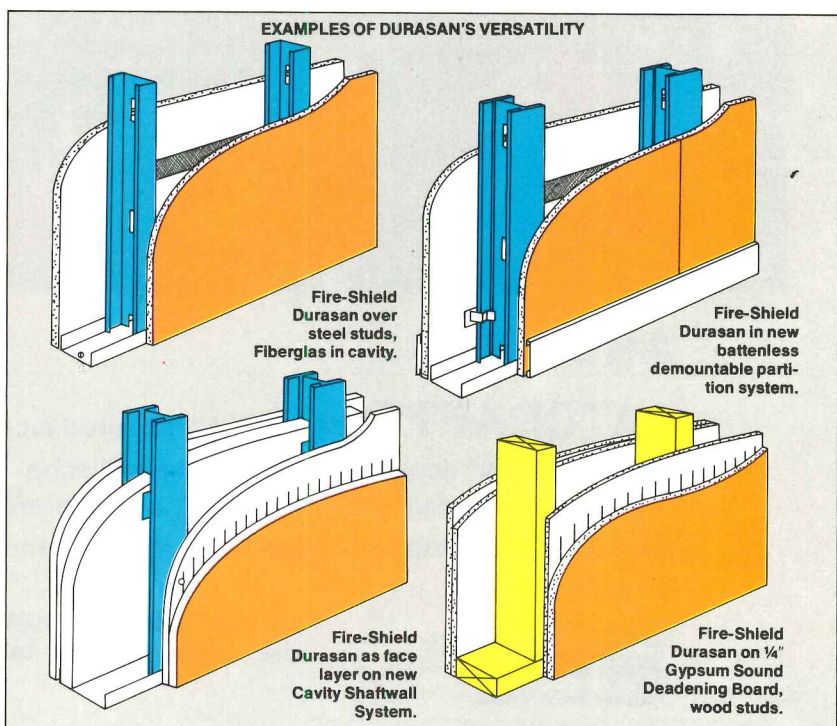
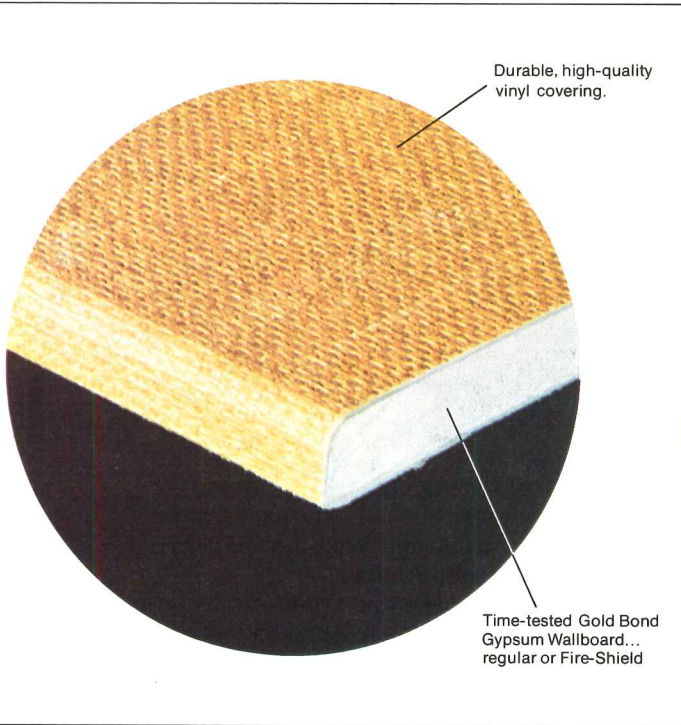
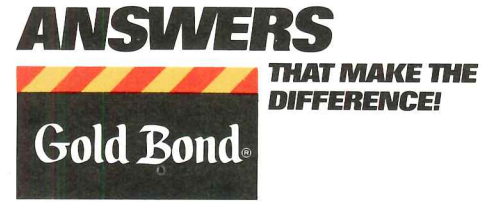

For more data, circle 11 on inquiry card



# AN ANSWER THAT MAKES THE DIFFERENCE TO THE NEED FOR EXCITEMENT IN PREFINISHED WALL SYSTEMS...

## DYNAMIC DURASAN.®

### NEW FREEDOM OF EXPRESSION

The many faces of Durasan...the distinctive look of Burlap and Cork Parquet, the textured elegance of Grass Cloth, the rich warmth of Woodgrains, the refinement of Classic Stripes and Stipples...give imaginative architects, designers and building owners completely new interior

design parameters. With Durasan you can decorate with flair, elegance, authority, warmth...and economy.

### NEW ECONOMY IN WALL SYSTEMS

Factory-finished, vinyl-clad Durasan is the solid answer to cost problems. It permits "instant decoration" with vinyl-surfaced panels, in a single time-saving operation. And thanks to the tough, abrasion-resistant covering, maintenance costs are almost nil with Durasan...even in high traffic areas.

*If movable walls are required, Durasan again provides the answer... with Contempo-Wall battenless*



## New year, new Administration, new hope, new concerns

It looks as if—for architects and architecture—this could indeed be, as the saying goes, a Happy New Year.

The numbers look good. As you have undoubtedly read (November RECORD, page 67), the Dodge/Sweet's Construction Outlook for 1977 predicts "a year of good cyclical expansion—not as good as it should be, but better than anything the construction industry has known for quite some time." Our favorite economist, George Christie, predicts a 17 per cent increase in commercial and manufacturing construction, a 5 per cent increase in institutional work, for a 10 per cent increase in total nonresidential; a small increase in single-family but a whopping increase back to a respectable 600,000 apartment-unit starts, for a 12 per cent increase in residential construction—almost all of it in the apartment area where architects are heavily involved.

Beyond the numbers (and those of you who are not optimistic will forgive me, I hope) there is a feeling of optimism in the air. Conversations over the phone and over lunch indicate to me that architects from around the country (and even New York) are starting to get phone calls, are making fewer desperate pilgrimages to Mecca and its environs, and are in general getting back to work.

Some good things for architects and architecture have happened in, of all places, Washington lately. Specifically, many of the recommendations of the Task Force on the Guiding Principles for Federal Architecture, organized by Nancy Hanks and Bill Lacy of the National Endowment for the Arts, are being incorporated into Federal law and agency policy. Item: Public Law 94-151—signed into law by the President on October 18th—greatly strengthens the adaptive use program of the General Services Administration and introduces the concept of mixed-use Federal buildings. As reported in the Endowment's newsletter, *Federal Design Matters*, the new legislation helps to "fulfill the Government's duty to provide leadership in the conservation and preservation of our cultural heritage. . . . [and] affirm the Government's commitment to an economy based on conservation rather than consumption." Under the Act's provisions, GSA will consult the Advisory Committee on Historic Preservation "to identify existing buildings of historic, architectural, or cultural significance suitable for Federal agency space needs. These buildings will be given priority over other available means of meeting the Government's public building requirements [that is, commis-

sioning new building or leasing space]."

Further under the Act—and this is a breakthrough—GSA is "authorized and encouraged" to "rent out space on pedestrian levels of existing and future Federal buildings to commercial, cultural, educational, and recreational enterprises and to create a lively environment in and around Federal public buildings through design and management initiatives." The first prototypical mixed-use Federal building will be the Home Loan Bank Board Building designed by Max Urbahn and nearing completion in Washington. It will have a courtyard ice-skating rink and shops on both the ground and mezzanine floors.

Other good news from Washington is that it seems clear some action on getting housing going again—especially urban housing and especially rehabilitation—is forthcoming soon. Last month's editorial commented on the views of Representative Thomas Ashley, chairman of the House Subcommittee on Housing and Community Development, who considers it likely, especially in view of Mr. Carter's election, that HUD will soon be encouraging low-income housing by means of block grants—perhaps in the \$2.5 to \$3 billion a year range. Another technique that sounds awfully good—though it is not getting enough of a run for meaningful analysis—is reported in this month's News Reports (page 36). This demonstration program has been launched jointly by outgoing HUD Secretary Carla Hills, Robert Georgine, president of the Building and Construction Trades Department of AFL-CIO, and the National Housing Rehabilitation Association. Under the program, being tested in cities across the country, the building trades locals agree to work on urban-housing rehab at wage rates averaging about 75 per cent of their usual scale, in return for a commitment by HUD, the contractors, and the city to rehab enough housing to create a significant number of jobs. If this does generate the volume of work predicted in these last weeks of the Ford Administration, surely it is worth a longer try after January 20th.

So . . . for the New Year, we have some real improvement in the marketplace, inflation in construction seems to have cooled off (though we can only cross our fingers on that), and the new Carter Administration—while it has not given us many clues on its commitment to quality architecture—clearly has a commitment to do something about urban housing. So, let's hope, Happy New Year!

Walter F. Wagner, Jr.

# Mutschler designs beautiful cabinetry...



...from the inside out.



The beauty of Mutschler cabinetry is more than exceptional good looks. Because Mutschler designs cabinetry to be exceptional from the inside out.

Inside, the beauty of Mutschler translates to exceptional features. Extraordinary design. And unique flexibility that make Mutschler truly the finest cabinetry you can buy.

## Interchangeable custom storage features have made our cabinetry famous.

The Mutschler way with space is ingenious—and apparent in each of our storage options. For example: Slide-out racks, oak shelf trays, baskets, bins and tote trays. A double swing-out pantry that holds an incredible array of goods. Wineracks, chopping blocks, cutlery trays, knife blocks and serving carts—all built



into beautiful, functional cabinetry. And with Mutschler you can rearrange as your needs change over the years, and add additional storage features in the future.

## A tradition of craftsmanship.

We conceive of our cabinets as fine furniture, and we build them that way. Mutschler cabinetry is built by consummate craftsmen, using extra-thick Oak, Maple and Cherry throughout. The drawers glide smoothly, and they feature dovetail



joints, found only in the finest furniture.

## Of course, Mutschler commands a higher price.

Because no detail is overlooked in creating cabinetry of unsurpassed beauty, quality and durability. And because it is exclusively for homeowners who want the utmost in design and workmanship. A Mutschler kitchen is an investment, designed to be a source of pride and enjoyment for years to come.

Your Mutschler Kitchen Specialist can answer all your questions. He's listed in the Yellow Pages under "Kitchen Cabinets."

**M** **MUTSCHLER**

Nappanee, Indiana 46550  
(219) 773-3111

a Triangle Pacific Company

The only name you need to know in cabinetry.

**FEATURES**

**129 Robin Hood Dell West  
Philadelphia, Pennsylvania  
MacFadyen/De Vido architects**

In Philadelphia's Fairmount Park, the largest and most extensively equipped of the country's new outdoor music facilities. Under its sheltering canopy, 5,000 music lovers can enjoy concerts, opera and ballet.



© Edmund H. Stoecklein

**133 "An Architecture for People and not for Things"**

John Portman describes the principles that underlie his design. He organizes his discussion around such topics as order and variety simultaneously achieved, movement, light, color and materials, water, nature, people watching people, and shared space.

**141 A low profile for IBM**

Architect Edward Larrabee Barnes has designed a headquarters building for the IBM World Trade Americas/Far East Corporation which responds to and fits into the landscape in an unusually effective manner.

**147 Delightful weekend retreat at The Sea Ranch**

Unpretentious in appearance, this house is characteristic of Donald Jacob's concern for and manipulation of form, light and spatial arrangement through subtleties in design to achieve an exciting interior.

**BUILDING TYPES STUDY 497**

**101 Record Interiors of 1977**

**101 5th Street Station**  
Philadelphia, Pennsylvania  
Ueland and Junker, architects

**104 Worcester Bank Restaurant**  
Worcester, Massachusetts  
Roche Dinkeloo and Associates, architects

**106 Architects' own offices**  
Watertown, Massachusetts  
Crissman & Solomon, architects

**108 Squash/1**  
Mamaroneck, New York  
Gordon/Spencer, architects

**110 Private apartment**  
Elkins Park, Pennsylvania  
Stern & Hagmann, architects



© Edmund H. Stoecklein

**114 Architects' own offices**  
Minneapolis, Minnesota  
The Design Consortium, architects

**116 Leisure World Electronics**  
Baraboo, Wisconsin  
Jack Fleig, architect

**118 Providence Journal Publishing Company**  
Providence, Rhode Island  
Warren Platner Associates, architects

**122 Relta Steamship Company headquarters**  
Long Beach, California  
Hugh Gibbs & Donald Gibbs Architects and SLS-Environetics, space planners/interior designers

**126 Private apartment**  
New York, New York  
Ulrich Franzen, architect

**ARCHITECTURAL ENGINEERING**

**151 Technical news and research**

Four different engineering techniques that either save money, or save money and energy, or that save money and produce interesting architecture. Four stories this month include: 1) a low-cost interstitial floor system of light-gage steel, 2) design aids for daylight, 3) off-peak thermal storage for a hospital, and 4) an unusual hyper roof for a zoo.

**159 Product reports**

**161 Office literature**

**220 Record impressions**

**226 Classified advertising**

**228 Advertising index**

**231 Reader service inquiry card**

**NEXT MONTH IN RECORD**

**Building Types Study: Recreation**

A recent proliferation of interest in athletics (and physical fitness) has produced in many of the nation's cities an almost new type of construction: the well-designed in-town recreational facility. Whether a club or a fee-by-the-hour arrangement and whether for squash, tennis, handball, swimming, skating or whatever, these new installations are proving commercially viable, and are using design as an extra incentive for their use. In February the RECORD will show a wide range of such facilities and explain the reasons for their functional and visual success.

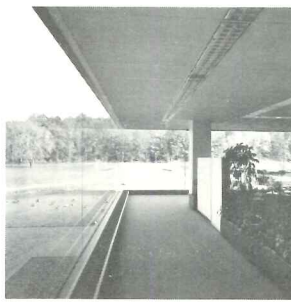

IBM World Trade Americas/Far East Corporation headquarters Mt. Pleasant, New York  
Architect: Edward Larrabee Barnes  
Photographer: Joseph W. Molitor

#### EDITOR

WALTER F. WAGNER, JR., AIA

#### MANAGING EDITOR

HERBERT L. SMITH, JR., AIA

#### SENIOR EDITORS

ROBERT E. FISCHER  
MILDRED F. SCHMERTZ, AIA

#### ASSOCIATE EDITORS

GERALD ALLEN  
GRACE M. ANDERSON  
BARCLAY F. GORDON  
CHARLES E. HAMLIN  
CHARLES K. HOYT, AIA  
WILLIAM MARLIN

#### ASSISTANT EDITOR

JANET NAIRN

#### PRODUCTION EDITOR

ANNETTE K. NETBURN

#### DESIGN

ALEX H. STILLANO, Director  
ALBERTO BUCCHIANERI, Associate  
ANNA-MARIA EGGER, Assistant  
MURIEL CUTTRELL, Illustration  
J. DYCK FLEDDERUS, Illustration  
JAN WHITE, Consultant

#### EDITORIAL CONSULTANTS

EDWARD LARRABEE BARNES, FAIA  
JONATHAN BARNETT, AIA, Urban design  
GEORGE A. CHRISTIE, JR., Economics  
ERNEST MICKEL, Hon. AIA, Washington  
PAUL RUDOLPH, FAIA

#### Foreign architecture:

*L'Architecture d'Aujourd'hui*, Paris

#### McGRAW-HILL WORLD NEWS

RALPH R. SCHULZ, Director  
9 domestic and 10  
international news bureaus:  
Bonn, Brussels, Buenos Aires,  
London, Milan, Moscow, Paris,  
Singapore, Tokyo, Toronto.

#### SALES MANAGER

LOUIS F. KUTSCHER

#### CIRCULATION DIRECTOR

HUGH S. DONLAN

#### ASSISTANT BUSINESS MANAGER

JOSEPH R. WUNK

#### ASSISTANT TO THE PUBLISHER

ELIZABETH HAYMAN

#### PUBLISHER

BLAKE HUGHES

## THE RECORD REPORTS

### 13 Editorial

New year, new Administration  
new hope, new concerns

### 4 Letters/calendar

### 35 News briefs

Short items of major  
national interest.

### 36 News reports

Trades unions, contractors and HUD  
develop agreements to foster  
urban housing rehabilitation  
through a combination of lower wages  
and funding commitments.

A committee of construction designers,  
businessmen and labor leaders  
propose a National Museum  
of the Building Arts in Washington.  
As a first step toward a Federal  
Office of Construction, the  
Commerce Department will create a  
Construction Program and Policy  
Coordination Committee.

### 39 Human settlements: world news

### 42 Buildings in the news

Gheytrahieh Apartments, Tehran, Iran.  
Hotel and Conference Center,  
Doha, Qatar. Souk, Salalah, Oman.

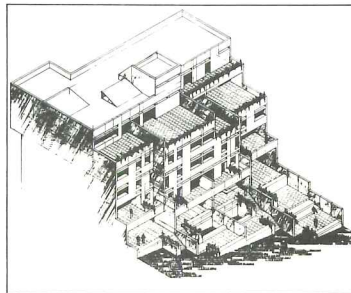

### 45 Required reading

### 173 Office notes

## ARCHITECTURAL BUSINESS

### 75 Construction management, in Miami test, saves \$1.5 million

In direct comparison with a  
high school built according to  
traditional design and contracting,  
a new prototype for the Dade  
County School District resulted in  
substantial savings without  
sacrificing quality.

### 81 Building costs

Renovation and remodel figures  
are included in the *1977 Dodge  
Manual for Building Construction  
Pricing and Scheduling*.

### 83 Building activity Tax cuts and Federal spending needed to revive economic recovery in 1977

According to George A. Christie,  
chief economist for McGraw-Hill  
Information Systems Company, the new  
Carter Administration may use two  
options to stimulate a sluggish  
economic recovery.

# The Roof System you can specify with confidence.

The diagram on the left shows a cross-section of the roof system with numbered components: 1. Female leg of Standing Seam Panel, 2. Clip bolted to purlin, 3. Male leg of Standing Seam Panel, 4. Clip bolted to purlin, and 5. Purlin. A sub-component 1A, Factory Applied Mastic, is also indicated. The photograph in the center shows a worker in a white hard hat and safety vest using a rubber mallet to secure the panels. The diagram on the right shows a different view of the panel and clip assembly, with components 4 and 5 labeled.

Panel seams are locked into position by striking along the seam length with a rubber mallet (no crimping devices or sealing machines). Clips hold panels to purlins.

American's Standing Seam Roof is available in colors.

## American's Standing Seam Roof System...with a class 90 wind uplift rating by Underwriter's Laboratories.

As one of the industry's largest manufacturers of pre-engineered steel buildings, American Buildings Company has been an innovator in research and development. Perhaps the most innovative of all is our Standing Seam Roof System. Its installation is so remarkably simple and its performance has been field-proven for nearly three years.

Because of the roof panel's locking configuration and special purlin clips, fasteners are used only at panel end laps. Roof penetrations are minimized.

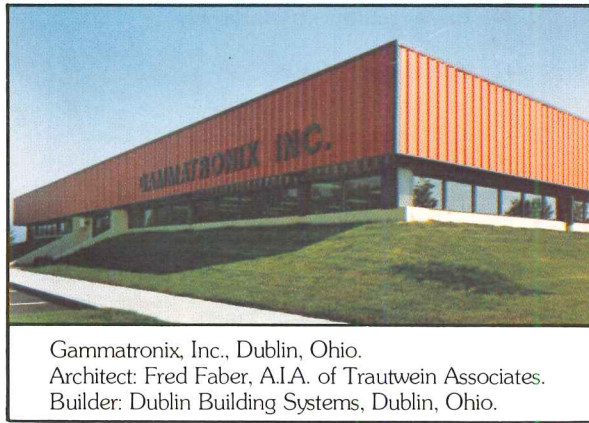

With an American building you are assured of economy, speed of construction and a predictable cost. On site errors are practically eliminated because workers are erecting components produced under factory, quality-controlled conditions.

For these reasons we believe you'll find it desirable to know more about American buildings and our Standing Seam Roof System. For

your copy of our Catalog for Architects, write on your letterhead to American Buildings Company, P. O. Box 800 A, Eufaula, Ala. 36027.

\*Patent Pending

Already, more than 3-million square feet of American's Standing Seam Roof are in use.



**AMERICAN BUILDINGS COMPANY**

Eufaula, Alabama 36027 • Jamestown, Ohio 45335 • Atlantic, Iowa 50022 • Southampton, Mass. 01073

For more data, circle 9 on inquiry card

# Introducing the CLEANLINE® Sprinkler.

A beautiful way to help save lives.

Now there's a new way to design in fire protection for life safety in modern high rise and other buildings without intruding upon design aesthetics.

Grinnell's new CLEANLINE® Recessed sprinkler is so unobtrusive, so trim and compact, once it's installed you'll hardly know it's there.

But don't let CLEANLINE's quiet good looks fool you. Beneath that attractive closure you'll find one of the most reliable sprinkler heads in the industry. When room temperature reaches a predetermined level, the attractive closure falls away,

exposing the *fast-response* Duraspeed sprinkler. As a second predetermined temperature is reached, the sprinkler activates, distributing a uniform water spray to put down a fire.

The standard finishes

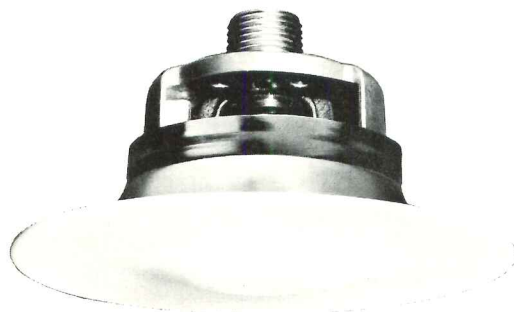

available are satin chrome and white. CLEANLINE Sprinklers are also offered in a variety of finishes to match any decor. All metallic finishes are UL-listed.

There's a lot more to tell about CLEANLINE. For more information and complete specifications, call your nearest Grinnell district office listed in the Yellow Pages, or write Grinnell Fire Protection Systems Company, Inc., 10 Dorrance Street, Providence, Rhode Island 02903.



**GRINNELL**  
GRINNELL FIRE PROTECTION SYSTEMS COMPANY, INC.

PROTECTING LIFE AND PROPERTY SINCE 1850.

For more data, circle 8 on inquiry card

# name in hatches... **Inryco**<sup>®</sup>

attractive new maintenance minimizer and energy saver for high traffic openings

## **Inryco**<sup>®</sup> Telescoping Door

U.S. Patent No. 3,430,676

This motor operated, vertically opening service door is a unique and practical departure from traditional design. Its curtain consists of U-shaped steel panels that glide smoothly and quietly within each other like the sections of a telescope. This construction eliminates the counterbalancing springs or weights and the multiple mechanical connections and pivot joints required in other service door designs. As a result, maintenance and upkeep costs are minimal, operation is extremely reliable, and damage repair is easy. The door will open and close without difficulty in high winds and doesn't rattle on windy days. It provides superior draft exclusion and has yielded a .51 "U" value in thermal transmittance tests... important considerations for energy conservation. Its compactness minimizes concern in planning for traveling cranes and other overhead equipment or for closely spaced multiple openings. For a complete description and product data, see Sweet's, section 8.9/In... or send for catalog.

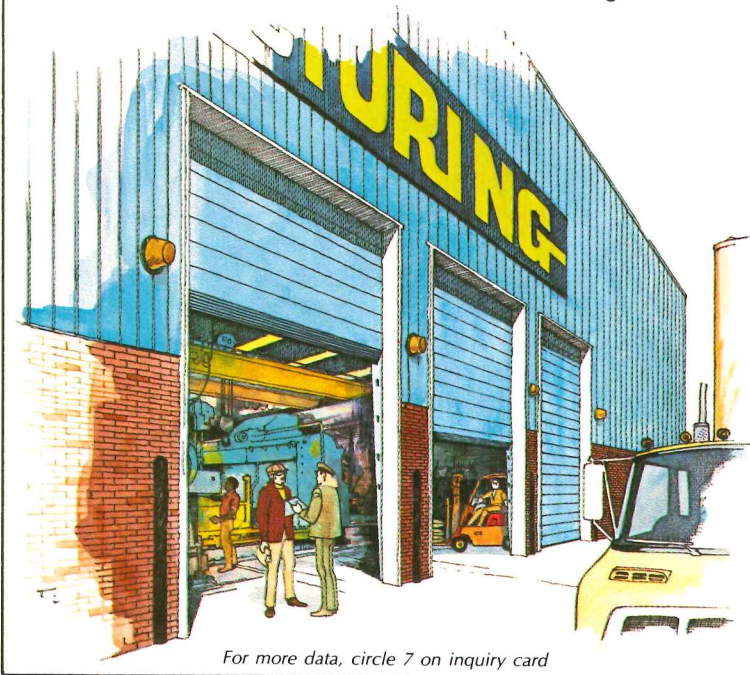

For more data, circle 7 on inquiry card



**Inryco**

an Inland Steel company

### **Literature Coupon**

**MAIL TO:**

Dept. A—4033  
Milcor Division  
INRYCO, Inc.  
P.O. Box 393  
Milwaukee, WI 53201

**Please send catalogs describing the items I've checked:**

- Steel access doors
- Vents, hatches and floor doors
- Telescoping door

Name

Title

Company

Address

City

State

Zip

sizes or custom modified designs for special needs.

7-39-1



# The dependable doors, vents and

long-time favorites for wall and ceiling access openings

## Milcor® Brand Steel Access Doors

These are the access doors most frequently mentioned in architectural specifications. Practical design, innovative product additions and careful workmanship account for their long-standing position of preference. The six basic styles include an Underwriters' Laboratories labeled door for fire rated construction and doors designed for the specific needs of drywall, plaster, acoustical plaster, acoustical tile or masonry surfaces. Each style is offered in a range of popular sizes—totaling 58 standard models altogether—most of them readily available at stocking locations throughout the U.S. and Canada. In addition, Inryco furnishes thousands of doors each year in non-standard sizes and custom modified designs to meet uncommon conditions. For complete product data on all styles, see our catalog in Sweet's, section 8.12/Inr, or secure a copy by sending in the coupon.

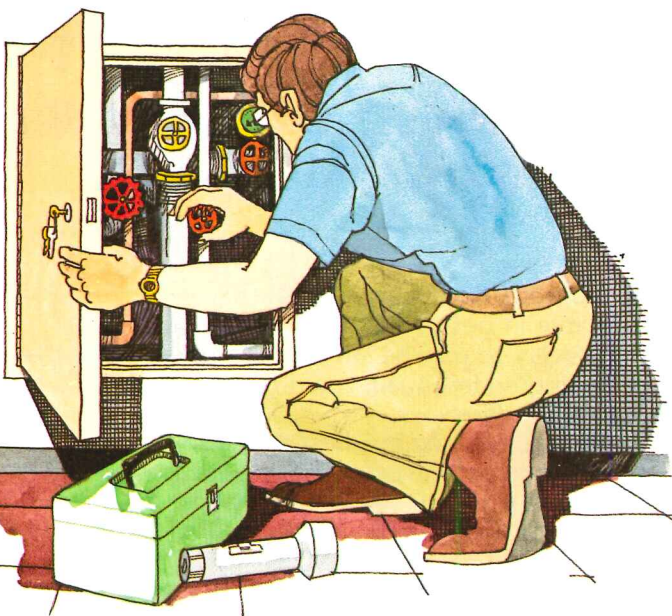

For more data, circle 4 on inquiry card

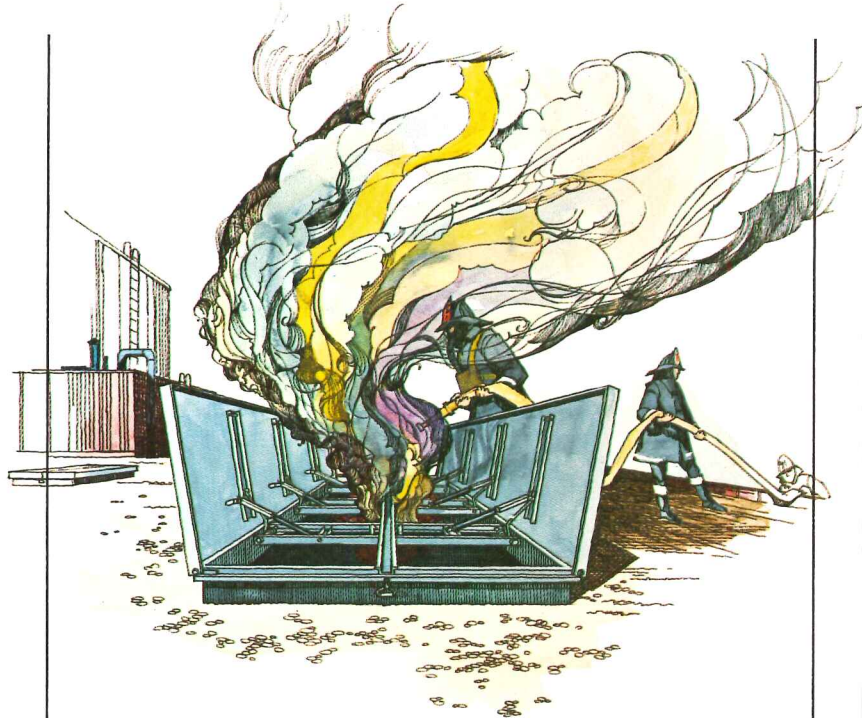

reliable closures for fire control, passage or access openings in horizontal surfaces

## Inryco® Heat and Smoke Vents; Roof Hatches; Floor and Sidewalk Doors

Inryco offers a wide range of steel and aluminum closure devices for openings in roof, floor and sidewalk. All are designed and constructed for efficient installation and long term reliable operation. Included are Underwriters' Laboratories listed and Factory Mutual approved Heat and Smoke Vents in sizes to span joist spacings of up to 6'0" o.c. They open automatically in the event of fire to draw off heat, smoke and noxious gas...retard the spread of flames...help firemen locate the blaze and fight it from above. They're equipped with composite design covers—an Inryco innovation. Lighter, stronger and more rigid than covers of traditional construction, they also provide better "U" factors and improved condensation control. The reduced weight saves on shipping charges and lowers imposed roof loads. For comprehensive data on all products in this group, see Sweet's, section 7.8/In, or send in the coupon for a catalog.

For more data, circle 6 on inquiry card

Any of these products can be fabricated to order in non-standard



## **The Sanserra Travertone™ ceiling from Armstrong. Rarely has the luxury look been more beautifully defined.**

There are good ceilings, great ceilings, and exceptional ceilings. And when you get to exceptional, one name stands out. Travertone from Armstrong. One of whose family members is the Sanserra ceiling you see above—installed in the Michigan Blue Cross and Blue Shield office tower in Detroit.

When a luxury interior calls for a luxurious finishing touch, this is a ceiling that can fill the bill with style to spare. Made from acoustically efficient

noncombustible mineral wool, Sanserra Travertone is available in both 12" x 12" tiles and 24" x 24" tegular lay-in panels. In a deep-etched design that can bring added quality and beauty to the most distinctive interiors.

So when only the best will do, you can't do better than Sanserra Travertone. Because Travertone ceilings are number one in the luxury league. To learn more, write Armstrong, 4201 Rock St., Lancaster, Pa. 17604.

*For more data, circle 3 on inquiry card*

FROM THE  INDOOR WORLD® OF  
**Armstrong**

## Letters to the editor

Once again I am saddened to note that buildings are published and the proper recognition of staff involved in the project is omitted. Among the exclusions, was an industrial facility for Trio Industries published in the November issue, and noteworthy for its simple, straightforward design and attention to details so often found lacking in such buildings. Unfortunately only the firm name was mentioned, with no credit given to either the designer or other key staff members.

In these hard times, in which layoffs abound and tenure within a firm is almost non-existent, the only way for professionals, particularly the younger practitioners, to earn professional recognition essential to proper career development is through publications such as this. Therefore, it is the responsibility of RECORD and the other professional journals to give architects the recognition and credit so often denied to them, even within the profession.

Edward C. Rubin, architect  
New York, New York

The American Psychological Association Convention was held in Washington, D.C., September 3-7, 1976. A portion of this convention consisted of several sessions concerning environment and behavior. As an architect who is very interested in behavioral sciences, I attended some sessions pertinent to this field, I felt compelled to write to state my feelings concerning sciences and our profession.

The enlightening thing about this entire convention, as seen from my perspective, is that these psychologists are interested in and are studying the environment. The environment of which I am speaking is the *one which we design*. Our buildings and our interiors, plus the landscape. These people are making deep studies of all these things on which we are supposed to be experts. Of course, they are studying, very thoroughly, how people use the environment and how the environment affects them, both psychologically and sociologically. But, in addition to all this, they are studying building forms, art and symbols, interior spaces, methods of teaching, how to research, and on and on. Each small node seems to lead on to another node. Therefore, it seems as if it will expand and expand with a new gain in knowledge with each expansion.

What are the implications of this for the design professions? Since we are doing very little of our own research, it would seem that in due time

the behavioral science profession is going to know a *lot* more about the environment than we do. They have already made deep inroads into the study of human beings and their use of the environment. In some instances, their studies have caused designers to be liable for designing environments that do not fit the user needs. It now seems as though they are looking at the artistic side of our profession and how it affects the human.

Why are we sitting back and letting this happen? Should we get involved ourselves, or should we put these people on the team, the same as a mechanical, electrical, or structural engineer, or other similar consultants that we might use, depending upon the particular project. We *must* do one or the other, or possibly both. If we don't do this, our credibility, as professional designers of the environment, will get to be less and less. We cannot remain in this static condition.

John M. Gibson  
Executive vice president  
Bohlem, Meyer, Gibson,  
& Associates, Inc.  
Architecture/interior design  
Indianapolis, Indiana

We were delighted to see *Frank Lloyd Wright's Usonian Houses* by John Sergeant reviewed in the November issue. But one aspect of the review caused us some concern.

Edgar Tafel implies that no one outside the charmed circle of Taliesin is really qualified to write knowledgeably about Wright's work and genius. Yet at the same time he seems to defend or at least condone Taliesin's policy of maintaining the exclusivity of the club. This is not the path to scholarship, nor does it do anything to enhance the reputation it so earnestly desires to keep pure and unsullied. Wright is surely of sufficient stature to withstand any amount of analysis. John Sergeant's is a serious book which seems to us to enlarge rather than diminish our understanding of the man and his work.

While we all look forward to Edgar Tafel's forthcoming book on Wright, we certainly believe that the profession and the public can benefit as much from the detached view of the scholarly outsider (even a Britisher) as from the intimate insights of the initiated.

Susan Braybrooke  
Senior Editor  
The Whitney Library of Design

## Calendar

### JANUARY

10 The American Society of Interior

Designers (ASID) Market Symposium, "The Sales Power of Display," the American Mart, Chicago. Contact: ASID, 730 Fifth Ave., New York, N.Y. 10019.

23-27 33rd Annual Convention Exposition, National Association of Home Builders, Dallas.

24-26 Architects and Engineers Lighting Conference, sponsored by the General Electric Company Lighting Institute, Nela Park. Contact: Manager, Lighting Education, Lighting Institute, GE Company, Nela Park, Cleveland, Ohio 44112.

### FEBRUARY

3-4 New York University School of Continuing Education seminar, "Energy Conservation in Plants," San Francisco. Contact: Ms. Heidi E. Kaplan, Information Services Manager, New York Management Center, Dept. 14NR, 360 Lexington Ave., New York, N.Y. 10017.

11 "Symposium on Thermal Analysis-Human Comfort-Indoor Environments," National Bureau of Standards, Gaithersburg, Md. Contact: Dr. B. W. Mangum, B122 Physics Building or Dr. J. E. Hill, B104 Building Research Building, National Bureau of Standards, Washington, D.C. 20234.

14-16 "Solar Energy For Domestic Heating and Air Conditioning," New York University's School of Continuing Education seminar, San Francisco. Contact: Ms. Heidi E. Kaplan, Information Services Manager, Dept. 14NR, New York Management Center, Inc., 360 Lexington Ave., New York, N.Y. 10017.

17-19 The 20th Annual American Institute of Landscape Architects International Convention, South Coast Plaza Hotel, Costa Mesa, Calif. Contact: Robert R. Cardoza, Convention Chairman, 1599 Superior Ave., Suite A4, Costa Mesa, Calif. 92627.

24-25 The fifth national Federal Programs Conference sponsored by the Committee on Federal Procurement of Architectural/Engineering Services (COFPAES), New Orleans. Contact: Patricia Parker, Federal Agency Liaison, The American Institute of Architects, 1735 New York Ave., N.W., Washington, D.C. 20006.

### MARCH

14-16 Conference, "How to Revitalize Your Downtown Through Urban Design Action," sponsored by the Downtown Research and Development Center, Warwick Hotel, New York City. Contact: Ms. Marion Spanbock, Coordinator, Downtown Research and Development Center, 555 Madison Ave., New York, N.Y. 10022.

ARCHITECTURAL RECORD (Combined with AMERICAN ARCHITECT, ARCHITECTURE and WESTERN ARCHITECT AND ENGINEER)

January 1977, Vol. 161, No. 1. Title ® reg. in U.S. Patent Office, copyright © 1977 by McGraw-Hill, Inc. All rights reserved. Copyright not claimed on front cover and editorial four-color separations. Indexed in Reader's Guide to Periodical Literature, Art Index, Applied Science and Technology Index, Engineering Index, and The Architectural Index. Published monthly except May, August, and October when semi-monthly, by McGraw-Hill, Inc. Quotations on reprints of articles available. Every possible effort will be made to return material submitted for possible publication (if accompanied by stamped, addressed envelope), but the editors and the corporation will not be responsible for loss or damage.

EXECUTIVE, EDITORIAL, CIRCULATION AND ADVERTISING OFFICES: 1221 Avenue of the Americas, New York, N.Y. 10020. Other Editorial Offices: 425 Battery Street, San Francisco, Cal. 94111.

PUBLICATION OFFICE: 1221 Avenue of the Americas, New York, New York 10020. Second-class postage paid at New York, New York 10001 and at additional mailing offices.

OFFICERS OF MCGRAW-HILL PUBLICATIONS COMPANY: Gordon L. Jones, president; Paul F. McPherson, executive vice president; Gene W. Simpson, group vice president; senior vice presidents: Ralph Blackburn, circulation; John B. Høglund, controller; Ralph R. Schulz, editorial; David G. Jensen, manufacturing; vice presidents: James E. Boddorf, planning and development; Edward E. Schirmer, marketing administration. CORPORATION OFFICERS: Harold W. McGraw, president, chief executive officer and chairman of the board; Robert N. Landes, senior vice president and secretary, Ralph J. Webb, treasurer.

SUBSCRIPTIONS: Subscriptions solicited only from architects and engineers. Position, firm connection, and type of firm must be indicated on subscription orders. Please allow 4-12 weeks for shipment.

CHANGE OF ADDRESS or subscription service letters should be forwarded to Fulfillment Manager, ARCHITECTURAL RECORD, P.O. Box 430, Hightstown, N.J. 08520. Provide old and new addresses, zip code or postal zone number. If possible, attach issue address label. Annual subscription prices: U.S., U.S. possessions: \$15.00 for architects, engineers and other individuals in the fields served; others \$24.00. Canada: \$17 for architects, engineers and other individuals in the fields served; others \$26.00. Other countries: \$30.00 to architects, engineers; others \$40.00. Single copies \$5.00. GUARANTEE: Publisher agrees to refund that part of subscription price applying to unfulfilled part of subscription if service is unsatisfactory.

ASSOCIATED SERVICES/McGraw-Hill Information Systems Co.: Sweet's Catalog Files (General Building, Engineering, Industrial Construction and Renovation, Light Residential Construction, Interiors), Dodge Building Cost Services, Dodge Reports and Bulletins, Dodge/SCAN Microfilm Systems, Dodge Management Control Service, Dodge Construction Statistics, Dodge regional construction newspapers (Chicago, Denver, Los Angeles, San Francisco).

THIS ISSUE is published in national and separate editions. Additional pages of separate editions numbered or allowed for as follows: Western Section 34-1 through 34-2. POSTMASTER: PLEASE SEND FORM 3579 to Fulfillment Manager, ARCHITECTURAL RECORD, P.O. Box 430, Hightstown, N.J. 08520.





In Quiet Zone II, practicality is built right in along with all its other benefits. Seams are readily sealed to provide essentially a seamless floor. Spills wipe up, promoting constant cleanliness. And as for meeting Hill-Burton requirements, Quiet Zone II has an ASTM E-84 flame-spread rating of 75 or less and an average NBS smoke density of 450 or less — as well as a Flame Propagation Index of less than 4.0 in the UL-992 Chamber test.

Quiet Zone II comes in rolls six feet wide and up to 75 feet long; in three different designs — Random Texture, Houndstooth Check, Grand Central; and in a total of 13 colorings. One of which can make this remarkable floor covering fit like the beauty it is into the beauty of your surroundings. To learn more, write Armstrong, 310 Rock St., Lancaster, Pa. 17604.

*For more data, circle 2 on inquiry card*

FROM THE  INDOOR WORLD® OF

**Armstrong**



**Quiet Zone® II flooring from Armstrong.  
A combination of cushioned comfort and vinyl practicality  
that adds up to one beautiful prescription.**

People who walk on it know it for the nice underfoot comfort. People who wheel equipment on it know it for the smooth, taut surface. And people responsible for the hospitals and nursing homes in which it's installed know it for the special characteristics that help meet all the requirements of the Hill-Burton Act regarding smoke-generation and flame-spread limits. And everybody who looks at it knows it's beautiful. That's

Quiet Zone II Vinyl Corlon® from Armstrong.

Start at the top, and Quiet Zone II gives you a hard-working vinyl wear layer that's built to take heavy traffic and embossed to help hide traffic scuffs. Go to the bottom, and Quiet Zone II gives you a vinyl foam backing with a refreshing resilience that makes standing or walking easier and quiets noise more effectively than any conventional vinyl floor covering.



Lighting includes 14" x 48" troffer (2- or 3-lamp) with standard or polarized lens; parabolic louvered fixtures (8- or 16-cell).



Further lighting is this 29"-square fixture with high-pressure sodium lamp, offered with standard or polarized lens or parabolic louver.



Air-handling options include air boot and bar for constant-volume systems as well as two variable-volume systems designed for energy savings.

specially designed to control brightness without seriously reducing the lamps' efficiency. Optional polarized lenses with these fixtures can further lower energy requirements as well as improve lighting quality by reducing veiling reflections.

With all three systems, the lighting efficiencies result in both immediate and long-term cost reductions. To deliver 70 footcandles, the pendant fixture can require only .9-1.0 watts per square foot; the high-pressure sodium, only 1.4-1.5; the standard troffer, only 1.9-2.0.

**The new grid** is three inches wide, with a flat flange, and features a 1 5/8" black reveal that extends down the side of the recess and takes partition studs. It has a five-foot on-center hanging capability and can be 100% slotted for air distribution.

**The new board** is nondirectional Cortega™ which, combined with the flat grid design, produces a subtle, unobtrusive look. A new super acoustically

efficient board called Silok™, shown in main illustration, is also available for use in open plan spaces.

**The new air handling** gives you a choice of high-capacity five-foot-long air bar designed for constant-volume systems as well as two variable-volume systems—each with two options—that save energy several ways. They require no reheat, thus saving the cost of reheating cooled air. They need no external power to operate either valves or thermostats. And by reducing air quantities, they allow a reduction in the size of ductwork and fans.

With all its newness, innovation, and energy efficiencies, the Synercon 60 Ceiling System gives you a sum total of flexibility you've never had available before. In fact, this new system offers so much, you think you'll want to read about it in depth. Write now for all the technical details. Armstrong, 4208 Rock St., Lancaster, Pa. 17604.

For more data, circle 1 on inquiry card

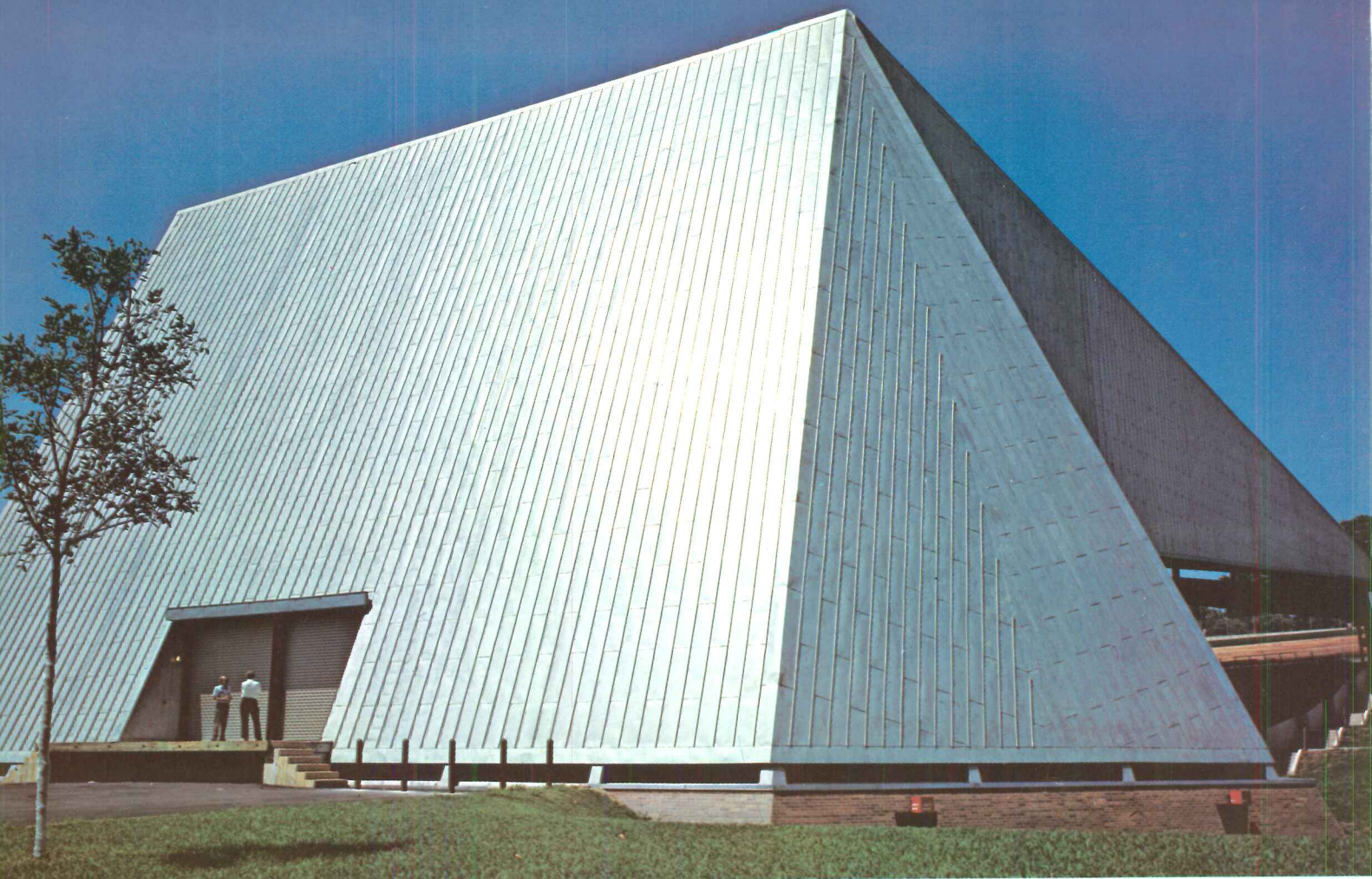

Robin Hood Dell West, Philadelphia, Pa. • Architects: John H. MacFadyen and Alfredo De Vido, New York • Associate Architect: I. Demchick, Philadelphia, Pa. • Roofing Contractor: Warren-Ehret-Linck, Philadelphia, Pa.

## TCS... THE LOGIC OF ITS USE

Rarely if ever has metal roofing been employed with more stunning visual impact than on Robin Hood Dell West, the Philadelphia Orchestra's new summer home, which will also serve as a creative center for other groups in the performing arts.

In specifying over 80,000 square feet of TCS (Terne-Coated Stainless Steel) on this exciting structure, the architects were primarily influenced by several practical as well as aesthetic considerations. Among them was the material's unsurpassed durability which is measured in generations rather than years. They were also aware that TCS weathers naturally to a uniform and attractive warm gray; that, properly installed, it will never need maintenance; and that it is highly resistant to even the most severe corrosive attack.

*For more data, circle 134 on inquiry card*



**FOLLANSBEE**  
CORPORATION

# You can't afford to waste water. Not at these prices:

## MONTHLY METERED COMMERCIAL RATES (Per 100,000 cubic feet or 748,000 gallons)\*

Boston	\$482
Chicago	283
Dallas	315
Denver	241
Hartford	446
Kansas City	250
Los Angeles	247
Minneapolis	350
New York	525
Pittsburgh	546
Portland, Ore.	270
San Francisco	285
Seattle	213
Tampa	360
Tucson	300
Washington, D.C.	300

\*From January 1976 survey conducted by *Business Statistics*.

## So you can't afford to install anything less than Sloan Flush Valves.

That's because a Sloan Flush Valve uses 12½% less water than a flush tank. And this difference increases with use because leaks in tanks go undetected to waste even more water. With today's water rates, it all adds up to a healthy saving on your water bill.

You also save on the energy needed to pump water within a building to upper floors and distant branches. The more water you save, the less energy you have to pay for.

Sloan Flush Valves save water another way, too. Because you can't hold a Sloan Flush Valve open, it meters out the same minimal amount of water needed to flush one fixture, then shuts off automatically.

Put an end to water waste that's costing you money. Find out how Sloan Flush Valves use 12½% less water. The facts are in a recent test report prepared by an independent laboratory. For your free copy, write us. We will send you the facts.

Sloan  
Flush Valves.  
Anything else  
is a waste  
of money.



**SLOAN VALVE COMPANY**

10500 SEYMOUR • FRANKLIN PARK, ILL. 60131