



JOHNS-MANVILLE WORLD HEADQUARTERS, DENVER, BY THE ARCHITECTS COLLABORATIVE
THE NATIONAL THEATRE, BY DENYS LASDUN & PARTNERS
LOGAN INTERNATIONAL AIRPORT'S NEW SOUTH TERMINAL
BUILDING TYPES STUDY: HIGH-DENSITY HOUSING
FULL CONTENTS ON PAGES 10 AND 11

ARCHITECTURAL RECORD

SEPTEMBER 1977

9

A MCGRAW-HILL PUBLICATION FIVE DOLLARS PER COPY





Lock Deck® laminated decking

Boards, standard and custom-processed

Potlatch



Our best efforts often go unnoticed.

What you see here is one small part of a unique restoration—the 123-year-old Kamm Brewery in Mishawaka, Indiana, now a complex of restaurants, theatres, a hotel, and 40 specialty shops.

Equally impressive is what you *don't* see. Despite the 3-foot solid masonry walls, you don't see any part of the modern communications system that serves the "100 Center" complex.

And that's a tribute to architect-developer Thomas Brooks Brademas and to the foresight of Ron Huseman, Building Industry Consultant for Indiana Bell.

It's also a graphic reminder of why it pays to meet with your Building Industry Consultant in the early stages of any project.

The system is the solution.



Bell System

The Brigantine® sheet vinyl floor from Armstrong.

In the school of hard knocks, it's the easy way to keep up appearances.

The school is West Hardin Elementary in Crump, Tennessee. Where the student body, from kindergarten through sixth grade, numbers 270. And where the clean, functional design of the architecture is enhanced by the beauty of Brigantine Vinyl Corlon® on the floor.

School authorities selected Brigantine sheet flooring for three sensible reasons: its lively, attractive appearance; its easy maintenance; and its will to survive in a world of active, busy children.

While Brigantine can be found in many of the classrooms, nowhere are its characteristics shown to better advantage than in the school's all-purpose "commons" area. Here, the students play basketball (boundary lines are painted on) and other games, eat their lunches, assemble for meetings, watch theatrical performances. And all that activity takes place on Brigantine's beautiful face.

Brigantine's beauty lies in its dirt-hiding pattern and its wide array of design-enhancing colors—two of which can be seen here. Its durability is provided by its tough sheet vinyl composition that stands up strong to the constant running, jumping and scuffing of youthful feet. A composition, by the way, that prevents spills from soaking in, helps the custodial staff clean up in short order.

The fact is, wherever long-lasting, easy-cleaning good looks are called for, you'll find Brigantine at the head of the class. A practical floor covering that comes in rolls 6 feet wide and up to 90 feet long that eliminate a lot of seams. A handsome floor covering that can attend the school of hard knocks and graduate with honors. To learn more, send for a free copy of our "First Family" booklet which describes Brigantine and other Armstrong commercial floors. Write Armstrong, 303 Rock Street, Lancaster, Pa. 17604.

For more data, circle 1 on inquiry card

Architect: H. G. Barnes and Associates, Jackson, Tennessee
Flooring Contractor: Markham & Hardin, Jackson, Tennessee
General Contractor: Pettigrew and Chandler, Adamsville, Tennessee



FROM THE  INDOOR WORLD® OF

Armstrong

Letter to the editor

I'd like to make two suggestions regarding the "Houses of the Year" competition which I feel would both broaden its scope and increase its impact on the housing market.

First of all, I recommend a separate category for houses constructed for less than \$75,000. As you know, the rules of the game are completely different at this level, and a good solution is often a much greater challenge than for the \$200,000 project. I believe that recognition of accomplishments at low budgets would stimulate more thought and interest in the profession on this topic, and could lead to a greater frequency of involvement between the architect and the average homeowner.

Secondly, I think we should see fewer vacation homes and luxury retreats. These propagate the popular impression of architects as men and women who do not deal with real problems, and whose work is not relevant to any market but the most elite.

Wright was the only architect who ever made any impression upon the nation as a whole. This was simply because he built houses which were affordable to a great number of people. With the cost barrier cleared, then the public could relate to design.

I believe these modifications could make the "Houses of the Year" a vehicle toward re-establishing those bonds between our profession and the majority of Americans.

*Jim Toohey
Designworks
Knoxville, Tennessee*

I have known Henry N. Cobb, or I. M. Pei & Partners, who designed the John Hancock Tower in Boston, for a very long time, and I can't imagine any respectable journalist, writing an article about him and his wonderful building, referring to him, from beginning to end, as *Harry*. His colleagues may call him *Harry*, and his good friends, or his family. But a journalist like William Marlin should know his place, and protocol, after all. It's *Henry*, if you don't mind.

*Peregrin Loste
Gene Autry, Oklahoma*

I am certainly happy to see solar energy receiving the attention of your editorial. Although I agreed with most of the article, I must take exception to your statement that "there are precious few professionals in this country who are really experts in solar system design."

The persons you identified are probably the most highly visible and often mentioned so-called "solar experts," but, along with our own firm, there are seldom published architectural and engineering offices throughout the United States (and the world, for that matter) who have built a solid background in utilizing solar energy systems for all kinds of projects.

Like a lot of firms specializing in solar energy projects, Burns/Peters is a young firm, just barely 3 years old, but we have developed an expertise in solar energy system design by hard experience in solar projects of various scopes and using different types of designs for both "active" and "passive" systems.

Our "passive" solar projects are designed to be tempered by the sun's rays. The projects include residences, greenhouses, and an animal control shelter. All of these projects include methods of retaining the stored sun's heat by using a nighttime insulating system. Some of these insulating systems are simple, manual operations; others are more complex, automated systems.

Our "active" solar projects include single-family residences, a prototype mobile home, townhouses, apartments, office buildings, a prototype portable classroom, a greenhouse for producing conifer seedlings, and an elementary school. These projects have used both air and water solar collecting systems. We have developed air collectors specifically designed for a particular situation; on other projects we have used a manufactured air collector system. These air systems have used conventional rock storage as well as an unique encapsulated water "tube bundle" storage system. Our other "active" solar systems have used flat-plate water collectors and concentrating, tracking water collectors.

The real purpose of this letter is to inform you that solar energy design is an established design service of not only Burns/Peters but of many architectural firms. Designers with solar energy experience can be identified by calling the toll-free telephone number of the National Solar Heating and Cooling Information Center (800/523-2929) or by contacting Michael Haggans of the American Institute of Architects Research Corporation, Washington, D.C.

*William L. Burns, AIA
Burns/Peters,
Albuquerque, New Mexico*

Calendar

SEPTEMBER

19-22 International Conference on the Use of Prefabricated Building Elements—Construction in Developing Countries, sponsored by the World Association for Element-Building and Prefabrication; Hamburg, Germany. Contact: H. S. Beisemann, Communication Management Consulting, Jungfernstieg 44, 2000 Hamburg 36.

21-23 Workshop series, "Developing an Accessible Campus for the Handicapped," sponsored by the National Center for a Barrier Free Environment; Hyatt Regency Hotel, Washington, D.C. Contact: National Center for a Barrier Free Environment, 8401 Connecticut Ave., Washington, D.C. 20015.

26-28 23rd National Electrical Exposition, sponsored by the National Electrical Contractors Association; Convention Center, Las Vegas. Contact: National Electrical Contractors Association, 7315 Wisconsin Ave., Washington, D.C. 20014.

28-30 Architects and Engineers Lighting Conference, sponsored by the General Electric Company; Nela Park. Contact: Manager, Lighting Education, General Electric Company, Nela Park, Cleveland, Ohio 44112.

through October 1 Retrospective Exhibition, 50 years of Princeton's School of Architecture from Labatut to Geddes. Contact: Princeton University, School of Architecture and Urban Planning, Princeton, N.J. 08540.

OCTOBER

2-4 World conference, "Alternatives to Growth '77," sponsored by The Club of Rome, University of Houston, Mitchell Energy & Development Corp.; The Woodlands, Texas. Contact: Jon Conlon, Mitchell Energy & Development Corp., 3900 One Shell Plaza, Houston, Tex. 77002.

3 Program of Courses entitled "Open Plan," Architecture in American Culture, sponsored by The Institute for Architecture and Urban Studies and The National Endowment for the Humanities. Contact: The Institute for Architecture and Urban Studies—Open Plan, 8 West 40th St., New York, N.Y. 10018.

6-8 The Fall Midwest Regional Conference, Association of Collegiate Schools of Architecture, Washington University, St. Louis. Contact: Carl Safe, School of Architecture, Washington University, St. Louis, Mo. 63130.

ARCHITECTURAL RECORD (Combined with AMERICAN ARCHITECT, ARCHITECTURE and WESTERN ARCHITECT AND ENGINEER)

September 1977, Vol. 162, No. 4. Title® reg. in U. S. Patent Office, copyright © 1977 by McGraw-Hill, Inc. All rights reserved. Copyright not claimed on front cover and editorial four-color separations. Indexed in Reader's Guide to Periodical Literature, Art Index, Applied Science and Technology Index, Engineering Index, and The Architectural Index. Published monthly except May, August, and October when semimonthly, by McGraw-Hill, Inc.

Quotations on reprints of articles available. Every possible effort will be made to return material submitted for possible publication (if accompanied by stamped, addressed envelope), but the editors and the corporation will not be responsible for loss or damage.

EXECUTIVE, EDITORIAL, CIRCULATION AND ADVERTISING OFFICES: 1221 Avenue of the Americas, New York, N.Y. 10020. Other Editorial Offices: 425 Battery Street, San Francisco, Cal. 94111.

PUBLICATION OFFICE: 1221 Avenue of the Americas, New York, New York 10020. Second-class postage paid at New York, New York 10001 and at additional mailing offices.

OFFICERS OF MCGRAW-HILL PUBLICATIONS COMPANY: Gordon L. Jones, president; Paul F. McPherson, executive vice president; Gene W. Simpson, group vice president; senior vice presidents: James E. Boddorf, planning and development; David G. Jensen, manufacturing; Ralph R. Schultz, editorial; vice-presidents: James E. Hackett, controller; Robert L. Leyburn, circulation; Edward E. Schirmer, sales.

CORPORATION OFFICERS: Harold W. McGraw, president, chief executive officer and chairman of the board; Robert N. Landes, senior vice president and secretary; Ralph J. Webb, treasurer.

SUBSCRIPTIONS: Subscriptions solicited only from architects and engineers. Position, firm connection, and type of firm must be indicated on subscription orders. Please allow 4-12 weeks for shipment.

CHANGE OF ADDRESS or subscription service letters should be forwarded to Fulfillment Manager, ARCHITECTURAL RECORD, P. O. Box 430, Hightstown, N.J. 08520. Provide old and new addresses, zip code or postal zone number. If possible, attach issue address label. Annual subscription prices: U.S., U.S. possessions: \$17.00 for architects, engineers and other individuals in the fields served; others \$26.00. Canada: \$19.00 for architects, engineers and other individuals in the fields served; others \$28.00. Australia, Brazil, and Japan: \$40.00 to architects, engineers; others, \$45.00. Other countries: \$35.00 to architects, engineers; others, \$45.00. Single copies: \$5.00.

GUARANTEE: Publisher agrees to refund that part of subscription price applying to unfulfilled part of subscription if service is unsatisfactory.

ASSOCIATED SERVICES/McGraw-Hill Information Systems Co.: Sweet's Catalog Files (General Building, Engineering, Industrial Construction and Renovation, Light Residential Construction, Interiors), Dodge Building Cost Services, Dodge Reports and Bulletins, Dodge/SCAN Microfilm Systems, Dodge Management Control Service, Dodge Construction Statistics, Dodge regional construction newspapers (Chicago, Denver, Los Angeles, San Francisco).

THIS ISSUE is published in national and separate editions. Additional pages of separate editions numbered or allowed for as follows: Western Section 32-1 through 32-2. POSTMASTER: PLEASE SEND FORM 3579 to Fulfillment Manager, ARCHITECTURAL RECORD, P. O. Box 430, Hightstown, N.J. 08520.





Mississippi Gulf Coast Junior College, Gautier, Miss./Architects, Planners: Slaughter & Allred, P.A., Pascagoula, Miss.

With our Soundsoak™ Wall Panels, this auditorium strikes just the right note in noise control and decorative beauty.

In an auditorium where music and drama are performed, nothing is more important than the control of unwanted sound reflections. And as the architects of this college building found out, a product most appropriate to the purpose is the Soundsoak Wall Panel from Armstrong. Especially since these panels radiate a lot of beauty while they absorb a lot of noise.

The reason they do both jobs so well is a function of the way they're made. Each 30' x 9' Soundsoak Wall Panel is acoustically

efficient because it starts with perforated mineral-fiber board. And each is visually attractive because the board is covered with a soft modacrylic fabric that blends fibers of various colorations with vertical embossing.

Available in twelve natural and accent colors, Soundsoak Wall Panels make beautiful sense wherever beautiful quiet is required. And they're easily installed on interior plaster, drywall surfaces, brick or block walls. To learn more, write Armstrong, 4209 Rock St., Lancaster, Pa. 17604.

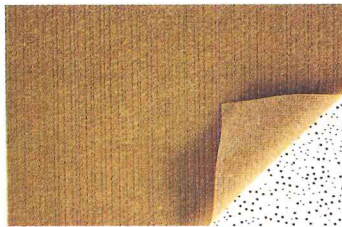

For more data, circle 2 on inquiry card

FROM THE  INDOOR WORLD® OF

Armstrong



Dimension lumber



Plystran® plywood sheathing

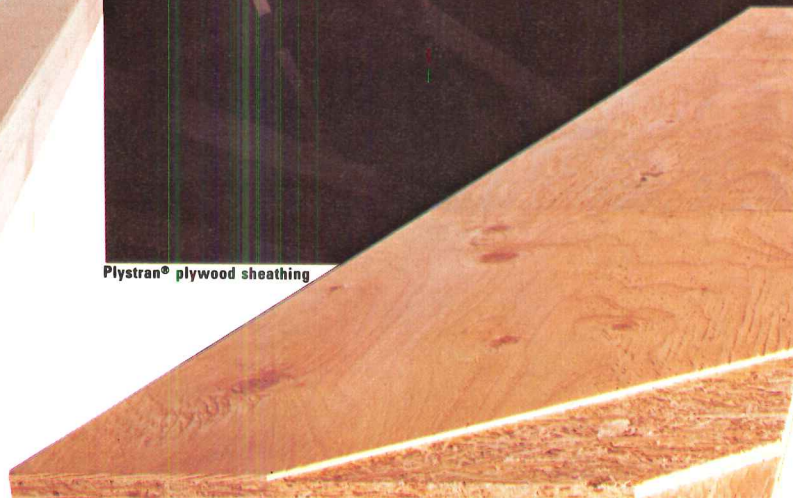

We grow the wood that works. For you.

Any wood that works for you had better work every time.

Your reputation depends on it. That's why your dimension lumber, boards, plywood, particleboard and laminated decking should come from Potlatch.

You can depend on every shipment, because the quality of every product from Potlatch starts from the ground up. Literally.

We grow the trees that make many of our products, on forest lands owned and managed by Potlatch since

the turn of the century. In the Northwest, our primary crop is Idaho White Pine, Inland Red Cedar, White Fir and Douglas Fir/Larch.

And because we produce only wood products, our plants concentrate on their specialty and do a better job consistently.

Add reliable Potlatch service, and you've got it. Wood you can stake your reputation on. Wood that works. For you.

Potlatch Corporation, Wood Products, Western Division, P.O. Box 5414, Spokane, WA 99205, (509) 455-4280.

For more data, circle 3 on inquiry card

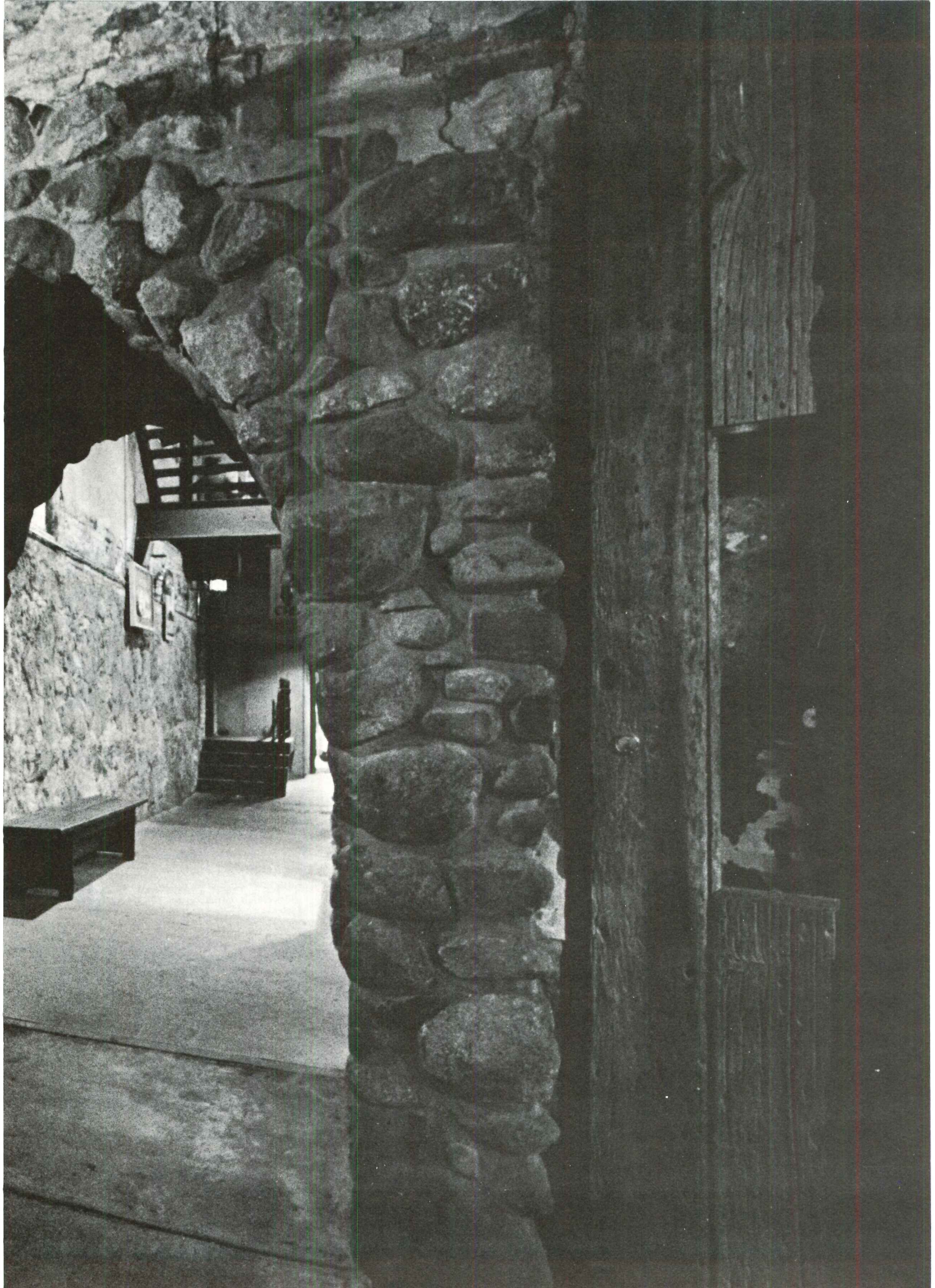

E CUBE 75

THE COMPUTER PROGRAM THAT NOW DOES MORE TO SAVE ENERGY AND MONEY.

The new, improved E CUBE 75 produces an accurate, three-part Life Cycle Energy Analysis at low cost. With many new features it computes the hour-by-hour energy requirements of your building or planned building for an entire year — taking into account all weather, design, operation, and occupancy factors.

Air Side Systems Simulations.

E CUBE 75 can now handle Variable Air Volume (VAV) systems directly. It also offers expanded treatment of Multizone, Dual-Duct, and Reheat air distribution systems. The energy consumption of various air side systems can be predicted — you can compare their performances and costs, and pick the one that's best. Other improvements make E CUBE 75 more complete and easier to use.

Energy Systems Simulations.

E CUBE 75 can simulate many different energy systems — from central stations to rooftops. It projects all costs, so you can choose the system or combination of sys-

tems that will work most efficiently and most economically for you.

E CUBE 75 is Inexpensive. For example, a life cycle energy analysis of a large building with 8 zones, 2 air side simulations, 4 system simulations and 4 economic comparisons costs less than \$160.

E CUBE 75 is Accurate. That's what it says in HUD Report "Study of Computer Utility Analysis." E CUBE is the most advanced program in this field with thousands of runs made by people in private practice, industry, American Gas Association member companies, and the U.S. government.

E CUBE 75 is Private. You give your information directly to the computer. Your project data and the results are never seen by any third party. Of course, we stand ready to provide assistance at your request.

E CUBE has been a big help to thousands. And the New Improved E CUBE 75 can help you even more to make the right decision. Right financially, and right for conserving America's energy.

For more information, or details of Seminars for new and advanced E CUBE 75 users, mail in the coupon or call Stephen A. Lewis (703) 524-2000.

Stephen A. Lewis, Manager
Energy Systems Analysis
American Gas Association
1515 Wilson Boulevard
Arlington, Va. 22209.



- Send more information on E CUBE.
 Send information on Seminars.

Name _____

Address _____

City _____

State _____ Zip _____

**ENERGY CONSERVATION
UTILIZING BETTER ENGINEERING**

AGA American Gas Association 

For more data, circle 4 on inquiry card



Torturous weather was only one reason why GE Silicone Construction Sealant was specified to butt glaze this Manhattan high-rise.

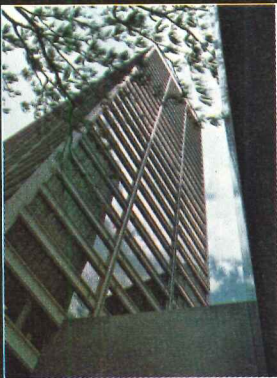

Wide open sight lines, changing stress loads and punishing weather created a tough set of performance considerations for the glazing sealant used at 88 Pine Street. Yet, after 6 years of shear stress and joint movement, of UV attack and airborne pollutants, of extreme heat and cold, GE Silicone Sealant still maintains its elasticity and bonding strength in a design that eliminates vision-obscuring mullions from window areas 7' high by 25' wide. And even after Hurricane Belle's 74 mph winds and torrential downpours, GE Silicone Construction Sealant is still performing. For more information, write Section 429, Silicone Products Dept., General Electric Co., Waterford, N.Y. 12188. **GE Silicones. The Performance Sealants.**

GENERAL  ELECTRIC

For more data, circle 5 on inquiry card

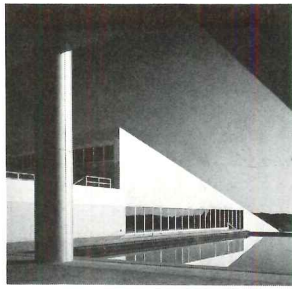

Cover: Johns-Manville World Headquarters
Jefferson County, Colorado
Architects: The Architects Collaborative
Photographer: Nick Wheeler

EDITOR

WALTER F. WAGNER, JR., AIA

MANAGING EDITOR

HERBERT L. SMITH, JR., AIA

SENIOR EDITORS

ROBERT E. FISCHER
MILDRED F. SCHMERTZ, FAIA

ASSOCIATE EDITORS

GERALD ALLEN
GRACE M. ANDERSON
BARCLAY F. GORDON
CHARLES E. HAMLIN
CHARLES K. HOYT, AIA
WILLIAM MARLIN

ASSISTANT EDITOR

JANET NAIRN

PRODUCTION EDITOR

ANNETTE K. NETBURN

DESIGN

ALEX H. STILLANO, Director
ALBERTO BUCCHIANERI, Associate
ANNA-MARIA EGGER, Assistant
MURIEL CUTTRELL, Illustration
J. DYCK FLEDDERUS, Illustration
JAN WHITE, Consultant

EDITORIAL CONSULTANTS

EDWARD LARRABEE BARNES, FAIA
JONATHAN BARNETT, AIA, Urban design
GEORGE A. CHRISTIE, JR., Economics
ERNEST MICKEL, Hon. AIA, Washington
PAUL RUDOLPH, FAIA

Foreign architecture:
L'Architecture d'Aujourd'hui, Paris

McGRAW-HILL WORLD NEWS

RALPH R. SCHULZ, Director
9 domestic and 10
international news bureaus:
Bonn, Brussels, Buenos Aires,
London, Milan, Moscow, Paris,
Singapore, Tokyo, Toronto.

SALES MANAGER

LOUIS F. KUTSCHER

CIRCULATION DIRECTOR

HUGH S. DONLAN

ASSISTANT BUSINESS MANAGER

JOSEPH R. WUNK

ASSISTANT TO THE PUBLISHER

ELIZABETH HAYMAN

PUBLISHER

BLAKE HUGHES

THE RECORD REPORTS

13 Editorial

On getting the public involved
and interested in architecture

2 Letters/calendar

33 News in brief

Short items of major
national interest.

34 News reports

New York State and the ABA
set guidelines for professional
advertising. GAO urges the
government to crack down
on A-Es committing errors and
omissions. Harry Weese leads team
studying landmarks preservation
in Chicago's Loop.

37 Human settlements: world news

39 Buildings in the news

National Gallery of Canada,
Ottawa. Honor Awards, Rhode
Island Chapter AIA

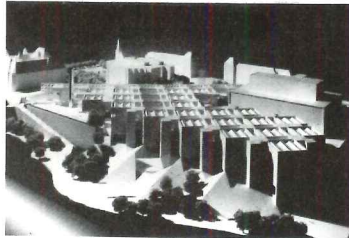

43 Required reading

ARCHITECTURAL BUSINESS

59 Business development

**Southern newsletter delivers
12 new project leads per week**

Florida-based Consulting Opportunities,
founded by an engineer, helps design
professionals locate new projects.

62 Building costs

**Range estimating: a way to predict
the accuracy of cost estimates**

Producing a good estimate of
construction costs means playing
a game of probability. Some
professionals see range estimating
as a way of assessing an
estimate's probable accuracy.

FEATURES

81 Triumph on the Thames

The National Theatre, in London, by Denys Lasdun & Partners, is jolly good.

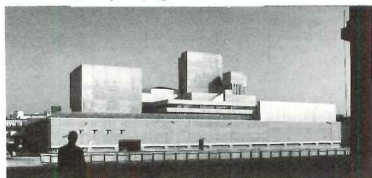

Donald Mill

89 Johns-Manville World Headquarters —A winner for J-M and TAC

The Architects Collaborative's competition design has been reproduced with remarkable faithfulness in a magnificent desert site near Denver, resulting in a building of extraordinary strength and beauty.

101 Shinjuku by Peter Gluck

Every day more than two million people pass in and out of Tokyo's Shinjuku district, the world's largest and most real megastructure. "Shinjuku," writes architect Peter Gluck, "is an example of an indigenous place that reflects the full breadth and complexity of a post-industrial society. Architects interested in designing for that society should learn to look at it, and places like it."

105 The linear airport comes to maturity at Boston's Logan International

Joint venture architects John Carl Warnecke & Associates and Desmond & Lord Inc. have recently completed Logan's new South Terminal, which represents the fully developed drive-to-the-gate airport.

BUILDING TYPES STUDY 507

111 High-density housing

Apartments and condominiums in the residential market have experienced a tremendous surge in growth in the past several years. High-density housing in the inner city—for middle- and upper-income levels—is particularly making a comeback, primarily as a result of changing cultural attitudes and values which are affecting the kind and location of housing people are seeking.

**112 Turtle Bay Towers
New York, New York**
Bernard Rothzeit & Partners, architects.

**116 Gateview at Albany Hill
Albany, California**
Hallenbeck, Chamorro & Associates, architects.

**120 Rokeby Condominium Apartments
Nashville, Tennessee**
Barber & McMurry Architects and Martin Holub Architect.

**122 240 East 26th Street Apartments
New York, New York**
Marvin H. Meltzer Architects.



Elliot Fine

**124 The Tannery
Peabody, Massachusetts**
Anderson Notter Associates, architects.

ARCHITECTURAL ENGINEERING

127 Plastic-composite design saves steel in large-bay framing of the Johns-Manville headquarters

Engineer William LeMessurier compares five different approaches to steel framing, and demonstrates the dramatic savings possible by exploiting the plasticity of steel and the composite action of steel working with the concrete slabs for the 54-ft bays of this building.

133 Product reports

135 Office literature

151 Office notes

192 Classified advertising

194 Advertising index

197 Reader service inquiry card

NEXT MONTH IN RECORD

Building Types Study: Hotels

Next month's issue will feature some unorthodox luxury hotels including a Hyatt in Cambridge, Massachusetts; a floating palace on the Mississippi; an urban hotel which forms the core of a city-within-a-city; and finally a hotel which is actually a recreational village on a 65-acre site for 3,500 vacationers.



Knoll

Milanese architect Gae Aulenti designs a new furniture collection for us.
Knoll International, 745 Fifth Avenue, New York 10022

For more data, circle 6 on inquiry card.

On getting the public involved and interested in architecture

A couple of Saturdays ago, I was invited to moderate a panel of local (Fairfield County, Connecticut) architects on "The Role of Architects in Connecticut Towns." The panel was part of "An Artists' Convergence" sponsored by the Connecticut State Commission on the Arts—one of a series of "design assemblies" being organized by the Commission to examine its best role as a catalyst for development of the arts and architecture around the state. The panel—first-rate architects and designers—got together ahead of time (as a good panel should) to discuss the framework of the discussion, talked about how we would handle the tough questions like how come so many of the new buildings in our surrounding cities and towns (all designed, mind you, by genuine registered architects) are so very bad and insensitive, and were ready with proposals for meaningful community-action programs in the various towns in our part of the state.

Well, nobody came. There were hundreds of people interested in the arts—or themselves artists of various disciplines—at the "Convergence." A session on dance programs in the state was well attended; and one on grantsmanship for painters and sculptors overflowed. Architecture attracted (it wasn't hard to count) 12 people, one of whom was an architectural delineator who (enterprisingly) came in hopes of showing his work to the assembled architects.

It wasn't a total loss—staffers from the state agency asked good questions and (reassuringly) took copious notes.

But it was disappointing. And the question is, of course: How can we get the public—citizens of our towns everywhere who buy houses, who want parks and other recreation facilities, who work in or shop in local office and retail centers, who vote on local school bond issues—to care about the quality of the environment? In the hopes that others are concerned about what kind of effort might successfully involve the public in concerns architectural, herewith is a list of some of the best-sounding (not yet all proven) of the proposals for public education that have been founded by the National Endowment for the Arts in recent years:

- The various tours of Chicago organized by The Chicago School of Architecture Foundation and its "Archicenter"—which include bus tours of the work of Louis Sullivan; a number of walking tours of the best older buildings as well as the best new; a Chicago River walking tour, and even "Put Your Arms Around a Building . . . a one-hour tour for children 6 to 12. By

touching, feeling, and comparing, children experience the diversity of structure and style found in downtown buildings and gain a new awareness of their own relationship to the urban environment."

- In Oak Lane, an older neighborhood of Philadelphia, a neighborhood "newspaper-magazine" was set up to comment on and, hopefully, coordinate a number of on-going community programs for preservation, renewal, ethnic awareness, and arts programs.

- To build public support for planning and redesign in Santa Cruz, the city developed (and showed to everyone who would look) a film and a slide presentation on city landmarks and amenities, developed a guide to local historic buildings, and held a widely publicized series of community forums on planning schemes for both historic and developing areas.

- An intriguing one: To dramatize the variety and quality of the visual environment as seen from Boston's elevated mass transit system, a series of short film scenarios made up of one thousand color slides shown in three minutes were developed and shown to community and neighborhood groups.

- A so-simple idea: One Endowment grant funded the writing (by a qualified professional) of 35 newspaper articles "on environmental, architectural, and urban design topics" which were published in the *Austin (Texas) American Statesman*.

- A "self-multiplying" public education idea: Under a grant to the ACSA, 31 "catalyst" fellowships given graduate students and faculty of ACSA-member schools taught courses in environmental and architectural concerns to over 600 public schools teachers across the country. And . . .

- Perhaps the most colorful idea: A theater group concerned (as citizens, not actors) with the preservation of the Midwest's wonderful historic courthouses, plans to present courtroom dramas ("The Night of January 6th," et al) in the historic courthouses of the towns on their theater circuit—and offer a brief description of the value of the buildings at orange-juice time between the acts . . .

There are, of course, hundreds of such efforts underway across the country. And it seems to me, for all of the reasons given at the beginning of this piece, that these efforts deserve the support and advice of architects everywhere. You might even think about getting such a program started in your community . . . It couldn't hurt . . .

—Walter F. Wagner Jr.

NEW BUILDING SWITCHES TO

The American Plaza tower in Evanston, Illinois, was initially conceived as a concrete framed building, until a close cost evaluation showed that a steel frame would be more economical.

“The savings from our study prepared for the owner amounted to 37 cents per square foot” said architect George Schipporeit, “or a total amount of about \$200,000”

The structural system for the new building consists of rigid frames in the perimeter walls of the building to resist lateral loads, and simple gravity load framing in the interior. Therefore, the drift requirements dictated the use of A36 steel for the spandrel beams, while all other main framing, beams and columns are A572-50.

The building is an eighteen story tower with floors measuring 120 feet by 150 feet. The large bay size of 30 feet square provides the flexibility



Parking deck structure.

STEEL—AND SAVES MONEY.

of space needed by the major tenant, The American Hospital Supply Corporation.

The office tower is served by a four level long span, steel framed parking deck with space for 384 cars. A cost evaluation was made on this structure, too. It also led to a decision to use steel. The bay sizes are 58 feet by 18 feet, and the floor beams act compositely with the concrete slabs.

In these new buildings, as in so many others, after a careful evaluation which considers current design and cost data, steel proved to be the most practical and economical structural system—while offering the

greatest operating flexibility. Clean cut lines, together with the simplicity of the overall design, provided American Hospital Supply with a maximum of useable space for their headquarters, in a most attractive setting.

When you're planning a new building, it will pay you to think about steel. For a structural report on the American Plaza and for further information, contact a USS Construction Representative through your nearest U.S. Steel Sales Office or write to United States Steel, P.O. Box 86 (C804), Pittsburgh, Pa. 15230.



TRADEMARK

United States Steel

For more data, circle 7 on inquiry card

DEVELOPER/OWNER: American Plaza Associates, Evanston, Illinois.

ARCHITECT: Schipporeit, Inc., Evanston, Illinois.

GENERAL CONTRACTOR: Power Construction Inc. and Power Contracting and Engineering Corp. (A Joint Venture), Elmhurst, Illinois.

STRUCTURAL ENGINEER: Rittweger & Tokay, Inc., Park Ridge, Illinois.

FABRICATOR: SR Industries Corporation, Schmidt Iron Works Division, Schaumburg, Illinois.

ERECTOR: Midwest Steel Erection Company, Inc. Chicago, Illinois.

LEASING AGENT: Hawthorn Realty Group, Chicago, Illinois.

Let our rainbow
color your thinking.





Florentine Atrium

We've captured Nature's rainbow. Multiplied it 37 times to give you an array of 222 beautiful colors. Everything from vibrant reds and brilliant yellows to muted greens and soft earth tones.

They're all in BFGoodrich's new Korolite™ Rainbow Collection. A full line of lightweight commercial Koroseal® vinyl wallcoverings.

The best designs, patterns, and textures of our previous Korolite collections. Plus many new styles. The exciting Mandarin. The refreshing Florentine. And the delightful Lively Lines.

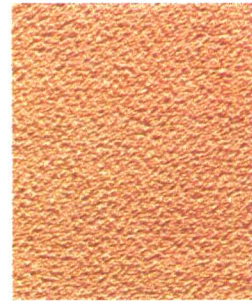

Lariat Buckskin



Mandarin Yangtze



Harborweave Hollywood Red

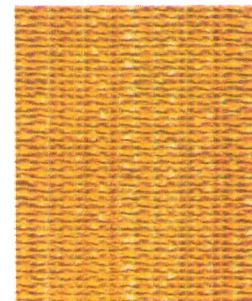

Mandarin Buddha

Hundreds of different solutions for offices, hotels, motels, or suite improvements and renovations.

Korolite wallcoverings are made of tough durable fabric backed vinyl to stay beautiful and attractive. They're heavier than most other Type 1 materials so they can handle a lot more punishment.

Vinyl means easy cleaning and maintenance too. Colors won't fade. So Korolite's original beauty lasts longer. And you won't be faced with costly painting.

While you're discovering our new Korolite Rainbow Collection, look into BFGoodrich's heavy-weight commercial wallcoverings. For commercial & residential uses, see our Elegance in Textures™ and Textures Unlimited™ wallcovering books.

Check Sweet's for your nearest BFGoodrich distributor. Or write, The BFGoodrich Company, General Products Division, 500 South Main Street, Akron, Ohio 44318.

BFGoodrich

For more data, circle 8 on inquiry card

DuPont now acrylic glazing materials design



Covered walkway provides safety for students at University of Delaware, Newark, Del. Architect: John Carl Warnecke & Associates.



Security glazing protects tellers at Aetna Federal Savings & Loan, Philadelphia, Penna. Architect: Obermaier & Falco.

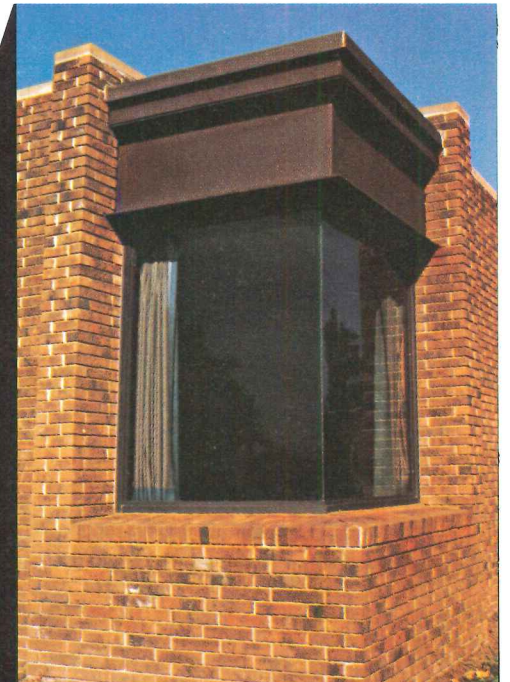

Windows retain sparkling clarity at Governor Bacon Health Center, New Castle, Del. Architect: Howard Greenhouse.



Decorative panels highlight First National Bank Cafeteria, Denver, Colorado. Architect: Gensler & Associates.



This skylight is representative of the type of skylights now being fabricated with "Lucite" cast acrylic sheet.

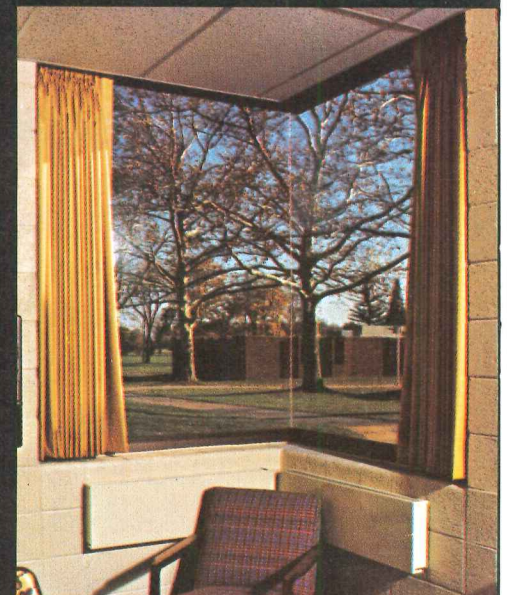

Inside view Governor Bacon Health Center.

has two LUCITE[®] to give architects more freedom.

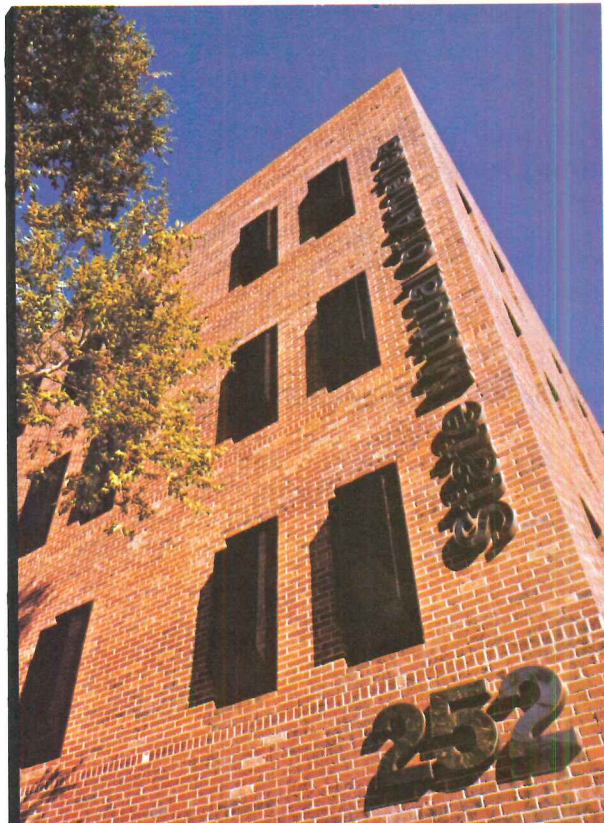

Windows combine beauty and durability at State Mutual of America Building, Denver, Colorado. Architect: Roark Associates.



Spectator glazing protects without obstructing view of game at University of Colorado Stadium, Boulder, Colorado. Architect: Herb Ross.

Now, with two forms of "Lucite" to choose from, you can be more innovative and imaginative than ever. Each offers specific performance benefits so you can select the one that best meets your requirements.

LUCITE[®] cast acrylic sheet

New "Lucite" cast acrylic sheet offers optical clarity greater than glass and up to 10 times the impact resistance for greater safety. Even if breakage does occur, it results in just a few large, easy-to-handle pieces. And "Lucite" keeps its initial beauty and clarity because it's essentially unaffected by prolonged exposure to moisture and natural weather conditions.

"Lucite" is lightweight—only half the weight of glass—so it's easier to fabricate and install. And it's thermoformable, even into compound curves and shapes, for unique styling concepts.

The low thermal conductivity of "Lucite" cast sheet (K 1.2) cuts winter heat losses. And it's available in solar tints to reduce air conditioning energy demand during the summer.

LUCITE[®] AR abrasion resistant sheet

"Lucite" AR abrasion resistant sheet combines all the best properties of "Lucite" cast sheet with a tough, permanent, invisible coating that provides outstanding abrasion resistance. It can be washed again and again with standard cleaners—even with strong detergents—without appearing hazy. It's also resistant to many chemicals, acids, hydrocarbons and alcohols.

You can use "Lucite" AR for those extra-tough applications where long-term clarity is important, such as security glazing in banks, door lights, decorative panels, and spectator glazing in stadiums.

Let "Lucite" cast acrylic sheet and "Lucite" AR abrasion resistant sheet give you more design freedom. Select the one that best meets the requirements of your design, and specify it for your next project. For more information and a test kit that demonstrates the abrasion resistance of "Lucite" AR, just write Du Pont Company, Room 35664, Wilmington, DE 19898. Or, look for us in Sweet's Catalog (8.26 Dp and Du).

Complies with ANSI Z97.1 1966/72

"Lucite" acrylic sheet is a combustible thermoplastic and, like many other synthetic and natural materials, should not be used in applications where codes or common sense would deem it unsafe.



GET MORE THAN JUST PRODUCT.

Specify Inryco/Milcor® Steel Framing Systems

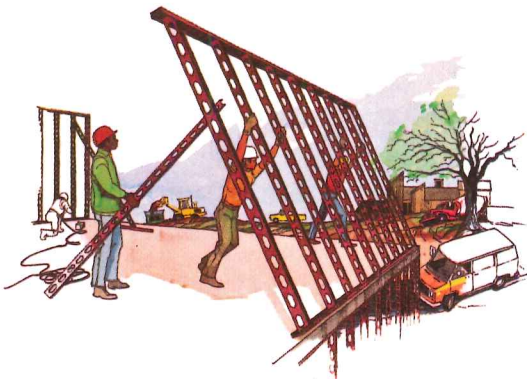

Structural components included in Inryco/Milcor steel framing systems can support the entire weight of buildings up to five stories high. Components are frequently pre-assembled for installation in large sections to save construction time.

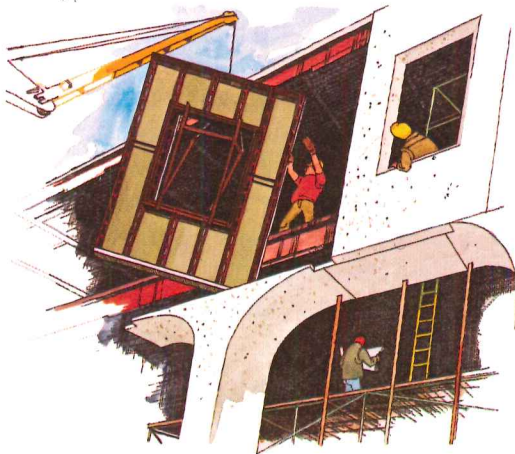

Prefabricated steel framing assemblies with exterior facing applied provide lightweight, easy to handle panels that speed curtain wall installation. Framed openings are incorporated. Curved or angled shapes are easily executed.

You'll get an honest appraisal of the suitability of steel framing for your project.

The versatility of our light structural steel components (steel studs and joists) makes them suitable for almost any wall or floor condition... with savings in time and costs, plus other desirable advantages. We'll review your projects in detail and show you how these benefits can apply. If our products will not suit your proposed application, we'll tell you so.

You'll get unexcelled design assistance when you need it.

Our experienced engineering staff furnishes design consultation and assistance on hundreds of projects each year... reviewing plans, detailing efficient solutions for complicated conditions, calling attention to over-design or under-design of specified systems.

You'll get experienced counsel for your framing contractor.

Through longtime involvement in both construction and manufacturing, Inryco has become the recognized leader in the steel framing field. We've worked closely with steel framing contractors to develop system innovations and improvements in fabrication and erection techniques. We stand ready to assist your contractor in developing proper framing construction techniques to help you achieve the maximum benefits of our systems.

Consider our systems and services for your next project.

Other companies manufacture and sell steel studs and joists. None have the experience, capability or desire to provide the extras you get from Inryco. Please review the information on Inryco/Milcor Steel Framing Systems in Sweet's Architectural File (section 5.3/In) or Light Construction File (section 5.3/Inr). Then give us a chance to discuss their application to your projects by contacting:

Milcor Division, INRYCO, Inc.; Dept. J-4033; P.O. Box 393; Milwaukee, WI 53201.

A7-37-1



Inryco

an Inland Steel company

General Offices: Melrose Park, Illinois

For more data, circle 10 on inquiry card

**Typical applications...low rise and high rise...
residential, commercial, institutional, industrial**



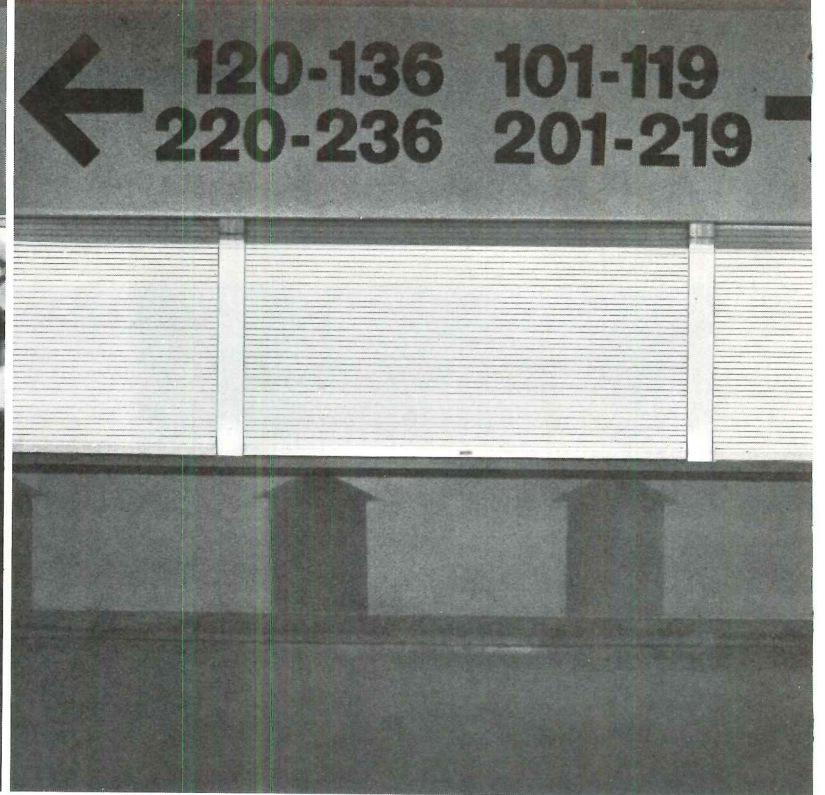

Even a half-time business needs full-time protection.

When the Golden State Warriors play at home in the Oakland Arena, hot dog and beer sales go way up. As soon as the Cookson counter doors go up. And when the Oakland A's or Raiders play next door at the Coliseum, the same thing happens.

During working hours, Cookson counter doors are coiled up, out of sight, out of the way. At closing time, they're easily rolled down, locked into position, fitted snugly to the counter.

They're easy to roll up and down because they're counter-balanced and equipped with lubricated ball bearings.

They're difficult to tamper with because the compact removable-crank operator is mounted at the top of the door, not at counter level.

The locking device is even hard to find: we conceal it in the footpiece.

Available with slats of galvanized steel, stainless steel or extruded alumi-

num, Cookson standard counter doors are trim, handsomely styled.

So are our sturdy, UL-listed steel rolling counter fire doors, and our custom-built unitized counter doors.

Cookson counter doors were the best way to close 80 refreshment stand openings in the giant Oakland-Alameda County Coliseum complex. Including the "hot dog-watch dog" above.

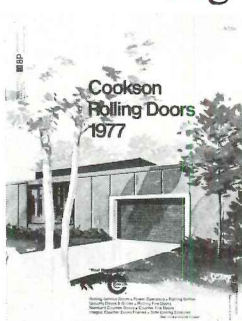

Cookson's **Catalog 77** is the most comprehensive compilation of rolling door, grille and counter door data ever published. See it in Sweet's (8.7/Co). Write or call for

your own copy to: The Cookson Company, 700 Pennsylvania Ave., San Francisco, CA 94107. Phone (415) 826-4422.

 **Cookson Rolling Doors**
Best way to close an opening.

AN UNFAIR COMPARISON.



Just in case you're not familiar with all those HID advantages, we've provided the cost comparison chart at the lower left to remind you. It shows a 10-year amortization of a typical 20,000 square foot store lighting system for equal footcandles.

You can see that Spectra V Series III HID lighting is quick to pay for itself and surpass fluorescent in efficiency of operation. You can also see that it often costs no more than fluorescent to buy and install, contrary to popular belief. Full specifications and cost data are available upon request.

And since it's from Wide-Lite, it gives you some HID advantages that other HID luminaires don't.

Thanks to the 90% reflectance of our superb UltraClad reflector, the Series III makes the most of metal halide or high-pressure sodium lamps to give you smooth, low-glare light-

ing for stores, offices, and schools. A heat and impact resistant tempered glass lens is standard equipment. As is our published 3-year limited warranty.

Like the rest of the renowned Spectra family, the Series III uses our cooler-running, high-grade encapsulated ballast. Which means years of trouble-free operation.

Installation is simple. And once installed, the Series III's entire optical assembly swings down on hidden hinges for easy access from below to the lamp and wiring compartment.

And because it's from Wide-Lite, the Series III is available with options like our Automatic Energy Control (AEC) and Dimming systems for maximum efficiency and minimum light bills.

Go ahead, send for our free brochure. You can bet all our competitors will.

IF FLUORESCENT LIGHTING DIDN'T COMPARE TO OUR NEW SPECTRA V IN PRICE, THERE WOULDN'T BE ANY COMPARISON.

To all the users and would-be users of fluorescent lighting for commercial indoor applications, Wide-Lite has welcome news.

It's called Spectra V Series III, and it gives you all the advantages of High Intensity Discharge (HID) lighting—and all the advantages of Wide-Lite—at a price comparable with fluorescent.

Average Annual Costs

A	\$3,138	\$587	\$7,600	\$11,325
B	\$3,022	\$603	\$5,184	\$8,809
C	\$4,032	\$664	\$3,965	\$8,661

A	Fluorescent Troffer with 4-F40 CW lamps - 250 fixtures
B	Wide-Lite Spectra V Series III with 400-watt Super Metalarc - 72 fixtures
C	Wide-Lite Spectra V Series III with 250-watt High Pressure Sodium - 84 fixtures

 Purchase and Installation	Store: 100' x 200' x 15' Reflectances: 80/50/20 Room Cavity Ratio: .68 Hours: 12 hrs/day; 6 days/week; 3,200 hrs/yr. Design Target: 70fc. maintained
 Cleaning and Relamping	
 Energy Costs (@ 5¢ per KWH)	

WideLite

P. O. Box 606, San Marcos, Texas 78666
Wide-Lite® products also manufactured in Australia, Belgium (for Europe), Canada, Mexico, Great Britain, Venezuela and South Africa.
A company of the  Esquire Lighting Group

An open-and-shut case for our better-insulated hospital window.

At Amelco, we believe a hospital room with a view should save fuel, too. And our E/C Series hospital window is designed to do just that.

The E/C Series has a compression-type weathering system that seals in heat and air conditioning, and allows for easier opening and closing; therefore weather-stripping lasts and lasts.

A 2⁵/₈" air space between panes provides better insulation than a standard window, and better soundproofing too. Dust-free internal venetian blinds maximize energy conservation.

Plus, of course, other Amelco quality features: an exclusive handle design that is compatible with Life Safety Code (NFPA

101-1976 Para. 10-2.3.7.1) and allows ease of emergency ventilation, yet assures patient safety.

In case of vandalism, vents are easily removed by your maintenance people without tools, and a stored replacement vent is immediately dropped in without interruption of hospital routine.

The fact is, Amelco has led the way in just about every important aspect of hospital window design. Our long list of repeat customers is a testament to our product*.

Rather than take a chance on a cheap window that can be a costly fuel-waster in the long run, look into our Amelco E/C Series hospital window. Write for our brochure, or call us at (516) 759-1010.

AMELCO®

The Amelco Window Corp.

Box 32, Glen Cove, New York 11542

(A Subsidiary of The Seagrave Corporation)

For more data, circle 13 on inquiry card

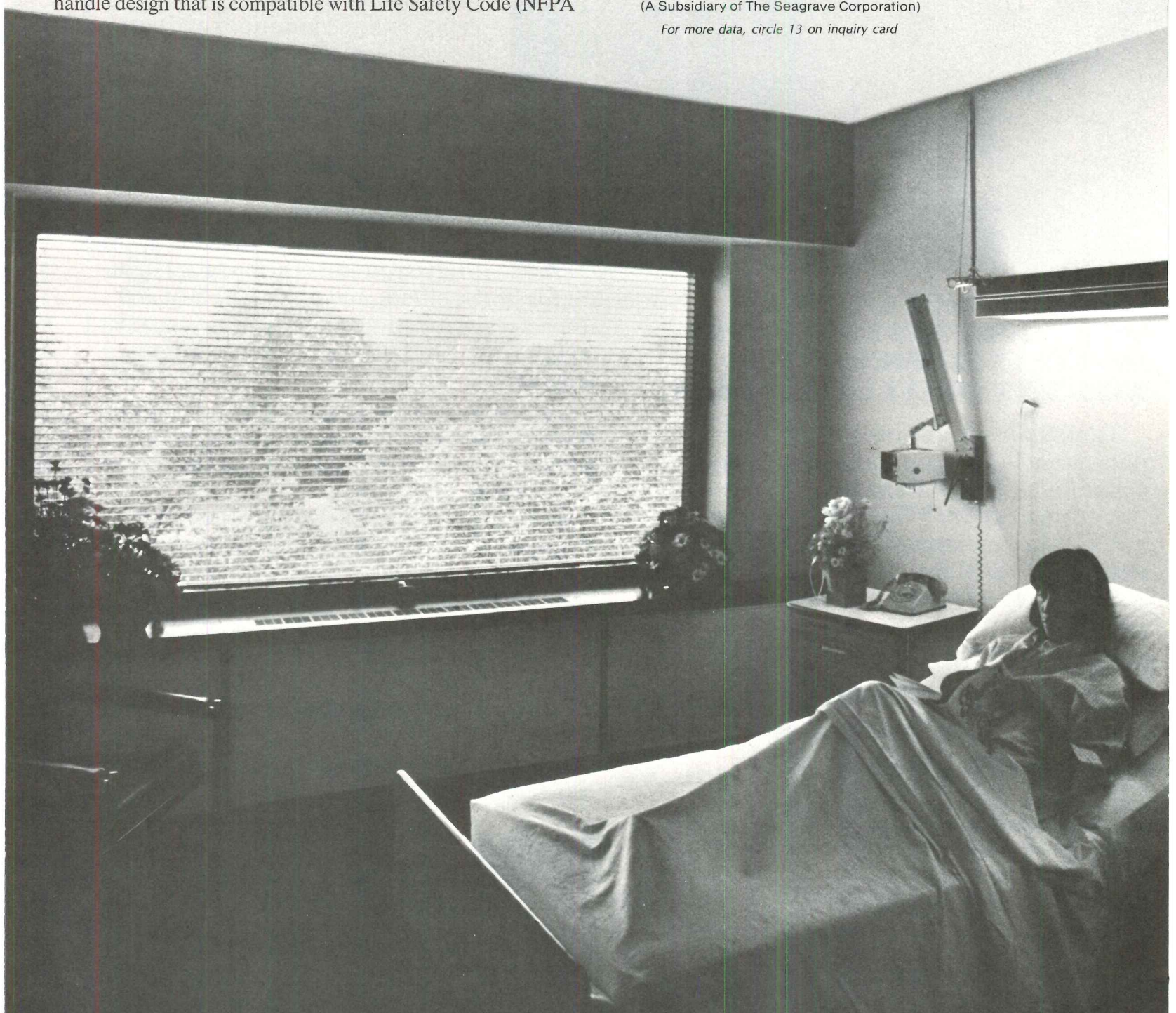

**A partial list of customers who have used Amelco windows in as many as 6 to 13 different projects includes: Rogers, Butler & Burgun, Architects, N.Y.C.; N.A.S.A., Cleveland; Ferrenz & Taylor, Architects, N.Y.C.; Columbia-Presbyterian Medical Center, N.Y.C.; Charles H. McCauley Assoc., Architects, Birmingham, Alabama.*

New Regal earth tube™

Now Regal offers you structural steel tubing with a beautiful yet tough weathering surface. The warm earth tones of its durable surface mature with age and blend naturally into any environment. Painting is never required. Available in square and rectangular shapes, dozens of perimeters and wall thicknesses for scores of uses. Earth tube. We think you'll agree its well named.

The Copperweld Tubemakers
REGAL TUBE COMPANY

7401 South Linder Avenue
Chicago, Illinois 60638 • 312/458-4820

For more data, circle 14 on inquiry card

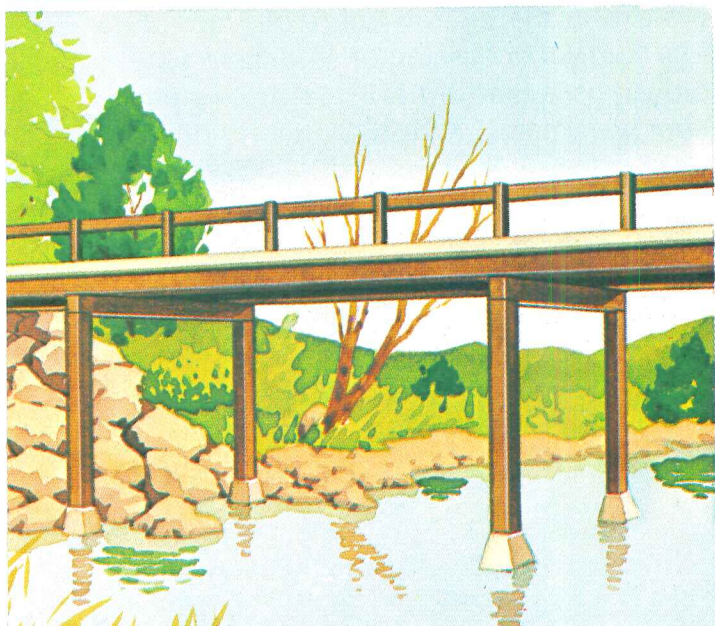
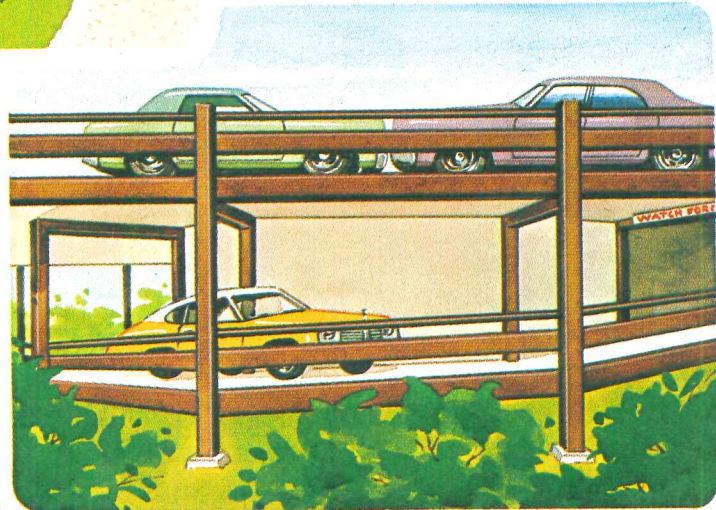
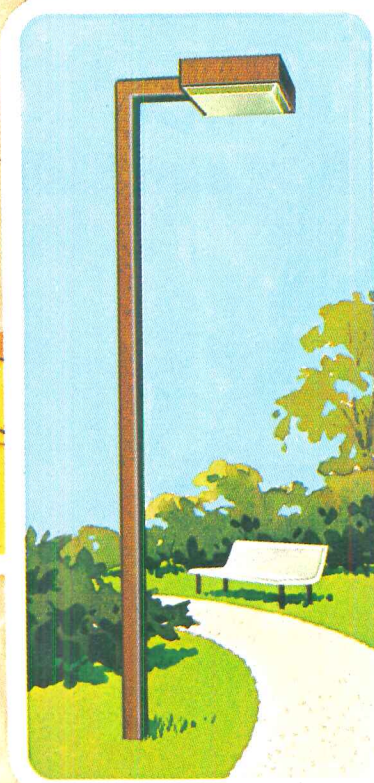
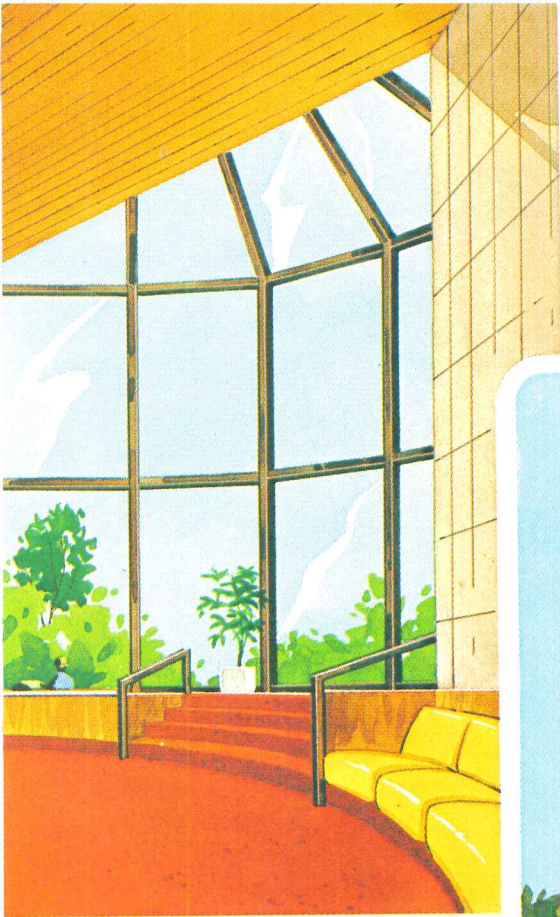

We invite you to send for
our earth tube catalog.

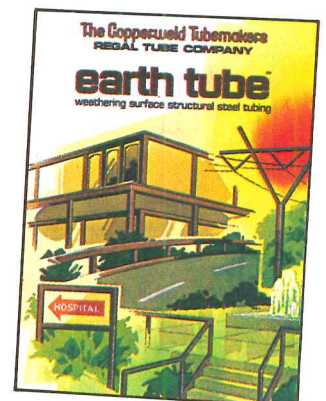

Copper solar collectors give you energy on the house.

Three roof-top solar collectors provide 75% of the domestic hot water for this Long Island, N.Y. house.



Solar energy is here today! It is dramatically cutting costs of heating water for homes, schools, recreation and commercial buildings in all types of climates. Solar collectors also provide energy for space heating and air conditioning.

When you design, specify or install solar collectors, insist on copper for the absorber plate and for the tubes which circulate the fluid. With a blackened surface

coating, it's the most efficient material for collecting the sun's heat. Copper needs practically no maintenance, is easy to work with, and resists corrosion.

Asarco is a major copper producer with a stake in the energy future of America. The Sunworks division of an Asarco subsidiary is a leading fabricator of solar energy systems. ASARCO Incorporated, 120 Broadway, New York, N.Y. 10005.

ASARCO

For more data, circle 15 on inquiry card

Your special door problems are solved!



Some doors have to take plenty of shock. Stanley's pivot reinforced hinges are unique: fit beveled edge doors perfectly — prevent loosened screws and hinge damage on all doors subject to severe abuse.



Some doors demand a completely clear opening. Stanley's Swing-Clear hinges let beds, carts pass through without damage to door edges and thus help to keep maintenance costs down.

Some doors must permit emergency entrance. Stanley's rescue hardware permits fast access to a disabled patient by allowing a door to swing back away from the problem.

Just a few of the reasons you should remember Stanley, next time you're stumped by a problem door. Because, chances are, Stanley has your special answer right in stock! For answers you need, quality you respect, and service that's quick, come to Stanley Hardware, Division of The Stanley Works, New Britain, Conn. 06050. In Canada: The Stanley Works of Canada, Ltd. See our catalog in Sweet's Architectural File.

STANLEY
helps you
do things right

For more data, circle 16 on inquiry card

PPG glass helps cast a new masterpiece in bronze.



The Hyatt Regency Dearborn: A breathtaking, crescent-shaped sculpture standing near downtown Dearborn with its great wings spread in warm welcome.

Its form, with its deep, rich bronze appearance, has made the Hyatt Regency an almost instant magnet for people. Which, after all, is the whole idea of a great hotel.

The beautiful concave glass curtain wall is formed of PPG Solarban® 575 Bronze Twindow® units. The architect called them "the absolutely perfect material for such a powerful esthetic statement."

However, PPG Solarban Twindow units provide much more than beauty. They are high-performance, reflective,

insulating glass units that conserve energy by reducing solar heat gain. On hot summer days they cut conducted heat gain. And in winter they reduce conducted heat loss for additional energy savings.

Learn more about how PPG Solarban Twindow units can glorify your next design. See Sweet's 8.26/Pg, or contact your local PPG architectural representative for information about any of our family of high-performance glasses.

Or write to: PPG Industries, Inc., One Gateway Center, Pittsburgh, Pa. 15222.

PPG: a Concern for the Future

The Luckman Partnership, inc., Architects, Los Angeles, California, utilized these performance characteristics of PPG Solarban 575 Bronze Twindow units for the Hyatt Regency Dearborn:

Shading coefficient: 0.23
U-Value: 0.31 Btu/hr-sq ft-F
(winter nighttime)
0.35 Btu/hr-sq ft-F
(summer daytime)
Relative heat gain: 51 Btu/hr-sq ft,
when ASHRAE Solar Heat Gain
Factor is 200 Btu/hr-sq ft and
the outdoor air temperature is
14 F warmer than the indoor
air temperature.

Owner: Ford Motor Land Development Corporation
Operator: Hyatt Hotel Corporation, Burlingame,
California

For more data, circle 17 on inquiry card



A

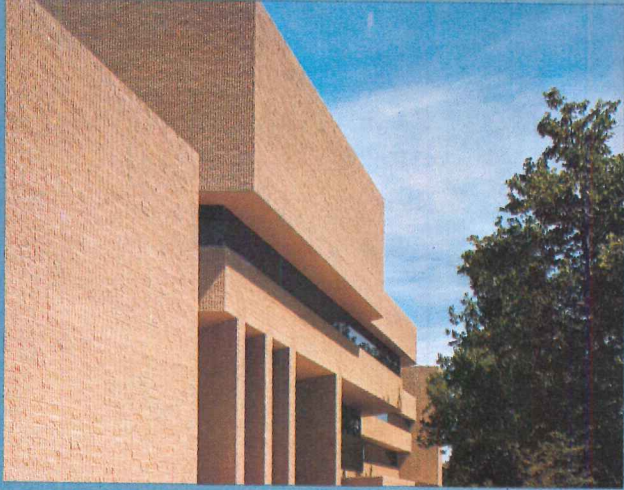

B



D



C



A. Police Headquarters, New Haven, Connecticut, Orr-deCossy-Winder & Associates B. Sid W. Richardson Physical Sciences Bldg., Texas Christian University, Paul Rudolf in association with Preston M. Geren C. General Studies C/I/R/C, S.U.N.Y. Agricultural/ Technical College, Delhi, NY Wm. A. Hall & Associates, Architecture & Planning D. Charles Ennis Residence, Frank Lloyd Wright

WE STILL MAKE THEM THE WAY WE USED TO. BY HAND.

Today's architects still call on the same masonry craft skills that architects and master builders of 200 —and 2,000— years ago relied on. For masonry is still the best way to build. Still the least expensive.

The mechanics of creating walls with mortar and brick, or block, or stone, have changed little. But technology in the production of masonry materials as well as on-site automation of materials handling have changed enough to maintain masonry's reputation: it's stingy with the tightest budget. In fact, masonry structures are usually lowest in initial cost. Consistently low in operating costs.

Masonry materials have taken on new dimensions, new colors, new textures. And innovative



design has demanded parallel innovations to execute them. Masonry panels afford the architect design flexibility not known before while still assuring unparalleled craftsmanship. Loadbearing masonry systems permit fast, economical construction and afford the designer a broader palette.

The reasons for masonry's ageless popularity are many. Permanence. Beauty. Flexibility. And economy. There is simply no more energy-efficient, durable, easily maintained building material known to man.

So it's no wonder we're still making them the way we used to. The trowel is still one of the building designer's handiest tools.



INTERNATIONAL MASONRY INSTITUTE

Suite 1001, 823 15th St., N.W., Washington, D.C. 20005, (202) 783-3908

The Mason Contractors and Bricklayers Union of the USA & Canada.

For more data, circle 18 on inquiry card

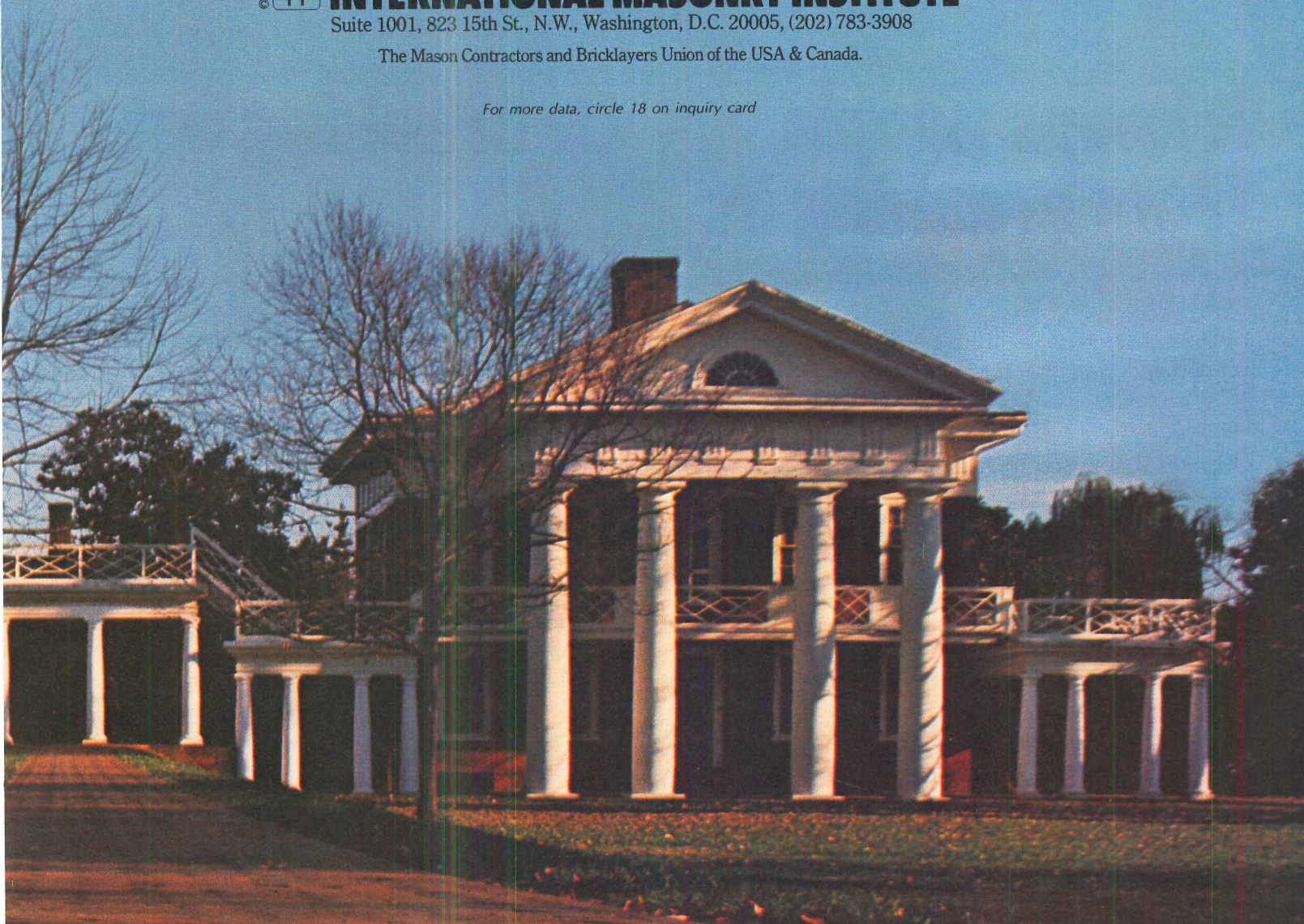

Laminated architectural glass.

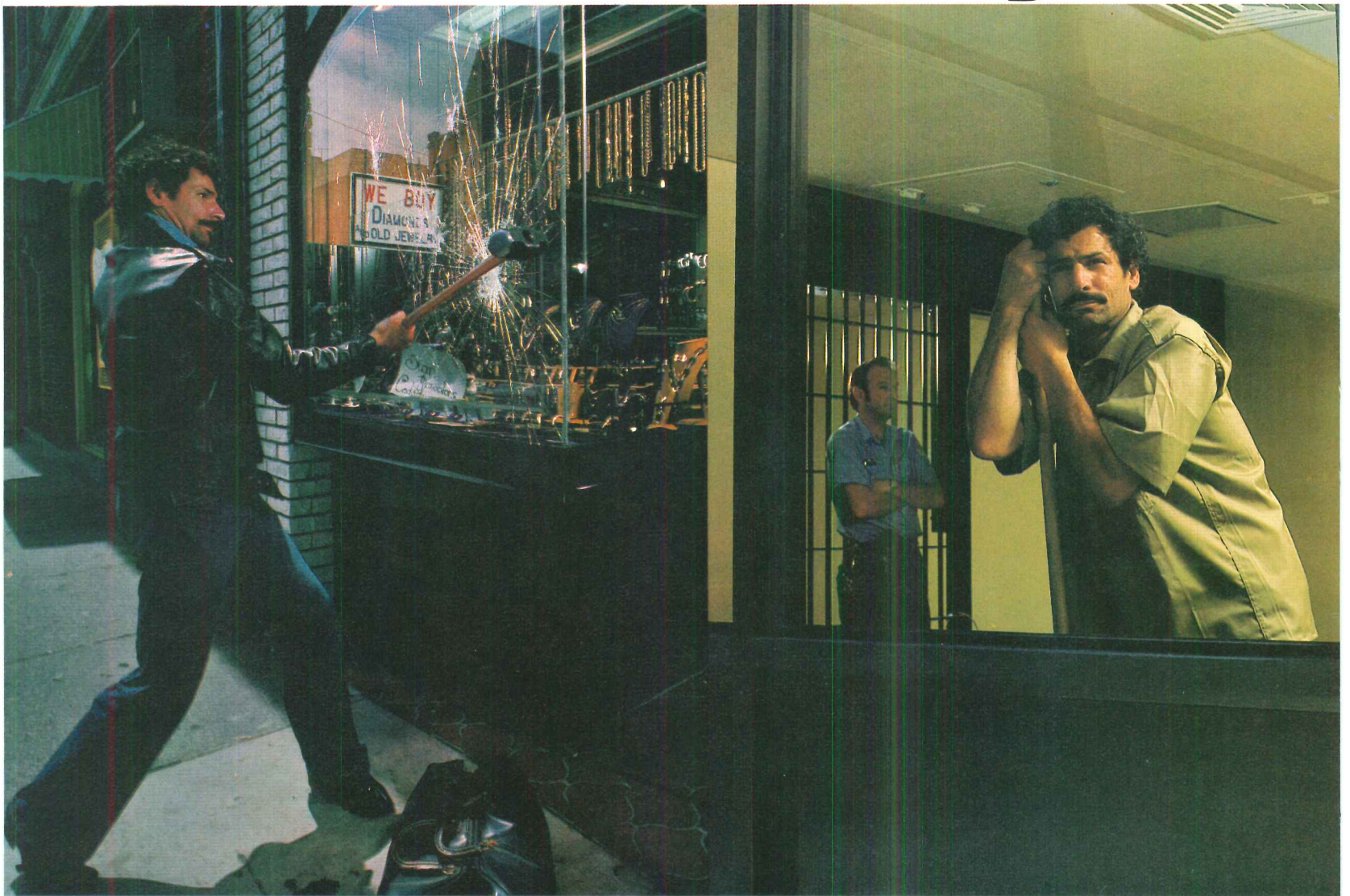

It keeps people from breaking in.

A building is only as secure as its weakest point. Which is, traditionally, the glazing.

Ordinary glass, of course, shatters easily on impact. But *laminated* security glass is a formidable barrier.* Even heavy attacks by brick, crowbar or pickax result in only localized fractures and limited penetration.

Of course, no construction of any kind will stop a sustained attack. But laminated security glass affords maximum delay. Frustrated, the attacker usually abandons the attempt. Or is detected and captured if he persists. And laminated security glass is just as clear as ordinary glass of the same thickness so store displays look as good as ever.

The new "barless" jails being built under government regulation are constructed with laminated security glass. The special

Or breaking out.

impact penetration resistance and optical properties make laminated security glass the recommended material for detention glazing. This new type of security construction is changing the look of penal institutions.

Laminated glass is constructed of two or more sheets of glass permanently bonded together with a plastic interlayer. Monsanto manufactures Saflex® polyvinyl butyral plastic interlayer used by leading producers of laminated security glass.

You'll also want to explore the other benefits of laminated glass. In addition to security applications, laminated glass offers sound attenuation and light and heat control.

Write for a list of manufacturers of laminated security glass to: Monsanto Plastics & Resins Company, Department 804, 800 N. Lindbergh Boulevard, St. Louis, Missouri 63166.

SAFLEX®

PLASTIC INTERLAYER BY **Monsanto**

*LAMINATED SECURITY GLASS CONSTRUCTION CAN MEET THE RIGID REQUIREMENTS OF UL STANDARD 972 FOR BURGLAR RESISTING GLAZINGS.

NEWS REPORTS
BUILDINGS IN THE NEWS
HUMAN SETTLEMENTS
REQUIRED READING

New York State and the American Bar Association have relaxed their bans on advertising by professionals, following the Supreme Court's recent ruling. Both groups also issued guidelines for acceptable ads. Details on page 34.

The construction industry will continue its present recovery until 1980, when it will equal 1973's peak in physical volume, according to F.W. Dodge's study "The Next Five Years." After 1980, the industry can expect "a pattern of slow growth," and by 1982 should show a 50 per cent increase in dollar volume over 1977, and a 15 per cent increase in physical volume.

In the first six months of 1977, construction contracts rose 27 per cent over the same period last year, according to the F.W. Dodge Division of the McGraw-Hill Information Systems Company. Although much of this increase reflects heavy commitments in nonbuilding construction (especially power plants), residential construction was up 40 per cent for the half, totalling \$28.6 billion, and nonresidential building was up 8 per cent to total \$15.7 billion. The latter figure includes a 17 per cent increase in contracts for industrial and commercial building.

The GAO suggests that Federal procurement agencies have been too easy on A-Es committing errors and omissions, and urges the government to exert more energy in litigating these cases. Details on page 34.

The California Council AIA has voted to make architects' license renewals contingent on continuing education. The proposal, scheduled to be introduced in the California legislature early next year, would require that candidates complete 80 hours of "acceptable continuing education" in the two-year period preceding recertification. A committee appointed by the State Board of Architectural Examiners would evaluate education programs.

The Construction Specifications Institute has established a program to certify construction specifiers. Certification, open to both members and nonmembers of CSI, will require candidates to pass a written examination offered annually. The exam will be based on the Institute's Manual of Practice and Conditions of Contract.

Finalists have been named in the competition for the Harvard Square site formerly set for the Kennedy Library. Three developer/architect teams will refine their plans in the competition's second phase. Details on page 35.

Alan M. Voorhees will be the first Dean of the new College of Architecture, Art and Urban Sciences at the University of Illinois at Chicago Circle. Mr. Voorhees, who will also hold the title professor of urban sciences, is founder and president of the urban planning firm Alan M. Voorhees and Associates. He is also former president of the American Institute of Planners.

Union wage increases in the construction industry averaged 6.5 per cent during the first half of 1977, the Associated General Contractors report. This compares to 7.2 per cent during the same period a year ago. The average building trades worker now earns \$11.60 an hour, including fringe benefits, according to the AGC.

An international symposium on roofing technology will meet in Gaithersburg, Maryland, September 21-23. Sponsored by the National Roofing Contractors Associations and the National Bureau of Standards, the conference will hear 31 papers, more than half from experts outside the United States. For information: National Roofing Contractors Association, 1515 North Harlem Avenue, Oak Park, Illinois 60302, or William Cullen or Robert Mathey, 8348 Building Research, National Bureau of Standards, Washington, D.C. 20234.

An AIA conference titled "Design: Work of Art? Working Object?" will meet October 26-27 in Washington, D.C., to discuss "the rapidly changing interpretations of design within the architectural profession." Major speakers will include Joseph Esherick, FAIA, London architect Norman Foster, sociologist Robert Gutman of Princeton and Rutgers, Tokyo architect Arata Isozaki, Philip Johnson, FAIA, and William Marlin, RECORD associate editor. George Nelson, FAIA, will moderate. For information: John Gaillard, AIA, 1735 New York Avenue, N.W., Washington, D.C. 20006.

The Building and Construction Exposition and Conference meets November 1-3 at Chicago's McCormick Place, and will revolve around the theme "New Opportunities '78 and the Energy Challenge," including sessions on the Administration's energy policy, solar energy and energy retrofit. Other sessions will address the opportunities in urban rehabilitation and in residential design. BCEC is sponsored by the Producers' Council. For information: Building and Construction Exposition and Conference, 331 Madison Avenue, New York, New York 10017.

The American Academy in Rome invites applications for the 1978/79 Rome Prize Fellowships, which are awarded in architecture, landscape architecture, and planning and design, among other fields. The prize carries travel allowance, residence at the Academy, and a modest stipend. Deadline for applications is November 15. For information and application forms: American Academy in Rome, 41 East 65th Street, New York, New York 10021.

New York and the ABA rule on professional ads

The traditional barriers against advertising by professionals are falling left and right—first to the U.S. Supreme Court, now to the State of New York and the American Bar Association.

The New York State Board of Regents has adopted new rules of professional conduct that will allow architects, engineers, physicians and other professionals to advertise their services. (The Board of Regents regulates the education, licensing and conduct of all professionals practicing in the state except lawyers and clergymen.)

Although the newly promulgated standards follow hard on the heels of the Supreme Court's ruling that attorneys be allowed to advertise as an exercise of their Constitutional right of free speech, the Board of Regents had in fact been studying the changes for nearly two years. Their actions, the Regents said, were in response to consumer group attacks on existing bans against professional advertising as "unreasonably interfering with the right of a potential patient or client to obtain the information necessary to make an informed choice, and as prohibiting competition among professional practitioners."

The rules, which take effect October 1, will, however, set some limits to permissible advertising. They specifically allow "advertising in a newspaper, periodical or professional directory of fixed prices, or a stated range of prices, for specified routine professional services, provided such

advertisement clearly states whether additional charges may be incurred for related services which may be required in individual cases." The rules also permit "informational" advertising, which the Board expects will cover such matters as services, hours and other aspects of practice.

Specifically prohibited as "not in the public interest" are false, fraudulent or misleading advertisements, as well as those that are "spectacular and flamboyant." Also forbidden are testimonials, intimidation, offers of gratuitous services and discounts, guarantees, and unsubstantiated claims.

The Regents will allow price advertising in print, but not on radio or television. (The Supreme Court's ruling failed to reach the issue of professional advertising in the latter media.)

Last month the American Bar Association, convening in Chicago, approved a 50-page set of guidelines for lawyers who plan to advertise. Members of the ABA will be allowed to advertise in the newspapers and on radio. (The question of television advertising was left to the states.) Permissible information includes education, military record, legal specialty, bank references, credit card acceptance, and fees.

The ABA's code is binding on no one except the association's members (about half the lawyers practicing in the United States), but it is expected to serve as a model for state bar associations and other regulatory bodies.

National Park Service funds study of Chicago landmarks

Historical buildings throughout the country should benefit from a Chicago-based Federal study to be completed later this year. The \$111,000 National Park Service study will focus on the revitalization of four famous Chicago office buildings built in the late 1800s. But the project is also expected to produce preservation techniques applicable to other distinguished old buildings in other cities.

Chicago architects Harry Weese & Associates, long involved in building renovation and restoration, head up a team of experts including the architectural firm Kaplan & McLaughlin; Professor James Marston Fitch, Director of Columbia University's Historic Preservation Program; Paul M. Lurie, an attorney specializing in real estate; and Jared Shlaes, an authority on landmark economics.

The four buildings chosen for the study—the Monadnock Block, the Manhattan, the Marquette Building, and Old Colony—are within a two-block area on Chicago's South Dearborn Street. They exemplify preservation problems. Reaching the end of their economic lives in terms of their original uses, the buildings have fallen prey to newer structures less expensive to operate.

"I don't have any magic formula," says Harry Weese, "It's all a matter of economics." And it is economics that forms the cornerstone of the study. The team plans to prepare physical, financial, and environmental profiles for each building. It will conduct market-

ing research to provide valuable information about each building's economic viability in its neighborhood and determine the costs needed to bring the building up to current building codes and to improve operations.

Beginning and ending with economic considerations, the study proposal lists 13 possibilities for funding preservation projects, including governmental rights of taxation and acquisition as well as private financing. The team also expects that last year's Federal legislation granting five-year tax write-offs for the rehabilitation of historic buildings will encourage cooperation.

Finally, guidelines will be drawn up to sell the idea of preservation to the public. "What is ironic," says Mr. Weese, "is that the National Park Service has to come in and rescue our landmarks. That's very telling." He attributes public apathy in part to the fact that "people only like new things."

Mr. Shlaes echoes this, and adds that traditionally in Chicago "everybody's eye has been on the challenge of building it new and better." But he is optimistic. "People," he says, "are beginning to feel that a landmark is as much a public amenity as a park." He says the depressed construction market and intensified interest in energy are factors in the increased awareness.

One thing is certain, he says: "Architects were responsible for tearing [landmarks] down. Now they are preserving them."—Lynn Stevens, *World News, Chicago*.

The GAO criticizes Federal procurement agencies for their leniency with A-E errors and omissions

In a newly published report, a Federal watchdog agency says that government agencies are too easy on architects and engineers. The agency, the General Accounting Office, says Federal procurement officers should be quicker to file suit against construction designers when errors and omissions are found in their drawings.

Construction change orders are a major cause of cost overruns, and some of these result from lapses on the part of the A-Es. The Congressional auditing agency says that while private clients often sue for errors and omissions, and win awards from architects and engineers, Federal clients almost never do so.

The report has a provocative title, "Procedures Used for Holding Architects and Engineers Responsible for the Quality of Their Design Work," but the GAO findings are really not all that strong. GAO concedes that the problem is not widespread and that the cost to the government is probably quite small.

"It shows that A-Es have a commendable record," says Burt L. Talcott, executive vice president of the American Consulting Engineers Council. He notes, however, that the report could cause an upswing in nuisance suits that might make liability insurance premiums rise.

The report only deals with the

Corps of Engineers, the Naval Facilities Engineering Command and the General Services Administration. It does not attempt to place a dollar amount on the losses to the government from the agencies' reluctance to pursue loss claims, and it even implies that losses are probably infrequent.

But the report strongly complains that agencies are so lax in checking up on A-Es that they have little idea how much may be lost. At the very least, the report says, agencies should look at all change orders to determine the responsibility, and they should document design deficiencies and determine any potential A-E liability for these.

Although the report was issued in mid-July, it was circulated to the affected agencies early this year. Generally, the agencies concur with the findings.

Jack M. Eckerd, General Services Administrator at the time, said the agency "fully agreed" with the key premise that agencies should pursue the government's rights in connection with A-E design deficiencies and should seek legal redress "when it is determined that this is an appropriate course of action."

Mr. Eckerd and other Federal agency officials, however, noted reasons why claims are dropped by the agencies: their prime concern is avoid-

ing construction delays; negligence is difficult to establish and prove; some design omissions do not harm the government; the cost of legal proceedings may exceed the recoverable amount.

GAO did not contest this logic, but it argued that agencies should sometimes pursue selected cases "solely to direct attention to the A-E responsible for the quality of the work." The accountants point out that the Internal Revenue Service audits sample tax returns even though auditing costs may exceed possible recoveries because the threat of an audit can result in "unmeasurable" benefits in causing taxpayers to file accurate returns.

The stickiest question in dealing with errors and omissions turns on the legal definition of "negligence." To prove negligence, a plaintiff must show that the professional "failed to exercise the ordinary care and skill expected of the average practitioner." Because this is a difficult point to prove, agency procurement officers sometimes negotiate a design fee reduction with the A-E to avoid costly litigation.

The Veterans Administration has the most formalized fee-reduction system. In regulations issued last year, the VA authorized its procurement officials to try to negotiate a settlement "and write a contract modification to reduce the A-E fee." When negotia-

tions fail, the procurement officer documents his efforts and asks the Agency's general counsel to determine whether legal action should be instituted.

Milton Lunch, general counsel of the National Society of Professional Engineers, prefers this approach when the amount is small because costly legal fees can usually be avoided. One possible problem with the approach, however, is that the design firm may not be able to recover its fee losses from its liability insurance carrier unless there is a formal finding of negligence. Mr. Lunch says, however, that typical liability policies have a \$5,000 deductible clause and most negotiated fee reductions will probably be less than that amount anyway.

Both Mr. Talcott and Mr. Lunch carefully avoided any defense of designers judged guilty of negligence.

Mr. Talcott's main complaint against the report is that it highlighted errors and omissions by designers, which account for only one of six causes for change orders. The others, he says, are the fault of the government.

"In its present form, the study is blowing smoke to divert attention from other causes of change orders and cost overruns which are attributable to the government," he says.—William Hickman, *World News, Washington*.

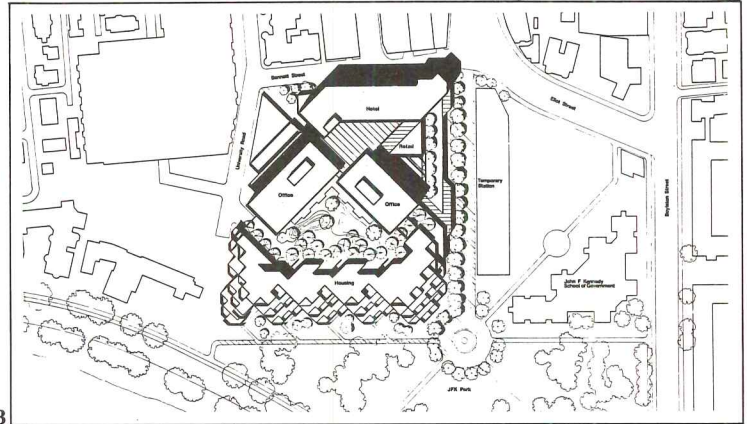
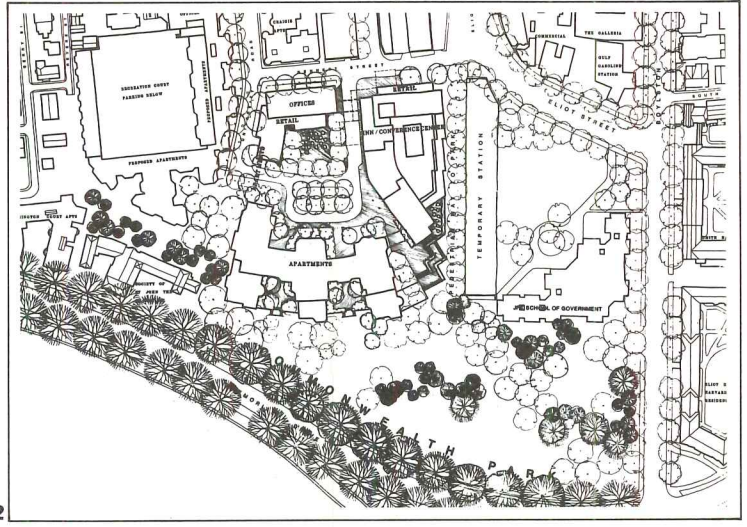
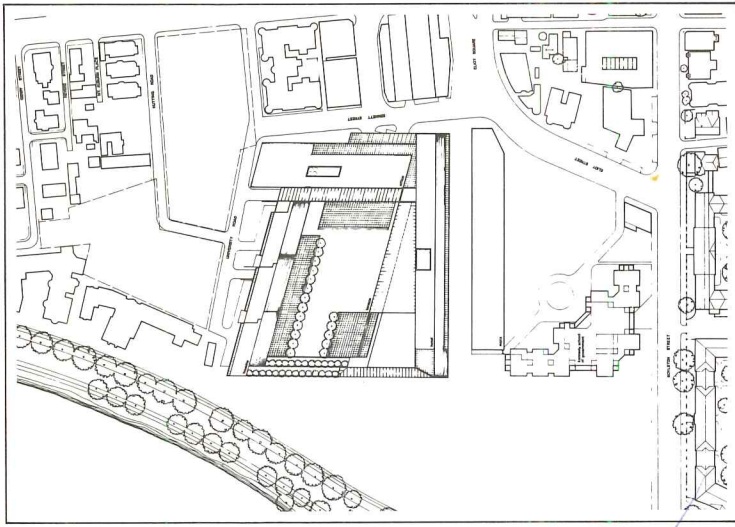

Three teams will compete in Harvard Square finals

When the projected Kennedy Memorial Library was moved from Cambridge to the Dorchester campus of the University of Massachusetts—after Cambridge citizens protested the overburden of traffic the library and museum would attract to neighboring Harvard Square—ownership of the land reverted to Massachusetts. The commonwealth thereafter decided to dedicate rather more than half of the site as the John F. Kennedy Park and to sell the remainder to a developer selected by competition.

The competition is being conducted by the MBTA Yards Project Review Board (the Massachusetts Bay Transportation Authority now has a temporary station on the site).

Proposals from competing developer/architect teams were judged on, among other things, their compliance with the Harvard Square Comprehensive Policy Plan. This plan was developed over a period of some months to set goals and criteria for Harvard Square development that Cambridge citizens would find acceptable. Among the objectives: a balanced

mix of uses—residential, offices, retail, community services—with no single use dominant; the orientation of commercial facilities to the existing business district in Harvard Square, and of residential facilities to the park and the river; and compatibility of scale to the neighborhood. The plan also called for off-street parking to repair an acute shortage in the area, and for a “safe, lively and clear pedestrian environment.”

Phase I of the competition has been completed with the announcement of three developer/architect teams as finalists: 1) Boston Urban Associates with The Architects Collaborative, 2) Cambridge Car barn Co. with Benjamin Thompson & Associates, and 3) Carpenter & Co. with Cambridge Seven Associates.

The Boston Urban/TAC proposal (1) disposes three main blocks—apartments, hotel and office building—around a plaza open toward the park and the Charles River. On the western edge, the apartment building steps down toward the park, and on the eastern edge a pedestrian arcade gives

access to shops and the hotel. The plaza roofs a three-level parking garage.

In the Cambridge Car barn/Thompson proposal (2), all elements open both to the outside and to the large courtyard, which covers a 750-car garage. Both the curving apartment block toward the river and the eastern hotel-conference center encompass their own mini-courtyards. Retail facilities face both Bennett Street to the north and the central courtyard.

The Carpenter/Cambridge Seven plan (3) calls for two major components—terraced condominiums

commanding river views in three directions, and a hotel-office-retail complex clustered around an eight-story atrium. These elements are tied together by a 4½-level above-grade garage camouflaged by building bulk and a landscaped deck.

In Phase II, the finalists will revise and refine their proposals according to critiques from the MBTA Project Review Board and final zoning and financial requirements. The board is expected to make its final recommendation to the commonwealth by the end of the year.

GSA head Jay Solomon sees his background in real estate development as good job experience for his new post

Jay Solomon, the new head of the General Services Administration, does not like to take details for granted, particularly when they involve architectural decisions on Federal office buildings.

He wants the architects and construction officials at the agency's Public Buildings Service to brief him thoroughly on all aspects of a proposed building and to be prepared to answer detailed questions so he can second-guess their approach to the subject.

“And I want to be sure they have visited the site and know what the situation really is,” he stresses.

In this regard, he functions largely as he did as chief of a large development firm, Arlen Shopping Center Co., a firm that owns or manages 184 shopping centers across the nation. He is confident that his background equips him well for homing in on architectural decisions. “I know as much as they do,” he says of the construction team leaders in GSA's bureaucracy.

Mr. Solomon, 56, assumed the post April 6. President Carter had originally intended to keep the Republican GSA chief, Jack Eckerd, but a flap developed over whether the White House or the GSA chief would choose top aides. Mr. Eckerd was overruled and he resigned.

The difference between Mr. Eckerd and Mr. Solomon is dramatic. Mr. Eckerd, a multimillionaire drug-chain owner, was content to take a passive role at GSA, leaving most of the detailed work to aides. But Mr. Solomon's approach is more attuned to that of Mr. Eckerd's predecessor, Arthur F. Sampson, who was a strong-minded activist and innovator at the agency.

In an interview last month, just as he was completing his fourth month on the job, Mr. Solomon said he had recently rejected six recommendations on architect selections from top PBS officials because he had not been adequately briefed on the projects involved. “They came in here with a big

stack of paper and wanted me to sign off on them. I sent them back.”

He added that his rejection of the selections had nothing to do with the merits of the firms involved, but only in his lack of preparation in making a decision.

Mr. Solomon says he has never met Mr. Sampson, and he refuses to pass judgment on the stormy tenure of GSA's most controversial chief. But he does favor a continuation of the construction management approach to building acquisition and experimental efforts in energy conservation and environmental compatibility—all efforts initiated during Mr. Sampson's reign.

When President Carter talked to the Chattanooga native about taking the GSA job, “He only told me one thing: use your best judgment,” Mr. Solomon says.

That's clearly what he intends to do, even in some areas that may be controversial. For instance, he asks PBS planners always to consider the use

of solar energy equipment in buildings even if the economic justification is shaky. He wants the government to take the lead in promoting the use of solar energy, as Mr. Carter does. But he adds that it is important for Federal buildings to have solar potential because there is a possibility that energy supplies will completely dry up. “It's not only a matter of cheap energy, but a matter of energy at all,” says Mr. Solomon, taking a long-range view of GSA's managerial and construction duties.

Mr. Solomon concedes that his attention to detail causes a tight schedule and he shows a reporter one day's calendar indicating a wide variety of meetings throughout the period. But he retains a strong interest in at least two outside activities: the motion picture business, which was the family business before it moved into shopping centers, and newspapers, which he studies as both editorial and commercial ventures.—William Hickman, *World News, Washington*.

Progress Lighting has gone commercial!

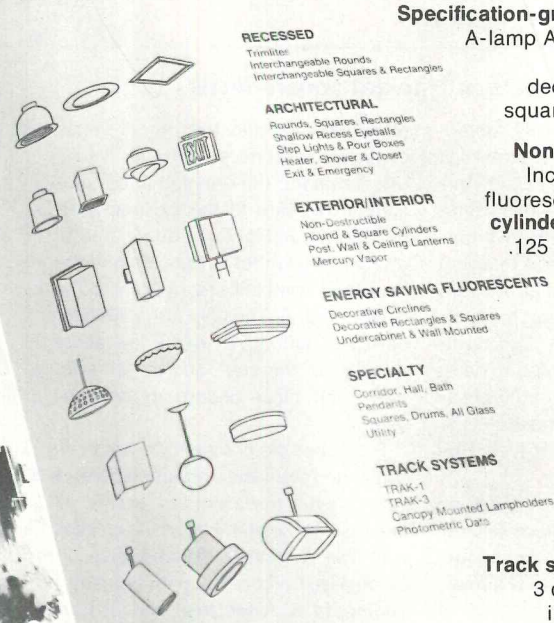
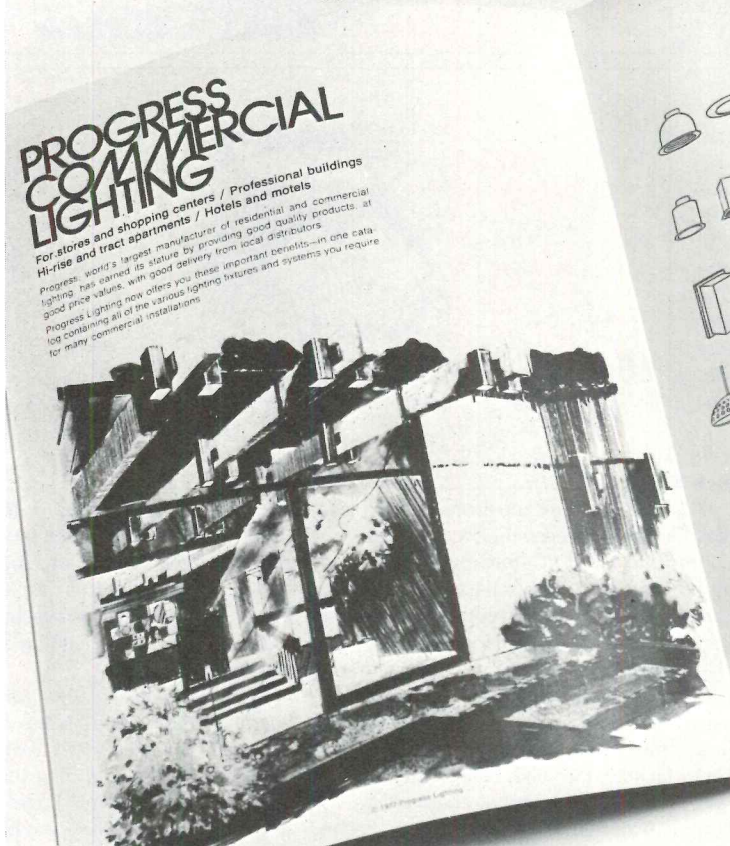

RECESSED
Trimless
Interchangeable Rounds
Interchangeable Squares & Rectangles

ARCHITECTURAL
Rounds, Squares, Rectangles
Shallow Recessed Eyeballs
Step Lights & Pour Boxes
Heater, Shower & Closet
Exit & Emergency

EXTERIOR/INTERIOR
Non-Destructible
Round & Square Cylinders
Post, Wall & Ceiling Lanterns
Mercury Vapor

ENERGY SAVING FLUORESCENTS
Decorative Circles
Decorative Rectangles & Squares
Undercabinet & Wall Mounted

SPECIALTY
Corridor, Hall, Bath
Pendants
Squares, Drums, All Glass
Utility

TRACK SYSTEMS
TRAK-1
TRAK-3
Canopy Mounted Lampholders
Photometric Data

Specification-grade recessed.
A-lamp Alzak reflectors,
wall washers,
deep step baffles,
squares, multipliers.

Non-destructibles.
Incandescent and
fluorescent. **Extruded
cylinders & squares.**
.125 wall thickness.

Track systems. 1 and
3 circuits. Faster
installation. No
on-the-job connector
wiring with UL listed
plug-in connectors.
Flex connector for
unique patterns.
Complete range of
luminaires.

You know Progress as the world's largest manufacturer of residential lighting fixtures. Now you can get Progress quality and value for your commercial lighting.

For individual stores. And shopping centers. In professional buildings. Apartments. Hotels and motels.

In this one catalog, for the intermediate commercial market, Progress now offers you a wider range of products than any other commercial lighting manufacturer.

And for prompt shipment, the entire line of commercial lighting is stocked by local distributors. Mail this coupon for the new Progress Commercial catalog.



Progress Lighting, Dept.
Box 12701, Philadelphia, PA 19134

Please send me the new 96 page Progress Commercial lighting catalog 201, and the names of stocking distributors.

Name (please print)

Company name

Street Address

City State Zip AR-9

progresslighting®

Subsidiary of Walter Kidde & Company, Inc.

KIDDE

For more data, circle 22 on inquiry card

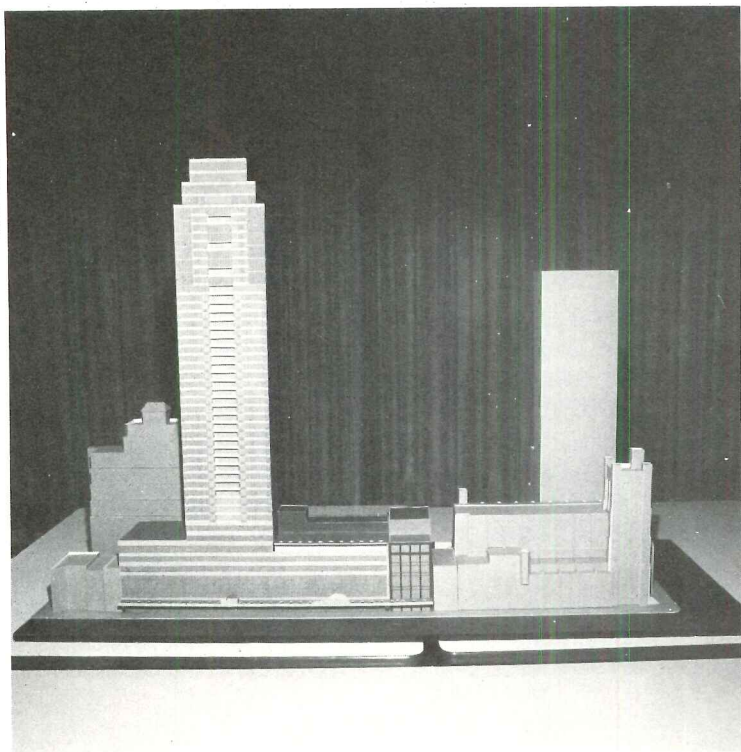

MOMA plans expansion—including an apartment tower

The internationally famous Museum of Modern Art has long prided itself on being at the forefront of the arts, including architecture. Now a proposal to double its gallery space and to surmount it with a 50-story apartment tower has raised heated debate among preservationists and defenders of Manhattan's small-scaled side streets, and has prompted questions about the proper role of cultural institutions as they affect the quality of city life.

The complex building program is the result of special state legislation designed to allow fiscally hard-pressed cultural institutions to use their air rights for commercial development and thus increase their income. In this case, Arlen Realty & Development Corp., developer of the apartment tower, will place part of its earnings in a state-established trust for MOMA's benefit.

Although the basic design decisions on the new building's massing and its location on the site were established some time ago by Richard Weinstein, a planner working for the Museum, Cesar Pelli was named architect of the new gallery and of the apartment tower only early this year. Architects Llewellyn Davies Associates have responsibility for the tower's floor plans.

One of the most controversial aspects of the current design is the placement of the bulky 50-story apartment building directly on a narrow congested side street (see photo below) and midway between two wide avenues, the more usual location for such massive structures. Another controversial aspect is the linear bulk of the gallery and apartment tower base, contrasted with what is now the intimate scale of the street. Yet a third controversial aspect is the effect of all this new construction on the famous sculpture garden, which will lose about 30 percent of its area and most of its afternoon sunlight.

Apart from destroying the street's ambience of small-scale galleries and shops, the Museum's project will replace or greatly affect a number of notable buildings. Of most interest nationally, the Museum's main facade (at right in photo below), designed by Philip Goodwin and Edward D. Stone and built in 1938, will be altered and incorporated in the much larger base of the high-rise tower immediately adjacent. It is argued that this American landmark of the International Style, now framed by neighbors of contrasting style, will virtually disappear.

These neighboring buildings include a 1949 office addition for the Museum, designed by Philip Johnson, an early example of floor-to-ceiling windows in 20th-century office building.

While a number of critics have entered strong objections to the project, major civic and professional groups have so far withheld either endorsement or disapproval. The local Community Planning Board, however, has approved the project, against the recommendation of its advisory committee. Though the Board's action does not constitute official approval, it is likely to carry weight with the City Planning Commission.



Charles K. Hoyt

Philippines delay start of Dagat-Dagatan project

The redevelopment of the Dagat-Dagatan squatter community outside Manila has been delayed, the Philippine government reports. The area was the subject of the International Design Competition for the Urban Environment of Developing Countries, a competition conceived by ARCHITECTURAL RECORD and *L'Architecture d' Aujourd'hui*, sponsored by The International Architectural Foundation, and won last year by New Zealand architect Ian Athfield.

The construction of the winning design was one of the provisions of the competition. Major General Gaudencio V. Tobias, general manager of the Philippines National Housing Authority and one of the competition's jurors, recently acknowledged, however, his government's inability so far to execute Mr. Athfield's design. The cause of delay lies partly in the difficulty of providing infrastructure for the development, partly in the revision of land-use policy for the area.

In a letter to the IAF, Gen. Tobias explained, "The need to replan the whole reclaimed area of Dagat-Dagatan to maximize the area's potential for low-income housing with complementary industrial-commercial activities" has held up construction. "This replanning would entail changes in patterns of land use—hence at this point in time it would be difficult to say if the original site would be residential."

Moreover, he said, "delay in completion of two critical bridges across the river to the site" prevents building now, and it will be almost a year before soil conditions in the reclaimed area will be suitable for construction.

Nonetheless, Gen. Tobias concluded, "We are still hoping to execute Mr. Athfield's winning design in the future."

Trinidad and Tobago plan meetings on low-cost housing

A conference on Housing and Urbanization, sponsored by the Trinidad and Tobago Society of Architects, will meet at the Trinidad Hilton Hotel November 14-19. The conference will deal specifically with the issue of housing low-income groups in the Caribbean and Central America.

Concurrently, the society will exhibit winners in its competition for designs and "ideas" in housing low-income families.

Twenty-five nations are expected to send representatives to the conference, including the 14 countries who compose the Caribbean and Central American Group in the Pan American Federation of Architects. Each of the participating countries will submit a paper on its experiences in the field, and will discuss case studies of low-income housing, either projected or built.

The competition has been or-

ganized in three sections so as to attract the broadest possible participation, from architects and city planners to schoolchildren.

Category A is a design competition, open to architects, planners, engineers and architectural students who are nationals of countries in the Caribbean and Central America. The competition problem is to design housing units for one of various sites selected by the National Housing Authority of Trinidad and Tobago. (The society hopes that the government will elect to build some of these designs, and that it would in such case pay the designer a fee for each unit it constructs, up to a total of 1,000.)

Category B, which calls for papers and other written reports, is open to academics, civil servants, writers and reporters in the housing field, and any members of the public over the age of 19; design professionals are eligible so long as they have not submitted entries in Category A.

Category C, open to children under the age of 19, will judge essays and ideas submitted by students in primary and secondary schools.

The society was inspired to call the conference by the chronic and continually increasing deficit of housing for the poor in Trinidad and Tobago. The country's construction industry is able to produce between 4,000 and 5,000 units yearly, against an annual need for 15,000 units. The escalating cost of land, infrastructure, materials and labor has so compounded the problem that it is now difficult for even the middle-income worker to afford suitable housing.—*John Babb, World News, Trinidad.*

Conference on tall buildings will convene in Paris

To examine "all aspects of the relationship between urban space and tall buildings" in both the developing and the industrialized nations, the Council on Tall Buildings and Urban Habitat will sponsor its Second International Conference. The meeting, titled "2001: Urban Space for Life and Work," will be held at UNESCO headquarters in Paris November 21-25.

The council hopes that both design and construction professionals and governmental officials will attend the conference to discuss "the sociological, architectural, managerial and engineering aspects" of tall buildings, "as well as their interactions with urban environments."

The council is a multiprofessional group of about 2,000 specialists (primarily architects, engineers and planners) from 70 countries. Founded in 1969, the nonprofit council draws its financial support chiefly from the U.S. National Science Foundation.

Information on the conference can be obtained from Dr. L.S. Beedle, Director, Council on Tall Buildings and Urban Habitat, Fritz Engineering Laboratory #13, Lehigh University, Bethlehem, Pennsylvania 18015.

At Raynor we're involved from the bottom up!

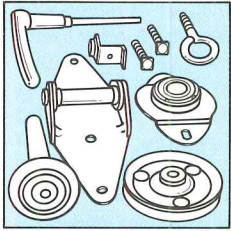

Raynor makes the best sectional overhead type doors money can buy. That's because we do a lot of things ourselves, when others don't.

We become totally responsible for every detail from design to field service including all of the steps in between.

When problems do arise, as they do in every business, Raynor can respond faster, more assuredly. Because we can't pass the buck.

Not to a spring manufacturer, nor a millwork, nor a shipping line. Not even to a contractor, because there are over 300 authorized Raynor distributors who install every door we build. It's this extra concern for quality that's made Raynor the brand you can depend on for residential, commercial and industrial doors made of wood, aluminum, fiberglass or steel. Call us for more specifics. 815/288-1431. Or write Raynor Manufacturing Company, Dept. AR, Dixon, IL 61021, for the name of the Raynor factory-trained distributor/installer near you.



RAYNOR™
GARAGE DOORS

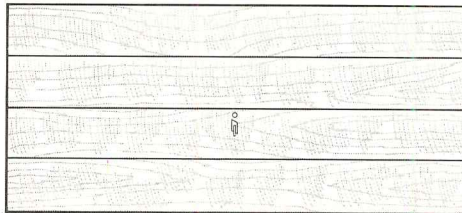

For more data, circle 23 on inquiry card



Parkin wins Canadian National Gallery competition

The Parkin Partnership of Toronto has won the architectural competition for the new National Gallery of Canada. (The first stage of the competition was open to all Canadian architects, from whom ten finalists were chosen.) Set on a dramatic site in the federal precinct overlooking the Ottawa River, the winning design is composed of a collection of three-story cubes, answering a program requirement for square galleries. The cubes are defined by cast concrete columns and a grid of connecting "circulation bridges" and light wells. The bridges enable the creation of long horizontal galleries for large collections and guide visitors through the galleries in proper sequence. The clerestory roofs carry triple-glazed skylights to satisfy a program requirement for "natural ambient light." The cubes are grouped diagonally to open vistas from the galleries both up and down the river. Though the language of the assessor's report seems rather half-hearted—the jury suggests a number of revisions in ex-

ternal circulation and facade treatment—they found the Parkin entry "the best conceptual design" among the competitors, and commended particularly its "sense of order," "measured proportions," and "diagonal location on the site." And though they observed that "in the formal sense the design is not a good neighbor," they felt that it "could create a new standard of architectural design for the area." Execution of the project may be delayed, however, because of the government's reluctance to commit the \$75-85 million estimated for construction. Members of the Board of Assessors were Fred Hollingsworth, past president of the RAIC; architect I.M. Pei of New York City; Dutch architect W. G. Quist; G. Stephen Vickers of the Fine Arts Department, University of Toronto; landscape architect Cornelia Hahn Oberlander of Vancouver; Dr. Hsio Yen Shih, director of the National Gallery; and architect Gordon Arnott of Regina, who served as chairman and professional adviser.

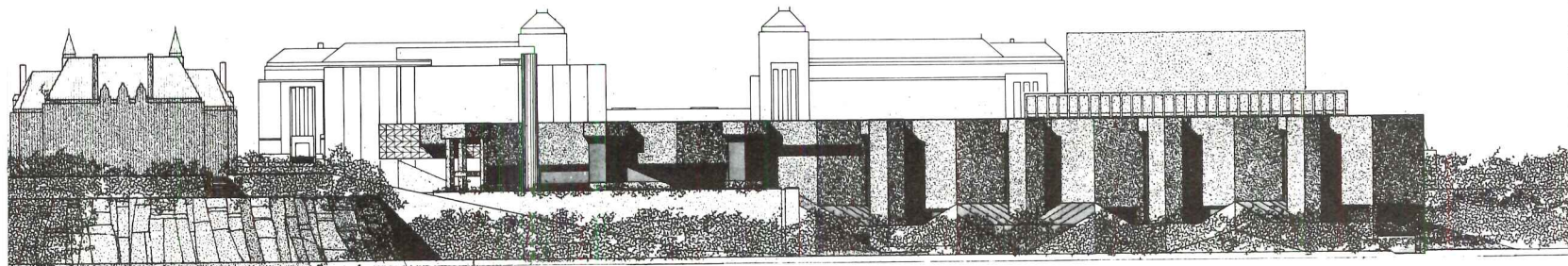
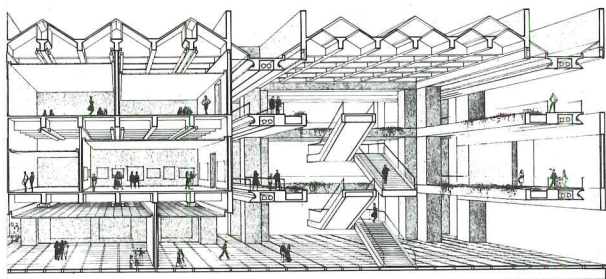
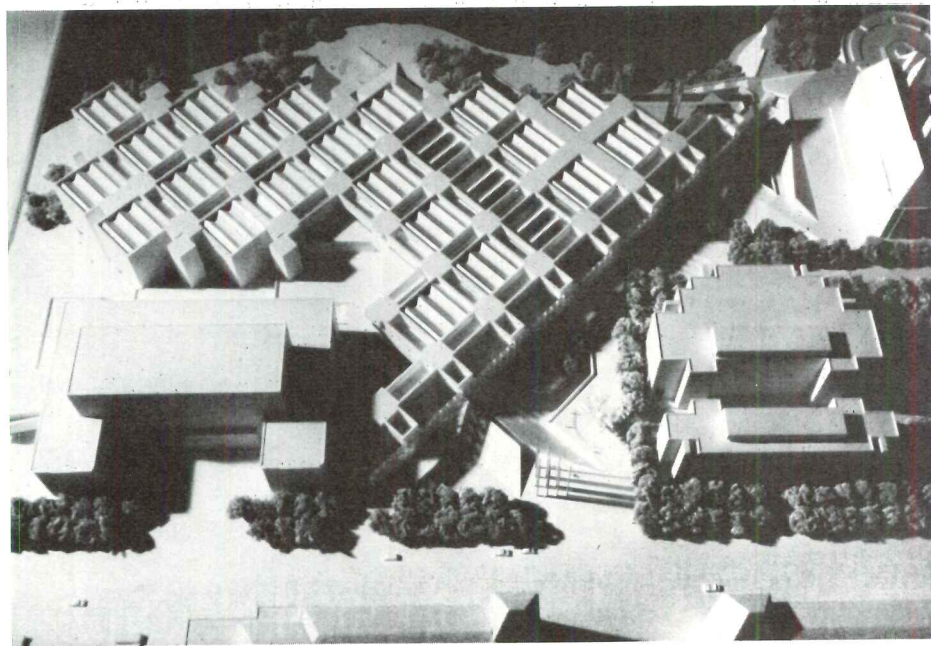
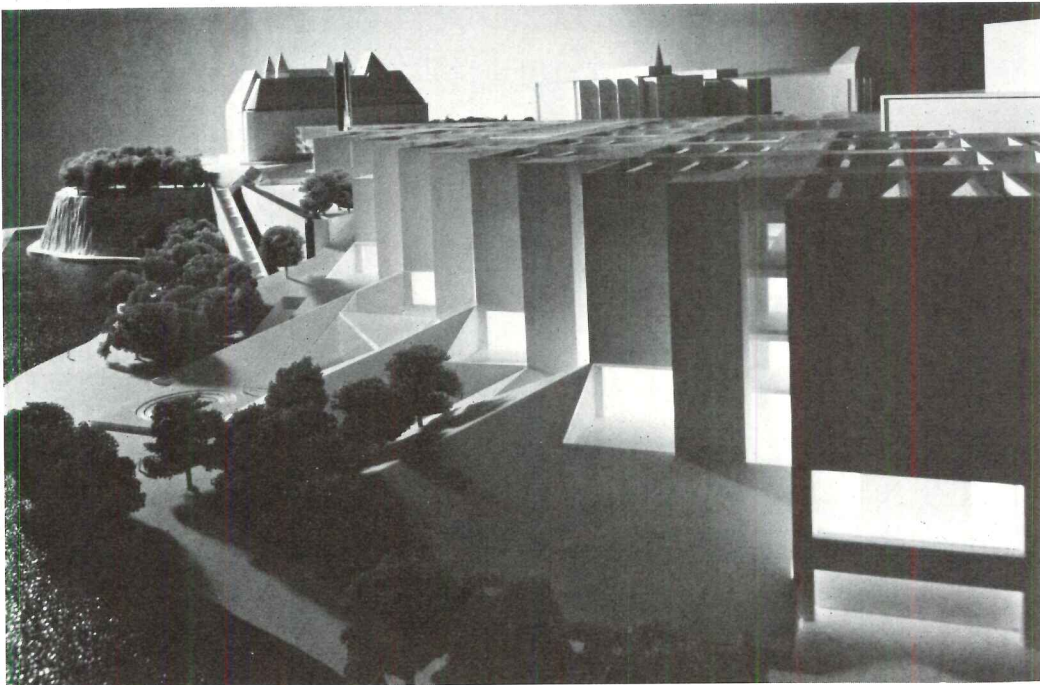

WHY COAT STAINLESS STEEL?

As nearly all architects are now aware, TCS (Terne-Coated Stainless Steel) is chrome-nickel stainless coated on both sides with an 80% lead/20% tin alloy.

But the question may still remain as to why any coating of stainless is desirable.

In the first place, the application of such a coating creates an end product which is demonstrably superior to both stainless and copper in durability and corrosion resistance. Secondly, TCS weathers to an attractive and uniform warm gray. Stainless, on the other hand, retains its original bright finish indefinitely, while the weathering of copper has been highly unpredictable in recent years. TCS also solders perfectly without special preparation whereas copper must be pretinned, and stainless requires a time-consuming and relatively costly procedure to obtain a leak-proof joint. Furthermore, TCS, unlike copper, is neutral toward other metals, and wash-off from it will not stain adjacent surfaces.

Expressed in the simplest terms, where roofing and weathersealing are involved there is no standard architectural metal available in the world today, including stainless and copper, which can match TCS in its performance characteristics and built-in safeguards against failure.

TCS

TERNE-COATED STAINLESS STEEL

FOLLANSBEE

FOLLANSBEE STEEL CORPORATION • FOLLANSBEE, WEST VIRGINIA

For more data, circle 24 on inquiry card



1
First Awards Program of Rhode Island AIA
honors four buildings for distinctive design

Four buildings have been commended for their distinctive design and execution in the first Honor Awards Program of the Rhode Island Chapter of the American Institute of Architects.

Conducted to recognize exemplary architecture in the state, the competition named one First Honor Award and three Honor Award winners from 19 entries. Only projects completed since 1973 and designed under the direction of an architect registered in Rhode Island were eligible. Awards were presented in July.

Winning architects and their projects include: (1) Woonsocket Harris Public Library, Woonsocket; William D. Warner, Architects and Planners, First Honor Award. Jury Comment: "A handsome, monochromatic building with consistent, sensitive use of materials on the exterior. The entrance is handled extremely well . . . minimizing the impact of the parking area."

(2) Warwick Police Station, Warwick; The Robinson Green Beretta Corporation, Honor Award. Jury Comment: "Well-sited, understated, not intimidating (especially for a police station). Simply seems to work."

(3) Private residence, Providence; William D. Warner, Architects and Planners, Honor Award. Jury Comment: "A cohesive building but with interesting shapes and spatial variety."

(4) East Side YMCA, Providence; Sturges Daugh Salisbury Incorporated, Honor Award. Jury Comment: "A straightforward building but fun. The supergraphics were effectively used . . . adding color. You get the feeling kids would have fun there."

Jurors were Sarah Harkness, national AIA vice president; Richard Bertman, AIA; Robert Gantner, AIA; David Macauley, author/illustrator; and Beth Wickenberg, Providence newspaper writer.

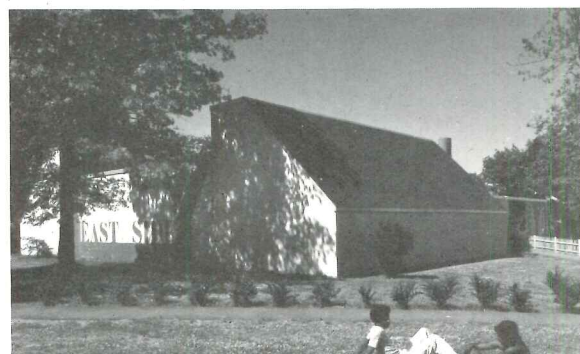
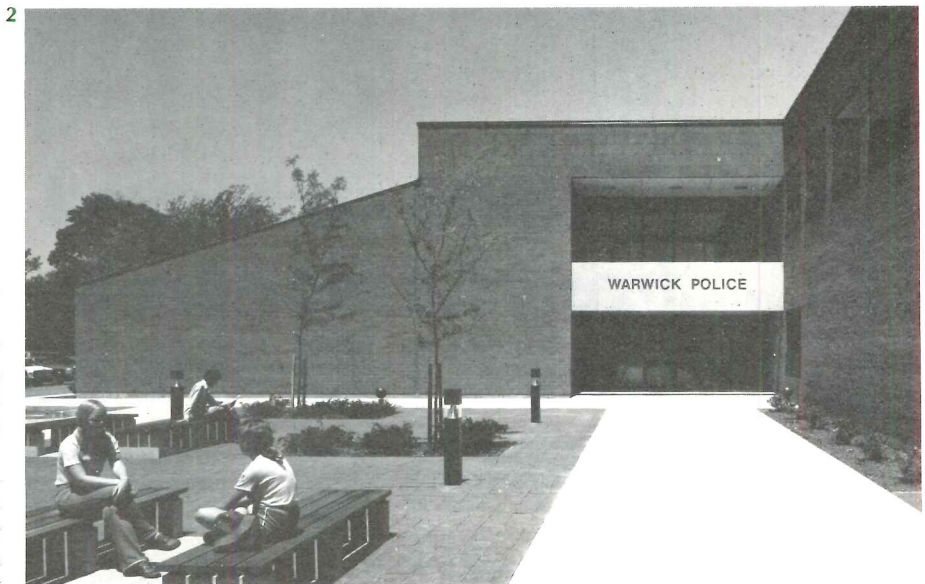

Stains SMEARS SPLASHES

are easily removed
from interior walls
coated with *Pitt-Glaze*[®]
Water Base Coatings

The *Pitt-Glaze* High Solids Acrylic-epoxy Coatings have a hard, tile-like finish that resists stains, smears and splashes — from grease to graffiti. When cleaned easily and quickly with warm water and mild detergent, the surface of the *Pitt-Glaze* Coating is like new again — ready for longer service life.

Bear in mind, too, that *Pitt-Glaze* has 50% volume solids (more than any water base epoxy that we know about) and usually gives one coat coverage.

So, before stains, smears and splashes drive you up a wall, send for our *Pitt-Glaze* Coatings brochure. PPG Industries, Inc., One Gateway Center, 3W, Pittsburgh, Pa. 15222.

PPG: a Concern for the future

PITTSBURGH[®] PAINTS



For more data, circle 25 on inquiry card

Guilty plea

FORM FOLLOWS FIASCO: WHY MODERN ARCHITECTURE HASN'T WORKED, by Peter Blake: Atlantic-Little, Brown, Boston, 1977, 170 pages. \$12.95.

Reviewed by Jonathan Barnett

Architecture is a profession that believes itself capable of saving the world. It is naturally beset by a sense of failure. Architects not only judge their profession by very high standards, but delight in criticism and self-criticism. A speaker who wishes to be a hit at any architectural meeting need only start blaming all the problems of modern life on architects and architecture, and the audience will applaud wildly. Doctors, lawyers and other professionals like, say, investment bankers, don't seem to expect so much from themselves, nor are they as anxious to confess to their shortcomings.

What clearly intrigues the publishers of Peter Blake's new book is the opportunity to present this quaint architectural custom of confessing failure to save the world to a large and appreciative audience. Here is an eminent architect, architectural educator, critic and writer turning on his own kind and producing a seemingly cogent and certainly entertaining indictment of his profession(s), full of convincing detail. "Peter Blake says the most outrageous things . . ." the book jacket bumbles.

Evidently Peter Blake also became rather intrigued by the idea of being "outrageous," and the opportunities it presented to settle a few old scores and deliver himself of some nifties he had been saving up for the right occasion.

I wish author and publisher hadn't tried so hard to be shocking, because their efforts end up getting in the way of the valuable parts of the book. But read the book anyway. It is true that important insights and cogent criticisms are hard to separate from the irritating rhetoric, but it can be done. Just put the book down for a few moments and count to ten.

There is not much point in discussing the title, which comes to mean less and less the more you think about it, but the subtitle qualifies as the most irritating rhetorical device of all: "Why Modern Architecture Hasn't Worked." Inside the book, the author has been careful—most of the time—to say "Modern Movement," not "modern architecture." There is a rather important difference, which art historians and critics committed to the Modern Movement have been doing their best to

obscure for the past fifty years.

The term "modern architecture" necessarily describes any building constructed since the beginning of the modern period, which most people would say dates from the industrial revolution, that is about the middle of the eighteenth century.

What the polemicists for the Modern Movement did was to divide modern architectural history into the work of the good guys, documented in detail, and that of the bad guys, whom they tried to erase from the record.

The "Modern Movement" was never an historical description, but polemic and predictions—many of which failed to come true. This false view of history is now coming apart. Architects whose work has long been neglected are being recognized again; architects practicing today no longer feel that historical destiny is forcing them in a particular direction. (Incidentally, using a term like "Post Modernism" to describe this phenomenon only perpetuates the original error. Let us hope that the term does not catch on, except to describe modern posts.)

I am sure that Peter Blake would agree that Louis I. Kahn's Kimball Art Museum in Fort Worth or Alvar Aalto's Pension Fund Office Building in Helsinki are as successful as the best work in any other historical period. What "hasn't worked" is the world view put forward by the propagandists for a certain kind of modernism. Perhaps this is a subtle distinction, and it may not sell books as well as the more sensational rhetoric that Blake has elected to use, but it is more intellectually consistent.

On the other hand, when Blake tells you what hasn't worked, he is speaking from an expert perspective. Architects may delight in criticism of the profession, but they usually draw the line when it comes to their own designs. Architectural magazines, which depend on the good will of their readers, traditionally give only the good news. Buildings the editors don't like are not shown; sometimes what is published is edited to bring out the exemplary features, and suppress what would be less edifying. Peter Blake first started writing for the architectural press in 1942; he was editor of *Architectural Forum* and *Architecture Plus*. Now that he has decided to tell all, he has a lot to tell.

His work contains eleven chapters, each entitled "The Fantasy of —." Unlike the fallacies outlined by Geoffrey Scott in the *Architecture of Humanism*, Blake's categories are not logically self-sufficient, and it is not always easy to understand why certain arguments are found under one heading rather than another. The headings are handy, however. The first of

them, "The Fantasy of Functionalism," introduces a good example of the way Blake combines perceptive analysis with rhetorical overkill. He uses successful examples of adaptive re-use to point out that a building can be perfectly functional within a form devised in quite another context, and cites Miesian universal spaces as form not determined by function at all. OK: interesting philosophical point. But Blake then goes on to say that form follows function was "the dogma of the Modern Movement," a dogma that he has just demonstrated is patently incorrect. Come on now. Did serious architects, architectural historians, or theorists ever maintain that form should or could literally follow function? E. R. deZurco did 25 years ago, in a painfully literally-minded book called *Origins of Functionalist Theory*, but how many others? The idea that buildings are "starkly modern" because they are "functional" is a notion that you might encounter at a cocktail party, but not in a serious discussion by professionals or theorists. "Form follows function" is a philosophical concept akin to Keat's "Beauty is truth; truth beauty." Like all philosophical concepts its meaning varies with interpretation. If symbolizing stability and tradition is part of the function of a bank building, classical columns could be considered perfectly functional.

What Blake leaves out of this argument (he is saving it for his "Fantasy of Technology" chapter) is the distinction between functionalism and the "machine esthetic," which does not require either functional appropriateness or actual construction by machines. The desire of "modern" architects to have their buildings look as efficient as machines has done a lot of damage, because this concept played into the hands of cost-cutting bureaucrats and profit-minded real-estate entrepreneurs, and—yes—the architects who aided and abetted them. To say that the "machine esthetic" leads to a great many simple-minded buildings is a reasonable conclusion from the evidence. That is quite another thing from saying that a basic reason why modern architecture has failed is that its central dogma is incorrect.

The same pattern pervades the rest of the book. One can't disagree with most of Blake's criticisms, but the sweeping conclusions he builds from them are not reasonable. The chapter that outlines the defects of Modern furniture is hilarious, but it is not quite fair to take Gerrit Rietveld as a representative Modern furniture designer. After all, some Modern furniture is comfortable: mass production of furniture is a significant development of the modern period,

More Required Reading on page 45

Jonathan Barnett has been questioning the validity of the "Modern Movement" for almost twenty years, often in the pages of ARCHITECTURAL RECORD.

Preserve the beauty of terrazzo floors like this one with Hillyard Onex-Seal II.®



Onex-Seal II® penetrates deep and fills pores to prevent the rising of efflorescence, bleeding and dusting. At the same time it keeps moisture, dirt and stains on the surface where they may be easily removed.

One application of Onex-Seal II provides both a seal and finish. It leaves terrazzo floors with a hard, high-gloss, non-flaking, non-tracking, mirror-like finish. One that resists traffic wear.

Onex-Seal II is the type of seal recommended by the National Terrazzo and Mosaic Association for Portland and Oxychloride Terrazzo in all colors (even white).

What's more, floors finished with Onex-Seal II are easy to maintain. Dust daily and buff periodically. Custodians may refinish after thorough cleaning, without stripping because Onex-Seal II won't "build-up." Reapplication of Onex-Seal II bonds to the old seal to become one integral film. This adds up to substantial savings in labor costs.

Onex-Seal II is U/L classified as to slip-resistance. When you specify terrazzo floors, be certain to give them the best chance for a long and beautiful life.

For complete details, contact the trained Hillyard Maintainer nearest you. Or look up our specifications manual in SWEET's.

Hillyard Floor Treatments, 302 North Fourth Street,
St. Joseph, Missouri 64502 (816) 233-1321



09-77

70 Years of Quality in Professional Floor Care Products.

LET HILLYARD HELP

- ALABAMA**
Birmingham ... Carlos Noblett ... (205) 933-2625
Montgomery ... J. Victor Akin ... (205) 288-6700
- ALASKA**
Anchorage ... Jim Harper ... (907) 276-5146
- ARIZONA**
Phoenix ... Hillyard of Arizona, Wendell Harper, Gen. Mgr. ... (602) 267-1341
- ARKANSAS**
Heber Springs ... Forrest E. Moss ... (501) 362-6229
Magnolia ... Bill Talbot ... (501) 234-2035
Springdale ... G. Van Horton ... (501) 751-1224
Star City ... William Phillips ... (501) 628-4572
- CALIFORNIA**
Anaheim ... Lenzi M. Allred ... (714) 637-0105
Stockton ... Jack G. Hoover ... (916) 988-6493
Escondido ... Donald J. Ervin ... (714) 234-9927
Los Altos ... Eldon P. Hart ... (415) 964-9687
Oakland ... Robert Klieman ... (408) 295-6000
Orange ... Michael Allred ... (714) 637-2143
Redding ... Ralph Young ... (916) 246-9476
San Gabriel ... Warren Sperling ... (213) 287-1223
San Jose ... Hillyard-Western West Coast Sales Office, Glenn Casto, Regional Mgr. ... (408) 295-6000
San Jose ... Robert Vossler ... (408) 268-6261
Ventura ... Herb Crapo ... (213) 287-1223
Walnut Creek ... Jerry Klieman ... (415) 939-4009
- COLORADO**
Contact Hillyard-Western General Sales Office, St. Joseph, Mo. ... (816) 233-1321
- CONNECTICUT**
Glastonbury ... John Zimms ... (203) 633-5131
- DELAWARE**
Folcroft, Pa. ... Joe Keenan ... (215) 586-5680
- FLORIDA**
Hollywood ... William H. Burk ... (305) 792-4274
Miramar ... Hartley Maxwell ... (305) 961-2937
Orlando ... Dan K. Minnick ... (305) 293-3121
- GEORGIA**
Atlanta ... Thomas L. Campbell (404) 237-9003
- IDAHO**
Iona ... G. Duane Browning (208) 522-8250
- ILLINOIS**
Chicago ... Robert F. Horwath ... (312) 782-0854
Mackinaw ... John G. Allred ... (309) 359-8292
Paxton ... Alan Allred ... (217) 379-4284
Rockford ... Jesse Daughtry ... (815) 633-3224
Shelbyville ... Jay Allred ... (217) 774-4723
- INDIANA**
Indianapolis ... William Rollinson ... (317) 293-3772
- IOWA**
Ames ... Richard Hade ... (515) 232-0792
Barnum ... Lyle C. Haldin ... (515) 542-3395
Des Moines ... Loren Baxter ... (515) 276-2458
Des Moines ... R. C. Bechtel ... (515) 277-3938
Des Moines ... Daryl Cummings ... (515) 266-5669
Sioux Center ... Floyd Achterhof ... (712) 722-4691
- KANSAS**
Topeka ... Fred Burnett ... (913) 272-0105
- KENTUCKY**
Lexington ... Walter Ferguson ... (606) 252-7511
Madisonville ... Don Hancock ... (502) 821-9345
Louisville ... Dave Ederheimer ... (502) 587-8818
- LOUISIANA**
Baton Rouge ... Howard Badon ... (504) 927-7849
Franklin ... Arthur J. Grey ... (318) 828-0551
Lafayette ... Ben Dawson ... (318) 984-3176
Linville ... Dan Bryan ... (318) 292-4201
Metairie ... Jack B. Jones ... (504) 887-0682
Natchitoches ... Walter LeDet ... (318) 357-6171
- MAINE**
Lincoln ... R. Gary Rivard ... (207) 794-8870
Rumford ... Roland Rivard ... (207) 364-2584
- MARYLAND**
Cockeysville ... Dennis B. Doherty ... (301) 628-6237
Columbia ... Edward W. Ganoczy ... (301) 730-7979
Silver Spring ... Lawrence Weyer ... (301) 585-3957
- MASSACHUSETTS**
Newton Highlands Walter Elcock ... (617) 969-4517
W. Springfield ... Thomas Allen ... (413) 781-5539
- MICHIGAN**
Detroit ... Dick Sheldon ... (313) 571-4476
Escanaba ... Harold Schermer ... (906) 786-5881
Grand Rapids ... John Hill ... (616) 455-9400
Grand Rapids ... Robert H. Hill ... (616) 455-9400
Jackson ... Bud O'Brien ... (517) 784-7891
Kalamazoo ... Thomas M. Hill ... (616) 345-2215
Northville ... Charles J. Bowser ... (313) 864-3416
- MINNESOTA**
Brainerd ... Jim Demgen ... (218) 829-7438
Minneapolis ... Hillyard-Western North Central Sales Office, Jerry Bird, Regional Mgr. ... (612) 533-7660
Minneapolis ... Jim Buis ... (612) 533-7660
Spring Grove ... Bob Bunge ... (507) 498-3384
Storden ... Harvey Iverson ... (507) 445-3954
Winnebago ... Bob Hynes ... (507) 893-4126
- MISSISSIPPI**
Moselle ... A. Grice ... (601) 752-5725
- MISSOURI**
Maryland Heights Art Werkmeister ... (314) 432-4600
Mexico ... Jim Inlow ... (314) 581-1314
St. Joseph ... Hillyard-Western General Sales Office ... (816) 233-1321

Shawnee Ms., Ks. James D. Brand . . . (913) 677-5936
 St. Joseph . . . Guy Humphreys . . . (816) 233-1321
 St. Joseph . . . Count Rush . . . (816) 233-1321
 Springfield . . . Joseph Newton . . . (417) 862-4235

MONTANA
 Billings . . . C. Ben Martin . . . (406) 252-5366

NEBRASKA
 Lincoln . . . R. H. Beckman . . . (402) 423-9015

NEW HAMPSHIRE
 Stratham . . . Thomas G. Binette . . . (603) 722-4012

NEW JERSEY
 Longport . . . Joseph E. Smith . . . (609) 823-2450
 Phillipsburg . . . John W. Benol . . . (201) 454-1859
 Trenton . . . Robert Myers, Jr. . . (609) 882-8862
 Trenton . . . Robert Myers, Sr. . . (609) 882-8862

NEW YORK
 Black Creek . . . John Musson . . . (716) 968-3809
 Brewster . . . R. Golankin . . . (914) 279-6060
 Buffalo . . . James Gallivan . . . (716) 884-8011
 Delmar . . . Clinton Atwood . . . (518) 439-0456
 Elbridge . . . Ted Platt . . . (315) 689-3796
 Endicott . . . William Schutte . . . (607) 754-1597
 Guilderland . . . Doak Dochak . . . (518) 482-6597
 Oceanside . . . William Zimms . . . (516) 766-7705
 Huntington . . . Gregory Rose . . . (516) 692-6240
 Huntington . . . Charles Rose . . . (516) 692-6240
 Morristown . . . James Smithers . . . (315) 375-8246
 Rochester . . . Murray Weeks . . . (716) 426-0828
 Saranac Lake . . . Daniel McNulty . . . (518) 891-1752
 Smithtown . . . Allan R. Ely . . . (516) 265-2228
 Syracuse . . . Lawrence Brennan . . . (315) 463-6182

NORTH CAROLINA
 Raleigh . . . Carl Jarvis . . . (919) 787-4050
 Charlotte . . . Ralph L. Jones . . . (704) 536-7856
 Greensboro . . . Ralph E. Norcom . . . (919) 292-1787

NORTH DAKOTA
 Fargo . . . Jim Heller . . . (701) 235-8970

OHIO
 Berea . . . Robert Gillespie . . . (216) 331-3580
 Bowling Green . . . Ron Tilman . . . (419) 352-1254
 Dayton . . . James Jackson . . . (513) 277-7695
 Rocky River . . . Harris Gillespie . . . (216) 331-3580
 St. Louisville . . . John C. Reynolds . . . (614) 745-5312

OKLAHOMA
 Oklahoma City . . . Walt Powers . . . (405) 751-8932
 Oklahoma City . . . James Randle . . . (405) 942-7861

OREGON
 Beaverton . . . Thomas G. Good . . . (503) 646-2888

PENNSYLVANIA
 Conneaut Lake . . . William Snyder . . . (814) 382-8211
 Folcroft . . . James A. Smith . . . (215) 586-8320
 Munhall . . . Lawrence Cullen . . . (412) 482-3165
 Nazareth . . . John F. Magdith . . . (215) 759-1041
 Pittsburgh . . . Roger K. Jorgensen . . . (412) 563-6812
 Pittsburgh . . . W. Gregory Snyder . . . (412) 366-0841
 Reading . . . Fred Harnar . . . (215) 678-4110
 Reading . . . Willard N. Wink . . . (215) 777-0857
 Peach Bottom . . . Bernard Richards . . . (717) 548-2061
 Wyoming . . . Clifton Miller . . . (717) 655-6089
 York . . . Emory E. Sterner . . . (717) 854-0030

RHODE ISLAND
 Warwick . . . Craig Swanson . . . (401) 739-4500

SOUTH CAROLINA
 Duncan . . . Ben Blackwell . . . (803) 439-3694

TENNESSEE
 Chattanooga . . . Harry Prater . . . (615) 624-0066
 Jackson . . . Billy Schrivner . . . (901) 422-2902

TEXAS
 Amarillo . . . C. W. Hefley . . . (806) 353-4551
 Austin . . . Lee Killeen . . . (512) 928-3833
 Brownwood . . . Lew Bennett . . . (915) 646-0619
 Corpus Christi . . . William Cleland . . . (512) 992-2266
 Carrollton . . . Scott Hillyard . . . (214) 242-1117
 Dallas . . . Hillyard-Western
 Southwestern Sales Office,
 Ted Trask, Regional Mgr. . . (214) 241-3174
 Dallas . . . Carl Montgomery . . . (214) 241-3174
 El Paso . . . Gene J. Dennehy . . . (915) 565-5829
 Houston . . . Neal MacAllister . . . (713) 526-1409
 Longview . . . Baxter Sales . . . (214) 759-2796
 Lubbock . . . George Francis . . . (806) 762-1489
 Schertz . . . Martin Gerber . . . (512) 658-1122
 Spring . . . Dwight Sandusky . . . (713) 367-7609
 Sulphur Springs . . . W. Laurence
 Willoughby . . . (214) 885-3802

UTAH
 Salt Lake City . . . Dale Y. Duke . . . (801) 943-2981

VERMONT
 Burlington . . . Edward Danaher . . . (802) 655-1120

VIRGINIA
 Afton . . . Louis DePiro . . . (804) 361-2144
 Harrisonburg . . . Elvin Miller . . . (703) 433-2471
 Virginia Beach . . . Conway Britton . . . (804) 481-4731

WASHINGTON
 Kent . . . Earl Kanz . . . (206) 631-4391
 Spokane . . . Lyle Guiles . . . (509) 624-4516

WEST VIRGINIA
 Huntington . . . Robert L. Dodson . . . (304) 522-7962
 Nitro . . . William Grimes . . . (304) 755-3251

WISCONSIN
 Manitowoc . . . Ken Schaller . . . (414) 682-0138
 Fond du lac . . . Earl Johnson . . . (414) 921-1067
 Sheboygan . . . Robert Raatz . . . (414) 457-4481
 Superior . . . Gordon Hunter . . . (715) 394-5255

WYOMING
 Cheyenne . . . Emil Eggert . . . (307) 632-8252

CANADA
 Thunder Bay . . . Bob McGonigal . . . (807) 344-3881
 Calgary . . . Hans van der Woerd . . . (403) 253-8660

and so is the arrangement of furniture to define space within a room—a most important innovation traceable in large part to Mies, and something that Peter Blake has nothing to say about in this context.

Yes, the traditional Japanese house, which influenced Wright and through him many others, usually required a subservient wife and a staff of servants to make it work, but so did the Victorian “boxes” that Wright was trying to change. To say, as Blake does, that “the open plan—that most ‘free’ of all modern dogmas—was copied from the authoritarian traditions of Japan,” is building an awfully big generalization on a rather slender assumption. Surely the open plan is an option opened up by modern, long-span construction. Undoubtedly it has been used foolishly, and there are many occasions when clearly defined spaces are preferable, but open planning evidently has its uses, in schools, for example. In setting up the open plan as an elitist concept that enslaves women, Blake is taking on more guilt than is necessary.

Confession is good for the soul, but people who confess to crimes they never committed are really rather a nuisance. Peter Blake enters a whole series of guilty pleas on behalf of the architectural profession, and I am afraid that they only impede the investigation into the real causes of problems. Saying that the dispersal of modern metropolitan areas is the result of zoning, and that zoning derives from the ideas of modern architects like Wright and LeCorbusier is such a sweeping generalization that it sweeps all good sense and rational argument before it. And are tall buildings always inappropriate? Could the typical building of today really have been constructed 100 years ago? Are architects really as guilty as all that?

The architectural profession's sense that we can save the world, or at least help save the world, is an important asset. I don't for a moment suggest that we change. But we have to acknowledge that not every element in the world is directly affected by what architects think and do, much as we might like that true.

There are also good architects and bad architects; and even good architects can make bad mistakes. But when we look at bad buildings and mistakes, do we have to conclude that all of modern architecture is a failure? The doctrines of the “Modern Movement” have not worked all that well, but only a minority of architects ever believed in them, and even fewer clients. It has surely been twenty or twenty-five years since any significant number of architects in the United States took the tenets of the Modern Movement seriously. I remember *The Architectural Review* chiding Americans for their apostasy from Modernism as long ago as the late fifties.

Peter Blake's catalog of errors and sillinesses committed in the name of Modernism is very much worth reading, but there is no need to consider it a refutation of all modern architecture, or of Blake's own life work, as he seems to do. I can't help wondering if this book isn't the result of Blake's moving from New York to Boston, which has a notoriously depressing climate.

Oh well; you had better read this book. You'll laugh, when you aren't grinding your teeth.

AZTEC



Almost 1,000 Aztec low temperature electric radiant ceiling panels were specified to provide perimeter heat along cold walls to supplement the heat generated by equipment, lights and people in an energy saving system especially designed for the AT&T Long Lines building at White Plains, N.Y.

Hellmer & Medved,
 Consulting Engineers,
 Kansas City, Missouri
 cfm Distributors, Inc.,
 1104 Union Street,
 Kansas City, Missouri 64101
 816-842-5400
 Aztec Engineering Representative

Aztec panels have a patented crystalline surface. A superior graphite element insures uniform heat across the panel. No moving parts. No maintenance. 10 year limited warranty.

For more information on Aztec electric radiant heating panels or for the Aztec engineering representative nearest you, call or write to:

Aztech International Ltd.
 3434 Girard N.E.
 Albuquerque, N.M. 87107
 505-345-5631
 TOLL FREE 800-545-8306

For more data, circle 27 on inquiry card

Plywood Design Series-1

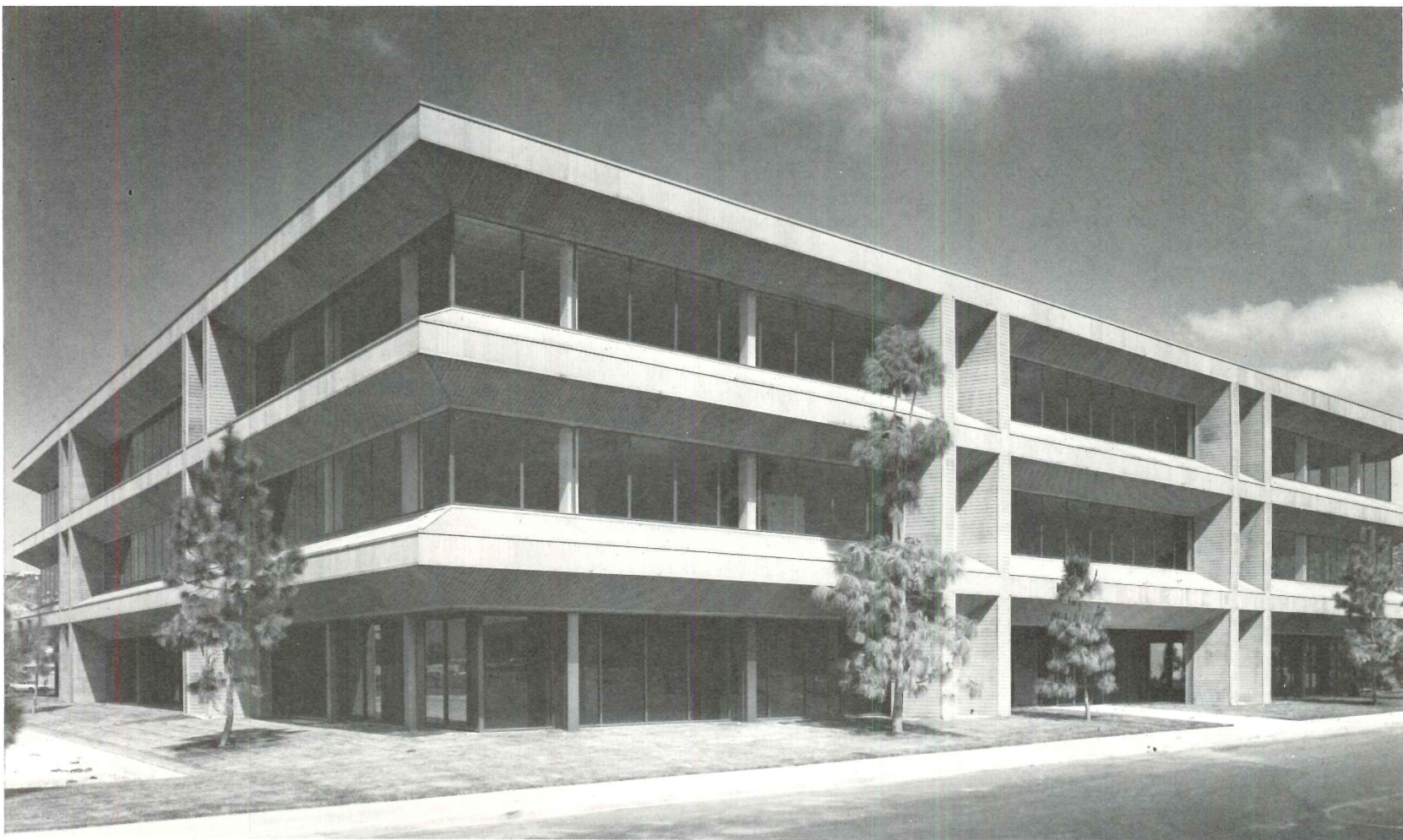

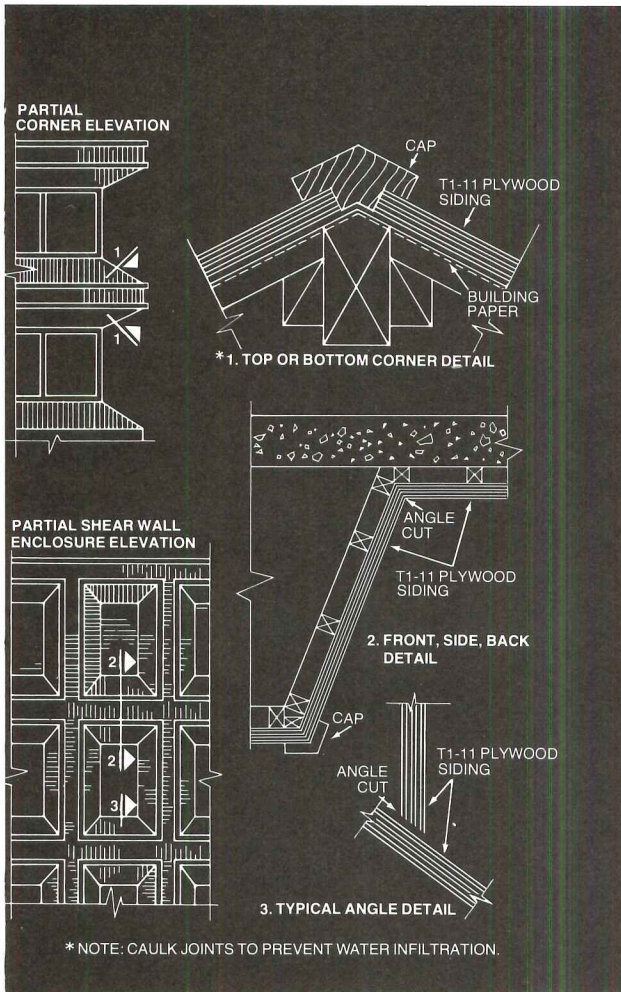

The end of the faceless office building.

Two things are responsible for the unique appearance of this large office building in San Diego, California.

Plywood, and the creative imagination of architect Brian Paul, AIA.

With plywood siding and sophisticated detailing, Mr. Paul integrated the building and its large inner courtyard into a refreshing environment for both tenants and their clients. The inherent warmth of plywood also helped form

an empathetic tie with the adjacent residential neighborhood.

Plywood offered economic as well as aesthetic benefits. Shiplapped $\frac{5}{8}$ " T-11 siding in a simple design needed only semi-skilled labor for installation. Spandrels were detailed to utilize $\frac{1}{2}$ - and $\frac{1}{4}$ -sections of a standard plywood sheet. And as sheathing for the floors and roof, plywood extended its cost savings into the structural system as well.

For design ideas and information, write American Plywood Association, Department AR-097, Tacoma, Washington 98401.

AMERICAN PLYWOOD ASSOCIATION
Plywood. The Performer.

A splendid opportunity for architects to have their work published
in two prestigious award programs:

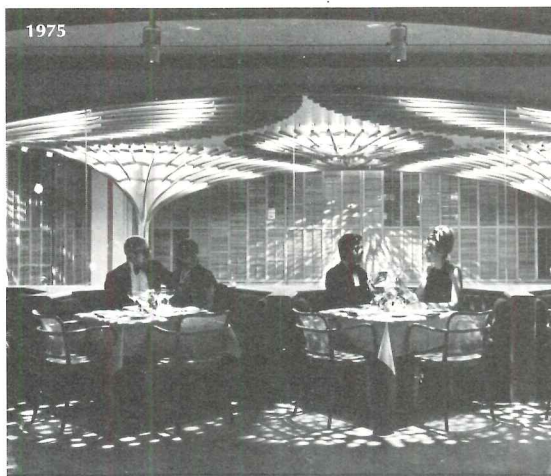

RECORD INTERIORS • RECORD HOUSES and APARTMENTS

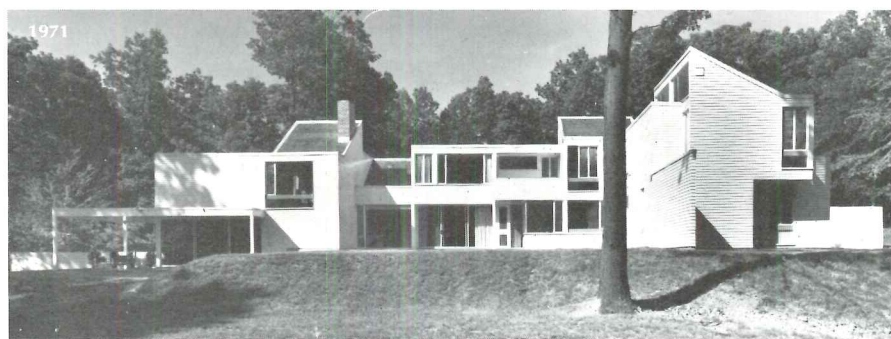

Both award programs are open to any architect registered in the United States and submissions of unpublished work will be welcome for Record Interiors until October 1, 1977 and for Record Houses and for Apartments until November 1, 1977. No formal presentation requirements are made, though materials submitted should include plan(s), photographs, and a general description of the project. Submissions will be returned but not before date of publication.

For more information:

Barclay F. Gordon, Architectural Record
1221 Avenue of Americas
New York City, 10020
Telephone (212) 997-2334

OR

Janet Nairn, Architectural Record
425 Battery Street, San Francisco, Cal. 94111



Ceramic mosaics: conversation pieces from American Olean.

Plate No. 1005

Give your clients something to talk about. Like a room tiled with American Olean ceramic mosaics, one of the most versatile design materials available.

Concentrate on a shape like new 2" hexagon (shown). Or colors like new Seal and Bone (shown above in 2" x 2"). With ceramic mosaics there's no limit to imaginative design possibilities. And because ceramic mosaics are stainproof, frostproof, dentproof and colorfast, what you design will last a lifetime.

Now ceramic mosaics are available in 43 colors—seven of them brand new—solid, flecked, and granitelike. And four shapes—2" x 2", 2" x 1", 1" x 1" and new 2" hexagon. And American Olean has a Ceramic Mosaics Design Service to help you develop a rough sketch or concept, color coordinate and even finalize your design. Or you can choose from a wide selection of attractive stock patterns and blends. For floors, walls or special areas, American Olean ceramic mosaics are the natural thing to use.[™] For more information and our new, free ceramic mosaics brochure, write to American Olean Tile Company, 2454 Cannon Avenue, Lansdale, Pa. 19446. Or visit the American Olean Color Center nearest you.

American Olean ceramic tile is available worldwide. Telex 84-6407

For more data, circle 29 on inquiry card

**American
Olean**
A Division of National Gypsum Company

Bold cantilevered design calls for great structural strength...

The owner of First Federal Plaza in downtown Austin, Texas, wanted a distinctive design that would focus on a park-like plaza in front of the building's main entrance.

The architects, 3D/Brooks Barr Graeber White, achieved the desired effect with a unique diamond-shaped structure featuring five stepped cantilevered levels. The apex of the cantilevered levels in front of the six-story building provides a focal point to the entry.

Only steel could carry the load

According to the structural engineers, W. Clark Craig & Associates, "The large cantilevers carrying the 72- and 90-ft-long walls required by the architect could only be framed in steel."

Competitive framing materials would have required prohibitively deep sections to carry the

high-strength steel trusses provide the solution

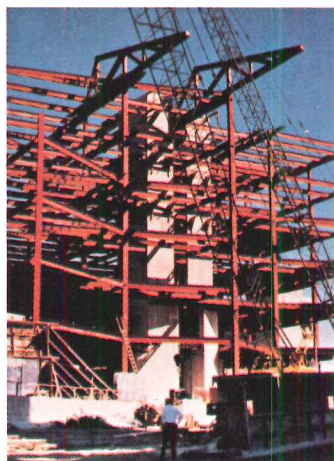

cantilevered loads, which would have detracted from the building's esthetics. In addition, steel proved to be more economical and faster to erect.

High-strength steel trusses

Three tapered-steel roof trusses, the longest of which is approximately 62 ft, carry the five-story-high, 72- and 90-ft-long cantilevered walls over the plaza. The trusses, 13 ft 6 in. deep at their highest point, are fabricated of ASTM A572 Grade 50 high-strength steel.

The east and west ends of the building are also cantilevered through the use of six-story-high exposed wall trusses. The west cantilevered end projects over the garage entrance to three sub-levels of parking. The east-end cantilever provides a sheltered drive-through area for the bank's drive-in teller units. The spans are 60 ft from the column to the ends of the cantilevered trusses.

The trusses minimized the number of columns required to support the loads. This, in turn, provided the additional advantage of increased interior space flexibility.



First Federal Plaza, clad in mirrored glass, is oriented on the site to reflect the sun's rays away from the eyes of passing drivers. The wall trusses, supporting the east and west ends of the building, are exposed on the interior to add an interesting architectural element. Three tapered roof trusses support the five stepped cantilevered levels below.



High-strength steel trusses enabled the architects to create a unique cantilevered design for this six-level bank and office building. Bethlehem supplied 340 tons of steel for the project.

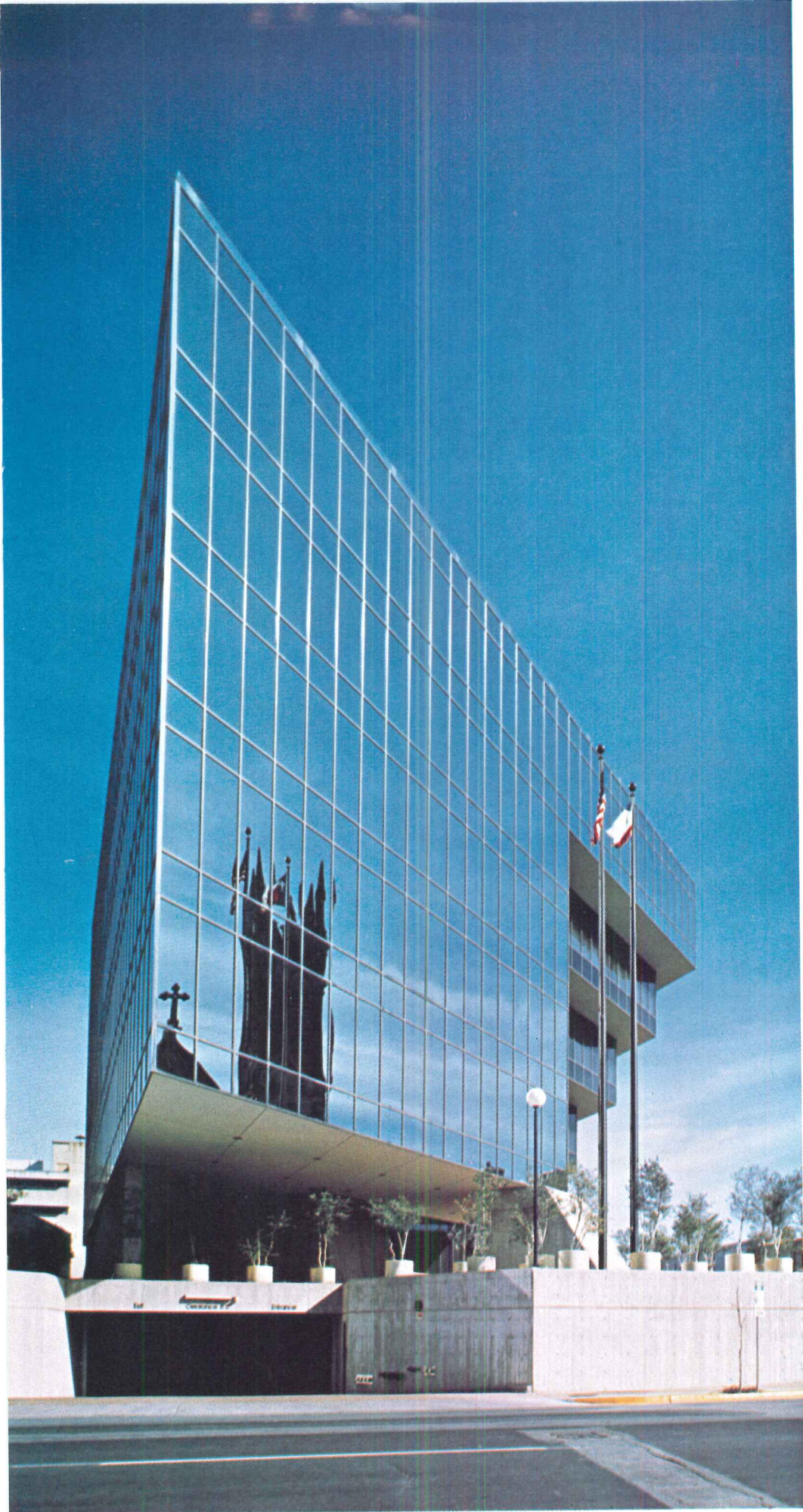

Composite design was used to economically reduce steel weight and permit smaller section sizes for the long spans. Composite beams and girders support and combine with the fire-resistive floor assembly of 3-in. composite steel floor deck topped with 3¼-in. lightweight concrete.

Our Sales Engineering Division offers a variety of technical and advisory services. Our preliminary frame analysis program, for example, is designed to help you select the best steel framing system for your building. It also enables

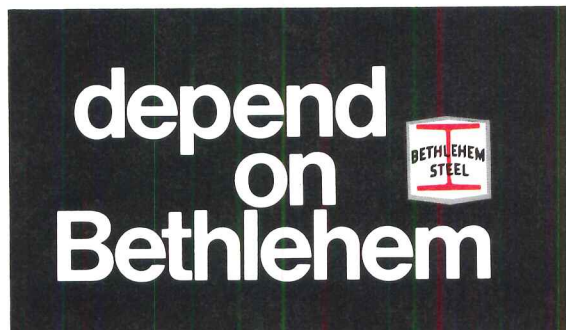

you to compare steel with competitive framing materials. This program is free with no obligation whatsoever.

We also have a large library of practical design and engineering aids, product catalogs, building case studies, and slide presentations. If you would like additional information on any of these services, call your Bethlehem Sales Engineer. He's available through the Bethlehem Sales Office located nearest you. Bethlehem Steel Corporation, Bethlehem, PA 18016.

Owners: First Federal Savings & Loan
Architect: 3D/Brooks Barr Graeber White, Architects
Structural Engineer: W. Clark Craig & Associates
Fabricator: Capital City Steel Co.
Erector: J. M. Borders Steel Erection Co.
General Contractor: Robert C. Gray Construction Co.
 All of the above firms are located in Austin, Texas.

SALES OFFICES

Atlanta (404) 522-4918
 Baltimore (301) 685-5700
 Boston (617) 267-2111
 Buffalo (716) 856-2400
 Chicago (312) 664-5422
 Cincinnati (513) 381-6440

Cleveland (216) 696-1881
 Detroit (313) 336-5500
 Houston (713) 659-8060
 Los Angeles (213) 726-0611
 Milwaukee (414) 272-0835
 New York (212) 688-5522

Philadelphia (215) 561-1100
 Pittsburgh (412) 281-5900
 St. Louis (314) 726-4500
 San Francisco (415) 981-2121
 Seattle (206) 285-2200
 Ask for Sales Engineer

Look who's hanging around Houston's Pennzoil Place.

It's us. LOF.

When Philip Johnson and John Burgee designed what many are calling "the year's most exciting new building," they had a variety of coated glasses to choose from.

They chose Thermopane® insulating glass with Vari-Tran® coating.

Available in a wide range of colors and shading coefficients, Vari-Tran is as practical as it is beautiful. It can cut down on heat gain significantly, keeping air-conditioning costs within reason.

To find out what LOF high performance glass can mean to a building you have in the works, contact an LOF architectural representative. He'll put our computers to work on a cost analysis to show how Vari-Tran products can result in savings in initial construction costs and annual energy consumption.

For more information, refer to our LOF Sweet's Catalog, "Glass for Construction," or write to Paul Corrad at Libbey-Owens-Ford Company, 811 Madison Ave., Toledo, Ohio 43695.

For more data, circle 30 on inquiry card

Developer: Gerald D. Hines Interests/General Contractor: Zapata Warrior Contractors—A Div. of Zapata Constructors, Inc.
Architect: Philip Johnson & John Burgee, New York and S.I. Morris Associates, Houston
Curtain Wall & Glazing Contractor: Cupples Products Div., H.H. Robertson Co., St. Louis, Mo.
Mechanical Engineers: I.A. Naman + Associates, Inc.



LOF

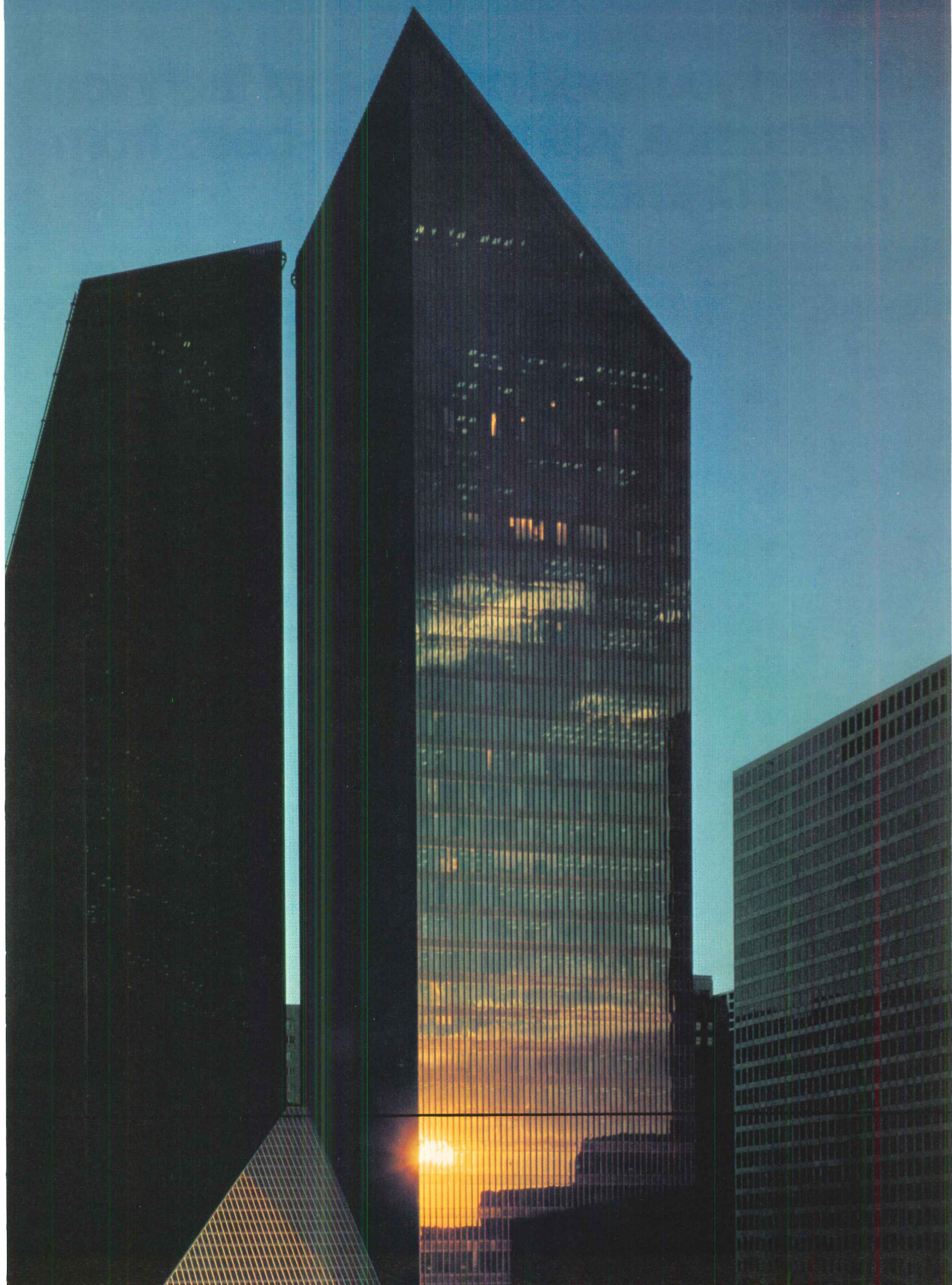

When you need on-the-roof technical assistance, you can get it - best - from a J-M District Engineer.



Best, for several reasons.

You see, we're the only roofing manufacturer with field engineers.

And as part of our team of roofing experts, J-M District Engineers (and there are 12 of them) devote full time to built-up roofing systems.

Together they offer over 200 years of roofing experience.

Their combined qualifications form a technical resource that's unmatched in the industry.



And their expertise is available to you on call. Whenever the need arises.

To assist with specifying, as part of J-M's guaranteed roof programs.

To provide on-site, technical advice on unusual roof situations.

To help keep you advised on new practices in the industry.

To provide information on local climatic conditions as they affect roof design and construction.

And, most of all, to help you solve roofing problems before they happen.

Backing them are the resources of one of the world's largest producers of built-up roofing materials. Plus knowledge assembled in solving roofing problems since 1868.

Reason enough to look to J-M when you're planning a new structure and need assistance designing a roof that will provide years of reliable performance.

For information on J-M single-source roofing systems, contact Grant Edmonds, Johns-Manville, Ken-Caryl Ranch, Denver, Colorado 80217, 303-979-1000. AR-9

For single-source built-up roofing systems.



Johns-Manville

For more data, circle 31 on inquiry card

"Otis glass-backed elevators help us sell our condominiums."



The Carlyle, a complex of five-story condominiums in Atlanta, Georgia, has had such success with glass-backed Otis elevators that the developers write "glass-back" into all their low-rise building specifications.

E. O. Mastin, of Mastin Associates, Inc., architects on the project and John L. Crawford, President of 2765 Peachtree Corp., the developers, said, "The glass-backed elevator has become a prime selling feature, and for little more than ordinary elevator cost." Older tenants are particularly pleased with the openness of the glass, a definite deterrent to both crime and vandalism.

The elevators at the Carlyle are five-story, 2500-lb. capacity pre-engineered hydraulic models. Mr. Mastin explained,



"With a little custom work on a standard pre-engineered package, we came up with something extraordinary. It's an instant, highly visual example of the architecture on the site."

"When we're showing a unit, the trip up isn't just a quiet, waiting ride," Mr. Crawford explains. "We start pointing out the solid features of the building."

The elevators at the Carlyle are under Otis Maintenance contracts, another source of security to the resident. Mr. Crawford said, "We have not had complaints about the elevators in our buildings."

When you want the best, you want Otis.

**OTIS ELEVATOR
COMPANY**

Subsidiary of
**UNITED
TECHNOLOGIES**

The Leader.

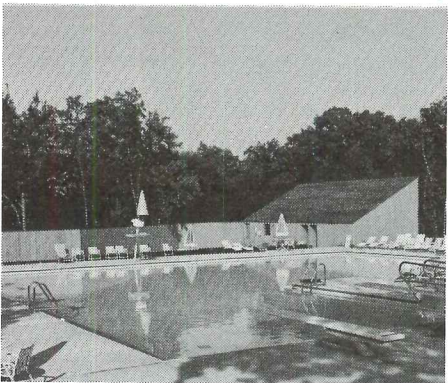
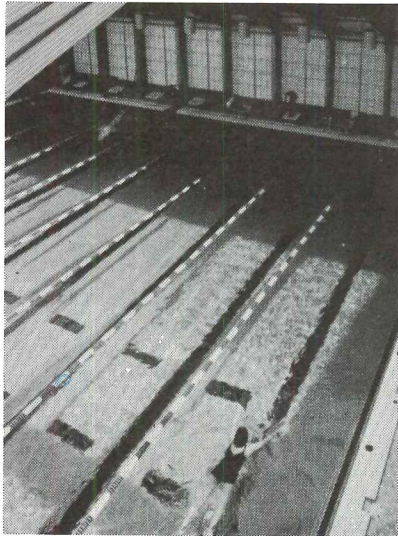

**Paddock pioneered the Pipeless Pool System.
Paddock perfected the Pipeless Pool System.
Over 1800 installations attest to its superiority.**

Since 1920, Paddock of California has led the industry in every major advancement in swimming pool design and construction. Their pipeless system of pool water recirculation has been field proven in over 1800 installations throughout the country.

Now, Paddock offers the SCRS® System. A pool perimeter recirculation system that responds automatically and instantaneously to the number of swimmers and their type of activity in the pool. Pool water level, gutter flow rate, action of surge weirs and main drain are monitored continuously and activated automatically to provide the most efficient water recirculation available. In addition,

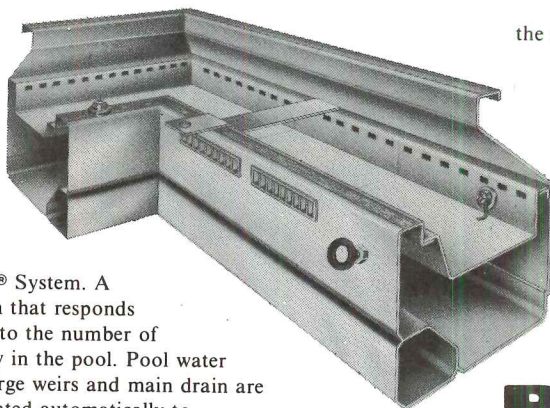

the system provides surge containment for competition and can carry flow rates up to 3,000 gallons per minute. For new construction or renovation. Consider a Paddock SCRS System atop of a gleaming stainless steel PermaWall sidewall panel. Untold economies and efficiencies are yours now and for the life of the swimming pool.

Write or call for full particulars, your inquiry will receive immediate consideration.

Paddock®
POOL EQUIPMENT COMPANY, INC.

P.O. Box 511
555 Paddock Parkway
Rock Hill, South Carolina, 29730
Telephone: (803) 324-1111

For new pools or remodeling existing pools.

For more data, circle 33 on inquiry card

Building overseas
is smoother
with a company
that's been doing it
for 65 years.

Like Robertson.

We provide a total involvement in quality construction anywhere in the world from our offices and plants around the globe. We offer total responsibility for the application, engineering, testing, manufacture and installation of wall, floor, roof and ventilation systems.

COULD YOU USE SOME
SMOOTH SAILING? CALL
ROBERTSON.

Pilgrim's Hall, Jeddah Port
Saudi Arabia



Robertson

H. H. Robertson Company
U. S. Export Division
400 Holiday Drive
Pittsburgh, PA 15220
(412) 922-9300

For more data, circle 34 on inquiry card

**New ALL-STEEL 2400 Series
helps waiting become
a positive experience.**

Understated elegance. Deep seated comfort. A very nice place to be. Surprisingly affordable. Seven seating styles, 11 coordinated tables.

Find out more: Write for our colorful new brochure. All-Steel Inc., Box 871, Aurora, Illinois 60507.



All-Steel Showrooms in New York, Los Angeles, Chicago, Aurora. In Canada, All-Steel Canada, Ltd. One of the **CIT** Companies.

For more data, circle 35 on inquiry card

- BUILDING COSTS AND FINANCING
- LEGAL PERSPECTIVES
- BUILDING ACTIVITY
- CONSTRUCTION MANAGEMENT
- OFFICE MANAGEMENT

Southern newsletter delivers 12 new project leads per week

Finding project leads for architects and engineers of nine states is the business of Richard Pugh, an engineer who—two years ago, founded Consulting Opportunities in Orlando, Florida. From a lead finding service limited to Florida initially, Mr. Pugh has expanded into Georgia, North and South Carolina, Virginia, Maryland, Pennsylvania, Ohio and southern California, and he plans to initiate service in New York, Michigan and Texas by the end of the year. Coverage will be extended to four to six states per year until the 30 most active in terms of construction are receiving the Consulting Opportunities newsletter (see illustration) which guarantees subscribers at least 12 different leads per week per state or a minimum of 624 per year, covering nearly 60 building types.

Purchased on a monthly basis (with a three-month minimum), the newsletter costs between \$225 and \$231 per month and lists for each of the projects identified, a description of the project, its status, and the name, address and phone number of the contact. According to Mr. Pugh, these are jobs for which no architect or engineer has been selected; which will be undertaken within 6 to 12 months of the notification; and which have a \$100,000 minimum construction budget (although this is

not always verifiable). Feasibility studies are also listed.

The method by which Mr. Pugh and his company gathers information is confidential, but it does involve telephone discussion with someone in the potential client's office. Subscriptions are limited to approximately 22 architectural and engineering firms (split 50/50) per state, so that subscribers are afforded some advantage over competition. Further, if any subscriber is being considered for a particular

job uncovered by the newsletter staff, that job is not placed on the opportunities list.

Most of the leads are for public and institutional work, with a sizable proportion of civil engineering jobs, although Mr. Pugh reports a dramatic increase in recent weeks in the number of private projects being contemplated in the states he serves. A look at a recent twelve-month period for Georgia, the Carolinas, Virginia and Maryland shows that the Consulting Opportunities newsletter provided leads to 351 water/sewer and solid waste treatment projects; 443 school/college jobs; 190 hospital and nursing home projects; and 147 housing authority projects, among others. Mr. Pugh does not keep records on the number of actual design commissions that are traceable to his newsletter, but reports a high level of subscriber satisfaction and a low subscriber turnover. At present, there are only one or two available subscriptions per state.

Two subscribers interviewed—one representing a larger, multi-office firm, and the other a partner in a small office—both praised the newsletter, in spite of a number of failings, including inaccuracies and a high proportion of civil engineering jobs listed. However, both firms are receiving the promised number of leads, and find the service to be a valuable marketing tool. Both firms reject the bulk of the leads supplied—because the budgets are too small or the jobs are out of the firm's service capability—but they are still left with some 20-25 possible jobs to pursue each month.

Although an expensive newsletter, the cost is modest for a professional design firm aggressively marketing its services, particularly the larger firms where the cost of locating and developing jobs can average \$10,000 or more per commission. Even for the smaller firm, the newsletter appears to be a good investment. As the partner in the smaller subscribing firm said, the "excitement" of a regular supply of job leads has caused his firm to refine its promotional activities through the required regular follow up procedures. This added presence in the marketplace has actually led to work not identified by the newsletter.

The spokesman for the larger firm said the newsletter is not a substitute for research, but it does cut down on the amount of time the marketing staff spends scanning local newspapers for job hints. The newsletter also serves to prompt the firm into faster action, particularly when a job previously uncovered by the marketing staff appears in the newsletter, and therefore, becomes free-circulating.

Twice a week subscribers to the Consulting Opportunities newsletter receive project lead information formatted as this sample. At least twelve project notifications per week are guaranteed. There is also a "misses" section, listing projects underway, so that subscribers will not waste time tracking committed work. (Names of projects and individuals have been blocked out in the sample because they are confidential.)



CONSULTING OPPORTUNITIES

Potential Projects for A E P Professionals

Mailing Address: P.O. Box 19814 • Orlando, FL 32814 • Phone (305) 671-2405
 Located at: 1029 South Semoran Blvd. • Winter Park, FL

VOL. 2 No. 65 AUGUST 5, 1977

POTENTIAL PROJECTS

CONFIRMED BY CONSULTING OPPORTUNITIES STAFF

_____ COUNTY (SC) _____ SAVINGS & LOAN ASSOCIATION
 - BRANCH _____

CONTACT: MR. CARL _____ EXECUTIVE VP/MANAGING OFFICER
 _____ SAVINGS & LOAN ASSOCIATION

POST OFFICE BOX _____
 _____ SOUTH CAROLINA 29 _____
 TELEPHONE: 803/_____

MR. _____ INFORMED US THE _____ SAVINGS & LOAN ASSOCIATION
 PLANS TO BUILD A BRANCH BANK IN THE IMMEDIATE VICINITY OF _____ ROAD _____
 _____ AND _____ DRIVE _____ ROAD IN _____ ESTIMATED COST
 OF THE PROJECT IS UNAVAILABLE AT THIS TIME, HE SAID. HE CONFIRMED THAT NO PROFESSIONAL
 HAS BEEN RETAINED, ADDING THAT A SELECTION SHOULD BE MADE WITHIN SIX MONTHS.

_____ COUNTY (SC) _____ METROPOLITAN COMMISSION - PUMPING STATIONS &
 TRUNK LINE/WASTEWATER TREATMENT

CONTACT: MR. _____ MANAGER
 _____ METROPOLITAN COMMISSION

POST OFFICE BOX _____
 _____ SOUTH CAROLINA 29 _____
 TELEPHONE: 803/_____

MR. _____ TOLD US THAT _____ METROPOLITAN COMMISSION INTENDS TO APPLY FOR
 \$1 MILLION IN FEDERAL FUNDS WITH WHICH TO CONSTRUCT SOME PUMPING STATIONS AND
 A TRUNK LINE, AND ALSO \$2.5 MILLION FOR A WASTEWATER TREATMENT PLANT. ASSUMING
 THE PROJECTS ARE FUNDED, PROFESSIONALS SHOULD BE SELECTED FOR PLANNING WITHIN A
 YEAR, HE SAID. INTERESTED FIRMS SHOULD CONTACT MR. _____

A Service of Richard Pugh, Inc.

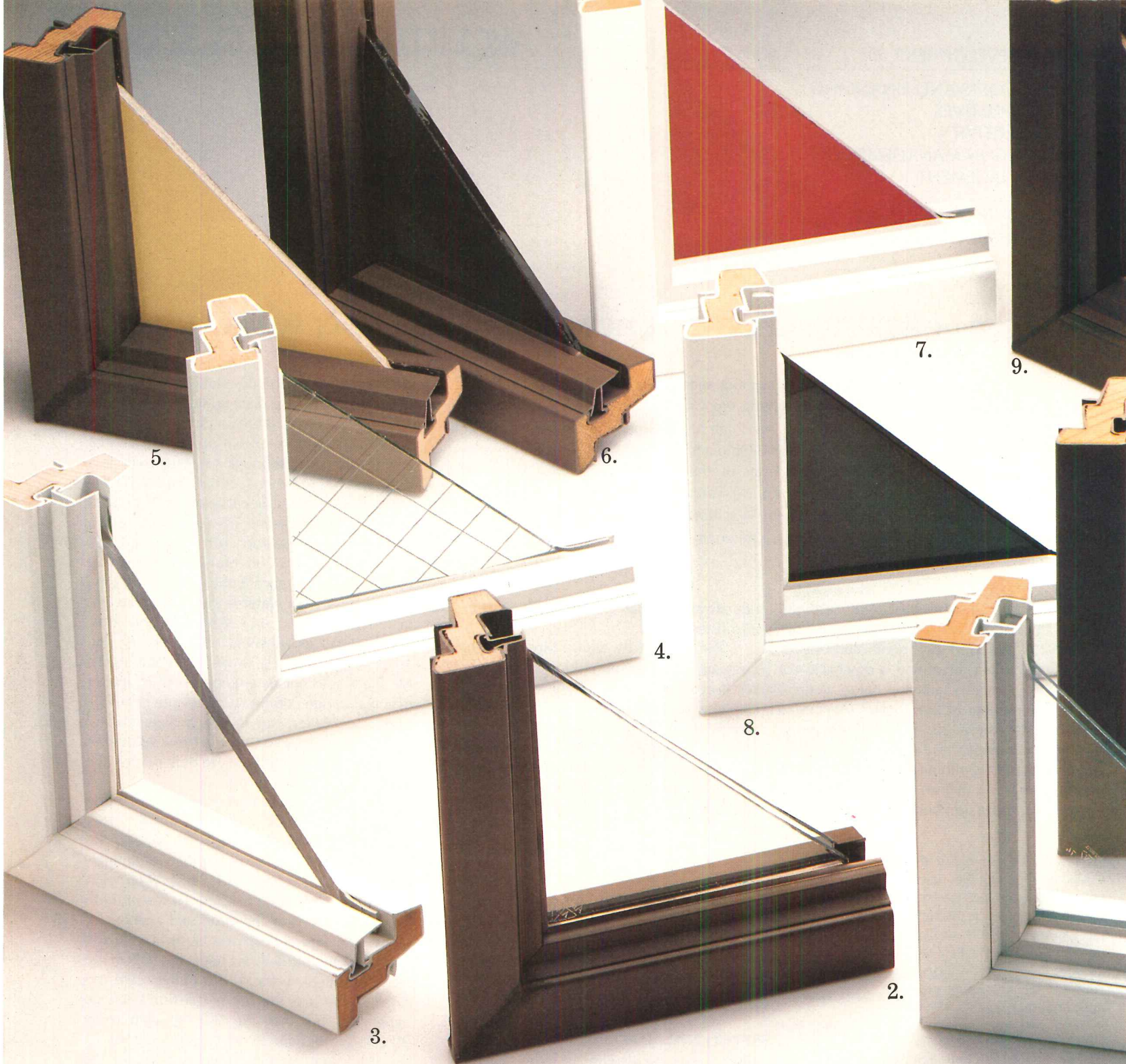

The beautiful ways

Presenting 1,060 Andersen® Window glazing options.

Single glazing or double-pane insulating glass in Andersen Windows and Gliding Doors have clearly been the beautiful way to complement any design. And they still are. But, they're only two of 1,060 optional glazings you can

1. Clear glass available single-pane or double-pane insulating glass.

Safety Glazing

2. Tempered Safety Glass. Hard to break safety glass. When broken, granular pieces lessen the chance of serious injury. Single-pane or double-pane insulating glass.

3. Lexan® Sheet safety glazing by General Electric and Plexiglas® acrylic sheet by Rohm and Haas. Extremely hard to break. Mar resistant. Lightweight. Transparent.

4. Mississippi Wire Glass by Combustion Engineering. Six patterns of clear, obscure or pattern safety glass with solid wire reinforcement.

Spandrel Panels

5 & 9. Mirawal® panels by Kaiser Aluminum. Spandrel glazing of porcelain enamel on steel with cement asbestos core. 46 colors. Insulated panel shown in illustration 9.

6. Vitrolux® spandrel glass by LOF. Spandrel panels of opaque glass, heat strengthened, fused ceramic color. 10 colors.

7. Glasweld® panels distributed by PPG. Opaque spandrel reinforced mineral panels. Mineral color surface. 31 colors.

8. Spandrelite® Glass panels by PPG. Heat strengthened opaque glass. Ceramic color fused to surface. 10 colors.

Decorative Glazing

10. Plexiglas decorative acrylic sheet by Rohm & Haas. High impact resistance. In translucent, transparent and semi-opaque colors.

11. Amberlite Pattern Glass by Combustion Engineering. Decorative effect in hammered amber patterns. Tempered or untempered.

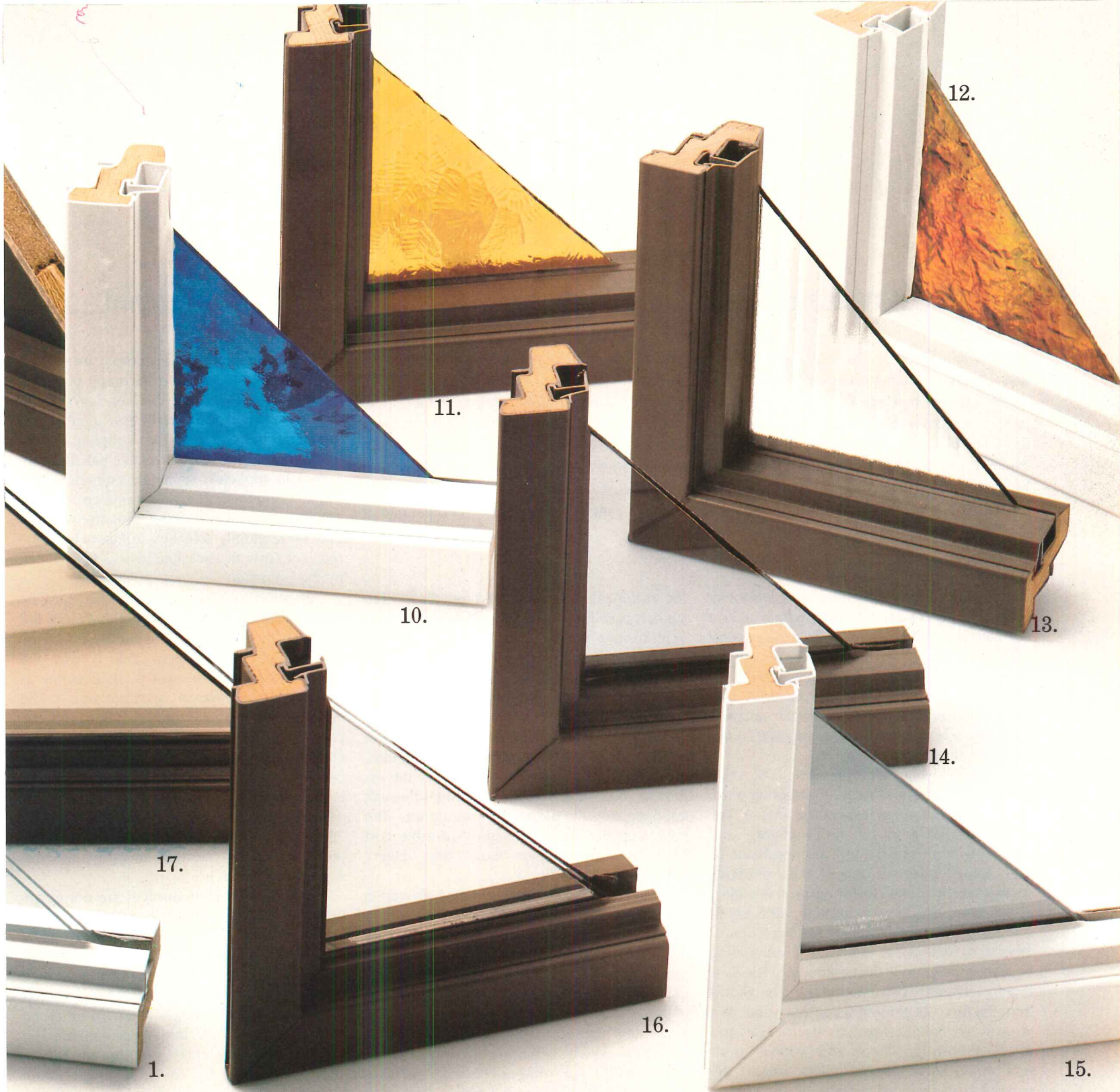

to glaze an Andersen.

fit into your plans. Clear, tinted, environmental, spandrel, safety glazing... whatever your design demands, Andersen Windows and Gliding Doors are an excellent choice.

While these glazing options are available in most Andersen

windows, there may be limitations in certain sizes and types. For specific availabilities, call your Andersen Distributor. He's in the Yellow Pages under "Windows." Or write us. Andersen Corporation, Box 12, Bayport, MN 55003.

12. Krinklglas® decorative panels by Dimensional Plastics Corporation. Translucent or opaque acrylic polyester fiber glass reinforced. Gives colorful, decorative effect. 324 options.

13. Other Pattern Glass by Combustion Engineering. 8 other patterns and textures. Distorts image. Glare reducing finish available. Tempered or untempered.

Environmental Glazing
14. Grey tinted glass from LOF, PPG and Cardinal. Available tempered or untempered. Single-pane or double-pane insulating glass.

15. Vari-Tran® coated reflective glass by LOF. Environmental mirror effect. Tempered or untempered. Reduces glare and heat gain. 4 colors.

16. Solarcool® reflective glass by PPG. Reduces solar heat gain and glare while providing tinted, mirror-like exterior effect. Tempered or untempered. 3 colors.

17. Bronze tinted glass from LOF, PPG and Cardinal. Available tempered or untempered. Single-pane or double-pane insulating glass.

The beautiful way to save fuel™

Andersen® Windowalls®
ANDERSEN CORPORATION BAYPORT, MINNESOTA 55003



Range estimating: a way to predict the accuracy of cost estimates

There is solid evidence that learning to control costs is a high priority of architects and engineers, and—if not overtaking programming and design ability in importance—cost control and budget analysis are often an equal partner in the marketing of professional design services. In fact, some firms make cost control the cornerstone of their marketing effort, and individuals within these firms are beginning to say that those professionals who do not emphasize cost control will eventually be working for those who do. That designer interest in cost control runs high can best be measured by the capacity attendances reported for cost estimating seminars and courses offered around the country. One aspect of cost estimating—range estimating—is a popular part of the curriculum.

Range estimating is something of a misnomer since the process does not produce a cost estimate at all; it is a way of analyzing a cost estimate prepared in the traditional way, to determine its chances for accuracy at bid time. As such, range estimating may be used from the very beginning of the project to analyze preliminary budgets, and to monitor the course of design development.

John F. Steffen Associates, Inc., a St. Louis mechanical and electrical engineering firm, has developed range estimating into a key service available to the firm's clients, and architects employing the firm as consultants. In fact, John Steffen is one of the concept's strongest proponents, lecturing on the subject at his own quarterly workshops, and semi-annually at the University of Wisconsin-Extension, where he conducts a continuing education program in cost estimating. The Steffen organization committed to the idea almost from the firm's beginning seven years ago, as a way of verifying estimated mechanical and electrical costs for schools and hospitals, projects where such systems greatly impact the over-all cost, comprising up to 47 per cent of the budget.

The effectiveness of range estimating relies on good historical cost data

The effectiveness of range estimating, first of all, depends on the estimator's access to accurate cost records on similar, completed projects, broken down by major building components as identified by the Uniform Construction Index format (the accepted specification format). Using good historical cost data, the estimator prepares his best estimate as he always would—using all the available information: knowledge of market, suppliers and costs for past, similar projects. Each component of the project, or line item, is given an estimate called the "target" (see Figure 1). The premise of range estimating is, obviously, that the more accurate the constituent part estimates, the more accurate the total estimate, and keeping

the historical cost data filed by these constituent parts helps the estimator make a direct item-for-item estimate. At least two previous costs for each item should be known.

In the example supplied by John F. Steffen, a typical small office building, all of the target costs are totalled for a "Total Project Cost," \$4,441,519, which is entered on the form along with the gross square footage requirement. With this information in place, the estimator must further establish—albeit through good guesswork based on experience—the lowest possible and the highest possible cost for each line item (see "Low" and "High" columns of Figure 1).

Even at this point, the estimator can start to draw some pertinent conclusions, particularly if the job is in preliminary design. For example, the estimator can pick out those portions of the job which—by virtue of their cost uncertainty—will greatly impact the accuracy of the estimate. The greater the range between a low and high cost, the less is known about the item, which will have to be carefully monitored through subsequent design activity. An "Impact Factor" is assigned to each line item, mathematically determined by dividing the difference between the low and high figures for each item by the total estimated project cost. The larger the resulting percentage, the greater the impact of the item (because the estimator does not know enough about it to tie down a probable cost). Calculating the "per cent of Total" project cost represented by the line item, and "per cent of Subtotal" is a way of further weighting the impact of the line item on the total project estimate.

Probable accuracy of the estimate depends on simulated bidding

To test the over-all estimate, the estimator would ideally take real bids. An alternative to this obviously impractical choice is a simulated bidding process, using a mathematical technique known as the "Monte Carlo Method." The validity of range estimating—which, it

must be remembered, is nothing more than determining the probable accuracy of a predicted outcome—is therefore based on simulating the real bidding process, a situation analogous to using a random sampling of public opinion to predict a probable election outcome. In the case of range estimating, the Monte Carlo Method surveys numbers, or more precisely, it is a way of producing many probable bids by randomly selecting numbers from the range of costs for each line item as determined by the estimator.

In short, a computer (and one must be used) produces 5000 different bids (in 6-7 minutes), randomly drawing numbers from the various line item ranges. (This is why the estimator's handwork must be as accurate as possible: "Garbage in, garbage out.") The costs are automatically adjusted for time and place of construction by the computer via a cost index from Dodge, Means or other accepted source. (Architects working with the Steffen firm have access to the computer via a lightweight terminal and telephone lines. Terminals can usually be leased as well as purchased, so the hardware investment for designers is minimal.)

The 5000 bids themselves are not meaningful information, since they range, as can be seen in Figure 2, in this case from a low of \$4,188,827 to a high of \$4,596,547. One more task must be performed by the computer.

The computer divides the high-low difference into ten equal ranges and sorts all of the 5000 simulated bids into these ranges. The "per cent" column of Figure 2 shows what per cent of the bids fell in each range. When plotted on a graph, these percentages form the classic bell curve achieved in random sampling distribution (see Figure 3).

Now the estimator can start to determine the probability of accuracy for his original estimate. The cumulative percentages in the "Accum %" column (Figure 2) are first plotted and superimposed on the distribution bell curve (see Figure 3). Finding the original estimate of \$4,441,519 on the graph, the estimator would draw a line down; where it intersects the accumulated percentage line, he could then read the per cent of probability that his original estimate will be on target or less. In this case, the chance of attaining the estimate, or less, is 78 per cent. An estimate that falls near 80 per cent is considered reasonable. Since the estimate line also intersects the bell curve at the peak or average value, the estimate falls well within the average for those 5000 simulated bids.

Figure 1

RISK ANALYSIS IN CONSTRUCTION COST FORECASTING—SAMPLE							
PROJECT SQUARE FEET = 117,188 TOTAL COST = \$4,441,519 COST INDEX = 100							
SITWORK	LOW	TARGET	HIGH	IMPACT	%TOT	%SUB	\$/SQ FT
PAVING	\$ 12,000	\$ 17,500	\$ 22,000	.23%	.4	22.6	\$.15
EXCAVATION	35,000	45,000	45,000	.23	1.0	58.1	.38
DEMOLITION	12,000	15,000	18,000	.14	.3	19.4	.13
—SUBTOTAL	59,000	77,500	85,000		1.7		.66
BUILDING SHELL							
CONC.							
MASONRY	4,500	5,500	7,000	.06	.1	.4	.05
CAULKING	9,000	12,000	15,000	.14	.3	.8	.10
CONCRETE WORK	715,000	750,000	760,000	1.01	16.9	48.9	6.40
ELEV. & LIFTS	360,000	420,000	435,000	1.69	9.5	27.4	3.58
ENTRANCE—							
ALUMINUM	5,500	7,000	7,800	.05	.2	.5	.06
GLAZING	125,000	140,000	165,000	.90	3.2	9.1	1.19
INSULATION	7,200	7,500	7,900	.02	.2	.5	.06
ROOFING	22,000	27,500	30,000	.18	.6	1.8	.23
ROOF INSUL.	7,500	8,000	8,900	.03	.2	.5	.07
WATER							
PROOFING	1,500	2,000	4,500	.07	.0	.1	.02
EXP.							
AGGREGATE	125,500	153,000	160,500	.79	3.4	10.0	1.31
—SUBTOTAL	1,382,700	1,532,500	1,601,600		34.5		13.08
INTERIOR FINISH							
ACOUSTIC WORK	27,000	30,000	45,000	.41	.7	6.1	.26
FLOORING	63,200	66,200	84,000	.47	1.5	13.5	.56
HARDWARE—							
FINISH	19,000	23,000	30,000	.25	.5	4.7	.20
HOLLOW							
MTL & DRS	38,000	40,000	48,000	.23	.9	8.2	.34
MILLWORK	10,000	12,000	18,000	.18	.3	2.5	.10
PAINTING	92,000	110,000	115,000	.52	2.5	22.5	.94
TOILET PART & ACCS.	12,500	14,000	17,000	.10	.3	2.9	.12
PLASTER	17,000	22,000	25,000	.18	.5	4.5	.19
TILE WORK	14,000	17,000	20,000	.14	.4	3.5	.15
DRYWALL	120,000	145,000	163,000	.97	3.3	29.6	1.24
METAL							
LOCKERS	8,000	10,000	14,000	.14	.2	2.0	.09
—SUBTOTAL	420,700	489,200	579,000		11.0		4.17
BUILDING SUPPORT SYSTEM							
ELECTRIC	402,500	453,500	485,000	1.86	10.2	26.7	3.87
HVAC	685,000	785,000	785,000	2.25	17.7	46.3	6.70
PLUMBING & GAS	327,000	342,000	350,000	.52	7.7	20.2	2.92
SPRINKLERS	110,000	115,000	125,000	.34	2.6	6.8	.98
—SUBTOTAL	1,524,500	1,695,500	1,745,000		38.2		14.47
GENERAL CONDITIONS							
G. C. CONT.	215,221	254,243	265,000	1.12	5.7	64.3	2.17
M/E CONT.	91,000	95,313	105,000	.32	2.1	24.1	.81
—SUBTOTAL	350,221	395,413	421,000		8.9		3.37
OVERHEAD & PROFIT*							
CONTINGENCY	5.5%	6.0%	6.3%	.7%			
ESCALATION	.0	.0	.0	.0			
—TOTAL	\$3,942,663	\$4,441,520	\$4,708,575		94.3%		\$35.76

* (contractor's)

Figure 2

BUDGET ALLOCATION: SAMPLE (BASED ON 5000 SIMULATIONS)				
CLASS	FROM	TO	PER CENT	ACCUM. PER CENT
1	\$4,188,827	\$4,229,599	.1	.1
2	4,229,599	4,270,371	.9	1.0
3	4,270,371	4,311,143	4.3	5.2
4	4,311,143	4,351,915	14.3	19.5
5	4,351,915	4,392,687	24.2	43.7
6	4,392,687	4,443,459	27.5	71.2
7	4,443,459	4,474,231	18.1	89.3
8	4,474,231	4,515,003	8.5	97.9
9	4,515,003	4,555,775	1.7	99.5
10	4,555,775	4,596,547	.5	100.0

84.1% CHANCE OF BID BETWEEN \$4,311,143 AND \$4,474,231
84.1% CHANCE OF BID OF \$4,392,687 ± 1.9%*
80.0% CHANCE OF BID OF \$4,453,192 OR LESS

* Median of the low of class 4 and high of class 7

Figure 3

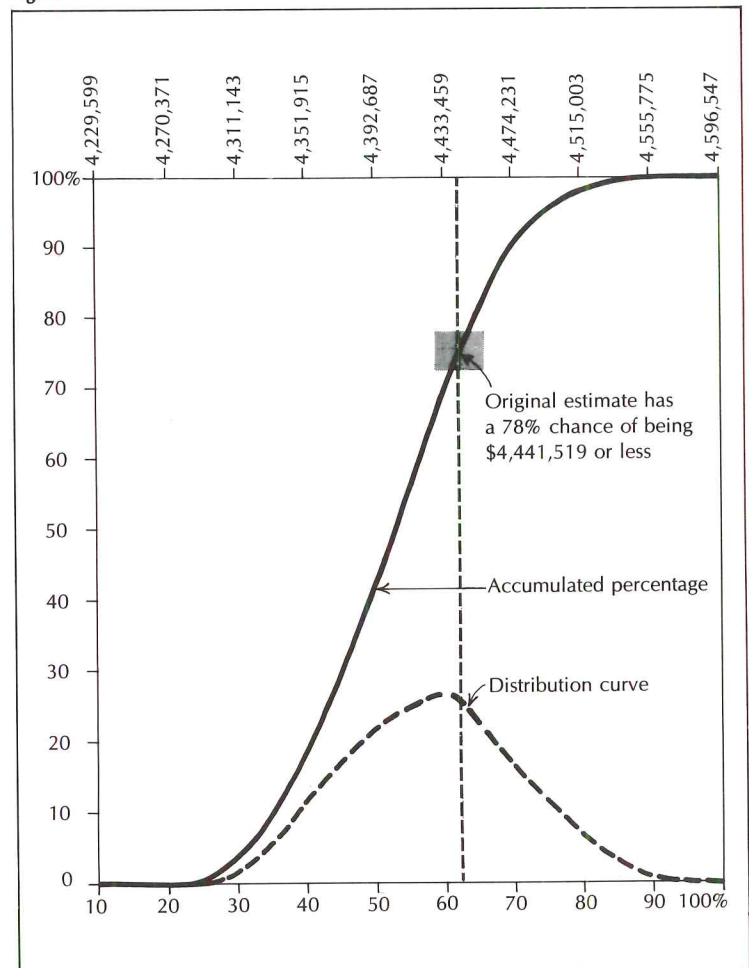

Jennison-Wright Kreolite Wood Block Floors are adding new life to all sorts of establishments. The naturally beautiful effects of wood, and particularly end grain wood, have captured the imagination of eclectic owners, architects and designers. Though end grain wood blocks were originally created for industrial floors and have served that purpose long and well (for over 60 years) our new process using a clear, transparent preservative has opened up many new fields for this handsome product. (Developers of shopping centers, book stores, restaurants, etc., please take notice) It not only enhances

blocks blend beautifully at **Abercrombie and Fitch, too!**

its environment with mellow warmth and charm, but it also offers extreme durability and relaxing "softness" for tired feet—and jangled nerves. This is truly a luxury floor that deserves the acclaim it is receiving. We'll welcome your expression of interest. Please write us .

The Abercrombie & Fitch Store, Oak Brook Plaza in Oak Brook, Illinois

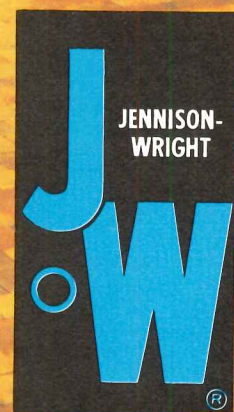

The Jennison-Wright Corporation, P.O. Box 691, Toledo, Ohio 43694 . . . you'll find us in Sweet's Catalog and in the Yellow Pages

For more data, circle 37 on inquiry card

INTRODUCING GUARDIAN REFLECTIVE GLASS BEETECLINE

**Now your building
can keep more of its cool.**

Guardian Industries' new TE-10 reflective glass reduces solar heat gain by as much as 85%. Yet, it allows visible light transmission of 10%. And thermal transmission in wintertime is reduced by 55%. So energy costs stay lower all year 'round.

With other Guardian reflective glasses you can reduce solar heat gain up to 92%, allow up to 30% visible light transmission, and reduce thermal losses by as much as 70%. So whatever your design needs may be, Guardian has the reflective glass to do the job.



Guardian S and T series reflective glass is now available for monolithic applications, as well as for double glaze units with Guardian "airspace" insulating glass. A variety of shades and colors are available to give you superior performance in both new and reglazing applications.

Specify new Guardian Industries' reflective glass. When you build buildings that keep more of their cool, you keep building your list of customers.

See sweet's section 8.26/GU



a new slant on roof insulation

Actual size cube, cut from Permalite roof deck.

Slope to drain...at lower cost...with more efficient insulation...and greater design freedom! Specify PERMALITE Perlite Aggregate concrete, poured in place with a slope to drain on a level roof deck. For a new slant on getting water off your roof as you insulate, call your local Permalite man or write for Bulletin C.A.

GREFCO, Inc./Building Products Division,
3450 Wilshire Blvd., Los Angeles, California 90010.

Permalite®

A subsidiary of General Refractories Company.

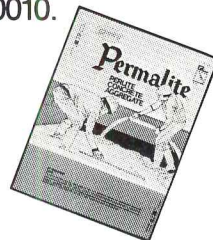

Bulletin CA

For more data, circle 40 on inquiry card

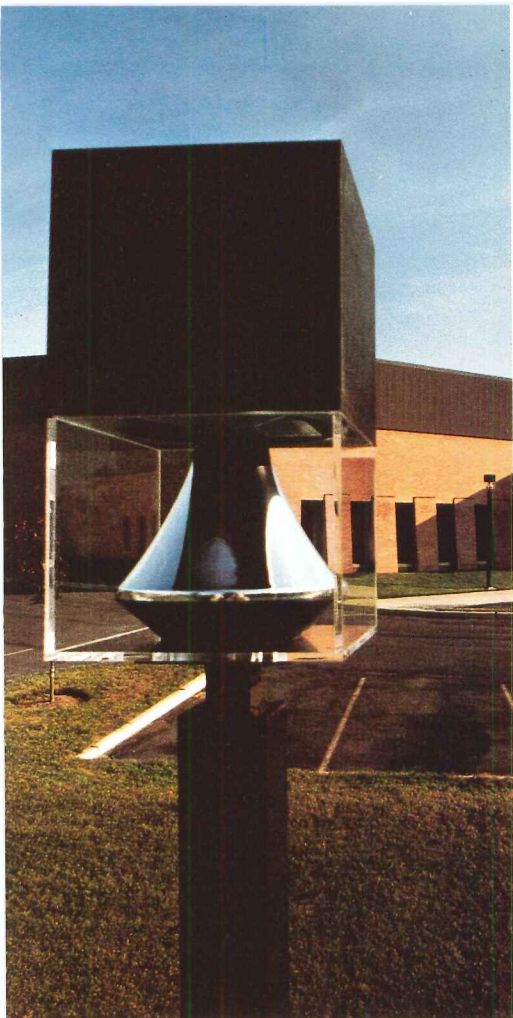

Contemporary Pericline

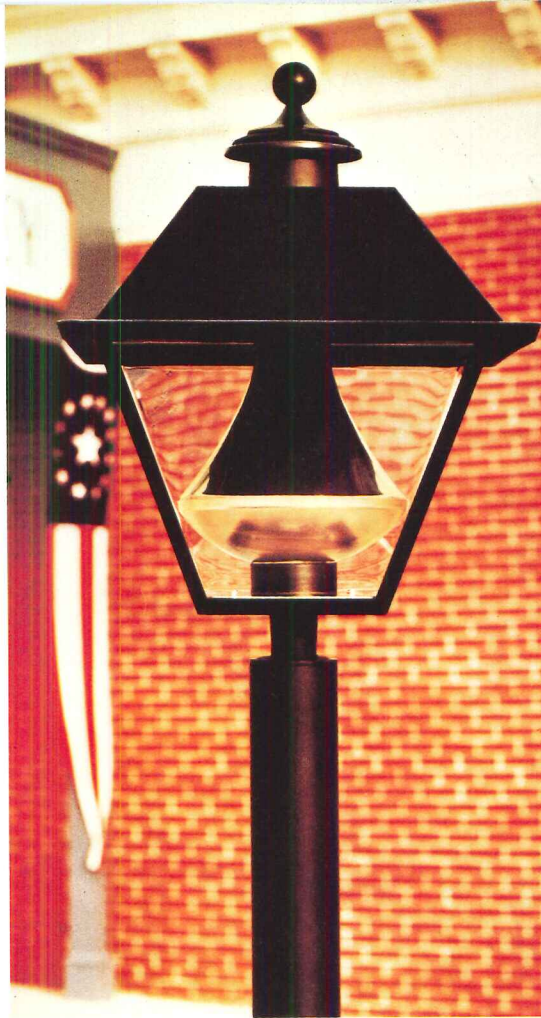

Traditional Pericline

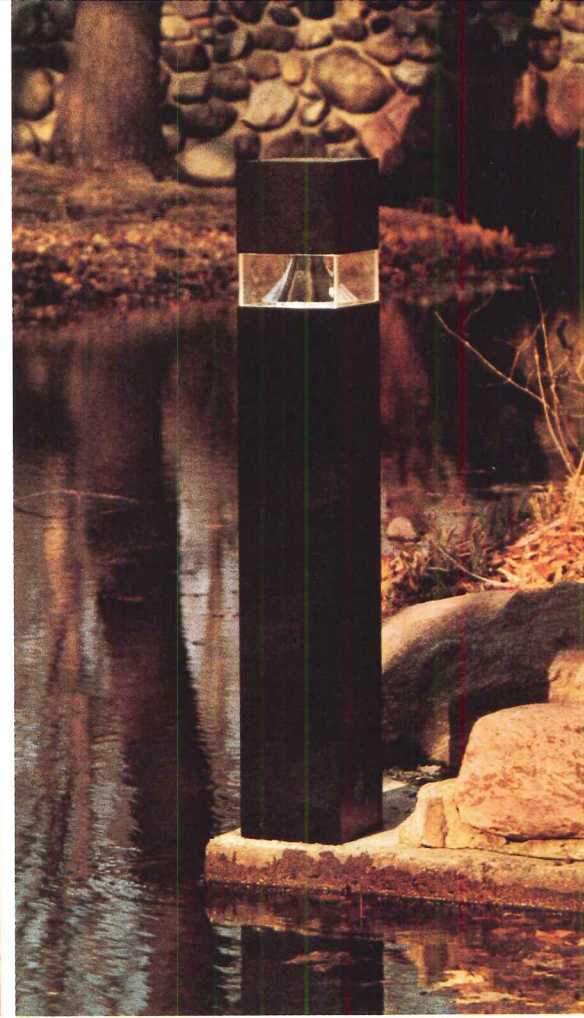

Bollard Pericline

Efficient Alternatives to Glare

The Pericline® Optical System

The Pericline Optical System eliminates harsh, vision destroying glare from the luminaire — yet, in actual comparison, outperforms other luminaire systems in its broad distribution of effective illumination on the ground. The result is evenly lighted environments with exceptional visual comfort *plus* the highest degree of energy efficiency available today.

As examples of this unmatched performance, the Moldcast® Pericline system provides up to 60%* more "square feet of illumination per watt" than the best box-shaped "cutoff" luminaires and over 30%* more than the harsh glare-producing "Cobra-head". This efficiency allows wider pole spacings, fewer luminaires and lower power consumption.

The patented Pericline system is available in contemporary and traditional luminaire styles each with a unique, softly illuminated appearance which makes them as beautiful at night as in the day. Models are available for pole and wall mounting in a wide range of sizes and finishes from 1000 watts HID for large area lighting to 70 watts HID for below-eye-level "Bollard" units.

If you want the pleasant, human appearance of a gaslight luminaire . . . yet, need the most efficient illumination available today, there is no substitute for the Moldcast Pericline Optical System.

For your next new project or restoration, contact us for lighting recommendations and efficiency comparisons. Write: Moldcast Lighting, Interstate 80 at Maple Avenue, Pine Brook, New Jersey 07058. In Canada: VARCO Industries, Ltd., Dorval, Quebec H9P 2N4.



Standard Prismatic Lens

Moldcast Pericline System

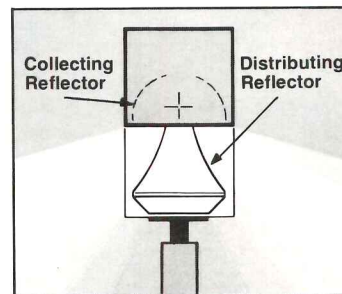

The Pericline Optical System. Light is projected outward by the patented dual reflector train in a highly efficient, graded beam. Maximum beam intensity strikes the ground 2½ to 3 times the mounting height from the pole. Beam intensities nearer to the pole are gradually reduced providing uniform levels of high illumination across wide areas.

At 75° above vertical, the beam of light abruptly disappears leaving the unit glare free throughout normal viewing angles with only a soft "gaslight" glow at the source.

* Based on minimum foot-candles required.

MOLDCAST
LIGHTING

A Division of Wylain, Inc,



For more data, circle 41 on inquiry card

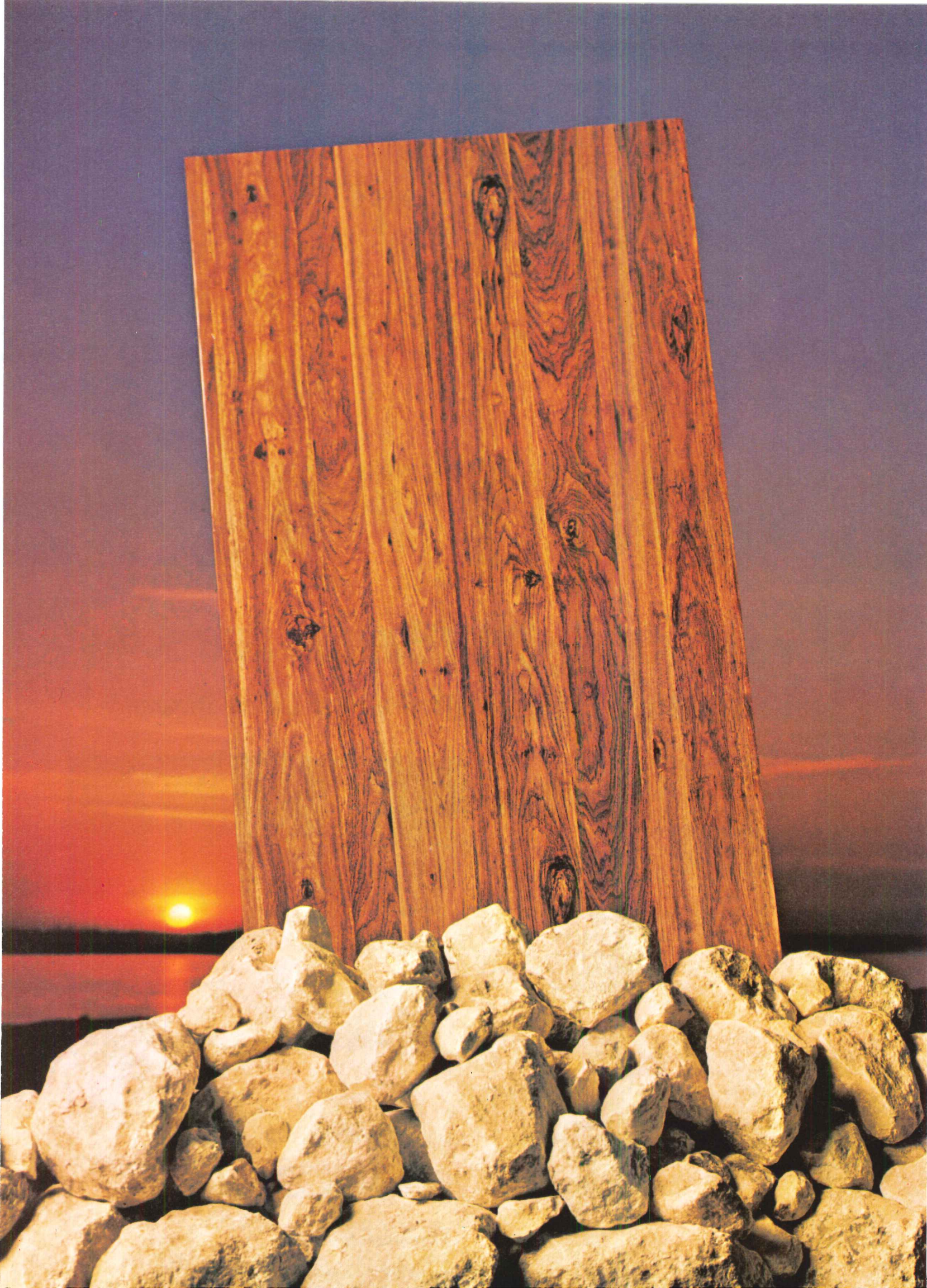

Born in the quarry... not in the woods.

Hickory Life is the newest face in the exciting Gold Bond Durasan collection of contemporary interior wall finishes. So "wood looking," it's difficult to believe new **Hickory Life** is a fire resistant, vinyl-clad gypsum panel.

Gold Bond has captured the sensitive sylvan patterns and textures of the forest and wedded them to the strength of rock with a technology that offers you new answers to fresh design challenges.

For you, it's a combination of elegant beauty and outstanding durability to encourage bold creative expression.

Hickory Life Durasan must be seen, touched and explored. Your Gold Bond salesman can arrange that. Call him or write Gold Bond Building Products, put your hands on a sample and see the exciting 3-D presentation of Hickory Life Durasan. For other Durasan patterns see Sweet's Architectural Catalog File 9.6/Go.



Gold Bond

Gold Bond Building Products

DIVISION OF NATIONAL GYPSUM COMPANY • BUFFALO, NEW YORK 14202

For more data, circle 42 on inquiry card

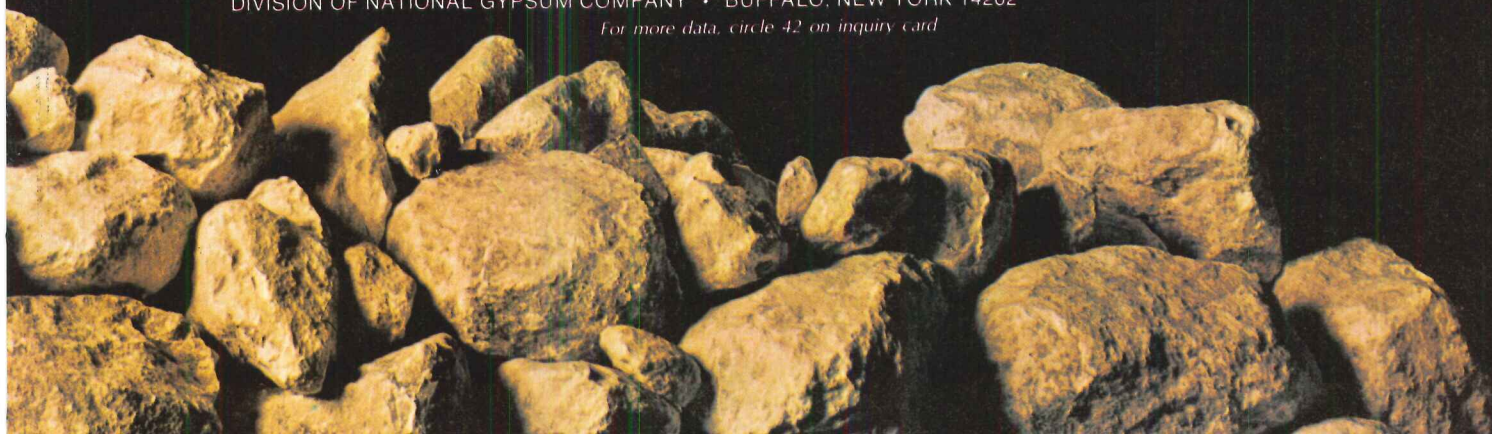



LEXAN[®] is SHEET guaranteed against breakage.

What do you make of that?

Whatever you make of it will withstand the worst punishment possible. LEXAN sheet is guaranteed against breakage,* even under the blows of a sledgehammer or the onslaught of a steamroller. That means lower replacement costs, more economy. LEXAN sheet is UL listed Burglar Resistant, complies with the Safety Glazing A.N.S.I. (Z97.1) standard and OSHA requirements. And new F-2000 flame-retardant grade meets the highest standards for reduced flammability.

There's LEXGARD[®] bullet-resistant laminate which meets UL ballistic level ratings up to a .44 Magnum (UL 752 standard).

For industrial glazing PROTECT-A-GLAZE[™] sheet offers an attractive, clear and tinted, translucent glazing for durability with economy.

And architects are finding more and more applications. LEXAN sheet is being used for lighting panels and lenses which are light weight and provide high light transmission.

Tough skylights.

LEXAN sheet's high impact resistance, clarity, and weather resistance make it ideal for durable, attractive skylights.

Photo: Nashville House
Nashville, TN
Architect: Robert Lamb Hart/HKS

NOTICE:

LEXAN[®] SHEET IS THE LEAST COMBUSTIBLE SAFETY GLAZING PLASTIC SHEET* BUT WILL IGNITE WHEN EXPOSED TO AN IGNITION SOURCE IN EXCESS OF 800°F (426°C).

FOR MAXIMUM SAFETY...

- Advise local fire officials of LEXAN glazing installations.
- Consider sprinkler systems for additional safety.
- Check local codes for construction applications.
- Observe fire precautions similar to wood.
- Consider emergency access sash construction.

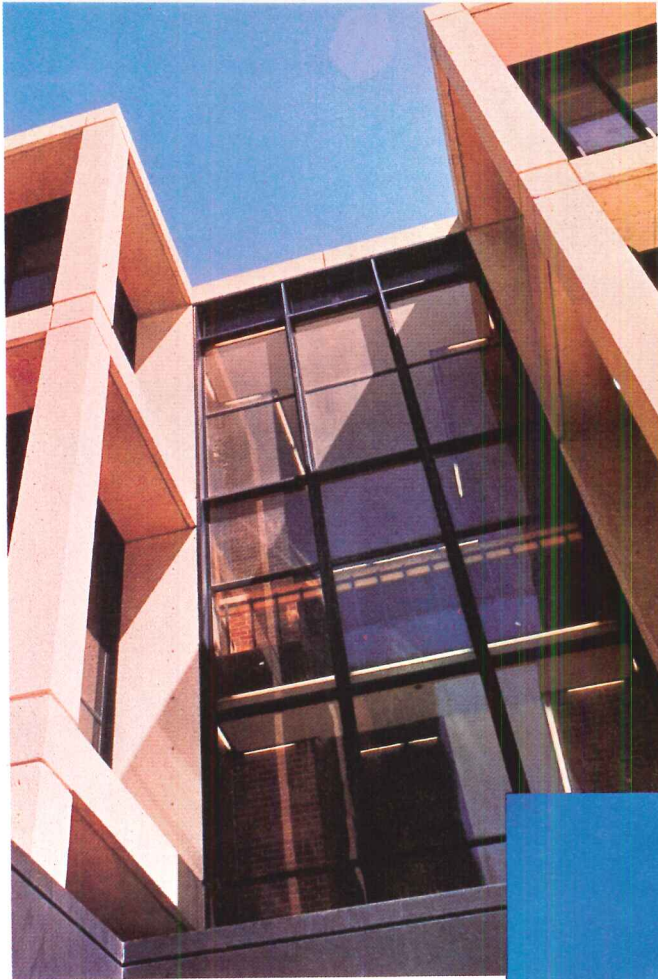

Safe school windows.

In school systems throughout the USA, LEXAN sheet secures buildings against vandalism and theft, with LEXAN sheet providing up to 25% more insulation than comparable thicknesses in glass.

Photo: Walt Disney Magnet School
Chicago, IL
Architect: Perkins & Will



Long lasting enclosed walkways.

Domes and enclosed walkways of LEXAN sheet are weather resistant, color stable, and offer high light transmission.

Photo: Provincial Court & Remand Centre
Calgary, Alberta, CANADA
Architects: Long Mayell & Associates

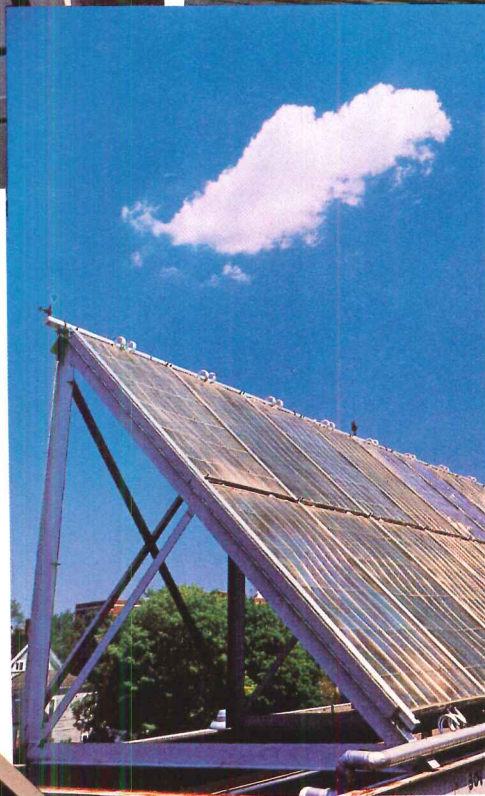

Light weight solar collector panels.

LEXAN sheet .040 and .080 mils thick offers high light transmission, physical toughness, high heat stability, and environmental resistance.

Photo: Grover Cleveland Junior High School
Dorchester, MA



Strong passenger shelters.

Durable passenger shelters with LEXAN MR-4000 mar resistant panels protect passengers from the weather, and resist damage by vandals.

Photo: TRI-MET System
Portland, OR
Architect: Skidmore, Owings & Merrill

Whatever you design that needs to be transparent, tough, and attractive—and safe—there's a grade of LEXAN sheet to design it with.

See Sweet's Architectural Catalog Ref. 8.26/GE

® Registered Trademark of General Electric Company
™ Trademark of General Electric Company

*Guaranteed by General Electric against breakage. If at any time during a three-year period from date of purchase, LEXAN sheet when used for glazing is broken, General Electric, as its sole responsibility under this guarantee, will give the purchaser a new LEXAN sheet. No warranty or guarantee is offered for residential use of LEXAN sheet.

LEXAN[®] SHEET Get behind it.

General Electric Plastics: What the world is coming to.
Sheet Products Section, 1 Plastics Avenue, Pittsfield, MA 01201

GENERAL ELECTRIC

For more data, circle 43 on inquiry card

ARCHITECTURAL RECORD September 1977 71

GAF® PRODUCTS FOR DESIGN.

Leonardo would have loved us.

Da Vinci:

ARTIST, SCIENTIST, SCULPTOR,
ANATOMIST, INVENTOR,
ARCHITECT, ENGINEER
AND MASTER DESIGNER.

His revolutionary ideas have come down to us on ordinary paper. But if GAF had been around in his time, there's no telling how many more we'd know about today.

You see, we've designed our products with a lasting difference. A professional edge. That little extra that separates the excellent from the ordinary. The difference that allows you to get the most out of a good product and show your work at its professional best.

We're the people who put that same

difference in diazo. Made it more efficient, automatic and dependable.

Got rid of the vent and gave it an economic edge.

And here are some of our Products for Design that you can count on, and Leonardo would have loved:

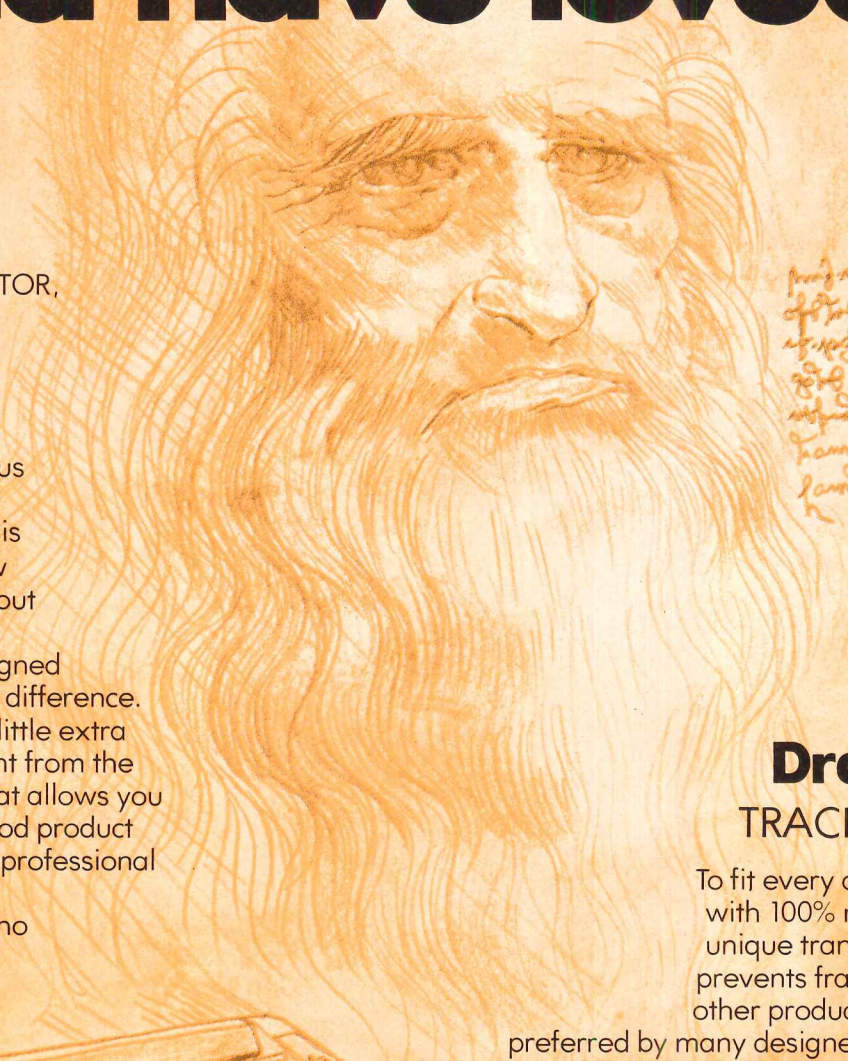

Handwritten cursive script, likely a detail from one of Leonardo da Vinci's notebooks.

Drafftrace®

TRACING PAPERS

To fit every design need, we start with 100% rag paper and use two unique transparentizing systems. One prevents fracturing and ghosting; the other produces the more "solid" sheet preferred by many designers. These vellums come in sheets, rolls, pads, standard formats or with your custom imprint. All accept pencil, ink and multiple erasures.

We even provide an untransparentized paper for those who prefer it.

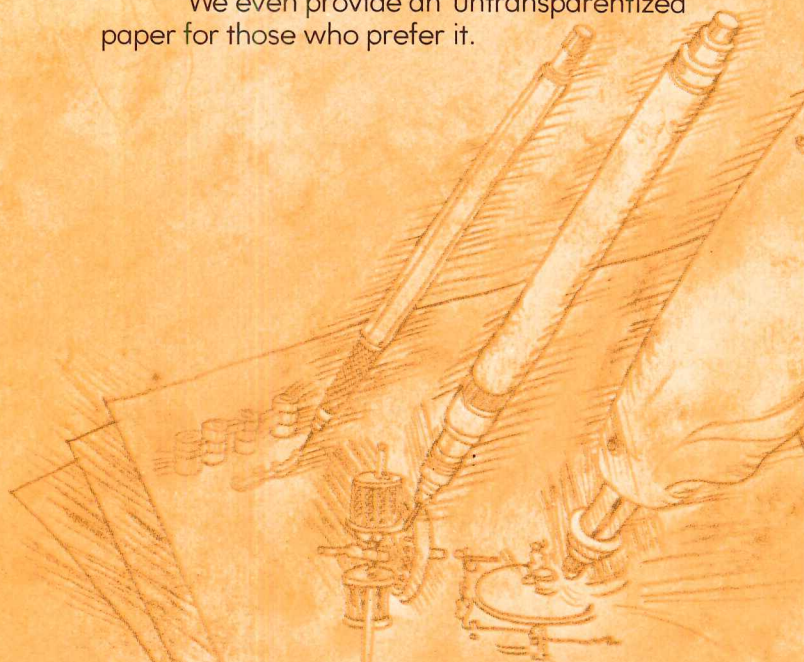
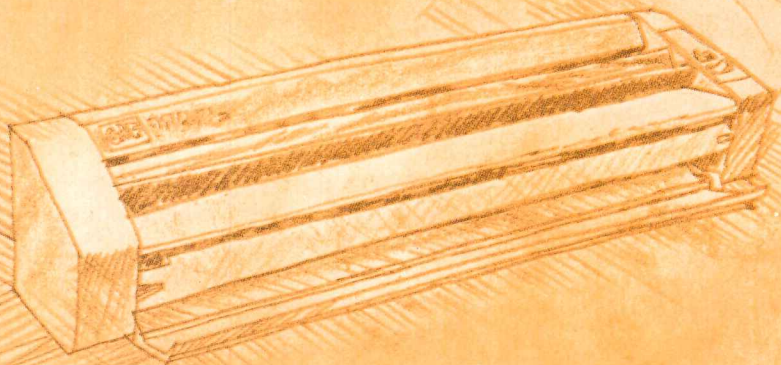

Polytrace® DRAFTING FILMS

Nearly indestructible, dimensionally stable and highly translucent, these films offer long lasting drawings from which you can quickly make accurate, sparkling prints.

Our drafting matte takes pencil or ink and withstands many erasures without affecting redraftability.

Films come in thicknesses from 2-mil to 5-mil, matte on one or both sides, with or without fadeout grids. Single matte films are anti-static treated.



Gafrace® DRAFTING LAMINATE

Our newest development in drafting media, GAFTRACE is a sandwich of 100% rag vellum laminated to both sides of a polyester film.

This means two splendid drafting surfaces for pen, pencil, even computer driven plotters...plus the flatness, toughness and dimensional stability of polyester.



Ultramediate® DIAZO INTERMEDIATES

They're the most economical way to make duplicate tracings for any reason—to protect or restore valuable originals, change designs, or eliminate repetitive drafting.

Both the conventional (fluid correctable) type and the new EZ dry-erasable style come in a variety of speeds to guarantee a fit with your printmaking machine, whether it's a low wattage fluorescent, or one of GAF's high speed models.

Scalemaster® POLYESTER INTERMEDIATES

SCALEMASTER films do everything ULTRAMEDIMATE papers do—plus some important extras. SCALEMASTER films have a doubly tough polyester base, so they're virtually indestructible.

They're also practically transparent. Which allows higher reprint speeds and top quality reproduction.

And they're quicker, cleaner, and less costly than silver photo films for most any kind of reprography.

To find out more about GAF Products for Design, the products with a difference, look for us in the Yellow Pages under the classification "Drafting Room Equipment & Supplies" and listed as "GAF Products for Design" or, write GAF Corporation, Products for Design, 140 West 51st Street, New York, N.Y. 10020.

They may not turn you into a Leonardo. But you'll appreciate the difference they'll make in your work.

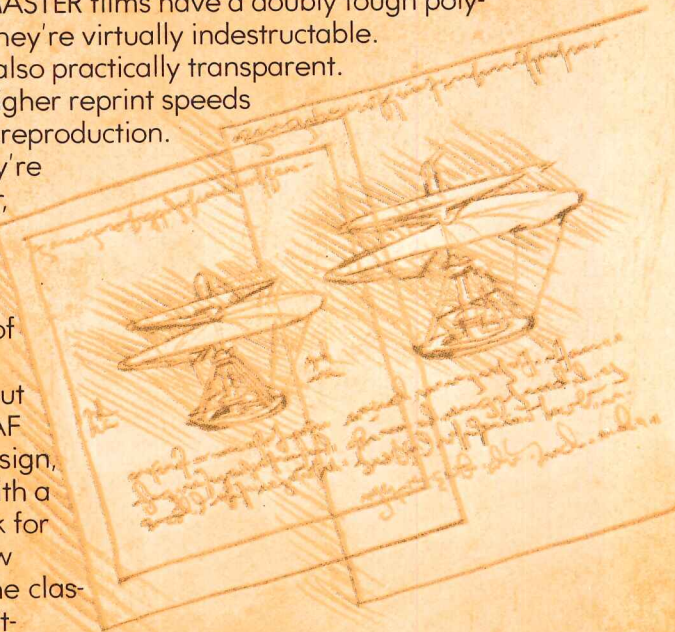

Products for Design

FOR THE MASTER DESIGNERS OF TOMORROW...TODAY.

THIS IS CEM-FIL AR GLASS FIBER REINFORCED CEMENT CLADDING.



Publix Super Market, Dunedin, Florida.
 Manufacturer: Lake Manufacturing Company, Palm Harbor, Florida.



Educational Center Building,
 Hagerstown, Maryland
 Architect: NES, Campbell
 and Associates.
 Manufacturer: Cem-Fil Corporation,
 Nashville, Tenn.

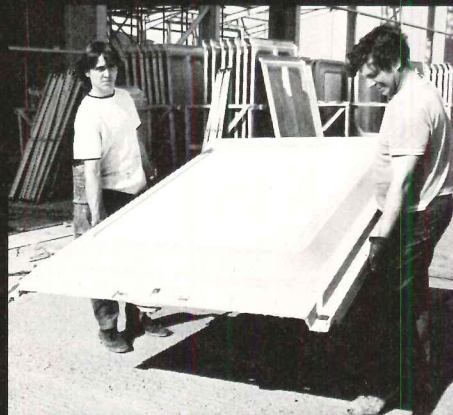

Construction workmen demonstrate
 light weight, ease of handling of 7' x 5'
 aggregate faced building panels of GRC.

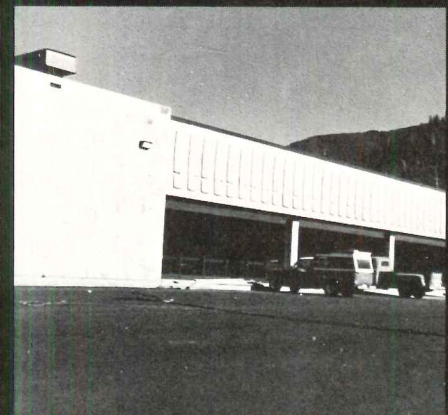

U.S. Post Office, Ketchikan, Alaska.
 Architects: Graham Associates.
 Manufacturer: Olympian Stone,
 Seattle, Washington.

These photographs illustrate recent installations in the U.S.A. Architectural cladding is just one of many applications for GRC. For more information, please contact John Jones, Cem-FIL Corporation.

cem-FIL®
 CORPORATION

Two International Plaza Drive
 Nashville, Tenn. 37217
 (615) 361-4664
 Telex 55-5120

When you specify GRC products, specify GRC reinforced with Cem-FIL® AR Glass Fiber. There is *no* equal.
 See Sweets General Building (Architectural File) 7.5/Cem

For more data, circle 45 on inquiry card

How to make every job in the office more attractive.



Specify Ad: Alma's open plan office system that provides for customized work space at every level of the corporate structure.

Designed by ISD and engineered by Alma Desk, Ad is the illuminated open plan system that lets you start with any budget, any space, any job specification. And create an office that meets today's needs and tomorrow's requirements.

See Ad at NEOCON '77. Or visit us at our showrooms in Chicago, New York and High Point. Or write Alma Desk Company, P.O. Box 2250, Dept. 42, High Point, North Carolina 27261 for more information.

Then, put Ad and your imagination to work. And make every job in the office more attractive.

ad/alma
Alma Desk Company

Showrooms: 280 Park Avenue, New York; 1140 Merchandise Mart Plaza, Chicago; Southern Furniture Market Center, High Point

Bilco builds them best...

It takes confidence to say Bilco products are best. Best in design. Best in workmanship. Best in reliability. And you'll find that confidence reflected in the wording of our catalog specifications for every Bilco product.

Proper operation is the most important requirement of a horizontal door. When you specify Bilco, you call for roof scuttles, automatic fire vents, ceiling access doors, sidewalk, floor and pit doors, equipment hatches and basement doors that are *guaranteed* to operate properly. You are also specifying performance proven products that offer long, trouble-free service and complete satisfaction for your clients.

For information, details and specifications, see our catalog in Sweet's Architectural, Industrial Construction and Engineering Files or write for a copy.



The Bilco Company, Dept. AR-97
New Haven, Connecticut 06505

from top



Roof Scuttle

Standard sizes in steel or aluminum for safe, convenient ladder access to the roof. Features floating cover action, automatic lock-open with operating handle for one-hand closing. Weathertight. Also standard sizes for ship stairs or normal stairs, as well as special sizes to order.

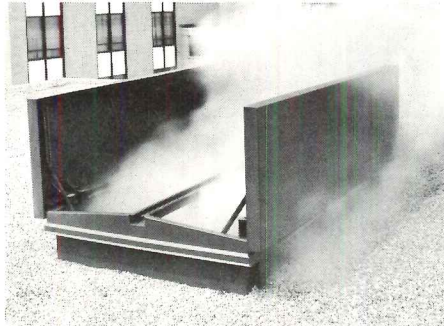

Automatic Fire Vent

Designed and built for complete reliability and long service. Insulated and gasketed for weathertightness. Exclusive Bilco Thermolatch™ mechanism is activated by fusible link or, when specified, by electrical signal from smoke detector or other emergency device. Sixteen standard sizes and types with UL and FM labels. Special sizes available.



Ceiling Access Door

Two sizes in choice of all steel or steel frame with aluminum door. Typical sturdy Bilco construction. Available in either upward-opening or downward-opening types. Spring lifting levers assist in opening and closing. When specified, provision can be made for application of acoustical tile by others.



Floor Door

Single and double leaf designs for every interior floor access requirement. Built-in torsion rods for easy operation of the steel or aluminum plate doors. Models with diamond pattern surface or to receive carpet or composition floor covering. Available in eight standard sizes and in special sizes.

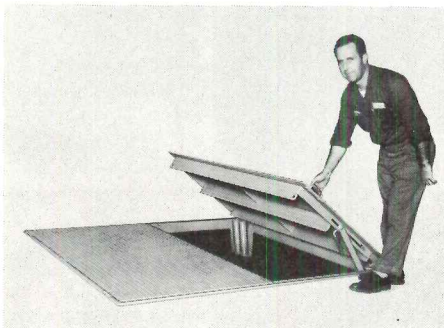

Vault, Pit or Sidewalk Door

Watertight doors in single or double leaf design, rugged steel or aluminum plate construction. Eight standard sizes or special sizes to order. Tubular compression spring operators afford smooth, easy operation.

to bottom.

For more data, circle 46 on inquiry card

The basic forms of light.

Crouse-Hinds Bollards.

Rugged, strong, and comfortable to view. Superbly constructed with seamless extruded aluminum housings. No exposed set-screws, fasteners, or other hardware to clutter the design. Simple. Clean. Vandal resistant. Basic.



Crouse-Hinds Company
Lighting Products Division
Syracuse, New York 13221.



CROUSE-HINDS

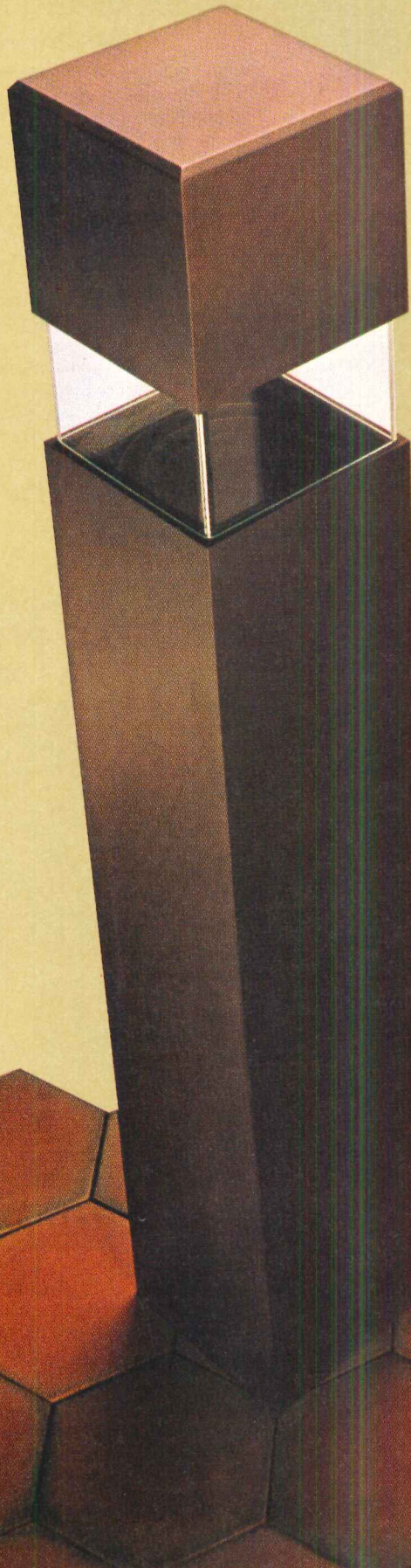

Bollards and people go together. Crouse-Hinds Bollards are designed for people. Beveled tops mean no sharp edges. The lamp is below the lens to keep the temperature down on the top housing. This makes our Bollards cooler to the touch.

And our unique "see-through" look is easy on the eye. The impact-resistant acrylic lens is an integral element of the housing. There are no reflectors, refractors, or other optical devices visible in the lens area. Polycarbonate lenses also available.

Crouse-Hinds Bollards are designed for use with 70 and 100 watt HPS and 100 watt mercury lamps to accent or set off almost any pedestrian area.

Bollards. A good example of basic shapes.

When you think of "basic forms of light," think of Crouse-Hinds. Write for our literature.

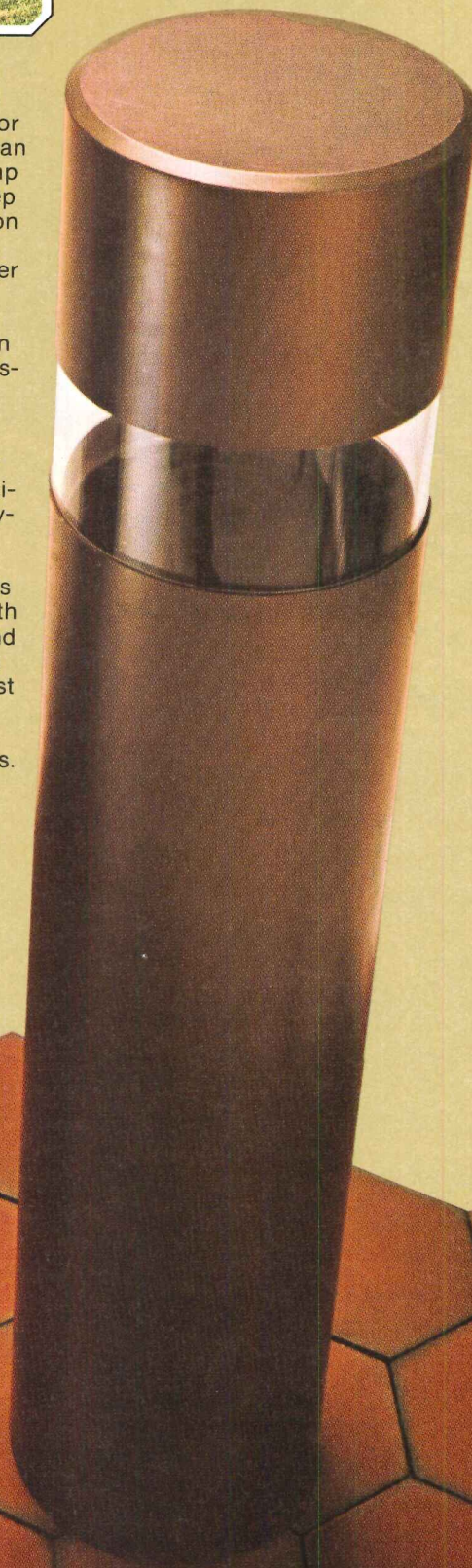

NOR-LAKE REFRIGERATION

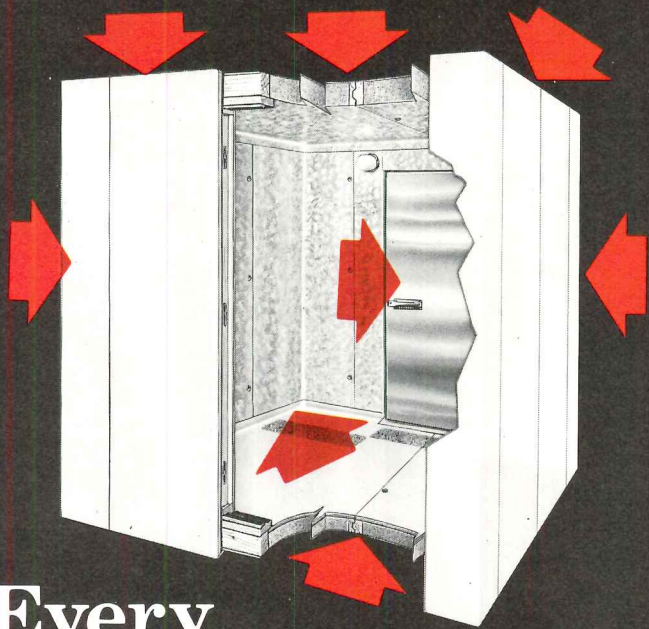

Every Nor-Lake Walk-In Panel Wears This



... and that's **IMPORTANT** to you as an Architect, Specifier, Consultant or Refrigeration System Designer

Every Nor-Lake metal clad walk-in panel — wall, ceiling, corner, floor, door — has earned the right to wear the UL Fire Hazard Classification Label. When you specify Nor-Lake, you specify a product made with non-combustible Fiberglas. And, in case of fire, that means the elimination of possible poisonous fumes.

It's your assurance the Nor-Lake Walk-In you specify will meet the toughest fire codes in the country ... Ohio, New Orleans, Pennsylvania, Maryland, New York City, Washington, D.C. and more.

Write or call for more details. You will find it makes life and sense to specify Nor-Lake Walk-Ins ... or any of the more than 200 Nor-Lake Fiberglas insulated products.

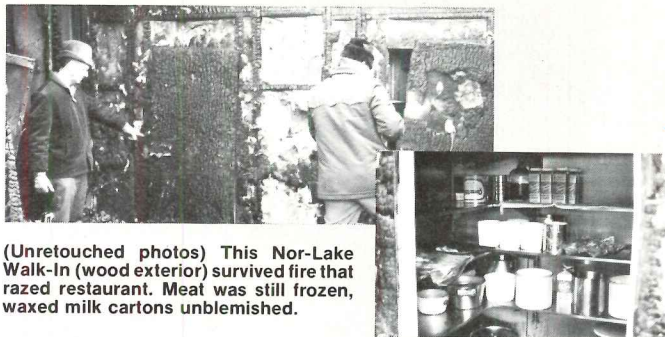

(Unretouched photos) This Nor-Lake Walk-In (wood exterior) survived fire that razed restaurant. Meat was still frozen, waxed milk cartons unblemished.

NOR-LAKE INC.

Second and Elm, Hudson, WI 54016 • Phone: 715-386-2323

For more data, circle 48 on inquiry card

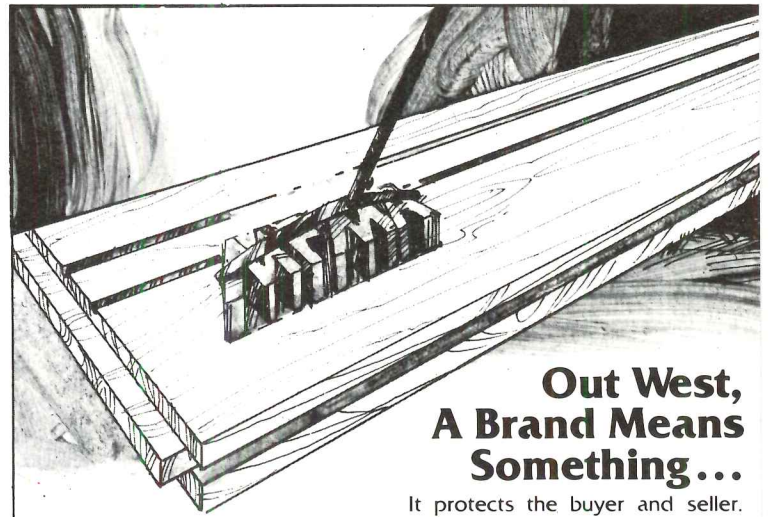

Out West, A Brand Means Something ...

It protects the buyer and seller. The MFMA trademark is your brand protection, too. It's your assurance that the flooring on which it appears is...

- **True to Species** — Genuine hard maple with no unspecified species intermixed.

- **True to Grade and Dimension** — Uniform in appearance and performance characteristics according to MFMA enforced grading rules.

- **Mill Inspected and Warranted** — Every single shipment is inspected and accompanied by the MFMA certificate — your assurance of quality.

- **Installed with Skill and Experience** — by an MFMA Associate Member. Specify MFMA trademarked flooring for dependable quality.



Maple Flooring Manufacturers Association, Inc.
1800 Tickwick Avenue
Suite 104 Dept. AR97
Glenview, Illinois 60025
Telephone (312) 724-7700
See MFMA Sweet's 9.22d/M2.

For more data, circle 49 on inquiry card

"Olympic or equal."



There is no equal.

When you specify "Olympic or equal," we sure hope you get what you want.

Because for quality, beauty and the tough guarantee your customers deserve, nobody in the business "equals" Olympic!

OLYMPIC
1148 N.W. Leary Way, Seattle, WA 98107
(206) 789-1000

For more data, circle 50 on inquiry card



Designer:
The Space Design Group,
New York

Fabricator:
Jaff Brothers,
New York

Building:
Johns-Manville
World Headquarters



THE SPACE DESIGN GROUP
selected **WILSONART**[®]
high-pressure laminated plastic
for decorative surfacing
in the new Johns-Manville
World Headquarters Building.

*Wilsonart...first choice
of many of today's designers.*

WILSONART[®]
WILSONART BRAND LAMINATED PLASTIC

Copyright © 1977, Ralph Wilson Plastics Co., Temple, TX 76501
Wilsonart—Manufacturers of Wilsonart high-pressure laminated plastics,
Chem-Surf, Tuf-Surf, Dor-Surf, Metallics and Contact Adhesives.

For more data, circle 51 on inquiry card



This simple ceiling helped GTE Sylvania save \$40,800 on heating and cooling costs in a year

It's a fact: Inadequate ceiling and roof insulation is a major source of heat loss—*especially in one-story, flat-roof buildings.*

That's why GTE Sylvania Incorporated put one of our Energy Saving Ceilings in a Massachusetts lab.

Result: Comparing similar buildings, 1975 heating and cooling savings totaled \$40,800. Savings on equipment needed for air conditioning: \$100,000.

A quick payback

First-year energy savings were almost *five and a half times* the added cost of our insulated ceiling.

You can save energy with our Fiberglas* 3" Ceiling Panels. Or Film Faced Ceiling Boards

with Sonobatt™ insulation. Both are easy to install on any standard exposed grid system.

Make old ceilings save, too

Just slip our Sonobatt insulation on top of your present ceiling. You'll increase thermal efficiency up to 731 percent, depending on thickness.

Find out how much energy *your* building can save—free. Any Owens-Corning sales office or ceiling contractor will analyze it in-depth using the most economical Energy Saving Ceiling for you. Write Mr. P.W. Meeks, Owens-Corning Fiberglas Corporation, Fiberglas Tower, Toledo, Ohio 43659.

Or call us today. You'll put a ceiling on your energy costs tomorrow.

*T.M. Reg. O.-C.F. ©1977 O.-C.F.

Owens-Corning is Fiberglas



For more data, circle 52 on inquiry card

TRIUMPH ON THE THAMES

The National Theatre
in London
by Denys Lasdun & Partners

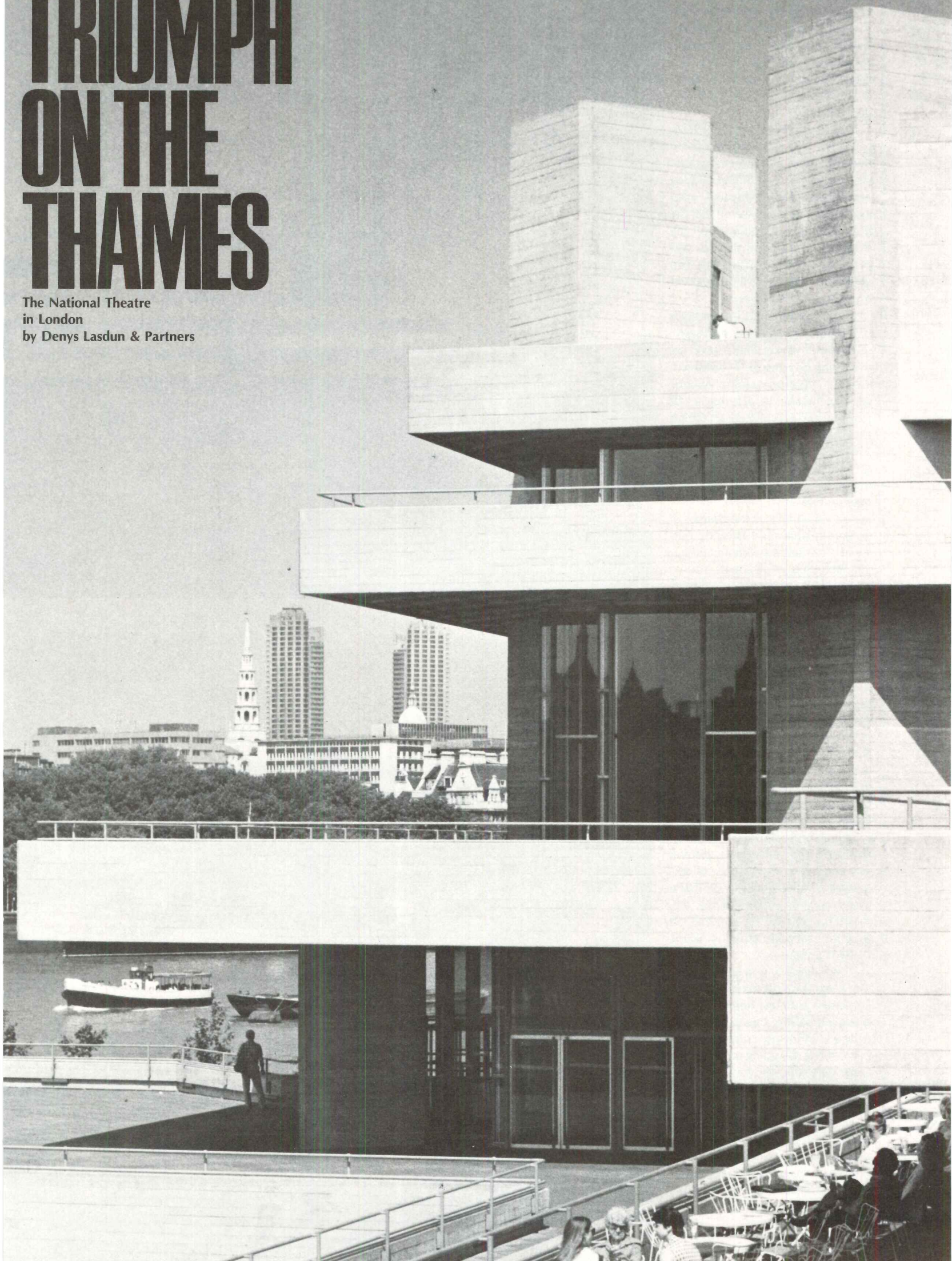

Sir Denys Lasdun, who got the Royal Gold Medal for Architecture in June, had not built a theater before, and that is an important reason why his first one, the National Theater, on the south bank of the River Thames, is such a jolly good show.

Way back in the early 1960s, Laurence Olivier, heading up the building committee, chose Lasdun, whose partners are Peter Softley and Alexander Redhouse, precisely because he believed that the firm, having no homage for the expert's usual handbook approach, would interpret the dynamic diversity of theatrical expression in a fresh spirit.

As triumphant as the tradition of the theater has been, especially in England, it is difficult, even diminishing, to wrap the evanescent, elusive, emotion-tugging experience of theater in a formula. As Lasdun recently related to Glenn Loney, the noted American professor and critic of theater, "I learnt a great deal, meeting with that committee, once a month at least, and over a two-year period. What I learnt, especially, is the danger of dogma in such an inherently personal area. Because what the theater offers you *is* personal. You've got to see the eyelashes, the flick of a nostril. You've practically got to smell the place."

There is a lot to sniff out, as it were, round about, not to mention within, the National, its strata-like massing situated long and low by the riverbank at King's Reach, where the Thames turns sharply to embrace a vista from Parliament to St. Paul's. Waterloo Bridge reaches over, at this point, and the building's generous esplanades and terraces, tying into the lines of the bridge, edge the bank. Stepping up from it, they create deep overhangs and shadows, effectively joining the over-all composition, of exquisitely formed concrete, with the mood and movement of the district. It is pure city, the National, an evocation of simultaneous, spontaneous action.

Simultaneity and spontaneity, too, might be said to be the working design principle here, because, being a repertory operation with a wide and innovative range, there is not only a lot going on at once theatrically but, by way of that, a lot going on in terms of the public's experience of and participation in the National's architecture. All of which, to borrow from the Bard, is a stage on which it is delightful, even when there is not a play going on, to be a player. It is this con-

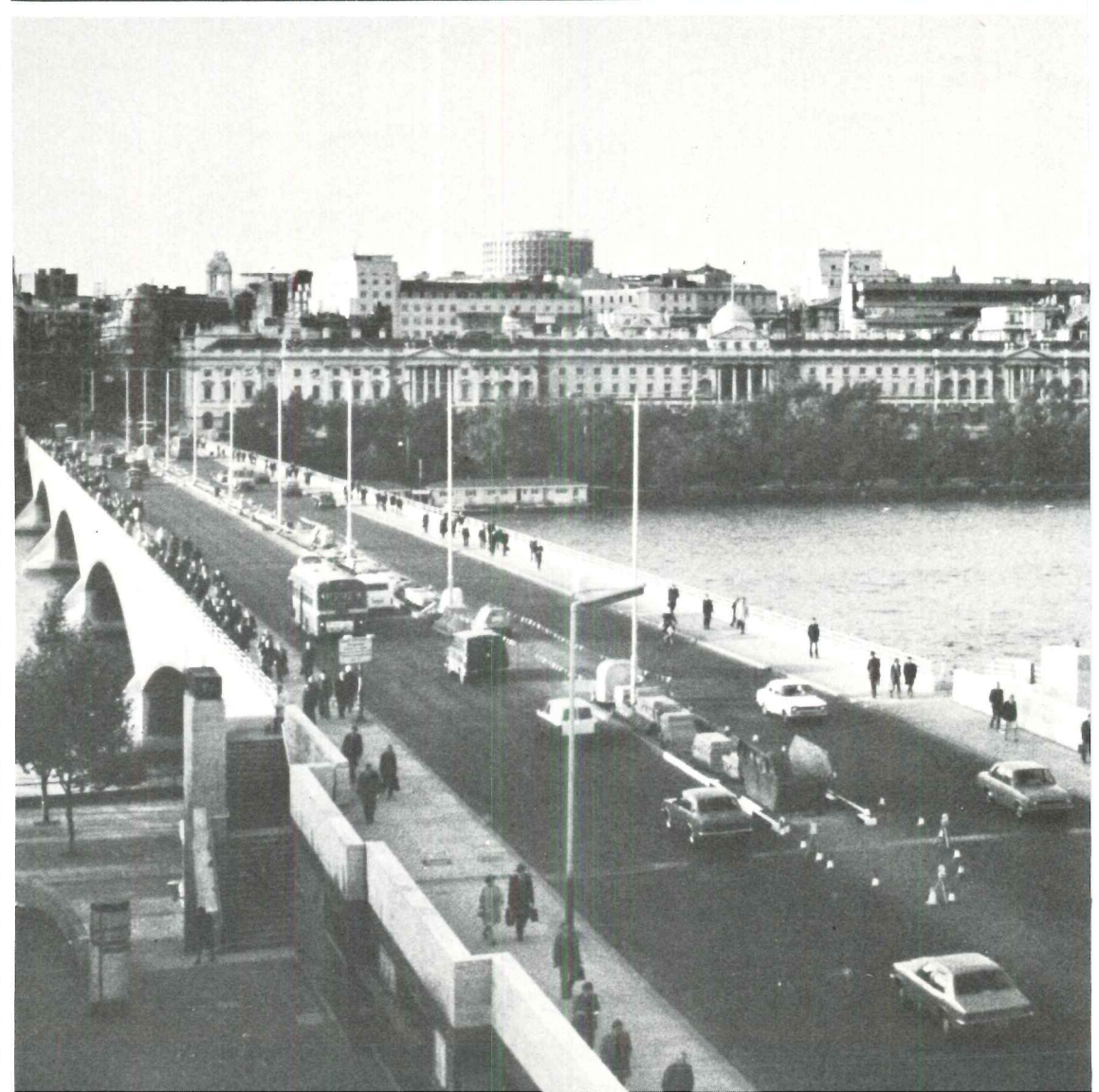
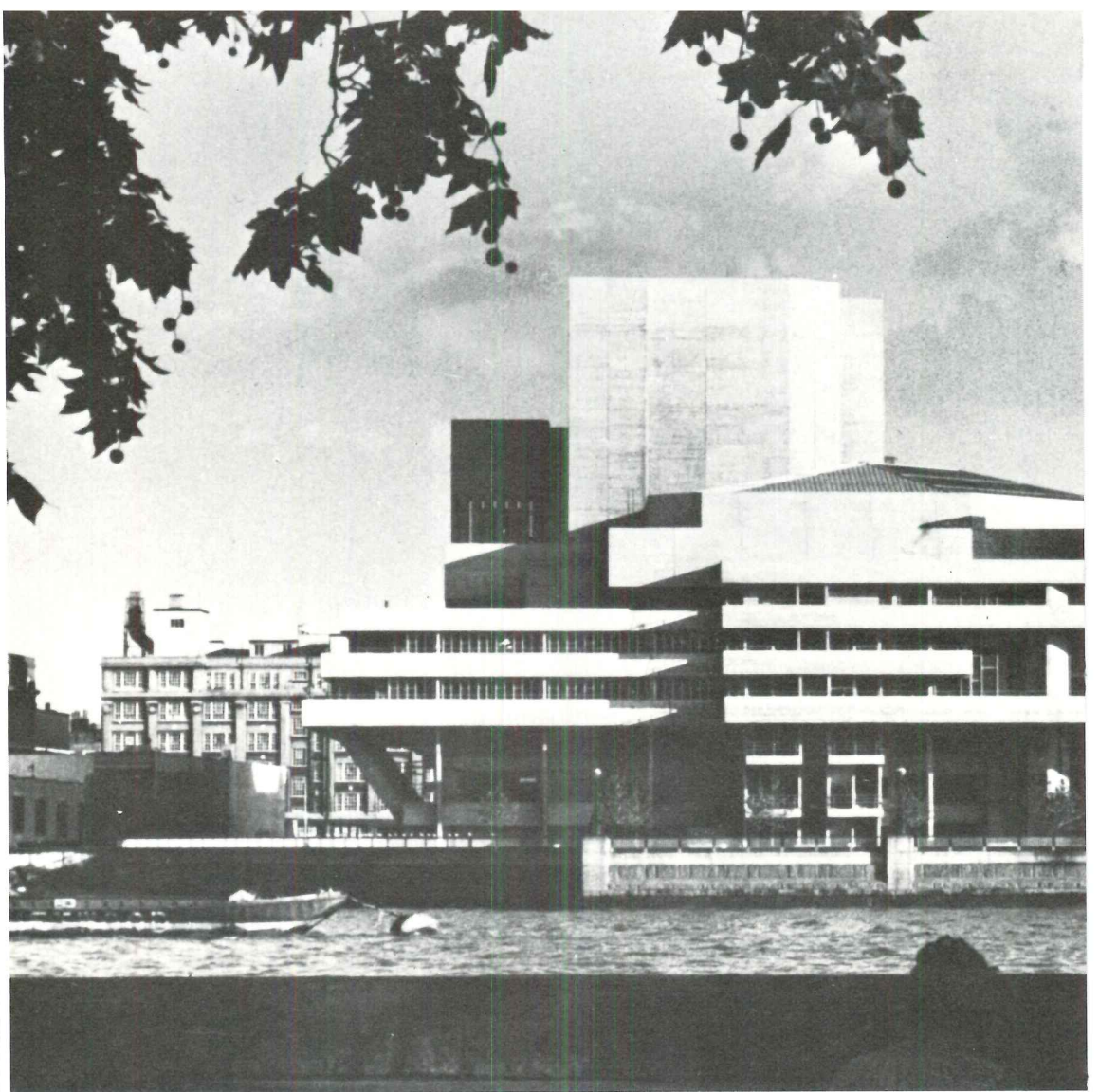

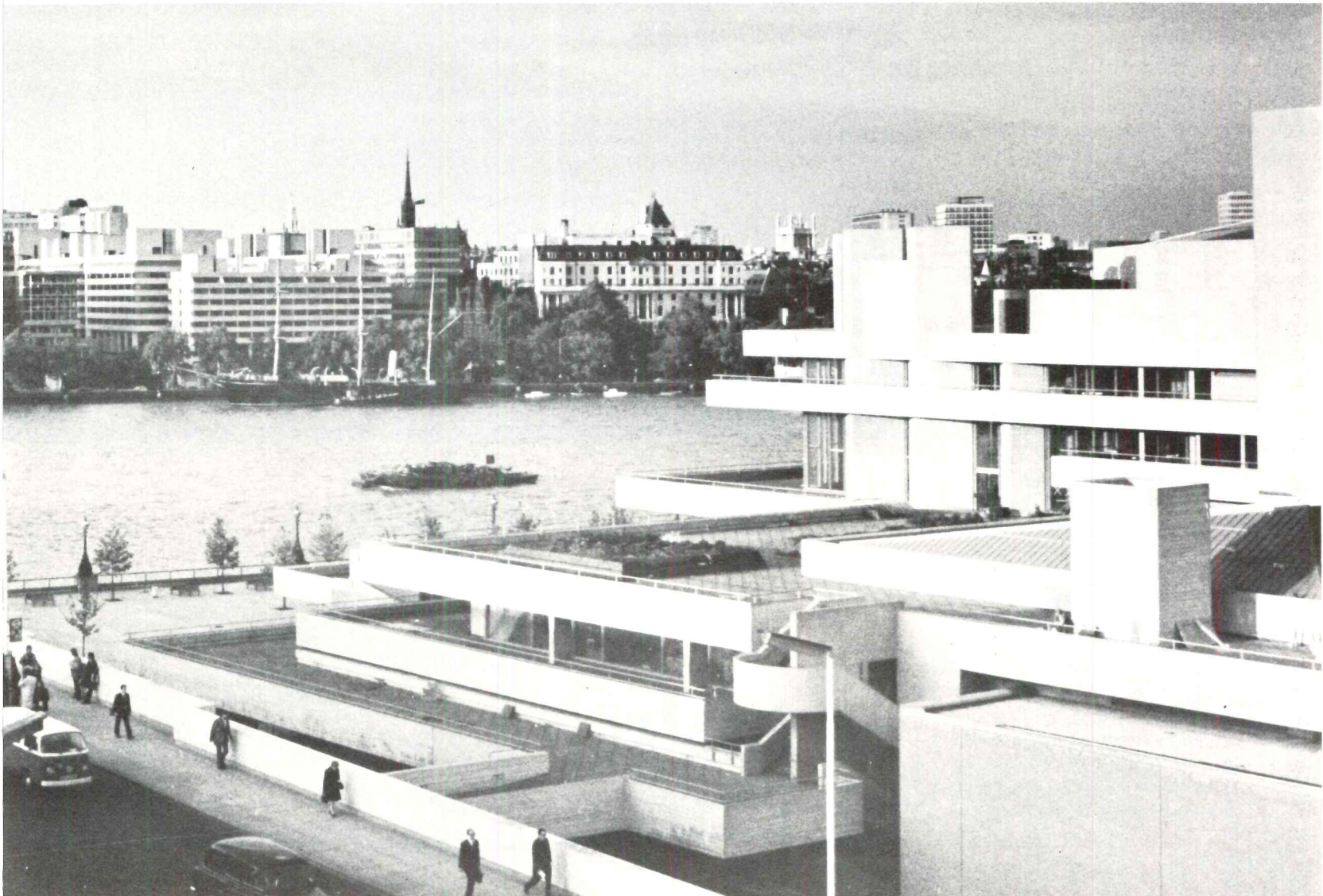

stantly reverberating relationship with the scale of the city, the presence of the river, the life of the street, and the people who come, which Lasdun aptly calls his "fourth theater"—that set of sensations, events, vistas, and experiences that are occasioned by the building which, inside, contains *three* theater facilities.

The decision to have three was painstakingly arrived at. Earlier on, there was an idea that one infinitely flexible facility might do, and indeed it might have were the functional and logistical problems of delivering performances all there is to theater. But a single room, even a single wonderful room, made over by way of elaborate mechanicals and lighting every morning, if need be, has some difficulties. Not the least of these is that such a single room, however adaptable its configuration of stage, seating, and equipment, cannot as automatically accommodate, much less enhance, the rich broad range of meaning, message, metaphor, and image of the theatrical tradition and repertoire—especially so, too, when those who go, the audience, are as vital to the full flowering of theater as those who play.

To be sure, Lasdun's team analyzed the idea of a single room, but in the context of program which, straight away, had been geared to ensure proper support for everything from Elizabethan to post-Elizabethan, to the classics of the 18th and 19th and 20th centuries, to the resuscitation of obscure or forgotten works, to the often idiosyncratic requirements of Experimental and post-post-post-Experimental theater. It became plain that a single room, and certainly one that would have to seat any number of people above three or four hundred, could not be infinitely adaptable because, more than changes of stage shape, absolutely everything else would have to change too if the shape of the audience, so to speak, were to be sympathetically tuned to the character of the highly varied performances. To make walls and floors and ceilings as agilely mobile as the stage would require monstrously ubiquitous (and very expensive) technology—more in keeping with the launching of missiles than with theater.

Not that mechanicals aren't mandatory, and in the case of a repertory environment like the National, sophisticated staging support, as well as lighting, are crucial. But even a bionic buff would find it

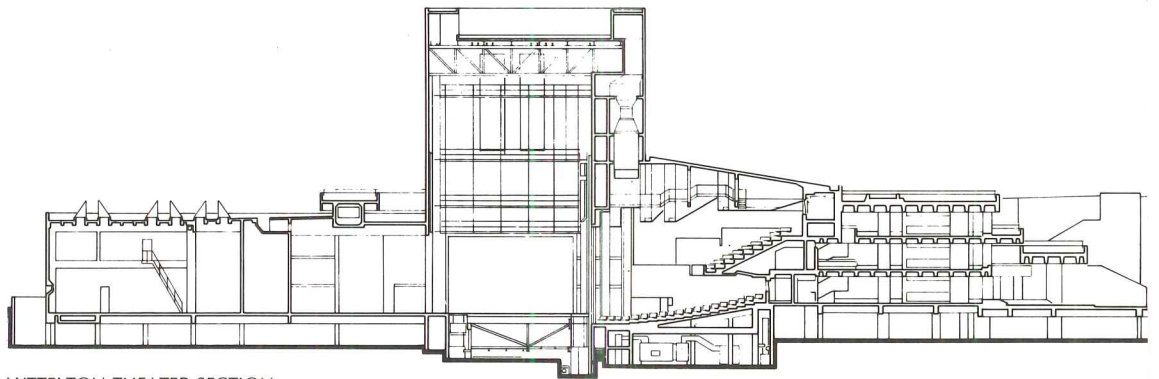

LYTTELTON THEATER SECTION

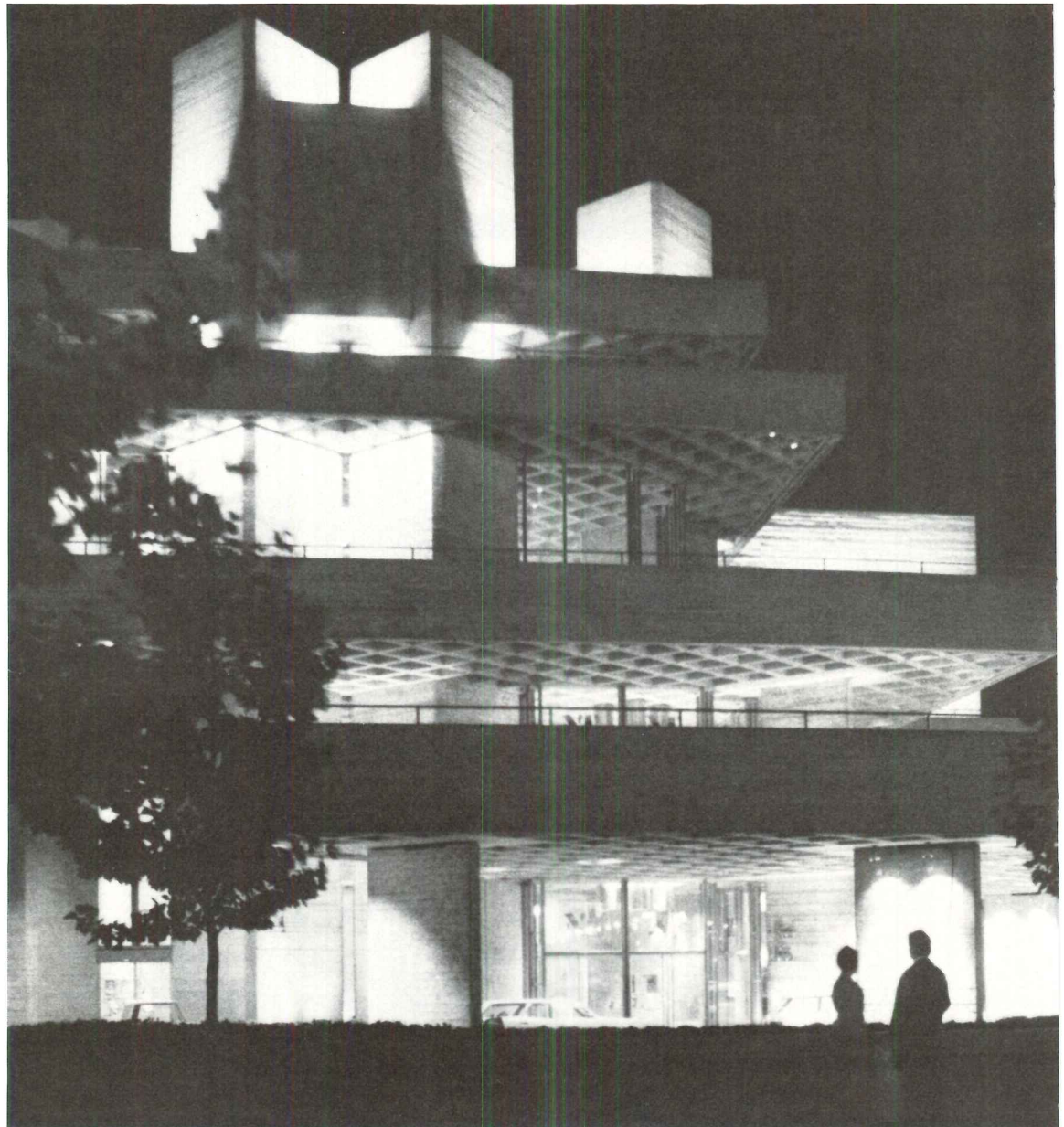

Denys Lasdun & Partners photos

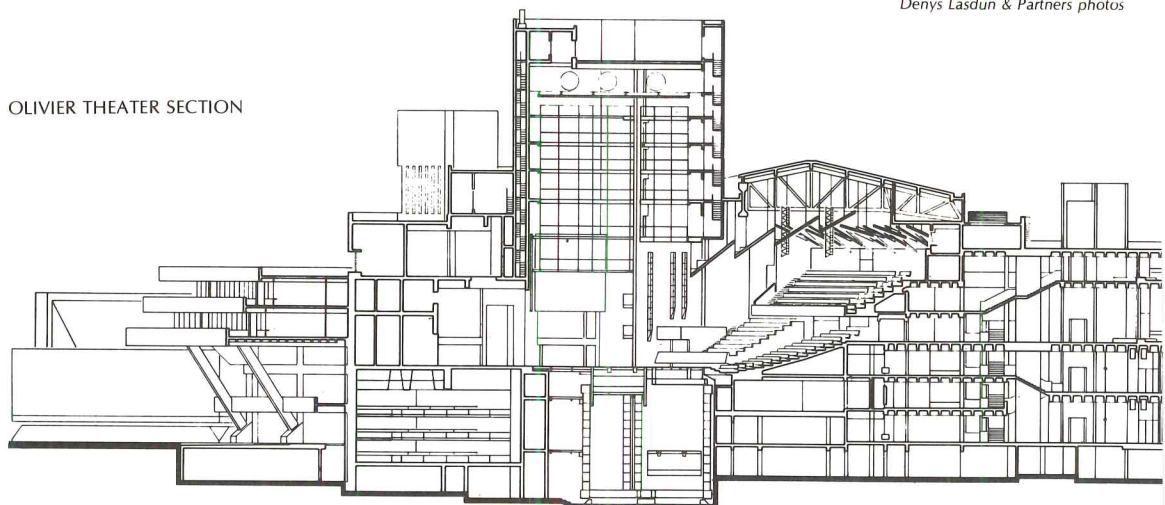

OLIVIER THEATER SECTION



The main entrance to the National Theater (opposite) points up the interplay between the strata-like layers of concrete structure and the strong anchoring thrust of the vertical elements, which contain elevators. This entrance, set on the diagonal axis of the Olivier, leads to an elegantly angular progression of interconnected foyer space, that of the Lyttelton being shown here, which is emboldened by the play of light and cadenced by columns. These spaces become what Lasdun calls his "fourth theater."

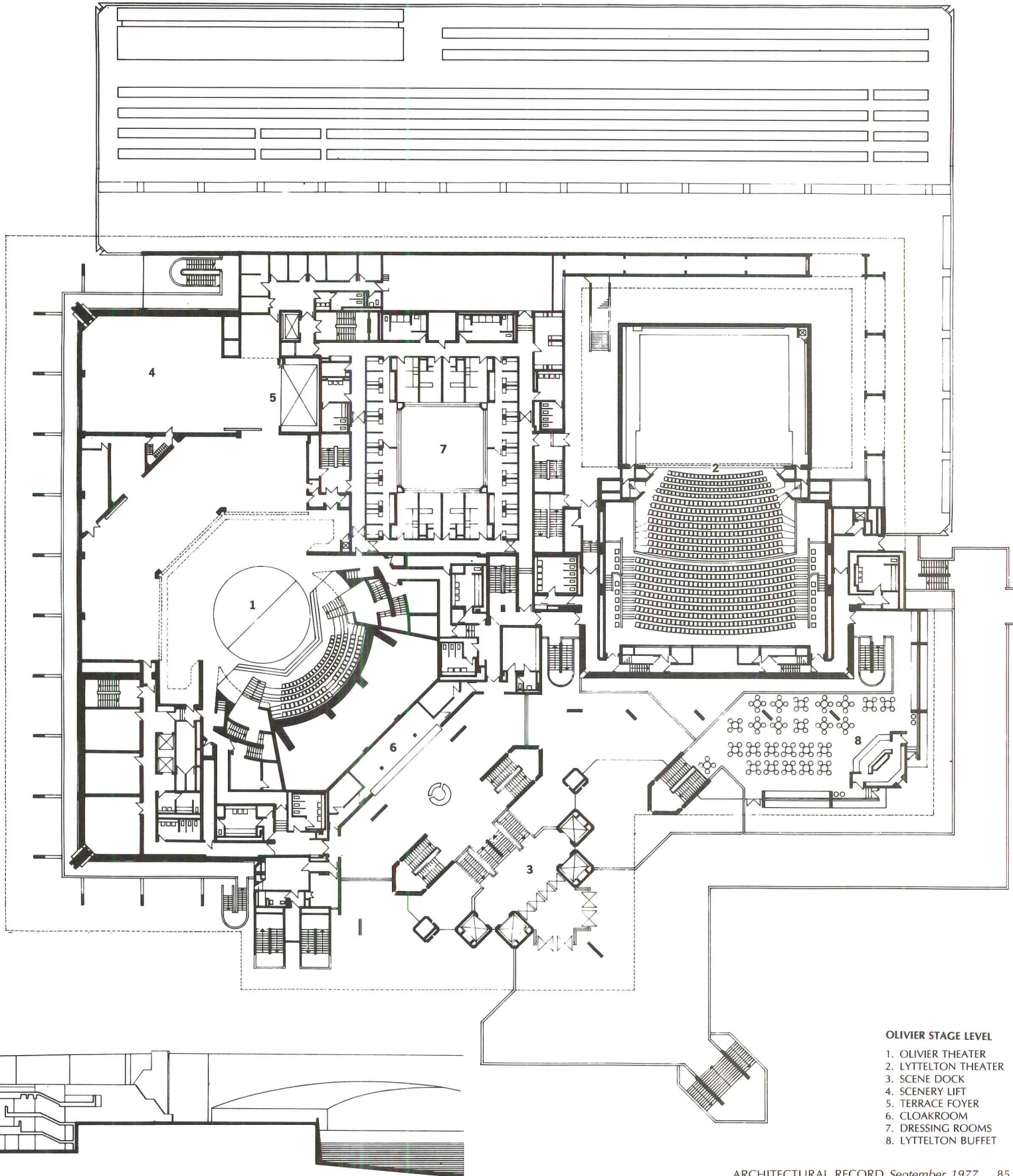

- OLIVIER STAGE LEVEL**
- 1. OLIVIER THEATER
 - 2. LYTTELTON THEATER
 - 3. SCENE DOCK
 - 4. SCENERY LIFT
 - 5. TERRACE FOYER
 - 6. CLOAKROOM
 - 7. DRESSING ROOMS
 - 8. LYTTELTON BUFFET

miserable in a room geared more to the manifestation of machinery than to engaging audiences.

And so the committee was brought around, slowly and skillfully, as was Her Majesty's Government which, after all, was paying for the building and, doing so, constantly calling for cutbacks. During the 13-year period that it took to get the National designed, up, and open, England, one hardly needs reminding, was performing a fairly stark tragedy of its own, and prices of every kind escalated. One of the things that cinched the multi-theater scheme was the architect's demonstration that such a simplistic resolution would not only fail the mission of the National (meant to be a spritely, exploratory, regenerative force in the nation's cultural and spiritual life) but that it would also, in the most raw economic terms, be an unseemly expenditure of pounds were the money available to be thrown into mesmerizing mechanisms.

The result of this give-and-take is a cluster of spatial characterizations, each adaptable within its unique format. It is also soundly successful as a conception because this differentiation is more responsive to, and expressive of, the inherently varied nuances and needs of different kinds of productions.

The mainstay of the National, in both its size and symbolism, is the 1,150-seat Olivier. And even before the theater as a whole was conceived, the nature of the Olivier was ferreted out by the architects and the committee. What a wonderful room. It is like a big kettle drum, and there is no stifling row-upon-row regimentation in the seating, which is broken up in sections at different levels and angles from each other. Quite a big room, as theaters go, but at the same time there is a compelling intimacy. On either side of the stage (the fly loft of which rises high above the general horizontal massing of the exterior, anchoring it), seating sections extend forward as to consolidate the sense of communication and confidentiality.

Professor Loney was saying, on visiting the National, "I had wondered whether breaking up the audience into such levels might interfere with the audience being able to respond as a psychological group; but the Olivier, you will notice, has no sensation of people being cut off from one another while, at the same time, those angles and levels permeate the room, as big as it is, with a personable atmosphere."

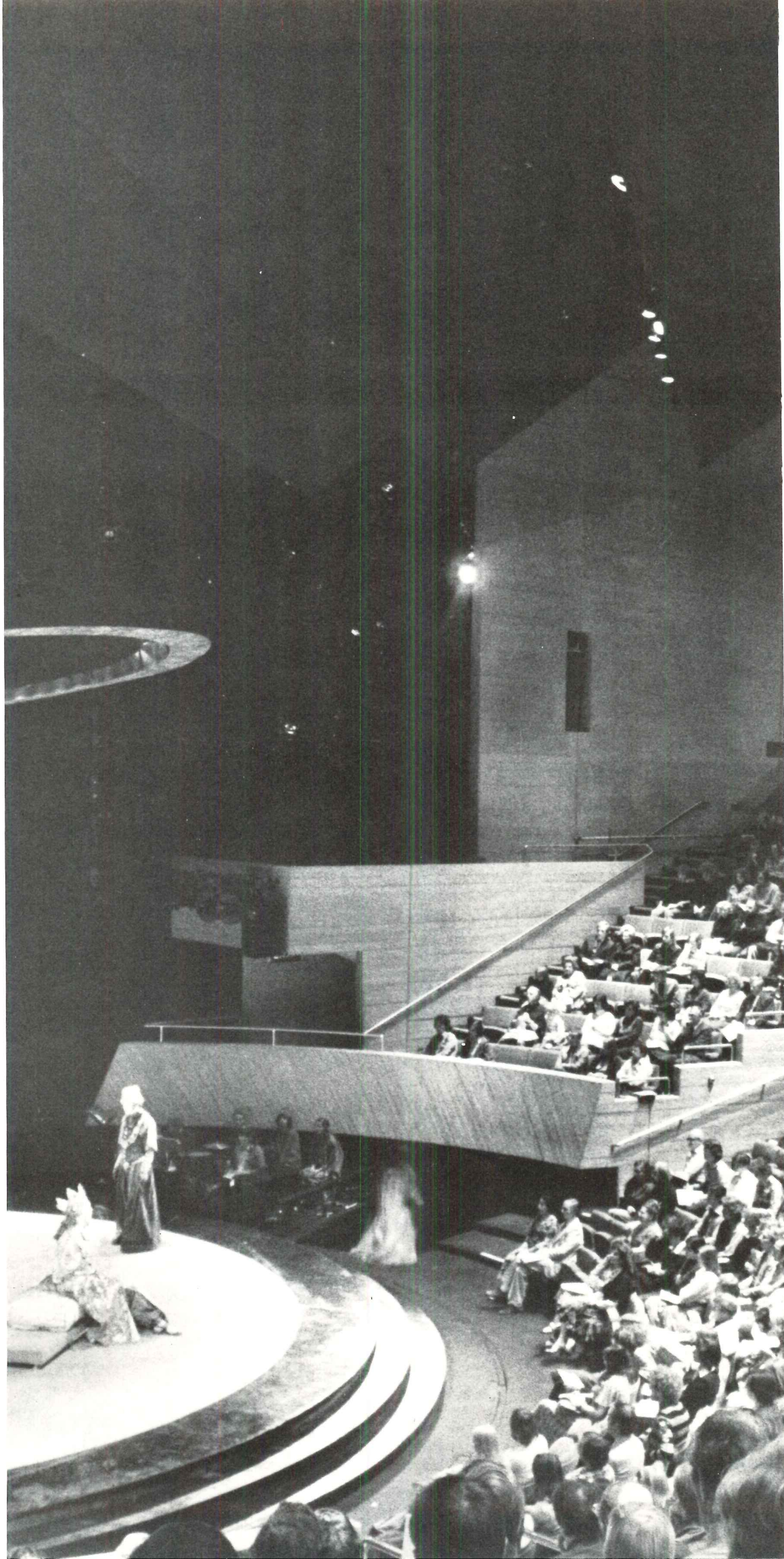



The foyers of the National Theater, deliberately a show in themselves, have been likened by architect Denys Lasdun to hypostyles with their columned halls and lively communal action. This sense of sharing is enclosed and concentrated in the 1,150-seat Olivier, a kettle-drum-shaped room with seating broken up in sections that are arrayed at different angles from each other—wow! This creates a feeling of family between the audience, embracing the action.

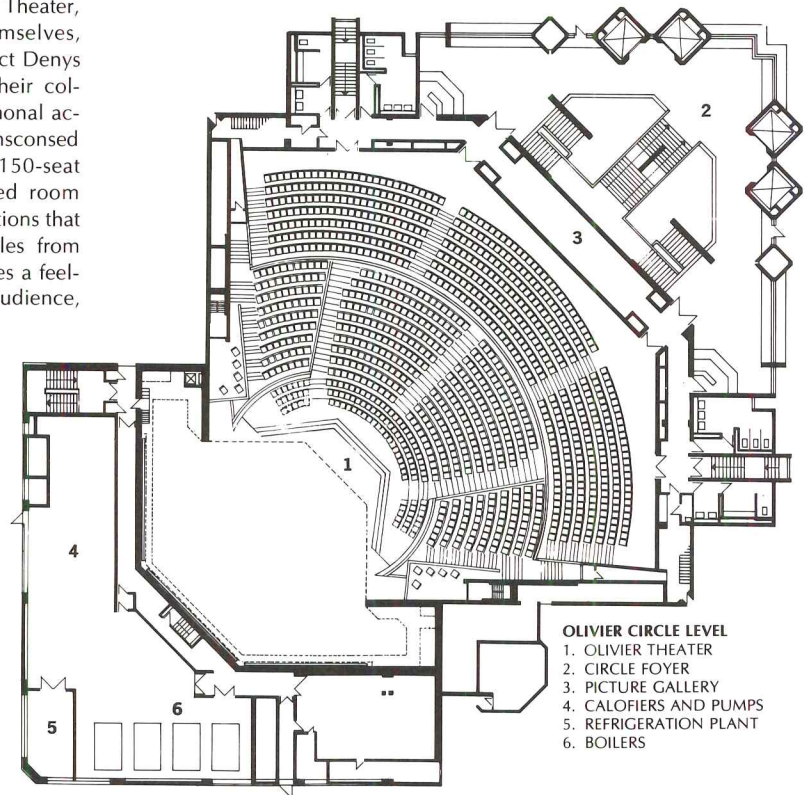

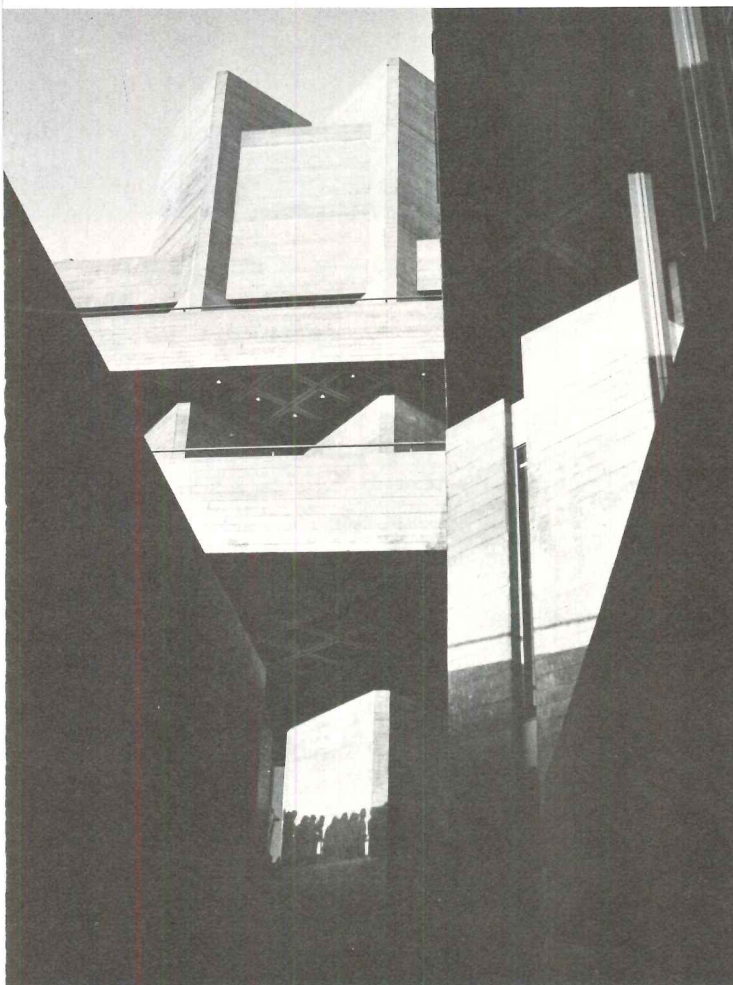
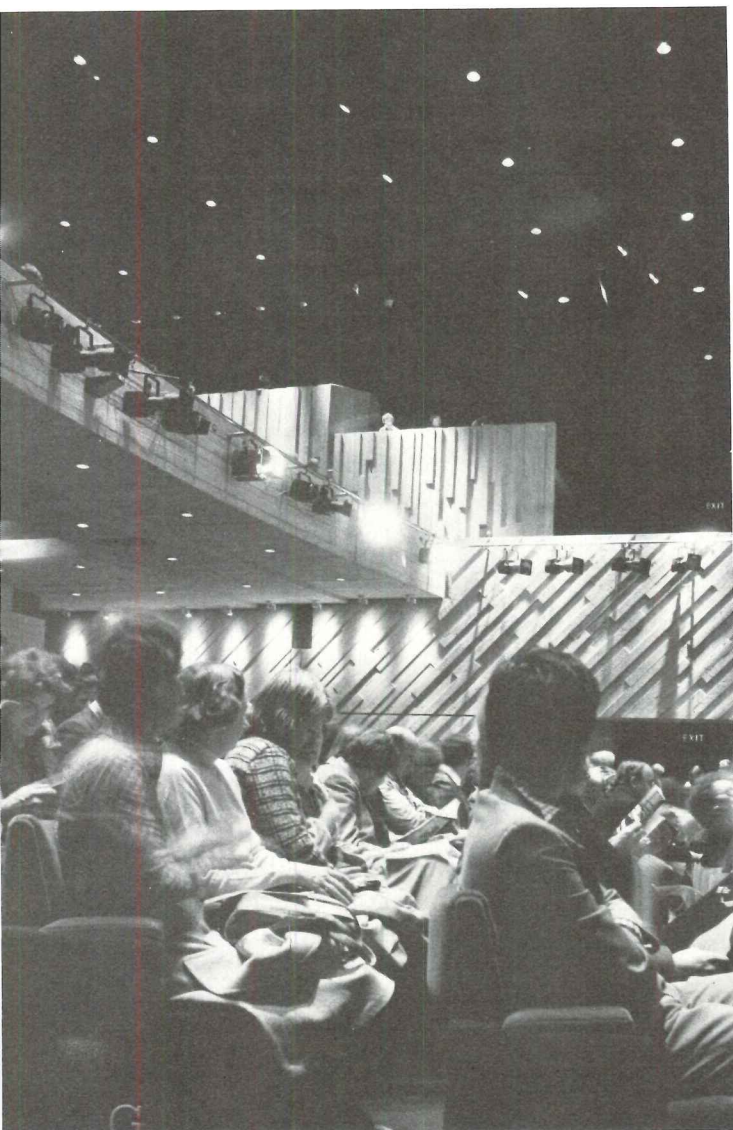

Quite right, and one *does* notice the immediacy and immense comfort of the sensory access that one has to the broad, open stage—while, at the same time, there is a clear but unintruding sense of neighborliness between sections of the audience.

The second largest of the three theaters is the 900-seat Lyttelton, which shares the main entrance-way with the Olivier. And its two tiers of seating, more conventional in arrangement, face directly on a proscenium stage, the opening of which is adjustable for a wide variety of scenery requirements. Whereas the stage of the Olivier is deliberately, dramatically expansive—a kind of “space stage,” as Lasdun describes it—that of the Lyttelton, with its long unbroken rows of seating, sets up, as deliberately, a sort of “me-audience, you-actors” relationship which is all the more striking, in the context of the proscenium format—because aglow amidst the blackness that frames it, the stage action vividly contrasts with the darkness, and one is glued to the goings-on like one is when, say, lying in bed, lights out, gripped by a late-late show, the television screen supplying the only illumination in the room.

This is what is meant by describing these theaters at the National as *characterizations*, because, as Lasdun astutely perceived, having gotten into the spirit as well as specifics of the art, there are different kinds of plays and each “has an architectonic space that suits it best.” With both the Olivier and the Lyttelton, the National (the director of which is Peter Hall, a member of the building committee from day one) can try out all kinds of old things in new ways—and all kinds of new things in old ways.

One can imagine Shakespeare or Molière or Brecht or Williams wanting their familiar scenic trappings and staging, and the option for familiarity is here. But so is the incongruous. One might expect, for example, that themes of emerging playwrights would be most at home amidst the unhampered mini-cosmos of the Olivier, but, then again, the surreal or suprasensory character of many such plays might be most dramatically conveyed by the television-screen-in-the-dark possibilities of the Lyttelton proscenium which, Lasdun points out, “is capable of closing down to a tiny peepshow, or of opening up into a full end-stage effect.”

In the theater, after all, as in life itself, what is incongruous in the context of common experience—like *Hamlet* being played on a bare-boards stage with the Prince wearing bluejeans and a turtleneck—can open up a whole new world of experiment and expression *within* the framework of so-called tradition.

At the same time, so-called *avant-garde* efforts, encrusted with ennui, isolation, alienation, craven grief, or hyped-up hope, could conceivably be as effective if set in, say, a consciously antique scenic backdrop. That is what was called, earlier on, the dynamic diversity of theatrical expression, and the National (the full capabilities of which are gradually being discovered by a staff dedicated to trying out just about anything at least once) is measuring up to that dynamic.

The third theater, the Cottesloe, is meant to be as much a laboratory as anything. Located on a lower level with separate access, it is a bare black box of a room that is surrounded, on three sides, by galleries. It can hold up to 400, and, with its fourth side free for various staging concepts (coupled with the ability to move the central floor up to stage height), the Cottesloe can be made to evoke anything from a communal psychiatrist's couch to the grimly luxuriant squalor of a Dickensian parlor.

One (the Olivier) plus One (the Lyttelton) plus One (the Cottesloe) do *indeed* add up to Four, and it is unforgettably Sir Denys Lasdun's synergetic “fourth theater” that, gathering these inner resources together, both plays skillfully within and supports its urban setting. Overlooking both the river and the foyer, one can dine; and in the lobby areas, as well as on the outside terraces, poets are being seen to recite, concerts are being seen to rouse attention, and artists, too, along with noontime strollers and tourists, can't seem to keep away. They come, using the National Theater, as it was meant to be: a point of perspective from which to interpret the flow and flux of that sometimes haughty, sometimes naughty, but always commanding example—London.

—William Marlin

THE NATIONAL THEATER, London. Architect: Denys Lasdun & Partners. Engineer: Flint & Neil. Consultants: Davis Belfield & Everest (costs); Theater Projects Consultants, Ltd. (stage, light, sound); Henry R. Humphries and Sound Research Laboratories (acoustics); Ken Briggs (graphics). Contractor: Sir Robert McAlpine and Sons, Ltd.

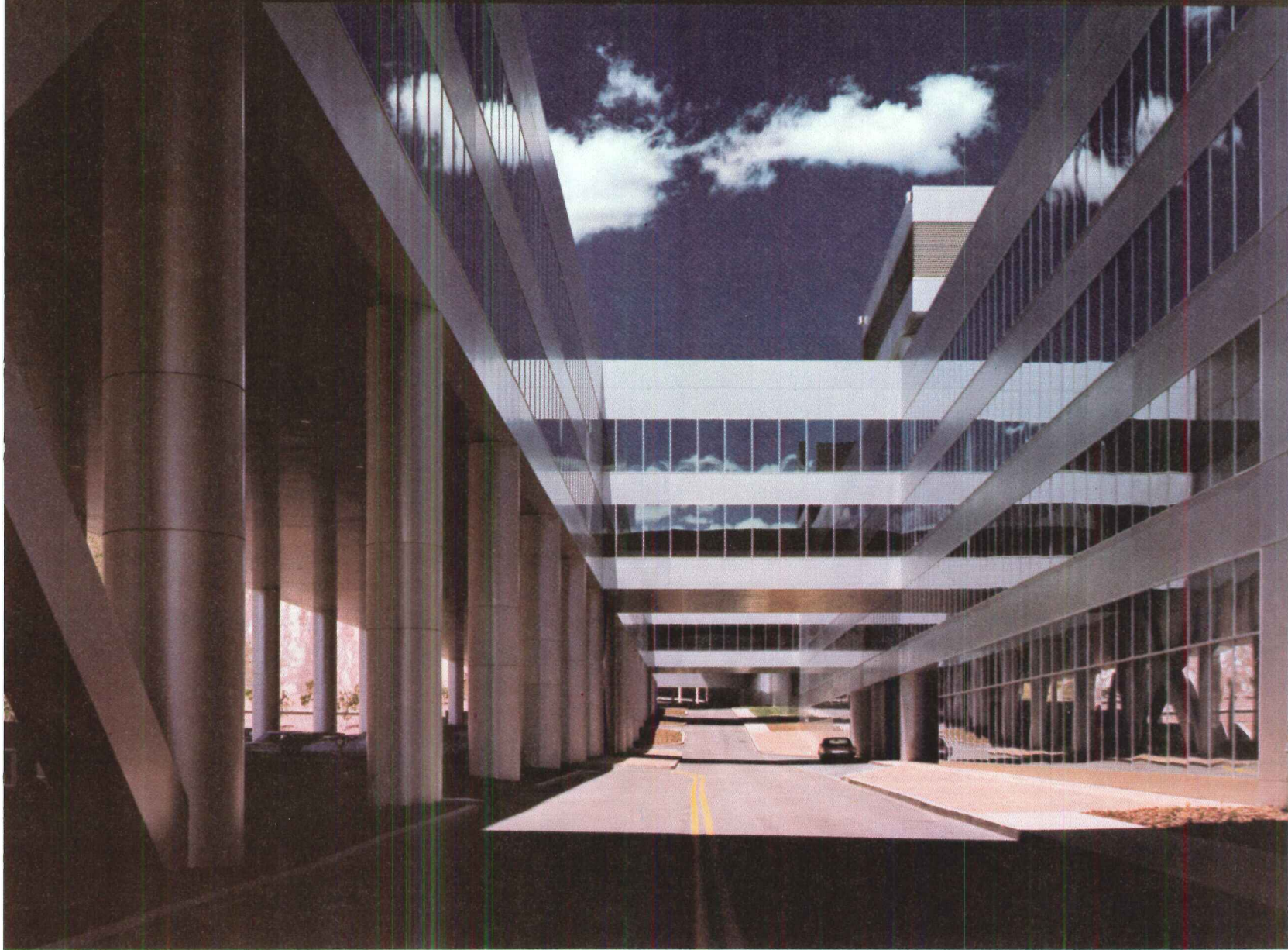

Nick Wheeler photos

THE JOHNS-MANVILLE WORLD HEADQUARTERS BUILDING— A WINNER FOR J-M AND TAC

At the AIA Convention in San Francisco in May 1973, not very long ago, Johns-Manville announced that The Architects Collaborative was the winner of a competition among nine selected firms for the design of its new headquarters on a ranch near the outskirts of Denver. Construction got underway almost before the TAC team had recovered from their victory and the results are spectacular. What is most remarkable is the degree to which the reality of the building is faithful to the dream of the winning design. This took courage on the part of Johns-Manville; tenacity from TAC; flexibility from Turner Construction Company, the construction managers; and brilliance from William LeMessurier, the structural engineer. His innovative work in "plastic design" of the long span structure with a minimum of steel is described in this month's Architectural Engineering section, page 127. The extraordinary strength and beauty of the building in its magnificent setting is shown in the photos beginning overleaf. The successful struggle among contending forces to create this work of architecture is described on pages 98-99.—Mildred F. Schmertz

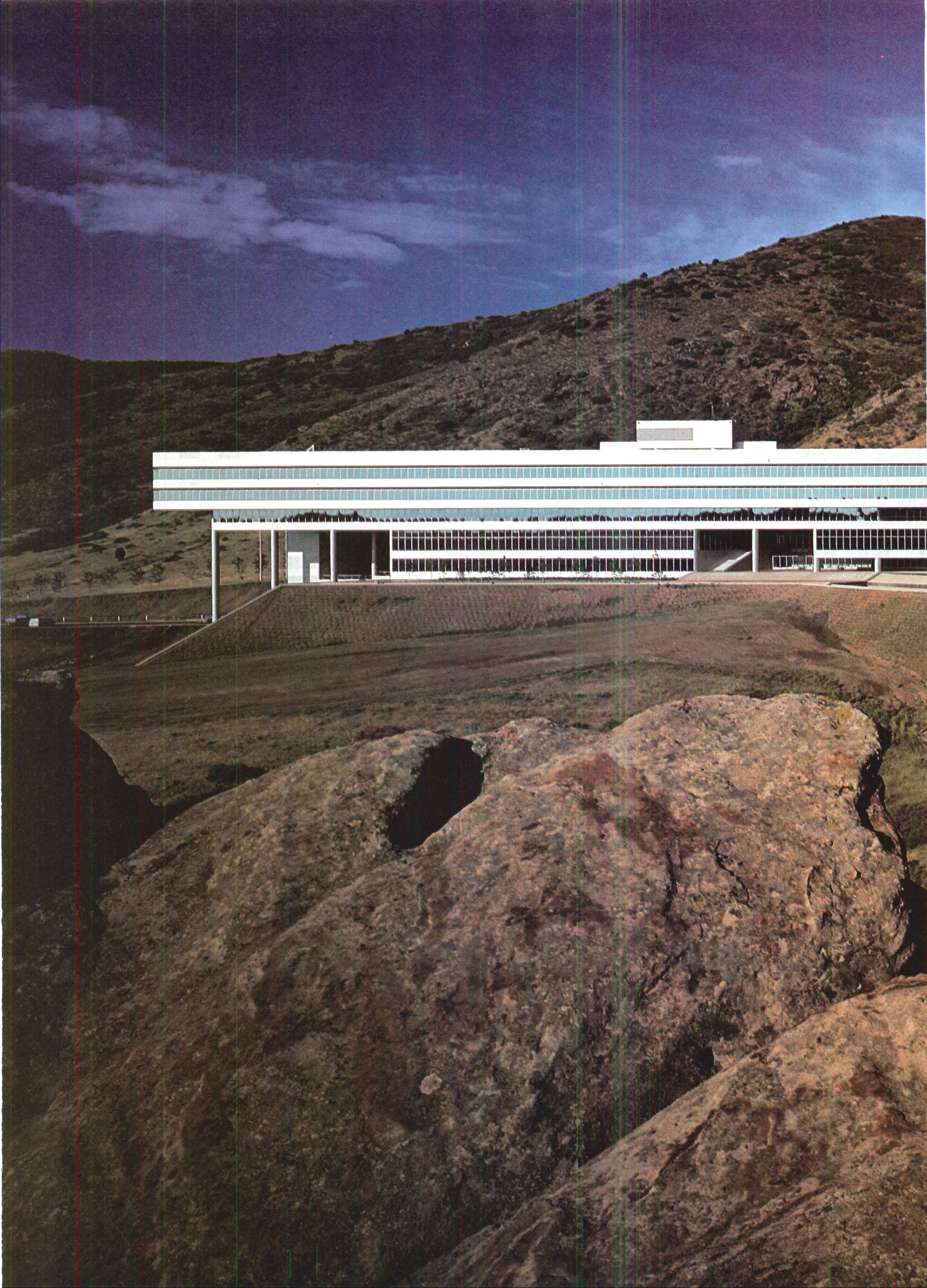

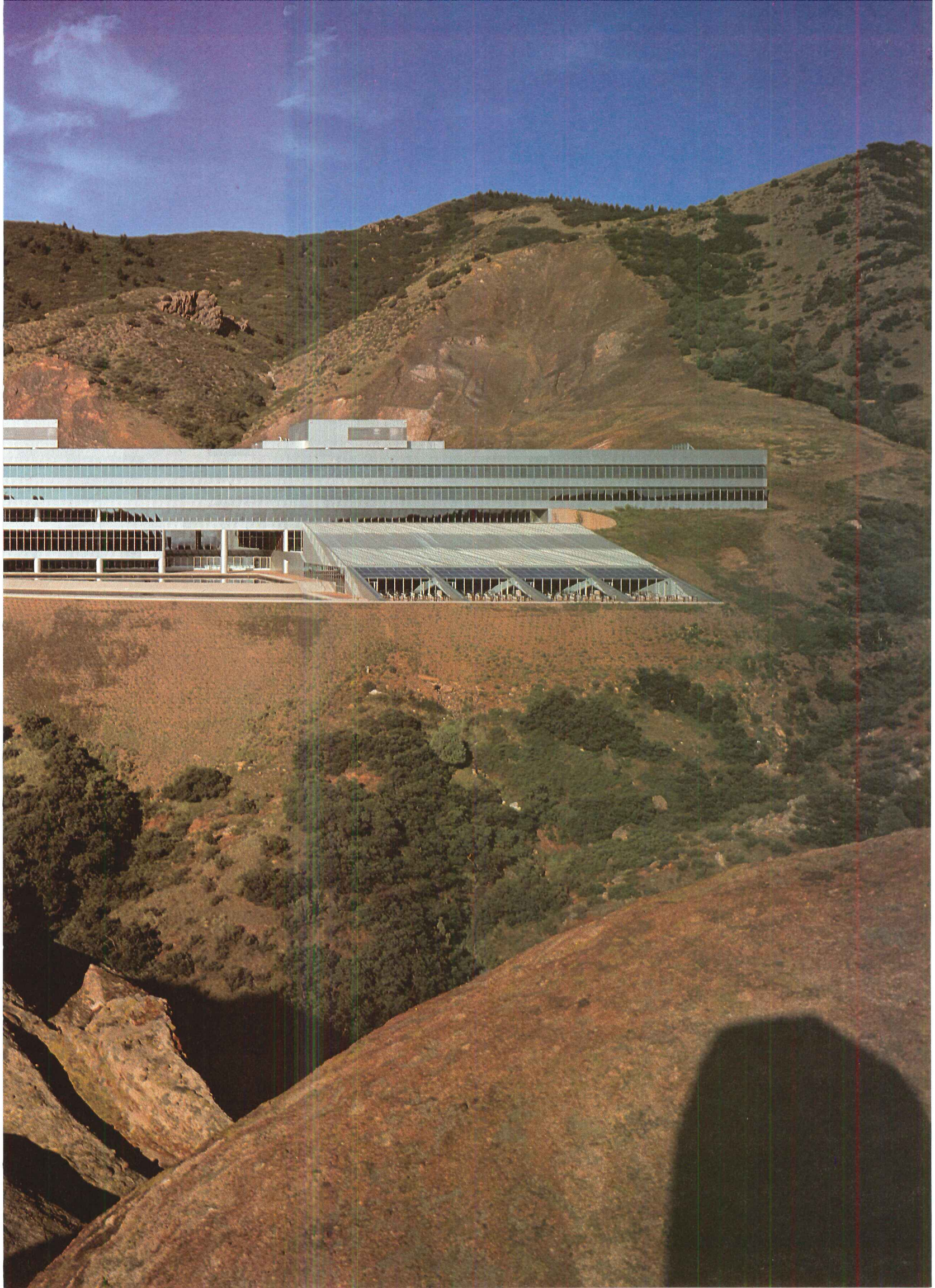



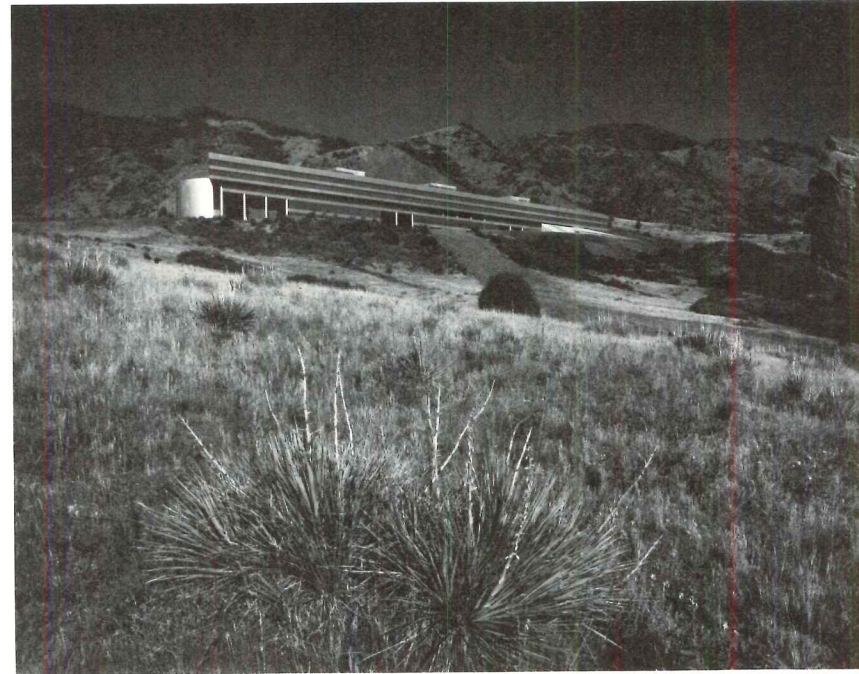
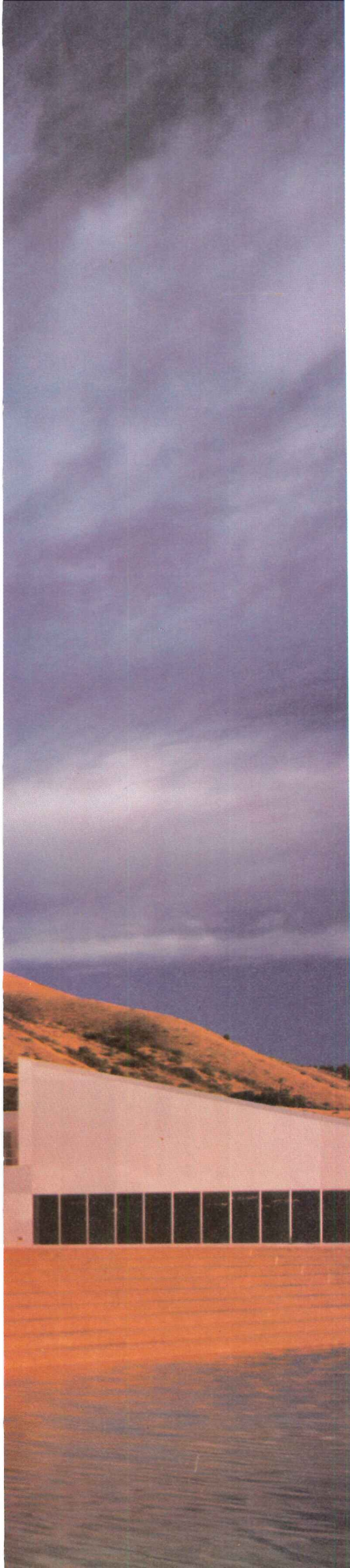

The building is sited as splendidly as a Greek temple. It occupies the land sparingly, yet powerfully, as it reflects the changes, by hour and season, of the desert sky. If great landscapes must be built upon, it is best to touch them lightly. For J-M, automobile circulation was a primary design factor, and 1300 cars can be parked on the roof and on the parabolic tiers carved into the uphill slope. From many vantage points, however, the building appears to be visited and served in secret, the landscape unmarred by the paraphernalia of the automobile. The building itself, however, is no secret. Unlike Taliesin West, for an example, which is built of desert materials, the J-M building is an avowedly machine-made object.

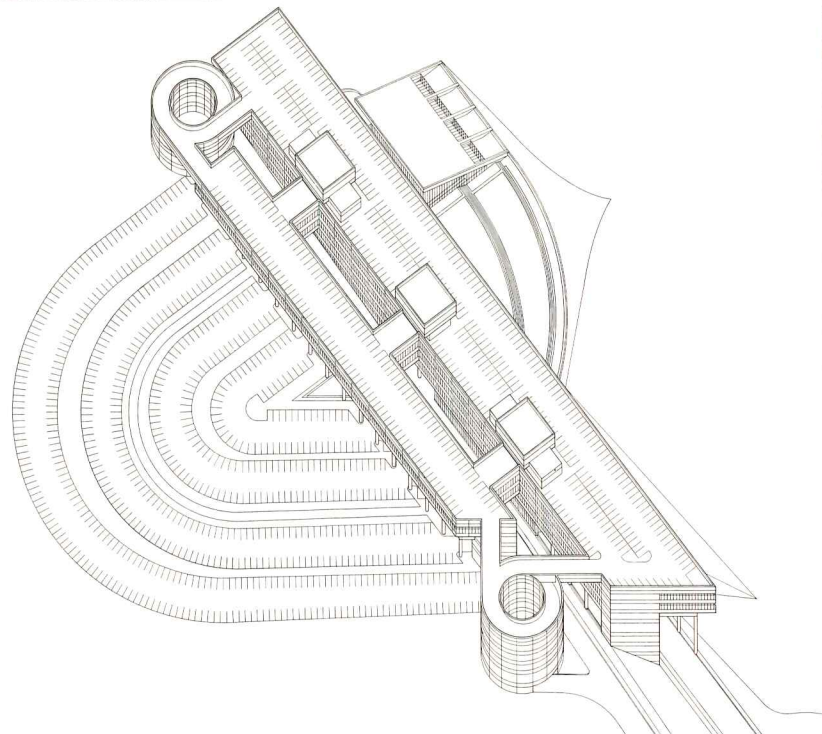

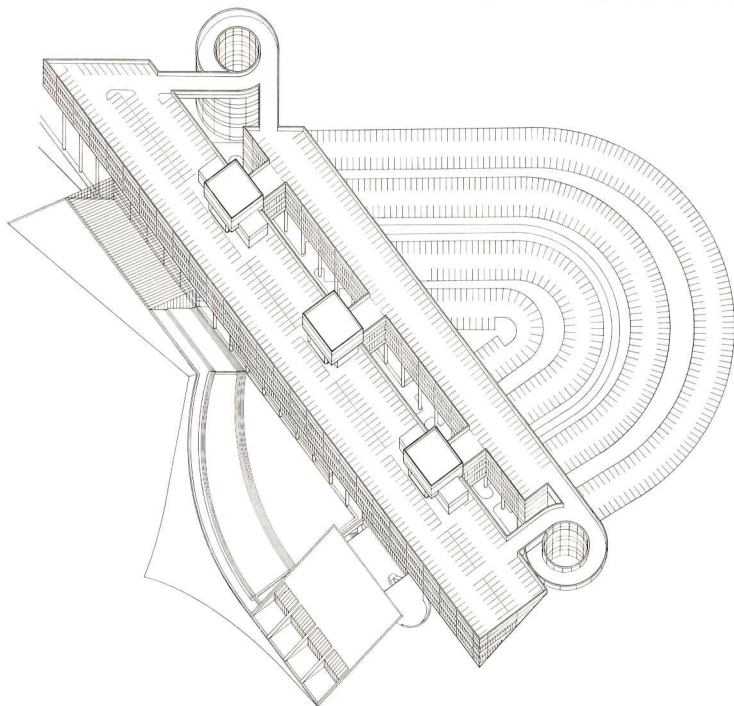
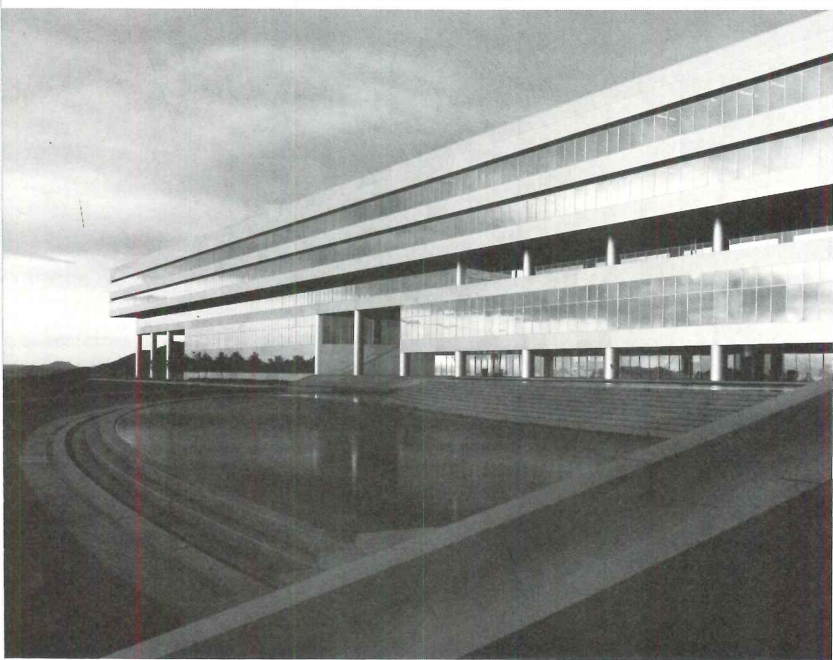
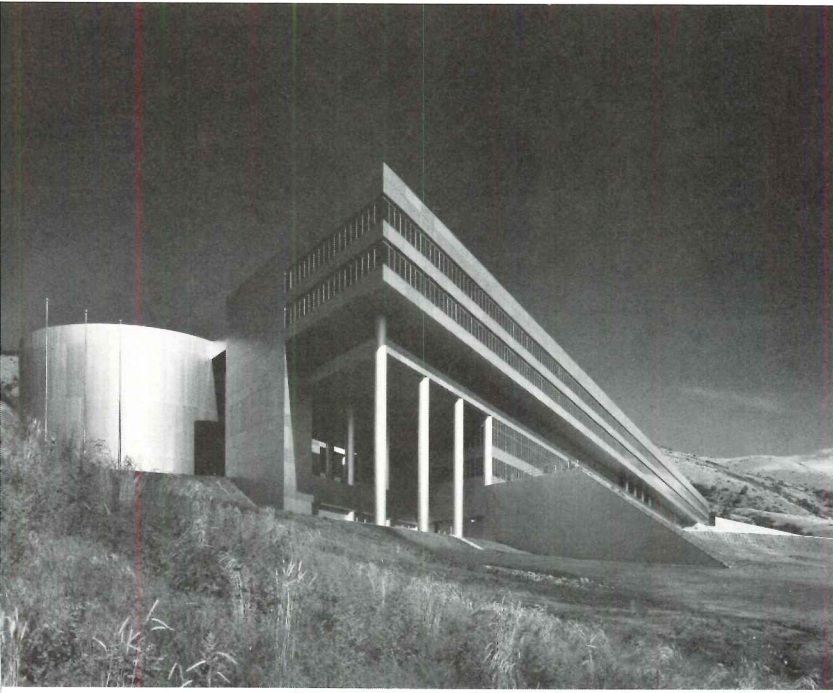

The axonometric shows two projecting wedge-shaped forms, the smaller of which is a greenhouse connected to the stately arcs of the pool by a terrace, and the larger a cafeteria. As can be seen in the photographs (middle left and opposite page), the greenhouse has not been built—unfortunately, since the pool and terrace need to be precisely contained by a second form and the cafeteria needs to be balanced visually by another projecting element. This dining facility has a friendly scale (see front cover), which partially counteracts the awesome horizontal stretch of the building, but the other scale-reducing shape is needed. A greenhouse would help the transition from indoors to outdoors.







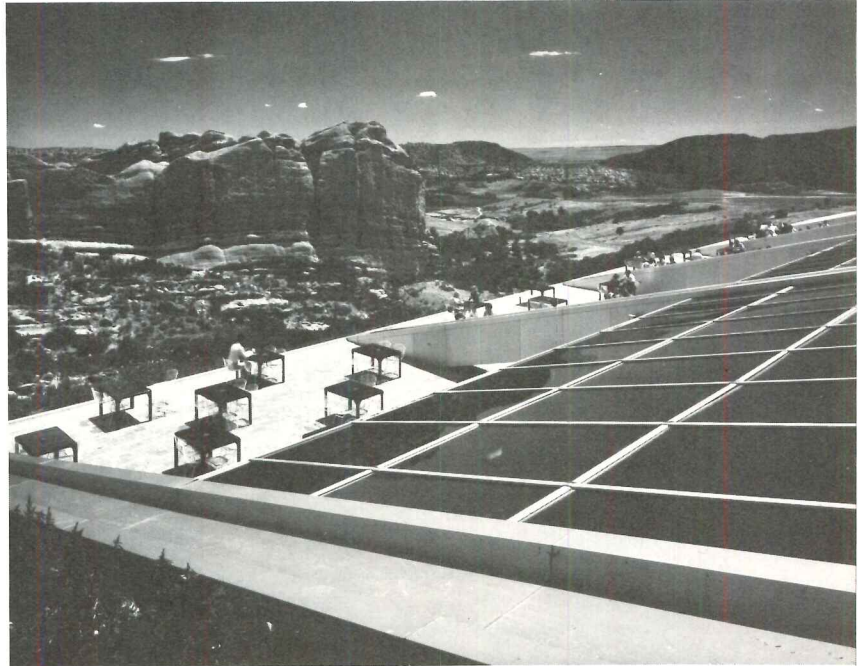
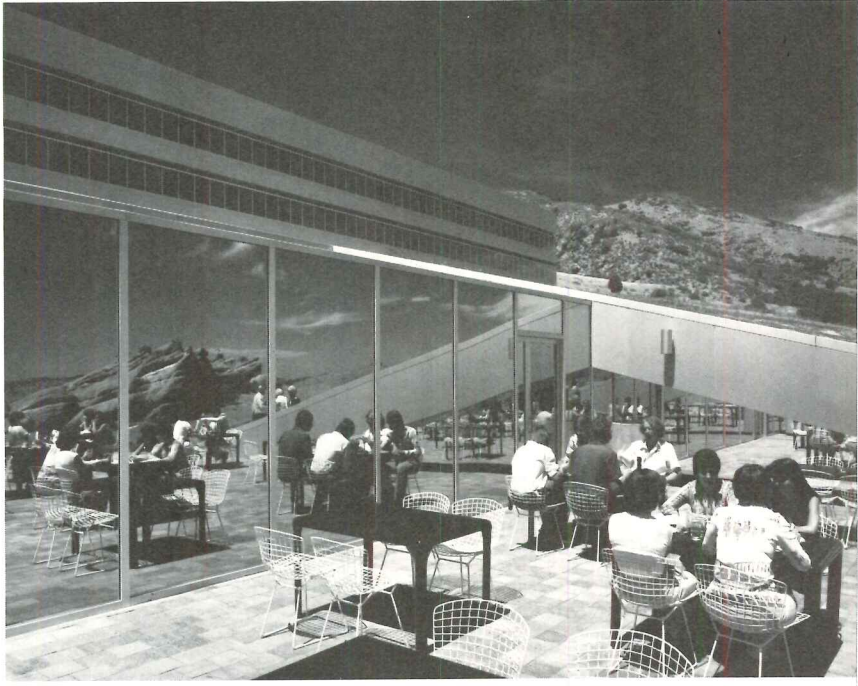
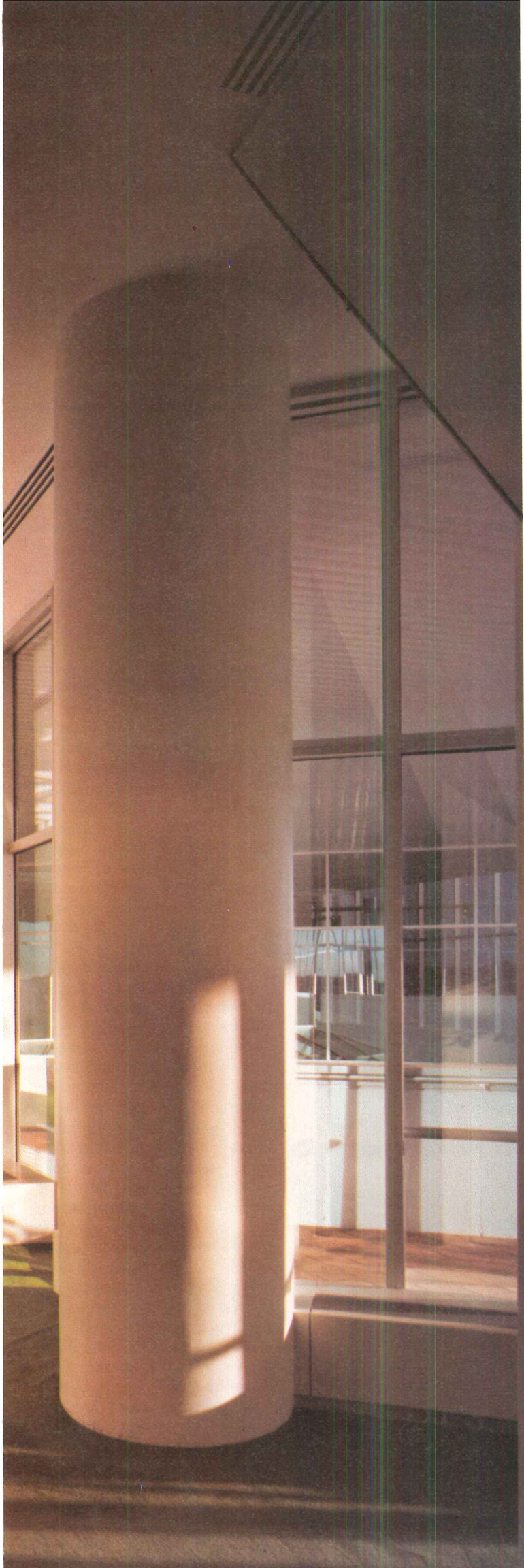

The aluminum skin is beautifully detailed and fabricated (left) as are the cafeteria skylights (above and right) and the great lines of window. The interiors are laid out to give the top executives the best views, through openings in the ridge across the valley, to the Denver skyline 22 miles away. All employees, however, may enjoy this most spectacular vista at lunch on the cafeteria terrace (above), or from within the dining area itself (right). Other amenities shared by all include a gymnasium, which is also oriented toward the major vista. Throughout the complex, the architects have exhibited great skill in devising ways to bring employees and visitors into visual contact with the building's surroundings.



The coming together of the Johns-Manville Corporation and The Architects Collaborative in the persons of W.R. Goodwin, J-M's former president, and Joseph D. Hoskins, until recently a principal at TAC, had everything to do with the fact that this corporate headquarters building is so spectacular. Although both men have moved on, Goodwin to found another company and Hoskins to start his own architectural practice, they have left behind them a building that reflects great credit upon J-M and TAC.

Goodwin was president of Johns-Manville during the period in which the company bought a 10,000-acre ranch, 22 miles from downtown Denver to become the site of its new headquarters; moved its personnel from New York City to temporary offices in Denver to await the construction of its proposed building; and held a limited design competition to find an architect for this facility. The building was substantially completed at the time Goodwin resigned.

From the beginning, Joseph Hoskins was TAC's man in charge of winning the competition against stiff competition—Welton Becket and Associates, Caudill Rowlett Scott, Inc., Vincent G. Kling & Partners, Neuhaus and Taylor, I.M. Pei & Partners, William L. Pereira Associates, RTKL, Inc. and Sert, Jackson and Associates, Inc. As principal-in-charge for TAC he saw the building through to completion, defending its design integrity against the many challenges that inevitably arose during the construction process. Goodwin unflinchingly backed up Hoskins throughout this period.

TAC won the competition for the masterful way Hoskins and his team placed the building on its site, using the foothills as a backdrop and building up against them, for the bold manner in which the architects took advantage of the vista toward Denver across an undefiled valley, for their elegant and minimal design of the roadway approach with its dramatic arrival under the building, and for their unobtrusive insertion of parking space on the roof and in tiers carved into the natural bowls at the rear of the building. The jury, chaired by architect Harry Weese and including Goodwin, architects Theodore C. Bernardi and Robert Geddes, and Hubertus J. Mittmann—regional landscape architect for the United States Forest Service, Rocky Mountain Region in Denver—commended TAC's de-

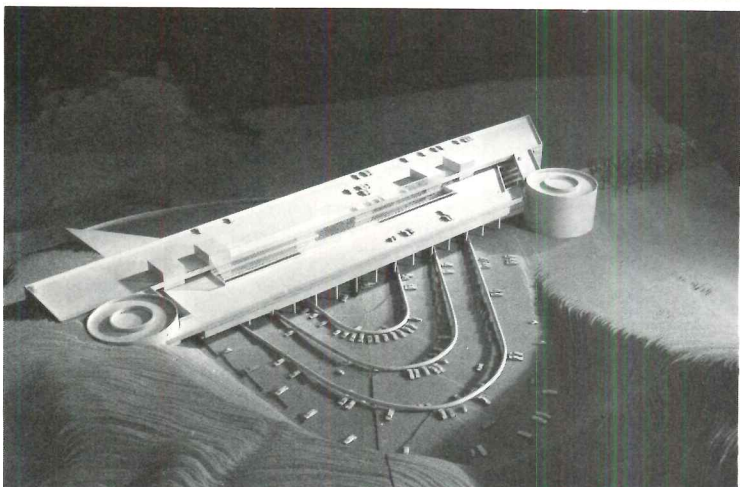
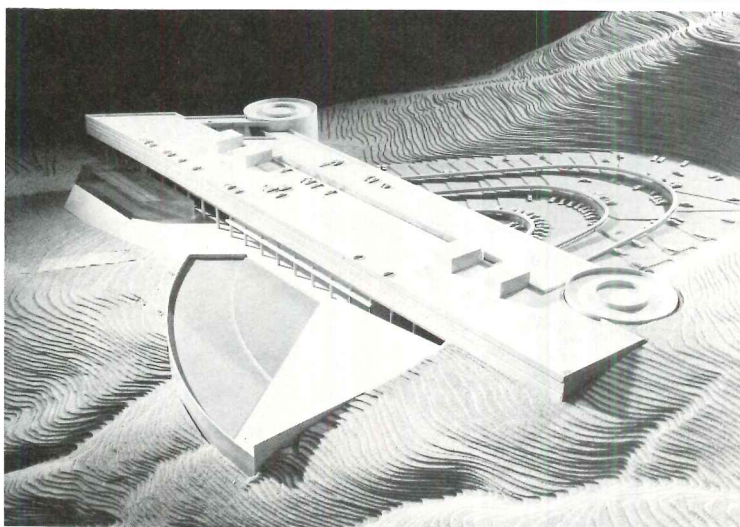

The photos above show the remarkable fidelity of the actual building to the model of the winning design.

sign for combining all the elements—parking terraces, helix ramps, reflecting pools, greenhouse (unfortunately not built) and open ground—into a sculptural composition of great interest and variety which had the potential of forming a very distinctive image from the air. The latter was an important consideration. Johns-Manville executives fly in and out in the company helicopter and the building can be seen at high altitude from the trans-continental flight path.

Mastering the site

Anyone who has flown out of Denver toward the Rockies in a small low-flying aircraft has seen a long ridge rising abruptly from the plain like a great wall of rock stretching to infinity. This ridge, called the "hogbacks," announces the beginning of the Rockies. Just beyond the hogbacks is a valley sloping westward to the foothills. The hogbacks start near Boulder and come to an end just south of the Johns-Manville ranch. They form a vista from the site which is unique. From the foothills of the mountains, which are included on the J-M property, one can look across the valley and through the hogbacks to the city of Denver, 22 miles away.

For TAC the design process began with a helicopter tour of the site. Said Hoskins: "I was looking for a location for the building that would make the most of what was there. The Rockies are great as seen from Denver, or when you are up in them, but the foothills as seen from the front range are not that spectacular. The most beautiful portion of the site is the valley itself as bounded by the hogbacks. I determined that we shouldn't build in the valley, but up on the edge of the mountains to encompass the view across it. The landscape architects on our team told me the site I wanted was unbuildable because the slopes were too steep, but we went ahead anyway, confident we could solve the site engineering problems as they arose."

The TAC design team next made a model at the scale of 2 feet to 100 miles. The building was tiny at that scale, but downtown Denver was on the model and so were the hogbacks and foothills. TAC wanted the building to be tied to Denver by a vista—an idea as old as architecture. The architects made further studies to determine the best wind and sun orientations and went on to consider the problems of access and parking.

The building site the TAC team selected was not ideal for

parking because it had very little flat land. J-M did not want to build a parking garage and had asked the competitors to come up with an imaginative outdoor parking solution. Hoskins wanted to make the parking an intrinsic part of the design of the building. Since he intended to make the structure long and low, providing the square footage called for by the program in as few floors as possible and thus providing the maximum square footage per floor, he knew that he could put many of the required parking spaces on the wide and long roof which would result. Further parking, the team reasoned, could be carved into one or more of the bowl-shaped natural forms on the building site. They envisioned that this carved space in the back, essentially closed, would be an effective contrast to the vastness of the space and view on the other side of the building. Early in the design, when the building was more linear, two bowls were carved into parking tiers, but as the building became less long and more wide, one bowl was settled upon.

Although the parked cars and access roads are scarcely visible from many viewpoints within the building and on the site, the movement and accommodation of the automobile shaped the building as much as did considerations of orientation and vista. The J-M employee driving to work is within the design as soon as the building appears on the horizon. He enters the structure by car between the two wings, turns into the parking lot or drives up one of the helix ramps to the roof. This automotive circulation system was kept extremely simple in order to be legible at driving speed, and it is completely separated from pedestrian pathways. It was, however, not so simple to devise.

According to Hoskins: "Four days before our submission was due we totally changed the design. We went five days without sleep. We barely got it on the plane. We barely got it there. We changed the design because the automobile circulation was unclear, the metaphorical recalls were not clear, and the entrance was not cleanly worked out. All the relationships were wrong—water, cafeteria, everything. We changed the approach, the circulation, the ramps and everything they affected. The metaphorical quality we sought finally emerged—the metaphor of the building as a bridge between morning and evening in which the day's work takes

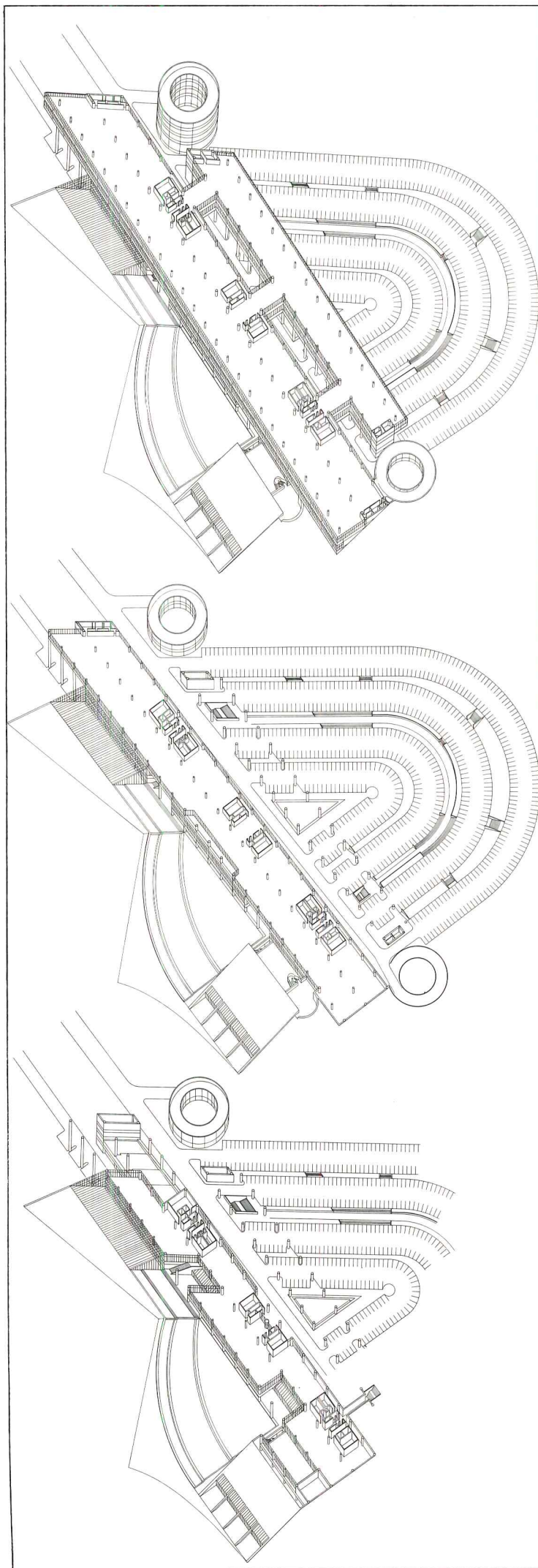

place. Coming to work one drives to the bridge, lives in the bridge and drives away from it toward home. When we got it right we had to rebuild the model. It was an incredible charette. The model-making firm had thrown in the towel so John Sheehy and I started to put it together and the rest of the team assembled it at the last minute in Denver. Since I think our earlier design would have won as well, but since construction of our winning design began almost immediately, with no time for further significant change, I'm glad we fixed it when we did."

Taking a chance

Anyone comparing TAC's design with the submissions of the eight other firms would note the elegant clarity of TAC's building, the simplicity of its shapes, the strength of its image, and contrast it favorably with the others, all of which were extraordinarily complicated and seemingly confused by comparison. Since TAC's competitors are all architects of stature, the question is—what happened? The answer is that the TAC team boldly deviated from the program because it could not have been successfully solved as written. The others did not. TAC won hands down.

The program established a poorly conceived ratio between linear feet of building perimeter and net square foot floor area which forced the other architects into surrounding relatively small portions of space with perimeter wall. This led to meandering plans with lots of ins and outs, or to multi-story pavilions strung together like beads on a necklace. Only a high-rise building could have successfully accommodated this ratio, but this was not considered a valid alternative by any of the competitors.

Hoskins had recently worked on another TAC project, the Shawmut Bank, which had demanded that the architects provide large floors. The bankers believed that large floor areas facilitate communication and that good communication is one of the secrets of successful business. Hoskins thought that large floors would be advantageous to Johns-Manville. Therefore he discounted the importance of the perimeter module as given but worked with the established floor areas reducing the linear feet of perimeter wall. This gave him the opportunity to develop a simpler building form and to take brilliant advantage of the opportunities

offered by the site.

The other buildings as designed were too sprawling and amorphous to perch in the foothills overlooking the valley. Each one had to be located somewhere on the valley floor—the wrong place as TAC's design makes clear.

Ideally, of course, office landscaping should have been used in TAC's building so that more employees would have a view from their work spaces. The J-M management preferred offices with floor-to-ceiling partitions, however, so the space was planned to allow all the employees to enjoy the view at various communal gathering points such as terraces and the cafeteria. This works very well.

TAC's gamble with the program paid off handsomely, but it is to the jury's credit that on the strength of Hoskin's design, they also decided to discount the perimeter ratio and declare TAC the winner.

The construction manager's role

Although the final completion of the building was held up because of delays in the fabrication of the aluminum skin, the Johns-Manville employees began moving in on schedule, as work continued around them. Costs were kept within a total of \$66 million. The Turner Construction Company considers this performance an excellent example of the value of construction expertise under conditions far from the ordinary: They point out that the construction site was over a mile from the nearest road and three miles from a major highway, making accessibility difficult. The siting of the building on the sloped side of the Rocky Mountain foothills, although wonderful, presented special problems. In the beginning there were no water or other utilities on the site, and the sheer size of the project (750,000 gross square feet), made it among the biggest ever constructed in Colorado. The 1070-foot-long building, if stood on end, would be the tallest west of the Mississippi River.

The building was dedicated on July 4, 1976, two years and nine months after construction was begun in October 1973. Work began promptly, approximately five months after the winning competitor was announced on May 7, 1973 at the AIA Convention in San Francisco. The TAC team had barely ceased celebrating when Turner was selected by Johns-Manville and TAC to be construction manager. According to Douglas Meyer, general superintendent

of Turner's Denver office: "The first thing we did was prepare cost estimates on TAC's schematic designs."

Despite the lack of detailed information, Turner was able to make early cost estimates to determine the approximate quantities of major items, such as excavation, structural steel, curtain wall, concrete and pouring material for the one-and-a-half-mile road that had to be built to reach the site. This schematic design phase was concluded in late September 1973, only four months after Turner joined the building team.

Immediately following came the design development stage which continued through early 1974, while excavation had begun. During this period Turner worked with TAC and Johns-Manville on the consideration of a number of alternative building systems. Budget figures were developed for each of the contract packages and agreed upon with TAC and Johns-Manville to become the final budget.

Following agreement on the budget estimate, Turner developed a comprehensive project schedule using a computerized "Project Scheduling System" developed by the firm a few years before (RECORD, April 1975, pages 57-59). "The system allows us to establish the over-all sequence of events with start and finish dates for each of the trades, lead times and milestone dates for all design and construction activities," Douglas Meyer explains.

Throughout the design phases of the project, a major function of Turner was to provide accurate cost estimates of the major alternate methods and systems being considered by the architect, as well as their availability and any labor situation which might affect the performance of any particular aspect of the work (RECORD, December 1974, page 69 and January 1975, page 69).

Central to Turner's success as construction manager at J-M was its use of the fast-track schedule, which helped keep costs as low as possible in a period of rapid price escalation, as well as keeping the project moving on time by pre-purchasing of materials. As an example, Joseph Consigli, general manager, real estate for J-M, cites the early purchase of structural steel well before completion of the final skin design as saving more than six months of price inflation estimated at between \$250,000 and \$500,000. Other pre-

purchased materials were stored at the site, and subcontractors and suppliers were reimbursed for advance deliveries of materials and equipment.

In all, Meyer estimates that total savings to Johns-Manville through the use of the fast-track method total over \$2 million on steel and other materials and systems.

It was after consideration of all these factors that Turner prepared final estimates that were then accepted and became a guaranteed maximum price for the duration of the project. It was procedures such as these and the early and continuing interaction among TAC, Turner and J-M that produced such impressive results in terms of schedule and budgets.

Also crucial to the success of the project, Meyer emphasizes, was the acceptance of responsibility and prompt decision making where and when necessary by J-M's Joseph Consigli. Says Meyer: "Phased construction under a construction management process requires decisiveness on the part of the owner and a willingness by the owner's representative to serve as the key figure for moderating between all parties. Joe Consigli's prompt and authoritative action throughout the project was a key to its success."

Prefabricating the skin

The J-M building has one of the most beautiful aluminum curtain walls ever seen. It is illuminated by a wide open desert sky, of course, and changes magnificently with the light, so much of the credit for its splendor must go to nature. But it doesn't "tin can," its color is even, its joints are precise. The skilled hand of man must be praised also as it labored in the drafting rooms of TAC and the fabricator. What makes this skin so wonderfully smooth and flat?

In the system developed by TAC and the fabricator's engineers, the panel skin is not welded to the stiffeners. Instead the panel is essentially "hung" on the stiffeners and allowed to ride "free" or "float." The stiffeners are anchored to the building as before, and provide the necessary bracing to meet performance specifications. As temperatures change, the panel skin changes dimension but—since it is not confined by welds—it does not distort. Color uniformity of the panels was checked by means of electronic color quality control equipment in the fabrication plant.

Planning the interiors

The interior design and planning of all the spaces within the J-M building, including the cafeteria pictured on page 97, is the work of The Space Design Group. That firm helped write the competition program that spelled out Johns-Manville's needs based upon their working knowledge of the company, its collective personnel needs, its physical requirements, and its corporate personality.

As pointed out earlier, the ultimate shape of the building did not reflect the wall-perimeter specifications called for by The Space Design Group in their program—but the shape provided the firm with interesting design opportunities—and also posed certain interior design problems.

One such problem was the treatment of the long passageways, which were an intrinsic part of the TAC design. Usually attempts are made by interior designers to obscure the length and regularity of such corridors. In the J-M complex, however, The Space Design Group saw these long arteries (several of them more than 1,000 feet in length) as an opportunity for drama. The interior designers used no artificial light in these corridors, but rather illuminated them with the light filtering through the glass that forms the upper level of the office partitions, and by the much greater quantities of light pouring in at the intervals where there are no partitions. These intervals occur at the secretarial areas, every one of which is opened to the exterior of the building.

To dramatize these major arteries further, the ceilings have been lowered and the partitions have a reflective laminate surface.—M.F.S.

JOHNS-MANVILLE WORLD HEADQUARTERS, Jefferson County, Colorado. Owner: Johns-Manville Sales Corporation. Architects: The Architects Collaborative—principal-in-charge: Joseph D. Hoskins; project architects for design: John P. Sheehy; Michael Gebhart; project architects for documents: Vernon Herzeelle, Eugene L. Hayes; team: Valdis Smits, Spencer Tart, Dushan Stankovich, Sam Fan, Alexis Morgan, Michael Miller; Robert DeWolfe and David Mittelstadt (landscape); Walter Rosenfeld (specifications); Harish Patel (graphics). Associate architect: Carl F. Groos, Jr. Consultants: LeMessurier Associates/SCI (structural); Golder, Gass Associates, Inc. (foundations); Cosentini Associates (mechanical, electrical, acoustical and lighting); The Space Design Group (interiors). Construction manager: Turner Construction Co.

SHINJUKU

"Shinjuku is an example of an indigenous place that reflects the full breadth and complexity of a post-industrial society. Architects interested in designing for that society should look at it. . . ."

by Peter Gluck

Shinjuku is a dense clutter of commercial activity at the largest interchange in Tokyo's mass transit system, a place where nine railroads and some 50 bus routes converge. Every day more than two of the twelve million people who live in Tokyo pass in and out of Shinjuku, and to accommodate them a vast shopping and entertainment center has grown up in and around and over and through the station. It includes four mammoth department stores and over three thousand small retail shops, restaurants, bars, and other entertainment facilities. The department stores have average monthly sales of well over \$40 million. At the other end of the scale are more than a thousand small stores—usually under a thousand square feet each—selling food, shoes, furniture, drugs, kimonos, and bedding. There are also 1,800 bars and restaurants, where the Yodobashi Tax Office and the Shinjuku branch of the Tokyo Retail Liquor Merchants' Union estimate that in one evening 85,000 bottles of beer, 100,000 bottles of sake, and 115,000 shots of whisky are consumed.

Movies, pin-ball palaces, *go* and *Mah-jongg* parlors account for more than 150 additional retail establishments. There are more than 150 hotels with over two thousand rooms, a considerable number of which are rented by the hour.

Land at the center of Shinjuku is the most expensive in the world (a deal was made in 1972 for over \$100 million an acre), but rents are comparatively low, since the deposits required are correspondingly high—about \$40 a square foot for the ordinary shops, with an additional annual rent of seven to ten dollars a square foot. Deposits for the fancier new shopping malls are higher still, and one area is said to command a deposit of over \$200 a square foot, with an annual rent of \$27 on top of that.

Megastructural chaos?

Shinjuku is a megastructure, a *real* megastructure perhaps ten times more complicated than any yet dreamed up on paper. Its pipes

Peter Gluck, an architect who practices in New York, organized and designed with historian Henry Smith and critic Koji Taki the exhibition "Shinjuku: The Phenomenal City" for the Museum of Modern Art, now touring art museums across the country.

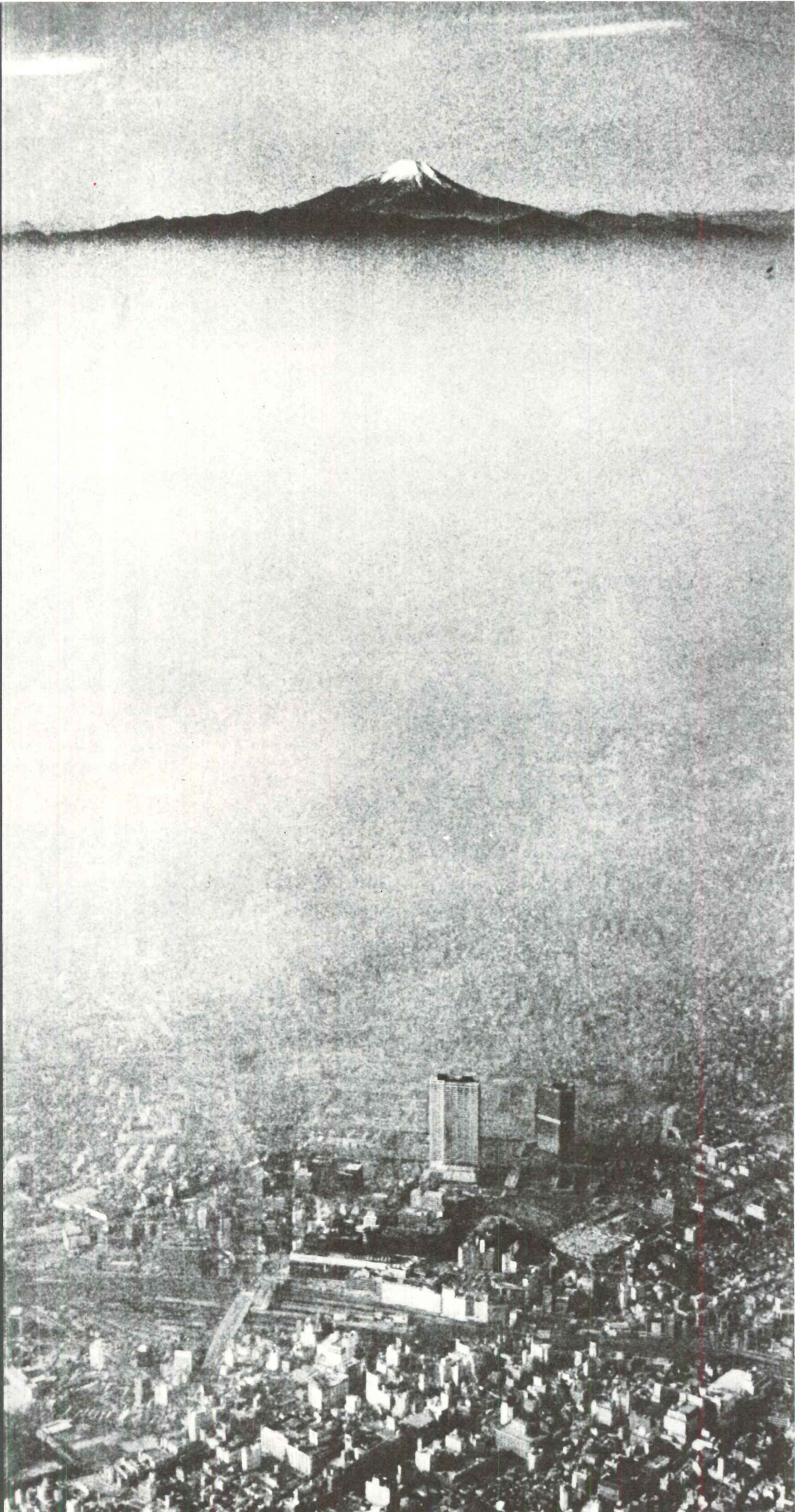

and ducts and other conduits channel people, machines, and services. The left-over spaces are snatched up by commerce. Streams of people flow constantly through it to and from the many interlaced mass transit lines. A typical trip takes a person into vast underground tunnels, along crowded sidewalks lined with shoeshine women and street vendors, down the tight and seductive alleys leading to bars and snack counters, and up into high-rise towers filled with restaurants, bowling alleys, nightclubs, and rooftop beer gardens.

Those with a taste for traditional Japanese order and design (and, in fact, those with a finely developed taste for any kind of order) risk being offended by the apparent chaos of the Shinjuku phenomenon. But is it really as chaotic as it seems, and is it really offensive? It is arguable, at least, that the answers might well be no, and that the very messiness and commercialism that disturb traditional tastes also allow for a degree of freedom and variety of expression that cannot easily exist in a more uniform or controlled environment—in the kind of environment, in other words, that “design” often produces.

Form follows function

Shinjuku has been a crossroads and a honky-tonk for centuries. As a post station it served both the feudal lords, the *daimyo*, making the long trek to and from Tokyo along the Koshu highway and also the local farmers carrying their produce into town. Today there is still a combination of long-distance and local traffic, with the “produce” of the latter now being clerical and managerial talent. In the past Shinjuku also had a steady flow of samurai who sneaked out from Tokyo in the evenings to enjoy the brothels; today students and workers make excursions there for its bars and cabarets.

Since the War, the expansion of Tokyo stimulated the development of suburban commuter lines and therefore heightened the importance of in-town terminals like Shinjuku, and it is this geographical location midway between places of work and places of residence that has been responsible for much of Shinjuku’s growth ever since.

Who says what happens

The process of change in Shinjuku can scarcely be called “planning.” There has never been a serious governmental attempt to plan it, maybe because it corresponds completely to no one administrative unit and therefore is dominated by no single bureaucracy. Inevitably, any one plan that is made for it is undone by the ultimate resolution of the real conflicts created by the implementation of the plan. We are used to thinking of the planning process as a resolution of disparate needs into a design of over-all purity. In that situation, the individual needs—the “special interests”—are sometimes thought of as subversive of the purity of the whole. But in Shinjuku, the purity of the whole is, in practice, treated as something subversive of individual

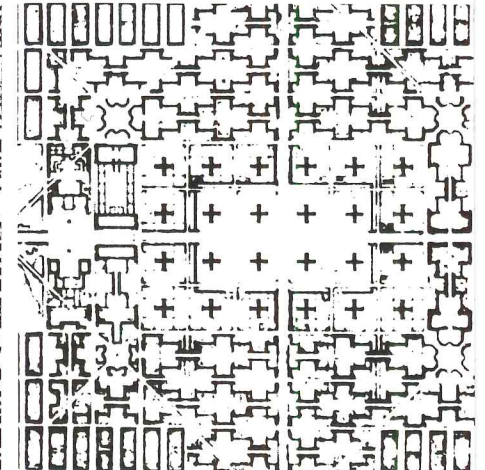
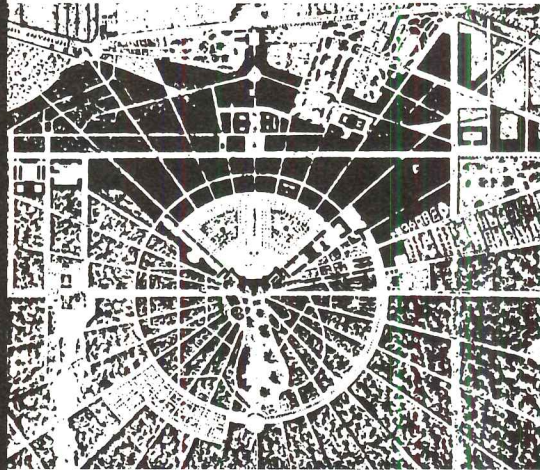
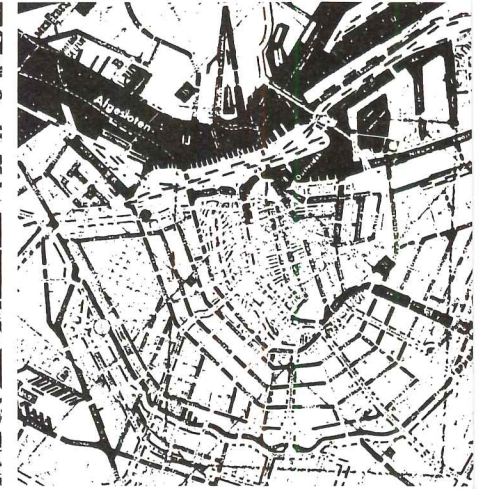
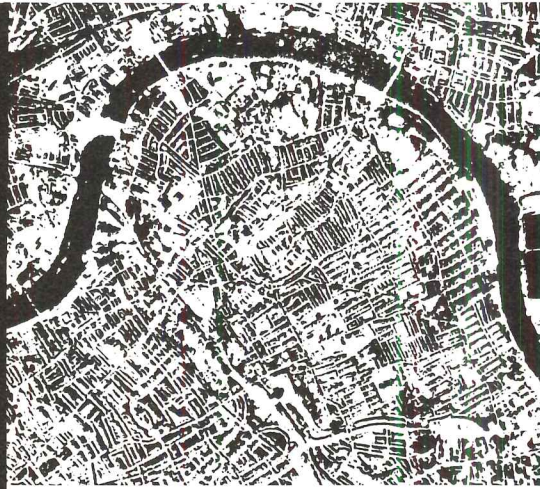

Shinjuku is a collage, the cumulative result of many independent systems. The four images above show four designs for traditional cities, with their strong sense of organization and visual order; the left half of the image below is all of the above images superimposed, while the right-hand half is Shinjuku.



needs. There is a constant process of accommodation and trade-off among the transport planners, local merchants, outside real estate developers, and city bureaucrats, each putting their particular pressure on the small amount of available land. The limited amount (and the correspondingly high prices for it) has also assured the pedestrian character of the place: the automobile simply would take up too much valuable space.

The hidden plans

Even though Shinjuku seems incoherent and disordered, it also seems to work very well for its peripatetic inhabitants—partly, maybe, because of the Japanese ability to accept visual “dissonance.” And though Shinjuku is “impure” as an over-all design, it is nonetheless highly structured. It is structured by two consistent systems: the apparently self-regulating commercial market and the apparently fulfilled needs and desires of the people who every day use it.

The station-market

Transportation centers like Shinjuku are centers in every sense, pedestrian places where short walking times and general convenience are paramount. No attempt is made to isolate buying and selling from traveling, and it is hard to distinguish public from private property.

Perhaps unique to Japan, though, is the vastness of the enterprise. Every inch is appropriated for shops, stalls, restaurants, and bars. These places in turn feed more people into the transportation system, and the greater number of people there increase the profitability of commerce. The shops in Shinjuku respond to the needs and fads and fashions of the day with stunning rapidity. World and national and local news is reflected instantly in wry advertising and timely product design. Change of season—so important to the Japanese sensibility—is logged by merchant-supplied street decorations: plastic cherry blossoms are replaced by vinyl willow branches which give way to orange maple leaves.

Shinjuku is not unique among Tokyo’s transportation centers, but it is the largest one and perhaps most clearly reflects the vitality of Tokyo’s rail-oriented “planning.” As large and chaotic as it seems, it is still a very personal place which both entices and repels. Happenings and sub-cultures have thrived in Shinjuku, making it successively a center of literary and artistic life in postwar Japan, the scene of student riots in the 1960s, the home of glue-sniffers and the future site of Tokyo’s metropolitan government center. All of these things color the name of Shinjuku in popular imagery. It is nearly impossible to meet someone from Tokyo who has no opinion about it. It is becoming too business oriented. . . . It has never regained the ambience it had in the 1950s. . . . All the best things are there. . . . The place is too low-class. . . . Thus the place, and all of the human-inspired events around it, assumes an importance and permanence in the minds of people.



Shinjuku is a warehouse of signs—signs of nature, signs of commerce, displays, directives and titillations. Food displays overreach themselves: the entire menu is revealed in exact replica in front of restaurants in plastic models with not a single noodle out of place; but the models outdo reality, and are an end in themselves.

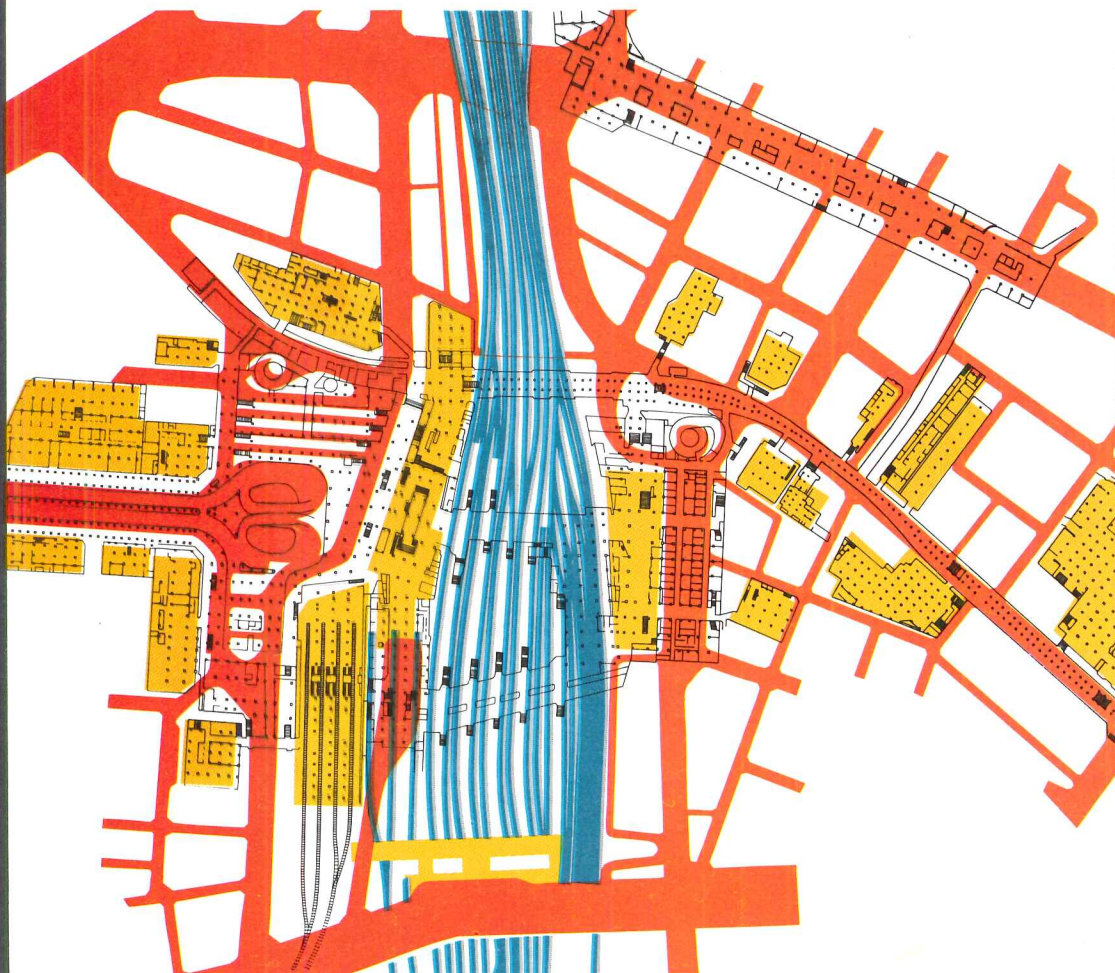

Experience

Almost anything and everything is available at random for millions of people in the five-block-square area of Shinjuku. How does a person use such a place? "At will" is probably the best answer. A person can choose among the hundreds of new shops that open each month, revisit redecorated restaurants and bars. Because of the tininess of Japanese houses and the tight structure of corporate life, Japanese businessmen spend evenings in business-related comraderie. Work-generated groups have favorite small bars and coffee houses which cater on a personal basis to that group alone. When the composition of these groups changes, so do the hangouts. If work goes well one kind of place is called for; if not so well another environment is appropriate.

To sample the pleasures of Shinjuku, a person has only to organize his or her time there—and, in fact, pre-programmed routes are offered in guide books. Such a course will organize a sequence of events to fit a particular mood. A Latin American night, for instance, might take one to restaurants, bars, and night clubs with completely authentic—albeit artificial—spots. Other popular courses ("young lovers," "old times," "folkways," "space ship," "bad boys") are also charted.

Spatial organizations here are almost completely absent. There are no boulevards leading one along a set path with tastefully designed urban villas or sequential spatial experiences. But there is experience galore nonetheless. Shinjuku is a feast for the imagination, a giant candy store with no restraints or controls on its offerings. The job of imposing restraints and controls—the job, in other words, of creating "order"—is performed each day by the millions of people who sample its wares. And it is a job that is done in as many ways as there are people.

What is the meaning of Shinjuku for the designer working not in Tokyo but in America, and working perhaps at a less exotic scale? One message is that Shinjuku is a successful place. It has a positive character and meaning to the people who use and continue to use it. This is to say, simply, that it is a place where the focus of the design decisions is always on the real users. In the sense that they can create for themselves a coherent form out of its apparent chaos, the users are the designers.

The history of our architecture has given us few means and less impulse to interpret, analyze, design, or even begin to understand such places. Indigenous, undesigned places have often been the inspiration for more sophisticated formal designs. Cape Cod fishing villages and the perennial Mediterranean hill towns come to mind, and the architect-designed places modeled on them are ostensibly the results of user-oriented attitudes. But these places tend to be reflections of relatively simple and uncomplicated societies. Shinjuku, by contrast, is an example of an indigenous place, but one that reflects the full breadth and complexity of a post-industrial society. Architects interested in designing for that society should look at it, and at places like it.

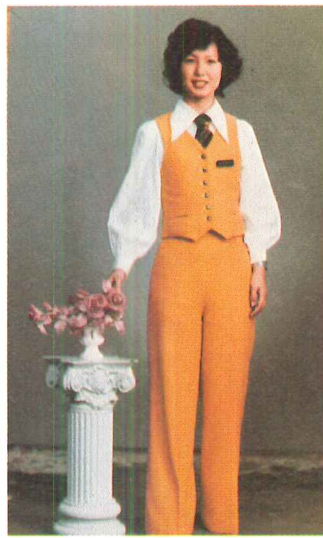

Just as in Japanese poetry, the sense of the seasons is marked in Shinjuku; celluloid cherry blossoms give way to summer greens and the plastic leaves of autumn, while sales personnel in the department stores change their uniforms and their styles. Another structural pattern is revealed in the time-lapse photograph of haste and repose.



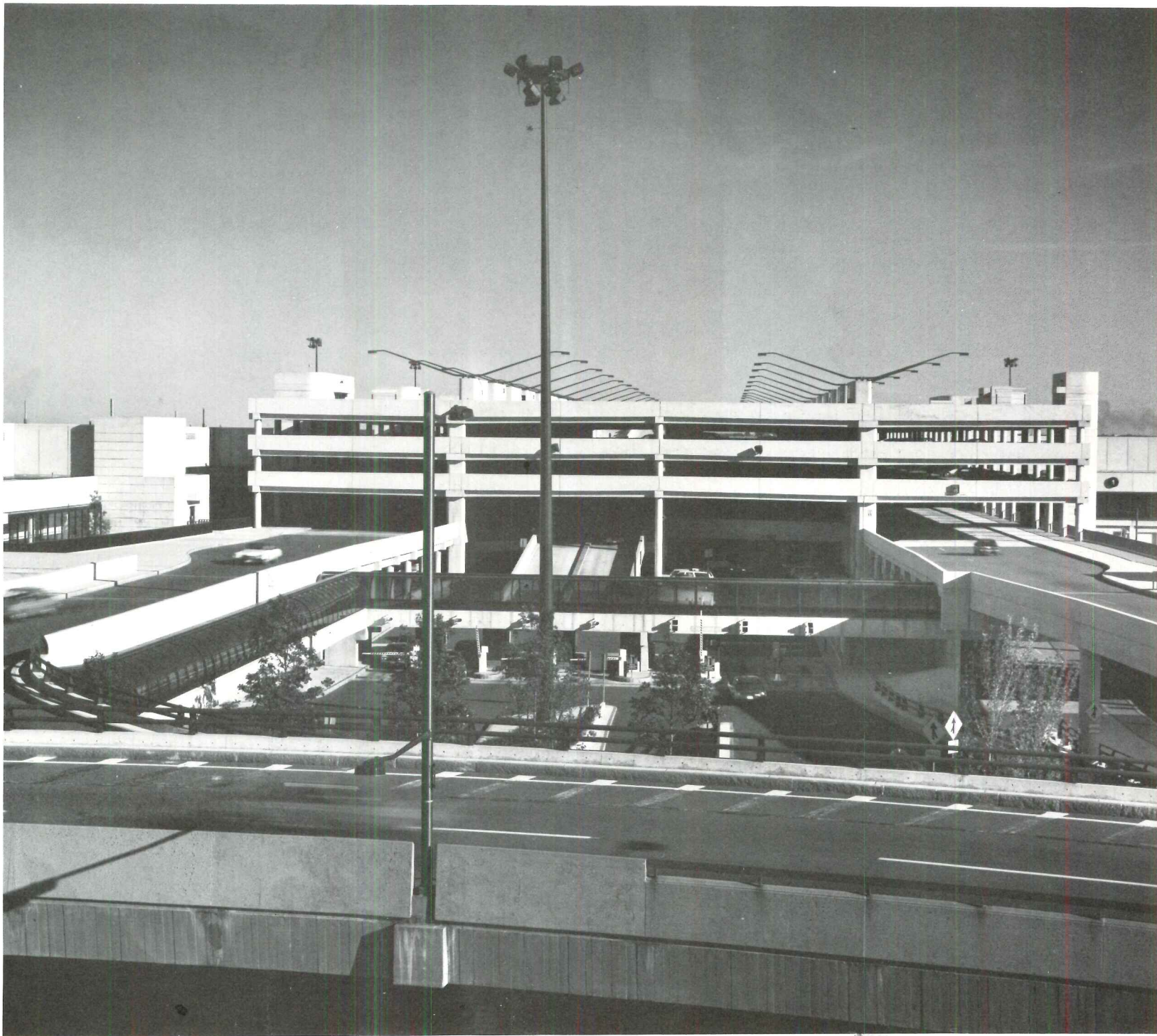

LOGAN AIRPORT

THE NEW SOUTH TERMINAL

The latest of four major terminal complexes built at Boston's international field in the last ten years, the new South Terminal was used by more passengers (3,123,000) in fiscal 1975 than used the entire airport sixteen years previously. In order to handle such a large volume of people, this building has an evolved form of the linear plan, which allows the most direct communication between ground and air transportation. In fact, the four terminals at Logan form an interesting display of such evolution from the centralized large lobby with radiating (and long) connections to the aircraft. This latest structure (section below) incorporates parking in the center, and an encircling road for on-the-target access to both parking and to the gate positions.

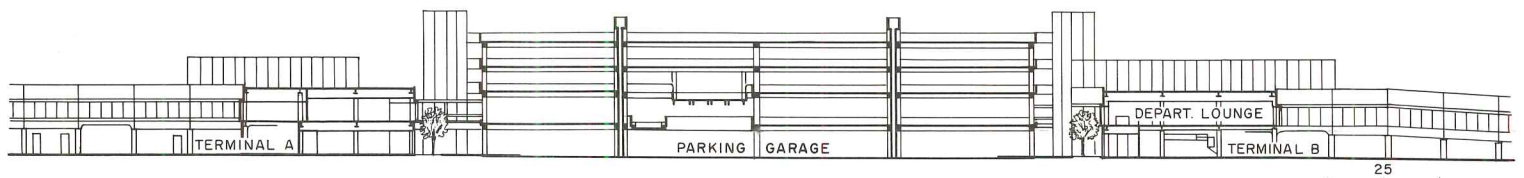

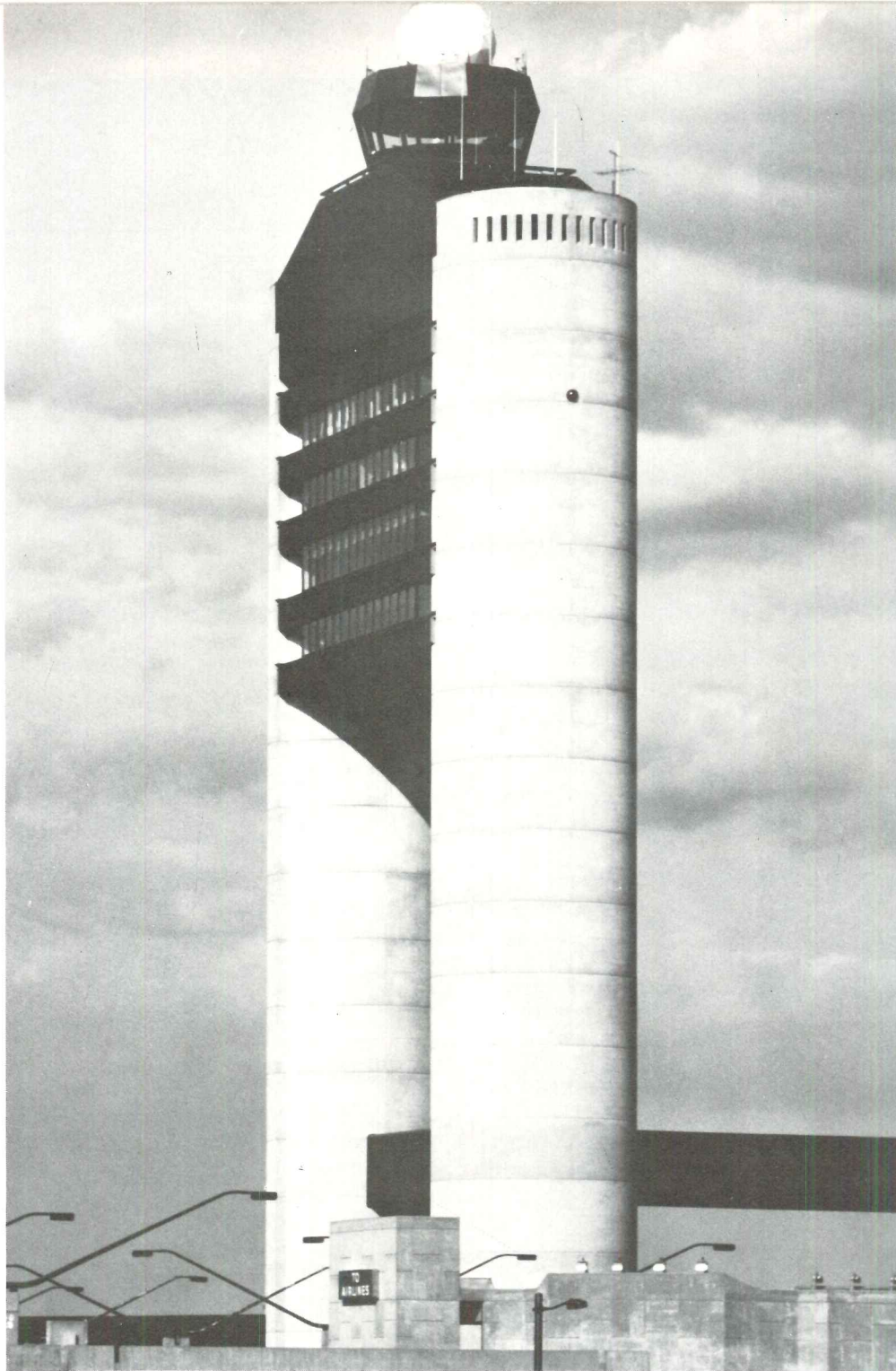

Arnold Savrann



The final planning of the new South Terminal has adhered to an increasingly understood view of what air terminals are all about—that they should provide the simplest possible transfer of passengers between planes and ground transportation as the first order of importance. (It is also essential that they do this with the greatest of reasonable economy, because the airlines—like other industries—are not as flush as they used to be.)

The solution born of this view is often the drive-to-the-gate terminal. Joint venture architects John Carl Warnecke & Associates and Desmond & Lord have produced such a terminal—in three parts—that is at once economical, pleasant to be in, and direct in that it is a literal expression of its functioning.

The concept is to bring vehicles right out into the landing field as close to the appropriate gates as possible, and even to park them there when they are owner-driven. It is similar

to that of Pan American's recent Terminal at Kennedy Airport in New York City (RECORD, October 1976, pages 132-133). Stated another way, the building is a 450,000-square-foot passenger facility which encloses an 800,000-square-foot garage. There are 29 aircraft positions and 2,700 parking spaces. And the narrow concourses, only 70 feet wide, stretch 625 feet and 1,175 feet respectively as minimal buffers between the planes and vehicles.

In order to legally qualify as separate buildings, the garage and the passenger facilities are separated by 30-foot-wide open wells (photos, overleaf) that are bridged at each level. These wells bring natural light and spatial interest to what would otherwise be a potentially oppressive and disorienting condition, if the three building elements were up against each other. The result is to form the sort of enclosed urban spaces that are usually missing from other airports. The passengers know that





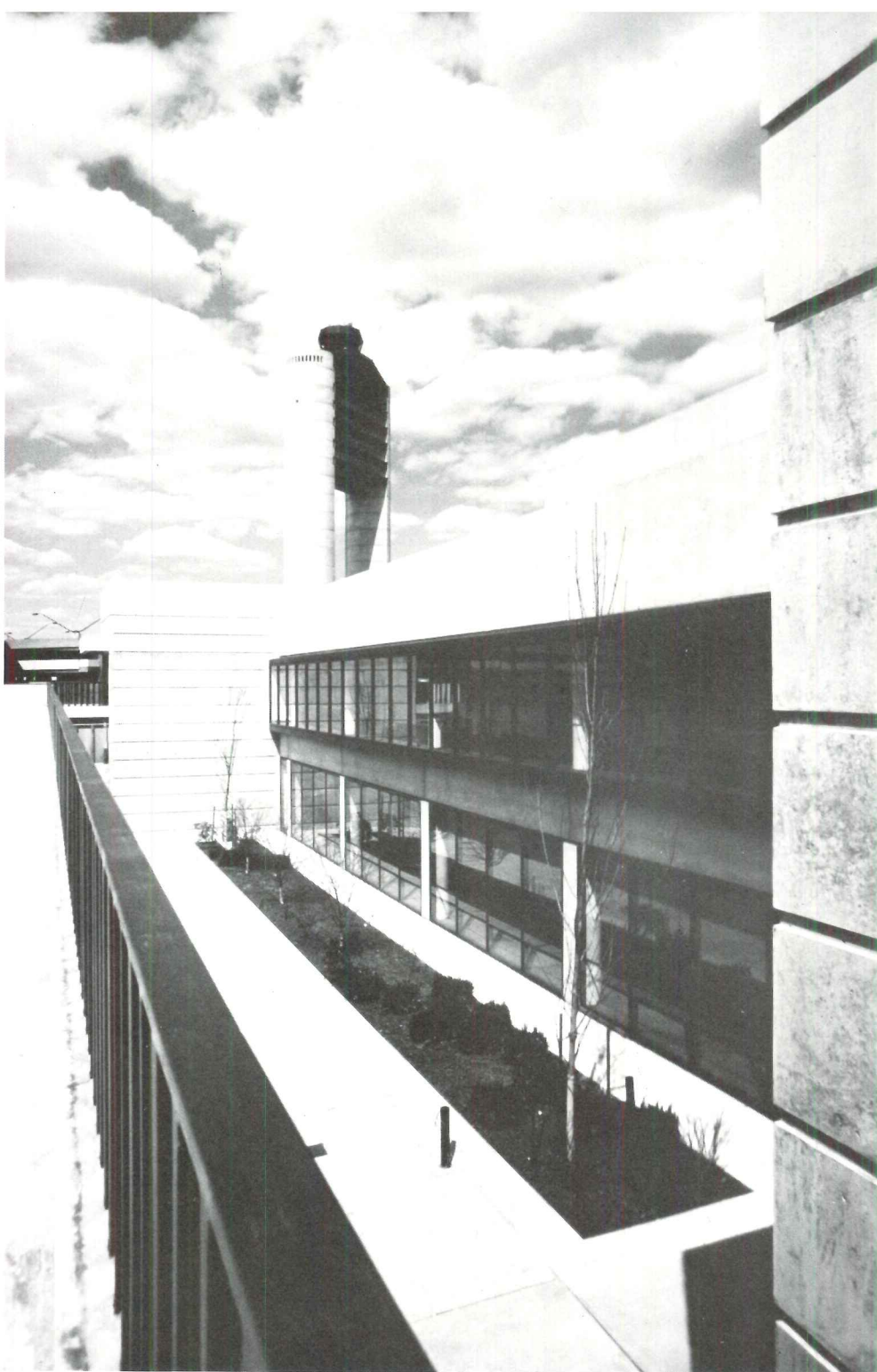

Arnold Savrann

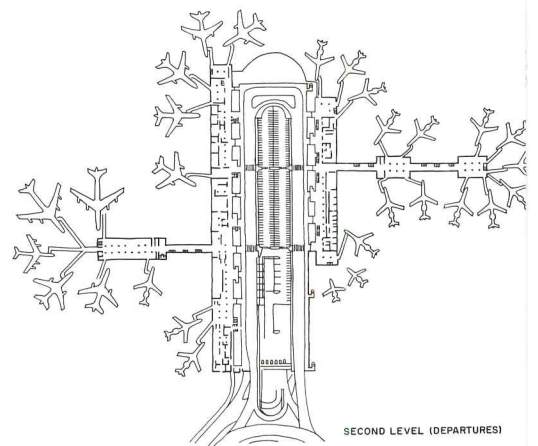

SECOND LEVEL (DEPARTURES)

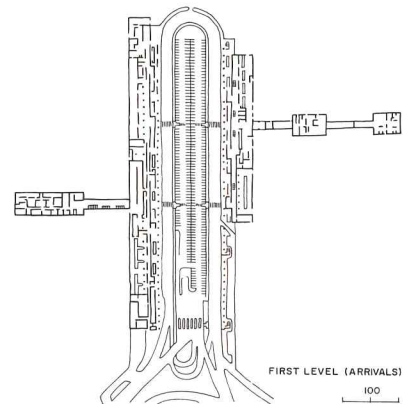

FIRST LEVEL (ARRIVALS)

100

they have arrived in a city.

The result of the linear scheme is—besides convenience—a surprisingly intimate scale for such a large building. Like it or not, the psychological effect of such a direct economic solution is a building which is not a ceremonial civic “gateway.” Instead, the result is an efficient way to do what is to be done as quickly as possible in pleasant surroundings.

The world’s tallest aviation control tower, with a height of 285 feet, was built by the same architects to serve the entire airport. It contains—besides the control room—airport offices, a restaurant, and the police station charged with airport security. The construction of this monumental structure was completed as the south terminals began. In a sense, the tower provides the ceremonial “gateway” to the city, that the efficient terminals cannot.

The structures for the passenger con-

courses are steel with floors of metal decking and poured concrete. The garages are built with precast concrete panels on steel columns, and the elevated roads are built with prestressed box beams, which are estimated to have saved 50 per cent of the cost of conventional construction. All buildings are built in 25-foot-square bays. Total cost for the buildings was \$39.7 million.

SOUTH TERMINAL, Logan International Airport, Boston, Massachusetts. Owner: *Massachusetts Port Authority*. Joint venture architects: *John Carl Warnecke & Associates* and *Desmond & Lord, Inc.*—principals-in-charge: *John Carl Warnecke* and *H. Jan Heespelink*. Engineers: *Lev Zetlin & Associates* (structural); *Joseph Loring & Associates* (mechanical/electrical). Landscape architects: *Carol Johnson & Associates, Inc.* Consultants: *Page, Arbitrio & Resen, Ltd* (graphics); *Leslie Buckingham* (costs). General contractor: *Vappi & Company, Inc.*



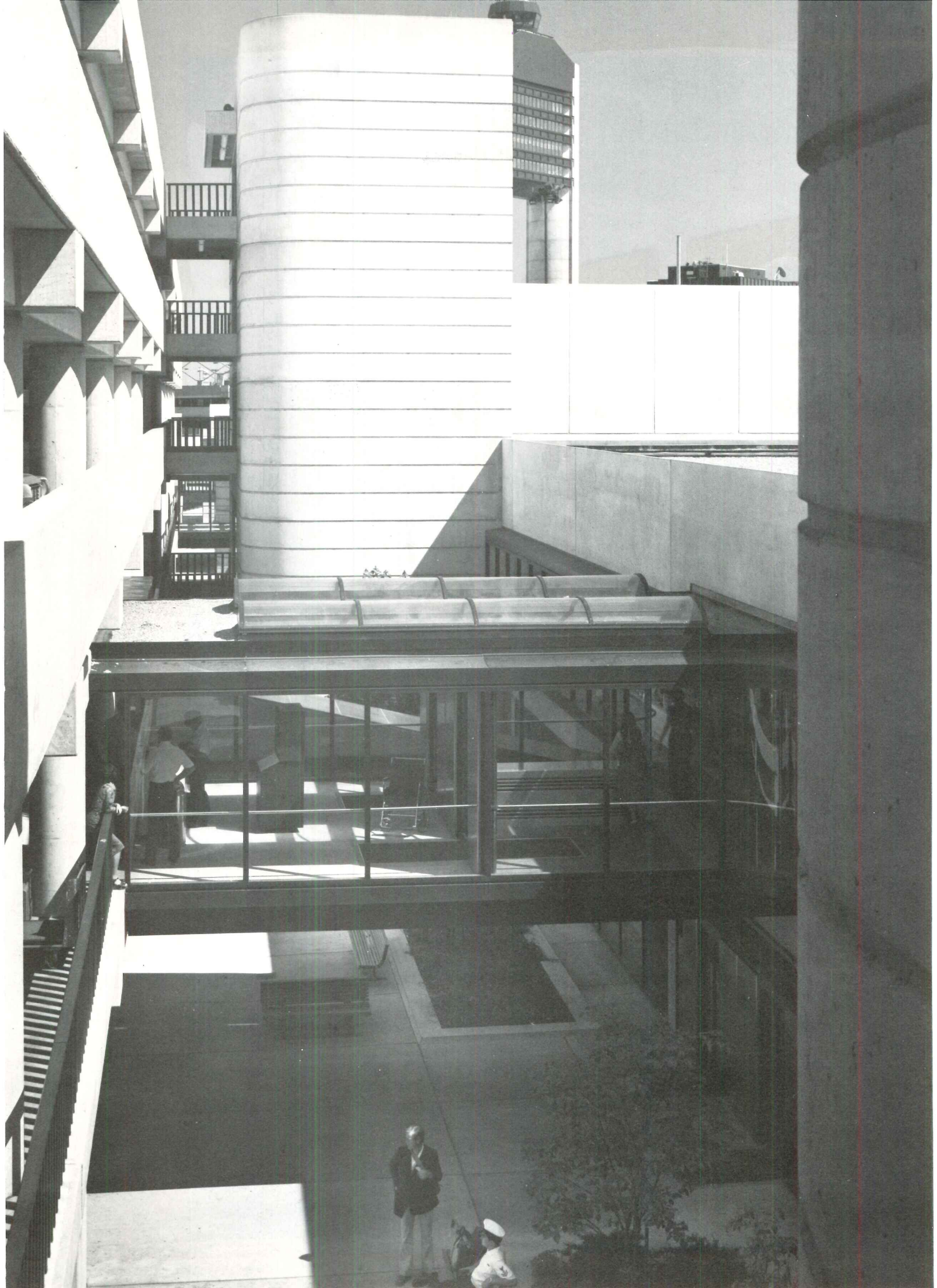



Passengers in either concourse are able to look clear through the central garage at the opposite concourse. Between the garages and the concourses there are linear wells open to the sky and bridged for connection to the roadway in the garage structure. The wells form a bit of urban-style open space, a quality lacking in many similar facilities. They also provide a sense of orientation, another commonly lacking quality.



HOUSING

While statistics have reported an upswing in housing markets since the pre-recession peak in 1972, the most dynamic aspect of the upturn has been in the construction of apartments. According to forecasts from the F.W. Dodge Division of McGraw-Hill's Information Systems Company, there will be an 80 per cent increase in housing construction contracts in 1977 over 1976. "For the past two and a half years, single-family housing has been the mainstay of the residential recovery, but now it has pretty much reached its upper limit," said George A. Christie, vice president and chief economist of the F.W. Dodge Division. "From now on," Christie continued, "the potential for further gains is in apartment buildings, which showed nearly a 50 per cent gain in June of 1977 over the same month in 1976." The outlook for apartment starts is for a continued rise in 1977, reaching a total of 600,000 to 700,000 units.

What has caused this increased need for other than single-family housing? The first, and most obvious, reason is the high costs of single-family housing—higher than most people are now able to afford.

Beyond these cost figures, some drastic changes have taken place in our culture which have affected the size and formation of households, which in turn, have influenced housing trends. There are more people living alone now than ever before. The Bureau of Census has reported that the number of adults under 35 years of age living alone has more than doubled since 1970. These statistics reflect the high divorce rate, growing career ambitions of women, a general independence of young people living separately from their parents, longer life expectancy and more older people living alone. Further statistics substantiate the new trends by indicating that the population nationally has grown by 5 per cent since

A strong demand for high-density apartments is a result of cost and cultural forces

1970 but the number of households has risen by 15 per cent. And while there has generally been a decline in numbers of people living in the large, metropolitan areas, the number of households has swelled.

There seems also to be an increase in people moving back into the center city after fleeing to the suburbs years ago to raise their families. The desire to be closer to work and services, coupled with inflationary transportation costs (particularly in gasoline prices) have had an impact on the need for inner-city housing.

How are the cities handling this rush for housing? Some, like New York, are providing tax incentives for converting older structures into housing. New York City's J-51 tax abatement program grants substantial tax reductions up to 20 years, determined by the amount of capital improvements. To receive such a tax adjustment a project must meet several regulations including keeping rents within reasonable guidelines, and the developer must provide bedrooms equal to half the number of apartments (to encourage couples and families to remain in the city).

Many states, like Massachusetts (the location of one project in this study) have housing finance agencies which aid in financing private projects, often for elderly or low-income groups. The Federal government has provided some other incentives, the most recent being the Tax Reform Act of 1976 which represents a reversal of former tax policy. It

gives major tax breaks to developers who rehabilitate structures on historic sites, for any purpose.

The need for housing has not solely been responded to by construction of new buildings; it has been caught up in the recycling boom (as evidenced in this study by inclusion of three renovated projects). Results in recycling have been so positive that bankers and developers now recognize the economic advantages of rehabilitation. Developers are looking for usable structures for investment purposes, and they are finding them in the inner city, often in neighborhoods which have experienced declining property values (a result of physical deterioration, crime and other social problems). It is not uncommon, however, to find that the renovation of one building in a dilapidated area has spurred other work, whether it be other rehabilitations, new construction, or just cleaning and painting. These projects have proven to be economically sound, as converted old commercial loft buildings, brownstones and industrial conversions have been fantastically well-received by the tenants. Most of these projects are not low-income housing, but for middle- to upper-income groups.

High-density housing is not a new answer to the problems of housing, but it has been rethought as a good solution to accommodate the large numbers of people staying or moving into the central city. Imaginative solutions have been derived, and it is some of these designs which are explored in this Building Types Study—in a variety that runs the gamut of all approaches to housing, from high-rise to low-rise (for high-density does not necessarily mean high-rise), from new construction to renovation, and for high-income to low-income levels, all located in the re-emerging inner core of metropolitan areas.—Janet Nairn

Transformation of office tower to apartments creates luxurious living space in New York City

The renovation of a New York City office building into apartments has not only given a boost to inner-city housing but has done so in a luxurious manner, providing a quality of living space that can be an inducement for people to stay or move into the center city. Even though the building was not originally designed as an apartment complex, it can seriously compete with other luxury housing in the city because of its design amenities.

Constructed in 1929, this 24-story office building, located near the United Nations on Manhattan's East Side, was severely damaged by a gas explosion in 1974. The explosion funneled up the elevator shafts on the west side, blowing out a 50-foot-wide section of the brick facade from the street level to the top story, but structural damage was confined to the bank of elevators. The architects converted the service elevators to passenger use and cut away the demolished shafts and bent steel end frame, leaving a V-shaped end wall (right). This provides a small street level courtyard and opens up the full 200-foot height of the west wall of apartments to natural light. This change also decreased the building's total volume, and zoning regulations permitted this "lost" space to be regained in the form of greenhouse-type windows installed on the exterior of most upper floors above the 17th level, where setbacks in the ziggurat building visually and functionally, as can be seen in each of the photographs and drawings shown.

The interiors were designed to capitalize on views, light and spatial variety. A total of 341 apartments benefit from the commercial proportions of the building—12-foot-high ceilings, and 8-foot-high windows running the width of most apartments. Because setbacks occur on nearly every floor, and the need to comply with regulations set by the

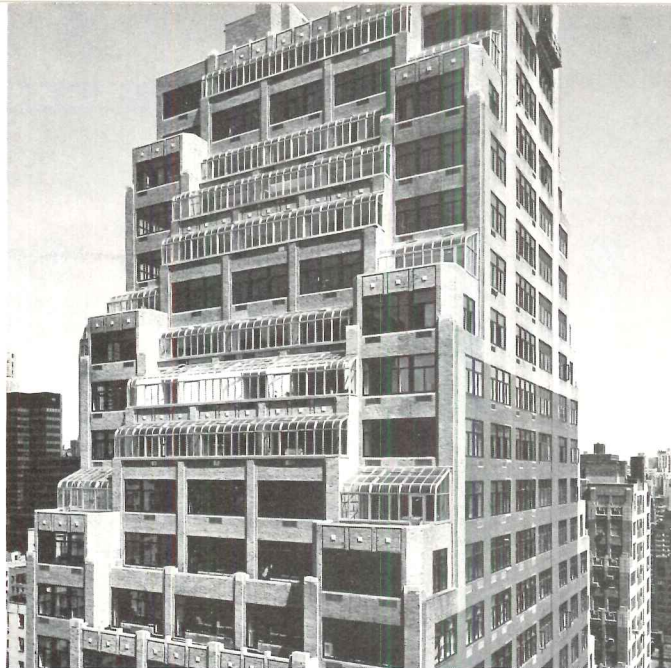

Bill Rothschild photos except as noted

The addition of greenhouses to the exterior is a major aspect of this conversion of office building to apartments. Each glass enclosure extends the apartment outward onto the terrace, and visually highlights the linear apartment design.

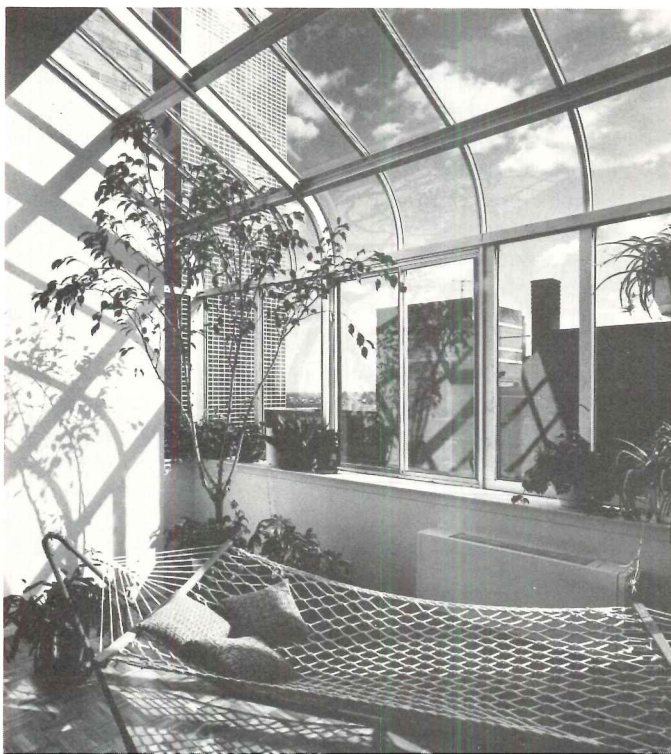
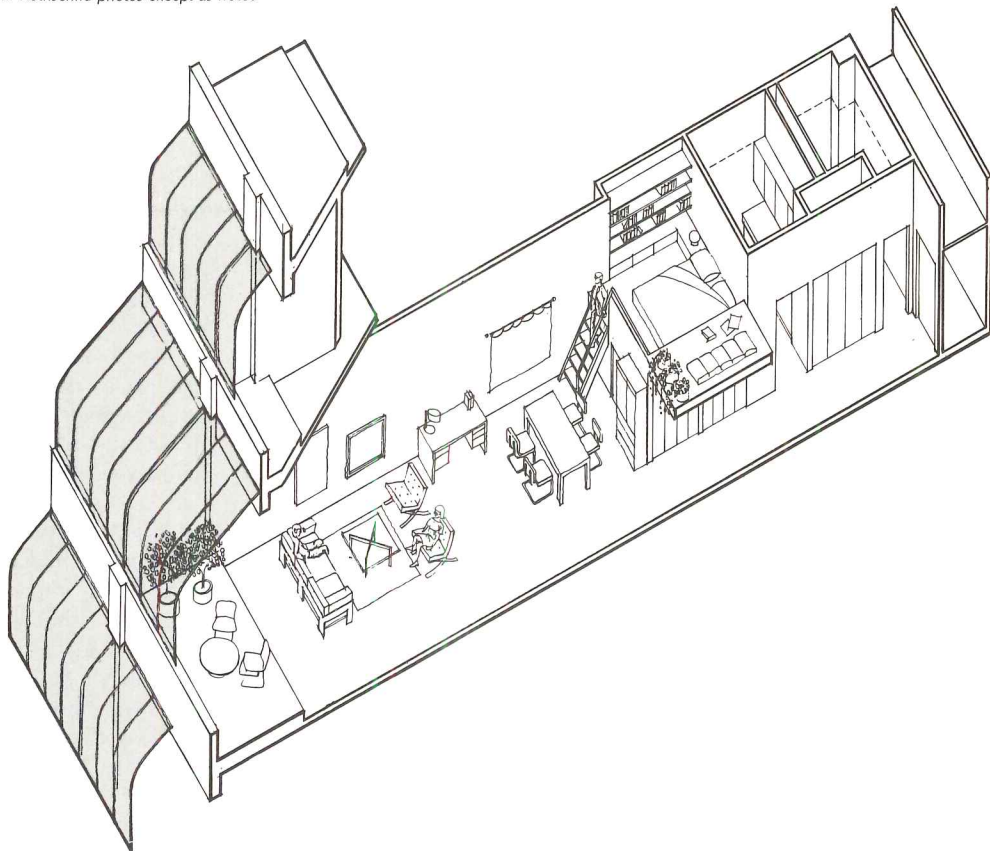



city's J-51 tax abatement program (which made this conversion possible) regarding the ratio of bedroom apartments to studios, each floor posed a separate planning problem. This was solved by the design of linear apartments (some 80 feet in length), running from the elevator core to the perimeter; kitchen and bath facilities that did not exist in the original were positioned near the central elevator core to simplify utilities. All the units are spacious, however, with the smallest studio 850 square feet.

An example of the creative utilization of the structure's idiosyncrasies is the redesign of the service elevators for passenger use. Because the cab platforms were larger than permitted by building codes, a glass-enclosed terrarium was located in the rear of each, providing an unexpected, yet pleasing experience.

The building's entrance was formerly the truck loading dock. Now multi-leveled (with a barrier-free access ramp) connecting a 100-foot-long lobby with elevators and street level entrance, it has been designed in a modern idiom but reminiscent of the building's 1929 origin.

The project is the largest carried out so far under New York City's J-51 tax abatement program, which provides tax incentives for the conversion of commercial properties into residential use (explained in detail on page 111). It also has turned a serious disaster into a very successful asset.

TURTLE BAY TOWERS, New York, New York. Owner: *Rockrose Development Corporation*. Architects: *Bernard Rothzeid & Partners—Peter Thomson, partner-in-charge; Bernard Rothzeid and Carmi Bee, project designers; Vinod Devgan, job captain*. Engineers: *Harwood and Gould* (structural); *George Langer* (mechanical/electrical). Consultants: *Ranger Farrell Associates* (acoustical); *Nathan Silberman* (codes); *Soloman Sheer* (Board of Standard Appeals). Interior design: *Bernard Rothzeid & Partners—Marjorie Colt*. General contractor: *Rockrose Construction Corporation*.



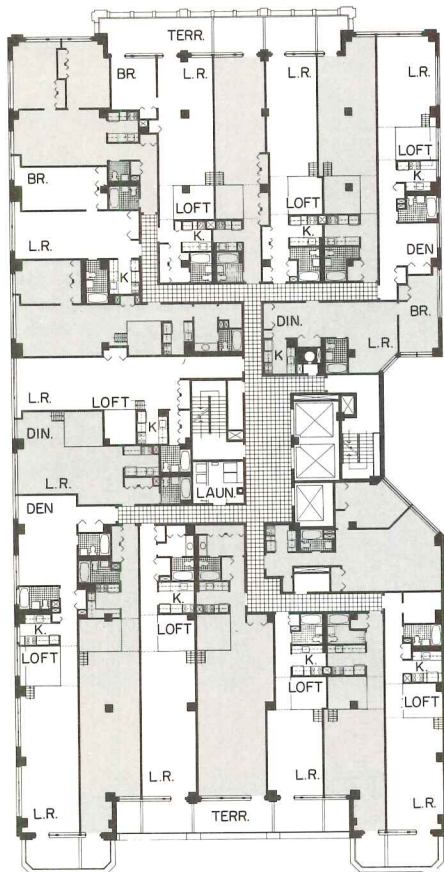

TENTH FLOOR

Lofts were included in the design of many apartments, especially studios, for they provide a spatial variety to the predominantly linear units. There are 341 apartments on the half-acre site, with configurations varying from studios to "townhouses" on the upper floors.

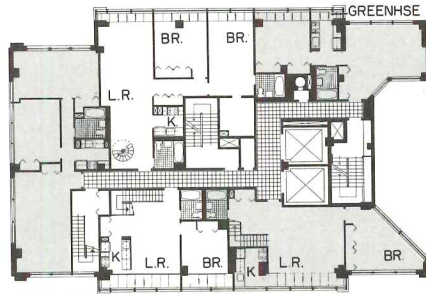

PENTHOUSE (LOWER FLOOR)

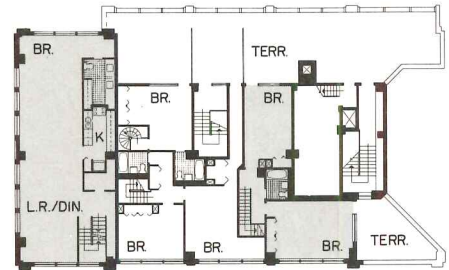

PENTHOUSE (UPPER FLOOR)

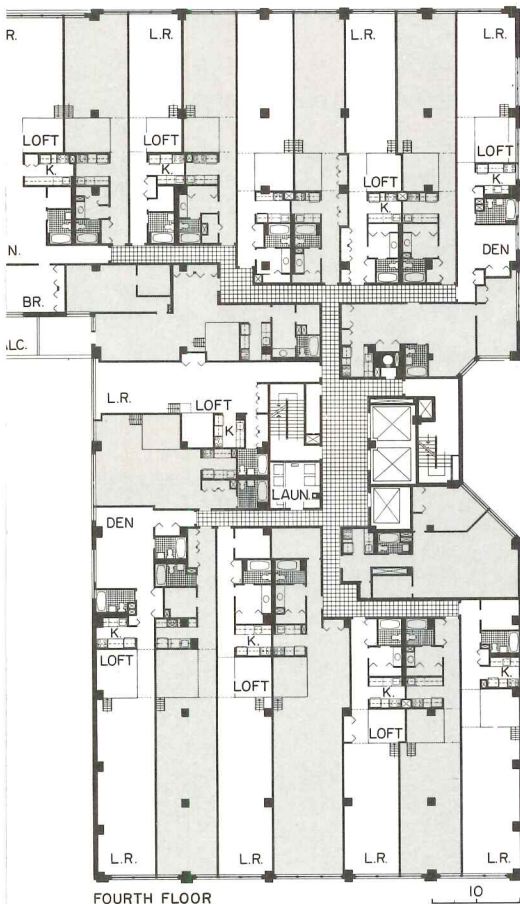

FOURTH FLOOR

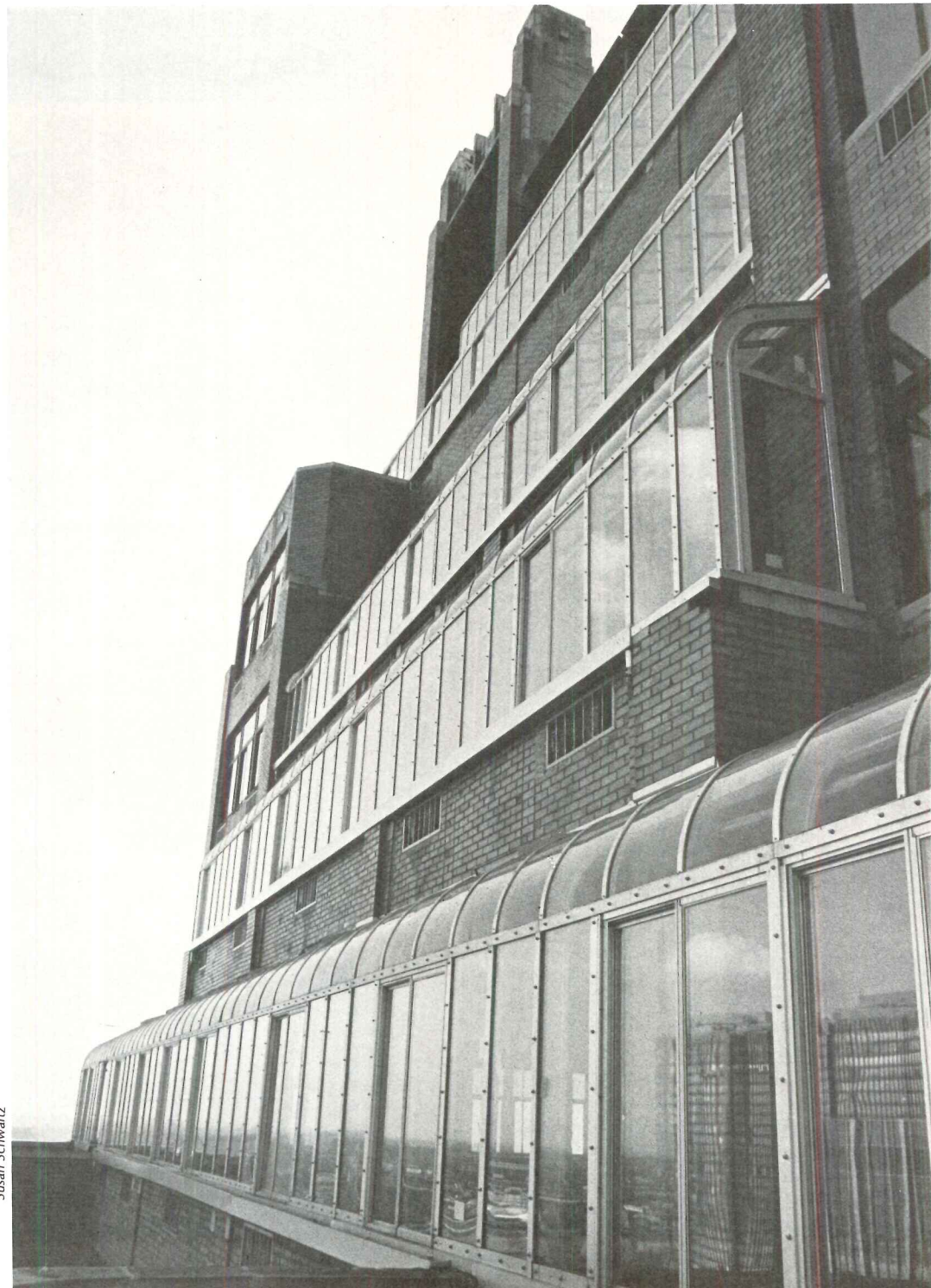

Urban living in San Francisco Bay Area enhanced by Albany Hill high-rise

A new high-rise high-density apartment project in the San Francisco Bay area combines the best aspects of a true urban living experience with an unencumbered, open location, excellent for views of the Bay Area (in an area primarily surrounded by low-rise structures). The first of five phases is now complete on Gateview at Albany Hill—a fine architectural solution to problems associated with providing human-scaled high-density housing (RECORD mid-August 1975, pages 90-91).

An unusual urban site, the project covers 36 acres, and is located near the east shore of San Francisco Bay, on the westerly face of 300-foot-high Albany Hill.

The master plan provides for all the units to be built over a 10-year period, with buildings ranging in height from 2 to 25 stories. The design objective was to develop all phases as a cohesive visual and functional whole, with each phase complete in itself.

Phase One buildings are clustered at the base of the hill, arranged diagonally to a main road and to the hillside, all atop a three-story garage. This arrangement diminishes the over-all bulk of the complex seen from the free-way, permits the best views of the waterfront from the apartments and allows diversity on the inter-connecting plaza level.

Presently there are three buildings with a total of seven towers, averaging a height of 15 stories. Each building has an identifiable color (blue, green or brown). Balconies accent the complex by both color (light-colored railings contrast with darker masonry blocks) and in form, particularly noticeable when seen from across the Bay (bottom right). The over-sized top floor "scoops" denote the location of penthouses.

A mixed-use concept—recreational, commercial and community facilities—are planned. It is a self-contained "city within a city," and will be the largest privately-developed



Charles F. Holbrook

A custom "shingle" masonry block was designed for the exterior with a large module easily perceivable from a nearby freeway. A system of building sections was conceived, each made of four to six units grouped in a way unique to that section. This is connected to one or two others until a total building plan is formed. While seemingly unnecessarily complicated, this system has assured diversity in individual apartment floor plans and differences between towers.

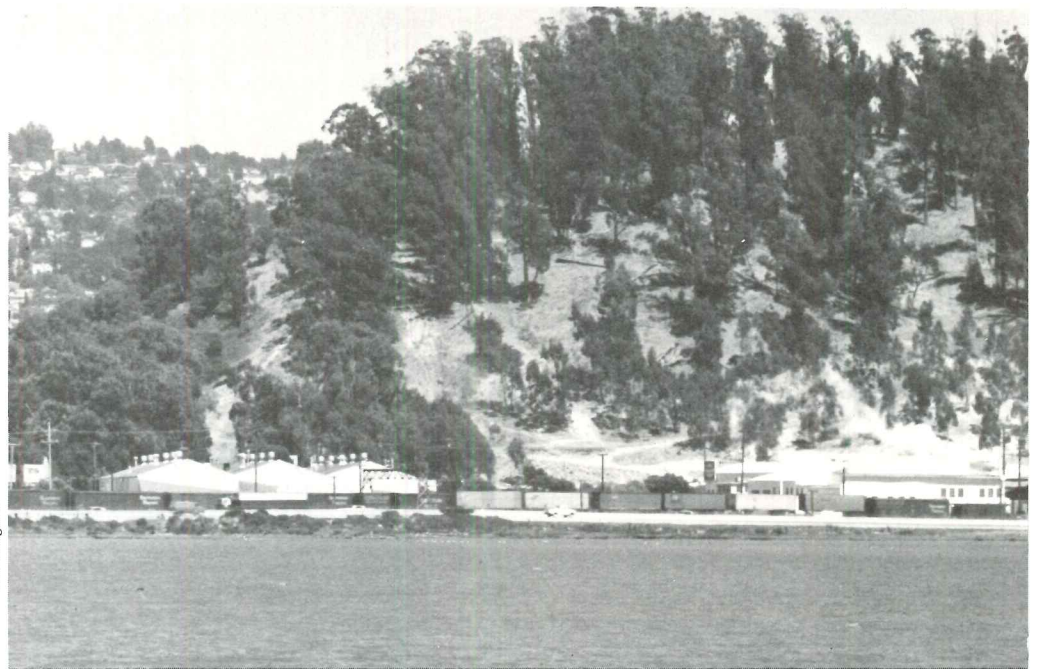

Fred English



residential community in the urban Bay Area.

It is a high-density complex, and development is expected to reach 2500 units built on one-third of the 36 acre site providing approximately 200 units per acre. The remainder of the land will be preserved as permanent open space. Phase One is composed of 482 units, with a total of 478,000 square feet of living space. The buyer's market is directed to middle-income groups.

To combat the alternate lifestyle offered in the suburbs, the architects placed emphasis on aspects of the project that would provide many amenities not found in the suburbs. There are uninhibited views of the San Francisco Bay and other parts of the area to the west, and to a tree-lined hillside to the east. The proximity to transportation corridors is important, in one direction to a nearby Bay Area Rapid Transit Station (which links major cities and counties of the Bay Area) and to another, a freeway which borders the site.

Sophisticated life safety, voice communication and security systems are provided—one of the most modern in the Bay Area. A central control room monitors all these functions with special capabilities to aid emergency personnel in any kind of crisis.

GATEVIEW AT ALBANY HILL, Albany, California. Owner: *Interstate General Corp.* Architects: *Hallenbeck, Chamorro & Associates* (formerly *Goetz Hallenbeck & Goetze, Inc.*)—*Harry C. Hallenbeck, partner-in-charge.* Engineers: *Shapiro Okino Hom & Associates* (structural); *Cooper Clark & Associates* (soils); *G.L. Gendler & Associates* (mechanical); *Yarnell & Ron* (civil). Consultants: *Harmon O'Donnell & Henninger* (planning); *Environmental Impact Planning Corp.* (for master plan); *Bolt, Beranek & Newman Inc.* (acoustical). Interior design (apartment shown); *the Inside Story Inc.-San Francisco.* Contractor: *Williams & Burrows.*



Charles F. Holbrook

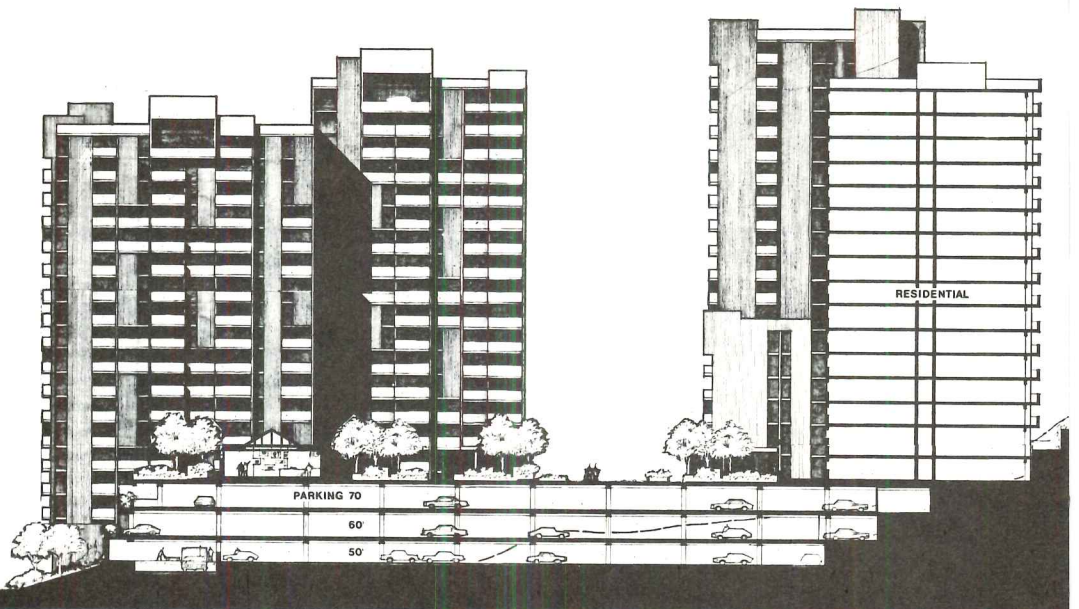

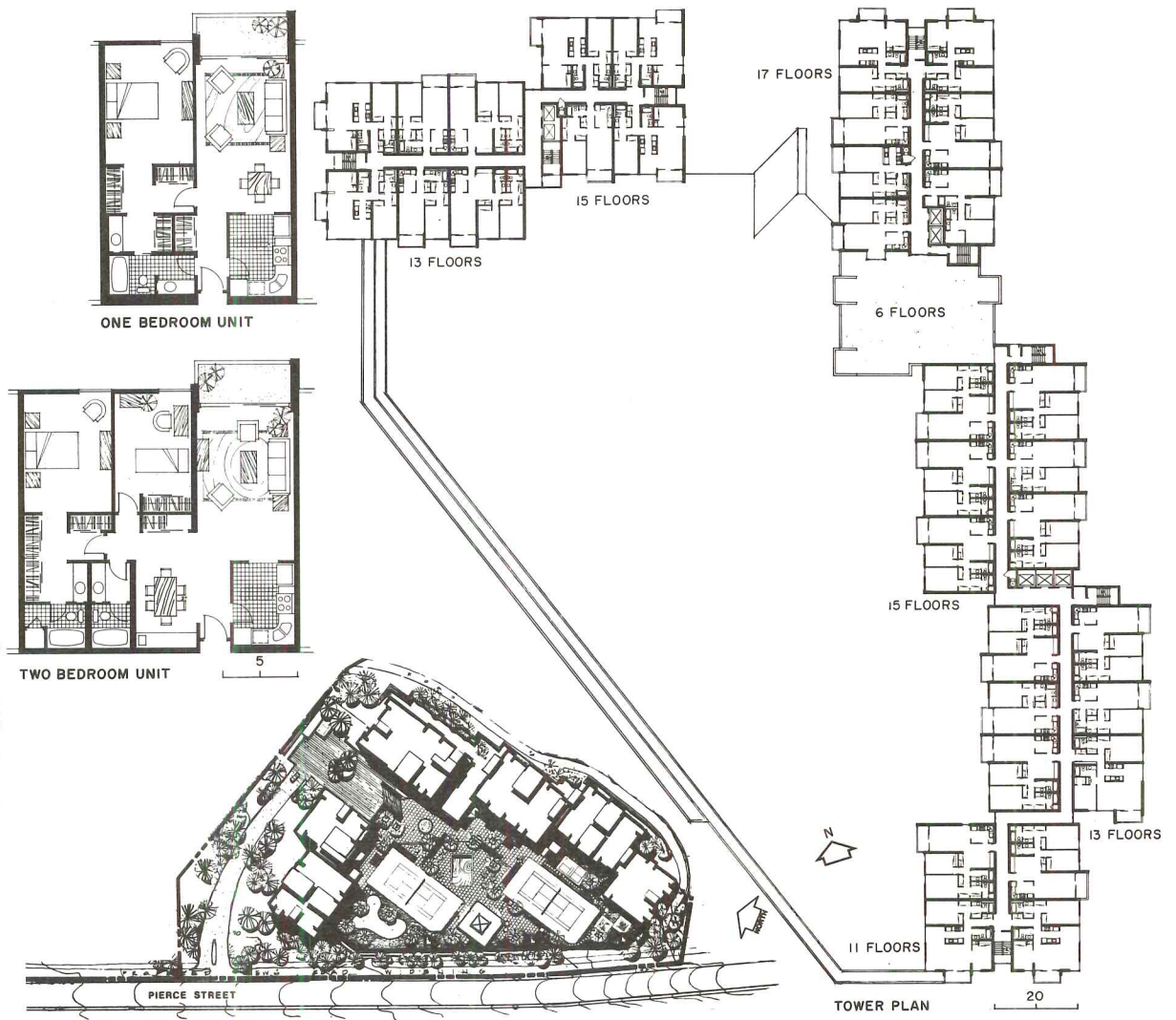

A seismic code limited the building height to a maximum of 160 feet, but the ultimate height, massing and scale of Phase One fits most appropriately with the natural setting and conforms to the slope of Albany Hill. A master plan for the complex evolved from a series of studies particularly dealing with the massing. Staggering the units—dismissing a more traditional grid-related siting system—provided a much more useful and interesting pattern to the complex while granting apartment orientation in all directions.



Custom tailored apartments in Nashville fit together like a high-rise jigsaw puzzle

In an innovative approach to the design of a new high-rise apartment complex, the developer permitted the market—the tenants/buyers—to determine the size, number and location of apartments in the building during construction.

The architects devised 23 possible apartment plans from which the tenants selected what best suited their needs. Over 50 possible floor configurations, ranging from ten one- to two-bedroom suites, were studied. As buyer commitments progressed, the architects fit all the pieces together like a jigsaw puzzle.

There were, of course, some inescapable parameters that predetermined fitting the pieces together, including (most obviously) the building size and shape, plus the placement of mechanical systems for function and economy, and the fenestration detailing. The location of a series of vertical chases (containing plumbing and air circulatory equipment) was set throughout a fan-shaped building with a centralized elevator core.

The most visual and intriguing aspect of the design is the handling of the fenestration. Since the market determined the unit placement and ultimately the elevations, the window pattern reflects the various combinations of units on each floor. (In practice, certain unit designs were chosen more often; the two-story townhouse received general favor because of its spatial amenities).

This wide-open planning flexibility was attractive to the tenants, enticing middle- and upper-income-producing persons to consider high-rise living and remain in the center city, all with a degree of choice not often available in apartment houses.

ROKEBY CONDOMINIUM APARTMENTS, Nashville, Tennessee. Owner: *The Rokeby Corporation*. Architects: *Barber & McMurry Architects*. Design consultant: *Martin Holub*. Engineers: *Quickel & Bennett* (structural); *Walter L. Montgomery* (mechanical); *Vreeland Associates Engineers* (electrical). General contractor: *W. F. Holt & Sons*.

Larry Taylor photos

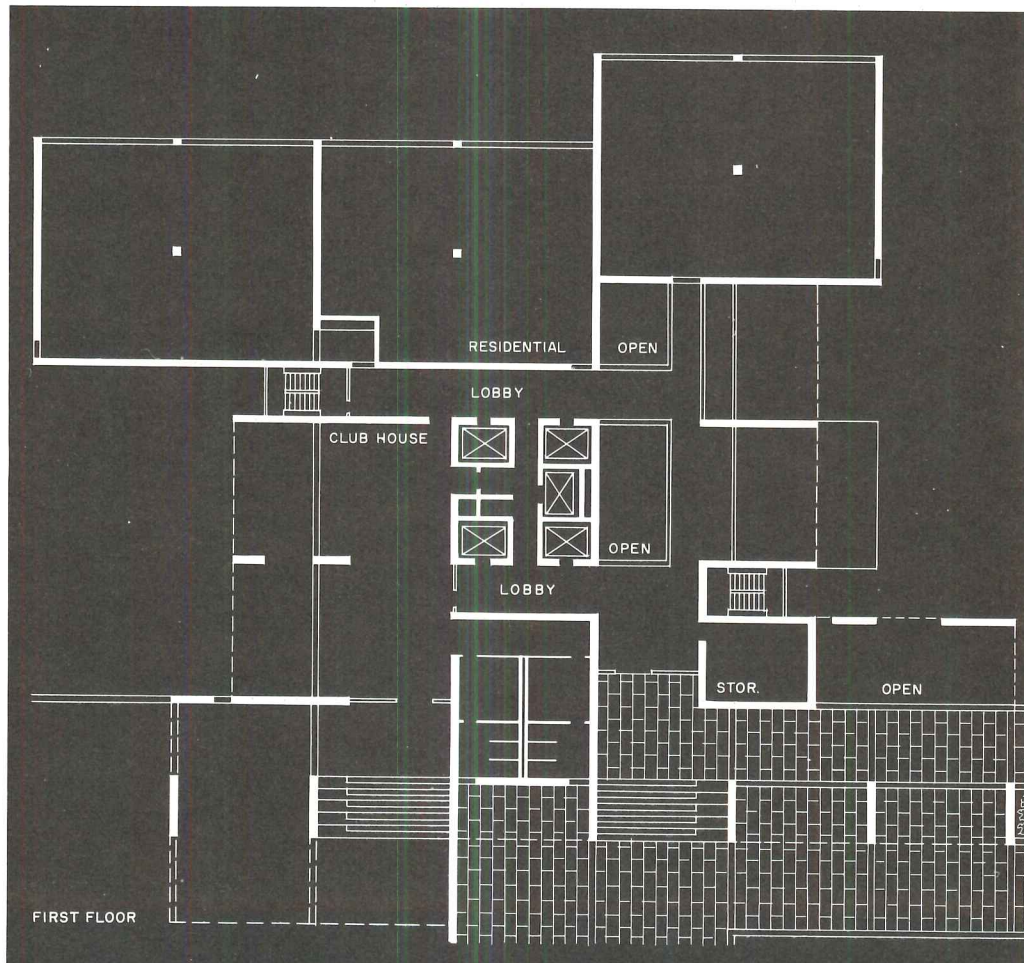
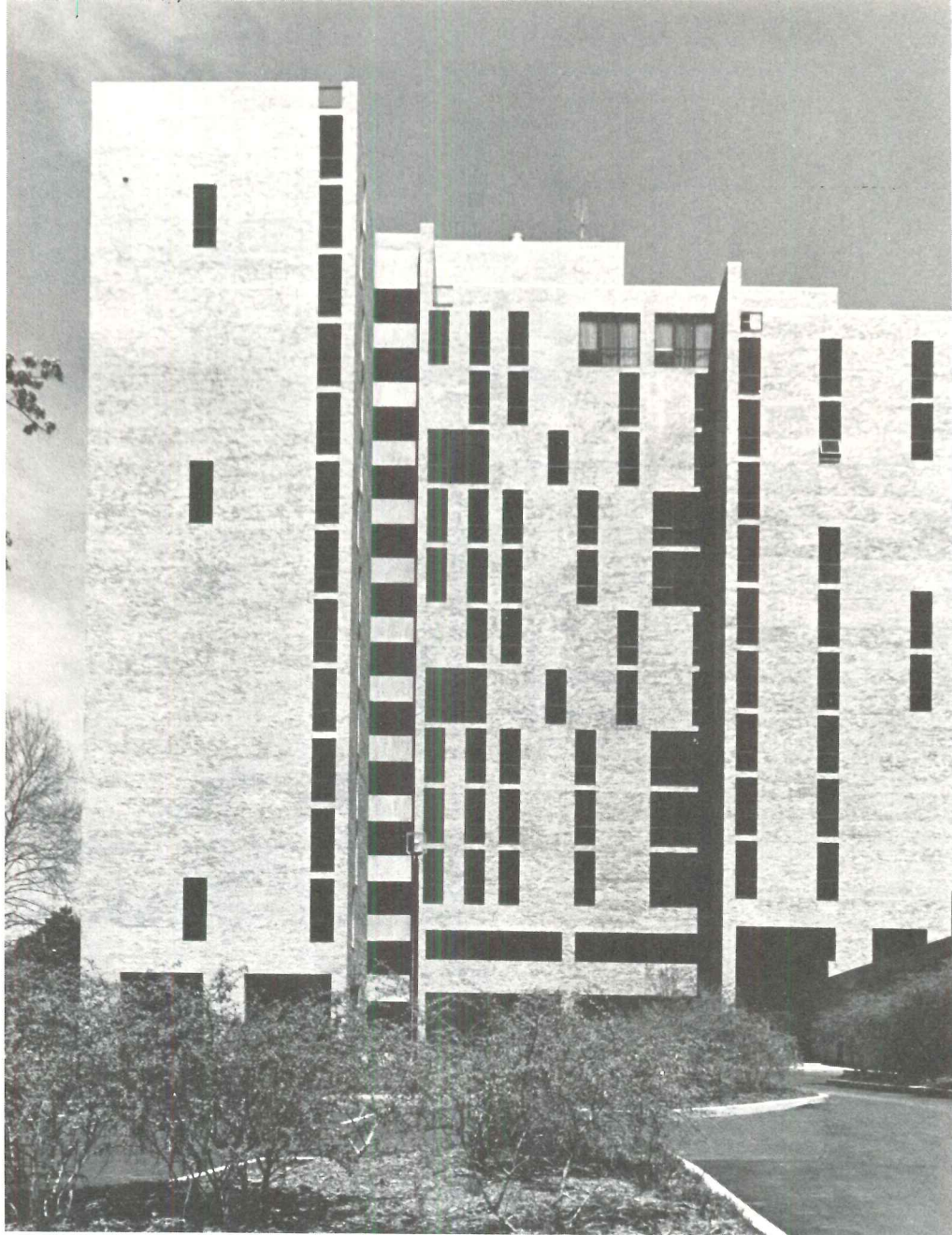

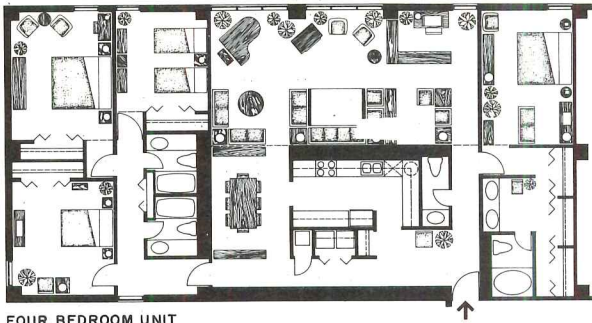

FOUR BEDROOM UNIT

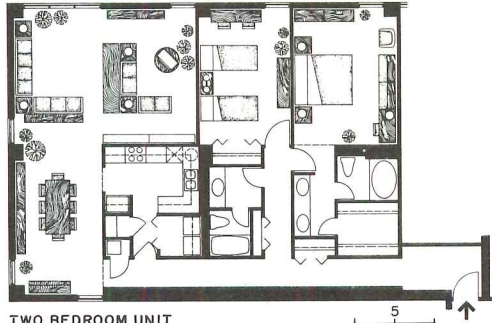

TWO BEDROOM UNIT

A variety of floor plans, from one- to four-bedroom units and townhouses, were designed in full cooperation with the tenants. All units interlock in different patterns, and there is no typical floor plan. Diverse unit combinations are noticeably reflected in the fenestration. One of Nashville's few high-rise residential structures, it is successfully competing with well-established low-rise and garden apartments. There is also a delightful, light-filled rooftop tea room (right).

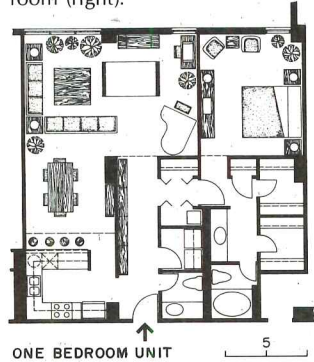

ONE BEDROOM UNIT



UPPER FLOOR

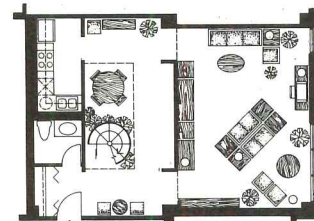

TOWNHOUSE UNIT MAIN FLOOR

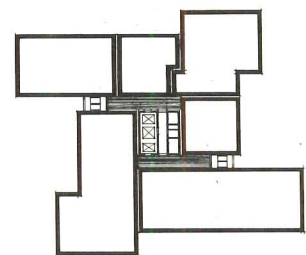

High-density apartment conversion in New York City affords special design amenities

An imaginative design concept for the renovation of an old blacksmith shop and rooming house into modern apartments has created a special living experience in the heart of New York City. The original structure had three distinct sections with varying roof heights—a four-story section at the front, a one-story section at the middle of the lot, and a two-story portion in the rear.

The four-story portion was a rooming house, now modernized as one-bedroom and studio units. The blacksmith shop had occupied the entire first floor, but in order to create an inner courtyard the one-story section (which housed the forge) was removed. The rear area was converted into apartments which overlook the courtyard.

Only minor structural changes were required. A new six-foot-high party-wall was erected and a new outside stairway, designed with special railing details, was installed to increase efficiency of circulation.

Recycling this building has helped to preserve the character of the neighborhood and encouraged business expansion through the inclusion of commercial space on the ground level.

The owner was able to take advantage of New York City's J-51 tax abatement program which encourages apartment conversions. In this case, a tax abatement for ten years has been exchanged for compliance with all the program's regulations, including rent qualifications and the proper ratio of bedroom apartments to studios.

There is a total of eight apartments on the 20- by 100-foot lot—a high density.

240 EAST 26TH STREET APARTMENTS, New York, New York. Owner: Barry E. Fallis/Arida Properties, Inc. Architects: Marvin H. Meltzer Architects—Marvin H. Meltzer designer; Len Pitkowsky, project architect. Engineers: Antony Vairamides (structural/foundation/soils); Hecht, Hartmann & Concessi (mechanical/electrical). General contractor: Malor Construction Company.



THIRD FLOOR

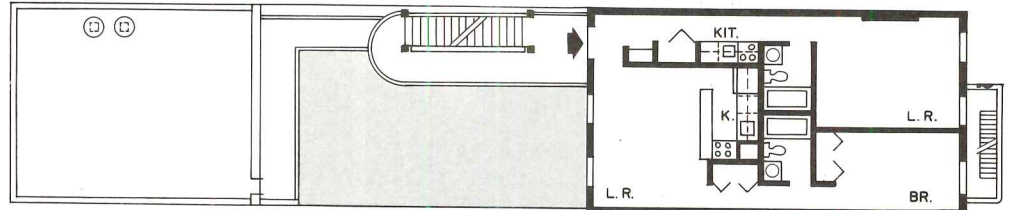

SECOND FLOOR

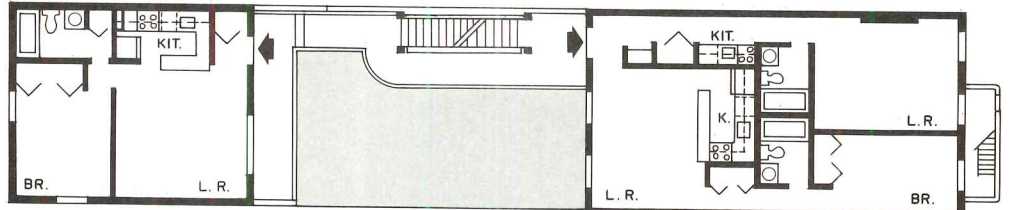

FIRST FLOOR

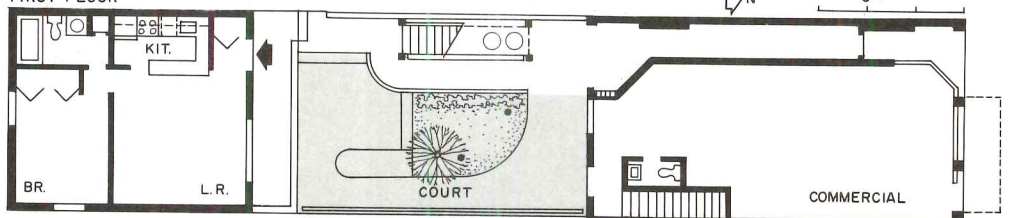



Elliot Fine photos

The courtyard is the main focal point of the complex (right). There is a contrast between the interior landscaped court and the street elevation—dramatically highlighted after entering through a covered walkway (bottom). The courtyard also serves as the main organizing and circulating space, while being a pleasant respite. Nearly all apartments have some view of the courtyard.

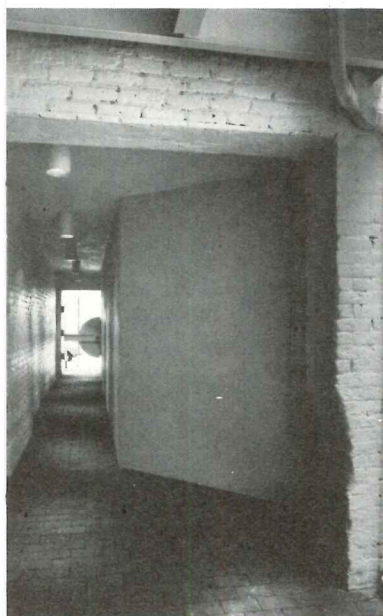

Recycled tannery provides historical and spatial amenities for elderly near Boston

An outmoded tannery complex has been recycled into housing for the elderly and has demonstrated the potential worth of such actions for smaller communities and for buildings that are less than landmark structures. The project has also brought new life to the neighborhood and a bit of history.

The complex was abandoned in 1971 because the buildings did not meet current industrial standards. The architects pinpointed and selectively demolished deteriorating structures, retaining three buildings (two six-story masonry and one three-story reinforced concrete building). Each was gutted and 284 apartments were constructed in a combination of efficiency, one- and two-bedroom apartments and duplex designs. Ten per cent of the units are specially equipped for handicapped tenants. Spatial variety in the original was maintained; in one instance, the roof of one building was jacked-up to provide space for duplex apartments. The exterior walls were cleaned and interior wooden beams and ceilings sandblasted to complete the recycling. Glass-enclosed bridges connect the two large apartment houses to the community center.

The project was financed by a \$6 million mortgage from the Massachusetts Housing Finance Agency. It was the first time such funds were applied to recycled construction outside the Boston area. Twenty-five per cent of the total units are low-income housing and subsidized by the state; the remaining 75 per cent are either partially subsidized by the state or are at full market rentals.

THE TANNERY, Peabody, Massachusetts. Owner: *Crowninshield Corporation*. Architects: *Anderson Notter Associates, Inc.* Engineers: *David M. Berg, Inc.* (structural); *Samuel Lesburg Associates* (mechanical); *Goodall Shapiro Associates, Inc.* (electrical). Landscape architect: *John G. Crowe*. Architectural historian: *George M. Wrenn III, Society for the Preservation of New England Antiquities*. General contractor: *Taylor Woodrow Blitman Construction*.



Remnants of the former tannery have been saved and reused, to provide "historic continuity" to the complex and site. Old tannery vats and drying wheels are now used as planters in the parking areas. Some foundations or walls (example left) are other than functional, lending an element of surprise or delight while retaining a special quality to the old structure. The pond was also cleaned-up to make a pleasant spot.

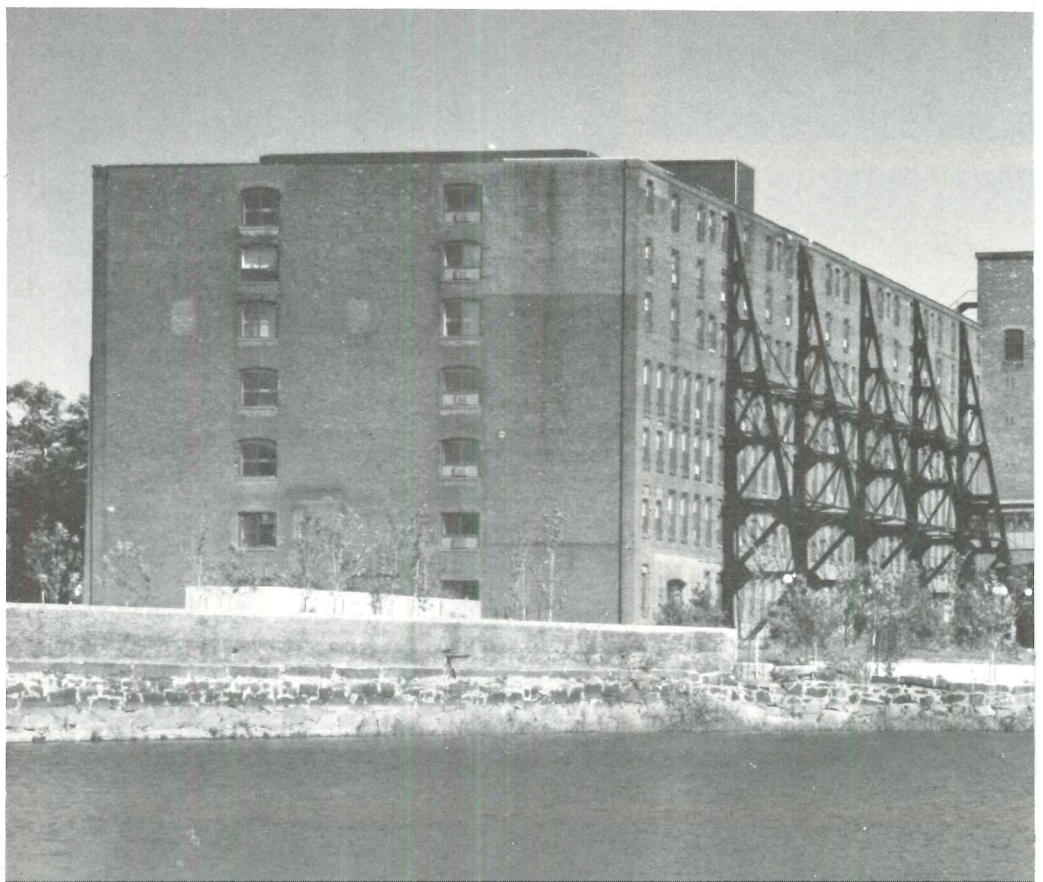
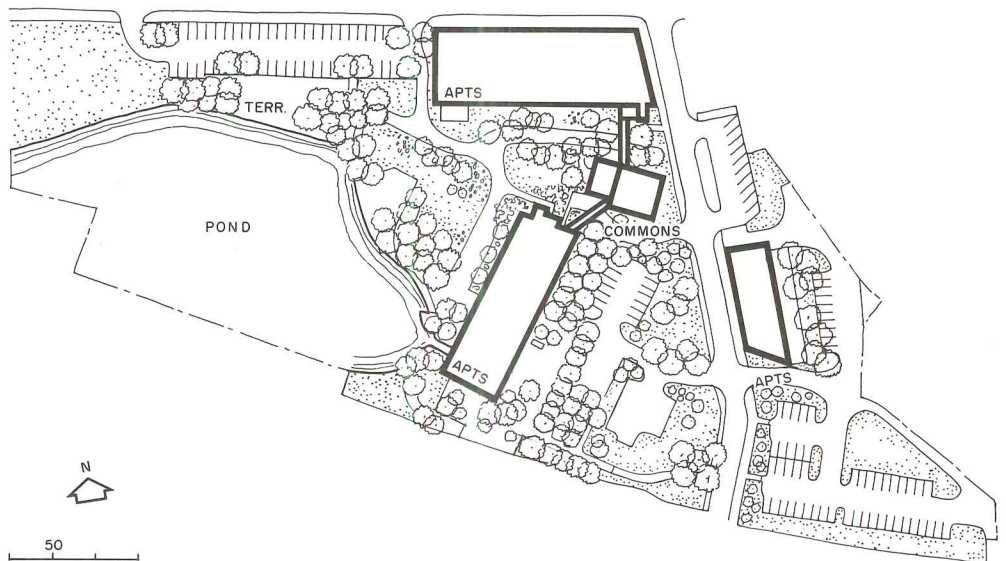



Phokion Karas photos





Community facilities, at the Tannery, including the management's offices, laundry and meeting rooms (left), are housed in an old mansion on the site. Due to varying structural and dimensional conditions, interior features such as high ceilings, heavy timber beams, exposed cast iron details provide attractive living and meeting spaces.

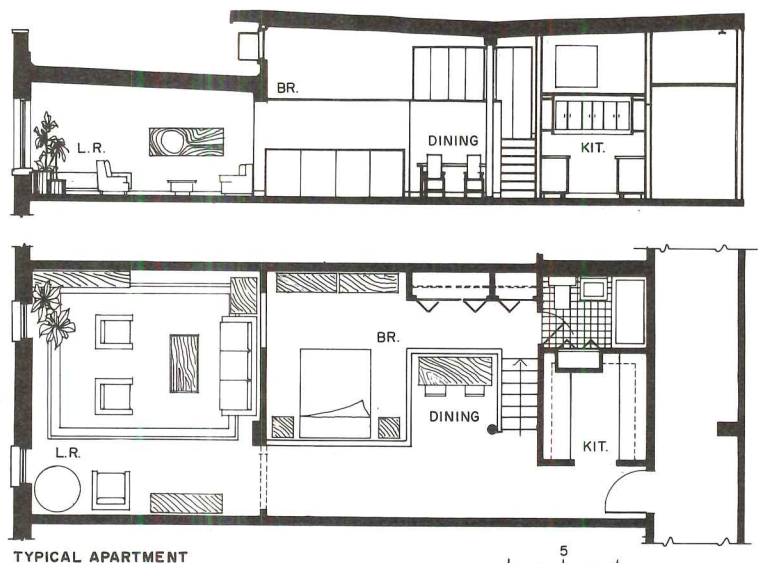

Plastic-composite design cuts steel tonnage in Johns-Manville's new headquarters building

The weight of long-span members is reduced substantially by exploiting the plasticity of steel and the composite action of steel and concrete

by William J. LeMessurier,
LeMessurier Associates/SCI,
consulting structural engineers

The structural challenge in the Johns-Manville building (pages 89-100) was to achieve an economical design while providing earthquake resistance and very large spans. The solution involved an unusual floor system (see framing plan next page) which has applications to other buildings with large spans.

Lateral strength for wind and earthquake was concentrated in three large cores. These cores, which measure 54 by 121½ ft, are framed with steel columns and steel diagonal braces. Each is approximately centered in one-third of the 1053-ft-long building. Since the cores can take both torsional and translational forces, other columns were assumed to be braced—a necessary condition if plastic design were to be used for the rest of the frame.

Plastic design in steel means that the structure is analyzed on the basis of its ultimate strength, allowing yielding to occur. The total margin of safety against collapse is the same as for simple beams. The unusual feature in the Johns-Manville building is the use of composite action of steel beams and concrete slabs simultaneously with plastic design, substantially reducing the required steel.





The chart below shows five ways of designing a steel beam to carry a uniform load. Case I is a basic simple span with maximum moment of $WL/8$. If a 24-in. steel beam is designed to span 48 ft carrying 1 kip per foot of live load, ceiling, and partitions and 1.3 kips per foot of concrete and steel, a W24 x 130 is required.

Case II is a composite steel and concrete design using a 5-in. slab anchored to the beam with shear connectors. An approximate rule of

thumb says that the capacity of steel is increased one-third by composite action with concrete. This means that the steel alone can be chosen for an equivalent moment of $3/4 \times WL/8$. For this case a W24 x 100 is required.

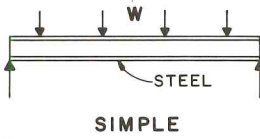
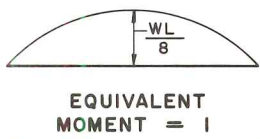
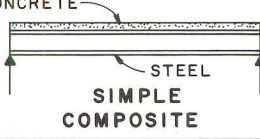
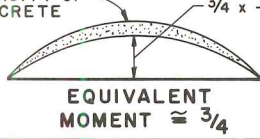
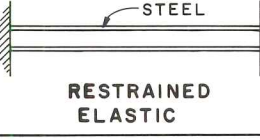
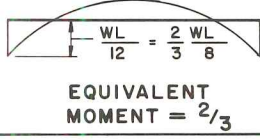
Case III is a beam restrained by rigid supports. Elastic analysis gives a maximum negative moment of $WL/12$ at the ends. Therefore, the equivalent moment is $2/3 \times WL/8 = WL/12$. A steel beam for this condition must be W24 x 94. This design assumes that maximum capacity occurs when yielding begins at the ends in the region of high negative moment.

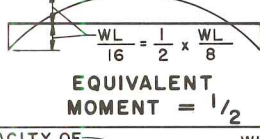
Case IV recognizes that failure in the sense of collapse does not happen until yielding of both the ends and the center occurs. Since the end and the center each carry one-half of the total moment, the equivalent moment is $1/2 \times WL/8$. For this case a W24 x 76 is required.

CASE	BEAM TYPE	MOMENT DIAGRAM	BEAM SIZE	DEAD, LIVE AND CREEP DEFLECTION	RELATIVE DEFLECTION EFFICIENCY
I	 SIMPLE	 EQUIVALENT MOMENT = 1	W 24 x 130	D = 1.33 L = 1.02 C = .00 Σ = 2.35"	1.00
II	 SIMPLE COMPOSITE	 EQUIVALENT MOMENT = $3/4$	W 24 x 100	D = 1.74 L = .59 C = .11 Σ = 2.44"	.53
III	 RESTRAINED ELASTIC	 EQUIVALENT MOMENT = $2/3$	W 24 x 94	D = .39 L = .30 C = .00 Σ = .69"	.22
IV	 RESTRAINED PLASTIC	 EQUIVALENT MOMENT = $1/2$	W 24 x 76	D = .49 L = .39 C = .00 Σ = .88"	.22
V	 RESTRAINED PLASTIC-COMPOSITE	 EQUIVALENT MOMENT = $3/7$	W 24 x 61	D = .66 L = .32 C = .03 Σ = 1.01"	.16

Case V, plastic-composite, recognizes that the beam's total strength is the sum of the plain steel capacity at the end and the composite steel and concrete capacity at the center. If the composite capacity is assumed to be 4/3 that of bare steel, the equivalent moment for choosing a section is $WL/8$ divided by $(1 + 4/3)$ or $3/7 \times WL/8$. Actual design results in a $W24 \times 61$.

It is obvious that substantial savings in steel are achieved by using restrained beams and composite action, but each of these devices has its cost. Composite design requires controlled concrete and shear connectors. Restrained design requires columns with extra strength to provide the restraining moment, especially for end spans. With short spans of 20 ft or less, composite action is rarely economical. Over 30 ft, composite simple-span beams are commonly used. Floor girders restrained by rigid connections to stiff columns become economical for gravity loads when spans are 40 ft or more. Using plastic-composite design for spans over 50 ft with normal story heights, the costs of shear connectors and extra column weight are more than offset by savings in girder weight.

In addition to increased strength, plastic-composite design is beneficial in terms of deflection control. The restraint of beams is the best way to reduce deflection on long spans where beam depth is limited. In plastic-composite design, deflections are fully elastic at working loads. Positive moments at working-load levels are low so that the concrete has very low stresses, which means that creep deflection will be minimal. The chart lists deflections for concrete and steel loads alone, assuming the beams are unshored. Also listed are deflections for loads added after concrete has hardened. In this case, both elastic deflection and creep deflection are given assuming 60 per cent of the added load is from a permanent ceiling and partitions. An index of efficiency is the relative long-term deflection from superimposed loads times beam weight, given in the last column of

the chart. Obviously, the plastic-composite design has the best performance.

Two typical bays of the Johns-Manville building are shown at the bottom of the page. Main girders are $W30 \times 116$. These span 54 ft and were designed as plastic-composite members. The secondary beams are $W24 \times 55$ and were designed as simple-span composite. Continuity for these beams was not necessary for deflection control. All steel had a yield point of 50,000 psi.

In designing the columns, we used the plastic design method. Exterior columns were rolled sections up to $W27 \times 177$. Heavier columns were built-up. The plastic-composite approach gives the lowest column moments of any of the three restrained cases.

If the $W30 \times 116$ girder in the Johns-Manville building had been designed as a simple span (Case I), a $W33 \times 220$ would have been required. Simple composite design (Case II) would have required a $W30 \times 190$. Both of these would have had substantially greater deflections under superimposed load than the actual design.

Plastic-composite design is not specifically described by the American Institute of Steel Construction Specification. In this writer's opinion, the intent of AISC will be met if the composite region at midspan is designed for a moment equal to the total simple span moment, $WL/8$, minus $1/1.7$ times the steel's plastic moment capacity. This assumes adequate strength and stiffness in restraining columns, adequate lateral bracing of the beam, and independent bracing of the whole building for lateral loads.

The analytical simplicity of plastic-composite design is an additional benefit. A complex indeterminate analysis is unnecessary for maximum moments. The method should be considered wherever long floor spans occur in braced buildings. The writer has successfully used it in structures with spans of 90 ft.

Structural bays in the Johns-Manville building are 54 by 40½ ft. In the long (54-ft) dimension, $W30 \times 116$ girders were designed for plastic-composite behavior. In the shorter dimension (40½ ft) the $W24 \times 55$ beams were designed as simple-span members, and, thus, only for composite action.

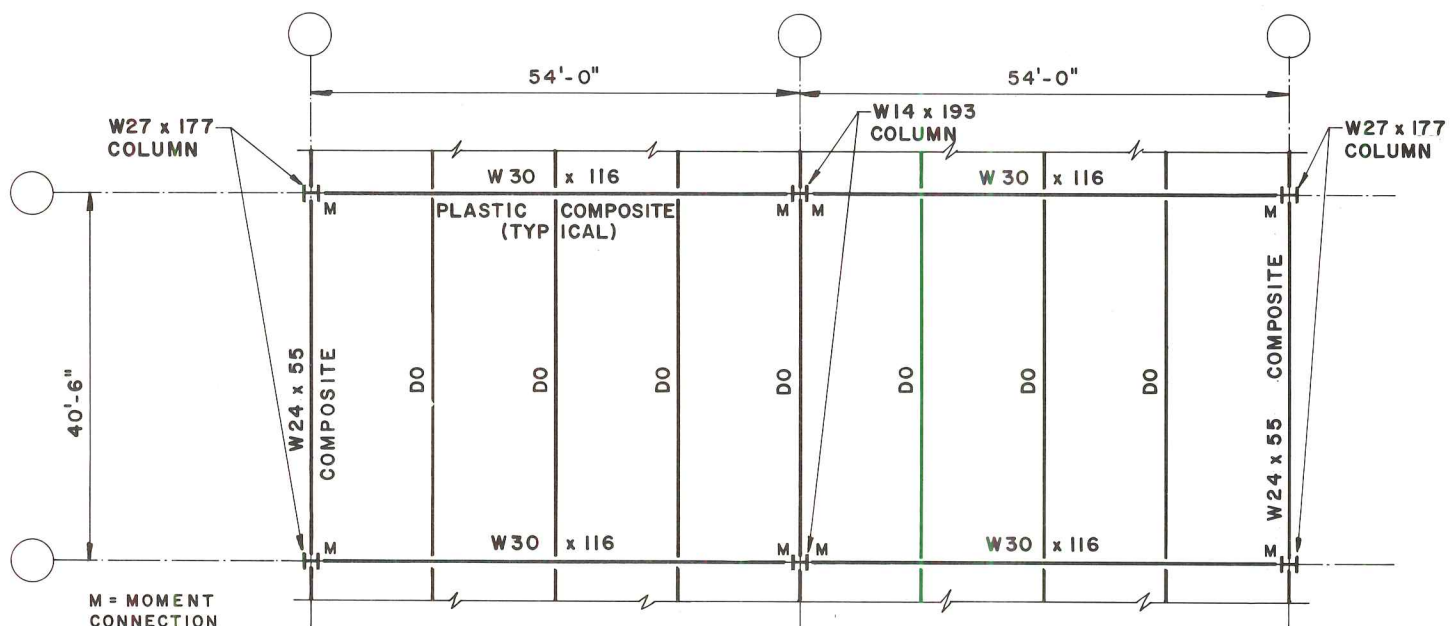

EVERYONE'S AHEAD BEHIND AN AMARLITE CURTAIN WALL.



The Architect is ahead because, by specifying Amarlite curtain walls to be combined with environmental glass, he has made the professionals on the Amarlite Anaconda curtain wall team available to assist him from conception to conclusion of the project. And in addition, he has provided his client with a building of thermally improved excellence, without compromising his own esthetics.

The Owner is ahead because the Amarlite Anaconda curtain wall team has helped with cost studies, bidding, engineering and even installation. And because Amarlite's thermally improved curtain walls cut down on air conditioning and heating needs, which can mean far less cost up front.

The Manager is ahead because the Amarlite thermally improved curtain walls,

designed to prevent heat transfer, keep the building evenly comfortable. Which means they reduce day-to-day heating and cooling operating costs, reduce interior climate system adjustments, and reduce tenant complaints to a bare minimum.

The Tenants are ahead because they're totally comfortable. Warm all winter and cool all summer since Amarlite's continuous thermal spacers isolate the curtain wall from interior to exterior, providing a highly efficient thermal barrier.

So if your project calls for architectural aluminum that meets the demands of today's market — anything from curtain walls to storefronts and Safetyline™ doors — pick up the phone and call Amarlite Anaconda.

Then you, too, will be ahead.

AMARLITE
ANACONDA Aluminum Division

Main Office: P.O. Box 1719, Atlanta, Georgia 30301. Regional Sales Offices: Atlanta, Ga. (404) 352-3260 • Chicago, Ill. (312) 352-3714
 Cleveland, Ohio (216) 267-8080 • Dallas, Texas (214) 631-6620 • Ft. Lauderdale, Fla. (305) 525-4768 • Paramus, N.J. (201) 262-1540

For more data, circle 53 on inquiry card



Architects: Prindle, Patrick, and Partners
 Construction Manager:
 Turner Construction Company

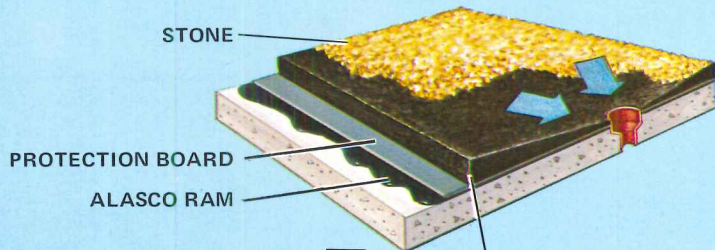
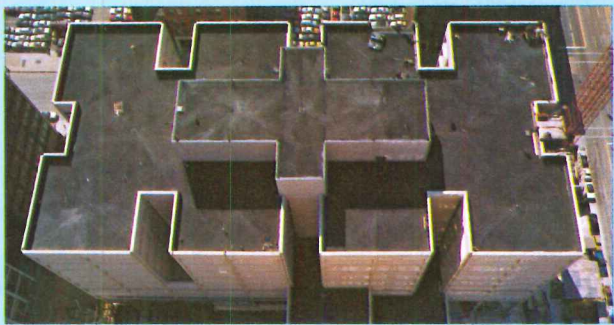

 **All-weather Crete®**

The defense never rests on the roof of the Cuyahoga County Justice Center!

To defend the roof and plaza decks of the Cuyahoga County Justice Center in Cleveland against energy losses and the onslaught of the elements was of prime importance to the designers. Over 200,000 square feet of deck had to remain water tight, perform efficiently and have little or no maintenance for years. All-weather Crete Insul-Top and Plaza Systems were used. Two unique materials account for the success of these systems. One is All-weather Crete, a monolithic insulating fill applied hot and dry, and having an excellent K factor. The other is Alasco RAM, a rubberized asphaltic waterproof membrane that retains it's elastic "life" indefinitely. On both roofs and plazas in the Justice Center, Alasco RAM was poured to form a seamless waterproof membrane

directly on the flat structural deck. Protection board was adhered to the hot Alasco RAM. All-weather Crete was then compacted over the membrane system, and sloped to drains. The result—a seamless insulating barrier with positive water runoff. Thus, for the life of the building, AWC defends the membrane against thermal shock, ultra-violet rays, the elements, puncture and water ponding. Send for AWC brochure.

 **SILBRICO CORPORATION**

6300 RIVER ROAD • HODGKINS, ILLINOIS 60525
 CHICAGO PHONE (312) 735-3322

For more data, circle 54 on inquiry card

Read a steel joist. You'll find profit between the lines.

Those open spaces in open web joists tell a convincing story in terms of faster, less expensive construction. That space can be there to start with because the joist is made from modern high-strength steel. Steel that gives structural muscle with less material weight and less cost. Open web joists are easy to handle. They go up fast and need no platforms or flooring. And, when it's time to install duct work, wiring or piping, that open web is beautiful. You can do them all simultaneously. Before you start your next job, read the latest edition of Standard Specifications and Load Tables. It gives the facts on Open-Web, Longspan and Deep Longspan Joists. It's free. Just mail the coupon.

between
the lines.

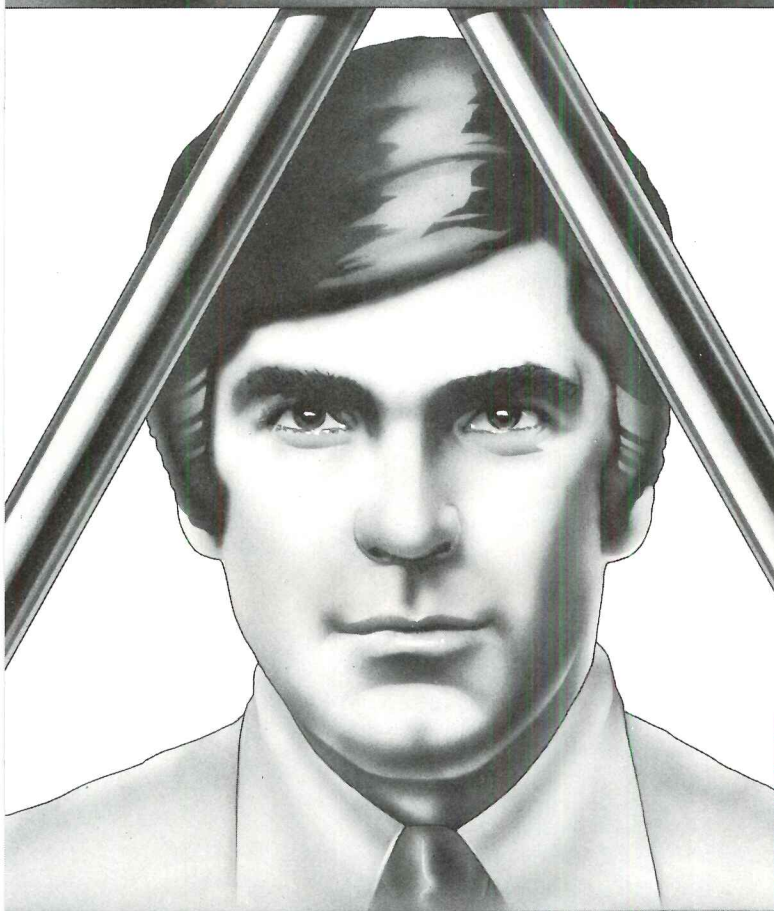

For more data, circle 55 on inquiry card

Mail to:
STEEL JOIST INSTITUTE
Room 204, 1703 Parham Road
Richmond, VA 23229



Please send me your latest copy of Specifications and Load Tables.

NAME _____

TITLE _____

FIRM _____

ADDRESS _____

CITY _____ STATE _____ ZIP _____

77-002

VERMONT MARBLE COMPANY
Proctor, Vermont 05765



**The mystery of jade.
The magnificence of marble.**

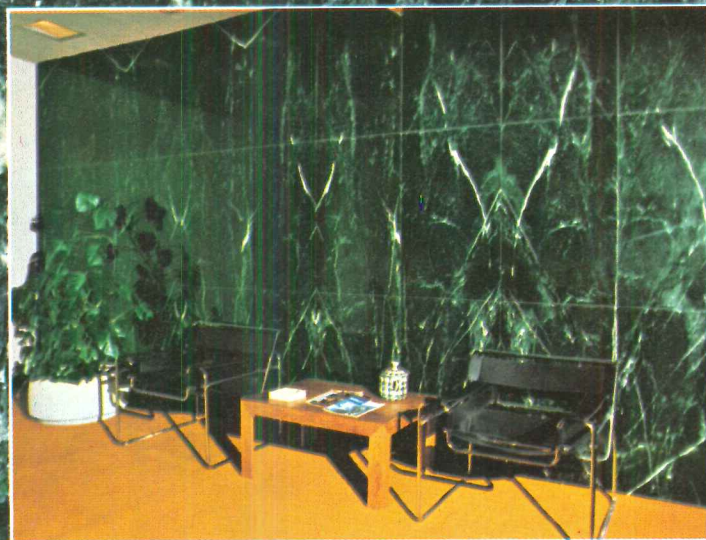

Vermont Verde

For more data, circle 56 on inquiry card.

For more information, circle item numbers on Reader Service Inquiry card, pages 197-198.

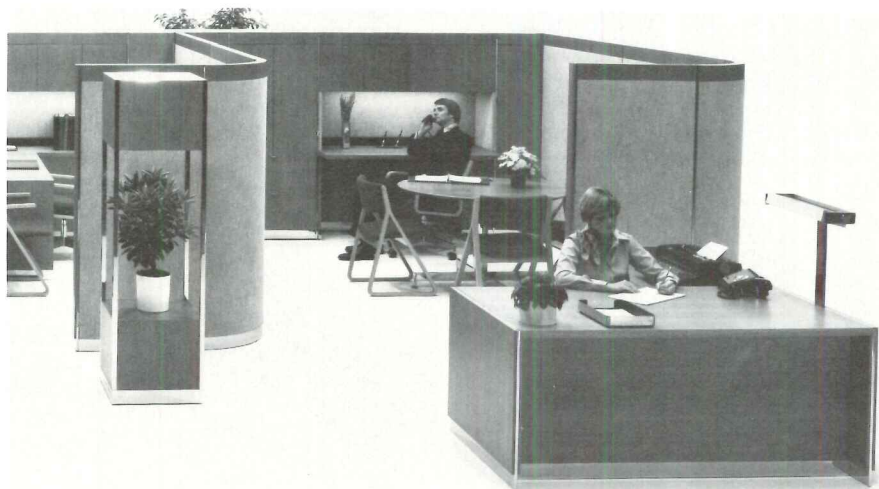

Stow/Davis will show task/ambient lighting at Designers' Saturday

The annual contract furnishings Wakefield Lighting for use with tional ambient lighting. Work station lighting is available with two or more 40-watt fluorescent lamps. ■ Stow/Davis, Grand Rapids, Mich.

Circle 300 on inquiry card

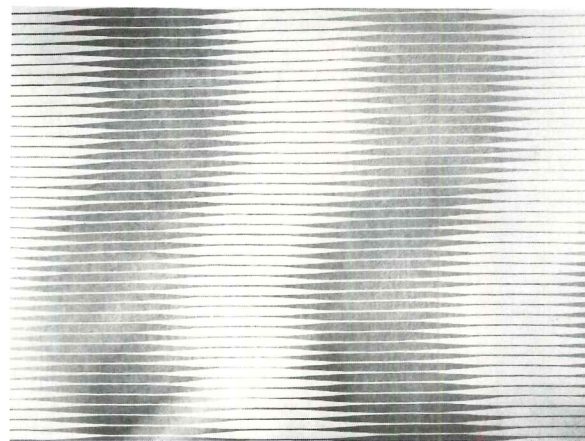

Knoll presents new furniture, fabrics next month

During New York's Designers' Saturday contract furnishings wood or chrome. Also to be exhibition, the company will shown: a line of casements (one show Charles Pfister's table col- shown top) designed by Christa Haeussler. ■ Knoll International, New York City.

steel bases can be finished as the Circle 303 on inquiry card

JG's task lighting on view at Designers' Saturday

Designed to reduce glare, the new freestanding "F Light" is enclosed on all sides to protect the user from direct brightness. It is also equipped with two sliding masks that block out light in front of the user; the light arrives from the side position and is reflected off to the other side of the user, avoiding veiling reflections. F Lights are available in lengths of 60 and 72 in., and can be placed on standard desks. ■ JG Furniture Co. Inc., Quakertown, Pa.

Circle 301 on inquiry card



Stacking chair from Thonet

This stacking chair, with or without arms, can be seen at the company's New York showroom during Designers' Saturday. The chair has a black polyethylene seat shell and solid oak legs. ■ Thonet Industries, Inc., York, Pa.

Circle 302 on inquiry card



Leather seating is new from Stendig

The "Davos" Group—a club chair, two-seat sofa, three-seat sofa and footstool—is upholstered in unsplit bull hide leather. On view at Designers' Saturday next month, the group has an understructure of hard-

Circle 304 on inquiry card

more products on page 141

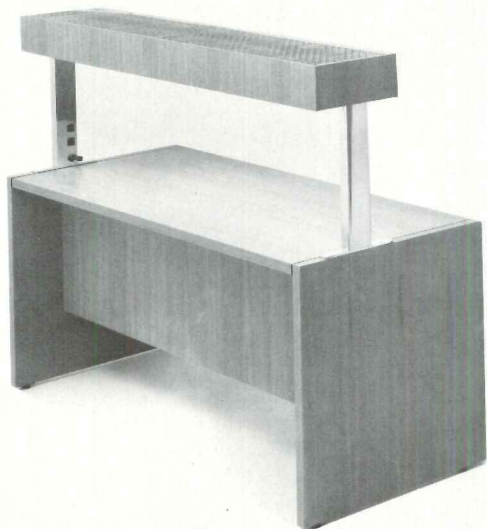

A beautiful way to make an exit and bar an entrance.



Russwin 900 Series labeled rim exit devices. Positive two-way protection styled to flow harmoniously in any decor. Oval-contoured cross bar provides sure grip . . . triggers instant release. Touch button deadlocks massive $\frac{3}{4}$ " latch against intruders.

Rugged stainless steel chassis. UL listed class "A". Available in a wide range of types and finishes.



HARDWARE DIVISION, EMHART INDUSTRIES, INC.
BERLIN, CONNECTICUT 06037

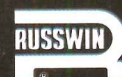

All Russwin exit devices work beautifully.

Russwin exit devices give you an easy way out on both styling and safety requirements. Let you smoothly blend function into the prevailing mood of interiors. Give you continuity in door hardware styling, throughout the building. Available in a wide selection of vertical rod, mortise and rim designs UL listed models. Narrow stile, concealed and low profile types. Add beauty to emergency duty with exit devices from the full, in-depth Russwin line. Write for more detailed information.

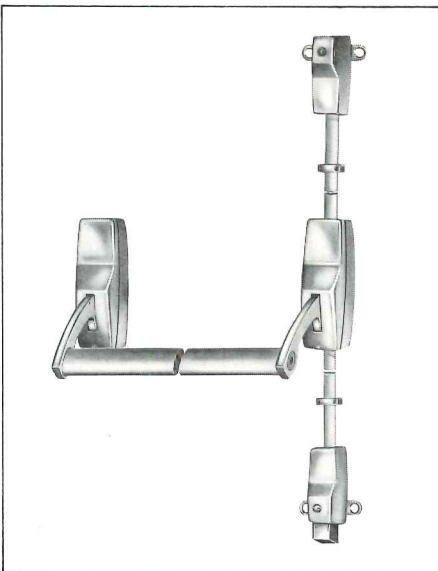

Exiter 780 Series UL listed heavy-duty vertical rod type



Exiter 630 Series Narrow Line heavy-duty rim type

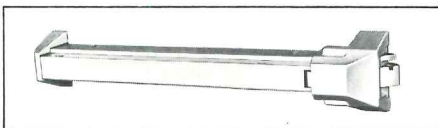

365 Series Low Profile rim type



For more data, circle 57 on inquiry card

For information, circle item numbers on Reader-Service Inquiry card, pages 197-198.

REFRIGERATION STRADDLE / An eight-page brochure gives product specifications and dimensions for preassembled refrigeration packages suitable for commercial and industrial applications from -20 to +65F, with electric or air defrost. Units are said to be easily installed over or through the walls of new or existing buildings; models are available from 2- through 20 HP. ■ Kramer Trenton Co., Trenton, N.J.

Circle 400 on inquiry card

VARIABLE AIR VOLUME TERMINALS / This manufacturer's complete product line for variable air volume terminal applications is described in a 62-page catalog. Photographs, tables and diagrams provide details on application recommendations, design features, performance and dimensional data, and the advantages and energy-saving features of the Fluidtech VAV terminals. ■ McQuay Group, McQuay-Perflex, Inc., Minneapolis, Minn.

Circle 401 on inquiry card

WASTEWATER TREATMENT PLANTS / An illustrated brochure presents the advantages of Activator modular prestressed concrete wastewater treatment plants: sections may be added as capacity requirements increase. The Activator plant uses the activated sludge process or any of its variations, which can include rapid sand filtration, chemical treatment for nutrient removal, and other types of wastewater treatment. These modular plants are said to achieve maximum performance, with an effluent that meets all Federal, state, and local regulations. ■ Pollution Control, Inc., Cincinnati, Ohio.

Circle 402 on inquiry card

ALL-WELDED PANELS / Lightweight, all-welded industrial panels made of aluminum, mild or stainless steel are described in a product catalog. Applications of the 2-in.-thick, 6- to 20-ft-long panels include instrument support tables, concrete forms, catwalks and decks, furnace walls and floors, and flat-work tables. Heat-resistant panels are capable of conducting gas or liquids, and resist racking shear and torsion. ■ Wirecomb, Inc., South El Monte, Calif.

Circle 403 on inquiry card

ROOF AND FORM DECKS / A revised steel roof and form deck catalog contains a finish selection guide, as well as expanded data on construction loads and material thicknesses. A "Deck Selection Chart" gives product specifications for a full line of composite floor decks. ■ Epic Metals Corp., Rankin, Pa.

Circle 404 on inquiry card

STEEL DECKING / A 32-page catalog contains cutaway illustrations, section properties, load span tables and dimensioned drawings for a full line of steel decks for floors and roofs. Other design information includes sound absorption data, fire ratings, general recommendations for erection, and design aids. The catalog features the "H Roof Deck," a profile said to be particularly suited for roofs and canopies where long spans are desired. ■ Bowman Construction Products, Elwin G. Smith Div., Cyclops Corp., Pittsburgh, Pa.

Circle 405 on inquiry card

AUTOMATIC LOUVERS / Product brochure describes Frost-Matic screen-operated louvers, designed to ensure continuous air flow into buildings under adverse weather conditions in which screen-protected louvers might fail because of blockage by frost or snow. ■ Delta Vent, Inc., Hibbing, Minn.

Circle 406 on inquiry card

DRYWALL FURRING / Use of "Z-Furring" channels for attaching gypsum panels and insulation to masonry permits a wide choice of insulation materials with no uninsulated pockets, according to an illustrated product brochure. The furring system comes in 1-, 1½-, 2-, and 3-in. depths; slots in the channel web are said to help prevent thermal dissipation. Power fasteners attach the furring directly to masonry walls without adhesives; gypsum panels or veneer base can be screw-attached to the channel's exposed flanges. ■ United States Gypsum Co., Chicago, Ill.

Circle 407 on inquiry card

BASEBOARD HEATERS / Sundura electric baseboard heaters are said to be easily installed with a simple nailing tool, with no dismantling of the unit necessary. A six-page bulletin describes the UL-listed heaters, available in lengths of from 27- to 120-in., and up to 277 single-phase power. Photos show how the unit's wide top and sloped bottom prevent dirt accumulation on walls and in the heater interior. ■ Gould Inc., Electrical Products Group, Spring House, Pa.

Circle 408 on inquiry card

CLEAN-ROOM FILTERS / Design, construction, engineering and application data for a line of high-efficiency ceiling filter modules are given in this product bulletin. CRFM filter modules feature a replaceable HEPA filter which can be installed without removing the entire filter housing from its position in the ceiling grid. ■ Comp-Aire Systems, Inc., Grand Rapids, Mich.

Circle 409 on inquiry card

DRAINAGE PRODUCTS / Carriers, fittings, clean-outs, floor and roof drains, hydrants, smokestops and interceptors are shown in product photos and dimensioned line drawings included in this 250-page catalog. Full size and weight information is given for all products, options and accessories; the catalog is indexed for cross-reference to competitive product lines. ■ Wade Div., Tyler Pipe, Tyler, Texas.

Circle 410 on inquiry card

HEAT RECOVERY SYSTEMS / A four-page bulletin gives operating characteristics, flow diagrams, and schematic unit drawings covering Twin-Cel heat recovery systems. Capable of recovering both sensible and latent heat, Twin-Cel is an air-to-air enthalpy system using a solution heat transfer agent between the supply and exhaust airstreams. Said to eliminate cross-contamination, units are suitable for hospitals, food plants, breweries, industrial processing areas, etc. ■ Ross Air Systems Div., Midland-Ross Corp., New Brunswick, N.J.

Circle 411 on inquiry card

FAUCETS/FITTINGS / A catalog covers general and residential fittings, laboratory fittings and food service products; a color-coded index provides a quick reference to the manufacturer's entire line of faucets and fittings. The 81-page book also includes a section on faucet maintenance and repair, complete with parts lists and assembly drawings. ■ The Chicago Faucet Co., Des Plaines, Ill.

Circle 412 on inquiry card

DOOR OPERATORS / Employing the Spec-Data format of the CSI, a four-page booklet provides a generic specification guide of electric operating systems for upward-acting sectional doors, including all units manufactured by members of the industry association. ■ Door Operator & Remote Control Manufacturers Assn., Chicago, Ill.

Circle 413 on inquiry card

more Office Literature on page 138

**The disabled
need not be
handicapped...
if buildings
are properly
designed.**



Barrier-Free Washfountain

Improved health care. Increased longevity. Heightened public concern. Tougher government regulations. These factors mean that barrier-free design is more important than ever before. And designing products and facilities for use by all people is often not just the most sensible answer—but also the lowest cost answer.

At Bradley, we've done our homework. We've listened to the advice of experts in barrier-free design. Based on their recommendations, we've created Bradley products that will accommodate everyone—not special designs just for the disabled. And, because washroom vandalism and water conservation also have to be considered, we've incorporated all we've learned about handling these challenges into the designs as well.

Our new barrier-free products catalog contains basic washroom design criteria plus specifications on our new products. For your copy, contact your Bradley representative, or write Bradley Corporation, 9101 Fountain Blvd., Menomonee Falls, WI 53051.



"Barrier-Free Washroom Design," a 30-minute filmed panel discussion, is now available. Contact your Bradley representative to arrange a viewing.

Another
right idea
from



Bradley

For more data, circle 58 on inquiry card



Bradpack® Wash Center



Modesty Module® Shower

CONCRETE CONSTRUCTION ACCESSORIES /

Practical information on concrete construction products is contained in a 130-page cross-indexed catalog. Nine sections cover light and heavy concrete formwork, *Slim Jim* ties, form hangers and accessories, anchors and inserts, rebar supports, tilt-up construction, miscellaneous accessories, and chemicals. ■ The Dayton Sure-Grip & Shore Co., Miamisburg, Ohio.

Circle 414 on inquiry card

METAL WALLS/ROOFS / New wall products such as "Three Hour Firewall" and "Foamwall 24" are featured in a 40-page metal wall and roof system catalog. Literature includes cutaway illustrations of exterior profiles, panel systems, dimensions, design features, load span tables, and color chart of available coatings. ■ Elwin G. Smith Div., Cyclops Corp., Pittsburgh, Pa.

Circle 415 on inquiry card

INSULATION BOARD / How *Thermax* sheathing insulation board saves energy in concealed construction applications is explained in a product brochure. *Thermax* is a foam plastic board reinforced with glass fiber, and protected by aluminum foil on both side surfaces; it is said to provide a high insulation value per given thickness. Sectional drawings illustrate methods for insulating interior or exterior wall surfaces of frame or masonry construction; insulation behind gypsum wallboard in ceilings; and under asphalt shingles in roofing. ■ Jim Walter Corp., Tampa, Fla.

Circle 416 on inquiry card

WATERPROOFING / An illustrated brochure describes waterproofing systems for below-, on-, and above-ground construction applications. Technical service and integral waterproofing products for plaza decks, roof terraces, promenade decks, bathrooms and foundation walls are explained; a selector chart gives data on a full line of liquid waterproofing polymers and masonry preservatives. ■ Tremco, Cleveland, Ohio.

Circle 417 on inquiry card

CONTROLLED ENVIRONMENTAL EQUIPMENT /

An eight-page catalog introduces more than 50 different industrial products, including ovens, furnaces, humidity chambers, freezers and water baths. Featured is a line of mechanically convected ovens for curing, drying and sterilizing, many with *Supermatec* fully proportional solid-state control, accurate within ± 0.1 C. ■ Hotpack Corp., Philadelphia, Pa.

Circle 418 on inquiry card

COMPOSITE BUILDING PANEL / Detailed product brochure explains the sound absorption and flame resistance benefits of *Petrical/Urethane* roof deck or building panels. The board consists of *PetriCal* structural cement fiber integrally bonded to urethane foam, with a top layer of asphalt-saturated roofing felt. Panels are available in plank, channel-reinforced, dual-tee or tile configurations. ■ Cornell Corp., Cornell, Wis.

Circle 419 on inquiry card

EPOXY/ACRYLIC COATING / Formulated to comply with environmental and safe-handling codes, *Sikagard 670* is a low-odor water-base epoxy/acrylic coating suitable for in-service use in hospitals, schools, etc. Product brochure shows how the two-component system protects interior and exterior concrete, masonry, steel and other materials even in heavy-abuse industrial locations. ■ Sika, Lyndhurst, N.J.

Circle 420 on inquiry card

SEALING SYSTEMS / Compression and mechanically-locked architectural sealing systems designed to accommodate pedestrian or vehicle traffic, movements of structures, or vertical or lateral forces, are explained in a detailed 16-page brochure. The full range of applications is covered with selection charts for joint sizes, installation instructions, physical properties and specifications for seals and systems for movements up to 8-in. ■ Watson Bowman Associates, Inc., Buffalo, N.Y.

Circle 421 on inquiry card

POST-TENSIONED CONCRETE / Illustrated brochures describe the *Monostrand* and *Multistrand* systems for post-tensioning of concrete. The *Multistrand* method has been approved for unbonded tendon construction in nuclear containment structures. Literature also discusses the various design and construction services available to owners, engineers, and architects. ■ VSL Corp., Los Gatos, Calif.

Circle 422 on inquiry card

CONCRETE/MASONRY TREATMENTS / Over 35 different products for specific concrete treatment requirements are presented in a 16-page illustrated catalog. Included are grouts, bond breakers, form treatments, concrete floor hardeners, bonding compounds, epoxies, moisture proofers, and masonry cleaners. Physical characteristics of each compound are given; application suggestions and cautions are listed. Laboratory test results for many items are shown in the catalog. ■ L & M Construction Chemicals, Inc., Omaha, Neb.

Circle 423 on inquiry card

SPECIALIZED DOORS / A full-line brochure shows specialized doors for engineered environments involving extreme temperature, pressure, blast load, high intensity noise, atmosphere, and chemical reaction. Photos and details of unique applications for many of these doors are included in the literature. ■ Jamison Door Co., Hagerstown, Md.

Circle 424 on inquiry card

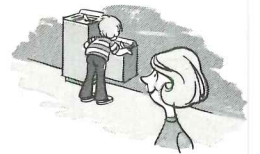

IT'S YOUR BUSINESS,
YOUR CLIENT,
YOUR REPUTATION.

**SPECIFY
ELKAY.**

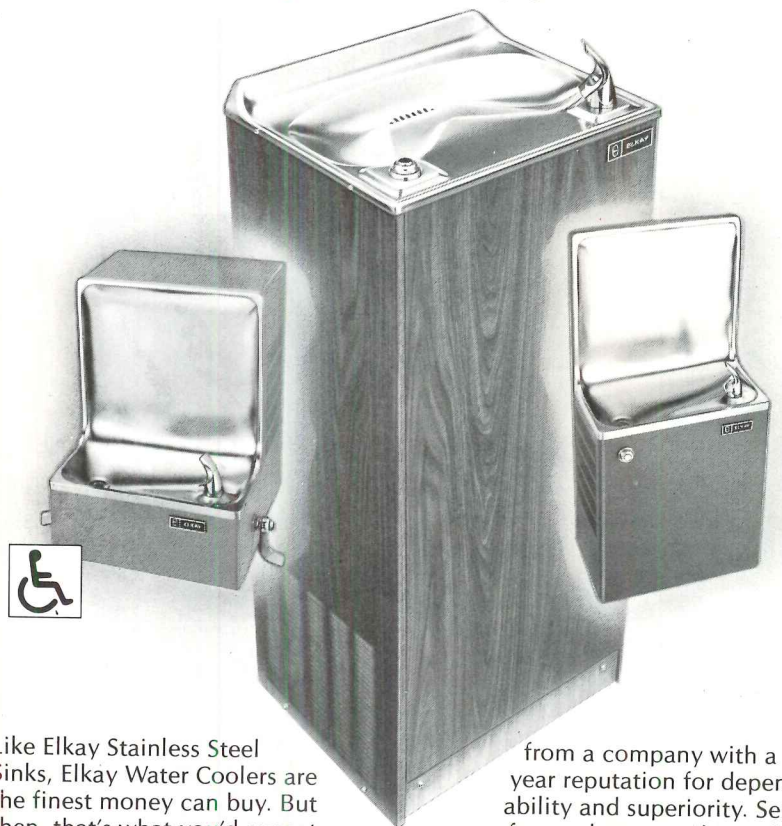

Like Elkay Stainless Steel Sinks, Elkay Water Coolers are the finest money can buy. But then, that's what you'd expect

from a company with a 50 year reputation for dependability and superiority. Send for our latest catalog today.

Elkay versus the ordinary. There's no comparison.

ELKAY

MANUFACTURING COMPANY
2700 South Seventeenth Avenue
Broadview, Illinois 60153 Department 32-20

PLASTIC BEARING STRIPS / An illustrated brochure explains the advantages of *Korolath*, an engineered multipolymer plastic material with high compressive strength, which is said to facilitate the placement of prestressed and precast concrete floors, walls, structural and architectural members. *Korolath* will not rust, rot or leach; it is manufactured in sheets of various thicknesses, pre-scored to be snapped apart as needed for shims, bearing strips, spacers, plugs, etc. ■ Koro Corp., Hudson, Mass.

Circle 425 on inquiry card

STEEL JOISTS / A 40-page catalog on steel joists describes the H, LH, DLH, J, LJ, and DLJ series. Tables give dimensions and properties, and show allowable total safe loads for each series. Information is provided on joist production, deflection, special design considerations and fire-resistance ratings. ■ Armco Steel Corp., Middletown, Ohio.

Circle 426 on inquiry card

HVAC ENERGY ANALYSIS / An eight-page program description manual gives information on the *Access* energy analysis computer program, designed to assist in selecting the optimum energy efficient and cost effective air conditioning system for a particular building. The manual describes the features and functions of the program, typical input and output data, and financial analysis; an energy flow chart and a systems logic flow chart are given, as well as a sample of the computer print-out. ■ American Air Filter Co., Louisville, Ky.

Circle 427 on inquiry card

STRUCTURAL LAMINATED TIMBER / Color catalog contains photographs of structural glued laminated timber—glulam—as used in religious structures, bridges, ice arenas, commercial buildings, athletic facilities, etc. Load tables, product data and connector details are also included. ■ American Institute of Timber Construction, San Francisco, Calif.

Circle 428 on inquiry card

PLASTIC PIPE / Five separate series of *Bondstrand* fiberglass-reinforced plastic pipe and fittings are described in a 16-page color brochure. This corrosion-resistant piping is used in such industrial applications as steam condensate lines, fire service piping, fuel lines, and certain acid and alkali handling lines. ■ Ameron Corrosion Resistant Piping Div., Brea, Calif.

Circle 429 on inquiry card

LOW-PRESSURE SODIUM LIGHTING / Specifications, application information and photometric data on *WallPak* low-pressure sodium luminaires are given in a six-page brochure. The literature details the energy-saving, high-lumen-output characteristics of the 35- and 55-watt low-pressure sodium lamps used in *WallPak* units. Intended for rough service areas indoors and out, luminaires have an ABS thermoplastic housing and polycarbonate lens sealed against weather and dirt; the unit is shock- and vandal-resistant. ■ QL, Inc., Northbrook, Ill.

Circle 430 on inquiry card

SURGICAL LIGHTING / A product brochure describes the "Challenge 22" optical system, which uses a tungsten-halogen light and specially designed filters to produce small-, medium-, or large light-beam patterns from a lighthouse-mounted control lever. Fixture has various mounting options, and can be installed in almost any ceiling, including those with laminar flow systems. ■ AMSCO/American Sterilizer Co., Erie, Pa.

Circle 431 on inquiry card

ENERGY SAVINGS / "Energy Conservation with Comfort" is a 56-page manual and workbook containing tested temperature-control modifications, a conservation checklist, fill-in-the-blank energy audit, and 24 energy-saving tips to facilitate business building efficiencies and compliance with ASHRAE Standard 90-75. Individual copies are available for \$6.50 each from: Honeywell, 10800 Lyndale Ave. South, Bloomington, Minn. 55420.

FIRE/SECURITY MANAGEMENT / A fire and security planning guide describes alarm circuits and systems for fire, security or integrated protection for commercial, industrial and institutional buildings. Application of basic or centralized systems with additional capabilities like access control, remote-building monitoring, and high-rise building fire management are explained. ■ Honeywell, Minneapolis, Minn.

Circle 432 on inquiry card

ENERGY CONSERVATION / Designed for use by commercial building owners and managers, a "Total Energy Management" manual describes techniques for interfacing both the energized and non-energized aspects of a structure to achieve maximum efficiency in the use of energy. Published jointly by NECA and NEMA, the book gives step-by-step instructions for making and interpreting energy surveys, plus more than 400 specific conservation tips. ■ National Electrical Contractors Assn., Washington, D.C.

Circle 433 on inquiry card

SELF-SUPPORTING STRUCTURES / Color catalog shows photographs of buildings using self-supporting, light transmitting "Skyroofs" and insulated enclosures as pool roofs, in malls, as corrosion-resistant structures for chemical plants, etc. Translucent, insulated panels are mounted on an aluminum box beam framework without rafters or joists. The structure is entirely pre-finished, inside and outside, and can be used immediately. Up to 50 per cent of the roof can be opened, either by motor or manually. ■ Structures Unlimited, Inc., Manchester, N.H.

Circle 434 on inquiry card

IF YOU'RE NOT USING ELKAY WATER COOLERS, LOOK AT WHAT YOU'RE MISSING:

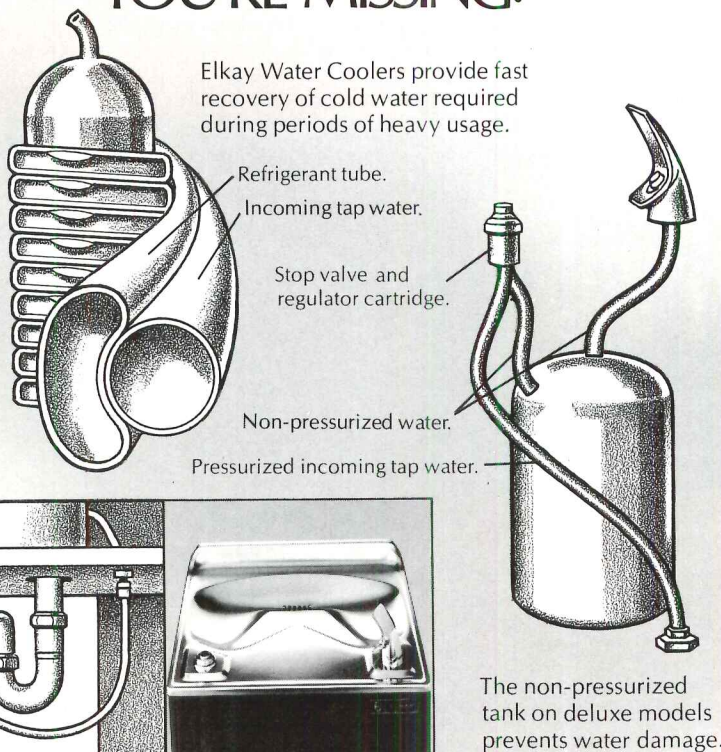

Elkay Water Coolers provide fast recovery of cold water required during periods of heavy usage.

Refrigerant tube.
Incoming tap water.

Stop valve and
regulator cartridge.

Non-pressurized water.

Pressurized incoming tap water.

The non-pressurized tank on deluxe models prevents water damage.

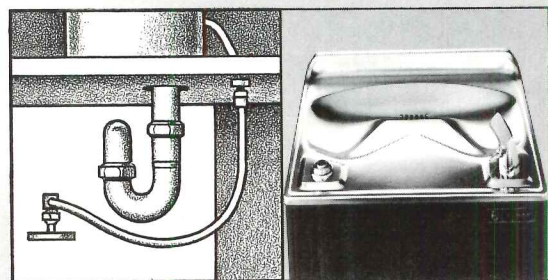

Unobstructed connections and center drain make installation and drain cleaning quick and easy.

The Elkay exclusive Cascade Basin prevents splashing. The strainer is built right into the basin so it can't be vandalized.

Elkay versus the ordinary. There's no comparison.

ELKAY
MANUFACTURING COMPANY
2700 South Seventeenth Avenue
Broadview, Illinois 60153 Department 33-20

Since ASG developed Sunadex™,
more solar energy is captured.

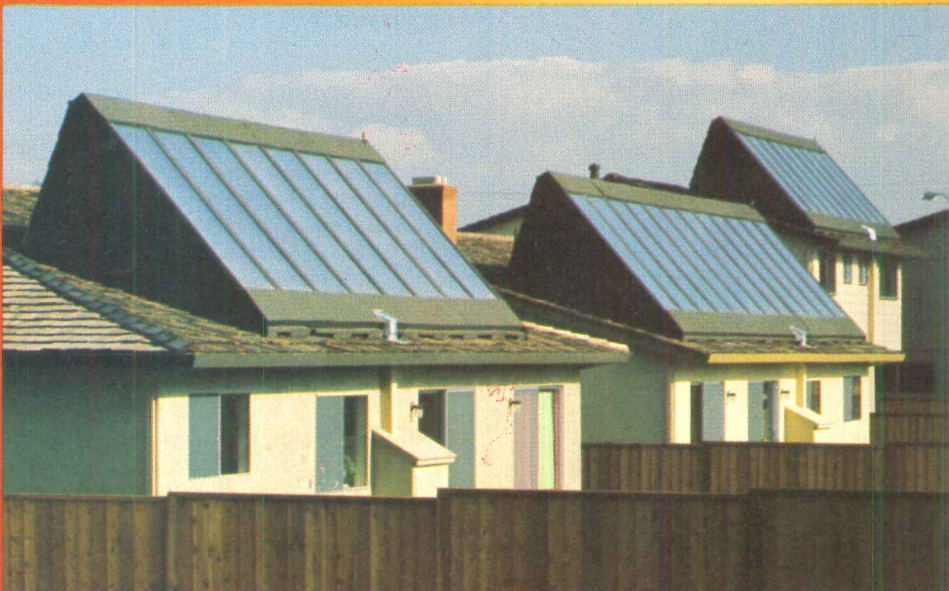

Solar heating development
at Laurel Park East,
Santa Clara, California,
utilizing tempered
Sunadex™ glass
Collector manufactured
by American Solar King, Inc.

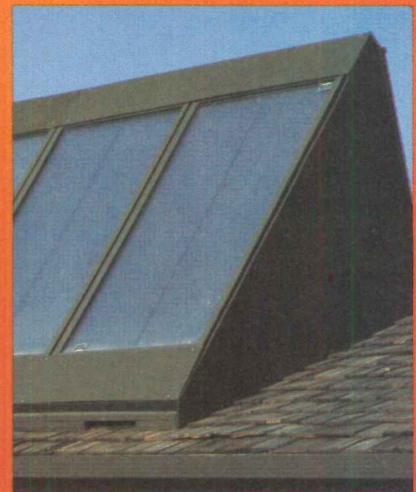

ASG has America's only full line of flat glass for solar applications. Sunadex™, our "water white" cover glass product, has the highest transmissivity of any untreated flat glass commercially available. Or, you can select our "low iron" Lustraglass® for solar applications where both economy and above average transmission are required. For parabolic mirrors and solar cell covers, we can slim glass down to 0.028" in thickness. And with these three examples, we're just warming up.

Glass is preferred for solar applications due to its durability, dimensional stability and high temperature operating performance. It resists abrasion and ultra-violet deterioration, is non flammable and requires little, if any, maintenance.

Write for our catalog and tell us whether your interest is in glass for flat plate collectors, lineal fresnel concentrators, solar mirrors or photovoltaics.

ASG Industries Inc., Dept. 2,
P. O. Box 929, Kingsport, TN 37662.
Or phone 615/245-0211.

SEE OUR CATALOG IN SWEET'S 

energy
glass
ASG 
CREATIVE IDEAS IN GLASS

For more data, circle 60 on inquiry card

PARABOLIC COLLECTOR / A 10-watt synchronous

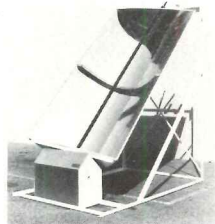

motor turns this parabolic solar collector at one revolution per day to follow the sun from morning to night. The 32-sq-ft mylar-coated mirror reflector concentrates the sun's energy, providing the space- or water-heating requirements for single- or multi-family buildings. The unit weighs less than 100 lbs; its electronic-free design is said to make the parabolic collector easy to install. ■ Z Z Corp., Los Alamitos, Calif.

Circle 305 on inquiry card

SPECIALITY LIGHTING / "Innervation 1001" modular lighting units may be used as an entire ceiling surface or deployed in groupings on the ceiling or wall. Each 2- by 2-ft module contains 24 50,000-hr incandescent lamps reflected many times by special mirrors. An inverted, black, T-grid system supports the lighting fixtures. ■ Neo-Ray Lighting Systems, Inc., Brooklyn, N.Y.

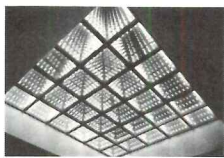

Circle 306 on inquiry card

INFRARED HEATER / This 5 kW maximum electric infrared comfort heater accepts one or two quartz tubes or lamps; the unit is 7 3/8-in.-wide by 34 1/4-in.-long. The "CH-300" heater is constructed of aluminumized steel, with gold anodized aluminum reflectors and end caps. Uniform construction is featured for 120v, 208v, 240v, 227v, and 480v. ■ Fostoria Industries, Inc., Fostoria, Ohio.



Circle 307 on inquiry card

HOT/COLD WATER COOLER / "Model ECPH-4"



provides both cold and hot water for coffee and other beverages; unit has a cooling capacity of 4.5 gph. There is also a cubic foot of refrigerated storage space for ice cubes and bottles, etc. The cabinet is heavy-gauge steel finished in baked acrylic enamel, with wood-grain vinyl on the compartment door. There is a cold-water-only model, also with storage compartment. ■ Elkay Mfg. Co., Broadview, Ill.

Circle 308 on inquiry card

MAGNETIC LOCK / The *Magnalock Model 61B*

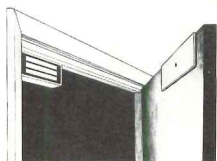

uses an electromagnetic force in excess of 3000 lbs to secure doors and other closeable openings. A 12-volt power supply operates the *Magnalock*, and will also provide

power for accessory items including position indicator lamps, smoke sensors, digital actuators, etc. Control and deactivation of the magnetic lock can be by key, micro- or toggle switch, ID card actuator, digital actuators, smoke and fire sensors and automatic timing devices, with indication of activity on a monitor panel. Applications include banks, psychiatric hospitals, stairwells and perimeter doors, etc. ■ Securitron Magnalock Corp., Los Angeles, Calif.

Circle 309 on inquiry card

more products on page 143

In the ENR 500 League, Shand, Morahan keeps raising its average.

One year ago, we supplied E&O coverage to 24% of the world's 57 largest design-constructors. This year, 35% of this group are our clients.

Of the remaining ENR top 500*, we've increased our share from 20% to 25% in the past year.

In short, the switch to Shand, Morahan & Company for E&O by big league design-constructors and design firms continues. And for good reasons: Flexible, custom designed coverage. Competitive rates. And the most prompt, courteous service available anywhere.

If your firm can benefit from a better E&O program, let us go to bat for you. Have your broker give us a call.

*Engineering News-Record; May 19, 1977

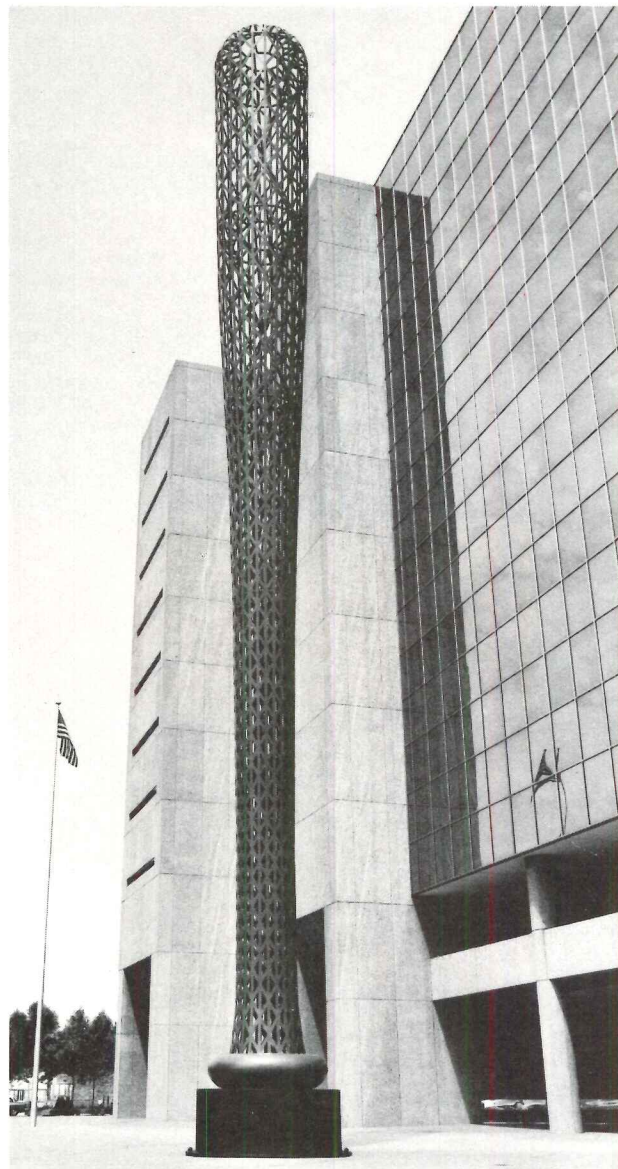

Shand, Morahan & Company, Inc.

For more data, circle 61 on inquiry card



Model 3352—Photographed at the Hyatt Regency, San Francisco.

Deftly executed in polished stainless steel, this drinking fountain by Haws was designed in the tradition of elegant simplicity to complement the most resplendent interiors that can be created by man. The columnar pedestal is pure, of classic proportions, and atop, the sculpted receptor is ridged to prevent splashing. Model 3352 is true perfection in a metallic alloy that is timeless.

If yours is a task of joining form with function for a truly complete effect, you will want to know more about this unique Model 3352 by Haws. Please contact Haws Drinking Faucet Co., 1441 Fourth Street, Berkeley, California 94710.

**SUPREMELY
DISTINCTIVE**

Haws[®]
DRINKING FOUNTAINS

For more data, circle 62 on inquiry card

SLIDING GLASS DOOR / The universal extruded aluminum frame of the "Series 3500" sliding glass door is designed to accommodate a variety of wall conditions; deep glazing pockets provide proper "bite" for insulated glass. Door slides open on the inside, away from wind, dirt or snow accumulations; screen placement facilitates installation of optional security locks where required. A full mortise adjustable lock retracts if the door is accidentally closed in the locked position, preventing damage to the door and accidental lock-outs. Concealed weatherstripping is on one plane to resist both positive and negative wind load. The "Series 3500" is intended for commercial, high-rise and residential applications; frames are available in clear anodized, painted, or bronze finishes. ■ Howmet Aluminum Corp., Greenwich, Conn.

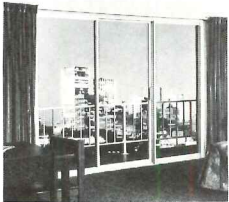

Circle 310 on inquiry card

THERMAL BREAK WINDOW / Designed for use with the manufacturer's "Panel-Unit Wall System," this thermal break window is offered in both fixed and operating sash versions. Windows are said to resist condensation; sash hinges provide access for exterior glass cleaning from the inside. Marine-type glazing accommodates up to 3/8-in. insulating glass; fixed, project-in and project-out models are available. Standard widths are 4- and 5-ft; standard heights are 18- and 24-in. Other dimensions, screens, and corrosion-resistant colored finishes may be ordered. ■ Kalwall Corp., Manchester, N.H.

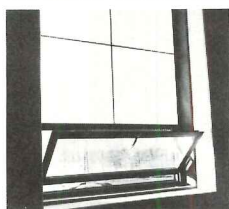

Circle 311 on inquiry card

AUTOMATIC DOOR CLOSER / An electro-pneumatic door closer allows free-swinging operation of the door; door closes gently from any position when the system is activated manually or by a signal from a fire alarm-smoke detection system. A multi-selection hold-open model is also available. Up to 100 door closers can be operated by one AC- or DC-powered control unit; electrical wiring to each door closer is not required. The 1/4-in. plastic tubing connecting each door unit with the master control may be surface applied or concealed; both installations are UL-listed. The "101 Life/Safety System" is adaptable to virtually all fire alarm systems, and is unaffected by momentary electrical failures or tests. ■ Reading Door Closer Corp., Reamstown, Pa.

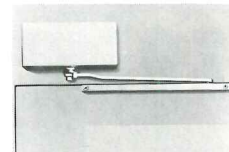

Circle 312 on inquiry card

OFFICE SEATING / Button-tufted seat and back cushions are features of the "Series 600" line of general office seating designed by Sid Gibson. The collection consists of two secretarial chairs, one with an adjustable back; a tilter chair; and a sled-based guest arm chair. Frames are 1-in. diameter 16-gauge steel tubing, finished in mirror chrome. ■ Curtis Products Ltd., Cobourg, Ont.

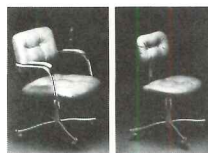

Circle 313 on inquiry card

more products on page 145

Introducing... Specialized technology in doors for engineered environments

- Pressure
- Blast Load
- Noise
- Temperature
- Atmosphere
- Chemical Reaction

Jamison can help you . . . now.

We can't guess what kinds of unusual door problems you're already into, or will be facing in the near future.

But we can say that more and more architects, designers, constructors, and owners are asking us to engineer and build specialized doors for specialized applications.

High intensity sound isolation for example. And virology laboratory atmospheric security . . . protection from arctic temperatures, searing heat and flood threats . . . controlled recreational environments . . . and many more.

Jamison has 70 years' experience in dealing with the complexities of door technology . . . from cold storage to blast load.

We understand door construction, gasketing, sealing, insulation, hardware, cladding materials, and power operation. We know how to put them all together to meet a wide range of critical requirements.

You should have two informative new booklets describing our capabilities. Ask for them today . . . send our coupon or use the reader service card.

For more data, circle 63 on inquiry card

Please rush me copies of Jamison's new literature on specialized door technology.

Please have engineering representative contact me.

JAMISON

JAMISON DOOR COMPANY
P.O. BOX 70
HAGERSTOWN, MD 21740

NAME _____

TITLE _____

COMPANY _____

STREET _____ TELEPHONE _____

CITY _____ STATE _____ ZIP _____



New standard for masonry wall insulation



Zonolite[®] Thermo-Stud[®] System

Here's an economical new system that makes it easy for you to design a complete, uninterrupted insulation envelope with no thermal shorts.

Called the Thermo-Stud system, it features a rigid Zonolite Styrene Foam insulation board in which a patented metal furring channel is factory-embedded. The system provides a complete insulation envelope that achieves outstanding insulation values with minimum thickness to deliver more useable interior space. And there's no deterioration of "R" values with time, either.

Positive Mechanical Attachment.

Mechanically fastened as a unit to masonry walls, the Thermo-Stud System permits immediate attachment of gypsum drywall to the metal channels with standard drywall screws. It goes up fast, and you get the

permanence, integrity, and safety only mechanical fastening can provide.

Low Installed Cost. The Thermo-Stud System is just about the most economical method for insulation and interior drywall finish. Installation rates up to 2,000 square feet per man day can be expected, minimizing construction time and labor costs.

For complete information on the new standard for masonry wall insulation and interior drywall installation, write Thermo-Stud System, W. R. Grace & Co., Construction Products Division, 62 Whittemore Avenue, Cambridge, Massachusetts 02140. In Canada: 66 Hymus Road, Scarborough, Ontario M1L 2C8.

GRACE

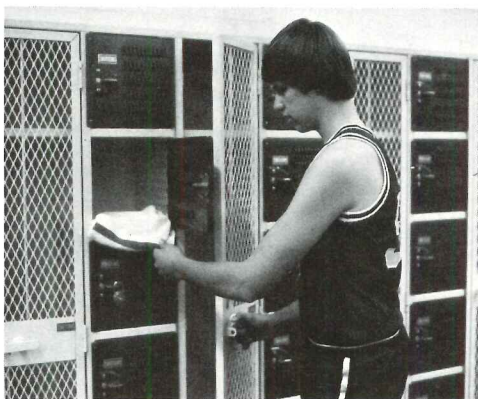

VANDAL-RESISTANT LOCKER / The Secur-N-Vent equipment and clothing locker combines ventilation with improved security features. Box locker doors are made of steel expanded in three dimensions, allowing air to flow in and out, but preventing anyone seeing inside or using a wire to pull out valuables. ■ DeBourgh Mfg. Co., Minneapolis, Minn.

Circle 314 on inquiry card

QUARRY PAVERS / This 3 $\frac{3}{4}$ - by 7 $\frac{5}{8}$ -in. brick-shape quarry-type paver tile is an addition to the manufacturer's "Romany" line. The brick-shaped tile may be used alone, or together with the 6-in.-square companion tile also shown, in a variety of floor patterns such as herringbone, soldier course, and random. Both tiles have a vitreous red shale body and are available in either blended red or flashed red colors. "Romany Pavers" are $\frac{3}{8}$ -in.-thick; unglazed and frost-proof. Applications include residential, commercial and institutional floors and walls of all types, interior and exterior. ■ United States Ceramic Tile Co., Canton, Ohio.

Circle 315 on inquiry card

OVERSIZE COPIER / The Graphic PC-24 can produce up to 99 17- by 24-in. static-free copies on a single setting. The PC-24 has an electric eye cutoff that automatically cuts each copy to the exact size of the original with no manual programming, no chance of operator error, and no waste. The copier has a flat bed and can copy any original materials on ordinary electrostatic paper rolls or sheets with widths from 8 $\frac{1}{2}$ - to 17-in., and lengths from 8 $\frac{1}{2}$ - to 24-in. Original materials never enter the machine, reducing the chance of damage. Copier requires only standard wall outlet power. ■ Graphic Enterprises, Inc., Canton, Ohio.

Circle 316 on inquiry card

EPOXY-ACRYLIC COATING / Equally applicable for use in occupied areas indoors, or outdoors, Permalux 100 epoxy-acrylic coating may be applied to cinder block, concrete, fiberglass, plaster, wall-board, wood, and (with an undercoating) metal. Said to retain its hard, tile-like gloss for years, Permalux 100 is available in 18 colors. The seamless coating features long pot life, zero flame spread rating, freeze-thaw stability and water clean-up of equipment; typical uses include food processing plants, laboratories, clean rooms, etc. ■ Permalux Chemical Coatings Co., Philadelphia, Pa.

Circle 317 on inquiry card

INDUSTRIAL LIGHTING CABLE ASSEMBLY /

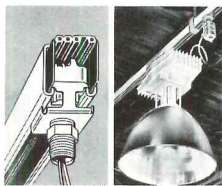

Chan-L-Wire lighting taps combine both electrical and support systems for 277V industrial lighting. The four-wire, three-phase flat cable assembly installs in U-shaped 1 $\frac{3}{8}$ - by 1 $\frac{3}{8}$ -in. structural strut used to support the lighting fixture, in a convenient position to feed lighting. Feed is through a series of three taps, each designed to connect one of the Chan-L-Wire's phases with neutral. Lighting layouts can be arranged, by phase, for desired switch control. Taps—which can also serve as fixture hangers—have wire leads which splice directly to a fixture, or to a receptacle installed in splice box, as shown, for fixture plug-in. ■ The Wiremold Co., West Hartford, Conn.

Circle 318 on inquiry card

SOLAR DIFFERENTIAL THERMOSTAT /

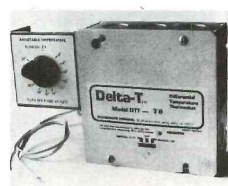

"Model DTT-70" adjustable thermostat can "fine-tune" solar domestic hot water heating systems to match the collector, the pumping volume, the time of year and the hot water usage of the household. The knob at the differential controller allows 21-degree adjustment of the turn-on temperature. The turn-on temperature is the level by which the solar collector panel exceeds the water storage tank temperature before the pump goes on. The ability to adjust to as low a differential as practical is said to enhance the performance of the system by increasing the Btus which can be transferred from the collector to storage. ■ Heliotrope General, Spring Valley, Calif.

Circle 319 on inquiry card

more products on page 147

Granite.

Tough enough to take the thunder of 10 billion feet.

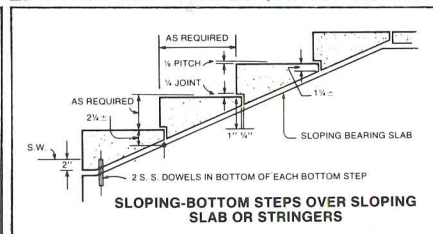
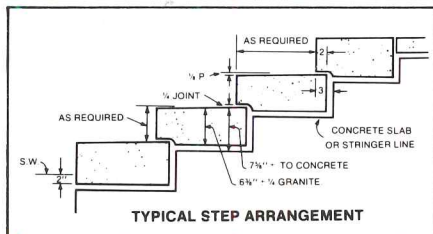
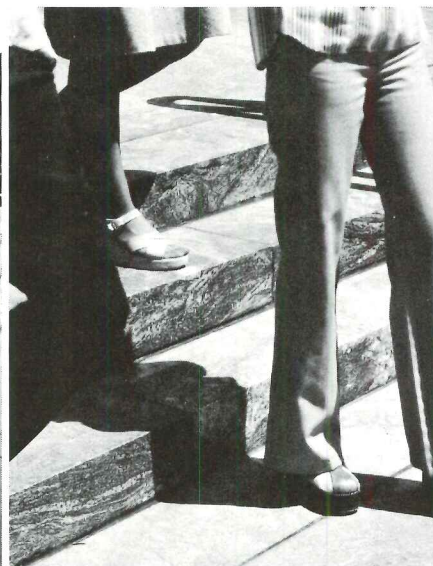
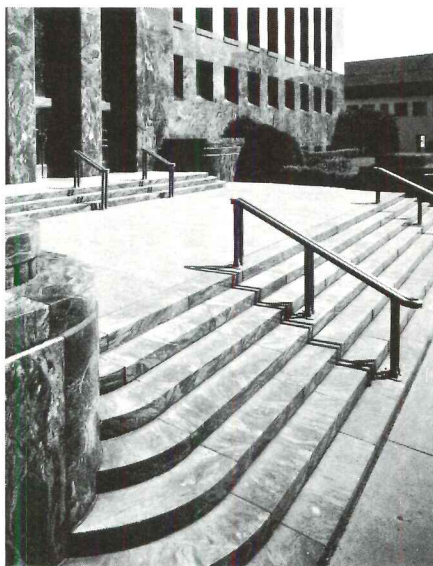

What else but granite can take 38 years of wear and weather without fading, staining, or showing measurable wear? That's what made Cold Spring granite the ideal choice for the Banker's Life Insurance Building when it was built in Des Moines, Iowa, in 1939. And that same unique combination of beauty and unsurpassed durability make it ideal for today's floors, facades, core walls, steps, malls and walkways — wherever you need maximum durability that's virtually maintenance-free.

For more information, plus a free copy of our 16-page, full color catalog showing all 18 Cold Spring colors available, call toll free **800-328-7038**. In Minnesota, call (612) 685-3621. Or write to the address below.



Cold Spring Granite Company, Dept. AR-9 202 South 3rd Avenue, Cold Spring, MN 56320

For more data, circle 65 on inquiry card

George Blanda puts in a plug for Walkertrak.

We asked George Blanda to help us show you how easy it is to install Walkertrak™ Overhead Raceway. Obviously, George is no wiring pro. But he knows how to put in a plug. And our raceway is just about that easy.

With our simple, two-piece system, you merely hang the raceway inside the ceiling, lay in the wires, splice in the plugs—and start plugging things in.

The light fixtures. The T/P® service poles (with built-in compartments for telephone cables). It's easy. So is moving them around. So is adding more components for more power, more communication equipment later on. By George, it'll really save you money.

The name on it—Walkerduct® Products—means it's easy to get too. It's sold through electrical distributors with backup service from your Walkerman's warehouse.

See George Blanda at our Booths #1120 and #1122 at the NECA Show.

Walkertrak is a trademark of Walker Parkersburg Division of Textron Inc.
Walkerduct and T/P are registered trademarks of Walker Parkersburg Division of Textron Inc.

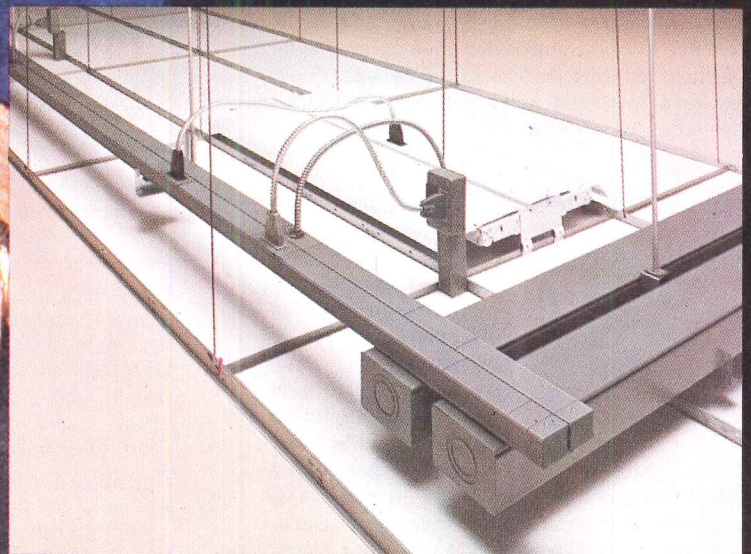

WALKER PARKERSBURG **TEXTRON**

Walker Parkersburg Division of Textron Inc.

An Equal Opportunity Employer, M.F.

For more data, circle 66 on inquiry card

When you want a small package delivered fast, it's in the bag.



Delta's DASH guarantees delivery on the flight or routing you specify between all Delta cities. Packages accepted up to 50 lbs. with length plus width plus height not to exceed 90"

And now your DASH shipment can be picked up at your door and delivered to your customer's door. All you have to do is call Delta's toll free number 800-424-1092. (In the Washington, D.C. area, call 466-3131.)

Or bring your package to Delta's passenger counter or air freight terminal at the airport at least 30 minutes before scheduled departure time. Package can be picked up at DASH Claim Area next to airport baggage claim area 30 minutes after flight arrival.

Charges for DASH shipments are nominal. Delta reservations will be pleased to quote actual charges between specific points. **DELTA**
The airline run by professionals

Rate examples (Tax included)

Atlanta-Washington.	\$26.25
Boston-Miami.	\$26.25
Los Angeles-New Orleans.	\$31.50
Dallas/Ft. Worth-Los Angeles.	\$26.25
San Francisco-Atlanta.	\$31.50
Philadelphia-Houston.	\$26.25
New York-Tampa.	\$26.25
Chicago-Orlando.	\$26.25
Detroit-Memphis.	\$26.25

For full details, call Delta reservations. Pick up and delivery at extra charge.

Delta is ready when you are.®

For more data, circle 67 on inquiry card

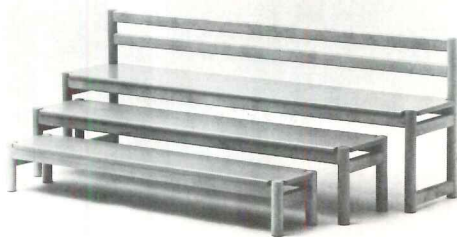

FURNITURE FOR CHILDREN / Durable enough for day-to-day activities at day care centers, pediatric hospitals, kindergartens, etc., this line of all-wood furniture was designed by Juhani Manner and is imported from Finland. The nesting bench set shown has solid birch frame and legs in a natural finish; birch plywood seats come in a choice of red or yellow non-toxic lacquer. Other pieces in the collection include a combination armchair/stool/table; four heights of tables; and an easily stored puppet theater/playstore unit. ■ Stendig Inc., New York City.

Circle 320 on inquiry card

ROLL-UP DOOR / For areas which cannot accommodate doors opening into them, the Magi door, mounted flush to the frame, rolls up.



Made of vinyl-coated Philippine mahogany, Magi doors are available in white, pecan or walnut finishes, and can be operated by hand or electrically. Said to be easy to install, units require a minimum width of 52-in.; doors are adjustable to fit any height opening. ■ Joanna Western Mills Co., Chicago, Ill.

Circle 321 on inquiry card

TEAK FLOORING / Square-edge teak flooring strips feature grooved "adhesive-locks" on edges and back that should assure a clean and strong installation bond.

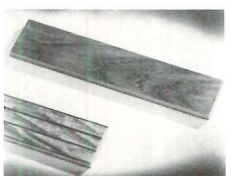

Available unfinished only, the 2- by 10- by 3/8-in. hardwood strips can be used to make up many patterns such as brick, herringbone, etc. ■ Bangkok Industries, Philadelphia, Pa.

Circle 322 on inquiry card

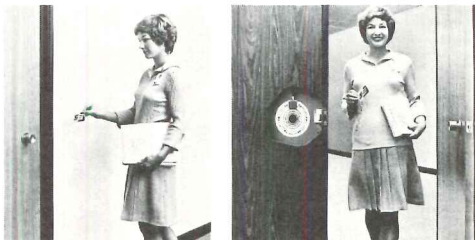

PROXIMITY CARD ACCESS CONTROL / Eliminating keyholes, push-buttons and card slots, this electronic access control system is activated when wallet size "command key" cards are held within 4 to 6 in. of a concealed sensor. The "Model 114" solid-state system is said to prevent some problems inherent in card-insert access methods: physical wear, card damage, environmental effects, and vandalism. Sensors are flat, circular 1/8-in.-thick discs which mount in or on wall, on plate glass or, when encapsulated, on exterior surfaces. Single coaxial cable connects to the control unit up to 1000 ft away. Options permit manual door control alarm shunting, three time-zone capability, variable door-open time, and standby power. ■ Schlage Electronics, San Mateo, Calif.

Circle 323 on inquiry card

Thinking about an ice rink?

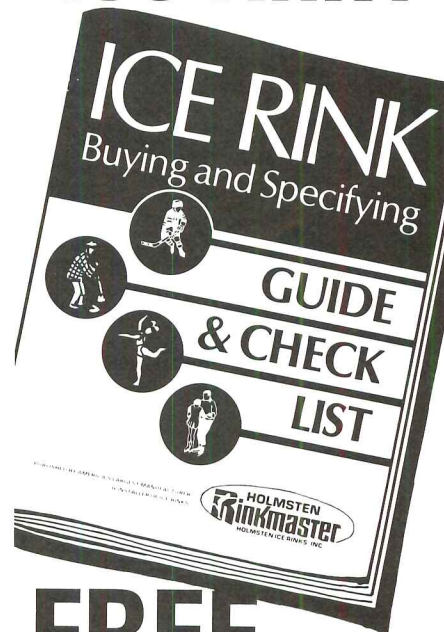

FREE FROM HOLMSTEN AMERICA'S LARGEST MANUFACTURER & INSTALLER OF ICE RINKS.

This 28 page guide explains the different kinds of ice rink refrigeration systems with cost and feature comparisons.

For your free copy, just write or call us.

If you are planning a new rink. . . or modernizing a present ice skating facility. . . **this guide will save you time and money.**

Whatever your ice rink needs. . . from planning to the finished rink. . . call on the Holmsten Ice Rink organization. . . by far the most experienced team of ice rink engineers and installers.

SINGLE SOURCE. . . TOTAL RESPONSIBILITY. . . from the rough grade to the finished rink in operation.

HOLMSTEN ICE RINKS, INC.
2301 Como Avenue
St. Paul, Minnesota 55108
612-646-8625

For more data, circle 68 on inquiry card

Take it from Dave Lennox . . .
**THIS NIFTY WEATHER
MACHINE IS YOUR
ANSWER TO**

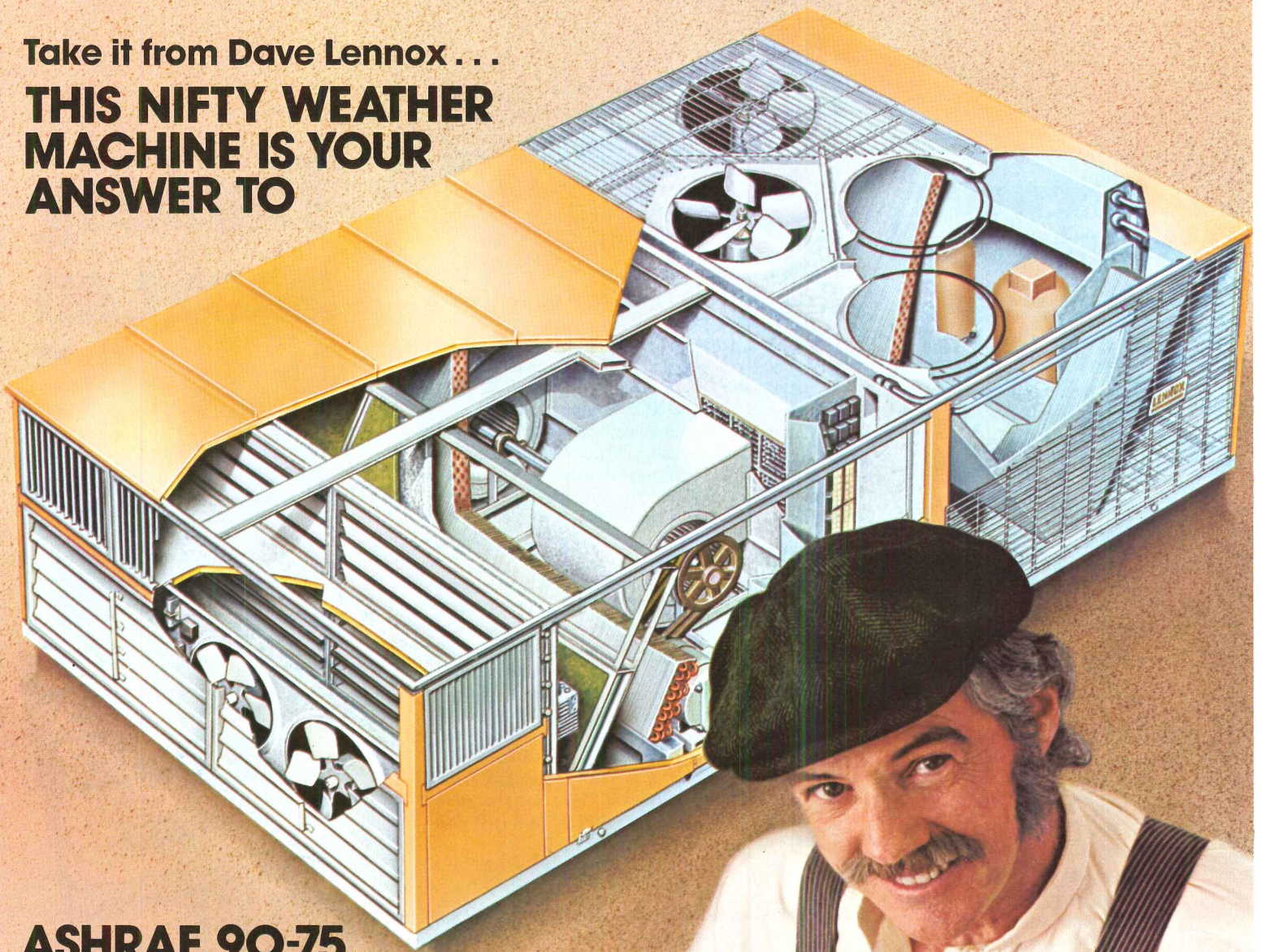

ASHRAE 90-75 ENERGY GUIDELINES.

The new Lennox DSS1 system lets you design your own single zone HVAC package to surpass ASHRAE 90-75 energy guidelines. The DSS1 offers extraordinary flexibility . . . efficient operation and service . . . exceptional energy savings . . . and consequent cost savings.

Here are a few of the many DSS1 options that give you the right size, right energy, right cost for your application:

- 26 to 45 tons cooling; up to 950,000 Btuh heating.
- Two-speed, first stage compressor saves energy.
- Heat recovery package (allows recovery of heat from refrigeration in supermarkets and restaurants; controls humidity without losing heat).
- Power Saver™ package (allows use of outdoor air for cooling).
- Power Saver II™ (allows recovery of heat from lighting).
- Latent Load Discriminator™ (increases partial-load EER up to 30%).
- Heat pump options available soon.
- Solid state, energy-saving control system.

Get the facts.

For complete information, see your Lennox Territory Manager. Or write: Lennox Industries Inc., 764 South 12th Avenue, Marshalltown, Iowa 50158.

LENNOX
AIR CONDITIONING • HEATING

"Attaboy,
Dave!"

Nifty problem-solving ideas from Lennox.

For more data, circle 69 on inquiry card

The only way to look at insulation

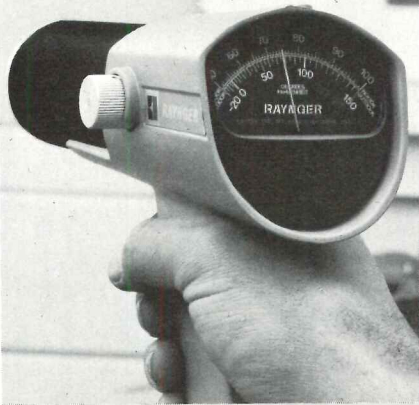

That's with a Raytek Raynger,™ the ultimate non-contact infrared thermometer for determining R values. With Raynger you can evaluate and verify insulation effectiveness with scientific precision. Hard numbers always prove the point!

Raynger makes the calculation of R values a simple, rapid and absolutely reliable procedure. The accuracy of these values is assured by the use of an 8-14 micron infrared filter which allows a reading sensitivity of 1°F regardless of atmospheric or surface conditions.

In just a few minutes, Raynger provides the quantitative heat transfer profile of a structure to document insulation effectiveness. It locates with pinpoint precision any areas where insulation does not meet requirements.

Priced at \$835, Raynger Model R380RV is the quality infrared thermometer with a long record of dependable performance. To find out more about it, contact:

Raytek

325 E. Middlefield Road
Mountain View, CA 94043
Phone (415) 961-1650/Telex 348351
Outside California, 800-227-8074

A Division of
Optical Coating Laboratory, Inc.

For more data, circle 70 on inquiry card

OFFICE NOTES

New associates, promotions

Allen & Hoshall, Inc., consulting engineers, have appointed **Harry L. Johnson** an associate in the firm.

Bucher & Willis, Consulting Engineers, Planners and Architects, have announced the following staff changes: **Raymond L. Voskamp, Jr.**, and **James Ray Flemons** have been named partners; **Carl Eugene Lewis** has been named an associate of the firm.

Daniel, Mann, Johnson, & Mendenhall of Los Angeles, planners, architects and engineers, have announced the acquisition of **Forsen Engineers Inc.** of Anchorage, Alaska, as a new division. **Kenneth Forsen** will remain president of the division and has been named vice president in the firm. **Vahe M. Melkonian** has been named vice president and deputy manager of the Overseas Group.

The Deltona Corporation, developers, have appointed **Robert C. West**, vice president, architecture.

Diaz-Seckinger & Associates, Inc., engineers and planners, have named **Sydney H. Stille, Jr.**, vice president in charge of environmental engineering.

Ellis/Naeyaert/Genheimer Associates, Inc., architects and engineers, have made the following staff changes: **J. Edward Genheimer**, president; **Linn Smith**, corporate secretary and a director; **Bruce A. Reno** and **L. James Battey**, directors.

Ford & Earl Design Associates, Inc., have named **Paul E. Benya** an associate.

Giffels Associates, Inc., architects, engineers and planners, have appointed **John V. Sheoris** as project executive. The firm has been headquartered at 25200 Telegraph Road, Southfield, Michigan, since June.

Grayson Associates, Inc., architects and planners, has named **Kasi Z. Hasan** as staff architect.

Phillips Swager Associates, Inc., architects, planners, and engineers, have announced the appointment of **Olga E. Petters** as vice president, health facility planning.

Higgins & Root, Associates, Architects, AIA, have appointed **Gerald L. Erickson**, the firm's chief of design, as vice president and member of the board of directors. The vice presidency has been vacant since the recent death of Chester Root.

The design firm of Howard Hirsch and Associates has named **Robert D. Zimmer** vice president and director of international operations.

Hoyem-Basso Associates, Inc., Consulting Engineers, have announced the appointment of **Albert N. Bayer** as vice president and assistant director of civil engineering and surveying.

J. Arthur Johnsen, architect and planner, has named **Louis Edward Barbieri** and **James T. Voorheis** project managers. The firm has opened a second office in Sussex, New Jersey.

Karlsberger and Associates, Inc., architects and planners, have announced the appointment of **Michael D. Tyne** as senior health planner.

more office notes on page 151

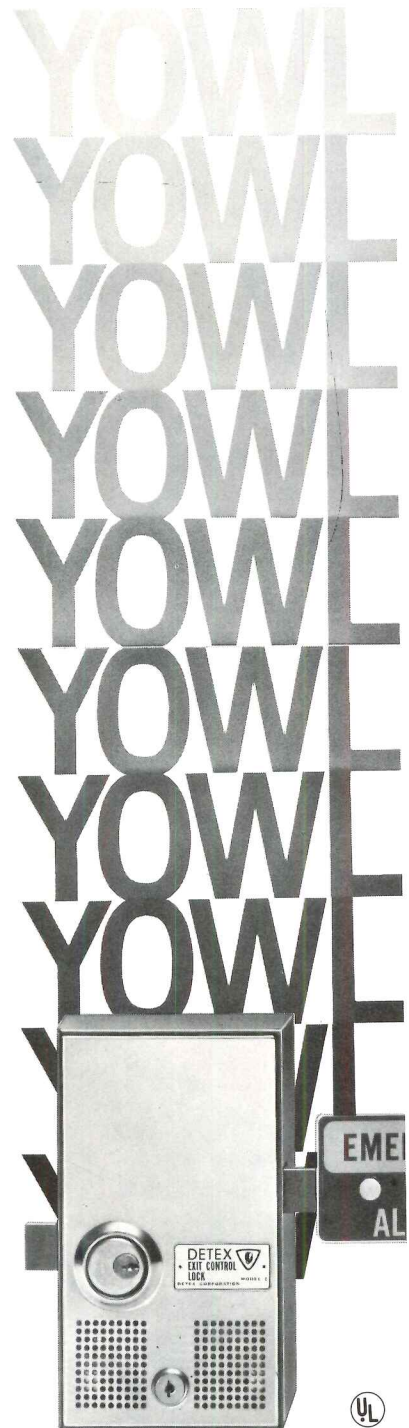

Beneath that calm exterior is a raucous alarm, ready to sound off at any attempt to misuse an emergency exit. Locks doors from the outside, but allows quick exit from inside in emergencies. Rugged No. 230 (shown) proven in thousands of buildings. Use in combination with Detex Vertical Rod Assemblies on double doors. Other models including the 2200

also available, all described in our new, free omnibus Security Hardware Catalog.

SOUND SECURITY DETEX

4147 Ravenswood Ave., Chicago, Ill. 60613

For more data, circle 71 on inquiry card



for ceilings and sidewalls
 economical spray application

USG

**SPRAY
 TEXTURE
 FINISH**

non-
 asbestos

25 LBS NET WT
 UNITED STATES GYPSUM

REGULAR FINISH
 Vermiculite
 Aggregate

NON-ASBESTOS

Imperial QT
 TEXTURE FINISH

USG

for light to
 medium light textures

USG

multi-
 purpose
 TEXTURE
 FINISH

USG multi-purpose TEXTURE FINISH

25 LBS NET WT
 UNITED STATES GYPSUM

U.S.G. Textures. The Elegant Cover-ups.

High fashion highlights your most complete choice of textures in the line with everything a professional could want.

Significant cost savings, thanks to special formulations that cover up more ceiling per pound. Asbestos-free spray applications meet OSHA and most state and municipal code requirements. And look at your options. A variety of acoustical looks... splatter... fog-splatter... orange peel... sand finish... high stipple... brocade... ripple. A truly versatile collection of superior finishes that readily bond to concrete, gypsum panels, plaster and wood.

For excellent pumpability, minimum fall-out and consistent results, with no asbestos content, look into U.S.G. Texture Finishes.

Call your U.S.G. Representative for a special audio-visual presentation. Or write to us at 101 S. Wacker Dr., Chicago, Ill. 60606, Dept. AR97

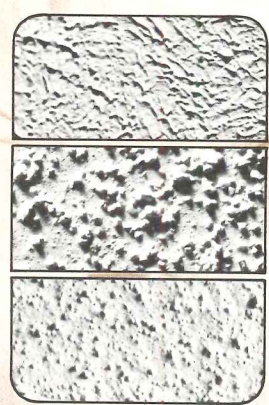

UNITED STATES GYPSUM 
 BUILDING AMERICA

For more data, circle 72 on inquiry card

Caution: Endangered Species

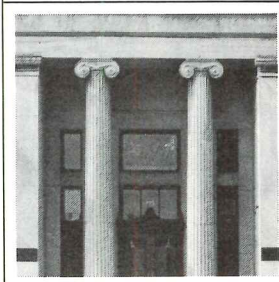
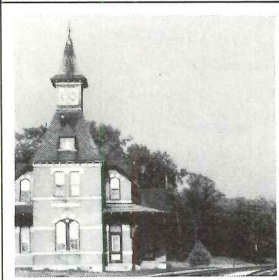
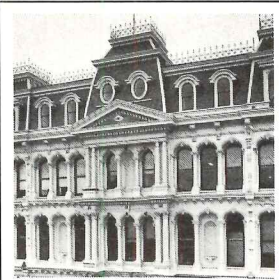
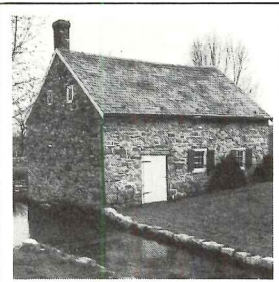

Since 1930, more than 4,000 important American landmarks have been needlessly destroyed... to say nothing of individual homes, entire sections of our cities. And, more are disappearing every year. The only way to stop this destruction is to get involved. Personally. For more information, write: National Trust for Historic Preservation, Department 0605, 740 Jackson Place, NW, Washington, DC 20006.



The Klein Partnership, Inc., architects and planning consultants, have named **David Burdick** a partner.

Kent State University has announced the appointment of **A. Peters Oppermann** as director of the School of Architecture and Environmental Design.

Kramer, Chin & Mayo, Inc., have added four members to its architectural and planning staff: **Michael S. Owen, Patricia Tusa Fels, Roger Oakdale** and **Sharon Davidoff**.

The architectural firm of **Howard R. Lane, AIA Associates**, has named **Abraham I. Lashin** director of production.

Lorenzi, Dodds & Gunnill, Incorporated, architects, engineers and planners, have announced that **Paul A. Dettor** has joined the firm as vice president of engineering.

Metz Train Olson & Youngren, Inc., architects and engineers, have announced the election of the following staff members: **Carl J. Hunter** and **Howard C. Pederson**, principals; **Don R. Belford, John Gillan, Robert J. Piper** and **Jorge J. Sirgo**, associates.

Mohasco Corporation has promoted **Ann Maria Baldine** to the position of interior designer in the corporate research and engineering division.

Moore Grover Harper, a Professional Corporation of Architects and Planners, has elected **J. P. Chadwick Floyd** and **Mark Simon** members of the board of directors.

Raymond Technical Facilities, Inc., engineering and designing firm, has appointed **Louis C. Amadio** executive vice president.

Massachusetts Governor **Michael S. Dukakis** has appointed **Richard Jay Bertman** to the State Board of Registration of Architects.

The **Ritchie Organization**, architects and planners, have named **Frederick Noyes** and **Robert Hoyer** project architects.

RTKL Associates Inc. has announced the promotion of **Gary A. Bowden** and **Vernon D. Moorer** to principals in the firm.

Sargent-Webster-Crenshaw & Folley, architects, engineers and planners, have named **Linda Evelyn Cronin** director of design of the Interior Design Group.

Sanders & Thomas, Inc., consulting engineers, have named **Thomas F. Hagerty** an assistant vice president. **Sanders & Thomas Western, Inc.**, has elected **James B. Hayes** a vice president.

The recently formed **Planning, Design, Research Corporation** has announced the appointment of **Christi Oliver** as vice president, director of programming, and **Jack Cade** as vice president, director of architecture.

Sippican Consultants International, Inc., have elected the following officers: **William J. LeMessurier**, chairman of the board; **Albert L. Romaneski**, president; **Edward J. Bayon, Henry P. Breen, Jr., Hans William Hagen, Phillip W. Sheridan** and **William L. Thoen**, vice presidents; **David W. Pollard**, controller.

Source/Inc., consultants for design and development, have announced the addition of **Bruce Layne** to the staff.

Square Industries, Inc., has named **Dan Jeremitsky** vice president and chief operating officer of the parking, planning and research services division.

more office notes on page 193

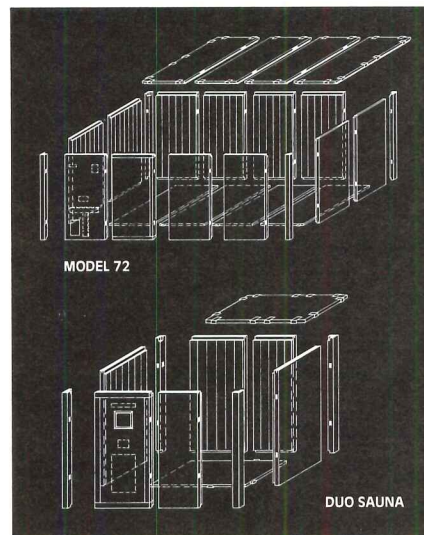

The last word in flexibility from the first name in saunas.

Eighty-seven different sauna room arrangements are possible with the six Universal pre-built rooms from Viking Sauna.

It's complete modularity — floor, benches and walls. Even control panels are modular.

With this kind of flexibility, there's probably a pre-built Viking Sauna that will meet your requirements. In homes. In offices. In any building. If not, Viking can custom design the sauna you want.

With more than 100,000 installations behind us, you know that when it comes to saunas, there is no "or equal" to Viking.

For the last word in saunas, return the coupon.



© V.S. Co., 1975

AR-9-7

Name _____
 Firm _____
 Address _____
 City _____
 State/Zip _____

Viking Sauna
COMPANY

909 Park Avenue, P.O. Box 6298
 San Jose, California 95150
Distributor Inquiries Invited

For more data, circle 73 on inquiry card

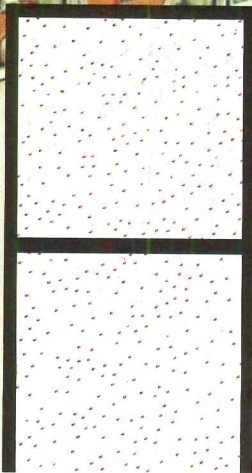
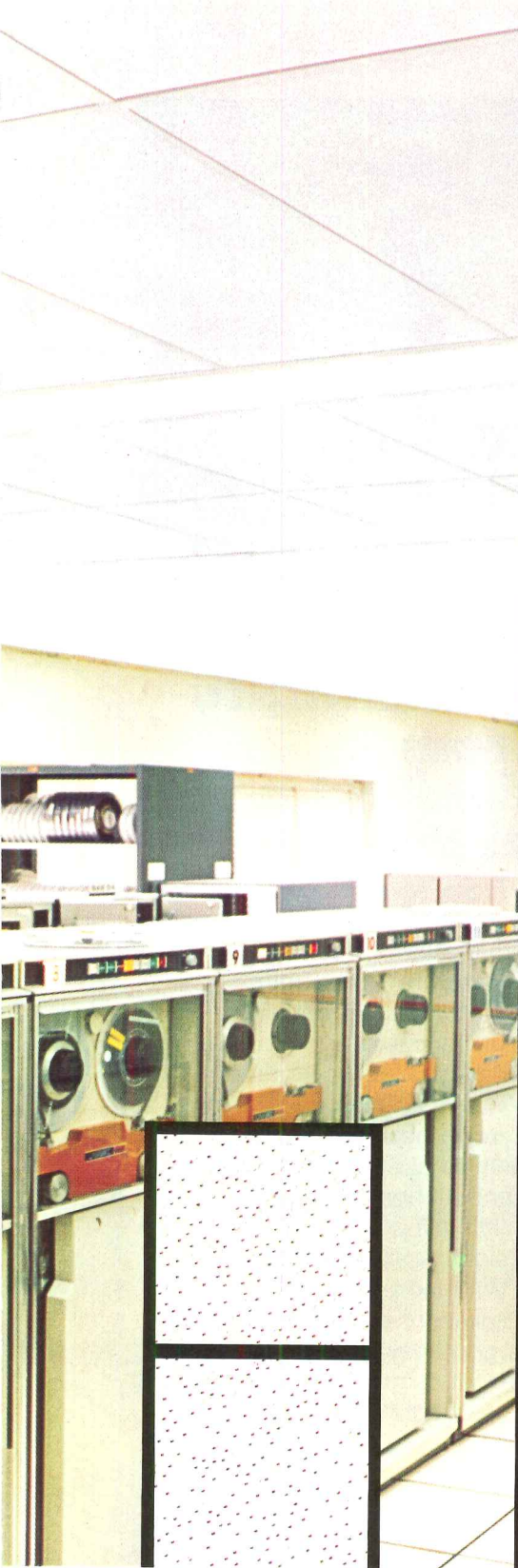

Particle-Gard LPC® Firedike®
Felted Mineral Panels

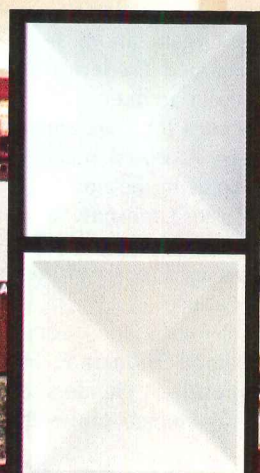

Sculptured Fiber Glass Panels:
Prismatic®, Profile®, Acousti-Shell®

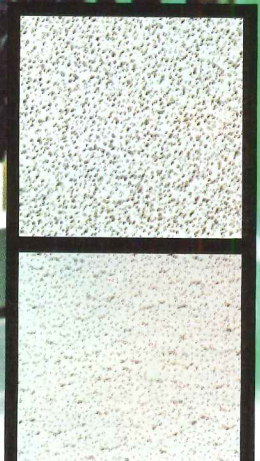

Temper-Tone® Felted Mineral Tile:
360, 720, DCF

Ceilings Unlimited from Johns-Manville.

A choice of acoustical ceilings that look great
and perform even better.



Open-Plan SpanAcoustic®
Fiber Glass Panels



Quadrette®
Reveal Edge Panels



Spintone® and Firedike®
Felted Mineral Panels:
360, Concord, DCF

J-M offers a selection of acoustical materials in almost unlimited sizes, textures and patterns to expand your design possibilities. Even in the face of tight budget restrictions.

Choose felted mineral tiles and panels for durability and dimensional stability. Or sculptured fiber glass panels to emphasize ceilings in large open areas like shopping malls and auditoriums. Or fiber glass panels that meet GSA speech privacy requirements in open plan

office landscaping.

We also have special purpose tiles and panels for clean rooms, high humidity areas, access ceilings, for ease of maintenance and for fire safety. All feature excellent acoustical properties.

For information, consult the Sweet's file, call your local Johns-Manville office or write: Johns-Manville Sales Corporation, Holophane Division, Department AR-9, Ken-Caryl Ranch, Denver, Colorado 80217.



Johns-Manville

Today's exorbitant energy costs demand a whole new approach to a building's exterior design.

The demand is for buildings that use sunlight as much as possible. *At the same time*, they must be highly insulated!

The Kalwall System is BOTH light transmitting and INSULATED.

This means the entire structure can have walls of Kalwall to let natural sunlight in all around. Yet, because Kalwall is so highly insulated, there isn't the terrible heat loss of transparent window-wall type buildings.



Some specifications of the Kalwall System

- Light transmission range 3% to
- U-Factors .40, .24, .15, and
- Shading Coefficients .85 to less than
- Weight per Square Foot 1 1/2 pounds
- Thickness of System 2 1/4 inches
- Design Considerations Unlimited
- Cost Try Kalwall on for

The KALWALL® SYSTEM is that NEW APPROACH

Jackie Robinson School
New Haven, Conn.
Stull Assoc. — Architects



Kalwall Systems Save Energy!

Full color literature gives complete details specifications. Call or write Bruce Keller return mail, you'll get all the literature plus name of an installation nearby!

Kalwall CORPORATION 1111 Candia Road, Manchester, New Hampshire 03103 Phone 603-627-3861
For more data, circle 75 on inquiry card



Listen. You can hear most water cooler compressors go on with just about every drink. But because of our cold water storage tank,

Oasis compressors don't go on nearly as often. Result? Oasis has fewer startups, which reduces wear and tear on the compressor. So listen to your water cooler. It's trying to tell you something.

OASIS®
The word for water coolers.

OASIS  Ebco Manufacturing Co., Columbus, Ohio 43213.

For more data, circle 76 on inquiry card

Choose EPICORE for telephone equipment buildings

A lifetime-access hanger system, heavy loading capacity, and unbeatable fire ratings are three reasons to specify the EPICORE® Composite Floor System.

These features are equally important for hospitals, electric power facilities, and warehouses, among others. Find out more from our EPICORE catalog. For immediate answers, call Bob Ault, Vice President - Engineering, at 412-351-3913.



EPIC
METALS CORPORATION

Eleven Talbot Avenue
Rankin (Pittsburgh), Pa. 15104
(412) 351-3913

For more data, circle 77 on inquiry card



noramment[®] makes luxury the most practical choice

Wear-resistant surface assures non-slip walking comfort, even on ramps.



Resists cigarette burns; char marks are easily removed

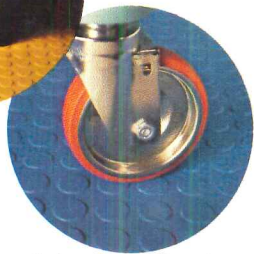

Carts roll smoothly and freely over surface.

Your clients' first impressions of NORAMENT will center on its beauty. Rightly so . . . the distinctive textured design and rich colors have exceptional visual appeal. It's only later, when the demands of day-to-day traffic become reality, that they'll appreciate its exceptional durability. Wear-resistant, slip-resistant and antistatic, NORAMENT shrugs off burns, chemical spills, oil and grease stains, cuts and scratches . . . as well as many other hazards that take their toll on ordinary flooring. This unique 100% synthetic rubber floor covering is increasingly seen in imaginative architectural projects around the world. Its superb blending of beauty and practicality may be just the answer for your next indoor or outdoor installation. Write for samples and complete information on NORAMENT . . . the flooring that makes luxury the most practical choice.



nora[®] flooring division

ROBUS PRODUCTS Corporation

4201 WILSON AVE., DEPT. 11 • MADISON, IN 47250 • (812) 273-4183

SALES OFFICE: 528 PENN AVE., WEST READING, PA 19611 • (215) 373-6797

IN CANADA: FREUDENBERG TRADING CANADA, 910 BEGIN ST., MONTREAL, CANADA H4M 2N5 • PHONE: 514 332-9440

For more data, circle 78 on inquiry card



When all of the various window requirements for this project were taken into consideration...

a Pella package was the only logical choice

When this student housing facility for Hahnemann Medical College was built, Pella windows were specified for some very sound, practical reasons. For example, a complete clad system was needed because the architect wanted matching clad panels below the clad windows. This allowed him to confine the masonry panels to vertical shapes, thus achieving the desired visual effect.

The need to keep maintenance costs at an absolute minimum called for windows that could be washed easily from

inside. Further, they had to be equipped with locks to prevent them from being opened during the air conditioning season. Pella Contemporary Double-Hungs with optional keylocks met these requirements beautifully, while their all-wood interiors provided a warm, home-like environment for the student apartments. Pella's Double Glass Insulation System was chosen for its superior insulating value. Add it all up and you have a package of features and options that are exclusive with Pella.

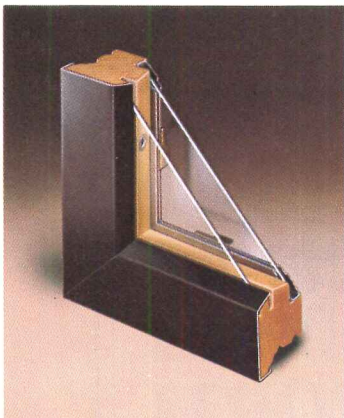

Pella's tough aluminum exterior cladding is first cleaned and etched, then coated with a baked-on acrylic polymer. It won't chip, crack or peel. Available in three standard colors, and 8 extra-cost optional colors.



Pella's Contemporary Double-Hung Window pivots for quick, easy washing of outside glass surfaces from inside the building. Can be equipped with optional keylocks to prevent unauthorized opening.

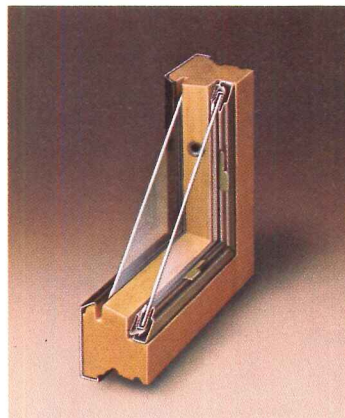

Pella's Double Glass Insulation System actually outperforms welded insulating glass, yet costs less. It has a full 13/16" air space between the panes. Precision wood construction and snug weatherstripping make it Energy-Tight.

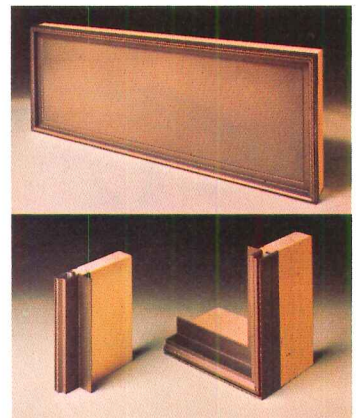

Pella's Clad System includes clad frames which will accept single glass, insulating glass, or matching clad panels. They offer outstanding flexibility and freedom for your design concepts.

For more detailed information, use this coupon to send for your free copy of our 28-page, full color catalog on Pella Clad Windows & Sliding Glass Doors. Call Sweet's BUYLINE number or see us in Sweet's General Building File. Or look in the Yellow Pages under "windows", for the phone number of your Pella Distributor.

Hahnemann Medical College
Student Housing Facility,
Philadelphia, PA

Architect:
L. Charles Scipione
Contractor:
J. J. White, Inc.

Name _____

Firm _____

Address _____

City _____ State _____ Zip _____

Telephone _____

Mail to: Pella Windows & Doors, Dept. T3117, 100 Main St., Pella, Iowa 50219
Also available throughout Canada. This coupon answered within 24 hours.

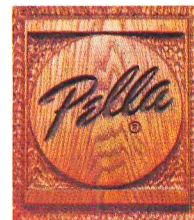

© 1977 Rolscreen Co.

For more data, circle 79 on inquiry card

**WE MAKE
AND INSTALL
OUR OWN
FENCE.
HOW MANY
COMPANIES
DO BOTH?**

USS Cyclone Fence is not a collection of components. It's a complete, pre-engineered system, which we provide ourselves – starting right with the steel.

We galvanize and aluminum-coat our own fabric. So we know it will last – not just look pretty. We roll-form our own posts, so we know they can really take abuse, and offer real security. And we install Cyclone Fence with expert crews. You get one single, all inclusive cost figure to work with. We take the headaches and responsibility – not you.

Cyclone Fence comes aluminum-coated, galvanized or in two colors: green or black. We think it will look better, last longer, and take less maintenance than any other chain link fence you could buy. Ask for sample specifications.

Look for Cyclone in the Yellow Pages. Or write Dan Hoover, U.S. Steel Supply, 13535 S. Torrence Ave., Chicago Ill. 60633.

USS Cyclone Fence
U.S. Steel Supply

USS and Cyclone are registered trademarks.

For more data, circle 80 on inquiry card

A Package Approach to Space Problems.

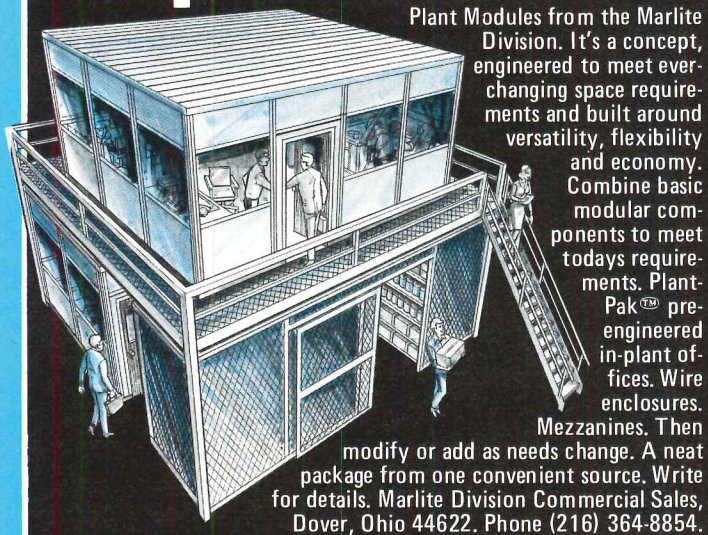

Plant Modules from the Marlite Division. It's a concept, engineered to meet ever-changing space requirements and built around versatility, flexibility and economy. Combine basic modular components to meet today's requirements. Plant-Pak™ pre-engineered in-plant offices. Wire enclosures.

Mezzanines. Then modify or add as needs change. A neat package from one convenient source. Write for details. Marlite Division Commercial Sales, Dover, Ohio 44622. Phone (216) 364-8854.

Marlite
MASONITE CORPORATION
DIVISION OF MASONITE CORPORATION
DOVER, OHIO 44622

MEETING THE CHALLENGE OF CHANGE

For more data, circle 81 on inquiry card

This Publication is Available in MICROFORM

from...

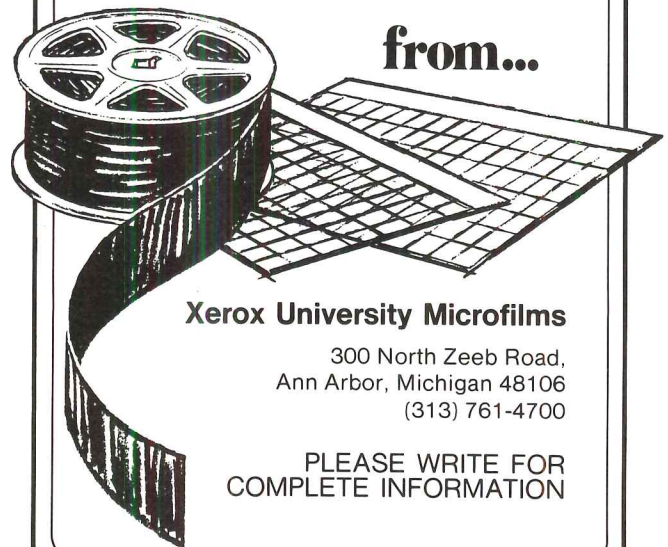

Xerox University Microfilms

300 North Zeeb Road,
Ann Arbor, Michigan 48106
(313) 761-4700

PLEASE WRITE FOR COMPLETE INFORMATION

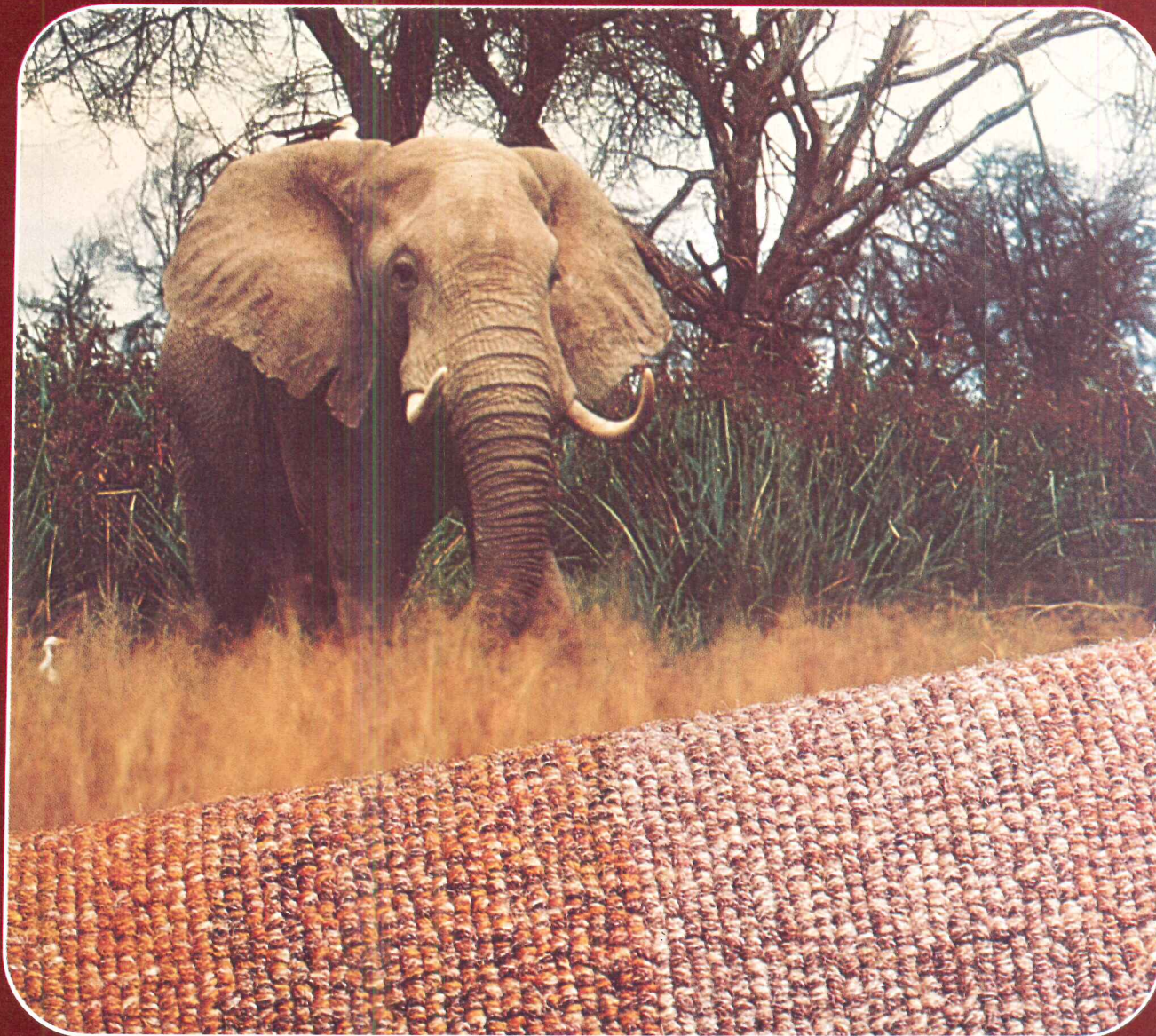

The Beast

Our carpet wearability and performance tests separate the beauties from the beasts.

A carpet made of Dow Badische fibers or yarns has to survive many brutish lab tests — with looks and performing talents intact — before it can carry our Performance Certification label in the market. That's how we make sure the beauty is more than "skin deep."

Take our Compression Test for pile retention. This simulates the crushing effect of heavy furniture legs on a carpet. We insist on a minimum of 85% pile height recovery for a passing grade.

Our Light Fastness Test is just as stiff. We expose the carpet to a high-intensity light source, simulating years of normal sunlight, to assure long-term color-and-light fastness. And these are only two of the tough tests we give finished carpets for Performance Certification.

Whenever you have to specify contract carpet, look for our Performance Certification label. That way you can be sure you're specifying a beauty and not a beast. For more information, contact our Contract Carpet Consultants Service and ask for our Performance Certification Booklet.

Dow Badische Company, Create Center
Williamsburg, Va. 23185
(804) 887-6573

**PERFORMANCE
CERTIFICATION**

**DOW
BADISCHE**

Dow Badische produces acrylic and nylon fibers and yarns especially engineered for carpets of beauty and performance.



**With one finger you can
locate any one of over
50,000 local sales reps
by name, address
and phone number.
In less than a minute.**



Every volume of Sweet's carries
our toll-free BUYLINE® number—
800-255-6880.

Any time you need to find a rep
whose company's in Sweet's, give us
a ring.

Our operator and her computer

will have your answer in less than
a minute.

BUYLINE's obviously a real time
saver. We've been averaging over
600 calls a day.

Which means Sweet's is really
working hard for you.

Sweet's. You can't beat The System.

The Sweet's System: Details on over 10,000 products from over 1,400 manufacturers ■ Instant information retrieval through triple indexing by product, trade name and firm name ■ GuideLines® Organization, the AIA-endorsed method for developing product information for specifiers and buyers ■ Yearly updating to keep data current ■ BUYLINE 800®, the fastest way to locate reps.

For more data, circle 83 on inquiry card



In Norfolk's Skyline:

A decade of Ceco formwork

Contractors and owners
coast to coast save on
forming costs with
Ceco services

Impressive architecture in concrete is adding excitement to Norfolk's modern, growing skyline. These four projects are typical of Ceco's concrete formwork in Norfolk over the past decade.

With Ceco services you get simplicity, speed and reliability.

— And a firm contract price that represents cost savings to contractors and project owners.

— And performance by formwork specialists who take pride in getting the job done right.

Ceco offers economical and time-saving formwork for rib-slabs, waffle-slabs, flat-slabs, columns and beams. Services are nationwide on a local basis. For more facts, please see Sweet's or contact your nearest Ceco office.

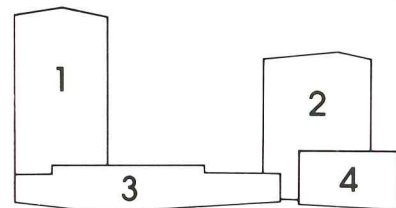

1. Virginia National Bank Building (1965)
Skidmore, Owings & Merrill, *architects*
Williams and Tazewell & Associates, *architects*
Weiskopf & Pickworth, *structural engineers*
Basic Construction Co., *contractors*

2. United Virginia-Seaboard Bank Building (1968)
Vlastimil Koubek, *architect*
Baskam & Chester, *structural engineers*
Thorington Construction Co., *contractors*
L. J. Martone and Associates, *concrete contractors*

3. I.C.C. Office Building (1975)
Toombs, Amisano & Wells, *architects*
Harald Nielsen & Associates, Inc.,
structural engineers
Batson-Cook Co., *contractors*

4. First Virginia Bank Building (1975)
Dudley, Morrisette, Cederquist & Associates,
architects & engineers
Basic Construction Co., *contractors*

 concrete
forming
CECO services

The Ceco Corporation • General Offices
5601 West 26th Street • Chicago, Illinois 60650

For more data, circle 84 on inquiry card

Brand-new, ALL-NEW Second Edition...

A lavishly illustrated guide to the best in multi-unit housing

From luxury resort condominiums to moderate-income garden complexes to entire villages of single-family townhouses—here's a timely collection of imaginative solutions to typical planning and design problems

APARTMENTS, TOWNHOUSES & CONDOMINIUMS

Second Edition

Edited by ELISABETH KENDALL THOMPSON
Senior Editor, Architectural Record

An Architectural Record Book

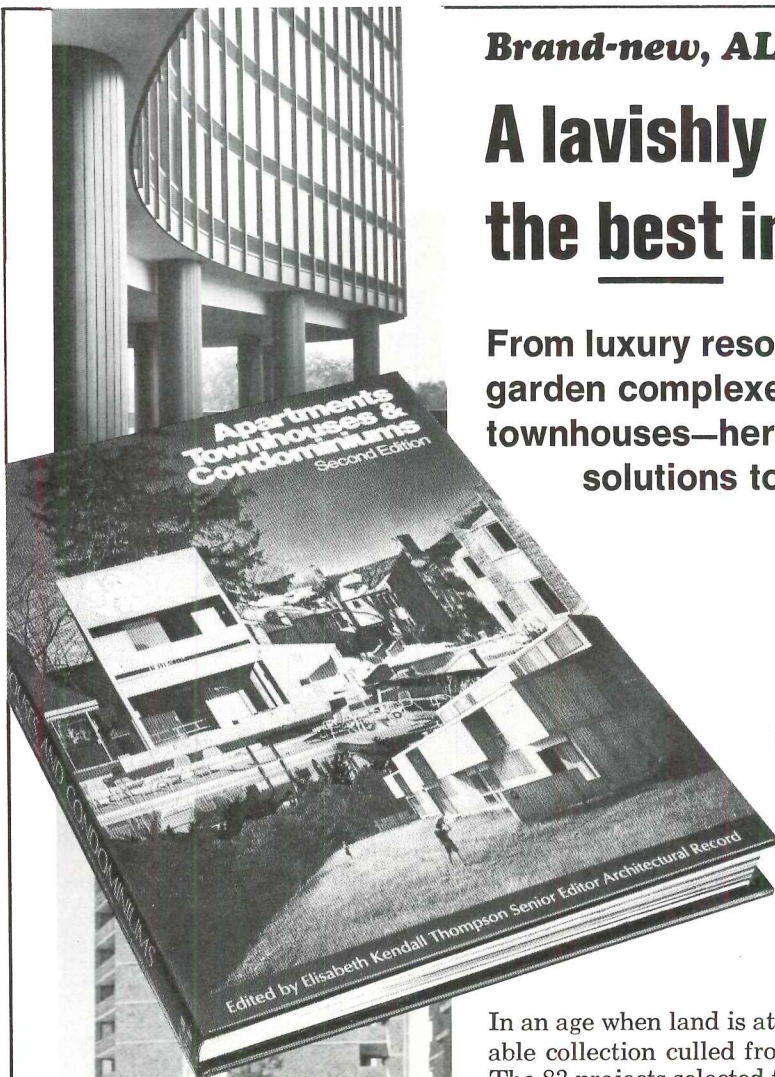

In an age when land is at a premium and multi-unit housing is on the increase, this valuable collection culled from the vast resources of *Architectural Record* fills a vital need. The 83 projects selected for this all-new Second Edition include some of the most imaginative and successful project designs of the past decade.

Turn to this handsome volume to discover what has worked best in apartment, townhouse, and condominium design—not only in housing units and buildings, but in land and site use, landscaping, and the general design approach to such developments as well. Superlative illustrations—nearly 550 of them—present in concrete visual form the wide range of stimulating ideas and ingenious solutions possible within a given framework and a given budget.

Here are the kind of aesthetically pleasing, people-oriented, high-density dwellings that can be achieved with the right combination of imagination, ingenuity, and dedication. Magnificent photographs are only part of the book's beauty and usefulness. There is also a profusion of floor plans, elevations, site plans, and perspective sections to show you how some of today's most creative minds are solving planning and design problems in a wide variety of building types.

216 pages, 550 illustrations, 9 x 12 format, \$21.95

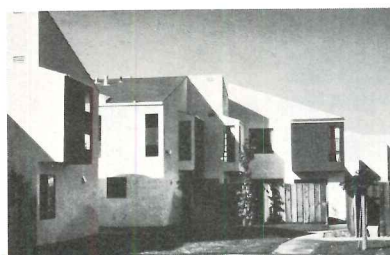
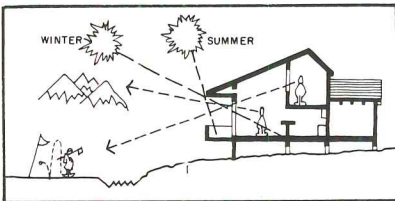

10 DAYS' FREE EXAMINATION

AR-9-77

McGraw-Hill Book Company
1221 Avenue of the Americas
New York, N.Y. 10020



Send me APARTMENTS, TOWNHOUSES & CONDOMINIUMS, Second Edition (002321-2) for ten days on approval. At the end of that time, I will remit plus local tax, postage and handling costs, or return the book postpaid without further obligation.

Name _____

Address _____

City _____

State _____ Zip _____

SAVE MONEY! Remit in full with this coupon, plus any local tax, and McGraw-Hill pays regular postage and handling costs. Same return and refund privileges still apply.

Offer good only in U.S. and subject to acceptance by McGraw-Hill.

23K227-4005-3



Halsey Taylor water coolers add a lot more than just water

You get a lot when you specify Halsey Taylor Water Coolers. And water is only the beginning.

There's beauty. Halsey Taylor coolers come in distinctive colors and functional designs to blend beautifully with any setting.

And flexibility. We make a wide selection of water coolers with over ninety models and colors to choose from. In addition to stainless steel, there are eight polychrome colors or your choice of vinyl clad steels.

Plus quality. Each cooler is constructed with top quality, heavy duty components to assure long life and dependable, trouble-free operation. Corrosion-resistant regulator valves. Positive start capacitors. Dual temperature controls. Overload protectors. Long-life fan motors. Unitized cabinet construction.

And most important, help is nearby. Halsey Taylor backs its water coolers with more Sales/Service Representatives than ever before and hundreds of leading wholesalers. We're always ready to help you in any way at any time.

So don't just specify a water cooler. Specify Halsey Taylor. You'll be assured of a refreshing drink of water. And, you'll also get a whole lot more. For sample specs, more information or free literature, write today to Halsey Taylor Division, Freeport, IL 61032.

Halsey Taylor®

KING-SEELEY **KST** THERMOS CO.

ROUTE 75, FREEPORT, ILLINOIS 61032

For more data, circle 85 on inquiry card

HAGER...TRADITIONALLY FIRST WITH THE RIGHT ANSWER.

Sparks of innovative genius flew off Charles Hager's anvil as early as 1848. In those days, his hardware outfitted Conestoga wagons. Later, his hinges were used on the early wooden Budweiser® beer cases.

A lot of things have changed since those early days, but the tradition of being first with the right answer is stronger than ever at Hager. Our technologies and skills are hard at work on new products to follow in the footsteps of the Camtrol, Torsion, Raconteur and our electric and pneumatic hinges.

That's why our promise for today and tomorrow remains the same...whatever the need, Hager will be first

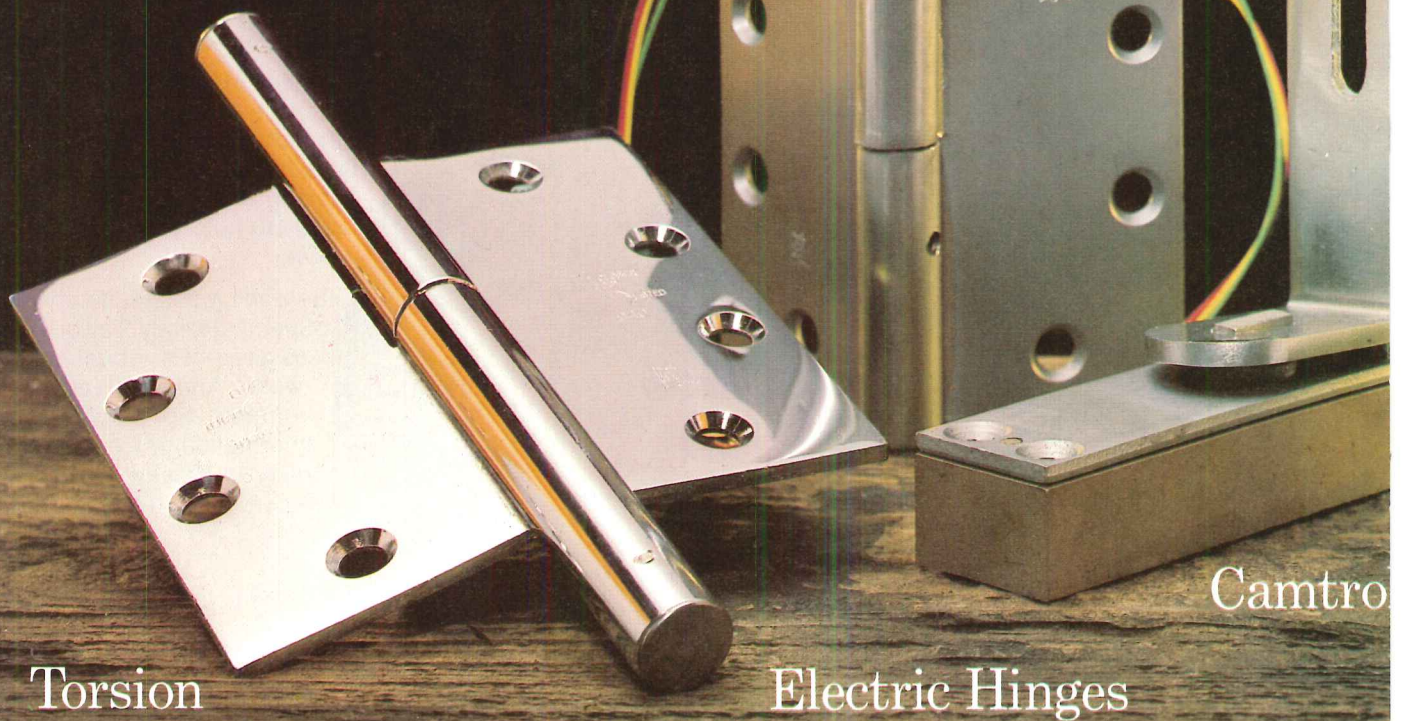

Torsion

Electric Hinges

Camtrol

with the right answer. We think Charles Hager would approve.

Hager Hinge Company
139 Victor Street
St. Louis, Mo. 63104
"Everything hinges
on Hager."



For more data, circle 86 on inquiry card



Tri Con®

Decorator Tip

Raconteur®

Econoline Kwik-Walls

portable
practicality



Durable and attractive walls as movable as furniture.

Kwik-Wall portable walls are factory assembled and shipped ready to install. Anyone can easily partition a large room for the best use of available space. No need for special tools or installation specialists. Kwik-Wall portable walls offer a broad choice of standard panel faces for long-lasting beauty, matching any room decor. Options, like matching doors, chalk boards, and light switches, provide that permanent look and function. Designed-in beauty and function are the marks of Kwik-Wall engineering. Send today for free catalog.



Kwik-Wall® Company, Dept. 42
P.O. Box 3267, Springfield, Illinois 62708

Name _____
 Title _____
 Firm _____
 Address _____
 City/State _____ Zip _____

For more data, circle 87 on inquiry card

MONRAY
ROOF TILE

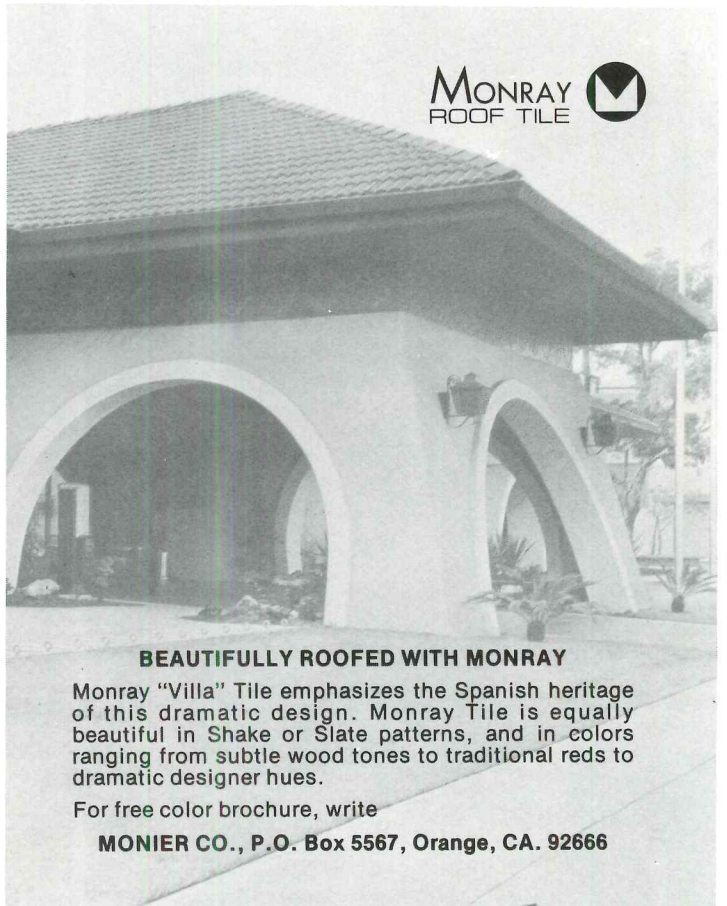

BEAUTIFULLY ROOFED WITH MONRAY

Monray "Villa" Tile emphasizes the Spanish heritage of this dramatic design. Monray Tile is equally beautiful in Shake or Slate patterns, and in colors ranging from subtle wood tones to traditional reds to dramatic designer hues.

For free color brochure, write

MONIER CO., P.O. Box 5567, Orange, CA. 92666

For more data, circle 88 on inquiry card

The terring® System

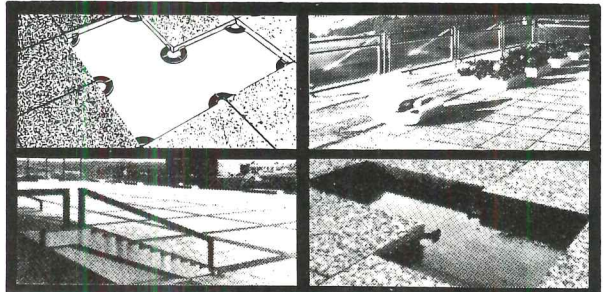

The **TERRING** System . . . an exciting way to easily install paving slabs on patios, decks, roofs or walkways. This system separates the slab from the substructure for a rigid, self-draining surface that also allows easy inspection. The separation increases the life of roofs and decks. Cracking, leaking and unevenness are practically eliminated.

WEGU 1707 Harbour St. WHITBY, Ontario (416) 668-2359
Agents throughout Canada and the U.S.



WRITE
FOR
HANDBOOK

NAME _____
 POSITION _____
 COMPANY _____
 ADDRESS _____
 CITY _____ STATE _____

For more data, circle 89 on inquiry card

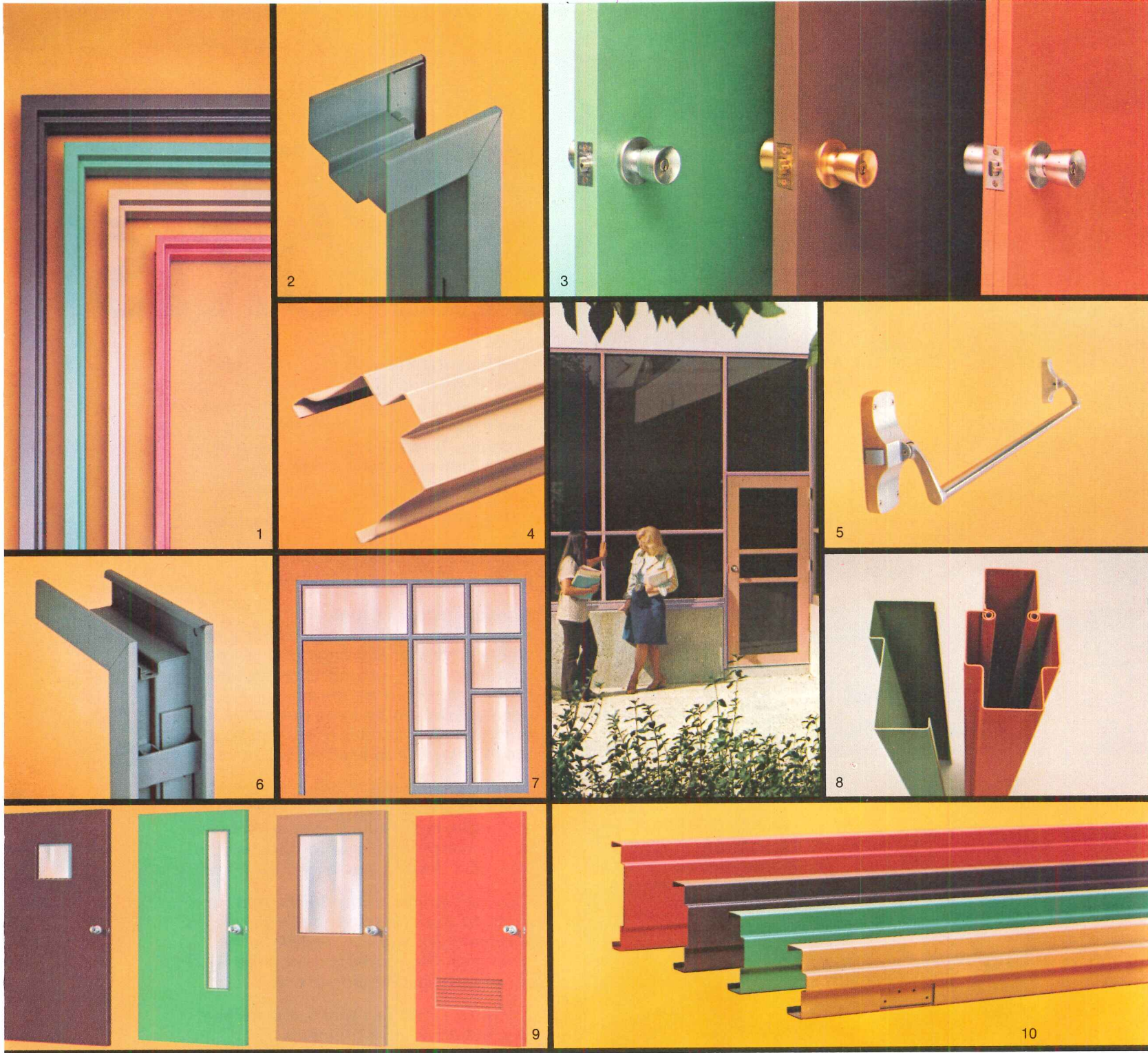

Curries means a little more freedom in steel doors & frames

Because we offer both pre-engineered and custom-made steel doors and frames, you can be more flexible in your design — without coordination problems. You can have your local Curries distributor fabricate special openings and provide finish hardware.

1. Five face widths: 1, 1¼, 1½, 1¾ and 2-in. 2. Pre-engineered flush frames, knocked-down or welded and ground smooth. 3. Pre-engineered and custom doors, full U.L. and F.M. labeling service. 4. Custom frame profiles. 5. Unlimited finish hardware preparations. 6. Pre-engineered drywall frames with compression anchors. 7. Local fabrication of transom, sidelight and borrowed-light openings using (8.) standard mullions and stick components. 9. Unlimited glass and louver combinations. 10. Jamb depths in flush and drywall frames from 3½ through 12-in. in ½-in. increments. For full details, call your Curries distributor. He's in the Yellow Pages under "Doors" or "Doors-Metal". Or see Sweet's 8.2/Cur or write Curries Manufacturing Inc., 251 9th St. SE, Mason City, Iowa 50401. (515) 423-1334.



For more data, circle 90 on inquiry card

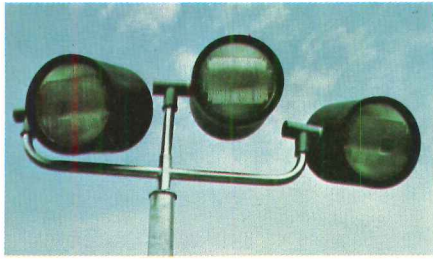

Coming in
mid-October



PRODUCT REPORTS

Architectural Record's *Product Reports* issue is devoted in its entirety to a comprehensive view of the year's most significant developments in building products. It represents an outstanding advertising value for manufacturers of building products because it offers . . .

- The largest paid architect and engineer subscriber audience ever made available to advertisers—some 45,000 architects and engineers.
- A unique editorial atmosphere. *Product Reports* is the only publication where architects and engineers can obtain, all in one place, a comprehensive view of the year's most significant developments in building products. With this issue in their hands they are totally receptive to learning more about products.
- Hard, repeated use. *Product Reports* is the most useful collection of new and improved products ever assembled in one convenient issue for the men who design, specify and buy.
- Close adherence to the 16-Division Uniform Construction Index—making feasible quick and easy review of the latest available products during the design and specification process.
- Full page advertisers may select division in which their advertisements will appear. Special positions are available too.
- *Product Reports* is the principal product update for Architectural Record's subscribers in the U.S. and Canada—those architects and engineers verified by Dodge Reports to be designing over 90 per cent of all architect-planned building in the U.S.
- Reduced charge for four-color advertising because four-color is used throughout the editorial as well as advertising pages.

Product Reports is where architects and engineers go for product ideas. What better time to reach them than when they are thinking product!

Closing date for advertising: September 15.





6 COMPELLING REASONS TO LOOK INTO PRE-ENGINEERED STEEL BUILDINGS.

These six award-winning buildings give you a good idea of the great design flexibility at your command with pre-engineered steel buildings.

You can use this type of structure with almost any design concept and finishing materials. You're not confined to simple projects either, as these pictures demonstrate. You can use the pre-engineered steel building for both low-rise construction and more complex, medium-rise projects, as well. It functions as a system in itself – or as an addition to another structure – or as a source of subsystems.

Computers have speeded up the tedious, repetitive aspects of a job. Procurement scheduling is precise. On the site, construction moves faster with less reliance on field work, more on factory-controlled quality. All this keeps your project costs highly predictable.

These architect-designed pre-engineered buildings were cited by the Metal Building Dealers Association for 1976. **1.** Gammatronix, Inc., Dublin, Ohio. Architect: Trautwein & Associates, Worthington, Ohio. **2.** Mirabel Racquet Club, Inc., Pte-Claire, Quebec. Architect: Tolchinsky & Goodz, Montreal, Quebec. **3.** Genova, Inc., Davison, Michigan. Architect: Richard L. Currie, Goodrich, Michigan. **4.** Olympia Technical Community College, Olympia, Washington. Architect: Bennett, Johnson, Slenes & Smith, Olympia, Washington. **5.** Acme Cleveland, Inc., Freemont, Ohio. Architect: Ray W. Covey Associates, Southfield, Michigan. **6.** Adams County Consumers Co-op, Brighton, Colorado. Architect: Robert Greenberg, Kansas City, Missouri.

FREE facts for architects and engineers

U.S. Steel has compiled a detailed, comprehensive library of design and specification booklets on this subject for practicing architects and engineers, called *Variations*. And "variations" is just the word for it. It's a storehouse of information and options available to you from 23 of the country's leading steel-building manufacturers, filed in a sturdy library case.

Nearly 5,000 architects and engineers have *Variations*. If you don't already have your copy, we'll be glad to send you one absolutely free. Write on your letterhead to: United States Steel, P.O. Box 86 (C801), Pittsburgh, Pennsylvania 15230.



United States Steel

Don't Let Your Clients Accept Substitute Docklevelers

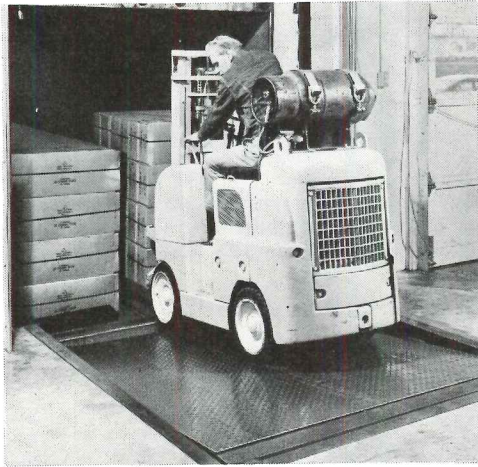

With today's high labor costs and safety emphasis you design loading docks to include permanent docklevelers. Facts prove they can easily pay for themselves in one year.

However, to assure maximum return on investment, specify genuine Kelley Docklevelers of the right type, size and capacity.

Docklevelers with patented automatic safety features and a predictable life span to stand-up

to high volume use year-after-year. Choose hydraulic or mechanical, standard heavy duty or extra-heavy duty models. Kelley Docklevelers cost about the same, or even less. So there's no reason to accept substitutes. Get the complete facts from your Kelley Representative or contact:

Kelley Company, Inc.
6768 North Teutonia Avenue
Milwaukee, Wisconsin 53209
Phone: (414) 352-1000



For more data, circle 92 on inquiry card

Architects! New Information now available!

ColorKlad

There is no "or equal" to ColorKlad:

- 20 year written warranty
- All metal masked at no extra cost
- Readily available — small or large quantities — 50 state distribution
- Technical assistance — 30 architectural representatives
- Highest integrity — lowest cost
- Flexibility not available in systems
- 9 colors
- 2 finishes
- Specify length and width

Send for Free Brochure



Vincent

Brass & Aluminum Co.
Building Products Division,
PO Box 360, Minneapolis, Mn 55440
or call **TOLL FREE 800-328-7772**

For more data, circle 93 on inquiry card

storage cabinets

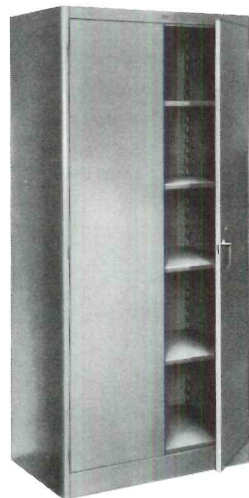

Meet every storage cabinet need — in Lyon quality! Five types: storage (illustrated), wardrobe, combination storage & wardrobe, counter type, desk high type. Quality features include modern styling with rounded corners, adjustable shelves, three point latch with key lock, polished chrome handle, and full 180 degree door opening. Dove Gray or Desert Sand finish.

Write for free catalog.
LYON METAL PRODUCTS, INC.
971 Monroe Avenue
Aurora, Illinois 60507

LYON METAL PRODUCTS

For more data, circle 94 on inquiry card

A dazzling new tower in Denver.

ELEVATORS BY DOVER

Anaconda Tower adds a sparkling new dimension to downtown Denver—forty floors wrapped in reflective glass. Tallest building in the Rocky Mountain region, the Tower is the focal point of Denver Square, a full-block complex that will include a 550-room Fairmont Hotel, attached parking structure, retail space and restaurants. Tenants of Anaconda Tower will speed to the top floors in six 1000-FPM Dover Elevators. Eight other Dover Elevators serve lower and midrise floors, and a service elevator handles maintenance needs for all forty stories. For more information on Dover Elevators, write Dover Corporation, Elevator Division, Dept. A, Box 2177, Memphis, Tennessee 38101.



Anaconda Tower, Denver
Owner: Oxford-Anschutz Development Company, Denver
Architects: Skidmore, Owings & Merrill, Denver/New York
Contractor: Poole-Hensel Phelps, A Joint Venture, Denver



Outside Salt Lake City, Vulcraft and the Army Corps of Engineers

544,400 square feet, to be precise. For a new warehouse facility at Hill Air Force Base. The completed 1361' by 400' building could accommodate thirteen football fields.

The Corps of Engineers and the Air Force first considered making it an all concrete structure like its twenty year old counterpart next door.

Then, Weyher Construction Company value engineered the structural system to see if they could reduce the contract price without altering the function or characteristics of the completed building. And to obtain the greatest possible savings they recruited Vulcraft to com-

puter design steel joists and joist girders specifically for the job.

The resulting Value Engineering Change Proposal showed that an estimated \$300,000 could be saved by using Vulcraft steel joists and joist girders instead of a reinforced concrete structural system.

When the Army Corps of Engineers and the Air Force saw that Vulcraft joists and joist girders were the least expensive structural system for the job, they gave Weyher Construction the go ahead. Weyher then issued Vulcraft's orders: deliver the joists and joist girders fast. In time to meet the original contract deadline.



covered a lot of ground together.

Vulcraft came through with flying colors. Weyher Construction came through with an on-schedule building. And the U.S. Government came through with an estimated \$300,000 savings.

The Vulcraft system might be able to save you money on your next job. So contact your local Vulcraft representative. Or write Vulcraft, P.O. Box 17656, Charlotte, N.C. 28211 for your Joist and Joist Girder Specification Guide (See Sweet's 5.2/Vu.). Or call 704/366-7000.

What you'll get is action above and beyond the call of duty. No matter how much ground you want to cover.

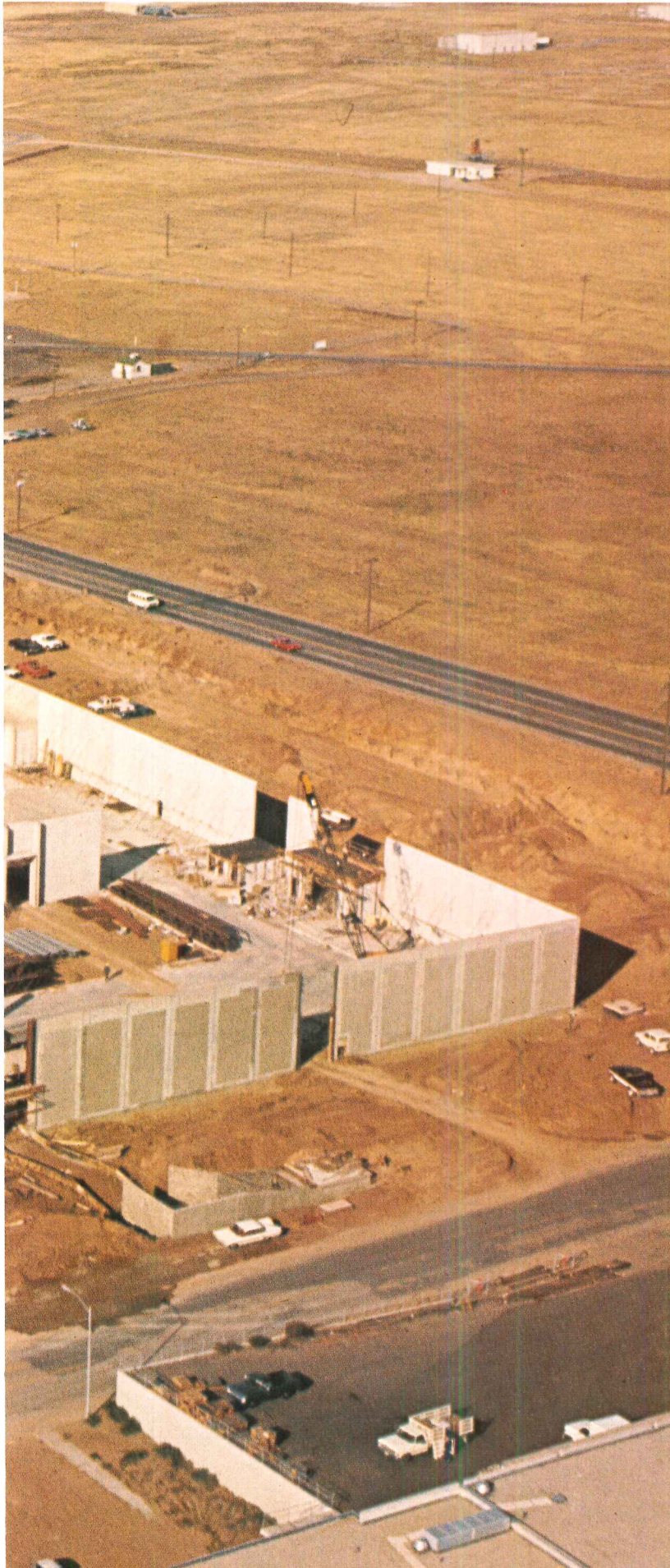

Economy results from high strength to weight of steel joists and joist girders. More efficient design and erection of primary structure is possible because fewer columns and beams are needed.

The efficiency of Vulcraft's standardized column connections speeds up steel erection and saves costs through faster construction, less jobsite labor and lower crane costs.

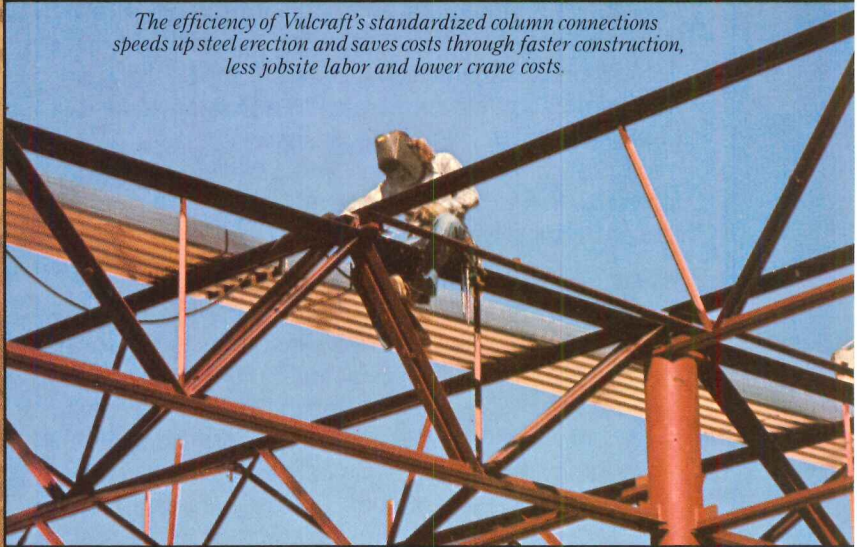

Maximum utilization of interior space is possible because all lighting, heating, air conditioning, wiring, ducts and pipes can be installed through the open web steel joist construction.

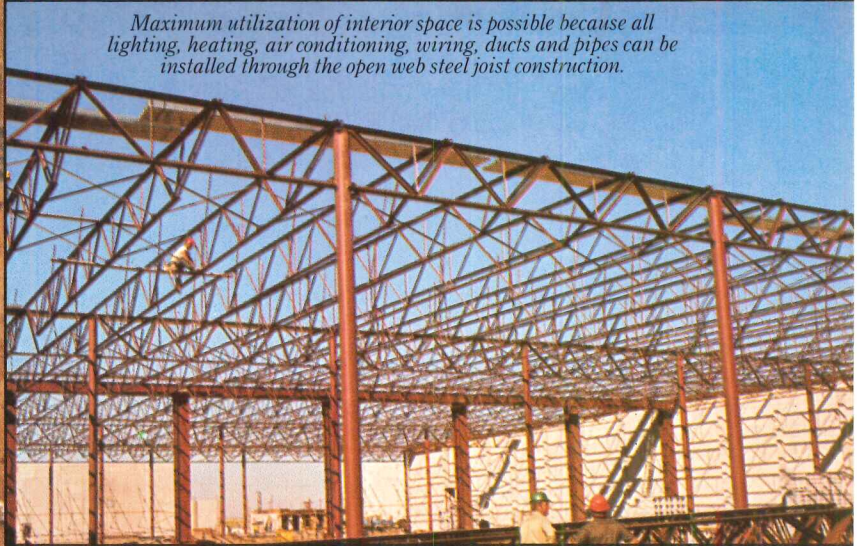

VULCRAFT

A Division of Nucor Corporation

P.O. Box 3009, Florence, S.C. 29501 803/662-0381

P.O. Box 169, Fort Payne, Ala. 35967 205/845-2460

P.O. Box 186, Grapeland, Tx. 75844 713/687-4665

P.O. Box 59, Norfolk, Neb. 68701 402/371-0020

P.O. Box 1000, St. Joe, Ind. 46785 219/337-5411

General Contractor: Weyher Construction Company, Salt Lake City, Utah.

Steel Fabricator: Utah American Steel, Salt Lake City, Utah. *Steel Erector:*

Masco, Inc., Centerville, Utah. *Architect and Engineer:* Reid & Tarics Association, San Francisco, California

For more data, circle 96 on inquiry card

Now Available THE NCARB ARCHITECTURAL REGISTRATION HANDBOOK

a vital tool for candidates
preparing for the December,
1977 Professional Examination

This *Handbook*, prepared exclusively by the National Council of Architectural Registration Boards, is *the only official publication* that deals with the NCARB Professional Examination — therefore, the best guide for exam candidate preparation! Each year NCARB publishes the *Handbook* to assist candidates preparing for the Exam as well as to provide the profession with an in-depth study and analysis of a particular building type.

As such, it is also invaluable to educators and practitioners who need to stay abreast of evolving testing processes as well as innovative solutions to various building types. The subject of the 1976 Professional Exam was an Infirmary and Health Care Center in a large correctional facility complex. An extensive bibliography on this building type was included in the 1976 edition of the *Handbook*. The subject matter for the 1977 Professional Exam deals with facilities for a state's judicial and historical/heritage functional needs.

As a study aid, the *Handbook* provides you with actual 1977 Professional Examination information:

- The identical Mission Statement sent to applicants — with specific information on:
 - Background data on the building being analyzed in the exam.
 - Information on the extent of each part of the exam.
 - Reference materials needed for the exam.
 - Exam scoring and reporting procedures.
- Exam preparation information
- A study strategy for the December 1977 examination

In addition the *Handbook* helps you prepare for the 1977 examination by bringing you:

The complete Test Information Packages and Mission Statement for the 1976 Professional Examination.

A "test-yourself" selection of questions and answers from the 1976 Exam.

Summaries of candidate performance on the 1976 Exam.

Valuable resource information on the building types covered in the 1976 and 1977 Professional Examinations.

Prepared by NCARB, this *Handbook* is published jointly by NCARB and Architectural Record Books.

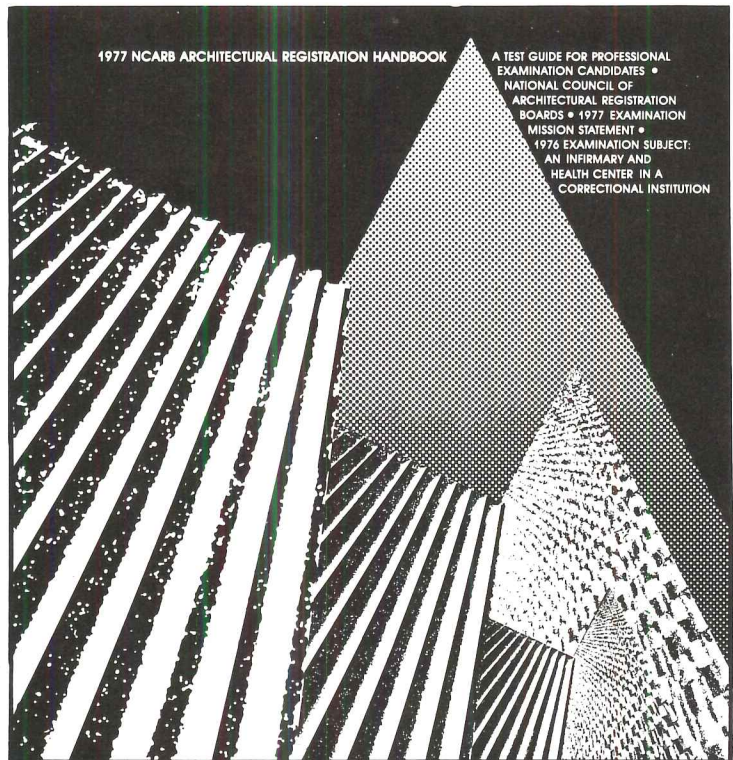

Only one printing of this book will be made. To make sure that you receive your copy promptly, please use the adjoining coupon or send your order to Architectural Record Books, Box 682, Hightstown, New Jersey 08520. Payment of \$20.00 (including postage) must be attached, made payable to Architectural Record Books.

TO:	AR-9-77
Architectural Record Books c/o Architectural Record Box 682 Hightstown, New Jersey 08520	
Enclosed is payment of \$ _____ for _____ copies of the 1977 Architectural Registration Handbook. Please forward im- mediately to:	

Name	

Street	

City	State Zip
c	

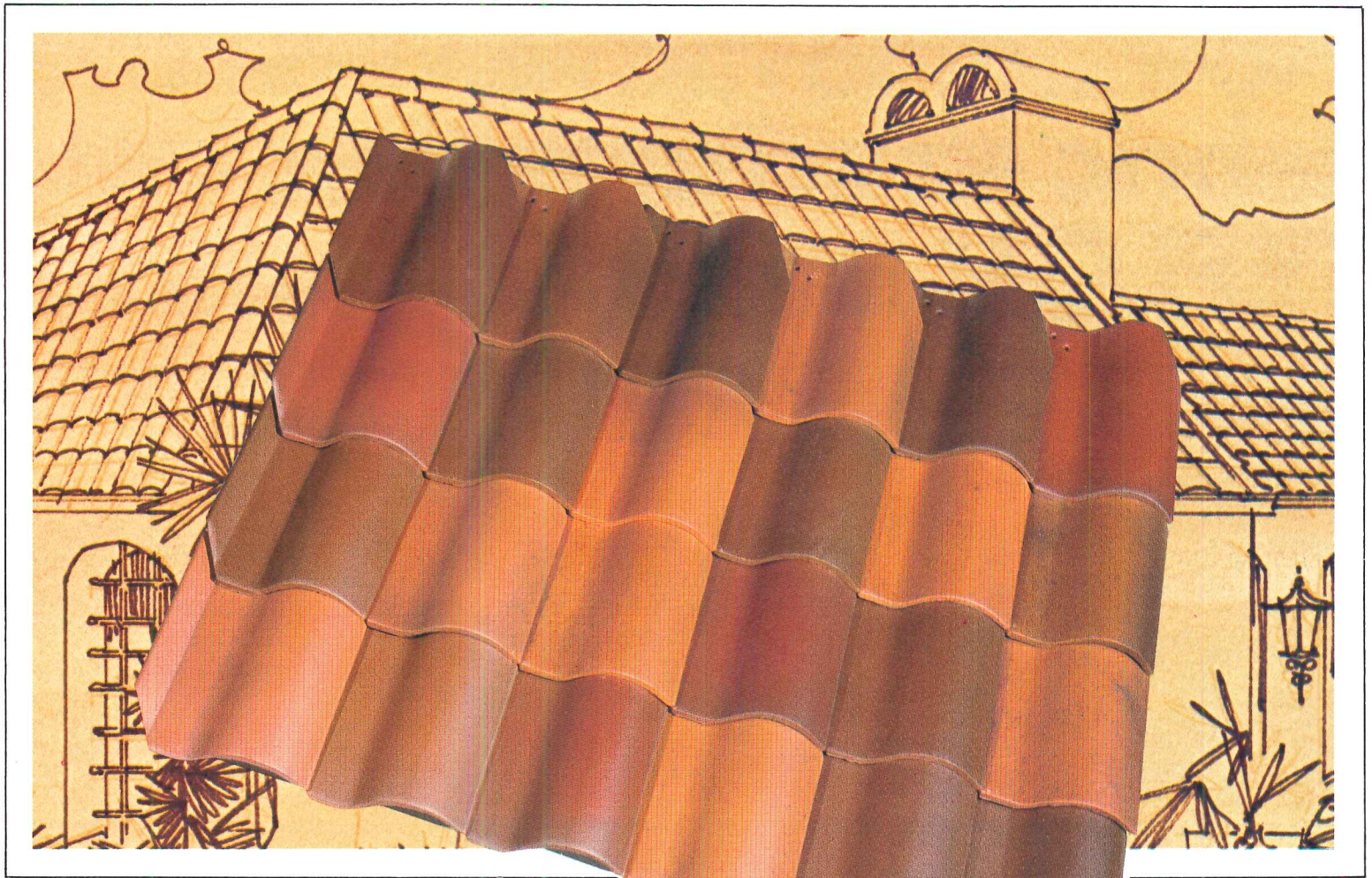

Subtle color achievement
in an art form of roofing.

GRANADA FLASH Spanish Roofing Tile by Ludowici.

Dancing sunlight captured on a gracious roof! Now made possible by Granada Flash, the latest Ludowici achievement.

Granada Flash is a combination of three fireglazed tones—a brownish cast, a beige hue and red hearts. Delivered orders are a random assortment that is blended on the job site to create a distinctly unique roof.

And, Granada Flash hues are durable, slowly mellowing as time passes. Of course, the tiles themselves are permanent, resisting storms and weather as they protect the structures they beautify.

Attractive, enduring Ludowici Spanish Tiles come in Mediterranean Blue, Barcelona Buff and Coral, as shown below, and many other colors and surfaces.

From the standpoint of beauty and longevity, Spanish Tile, and all fireproof Ludowici tiles offer the greatest value among the roofing materials available today.

For additional information on all Ludowici Tiles look under "Roofing Materials" in the Yellow Pages, or see Sweet's Catalog 7.7/Lu. Or mail coupon.



Mediterranean Blue

Today's most popular high glaze blue tile. Reminiscent of the varied sea tones of the Mediterranean.

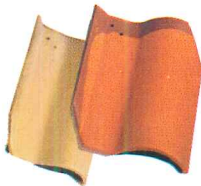

Barcelona Buff (left) and Coral

Two subtle matte finish tiles frequently used to accent Granada Flash tiles.



LUDOWICI-CELADON

Division of CSC, Incorporated.
201 N. Talman Ave., Chicago, Illinois 60612

Send information on Spanish Tile I'm interested in other Ludowici Tiles.

NAME _____

FIRM _____

ADDRESS _____ COUNTY _____

CITY _____ STATE _____ ZIP _____

For more data, circle 97 on inquiry card

Now...innovative, versatile fabric structures that last. TEFLON makes it possible.

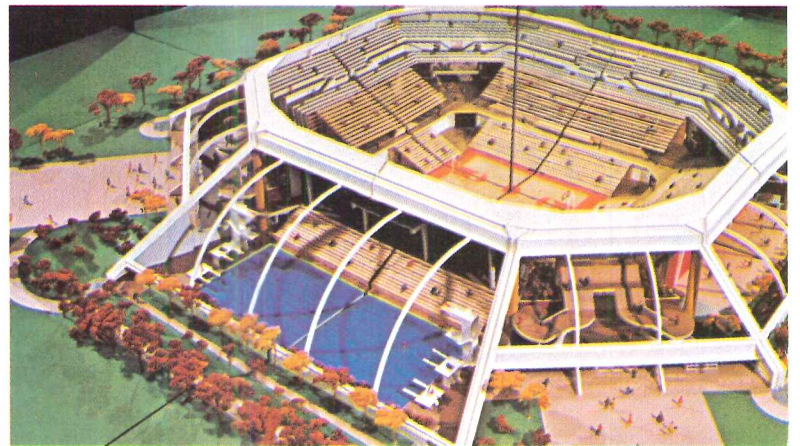

Model of proposed student activities center, University of Florida, Gainesville, Florida.
Architects: Caudill Rowlett Scott, Houston, Texas; Moore, May & Harrington, Gainesville, Florida.
Engineers: Geiger-Berger Associates, P.C., New York City.

Permanent fabric exterior removed from model to illustrate column-free interior.

The University of Florida at Gainesville needed a new student activities building. They wanted a basketball court, olympic-size swimming pool, high diving area, indoor track, court sports and gymnastic area, locker rooms and administrative offices. They wanted an attractive permanent building...not a temporary structure. And, they had the inevitable limitations of a budget.

The architectural firms of Caudill Rowlett Scott and Moore, May & Harrington met their needs by proposing a permanent building of architectural fabric coated with TEFLON® fluorocarbon resin. Pound for pound stronger than steel, the glass-fiber fabric can be supported by light air pressure or high strength cables providing large, clear spans without bulky, expensive supporting columns. Enclosed space is free and uncluttered. And the translucence of architectural

fabric coated with TEFLON adds to the feeling of openness. It admits enough natural light to grow plants and carry on sports activities even on cloudy days. The new facility is designed to resist Florida hurricane forces.

TEFLON makes it possible. Architectural fabric coated with TEFLON resists sunlight, industrial smogs, aging and weather. It washes clean in rain. Its excellent flame resistance has permitted it to be accepted under all code requirements for permanent buildings for which it was submitted.

To learn more about permanent buildings with architectural fabric coated with TEFLON, send for our free 16-page, full-color brochure. Write: Du Pont Company, Room 35743, Wilmington, DE 19898. In Europe: Du Pont de Nemours International, S.A. P.O. Box CH-1211, Geneva 24, Switzerland.



INTRODUCING THE PASSWALL® AUTOMATIC STAINLESS STEEL POOL SYSTEM!

Paragon is proud to introduce the PassWall® system, embodying the latest in swimming pool technology.

PassWall® is an unsurpassed, complete system comprising an automatic, recirculating overflow gutter combined with a stainless steel wall. Backed up by steel buttresses, it forms a structurally stable pool wall section containing a complete, pipeless hydraulic system - eliminating all perimeter piping.

PassWall® is suitable for installation in any climate! It will not crack, spall, bulge, or leak. Fabricated entirely of 12-gauge, polished stainless steel, it requires neither coating for protection nor any annual maintenance other than wiping. It is shop fabricated and delivered to the job site in long sections. Erection and welding are by factory-trained crews. The installation is completed quickly and accurately.

A recirculating overflow gutter is the preferred system for competitive pools. (It is a requirement for pools in which national meets are to be held.) The absorption of turbulence by the gutter makes such pools quieter and results in faster swimming times. And with our recirculation duct removed from the gutter - an exclusive feature - we offer greater surge storage capacity than all other systems.

PassWall® is an economical system, offering the latest in pool technology. You can now obtain all the components for your pool from one source, with a single responsibility; the pool wall with recirculating overflow gutter, a superior line of deck equipment, complete filtration systems, chlorination and mechanical equipment, moveable bulkheads.

We've been manufacturing quality equipment for institutional and commercial pools for the past twenty years. When you specify Paragon, you'll be getting quality and reliability from a firm dedicated to excellence in design and manufacturing.

For further information, see us in Sweet's Architectural File 13.22, or contact us. Area representatives who can offer advice or assistance are located throughout the country.

**KDI Paragon Inc.,
The People Who Care.
12 Paulding Street
Pleasantville, New York 10570
914-769-6224
TWX 710 572 2202**

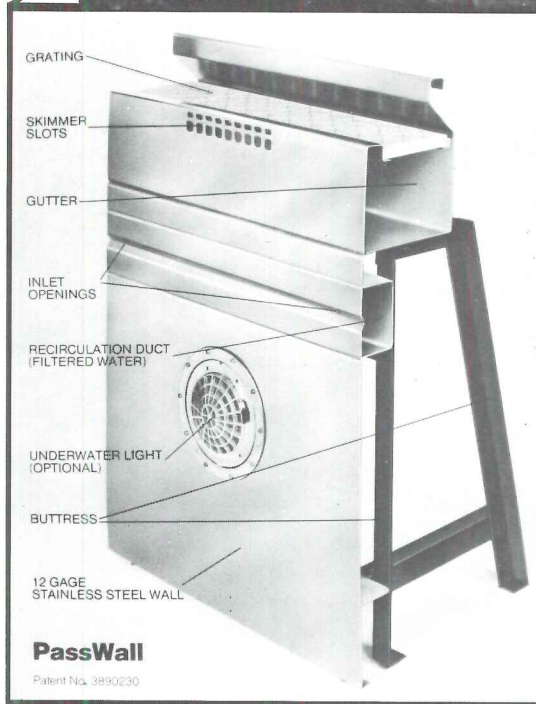
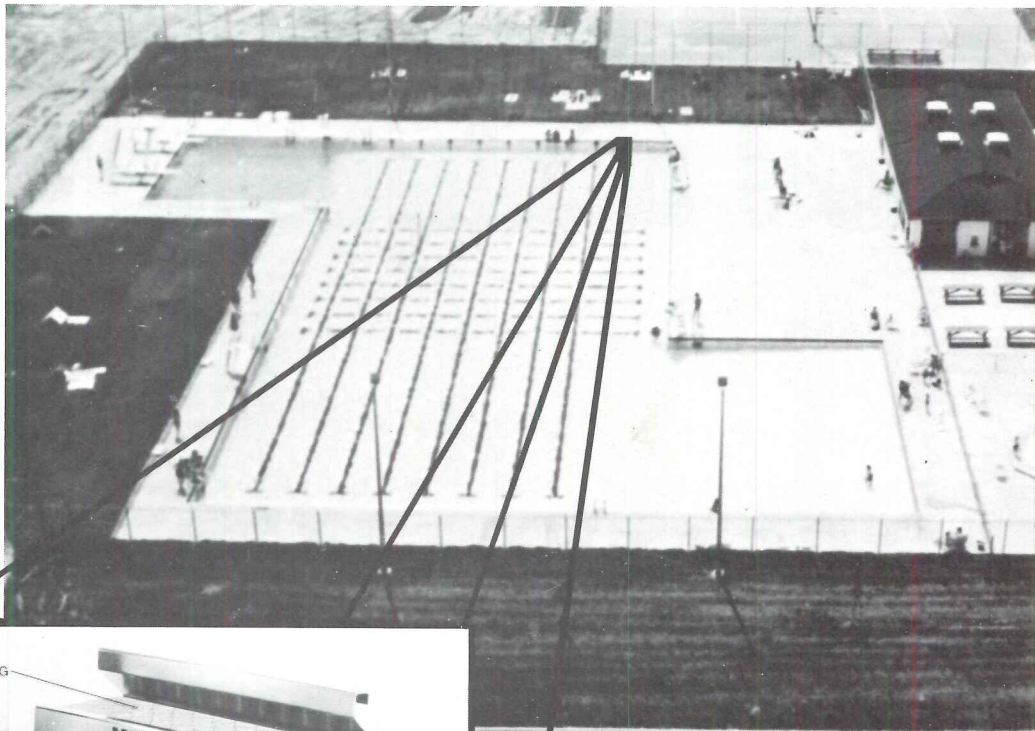

**Colonial Park Pool
640 Lin. Ft. of PassWall
16,400 Sq. Ft. of Pool Area**

**PassWall
Wall and Gutter Section.**

**FROM PARAGON:
20 YEARS OF MANUFACTURING
THE BEST IN SWIMMING
POOL EQUIPMENT.**

For more data, circle 99 on inquiry card

On your next school, motel, hospital, store, offices, or apartments...

Super-C Steel Framing can cut both construction and maintenance costs.

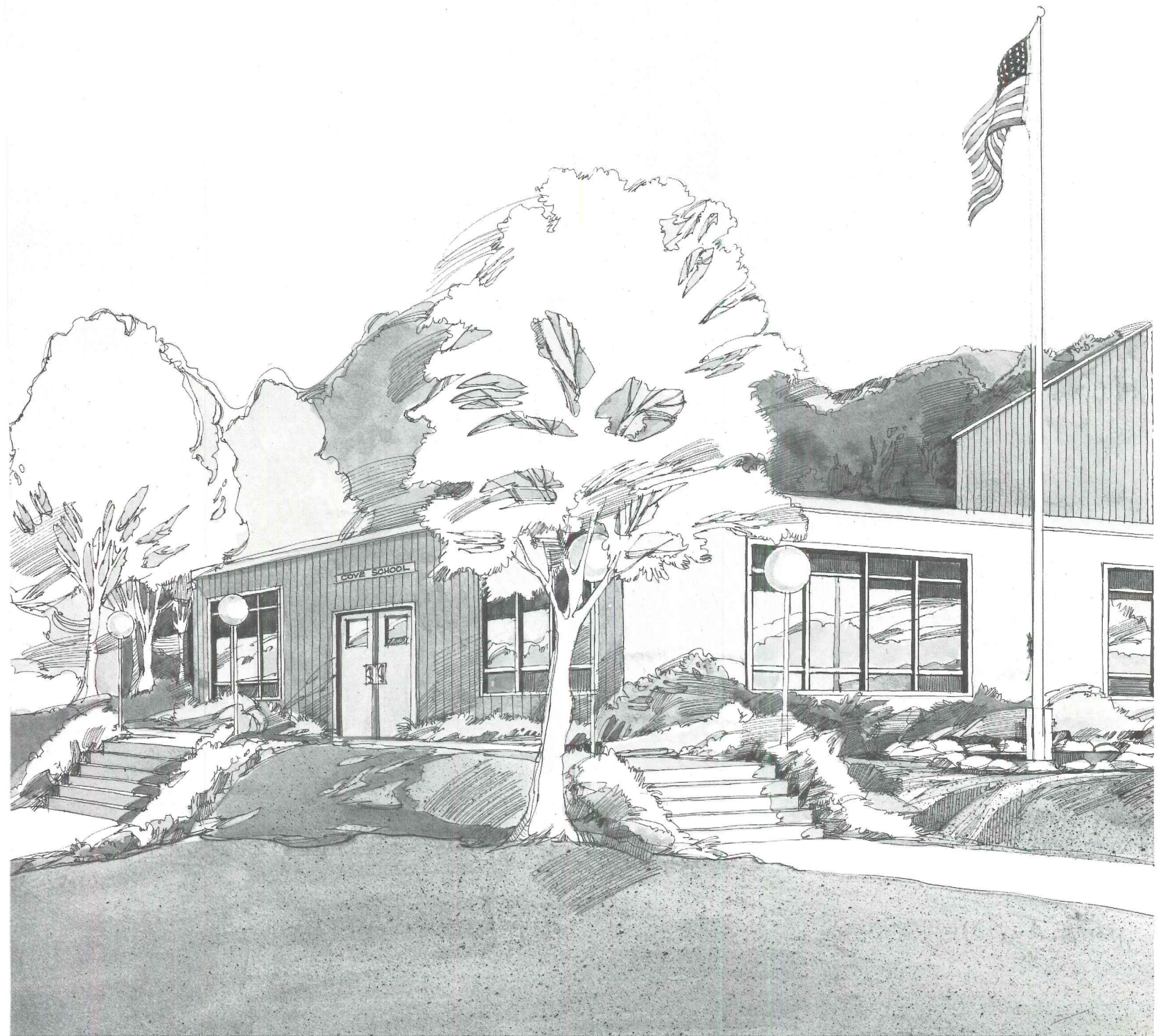

Super-C Steel Framing members are a load-bearing framing system that can be used to provide the entire structural framework for most light commercial projects you may be planning...one to three stories with overhangs or balconies, surfaced with brick, stucco, or other exterior treatment.

In fact, Super-C Steel Framing members—developed by U.S. Steel and manufactured by independent licensee-fabricators—are being used in dozens of such projects round the country right now. And significant life cycle cost savings are built right in.

Installed cost can be lower, because Super-C Steel Joists and Studs are pre-cut to specified lengths for fast installation, pre-punched to speed plumbing and wiring. Your project can be ready for use more quickly.

But the cost advantages don't stop there. Floor/wall separation, door realignment, and other maintenance costs can also be lower, because Super-C members don't

crack or warp, are dimensionally stable and can give you a virtually trouble-free framing system.

Super-C is compatible with almost any type of building materials you want to use—all standard floorings, sheathing, and exteriors (including curtain walls). It has national code approvals and offers one-hour and two-hour fire ratings.

Free information on Super-C Steel Framing.

We'd like to send you more information about Super-C, including an analysis on life-cycle costs by a leading architectural firm—plus the names of independent licensee-fabricators serving your area. Check the reader service card. Or write: United States Steel, P. O. Box 86 (C737-4), Pittsburgh, PA. 15230.

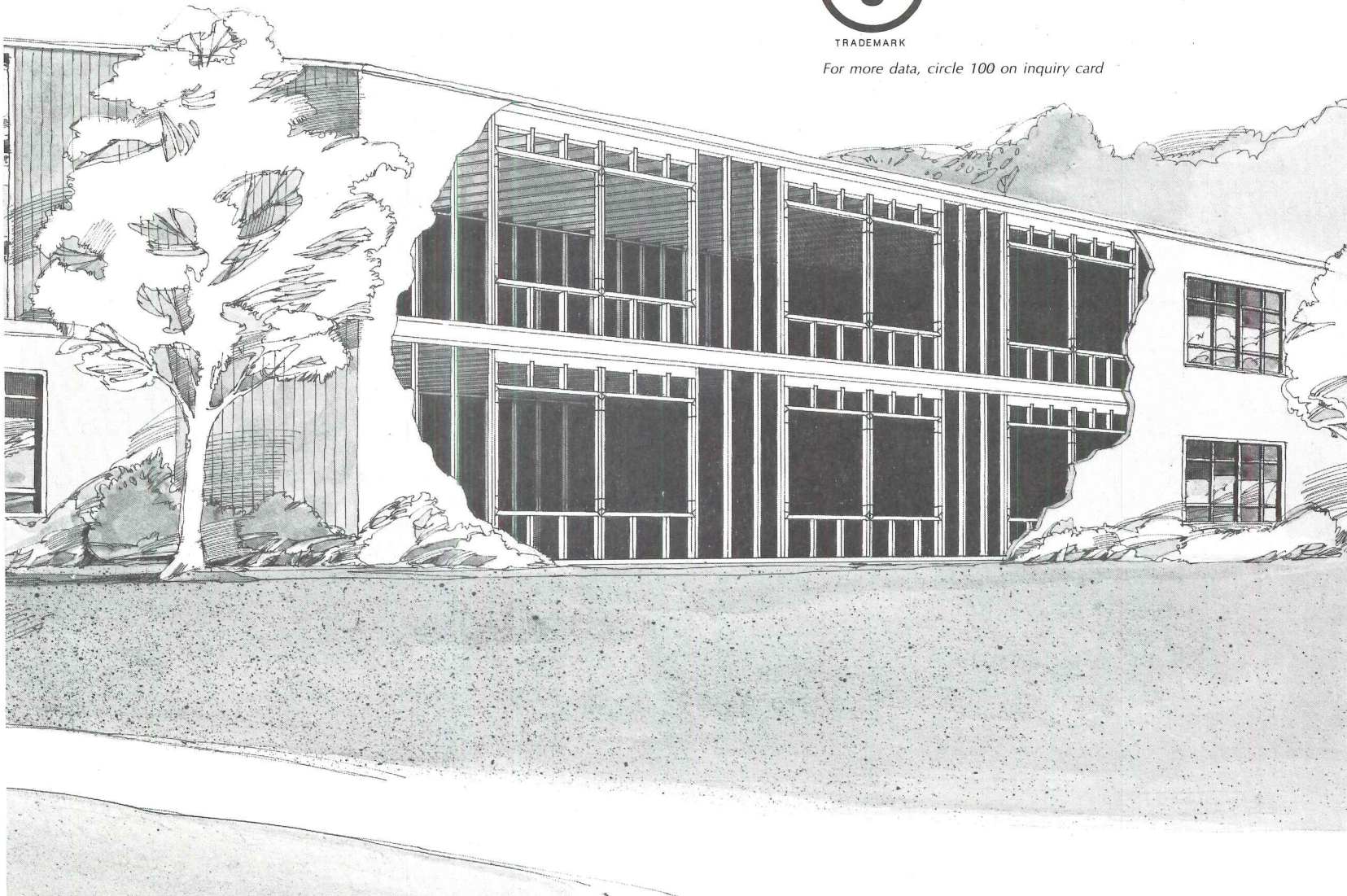

United States Steel

TRADEMARK

For more data, circle 100 on inquiry card

For inspiration, for information, for ideas... 10 books from McGraw-Hill

UNBUILT AMERICA

By Alison Sky and Michelle Stone

A tantalizing look at structures planned, designed but never built: an underwater restaurant by Norman Bel Geddes, Frank Lloyd Wright's mile-high "The Illinois," Joseph Murphy's aerial restaurant, Thomas Jefferson's "President's Palace" and over 300 other startling proposals that, for beauty, ingenuity and audacity, often outdo the more familiar landmarks of American architecture.

304 pp., \$14.95.

THEATRE DESIGN

By George C. Izenour

The entire panorama of Western theatre building from ancient to modern times, showing what makes theatres "right" or "wrong" in acoustics, seating, viewing, engineering, structure, aesthetics, and economics.

Over 900 superb plans, photographs, isometric analyses, sections and perspective drawings cover more than 100 remarkable structures.

631 pages, \$49.50.

PERCEPTION AND LIGHTING AS FORMGIVERS FOR ARCHITECTURE

By William M. C. Lam

From America's foremost lighting expert, the first book ever to cover the fundamental conceptual issues of lighting—the vital **how** and **why** (not just the usual hardware and foot candle calculations)—to show how the integration of structure and services with lighting can fill the real visual needs of people. Includes 55 actual case studies, hundreds of illustrations.

310 pages, \$32.50.

BEHAVIORAL ARCHITECTURE

Toward An Accountable Design Process

By Clovis Heimsath, A.I.A.

A revolutionary book on the psychological effects of buildings on the people who inhabit them; packed with step-by-step guidelines and procedures to help you create effective behavioral designs, and eliminate the thoughtless mismatches of buildings and human beings. Fundamental, fascinating and practical, this book will fire your imagination with new solutions to old problems.

203 pages, \$15.50.

DICTIONARY OF ARCHITECTURE AND CONSTRUCTION

Edited by Cyril M. Harris

The most comprehensive work of its kind, this indispensable reference provides over 20,000 definitions of terms not only in architecture and construction but related fields as well... from Angstrom to Zwinger... from Classical, Medieval and Renaissance terms to the latest definitions of standards groups and technical committees. Prepared by 52 contributing experts in their fields, with 1,750 illustrations, photographs, drawings, diagrams.

553 pages, \$37.50.

THE ARCHITECT AS DEVELOPER

By John Portman, F.A.I.A., and Jonathan Barnett, A.I.A., A.I.P.

The first-hand account of America's leading architect-developer on integrating architectural design and real estate development into a single process that achieves architectural quality and financial success. Discusses in depth Portman's design principles, their applications, the seven areas of real estate development critical to an architect's understanding, the design issues that have a crucial effect on a project's financial success. Fully illustrated throughout.

202 pages, \$22.95.

HISTORIC ARCHITECTURE SOURCEBOOK

Edited by Cyril M. Harris

Over 4,500 concise definitions and over 2,000 instructive illustrations detail the great design and structural achievements throughout the history of civilization—Ancient, Greek and Hellenistic, Roman, Early Christian, Chinese, Japanese, Indian, Islamic, Mesoamerican, Romanesque, Gothic, Renaissance, Modern—from decorative devices and structural details to homes and palaces.

581 pages, \$19.95.

THE NEW DOWNTOWNS

Rebuilding Business Districts

By Louis G. Redstone, F.A.I.A.

An eye-opening, how-to book that shows how cities throughout the U.S. and elsewhere are being

saved—the full financial and political backgrounds (including sources of funds, tax structures, landuse laws, etc.), the complete design and planning details (pedestrian malls, relocating tenants, transit systems, preservation of historical landmarks, etc.), and the practical specifics on their completion in 100 successful renewal projects—from Allentown, Pa. to Zurich, Switzerland.

352 pages, 524 illustrations, \$22.95.

PLANNING FLEXIBLE LEARNING PLACES

By Stanton Leggett, C. William Brubaker, Aaron Cohodes, and Arthur C. Shapiro

Innovative analyses and solutions of design problems in today's changing school systems. Firmly grounded in economic realities, the book covers the full spectrum of educational planning, offers hundreds of fresh ideas about new school facilities and remodeling existing ones, about equipment and furnishings, and about better learning environments—for elementary, middle, junior and high schools.

183 pages, \$18.50

PLANNING THE OFFICE LANDSCAPE

By Alvin Palmer and M. Susan Lewis

The first and only book to examine this approach to office planning—the thinking behind the office landscape concept, what steps to follow in using it—completely or in part—the pitfalls to avoid, what furnishings and equipment best meet the needs of a successful office landscape, and just what benefits it offers in employee efficiency and morale and company productivity and profitability. Fully illus.,

181 pages, \$17.50.

Available at your local bookstore or use this coupon for

FREE 15-DAY EXAMINATION

McGRAW-HILL BOOK CO., INC.

1221 Avenue of the Americas/New York, N.Y. 10020

Send me the book(s) checked below on approval. In 15 days I will remit the price of the book(s) plus local tax and handling charge, or return book(s) with no further obligation.

<input type="checkbox"/>	Unbuilt America (057760-9)	\$14.95
<input type="checkbox"/>	Theatre Design (032086-1)	\$49.50
<input type="checkbox"/>	Perception and Lighting as Formgivers for Architecture (036094-4)	\$32.50
<input type="checkbox"/>	Behavioral Architecture (027890-3)	\$15.50
<input type="checkbox"/>	Dictionary of Architecture & Construction (026756-1)	\$37.50
<input type="checkbox"/>	The Architect as Developer (050536-5)	\$22.95
<input type="checkbox"/>	Historic Architecture Sourcebook (026755-3)	\$19.95
<input type="checkbox"/>	The New Downtowns (051369-4)	\$22.95
<input type="checkbox"/>	Planning Flexible Learning Places (037060-5)	\$18.50
<input type="checkbox"/>	Planning The Office Landscape (048415-5)	\$17.50

NAME _____

ADDRESS _____

CITY _____

STATE _____

ZIP _____

SAVE MONEY. Remit the full price, plus tax, with this coupon and McGraw-Hill pays postage and handling. Same refund privilege. Offer good only in the U.S. and subject to acceptance by McGraw-Hill.

F-844-4005-3

Plaster in a roll™ the no problem heavy duty wallcover that covers problem walls ...including concrete block!

Plaster in a Roll™ goes up like wall paper over every conceivable surface including *poured masonry, concrete block, plaster, gypsum board, expanded foam, metal, glass, wood and plastic.*

Easily installed by any wall covering applicator, this unique *gypsum impregnated jute* product bridges small voids, hides blemishes and bumps. An optional *anti-graffiti* protective coating provides a tough, clear, low-gloss finish, highly resistant to most common stains.

If you're involved in renovation or construction in *hospitals, hotels, motels, schools, apartments, public buildings* or any *high traffic area*...if you're looking for *lead paint hazard elimination* or want a one-step process that takes you from a problem to a finished wall... take a look at *Flexi-Wall* covering systems.

We're a one-step time and money saver which can turn your problem walls into a decorator's dream. Specify *Flexi-Wall Plaster in a Roll™* wherever you would use *Type III heavy duty vinyl wall-covering.*

**Call
(803) 855-0500**

For complete architectural data and swatch book, write Flexi-Wall Systems, P.O. Box 477, Liberty, South Carolina 29657.

(Sweet's Architectural and Interior Design Files #9.13/Fl., Spec/Data File, Section 9/Wall Coverings. Means Building Construction Cost Data/Wall Covering Gypsum.)

 **FLEXI-WALL®**
Plaster in a Roll™

For more data, circle 101 on inquiry card

The Original Odorless.



WHAT'S THAT
I DON'T SMELL?

Bruning's PD80 introduced the ventless, odorless PD® development process. It worked so well, the PD80 became today's most popular convenience copier.

Energy-saving, instant on-off, 110-volt—it delivers dry prints of engineering drawings in

seconds. And it's nice to be next to, because there's no ammonia.

Ask your Bruning man to demonstrate the PD80 or one of the other "fresh as a daisy" machines. Or write Bruning, 1834 Walden Office Square, Schaumburg, Illinois 60196.



BRUNING

DIVISION OF
ADDRESSOGRAPH MULTIGRAPH



For more data, circle 102 on inquiry card

New from Bally

A comprehensive guide for erecting walk-in coolers and freezers outdoors.

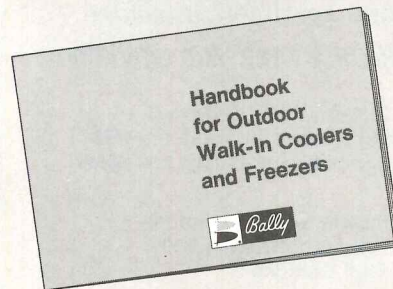
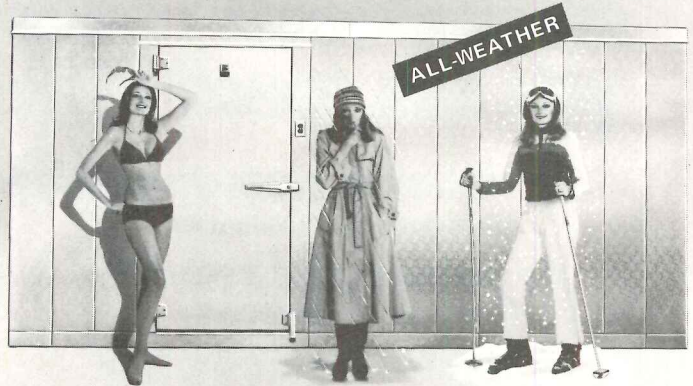

It contains everything you need to know about erecting walk-ins outdoors, including critical facts that many refrigeration people don't even know. It has 16 pages of drawings, and specifications covering concrete slabs, weatherproof roofs, electrical and refrigeration characteristics, and other needed information.

FREE FOR YOUR
REFERENCE LIBRARY



©1976

Bally Case & Cooler, Inc.
Bally, Pennsylvania 19503

Call 215-845-2311 or write Dept. AR-9

For more data, circle 103 on inquiry card

Cabot's new TRANSPARENT STAINS

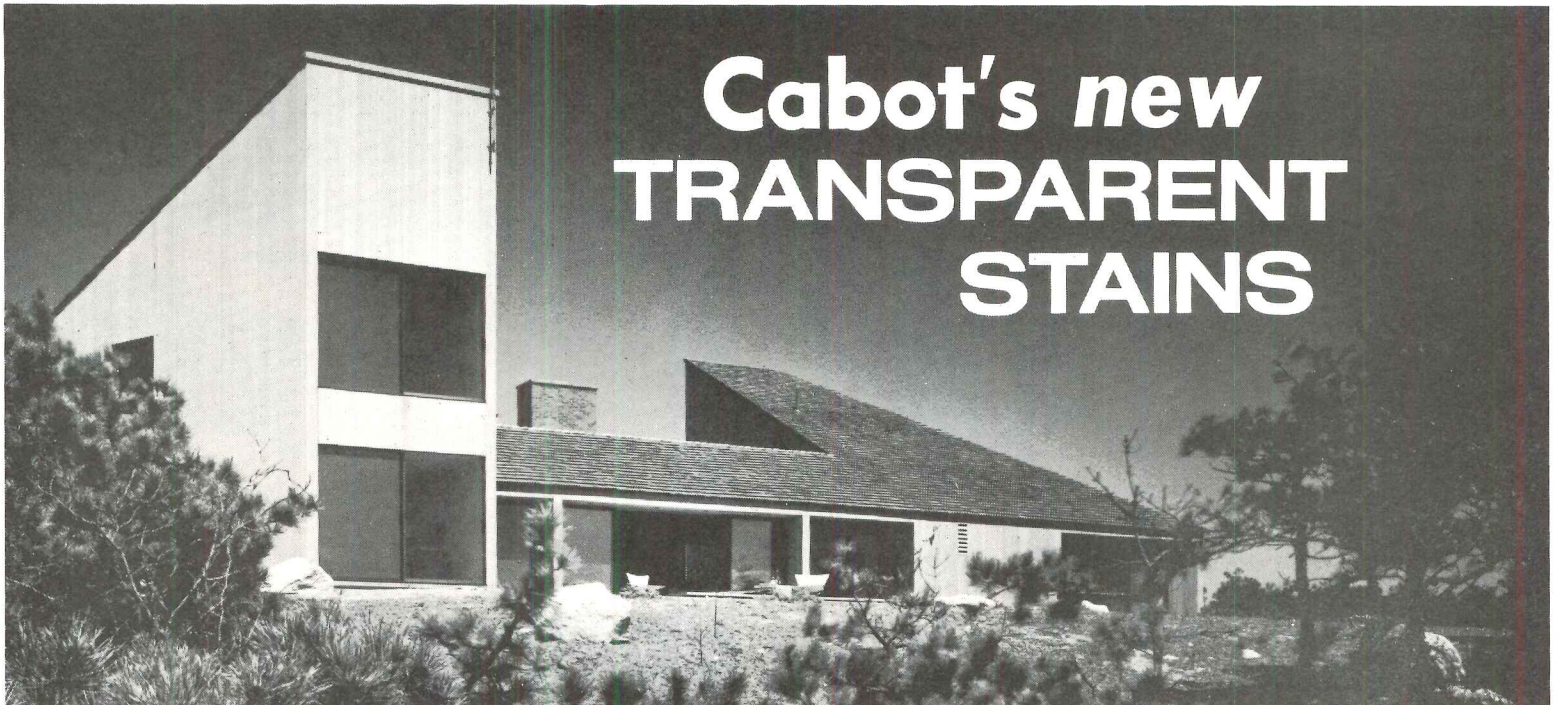

East coast home: Architect James Walker, Boston, Mass. Cabot's Stains on exterior and interior wood surfaces.

Naturally beautiful for wood... the stain that shows the grain.



Cabot's new Transparent Stains bring out the best in wood, produce rich, lively colors in a variegated effect depending on the porosity of the wood surface and the exposure. These new stains accent the beauty of wood grain and texture, beautify in a choice of 28 colors. Like other stains in the Cabot line, Cabot's Transparent Stains will not crack, peel, or blister... are applicable to all types of wood.

Cabot's Stains, the Original Stains and Standard for the Nation since 1877

Samuel Cabot Inc.

One Union St., Dept. 929, Boston, Mass. 02108

Send color card on Cabot's Transparent Stains.

Send Cabot's full-color handbook on wood stains.

For more data, circle 104 on inquiry card

now! new TELECENTER II communications systems you can specify for:

- ☆ **internal communications**
in schools and institutions
- ☆ **paging and security**
in business or industry
- ☆ **high-rise life safety**
in office and apartment buildings

AT THE TOUCH OF A FAMILIAR BUTTON:



instant, direct two-way
telephone conversations with
and between all key personnel

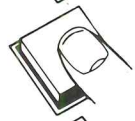

instant, direct communi-
cations with up to 100
Staff Stations



instant positive "all-call"
emergency announcement
capability



EXCLUSIVE DIGITAL READOUT
sequentially identifies
incoming calls—a unique,
invaluable feature . . .

DOZENS OF
OTHER
FEATURES



utilizing
computer logic
circuitry

solid-state
maintenance-free
switching

TODAY'S BETTER IDEA IN TOTAL COMMUNICATIONS

Rauland TELECENTER II™

ASK FOR full information. An Authorized Rauland Communications Specialist in your area will be glad to provide full details and engineering data for your consideration and use. Check the reader service card or write us.

RAULAND-BORG CORPORATION
3535 W. Addison St., Dept. R., Chicago, Ill. 60618 • 312-267-1300

For more data, circle 105 on inquiry card



The only window covering that combines light control, privacy, beauty, and the*Guardian Tilter.®

Levolor Riviera Blinds.

We've added a safety clutch to our Magic Wand tilter...to protect your blinds from damage caused by "overturning."

This is just one of many reasons why your window treatment specs should read: Levolor Riviera. Send for our complete manual. Levolor Lorentzen, Inc., 720 Monroe St., Hoboken, N.J. 07030.



*Guardian Tilter is a trademark of Levolor Lorentzen, Inc.

For more data, circle 106 on inquiry card

Use these To Select and Specify Overhead Doors

HANDY REFERENCE GUIDE to Overhead Doors and Operators

This handy reference guide is provided generally for information only and does not constitute an offer of insurance. It is not intended to be used as a substitute for a professional engineer's or architect's advice. For more specific information, see the Door & Op. and O. & P. sections.

Door Type	Material	Weight	Height	Width	Speed	Motor	Operator	Notes
Aluminum	Aluminum	100-150	7-8	16-20	1-2	1/2-1	1-2	Standard
Steel	Steel	150-200	7-8	16-20	1-2	1/2-1	1-2	Standard
Wood	Wood	100-150	7-8	16-20	1-2	1/2-1	1-2	Standard
Insulated	Insulated	100-150	7-8	16-20	1-2	1/2-1	1-2	Standard
Roll-up	Roll-up	100-150	7-8	16-20	1-2	1/2-1	1-2	Standard
Sectional	Sectional	100-150	7-8	16-20	1-2	1/2-1	1-2	Standard
Garage	Garage	100-150	7-8	16-20	1-2	1/2-1	1-2	Standard
Commercial	Commercial	100-150	7-8	16-20	1-2	1/2-1	1-2	Standard
Industrial	Industrial	100-150	7-8	16-20	1-2	1/2-1	1-2	Standard
Residential	Residential	100-150	7-8	16-20	1-2	1/2-1	1-2	Standard
Garage	Garage	100-150	7-8	16-20	1-2	1/2-1	1-2	Standard
Commercial	Commercial	100-150	7-8	16-20	1-2	1/2-1	1-2	Standard
Industrial	Industrial	100-150	7-8	16-20	1-2	1/2-1	1-2	Standard
Residential	Residential	100-150	7-8	16-20	1-2	1/2-1	1-2	Standard

Door Specifications
Check List:
1. Door Material: Aluminum, Steel, Wood, Insulated, Roll-up, Sectional, Garage, Commercial, Industrial, Residential.
2. Door Weight: 100-150, 150-200, 200-250, 250-300, 300-350, 350-400, 400-450, 450-500, 500-550, 550-600, 600-650, 650-700, 700-750, 750-800, 800-850, 850-900, 900-950, 950-1000.
3. Door Height: 7, 8, 9, 10, 11, 12, 13, 14, 15, 16, 17, 18, 19, 20, 21, 22, 23, 24, 25, 26, 27, 28, 29, 30, 31, 32, 33, 34, 35, 36, 37, 38, 39, 40, 41, 42, 43, 44, 45, 46, 47, 48, 49, 50, 51, 52, 53, 54, 55, 56, 57, 58, 59, 60, 61, 62, 63, 64, 65, 66, 67, 68, 69, 70, 71, 72, 73, 74, 75, 76, 77, 78, 79, 80, 81, 82, 83, 84, 85, 86, 87, 88, 89, 90, 91, 92, 93, 94, 95, 96, 97, 98, 99, 100.
4. Door Width: 16, 17, 18, 19, 20, 21, 22, 23, 24, 25, 26, 27, 28, 29, 30, 31, 32, 33, 34, 35, 36, 37, 38, 39, 40, 41, 42, 43, 44, 45, 46, 47, 48, 49, 50, 51, 52, 53, 54, 55, 56, 57, 58, 59, 60, 61, 62, 63, 64, 65, 66, 67, 68, 69, 70, 71, 72, 73, 74, 75, 76, 77, 78, 79, 80, 81, 82, 83, 84, 85, 86, 87, 88, 89, 90, 91, 92, 93, 94, 95, 96, 97, 98, 99, 100.
5. Door Speed: 1, 2, 3, 4, 5, 6, 7, 8, 9, 10, 11, 12, 13, 14, 15, 16, 17, 18, 19, 20, 21, 22, 23, 24, 25, 26, 27, 28, 29, 30, 31, 32, 33, 34, 35, 36, 37, 38, 39, 40, 41, 42, 43, 44, 45, 46, 47, 48, 49, 50, 51, 52, 53, 54, 55, 56, 57, 58, 59, 60, 61, 62, 63, 64, 65, 66, 67, 68, 69, 70, 71, 72, 73, 74, 75, 76, 77, 78, 79, 80, 81, 82, 83, 84, 85, 86, 87, 88, 89, 90, 91, 92, 93, 94, 95, 96, 97, 98, 99, 100.
6. Door Motor: 1/2, 3/4, 1, 1 1/2, 2, 3, 4, 5, 6, 7, 8, 9, 10, 11, 12, 13, 14, 15, 16, 17, 18, 19, 20, 21, 22, 23, 24, 25, 26, 27, 28, 29, 30, 31, 32, 33, 34, 35, 36, 37, 38, 39, 40, 41, 42, 43, 44, 45, 46, 47, 48, 49, 50, 51, 52, 53, 54, 55, 56, 57, 58, 59, 60, 61, 62, 63, 64, 65, 66, 67, 68, 69, 70, 71, 72, 73, 74, 75, 76, 77, 78, 79, 80, 81, 82, 83, 84, 85, 86, 87, 88, 89, 90, 91, 92, 93, 94, 95, 96, 97, 98, 99, 100.
7. Door Operator: 1, 2, 3, 4, 5, 6, 7, 8, 9, 10, 11, 12, 13, 14, 15, 16, 17, 18, 19, 20, 21, 22, 23, 24, 25, 26, 27, 28, 29, 30, 31, 32, 33, 34, 35, 36, 37, 38, 39, 40, 41, 42, 43, 44, 45, 46, 47, 48, 49, 50, 51, 52, 53, 54, 55, 56, 57, 58, 59, 60, 61, 62, 63, 64, 65, 66, 67, 68, 69, 70, 71, 72, 73, 74, 75, 76, 77, 78, 79, 80, 81, 82, 83, 84, 85, 86, 87, 88, 89, 90, 91, 92, 93, 94, 95, 96, 97, 98, 99, 100.

Overhead Doors & Operators

**SELECTOR GUIDE
for ARCHITECTS &
CONTRACTORS**

"The selection of overhead doors and operators doesn't have to be difficult"

McKee Door
McKee Door Company
85 Hanks Avenue
P.O. Box 1108
Aurora, IL 60507
800/323-0810 Toll Free
312/897-9600 In Illinois
A McKee Industry

Write or Call Toll Free
Overhead Door Hotline*
800-323-0810

Serving Architects & Builders Since 1928

McKee Door
A McKee Industry

McKee Door Company
85 Hanks Avenue
Aurora, IL 60507
800/323-0810 Toll Free
312/897-9600 In Illinois*

The Nationwide Family of Professional Door Contractors®

For more data, circle 107 on inquiry card

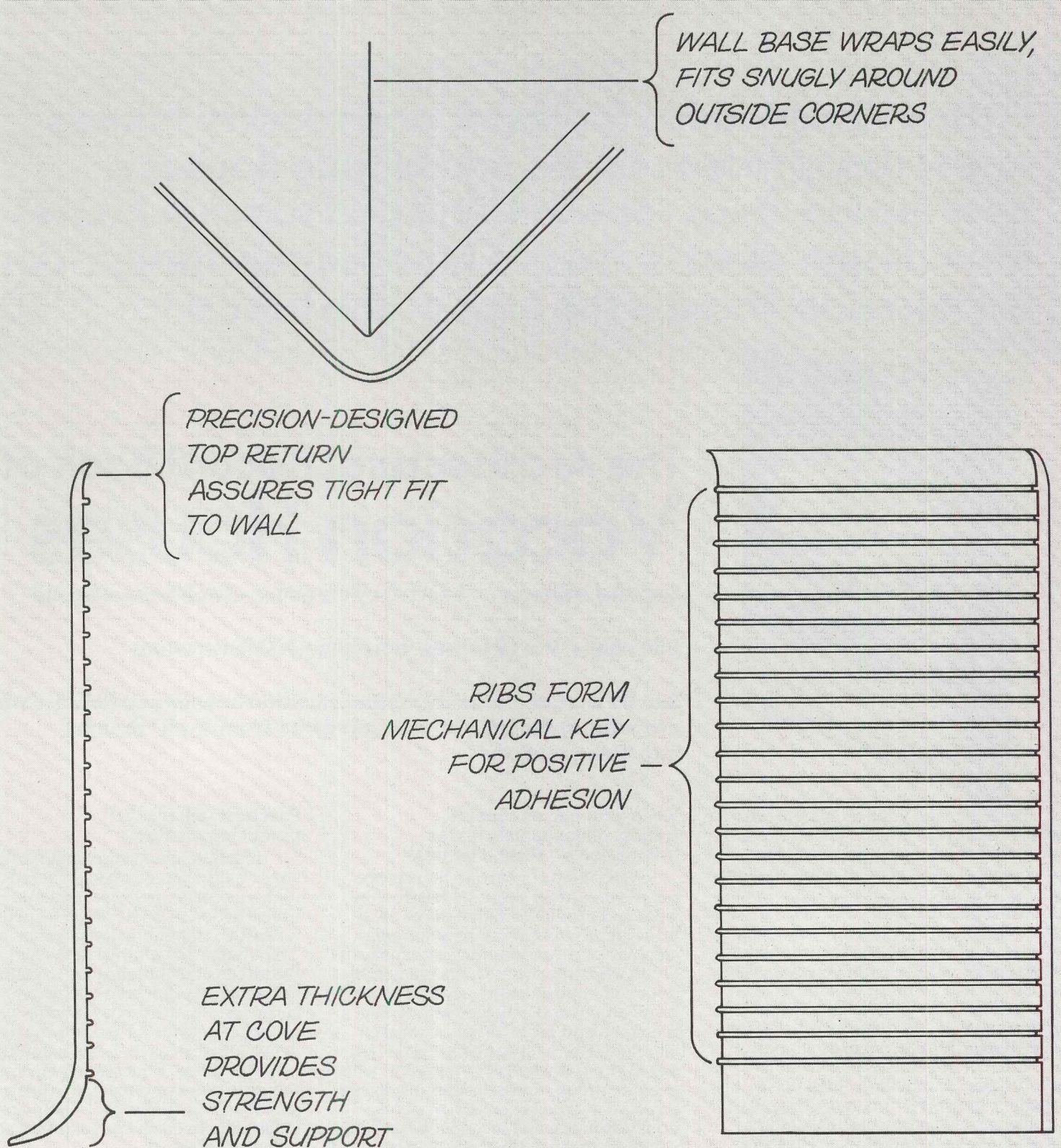

The engineered wall base line is now engineered in rubber, too.

Now you have an even broader choice in wall base. From VPI, the single source for the industry's quality line of wall base systems.

Specify attractive, durable vinyl wall base. Straight or cove. In 10 colors, 3 heights, rolls, and 4' lengths. Or select new rubber wall base in 6 colors, 3 heights, 4' lengths, straight or cove. Both are flexible to conform to minor floor and wall irregularities and wrap around corners.

Why specify VPI base, either vinyl or rubber? Performance is one reason: the easy way it installs, its precise fit, and lasting

good looks. Skillful engineering is another: ribs that form a mechanical key for positive adhesion; the precision-designed top return that assures a tight fit to wall; the extra thickness at the cove for strength and support; the VPI #300 Wall Base Adhesive system for trouble-free performance when used according to label directions. And there's more.

For the complete VPI wall base story, write or phone VPI, 3123 S. 9th St., P.O. Box 451, Sheboygan, Wis. 53081. Phone 414-458-4664. Or see our catalog in Sweets.

VPI

New design ideas for resort and country houses
■ new design ideas for ski and hillside houses ■
new design ideas for weekend and summer houses ■
new design ideas for beach houses ■ new design ideas
for lakeside houses ■ the best of the best since 1970

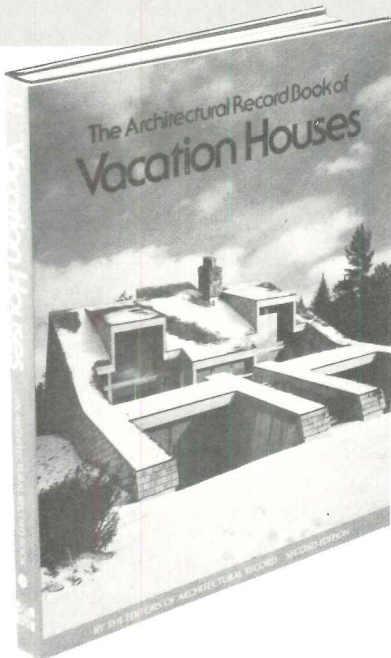

The Architectural Record Book of Vacation Houses

Second edition Selected by the editors of Architectural Record

256 pages, 9 x 12 inches, more than 300 illustrations

See 62 of today's most exciting vacation houses and how architects are turning America's "let's-get-away-from-it-all" dreams into living realities . . .

Both you and your clients will put this rich edition of VACATION HOUSES to the best of uses—to glean inspiring and practical ideas from it! Bursting with exterior and interior photographs (black and white and full color), site plans, floor plans, and such specifics as cost range, this beautiful sourcebook shows you and discusses 62 of the very best new designs architects have come up with for vacation sites in the United States since the first edition in 1970. As many as 43 of these were **Record House Awards** winners.

Each of the houses you'll visit is provocative, stimulating, idea-filled. All together, they offer concrete answers to a considerable variety of sites, dreams, desires, needs, and budgets. They will not only help prospective owners to crystalize their unformed notions, but will give you, the architect, a springboard for exchanging with clients specific verbal and visual ideas about approach and appearance, feeling and form. They're the best of the best from the pages of **Architectural Record!**

Here are the top successes—for all climates, terrains, tastes

Wooded hideaways, lakeside cabins, country cottages, meadow-framed farm-houses, studios by the sea, slope-side chalets, dune nests, mountain aeries, private oases within planned communities—they're all here! And they're all models of intelligent, sound development—economically, architecturally, and ecologically.

Keep your eye on today's trends, philosophies, styles in America's "second homes"

What kinds of second houses are people dreaming about? What do they want and expect from that home away from home—whether it be a summer stopover or a year-round vacation haven? Often what the owner wants is a combination of opposites. Privacy **and** more involvement and activities with family. Elegance **and** ease. Simplicity **and** excitement. Formality **and** casual day-to-day living. But whatever they want, whatever the mood, these designs display an amazing degree of sensitivity, perception, freshness, and inventiveness. And whatever the individual site, whatever the individual taste, the designs promote full enjoyment of life and nature—and a deep experience of the site itself.

Practical talk for the practicing architect

Inspiration and stimulation aside, stress is also placed on such practical topics as costs, methods, and materials. Construction budgets range from under \$12,000. Upper brackets include a "mini-hotel" for a family of twelve! Hundreds of techniques are explained. For achieving dramatic effects and visual surprises. For accommodating a wide variety of activities. For applying eye-deceiving devices that can expand or contract space. For creating environments that are **at once** bold, quiet, sophisticated, and rustic! There are also ideas that are easily repeatable in several different versions!

MAIL THIS COUPON TODAY FOR 15-DAY FREE EXAMINATION

ARCHITECTURAL RECORD

1221 Avenue of the Americas
 New York, New York 10020

Please send me VACATION HOUSES, Second Edition (002337-9), for 15 days' free examination. At the end of that time I will remit \$17.95, plus local tax, postage, and handling, or return the volume without obligation. This offer good only in the U.S. and subject to acceptance by McGraw-Hill.

Name _____

Street Address _____

City _____

State _____ Zip _____

SAVE MONEY! If you remit in full with this order, plus local tax, McGraw Hill pays all regular postage and handling costs. Return books in 15 days for full refund if not completely satisfied.

23K409-4005-3

Meet the Cornell family of quality metal closures

Rolling Service Doors with innovative THERMAGUARD insulation for energy conservation, and dark metallic brown baked-on paint finish.

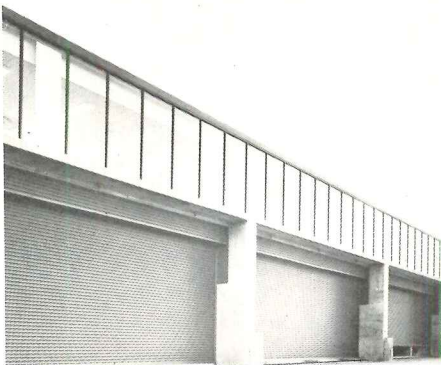

Rolling Fire Doors. U.L. listed, automatic closing by fusible link or electromagnetic release, with smoke detector.

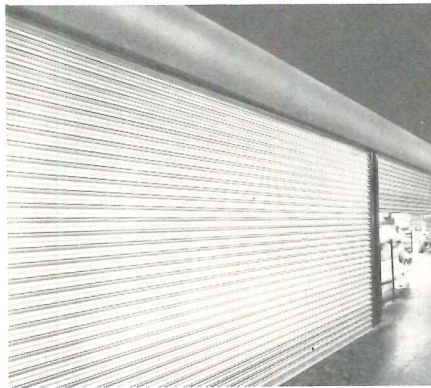

Rolling Shutters, Fire Shutters and Shutter/Frame Units. U.L. listed in 300 series stainless steel, with or without four-sided frames. Automatic closing by electromagnetic release.

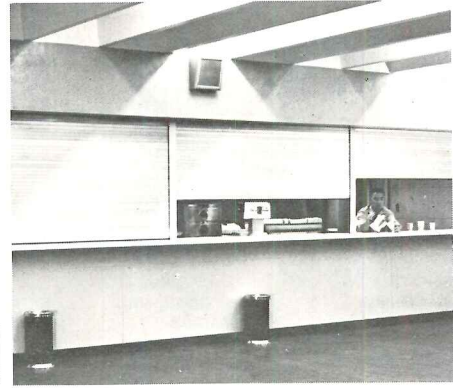

Rolling Grilles. Choice of finishes includes Duranodic bronze and black.



Sliding Chain Link Grilles. Economical, side-storing traffic control closures.

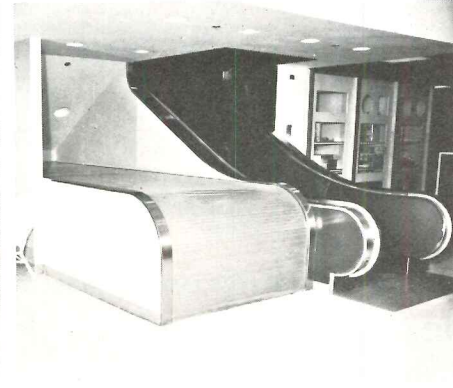

Smoke/Fire Enclosures for Escalators and Conveyors. Automatic closing by motor when smoke or heat activated.

For more information send for free copy of our 20-page 1977 product catalog, or consult our catalog in Sweet's Architectural or Industrial files (8.7). Call us or Sweet's BUYLINE number for the location of your Cornell Representative.

MAIL TO:
CORNELL IRON WORKS, INC.
CRESTWOOD PARK, MOUNTAINTOP, PA. 18707
Please send me your 20-page 1977 product catalog.

Name _____

Firm _____

Address _____

CORNELL
IRON WORKS, INC.
Crestwood Park
Mountaintop, Pa. 18707
717-474-6773

ESTABLISHED 1828

Member, American
Rolling Door Institute

For more data, circle 109 on inquiry card



Wall Mounted Sphere, G40 Lamp



3-Sphere Cluster, with Refractors



Cylinder, with G40 Lamp



Sphere with Canopy, with Refractor



Tapered Cylinder, with Refractor

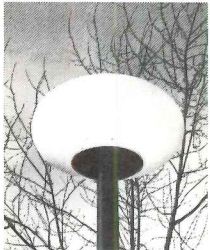

Opal-White Ellipse

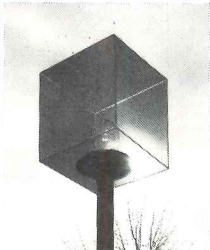

Hard Cube, with G40 Lamp



Soft Cube, Opal-White



Sphere with Planes, G40 Lamp

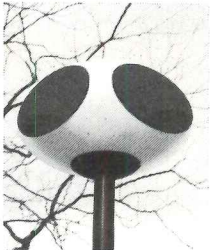

Ellipse with Planes, 4 faces



Drum, with Refractor

APPLETON GLO-METRICS LUMINAIRE SYSTEM

Contemporary outdoor lighting with wide choice of diffusers, light sources, and mountings

The Appleton Glo-Metrics luminaire system offers unlimited architectural lighting design flexibility, permitting a variety of lighting effects in a visually unified lighting layout. There are ten contemporary diffuser shapes. Most shapes include choice of opal, transparent clear or tinted diffusers. They are available for use with incandescent, mercury, or high-pressure-sodium lamps in a wide range of wattages (and with refractors where appropriate). Wall mounting brackets and pole-top cluster brackets for 2, 3, or 4 diffusers are offered; also matching poles for single diffuser pole-top mounting and cluster arrangements. All components, including "in-pole" ballasts for HID luminaires, are furnished pre-wired. Write for 28-page full color Glo-Metrics Catalog. Appleton Electric Company, 1701 Wellington Ave., Chicago, Ill. 60657.

6-226



APPLETON

For more data, circle 110 on inquiry card

For the record...

We'd just like you to know that Simpson Ruf-Sawn 316 plywood siding takes paint and solid color stain better than any other siding available today.

Ruf-Sawn 316 offers excellent weatherability a beautiful woodgrain texture and the kind of performance only Simpson's leadership in the overlaid plywood field could give.

For further information write Simpson Timber Company, 900 Fourth Avenue, Seattle, Washington 98164.

Ruf-Sawn 316
Simpson

For more data, circle 111 on inquiry card



Glasbord® frp flat panel - for walls, ceilings, doors, wainsco

- a tough, hard, durable fiber glass reinforced plastic
- embossed surface for scratch and abrasion resistance
- available in a variety of thicknesses and sizes for every application
- highly suitable for use in conventional construction
- compatible to prefabricated systems
- for building new or refurbishing
- easy to install, easy to maintain, easy to clean
- U.S.D.A. accepted, meets F.D.A. requirements
- also available with fire rating

See Sweet's File ICR/X 9.17.

Get the full story today.



KEMLITE CORPORATION
P. O. Box 429, Joliet, Illinois 60434

© 1977 by Kemlite Corporation. Glasbord Reg. U. S. Pat. Off.

For more data, circle 112 on inquiry card

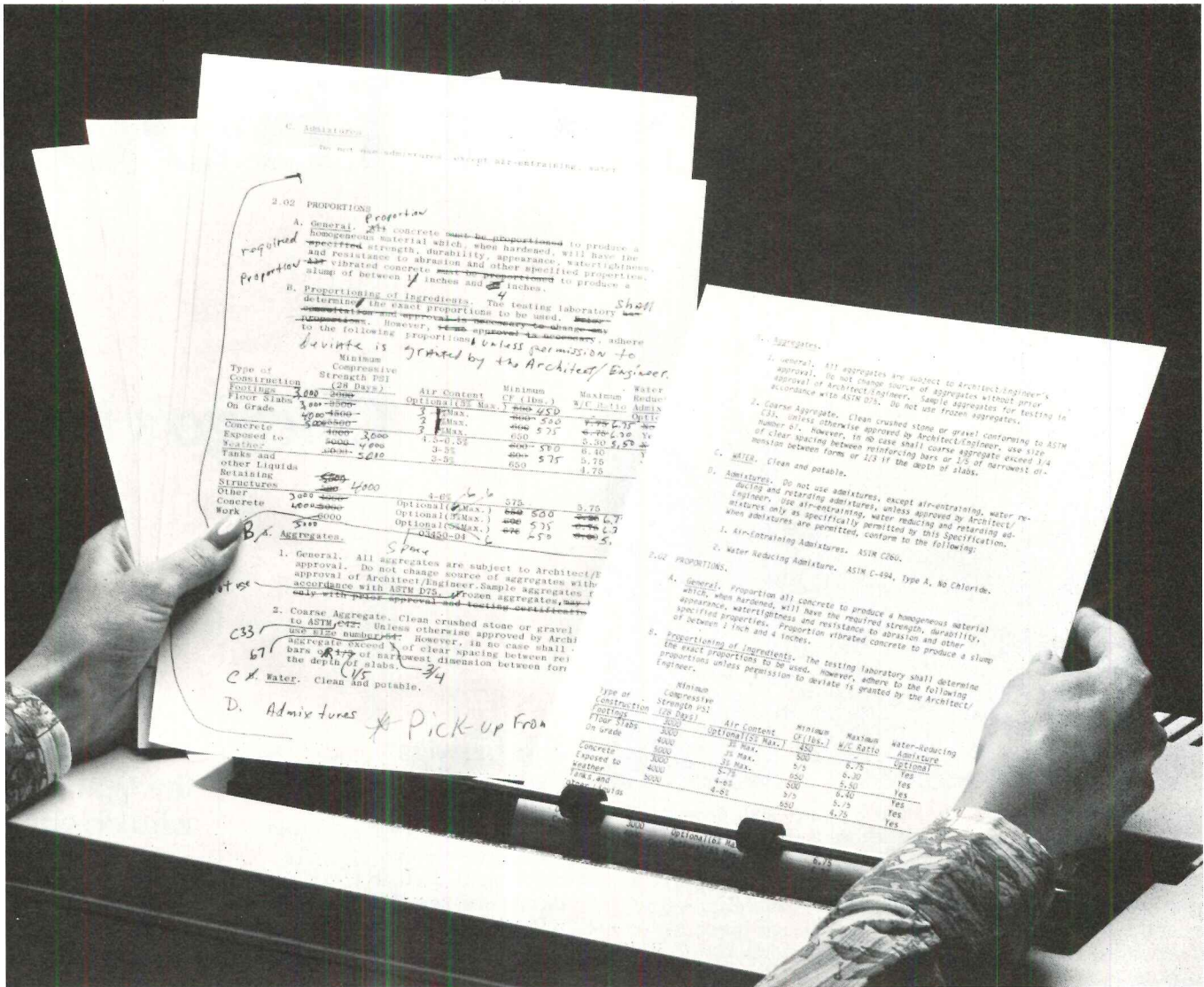

12 minutes' work for Lanier's Automatic Typing System.

That's all it took to make these changes and retype this design proposal. If you're not getting work back this fast, you should talk to Lanier.

Lanier's Automatic Typing System also lets you do purchase orders, contracts, forms or any other kind of typing. Faster than ever before and with greater accuracy.

Lanier uses advanced micro-processor technology to automate typing, revisions, and printing. And secretaries love this system because it's so easy to learn and operate.

Typed work appears on the TV-like screen for easy editing. It's then stored in Lanier's memory, up to 128 pages per magnetic disc. If changes are needed, they're typed in and the finished document is retyped at up to 540 words



per minute, a page every 30 seconds.

If you want more work done faster and more accurately, call Sue Anderson toll-free at (1-800) 241-1706. In Georgia call (1-404) 321-1244. Or mail this coupon today.

LANIER[®]
LANIER BUSINESS PRODUCTS

Lanier Business Products
1700 Chantilly Dr. N. E.
Atlanta, Ga. 30324
AR-9-77

Please have a representative call me to arrange a free demonstration.

Name _____

Title _____ Phone _____

Company _____

Company Address _____

City _____ State _____ Zip _____

For more data, circle 113 on inquiry card

IT'S AS THOUGH



From 1916 well into the 20's, excursion boats, cargo ships and lake steamers moored alongside Navy Pier's 100-foot-wide sheds jumping with stevedores, passengers and freight. At its outermost reach, two-thirds of a mile from shore, crowds attended art shows, plays, trade fairs, picnics; and they danced until dawn inside Navy Pier's cavernous, domed concert hall. Navy Pier was a place without care, a place where Chicagoans could tap their feet.

The depression and World War II brought the merrymaking to a halt. Lake Michigan's winter winds ripped the copper roofs and blew the pier bit by bit into the water. And Navy Pier became another spot on Chicago's geography of blight.

In 1974, the late Mayor Daley, full of Bicentennial fervor, called up his city architect, Jerome Butler, head of the Chicago Bureau of Architecture*, to find out what could be done to shore up the old swinger. Butler came up with a plan; Daley came up with the money.

Butler and his Bureau architects succeeded admirably. The Navy Pier restoration is an architectural triumph and a civic success. Earlier this year, the project was awarded the American Institute of Architect's Honor Award. Moreover, Navy Pier is once more a focal point for fun and commerce and the pride of Chicago.

The Bureau's staff of some 50 registered architects plus interior designers, landscape designers, technical support personnel (in close collaboration with the Chicago Bureaus of Engineering and Construction) and consultants are continuously engaged in an exemplary design, specification and project management effort encompassing a wide range of building types: police area centers and district stations, fire stations, airport buildings, neighborhood health centers, community service centers, regional and branch libraries, ward office buildings, municipal buildings, mass transit stations, transit malls, community improvement, recreation and historical preservation projects.

The Chicago Bureau of Architecture is one of hundreds of building agencies in the public sector. Architects and engineers in city, state and federal organizations are constantly recycling and restoring precious landmarks, designing and specifying for new buildings, and making optimum use of their cultural and people resources to make their hometowns and states more liveable and commercially attractive.



Chicago's Navy Pier

the bigwigs

A relatively small group of architects and engineers working for federal, state, and local governmental organizations wield a whole lot of design and specification clout.

These architects and engineers act as "owners" of hundreds of billions of dollars worth of buildings and real estate for their governmental organizations. They engage in projects encompassing virtually every building type, employing almost every known building product. They know what's best for their communities so they keep tight rein on the flow of building products that go into their organizations' buildings.

However, locating these departments within the governmental complex is a tedious process. There is no standard nomenclature for departments housing those architects and engineers responsible for design and specification.

Some representative governmental organizations with building departments

NEW HAVEN CITY PLAN DEPT.
N.Y. - N.J. PORT AUTHORITY
U.S. DEPT. OF HEALTH,
EDUCATION & WELFARE
NEW YORK CITY HOUSING
AUTHORITY
U.S. PUBLIC HEALTH SERVICES
DEPARTMENT OF JUSTICE BUREAU
OF PRISONS
VIRGINIA DEPT. OF
COMMUNITY COLLEGES
ALABAMA MENTAL HEALTH
DEPARTMENT
DADE COUNTY AVIATION
DEPARTMENT
GENERAL SERVICES ADMINISTRATION

even if you do find the right department, who do you talk to?

The architects and engineers who control design and specification within governmental organizations are not easy to locate. They are known by many and often confusing titles that signify many levels of responsibility.

In a recent Architectural Record study of its subscribers in governmental organizations 230 respondents listed 134 separate titles. Their common bond is that they are architect and engineers.

Some representative subscriber titles

REGIONAL HISTORICAL ARCHITECT
CHIEF DESIGN BRANCH
DIRECTOR-BUREAU OF A/E
ARCHITECTURAL DESIGN ENGINEER
ARCHITECTURAL SECTION LEADER
ARCHITECTURAL SERVICES
MANAGER
FACILITIES DESIGN SPECIALIST
STATE ARCHITECTURAL ENGINEER
ARCHITECT-PROJECT
COORDINATOR
CIVIL ENGINEER
SUPERVISING ARCHITECT
FACILITIES ENGINEER
ARCHITECTURAL DESIGNER
TOWN ENGINEER
PROJECT MANAGER
COORDINATING ARCHITECT
HEAD-DESIGN DIVISION
CITY ARCHITECT
CHIEF BUILDING OFFICIAL
SUPERINTENDENT OF BUILDINGS
CHIEF BUILDING CONSTRUCTION
ENGINEER
ASSOCIATE PLANNER
BASE ARCHITECT/CIVIL
ENGINEER OFFICER
BUILDING & ZONING OFFICIAL
AREA ENGINEER
SUPERVISOR OF BUILDINGS
& CONSTRUCTION

*Department of Public Works, Marshall Suloway, Commissioner.



SCOTT JOPLIN LOOK UP ARCHITECTURE

resurrects the ragtime era.

cutting through red tape

Military bases, park buildings, housing projects, office buildings, hospitals ... It's a multi-billion dollar market for building product manufacturers. But at the going rate of seventy-one dollars per line call,* it's an expensive and often frustrating proposition for designers to locate those architects and engineers who design and specify. There has to be a better way—and there is! Architectural Record.

Architectural Record offers advertisers by far the most paid circulation among architects and engineers in governmental organizations.

Why? Because Architectural Record directs more award-winning editorials of interest to governmental specifiers—more by far than any publication in the field. That's why government architects and engineers subscribe to the Record in unequalled numbers.

©Graw-Hill Research Dept.

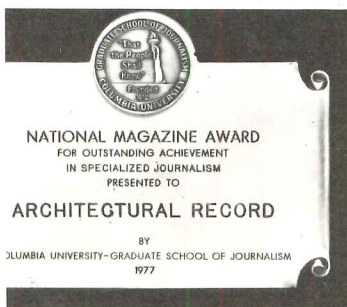

wherever architects and engineers practice

Architectural Record offers you waste-free coverage of architects and engineers *wherever they practice*. Specifically, the Record delivers over 45,000 architect and engineer paid subscribers in the five primary "market groups."

- architectural and architectural-engineering firms
- consulting engineering firms
- general contracting and "design-build" firms
- governmental organizations
- commercial, industrial and institutional organizations

It all adds up to the largest architect and engineer circulation of any architectural magazine, paid or free.

Not only does Architectural Record have the *most* architects and engineers, it has the *right* ones—an audience of doers responsible for over 90 per cent of the dollar volume of all architect-planned building.

Architectural Record attracts the majority of active architect and engineer subscribers because its editorial is timed and balanced with the aid of Dodge Reports to bring architects and engineers the kind of information they need *when they need it*.

Maybe that's why advertisers also prefer Architectural Record. This is the 31st consecutive year that building product advertisers have placed more pages in the Record than in any other architectural magazine. This year almost 50% more.

Wherever architects and engineers practice—in architectural firms or corporate building departments, design-build firms or governmental organizations, in Iowa or Iran ...

Whatever they are planning—a city or interior, a solar plant or structural system, a hospital or home ...

Whenever building design and specification is in progress—Architectural Record is there.

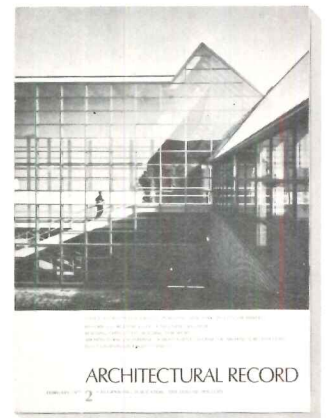

ARCHITECTURAL RECORD

1221 Avenue of the Americas New York 10020



See where your firm fits into the design and specification process. See "Covering the Bases"

An Architectural Record District Manager will show you this 20-minute Architectural Record sound-slide presentation that highlights the seven stages of building and exactly where building products are "designed-in" and specified by architects and engineers. Since its release, many building products manufacturers have used "Covering the Bases" as a sales training tool. Use this coupon to schedule a showing—it's time well spent.

Schedule a showing

The Governmental Building Department is defined. Send for it!

This coupon will bring you a major Architectural Record study of Governmental Building Departments and the people who run them:

- Profile of subscribers, architects and engineers in Governmental Organizations. Defines the work and responsibilities of governmental building departments.

Please send materials

Name _____
 Title _____
 Company _____
 Address _____
 City _____ State _____ Zip _____
 Telephone No. Area () _____

CLASSIFIED SECTION

POSITIONS VACANT

ARCHITECT

HBE, prominent in design and construction of commercial and institutional facilities throughout the United States, has introduced its expertise to the banking and financial community.

To sustain an enviable growth pattern, HBE Bank Facilities Corporation will add to its staff an experienced Architect well versed in the design and development of architectural programs for banks and other financial institutions.

Ideally, this person will have extensive exposure to the total spectrum of architecture—concept through site inspection. Persons evidencing successful private practice will find this a unique situation. A solid base in contract documents, client relations and working drawings is a must. To qualify for consideration you need a college degree, registration, and a proven track record in all or most of these areas.

We offer competitive compensation, a comprehensive benefits package, and a liberal relocation allowance combined with a stimulating work environment in suburban St. Louis, Missouri. To learn more write or phone W. D. Powers. (314) 567-9000.



HBE Bank Facilities Corporation

717 Office Parkway
St. Louis, Missouri 63141

An Equal Opportunity Employer M/F

Architect, NCARB and five years of registered responsible charge. Must be strong design and production. For a responsible position in New Mexico. Send resume and other data to P-4982, Architectural Record.

Business Development Specialist Major International architecture and design firm in South West with multiple U.S. offices has an opening for a Business Development Specialist. Professional degree in architecture or engineering and a minimum of three to five years experience in business development for a professional design firm with national exposure required. Salary will be commensurate with experience. We offer excellent benefits and an outstanding career opportunity to qualified professionals. Send resume with salary history in confidence to: P-5495, Architectural Record. We are an Equal Opportunity Employer M/F.

"Architect, NCARB and five years of registered responsible charge. Must be strong in design and production. For a responsible position in the Four Corners Area of New Mexico. Send resume and other data to Mauck Stastny & Rassam, P.A. 333 East Main Farmington, NM 87401"

POSITIONS VACANT

ARCHITECTURAL SPECIFICATION WRITERS

Minimum 5 years experience required with an architectural design or consulting engineering firm.

ENJOY EXCELLENT BENEFITS

Good pay Advancement Opportunity
Steady Employment Pension Program
Paid Holidays Profit Sharing Program
Liberal Vacations Life Insurance
Major Medical Program

ALBERT KAHN ASSOCIATES, INC.
New Center Building, Detroit, MI 48202

An Equal Opportunity Employer

Architect/Senior Designer—Position available with a growing A-E urban design firm serving corporate, governmental and private clients. Skills required for the conceptualization and graphic presentation for variety of architectural projects. Responsibilities include developing projects from initial conceptual design through contract documentation. Resumes to: The Arroyo Group, 230 E. Union Street, Pasadena, Calif. 91101.

University of Petroleum and Minerals Dhahran, Saudi Arabia—The Department of Architectural Engineering, University of Petroleum and Minerals, Dhahran, Saudi Arabia, will have faculty positions open for the Academic Year 1978-79, starting 1 September 1978. Architects and Architectural Engineers with teaching and/or practical experience in Architectural Design, Architectural Engineering Systems, Cost Analysis and Management are invited to apply. Candidates with Doctoral Degrees in Architectural Engineering are desirable. English used for instruction. Minimum regular contract for two years, renewable. Excellent salaries and allowances, free air-conditioned housing, free air transportation to and from Dhahran each two-year tour. Attractive educational assistance grants for schoolage dependent children. Local transportation allowance in cash each month. All earned income without Saudi taxes. Ten month duty each year with two months vacation paid and possibility of participation in University's ongoing Summer programs with adequate additional compensation. Apply with complete resume on academic and professional background, list of references, a complete list of publications published in refereed professional magazines/journals with research details, and with copies of degrees including personal data such as, family status (wife's maiden name, names of children, age and sex) home and office addresses, telephone numbers to: University of Petroleum and Minerals, c/o Saudi Arabian Educational Mission, 2223 West Loop South, Suite 400, Houston, Texas 77027.

POSITIONS WANTED

Managing Partner of NYC architectural firm with excellent local reputation but severely limited activity and uncertain prospects, seeks opportunity with broader-based and/or more diversified organization. Solid experience in firm management, marketing and project administration. Age 42. A.B. and B.S. degrees. NCARB Certificate. Registered in NY and most northeastern states. Prefer NYC or vicinity. PW-5534, Architectural Record.

Architect, Registered, 37—NCARB, 14 years diversified experience in design, production and supervision seeks permanent and challenging position anywhere in the U.S. and Canada. Highly productive, willing to travel. Reply to PW-5385, Architectural Record.

POSITIONS WANTED

Financial Executive—Heavyweight—Listed co. V.P. Contoller—CPA (Big 8 exp.)—Attorney—Acquisitions, financial, controls, taxes, Exp'd. real estate, construction industries. Combines technical skills with imagination. \$28-32,000 required. For resume: PW-5535, Architectural Record.

SELLING OPPORTUNITIES AVAILABLE

Architectural Reps. Wanted—Established manufacturer of interior architectural/acoustical wall, ceiling, and partition products seeks representatives in all trading areas to work with architects and owners to gain specifications and enforce specifications with contractors. Reply to: RW-5437, Architectural Record.

Sales Representatives Wanted—Custom architectural ceramics, walls, floors, murals. Several areas open for architect/designer oriented salesman. Reply to: RW-5531, Architectural Record.

SPECIAL SERVICES

Vitruvius Designs Corp.—artistic renderings & scale models for a better image. Regular drafting services available. Box 1316 Dept. AR, Radio City Sta., New York, NY 10019. (212) 697-5499.

Interior Landscaping Consultant—Specialist in planning commercial interior spaces anywhere in U.S.A. and Canada for interior foliage plant material. For help with lighting, skylights, planter design, drainage, soils, moisture supply, etc., contact Richard L. Gaines, consultant and registered architect, at "Plantscape House", P.O. Drawer AC-CS, Apopka (Orlando), Florida 32703. (305) 886-1511.

Transparent Pressure Sensitive Title Blocks, repetitive texts and details printed from your master. Shadowless diazo reproduction! Low minimum runs! Cut your drafting costs! Send dimensions and quantity for quote. Typiton, 50 Old Hill Road, Hamden, CT 06514.

Architectural translation by experienced professionals. Technical architectural translation English to Arabic, vice versa. Working drawings, construction documents, specifications, zoning codes, letters, etc. 15 Saint Paul St., Cambridge, MA 02139 (617) 547-5374.

BOOKS

Europe: Architectural Guide 1860-Today by Jeryll Habegger. 13 countries-500 Bldgs. with address, architect + date. 150 Illus. \$4.50 Order from: Architectural Guidebook, 421 West Belden, Chicago, Illinois 60614.

OVERSEAS JOBS GUIDE

Job Hunting Guide + Directory of 650 Firms. Details on job sources, resumes, taxes. US \$6.00 + 50¢ P&H (US & Canada). To foreign addresses—add \$1.50 P&H. Friar Books, Dept. AR, 8956 E Ardenale, San Gabriel, CA 91775.

EXAM STUDY AIDS

Concise, inexpensive, highly productive NCARB professional exam preparation publications to maximize your score. For descriptive brochure, write; Bonus Pointers, c/o Arts International, 165 Jefferson St., San Francisco, CA 94133.

POSITIONS VACANT

**FACULTY POSITIONS AVAILABLE,
HARVARD UNIVERSITY,
GRADUATE SCHOOL OF DESIGN**

ARCHITECTURAL DESIGN AND THEORY: Full-time professorial positions are available at both junior and senior levels for persons qualified in architectural design and one other basic theory area of the program. Duties include teaching design studio, lecturing in a theory area, plus academic administration and scholarship. **URBAN DESIGN AND THEORY:** A full-time professorial position is available at the senior level for a person qualified in Urban Design and either Architecture or Landscape Architecture. Duties include teaching design studio, lecturing in a theory area, and a term appointment as Director of the Urban Design Program. **CONSTRUCTION THEORY AND PRACTICE:** A full-time professorial position is available at either junior or senior level for a person qualified in construction, including technological, economic, and institutional aspects of theory and practice. Duties include teaching introductory lecture courses and advanced seminars, conducting research, plus academic administration and scholarship.

APPOINTMENT CRITERIA: For all positions, preference will be given to candidates with advanced scholastic preparation as well as teaching and research or practice experience in the areas of teaching specialty. Preference may also be given to persons qualified to teach in more than one area within the program. Extent of achievement is considered relative to the candidates stage of career, and performance is evaluated in teaching, creative work in research or design, and administration. The candidates creative work must demonstrate a coherent development of theoretical issues relevant to the areas of teaching specialty. **APPLICATION:** In order to be considered, application must be made on the form available from the **Appointments Committee, Department of Architecture, Gund Hall, Harvard University, Cambridge, Massachusetts, USA 02138.** Please do not send dossiers at this time, additional material may be requested after initial screening of candidates. Applications will be received after September 1, 1977, and the selection process will begin January 1, 1978.

**Classified Section
Non-Display Order Form**

To place a non-display advertisement, fill out this form, including your name, street address, city & state with ZIP code, attach it to a separate sheet containing your advertising copy, and mail it to:

ARCHITECTURAL RECORD/
P.O. BOX 900
NEW YORK, N.Y./10020

Rates: \$4.00 per line, minimum insertion three lines, six words to a line, box number counts as one additional line. Display rates on request.

Payment Enclosed \$ Bill me

Use Name & Address Use Box No.

Advertisement to appear time(s)

Signature

PROFESSIONAL SERVICES

**MATERIALS HANDLING
CONSULTANT****DISTRIBUTION CENTERS
Warehousing and Storage Arrangement
Equipment Design and Specifications**

Twenty Years of Successful Practice
Metropolitan New York
Fee or Per Diem

PETER GONDELL
19 Crest Drive · White Plains, N.Y. 10607

**INFRA - RED
SCANNING SERVICES**

Edward R. Schaufler, P.E.

AGA Thermovision Surveys P.O. Box 343
Phone (412) 775-3735 Beaver, Pa. 15009

INSTRUCTION

Registration Exam Preparation System has helped hundreds score higher on the NCARB tests. Covers multiple-choice tactics, judgment skills, team study strategy, countdown checklist, 12 month study plan, oral interviews, more. For details, write: Bonus Pointers, c/o Arts International, 165 Jefferson St., San Francisco, CA 94133.

FOR SALE

Original Saint Peters Cathedral Doors Rome. Replaced by bronze Manzu doors 1962. Made from cedar of Lebanon support beam of former Basilica of Constantine about 350 AD. Also holy doors hazelnut clad with bronze used six holy years between 1750-1933. Full documentation available sale by owner. FS-5162, Architectural Record.

**Public Notice
County of Westchester, New York
Professional Prequalification Board
Architects, Engineers, LandSurveyors**

A list of architects, engineers, and land surveyors licensed or registered in the State of New York, eligible for future selection for consultant contracts with the County of Westchester, N.Y. for public works in their fields of experiences and/or specialty, will be established for the calendar year 1978.

Application for consideration is made by completing and submitting to the County of Westchester Prequalification Board, Room 512, Westchester County Office Building, 148 Martine Avenue, White Plains, N.Y. 10601 prior to 31 October 1977, one copy of Standard Form 254 of the U. S. Government General Services Administration. Copies of same may be obtained from the U. S. General Services Administration or by sending a self-addressed stamped envelope to the Prequalification Board.

The eligibility list will be established on or before 31 December 1977 for the calendar year 1978.

For consulting services that may be eligible for Federal Funding under the provisions of Public Law 92-500, the following paragraph will apply:

Any contract awarded under this request for qualifications is expected to be funded in part by a grant from the United States Environmental Protection Agency. This procurement will be subject to regulations contained in 40 CFR 35.936, 35.937, and 35.939. Neither the United States nor the United States Environmental Protection Agency is nor will be a party to this request for qualifications or any resulting contract.

3D/International, a management, architectural, engineering and planning firm, has announced the appointment of **Richard W. Jennings** as senior vice president and director of the Austin office.

The architectural firm of Total Design Four has elected **Homer C. Innis** as an associate member.

John Carl Warnecke and Associates have announced the promotion of senior designer **John R. Smart** to associate in the firm.

New firms, name changes

Mirick Pearson Ilvonen Batcheler, architects and planners, have announced the formation of a new interior design affiliate, **Merlino • MPiB Design**, to be headed by Samuel J. Merlino.

Charles Luckman Associates has been renamed **The Luckman Partnership, Inc.**, following a major change in its organizational and ownership structure. Partners with Luckman are Richard Niblack and Edward Jones. Richard McKnew, Samuel Burnett, Christopher Stockton and Fred Yerou are new associate partners.

Weinberg Teare & Herman, Architects, and **James D. Gibans, AIA**—Architect have announced the combining of their offices at the present office of Weinberg Teare & Herman.

Steely and Brailas Architects, Inc., have announced the formation of a new firm for the practice of architecture and related services at 6610 Harwin Drive, Houston, Texas.

SBRA International Incorporated, a subsidiary of Shepley Bulfinch Richardson and Abbott, Architects, has opened a new branch office at One Ahmed Orabi Street, Alexandria, Egypt. Wagdy A. Y. Anis will manage the new branch.

Barry L. Rafter has announced the opening of his independent practice of architecture at 307 South B Street, San Mateo, California.

Western Health Management Services has changed its name to **Pacific Health Resources** to reflect the scope of its activities in the health care field.

Arron F. Latt has dissolved his partnership with Latt, Jackson & Associates, and has opened the new firm of **Arron F. Latt & Associates, Inc.**, at 9350 Wilshire Blvd., Beverly Hills, California.

The principal owners of **John Latenser and Sons, Inc.**, an architectural and engineering firm, have announced the formation of separate architectural and engineering companies.

Rolf Jensen & Associates, Inc., fire protection engineers and building code consultants, have opened an office at 921 Front Street, San Francisco. Randolph W. Tucker has been named manager of marketing services; new project engineers are James G. Gallup, Deerfield, Illinois, office and James R. Quiter, Washington, D.C., office.

Erratum

The ambient/task lighting product published on page 143, item 314, of the August 1977 issue was incorrectly identified. The manufacturer is GF Business Equipment.

ADVERTISING INDEX

Prefiled catalogs of the manufacturers listed below are available in the 1977 Sweet's Catalog File as follows:

- G General Building (green)
- E Engineering (brown)
- I Industrial Construction and Renovation (blue)
- L Light Residential Construction (yellow)
- D Interiors (white)

A

- All-Steel Inc., One of the
C.I.T. Companies 58
- Alma Desk Co. 75
- G Amarlite Products Div.
of Anaconda Aluminum Co. . . 129
- G Amelco Window Corp. 24
- American Gas Association 8
- G American Olean Tile Company . . 49
- G-I-L American Plywood
Association 46-47
- American Telephone &
Telegraph Co. 6-7
- Anchor Post Products Inc. 195
- G-L Andersen Corp. 60-61
- G Appleton Electric Co. 188
- Architectural Record 48, 168
- Architectural Record
Books . . 64A, 64D, 162, 174, 186
- Armstrong Cork Co. Cov II, 1, 3
- ASARCO Incorporated 26
- E-G ASG Industries Inc. 140
- Aztech International Ltd. 45

B

- G Bally Case & Cooler, Inc. 183
- Bethlehem Steel Corp. 50-51
- E-G-I-L Bilco Co. 76
- G-I Bradley Corp. 136-137
- Bruning Division-Addressograph
Multigraph Corporation 183
- Building & Construction
Exposition and Conference ... 180

C

- G-L Cabot, Inc., Samuel 183
- G-I Ceco Corp. 161
- G Cem-Fil Corp. 74
- Clayburn Industries Ltd. 32-2
- G-I Cold Spring Granite Co. 145
- G-I Cookson Company, The 22
- G-I Cornell Iron Works 187
- Crouse-Hinds Company 77
- G-I Curries Mfg. Inc. 167

D

- Delta Air Lines 147
- Detex Corp. 149
- G Dover Corp., Elevator Div. 171
- G-D Dow Badische Co. 159
- D-E-G-L DUPONT DE NEMOURS & CO.
INC., E.I. LUCITE 18-19, 176

E

- G-E-I Ebco Mfg. Co. 154
- E-G Elkay Mfg. Co. 138-139
- F Epic Metals Corp. 154

F

- G Flexiwall-Systems 182
- G Follansbee Steel Corp. 40

G

- GAF-Diazo 72-73
- E-G-I General Electric Co., Plastics
Div. 70-71
- E-G-I General Electric Co.,
Silicone Products Dept. 9
- G-I-L Gold Bond Building Products
Division of National Gypsum
Company 68-69
- G-E-I-L-D Goodrich General Products
Co., B.F. 16-17
- G-I-L Grace & Co., W. R., Construction
Products 144
- E-G-I Grefco Inc., Building Products
Division 66
- G-E-I Grinnell Fire Protection
Systems Co. Inc. 196
- G Guardian Industries 65

H

- Hager Hinge Company 164-165
- E-G Halsey Taylor Div., of King
Seeley Thermos Inc. 163
- G Haws Drinking Faucet
Company 142
- G-I Hillyard Chemical Co. 44-45
- Holmsten Ice Rinks, Inc. 147

I

- G-I-L INRYCO, Inc. 20-21
- E-G International Masonry
Institute 30-31

J

- G Jamison Door Co. 143
- D-G-I Jennison-Wright Corp. 64
- D-E-G-I-L Johns-Manville-Building Systems
Division 54
- D-G-I Holophane Division 152-153

K

- G-E Kalwall Corp. 154
- G KDI Paragon 177
- G-I Kelley Co., Inc. 170
- I Kemlite Corp. 188
- Knoll International 12
- G Kwik-Wall Co. 166

L

- Lanier Business Products 189
- E-G-I-L Lennox Industries Inc. 148
- D-G Levolor Lorentzen Inc. 184
- G-E-I-L-D Libbey-Owens-Ford Co. 52-53
- G Ludowici-Celadon Co. 175
- G-I Lyon Metal Products Inc. 170

M

- G Maple Hardwood Flooring
Mfg. Assn. 78
- I-L Marlite, Division of Masonite
Corp. 158
- G-I-L-D Masonite Corp. COVIII
- McGraw-Hill Books 181
- G McKee Door Co. 184
- Moldcast Ltg. 67
- G-I Monier Company 166
- G-D Monsanto Company, Textiles
Div. 32

N

- G-I-L National Gypsum Company,
Gold Bond Building Products
Division 68-69
- G Nor-Lake Inc. 78
- Nora Flooring Division of
Robus Products Corp. 155
- G Nucor Corp. Vulcraft
Div. 172-173

O

- G-L Olympic Stain Company 78
- G Otis Elevator Inc. 55
- G-E-I-L-D Owens-Corning Fiberglas
Corp. 80

P

- E-G Paddock of California, Inc. 56
- D-G-L Pella Rolscreen Co. 156-157
- Phillips, Eindhoven 64B-64C
- G-L-D Potlatch Corp. 4-5
- G-I PPG Industries Inc.
Coatings & Resins 42
- G PPG Industries Inc.,
Commercial Glass 28-29
- Progress Lighting Div. of
LCA Corp. 36

R

- Rauland-Borg Corp. 184
- G-I-L Raynor Mfg. Co. 38
- Raytek Inc. 149
- Regal Tube Co. 25
- E-G-I Robertson Co., H. H.
Russwin, Div. 57
- Emhart Corp. 134-135

S

- Shand Morahan & Co., Inc. 141
- E-G-I Silbrico Corp. 130
- G-I-L Simpson Timber Co. 188
- E Sloan Valve Company COVIV
- Southern California Gas
Company 32-1
- G-E-I Stanley Works 27
- Steel Joist Institute 131
- Sweet's Catalog
Div. of McGraw-Hill 160

U

- G-E-I-L United States Gypsum Co. 150
- E-G-I United States Steel
Corp. . . 14-15, 158, 169, 178-179

V

- G Vermont Marble Co. 132
- G-L Viking Sauna 151
- G Vincent Brass & Aluminum Co. . 170
- G Vinyl Plastics Inc. 185

W

- Walker/Parkersburg
Div. of Textron Inc. 146
- WEGU Canada Inc. 166
- Wide-Lite Corporation 23
- Wilson Art 79

Because Anchor Fence[®] is different, Anchor Fence looks different.

We've learned something in 85 years of fence building. We've learned how to engineer a gate for any application. We've learned that square posts are more attractive, yet harder to climb. We've learned that fabric is more durable when galvanized *after* weaving than before. We've learned that plastic coated fabric is more durable when the vinyl is *bonded* to the core. We've learned that a company draws and holds more customers with superior engineering, superior service and the industry's widest chain link selection.

We learned, too, that since most chain link fences look alike at first glance, when you create a better one, you call attention to it by creating a special trademarked top that says "Anchor." It also says quality.

For the latest data and specs on fence innovations, send for our free catalog.

Anchor Fence
Dept. E097
6500 Eastern Ave.
Baltimore, Md. 21224

Name _____

Title _____

Company _____

Please send Anchor Fence catalog and specs.

Address _____

City/State/Zip _____

Send coupon for free catalog.



ARCHITECTURAL RECORD

McGraw-Hill, Inc., 1221 Avenue of the Americas, New York
New York 10020

Advertising Sales Mgr.: Louis F. Kutscher (212) 997-2838

Business Mgr.: Joseph R. Wunk (212) 997-2793

Sales Promotion Mgr.: Richard M. Gross (212) 997-2815

Research Mgr.: Camille Padula (212) 997-2858

Classified Advertising: (212) 997-2557

District Offices:

Atlanta 30309

J. L. Moran, 100 Colony Square, (404) 892-2868

Boston 02116

Robert L. Tagen, 607 Boylston St., (617) 262-1160

Chicago 60611

James A. Anderson, Robert T. Franden, Edward R. Novak,
645 N. Michigan Ave. (312) 751-3770

Cleveland 44113

Edward C. Weil, III, 55 Public Square, (216) 781-7000

Denver 80203

David M. Watson, 123 Speer Blvd., #400 (303) 837-1010

Detroit 48202

John W. Maisel, 1400 Fisher Bldg., (313) 873-7410

Houston 77002

Lockwood Seegar, 375 Dresser Tower, 601 Jefferson St. (713) 659-8381

Los Angeles 90010

Donald O. Hanson, 3200 Wilshire Blvd.-South Tower (213) 487-1160

New York 10020

Blair McClenachan, 1221 Avenue of the Americas (212) 997-3584

Philadelphia 19102

Robert G. Kliesch, Three Parkway
(215) 568-6161

Pittsburgh 15222

Edward C. Weil, III, 2 Gateway Center, (412) 391-1314

San Francisco 94111

Richard R. Butera, 425 Battery Street (415) 362-4600

Overseas Offices:

Brussels

Galerie Porte de Namur, 22-26, Chaussée de Wavre
1050 Brussels, Belgium

Frankfurt/Main

Elsa-Brandstroen Str. 2, Frankfurt/Main, Germany

London

34 Dover Street, London W.1, England

Milan

Via Baracchini No. 1, Milan, Italy

Paris

17, rue Georges Bizet, 75 Paris 16e, France

Tokyo

2-5, 3-chome, Kasumigaseki, Chiyoda-ku, Tokyo, Japan

For more data, circle 114 on inquiry card

Unsprinklered buildings need not apply.

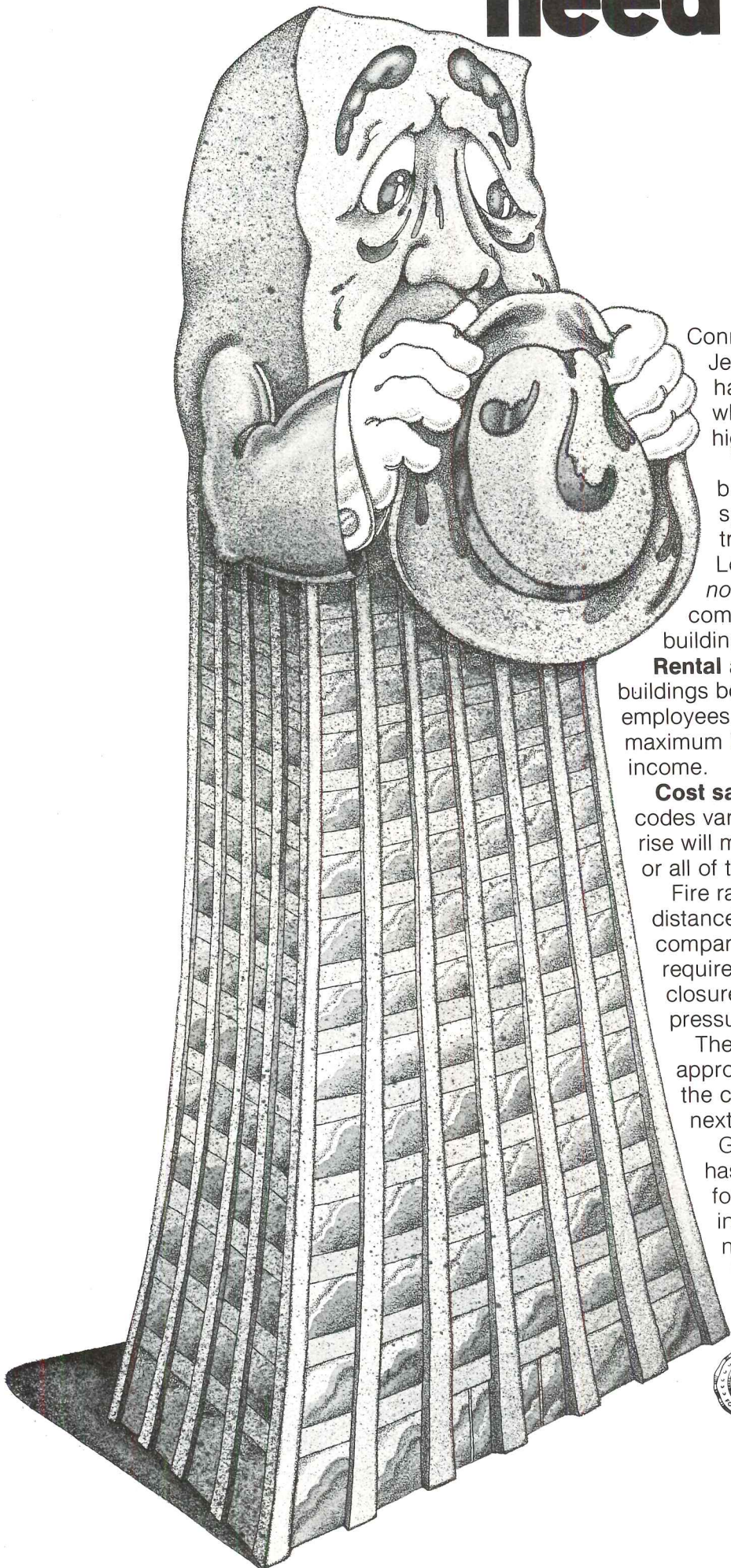

Connecticut, Maryland, Massachusetts, New Jersey, Virginia and scores of cities and towns have adopted new building codes and ordinances which make automatic sprinklers mandatory for high-rise buildings.

The implications are clear: whether you're a building owner or developer, an architect or specifying engineer, you should be aware of the trend to stricter fire protection regulations. Learning all you can about sprinklering properly *now* could save you money in the future when you come face to face with one of these tough new building codes.

Rental appeal. Nowadays many firms insist their buildings be sprinkler-protected for the added safety of their employees. In addition, sprinklers give building owners the maximum in usable rental space and provide more rental income.

Cost savings. Of course, permissive clauses in building codes vary from city to city, but sprinklering your next high-rise will make it safer and could save you money in many or all of the following ways:

Fire ratings of walls, doors, etc. can be reduced. The distance between fire exits can be increased. Larger non-compartmented areas are permissible, and fire barrier requirements can be eliminated. Smokeproof entrance closures to exit stairs can be eliminated if stairways are pressurized.

The average high-rise can be sprinklered for approximately \$1 a square foot. Why not investigate the construction cost savings involved in your next high-rise? The results may surprise you.

Grinnell Fire Protection Systems Company, Inc. has been designing and installing sprinkler systems for more than 125 years. If you'd like more information on how we can help you, call the nearest Grinnell district office listed in the Yellow Pages, or write Grinnell Fire Protection Systems Company, Inc., 10 Dorrance Street, Providence, Rhode Island 02903.



GRINNELL
GRINNELL FIRE PROTECTION SYSTEMS COMPANY, INC.
Protecting Life and Property Since 1850

For more data, circle 115 on inquiry card



Legacy[®] is Trump

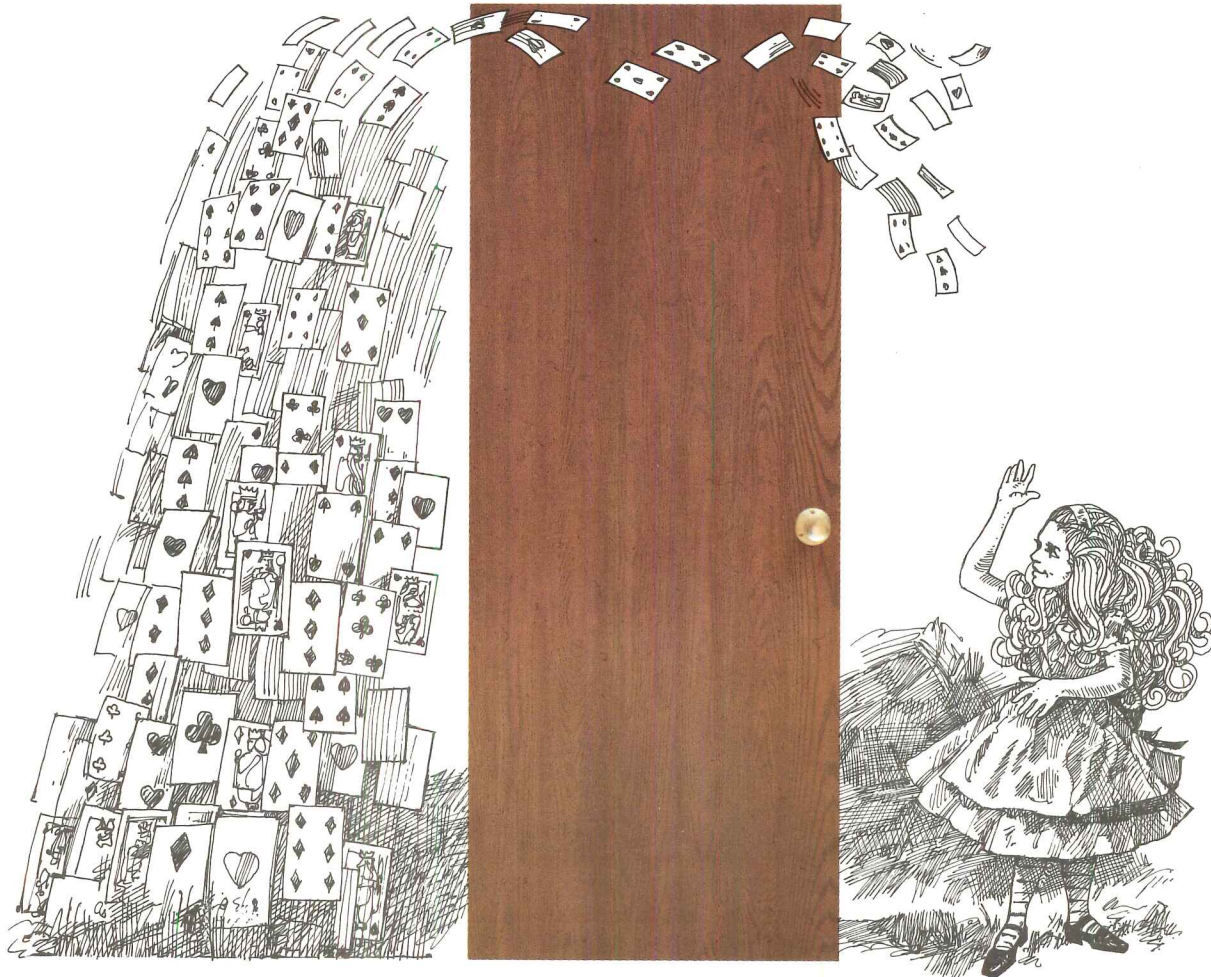

Other Doors Only Follow Suit



No Other Door Looks or Feels Like It

Most hardboard door faces are like Tweedledee and Tweedledum: it's hard to tell one from another. But you'll know Legacy when you see it. Because Legacy's wood grain isn't just lines on the surface; its pattern is deeply embossed. You see a grain rich in natural highlights and you can feel the texture as well. So Legacy faced doors are more than doors. They're a dramatic accent piece for every room.

Not To Mention Durability

Some door facings seem as fragile as Humpty Dumpty. Not Legacy. Fifty percent denser than wood, hardboard Legacy is finished with an equally tough stain and mar resistant coating. The result is a door face highly likely to remain blemish free through installation manhandling and years of rugged use.

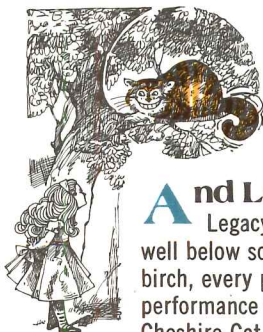

And Low Cost

Legacy's high card trump is low cost. Priced well below solid real wood doors and just a bit above lauan and unfinished birch, every penny spent on Legacy faced doors buys more beauty and performance than money spent on any other door. So, go ahead. Smile like a Cheshire Cat. Your Legacy purchase will be a very clever buy.

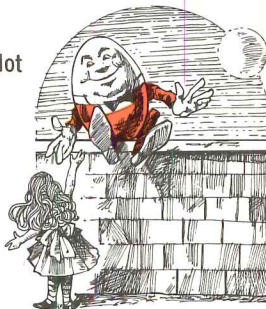

All of Which Means Legacy Stands Alone

Through past fluctuations in building starts, Legacy sales have moved ever upward. It takes a product without equal to generate such continually growing demand and Legacy is that kind of product. But then, it's what you'd expect from us. Hardboard's first name is Masonite.

For the names of quality door manufacturers using Legacy write: Masonite Corporation, 29 North Wacker Drive, Chicago, Illinois 60606.



Oak-tone



Walnut-tone

Masonite and Legacy are Registered Trademarks of Masonite Corporation.



You waste
a lot of water
when you use flush tanks
instead of
Sloan Flush Valves.

Figure it out for yourself.

Number of
tank toilets in
your building

Number of gallons
a Sloan Flush Valve
saves compared
to a flush tank

Total number of
gallons wasted
by flush tanks
on every flush

Plus the number
of gallons wasted
by unnoticed leaks

$$\boxed{} \times 0.64 = \boxed{} + \boxed{?}$$

No matter what figure you got, remember it's only for a single flush. Think of how many times all the toilets in your building are flushed every day. Every month. And since every Sloan Flush Valve uses 0.64 gallon less than a flush tank, think of how much water you could be saving, instead of wasting. What's more, a Sloan Flush

Valve saves you money by using this same minimum water volume with every flush. No more, no less. That's because it completes its cycle, then shuts off automatically. Again, there's less water wasted and a lower water bill. Remember, it takes energy to pump water. The less water you have to pump, the less energy you

have to pay for. So stop wasting water and start saving money. To tell you how, we'd like you to have the test report from an independent laboratory that proves Sloan Flush Valves use 0.64 of a gallon less than tanks. For your free copy, just write to us.



Sloan
Flush
Valves.
Anything else
is a waste
of money.



SLOAN VALVE COMPANY

10500 SEYMOUR • FRANKLIN PARK, ILL. 60131