



BUILDING TYPES STUDY 539

NEW PERCEPTIONS FOR THE 1980s

THE NEED FOR A NEW KIND OF PIONEERING IN DESIGN AND
THINKING ABOUT DESIGN, IN REBUILDING OUR CITIES AND
TOWNS, AND IN MEETING THE NEEDS OF ALL THE PEOPLE

FULL CONTENTS ON PAGES 10 AND 11 SEMI-ANNUAL INDEX ON PAGES 201-204

ARCHITECTURAL RECORD

DECEMBER 1979

12

A MCGRAW-HILL PUBLICATION \$5.50 PER COPY

Letters to the editor

The report of your Round Table discussion on risk and liability (RECORD, mid-August 1979, pages 76-85) is most timely. I do feel, however, that the most serious problem facing architects and engineers that was not mentioned is the flagrant practice of attorneys who prey on the obvious weaknesses of the construction industry.

None of us will deny that "there are errors and omissions out there," but the posture of the insurance companies and their preference to settle rather than fight has fostered a breed of lawyers who are milking our profession on an indiscriminate basis.

The theory of suing everyone in the hope of collecting from someone places the firm with the most coverage in a very vulnerable position.

If it is true that 30 per cent of all A-Es are currently beset by litigation and that the rate is increasing by 20 per cent per year, it will not be long before all of us are involved.

With this ominous prospect we professionals must do more than talk about this sickness or we shall find ourselves in litigation more than the practice of architecture.

*Bernard J. Grad, FAIA
The Grad Partnership
Newark, New Jersey*

One of your subscribers, an architect in Detroit, sent me a copy of the editorial in your mid-August issue criticizing the automobile industry for not having done as good a job as your industry in responding to the energy crisis. His note said, "I suspect that both his facts and his logic are faulty, but the magazine reaches most of the design professionals in our country, and I think they should have your comment."

At General Motors, we did see the shortage coming, and began the first of our redesign programs well before the OPEC embargo in 1973. We have improved the fuel efficiency of General Motors cars every year since 1974; they now get 75 per cent better fuel economy than the 1974 models. Our corporate average fuel economy for 1980 is projected to be 21 miles per gallon on the composite EPA driving schedule—more than one mile per gallon higher than the Federal standard.

Those gains were not made, as you say, with "a lot of taxpayer money," but out of our own earnings. At General Motors, we calculate that our corporate fuel economy gains have cost us about \$2 billion for every additional mile per gallon so far. The Motor Vehicle Manufacturing Association estimates that over the next seven years the automobile industry will spend from \$70 to \$80 billion improving fuel economy—more than twice the cost of putting a man on the moon. The industry-wide effort has been described as "the

greatest retooling of a single huge industry ever undertaken in the peacetime history of America."

Your suggestion that our engineers should "buy a foreign car . . . and take it apart to see how it works" is inappropriate. Many imported cars do have inherently greater fuel economy because they are much lighter than domestic cars, not because they have superior technology for emissions control or fuel economy. Indeed, any unbiased examination of the facts would show that for saving energy, keeping operating costs down, and cleaning up exhaust emissions, no technology in the world is better than the catalytic converters, pioneered by General Motors. Here are some points:

- In the 1979 Federal EPA fuel economy ratings, the gasoline-powered car with the best mileage is a subcompact that uses a catalytic converter and gets 35 miles per gallon. In the same size category, the best non-catalyst subcompact gets only 28 miles per gallon.
- In every EPA weight class except one, a catalyst-equipped car gets the highest mileage in the Federal fuel economy ratings.
- In the same listing, the average mileage of all catalytic cars in any given EPA weight class is higher than the average for all non-catalyst cars.

I think the domestic automobile industry has done an outstanding job in responding to the energy crisis. At GM, in addition to improving our products' efficiency, we have reduced the energy it takes to build each vehicle by 22 per cent since 1972. But apparently, despite all of the advertising and publicity, we haven't done as good a job in telling people about our progress. It does seem to be hard to communicate effectively these days.

For example, I honestly did not realize that the building industry had done as much as the editorial reported in reducing energy consumption. Now that I know it, I heartily congratulate you. And now that you know about the automobile industry's accomplishments, why not write an editorial for the next issue congratulating us? Or at least publish my letter.

*E. M. Estes
President
General Motors Corporation
Detroit*

Calendar

DECEMBER

December through January Retrospective Exhibition, "Franco Albini in his times—architecture and design 1930-1970," sponsored by the Department of Culture of the Comune di Milano; held at the Rotonda di via Besana, Milan. Contact: Ufficio Pubbliche Relazioni della Ripartizione Cul-

tura e Spettacolo del Comune di Milano, via Marino 7, 20121 Milano.

7-9 ACSA/CSBA Joint Annual Conference "Public Education Meets the Challenges of the 80s"; held at Brooks Hall & Civic Auditorium, San Francisco. Contact: Jacquie Howell, Conference Executive, ACSA, 1575 Old Bayshore Highway, Burlingame, Calif. 94010.

10-11 Seminar, "Building Re-Use: Managing Costs, Codes and Design," Carillon Hotel, Miami. Program will be repeated February 4 in Los Angeles. Contact: ARCHITECTURAL RECORD SEMINARS, 1221 Avenue of the Americas, New York, N.Y. 10020 (212/997-3088).

10-12 The Eastern Plant Engineering & Maintenance Show & Conference, at the John B. Hynes Veterans Auditorium, Boston. Contact: Clapp & Poliak, Inc., 245 Park Ave., New York City, 10017 (212/661-8410).

13 Workshop, "Visual Marketing for Design Professionals," sponsored by Ernest Burden Presentation Consultants; at the Sheraton Palace, San Francisco. Contact: Ernest Burden, 20 Waterside Plaza, New York, N.Y. 10010.

13 Seminar, "Design Cost Analysis for Architects & Engineers," Carillon Hotel, Miami. Program will be repeated February 7 in Los Angeles. Contact: ARCHITECTURAL RECORD SEMINARS, (see Dec. 10).

16-21 5th World Congress of Engineers and Architects in Israel, "Dialogue in Development—Towards the 21st Century"; Tel Aviv, Israel. Contact: Prof. Dan Soen, Congress Coordinator, ITCC, Engineer's Institute, P. O. Box 3082, Tel Aviv, Israel.

27 through January 13 Syracuse University China Study Group, sponsored by the College for Visual and Performing Arts and the Division of International Programs Abroad. Contact: Nirell Galson, Associate Director, Division of International Programs Abroad, 335 Comstock Ave., Syracuse, N.Y. 13210.

JANUARY

5-10 International Symposium on Islamic Architecture and Urbanism, sponsored by King Faisal University with the support of Saudi Arabian Ministry of Municipal & Rural Affairs and the Ministry of Public Works and Housing; held in Dammam, Saudi Arabia. Contact: Chairman, Technical Committee for the International Symposium on Islamic Architecture and Urbanism, King Faisal University, P. O. Box 2397, Dammam, Saudi Arabia.

18-20 Annual convention, National Association of Home Builders, Las Vegas.

3-7 Semi-annual meeting, American Society of Heating, Refrigerating and Air-Conditioning Engineers, on energy alternatives and energy conservation in buildings and appliances; Los Angeles Hilton. Contact: Ralph Burrowsky, ASHRAE, 345 E. 47th St., New York, N.Y. 10017.

ARCHITECTURAL RECORD (Combined with AMERICAN ARCHITECT, ARCHITECTURE and WESTERN ARCHITECT AND ENGINEER) (USPS 132-650)

December 1979, Vol. 166, No. 8. Title reg. in U.S. Patent Office, copyright 1979 by McGraw-Hill, Inc. All rights reserved. Copyright not claimed on front cover and editorial four-color separations. Indexed in Reader's Guide to Periodic Literature, Art Index, Applied Science and Technology Index, Engineering Index, and The Architectural Index.

Quotations on reprints of articles available. Every possible effort will be made to return material submitted for possible publication (if accompanied by stamped, addressed envelope), but the editors and the corporation will not be responsible for loss or damage.

EXECUTIVE, EDITORIAL, CIRCULATION AND ADVERTISING OFFICES: 1221 Avenue of the Americas, New York, N.Y. 10020.

OFFICERS OF MCGRAW-HILL PUBLICATIONS COMPANY: president: Paul McPherson; executive vice president: James E. Boddorf, Gene W. Simpson; group vice president: Thomas H. Kinsey; senior vice president-editorial: Ralph J. Schulz; vice presidents: Kemp Anderson, Business Systems Development; Stephen C. Croft, manufacturing; Robert B. Dodge, circulation; James E. Hackett, controller; William H. Hammond, communication; Eric B. Herr, planning and development; John W. Patten, sales; Edward E. Schirmer, international.

CORPORATION OFFICERS: Harold W. McGraw, president, chief executive officer and chairman of the board; Robert M. Landes, senior vice president and secretary; Ralph J. Webb, treasurer.

ASSOCIATED SERVICES/McGraw-Hill Information Systems Co.: Sweet's Catalogs (General Building, Engineering, Industrial Construction and Renovation, Light Residential Construction, Interiors), Dodge Building Cost Services, Dodge Reports and Bulletins, Dodge/SCAN Microfilm System, Dodge Management Control Services, Dodge Construction Statistics, Dodge regional construction newspapers (Chicago, Denver, Los Angeles, San Francisco).

SUBSCRIPTIONS: Subscriptions solicited only from architects and engineers. Position, firm connection, and type of firm must be indicated on subscription order. Please allow 4-12 weeks for shipment. Subscription rates for U.S., U.S. Possessions: \$21.00 for architects, engineers and others in the field served; all other countries: \$29.00. In Canada: \$23.00 for architects, engineers and others in the field served; all other countries: \$31.00. In all other countries: \$45.00 for architects and engineers; all other countries: \$49.00. Domestic and Canadian single copy price: \$5.50 except the microfilm issue which is \$5.95. Foreign single copy price: \$7.00.

GUARANTEE: Publisher agrees to refund that part of subscription price applying to unfulfilled part of subscription if service is unsatisfactory.

CHANGE OF ADDRESS: Forward change of address or service letters to Fulfillment Manager, Group A, ARCHITECTURAL RECORD, P.O. Box 430, Hightstown, N.J. 08520. Provide both old and new addresses including zip code; if possible attach issue address label.

PUBLICATION OFFICE: 1221 Avenue of the Americas, New York, New York 10020. ARCHITECTURAL RECORD (USPS 132-650) published monthly except May, August and October when semi-monthly by McGraw-Hill, Inc. Controlled circulation postage paid at Strasburg, Virginia. POSTMASTER: PLEASE SEND FORM 3576 to Fulfillment Manager, ARCHITECTURAL RECORD, P.O. Box 430, Hightstown, N.J. 08520.

THIS ISSUE is published in national and separate editions. Additional pages of separate editions numbered or allowed for as follows: Western Section 32-1 through 32-2.





Resolve the restroom rip-off.

Don't design a washroom that will cost unnecessary maintenance dollars.

Our "School Board Special" Washfountains are custom-built to take the beating we know they'll get. And they're about as vandal-proof as anything can be.

Bradley Washfountains have been installed in many of the largest urban school districts in the nation. And have survived.

Your Bradley representative will work with you to select a Washfountain with the features you need. And he'll detail the corridor washroom concept that can reduce supervision, too.

WRITE FOR OUR WASHROOM/SHOWER ROOM PLANNING GUIDE. Bradley Corporation, 9107 Fountain Boulevard, Menomonee Falls, WI 53051.

Another
right idea
from  **Bradley**

Circle 7 on inquiry card



heuga u.s.a., inc. 185 Sumner Ave., Kenilworth, NJ 07033 201-245-3480
THE ORIGINAL CARPET SQUARES

Client: Royal Bank of Canada, Toronto, Ontario; *Royal Bank Plaza* Architecture: Webb, Zerafa, Menkes, Housden
Interior Design: J.C. Preston Ltd. Product(s): heuga flor-s, heuga 575 Installation: 40,000 sq. yds., 360,000 sq. ft.
Installation Date: November 1976-April 1977 Photography Date: February 1977

In Canada: heuga canada ltd. 185 Carlingview Drive Rexdale (Toronto) Ontario 416-675-2410

Circle 8 on inquiry card

Revolution, evolution, and the market in the 1980s

Throughout this issue on "New Perceptions for the 1980s" you will find, I hope, a sense of evolutionary change for the years ahead.

This is not to speak of a period of calm or retrenchment in either building or design thinking. Rather, we have tried to show in this issue how the drive through the 1980s needs to be to *accomplish* things we have all long been talking about. For example: getting on with the job of making better use of our existing stock of worthwhile older buildings as a fundamental to rebuilding our cities and towns; getting back to our professional commitment to social responsibility as architects, finding and making ways to help those least able to help themselves; continuing the effort to find not just new techniques but new concepts for conserving energy (an effort to which architects and engineers have contributed more than most); and—since design is, after all, what architects and engineers and planners are all about—we need to continue to *evolve* in the direction of design skill and quality (instead of having our energies diverted by arguments for "revolution" in design).

Those things are all discussed in this issue—beginning with the introduction on page 85.

Another altogether critical question is how the marketplace for architects and architecture will evolve in the 1980s. There's no one smart enough (or dumb enough) to try and predict the market—the construction outlook—for the 1980s. Next year is difficult enough. But what economist George Christie had to say in his Dodge/Sweet's Construction Outlook (reported in detail in *RECORD*, November, page 65) about next year suggests that in the marketplace too we should look for evolution not revolution.

For example, he made it clear that the long-predicted recession is going to happen: Christie expects a decline of about 10 per cent in nonresidential building next year.

But . . .

The critical point—the major argument for accepting the premise of evolutionary change in the marketplace—is this analysis by Christie: "Although there are obvious similarities to the mid-1970s recession [in which one-quarter of the market collapsed], there are some important differences to keep in mind. The absence of a serious imbalance in the economy improves the changes of a shorter, less severe recession than in 1974-75. In addition, recent structural changes in the

credit market [especially Money Market Certificates, which have attracted or retained nearly \$100 billion in the thrift institutions, most of it channeled into mortgages] have greatly reduced housing's traditional vulnerability in periods of high interest rates. . . . And (in contrast to 1974-75) few, if any, building markets can be considered overbuilt in 1979. Without the need to absorb a surplus in 1980, recovery can take place sooner. . . . "If runaway inflation can be reversed in the next six months, most building markets will be beginning to make their recovery during 1980's second half, responding to the strongest demand the construction market has ever experienced."

One final point from Christie's important speech to the Building Product Executives Conference—predictions that are of course just as important and useful to architects and engineers as they are to the suppliers:

"Selectivity can uncover growth even in a no-grow market. Total construction may be stagnant, but some individual construction markets will be doing quite well in the 1980s. The environmental and energy-related markets are obvious examples. There are others.

"Selectivity on a geographic basis is another route to growth in a no-grow universe. The South and West will continue to offer better potential in the 1980s than the Northeast and Midwest.

"Sensitivity to the building cycle will be more important than ever. If three years out of every five are going to be better than the other two, they are obviously the ones to key in on.

"Finally, there's the rehabilitation market . . . which appears to have a potential for solid growth . . . the total of all nonresidential retrofit may be close to \$25 billion [nearly as big a market as improvement!] and growing fast!"

And thus—in an evolutionary fashion—the concept of new life for old buildings, which *RECORD* first focused on in the December 1971 issue, has become the major force we have all long thought it should be. For—to return to the over-all concept of this issue—it is from our heritage of older buildings that so much of our current design philosophy is emerging, and from our heritage of older buildings that we can maintain (as we also build new) the character of the neighborhoods and towns and cities.

And there is a goal for the 1980s.

—W.W.



Steelcase chairs
equipped with Unitrol
deliver an easy, even
"ride" throughout the
full tilt range.

The dollar volume of September contracts for new construction fell 13 per cent below last September's level, according to the F.W. Dodge Division of McGraw-Hill Information Systems Company. Nonresidential building contracts, at \$4.5 billion, declined 6 per cent for the month, with "the month's loss . . . concentrated in commercial and industrial projects, which were down 18 per cent," said George A. Christie, Dodge's chief economist. September's residential contracts, at \$6.2 billion, fell 4 per cent, but multifamily housing was an exception in the over-all situation, showing a 26 per cent gain over last September's level.

Inflation over the 12 months ending with September pushed U.S. construction costs up an average 13.8 per cent, according to the Cost Information Systems Division of McGraw-Hill Information Systems Company. These figures include a 16 per cent increase in the cost of materials and an 8 per cent increase in the cost of labor. The regions hardest hit were the Pacific Coast and Rocky Mountain states, up 15.3 per cent, and the Southeastern and South Central States, up 15.2 per cent. The smallest increase, 10.5 per cent, was recorded in New England.

GSA, concerned about A-E productivity for Federal buildings, will provide more precise predesign information in order to establish better criteria for its evaluation of completed buildings, PBS Commissioner Albert A. Marschall announced at a recent BRAB conference in Washington, D.C. At the same time, the agency will reduce its number of construction phases and will discontinue the use of construction managers. Details on page 36.

San Francisco voters last month defeated an anti-high-rise proposition that would have limited building height to 260 feet. Proposition O threatened a number of projected office buildings. Details on page 37.

Leon Bridges, AIA, took office as president of the National Organization of Minority Architects at the association's recent annual convention in New Orleans. Mr. Bridges, who heads the Baltimore firm The Leon Bridges Company, succeeds Andrew L. Heard of Chicago. NOMA's first vice president, who is also president-elect, is Paul Devroux, AIA, of Washington. New vice presidents of the association include Ernest Clay, Jack Young and J.W. Robinson. NOMA also elected Marshall E. Purnell as secretary and Yettkov Wilson as treasurer.

The Federal government aims to increase the number of contracts it awards to businesses owned by women. The Office of Federal Procurement Policy indicates that it will raise its goal for contracts to women's business enterprises to \$300 million in the next fiscal year. Details on page 39.

The city of Boston has announced still another major redevelopment project: the Safdie Plan. It calls for the development of a central 70-acre site between City Hall and the Charles River. Details on page 37.

The National Gallery of Art made the 50th anniversary of Mies's Barcelona Pavilion the occasion of a major show on the building and its furniture. The show will travel to Europe after closing this month. Details on page 37.

The AIA Research Corporation will study the integration of conflicting problems in designing against hazards. With a \$200,000 grant from the National Science Foundation's Division of Problem-Focused Research Applications, AIA/RC will investigate conflicting and mutually reinforcing aspects of design standards for earthquakes, fire, flood and wind resistance and the implications of energy conservation. Robert Sockwell is the project manager.

Edward H. Matthei, AIA, has received the first Leon Chatelain Award for barrier-free design. The National Easter Seal Society established the award for "outstanding leadership in advancing barrier-free environments for people with handicaps." Mr. Matthei, a partner in the Chicago firm of Matthei and Colin, has long advised the Institute, the Easter Seal Society and ANSI on barrier-free issues. The late Mr. Chatelain was a former president of AIA, as well as of the National Easter Seal Society.

National and local preservation forces have combined to sue the government and block construction of a convention center in Charleston, South Carolina. The National Center for Preservation Law, the Preservation Society of Charleston and two local associations have retained the Washington law firm of Arnold & Porter to argue that HUD, the President's Advisory Council on Historic Preservation and EDA, in funding and supporting the privately developed Charleston Center, have not complied with the National Environmental Policy Act or the National Historic Preservation Act. Plaintiffs hope to prevent the release of a \$4.15-million HUD action grant.

New services for designers: McGraw-Hill has announced the establishment of two programs to provide information to architects. Energy Requirement Analysis uses a computerized program to evaluate future energy consumption of buildings at an early stage of design, information required by some government units before they issue construction approvals. The Regulatory Impact Service will analyze the impact of Federal activities on the building design community. RIS, which will publish monthly, issued its first set of binder sheets last month.

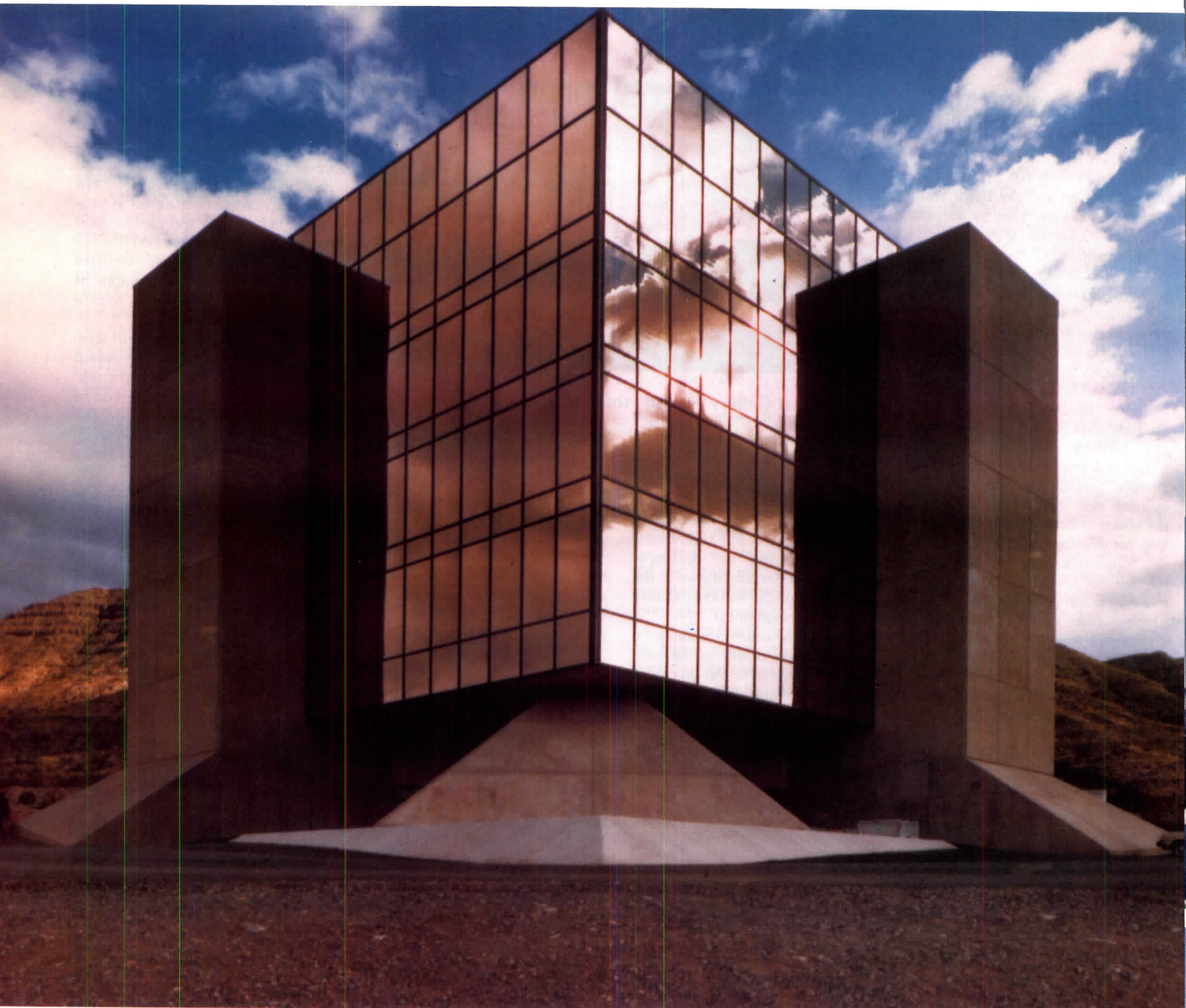

Architect: Charles E. Nolan Jr. & Associates, Alamogordo, New Mexico

As contemporary and modern in style as the space age itself, the International Space Hall of Fame was built to house the historic documents and exhibits of our nation's space story. The building is sheathed with EGP's COOL-VIEW 400-8 insulating glass which screens out the New Mexico sun to reduce air cooling costs.

EGP, the architectural division of Shatterproof Glass Corporation, furnishes a complete line of architectural glass products that provide architects, owners and glaziers with a total environmental glass package.

- COOL-VIEW reflective glass
- WEATH-R-PROOF 10 insulating glass
- TRANS-VIEW transparent mirror
- EGP HEAT STRENGTHENED glass
- COL-R-SPAN spandrel glass
- TEMP-R-LITE tempered glass
- SHAT-R-PROOF laminated glass — for safety, security, sound control and detention

Look for us in SWEETS, section 8.26/Egp



Environmental Glass Products

ARCHITECTURAL DIVISION, *Shatterproof* GLASS CORPORATION
4815 CABOT AVENUE • DETROIT, MICHIGAN 48210 • PHONE 313 • 582-6200

Circle 24 on inquiry card

"Solar envelope" zoning would allow high densities

Reporting that the utilization of solar energy can be extended to cities of medium density rather than confined chiefly to low buildings on open sites, Ralph Knowles, professor of architecture at the University of Southern California, brought good news for President Carter's solar energy goals.

At the Second Open Workshop on Solar Technology, sponsored by the Solar Energy Research Institute (SERI) in Washington, D.C., at the end of October, Mr. Knowles said that he had been able to apply his "solar envelope" zoning concept to urban areas with densities of 5 to 6 FAR.

"We took the notion of solar access a step beyond access to a single building, to a step that guarantees access to the entire site," he said. "The characteristic sloping surfaces of our three-dimensional approach to zoning can be shown topographically, with potential floor area ratios in excess of five."

One condition of Mr. Knowles's study, which centered on an existing commercial district near downtown Los Angeles, was to ensure six hours of solar access (9 AM to 3 PM) in in-fill situations. "Our solar envelope varies with spatial conditions," he said. "Streets are allowed to be shadowed, 30 per cent of future walls can also be shadowed, and the envelope can extend over adjacent underdeveloped properties."

Though the spatial constraints of the solar envelope tend to limit three-dimensional solutions, Mr. Knowles said, the concept nonetheless offers considerable potential for variety.

Mr. Knowles hopes to show that his solar zoning concept can be applied to densities as high as 100 or more units per acre. He is presently engaged in the study of an 8.5-acre site in downtown Los Angeles. "This is a community development agency project in which we are going to try to achieve average densities of about 8 to 10 FAR while guaranteeing solar access to the surround." —*Beryl Laccoste, World News, Washington.*

Government office urges contracts for women's firms

Federal agencies will be encouraged to award contracts to businesses owned by women.

Regulations proposed by the Office of Federal Procurement Policy set a goal of \$150 million in prime contract awards for Women Business Enterprises in this fiscal year and indicated that the goal next year will be \$300 million. At the same time, the OFPP is developing regulations that will encourage non-women prime contractors to employ more WBEs as subcontractors.

What OFPP wants is for all procurement contracts to include language specifying that WBEs be hired

as subcontractors "to the maximum degree feasible." It would also like to study the possibility of including an incentive clause for prime contractors agreeing to subcontract with WBEs.

The procurement action is an outgrowth of an Executive Order signed by the President, which created a national women's business enterprise policy. Comments on the procurement regulations will be accepted until December 28. —*William Hickman, World News, Washington.*

Park Service conducts study of adobe's properties

A Federal laboratory has set out to study adobe as a building material.

The work is being handled by the Center for Building Technology, an arm of the National Bureau of Standards, at the request of the National Park Service. The research will help the Park Service in its preservation of historic adobe structures.

Research will center on developing standard methods to define the composition and physical properties of adobe soils, finding nondestructive methods to measure the water content in adobe structures, evaluating the effectiveness of different types of preservation materials and methods, and determining the effect on the mechanical properties of adobe.

Already, scientists at the center have found "that particle size distribution, mineral composition or particle size fractions, presence of soluble salts, the microfabric of the silt-clay matrix, and the rheological response to moisture appeared to have the most significant effect on durability." —*William Hickman, World News, Washington.*

Cities spend block grants on neighborhood projects

Cities and towns receiving \$3.4 billion a year in community development block grants are now putting more of their grant money into neighborhood projects and less into downtown redevelopment.

According to a report prepared by HUD on spending in fiscal year 1978, projects in central business districts got 67 per cent of the economic development funds in fiscal 1975, but only 27 per cent in 1978.

"The dominant and fastest growing" use of block grant funds, the report says, goes for neighborhood preservation, which received 40 per cent of all community development funds in fiscal 1978.

In that year, 44 per cent of the cities said they spent more than half their grant money for neighborhood preservation projects, compared with 29 per cent in fiscal 1975. Most of the funds are used for housing rehabilitation, which gets quick results. —*Donald Loomis, World News, Washington.*

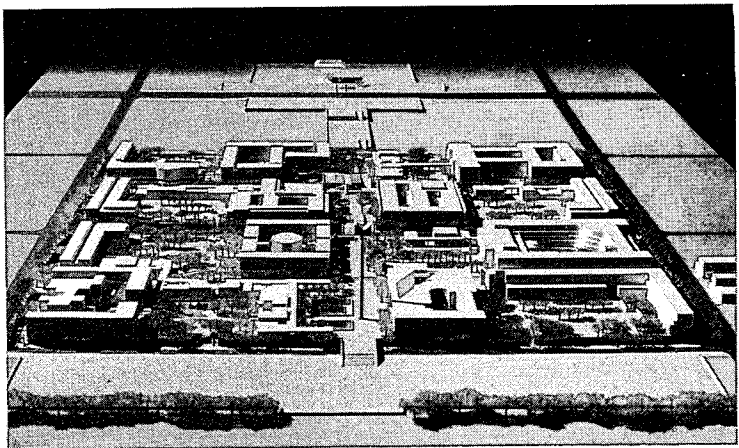

C. Amaga

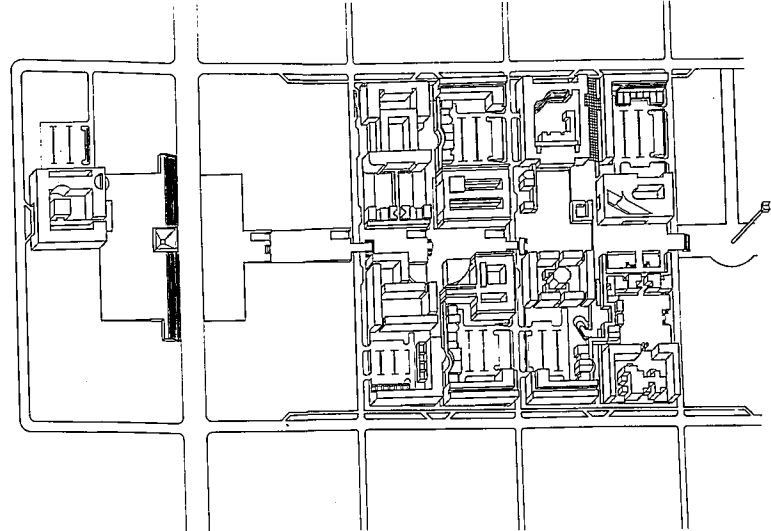

Tanzania moves its national capital inland to Dodoma

In Tanzania, the government of President Julius K. Nyerere plans to abandon Dar es Salaam, a century-old trading center on the Indian Ocean, in favor of a new capital at Dodoma, a city of 70,000 that lies 350 miles inland on a high, sloping plain dotted with low mountains and inselbergs.

Tanzania's seat of government will occupy the new National Capital Center, planned by the New York City architectural firm Conklin & Rossant. Because traffic is overwhelmingly pedestrian—farmers, craftsmen and shoppers may walk from as far as 10 miles out to attend the city's markets—the designers deliberately mixed and concentrated accommodations. The first phase of construction, scheduled for completion in 1985, will combine buildings for six ministries, commercial office space, a 200-room hotel, 400 units of housing, retail arcades, covered shopping space and open markets.

The capital center will stand on a series of six terraces divided by a central pedestrian axis leading, via stairs, ramps and bridges, to People's Square at the summit. (During the second phase of construction, the High Court and the Prime Minister's office will be built around the plaza.) Perpendicular access thoroughfares will cross the central mall at the base of each terrace, alternating pedestrian and vehicular traffic, and the precinct will be bounded east and west by boulevards. Numerous paths

and open spaces will connect the buildings, which will also conceal some parking areas.

Energy conservation was also an issue, as it is in many developing countries. A height restriction of about 40 ft reflects not only the government's preference for modest surroundings—Tanzania's National Center will be no monumental Brasilia or Chandigarh—but also a determination to eliminate energy-intensive elevator systems. Neither will the buildings be air-conditioned. In a climate that the architects describe as much like Arizona's—semi-arid, with hot days and cool nights—narrow structures encircling courtyards will encourage natural cross-ventilation.

Despite Tanzania's modest demeanor at Dodoma, plans also call for more visible signs of national dignity. A tall Mwenge wa Uhuru (Torch of Freedom) will burn at the lower end of the central mall, and a sculpture of an Ujamaa Tree, the tree that typically serves as the social and market shelter in the midst of President Nyerere's ideal centralized village (Ujamaa), will rise on People's Square.

A master plan for the development of Dodoma from a city of 70,000 to a capital of half a million people has been completed by Project Planning Associates, Ltd., of Toronto. The first two ministries in the capital center are being designed by Pedro Ramirez Vasquez of Mexico City.

Ceco can put together a door package for your entire project.



*the high
performance
door
people*

Ceco has what it takes to outfit your entire project: thousands of high performance steel door and frame combinations. Plus a complete selection of builders' hardware.

Rugged, attractive Ceco doors are designed to install fast — and last. It's been that way for 30 years.

What's more, there is a Ceco door package to fit every functional and esthetic need. Our Colorstyle finishes are available in a wide spectrum of colors. And Ceco doors meet all nationally recognized performance standards for hospitals, schools, hotels, industrial plants and institutional buildings of all kinds.

Where do you get them? Anywhere in the U.S. With 18 Ceco warehouses coast-to-coast and over 200 stocking distributors, you can get what you want, when you need it, wherever you are.

Whether you need high performance fire doors, added building security or the complete steel door, frame and hardware package, your Ceco high performance door specialist is a good man to know. See us in Sweet's, call us or one of our distributors — we're in the Yellow Pages under "Doors," or contact The Ceco Corporation, 5601 W. 26th Street, Chicago, IL 60650.



"The door people"™

Circle 25 on inquiry card

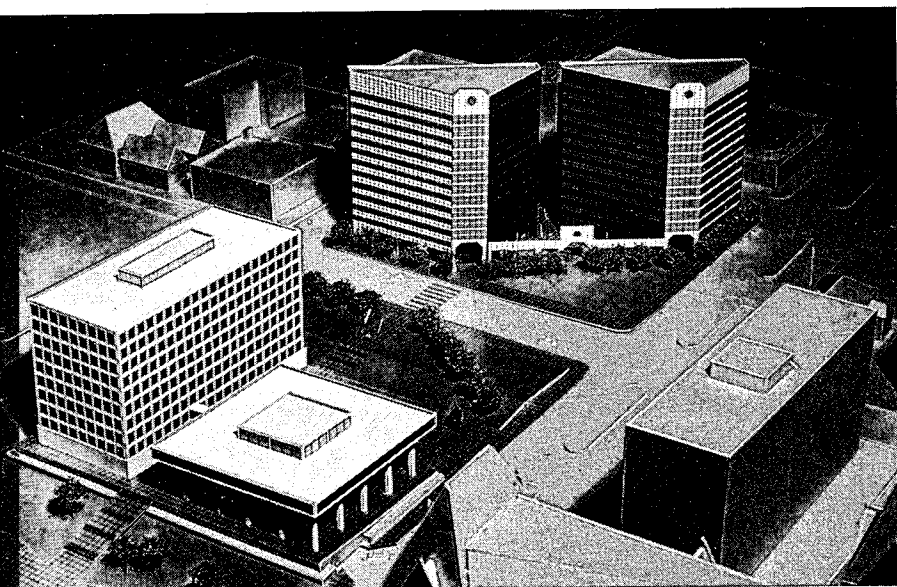

Paired office towers flank a formal gateway in Milwaukee

C.F. Murphy Associates have drawn on the formal gateway as the metaphor for their design of a pair of commercial office buildings in downtown Milwaukee. The beveled apexes of the triangular plans will frame a connecting colonnade, and the circular motif

above the central gate, which opens onto a pedestrian plaza, will be repeated at the top of the flanking towers. The curtain walls were designed to be different colors on different facades—slightly darker on the walls facing across the plaza, slightly paler toward the

street. Joint developers of the project are Urban Investment and Development Co. of Chicago and MGIC Investment Corporation of Milwaukee, whose offices across the street also appear in the model. Construction of the first building will begin this spring.

Louvered curtain wall will conserve energy

To consolidate 500 of its employees in Niagara Falls, Hooker Chemical plans a \$17.6 million building overlooking the Falls and Rainbow Bridge. The new offices, designed in joint venture by Cannon Design, Inc., and Hellmuth, Obata & Kassabaum, will have an innovative curtain wall designed for energy conservation. Two walls of glass, set 4 ft apart, will enclose operable

louvers controlled automatically by the sun, so that the wall may be entirely open on one side and entirely closed on the other, or completely sealed when the offices are unoccupied. The enclosed space will also set up a chimney effect to vent hot air in the summer. The louvers will have a knock-down mechanism to allow free movement for maintenance workers.

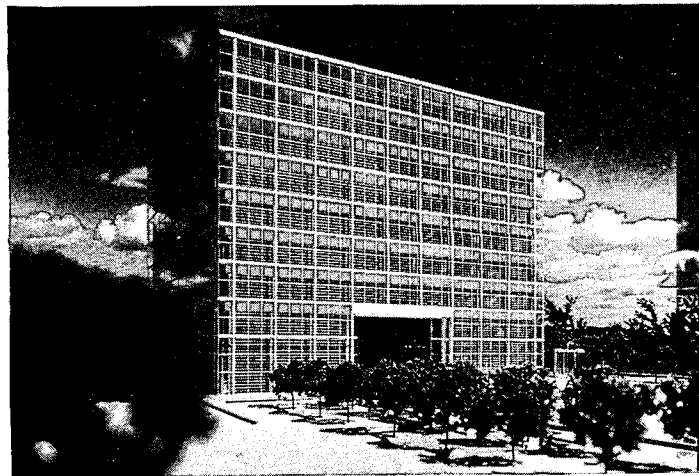

Barbara Elliott Martin

School at Boston's Museum of Fine Arts builds an addition

©Steve Rosenthal

In the 50 years since Boston's School of the Museum of Fine Arts built its present quarters, it has quintupled its enrollment to 1,200 and expanded its curriculum. Apart from discomfort, the overcrowding re-

sults in the impingement of "dirty" arts like sculpture and metal-working on the practice of "clean" arts like photography and film. Graham Gund Associates has designed an addition for the school of

nearly the same size and shape as the original building. The three-story building, plus a finished basement, will house a gallery and a library, in addition to skylighted studios on the top floor. The old and new

buildings will be joined by a glass entrance atrium that will provide space for student congregation. The new building, scheduled for completion in fall of 1981, will cost an estimated \$4.1 million.

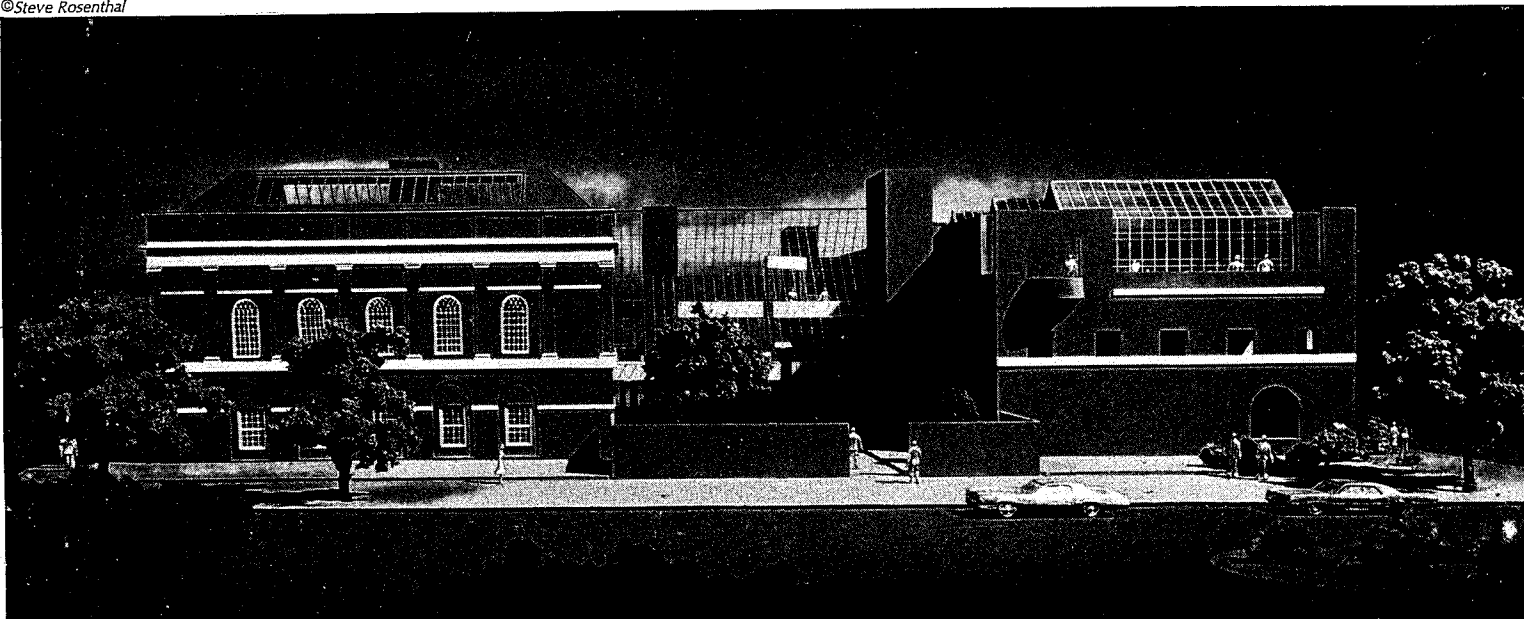

For your next project, why not put a message in the sky? With Moduspan® Space frame that turns a ceiling into a skyline, a building into a view. The view on the right is a branch bank of the City Federal Savings and Loan in Summit, New Jersey. Where an architect built on an idea with the technical assistance of our space frame experts. For more information, call the Unistrut Service Center nearest you. Or see our catalogue in Sweets. And see how Moduspan can be a new company's most important overhead investment.

Open up a business.

Architect: Edward Durrell Stone Assoc. PC
General Contractor: Skinner & Cook Inc.

UNISTRUT

GTE

An exhibition at the Octagon in Washington: designs for five international chanceries

A flurry of diplomatic building begins in Washington with the construction of five new chanceries at International Center: Bahrain, Ghana, Israel, Kuwait and Yemen. The designs, each by a different American architect, by and large combine building materials common to both Washington and the country establishing the mission—but since Washington is no stranger to architectural eclecticism, there appears to be less design constraint than one might at first guess. The International Center occupies a large site abandoned by the National Bureau of Standards when it moved to Gaithersburg, Maryland, some years ago. A brainchild of the National Capital Planning Commission, it will eventually accommodate 14 chanceries, of which five more are now in the planning stages: Bulgaria, Jordan, Libya, Nigeria and the United Arab Emirates. The five projects shown here are the subject of an exhibition, "A Celebration of Diversity: Planning the International Center," sponsored by the American Institute of Architects Foundation and on view at the Octagon in Washington until the end of this month.

The Chancery of Ghana, designed by Brown & Wright Architects, of Washington, D.C., will, in plan, resemble a traditional palace of a Ghanaian Paramount Chief. The glass-roofed central courtyard, dropped three steps to add height and provide seating,

will house a porch for talking drums and a pedestal for sacrificial libations, as well as tiered balconies of Ghanaian plants: orchids, ferns, vines and small trees. The building will also provide office space around the courtyard, a reading room, and an auditorium.

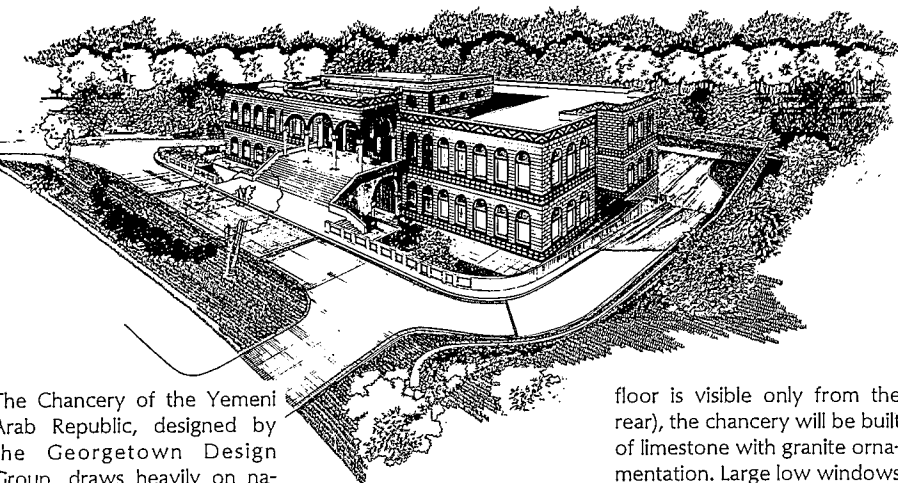
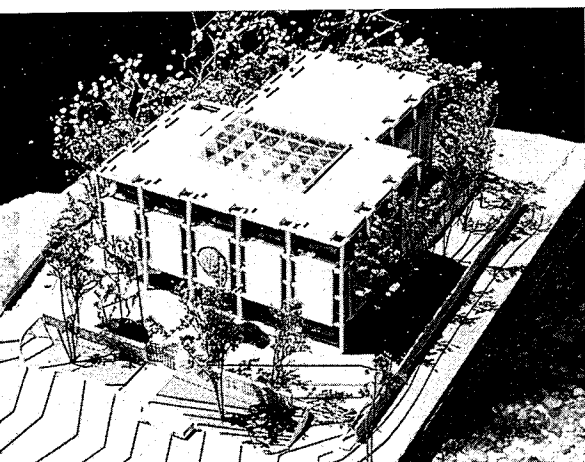

The Chancery of the Yemeni Arab Republic, designed by the Georgetown Design Group, draws heavily on national building tradition, perhaps because architect Mokhless Al-Harri observed on an exploratory trip that "in Ye-

men, every person has an incredible sense of Architecture." Located on a steeply sloped site (the lower service

The Chancery of Israel, designed by Cohen and Haft, Holtz Kerxton & Associates of Washington, will be built of brick and granite, materials indigenous to both Washington and the Mediterranean region. Windows, capped by large arches on the upper floors, have deep reveals. While the Israeli ambassador requested a modest office building for his own staff, the chancery must also accommodate social and cultural affairs. Offices and balconies behind masonry parapets will overlook a daylighted atrium.

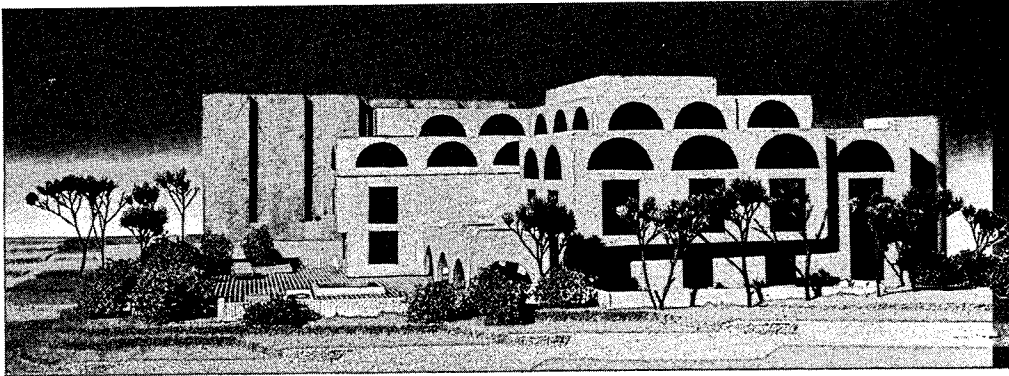

Ronald N. Anderson

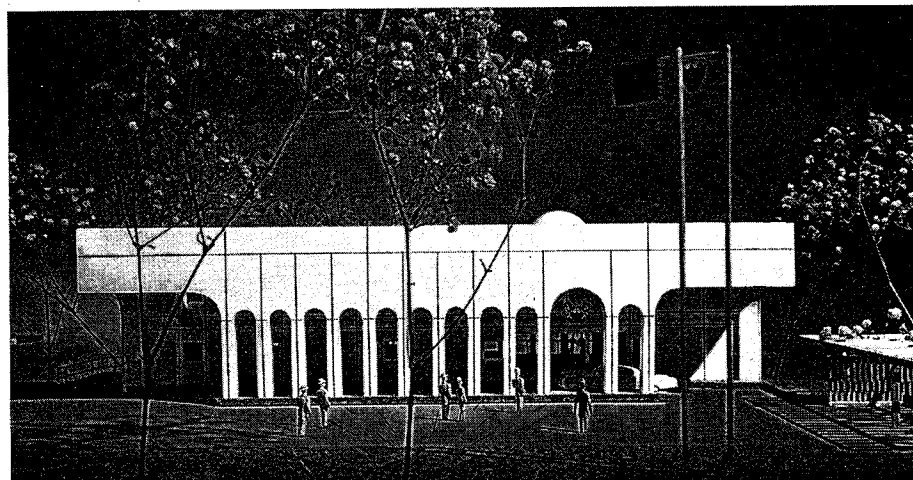

© Steve Rosenthal

The Chancery of Bahrain, designed by The Architects Collaborative, will occupy a half-acre site. The relatively small building will house 10 employees initially, double the number by 1990. The two-

story building will expand upward to its full height on the inside at the entry, a domed atrium with a fountain; reception space in the atrium can be opened to include the conference room and the dining

room in a sequence that culminates in an outdoor terrace. The front facade will be concealed behind an arcaded porte cochère, and employees will park their cars in a vine-covered pergola at one side.

The Chancery of Kuwait, designed by Skidmore, Owings & Merrill's New York office, will be, at 62,790 sq ft, a relatively large building at the center, but about two-thirds of it will lie below grade. The ground floor, which will have clear

glazing, will contain reception areas and information services, while the second floor, with slightly reflective glazing, will contain offices for cultural and military attachés. The project will also provide a small apartment for a resident engineer.

Jack Horner

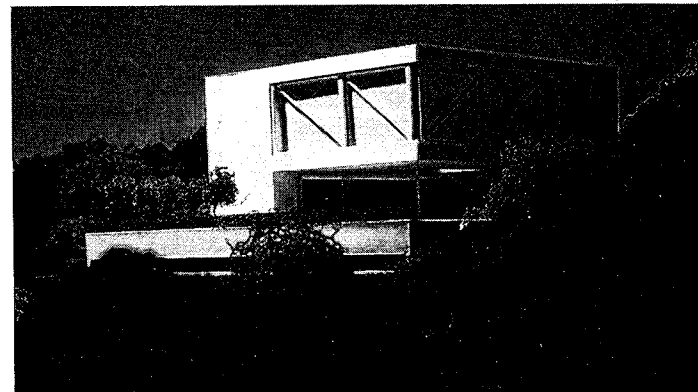

26 on inquiry card

Mr. Perkins is senior vice president and general manager of Perkins & Will.

architecture new responses are evolving to answer the challenges raised by the current problems. The business school translation of

will prosper, it will be a difficult period to start a new firm or mold a young firm into a major leader. As noted above, most of the

When you order an open office ceiling

THE CORRIDOR SOLUTION

We couldn't help but notice that most corridors are 8 feet wide. So we make our beautiful Flor-Ever[®] sheet vinyl flooring 9 feet wide. And look-no seams!



THE ALTERNATIVES

Any way you look at it, the 6' alternative to our 9' commercial vinyl produces unnecessary seams.

The Congoleum[®] corridor solution saves installation time and money, too. Furthermore, maintenance is minimal. Our

commercial grade Congoleum sheet vinyl has a tough, non-porous wear-layer that usually needs nothing but damp mopping or buffing to keep it looking new for years.

The real workhorse of our commercial line is called *Flor-Ever* which is engineered for durability at an extremely competitive price, making it the best value on the market. Also, *Flor-Ever* is styled and colored to meet your design needs.

In addition to our efficient 9' designs, all Congoleum commercial vinyl comes in 12' widths, too. So for every corridor or floor you specify, you'll find we have a beautiful solution.

For further information, call a Congoleum flooring contractor, Sweet's Toll-Free Buy Line (800) 447-1980, or write Contract Sales Mgr., Congoleum Corp., 195 Belgrove Drive, Kearny, NJ 07032.

Congoleum

THE COMPANY OF FIRSTS

First printed felt based flooring 1906 • First inlaid vinyl sheet flooring 1948 • First 12' rotogravure vinyl flooring 1957 • First chemical embossing 1963 • First family of no-wax floors 1968 • First 15' vinyl flooring 1974 • First Chromabond system 1978 •

Circle 38 on inquiry card

trends in the award of the types of projects that build large reputations and/or large offices will be against the small or new firms. Unless the established firms commit organizational suicide during the changing of the guard as the founders retire, or by bad management, new firms will not have the great opportunities created by the elimination of the establishment in the 1930s, or expansionist market of the fifties and sixties.

To achieve balance, the status of specialists—particularly the increasingly rare people who know how to really plan or detail a complex building—will finally move toward parity with designers, salesmen and the other traditional stars.

The search for good people combined with government pressures, growing numbers, and the rapidly crumbling barriers of prejudice will see more women and minorities in senior positions within the profession. In spite of government support, however, minority-owned firms will not have an easy decade unless they can compete on even terms. In a decade of intense competition, they will be hampered by the same trends that will affect all less-established offices.

Many more architectural school graduates will look outside the profession for work

The architectural schools will continue to produce more architects than the profession can absorb. This oversupply, combined with the broader career interests of many architects and an increased interest by public and private employers in architects' technical knowledge, will spur a further expansion of architectural employment in banking, government, and many other fields.

It is probably too optimistic to predict that many firms will move away from the extremely hierarchical, one-star organization structures common today. However, some of the more successful firms in the next ten years will follow the leading firms in other professions' ability to accommodate several leaders (and their egos) in a single firm.

The shift from the founding entrepreneurs to a second generation will have the same impact as it has in other industries. The second generation is likely to be more conservative, more management oriented, and more likely to accept more horizontal organizational structures. Unfortunately, it is unlikely that many of them will be hospitable environments for most of the personalities that still are the design leaders and innovators in the profession. The firms that do find a way to accommodate the yeast of these leaders in the dough of a strong organizational structure will undoubtedly emerge as the decade's leaders.

Pressures for specialization and performance will fuel the continuing growth of the various new professionals that have invaded the traditional turf of the architect. Some of them—construction managers, project management consultants, and the professional staff brought on by owners, in particular—will fill the void left by architecture's failure to respond adequately to client's demands for effective management at a time when proj-

ects are becoming increasingly difficult to manage. There is a sharp rise in respect for management in architectural practice and education, but it is too early to tell whether the profession or even many of its members will forcefully re-assert a traditional claim to primacy as leaders of the building team. The opportunity is there because someone must assume the generalist management role created by the need to orchestrate all the new specialists.

Interior design, energy, and historic preservation offer practice potential

In at least one area, however, the architectural profession is showing some signs of reasserting its leadership: interior design. Many architects have finally come to terms with the fact that this is a separate set of skills. They also are finding these skills learnable as well as important for a successful design practice.

There will, of course, be many new markets in the next decade. Some of today's concern's—energy, historic preservation, life-cycle cost analysis, environmental planning, etc.—are still up for grabs, but architects seem to be staking claims on at least a part of these markets. Still other issues, such as the new, less-auto-dependent lifestyles, changes in growth caused by water shortages, etc., will emerge during the decade which, if recognized and responded to by the profession, will serve as major new sources of stimulation for architectural services.

An interesting common thread in many of the new areas of architectural involvement is the need for real research. Historic preservation analyses, housing maintenance studies, energy analyses, analyses of the relationship between capital and operating costs, and the question of far more inquisitive clients are just some of the rapidly expanding areas requiring a legitimate research effort. To date, architectural design theory has been almost unscathed by scientific or any other form of rigorous analysis. In the next decade, the profession should see the fruits of the first large-scale combination of individuals interested in research issues and clients willing to pay for it. The results should begin to affect design as well.

Possibly, the international market is the only one that will continue to resemble the 1960s. There is a strong respect for American design services and the decline of the dollar has even made U.S. firms cost-competitive. This will be one of the few, large markets where master plans, entire new cities, universities, and monumental design will continue to be in vogue. As noted earlier, fewer firms may be operating internationally than during the last recession and post OPEC gold rush. Nevertheless, it is now, and will probably continue to be, an essential source of many firms' work.

The greater involvement of government and public interest groups will be another major factor in the emerging markets. Planning—in the sense of campus, new town or urban renewal master plans—is in disrepute and is not likely to re-emerge as a major service area. Planning with more achievable

ends in mind and planning to assist a project through the increasingly complex approval processes will be a major service area for architects if they equip themselves for it.

In an era of profit squeezes, financial management will be more sophisticated

But the most troublesome consequence of all the trends noted at the beginning of this article, is the fact that it will be a very difficult period in which to make money. It has never been easy and during the recent recession it was almost impossible, but there is no respite in sight. Fees will be increasingly competitive while business development, insurance, salary, rents and other expenses rise. This narrowing of the margin will be complicated still further by the even more erratic swings in workload. This will make balancing of volume and expenses—the key to profit management—very difficult. One consequence of these pressures on profitability will be greater conservation and sophistication in firms' financial management. At the same time, though, there will be creative responses which find virtue in necessity. Long-term joint ventures will emerge instead of new departments or offices as a low-cost way to respond to new markets or obtain staff for peak periods.

Computers as architectural design aids are still a long way off as a major force, but word processing and other tools will be employed to increase productivity. There will be less reinventing of the wheel and more repetitive detailing.

Other firms will ignore the many disasters of the early seventies and move into the two areas where significant profits still exist for the lucky and the skillful: design/build and development. Some of the current trends are working in the architect's favor in this regard. More conservative banking, more difficult access to risk capital, and a growing awareness of the value of good design in both sales and the approval process make it good business for developers to invite architects in as partners. Due to the lack of good general contractors or developers, other architects are taking the lead in smaller projects. Financing is too conservative these days, however, to expect to see many new entrepreneurs like John Portman.

Over-all, the area for greatest optimism is design. The many pressures on the practice of architecture will undoubtedly place greater emphasis on functionalism, renovation vs. new, budget, operating costs, and conservative detailing. These forces probably will not be a straitjacket. Their effect, combined with the general relaxing of modernist dogma, should result in more emphasis on creative and diverse efforts to humanize the built environment. The architecture of the eighties should be more fun to be in than the results of the other post-war decades. One of the more hopeful notes in this series of predictions is that in the coming decade design creativity will be the major way of differentiating among firms who have been forced by other factors to minimize their management and technical differences.



All-Steel 8000 Series Systems Furniture: **New freedom of choice for your office plan.**

Consider the possibilities inherent in the 8000 Series. At one extreme, it is a complete system of integrated, modular components which can be combined to create the total office plan.

At the other extreme, 8000 Series components can be introduced into any existing office piece-by-piece, over an extended period of time. The transition will be smooth because Series 8000 components are compatible with conventional free-standing furniture.

As growth, change, or relocation require, Series 8000 com-

ponents can be rearranged quickly and easily to meet new needs.

To learn how smoothly our 8000 Series Systems furniture can meet the present and future needs of your clients, write All-Steel Inc., Aurora, IL 60507.



ALL-STEEL
ONE OF THE **GTI** COMPANIES

Showrooms in:

New York: 212/752-2610
Aurora: 312/859-2600
Chicago: 312/321-9220
Los Angeles: 213/659-2000

In Canada:
All-Steel Canada Ltd.
Montreal, Toronto

Circle 39 on inquiry card

Life cycle costing: increasingly popular route to design value

In this era of rapidly rising prices for materials, escalating labor wages caught by inflation, increasing energy costs and Congressional and Presidential scrutiny of new construction and major repairs and alterations, owners are seeking every avenue to improve value and conserve resources. The Building Owners and Managers Association (BOMA) in Chicago collects and shares its experience each year concerning the costs of owning and operating commercial office buildings. **Figure 1** graphically displays what has happened to these costs in the past few years. To combat these trends, the technique of life cycle costing has been promoted by both owners and designers to satisfy the requirement for further design analysis. This first installment of a two-part article introduces the concept of life cycle costing as it is currently practiced in the architectural and engineering firm of Smith, Hinchman & Grylls Associates, Inc. The material stems from the author's efforts as co-author with Alphonse Dell'Isola of a forthcoming McGraw-Hill book, "Life Cycle Costing for Design Professionals." The material will also be presented in 1980 around the country in a series of workshops sponsored by the American Consulting Engineers Council and the American Institute of Architects.

by Stephen J. Kirk, AIA, CVS

Life cycle costing can be defined as "An economic assessment of competing design alternatives, considering all significant costs of ownership over the economic life of each alternative, expressed in equivalent dollars." The subject was summarized in 1972 by Robert Blake, speaking for the U.S. Department of Health, Education and Welfare, who referenced life cycle analysis as the systematic consideration of "... Cost, time and quality." Life cycle costing most certainly addresses these as well as other issues related to decision processes, analytic methods, data bases, component performance, etc.

Federal, state and industrial clients each has initiated directives to the designers of their facilities. The President has established a goal to reduce energy consumption by 45 per cent for all Federally-owned new buildings over their prior 1975 counterparts. The state of Nebraska has recently passed legislation requiring a life cycle cost analysis to be performed on every state facility that has a project cost in excess of \$50,000. Nebraska is not alone. The states of Alaska, Florida, Massachusetts, Maryland, Kansas, Wyoming, Colorado, Illinois, Idaho, Hawaii, Iowa, Louisiana, Nevada, New Jersey, North Carolina, North Dakota, Oklahoma, Pennsylvania, Texas, Washington, and Wisconsin, among others, either have legislation or it is pending. The General Services Administration has developed elaborate procedures for predicting a facility's total cost. The cities of Atlanta, Phoenix, and Chicago also require a life cycle analysis from their designers.

Stephen J. Kirk is a project manager and as associate in the Value Management Division of Smith, Hinchman & Grylls Associates in Washington, D.C.

Life cycle costing can provide a 10-to-1 return on investment

Why are so many owners interested in LCC? Fifteen years' experience at Smith, Hinchman & Grylls has shown that active application of life cycle costing can provide owners with a return on investment (ROI) in excess of 10 to 1 depending on decisions made during concept/schematic/design development phases of a project. Life cycle costing methodology may be applied at any point in the design process from early feasibility planning through construction and occupancy. As with any heuristic approach however, its greatest potential in the design process is in the "early stage" decisions. These may include: facility versus other economic investment; new facility versus retrofit existing structure; high-rise versus low-rise construction; active/passive solar energy versus conventional hvac; structural framing versus design modules; design layouts versus staffing efficiencies; spacial flexibility versus interior partitioning; natural lighting versus artificial means; native landscaping versus conventional landscaping; fire sprinkler systems versus insurance premiums; fixed partitions versus demountable partitions (tax credits); interstitial space versus floor-to-floor height; insulation and glazing versus energy requirements; fenestration & shading versus lighting requirements.

As the project becomes more defined, the number of potential study areas becomes more complex. Each system (mechanical, electrical, structural, etc.) must be selected with regard to each of the other systems being selected. It thus becomes an interactive process not unfamiliar to the architect. Once the designer has estimated the economic

consequences of these various courses of action, he will be in a position to better assess the over-all effect of those combinations of systems.

From a design standpoint, a substantial gap exists today in the government's and industry's ability to apply LCC analysis techniques during early design because of the lack of an appropriate costing framework. Uniform Construction Index (UCI) sixteen division cost accounting is sufficient at the construction documents phase because it is trade- or construction-oriented and can be compared with contractors' bid figures. However, this organization is directed to products and materials and as such it does not relate well to the "functional" aspects of a facility, i.e., space enclosure, and environmental control. For some years, those involved with construction cost control problems during design have developed systems based on an elemental form of cost analysis and estimating. This approach involves the separation of building components or functional parts, elements, and subsystems.

The Uniform Building Component Format (UNIFORMAT) is one such development of the General Services Administration. It is

Figure 1

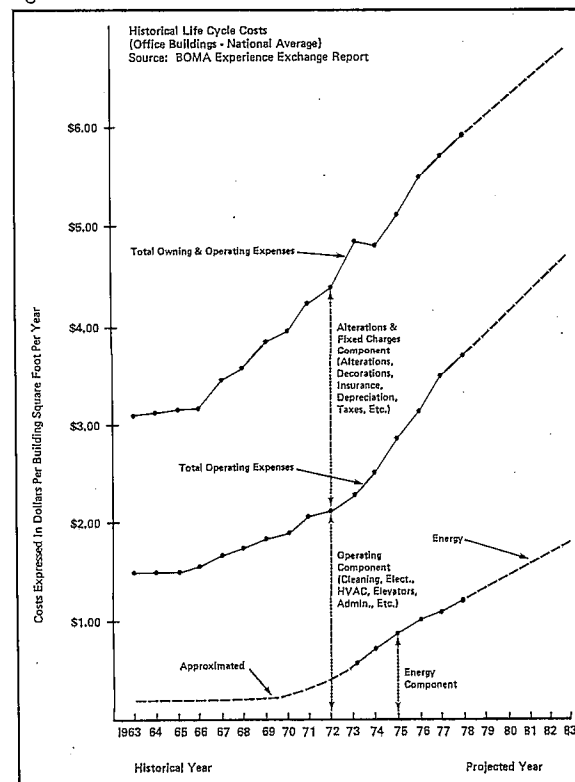

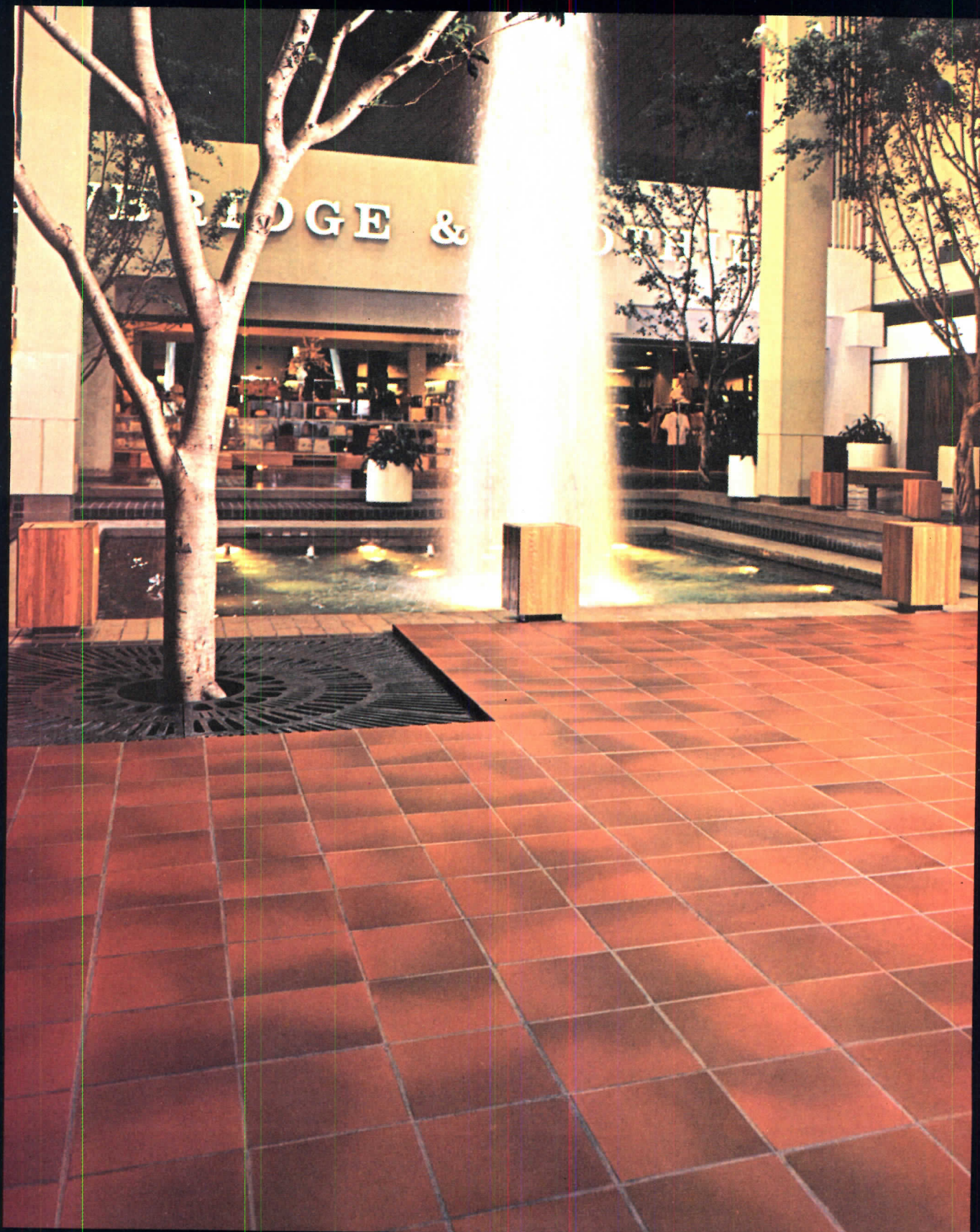

Imber Hash - Plate No. 689

The floor? It's American Olean Quarry Tile, naturally.



A National Gypsum Company

2647 Cannon Avenue, Lansdale, Pa. 19446

Circle 40 on inquiry card

LYON doesn't box you in on lockers. We mix or match to suit your needs.



Your Lyon Dealer adds the touch of a storage architect—helping you select the sizes and types of Lyon lockers to meet your needs exactly.

Choose from single tier lockers for full length storage... two person or duplex models where space is limited... box lockers for smaller items... see-through lockers of expanded metal for maximum ventilation.

In fact, Lyon has a handsome free-standing, built-in or combination locker *system* to meet every storage requirement. Colors by Lyon is the frosting on the cake for color contrast, accent or harmony with your environment. And you can count on durability and security—over 75 years of Lyon experience assure it.

LYON® *the STORAGE ARCHITECTS*

LYON METAL PRODUCTS, INCORPORATED General Offices: Aurora, Illinois 60507

Circle 42 on inquiry card

Mail the coupon (or circle Reader Service Number) for your copy of our booklet, "The Touch of a Storage Architect," plus a comprehensive product catalog. Or call your Lyon Dealer. He's in the Yellow Pages under LOCKERS. Dealers and branches in all principal cities.

Cut yourself in!

Lyon Metal Products, Inc.
1271 Monroe Avenue, Aurora, IL 60507



Please rush new booklet "The Touch of a Storage Architect" and catalog covering steel shelving, lockers, shop equipment and office products. No obligation, naturally.

Name _____ Title _____

Company _____

Address _____

City _____ State _____ Zip _____

Telephone _____

payments at 10 per cent yearly interest) rather than pay \$50,000, one time, today. For both the present worth and the annualized methods, the life cycle cost is the sum of the initial, recurring and non-recurring costs (all expressed in equivalent dollars).

Old-fashioned brainstorming is the first step toward the best proposal

Once the areas of study have been identified and study teams have been assigned, creative effort is directed toward alternative means to accomplish the necessary functions. The creative approach is an idea-producing process intended specifically to generate a number of solutions, anyone of which will solve the problem at hand. All solutions will work, but one is better than the others.

Brainstorming is a free-wheeling type of creativity, usually done on a group basis. This is the process utilized most often in a life cycle alternative generating session. A typical brainstorming session consists of a group of three to five people spontaneously producing ideas designed to solve a specific problem. During this period, no attempt whatsoever is made to judge or evaluate ideas. The greater the number of ideas, the more the likelihood of success. In addition, combinations of previous ideas and suggestions of improvement are sought. Brainstorming however, does not always give ideas ready for immediate implementation. What is obtained, is a sufficient number of ideas which then can be narrowed, combined and modified through the evaluation process to arrive at a "better" final solution.

An initial evaluation usually takes place to screen the number of ideas based on the following criteria: 1) Will the idea work? Can it be modified or combined with another? 2) What is the life cycle cost savings potential? 3) What are the chances for implementation? 4) Will it satisfy all of the user's needs?

Listing the advantages and disadvantages of each idea also helps to objectively judge and initially screen the most promising for the life cycle cost comparisons. No idea is discarded until it receives a preliminary evaluation. The alternatives that survive are developed further to obtain more detailed cost estimates from sketches, etc. The most promising alternatives are then listed on life cycle costing forms similar to Figure 4, along with the "original" situation. The general purpose form may be used for any number of life cycle cost study areas. Costs are clustered by LCC categories; i.e. initial, operation (energy), maintenance, replacement/alterations, tax elements, associated and salvage. The original and up to three alternates can be compared on a single sheet. Columns under each alternative are set aside to document estimated costs and to convert those estimations (using engineering economics) into present worth. The total present worth costs are summarized at the bottom of the figure. These sheets may also be used as presentation documents to the client illustrating the depth of the analysis.

The chart below shows how alternatives for daylighting are compared for life cycle impact. Columns under each alternative are set aside to document estimated costs and to convert those estimations into present worth. The total present worth costs are summarized at the bottom of the chart. These sheets can be used to show clients the depth of the analysis.

Life Cycle Costing Estimate		Original Describe: Two 4'-0" Windows, Reflective Louvers and Coffered Ceiling Fixed Sash		Alternative 1 Describe: Coffered Ceiling w/One 6'-0" Window Fixed Sash		Alternative 2 Describe: Two 4'-0" High Windows, No Reflective Louvers, Fixed Sash		Alternative 3 Describe: Recessed Single Sloped 4'-0" Windows Fixed Sash				
General Purpose Work Sheet		Estimated Costs	Present Worth	Estimated Costs	Present Worth	Estimated Costs	Present Worth	Estimated Costs	Present Worth			
Study Title: Day-Lighting Schemes												
High Pressure Sodium* Fixtures - Switched 1/2 Bay												
Discount Rate: 10% Economic Life: 40 Years												
*New (w) Lamp 250W H S 7500 HRS/Life												
Initial Costs	A. Alum. & Glass Curtain Wall - N&E Elev.	\$22.00/SF	800,800	\$19.50/SF	691,580	\$22.00/SF	800,800	\$22.00/SF	800,800			
	B. Venetian Blinds, Vertical, Reflective Backing	\$10.76/SF	16,000	\$10.76/SF	12,000	\$10.76/SF	16,000	\$10.76/SF	8,000			
	C. Parabolic Reflective Louvers, 4' High, E. Elev.	\$50.00/LF	60,000									
	D. Baseboard Convactor HVAC Syst. (Differentials)	\$25.00/LF	60,000		0	\$25.00/LF	60,000		0			
	E. Reflective Surface - Alzak 24 Ga. & Furring	\$3.00/SF	18,000									
	F. Layin Ceiling System (22 1/2 LF)							\$1.04/SF	49,550			
	G. Acoustical Tile on Furring	\$1.31/SF	67,746	\$1.31/SF	59,000	\$1.31/SF	67,746					
	H. Ceiling Furring - 5/8" GYP. & Paint (30,000 SF)	\$1.84/SF	36,000			\$1.70/SF	36,000	\$1.80/SF	15,120			
	I. H.P. Sodium Fixtures-Switched, Distribution, Controls		354,040		354,040		354,040		354,040			
	J. Contingencies .5%		1415286		1114620		1337586		1222510			
	K. Escalation .5%		79,779		55,831		66,879		61,126			
	Total Initial Cost		1,557,144		1,228,282		1,474,374		1,349,762			
	Operations (Annual) Energy	A. High Pressure Sodium-	Diff. Escal. Rate PWA W/Escal.	0% 9.779	7,032	60,766	7.695	75,249	6.833	162,820	8,889	86,926
		B. HVAC, Space Cooling	0% 9.779	13,589	132,887	11,000	107,569	13,589	132,887	11,000	107,569	
		C. High Pressure Sodium (Remaining Area)	0% 9.779	14,742	144,162	13,742	143,162	14,742	143,162	14,742	144,162	
D.												
E.												
F.												
Total Annual Operations Costs				345,815		326,980		465,741		338,657		
Maintenance (Annual)		A. Alum. Panel-Clean (\$.09/SF/Yr)	Diff. Escal. Rate PWA W/Escal.	0% 9.779	1,400	13,692	1,750	17,115	1,400	13,692	2,800	27,384
		B. Window - Washing (\$17 /SF/YR)	0% 9.779	3,543	34,150	2,657	25,985	3,543	34,150	1,712	14,324	
		C. Parabolic Louver (\$.25/SF/YR)	0% 9.779	1,200	11,735							
		D. Baseboard HVAC (\$.32/LF/YR)	0% 9.779	806	7,885			806	7,885			
		E. Reflective Surface (\$.25/SF/YR)	0% 9.779	1,500	14,669							
		F. Venetian Blinds (\$.20/SF/YR)	0% 9.779	3,200	31,293	2,700	23,170	3,200	31,293	1,600	15,676	
		G. H.P. Sodium Fixt. (6.00/Fixt./Yr)	0% 9.779	12,822	125,386	12,822	125,386	12,822	125,386	12,822	125,386	
		Total Annual Maintenance Costs			239,310		191,956		212,906		185,740	
Replacement/Alterations (Single Expenditure)	A. Parabolic Reflective Louvers	Year PW Factor	10 .386	60,000	23,160							
	B. Parabolic Reflective Louvers	20 .149	60,000	8,240								
	C. Parabolic Reflective Louvers	30 .057	60,000	3,420								
	D. Venetian Blinds	10 .386	16,000	6,176	12,000	4,632	16,000	6,176	8,000	3,088		
	E. Venetian Blinds	20 .149	16,000	2,384	12,000	1,788	16,000	2,384	8,000	1,192		
	F. Venetian Blinds	30 .057	16,000	918	12,000	489	16,000	918	8,000	456		
	G. Baseboard Convactor HVAC	20 .149	20,000	2,980			20,000	2,980				
	H. High Pressure Sodium Fixture	20 .149	354,040	52,752	354,040	52,752	354,040	52,752	354,040	52,752		
	I.											
	J.											
	Total Replacement/Alteration Costs			109,124		59,856		65,204		59,488		
	Tax Elements 10% Investment Tax Credit (Single Expenditure)	A. Parabolic Reflective Louvers	Diff. Escal. Rate PWA W/Escal.	1 .909	(6,000)	(5,454)						
		B. Reflective Surface	1 .909	(1,800)	(1,636)							
		C. High Pressure Sodium-										
		D. Depreciation over 7 Yrs.			(22,457)		(22,457)		(22,457)		(22,457)	
E.												
F.												
G.												
Total Tax Elements			(29,917)		(22,457)		(22,457)		(22,457)			
Associated (Annual)	A. Denial of Use (Space) Loss (\$10.00/SF/YR x 7560 SF)	Diff. Escal. Rate PWA W/Escal.	0% 9.779						75,600	739,500		
	B.											
	C.											
	Total Annual Associated Costs									739,500		
Total Owning Present Worth Costs												
Salvage	Salvage At End Of Economic Life (Struc. Arch. Mech. Elec. Equip.)	Year PW Factor	40 .022	(41,555)	(3,114)	(111,622)	(2,456)	(132,759)	(2,502)	(122,511)	(2,689)	
	Sitework											
	Total Salvage				(3,114)		(2,456)		(2,502)		(2,689)	
LCC	Total Present Worth Life Cycle Costs			2,210,332		1,782,164		2,068,364		2,640,801		
	Life-Cycle Present Worth Dollar Savings					428,171		141,968		(430,469)		

PW - Present Worth PWA - Present Worth Of Annuity

Figure 4

In next month's conclusion to this two-part article, Mr. Kirk will explain the technique of life cycle costing.

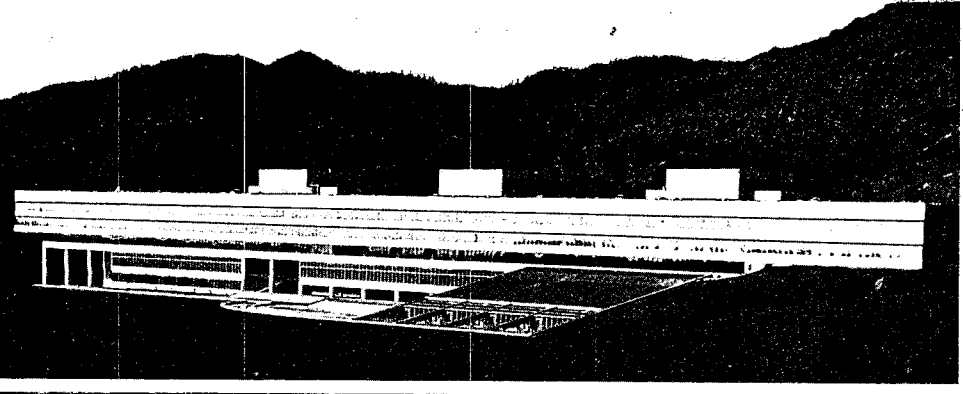

Designed by The Architects Collaborative, Cambridge, Mass.

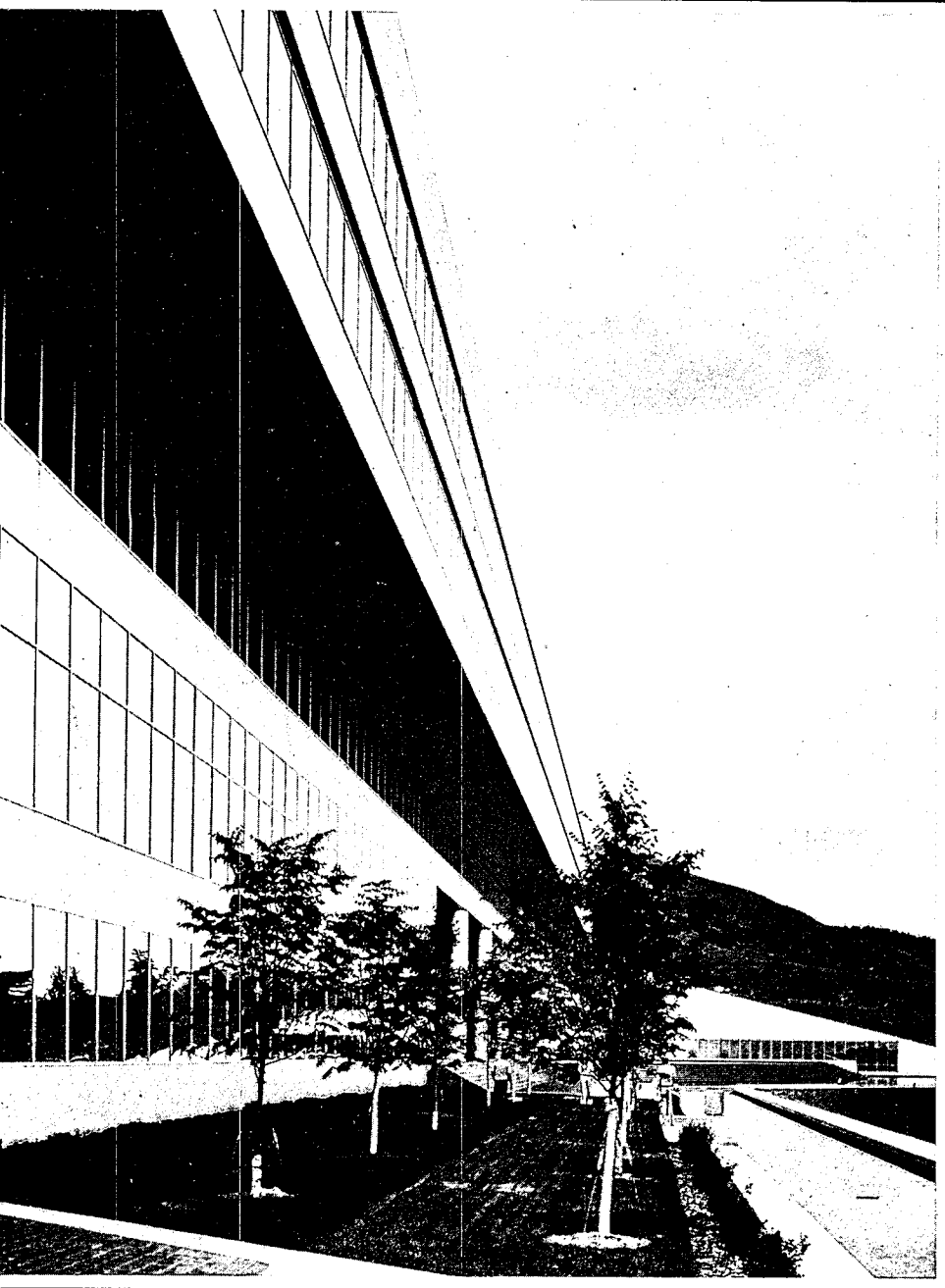

This is the Johns-Manville World Headquarters near Denver, Colorado. It is one of the most impressive buildings in the country.

Over 2500 insulating glass units are used to conserve energy. And every unit is manufactured with sealant based on LP[®] polysulfide polymer.

We rest our case.

Specifying insulating glass for a project is not a responsibility to be taken lightly, especially when the building is as prestigious as the Johns-Manville World Headquarters. Past performance is often the criterion.

Past performance is, in fact, the reason why more than 80% of the insulating glass manufacturers rely on sealants based on LP polysulfide polymer to produce high quality insulating glass units for commercial, industrial and residential buildings.

Polysulfide polymers have been serving the building industry for over 30 years, not only as the base for insulating glass sealants but for building sealants as well.

Not many materials have such a track record. We're proud of it; we hope you'll keep it in mind when specifying insulating glass units and building sealants for your next project.

For complete information on LP polysulfide polymers and the many prestigious buildings where they have been used write to Thiokol/SPECIALTY CHEMICALS DIVISION, Marketing Communications, P.O. Box 8296, Trenton, N.J. 08650.

***Thiokol* / SPECIALTY
CHEMICALS DIVISION**

P.O. Box 8296, Trenton, N.J. 08650

polysulfide polymers and rubbers • plasticizers • epoxy modifiers and curing agents
urethane oligomers • acrylic monomers

Circle 43 on inquiry card

Architecture and law in the 1980s

The past quarter century has been a period of significant developments in the relationship between architecture and the law. From the architect's viewpoint, much of what transpired has seemed revolutionary. Most changes, in fact, were not dramatic, but they affected the practice of architecture nonetheless. Developments in the courts and arbitration, in insurance, in legislation (Federal, state and local), in professional ethics and rules of conduct, and in professional education will have affected the law and its implications for architecture. The 1980s will see a continuation of change, with architects becoming increasingly aware of their status within the legal system. To close out the year and the decade, *Legal Perspectives* takes a look at how the law and architecture have changed and offers some thoughts on what to expect in the future.

by Arthur T. Kornblut, Esq.

The legal aspects of architecture continue to change in many diverse ways: new statutes will be enacted, while existing ones will be challenged; more government regulation will influence the design process; traditional concepts of professional liability will continue to be tested by aggressive plaintiffs' attorneys; more lawyers will acquire skills to better represent design professionals. These continuing changes will both enhance the practice of architecture and challenge architects to improve their own skills as design professionals.

Legislative activity: points for architects

Prior to the Second World War, each state's licensing law was the only piece of major legislation directly related to architects. In recent years, however, design professionals have turned increasingly to the legislative process to deal with problems that affect their professional lives. In order to protect their right to payment for services, some states have enacted laws to give architects mechanic's liens on property involved with the professional services rendered.

More than 40 states have enacted special statutes of limitations to place reasonable time limits on when architects could be sued because of projects they designed. These laws were needed to overcome court decisions which applied a "discovery rule" to lawsuits and substantially lengthened the time of exposure to suit.

Other state-level legislation has tried to deal with the professional liability problem. California recently enacted a law to require

plaintiffs' attorneys to investigate allegations of professional negligence against architects before filing suit. Section 441.35 of Chap. 973 of the California Code now requires the attorney to file a certificate stating that another architect has been consulted to determine if reasonable cause exists for filing the action against the defendant architect.

At the Federal level, efforts have been underway in recent years to support legislation to alleviate claims from injured construction workers by mandating changes in state workers' compensation laws. Other proposals at the national level have involved changes to the tax laws to facilitate setting aside financial reserves to pay for professional liability claims. Each of these efforts represents major legislative activity, and this portends other such efforts in the future.

Regulatory impact: cause for vigilance

The 1970s saw a tremendous surge in Federal regulatory activity. Although not directed at building design, its impact became quickly obvious. While it is unlikely that the next decade will see a repeat in the level of Congressional action that brought forth OSHA, Consumer Product Safety laws, and environmental and other public interest legislation, the fallout from the seventies will continue unabated.

The Federal agencies established by each of the above laws will continue to issue regulations to consolidate and expand their spheres of authority. Similar laws can be anticipated at the state level to supplement and augment localized replicas of the Federal examples. If design professionals are to avoid having creativity stifled by government regulation, substantially more effort will be required to monitor such laws (before and after enactment) and the regulators who are charged with interpreting and enforcing them.

Professional liability: hinges on contracts

Professional liability—practically non-existent 25 years ago as a concern for architects—is a major topic today. Whether it's paying insurance premiums, defending against claims, attending continuing education seminars, or instituting internal quality control procedures, architects no longer view professional liability as somebody else's problem. There have been changes in the law—changes making the threat of a lawsuit a greater possibility today than it was ten or fifteen years ago.

Fortunately, however, the fundamental legal premise that an architect's liability must be predicated on a showing of professional negligence remains as well established today as it was 80 years ago. Plaintiffs' attorneys have been thwarted in their continuing efforts to impose standards of strict liability and implied warranties on architects. Although these attacks will continue, an increasing willingness to learn about and use improved professional service contracts and practice procedures is, and will continue to be, the profession's best defense.

Architect-lawyers: important new breed

In the 1960s, very few law school graduates had any architectural training. In 1970, I could identify less than five people in the entire United States who were both licensed as an architect and admitted to the practice of law. Today, there is a growing roster of professionals with these dual credentials. All signs point to a strong continuation of this trend. The importance of this in the over-all relationship between architecture and the law should not be overlooked.

Most dual professionals began their academic efforts in the field of architecture. In subsequent professional careers, whether as architects, lawyers, developers, government officials or otherwise, their concern for architecture remains apparent.

The future of architects and the law will continue to be one of increasing mutual involvement. In the 1950s and '60s, architects learned that a lack of awareness of the law would adversely affect their professional practices. In the 1970s, architects became better educated about the law—willingly through continuing education and lobbying efforts and unwillingly through liability suits. The 1980s could be a decade in which the awareness gained in the past years will be applied in practice to reaffirm the architect's leadership role in the construction process.

Mr. Kornblut is a registered architect and practicing attorney in Washington, D.C.

"Legal Perspectives" is published with the understanding that the publisher is not rendering legal services. If legal advice is required, the services of a competent professional should be sought.

big professional firms.

Currently in this country the more conservative architecture schools are still basking in the light of the Decade of the Diagonal—condominiums with shed roofs and trapezoidal branch banks—while some of the bigger firms are, even now, painting on supergraphics, which is perhaps appropriate since it was the basic dreariness of much of their work that supergraphics were best able to liven up quickly. In schools that fancy themselves somewhat more progressive, "Post" Modernism of both the gray and white persuasions now seems to hold fairly undisputed sway. Though many of the "New York Five" architects seem to have peaked, Michael Graves seems still on the wax. Here, though, Robert Venturi's work is seldom discussed seriously perhaps because, in spite of the famous slogans which precede it, it is in the end too complicated in meaning to be characterized very simply. In really avant-garde institutions there is much talk of Aldo Rossi, and other Europeans.

But almost everywhere, in what conventionally are regarded as both the sophisticated and the parochial schools, there are small but encouraging signs about fads (and more about just why they are encouraging anon). These are that students are beginning to regard perennial favorites on the architecture school lecture circuit with some of the asperity which plain townfolk used to reserve for visits from the snake-oil peddler. At one university lately, after a sophisticated lecture by one of the "Five," the first question from the floor—simply and honestly put, more so indeed than the answer—was "Why are all of your buildings white?" Fear not. All this will finally come out in the real-world wash. To say that it won't is downright silly.

Narrowness in doctrines

A problem with architectural doctrine, or in fact with almost any kind of doctrine, is that, though it may be powerfully effective, its content too often seems embarrassingly limited. From a late-twentieth-century vantage, *Vers une architecture* seems about as quaintly narrow-minded as Downing's *The Architecture of Country Houses*.

Every cause deserves a polemic, and doctrines are the polemics. A perfidious result is that the polemic can become the cause, justifying while at the same time inaccurately describing it, as in Banana Republics of yore, where the cry "*Arriba el pueblo!*" ("Power to the people!") became the motto for the most reprehensible dictatorships.

Why must doctrines—political, architectural, and otherwise—oversimplify and indeed lie outright? A common and obvious explanation is that causes themselves (like "human rights") are in reality too knotty, too problematical, to be understood clearly and in unison by a mass of people without a slogan that suggests their implementation (like "Vote for Carter").

But perhaps this is not in the end the real explanation. The real reason people need polemics is maybe not so much that they cannot understand complex causes as that they in fact simply do not want to understand them. People, it seems, feel more comfortable with a slogan, and they apparently need the sometimes illusory reassurance that one can bring. "I am not the Messiah," says Brian in Monty Python's latest flimsy spoof. "I have no answers; you must find the answers; you are individuals." "We are individuals," the multitude respond with one voice.

Meaning and doctrines

However simplified, doctrines do nonetheless convey meaning. Andrew Jackson Downing's did, so did Le Corbusier's, and so indeed do most of our very own.

But it must strike most casual observers of the architectural scene as remarkably frivolous that architects can spend countless hours debating the doctrinal subtleties of a particular building or energetically describing its taxonomy without ever bothering blithely



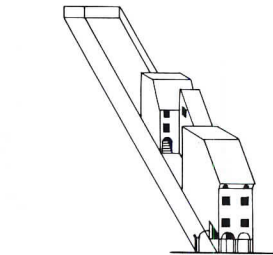
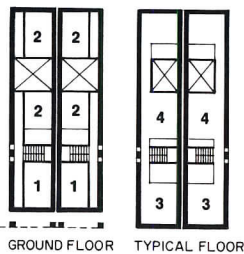
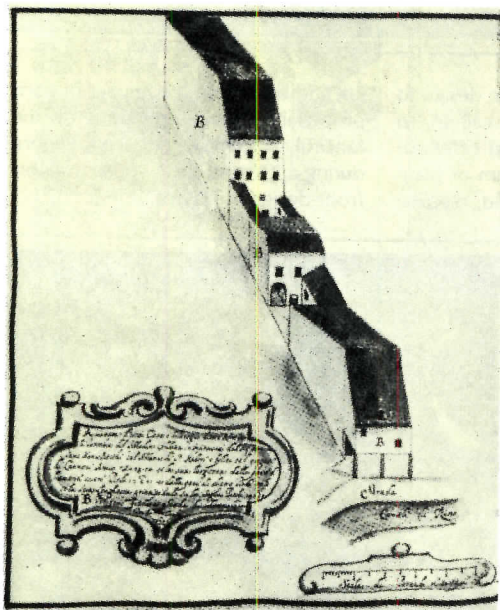
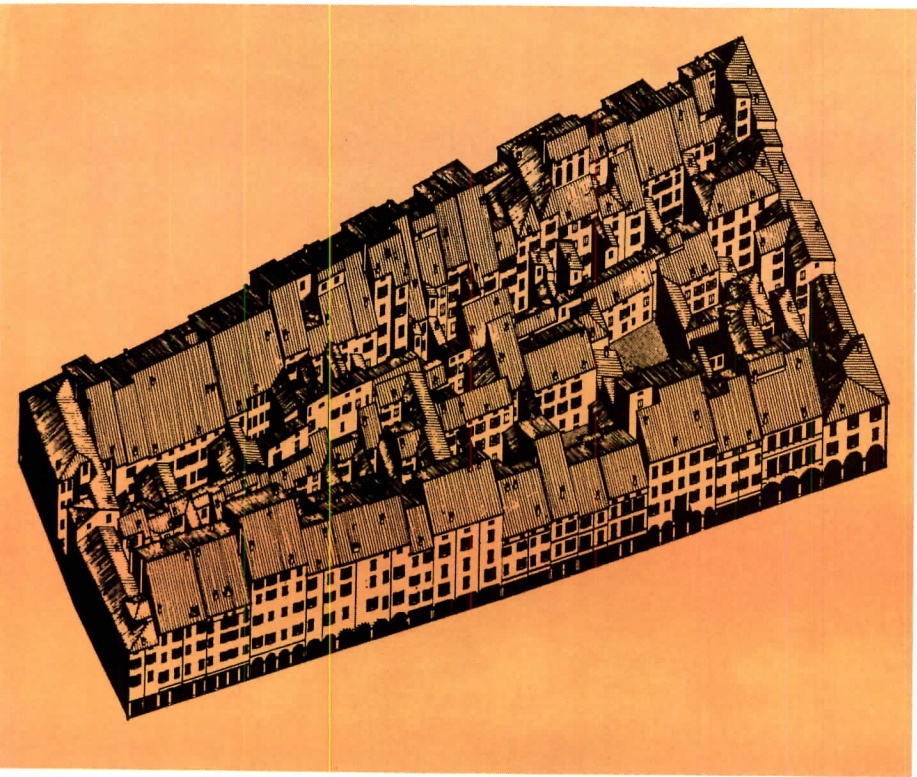

- 1 Commercial
- 2 Service
- 3 Small apartment
- 4 Standard apartment

Planning for Bologna's historic core starts with the assumption that its architectural delights are a common heritage and should benefit all the city's people. Each neighborhood is carefully surveyed and every building fully documented, then studied to match its restored form to an existing family or community need. New infill structures provide continuity to the traditional arcades and pastel walls of Bologna's medieval streets. Every neighborhood is planned as a complete urban unit containing workplaces, services, shops, as well as residences. Monumental buildings are systematically acquired for schools and other public uses.

Preservation without tears: Avoiding the social destruction caused by gentrification, Bologna, Italy will be conserved for the benefit of all

Bologna's historic core is among the largest collections of medieval and Renaissance buildings in Europe. It is the scene of the largest preservation effort anywhere. What is noteworthy is that Bologna is seeking to preserve far more than its architectural heritage. It plans to preserve a way of life.

Aware of the fate of most European and United States' cities, Bologna's progressive city government has managed to avert both demolition for speculative development and social destruction caused by gentrification. Acting just in time, a Master Plan for Bologna was drawn up in 1969 under the direction of

architect Pier Luigi Cervellati. It stressed:

1. Redevelopment in the core rather than growth at the periphery, to minimize transportation and infrastructural costs and to preserve the special quality of Bolognese life (Bologna contains the finest restaurants in Italy).
2. The need for careful historical analysis to classify culturally valuable buildings for future uses and to establish rules for restoration.
3. The strategic use of public housing funds for conservation and rehabilitation.
4. Adaptive reuse of nonresidential, historic buildings to provide comprehensive educational and social services in every neighborhood.
5. The importance of democratic participation in planning at every level.

The plan defines the city as a *bene publico*—a public good, something like our old-fashioned notion of a commonwealth,

created by all and intended for the benefit of all people.

The tools Bologna uses to implement these concepts are strict zoning, rent controls, advanced preservation regulations, and the clever use of national legislation. After the early sixties "opening to the left," the government in Rome passed two key planning bills. One established minimum standards of urban space for education and leisure. The second, foreseeing the need for eminent domain to satisfy these standards, set out a vague formula for compensating property owners.

Bologna took full advantage of these laws. The Council set the city's standards for public land at 688 square feet per person—nearly four times the minimum set by Rome. And it interpreted the second law so as to pay, not the market price, but the agricultural value of the land needed. Thus, 7,067 acres of land were recaptured from speculators.



Bruce Dale photos

The holdings of small property owners were not taken. But they were obliged to sign long-term agreements with the city, which limit rents and assure every tenant the right to stay. In return, the city offers grants and low-cost loans—and provides the architectural services which guarantee both sensitive restoration and functional rehabilitation. Large buildings of historic value are systematically acquired and converted for cultural, educational, and administrative purposes.

Throughout this extensive urban transformation the attention to architectural detail and traditional construction methods is extraordinary. But the status of a building as art is not more important in the decision to restore and adapt than its function, its role in the cityscape, its meaning in its context. In Cervellati's words, the historic city represents "the collective memory of the population." A better future requires an understanding of the past.

It also requires an active, involved citizenry. To encourage participation, power must be shared. In 1974, the city council adopted a new *Ordinamento del Quartiere*. It gave each neighborhood the right to elect local officials; to formulate its portion of the city budget; to make plans for physical and economic development; to control traffic; to grant—or withhold—building permits; to administer its education, health, and cultural institutions.

Direct democracy, self-governance, elimination of slums and speculation, popular demand for environmental quality—these are the hallmarks of the new Bologna.

In Bologna's historic core, young couples, workers, elderly pensioners—not architects and art directors—occupy carefully renovated houses. A colleague of Cervellati's sums up: "This is admittedly not the revolution, but it is revolutionary." And a lesson for American cities.



ARCHITECTURAL RECORD December 1979 105

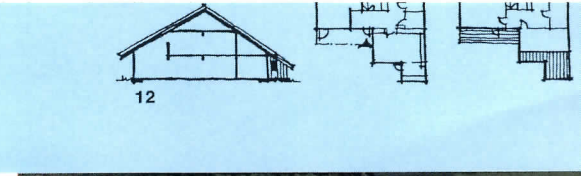
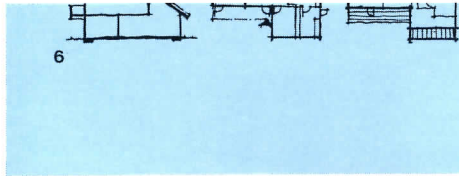

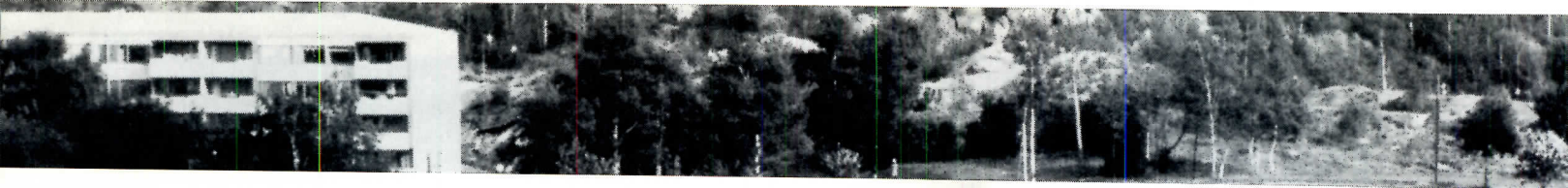

New perceptions of opportunity for cities

We've all been talking about the potential of revitalizing our cities for a long time. We've tried a lot of major and heavily subsidized "urban renewal" programs that promised wholesale solutions. But they didn't recognize the things that made cities vital in the first place: the great visual variety; the combination of old and new; the accidental excitement and the just plain urbanity that gives cities their character, differentiates cities from each other, and differentiates cities from "all-new" developments such as shopping malls and office parks. But as we enter the 1980s, it is possible to hope that a combination of forces—all of them pressing in on us right now—might in the 1980s create the conditions for actually getting done in our cities some of the things we should have been doing all along.

In a time of growing concern about the availability of resources and the inevitability of more constraints, our cities offer a great untapped reservoir of worthwhile and in-place buildings and facilities. This reservoir could be thought of as a hidden bank account—hidden by the grime of calculated neglect or consequent abandonment. It is part of the American concept of disposability that we have come to accept: cable cars whose cables have been allowed to rust; new utility and subway tunnels closed because of political or union disagreements, and (something RECORD has discussed all along) countless buildings passed by fashion or because 1960s' real estate arithmetic "proved" that they were in the way of moving ahead.

But these unclaimed resources are all there waiting to be used. And renovation of facilities is going to be a big and fast-growing area of the construction business when there is slowdown elsewhere. According to economist George Christie in his *Dodge/Sweet's 1980 Construction Outlook*, close to a quarter of the \$230 billion currently being spent on the construction of buildings is being spent on renovation. With a predictable forecast of continuing cyclical plateaus and dips in new construction and of a steady increase in renovation, the latter's share is obviously going to rise dramatically. The time for conservation is here—and the cities stand to gain by it in all those visual attributes that make cities vital.

To make cities cities, there have to be people, and especially people whose attitudes will foster the scenario of urbanity. Here, another resource shortage—of fuel—will help foster the return to cities. While the old gas-guzzling habits of rural and suburban areas are likely to persist until mass transportation can finally clean up its act (see page 120), they can easily be eliminated where facilities are only a walk—or even a bus or bicycle ride—away. Other incentives to draw people to the city will be backlash reactions: the rising costs of now-crowded suburban land, and the arrival of many of those once peculiarly urban problems, such as crime and deteriorating schools, to once pastoral areas. And the cities are going to look better to people because their much-discussed fiscal crises often turn out to be more sensational news than fact, according to a recently completed study by the First National Bank of Boston. Most of our cities *are* solvent.

But the real draw of new, more affluent residents toward cities will come from changing attitudes about lifestyles. With more and more childless and single-person households, there is a release from those family concerns that took residents to the suburbs and their "better" school systems in the last decades. These new households see the cities as providing outlets and nourishment for personal awareness and fulfillment. This urban migration of small households, of course, is already in effect, as illustrated by the current demand for decent living space at any price in most cities. And it is more than possible that the return in numbers of a strong, self-sufficient popu-

lace will provide the determination to not only make cities more urbane, but also solve some of the much-publicized social, political and financial adversities at the same time.

And so, the stage can be set in earnest. But, the directors—planners, architects and local government—still need to rethink priorities and win some arguments if conservation is to be a critical hit in the eyes of many lenders, developers, and owners. The script could well produce a happy three-way marriage of necessity, successful investment, and an enhanced quality of life. In RECORD, December 1974 (pages 106-109), planner Michael Seelig recommended a then-revolutionary reversal of the traditional planning scenario in order to achieve a more humane environment: a consideration of existing assets, including character and structures, as a basis for future development—instead of hindrances to be worked around later. He argued that people are not so much against growth as they are against removal of all that is familiar. What seemed like a civilized idea five years ago, now becomes the only script that makes sense. Putting first things first becomes the way of cashing in the badly needed "hidden bank account" of built resources *and* a growing source of strong emotional appeal, growing in the ratings as a source of both intellectual and commercial vitality. Architecturally, the way seems open to a rich mix of buildings and spaces from varied periods (including today) that would give a tangible sense of city qualities: excitement, individual character, and comforting continuity.

Important to conservation, there has to be vitality all over the stage, instead of under one small spotlight on a central core where all of the actors are jammed together.

If the producers and backers of our "new" cities ignore the authors' delicate scripts (as they have done in the past), they could produce another short-run thriller, in which the goodies and badies battle over a few preservation niceties in the fashionable city center—while the potential for diversified development in the rest of the city is ignored. We have seen this play before. Indeed, the pattern of fashion—encouraged by conventional city planning and traditional development—has been to lump all new projects into one central location while the rest of the city continued to doze and deteriorate. The possibility of dispersing new projects throughout—hopefully at a compatible (not high-rise) scale that would fit the context of the existing buildings and neighborhoods—just never seemed to take hold. In the compact core areas—with inevitably high land costs—developers have been justified in building as massively and as densely as they could get the financing and approvals to do. But the unfortunate effect is that—while, again, the rest of the city loses vitality—the core undergoing the change is invariably just that area which, because of the attentions of previous fashion, already had the most

Urban vitality strongly depends on visual variety (here, a sampling of some older types that make various points). True urbanity depends on fitting this variety together comfortably—or even elegantly as in the bottom photo. While the appreciation of landmarks and even buildings of lesser quality grows, there is still a problem maintaining urban characters. For instance, American corporations generally decline the quiet sort of re-use that Europeans take for granted (photo below: the Cado headquarters in Copenhagen, remodeled from a 1910 student league by architects Raaschou-Nielson). While

Mandelmann

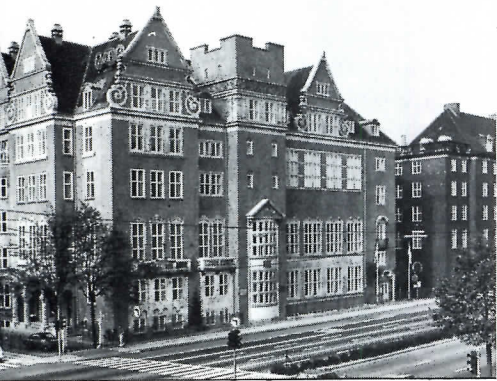

such "corporate image" problems may block many useful re-uses, there is better news for conservation in terms of economic-feasibility. For instance, Radio City Music Hall (photo above, right) not only has been faithfully restored by new entrepreneurs, but it finally has gained a new entertainment format that fits the large number of seats that have plagued its survival. And in fact, fully seventy-five per cent of those "Sitting Ducks" described in RECORD, December, 1974 (of which Radio City was one) have found new and useful lives. In the photo below, right, older buildings serve as a foil to a new commercial complex in Winston-Salem by architects Newman Calloway Johnson. In the photo below, urbane character relies on a good mix on New York's Fifth Avenue.



Far from being seen as resources, existing buildings are still seen by many developers as stumbling blocks to new construction. And even when they are seen as resources, are often "saved" and remodeled without regard for character or context. For old buildings to be economically attractive and appreciated on their own grounds, there have to be new priorities in planning, in attitudes about urban texture, and in just plain urban spirit.

The conservation of older buildings needs to be seen not just as a one-by-one opportunity for "preservation" and profit—but as the basis for planning on the urban scale. We need to guard against Trojan horses. . . .

promising concepts have served as subjects of study in other cities. And it is clear that some fresh approaches to zoning are needed to help us meet the concerns of the 1980s.

There can be a lot of arguments about how to control the character of cities in the 1980s. But—when all is said and done—it will have been the spirit of the performance that counted.

Architects, many with their own offices and homes in older buildings, have long appreciated the esthetic—and dare it be said, emotional—appeal of the past's varied and decorative design approaches. Expressions of other times, the older buildings are now realized to be irreplaceable in any meaningful way within the limitations of current techniques or within the thrust of current thinking about what we should be building. And—at the same time—these serviceable older buildings clearly give a sense of continuity and texture to what *is* built new. Much of the public has joined in the spirit of preservation—perhaps some seeking happier times in their perception of the past. And the popular idea of what should be saved is constantly growing. We now understand that more is good than we used to think was good. But many developers have little objectivity on the quality of older buildings, of cities or of character in general. They prefer more familiar economic formulas that make sense in short-term profits. In the short term, we *are* going to see those formulas change a little to accommodate conservation and re-use. But it is going to be the responsibility of every architect involved in such projects to try to educate, to try to change attitudes—so that conservation does not become another catchword applied to older buildings along with plastic brick.

On the occasion of announcing a lobby renovation in the U.S. Department of Commerce's headquarters, Under Secretary Luther Hodges, Jr. said: "Let's acknowledge it. We have allowed an elegant structure to become dingy and gloomy." But, he need not have apologized—at least he recognized the problem. Misplaced "improvements," like the siding that covers the once-proud range of marble arches in the photo on page 117, are the familiar sort of *investment* that owners have been willing to make in the interests of quick rentals and quick tax write-offs, while the basic buildings decayed. These prototypical attitudes have spoiled potentially valuable buildings and whole downtowns—and new attitudes and new directions are needed in the form of stronger (but environmentally sensitive) tax incentives, in the revision of building codes to make them responsive to specific needs, and in assembling the growing body of technical knowledge that will make economically feasible a truly urbane combination of new and old. Maybe in this decade—given those conditions in favor of cities with which we began this article—we can get done, in the cause of our cities and culture, some of those things we should have been doing all along. —Charles Hoyt.

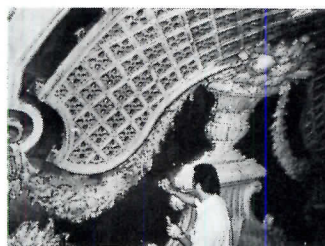
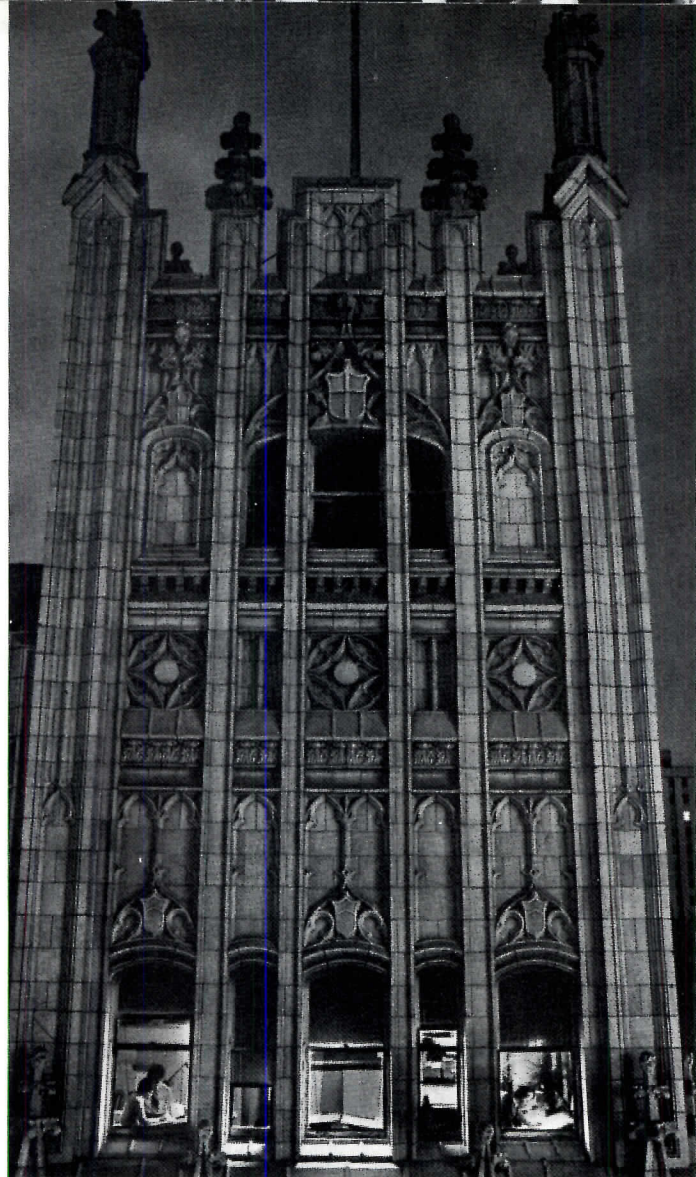

Architects have been no strangers to promoting the old with the new. Photo above: the offices of architects Corgan Associates in a confectionary tower in Dallas. Photo left: remodeling by Leo A. Daly of the Orpheum Theater in Omaha. Below: apartment of Kenneth Parker on the top of his remodeled granary in Philadelphia.

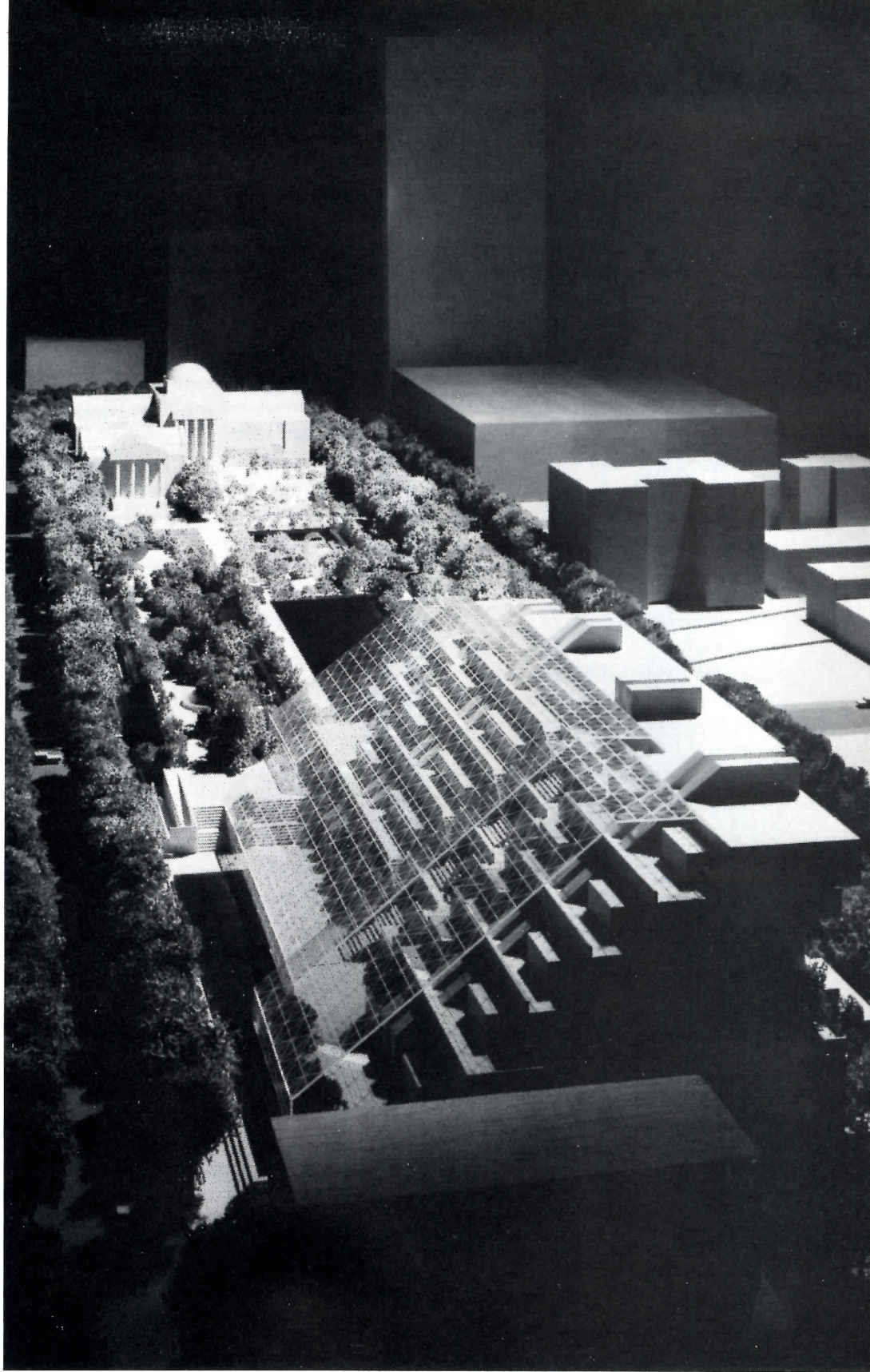



Photo above: a 1910 office skyscraper in lower Manhattan being remodeled into apartments by architect Joseph Pell Lombardi. Photo below: The Open Design Office became activist planners for this renovation of the once-threatened Roxbury district of Cambridge Massachusetts. Bottom



photo: A row of remodeled nineteenth century buildings in Denver housing various uses, including the design offices of Neville Lewis Associates. Photo right: Arthur Erickson Architects design for a three-block area of downtown Vancouver began with the scale of the existing landmark courthouse in providing for both new government buildings and a rallying point for downtown rejuvenation. (It will be explored in detail in an upcoming issue of the RECORD.) Drawing below: The Boulevard Shops in downtown Miami are in an "Art Deco" building being remodeled into a shopping complex by architects Bouterse Perez & Fabregas.



Simon Scott



NEW PERCEPTIONS OF MOBILITY

Transportation planning will be one of the most critical issues during the 1980s. Its success—based on the comprehensive integration of new design ideas with existing mass transit systems, the automobile, and pedestrian spaces—will change the face of business, retail and housing centers, affect what and where we build, and most dramatically affect the safe, efficient mobility of people. The solutions will not be Buck Rogers technology, but plain old hard work in rebuilding our existing systems.

Americans think of the freedom of mobility as a "right"—almost the equal of those outlined in the Bill of Rights. We move around so much, in fact, that we are labeled the mobile society. And we are shocked at the thought of losing part of that freedom to fuel shortages. What does the future of transportation look like for the 1980s? or until the year 2000? The fact is that we will (we must) change our transportation habits, but continue to use the same kinds of systems that exist today. The primary changes will be in fuels and transportation costs, and as the use of the automobile will have to be selective, we will turn to mass passenger transportation as the only alternative. A government report prepared by the National Transportation Policy Study Commission forecasts a capital investment of \$4 trillion between now and the year 2000, with "the demand for transportation growing dramatically, outdistancing the rate of population growth by nine times for freight and four times for passengers." Work will abound for architects and engineers, as innovative designs in individual stations, whole transit systems and urban planning will be necessary to strengthen the links in the mobility chain.

The technology that allowed us to design, implement and enhance our traveling now ironically governs the ease in which we do it. We often return from traveling with tales of long waiting lines, being "bumped" from overbooked airlines, congested freeways, inability to buy gasoline, delays on trains and dilapidated stations. Our ability to work sometimes hinges on the willingness to relocate, with corporate advancement so often synonymous with transfers. But even this pattern may have to change, as long-distance mobility begins to be curtailed because of the difficulty in obtaining mortgages at affordable prices because of government attempts to curb inflation. More leisure time puts a greater demand on recreation services which of necessity, will be focused nearer to home. Our mobility within the city has been by conventional means of walking, cars, bicycles and motorcycles interrelated with mass transit. But it is not uncommon today to see adventurous young people on skateboards and roller skates, weaving in-and-out on crowded sidewalks.

Our love affair with the automobile grew, of course, from the personal freedom it affords. And the concept of unlimited fuel sources led to Congressional action appropriating millions of dollars to build a 42,500-mile Interstate Highway network, opening up areas of our vast nation to the worker and sightseer. "The future of the automobile will be affected by the projected increase in almost all the other more essential uses of oil, including heating homes and powering transit, trucks and buses," states Lester R. Brown, president of Worldwatch Institute of Washington, D.C. Yet it seems unlikely that Americans will ever relinquish the automobile.

People are being selective in their auto trips, and are looking to mass transportation, but they do this reluctantly, for the image of mass transit is so disparaging. This image is based on real problems, including high crime rates and lack of security; consistent mechanical

failures; inconsistent schedules; unpleasant stations and vehicles with graffiti, poor lighting, poor graphics and even stench.

There has never been a time in our history when mass transit has been so disgraceful, yet there has never been a time of greater promise for its revival. The light-at-the-end-of-the-tunnel is our realization that we must do something now, and that with sensitive and sophisticated planning we can develop systems that will restore our freedom of mobility.

The first and most significant step towards revitalizing mass transit has been taken—that of recognizing the problems. Newspaper headlines, stories and editorials reflect its importance. And President Carter has publicly focused on our energy problems and mass transportation.

In his televised speech to the nation on energy problems—the "Erosion of Confidence" speech—on July 15, he declared war on our "intolerable dependence on foreign oil." A six-point statement of goals included a massive peacetime commitment of funds for research and development of alternative sources of fuel, and to further conserve energy by strengthening public transportation systems. The next day in Kansas City while speaking to the Association of Counties, he talked of the investment of the staggering figure of \$140 billion for "American energy security," a sum to be derived from passage of the windfall profits tax. Carter "earmarked \$60.5 billion [of that total] for the next 10 years to improve buses, subways and other mass transit, and to build more fuel-efficient automobiles." And in Carter's most supportive speech for mass transit, given in New York City to the American Public Transit Association (APTA) on September 25, he stated, "We will build subways and elevated trains, trolleys, people movers, and commuter trains. We will repair track beds, modernize stations, improve signaling and control stations, replace aging rail cars, expand the size of fleets, extend lines to new areas, and encourage new technologies. In short, we will reclaim and we will revitalize America's transit systems."

Despite these forthright commandments, there could be a bleak future for transportation if government cannot be resourceful in funding, for cities never have been able to afford the design and construction of new systems and the addition of vehicles without the 80 per cent Federally-funded/20 per cent locally-funded ratio that has been the norm. The newly-proposed transit appropriations hinge on the passage of the windfall profits tax.

The one overriding factor for systems of the future is that there will be no space-age, Buck Rogers solutions. It was once thought that the developments that shot us out of our atmosphere to explore the moon and "other worlds" would swiftly change our lives on the ground, but this has not proven so. And so, we come instead to the tedious task of improving our outmoded existing systems and facilities, recognizing that wholly new systems can take as long as 20 years to construct. The following pages explore each mode of conventional transportation, focusing on the best-of-the-old devices and the proposed developments for the future. The revitalization of downtowns rely on the integration of public spaces and varying modes of transport, with transit malls a key factor. Continued development of subways will be approved for large cities with special needs, augmented with purchase of newly-designed buses; stations and pedestrian shelters will be better designed for the user. *Amtrak* will refurbish existing rail beds and stations, buy new trains and move faster with better service in the years to come. While no major new airports are scheduled to be designed, in-fill structures will be built and linked with better circulation systems. Fixed-guideway systems will continue to be designed, but implemented only on special sites. Innovative and sophisticated equipment and systems will, of necessity, interface with existing network. The new job of Transportation Manager will become widespread, a job commanding the whole scope of urban planning and its relationship with transportation. It is in these ways, that we will literally move into the decade of the 1980s. —Janet Nairn

Revitalization of our downtown centers will hinge on the integration of transportation systems and people spaces

Since redevelopment of our cities is clearly such an important priority, the interlinking of transportation facilities with specialized pedestrian spaces and open space is being stressed as a government priority through a new proposal by President Carter called "urban conservation guidelines." This proposed policy would enable the government to weigh the advantages and disadvantages to cities of various Federal loans and grants, and to redirect those programs that would "clearly weaken established central business districts in distressed communities or promote unnecessary urban sprawl." This could influence the amount of money allocated through departments such as Transportation and Housing and Urban Development. Transportation planning will be in the immediate forefront in this development, but its planning "involves a variety of interrelated and complex issues," says William Johnston, special advisor to the Secretary of Transportation. "We must plan sensitively because what we do will affect our daily lives and business. As a general policy, there will be little encouragement to extend the highway system, but rather simply maintain it, for it has created a decentralization and low density."

One example of this transit pedestrian space integration is a newly-completed project in Detroit, called Hart Plaza, designed by Noguchi with Smith Hinchman Grylls as associated architects (top right). It provides all the wonderful amenities of its location with a wide open swath along the waterfront. Autos and buses bring people to and from, and a colorful (and fun to ride) trolley system connects the plaza with the city's revitalized Washington Boulevard (the Fifth Avenue of Detroit).

Another project being developed that combines new transit ideas is in Buffalo, New York, with the Main Street Transit Mall (middle right), designed by Harry Weese and Associates. Handsome pedestrian shelters, lighting, benches and tree-lined street will provide the esthetic and safety amenities to this transportation hub.

Pedestrian links are popular, like the Willamette Center in Portland (bottom right), designed by Zimmer Gunsul Frasca architects with Pietro Belluschi as design consultant. The space frame bridge system was designed to create prism-like light patterns over pedestrian areas to make them more pleasant. A pathway now connecting the Franklin County Administration building's new parking garage and new Municipal Court building in downtown Columbus, Ohio (far right)—70 feet above street level—is believed to be the longest unsupported pedestrian bridge constructed. It is 160 feet long.

Subway systems will continue to flourish in those cities that require this special mode to move large numbers of people

Only cities that truly require subway systems (overleaf) can expect to be funded by the Federal government, as the costs are so high



Balthazar Korab

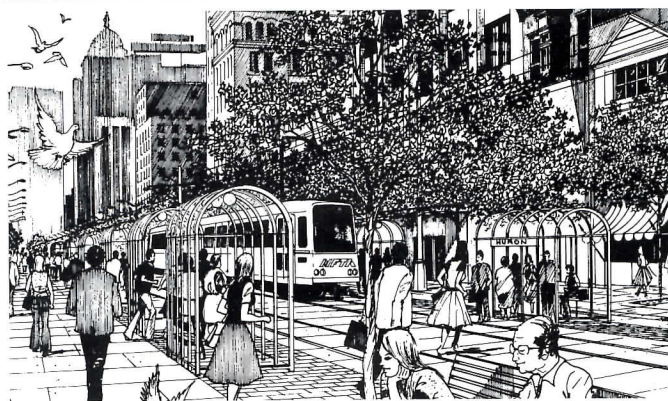

Gene Streett



Ed Hershberger

Pedestrian spaces of different varieties will be integrated into existing cityscapes, being interlinked with transportation systems. Hart Plaza in Detroit (top) opens up the waterfront area with a multi-purpose open space, while a proposed transit mall (center) will become a transit hub in Buffalo. Specialized pedestrian spaces such as elevated walks will continue to be incorporated into downtowns such as in Willamette Center in Portland (bottom left) and between two municipal buildings in Columbus (bottom right), providing shelter from bad weather and safety from traffic-ridden streets.



and construction time is as long as 10-20 years. The Metro subway in Washington, D.C. (far right) with its magnificent coffered and vaulted encasement has been called the "Cadillac of mass transit." While it is expected to cost \$7.2 billion for the completed 101-mile system, it is the most spectacular and efficient system of its kind to date within the U.S. Riding Metro is a delight, with clean, swift and quiet cars and stations. Designed by Harry Weese & Associates, it is becoming a showplace in a city of showplaces.

Subway systems will soon become "intermodal"—related and linked to various forms of transportation including autos and highways, parking, and buses. For example, the Alewife station/garage complex (right) designed by Wallace, Floyd, Ellenzweig, Moore Inc. will function as transfer and terminus facility on the Massachusetts Bay Transportation Administration's Red Line Extension. The station is intended to be the newest element in the city's strategy to intercept commuter traffic before it enters congested neighborhoods and the downtown areas.

New designs for buses and stations will afford more comfort

As the most commonly used mode of transportation, bus ridership has increased substantially. Within the first eight months of 1979, ridership has increased 7 per cent over the same period in 1978; and August marked the 25th consecutive month that national transit ridership has risen. Cities with populations of 50,000 to 200,000 have experienced the largest gains in ridership. The newest bus to be bought throughout the country is the European-designed "articulated" bus (middle right). A prototype for another new bus has been designed, in which the bus actually slumps at curbside. Called the "kneeling" bus, it may be recommended for use by the handicapped.

Intercity bus travel will expand. Greyhound, which accounts for 60 per cent of the intercity market, is thinking of providing a "first class" service with buses that will feature plush interiors and seat only 15 to 25 passengers. Innovative stations, like the San Bernadino Busway-University station in Los Angeles (right), designed by Daniel Mann Johnson & Mendenhall, will handle people interfacing with freeway systems. Share-riding, paratransit and jitneys will slowly develop as on-call systems, linking areas that have limited or no bus service. Attractive bus shelters will dot transit malls, like the ones in Portland (bottom right).

The greatest change will be in passenger trains as they come back—and they will

Passenger trains perhaps have been the weakest link of mass transit in the past, having been allowed to nearly disappear because of lack of funding.

Amtrak will make incredible strides in its service if a proposed \$220 million appropriation is received. The best of the older locomotives, such as the engine designed by

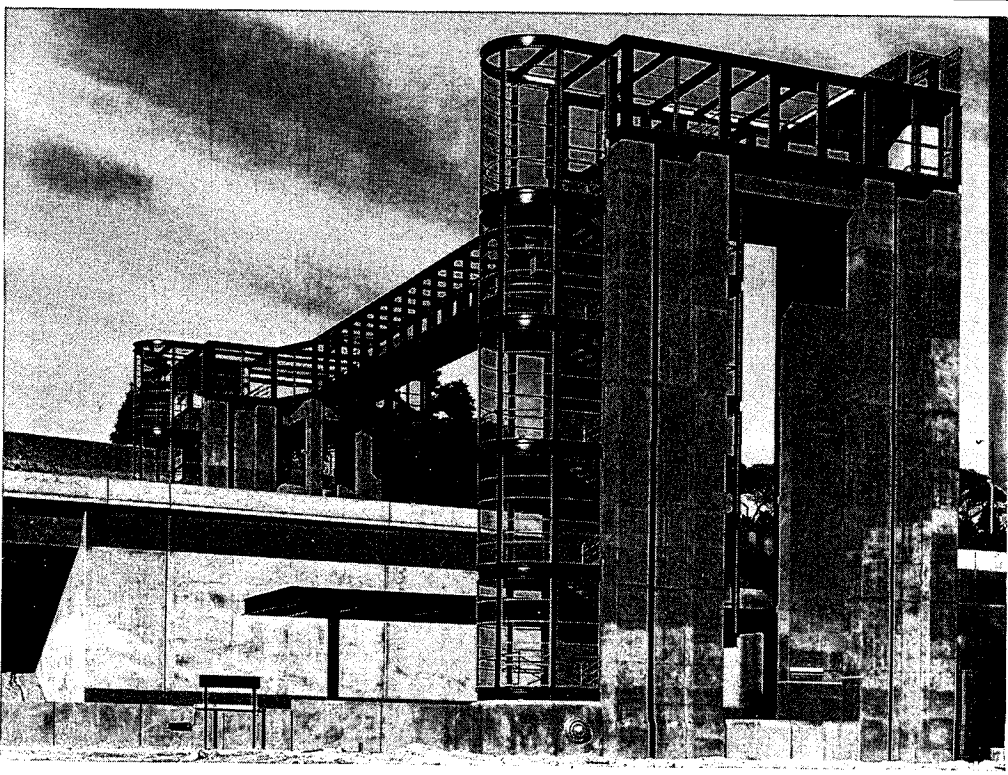
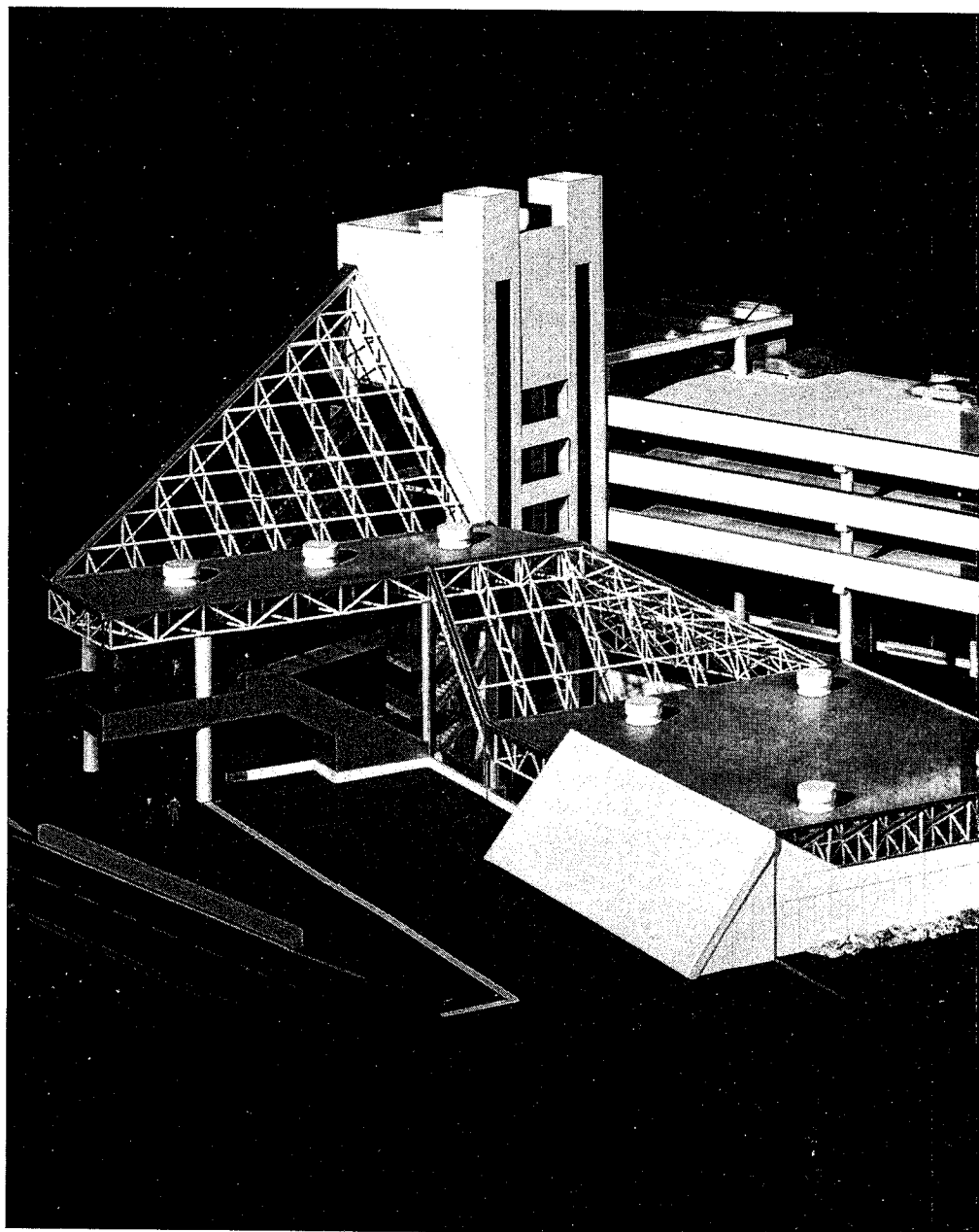

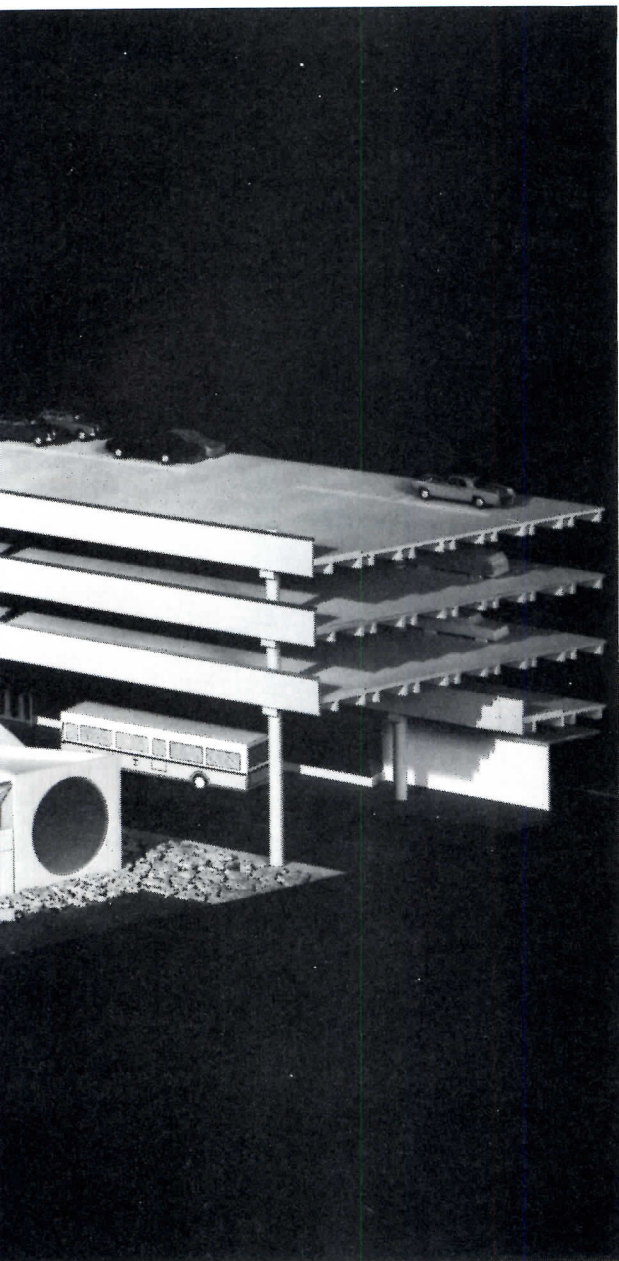

Subway stations will be, as they have been in the past, the best solution for moving large numbers of people to-and-from their jobs in the metropolis. Existing systems like the Metro in Washington, D.C. (below) and the proposed Alewife station in Cambridge, Massachusetts (left and right) were designed as "intermodal"—a point of interchange for various transportation modes including autos and buses. Both of these examples combine conventional methods of moving people (escalators, stairs, ramps and elevators) in new and exciting environs.

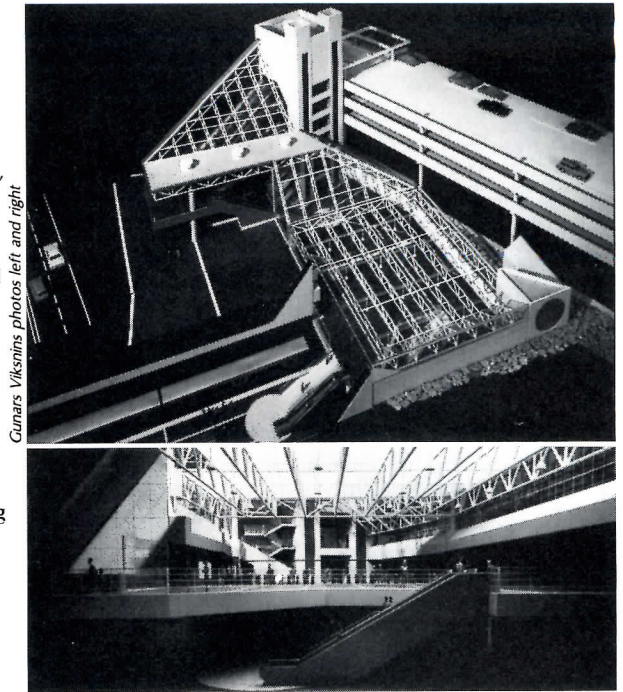

Gunnars Viksmins photos left and right

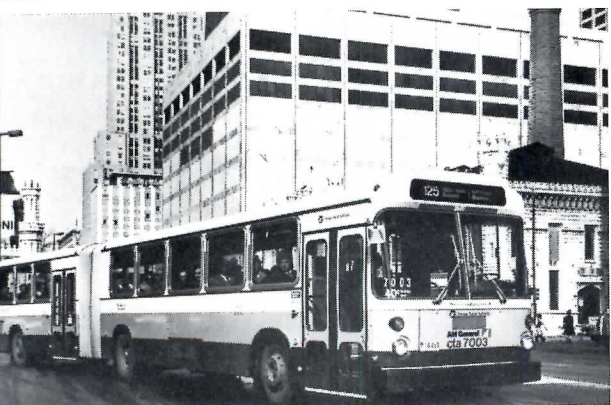

Rail transit for the future will concentrate on station revitalization and new design, upgrading engines and cars and railbeds. The workhorse of the present fleet is the Raymond Loewy-designed locomotive (right), but will be augmented with new Turboliners (below). Amtrak's clever promotional ridership campaigns have included "America's getting into training" newspaper ads and "We've been working on the Railroad" slogans.

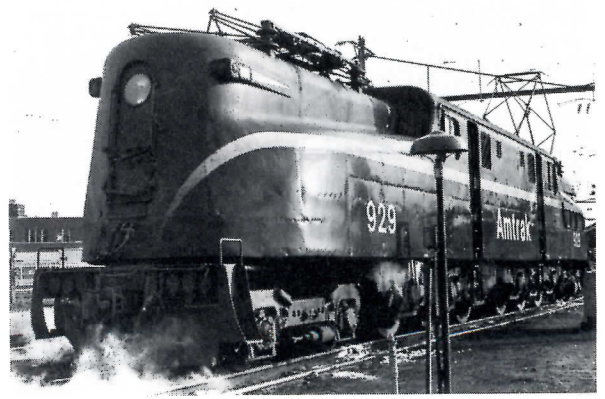

Bus transportation— the most common mode in all sizes of cities— will make great strides in user comfort, whether in bus design, like the articulated model (above) or in pedestrian shelters like the one along the Portland Transit Mall (left). Inventive bus station design, exemplified by the Los Angeles station (far left), can provide visual excitement.

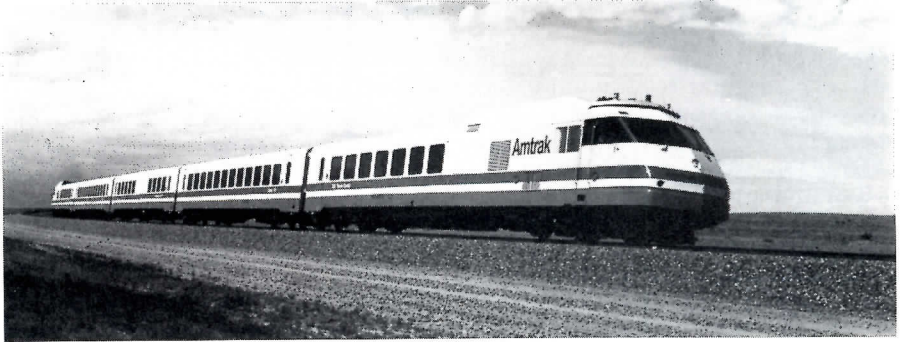

famous industrial designer Raymond Loewy (overleaf), will remain in action because of their reliability. Some of the newest trains (like the Turboliner, overleaf), are in service now. These represent a blend of American and French designs, with sleek lines and comfortable interiors. By 1985, Amtrak estimates a 25 per cent increase in ridership. Amtrak plans to upgrade all its services, including station revitalization and purchasing new cars. Plans call for ordering 200 new cars that would be received within two years. "It's a game of catch-up," explains Amtrak management, "but this will be an exciting business in the next 10 years!"

An unconventional plan, called "Auto-Train," provides the transporting of passengers and autos along the railroad. In operation between Lorton, Virginia and central Florida, people drive to the loading dock, load their cars onto an auto carrier, board two-level coaches and sleepers, and depart in comfort and relaxation.

Air transportation will continue to dominate long-distance traveling

"As incomes rise, the value of time rises, and air travel becomes more desirable because of its speed," states a report by the National Transportation Policy Study Commission. Air ridership is expected to continue to increase over 1978 figures in which 280 million airline passengers traveled to 620 commercial points of service. Air travel will grow from 148 billion passenger-miles to 472 billion passenger-miles, as wide-body planes are used almost exclusively. This, of course, means the use of more fuel, but according to Langhorne Bond, Administrator of the Federal Aviation Administration, "Aviation is a shining example of fuel efficiency when one considers the number of people transported over great distances. Presently the airlines use eight per cent of the available fuels, with 90 per cent of that used by aircraft and 10 per cent for related uses." There is a trend toward more fuel efficient aircraft in new designs as the Boeing 767, 757 and 727/200, and the Airbus A300 for commuter flights. "There will be very few runway expansions in the near future and no new major airports," continues Mr. Bond. Existing airports will expand with in-fill structures, with more rail connections to and from airports to ease the auto traffic loads. The FAA also has announced that it would improve 86 satellite airports, in a \$100 million four-year program. These airports are usually smaller, older, but more convenient to downtown centers.

The current thinking for design of airport expansion is the megastructure—with long arms to which aircraft connect for enplaning and deplaning, as is shown for Panama's Tocumen International Airport, designed by Bernard Johnson Inc. of Houston (right). A more stylized, sculpted airport (far right) is a proposed design for the Doha International Airport in the Middle East, by TRA architects of Seattle.

A new twist in airport design history is that Dulles International Airport in Washington, D.C., designed by Eero Saarinen, has

been placed on the National Register of Historic Places. Designed 20 years ago (see RECORD March 1960 and July 1963), it represents a classic design for the jet age. Increased passenger use, inadequate baggage handling areas, and now-required security measures, have required an addition—designed by Hellmuth Obata & Kassabaum now under construction. One of Saarinen's visionary schemes was the "mobile lounge"—which provided transport for passengers from concourse interior to plane interior. It has been so successful that the original manufactured cars are still operational and the fleet has been expanded with a second generation Plane-Mate, (not shown), designed for the newer wide-bodied jets.

Inland waterways will be used for more passenger transportation where suitable —with shipping dominating

While three basic types of vessels transport goods on waterways—inland vessels, Great Lakes ships and oceangoing ships—there will be a slow increase in passenger transit on the water. Presently, there are few ferry lines that service large numbers of people; the bay areas of San Francisco and Seattle prove it can be a successful alternative to other forms of urban transit. This travel experience is one of the most fun, varied and unique ways of moving around. Boeing has developed hydrofoils (right) which combine the best features of the airplane and ship to give passenger comfort at high speeds.

An elegant means of transportation, though primarily recreational, is on the *Mississippi Queen* (right) operated by the Delta Queen Steamboat Company on the Mississippi and Ohio Rivers.

"People-movers"—another alternative for the 1980s

The people-mover has been successfully used at airports (such as Seattle/Tacoma, Dallas/Ft. Worth and Tampa), in communities (like Morgantown, West Virginia), and within recreational parks (like Disneyland). The "standard" design for a people-mover looks like a miniature heavy-rail system that runs on rubber tires and picks up power from a third rail. It can normally carry 5,000 people per hour at speeds under 30 miles per hour, and is, therefore, restricted to certain operations.

A downtown people-mover (DPM) has been proposed for Los Angeles (far right) designed by Daniel Mann Johnson and Mendenhall with associated architects Jenkins-Fleming in cooperation with the Community Redevelopment Agency of Los Angeles.

The newest design for a people mover is a prototype (corner, far right) being tested by Otis Elevator Company, which has been awarded a \$24.2 million contract by the Urban Mass Transit Administration. Called the Advanced Group Rapid Transit System (AGRT) it is being designed as wheel-less vehicles, electromagnetically-propelled and traveling on a thin cushion of air. An experimental system is being installed at Duke University Medical Center in Durham, North Carolina.

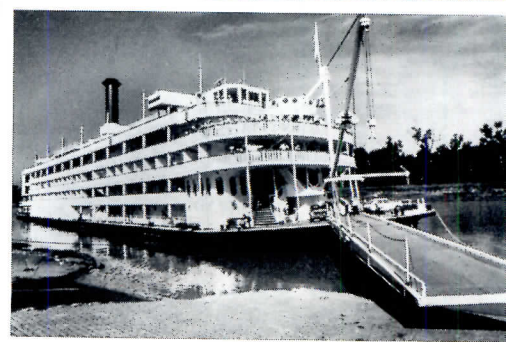
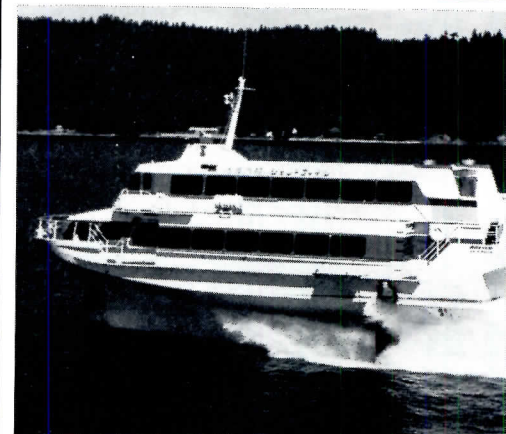
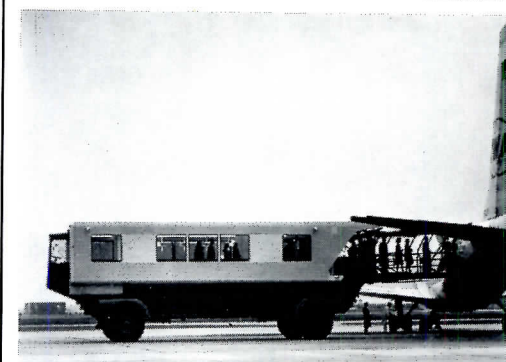

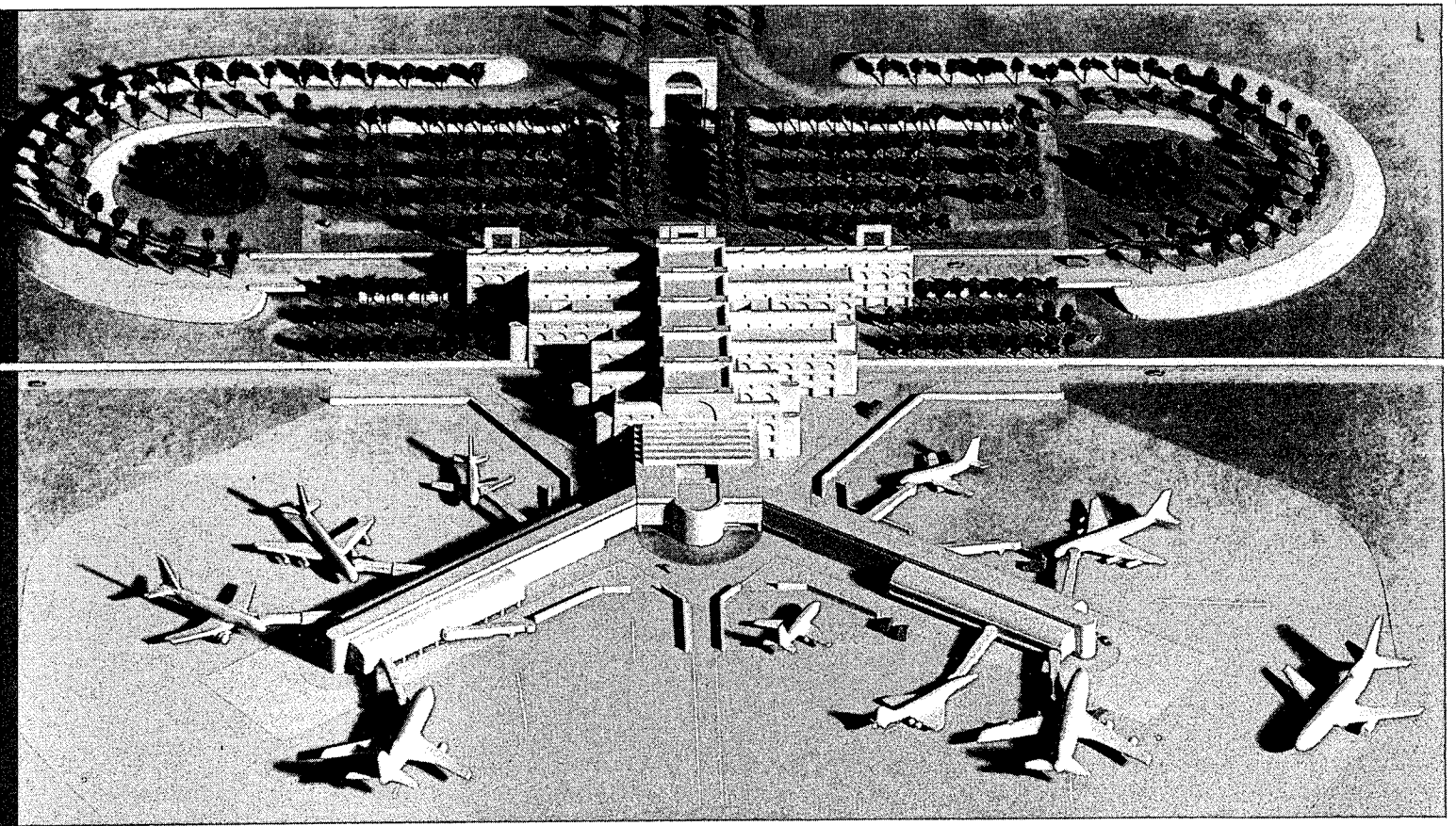

Airport construction will be limited to expansions within the U.S., like the Dulles International Airport in Washington, D.C. (right) retaining Saarinen's visionary design of the mobile lounge (left). New airports will be more common outside the U.S., like the proposed Doha International Airport (above) and the Panama Tocumen International Airport (top left).

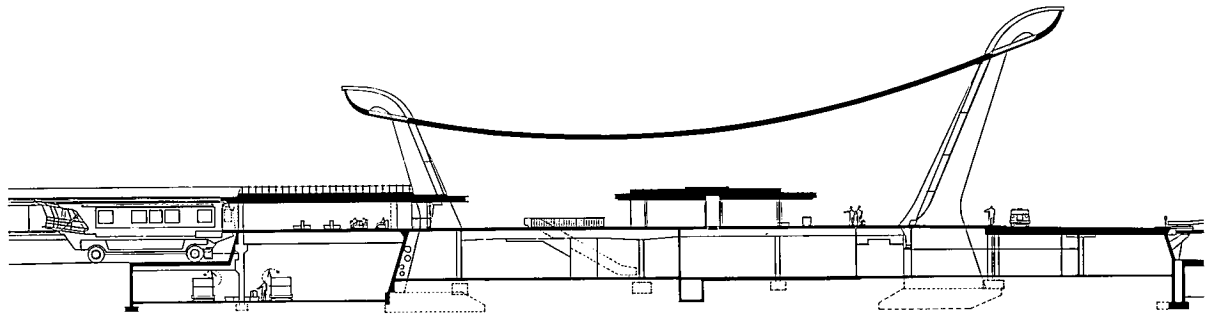

Waterborne transportation will be utilized more in the 1980s with further development of unique craft like the Boeing hydrofoils (above). As these kinds of systems expand, new docks will be designed to link with other modes of transportation. The revitalized *Mississippi Queen* (left), provides another kind of unique transportation.

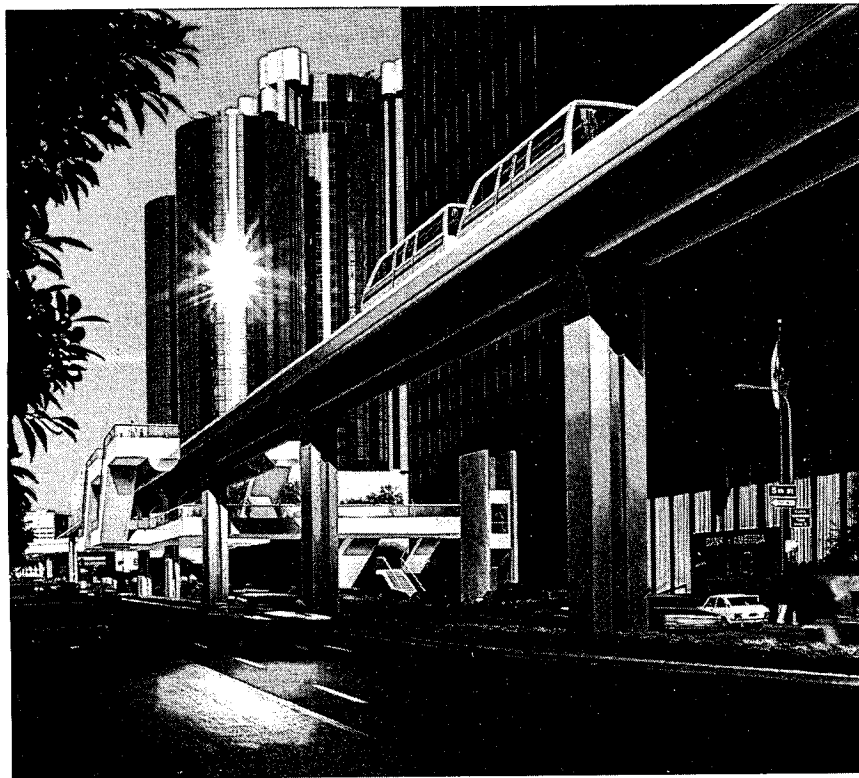

People movers may be the only "high tech" solution to solve specialized kinds of mobility problems; it will be augmented in relatively few locations. Intended to interact with other modes of transit, it has been proposed in downtown Los Angeles (left) to move people in-and-around the business and retail district. A most unusual solution today is Otis Elevator's design (below) for a vehicle that can move horizontally and be switched onto a lift for vertical circulation; to be installed at Duke Medical Center.

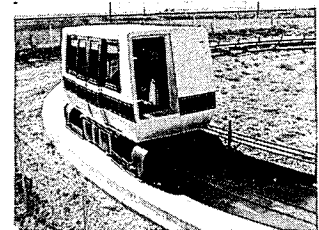

O'NEIL FORD

Musings of a National Landmark



Zintgraff

O'Neil Ford, architect and sage of San Antonio, has been at a loss for words maybe once. One time for sure was five years ago. That was when the National Council on the Arts, meeting on the banks of the San Antonio River, made him a National Historic Landmark.

There had not been a landmark person before. But since the Council, which is appointed by the President to give direction to the National Endowment for the Arts, had become a powerful force for spurring the arts in America, and since the Endowment's architecture program had prospered in achievement and reputation, and since the Alamo had not been torn down to park a bunch of cars and the San Antonio River itself had been turned into one of the urban triumphs of the country, and since many fine buildings—done by Ford, or inspired by his example—had come into existence with architectural quality, human scale, and respect for the materials they were built of and the places they were part of, and since all these things and much, much more could be in part traced to this man Ford's imagination, perseverance, and genius, making him a landmark was only fitting. Bewildered, pleased, and moved, he asked, "Does this mean I can never be altered?"

Anyone who has ever ridden around the San Antonio area with O'Neil Ford in that old Bentley or MG or Mercedes, and seen him screech to a halt in front of an old house being restored near his office in the King William Street Historic District, and heard him yell out, "I hope you are going to put the fence back; where *is* the fence; oh, thank God, you *are* going to put it back?"—anyone who has ever ridden around with Ford knows he cannot be altered and shouldn't be, except for the innumerable additions he has built onto himself. And in this resides our tale of one of the most profound, effortlessly enchanting, earnest, and generous souls of our time. He is a man who has inspired, needled, and advised some of the great political and cultural characters of the last 50 years. He is a man who will take a call during the Christmas holidays from some enthusiastic young stranger who had heard about him and then spend two days showing the kid all over the city and countryside, spreading his arms and memories and observations wide to take in all the history of the place. There is



RABA Collection, San Antonio Express and News

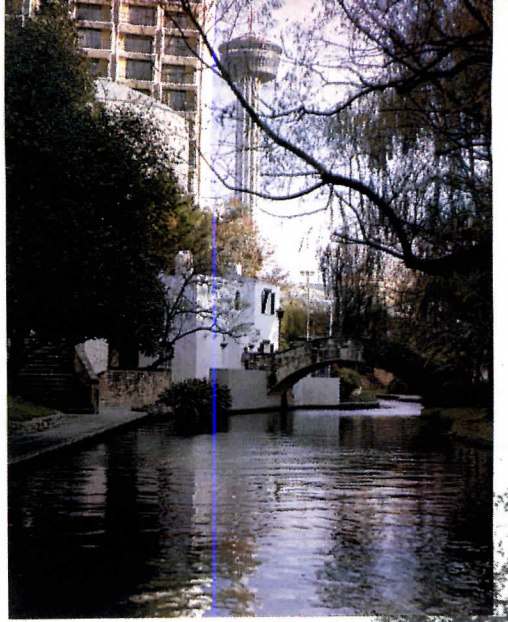

something in Ford's encouraging character that has sent many such strangers on to creative roles.

One of them is architect Bill N. Lacy, who hails from Broken Bow, Oklahoma, headed the Endowment's architecture program when Ford (along with Charles Eames and Lawrence Halprin) was serving on the National Council, has more recently served as president of the American Academy in Rome, and who will next month become president of The Cooper Union for the Advancement of Science and Art in New York: "I knew the legend long before I knew the man. It was not possible to grow up in the Southwest and have anything to do with architecture without having heard of O'Neil Ford. I finally met him while I was on the faculty at Rice University. He spoke at a lecture program we devised around the theme of 'The People's Architects.' The year was 1964 and, in his predictable iconoclastic fashion, he took on all targets in sight, ranging from civil rights to the deteriorating quality of the visual environment. I still remember one of his comments: 'Yes, I'm still on the brick kick and the column and beam kick and I shamelessly make big glass walls now and then.' It was a typical, no-nonsense statement from a man whose architecture has, over the years, exhibited the same qualities."

The values and characteristics exhibited by the architecture of Ford and the firm of Ford Powell & Carson are qualities that have been talked about a lot lately. In a period when rigid doctrines of design are being shown the door, when ventilating breezes are again wafting through the awareness and work of architects, we find that O'Neil Ford, all these years, has been an exemplar for honesty, craft, simplicity, and quiet scholarship in the forging of form.

Ford's devotion to history generally, to architectural history passionately; his understanding of the nature of materials, places, and the contours of landscapes and the cultures cropping up from them; his attention to the qualities of climate, the behavior of breezes, the movement of the sun; his belief that esthetic and theoretical positions should not impose preconceived solutions upon the direct, simple expression of the needs of living; his understanding that architecture and architects must become a serious subject of interest for society generally and that this can only come about through persistent, skillful participation in the civic, social, cultural forums of the land—all these qualities anticipate both the emancipation of ideas today and the longing for some common ground on which the diversity of motives and motifs can again meet. Which is why this article seems to us a suitable final piece for this issue. . . .

Ford, who has always been in wonder of words, ideas, and clear, graceful expression (and who has always been a wonder at them) believes that too many architects today are *listening* to each other build. At the same time, or just a split second later, his arms are flapping with all manner of outpourings about positive developments in the profession—albeit still interspersed with *profanity* so hot and glowing that it could have come out of a

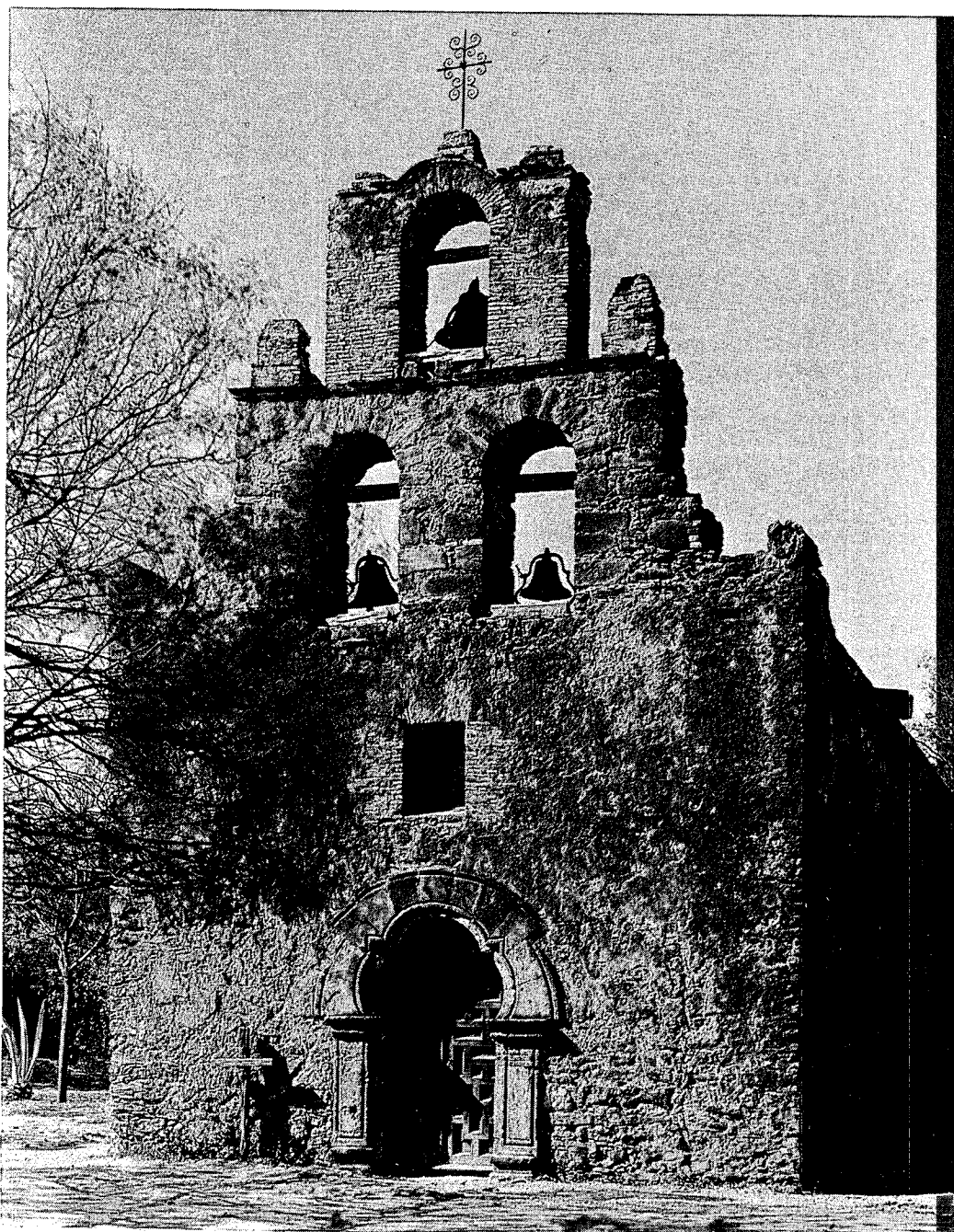
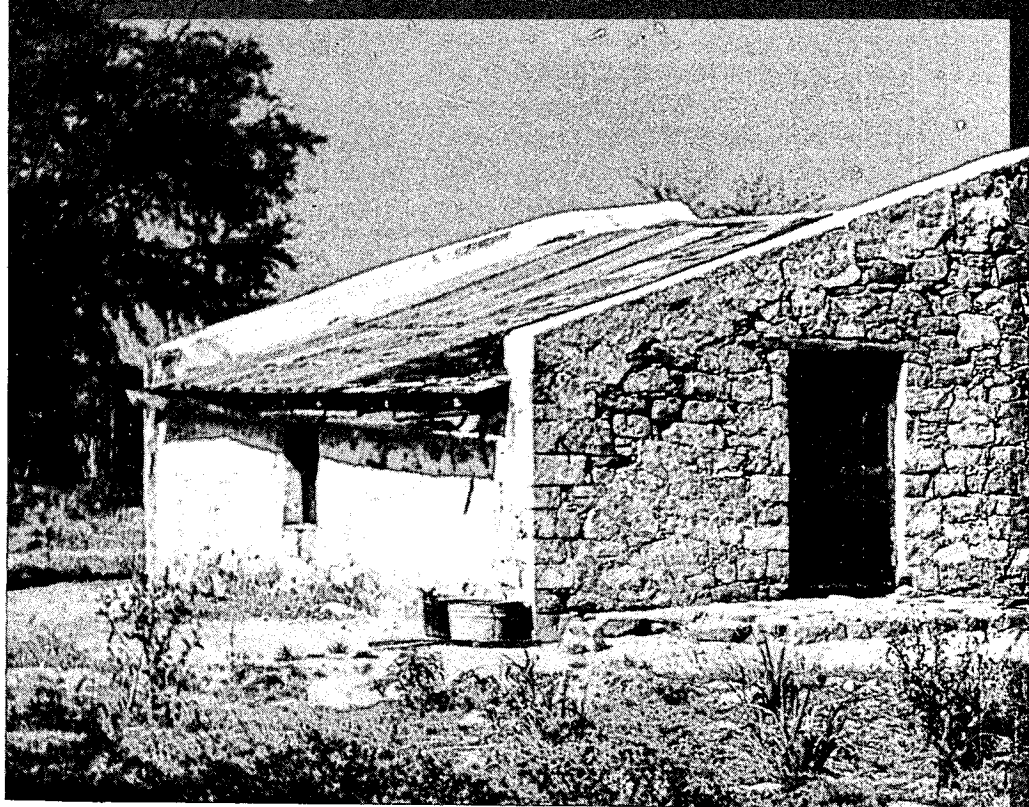

O'Neil Ford photos

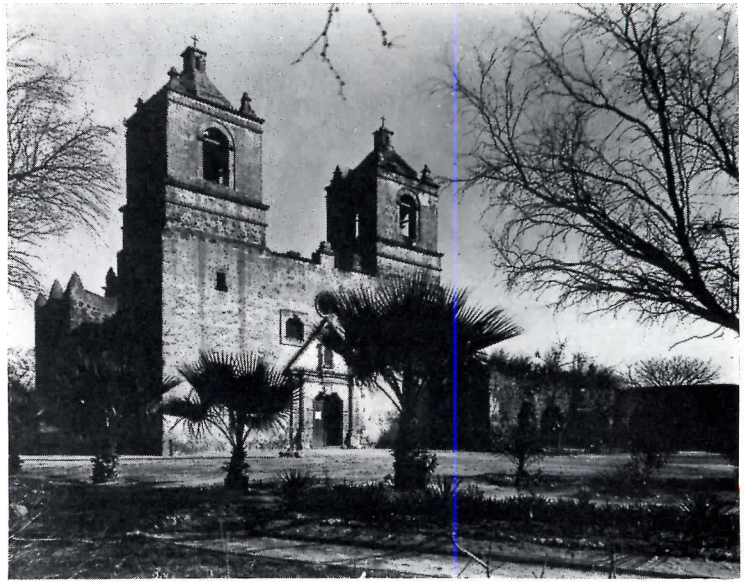

Going back to the early 1920s, O'Neil Ford has traveled the side roads of Texas, looking for, sketching and learning from the simple native houses, the humblest of which, like the one on the banks of the Rio Grande above, showed a certain audacity amidst grating limits. Said actor Gregory Peck, seeing this photo of Ford's, "Where is the script!"



Of San Antonio's five missions, Ford can spin absorbing yarns about how their naiveté of massing and detailing has nobility and grace despite (or because of) the lack of "a refined esthetic." These missions have now been brought back from ruin, due in no small part to his catalytic encouragement over the years. Mission Espada is opposite; Mission San José, above and near right (O'Neil and Wanda Ford were married here in 1940); Mission Concepción is in the far upper-right. These are strung along seven miles of river.

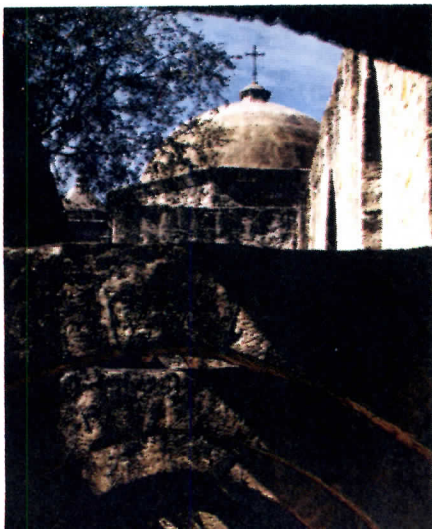

kiln. (There is a feeling that he has a glint of admiration hidden away for at least a few of what he calls the smart-alecks.)

Ford walked away from the applause and the crowd that sunny day having designed a house on the back of an envelope and composed a poem to autumn. He stuck them into a diary, already bulging with extra notes, newspaper clippings, and assorted business cards. He's been keeping this diary for 28 years now and it is quite simply one of the most enthralling, thorough records of any mature life yet expressed in the English language. The "landmark" walked out onto the Paseo del Rio, the River Walk, one of the most absorbing experiences in any city, anywhere—and everybody knew him.

Back in the 1930s, Ford had pitched in on a number of WPA projects, and called to San Antonio on a project, he quietly encouraged Mayor Maury Maverick to get going on a plan to turn a then-sluggish creek, given to infrequent but formidable floods, into a safe series of winding promenades along the banks, even planting some of the cypresses. This became the basis for the fiesta of shops and restaurants that have stuck their economic toes in this splendid stream since mid-1960s. His real bread-and-butter job nearby was turning a deteriorated 18th-century residential quarter into a Mexican-American showcase of restoration and cultural history called La Villita. This paid \$10 a day, and he will proudly show a ragged, yellowing time sheet. Back then, as later in the 1960s when the legislation for the National Endowment was moving through the Washington mill, Ford's highly pragmatic kind of passion for such initiatives—for the economic as well as cultural vigor they can bring about—got the attention of Lyndon Baines Johnson, who had headed the National Youth Administration in Texas.

This close relationship to the affairs of the day points up Ford as an especially valuable inspiration, as much as his renown as a designer of buildings that delight in places they are part of, as much as his uncanny ability to evoke the history of a place and its people (one might say the cumulative memory and image of a locale). He's not been "stylistic" about any of this, poking at *piñatas* in the hope that some deluge of details will fall into his lap. Rather, he has been commonsensical, authentic, and visually his buildings are vivid and serene. With a rambunctious, agile mind, a deeply embedded Celtic streak for saving and sharing the parables, tales, and myths of the race, and a wit that can assume almost any visage or voice to press a point, enliven a story or recall some famous or infamous personality, Ford has long been valued, in many diverse quarters of life, not only for all that he knows but also for all that he *feels*—for his way of perceiving things, and ventilating stuffy surrounds.

The tale begins in Pink Hill, Texas, up in the northeast part of the state near the Oklahoma border, where the train would stop if you put the flag up in time, which doesn't exist anymore, and where O'Neil Ford was born 74 years ago. He spent two years at



Michael Riehm





Michael Riehm



The firm of Ford Powell & Carson, formed in 1967, continues and expands O'Neil Ford's long practice (Boone Powell joined him in 1960; Chris Carson, in 1959). The firm as a whole is one of the best balanced, most thoughtful, and visible in the region, its work ranging from residences, to museums, theaters, and educational buildings, to industrial work, to a great role in the restoration and reuse of old buildings and districts. Opposite, near left is the McNay Art Institute in San Antonio, three wings built around the courtyard of a turn-of-the-century mansion. The forthrightness, practical but enchanting spaces, and extraordinary craftsmanship so typical of the firm is found here, from the durable, rich flooring of mesquite to the gentle shaping of stones around the fountain. Above is the great yard of Skidmore College in Saratoga Springs, New York—a tight-knit weave of brick buildings. Right, above is the plaza of the University of Texas at San Antonio over which hovers a "sombriilla"—a system of wood sun shades; it was handled by Milton Babbit, a principal of the firm. Right, below is the Holland Hall School in Tulsa, done in association with Barnard & Starr, the local firm.



Rick Gardner photos

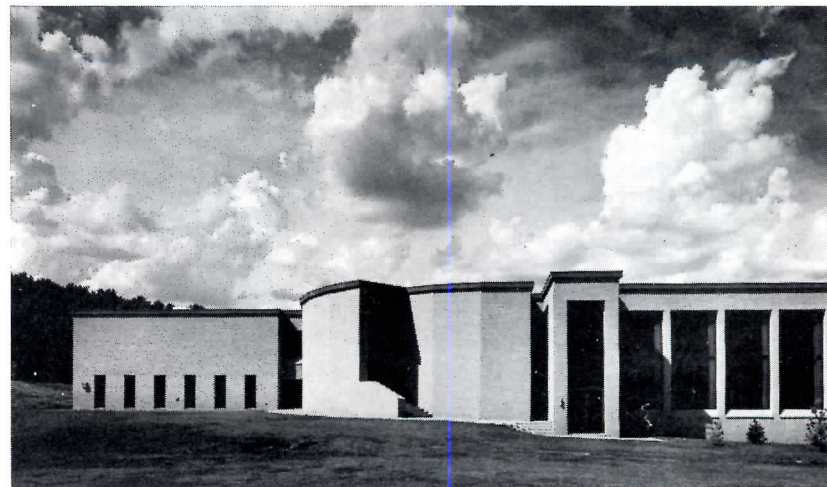

North Texas State Teachers College, in Denton, where he concentrated on wood-working and Shakespeare amidst what he calls, being the truest of Anglophiles, the Chaucerian area of the state (Anglo-Saxon families in this area still sing Old English songs). The family, though struggling, kept extra places set at the table for art, books, and ideas; so when young O'Neil dropped out of college he kept them set too, running a hamburger stand while taking a correspondence course in mechanical drawing. In addition to his mother's artistry in weaving, and the memory of his father's love of reading (his father passed on when he was very young), he was initially spurred toward a creative life by his utter fascination with the Denton County courthouse; designed by W.C. Dodson, who did 18 Texas courthouses, it is an audacious pile of Romanesque persuasion with French Empire fillips.

"I used to just stand there, wondering how they ever got it up there, and (do you know?) I was in Denton just the other day for the rededication of the Little Chapel in the Woods that my old friend and partner Arch Swank and I built in 1939 under the National Youth Administration program. So I went over to look at the courthouse again and *still* don't know how they ever did that blasted, blessed thing."

In 1926, Ford decided to apply for work in an architectural office, and sent some letters of inquiry, including one to David Williams, a well-known Dallas man, who didn't write back. Williams never answered letters, it seems, but Ford's letter was so full of enthusiasm for architecture (and for Texas architectural history, in which Williams was also absorbed) that when Ford finally got around to calling in person, Williams said, "Where have you been?" Having Ford copy some classical details out of a fancy book to test the young man's hand, Williams hired the kid who proceeded, in the next several years, to nurture his and his boss's fascination with the old Texas buildings, which range from the gold-and-cream-colored limestone houses of the pioneers to the more studied (and first-rate) subtleties of the buildings gotten up by the German and Alsatian settlers.

Where had Ford been? Among other things, he had been all over Texas, starting with a trip of several days with his uncle in a "brass radiator T-model Ford" in 1924. Driving downstate from Denton, they hit the little towns in the eerily beautiful Hill Country near San Antonio, went on down to the towns along the Rio Grande, tracing their way back upstate. "I was just absolutely dumbfounded and lastingly spellbound by the logic, simplicity, invention, and very real beauty of those old towns and those old houses. I must confess that I never knew that I had become a so-called *regionalist architect* until all of a sudden, much later, a lot of smart thinkers began telling me that I was one. But if it can be said that I have worked for a way of designing that is also a way of relating considerably to the intrinsic physical, cultural, and climatic conditions of the regions I am building in, that trip in 1924 was what showed me



Rick Gardner



According to his biographer, Mary Carolyn Jutson, there is only one thing better than having your very own O'Neil Ford anecdote, and that is having your very own O'Neil Ford house. Since setting up his own office in 1930, Ford has turned out houses with enormous indigenous energy and sparing references to native stylistic traditions. From the early 1930s' work in Dallas, is the Bywaters house (opposite, top) and the Kahn house (opposite, middle), this last done in association with Joe Linz. From the 1950s is the Haggerty house in Dallas (above), an adroit, composed intermingling of terrain and materials. And from the 1960s is the resplendant Marshall Terrell Steves house (near left, right) with its scholarly and exquisitely subtle adaptation of Mexican materials, crafts, and an old system of masonry vaults called *bovedas* (masons follow the brims of their hats in fashioning the curving contours of the vaults).



the way. It was also the first time that I had really looked at San Antonio, this river waiting to be reborn, the four very significant missions waiting to be restored outside of town, its modest but richly interesting Mexican-American neighborhoods waiting to be rediscovered and given some serious attention. I had a feeling I would be back."

Ford's skill at tending cultural and artistic roots, shaped up out in the cotton fields he worked as a teenager, has never deflected his attention to, and inventive expression of, contemporary structural and technical matters. The many state and national awards that have come to the firm of Ford Powell & Carson recognize an influence in technology as often as a profundity and care in dealing with the dimensions of art. This work ranges from the on-going construction of Trinity University, begun in 1949, a hilltown-style composition not unworthy of Urbino, Italy, that makes magic out of an old quarry with steep limestone bluffs, to the knowing restoration of such historical structures as San Antonio's San Fernando Cathedral.

"The original 18th-century church was buried back in behind 19th-century additions that were massive in their scale and, believe me, massive in the mediocrity of the many, many additions of furnishings and colors over the years," recalls Ford. "We cleaned the 'new' stuff up, got it right down to something more simple and therefore more spiritual, and we found the 'old' church, the original front wall, fixed up a lot of structural problems, and brought the original dome back."

If it takes a good deal of technical insight to rediscover and fulfill the artistic heritage living in a project like San Fernando, it also does in one like Trinity, where—with his associate, Bartlett Cocke—the use of lift-slab construction was pioneered in its first major permanent installation. A lot of convincing had to be done to get the go-ahead, and when the first concrete slab was successfully jacked off the ground, moving slowly upward on the steel columns, O'Neil and the college president, triumphantly perverse, stood beneath the slab since, in the president's words, "You and I will both be better off here if this thing doesn't stay jacked up." If the Little Chapel in the Woods, La Villita, and the helping hand on saving the San Antonio River established Ford as a champion of humanism, regionalism and urbanism, Trinity established him as a technical wizard as well, one who is eager to ferret out, refine, apply, and aggressively credit his collaborators for their structural or technical contributions. One of the comelier aspects of Ford's character is his penchant for praising so many people—even as many in Texas and especially in San Antonio know he is disconcertingly, effectively eloquent in damning those "ugliflers" who through default, expediency, or premeditated malice commit environmental indignities.

Ford is also genially biting when it comes to discussing the general state of architectural thinking today, especially that on the "forward edge." As one who has read, and who continues to read, everything he can get his hands on about architectural history, the

Rick Gardner

current historicist bent for stylistic allusion to past periods is askew. He does not say so in sanctimonious admonition, as if to cut the historicists off at the pass; it is said in serious caution, for Ford knows the difference between style as an intellectual exercise and *style* as the natural flowering of a situation in real living. "If you understand history really well," he says, "there is no need to Renaissance things up like some smart people are."

For the best look at Ford's own situation in real living, one's best bet is a drive with him out to the south of town, past Mission Concepcion, to the vast old vegetable gardens of Mission San Jose near the banks of the river (this whole area is in the process of being developed into a national park, which is good poetry considering Ford's unique status). Here, at the end of a rough dirt road, round a couple bends, past weirdly shaped piles of rubble stone vaguely Druidic is Willow Way, the rambling, pastoral, preposterous, incessantly diverting home of O'Neil Ford and his wife Wanda—the daughter of Elizabeth Graham, an outspoken, strong-minded founder of the San Antonio Conservation Society whose home it originally was. Wanda Ford, who once studied the dance and whose motions blend athletic bearing with esthetic grace is the only woman a bull-dozer has ever laid down in front of. For 15 years she, her husband, and a hearty band of citizens led a fight against a northbound expressway to cut through Breckenridge Park. Indeed, the "road gang" was held up a long time, and when it was finally approved, the fight had at least produced a more attractive routing. Willow Way expresses the diversity and zest of this couple's causes. It is pluralism incarnate or, with a bow to Mr. Venturi, complexity and contradiction. Post-modernism is as nothing to reckon with amidst the pre-modernist impulses of this place. Dogs and cats lie regally everywhere. Hens, roosters (including two that crow at dusk), guinea fowls, hundreds of parakeets, huge turkeys, all are housed in cages that resemble vast, screened-in porches situated around the grounds, many of them overgrown with plants. Peacocks pose on roof peaks or at the extremity of walls—often letting out with ear-splitting screams and sonorous squawks that are not unlike Ford's loving impersonations of certain political figures, past and present. Then there is Elizabeth Graham's big old limestone house with the eight fireplaces and the generous overhangs and the deep porches and the big rooms cluttered with books and papers and art objects and junk. Out buildings also abound, almost overgrowing the main house. Over the years, fine craftsmen, like Ford's late brother Lynn, have worked out here, in wood and tile and metal—feeding Ford's inexhaustible appetite for the tactility, sensation, tempering, and spiritual concentration that the best crafts embody, producing things to go with his own buildings (if there were craftsmen laureates, Lynn Ford would have been the first choice in Texas). In fact, Ford has collected, encouraged, and recognized

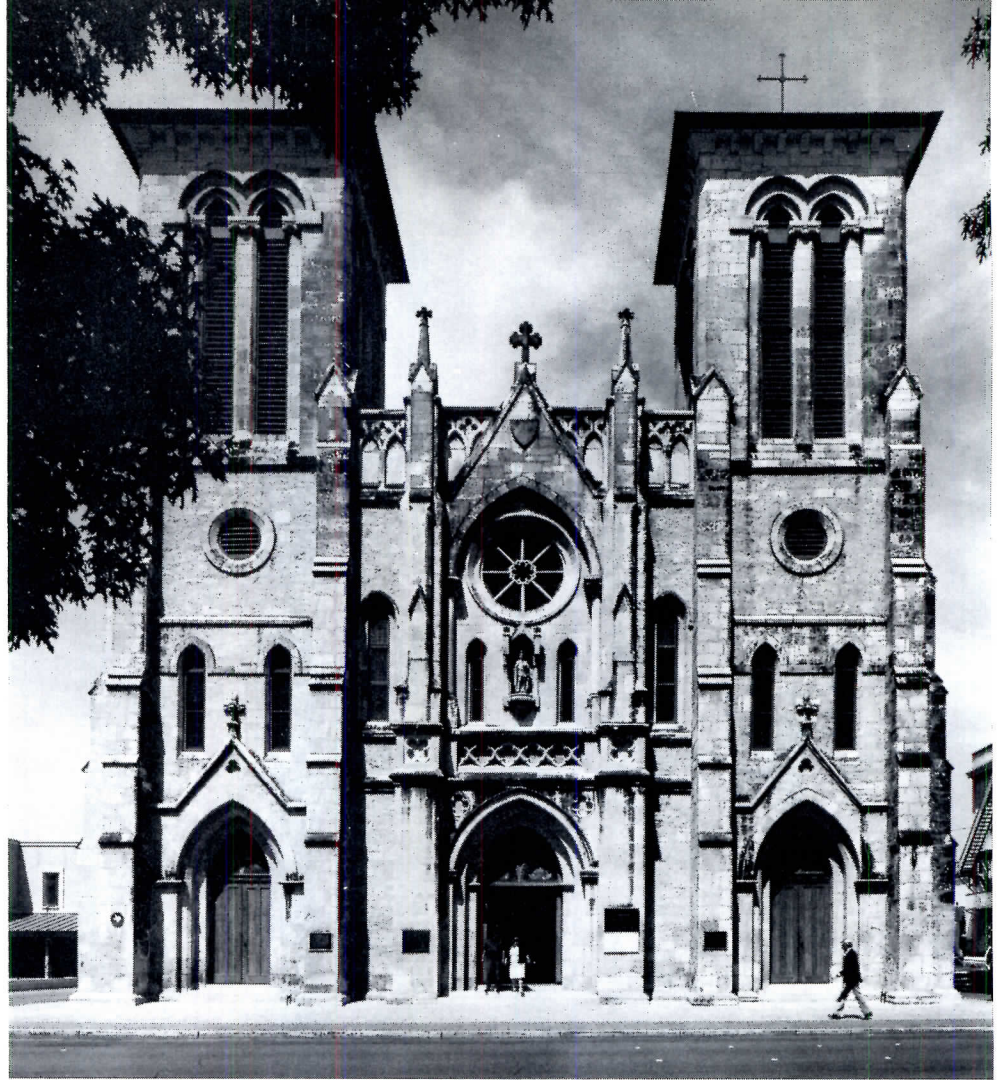

Rick Gardner photos





Ford Powell & Carson's recent restoration of San Antonio's San Fernando Cathedral (opposite) and the Little Chapel in the Woods at Denton, Texas, done by Ford and his old associate A.B. Swank in 1939 bracket a regional epoch. The cathedral was handled by Ford's close associate, Carolyn Peterson. The original interior of the 18th-century cathedral, a simple domed cross, was brought back out in the open,



and the big 19th-century structure was stripped to simplicity. The Little Chapel at the Texas Women's University was dedicated by Eleanor Roosevelt. Says "pre-modernist" Ford, "If you use a brick honestly, you'll relate to tradition."



such talent all his life (all great architects have done this and it's time to revive the tradition). Such people were drawn into dreamships with him back in the earliest days with Williams in Dallas: people like Thomas Stell, who did the sets for "Metropolis" and went on to do the best mosaic work one can find, and Martha Mood with her ceramics and stitchery. Now Willow Way—near the river he helped LBJ, the Conservation Society, architect R.H. Hugman, and that colorful Mayor Maverick to save, near the missions he has helped to shore up—is the place where one goes to understand all the other places Ford has been moved by and all the other places Ford has himself created.

"We must take our land seriously," he gestures about, "and we must take our traditions seriously. We must take our nature as human beings seriously. And we must realize, certainly now more than ever before, that one cannot take liberties in the name of art with an art that has that crucial, distinguishing limitation—the limitation of use. We must always look for the elements of this limitation and reckon with them with imagination."

This teller of stories, this thrower of cultural passes is not about to preach without a twinkle in his eye (it's always there), but he does dig out a piece of paper that, he says, sums up his feelings as nothing else quite can. It is a quote from Walter Lippmann:

"You don't have to preach honesty to men with creative purpose. Let a human being throw the energies of his soul into the making of something and the instinct of workmanship will take care of his honesty. . . . A genuine craftsman will not adulterate his product. The reason is not because duty says he shouldn't, but because passion says he couldn't."

O'Neil Ford, who couldn't, had a big party given for him just the other day, December 3, his 74th birthday, and crack of dawn he was out to the airport to make a plane for Washington where he, with Don Emmons and Francis Lethbridge, is an advisor to the Foreign Buildings Office of the State Department, now run by William Slayton. Someone had mentioned to him, that previous evening, that so many new and wonderful ideas were in the architectural air, now that expression had been liberated from doctrine, now that architects could again exercise their "passion" as artists. It is precisely on this point, thinking back to what Lippmann wrote, where Ford feels most strongly, and so deeply, that he utters the words passion and art seldomly—and then with the quietest imaginable intensity: "Don't think that expression is ever liberated from discipline." Passion in art, at least for him, is not that which lets you; it is that which, in an almost ecstatic kind of discipline, prevents you—especially prevents you from pretending "that architecture is something that it is not . . . that it is sculpture—that it need not be responsible. The very limitations of archi-

ture (cost—sound construction—usefulness—beauty of one or another or a thousand kinds—wonder of material combinations—wonder of technical miracles and changes) are the elements that give us (in vastly differing ways) opportunity, inspirations . . . gawdamn, this air is rough."

That this honesty, this passion, this total sense of art has soaked into his work and thereby is acting as a conscience for many thoughtful architects is now widely understood—much as it is understood that William Faulkner, playing an analogous role in literature, became an "international" presence precisely because of his insight into "regional" qualities and impulses. Says I. M. Pei, "There is not a thing phony about Ford. In the work of so many of us, there is, even in what we think are our finer moments, a sense that we have only partly digested an idea or an inspiration—a sense that there is something



that doesn't quite ring true. Ford has digested everything. He rings true."

What allows this ringing so true? Ford, first of all, tosses aside with vehemence the notion that the worst thing that can happen to an architect is to lose a prospect or a job (he has lost some of both, fighting for what he believes):

"I have a check list of things to do to be a good architect, and all I know is that it seems to work for me, though I cannot begin to figure out how I find the time. . . . I give many lectures, perhaps too many, for the causes I believe in. I walk in the country and in every new town I visit in Europe, Mexico, and the United States. Mostly, I work—evenings, and many holidays. When I am not working, I read. This reading is history of architecture and the other arts, history of

religion, and of western civilizations, history of Texas and the Americas. I have read every book on the architecture and the art of Byzantium, on Moslem architecture, on the architecture of the Middle Ages, on the architecture of Latin America that I could get or crowd into flights or into nights."

This is the essence of his skill, reasonableness, and wisdom—the essence of one who doesn't just "know" cultural history but, in a strangely real sense, personifies it: "When will some teacher in some school learn that he must teach the whole of architecture as it has grown, bloomed, and decayed, the results sometimes having been humble and beautiful, sometimes pompous and beautiful, sometimes brilliantly and even laboriously devised, or sometimes—in the indigenous vernacular—just grown? When will the extraordinary pleasure of learning about architecture be made more significant by presenting the subject not just in dull, contrived, academic chronology, but in solid, analogous parallel to all history? There must be a way to learn the significance of all process and change instead of just the bold incidents and typical monuments."

One comes away from a visit with O'Neil Ford all the more assured that, in this time of frenzied peering into the future, there is nothing old under the sun and that if "form follows" any one thing at all, it is not other forms. This man, wearing the primrose in his lapel, who has been out on all these side roads of history, knows it is found deeper, that beauty is in the world and that "design"—in contrast to random happenstance—is an on-going, deliberate effort to find it, to experience all its evidence, and to set the facts and feelings of it in some useful order. He recalls that back in Denton "the standards of beauty may have been unintentionally low, but the standards of ugliness sure weren't intentionally high," and it is along those early side roads that he began his search for the beauty of basic, even commonplace qualities—tracing the roots of his search so far back that he's been known to trace his architectural inspirations all the way back to Iberia and Sumeria as though there are no boundaries of time and space and place in the storehouse of man. "My God," he says, genuinely amazed, "I think back and (you know what?) we really have been around. Why my grandfather was born the day the Alamo fell. We Fords pretty near hit four centuries with just five generations 'cause we wouldn't get married until we were really grown up; so we took our time, you see." O'Neil Ford has got the future pegged too, yet being around him is to realize the truth of what the poet Kate Farrell wrote in a verse called *River*: "And every day, it seemed, was like starting all over. The idea you grew up with, it was that—the vanishing point of all meaning; and you, the center of a proof being revealed."

—William Marlin

For more information, circle item numbers on Reader Service Inquiry Card, pages 209-210

Contemporary rug designed with Oriental inspiration

Called "Rust Red," this rug design (right) was inspired by the Ming dynasty. It contrasts a warm rust color with blue and tan colors. The lotus flower and the knot of destiny are among the many symbols present. The rug is handmade in India in 100 per cent luster wool. ■ Dylan Carpet, Inc., New York City.

circle 300 on inquiry card

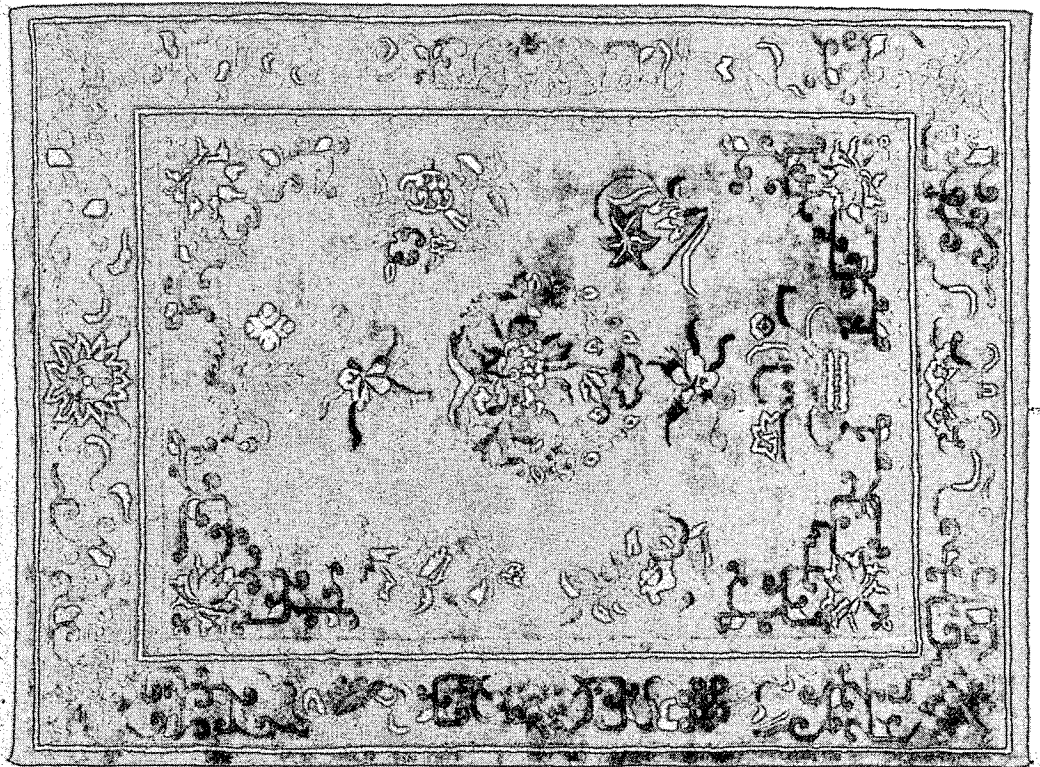

New area rugs for bath and kitchen

A striking windowpane plaid design (right) is called "Boxwood." Basic color combinations are black/white, beige/cognac, green/white and yellow/white. Standard sizes are 22- by 35-in. and 30- by 48-in. All rugs are made of 100 per cent vat-dyed cotton. ■ Regal Rugs, Inc., North Vernon, Ind.

circle 302 on inquiry card
more products on page 145

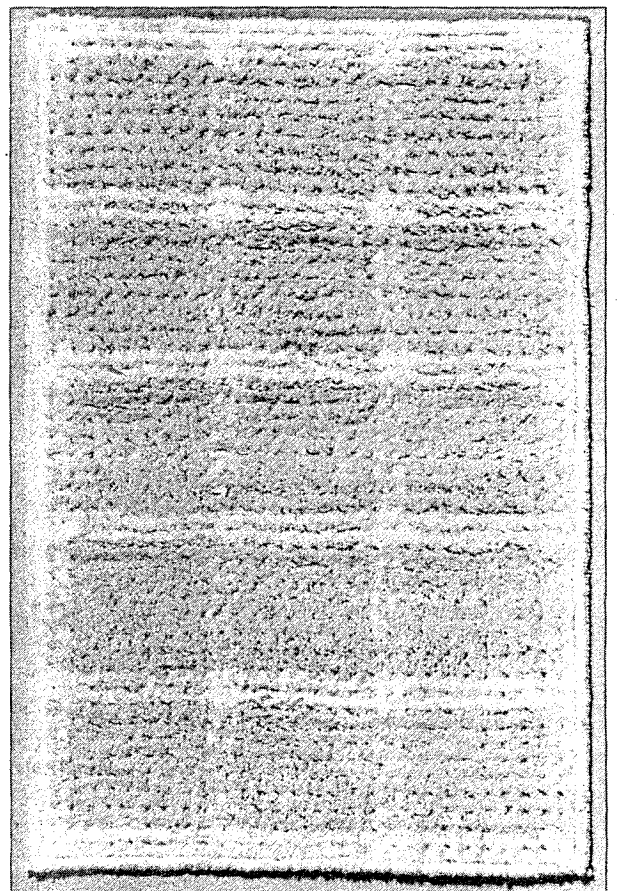

Custom rug designs include Chinese design

As part of the over-all collection of area rugs, wallhangings and carpeting for residential and commercial markets, the round "Manchu" rug uses a stylized Chinese dragon motif. It coordinates with the "Man-

chu" wallpaper and fabric collection. Customized colors and sizes are available. The rug is made of 100 per cent wool. ■ Form III, North Vernon, Ind.

circle 301 on inquiry card

For more information, circle item numbers on Reader Service Inquiry Card, pages 209-210

SOLAR COLLECTORS / Technical brochures and case histories describe the *Sunmaster* round glass tube solar collector, an efficient energy source for solar hot water heating systems. Design of cylindrical tubes and reflectors permit collection of energy up to 10 hours a day, even in cloudy or sub-zero weather. Literature features a *Sunmaster* installation in Amherst, Mass., which supplies over 75 per cent of the year-round heating, hot water and air conditioning requirements of a 50,000 sq ft college complex. ■ Sunmaster Corp., Corning, N.Y.

circle 400 on inquiry card

ACCESSIBLE WASHROOMS / A "Planning Guide" based on ANSI A-117.1 specifications on making buildings accessible to, and usable by physically handicapped people, helps the professional select and place washroom equipment. ■ Bobrick Wash-room Equipment, Inc., North Hollywood, Calif.

circle 401 on inquiry card

WATER COOLERS / Color catalog contains recessed and semi-recessed water coolers; floor-standing, pedestal and counter top fountains. The "Modular Service Wall" system, which groups mechanical facilities, phones, etc. in one space-saving wall cut-out, is briefly described; color options are shown. ■ Halsey Taylor, Freeport, Ill.

circle 402 on inquiry card

SOLAR DAYLIGHTING / "Handbook of Solar Energy Skylighting" provides architects, lighting engineers and building owners with performance data, installation examples, and energy-saving figures on the *Skydome* as a source of light and heat. ■ Wasco Products Inc., Sanford, Maine.

circle 403 on inquiry card

KITCHEN/BATH / Decorating ideas for kitchen, bath and powder room are illustrated in the "Elegance" plumbing fixture brochure. Color photos show whirlpool baths, tubs, shower coves, toilets, lavatories, sinks, faucets, etc. in room settings. ■ Kohler Co., Kohler, Wisc.

circle 404 on inquiry card

BARRIER-FREE SHOWER / Preamsembled shower modules designed to meet all known accessibility codes are featured in a 16-page equipment brochure. Detail drawings illustrate various barrier-free shower room renovation suggestions. ■ Bradley Corp., Menomonee Falls, Wisc.

circle 405 on inquiry card

PLUMBING FIXTURES / Condensed catalog presents wash fountains, showers and safety fixtures for institutional, commercial and industrial use. Barrier-free and "vandalproof" products are featured. ■ Bradley Corp., Menomonee Falls, Wisc.

circle 406 on inquiry card

STEAMBATH / The *Steambath* non-electric hand-held shower atomizes hot water from the bath faucet into a steamy mist. A catalog sheet describes the *Steambath* priced to retail for \$44.95. ■ Jaclco Inc., Brooklyn, N.Y.

circle 407 on inquiry card

OFFICE ENERGY SYSTEM / Written for those concerned with developing and maintaining capabilities for open plan equipment, the "Action Office Energy Distribution Handbook" describes new relocatable electrical systems and how they interface with the *Action Office*. Problems such as change inhibition, service delivery failure and safety hazards are discussed; circuitry, codes and telephone systems are among the topics covered. The softcover guide is published by Herman Miller Research Corp., 3970 Varsity Dr., Ann Arbor, Mich. 48104. Individual copies are \$7.50 prepaid; quantity discount available.

INTERCOMS / Home, apartment, office, business and industrial intercoms are explained in a product catalog. *Talk-A-Phone* systems provide for Master-sub-station, all-Master, and wireless installations. ■ Talk-A-Phone Co., Chicago.

circle 408 on inquiry card

LIGHTING / Updated catalogs describe two lines of *Halo* lighting fixtures. The "Surface" group offers soft squares, spheres, shades, *Lexan* drums, brackets, shelf lights and communication lights. The "Recessed Architectural" lighting catalog contains downlights, telescoping spots, eyeballs, brick and aisle lights, etc. ■ Halo Lighting Div., McGraw-Edison Co., Racine, Wisc.

circle 409 on inquiry card

LANTERNS / Short-form catalog shows traditional and Victorian-styled exterior lighting fixtures, offered in black, verde, copper, bronze and Swedish iron finishes. ■ Norlett Ltd., Denver.

circle 410 on inquiry card

RECESSED LIGHTING / Offered in-stock, the "21MV100" is a 100-Watt mercury vapor recessed housing based on the *21 Plus* series. Brochure explains the versatile applications of the compact housing, and illustrates the seven trim styles. ■ Prescolite, San Leandro, Calif.

circle 411 on inquiry card

LARGE LAMPS / "Ordering Guide 79-1" provides product data and ordering information, including prices, on energy-saving lamps for commercial and industrial applications. ■ Sylvania, Fall River, Mass.

circle 412 on inquiry card

GARAGE LIGHTING / A 12-page guide outlines all the basic criteria involved in lighting parking garages, and shows how the *Light Watt* hps luminaire meets these requirements. ■ The Miller Co., Meridan, Conn.

circle 413 on inquiry card

DC CONSOLES / Central DC system consoles available in 12, 24, 32, 48 and 100-volt sizes provide standby power using nickel cadmium, extra long life lead and medium-life lead batteries. Literature describes these units, which feature solid-state fully-automatic chargers. ■ Dual-Lite Inc., Newton, Conn.

circle 414 on inquiry card

BEFORE

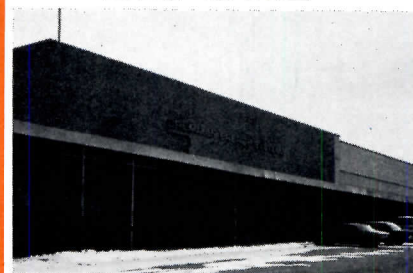

History was made in this late fifties factory on Jericho Turnpike, Syosset, L.I. Here, Grumman manufactured LEM equipment for the Moon shot.

History of a different kind was made when Reckson Associates acquired the property. How they met the challenges of turning an old plant into a dynamic office structure illustrates the beautiful economics of

THE DRYVIT® SYSTEM.

A unique system, Dryvit literally wraps your structure in an overcoat. An insulating skin that equalizes the effects of outside temperatures. With high crack resistance. Maintenance-free color and texture. And important cost savings.

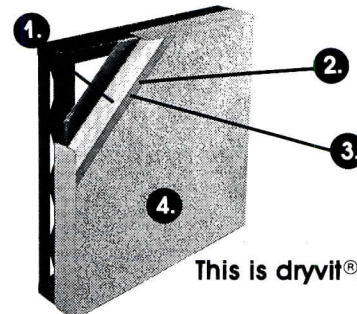

This is dryvit®.

1. **Dryvit Insulation Board:** a rigid panel of expanded polystyrene with optimum insulating characteristics. Board sizes, thicknesses and shapes are available as required by design.
2. **Dryvit Reinforcing Fabric:** specially woven and treated fiberglass fabric is embedded in the Primus coating to prevent surface cracking.
3. **Dryvit Primus/Adhesive:** Dryvit's unique plaster material mixed with Type I Portland Cement is used to adhere Dryvit Insulation Board to backup surface. It is also used to embed Dryvit Reinforcing Fabric on the face of the board.
4. **Dryvit Quarzputz Finish:** one of four finishes available. This synthetic plaster material has high bond strength, permanent integral color and an applied texture that provides a weather-proof jointless exterior surface.

DRYVIT SYSTEM, INC.

420 Lincoln Avenue, Warwick, RI 02888
(401) 463-7150
Plant Locations: Warwick, RI and Tulsa, OK

Circle 57 on inquiry card

AFTER

In Retrofit,
energy saving
can be
beautiful.



OUTSULATION™

Massive insulation placed on exterior walls shaped a new future for this former factory.



Reckson Associates overcame interesting challenges when retrofitting this one-story plant into a luxurious two-story office building.

The existence of 24 ft. ceilings prompted the creation of atrium areas where plants and light make a pleasant backdrop for business. The addition of a sports deck for tenant use became another challenging feature.

Penthouse suites, twin 2-story lobbies, flexible office layouts with total sound control, concealed loading and trash removal bays, offer tenants the kind of luxury only a modern concept can provide.

How to wrap this premium office package in a dramatic contemporary skin was the ultimate challenge. And Dryvit was the choice.

The Dryvit System offers many advantages to the architect and developer. The dynamic structural shapes are factory fabricated. Light in weight, they're easy to work with. And while Dryvit covers, it provides massive insulation. Thermal bridges are sealed. Outside temperatures are equalized, minimizing thermal stress. Permanent energy savings are achieved at a competitive cost.

The Dryvit System works beautifully at the North Shore Atrium Office Building. Let us prove it can work for you. Call or write stating your application: new construction or retrofit.

dryvit® SYSTEM, INC.

420 Lincoln Avenue, Warwick, RI 02888 (401) 463-7150 • Plant Locations: Warwick, RI and Tulsa, OK

Circle 57 on inquiry card

Bally created the state of the art

...backing your judgement all the way when you specify
Bally Prefab Walk-In Coolers/Freezers and Refrigerated Buildings

CLASSIC EXAMPLE: WHAT WE DO WITH OUR PATENTED SPEED-LOK®.

We make it an intricate part of every panel, along with a patented steel strap joining system that breaks records for fast, easy and accurate assembly of Bally Walk-In Coolers/Freezers or Refrigerated Buildings. The "lock to lock to lock" straps gird the entire perimeter of every Bally Prefab. This provides maximum strength and an absolutely airtight panel seal that requires no caulking. It also makes it possible for Bally panels to be easily taken apart for enlargement or relocation of the Prefab. Bally Walk-In Coolers/Freezers/Refrigerated Buildings can be assembled in any size for indoor or outdoor use. Refrigeration systems from 50°F. cooling to minus 40°F. freezing. Subject to fast depreciation and investment tax credit (ask your accountant).

Write today on your letterhead for our 182-page Working Data Catalog or see your Sweet's Catalog 11.23b/Ba for immediate information.

Specify a Bally—it's something special.

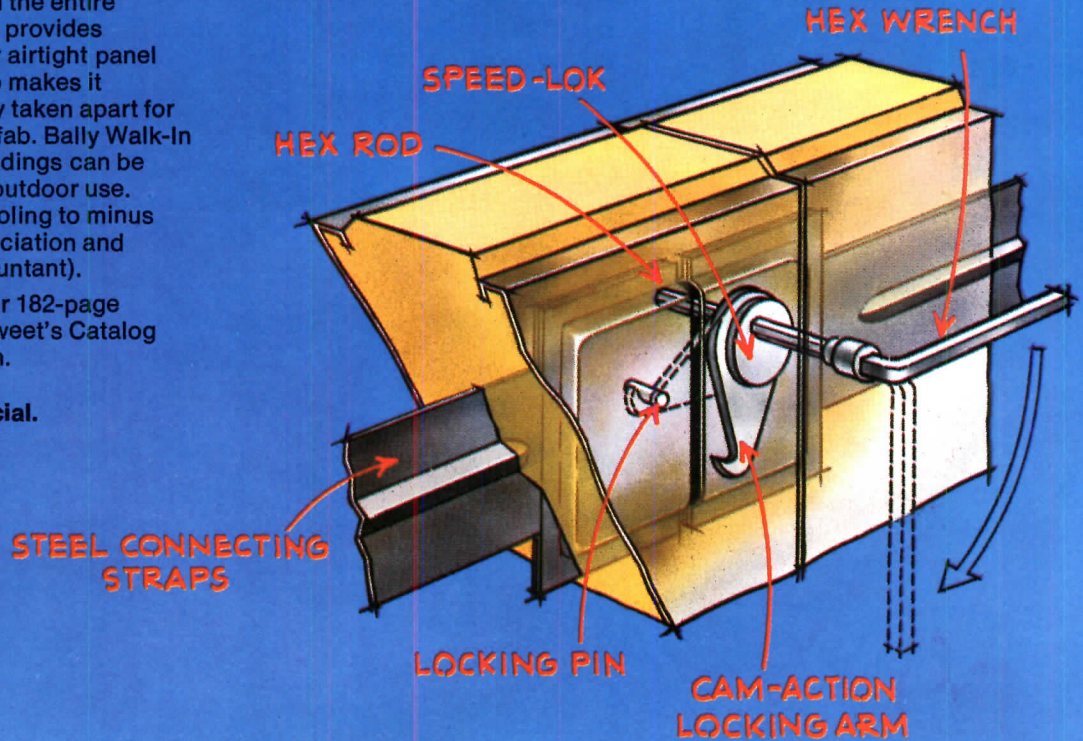

Bally Case & Cooler, Inc., Bally, Pennsylvania 19503

Phone: (215) 845-2311

Address all correspondence to Dept. AR-12

Circle 58 on inquiry card



BRaille/TACTILE SIGNAGE / Molded plastic "Three-In-One" signs include Braille letters, tactile (raised) letters for non-Braille readers, and contrasting letters and background for readers with partial or full sight. Signage was especially developed to meet the requirements of Section 504 of the Federal Rehabilitation Act and proposed new ANSI A117.1 (1977) specifications. Stock and custom wordings are available, as well as Braille tactile plates for elevators and control panels. ■ Seton Name Plate Corp., New Haven.

circle 303 on inquiry card

METERING FAUCET / The "90-75" self-closing faucet meets new ASHRAE/BOCA criteria for conservation of water and energy in public restrooms, limiting flow of warm water to a maximum of 0.45 gpm at less than 110F. For use with tempered water, the valve can be pre-set to flow from 5 to 15 seconds; the cycle can be repeated indefinitely. The push-button control takes only two lb. pressure to activate, making it suitable for barrier-free applications. ■ Bradley Corp., Menomonee Falls, Wisc.

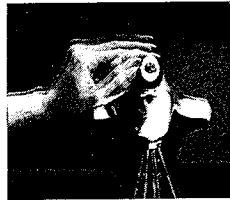

circle 304 on inquiry card

NURSERY FURNITURE / Designed by Kartell of Italy for nursery and pre-school use, this 17-in.-high table is constructed from polyurethane, pvc and melamine components; a molded "key" permits ganging in groups or rows. The frame supports a removable writing surface with storage tray underneath; the frame accommodates hooks and a hanging basket. Table comes in yellow, red, blue and light gray colors. ■ Beylerian Ltd., New York City.

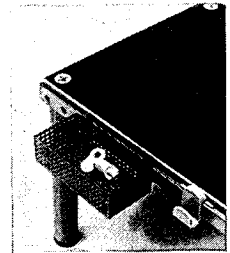

circle 305 on inquiry card

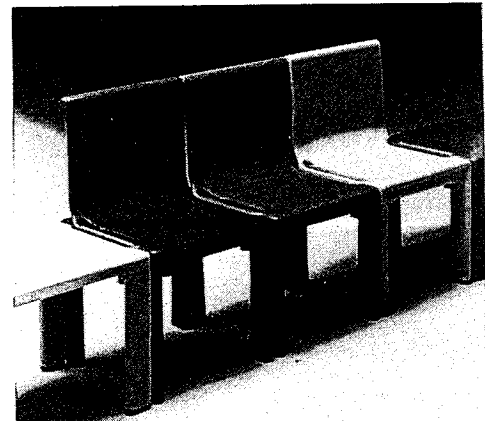

CHILD SEATING / Also part of the "School System" offered by Kartell of Italy, these stackable seats are molded of sturdy plastic. They connect with each other and a matching bench to form space-saving rows. ■ Beylerian Ltd., New York City.

circle 306 on inquiry card

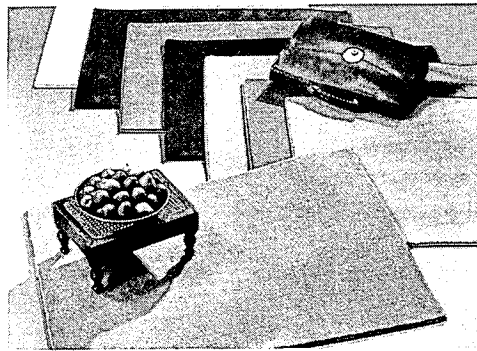

WOOL BROADLOOM / Domestically manufactured all-wool velvet-cut carpeting is suitable for both heavy-duty contract and residential applications. The "Sovereign" broadloom shown comes in 12-ft widths, and is available in eight subdued luster colors. ■ Robbins Brothers, Inc., New York City.

circle 307 on inquiry card

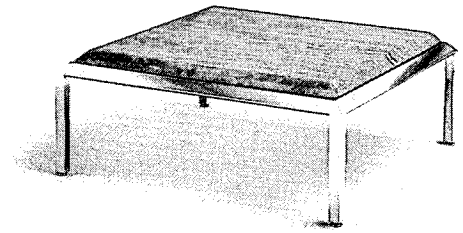

CONTRACT TABLE / Available in both square and rectangular versions and in either 15- or 22-in. heights, the "Pyramid Table" has a stainless steel, four-legged base with inclined edge, topped by a center unit that continues the sloped design. This top may be ordered in a number of wood species including elm burl and mahogany; marble, onyx, and travertine (pictured). ■ Helikon Furniture Co., Inc., Taftville, Conn.

*circle 308 on inquiry card
more products on page 147*

Granite.

The best in first impressions.

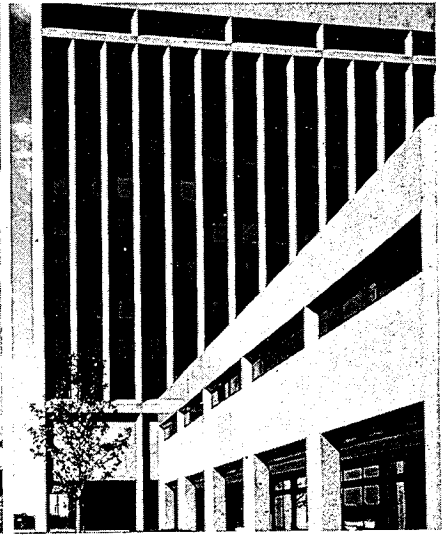
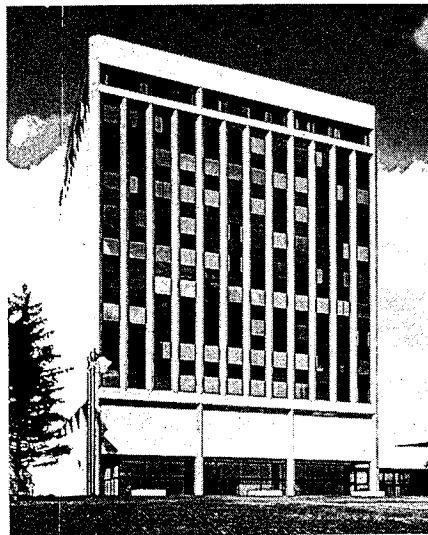

Architect: Graham Anderson Probst & White, Chicago, IL

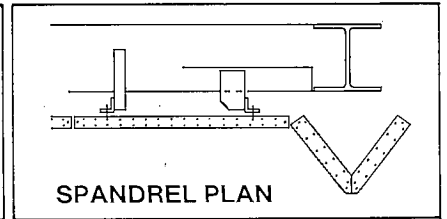
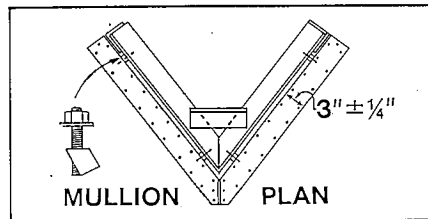

The first impression is the important one. Granite can make that impression more vivid than any other building material available. That's why Motorola, Incorporated, selected Cold Spring's Texas Pearl for their corporate headquarters in Schaumburg, Illinois.

Granite affords the architect a resource from which he can create a building that reflects an image of quality... a corporate image. For lasting first impressions, specify Cold Spring Granite.

For more information, plus a free copy of our 16-page, full-color catalog showing all 18 Cold Spring colors available, call toll free **800-328-7038**. In Minnesota call (612) 685-3621, or write to the address below.



Cold Spring Granite Company, Dept. AR-12 202 South 3rd Avenue, Cold Spring, MN 56320
Circle 59 on inquiry card

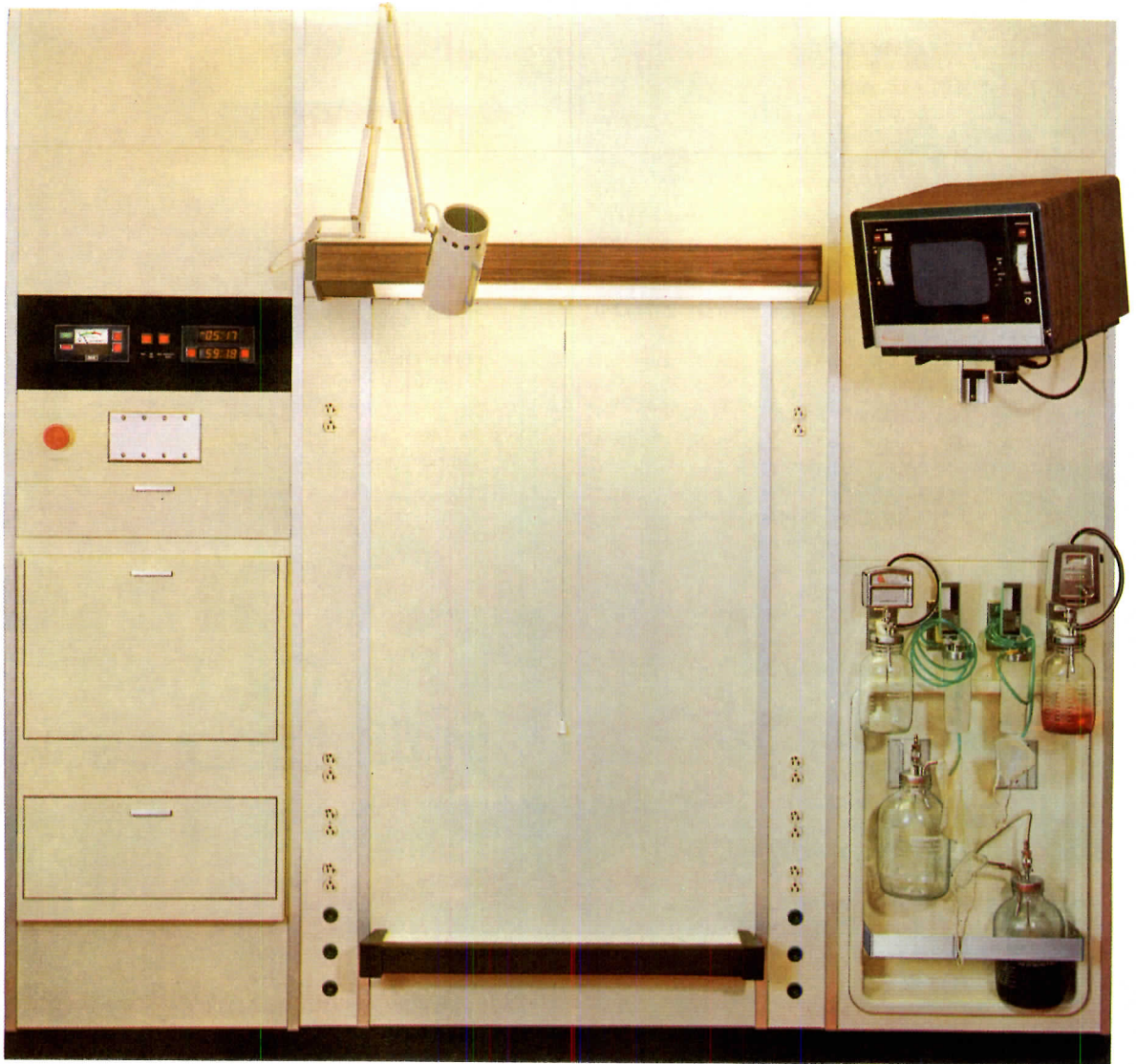

The modular medical wall system that cares for the nurse as well as the patient.

For ICU/CCU, recovery or general patient care areas, Square D Company offers a system of attractive modular hospital walls that are highly versatile yet surprisingly economical.

And for the nurse who makes use of these Series 3000 medical walls to speed patients toward recovery, Square D

offers a special storage/work area as an integral part of the system. This Nurse's Cabinet has a fold-down door that doubles as a desk top for record-keeping or for holding service equipment. Inside, there's plenty of storage space for

medication, service supplies and diagnostic equipment. And the cabinet is specifically designed not to hamper emergency procedures. Another storage compartment below the door holds bedpans and other equipment.

Square D modular medical walls are manufactured using the latest production techniques for the highest possible quality at the lowest possible cost. Because each wall is piped and wired at the factory, installation time is cut to hours instead of days, dramatically reducing costs.

Key components are strategically located and color-coded for fast identification and use. Because the walls are built on a standard modular design, new components can be adapted to existing walls in minutes. Vertical raceways are easily removed for service, and essential electrical components are accessible from the hinged door of the service module.

The wide variety of attractive finishes, including wood tones, is backed up by sturdy steel for long life as well as quality appearance.

For the best buy in modular hospital walls for top patient—and nurse—care in new construction or renovation projects, contact your nearby Square D field office. Or write Square D Company, Dept. SA, 3300 Medalist Drive, Oshkosh, WI 54901. (414) 426-1330



SQUARE D COMPANY

Wherever Electricity is Distributed and Controlled

WE FIT IN

STAINLESS STEEL UNDER COUNTER LAB REFRIGERATORS AND FREEZERS

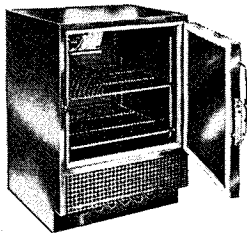

UC-5-BC refrigerator has a blower coil cooling system with automatic off-cycle defrosting and condensate evaporator in condensing unit compartment. Two adjustable stainless steel shelves are provided.

UC-5-F-BC freezer is equipped with automatic timer electric defrost. Capacity—5.4 cu. ft. (155 ltr.)

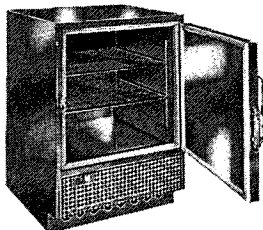

UC-5-CW* refrigerator with cold wall cooling system is equipped with push-button defrost, automatic reset and condensate evaporator. Capacity—5.4 cu. ft. (155 ltr.)

UC-5-F-CW* freezer is equipped with manual hot gas defrost. Capacity—4.6 cu. ft. (130 ltr.)

UC-5-CW-E refrigerator has the same interior features as the UC-5-CW but modified to make it totally explosion-proof. Capacity—4.9 cu. ft. (140 ltr.)

*With explosion proof interior only.

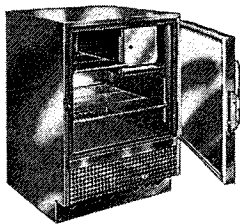

UC-5 features a two-tray ice cube cooling system with manual defrost and stainless steel defrost water tray. The cooler section has two adjustable stainless steel shelves. The entire UC-5 series features polyurethane insulated thin wall construction and air-tight neoprene thermo-break door seals. Capacity—5.4 cu. ft. (155 ltr.)

Jewett also manufactures a complete line of blood bank, biological, and pharmaceutical refrigerators and freezers as well as morgue refrigerators and autopsy equipment for world wide distribution through its sales and service organizations in over 100 countries.



Circle 97 on inquiry card

Refer to Sweet's Catalog 11.20/Je for quick reference.

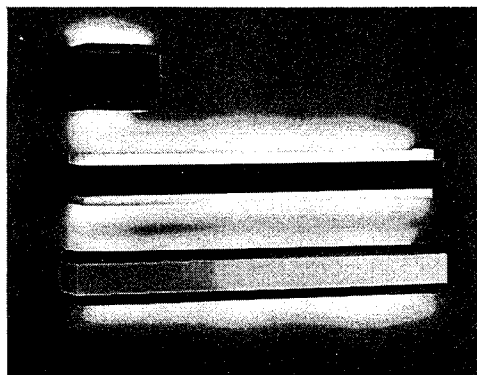

WALL BRACKETS / "Lumiframe" fluorescent fixtures provide local direct illumination for wall graphics and signage, as well as general indirect lighting. The outer frame redirects spill light to cast a soft glow against the inner frame. There are 20W "Circline" and two-lamp 40W versions, in all-steel or natural oak and steel construction; wall brackets open top and bottom for easy maintenance. ■ Lightolier, Jersey City, N.J.

circle 309 on inquiry card

SURFACE FLUORESCENT / Said to be ideal for use

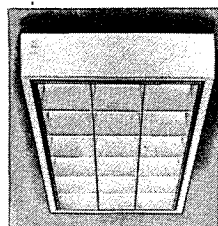

where critical visual tasks are to be performed, the "Surface 90+ Luminaire" is highly efficient, combining very low apparent brightness with wide candlepower distribution. Parabolic-shaped cells of semi-specular anodized

aluminum control veiling reflections and eliminate glare from the ceiling. Matte white housing has a shallow regressed matte black chassis that forms a continuous reveal at the ceiling line. Concealed hinges and snap-action latches simplify maintenance. ■ Lightolier, Jersey City, N.J.

circle 310 on inquiry card

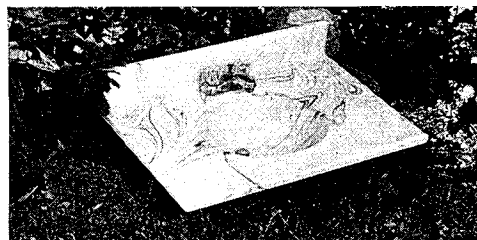

VANITY TOP / Offered in standard and custom sizes and three bowl designs, the translucent "Luminar" vanity features deeply colored swirls in its Cerilean Marble top. Customized coloring is available to match all manufacturers' fixture shades. ■ Cerilean Products, Inc., South Bend, Ind.

circle 311 on inquiry card

ITALIAN FURNITURE / The "Elogio" components

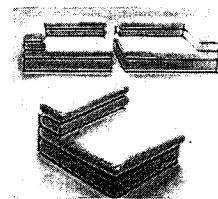

shown here work three ways: as a deep seated sofa, an oversized bed, or as a sofa with seats that are not as deep. Combine a left and right unit to form a deep sofa; remove the cushions for

use as a bed. Base, arms and back panel have a welded steel frame embedded in resilient polyurethane; seat, back and arm cushions of molded polyurethane are wrapped in Dacron fiberfill. Upholstery options include textiles, leather, or OOM. ■ B&B America, New York City.

circle 312 on inquiry card

Write today for free sample of one of world's best roof insulations:

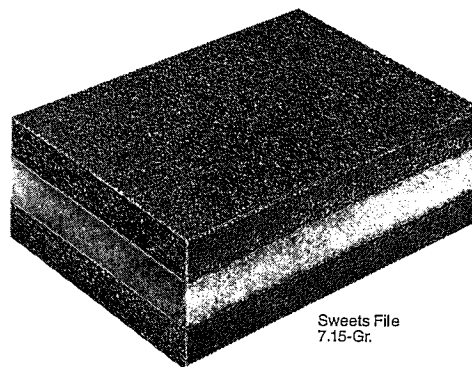

Sweets File 7.15-Gr.

Permalite[®] Pk[®] Plus perlite/urethane/perlite 3-part composite roof insulation

Specify it when you want long-life insulation having a "C" value of .10 or better for industrial/commercial roofs.

• Permalite Pk Plus is a true sandwich board. The top and bottom perlite layers maintain the efficiency of the polyurethane core by protecting it from the effects of high rooftop temperature changes. The top perlite layer also protects the core from hot asphalt during membrane application. And both perlite layers contribute to the dimensional stability of the insulation panel and help dissipate both heat and moisture during application. SEND FOR FREE SAMPLE.

Permalite[®]

GREFCO, Inc./Building Products Division
GENERAL OFFICE: 3450 Wilshire Blvd., Los Angeles, CA 90010
SALES OFFICE: 2905 Butterfield Road, Oak Brook, IL 60521 (312) 654-4500

A subsidiary of General Refractories Company

Circle 61 on inquiry card

See how America's leading architects are giving new life to old buildings.

Inspiration for those who want more than glass and steel.

Now you can discover the finest collection of "new use" ideas ever brought together in one source.

Drawn from the pages of **Architectural Record**, here is an intriguing look at what top architects are doing to preserve our architectural heritage.

You'll see new "recycling" ideas which can save time and money. And you'll use the design solutions presented here as a convenient starting point for your own "new use" projects. What's more, you'll get a firsthand look at the way in which technical problems were solved and see how much labor and capital were needed.

Recycling Buildings

Renovations, Remodelings, Restorations, and Reuses

an **Architectural Record** Book

Edited by Elisabeth Kendall Thompson, FAIA

213 pages • \$24.95

Full of photos (many in full color) plus drawings, specifications, and fascinating stories about buildings that have been saved.

Recycling Buildings covers every major building type, every region of the country, and every kind of architectural approach. It's a must for architects who want to be part of the creative force of their profession. And it's a valuable source of inspiration and ideas for nonarchitects who want to help save our architectural heritage.

See examples of some of the finest work that has been done in remodeling, renovating, and restoring buildings—

- houses
- apartments
- condominiums
- office buildings
- individual offices
- professionals' offices
- retail stores
- shopping centers
- malls
- theaters
- concert halls
- movie theaters
- hospitals
- libraries
- youth centers
- clubs
- community arts facilities

Table of Contents

1. Renovation and Remodeling for Living
2. Renovation and Remodeling for Business
3. Renovation and Remodeling for Selling and Shopping
4. Renovation and Remodeling for Community Use
5. Rehabilitation and Renovation for Reuse
6. Restoration and Preservation of Historic Buildings
7. Additions Designed for Neighborhood Preservation

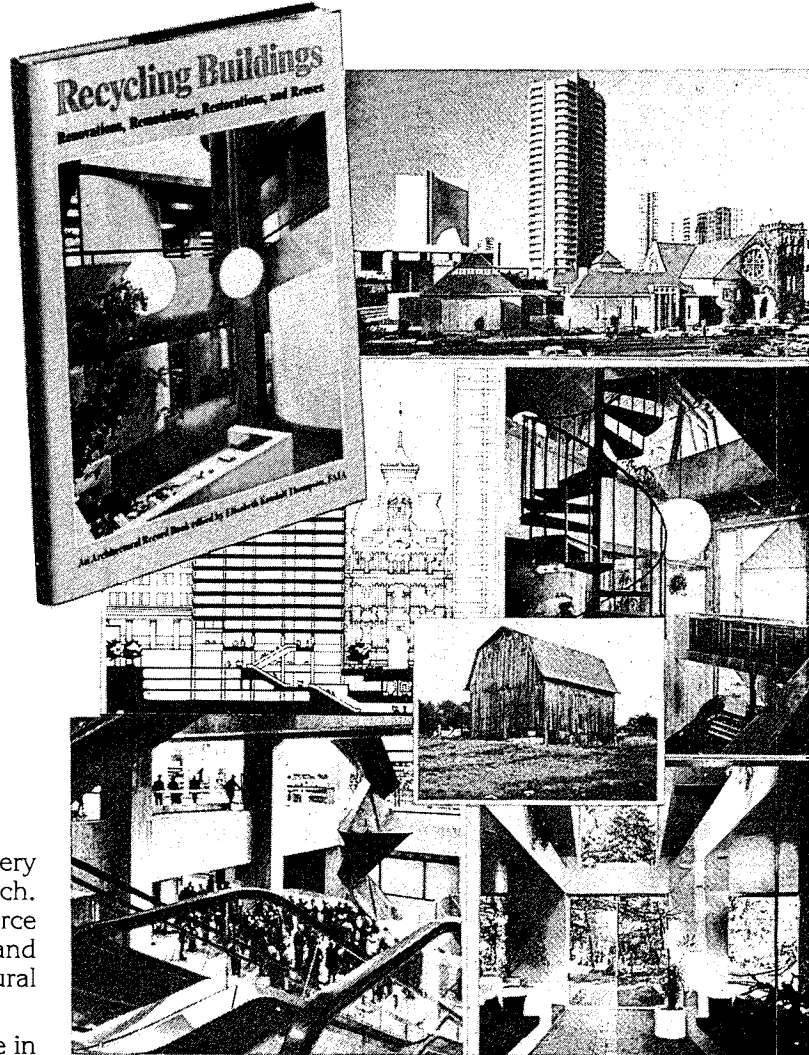

15-DAY FREE EXAMINATION OFFER

Architectural Record
1221 Avenue of the Americas
New York, N.Y. 10020

AR 12-79

Please send me _____ copy (copies) of RECYCLING BUILDINGS (002335-2) on a 15-day free examination basis, after which time I will remit the full price of \$24.95 plus local tax, postage, and handling if I decide to keep the book, or I will return it postpaid. I understand that if I remit in full with this order, plus local tax, McGraw-Hill pays all regular postage and handling, and that return privileges still apply.

This offer good only in U.S., and is subject to acceptance by McGraw-Hill.

Name _____

Address _____

City _____ State _____ Zip _____

Please initial _____ 03K-730-4005-3

Taliesin revisited

APPRENTICE TO GENIUS. YEARS WITH FRANK LLOYD WRIGHT, by Edgar Tafel, McGraw-Hill, \$19.95.

Reviewed by Frederick Gutheim

The final page of the 1943 (Duell) edition of Frank Lloyd Wright's *An Autobiography* shows Wright as he would most like to be remembered, the master, seated at his drafting board, surrounded by eager, attentive apprentices. The scene could be an advertisement for the Taliesin Fellowship, Wright's Depression-born, dimly conceived, money-earning, educational enterprise which still endures. In the picture, fifteen apprentices crowd around, the one on the extreme right, his face partially obscured, is Edgar Tafel. His story, *Apprentice to Genius*, now gives the best view we have of Wright during Tafel's nine years at Taliesin, from 1932 when the Fellowship was established, until 1941 when he left "between breakfast and lunch." It is a powerful, detailed, anecdotal and sympathetic account of Wright, written within acknowledged limits. One hopes without much confidence that other apprentices will write similarly of their experiences. We cannot have too many books about Wright, and there are many questions about his subject that Tafel does not address. Besides this is Tafel's story, and he went back to New York from Wisconsin to make it on his own and become one of the few architects we can recognize who grew rather than were crushed by their experiences at Taliesin. This pleasant, well-written account deserves notice at some length, and there are few architects who will not enjoy reading it.

Many of the questions that frequently have been asked about the Taliesin Fellowship are addressed in Tafel's book. He discusses the dilemma of being a devoted apprentice, an extension of Wright's own genius, and of finding one's individual self-expression. Some of one, some of the other, he concludes. In the end, each apprentice has had to work out his own identity. But these circumstances were not so different from that other great architectural forcing bed, Eliel Saarinen's Cranbrook (derisively called at Taliesin "the country club.")

From the beginning of Tafel's book one learns to proceed with caution with respect



Mildred F. Schmetz

to the facts. In his account of Wright's early life it is clear Tafel is following the treacherous *An Autobiography* and has ignored the biographical studies of Robert Twombly and others. Obviously Tafel is not an architectural historian. He is a participant-observer. Other questions must therefore be asked. For example, to what extent the Fellowship offered an experience different from that of earlier Taliesin draftsmen is not shown. Was it a monastic institution, with "Ins" and "Outs" like choir brothers and lay brothers? How did the apprentices learn how to design? How important and what was intended by Olgivanna Wright and her ideas of "organic living" which extended to work schedules, diet and attire? Beyond such questions one must note that the interest and the value of Tafel's book would have been increased had he included names of apprentices, dates of photographs and other specific details.

The first day he arrived at Taliesin, Tafel was put to work: he whitewashed two bathrooms. But before he left he was meeting clients, superintending jobs and playing a responsible part in design. When he writes about Wright in the 1930s he is describing a time when Wright's practice was expanding and, in particular, he was designing many small houses that gave the apprentices many opportunities for on-the-job experience. Tafel makes good use of this to deal with an aspect of architecture many books ignore—the realities of the building process at the site. But he also entertains us with anecdotes of his experiences as chauffeur, photographer, pianist-in-residence, secretary and factotum; and thus we get accounts of Wright's

encounters with Gropius, Mendelsohn, Mies and other foreign architects, as well as clients and builders. We also get informal snapshots of Wright on the job, work under construction, and happenings en route. One of Tafel's best efforts describes Wright's visits to his own buildings, his interpretations of them; and his account of a tour of Chicago and a visit to the Robie House is as good as anything in the book—except possibly the description of their visit to the Larkin building in Buffalo. (Unfortunately Tafel was scooped in his account of the presentation of Falling-water to Edgar Kaufmann.)

I hope that I am giving the impression of a thoughtful, observant, and intelligent writer, as one who tells his story in a straightforward and attractive fashion. Tafel began his book as a lecture, and then expanded it in its biographical and historical dimensions. Reading it, one has difficulty in knowing where his recollections of his own experiences stop and the results of his other studies begin—but so assimilated has become the narrative as a whole that one seldom thinks to ask. If you don't believe Tafel is an irrepressible storyteller, read his account of the D.D. Martin house in Buffalo which Tafel later restored as architect for the State University of New York.

Tafel's method is to weave together the autobiographical account of his experiences as an apprentice at Taliesin, his view of the evolution of American architecture (not quite the Taliesin party line), and glimpses of Wright. This cinematic cutting makes for good reading for those who come to it without much background in architecture, or who know little about Wright. Those who do will be prompted to skip; but if they do they will miss some fine anecdotes. The account of Wright's split with Sullivan (over "moonlighting," in violation of their working agreement) is one good example, and it is a good example of Tafel's talent with such a thrice-told tale. Indeed, as Tafel admits, "one of the hardest things at Taliesin was hearing him repeat a story for the twelfth time and trying to respond as if it were a new story." One has the impression Tafel was enough of an apple-polisher to try to respond, but his book is not an uncritical acceptance of his hero, warts and all. His anecdotal approach sustains a great deal of talk about what architecture is, illustrated in particular by examples drawn from Wright's buildings. Tafel makes effective use of Wright's mini-sermons at the drafting board, not to mention his longer and more formal periodic Sunday morning talks to the apprentices. Seldom has Wright in his role

continued on page 195

Frederick Gutheim is adjunct professor of American history at George Washington University, a principal in the firm of Gutheim/Seelig/Erickson, and editor of *In the Cause of Architecture*, Wright's RECORD essays.

ARCHITECTURAL RECORD BACK ISSUES



Back issues of **ARCHITECTURAL RECORD** are always in demand by building design professionals. Perhaps you may want a certain Building Type Study as an aid to your current design work, or you may want to review specific features.

Whatever the reason, remember the supply of each issue is limited, and dwindling steadily. Back issues available are listed.

Indicate your selections on the card order form on the following page.

Each back issue is \$6.00 in the U.S., \$7.00 per copy elsewhere, POSTAGE PAID.

(PAYMENT MUST BE INCLUDED WITH ORDER)

1. May, 1976.

An issue on one of the most urgent problems of our time:
HUMAN SETTLEMENTS
An award-winning, thought provoking issue on housing the world's urban poor.

2. February, 1977.

**A MAJOR BUILDING TYPES STUDY...
BUILDING FOR SPORT
A SCHOOL FOR THE DANCE**—By Gunnar Birkerts
4 Projects by R.M. Kliment and Frances Halsband.

3. April, 1977.

40 YEARS OF AMERICAN ARCHITECTURE as explored in 499 Building Types Studies... a remarkable collection of the best buildings in the last 40 years.

4. Mid-May, 1977.

**RECORD HOUSES OF 1977...
PLUS APARTMENTS OF THE YEAR.**
20 houses and 6 multi-family projects selected for the 1977 AWARDS OF EXCELLENCE FOR DESIGN.

5. July, 1977.

**A MAJOR BUILDING TYPES STUDY...
RELIGIOUS BUILDINGS**
Plus:
LOFT LIVING: big spaces, fresh images.
TWO LEARNING PLACES: by Metz Train Olson & Youngman.

6. Mid-August, 1977.

**A MAJOR BUILDING TYPES STUDY...
ENGINEERING FOR ARCHITECTURE...**
featuring ten examples of effective architect-engineer collaboration.
also: **SOLAR ENERGY—NOTES FROM THE FIELD.**

7. October, 1977.

**A MAJOR BUILDING TYPES STUDY...
DESIGNS FOR LEISURE.**
New Buildings by Teodoro Gonzalez de Leon and Abraham Zabludovsky.
THE MALLS AT WATER TOWER PLACE, Chicago, by Warren Platner Associates.

8. November, 1977.

**BUILDING TYPES STUDY... COLLEGE BUILDINGS.
A PORTFOLIO OF RESIDENTIAL ADDITIONS.**
"POSSIBILITIES IN ARCHITECTURE," by Robert Geddes.

9. December, 1977.

**THE CASE FOR DESIGN QUALITY IN
TODAY'S MARKETPLACE.**
Four studies of Collaboration Between Architects and Developers That Explore the Arithmetic of Excellence.
BOSTON'S HISTORIC FANEUIL HALL MARKETPLACE restored and transformed into a successful downtown center.

10. May, 1978.

**ARCHITECTURAL ENGINEERING: QUALITY LIGHT
WITH LOW ENERGY CONSUMPTION.**
PUBLIC CONSTRAINTS AND GOOD DESIGN: two community buildings by Ciardullo Ehmann.
**A MAJOR BUILDING TYPES STUDY: DESIGNING
FOR CULTURE.**

11. Mid-May, 1978.

RECORD HOUSES OF 1978. Featuring the winners for the 1978 AWARDS OF EXCELLENCE FOR DESIGN.

12. July, 1978.

**A MAJOR BUILDING TYPES STUDY...
BUILDINGS FOR INDUSTRY.**
3 Designs by Johnson/Burgee
**PLUS... NEW CORPORATE COMPLEX FOR
FLUOR CORPORATION,**
by Welton Becket Associates.

13. Mid-August, 1978.

**BUILDING TYPES STUDY...
ENGINEERING FOR ARCHITECTURE.**
Featuring the exciting Washington, D.C. and Toronto Metro systems. The innovative treatment of lighting for the underground offers distinctive design approaches.
GAUDI: MASTER OF FORM AND CRAFT.

14. October, 1978.

LOW-RISE HOUSING ... illustrating some interesting solutions to problems with new and renovated apartments.
ST. LOUIS MUSEUM OF ART RESTORATION
—by HARDY HOLZMAN
PFEIFFER ASSOCIATES.

15. Mid-October, 1978.

PRODUCT REPORTS 1979.
A veritable trade show in print. Nearly 1000 new products arranged in the handy 16-division UCI format. A "must-have" issue for all that is new for the design professional. Includes reader service cards enabling you to obtain additional information directly from the manufacturer.

BUSINESS OPPORTUNITIES

BUSINESS OPPORTUNITY

British architectural, structural and civil engineering firm, based in London, with licensed practice in Dam-mam, Saudi Arabia, invites established professional firm or individual with similar expertise and sufficient investment capital to participate in developing further work in the Middle East and Europe.

Interested parties should contact:

**Mr. Ken Beattie
Robert Fish Group
London, England
Telex 918986 Fish G.**

OFFICIAL PROPOSAL

**City of Camden, New Jersey
Camden Transportation Terminal
Request For Qualifications
Architect/Engineer**

The City of Camden is planning to construct a \$19 million transportation facility, financed with U.S. Department of Transportation, Urban Mass Transportation Administration (80%) funds, and State of New Jersey (20%) funds. This inter-modal terminal, consisting of a bus terminal, 600 car parking garage, and mass transit station and concourse, will be constructed at the existing Broadway station of the Delaware River Port Authority (PATCO) transportation line.

The City is beginning the selection process for design, engineering, and inspection services required for the completion of this project. Firms with experience in this field are asked to submit resumes, brochures, and background information in order to be considered for a response for a Request for Proposal (RFP). Please submit information on your firm by January 1, 1980 to: Department of Community Development 10th Floor, City Hall Camden, New Jersey 08101

EXAM STUDY AIDS

Current N.C.A.R.B. Qualifying Tests, Professional Exam & Oral Exam, books & study aids now available. Free brochure. Archinform, P.O. Box 27732, L.A., CA 90027, (213) 662-0216.

**CALL
IN YOUR
NON-DISPLAY
AD**

212/997-2750

PROFESSIONAL SERVICES



**Sippican
Consultants
International, Inc.**

1033 Massachusetts Avenue
Cambridge, Massachusetts 02238
(617) 868-1200



roof engineering, inc.

p.o. box 335
hobbs, new mexico 88240
505-393-8949

Jim D. Koontz, p.e.
president

roof design, inspection, investigation, laboratory analysis

SPECIAL SERVICES

SIGN DESIGN/PRODUCTION

Growth oriented wooden sign graphics firm desires potential clients. Top notch portfolio. Write for free brochure. Hand Carved Sign Systems in Wood. 644 Ridgecrest Drive N.W., Roanoke, VA 24019.

Computer Applications—Software development services for architectural, engineering and construction management applications. Automated solutions in the areas of computer graphics, space planning, data base systems, cost estimating, and the analysis and maintenance of project and office management information. Write Robert J. Krawczyk, 1220 North LaSalle Suite 3E, Chicago, IL 60610, (312) 337-1356.

EDUCATIONAL OPPORTUNITIES

Earn B. Arch. while you work and live in historic, dynamic Boston. Fully accredited/open admissions/work curriculum with job assistance service/low tuition/largest faculty and course selection of any architectural school. Now accepting new and transfer students. For spring semester (classes starting Jan. 28) apply before Jan. 15, 1980. Write Admissions, Boston Architectural Center, 320 Newbury St., Boston, MA 02115.

SELLING OPPORTUNITIES

Sales Reps Wanted—Exceptional opportunity to build a substantial income for qualified reps with contacts. Unicube Corp. is a leading national manufacturer of tubular chrome systems for exhibits, furniture, fixtures and displays. We will supply you with sales leads from our extensive advertising and public relations campaigns. Showroom space desirable. Exclusive territory arrangements. Contact: Mr. Richard Kamlet, Unicube Corp., 540 Manida St., Bronx, N.Y. 10474. Tel: 212/378-1700.

MATERIALS WANTED

Wanted—Photographs of architect designed houses that can be made available for plan sales sections of bi-monthly publication. 500,000 circulation offers good royalty potential to the architect. Write Country Living Magazine, Box 622, Princeton, N.J. 08540, 609-452-8860.

will advance their own recollections, and that we shall have some documentary evidence as well as alumni memoirs. In the later years that Tafel does not record, the Fellowship responded to influences other than those of Wright himself. The rise of similar educational experiments, like the neighboring Cosanti Foundation of Paolo Soleri, is a case in point. But even within Tafel's time frame there are important questions that should be considered by others. How did Taliesin differ from conventional architectural education, by 1932 beginning to respond to the great changes taking place in architectural design and practice? Wright was keenly aware of this, and saw the arrival of Gropius, Mies and other refugees as a threat to his more distinctly American philosophy. But did any of the ideas Wright had learned from Sullivan, who received his education at the Ecole des Beaux Arts, find reflection at Taliesin? These are questions of which Tafel is aware but which he does not want to discuss in this book. We are left with the new and fundamental realization that Wright needs to be assessed carefully as a teacher and that his work is related to large issues in architectural education.

You may gather that Tafel is not too much concerned with historical scholarship. In his summing up he concludes, "The sheer force of Mr. Wright's personality had more impact on the Fellowship than any philosophers or precedents. Mr. Wright was the Fellowship. We lived from hand-to-mouth at first and never had a fixed routine to cling to, but we adored him nevertheless." What Tafel calls Wright's "romantic and automatic legend-making mechanism" is thus sympathetically recognized, but Tafel knows Wright too well to be fooled by these posturings. Instead, he gives depth and color to the experience of being with Wright in those years when the practice was working its way upward from the trough of economic depression. This is an intimate view of Wright at work, his processes of conception and creation and (since no architect produces buildings alone) his relations with his design associates and the building team. However intimate the view, Tafel invariably refers to him as Mr. Wright. (To the apprentices, behind his back, he was "Daddy Frank," or DF.) Here is Tafel's best description of the essential Wright, "He speaks not as a man who designs buildings but as an artist and a poet. He could be a businessman, and he knew how to run a farm, and he was involved with many other interests—but he saw the world with an artist's eye. Beauty and harmony were the qualities he sought in everything—a face, a woman's dress, an arrangement of greens, an Oriental sculpted figure, a house on its site, a landscape. His extraordinarily retentive mind stored visual details, but it was not the mind of a cataloger. He bought art objects because they were beautiful, not for documentary reasons."

There have been biographies of Wright from many hands, but Tafel has provided the clearest and most appealing portrait,

Blinds on sunny east side are lowering automatically in response to programmed and/or electric eye control. Blinds on south side will be lowered from their concealed storage pockets later in the day. In winter, the controls can be set to close Blinds after dark to hold in building heat.



Exterior Solar Control Blinds by Nichols-Homeshield

Save more than they cost

Control Energy Costs

The energy efficient key to solar control is to keep the sun from striking the glass on your building. Reflective or tinted glazing, interior drapes and blinds, all allow interior heat build-up which must be counterbalanced by the mechanical AC system.

Minimize Capital Expense—Lower Operating Costs

Nichols-Homeshield Exterior Solar Control Blinds have a shading coefficient of 0.17. They keep the sun from striking the glass and minimize capital expenses by allowing smaller AC systems and less interior lighting. And they provide long range utility savings by reducing energy consumption.

In addition, expensive multiple glazing may be eliminated along with drapes, interior blinds, and the permanent shading systems which never allow your building to take off its "dark glasses". When retracted, Nichols-Homeshield Blinds allow an unobstructed view and added light levels on overcast days.

Immediate to Eight Year Payback

Depending on geographic location and the local cost of energy, projected payback may be immediate, or may take any amount of time up to eight years.

New Construction or Retrofit

With Nichols-Homeshield Exterior Solar Control Blinds, you can choose either to accept or to reject the sun. And you can choose them for your next new building, or as a retrofit installation on an existing energy-hungry building.

See us in Sweet's 10.24/Ni or call or write:

Nichols-Homeshield, Inc.
Architectural Products Division
1000 North Harvester
West Chicago, IL 60185
(312) 231-5600



NICHOLS-HOMESHIELD, INC.

AN  COMPANY

Circle 98 on inquiry card

ARCHITECTURAL RECORD. Published by McGraw-Hill, Inc., 1221 Avenue of the Americas, New York, New York 10020. ©1979. All rights reserved

Readers using the index will find buildings entered in three ways: by architect's name, by building's or owner's name, and by building type (banks, hospitals, schools, etc.). Other categories cover subjects in the engineering section (concrete, lighting, prefabrication, etc.). ABBREVIATIONS: AB—Architectural Business; AE—Architectural Engineering; BA—Building Activity; BTS—Building Types Study; LP—Legal Perspectives.

A

- Addition to the American Cyanamid Corporate Headquarters, Wayne, N.J.; Schofield/Colgan, archts.—Nov. 1979, pp. 113-118.
- Addition to the Chicago Board of Trade, Chicago, Ill.; C.F. Murphy Assocs., Shaw Swanke, Hayden & Connell, joint-venture archts.—July 1979, pp. 106-107.
- Administration and Visitors Center, Botanic Garden of the Chicago Horticultural Society, Glencoe, Ill.; Edward Larrabee Barnes, archt.—July 1979, pp. 89-96.
- Aga Khan Award for Architecture conference in Jakarta, "Housing in Islam"—Aug. 1979, pp. 87-92.
- Agricultural Engineering Building, University of Illinois, Urbana-Champaign, Ill.; C.F. Murphy Assocs., archts.—July 1979, pp. 104-195.
- Airports. Jeddah International Airport, Hag terminal tents, Saudi Arabia; Skidmore, Owings & Merrill, archts.—Mid-Aug. 1979, BTS, pp. 86-89.
- American Cyanamid Corporate Headquarters Addition, Wayne, N.J.; Schofield/Colgan, archts.—Nov. 1979, pp. 113-118.
- AIA. "AIA Convention: A dialogue on design," Editorial by Walter F. Wagner, Jr.—July 1979, p. 13. "The Florida AIA devotes its whole convention to design. . ." Editorial by Walter F. Wagner, Jr.—Nov. 1979, p. 13.
- Architectural Business. "An architect's checklist to planning building security," by Walton N. Hershfield—Aug. 1979, pp. 53-57. Barrier-free design series by Edward Steinfeld: "Designing entrances and internal circulation to meet barrier-free goals"—July 1979, pp. 65-67; "Designing barrier-free toilet rooms within old & new buildings"—Oct. 1979, pp. 57-59. "Byword for success in the eighties: trimmer management," by Bradford Perkins—Dec. 1979, pp. 59-61 "The Committee for the Preservation of Architectural Records moves on"—Aug. 1979, pp. 77-82. "Construction costs show a 13.8 per cent twelve-month increase"—Nov. 1979, p. 75. "Design firm overhead found to be well over twice direct labor costs"—Mid-Aug. 1979, p. 43. "Dramatic materials price increases grow from energy short-fall"—Aug. 1979, p. 59. "The Ehrenkrantz Group: bridging the technical barrier," by Margaret F. Gaskie—Mid-Aug. 1979, BTS, pp. 94-101. "Federal actions will have a negative impact on housing credit"—July 1979, p. 69. "Life cycle costing: increasingly popular route to design value," by Stephen J. Kirk—Dec. 1979, pp. 63-67. "Post-occupancy study leads to insights on elderly housing"—Sept. 1979, pp. 67-76. "Value of nonresidential rehabilitation will double by mid-1980's"—Oct. 1979, p. 61. "Word processing has a positive impact on one firm's production," by Mark J. Kalin—Mid-Oct. 1979, pp. 19-20.

- Architectural Education. "NCARB: reassessing itself—and the training and skills of architects," Editorial by Walter F. Wagner, Jr.—Sept. 1979, p. 13.
- Architectural Engineering. "Engineering for Architecture," Building Types Study 535—Mid-Aug. 1979; pp. 53-116. "Building systems: something special in a Pei high-rise"—Nov. 1979, pp. 131-133. "Conversation: Cesar Pelli on architectural technology"—Mid-Aug. 1979, BTS, pp. 66-67. "The Ehrenkrantz Group: bridging the technical barrier," by Margaret F. Gaskie—Mid-Aug. 1979, BTS, pp. 94-101. "Fission and fusion and free-style architecture," by Gerald Allen—Dec. 1979, BTS, pp. 92-95. "Lighting in transition: The search for quality with lower energy consumption"—July 1979, pp. 131-136. "Massive Trombe wall saves energy in a Vermont warehouse"—Nov. 1979, 134-136. "Round Table: Risk-taking in design and building"—Mid-Aug. 1979, BTS, pp. 76-85. "Single ply: a promising approach for ailing roofs and new roofs"—Oct. 1979, pp. 127-132.
- Argonne National Laboratories, Program Support Facility, Department of Energy, Ill.; C.F. Murphy Assocs., archts.—July 1979, pp. 102-103.
- Art Galleries. Sainsbury Centre, University of East Anglia, England; Foster Assocs., archts.—Mid-Aug. 1979, BTS, pp. 60-63.

B

- Babcock, James A. & Donald Sandy, Jr., archts.; Quail Cove Condominiums, Stockton, Cal.—Sept. 1979, BTS, pp. 134-135.
- Baldwin Building for Community Medicine. The Mayo Clinic, Rochester, Minn.; Skidmore, Owings & Merrill, archts.—Oct. 1979, BTS, pp. 111-117.
- Banks. First Bank Center, South Bend, Ind.; C.F. Murphy Assocs., archts.—July 1979, pp. 108-109.
- Banwell White & Arnold, Inc., archts.; Famolare Headquarters warehouse addition, Brattleboro, Vt.—Nov. 1979, AE, pp. 134-136.
- Barnes, Edward Larrabee, archt.; Administration and Visitors Center, Botanic Garden of the Chicago Horticultural Society, Glencoe, Ill.—July 1979, pp. 89-96.
- Barovetto, Ruscitto & Barovetto, archts.; Victoria Mews, San Francisco, Cal.—Sept. 1979, BTS, pp. 126-129.
- Bather Ringrose Wolsfeld & Assocs./Kaiser Engineers, archts.; People mover, St. Paul, Minn.—July 1979, BTS, p. 130.
- Belgium. Catholic University of Louvain Medical School, Brussels; Lucien Kroll, archt.—Dec. 1979, BTS, pp. 98-99.
- Beyer Blinder Belle, archts.; CBS Offices, New York, N.Y.—Sept. 1979, pp. 115-118.
- Birkerts, Gunnar & Assocs., archts.; The Calvary Baptist Church Detroit, Mich.—Oct. 1979, pp. 92-96. IBM Southfield Center, Southfield, Mich.—Oct. 1979, pp. 87-92.
- Bobrow/Thomas & Assocs., archts.; Center for Diagnostic and Rehabilitative Medicine, The Daniel Freeman Memorial Hospital, Inglewood, Cal.—Oct. 1979, BTS, pp. 120-123.
- Bologna Master Plan, Bologna, Italy; Pier Luigi Cervellati, archt.—Dec. 1979, BTS, pp. 102-103.
- Botanic Garden of the Chicago Horticultural Society, Administration and Visitors Center, Glencoe, Ill.; Edward Larrabee Barnes, archt.—July 1979, pp. 89-96.
- Brown, Daltas & Assocs., archts.; "Word processing has a positive impact on one firm's production," by Mark J. Kalin—Mid-Oct. 1979, AB, pp. 19-20.
- Building Activity. "Dodg/Sweet's construction outlook, 1979: second update"—Aug. 1979, pp. 49-51. Dodg/Sweet's construction outlook: 1980 is not 1975"—Nov. 1979, pp. 65-73.
- Bullock's Oakridge, San Jose, Cal.; Environmental Planning & Research, Inc., archts.—Mid-Aug. 1979, BTS, pp. 90-93.
- Burdette Keeland & Assocs.; archts.; Four Speculative Townhouses, Houston, Tex.—Sept. 1979, BTS, pp. 130-131. Five Speculative Townhouses, Houston, Tex.—Sept. 1979, BTS, pp. 132-133.

- Butler Hospital, Providence, R.I.; The Hillier Group, archts.—Oct. 1979, BTS, pp. 124-126.
- Byker Redevelopment, Newcastle-upon-Tyne, England; Ralph Erskine's Arkitektkontor AB, archts.—Dec. 1979, BTS, pp. 104-105.

C

- CBS Offices, New York, N.Y.; Beyer Blinder Belle, archts.—Sept. 1979, pp. 115-118.
- Calvary Baptist Church, Detroit, Mich.; Gunnar Birkerts & Assocs., archts.—Oct. 1979, pp. 92-96.
- Cambridge Seven Assocs., archts.; Porter Square Station, Cambridge, Mass.—July 1979, BTS, pp. 124-125.
- Canada. False Creek Co-op Housing, Vancouver, B.C.; Henriquez Architects Urban Designers, archts.—Sept. 1979, BTS, pp. 136-137.
- Cathedral Church of Saint John the Divine, New York, N.Y.; Ralph Adams Cram and Grant La Farge, original design; Hoyle Doran & Berry, archts. for addition—Nov. 1979, pp. 119-126.
- Catholic University of Louvain Medical School, Brussels, Belgium; Lucien Kroll, archt.—Dec. 1979, BTS, pp. 98-99.
- Caudill Rowlett Scott archts.; Shell Oil Company office building, Houston, Tex.—Mid-Aug. 1979, BTS, pp. 102-105.
- Center City, "new perceptions of opportunities for cities," Dec. 1979, BTS, pp. 114-119
- Center for Diagnostic and Rehabilitative Medicine, The Daniel Freeman Memorial Hospital, Inglewood, Cal.; Bobrow/Thomas & Assocs., archts.—Oct. 1979, BTS, pp. 120-123.
- Cervellati, Pier Luigi, archt.; Master Plan for Bologna, Italy—Dec. 1979, BTS, pp. 102-103.
- Chicago Board of Trade Addition, Chicago, Ill.; C.F. Murphy Assocs., Shaw Swanke Hayden & Connell, joint-venture archts.—July 1979, pp. 106-107.
- City Hall, Durham, N.C.; John D. Latimer & Assocs., Inc., archts.—Aug. 1979, BTS, pp. 98-101.
- Community College of Baltimore, Harbor Campus, Baltimore, Md.; Daniel, Mann, Johnson & Mendenhall, archts.—Nov. 1979, BTS, pp. 98-99.
- Conservatory, Administration and Visitors Center, Botanic Garden of the Chicago Horticultural Society, Glencoe, Ill.; Edward Larrabee Barnes, archt.—July 1979, pp. 89-96.
- "Corbusier (Le): structural mastery supports art," by Herman Spiegel—Mid-Aug. 1979, BTS, pp. 68-75.
- Cram. Ralph Adams and Grant La Farge, original design; Hoyle, Doran & Berry, archts. for addition; Cathedral Church of Saint John the Divine, New York, N.Y.—Nov. 1979, pp. 119-126.

D

- Daniel, Mann, Johnson & Mendenhall, archts.; Community College of Baltimore, Harbor Campus, Baltimore, Md.—Nov. 1979, BTS, pp. 98-99.
- Daniel, Mann, Johnson & Mendenhall and Envirodynamics, Inc., archts.; Northlake Community College, Irving, Tex.—Nov. 1979, BTS, pp. 94-97.
- Daniel, Mann, Johnson & Mendenhall and Jenkins-Fleming, archts.; People mover, Los Angeles, Cal.—July 1979, BTS, p. 130.
- Daniel, Mann, Johnson & Mendenhall and Reynolds, Smith & Hills, archts.; Florida Community College, Cumberland Campus, Jacksonville, Fla.—Nov. 1979, BTS, pp. 100-102.
- Doud, Ron Inc., designers; Apartment, New York, N.Y.—Nov. 1979, pp. 127-130.
- Dune house, Quogue, L.I., N.Y.; Gwathmey Siegel, archts.—Sept. 1979, pp. 96-99.

E

- Edelman & Salzman, archts.; Jennings Hall Senior Citizen Housing, Brooklyn, N.Y.—Dec. 1979, BTS, pp. 100-101.

Editorials. "About commitments to energy conservation: three cheers (relatively speaking) for our team," by Walter F. Wagner, Jr.—Mid-Aug. 1979, p. 7. "AIA Convention: A dialogue on design," by Walter F. Wagner, Jr.—July 1979, p. 13. "Architects' involvement in housing: Encouraging trends. Can we hope for more?," by Walter F. Wagner, Jr.—Aug. 1979, p. 13. The Florida AIA devotes its whole convention to design . . .," by Walter F. Wagner, Jr.—Nov. 1979, p. 13. "The manufacturers and suppliers: Let's not forget their role—and risk," by Walter F. Wagner, Jr.—Mid-Oct. 1979, p. 21. "NCARB: reassessing itself—and the training and skills of architects," by Walter F. Wagner, Jr.—Sept. 1979, p. 13. "On building awareness by architects of the new needs of our changing families," by Walter F. Wagner, Jr.—Oct. 1979, p. 13. "Revolution, evolution, and the market for the 1980s," by Walter F. Wagner, Jr.—Dec. 1979, p. 13.

"The Ehrenkrantz Group: bridging the technical barrier," by Margaret F. Gaskie—Mid-Aug. 1979, BTS, pp. 94-101.

Energy Conservation. "About commitments to energy conservation: three cheers (relatively speaking) for our team," Editorial by Walter F. Wagner, Jr.—Mid-Aug. 1979, p. 7. Famolare Headquarters warehouse addition, Brattleboro, Vt.; Banwell White & Arnold, Inc., archts.—Nov. 1979, AE, pp. 134-136. House/Test Rig, England, Foster Assocs., archts.—Mid-Aug. 1979, BTS, pp. 64-65. "Lighting in transition: The search for quality with lower energy consumption"—July 1979, AE, pp. 131-136. Program Support Facility, Department of Energy, Argonne National Laboratories, Ill.; C.F. Murphy Assocs., archts.—July 1979, pp. 102-103. Shell Oil Company office building, Houston, Tex., Caudill Rowlett Scott, archts.—Mid-Aug. 1979, BTS, pp. 102-105.

England. Byker Redevelopment, Newcastle-upon-Tyne; Ralph Erskine's Arkitektkontor AB, archts.—Dec. 1979, BTS, pp. 104-105. Hammersmith Centre, London; Foster Assocs., archts.—Mid-Aug. 1979, BTS, pp. 56-59. Hexagon, Reading; Robert Matthew, Johnson-Marshall & Partners, archts.—Mid-Aug. 1979, BTS, pp. 114-116. House/Test Rig; Foster Assocs., archts.—Mid-Aug. 1979, BTS, pp. 64-65. Sainsbury Centre, University of East Anglia; Foster Assocs., archts.—Mid-Aug. 1979, BTS, pp. 60-63.

Envirodynamics, Inc. and Daniel, Mann, Johnson & Mendenhall, archts.; Northlake Community College, Irving, Tex.—Nov. 1979, BTS, pp. 94-97.

Environmental Planning & Research, Inc., archts; Buirrock's Oakridge, San Jose, Cal.—Mid-Aug. 1979, BTS, pp. 90-93.

Erskine's Ralph Arkitektkontor AB, archts.; Byker Redevelopment, Newcastle-upon-Tyne, England—Dec. 1979, BTS, pp. 104-105.

F

False Creek Co-op Housing, Vancouver, B.C., Canada; Henriquez Architects Urban Designers, archts.—Sept. 1979, BTS, pp. 136-137.

Famolare Headquarters warehouse addition, Brattleboro, Vt.; Banwell White & Arnold, Inc., archts.—Nov. 1979, AE, pp. 134-136.

Federal Building, U.S. Courthouse, Fort Lauderdale, Fla.; William Morgan Architects and H.J. Ross Assocs., Inc., archts.—Oct. 1979, pp. 81-86.

Ferendino. Grafton. Spillis. Candela, archts.; Third District Court of Appeal, Miami, Fla.—Aug. 1979, BTS, pp. 110-112.

First Bank Center, South Bend, Ind.; C.F. Murphy Assocs., archts.—July 1979, pp. 108-109.

Five Speculative Townhouses, Houston, Tex.; Burdette Keeland & Assocs., archts.—Sept. 1979, BTS, pp. 132-133.

Florida Community College, Cumberland Campus, Jacksonville, Fla.; Reynolds, Smith & Hills and Daniel, Mann, Johnson & Mendenhall, archts.—Nov. 1979, BTS, pp. 100-102.

Floyd, Chad with Charles Moore, archts.; Roanoke Design 79, Roanoke, Va.—Dec. 1979, BTS, pp. 100-101.

Ford, O'Neil, archts.; San Antonio, Tex.—Dec. 1979, BTS, pp. 126-130.

Foreign Architecture. See individual country.

Foster Associates, archts.; Hammersmith Centre, London, England—Mid-Aug. 1979, BTS, pp. 56-59. House/Test Rig, England—Mid-Aug. 1979, BTS, pp. 64-65. Sainsbury Centre, University of East Anglia, England—Mid-Aug. 1979, BTS, pp. 60-63. Whitney Museum of American

Art, Mixed-Use Building, New York, N.Y.—Mid-Aug. 1979, BTS, pp. 54-55.

Four Speculative Townhouses, Houston, Tex.; Burdette Keeland & Assocs., archts.—Sept. 1979, BTS, pp. 130-131.

France. Institute for Research and Coordination Acoustics/Music, (IRCAM), Paris; Piano and Rogers, archts.—Mid-Aug. 1979, BTS, pp. 106-107. "LeCorbusier: structural mastery supports art," by Herman Spiegel; two houses: Villa Savoye, Poissy; Maison Jaoul, Neuilly—Mid-Aug. 1979, BTS, pp. 68-75.

Freeman, Daniel Memorial Hospital, Center for Diagnostic and Rehabilitative Medicine, Inglewood, Cal.; Bobrow/Thomas & Assocs., archts.—Oct. 1979, BTS, pp. 120-123.

G

General Foods Corporate Headquarters, Rye and Harrison, N.Y.; Kevin Roche, John Dinkeloo & Assocs., archts.—Aug. 1979, pp. 93-96.

Glassell, The Alfred C., Jr. Art School, Houston, Tex.; S.I. Morris Assocs., archts.—Sept. 1979, pp. 119-124.

Goldfinger, Myron, archt.; McGrath Residence, Westchester, N.Y.—Aug. 1979, pp. 83-86.

Graphics. "The Committee for the Preservation of Architectural Records moves on"—Aug. 1979, pp. 77-82

Gwathmey Siegel, archts.; "A section through the thinking of Gwathmey Siegel architects"; three buildings: Thomas & Betts Headquarters, Raritan, N.J.—Sept. 1979, pp. 91-95; Dune house, Quogue, L.I., N.Y.—Sept. 1979, pp. 96-99; New York State College dormitory and dining hall, Purchase, N.Y.—Sept. 1979, pp. 100-102.

H

Hammersmith Centre, London, England; Foster Assocs., archts.—Mid-Aug. 1979, BTS, pp. 56-59.

Hardee Center, Wauchula, Fla.; Zoller/Abbott Archts., archts.—Aug. 1979, BTS, pp. 108-109.

Harvard Square Station, Cambridge, Mass.; Skidmore, Owings & Merrill—Boston office, archts.—July 1979, BTS, pp. 122-123.

Henriquez Architects Urban Designers, archts.; False Creek Co-op Housing, Vancouver, B.C., Canada—Sept. 1979, BTS, pp. 136-137.

Hertzberger, Herman, archt.; Muziekcentrum Vredenburg, Utrecht, Netherlands—Mid-Aug. 1979, BTS, pp. 108-113.

Hexagon, Reading, England; Robert Matthew, Johnson-Marshall & Partners, archts.—Mid-Aug. 1979, BTS, pp. 114-116.

Hillier Group (The), archts.; Butler Hospital, Providence, R.I.—Oct. 1979, BTS, pp. 124-126.

Hirsch Residence, Pittsburgh, Pa.; Tasso Katselas, archt.—Nov. 1979, pp. 108-112.

Hospitals. "Medical facilities," Building Types Study 537—Oct. 1979, pp. 111-126. Butler Hospital, Providence, R.I.; The Hillier Group, archts.—Oct. 1979, BTS, pp. 124-126.

Center for Diagnostic and Rehabilitative Medicine, The Daniel Freeman Memorial Hospital, Inglewood, Cal.; Bobrow/Thomas & Assocs., archts.—Oct. 1979, BTS, pp. 120-123. See also Medical Facilities.

Hotels & Motels. Ishikawa Cultural Center, Ishikawa Prefecture, Japan; Kisho Kurokawa, archt.—Aug. 1979, pp. 65-67.

Houses. Byker Redevelopment, Newcastle-upon-Tyne, England; Ralph Erskine's Arkitektkontor AB, archts.—Dec. 1979, BTS, pp. 104-105. Dune House, Quogue, L.I., N.Y.; Gwathmey Siegel, archts.—Sept. 1979, pp. 96-99. Hirsch Residence, Pittsburgh, Pa.; Tasso Katselas, archt.—Nov. 1979, pp. 108-112. House/Test Rig, England; Foster Assocs., archts.—Mid-Aug. 1979, BTS, pp. 64-65. Katselas Residence, Pittsburgh, Pa.; Tasso Katselas, archt.—Nov. 1979, pp. 103-107. Klostermuren Residential Community, Göteborg, Sweden; Johannes Olivergren, archt.—Dec. 1979, BTS, pp. 106-107. "Le Corbusier: structural mastery supports art," by Herman Spiegel; two houses: Villa Savoye, Poissy; Maison Jaoul, Neuilly—Mid-Aug. 1979, BTS, pp. 68-75. McGrath Residence, Westchester, N.Y.; Myron Goldfinger, archt.—Aug. 1979, pp. 83-86.

Housing & Apartments. "Housing," Building Types Study 536—Sept. 1979, pp. 125-140. Apartment, New York, N.Y., Ron Doud Inc., designers—Nov. 1979, pp. 127-130. "Architects' involvement in housing: Encouraging trends. Can we hope for more?," Editorial by Walter F. Wagner, Jr.—Aug. 1979, p. 13. Byker Redevelopment,

Newcastle-upon-Tyne, England; Ralph Erskine's Arkitektkontor AB, archts.—Dec. 1979, BTS, pp. 104-105. False Creek Co-op Housing, Vancouver, B.C., Canada; Henriquez Architects Urban Designers, archts.—Sept. 1979, BTS, pp. 136-137. Five Speculative Townhouses, Houston, Tex.; Burdette Keeland & Assocs., archts.—Sept. 1979, BTS, pp. 132-133. Four Speculative Townhouses, Houston, Tex.; Burdette Keeland & Assocs., archts.—Sept. 1979, BTS, pp. 130-131. "Housing in Islam," Aga Khan Award for Architecture conference in Jakarta—Aug. 1979, pp. 87-92. Jennings Hall Senior Citizen Housing, Brooklyn, N.Y.; Edelman & Salzman, archts.—Dec. 1979, BTS, pp. 100-101. "On building awareness by architects of the new needs of our changing families," Editorial by Walter F. Wagner, Jr.—Oct. 1979, p. 13. "Post-occupancy study leads to insight on elderly housing"—Sept. 1979, AB, pp. 67-76. Quail Cove Condominiums, Stockton, Cal.; Donald Sandy, Jr. & James A. Babcock, archts.—Sept. 1979, BTS, pp. 134-135. Resort Condominium, Kiawah Island, S.C.; Jove/Daniels/Busby, archts.—Sept. 1979, BTS, pp. 138-140. "Round table: Housing and community design for changing family needs"—Oct. 1979, pp. 97-104. Victoria Mews, San Francisco, Cal.; Barovetto, Ruscitto & Barovetto, archts.—Sept. 1979, BTS, pp. 126-129.

Hoyle, Doran & Berry, archts for addition; Ralph Adams Cram and Grant La Farge, original design; Cathedral Church of Saint John the Divine, New York, N.Y.—Nov. 1979, pp. 119-126.

I

In Season Restaurant, Philadelphia, Pa.; James Oleg Kruhly, archt.—Oct. 1979, p. 110.

Industrial Buildings. "An architect's checklist to planning building security," by Walton N. Hershfield—Aug. 1979, AB, pp. 53-57. Famolare Headquarters warehouse addition, Brattleboro, Vt.; Banwell White & Arnold, Inc., archts.—Nov. 1979, AE, pp. 134-136.

Institute for Research and Coordination Acoustics/Music, (IRCAM), Paris, France; Piano and Rogers, archts.—Mid-Aug. 1979, BTS, pp. 106-107.

Interiors. Apartment, New York, N.Y.; Ron Doud Inc., designers—Nov. 1979, pp. 127-130. CBS Offices, New York, N.Y.; Beyer Blinder Belle, archts.—Sept. 1979, pp. 115-118. In Season Restaurant, Philadelphia, Pa.; James Oleg Kruhly, archt.—Oct. 1979, p. 110. Rusty Scupper Restaurant, Pittsburgh, Pa.; Edmund Stevens Assocs., archts.—Oct. 1979, pp. 108-109. The Whole Grain, Cleveland, O.; Wudtke Watson Davis, Inc., archts.—Oct. 1979, pp. 106-107.

IBM Southfield Center, Southfield, Mich.; Gunnar Birkerts & Assocs., archts.—Oct. 1979, pp. 87-92.

International Headquarters for Gelco Corporation, Eden Prairie, Minn.; The Leonard Parker Assocs., archts.—Sept. 1979, pp. 109-114.

Ishikawa Cultural Center, Ishikawa Prefecture, Japan; Kisho Kurokawa, archt.—Aug. 1979, pp. 65-67.

Islam. "Housing in Islam," Aga Khan Award for Architecture conference in Jakarta—Aug. 1979, pp. 87-92.

Italy. Bologna Master Plan; Pier Luigi Cervellati, archt.—Dec. 1979, BTS, pp. 102-103.

J

Japan. "Kisho Kurokawa: A study in cultural connections—three buildings"—Aug. 1979, pp. 65-72. Ishikawa Cultural Center, Ishikawa Prefecture—Aug. 1979, pp. 65-67; Japan Red Cross Headquarters, Tokyo—Aug. 1979, pp. 68-69; National Ethnological Museum, Osaka—Aug. 1979, pp. 70-72.

Japan Red Cross Headquarters, Tokyo, Japan; Kisho Kurokawa, archt.—Aug. 1979, pp. 68-69.

Jeddah International Airport, Hag terminal tents, Saudi Arabia; Skidmore, Owings & Merrill, archts.—Mid-Aug. 1979, BTS, pp. 86-89.

Jenkins-Fleming with Daniel, Mann, Johnson & Mendenhall, archts.; People mover, Los Angeles, Cal.—July 1979, BTS, p. 130.

Jennings Hall Senior Citizen Housing, Brooklyn, N.Y.; Edelman & Salzman, archts.—Dec. 1979, BTS, pp. 100-101.

Johnson. Hotvedt. DiNisco, archts.; Public Safety headquarters, Portland, Me.—Aug. 1979, BTS, pp. 104-107.

Johnson-Marshall & Partners, Robert Matthew, archts.; Hexagon, Reading, England—Mid-Aug. 1979, BTS, pp. 114-116.

Jova/Daniels/Busby, archts.; Resort Condominium, Kiawah Island, S.C.—Sept. 1979, BTS, pp. 138-140.

K

- Kaiser Engineers/Bather Ringrose Wolsfeld & Assocs., archts.; People mover, St. Paul, Minn.—July 1979, BTS, p. 130.
- Kaplan/McLaughlin/Diaz, archts.; "Post-occupancy study leads to insights on elderly housing"—Sept. 1979, AB, pp. 67-76.
- Katselas, Tasso, archt.; Hirsch Residence, Pittsburgh, Pa.—Nov. 1979, pp. 108-112. Katselas Residence, Pittsburgh, Pa.—Nov. 1979, pp. 103-107.
- Katz Waisman Weber Strauss Blumenkranz & Bernhard and Warner Burns Toan & Lunde, archts.; Kingsborough Community College, Brooklyn, N.Y.—Nov. 1979, BTS, pp. 88-93.
- Kingsborough Community College, Brooklyn, N.Y.; Katz Waisman Weber Strauss Blumenkranz & Bernhard and Warner Burns Toan & Lunde, archts.—Nov. 1979, BTS, pp. 88-93.
- Klostermuren Residential Community, Göteborg, Sweden; Johannes Olivergren, archt.—Dec. 1979, BTS, pp. 106-107.
- Kroll, Lucien, archt.; Catholic University of Louvain Medical School, Brussels, Belgium—Dec. 1979, BTS, pp. 98-99.
- Kruhly, James Oleg, archt.; In Season Restaurant, Philadelphia, Pa.—Oct. 1979, p. 110.
- Kurokawa, Kisho, archt.; "A study in cultural connections: three buildings"—Aug. 1979, pp. 65-72. Ishikawa Cultural Center, Ishikawa Prefecture, Japan—Aug. 1979, pp. 65-67; Japan Red Cross Headquarters, Tokyo, Japan—Aug. 1979, pp. 68-69; National Ethnological Museum, Osaka, Japan—Aug. 1979, pp. 70-72.

L

- La Farge, Grant and Ralph Adams Cram, original design; Hoyle, Doran & Berry, archts. for addition; Cathedral Church of Saint John the Divine, New York, N.Y.—Nov. 1979, pp. 119-126.
- La Lumiere Athletic Facility, La Porte, Ind., C.F. Murphy Assocs., archts.—July 1979, p. 99.
- Latimer, John D & Assocs., Inc., archts.; City Hall, Durham, N.C.—Aug. 1979, BTS, pp. 98-101.
- "Le Corbusier: structural mastery supports art," by Herman Spiegel—Mid-Aug. 1979, BTS, pp. 68-75.
- Legal Perspectives. "Architecture and law in the 1980s," by Arthur T. Kornblut, Esq.—Dec. 1979, p. 69. "Key to avoiding litigation is performing defensively," by J. James Wulfsberg—July 1979, p. 63. "Weighing your decision to settle, or defend against, liability claims," by Arthur T. Kornblut, Esq.—Oct. 1979, p. 55.
- Libraries. Yale University Library and Lecture Hall, New Haven, Conn.; Herbert S. Newman Assocs., archts.—July 1979, pp. 111-114.
- Lighting. "Lighting in transition: The search for quality with lower energy consumption"—July 1979, AE, pp. 131-136. Shell Oil Company office building, Houston, Tex.; Caudill Rowlett Scott, archts.—Mid-Aug. 1979, BTS, pp. 102-105.
- Lowell (The) Team (a joint venture of David A. Crane & Partners, Gelardin/Bruner/Cott and Michael Sand & Assocs.), archts.; Lowell's National Historical Park, Lowell, Mass.—Sept. 1979, pp. 103-108.
- Lowell's National Historical Park, Lowell, Mass.; Lowell (The) Team (a joint venture of David A. Crane & Partners, Gelardin/Bruner/Cott and Michael Sand & Assocs.), archts.—Sept. 1979, pp. 103-108.

M

- "Marshall, Mich.: The small town is coming back"—Dec. 1979, BTS, pp. 108-113.
- Matthew, Robert, Johnson-Marshall & Partners, archts., Hexagon, Reading, England—Mid-Aug. 1979, BTS, pp. 114-116.
- Mayo Clinic, Baldwin Building for Community Medicine, Rochester, Minn.; Skidmore, Owings & Merrill, archts.—Oct. 1979, BTS, pp. 111-117.
- McGrath Residence, Westchester, N.Y.; Myron Goldfinger, archt.—Aug. 1979, pp. 83-86.
- Medical Facilities. "Medical Facilities," Building Types Study 537—Oct. 1979, pp. 111-126. Baldwin Building for Community Medicine, The Mayo Clinic, Rochester, Minn.; Skidmore, Owings & Merrill, archts.—Oct. 1979, BTS, pp. 111-117. See also Hospitals.
- "Missing Mies," (Ludwig Mies van der Rohe) comments from Stanley Tigerman, James Ingo Freed and R. Ogden Hannaford—July 1979, pp. 97, 110.

- Moore Charles with Chad Floyd, archts.; Roanoke Design 79, Roanoke, Va.—Dec. 1979, BTS, pp. 100-101.
- Moore-Heder, archts.; Ocean Spray Cranberries, Inc., Plymouth, Mass.—Aug. 1979, pp. 73-76.
- Morgan, William Architects and H.J. Ross Assocs. Inc., archts.; Federal Building, U.S. Courthouse, Fort Lauderdale, Fla.—Oct. 1979, pp. 81-86.
- Morris, S.I. Assocs., archts.; The Alfred C. Glassell, Jr. Art School, Houston, Tex.—Sept. 1979, pp. 119-124.
- Murphy, C.F. Assocs., archts.; "New directions and new designs at C.F. Murphy Associates," by Helmut Jahn—July 1979, pp. 98-109. Six projects: La Lumiere Athletic Facility, La Porte, Ind.—July 1979, p. 99; Rust-Oleum Headquarters, Vernon Hills, Ill.—July 1979, pp. 100-101; Program Support Facility, Department of Energy, Argonne National Laboratories, Ill.—July 1979, pp. 102-103; Agricultural Engineering Building, University of Illinois, Urbana-Champaign, Ill.—July 1979, pp. 104-105; Addition to the Chicago Board of Trade, Chicago, Ill.—July 1979, pp. 106-107; First Bank Center, South Bend Ind.—July 1979, pp. 108-109.
- Museums. National Ethnological Museum, Osaka, Japan; Kisho Kurokawa, archt.—Aug. 1979, pp. 70-72. Whitney Museum of American Art, Mixed-Use Building, New York, N.Y.; Foster Assocs., archts.—Mid-Aug. 1979, BTS, pp. 54-55.
- Muziekcentrum Vredenburg, Utrecht, Netherlands; Herman Hertzberger archt.—Mid-Aug. 1979, pp. 108-113.

N

- National Ethnological Museum, Osaka, Japan: Kisho Kurokawa, archt.—Aug. 1979, pp. 70-72.
- Netherlands. Muziekcentrum Vredenburg, Utrecht; Herman Hertzberger, archt.—Mid-Aug. 1979, BTS, pp. 108-113.
- New York State College dormitory and dining hall, Purchase, N.Y.; Gwathmey Siegel, archts.—Sept. 1979, p. 100-102.
- Newman, Herbert S. Assocs., archts.; Yale University Library and Lecture Hall, New Haven, Conn.—July 1979, pp. 111-114.
- N.E. Corridor Improvement Project; Skidmore, Owings & Merrill—Washington, D.C. office, archts.—July 1979, BTS, pp. 120-121.
- Northlake Community College, Irving, Tex.; Envirodynamics, Inc. and Daniel, Mann, Johnson & Mendenhall, archts.—Nov. 1979, BTS, pp. 94-97.

O

- Ocean Spray Cranberries, Inc., Plymouth, Mass.; Moore-Heder, archts.—Aug. 1979, pp. 73-76.
- Office Buildings. American Cyanamid Corporate Headquarters addition, Wayne, N.J.; Schofield/Colgan, archts.—Nov. 1979, pp. 113-118. "An architect's checklist to planning building security," by Walton N. Hershfield—Aug. 1979, AB, pp. 53-57. Chicago Board of Trade Addition, Chicago, Ill.; C.F. Murphy Assocs., Shaw Swanke Hayden & Connell, joint-venture archts.—July 1979, pp. 106-107. Famolare Headquarters warehouse addition, Brattleboro, Vt.; Banwell White & Arnold, Inc., archts.—Nov. 1979, AE, pp. 134-136. 499 Park Avenue, New York, N.Y.; I.M. Pei & Partners, archts.—Nov. 1979, AE, pp. 131-133. General Foods Corporate Headquarters, Rye and Harrison, N.Y.; Kevin Roche, John Dinkeloo & Assocs., archts.—Aug. 1979, 93-96. Hammersmith Centre, London, England; Foster Assocs., archts.—Mid-Aug. 1979, BTS, pp. 56-59. IBM Southfield Center, Southfield, Mich.; Gunnar Birkerts & Assocs., archts.—Oct. 1979, pp. 87-92. International Headquarters for Gelco Corporation, Eden Prairie, Minn.; The Leonard Parker Assocs., archts.—Sept. 1979, pp. 109-114. Japan Red Cross Headquarters, Tokyo, Japan; Kisho Kurokawa, archt.—Aug. 1979, pp. 68-69. Ocean Spray Cranberries, Inc., Plymouth, Mass.; Moore-Heder, archts.—Aug. 1979, pp. 73-76. Rust-Oleum Headquarters, Vernon Hills, Ill.; C.F. Murphy Assocs., archts.—July 1979, pp. 100-101. Shell Oil Company office building, Houston, Tex.; Caudill Rowlett Scott, archts.—Mid-Aug. 1979, BTS, pp. 102-105. Thomas & Betts Headquarters, Raritan, N.J.; Gwathmey Siegel, archts.—Sept. 1979, pp. 91-95.
- Offices. CBS Offices, New York, N.Y.; Beyer Blinder Belle, archts.—Sept. 1979, pp. 115-118.
- Olivergren, Johannes, archt.; Klostermuren Residential Community, Göteborg, Sweden—Dec. 1979, BTS, pp. 106-107.

P

- Parker, The Leonard Assocs., archts.; International Headquarters for Gelco Corporation, Eden Prairie, Minn.—Sept. 1979, pp. 109-114.
- Parks. Hammersmith Centre, London, England; Foster Assocs., archts.—Mid-Aug. 1979, BTS, pp. 56-59. Lowell's National Historical Park, Lowell, Mass.; Lowell (The) Team (a joint venture of David A. Crane & Partners, Gelardin/Bruner/Cott and Michael Sand & Assocs.), archts.—Sept. 1979, pp. 103-108.
- Patty Berkebile Nelson Associates Architects Inc., archts.; South Central Patrol Division, Kansas City, Mo.—Aug. 1979, BTS, pp. 102-103.
- Pei, I.M. & Partners, archts.; Office building, 499 Park Avenue, New York, N.Y.—Nov. 1979, AE, pp. 131-133. Transitway/Mall, Denver, Colo.—July 1979, BTS, pp. 126-127.
- Pelli, Cesar, architect and Dean of the School of Architecture at Yale Univ. (taped interview); "Conversation: Cesar Pelli on architectural technology"—Mid-Aug. 1979, BTS, pp. 66-67.
- People movers: Los Angeles, Cal.; Daniel, Mann, Johnson & Mendenhall with Jenkins-Fleming, archts.; St. Paul, Minn.; Bather Ringrose Wolsfeld & Assocs./Kaiser Engineers, archts.—July 1979, BTS, p. 130.
- Performing Arts Buildings. Hexagon, Reading, England; Robert Matthew, Johnson-Marshall & Partners, archts.—Mid-Aug. 1979, BTS, pp. 114-116. Institute for Research and Coordination Acoustics/Music, (IRCAM), Paris, France; Piano and Rogers, archts.—Mid-Aug. 1979, BTS, pp. 106-107. Ishikawa Cultural Center, Ishikawa Prefecture, Japan; Kisho Kurokawa, archt.—Aug. 1979, pp. 65-67. Muziekcentrum Vredenburg, Utrecht, Netherlands; Herman Hertzberger, archt.—Mid-Aug. 1979, BTS, pp. 108-113.
- Piano and Rogers, archts.; Institute for Research and Coordination Acoustics/Music, (IRCAM), Paris, France—Mid-Aug. 1979, BTS, pp. 106-107.
- Planning. "New perceptions for the 1980s: the need to pioneer," Building Types Study 539—Dec. 1979, pp. 85-136. Bologna Master Plan, Bologna, Italy; Pier Luigi Cervellati, archt.—Dec. 1979, BTS, pp. 102-103. Byker Redevelopment, Newcastle-upon-Tyne, England; Ralph Erskine's Arkitektkontor AB, archts.—Dec. 1979, BTS, pp. 104-105. Catholic University of Louvain Medical School, Brussels, Belgium; Lucien Kroll, archt.—Dec. 1979, pp. 98-99. Center City, "New perceptions of opportunities for cities," Dec. 1979, BTS, pp. 114-119. "The Ehrenkrantz Group: bridging the technical barrier," by Margaret F. Gaskie—Mid-Aug. 1979, BTS, pp. 94-101. "Fission and fusion and free-style architecture," by Gerald Allen—Dec. 1979, BTS, pp. 92-95. Jennings Hall Senior Citizen Housing, Brooklyn, N.Y.; Edelman & Salzman, archts.—Dec. 1979, BTS, pp. 100-101. Klostermuren Residential Community, Göteborg, Sweden; Johannes Olivergren, archt.—Dec. 1979, BTS, pp. 106-107. "Marshall, Mich.: The small town is coming back"—Dec. 1979, BTS, pp. 108-113. "On building awareness by architects of the new needs of our changing families," Editorial by Walter F. Wagner, Jr.—Oct. 1979, p. 13. "Perspectives on mobility"—Dec. 1979, BTS, pp. 120-125. Pratt Institute Center for Community and Economic Development, Brooklyn, N.Y., Community Design Center—Dec. 1979, BTS, pp. 100-101. Roanoke Design 79, Roanoke, Va.; Charles Moore with Chad Floyd, archts.—Dec. 1979, BTS, pp. 100-101. "Round Table: Housing and community design for changing family needs"—Oct. 1979, pp. 97-104. San Antonio, Tex.; O'Neil Ford, archt.—Dec. 1979, BTS, pp. 126-130. "Social architecture: giving form to life," by C. Richard Hatch—Dec. 1979, BTS, pp. 96-107.
- Porter Square Station, Cambridge, Mass.; Cambridge Seven Assocs., archts.—July 1979, BTS, pp. 124-125.
- Pratt Institute Center for Community and Economic Development, Brooklyn, N.Y., Community Design Center—Dec. 1979, BTS, pp. 100-101.
- Product Reports. Product Reports 80—Mid-Oct. 1979, pp. 23-188. "Case studies: Design solutions through product application"—Mid-Oct. 1979, pp. 12-18. "Introduction"—Mid-Oct. 1979, p. 11. "The manufacturers and suppliers: Let's not forget their role—and risk," Editorial by Walter F. Wagner, Jr.—Mid-Oct. 1979, p. 21.
- Program Support Facility, Department of Energy, Argonne National Laboratories, Ill.; C.F. Murphy Assocs., archts.—July 1979, pp. 102-103.
- Public Buildings. "The New Public Pride in Local Government Buildings," Building Types Study 534—Aug. 1979,

pp. 97-112. Administration and Visitors Center, Botanic Garden of the Chicago Horticultural Society, Glencoe, Ill.; Edward Larrabee Barnes, archt.—July 1979, pp. 89-96. City Hall, Durham, N.C.; John D. Latimer & Assocs., Inc., archts.—Aug. 1979, BTS, pp. 98-101. Federal Building, U.S. Courthouse, Fort Lauderdale, Fla.; William Morgan Architects and H.J. Ross Assocs., Inc., archts.—Oct. 1979, pp. 81-86. The Hardee Center, Wauchula, Fla.; Zoller/Abbott Archts., archts.—Aug. 1979, BTS, pp. 108-109. Ishikawa Cultural Center, Ishikawa Prefecture, Japan; Kisho Kurokawa, archt.—Aug. 1979, pp. 65-67. Public Safety Headquarters, Portland, Me.; Johnson. Hotvedt. DiNisco, archts.—Aug. 1979 BTS, pp. 104-107. South Central Patrol Division, Kansas City, Mo.; Patty Berkebile Nelson Associates Architects Inc., archts.—Aug. 1979, BTS, pp. 102-103. Third District Court of Appeal, Miami, Fla.; Ferendino. Grafton. Spillis. Candela, archts.—Aug. 1979, BTS, pp. 110-112. Public Safety Headquarters, Portland, Me.; Johnson. Hotvedt. DiNisco, archts.—Aug. 1979 BTS, pp. 104-107.

Q

Quail Cove Condominiums, Stockton, Cal.; Donald Sandy, Jr. & James A. Babcock, archts.—Sept. 1979, BTS, pp. 134-135.

R

Recreational Facilities. Hammersmith Centre, London, England; Foster Assocs., archts.—Mid-Aug. 1979, BTS, pp. 56-59. Ishikawa Cultural Center, Ishikawa Prefecture, Japan; Kisho Kurokawa, archt.—Aug. 1979, pp. 65-67. La Lumiere Athletic Facility, La Porte, Ind.; C.F. Murphy Assocs., archts.—July 1979, p. 99.

Religious Buildings. Calvary Baptist Church, Detroit, Mich.; Gunnar Birkerts & Assocs., archts.—Oct. 1979, pp. 92-96. Cathedral Church of Saint John the Divine, New York, N.Y.; Ralph Adams Cram and Grant La Farge, original design; Hoyle, Doran & Berry, archts. for addition—Nov. 1979, pp. 119-126.

Renovations & Restorations. "New perceptions for the 1980s: the need to pioneer," Building Types Study 539—Dec. 1979, pp. 85-136. Bologna Master Plan, Bologna, Italy; Pier Luigi Cervellati, archt.—Dec. 1979, BTS, pp. 102-103. Byker Redevelopment, Newcastle-upon-Tyne, England; Ralph Erskine's Arkitektkontor AB, archts.—Dec. 1979, BTS, pp. 104-105. "The Ehrenkrantz Group: bridging the technical barrier," by Margaret F. Gaskie—Mid-Aug. 1979, BTS, pp. 94-101. Jennings Hall Senior Citizen Housing, Brooklyn, N.Y.; Edelman & Salzman, archts.—Dec. 1979, BTS, pp. 100-101. "Marshall, Mich.: The small town is coming back"—Dec. 1979, BTS, pp. 108-113. Ocean Spray Cranberries, Inc., Plymouth, Mass.; Moore-Heder, archts.—Aug. 1979, pp. 73-76. San Antonio, Tex.; O'Neil Ford, archt.—Dec. 1979, BTS, pp. 126-130. "Value of nonresidential rehabilitation will double by mid-1980's"—Oct. 1979, AB, p. 61.

Research Buildings. Institute for Research and Coordination Acoustics/Music, (IRCAM), Paris, France; Piano and Rogers, archts.—Mid-Aug. 1979, BTS, pp. 106-107. Program Support Facility, Department of Energy Argonne National Laboratories, Ill.; C.F. Murphy Assocs., archts.—July 1979, pp. 102-103.

Resort Condominium, Kiawah Island, S.C.; Jova/Daniels/Busby, archts.—Sept. 1979, BTS, pp. 138-140.

Restaurants. In Season Restaurant, Philadelphia, Pa.; James Oleg Kruhly, archt.—Oct. 1979, p. 110. Muziekcentrum Vredenburg, Utrecht, Netherlands; Herman Hertzberger, archt.—Mid-Aug. 1979, BTS, pp. 108-113. Rusty Scupper Restaurant, Pittsburgh, Pa.; Edmund Stevens Assocs., archts.—Oct. 1979, pp. 108-109. The Whole Grain, Cleveland, O.; Wudtke Watson Davis, Inc., archts.—Oct. 1979, pp. 106-107.

Reynolds, Smith & Hills and Daniel, Mann, Johnson & Mendenhall, archts.; Florida Community College, Cumberland Campus, Jacksonville, Fla.—Nov. 1979, BTS, pp. 100-102.

Roanoke Design 79, Roanoke, Va.; Charles Moore with Chad Floyd, archts.—Dec. 1979, BTS, pp. 100-101.

Roche, Kevin, John Dinkeloo & Assocs., archts.; General Foods Corporate Headquarters, Rye and Harrison, N.Y.—Aug. 1979, pp. 93-96.

Rockrise Odermatt Mountjoy Assocs., archts.; Woods Motor Coach Center, San Francisco, Cal.—July 1979, BTS, pp. 128-129.

Roofing. "Single ply: a promising approach for ailing roofs and new roofs"—Oct. 1979, AE, pp. 127-132.

Ross, H.J. Assocs., Inc. and William Morgan Architects, archts.; Federal Building, U.S. Courthouse, Fort Lauderdale, Fla.—Oct. 1979, pp. 81-86.

Rust-Oleum Headquarters, Vernon Hills, Ill.; C.F. Murphy Assocs., archts.—July 1979, pp. 100-101.

Rusty Scupper Restaurant, Pittsburgh, Pa.; Edmund Stevens Assocs., archts.—Oct. 1979, pp. 108-109.

S

Sainsbury Centre, University of East Anglia, England; Foster Assocs., archts.—Mid-Aug. 1979, BTS, pp. 60-63.

San Antonio, Tex.; O'Neil Ford, archt.—Dec. 1979, BTS, pp. 126-130.

Sandy, Donald Jr. & James A. Babcock, archts.; Quail Cove Condominiums, Stockton, Cal.—Sept. 1979, BTS, pp. 134-135.

Saudi Arabia. Jeddah International Airport, Hag terminal tents; Skidmore, Owings & Merrill, archts.—Mid-Aug. 1979, BTS, pp. 86-89.

Schofield/Colgan, archts.; Addition to American Cyanamid Corporate Headquarters, Wayne, N.J.—Nov. 1979, pp. 113-118.

Schools. Glassell, The Alfred C., Jr. Art School, Houston, Tex.; S.I. Morris Assocs., archts.—Sept. 1979, pp. 119-124.

Shaw Swanke, Hayden & Connell, C.F. Murphy Assocs., joint-venture archts.; Addition to the Chicago Board of Trade, Chicago, Ill.—July 1979, pp. 106-107.

Shell Oil Company office building, Houston, Tex., Caudill Rowlett Scott, archts.—Mid-Aug. 1979, BTS, pp. 102-105.

Shopping Centers. Muziekcentrum Vredenburg, Utrecht, Netherlands; Herman Hertzberger, archt.—Mid-Aug. 1979, BTS, pp. 108-113.

Skidmore, Owings & Merrill, archts.; Baldwin Building for Community Medicine, The Mayo Clinic, Rochester, Minn.—Oct. 1979, BTS, pp. 111-117. Jeddah International Airport, Hag terminal tents, Saudi Arabia—Mid-Aug. 1979, BTS, pp. 86-89.

Skidmore, Owings & Merrill—Boston office, archts.; Harvard Square Station, Cambridge, Mass.—July 1979, BTS, pp. 122-123.

Skidmore, Owings & Merrill—Washington, D.C. office, archts.; N.E. Corridor Improvement Project—July 1979, BTS, pp. 120-121.

Solar Energy. "About commitments to energy conservation: three cheers (relatively speaking) for our team," Editorial by Walter F. Wagner, Jr.—Mid-Aug. 1979, p. 7. Famolare Headquarters warehouse addition, Brattleboro, Vt.; Banwell White & Arnold, Inc., archts.—Nov. 1979, AE, pp. 134-136. House/Test Rig, England; Foster Assocs., archts.—Mid-Aug. 1979, BTS, pp. 64-65. Program Support Facility, Department of Energy, Argonne National Laboratories, Ill.; C.F. Murphy Assocs., archts.—July 1979, pp. 102-103.

South Central Patrol Division, Kansas City, Mo.; Patty Berkebile Nelson Associates Architects Inc., archts.—Aug. 1979, BTS, pp. 102-103.

Stevens, Edmund Assocs., archts.; Rusty Scupper Restaurant, Pittsburgh, Pa.—Oct. 1979, pp. 108-109.

Stores & Shops. Bullock's Oakridge, San Jose, Cal.; Environmental Planning & Research, Inc., archts.—Mid-Aug. 1979, BTS, pp. 90-93. Hammersmith Centre, London, England; Foster Assocs., archts.—Mid-Aug. 1979, BTS, pp. 56-59. Muziekcentrum Vredenburg, Utrecht, Netherlands; Herman Hertzberger, archt.—Mid-Aug. 1979, BTS, pp. 108-113.

Sweden. Klostermuren Residential Community, Göteborg, Sweden; Johannes Olvergren, archt.—Dec. 1979, BTS, pp. 106-107.

T

Tent Structures. Bullock's Oakridge, San Jose, Cal.; Environmental Planning & Research, Inc., archts.—Mid-Aug. 1979, BTS, pp. 90-93. Jeddah International Airport, Hag terminal tents, Saudi Arabia; Skidmore, Owings & Merrill, archts.—Mid-Aug. 1979, BTS, pp. 86-89.

Third District Court of Appeal, Miami, Fla.; Ferendino.Grafton.Spillis.Candela, archts.—Aug. 1979, BTS, pp. 110-112.

Thomas & Betts Headquarters, Raritan, N.J.; Gwathmey Siegel, archts.—Sept. 1979, pp. 91-95.

Transitway/Mall, Denver, Colo.; I.M. Pei & Partners, archts.—July 1979, BTS, pp. 126-127.

Transportation. "Mass transit: A look at trend-setting designs that keep us moving," Building Types Study 533—July 1979, pp. 115-130. Hammersmith Centre, London, England; Foster Assocs., archts.—Mid-Aug. 1979, BTS, pp. 56-59. Harvard Square Station, Cambridge, Mass.; Skidmore, Owings & Merrill—Boston office, archts.—July 1979, BTS, pp. 122-123. N.E. Corridor Improvement Project; Skidmore, Owings & Merrill—Washington, D.C. office, archts.—July 1979, BTS, pp. 120-121. People movers: Los Angeles, Cal.; Daniel, Mann, Johnson & Mendenhall with Jenkins-Fleming, archts.; St. Paul, Minn.; Bather Ringrose Wolsfeld & Assocs./Kaiser Engineers, archts.—July 1979, BTS, p. 130. "Perspectives on mobility"—Dec. 1979, BTS, pp. 120-125. Porter Square Station, Cambridge, Mass.; Cambridge Seven Assocs., archts.—July 1979, BTS, pp. 124-125. "Transit work around the country"—July 1979, BTS, pp. 116-119. Transitway/Mall, Denver, Colo.; I.M. Pei & Partners, archts.—July 1979, BTS, pp. 126-127. Woods Motor Coach Center, San Francisco, Cal.; Rockrise Odermatt Mountjoy Assocs., archts.—July 1979, BTS, pp. 128-129.

U

University & College Buildings. "Designing the campus as one big building," Building Types Study 538—Nov. 1979, pp. 87-102. Agricultural Engineering Building, University of Illinois, Urbana-Champaign, Ill.; C.F. Murphy Assocs., archts.—July 1979, pp. 104-105. Catholic University of Louvain Medical School, Brussels, Belgium; Lucien Kroll, archt.—Dec. 1979, BTS, pp. 98-99. Community College of Baltimore, Harbor Campus, Baltimore, Md.; Daniel, Mann, Johnson & Mendenhall, archts.—Nov. 1979, BTS, pp. 98-99. Florida Community College, Cumberland Campus, Jacksonville, Fla.; Reynolds, Smith & Hills and Daniel, Mann, Johnson & Mendenhall, archts.—Nov. 1979, BTS, pp. 100-102. Kingsborough Community College, Brooklyn, N.Y.; Katz Waisman Weber Strauss Blumenkranz & Bernhard and Warner Burns Toan & Lunde, archts.—Nov. 1979, BTS, pp. 88-93. New York State College dormitory and dining hall, Purchase, N.Y.; Gwathmey Siegel, archts.—Sept. 1979, pp. 100-102. Northlake Community College, Irving, Tex.; Envirodynamics, Inc. and Daniel, Mann, Johnson & Mendenhall, archts.—Nov. 1979, BTS, pp. 94-97. Sainsbury Centre, University of East Anglia, England; Foster Assocs., archts.—Mid-Aug. 1979, BTS, pp. 60-63. Yale University Library and Lecture Hall, New Haven, Conn.; Herbert S. Newman Assocs., archts.—July 1979, pp. 111-114.

Urban Planning. See Planning.

V

van der Rohe, Ludwig Mies, "Missing Mies," comments from Stanley Tigerman, James Ingo Freed and R. Ogden Hanaford—July 1979, pp. 97-110.

Victoria Mews, San Francisco, Cal.; Barovetto, Ruscitto & Barovetto, archts.—Sept. 1979, BTS, pp. 126-129.

W

Warner Burns Toan & Lunde and Katz Waisman Weber Strauss Blumenkranz & Bernhard, archts.; Kingsborough Community College, Brooklyn, N.Y.—Nov. 1979, BTS, pp. 88-93.

Whitney Museum of American Art, Mixed-Use Building, New York, N.Y.; Foster Assocs., archts.—Mid-Aug. 1979, BTS, pp. 54-55.

Whole Grain (The), Cleveland, O.; Wudtke Watson Davis, Inc., archts.—Oct. 1979, pp. 106-107.

Woods Motor Coach Center, San Francisco, Cal.; Rockrise Odermatt Mountjoy Assocs., archts.—July 1979, BTS, pp. 128-129.

Wudtke Watson Davis, Inc., archts.; The Whole Grain, Cleveland, O.—Oct. 1979, pp. 106-107.

Y

Yale University Library and Lecture Hall, New Haven, Conn.; Herbert S. Newman Assocs., archts.—July 1979, pp. 111-114.

Z

Zoller/Abbott Archts., archts.; The Hardee Center, Wauchula, Fla.—Aug. 1979, BTS, pp. 108-109.

Uncommon strength. Incomparable control.



Crouse-Hinds wall-mounted WAL luminaires for small-area lighting.

■ When you need a luminaire strong enough to stand up to both environmental and human abuse, specify Crouse-Hinds WAL. The WAL luminaire's base housing is made of rugged die-cast aluminum, finished in a dark-bronze thermoset acrylic enamel. Its sturdy one-piece polycarbonate front cover and lens is virtually vandal-resistant. No unsightly, inefficient shields or guards are required. A specially formulated finish applied to the inside of the front cover gives it a long-lasting dark-bronze appearance unaffected by outside elements. Naturally, the WAL is UL listed for wet outdoor locations.

* Photos taken under similar photographic conditions.

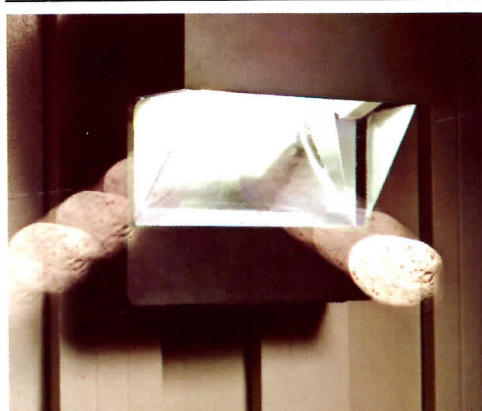

VIRTUALLY VANDAL RESISTANT

■ When light is needed for walkways, entrances, courtyards or for building security, WAL luminaires provide controlled and efficient area illumination. A clear lens provides a soft, low-glare illumination level in front of the fixture and maximum light output on the sides. This allows you to increase spacing between fixtures. Or you can specify a special prismatic lens that provides a higher overall light distribution to the front and sides of the fixture.

CROUSE-HINDS WAL LUMINAIRE*

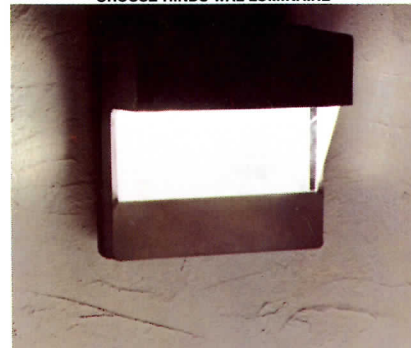

CONVENTIONAL WALL-MOUNTED LUMINAIRE*

■ WAL wall-mounted luminaires are designed to use energy-saving HID sources. Choose from 70-, 100- and 150-watt HPS lamps; 100- and 175-watt mercury vapor lamps; or 175-watt super metal halide lamps. A formed specular Alzak® aluminum reflector assures maximum utilization and performance.

The wall-hugging WAL luminaire won't detract from the clean design lines of any structure. With their low profile and matte surface, they look like an integral part of a building . . . not an afterthought.

Write for our new full-color selection guide.

Crouse-Hinds Company
Lighting Products Division
P.O. Box 4999
Syracuse, NY 13221

Or call (315) 477-8291



CROUSE-HINDS

Circle 102 on inquiry card

See the colorful world of
Rimini...
a new vinyl wallcovering from
VICRTEX™

Richly and deeply textured, "Rimini" has the appealing color story of Italy itself. Virtually impervious to scuffs, stains and mildew—requiring no additional backing
"Rimini" is available in 25 span-the-spectrum colors in a 54" width.
Marvelously applicable to contract and residential interiors. Swatches available.

L.E. CARPENTER and Company  A Dayco Company. 170 North Main Street, Wharton, N.J. 07885, (201) 366-2020/ NYC (212) 751-3565
DISTRIBUTED BY: VICRTEX SALES DIVISION, New York, Atlanta, Chicago, Dallas, Los Angeles, San Francisco, Boston,
Minneapolis, Toronto, Montreal. HOWELLS, INC., Salt Lake City/PAUL RASMUSSEN, INC., Honolulu
Circle 103 on inquiry card

