



ARCHITECTURAL
RECORD

Business Design Engineering
A McGraw-Hill Publication, Six Dollars a Copy
May 1986

Installed, these patterns generally range from \$1.50 to \$6.00 per square foot.

Ceilings that say it straight.

Presenting five of our 10 linear patterns in acoustical tiles and panels.

For free samples, call 800 233-3823 and ask for Linear Ceilings.

Circle 1 on inquiry card

 **Armstrong**

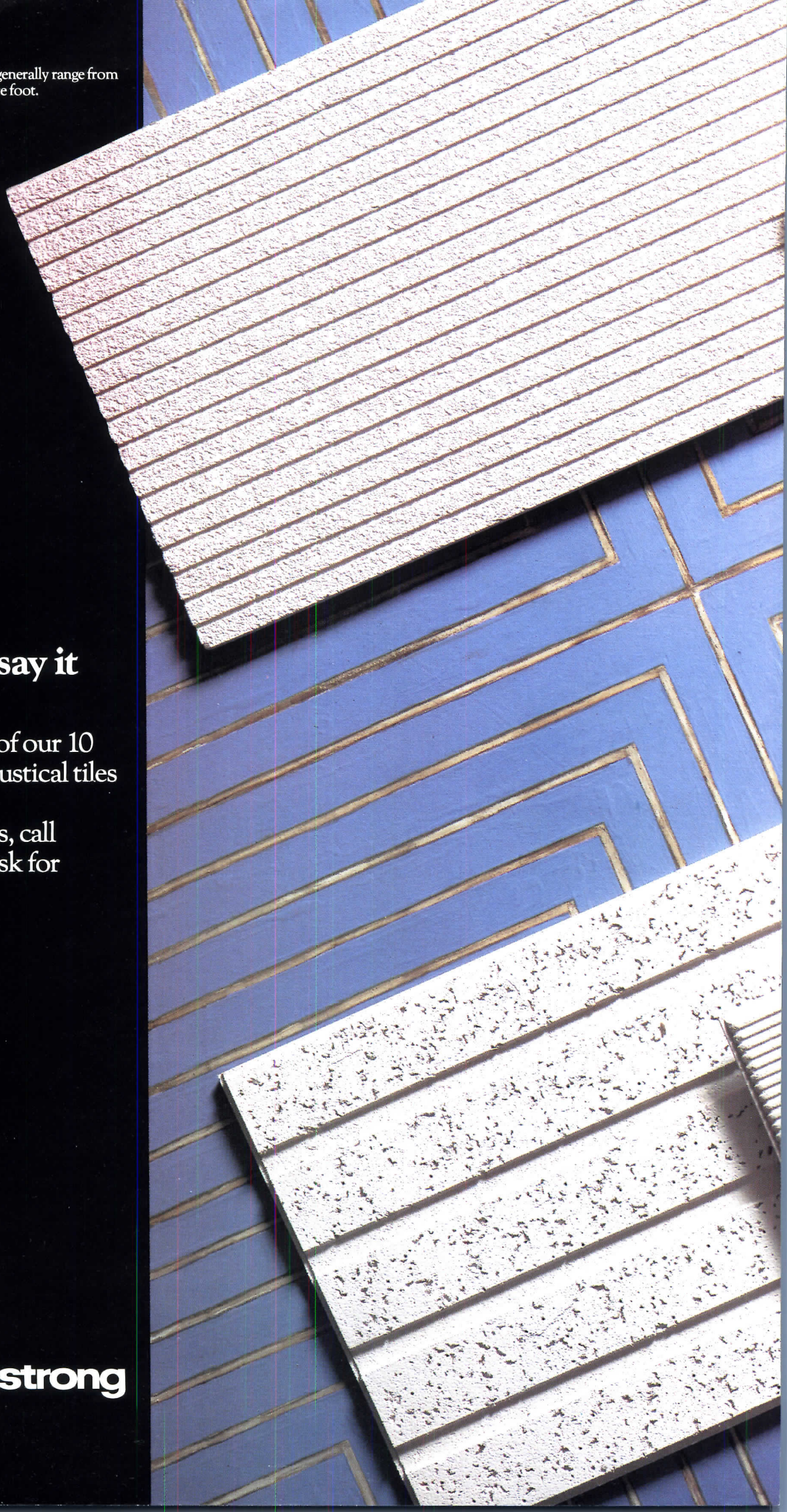



A R M S T

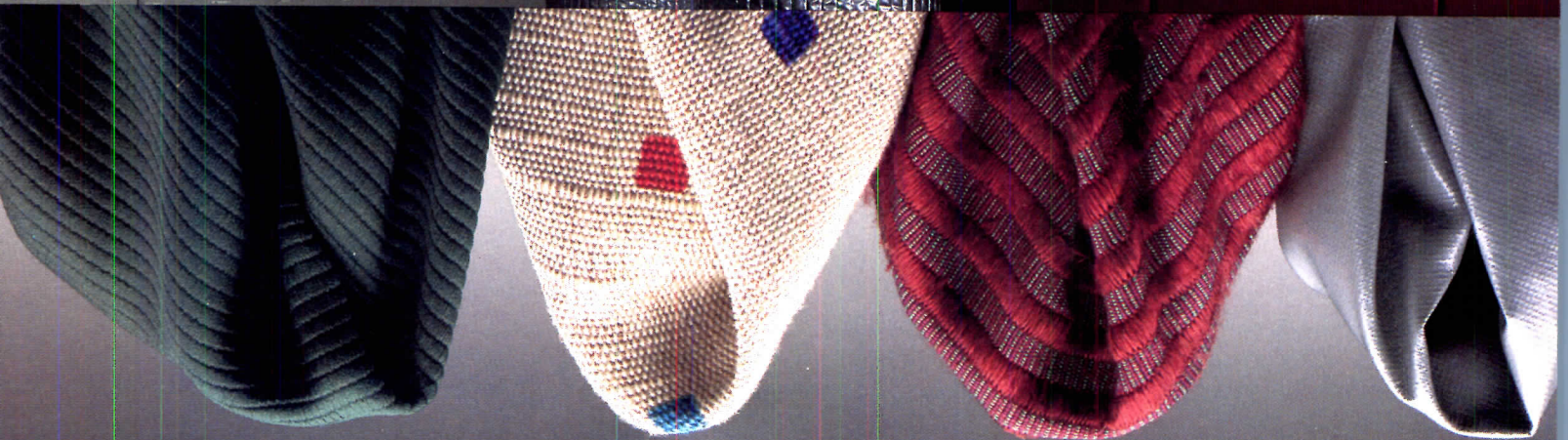
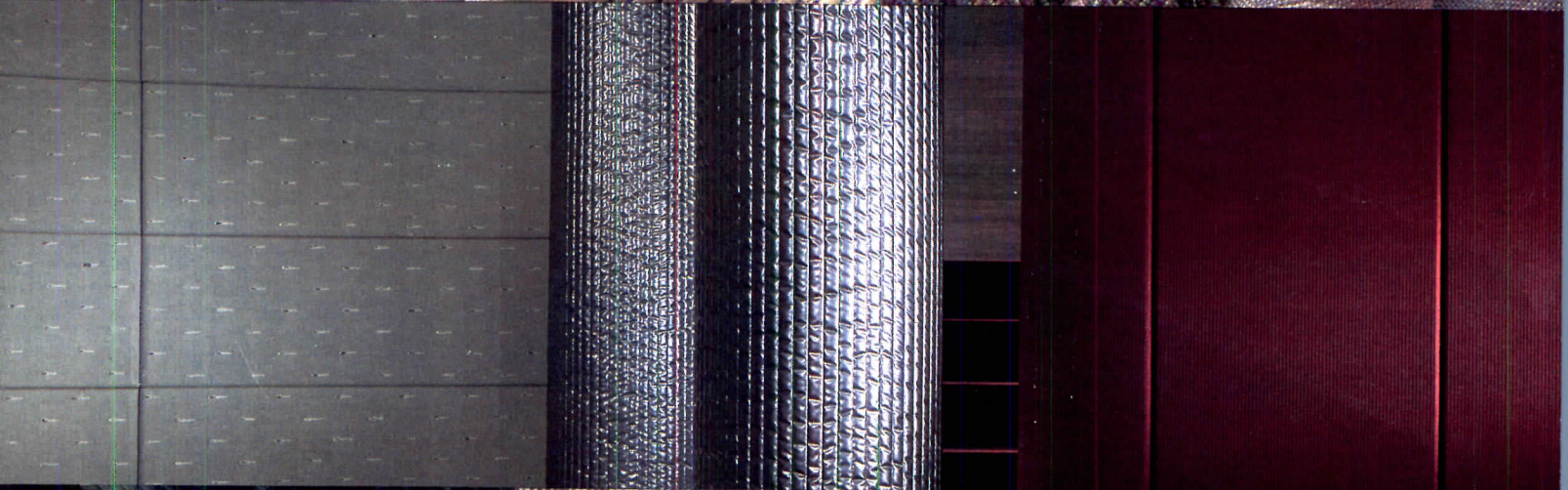



© O.-C.F. Corp. 1985

to 1.00) makes it the natural choice for your
office, or even your next Greek temple.
For more information contact Bill Phelan,
Regional Sales Manager, Interior Products,
Owens-Corning Fiberglas, Fiberglas Tower,
Toledo, Ohio 43659. Or call 1-419-248-6860.



**NUBBY REVEAL
CEILING**

OWENS/CORNING
FIBERGLAS
1985/1986

Circle 20 on inquiry card





**TO SHOW YOU
THAT OUR CEILINGS
GO ANYWHERE,
WE WENT TO EXTREMES.**

Outrageous. Install a mere acoustical ceiling in one of the great monuments of civilization?

Well, it's only to make a point. Owens-Corning Nubby Reveal ceilings can add classic good looks to the most venerable of spaces... or to the mundane.

Notice the clean, monolithic look, crisp-ed detail and minimal grid pattern. Properly installed glass fiber panel construction means you can forget problems with warping or sagging, even with our largest panel size of 48" x 60".

Nubby Reveal's ability to absorb sound (N

REPRINTS OF ARCHITECTURAL RECORD ARTICLES

Reprints of articles that have appeared in Architectural Record over the past five years are available for use in mailings and presentations. These custom promotion brochures reproduce the article exactly as it appeared in Record—if the article was published in color, the minimum order is 500 copies; if published in black-and-white, the minimum order is 100 copies.

For more information, cost estimates, and help with the layout and design of your reprints, call: Janice Austin 609-426-5494

ARCHITECTURAL
RECORD



Liquid Asset.



Water adds immeasurable value to an environment. A source of powerful fascination or peaceful inspiration, its vital presence transforms the ordinary into the extraordinary. Its sight and sound invite people to gather, relax and enjoy.

What makes fountains and waterscapes even more attractive investments is the exclusive WaterWorks® series of fountain systems from Imperial Bronzelite. These state-of-the-art modular systems are available with a dirt-burial enclosure or skid-mounted for easy equipment room installation. Each one is custom-tailored, pre-engineered, pre-assembled and pre-tested to virtually eliminate design, installation and maintenance problems for high performing, economical water features of any type and size.

Before you begin your next project, invest a few moments to call or write for our new *Architectural Fountain Systems Catalog*, Bulletin 8005. It will be time well spent.

**Imperial
Bronzelite**
a GENLYTE company

Architectural Fountains and Lighting

P.O. Box 606
San Marcos, Texas 78667
(512) 392-8957

Two of the unique effects at the Imperial Bronzelite WaterWorks® installation at Home Savings of America Headquarters in Irwindale, California. *Landscape Architects: Fong and Associates (Costa Mesa, California)*

Circle 42 on inquiry card



Com – a different way to think about the workplace.

With its distinctive European aesthetic and remarkable versatility, the Com System offers alternative solutions to the problems of the electronic office. Com also provides the means to satisfy special requirements – from writer to art director to corporate executive . . . in advertising, publishing or manufacturing.

Workstations that encourage information exchange are easily formed from Com's beam-supported worksurfaces. And the addition of acoustical panels and privacy screens creates a sense of personal space, while controlling sound and preserving visual privacy.

The Com System's wire management capability is now extended to acoustical panels. Large capacity raceways conceal telephone, data, and power cables. New overhead storage units, shelves and a paper management system complement pedestals, cabinets and files to provide a total storage program.

For details on more productive work alternatives, call Krueger at (414)468-8100, or write to us at P.O. Box 8100, Green Bay, WI 54308-8100.

The Com System was designed by F. Frascaroli and C. Biondi for C.O.M., Bologna, Italy, and is distributed under license by Krueger.

krueger

Technical innovation . . . by design

Circle 41 on inquiry card

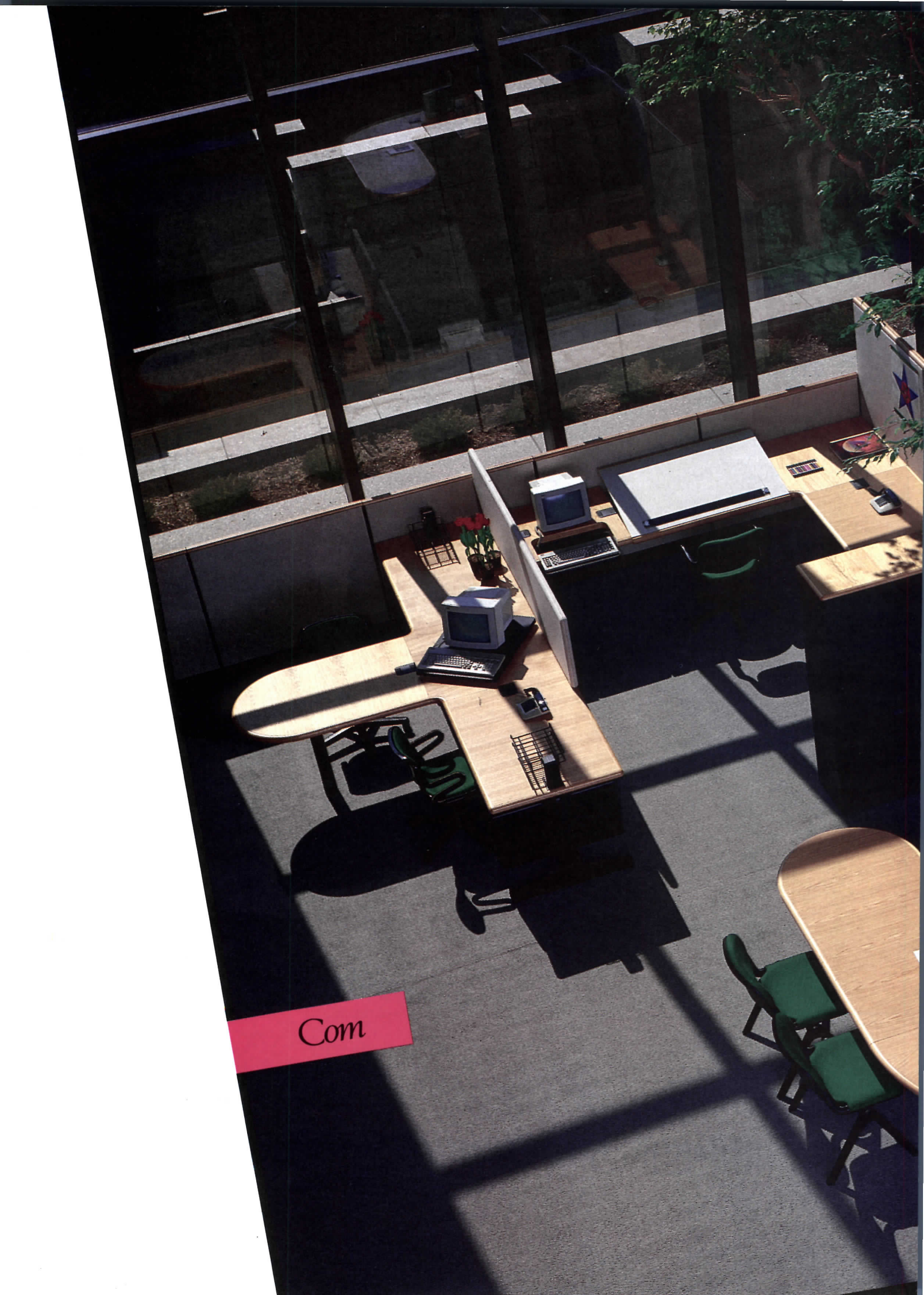

Com



Aptā

Apta – seating for the masses.

This IBD Gold Award winning chair displays an uncanny ability to detect occupant weight and movement. A dynamic seating machine, it mechanically translates this information into a positive reaction. The result is supportive seating that provides comfort to most everyone... in arm, armless or tablet arm models that gang and stack.

Find out why Apta has mass appeal. Call Krueger's International Division at (516) 589-0707, or write to P.O. Box 509, Bohemia, NY 11716.

Castelli furniture is now distributed in the U.S. by Krueger.

Circle 40 on inquiry card

CASTELLI
Collection

krueger
International Division

DOOR SCHEDULE							
DOOR NO.	TYPE	MATERIAL	DOOR SIZE			DOOR FINISH	REMARKS
			W	H	T		
1	A	H.M.	36"	80"	1 1/2"	PAINT	'B' LABEL
2	A	H.M.	30"	80"	1 1/2"	PAINT	'B' LABEL
3	B	WOOD H.C.	36"	80"	1 1/2"	PAINT	'D' LABEL
4	C	WOOD H.C.	36"	80"	1 1/2"	PAINT	'B1' LABEL
5	B	WOOD H.C.	30"	80"	1 1/2"	PAINT	
6	B	WOOD H.C.	30"	80"	1 1/2"	PAINT	
7	B	WOOD H.C.	30"	80"	1 1/2"	PAINT	
8	CLIP	ALUM.	40"	80"			
9	B	H.M.	30"				
10	B						
11	O.H.						
12	O.H.						

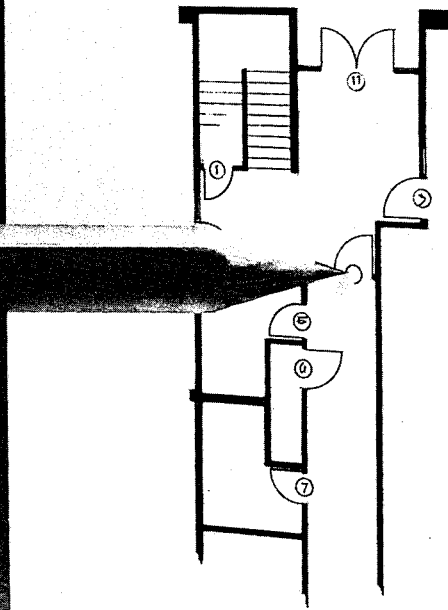

Finally, A Practical Way To Integrate Drawings And Data.

Introducing Drawbase™

In today's architectural marketplace, you

PC-based system to integrate advanced color graphics and powerful data management into one interacting system. So changes you make graphically are automatically reflected in the data base, and vice versa. You get better information, so drawings and reports are more complete. All at a cost that will keep your business manager smiling.

and more. Plus, information is updated automatically as the design evolves according to client and market demands.

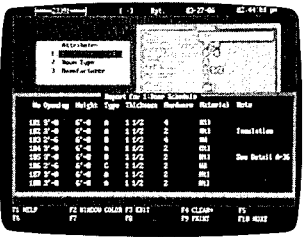

The data management screen, responding to changes in graphics, provides current reports, calculations, and system information...

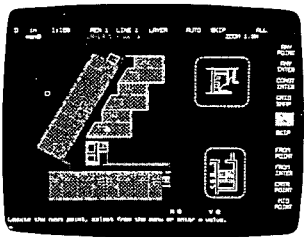

... while the full color graphics screen provides the user with advanced drawing creation and manipulation tools.

Drawbase Gives You The Whole Story.

Drawbase helps you analyze and report on your designs. You give your clients the kind of valuable data they need to understand the whole picture. Accurate square footage, cost analysis, conformance to the program, income projection,

The More, The Better.

More information. Better information. No PC-based architectural tool gives it to you like Drawbase. Get it as software alone, or in a package featuring either the IBM AT® or HP Vectra PC.

Drawbase from SKOK. Be practical about it and get all the facts by calling 1-800-225-SKOK. Or write SKOK at 222 Third Street, Cambridge, MA 02142. Circle 39 on inquiry card



IBM AT is a registered trademark of International Business Machines Corp. HP Vectra is a registered trademark of Hewlett-Packard.

determination. Typical factors are the amount of new business that partners develop, on billable time, on non-billable time in firm management, and on activities that promote the general reputation of the firm such as writing, lecturing, and teaching.

Another key point of the partnership agreement is how the firm will be managed. Many partnership agreements provide for decisions to be made by the majority of all partners, with each partner having an equal vote. However, others provide for decisions to be made by only those partners that the agreement designates. Still others stipulate that the partners with majority interest in a partnership's capital shall determine a firm's decisions.

Often, the agreement will include a provision that certain major, specified decisions require a different type of approval than routine ones. Partners who have a majority interest in partnership capital frequently want to retain veto power over major firm decisions, such as borrowing funds in excess of a designated amount, mortgaging assets of the partnership, signing leases, guaranteeing performance of obligations, investing in assets in excess of a designated amount, lending money to others, selling certain specified assets, and making new partners.

The agreement must define the partners' duties. For example, a clause stating that partners are required to devote their full time and attention to partnership affairs is important. Architects very often write, teach, lecture, or work on projects on their own. Thus, a provision should specify the amount of time that can be spent on these activities, and whether the income that they generate is income to the partnership or to the individual.

The partnership agreement should also have provisions concerning banking and the books and records of the partnership. For example, the partnership agreement should state: "All funds in the partnership shall be deposited in its name in its checking account or in accounts that are designated by the partners." It should also specify who can sign checks. The partnership agreement should state that the firm's books and records shall be maintained at its principal office and each partner shall have access at all times. The books shall be kept on a fiscal-year basis, and shall be closed and balanced at the end of each fiscal year. An audit shall be made as of the closing date by the partnership's accountants. These provisions should not be

controversial; however, to keep things running smoothly, they should be contained in all partnership agreements.

Some of the more difficult provisions are those dealing with partners who leave the firm. These are difficult because a partner's exit may be caused by many reasons—either voluntary or not—that include death, expulsion, retirement, or disability.

Let us deal first with the provisions concerning a partner's death. There are three basic alternatives to consider here:

- First, the partnership agreement may be silent on the subject.
- Second, the agreement may provide that the partnership shall terminate upon the death of a partner and that all rights of the deceased partner, as they affect his estate, are to be determined as of the date of his demise.
- Third, the agreement may give the decedent's estate some financial interest in the operation of the business.

The absence of a death clause in a partnership agreement will generally create significant practical problems. First and foremost is that the surviving partners and the deceased's legal representatives must then negotiate a redemption of his interest in the firm. The legal representatives are entitled to demand, as ordinary creditors, the value of the deceased partner's interest. Thus, the decedent's estate acquires an interest in partnership operations for some period after death, whether this was anticipated or not—an undesirable circumstance that could have been avoided by an express definition of the rights of all parties. There are also serious adverse tax consequences to this arrangement.

We recommend that the surviving partners be required to purchase the partnership interest of the deceased partner and that a formula be set for measuring that obligation. The best formula requires the addition of the decedent's capital account as of the date of death, his income account as of the end of the prior fiscal year, and an increase or decrease for his share of partnership profits or losses during the fiscal year up to the end of the month in which he died.

Once the amount to be paid to the estate is set, the partnership agreement must stipulate when the payments are to be made.

The agreement should also provide for the expulsion of a partner and for what constitutes a quorum that can do this—usually again determined by either a majority in numbers or by a

majority interest in capital. It is not necessary that the partnership agreement provide for the automatic expulsion of members for certain specified acts.

In the case of a withdrawing partner, we recommend that adequate notice of the intention to withdraw be specified (three months should be sufficient). When appropriate, we suggest that non-compete clauses be included in partnership agreements. There is a plethora of very often conflicting rules on whether such covenants are, in fact, enforceable and it is a good idea to have counsel state the appropriate language so that they are sure to be.

Next, the partnership agreement must contain a disability provision that should assure, at the very least, that the partner is not deprived of any rights during a specified period of time. However, it should also state that, should the disability continue for a further specified period, the partner's rights to such emoluments as drawings and profits will be reduced to a designated amount during that time. Eventually, if the disability continues, the other partners should have the right to purchase the incapacitated partner's interest in the partnership as if the partner had withdrawn from the firm.

And then there are some miscellaneous provisions that must be considered

There should be language in the partnership agreement that deals with indemnification. More specifically, a clause stating that each partner who breaches the partnership agreement, or any fiduciary duty owed to any other partner, must indemnify the partnership, or the partner owed, for all resulting expenses incurred or damages sustained. The indemnification should be broad enough to include the payment of all expenses incurred—including legal fees.

Generally speaking, without a provision to the contrary, the partnership is required to indemnify each partner for any reasonable expense incurred in the ordinary and proper course of partnership business. However, consideration should be given to limiting the common-law right of a partner to seek indemnification.

Certain other miscellaneous provisions should also be included in the agreement. For example, it should state that the partnership is governed by the jurisdiction of its principal place of business. The agreement should say that it cannot be modified and that its terms cannot be waived or discharged orally except by a written statement

signed by all of the partners. Finally, the agreement should contain a severability clause stating that if any of the provisions of the agreement are found to be invalid, the remainder of the agreement shall not be affected.

Also because of the nature of architectural practice and the growing litigiousness in general of the world in which we live, the agreement should provide for the continued inclusion of withdrawn partners in the firm's malpractice insurance.

There must be a provision stating that a partner may not sell, pledge, assign, nor make any other disposition of his partnership interest without the prior written consent of the other partners.

Finally, a word should be said with respect to a typical provision in a partnership agreement that we counsel our clients to omit—the arbitration clause. We continue to believe that arbitration is not the most expedient or sane way to resolve disputes and, therefore, that agreeing to resolve differences under the partnership agreement by arbitration is not sound.

In conclusion, if you do not have a partnership agreement, you should have one prepared. If you have one, you should have it reviewed by counsel to see that its terms meet the present needs of the partnership. The agreement should be as brief as possible; it should be written clearly so that there is no ambiguity in the meaning of any provision; and it should be viewed as a working document that must be revised from time to time to meet the current needs of the partnership.

This article is published with the understanding that the publisher is not rendering legal services. If legal advice is required, the services of a competent professional should be sought.

Are you ready for UL924?

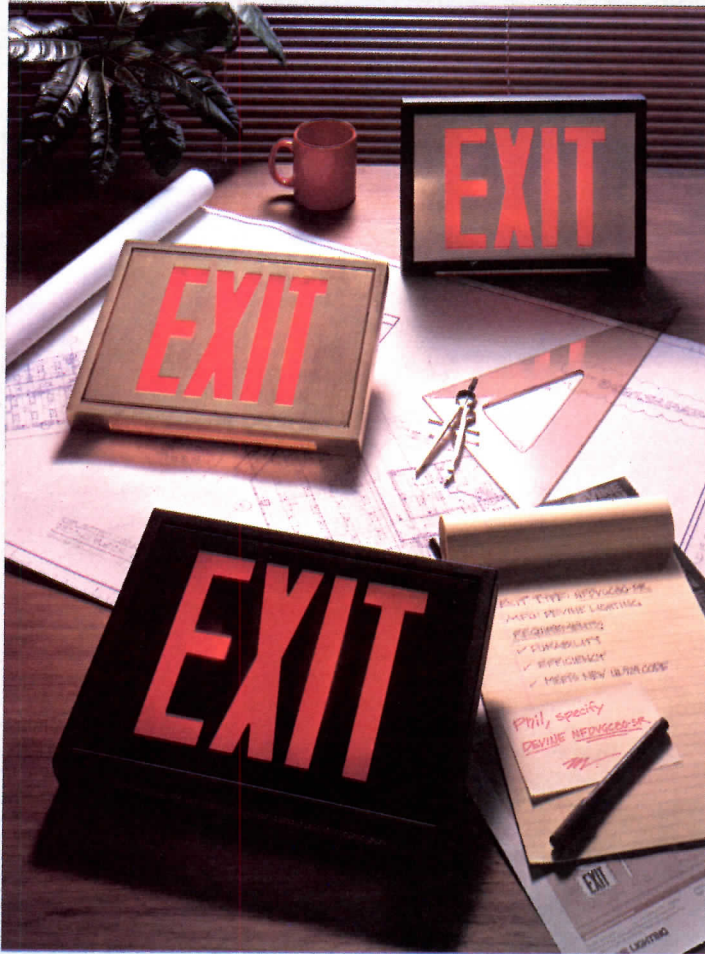

SPECIFY DEVINE EXITS. MEET NEW UL924 CODE.

You can specify quality emergency exits today that comply with tomorrow's new requirements.

The NFDVG80 emergency profile exit from Devine Design is now available.

The new guidelines were developed with a single goal in mind: save lives. Performance in the emergency mode demands reliability and visibility. That's why UL924 requires signage letters at least six inches tall with a minimum stroke width of 3/4 inch. Furthermore, luminance must be high enough to provide a contrast ratio at least .5 even after 90 minutes of battery operation. Designing an exit to meet these requirements wasn't easy but we did it. Availability isn't the only reason to select this exit though; we have four other good reasons to specify Devine.

VERSATILITY

No matter the application, the NFDVG80 can handle the job. The crisply styled exit offers six mounting arrangements including the UM Universal Mount, six face styles, and incandescent sources. We even offer this as a standard exit—the NFG50 exit—with the option of

adding a battery pack for future conversion to meet UL requirements.

DEPENDABILITY

Our exits are constructed of rugged die cast aluminum for long term trouble free service. Energy efficient sources and state of the art electronics. A wide selection of tough thermosetting acrylic enamel finishes ensure attractive appearance year after year. Exits that work—and look like new for the long run.

VALUE

Combine quality, dependability and versatility and you find extraordinary value in this exit from Devine.

How else is there to describe an exit that offers all this at a competitive price?

UL APPROVAL

The most important factor of all, UL924 was drafted to help save lives by providing clear information in emergencies. The NFDVG80 allows you to meet that responsibility . . . now.

Five good reasons. Versatility, dependability, value, UL approval and

availability. An early, logical answer

to UL924 requirements. The remarkable NFDVG80 emergency exit from Devine Design. **WILL EXITS YOU SPECIFY TODAY MEET TOMORROW'S CODE? OURS WILL.** Like more

information? Call us on our toll free number: **1-800-826-5496** in the U.S.; **1-800-361-1441** in Canada.

DEVINE

Subsidiary of Kidde, Inc.

KIDDE

KANSAS CITY ■ MONTREAL

Circle 38 on inquiry card



UL File number: E71392

The profitable professional: Put your partnership agreement in writing

*The author offers a blueprint for
an architects' partnership agreement*

By Larry F. Gainen

It is surprising how many architectural firms that operate as partnerships do so without agreements on the basic relationships of the partners. There are two frequent reasons, both mistaken, why firms fail to write out partnership agreements.

First, there is the widely held belief that, because the partners get along well, any disputes over issues that might be covered by a written agreement can be decided as they arise. Unfortunately, when a serious problem does arise, the partners' friendship often dissipates while the problem is addressed less dispassionately than they could have imagined.

Second, while many firms have made an attempt at such an agreement, it was never executed because there was not a consensus on key issues. There is a misguided belief that non-billable time should not be spent on trying to resolve such issues.

In the absence of an agreement, each state has laws that will govern a partnership's affairs, and which may or may not conform to the intentions of the partners. It makes good sense to insure that their affairs are resolved by an agreement of the partners, rather than by public mandate.

There are certain basics that a partnership agreement, to be effective, should contain

Essentially it should resolve such elementary, but sometimes treacherous, issues as the firm name and business purpose. It should also spell out the term of the partnership; initial and subsequent capital contributions; interest on capital and return of capital; the method of setting partner compensation; the method of firm governance and management; banking methods; how books and records will be kept; how the disability, retirement, withdrawal, or death of a partner will be handled; the indemnification of partners; and the continuation of liability insurance for withdrawing or retiring partners.

The agreement usually states: "The parties hereby form a partnership under the name of [inserted] to conduct the practice of architecture." Under New York law, and the laws of most other states, each partner in an architectural firm must be licensed. Thus, the signatories to the agreement must be registered architects. Further, the firm name must be a combination of the names

Mr. Gainen is a partner in the law firm of LePatner Gainen & Block, New York City, which specializes in representing architects, engineers, and interior designers.

of some or all of the present partners. For example, a deceptive name, such as one which gives the partnership the appearance of being a larger entity than exists in reality, is forbidden. There are also limitations on the continued use of the name of a withdrawing partner.

Almost always, there is a provision in the agreement designating the term of the partnership. The language specifying the beginning of the partnership is often overlooked, but should be included; it has, as we shall see, important long-term effects on the legal relationship between the partners.

One of the more difficult decisions in making an agreement is how capital will be handled

The agreement should state whether all partners contribute to the capital of the firm, and should specify the amount each contributes. If certain partners are not to make capital contributions but are intended, nevertheless, to have rights to partnership property, such a provision must be included. It is, therefore, imperative that the agreement provide for any portion of a partner's share of future profits that is to be allocated to his or her capital account.

Very often agreements permit capital to be contributed in some other form than money. Of course, non-cash contributions should be described and their value specified.

The next issue is whether subsequent capital contributions will be provided for and, if so, whether they are mandatory or optional. If future contributions will be mandatory, the partners must decide whether there will be no cap on them (that is, they will be whatever the subsequent needs of the firm are) or, in contrast, they will be fixed at some multiple of the initial capital contributions each partner has made.

Appropriate language must describe how the firm will decide that mandatory subsequent capital contributions are required. Usually, this is a determination by all partners, by a majority of partners, or by partners representing a majority or other specified interest in the partnership capital.

If the partnership opts for mandatory contributions, a provision is required defining the consequences to a partner who defaults. A typical provision reduces the partner's share in future profits until the capital account is brought current, or gives the other partners the right to purchase the defaulting partner's share of the company represented by the capital call.

Depending on various factors, such as the protection of the future

profitability of the firm, general borrowing conditions in the economy, and the capital structure of the firm, we at times advise our clients to include a clause providing for the payment of interest on partnership capital. If they elect this provision, the agreement should designate either the rate applicable or the method of establishing the rate, and when interest payments are to be made.

Interest payments on capital are guaranteed payments and are made without regard to partnership income. They are treated as an expense deduction by the firm and as income by the recipient. Providing for interest on capital can, in effect, allow the founding partners of an architectural firm to direct profit distribution in a way that benefits them, without regard to the year-to-year profitability of the firm.

The way in which partners are compensated is a subject of special interest

The agreement should provide for a separate income account for each partner. It should also provide for partners' draws—the periodic withdrawal of a specified sum, which is then charged against each partner's distributive share of the net profits.

Partners do not receive a salary, but are entitled to share in the profits and losses of their partnership. One of the most important sections of a partnership agreement deals with how the sharing is done.

Generally speaking, there are four ways in which partnership agreements provide for the division of net profits and losses. Some agreements stipulate that partnership profits and losses are shared in the same proportion that the capital contribution of each partner bears to total capital. Other agreements provide that profits and losses are shared equally. Still others provide for a division in accordance with certain other stipulated percentages.

Also, many partnership agreements, rather than providing for a pre-arranged formula for sharing profits and losses, describe a method by which such determinations are made, e.g., that such a decision shall be made by only certain partners. This type of provision is most often found when there are founding partners who play a disproportionate role in the success of the firm.

Where the choice is made that certain partners shall make the decision on income distribution, it is preferable to spell out the criteria that they shall use and to weight those factors that go into the

Continued

Every washroom design is a different animal.



Free Bradley guide helps you tame every challenge.

High-usage washroom jobs pose many different challenges. That's why Bradley offers you so many Washfountain models — and our new, 16-page Washfountain guide.

Our free guide will help you select the Washfountain that's best for each application. It's indexed by type of job for easy reference.

Return coupon or circle reader service number today! Or call: 1 414 251-6000.

Circle 37 on inquiry card

© 1986 Bradley Corporation

Bradley CORPORATION

We get the job done better.

Yes! Please rush my free guide!

Name _____

Title _____

Company _____

Address _____

City _____ State _____ Zip _____

Telephone (_____) _____

Mail to: Bradley Corporation, Dept. A, 9101 Fountain Blvd.,
Menomonee Falls, WI 53051 AR 512



1986 Regional Estimates Dodge Construction Potentials

First Update
March 1986

North-east	CT, ME, MA, NH, NJ, NY, PA, RI, VT	1985 Actual	1986 Forecast	Percent Change 1986/85
Contract Value (millions of dollars)	Nonresidential Buildings			
	Commercial and Manufacturing	\$ 8,176	\$ 8,000	- 2
	Institutional and Other	4,648	4,900	+ 5
	Total	\$12,824	\$12,900	+ 1
	Residential Buildings			
	One-Family Houses	\$11,497	\$13,775	+20
	Multi-Family Housing	5,470	5,425	- 1
	Nonhousekeeping Residential	1,031	925	-10
	Total	\$17,998	\$20,125	+12
	Nonbuilding Construction			
	Transportation-Related Construction	\$ 4,874	\$ 4,700	- 4
	Water-Related Construction	2,192	2,300	+ 5
	Utilities	380	400	+ 5
	Total	\$ 7,446	\$ 7,400	- 1
Total Construction	\$38,268	\$40,425	+ 6	

North Central	IL, IN, IA, KS, MI, MN, MO, NE, ND, OH, SD, WI	1985 Actual	1986 Forecast	Percent Change 1986/85
Contract Value (millions of dollars)	Nonresidential Buildings			
	Commercial and Manufacturing	\$10,275	\$ 9,675	- 6
	Institutional and Other	5,669	5,675	—
	Total	\$15,944	\$15,350	- 4
	Residential Buildings			
	One-Family Houses	\$10,593	\$12,850	+21
	Multi-Family Housing	4,387	4,650	+ 6
	Nonhousekeeping Residential	1,102	1,025	- 7
	Total	\$16,082	\$18,525	+15
	Nonbuilding Construction			
	Transportation-Related Construction	\$ 5,985	\$ 5,875	- 2
	Water-Related Construction	2,659	2,725	+ 2
	Utilities	313	450	+44
	Total	\$ 8,957	\$ 9,050	+ 1
Total Construction	\$40,983	\$42,925	+ 5	

South	AL, AR, DE, DC, FL, GA, KY, LA, MD, MS, NC, OK, SC, TN, TX, VA, WV	1985 Actual	1986 Forecast	Percent Change 1986/85
Contract Value (millions of dollars)	Nonresidential Buildings			
	Commercial and Manufacturing	\$21,675	\$19,950	- 8
	Institutional and Other	10,253	10,725	+ 5
	Total	\$31,928	\$30,675	- 4
	Residential Buildings			
	One-Family Houses	\$29,492	\$33,950	+15
	Multi-Family Housing	11,775	11,300	- 4
	Nonhousekeeping Residential	2,642	2,450	- 7
	Total	\$43,909	\$47,700	+ 9
	Nonbuilding Construction			
	Transportation-Related Construction	\$ 9,236	\$ 8,700	- 6
	Water-Related Construction	5,274	5,250	—
	Utilities	601	750	+25
	Total	\$15,111	\$14,700	- 3
Total Construction	\$90,948	\$93,075	+ 2	

West	AK, AZ, CA, CO, HI, ID, MT, NV, NM, OR, UT, WA, WY	1985 Actual	1986 Forecast	Percent Change 1986/85
Contract Value (millions of dollars)	Nonresidential Buildings			
	Commercial and Manufacturing	\$13,663	\$12,775	- 6
	Institutional and Other	6,400	6,625	+ 4
	Total	\$20,063	\$19,400	- 3
	Residential Buildings			
	One-Family Houses	\$17,479	\$20,700	+18
	Multi-Family Housing	8,900	8,775	- 1
	Nonhousekeeping Residential	2,409	2,100	-13
	Total	\$28,788	\$31,575	+10
	Nonbuilding Construction			
	Transportation-Related Construction	\$ 4,741	\$ 4,625	- 2
	Water-Related Construction	2,930	3,025	+ 3
	Utilities	945	900	- 5
	Total	\$ 8,616	\$ 8,550	- 1
Total Construction	\$57,467	\$59,525	+ 4	

what lies ahead in the near future.

What makes the present situation different is the status of tax-sheltered apartments. In 1983, while single-family housing was responding to falling interest rates, multifamily building received a simultaneous boost from the acceleration of depreciation allowances. Since 1983, as much as 20 percent of all multifamily building (probably more) has been stimulated by the market's response to tax shelters, as opposed to credit conditions. There is little reason why falling interest rates should elicit a gain in multifamily building in 1986. With vacancies rising, it is more likely that apartment building will decline a bit in 1986, and more than a bit in 1987 when tax reform changes the investment rules.

In 1986 (and 1987), the response to falling mortgage rates is likely to be more restrained than it was in 1983. Any backlog of demand attributable to the extremely high interest rates of the early 1980s, has been substantially reduced by three years (1983-85) of reasonably high-level building. The demographics of the mid-1980s imply that the sustainable demand for housing is roughly 1.8 million units per year (not counting mobile homes), a volume not far from the current rate of output. What's more, demographic support is diminishing, not expanding.

Declining mortgage rates (e.g., 30-year conventionals down from 12 1/2 percent in 1985 to an average of 9 1/2 in 1986) are expected to lift single-family homebuilding by nearly 15 percent this year to 1.1 million units (F. W. Dodge basis). Multifamily building, however, is vulnerable to a decline of as much as 5 percent, now that the vacancy rate is pushing 7 percent (an historic ceiling).

On balance, 1986 promises to be a very good year for housing, with a total of 1,850,000 units started—the best the 1980s have offered so far.

The total picture for construction in 1986 is better than it looked like it would be

The modifications needed to keep last October's construction outlook (RECORD, November 1985, pages 35-43) apace with political and economic events are pointing to a slightly improved outcome in 1986 compared with the way things looked they might be in 1986 six months ago.

- The year 1986 now offers greater potential in residential building. (Caution: don't expect too much from falling interest rates. Other considerations will temper the home buyer's final response.)

- On the other hand, public-works construction is being squeezed

harder than last October's circumstances indicated it would be, now that another layer of budgetary restraint has been applied.

- On the bright side again, commercial and industrial building appears headed for a smaller decline than was expected this year.

Together, these interim adjustments to all multifamily construction outlook will be stretching the peak rate of contracting all the way through 1986.

©1986 McGraw-Hill, Inc. with all rights reserved.

DISCOVER INFINITY.

Styles. Sizes. Colors. Classic. Ultra-contemporary. The choice is yours. EAGLE offers a complete line of premium pre-finished aluminum and wood windows built with our special patented design. Casements, double-hungs, awnings, circle-head, full-circle, and quarter-circle windows, patio doors, EAGLE Geometrics, skylights, slope-glazing, and the EAGLE Green-erie Room -- all EAGLE products match inside and out.

Exteriors are heavy extruded pre-finished aluminum in a range of colors and are a structural part of each unit, not just a cosmetic covering. Interiors are warm clear pine to finish just the way you want. Plus sealed true insulated glass is the standard and EAGLE Maximizer glass is available as well as two systems of the EAGLE Trimshade.

The options are limitless. Any EAGLE product can be combined with any other EAGLE product for a totally coordinated low-maintenance window system. Standard modular sizing fits any application -- commercial, residential, or replacement.

We designed EAGLE windows to fit today's energy and esthetic needs. Our airtight engineering offers some of the lowest air infiltration ratings available today tested under Class A ANSI/NWMA IS-2-80.

Feel free with EAGLE's flexibility of design -- it works in any architectural style! Discover the infinite choices of EAGLE--and the excellence of EAGLE engineering.

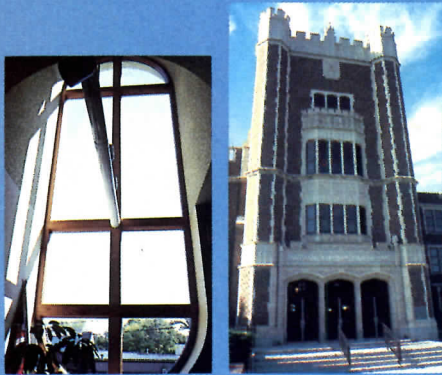

If You Don't Have Eagle,
You've Settled For Less.

EAGLE
WINDOWS · DOORS
CIRCLE-HEADS · GEOMETRICS

375 East 9th, Dubuque, IA 52001
319/556-2270 Circle 36 on inquiry card

This photo courtesy of Brooks Borg and Skiles Architects-Engineers. ▲

See Us in Booth #450-451.
American Institute of Architects
San Antonio, Texas, June 8-11

Full Circle
Shown With
Extension
Jambs.

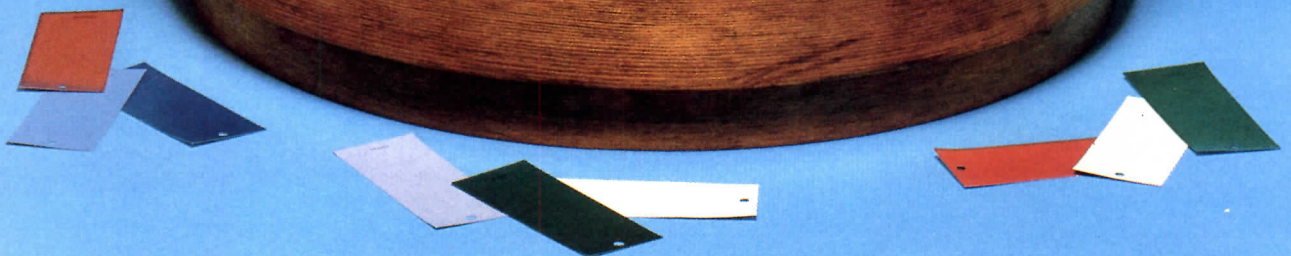
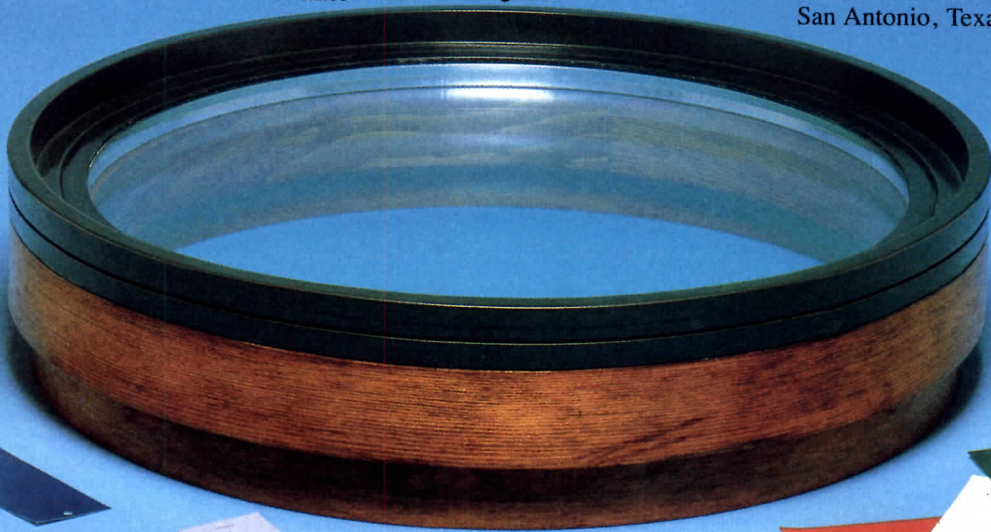

Discover Eagle Excellence

1986 National Estimates
Dodge Construction Potentials

First Update
March 1986

Nonresidential Buildings		1985 Actual	1986 Forecast	Percent Change 1986/85
Floor Area (millions of square feet)	Office Buildings	330	265	- 20
	Stores & Other Commercial	585	580	- 1
	Manufacturing Buildings	149	145	- 3
	Total Commercial & Manufacturing	1,064	990	- 7
	Educational	98	99	+ 1
	Hospital & Health	71	69	- 3
Other Nonresidential Buildings		134	137	+ 2
Total Institutional & Other		303	305	+ 1
Total Nonresidential Buildings		1,367	1,295	- 5
Contract Value (millions of dollars)	Office Buildings	\$ 23,929	\$ 19,975	- 17
	Stores & Other Commercial	22,634	23,050	+ 2
	Manufacturing Buildings	7,226	7,375	+ 2
	Total Commercial & Manufacturing	\$ 53,789	\$ 50,400	- 6
	Educational	\$ 8,643	\$ 9,000	+ 4
	Hospital & Health	7,583	7,550	-
Other Nonresidential Buildings		10,744	11,375	+ 6
Total Institutional & Other		\$ 26,970	\$ 27,925	+ 4
Total Nonresidential Buildings		\$ 80,759	\$ 78,325	- 3
Residential Buildings				
Dwelling Units* (thousands of units)	One-Family Houses	965	1,100	+ 14
	Multi-Family Housing	790	750	- 5
	Total Housekeeping Residential	1,755	1,850	+ 5
Floor Area (millions of square feet)	One-Family Houses	1,510	1,716	+ 14
	Multi-Family Housing	751	716	- 5
	Nonhousekeeping Residential	103	90	- 13
	Total Residential Buildings	2,364	2,522	+ 7
Contract Value (millions of dollars)	One-Family Houses	\$ 69,061	\$ 81,275	+ 18
	Multi-Family Housing	30,532	30,150	- 1
	Nonhousekeeping Residential	7,184	6,500	- 10
	Total Residential Buildings	\$ 106,777	\$ 117,925	+ 10
Nonbuilding Construction				
Contract Value (millions of dollars)	Transportation-Related Construction	\$ 24,836	\$ 23,900	- 4
	Water-Related Construction	13,055	13,300	+ 2
	Total Public Works	\$ 37,891	\$ 37,200	- 2
Utilities		\$ 2,239	\$ 2,500	+ 12
Total Nonbuilding Construction		\$ 40,130	\$ 39,700	- 1
All Construction				
Contract Value (millions of dollars)	Total Construction	\$227,666	\$235,950	+ 4
	Dodge Index (1977 = 100)	161	167	

*F.W. Dodge basis.

Prepared March 1986 by the Economics
Department of the McGraw-Hill
Information Systems Company,
George A. Christie, vice president
and chief economist

year's funding (e.g., waste treatment facilities).

Considering the high priority being given to deficit reduction, a mere \$1-billion impact on public-construction programs in 1986 must be thought of as an "acceptable casualty" in the battle of the deficit. By 1987, however, Gramm-Rudman goals become awesome. To reach the deficit target of \$144 billion (having "cheated" in 1986) means finding an additional \$50 billion or so of budgetary savings. This will be Congress's major preoccupation for the next month or two.

Until the Supreme Court rules on the constitutionality of Gramm-Rudman, only the deficit targets are binding. The manner in which they are reached remains vague (except for 1986), but it becomes increasingly obvious that a significant source of additional revenue (just don't call it a tax) will be an essential part of the process. Our five-year construction forecast is based on the assumption that some form of "revenue enhancement" will be forthcoming by 1987. For 1986, however, the revised federal budget, requiring \$11.7 billion of extra, pro-rata spending cuts effective March 1, is the most practical guide to public-works construction.

Here are a few of the public-works programs that may be affected and the reasons why

Transportation-related construction (highways, bridges, mass transit) is headed for its first decline since the major escalation by the 1982 Surface Transportation Assistance Act. Having reached a peak of just under \$25 billion in 1985 (up from \$16 billion per year prior to the act), contracting for transportation construction now faces two handicaps. Because disbursements from the Highway Trust Fund—the mother lode of construction money—were outrunning receipts, 1986 obligations had to be reduced by half a billion dollars in order to sustain liquidity. Following that, Gramm-Rudman "adjustments" lowered 1986 spending by an additional half-billion dollars. The result: a 4-percent decline in contracting this year to \$23.9 billion.

Water-related construction (water resources, water supply, and wastewater-treatment facilities) has been slow to make the required transition from federal to local sources of funding as EPA's construction grant program has been winding down. However, a 20-percent surge in contracting for sewage-treatment plants in 1985 may be a sign that falling bond rates and strengthened state and municipal finances have ended the several-year-long construction slump. In 1986, it is expected that modest

gains in water resource development and transmission will slightly more than balance off a 5-percent reversal of last year's exceptional gain in sewer projects, resulting in a 2-percent advance to \$13.3 billion.

In total, public-works construction will be living up to (more accurately, down to) expectations as deficit reduction is given greater emphasis in the years immediately ahead. Contracting for total public works construction in 1986 is estimated at \$37.2 billion, a decline of 2 percent. With adjustment for inflation, the "real" value of newly started projects will fall 5 percent.

The bright side is housing; deficit reduction means a further fall in mortgage rates

Publicly funded construction's ill wind of enforced budgetary restraint will blow the housing market some much-needed good. The rewards from deficit reduction—by whatever combination of revenue increases and spending cuts that is required—will be realized through the monetary sector:

- Treasury borrowing demands will diminish.
- The Federal Reserve will be relieved of the need to "lean against" the deficit's inflationary potential.
- To offset the "fiscal drag" of deficit reduction, conventional central banking strategy calls for a more expansive monetary policy. The recent lowering of the discount rate showed which way the federal government is leaning.

All of these consequences of deficit reduction have one thing in common: they will help to exert downward pressure on mortgage rates. This role reversal of monetary and fiscal policy is undoubtedly the best thing the construction and building-products industries will have going for them during the next few years. Declining interest rates won't solve the unique problems facing the commercial building and public-works markets, but by supporting the credit-sensitive housing market, they will postpone the inevitable decline of the construction market for perhaps another year.

Mortgage rates are finally leaving the double-digit zone for the first time in the 1980s, and appear headed still lower. The initial reaction—a stampede of borrowers—suggests that a secondary wave of pent-up demand has been unleashed. The first wave, 1983's surge of homebuying as mortgage rates dropped rapidly from 17 to 13 percent, may not, however, be a reliable guide to

Continued

The Corbin Museum of Modern Art. Striking, isn't it?

Futurabar™ 39 Series Exit Device

- Solid push bar strength
- Wide range of functions and finishes
- Contact your Corbin Distributor.



HARDWARE GROUP

EMHART

Emhart Hardware Group
225 Episcopal Road
Berlin, CT 06037
1 203 225-7411



Circle 35 on inquiry card

Construction economy update: Stretching a peak into a plateau

By George A. Christie

When a building cycle has been in its expanding phase as long as this one has, the odds that a downturn will occur sometime in the next year start to mount. The last two cyclical upswings—one in the early 1970s and the other spanning 1976 through early 1979—lasted an average of 13 quarters. This one, with 14 quarters behind it and still hanging in, is challenging the law of averages.

If a cyclical decline is approaching, it is a peculiar one. Conventional wisdom tells us that homebuilding is the leading edge of the construction market, and that commercial and industrial building normally lags housing by as much as a year. Thus, the "typical" cyclical downturn begins when rising interest rates topple the credit-sensitive residential side of the construction market. Sometime later, nonresidential building activity follows.

Contrast that idealized market behavior with what is happening in 1986. Commercial/industrial building, which is usually at its best this late in the cycle, is dragging total construction down. At the same time, with interest rates falling, homebuilding is gaining strength, and could support total construction activity at its recent peak for as much as another year. This is no way for a three-year-old building cycle to behave.

Fortunately, even at a time like this, there are some fundamentals that hardly ever change. In 1986, as always, the construction industry will continue to be supported by a "tripod," which consists of business capital spending, government programs, and interest rates. These are the means by which political and economic events are transmitted to the marketplace. In 1986, two legs of the tripod are wobbly. But one of them—interest rates—offers a prospect for improvement. It should be enough to carry the building business through another good year.

Spending for nonresidential building probably won't increase even without tax reform

The biggest threat to commercial and industrial building in 1986—tax reform—lost much of its urgency over the winter months when the more compelling issue of deficit reduction captured Congress's attention. Although the postponement of tax reform for another year (and, by implication, the extension of the Economic Recovery Tax Act's generous investment incentives) may cushion the coming decline of business-related construction, the recent commercial building boom has already lost its momentum.

Not long after ERTA's passage,

the incentives of accelerated depreciation and investment tax credits seemed to be triggering the capital-spending boom that its supply-side authors intended. In 1984, nonresidential fixed investment (structures and equipment) surged 20 percent. But with the overvalued dollar attracting a record volume of imports, capital spending soon outran the economy's potential for internal growth. The result: excess capacity in manufacturing, and a glut of empty office space.

With fiscal restraint adding to the economy's growth problems in 1986, capacity utilization in the manufacturing sector is not likely to advance much beyond its recent 80-percent plateau. And with another 300 million square feet of newly started office space being added this year to the already excessive supply, the office-vacancy rate will soon be breaking through the 20-percent threshold.

Two recent surveys of 1986 plans for capital spending (one by McGraw-Hill, the other by the Commerce Department) confirm the obvious: investment spending will barely match the 1985 total. And, after adjustment for inflation, capital spending appears headed for a decline of about 5 percent.

Contracting for commercial and industrial building in recent months has been pointing the way to a decline in 1986 even without tax reform. Peak volume was reached in 1985's third quarter at an annualized rate of 1,096 million square feet, as revealed by last year's closing-quarter setback to 1,068 million square feet. Office building, the highest risk category by far, was where the recent slippage of commercial and industrial building was concentrated.

What the indicators say is going to happen to office, store, and factory construction in 1986

Office building is long overdue for a return to reality. In 1986, as market forces begin to restore supply-and-demand balance, building is forecast to decline by 20 percent to 265 million square feet. In 1987, passage of tax reform legislation will hasten the inevitable adjustment to several years of overbuilding.

Retail building (stores, warehouses, and other commercial structures) will continue to support the commercial and industrial group through 1986. In response to strong residential building both last year and this year, retail building should sustain a volume close to 1985's total of just under 600 million square feet.

Industrial building, which bogged down at a weak 150 million square

feet in 1985 when the economy's growth stalled, is destined for at least another year of sluggishness. Until stronger industrial production takes up some of the existing slack in manufacturing capacity, a sequence that implies a reversal of the trade deficit, square footage of industrial construction will be restricted to the range of 145 to 155 million square feet—probably through mid-1987.

Total commercial and industrial building, dominated in 1986 by the denouement of the wildest office boom in history, will be making its first step down from 1985's cyclical peak. Support from retail building, through 1986, will limit the initial decline to less than 10 percent but, by 1987, the added dimension of tax reform will cause the slide to accelerate into double digits.

Deficit reduction could mean big reductions in government programs and public works

The constitutionality of the Gramm-Rudman deficit-control act may be in question, but there can be no doubt about the intent of Congress and the President concerning this law, which would systematically reduce Federal deficits. As one Congressman put it, "Even if Gramm-Rudman dies in the Supreme Court, it will rule from the grave."

The controversy over Gramm-Rudman's "sequestration" formula—that would require across-the-board budget cuts whenever deficit targets aren't met—won't affect how the program works in 1986. With the current fiscal year's budget already in place before it was passed, the deficit-reduction act applies in a unique and somewhat complicated way:

- Strict application of the deficit targets would have required a total budget cut of \$30 billion (reducing the fiscal year 1986 deficit to \$172 billion), but instead, the 1986 budget cut was arbitrarily capped at \$20 billion.

- Because the law will apply to only seven months of the fiscal year, the mandatory \$20 billion cut was further reduced to \$11.7 billion.

- The controversial sequestration formula applies rigidly in fiscal year 1986, even though its application in future years is as yet unresolved.

- The share of the \$11.7 billion spending cut that was allocated to the various federally funded construction programs (which represent roughly 15 percent of non-defense "controllables") amounts to almost exactly \$1 billion. This extra billion will be squeezed from program budgets which were already frozen at 1985 spending levels (e.g., highways), or had been previously cut below last

Continued

When you make America's best floor tile, the only way to go is up.



Since IAC was founded in 1981, we have dedicated ourselves to producing the best glazed ceramic floor tile in America. So, when we decided to enter the ceramic wall tile market, we committed ourselves to maintaining that same standard.

That's why we chose to merge with LAUFEN, a recognized worldwide leader in fine ceramic products including INCEPA wall tile. INCEPA's full range of elegant colors and patterns and rich waterfall-glaze finish offers our customers the kind of quality they have come to rely on.

INCEPA's 6" x 6" European sizing makes this fine ceramic wall tile easier and quicker to install. It requires 50 percent less grout, fewer trim pieces, and costs less per square foot to install than standard 4 $\frac{1}{4}$ " x 4 $\frac{1}{4}$ " tile. And INCEPA wall tile conforms to all ASTM standards including sizing, squareness, and warpage.

INCEPA is available only from IAC. So, if you're looking for a ceramic wall tile with the beauty and durability you can depend on, look no further than America's best ceramic floor tile manufacturer—IAC. We're moving up in the world.

For more information on an IAC distributor near you, call IAC at 1-800-331-3651.



Circle 34 on inquiry card

New AIA contract provisions would limit liability

Although they still must be put in final form and voted on by the AIA board of directors, a number of new proposed contract provisions that would limit or shift liability have been released with the caution that legal counsel should be sought before their use. Of special concern to architects who might try to use them are anti-indemnification statutes enacted in some states and other public policies, such as those held by government agencies or school boards, that would invalidate some or all of the provisions.

Of special interest are clauses on "reasonable standard of care" that would absolve architects from legal responsibility for hazardous materials found in an existing building, that would prohibit the alteration of drawings not approved by the architect, and that would not hold an architect responsible for completion of a terminated contract. Blanket clauses would disclaim liability to an owner for indirect damages and would limit direct damages to the amount of the design fee plus the amount of insurance carried—even though the architect may carry none.

Care must be taken, notes the AIA, that, to be effective, such clauses must be agreed to by the owner, and show that the owner was aware of them when he signed the contract. It is recommended that they be signed separately and/or printed in capital letters. It is indicative of the sensitivity of such provisions that the AIA also includes wording that would allow a court that found the provisions overly broad to enforce some limited variation that it did find appropriate. Wording is also included that would allow the remainder of a contract to continue in effect even though one contract provision was entirely disallowed.

First graduate program in architectural criticism offered

Parsons School of Design, in cooperation with the New School for Social Research, will launch the nation's first graduate program in architectural criticism this coming fall. Designed to develop "strong voices capable of analyzing and assessing the contemporary built environment," the program will offer publishing opportunities through internships and independent study projects. The

Two states open up old controversy on who can design buildings

Despite the fact that most states allow both architects and engineers to design buildings, two states, New Jersey and Illinois, would alter existing legislation to give architects the upper hand. In New Jersey, the state board of architects has proposed a statute that would allow engineers to do only "incidental" architectural work on all types of buildings, except certain types of industrial facilities, for which engineers could hold the primary contract, and has already moved against engineers for work on other types of structures. Illinois is considering legislation, drafted by the AIA State Council and now lodged in a Senate committee, that would produce a similar effect, limiting engineers' ability to hold primary contracts to those for buildings not mainly intended for human occupancy.

Countering the Illinois architects' contention that only they are qualified to master all the disciplines involved in building design, president Paul Lavicka of the Illinois Structural Engineers Association asserts that while "architecture is fickle," "structural engineering is based on science and math, and is concerned solely with public safety."

Vice president M. S. Markson of the Society of American Registered Architects' Illinois Council points to the differing licensing qualifications for the two professions. The engineers' exam consists of basic technical disciplines and lasts 16 hours, while the architects' exam includes both basic technical parts and other sections that test ability to deal with safety, esthetics, and health. Markson states that "it is obvious that if it were intended that both professions do the same thing, there would be one license category and exam for both."

program was developed in consultation with an advisory committee that includes Catholic University architecture chairman Peter Blake, Museum of Modern Art architecture director Arthur Drexler, *The New York Times* critic Paul Goldberger, and RECORD editor Mildred Schmertz. Contact Parsons' Department of Environmental Design, 66 Fifth Avenue, New York, N. Y. 10011 (212/741-8955).

Engineers' peer-review program pays off in lower liability-insurance premiums

One company, Design Professionals Insurance Company, will now offer a 5-percent credit on premiums for those engineers who participate in the American Consulting Engineers Council's program of peer review. The voluntary program, begun some time back, involves the reciprocal monitoring of participating firms' business and quality-control practices, so that similar firms can share each others' knowledge and experience in these areas.

Meanwhile, an Administration task force found that the current state of tort law—including the lack of a fault-based standard and attorneys who work on contingency—is the primary cause of the insurance crisis and, while opposing federal indemnification plans in general, found that work in toxic-waste and asbestos might need special consideration.

Will GSA readopt construction management in light of PCB problems?

Hill International Inc. has been selected to study the problem of the toxic cooling liquid PCB, currently found in some 700 large transformers in 55 government buildings. The affected buildings include the Pentagon and those of the CIA, the FBI, and the Veterans Administration. Hill will have a construction-management contract for the replacement work, which the GSA hopes to complete in three years. (Potential exposure problems to PCB caused evacuation of the Washington Hilton during a fire late last year, which immediately persuaded the GSA to refill the transformers in several White House office buildings.)

Industry sources speculated Hill's contract foreshadowed the GSA's return to construction management, which was practiced to a great extent by the agency in the 1970s but was halted after a variety of legal and other problems. But GSA director Walter Huber says, "This is a one-shot deal."

Still, GSA officials have indicated in recent months that the agency will issue new CM guidelines. Last week, a spokesman said that draft guidelines were being reviewed by several industry groups and may be released within 60 days. *Peter Hoffmann, World News, Washington, D. C.*

Firm Foundations

McGraw-Hill books on the building art

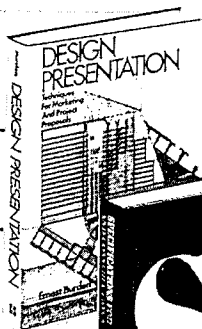

1. MASONRY IN ARCHITECTURE

By Louis G. Redstone, FAIA.
192 pp., 260 illus., 8½ x 11

One of the world's foremost masonry authorities shows the best methods — developed through 5,000 years right up to the skyscraper — for working this exciting material to achieve both form and aesthetics. *Just published!*

2. THE AIA GOLD MEDAL

By Richard Guy Wilson. 246 pp., 222 illus.
(8 pp. in full color), 8½ x 11

The first chronicle of the coveted AIA Gold Medal, this lavish commemorative volume gives full profiles, with photographic portraits, of the 44 medalists to date and examples of their work. *Just published!*

3. HOLDOUTS!

By Andrew Alpern, AIA, and Seymour Durst, real estate developer. 173 pp., 221 illus., 8½ x 11

A lively illustrated history of holdouts in New York since the 1800s — and how they were dealt with — shows what can happen when an obstinate owner forces major changes in planning and building design. *Just published!*

4. GROUND ENGINEERING EQUIPMENT AND METHODS

By Frank Harris. 256 pp., with diagrams and tables

Here are the principles and working knowledge for determining the best construction methods and alternative procedures, devising proper temporary works, and selecting the right plant and equipment to achieve faster construction times and higher quality.

5. AWARD-WINNING PASSIVE SOLAR DESIGNS Professional Edition.

By Jeffrey Cook, AIA. 288 pp., 208 illus.
(including 68 photos), 8½ x 11

These 41 winning designs from the First National Passive Solar Design competition demonstrate an impressive number of passive solar solutions for a diversity of structures, from commercial buildings to residences, in a wide variety of terrains and climatic locations. *Brand new!*

6. CHECKING AND COORDINATING ARCHITECTURAL AND ENGINEERING WORKING DRAWINGS

By John Frederick Duggar III.
160 pp., 22 illus. (8 in full color)

How to use the author's unique color-coded graphic systems for marking up check-prints, coordinating construction components, making and recording revisions, eliminating errors, omissions, and duplications, communicating, and retrieving information.

A new title!

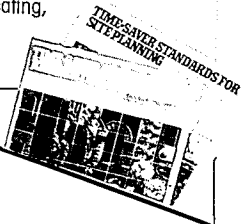

15. TIME-SAVER STANDARDS FOR SITE PLANNING

By Joseph DeChiara, AIA., and Lee E. Koppelman.
864 pp., 1,037 illus.

All-inclusive information and data on site investigation, analysis, development, and use. Plus plans.

16. TIME-SAVER STANDARDS FOR RESIDENTIAL DEVELOPMENT

By Joseph DeChiara, AIA. 908 pp., 1,300 illus.

A vast collection of data and criteria for planning and designing dwellings, from apartments to mobile homes to adult housing.

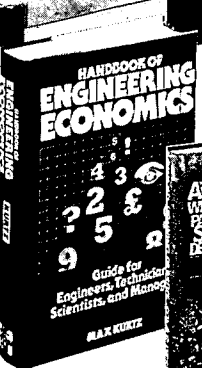
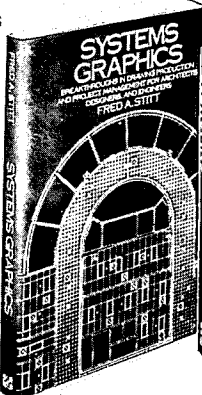
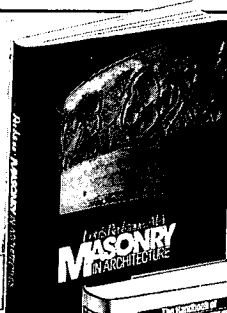

7. HANDBOOK OF ENGINEERING ECONOMICS

By Max Kurtz, PE. 1,020 pp., 317 illus.

Made marvelously easy to understand and to use — every statistical and financial analysis tool you need to control the effects of time and money on every type of engineering project and area of responsibility. The first such aid in the field. *Brand new!*

8. SPECIFICATIONS FOR ARCHITECTURE, ENGINEERING, AND CONSTRUCTION Second Edition.

By Chesley Ayers, AIA, PE. 544 pp., 70 illus.

Specifications can make or break a project, and can even cause construction disasters. Here, in a new, up-to-date edition, is the one book to coordinate the requirements of spec writing and checking into a unified whole — with special emphasis on techniques to build safety into a project.

9. CONSTRUCTION MARKETING AND STRATEGIC PLANNING

By Warren Friedman. 288 pp., 70 illus.

Shrinking construction profits make it mandatory that contractors — large and small — grasp and use every business, management, marketing, and strategic planning tool known to work best. Here they are — detailed with the assistance of the Associated General Contractors. *Just published!*

10. CONSTRUCTION DISASTERS Design Failures, Causes, and Prevention

By Steven S. Ross and the Editors of *Engineering News Record* 407 pp., 144 photos, 62 line illus.

The valuable lessons builders have learned from collapsed roofs, broken dams, floods, and earthquakes are packed into this survey of 24 major disasters of the past five decades, why they happened, and what would have minimized or prevented them. *New title!*

11. THE HANDBOOK OF CONSTRUCTION ACCOUNTING AND FINANCIAL MANAGEMENT Third Edition.

By William E. Coombs and William J. Palmer. 592 pp., 158 illus.

Reflecting the newest trends in accounting and management techniques used in the construction industry, this edition of a well-known work updates your handling of problems in every area from procurement to costs, receipts, taxes, and more.

12. DESIGN PRESENTATION Techniques for Marketing and Project Proposals

By Ernest Burden. 256 pp., hundreds of illus.

From the initial planning and preparation to the actual visual presentation of your design project (including models and computer-aided graphics) to the all-important follow-up — here are the techniques that win clients and keep them coming back for more.

13. PRESERVING AND MAINTAINING THE OLDER HOME

By Shirley Hanson and Nancy Hubby. 256 pp., 323 illus., 8½ x 11

How to accurately and sensitively repair, restore, and renovate those treasured older homes (built between the 1800s and 1940) to bring out their best interior and exterior features, find trouble spots, modernize without disfiguring — *economically.*

14. SYSTEMS GRAPHICS Breakthroughs in Drawing Production and Project Management for Architects, Designers, and Engineers.

By Fred A. Stitt. 262 pp., 157 illus.

Want to save 30%, 40%, 50% of the time and money you spend producing design and working drawings? Here's the practical how-to for using and linking together today's new, inexpensive forms of in-house reprographics — by one of the best-regarded pros in the industry.



Please send me the book(s) I have circled for 15 days' FREE examination. At the end of that time, I will pay in full, plus local tax, postage, and handling, or return the book(s) postpaid with no further obligation.

- | | |
|-----------------------|------------------------|
| 1. (051387-2) \$47.50 | 9. (022437-4) \$42.50 |
| 2. (070810-X) \$60.00 | 10. (053865-4) \$39.50 |
| 3. (001377-2) \$34.50 | 11. (012611-9) \$45.00 |
| 4. (026747-2) \$41.95 | 12. (008931-0) \$45.00 |
| 5. (012478-7) \$34.50 | 13. (026086-9) \$24.95 |
| 6. (018023-7) \$32.50 | 14. (061551-9) \$39.00 |
| 7. (035659-9) \$69.50 | 15. (016266-2) \$79.00 |
| 8. (002642-4) \$42.00 | 16. (016217-4) \$79.00 |

McGraw-Hill Book Co.
P.O. Box 400 Hightstown, NJ 08520

Name _____
Address/Apt. _____
City _____ State _____ Zip _____

Offer good only in U.S. Order subject to acceptance by McGraw-Hill. SAVE MONEY: Pay in full, plus local tax, with this order and McGraw-Hill pays all regular postage and handling costs. Same refund privilege applies!

In Canada available from McGraw-Hill Ryerson, Ltd.,
330 Progress Avenue, Scarborough, Ontario M1P 2Z5
Prices slightly higher outside the U.S. 03-K742-4000-3

SHELTERING AMERICA FOR OVER TWO CENTURIES.



When housing was needed for Hampden-Sydney College, a fine school with a tradition that dates back to 1776, Buckingham-Virginia Slate was selected as a natural roofing material. This is the same non-fading, blue-black, grade A slate that was used on original buildings still integral to campus life.

With a proud heritage of its own, Buckingham-Virginia Slate was often specified by Thomas Jefferson; and is still selected by eminent architects of our time for its permanence and natural beauty.

Because it blends with either contemporary or

traditional architecture, and helps to blend both, it's a natural, superlative choice for residential work, churches, schools, commercial and municipal jobs.

If you want to create shelter that will be around for generations to come, above all, use a permanent roof of world-class Buckingham-Virginia Slate.

 **Buckingham-Virginia
Slate Corporation**

4110 Fitzhugh Avenue • P.O. Box 11002
Richmond, VA 23230-9990 (804) 355-4351

Circle 22 on inquiry card

Generations will appreciate the distinctive, handmade quality, natural cleft and texture of Buckingham-Virginia Slate roofing products that make any roof enhancingly beautiful. Call or write for our free catalog and specifications catalog today.

Philip M. Chu Associates, Architects and Planners, Chappaqua, NY

PRACTICE POINTERS: INVESTIGATE YOUR OPTIONS

Control insurance costs with Project Liability Insurance.

More and more architects are finding Project Liability Insurance an effective way to control insurance costs.

The concept, developed by CNA Insurance and Victor O. Schinnerer & Company, Inc., provides coverage for a specific project. One policy protects you and all design consultants during the design and construction phases of the specific project. This protection continues up to five years after the construction is completed.

To help control your costs, the premium can be negotiated as a reimbursable item in the con-

struction budget. The cost of your annual policy will be reduced because billings from jobs covered by Project Insurance are not included under your annual policy. Also, any claims under your project policy will not impact the premium charged for your annual policy.

You have come to expect innovative product ideas like Project Liability Insurance from our professional liability program. You can also count on our expertise that comes with nearly 30 continuous years of experience. Contact Schinnerer. We offer you a program worth investigating.

Victor O.

Schinnerer
& Company, Inc.

Underwriting Manager
5028 Wisconsin Avenue, NW
Washington, DC 20016 (202) 885-9500
Coverage is underwritten by
Continental Casualty Company, one of the CNA Insurance Companies.

CNA

For All the Commitments You Make®

Circle 19 on inquiry card

Introducing Cordura[®] for upholstery. Made tough to survive the corporate jungle.

Contract upholstery will never be the same, now that Du Pont brings CORDURA* to the office. CORDURA nylon has proved itself tough enough for backpacks and luggage, durable enough for hunting gear and boots.

It exceeds the standard Wyzenbeek Double Rub Abrasion Test by such a wide margin that an even more stringent Wyzenbeek Test had to be developed (see results at right).

And CORDURA is a soft touch indoors. We've given it a luxurious hand, a satisfying touch and a smart look that make the most of fabrics for contemporary or classic furniture.

Fabrics of CORDURA nylon are available in a whole range of colors, styles and weaves. In 1000/280 denier, or newer 2000/560 with an even softer surface.

For good looks with strong character, ask about CORDURA. Contact Du Pont at (215) 855-7765, and let us give you samples, specifications and names of suppliers.

CORDURA. The survivor.

More stringent modified Wyzenbeek Abrasion Test.

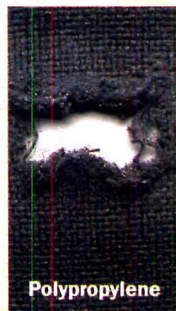

Polypropylene

Polypropylene failed at 164 double rubs.



Spun Nylon

Spun nylon failed at 445 double rubs.

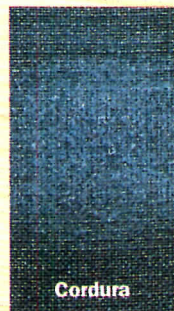

Cordura

CORDURA hardly affected after 445 double rubs. Failed at 1,464.

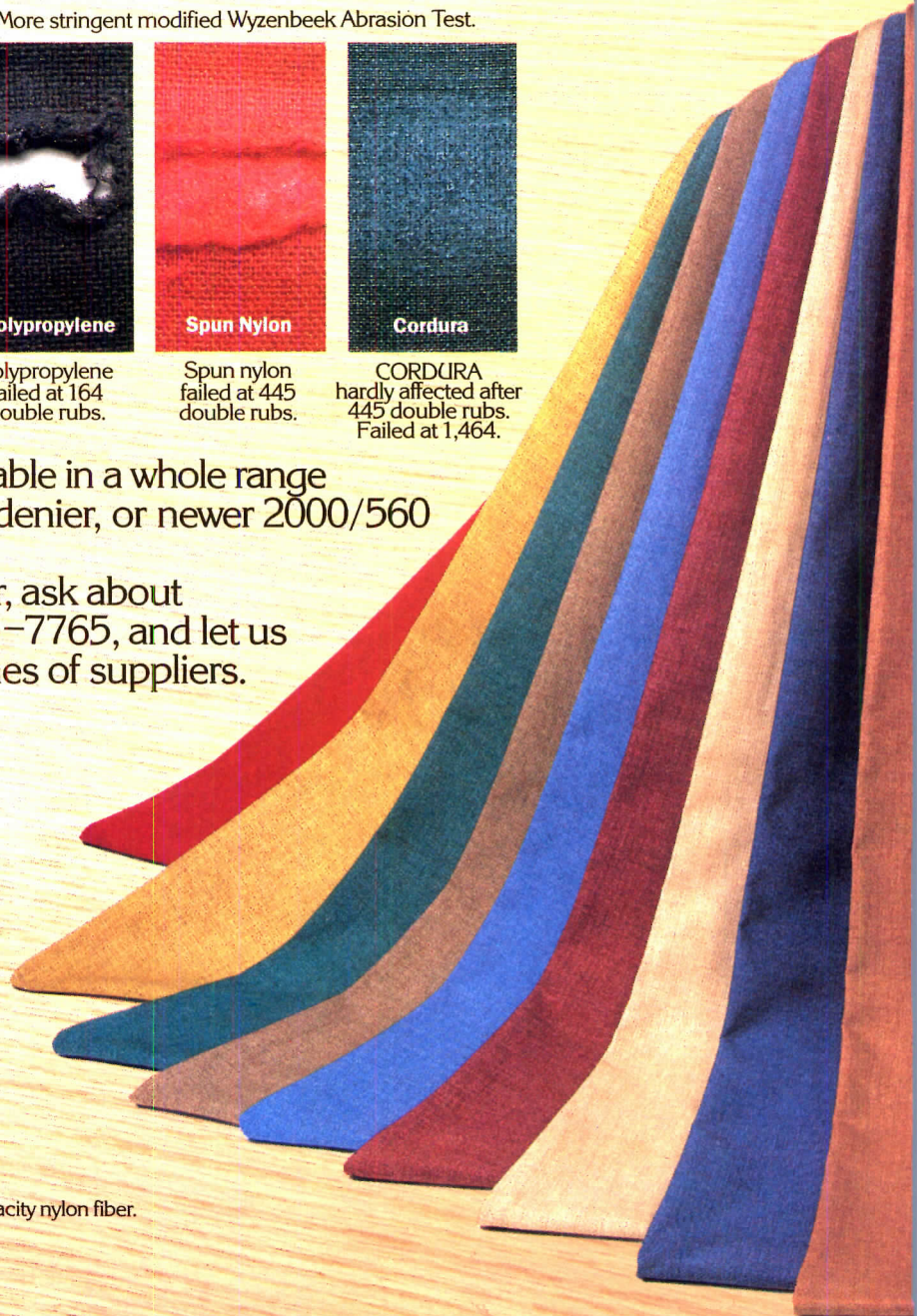

*Registered trademark of the Du Pont Company for its air-textured, high-tenacity nylon fiber. Du Pont makes fiber, not fabric.

Circle 18 on inquiry card



STOOD THE TEST OF TIME. STAND THE TEST OF ANDERSEN.

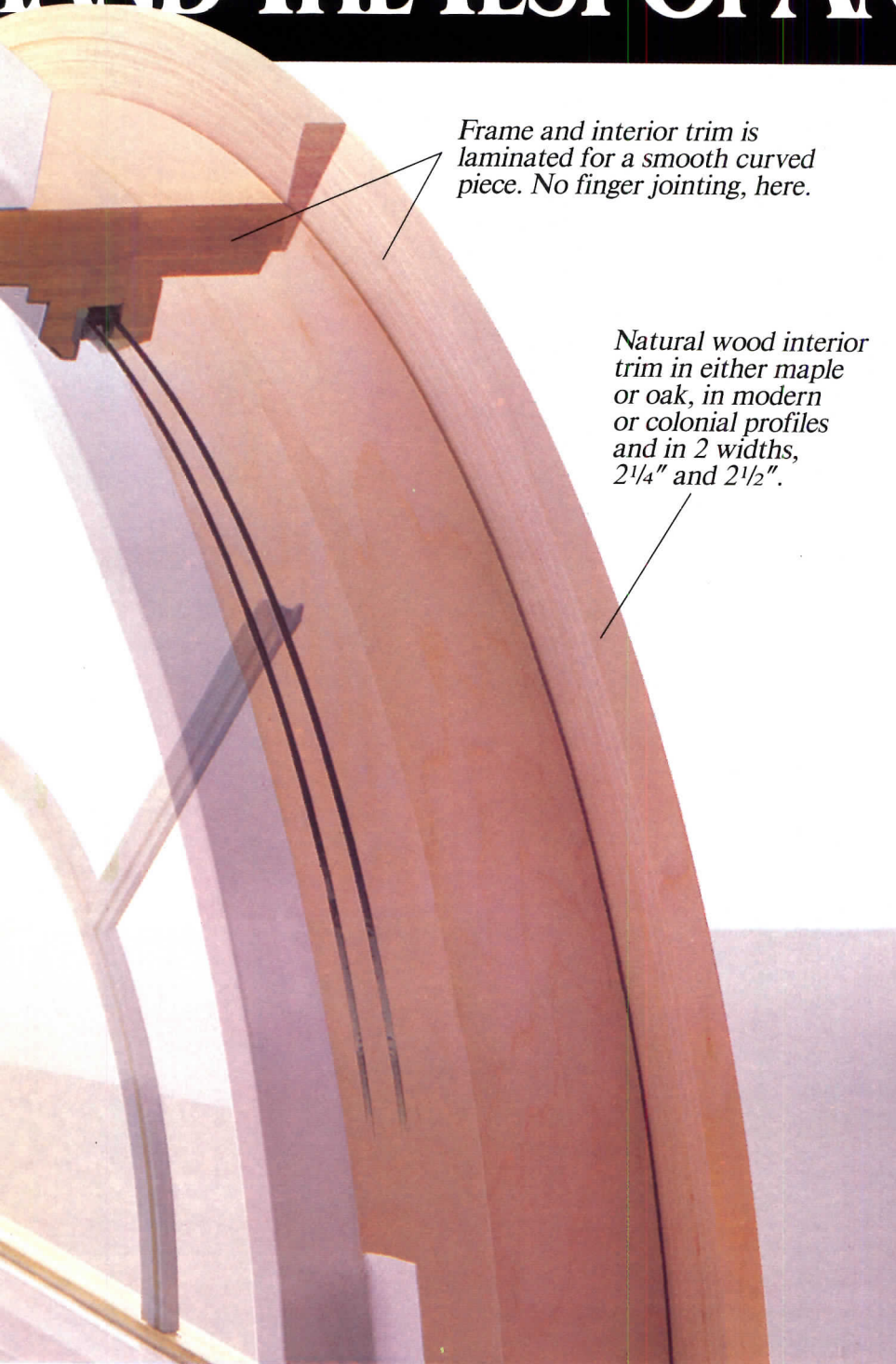

Frame and interior trim is laminated for a smooth curved piece. No finger jointing, here.

Natural wood interior trim in either maple or oak, in modern or colonial profiles and in 2 widths, 2 1/4" and 2 1/2".

finest insulator, with a rigid vinyl sheath that makes for a nearly maintenance-free exterior, while the natural wood interior lends its beauty inside whether stained or painted.

**APPEALS TO THE MIND
AS WELL AS THE EYE.**

Andersen circle top windows deal in two concepts of performance that have a beauty you can't necessarily see. Weathertightness and energy efficiency.

Since Andersen circle top windows were designed to be a perfect fit with either Narroline double-hung or Perma-Shield casement units, the fit will be precise and tight.

Plus, we offer 6 exclusive glazing options. 3/8-inch double pane insulating glass; High-Performance; and High-Performance Sun. For installations where altitude exceeds 3,500 feet we also offer a high altitude option for each of these three glazings.

So, no matter what the climate or location, Andersen circle tops add beauty to the design and intelligence to the construction.

SOME FINAL THOUGHTS TO ROUND OUT THE PICTURE.

In creating our new circle top windows, we sought to add details and options the others had somehow left out.

Take interior trim for example. Two standard interior profiles are available, modern and colonial. And, they are available in either maple or oak. There's no finger jointing on the face here, either. The detailing is smooth and rich looking, instead of looking puzzled together. The exteriors are available in either white or Terratone.

Even the grillwork has the exclusive Andersen touch. The grilles are vinyl but have been treated so that they can be painted or stained on the inside.

There are, of course, a myriad of other details and finery regarding new Andersen circle top windows. And, we would be delighted to talk at length about them. For more information and persuasion, contact your Andersen distributor or see Sweet's File 8.16/AN. Or, write us direct. Andersen Corp., Box 12, Bayport, MN 55003.

Circle 17 on inquiry card

**Come
home to
quality.**

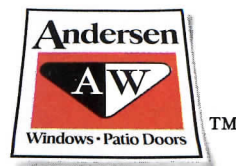

Andersen

CIRCLE TOP WINDOWS HAV UNTIL NOW, THEY JUST COULDN'

Circular windows have been a staple of architectural design for literally hundreds of years. Featured in homes of gentry, of substance, those who desired style, even some who just simply thought they looked nice. However, even with their aesthetic qualities they have lacked certain details. Not the least of which is the absence of the Andersen® label.

For you see, nothing bears this label until it promises the same precision and quality you've come to know and recommend in other Andersen products. Therefore, it is with considerable pride that we introduce this several-hundred-year-old concept into the Andersen line.



**ONE STYLE
NEVER FITS ALL.**

Most window manufacturers feature a universal circle top unit to be used with all window styles. It would seem that a shade of difference here and there is acceptable.

Perhaps to some, but not to Andersen. We not only offer more stock sizes than any other manufacturer. We produce them in two styles. One

compatible with Andersen Narroline® double-hung window, the other a perfect match with the Perma-Shield® casement/awning window. This allows only Andersen circle top windows to blend with the profile of both window styles inside and out. Which, if you follow the logic, makes any job you complete look like you planned it that way.

Our exclusive pre-formed rigid vinyl sheath on frame continues to form a full perimeter flashing and anchoring fin.

Andersen offers 6 exclusive glazings. Including special glass for high altitude.

Perma-Shield exterior is available in either white or Terratone.

Grilles snap out for easy cleaning and can be painted or stained to match any interior.

86110 ©1986 Andersen Corp.

**THE ONLY CIRCLE TOPS
WITH ANDERSEN WINDOW
DESIGN AND PERFORMANCE.**

The soul of every Andersen Perma-Shield window is its exclusive construction. Andersen circle top windows are no exception. A solid wood core, nature's



**Protection
you never
thought
possible
with
exterior
insulation
systems.**

*Heat.
Frigid Temperatures.
Moisture. Time.
All can take their toll
on even the best
designed buildings.*

STO Exterior Insulation Systems offer the full above and below grade protection other materials just can't. They create a thermal shield against the elements that maintains high energy efficiency —they envelop the outside of your building like a protective skin that's flexible, breathes, and resists moisture, yet retains its original beauty for many years to come.

STO INDUSTRIES, INC.
Quality Lane, Box 219
Rutland, Vermont 05701
Toll Free: (800) 851-5533
Circle 16 on inquiry card



Exterior
Insulation
Systems

1

Hambro®...the most cost efficient floor system you can use.

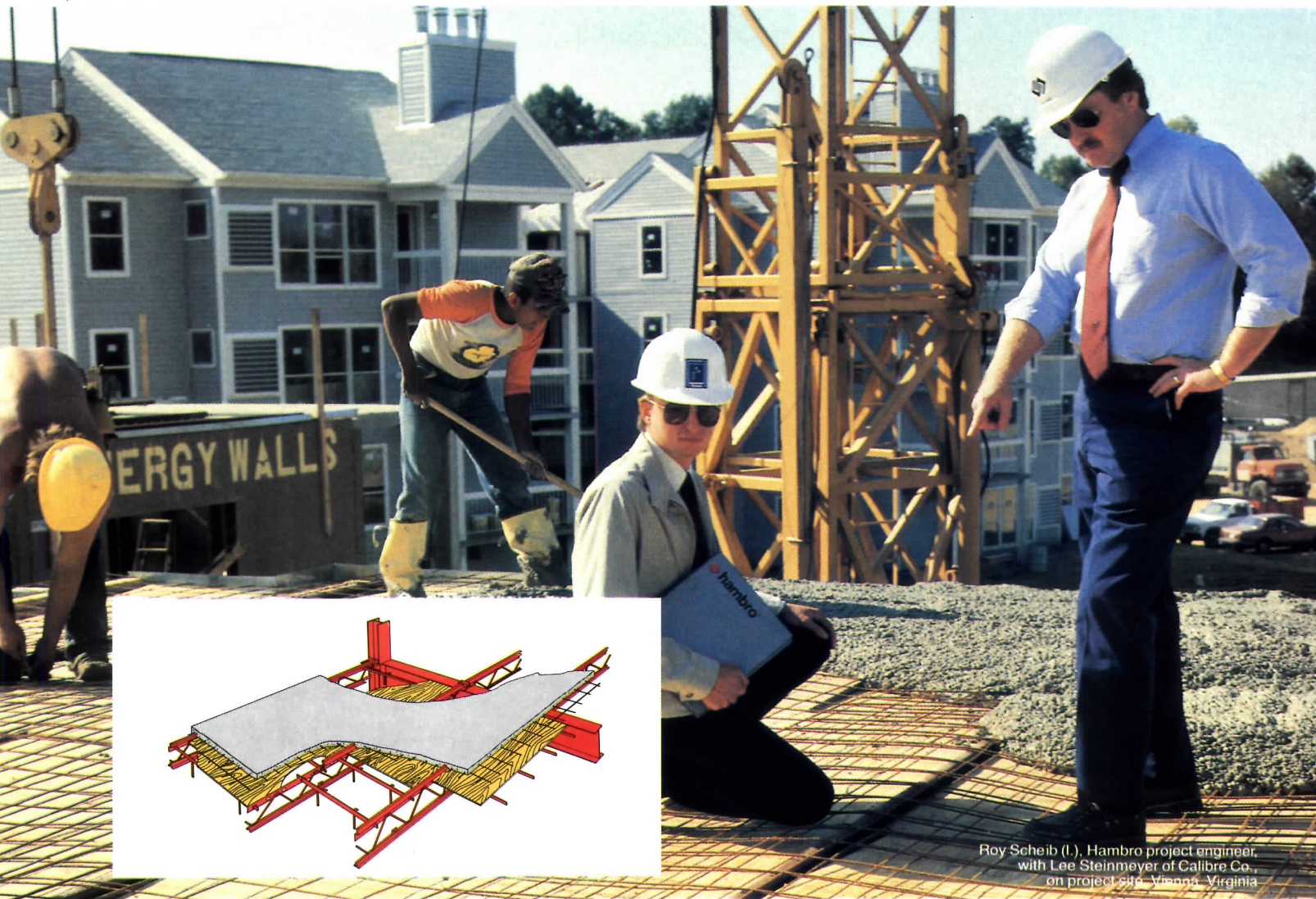

Roy Scheib (l), Hambro project engineer, with Lee Steinmeyer of Calibre Co., on project site, Vienna, Virginia

“The Hambro team helped save us money when it counted... before construction.”

Lee Steinmeyer, Project Manager
The Calibre Companies

“We talked to the engineers at Hambro about their composite floor system when we started thinking about the Summit Square project,” says Steinmeyer. “They worked closely with our architect, structural engineers, and HVAC engineers, and helped us develop the most economical fire-rated construction package. They showed us how the Hambro system would achieve dramatic savings in our HVAC, plumbing and electrical assemblies, before we even went to bids.

“In addition, the latest UL fire test on the Hambro system allowed us to eliminate fire dampers. And by specifying Hambro, we could substitute 1/2” for 5/8” gypsum board at the ceilings.”

Hambro’s UL fire ratings are achieved without applying the 22/30 factor for reduction of capacity required for conventional “H” series joists. This, together with Hambro’s superior sound rating of STC 57, make it the ideal floor construction system for high or low rise commercial and residential buildings. Call or write for brochure.



P.O. Box 223, Needham Heights, MA 02194 (617) 444-5504
Regional Offices and Distributors throughout the U.S.
In NYC, NJ, Eastern PA, MD, VA and DE: Mid-Atlantic Hambro, Inc.
114 East 25th St., Baltimore, MD 21218 (301) 338-1122 Telex: 87938

A subsidiary of  canam manac

Circle 15 on inquiry card



ent™ Wall Panels and Textone® Vinyl-faced Drywall
panels. Join the colorevolution to integrate your total
interior designs.
Come up with color now with USG ceilings!

For color brochure, SC-937 see
our representative. See 9.1 Usq
in Sweet's Catalog Files. Or write
to us at 101 S. Wacker Drive,
Chicago, IL 60606-4385, Dept. AR586G

Circle 14 on inquiry card

ACOUSTICAL PRODUCTS COMPANY © 1986 USG Acoustical Products Co.



Up with

Color ceilings are all the news. And no wonder. Color's so elegant, so essential to truly coordinated decor. Now we're making color ceilings so available, so affordable, you'll want to use them to set moods, shape settings, ornament and modify space on any

budget you have to work with! We've made 24 color **STANDARD** on selected Acoustone® and Aurator Panels—the broadest new line of colors in the industry. We make it easy for you to coordinate with any furniture and fabric colors of leading office equipment manufacturers.

AFFORDABLE COLOR CEILINGS FROM US

WITH

PC GLASSBLOCK® PRODUCTS

**Design Structures, Shape Space,
Control Light in New and
Exciting Ways!**

Set your imagination free.

Create exciting structures displaying the beautiful light-transmitting qualities of glass — yet offering the strength of masonry.

Shape space. Re-define the contours. Sculpt PC GlassBlock® products into sinuous curves or dramatic straight walls.

Play with patterns. Select from the PC GlassBlock® patterns, the one which will achieve the appropriate texture and just the right amount of light transmission.

PC GlassBlock® products let you use light in most inventive ways. SOLAR REFLECTIVE units in bronze or gray provide a striking yet practical way to reduce solar heat gain and light transmission. Or you can select a pattern which allows more light to pass through and create a visual panorama!

But don't let our good looks fool you. PC GlassBlock® products are not just another pretty facade. Thick, break-resistant, mortared units provide superior insulation. And PC GlassBlock® products help to reduce heating and air conditioning requirements and they need little maintenance.

American-made PC GlassBlock® products can spark **your** imagination. For information, contact Pittsburgh Corning Corporation, Marketing Department, AGB-6, 800 Presque Isle Drive, Pittsburgh, PA 15239, Tel.: (412) 327-6100. In Canada, 106-6 Lansing Square, Willowdale, Ontario M2J 1T5, Tel.: (416) 222-8084.
Circle 13 on inquiry card



SEPTA
(Philadelphia
Mass Transit)
11th Street
Station

Architect:
Ueland & Junker
DECORA® Pattern

Corporate Offices,
Atlanta, GA
Architect:
Godwin & Associates
VUE® Pattern

PITTSBURGH
pc
CORNING



Let Your Imagination Soar



INTELSAT
(International
Telecommunications
Satellite
Organization)
Architect:
John Andrews
International Pty. Ltd.
Solar Reflective
Glass Block



ator keeps up Joneses.

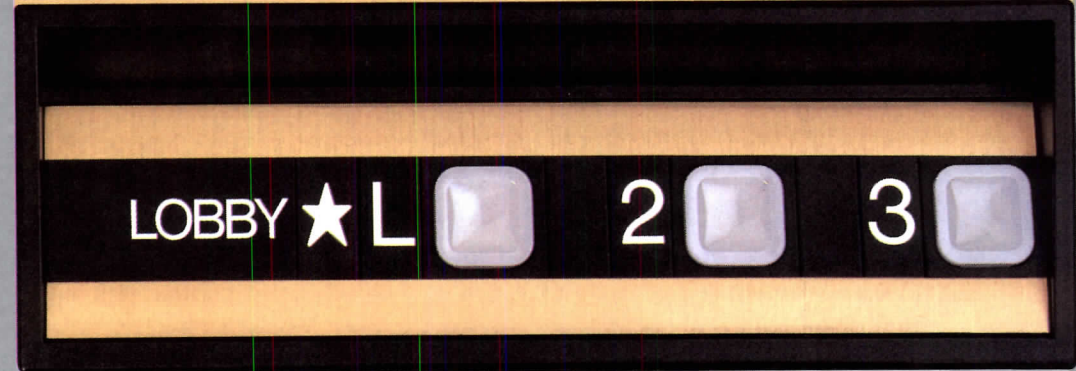
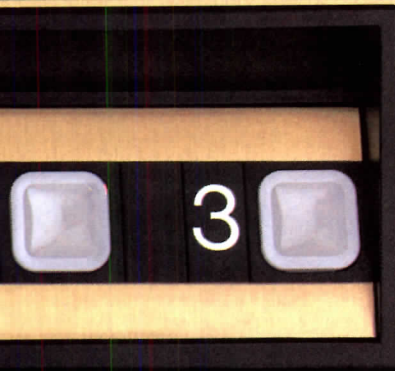
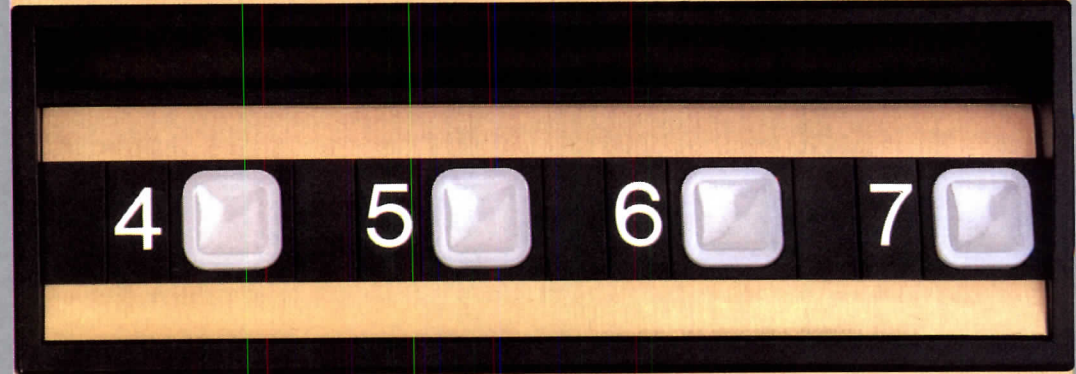
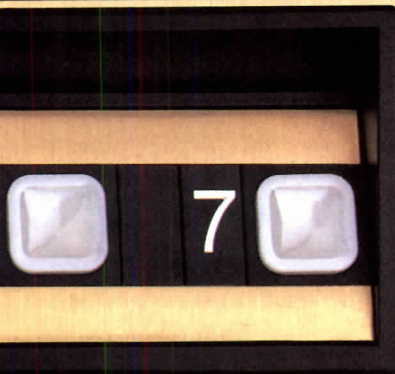
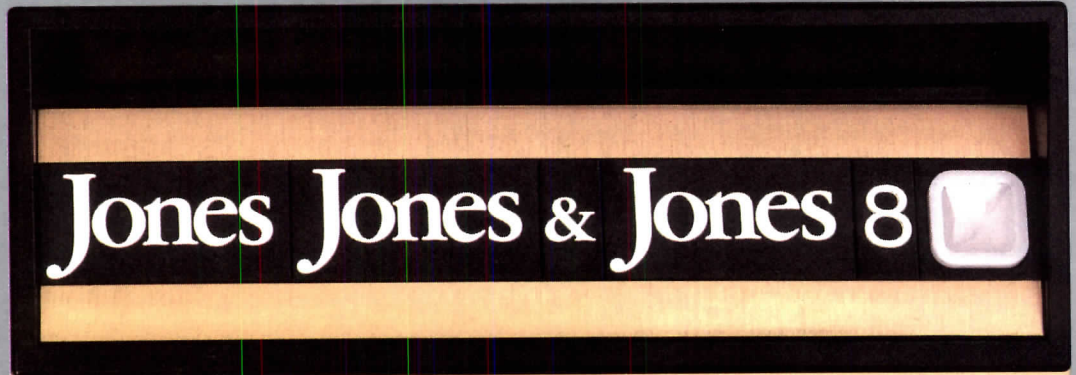
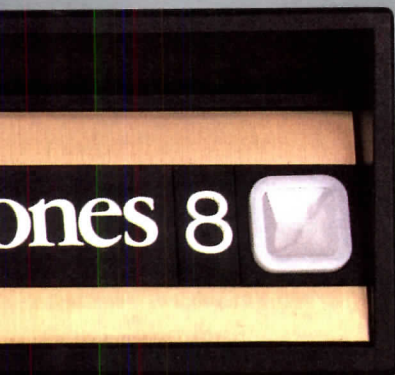

Signage and buttons are recessed at a 20° angle facing up, so they're easy to read, easy to use.

Since it's pre-engineered, Impulse can be assembled and delivered quickly. Which can be important when you're keeping up with the Joneses.

For more information on Impulse signal fixtures, call your local Dover office or write Dover Elevator Systems, Inc., P.O. Box 2177, Memphis, TN 38101.

DOVER[®]
ELEVATORS

*Making more
elevators makes
Dover No.1*

Only Dover Elevators with the

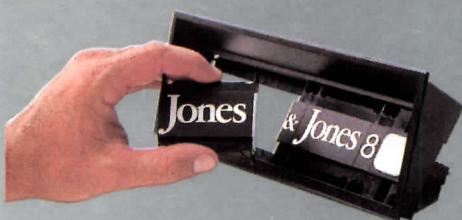
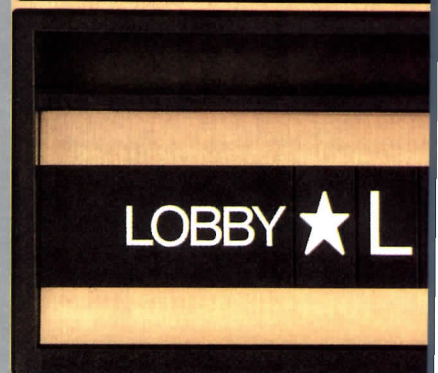
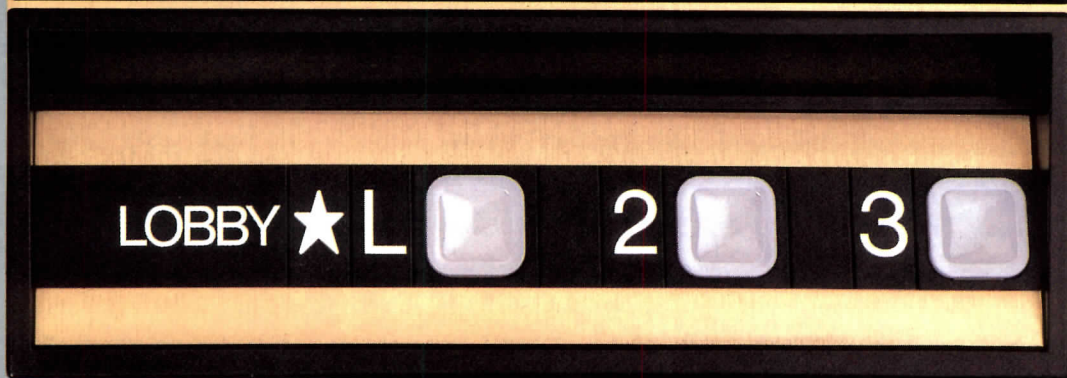
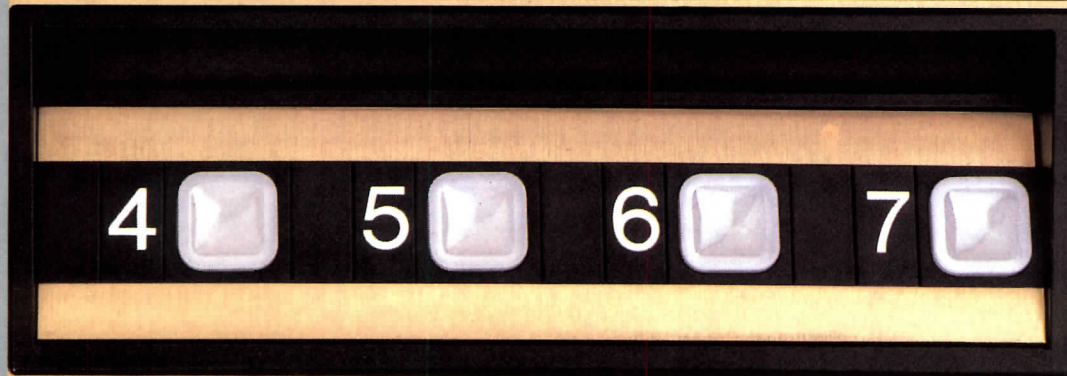

In a changing world, count on Dover to keep you current. With an innovative and flexible approach to elevator signal fixtures—Impulse.

Impulse® is the first system that lets you integrate signage directly into the cab operating panel. So tenants' names (or any other kind of ID) can be right there by the button. Even better, it's completely modular. You can add to, delete, re-arrange elements as needed.

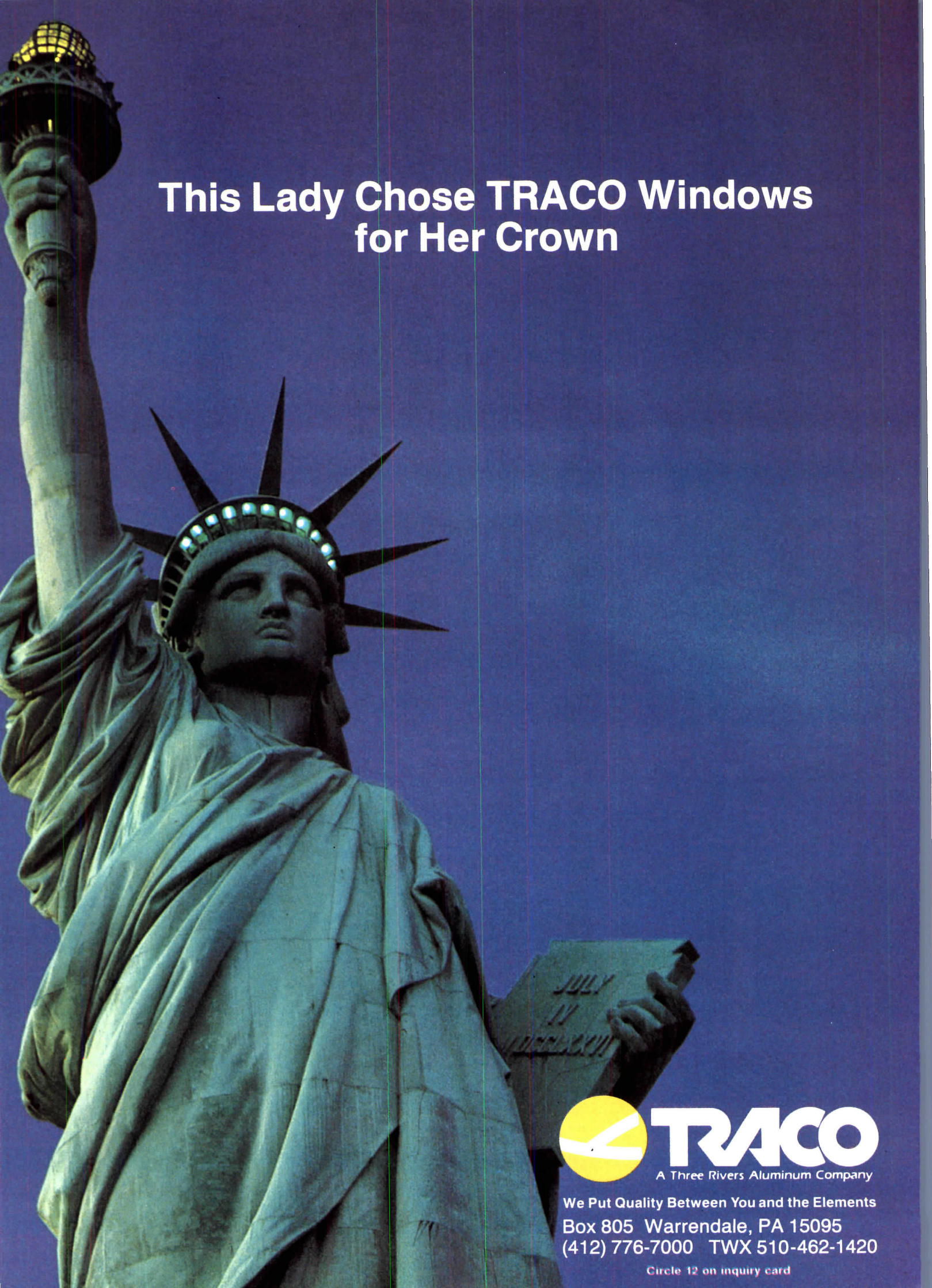
A photograph of the Statue of Liberty at night, illuminated with a blue-green light. The crown is replaced with a modern, illuminated crown made of small lights. The statue holds a tablet in her left hand with the date 'JULY 4 1776' visible.

This Lady Chose TRACO Windows for Her Crown



We Put Quality Between You and the Elements
Box 805 Warrendale, PA 15095
(412) 776-7000 TWX 510-462-1420

Circle 12 on inquiry card

When you have an asbestos-free,
sprayed fireproofing material that is
efficient, versatile and economical,
you don't have to shout it...
your customers will do it for you.

For complete information and specifications, contact:



United States Mineral Products Company
Stanhope, New Jersey 07874 Toll-free 1-800-631-9600 In N.J. 1-800-562-0256 Telex 136439 CAFCO STPE

Circle 11 on inquiry card

The Pilkington Wall

You won't find a better supported system.
Anywhere.



And by 'anywhere', we mean anywhere in the world. Not that you'd expect anything less from the world's foremost pioneers in glass and glazing technology.

The experience of Pilkington Glass in sweeping, sky-reaching walls of glass is second to none. We make the finest tempered and solar control glasses available. We redefined the state-of-the-art with our Suspended Glass Assembly system. We gave flush glazing a new dimension of safety with our 'Armourplate' 'Planar' system.

So it isn't really surprising that we support it all with the most comprehensive design and technical advisory service available . . . a service that runs from conception

through to completion, and which can uniquely call upon international expertise. This service and expertise is available to you on a Federal basis, through any of the

carefully selected companies below.

Chances are our technical team has already solved your specific all-glass walling or roofing problems. Many times over. If they haven't, you'll find no one more experienced or better placed to come up with the most practical and cost-effective answers.

Get the Pilkington Glass team working for you. For literature and further information contact

Ray Read, or any of the companies listed below.



PILKINGTON

◀ Glass for Buildings and Transport ▶

Ray Read, Pilkington Sales (North America) Ltd.
25 Imperial Street, Toronto, Ontario, Canada M5P 1B9.
Telephone (416) 489-6773. Telex 06-218804.

Binswanger Glass Co.,
965 Ridge Lake Blvd.,
Memphis, Tennessee 38117
(901) 767 7111

The Major Glass Co. Inc.,
285 Salem St.,
Woburn, Mass. 01888
(617) 935 4870

Diamond Architectural Inc.,
27 Horton Ave.,
New Rochelle, New York 10801
(914) 636 4900

Tom Benson Industries Inc.,
1350 N.W. Raleigh St.,
Portland, Oregon 97209
(503) 226 7611

Glassalum Engineering Corp.
7933 N.W. 71st. Street,
Miami, Florida. 33166
(305) 592 1212

Welling Co. Inc.,
7223 Dixie Highway
Fairfield, Ohio 45014
(513) 874 7733

Harmon Contract Glazing Inc.,
660 Kasota Ave. S.E.
Minneapolis, Minnesota 55414
(612) 623 1997

West Detroit Glass Co.,
4500 Stecker Ave.,
Dearborn, Michigan, 48121
(313) 582 8400

'Armourplate' and 'Planar' are trade marks of Pilkington Brothers plc

Circle 10 on inquiry card

Spring Rain...Summer Sun.



And Winter snow. In every season of the year, Helios Modular Shelters are graceful, colorful structures for shade and shelter. Translucent by day, at night they are a cheerful, luminous accent that glows with underside lighting.

The pre-engineered Helios Modular Shelter is versatile. It can stand alone, or be joined and clustered in any formation that adapts to the requirements of your space. Hexagonal or square configurations in umbrella or inverted tulip shapes are standard.

More than just a pretty parasol, the Modular Shelter is the ultimate in practicality. It has a durable, ten-year-warranty membrane that can be left up through the year or demounted easily. The sturdy steel framework and membrane are engineered for heavy wind and snow loading, meeting many model building codes, and are shipped ready to install in less than a day.

Explore the many possibilities of the Helios Modular Shelter. Our literature tells all.

Helios is a leading fabricator of custom designed soft shell structures, used around the world for their flamboyant, curvilinear shapes, light weight and long life. Send us your idea sketch, we'll help turn it into reality.

Helios Modular Shelters

at Saddlebrook, Wesley Chapel, Florida U.S.A.



HELIOS INDUSTRIES, INC.

Soft Shell Structures Division

Helios Industries, Inc.
20303 Mack Street
Hayward, California 94545, U.S.A.
Telephone (415) 887-4800
Telex 176226
Facsimile 4158870134



Helios Modular Shelters

at Lighthouse Cove, Pompano Beach, Florida U.S.A.

Circle 9 on inquiry card

Preserving the architecture of Ellis Island

The public never goes to see the United States Immigration Station on Ellis Island, closed since it suspended operations for good in 1954. Before I visited the 23-acre island for the first time a few weeks ago, I knew that its buildings possessed architectural curiosity and merit. I was unprepared, however, for the beauty and power of the site, with its splendid vistas of the Statue of Liberty and lower Manhattan. I had not realized, furthermore, that the structures—reception buildings, hospital, contagious disease wings—were part of a masterfully ordered single composition, completed between 1892 and 1912 after designs by the architectural firm of Boring and Tilton. This collection of fine buildings (over 30 in all) speaks eloquently of the hopes and sufferings of the 16 million poor steerage passengers who passed through them on the way to a new life, unless they were detained by illness, or deported back to where they came from. There are very few such splendid ensembles still extant in New York City. Only the Columbia University campus comes to mind.

To the north of the ferry slip is the Great Registry Hall, an immense brick and stone edifice, boasting quoins, rustication, and splendid belvederes, as awesome and overpowering a structure as the 19th-century Parisian railway stations that inspired it. To the south, running the whole length of the dock, is the principal hospital building, quieter, more delicately scaled than the building opposite, more like a late Renaissance French chateau. At the end of the slip, connecting these grand wings, is a stylish little Art Deco structure built by Robert Moses in the '30s. The south facade of the hospital faces the former contagious disease wings, a series of smaller pavilions on the opposite side of a vast open space, once an additional ferry slip, now filled in. The Great Registry Hall is being preserved and restored by the National Park Service with architects Beyer Blinder Belle, to open as an immigration museum in 1988. All the rest of the buildings are in various stages of ruin.

Ellis Island and its buildings are part of the Statue of Liberty National Monument, administered by the National Park Service. Since 1982, the Park Service has been trying to get the official go-ahead to transform all the hospital buildings and the grand meadow these enclose, into a nonprofit, self-supporting international conference center. This concept, proposed by preservationist and developer William Hubbard of the Center for Housing Partnerships and by the architectural firm of Conklin Rossant, is considered by the Park Service to be the most feasible received in response to the Department of the Interior's formal request for applications for the private use of the island. Strong voices, however, oppose this scheme. Lee Iacocca, recently fired as chairman of the Statue of Liberty-Ellis Island Centennial Commission by Secretary of the Interior Donald Hodel, but still head of the fund-raising foundation, and his architectural consultant, John Burgee, who has resigned from the commission in protest against Iacocca's dismissal, argue that the National Park Service has no right to lease any portion of such historic land to a private developer. They assert that "international conference center" is but a euphemism for "hotel," and a hotel, by whatever name, or indeed any private commercial use would violate the integrity of the landmark.

Alternatively, Burgee proposes that portions of the hospital form settings for ethnic displays and the grand meadow be used for outdoor folk festivals (an "ethnic Disneyland" in the words of his opponents). The smaller pavilions (of no esthetic merit in Burgee's view) should be demolished, he believes. Appropriate contemporary structures, including a 90-foot-high glass dome to be designed by his firm, would be added. Other proposals for keeping the southern sector of Ellis Island in the public domain are under review. It has even been proposed that the buildings be stabilized ("mothballed") in their present ruinous yet picturesque state.

The public-versus-private-use debate may not be settled in time to fix up the southern portion of the island by its centennial in 1992. Advocates of the conference center hope that Iacocca will quietly remove himself from the conflict after he is appropriately honored this July 4th for raising over \$233 million thus far to restore the Statue of Liberty and begin the transformation of the Great Registry Hall into the immigration museum. If the issue thus becomes moot, Hodel might promptly approve the Conklin Rossant scheme. This would be the best of all possible outcomes. Public funds alone would be insufficient to restore and maintain the entire ensemble, but fortunately there are successful precedents for public-private development of historic landmark sites. An international conference center need not completely exclude the public, any more than a college campus does. Vistas, promenades, and the spectacle of the beautiful and evocative buildings themselves could be accessible to everyone. Unfortunately, this fine concept is in danger of being frittered away by official indifference and indecisiveness. Ellis Island is deteriorating rapidly. It can't wait much longer. *Mildred F. Schmertz*

Glass Distinction

Naturalite Skylights Make Atrium Concepts Work Beautifully.

The handsome Bent Tree Green office condominiums in north Dallas capitalizes beautifully upon the atrium concept through use of structural ridge skylights by Naturalite.

The Naturalite engineered glass skylight system encloses two identical areas measuring 50' x 71'. Glazing consists of 1/2" heat strengthened reflective laminated glass with an .060 poly vinyl inter-layer. The finish of the aluminum structural ridge is dark bronze anodized.

General contractor, Bramcon General Contractors. Architects, Harwood K. Smith and Partners, Inc., Dallas.

Whatever your design calls for, Naturalite can execute it beautifully in acrylic, glass or polycarbonates. And, we are equipped to install larger custom and monumental applications almost anywhere.

See Sweets insert 7.8/Na or contact the factory. Naturalite, America's largest skylight company. Your single source for skylights.



NATURALITE[®], INC.

3233 West Kingsley Road, Garland, Texas 75040
For information call: John Rowan
(Toll Free) 1-800-527-4018

Circle 8 on inquiry card

EVEN AFTER 20 YEARS, THIS IDEA STILL HOLDS WATER.

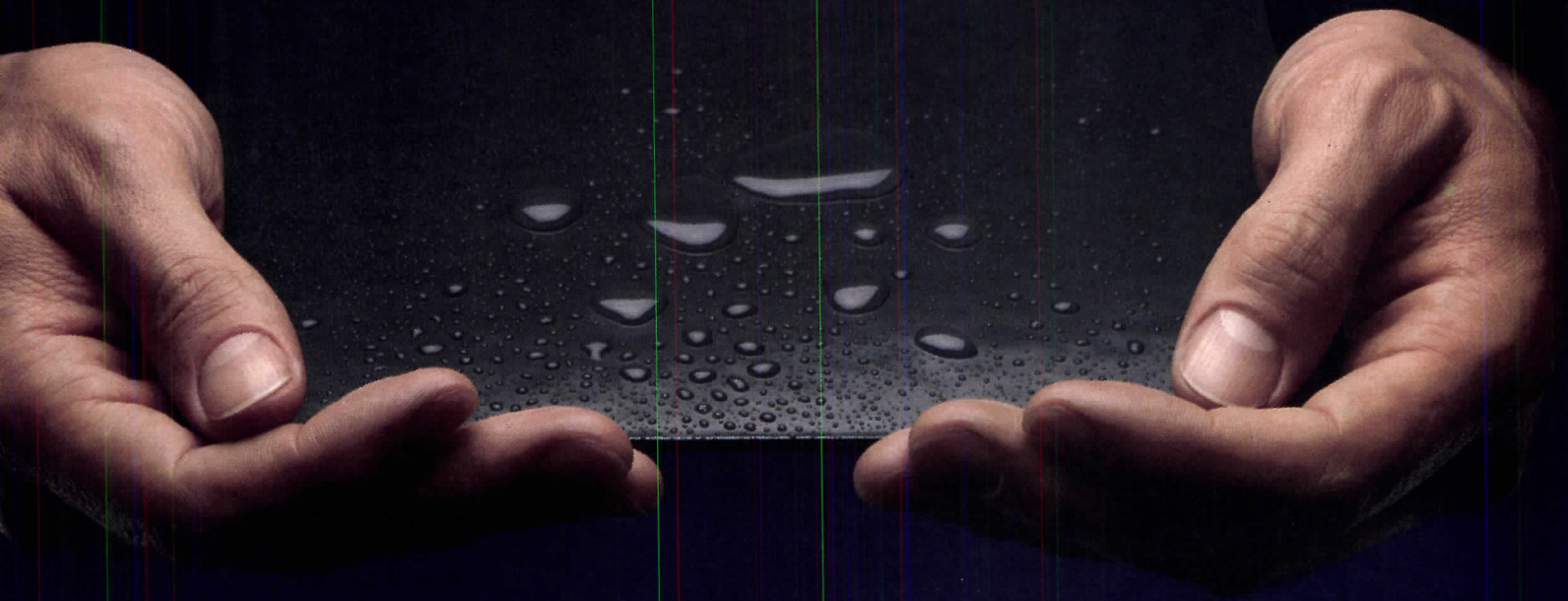

BITUTHENE[®]

The waterproofing system engineered
to keep water out. Once and for all.

Twenty years ago, we introduced a bold way of guarding structures from the ravages of water and time — Bituthene. And it has been preserving the integrity of foundations, plaza and parking decks, subways and tunnels ever since. Now more than 2 billion square feet of Bituthene protection have been installed around the world.

Once it's in place, it's in for good. A rugged, pliable, self-adhering membrane system that was

built to go in once. To go in easily. To stay put. Resist cracking. And never stop working. No matter what the climate.

And it comes to you armed with Grace technical expertise and engineering experience. Protect your structures with a water-tight idea. Bituthene — the waterproofing system with a proven past.

GRACE
Construction Products

I've just read your February 1986 issue featuring Stern's Point West Place [pages 128-135]. Good job by architects Stern and DRA, photographer Hursley, and writer Smith.

While reading, what struck me about the Postmodern movement is not so much its visual qualities but the fact that it has rescued the foreign phrase, added fingerprints to dusty Banister Fletchers, and pushed the quotation mark to astonishing new heights. It's a lively—and perhaps necessary—writing technique and I felt pretty good; I think I caught the meaning of all of the quotes, understood all but one of the foreign phrases, and was simply willing to believe that *acroterion* is correct. As one who comes down on the P. M. side, I say to architects and publishers alike: keep those quotation-mark buildings coming!

Or... would it be better if buildings had columns rather than "columns," keystones rather than "negative keystones," wings rather than "wings"? Nah, probably not. Costly, you know.

Gotta close now, the quotation mark just sheared off the print wheel. Funny, for a time there it was the period and then the question mark that went first.

*J. Bruce Spencer
Haynes Spencer Richards,
Architects
Coral Gables, Florida*

*Writer Smith confirmed
acroterion in his own beat-up copy
of Banister Fletcher.—Ed.*

Re: RECORD's study on SOM projects in Washington, D. C., [January 1985, pages 91-105]:

Smart as this crowd thinks it is, you sent 100 percent of us divagating* from our tasks to look up a word or two in the dictionary! *Richard Giegengack
Skidmore, Owings & Merrill
Washington, D. C.*

*I thought it meant what a mezzo-soprano does at the back of her station wagon before a football game. *R. G.*

Carter Wiseman's elegy on the lost opportunity of Westway and the city's megaprojects mesmerization [RECORD, February 1986, page 81 et seq.] deserves some comment:

• With the rare exception of the Whitney addition or maybe St. Bartholomew's, architects are unlikely to close ranks and denounce the overbuilding of parts of Manhattan. There are too many other architects waiting in the wings for their commissions.
• The obsession with Manhattan—its specialness not denied—comes at the cost of balanced growth

elsewhere in the city. (Why invest in Brooklyn when you can get whipped cream on top of the richest of desserts?) This is a refusal to recognize that the granting of major bulk bonuses is a very real long-term economic benefit to the property owner/developer.

Unfortunately, planning has never established professional standards within this country. Its theoretical practitioners have been either isolated in a generally no-win environmental review process or have jumped on the real-estate development bandwagon.

• Those flocking to Manhattan over the past decade have accepted virtually anything as living accommodation just to be there—and at any price. The market has therefore failed to impose quality controls.

In any case, keep plugging!
*Bruce Rosen
Forest Hills, New York*

*For the information of strangers
to New York City geography,
Forest Hills lies in Queens, one of
the city's five boroughs.
Manhattan is another.—Ed.*

Your February 1986 issue had a prominent news feature on the Suffolk County Courthouse Design Competition [page 70]. In this competition, as in many, the role of the professional advisor was critical.

I was approached two years ago by the County Executive, Peter Cohalen, to run a competition for them. At the time they had no program, no site, and no jury. Since Suffolk County has been notable for its lack of fine architecture, I proceeded to insist on strict rules for excluding political tampering.

Since the county had no program, our space planning division wrote a program indicative of the best thinking available for modern court facilities.

The jury sifted through 64 entries by some of the best design firms in the country, narrowing the field down to five. I twisted many arms to raise the competition stipend for each finalist to \$25,000 from a fee set by the county far below that.

We are pleased that the resulting scheme has a high probability of being built and being appreciated by the county residents.

*Jordan L. Gruzen, FAIA
The Gruzen Partnership
New York City*

Correction

RECORD's report on Mark Mack's design for a SunarHauserman showroom in San Francisco (February 1986, page 61) should have made clear that the firm has a continuing arrangement with architect Michael Graves.

Through June 7

Moving Arrows, Eros and Other Errors: An Architecture of Absence, an exhibition of Peter Eisenman's 1985 Venice Biennale project; at John Nichols, Printmakers and Publishers, 83 Grand St., New York City.

Through September 1

Frank Lloyd Wright and the Johnson Wax Buildings: Creating a Corporate Cathedral; at the Renwick Gallery, Washington, D. C.

May 27-29

Air Movement and Distribution Conference, sponsored by the Ray W. Herrick Laboratories at Purdue University and the U. S. Department of Energy; at Purdue University, West Lafayette, Ind. For information: Victor W. Goldschmidt, Conference Chairman, Ray W. Herrick Laboratories, Purdue University, West Lafayette, Ind. 47907 (317/494-2132).

June 8-11

Annual convention of the American Institute of Architects; at San Antonio. For information: Paul Knapp, Administrator, Communications, AIA, 1735 New York Ave., N. W., Washington, D. C. 20006 (202/625-7300).

June 8-14

Annual Meeting and the 11th National Passive Solar Conference of the American Solar Energy Society; at the University of Colorado, Boulder. For information: Susan Burley, American Solar Energy Society, Inc., 2030 17th St., Boulder, Colo. 80302 (303/443-3130).

June 9-13

23rd Annual Conference and Technical Exhibitions, American Society for Hospital Engineering of the American Hospital Association; at the Clarion Hotel, St. Louis. For information: Nancy Montenegro, ASHE, 840 N. Lake Shore Dr., Chicago, Ill. 60611 (312/280-6139).

June 10-13

NEOCON 18, the World Congress on Environmental Planning and Design, conference and exhibits on contract furnishing; at the Merchandise Mart, Chicago. For information: NEOCON 18, Suite 470, The Merchandise Mart, Chicago, Ill. 60654.

June 15-20

26th Annual International Design Conference in Aspen, "Insight and Outlook... Views of British Design"; in Aspen, Colo. Inquiries: Deborah Murphy, IDCA, P. O. Box 664, Aspen, Colo. 81612 (303/925-2257).

June 16-18

"Intelligent Buildings: The Business Strategy," conference and exhibits, considering design topics for architects and technologists, sponsored by Online International, Inc.; at the New York Hilton. For information: Online International, Inc., 989 Ave. of the Americas, New York, N. Y. 10018 (212/279-8890).

ARCHITECTURAL RECORD (Combined with AMERICAN ARCHITECT, and WESTERN ARCHITECT AND ENGINEER) (ISSN0003-858X) May 1986, Vol. 174, No. 6. Title © reg. in U.S. Patent Office, copyright © 1986 by McGraw-Hill, Inc. All rights reserved. Indexed in Reader's Guide to Periodical Literature, Art Index, Applied Science and Technology Index, Engineering Index, The Architectural Index and the Architectural Periodicals Index.

Every possible effort will be made to return material submitted for possible publication (if accompanied by stamped, addressed envelope), but the editors and the corporation will not be responsible for loss or damage.

Executive, Editorial, Circulation and Advertising Offices: 1221 Avenue of the Americas, New York, NY 10020.

Officers of McGraw-Hill Information Systems Company: President, Richard B. Miller. Executive Vice Presidents: Frederick P. Jannott, Construction Information Group; Russell C. White, Computers and Communications Information Group; J. Thomas Ryan, Marketing and International. Senior Vice President: Francis A. Shinal, Controller. Senior Vice President-Publisher: David J. McGrath, Engineering News-Record. Group Vice President: Peter B. McCuen, Communications. Vice Presidents: Fred O. Jensen, Planning and Development; Michael J. Koeller, Human Resources; Talat M. Sadiq, Systems Planning and Technology. Vice President-Publisher: Paul B. Beatty, Architectural Record and Building Economics.

Officers of McGraw-Hill, Inc.: Harold W. McGraw, Jr., Chairman; Joseph L. Dionne, President and Chief Executive Officer; Robert N. Landes, Executive Vice President and Secretary; Walter D. Serwatka, Executive Vice President and Chief Financial Officer; Shel F. Asen, Senior Vice President, Manufacturing; Robert J. Bahasi, Senior Vice President, Finance and Manufacturing; Ralph R. Schulz, Senior Vice President, Editorial; George R. Elsinger, Vice President, Circulation; Ralph J. Webb, Vice President and Treasurer.

Associated Services/McGraw-Hill Information Systems Co.: Sweet's Catalog Files (General Building, Engineering, Industrial Construction and Renovation, Light Residential Construction, Interiors), Dodge Building Cost Services, Dodge Reports and Bulletins, Dodge/SCAN Microfilm Systems, Dodge Management Control Service, Dodge Construction Statistics, Dodge regional construction newspapers (Chicago, Denver, Los Angeles, San Francisco).

Subscription rates for personnel of Architectural, Engineering, Interior Design, Design and other directly related firms and students thereof, are as follows: U.S. and U.S. Possessions \$35.00; Canada \$37.00; all other countries \$70.00. Single copy price for Domestic and Canadian: \$6.00; for Foreign: \$7.00.

Change of Address: Forward changes of address or service letters to Fulfillment Manager, ARCHITECTURAL RECORD, P.O. Box 2025, Mahopac, NY 10541. Provide both old and new address; include zip code; if possible attach issue address label.

Guarantee: Publisher agrees to refund that part of subscription price applying to unfulfilled part of subscription if service is unsatisfactory.

Copyright and Reprinting: Title © reg. in U.S. Patent Office. Copyright © 1986 by McGraw-Hill, Inc. All rights reserved. Where necessary, permission is granted by the copyright owner for libraries and others registered with the Copyright Clearance Center (CCC) to photocopy any article herein for the base fee of \$1.50 per copy of the article plus 10 cents per page. Payment should be sent directly to the CCC, 21 Congress Street, Salem, MA 01970. Include code with request: ISSN0003-858X (\$1.50 + .10). Written permission must be secured for any other copying. Write Reprint Manager for such permission at address below, or to obtain quotations on bulk orders.

Subscription List Usage: Advertisers may use our list to mail information to readers. To be excluded from such mailings, subscribers should send a request to: ARCHITECTURAL RECORD, Mailing List Manager, P.O. Box 555, Hightstown, NJ 08520.

Publication Office: 1221 Avenue of the Americas, New York, NY, 10020. ARCHITECTURAL RECORD (ISSN0003-858X) published monthly with additional issues in April and September by McGraw-Hill, Inc. Second-class postage paid at New York, NY and additional mailing offices. Postage paid at Windsor, Ontario, Canada. Registration Number 9617.

Postmaster: Please send address changes to: Fulfillment Manager, ARCHITECTURAL RECORD, P.O. Box 2025, Mahopac, NY 10541. THIS ISSUE is published in national and separate editions. Additional pages or separate editions numbered or allowed for as follows: Eastern Section 32Ea through 32Ef. Central Section 32Ca through 32Cb. Western Section 32Wa through 32Wf. Sunbelt Section 32Sa through 32Sd.

Framing. As a result we can provide a decided edge over competition. Complete, readily available detail recommendations. In improved fastener technology. And in compatibility with a variety of exterior materials. You get the basic benefits of lightweight

steel framing systems. Now look into USG® Steel Framing advantages. You'll find nobody supplies more building systems support to help you complete projects sooner. Phone today. Or write to us for specifics at 101 S. Wacker Dr., Chicago, IL 60606-4385. Dept. AR586.

CALL US NOW:

Atlanta (404) 393-0770

Dallas (214) 357-6271

Chicago Area (312) 456-1086

Los Angeles Area (213) 320-4062

New York Area (201) 263-4635

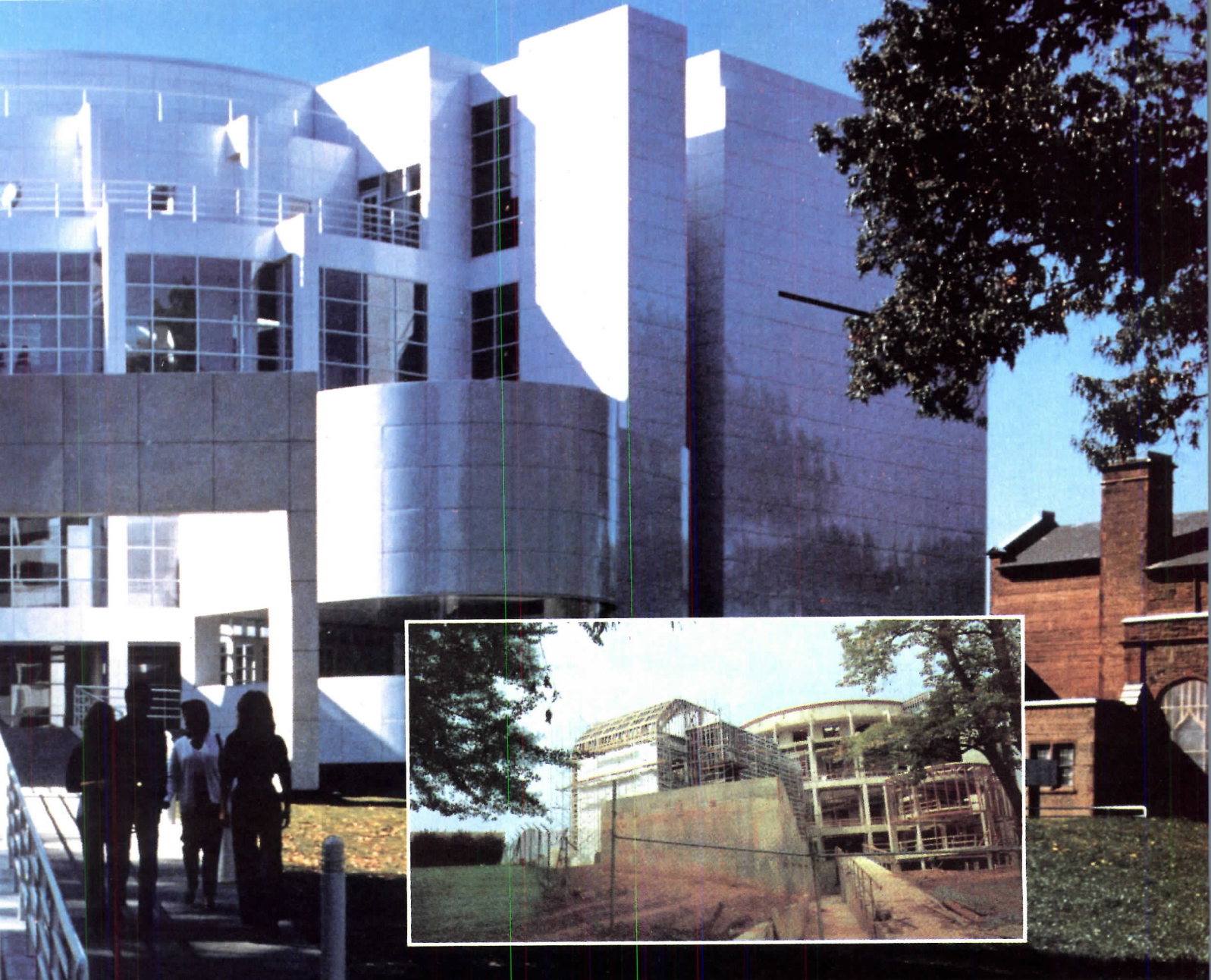
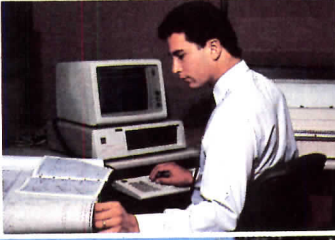

UNITED STATES GYPSUM COMPANY 

© 1985 U.S. Gypsum Co.

USG® is a registered trademark of USG Corporation

BUILDING AMERICA

Circle 87 on inquiry card



USG® STEEL FRAMING

**Big job expertise
is yours for the asking!**

Building systems capability makes the major difference. United States Gypsum Company works with you to optimize systems performance—computer-sizes framing components from a total job perspective—delivers utmost economy in quantities, sizes and weights of USG®

Editor
Mildred F. Schmertz, FAIA

Managing editor
Carolyn De Witt Koenig

Senior editors
Herbert L. Smith, Jr., FAIA
Charles K. Gandee
Douglas Brenner
Grace M. Anderson
Margaret F. Gaskie
Paul M. Sachner
Charles K. Hoyt, AIA

Associate editors
Darl Rastorfer
Deborah K. Dietsch
Karen D. Stein

Production editor
Annette K. Netburn

Design
Alex H. Stillano, director
Alberto Bucchianeri, senior associate
Anna Egger-Schlesinger, associate
Muriel Cuttrel, illustration
J. Dyck Fledderus, illustration

Design consultant
Massimo Vignelli

Editorial consultants
George A. Christie, Jr.
Jonathan Barnett, FAIA, AICP

McGraw-Hill World News
Peter Gall, director

Director of information systems
and circulation
Richard H. Di Vecchio

Director of business
and production
Joseph R. Wunk

Director of marketing
Camille H. Padula

Assistant to publisher
Elizabeth Hayman

Publisher/Vice president
Paul B. Beatty

Inquiries and submissions of work for publication may be addressed to any editor, though the editors listed below have a special responsibility for the subject areas named:

Charles Gandee, interior design
Herbert Smith, architectural education
Charles Hoyt, business
Paul Sachner, design news,
competitions, book reviews
Darl Rastorfer, engineering
Karen Stein, new products and
product literature

Letters/calendar, 12
Editorial: Preserving the architecture of Ellis Island, 15

Business

News, 33
Construction economy update: Stretching a peak into a plateau, 35
The profitable professional:
Put your partnership agreement in writing, 41
Architectural education:
Current confusions—is architecture allegory, craft, or art?, 49

Design

News, 55
Design awards/competitions, 66
Observations/books, 71
"Pride misplaced: Stern lessons in American architecture," 77
By Roger Kimball

Building Types Study 627: Academic buildings, 91
Belfer Center for Public Management, John F. Kennedy School of Government, Harvard University, 92
Architectural Resources Cambridge, Inc., Architects
Fisher-Watkins Library/Learning Center, Cushing Academy, Ashburnham, Massachusetts, 96
The Stubbins Associates, Inc., Architects
The Jewish Theological Seminary of America, New York City, 98
The Gruzen Partnership, Architects
Seeley G. Mudd Math and Computer Center, Amherst College, 102
Edward Larrabee Barnes Associates, Architects

Okanooyama Graphic Art Museum, Nishiwaki, Hyogo Prefecture, Japan, 106
Arata Isozaki & Associates, Architects

The Poynter Institute for Media Studies, St. Petersburg, Florida, 116
Jung/Brannen Associates, Architects

Quady Winery, Madera, California, 124
Stanley Saitowitz, Architect

Engineering

Bethesda Terrace restoration, Central Park, New York City, 130
The Ehrenkrantz Group, Architects

New products, 138
Product literature, 140
Manufacturer sources, 198
Classified advertising, 188
Advertising index, 202
Reader service card, 205

Cover:
Okanooyama Graphic Art Museum, Nishiwaki, Hyogo Prefecture, Japan
Arata Isozaki & Associates, Architects
Photographer: Taisuke Ogawa/SHINKENCHIKU
©The Japan Architect

The PHOENIX,* by Alumax: It's attractive; It's aluminum; It's 90-minute fire rated.

On July 10, 1985, the independent laboratories of Warnock Hersey International conducted a 90-minute fire endurance and hose stream test on a prospective product by Alumax/Magnolia Division. The result was PHOENIX, the first aluminum door frame to receive a 90-minute fire rating.

PHOENIX combines the fire resistance of steel with the aesthetics of aluminum. Few materials are so fire resistant as steel. Steel alone, however, does not have the design flexibilities or aesthetic appeal of aluminum. To achieve the advantages of both metals, therefore, a bi-metal frame system was devised which consists of unexposed 16-gauge steel sub-frame and 6063-T5 alloy outer aluminum frame.

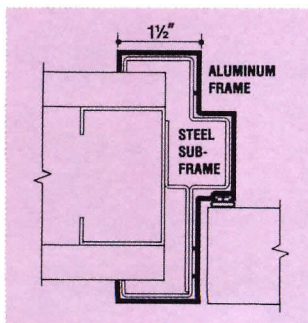
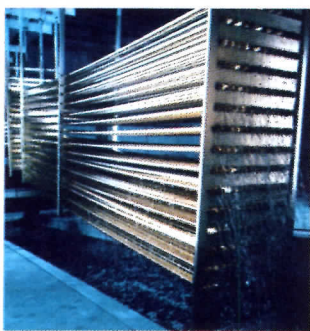

*Patent Pending

PHOENIX permits design consistency — with no job site finishing.

New PHOENIX matches Alumax's 20-minute *Royal* and *Imperial* frame lines in both color and configuration. Available are factory finishes of clear, bronze and black anodized, plus a variety of electrostatically applied, baked on paint finishes. The steel sub-frame, too, is bonderized, dip process painted and oven dried.

PHOENIX is a free-standing system which can accommodate multiple sizes of doors. PHOENIX units utilize single doors up to 4 feet by 8 feet, 10½ inches; double doors up to 6 feet by 8 feet, 10½ inches. Throat sizes range upward from 3½ inches, and corner tabs are included for convenient field installation.

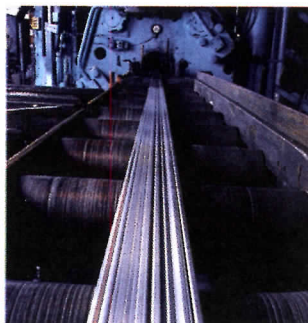

PHOENIX is produced by Alumax, an integrated company. Each aspect of production, from smelting to extrusion, machining to fabrication, is Alumax owned and operated. As a result, it is able to offer not only an exceptional level of quality, but a custom capability which is second to none.

Complete data on PHOENIX is now available. *Imperial*, *Royal* and other architectural products by Alumax are covered in your current Sweet's Catalog. For more on PHOENIX, write: Alumax/Magnolia Division, Interior Products Group, Post Office Box 40, Magnolia, Arkansas, 71753. Or call 800-643-1514 (In Arkansas, 501-234-4260).

ALUMAX
MAGNOLIA DIVISION

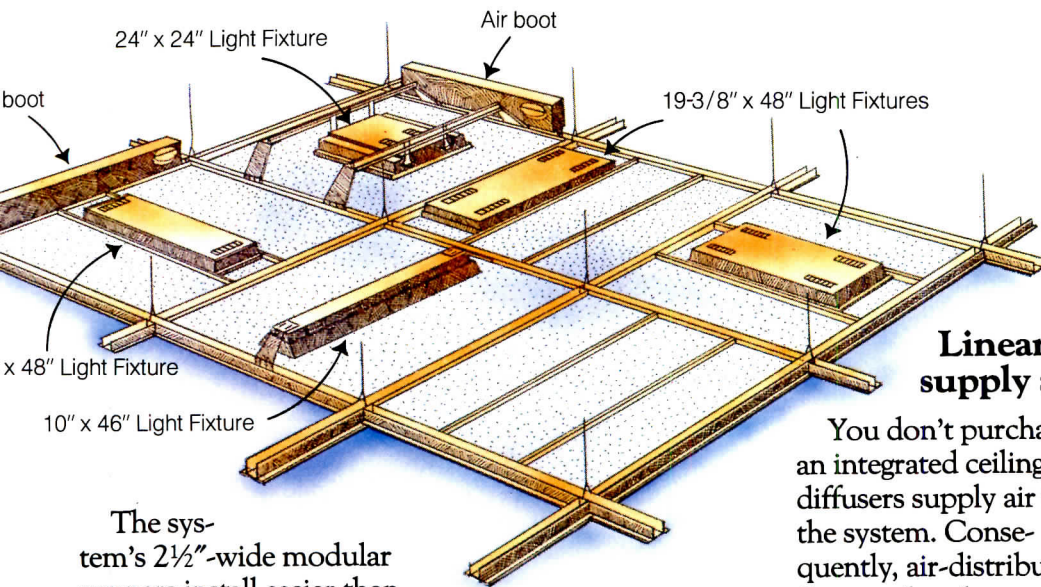

The system's 2½"-wide modular runners install easier than standard versions. They're also considerably stronger, supporting hardware without additional bracing. These pre-slotted runners accommodate air diffusers on all four sides of the module.

The center black regress conceals openings for diffusers and power cables.

Lighting systems reduce glare.

An integrated ceiling lighting system pleases the eye in two important ways.

First, it comfortably illuminates areas to enhance productivity. This is especially critical for spaces containing video display terminals. System fixtures properly light the horizontal paper-based task while controlling glare on the vertical terminal screen.

Second, integrated ceiling fixtures are aesthetically pleasing to the eye. They offer a variety of dramatic looks. Parabolic louvers. Flat prismatic lenses. Large- or small-cell louvers in aluminum or plastic. All ensure high-quality lighting at economical prices. All save you time during the designing stage.

And during installation. Integrated fixtures rest on a support frame built into the grid. This assures quick interfacing and eliminates the problem of fixture flanges improperly designed for narrow grids.

Another installation advantage of integrated fixtures is their flexibility. They can be positioned virtually anywhere in the module and be easily relocated later.

Linear air diffusers supply air uniformly.

You don't purchase separate air diffusers for an integrated ceiling. Pre-engineered linear air diffusers supply air throughout the system. Consequently, air-distribution level, flow, and cycle are more uniform, more comfortable.

And less unsightly. Integrated diffusers are concealed, so there's no visual clutter. Plus, you can place them on any of the module's four sides and relocate them later without problems.

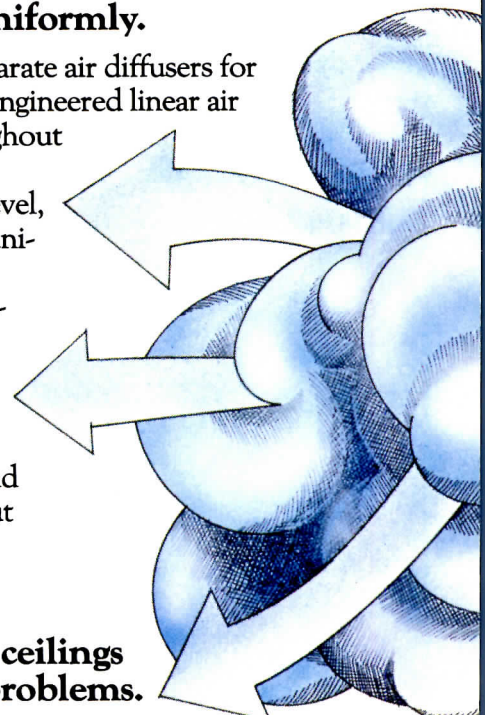

Integrated ceilings solve your problems.

Pre-engineered. Flexible. Easy to install. Visually cleaner.

An integrated system offers cost-effective, time-efficient advantages for mixed open-closed office environments. Performance and aesthetic qualities benefit you from the design stage through installation.

For more information on this ceiling alternative, send for the Armstrong integrated ceiling systems package. Write Armstrong, Dept. 57NAR, Box 3001, Lancaster, PA 17604.

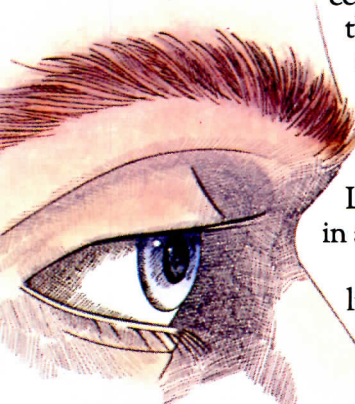

Understanding the most misunderstood ceiling.

An architect's guide to Armstrong integrated ceiling systems.

Among all ceiling specifiers, architects should most appreciate the advantages of integrated ceiling systems.

Yet many architects seem to be unaware of the systems' benefits. Consequently, they consider these ceilings to be too involved. Too expensive. Or both.

This guide will help clear those misconceptions. It explains the many cost-saving features, functions, and benefits of an integrated ceiling system.

Pre-engineered elements relocate easily.

Unlike lay-in ceilings, an integrated system is totally pre-engineered. Its four major elements — acoustical panels, suspension, lighting, air handling — are fully compatible.

Pre-engineering saves you the time spent detailing and organizing ceiling elements. You no longer have to piece together a system during investigation. It's all done for you in advance.

Better yet, it's all done by one supplier. You won't have to call one manufacturer for fixtures, another for diffusers, then hope the components will integrate properly.

With an integrated ceiling, it's one system from one supplier.

Acoustical panels control noise to 1.0 NRC.

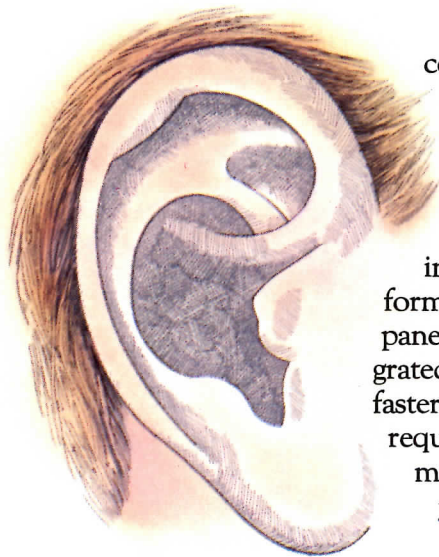

Large-size integrated ceiling panels provide superb acoustical control in any environment. You enjoy numerous acoustical options, including high-performance glass-fiber panels. These integrated ceiling panels are faster to install because they require no exposed sub-modular tees. And no job-site cutting.

Suspension systems conceal diffusers.

Medium-width integrated suspension systems increase your design flexibility. They allow you to locate partitions virtually everywhere. Or to relocate lighting fixtures after installation. And they handle air-diffusion requirements.

As a result, you organize your space and grid configurations much more efficiently.

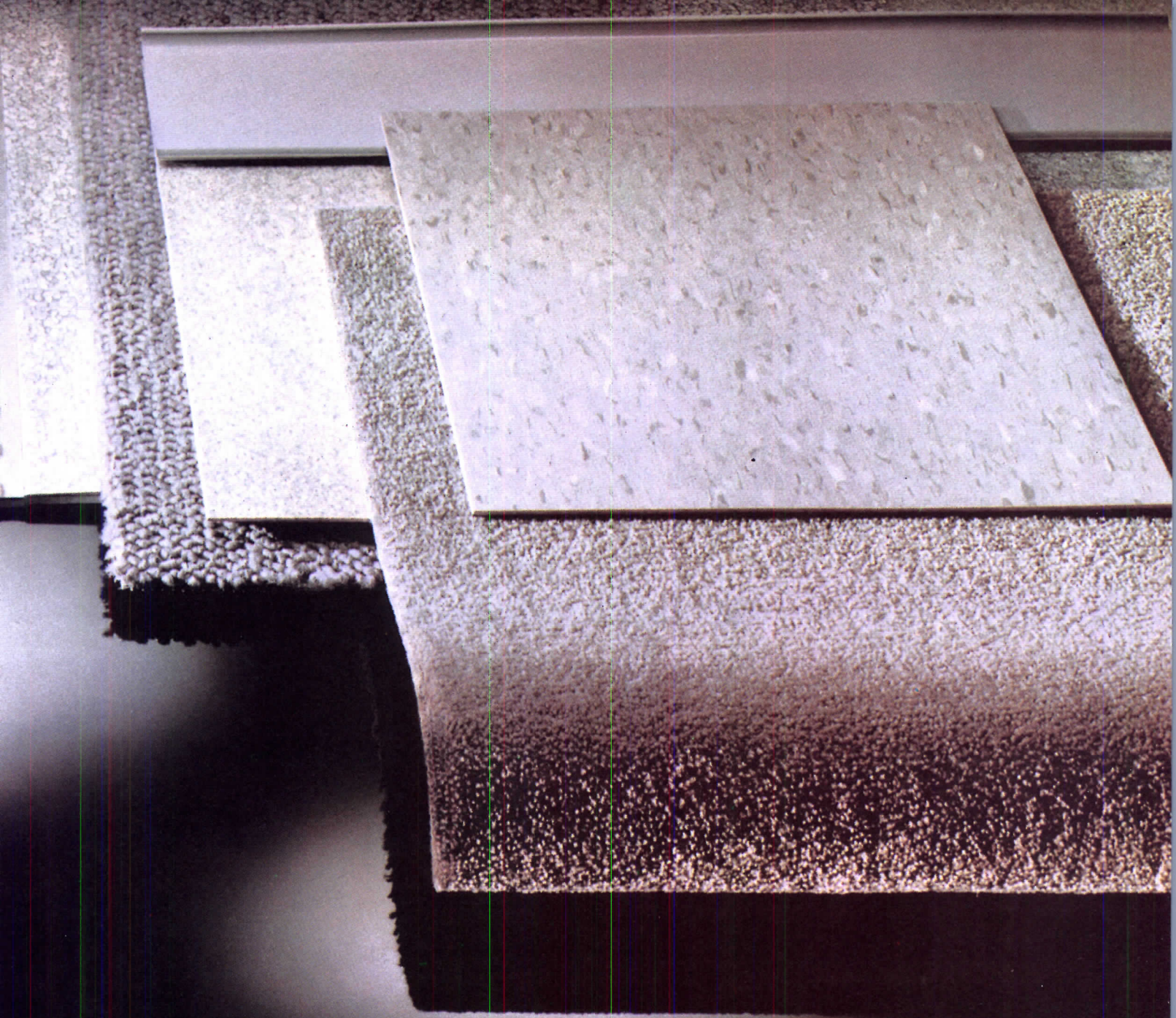

DUPONT
ANTRON 

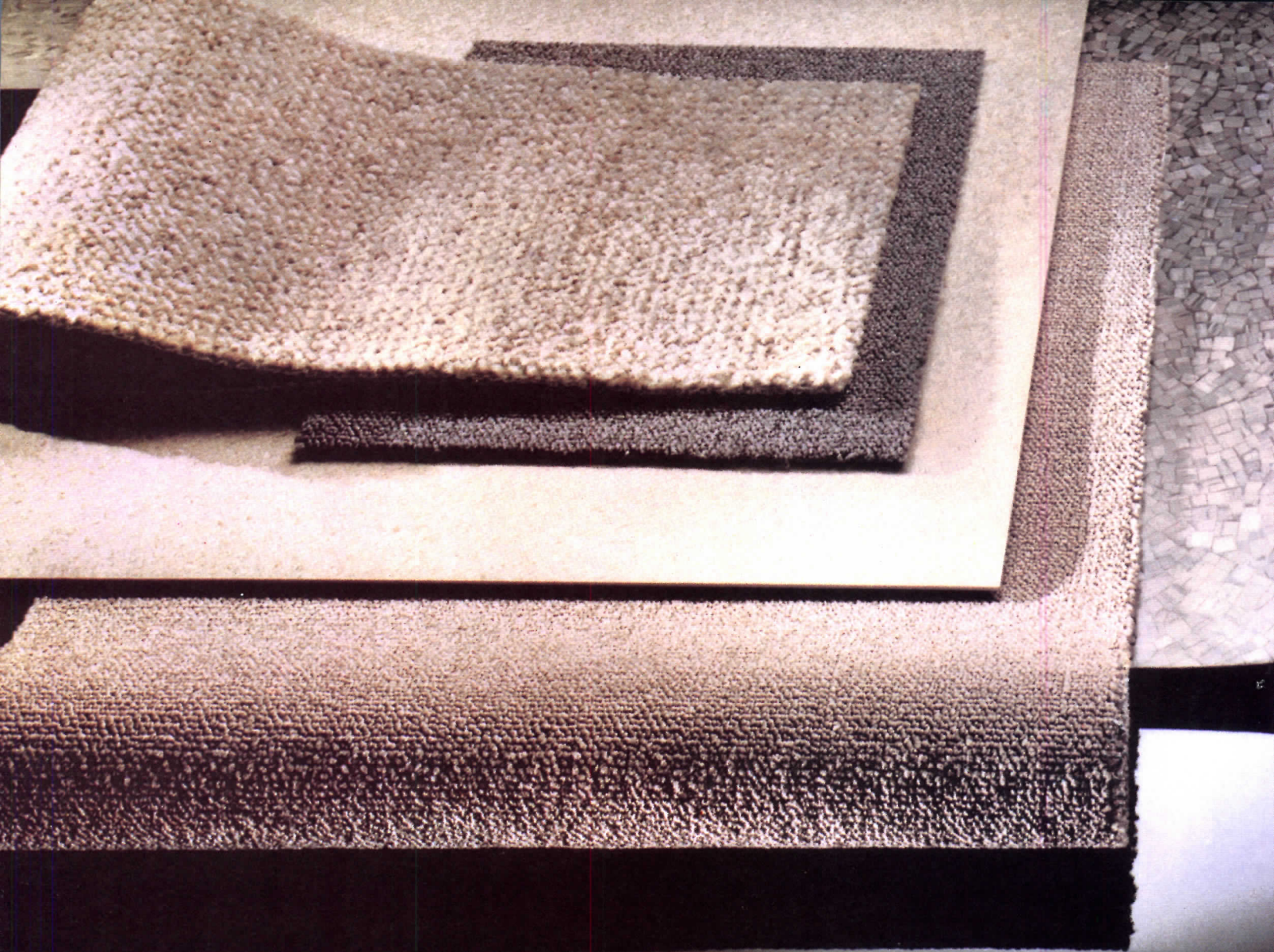

ARCHITEXTURAL VARIETIES

Armstrong coordinates textures across the flooring plane. Carpet. Resilient sheet and tile. Vinyl wall base.

Textures with various looks. Feels. Performance specs.

Multiple textures. One manufacturer. Armstrong.

For a package of coordinated texture samples, call 800 233-3823 and ask for Dept. Textures.

 **Armstrong**

Circle 3 on inquiry card

R O N G

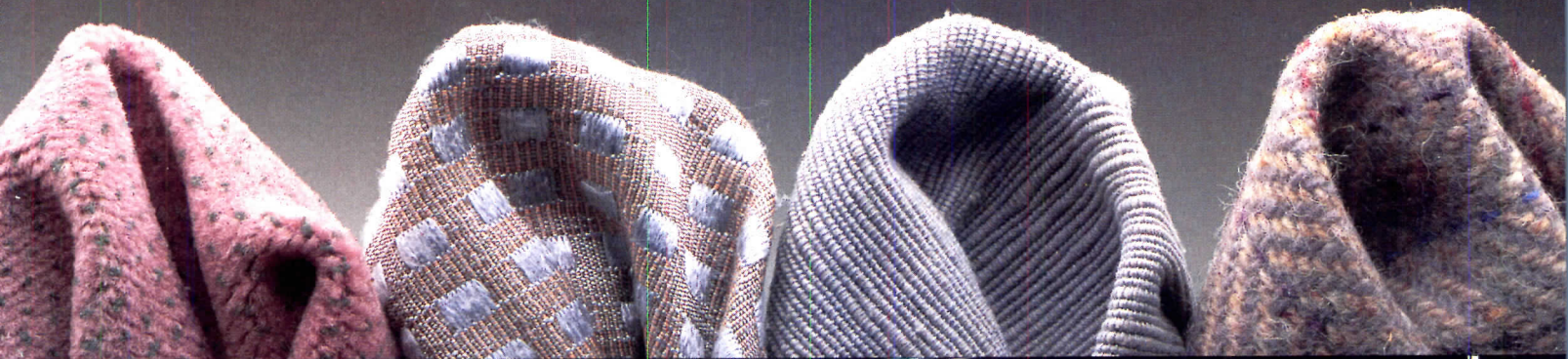

Sonotrol custom walls.
You choose the sizes. Shapes. Fabrics. Acoustical capabilities.
We add the availability. National distribution. Dependable service.
Your ideas. Our realities. Endless possibilities.
Call 800 233-3823 and ask for Sonotrol.

Armstrong

Circle 2 on inquiry card



**TO SHOW YOU THAT
OUR WALL TREATMENTS
GO ANYWHERE,
WE WENT TO EXTREMES.**

What nerve! A simple acoustical wall treatment gracing the hallowed walls of this great Egyptian monument.

Well, we just want to make a point. Our new Serenity™ wall treatments can add classic good looks to the most venerable of spaces...or to the most mundane.

Choose from the largest selection of colors and tones in the market. (Eyes right.) These beautiful shades have been designed and market tested to work harmoniously with new color trends and contemporary carpeting, upholstery and other interior finishes.

Serenity™ performs as well as it looks. It absorbs 80 percent of the ambient sound striking the wall surface to produce an environment as serene and peaceful as, well, an Egyptian tomb.

For more information contact Bill Phelan, National Sales Manager, Interior Products, Owens-Corning Fiberglas, Fiberglas Tower, Toledo, Ohio 43659. Or call us direct at 1-419-248-6860.

**SERENITY™
WALL TREATMENTS**





If you still believe in me, save me.

For nearly a hundred years, the Statue of Liberty has been America's most powerful symbol of freedom and hope. Today the corrosive action of almost a century of weather and salt air has eaten away at the iron framework; etched holes in the copper exterior.

On Ellis Island, where the ancestors of nearly half of all Americans first stepped onto American soil, the Immigration Center is now a hollow ruin.

Inspiring plans have been developed to restore the Statue and to create on Ellis Island a permanent museum celebrating the ethnic diversity of this country of immigrants. But unless restoration is begun now, these two landmarks in our nation's heritage could be closed at the very time America is celebrating their hundredth anniversaries. The 230 million dollars needed to carry out the work is needed now.

All of the money must come from private donations; the federal government is not raising the funds. This is consistent with the Statue's origins. The French people paid for its creation themselves. And America's businesses spearheaded the public contributions that were needed for its construction and for the pedestal.

The torch of liberty is everyone's to cherish. Could we hold up our heads as Americans if we allowed the time to come when she can no longer hold up hers?

Opportunities for Your Company.



You are invited to learn more about the advantages of corporate sponsorship during the nationwide promotions surrounding the restoration project. Write on your letterhead to: The Statue of Liberty-Ellis Island Foundation, Inc., 101 Park Ave, N.Y., N.Y. 10178.



**KEEP
THE
TORCH
LIT**

Save these monuments. Send your personal tax deductible donation to: P.O. Box 1986, New York, N.Y. 10018. **The Statue of Liberty-Ellis Island Foundation, Inc.**

Architectural education: Current confusions—is architecture allegory, craft, or art?

By William S. Saunders



Douglas Cotter photo

Coming from the teaching of literature and esthetics to an administrative position within the Harvard University Graduate School of Design, I approach a consideration of current architectural education with the limitations and advantages of being an outsider: the picture I see may be incomplete, but I have not been pressured to adopt any particular angle of vision. There is much to admire: tireless dedication, genuine seriousness, and some true creative sparks.

Yet some of what I see troubles me: at times art is being confused with conceptual discourse. Some students are being criticized if their schemes don't start from and resolve into "an idea."

Designs in which elements are primarily to be "read" as "standing for" or "referring to" abstractions only semiotically noted in the physicality of the form—historical precedents, geometric or mathematical patterns, "statements" on society, on the users of the building or on anything else—are often thought to demonstrate intellectual superiority and sophistication.

Projects that are very hard to talk about because they are not allegorical in this way, projects in which the designer's primary thinking cannot be separated from his feeling-based choices of shapes, textures, colors, spaces, and proportions, are often found suspect, as if their designers were naive, unintellectual, provincial, even stupid.

Glibness and artistic refinement clash

Yet it may be true that the students who have the most subtle and refined artistic sensibilities, who "say" the most in their selection of sensuous elements, are the very students who can't have articulate (or glib) responses in reviews and who make jurors uncomfortable, because the unavoidably discursive language of criticism can touch these students' work only with

William S. Saunders is Associate Director of Special Programs at the Harvard University Graduate School of Design, where he is responsible for noncredit professional development programs and courses. He has published poems, essays on education, poetry, and fiction, and a book on the American poet James Wright. His doctoral thesis was on the English poet Charles Tomlinson. Before becoming an administrator at Harvard in 1980, he taught English in universities for seven years. In 1982, he taught a course on the functions of studying art at the Harvard Graduate School of Education.

William Saunders presents a challenging point of view about verbalizing architecture—that "art does what discourse can't." Now associated with the Harvard Graduate School of Design, he brings a background of literature and esthetics to bear on the world of architecture

great difficulty. But the student who chooses the design's sensuous elements primarily for their reference to something beyond those elements—an idea or precedent—can usually talk easily about that idea or alluded-to subject, and help his reviewers talk just as comfortably, as if the colors, shapes, and proportions of the drawings and models were really not, thank God, requiring much strenuous pre-verbal attention in themselves.

At times, the demand for an idea in a design seems to be, really, an insistence that there be a unifying core of some unspecified kind, something to prevent the project from being haphazard or arbitrary. Although the word "idea" is being misused, one can hardly object to this demand. In fact, however, "idea" is what is truly meant at other times, and these designs with "ideas" are allegorical: their symbolic elements are denotative not connotative.

"One liner" architecture is a symptom of recent confusion. But it is not just at design schools and not just because of the review system that this preference for art as allegory shows up. One of the most frequent complaints I have heard among architects and their critics seems to be that too many recent buildings are "one-liners." What does it mean for a building to be a one-liner? It means that what it "says," however hard it is to discover what that may be, is very little: once you "get it," you don't need or want to look at the building again. The building is experienced in the head, not the body and head.

Understanding a one-liner building is like completing a crossword puzzle; there's no good motivation for savoring how the puzzle was created and the cleverness needed for solving it. A building that "says" what it says primarily in its physicality, when designed with intensity and depth of feeling and with the self-critical rigor that removes inharmonious elements, can be returned to endlessly, since the discursive thinking of the appreciator can only point to and evoke the artistic core and can never be its equivalent.

Despite their bemoaning one-liners, even the finest architects often reveal this confusion of art with conceptual discourse in their statements. Here are some examples taken from *American Architecture Now II* (Rizzoli, 1985) and *The Charlottesville Tapes* (Rizzoli, 1985): "... architecture as a vehicle for describing in physical terms ideas about society and about how men and women might live together." "The house is a study in dematerialization versus

measurability." "This project has a theme, and that was very important to me. Call it a conceptual building, if you want. The building is a gate." "Thus an internal dialogue is set up between the vertical plane and the horizontal plane." (Here forms themselves are treated as ideas.)

Why so much allegorical architecture?

I'm not enough of an historian to tell you why this confusion of architecture with conceptual discourse seems so prevalent. As I implied above, I suspect it has to do with a deeper embedding of high design in the academy, where intellectual or intellectualistic talk is necessarily the currency of the kingdom, where glibness often has its rewards.

Of course, the Romantic image of the artist as a wild-eyed visionary who can speak only with his hands sets no present norm. Yet still, here at Harvard, no one knows quite where to fit painters, sculptors, and musicians into a legitimate curriculum. Understandably, the kind of thinker who draws the biggest response in the academy is epitomized by the French Structuralists and Post-Structuralists, weaving their ever more abstruse webs of words, however wise or unwise. Other reasons for one-liner art? Perhaps, people in our culture are taught by television and newspapers and the rhythm in the streets that patience and care are not as virtuous or as profitable as quickness and motion: the one-liner is all we think we have time for. (Of course, we occasionally get the 1,001 liner, but that is no more than an inflated version of the one-liner: once you get it, you can forget it.)

Perhaps, too, we are still lashing back against the '60s, when even in the academy the dirty currency of undisciplined self-expression was briefly grasped.

Most of art history can, with a bit of pushing and trimming, be viewed as an alternating domination of intellectualism and emotionalism, with each era reacting against the prior era. The dialectic has its set of perennial opposites: Apollo-Dionysus, analysis-intuition, classicism-romanticism, detachment-oneness, allegory-imagism; John Dryden set against William Blake, John Ashbery against Robert Bly, Antonioni against Fellini, Peter Eisenman against Christopher Alexander, etc. Much of the history of esthetic theory is, however, an attempt to unite these opposites in a vibrant tension that avoids extremism. That kind of theory is what designers might turn to in order to escape the trap of intellectualism.

Continued

STOCK OPTIONS.

The assignment: Redesign a seaside vacation home to complement a client's contemporary lifestyle.

The media: WILSONART Design Group I™ decorative laminates and Decorative Tambours.

The designers: Bertram Laudenslager and Arthur L'Esperance, both ASID members, Whitmarsh Interiors, Flourtown, Pennsylvania. (L'Esperance is now with Witte Interiors, Inc., in Philadelphia).

Laudenslager comments: "A vacation home must be attractive — welcoming — and very easy to maintain. WILSONART surfacing products were key to achieving this."

L'Esperance adds: "Our clients do a great deal of casual entertaining here. So we wanted both actual openness and a real sense of space. We also wanted a palette that carried the wonderful colors of the shore indoors. WILSONART gave us our solution."



Bertram Laudenslager
Arthur L'Esperance

Bertram Laudenslager and Arthur L'Esperance,
ASID members
Whitmarsh Interiors

In the kitchen (shown below), upper cabinets are completely surfaced in WILSONART Cayenne decorative laminate; complementary Sea Breeze clads the lower storage bank. And Cayenne reprises on the island rim.

The soft stone look on the breakfast table and on countertops around the sink comes from WILSONART Shadow Millstone decorative laminate. Matching Shadow Millstone Decorative Tambours panel the refrigerator, island cabinets, and the legs of the breakfast table.

The result: Happy clients, whose weekend home offers true escape from routine stresses, with no sacrifice of the amenities of their primary residence.

HOTLINE:

If you have a project you think belongs in this space, please call us.

For product samples, literature and technical information, call toll-free (within the continental USA):

1-800-433-3222

In Texas: 1-800-792-6000

Circle 43 on inquiry card

WILSONART®
BRAND DECORATIVE LAMINATE

Bringing new solutions to the surface™

©1986, Ralph Wilson Plastics Co., Temple, TX



Art does what discourse can't. The notions that art must communicate ideas or information, that it should "make a statement," or that it should be centered on mathematical or purely formal systems (the grid seems now in favor)—these notions are destructive because they potentially deprive us of what art and nothing but art can do for us: provide worlds that are given meaning and value through the medium of human feeling.

If you want to make a statement or present an idea, the most efficient and effective way to do it is to write in prose. How pathetic are the kinds of statements that artists or students of art usually come up with when they say what works of art are trying to "say"! The "themes" are so often sophisms, truisms, and platitudes, painfully simplistic. Had they tried to communicate those ideas in straight, discursive prose writing, they would have been challenged to say something with more substance.

It is easier to hide facile ideas in art than in prose. People with something to say should say it; people who feel something that would only be thinned out and simplified in straight prose, should perhaps use the pre-conceptual resources of artistic creation.

Art embodies feeling, not emotion. The trouble with using a word like "feeling" is that most people think you mean emotion, a state of being, passively undergone, like indigestion. "Self-expression" is normally conceived of as a kind of automatic letting go of emotion. Any sadness or anger or desire expressed has very little to do with anyone or thing other than itself. It's all subject and no object.

Feeling, on the other hand, is subject reaching out to object—it's our fundamental and primary way of apprehending the world. Before we know something, we feel it; or rather, we know it by feeling it. All ideas, all prose discourse, all theories and all verbalizations (including unspoken thoughts) begin with feeling, or they are empty and arid, lacking an experiential base. As Michael Polanyi, scientist turned philosopher, said: "We know more than we can tell." (See his *The Tacit Dimension*, Doubleday, 1966.)

The function of art is precisely to tell us in its own way what is known but can't be told any other way. Artistic experience—experience dominated by feeling—provides the bedrock of all thoughts. Feeling is knowing in the whole body. It is not an enemy of thinking. It is instead a special and valuable kind of thinking.

Another kind of thinking, critical thinking, is also necessary in art: it is what allows artists to judge whether the forms they choose to embody their feelings are adequate for the job. We can look over and over without boredom at some Cézanne landscapes because Cézanne succeeded in finding shapes, lines, and colors that embody how his feelings (of solidity, body, and strength) have related him to his world. We seek to share those feelings, not pigeonhole them and move on. His paintings are meaningful, not because they tell us anything about the French countryside or because they present a late 19th century idea about the nature of perception, but because they give us a felt world, a world given value through its meeting with the human heart.

In art, the feeling is the meaning. The very last bit of Bach's "Goldberg Variations" is exquisite art because in perfectly suited forms—neither bursting with nor stifling of feelings—we are given sensuous, bodily knowledge of a world that is thoroughly heartbreaking, yet precious.

Thinking has a vital place in art. There is no need to be anti-intellectual, only resistant to intellectualism. Clearly enormous amounts of hard thinking—analysis, philosophy, self-conscious attention to precedents, sociological reflection, etc.—play a major role in most great art.

Literary critics do not want to dismiss Alexander Pope from the ranks of poets because his long poem, "An Essay on Man," contains lots of explicit philosophizing. Palladio's buildings are no less cherished because mathematical analysis plays such an important role in their making. Ultimately, Pope is not a philosopher and Palladio is not a mathematician. That is because overall and primarily their works speak to our feelings, and their thinking evolves more from the pressures of feeling than from the pure exigencies of logical analysis. Were it not that Palladio's mathematics helped produce and express such dignity, serenity, and delight, no one would give his buildings much attention.

Can we accept the morality of art in architecture?

But architecture may be the most impure—the most distracted—and therefore the most difficult to produce of the arts. Because the sole responsibility of the artist is to find form adequate to his feeling, art is amoral and asocial.

Yet oddly enough, people actually live in one art form. Strictly speaking, we may have to say that a house that would be abominable to

live in is a true work of art. Philip Johnson's glass-box house, had he designed it for anyone but himself, should probably be considered immoral: it violates most of our emotional needs in housing. But what feelings of delicacy and purity it embodies and instills in us!

At the Final Review in the sky, however, architects who choose to be responsible to their feelings alone may be cast down: perhaps the great architect, like the great dramatic poet (Shakespeare), must be capacious enough in his feelings to include the feelings of others, to have civic responsibility feelingly.

Architecture as responsible craft—an alternative paradigm

The pressure to think of architects as responsible to other people, to cities and to whole societies as much as or more so than they are responsible to their own feelings, is so great and so compelling, that it is very tempting to view architecture as a craft (albeit a High Craft) rather than an art.

In a craft, beauty and utility are primary goals; in art, genuineness and vibrancy. Indeed, recent statements by the critic Robert Campbell seem to espouse such a position. In the February 11, 1986 issue of *The Boston Globe*, Campbell speaks of Mies van der Rohe as "an instance of the disastrous confusion between art and architecture."

According to Campbell, architects should be the most humble and self-effacing of mortals, since the best buildings are those that blend harmoniously, civilly, and civically the spirit of their locations, and that most sensitively respond to the needs of their users for the best possible quality of life in them.

In this paradigm, Paris is the great city, humanly scaled, homogeneous, and mostly designed by forgotten architects. Many builders in New York City or Houston, in this view, become like the factional politicians of Florence in Dante's *Divine Comedy*: monsters of egotism and civic evil, whose buildings seem to be made primarily to puff themselves up more self-importantly than their neighbors. But New York and Houston may have a certain kind of vitality that Paris lacks precisely because there are so many distinctive selves standing out vividly in the best of the newer buildings.

Paris is a wonderfully crafted city. Like the finest pottery, it has the virtues of craft: beauty, harmony, and ease of use. Artistic architecture, however, can be ugly, disharmonious, and discomforting, as long as it embodies well the vitality and richness of its maker's feelings. We may wish to banish

such architecture from our cities and keep it on the drawing boards, separating it off from the rest of our lives as we can the disturbing, unpleasant paintings of Francis Bacon, but we can't deny it its own particular validity.

Art must follow its own shadowed, primitive and yet disciplined and sophisticated ways. Conceptual discourse is another matter altogether.

Note: Works that seem to me to make many accurate statements about art include: Benedetto Croce, "Aesthetica in Nuce," in Philosophy, Poetry, History (Oxford University Press, 1966) and Guide to Aesthetics (Bobbs-Merrill, 1965); John Dewey, Art As Experience (Capricorn Books, 1958); Giovanni Gentile, The Philosophy of Art (Cornell University Press, 1972).

For a treatment of the differences between art and allegory and of how allegory can become art, see Benedetto Croce, The Poetry of Dante (G. Allen and Unwin, 1922), and Francesco De Sanctis, "The 'Divine Comedy'" in History of Italian Literature (Oxford University Press, 1931). F. R. Leavis is the most eloquent spokesman I know for the special, rigorous thinking of artists and their critics; see especially his Living Principle (Oxford University Press, 1975). The amorality of art is brilliantly explored in Friedrich Schiller's On the Aesthetic Education of Man (Frederick Ungar, 1983).



The sole

Presenting carpet of Antron Precedent™—
carpet that looks newer, longer than any other.

Acknowledged Industry Leader New	Antron Precedent New
400,000 traffics	400,000 traffics
1,000,000 traffics	1,000,000 traffics

Finally, there's a carpet fiber system that's a step above all others: Du Pont ANTRON PRECEDENT. Because carpet of ANTRON PRECEDENT looks newer *up to two times longer* than any other carpet.

We've proven it. In a side-by-side test held in a busy New York City university, more than a million people walked across two contract carpets: one made of Du Pont certified ANTRON PRECEDENT, the other an equal construction of the acknowledged industry leader.



survivor.

Take a close look. Not only did the carpet of ANTRON PRECEDENT excel in soil and stain resistance; it also succeeded in retaining its original look and texture longer.

In the revolutionary system behind ANTRON PRECEDENT, state-of-the-art hollow filament fibers are combined with DuraTech[®], an advanced commercial treatment based on the latest in Teflon[®] carpet protector technology. This, along with stringent Du Pont construction

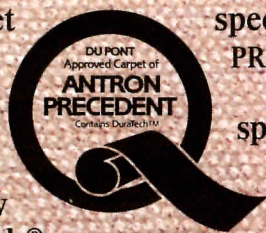

specifications, is what sets ANTRON PRECEDENT apart.

So, for a carpet that will stand up better, specify one backed with Du Pont's signature of quality, the quality "Q".

Find out how your next carpet project can outlive more soles, with ANTRON PRECEDENT. Call us today at:

800-448-9835



Circle 44 on inquiry card

Introducing Restoration® Vinyl.

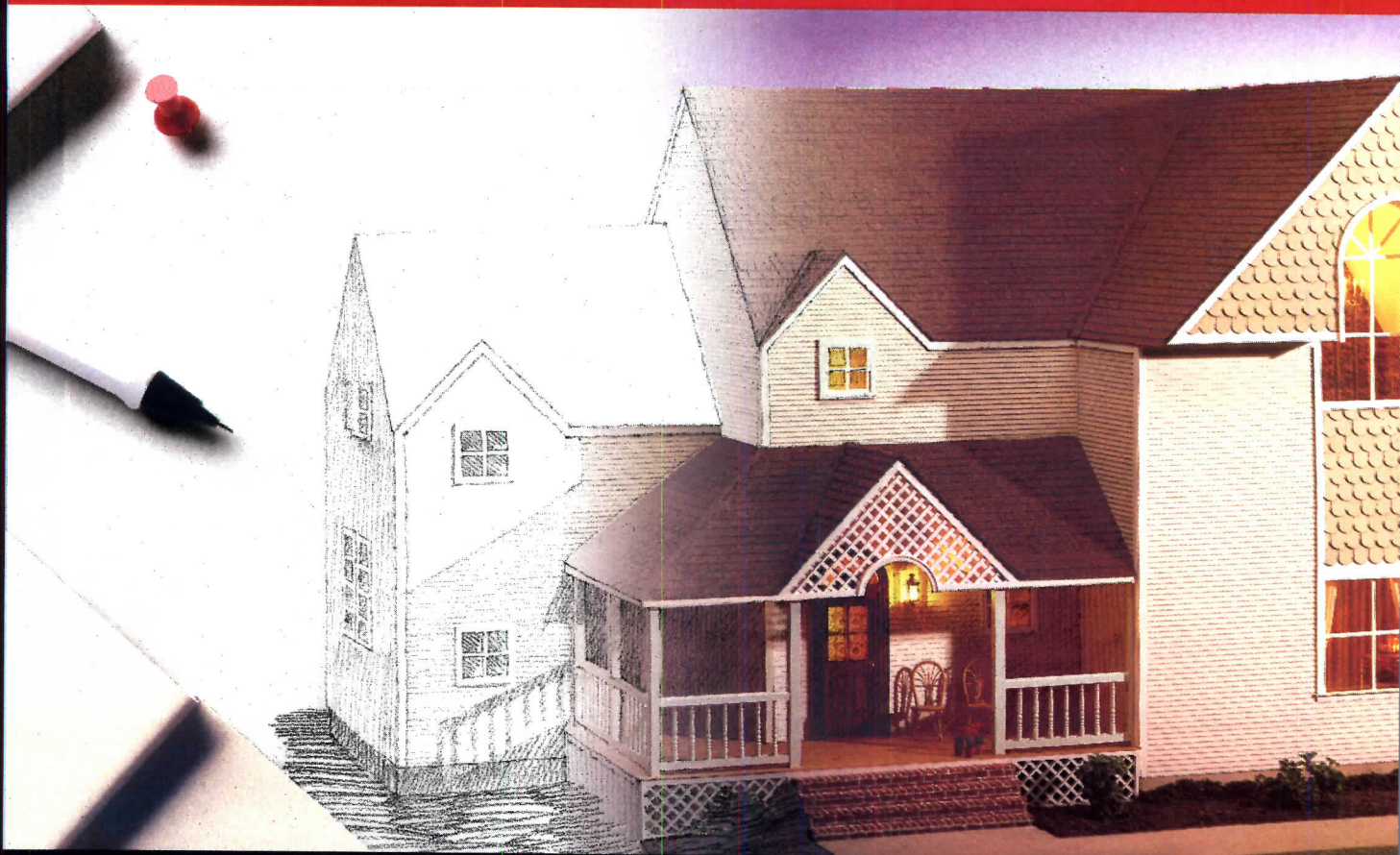

Everything You Thought Vinyl Could Never Be.

Used to be, vinyl siding looked like, well, vinyl siding. Most architects probably thought that this would always be the case. Not so.

Now there's Restoration solid vinyl siding. Restoration looks like real painted wood. You have to see it to believe it.

Budget and aesthetics often pull at a design from opposite directions. When a client not only wants the appearance of painted wood, but also the economy and durability of vinyl, Restoration solid vinyl siding provides the balance. It has all of the advantages of



The Restoration Collection includes beaded panel and lattice.

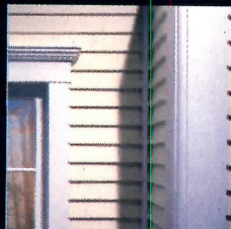

Faithfully detailed window moldings, trim and this extra-wide corner post.

vinyl – lower cost, durability, low maintenance; plus all the aesthetic advantages of real wood.

Through sophisticated technology we've achieved a smooth low gloss finish on a panel that's guaranteed to last a lifetime.* To provide flexibility, we've created the Restoration Collection, a full line of architecturally accurate vinyl accessories.

For more information on the entire Restoration Collection, call 1-800-521-9020 (in Michigan, call 313-386-0800).

After all, seeing is believing.

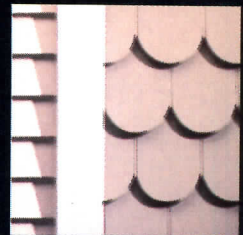

Restoration Collection Great Shapes.

RESTORATION COLLECTION™

Enduring Appearance, Uncommon Economy.

*A copy of the Lifetime Warranty is available by writing Wolverine Technologies Inc., 1650 Howard Street, Lincoln Park, Michigan 48146. ©1986 Wolverine Technologies Inc.
Circle 45 on inquiry card



As seen on
"This Old House."

Along the banks of the Potomac,
every kind of grandeur

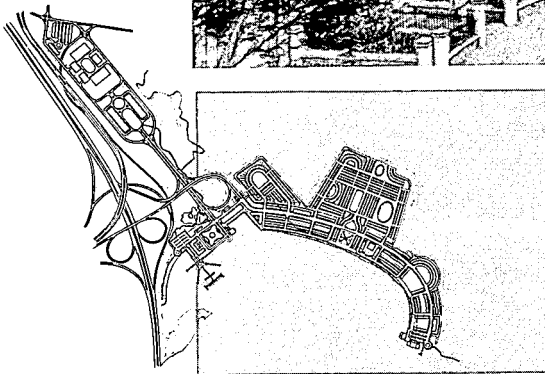
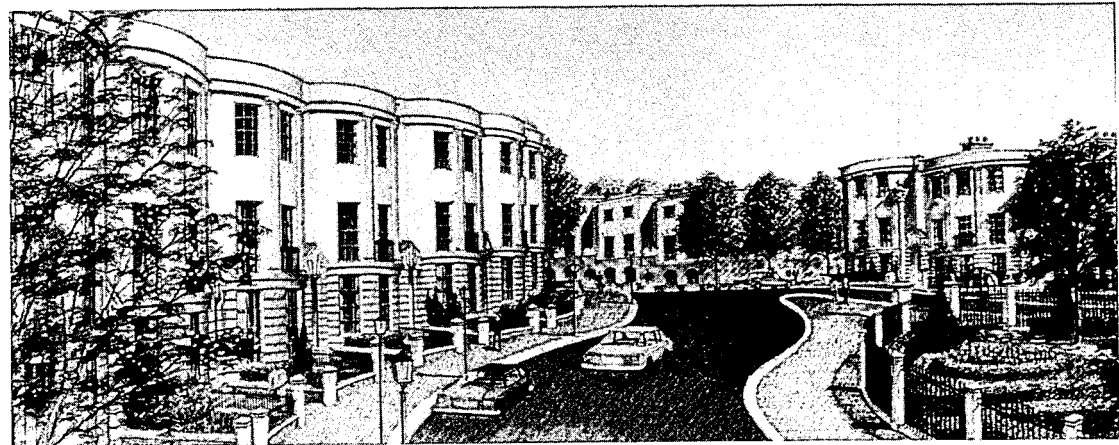
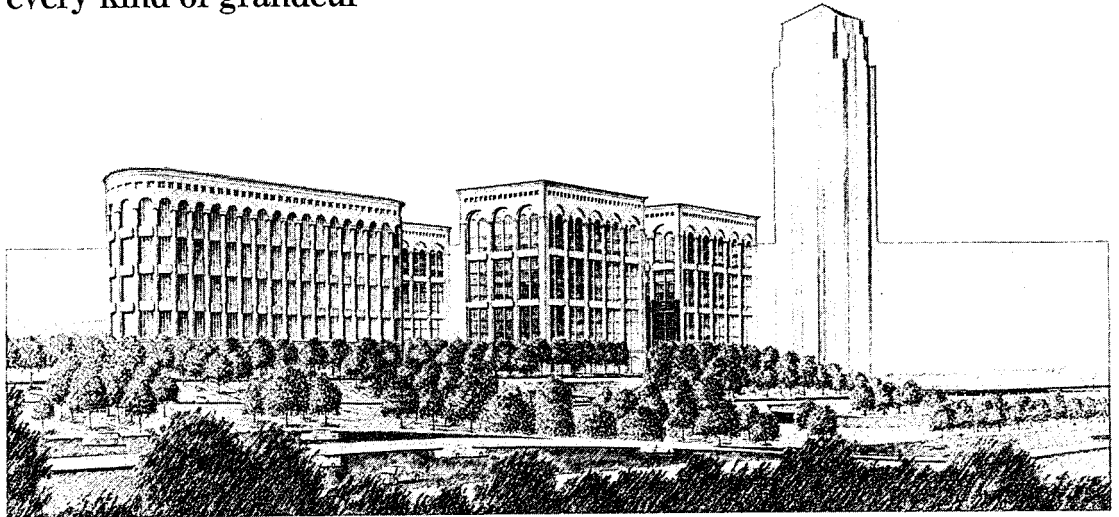

Ever since their plans for the AT&T Building catapulted them into the vanguard of Postmodernism, Philip Johnson and John Burgee have been riding a heady historicist roller coaster en route, it turns out, to the shores of the Potomac River in Prince George's County, Maryland. Here, on a highly visible 223-acre site adjoining the Capital Beltway, Johnson and Burgee are planning their most ambitious project to

date—a \$1 billion mixed-use proposal, dubbed PortAmerica, that will exhibit a mind-boggling palette of allusions to architectural modes of the past. The project's commercial phase (left on site plan) will focus on the 52-story World Trade Center, a faceted, reflective glass tower that will be flanked by two 3,000-car garages and five vaguely Italianate office buildings (top rendering). A broad boulevard will connect this commercial complex to a waterfront marina and hotel, the latter topped by a gold dome. The remainder of the site, a curving parcel along the Potomac that the architects have likened to the shorelines of Nice or Bombay, has been named Oxford Landing, a mixed-use "new town" comprising a 12-foot-wide pedestrian promenade, two-story Neoclassical waterfront pavilions housing retail space and recreational facilities (middle

rendering), and 1,200 town houses and condominiums whose bow fronts, clustered around a series of small parks, are meant to evoke the crescents of Georgian England (bottom rendering). Unsurprisingly for a project of this size, there has been a good deal of promotional hoopla surrounding PortAmerica. Developer John W. Lewis has labeled the site "one of the most breathtaking in the world," and Johnson calls the opportunity to design a total environment "every architect's dream." According to a recent article in *The Washington Post*, there has also been some local opposition to the development, centering mainly on the height of the World Trade Center tower. A suit filed by opponents has lost in court, however, and Lewis expects to break ground sometime this summer, with completion of the overall project scheduled for 1996.

**WE DON'T
KNOW WHO
WILL WIN
OUR \$10,000
DESIGN
COMPETITION,
BUT WE KNOW
WHO WON'T.**

One of Haworth's most exciting design ideas was the creation of a wood system that can actually be mixed and matched with our standard furniture system. In almost any way you can possibly imagine.

What better reason to hold our first-ever design competition.

It's open to architects and design pro-

professionals, upper level design students, and recent graduates. You'll be asked to design a unique work environment in the Pantheon (that's right, in Rome) using Haworth furniture systems.

Finalists will be flown to our awards presentation in New York. Where we'll hand out a first prize worth \$10,000.

The winner will also be featured in full page ads in top international trade publications. (Of course, if your entry resembles this guy's, it may only be featured in an ad like this.)

For more details, call 1-800-442-9678, Ext. 567. And we'll send you an entry kit.

HAWORTH
They're built.



News briefs

Gottfried Boehm, a third-generation architect from Cologne, West Germany, has been named the 1986 laureate of the Pritzker Architecture Prize. He is the eighth recipient of the prestigious international award.

Brendan Gill, drama critic of *The New Yorker* and a leading spokesman on architecture and historic preservation, will give the opening keynote address at this year's AIA National Convention, scheduled for June 8-11 in San Antonio.

Following successful collaborations with Arata Isozaki on the Palladium (RECORD, mid-September 1985, pages 126-137) and Andrée Putman on Morgans Hotel (RECORD, March 1985, pages 144-151), New York entertainment impresarios Steve Rubell and Ian Schrager have turned to current superstar Philippe Starck for the complete redesign of the Royalton Hotel in midtown Manhattan.

The team of Pyatok and Associates and William Vitto & Ira Oaklander, Architects has won a national competition to design infill housing on four adjacent sites in the Harlem section of New York City. RECORD will feature the results of the competition in its July issue.

Bernard Rothzeit has been awarded the Augustus Saint Gaudens medal for his achievements in architecture by The Cooper Union in New York.

Eberhard Zeidler of the Zeidler Roberts Partnership in Toronto has been awarded the 1986 Gold Medal by the Royal Architectural Institute of Canada. The medal was established in 1930 to acknowledge "great achievement, and contribution to Canadian architecture and its recognition abroad."

"The Guild: A Sourcebook of American Craft Artists" will be published in June. The annually updated directory is aimed at linking 320 leading American craftspeople with architects, interior designers, and other design professionals. For information on obtaining the book, contact Kraus Sikes, Inc., 19 East 95th St., New York, N. Y. 10128 (212/289-5247).

Riverwalk in New Orleans, the latest festival marketplace to be developed by The Rouse Company, will officially open on August 28. Designed by Perez Associates, the 200-shop riverfront center at the foot of Canal Street occupies the site of the 1984 New Orleans World's Fair.

Arcadia comes to southern California: A new mixed-use complex in San Diego . . .

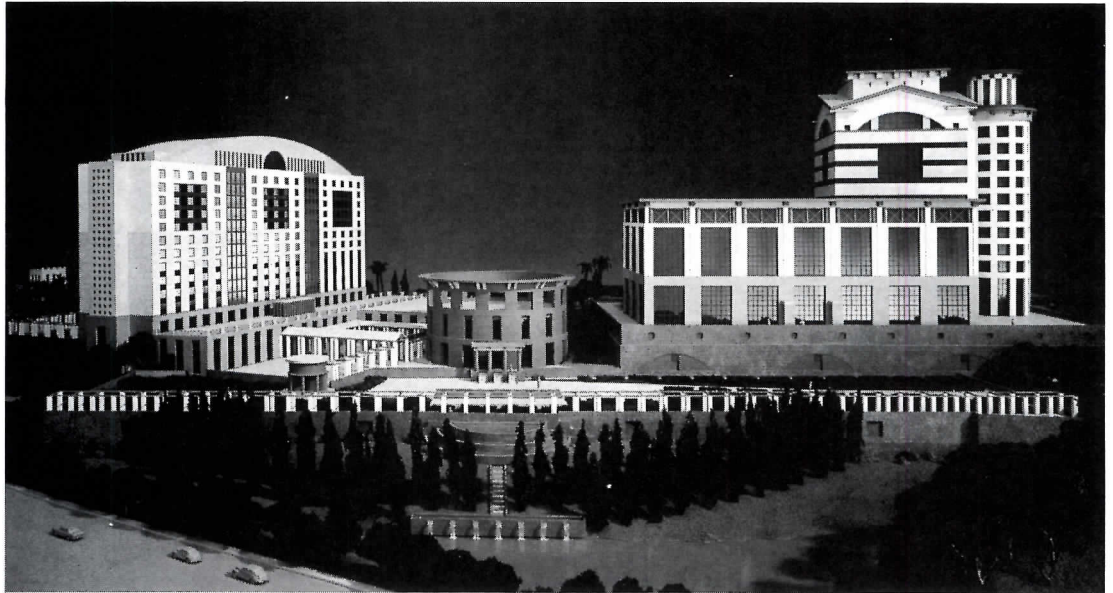

The Aventine is one of Rome's seven hills. It is also the name of Michael Graves's latest effort to adapt the architectural values of the ancients to the frankly commercial exigencies of the 20th century. The current object of Graves's attention is a mixed-use complex in the coastal foothills of San Diego comprising (from left to right in model) a 400-room hotel, a health club located in a Classical rotunda,

and 226,000 square feet of office space housed in a six-story "palazzo" and in two 11-story towers, one of which bears an uncanny resemblance to a certain architectural icon in Pisa (but without the tilt). The project is the latest example of what might be characterized as Graves's California Classical style—a regional mode already seen in the architect's library at San Juan Capistrano and

in his plans for the Domaine Clos Pegase winery near San Francisco. Considerably more romantic than Graves's work in colder climates, the San Diego buildings will be clad in a combination of red Spanish quartzite and light-hued stucco, and will exhibit a typically Gravesian palette of Roman grilles, urns, and pergolas—elements that reflect the architect's stated wish to "continue Classicism" rather than restore it.

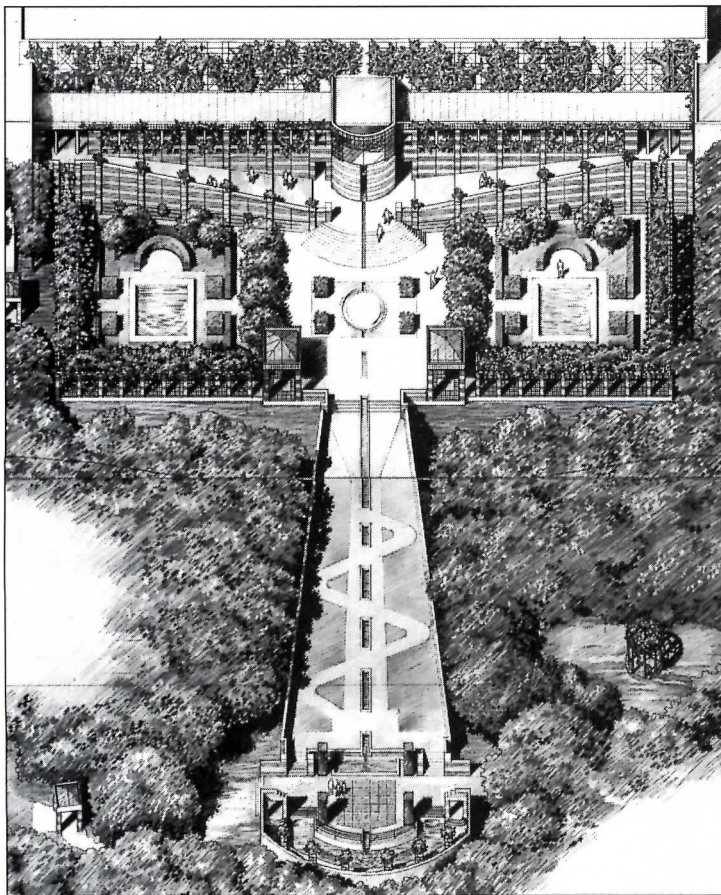

. . . and a resource recovery center in San Marcos

Fifteen miles north of Graves's project, James Stewart Polshek and Partners are applying the lessons of the past to an even more unlikely building type—a seven-acre processing plant in San Marcos that will convert 1,500 tons of trash per day into reusable raw materials and 30 megawatts of electric power. In order to shield unsightly processing machinery from view, the architects have positioned the plant at the bottom of a valley and buried it in a stand of eucalyptus trees, irrigated with recycled water. Pedestrian access is via a stepped ramp leading to a picturesque formal garden and visitors gallery (left) that overlook the main waste-processing area. The plant itself will be bedecked with wire lattice and flowering vines—a design meant, according to the architects, to "emphasize recycling as a collaboration between man and nature."

INTERCERAMIC

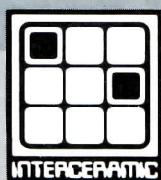

PROBLEM:

Furnish glazed ceramic floor tile for an exclusive home. Intricate herringbone pattern calls for 4"x8" tile with a skid-inhibiting, easy-to-clean surface. Stunning color with even tone a MUST! Deliver immediately.

SOLUTION:

Interceramic Tile from North America's largest (and soon to be larger) producer of frostproof monocottura floor tile. Factory and national distributor network has readily available inventories of 4"x8", 8"x8" and trim.



Private Residence
Las Cruces, New Mexico

Tile: Montaña Series, Terracotta 4"x8"

Designer/

Contractor: Quiñones Construction, Ltd.

To find out the name of your Interceramic Distributor call 1-800-351-2377. In Texas call collect (915) 593-7359.

INTERCERAMIC

El Paso, Texas

See our catalog in the 1986 Sweet's General Building Section 2.18/Int.

Circle 47 on inquiry card

Next stop, San Francisco

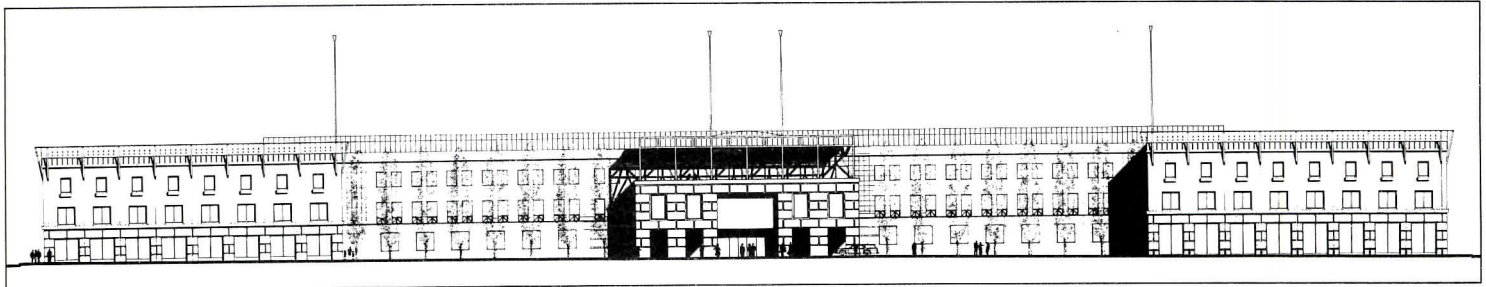

If the City of San Francisco gives the necessary nod of approval, and if a pre-specified core group of manufacturers signs on the dotted line, construction will begin late this winter on the San Francisco Design Center (SFDC), a 350,000-square-foot trade mart intended to offer the City by the Bay what the Merchandise Mart offers Chicago, the Pacific Design Center offers Los Angeles, Innova offers Houston, and IDC/NY is hoping to offer New York—i.e., one-stop shopping for contract furniture. Though those are two significant ifs, there is ample reason to be optimistic about this late entry into the burgeoning portfolio of American contract furniture marts. Affiliated Capital Corporation, a real-estate investment, development, and management company, has committed \$46 million to the project—which is located in the city's wholesale merchandise area south of Market Street—and enlisted the services of an impressive team of planners and designers. Not incidentally, of course, San Francisco needs the facility, as The Burdick Group discovered after researching the viability of the center for Affiliated by polling potential tenants. The resultant program Burdick devised includes a lively mix of crowd-enticing amenities—ranging from

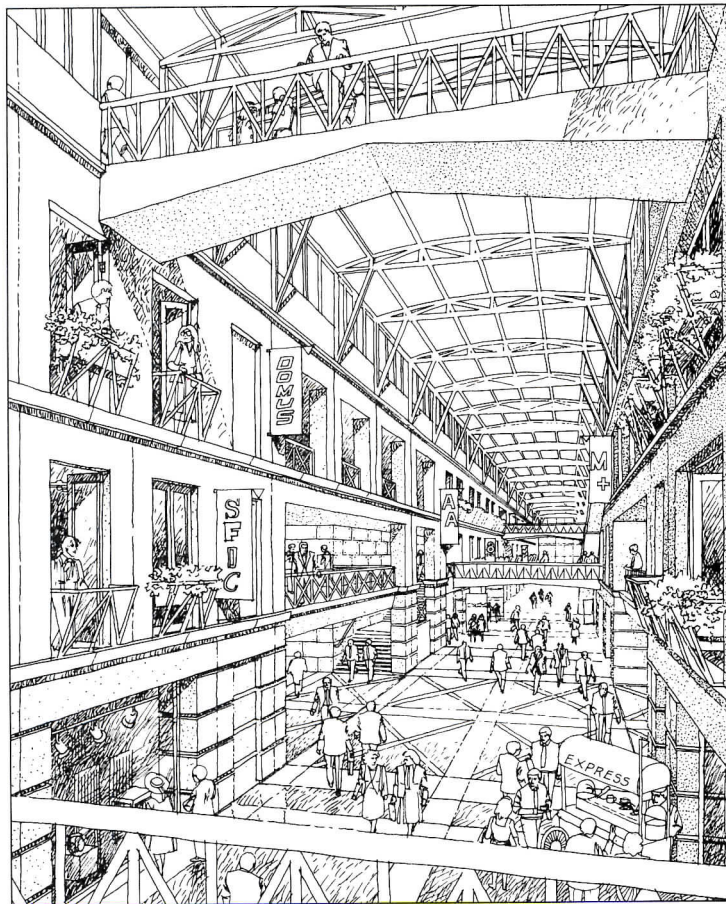

restaurants and “design magnate” retail shops to exhibition and auditorium facilities—intended to complement the requisite showrooms. Similarly, the marriage of architect Mark Mack and the firm of Robinson Mills & Williams, which Burdick also put together, ensures the appropriate balance of design talent and constructional know-how. The most sensational aspect of the architects' scheme is surely the arcaded interior street, inspired by the Milan Galleria, that bisects the 550-foot-long building (perspective left). This skylit spine provides a public facade for every tenant, as well as a simple organizational scheme that promises to be as clear as it is festive. Although the budget dictated economical tilt-up concrete construction (which will be colored but left exposed), SFDC will be no windowless bunker. The architects have broken down the apparent bulk of their massive structure by extending corner pavilions and an entrance bay beyond the main building line, and by adhering to a tripartite vertical organization comprising a 14-foot-high rusticated stone base, a generously fenestrated middle section, and a 10-foot cornice crowned by a trellislike frame of turquoise steel brackets that conceal rooftop parking. C. K. G.

Secure amidst an uneasy world: A new American embassy in Syria

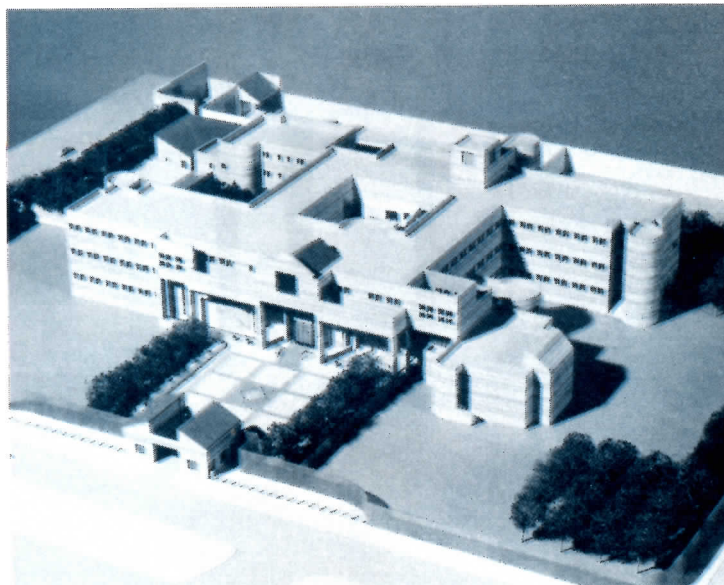

Although architects of American embassies have always had to reconcile an image of openness with provisions for rigorous security, especially in such trouble-prone regions as the Middle East, perhaps no building in recent years has proved as challenging as the current proposal for a new embassy complex in Damascus, Syria. Designed by Gatje Papachristou Smith, the project will incorporate such antiterrorist elements as a 100-foot setback from the property line, a heavily reinforced concrete structural system, and small windows placed six feet above the floor to eliminate the danger of shattering glass. The ancient monuments of Damascus also played a role in the design: witness the building's central courtyard, facade of pink and tan local stone, and round towers that refer to the minarets of nearby Syrian mosques.

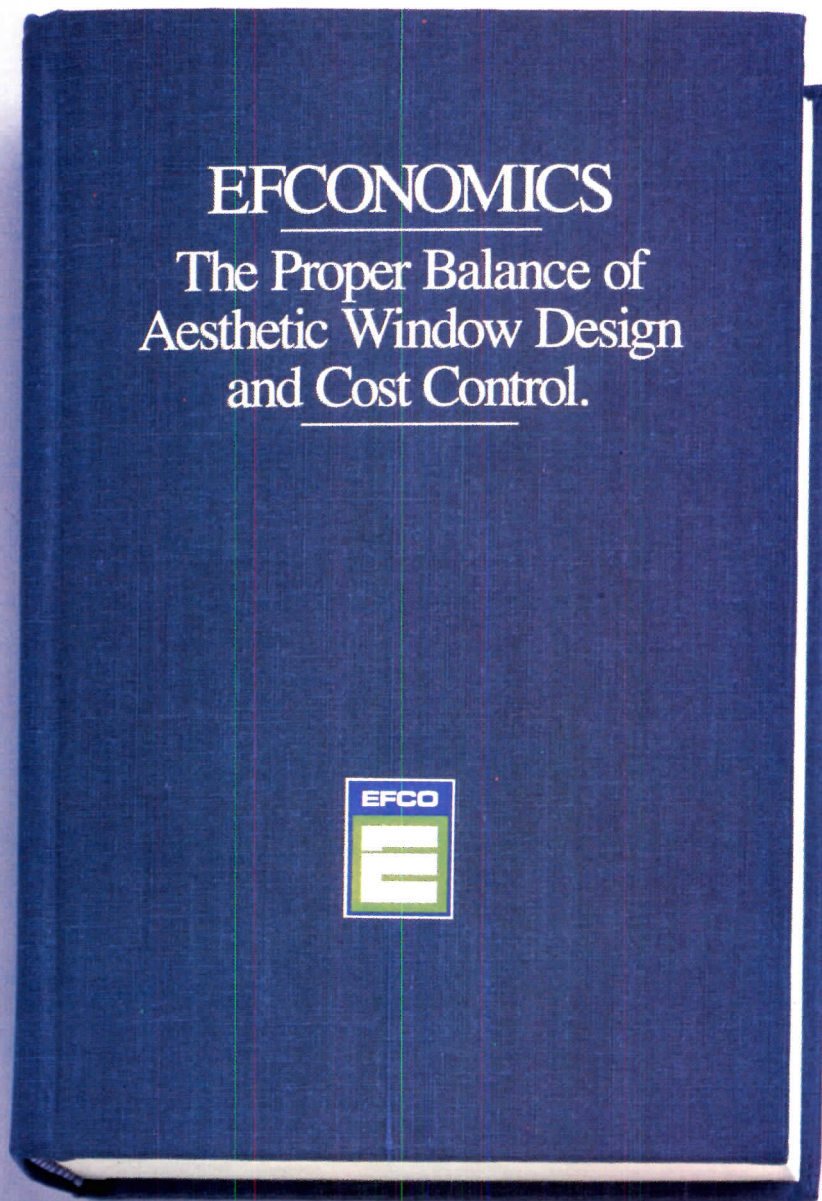

We wrote the book.

When it comes to balancing aesthetics and cost control, EFCO wrote the book. Offering a wide variety of custom aluminum windows, EFCO has the right window for any job. From new construction to historical replacement. Structural glazing to Gothic arch. Factory-glazed or unglazed. Thermal or non-thermal. A-2, A-2.5 or A-3. Standard or custom finishes. And a full range of accessories. All at the right price.

Next time, specify EFCO for a guaranteed best seller.



Look for EFCO in the Sweet's Catalog (section 8.15/Efd) or call toll free for more information.

Call 1-800-221-4169



**More windows,
more ways,
than anyone.™**

EFCO CORPORATION
P.O. Box 609 Monett, Missouri 65708-0609
TELEX: 332165 EFCO CORP MT

NEOCON 18 will examine the global view of architecture

An unusually diverse group of international architects, interior designers, and facilities managers will participate in NEOCON 18, the annual furnishings market and design symposium scheduled for June 10-13 at the Merchandise Mart in Chicago. One of the highlights of this year's event will be the granting of the third annual Chicago Architecture Award, sponsored jointly by RECORD and the Illinois Council of the American Institute of Architects, to Cesar Pelli, Charles Correa, and Mario Botta. The following NEOCON workshops, seminars, and lectures will be of particular interest to architects:

Tuesday, June 10

4:30 PM: Seminar and video presentation on office ergonomics.

Wednesday, June 11

8:30 AM: NEOCON keynote speech by Dr. Karl Albrecht, author of *Service America: Doing Business in the New Economy*.

10:30 AM: Workshop on the adaptive reuse of old buildings with architects Herbert McLaughlin and Bartholomew Voorsanger.

4:30 PM: Seminar on current trends in corporate design with architects Roz Brandt, Charles Pfister, Orlando Diaz-Azcuy, and Sally Walsh.

4:30 PM: Barcelona architect Ricardo Bofill will lecture on his recent work in Europe.

Thursday, June 12

8:30 AM: Keynote speech on the future of American corporations by Joseph Dionne, chief executive officer of McGraw-Hill.

8:30 AM: Seminar on product design with James E. Terrell, Lella Vignelli, and Richard Himmel.

4:30 PM: Seminar on architectural pluralism in Europe, Asia, and North America with Cesar Pelli, Charles Correa, and Mario Botta.

Friday, June 13

8:30 AM: Seminar on architectural expressionism with Charles Moore and Tomas Taveira.

8:30 AM: Seminar on the creative process of design featuring Philippe Starck.

12:00 noon: Chicago Architecture Awards luncheon. Featured speaker is John Busby, president of the American Institute of Architects.

3:00 PM: An international symposium on modern architecture, focusing on the work of Mies van der Rohe, Charles Correa, Mario Botta, Charles Moore, Cesar Pelli, Tomas Taveira, and Ricardo Bofill will speak.

For a complete schedule of NEOCON events, contact the Communications Department of the Merchandise Mart (312/527-4141). The New Products section of RECORD's August issue will spotlight a selection of furnishings introduced at NEOCON 18.

Forming a more perfect Union Square



The commercial and residential revitalization of New York's once-fashionable 14th Street area received added momentum with the recent unveiling of plans for One Union Square East, a one-million-square-foot mixed-use development that will occupy the 1.8-acre former site of S. Klein's department store. Over a decade in the planning stages, the project follows on the heels of the successful restoration

of Union Square Park, a 19th-century pleasure ground that had deteriorated into an ill-maintained haven for drug dealers during the 1960s and '70s. Designed by Davis, Brody & Associates, One Union Square East will consist of 50,000 square feet of ground-floor retail space, a five-story base housing 320,000 square feet of offices arrayed around a midblock atrium, and four 20-story residential towers

whose open pyramidal crowns are meant to recall the landmark clocktower atop the adjacent Consolidated Edison Building. The complex is expected to form the southern anchor of a burgeoning office and loft district that has proved especially popular to publishing companies, advertising agencies, and architectural firms fleeing the skyrocketing rents of midtown Manhattan.

Richard Morris Hunt at the Metropolitan Museum

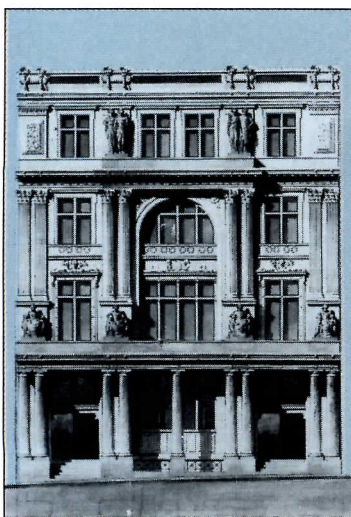

Proposed elevation for the New York Stock Exchange, 1880.

At last the prophet is honored in his own land. The Metropolitan Museum of Art in New York is exhibiting architectural drawings and photographs of the work of Richard Morris Hunt, whose 1895 design for the museum's great Fifth Avenue entrance hall gave the Metropolitan the image it still bears today. The first major retrospective of Hunt's work since his death, the exhibition has been organized by Susan Stein, former curator of the Richard Morris Hunt Collection at the AIA Foundation, and Morrison Heckscher, curator of American decorative arts at the Metropolitan. It remains on view through June 15 before traveling to the AIA Octagon in Washington, D. C. (Sept. 8-Dec. 23) and the Art Institute of Chicago (Feb. 9-Mar. 29, 1987).

Hunt was born in 1827 to a socially prominent and artistically inclined family (his elder brother William became an influential painter and teacher). His family went abroad in 1845, and Richard became the first American to study architecture at the Ecole des Beaux-Arts in Paris. Deeply influenced by Continental culture, Hunt became the champion of French urbanistic values in an America dominated by an English tradition of romantic naturalism. The exhibition begins with Hunt's student work—careful, if undistinguished—and his lively

sketchbooks, evidence of a sensitive, sanguine temperament. An extensive selection of early civic projects shows Hunt's initial attempts to reconcile Beaux-Arts forms with a Ruskinian environment. The proposed gateways to Central Park illustrate his frankly urban vision, his fluid, evolving esthetic, and—in the controversy they generated—the magnitude of the task he faced.

Subsequent sections of the show examine Hunt's commercial work and his city and country houses. During the 1860s Hunt experimented with a diversity of styles and materials. Though the buildings sometimes lacked "harmony and repose" (his own criteria for successful design), their innovations ranged from lively compositions in cast iron to picturesque Stick Style houses.

Hunt's Studio Building in New York was the first structure in America designed specifically for artists. John LaFarge and Frederick Church, among others, joined him there, and his influential atelier included George B. Post, Henry Van Brunt, William Ware, and Frank Furness. Hunt's early career culminated with the Lenox Library, a building that combined coherent Classical design with a highly successful plan for circulation and

At Russwin, we believe the exit should be
as grand as the entrance.

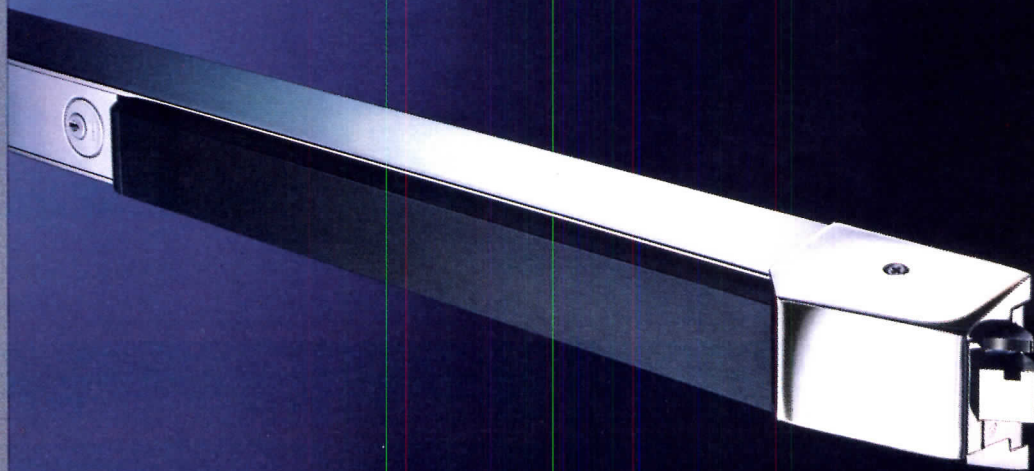

That's why we developed our 500 Series Designer Bolt. Available in a variety of handsome finishes, these heavy-duty push bar exit devices set new standards for low-profile beauty, long-wearing durability and easy installation. They can also be equipped with alarms to give you tighter access and exit control. And since aesthetics mean so much to your work, you can be sure that we'll live up to your grandest designs. 

Circle 49 on inquiry card

RUSSWIN
HARDWARE GROUP

EMHART

The final measure of security.

Design news continued

lighting. Montgomery Schuyler called it "perhaps the most monumental public building in New York." Then, in 1874, Hunt collapsed from overwork.

After a long convalescence in Europe, Hunt entered the second, more familiar phase of his development, centered around extravagant houses on Fifth Avenue and in Newport. One third of the exhibition is given over to the documentation of these lavish residences, focusing on esthetics (perspectives and elevations) rather than function (plans, sections, details). This approach—more sociological than architectural—confirms the contention of catalog essayist David Chase that Hunt's domestic work is "looked at, not considered." Perhaps the image of Gilded-Age excess is still too potent to be very closely analyzed.

As a founding member and president of the American Institute of Architects, from whose archives most of the exhibit is drawn, Hunt expounded the social value of high culture. A section devoted to his public monuments—including the pedestal for the Statue of Liberty—culminates in the 1893 World's Columbian Exposition in Chicago and the East Wing (main entrance) of the Metropolitan Museum. These works confirmed the predominance of Hunt's much-favored Beaux-Arts Classicism, whose symbolic and spatial values are once again the basis of America's public architecture and urban planning.

Hunt found certain historical styles congenial—notably the early French Renaissance, or Loire, style—but he was no revivalist. He knew that a valid modern architecture must respond to contemporary needs and possibilities. The stylistic eclecticism and functional diversity of his buildings shows Hunt's development as he struggled to respond directly to the social and esthetic conditions of his day.

The exhibition generally provides a clear exposition of the architect's long career. Because of gaps in the archives, however, some of Hunt's best buildings are absent (the Williams and Morland houses in Boston, for example, and his library and chapel at Princeton), and the consequent emphasis on unbuilt projects may give a skewed impression of an architect who completed over 200 buildings. Moreover, where authorship can be ascertained, it would be helpful to know which drawings are in Hunt's own hand.

But overall—and especially informed by the varied and suggestive essays in *The Architecture of Richard Morris Hunt*, edited by Susan Stein and published in conjunction with the show—the exhibit succeeds in focusing attention on a neglected master. Perhaps Hunt's flexibility and conservative taste worked against any achievement of a revolutionary program. But in his work and in his life, Richard Morris Hunt struggled to reconcile the needs of a rough materialism with the highest cultural values. The result was a virile yet graceful civility, rare in any age.

Thomas Matthews

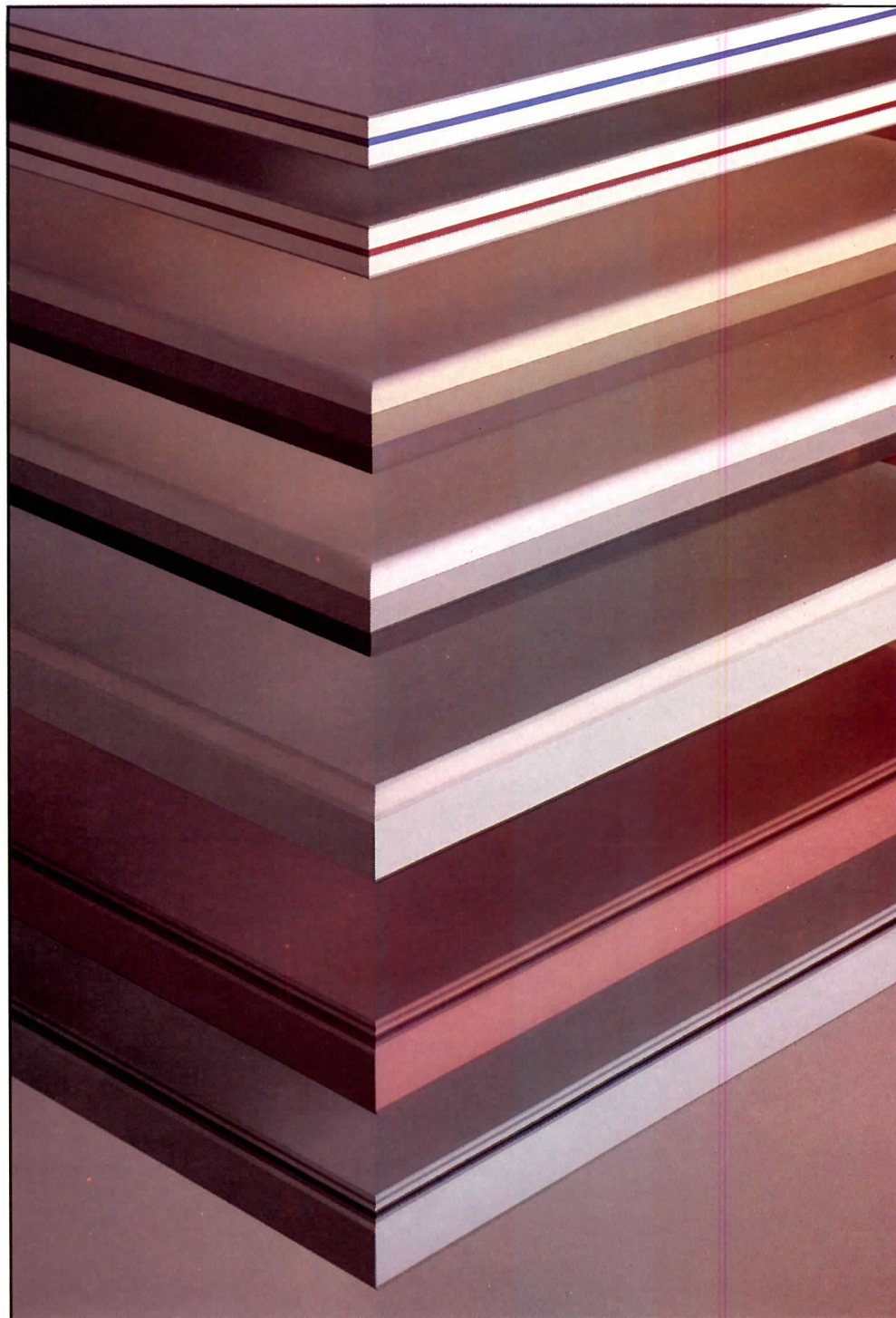

Color-Tiers.™ The leading edge of creativity.

Formica Corporation invites you to get the creative edge with new Color-Tiers edge strips. Color-Tiers strips provide unlimited design and color flexibility in both residential and commercial applications. Tough and beautiful, they're extremely durable and impact resistant.

Color-Tiers strips are available now in 6 in-stock combinations and an almost endless variety of custom designs.

So incorporate Color-Tiers strips into your next design. And enjoy the creative edge. For samples, call our ZIP CHIP line 1-800-524-0159, (in New Jersey 1-800-624-1914).

Circle 50 on inquiry card



BELZONA MOLECULAR[®]

"The Right Stuff"

The U.N. headquarters, as global forum and architectural landmark, must be one of the most carefully maintained buildings in the world. And Belzona Molecular products and techniques are part of the effort. Repairing waste water piping and erosion/corrosion damage in massive air conditioning condensers are just two examples. We began developing and applying our molecular technology in 1952, and are still finding tough new problems it can solve. From engine blocks to flooring, heat exchangers to conveyor belts, Belzona Molecular can make them good as new.

Maybe better.

Whatever your maintenance needs, you'll see substantial savings in replacement costs and downtime when you add "The Right Stuff" to your resources.



"The Right Team"

Belzona Technical Consultants are available around the clock — for advice on ideal solutions to maintenance problems and to provide technical support that takes the questions out of the job.

Belzona Molecular, your local Technical Consultant, and You — "The Right Team."

For more information and the name and phone number of the Belzona Consultant in your area,

CALL 1-800-542-6789
(in New York State 516-542-1000)

BELZONA[®] MOLECULAR[®]

CONSERVATION OF MAN-MADE RESOURCES

MOLECULAR METALS • MOLECULAR ELASTOMERS • MOLECULAR MAGMA QUARTZ • MOLECULAR MEMBRANES

BELZONA MOLECULAR, INC.

100 Charles Lindbergh Boulevard, Uniondale, Long Island, New York 11553 • (516) 542-1000,
Telex: 6435 49 • FAX: (516) 222-8259

BELZONA MOLECULAR LIMITED

Claro Road, Harrogate, HG14AY, England • (423) 67641, Telex: 57938 • FAX: 423:55967

Circle 51 on inquiry card

© Copyright 1986 Belzona Molecular Metalife Inc. All Rights Reserved

YOU CAN'T TOP THIS.

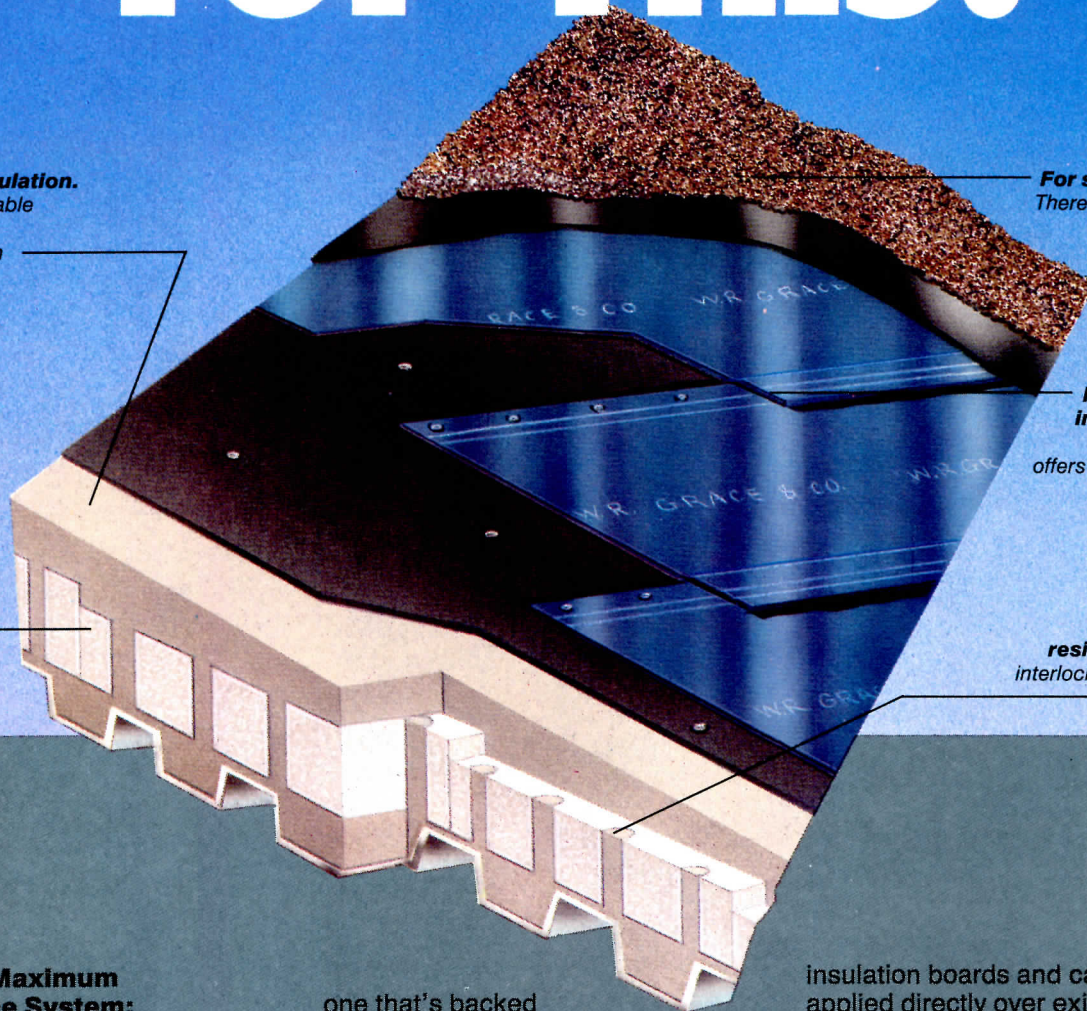

For permanent insulation.
Our dimensionally stable Roofing Base is an ideal substrate which is also reroofable.

For surfacing options.
There are three, including smooth white.

For waterproofing integrity. GRM is so tough, this System offers a 15-year warranty.

For energy conservation.
Grace Insulperm Insulation Board provides U-factors as low as .03. Stairstepped Boards add slope-to-drain the easy way.

For wind-uplift resistance. Our unique interlocking System has top UL & FM ratings.

The Grace Maximum Performance System:

No other roofing system keeps water out, energy in and roofing problems at bay quite like this one.

We've spent 20 years and millions of dollars researching the best in roofing products and the problems associated with roofing systems. We know the problems architects and owners face — and the risks.

If we weren't totally convinced of the integrity of this system, we wouldn't make a statement like, "You Can't Top This". We believe the combination of GRM (Grace Roofing Membrane) and Zonolite Roof Insulation (Insulperm Board and Roofing Base) provides you with a system you can count on for years —

one that's backed by the best 15/20 year warranty in the business.

For all your roofing needs, we offer a variety of systems that satisfy a wide range of demands. Our GRM Membrane is compatible with many

insulation boards and can often be applied directly over existing BUR's. Our PRMA System (Protected Roof Membrane Assembly) is a proven, inverted system that extends membrane life. Like our Maximum Performance System, it provides you with the added advantage of single source responsibility. And, like all Grace systems, it's expertly installed by our nationwide network of approved contractors.

Whether you need new or retrofit roofing, look into Grace Roofing Systems — you'll like what you see.

Call us today at 800-242-4476. Grace Construction Products, 62 Whittemore Avenue, Cambridge, MA 02140.

GRACE
Construction Products

OR THIS.

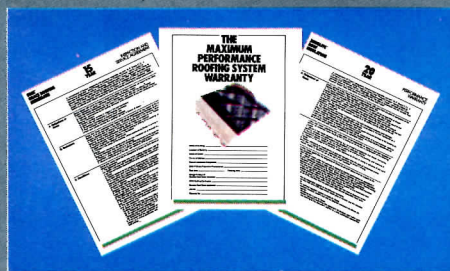

GRACE ROOFING SYSTEMS. THEY TOP THEM ALL.

Circle 53 on inquiry card

Design awards/competitions: California Council/AIA 1986 Design Awards

A cinnamon-roll shop in San Diego, a university gymnasium in Berkeley, and a water reclamation plant in Van Nuys were among 15 architectural projects recently cited by the California Council of the AIA in its annual design awards program. The event was open to California architects for projects located anywhere in the world, and to architects practicing outside California for buildings located in the state. The CCAIA received 250 entries to this year's competition, and the jury's citations included six honor awards, seven merit awards, and two restoration awards. Commenting on

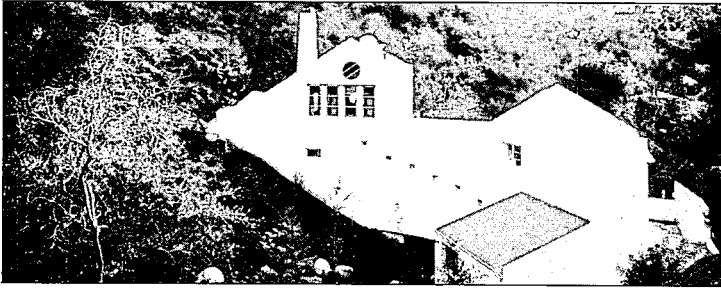

David Glomb

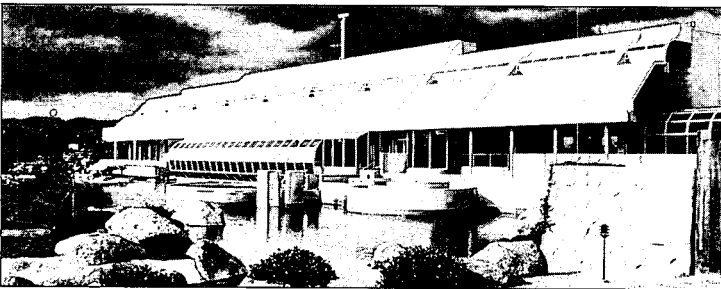

Makashima Tachougi & Associates

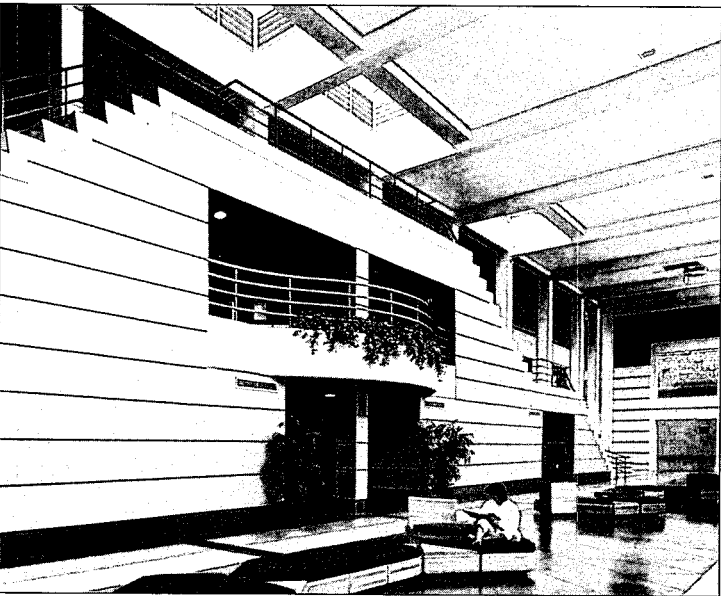

Mark Citret

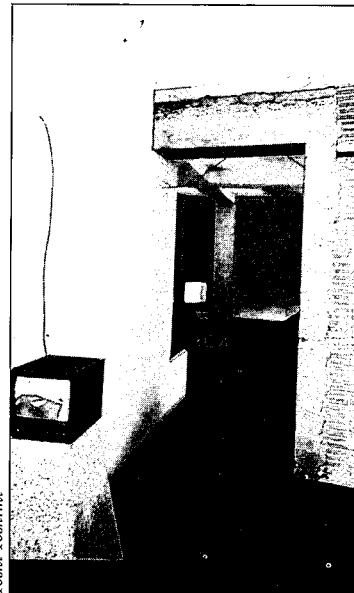

Toshi Yoshimi

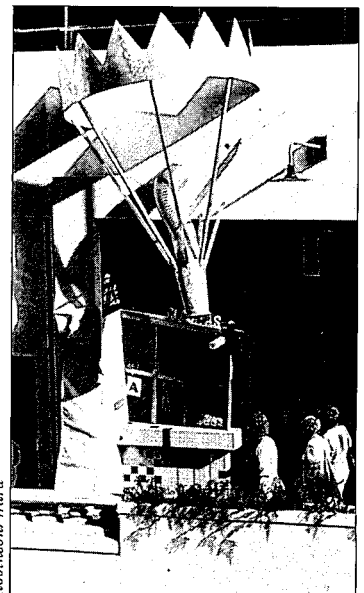

Robinson/Ward



6

1. **Arroyo House, Los Angeles, California;** Barton Phelps, Architect (Honor Award). Owing to winter run-off that cuts a wide channel across the building site, the architect had to design two pavilions on separate foundations, bridged by a 17-foot-high stairway. A lofty living room at the top of the stairs overlooks a canyon landscape. Thick stucco walls and a deliberate ambiguity of indoor and outdoor space derive from early 20th-century regional architecture. "The architect has a beautiful sense of siting, a beautiful sense of creating vistas, . . . and an incredible concept of procession," said the jury.

2. **Donald C. Tillman Water Reclamation Plant, Van Nuys, California;** Daniel, Mann, Johnson, Mendenhall, Architects (Honor Award). To symbolize this building's function as a water-treatment plant and to soften its

high-tech appearance, the architects surrounded an aluminum-clad structure with ponds and a Japanese garden irrigated with reclaimed waste water. The jury observed that the project exhibits "a wonderful dialogue between the romantic and the abstract. It celebrates the process [of water reclamation], evokes technology, and juxtaposes it against the lyrical statement of the garden."

3. **Recreational Sports Facility, University of California, Berkeley;** ELS/Elbasani & Logan, Architects (Honor Award). The jurors praised this new Berkeley athletic center (RECORD, September 1985, pages 90-95) for "doing what a significant urban building should do: recognize pedestrians and invite them to partake of the fabric. Its color treatment helps articulate function and complements existing facilities."

4. **Video Porch, La Jolla Museum of Contemporary Art, La Jolla, California;** Rob Wellington Quigley, Architect (Honor Award). The challenge was to convert a 20-foot-square janitorial storage area into a new museum video room. The architect acknowledged the room's location next to the historic Irving Gill-designed Scripps House by peeling back various layers of remodeling to expose Gill's original concrete wall. The jury called the results "lyrical as well as mystical. It's a time machine appropriate to the medium of video that is being investigated."

5. **Claudia's, Horton Plaza, San Diego, California;** Grondona Architects (Honor Award). Wishing not to compete with the Postmodernist architecture of a new downtown shopping mall in San Diego, the architects chose a whimsical art installation for their

design of a small shop selling cinnamon buns. A twisted pipe that emerges through a wall forces the aroma of fresh-baked goods into the mall and effectively draws customers into the shop. "This turns the mundane into sheer poetry . . . and raises chaos to the element of art," said the jury.

6. **Bergren Residence, Venice, California;** Morphosis, Architects (Honor Award). The architects designed a 750-square-foot residential addition as "a prototype for a scaled-down urban house for a small family on a small urban lot." The jury viewed the project's conceptual basis as "absolutely ethereal. It's almost a metaphor for the history of architecture, which grows out of a powerful masonry representational vocabulary into the dilemma of the new mechanistic age. That collision and growth give this house a poetic quality."

the submissions, jury chairman Paul Kennon observed that "the special place that California architecture has within this country is one of diversity, innovation, experimentation, of developing a laboratory for a new esthetic and a new meaning for architecture. You can see it all in California. . . . Californians dare." In addition to Kennon, who is president and design principal of CRS Serrine in Houston, the jury consisted of Peter Papademetriou, professor of architecture at Rice University in Houston, and Tod Williams, principal of Tod Williams Architects in New York City.

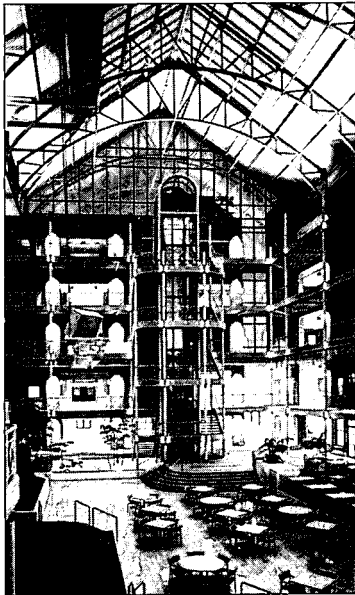

Franz Hall



Christopher Irwin



11

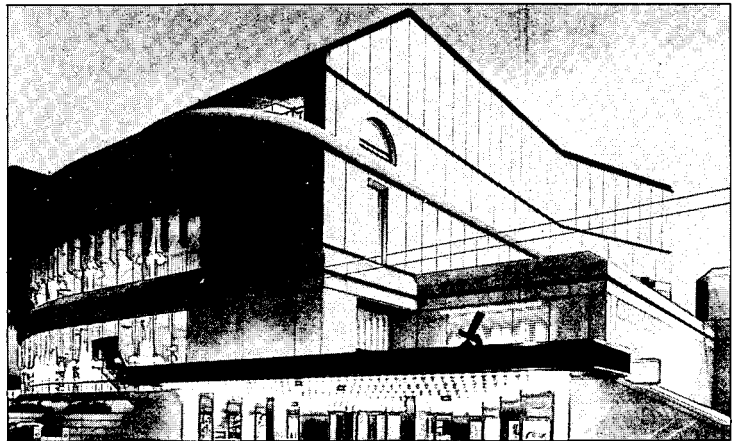

12

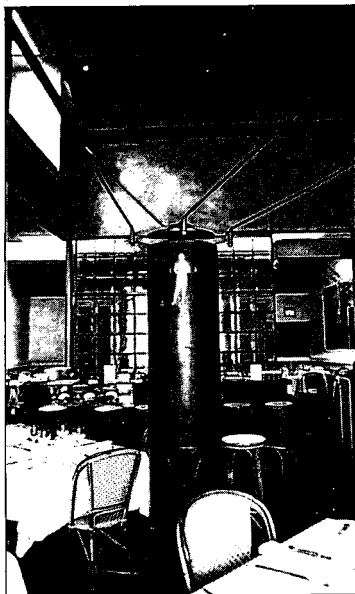

Tim Street-Porter



Tim Street-Porter

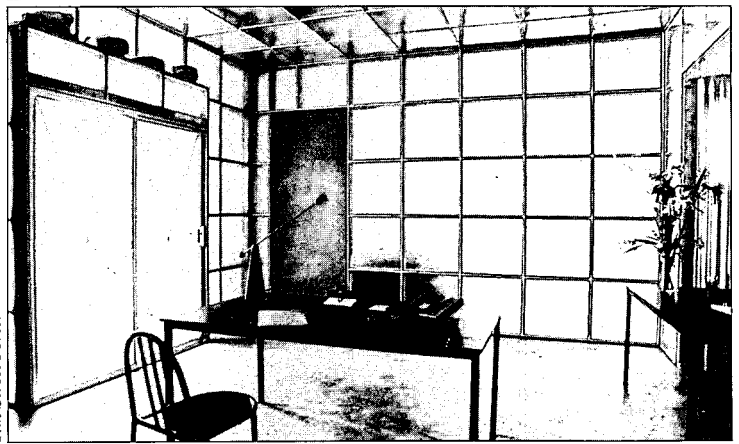

13

7. International Market Square, Minneapolis, Minnesota; Kaplan/McLaughlin/Diaz, Architects (Merit Award). The architects converted the former headquarters of an apparel manufacturer into a regional design center comprising 650,000 square feet of showroom space. A five-story atrium, built over a former loading dock, serves as the project's focal point. The jury called the complex "a brilliant execution [that] takes a mundane group of buildings and transforms them, creating a marvelous place within an urban context."

8. 72 Market Street Restaurant, Venice, California; Morphosis, Architects (Merit Award). "An incredible piece of urban architecture" was the jurors' characterization of a restaurant that reflects the ambiguity of its seedy/stylish neighborhood (RECORD, mid-September 1985,

pages 156-161). "The architects give the room even more significance by breaking it away and expressing it as an external building within another envelope."

9. Shay Residence, San Francisco, California; James Shay, Architect (Merit Award). "A sense of monumentality is created in this small, well-crafted house," noted the jury. "The barrel-arch roof is beautiful, and the architect had a sure hand in the detailing and in the continuity of space."

10. Petal House, Los Angeles, California; Eric Owen Moss, Architect (Merit Award). The jurors called a two-story addition to a postwar tract house "brilliant," and they reserved their highest praise for the manner in which the architects broke open a hipped roof to create a third-story deck. In suburban Los Angeles, they noted, "not many houses do that."

11. Prospect Point, La Jolla, California; Martinez/Wong & Associates; Robert A. M. Stern and Wheeler/Wimer, Associated Architects (Merit Award). The jury lauded a 35,000-square-foot mixed-use building at the edge of downtown La Jolla for its "happy relationship with Irving Gill's Women's Club and the Spanish character of the village. It creates a strong urban statement within that setting."

12. Louise M. Davies Symphony Hall, San Francisco, California; Skidmore, Owings & Merrill, Architects (Merit Award). The main facade of a 3,000-seat concert hall features a sweeping curve oriented toward San Francisco's Beaux-Arts City Hall. By treating lobbies as glazed pedestrian promenades, the architects strengthened the link between the building and the public space of the adjoining civic center.

13. Pytka Temporary Studio, Venice, California; William Adams Architects (Merit Award). Wood studs, translucent fiberglass, corrugated metal, and polished concrete floors were used in the design of offices for a production company. The jury observed that "the esthetic qualities of structure and materials were pretty basic, yet the sense of light and space is very pleasing. The fact that this creative architect would take such an incredible intellectual exploration in a temporary situation speaks well of culture in California."

In addition to the projects illustrated, the jury awarded special preservation awards to Eric Lloyd Wright and Martin Eli Weil for the restoration of the Storer House in Hollywood, and to Gillis-Judson-Wade for the restoration of All Saints Church in Hayward, California.

International Association of Lighting Designers 1985 Awards Program

The International Association of Lighting Designers has cited seven completed projects in its annual awards program for excellence in lighting design. The program was initiated three years ago "to recognize lighting design that reinforces the architectural concept and demonstrates high esthetic achievement, backed by technical expertise." Jurors were IALD members Robert Prouse of Jules Fisher & Paul Marantz, Inc.; Donald Gersztzoff of Wheel/Gersztzoff Associates, Inc.; Anne Robinson of Robinson Roth & Associates; and Alfred Scholze of Alfred Scholze Associates. An advisory panel of

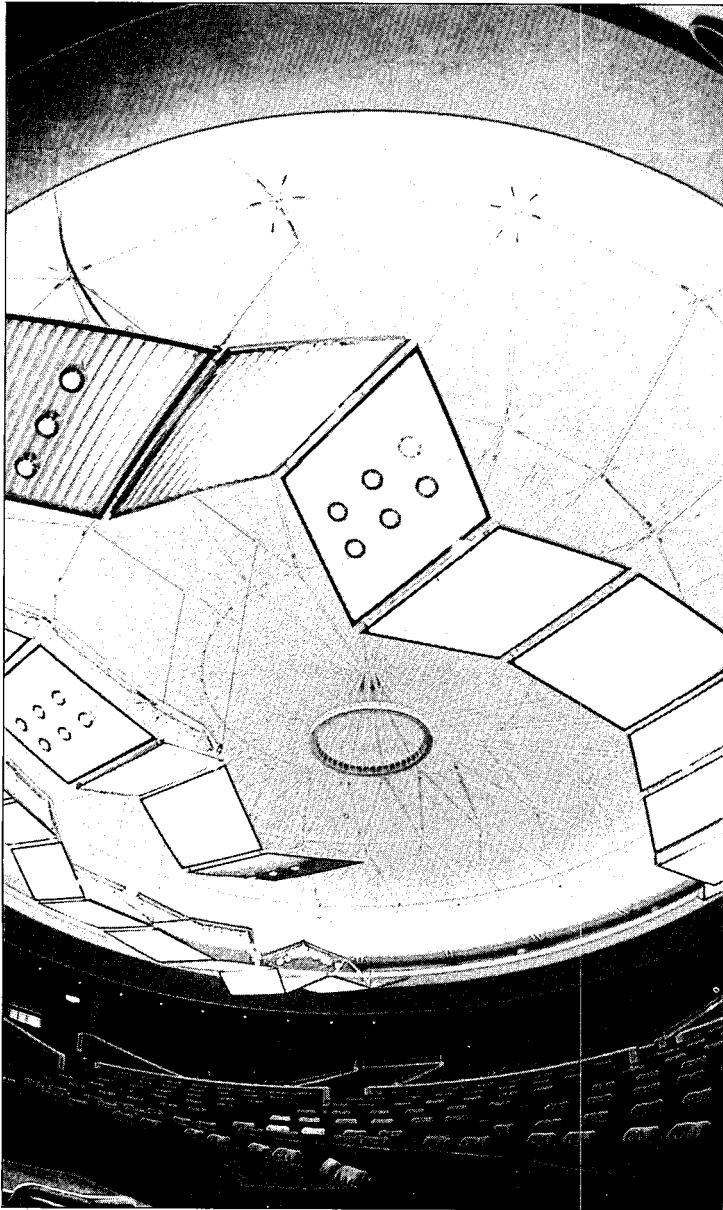

H. Ohno

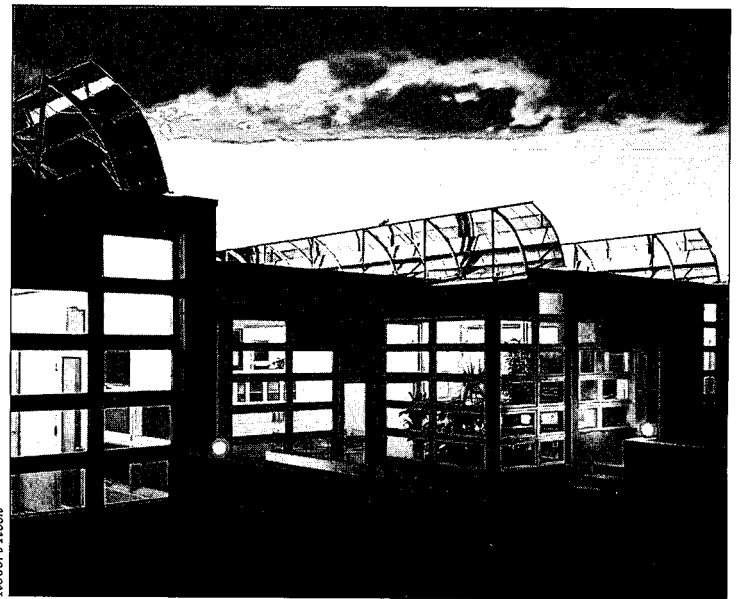

Robert Reck

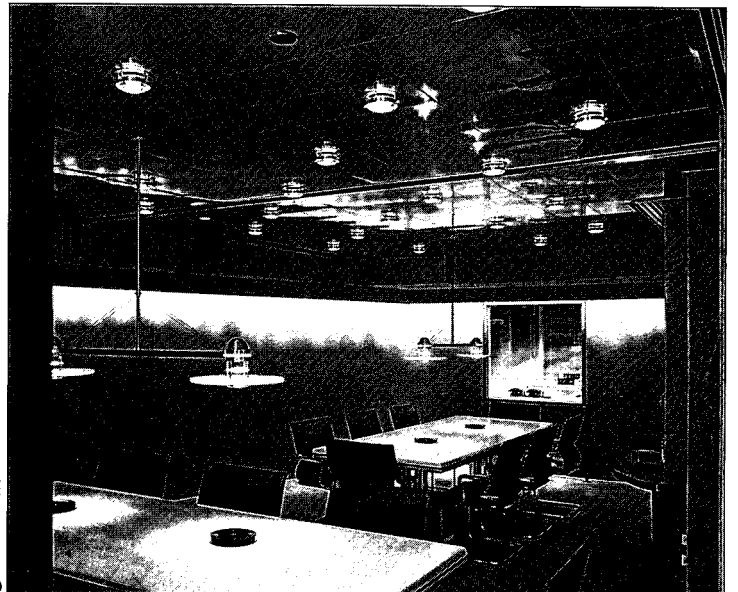

Paul Warchol

1. YKK 50, Kurobe, Japan; Hidetoshi Ohno, Lighting Designer (Award of Excellence). YKK 50 is an office, meeting, and exhibition center erected by the Yoshida Kogyo Company, a Japanese manufacturer of zippers and sliding fasteners, to commemorate the firm's 50th anniversary. The lighting designer's greatest challenge was the facility's International Conference Hall, a raked auditorium whose lofty domed ceiling posed problems of acoustics and light-bulb maintenance. Ohno's solution called for fixtures mounted on three motorized frames that can be electronically raised or lowered. Soft light is transmitted through opalescent acrylic panels that

appear as giant strips of cloth suspended in the air. The intention of the design, according to Ohno, was to express Japan's "poetical attachment to nature, the sky, and the wind."

2. Sawyer House, Albuquerque, New Mexico; Don Felts, Lighting Designer and Architect (Award of Excellence). Energy conservation was a major consideration in the design of this private residence, located on a flat, two-acre site at the base of the Sandia Mountains in north Albuquerque. In most of the living areas, south-facing skylights have combination reflector/sunshades whose mirrored surfaces

substantially increase solar gain. During summer the reflectors can be lowered to shade the skylights; at night the mirrors glow with reflections of interior lighting. Natural daylighting is provided through large stepped windows set into stucco-covered walls. In order to eliminate any shadows, all interior walls and ceilings are flush with skylight and window openings.

3. Générale Bank, New York City; Jerry Kugler, Lighting Designer, in association with Riykin-Weisman Architects (Honorable Mention). The jury cited two lighting fixtures that were custom-designed for the new American headquarters of a Brussels-based international trading bank, located on the 22nd floor of a midtown Manhattan office tower (RECORD, mid-September 1985, pages 114-119).

One of the fixtures, a semi-recessed in-ceiling downlight, is used throughout the elevator lobby, reception area, and conference rooms to add sparkle to softly finished wood and fabric walls. Consciously nautical in appearance, each downlight has two brushed aluminum collars that seem to float below the ceiling. Pendant fixtures in a conference room were designed to be seen both from above (when one enters the room) and from below (when one is seated at a table). Light from mirror-reflector quartz lamps passes first through a diffusing lens and then through an aperture in a large glass disk at the bottom. Some of the beam is dispersed around the diffusing glass to illuminate a sandblasted lower disk.

architects and designers assisting the jury included Woodson Rainey of McDonough/Rainey Architects; Paul Broches of Mitchell/Giurgola Architects; Judith Stockman of Judith Stockman and Associates; and Norman Diekman of Norman Diekman Designers.

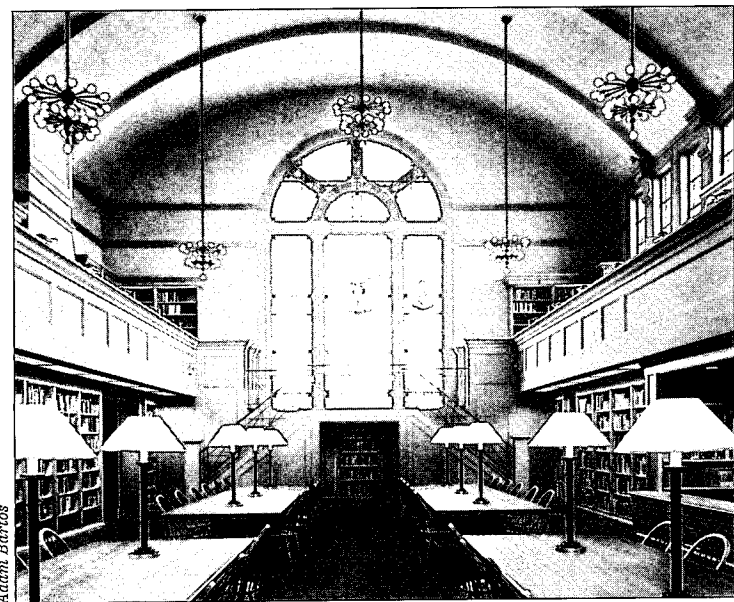

Adam Barrios

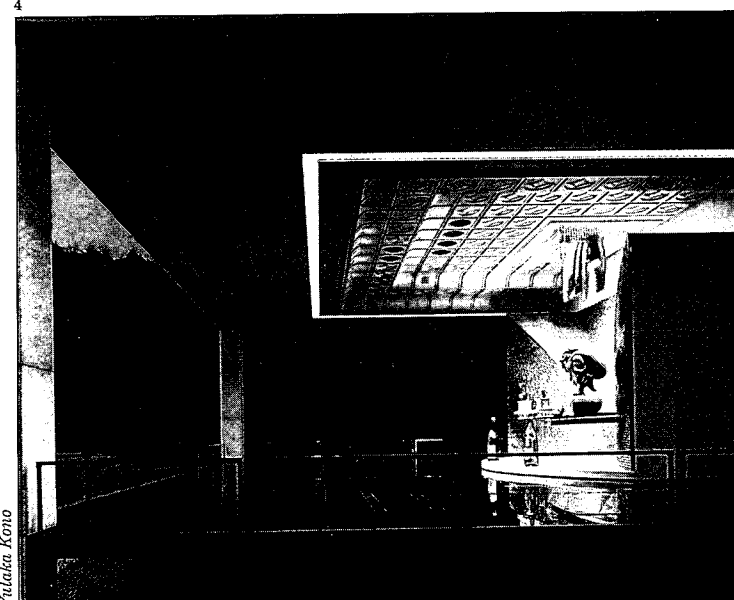

Yutaka Kono

4. Kaskel Library, Hackley School, Tarrytown, New York; Francesca Bettridge of Cline, Bettridge, Bernstein, Lighting Designer, in association with Keith Kroeger Architects (Honorable Mention). This adaptive reuse project involved the conversion of Goodhue Hall, a Neoclassical academic building designed in 1900, into a new library for a private school near New York City. In a large barrel-vaulted room dominated by high windows and a pair of tall fireplaces, the lighting designer sought to respect existing architectural features by restoring and relamping original chandeliers, and modifying green-glass fixtures in study carrels, creating harmonious new table lamps, and integrating fluorescent fixtures into the cabinetwork.

5. Daikoku-Sama Shrine, Shiga, Japan; Motoko Ishii, Lighting Designer, in association with Itoh Architects & Associates (Honorable Mention). An atmosphere of simplicity and solemnity was the architects' goal in their design of a shrine for Daikoku-Sama, one of Japan's seven lucky gods. In order to provide for open space required during ceremonial functions, the architects designed interior walls that can be mechanically lowered into the floor. The shadowless lighting was carefully conceived to keep fixtures out of view and make it appear that Daikoku-Sama floats in the air. Halogen spotlights illuminate the effigy and back

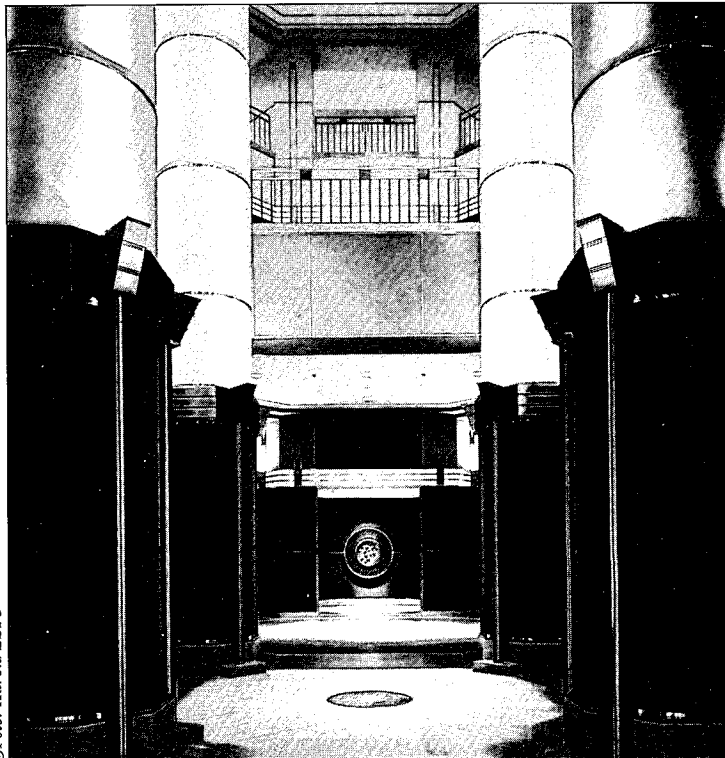

© Peter Aaron/ESTO

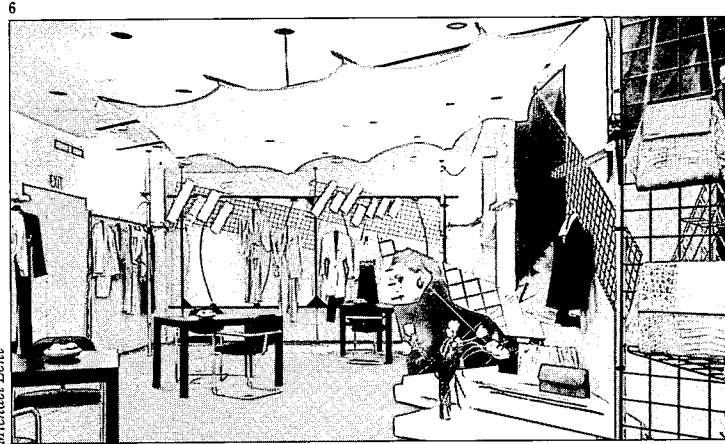

Michael Lent

6. Procter & Gamble Headquarters, Cincinnati, Ohio; Jules Fisher & Paul Marantz, Inc., Lighting Designers (Jerry Kugler and Barry Citrin, project managers), in association with Kohn Pedersen Fox, Architects (Honorable Mention). The jury cited the overall lighting program developed for a new 800,000-square-foot addition to Procter & Gamble's existing world headquarters. The lighting designers worked closely with the architects on a wide array of custom fixtures and integrated illumination for the main entrance pavilion, cafeterias, atrium towers, and auditorium.

7. Donna Karan Showroom, New York City; Nicholas Goldsmith of FTL Associates, Lighting Designer and Architect (Honorable Mention). For a showroom located in New York City's Garment District that must function as space for small fashion shows and customer sales, the architect designed a deliberately "chaotic, deconstructed backdrop" as a contrast to the simple silhouettes of the clothing line on display. A pair of custom-fabricated lighting wings, made of flame-treated nylon, is suspended on an angle overhead. This translucent fabric distributes bright, but diffuse, light that is said to allow good color balance for fashion photographers working in the showroom.

MARAZZI'S "NOBEL™" CERAMIC TILE

Classical Inspiration For Today's Living & Working Environments

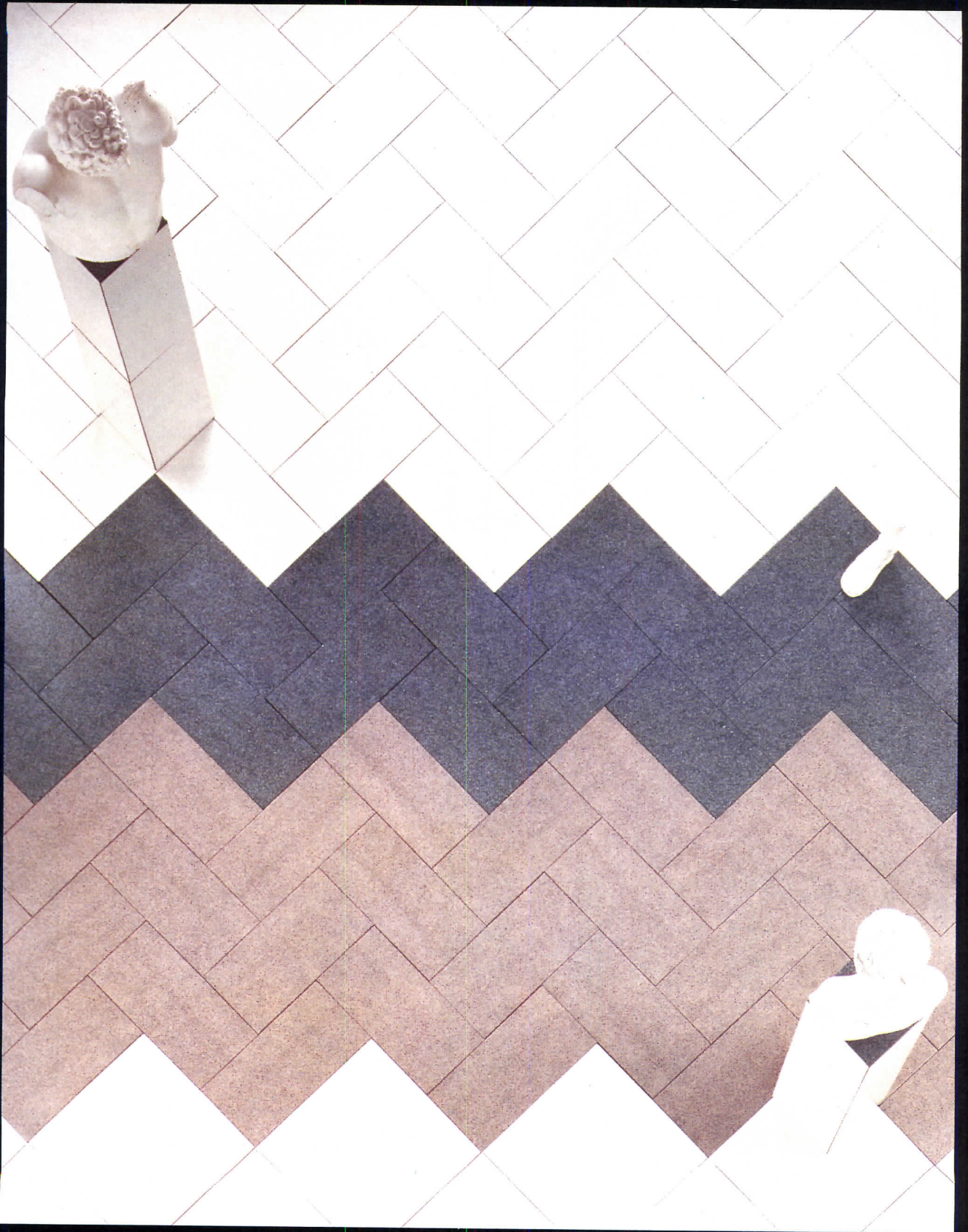

"Nobel™", with its five sizes ranging from 8"x 8" to 24"x 24" and its nine unique granite colors, allows specifiers total design flexibility for those residential and commercial installations where elegance and function are required. Produced by Marazzi's patented manufacturing process, "Nobel™" offers a durable glazed finish, easily maintained for a timeless appeal. For more information, contact American Marazzi Tile's Marketing Department at (214) 226-0110.



AMERICAN

MARAZZI TILE

55 Clay & Scyene Roads
Sunnyvale (Dallas), Texas 75182
(214) 226-0110

An affiliate of Marazzi Ceramiche Group Italy
(Formerly Marazzi USA, Inc.)

Circle 54 on inquiry card

Googie: Fifties Coffee Shop Architecture, by Alan Hess. San Francisco: Chronicle Books, 1986, \$12.95 (paperback).

Revisionists have been especially active over the past two decades, attempting to re-establish the reputation of once-spurned architectural modes. Late 19th- and early 20th-century revival styles—at one time dismissed as hopelessly derivative if not downright garish—have been the objects of recent scholarly affection, fueled in part by the historic preservation movement and a growing disenchantment with the tenets of orthodox Modernism. A newer, and at this point more limited, phenomenon has been the rediscovery of American commercial architecture of the 1950s and early '60s—the roadside motels, restaurants, bowling alleys, and gas stations whose space-age imagery and technological high-jinks embodied postwar consumers' boundless fascination with atomic power, sleek cars, and the new medium of television.

Although Robert Venturi glorified the American commercial strip as early as 1970 in his classic *Learning from Las Vegas*, most critics have spurned this postwar vernacular as the detritus of the Modern movement—antiurban architectural kitsch that despoiled the American landscape and sapped downtown of its vitality. In *Googie: Fifties Coffee Shop Architecture*, Alan Hess takes a heady trip down memory lane or, more specifically, down the wide commercial boulevards of southern California in an attempt to elucidate the historical underpinnings of a building type that falls somewhere between the streamlined Moderne diners and roadside sheds of the early 20th century and the mansard-roofed fast-food eateries of the present. The book's title refers to Googie's, a particularly outlandish Los Angeles coffee shop designed by John Lautner in 1949. This restaurant, writes Hess, was an early example of an architectural genre characterized by gravity-defying cantilevers, vaults, parabolas, and boomerangs—futuristic forms made possible by technological advances in the bending of steel, glass, plywood, and plastic achieved during World War II. The author defines L. A.'s commercial vernacular as "a style of action, of movement, of direction. It is an esthetic of articulation and contrasts, [and] its collage design threw together bubbling circles, out-of-whack squares, and unexpected angles, . . . surrounded by an aura of dingbats (the starburst motif borrowed from printing) and sparkles."

If "Googie architecture" was as symbolic of the decade as a '59 Cadillac or rock-and-roll music, the style, according to Hess, was also part of a more serious tradition stemming from the organic work of Frank Lloyd Wright. To prove his point, the author juxtaposes a rendering of Romeo's Times Square, a sweepingly cantilevered coffee shop on Wilshire Boulevard designed by Armét and Davis in

1955, with a photo of Wright's Taliesin West. He also invokes the names of such "respectable" architectural expressionists of the period as Eero Saarinen, Hugh Stubbins, Felix Candela, and Charles Eames in an effort to give Googie some additional legitimacy.

Whether or not one agrees with Hess's contention that "the coffee shops are Gropius's dream come true—a new architecture used and

appreciated by the masses, expressing the high standard of living brought by advancing technology," it is difficult not to admire this book's evocative duotone photos, '50s-style graphics, and nostalgic depiction of a seemingly happier time. More than just a chronicle of an architectural mode, *Googie* is an affectionate portrait of a way of life that no longer exists. *P. M. S.*

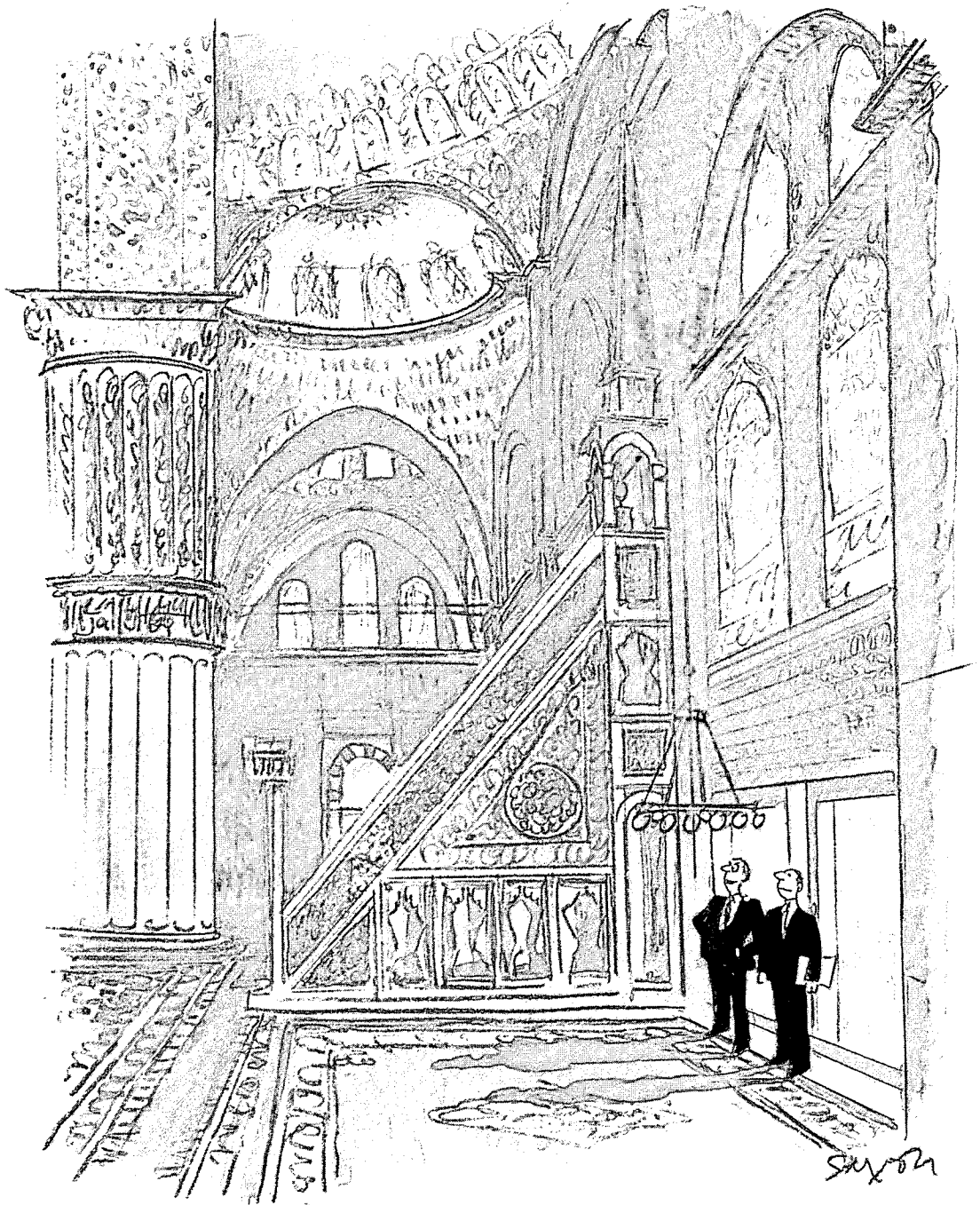

Terrific! Love the ambiance! Love the graphics!

	Armstrong Soundsoak60™ Acoustical Wall Panels	Capaul CapCell™ Acoustical Wall Panels
Washable Standard Finish	NO	YES
C.O.M. Option	NO	YES
Standard Colors	16	40
Noise-Reduction Coefficient (NRC)*	.60	.70
Speech Privacy Range*	.69	.85
Square or Radiused Edge Detail	NO	YES
Impact-Resistant Honeycomb Core	NO	YES
Velcro® Reusable Mounting	NO	YES
Matching Wall Covering	NO	YES
National Distribution	YES	YES

*Panel mounted directly against wall.

CapCell™ 10 Soundsoak™ 1

The facts are on the table. When you put Capaul's CapCell Acoustical Wall Panels up against the comparably priced Armstrong Soundsoak 60™, CapCell wins all the contests that really count. Like better acoustical performance. Richer-looking woven fabric that resists the toughest punishment and stains. More standard color choices—plus a C.O.M. option for virtually unlimited design possibilities. And our exclusive Velcro® mounting system makes CapCell the most portable, practical panel anywhere.

In fact, CapCell's advantages are too important to keep quiet any longer. And too good to pass up on your next acoustical wall treatment. To find out why more and more designers are including CapCell in their specifications write Capaul Corporation, 1300 Division Street, Plainfield, IL 60544, or call Capaul toll-free today.

Ten to one, you'll be glad you did.

Have a project that can't wait? Call 1-800-421-8368 for more information. In Illinois call 815/436-8503.

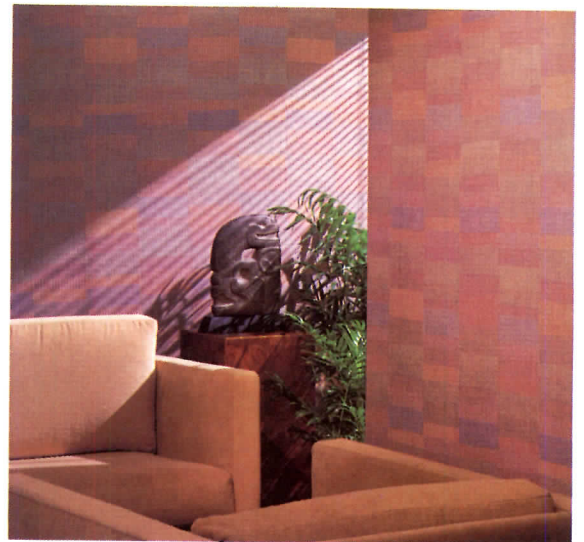

 **Capaul**
Architectural Acoustics.

Books

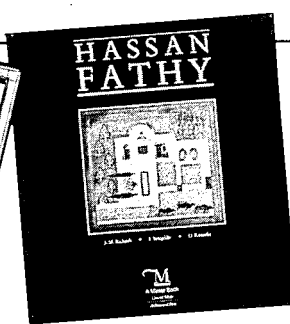
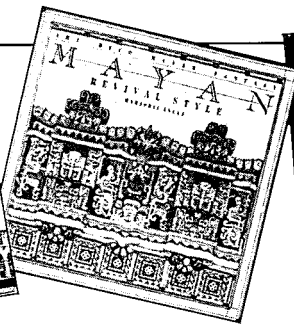

California's Mission Revival, by Karen J. Weitze. Los Angeles: Hennessey & Ingalls, 1984, \$22.50.

The Mayan Revival Style, by Marjorie Ingle. Salt Lake City: Peregrine Smith, 1984, \$15.95.

Reviewed by Paulina Borsook

The romanticizing of a tradition occurs when it begins to slip away. The English Romantic poets glorified nature as the British countryside began to suffer from the effects of the Industrial Revolution, and the Pre-Raphaelites tried to resurrect a medieval idea of craftsmanship that had become obsolete in an era of mass production. In this country the glorification of a past that never quite was is exemplified by the California Mission and Mayan revivals, two building modes that came into prominence early in the 20th century. Two recent books that began as their authors' graduate-school theses serve as solid introductions to any discussion of the styles. In dogged academic fashion the books document the commercial consequences of the revivals and show how the low cost and plasticity of reinforced concrete made the styles economically and artistically feasible.

California's Mission Revival delineates the rise of an architectural mode that took shape after the California missions had fallen into disrepair and the colonial Spanish and Mexican cultures had become remote enough to be viewed as a lost idyll instead of a political threat. Karen Weitze goes into excruciating detail to recount elements in the development of the style: boosterism, commissions for the California buildings at the 1893 World's Columbian Exposition in Chicago, experimentation with a Western version of the Arts and Crafts movement, the founding of Stanford University.

The author shows how architects, in their struggle to move away from Eastern and Beaux-Arts training and to discover a building method appropriate to California's terrain, found ways to adapt the forms of the Franciscan mission to public and private structures. The homey virtues of patio living and the clean lines of adobe and tile were thought especially appropriate to the new land's gentle climate and open spaces. Weitze includes numerous sketches, elevations, and competition entries to demonstrate the Mission Revival's evolution as it moved from Richardsonian Romanesque to distinctively Spanish features.

Paulina Borsook is a writer based in New York City. She is a native Californian.

Many of the first Mission Revival houses and hotels were built for wealthy transplanted Easterners lured to the paradise promised in southern California resorts. While the Revival's reign as high style was relatively brief, it nonetheless spawned a way of ordinary building that became an integral part of California's real-estate development for years to come.

Perhaps because of its idiosyncratic ornamentation and nuance, the Mayan Revival's story has a different outcome. A curious variant of Art Deco, this mode was largely confined to such specialized building types as movie theaters, skyscrapers, museums, and a few privately commissioned houses. The color photographs and renderings in *The Mayan Revival Style* illustrate the intricacy of murals, mosaics, and friezework that often referred directly to Mexican archaeological originals—and suggest why efforts at reproducing the style in quantity met with limited success.

The book dates the genesis of the Mayan Revival from the 1908 competition for the Washington, D. C., headquarters of the Organization of American States. During the 1920s and '30s, the style's zigzags found a natural affinity with the requirements for skyscraper setbacks. Like the Mission Revival, the Mayan Revival stemmed from a romance with ruins, in this case the remnants of an enigmatic Mesoamerican civilization. Yet, as Marjorie Ingle's thesis explains, this manner of building and, more commonly, decoration had roots in a yearning for an artistic tradition native to the Western Hemisphere.

Ingle carefully lists the reasons behind the idolization of this native American exoticism. She pulls in a wide variety of sources, including Erich Von Daniken (author of the "Chariots of the Gods" series) and the writings of Viollet-le-Duc and Robert B. Stacy-Judd to explain the fascination with the Pre-Columbian. A 1927 pamphlet called "The Story of the Maya: The Greeks of the New World," written by an archaeologist and originally published for the opening of the Fisher Theater in Detroit, is reprinted as an appendix.

While both books cite numerous figures, *The Mayan Revival Style* scores a coup of a sort. As one might have predicted, the Mission and Mayan revivals intersected in California, and Ingle provides an example of both styles in a single building—the Neil Monroe House in Lake Sherwood. This structure is the offspring of cultures separated by time but united in nostalgia: two New World traditions blended as only romance and modern building methods can.

Hassan Fathy, by J. M. Richards, Ismail Serageldin, and Darl Rastorfer. Singapore: Concept Media Pte. Ltd., in joint venture with The Architectural Press, London, 1985.

Reviewed by Roger Kimball

This lavishly illustrated appreciation of the Egyptian architect Hassan Fathy is the second in a series of monographs on "Architects of the Third World." Replete with over 100 color plates and 130 black-and-white drawings and photographs, three critical essays, excerpts from Fathy's reflections on the tasks of contemporary architecture, testimonials by admirers, and a detailed chronology of his works, the book succeeds in providing the Western reader with a vivid introduction to the sensibility and accomplishments of this controversial architect.

The first essay, by the English architect and critic J. M. Richards, situates Fathy in the international context and shows how his reaction against the anonymous, "transhistorical" character of much modern architecture led him to embrace various indigenous building techniques in his search for a workable regional vernacular. The Egyptian architect and planner Ismail Serageldin then provides a brief overview of Fathy's place in the life of Arab-Egyptian architecture, stressing the important influence of his traditionalist, craft-oriented planning theories on the development of contemporary Egyptian rural architecture. In Serageldin's estimation, Fathy is "the dominant figure in the Egyptian architecture of the 20th century." The final, most detailed, essay, by RECORD associate editor Darl Rastorfer, includes a précis of Fathy's career and an examination of his major building projects.

Born in 1900 to a wealthy Egyptian family, Fathy studied architecture at the University of Cairo, where he was graduated in 1926. His earliest projects date from the late 1930s, but his first completed commission—a spacious private residence in Giza—was not until 1940. Fathy soon found himself in rebellion against the homogenizing, technologically oriented incursions of advanced Western architecture in his homeland. Of "international architecture," he asked, "is it not international ill-respect of art and international loss of culture?" In his search for an architectural idiom that was at once indigenous yet

Roger Kimball is a frequent contributor to RECORD and other magazines.

practical, Fathy's work pioneered the combination of traditional Egyptian mud-brick village architecture with ancient Nubian arch and vaulting techniques. His self-consciously traditionalist architectural values stressed building that returned to a human scale and affirmed the heritage and way of life of the people it is meant to serve. "Every building should add to the culture of man," he wrote. "But how can it do this when it does not respect human reference and human scale? We should reintroduce man into our architecture; we must reintroduce human scale, human needs, and human tradition."

While Fathy has devoted much of his effort to private residences for the well-to-do, his most influential work has been his relatively small-scale village architecture for the rural poor. Probably his best known work is New Gournia Village (1948), a government-sponsored planned community near Luxor. Originally designed for some 900 families, the project as built accommodates only 130 families and occupies one fifth of the site. Nevertheless, the village, carefully planned to reflect Fathy's emphasis on traditional Egyptian architecture, is widely held to be a landmark solution to improving the living conditions of an impoverished, rural population.

During his long career, Fathy has seen a modest total of 30 projects built—most of them in Egypt—and has designed approximately 20 others. But his considerable influence in the Middle East would seem to have its source more in his efforts as a teacher and proselytizer than in his completed works. "His strength," as Ismail Serageldin observes in his essay, "is the strength of ideas more than buildings." Indeed, according to J. M. Richards, Fathy has become "a kind of guru" for young Egyptian architects. His commitment to the legacy of traditional Egyptian architecture, insistence on serving simple, well-defined human needs, and a healthy dose of Islamic-inspired mysticism combine to give his teaching a strong native appeal.

In the end, as Darl Rastorfer suggests, what we see in Fathy is a "mixture of social realism and utopian vision." His completed body of work, small and parochially rural, is frankly too marginal to be considered a major force in 20th-century architecture. But, by providing an economical, indigenously based alternative to modern Western architecture, he has articulated building principles that are at once humane, sensitive to local tradition, and widely applicable in less developed areas of the Third World.

HOW TO STAND UP TO THE DAILY GRIND.

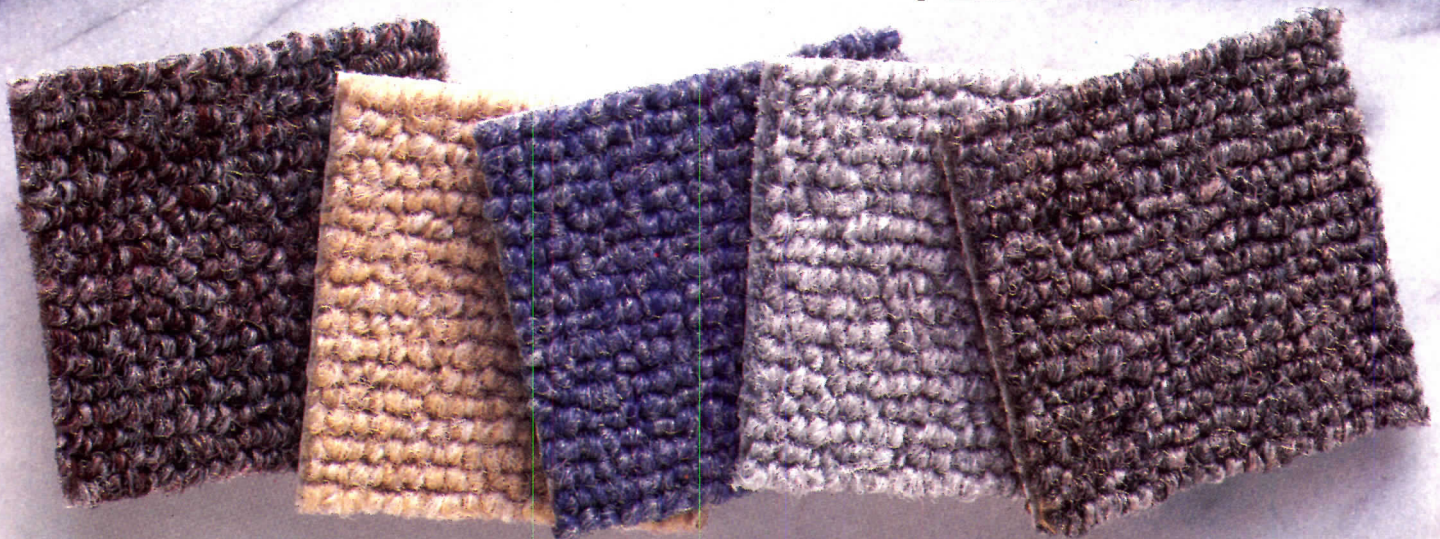

Specify our newest commercial carpet: the rugged and durable New Force. Because it's constructed with a tough, high-density stitch rate of Herculon Nouvelle fiber, it stands up to more of the daily grind. For a lot less money.

Ask your Stevens representative for facts and figures. Or, you can write to us at Stevens Carpet, P.O. Box 2023, Cathedral Station, Boston, Massachusetts, 02118, for the complete story.

STEVENS
Gulistan® Carpet

HERCULON
Nouvelle
The Contract Fiber



Circle 56 on inquiry card

Books

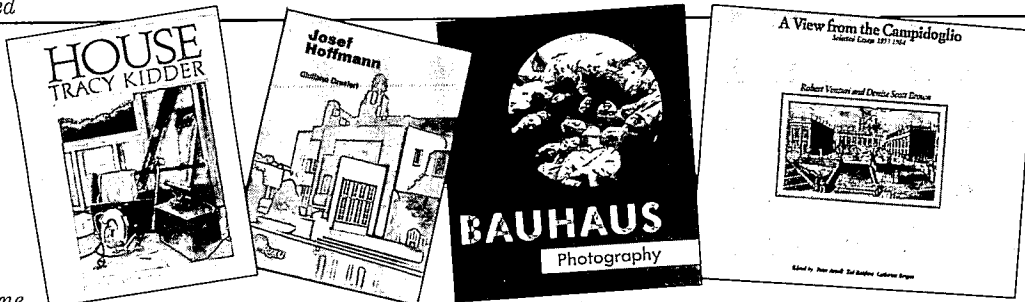

Reviewed by Julie Iovine

House, by Tracy Kidder. Boston: Houghton Mifflin, 1985, \$17.95.

Tracy Kidder has a talent for transforming deadly subjects into something vital. He did it with computer nerds in *The Soul of the New Machine*, and now he has brought his considerable skills to bear on a blow-by-blow description of building a house. It's a perfect frame-up: young professionals with a vestigial '60s morality want a not-too-showy showplace in Amherst, Massachusetts; their architect Bill Rawn, formerly of Davis, Brody Associates (no names have been changed to protect the innocent) wants to launch his career with a Postmodernist Greek Revival "box with some ornament;" and a team of four carpenters is intent on bringing back as much of the Arts-and-Crafts movement as is profitable. The snags, compromises, betrayals, and esthetic horrors (vinyl shutters at the clients' insistence) that constitute this cautionary tale should come as no surprise to anyone familiar with a construction site. Equal time for every argument is offered in a near-ery of voyeuristic sympathy for all sides: "I was embarrassed. I felt like I was being handled," says the carpenter of the owner. "He makes me uptight. I feel as if I say the wrong thing, he'll get offended," is the response. But for architects, the most informing passages will no doubt be the microscopic analysis of the age-old tension between builders and architects. Kidder traces it back to about 1850, when architects had "to persuade their countrymen that important distinctions existed between the art of designing and the act of building." The portrait emerges of architects who help their clients pick a style and then terrorize them with refinements beyond their esthetic and budgetary means. In *House*, even mild-mannered Rawn takes on a faint resemblance to Ayn Rand's Howard Roark. The implication is that it's practically un-American to be so concerned with style, and it is the carpenters who really impart soul to the new machine for living. No doubt, *House* has hit the best-seller list as a guide for future homeowners who want to read up on how to manage the hired hands. Architects should read it to get a glimpse of themselves in someone else's mirror.

Josef Hoffmann, by Giuliano Gresleri. New York: Rizzoli, 1985, \$12.50 (paperback).

When it comes to chairs, Josef Hoffmann is much in vogue, although most people would probably be hard-pressed to describe very much else about his major works and themes. In fact, until this year remarkably little on Hoffmann was available in English. Now, we have two books: Eduard F. Sekler's definitive catalogue raisonné, recently translated from the German and published by Princeton, and Giuliano Gresleri's 1981 monograph translated from the Italian. The Sekler tome—the product of over 20 years of intense research—would certainly seem to supersede any other effort, and in terms of comprehensibility, it does. However, Gresleri's moderately priced, pocket-sized paperback also has its purpose. Organized chronologically by project, with a brief entry for each, and accompanied by a selection of serviceable photographs, Gresleri's book has the advantage of being a handy guide for anyone in need of a quick, opinionated interpretation of Hoffmann's work. The Villa Ast in Vienna, for instance, "has only really been discovered by modern critics; it was kept secret from the history of architecture for a long time." And as for the formidably gaudy Palais Stoelet in Brussels, it is a modern "first" because it lacks "an apparent relationship to the past." At the core of Gresleri's argument is an attempt to revise the standard judgment that has been passed on Hoffmann's work as an expression of bourgeois decadence in the throes of excess. Instead, Gresleri detects a more revolutionary spirit reacting "to a climate of general precariousness" by subverting traditional forms in his own unique way. Hoffmann's engrossing desire to simplify ultimately led to an architecture based on compositional elements, such as walls, apses, tympanums, and niches, manipulated in scale every which way to draw attention to their object-ness. Long before AT&T, the Purkersdorf Sanatorium in Vienna transformed a famous Hoffmann cabinet of 1901 into a full-scale building. Clearly, Hoffmann's work deserves all the attention it is now receiving.

Bauhaus Photography, foreword by Eugene J. Prakapas. Cambridge: MIT Press, 1985, \$30.

Photography came late to the Bauhaus in 1929, the tenth year of its 14-year life, but it was taken up by everybody with immense enthusiasm, from directors Gropius and Meyer right down to scores of anonymous students. Laszlo Moholy-Nagy was the school's most significant photographer, although he never took up camera work professionally as his wife Sibyl did, and Otto Umbehrr was considered the most gifted. *Bauhaus Photography* assembles 500 Bauhaus photographs for the first time in one place. An initial group of 128 shots, including several by the Moholy-Nagys and Umbehrr, was shown in photo exhibitions throughout Europe during the 1920s and '30s. Every technique, from photomontage, close-up, and worm's-eye view to solarization, was tested, but no identifiable "Bauhaus style" emerged. The book's second section consists of over 300 "informal" photographs of record, and while many carry on the experimentation with bold and unusual techniques, many more are just snapshots of Bauhaus students—not many of them recognizable—camping it up before the camera. Even these are remarkable, particularly series on plays staged by the Bauhaus in the late 1920s (and one of ramrod ideologue Hannes Meyer down on the floor clasping a woman's knees). They underscore the depressing realization that the avant-garde today hardly ever seems to have, or offer, so much fun. Although the photographs speak lucidly for themselves, there is a brief introduction by Eugene Prakapas, followed by a series of short articles by such Bauhaus regulars as Laszlo Moholy-Nagy, Walter Peterhans, Friedrich Vordemberge-Gilewart, and Ernst Kallai, among others, arguing "the fateful question" of photography versus painting. While that particular debate rages on, Moholy-Nagy's claim that "the illiterate of the future will not be one who cannot write, but who does not know photography" has perhaps lost some of its urgency. As this book admirably reveals, however, the work of the Bauhaus photographers still exhibits the flash of its own original genius.

A View from the Campidoglio: Selected Essays 1953-1984, by Robert Venturi and Denise Scott Brown; edited by Peter Arnell, Ted Bickford, and Catherine Bergart. New York: Harper & Row, 1984, \$25.

Reviewing essays by Robert Venturi and Denise Scott Brown feels, at first, like a dicey undertaking. After all, three of the pieces are hatchet jobs on past reviewers, including "Pop Off," a deadly dismissal of Kenneth Frampton, who "misses the agony in our acceptance of Pop." In the end, it's exhilarating: everyone knows how verbally fresh the Venturi-Scott Brown team can be. The fun in this collection is trailing the bees in their bonnet over 20 years of buzzing. The role of, or even craving for, symbolism in architecture continues as one of their central themes. Little has changed since the 1960s, when Venturi wrote, "Symbols with architecture enrich meaning. They can evoke the instant associations crucial for today's vast spaces, . . . and, perhaps, jaded senses which respond only to bold stimuli." *Learning from Las Vegas* said much the same, but Venturi thinks that "hardly anyone has read that book or reads books in general anymore" (which might be the reason why, in 1982, he was determined "to do more and speak less"). In later essays the emphasis shifts from a call for bold symbols to pique the weary, to using diverse symbols that respond sensitively to today's "plurality of tastes" and variety of heritages. Postmodernism has disappointed Venturi by missing an opportunity for diversification and by merely replacing the didactic canon of Modernism with its own dogmatic and limiting vocabulary. What architecture should be, according to Venturi, is simply "appropriate," a word that is just as loaded as it sounds. As for what Venturi expects of himself, he writes in the last essay, delivered in 1983 at Harvard, "I consider myself an architect who adheres to the Classical tradition of Western architecture." Obviously, learning from Las Vegas, from Lutyens, from Pop, from the Beaux Arts, from Aalto—from anything, in short, that doesn't move—has brought Venturi and Scott Brown a long way from 1970, when they wrote about their "pathetic, imperfect, expedient, limited, activist approach."

Julie Iovine is a freelance writer who contributes frequently to RECORD.



BRAI ROLLS ON

u.s.intec/
brai 

AND ON. WE'VE ROLLED OUT OVER 200 MILLION SQ. FT. SO FAR.

U.S. Intec is the world's largest producer of A.P.P. modified bitumen. And for very good reasons. Our Brai roofing and waterproofing is easy to install and impossible to beat. Membranes are torch applied, requiring small crews and less time. It's proven to withstand virtually all climatic conditions. Brai fits the project, the timetable and budget. And comes with warranties for up to 12 years. Talk to our people in the field. Use our toll-free number and a regional representative will contact you. We're rolling.

u.s.intec/
brai  We're
on a roll

P.O. Box 2845 □ Port Arthur, Texas 77643

Regional Offices

Fort Worth, Texas □ North Branch, N.J.

Texas 1-800-392-4216 National 1-800-231-4631

Circle 57 on inquiry card

Pride misplaced: Stern lessons in American architecture

By Roger Kimball

"Pride of Place: Building the American Dream" is public television's latest effort to bring the trappings of art and knowledge to its throngs of culture-hungry enthusiasts. Sponsored by Mobil Oil and scheduled to air weekly through the middle of May, the eight-part series is billed both as a documentary and as a "personal view" of American architecture. Presumably, this means that it aims to provide us with a straightforward, factual account of the heritage and achievements of American architecture and, at the same time, to present us with one man's view of its idiosyncrasies, its successes and failures, its current challenges and prospects. Having sat through all eight episodes of "Pride of Place" in three days, I can assure the reader that, if nothing else, the view of American architecture that it offers is "personal" indeed.

The view in question is that of our "host" for the series, the New York architect Robert A. M. Stern, a professor of architecture at Columbia University and director of Columbia's Temple Hoyne Buell Center for the Study of American Architecture. Stern narrates the show, traveling with the television cameramen to more than 100 locations across the country. From the South Bronx to San Simeon, William Randolph Hearst's "dream house" in California, Stern tours America's cities, campuses, villages, buildings, monuments, and parks. In each episode, he pauses for a prearranged chat on location with one or two architects or architectural critics about the topic at hand: Philip Johnson, Vincent Scully, Peter Eisenman, Charles Jencks, Paul Goldberger, and Cesar Pelli are among Stern's guests on the show. With the help of two associates, Stern has also written a companion volume by the same title to accompany "Pride of Place." The book, published by Houghton Mifflin/American Heritage, is a copiously illustrated, 300-page text that propagates a somewhat elaborated version of the "personal view" of American architecture that Stern offers his television audience.

But however personal his view, no one, I think, will accuse Robert Stern of being an overly charismatic or engaging narrator; his reedy, high-pitched voice, energetically distracting hand movements, and reluctance to take his eyes off the teleprompter and look directly at the camera make his performance comically wooden. And the inept cinematography doesn't help matters, either. One of my favorite moments occurred when Stern painstakingly described the sense of vertical flow that a grand staircase inspired while the camera panned



slowly across the stairs from left to right: so much for the vertical flow. Architecture is notoriously difficult to present effectively on film, but it helps if the cameraman makes some effort to follow the narrator's cues.

Stern's itinerary includes all the expected stops: suburbia, the campus, the skyscraper, resorts, urban gardens, commercial interiors, and grand domestic architecture. But the basic components of his personal view of American architecture are set forth most clearly in the first—and in many respects, the best—episode, "The Search for a Usable Past." According to Stern, the "critical issue" facing American architecture today is its relationship to the past. Tradition, history, rich and evocative ornamentation—these are the things that for Stern allow architecture to transcend its merely utilitarian tasks and "build a dream." Looking back to his youth in New York City, Stern contrasts the fanciful skyscrapers of the 1920s and '30s with the cooler Modernist productions of the 1950s and '60s. In his view, Modernist architecture, enslaved to an ethic of functionality, "fiercely negated the past in favor of single-minded orientation to the present." More than that, Stern associates the ascendancy of Modernism with all manner of social and political dereliction. "A new postwar era had dawned," Stern reminisces about the 1950s in his book, "and just as I must learn to love the bomb—or at least live with it—I must learn to love an architecture that exalted function and structural technique as the determinants of significant form." And in case we don't get the point, the extraordinarily manipulative soundtrack helps us out: the sweet, elevating strains that play as Stern describes the

Robert A. M. Stern, on location amid the towers of his native New York, narrates "Pride of Place: Building the American Dream." The eight-part television series is currently airing on PBS.

wonders of old New York suddenly give way to a gloomy dirge-like lament as he castigates the "insensitive, uniform boxes" of Modernist architecture.

Stern begins by reminding us that American architecture, lacking an indigenous tradition, has had to forge a tradition for itself out of a wide variety of disparate elements; where Europe was born to its history and an architectural tradition, America has always had to concoct its tradition, "inventing and reinventing" the past. Of course, this idea is as familiar as it is banal; but as it happens, Stern has good reason for insisting that history and tradition in American architecture are products of "invention." For, in his hands, the history of American architecture is nothing if not invented. His guiding theme is that Modern architecture represented a lamentable break with history and tradition that is only now being repaired by the triumph of Postmodernism. Finally, after the depredations of Modernism, American architecture has again "come to its senses," largely, Stern tells us, because of the kindly influence of architects like Philip Johnson, Michael Graves, and Robert Venturi.

The ironies that surround Stern's presentation are probably endless. But perhaps the greatest irony arises from his insistence on the importance of history and tradition in architecture. His own performance in "Pride of Place" is woefully irresponsible when it comes to the historical record. For one thing, the entire series rests on a systematic distortion of the character and ambitions of Modern architecture. It is true, of course, that Modernism challenged the ethos of 19th-century historicism, but to conclude that Modernism is

therefore "antihistorical" or "antitraditional" is less than simplistic: it is a blatant misrepresentation. In this context, one need think only of the oft-noted continuities between neo-Classicism and Modernism. Further, in Stern's version of the history of American architecture, every ornamental flourish is anachronistically interpreted as a prelude to the flowering of Postmodernism. Thus, for example, he describes Thomas Jefferson in terms that make him out to be, as it were, a Postmodernist before his time. In fact, what we see throughout Stern's presentation is the same arbitrary, essentially un-historical, approach to history and tradition that characterizes Postmodernism itself—an approach which pretends that applying a Chippendale top to a Miesian skyscraper somehow represents a recovery of tradition or history. History, from this point of view, is fundamentally a matter of packaging, decoration, and facades.

Indeed, the important thing to grasp about "Pride of Place" is that it, too, is fundamentally a matter of packaging, decoration, and facades. At a screening of the first episode, Mobil vice president Herbert Schmetz assured us that the series was a serious exploration of architectural and cultural themes, not to be confused with such television pabulum as "Lifestyles of the Rich and Famous." But in fact, "Pride of Place" has precious little to do with architecture and everything to do with "lifestyle." I do not remember a single architectural plan being discussed in the entire series, nor was structure or the relation between structure and style a subject that greatly interested Stern. Rather, we were shown innumerable picture-postcard views of places and buildings—especially the opulent homes of the very rich—intermixed with endless footage of children playing in the grass, soldiers marching, and Stern himself driving around the country in his red convertible. Architecture was merely the excuse, merely the occasion, for this tedious exercise in sentimentality. It was entirely appropriate, then, that near the end of the last episode of "Pride of Place" we should see Stern and the utopian architect Leon Krier being taken around Williamsburg, Virginia, in a horse-drawn carriage and agreeing that in many respects, the reconstructed colonial town represented the best hope for the future of American architecture. Whatever its origins, Williamsburg has by now become a cosmetic concoction of the tourist industry. Could one invent a better symbol for Stern's Postmodernist conception of history and tradition?



The Wood Forest Emporium Shopping Center, Houston, Texas keeps occupants and merchandise dry with the Vulcraft Standing Seam Roof System.

VULCRAFT WRAPS UP THE CONSTRUCTION PACKAGE

In Texas, it's not unusual to have heavy downpours dropping as much as 4 inches of rain in 6 hours, or even 10 inches in 15 hours. In constructing the Wood Forest Emporium Shopping Center in Houston, Bob Greenlaw, President of Property Enterprises Company of Texas, wanted a roofing system that would stand up to that kind of weather. The Vulcraft Standing Seam Roof was the clear choice.

Even in the heaviest Texas rain storms, the Vulcraft Standing Seam Roof is uniquely designed not to leak; thus assuring that tenants, customers and merchandise stay dry. Vulcraft's complete roofing system for the shopping center combined the lightweight standing seam roof with Vulcraft joists and joist girders. This expertly engineered and completely compatible building

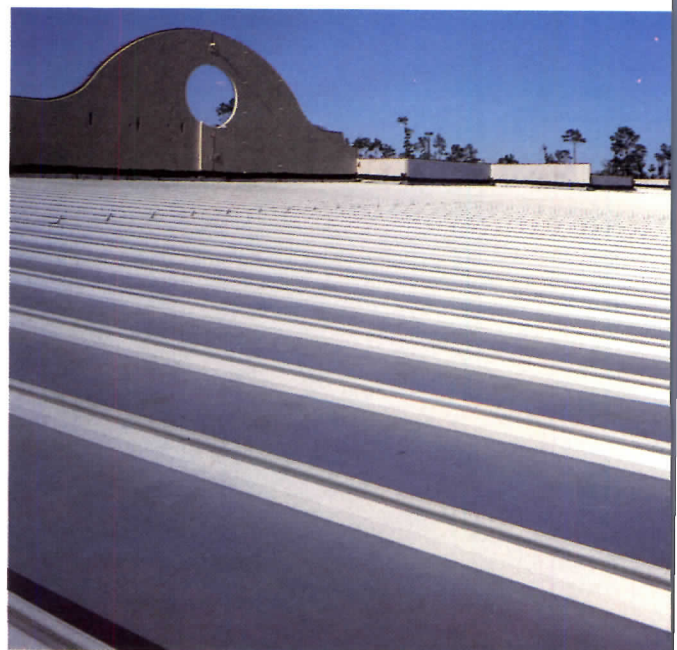

Weathertight Vulcraft Standing Seam Roof



PERFECT SHOPPING CENTER

system eliminated the need for expensive interior columns making it easier to sub-divide and lease the commercial space. Since the Vulcraft Standing Seam Roof system requires virtually no maintenance, additional cost savings will be realized over the life of the shopping center.

Throughout the job, Vulcraft worked closely with the architect and Property Enterprises, providing needed assistance and support. In fact, Vulcraft provided preliminary cost estimates before the final drawings were actually completed. Thus, an early and successful bid could be prepared and submitted.

In addition, the installation of the Vulcraft system was quick and easy. Since the standing seam roof installation manual, provided by Vulcraft, was thorough, clear and easy-to-follow, the need for costly specialized crews and equipment was eliminated.

To keep the project on schedule, Vulcraft not only delivered all materials and components to the construction site on time, but also sequenced them for their designated location within the site.

As a result of expert engineering and design, the combination of the Vulcraft Standing Seam Roof, joists and joist girders proved to be a weathertight, cost-effective package for the Wood Forest Emporium Shopping Center.

For more information concerning the Vulcraft Standing Seam Roof, joists and joist girders, or for a copy of our catalog, contact the nearest Vulcraft plant listed below. Also see Sweet's 7.2/Vu or 5.2/Vu.

*Owner/Developer: Property Enterprises Company of Texas
Structural Engineer: Joseph Banki*

P.O. Box 637, Brigham City, UT 84320 801/734-9433
P.O. Box F-2, Florence, SC 29502 803/662-0381
P.O. Box 169, Fort Payne, AL 35967 205/845-2460
*P.O. Box 186, Grapeland, TX 75844 409/687-4665
P.O. Box 59, Norfolk, NE 68701 402/644-8500
*P.O. Box 1000, St. Joe, IN 46785 219/337-5411

*Standing Seam Roof manufacturing locations

VULCRAFT

A Division of Nucor Corporation

Circle 58 on inquiry card

He who travels much appreciates daily service.

You don't need an ancient proverb to know daily service is important to business travelers.

That's why United offers daily service to Tokyo, Hong Kong, Osaka, and Sydney from more top business centers than any other airline.

And United offers daily nonstop service to Tokyo from five U.S. gateways.

You'll enjoy all the convenience of one-airline service from Tokyo to Seoul, Manila,

Singapore, Bangkok, Beijing and Shanghai.

And now, Mileage Plus offers a 50% bonus in First Class, a 25% bonus in Business Class and several other generous Royal Pacific mileage bonuses.

United's Royal Pacific Service.

Call your Travel Agent.

Or call United.

*You're not just flying,
you're flying the friendly skies.*



United

If you're looking for new ways to achieve the unexpected, to add life, beauty and interest to otherwise plain surfaces, Luxalon precision engineered ceiling systems will let you create the most surprising spaces you've ever seen.

The Luxalon systems available from one source include: linears, planks, tiles, cells, straight and curved sections, and virtually any custom geometric shape you can think of. By varying the basic components, many different visual effects can be achieved.

Our wide range of colors should satisfy most of your decorative needs. If you want something different, like a corporate color, we'll match it perfectly. Luxalon finishes include gloss, matte, brushed and mirror. Panel surfaces may be embossed, perforated or wood-laminated. No matter what the design challenge—in new construction or renovation, interior or exterior, large space or small—Luxalon ceiling systems will bring your vision to life.

With Luxalon, the sky isn't the limit. It's only the beginning.

LUXALON®

Ceilings
Sandwich Walls
Cladding
Sun Louvers

HunterDouglas Architectural Products

Surprising Spaces
The World Over.

Surprise a Space with Luxalon Products.



Luxalon Linear Ceilings

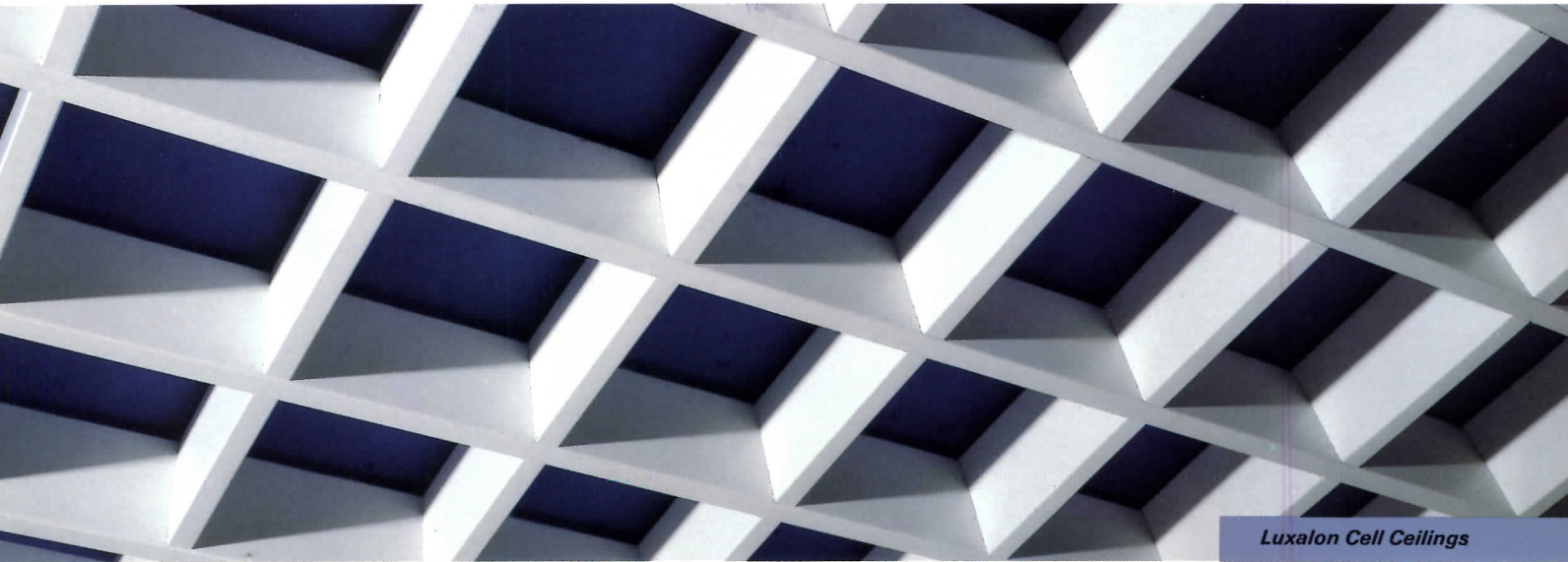

Luxalon Cell Ceilings

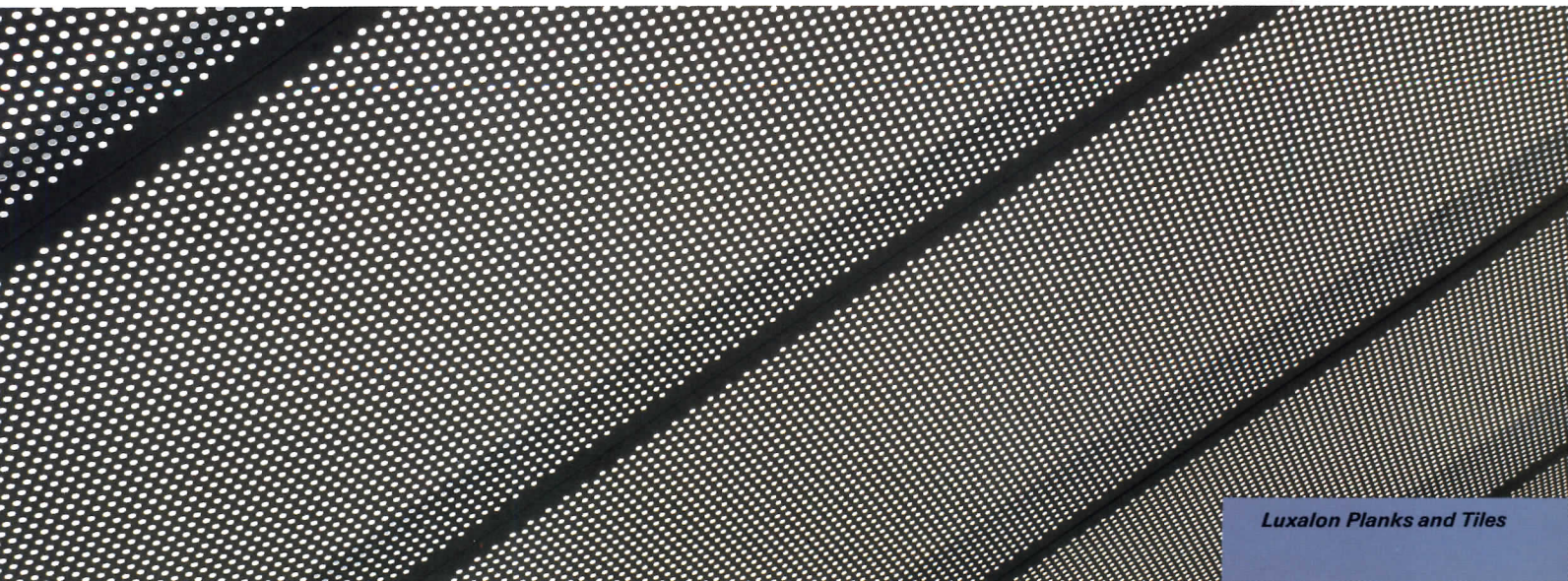

Luxalon Planks and Tiles

Luxalon® Cell Ceilings

The geometry of a Luxalon cell ceiling system combines a comfortable feeling of order with spaciousness.

Design flexibility

Square and rectangular modules can be made from any combination of standard 3, 4, 6 and 8 inch cells. Other sizes are available. Cells come in a wide range of colors, in matte or high gloss finishes. Metallic finishes are also available.

Quality and uniqueness

Because of precision metal forming techniques, the profiles of our ceiling cells are uniform, perfectly straight and rigid. A stringent quality assurance program also ensures that our high standards of production are strictly followed.

Practicality

Luxalon cell ceilings are easily demountable for plenum access. Just slide the clips and drop; no raising or twisting necessary. A special tool allows on-site adaptations along the room's perimeter. As a result, cell ceilings run wall-to-wall.

Luxalon Linear Ceiling

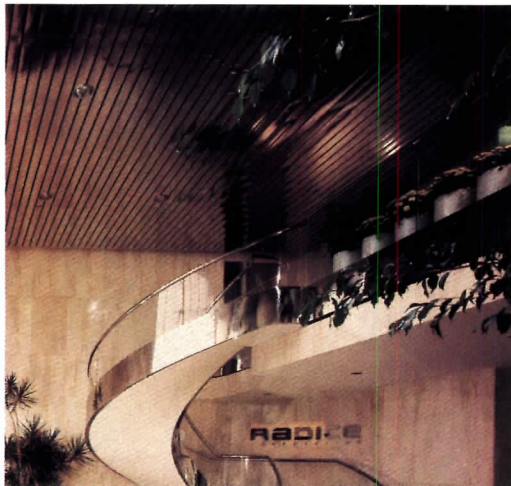

Luxalon Linear Ceilings

With many standard profiles, ranging from a 2 to an 8 inch module, and with factory-cut custom lengths, all the basic ingredients exist to create a unique ceiling design.

Unlimited combinations

Your imagination can easily adapt the system to create arched, pyramid, herringbone, square, checkerboard, undulated, stepped and even curved configurations. Aluminum panels come in a wide range of standard colors or, in large quantity orders, in the color of your choice. Finishes can be glossy or matte, brushed or mirror—even laminated with a wood veneer for a rich, natural look.

Adaptable to all services

All components are corrosion-resistant and non-combustible. Acoustical pads provide sound control. Spacing between carriers accommodates electrical and mechanical services in the plenum. The system readily accepts standard ventilation, sprinkler and lighting components. After installation, panels may be easily removed for plenum access.

Luxalon Cell Ceiling



Luxalon Planks and Tiles

Standard Luxalon ceiling systems are based on modular designs and dimensions which permit both the creation of large, monolithic expanses as well as smaller, more compact areas.

Total versatility

Used most frequently in large areas, planks are available in widths up to 10 feet and lengths up to 13 feet. Square and rectangular tiles are more appropriate for smaller spaces. Both can be used in snap-in, hook-on or lay-in installations—in new or existing construction, renovation, decoration, screening or open plan—both inside and out.

Planks and tiles come in a full range of standard colors or in an almost infinite variety of custom colors. Our recently installed, state-of-the-art paint line permits us to match any color you propose.

You may select any perforation pattern—standard or custom—for aesthetic reasons, yet maintain acoustical values.

Practical and adaptable

Constructed entirely of metal—steel, stainless steel, or aluminum—Luxalon planks and tiles offer a long life cycle. Their durable paint finishes resist fading and can be easily cleaned without damage. Planks and tiles are individually demountable for easy access to service plenums. Panels may be removed and replaced without damage.

Luxalon Plank System with Perforation



Luxalon Custom Ceilings

Would you like to design a ceiling that's never existed before? Not only color, finish, surface treatment and dimensions, but also in the basic configuration itself? Inherent in this product mix are a virtually limitless number of combinations. But beyond these choices lie others — concepts for which no current product exists, ideas that no one but you has ever envisioned before.

It is precisely in this unexplored area of vision and concept that Hunter Douglas can provide unmatched assistance. Blend existing products, match existing with custom products, or use our staff and proprietary Computer Aided Design and Drawing (CADD) service put together a totally new and unique custom system.

The following Luxalon configurations will go a long way toward helping you design that "never before" ceiling.

Cannister System

Some striking decorative and lighting effects can be achieved with cannisters. An option with Luxalon tile, the cannister system is factory formed by pre-punching a number of holes through a tile and inserting open-end or closed-end cannisters.

Delta System

The one-piece, triangular design is strong and sturdy. It lets you add interest to a room with a wide variety of two- or three-dimensional configurations. A complete range of finishes, including mirror, is available.

Baffle System

Individual metal panels let you create a variety of different geometric shapes to achieve a contemporary look. Available in a variety of sizes, shapes and colors, baffles create a screen and provide an open plenum for easy access to services. The baffle system is also ideal for acoustical control in high-noise areas.

With Luxalon custom components you get the same wide choice of colors, lusters and finishes that characterizes the line as a whole. Backing its full line of ceiling products, Hunter Douglas offers a fully trained sales network plus complete technical assistance, including CADD, that can help make your dream a reality.



Luxalon Delta System



Luxalon Baffle System

Other Luxalon Systems

Aesthetic solutions to functional problems.

Of all the materials that an architect has at his command, few have proved more satisfying than Luxalon exterior systems. They provide a unique degree of creative freedom in meeting the functional need to close the building and protect it from the elements.

The Luxalon line of architectural products is comprised of several systems that together meet the full range of external requirements, including insulated wall construction, renovation, exterior ceilings and soffits, and solar and visual screening.

Type 150F Claddings and Soffits

Close-fitting, nominal 6 inch panels provide a sheer facade, equally at home on prestige buildings or industrial projects. Their size makes them ideal for smaller fascias.

Type 300 Claddings and Soffits

These nominal 12 inch panels are generally specified for prestige industrial and commercial projects. They afford a smooth, monolithic facade and are ideal for large, bold expanses. Preformed corner sections complement the line.

Sandwich Panel Systems

The insulating sandwich panel system is a marriage of cladding and building materials. Because of its design, finish, and range of profiles and fittings, it can be used in the most sophisticated and prestigious applications. It is available in nominal 8, 12 and 24 inch panel widths with round or square corners, and custom lengths up to 30 feet.

Bi-Modular Sandwich Panel System

Developed from the sandwich panel system, the bi-modular system permits vertical, horizontal or mixed panel layouts in a single installation.

Type 84R/84G Claddings and Soffits

Designed principally for use in renovations, Type 84R panels can be used to achieve many different formations, depending on the carrier or combination of carriers used. Joints may be flush or recessed. Curved panels extend the creative possibilities with their smooth, clean lines.

Type 84R Sun Louvers

Exterior louvers control the sun's rays with outstanding efficiency while at the same time contributing to the appearance of the building, by modifying or enhancing perspectives or breaking up the formality of the facade.

Our Unique, Computer Aided Design and Drawing Systems Takes A Project From Concept To Installation — Fast!

At Hunter Douglas we value good design. You can see it in the way our products look and work, and in our efforts to support you in your creative and unique designs. Using our one-of-a-kind CADD system, we can convert your most imaginative designs to technical and practical reality in a very short time.

HunterDouglas
Architectural Products
Surprising Space
The World Over

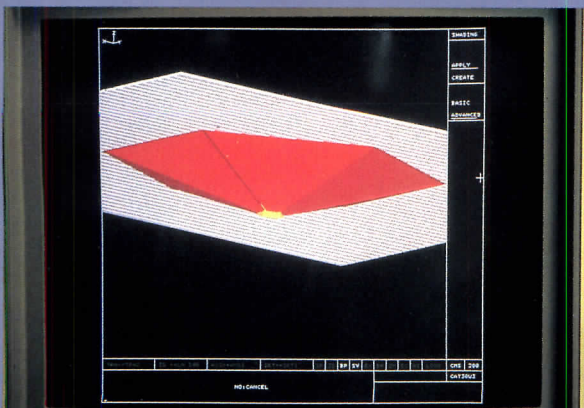
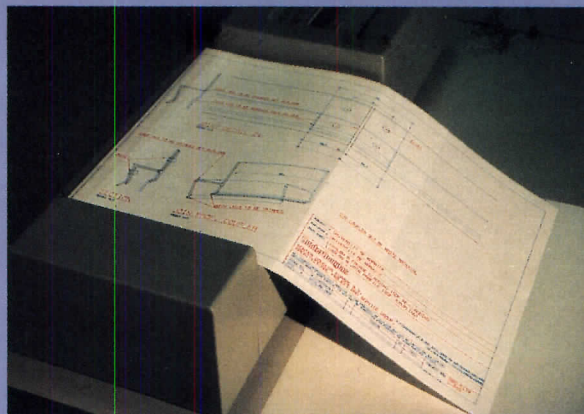
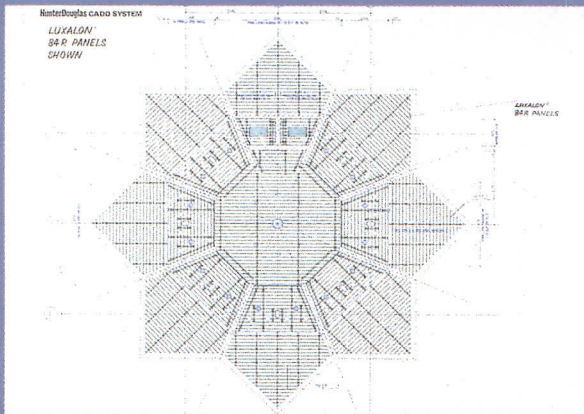

Hunter Douglas CADD System Material Specification for 8 Kiosks

POS. NR.	CODE NR.	COLOR	DESCRIPTION	LENGTH	NOS.	TOTAL
019	331010	RAL9010	Luxalon Panel 84 R.	12	128	1536
032	331010	RAL9010	Luxalon Panel 84 R.	16	784	12544
054	331010	RAL9010	Luxalon Panel 84 R.	14	312	4368
	332703	1863	Luxalon FE Carrier 100			1000
	332781	1863	Luxalon FE Carrier UNP			600
	334034	1863	Luxalon Panel Clip			2112
	334795		Luxalon Susp Adj Spring			1232
	334878		Luxalon Rod Hanger			2128
	334862		Luxalon Rod Hanger			336

To contact your nearest Hunter Douglas Representative
Sweets' Buyline: (800) 44

For more information on our products, call toll-free: 1-800-432-7462. In Georgia 404-432-1364

Hunter Douglas Architectural Products, Inc. P.O. Box 724568 Atlanta, GA 30339

From Du Pont:

**A MATTER OF
TOP
SECURITY**

How HYPALON® can lower your defense budget.

A good roof is your best defense against spiraling maintenance costs. This is especially true in today's market where you can sink a lot of extra money into roofing that may not be the best for you over the long haul. But you can lower your defense budget by understanding a few facts about Du Pont and a polymer product known as HYPALON® synthetic rubber.

Time tested

For more than 30 years, HYPALON synthetic rubber products have held up under some of the most demanding industrial conditions — as jackets for power transmission mining cables; as automotive hose covers for the extreme heat and corrosive atmosphere of the engine compartment; even as liners for landfills, reservoirs and industrial waste treatment ponds.

Success in roofing

Still, the transition to roofing was not a simple one. Extensive dialogue with Du Pont customers led to the conception and development of this polymer as a single-ply roofing material. And since the early 1960's, HYPALON has proven to be ideal for this demanding application.

The secret is out

Today, you'll find roofs based on HYPALON on plants, offices, shopping centers, churches, schools — any building where cost and efficiency are primary concerns. That means buildings like yours. Whether you're an owner, contractor, architect or engineer, it pays to specify roofing systems based on HYPALON. They offer durability, weatherability, and oil, chemical, and flame resistance. What's more, roofing systems based on HYPALON are among the most economical on the market today.

It's a matter of top security. Commercial systems based on Du Pont HYPALON are your best defense against spiraling maintenance costs and the whims of weather.

For more information about Du Pont HYPALON and the companies who manufacture roofing systems based on HYPALON, call 1-800-441-7111.

**Only Du Pont makes HYPALON®.
Specify it by name.**

*Du Pont manufactures HYPALON® not single-ply roofing membranes or systems.



Circle 60 on inquiry card

MORE ARCHITECTS FREE THEIR MINDS WITH CALCOMP THAN ANY OTHER CAD SYSTEM.

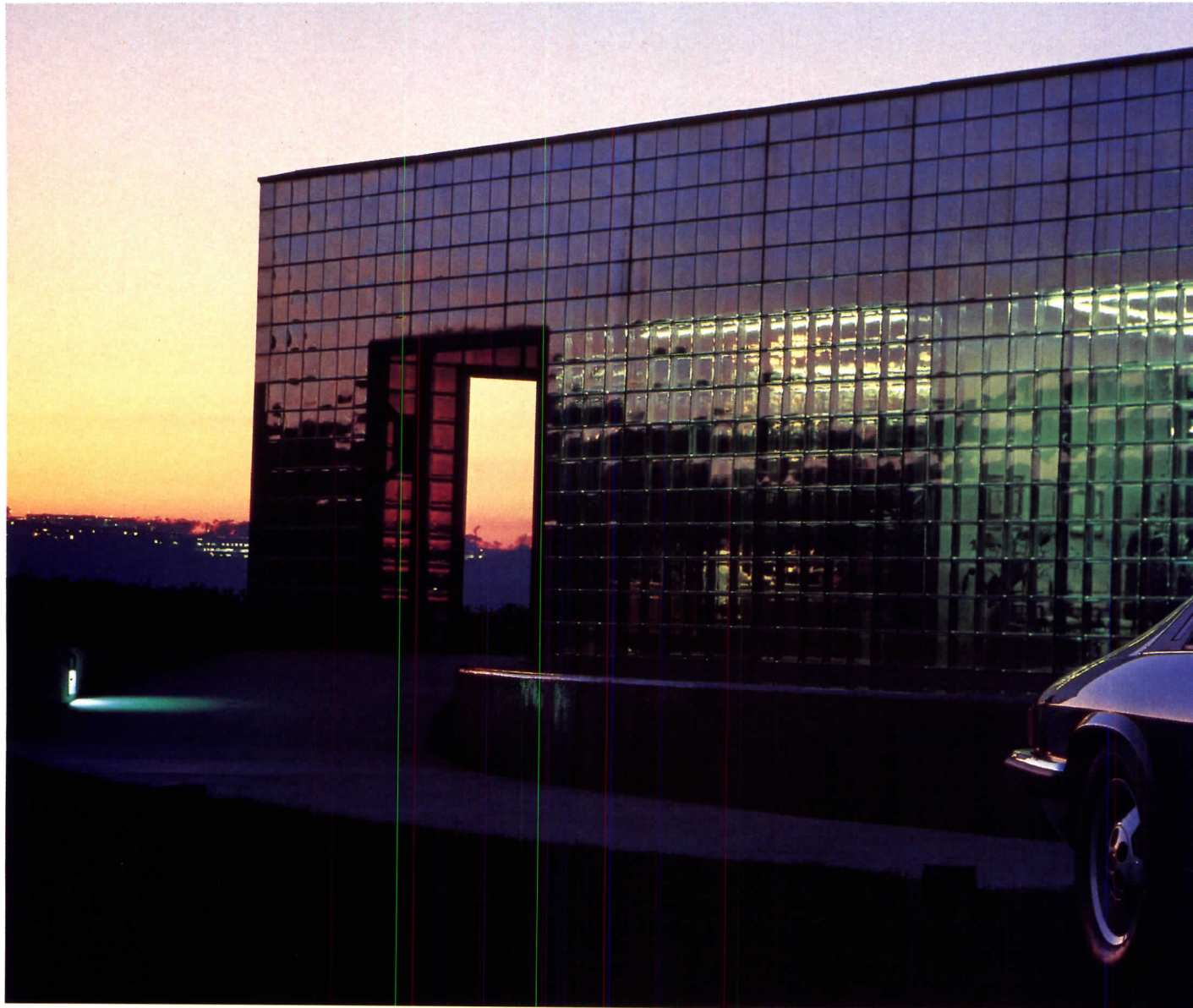

Before you buy a CAD system, consider this.

In computer-aided design, CalComp has more going for it. More professional design software for both PCs and large-scale systems. More production drawing speed in its architectural CAD System 25. More built-in system simplicity, so it is especially easy to learn and use. Productivity gains of 5:1 or more are common.

As a result, more architects have gone to computer-aided design with CalComp than any

other CAD system.

Worldwide, more architects leave the design options and drafting, materials, and cost estimating to CalComp, so they are free to keep on creating.

As one CalComp user with a large firm in Seattle said, "We had 36 sheets of drawings on the system for a 28 story high-rise. There were lots of changes. At one point, the entire set of drawings had to be changed. Two system operators turned it around in three days. Our fee would have been lost if

we weren't working with System 25."

You see, System 25 is not a typical all purpose computer for all types of businesses. The System 25 family is strictly for architecture and facilities management. It was developed by architects specifically for designing, drafting, space planning, materials and cost estimating. So you don't have to adapt to it. System 25 is already adapted to your needs.

Another user in Fort Wayne said, "The ability to learn on



the system is so quick, I feel very comfortable with it. It's not intimidating. You become proficient easily."

Unlike other Architectural CAD systems, System 25 is a continuum, from the PC-based 100 Series through the 300 Series to the high-performance multi-user 600 Series. So it fits the needs and budget of every size architectural firm.

And System 25 is backed by the world-wide resources of a Fortune 500 company. CalComp's commitment

includes installation, training, regional support teams and an 800 number hotline.

To learn more about why more architects free their minds with CalComp, just write or call for our 8-minute video. It's titled "CAD to Reality," and you can order it on VHS or Beta for just \$5 to cover mailing and handling.

After seeing it, then decide which CAD system to buy.

CalComp, P.O. Box 3250,
Anaheim, California 92803.
Call toll free 1-800-CALCOMP.



CALCOMP
A Sanders Company

Circle 61 on inquiry card

SPECIFY THIS WINDOW OR SPECIFY A WALL.

For high performance and low maintenance in a commercial setting, the alternatives to a Marvin Magnum Tilt-Turn are somewhat limited. The only one we can recommend with absolute certainty is the one suggested above.

And even then there are drawbacks. A properly constructed wall may perform as well, but it certainly won't be nearly as beautiful.

THE WINDOW THAT SHATTERS COMMERCIAL STANDARDS.

When we tested a 48" x 64" Magnum Tilt-Turn, we found the results tested our imaginations. So we tested the window again. And again. Always with the same results: Air infiltration: .01 cfm @ 25 mph (.02 @ 50 mph). Ten times lower than the toughest proposed commercial standards. Wind loads: 200 mph positive pressure. 256 mph negative pressure.

Water infiltration: 0 @ 66 mph.

U values: as low as .22.

R values: as high as 4.55.

A perfect design, superb materials and Marvin's meticulous craftsmanship make the Magnum Tilt-Turn the new commercial standard in windows.

SINGLE-MINDED QUALITY THAT OPENS TWO WAYS.

The Tilt-Turn swings into the room for cleaning. It also tilts in for ventilation. It's a technical feat other companies gladly let us perfect.

Because it took a commitment to quality. Every step of the way. From research and development, through start-up and on into full production.

We use only the best materials, starting with carefully

selected western Ponderosa pine. Every piece is pressure treated with insecticide and water repellent solutions to protect against rot and decay.

And only the highest quality hardware will do. A window that performs this well must operate precisely.

Once we have a precise fit, we add a tight seal with weatherstripping that's welded at all four corners. We know of no window in production that's crafted as carefully as our Tilt-Turn.

QUALITY COMES STANDARD. NOW HERE ARE YOUR OPTIONS:

In addition to a beautiful standard unit, our Tilt-Turn comes in a Round Top

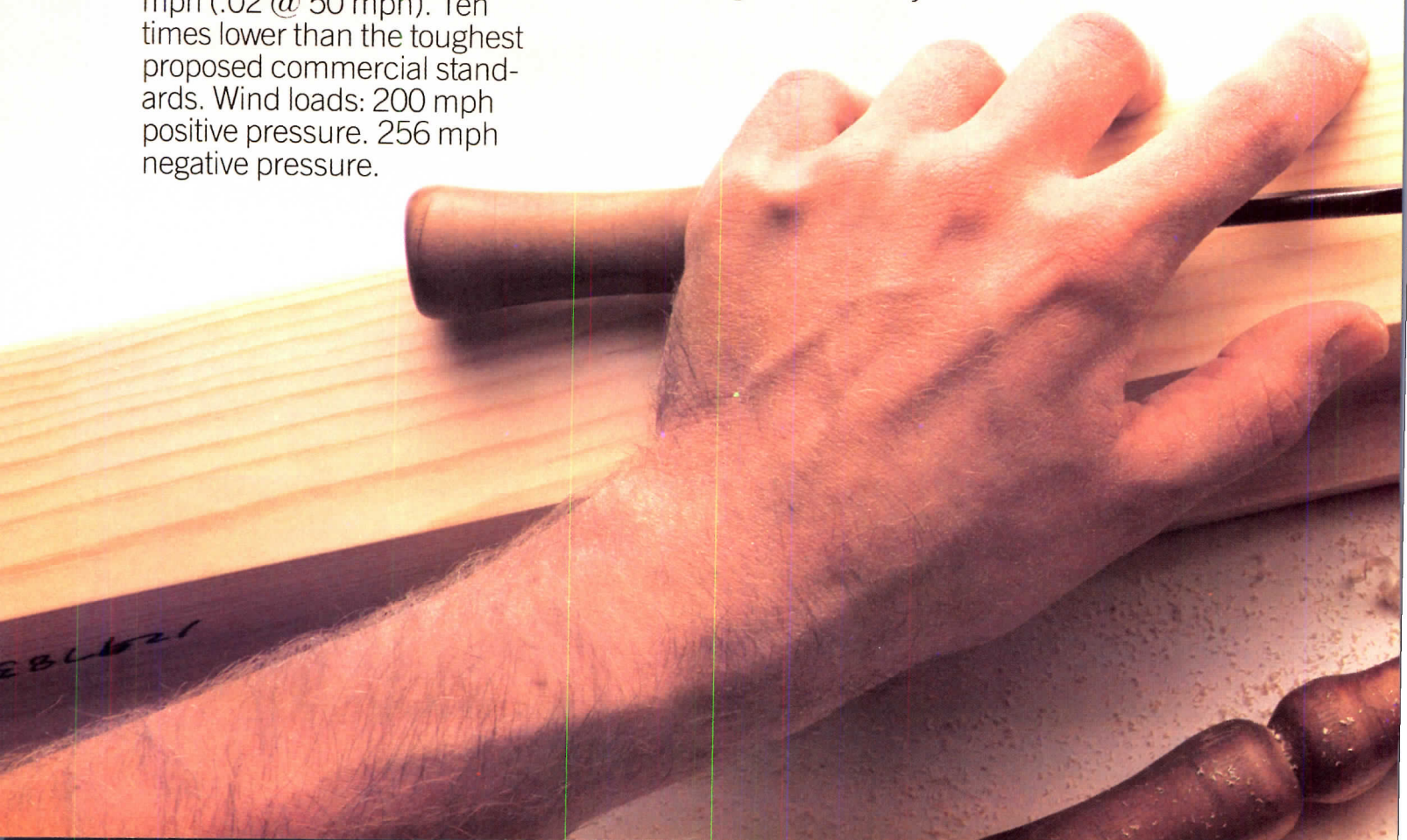



Magnum line, you'll find a tilt-only hopper and an authentic double hung.

The Magnum line also gives you a wide range of application options. They're equally at home in high rise, low rise, renovation, new construction, hospitals, schools and office buildings. The only limitation is your imagination.

In glazings, your choices include $\frac{7}{8}$ " insulating, 1" insulating, solar bronze, solar gray, solar cool, Low-E or Low-E with Argon. And, for extra-low maintenance, you can specify a medium bronze

cladding or Polycron.

WE'D LIKE TO OPEN A CONVERSATION.

We'd like to send you more information and give you the name of your nearest qualified Marvin Magnum distributor. Call us toll-free at **1-800-328-0268** (in Minnesota 1-612-854-1464). Or write Marvin Windows, 8043 24th Avenue South, Minneapolis, Minnesota 55420.

Because we think this is the best window you can specify. And because we engineered it to open your mind.

Circle 62 on inquiry card

MARVIN MAGNUMS

ENGINEERED TO
OPEN THE MIND.



and a simulated double hung. Where you must consider security, there is a unit with keyed locks for maintenance access. Elsewhere in the

s e n s o r

Steelcase announces the
Sensor™ chair.

It senses the body's need for
comfort and responds intuitively,
as though it were alive.

Sensor. An unobtrusive
application of high technology for
today's office environment.

For information about the new
Sensor chair, visit one of our
Regional Offices or contact
your Steelcase representative.
Steelcase Inc., Grand Rapids,
Michigan 49501.

Circle 63 on inquiry card

Steelcase

The Office Environment Company

Affinities and amenities

Appropriateness in design (or, as current jargon would have it, contextualism) can be interpreted in a lot of ways these days, especially in a collection of academic buildings. The most obvious friendliness, of course, is to create another background building in the stylistic mode of its neighbors. However, although most established campuses do possess a good amount of individual character, they only occasionally have been built in any single style. Rather, some affinity has been developed, with stand-outs here, submergences there—all in a varied mix of open spaces and period buildings that spell out the historical progression of the school. Tastes, methods, and needs have continually changed, inevitably stamping a certain individuality on each of its buildings. So, as a contextual proposition, to what should a new addition relate—its immediately adjoining structures, or the spirit of the entire complex? Or both?

Shouldn't a really good new addition to a school play a strong role in enhancing that basic campus character, do more than just adequately fit in? Shouldn't it add some amenities to its total environs, as well as provide needed, up-to-date (and often quite special) facilities within its own walls? Shouldn't it have some individuality of its own, without necessarily trying to dominate the area—though, in some unresolved situations, wouldn't a new, bold, focal point be a good idea?

Included here is a group of four campus additions that make positive steps to approach all these questions. They form only a small sample of possibilities, but do point to some interesting directions.

In the first, ARC extends the special spaces needed to teach government at Harvard's Kennedy School, and also strengthens the School's visual relationship to the entire campus. Stubbins gives Cushing Academy a quite contemporary library and audio-visual facility, which preserves its pastoral tradition and defines a couple of outdoor functional spaces. Gruzen has designed a "background" addition (externally) for New York's Jewish Theological Seminary—but internally has created a new, sparkling, and private little campus. And Barnes, at Amherst, has created a personal, but sympathetic, center for math and computers that strongly finishes the design of the main quadrangle.

Hopefully, these buildings help reinforce the thoughts that style, whatever its genesis, can have affinity, yet also have a degree of *éclat*; and that amenity can mean much more than just functionalism or fashion, and can add to visual and emotional impact. *Herbert L. Smith, Jr.*

Sympathetic streetscape



© Nick Wheeler photos

Taller and more vigorous than its adjoining, first-phase building for Harvard's John F. Kennedy School of Government, this new addition—the Belfer Center For Public Management—more than reinforces the concepts of its earlier neighbor.

Now known as the Littauer Center of Public Administration, that first building makes quiet and subtle use of abstract gable-end and chimney shapes—as well as red Harvard brick and pitched slate roofs—to effectively relate to the neo-Georgian Kirkland and Eliot Houses across the street. Projecting bays help to visually break up its four-story length (RECORD, June 1979, pages 99-106). With all the debate at that time over use of its site—the tourist-magnet Kennedy Library, with all its attendant parking, was originally proposed there—a relative modesty was obviously in order.

Architectural Resources Cambridge, Inc., architects of both buildings, have not only emphasized again their earlier, sympathetic kit-of-parts to complement the Harvard Houses and Littauer Center, but have emboldened all profiles of the new Belfer Center to progressively relate to other towers and spires punctuating the campus skyline. A greater use of glass in Belfer's higher levels tempers the impact. Seen from the Charles River bridge, across John F. Kennedy Park, the structures now rise in a gently animated crescendo to form a main gateway into the campus.

Also echoing the Houses along the street is the development of the school's garden courtyard—a retreat accessible only from the buildings or by a service drive. Glass walls at the entrance of Belfer give the public a glimpse into a court similar to those seen through the arched entries of the Houses.

The new building expands the Kennedy School by adding 45,000 square feet to house eight executive education programs and three research centers that were previously scattered through the campus. The plan (overleaf) focuses on four big multiuse spaces stacked in the center—the "Town Hall," Harry Starr Auditorium, Edwin Land Lecture Hall, and the Bell conference center at the top. These are ringed by small clusters of rooms and spaces (some ranged on mezzanines) for seminars, meetings, study, and research.

As there is a drop in level on the site—between the street and the courtyard—the new Belfer center makes the transition within each level of the building itself (section overleaf), but ties into the four original levels of Littauer Center, which has a half-basement with an entrance opening on the court. RECORD said of Littauer in that 1979 article, "the new building seems to be just right"—the same can be said with enthusiasm of its sibling.

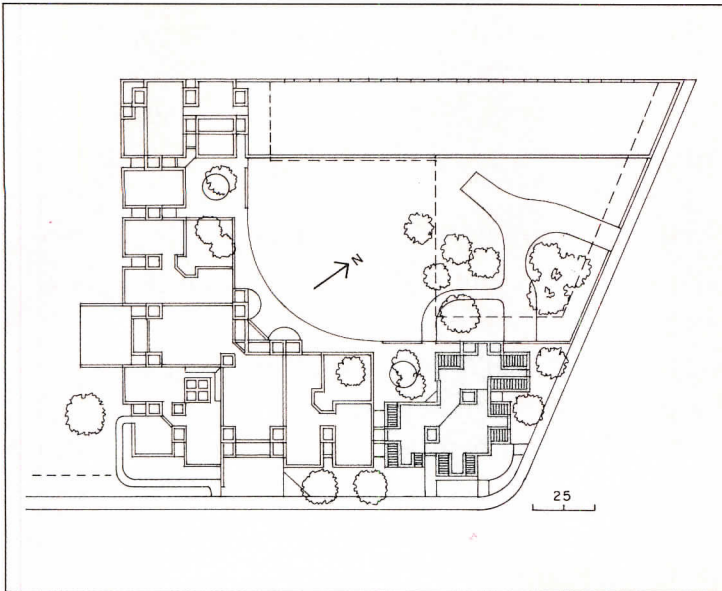

Belfer Center for Public Management
John F. Kennedy School of Government
Harvard University
Cambridge, Massachusetts
Architectural Resources Cambridge, Inc., Architects



The first addition to a planned, phased development of Harvard's John F. Kennedy School of Government, this new Belfer Center forms a positive corner anchor for the eventual complex. It ramifies the design concepts of the School's original Littauer Center (middle-distance in photo opposite) and also echoes shapes and materials of the neighboring Kirkland and Eliot Houses (above).

The ground and first levels of Belfer Center surround a multipurpose, two-level "Town Hall" (bottom photo, opposite), which is a smaller version of the successful "Forum" space that the earlier Littauer Center focuses on. A mezzanine contains a variety of office, study, and meeting spaces. The next major level contains the Starr Auditorium and its mezzanine (below). And above that are the Land Lecture Hall, and the

Bell Conference Center (top photo, opposite), each of which is a staggered, one-level height. The level change in the big rooms provides stepped slopes for seating. In some contrast to the architects' fairly monochromatic angularities in the earlier interiors of the adjoining Littauer Center, the dominant note here, especially in the big spaces, is one of curves and soft colors—blue, green, beige, and plum.

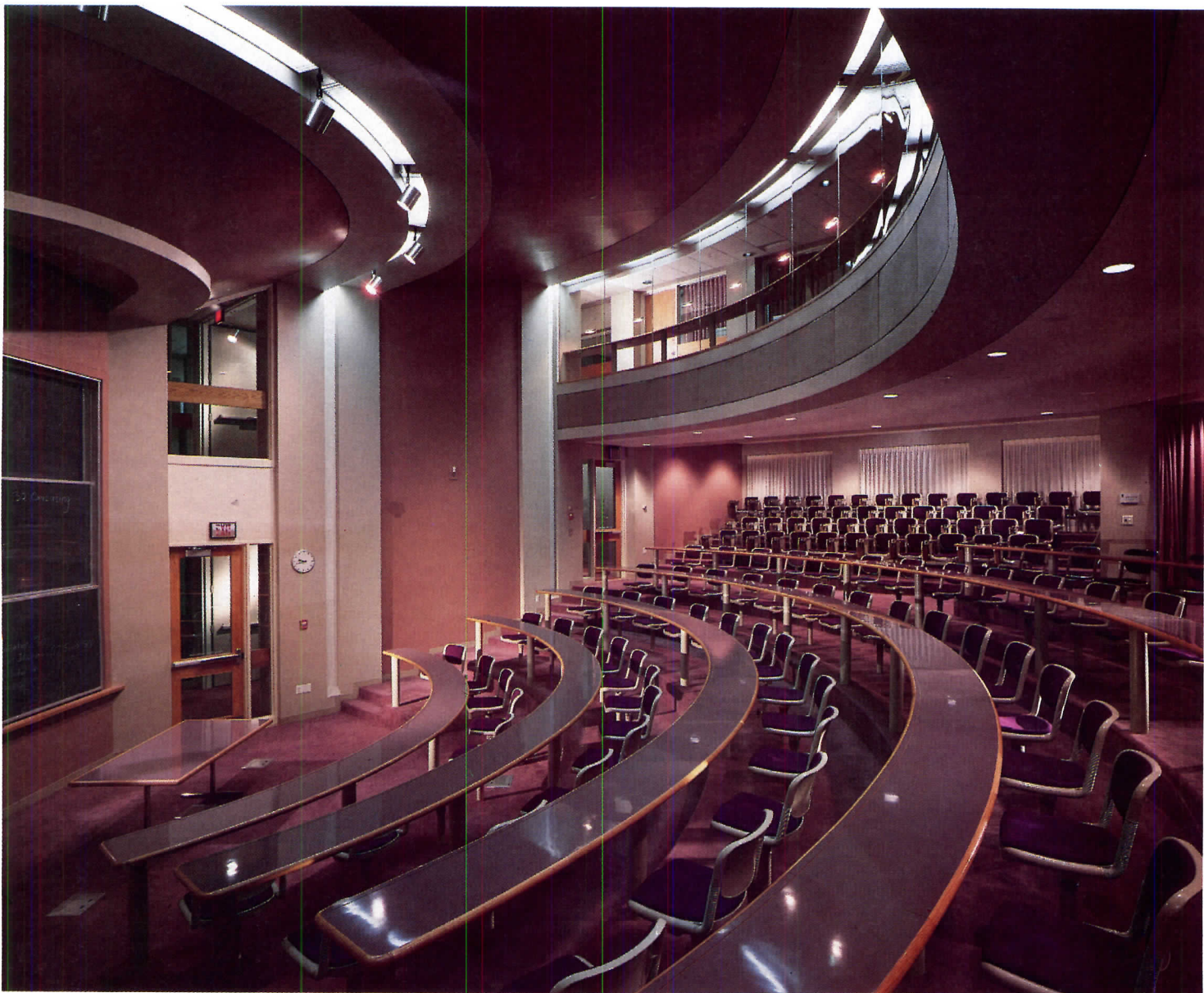

Belfer Center for
Public Management
John F. Kennedy School
of Government
Harvard University
Cambridge, Massachusetts

Owner:
Harvard University
Architects:
Architectural Resources Cambridge,
Inc.—Henry S. Reeder, Jr., project
principal; Joseph Maybank, design

principal; James F. Davies,
planning principal; Robert H.
Quigley, Jr., project architect; Been
Zen Wang, design associate; Thomas
Loring, job captain; Daniel Costa,
Philip Laird, Frank Montillo,
Timothy Whitney, project team;
Olive Holmes, Sandra Sunderlage,
furniture and finishes
Engineers:
LeMessurier Consultants, Inc.
(structural/mechanical); Thompson

Engineering Co., Inc. (electrical);
L. G. Copley Associates, Inc.
(acoustical)
Landscape architects:
John Crowe Associates, Inc.
General contractor:
Gilbane Building Company

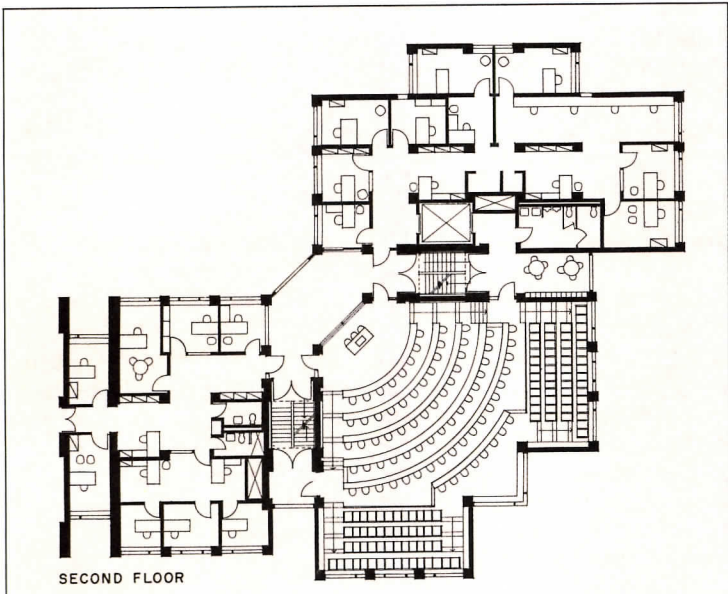

SECOND FLOOR

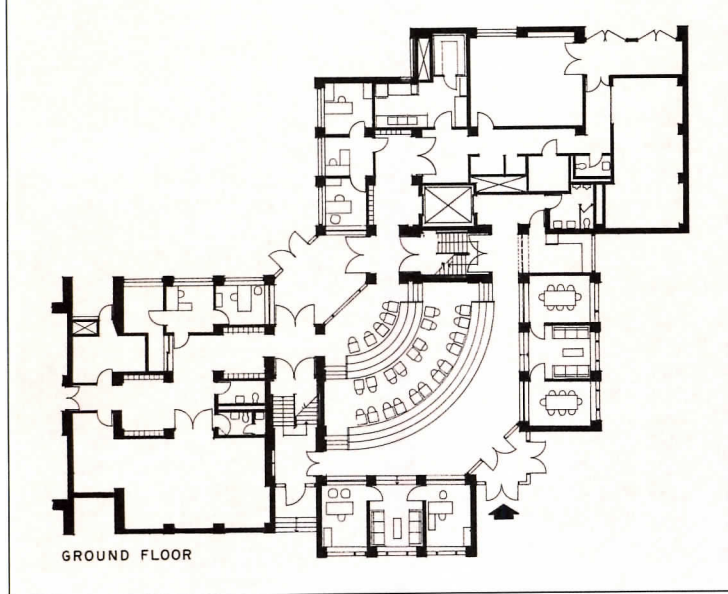

GROUND FLOOR

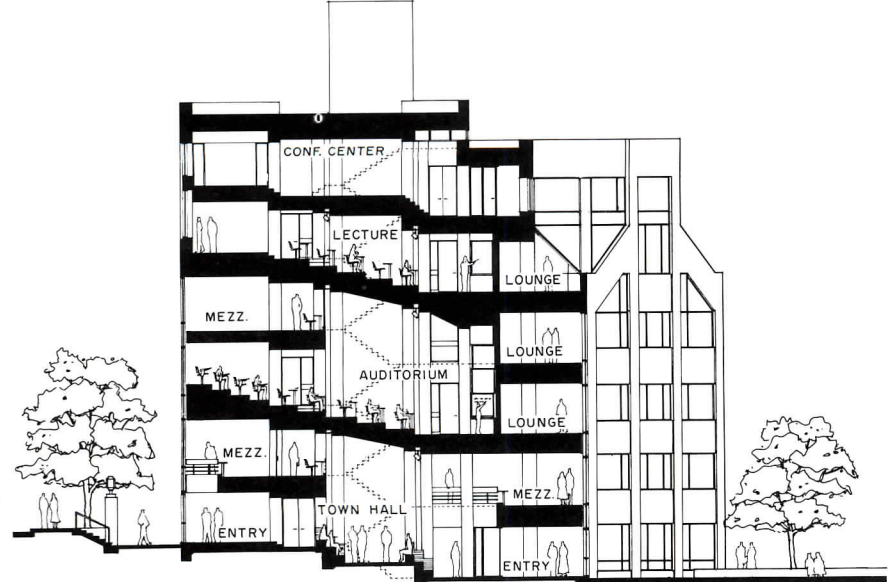

Sylvan respect

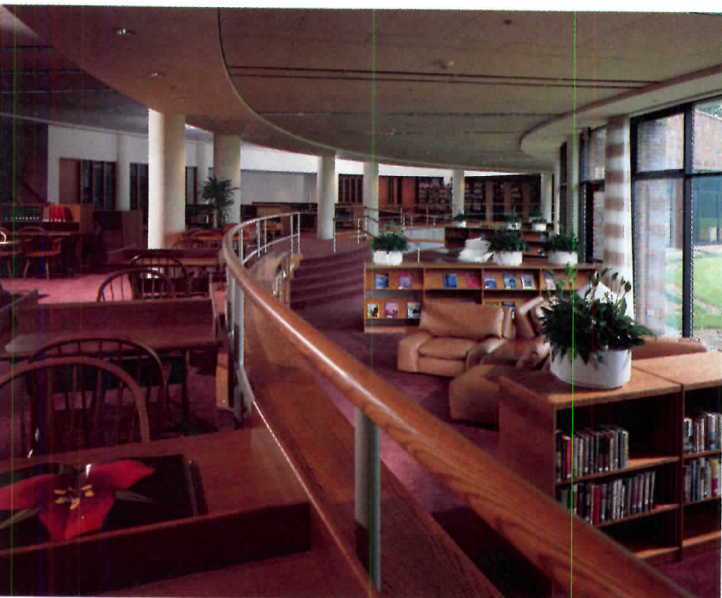
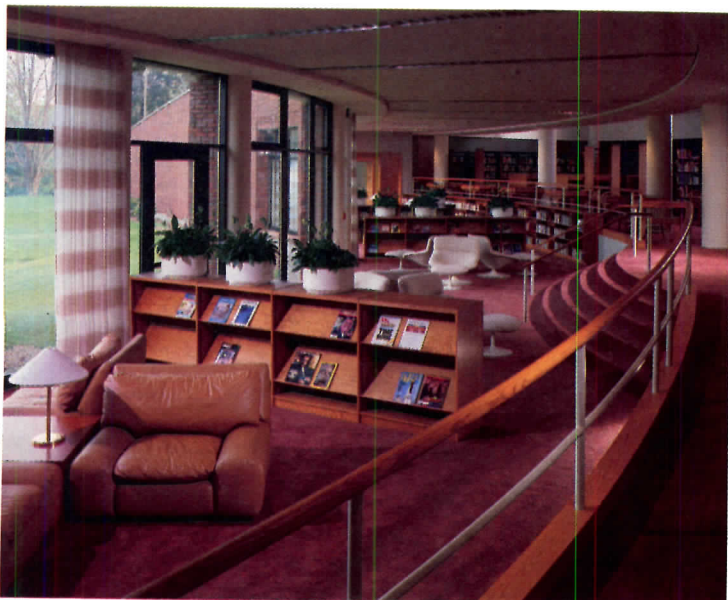

© Nick Wheeler photos

If the facade of the new library for Cushing Academy is very modest (opposite), the interior is spacious and warmly urbane. Natural oak, leather, and carpets combine into an ambiance of pleasant comfort and efficiency. The reading areas, on a lower level, are furnished as a series of lounge-like spaces (top). The "working" area (above) has a curved ceiling (see section).

*Fisher-Watkins Library-Learning Center
 Cushing Academy
 Ashburnham, Massachusetts*
Owner:
 Cushing Academy
Architects:
 The Stubbins Associates, Inc.—
 W. Easley Hamner, principal-in-charge; William A. McGee, project designer; William E. Ralston, production architect; Philip T. Seibert, director of interior design; Michael Gilligan, Chien Wu, landscape; Mavis Gibson, interiors
Engineers:
 LeMessurier Consultants Inc. (structural); SAR Engineering Incorporated, (mechanical/electrical)
Construction manager:
 A.J. Martini, Inc.

Tucked into a pastoral sweep of wooded lawns, like some Aladdin's cave of knowledge, this new library provides a much-needed, up-to-date facility, while keeping intact the character of the mellowed old campus.

Underground libraries are, of course, hardly a new idea. Indeed, The Stubbins Associates, Inc., architects of this structure, have themselves previously designed one for the Harvard campus—the Nathan Marsh Pusey Library.

Usually, however, such structures have been used to preserve a valued patch of green in a crowded complex. Here it is a sensitive act of homage to a sylvan landscape, with its citadel of rusticated-stone and brick, Italianate buildings and towers. The new addition's only intrusion is that of an utterly simple, tapering and curved, brick retaining wall—a sloping terrace that creates a new forecourt to the main building entry, and forms a grassy amphitheater for graduation and other ceremonies.

The 1,500-square-foot plan is a radial one, with all spaces focused on downhill views. Casual, comfortable lounge and reading areas are grouped nearest the wall of windows, with low bookcases serving as dividers. Ranged, balcony-like, three feet above this are tables and carrels for more intense study, card catalogs, and book stacks for 30,000 volumes—all following the radial pattern to allow maximum light penetration.

Spaces which require less natural light—a soundproof audio-visual center, glass-enclosed staff areas, and conference rooms—ring the back wall. Carefully studied artificial lighting and fabric-wrapped, acoustical ceiling panels top all areas. Direct entry from the existing main academic building is by a new, skylighted stair fitted into an existing, but unused porch (see section).

The structure is of cast-in-place, reinforced concrete. Water problems and soil loads obviously complicated construction. Intricate forming methods had to be used to allow the sloped roof to conform to site contours and loads, and significant underpinning of the aging, existing building's foundations was needed.

In addition to underslab and perimeter foundation drainage systems, the new library was further waterproofed by special asphalt-impregnated, rubberized sheet material applied to the concrete roof and walls.

During the original feasibility studies for the new addition, the Academy's Headmaster, Dr. Joseph Curry (who was familiar with the Stubbins underground Harvard library), suggested that a below-grade scheme be considered here. It was, at the least, a fortuitous concept: no clash here between the desired, efficient modernity and the established, revered campus!

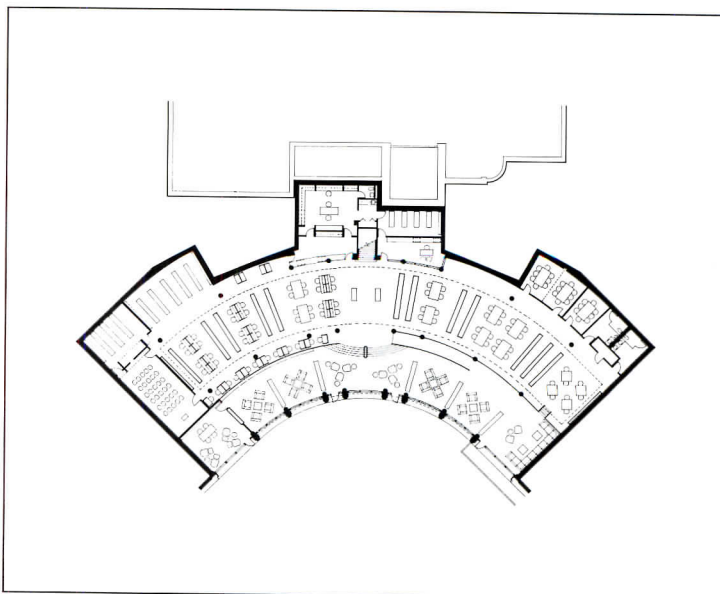

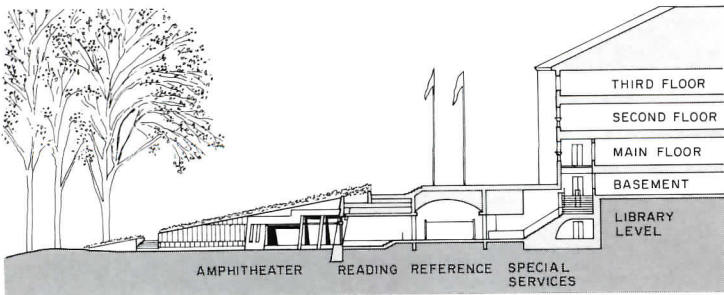

Urban oasis

© Wolfgang Hoyl/ESTO photos



An unexpected urban delight has been created by the Gruzen Partnership's new addition to New York's Jewish Theological Seminary. On entering through the vaults of the original tower, one encounters a serene, cloistered garden, backed by a cascade of light-filled terraces and sloping, glazed skylights.

Located in that dense assortment of educational, religious, and housing centers around Columbia University in Morningside Heights—where few of the institutions have any real sense of individual campus—this Seminary now focuses on its own private world, replete with needed amenities to complement its studious and devotional purposes.

The genesis of the addition started with a rather disastrous fire some years ago, which destroyed or damaged a goodly amount of the institution's library. Subsequent donations and acquisitions of books and manuscripts increasingly pointed up the need for adequate, secure facilities to house them. The Seminary held a limited, invited design competition, which Gruzen Partnership won with this thoughtful scheme—and by transmitting a conviction that sensitive architecture could be a positive additive, and not a material distraction, to the desired spiritual ambience. An appreciative awareness seems to have followed suit.

To smooth the transition from the old building to the new, a good bit of simplified recall has been used: in the materials (red brick, granite, limestone trim), in alignments (floor heights, cornice lines, adjoining window sizes), and in such devices as keystones and a colonnade screening an outdoor stairway.

An arcade provides cloistered circulation around three sides of the court, and is linked on the fourth by a top-lighted, museum-gallery ranging along a big synagogue-auditorium (overleaf). In contrast to the warm vivacity of the courtyard facades, the street front of the new wing (top left) is one of sidewalk-hugging plainness and security, leaving design interest to the original corner tower.

In addition to the partly sunken auditorium, the main level of the plan provides a refurbished dining room in the old part (which now opens through its arcade to the landscaped courtyard terraces for outdoor meals); new kitchen and receiving facilities; a big lobby and lounge forming a sort of commons; and an area for library services. The next two levels contain the main, open-stack library, with reading areas and lounges, terraces, and seminar and meeting rooms. On the top floor, as a "symbolic and functional crown," is the treasured rare books library.

The Gruzen Partnership, which has added many civic amenities to New York City through the years, has provided yet another.

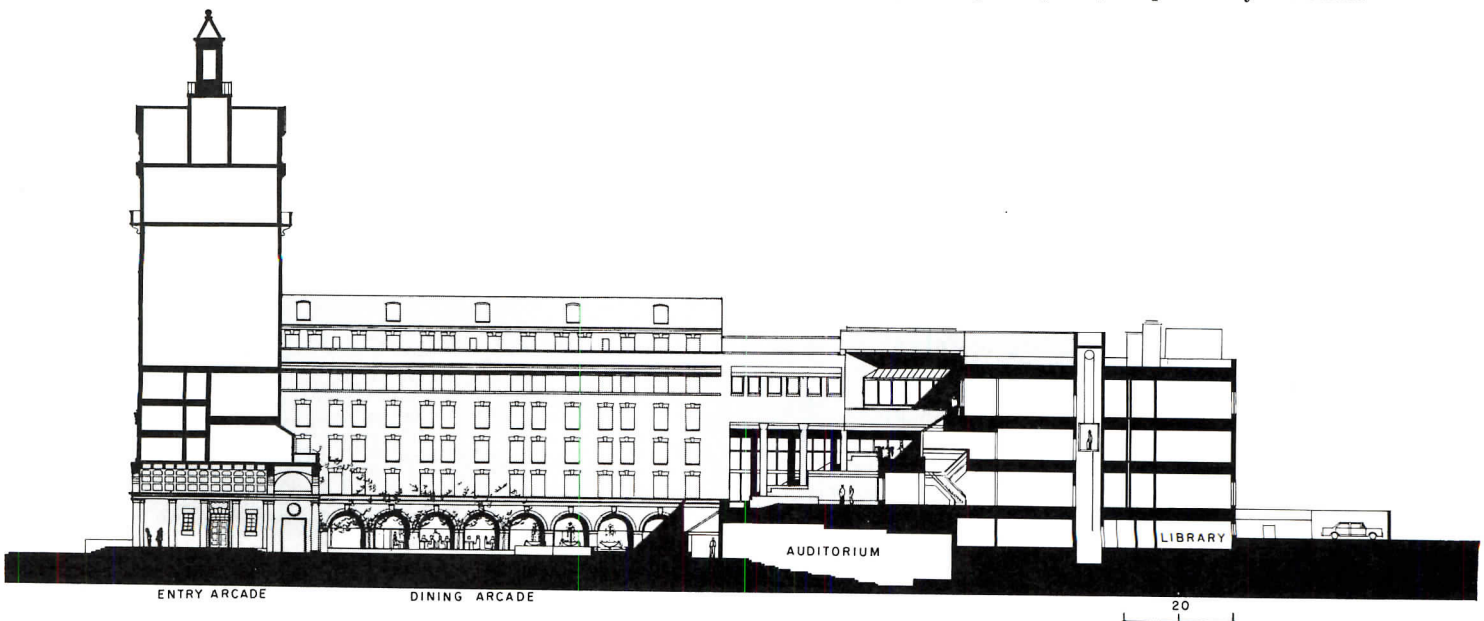
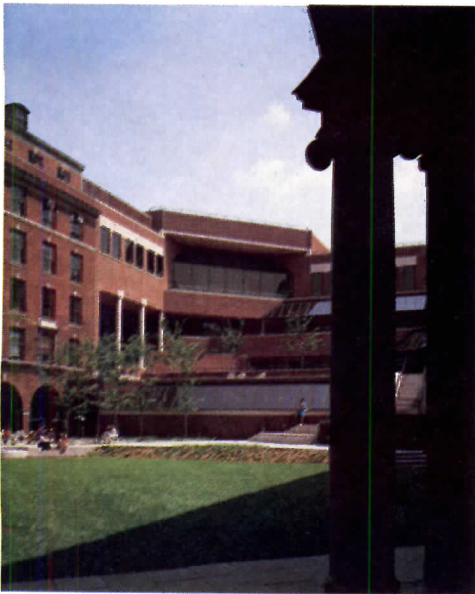

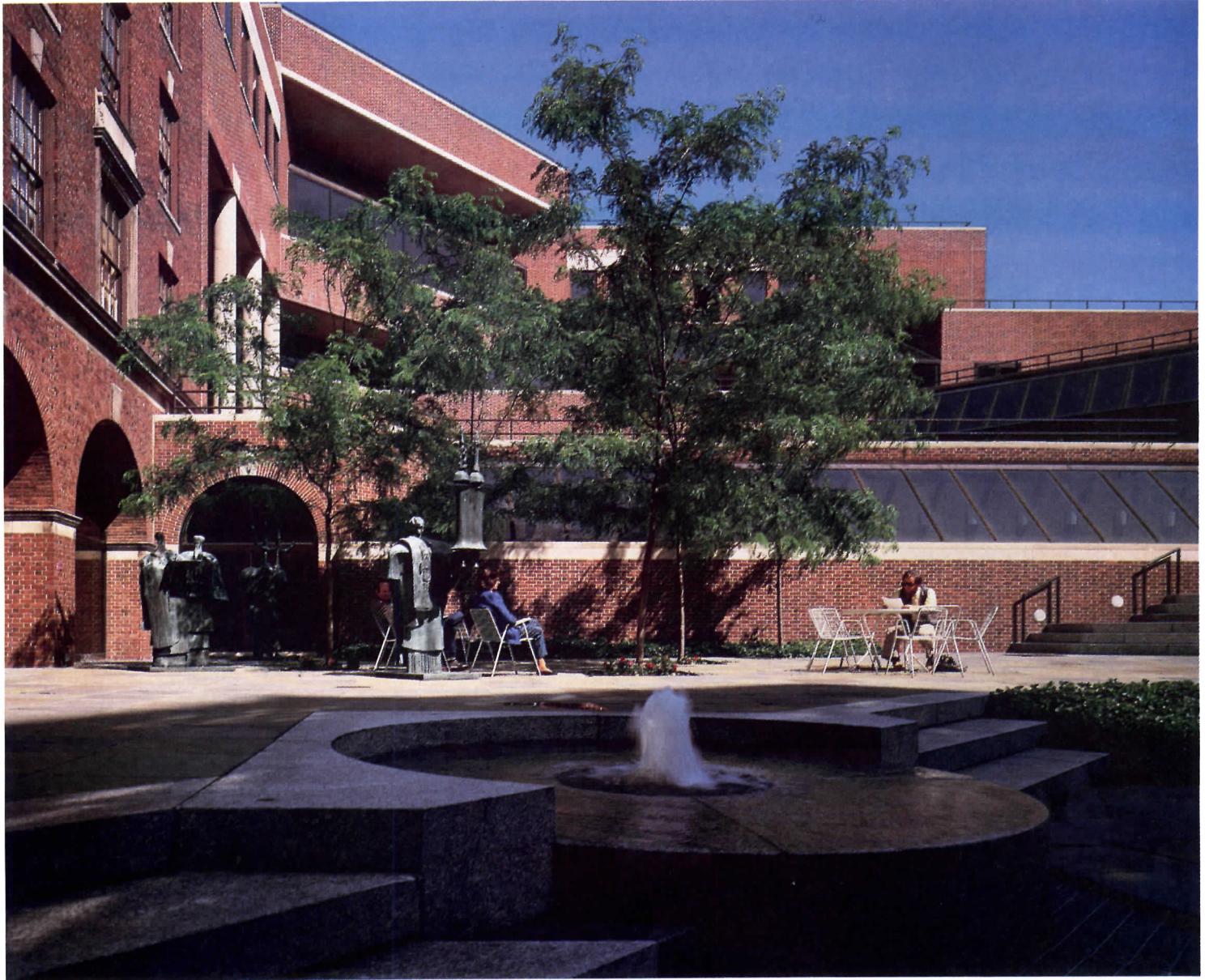

The street facade of the new wing of the Jewish Theological Seminary (opposite top left) gives little indication of the garden-oasis seen as one enters (opposite bottom left). Diagonally facing the entrance is the terraced addition, stepped to add sunlight and topped by the bold fenestration of the lounge in the special rare books floor. As can be seen in the section at left, arcades and a gallery surround the court.

As light-struck as the courtyard, each level has big windows and skylights, afforded by the terraced setbacks of the addition. The use of toplighting for the first-floor gallery along the auditorium (opposite) gives wall space for art display and seating. The stairway linking the open-stack, main library levels (below) has broad bands of windows and sloping skylights. Comfort abounds, with reading areas and

lounges for informal discussion and more display of art on all four levels. A quiet atmosphere is emphasized by soft pastel colors as can be noted in the convertible synagogue/auditorium (bottom), and by carpets and acoustical ceilings. Tighter security is maintained in the rare books section on the topmost level.

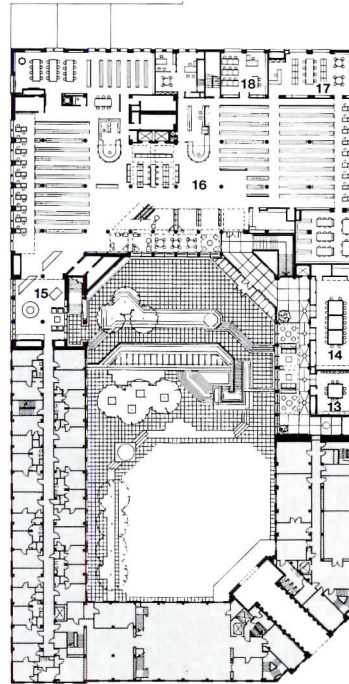

SECOND FLOOR

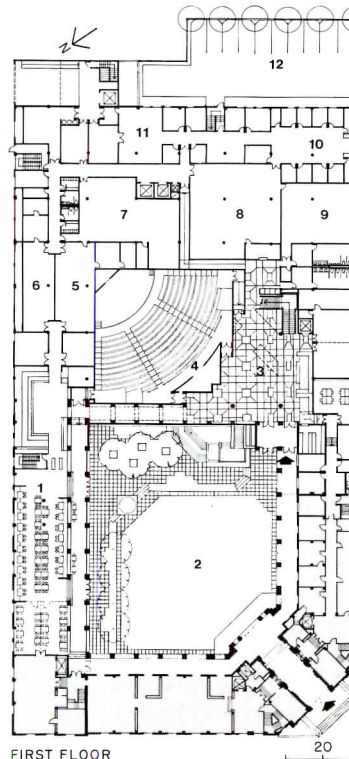

FIRST FLOOR

EXISTING

1. Dining
2. Courtyard
3. Lobby
4. Auditorium
5. Dairy kitchen
6. Meat kitchen
7. Kitchen storage
8. Library storage
9. Mechanical
10. Catalog division
11. Acquisitions division
12. Parking
13. Seminar
14. Board room
15. Exhibition
16. Main library
17. Music
18. Microfilm

The Jewish Theological Seminary of America
 New York City
Owner:
The Jewish Theological Seminary of America
Architect:
The Gruzen Partnership—Jordan Gruzen, Peter Samton, design partners; Michael Kolk, project manager; Robert Genchek,

project designer; Philip Fishner, interior designer
Engineers:
Kallen-Lemelson (mechanical/electrical); Irwin Cantor (structural); Romano & Gatland (kitchen consultants)
Construction manager:
Morse Diesel, Inc.



Completing the quad



©Nick Wheeler photos



As fresh and logical as its purpose—a center for today's computers and mathematics—this new addition to the Amherst campus adds yet another dimension to the idea of being sympathetic to context. It not only exerts all those expected curtsies to its neighbors, but is irrefutably “Ed Barnes,” unmistakably Modern, and it seems to belong there.

The buildings at Amherst are mostly red brick, and there are many hipped roofs. Stylistically they are a mixed bag—a number are Richardsonian or New England Colonial, a few are overtly Victorian, and there is a Modern music building and a parabolic-roofed gym. An inquiring glance can find allusions to all that in the new building. And in massing and scale, it seeks to relate to the building in front, the Pratt Museum, by its horizontal wing, and with its tower to the big Biology Building opposite the focal War Memorial. Barnes shifted the original site a bit, pulling the building in towards the center to anchor the corner of the quadrangle, and to frame the view of the white-pine-surrounded Memorial and the Holyoke Mountains beyond.

As the site falls off sharply at the back of the building, use was made of the slope to logically divide the floors into the four principal functions of the program—and, not incidentally, to expedite circulation patterns. The heaviest student traffic is concentrated on the ground level, opening directly off the quadrangle. Here are grouped a social lounge, classrooms, and seminar rooms. Computer laboratories are on the level below, built into the side of the hill. The tower contains two floors of faculty offices, topped by a math library.

Barnes comments that the library was sequestered in its tower “like a think tank,” adding, “there was no worry about the loss of books—all are almost impossible to understand.”

But, with all the logic and current allusions that can be read into this gentle building, the true genesis of the design goes well back into Barnes's career—to buildings he created for St. Paul's School in Concord, New Hampshire (RECORD, June 1963, pages 125-132) and, especially, to a complex for Emma Willard School in Troy, New York (RECORD, June 1969, pages 163-174). In those structures, Barnes began experimenting with abstract design esthetics—varied roof shapes, and tipped-square and arched windows puncturing flat planes of simple, textured materials. “Playing with prime forms,” Barnes dubs it. “It's important to come back to that.”

It is a very personal, elemental style that he has come back to. There is a fairly timeless simplicity that, somehow, seems very appropriate to the New England academic scene. At the very least, one could say that Barnes is a very discerning and far-sighted Pre-Postmodernist!

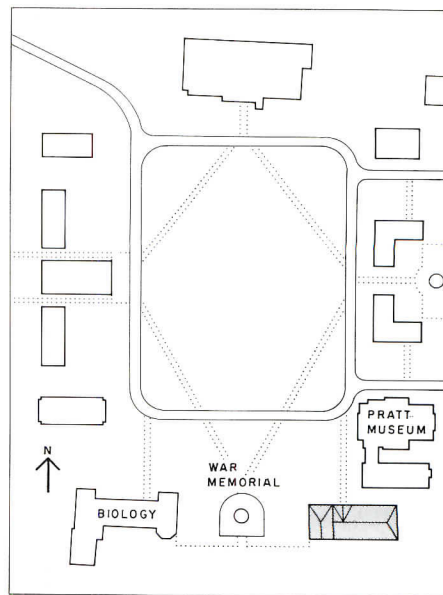



The dominant arch of the main entrance (opposite top) opens onto the main classroom floor from the quadrangle. The computer center is set into the slope below, with a secondary entrance at the far end (above). The horizontality of this block is emphasized by courses of green glazed brick. The three-story tower, with its big tipped-square window in the library, has a roof hipped in front, gabled at back.

Barnes's concern with "prime forms" is quite overt in his fenestration for the ground-floor lobby of the Amherst Math and Computer Center (below), and for the "think tank" library (opposite top). On the interiors, attention to shapes is reinforced by contrasting wood moldings (which can be seen from the outside of the entrance lobby), and the soaring pitch of the library ceiling is ramified by the

impact of the unexpected angle of the big window. As in the computer terminal area on the lower level (opposite bottom), all the interiors are comfortable and durably surfaced and finished. Above the two main levels (plans below), two floors of the tower each contain six faculty offices flanking a reception area, and the library floor is half stacks, half reading room.

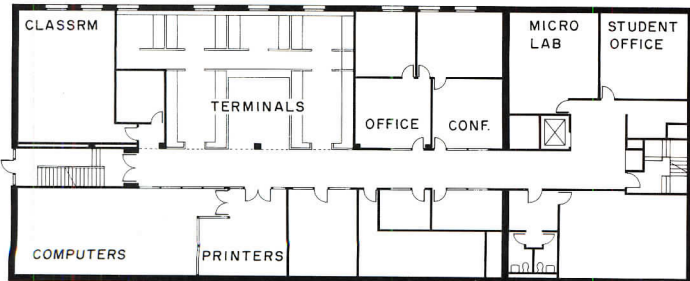

LOWER LEVEL - COMPUTER CENTER

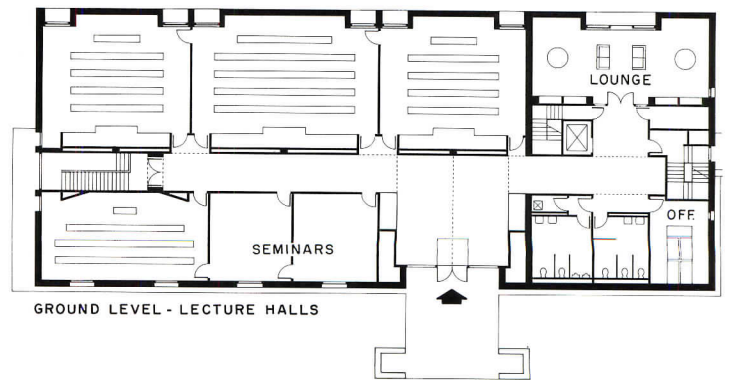

GROUND LEVEL - LECTURE HALLS

*Seeley G. Mudd Math and
Computer Center
Amherst College
Amherst, Massachusetts*

Owner:
Amherst College

Architects:
*Edward Larrabee Barnes
Associates—John M.Y. Lee, partner-
in-charge; Henry I. Myerberg,
project architect*

Engineers:
*Lev Zetlin Associates
Inc.(structural); Robert Hall
(mechanical)*

Consultant:
Donald Bliss (lighting)

General contractor:
Fontaine Brothers



Orient Express



Okanoyama Graphic Art Museum
Nishiwaki, Hyogo Prefecture,
Japan
Arata Isozaki & Associates,
Architects



By Martin Filler

While the worlds of art and architecture eagerly await the opening of Arata Isozaki's Museum of Contemporary Art in Los Angeles this coming December, a much smaller and more specialized new museum in Japan offers further evidence of why its architect ranks among the most versatile masters of that building type today. Isozaki's international reputation since the mid-'70s has rested largely on his widely acclaimed museum designs, beginning with his Gunma Prefectural Museum of Fine Arts of 1971-74 and his Kitakyushu City Museum of Art of 1972-74, augmented by several superb temporary exhibition installations, and culminating in the coveted (if conflict-ridden) MOCA commission. Though modest in size, his most recently completed museum is an impressive advance. As is customary in Isozaki's galleries, it displays the art within it to its best advantage. But more importantly, the architect's assured resumption of ideas he had begun to explore with such promise before the digression of his overly historicizing Tsukuba Civic Center of 1979-83 (RECORD, October, 1983) comes as a welcome reaffirmation. The Okanoyama Graphic Art Museum marks Isozaki's return to an architectural direction that has offered much hope to those in search of alternatives to the banality of much late Modernism and the triviality of much Postmodernism.

For almost 30 years Arata Isozaki has known Tadanori Yokoo, best remembered in this country for the 1972 retrospective of his bizarre but witty Pop Art posters at New York's Museum of Modern Art. The two are good friends and occasional collaborators; Isozaki has designed a house and studio in Tokyo for Yokoo, and together they have made one of the most memorable contributions to the "Tokyo: Form and Spirit" show now at the Walker Art Center in Minneapolis. (Entitled "Street," it displays seven brilliantly colored ceramic-tile murals by Yokoo, each depicting a successive stage in Tokyo's history, framed within an appropriately referential architectural surround by Isozaki.) Not long ago, Yokoo, who turns 50 this year, asked Isozaki to design a museum devoted to his art in his hometown of Nishiwaki, a small city northwest of Osaka and close to the geographic center of Japan. Although Isozaki has not been as concerned with contextualism as it is generally understood among his Western co-professionals—the architectural chaos of the Japanese urban scene makes such considerations largely irrelevant—here he has simultaneously created a symbol of the continuing lifework of Yokoo, a civic presence of considerable dignity and distinction, as well as an ironic response to a less-than-ideal site.

Isozaki's interest in architectural metaphor is longstanding, sometimes put forth directly (as in his famous question-mark-shaped Fujimi Country Clubhouse of 1972-74), but more often expressed with a high degree of subtlety that prevents allusive content from conflicting with more mundane requirements. In this scheme he has achieved one of his most satisfying syntheses yet: this building is neither belabored by excessive quotations from the past (though it does integrate a few bits of historical recall quite deftly), nor is it as surrealistically disengaged from convention and context as some of his startling early projects. Though the Okanoyama Graphic Art Museum incorporates a number of traditional architectural devices both Classical and Modern, it is in no sense retrograde, and seems as authentically of its time as James Stirling Michael Wilford & Associates' vastly different Neue Staatsgalerie in Stuttgart (RECORD, September 1984). Isozaki's beautifully resolved scheme endorses its designer's belief that containers for art must not be artless and need not be neutral. Though Isozaki has invested an enormous amount of emotional capital in the success of MOCA, which he sees as the crucial endeavor of his career to

date, he need not worry about his powers, which, as this work demonstrates, are obviously at their peak.

Situated next to a Japan National Railways line, the Yokoo museum property faces an unfortunate prospect, though its general setting in a park on the outskirts of the city is wonderfully verdant. Rather than ignoring the train tracks, Isozaki has effectively defused their intrusiveness by giving the museum the schematic form of a train: a frontal portico on the narrow north end signifies the "locomotive," with a series of three "cars" deployed in single file behind it. There is, however, no explicit railroad iconography, and the architect's distillation and admixture of motifs both Japanese and Western gives this building a worldliness not at all expected in such a remote locale.

The Okanoyama Graphic Art Museum is entered through a porch of eight, 18-foot-tall poured-in-place concrete columns (six freestanding, two engaged) in a colossal order the full two-story height of the structure. Their vestigial, gilded capitals are circumscribed with horizontal stripes and hint at Streamline Moderne. The entry door is surrounded by a border and flanked by a dado of light- and dark-gray ceramic tiles in the checkerboard pattern known in Japan as *koshimoyo* but also emblematic of such illustrious early Modernists as Charles Rennie Mackintosh and Josef Hoffmann. Behind is a double-story vestibule with a central marble stairway leading up to the main exhibition level (two small, lateral flights lead down to a ground floor office, seminar room, and storage). The ascending steps dominate the anteroom in a manner suggested by Michelangelo's Laurentian Library, an Isozaki favorite, and the paired bands of tile on the vestibule walls further allude to the strongly outlined moldings of that Italian Mannerist masterpiece.

The piano nobile of the museum is composed of three simple rectangular galleries (one for each decade of Yokoo's work since 1960) separated by smaller connecting chambers that are as richly colored and ornamented as the exhibition rooms they lead to are spare. After leaving the white-walled and skylit '60s room, one comes to a square chamber with a large palm tree rising up through a well cut in the glass-block floor. Rooted in a planter on the ground level, the palm is reminiscent of those in Yokoo's depictions of a tropical paradise, one of his recurring themes during the late '60s and early '70s. It is complemented here by Isozaki's ethereal, mosaic-like wall treatment of ceramic tile ranging from deep blue at the base of the two-story space and lightening to glittering gold closer to the skylight surmounting this one-specimen greenhouse. On the other side of the '70s gallery, which is identical to the rooms for the decades before and after it, stands another, quite different, link: this circulation space, with a spiral staircase leading down to the ground floor, is an illusionistic enigma: walls and ceilings are scored with a skewed grid pattern that subverts our perception of true horizontals and verticals.

The enfilade arrangement is intended to be expanded with each new decade of Yokoo's career, and the visitor must thus retrace his path through this linear route. A door on the west side of the palm room leads out to the museum's most mysterious precinct: a tiny freestanding pavilion with curving glass-block walls. Underneath its peaked roof is a meditation room, which one enters through an extremely low-ceilinged passage forcing one into a crouching posture, an old Japanese strategy used at thresholds to reinforce the sensation of spatial transition. The interior is magical, glowing with filtered and reflected light. Its contrasting, primal geometric forms—the gold-leafed pyramidal ceiling coffer above an altar-like black granite cube—together form a unit with a power rare in contemporary religious architecture. That small, intense space is itself a metaphor for the man whose spiritual quest inspired it. No opportunity has been missed to invest this extraordinary structure with a vivid, specific personality, one that delights in the material but remains open to the infinite.

Martin Filler is editor of *House & Garden* and frequently writes on architecture and design. His two-part series on the recent work of Arata Isozaki appeared in the October 1983 and May 1984 issues of *RECORD*. With his wife, the architectural historian Rosemarie Haag Bletter, he was writer and consultant for the 1985 documentary film *Arata Isozaki*, directed by Michael Blackwood.



Isozaki gave the Okanoyama Graphic Art Museum the mimetic form of a train in response to its site adjacent to railroad tracks (right). He sees the columned portico as a "locomotive," and the three galleries faced in yellow-painted stucco (one for each decade of Yokoo's work since 1960) as the "cars." Circulation spaces are housed in the orange-painted links between exhibition rooms. As is usual with this

architect's use of metaphor, there is a practical aspect to the image as well: the simple enfilade arrangement will easily allow for future expansion, a necessary requirement for a museum devoted to the work of an artist still at mid-career. Detailing is similarly multivalent: the checked tile border outlining each panel, further emphasizing the division between each segment, is a motif common to

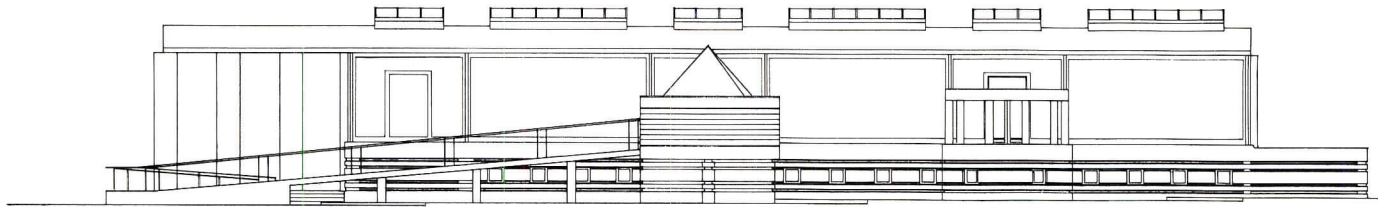

WEST ELEVATION



NORTH-SOUTH SECTION A-A

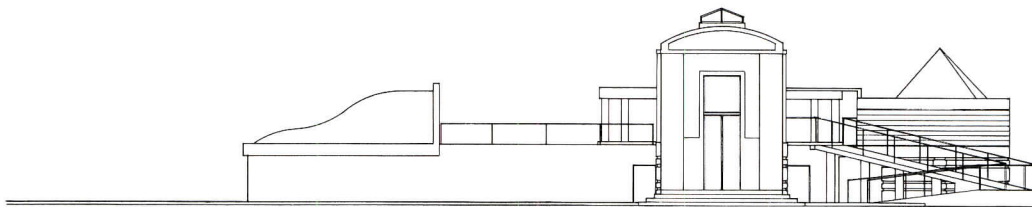

NORTH ELEVATION

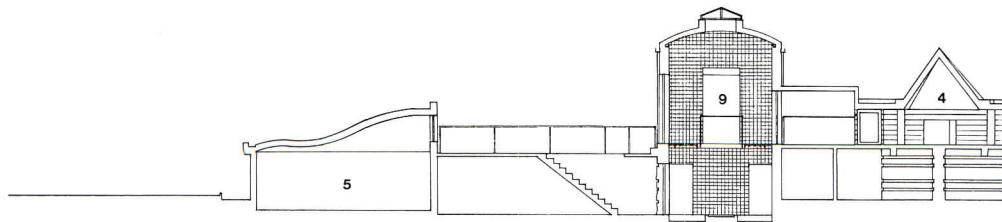

EAST-WEST SECTION B-B

both Japanese tradition and the Wiener Werkstätte. In section (opposite below) the building displays the geometric clarity that consistently underlies even Isozaki's most flamboyant designs. Ideas from past and future Isozaki projects recur as well: the illusionistically skewed grid of the third circulation room was used at Tsukuba, the pyramidal roof of the meditation pavilion relates to the skylights at

MOCA. The site plan (right) shows part of the ripple-pattern landscaping that will eventually surround the building, a concept that Yokoo calls a "navel park." The ground- and first-floor plans (below) conform to the attenuated spine configuration often seen in Isozaki's oeuvre. The meditation pavilion, with its curving glass-block walls and bold ramp, recalls Le Corbusier's Carpenter Center at Harvard.

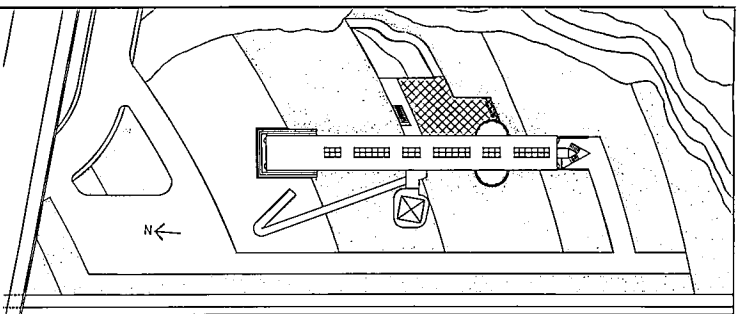

- 1. 1960s Gallery
- 2. 1970s Gallery
- 3. 1980s Gallery
- 4. Meditation Room
- 5. Atelier
- 6. Office
- 7. Seminar Room
- 8. Circulation Room 1
- 9. Circulation Room 2
- 10. Circulation Room 3
- 11. Storage
- 12. Mechanical
- 13. Courtyard

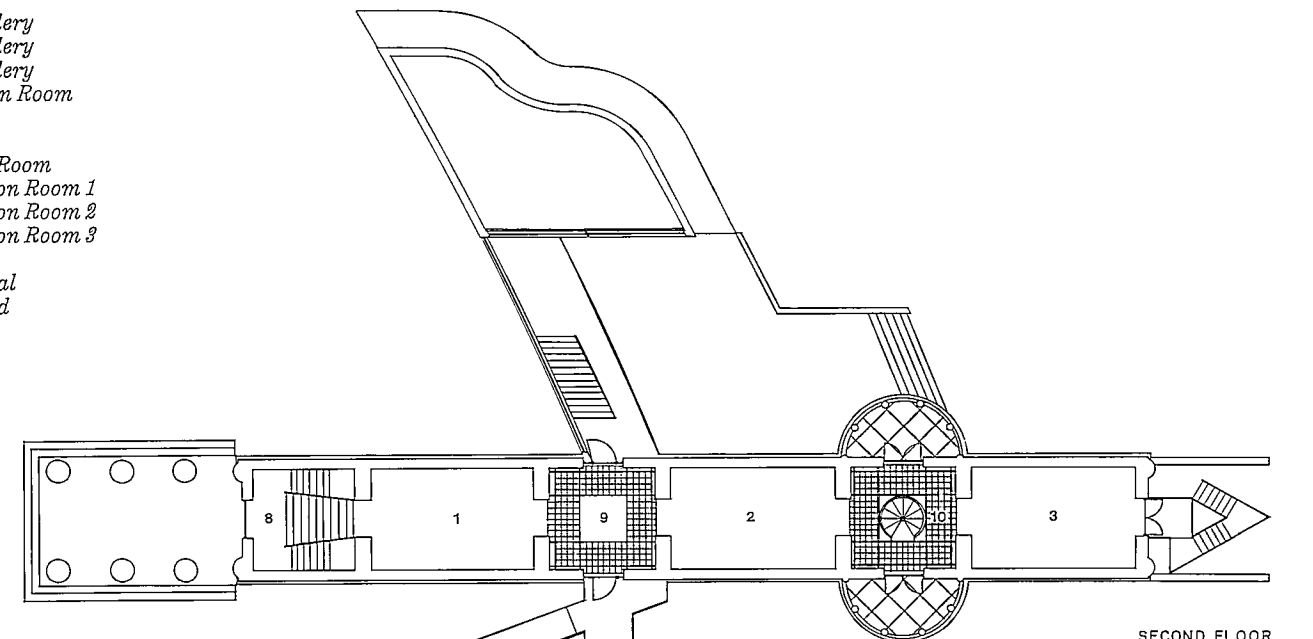

SECOND FLOOR

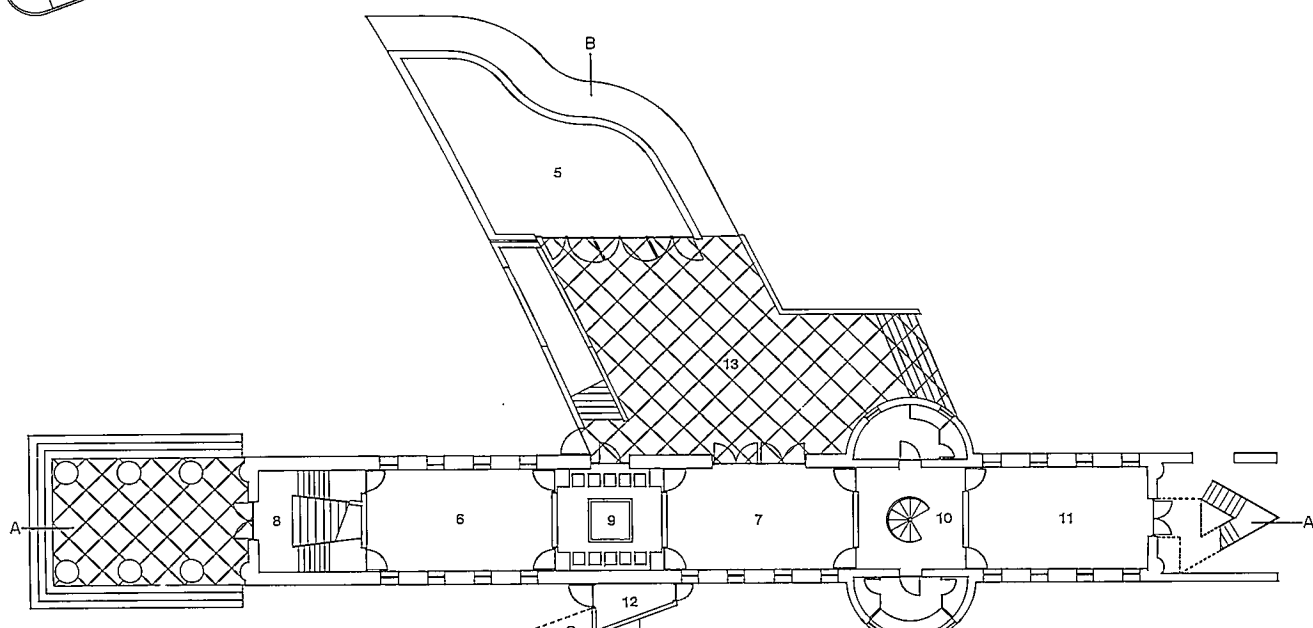

FIRST FLOOR



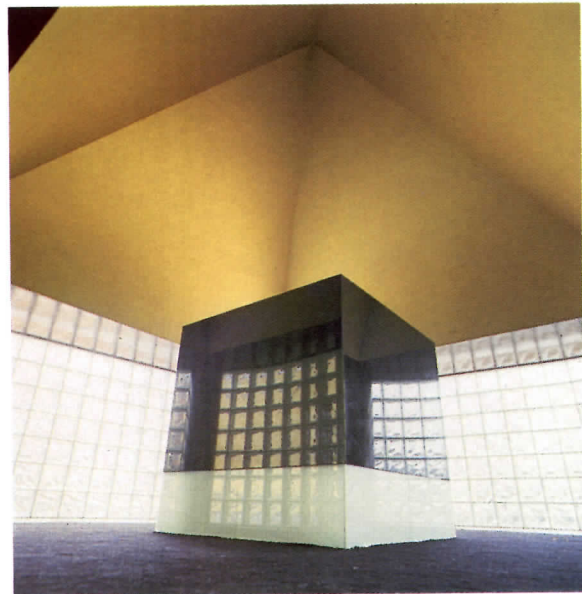

The entry hall (opposite and top left) repeats the same materials and colors used on the exterior of that segment, with the addition of four pairs of checked ceramic tile courses. The marble staircase to the gallery floor is flanked by mannerist balusters similar to those in Isozaki's Tsukuba Dai Ichi Hotel: the balusters span a diminishing number of steps at each ascending interval. The skylit exhibition

galleries, including the 1960s room (above left), are set off by dramatic connective spaces. Between the galleries for the '70s and the '80s is a room inscribed with the grids of Isozaki's tilted cube motif (top right). The meditation room (above right) with its "floating" cube of black granite above an illuminated strip and its gilded pyramidal ceiling reflects Yokoo's interest in occult spiritualism.



The museum's most dazzling interior is the second circulation room, the walls of which are clad in ceramic tiles gradating from cobalt blue at the bottom of the two-story space (opposite) to bright gold on the upper level beneath a skylight (above). The effect brings to mind the feverish glitter of the paintings of Gustav Klimt and the designs of his architectural contemporaries in the Vienna Secession. Additional light is introduced to the lower portion through the gallery-level floor paved with clear glass blocks. Planted at the center is a palm tree, a reference to the paradisaical imagery Yokoo employed in his works of the late '60s

and early '70s. The doorway at the left (above) leads to the exit ramp and connects the main building with the freestanding meditation pavilion.

*Okanoyama Graphic Art Museum
Nishiwaki, Hyogo Prefecture*

Architects:
Arata Isozaki & Associates—Makoto Kikuchi, assistant

Engineers:
Kawaguchi and Engineers (structural); Yoshida Design Studio and Fujigo Mechanical Engineers (mechanical)

General contractor:
Ohbayashi-Gumi, Ltd.



Of earthly delights



Steven Brooke photos



Jung/Brannen Associates was not his first choice to design the new headquarters of The Poynter Institute, confesses institute president and *amateur* of architecture Robert J. Haiman: Frank Lloyd Wright was. But he plunged into the collaboration with the firm of second choice with an enthusiasm now rewarded by a building whose delights, the architects insist, owe much to an informed and articulate client.

Haiman's pivotal contribution was a lengthy wish-list that elaborated a carefully spelled-out space agenda with musings on the intangibles through which he hoped Poynter's setting might abet its formal program of seminars and symposiums in fashioning "memorable experiences" for participant journalists ranging from local high-school newspaper reporters to national media executives. How? Well, to abridge his two-page memo, the building should announce an enduring "100-year" institution, signaling stability and strength tempered by elegance and warmth. . . . It should recognize its location. . . . look both new and timeless. . . . include surprises—but no tricks. . . . And it should delight the eye and fire the imagination. . . .

From the full adjectival flow of this stream of desiderata, partner-in-charge Robert Brannen and design partner Robert Hsiung distilled two themes they capsulize as "resonance" and "richness": resonance implying a gestalt of people and place more inclusive than mere



obedience to the demands of program and site; richness, the blending of discrete parts into a vibrant, sense-satisfying whole. If Haiman's pride in the Poynter building is echoed in the corridors of Jung/Brannen, it comes of having evoked these elusive qualities in "a straightforward rational way."

Because the planning issues were themselves straightforward—to accommodate in a collegial atmosphere freely coalescing and dissolving groups of varying size, from classes large and small up to gatherings of hundreds for institute assemblies and down to the solitary learner—the sought-for resonance emerged primarily from the designers' perfect pitch in tuning the inner workings of the institute to its surroundings.

Shunning both the outlander's generalization of Florida as an immense condo-ringed sandbar and the particulars of a not-yet-lovely location in an emerging bayside redevelopment area, the designers turned to a more elemental Florida of blazing sun and healing shade, flourishing greenery, and garden courts and terraces both look-able and livable. The entire site, accordingly, was conceived as an encompassing, ever-present landscape of outdoor rooms defined by, and interwoven with, inner spaces that focus on a skylit, glass-edged, two-story atrium commons bordered by teaching and administrative areas. Gently floated on smaller matching pavilions at each corner, the

spreading hip roof over the large central enclosure evokes a Floridian, if Brobdingnagian, house familiarly clad in native dress of red barrel-tiles, milk-white stucco, palm-trunk-gray rough-hewn cedar, and fossil-laden local Keystone. There is little indigenous, though, in the understated decoration, flawless detailing, and furniture finish that lift the building's down-home forms to seigniorial grandeur. Indeed, much of its eloquence—which has elicited images from Disneyland "Kon-Tiki" to the Seminole's thatched chickees—arises from composed contrast and ordered variety in the ways it is seen and sensed.

Only to arrive and enter is a small adventure. To drive through the gatehouse pavilion and sweep around the forecourt, or more prosaically proceed direct to pergola-sheltered parking stalls. To pass between landscaped lawns to the deep-recessed portico of the formal entrance, or stroll to the east-front "side" door by way of a trellised walkway between the nearby bay and its miniature in a terraced pool. To move from sun to shade and shelter to the daylight flooding an atrium agleam with marble and mahogany—an inner landscape that, like the outer gardens, is a constant companion to the institute's daily life.

President Haiman's response is a second confession. He did not at first accept the architectural credo that a building can nourish the spirits of those who use it. Now he believes. *Margaret Gaskie*

The Poynter Institute's pavilions-in-a-garden (site plan) constitute a private enclave in St. Petersburg's Bayboro redevelopment area, now a haphazard mix that includes, in addition to small houses and commercial buildings, a bus yard, the Dali Museum, and a working bayfront wharf. Later, the enclosed landscape will continue to preserve the institute's identity in the face of envelopment by the University of

South Florida, which plans expansion to the area from its present campus east of the endowed green strip and bay inlet that are the Poynter building's front yard. The one-story pavilions at the corners of the central enclosure also combine with trellised walkways to frame a variety of outdoor rooms: on the east a travertine and marble terrace around a reflecting pool (opposite); on the west a walled lawn with a

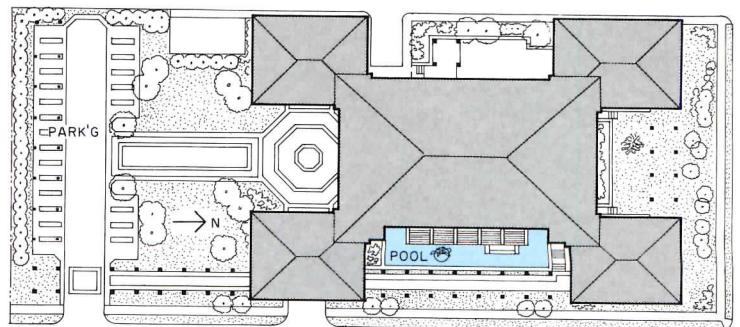

gazebo that often serves as a classroom; on the north a small flower garden; and on the south the richly planted lawns and paved court introducing the formal entry (opposite). The greenery of gardens and courts is set against exteriors whose modest materials nonetheless answer the client's call for dignity and elegance. Beneath the sheltering tile roof, whose rippled edge is smoothed by gutter-masking copper

soffits, stucco-over-block walls are set on a plinth of the Keystone that also masks chunky columns at the drive-through pavilion and recessed south entrance. The walls are alternately adorned with cedar paneling stained the warm, palm-trunk-gray of the pergolas, or with an echo of the rectangular panels rendered in cinnamon and toast-brown paint accented by sky-blue vertical strips and lavender "shadows."



Among the Poynter Institute's most popular oases for relaxation is the pool patio tucked behind the walkway along its east front, overlooking the front-yard park and the bay beyond. Soon to be vine-covered, the trellis frame with its shadow box between notched doubled outriggers is supported on four-legged columns that recall both the four pavilions "supporting" the large central mass and the

proportions of the four-square Keystone-clad columns at the entry. (Designer Robert Hsiung in fact first contemplated stone columns for the pergolas as well.) At the building face, a matching trellis seemingly continues on through the wood-framed glass wall to cantilever from interior columns similar in plan dimension to the pergola supports. There, though, similarity ends. Among the building's nicer surprises

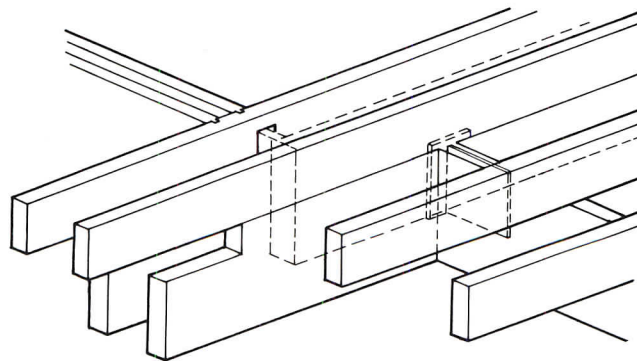

is the abrupt transition of the trellis and curtain-wall frames from rough gray cedar outside (opposite) to sleek hand-rubbed mahogany inside (below). The same mahogany, in book-matched panels from fitches of just two massive trees, gleams ruddily everywhere in the commons, in contrast to the higher but cooler gloss of a floor patterned in red and white marble and tan travertine. The wood also lends warmth to a 40-by

80-foot space that soars from 28-foot-high columns to a 55-foot peak. Other scale-reducing devices include placing the interior trellis and false outriggers at the height of the second-floor mezzanine that embraces the commons on three sides, and carefully sizing and spacing the wood mullion-covers over the curtain wall's tough, hurricane-defying steel and aluminum frame to lighten visually as they rise.



In addition to reserving for landscaping and outdoor living all but 20,000 square feet of the 70,000-square-foot site, the parti of large and small pavilions (a total of 31,200 square feet) permits relegating some activities to the latter, and so freeing the former for the "great hall" (right opposite), which is used by the public as well as the institute for large meetings and social functions. Aside from the porte cochère, the

remaining pavilions house an amphitheater, a graphics lab, and publishing operations. Around the atrium, the ground floor of the main pavilion is dedicated to classrooms and seminar rooms; the upper floor also includes the administrative suite and a library (left opposite). The architect-designed furnishings throughout exemplify the finesse of detail and finish characteristic of the building as a whole. (In two typical

labors of love, partner Robert Brannen himself detailed much of the woodwork, and four cabinet-makers devoted more than a month to crafting the staircase.) Set on a structure of reinforced concrete, the main pavilion roof is framed of laminated trusses. From the central rows of columns, diagonals branch tree-like to support the skylight and brace the roof, obviating the need for a heavy ridge beam.

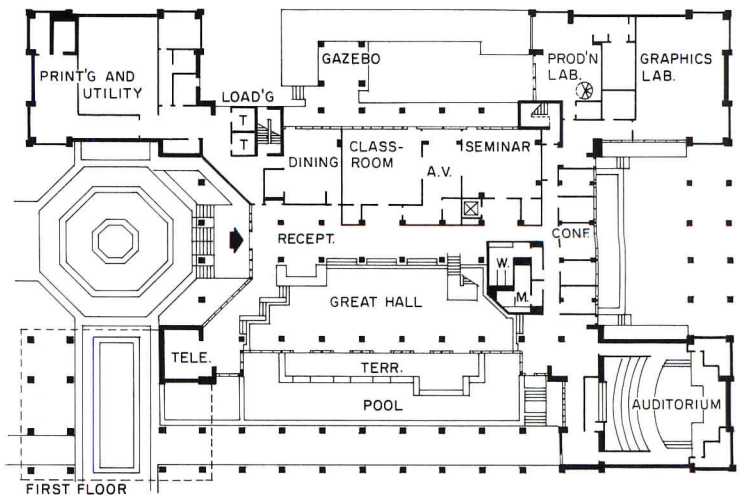

*The Poynter Institute
for Media Studies
St. Petersburg, Florida*

Owner:
The Poynter Institute
Architects:
*Jung/Brannen Associates—Robert
Brannen, principal-in-charge;
Robert Y. C. Hsiung, designer; Jerry
Seelen, project director; David Rib,
project architect; Tom Walsh, Rich
Hometchko (plans); Frank Montillo*

*(elevations and stone details); Ho
Ning Goon (exterior skin details);
Marsha Lea, Kathy Hirsch (site
design); Donald Biehl (graphics);
Donna Esteves, Suzanne Forte
(interiors); Richard White
(specifications)*
Engineers:
*Weidlinger Associates (structural);
Wedding & Associates (mechanical/
electrical); Cavanaugh & Tocci
Associates (acoustical)*

Consultants:
*Phil Graham & Company
(landscape); Law Engineering &
Testing Company (geotechnical)*
General contractor:
Federal Construction Company

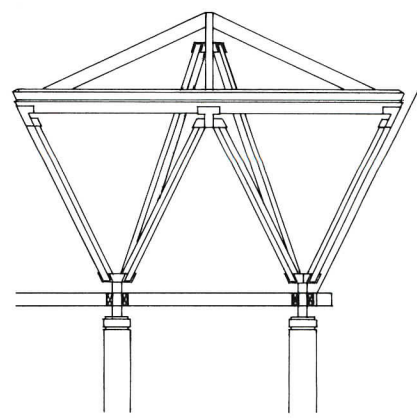
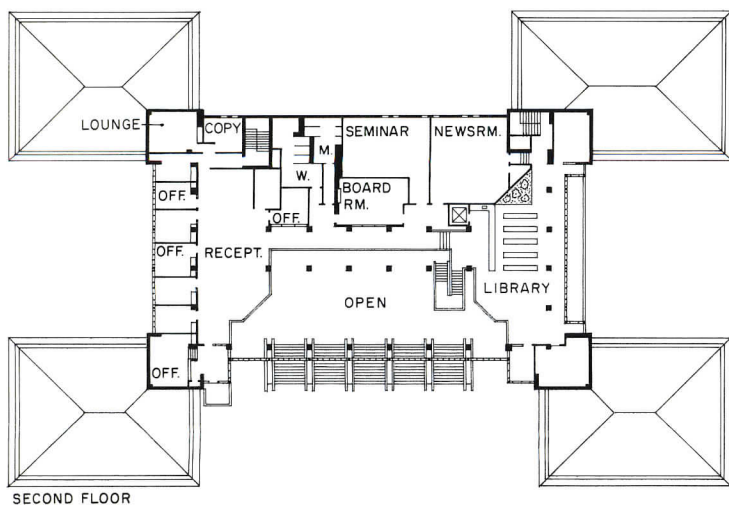



Above the fruited plain

Quady Winery
Madera, California
Stanley Saitowitz, Architect

Stephen Simpson photos

The Quady Winery in Madera, California, is best known for Essensia, a white dessert wine redolent of orange blossoms and honey, which has won high honors at tastings around the country. Andrew Quady, who founded his small but ambitious enterprise in 1975, also produces port and Elysium, a sweet red with a roselike bouquet. Considering the current American fashion for light, dry beverages, Quady's specialization in rich, ambrosial vintages marks him as an individualist. The same independent spirit prompted him to commission wine-label art from Los Angeles painter Ardisson Phillips and to engage San Francisco architect Stanley Saitowitz to design the building where Quady wines are fermented, bottled, and stored. Back when he was still operating out of a makeshift shed behind his house, Quady had seen published drawings of Saitowitz's Storybook Winery in Calistoga, California, and admired the originality of the vaulted structure partially embedded in a hillside. Above all, Quady was impressed by work spaces open to the landscape, an efficient accommodation of enological processes, and craftsmanlike, unabashedly modern architecture, devoid of little-old-winemaker cuteness or pseudo-château pretense.

Stanley Saitowitz has never relied on ornament or style as prime esthetic determinants. He chooses instead to shape his buildings in response to terrain, climatic cycles, materials, and a symbolic "human geography" traced by the comings and goings of daily life. This attunement of art to the morphologies of man and nature has inspired such diverse works as a South African cottage that reflects the prismatic geometry of crystals and snowflakes, a "sundial house" in California that acts as a habitable clock and calendar, and a series of emblematic maps that delineate both the topography and the personality of four American cities. The location of the Quady Winery on the broad flats of the San Joaquin Valley prompted Saitowitz to conceive the building as a "horizon piece." A narrow 4.5-acre site crowded by an extant house and tennis court, and hemmed in by vineyards, reinforced the suitability of a linear parti, and also permitted a sequential organization of winemaking operations and truck access.

The 5,500-square-foot plant erected last year realizes the first of three projected phases (drawings overleaf), whose total floor area will nearly treble the present dimensions. With an eye to rural character, functional adaptability, and economy (phase-I construction costs averaged \$48 per square foot), Saitowitz developed a barnlike enclosure that reuses Quady's original shed as one of its corner bays. The interior layout now installed, which places offices on an open mezzanine above the bottling area, will be rearranged as the winery expands. Plywood panels have been left exposed indoors and coated in rose-colored stucco without; arched laminated beams, also visible inside, carry a blue-enameled standing-seam metal roof. As Saitowitz intended, the wooden walls and the curved shell overhead compose a visual analog to the wine barrels they shelter. The metaphor is subtle, however, and ultimately subordinate to the outward image of a warehouse at home in the country. During the growing season, when grapevines carpet the ground in bright green foliage, the contrasting bands of pink wall and cerulean roof seem to proclaim the role of architecture as an intermediary between earth and sky. At the same time, rhythmically repeated windows and columns echo the cultivated rows that promise the vintages of years to come. *Douglas Brenner*



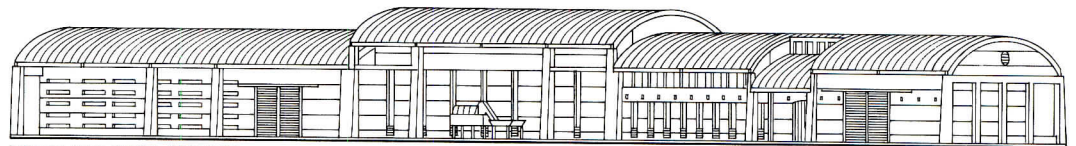
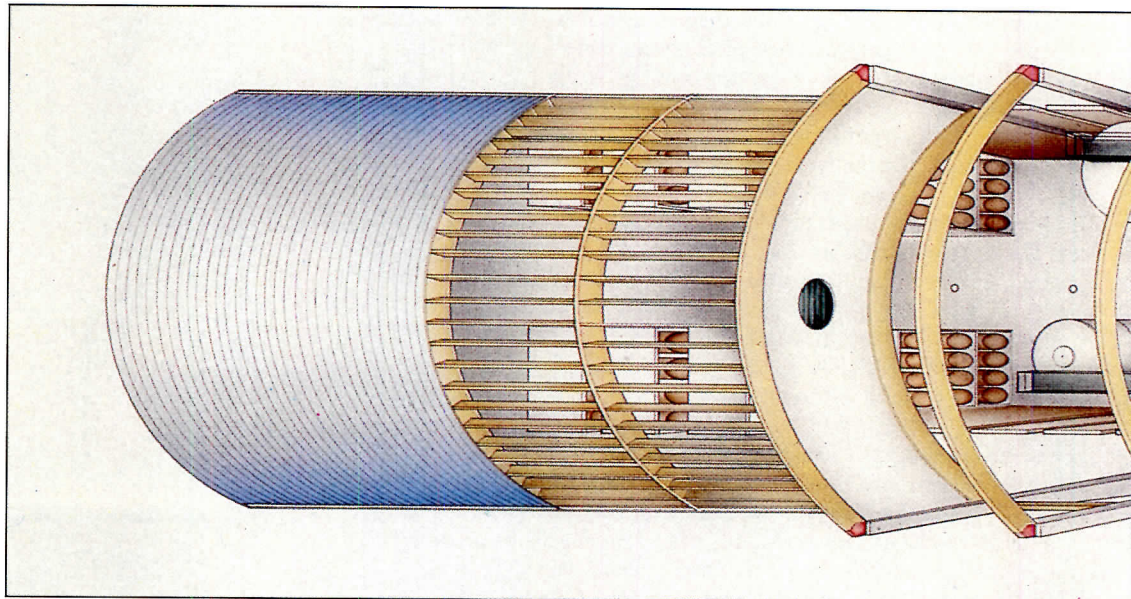

NORTH AND WEST FACADES

GROUND FLOOR

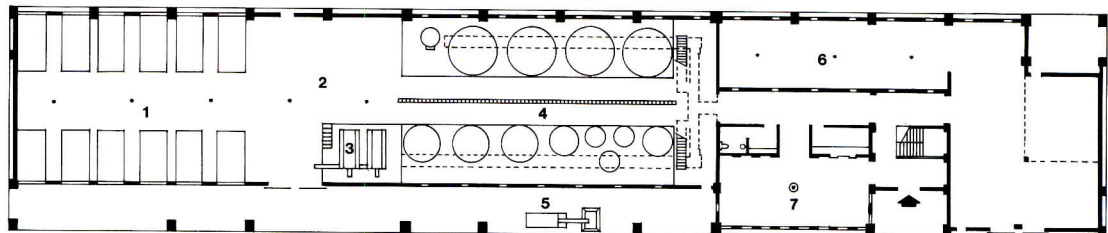

Saitowitz's open-span, warehouselike shell leaves interiors as flexible as possible, to accommodate changeable production requirements and the continuing growth of Qady's operations. The structure is by no means an indeterminate box, however. The barrel vault steps up in the four central bays to furnish extra height for fermentation and storage tanks, and steps down on the north

facade to signal entry and insert a clerestory. Porticoes and a second-floor porch to the left of the entry answer Andrew Qady's request for work areas with ready access to fresh air and views. An entry bay at the southwest corner (top right in plans) doubles as a viewing stand for adjacent tennis courts. The shed that served as the original winery has been salvaged in the enclosure for case-goods storage. At present, the

first third of the three-phase scheme to be constructed (at right in drawings) houses functions that will later be distributed throughout the building. This temporary layout accounts for discrepancies between the plans and the interiors shown overleaf. Offices, for example, are now confined to an open mezzanine, and tanks and barrels fill the case-goods area.

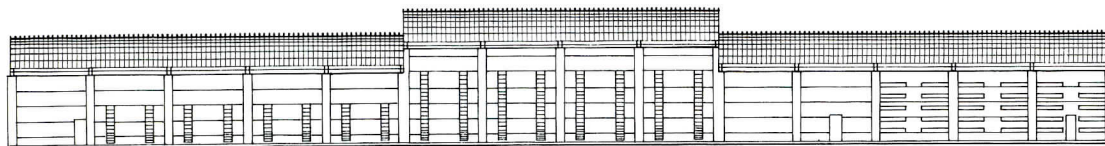
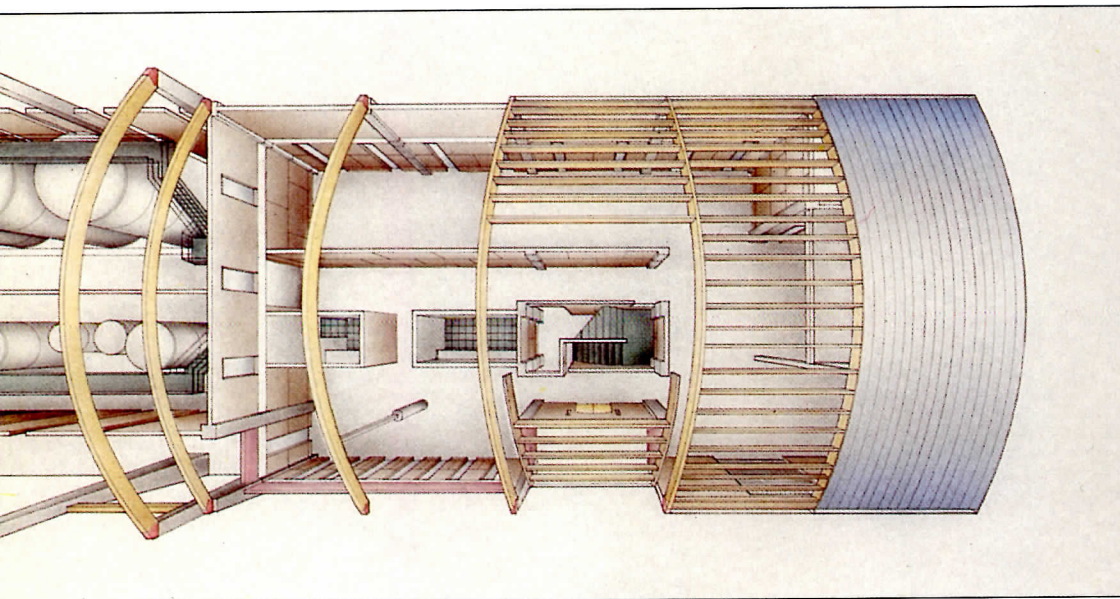

SOUTH FACADE

SECOND FLOOR

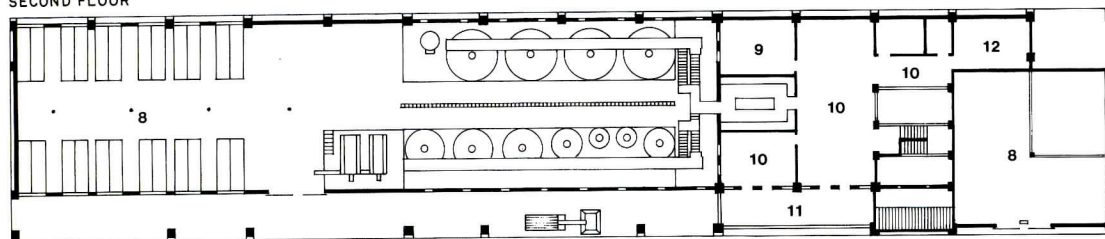

Fenestration reflects both the repetitive nature of winemaking processes and the orderly planting of vineyard rows. The battered profile of buttresslike piers is meant to afford a visual transition between the ground plane and the curved roof. Saitowitz plans to space the characters of the winery's name in neon above the five pillars supporting the segmental west gable, which is the facade that visitors see

first. A half-century-old grape-crushing machine outside the north facade, still in working order, is to be painted yellow. Because the 4.5-acre winery site is too small for adequate viticulture, Quady purchases the orange muscat, black muscat, and zinfandel grapes used in its products from independent growers. Last year Quady produced about 12,000 cases of wine.

1. Barrel storage
2. Workshop and storage
3. Grape presses
4. Fermentation and storage
5. Grape crusher
6. Bottling
7. Entertainment
8. Open to below
9. Conference room
10. Office
11. Porch
12. Wine library

Although this winery, unlike many, is not primarily a tourist showplace, Andrew Quady wanted a hospitable building that would express the firm's pride in craftsmanship. He also hoped for a pleasing addition to the landscape, since he and his family look out at the winery from their adobe house next door. Quady and Saitowitz also put cleanly detailed, well-lighted, low-maintenance working quarters at the top of their priority list. Natural plywood walls exemplify this elegantly utilitarian outlook.

Translucent plastic sandwich panels in south-facing windows (left in top photo) admit ample daylight to the bottling room while tempering the sun's heat (exposed ductwork is part of an hvac system that maintains an ideal winemaking temperature of 64°F). Similar windows will illuminate barrel storage racks where staff must constantly watch for leaks. Until upper-level offices are extended the full width of the building, supplementary light will continue to come from the clerestory, the mezzanine, and fluorescent tubes between the roof joists. Reflective panes in the tall north-facing windows are largely an esthetic device to extend the prospect of vineyards stretching toward the horizon—whether viewed from outside (pages 124-125) or from inside. The vista of a neighbor's zinfandel vines composes an agreeable backdrop for the entertainment room where Quady holds wine tastings for friends and business associates (through central doorway opposite). Original art for the Essensia label adorns the bottling room (at left in lower photo).

Quady Winery
Madera, California

Owner:

Andrew Quady

Architect:

Stanley Saitowitz, Architect—
Stanley Saitowitz, design architect;
Jes Slavik and Daniel Luis,
assistants; Doug Tom, specifications

Engineers:

R. B. Welty Associates, Inc.

General contractor:

Basila Favini Construction



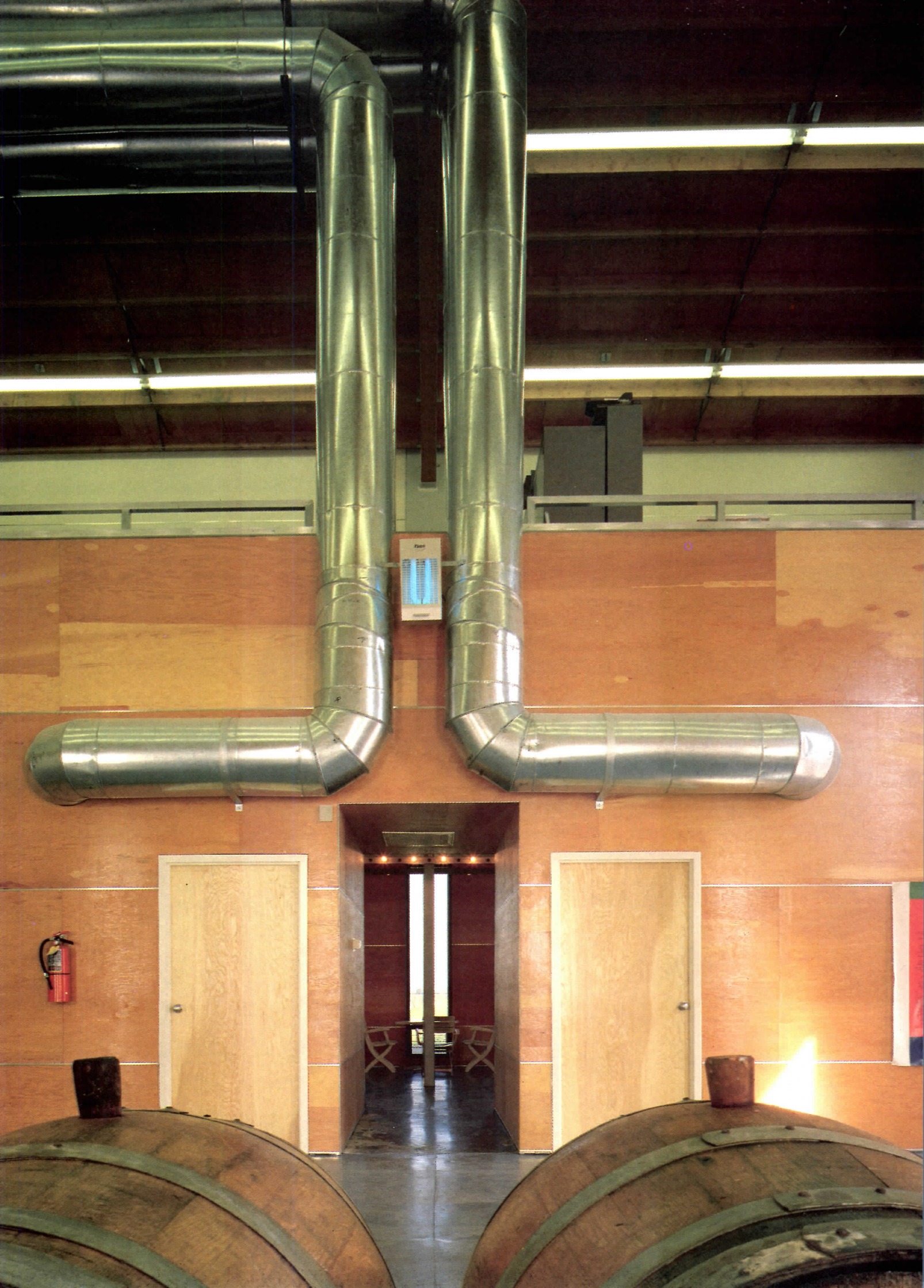

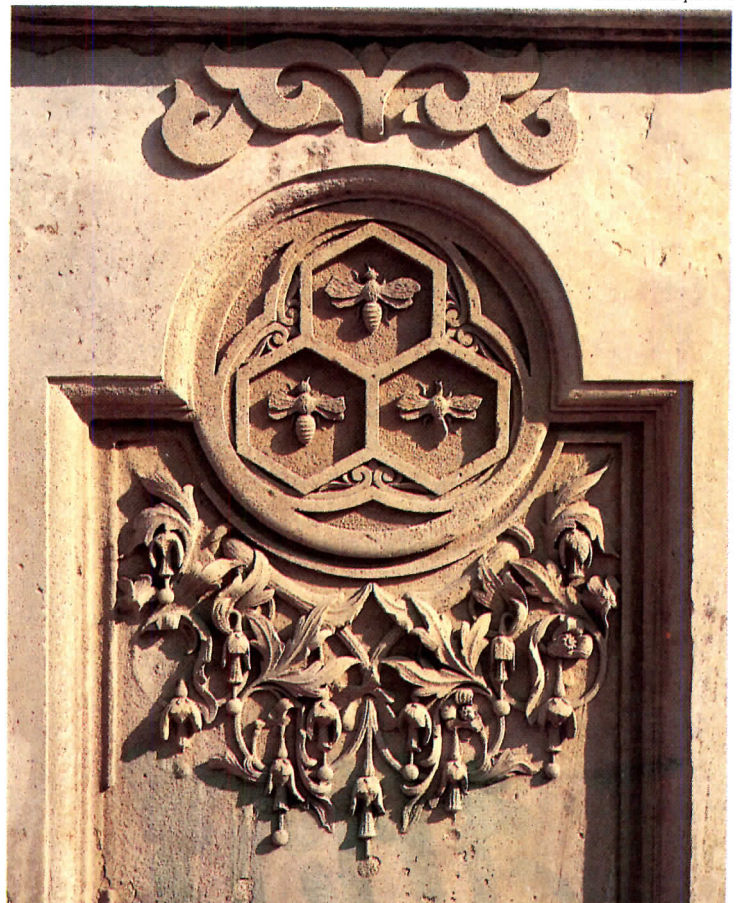

Saving sandstone

Bethesda Terrace restoration
Central Park, New York City
The Ehrenkrantz Group,
Architects

Quarried in a variety of earth-toned colors and textures, and easily worked, sandstone became the preferred choice of mid-19th century architects in search of a picturesque "naturalism." By the post-Civil War "brown decades," it not only had become synonymous with the era as its most fashionable building material, but also had become notorious for its tendency to decay. A case in point is Bethesda Terrace in New York City's Central Park, designed by Calvert Vaux and Jacob Wrey Mould, and completed in 1873. Richly embellished with scientifically accurate and fantastic carving (facing page), the soft, finely-grained Nova Scotia sandstone of its monumental staircases began to show signs of weathering as early as 1890. Nearly a century later, its decay finally is being remedied by The Ehrenkrantz Group in an ongoing restoration that comprehensively illustrates the current techniques in saving sandstone (following pages).

Sandstone deterioration stems from the geological structure of the stone itself and the way in which the material was laid in building construction. Formed from layers of sand held together by natural cements, the sedimentary rock is constructed with inherent areas of weakness, where each layer, or bedding plane, comes into contact with adjacent layers. Historically, sandstone buildings often were constructed with the bedding planes placed parallel, rather than perpendicular, to their facades. This practice of *face-bedding* causes the layers of stone to peel off from the surface when subjected to weathering by water or wind, a process called *exfoliation*. *Face-bedding* also can result in a type of delamination referred to as *blind exfoliation*, characterized by the internal separation of sandstone layers behind the surface. Other types of sandstone decay include *blistering* as a result of crusts formed from airborne chemicals or crystallized salts beneath the surface; *detachment* of the stone's layers due to structural settlement; and *cracking* as a result of trapped water freezing, expanding, and splitting the stone.

While the options for conserving sandstone are numerous today, including the application of synthetic resins and epoxies, architects and preservationists remain wary of the experimental repair, replacement, and waterproofing techniques developed in the early 1970s, which have contributed to notable sandstone conservation disasters such as the initial restoration of the Smithsonian's Renwick Gallery in Washington, D. C. "There is less willingness to experiment with new techniques that are irreversible," notes Ann Beha, a Boston architect who specializes in preservation. She emphasizes the need to understand sandstone restoration within the context of a building system, rather than as an isolated technical problem. The choice of cleaning, replacement, or repair techniques should depend on the type of sandstone, location within a structure, and depth of deterioration. Not all sandstones are created equal; the common Triassic "brownstones" quarried in Connecticut, Massachusetts, New Jersey, New York, and Pennsylvania are softer and more prone to exfoliation than the light gray, yellow, and olive green Carboniferous sandstones from Nova Scotia and New Brunswick, Canada (facing page). The binders between the grains of sand within the stone also vary, from clays containing iron oxides, to carbonaceous and siliceous cements.

Once identified, the first step in restoring the masonry usually is to clean it, in order to prevent further chemical attack by pollutants, and to expose problems such as settlement detachment, open joints, and weathering under surface dirt. But as Beha warns, "There is no second chance if you overclean. Sometimes it's better to leave a building's patina of age alone." In cleaning sandstone, prolonged water and steam washing are not recommended because they can result in efflorescence, or migration of salts in the stone to the surface. More effective, with faster results, are acidic chemical agents, such as a weak solution of hydrofluoric acid, or a combination of an alkaline prewash (sodium or potassium hydroxides) followed by an acidic rinse to clean pollutants chemically bonded to the stone. Sandblasting and other pressure-

applied abrasives are frowned upon, unless very carefully monitored. Deeply embedded graffiti stains require removal with inorganic and alkaline paint strippers, applied with a self-contained system such as poulticing to avoid bleaching adjacent areas.

The most logical way of restoring damaged sandstone is to replace it with matching stone from the same quarry. However, most of the sandstone quarries in this country have been closed, and only a few Ohio, Colorado, and Canadian sandstones are commercially available. Sandstone from English and West German quarries can be imported, but these products are extremely costly and rarely match the color and texture of Triassic sandstones. Other replacement alternatives include recycled sandstone from salvage yards, precast concrete, and sandpainted fiberglass, wood, or masonry units. Partial replacement of an architectural element is called a "*Dutchman*" repair and is attached to the structure with noncorrosive stainless-steel or thermoplastic (Teflon) pins (page 135). In reconstructing smaller areas (generally less than 6 inches deep), the commonest method is to cut back the damaged stone to a sound substrate and to apply a mortar patch, consisting of lime, sand, and cement mixed with crushed brownstone or pigments. This process is called *composite patching* or *plastic repair*. Recently introduced to sandstone preservation practice are Dutch (Jahn products) and German (Keim) premixed masonry compounds that are easily worked with low shrinkage. Similarly, latex admixtures can be blended into a conventional mortar-patching compound to increase cohesion, adhesion, and durability. However, some bonding agents may break down in the presence of moisture, creating a glossy surface and greenish tint.

Other methods of sandstone repair include removal of deteriorated layers and finishing the remaining surface by *chiseling* or *honing*. Stabilizing weathered areas to prevent further deterioration can be achieved through chemical *consolidation*, which acts to replace the dissolved binding agent in the stone by penetrating the surface and cementing the grains. Although first developed in the 19th century, consolidants remain an expensive, highly toxic method of treatment. To be effective, they must penetrate deeply enough into the stone to avoid formation of a surface skin, and may cause staining on light-colored sandstones, and reduce permeability. However, consolidants containing ethyl silicates have been used with some success, because they simulate certain sandstones' natural siliceous cements and "offer good reintegration without changing the physical or chemical properties of many sandstones, unlike acrylic resin polymers which change a stone's permeability," according to Frank Matero, director of Columbia University's Center for Preservation Research. Adds Dr. Judith Selwyn of Preservation Technology, "Consolidation must be applied to reasonably sound stone to be effective. It is not a cure for exfoliation." Still in the experimental stage are repair techniques for readhering delaminating stone through pinning and adhesive grouting (page 135).

Architects experienced in conserving sandstone emphasize the need for testing any repair technique within a confined area of the affected structure. Ideally, this experimentation should take place a year from the date restoration is due to begin so that the test area is subject to a full season of weathering. No matter what the technique, the success of any sandstone repair is heavily dependent on the skill with which it is installed. The number of contractors allowed to bid on any restoration project should be limited to those who have proven experience, and to masons flexible enough to change their standard procedures to include specialized conservation techniques such as poulticing and consolidation. Specifications should be based on known products or comparable equals with a proven record of performance. "Know your materials and choices in treatment," states Matero, adding, "Don't try to overrestore. Technological advancements only extend the possibilities of saving buildings, but are no substitute for sound preservation principles." *Deborah K. Dietsch*

Designed in the 1860s by Calvert Vaux and Jacob Wrey Mould, and completed in 1873, Bethesda Terrace mediates between the formal, tree-lined axis of Central Park's Mall and the Romantic landscape surrounding its Lake. The arcade and monumental staircases of the Terrace (section and bottom photos both pages) descend from the upper level of the Mall to a lower plaza, focused on a fountain designed by

Emma Stebbins, that still serves as a major gathering place in the Park (right of plan and facing page). Constructed in a siliceous sandstone from New Brunswick, Canada, called "Dorchester freestone," the Terrace began to display noticeable signs of abrasion as early as 1890. It has since continued to decay, prompting the New York City Department of Parks and Recreation to commission its

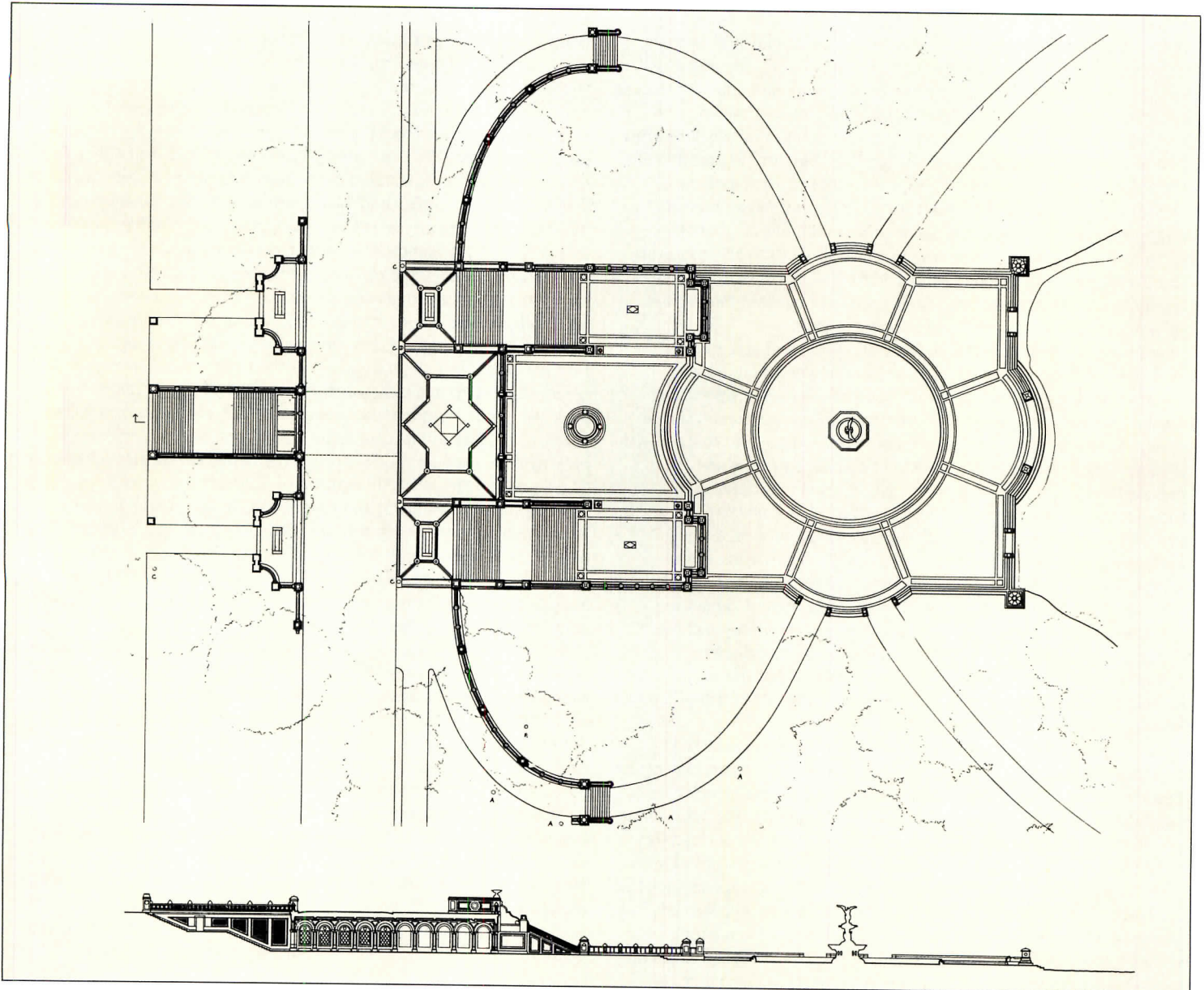

restoration under the direction of The Ehrenkrantz Group, beginning in 1982. "Our philosophy has been to retain as much of the original fabric as possible, and treat it so that the full architectural and sculptural quality of the Terrace could be read again," explains Ehrenkrantz principal-in-charge, Theodore Prudon. A diversity of repair techniques, including cleaning, consolidation, resurfacing, and

patching, was drawn upon to conserve components eroded by water and wind, and defaced by graffiti. Decorative caps and balustrades were disassembled and reset with new mortar (bottom). Badly deteriorated, structurally unsound, and missing details, such as balustrade screens (bottom), were replaced by newly carved sandstone elements from the same Canadian quarry as the original stone.

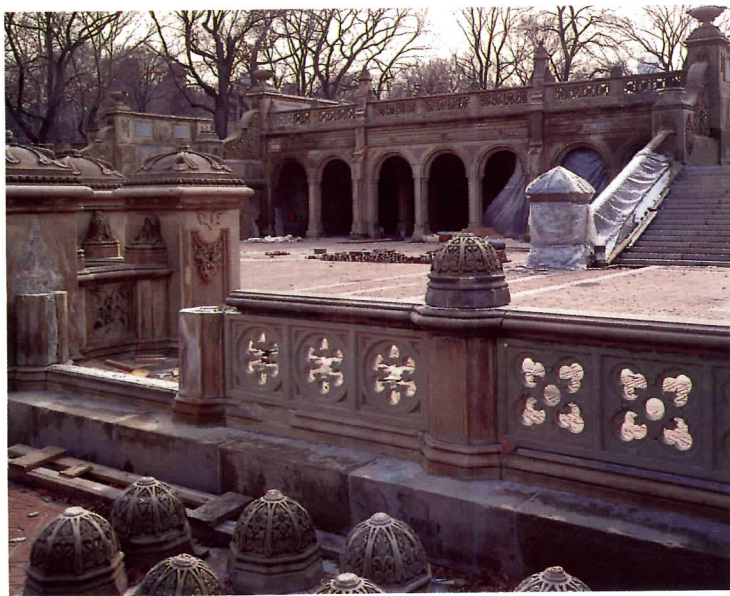

Richly embellished with naturalistic carving to represent the four seasons, the grand staircases that descend from 72nd Street to Bethesda Fountain were treated with cleaning, patching, and replacement techniques. The architects began their restoration by low pressure-washing the sandstone with a diluted, commercially available cleaner containing a solution of hydrofluoric acid (3 parts water to 1

part cleaner). The graffiti that once disfigured Mould's masterpiece (bottom) were removed by brushing a methylene chloride-based paint stripper onto the affected areas, and rinsing it off with water 12 hours later. Friable areas of stone were retooled or honed, depending on the degree of deterioration. Severely damaged sections were cut back to a sound substrate that was drilled and scored to receive a new masonry



patch (left). A mixture of sand, lime, cement, water, and pigments in varying proportions was applied in three layers to achieve the proper depth (left diagram). Missing decoration such as birds' heads and trefoil cusps (top and bottom right) was replaced with newly carved sandstone replications to restore the original sculpted appearance. The new pieces were attached onto the old stone by

concealed stainless steel pins, held in place by epoxy and inserted into drilled holes in the adjacent fabric (right diagram). Pinned reinforcement can be combined with adhesive grouts and composite patching to repair delaminated sandstone (middle diagram). Although Bethesda Terrace does not exhibit exfoliation, this experimental method will be employed to repair a lower pier damaged in construction.

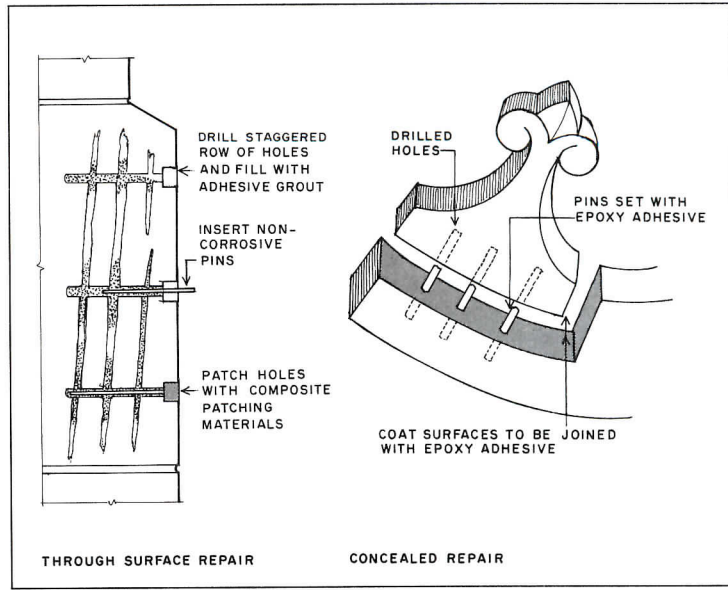
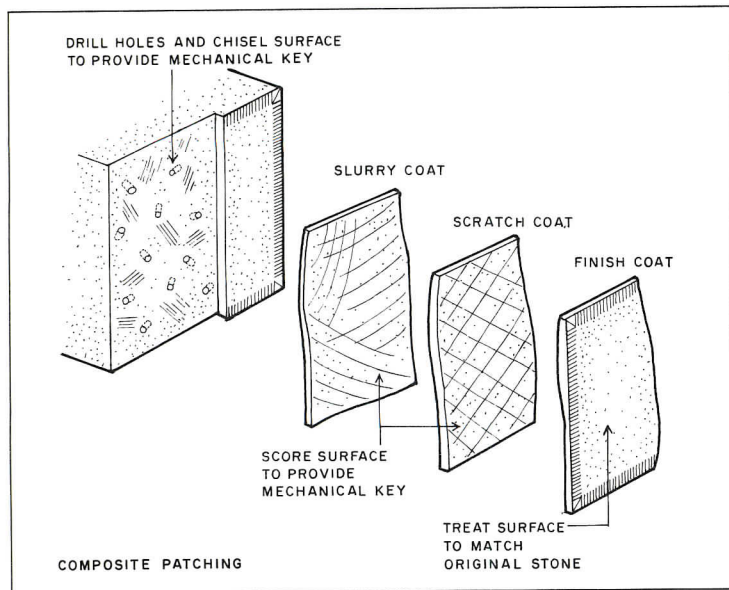

The existing conditions of the Terrace and proposed solutions to its decay were thoroughly documented by The Ehrenkrantz Group in drawings (below). The balustrades on the lower Terrace, and the walls of the staircase descending from the Mall to the underpass below 72nd Street, presented the most complex conservation problems. On the right pier of the balustrade (below), a poorly installed patch below the inset

panel will be replaced with a new plastic repair. The missing corner molding will be infilled by a "Dutchman," cut to match the original and pinned in place. Similarly, the balustrade screen between the piers, decayed beyond repair, was replaced by a new panel, carved to replicate the original. Crumbling stone, caused by freezing water and crystallized salts beneath the surface, was retooled or honed,

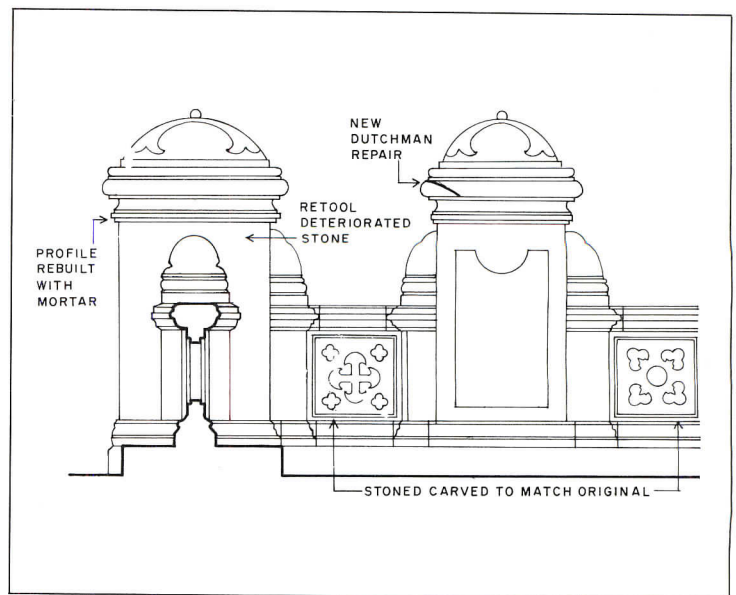

depending on the severity of the deterioration. The weathered sections of the diaper-patterned wall of the staircase (section and photos below) were consolidated with a solution of ethyl silicate, under the direction of Metropolitan Museum conservator George Wheeler, who monitored test areas for 18 months. Though consolidation serves as a means of stabilizing the stone, not reinstating the artifact, the

architects felt that enough of the original decoration was present on other areas of the wall to represent the design, and replacement would be inappropriate. The exposed anchor between the panels (left) will be brushed clean, primed, and patched. The architects attribute the irregular patterns of weathering (right) in this area to wind and water erosion, and to inherent deficiencies in the durability of the sandstone.

Bethesda Terrace
Central Park
New York City
Architects:
The Ehrenkrantz Group—Theodore Prudon, principal-in-charge; Kate Burns Ottavino, architectural conservator; Christina Zakalak, resident engineer; Frederick Rehkopf, principal-in-charge, 1982-83; Jean P. Murphy, project

manager, 1982-83; Steve Zalben, resident engineer, 1983-84
Engineers:
Geiger Berger
General contractor:
Thomason Industries
Stone restoration contractor:
Pallau-Collins, Inc.
Consultant:
George Wheeler (conservation)

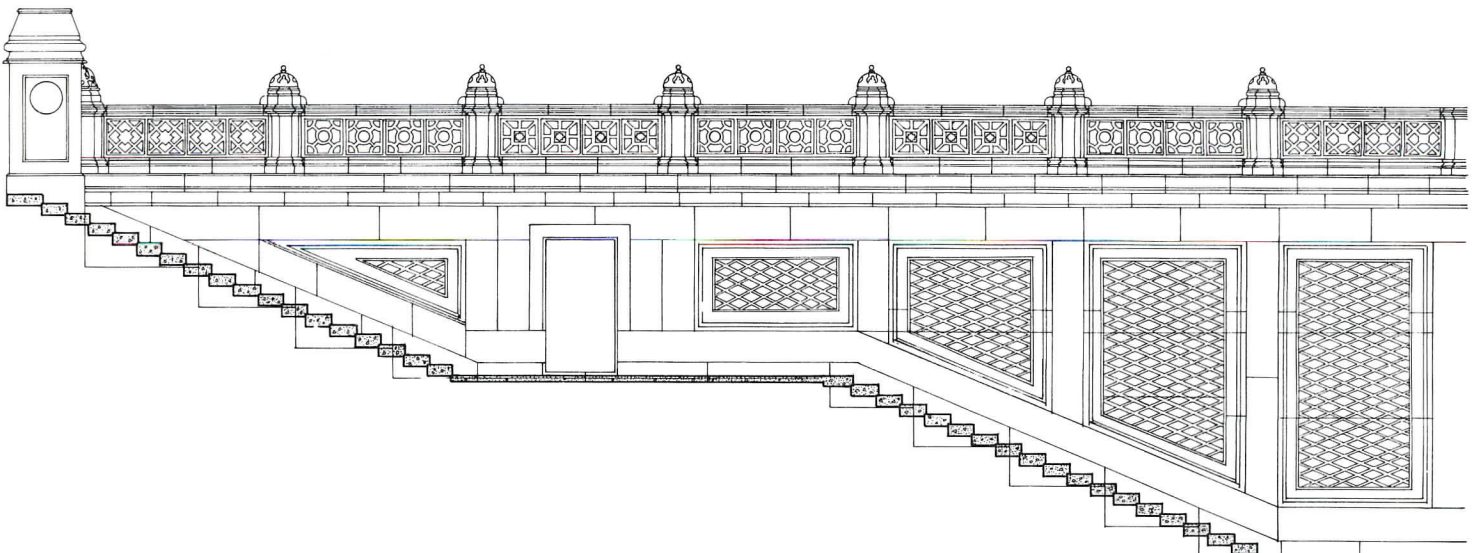

New products

West Week 1986

From March 19-21 the nation's contract furnishing manufacturers, invited speakers, and members of the press joined with local designers at the Pacific Design Center in West Hollywood for West Week 1986. This year's program, entitled "Art, Technology & Design," combined a series of lectures and panel discussions, which brought an impressive number of architectural luminaries to Los Angeles, with a showcase of the manufacturers' newest products. Several of these products are shown here.

1. Fabric

The *Lembo/Bohn Leaf and Berry* collection of fabrics includes woven tapestry and jacquard and printed velvet designs. Intended for use with the manufacturer's office and full-height partition systems, each nature-inspired design is available in a selection of 15 colors. SunarHauserman, Norwalk, Conn. Circle 300 on reader service card

2. Seating

The *QQ Seating Line* designed by Robert Taylor Whalen features managerial chairs with polystyrene shells, molded polyurethane foam cushions, self-skinned polyurethane armrests, and five-star injection-molded thermoplastic bases. A variety of models is available, and all versions come with either a mechanical or gas height-adjustment mechanism. Fabric, vinyl, or leather upholstery may be specified. Corry Jamestown Corp., Div. of Hon Industries, Corry, Pa. Circle 301 on reader service card

3. Desks and credenzas

The new *1000* and *1500* series of desks and credenzas are additions to the manufacturer's collection of wood office furniture. Designed by Robert Taylor Whalen, the desks and credenzas can accommodate electronic office equipment. A variety of configurations is available. Stow & Davis Furniture Co., Div. of Steelcase, Inc., Grand Rapids, Mich. Circle 302 on reader service card

4. Open office system

After five years of design development, the manufacturer has introduced the *Morrison System* for open offices. The work of a design team headed by Andrew Morrison, the system consists of three basic components: freestanding steel and fiberglass vertical panels, available in four heights; work surfaces cantilevered from the panels or supported by pedestals that provide storage space; and overhead storage cabinets and shelves, also cantilevered from the vertical panels. Available finishes include 17

textile lines, three plastic laminates, and seven wood veneers. Knoll International, Inc., New York City. Circle 303 on reader service card

5. Chairs

The *Quinta* chair (left) and *Sesta* armchair (right), designed by Mario Botta, are recent additions to the manufacturer's collection of the Swiss architect's furniture. The *Quinta* has a metal tube frame and a resilient perforated metal seat and backrest. The *Sesta* has a perforated metal frame and a leather seat and backrest, and is available in three sizes. International Contract Furnishings, Inc., New York City. Circle 304 on reader service card

6. Task lighting

The *Ciao* table lamp was designed by Ezio Didone. The octagonal extruded-aluminum base is 5 in. wide, 5.5 in. long, and 3 in. high, and is connected by a flexible steel tube neck to the lamp head, which contains a 20-watt halogen bulb. The lamp head can rotate 330 deg, and the base can be wall-mounted. Both lamp head and base may be specified in white or red enamel or matte black enameled aluminum. Atelier International Lighting, Inc., New York City. Circle 305 on reader service card

7. Fabrics

New additions to the manufacturer's *Millennium* collection include *Jardiniere* (left) and *Crescendo* (right). *Jardiniere* features alternating bands of silk and satin woven into a floral pattern. The curved lines of *Crescendo* are woven into a cotton velvet. Each pattern is available in a selection of colors. Jack Lenor Larsen, New York City. Circle 306 on reader service card



Bill Kowitz



For more information,
circle item numbers on
Reader Service Card

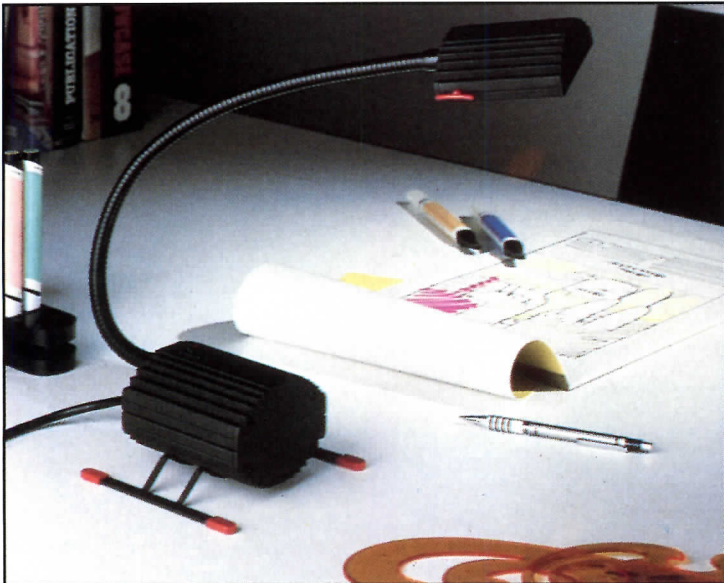
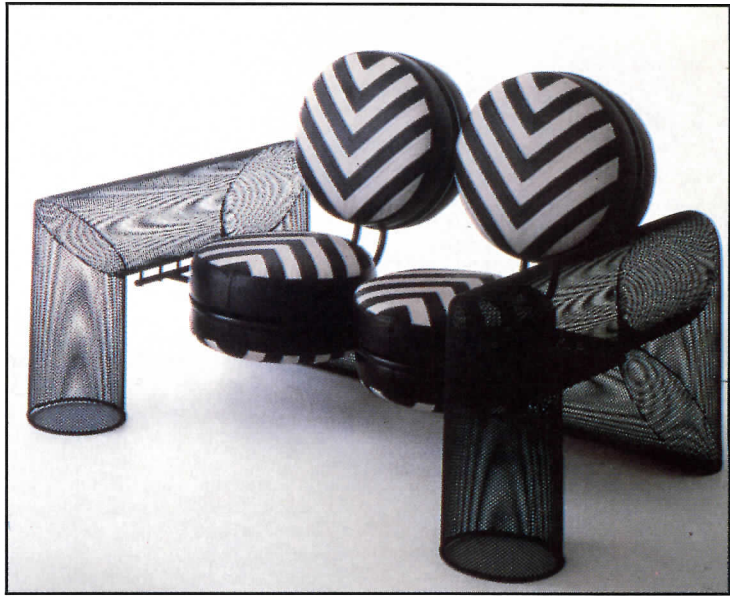
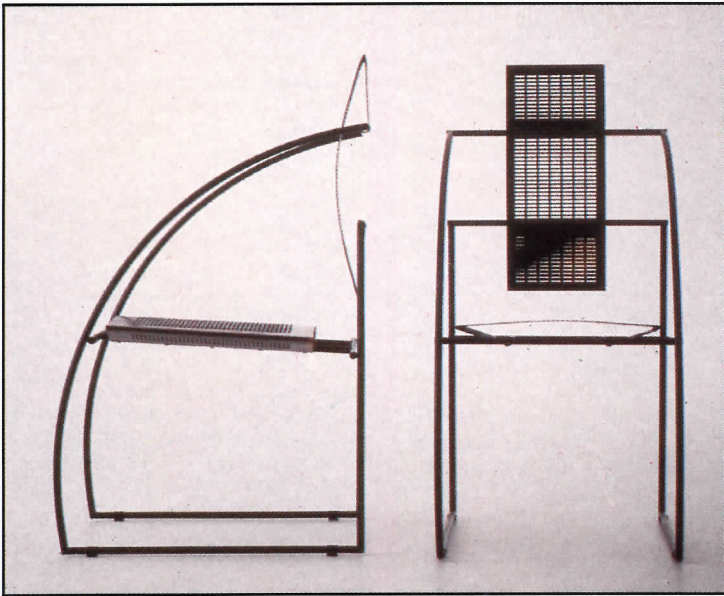
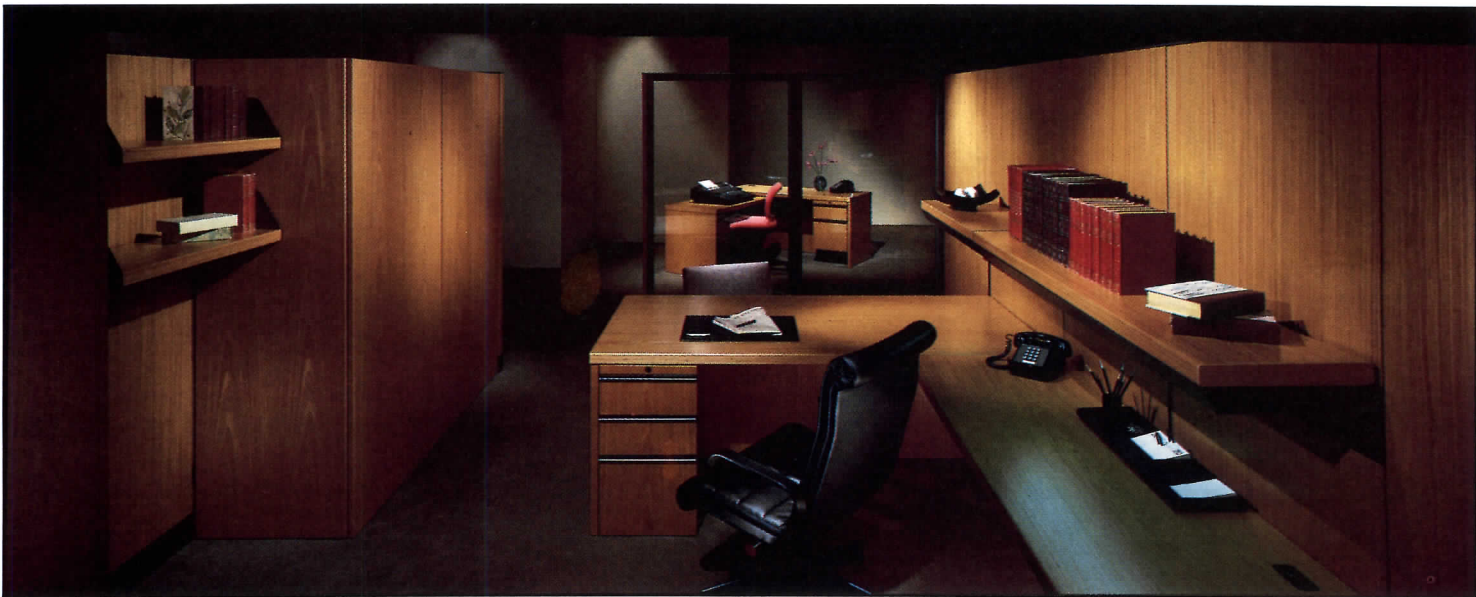



Greenhouses

A 32-page color brochure describes the manufacturer's line of solariums and greenhouses. The literature offers information on optional accessories and examples of recommended applications. Detailed specification guides, pricing charts, and other ordering information are also included. Lord & Burnham, Irvington, N. Y.
Circle 400 on reader service card



Faucets

A 12-page color catalog features the manufacturer's *Renaissance* and *Chalyce* collections of decorative faucets and fittings for bath, kitchen, and bar applications. The catalog contains photographs of a variety of different styles as well as the five finishes that are available. Chicago Faucets Co., Des Plaines, Ill.
Circle 406 on reader service card



Windows and doors

Insulation properties, performance ratings, and safety code approvals are included in a 16-page color catalog describing residential and commercial replacement windows and doors. The catalog features nine different styles of windows and a rolling patio door: Vinyl Building Products, Inc., Oakland, N. J.
Circle 401 on reader service card



Flooring

An 8-page color brochure describes the manufacturer's standard- and heavy-duty safety flooring, designer flooring, and textured flooring for wet conditions. The information includes detailed descriptions, diagrams, and examples of recommended applications. Compass Flooring, Inc., South San Francisco, Calif.
Circle 407 on reader service card

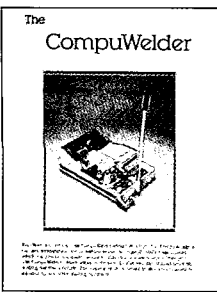

Roof welder

A 4-page brochure contains a case study comparing the *CompuWelder* computerized hot-air welding device for single-ply roofing applications to two other welders. The study discusses projected savings, strength of the weld, uniformity of the seam, and peel resistance. J. P. Stevens & Co., Inc., Northampton, Mass.
Circle 402 on reader service card

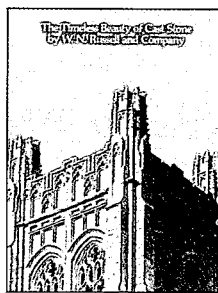

Cast stone

Ten examples of the manufacturer's cast stone designed to simulate brickwork, terra cotta, limestone, brownstone, sandstone, granite, bluestone, and slate are shown in an 8-page color brochure. Each example includes the architect, year of construction, and salient features. W. N. Russell and Co., Westmont, N. J.
Circle 408 on reader service card

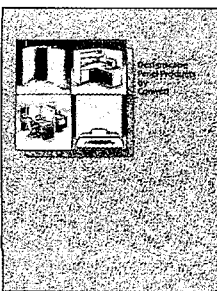

Acoustical panels

Acoustical and non-acoustical panels designed to stand alone or as complete furniture systems are featured in an 8-page color brochure. The literature includes information on ordering and installation as well as on the variety of sizes, colors, and finishes available. Conwed Corp., Minneapolis.
Circle 403 on reader service card

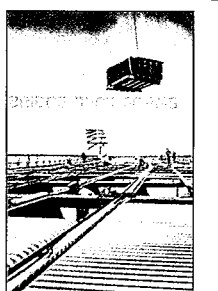

Bridge deck form

A 6-page color brochure features the manufacturer's flat soffit-long span bridge deck forms. The literature contains detailed specifications, descriptions, and section properties (per ft of width) as well as cross-sectional diagrams. Bowman Metal Deck Division, Pittsburgh.
Circle 409 on reader service card

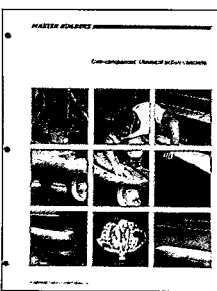

Concrete repair

A 4-page brochure featuring *Set-45*, a chemical-action concrete repair product, includes charts detailing compressive strengths, freeze/thaw durability, and scaling resistance of both the normal- and hot-weather formulas. Master Builders, Inc., Cleveland.
Circle 404 on reader service card

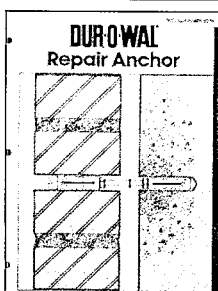

Masonry accessories

The manufacturer's repair anchors are described and illustrated in a 4-page bulletin. The literature contains detailed product information on concrete, concrete block, steel, and wood stud anchors as well as installation accessories that are also available. Dur-O-Wal, Inc., Northbrook, Ill.
Circle 410 on reader service card

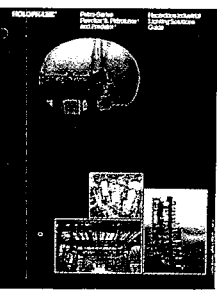

Industrial lighting

Hazardous location industrial lighting is featured in a 32-page color solutions guide. Summaries of typical hazardous atmospheres, application examples, and performance characteristics of the manufacturer's line of lighting products are included. Holophane Div. of Manville, Denver.
Circle 405 on reader service card

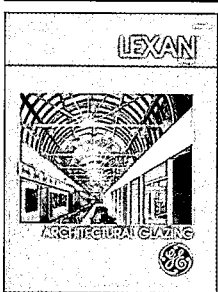

Polycarbonate glazing

An 18-page color brochure features the manufacturer's overhead, vertical, thermal, and bullet-resistant glazing products. Code compliance data, cleaning and maintenance information, technical product data, and glazing and installation guidelines are also included. General Electric Co. Plastics Group, Pittsfield, Mass.
Circle 411 on reader service card

Nothing tops a Hi-Tuff™ roof.



Building owner: Critikon, Inc., a Johnson & Johnson company; Architect: The Kling Partnership; General contractor: The Henderson Corporation; Roofing contractor: Roth Brothers of Florida, Inc.

This Stevens Hi-Tuff single-ply roofing system will provide Critikon, Inc., a Johnson & Johnson company in Tampa, Florida, with attractive, weather-resistant protection for years to come.

Hi-Tuff, based on Du Pont Hypalon* synthetic rubber, is extremely UV resistant. It's hot-air welded on the roof to create watertight seams. Because Hi-Tuff is mechanically fastened, no ballast is needed, yet Hi-Tuff roofs exceed by 50% the Factory Mutual I-90 rating for wind resistance. Hi-Tuff is rated UL Class A for fire resistance. Its white, highly reflective surface is aesthetically pleasing and can provide measurable energy savings as well.

Single-ply technology is state of the art in roofing systems today, and among single-ply systems, nothing tops a Hi-Tuff roof. Each Hi-Tuff roofing system is backed in writing by Stevens, one of America's largest corporations.

For more information and a welded sample, write to J.P. Stevens & Co., Inc., Roofing Systems, Northampton, MA 01061-0658, or call 413/586-8750.

*registered trademark of Du Pont

Circle 64 on inquiry card

STEVENS
Roofing Systems

The personal computer that continues to raise high performance to new heights.

If you work with high volumes of information, you need answers fast.

Which is why IBM created the Personal Computer AT.[®] The PC designed to push high performance even higher.

The power of Advanced Technology.

Turn on the power, and you'll notice the advances right away.

To begin with, the Personal Computer AT can compute with astonishing speed. That's something you'll appreciate every time you recalculate a spreadsheet. Or search through a data base.

It can store mountains of information—up to 15,000 pages' worth—with a 30-megabyte "hard file" (fixed disk). And when business gets bigger, you can double your capacity to 60MB with a *second* hard file.

Advanced Technology advances again.

Fast as it is, new models of the Personal Computer AT run up to 33% faster.

Plus, you can now select an enhanced keyboard. It has separate cursor keys, a separate numeric keypad (for easier data entry) and twelve function keys. It also has a main typing section patterned after the classic IBM Selectric[®] keyboard, which makes word processing easier than ever.

In addition, you can also choose a new option that lets you use 3.5-inch diskettes with your Personal Computer AT.

Family ties.

The Personal Computer AT is compatible with the IBM PC and PC/XT. So it can run many of the thousands of programs written for the IBM PC family.

And with new IBM products, the Personal Computer AT can more easily communicate with other PCs.

IBM's networking options, for example, let you share files from a variety of popular programs.

While the IBM PC 3270 Emulation programs let you retrieve information from a mainframe.

You can also use the Personal Computer AT to run IBM PC XENIX[™]—an enhanced multi-user, multi-tasking operating system.

A powerful value.

Only the Personal computer AT offers these capabilities *and* IBM's commitment to quality, service and support. A combination that can't be cloned.

Better still, you'll find that the new models offer higher performance without a higher price. And if you qualify, you can conveniently charge your Personal Computer AT on IBM's Credit Card. Or lease one with the IBM Commercial Lease Agreement.

See the Personal Computer AT at an Authorized IBM PC Dealer or IBM Product Center. Or call your IBM representative.

For the name of a store near you, call 1-800-447-4700. In Alaska, call 1-800-447-0890.

The IBM Personal Computer AT, for Advanced Technology.

IBM, PC/XT and Personal Computer AT are trademarks of International Business Machines Corporation. XENIX[™] is a trademark of Microsoft Corporation. Based on SYSTEM V.

Circle 65 on inquiry card



IBM[®]

©Copyright IBM Corporation 1986



In restoring this venerable hotel on the Grand Canyon, window replacement by Pella helped meet the grand challenge.

It was 1905 when El Tovar Hotel first extended a splendid Grand Canyon welcome to passengers at the end of the Santa Fe Railroad line. Over the decades, the intense sun and windy winters had taken their toll on this flagship of the Harvey Hotel fleet. The hand-stripped Oregon pine logs were irreparably weathered. The roof and windows leaked. And this great lady had been shorn of much charming detail.

Now, El Tovar has been restored to its original grandeur on a scale that befits its setting and its illustrious past, recalling the days when it sported verandas and roof gardens, a dairy and greenhouse and the luxury of steam-generated electricity.

But the days are gone when a room without bath commanded a princely four dollars a night. In the 11-million-dollar adaptive restoration, the hundred guest rooms were reduced to 77 to accommodate private baths.

The architects met monumental challenges at El Tovar. A sway-backed roof was jacked up and replaced while the kitchen below never missed a meal. The entire exterior had to be reskinned but no modern mill was found who could duplicate the hand-peeled exterior slab logs, until an ad placed in a lumber magazine drew a response from an Idaho mill.

For historical accuracy, the architects worked largely from old photos and blueprints to replace windows and duplicate such exterior details as railings, scrollwork, peculiar decorated posts and wood finials which had been removed 25 years earlier.

Pella fits the demands.

To replace over 150 rotting windows on a tight schedule, the architects turned to Pella for a wide variety of clad wood windows in the same patterns and sizes as the originals. A mix of casement, awning and double-hung windows from Pella's full range of standard sizes, as well as custom Pella Windows, fit the hotel's original openings precisely with no special trim or labor-intensive shimming required.

The local Pella distributor built fixed transoms, assembled them into composites with Pella Casement Windows and installed

Pella-made wood muntins which duplicate the initial window details, as well as custom hardware.

Custom Clad Colors

When the Forest Service insisted that the frames be black for authenticity, Pella gave much more. In specifying a custom color, only one week is added to normal delivery time. The Pella Clad System of enameled aluminum combats the hot sun, chilly nights and high altitude UV radiation that conspire to break down painted and stained surfaces. Pella Clad Windows maintain color stability and resist fading, chalking, chipping, peeling and other signs of age. Inside, the authentic beauty of real wood.

Energy savings

Pella's Double Glazing Panel System and insulating glass were chosen to save energy. Pella offers seven different standard glazing and shading options to meet energy requirements for any climate. Pella Casement Windows seal out air infiltration up to 16 times better than industry standards require.

Some code-required Pella egress windows were specified, while the rest of El Tovar's casement, awning and double-hung sash move toward the center of the frame or pivot for easy washing from indoors.

Your Pella distributor can tell you more about it. For information, look for Pella in the Yellow Pages under "Windows". Call Sweet's BUYLINE or see Sweet's General Building File. Or send the coupon below.

Please send me the latest literature on Pella for replacement and new construction.

Name _____

Firm _____

Address _____

City _____

State _____ Zip _____

Telephone _____

This coupon answered in 24 hours.

Mail to: Pella Windows and Doors, Commercial Division, Dept. T31E6, 100 Main Street, Pella, IA 50219. Also available throughout Canada.
©1986 Rolscreen Co.

Pella. The significant difference in windows.

El Tovar Hotel

Owner
Fred Harvey, Inc., Grand Canyon, AZ

Architect
Alton S. Lee and David A. Lee, Architects, Menlo Park, CA

Contractor
D.L. Norton General Contracting, Inc., Scottsdale, AZ

Circle 66 on inquiry card



When your new concept has you between a rock and a hard place, call us in.

Vistawall's expert engineering turns difficult stone installations into flexible, cost-efficient curtain wall systems.

Architect: Smallwood, Reynolds, Stewart, Stewart & Associates, Inc., Atlanta, Georgia.

It involves many painstaking hours to design an intricate stone exterior. However the job doesn't end there.

Further precision engineering is required. And then it all has to work within a budget.

Vistawall has created stone-capable curtain walls that put the installed cost of a stone exterior

well within the range of traditional curtain wall systems.

Our advanced systems give your project the natural, aesthetic appeal of stone and yet often require less structural steel than ordinary stone systems. And it's all backed by our staff of engi-

neers who make sure your exterior will be rock solid.

See how easy it is to fill the void between your rock and a hard place. Write Vistawall at P.O. Box 629, Terrell, TX 75160. Or call (214) 563-2624. (Sweets 8.14/VIS)

VISTAWALL
ARCHITECTURAL PRODUCTS
A division of Butler Manufacturing Company

Circle 67 on inquiry card



Signage
A 58-page color catalog features the manufacturer's interior and exterior signage series. Detailed product specifications such as materials, lettering processes, typefaces, sizes, and available mounting methods are included along with ordering information. Adelpia Graphic Systems, Exton, Pa.
Circle 412 on reader service card

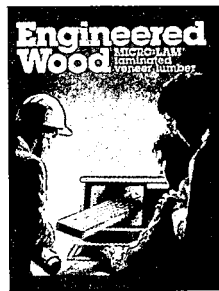

Laminated lumber
A 6-page brochure provides information on the manufacturer's *Micro=Lam* laminated veneer lumber. Included in the material are product descriptions, strength range comparisons, and a table of acceptable design stresses designated by the Council of American Building Officials. Trus Joist Corp., Boise, Idaho.
Circle 418 on reader service card



Home management system
A one-page fact sheet highlights the *HomeBrain* computerized management system. The system is said to control home heating and cooling systems, lights, appliances, and security to the homeowner's specifications. The literature discusses standard features and general background information. Hypertek, Inc., Whitehouse, N. J.
Circle 413 on reader service card



Bathroom design
A 10-page color brochure features eight bathrooms designed by Mark I. Kaufman and Beverly Trupp. Detailed descriptions of each bathroom along with floor plans and fixture specifications are also included. Owens-Corning Fiberglass Corp., Toledo, Ohio.
Circle 419 on reader service card

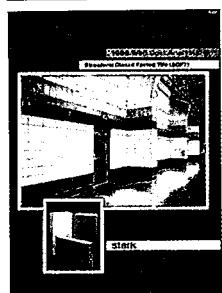

Wall-cost guide
The benefits and costs of various interior wall types are contained in a 4-page color brochure. The literature includes a cost comparison chart for glazed facing tile walls, painted and prefaced concrete block walls, and gypsum drywall on metal studs. Product descriptions are also included. Stark Ceramics Inc., Canton, Ohio.
Circle 414 on reader service card

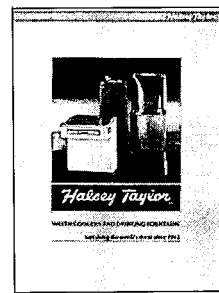

Drinking fountains
The manufacturer's line of water coolers and drinking fountains including its upright stone pedestal drinking fountain and fully recessed cup dispenser/glass filler are included in a 24-page catalog. The information contains dimensional drawings, performance data, and product summaries. Halsey Taylor, Freeport, Ill.
Circle 420 on reader service card

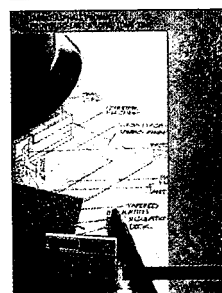

Asphalt roofing products
A 32-page color booklet provides detailed information on the manufacturer's line of asphalt roofing products. Built-up roofing specifications, roof deck requirements, vapor retarders, application recommendations, and available options are also included in the literature. Tamko Asphalt Products, Joplin, Mo.
Circle 415 on reader service card



Exhaust fans
Ceiling, in-line, wall, and cabinet fans are highlighted and illustrated in a 12-page color brochure. The literature includes product descriptions, certified ratings, performance and dimensional data, and typical applications. Optional accessories and controls are also included. Penn Ventilator Co., Inc., Philadelphia.
Circle 421 on reader service card



Conference tables
The *Series 7000* line of conference tables is featured in a 16-page color brochure. Eight different table types are highlighted along with their respective selection of base alternatives. Table measurements and available wood and metal finishes are also included. Dar/Ran Furniture Industries, High Point, N. C.
Circle 416 on reader service card

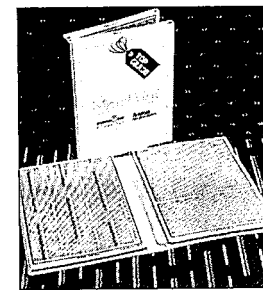

Carpet
A sample book of *Micro Point* commercial carpeting is available from the manufacturer. The book features the *Striata*, *Duo-Dot*, and *Quadra Point* design collections. The carpeting comes in 11 colors; is made of synthetic construction, and can be installed with either padding or by direct glue-down process. Top Grade, Inc., Metuchen, N. J.
Circle 422 on reader service card

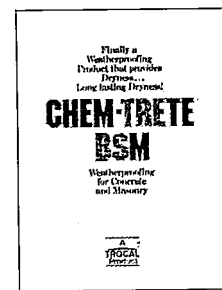

Concrete sealant
Chem-Trete BSM concrete and masonry sealant is described in a 12-page booklet. The literature contains descriptions of product features, listings of applicable surfaces, examples of product use, and detailed information on application specifications and techniques. Dynamit Nobel of America, Inc., Rockleigh, N. J.
Circle 417 on reader service card



Seamless flooring
A 4-page selector guide features the manufacturer's line of seamless epoxy flooring. The guide includes comprehensive product descriptions, detailed mechanical and physical property explanations, and information regarding the flooring's resistance to various chemicals. Hallemite, Providence, R. I.
Circle 423 on reader service card

Door Control – The DORMA Way

As the world leader in hydraulic door closers, we have a commitment to excellence. With manufacturing facilities in West Germany, Brazil, Singapore, the United States and DORMA Sales and Marketing Subsidiaries in all five continents; we carefully listen to the architects' professional demands.

From simple door closing to sophisticated fire/life safety, our European designed DORMA TS fleet provides positive door control, without compromising your aesthetic values.

All DORMA TS and Fire/Life Safety door closers are certified to meet all major codes and standards.

To learn more about door control — the DORMA way, call or write:



DORMA Door Controls Inc.
Dorma Drive, Reamstown, PA 17567
215-267-3881

DORMA Door Controls Ltd.
1680 Courtney Park Drive, Unit 13
Mississauga, Ontario, Canada L5T 1R4
416-673-1281
Circle 68 on inquiry card

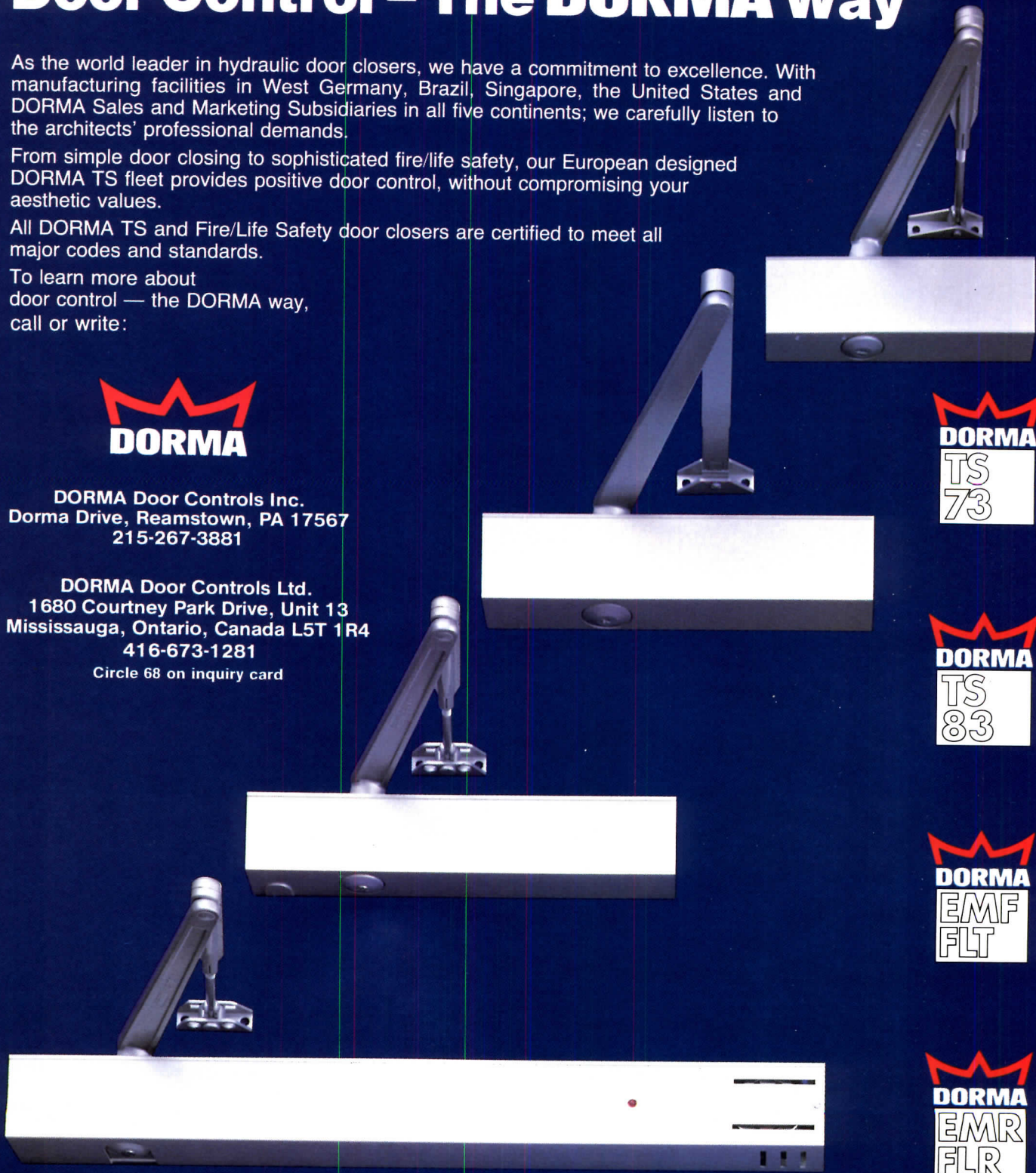



Alluring. Sleek. Conspicuously colorful.

Fluid, sweeping lines. And a wealth of graceful curves. But sharp as a knife when cornered.

Paraline® linear metal ceilings. From Donn Corporation.

A whole new perspective in design.



Donn Corporation
Westlake, Ohio 44145

Circle 69 on inquiry card

©1985 Donn Incorporated

Litho in U.S.A.

Donn®, the Donn logo and Paraline® are trademarks of Donn Incorporated.

To Measure Building Quality, Take the Back Stairs.

When you enter any building, go to the interior stairs. That's where you'll see and feel the building's quality up close. The stairs' design, strength, accuracy of fit, and overall appearance say more about the building than all the brochures, models, and renderings ever will. The stairs are seen and used every day by the people who count the most — the occupants. How will they perceive your building?

For over thirty years, the American Stair Corporation has been helping architects and contractors. Innovative products and modern design concepts are just part of the American Stair story. The *major* factor is quality.

Leading architects have found that exit stair systems from American Stair fit well with their designs. They have incorporated Speed Stair® in many award winning buildings.

For modern high quality stairs, go beyond the old "industrial" look of traditional fire stairs. Take advantage of the Early Design Development ServiceSM, exclusively from American Stair Corporation. Join the thousands of architects who have used American Stair products. We'll put our expertise to work for you, giving you more time to work on the more challenging and creative tasks.

Get your copy of "An Architect's Guide to Designing Stairs," the informative worksheet that organizes stair design efforts.

Call today! 1-800-USA-STAIRS.

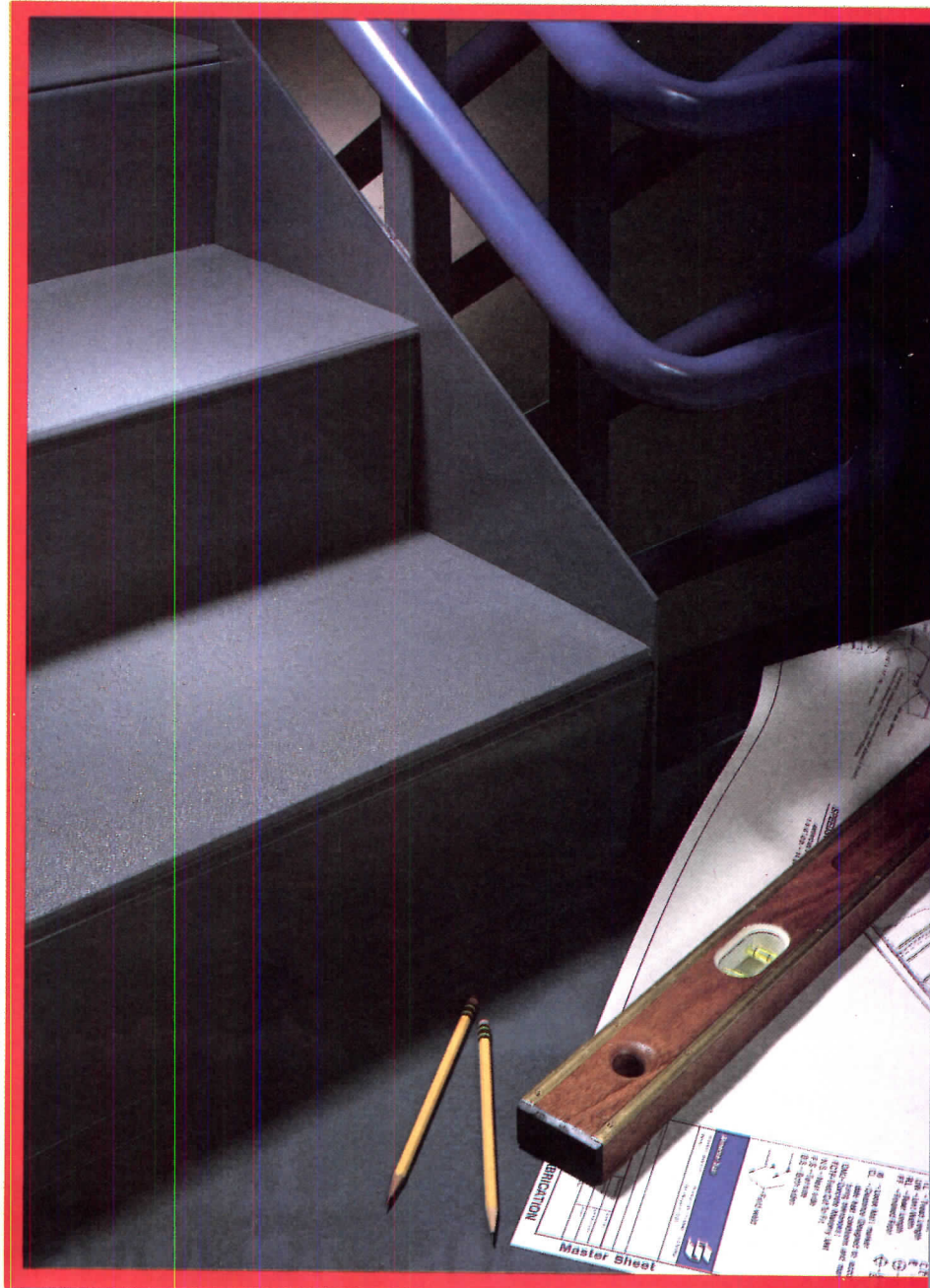

 **American
Stair**

American Stair Corporation
One American Stair Plaza
Willow Springs, Illinois 60480
800-USA-STAIRS/800-872-7824

Circle 70 on inquiry card

Who says you can only have one original?

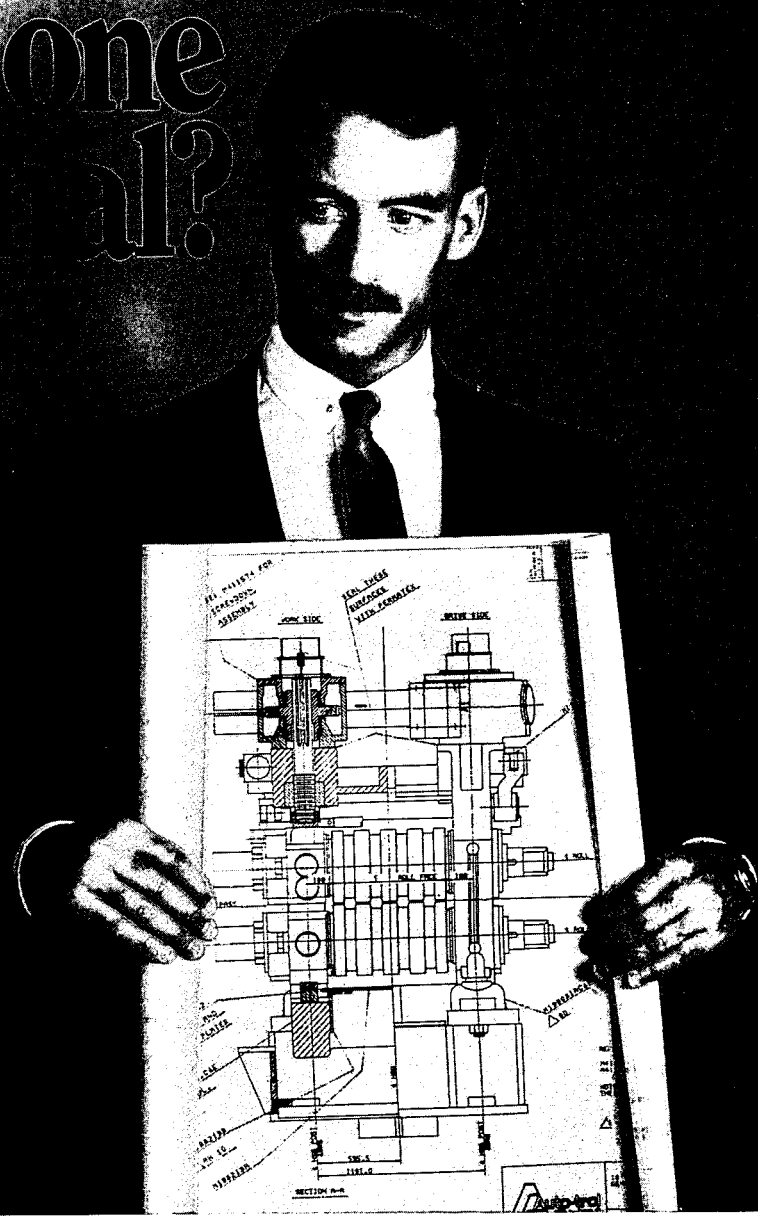

Clearprint No. 1000H-EE and No. 1020-EE vellum are manufactured specifically for use with engineering-size electrostatic copiers, such as the Xerox® 2080™, Shacoh® 36 Screen, and the Shacoh 920.

So you can have as many second "originals" as you'd like.

Each one will be permanent, transparent and reproducible. And give you the same unexcelled drafting, erasing, and handling characteristics as your original "original" on regular Clearprint vellum.

Like our regular vellum,

Clearprint EE stock is manufactured of 100 percent new cotton fiber. Treated with the same proprietary process we perfected more than 50 years ago.

It doesn't crack. Or discolor with age.

And it's available in both rolls and sheets, in both 16- and 20-pound weights.

You can try our regular drafting vellum by returning

the coupon below. We will send you a free kit containing all the tools you need to prove why it's the industry standard.

CLEARPRINT®
Making paper work

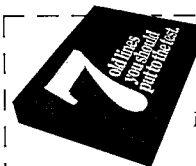

Please send me my free kit.

Mail to: Clearprint Paper Co.
P.O. Box 8703
Emeryville, CA 94662.
AR/P/56

Name _____ Phone _____

Title _____

Company _____

Address _____

City _____ State _____ Zip _____

Circle 71 on inquiry card

At last, the world's
best-selling portable computer
has a little competition.

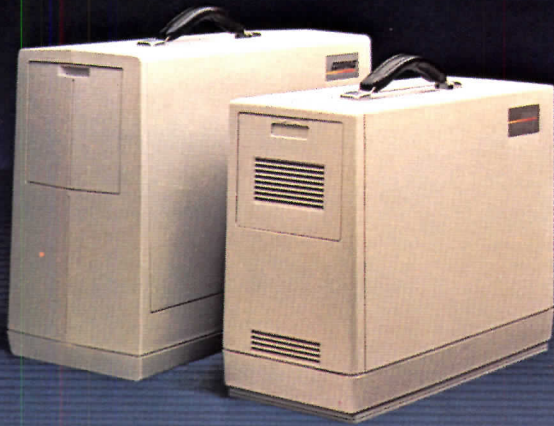

It's 30% smaller

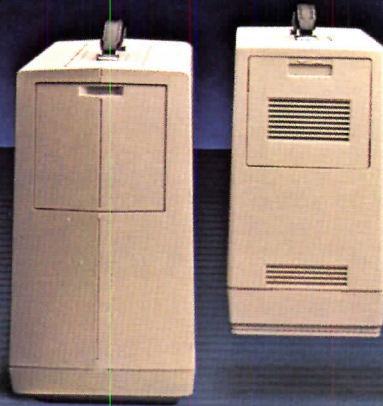

17% lighter

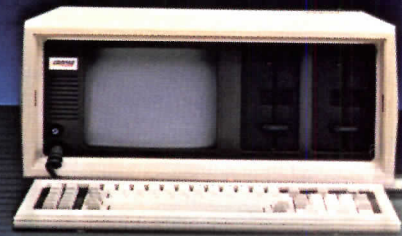

400% faster

Introducing the remarkable new COMPAQ PORTABLE II

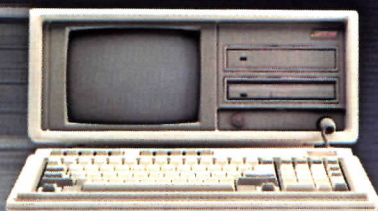

Now there's a portable personal computer so small, so light, and so fast it defines a new industry standard. From the same company that set the standard—COMPAQ®

The new advanced-technology COMPAQ PORTABLE II™ has all the advantages of the world's best-selling full-function portable—the original COMPAQ Portable—plus it's even more portable. And it's far more powerful than most desktop computers.

With its 80286 microprocessor, the COMPAQ PORTABLE II can run all the popular business software written for IBM® Personal Computers. At speeds *three to five times faster* than the COMPAQ Portable, IBM PC/XT™, and other compatibles.

It's more computer in less space

Never before has a computer this small been capable of so much. Making the COMPAQ

PORTABLE II 30% smaller and 17% lighter—with no reduction in monitor size and a big gain in functionality—was an engineering triumph. The result is a full-function, advanced-technology personal computer that's easy to take on business trips or carry from desk to desk.

A computer for now and for the future

The COMPAQ PORTABLE II excels in compatibility. And because of its standard 360-Kbyte diskette drive format, your data diskettes will be fully interchangeable with other COMPAQ, IBM, and compatible personal computers.

Expandability? An optional 10-Megabyte fixed disk drive stores over 5000 pages of data. RAM expands to 2.1 Megabytes without an expansion slot, and with one expansion slot RAM can expand to 4.1 Megabytes. Since interfaces for the most popular peripherals are already

built in, the two expansion slots can be used for *connecting* your computer to others: add a modem, a networking board, or a board for communicating with your mainframe.

No compromises

The COMPAQ PORTABLE II puts tremendous computing potential within the grasp of every computer user. It's backed by the service and the support of over 2900 Authorized COMPAQ Computer Dealers worldwide. Plus, it's made by the undisputed world leader in portable personal computers. And for that title, there's no competition.

For the name of the dealer nearest you, call toll-free 1-800-231-0900 and ask for Operator 16. In Canada, call (416) 449-8741. In Europe, telex 84117898630AB; 898630 COMPAQ TTX D.

IBM® is a registered trademark and IBM PC/XT™ is a trademark of International Business Machines Corporation. ©1986 COMPAQ Computer Corporation. All rights reserved.

It simply works better.

COMPAQ
PORTABLE II™

10 Of The Many Bright Ideas From Visa Lighting



CB780

CB780: 23" wide, 7" height, 6" extension.

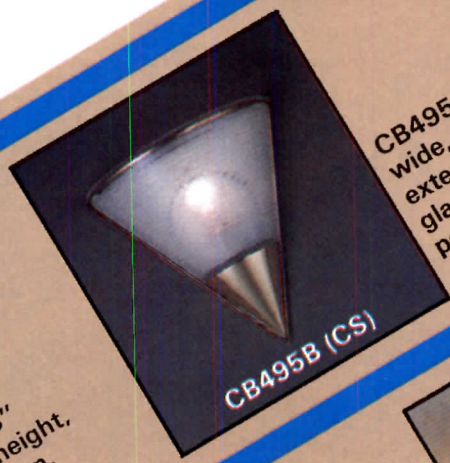

CB495B (CS)

CB495B (CS): 10 1/2" wide, 11" height, 5 1/2" extension, etched glass diffuser. Solid polished brass.

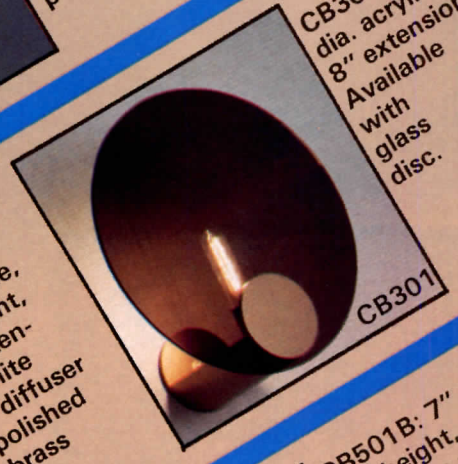

CB301

CB301-SGD: 15" dia. acrylic disc, 8" extension. Available with glass disc.

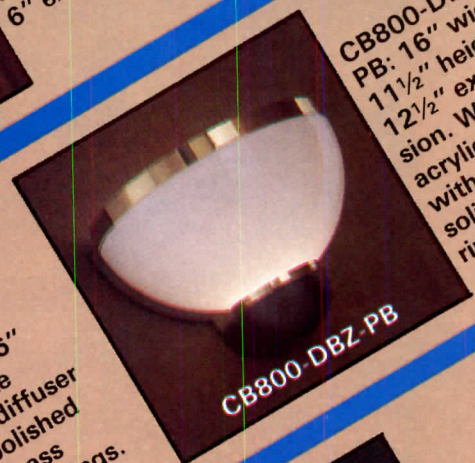

CB800-DBZ-PB

CB800-DBZ-PB: 16" wide, 11 1/2" height, 12 1/2" extension. White acrylic diffuser with polished solid brass rings.

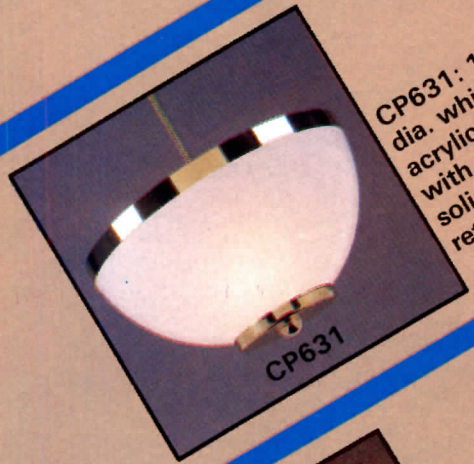

CP631

CP631: 16" dia. white acrylic diffuser with polished solid brass retaining rings.

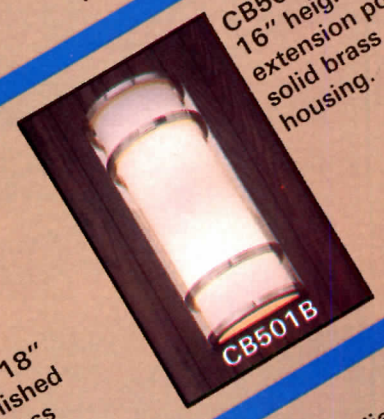

CB501B

CB501B: 7" dia., 16" height, 4 1/2" extension polished solid brass housing.

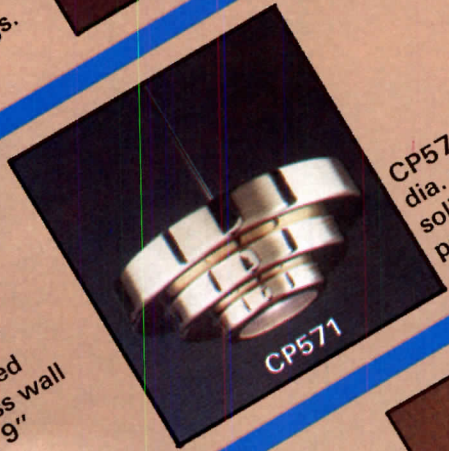

CP571

CP571: 18" dia. polished solid brass pendant.



CB931

CB931: 18" dia. polished solid brass wall sconce, 9" extension, 6 1/2" height.

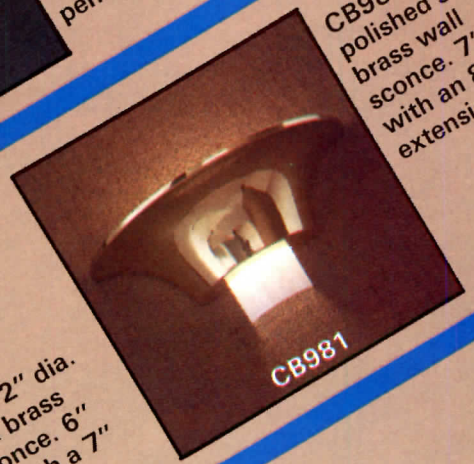

CB981

CB981: 16" dia. polished solid brass wall sconce, 7" height with an 8" extension.

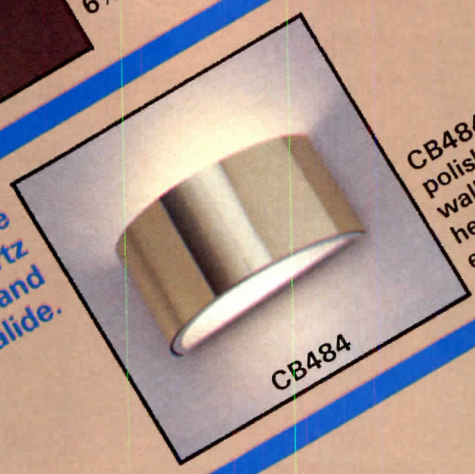

CB484

CB484: 12" dia. polished brass wall sconce, 6" height with a 7" extension.

Various lamping available including fluorescent, quartz halogen, incandescent, and metal halide.

Visa Lighting
8600 W. BRADLEY ROAD
MILWAUKEE, WI 53224
(414) 354-6600

Circle 72 on inquiry card

COPPER COMES OF AGE

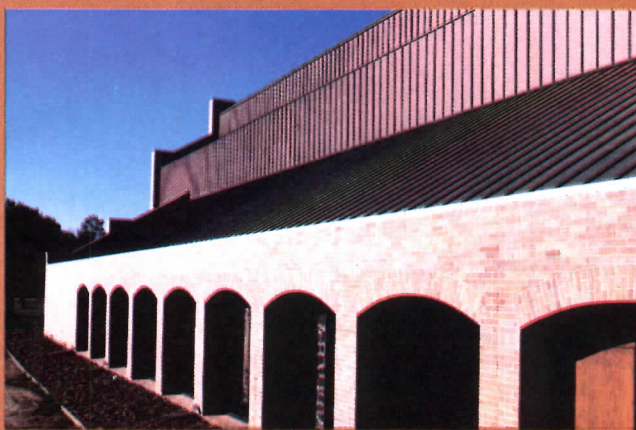

Copper comes of age! Alumax offers a wide range of simulated copper coatings. The selection includes Metallic Copper (non-ageing), Ageing Copper, Pre-Aged Copper, Patina Green and 16 oz. Pure Copper. Call or write today for complete specifications.



ALUMAX
BUILDING SPECIALTIES DIVISION

P.O. Box 163 • 227 Town East Blvd.
Mesquite, Texas 75149 • (214) 285-8811

Circle 73 on inquiry card

FINALLY!

A FLUSH POKE-THRU



The Headless Poke-Thru is here.

If you're an architect or interior designer we just "made your day". We finally got rid of the electrical outlet "doghouse".

If you're a specifying engineer, you'll be happy to hear that Raceway has developed the first **Flush Poke-Thru** with full capacity... two services

in a single 3" hole; 15 or 20 amp, 125V duplex receptacle power. Plus two individual openings for low tension wiring for telephone, signal or data communications. **U.L. Classified and Listed.**

If you're a contractor, put this into your calculator. The Raceway **Flush Poke-Thru** comes factory pre-wired, terminating in a junction box which is **integral to the fitting.** (Perfect for renovation since it installs over

existing wires.) Just drill the hole... step on it... you're finished.

There are so many more exciting features. Color-coordinated choice of retainer ring... a sliding polycarbonate receptacle cover... but that's why we printed a brochure. It's all in there.

Send for it. Join the rush to get flush. Write or call Raceway Components, Inc., 263 Hillside Avenue, Nutley, N.J. 07110. 201-661-1116.



RACEWAY COMPONENTS, INC.

Mfg. I.B.E.W.

U.L. Classified and Listed

Pat. Pending

Circle 74 on inquiry card

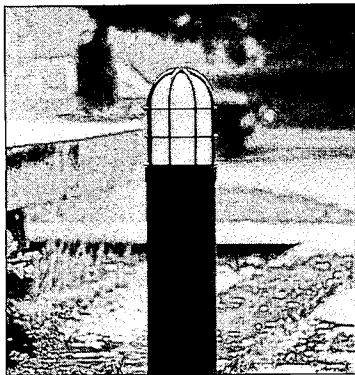

Outdoor lighting

The *BEGA* collection of outdoor lighting includes location and directional luminaires, wall and ceiling luminaires, bollards, floodlights, and pole-top luminaires. The fixtures are available with incandescent, compact fluorescent, and H.I.D. light sources, and the housings are said to withstand the damaging effects of dirt and moisture. Forms + Surfaces, Santa Barbara, Calif.

Circle 313 on reader service card

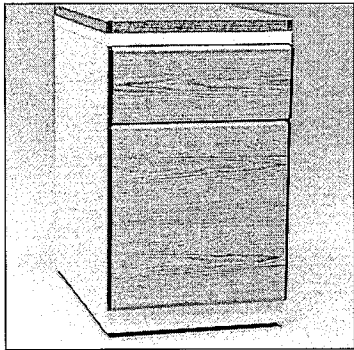

Storage units

The manufacturer's line of steel storage units is now available with red oak veneer door and drawer fronts. The *Storage Centers* and *WorkStore Personal Pedestals* can also be specified in a variety of laminate and enamel colors. Office Specialty, Chicago.

Circle 315 on reader service card

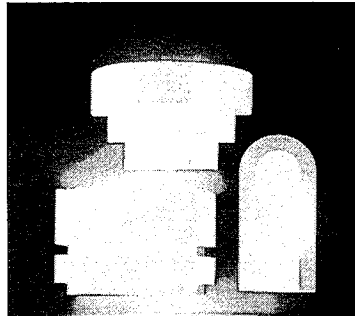

Wall sconces

A new series of wall sconces includes the *Metro Quarter Sphere*, which provides indirect illumination; the *Cascade I* and *Cascade II*, for both direct and indirect lighting; and the *Deco* low-wattage compact fluorescent lamp. Each sconce is available in several finishes. Halo Lighting, Elk Grove Village, Ill.

Circle 316 on reader service card

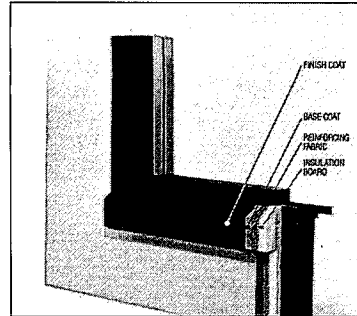

Exterior wall-finish system

The manufacturer's exterior insulation finish system includes prefabricated panels that consist of expanded-polystyrene insulation board, reinforcing fabric, a base coat, and a finish coat over a steel stud/gypsum sheathing panel. Synergy Methods, Inc., Cranston, R. I.

Circle 317 on reader service card

Continued on page 165

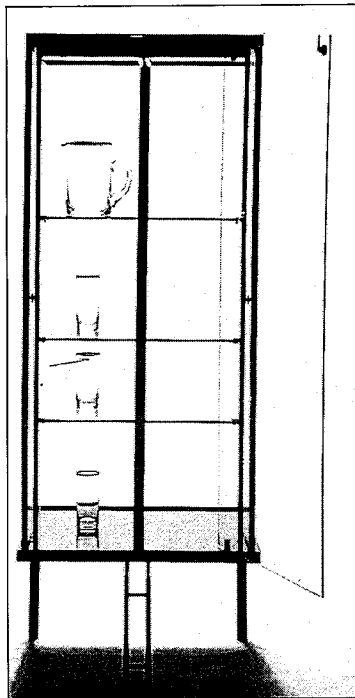

Display case

The *Asolo Junior* display case features three adjustable shelves, a lockable tempered glass door, and optional halogen lighting. The top and bottom of the case's metal frame can be specified with a shiny or matte lacquer finish, and the vertical supports can be painted with matte black or white epoxied powders. Ambienti, Redondo Beach, Calif.

Circle 314 on reader service card

Zero

"sound-stop" door systems mean higher STC ratings

Easier installation means lower total costs

Write for our 28 page catalog today. Over 200 full scale drawings featuring zero systems including saddles.

ZERO INTERNATIONAL, INC.,
 415 CONCORD AVENUE BRONX, NEW YORK 10455-4898
 TELEPHONE: 212-585-3230 TELEX: 239777 ZERO UR

Circle 78 on inquiry card

How does the Hartsfield Atlanta International Airport manage 45 football fields of facilities? With CADVANCE. The PC-based professional architectural Computer-Aided Design system.

DMA Architects Inc. maintains the entire airport design on CADVANCE—including more than 130 gates at 5 concourses, 4 runways, and an underground transit system. And that lets DMA's 5-person firm operate at a 25-person level.

DMA uses each of CADVANCE's 127 layers to define one aspect of the drawing. From walls to plumbing. From landscaping to aircraft configurations. So it's easy to consider proposed modifications. Recently, for example, four alternative International Concourse gate

configurations were developed in 20 minutes.

Hartsfield has been called the airport of the future. And CADVANCE helped make it happen. CADVANCE is the latest in a continuum of CalComp design products from PC-based software to large systems. No wonder CalComp has the most CAD products installed among architects and facilities planners. Call (800) CALCOMP for the name of your nearest CADVANCE dealer. Or write: CalComp, 200 Hacienda Drive, Campbell, CA 95008 (TELEX 188746).

And start designing the future yourself.

CALCOMP
A Sanders Company

**“EVEN THE
WORLD'S
LARGEST
AIRPORT
ISN'T TOO BIG
FOR
CADVANCE.™”**

Deryck Muehlhauser, A.I.A.

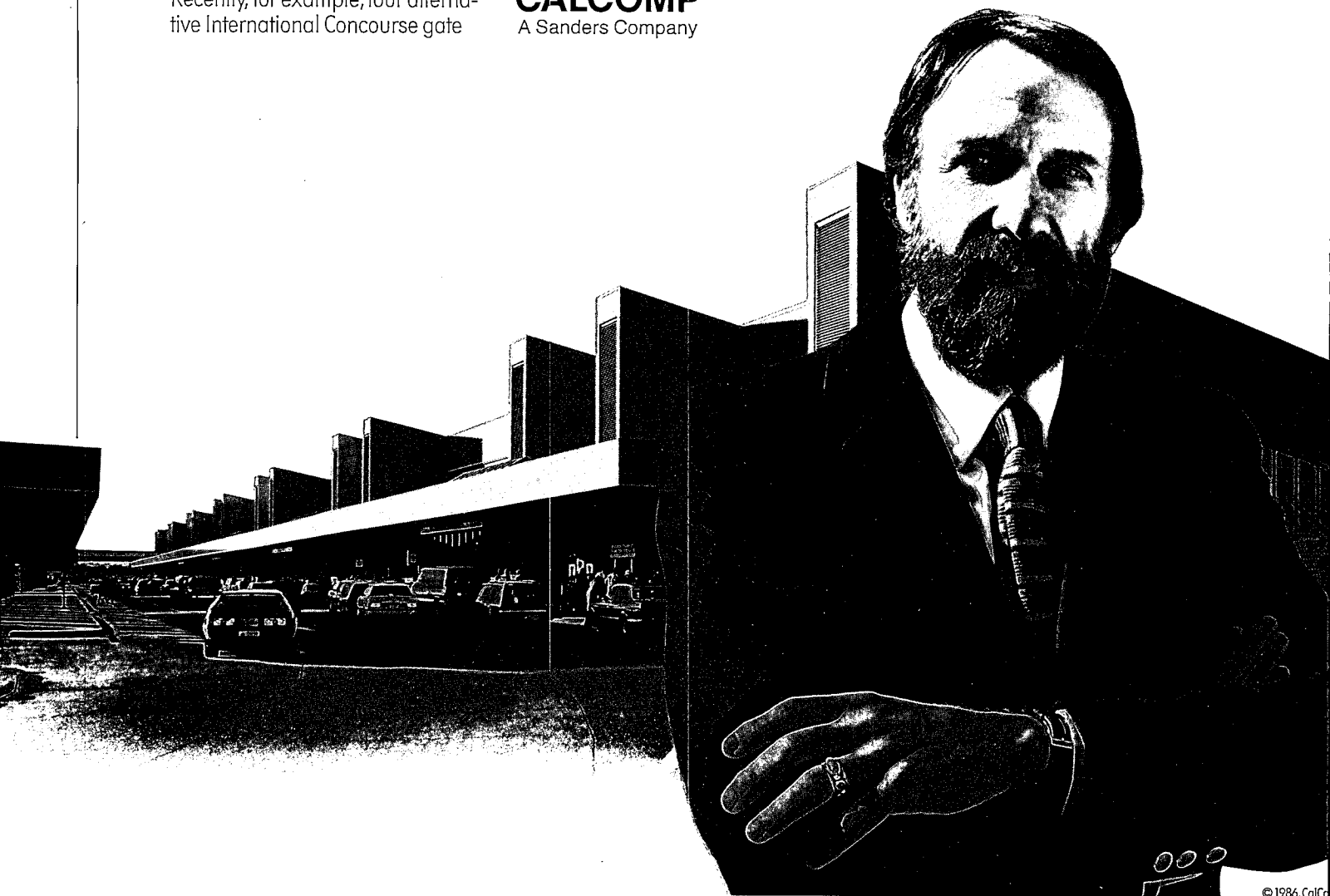

© 1986, CalCo

C A D V A N C E

THE ARCHITECTURAL CAD SYSTEM.

Circle 79 on inquiry card



Cabinet hardware

A collection of tubular nylon cabinet handles is designed to coordinate with the manufacturer's line of bathroom hardware and accessories. Available in a selection of 15 colors, the handles and knobs come in several shapes and sizes. Normbau, Inc., Addison, Ill.
 Circle 318 on reader service card



Sealant products

The manufacturer's line of sealant products includes a siliconized acrylic latex that is said to form a weatherproof gasket; a butyl sealant made of non-sag rubber caulk; and a silicone building

sealant designed for expansion and control joints. Rechargeable caulking guns are also available. Elco Industries, Inc., Rockford, Ill.
 Circle 321 on reader service card



Spiral staircases

Wood spiral staircases designed and hand-crafted by David G. Mulder can be tailored to individual requirements. The staircases can be specified with a variety of newel, baluster, volute, and handrail styles. David G. Mulder, Battle Creek, Mich.
 Circle 322 on reader service card
 Continued on page 167

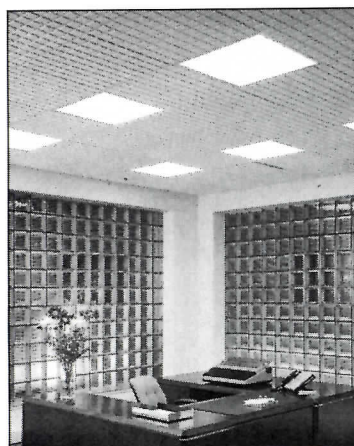

Acoustical grid

The *Centricitee* 9/16-in. acoustical grid system features a self-centering device to correctly position infill panels within grid openings. The system can accommodate standard module sizes from 2- by 2-ft to 5- by 5-ft. Donn Corp., Westlake, Ohio.
 Circle 319 on reader service card



Video telephone

Photophone is designed to send images of people, objects, and illustrations over the telephone lines. Intended to improve communication between the architectural office and the construction site, the videophone is said to transmit pictures within eight seconds, during which time voice communication is interrupted. Image Data Corp., San Antonio, Tex.
 Circle 320 on reader service card

DIMENSIONAL STONE

Marble • Travertine

Granite • Limestone

Slate • Sandstone

Onyx • Quartzite

SOURCE INFORMATION

TECHNICAL ASSISTANCE

SPECIFICATIONS

JOB INSPECTION SERVICE

Publishers of "Dimensional Stone—Volume III," the industry design and specification manual.



MARBLE INSTITUTE OF AMERICA, Inc.
 33505 State St., Farmington, MI 48024
 (313) 476-5558

Quality.

It began as an unassuming little word that, when paired with other words, became a compound adjective conveying a measure of status, as in, "He is a high-quality roofing contractor."

Then, to the considerable annoyance of grammarians and other linguistic gatekeepers, it evolved into a single descriptive term that meant the same thing, as in, "He is a quality roofing contractor."

And in a final blow for brevity, we began delivering our judgment about an individual's entire character with awesome subtlety by declaring, "He is *quality*."

Of course, if we follow this line of reasoning, then in the future we'll be able to simply say, "He is a *roofing contractor*." And it will mean the same thing.

At NRCA, we're working on it.



Circle 81 on inquiry card

**THANK GOODNESS
THIS AD ONLY RUNS
ONCE A YEAR.**



The following are some of the valued registered trademarks of Andersen Corporation, Bayport, MN: Andersen®, Windowwalls®, Perma-Shield®, the AW triangle, Flexivent®, Flexiview®, Beauty-Line®, Narroline®, Flex-Pac®, Strutwall®, Perma-Fit®, Flexiframe®, Terratone®, Perma-Clean®, Anderson®, Andersen Concept IV®, "Only the Rich Can Afford Poor Windows," The Beautiful Way to Save Fuel®, The Beautiful Way®, and Come Home to Quality. Come Home to Andersen.®

We'd rather be telling you about the many time, money and fuel-saving features of Andersen® windows, roof windows and patio doors.

But our lawyer advises us that periodically, in your best interest as well as ours, we should run an ad about the Andersen® Windowwalls®, Perma-Shield® and other valued Andersen Corporation trademarks.

You see, they've been our signs of quality for many years and some companies may try to trade on them.

By either incorporating part of our trademarks with theirs or perhaps just by spelling them a little differently.

And from your standpoint that can be very misleading.

Our trademarks shouldn't be used for anything other than identifying our products. Because only Andersen makes Windowwalls® brand windows, roof windows and patio doors.

So look for the Andersen®, Windowwalls®, Perma-Shield® and our other valued trademarks. And don't forget that our name ends with "sen." Thank you.

Now back to our regular schedule of product advertising.

Andersen Corporation, Bayport, MN 55003.

86148 © 1986 Andersen Corp.

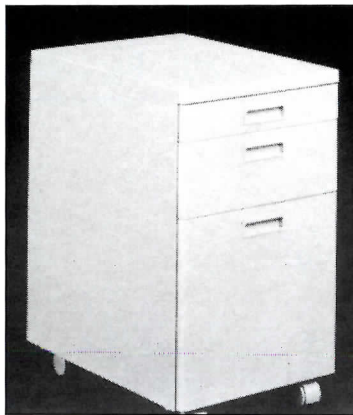

Storage cabinets

The *Radius Group* of rounded-corner storage pedestals includes lateral files, cupboards, and suspended drawer units. The pedestals are available in 20-in., 24-in., and 30-in. depths, and in eight heights. The units come in 40 enamel colors. Storwal International, Inc., Northfield, Ill. Circle 323 on reader service card

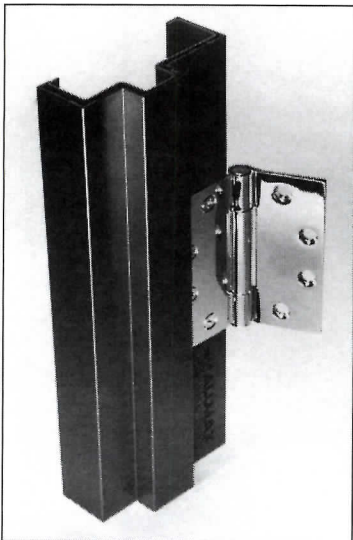

Door frame

The *Phoenix* system consists of a 16-gauge steel sub-frame and an aluminum-alloy outer frame. Available with clear, bronze, black anodized, and applied or baked-on paint finishes, the frame comes in a variety of sizes. Alumax/Magnolia Division, Magnolia, Arkansas. Circle 324 on reader service card

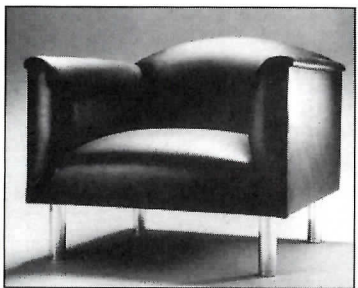

Seating

The *Virage* collection of upholstered chairs and sofas features kiln-ash frames attached to enameled or stainless steel legs. The chair is 33 1/2 in. wide, 31 3/4 in. deep, and 28 in. high. The sofas come in 66- and 72-in. widths. Scope Furniture, Ltd., New York City. Circle 325 on reader service card
Continued on page 168

**FOR YOUR
BOOKSHELF...**

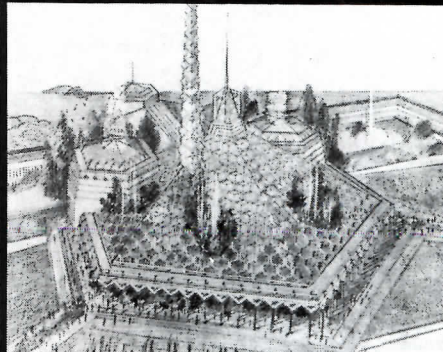

TREASURES OF TALIESIN

**76 Unbuilt Designs
Of Frank Lloyd Wright**

By BRUCE BROOKS PFEIFFER, Director of Archives, Frank Lloyd Wright Memorial Foundation, Taliesin West. "There is superb, rarely seen Wright here, from every period of the architect's career."—*The New York Times Book Review*. "A magnificent album."—*Publishers Weekly*. (Co-published with The Press at California State University, Fresno.) 106 color plates. \$60.00

BUILDING WITH FRANK LLOYD WRIGHT

An Illustrated Memoir

By HERBERT JACOBS with KATHERINE JACOBS. This is the first-hand account of a young couple who in 1938 challenged Wright to produce a decent house for \$5000, prompting him to come up with the innovative design for "Usonia Number One." "It's an experience to read this fascinating book, rare in itself in that it is a client's full report on a genius."—*American Institute of Architects Journal*. \$14.95 paper; \$24.95 cloth

RICHARD NEUTRA: PROMISE AND FULFILLMENT, 1919-1932

**Selections from the Letters and
Diaries of Richard and Dione Neutra**

Compiled and translated by DIONE NEUTRA. Foreword by Shirley Hufstедler. Introduction by Thomas S. Hines. "The story of Richard Neutra is a varied and powerful one. . . . No one is in a better position to tell that story than Dione."—Norman Cousins. Illustrated with personal photographs and photographs of Neutra's work. \$19.95

Add \$1.50 when ordering by mail.

**SOUTHERN ILLINOIS
UNIVERSITY PRESS**

Dept. AR16, P.O. Box 3697,
Carbondale, IL 62902-3697

Fast Forward.



When you use your AT&T Card at a public phone, you don't have to hang up after each call. Just hit this button after your first conversation, and dial the number of your next long distance call. The phone automatically remembers your AT&T Card number. So you have more time to take care of business.

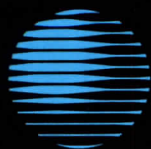

AT&T
The right choice.

Continued from page 167

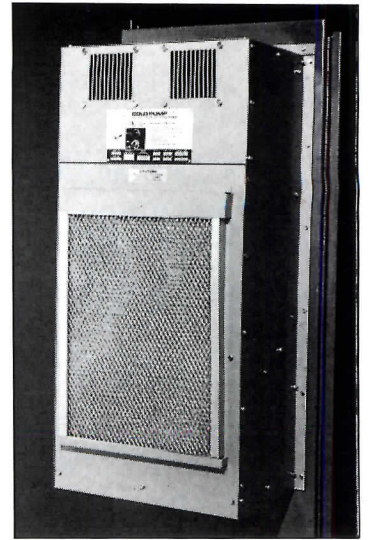

Electronic cooler

The *Cold Pump* electronic enclosure cooler is a closed-loop, compressed freon air conditioner that is said to prevent tripping, breakdowns, and other problems caused by overheating. Two models are available with 3,000- and 6,000-Btu/hr capacity. Vortec Corp., Cincinnati.

Circle 326 on reader service card



Electronic keying system

Designed for use in defense plants, office towers, residential condominiums, college dormitories, and additional applications, the *Gibraltar 2000* electronic keying system uses an electronic code imprinted along the blade of a key. The system features a reusable, recodeable, metal or polycarbonate key. Falcon Lock Co., Huntington Beach, Calif.

Circle 327 on reader service card



Drinking fountain

An upright pedestal drinking fountain is constructed of concrete with exposed stone aggregate. The fountain features a tapered configuration with beveled corners, a stainless-steel receptor, and a chrome-plated brass projector that is said to be vandal resistant. Halsey Taylor, Div. of Household International, Inc., Freeport, Ill.
Circle 328 on reader service card

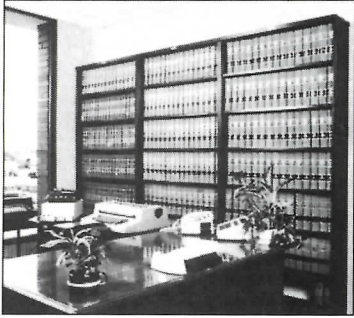

Library shelving

The manufacturer's library shelving system features double-wall construction. The adjustable 20-gauge steel shelves are said to hold up to 50 lb psf, and the bottom shelf is angled to permit easier reading of book bindings. Burroughs, Div. of Lear Siegler, Santa Monica, Calif.
Circle 329 on reader service card

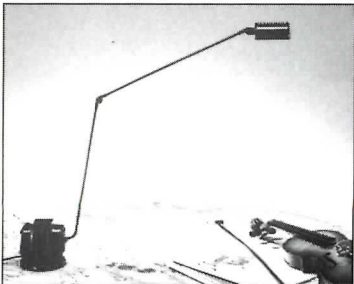

Lighting

A collection of halogen lighting fixtures designed by Tommaso Cimini includes *Daphne*, available in floor and table-top versions. *Daphne* features a rotating lamp head and adjustable metal arms in black, white, or red. Lighting Associates, Inc., New York City.
Circle 330 on reader service card
Continued on page 190

Friendly Face.



When you're traveling on business, look for this friendly face—the AT&T Card Caller. It'll give you simple instructions on any call, including AT&T Long Distance Service calls. And you can use it with or without your AT&T Card. The AT&T Card Caller—a face you should get to know.

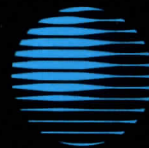

AT&T

The right choice.



“Sometimes building it is the easy part.”

“A lot goes on before anything goes up at a construction site. And a lot of it is far from simple.

“You’ve got to select and specify the kinds of building products you need. You’ve got to locate them. Then you’ve got to get them.

“I’m Perry Sells, vice president and general manager of Sweet’s. Being a part of a service that’s been around for 80 years gives me a pretty good idea of what you’re up against. And we’re doing a couple of things to make your life a lot easier.

“First, we’ve started adapting Sweet’s to the CSI’s MASTERFORMAT classification system. So the 1987 edition of the leading selecting and specifying tool—Sweet’s—will be right in line with the leading construction industry classification system. And the new Electronic Sweet’s will be on MASTERFORMAT, too.

“Next, we’ve started turning our BUYLINE telephone information service into a completely automatic system. By January of 1987, you’ll be able to dial the BUYLINE number, punch a special code for each manufacturer into your telephone, and a computer will instantly tell you where you can find the nearest sales reps for the products you need.

“Both these Sweet’s improvements are on the way. To find out how they’re coming, drop me a line. It’s that easy.”

Sweet’s Division, McGraw-Hill Information Systems Company,
1221 Avenue of the Americas, New York, NY 10020.

SWEET’S | **MCGRAW-HILL**

Where Construction Gets Its Start

24th MARMOMACC

SANT'AMBROGIO DIVALPOLICELLA,
VERONA (ITALY)

21 - 28 SEPTEMBER 1986

INTERNATIONAL EXHIBITION OF STONE, MARBLE,
GRANITE, ETC. FINISHED PRODUCTS.
MACHINERY & EQUIPMENT FOR
THE STONE INDUSTRY.

70,000 M2 EXHIBITION GROUND, 982 EXHIBITORS.
47,000 TRADE VISITORS.

On Saturday, 20th September 1986
International Conference on
"The Use of Stone in Architecture Today"



Organizer:
E.A. FIERE DI VERONA,
P.O. BOX 525, 37100 Verona (Italy)
Tel. (45) 588111 - Telex 480538 FIERE VR I

Circle 82 on inquiry card

LIBRARY STORAGE

SPACESAVER STORAGE SYSTEMS

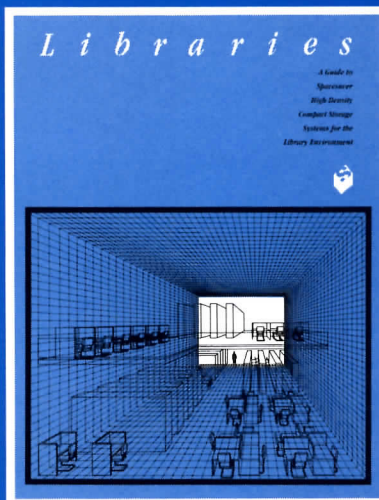

**Your Source for
Planning High-Density
Storage Systems
in the Library
Environment.**

24 pp. Planning Guide presents data on selecting proper high-density storage systems for library needs. Aids in solving specific library storage problems such as calculating book-capacity in bookstack areas, activity & retrieval analysis, mutilation & theft, collections storage, open access and high-density configurations. This guide for the professional planner is yours for the asking. Call Toll-Free for details: 1-800-492-3434.

Spacesaver

When performance counts.



Spacesaver Corporation 1450 Janesville Ave., Ft. Atkinson, WI 53538 (414) 563-5546
Spacesaver Mobile Storage Systems, 7027 Fir Tree Dr., Mississauga, Ontario L5S 1J7, (416) 671-0391

Circle 83 on inquiry card



ADD A NEW MERCEDES-BENZ TO YOUR EUROPEAN VACATION PLANS. AND SUBTRACT SOME OF THE COST.

Plan to make European delivery of a new Mercedes-Benz part of your 1986 European vacation plans. Select any 1986 gasoline or diesel model,* pick it up at the factory European Delivery Center—and embark on a deluxe driving vacation. Avoiding costly rentals while saving on the price of your new Mercedes-Benz. Send coupon for a free European Delivery brochure today.

*Subject to availability.

Send coupon to: MHMA86-2
Mercedes-Benz of North America, Inc.
Marketing Communications Division
One Mercedes Drive, Montvale, NJ 07645



Name _____

Address _____

City _____

State _____ Zip _____

© 1986 Mercedes-Benz of N.A., Inc., Montvale, NJ.

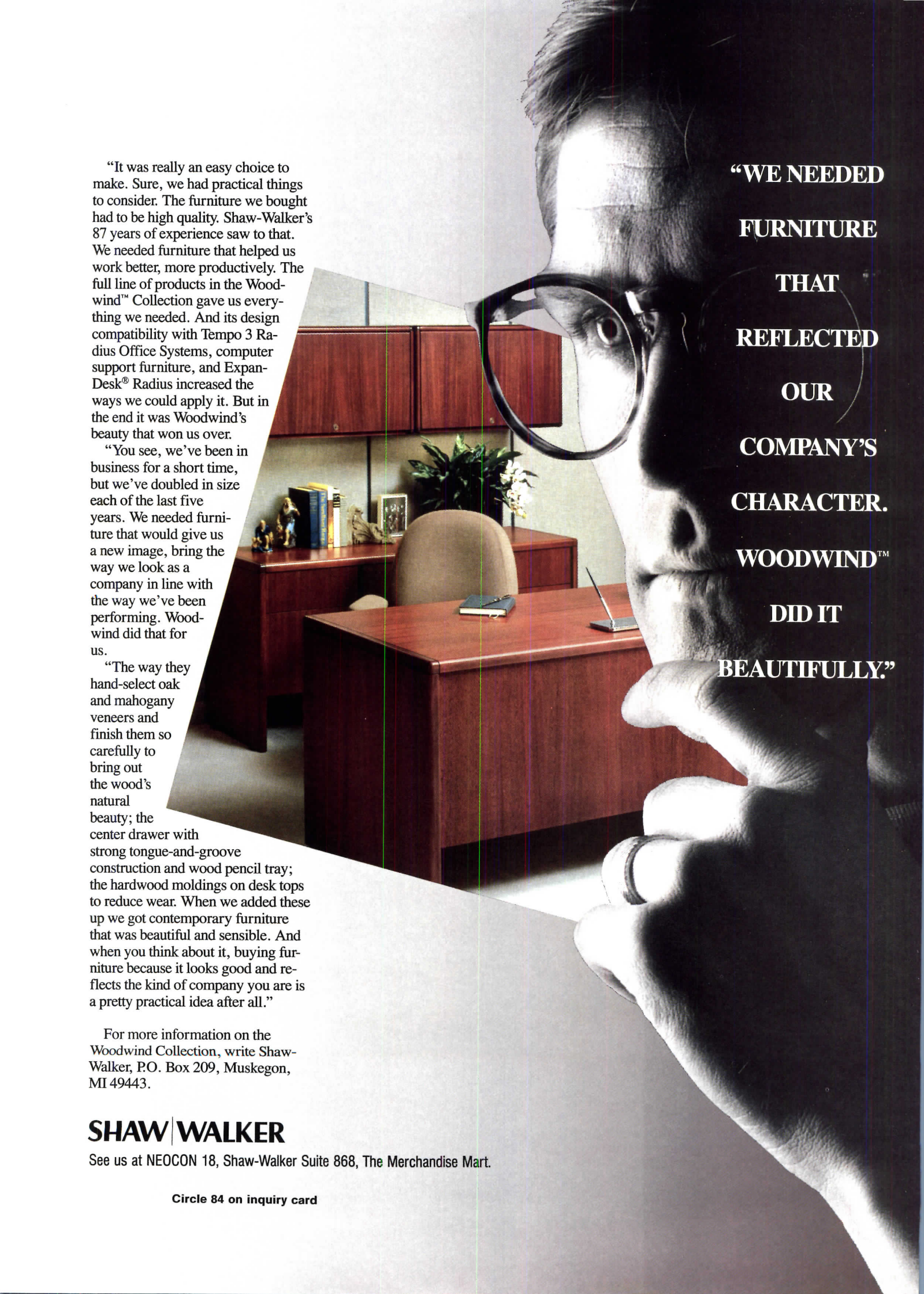

"It was really an easy choice to make. Sure, we had practical things to consider. The furniture we bought had to be high quality. Shaw-Walker's 87 years of experience saw to that. We needed furniture that helped us work better, more productively. The full line of products in the Woodwind™ Collection gave us everything we needed. And its design compatibility with Tempo 3 Radius Office Systems, computer support furniture, and Expan-Desk® Radius increased the ways we could apply it. But in the end it was Woodwind's beauty that won us over.

"You see, we've been in business for a short time, but we've doubled in size each of the last five years. We needed furniture that would give us a new image, bring the way we look as a company in line with the way we've been performing. Woodwind did that for us.

"The way they hand-select oak and mahogany veneers and finish them so carefully to bring out the wood's natural beauty; the center drawer with strong tongue-and-groove construction and wood pencil tray; the hardwood moldings on desk tops to reduce wear. When we added these up we got contemporary furniture that was beautiful and sensible. And when you think about it, buying furniture because it looks good and reflects the kind of company you are is a pretty practical idea after all."

For more information on the Woodwind Collection, write Shaw-Walker, P.O. Box 209, Muskegon, MI 49443.

SHAW | WALKER

See us at NEOCON 18, Shaw-Walker Suite 868, The Merchandise Mart.

Circle 84 on inquiry card

**"WE NEEDED
FURNITURE
THAT
REFLECTED
OUR
COMPANY'S
CHARACTER.
WOODWIND™
DID IT
BEAUTIFULLY."**

*"It rained yesterday
and we didn't
even know it."*

*Commodore Business Machines
Director of Facilities,
Fred Walker*



Commodore Business Machines, West Chester, PA. Protected from the elements by a new 480,000-square-foot Design NP Golden Seal roofing system from Carlisle SynTec Systems. Roofing contractor: United States Roofing Corporation, Norristown, PA.

Commodore is now staying dry under a new Carlisle Golden Seal roof. So is their valuable, high-tech inventory.

"Our built-up roof leaked from day one. We wanted to solve the problem once and for all. We wanted the best roof. And the smartest buy. With Carlisle's Design NP™ Golden Seal™ roofing system, we got both."

Commodore's U.S. headquarters includes an office complex, a plant, two research centers, and several warehouses. It houses millions of dollars in high-tech equipment and inventory. All under one roof. You can see why that roof has to be the best.

When Commodore decided to solve their roofing problems, one solution presented itself as the *only* logical choice.

A Design NP total roofing system from Carlisle SynTec Systems. Complete with a 15-year Golden Seal warranty.

Golden Seal System—Carlisle from the deck up

You can count on a Golden Seal roofing system to meet the toughest quality standards. Because all components are genuine Carlisle Sure-Seal® products. Every Carlisle roofing system is installed by an authorized Carlisle applicator. And we meticulously inspect every roofing system to be sure it meets our standards.

The Golden Seal warranty—15 years of warranted protection
Because Carlisle is so particular

about our Golden Seal roofing systems, we confidently offer one of the best warranties in the single-ply industry. Up to fifteen years protection. On *all* materials. And on *all* workmanship.

Design NP—the roof that snaps on

Design NP is a lightweight system that snaps on fast and easy. Saving you costly labor.

The best research—the best products

For twenty-five years Carlisle has been the leader in single-ply innovation. And with our four-million-dollar research center, we'll be a leader in

quality and innovation for years to come.

The Carlisle track record
We're the number one maker of single-ply roofs in America. And with more than 45,000 roofs under warranty, probably in the world as well.

Compare Carlisle. Our roofing systems. Our warranty. Our track record. We think you'll discover, as Commodore has...there is no equal.

Call toll-free, **800-233-0551**. In PA, 800-932-4626. In Canada, 1-800-387-4990.

Sure-Seal, Golden Seal, Design NP and Carlisle are trademarks of Carlisle Corporation.

M.A.R.S. Design NP Patent Pending.
©1986 Carlisle Corporation



There is no equal.

CARLISLE

Carlisle SynTec Systems

Division of Carlisle Corporation, P.O. Box 7000, Carlisle, PA 17013

Circle 85 on inquiry card

What Do These Prestigious Buildings Have In Common?

FORDHAM UNIVERSITY

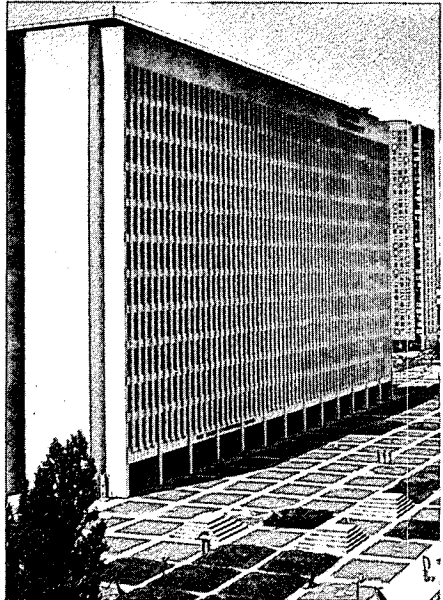

SEALED WITH POLYSULFIDE 1965

Lincoln Square of Fordham University
 New York, NY
 Architect: The Perkins & Will Partnership

United Airlines Headquarters
 Libertyville, Illinois

CARPENTER CENTER, HARVARD UNIV.

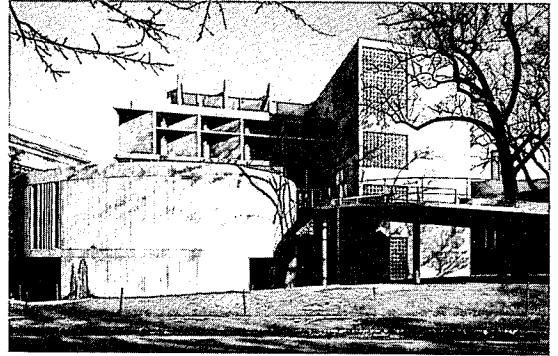

SEALED WITH POLYSULFIDE 1963

Carpenter Center For The Visual Arts
 Harvard University
 Cambridge, Massachusetts
 Architect: Le Corbusier

UNITED AIRLINES HEADQUARTERS

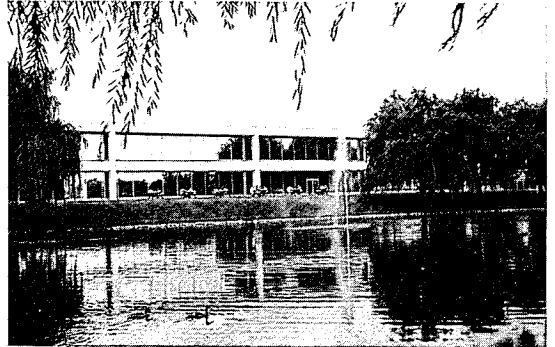

SEALED WITH POLYSULFIDE 1966

It all started here...



For more than 30 years, LP® polysulfide base sealants have been effectively sealing curtain walls, concrete and masonry buildings against the elements.

Morton Thiokol, Inc.

To find out about other prestigious buildings that have been sealed for more than 15 years with Morton Thiokol LP® polysulfide base sealant, send for your copy of, "It All Started Here".

Morton Thiokol, Inc.
 Morton Chemical Division
 Mkt. Comm. Dept AR
 CN 5305
 Princeton, New Jersey 08540

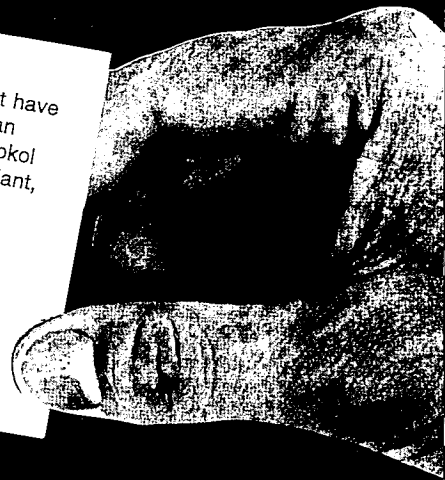

Circle 86 on inquiry card

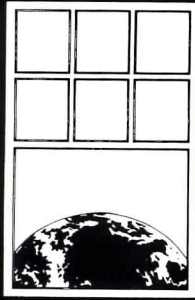

JUNE
10-13

THE MERCHANDISE MART CHICAGO

The World Congress on Environmental Planning and Design:

NEOCON continues as the world's foremost conference at the cutting-edge of new design concepts, architecture, interiors, urban planning, criticism, aesthetics, technologies, behavior, telecommunications, corporate facility planning, ergonomics, rehabilitation, productivity, management, human progress and new developments in the work environment, health care, hospitality, and merchandising interiors.

The International Symposium on Modern Architecture III:

A further evaluation of the fate and future of modern architecture with a special emphasis on this year's retrospective of Mies van der Rohe. Panelists debate the merits of Mies and his followers and indicate their impact on the direction of contemporary architecture and design for the 1980s.

The Chicago Architecture Award:

Receipients for 1986 are Mario Botta, Charles Correa and Cesar Pelli



Aldo Bofill

Mario Botta

Charles Correa

Charles Moore

Cesar Pelli

Philippe Starck

Tomas Taveira

Gathering of Design Disciplines

Albrecht, Author, "Service America: Doing Business in the Economy," San Diego
 Bofill, Taller de Arquitectura, Barcelona
 Botta, Architect, Lugano, Switzerland
 Busby, Jr., FAIA, President, American Institute of Architects, Washington, DC; Principal Architect, Jova/Daniels/Busby, Inc.,
 Carlsson, Secretary General, UIA, Stockholm
 Correa, AIA, Charles Correa Architects, Bombay
 Diaz-Azcuy, Owner, Orlando Diaz-Azcuy Designs, Inc; Vice President/Design Principal, Gensler & Associates/Architects, San Francisco
 Dionne, President, Chief Executive Officer, McGraw-Hill Inc., New York
 Gardner, Chairman of the Board, Diamond Star Motors, Sterling Heights, Michigan
 Hackl, FAIA, President-Elect, American Institute of Architects, Washington, DC; President, Loeb, Schlossman & Hackl, Chicago
 Hansen, President, Hansen Line Meyer, Iowa City
 Harman, Ph.D., Author, "Higher Creativity," President, Institute of Noetic Sciences, Sausalito
 Himmel, Interior Designer, Lubliner & Himmel Corp., Chicago
 Hirsch, Chairman, Hirsch/Bedner, Santa Monica
 Krebs, Senior Vice President, Interspace, Inc., Philadelphia
 Malino, Vice President, Hellmuth Obata Kassabaum, Washington, DC
 McLaughlin, Senior Partner, Kaplan/McLaughlin/Diaz, San Francisco
 Moore, Principal Architect, Urban Innovations, Chicago
 Pelli, Partner, Cesar Pelli & Associates, New York

- Charles Pfister, President, Charles Pfister Associates, San Francisco
- Janet Schirn, FASID, President, American Society of Interior Designers; President, Janet Schirn Interiors, Chicago
- Philippe Starck, Designer, Paris
- Sarina Tang, President, Art Options, New York
- Tomas Taveira, Architect, Lisbon
- James E. Terrell, President, Hambrecht Terrell Interiors, New York
- Lella Vignelli, Executive Vice President, Vignelli & Associates, New York
- Bartholomew Voorsanger, Partner, Voorsanger & Mills Associates Architects, New York
- Sally Walsh, Designer, Houston
- James Walter, Vice President, Construction and Design, Humana Corp., Louisville
- Spiros Zakas, Director of Design, Zakaspace, New York

Chicago: The City of Architecture

Exhibitions:

- "Mies van der Rohe Centennial Exhibition," The Museum of Contemporary Art
- "Mies van der Rohe the Educator," Illinois Institute of Technology, sponsored by the Mies van der Rohe Centennial Committee.
- "The Drawings of Rita Wolff," The Graham Foundation for Advanced Studies in the Fine Arts
- "Made in Germany," Museum of Science and Industry
- "The Bauhaus Exhibition," Museum of Science and Industry
- "Telematic Ulysses: The New Office Landscape," The University of Illinois, Illinois Room, Circle Center.

Tours:

- Architectural Walking Tours of New Chicago Skyscrapers, Chicago Archi-Center
- Frank Lloyd Wright Home and Studio Tours, Oak Park

Seminar Program

**Tuesday
June 10**

- **4:00 p.m.**
1. **Ergonomics in the Office: The Need for User Awareness**, John J. Connell, Executive Director, Office Technology Research Group, Pasadena; Marvin Dainoff, Ph.D., Dept. of Psychology, Miami University, Oxford, Ohio; Dr. A.C. Mandal, TARBAEK, Denmark; Rani Leuder, Human Factors Specialist, Humanics, Agoura Hills, California

**Wednesday
June 11**

- **8:30 a.m.**
2. **NEOCON Keynote Address: Service America: Marketing the "Invisible Product,"** Dr. Karl Albrecht, Author, "Service America: Doing Business in the New Economy," San Diego
- **4:30 p.m.**
3. **The Leading Edge in Corporate Office Design: Setting the Trends**, Orlando Diaz-Azcuy, Owner, Orlando Diaz-Azcuy Design, Inc., Vice President/Design Principal, Gensler & Associates/Architects, San Francisco; Charles Pfister, President, Charles Pfister & Associates, San Francisco; Sally Walsh, Designer, Houston
- **4:30 p.m.**
4. **Visionary Architecture: The Work of Ricardo Bofill/Taller de Arquitectura**, Ricardo Bofill, Barcelona.

**Thursday
June 12**

- **8:30 a.m.**
5. **Planning the Corporation of the 21st Century: A Strategy for Growth**, Joseph Dionne, President and Chief Executive Officer, McGraw-Hill, Incorporated, New York
- **8:30 a.m.**
6. **Product & Design: Image is What Sells**, James E. Terrell, AIA, President, Hambrecht Terrell Interiors, New York; Lella Vignelli, Executive Vice President, Vignelli & Associates, New York; Richard Himmel, ASID, Lubliner & Himmel Corp., Chicago
- **4:30 p.m.**
7. **Productivity: A Dialogue for the Future**, T.J. Springer, Ph.D. President, Springer Associates, Inc., St. Charles; Steven L. Sauters, Ph.D., Chief, Motivation & Stress Section, NIOSH, Cincinnati; Franklin Becker, Ph.D., Dept. of Human Ecology, Cornell University, Ithaca, Jim Dailey, President, Dailey's Office Productivity Center, Little Rock

**Friday
June 13**

- **4:30 p.m.**
8. **International Translations: Pluralism in Europe, Asia and North America**, Mario Botta, Architect, Lugano, Switzerland; Charles Correa, Charles Correa Architects, Bombay, India; Cesar Pelli, Partner, Cesar Pelli & Associates, New York
- **8:30 a.m.**
9. **The Architecture of Fantasy and Imagination: Expressionism in Today's Design**, Charles W. Moore, Principal Architect, Urban Innovations, Los Angeles; Tomas Taveira, Architect, Lis Donald Hackl, FAIA, President-Elect, American Institute of Architects
- **8:30 a.m.**
10. **Higher Creativity: The Process of Design**, Willis Harman, Ph.D., Author, "Higher Creativity"; Mario Buatta, Mario Buatta, Inc., New York; Philippe Starck, Designer, Paris; Massimo Vignelli, Principal, Vignelli & Associates, New York
- **3:00 p.m.**
11. **The International Symposium on Modern Architecture: The Year of Mies**, Charles Correa, Bombay; Mario Botta, Lugano; Charles W. Moore, Los Angeles; Cesar Pelli, New York; Tomas Taveira, Lisbon; Ricardo Bofill, Barcelona

Workshops

**Wednesday
June 11**

- **10:30 a.m.**
D. **Adaptive Re-Use Update: The Challenge of Recycling Interior Space Continues**
- **2:30 p.m.**
E. **New Findings in Illuminating the Office Space: Solving the Unforeseen Problems of Office Lighting & Ambient Lighting**

**Thursday
June 12**

- **10:30 a.m.**
H. **Corporate Art in the Office: Assembling a Total Collection**
- **2:30 p.m.**
I. **Hospitality Design: The New American Theatre**

VIP Pre-Registration

Pre-register today to receive NEOCON 18 admittance badge and first consideration for session tickets.

There is no conference fee for NEOCON; your costs include only travel, hotel and meals.

Name: _____

Title: _____

Company: _____

Address: _____

City: _____ State: _____ Zip: _____

Area Code/Phone Number _____

I will attend the following:
Day

Day	Seminars	Workshops
Tuesday, June 10	1 <input type="checkbox"/>	
Wednesday, June 11	2 <input type="checkbox"/>	D <input type="checkbox"/>
	3 <input type="checkbox"/> or 4 <input type="checkbox"/>	E <input type="checkbox"/>
Thursday, June 12	5 <input type="checkbox"/> or 6 <input type="checkbox"/>	H <input type="checkbox"/>
	7 <input type="checkbox"/> or 8 <input type="checkbox"/>	I <input type="checkbox"/>
Friday, June 13	9 <input type="checkbox"/> or 10 <input type="checkbox"/>	
	11 <input type="checkbox"/>	

I am interested in attending the Chicago Architecture Awards Luncheon
Friday, June 13, 12:00 noon:

Make it or break it

When it comes to outdoor seating, a lot of different manufacturers make it. And a lot of use usually breaks it. However, that's not the case with Kroin Garden and Park Furniture.

This collection of chairs, tables, bench seating and lounges is built to last. Through weather and heavy traffic abuse, it holds up and stands up to any extreme. Because no one makes seating with the kind of heavy tubular steel and fused

synthetic coating that we do. And it's appropriate for just about any site you can think of; from indoor malls, to outdoor plazas, to hotels and restaurants.

So, remember Kroin Garden and Park Furniture. It's the outdoor seating that could make or break the success of your next site.

Circle 6 on information card.

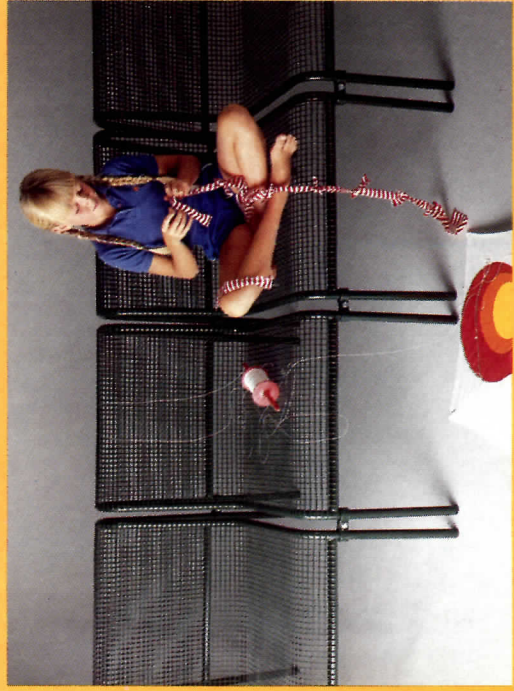
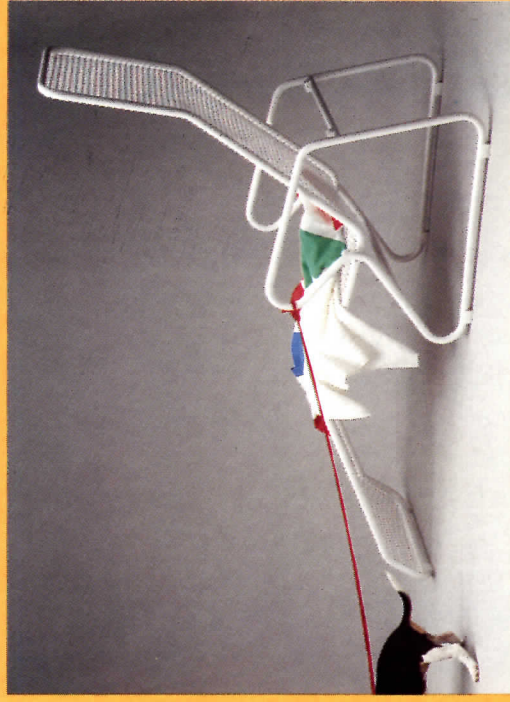

A Prime discovery: There are four sides to every building.

Nobody looks at a building design quite the way architects do.

When a contractor sees a plan, he thinks of materials and schedules.

Engineers envision system design and analyses. And facility managers look at your project with the bottom line in mind.

All of which can make designing a building that pleases everyone virtually impossible.

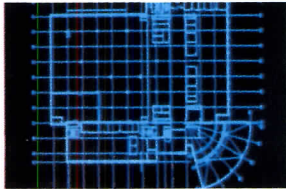

Structural grids
created automatically.

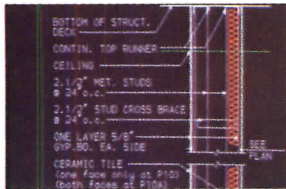

Symbol and detail
libraries with CSI format.

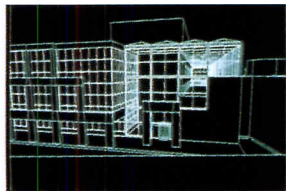

Visualize design
with 3-D solids modeler.

That's why Prime Computer offers this solution: An integrated approach to automating the building process that takes all sides into account. It not only ties together all of the people involved in the building process but also offers management tools for making the business profitable. Plus you can start anywhere in the automation process and grow at your own speed.

When you use our program for Computer Aided Design (we call it PRIME MEDUSA™ AEC software) you're doing a lot more than just drafting. You're also creating a database that can be used by others on the project team.

The database contains information that engineers and contractors can begin to work with before you even finish your design. Facility managers can use the database to put together floor plans, budgets and schedules.

And if you make a change in your plans it doesn't take days or weeks for everybody to find out about it.

In short, Prime can help make your job as an architect a lot easier by bringing everyone involved in the building process closer together.

But then, you'd expect that from a Fortune 500 company that offers total solutions. You see, like you, when we design something, we look at the total picture, instead of taking a one-sided view.

Call Prime at 1-800-343-2540 (in MA, 1-800-322-2450; in Canada, 1-800-268-4700).

See us at AE Systems in Chicago, Booth 1033, June 24-27,
and at the AIA Conference in San Antonio, Booth 300, June 8-11.



It's time you knew.

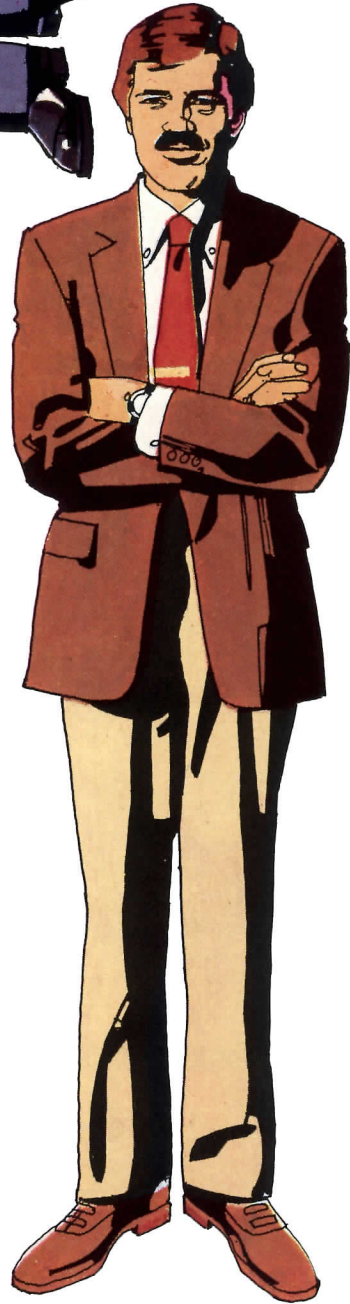
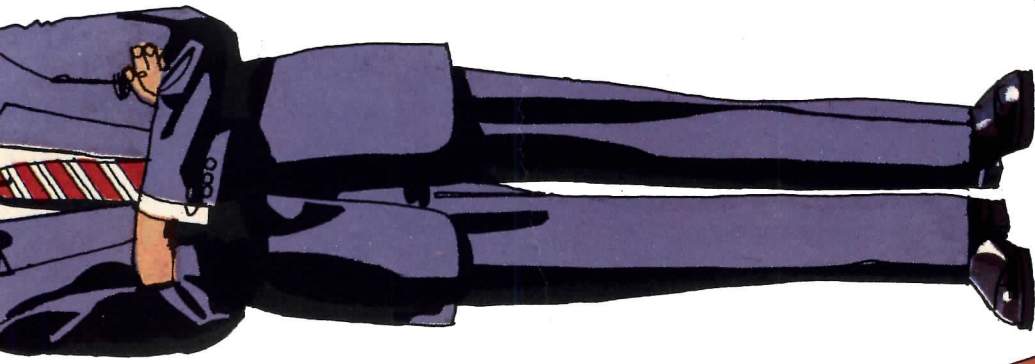

FACILITY MANAGER

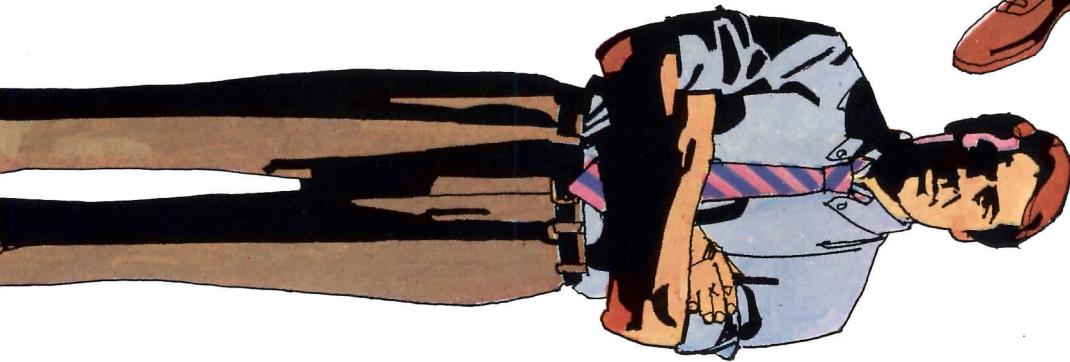

ARCHITECT



ENGINEER

Design Estimator

Dodge MicroSystems



New!!! Design Estimator Demonstration Kit from Dodge MicroSystems

Prepare cost estimates easily, quickly Save time and money

If you have an Apple II or IBM Personal Computer or compatible equipment, you should get this new Demo Kit right now.

You'll see how easy it is, and how fast you'll be able to put an estimate together.

The kit is complete with a full set of instructions and two discs (one for the demonstration system, one for the data).

The cost for the kit is only \$15.00, and we deduct this charge from the purchase price if you buy the **Design Estimator Program** which is \$795.00, including an update six months after purchase.



Call **1-800-257-5295** now,
In N.J. call (609) 426-7300
(ask for Pat Carr)
and place your order for
the Design Estimator
Demonstration Kit.



Cost Information Systems
North Office Bldg.
Princeton-Hightstown Rd.
Hightstown, N.J. 08520

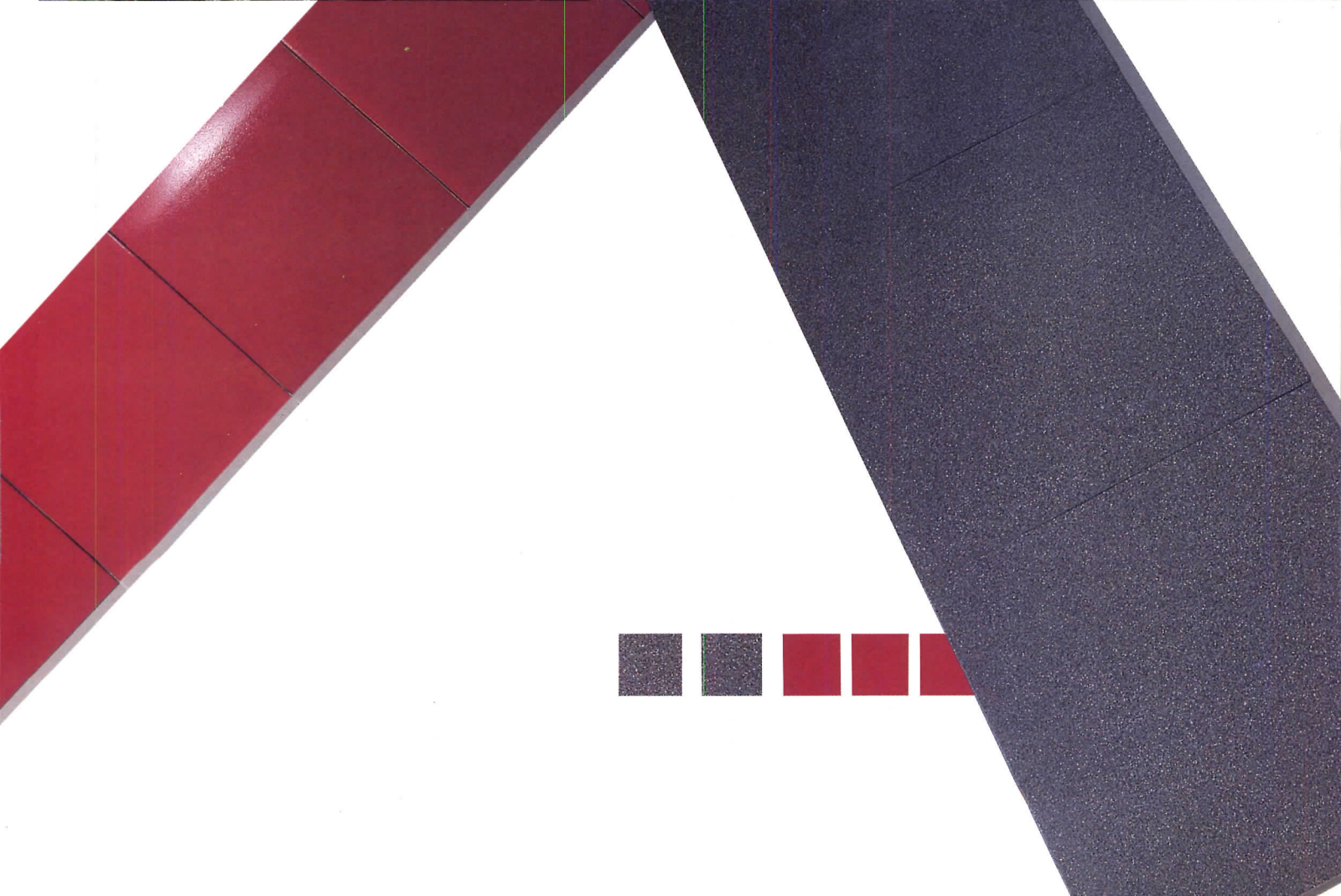

CERAMIC STATEMENTS

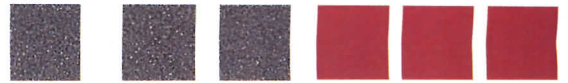

Exterior ceramic cladding. A design statement used by innovative architects to achieve enduring color, proportion, and resistance to weathering.

Buchtal ceramics are available in an interesting variety of colors, textures, and sizes...6" x 6," 8" x 8," 12" x 12," 18" x 18," 2' x 2', and 2' x 3'. Lightweight, non-porous, modular and delightfully colorful statements for your next design.



Shown: *IBM San Diego Branch Office*
Architect: *Skidmore, Owings and Merrill*
Products: *2 x 2 Keraion®, Custom Grey*
12 x 12 Atlantis Porcelain, Granite Grey Polished
12 x 12 Chroma, Intensive Carmine

BUCHTAL 

105 Hembree Park Dr./Suite H/Roswell, GA 30076/(404) 422-5500
20625 Valley Blvd./Suite B/Walnut, CA 91789/(714) 598-2288
Circle 89 on inquiry card

More Tambour Than Ever Before.

Formica® brand tambour introduces an exciting and extensive new line to the industry. Including Fire Rated tambour for applications governed by building codes.

All Formica brand tambour is available in a wide range of colors, patterns, and finishes. These include natural wood and other surfacing materials. As well as ColorCore® brand surfacing material and the entire Formica brand laminate collection of nearly 250 solid colors, woodgrains, patterns and dimensionals. In matte and lacquer finishes.

For samples and more information, contact Formica brand tambour Information Center, P.O. Box 997, Morton Grove, Illinois 60053. Or call, 312-470-8111.

Circle 90 on inquiry card



"Deserves to be added to every collection of books on the profession of architecture."—*Journal of Interdisciplinary History*

The Architect
Edited by
Spiro Kostof

A collection of essays by such eminent historians and architects as **William L. MacDonald**, **Leopold D. Ettlinger**, and **Joseph Esherick**, *The Architect* surveys the development of the architect's profession from its beginnings in ancient Egypt to the modern day.

"An excellent anthology."—*AIA Journal*

"One of those infrequent books that satisfies very well the disparate needs of the general reader, the student, and the serious scholar... a significant contribution to our understanding of history."—*American Historical Review*

\$9.95 384 pp., 75 halftones

Available at better bookstores or directly from:
OXFORD PAPERBACKS • Oxford University Press
200 Madison Avenue • New York, NY 10016

The Canon Bubble-Jet Printer is very compatible with all these units.



security + design

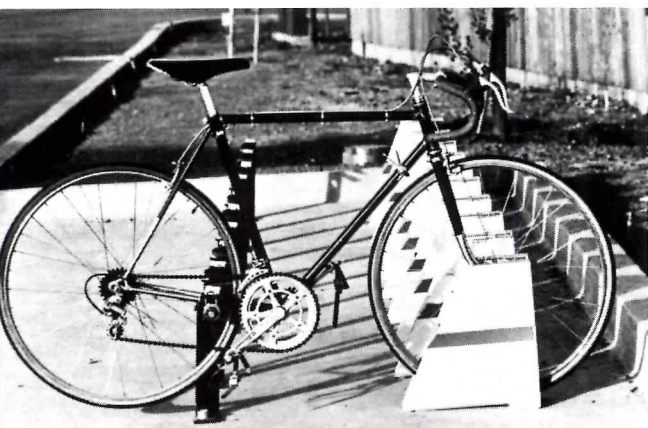

Model RR300 shown

Rally Racks are architecturally designed to be maintenance free with no moving parts. They accept all bicycles and locking devices recommended for safety. Modular components for flexible site enhancement. Vandal proof installation hardware included. Diverse economical models to choose from, as well as models for mopeds and motorcycles.

since 1971

**Rally
Racks**®

Send for our free color catalog . . .

P.O. Box 299, Sonoma, CA 95476
707-938-4744

See us in Sweets and LA file
Available under GSA & HUD contracts

Circle 91 on inquiry card

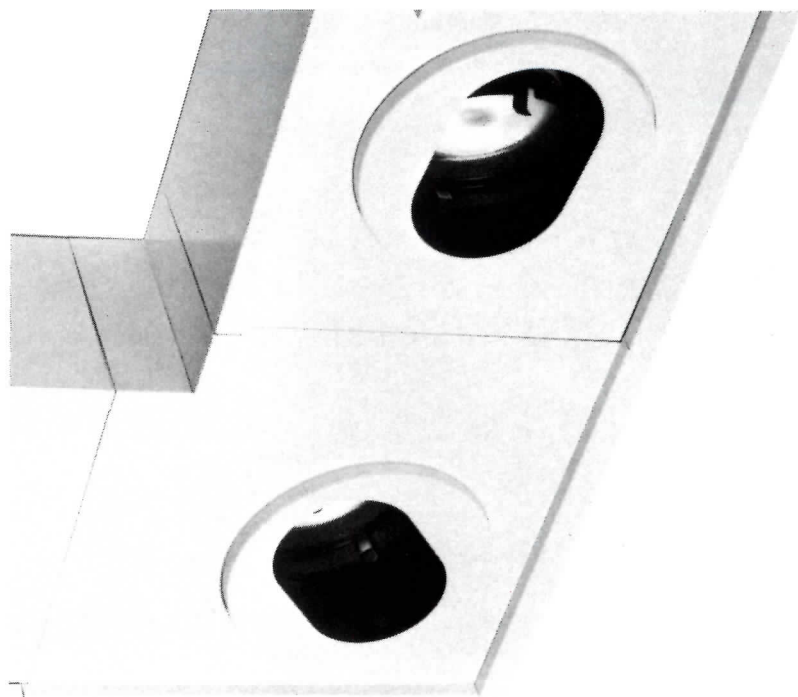

THE AIR & SPACE LIGHT

This architecturally unobtrusive modular system can expand, adopt, even relocate quickly and without tools. It remains unnoticed by thousands daily at the National Air & Space Museum.

For an information kit, write on your letterhead to: Lighting Services Inc., 150 East 58 Street, New York, NY 10155

Circle 92 on inquiry card

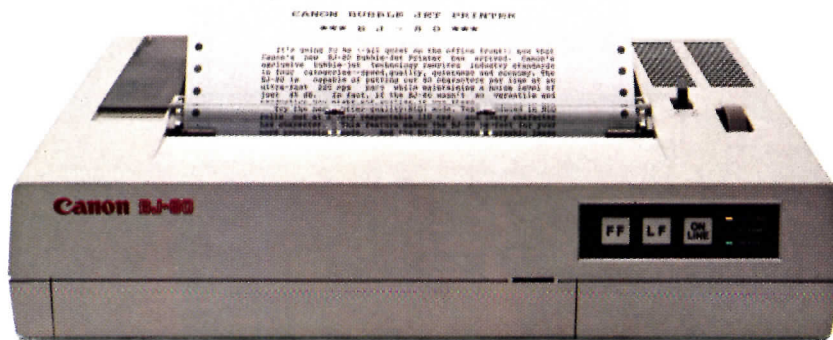

Because high-speed, high-quality printing should be seen, not heard.

The Canon Bubble-Jet Printer uses an exclusive system that combines thermal and ink-jet technology to print an ultra-fast 220 cps. While keeping the decibels down to a whisper.

For professional word processing, the Near Letter Quality mode (NLQ) churns out crisp, clear copy at a brisk 110 cps. And the BJ-80 has three graphic

image modes for high-resolution printouts of charts, graphs and diagrams.

Of course, the Bubble-Jet is fully compatible with Canon's fine line of Personal Computers and plug-compatible with the IBM PC. It's compact, lightweight and surprisingly affordable.

Ask your dealer about the full line of fast, efficient, economical Canon Printers. Find out what all the quiet excitement is about.

Canon
PRINTERS

Printouts that stand out.

Circle 93 on inquiry card

C A L L F O R E N T R I E S

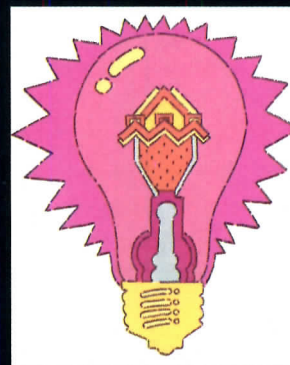
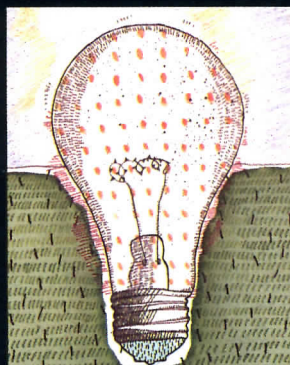
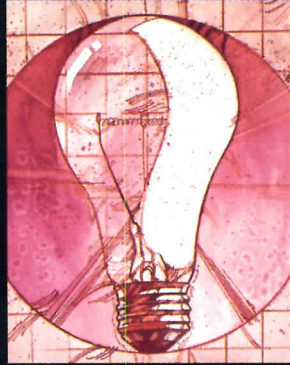

No matter how bright the idea, no two people will interpret it in exactly the same way. Consider, for example, the idea of using polyvinyl chloride (PVC) as an architectural material. More familiarly known as vinyl, PVC's light weight, durability and flexibility make it adaptable for a variety of applications. But how it can be used is what makes it exciting.

That's why we're sponsoring a design competition for new uses of PVC in architectural applications. Interior or exterior, structural or decorative, original or retrofit.

Our national competition is open to all architects, designers and architectural students interested in creating designs for PVC

products. Team submissions will be accepted. The creator of the winning design will be awarded a \$1,500 honorarium. Two honorable mention winners will each be awarded with a \$500 honorarium.

Turn your interpretations of PVC as a building material into bright ideas.

For more information and competition guidelines, circle the reader service card number or write to:

Wolverine Technologies Inc.
Design Competition
P.O. Box 1864
Ann Arbor, MI 48106

Wolverine Technologies Inc.

Circle 116 on inquiry card

Now you can specify
an engineered
ballast system:

THE ROOFBLOK BALLAST SYSTEM

At only 11.5 psf, the ROOFBLOK Ballast System provides the most complete membrane protection possible against puncture, cutting, scouring, ultra-violet rays and wind uplift. The ROOFBLOK System is the result of 4 years of research and extensive testing.

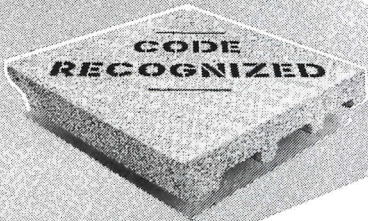

- ICBO Research Report #4149
- CABO Research Report #NER 291
- Sweet's 7.1² / Roo

ROOFBLOK™
BALLAST SYSTEM

For complete technical information, including details and specifications, write or call ROOFBLOK, Ltd., P.O. Box 2624, Fitchburg, MA 01420 (617) 582-9426.

Circle 95 on inquiry card



THE 1,000 EYED LIGHT

With this Q-Lens Beamshaper you can produce limitless variations of quadrilateral or round beam patterns, precisely framing paintings, signs or photographs for remarkably dramatic effects.

For an information kit, write on your letterhead to: Lighting Services Inc, 150 East 58 Street, New York, NY 10155

Circle 96 on inquiry card



S T O R A G E P L A N N I N G

**SEND FOR YOUR
FREE LIBRARY OF
STORAGE PLANNING
BROCHURES FROM
SPACESAVER**

IDEAS



Ask Yourself.

Should I know more about high-density mobile storage?
What part can it play in current and future projects?
How will my clients benefit by specifying high-density storage systems?
The answers are in this free library of comprehensive, fully-detailed planning brochures, written for the Architect... and yours for the asking.

In addition to receiving my Storage Planning Library, I want to review your complete Designer's File.

Name _____
Firm _____
Address _____
City _____ State _____ Zip _____
Telephone _____

Spacesaver
When performance counts.

TM
Spacesaver Corporation
1450 Janesville Ave.
Ft. Atkinson, WI 53538
Spacesaver Mobile
Storage Systems
Corporation
7027 Fir Tree Drive
Mississauga, Ontario
Canada L5S1J7
Tel: (416) 671-0391
AR



Circle 97 on inquiry card

DESIGN MANAGER

Directs and coordinates development and implementation of Airport Master Plan, capital improvement budget, and design and construction of Airport capital improvements.

MINIMUM QUALIFICATIONS

- * Bachelor's degree in Architecture, Engineering or related field.
- * Ten years progressively responsible experience in design of buildings and other related facilities.
- * A Master's degree in architecture, engineering or related field may be substituted for one year of above experience.
- * Five years supervisory experience.
- * Three years experience in a management role.
- * Knowledge of laws and regulations relating to Airport development.
- * Knowledge of principles and practices applied in planning, location, design, construction and maintenance of public service engineering and architectural projects, including knowledge of all disciplines (architectural, civil, structural, mechanical, electrical and plumbing.)
- * Knowledge of major types of building construction, materials and equipment, and of all stages of construction when possible defects may most easily be observed and corrected.
- * Ability to pass a pre-employment medical physical examination.

SPECIAL REQUIREMENT

Registration as a professional architect or professional engineer in the State of Texas, or ability to obtain such through reciprocity.

APPLICATION PROCESS

Applications or resumes may be submitted to the Dallas/Fort Worth Airport Board Personnel Office, 3236 East Airfield Drive, P.O. Drawer D/FW, Dallas/Fort Worth Airport, Texas 75261. Applications will be accepted through 4:30 p.m. June 13, 1986.

We are an Equal Opportunity Employer

ARCHITECT

A/E consulting firm headquartered in Rochester, New York, seeks an Architect for its branch office in Canton, New York.

Position requires a Bachelor's degree in Architecture; license preferred, plus 5-10 years' experience in commercial and industrial projects desirable. Good client and marketing skills are essential.

We offer a very competitive salary and fringe benefits program. Please send your resume to: **SEAR-BROWN ASSOCIATES, P.C.**, 85 Metro Park, Rochester, NY 14623. An Equal Opportunity Employer M/F.

SEAR-BROWN ASSOCIATES, P.C.

Engineers/Architects
Surveyors/Landscape Architects

PROFESSIONAL SERVICES

ARC DESIGN CONSULTANTS (UK) LTD.

London-based architectural firm with extensive experience of large overseas projects offers comprehensive support services to U.S. practices with commitments in Europe, the Middle East and Africa.

Take advantage of the favorable overhead and production costs that having a base in Europe will give you today. Our teams are fully experienced in the use of CAD for working drawings, and also provide specification, quantity surveying and engineering support.

Enquiries: **Arc Design Consultants (UK) Ltd.**,
1 Cambridge Gate
London NW1 4JN
Telephone: 01-935 3464
Telex: 295617 ARCH G
Telefax: 01-935 5950
(Groups 2 & 3)

SPECIAL SERVICES

Architects & Engineers Professional Liability Insurance. Competitive rates and excellent service. Representing the Schinnerer & Co. program commended by AIA and NSPE. Ask for a quote — no obligation. Stuart E. Cohen Ltd., 208 Gramatan Ave., Mt. Vernon, NY 10550 (914) 667-6633.

**CALL IN
YOUR
CLASSIFIED ADS
212/512-2556**

POSITIONS VACANT

Senior Design position avail. with New England firm. Qualified person must have degree and reg. coupled with proven exp. and reputation in the ds. of inst., office and corporate facilities. Ability to conduct presentation, sketch and assume key design respon. for the firm is essential. Highly visible position offers excellent comp. and long term growth in a challenging environ. Contact our reps with *conf. resume* at: G. Marshall Assoc. — P.O. Box 66083 — Chicago, IL 60666.

Project Architect req. by growing Midwest firm. Qualified person should have degree and reg. coupled with 5+ yrs. exp. in the supv./coord. of comm. and inst. projects. Proven ability in assuming project respon. from design through complete production phases including client liaison is essential. Excellent long term growth position with stable firm in mid-sized community. Contact our reps. in *conf.* at: G. Marshall Assoc. — P.O. Box 66083 — Chicago, IL 60666.

Project Architect position open with growing NorthEast firm. Qualified person should have degree and reg. along with 5-8+ yrs. exp. in the supv./coord. of comm. and inst. projects from schematic phases through complete production and successful conclusion. Ability to lead staff and maintain client liaison a must. Firm offers excellent long term prof. and personal growth and compensation. Contact our reps in *conf.* at: G. Marshall Assoc. — P.O. Box 66083 — Chicago, IL 60666.

Architect — Facilities Design. An immediate opening exists in the Architectural Services Division of the City of Rochester, New York. Successful candidate must possess New York State Registration or NCARB certificate plus minimum 3 years experience in providing professional architectural services with emphasis in planning, design and analysis of new construction projects and alterations of existing structures; some supervisory experience is required. The Architectural Services Section is responsible for providing professional services in development, design, construction, renovation, alteration and repair of all real property owned by the City including office buildings, fire stations, libraries, recreation facilities, police stations, city parking structures and various maintenance and repair facilities. Excellent benefits package. Submit letter of application and resume to Thomas Johnson, City of Rochester, Bureau of Employee Relations (Room 103-A) 30 Church Street, Rochester, New York 14614. EEO Employer/Handicapped.

Architect — Progressive Firm on Maryland's Eastern Shore invites an Architect to join them for stimulating work in an area that emphasizes quality of life. Candidate should have good design skills with 10 years of working experience and an acute awareness of client's needs (good listener). Interested candidates should apply to James Thomas at: George, Miles & Buhr, Architects, Engineers, Planners, 724 E. Main Street, Salisbury, Maryland 21801. 301 742-3115.

Architect wanted to plan and design interior and exterior of buildings for project located in the Middle East; analyze the functional and spacial requirements of clients and integrate engineering elements into unified design. Project will entail facets of Islamic architecture; Requires M.S. in Architecture and one year experience; \$10.00 per hour; \$15.00 per hour overtime; 40 hours per week. Send resume to 7310 Woodward Ave., Room 415, Detroit, MI 48202. Ref. #71085. Employer Paid Ad.

COMPUTER SOFTWARE

SF-254 + SF-255 IN ONE HOUR

DEMO PROGRAM + MANUAL \$20 (RISK FREE)
PROGRAMS + MANUAL \$300
*runs on IBM-PC & compatibles. CPM-80

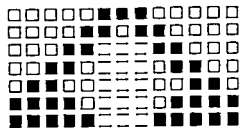

RCHSOFT CONSULTANTS
LANDSCAPE ARCHITECTURE
137 1/2 PARK LANE · KIRKLAND, WA 98033 · TEL (206) 822-9612

We've created a Marketing Database Program just for design professionals like ourselves. From simple menu selections you can quickly enter, edit, sort and retrieve your project and consultant information. Directly prints on SF-254 & SF-255 government forms, along with your choice of mailing labels. All you need is a microcomputer and any printer.

Call us today and order a demo package. If not satisfied, RETURN FOR FULL REFUND
Tel (206) 822-9612

DESIGN SOFTWARE

PROFESSIONAL ACCOUNTING & MANAGEMENT SYSTEM

Fully integrated project management/accounting package; includes Job Cost, Predictive Budgets, Billing, Payroll, Aged A/R, A/P, and G/L. IBM XT/AT compatible—link to Lotus 123 tm.
ACS (805) 962-4962 PO Box 4811 SB CA 93140

Billing and Job Costing
using the Apple Macintosh. . . .
Applied Micronetics, Inc
1078 Carol Lane, Suite 202 Lafayette, CA 94549
(415) 283-4498

GEOCAD

Rudolph
Horowitz
Associates
Architects

Laurel Road, Pound Ridge, N.Y. 10576
Telephone 914/764-4072

GEOCAD, a low cost drafting system for architects, is gaining wide acceptance among architects and other design professionals. It is structured around AutoCAD™ the most popular CAD program in the world.

The complete GEOCAD Turnkey System, based on the NEC APC computer, Hitachi digitizer, Houston Instrument plotter, complete with AutoCAD and GEOCAD software, including on site installation and two days of training is priced at \$12,800

GEOCAD software package (if purchased separately)	\$ 800
GEOCAD software package (if purchased with AutoCAD)	\$ 500
GEOCAD generic menu and templates	\$ 200
GEOCAD estimating module (to be released soon)	\$ 800

AutoCAD is a registered trademark of Autodesk Inc.

Group 4, Inc. now has available the Disk Library service for MASTERSPEC® Specifications System. This automated specification production system will save you time and money.

The MASTERSPEC Disk Library is available for use with WordPlus-PC and Word Perfect word-processing software systems for IBM and IBM-compatible desktop computer systems. It is available in the Basic and Short Language Versions.

The Disk Library is easy to use. No special training is necessary. You can use the MASTERSPEC Disk Library immediately upon arrival.

Call (409) 775-7472 today for more information on the Group 4, Inc.-MASTERSPEC Disk Library service.

group 4
architects planners
suite 200
121 north main street
bryan, texas 77803
409/775-7472

Call now.

Estimate faster,
more accurately
by next week.

With the Dodge
Computer Data Base,
the most extensive
in the industry.
Linked by phone
to your own terminal.

Do Conceptual Budget Analyses
and Preliminary Design Estimates
in minutes with on-line access to:

- Costs for 25,000 building components
- Precise labor costs/time estimates for 22 trades
- Cost adjustments for 720 zip codes

For details, call toll-free
1-800-257-5295

(in N.J. 1-609-426-7300)



Cost Information Systems

McGraw-Hill Information Systems Company

NEW!

Advertise
your classifieds
regionally in
Architectural Record
For details,
call 212/512-2556.

Advertise
your
software
for only
\$139.00
Per Inch
Call
Ilene Fader
212/512-2984

\$5,995.00
Complete Job Costing & Accounting
HARDWARE & SOFTWARE

Hardware includes IBM/XT compatible computer with
10MB hard disk, wide carriage
printer, CRT, and keyboard.

CMAS Software includes accounts payable, general
ledger, job costing, and construction
payroll.

Optional Software: accounts receivable, estimating,
and service billing.

Multi-Terminal XENIX/UNIX IBM/AT
and other Super Micros also available.



DATA-BASICS

WEST COAST OFFICE:
Newport Beach, California

CORPORATE OFFICE:
11000 Cedar Road
Cleveland, Ohio 44106
(216) 721-3400

12 Years in Business—Over 500 Installations

MOBIUS II®

Architects' Management System

Project generated, MS-DOS/hard disk resident. Free
demo disk. Call:

MOBIUS II®
(212) 334-9100

POSITIONS VACANT

Concept Estimator position avail. within major New England branch office of nationwide dsn/bid firm. Qualified person must have proven exp. in prelim. concept estimates for office and comm. building design projects; preferably in an A/E or Architectural environment. Will assume key respon for dept and staff mgmt in concept estimate and proposal prep for both new and renovation dsn projects encompassing architectural and interiors, mech and elect, etc. systems. Position offers excellent comp and highly visible stature within a growing office. Contact our reps in conf. at: G. Marshall Assoc. — P.O. Box 66083 — Chicago, IL 60666.

Sr. Tech/Job Captain position avail. with growing firm in the South. Qualified person should have 5+ yrs. exp. in schematic dev. and production documentation for comm. and inst. design projects. Ability to participate directly as well as lead additional staff and assume respon. for complete project production phases is essential. Firm offers comp. compensation along with paid interview and relocation exp. Contact our reps in conf. at: G. Marshall Assoc. — P.O. Box 66083 — Chicago, IL 60666.

Sr. Tech/Job Captain req. by prominent firm in the NorthEast. Five plus yrs. exp. in design and production documentation for diverse comm., ind. and inst. projects; the ability to lead staff and assume complete responsibility for all project production phases is required. Firm offers excellent comp. and long term growth in a challenging environment. Interview and relocation exp. paid. Contact our reps in conf. at: G. Marshall Assoc. — PO Box 66083 — Chicago, IL 60666.

Project Architect. Major Ohio Healthcare Company requires a self motivated and well organized Project Architect. Individual will be responsible for supervision of design and production of plans for renovation projects in the \$250,000-\$1M range. Requirements: NCARB, 5 year experience preferably in Healthcare and/or Commercial Renovations. Good salary and benefit package. Immediate opening. Relocation required. Equal Opportunity Employer. Send resume to Healthcare and Retirement Corporation of America 1885 North McCullough Street, Lima, Ohio 45801, Attention: Human Resource Manager.

Architectural Design Manager — Requires 5 year College Course with BA Degree in Architecture, 2 years experience or 2 years experience as Architectural Designer and Construction Supervisor. Requires supervisory experience to be in Architectural Construction field. 40 hours per week, 7:30-4:30, \$20,800/yr. Send resume to: Dept. of Employment Security, care of BJ Lyell, 301 James Robertson Parkway, Nashville, Tenn 37201.

Major equity position available in well estab- lished, highly successful Palm Springs, California Architectural Firm. Ideal opportunity for highly motivated individual to live and work in one of the world's most beautiful communities. Send resume to: David L. Christian Associates, Inc., 1000 S. Palm Canyon Drive, Palm Springs, California 92264.

Growing, 150 person Design/Build Firm, specializing in restaurants and medical office construction and remodeling nationwide, is looking for a registered architect. This individual will be the first architect on our team with responsibilities to include developing the Department. Must be a take-charge individual, extremely creative with a good technical base. Prefer NCARB or working toward same, with 3-5 years of experience. Must respect the interior design discipline. Need outstanding people skills. Competitive salary and benefits. Reply to: Architect, P.O. Box 1049, Fond du Lac, WI 54935.

POSITIONS VACANT

Group One Search — Executive Recruiters. Specializing in Architectural positions. \$22,000-60,000 with regional and national firms. Confidential. No Fee. Include salary requirements. 3812 W. Linebaugh Ave., #26, Tampa, FL 33624; 813-969-0544.

POSITIONS WANTED

Architect — Planner with 20 years diversified international experience in design and management seeks senior position or partnership. Experience includes project and contract development, negotiation and client liaison, budgeting, administration and managerial skills. Work includes master plans, new townships, residential, commercial, institutional, educational and sports buildings. Winner of competitions and awards. Buildings illustrated in professional publications in U.S. and Europe. All locations will be considered. PW-4119, Architectural Record.

BUSINESS OPPORTUNITIES

A Techline Studio — An opportunity to prac- tice Architecture or Interior Design in a unique hands-on environment. We are a well established national Architectural and Building firm that specializes in design and construction of Medical Facilities. We have designed and are now manufacturing a unique system of Techline furniture and cabinetry that has no equal in precision, quality and price. This system serves homes, offices and medical buildings. Our factory is the most advanced technically in the U.S. There are already 8 very successful studios owned and operated by Architects and Interior Designers. We are not looking for absentee investors but for owners who are willing to operate a studio. These studios provide traditional architectural services as well as Techline furniture and cabinetry in a showroom environment. Besides design ability, it requires a person with management ability and \$50,000 equity capital to set up the studio. Our goal is to develop a mutually beneficial relationship with creative and ambitious people who enjoy a hands-on operation, as well as economic rewards. Marshall Erdman and Associates, 5117 University Ave., Madison, WI 53705. (608) 238-0211.

SELLING OPPORTUNITIES AVAILABLE

Manufacturer's Reps Wanted — International structural decorative manufacturer of RP, "KRINKGLAS", plastics is seeking manufacturers reps to call on the dealer trade, architects, specifiers and corporate accounts. Only qualified personnel catering to this market segment should apply. Retired or Semi-retired applicants will be considered. All inquiries will be handled in strictest confidence. Reply: P.O. Box #3337, Bright Station P.O., Hialeah, FL 33013.

Firm Wanted — Engineering organization is interested in purchasing a NY State practicing AE or Architectural Corp. Objectives are combine current management, marketing and professional capabilities with our Intergraph CADD System, (40 station capacity), to develop a dynamic diversified A.E. firm. Interested parties should contact: BO-2773, Architectural Record.

Arizona Architectural Firm will consider sale of 25 year old small, but highly profitable and reputable practice. Principal is nearing retirement. Average annual net to principal has been in excess of \$100,000. Reply to: BO-2807, Architectural Record.

Continued from page 169

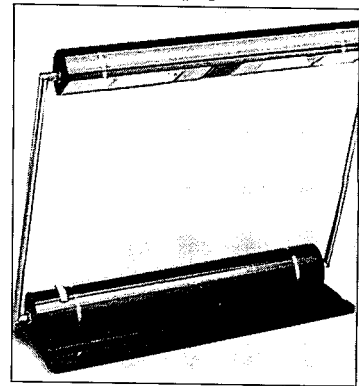

Desk lamp
The manufacturer's desk lamp has a gun-metal gray finish, is 17 in. wide, and is furnished with halogen bulbs and a dimmer switch. The adjustable lamp head is attached to pivoting brackets for increased flexibility. Paul Associates, Long Island City, N. Y.

Circle 331 on reader service card

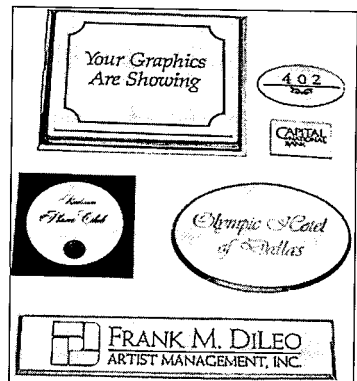

Brass signage
The manufacturer's line of brass signage is available in etched and polished brass with round, coved, and beveled edges. The signs may be specified in satin, chrome, and polished mirror finishes or with an oxidized patina. All plates are coated with clear urethane containing a corrosion inhibitor. Environmental Signing, Inc., Sepulveda, Calif.

Circle 332 on reader service card

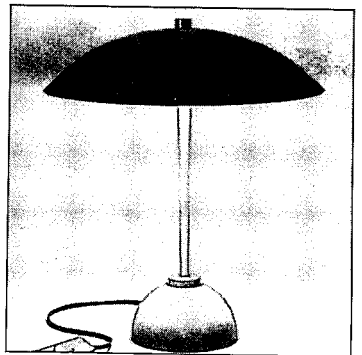

Lamp
Designed by Antony Howard, the T-500 Nottingham table lamp is 12 in. high. The base has a 4-in. diameter and the shade has a 10 1/2-in. diameter. The stem is available in polished brass, chrome, and red or yellow glossy enamel, and the shade and base are available in a gray suede-like finish that is said to be dust-proof, scratch-resistant, and nonreflective. Koch + Lowy, Inc., Long Island City, N. Y.

Circle 333 on reader service card

Hurd is the innovative leader of the window industry.

Hurd standards are designed to perform.

R-4

Hurd makes classic windows in the most carefully controlled modern environment, infusing the best of today's technology into our craft. We offer the sizes, shapes and window types necessary

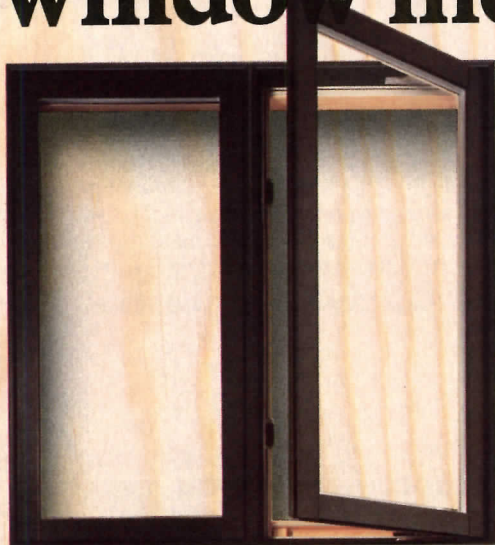

Consider the Hurd clad casement. A standard product for us, by any other criteria, this is a very exceptional window. The .050 inch thick aluminum cladding on the frame and sash is electrostatically coated so it won't chip, fade or peel. The full one-inch insulating glass is also available with two different Heat Mirror™ glazings. Top performance is further guaranteed by triple weatherstripping and a thick wood frame.

Although a single glance qualifies this Hurd window as a good choice, further investigation of the adherence to detail will convince you that it's the only choice. You can build a reputation with Hurd.

to produce buildings of character and imagination. We also offer R-Values above 4.0, superior comfort and economy.

Hurd gears efficiency to specific climates.

Different areas of the country have different solar exposures and varying heating and cooling demands. Plus, some climates are extremely hot in summer but bitter cold in winter. Hurd won't pretend that one window could be right for all these conditions. Instead, we offer specific glazing options, such as Heat Mirror 88

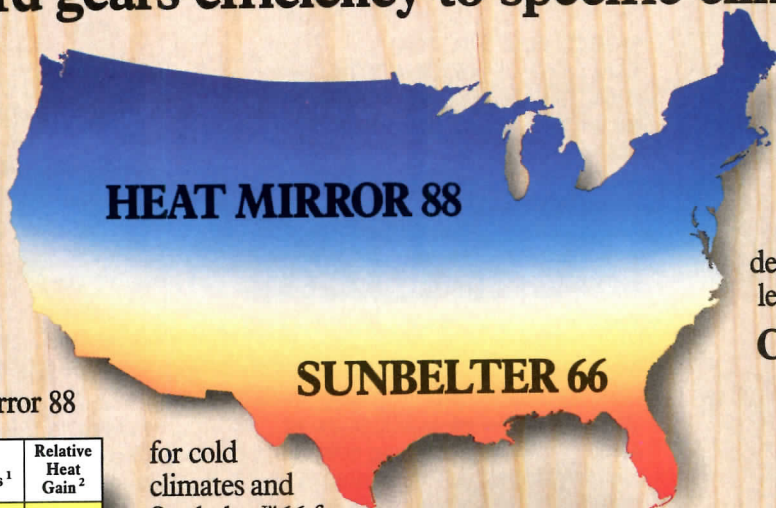

Join the leader. Specify Hurd.

You can improve the efficiency and beauty of every project you design by joining the innovative leader. Don't you deserve the best?

Call: 1-800-2BE-HURD



GLAZING OPTIONS	U Values ¹	R Values ¹	Relative Heat Gain ²
Clad Casement w/1" insulating	.43	2.31	186
Clad Casement w/1" Heat Mirror 88	.25	4.05	149
Clad Casement w/1" Sunbelter 66	.24	4.20	103
Clad Casement w/Bronze Sunbelter 66	.24	4.20	86

for cold climates and Sunbelter™ 66 for hot climates. Each is intended to minimize energy usage and maximize interior comfort. Yet neither restricts or limits the view. Although you can include this custom feature as a premium, it's a standard offering from Hurd.

¹ Standard ASHRAE (1981) winter conditions.
² Standard ASHRAE (1981) summer conditions.

The full line filled with leading ideas.



INVEST IN THESE.

ALL NEW!
With exclusive section on Asbestos Abatement & Removal



DODGE REMODELING AND RETROFIT COST DATA

The most comprehensive cost reference book ever published in remodeling and retrofit. Over 200 pages of accurate costs for every type of renovation project. *Indispensable in today's building market.*

Reg. Price \$35.00 **Your Price \$33.25**

NEW!
Doors and finishing hardware section.

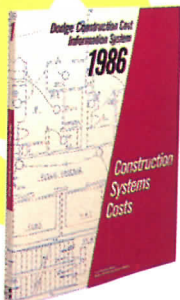

DODGE CONSTRUCTION SYSTEMS COSTS

For high-speed, accurate calculation of alternate designs at the programming, schematic, and preliminary stages. With new Space Planning Guide expanded to 100 different building types.

Reg. Price \$64.50 **Your Price \$61.28**

NEW!
Expanded HVAC Section.



DODGE MANUAL FOR BUILDING CONSTRUCTION PRICING AND SCHEDULING

All the "real-world" data needed for estimates, scheduling, and check change-orders — at any project stage, for any building type. Covers over 12,000 building materials paired with rates for 22 building trades.

Reg. Price \$48.50 **Your Price \$46.08**

NEW!
Innovative graphics and expanded source data.

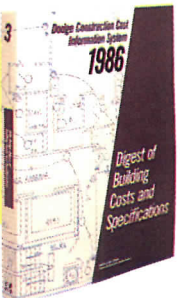

DODGE DIGEST OF BUILDING COSTS AND SPECIFICATIONS

The only reference available using actual "real world" building costs for the fastest "ballpark" estimates ever. Includes more photos and floor plans, and nearly 6,000 case histories for comparisons.

Reg. Price \$186.50 **Your Price \$177.18**

NEW!
Updated features on methods and equipment.



DODGE GUIDE TO PUBLIC WORKS AND HEAVY CONSTRUCTION COSTS

Indispensable for creating or evaluating estimates with the highest degree of accuracy. Includes all critical cost factors — labor rates, production output, material unit costs, equipment unit costs — fully adjustable to over 600 U.S. and Canadian Cities.

Reg. Price \$52.00 **Your Price \$49.40**

Suddenly all other construction cost estimating libraries are obsolete.

The 1986 Dodge Construction Cost Information System Library is more than just updated numbers. Which are crucial in themselves.

We've also added sections, expanded data, and made innovative graphic changes.

Plus we've added a totally new volume on Remodeling and Retrofit Cost Data, reflecting retrofit's projected 50% of the 1986 market.

All of which means you could be at a tremendous competitive disadvantage without the 1986 Dodge Estimating Data.

And the sooner you order, the sooner your firm will have the best estimating advantage in the business.

Complete 5-volume sets are delivered in rigid organizer sleeves for easier desktop usage.
Reg. Price \$386.50
Your Price \$347.85



GET THESE FREE.

Plus 10% discount on all Library sales.
5% discount on individual volumes.

Who was to blame?

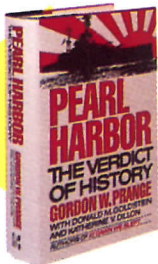

PEARL HARBOR: The Verdict of History

By Gordon W. Prange with Donald M. Goldstein and Katherine V. Dillon

A dramatic sequel to the author's great best seller, *At Dawn We Slept*. This time Prange analyzes the roles and degrees of culpability of Roosevelt, Stimson, Hill, J. Edgar Hoover, General Marshall, General Short and Admiral Block, among others.

Value: \$19.95

The latest scoop on "Give 'em Hell Harry."

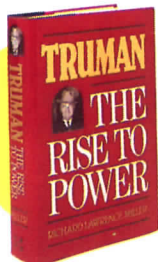

TRUMAN

By Richard Lawrence Miller

Includes previously unpublished information about his life before the White House. Including sometimes shady dealings, bankruptcy, and problems with wife Bess.

Value: \$19.95

Make your wife laugh. Yourself too.



FOUR OF A KIND

By Erma Bombeck

Four of Erma Bombeck's best sellers in one volume.

- THE GRASS IS ALWAYS GREENER OVER THE SEPTIC TANK
 - IF LIFE IS A BOWL OF CHERRIES – WHAT AM I DOING IN THE PITS?
 - AUNT ERMA'S COPE BOOK
 - MOTHERHOOD – THE SECOND OLDEST PROFESSION
- Great gift, especially for mothers.

Value: \$16.95

Blockbuster about a bundle of dynamite.



MARY LOU

By Mary Lou Retton and Bela Karolyi with John Powers

Family reading, inspirational for budding athletes. Has your favorite kid read it?

Value: \$16.95

The "Little Tramp" was really a giant.



CHAPLIN His Life and Art

By David Robinson

The biography of the genius who could make America laugh during the Depression when nothing else could but bootleg gin. Previously unpublished information, including private letters and records obtained from his widow.

Value: \$24.95

Special Offer:

FOR EVERY 1986 DODGE ESTIMATING BOOK YOU BUY GET ONE OF THESE BESTSELLERS FREE.

Plus

10% discount if you buy the 5 Volume Library.
5% discount if you buy individual volumes.

CALL TOLL FREE 1-800-257-5295

In New Jersey, 1-609-426-7300.

Ask for Chris Day at either number.
(VISA, Mastercard, American Express)



Cost Information Systems

McGraw-Hill Information Systems Company
P.O. Box 28
Princeton, NJ 08540

Attention All 1986 Exam Candidates.

Whether you are planning to take the entire nine-division Architect Registration Examination, or just parts of it, these NCARB-published 1986 Handbooks are structured to satisfy your particular needs. Volume 1 offers comprehensive help in preparing yourself for Division A, B, and C (Pre-Design, Site Design, and Building Design). Volume 2 covers subject matter in the other six Divisions—D through I (Structural Technology—General; Structural Technology—Lateral Forces; Structural Technology—Long Span; Mechanical, Plumbing, Electrical, and Life Safety Systems; Materials and Methods; and Construction Documents and Services).

■ **NCARB's two new Handbooks are now available to help you get ready for the June exam.**

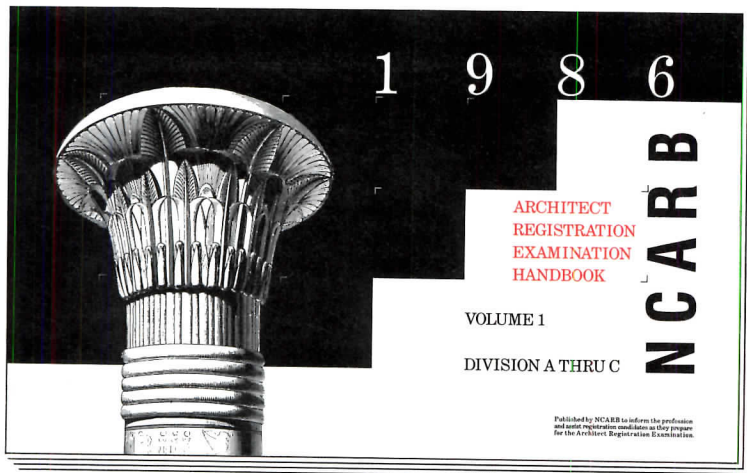

Volume 1

- Expert crits of actual solutions from last year's exam
- Sample questions from last year's Divisions A and B
- Contents of the test information booklets for the 1985 Site and Building Design Tests
- Practical advice from NCARB on how to prepare yourself for the June exam

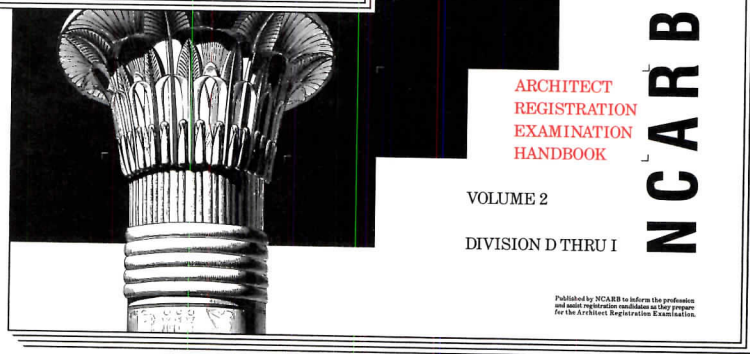

Volume 2

- Official test information provided for last year's candidates taking Divisions D through I
- A definitive sample of the actual questions from Divisions D through I of the 1985 Architect Registration Examination.

Your Handbooks Order Form

The 1986 Architect Registration Examination Handbook is published by the National Council of Architectural Registration Boards. Please allow up to 4 weeks for delivery.

Payment must be included with order. No phone orders accepted. **UPS does not deliver to Post Office boxes:** Please give a street address. Someone must be at the address given on coupon during business hours to receive delivery.

VOLUME	QUANTITY	TOTAL
Set of two Volumes	@ \$70.00	
Volume 1 (covering Divisions A,B,C)	@ \$50.00	
Volume 2 (covering Divisions D thru I)	@ \$30.00	
Price includes UPS postage		Total
Name _____		
Address _____		
City _____	State _____	Zip _____
AR 5/86	Suite 700 1735 New York Avenue, NW Washington, DC 20006	NCARB

**Hurricane
Proved**



Architects: Gatje, Popachristou, Smith and Miller and Meier, a joint venture.

Past experience shows that windblown debris is a primary cause of glass breakage in a hurricane. Laminated safety glass effectively protects a building's interior from wind-blown debris. That is why it was specified for the first three floors of Ft. Lauderdale's new

Broward County Main Library. In the event of breakage, laminated glass tends to remain in its frame, minimizing water damage and glass-related injuries. For hurricane protection, specify hurricane proved laminated safety glass.



3310 Harrison, Topeka, KS 66611 • 913-266-7014

Circle 99 on inquiry card

Sentry SBP



The Traditional Luminaire of Battery Park City

Sentry SBP luminaires stand along the Hudson River Esplanade of Battery Park City, evoking past eras to contemporary New Yorkers. At night the SBPs become energy-efficient H.I.D. light sources that extend the Esplanade's usefulness well into the evening. Indestructible polycarbonate globes make them virtually vandal-proof. Available with New York Type B or other suitable post. Write or call for information.



Sentry
Sentry Electric Corporation
185 Buffalo Avenue
Freeport, New York 11520
516-379-4660

Circle 100 on inquiry card

SPECIFY THE ONLY PRACTICAL METHOD OF MEETING ARMA ATTIC AND ROOF VENTILATION REQUIREMENTS.

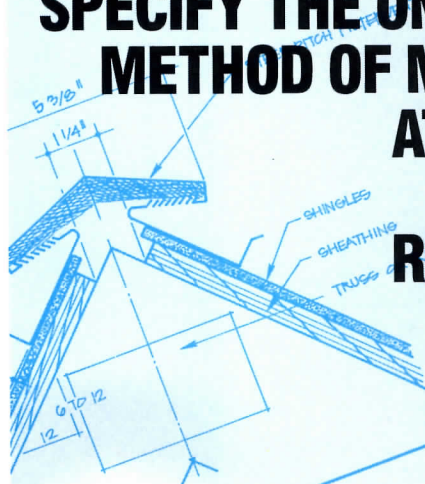

steep pitch **Filtervent**[™]
Keeps the weather out

The Asphalt Roofing Manufacturer's Association (ARMA) recognizes the importance of proper ventilation. And most shingle warranties require 1 square foot of net free ventilation per 300 square feet of attic floor. Filtervent provides proper ventilation on every pitched roof... even 12/12 pitch roofs.

SPECIFY THE BEST.
Filtervent



AIR VENT INC.

4801 N. Prospect Rd., Peoria Heights, IL 61614
PHONE TOLL FREE 800/AIRVENT

Circle 101 on inquiry card

WalltoWall

Floor-to-Ceiling, One Solution, Most Appealing. Trendway this NEOCON.

Trendway invites you to witness the marriage of office construction and office furnishings this NEOCON. Start-to-finish, floor-to-ceiling, wall-to-wall, Trendway offers the

ease, simplicity, and beauty of an office interior system that you can build with . . . and upon.

Visit the all new Trendway National Showroom this NEOCON. Space 1086, The Merchandise Mart, Chicago, June 10-13.

Floor-to-ceiling, wall-to-wall, the best solution, over all, is Trendway, P.O. Box 1110, Holland, Michigan 49423.

 **TRENDWAY**

Private and Open Office Environments



Circle 102 on inquiry card

Beadex wants to keep you from cracking up. . .

Beadex is offering their tape-on trim!

Beadex Tape-On Corners are pre-applied adhesive coating. Unlike Nail-On Corners, Tape-On Corners do not crack along the outer edge if stud movement or drywall shrinkage should occur.

- Ease of application
- No nail pops
- Shallower bead means less shrinkage
- More rust resistant
- Better surface for joint compound adhesion
- Paint adheres better to bead portion than to bare steel
- Available in 90 degree and 3/4" radius corners

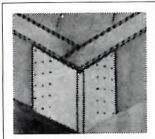

STYLE	DIMENSIONS				DESCRIPTION
	A	B	C	D	
B-1	15/32"	23/32"	5/8"	5/8"	BEADEX OUTER CORNER Concealed Metal. Galvanized metal corner bead laminated to exposed paper tape offers an excellent bond for joint cement and paint. For use on any thickness of wallboard.
B-1W	19/32"	27/32"	13/16"	13/16"	
B-1XW	23/32"	31/32"	11/16"	11/16"	

3-1/8" TAPE
CORNER
1-1/2" LINE COVE

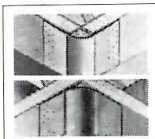

BEADEX SOFTLINE
Softline corner and cove products help create the appealing, rounded inner and outer corners favored by many designers. Paper tape laminated to galvanized metal assures excellent adhesion. The 3/4" radius adapts well to either 1/2" or 5/8" drywall.

BEADEX MANUFACTURING COMPANY, INC.



833 Houser Way North
Renton, Washington 98055
(206) 228-6600

1325 El Pinal Drive
Stockton, California 95205
(209) 462-6600

Patented under U.S. Pat. No's. 2,649,890, 2,593,859
Patents pending.

Circle 103 on inquiry card



ARTHUR BERNARDON SPEAKS WITH AN ACCENT.

Sometimes the art in a building can come from the materials themselves as much as the design. Shakertown Fancy Cut Shingles, with their intricate textures, are one of those rare materials. They add a rich accent to this architectural statement.

—Arthur A. Bernardon AIA & Associates

SHAKERTOWN FANCY CUTS®

Send for a free design ideas portfolio: Shakertown, Box 400-ARF-5, Winlock, WA 98596.

Circle 104 on inquiry card

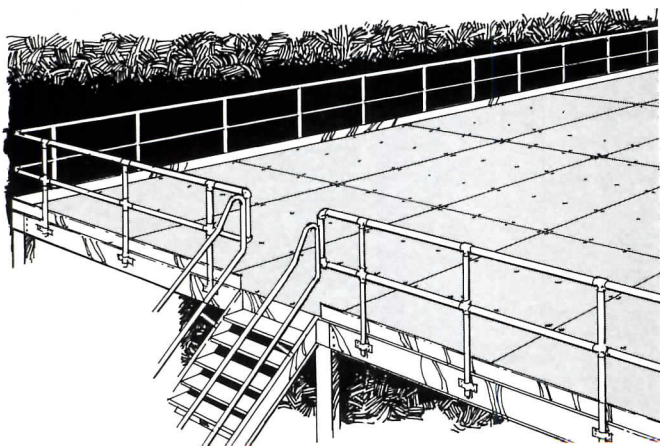

Have you considered a mezzanine?

The WILDECK professionals can engineer and fabricate one to your exact needs.

Save planning time and costs on your next project, with a WILDECK custom mezzanine. It's the most cost effective for any type of installation, with virtually no size, load, span or height limitations! And only WILDECK offers three designs: Bolted C-section, beam and bar joist, and beam and beam. All meet ASIC and ASTM standards, plus specified national, state and local codes. **Write for specs and details, or call toll free 1-800/325-6939. In Wisconsin, call 1-414/549-4000.**

930-019

WILDECK® MEZZANINES, INC.
P.O. Box 89
Waukesha, Wisconsin 53187

Circle 105 on inquiry card

SPECIFY THE ONLY ATTIC AND ROOF VENTILATOR THAT KEEPS OUT RAIN AND SNOW.



Ridge FilterVent™
Keeps the weather out

Only the patented line of Filtervent products from Air Vent Inc. have the exclusive glass fiber weather filter to "Keep the Weather Out" under all weather conditions and wind directions. The filter does its job without restricting air flow.

SPECIFY THE BEST.
FilterVent.



AIR VENT INC.

4801 N. Prospect Rd., Peoria Heights, IL 61614
PHONE TOLL FREE 800/AIRVENT

Circle 101 on inquiry card

What is a Best Western?



"My home office wherever I travel."

The right place at the right price.

Make reservations at any Best Western, see your travel agent, or call toll-free
1-800-528-1234



"World's largest chain of independently owned and operated hotels, motor inns and resorts"

Manufacturer sources

For your convenience in locating building materials and other products shown in this month's feature articles, RECORD has asked the architects to identify the products specified

Pages 92-95

Belfer Center for Public Management by Architectural Resources
Brick: Kane Gonic. Curtain wall, entrance: Alumiline. Triple glazing: Hordis Brothers. Reflective glazing: PPG. Roofing: Carlisle. Bollards: Voigt.
Laminate: Nevamar; Laminart. Wood doors: Weyerhaeuser. Carpet: Milliken. Paints: DeVoe; Benjamin Moore.
Locksets: Corbin. Exit devices: Von Duprin. Lighting fixture: Allied. Drywall: U. S. G. Metal doors: E.H. Friedrich Co. Acoustic tile: Armstrong. Suspension system: Donn. Diffusers: Leonhart. Drapery fabric: Coral. Brick flooring: Stiles & Hart.

Pages 96-97

Fisher Watkins Library by Stubbins Associates
Unit framing: Cronco-Lite. Windows: Kawneer. Carpeting: Bentley. Pedestal seating: Artifort through Castelli. Sofas: David Edward. Leather seating: Beylerian. Carrels, tables: custom by Nescor
Woodworking. Chairs: Claude Bunyard. Ceiling: Decoustics.

Pages 98-101

Jewish Theological Seminary by The Gruzen Partnership
Brick: Merritt Sales Co. Lights: Lighting Associates. Curtain wall: Kawneer.
Granite: Cold Spring. Skylight: Lynbrook Glass. Railing: G. E. R. Bookshelves: All Steel. Card catalogs, periodical display: Library Bureau. Paints: Century Paint; Benjamin Moore. Ceiling tile: Armstrong. Downlights and ceiling fixtures: Lighting Associates.
Seating: Irwin. Locksets: Best. Sprinklers: Premier. Terrazzo: Magnan & Co.

Pages 102-105

Mudd Center, Amherst College by Edward Larrabee Barnes Associates
Brick: Morin Brick Co. Green glazed brick: Claycraft. Roofing: Vermont Structural Slate Co. Windows: DuraTherm.
Paints: Pratt and Lambert. Drywall: U. S. G. Exit devices: VonDuprin. Locksets, closers: Yale. Vinyl flooring: Kentile. Carpet: Lees.
Chairs: Jasper Chair Co. Tables: Adden. Office furniture: Steelcase; Adden. Raised flooring: Donn Corp.

Pages 116-123

The Poynter Institute by Jung/Brannen Associates, Inc.
Roofing: Ludowici-Celadon. Skylight: EPI Architectural Systems. Bollards: Kim. Windows: Vistawall. Wood doors, library shelving: custom by architects, fabricated by Anderson Lumber Co. Locksets: Russwin.
Flooring: Quality Marble. Downlights: Lithonia; Kurt Versen. Wall lights: Koch & Lowy. Paints: Polomyx. Wood trusses: Structural Wood Systems. Chairs: Worden.

Pages 124-129

Quady Winery by Stanley Saitowitz
Windows: Kalwall. Roofing: Rib Roofing Co. Lighting: Halo. Paints: Fuller. Sinks: American Standard. Locksets: Schlage.

Need Research That Utilizes Computer-Assisted Telephone Data Gathering?

Want to gather information rapidly using state-of-the-art computer-assisted telephone interviewing? Need fast access to tabulated results? Require integrated graphics with sophisticated analysis? Are you seeking real-time information?

Call **RESEARCHNET** at McGraw-Hill Research

ResearchNet is the leading edge approach to research that integrates study design, computer-assisted telephone interviewing, on-line tabulation, and report analysis capabilities as well as real-time data gathering. ResearchNet links together McGraw-Hill Research project teams, interviewers' terminals, respondent input, and you—to produce timely, accurate and meaningful study results.

For a quote or proposal call Sheryl R. Fox (609) 426-5946 (Information Data Gathering) or Joseph T. Collins (212) 512-3264 (Full-Service Research) or write David P. Forsyth at McGraw-Hill Research, 1221 Avenue of the Americas, NY, NY 10020



If it's a marketing research problem, we probably pioneered the solution.

Made to be walked on!

Cabot's® Decking Stains

America is moving outdoors to the patios, porches, and poolsides...and Cabot has a product that goes along with the trend. Cabot's Decking Stains, especially formulated for wood, decking, fencing, and furniture, is decorative and durable, will add color in natural wood tones to the outdoor scene. Available in eight colors; will not rub off or track off; resist cracking, peeling, and blistering; meet federal standards for water-repellency and wood-preservation. For color card and information write:

Samuel Cabot Inc.

One Union St., Dept. 529, Boston, MA 02108
442 Valley Drive, Dept. 529, Brisbane, CA 94005

Circle 107 on inquiry card

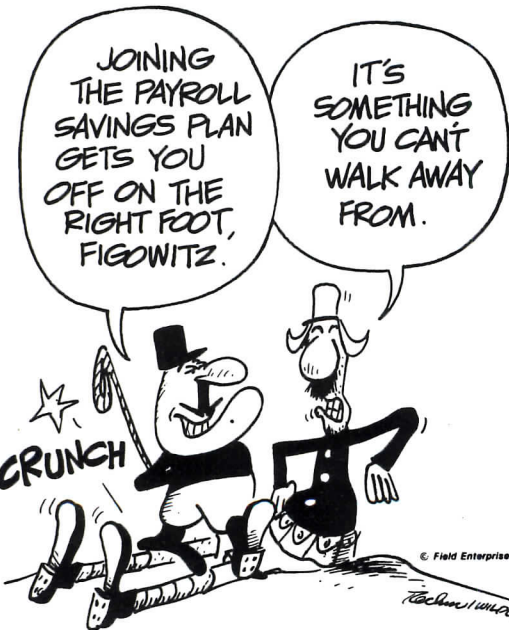

**Payroll Savings really works
...and that's no CROCK!**

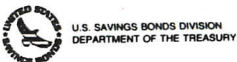

SPECIFY THE ATTIC AND ROOF VENTILATOR THAT REMOVES HEAT AND BEAUTIFIES THE HOME.



flash Filtervent™
Keeps the weather out

Roof vents, turbines and power vents are not effective in removing attic heat... and they detract from the beauty of the home. Filtervent provides superior heat and moisture removal and aesthetics. Available in four attractive finishes.

**SPECIFY THE BEST.
Filtervent**



AIR VENT INC.

4801 N. Prospect Rd., Peoria Heights, IL 61614
PHONE TOLL FREE 800/AIRVENT

Circle 101 on inquiry card

Page® ArmorLink™ fence fabric... stands the test of time.



Now, an ASTM study has proved it!* ASTM conducted a 20-year study on the atmospheric corrosion effects on aluminum-coated and galvanized steel wire products. The tests reflected diverse atmospheric exposure experiences ranging from high humidity and salt spray through agricultural to heavy industrial environments. Here are some of the results:

CHAIN LINK FENCE 20-YEAR ASTM TEST (% RUST AND/OR CORROSION)

	Galvanized Steel		Aluminized Steel	
	Sample 32	Sample 33	Sample 36	Sample 37
Brazos River, TX	95%	95%	10%	15%
Kure Beach, NC (1)	100%	100%	7%	20%
Kure Beach, NC (2)	90%	90%	7%	27%
Newark, NJ	100%	100%	0	0
State College, PA	85%	93%	1%	15%

*Source ASTM STP 585A.

Page, ArmorLink, aluminum-coated fabric lasts longer and has a longer corrosion-free life than competition.

Now look at ArmorLink's other advantages!

Self Healing — ArmorLink aluminized fabric has a unique healing process versus competition. When an abrasion in the fabric occurs, the adjacent aluminum coating inhibits its corrosion. This means less maintenance and longer life.



Galvanized



Aluminized

Safer — ArmorLink fabric is safer than galvanized due to the coating process. It does not have the barbs and rough spots of galvanized fabric that can cause injury to people and animals.

More Fire Resistant — ArmorLink is far more resistant to fire because the aluminum coating has a much higher melting point than either galvanized or vinyl.

Circle 109 on inquiry card

Exclusive 25 Year Guarantee!

We're So Confident — Starting this year ArmorLink fence fabric is guaranteed for 25 years. Ask your ArmorLink Dealer for details of the warranty on the fence that "Stands the Test of Time."

For additional information contact:

Page-Wilson Corporation
Page Fence Division, Dept. 102
100 Monongahela Street
Monessen, Pennsylvania 15062
(412) 684-4000

PAGE®
ARMORLINK™

Stands the test of time.

The BLU-RAY Model 248 Whiteprinter.

Consider features and functions
second to none.

Optional Front or
Rear Print Exit -
complements your
space requirements.

Larger Development Area.

Instant Start-Up.

Dual-Range Speed Control -
allows consistent performance.

1/2-25 Feet Per Minute
50" Throat Width

Dual-Range Heat & Pump Controls -
assure quality prints regardless
of media.

See us at Booth # 1251

A/E/C SYSTEMS '86

June 23-27 McCormick Place, Chicago

Ask us for a demonstration.
Call 203-767-0141 or write us for your
nearest BLU-RAY dealer. Once you
see the New BLU-RAY Model 248
in action, you'll agree this Whiteprinter
has the performance to surpass all
others in its class.

BLU-RAY

Manufacturers of Quality Whiteprinters since 1957
BLU-RAY, Inc. • Westbrook Rd. • Essex, Connecticut 06426

Circle 110 on inquiry card

SPECIFY THE MOST EFFECTIVE ATTIC AND ROOF VENTILATOR AVAILABLE.

filtervent™ The name that means year-round
protection from *all* ventilation problems.

Filtervent provides a continuous, uniform air flow along the entire roof undersheathing. Old fashioned roof vents, turbine vents and power vents don't. And only Filtervent has the exclusive, patented weather filter to keep out rain and snow.

Filtervent draws moist air from the attic in the winter to prevent condensation and ice dams . . . hot air in the summer to stop heat build-up and reduce cooling costs.

Filtervent looks good and outperforms all other ventilation methods. In fact, 32 ft. of Ridge Filtervent provide more net free area than 11 roof vents, 5 turbine vents or a 1,200 CFM power vent. Superior ventilation *and* pleasing aesthetic qualities — in one product!

Join the architects and builders who specify **Filtervent** — for total ventilation protection.



FREE LITERATURE! Please send me full details on the full line of Filtervent products.

Name _____

Company _____

Address _____

City _____ State _____ ZIP _____

Phone (____) _____

Mail to: Air Vent Inc., 4801 N. Prospect Rd.,
Peoria Hts., IL 61614

Call
800-AIR-VENT for
architectural drawings,
specifications and technical
data on the full line of Filtervent
products.

Circle 101 on inquiry card



Advertising index

Bold face—page number

Italics—Reader Service number

A

Air Vent, Inc., **195,197,199,201**;
101 [G]
(800) 243-8368
Alumax Building Specialties, **8**;
5,155; *73* [G-L-D]
(717) 656-4106
American Marazzi Tile, Inc., **70**; *54*
[G-L-D]
American Stair Corp., **150**; *70* [G]
Andersen Corp., **28-29**; *17*, **167**
[G-L]
Architect's Book Club, **157 to 159**
Architectural Precast Assn.,
32Ea-32Eb, **32Ca-32Cb**; *25*
Armstrong, **CovII-1**; *1*, *2-3*;
2,4-5; *3*, *6-7*; *4* [G-D]
AT&T Communications, **168,169**

B

BeadeX, **197**; *103* [G]
(206) 228-6600
Belzona Molecular, Metalife, Inc.,
64; *51*
(516) 542-1000
Best Western International, **198**
Blu-Ray, Inc., **201**; *110*
(203) 767-0141
Bradley Corp., **40**; *37* [G-E-I]
(414) 251-6000
Buchta USA, **182-183**; *89* [G]
(404) 256-0999
Buckingham-Virginia Slate Co.,
32Ec; *22* [G]
(804) 355-4351

C

Cabot, Inc., Samuel, **199**; *107* [G-L]
(617) 723-7740
Calcomp Systems Div., **86-87**; *61*,
164; *79*
(800) 858-6384
Canam Steel/Hambro Div., **26**; *15*
(617) 444-5504
Canon USA, **184-185**; *93*
Capaul Corp., **72**; *55*
Carlisle Syntec Systems, Div. of
Carlisle Corp., **173**; *85* [G-E-I]
(800) 233-0551
Clearprint, **151**; *71*
(415) 652-4762
CNA Insurance, **32**; *19*
(312) 565-2424
Compaq Computer Corp., **152-153**
1 (800) 231-0900
Corbin Hardware Div., Emhart, **36**; *35*
[G]
(203) 225-7411
Cost Information Systems, **180-181**;
115, **192-193**

D

Devine, Sub. of Kidde, Inc., **42**; *38*
Donn Corp., **149**; *69* [G]
(419) 893-2500
Dorma Door, **148**; *68*
(416) 673-1281
Dover Elevator Systems, **20-21** [G]
(601) 393-2110
DuPont-Textile Fibers, **52-53**; *44*
DuPont-Cordura Upholstery Fabric,
30-31; *18*
(302) 999-3234
DuPont-Hypalon, **85**; *60* [G-E-L-D]

E

Eagle Manufacturing, **38**; *36* [G]
Efco Corp., **60**; *48* [G-E-I]
Endura Div., The Biltrire Corp.,
CovIII; *113* [G-I-D]
(800) 447-1982

F

Fiere Di Verona, **171**; *82*
Formica Corp., **63**, *50*, **184**; *90* [G]
(800) 543-3000
Futura Coatings, Inc., **161**; *76*
(314) 521-4100

G

Grace, W.R. & Co., **13**; *7*, **65**; *53*
[G-I]
(617) 876-1400

H

Haworth, Inc., **56**; *46*
(616) 392-5961 ext.3289
Helios Industries, Inc., **16**; *9* [G]
(415) 887-4800
Hoggan Health Industries, Inc.,
32Wb; *28*
(801) 572-6500
Hunter Douglas, **81to84**; *59* [G]
Hurd Millwork, **191**; *98* [G-L]
1 (800) 224-4873

I

IBM, **142-143**; *65*
1 (800) 447-4700
Imperial Bronzelite, **48**; *42*
(512) 392-8957
Interceramic, **58**; *47* [G]
International American Ceramics,
Inc., **34**; *34* [G]
(918) 428-3851
Iron-Craft, Inc., **32Wb**; *27*
(415) 632-4612

K

Kroin, **177**; *87* [G]
(617) 492-4000
Krueger, **45 to 47**; *40,41* [G]

For detailed data, prefiled catalogs of the manufacturers listed below are available in your 1986 Sweet's Catalog File as follows:

L

Laminators Safety Glass Assn., **195**;
99
Laticrete International, Inc., **160**;
75 [G]
(800) 243-4788
Lighting Services, Inc., **185**; *92*,
187; *96*
Loadmaster Systems, Inc., **32Sc**; *33*

M

Marble Institute of America, **165**; *80*
Marvin Windows, **88-89**; *62* [G]
(800) 346-5128
Mercedes Benz of North America,
Inc., **171**
Merchandise Mart Properties, Inc.,
175-176, 20 page advertising supplement included with Central region copies only
MicroAge Computer Stores, Inc.,
32Sb; *32*
Monier Co., **32Sa**; *31* [G-L]
(714) 538-8822
Morton Thiokol, Inc., Morton
Chemical Div., **174**; *86* [G]

N

National Roofing Contractors Assn.,
166; *81*
Naturalite, Inc., **14**; *8* [G-I-L]
(800) 527-4018
Nemo Tile, **32Ee**; *24*
(212) 505-0009
Nucor Corp., **78-79**; *58* [G]

O

Owens-Corning Fiberglas, **48B to 48E**;
20,21 [G-E-I-L]
(800) 537-3476
Oxford University Press, **184**

P

Page Fence Corp., **200**; *109* [G]
Pella Rolscreen Co., **144-145**; *66*
[G-L-D]
Philips Lighting, **64A**; *52*
Pilkington Glass, **17**; *10* [G-E]
Pittsburgh Corning Corp., **22-23**; *13*
[G-E-I]
(412) 327-6100
Prime Computer, Inc., **178-179**; *88*

R

Raceway Components, Inc., **156**; *74*
(201) 661-1116
Rally Racks, **185**; *91*
(707) 938-4744
Rockaway, Inc., **32Ed**; *23*
(516) 239-1000
Roofblok Ltd., **187**; *95* [G-I]
Round Office, Inc., **32Wc**; *29*
Russwin, Inc./ Hardware Div., **62**;
49 [G]
(203) 225-7411

(G) General Building & Renovation (green)
(E) Engineering & Retrofit (brown)
(I) Industrial Construction & Renovation (blue)
(L) Homebuilding & Remodeling (yellow)
(D) Contract Interiors (white)

S

San Valle Tile Kilns, **32Wa**; *26*
Sentry Electric Corp., **195**; *100* [G]
(516) 379-4660
Shakertown Corp., **197**; *104* [G-L]
(800) 426-8970
Shaw-Walker, **172**; *84*
SKOK Systems, Inc., **44**; *39*
Sloan Valve Co., **CovIV**; *114* [G-E-I]
Southern Illinois University Press,
167
Spacesaver Corp., **171**; *83*, **187**;
97 [G-I]
(414) 563-6362
Steelcase, Inc., **90**; *63*
(800) 447-4700
Stevens & Co., J.P., **74**; *56*, **141**;
64 [I]
(413) 527-0700
Sto-Industries, **27**; *16* [G]
(802) 775-4117
Sub-Zero, **163**; *78* [G-L]
(608) 271-2233
Sun System Solar Greenhouses, **203**;
112 [G]
(516) 543-7600
Sweet's Div., McGraw-Hill Systems,
170

T

Traco, Inc., **19**; *12* [G]
Trendway, **196**; *102*

U

United Airlines, **80**
U.S. Intec, **76**; *57* [G-I]
United States Gypsum Co., **10-11**; *6*,
24-25; *14* [G-E-I-L-D]
(312) 321-4180
United States Mineral Prods. Co.,
18; *11* [G-E]

V

Visa Lighting, **154**; *72*
(414) 354-6600
Vistawall Architectural Prods.,
146; *67* [G]
(214) 563-2624

W

WeatherShield Mfg., Inc., **162**; *77*
[G]
(715) 748-2100
Western Wood Prods. Assn.,
32Wd-32We; *30* [G]
Wildeck Mezzanines, Inc., **197**; *105*
WilsonArt, **50**; *43* [G-D]
(800) 433-3222
Wolverine Technologies, **54**; *45*,
186; *116* [G-L]
(313) 386-0800

Z

Zero International, Inc., **163**; *78*
[G]
(212) 585-3230

Sales offices

Main Office

McGraw-Hill, Inc.
1221 Avenue of the Americas
New York, New York 10020

Director of Business and
Production
Joseph R. Wunk (212) 512-2793

Publisher/Vice President
Paul B. Beatty (212) 512-4685

Director of Marketing
Camille Padula (212) 512-2858

Administrative Asst.
Donna O'Reilly (212) 512-4686

Classified Advertising
(212) 512-2556

District Offices

Director of Sales/East
George Broskey
3 Parkway
Philadelphia, PA 19102
(215) 496-3821

Director of Sales/West
John W. Maisel
4000 Town Center, Suite 770
Southfield, MI 48075
(313) 352-9760

Atlanta
4170 Ashford-Dunwoody Road
Atlanta, Georgia 30319
Gregory Bowerman (404) 252-0626

Houston
7600 W. Tidwell, Suite 500
Houston, Texas 77040
Lockwood Seegar (713) 462-0757

Boston
607 Boylston St.
Boston, Massachusetts 02116
Louis F. Kutscher (617) 262-1160

Los Angeles
3333 Wilshire Blvd., Suite 407
Los Angeles, California 90010
Stanley J. Kassir (213) 487-1160

Chicago
645 N. Michigan Ave.
Chicago, Illinois 60611
Anthony Arnone, (312) 751-3765
Cheryl L. Shores, (312) 751-3705

New York
1221 Avenue of the Americas
New York, New York 10020
Theodore C. Rzempoluch
(212) 512-3603

Edward R. Novak, (312) 658-7133
ER&J Associates, Inc.
P.O. Box 348,
Algonquin, IL 60102

Philadelphia
Three Parkway
Philadelphia, Pennsylvania 19102
Blair McClenachan (215) 496-3829

Cleveland
55 Public Square
Cleveland, Ohio 44113
George Gortz (216) 781-7000

Pittsburgh
6 Gateway Center, Suite 215
Pittsburgh, Pennsylvania 15222
George Gortz (412) 227-3640

Denver
7400 S. Alton Ct. Suite 111
Englewood, Colorado 80112
John J. Hernan (303) 740-4634

San Francisco
425 Battery Street
San Francisco, California 94111
Stanley J. Kassir 1 (800) 621-7881

Detroit
4000 Town Center, Suite 770
Southfield, Michigan 48075
Thomas J. Shaw
(313) 352-9760

Stamford
777 Long Ridge Road
Stamford, Connecticut 06902
Louis F. Kutscher
(203) 329-3001

Vice President Market
Development
Federal Government
Paul R. D'Armiento
1750 K Street NW
Suite 1170
Washington, D.C. 20006
(202) 463-1725

Cost Information Systems
McGraw-Hill Information
Systems Co.
Percival E. Pereira
P.O. Box 28
Princeton, N.J. 08540
Toll Free 800/527-5295
N.J. (609) 426-7300

Overseas Offices

Frankfurt/Main
Elsa-Brandstroem Str. 2
Frankfurt/Main, Germany

Tokyo
2-5, 3-chrome
Kasumigaseki, Chiyoda-ku
Tokyo, Japan

Sheffield
146 West St.
Sheffield S14ES, England

Milan
Via Baracchini No. 1
Milan, Italy

South America
Empresa Internacional de
Comunicacoes Ltda.
Rua da Consolacao, 222
Conjunto 103
01302 Sao Paulo, S.P. Brasil

Paris
17, rue Georges Bizet
75 Paris 16e, France

Specify Sun System for the tough ones!

There's no sunspace project too tough for our 53 years of construction experience. Judge for yourself: The Gallery Plaza in Knoxville called for 10,000 square feet of canopy glazing. Bays were specially designed on 30" centers. Valley roofs were added to facilitate turns. Eaves were formed on-site to assure a perfect fit.

In Utah, we opened-up Fryer Tucks restaurant to the sun, the moon and the stars. First floor bars were extended 10' to achieve the desired height. All glass was customized and the vestibule, assembled on site, matched the contour of the building.

If your specs call for one of our 37 standard units or creative glazing that's both functional and fashionable, specify with confidence — specify Sun System.



SPECS:
SAW TOOTH PATTERN
45° PITCH
10' STRETCHES OF GLASS
CALL SUN SYSTEM
516 543-7600

 **SUN SYSTEM®**
SOLAR GREENHOUSES

Copyright 1985

60 Vanderbilt Motor Parkway, Dept. AR, Commack, NY 11725 • 516 543-7600

Distribution Worldwide. See us in Sweets, 13.2c/Sty
Circle 112 on inquiry card

READY TO DO BUSINESS?

Architectural Record introduces Sweet's BUYLINE® 800.

ARCHITECTURAL RECORD presents BUYLINE® —the toll-free telephone information service for construction product manufacturers and ready-for-business specifiers.

All you need is a phone.

Here's how it works. You see an ad in ARCHITECTURAL RECORD. You want to specify the product. Call the toll-free BUYLINE® number:

1-800-447-1982

any time of the day...any day of the week... 365 days a year.

You will immediately receive the name, address, and telephone number of the nearest sales representative...and you're ready to buy. It's that simple.

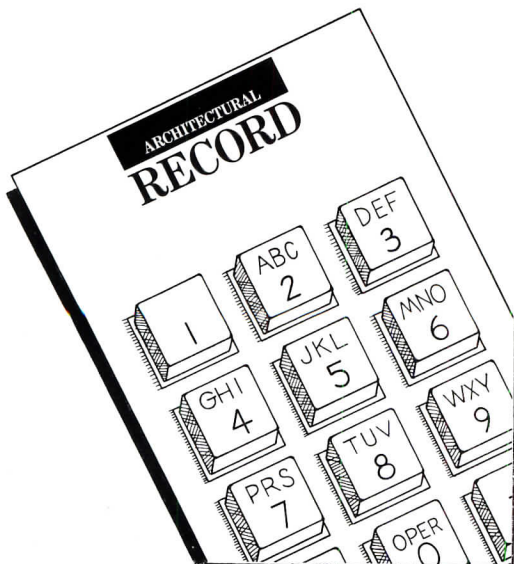

Use your STAC card!

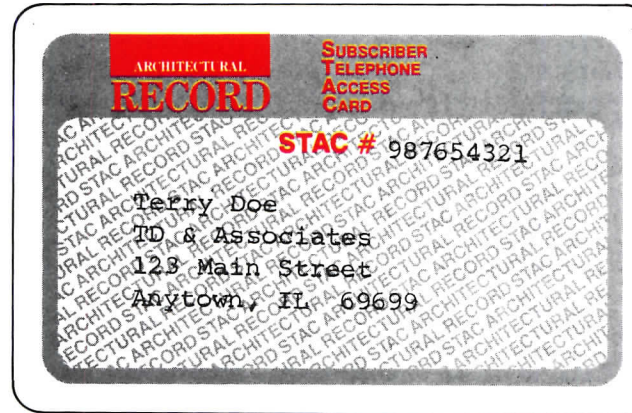

Need product information fast? Your Architectural Record Subscriber Telephone Access Card can help speed information to you about product or service in these pages.

When you key your more-information requests directly into our computer touch-tone telephone—through Architectural Record's exclusive S™ system—you save days, even weeks of mail-delivery, handling and processing time.

The day after you call, advertisers can access your request by phone from computer, and begin the process of mailing you the materials you request. When you need information for a right-now project, fast, free help is as close as your STAC card. And STAC service is available to you 24 hours a seven days a week.

BEFORE YOU DIAL:

1. Write your STAC ID number, as imprinted on your STAC card, in the boxes in Step 4 below. Do not add 0s.
2. Write the Reader Service numbers for those items about which you want more information in the boxes in Step 6 below. Do not add 0s.

CALL STAC:

3. Using a standard touch-tone telephone, call 413/ 442-2668, and follow the computer-generated instructions.

ENTER YOUR STAC NUMBER AND ISSUE NUMBER:

4. When the recording says, "Enter your subscriber number..." enter your STAC number by pushing the numbers and symbols (# or *) on your telephone keypad. Ignore blank boxes. Enter:

#

5. When the recording says, "Enter magazine code and issue code..." enter these numbers and symbols:

#

ENTER YOUR INQUIRIES:

6. When the recording says, "Enter (next) inquiry number..." enter the first Inquiry Selection

Number, including symbol from your list below. Ignore blank boxes. Wait for the prompt before entering each subsequent number (maximum numbers).

1.	<input type="text"/>	<input type="text"/>	<input type="text"/>	<input type="text"/>	#	#
2.	<input type="text"/>	<input type="text"/>	<input type="text"/>	<input type="text"/>	#	#
3.	<input type="text"/>	<input type="text"/>	<input type="text"/>	<input type="text"/>	#	#
4.	<input type="text"/>	<input type="text"/>	<input type="text"/>	<input type="text"/>	#	#
5.	<input type="text"/>	<input type="text"/>	<input type="text"/>	<input type="text"/>	#	#
6.	<input type="text"/>	<input type="text"/>	<input type="text"/>	<input type="text"/>	#	#
7.	<input type="text"/>	<input type="text"/>	<input type="text"/>	<input type="text"/>	#	#
8.	<input type="text"/>	<input type="text"/>	<input type="text"/>	<input type="text"/>	#	#
9.	<input type="text"/>	<input type="text"/>	<input type="text"/>	<input type="text"/>	#	#
10.	<input type="text"/>	<input type="text"/>	<input type="text"/>	<input type="text"/>	#	#
11.	<input type="text"/>	<input type="text"/>	<input type="text"/>	<input type="text"/>	#	#
12.	<input type="text"/>	<input type="text"/>	<input type="text"/>	<input type="text"/>	#	#
13.	<input type="text"/>	<input type="text"/>	<input type="text"/>	<input type="text"/>	#	#
14.	<input type="text"/>	<input type="text"/>	<input type="text"/>	<input type="text"/>	#	#
15.	<input type="text"/>	<input type="text"/>	<input type="text"/>	<input type="text"/>	#	#
16.	<input type="text"/>	<input type="text"/>	<input type="text"/>	<input type="text"/>	#	#
17.	<input type="text"/>	<input type="text"/>	<input type="text"/>	<input type="text"/>	#	#

END STAC SESSION:

7. When you have entered a Inquiry Selection Number, the recording prompts, "next inquiry number." Enter call by entering:

9 1 # #

If you are a subscriber and need assistance, call 212/512-3442. If you are not a subscriber, fill out the subscription card in this issue, or call Architectural Record Subscription Services at 914/628-0821.

ENDURA®



ENDURA rubber flooring and accessories exceeds your current expectations of maintenance, hazard resistance, longevity and cosmetics in rubber flooring. And, it never goes out of style. Which is important, considering how long it lasts!

Manufactured in 11 beautiful colors with 5 profiles, Endura is compounded with internal waxes and comes with a 10-year limited wear warranty.

For additional information and a complete reference guide, contact:

ENDURA
Division of the Bilrite Corp.
2 University Office Park
51 Sawyer Road
Waltham, Massachusetts, U.S.A. 02254
Telephone: 617-647-1700
Telex: 94-9408

Manufactured in U.S.A.

Circle 113 on inquiry card



Built in 1981 at a cost of \$330 million, the Tropicana Hotel & Casino is a special blend of elegance and excitement. With 515 guest rooms, 4 lounges, 7 restaurants, 8 shops, and a 50,873 sq. ft. casino, the Tropicana is an emporium of activity with all the conveniences of home.

“There’s no gambling on efficiency or comfort in the Tropicana Hotel and Casino with Sloan OPTIMA® No-Hands system.”

Atlantic City’s Tropicana Hotel and Casino never leaves the service and accommodations of its patrons to chance. Their concern for comfort and cleanliness amid the glitter of neon and mirrors was the main



reason for installing Sloan OPTIMA® No-Hands

automated flushometers in the casino washrooms.

A Sloan OPTIMA system uses an electronic device to “sense” the user and automatically flushes the

sanitary fixture—or turns the faucet or appliance on or off—only as needed. This insures that faucets and hand dryers are turned off after use and eliminates unflushed urinals and toilets.

The results: Improved comfort and convenience for patrons with more sanitary washrooms. Reduced costs for management with fewer repairs, reduced water usage and less daily maintenance.

The Sloan OPTIMA system meets all building code requirements and installs easily—and unobtrusively—in any new or retrofit situation. The

system also adapts to soap dispensers, hand dryers, shower heads, and more.

Ask your Sloan representative about Sloan No-Hands automated systems. Or write us.

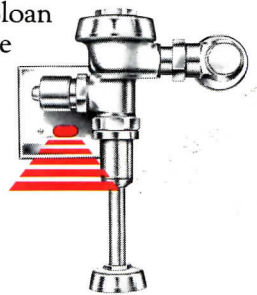

SLOAN VALVE COMPANY
10500 Seymour Avenue, Franklin Park, IL 60131
A Tradition of Quality and Pride