

ARCHITECTURAL RECORD

Business Design Engineering
A McGraw-Hill Publication, Seven Dollars
May 1989

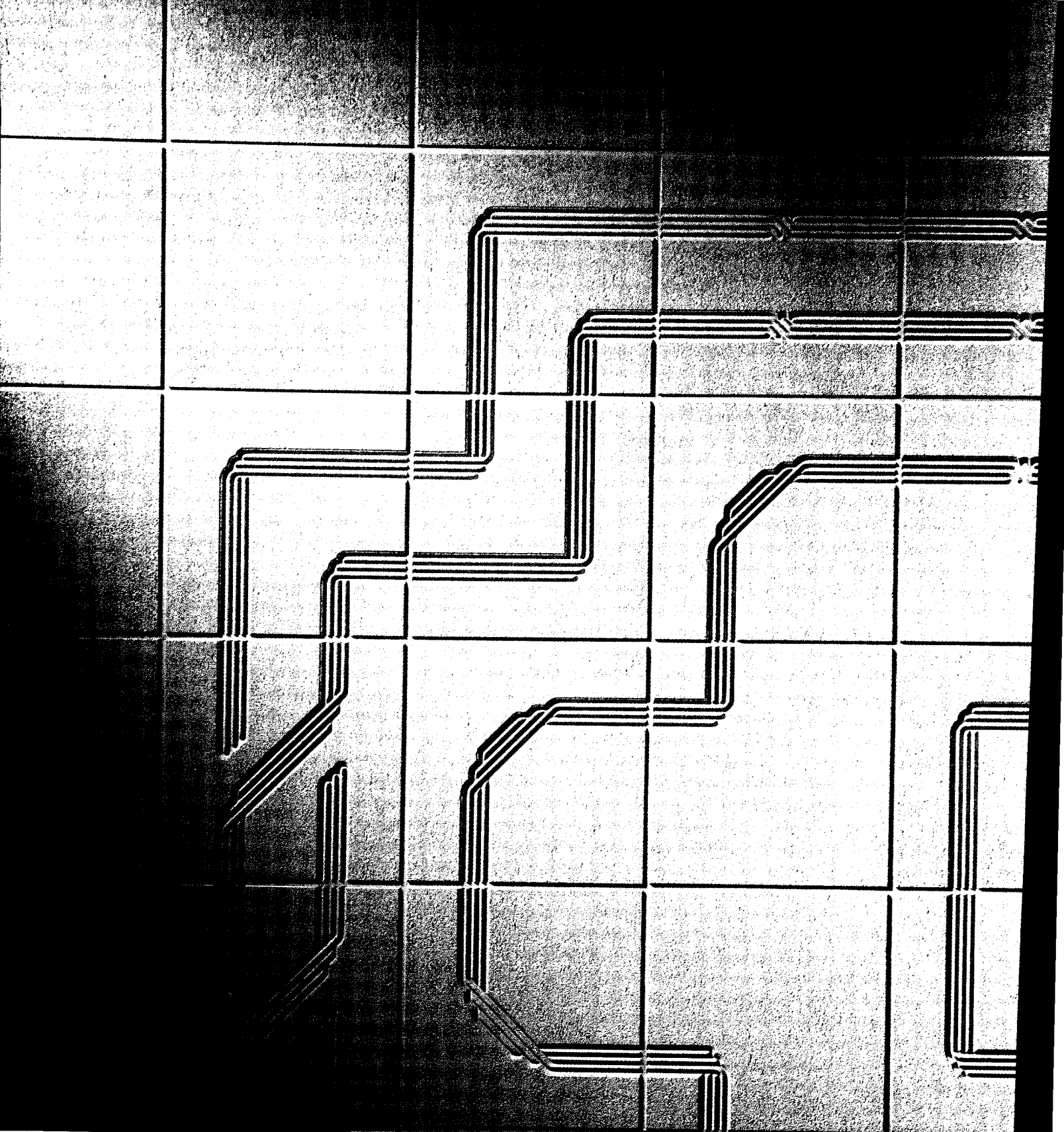



CUSTOM CEILINGS

New 2' x 2' Syllables[®] ceiling system. Seven systems available. Each offers unlimited custom opportunities. For our brochure, call 1 800 233-3823 and ask for Custom Ceilings.



ARMSTRONG CONTRACT INTERIORS

CEILINGS
CARPETS
FLOORS
WALLS

Armstrong

Circle 1 on inquiry card

IBD Design Award Winner



NEW FLOOR COLORS

Four new colors in vinyl sheet flooring.
Turquoise. Garnet. Blue Topaz. Copper. 14 colorways in all.
For information on Suffield,[™] call 1 800 233-3823 and ask for Colors.



ARMSTRONG CONTRACT INTERIORS

FLOORS
CEILINGS
CARPETS
WALLS

Armstrong

Circle 2 on inquiry card

I am writing in response to the article about Jack Kemp and his new role as Secretary of Housing and Urban Development [ARCHITECTURAL RECORD, February 1989, page 23]. I found that the article was extremely biased in favor of Kemp. I am a Republican and generally support the initiatives of George Bush; however, Jack Kemp has little expertise in the fields to which his new home caters.

Yes, I realize the article stated that he is best known for "championing supply-side economics and urban enterprise zones," but in reality Kemp is known because he is one of the good old buddies within the Republican Party's inner-circle. The author implied that Kemp was at odds with Bush because of the competition back in the presidential primaries, and that Kemp won out in the HUD nomination because of his overwhelming attributes. Let's take a look at reality: Kemp was nominated because he is a rising star within the party and his nomination is a resumé-stuffing mechanism to benefit the party as a whole in the future.

The author quoted sources such as "a cautious AIA staffer" and several people who represent the construction industry in some fashion. It is not my contention that the building industry should not prosper (quite the contrary), but those quoted are not in positions to be objective about housing and community development. Why weren't people from such organizations as the Urban Land Institute or the American Planning Association interviewed—people who are experts in the area yet don't depend on the industry for their livelihoods?

As for enterprise zones, this idea clearly falls within the local home-rule precedent, which is firmly established in the United States. When considering the

urban homesteading program, we find that it did offer a better housing alternative for some economic groups, but the anticipated result of encouraging the neighbors of the homesteaders to upgrade their houses and neighborhoods never really materialized. I would hope that RECORD could flag the myth that better housing for all means a continuous cycle of new construction—which gets back to my point about those who were quoted in the article being biased toward the construction industry.

Let's not face America's housing and development problems with the "Build! Build! Build!" attitude attempted several times in the past with questionable success.

*Kevin Wall
Cincinnati*

Corrections

In the story on Central Park Zoo [RECORD, February 1989, pages 84-89], Jerry M. Johnson Productions, Inc., should have received credit as a consultant for the exhibit design.

The report on the Royalton Hotel [RECORD, March 1989, pages 94-99] should have included credit to Haigh Space, Architects, for the design of the facade and sidewalk, and to Tracy Turner Design, Inc., for graphics, signage, and guest-room amenities.

The John Wayne Airport in Orange County, California, which appeared in Ken Sanders's article on CAD systems [RECORD, March 1989, page 133], should have been credited to Gensler and Associates/ Architects as design architects and Leason Pomeroy Associates as architect of record.

Through May 20

"New Projects by Architects," showing the work of Ricardo Bofill, Peter Eisenman, Zaha M. Hadid, Arata Isozaki, Rem Koolhaas, and Bernard Tschumi; at the Max Protetch Gallery, New York City.

Through May 21

"Morphosis: A Decade of Architectural Confrontation," an exhibition of models and drawings; at the Cheney Cowles Museum, Spokane.

Through May 27

"Alternative Visions: Chicago," an exhibition of theoretical works to alter the look of the city, by architects under 35; organized by the Young Architects Committee, Chicago Chapter, AIA, and the Architecture & Law Committee, Young Lawyers Association, Chicago Bar Association; at Cultural Center, Chicago.

May 18-June 2

Exhibit of the results of Competition Diomede, an architectural competition to unite the Diomede Islands between the U. S. and the U. S. S. R., sponsored by the Institute for Contemporary Art in New York and the U. S. S. R. Union of Architects, Moscow; at the Clocktower Gallery, 108 Leonard St., New York City.

June 6-8

CAFM '89, sponsored by the International Facility Management Association; at the Anaheim Marriott Hotel, Anaheim, Calif. For information: Nancy G. Minni, Director of Education and Research, IFMA, 11 Greenway Plaza, Suite 1410, Houston, Tex. 77046 (713/623-4362).

June 13-18

The 39th annual International Design Conference in Aspen, "The Italian Manifesto: The Culture of Nine Hundred and Ninety-Nine Cities," with Bill Lacy and Paolo Vitti as co-chairman. For information: IDCA, P. O. Box 664, Aspen, Colo. 81612 (303/925-2257)

ARCHITECTURAL RECORD (Combined with AMERICAN ARCHITECT, and WESTERN ARCHITECT AND ENGINEER) (ISSN0003-858X) May 1989, Vol. 177, No. 5, Title © reg. in U.S. Patent Office, copyright © 1989 by McGraw-Hill, Inc. All rights reserved. Indexed in Reader's Guide to Periodical Literature, Art Index, Applied Science and Technology Index, Engineering Index, The Architectural Index and the Architectural Periodicals Index.

Every possible effort will be made to return material submitted for possible publication (if accompanied by stamped, addressed envelope), but the editors and the corporation will not be responsible for loss or damage.

Executive, Editorial, Circulation and Advertising Offices: 1221 Avenue of the Americas, New York, NY 10020.

Officers of McGraw-Hill Information Services Company: President: Walter D. Serwatka, Senior Vice President: Robert D. Daleo, Finance; Vice President-Circulation: George R. Elsingner, Executive Vice Presidents: Russell C. White, Construction Market Focus Group; Kenneth E. Gazzola, Aerospace and Defense Market Focus Group; Brian H. Hall, Legal and Accounting Market Focus Group; Ira Herenstein, Computers and Communications Market Focus Group; Robert P. McGraw, Healthcare Market Focus Group; Vice President-Group Publisher, Construction Magazines: Ted R. Meredith.

Officers of McGraw-Hill, Inc.: Chairman, President and Chief Executive Officer: Joseph L. Dionne, Executive Vice President, Office of the Chairman: Richard B. Miller, Executive Vice President, General Counsel and Secretary: Robert Landes, Senior Vice President, Treasury Operations: Frank D. Penglase, Senior Vice President, Editorial: Ralph R. Schulz.

Associated Services/McGraw-Hill Information Services Co.: Sweet's Catalog Files (General Building, Engineering, Industrial Construction and Renovation, Light Residential Construction, Interiors), Dodge Building Cost Services, Dodge Reports and Bulletins, Dodge/SCAN Microfilm Systems, Dodge Management Control Service, Dodge Construction Statistics, Dodge regional construction newspapers (Chicago, Denver, Los Angeles, San Francisco).

Subscription rates for personnel of Architectural, Engineering, Interior Design, Design and other directly related firms and students thereof, are as follows: U.S. and U.S. Possessions and Canada \$42.50; Europe: \$150.00 (incl. Air); Japan: \$160.00 (incl. Air); all other Foreign: \$125.00. Single copy price for Domestic and Canadian: \$7.00; For Foreign: \$10.00. For Subscriber Services (U. S. only): 1-800-325-5003; (Canada & Foreign): 609/426-7070.

Change of Address: Forward changes of address or service letters to Fulfillment Manager, ARCHITECTURAL RECORD, P.O. Box 566, Hightstown, NJ 08520. Provide both old and new address; include zip code; if possible attach issue address label.

Guarantee: Publisher agrees to refund that part of subscription price applying to unfiled part of subscription if service is unsatisfactory.

Copyright and Reprinting: Title © reg. in U.S. Patent Office. Copyright © 1989 by McGraw-Hill, Inc. All rights reserved. Where necessary, permission is granted by the copyright owner for libraries and others registered with the Copyright Clearance Center (CCC) to photocopy any article herein for the base fee of \$1.50 per copy of the article plus 10 cents per page. Payment should be sent directly to the CCC, 21 Congress Street, Salem, MA 01970. Include code with request: ISSN0003-858X (\$1.50 + .10). Written permission must be secured for any other copying. Write Reprint Manager for such permission at address below, or to obtain quotations on bulk orders.

Subscription List Usage: Advertisers may use our list to mail information to readers. To be excluded from such mailings, subscribers should send a request to: ARCHITECTURAL RECORD, Mailing List Mgr., P.O. Box 555, Hightstown, NJ 08520.

Publication Office: 1221 Avenue of the Americas, New York, NY, 10020. ARCHITECTURAL RECORD (ISSN0003-858X) published monthly with additional issues in April and September by McGraw-Hill, Inc. Second-class postage paid at New York, NY and additional mailing offices. Postage paid at Windsor, Ontario, Canada. Registration Number 9617.

Postmaster: Please send address changes to: Fulfillment Manager, ARCHITECTURAL RECORD, P.O. Box 566, Hightstown, NJ 08520. THIS ISSUE is published in national and separate editions. Additional pages or separate editions numbered or allowed for as follows: Eastern Section 32Ea through 32Eh, Central Section 32Ca through 32Cb, Western Section 32Wa through 32Wb, Sunbelt Section 32Sa through 32Sd.



Editor
Mildred F. Schmertz, FAIA

Managing editor
Carolyn De Witt Koenig

Executive editors
Paul M. Sachner
Deborah K. Dietsch

Editor-at-large
Herbert L. Smith, Jr., FAIA

Senior editors
Grace M. Anderson
Margaret F. Gaskie
Charles K. Hoyt, AIA
Karen D. Stein

Associate editors
James S. Russell, AIA
Joan F. Blatterman

Design director
Alberto Bucchianeri
Anna Egger-Schlesinger, senior associate
Muriel Cuttrell, illustration
J. Dyck Fledderus, illustration

Design consultant
Massimo Vignelli

Editorial production manager
Annette K. Netburn

Editorial consultants
George A. Christie, Jr.
Steven S. Ross

Group circulation director
Richard H. Di Vecchio

Circulation manager
Phyllis Josselson

Director of business
and production
Joseph R. Wunk

Director of marketing
Camille H. Padula

Assistant to publisher
Elizabeth Hayman

Associate publisher
Roscoe C. Smith III

Publisher
Ted R. Meredith

Inquiries and submissions of work for publication may be addressed to any editor, though the editors listed below have a special responsibility for the subject areas named:

Deborah K. Dietsch, houses
Karen D. Stein, interior design
Grace M. Anderson, design news and competitions
Charles K. Hoyt, business
James S. Russell, engineering
Joan F. Blatterman, new products and product literature

Letters/calendar, 4
Editorial: Making history in St. Louis, 9

Business

News, 33
Practice: Protecting your designs, by Steven A. Glazer, 37
Construction costs: No inflation here, 42
Management: Estimating your estimates, by Charles C. Munroe III, 44

Design

News, 53
Design awards/competitions, 60
Observations/books, 79

In this issue, 109

Museum of the Moving Image, London, 110
Avery Associates, Architect
American Museum of the Moving Image, New York City, 116
Gwathmey Siegel & Associates, Architect

Two on the town, 122
Heritage on the Garden, Boston
The Architects Collaborative, Inc., Architect
San Francisco Centre, San Francisco
Whistler-Patri, Architect

Delta Air Lines Reservations and Training Center, Salt Lake City, 128
Lord & Sargent, Inc., and MHT Architects, Inc.

"The recovery of ornament," by Roger Kimball, 132
Dai-ichi Tokyo Bay Hotel, Tokyo, Japan
Ellerbe Becket, Inc., and Kajima Corporation, Architects
Roger Ferri, design partner

Building Types Study 666: Corporate interiors, 138

Engineering

Living on borrowed light, 150
The firm of Jules Fisher and Paul Marantz, Inc., is finding that daylight is increasingly useful in lighting design.

New products: NEOCON 21, 154

Computers: Technology, 158
A/E/C Systems: Pre-meeting products preview, 158
Software reviews for architects, by Steven S. Ross, 167

Product literature, 171
New products, 175
Manufacturer sources, 193
Classified advertising, 212
Advertising index, 218
Reader service card, 221

Cover:
American Museum of the Moving Image, New York City,
Gwathmey Siegel & Associates, Architects
Photographer: ©Jeff Goldberg/ESTO

Stock Options

AlternatTM Faucets. Choose the faucets with all the options—Alternat faucets by Kohler. And create color coordination between faucets, fixtures, and decor with unique ceramic inset options available in 24 Kohler colors. Plus the new secure inset system comes in a wide array of additional materials including woods, metals, onyx, and semi-precious stones, exclusive Champlevé and custom monogram. Choose from a variety of spouts and five beautiful finishes. Kohler's System CTM ceramic washerless cartridge assures years of dependable performance. With Alternat faucets by Kohler only two things are not optional—Kohler quality and dependability.

THE BOLD LOOK
OF **KOHLER**®

See your Kohler® distributor or write: Kohler Co., Dept. TB5, Kohler, WI 53044.

© 1989 by Kohler Co.

Circle 5 on inquiry card



Making history in St. Louis

For the first time ever, the AIA National Convention will "go public." This month in St. Louis, on the next to the last day of its annual gathering, the AIA will have held what it calls a "Public Day" so that local citizens interested in architecture can get a first-hand glimpse of the architect's complex and challenging world. I haven't been able to find out who first had the splendid idea to invite the general public for a day at the convention, or how the fine program got put together. There can be few better ways to help ordinary citizens understand that there is more to architecture than fashion and style.

If all goes as planned, the public, lured by the local media, will have heard internationally famous architects discussing global trends, design issues, and their works. The public will have attended student design-studio reviews held by the American Institute of Architecture Students (AIAS) in which the students themselves, faculty, and alumni do the critiques.

Although it is hard to believe that there may be members of the public who need help in understanding the catastrophic consequences of nuclear and conventional war, Architects, Designers, and Planners for Social Responsibility (ADPSR), a national, nonprofit organization of design professionals and students formed to give such help, are sponsoring a symposium on the subject with guest speakers: HOK chairman/president Gyo Obata of St. Louis; environmentalist Dr. Peter H. Raven, director of the Missouri Botanical Gardens; and Crombie Taylor, associate dean of architecture at the University of Southern California.

The public will also have attended a workshop under the auspices of the Missouri Council of Architects conducted by its "built-environment education coordinator," Ginny Graves, to teach the teachers to teach environmental concern. The St. Louis Chapter of the Women in Architecture Committee has invited the public to participate in a session on "The changing American family's impact on the architectural office."

After a long day of shared dedication to architecture-related social and environmental issues, architects and public will gather at the foot of a transcendent achievement in the domain of pure design—the St. Louis Gateway Arch—to dedicate a plaque honoring its creator, the 1962 AIA Gold Medalist Eero Saarinen.

"Public Day" seems certain to be a great success. May it continue to be a part of every AIA National Convention program from now on. *Mildred F. Schmertz*

“A traditional panel-based system is a two-dimensional planning concept. This system invites you to think in the third dimension.”

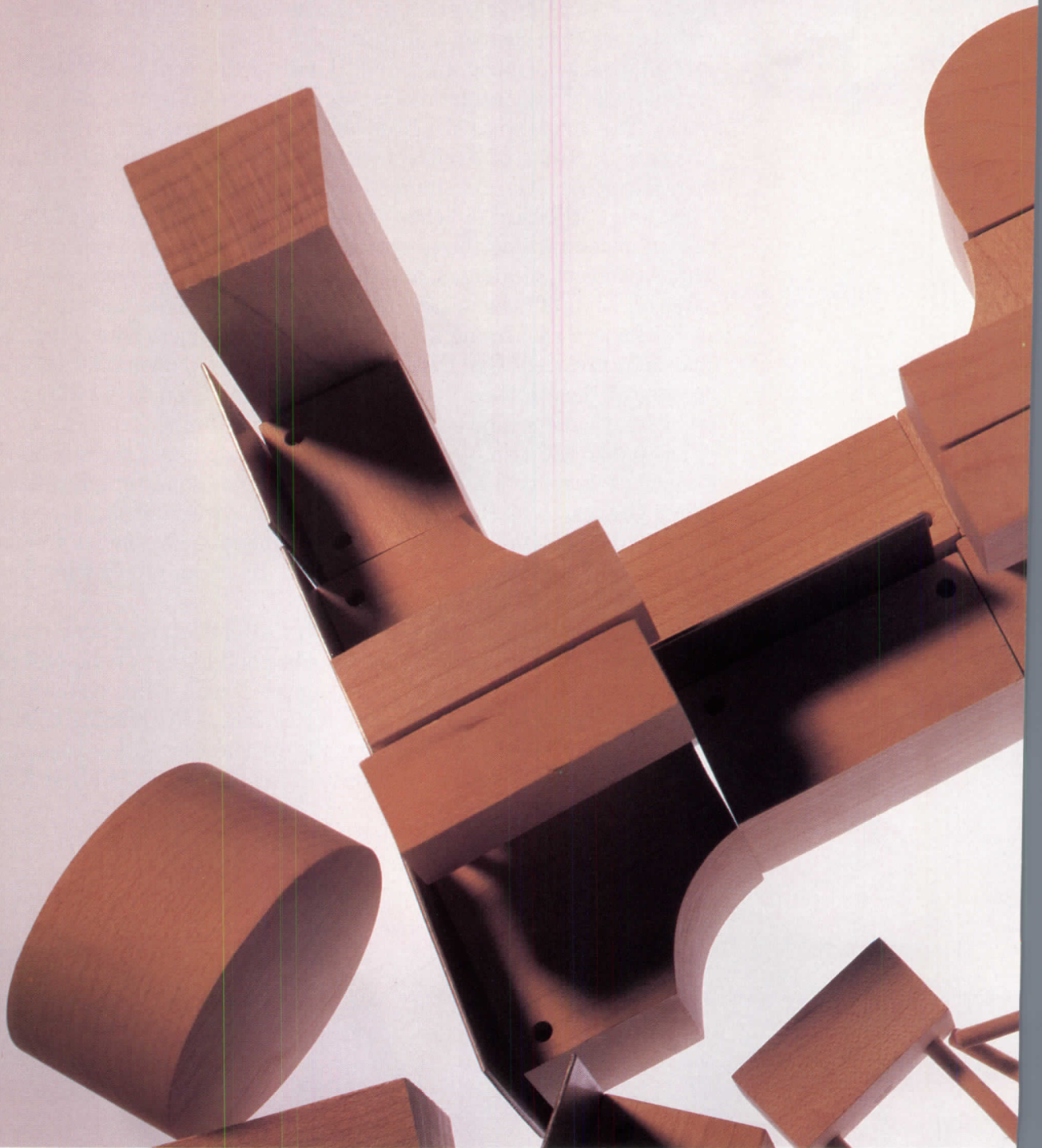

Survey finds interest in continued growth of architecture firms but uncertainty on how to go about it

A survey by practice consultants Birnberg & Associates, publishers of *The Profit Center* newsletter, found 96.1 percent of responding architecture firms want to grow, but are generally uncertain how to do that (and, indeed, did not know how they had grown to their current size). Less than half had any set plans for growth (or even survival), lacking essentials like annual budgets, marketing programs, and long-range goals. "Many managers outside of design," notes Howard Birnberg, "would find this inconceivable."

How would the firms like to grow? Some 85 percent wanted

greater profits; 77 percent, more productivity; 68 percent, larger staff; 59 percent, diversified services; and 40 percent, a wider geographic market. Clearly, growth is not confined to size.

Are firms growing in size? Some 78 percent had added more staff in the past five years, but little within the past year—"a sign," says Birnberg, "of a mature economic expansion." Still, a few saw the lack of qualified job applicants as a barrier to growth. Other barriers include low energy levels. Contact Birnberg & Associates, 1227 West Wrightwood Ave., Chicago, Ill. 60614 (312/664-2300). *C. K. H.*

Let Dodge do the digging

Things have progressed a piece since Mr. F. W. Dodge pedaled around Boston in the 1890s to provide the latest status on current local construction projects. Dodge, which tracks the status of virtually every major U. S. construction project and most smaller ones, has introduced DataLine, a computerized service transmitting construction-project information by modem on a daily basis to clients' offices. While many of the projects it is tracking are beyond the architect-selection stage (and will be of primary interest to contractors and material suppliers), Dodge director of DataLine services Donald Kitzerow says that thousands at any given time are not. For these, DataLine's "preplanning-phase" reports supply information on clients, contacts, how to reach them, and their current status of readiness—e.g., in fund-raising, looking for

a developer, or looking at feasibility—information architects could find useful.

Then, too, reports on buildings for which the architect has been chosen can be useful since such architects can be sources of information to others, says Kitzerow. Queries to the system can be made by building type and features, and a particularly competitive user can query the system to find out type and current number of projects by firm. The status of proposals on a project can be checked via Dataline, adds Kitzerow.

Subscriptions to the service to cover the entire U. S. could cost as much as \$100,000 per year. The price to access regional areas begins at \$3,200, according to Kitzerow. For more information, contact F. W. Dodge Marketing Services, McGraw-Hill Information Services Co., 1221 Ave. of the Americas, N. Y., N. Y. 10020 (212/512-6184). *C. K. H.*

NCARB moves on qualification procedures and against licensing for interior designers and unlicensed architecture



NCARB president George B. Terrien believes in the architect as leader of the team.

Under the leadership of its new president, George B. Terrien, the National Council of Architectural Registration Boards is entering the computer age in the administration of its national qualification examinations; taking a strong stance against licenses for interior designers; and attacking architectural practice by those without a license.

Most controversial is its position against interior-designer licensing—especially considering the substantial accord reached by the AIA in support [RECORD, February 1989, page 25]. The NCARB's rationale? The AIA accord accepts the principle of title registration for the designers. "In reality," says Terrien, "title registration has proven itself nearly as restrictive as practice registration." And, he adds, the criteria justifying registration are not met by interior designers in usual roles.

Asked to elaborate, Terrien said, "Interior designers who perform architectural services that directly affect the public health, safety, and welfare should be registered as architects." (In a position paper published by the NCARB, it was noted that the majority of persons engaged in interior design are employed to give consumers access to products not otherwise available and to help develop a sense of taste, style, and esthetics—not to determine structural, mechanical, or life-safety issues.) "To take any other position," added Terrien, "would lead to the conclusion that we should register architects separately as

specification writers, construction administrators, production specialists." He strongly supports the concept of the architect as supreme generalist, orchestrating all related disciplines—including interior design.

It is this same fervor that leads him to attack the inroads others have made on the practice of architecture. Chief among his targets: engineers. "It is an issue of their extending services beyond engineering into areas that clearly can harm the public. Virtually none have been qualified to coordinate [all] the disciplines of putting together buildings, much less qualified to uphold social values in the built environment. Altogether, I think you will see why the issues are not territorial contest; they are concerns of the public."

Last October, the NCARB implemented the pilot phase of its program to administer the registration examination by computer, using volunteer applicants. "The examination is efficient," says Terrien. "It takes less time and [pinpoints] the minimally qualified candidate far more accurately than the old one." It is to be phased in over the next three years as standard and, says Terrien, will look quite different from the current multiple-choice and graphic formats. But will it discriminate against those without computer training? "It will not be limited to those who are hackers," he assures. Other advantages: "The computer will give candidates their exam results immediately or, if unsure of their qualifications, administer additional questions." There will no longer be the traditional seven parts. "Disciplines will be integrated," he explains—much as they are in actual practice. *Charles K. Hoyt*

See Us At the
A.I.A. National Convention
Cervantes Convention Center
St. Louis, MO
May 5-8, 1989
Booth #263



ARCHITRION

The architectural software you've been waiting for.

Created by architects for architects, Architrion™ is a powerful CAD software package for use on the Macintosh™ computer. Its many features and ease-of-use allows you to maximize your creative abilities at every stage of the design process – from conception to completion. Architrion is available in two versions: the original black

& white version and our advanced full-color Architrion II™ now featuring: create and modify in section; multicolor shading in perspectives and elevations with shadows; and DXF import/export.

Explore your most complex ideas in minutes. With Architrion, quickly build your schematics, produce alternative

studies and base your decisions on a realistic 3D representation of your design.

Experience a better relationship with your clients and consultants. Architrion allows you to communicate your ideas effectively. Walk throughs, details, modifications or enhancements take shape in a few minutes as you easily produce any interior or exterior perspective, axono or isometric, section or plan.

Document your design anytime and get take-offs along the way. While designing, send your automatically generated plans, sections and elevations to the drafting module for further

delineation (before printing or plotting). And, at any moment, check your construction costs with Architrion's estimating module.

ARCHITRION
The essential tool
for today's architect.

For more information, or to find out the name of your nearest dealer, contact us today.

Circle 33 on inquiry card

Gimeor 
PROGRESSIVE CAD SOFTWARE

420 10th Street S.E.
Washington, DC 20003
Telephone: (202) 546-8775

Canadian distributor, B.A.G.H. Consultants, 411 St. Dizier – Suite 104, H2Y2Y1 Montreal P.Q., Telephone: (514) 843-4397

Architrion and Architrion II require a Macintosh Plus, SE or Mac II with a hard disk drive. Architrion and Architrion II are trademarks of Gimeor S.A. Macintosh, Plus, SE and II are registered trademarks of Apple Computer Corp.

Florida program anticipates profession's changing complexion

A three-week summer course at the University of Florida in Gainesville was instituted by associate professor William Tilson six years ago to introduce high-school students to architecture. What Tilson has found is that it is also dispelling any misunderstandings that the profession will continue to be the almost exclusive province of white males. Fully half of the students are women, and minorities are a growing proportion. This is in line with similar observations by AIA president Benjamin Brewer [RECORD, April 1989, page 23].

Why did Tilson start the program in the first place? "The public doesn't understand what architects do for a living," he says. "And these students don't understand the time and steps involved in designing a structure. By the third week, they develop a healthy appreciation." Tilson readily admits that the program also is a good recruiting tool. Some 20 percent of the graduates return to attend the university's

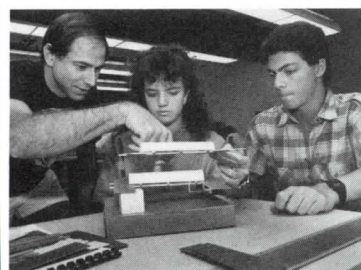

Architect Jeffery Gross shows high-school students Emely Sanchez and Michael Alpert the professional ropes.

architecture school. While no specific background is required, students must have achieved minimum grade standards to be eligible. "We don't see ourselves as a summer camp or vo-tech course," he adds. Contact the University of Florida College of Architecture, Gainesville, Fla. 32611 (904/392-0186). C. K. H.

Want to lock up a new market?



Sing Sing Prison. The Bettmann Archive, Inc.

Changing attitudes towards incarceration may be revealing the true potential of work in a very strong architectural market—designing prisons—according to research by the GenCorp company. Sentencing laws have been changing to reflect the growing law-and-order mood of the country—particularly as the drug problem accelerates—and imprisonment is increasingly seen as the appropriate response to criminal activity. The result? Overcrowding of existing facilities is unprecedented and growing rapidly. Almost three out of four states are under court order to improve conditions. As they wrestle with the problem, they are coming up with new ways to finance construction, some of which mean that the client may not be government but private entrepreneurs. Besides special bond issues to finance their own construction, states are turning to lease-buy arrangements with developers and even farming out business to private prison operators. The market may also hold potential in the renovation of large unused buildings such as hospitals and schools, and in modular construction. C. K. H.

Lead in paint: the asbestos issue of the '90s?

The nation's architects are facing what has been described as a powder-keg issue: lead in paint. In mid-March, the National Institute of Building Sciences produced its 237-page *Guidelines for the Testing, Abatement, Clean-Up and Disposal of Lead-Based Paint in Housing*. Its client: the Department of Housing and Urban Development at the orders of Congress.

Concern over possible health problems associated with lead in paint has been simmering since the early '70s (when its use in most building paints was prohibited). Some people familiar with the problem believe the issue is as serious—and potentially as contentious—as asbestos in buildings.

The NIBS report is the first national one to present consolidated technical guidelines on how to deal with lead in paint. Technically, the guidelines address only Public and Indian Housing. But buildings of all types may quickly become the subject of concern.

Unlike asbestos, which causes cancer, lead is not a carcinogen. But it affects the brain and the central nervous system. Other bodily functions at risk are the systems forming blood, the vitamin-D regulating system in the kidneys, and calcium metabolism. Children under seven are most vulnerable. In pregnant women, lead represents danger to the fetus. For middle-aged men, recent studies have tied lead exposure and high blood pressure.

A report by the Agency for Toxic Substances and Disease Registry indicates there are about 42-million houses in the U. S. built before 1980 containing lead-based paint. That report also estimates that 52 percent of all U. S. housing units have paint with significant lead levels.

Applied lead paint turns into chalks and powders due to moisture and ultra-violet light or



NIBS president David A. Harris: "The guidelines give techniques that are most effective to avoid getting the stuff in the human body."

simply aging. This increases the probability that lead contained in increasing dust levels will enter the body through normal hand-to-mouth activity.

The NIBS guidelines contain detailed specifics on how to minimize dust during abatement—whether to dry- or wet-sand, burn paint off, or to encase paint in another covering.

NIBS recommends that HUD disseminate its document. But, sources speculate HUD has been reluctant to release it because of high-cost implications (RECORD obtained its copy from a source other than NIBS or HUD). One guess is \$10,000-15,000 per federally controlled housing unit.

Says NIBS president, architect David A. Harris: "Members of the health-sciences community are concerned that, if such a program turns out to be expensive, nothing would or could be done and it would be business as usual, with no improvement at all." There is also a concern that, once a costly national cleanup program appears, unscrupulous operators will remove lead paint in unsafe fashions, "dumping it under bridges," as Harris put it. "We have both a medical and an engineering problem, with no agency that deals with both. There are no reliable cost-effectiveness figures. And it's a powder-keg issue because of liability problems." Peter Hoffmann, Washington, D. C.

CONTROL PLENUM SYSTEMS FOR AIR DISTRIBUTION:

Plagued by the 'Sick Building Syndrome' or annoyed by drafts? The cure may be right at your feet.

Distributing air through an access floor can result in a healthier, more productive, comfortable and cost-effective office environment.

When it comes to heating and cooling, tradition abounds: use ductwork in the ceiling plenum to introduce and remove air from the office space below. For a number of financial and health-related reasons, however, ceiling air distribution may be a tradition that needs re-thinking.

In recent years, poor quality of air in offices—deemed the “sick building syndrome”—has received considerable attention. The American Journal of Medicine reports that billions of dollars are spent every year in medical costs, due to respiratory infections often caused by poor quality air. This widespread problem has some experts predicting that indoor air quality monitoring will be mandatory by the end of the next decade.

With over 500 air pollutants residing indoors (according to Environmental Protection Agency reports), energy conservation efforts to seal buildings and reduce air infiltration/exfiltration are one reason why buildings get “sick.” A building needs to be constantly purged of pollutants, and replaced with fresh air to assure good overall air quality.

The other problem employers and building owners face is lost productivity through non-uniform distribution of air. According to BOSTI research, one of the most frequent and disruptive complaints concerns hot-cold temperature fluctuations. Workers close to the diffuser may be in a cold draft, while a person a few feet away may be too warm. This is because the low-temperature, high velocity ceiling diffuser concept is not effective in open-plan office layouts featuring movable workstations.

The ideal air distribution system would benefit its inhabitants by maintaining a more consistent temperature and purging air contaminants more thoroughly. Here is a list that addresses these needs in detail:

User-friendly: Has controls for increased worker comfort.

Air quality: Removes air pollutants quickly and effectively from comfort zone.

Air Control: Gives mechanical engineers the ability to provide workstations with proper airflow and temperature.

Draft-free: Able to deliver air at lower velocities and less extreme supply temperature.

Flexible configuration: Diffuser outlets may be easily moved to conform to changing office layout.

Initial cost: Less ductwork may reduce slab-to-slab height to lower building cost.

Operating expenses: Makes energy consumption cost-effective through life of building.

Compatibility: May be integrated with other user services, such as wire and cable distribution for power, data and telecommunications.

The air distribution system that satisfies all these criteria is the DONN® Control Plenum System from USG Interiors. Designed to work with DONN Access Floors, the air concept functions “upside-down” to provide a more comfortable, cleaner, and healthier environment, as well as a more cost-effective way to distribute air.

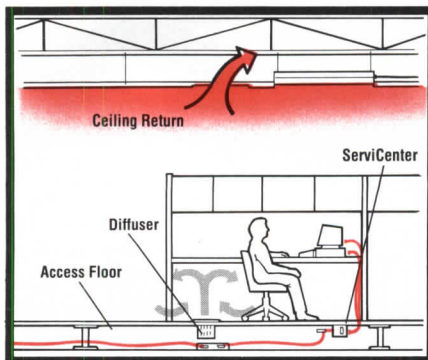

Relocatable diffusers in access floor introduce supply air at temperatures to cool work zones easily, while stale air is exhausted through ceiling returns.

Pioneered by Krantz of West Germany and used in office and computer room applications for years, the control plenum system accomplishes all these objectives by eliminating the diffusers and ductwork in the ceiling and bringing air up through the floor. The air travels through a pressurized access floor plenum and is delivered into the workspace through high induction diffusers. Within each outlet are “twisting” air jets which mix room and cool supply air. The process is so efficient that little sensation of draft or temperature change can be felt even when only inches from the diffuser.

Feeding the supply air from below generates an upward current—the same direction as the “thermal lift” produced by warm machines, lamps and people. The warm, stale air and air pollutants are directed to the ceiling return and exhausted, leaving no stagnant air in the workspace.

The lack of major ductwork in the ceiling or floor can lower building costs by reducing slab to slab height. And with an investment in the flexible DONN Access Floor System, long range costs for office reconfiguration are also brought under control. Using no hardware, maintenance personnel may easily and quickly move the floor panel and diffuser assembly as a unit. Wiring is also simplified when the access floor system includes the user-friendly DONN ServiCenter™ outlets. These outlets and panels allow all electrical, data and communications services to be easily brought from the underfloor plenum to accommodate work stations in any configuration.

For more information about the DONN Control Plenum System or the USG Leasing Program now available, write to USG Interiors, 101 S. Wacker Drive, Chicago, IL 60606-4385. Or call 1-800-522-3666. Dept. AR589

DONN, SERVICENTER and USG are trademarks of USG Corporation or its subsidiaries.
© 1989, USG Interiors, Inc.

Practice: The pitfalls in protecting your designs from the clutches of others

By Steven A. Glazer

Within the realm of law, plans and specifications for the design of structures are considered "intellectual property." Like any property owners, architects want to protect their work from misappropriation by others. The legal means to do that include the contract, copyright, design patent, and unfair-competition laws. No security system to protect property, however, is 100-percent effective, and these means, too, do not stop entirely the unauthorized use of plans and specifications by other designers. Let us look at some of the limitations:

The AIA architect-owner agreement only covers those who have signed it

Article 6 of the standard agreement (Form B141-1987) provides that "The Drawings, Specifications and other documents prepared by the Architect for this Project are instruments of the Architect's service for use solely with respect to this Project and, unless otherwise provided, the Architect shall be deemed the author of these documents and shall retain all common-law, statutory, and other reserved rights, including the copyright." It goes on to restrict document reuse "except by agreement in writing and with appropriate compensation to the Architect."

This clause constitutes a licensing agreement between the architect and the owner. It contains no restraint, however, on others who are not "in privity of contract." Such parties might be sued under a "third-party-beneficiary" theory or an "interference-with-contract" theory, but the right set of facts must be present to make such a case. Generally, the AIA

contract does not stop an unrelated person who, without consent of the architect or the owner, copies plans and uses them to duplicate a design.

Copyright laws cover a broader range of players

Under the Copyright Act of 1976, the author of a work has the exclusive right to reproduce, distribute, and publicly display that work, as well as the exclusive right to prepare derivative works. The latter right is very important to the architect because of its control over the right to make changes or additions to drawings and specifications, or to use a set of drawings as the basis for a derivative design. Generally, one who creates a work that incorporates the copyrighted work of another is liable for infringement unless the consent of the original's author is obtained. Thus, an architect who duplicates and modifies copyrighted drawings and specifications without consent can be sued for infringement, even though the modification changed the design.

Architects acquire the full protection of the copyright laws for their designs by:

- Affixing a "notice of copyright"—a © together with the year of first publication of the design and the architect's name or firm name to every published copy of the design (e.g., ©1988 John Smith, AIA).
- Filing a Form VA Application for Registration of Copyright together with one complete copy of the plans and specifications and the required application fee (currently \$10) with the Copyright Office of the Library of Congress in Washington, D. C. The application should be filed as soon as possible after creation of the design, but no later than three months after first publication. "Publication" means the distribution of copies to clients or to persons for the

Knowing the available legal means that can prevent purloining of your design work means knowing their limitations.

purpose of distribution or display. Failure to affix the notice of copyright to every copy, or to register with the Copyright Office within the three-month period, results in a variety of consequences that dilute the statute's protective powers depending upon the step overlooked. (For a full recitation of such horrors, see 17 U. S. C., Sections 405, 411, and 412.)

But copyright laws do not protect the idea or the utilitarian aspects of a design

One of the oldest and most important limitations on copyright protection is the legal principle that the right extends only to a work's particular expression of an idea, not the idea itself (Baker vs. Selden, 1879). This principle stems from our nation's traditional belief in the free flow of ideas—meaning that exclusive rights to an idea are the exception, not the rule. As the Supreme Court held in the 1966 case of *Graham vs. the John Deere Company*: "The grant of an exclusive right to an invention was the creation of society—at odds with the inherent free nature of disclosed ideas—and was not freely given."

Another limitation of the copyright law is that it does not extend to the making, distribution, or display of any "useful article" that is portrayed in a copyrighted design. A useful article is defined as one "having an intrinsic utilitarian function." As a building itself is a useful article, its unauthorized construction may not constitute copying and therefore may not be an infringement of copyrighted plans, even though the copying of the *plans themselves* would be. Moreover, the design of a useful article is deemed copyrightable by the statute "only if, and only to the extent that, such design incorporates pictorial, graphic, or sculptural features that can be

identified separately from, and are capable of existing independently of, the utilitarian aspects of the article." Thus, a design of all or a portion of a building may be so inseparable from the building's function as to be incapable of being copyrighted. This limitation appears to be especially true with the more minimalist designs in which "form follows function." In short, it has been noted that the copyright statute does not confer on an architect the exclusive right to build the structure described in his plans, but only the right to prohibit unauthorized copying of the plans themselves.

Another limit on enforcement of a copyright in court is the subjective nature of proving infringement. To prove infringement, a plaintiff must show two elements: his ownership of a valid copyright and copying by the defendant. Direct proof of copying, however, is often difficult to obtain. Therefore, the law allows circumstantial evidence of copying, in the form of proof that the defendant had access to the plans and that a "substantial similarity" exists between the original and the copy. Deciding whether two designs are similar is highly subjective. An architectural design presents special considerations because of the myriad of details that can differentiate two designs that are otherwise similar. Coupled with the other limitations, this problem makes prosecution of a copyright infringement action very difficult.

It is possible to achieve more protections through less-used laws

Other routes that have been used to protect designs include "trade-dress" infringement. This federal statute, an offshoot of the Trademark Act, protects the "packaging" of a product to the extent that it identifies the

Mr. Glazer is an attorney with the firm of Wyman, Bautzer, Kuchel & Silbert in Washington, D. C. He specializes in real-estate and general corporate matters.



**Your warm relationship with gas
is about to get cooler.**

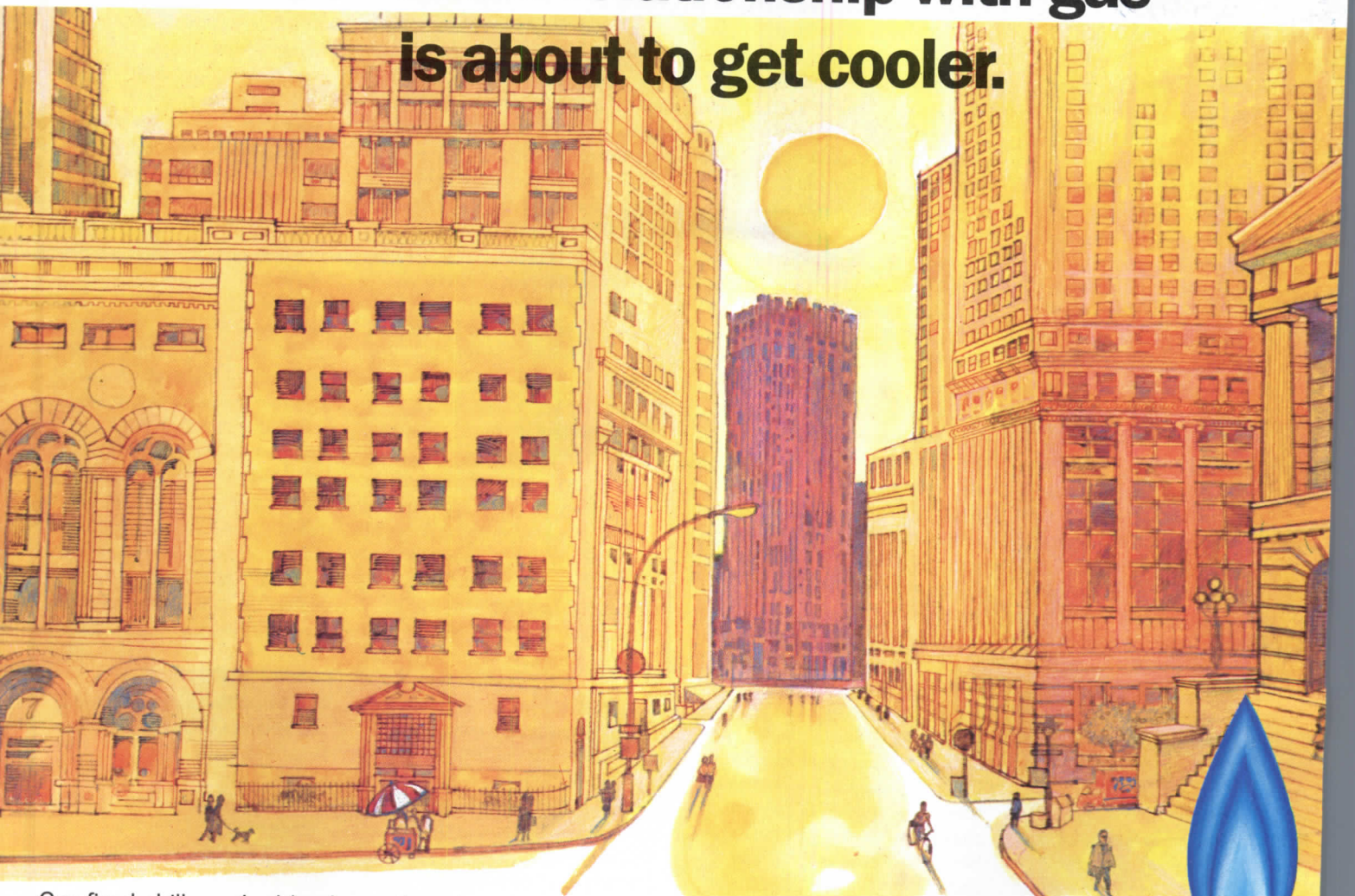

Gas-fired chillers, double-absorption, dessicant systems, gas cogeneration... today's new gas technologies give you so many more options for cooling commercial projects. And, with the additional benefit of unbeatable economy. Now, year 'round, gas is your client's best energy value. © 1989 American Gas Association

Circle 35 on inquiry card

Legal protection for design concepts is limited in scope. Ideas are in the public domain so it will always be difficult to prevent duplication.

product's source. To be eligible for such protection, the packaging must be again "nonfunctional," meaning that the particular feature in question must not be "essential to the use or purpose of the article" or "affect the cost or quality of the article." The packaging also must have acquired "secondary meaning," by which its design is readily identified with its producer or source.

The trade-dress statute was invoked in one reported case involving a house and was not successful (photo). In that case, the architect argued that his houses were "unique" and that each house that he designed was "one-of-a-kind." This argument, however, did not persuade the court that secondary meaning was established, because it tended more toward the opposite inference—namely, that there was no "unique ornamental design or unique fixture" common to all of the architect's houses that was a "signature." As to nonfunctionality, the judge in that case had difficulty with the notion that "[a] home, with its roof, siding, doors, windows, etc." is anything but "an inherently functional structure."

There may, of course, be notable candidates for secondary meaning, like the distinctive features of a Frank Lloyd Wright house or the Chippendale roof of the Johnson & Burgee design for the AT&T building in New York City. Such features, however, do not always identify their originating architects by appearing on every one of their designs. And such features are not as common in the work of lesser-known designers.

Several states recognize a common-law or statutory-law remedy for unfair competition that affords redress for various forms of unfair or deceptive trade practices. The scope of the law of unfair competition defies precise definition. But one

doctrine in this area touches upon the concern of architects in protecting their designs.

Generally speaking, the law of misappropriation prohibits the use of intangible property that possesses commercial value without the owner's consent. Occasionally courts also award damages for misappropriation. It was devised to prohibit the misappropriator from trying "to reap where he has not sown" and "appropriating to himself the harvest of those who have"



A house very closely resembling this one designed by architects Nadler, Philopena & Associates was built last year only a few doors away from the original

(International News Service vs. Associated Press, 1918). This law has been used to prevent the use of intangible property to compete against its owner without his consent. It is limited, however, to instances in which the defendant, by misappropriating, was directly and substantially saved from the need to perform work himself. If the defendant takes only the idea of the product and spends his own time and efforts to develop an image of the idea for himself, then he is not guilty. This, of course, lands the plaintiff in the same area of uncertainty as exists with the theories discussed earlier in this article.

A problem generally with unfair-competition claims based on state law, especially in architectural-design cases, is the degree to which the state-law remedy is pre-empted by federal copyright law. Under the U. S. Constitution, federal law is the "supreme Law of the Land." Therefore, to the extent that a common-law unfair-competition claim adds no extra element to a claim within the scope of the federal copyright statute, the state-law claim is precluded.

in Scarsdale N. Y., and provoked national publicity when the "copycat's" builders were taken to court [RECORD, June 1988, page 33].

If a suit is successful, what does the plaintiff stand to get?

The copyright statute specifies that a plaintiff may elect to receive either "the actual damages he suffered from infringement plus any profits of the infringer that are attributable to the infringement" or statutory damages of up to \$10,000 (up to \$50,000, if the infringement is willful). Also, a court is granted discretionary power to award attorney's fees to the prevailing party. The right to be awarded attorneys' fees as well as the right to elect to receive statutory damages instead of actual damages, however, is lost if the copyright holder fails to register with the

Copyright Office within three months after the first publication of the work. The issue of measuring damages has been addressed in two reported cases and the outcomes have been somewhat different:

In one case, architects Aitken, Hazen, Hoffman, Miller sued the Empire Construction Company in 1982 for actual damages plus Empire's profits and was awarded the fair-market value of the architectural plans (less the cost to the defendant of revising the plans); the entire net profits of the developer and construction company in building and selling the project; and the costs of the suit (but not attorneys' fees). In another case, Robert R. Jones Associates recovered only actual damages equal to 15 percent of the gross profit on the average sale of an infringing model house from Nino Homes. Interest on awards is not allowed for the period prior to judgment in a copyright case. This is important in assessing the value of time lost while awaiting recovery in litigation—especially in federal courts that have overcrowded dockets.

Working under the AIA form contract and properly copyrighting drawings are the most practical steps to take in protecting a design from piracy, but legal protection for design concepts is limited in scope. Ideas are in the public domain, and therefore it will always be difficult, absent new legislation, for architects to prevent other design professionals from duplicating their concepts or using them to build another structure. If the problem is blatant copying of plans, however, the copyright statute affords an adequate remedy. Architects should be aware of the importance of a © on plans, both from the standpoint of what to protect and what not to duplicate.

PRECAST/ RESTRESSED CONCRETE INSTITUTE

The Precast/Prestressed Concrete Institute invites Architects, Engineers and Designers to submit their outstanding precast/prestressed concrete structures for its 1989 Design Awards Competition. Any type of structure, including short, medium and long span bridges in the United States and Canada, using plant manufactured precast/prestressed concrete, architectural precast concrete or glass fiber reinforced concrete is eligible. All entries will be judged by a nationally recognized panel of jurors. Winners will be

call for entries

honored and will receive national publicity in major architectural publications. For PCI Awards Entry Kit or additional information, contact Brian D. Goodmiller, PCI Marketing Director.

**SUBMISSION
DEADLINE IS:
July 31, 1989**

pci

The Precast/Prestressed Concrete Institute
175 West Jackson Blvd.
Chicago, IL 60604
Phone: (312) 786-0300. Fax: (312) 786-0353
Photos: Several 1988 PCI Award Winners.

Circle 36 on inquiry card

Idea File: Recessed wall systems for stores, offices, libraries, hospitals, etc.

CORNICE BRACKET

FACE OUT

STUD-EZE® hidden standard mounts between 2 metal studs.

A clothing store in Indiana is shown here as an effective use of Crown Metal studs and hardware.

U.S.G. METAL STUDS 24" ON CENTER

LAMINATED WOOD SHELF **SHELF BRACKET**

Crown Metal
FOR MORE INFORMATION:
CROWN METAL MFG. CO., INC.
5925 SOUTH LOWE AVENUE
CHICAGO, ILLINOIS 60621-2896
TELEPHONE: 312/873-3833 FAX NUMBER: 312/873-8878

Circle 37 on inquiry card

PUTTING YOUR BUSINESS STEPS AHEAD.

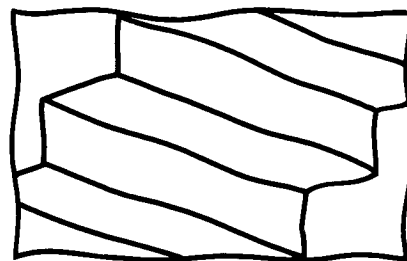

Wind-2™

Fully Integrated Financial Management and Accounting Software Designed Specifically for Architects and Engineers.

**Business Management • General Ledger
Accounts Payable • Payroll • Fixed Assets
Custom Reporting Query**

For product, price, or dealer program information call or write:

Wind-2 Research, Inc.

1901 Sharp Point Drive, Suite A
Fort Collins, CO 80525 • 303 482-7145

Circle 38 on inquiry card

New TRACTION TREAD[®] from ZERO.

The best thing to happen to saddles and nosings since feet.

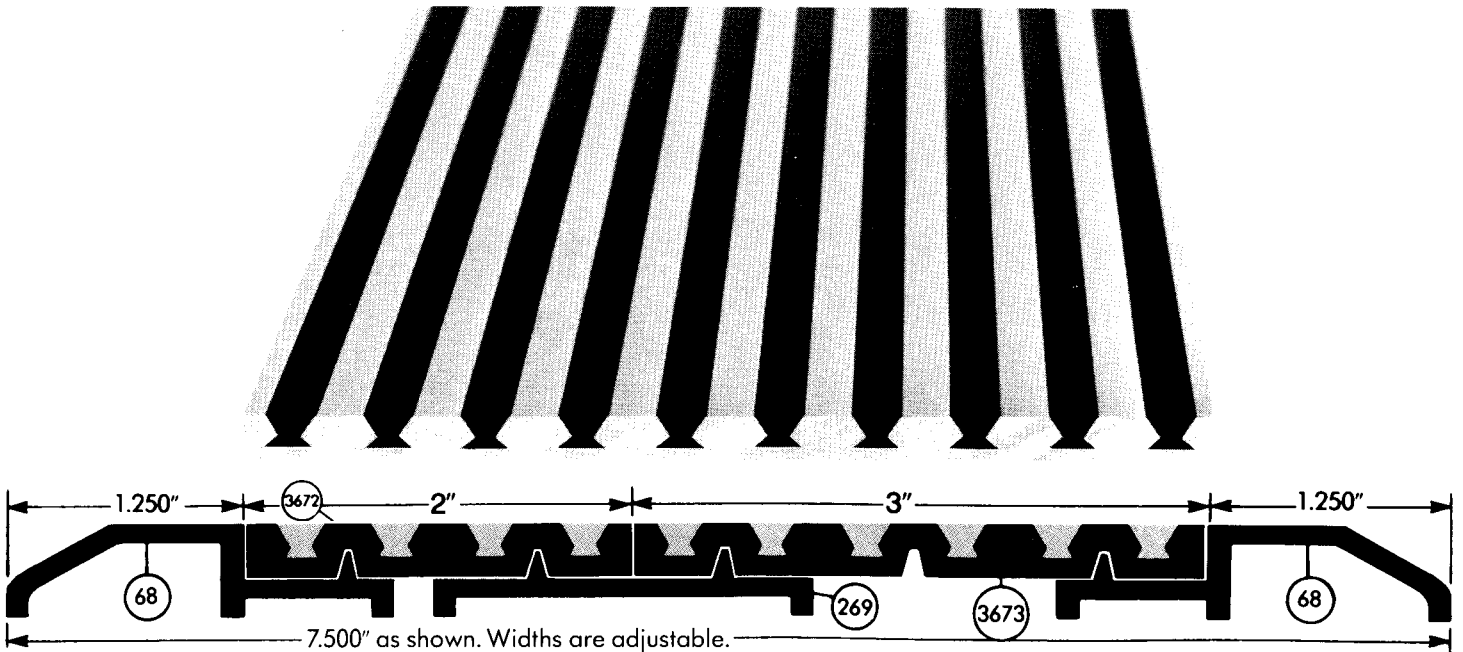

When you specify **Traction Tread**, you've crossed the threshold into better door and stairway design.

Traction Tread comes from a 65-year tradition of constant innovation, construction integrity and solid design excellence.

You'll actually be able to see the quality construction in the gauge of the metals and the high degree of finish. Our specially formulated rubber inserts are fitted within rugged profiled aluminum saddle grooves. So metal and rubber wear evenly. And since the treads are closed, water, dust and contaminants can't collect. That simplifies maintenance. And increases customer satisfaction.

Unlike abrasive-coated treads, **Traction Tread** can be easily cut, shaped and drilled with hand-tools for fast, problem-free, on-site installations.

Slam the door on sealing problems with Zero advanced technology.

Dust, smoke and fire, contaminants, noise, light, temperature and air loss problems need never challenge you again. The solutions are waiting for you on our shelves, and in our new 28-page, fully illustrated **1989 Catalog**.

From smoke-stopping head and jamb systems, to automatic door bottom seals, all the information you need is included. Plus, you'll find precisely scaled, detailed

drawings that make specifying saddles, sills, seals and stiles even easier and more accurate. Virtually everything in our catalog can be custom tailored to your specifications.

When Zero becomes part of your plans, you know the completed project will be as safe and as well-made as possible.

Write or call our sales engineers for our 1989 catalog or more information and technical assistance today.

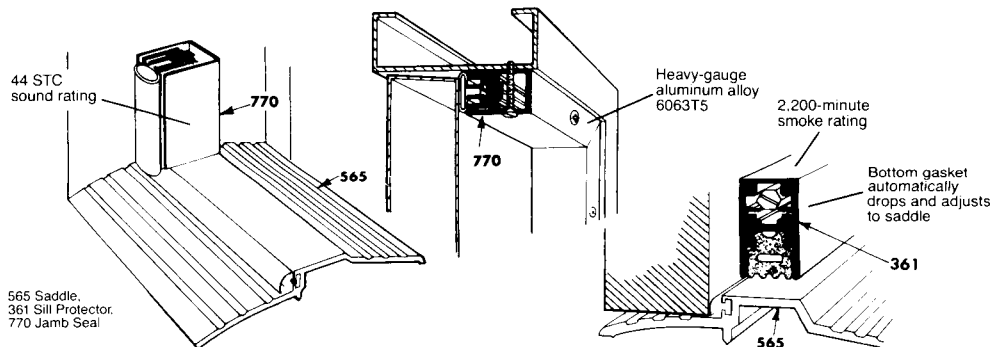

ZERO INTERNATIONAL, INC.
415 Concord Avenue, Bronx, NY 10455-4898
1-800-635-5335
In NYC, call 212-585-3230
FAX 212-292-2243
TELEX 239777 ZERO UR



WHEN NOTHING ELSE
IS GOOD ENOUGH
FOR LONG ENOUGH.

Construction costs: No inflation here

Summary of Building Construction Costs

	Number of metro areas	10/88 to 1/89	1/88 to 1/89	1977* to 1/89
Eastern U. S.				
Metro NY-NJ	18	0.45	3.90	1937.03
New England States	33	-0.07	2.13	1829.67
Northeastern and				
North Central States	120	-0.17	2.23	1730.87
Southeastern States	106	0.21	3.76	1796.50
Average Eastern U. S.	277	0.02	2.91	1781.15
Western U. S.				
Mississippi River and				
West Central States	122	-0.50	0.50	1697.78
Pacific Coast and Rocky				
Mountain States	106	-0.31	3.49	1808.11
Average Western U. S.	228	-0.12	1.89	1749.07
United States Average	505	-0.04	2.45	1766.67

*Using only cities
with base year of 1977

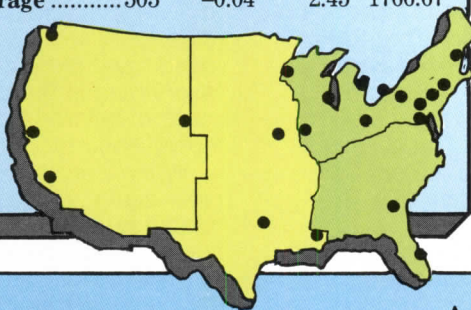

Since the beginning of 1988, construction costs have risen at rates higher than any seen since 1984. The greatest increase was in the first quarter—0.89 percent on national average. But it did not seem all that worrisome, indeed an aberration fed by an unexpected 10-percent spurt in February construction volume (supply and demand in play) and the consequent high expectations of many labor unions just then negotiating new contracts. What a surprise, then, to find costs in the second quarter rising at almost as strong a pace as in the first. The volume of construction was finally turning down and the major labor contracts were done.

It seemed, as Marshall + Swift analyst Frank Benz so ominously put it, the effects of dreaded inflation were upon us. And worries were not eased in the third quarter when costs continued to climb vigorously. Indeed, the theory of inflation's grip taking hold was additionally borne out by a reversal of the usual roles that regions play in either pulling up or moderating national averages. Metropolitan New York-New Jersey and New

England, which had been the leaders in cost rises for some time (presumably because of a residue of continued strong construction rates when compared to the rest of the nation), fell behind the Southeast and the Pacific Coast by a substantial amount. This seemed to eliminate the last vestige of argument that the rises were due to regional imbalances of supply and demand.

What a relief, then, to find in this fourth-quarter report, costs not only in check but falling—by 0.04 percent on national average. This was despite some healthy material-cost increases. Specific percentage rates were concrete, 0.4; plywood, 2.2; gypsum board, 3.5; and all materials, an average of 0.4. Some materials did manage to decline. Their rates: lumber, 0.7; asphalt 0.9; structural steel, 0.2; and copper pipe, 0.6. There is a lot more volatility in these prices than there has been in recent years and the results ahead bear watching. *Charles K. Hoyt*

Data supplied by Dodge Cost Systems, Marshall + Swift

Historical Building Costs Indexes

Metropolitan area	1977	1978	1979	1980	1981	1982	1983	1984	1985	1986	1987	1988	1989	
													1st	2nd
Atlanta	1171.5	1712.6	1925.6	2098.6	2078.0	2360.6	2456.7	2448.7	2518.3	2561.9	2580.9	2697.3		
Baltimore	1018.4	1107.7	1304.5	1446.5	1544.9	1639.5	1689.7	1703.7	1743.8	1765.2	1780.2	1849.1		
Birmingham	1029.7	1142.4	1329.9	1407.2	1469.9	1468.1	1535.7	1594.7	1565.7	1587.4	1542.6	1612.5		
Boston	1028.4	0998.6	1236.0	1283.7	1432.5	1502.0	1569.9	1646.0	1721.0	1773.6	1883.0	1921.6		
Chicago	1007.7	1032.8	1199.7	1323.6	1344.7	1425.8	1439.5	1476.7	1528.0	1599.9	1591.4	1636.5		
Cincinnati	0848.9	0991.0	1323.9	1385.2	1350.4	1362.6	1430.8	1484.5	1486.6	1499.4	1510.9	1526.8		
Cleveland	1034.4	1040.8	1287.5	1388.2	1459.5	1511.4	1475.9	1464.0	1474.1	1525.7	1541.8	1550.7		
Dallas	1042.4	1130.6	1431.9	1481.9	1750.6	1834.3	1925.9	1958.0	1963.3	1973.9	1947.2	1927.2		
Denver	1038.8	1100.4	1495.6	1487.4	1632.2	1679.1	1800.1	1824.3	1821.8	1795.8	1732.7	1725.3		
Detroit	1018.1	1087.3	1275.3	1447.4	1580.3	1638.0	1672.1	1697.9	1692.6	1696.6	1689.3	1734.4		
Kansas City	1023.5	0951.5	1125.8	1233.2	1323.4	1381.8	1407.5	1447.1	1472.5	1484.7	1493.7	1505.6		
Los Angeles	1022.5	1111.0	1255.3	1387.5	1474.3	1503.3	1523.9	1555.1	1571.0	1609.7	1675.1	1789.5		
Miami	1004.5	1080.9	1330.1	1380.6	1369.1	1392.1	1467.6	1522.2	1540.6	1566.2	1589.2	1625.2		
Minneapolis	1060.2	1196.8	1286.9	1327.7	1442.6	1576.8	1624.6	1640.4	1661.0	1674.0	1677.0	1690.6		
New Orleans	1001.3	1138.8	1291.9	1505.7	1572.7	1616.9	1650.5	1691.4	1762.5	1760.2	1699.8	1707.3		
New York	1005.4	1043.0	1247.1	1319.4	1419.2	1491.8	1672.5	1747.2	1806.7	1899.9	1980.9	2065.3		
Philadelphia	1013.8	1074.2	1487.5	1539.5	1660.7	1769.4	1819.5	1922.1	1967.9	1992.7	2023.5	2171.4		
Pittsburgh	1016.1	1015.0	1227.0	1341.7	1493.2	1479.5	1497.2	1576.1	1611.0	1665.8	1647.3	1700.3		
St. Louis	1039.1	1198.8	1275.9	1320.0	1397.3	1451.2	1524.9	1625.5	1641.8	1647.4	1653.5	1705.7		
San Francisco	1083.2	1326.8	1473.4	1644.8	1776.4	1810.1	1856.8	1935.3	1961.8	1995.5	1992.0	2090.9		
Seattle	1142.5	1137.9	1373.4	1616.8	1814.9	1962.7	1979.0	1948.9	1937.9	1925.3	1874.7	1968.0		

ONE OF THE
BEAUTIES OF CORIAN®
IS WHAT IT LEAVES
TO THE IMAGINATION.

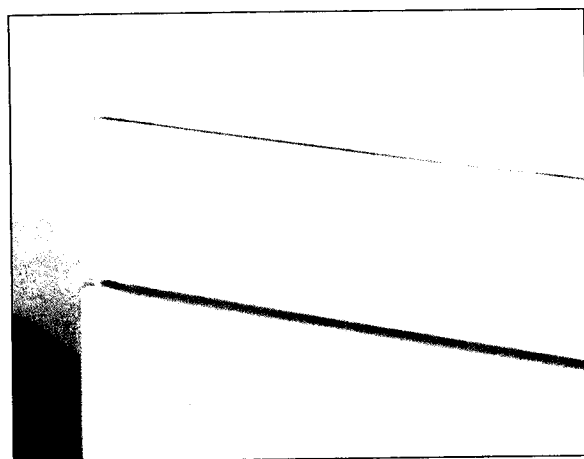

Management: Estimating your estimates

By Charles C. Munroe III



Whether an architect uses his own staff or a consultant, he will want to know how many manhours to allot to providing a client with the probable cost of construction for a project. The question becomes critical if, for whatever reason, the preparation of the estimate has been delayed until just before a deadline. Then, the scheduling process is complicated by the problem of deciding whether to assign more personnel to the task, authorizing overtime, or both.

It is an axiom of estimating that the quality of an estimate is directly proportional to time spent on its preparation. One prepared in haste simply will not have the integrity of one prepared without the pressures of an imminent deadline. The problem of how many manhours to assign to the preparation of an estimate could be greatly simplified by a formula or rule of thumb. Unfortunately, until now, there were none.

A recent survey by the American Society of Professional Estimators queried the membership on how each firm calculated the manhours necessary to prepare estimates

Mr. Munroe is currently president of the Los Angeles chapter of the American Society of Professional Estimators; a certified professional estimator; a member of the American Association of Cost Engineers; and principal project estimator for EuroDisneyLand, Walt Disney Imagineering.

in the various disciplines of construction. A statistical average was generated from the responses. The result? There are at least eight different methods. One rather primitive technique involves hefting the roll of drawings and prognosticating the manhours from the weight. Fortunately, this method does not enjoy a wide following. The two most frequently employed methods are the sheet-count and percentage-of-total-cost methods.

In the sheet-count method, the manhours are proportional to the number of drawings

Its utilization starts with the removal of those sheets that will not be used in the preparation of the estimate (such as the title sheet, index sheets, symbol sheets, etc.) The balance is

work entail extraordinary detail, or the mechanical and electrical work be exceptionally complicated, then the manhour rates should be increased accordingly. In addition to manhours, extra monies must be added on for such activities as client conferences, site visits, plan pickups and deliveries, change-order work, bid tabulations, etc.

The percentage-of-total-cost method requires the estimator to have a rough idea of the cost of a project beforehand

This method may seem a little like putting the cart before the horse. In actual practice, the estimator develops a rough order-of-magnitude estimate by totaling the gross floor area in a project and multiplying that by

larger percentage of the total project cost and vice versa.

A major weakness of this method could be its failure to take into consideration buildings having a high repetition of elements, such as a hotel in which all guest-room floors are identical. Obviously, it would be a waste of time to estimate the cost of each of these identical floors when only one need be estimated and multiplied by the number of identical floors. Again, in the case of a housing development in which there may be many houses, but only a few models, it is unnecessary to estimate every house. Discretion must be employed when using this method and, when a project does have repetitions, either another method selected or a factor for the repetitions taken into consideration. Obviously, as in the sheet-count method, allowances must be made for services entailed by providing the estimate in the first place.

The hourly rates charged by estimating consultants vary widely

They can range from a low of \$25 per manhour to as high as \$75 per manhour. Higher rates tend to be charged by large consulting firms with high overheads rather than free-lance estimators on their own, so that the value of employing an established firm must be weighed against the necessity of having to evaluate the free-lancer's expertise. Rates also vary by region of the country—averaging \$29 per manhour in the Southeast, \$31.50 in the Northeast, \$33 in the Central States, \$41.50 in the Southwest, and \$38.50 nationally. Armed with the basics of time and costs, you should have an easier time budgeting your next construction-cost estimate.

Percentage of Total-Cost Method

Total project cost (\$ 1000)	Estimating cost (percent)		
	Low	Average	High
Under 100	0.560	1.000	1.500
100 - 199	0.330	0.770	1.250
200 - 399	0.270	0.750	1.200
400 - 599	0.220	0.600	1.125
600 - 999	0.170	0.550	1.000
1,000 - 2,499	0.150	0.450	0.750
2,500 - 4,999	0.100	0.350	0.500
5,000 - 9,999	0.087	0.250	0.380
10,000 - 19,999	0.077	0.210	0.340
20,000 - 39,999	0.066	0.180	0.300
40,000 - 100,000	0.050	0.100	0.200

segregated according to discipline, counted, and rates applied: 2.65 manhours per sheet for civil and site work, 3.00 for architectural and structural work, 3.25 for mechanical, and 3.50 for electrical.

These rates apply only to definitive estimates and assume normal construction. If the civil work should require extensive cut-and-fill calculations, the architectural and structural

an average cost per-square-foot (such as that provided by Marshall + Swift, R. S. Means, or the estimator's own historical cost figures derived from experience). The result is then multiplied by a percentage factor (see table) to arrive at the cost of preparing an estimate. The percentage factor applied varies with the size, complexity, and gross value of the project. Smaller projects command a

U.S. Post Office Station E, Chicago, Illinois
Interior design by Loeb, Schlossman and Hackl, Inc.

Surprising as it may seem, you're actually looking at a U.S. Post Office in Chicago, Ill.

But clearly no ordinary one.

Because its designers found a material that perfectly expressed their imagination. CORIAN®

The material with an incredible design versatility matched only by its durability and ease of maintenance.

As a result, what you envision remains intact for years and years. And, as you can see, you can envision just about anything.

For more information, see your CORIAN distributor. Or call 1-800-527-2601. Or write Du Pont CORIAN, Room G-51550, Wilmington, DE 19801.

Then leave it to your imagination.

CORIAN

CORIAN® The premium quality brand of solid surface products from Du Pont.

Circle 40 on inquiry card



Close

Move

Open

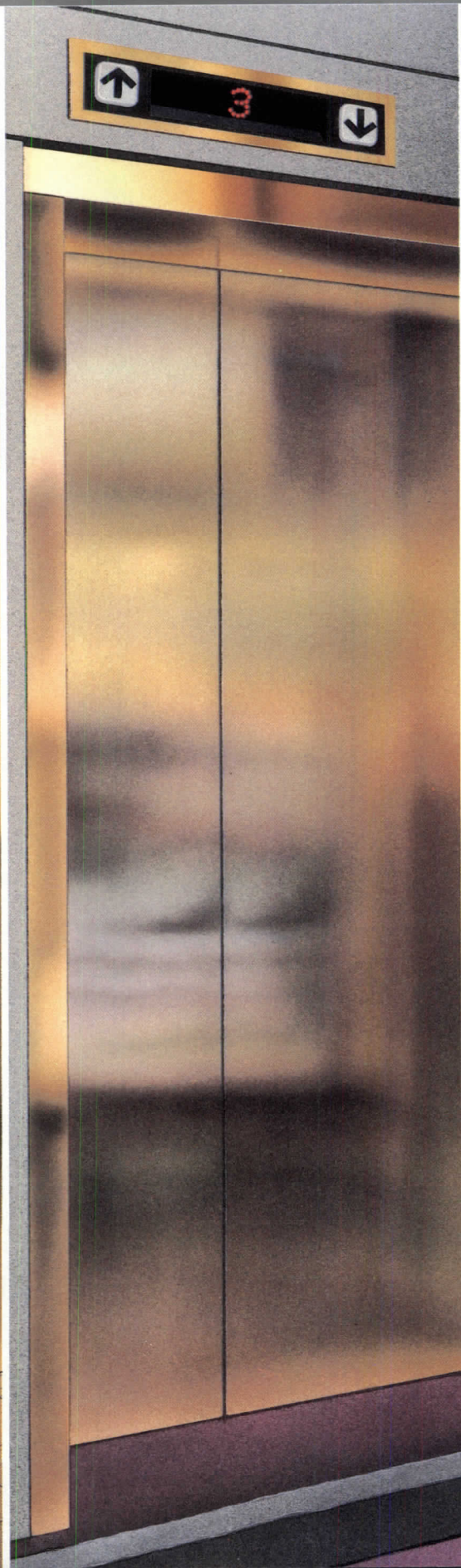

Another Hardheaded Dover Breakthrough On The Three Basic Elevator Functions.

The World's First Totally Integrated Microprocessor
Control System For Hydraulic Elevators.

We're particular, actually stubborn, about refinements in state-of-the-art technology for hydraulic elevators. Remember, we invented them.

Other manufacturers have made a lot of noise with assorted bells and whistles. Dover has been quietly and patiently perfecting the greatest advance in hydraulic elevators since we invented them 51 years ago. DMC-I® — the first totally integrated microprocessor control system.

Our new DMC-I elevator closes the doors more reliably. Moves the car to the next floor more efficiently. Opens the doors more dependably. What else is an elevator for?

Other brands have offered add-on microprocessor functions on a onesy, twosy basis, like bandages. Only Dover has taken the years and millions of dollars necessary to perfect a total, built-in system. Because only Dover's volume as the industry leader made it feasible for us to invest such vast resources in its development.



Dover F.A.S.T. unit gives instant performance analysis.

DMC-I has a unique new hand-held F.A.S.T. unit that is literally a "window" into

the microprocessor controls. It allows us to reprogram up to 40 elevator functions in minutes. It provides instant analysis of existing performance, permitting faster, more thorough preventive maintenance.

If you're buying or specifying elevators for low or mid-rise buildings, you need to see what DMC-I can do. Call your local Dover office or write Dover Elevator Systems, Inc., P.O. Box 2177, Memphis, TN 38101.

DOVER[®]
ELEVATORS
*Making more
elevators makes
Dover No. 1*

Buy Ulrich Planfile and Get FREE Office Space

When you choose the right kind of large document filing system you can actually get extra office space for free. Ulrich's vertical filing cabinets not only keep your drawings organized in perfect condition, they take up far less space than any alternative. In fact it takes 6 five drawer flat

files to store 3,000 drawings — the same number that can be maintained in just one Ulrich cabinet. And Planfiles are top loading so they only require 24" of aisle space. Flat files need 50" of clearance. There are other advantages besides free real estate. Planfiles are cas-

ter mounted for easy relocation. Flat files are not designed to be moved. Ulrich cabinets offer fire protection. Flat files don't. The list goes on — easy filing access, water protection and more. For all this you would think Ulrich Planfiles cost more, but they don't.

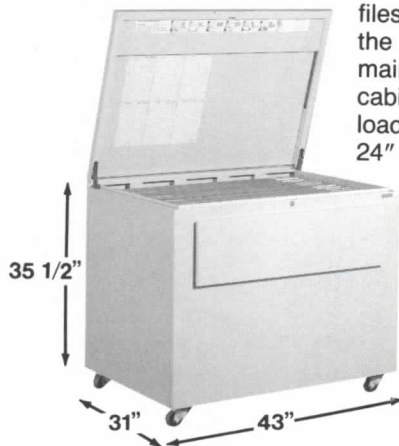

For free brochures that detail the entire product line, call or write:



Ulrich Planfiling Equipment Corporation
2120 Fourth Avenue, Lakewood, NY 14750
1-800-346-2875

Circle 41 on inquiry card

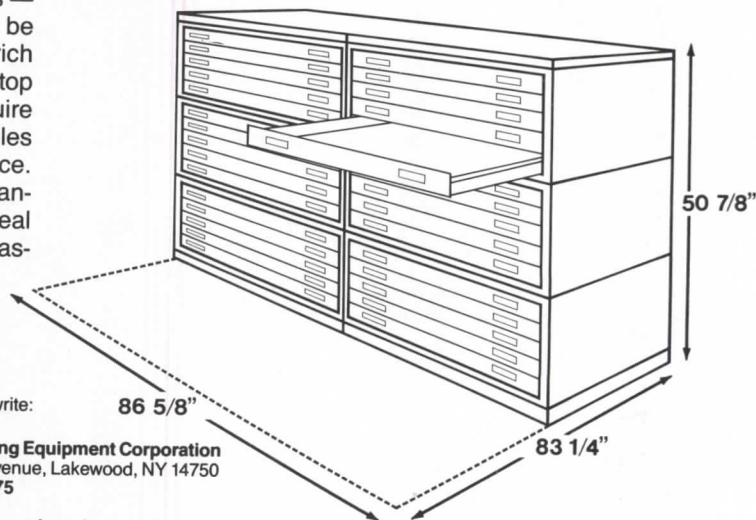

Acoustical Doors

In famous performing arts centers, noisy industrial environments, or in radio and TV facilities—whether to close sound out, or close sound in—Overly acoustical doors are available in a wide variety of configurations. A continuous testing program certifies all Overly acoustical products. Overly acoustical doors close the door on sound.

overly
MANUFACTURING CO.

(East)
P.O. Box 70
Greensburg, PA 15601
(412) 834-7300
TWX: 510-468-0539
FAX: 412-834-8221

(West)
P.O. Box 947
Fallbrook, CA 92028
(619) 723-1105
FAX: 619-728-7512

A sound idea from Overly Manufacturing.

Circle 42 on inquiry card

Every dock needs a lift



Step Vans
Bed Height Range
24" - 30"

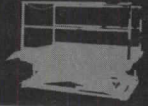

City Delivery Trucks
Bed Height Range
33" - 48"



High Cube Vans
Bed Height Range
24" - 39"



Whether you're handling a panel truck or a semi, most dock levelers can only give you 18" of operating flexibility. For today's trucks, you need more than 18". You need Superdok.

With just one Superdok and its 58" operating range, you can handle panel and pick-up trucks, high cube and semi trailers — without hassle.

**Superdoks. More than versatile,
Universal.**



ADVANCE LIFTS

Advance Lifts, Inc., 3575 Stern Ave., St. Charles, IL 60174 312-584-9881

Circle 43 on inquiry card

ELEGANCE IN PROFILE



ENJOY
THE
RICHNESS
THAT ONLY
FINE
MARBLE
AND
GRANITE
CAN
ACHIEVE



CALIFORNIA

8436 West Third Street
Los Angeles, CA 90048
(213) 653-5533 • Fax# (213) 653-6072
1-800-62 STONE

NEW YORK

470 Smith Street
Farmingdale, NY 11735
(516) 752-0318 • Fax# (516) 752-0411
1-800-62 STONE

EUROPEAN HEADQUARTERS

Florence Italy

Circle 45 on inquiry card

Interiors from every angle.

Ceilings. Floors. Walls.

All the basics of interior space.

All sparked with a new verve.

All from one source—

USG Interiors, Inc.

Where the best lines meet.

The USG logo is rendered in a bold, white, sans-serif font. The letters 'U', 'S', and 'G' are stacked vertically, with the 'U' on top, 'S' in the middle, and 'G' at the bottom. The 'S' and 'G' are slightly offset to the right relative to the 'U'. The background behind the logo is a dark, textured surface that appears to be part of the interior design elements shown in the advertisement.

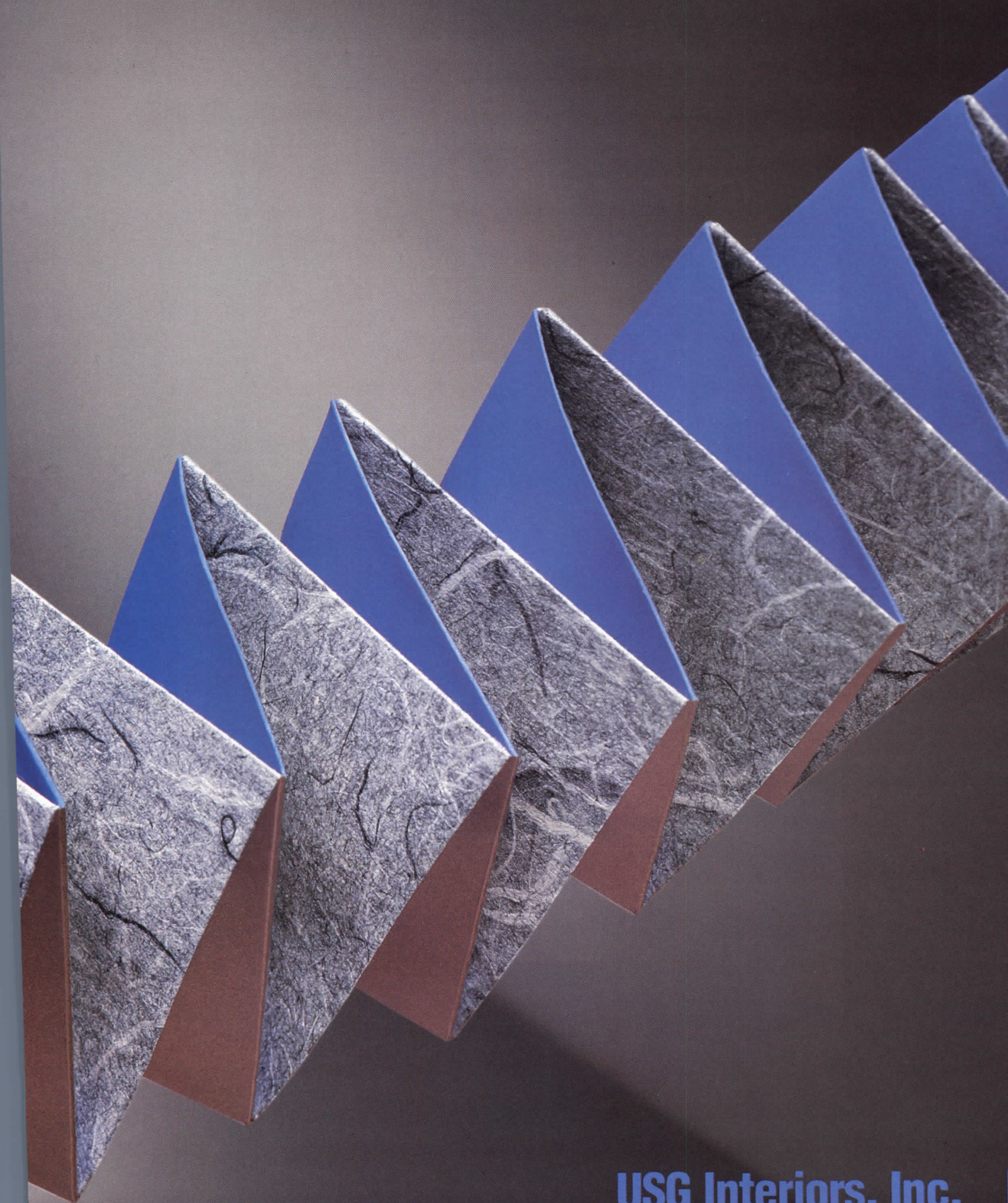

USG Interiors, Inc.

Circle 46 on inquiry card



Imagine the design possibilities.

**Interior solution:
SILENT™ 95 Walls
AURATONE® Ceilings
DONN® Grid**

Whatever you can imagine, you can design. We'll provide the full complement of solutions for your absorbing possibilities. From the tremendous variety of patterns, colors and textures of our ceiling panels and grids, to the lush abundance of fabric choices from our wall collection. All color-coordinated. All from USG Interiors, the people who can make design a product of *your* imagination. Contact: USG Interiors, Inc., 101 S. Wacker Drive, Chicago, IL 60606-4385, Dept. A

Interiors from every angle.™

USG Interiors, Inc.

USG

© 1988 USG Interiors, Inc.
Trademarks owned by USG Interiors, Inc.: AURATONE, DONN, SILENT.

The Boolean cube made tangible

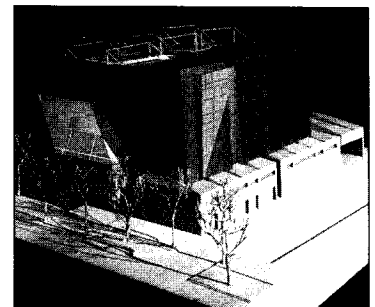
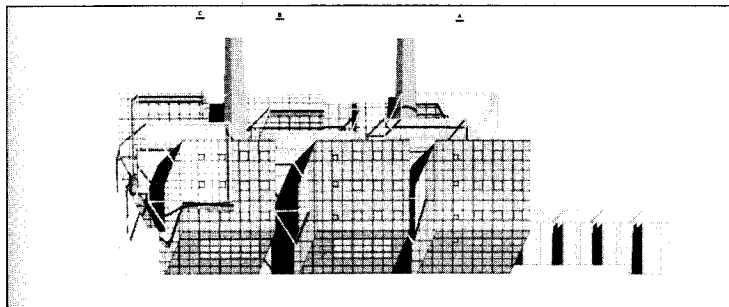
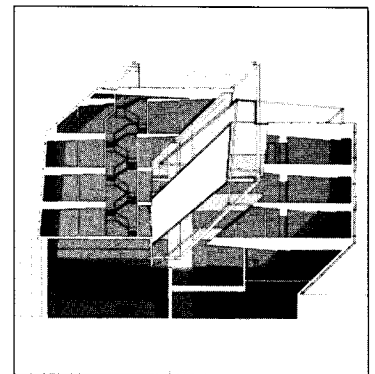
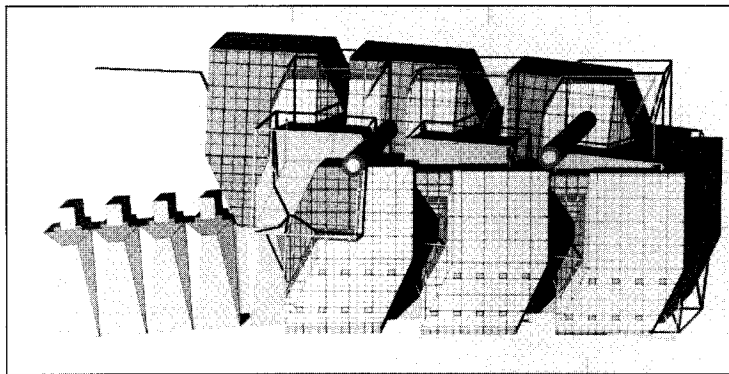
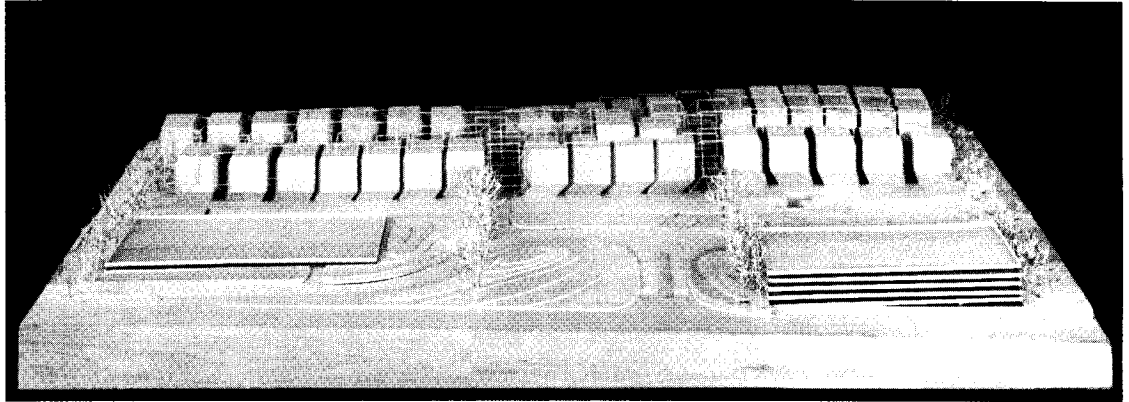

The exceedingly unusual architectural geometry for this pair of buildings was devised by Peter Eisenman in direct response to a gauntlet thrown down by his client. The proposed buildings—the Carnegie Mellon Research Institute at the right end of the model (top) and the privately developed Pittsburgh Technology Center office building at the left—will house advanced computer research in such areas as artificial intelligence. Richard Cyert, president of Carnegie Mellon University, challenged Eisenman to design a building that would leave behind old-fashioned

architecture and symbolize the current knowledge revolution and the theories behind it.

The so-called Boolean cube, or n -cube, was the basis of Eisenman's design. Among other qualities, Boolean geometry (named for 19th-century mathematician George Boole) provides many possible connections from corner nodes (connections are important in Boolean geometry and in artificial-intelligence modeling). As described by Eisenman, "Each building is made up of three pairs of $4-n$ Boolean cubes. Each pair contains two solid cubes with 40-foot and 45-foot

members and two frame cubes with 40-foot and 45-foot members. Each pair can be seen as containing the inverse of the other as solid and void."

The Carnegie Mellon Research Institute appears in the center row of drawings above and shows solid $4-n$ cubes and frame $5-n$ cubes. The central trapezoid in the section is an ornamental representation of an internal geometric connection in the atrium. The bottom row shows the CMRI in elevation at the left. A model of the office building (right) shows a simpler geometry of "solid" cubes connected by "hollow" frame cubes.

WALL SYSTEMS WITH YOUR DIRECTION

IN MIND. Give us your expectations for comfort and style. Your technical

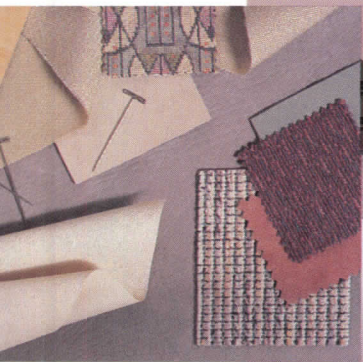

Our newest solution
—PASSAGE™ Wall
System displayed
here. We also offer
ULTRAWALL™
ONSET™
CENTURION™
TRITON™ and HSC™
FULL HEIGHT WALL
and INSTAR™

requirements for sound and fire ratings, flexibility, and accessibility... your strict budgets.

We'll provide you with great value in vertical, horizontal and specialty wall systems,
great choices in color and texture, and some of the best Licensed Contractors around

to guide your project from selection through installation. Phone

1-800-USG-WALLS, or write Wall Division, 101 S. Wacker Drive,

Chicago, IL 60606-4385. Dept. AR589

Circle 48 on inquiry card

USG

Interiors from every angle.™

USG Interiors, Inc.

Showroom at IDCNY
Copyright 1989, USG Interiors, Inc.

News briefs

By the book

The AIA's 25 Year Award will go this year to the Vanna Venturi house, designed in 1964 by Robert Venturi for his mother. In selecting the house, the AIA Honor Award Jury observed, "By giving architects a new way of seeing, this modest structure both liberated and energized the profession and added new life to the American environment."

The Hôtel des Invalides in Paris will undergo renovations and repairs as part of the 1989 Bicentenary Celebration of the French Revolution. The hôtel, for which Mansart was one of the architects, is Napoleon's burial place. The French government will pay for exterior regilding of the famous dome, and the World Monuments Fund will help organize repairs of interior décor and its 17th-century paintings.

James Marston Fitch has been awarded the \$20,000 Distinguished Designer Fellowship by the National Endowment for the Arts. Fitch, who is director of historic preservation for the New York City architectural firm Beyer Blinder Belle, will use the award to finish his book, *The Architecture of the American People: 1565-1969*.

Educational materials for architects teaching general students, from preschoolers to adults, about their profession are provided in *The Sourcebook 2*, published by the American Institute of Architects.

Architectural commissions: Michael Graves has been appointed master planner and architect for the renovation and expansion of the museum of the Detroit Institute of the Arts; Gwathmey Siegel & Associates will design renovations for the School of Architecture at Pratt Institute in Brooklyn, New York; Cesar Pelli & Associates will design a \$26.5-million School of Law and the Babcock Graduate School of Management in Winston-Salem, North Carolina.

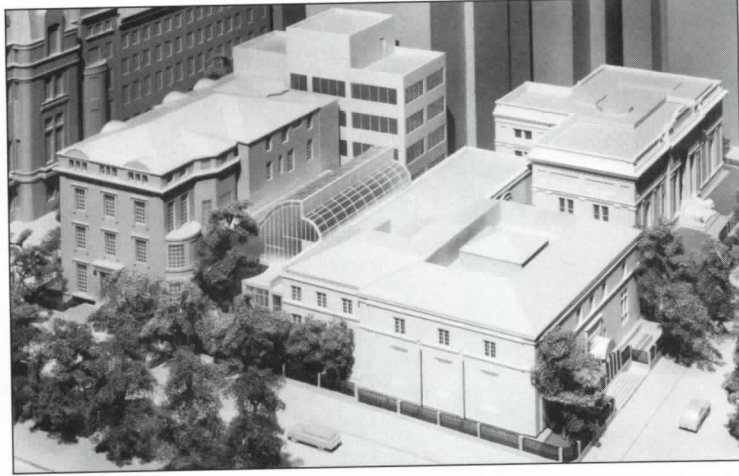

The calm elegant presence of the Pierpont Morgan Library in Manhattan's Murray Hill district has special appeal for New Yorkers, partly because of McKim, Mead & White's superlative design for the building, partly because of the institution's energetic programs of collection and exhibition. Both operations, however, led to serious overcrowding in McKim's building (upper right corner of model) and its 1920s addition. Last year, the library bought an imposing brownstone mansion on one corner of the Madison Avenue site (left edge of model) and asked architects Voorsanger & Mills Associates to join the mansion and the library.

The architects considered that their chief challenge was to maintain "the intimacy of the institution and the integrity of the architecture." The major changes will thus be inside, the mansion becoming an education center and meeting center with exhibition and office space. The existing building will gain a permanent-collections gallery.

The only new construction will offer a covered garden under a clerestoried glass vault. The court, to be designed by landscape architect Dan Kiley, will connect the buildings with a tranquil sitting area.

NEOCON 21: Furnishings show-and-tell

NEOCON 21, this year's version of the annual furnishings exposition, will take place June 13-16 at Chicago's Merchandise Mart. Its opening session, "World Culture: Agenda for the 1990s," will field an international panel, with Emile Biasini, of the French Ministry of Culture,

Viacheslav Leonidovich Glazychev, journalist and vice president of the Union of Architects, USSR, and Adele Chatfield-Taylor, president of the American Academy in Rome.

As usual, much of the exposition will focus on office furnishings, and the Institute of Business Designers will hold its fifth annual conference during the first two days of Neocon. Seminars will also address such topics as showrooms and healthcare facilities. This year, moreover, a related exposition will expand available interiors information beyond furnishings: "The Environmental Products &

Services Exposition," scheduled for June 12-14 at Expocenter/Chicago, will show such building products and office equipment as business machines and computers, security and fire-protection systems, electrical and lighting systems, and other products.

This year's Chicago Architecture Awards, cosponsored by ARCHITECTURAL RECORD and the Illinois Council, American Institute of Architects, will be presented to Philadelphia urban planner Edmund N. Bacon, Chicago landscape architect Alfred Caldwell, and French architect Jean Nouvel.

Handles Are A Risk . . .

*Eliminate Them With the
Delany Sensor Faucet®*

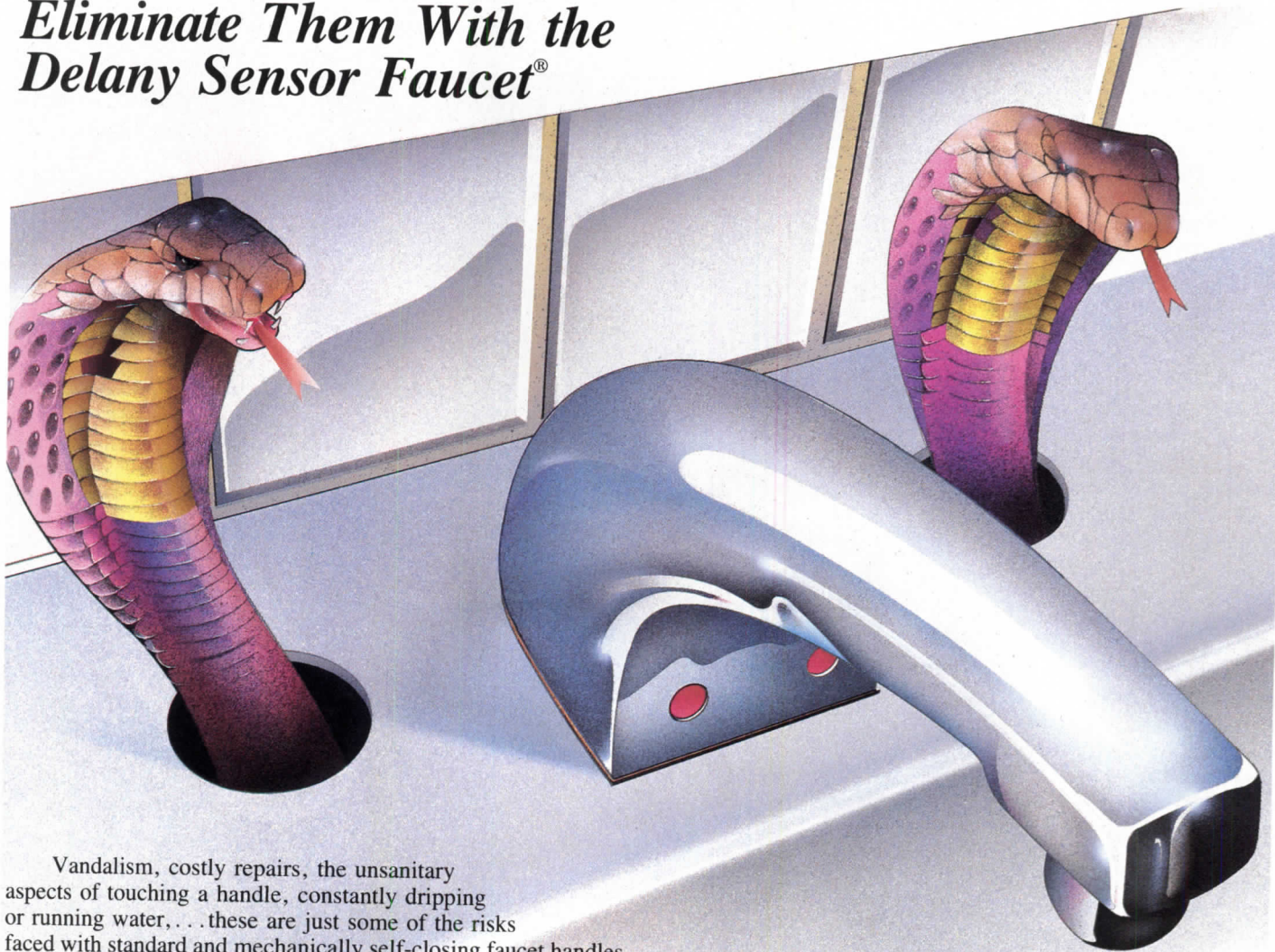

Vandalism, costly repairs, the unsanitary aspects of touching a handle, constantly dripping or running water, . . . these are just some of the risks faced with standard and mechanically self-closing faucet handles.

The new Coyne & Delany Sensor Faucet® eliminates these risks.

The Sensor Faucet operates without touch. When the user places his hands under the faucet, an infrared beam is reflected back to the receiver. A solenoid valve opens and the temperature controlled water flows automatically at a standard .5 GPM. Withdrawing hands stops the flow with a positive shut-off. Because the system is solenoid activated, there is virtually nothing to wear out. This assures years of trouble free service. The solenoid can also be located in a secure place, eliminating vandalism.

Replaceable infrared filters and adjustable beam range are two more elements that make the Delany Sensor Faucet® unique in the industry.

Contact your Delany representative and eliminate the risk of handles.

 **Delany**
FLUSH VALVES
SINCE 1878

Coyne & Delany Co.
P.O. Box 411
Charlottesville, Va. 22902
(804) 296-0166

News briefs

For the mall in Minneapolis

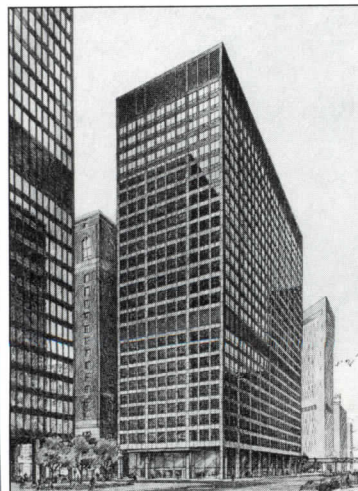
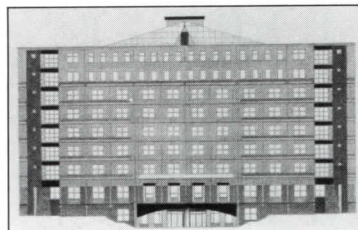
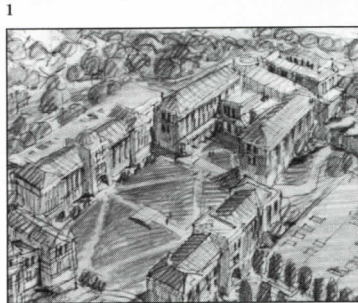

Cervantes Convention Center in St. Louis will double its overall space with new exhibition area, meeting rooms, lobby and registration area, and kitchen and mechanical space. Designed by Hellmuth, Obata & Kassabaum, the additions will include two new brick and granite entrances marked by three-story arched windows (1); the new wings will be topped with lighted towers. Construction is scheduled to begin in July.

The Catholic University of America will build a law school on its campus in Washington, D. C. (2). Architects Keyes Condon Florance won the commission in a two-day charette/competition conducted by the university's school of architecture. The firm attributes the victory to its concentration on siting, in which it used the new building and courtyards to resolve disparate grids and axes generated by existing buildings and streets.

The Residence Life Complex at the New Jersey Institute of Technology in Newark (3) was designed by the Hillier Group. The building will house 434 students, as well as providing commons and lounges, rooms for staff, and a campus bookstore. The patterned brickwork is meant to fit with existing buildings on campus. Construction of the 110,000-square-foot building began earlier this year.

A new Federal Building is planned by the General Services Administration in Chicago's south Loop (4); construction of the offices will start this fall. Fujikawa, Johnson & Associates designed the 27-story black thermal-finished granite exterior to agree with other federal buildings in the city's central business district. The building will be developed by Stein & Company Federal Center, Inc.

Planned by Lohan Associates as part of Minneapolis's renovation and beautification of its downtown Nicollet Mall, the mixed-use Dain Bosworth/Neiman-Marcus Plaza will be built by BCE Development Properties. The four-story retail base will have a glass tower at one corner to serve as a visual and physical link with the city's pedestrian skyway system. Although the top of the 33-story asymmetrical office tower is Modernistically flat, its sides and corners are more complexly articulated than one expects of the style, and thus the building will assert itself on the skyline.

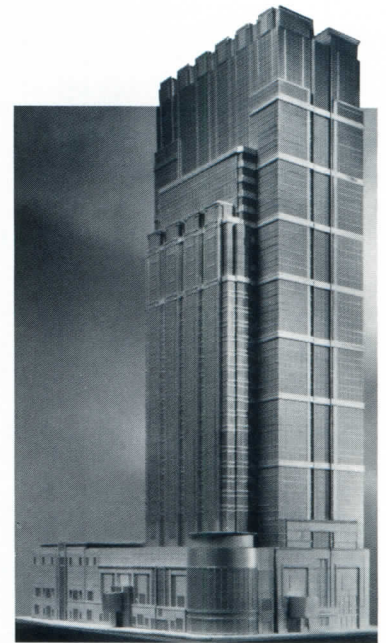

Museum as moderator

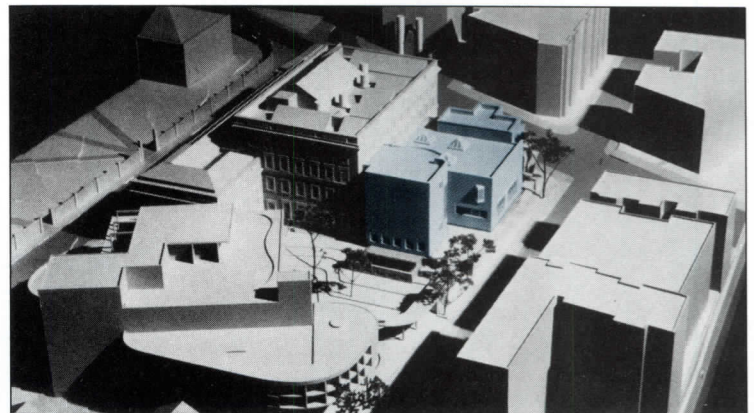

The new Werner Otto Hall at Harvard University, designed by Gwathmey Siegel & Associates, has a complex program that calls for a reading room, curatorial offices, art storage, and second-floor galleries for the Busch-Reisinger Museum's collection of 20th-century Central and Northern European art—all to be built above underground space for the Fine Arts Library.

An even more difficult architectural necessity, though,

was to mediate somehow the neo-Georgian presence of the Fogg Art Museum along one side and the Modern presence of Le Corbusier's Carpenter Hall on the diagonal. The resolution interposes the new building between the street and the Fogg, capturing Corbu's rectilinear pavilion in a partially enclosed courtyard. Otto Hall will be faced with gray porcelain enamel tiles and trimmed with green slate and pink granite.

Nature has proven that color is one of the best ways to blend into an environment. But that lesson seems to have been lost on most sunroom manufacturers, who offer a limited choice of colors that seldom match a home's color scheme. ■ But at Solarium

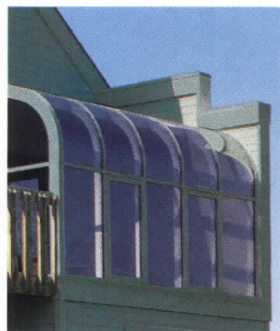

Systems International, we offer a choice of 30 standard colors on our sunrooms, without charging a custom price. And without a long wait for delivery, like some sunroom manufacturers. So you can offer customers a sunroom that blends in with any home, or any environment. Our system even allows different colors to be applied to the interior and exterior of our sunrooms, so they can match a home both inside and out. ■ However, color is just one of the ways our sunrooms can adapt to their environment.

Borrowing On An Idea, We Make Sunrooms That Take On The Color Of Their Surroundings.

In addition to our standard sunroom designs, for example, we can work with you to develop custom designs that closely match the style or size of a particular home. ■ And we're the only sunroom maker to offer our exclusive high-performance SolarScreen™ glass on both straight and curved eaves. It provides maximum light while keeping our sunrooms warmer in the winter and cooler in the summer. ■ Of course with every Solarium Systems sunroom, you get clean architectural lines, quality materials and engineering, and the peace-of-mind of working with a sunroom builder that's as committed to this business as you are. ■ If you're looking for a sunroom with a custom look, without a custom price, call Solarium Systems International at 1-800-225-6423. We'll send you a brochure with more information about the sunrooms that adapt to the situation.



SSI SOLARIUM SYSTEMS INTERNATIONAL
5340 Shoreline Boulevard, Mound, Minnesota 55364

Part of Cerritos's larger picture

Praise and commissions

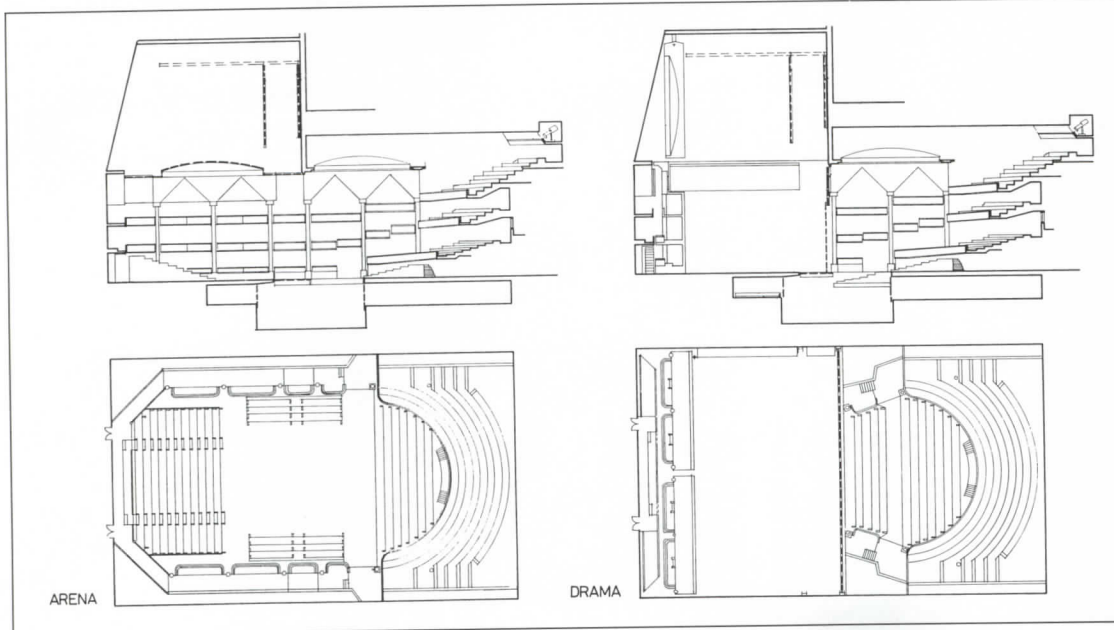
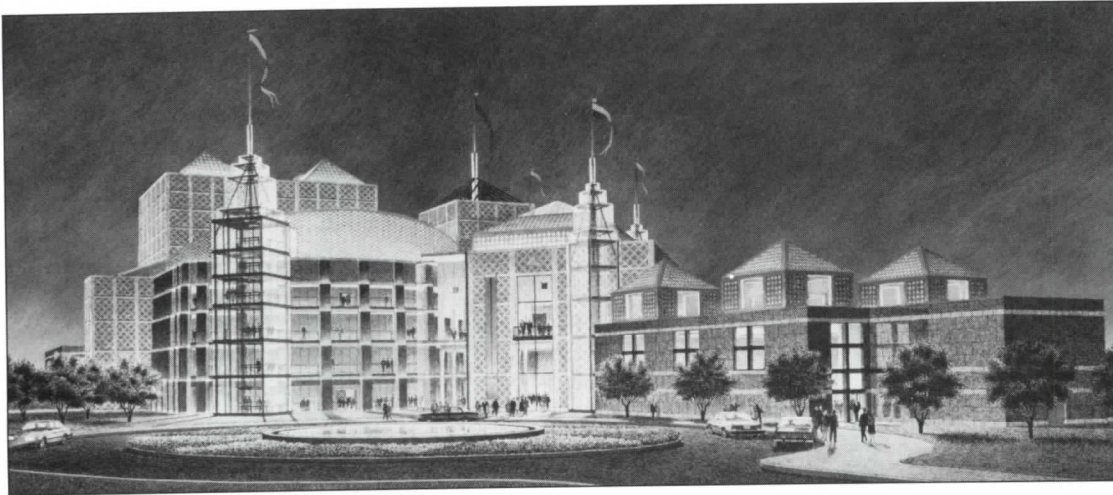

Cerritos, a town of 50,000 in Southern California, has big plans for itself: the first building in its new community center is not the conventional mall or generalized meeting hall, but a good-sized multipurpose theater for concerts and plays.

Festival Hall, designed by Barton Myers Associates as part of the firm's master plan for Cerritos Town Center, will be completed next year. The working core of the \$30-million complex is, of course, the theater itself, which can assume five configurations when hydraulic lifts rearrange seats and boxes. Configurations range from the

1,684-seat arena theater format (plan left) to the 1,011-seat drama format (plan right). Other possibilities include a 1,670-seat concert hall, a 1,450-seat lyric format for musicals and ballet, and a flat-floor format for art festivals, dinner dances, and the like. In addition, the theater complex includes a large lobby with such adjacent open public spaces as the Poets Garden and the Actors Garden. The building will also include a large and a small meeting/dining hall and offices.

Rather than impose a megastructure on the small city, Myers carefully separated the

contents to suggest a cluster of small buildings. Thin spires with pennants will ornament the entry portals and look down on the stage house, which has itself been reduced in apparent scale with four pyramidal caps instead of a bleak flat top (at the back of the rendering at top). The large meeting hall has four lower caps. Each part of the complex can operate independently of the others.

The project's next phase will be a hotel opposite the entry shown above, and following phases call for three office buildings.

Thomas S. Monaghan, architecture buff and chairman of Domino's Pizza, has established the Domino's 30 Architects Award. On May 2 in New York City, he presented each of the 30 with a 5-inch bronze sculpture by architect/sculptor Charles Perry. Moreover, not content with lip service, Monaghan has commissioned designs for sizable buildings from five of the honorees. Charles Moore will design a lodge and other buildings for a resort, a petting zoo at Domino's world headquarters, and a 160-unit condominium near the company's headquarters. Arthur Erickson has been commissioned for a convention center addition to the Ann Arbor, Michigan, Marriott Hotel, while Hugh Hardy will design a convocation center for the University of Steubenville (Ohio). E. Fay Jones has already designed Monaghan's house, to be built in Ann Arbor, and Gunnar Birkerts will carry forward the next phase of his design for Domino's head office, also in Ann Arbor.

The other honored architects include Tadao Ando, Gae Aulenti, Edward Larrabee Barnes, Aurelio Galfetti, Frank Gehry, Michael Graves, Charles Gwathmey, Hans Hollein, Arata Isozaki, Philip Johnson, Henning Larsen, Fumihiko Maki, Richard Meier, Jean Nouvel, I. M. Pei, Reima Pietila, Cesar Pelli, Renzo Piano, Kevin Roche, Richard Rogers, Paul Rudolph, James Stirling, Benjamin Thompson, Aldo Van Eyck, and Robert Venturi. The architects were chosen by an international panel that included Toshio Nakamura, editor of the Japanese magazine *Architecture and Urbanism*, Arno Ruunsovuori, director of the Museum of Finnish Architecture, Ted Pappas, then president of the American Institute of Architects, and Mildred F. Schmertz, editor of ARCHITECTURAL RECORD.

Design awards/competitions: American Institute of Architects 1989 Honor Awards

The 12 buildings cited in the American Institute of Architects 1989 Honor Awards program exhibit a kind of architectural pluralism not visible even half a dozen years ago. Not only do the selected buildings range widely in style, geography, and building type—they include, of all things, a suspension bridge—but a quarter of them are older buildings restored or expanded. What the buildings have in common is their size: most are quite small. Writing the jury report, chairman David Childs of Skidmore, Owings & Merrill, New York City, observed



Jon Miller, Hedrich-Blessing



Chad Floyd

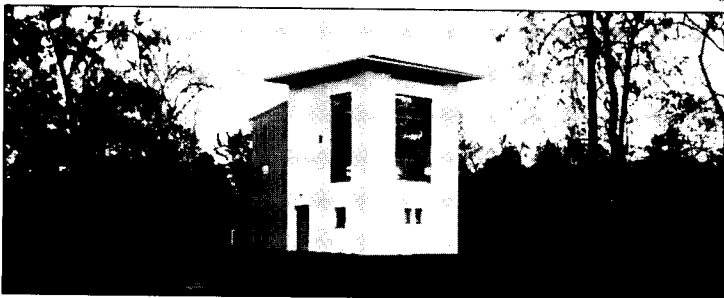

Mick Hales Photography



David Verrico

1. Martin May House Museum, Grand Rapids, Michigan; Tilton + Lewis Associates, Inc., Architects. The owners, Steelcase, Inc., wanted to restore this "extraordinary" 1909 Frank Lloyd Wright Prairie Style house as a museum with Wright's furniture and to undo many unsympathetic alterations. Commending the "adroit restoration," the jury said "this house radiates with the energy and enthusiasm of Wright himself and feels more like a private house than a museum. The architects have done more than restore a building—they've brought back a once lost friend."

2. Reid House, Johns Island, South Carolina; Clark & Menefee Architects [RECORD, mid-April 1988, pages 70-75]. Among the most modest of this year's honor awards, "this noble little farmhouse" has two structural components: a concrete-block section and a wooden shed, with an asphalt-shingle roof and pine flooring. After commenting on the design's classical architectural elements, the jury said, "Its humble materials and placement in the landscape give this home a poignant quality, as though it were a proud remnant from a past civilization."

3. Seneca Lake Pier and Pavilion, Watkins Glen, New York; Chad Floyd, of Centerbrook, Architect. Though this is a newly built fishing pier and pavilion intended to revitalize a moribund little tourist town on one of New York State's Finger Lakes, it resembles the Adirondack boathouses and Victorian architecture that used to characterize the district. "The success of this lakeside project lies in its simplicity," the jury said, and it called the project "a charming architectural gateway linking the past to the present."

4. Miller Park Plaza, Chattanooga; Derthick, Henley & Wilkerson/Koetter, Kim & Associates, Architects. The first component to be built for a five-block plaza that will embody the city's determination to draw its citizens back downtown, this glass pavilion is meant to be a public room for meetings, receptions, recitals, craft fairs, what-you-will. "The handsome, welcoming structure and park provide a public meeting place that brings new vitality to this once lifeless block."

that the smallness raised "a significant and debatable question"; to wit, "must a complex, large-scale project achieve the same uniform degree of perfection and consistency that a more modest undertaking . . . can perhaps more easily achieve?" The jury also urged that in future "more urban design and planning projects be offered."

The jurors included, in addition to Childs, architects Peter Bohlin of Bohlin Powell Larkin Cywinski, Wilkes-Barre, Pennsylvania; Steven Ellinger of Abilene, Texas; Kathleen S.

Hoeft of Long Hoeft Architects, Denver; Jaquelin T. Robertson of Cooper Robertson & Partners, New York City; Michael Rotondi of Los Angeles; and John Whiteman of the Skidmore, Owings & Merrill Foundation, Chicago, as well as architectural critic Brendan Gill of *The New Yorker*, New York City, and, as a nonvoting juror, architectural student Joyce S. Lee of the Massachusetts Institute of Technology.

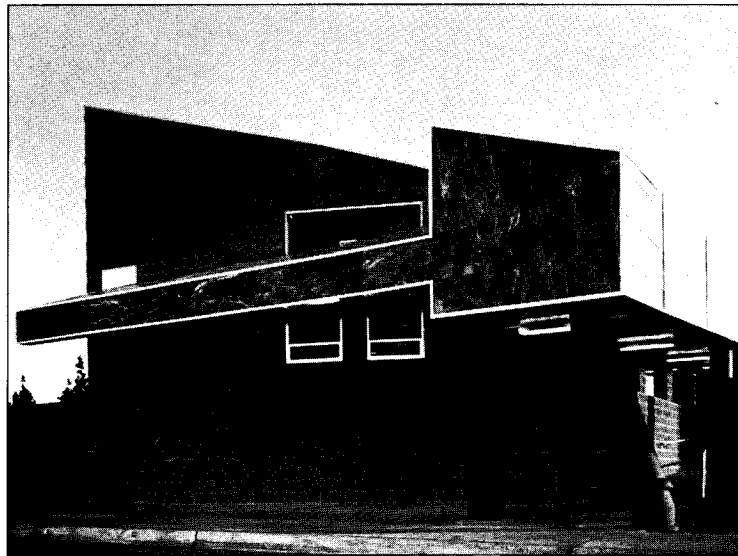

Tom Bonner

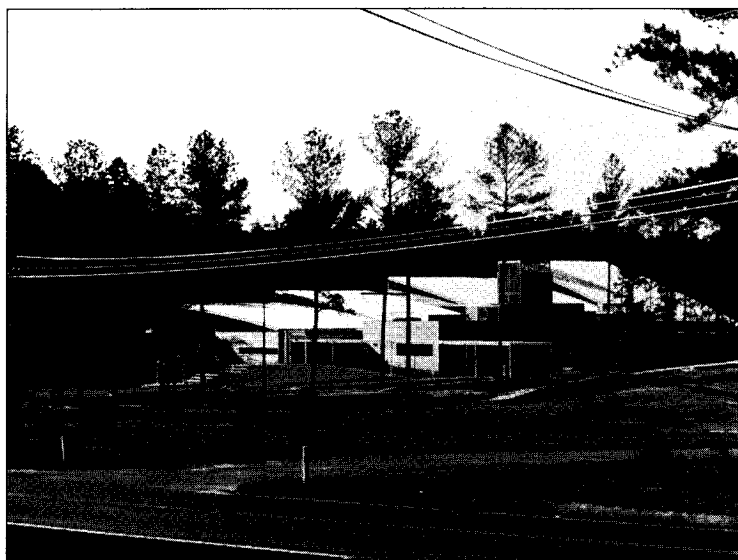

©Timothy Hursley/The Arkansas Office

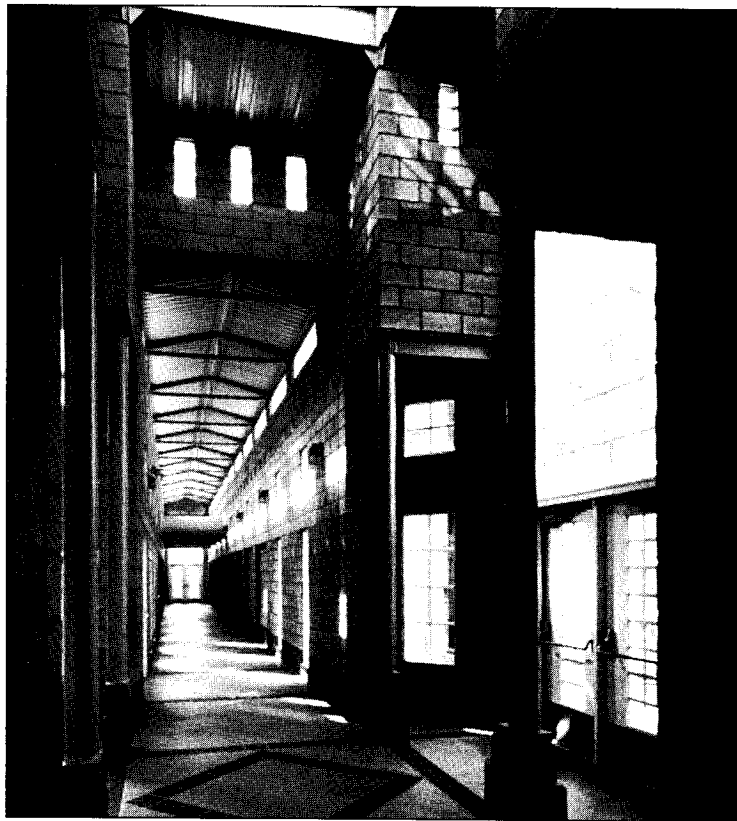

Robert Reck

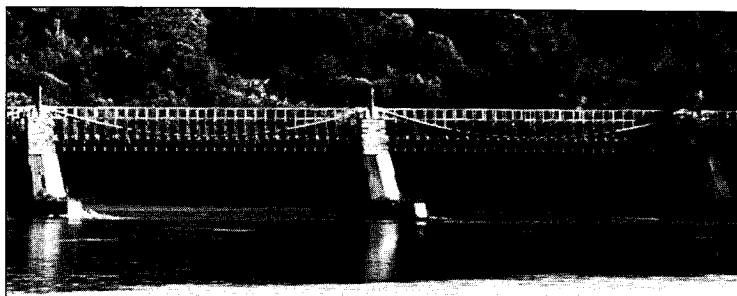

Alan Schindler

5. Central Housing Office Building, University of California, Irvine; Eric Owen Moss, Architect. The 10,000-square-foot building, which accommodates a staff of 25 and a large number of visitors, includes five open-office components, as well as closed offices. "The architect challenges our perceptions of form and materials through the sharp angles of the roof, the juxtaposition of common with more elegant materials, and the use of unusual windows, creating a building of powerful intensity," said the jury.

6. Headquarters Library of the Clayton County Library System, Jonesboro, Georgia; Scogin Elam and Bray Architects. Built at one end of the Atlanta airport and near a highway "strip," the library is described by the architects as "a filling station for information relevant to living life." The facility is enclosed by speckled black and white corrugated metal walls. "This startling building defies the notion that libraries are stuffy places," the jury commented, calling the library "a playful, delightful building with a serious purpose."

7. Desert View Elementary School, Sunland Park, New Mexico; Perkins & Will, Architect [RECORD, September 1988, pages 106-109]. For a prototype school in an area inhabited by recent immigrants from Mexico, the design sought to provide urban significance. "Comfortable and durable, this building incorporates many elements of local architecture, including sloping metal roofs and earth-toned concrete-block walls . . . With its expansive corridors, child-size scale, and brightly lit interiors, this school supports the idea that learning is a joy," the jury wrote.

8. Delaware Aqueduct, Minisink, New York/Lackawaxen, Pennsylvania; Beyer Blinder Belle, Architect. Built in 1847 as a canal aqueduct, this suspension bridge is the earliest surviving example of John A. Roebling's work. The architects and the owner, the National Park Service, wanted to re-open the bridge to vehicles and to retain the integrity of the cable and timber truss structure. "Through meticulous research and uncompromising craftsmanship, this skillful conversion stands as a monument to the genius of . . . John Roebling." *Continued on page 62*



9 ©Timothy Hursley/The Arkansas Office

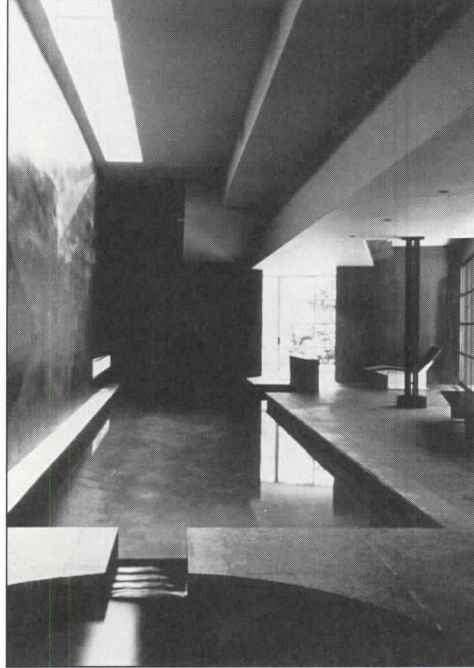

10 Michael Moran

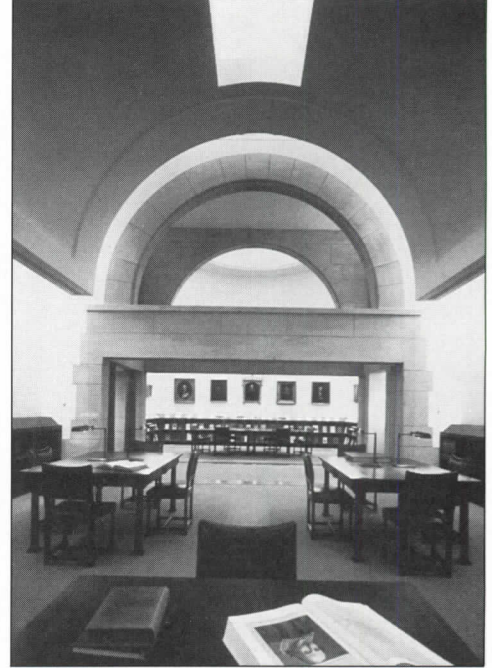

11 ©Cervin Robinson

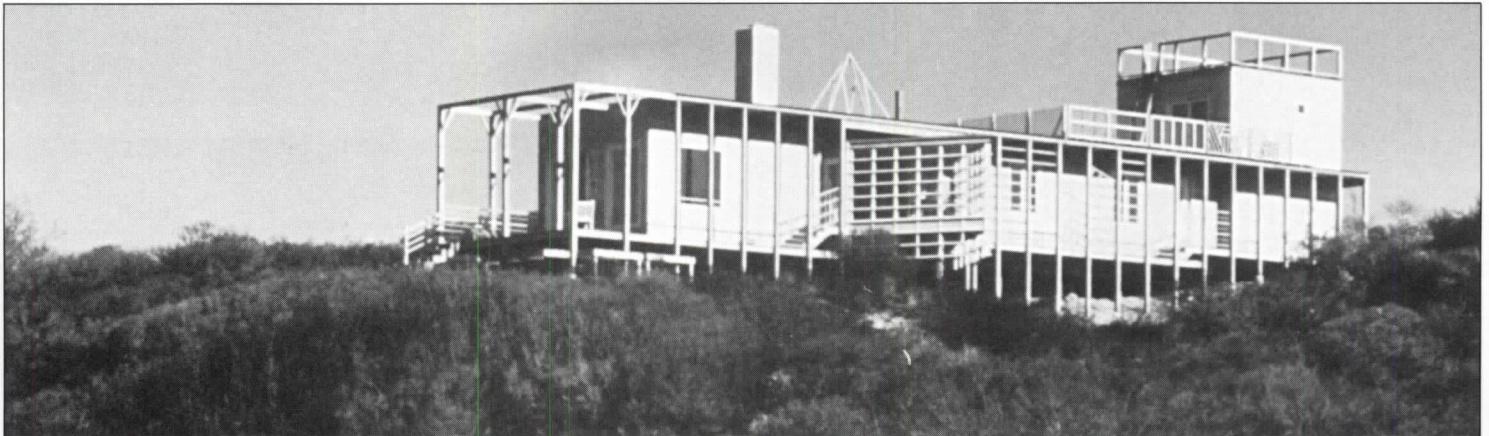

12

9. Hansen House, Wilmette, Illinois; Hammond Beeby Babka, Inc., Architect [RECORD, mid-April 1987, pages 104-107.]. Building in an old suburb on a tree-lined street with large houses, the owners were willing to sacrifice space for quality construction. Upon seeing the resultant 1,600-square-foot house, the jury admired the "white, wispy columns and the thin railings of the porch that form a dainty skirt around the gray-stuccoed building . . . Understated, yet elegant, formal, and inviting, this handsome house is imaginative without upstaging its older neighbors."

10. Kings Point Pool Addition, Long Island, New York; Tod Williams Billie Tsien & Associates, Architect [RECORD, mid-September 1988, pages 108-111]. Meant for the personal use of the owners, Emily and Jerry Spiegel, this indoor pool house frames Sol LeWitt's wall painting, *Triple Pyramid*. The designers considered the sound of the water an architectural material. "With its splendid wall frescoes, elegant details, and subtle siting, the architects have created a building that is sculptural as well as functional. . . It is a place to exercise the soul as well as the body."

11. Folger Shakespeare Library, Washington, D. C.; Hartman-Cox Architects. The new Reading Room, which is built parallel with the Folger's existing Reading Room, is top lit with skylights inserted in suspended vaults. Rusticated brown plaster walls recall rusticated limestone walls at the entry. "The classically inspired forms reinforce the historic significance of the library's collections, while the room's freshness and vitality reflect the enduring importance of scholarly explorations in the modern world," the jury wrote.

12. Martha's Vineyard Residence, Massachusetts; Steven Holl Architects. Likening this house, owned by Steven Berkowitz and Janet Ogdis, to an Indian dwelling built of whale skin and skeleton, the architect calls it "an inside-out balloon frame." The structure meets sand on point foundations, and for roofing a rubber membrane is unrolled like a skin. "On a bright day, rows of exposed wood framing on the exterior cast strong shadows that form graceful patterns of crisscrossing lines . . . this taut, trim, jaunty structure is very much at home [at the seaside]."

Your Duro-Last Roof Will Be Known By The Company It Keeps.



Lake County Village Shopping
Center — Phoenix, AZ

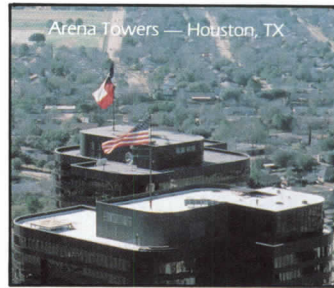

Arena Towers — Houston, TX



Con-Rail — Altoona, PA

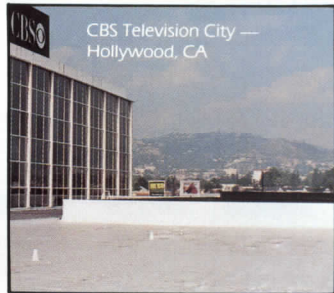
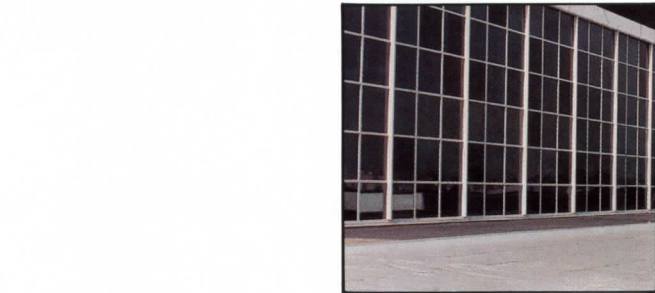

CBS Television City —
Hollywood, CA

With a Duro-Last single-ply roofing system, you're joining some pretty good company . . . like CBS Television City, The Wall Street Journal, Con-Rail, Transwestern Property Company, Lake County Village Shopping Center, just to name a few.

These satisfied customers know Duro-Last is the top single-ply performer. And for a variety of reasons:

- Duro-Last **custom** fabrication to your specifications gives you a roofing system big on performance and low on waste.
- A Duro-Last roof goes down quick and that means a savings of time and money.
- Duro-Last means durability with our exclusively designed Celanese Fortrel™ polyester high tenacity fabric, coated on each side with a specially formulated thermoplastic polymer.
- Duro-Last gives you double protection with a 20-year warranty and \$6,000,000 liability insurance policy.

Those are just a few reasons why more and more Duro-Last roofs are being seen in some pretty good company. Shouldn't you join the long list of satisfied Duro-Last customers who are buying the "system" and not just roll goods?

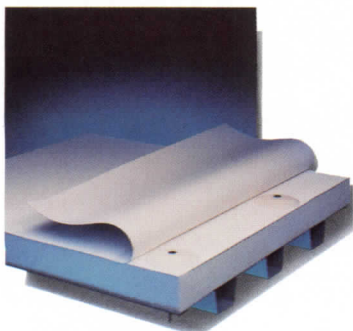

Call today. It's your first step to putting . . . and keeping . . . your roof in some pretty good company.

1-800-248-0280

1-800-356-6646 (West of the Mississippi)

**DURO-
LAST®**
Roofing, Inc.

Kroy Wants Your Name.

Mail This Coupon For Your FREE Desktop Nameplate, Produced With The Kroy 360 Digital Lettering System.

We own a _____ lettering system. I'm interested in using the Kroy 360 with a PC.

Please carefully print or type your name and title exactly as you want them to appear on your nameplate.

Name _____

Title _____

Business Phone () _____ (Required)

Business Name _____

Business Address _____

City _____ State _____ Zip _____

MAIL TO: Kroy Inc., 14555 N. Hayden Road, Scottsdale, Arizona 85260

One nameplate request per company, please (Subject to availability. Void where prohibited.)

Kroy and Kroy 360 are registered trademarks of Kroy Inc.

3088-A

(We Promise To Send It Back. Free.)



Even if you already use desktop publishing, you'll be amazed at what the Kroy 360 digital lettering system can do for you. In fact, we're so confident you'll like what you see, we'll send you a personalized nameplate produced with the 360, *absolutely free*. Simply mail us the coupon above.

Not only can the Kroy 360 letter names, its laser-printer quality lettering makes it perfect for creating report covers, flyers, badges, bar codes, file

labels, overhead transparencies, signs—you name it.

And operating it is as simple as typing. With the easy-to-understand instructions, you can create lettering in a wide range of sizes and styles in seconds. Plus there are over a dozen color combinations to choose from. As well as a library of drop-in typestyle cartridges.

So send us the coupon, and we'll send you back your name...along with more information on all the amazing

capabilities of the 360. Your nearby Kroy dealer will contact you soon for a hands-on demonstration.



KROY®

Winners Use It.

TRADITIONAL RAILINGS FROM JULIUS BLUM.

Julius Blum ornamental railing components add traditional elegance to a variety of environments. Engineered for design flexibility and structural soundness, they exhibit superior performance characteristics, as well as classic good looks.

Providing clear and complete details of stock components, Blum's comprehensive catalogs enable the designer to specify railings for style, appearance and building economy. Engineering data is also included so that architects and designers can ensure their installations meet applicable codes and safety requirements.

Julius Blum's metal railing components are available in steel, aluminum and bronze. They are stocked in substantial quantities and ready for prompt shipment. For more information, please refer to Sweet's catalogs or call or write for Julius Blum Catalog 14.

BROOKS BROTHERS
Dallas, Texas

JB®

JULIUS BLUM & CO., INC.

P.O. BOX 816, CARLSTADT, NEW JERSEY 07072
(800) 526-6293 (201) 438-4600 FAX: (201) 438-6003

Julius Blum is the nation's most complete source for architectural metal products.

Circle 54 on inquiry card

Arch: Mayer, Garfield, Gawron & Associates
Fabr: Trinity Brass & Copper



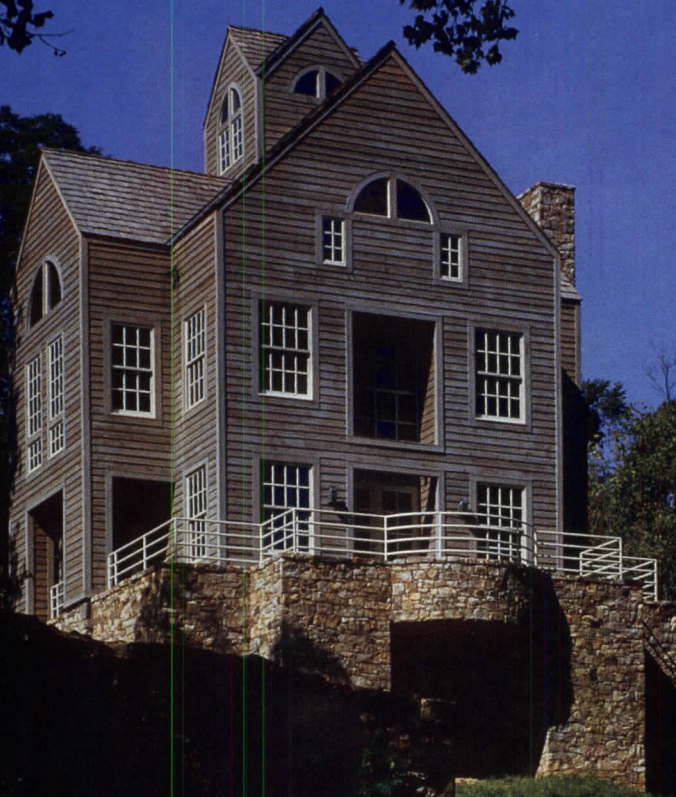

Sash and frame milled from Ponderosa pine that is preservative treated.

Williamsburg True Divided Lite units feature $\frac{5}{8}$ " insulating glass and $1\frac{3}{8}$ " wide divided lite bars. Optional Low E with Argon gas also available.

Specially designed security sash lock seals both sash securely and tightly.

Sash engage full length vinyl jamb liners for ease of operation and a positive seal at sides.

HAZZARD MILL HOUSE...

Selection of the window manufacturer was as important as the window.



Situated high on the banks of the beautiful Shenandoah River overlooking the site of the original mill stands the new Hazzard Mill House. Quality Weather Shield wood windows and doors help create a playful character, while at the same time framing fantastic views of the river and the surrounding mountains.

But this project is more than just re-creation of a piece of America's past history. This project presented some very unique opportunities and challenges.

Mark Kohler, AIA, of Karl E. Kohler Associates Architects, Vienna, VA, defined the needs of this special project by saying, "The Hazzard Mill House was designed to recall the image of the original Hazzard Mill House. Exterior materials such as stone, horizontal cedar siding, a shake roof and authentic looking real wood windows with the integral wood muntins were used to be consistent with the materials believed to have been used on the original mill."

Mark goes on to say, "We chose Weather Shield windows because they could provide us with oversized wood tilt, wood casement, wood awning and fixed wood quarter rounds in all sorts of custom sizes. But we didn't stop at just the windows. We also chose a set of 8 foot high custom sized French doors for a very special effect."

You may never get the opportunity to be involved in a project steeped in as much history as Hazzard Mill. But when you choose Weather Shield you are insuring that your choice of wood windows and doors will stand the test of time for beauty, adaptability and performance.

Weather Shield... **"Better Ideas In Wood Windows!"**

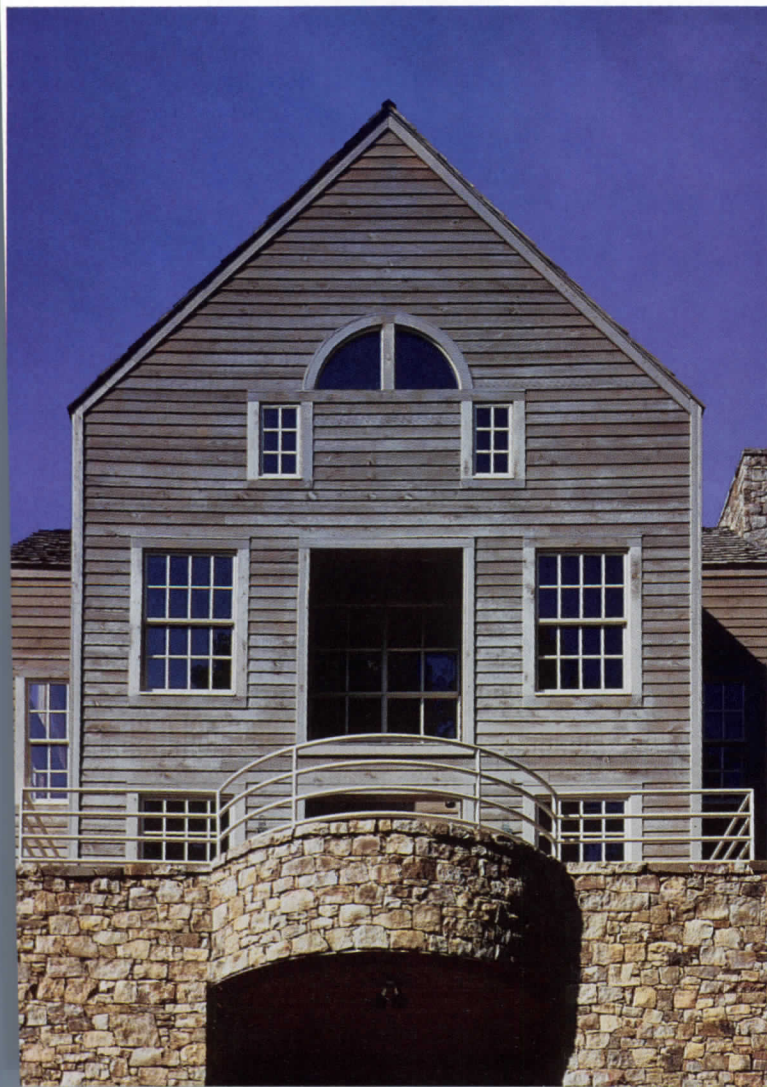

All Weather Protection - Always!



Weather Shield Mfg., Inc.
Medford, WI 54451 • 715/748-2100

See us at the CSI show, Booth 136-138

Hazzard Mill House:

Designed by Mark A. Kohler, AIA and Nicholas Diffenbaugh, AIA of Karl E. Kohler Associates Architects, Vienna, VA (703) 281-7570.

Photographs:
James Ritchie

Circle 55 on inquiry card

GE IS THE LIGHT THAT WILL RESHAPE THE WAY



**GE BIAX lamps
make everybody and everything,
including operating costs, look better.**



It won't take you long to discover that with GE BIAX™ 40-watt lamps, the design possibilities are endless.

Because they're only 22.5 inches long, yet deliver all the light of standard four-foot fluorescents, you can design with smaller fixtures. And that means more attractive ceilings.

And because BIAX lamps make colors look richer and more vibrant than standard fluorescents,

YOU DESIGN LIGHTING.



nts can, the lighting you design will make the
vironment and the people who work in it
ore attractive.

Equally attractive is the amount your clients
l save on operating costs. GE BIAX 40-watt
lamps, you see, last up to 8,000 hours longer
than conventional U-shaped tubes. And 13
times longer than incandescents.

Feast your imagination on the endless pos-

sibilities of the GE BIAX family of lamps.

For more product or application informa-
tion, call your local GE Specification Area
Manager. Or call the GE Lighting Information
Center at 1-800-523-5520.

GE is Light.



GE Lighting

GRES FAENZA®

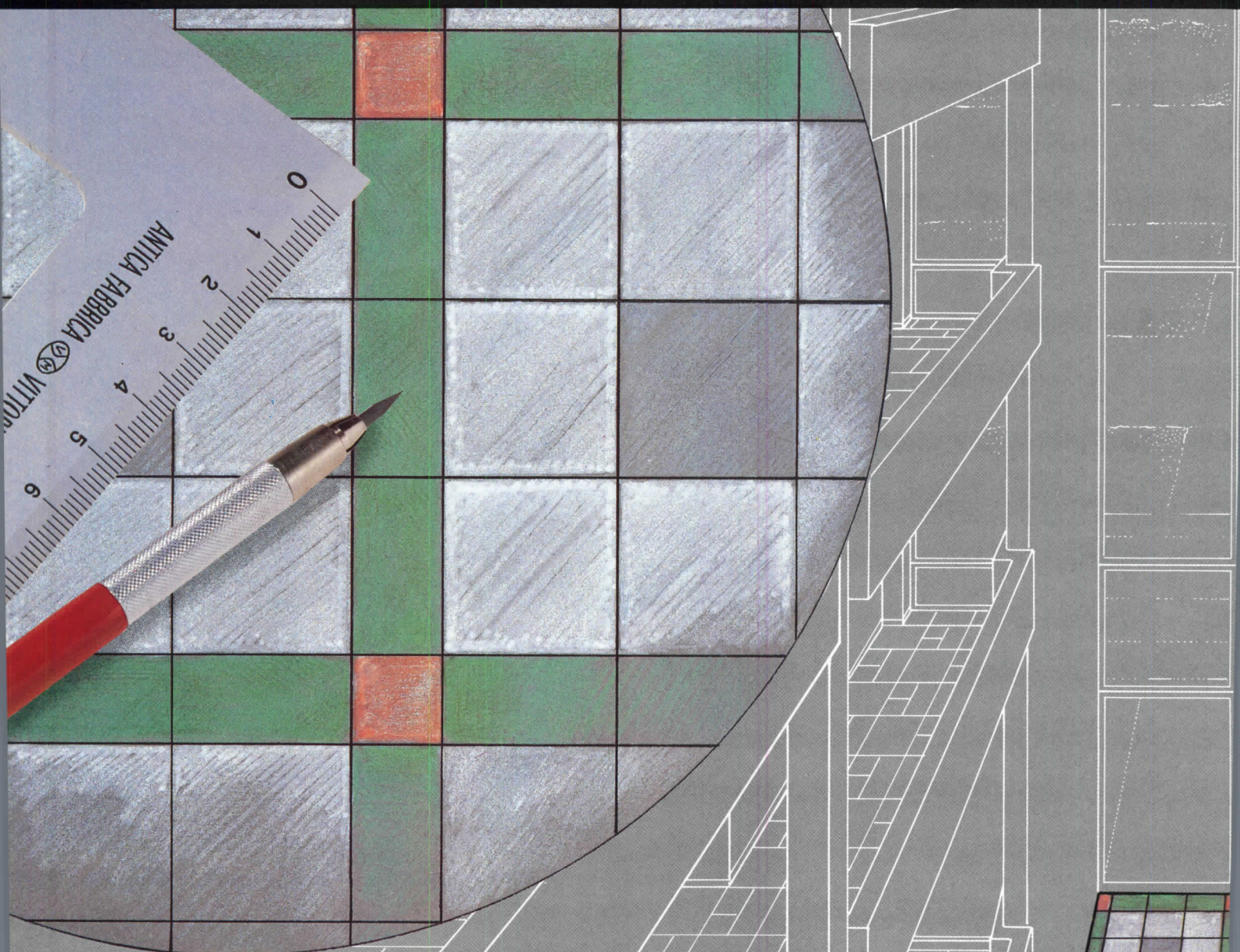

MODULAR SIZES:

**19³/₄" x 19³/₄" - 10" x 19³/₄" - 10" x 10"
12" x 12" - 4" x 12" - 8" x 8" - 4" x 4"**

3 LINES:

HARD LINE. SOLID LINE. HIGH LINE.

18 MATCHING COLOURS

SPECIAL PIECES FOR PERFECT FINISHING.



CERAMICHE
LAFENZA

LAFENZAAMERICA INC.
1900 Powell Street, Suite 520
Emeryville, California 94608
Phone (415) 655-1395 (800) 223-4982
Fax (415) 655-2193

Circle 57 on inquiry card

NEW CERAMIC GENERATION

ABRASION RESISTANCE :

PEI 4 (UNI-EN. 154).

DEEP ABRASION:

OVER 110 TURNS (UNI-EN. 102).

**ESPECIALLY SUITABLE
FOR HEAVY TRAFFIC PLACES.**

FULLY FROSTPROOF.

IDEAL BOTH INDOORS AND OUT.

ACID-PROOF

(UNI-EN. 122).

**10 YEAR WARRANTY AND INSURANCE
AGAINST ANY AND YET UNPROBABLE
EXPENSES FOR REPLACEMENT,
RELATED SUSPENSION OF ACTIVITIES
AND DAMAGES TO THIRD PARTIES.**

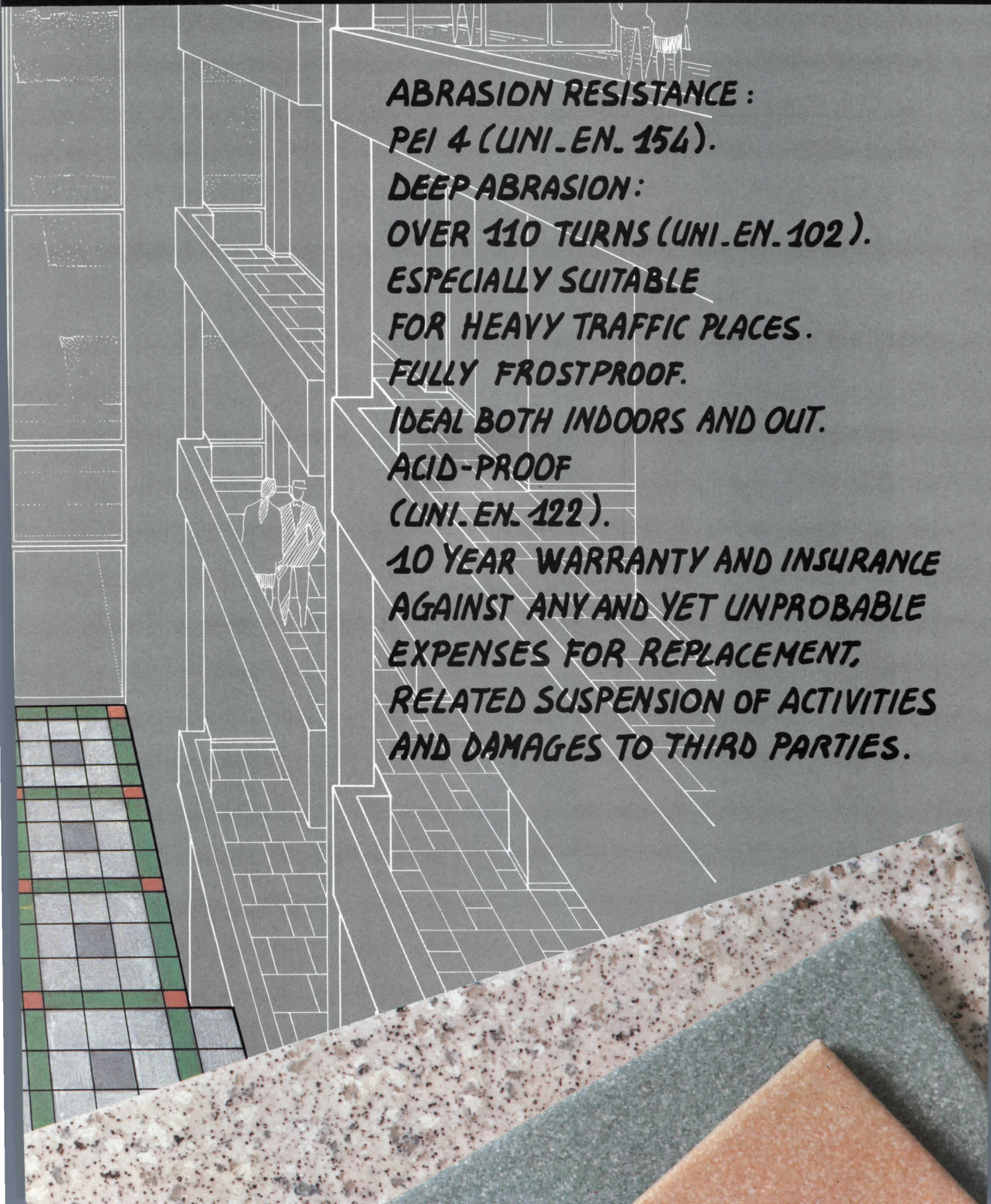

© 1989 Carey-McCall Corporation. A division of Springs Industries, Inc. 

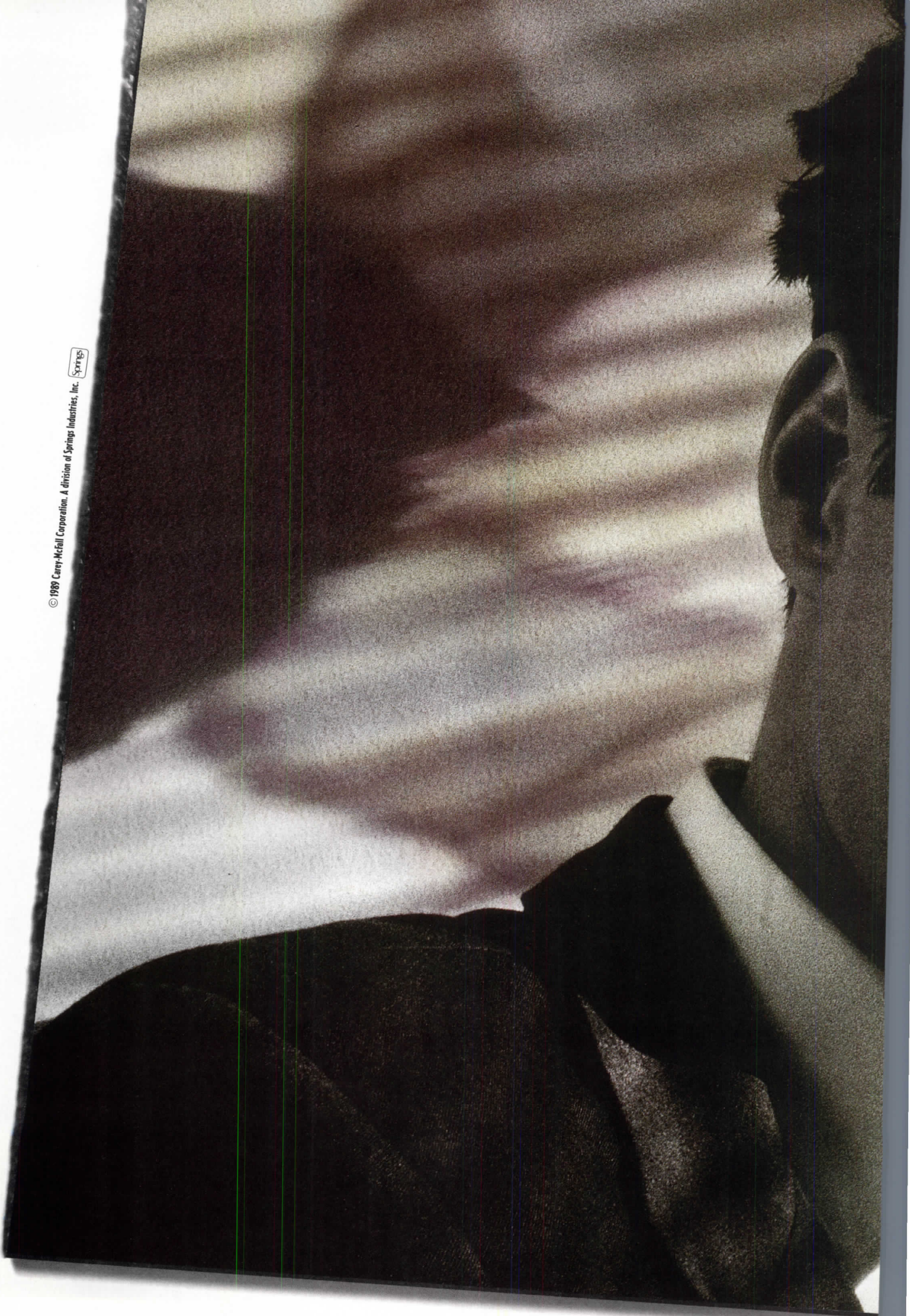

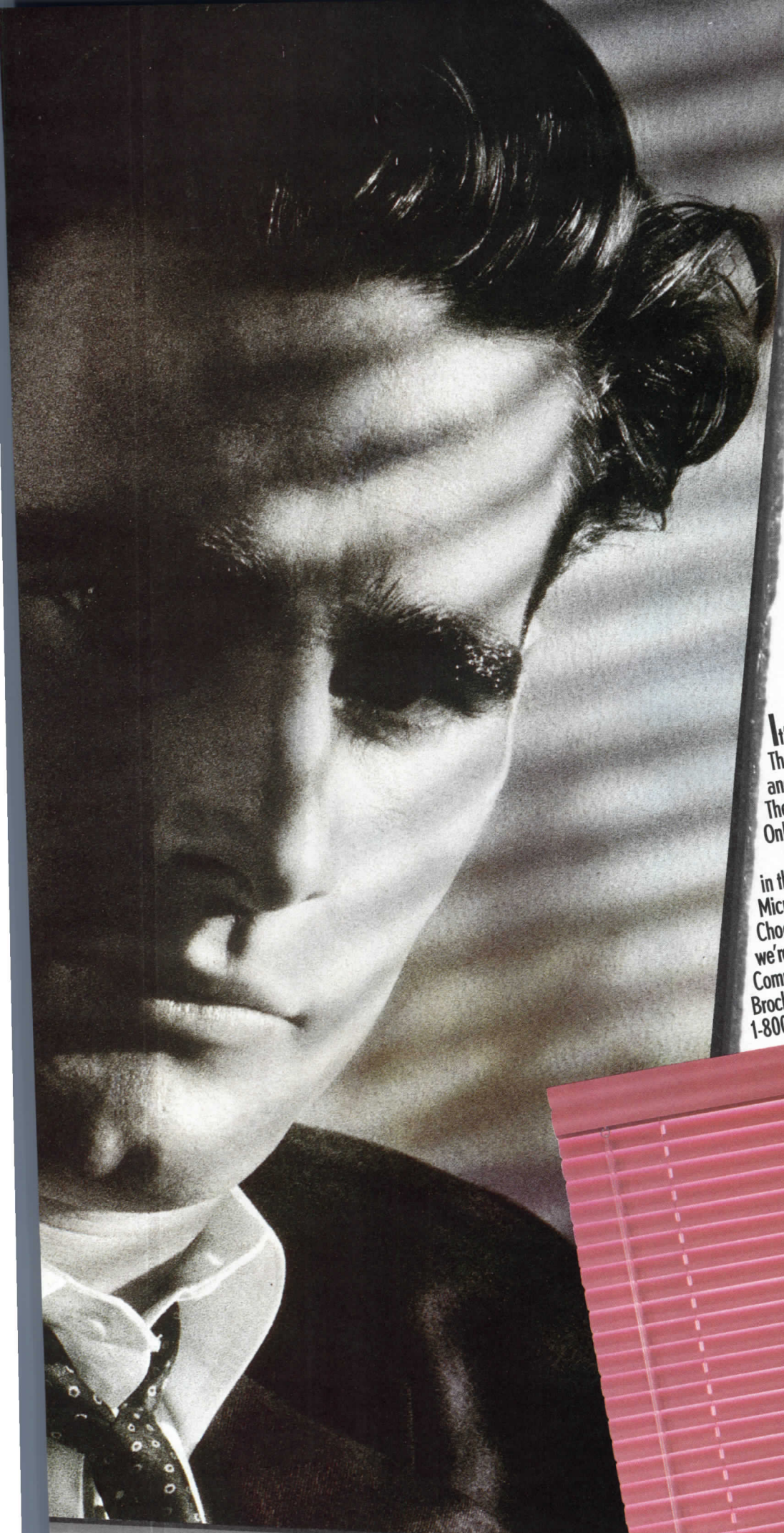

It's exactly right. The look, the color.
The way you feel when you step back,
and you know it's perfect—just perfect.
The lines. The way the light falls.
Only Bali®

Our custom horizontal blinds come
in three sizes: one-inch Mini, half-inch
Micro and the new 3/4-inch MidSize™.
Choose from 140 colors—a palette
we're continually updating. For a Bali
Commercial Window Treatment
Brochure, call 1-800-433-7138.

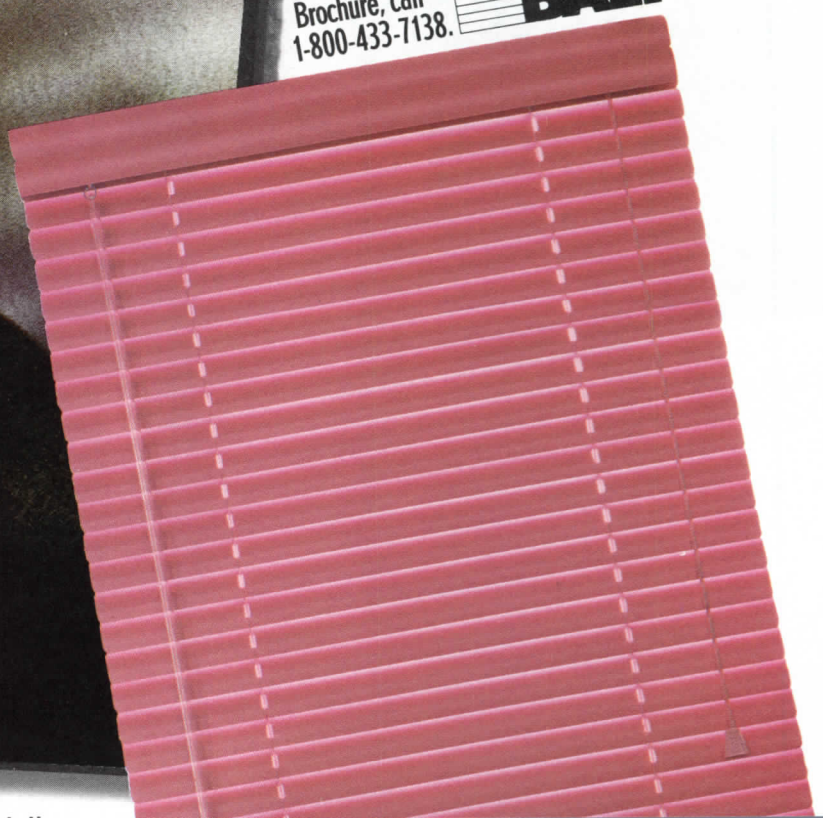

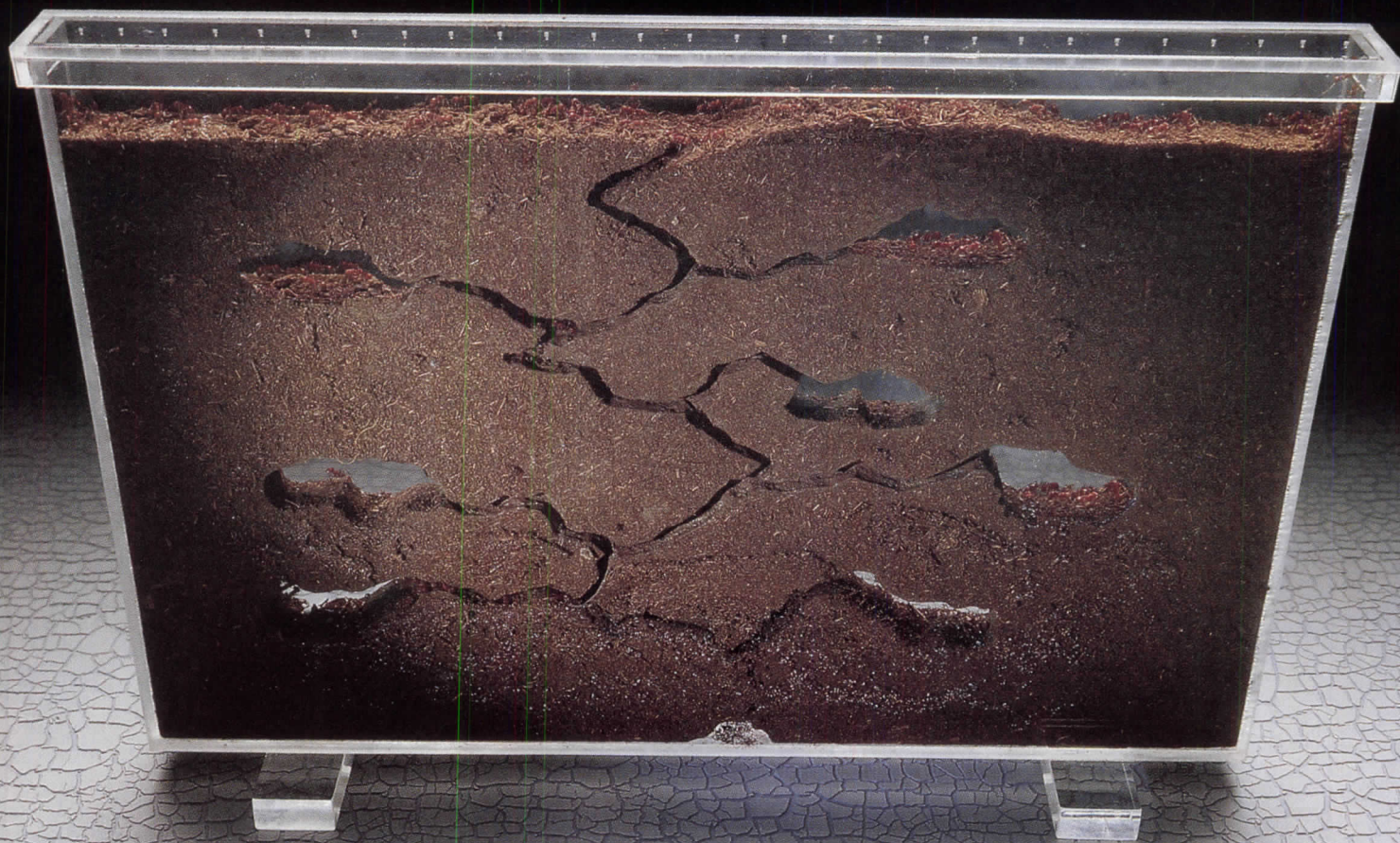

Until now, this \$12.95 ant farm had a better drainage system than any building you ever built.

We could learn a thing or two from ants. And we have. They make it easy for ground water to drain down past their nests. Even the dirt around them stays dry.

And to think there wasn't a single system in the world that would do all this for humans and their nests. Until now.

Now there's a unique below-grade insulating drainage panel from Dow. It takes care of ground water the way ants do, only better. How? *It drains and insulates.*

THERMADRY* brand insulating drainage



panels are fabricated using rigid, water-resistant STYROFOAM* brand insulation. The drainage channels are covered by a geotextile fabric that allows ground water through, but not dirt.

Water drains, "R" remains. So below-grade spaces remain dry and energy-efficient.

Phone 1-800-258-2436, Ext. 25, for our brochure on new STYROFOAM* THERMADRY* brand insulating drainage panels.

Even ants never had it so good.



CAUTION: STYROFOAM brand insulation is combustible and should be handled and installed properly according to Dow literature available from your supplier or Dow.
*Trademark of The Dow Chemical Company

Circle 60 on inquiry card

Books

Gordon Bunshaft of Skidmore, Owings & Merrill, by Carol Herselle Krinsky. Cambridge: The Architectural History Foundation with The MIT Press, 1988, \$50.

Reviewed by Philip Johnson

With the recent florescence of architectural form, young and "with it" historians have not focused their attention on the strict Modernism of Gordon Bunshaft's work, with the result that his reputation has long suffered. Let us consider the period from 1950 to 1980. For an entire generation steeped in the work of Mies and inspired by the example of Le Corbusier, the International Style was the dominant force in the design world. The Seagram Building, of 1957, was the effective end of this era; the epigones have been picking at the bones of Modernism's Heroic Period, as the British call it, ever since. Perhaps it is now time to reconsider the 1950s work in its own context, and without the Monday-morning oversimplification that we pluralists of the late '80s employ in our hourly reports on the latest ism.

For the sake of simplicity, I would like to discuss as typical of the 1950-1980 generation only the primary building type of our American midcentury, the headquarters office building—the highrise version in the city, the low silhouette in the country. In our time, after all, this building type plays the same role as the temple in Greek and Roman times, the church in the Middle Ages, the palace in the Renaissance and Baroque periods, and the house in the Edwardian era. There were, to be sure, many outstanding architects who designed exemplary Modern commercial

Philip Johnson practices architecture in New York City.

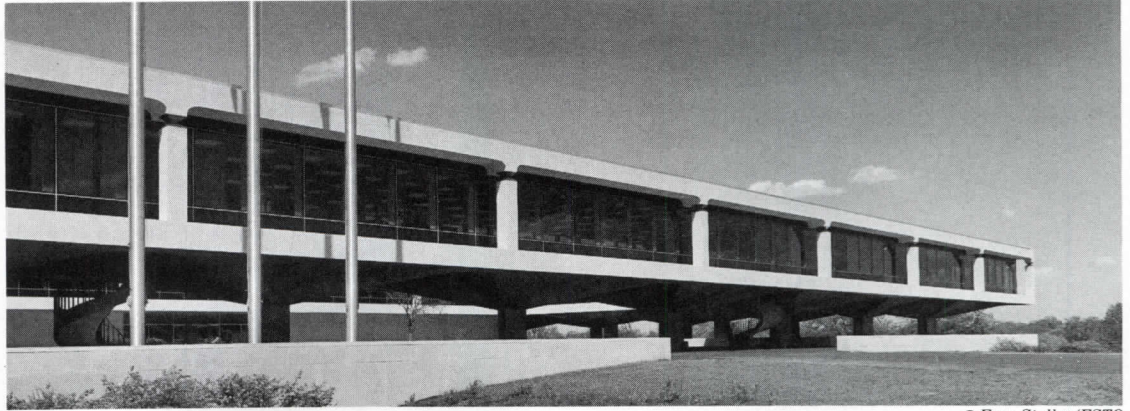

© Ezra Stoller/ESTO

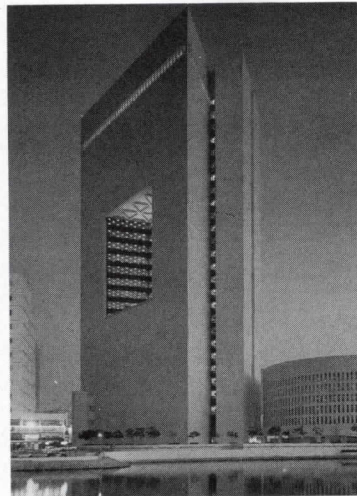

© Wolfgang Hoyt/ESTO

buildings after Bunshaft's Lever House of 1951. Shiny blue-green boxes proliferated, but SOM became by far the largest and busiest team in the country, and Gordon Bunshaft was, in my opinion, their best designer. In looking back, we must not forget that it was a very restrictive palette that the Moderns were working with, somewhat akin to a painter limited to Mondrian's lines and colors. With the elements of International Style Modernism, however, Bunshaft created surfaces that were sheer, unbroken, and undecorated; perfectly proportioned flat tops; and hovering planes that were somehow right.

Two designs seem to me to transcend the rest of Bunshaft's enormous output, indeed to soar: the Emhart headquarters in Bloomfield, Conn., of 1963, a low

Two by Gordon Bunshaft. Top: Emhart Corporation headquarters, Bloomfield, Conn., 1963. Bottom: National Commercial Bank, Jeddah, Saudi Arabia, 1983.

building; and the National Commercial Bank, in Jeddah, Saudi Arabia, of 1983, a tower. (I am sure the architect will be annoyed with me for discussing only two projects, but he is always getting annoyed with me.) While Lever House was certainly Bunshaft's break to the Modern (to which he is, 38 years later, still faithful), it was just the beginning. By 1963 he had hit his stride in the Emhart Building, a masterpiece of the country office genre. First, the treatment of functions in the building is super clear: the entrance is monumental, the offices arranged in a large, flexible space, the automobile banished. But functionality hardly bears mentioning, since these aspects are always well worked out in Bunshaft's buildings. Second, the relationship between Bunshaft and his clients was close, which is hard to overemphasize. Critics and the lay public have no idea how important client-architect give-and-take is to great design. Even the best architects from time to time have unsympathetic clients, but good patrons make good architecture (another example: Mies's Seagram Building).

Third, Bunshaft knew his structural engineering: the cantilevers, the floor and roof slabs, the pin-connectors are rigorously correct. Bunshaft and his team totally comprehended construction methods, and their

practical yet artistic detailing remains evident in the appearance of the finished building. Fourth, Bunshaft knew his history: he understood the pilotis and *prisme pur* of Le Corbusier, the spread-fingered columns of Nervi, the implacable module of Mies.

All of these ingredients, however, do not fully encompass the artistic value of the finished object. This thin plane of a building soars horizontally from the brow of its ridge-top site. It hovers like a dancing space ship. The inexorable, endlessly repetitive march of the identically spaced columns could have been boring, but the proportions of pier to floor slab, and of column to roof slab, although complex, are completely satisfying. The glass walls are set far back from the precast skeleton so that it can be read as a separate system, not as a box. In one brilliant detail, Bunshaft breaks this system by strategically placing a pin connection just below where the column meets the roof plane, the point at which a capital would occur in Classical architecture. Bunshaft's "capital" is expressed, not by an echinus, but by a quarter-circle swelling of the precast entablature above the revealed pin connector, enormously accentuating it and adding a subtle "embrace" to what is otherwise a simple trabeated-bay system. It is understated, yet more successful

KICK ME!

THEN USE ME AS YOU LIKE

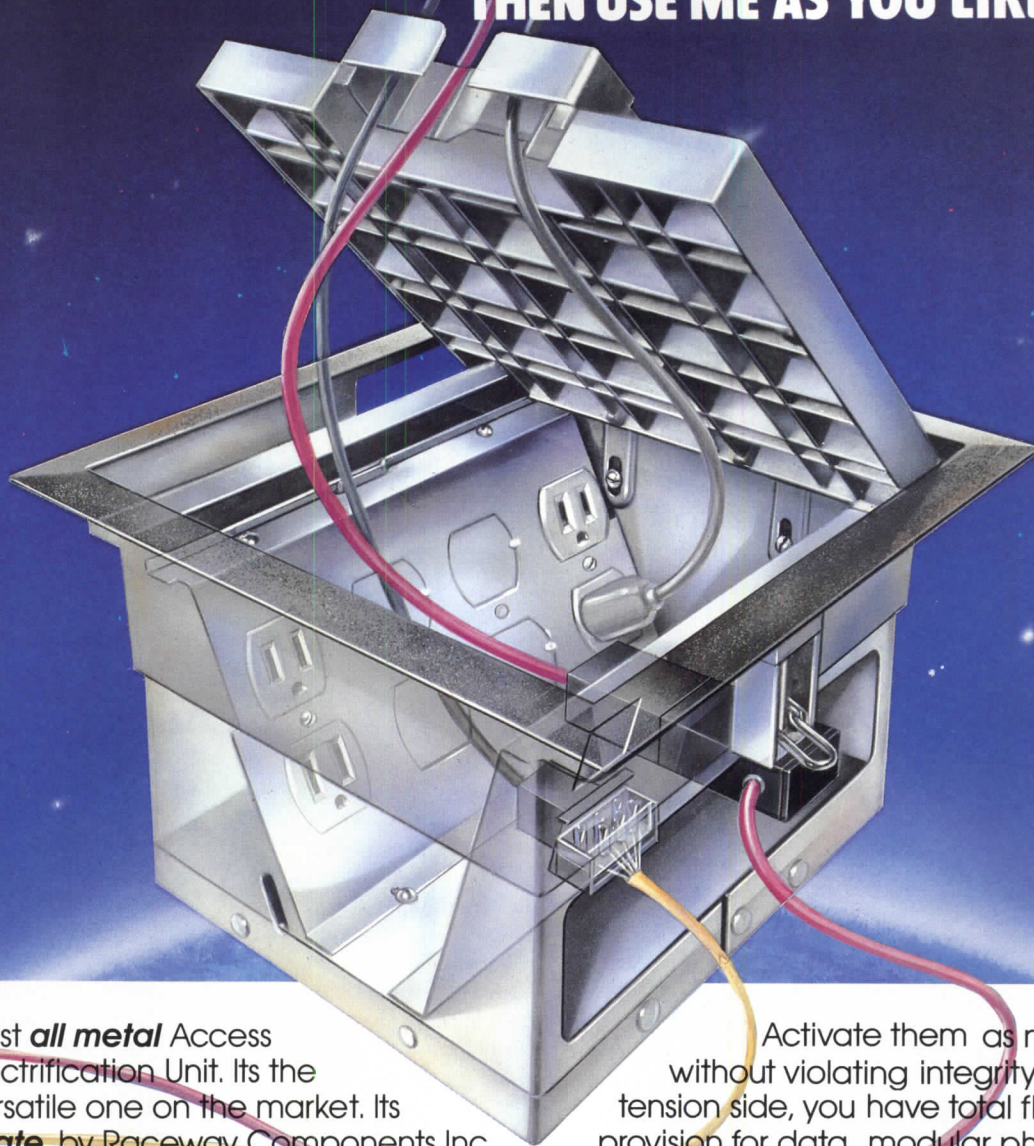

Its the first **all metal** Access Floor Electrification Unit. Its the most versatile one on the market. Its **Floor-Mate**, by Raceway Components Inc., the innovative leader in thru-floor electrification technology.

This Zamak III die-cast/steel unit offers unequaled protection from pounding, piercing and pouring. The patented cable exit or "Cable Guard" rises to a vertical position, encasing wires in a protective well...so kicks and knocks won't shear the cable.

We said "most versatile" too. There are four duplex knockouts on the power side (standard duplex, isolated ground, surge suppressor plus one optional).

Activate them as needed, without violating integrity. On the low tension side, you have total flexibility with provision for data, modular phone, communications, twin axial and coaxial connections.

If you're interested in a "Floor-Mate" that doesn't mind a little punishment...and is very accommodating, write or call us: Raceway Components, Inc., 208 19th Avenue, Paterson, NJ 07524, (201) 661-1116.

 **RACEWAY
COMPONENTS, INC.**

Books

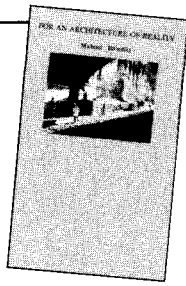

than later mid-column "jointed" facades, such as his IBM headquarters, in Armonk, N. Y.

Bunshaft's strongest tall building is his latest, Jeddah. Here he has taken advantage of everything he has learned in his 40 years of office-building experience. He has made the National Commercial Bank a work of art so persuasive that it transcends its type. He has done this by turning the functions inward and creating a solid skin. He has freed himself, and designed a building that suits the client and its program in a totally new way. But in so doing, he does not lose sight of artistic attitudes he has long held: the cylindrical parking garage, the triangular office block, and its ancillary rectangular elevator-lobby shaft are proper Modern. The great voids in the facades, the frieze of tiny windows decorating the top, and the all-important, but much tinier still, rhythm of balustrades are the result of an architect's *will*—very rare in the '70s. The design is an enrichment of Modernism's spirit rather than a departure from it, and it is a stirring conclusion to Bunshaft's entire oeuvre.

Bunshaft's career succinctly brackets the late-Modern International Style of architecture. Before him were the giants of the Heroic Period. After him, and inching into the time of his late work, pluralism took over. He would surely call what is happening now decadent, but, whatever comes next, nothing can detract from his stellar accomplishments.

The book by Carol Krinsky fits the subject. It is late, but who is to say it is too late? Bunshaft has been badly underappreciated, and it is good to have his work properly recorded here by the architect himself working with an accomplished and deservedly renowned chronicler of contemporary architecture.

For an Architecture of Reality, by Michael Benedikt. New York: Lumen Books, 1988, \$9.95.

Reviewed by Roger Kimball

Every literate architect should take an afternoon off to read and ponder this brief, thoughtful, and thoroughly engaging book by the Texas architect and university professor Michael Benedikt. Fewer than half of its 74 pages are filled with text (the rest sport illustrative photographs or are provocatively blank). Yet in this short compass Benedikt says more about some central esthetic and philosophical issues confronting contemporary architecture than many celebrated pundits manage to squeeze into a shelfful of books.

Benedikt's theme is what he calls "direct esthetic experiences of the real." We should not be misled by the somewhat elusive nature of this phrase into thinking that he is championing some new species of esthetic mystification. Language regularly falters before our most powerful experiences of reality, be they occasioned by love, art, or nature. The notion of a "direct esthetic experience of the real" is no more mystifying than any of a dozen other phrases we might propose to describe that sense of revelation, tinged with mystery, with which we are all familiar but find difficult to put into words.

Benedikt suggests that architecture as traditionally understood helped to preserve this dimension of experience. Both in its esthetic form and its persistence through generations, architecture did much to articulate a culture's identity and

Roger Kimball, a frequent contributor to RECORD, also writes for The New Criterion, The London Times Literary Supplement, Commentary, and other publications.

ethos, helping to orient and nourish the spirit as well as shelter the body. But under the pressures of modern life, architecture too threatens to become anonymous, ersatz, less the guardian of cultural stability than a barometer of its hollowness and superficiality.

Of course, this is not to say that simply intoning the words "an architecture of reality" changes anything. As Benedikt acknowledges, our very modernity makes it difficult for us to use words like "reality" *straight*, without quotation marks. Honesty compels skepticism about such lofty abstractions, while the "postmodern" self-consciousness that is our lot tends to inspire irony about any ideal beyond self-interest. In this relativistic age, the term "real" often appears to be an arbitrary term of commendation, not a description of what is most meaningful and ineluctable in our experience; in this sense, "reality" is only one more word interposing itself between us and that "direct" experience that Benedikt hankers after.

But it is one of the strengths of this brief essay that Benedikt is able to give his readers a vivid sense of architecture "in which the quality of *realness* is paramount." Drawing on a wide range of architectural models—from Louis Kahn's great Kimball Art Museum, in Fort Worth, to humble vernacular building in the American Southwest and Mexico—he elaborates a four-part scheme to explain why some buildings achieve the authenticity and esthetic immediacy he seeks while others fail. I suspect that many readers will find the terms in which he analyzes the experience of "realness" somewhat idiosyncratic, even dispensable. "Presence," "materiality," "significance," two kinds of "emptiness": in the context of such a brief,

unsystematic essay, these abstract terms emerge as little more than talismans, pregnantly elusive fragments from a personal vocabulary; yet what counts is not Benedikt's semantic precision but the acuity and occasionally almost poetic evocativeness of his discussion.

Benedikt devotes a good deal of critical attention to recent attempts to recoup the architectural past by plundering the *look* of traditional ornamentation. "The rise of Postmodernism," he notes, "had little to do with its proclaimed ideals, namely, the creation of a richer, more complex, more symbolic and, therefore, more humane architecture than was possible on the canons of the Modern Movement. When architects create plywood arches, chromed Ionic columns, or concrete garlands, the arch is not a real arch to anyone, nor the column a real column, the garland a garland." Ultimately this orgy of phoniness undermines its own proclaimed end, and "one is left with ribbons." Indeed Benedikt is at his best in exposing the folly of Postmodern pomposity. "For example, while no one would contest that a medieval bell tower was a fine and meaningful architectural element, 'putting one in,' say, a shopping center inevitably subverts its symbolic power. If the bell tower arrived by flatbed and crane, then . . . its significance will always include the lack of correspondence between its true history and its 'historicity,' a lack that nags at and hollows the swell of nostalgia it begins." What it betokens, he observes later, is a "cynicism about the very possibility of authenticity."

In the course of his meditation, Benedikt also offers some astute observations on several "extra-architectural" matters. "We depend," he writes, "upon the world's broad indifference to our designs, its

DESIGN YOUR FLOOR WITH FLEXCO'S SPEC 1™ SYSTEM AND ALL THE PIECES FALL INTO PLACE.

Flexco just made your job easier. Because now, with the Spec 1 system, you can actually see the floor you're designing before you install it. In fact, you can see several flooring variations—all in a matter of minutes.

The Spec 1 flooring system from Flexco contains a supply of one-inch tiles in more than 25 exciting colors, and several styles and textures, plus a large grid on which to build your floors. You choose the colors you want—in the styles you want—to create endless floor design possibilities. As a result, Spec 1 system not only helps you design better, more applicable flooring solutions but it makes it a lot easier to sell those designs to your clients.

Order Spec 1 through your participating Flexco distributor. Or, for more information, call 1-800-633-3151 or write Flexco, P.O. Box 81368, Atlanta, GA 30366.



FLEXCO

WORKING FLOORS FOR THE WORKING ENVIRONMENT.

Circle 62 on inquiry card

Books

capacity for surprise, and its resistance to our touch for our very sanity. We can find the world inescapably meaningful and real precisely *because of*, and not in spite of, its 'obstinacy.' His point—and it is a point well worth making—is that in this age of high technology and engineering prowess, an age in which we are sometimes tempted to believe that every problem we confront is susceptible to technological intervention and management, we need to remind ourselves that much of what matters most deeply to us eludes our rational control and analysis.

While it is clear that Benedikt has read widely in the philosophy of art—there is an abundance of references to philosophical and literary sources—what strikes the reader is not his erudition but the *intimacy* with which he has pondered his subject. Whatever he has read he has made his own. And one senses that he has bothered to read so much in the first place not to provide himself with a substitute or alibi for experience, but to illuminate and explain a number of things that he has experienced so deeply that they resist easy explanation. Thus, unlike so many of our contemporary academic "theorists," Benedikt does not serve up yet another second- or third-hand rendition of Nietzsche or Heidegger or Derrida, yet another confection of half-understood philosophical and literary terms ripped out of context and jumbled together. Instead, he offers a straightforward account of his own struggle to understand the pleasures and responsibilities of architecture in an age when esthetic pleasure is all but indiscernible from entertainment and responsibility is often a cover for thoughtless conformity.

High Tech Architecture, by Colin Davies. New York: Rizzoli, 1988, \$45.

*Reviewed by
Hugh Aldersey-Williams*

Contrary to the view of Colin Davies, High Tech architecture continues to hit new heights. Hardly had we got used to Richard Rogers's Lloyd's of London building, of 1986, as an apotheosis of the style when Norman Foster's HongkongBank came along, hard on its heels. Today a cluster of buildings and projects have broken new ground in London, Paris, Hong Kong, Tokyo, and Houston. It is foolhardy, then, for Colin Davies to date the death of High Tech to the day a failed neoprene gasket caused the Challenger space shuttle to blow up. True, it's cute to ape Charles Jencks's proclaiming the death of Modernism as the 1972 demolition of Minoru Yamasaki's Pruitt-Igoe housing project in St. Louis. But Jencks's mischievous obituary in *The Language of Post-Modern Architecture* at least proposed an alternative.

Davies's problem is that he loves the work of the British High Tech architects. He does not want to reject it, but he cannot quite turn a blind eye to its obvious faults. The result is a book that is part paean and part exposé. He is at pains to separate today's style of architecture from the American High Tech interior-decorating esthetic, the subject of a well-known earlier book. This done, he gives a definition of his High Tech that is no less a *style*, since he makes no case for its being an ideology or science. He claims that High Tech architects wish their buildings to be judged

Hugh Aldersey-Williams, based in London, writes on architecture and design. His New American Design was recently published by Rizzoli.

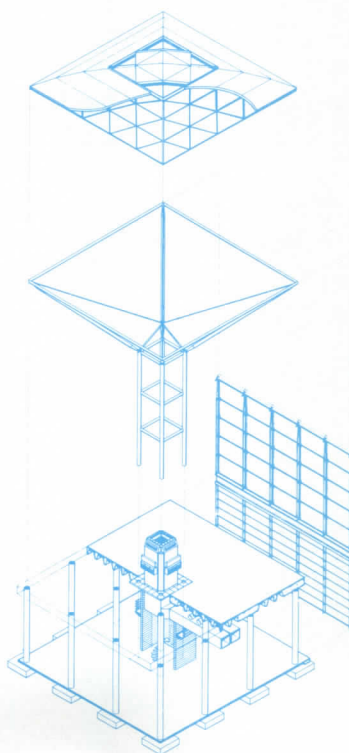

Isometric of a typical bay, Airport Terminal at Stansted, England. Foster Associates, Architects, 1986.

on performance criteria rather than appearance (a decidedly unfashionable basis for criticism these days and one that many High Tech buildings would not bear particularly well).

Norman Foster and Richard Rogers are the predictable priests, Michael Hopkins and Nicholas Grimshaw their curates. All of this group's buildings (with a few judicious exceptions) are High Tech; everything by everybody else, by implication, is not. De facto, High Tech is a British style. Whether it really is—and if so, why it is—is not explored. The condemnatory introduction, which is the best part of the book, catalogs some of the endearing deceits of the "honest" High Tech style, from the impracticality of exposed tension-steel components to the amazing assertion that none of

the supposedly identical mass-produced pods on the HongkongBank is actually the same as any other.

This critique jars with the color portfolios celebrating 40-odd projects, accompanied by what appears to be the architects' own dully written descriptions and by plans and sections that do little to enlighten. Davies's choice of architects and buildings is expedient and jingoistic. In a misguided attempt to make out that High Tech is somehow peculiarly British, he omits any work by, for example, I. M. Pei, Hugh Stubbins, Emilio Ambasz, Frei Otto, Fumihiko Maki, and Jean Nouvel. His selection thus biased, no rational case is then put forward for this alleged Britishness. High Tech, says Davies, does not offer political criticism. But he can only claim this by refusing to consider Foster's Willis Faber building, HongkongBank, and BBC headquarters project, all of which in their plans, lighting, and finishes attempt to break down the barrier between boss and worker, and between resident and passer-by. He argues that High Tech architects are no urbanists, and bolsters this point of view by leaving out Grimshaw's Sainsbury Superstore, Foster's urban plans for King's Cross, in London, and Nancy, in France, and Rogers's visionary scheme for the riverside areas of London. He captions Foster's BBC project a "curiously subdued building, hypersensitive to its urban context." What he means is that it doesn't meet *his* definition of High Tech. The architects Davies admires are now finding that a genuine technological *interest* does not demand a High Tech *look*. His book has missed a *valuable opportunity* to help the rest of us realize this too.

Do height limits, setbacks, proffers, land cost and FAR make designing in enough floor area a little tough?...

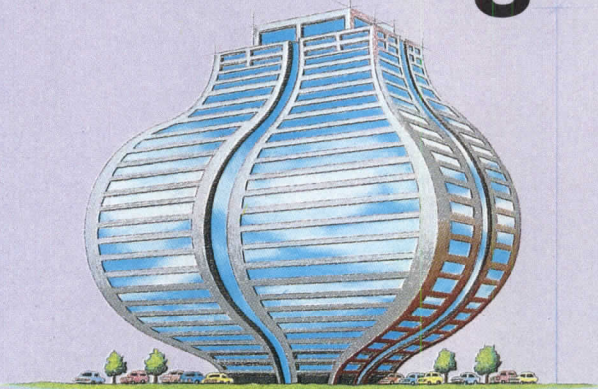

...just dig a little deeper.

The most cost-effective opportunity to add valuable floor space to your next commercial development lies just below grade. Development below grade is essentially unaffected by FAR limitations, and is ideal for many commercial uses, such as parking, utilities, movie theaters, retail and much more. Increasing the amount of the structure that is constructed below grade enables FAR space to generate the maximum possible revenue for the owner.

Tiedback excavations are cost-effective.

Schnabel Foundation Company, founded in 1959, is a nationwide design/build contractor that specializes

in the construction of tiedback retaining structures that make extensive underground development a rapid and routine construction procedure. With professional engineers registered in 43 states, Schnabel Foundation Company



Two Renaissance Square, Phoenix, AZ — 483,000 Square Feet Above Grade—453,000 Square Feet Below; including a portion of the structure constructed under an existing street.
Owner: Trammel Crow Company Architect: Pierce Goodwin & Alexander
General Contractor: McCarthy Western

works closely with architects, structural engineers, construction managers, developers and contractors during the early stages of project development to determine the feasibility, scope, and cost of increasing the density of below-grade development.

For more information on a cost-effective method for adding floor space to your building, please contact a Schnabel Foundation Company office.

Schnabel FOUNDATION COMPANY

A nationwide design/build contractor specializing in earth retaining structures since 1959.

4720 Montgomery Lane, Suite 300
Bethesda, MD 20814

Circle 63 on inquiry card

Atlanta
(404) 971-6455

Boston
(603) 622-8427

Chicago
(312) 639-8900

Dallas
(214) 699-7854

Denver
(303) 696-7268

Houston
(713) 531-1103

Philadelphia
(215) 277-2950

San Francisco
(415) 947-1881

Washington, D.C.
(301) 657-3060

MATICO

Luxury Vinyl Floorings for Commercial and Residential Use

The Look . . .

The Feel . . .

The Touch . . .

. Beyond the Innovative!



Experience the Matico look and touch now; call or write:



MATICO, Div. of CBA
55 Mall Drive, Commack, N.Y. 11725
Tel: 516/864-4343 Fax: 516/864-9710
516/864-9700

Circle 64 on inquiry card



Now, Pella doubles your choice of window colors.

Pella® introduces Tan and Gray colors to their standard brown and white offerings to meet your need for greater design flexibility.

We've always listened to what features architects and owners want in windows and doors. Today, owners are demanding a greater color selection. That's why we're offering new tan and gray clad finishes in an accelerated availability—to complement our already popular standard white and brown clad colors.

Just color your thinking.

These are the same high quality architectural finishes for which Pella Clad Colors are famous. They're baked-on, electrostatically applied finishes that stand up to the many ills that windows are heir to: staining, chipping, cracking, peeling, blistering, chalking. Not to mention their resistance to the corrosive action of rain, salt spray, airborne pollutants and corrosive chemicals. All conform to AAMA spec 603.8—assurances that these windows endure and endure.

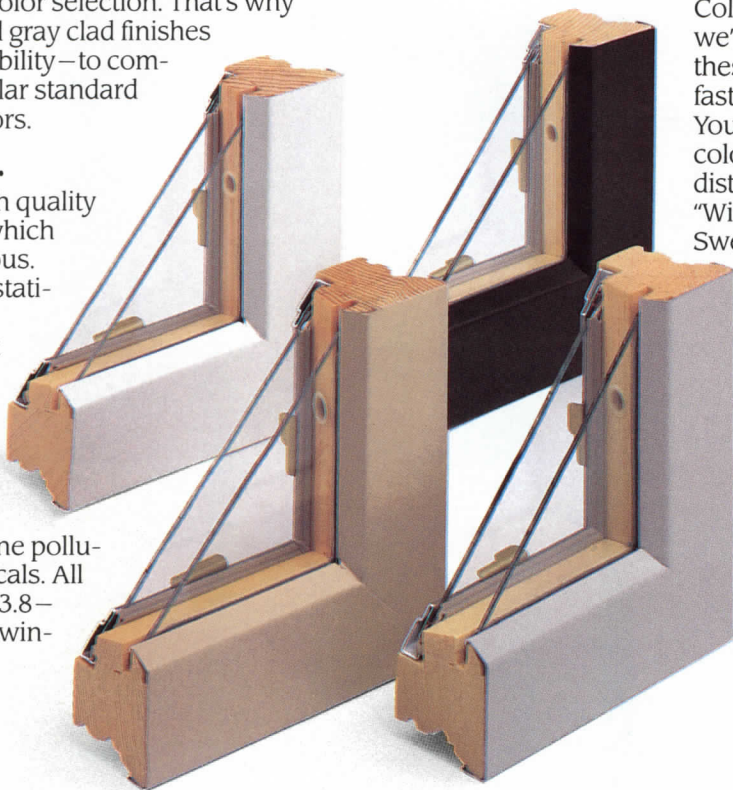

Accept no limitations.

Of course, we still offer dozens of Pella Custom Clad Colors. If you have a specific color in mind, we'll match most any sample. But even on these custom orders you'll marvel at our fast turnaround time.

You can obtain information on these new colors and free samples from your Pella distributor. Look in your Yellow Pages under "Windows", call Sweet's BUYLINE or consult Sweet's General Building File. Or send us the coupon below.

Bring your designs to Pella.

Please send me the current literature on new Pella Clad Colors.

Name _____
Firm _____
Address _____
City _____
State _____ Zip _____
Telephone _____

Pella Windows and Doors, Commercial Division
Dept. T31E9, 100 Main Street, Pella, Iowa 50219
Also available throughout Canada.
© 1988 Rolscreen Company



Photography: Tom Crane

*La Seine a Suresnes, Alfred Sisley;
Giraudon. Nascita di Venere, Botticelli;
Scala. Art Resource.*

Modular carpet systems in Antron® nylon by
DuPont have soil-resistance and static
protection built-in.



Getting Square

When the project calls for innovative applications of color and design plus trouble-free mechanical function plus quick delivery, get squares. Carpet squares from Lees.

You get more options—including broadloom coordinates—with Lees modular carpet systems. Choose from four different textures, including loop-pile; three backing systems; either 18" or 24" squares; and custom pattern capability from the SurTex program that is virtually without limit.

This system doesn't box you in.

Filing systems. For detailed construction and performance specifications, see Sweet's General Building & Renovation and Contract Interiors files 09685.

Call toll-free. For literature, warranties, installation and maintenance guides, call 800/523-7888. FAX 215/666-1094.

There's no 'or equal' for performance.

**Lees
Commercial
Carpet
Company**



A Division of Burlington Industries, Inc.
King of Prussia, PA 19406

Circle 66 on inquiry card



A BAD ROOF CAN BE THE RUIN OF A GREAT IDEA



Consider the Parthenon. Then
imagine its beauty today if the roof
had stood the test of time.

HOW HYPALON* HELPS PUT YOUR BRIGHT IDEAS ON TOP.

With roofing systems based on
HYPALON® synthetic rubber, im-
itative colors and inventive design
make the roof an integral part
of your architectural statement. Roof-
ing systems based on HYPALON are
easy to install, even over complex
structures. They're simply unrolled,
cut in place, and heat or
cold-welded—all at competitive in-
stallation costs. And even when
the membranes are fully cured, additions
and repairs are easy to do.

WHY NOTHING UNDER THE SUN—OR RAIN— IS BETTER THAN HYPALON.

With HYPALON, design versatili-
ty does not diminish roofing inte-
grity. The sunlight that can weaken
other roofs actually strengthens roof-
ing systems based on HYPALON.
When installed, these roofing sys-
tems exhibit high strength and flexi-
bility—and resist attack from snow,
ozone, acid rain, corrosive chemicals
and temperature extremes.

Also, the chlorine in the molecu-
lar makeup of HYPALON gives
these roofing systems a flame propa-
gation resistance that can qualify
them for UL Class A and FM Class
1 fire ratings.

SPECIFY HYPALON AND PROTECT YOUR CLIENTS' MONUMENTAL INVESTMENTS.

For over 20 years, HYPALON
synthetic rubber for single-ply
roofing systems has been proving
itself in hundreds of installations
throughout the world. To give your-
self and your clients the security
and value of a long-lasting roof,
specify roofing systems based on
HYPALON. To learn more just call
1-800-441-7111.

*Du Pont's registered trademark for its synthetic rubber.
Du Pont manufactures HYPALON, not single-ply roofing membranes
or systems.

**DU PONT HYPALON®
A MATTER OF TOP SECURITY.**





**KEEPING THE LEAD
TAKES MORE THAN SIMPLY**



N WOOD FURNITURE TICKING TO TRADITION

TRADITIONAL, TRANSITIONAL, CONTEMPORARY. NO ONE MAKES MORE OUT OF WOOD THAN KIMBALL. AND NO ONE CONTROLS MORE OF THE FURNITURE MAKING PROCESS, FROM GROWING TREES TO DELIVERING ON TIME. KIMBALL. THE CHOICE THAT WORKS. FOR WOOD. 1-800-482-1616.

KIMBALL  **ARTEC**

Circle 68 on inquiry card

As You Can See, We
Just As Easily As We

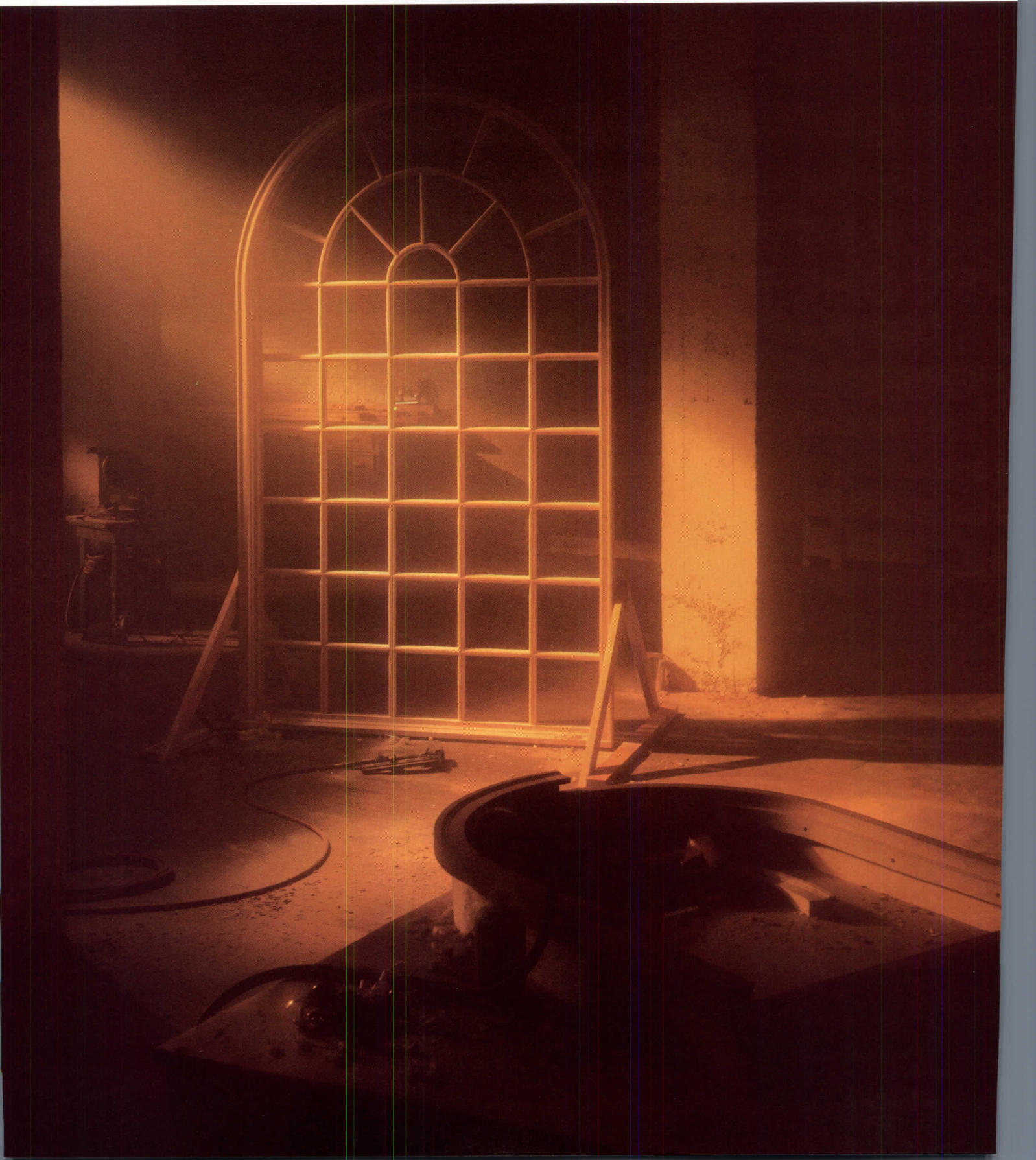

Handle Brainstorms Do Thunderstorms.

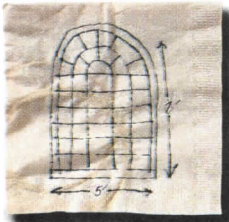

We're always anxious to work with architects. Or talented designers like this.

At Norco, our most innovative designs don't always come from a catalog. They come from cocktail napkins. Matchbook covers. Any place our customers capture their ideas. (Blueprints, of course, also do quite nicely.)

You see, as proud as we are of our standard windows, we know that architects want more. A window that not only fits your design, but enhances it as well.

That's why we build custom windows. In any shape. Any style. Virtually any form your mind can conjure up. To be the focal point for a single room. An entire home. Or any other structure.

And we're not merely order takers. We'll work with you. And see to it that absolutely nothing gets lost in the translation.



Norco won't settle for anything less than premium-grade Ponderosa pine. Neither should you.

Triumphs Of Art Or Marvels Or Science? Or Both?



With apologies to high technology, we think building windows is still a job for human hands.

Naturally, our customs look great from a distance. They're designed to match our standard windows in both profile and design detail. And for renovation projects, we can duplicate even the most unusual sizes. But what sets our windows apart is how they fare under closer scrutiny.

We settle for nothing but premium-grade, clear Ponderosa pine. Superior for its ability to insulate and accept a finish. For still more energy efficiency, we offer Argon-filled, Low-E insulating glass. Covered by Norco's 10-year warranty. One of the best in the business.

We even take the time to build our custom windows one at a time. With a single craftsman responsible for each window from the start to the very finish. No assembly lines here.

The bottom line? You get a window that starts beautiful, and stays beautiful for years.

Round Tops And Other Strong Points.

Not every window company goes to the trouble to build Round Top windows. And among those who do, few do it like us: By hand. From layer upon layer of long, one-piece veneers. So they're uniform in strength around the window's entire radius.



Even our standard windows are far from standard. Shown here, the American Renaissance.

No seams that can cause warpage or bowing.

You want a true divided lite window? Exterior cladding in a choice of three different colors? Norco can say yes to both. In either standard or custom designs.

And we put as much effort into supporting Norco products as we do building them. Our field service representatives will work with the contractor. Make certain the order arrives as scheduled. Visit the job site to check installation. Then follow up after the job is completed.

Delivery? Norco has no fewer than four manufacturing facilities, nine distribution centers and 1700 independent dealers across the country. So you can get the right window for any climate. Fast.

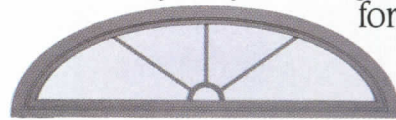

We really handle the curves. With one-piece veneers to eliminate weak spots.

The fact is, no matter what type of window you need, you need

only one window company. Norco.

We'll Go To Extremes For You.

You get the idea by now: Norco is not your run-of-the-mill window company.

Our people believe that building windows is as much a matter of pride and commitment as it is wood, glass and weatherstripping.

So call Norco today for more information. No other company handles customs the way we do. Not to mention rain, sleet, snow, heat and cold. **NORCO** Working To Build You A Better Window.

Norco Windows, Inc., P.O. Box 140, Dept. 1007, Hawkins, WI 54530-0140. (715) 585-6311.

**We borrowed one of
from some very**

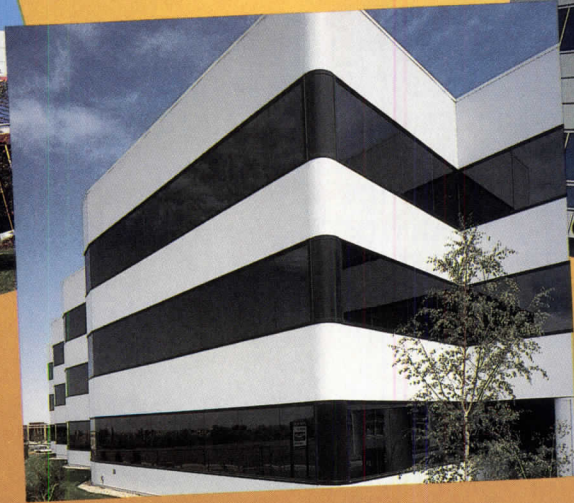
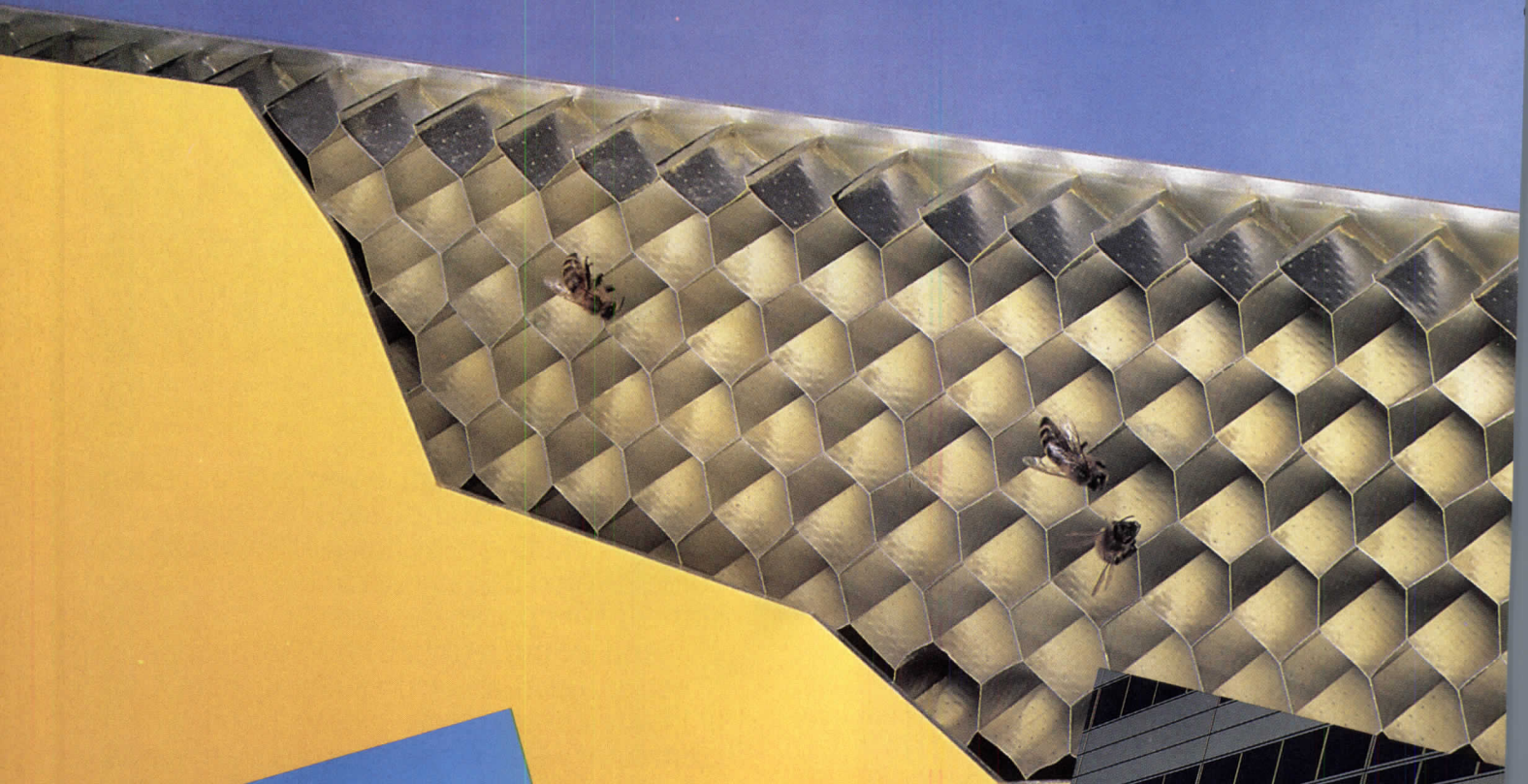

Our best panel ideas good designers.

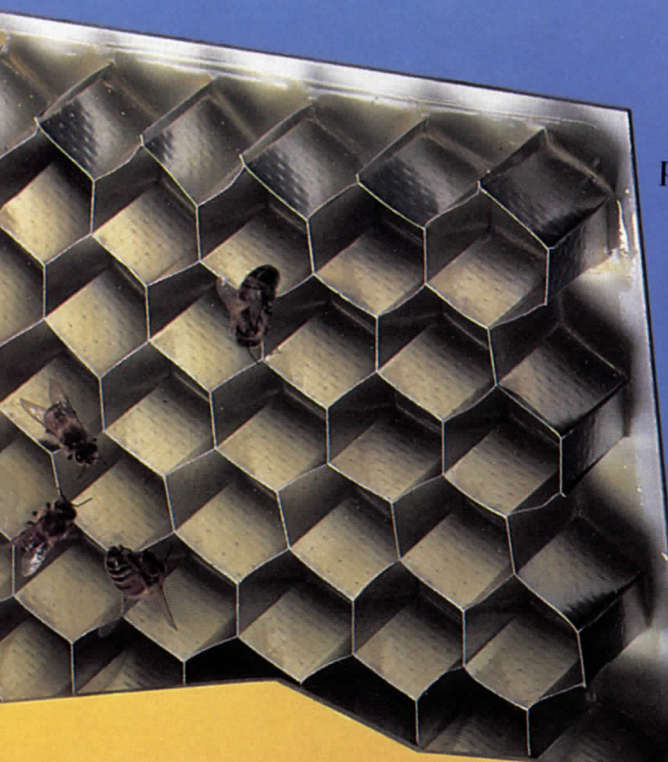

We're not ashamed to admit it.

Our engineers got the idea for our Alveus panels and curtain walls from somewhere else.

They took it from nature.

The honeycomb core in a beehive is a masterpiece of engineering and art. It can support 25 times its weight in spite of its ultra thin shell.

Which is just what we were looking for.

So inside Alveus panel products you'll find a rigid aluminum honeycomb core. Making them lightweight, yet still able to maintain exceptionally high strength-to-weight ratios.

It also gives you surfaces with absolute flatness.

And lets you curve them into almost any configuration you want. From rounded corners to column covers.

So when you need a smooth surface design that blends with glass to create an uninterrupted flush, monolithic surface, look for Alveus panel and curtain wall.

The ones with the honeycomb core. After all, four-hundred million bees can't be wrong.

For complete architectural design specifications, contact Kawneer Company, Inc., Department C, Technology Park-Atlanta, 555 Guthridge Court, Norcross, GA 30092.

Kawneer
Panel Products

Circle 70 on inquiry card

Every time
you buy
a carpet,
you're
putting
your
reputation
on the floor.

Carpet performance is a reflection of your performance. Which is precisely why you should know about BASF Fibers' extensive Performance Certification program. For the last 20 years, BASF has led the industry in testing carpet performance. Subjecting every carpet made from Zeftron fibers to more than 21 rigorous tests. Ensuring that when you specify BASF Fibers, you can be sure you're going to enhance your reputation. That's something you should keep in mind. Call 1-800-446-8953 for a free brochure that tells you more about the company driven by the spirit of innovation.

BASF Corporation
Fibers Division

Zeftron[®] nylon

BASF

Circle 71 on inquiry card

RAPIDOMATIC® FINE LINE PENCILS

*Look-alikes don't
offer the same
high performance!*

**...best for the money,
designed beyond
its price.**

RAPIDOMATIC® is the professional's ultimate choice in drafting, drawing or lettering. Now available in 4 precision line widths: 0.3mm, 0.5mm, 0.7mm, 0.9mm. The RAPIDOMATIC® Pencil is designed beyond its price, providing features usually found only in more expensive pencils.

- Pushbutton continuous feed for as many as 12 leads.
- Non-tapered bushing for positive control with a variety of straight edges.
- Finely balanced weight distribution.
- Non-slip machined-metal finger grip.
- Sure-grip degree indicator.

For more information see your Koh-I-Noor dealer, or send coupon to Koh-I-Noor Rapidograph, Inc., 100 North St., Bloomsbury, NJ 08804 (201) 479-4124. In Canada: 1815 Meyerside Dr., Mississauga, Ont. L5T 1G3 (416) 670-0300.

0.3mm — No. 5633 (red barrel)



0.5mm — No. 5635 (white barrel)

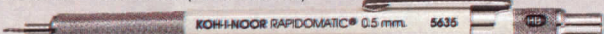

0.7mm — No. 5637 (grey barrel)



0.9mm — No. 5639 (blue barrel)

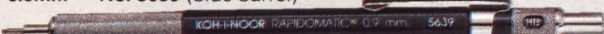

POLY-MAX® leads for Rapidomatic® pencils are the strongest, blackest of any fine-line polymer leads available anywhere. Tubes contain 12 leads of one degree. Tube caps are color coded to simplify correct diameter selection.

KOH-I-NOOR
RAPIDOGRAPH®
a **rotring** company



YES, Koh-I-Noor! Please send your catalog to show me more about Rapidomatic pencils, Poly-Max leads and your other drawing materials.

Name _____
Title _____
Firm _____
Address _____

City _____ State _____ Zip _____
KOH-I-NOOR RAPIDOGRAPH, INC. 100 North St., Bloomsbury, NJ 08804

In Canada: 1815 Meyerside Dr., Mississauga, Ont., L5T 1G3
*RAPIDOMATIC and POLY-MAX are Registered trademarks of Koh-I-Noor Rapidograph, Inc., ©1988

AR-5/89

S E L E Z I O N E
A R C H I T E T T V R A



Mario Lenzi & Ass. Prog. grafico M. Pavani

Carlo Zauli: terza dimensione Selezione Architettura 1988

Art and Industry
Proposals of art
in industrial production

Selezione Architettura is a programme of products and services developed by LaFaenza architects for the designers and architects of the whole world.



LAFENZAAMERICA INC.
1900 Powell Street, Suite 520
Emeryville, California 94608
Phone (415) 655-1395 (800) 223-4982
Fax (415) 655-2193

From concept

to beautiful finish.

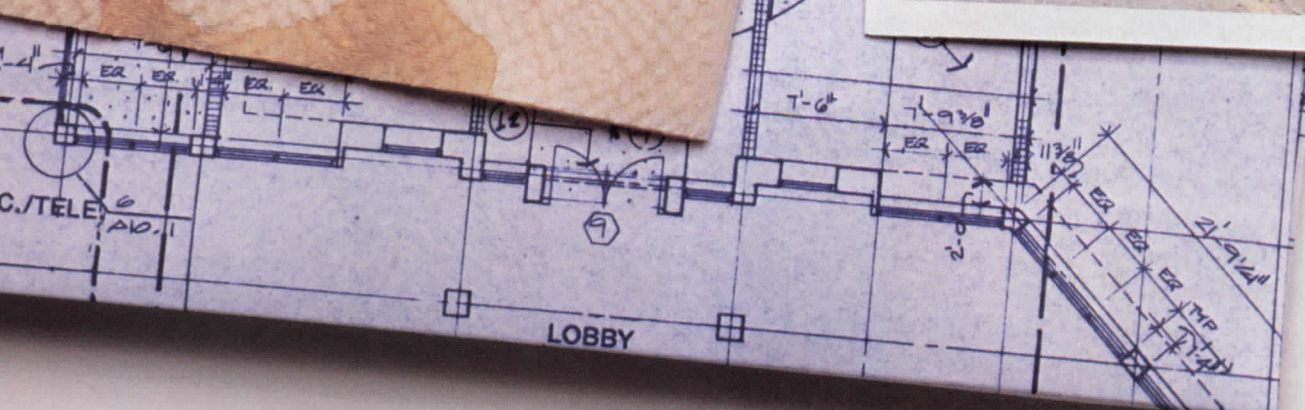
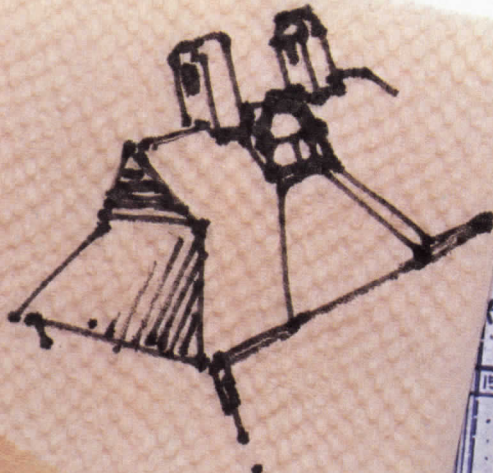

ECI Metal Roofing Systems bring your ideas to life.

When crisp, clean lines are needed to show your roof design at its best, only ECI's broad line of metal panels can give you the choice you want. When your plan calls for just the right color to highlight a contour, ECI long-lasting metal finishes can stand up to the job. When you ask texture, style and shapes to blend into a new form, ECI architectural panels have the answers.

ECI metal roofing systems are a beautiful way to show your

designs at their best. And ECI is ready to help you break new ground in design—from planning to engineering to a network of builders that will make the installation go smoothly.

If you're ready to reach new heights in roof design, write for our free design manual for metal roofing systems. It's all you need to know to get started and all you need to know for your designs to stand the test of time.



BUILDING COMPONENTS, INC.

Quality, American Style.

Offices and plants: Houston, TX/Amarillo, TX/Jemison, AL/Lodi, CA/Tualatin, OR/Lakeland, FL/Williamsburg, MO. See the Yellow Pages under "roofing" for the ECI Authorized Builder in your area.

Circle 74 on inquiry card

- Please send me a free copy of the ECI design manual for metal roofing systems.
- Please have a representative call me.

Name: _____

Title: _____

Company: _____

Address: _____

City: _____ State: _____ Zip: _____

Phone: () _____

Mail to: ECI Building Components, Inc.
PO. Drawer C
Stafford (Houston), Texas 77477,
713/499-5611

Telex: 910-880-4435
Fax: (713) 499-0809



Consultants:
 Structural Engineer:
 Aristo Engineers and Associates
 1990 Michigan Avenue, Suite 1400, Detroit, MI 48226
 Electrical and Mechanical Engineer:
 Frippin Stroski Cohn and Johnson
 1400 Bluewater Boulevard, Suite 1000, Detroit, MI 48226
 Associates:
 [unreadable]
 [unreadable]
 [unreadable]

E 8
 A member of
 GROUP F&G ASSOCIATES
 F 25
 A member of
 GROUP F&G ASSOCIATES

AT ANDERSEN, WE DON'T SUBSCRIBE TO THE THEORY THAT BEAUTY IS ONLY SKIN DEEP.

Beauty, we believe, comes not merely from a building's exterior, but also from within. And perhaps no other commercial window offers the exterior design freedom and inner beauty of low maintenance Andersen®

Perma-Shield® Flexiframe® windows.

For with this versatile window line comes the natural warmth and understated elegance of a wood interior. One that can be stained and painted to complement any decor, any time the decor changes.

Andersen Flexiframe window systems offer many custom design advantages. You can create large, unobstructed views or add dramatic shapes. With the crisp clean lines and smooth tight corners that characterize all Andersen® windows.

So to those who would prefer to judge a building solely by its cover, might we suggest that you respond instead to an inner calling. Call 1-800-635-7500 for the name of your local Andersen commercial representative. Or write Andersen Commercial Group, P.O. Box 12, Bayport, MN 55003.

ANDERSEN
COMMERCIAL
GROUP







If you haven't seen how versatile our carpet is, perhaps we should paint you a picture.

Introducing The Gallery of Modular Art. A collection of 32 extraordinary modular carpet products, with over 250 colors available as standard. So you'll find a choice that's right for projects from airport lobbies to executive dining rooms.



And this carpet does more than look good. They all come with Milliken's high standards of quality and value. Each is made exclusively with DuPont Antron® XL Nylon and Antron Precedent® Nylon fibers for outstanding appearance retention and resistance to soil and stains. Which is something any client will appreciate.

Best of all, **The Gallery of Modular Art** selections are available through Milliken Full Service Dealers. And with Pattern Express™, orders up to 1,000 square yards per product selection are ready to ship in 7 days.

Words alone can't describe The Gallery of Modular Art. But our free 78 page, full color catalog can. Just call **1-800-241-2327** (in Canada, 1-800-267-0955).

Call us today. Because we've got modular carpet down to an art.



**MILLIKEN
CONTRACT**

© 1989 DESIGN MILLIKEN AND COMPANY

Carpet Shown: Milliken's Marbleine.™

Circle 76 on inquiry card



Trial by fire.

When the Edmonton Law Courts wanted a fire-retardant panel for their expansion project, the decision was in favor of Duraflake® FR. The Class I fire-rated particleboard that's gone through trial after trial.

It has a UL flame spread rating of 20. And a smoke developed rating of 25. Plus it's stable and won't bleed chemicals. Important requirements when laminating fine veneers such as the teak used in Edmonton's courtrooms.

You can order Duraflake FR cut-to-size, or in four- or five-foot wide panels of standard length. Four-foot wide panels are also available up to 18 feet in length. It's even available as a high-pressure laminate panel called DuraDesign® FR, for use in casegoods and furniture.

If you have to meet strict fire codes, call (503) 926-5866 for Duraflake FR. And give it a trial.



 **Duraflake® FR**

Duraflake Division
Willamette Industries, Inc.
Albany, Oregon 97321
(503) 928-3341

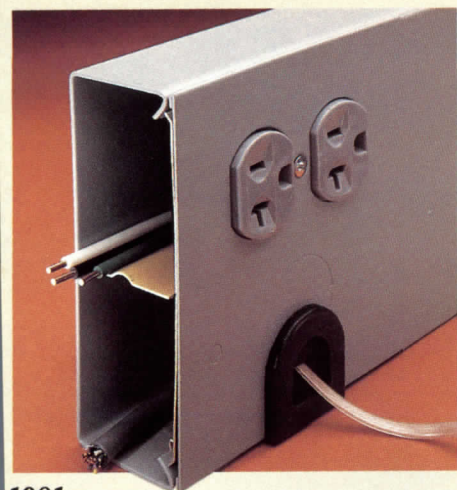

1981:
newly installed Wiremold®
G-4000 raceway with divider
carries power circuits and a single
telephone cable.

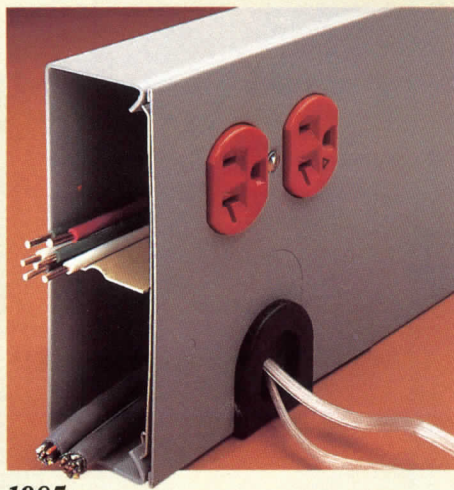

1985:
a dedicated/isolated
ground circuit is added to the
same raceway; telephone service
is doubled.

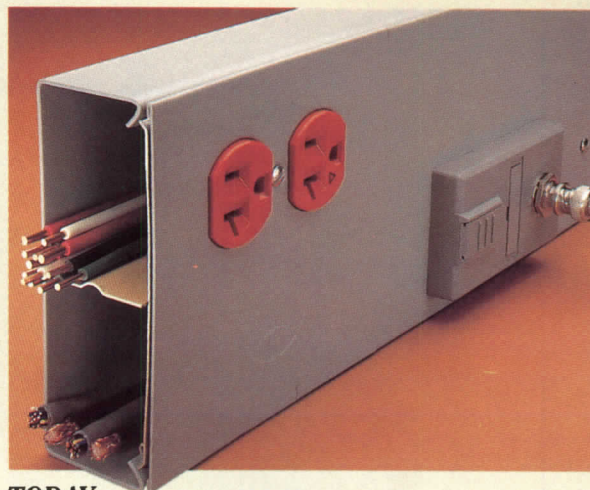

TODAY:
now a cabling network adapter
interfaces with a computer system and
other tele/data equipment. Wiremold race-
way still has room to grow!

The wiring system you can't outgrow.

Expand your power, telephone and data wiring as needed with Wiremold perimeter raceway system. Now, you can get at your wiring whenever you want to. All you do is remove the Wiremold raceway covers and lay in the additional wiring and fittings: electrical power in one compartment, low voltage data and phone cables in the other. That's the distinct advantage Wiremold perimeter raceway has over conventional wiring systems.

A Wiremold raceway system grows as you're ready to grow. Maybe you change your office layout. Or you add new factory equipment. Perhaps you bring in more sophisticated telecommunications equipment. Or add additional LAN cables. There's capacity for these and more. So everything's

updated quickly and efficiently.

Large capacity Wiremold perimeter raceway comes in a range of sizes and finishes. Available in baked enamel finish, satin anodized aluminum or plastic, they can be used as is or painted to match or contrast. Available, too, are all the interconnecting fittings you need to extend and expand your raceway system, one that can grow as your business needs grow.

If you're renovating or retrofitting a building, Wiremold raceway reduces the high cost of labor and general disorder involved in breaking through walls – not just today but in the future. Designing a new building? It makes good sense to design in, from the beginning, a

Wiremold perimeter raceway system – so you're prepared for future

expansion of your wiring needs.

To view a specially-prepared video about Wiremold perimeter raceway systems, call 1-800-621-0049 (In Connecticut 1-800-992-2277).



Installed at desktop level, the Wiremold perimeter raceway in this office handles both standard power and low voltage communications wiring.

For a fact-filled color brochure, write today to The Wiremold Company, Electrical Division, 60 Woodlawn Street, West Hartford, CT 06110-0639.

FREE
LITERATURE



Removable covers make it easy to quickly access and update power wiring, telephone and data network cables.

 **Wiremold®**

Circle 78 on inquiry card

The Beautiful Lock With An Ugly Past



R.R. BRINK
LOCKING
SYSTEMS, INC.

Its basic model is one of the leading electric locks used in today's prisons—where reliability and security are daily matters of life and death.

But it fits a standard metal door frame or aluminum tube, and uses a conventional mortise key-cylinder. Its electric controls and sensors are designed for fast, plug-in installation. And beneath its elegant finish all working parts are rugged stainless steel.

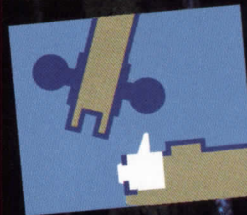

The installation is architecturally unobtrusive, yet affords superior structural integrity and tamper resistance.

Extra measures of security in a business, school, hospital, museum, bank, or embassy do not have to be ugly.

If your locking systems come from R. R. Brink.



R. R. BRINK LOCKING SYSTEMS

500 Earl Road
Shorewood, IL 60436
815.744.7000
FAX 815.744.7020

Circle 79 on inquiry card

In this issue

If there is an underlying theme to the projects featured in this month's RECORD, it is the scenographic role that architecture can play in a variety of urban situations. In our cover story, for example, Avery Associates and Gwathmey Siegel & Associates took the notion of architecture as stage set quite literally for a pair of museums, both carved out of existing buildings in London and New York, that are devoted to interpreting the history of film and television (pages 110-121).

Less dramatically, perhaps, but no less effectively, The Architects Collaborative and Whistler-Patri have produced two buildings that reaffirm the validity of architectural understatement along two important commercial boulevards in Boston and San Francisco (pages 122-127). Heritage on the Garden and San Francisco Centre are humanely scaled alternatives to behemoths that were initially proposed for their respective sites on Boylston Street and Market Street, and their success reminds us that big buildings are not necessarily the best measure of urban greatness.

By contrast, Lord & Sargent recognized that the wide-open spaces surrounding Delta's new reservations and training center (pages 128-131), located near Salt Lake City International Airport at the base of Utah's Wasatch Range, demanded a more arresting solution. The Atlanta firm responded by enlivening what ordinarily would have been an undifferentiated suburban-style box with earth-colored brick striations and bold geometric volumes—elements that Delta passengers can discern clearly as they descend onto the runway.

For the Dai-Ichi Tokyo Bay Hotel (pages 132-137), Roger Ferri, former design principal at the New York office of Welton Becket Associates, devised an iconographically rich palette of ornament that helps give civic presence to a new metropolitan district of the Japanese capital.

Finally, our Building Types Study (pages 138-149) features a quartet of modestly proportioned commercial interiors. The relatively young architects and designers who created this four-act presentation might make up the cast of a play entitled "How to Succeed in Business Without Trying to Upstage Your Clients." Their leitmotif? Modernism's enduring validity in the office arena, whether as boldly conceived showstopper or as quiet backdrop for a client's own set of ideas.

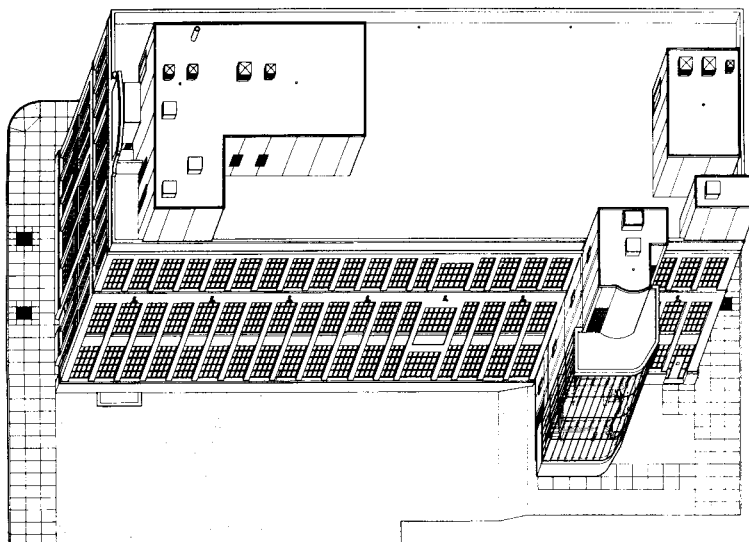

*American Museum of the Moving Image, New York City
Gwathmey Siegel & Associates,
Architects*

Double feature

Two museums of the
moving image

How does an architect design a repository devoted to documenting the art, history, and technique of movies and television? For Avery Associates, the architects of the Museum of the Moving Image (MOMI) in London, and Gwathmey Siegel & Associates, the firm responsible for the American Museum of the Moving Image (AMMI) in New York, determining a solution for such a new type of institution wasn't easy. Instead of being presented with the opportunity to create a building containing state-of-the-art technology, the architects were commissioned to adapt historic structures in remote urban locations for fledgling institutions. While Avery Associates faced the seemingly impossible task of inserting a structure under the South Bank ramp of Waterloo Bridge, Gwathmey Siegel & Associates confronted the rehabilitation of a derelict warehouse within the legendary Astoria Studios complex in Queens. Both firms designed their museums with spaces that aren't *too* designed—flexible lofts for exhibiting photographs, costumes, cameras, stage sets, and memorabilia, as well as film and video presentations, and art installations. Opened last September, MOMI and AMMI reflect the architects' resourcefulness in supporting each museum's divergent philosophy. Avery Associates' steel and glass facade (opposite and below left) advertises MOMI's romantic approach to the history of film and television, and Gwathmey Siegel's industrial warehouse (below right) underscores AMMI's more didactic and technological viewpoint. Faced with similar challenges, the architects couldn't have devised more different solutions. *Deborah K. Dietsch*



©Richard Bryant



©Jeff Goldberg/ESTO





- ← Festival Pier
Museum Of The Moving Image
- ← Hayward Gallery
- ← Queen Elizabeth Hall
- ← Royal Festival Hall
Jubilee Gardens

- Royal Albert Hall
- Hayward Gallery
- Queen Elizabeth Hall
- Royal Festival Hall
- Jubilee Gardens
- National Theatre

NO ENTRY

Structural showmanship

Museum of the Moving Image
London
Avery Associates, Architects

"A simply serviced shell," is how architect Bryan Avery describes his design for the Museum of the Moving Image on London's South Bank. His modesty, however, belies the structural and formal ingenuity of the 55,000-square-foot building, which is tucked beneath Waterloo Bridge over a parking garage. In collaboration with engineer Anthony Hunt, Avery developed a structure independent of the bridge based on the column grid of the garage bays. In determining where to place the deep piles of his foundation, he had to grapple not only with the existing piers of Waterloo Bridge, but also with footings of previous bridge constructions, public sewers, gas and electricity lines, communications cables, and a high-pressure water main, which had to be rerouted. Once this engineering feat was accomplished, Avery superimposed a steel frame over a concrete deck to form 9-foot-wide colonnades on either side of the bridge, which distinguish the infill structure with identifiable elevations. Capped by domed skylights and fiberglass roof panels colored in the bright red of London's buses (opposite and top section), these freestanding galleries—authorities would not permit any connections to the bridge—contain circulation, mechanical equipment, and ancillary exhibition space. On the side facing the National Film Theater (bottom right), the architect designed an elegantly detailed glass "image wall" braced by bowed struts that acts as a star-studded billboard (page 111) to draw attention to the museum within the South Bank's Brutalist concrete context.

Since MOMI serves as a sister institution to the National Film Theater next door, Avery was not required to furnish the museum with a large-capacity auditorium for film screenings. He did, however, design a "moving image workshop," a 135-seat experimental theater at the south end of the building that is equipped with an adjustable proscenium to accommodate various types of media. At the center, the architect designed the galleries as a double-height "black box," with a mezzanine for temporary exhibitions (bottom section), surrounded at the perimeter by functions requiring daylight: staff offices, a café, and book shop (plans). Ironically, the parking garage that Avery so diligently preserved has been subsequently converted by the museum into additional exhibition space and a mechanical room for a new air-conditioning unit. *D. K. D.*

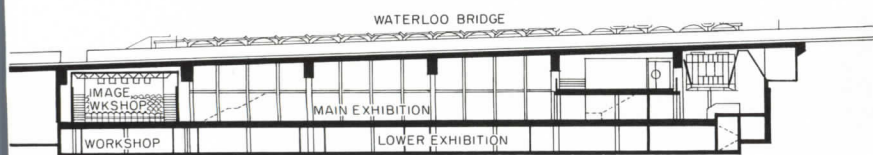
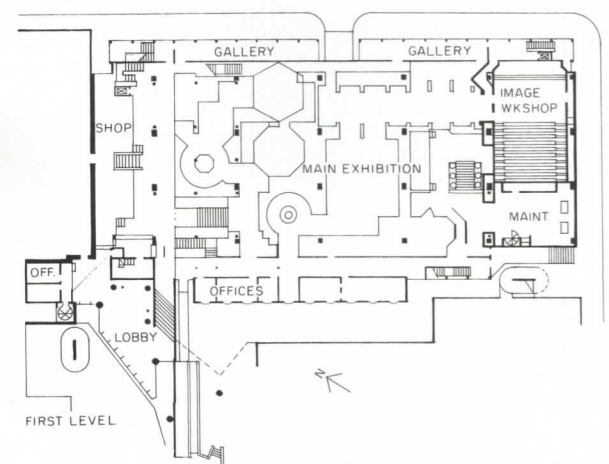
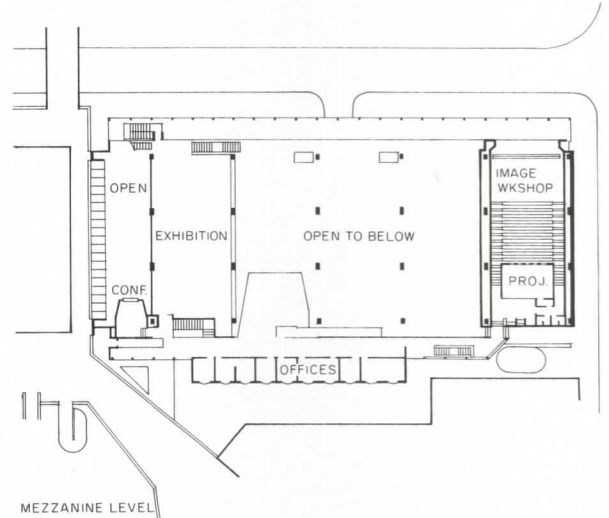

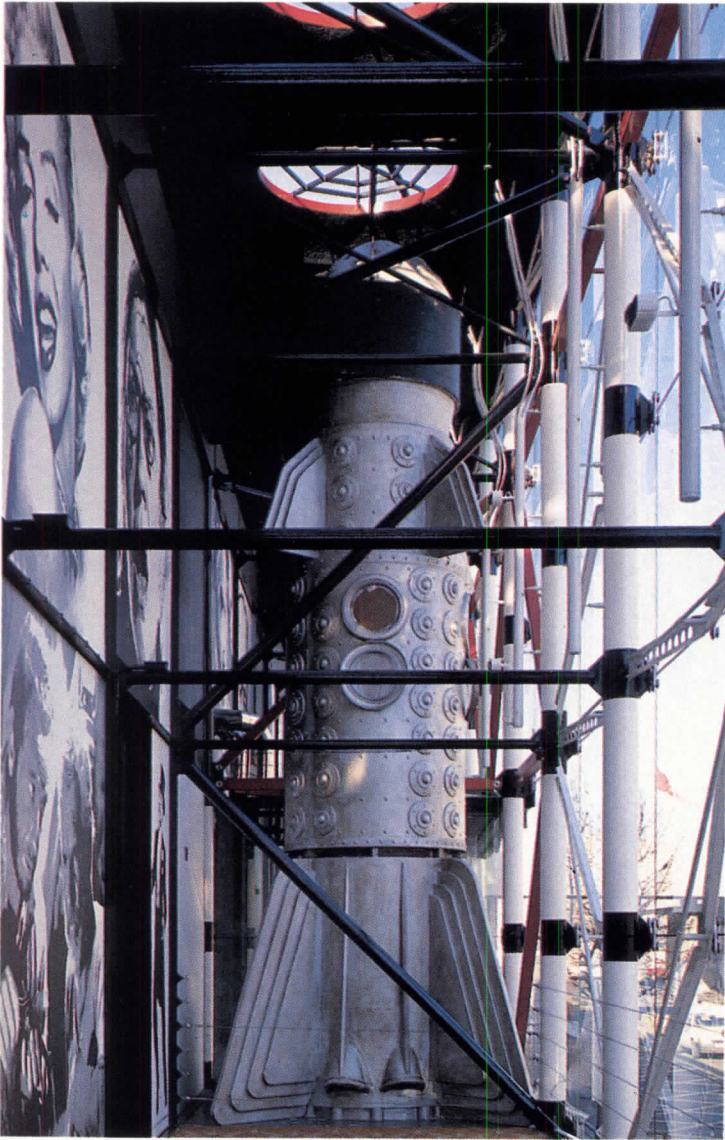

1

MOMI's exhibits are international in scope and arranged in chronological order from pre-cinematic images to the latest fiber optics. Designed by Neal Potter, the displays comprise interpretative environments that emphasize fantasy and

showmanship over a didactic and technological approach. 1. The east-facing colonnade is decorated with movie stars and a rocket ship inspired by the 1902 movie, Trip to the Moon. 2. Kinetic displays are programmed from a console within the gallery.



2

3., 4. The British film industry is represented by a reproduction of a 1930s Odeon cinema, complete with marquee, foyer, and tea room. 5. The entrance gallery is designed as an optical illusion, intended to challenge visitors' visual perceptions.

6. The silent-screen era is celebrated by the Temple of the Gods, supported by caryatids of movie stars. Visitors can enter a replica of a 1919 Russian "Agit train," in which revolutionary propaganda films were shown (background). 7. Temporary exhibitions, such

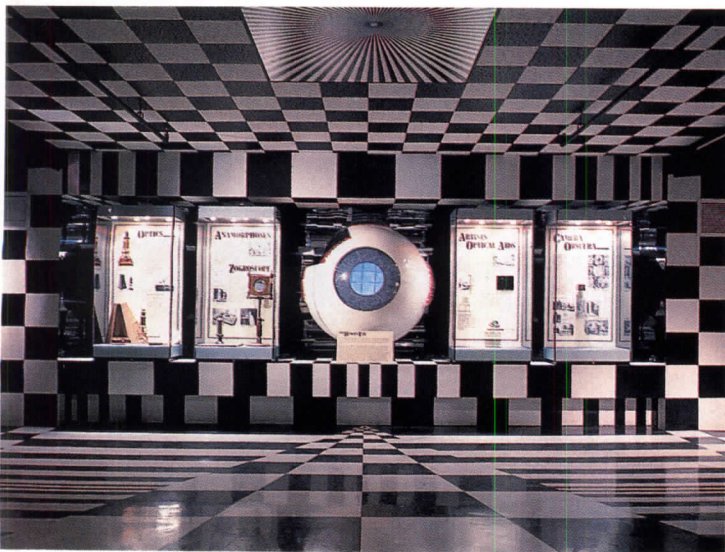

5

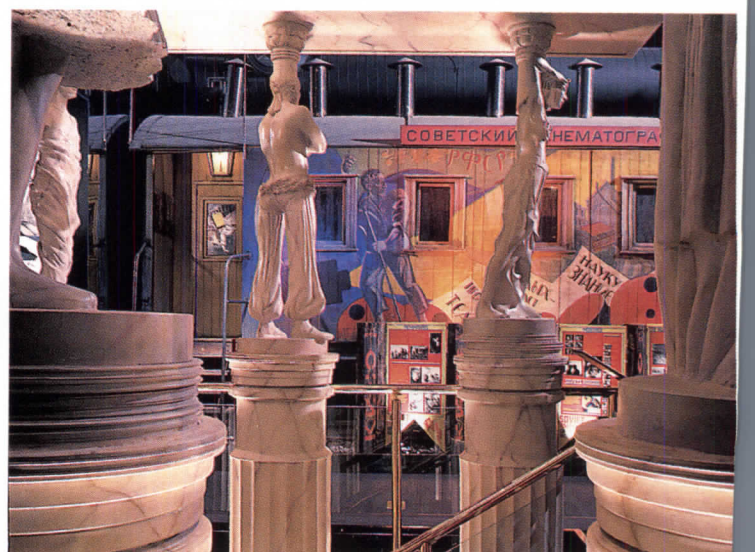

6

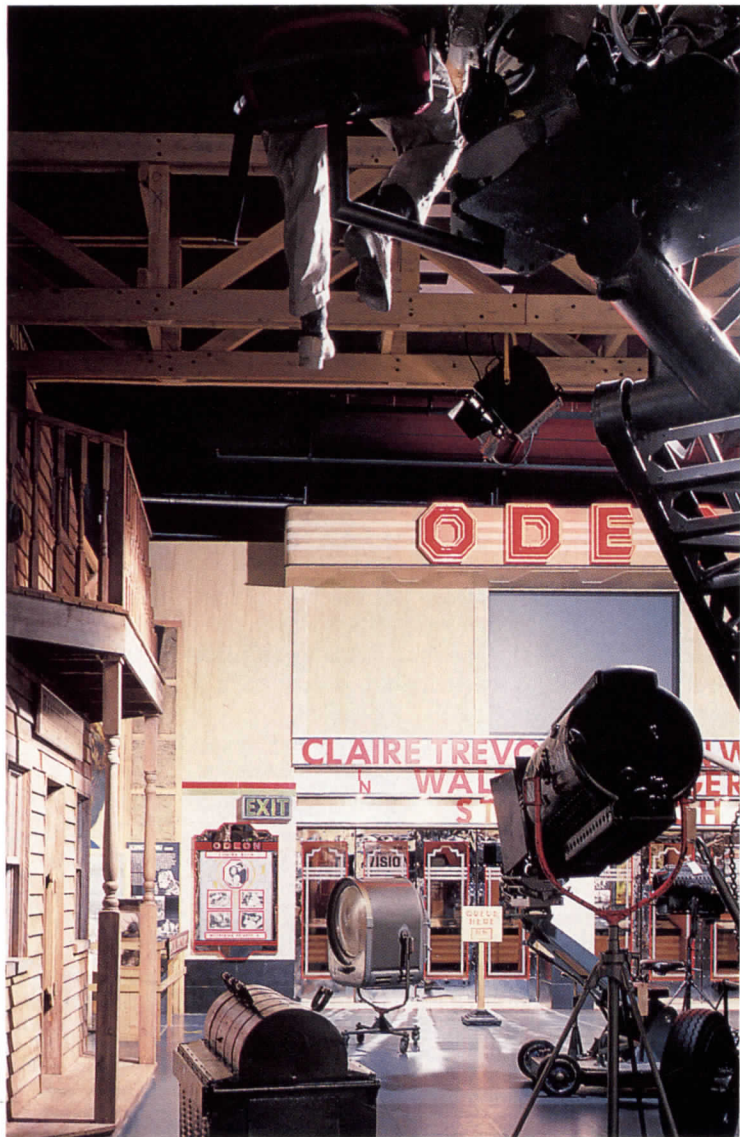

3
as the "World of Jim Henson," are staged on the mezzanine.
8. A display devoted to German expressionist films includes the robot from Fritz Lang's *Metropolis*.

Museum of the Moving Image
London
Architect:
Avery Associates—Bryan Avery, principal-in-charge; John Dawson, project architect; Simon Grout, Tim Thompson, Dean Buchanan, Arthur Collin, Richard Crawford, Paul



4
Kerr Hislop, Giuseppi Intini, John Randle, Thierry Reinhardt, Paul Summerlin, Wes Spees, Michael Walter, project team
Engineers:
Anthony Hunt Associates (structural); Voce Case & Partners; R. W. Gregory &

Partners (mechanical)
Consultants:
Neal Potter (exhibit design); Northcroft Neighbour and Nicholson & Hanscomb Partnership (cost); Bickerdike Allen Partners (acoustics)
General contractor:
Bovis Construction

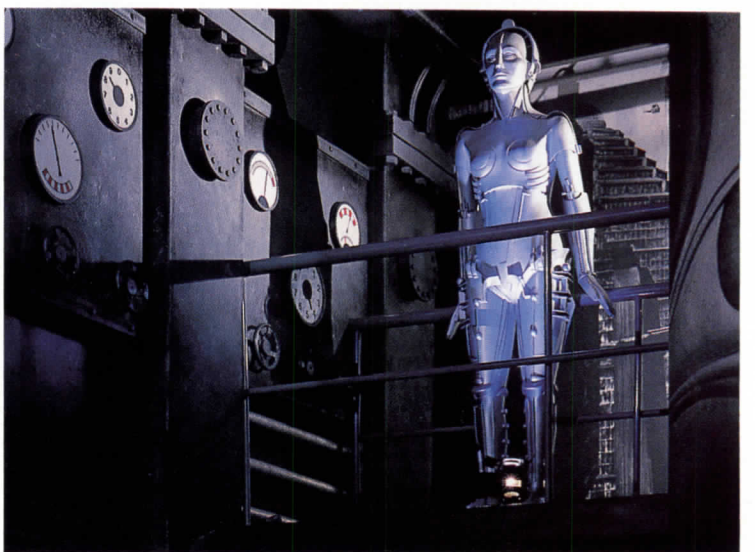

8

American Museum of the
Moving Image
New York City
Gwathmey Siegel & Associates,
Architects

Art and industry

©Jeff Goldberg/ESTO photos

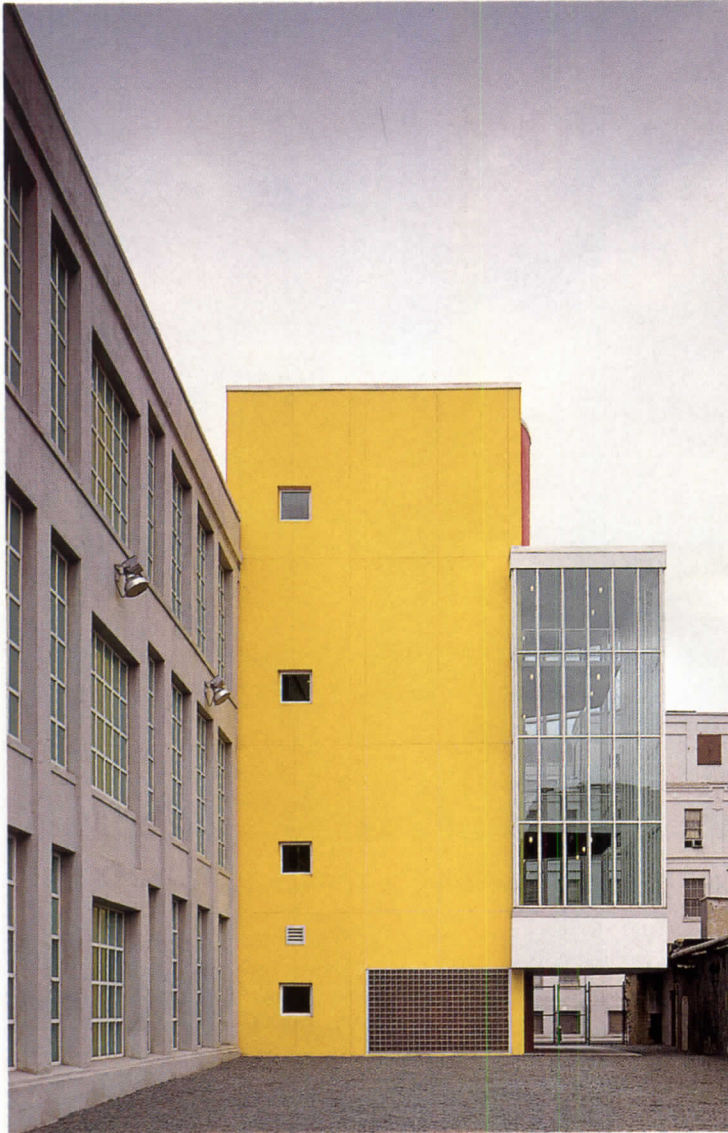

"We examine film, television, and video in a very unromantic way," says Rochelle Slovin, director of New York City's newest cultural institution, the American Museum of the Moving Image in Astoria, Queens. Slovin's behind-the-scenes approach is reinforced by Gwathmey Siegel & Associates' museum design, a tough-minded renovation of a three-story industrial warehouse that opened last fall. During the seven years it took to complete the museum, the architects confronted many of the roadblocks associated with city-funded projects: a tight budget, phased construction schedule, and the Wicks Law, which requires separate contractors for each job. And, since the building is located within the 1920s Astoria Studios complex (site plan), a landmark listed on the National Register of Historic Places, all proposed changes to the structure were subject to scrupulous government review.

Despite these challenges, Gwathmey Siegel capitalized on the industrial character of the warehouse to create a rigorous framework for AMMI's growing collection, film programs, and future expansion—for only \$130 per square foot. "Our building has an unfinished quality, with details that are built to last. It doesn't have the preciousness associated with a fine-arts museum," explains Charles Gwathmey. He likens his parti to the Centre Pompidou, in which public circulation is pulled outside the perimeter to maximize the "black box" functions—galleries and theaters—at the center of the museum. At AMMI, the escalators at Pompidou are reinterpreted as a glazed, joist-braced stairway and elevator core that extend from the rear of the building. Rendered in primary colors, their sculpted volumes animate the repetitive building envelope within the neighborhood's gray uniformity (left and opposite). Gwathmey's other major intervention into the warehouse is a 190-seat theater inserted into the ramp of a former loading bay that he surrounded by a museum shop, café, community meeting room, and temporary exhibition space. On the second floor, the architect arranged staff offices around a 7,200-square-foot loft, which currently houses AMMI's core exhibit, "Behind the Screen: Producing, Promoting, and Exhibiting Motion Pictures and Television." Another gallery on the third floor is scheduled to open this summer with a display of video games, and a fourth-floor penthouse is now under design development. *D. K. D.*

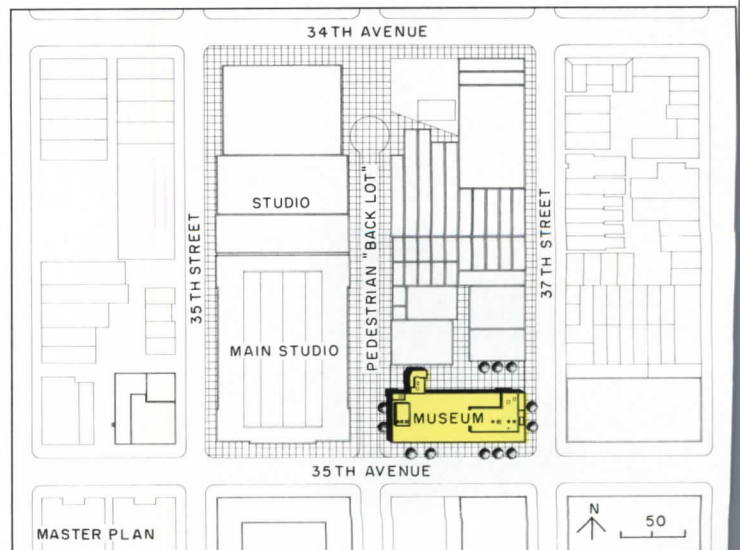



"AMMI is a study in inexpensive materials used in an appropriate way," explains Charles Gwathmey, who underscored the industrial character of a former warehouse to enhance the museum's behind-the-screen philosophy. On the first floor,

he exposed the concrete structure in the lobby (below top left) and modulated the ceiling with a curved soffit that extends from a gift shop (below right) at the southwestern corner to a café along the perimeter (plan below). Within a former truck dock, the



- | | |
|----------------------------|----------------------------|
| 1. Lobby | 12. Exhibition |
| 2. Museum store | 13. Public stair/elevator |
| 3. Café | 14. Courtyard |
| 4. Theater | 15. Handicap entrance |
| 5. Serving/prep | 16. Soundstage |
| 6. Green room | 17. Administration offices |
| 7. Screening room | 18. Conference room |
| 8. Projection booth | 19. Workroom |
| 9. Community board offices | 20. Holding area |
| 10. Staff/service entrance | 21. Lounge |
| 11. Stage platform | |

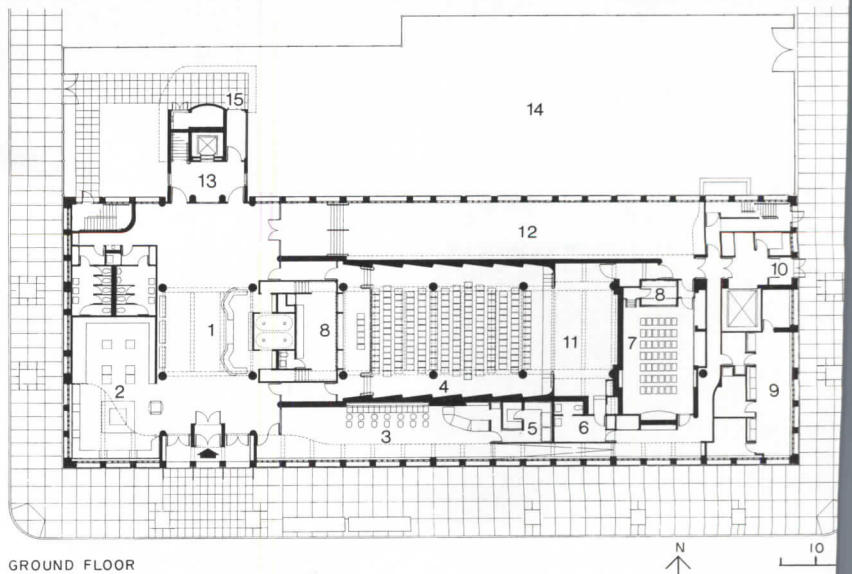

GROUND FLOOR

architect inserted a 190-seat theater (opposite bottom left), equipped for screening various sizes of films, videos, and rare nitrate prints. Gwathmey Siegel's most visible addition is a circulation hub at the rear that provides access to three levels of galleries. Cantilevered

from an elevator core, the concrete stairway is wrapped in tinted laminated-glass panels braced by off-the-shelf joists (below left and top right). On each curved stair landing is a niche for displaying artwork, such as "Point Oh View" by Paul Davis (bottom right).

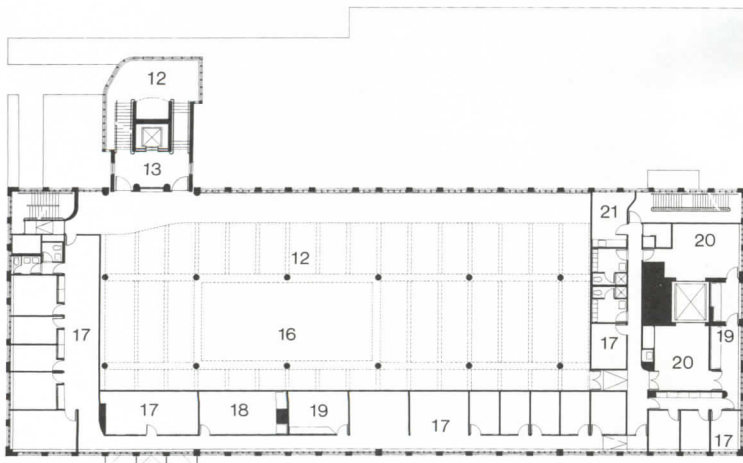

SECOND FLOOR



1
"I wanted the artifacts to be seen within their architectural setting without a lot of graphics," explains director Rochelle Slovin of AMMI's core collection on the second floor, which is devoted to the exhibition, production, and promotion of film and TV.

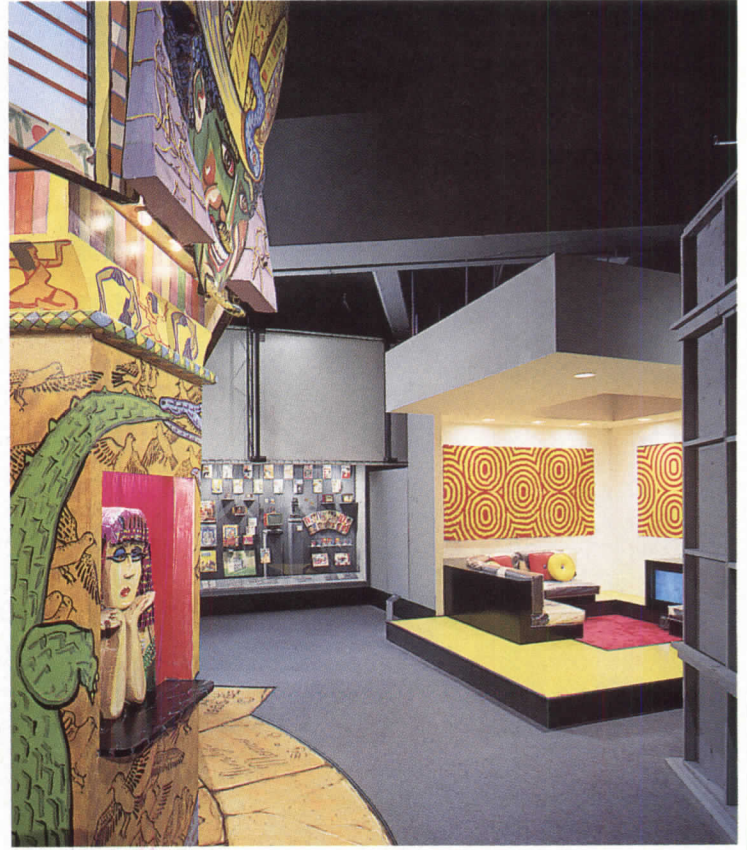

2
Adhering to Slovin's philosophy, exhibit designer Murry Gelberg clearly differentiated his flexible displays from the museum's exposed structural and mechanical systems. Tentlike screens, for example, frame an area for viewing videos on directors and scriptwriters (7), and a display of costumes and related promotional material (8). Movable sound booths offer commentary by producers on TV shows and movies shown on monitors overhead (6). AMMI's collection also includes commissioned artworks, including "Tut's Fever," an exuberantly decorated, 40-seat theater designed by Red Grooms and Lysiane Luong (1, 3, 4); Jim Isermann's "TV Lounge," a 1960s-inspired family room (2); and Naim June Paik's "Getaway Car," an 80-monitor installation (5).



5



6



3

American Museum of the Moving Image
 New York City
Architect:
 Gwathmey Siegel & Associates, Architects—Jacob Alspector, senior associate; Paul Aferiat, associate; Alissa Bucher, Pierre Cantacuzene, Stephen Connors,

Steven Forman, Tim Greer, Lee Hagen, Dirk Kramer, Jude LeBlanc, Ming Leung, Jay Measley, Carlene Ramus, Shalini Taneja, project team
Engineers:
 Severud Szegezdy (structural); John L. Altieri (mechanical)



4

Consultants:
 Imero Fiorentino Associates (theater/video); Jaffee Acoustics (acoustics); H.I. Sigman (codes/zoning); Carl Hillmann Associates (lighting); Della, Femina, Traviso & Partners (graphics); Murry Gelberg & Co. (exhibit design); Terry/

Chassman Associates (exhibit lighting); Paul Davis Studio (exhibit graphics)
Contractors:
 Milnor Construction Corp. (general); Delphi Mechanical (hvac); Abra Construction Corp. (plumbing); Five Star Electric Corp. (electric)



8

Two on the town

Among major American cities, Boston and San Francisco are kindred spirits that bear some striking similarities. Nearly identical in physical dimension (46 square miles), both cities are the hubs of sprawling urban agglomerations that rank among the country's 10 most populous metropolitan areas (San Francisco is fourth, Boston seventh). Despite their ample size, both Boston and San Francisco lie in the economic shadow of even larger metropolises: Boston's East Coast preeminence diminished during the last century with the rise of New York City as the nation's premier port, while the transfer of West Coast financial power from San Francisco to Los Angeles remains an ongoing process. Even as their relative influence has waned, however, the Massachusetts state capital and the City by the Bay have continued to flourish in the minds of most Americans. Thanks to a happy blend of history and geography, the two cities boast well-established cultural institutions (especially Boston) and recreational amenities (San Francisco has the edge here), and their residents enjoy two of the best public-transportation systems in the country (though Boston's beloved "T" is older and more comprehensive than San Francisco's BART/MUNI network). They are cities whose distinction owes less to major monuments (the gold dome of Bulfinch's Massachusetts State House and the red towers of the Golden Gate Bridge notwithstanding) than to a tightly knit urban fabric almost European in its density.

Then, too, San Francisco and Boston are progressive cities where actions traditionally have spoken louder than words. Boston, for example, is about to implement a plan, thought visionary just 10 years ago, to replace the intrusive Central

Artery with a subterranean highway, and San Francisco continues to debate a like-minded proposal to demolish the Embarcadero Freeway. It seems no accident that when RECORD awarded its first In the Public Interest honors for excellence in specialized housing (November 1988), four of the 11 premiated submissions, as well as a disproportionate number of runners-up, were located in the two cities or their suburbs.

For all their positive attributes, however, neither Boston nor San Francisco is quite the urban paradise its boosters might have one believe. Ironically given the traditional liberalism of its well-educated population, Boston remains one of the most racially divided cities in the country, while many San Franciscans live in a state of continuous mourning, the result of the city's highest-in-the-nation rate of AIDS-related deaths. What is more, although neither city suffered the wholesale population exodus after World War II that afflicted, say, Detroit or St. Louis, both allowed their once-cohesive business districts to expand (some might say explode) during the last 30 years into an undistinguished, overscaled forest of high-rise office and residential towers—generic icons of postwar Modernism that mingle uneasily with the stately red-brick and brownstone row houses of the Back Bay or the wood-frame painted Victorians of Russian Hill. San Francisco's so-called "Manhattanization" has been more highly publicized, but a similar Boston syndrome has perhaps had even more serious consequences in a city whose downtown core comprises small blocks and twisting streets that date back to Colonial days.

During the early 1980s public officials and increasingly vocal community leaders in San Francisco and Boston started to reexamine the financial benefits

Heritage on the Garden, in Boston, and San Francisco Centre exemplify the smaller-is-better mentality that has transformed architecture and urbanism in America's two best-loved cities.



1. *Heritage on the Garden, Boston. The Architects Collaborative, Architects.*
2. *San Francisco Centre, San Francisco. Whistler-Patri, Architects.*



©Steve Rosenthal



David Wakely

Heritage on the Garden:

3. *View from Public Garden*

4. *View from the Ritz-Carlton Hotel*

5. *View from Park Plaza*



©Steve Rosenthal



©Steve Rosenthal



©Steve Rosenthal

of unbridled development vis à vis concerns that have since become known as quality-of-life issues. After much debate San Francisco passed its celebrated Downtown Plan, a sweeping revision of the city's zoning ordinance that limits construction in the overbuilt commercial core to just 450,000 square feet per annum, encourages new construction in a less-developed area of the city south of Market Street, and provides an architectural review process—dubbed “The Beauty Contest” by local architects—to judge the merits of all new-building proposals. Boston, with what might be considered typical New England reserve, adopted less drastic measures. In addition to modestly downzoning certain commercial areas of downtown and the Back Bay, the city, under the aegis of the Boston Redevelopment Authority (BRA), turned to the dual mechanisms of architect-developer competitions and site-specific design guidelines governing setbacks, materials, and usage for new construction on selected urban-renewal parcels. (The best-known architect-developer project to date erected under BRA-initiated mandates is Rows Wharf [RECORD, March 1988, pages 86-93], the highly acclaimed mixed-use complex on Boston Harbor designed by the Chicago office of Skidmore, Owings & Merrill.)

Although Boston and San Francisco have adopted different urban-planning strategies, both cities clearly are struggling with the same urban-planning issue: how to preserve human scale and *public* character in private-development projects, concerns that city-builders of the more distant past seemed to understand as a matter of course. Two recently completed projects—Heritage on the Garden, by The Architects Collaborative, and San Francisco Centre, by Whistler-Patri—

convincingly address these matters in surprisingly similar ways. To be sure, on paper the two projects do not seem all that alike. Heritage on the Garden is a 490,000-square-foot mixed-use complex comprising 50,000 square feet of ground-floor retail and restaurant space, three floors of offices, seven floors housing 87 condominiums, and a 175-car below-grade garage. San Francisco Centre, by contrast, is a single-use, 670,000-square-foot retail mall comprising four levels of shops topped by five levels given over to the city's first branch of Nordstrom, the Seattle-based department store. There is no garage, though valet parking is available.

Yet like the cities themselves, these two highly visible projects were developed along remarkably parallel lines. Both buildings are situated at the junction of two urban neighborhoods, on once-seedy sections of important commercial thoroughfares (see maps, page 122). Both lie on the south side of major public open spaces, a factor that helped dictate low-rise, setback structures that would not cast long shadows, even on the shortest winter days. Both projects were years in the making and were shaped in part by controversial proposals for much larger buildings on their sites. They were carried out by enlightened developers who understand that financial viability does not necessarily preclude civic quality, and by architects who comprehend that thoughtful contextualism and imaginative design are by no means mutually exclusive. Unabashedly “up-scale,” they reflect, for better or for worse, Boston's and San Francisco's increasingly gentrified character. Finally, despite (or perhaps because of) their obvious debt to architectural modes of the past, Heritage on the Garden and San Francisco Centre are very much buildings of the present, and

*San Francisco Centre:
6. View down Hyde Street
7. View along Market Street
8. Market Street entrance*

they actually presage what other American cities will demand of developers and architects well into the 21st century.

Reaffirming a Boston heritage

When Howard Elkus, principal at The Architects Collaborative until the recent founding of his own firm, speaks of Heritage on the Garden, the project that has occupied much of his time since 1982, he understandably lapses into a bit of hyperbole. Of Heritage's prominent setting at the southwest corner of the Public Garden, he says, "Anything less than a landmark building on this site would have been a tragedy. [Developer] Ronald Druker knew this, and so did we." Strolling past the elaborately articulated 12-story building that now presides over the intersection of Boylston and Arlington streets (1), he exclaims, "This is one of the richest walks in the United States." Elkus's enthusiasm is echoed by a more objective local observer: writing in *The Boston Globe*, Robert Campbell calls Heritage "a watershed building in the history of recent Boston architecture . . . a model of what an urban building ought to be."

Strong words, perhaps, but justifiable given what was originally proposed for the corner, which, despite its attractive parkside location overlooking Swan Pond, had deteriorated after World War II into a gap-toothed assemblage of marginally used commercial buildings. In the early 1970s, local developer Mortimer Zuckerman proposed a mega-project called Park Plaza that would have placed an office tower as tall as 50 stories on the Heritage site. Citizens from the surrounding neighborhoods arose in opposition and formed the Park Plaza Civic Advisory Committee (PPCAC). Working in joint venture with the BRA, the PPCAC in 1982 drew up a series of guidelines for the site, calling

for a mixed-use, but mainly residential, structure that would rise 80 feet along Boylston Street before stepping back a generous 50 feet and continuing to a maximum height of 135 feet. Ground-floor shops and restaurants were mandated to strengthen Boylston's existing retail character, and materials were to respect the area's brick and stone masonry tradition.

In winning the BRA's subsequent architect-developer competition in 1983, TAC and The Druker Company came up with a remarkably well-mannered transitional design that neatly bridges the gulf between the business scale of Boston's midtown theater district to the east and the bow-fronted domesticity of Bay Village and the Back Bay to the south and west. The architects picked up what Elkus calls the "Boylston Street beat" by breaking the building's 311-foot-long mass into a series of five bays and cladding the structure in a combination of Harvard blend brick, precast concrete, and rusticated local limestone. The building's 80-foot-high park facade lines up precisely with the cornice line of the adjacent Bradley Building (far left in photo 1), and its distinctive trio of towers—or "belvederes," to use the architects' word—are topped by pyramidal copper crowns that subtly allude to the hipped roof of the original John Hancock Building nearby (3, 4). Heritage's south-facing facade is similarly variegated, but here the architects allowed the building to rise agreeably its full 12 stories, roughly mimicking the scale of the Park Plaza Hotel across the street (5). One only has to compare the building with the much less successful Four Seasons Hotel next door (far left in photo 4), which was created under similar community-initiated guidelines, to appreciate the sensitivity and sophistication of TAC's design.



6

©Bill Hedrich, Hedrich-Blessing



7

David Wakely



8

©Bill Hedrich, Hedrich-Blessing

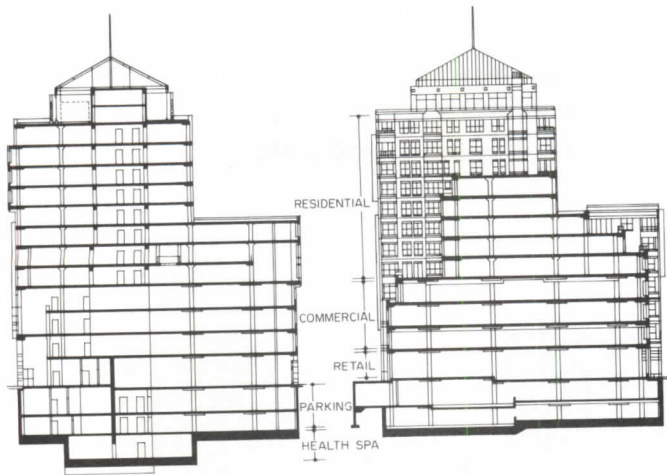

Plan legend:

1. Residential lobby
2. Office lobby
3. Retail
4. Restaurant
5. Service

Heritage on the Garden:

9. Transverse sections
10. Ground-floor plan
11. Residential lobby
12. Office lobby

Inside, moreover, Heritage on the Garden exhibits an air of quality not often associated with late 20th-century construction. The apartments, which average 1,900 square feet, are commodious by any current standard, and the residential lobby off Boylston Street (11) is opulently turned out with Honduran mahogany paneling, green and white Italian marble floors, etched-bronze elevator doors, silk wallcovering, and TAC-designed custom rugs. The two-story office lobby off Park Plaza (12) is less elaborately articulated with painted drywall and a combination of polished and honed, black and gray granite floors.

towers placed atop a retail podium. Although San Francisco had not yet passed its growth-restrictive downtown plan, change was clearly in the wind, and then-mayor Dianne Feinstein rejected any project that would cast Halladie Plaza into shadow. Two years ago, moreover, as the city's hot office market began to cool down, the notion of a building on the site devoted exclusively to retail use became more and more attractive, particularly when Seattle-based Nordstrom agreed to open its largest branch store on the building's top five levels. Nordstrom, it was felt, would effectively draw people up past some 120 shops that will eventually occupy the building's four lower levels.

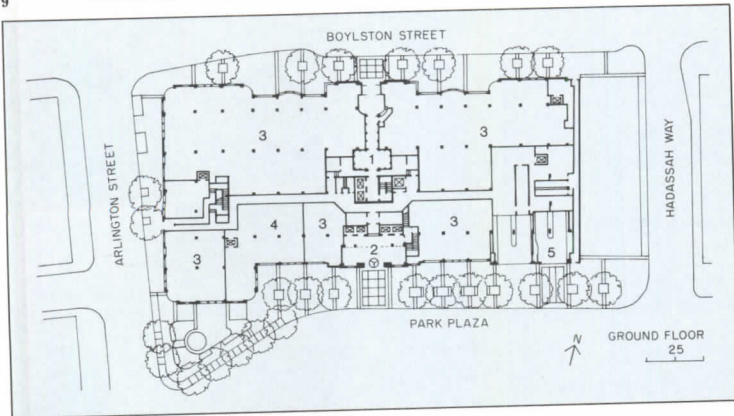

Glitter by the bay

Most visitors to San Francisco know Halladie Plaza as the place where the city's cherished cable cars begin their up-and-down journey to Fisherman's Wharf. For commuters from Daly City and the East Bay, the sunken esplanade denotes the entrance to one of downtown's most heavily used transit stations. For local residents, however, the busy crossroads of Powell and Market streets marks the spot where the smart Union Square shopping district fades unceremoniously into Skid Row and the honky-tonk remains of San Francisco's original retail core. It was here, on a 275-foot-square parcel located on the south side of Market Street, that The Gordon Company, a Los Angeles-based developer, decided to take a gamble and erect San Francisco Centre, a nine-level vertical shopping mall that decisively terminates the vista down Powell Street (6).

The architects at Whistler-Patri utilized some flamboyant design devices in configuring San Francisco Centre's interior. They organized the center around a spectacular 160-foot-high elliptical atrium (15, 16), and specified the first American application of six Japanese-manufactured spiral escalators to link the building's four mall levels. "The Guggenheim with glitz" is how at least one Bay Area critic characterizes this bronze- and marble-trimmed space. While project architect Curtis Owyang acknowledges that he and his colleagues turned for inspiration to Frank Lloyd Wright's masterpiece, along with the spiraling lanterns of Francesco Borromini's Italian Baroque churches in Rome, he admits that the cerebral impulses of art and religion that motivated his forebears were secondary in San Francisco to the more pragmatic concern of attracting money-spending shoppers into the center. (The strategy seems to be working: the crush of patrons on opening day last October was so great that the spiral escalators temporarily broke down, and business remains brisk, even



©Steve Rosenthal



©Steve Rosenthal

San Francisco Centre:

- 13. Longitudinal section
- 14. Ground-floor plan
- 15. Atrium from Nordstrom's
- 16. Atrium from ground floor

Section legend:

- 1. Nordstrom
- 2. Mall
- 3. Concourse/BART level
- 4. Loading/service
- 5. Emporium

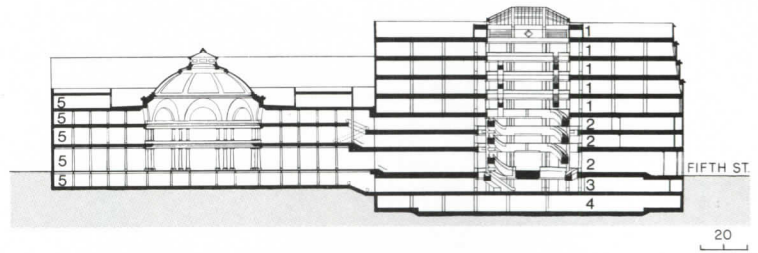

though only a third of the shops are open.)

Beyond its commercial success, however, San Francisco Centre is a new model for responsible urbanism in a city clearly fed up with planning mistakes of the past. Most significantly, perhaps, the center is linked directly to the Powell Street BART station via a below-grade concourse, while short escalators and stairways connect each mall level to the Emporium (far left in photo 2 and section above), the last great department store left over from Market Street's retail heyday. Carefully aligned with Market's existing building wall, the center ascends 85 feet, the exact height of the former Hale Brothers Department Store across Fifth Street (far right in photo 7), before rising in a series of 32-foot-deep setbacks to an ultimate height of 160 feet. The architects sheathed the center's facades in a combination of gray-green precast concrete, North African granite, and bronze-painted aluminum grilles set in front of back-painted spandrel glass—the latter details meant to ape windows in a building that has no need for them. The center's arched entrance was influenced by a similar motif on the Emporium, and its precast piers reflect the vertical rhythm of upper-story colonnades on both the Emporium and Hale Brothers buildings. Viewed alone, these elements do not add up to a major work of architecture; by respecting its neighbors along Market Street, however, San Francisco Centre has made a great city even greater. *Paul M. Sachner*

principal-in-charge; J. B. Jones, senior project architect; competition team: Mark Robitz, Scot MacPherson, Brenda Stanfield, Jamie Devo, Jonathan Seely, Sam Norod; project team: William Hall, project manager; Mark Robitz, project architect; Elizabeth Stern, interior design; George Bregianos, Sherry Caplan, Joseph Carroll, Ben Cheung, C. S. Chou, Natalie Gray, Brad Guarino, Robert Koup, Laurie Lieberman, Vicki Madara, Peter Merrell, Brenda Stanfield, Eve Tenzler, Edward Wood; landscape team: Vince Nauseda, Peter Spellmeyer, Joanne Hiromura, Gary Hilderbrand

Engineers:
Weidlinger Associates (structural); Cosentini Associates (mechanical); Cullinan Engineering Co. (civil)

Consultants:
Cavanaugh Tocci Associates (acoustics); Wheel-Gersztovf Associates (lighting); Lerch, Bates & Associates (vertical transportation)

General contractor:
Turner Construction Company

*San Francisco Centre
 San Francisco*

Owner:
*The Gordon Company—
 Sheldon Gordon, president*

Architect:
Whistler-Patri—Piero Patri, principal-in-charge; Curtis Owyang, Steve Guest, project designers; Jeff Pribyl, project manager; Marie Zeller, planning approvals

Engineers:
CYGNA Consulting Engineers (structural); YOSHPE (mechanical)

Consultants:
Bovis International (construction manager); Robinson, Mills & Williams (tenant architect)

General contractor:
Swinerton & Walberg

*Heritage on the Garden
 Boston*

Owner:
*The Druker Company—
 Ronald M. Druker, president*

Architect:
The Architects Collaborative, Inc.—Howard F. Elkus,

13

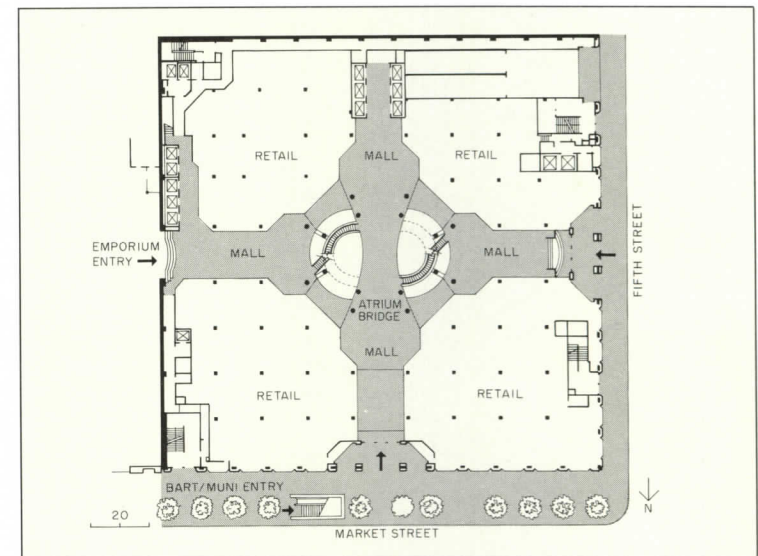

14

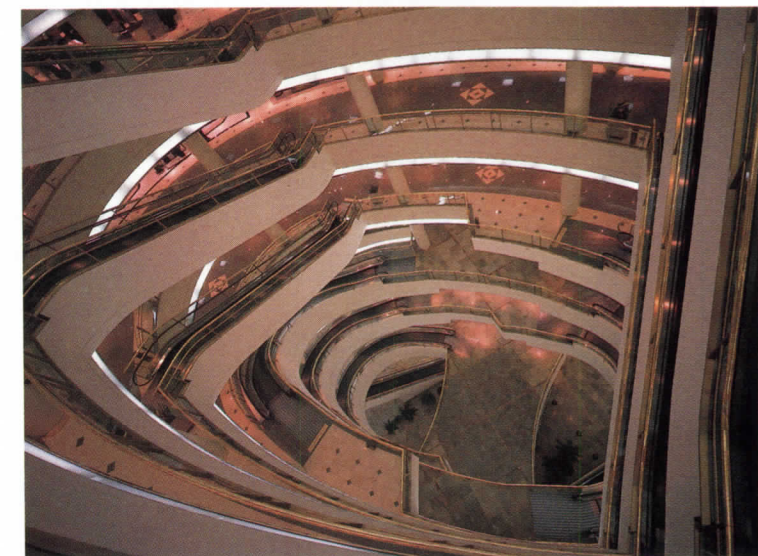

15

©Bill Hedrich, Hedrich-Blessing



16

©Bill Hedrich, Hedrich-Blessing

Delta Air Lines Reservations
and Training Center
Salt Lake City
Lord & Sargent, Inc., and
MHT Architects, Inc.

Making a little look like a lot

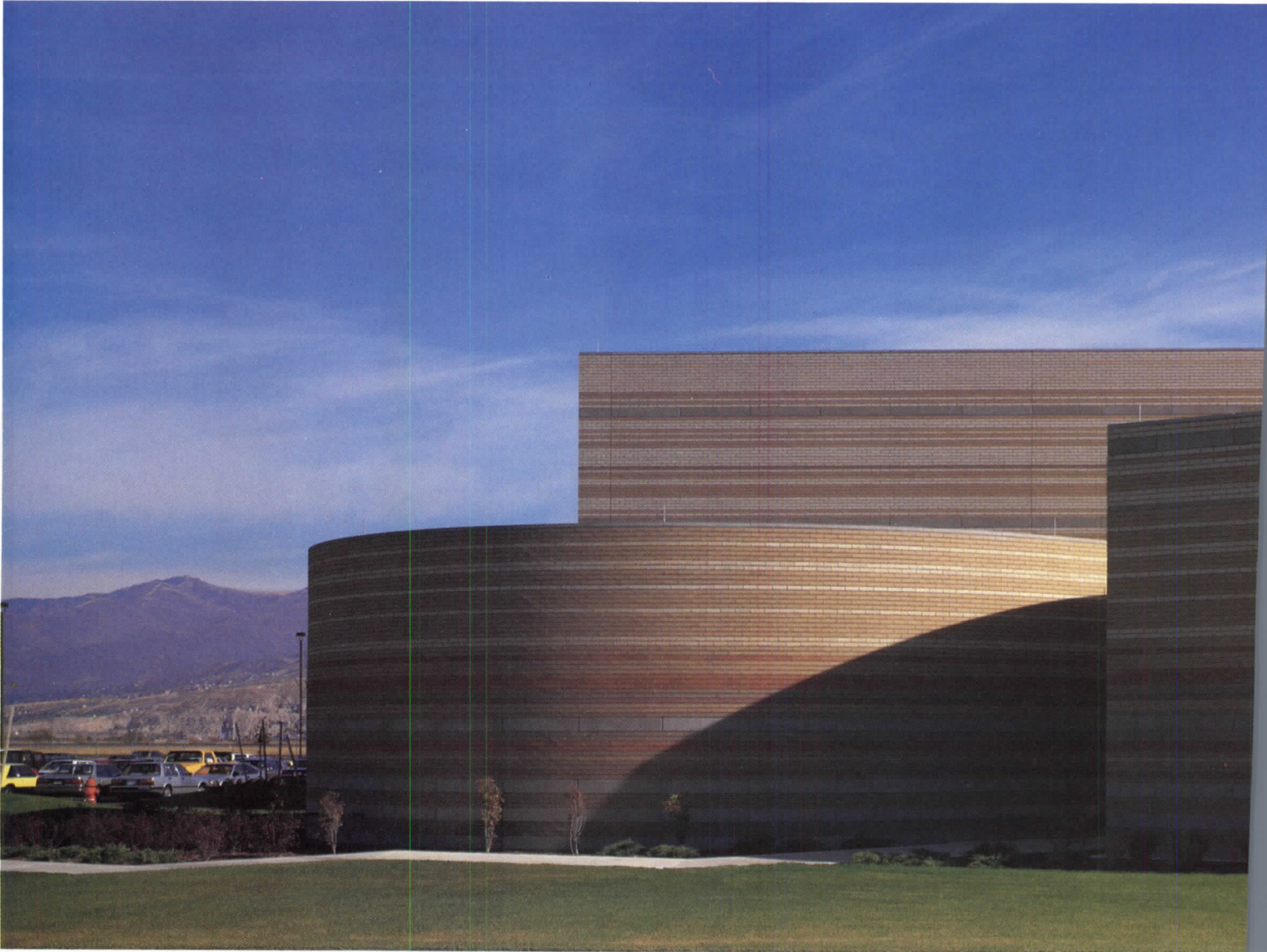

For this extremely simple utilitarian box, architects Lord & Sargent used extremely simple utilitarian means to give it geometric complexity and visual richness.

The striated earth-colored brick and precast concrete wall that constitutes the Delta reservations center's most arresting component was designed for the most compelling reasons of time and function. The \$6-million fast-track building, completed in six months from start of design to occupancy, was originally designed with red, white, blue, and silver metal sheathing, but two months into the tight schedule the client opted for greater subtlety. According to architect Terry Sargent's narrative, the designers thereupon hastened to the nearest brickyard, which had available nine standard and very suitable colors of brick veneer made from Utah earth. And the design team thereupon did some fast-tracking of its own to produce the artfully artless surface pattern of striped hand-laid brick and precast concrete.

The slightly mysterious solid geometric forms at one end of the building (top), featureless except for the earth-colored stripes, in fact represent the most practical of purposes: the cylinder is the

For the sort of commonplace building usually left to the devices of industrial-park developers, architects Lord & Sargent used simple means to give its client what the Georgia AIA, giving the design its top award, called "an extraordinary gift wrapping for an ordinary box."

©Jonathan Hillyer Photography



cooling tower and the cube houses the mechanical plant. Moreover, the most functional of reasons prompted the extraction of these components from inside to outside. The first floor of the 88,000-square-foot building accommodates classrooms and training facilities for pilots and other in-flight personnel, including a flight simulator and a fire-extinguisher practice room; the second floor houses 450 telephone bays and computer equipment for reservations clerks, as well as lockers and lounges. Because this building is near the Salt Lake City airport (one of Delta's hubs), and because future plans call for an adjacent engine-testing facility, and because the telephone clerks will need the greatest possible freedom from extraneous noise, considerable effort was expended on sound control. Mechanical equipment was therefore placed out of doors and out of earshot, and the curtainwall and fenestration were carefully detailed for sound isolation of the interior space (see section on page 131). (Not incidentally, the external mechanical blocks clear the roof of unsightly impedimenta so that it will offer a clean face to Delta's passengers landing at the airport.) *Grace Anderson*



To relieve the building's boxiness, some features were taken outside and set askew: revolving doors with metal awnings (below left) and fire stairs at each end of the building (below right). To protect the interior against noise from an adjacent runway

and from a projected engine-testing facility, the composite structure was detailed with isolation mats and joints and with many air spaces (section opposite). An outer window with two lights and an inner window with a single light are separated by perforated

aluminum jambs, sill, and soffit. The interior, a simple environment of wallboard and computer stations, gains a measure of grandeur from a double stairway (opposite right), its colorful brick support bringing a touch of the desert indoors.

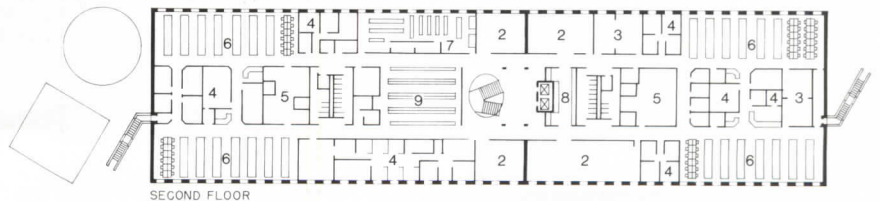
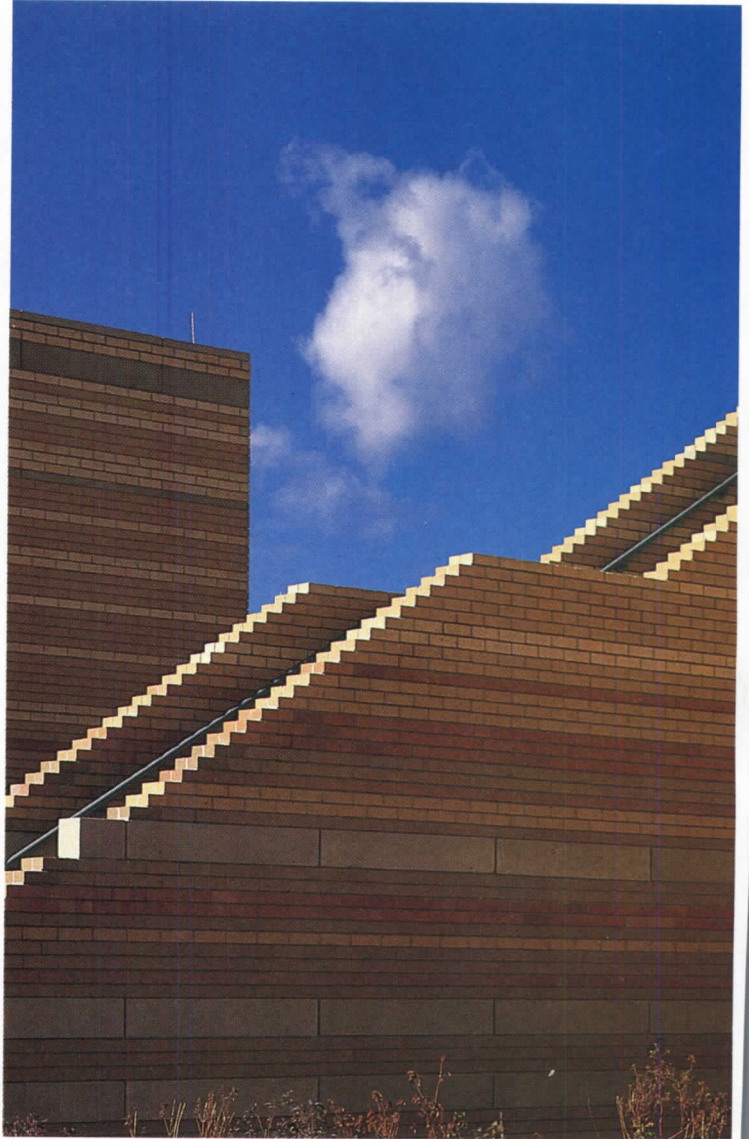

- | | |
|-----------------------|------------------------------|
| 1. Training simulator | 7. Computer room |
| 2. Lounge | 8. Vending |
| 3. Classrooms | 9. Lockers |
| 4. Offices | 10. Central mechanical plant |
| 5. Mechanical | 11. Cooling tower |
| 6. Reservations bays | |

*Delta Air Lines Reservations and Training Center
Salt Lake City*

Owner:
Delta Air Lines, Inc., Atlanta—Maurice Cain, Director of Facilities; Marcey McCann, Assistant Vice President, Reservations Sales

Architects:

Lord & Sargent, Inc., and MHT Architects, Inc.—Larry Lord, Terry Sargent, David R. Hayes, principals-in-charge; Jack Hughes, Dennis Cecchini, co-project architects; Allen Duncan, Jimmy Hawkins, William Hoster, Harriet

Cherry Leavens, Klaudia Keilholz, Jane Seville, John Stephenson, Howard Wertheimer, staff architects

Engineers:

Reaveley Engineers and Associates (structural); R. L. Daniell & Associates (mechanical/electrical); Olsen

& Peterson (mechanical); Becherer Nielson Associates (electrical); Acoustics Engineer, Inc. (acoustical)

Consultants:

Dell R. Cook & Associates (landscape architects)

General contractor:
Oakland Construction

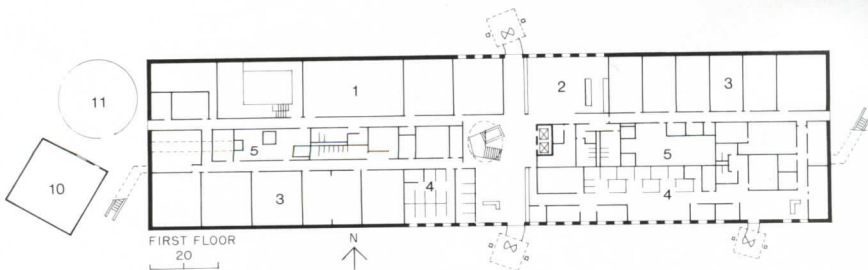
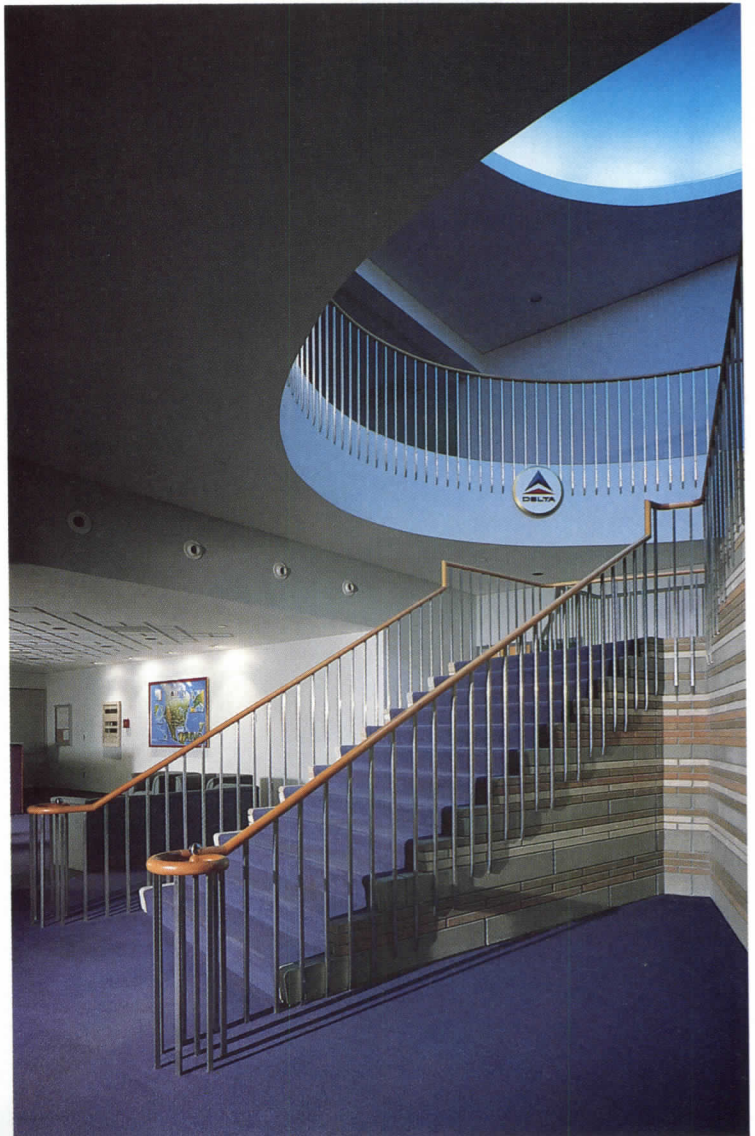
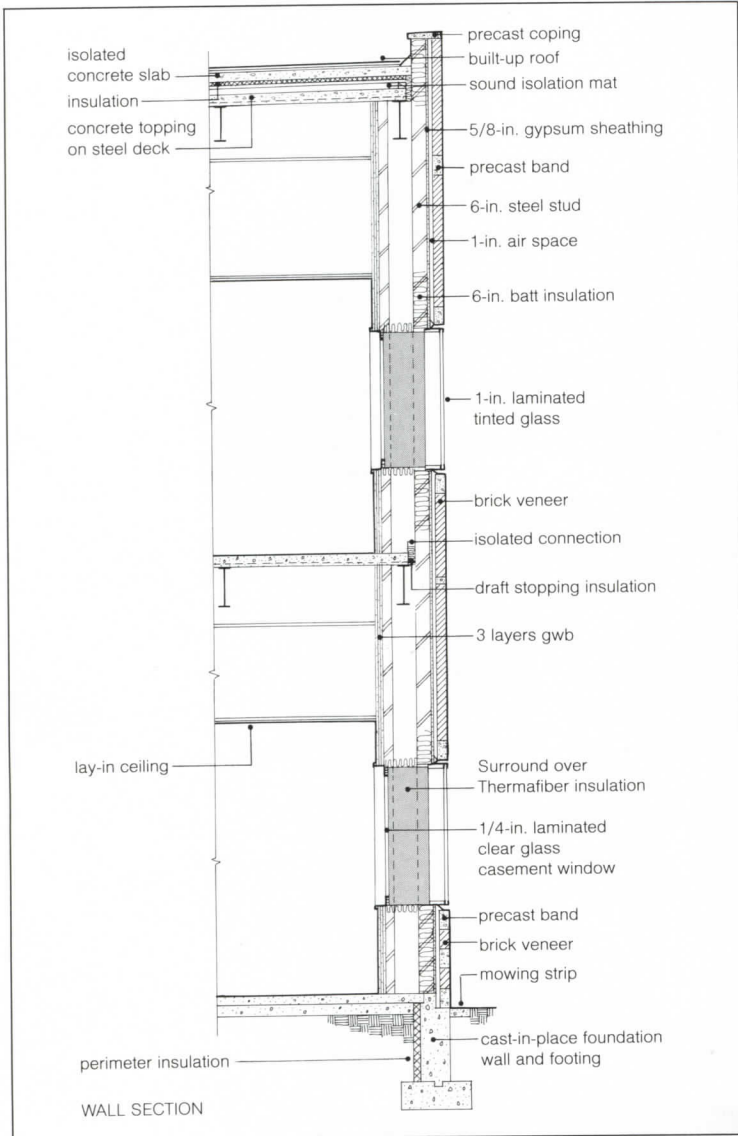



The recovery of ornament

Roger Ferri first came to public notice in 1978 when, six years out of the Pratt Institute and not yet 30 years old, his designs for a pedestrian city were exhibited at New York's Museum of Modern Art. The word "visionary" was tossed around then to describe his beautifully rendered paintings and drawings for a two-mile-diameter circular city in the American Southwest. Eleven years later, the word still seems appropriate. Initiated partly in response to the cumulative ecological crises of the 1970s—crises that are very much with us today—Ferri's idealized community for the "post-petroleum age" was cleverly planned to dispense with the internal-combustion engine within the city proper. Though driven by the dream of what Ferri describes as "a reintegration of the man-made environment and nature," the pedestrian city represents not a retreat from modern technology but an attempt to perfect technology by using it with greater circumspection and care. For example, cars and buses would not be banned from the pedestrian city, but would be left at its outskirts. The city itself is small enough to negotiate comfortably on foot; underground tunnels would provide service access, while ample public transportation would be provided above ground by electric tram.

As the idea of the pedestrian city suggests, Ferri can be described as an architectural ecologist. His interests go far beyond designing particular buildings to embrace urbanism at the highest—what almost seems a metaphysical—level. While there has been no dearth of architects raising the banner of ecology in recent years, it is rare indeed that one finds a practitioner who combines so thoughtful an approach to the large questions of urbanism—questions that ask not only what should we build but also how should we live—with architectural designs that are strikingly and exquisitely drawn. Indeed, Ferri's alternative to what he describes as the baneful "academicizing tendency in the arts" begins with a return to drawing and "visual thinking" in architecture. But it is worth stressing that he is not simply an esthete extolling good drawing and visual sensitivity for their own sakes, however important that pursuit might also be. His entire oeuvre to date has, one way or another, aimed at the goal of reintegration. This means that Ferri strives to put visual acuity and artistic technique at the service of an architectural vision that emphasizes community and the union of man with nature.

It also means that one of Ferri's chief ambitions is the recovery of ornament, a goal apparent in his design of the Dai-Ichi Tokyo Bay Hotel. In this sense, his work represents a more or less complete reversal of Adolf Loos's famously stern dictum that "freedom from ornament is a sign of spiritual strength." For Ferri, ornament, when properly understood and applied, is a key to reanimating architecture and restoring its civic appeal. To be sure, the difficulties are formidable. In order to be more than mere decoration, more than Postmodernist appliqué, ornament must be capable of expressing shared, communal meanings. And it must also be organic, representing, as Ferri puts it, the "unity of outward appearance and inner structure." These are tall orders in a world that is increasingly heterogeneous and where the whole idea of "inner structure" is often dismissed as a romantic fiction. It is too early to say for certain whether Roger Ferri's architecture will really succeed in helping us to reclaim the spiritual function of ornament. But, as his ambitious design of the Dai-Ichi Tokyo Bay Hotel shows, his efforts will at the least give us buildings that are civilized, urbane, and sumptuously embellished. That in itself is no small feat. *Roger Kimball*

Roger Ferri designed the Dai-Ichi Tokyo Bay Hotel while he was a principal with Welton Becket Associates (now Ellerbe Becket). One of Ferri's chief esthetic concerns was to provide the hotel with a unified, emotionally rich system of architectural ornamentation.

Akio Kawasumi



Akio Kawasumi

Dai-Ichi Tokyo Bay Hotel
Tokyo, Japan
Ellerbe Becket, Inc., and
Kajima Corporation, Architects

The art and process of architectural iconography

Set on what Roger Ferri generously describes as an "undistinguished" site of landfill and surrounded on three sides by a chaos of urban sprawl (previous page), the Dai-Ichi Tokyo Bay Hotel makes the most of the one great natural asset of its site, Tokyo Bay. The hotel, which opened in July of last year, consists of a U-shaped set of interlocking pavilions that extend toward the bay.

Though the hotel will cater largely to an Asian clientele, the program called for Western-style architecture. Accordingly, Ferri organized the various wings that comprise the hotel around a central courtyard, thus adopting one of the most venerable motifs in Western architectural vocabulary. "I sought," notes the architect, "an urban character and a rich formal and iconographic agenda rooted in perennial traditions of Western architecture." The courtyard functions as both the physical and emotional center of the complex. Viewed from the guest rooms rising on three sides above it, the courtyard appears as a serene mandala (2). In fact, the large central tondo depicts an abstract version of the orbital street pattern of Ferri's pedestrian city, complete with a stylized agricultural parterre composed of interlocking marble squares. His original design also called for a 12-foot-wide mosaic band (unexecuted) by the artist Ned Smyth to encircle the tondo and depict man in harmony with nature.

The grand ballroom pavilion (2, 3) faces the south side of the courtyard. Its copper-green enameled aluminum roof curves like a gently rolling wave, across which dance a row of 7-foot-tall cast-concrete sculptures of leaping porpoises (1). These figures are meant, Ferri has written, to be "emblematic of benign intelligence on the planet." The sculptures were painstakingly modeled at

1. Cast-concrete porpoises
2. View into courtyard



Roger Ferri



Katsuaki Furuda

- 3. Ballroom entrance
- 4. Clay model of porpoise
- 5. Plaster model of porpoise
- 6. Full-size mock-up of porpoise

Katsuaki Furudate



Roger Ferri

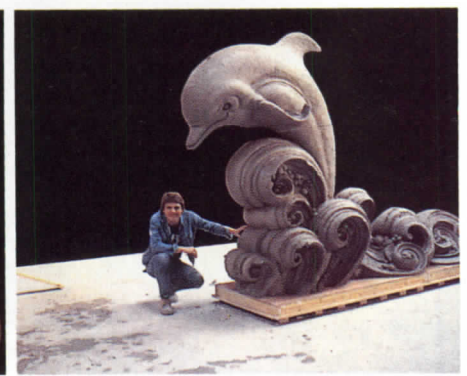

5

6

quarter-scale in clay (4) and plaster (5), and were cast in full-size mockups under Ferri's supervision by New Orleans sculptor Joe Barth (6) before being fabricated in Japan from molds. The ocher-colored tile walls of the hotel are broken by bands of terra cotta and terminate in sets of oversized floral columns (3) that complete the suggestion of burgeoning vegetation begun below in the courtyard walls. The columns stand within multistory recesses carved from the wall and illustrate how Ferri was able to modulate the building's mass and volume.

The arcade defining the central courtyard is articulated by cast-in-place concrete columns that rise in the form of stylized budding plant stalks (8). The curves of the columns' leaf sheaths open outward to trace the arcade's arches, while the surmounting "blossoms" anticipate the floral capitals of the oversized columns above. Ferri worked closely with Japanese craftsmen to achieve the correct proportions and delicately sloping curves in the scroll and finial capitals used throughout the building (10-13). As with most projects, the finished version of the Dai-Ichi Tokyo Bay Hotel (which is Ferri's largest commission to date) departs in certain respects from the architect's original schematic design. Some of the alterations, like the substitution of painted aluminum for copper in the ballroom roof, do not compromise Ferri's artistic intentions; other changes like the elimination of entasis the architect had specified for the huge columns that help define the hotel's skyline are more disappointing. Nevertheless, more than enough of Ferri's original vision survives to reveal his successful attempt to animate architecture with an iconographically complex palette of ornament. *R. K.*

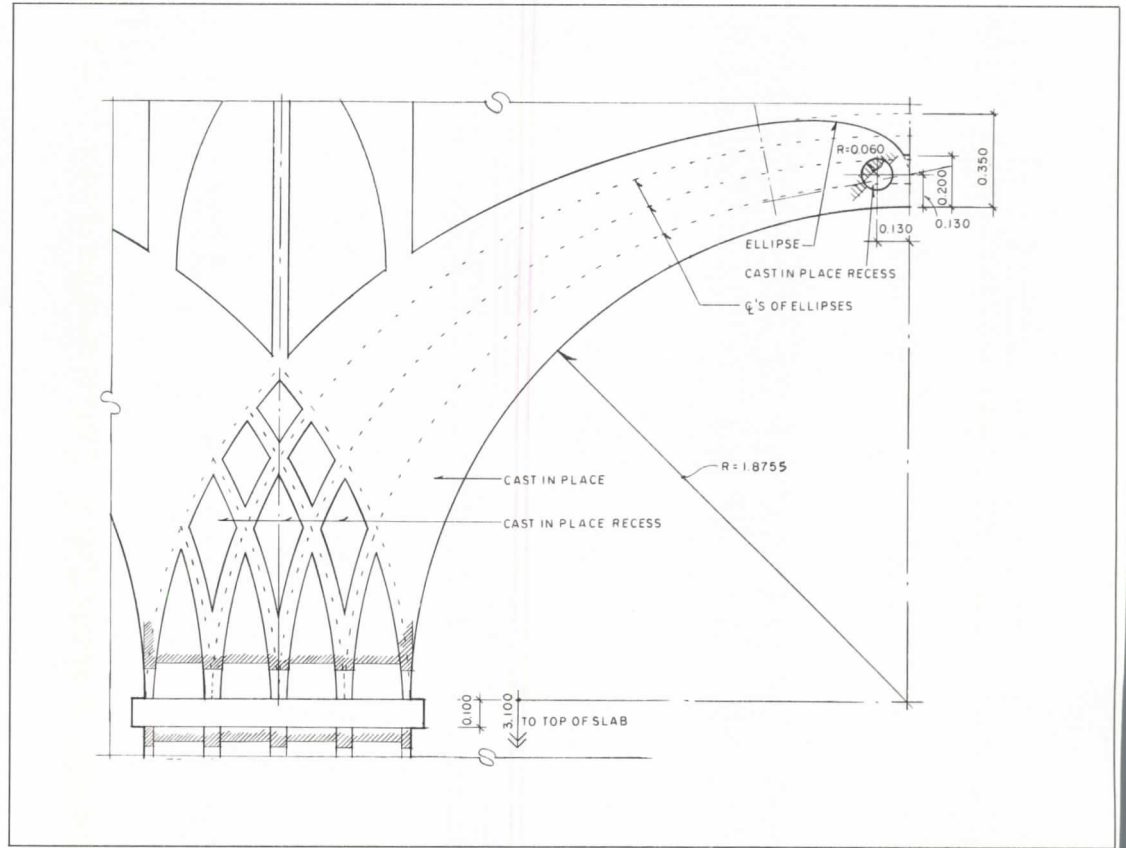

- 11. Column elevation
- 12. Full-scale capital mockup
- 13. Full-scale capital mockup

Dai-Ichi Tokyo Bay Hotel
 Tokyo, Japan
Owner:
 Tokyo Bay Dai-Ichi Resort
 Company Ltd.
Architects:
 Kajima Corporation (architect
 of record) and Ellerbe Becket,

*Inc. (schematic design and
 design development)—*
 MacDonald Becket, chairman,
 The Becket Group; William P.
 Scott III, director, New York;
 Robert E. Zumwalt, senior
 project principal; Roger Ferri,
 design principal; Julio Ruiz-
 Gomez, project architect; Tom

Eisele, Robert Barringhaus,
 design staff
Engineers:
 Kajima Corporation
Consultants:
 Media Five Architects (interior
 design); Tino Kwan Lighting
 Consultant (lighting); Kajima
 Corporation (landscape)

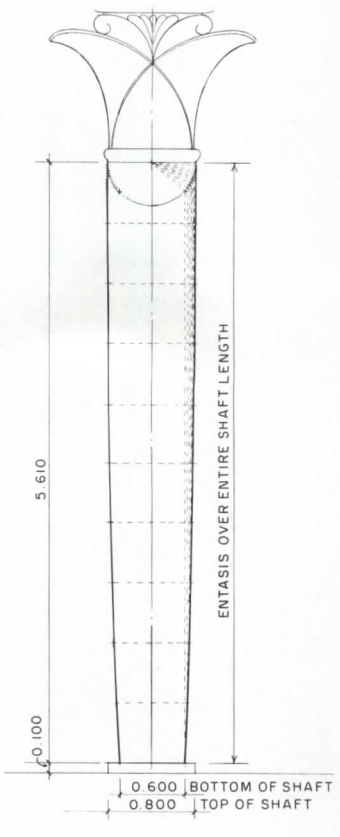
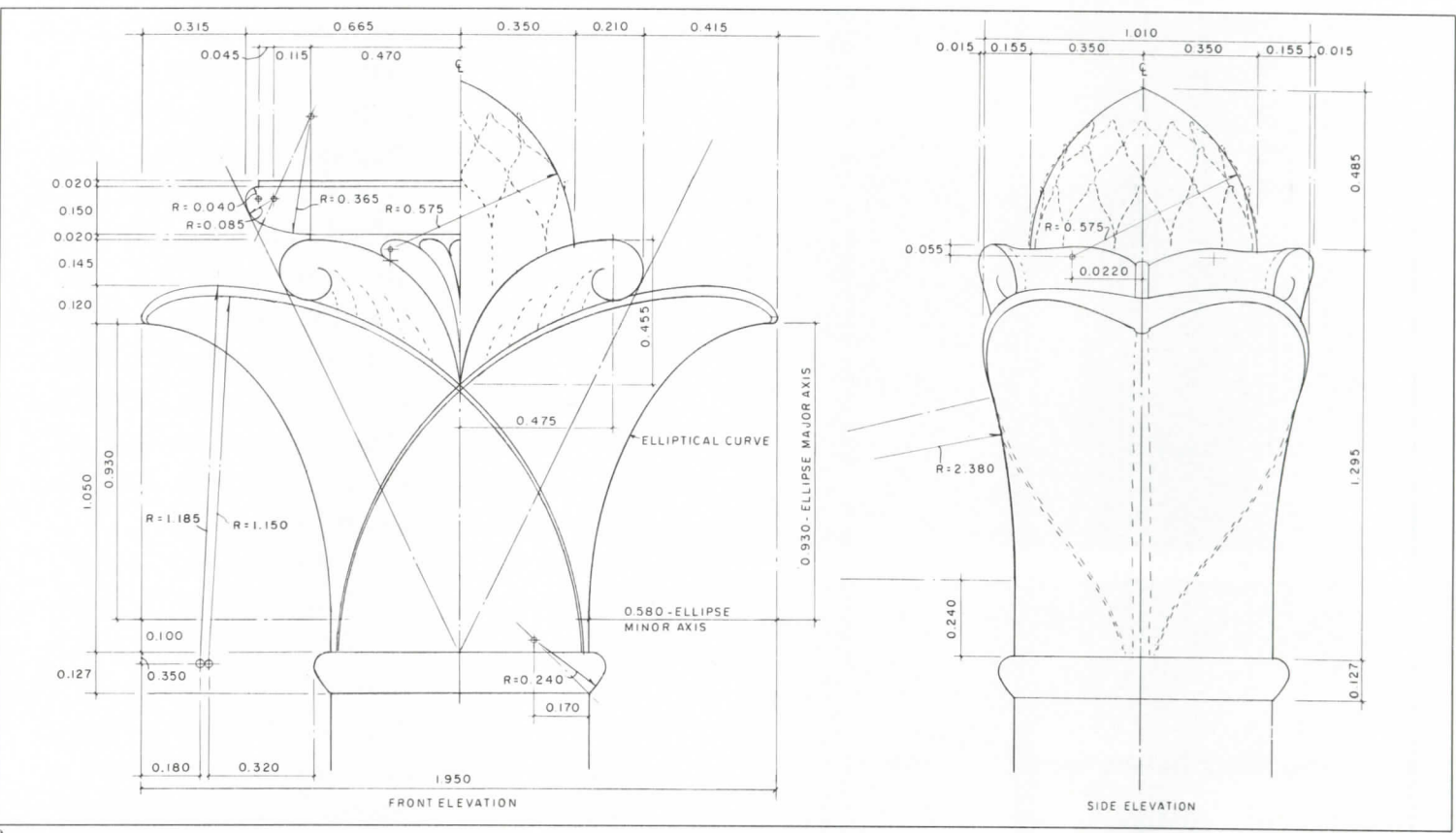

Show offices



© Elliott Kaufman

Private office, New York City



© Jon Miller/Hedrich-Blessing

Woodwork Corporation of America, Chicago



© Elliott Kaufman

National Shopping Centers Management Corporation, Harrison, New York

Corporate office interiors by necessity must fit a variety of requirements. The successful outcome of any commercial project depends on how effectively the architect or interior designer is able to integrate a client's particular agenda with the more generalized, but no less important, goals of functional efficiency and esthetic innovation. Though the offices featured on these pages have varying programs, their designers all addressed the workaday exigencies of corporate life without losing sight of their patrons' idiosyncracies. For example, Corinne Calesso and Peter Samarin's renovation of a suite on the 40th floor of the Empire State Building creates an established look for an up-and-coming entrepreneur (top left and pages 142-143), while Powell/Kleinschmidt's design of executive and sales offices for the Woodwork Corporation of America, in Chicago, shows off the company's own custom millwork (middle left and pages 144-147). Karen Bausman and Leslie Gill's design of offices for the National Shopping Centers Management Corporation, in Harrison, New York, were inspired by owner David Bermant's vast collection of electrically powered artwork, and the architects neatly integrated Bermant's personal avocation with his professional vocation (bottom left and pages 148-149). In their scheme for the New York outpost of Finlandia Vodka, Anderson/Schwartz looked to the company's Nordic cultural roots for inspiration. The result: partner-in-charge Frederic Schwartz's homage to Finnish architect Alvar Aalto is intended to make company employees feel right at home on the 43rd floor of the RCA Building (opposite and pages 140-141). Even in a milieu as decidedly corporate as Rockefeller Center, the home-away-from-home imagery is appropriate, given that for many busy executives, the office has become just that. *Karen D. Stein*



Finlandia Vodka, New York City

Finnish spirits



When Finlandia Vodka asked Anderson/Schwartz to design its New York sales offices in Rockefeller Center, partner-in-charge Frederic Schwartz decided to re-create select elements of the Finnish national distillery's native surroundings on the 43rd floor of the landmark RCA Building. "Distributors come to the office not only to purchase Finlandia vodka, which bears the country's Latin name, but also to participate in the cultural heritage that the brand name represents," explains Tom Wilen, former president of the company's Western Hemisphere division. The architect accordingly drew much of his inspiration from Finland's most celebrated practitioner of 20th-century Modernism, Alvar Aalto.

In order to set the stage for his homage to the Finnish master, Schwartz divided the 4,000-square-foot space down the middle, creating two distinct areas with a corridor in between (plan below). A "light" north-facing row of private offices is delineated by angled surfaces with smoked-glass panels (middle left), while "dark" windowless communal areas, including a kitchen/dining room and storage space, are enclosed by conventional walls. Schwartz employed the orthogonal surfaces to heighten the contrast between the private offices and the more public reception area, where a curved ash partition masks secretarial workstations (top left). Recalling the bentwood frames of Aalto's own furniture designs, the desk is also meant, according to the architect, "to be symbolic of flowing liquid." In another more overt reference to the Finlandia product line, Schwartz incorporated the company logo of two reindeer locking antlers beneath a bright-red sun into wall-to-wall carpeting. For the president's suite, Schwartz designed a kidney-shaped work surface that rests on top of two Aalto file pedestals (page 139 and top opposite). Custom-made cabinetry in both the president's office and the adjoining conference room (bottom opposite), was finely handcrafted in the spirit of Aalto. In a departure from the typical corporate office brief, Finlandia's program included a sauna, which Schwartz incorporated into a locker room partially shielded by a wood screen (bottom left). All employees are encouraged to indulge in the Finnish ritual, which company officials maintain helps cement Finlandia's cultural ties to its homeland. Says Wilen of the sauna's role in business negotiations: "It's a great icebreaker." *K. D. S.*



© Elliott Kaufman photos

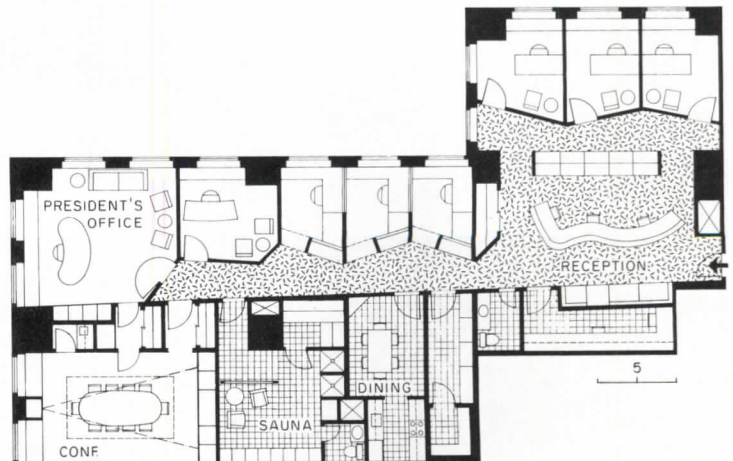
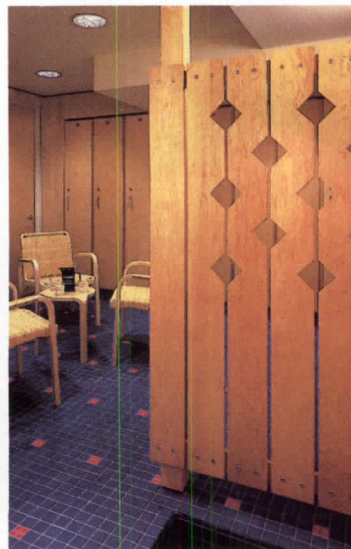

Finlandia Vodka
New York City

Architect:
Anderson/Schwartz—Frederic
Schwartz, partner-in-charge;
Samuel Tonos, project
architect; Ross Anderson, Terry
Nelson, David Smiley, Jaime
Vasquez, Noah Carter, Corey

Delaney, and Sharon Portnoy,
project team

Engineer:
Hartmann & Concessi, P. C.
(mechanical/electrical)

Consultant:
Johnson/Schwinghammer, Inc.
(lighting)

General contractor:
McHugh DiVincent Alessi, Inc.;
Leinoff Woodworking (custom
cabinetry)



Private offices
New York City
American Design Company,
Designers

Keeping up appearances



©Elliott Kaufman photos



A starter office often looks like just that: an unfinished shell equipped with the bare minimum of necessities. But not the new headquarters of a privately owned company that trades plastic film with manufacturers in Europe and Asia. After successfully conducting business for several years out of his Manhattan apartment, the company's owner (who requested anonymity) decided to move to more respectable corporate quarters, envisioning a milieu (and an address) that would impress his growing roster of foreign clients. To achieve the desired effect, he selected an office suite on the 40th floor of the Empire State Building, and asked Corinne Calesso and Peter Samarin of American Design Company to draw up new plans for the 745-square-foot-space. His charge to them reflected ambitions typical of any young entrepreneur dealing with large sums of other people's money. "He wanted to appear stable and trustworthy," recalls Calesso. And, not surprisingly, he wanted the job done for a modest price.

Toward that end, Calesso and Samarin carved out a security vestibule/waiting room where visitors are screened by telephone before they are granted entry to the inner sanctum (top photo page 138 and plan below). To enhance the windowless reception area, the designers devised a custom-made translucent screen of back-lit laminated-fiberglass panels that give the appearance of Japanese shoji. The partition also provides a neutral backdrop for an assortment of furniture, including a wood cabinet designed by Calesso and Samarin, a Joe D'Urso granite-topped table, a 1940s chair by Jean Prouvé, and more up-to-date ergonomic seating (top left). The panels are repeated as sliding doors along a narrow hallway (bottom left) to the owner's private office, where Calesso and Samarin removed a dropped ceiling to open up dramatic south-facing views of the New York City skyline (opposite). The compendium of furniture styles in this room includes a shelf and glass side table by American Design Company, a desk by Bruce Burdick, and a Josef Hoffmann black-leather sofa (not shown). The intentionally eclectic mix of antiques and contract furniture throughout the offices appears to have been assembled over time, subliminally reminding all who conduct business here that this upstart firm is no fly-by-night operation. *K. D. S.*

Private offices
New York City
Designer:
American Design Company—
Corinne Calesso and Peter
Samarin, principals-in-charge

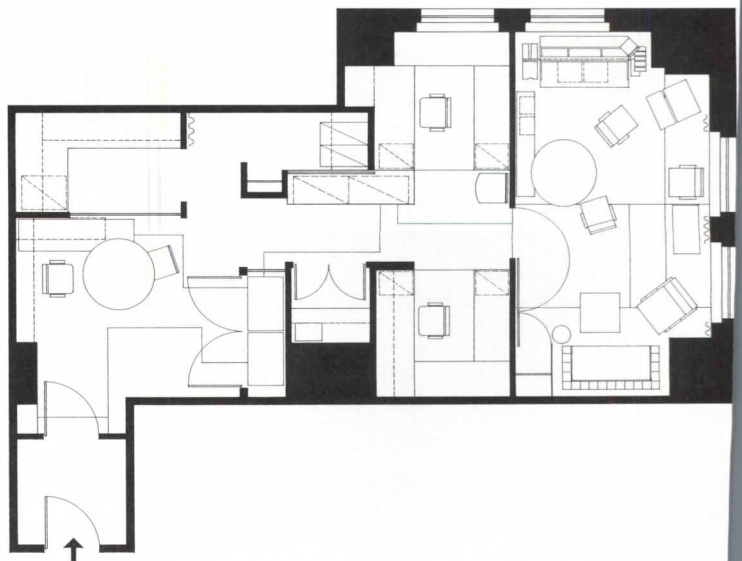

Designers Corinne Calesso and Peter Samarin, of American Design Company, removed an existing dropped ceiling to raise the height of a private office by three feet. South- and east-facing windows light the room by day, and track lighting was installed for

nighttime use. The duo echoed the asymmetry of the office footprint in the one-of-a-kind rug assembled from a patchwork of standard carpet pieces.



Tools of the trade



©Jon Miller/Hedrich-Blessing photos

To mark its 75th anniversary, the Woodwork Corporation of America (WCA) decided to renovate its suite of offices, located within a converted Chicago warehouse. The company, the largest manufacturer of custom millwork in the Midwest, asked Powell/Kleinschmidt, faithful disciples of the city's Modernist tradition, to give visual unity to a varied program. WCA's owners stipulated that the architects not only accommodate the functional requirements of company executives and a 10-person sales staff, but also devise innovative paneling and cabinetry applications that in effect would make the offices a living catalog of the firm's woodworking capabilities.

While WCA employees set up temporary quarters in their adjacent factory, the architects reconfigured the 5,400-square-foot, second-floor space, retaining only an original wood-paneled conference room as a historical artifact (not shown). In a new reception area (page 138 middle, and above), the architects established a pattern of blond French white-ash paneling with 3 1/4-inch-wide American cherry banding at approximately three-foot intervals. These darker wood stripes were continued along a

Woodwork Corporation
of America
Chicago
Powell/Kleinschmidt,
Architects



central corridor to define discrete areas within the facility's open-plan layout. Although two veneers dominate the material palette, other woods were employed in specially designed furnishings, and the architects integrated a variety of WCA's finishes into their scheme (in the reception area, for example, a plywood column and particleboard desk are coated in automotive paint, which is buffed to a high-gloss sheen). To mask a dilapidated glass-block exterior wall, Powell/Kleinschmidt covered the south side of the inner shell with wood screens. Forming a nine-inch reveal, the series of egg-crate louvered doors are lined with sheets of mylar to diffuse light from incandescent fixtures recessed in the ceiling and floor. Partner-in-charge Robert Kleinschmidt selected several multimedia art pieces to "expand on the sense of craft" exhibited throughout the offices, but perhaps the most intriguing installation was wrought at the hands of WCA's president, Robert Kay. The architects supplied his office with a fabric-wrapped panel, a standard WCA product, on which he artfully arranged his collection of antique tools—another strikingly appropriate symbol of the company's history. *K. D. S.*

Powell/Kleinschmidt repeated the pattern of blond ash with cherry-wood stripes that they established in the Woodwork Corporation of America's reception area along the central corridor and inside individual rooms, including a new conference room (below).

Although the reception area's built-in seating is a variation on Sunar-Hauseman's existing Kleinschmidt Collection (page 144), the architects designed several furnishings specifically for WCA, including the ebony desk and credenza in the vice president's office



*Woodwork Corporation of America
Chicago*
Architect:
Powell/Kleinschmidt, Inc. — Robert D. Kleinschmidt, partner-in-charge; Thomas Boeman, project architect; Donald Los, technical director; William Arnold, project designer

Engineer:
Mid-Continent Engineering, Inc.
Consultant:
Emily Berlinghof (colors and materials)
General contractor:
Woodwork Corporation of America

(right opposite). The architects used center-pivot louvered doors as screens along the south side of the office suite to hide an old glass-block wall. In the president's office, the screens also serve as a neutral foil to a panel of antique woodworking tools (below).

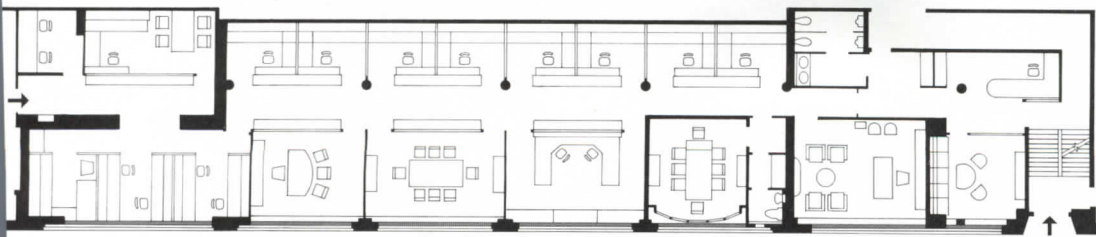

Offices for National
Shopping Centers Management
Corporation
Harrison, New York
Bausman•Gill Associates,
Architects

Opposites attract



©Elliott Kaufman photos



*National Shopping Centers
Management Corporation, Inc.
Harrison, New York*

Owner:

David Bermant, President

Architect:

*Bausman•Gill Associates—
Karen Bausman and Leslie
Gill, partners-in-charge; Adi
Shamir, associate*

Engineer:

Gilbert Dias (structural)

General contractor:

CSR Construction Corporation

As Karen Bausman and Leslie Gill tell it, they spent five years together in a class of some 25 other architecture students without exchanging more than a perfunctory “hello.” Almost immediately following their graduation from The Cooper Union in 1982, however, the two banded together to form Bausman•Gill Associates. Although both architects cite neighboring seats at the New York State licensing exam as the prologue to their partnership, they credit the firm’s creative development to the discovery that their seemingly opposing personal styles are actually based on similar architectural concerns. Together, Bausman, an accomplished painter, and Gill, a designer whose style is more rigorously geometric, create work that is at once sensuous and ordered. Their collage of approaches is perhaps best exemplified by an ongoing series of three-dimensional studies in point, plane, and volume that are confined within the boundaries of discarded cigar boxes—miniature design laboratories that represent a continuing evolution of their esthetic ideas.

Bausman and Gill’s approach proved to be ideally suited to the two-part program supplied by David Bermant, who commissioned the firm to design a 3,400-square-foot suite of offices in the New York City suburb of Harrison. The offices serve as headquarters of Bermant’s vocation (with his brother, Joseph, he is a developer of shopping centers) and avocation (he heads a nonprofit foundation called Color, Light, Motion that has amassed what is reportedly the world’s largest collection of kinetic sculpture). Perhaps inspired by the client’s mechanically powered objects, the architects devised a system of movable panels that serve both as office partitions and display backdrops. When a substantially revised budget precluded the use of pulleys and gears, they reconfigured the space with less elaborate wall sections. To emphasize planarity, Bausman and Gill repeated the lines separating differently colored plaster sections in parallel steel bands that frame glass walls and wood doors, giving a regulated appearance to all vertical surfaces (bottom page 138 and top left). The architects placed opposing sections of wall into what they call “face-offs”—a deliberate contrast of recessed and projecting areas (opposite). Although a material palette of pigmented plaster, ash, acid-etched copper, steel, and slate seems discordant, the finished offices somehow coalesce, much like the architects’ own practice, into a unified whole. *K. D. S.*

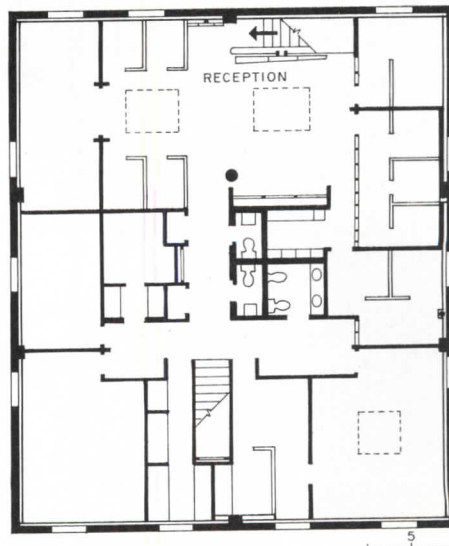

Karen Bausman and Leslie Gill's design for offices in Harrison, New York, is based on a system of regulating lines that appear between panels of integral-colored plaster (below) and are repeated in the steel framing of glass office partitions. Acid-etched copper

panels, attached to recessed wood-framed surfaces, serve as backdrops for the owner's collection of electrically powered artwork.



Living on borrowed light

Everybody talks about daylighting but not too many designers do much about it for the same reasons no one can do much about the weather. Outdoor light has proven difficult to use without distracting brightness and solar-heat gain. Like most lighting design firms, Jules Fisher & Paul Marantz, Inc., came to architectural lighting design from work in the artificial realm of the theater. Over the years, however, the firm has assisted architects in the increased use of daylight as part of a total lighting scheme, particularly in museums, and has worked with such firms as Moshe Safdie & Associates, on the National Gallery of Canada in Ottawa (mockup below right; see also RECORD, October 1988, pages 120-129). Fisher & Marantz is currently the consultant to Venturi Rauch and Scott Brown (VRSB) on four projects, which harness daylight to an unprecedented degree.

Lighting the Sainsbury Wing

The National Gallery in London is advised by a group of scientists who have pioneered research on art-conservation techniques, including the role of light. The former head of the group, Garry Thomson, wrote *The Museum Environment* which, according to Paul Marantz, is still considered the bible of museum lighting. Given such expertise it should not be surprising that the museum hopes to break new ground in the design of its extension. Both architect and client called for toplit spaces that offered a visible continuity with the existing Neoclassical structure. VRSB chose as its model Sir John Soane's Dulwich Art Gallery of 1814, and designed rooms with similar clerestories and windows.

Unfiltered sunlight can be as bright as 100,000 lux (the metric measure of illumination, each unit roughly equal to 10 footcandles). The curatorial staff required a dramatic reduction in the amount of light actually reaching the works of art to no more than an average of 200 lux, a level that the eye is flexible enough to perceive as adequate. The lighting designers and VRSB worked together to configure chambers above and between the rooms to catch, reflect, and filter light into galleries, whose shapes themselves were manipulated to enhance diffusion (section, page 153). The long north-south sides of the chambers will be roofed with a gabled skylight to pick up morning and evening sun; the other sides have single-sloped skylights to capture south light. Louvers under the skylights are to be controlled by a computer which, as Marantz puts it, "acts like a guard looking out the window and adjusting the blinds according to the weather." Every two hours, for a period of several minutes, it will "interview" the light falling on the skylights (to avoid adjusting the system for a passing cloud or brief period of sunlight), and change the louvers, if needed, gradually ("to keep visitors from being aware of shading 'bells and whistles'"). Electric illumination is to be provided at 75 lux; other sensors will cause this lighting to be

The firm of Jules Fisher & Paul Marantz, Inc., is finding that daylight is increasingly useful in lighting design, even in situations requiring very careful control, as four projects with architects Venturi Rauch and Scott Brown demonstrate.

supplemented at any time that natural light falls below preset minimums. The concept has been tested for more than a year on gallery mockups (below, three left photos). Graphs on a given day show dramatic spikes and drops in measured light, reflecting the desired variations for season and time of day, while the computer program will adjust the system to keep the overall amount of light falling on artworks to within curator-specified limits.

Whither daylighting?

"You can't truly fake the color rendering of sun, nor the variation in seasons and time of day that comes with natural light," says Marantz. Yet, for a time after World War II, sunlight was banished: "The idea became to totally control everything. Old skylights were tarred over to reduce air-conditioning loads and to make room for mechanical systems." Textiles, and works on paper and wood, are still regarded as too fragile to be exposed to *any* natural light, which is why some curators prefer the total control inherent in spaces entirely lit by electric light. For curatorial flexibility, VRSB will make very limited use of the Texas sun at the Laguna Gloria Art Museum, in Austin (opposite). At the La Jolla Museum of Contemporary Art, monitors are intended to light only specific and limited areas (pages 152-153).

Finding the tools

The dramatic main reading room of the Furness Building at the University of Pennsylvania, designed by Frank Furness and finished in 1891 (pages 152-153), might be thought a daylit dream: outdoor light pours in through high clerestories and from above through an elegant leaded-glass laylight, avoiding glare on readers three stories below, but it has always had lighting problems. As part of a phased restoration by VRSB with the Clio Group, task lighting at study tables will be combined with new concealed ambient lighting because the design team did not want to dilute the restoration with in-the-style-of-Furness fixtures. In other areas of the library, glazing over study alcoves that were often much too hot and too bright has been replaced with tinted, patterned glass. The book stacks incorporated a skylight roof, which has long been tarred over. Though the roof will be repaired, the skylight will not be restored to avoid damage to the book collection. Instead, the intricate tracery of steel supports will be lit from below.

Lighting design is not all counting footcandles and choosing lamps. At Fisher & Marantz, some refinements come from do-it-yourself R & D: photochromic glass has been tested on the roof of Marantz's home; a film intended for use in solar collectors was adapted as a reflective lining for a deep light monitor at the Canadian National Gallery. As Marantz explains, "we have to figure out the reality of the project and *find* the tools." *James S. Russell*



National Gallery, 1:5 mockup



Interior of light-refracting chamber



Exterior of full-scale mockup



Ottawa Gallery mockup

Most of the galleries at the Laguna Gloria Art Museum, in Austin, will be lit by electric light, a flexible arrangement that will accommodate its 20th-century permanent collection as well as traveling shows. But in the North Gallery, which stretches the length of the long

and relatively narrow structure, the design team has mixed limited and carefully controlled natural light with both fluorescent and incandescent sources. Venturi Rauch and Scott Brown is associated on the project with The Rio Group, an Austin firm.

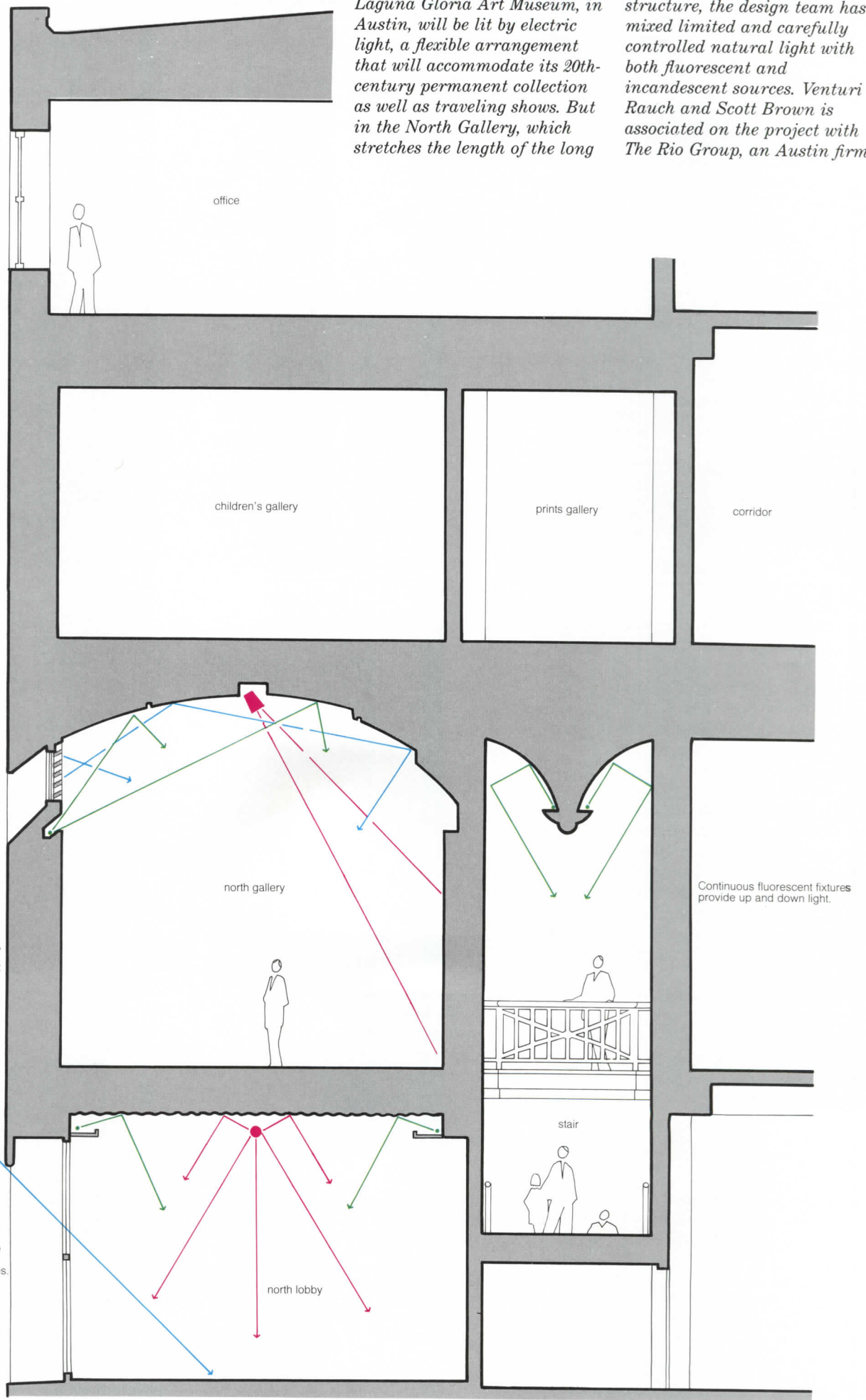

The Sainsbury Wing

From within the rooms of the extension of England's National Gallery, outdoor light appears to stream directly from the outside (right), but it is actually controlled through a complex system of glazing. An exterior insulating skylight unit of clear and untinted laminated patterned glass filters light that then passes through adjustable louvers into a light-reflecting chamber. The sun's rays are in turn bounced through clerestories of laminated glass (section). The clerestory lights

have been sandblasted on the gallery side to reduce interior reflections. Fluorescent fixtures above the clerestories will provide ambient light after dark. Supplemental incandescent fixtures, set in ceiling recesses at an acute angle to the wall, will eliminate reflections from the surface of the artworks.

In the main lobby, coffers will be painted with a plaid pattern, reminiscent of a medieval decorated ceiling, and lit by recessed fluorescent fixtures (below). VRSB is associated on the project with Shepard Robson.

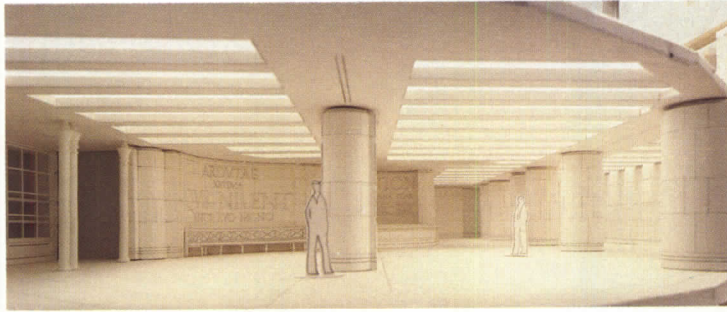

Matt Wargo



Matt Wargo

La Jolla Museum of Contemporary Art

The project is an addition that will flank the former Ellen Browning Scripps house, designed by Irving Gill in 1915. North-facing light monitors, while of consistent widths, are of varying lengths in order to create areas of special significance within galleries that are otherwise lit by incandescent track fixtures. The soft marine light of this southern California village will not require specially diffusing glass or mechanical controls; the curve of the monitors has been conformed to disperse direct sun.

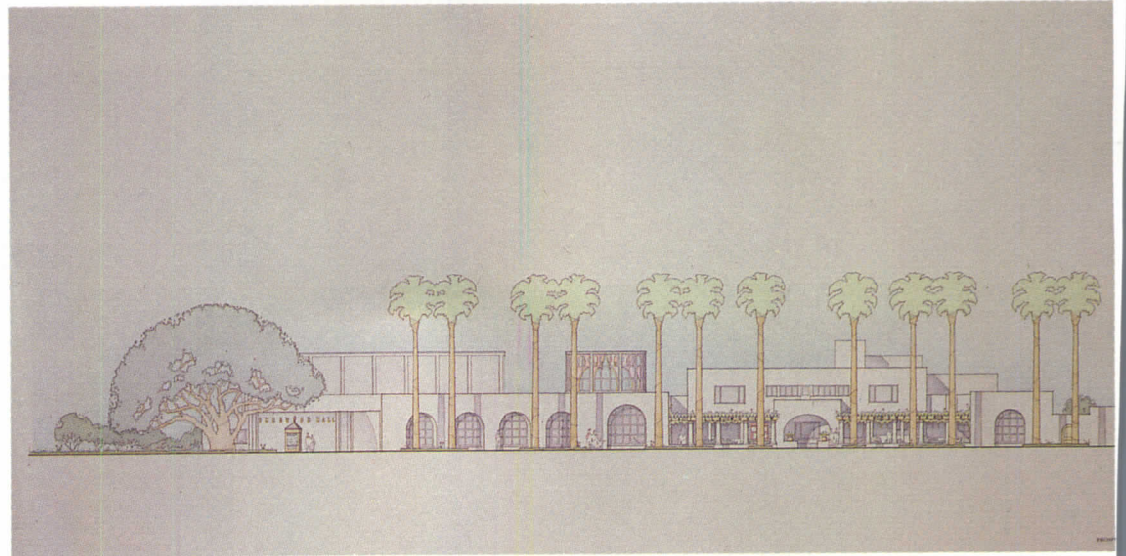

The Furness Building

"Idiosyncratic" seems too weak a word to capture the work of Frank Furness. Restoring the terra-cotta-clad library, which houses the fine arts and architecture collection at the University of Pennsylvania, presented unique challenges to VRSB and, as preservation consultants, the Clio Group. Skylights over low study alcoves (visible at left in original exterior photo right) were refitted with light-filtering glass, but reconstructing the skylight over the stacks (right in photo) was considered too harmful to books.

A layer of laminated glass has been installed above the leaded-glass laylight in the main reading room (original photo, opposite) as a safety precaution, and the designers added fluorescent strips here as well for ambient lighting. The fixtures and glass will be serviced from a new trolley that will be installed in the attic above the glass. Lacking full documentation, some historic fixtures had to be recreated from photos. The design team hung a mockup in the monumental porch for testing (opposite, right).

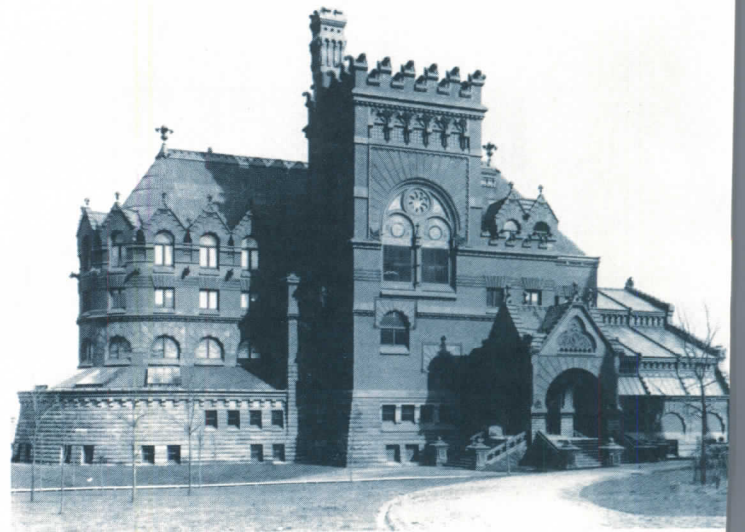

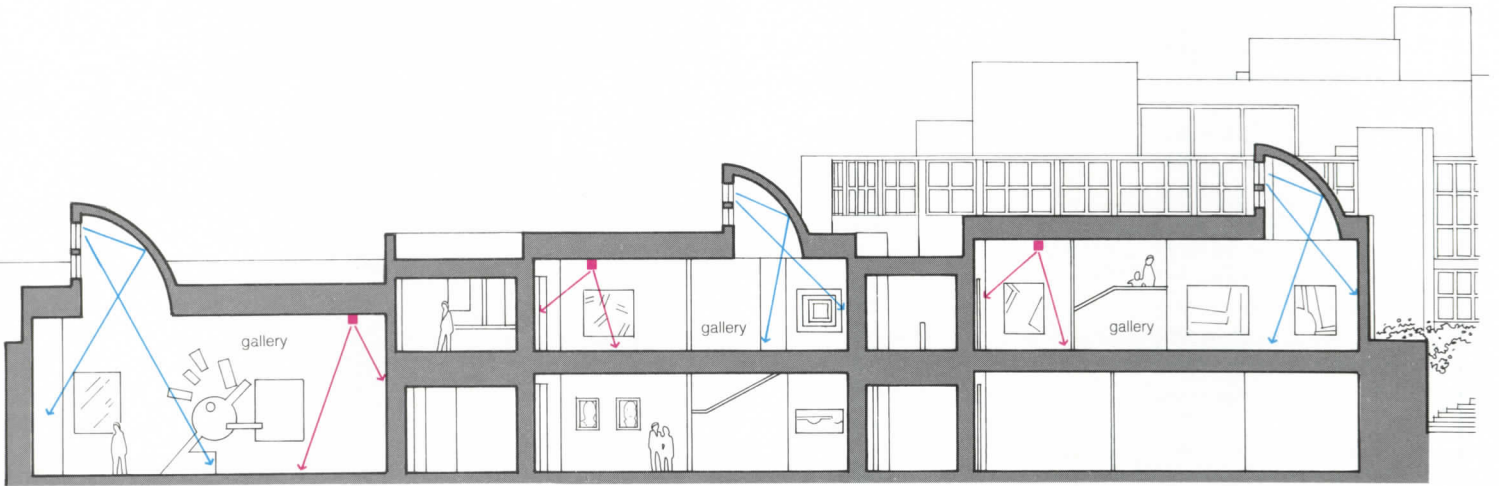
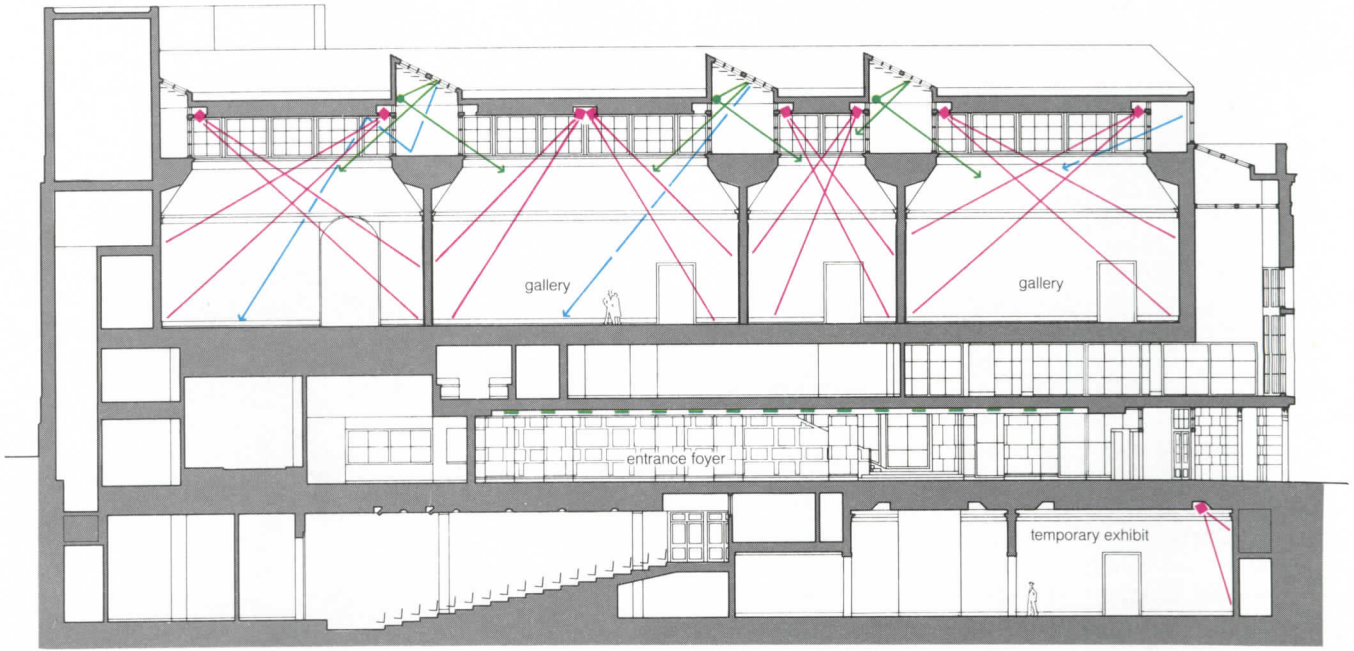

Matt Wargo

New products: NEOCON 21

Chicago, June 13-16: the Cubs (under lights now), the White Sox, and NEOCON 21. Along with an unusual cast of Modernists, futurists, urbanists, and Classicists, there will be some dynamite new contract furnishings. A reconnaissance, below. J. F. B.

1. Routed out

Each side panel of Calvin Morgan's Silhouette Chair—an arm rest and front and back legs—is made of a single piece of 1-in.-thick maple-veneer, cut in a distinctive pattern of solids and voids on a computerized router. Six cut-out designs are offered, in both standard and custom finishes. Hickory Business Furniture, Hickory, N. C.

Circle 200 on reader service card

2. Desks of steel

The design details of Haworth's wood-based Places office system are incorporated in a new line of steel furniture. Single-, double-, and clear-pedestal desks have a polyurethane radius edge in colors that can match or contrast with the work surface. Haworth, Inc., Holland, Mich.

Circle 201 on reader service card

3. Team effort

Steelcase will display a new office system at NEOCON. Called Context, it is the result of a multidisciplinary long-range look at the office requirements of the next decade and into the 21st century. The furniture is an ambitious attempt to incorporate the state of the art in electronic support, ergonomics, the churn rate of the modern corporation, VDT-sensitive design, and the concepts of collegial management—coves and caves—into a desk-based office system. The basic element, a curving worksurface with minimal underdesk obstructions, comes in a simplified range of sizes and shapes. This core supports acoustic panels and overhead storage units with task

lighting. Freestanding towers hold coats, personal items, and files, while seeming to enclose work areas. The standard desk drawer is replaced with accessories such as a 7 1/2-in.-wide vertical Dayfiler, and user-adjustable paper-management accessories carried by a rail in back of the desk.

New surface materials—composite wood veneers, no-glare soft-touch laminates, 64 colors of textured fabric, and 20 paint colors—were developed to enhance the three-dimensional aspects of the system, with details increasing in complexity as the user gets closer. Steelcase, Inc., Grand Rapids, Mich.

Circle 202 on reader service card

4. Textured loop carpeting

A new multitufting process can create a true pattern on multilevel loop carpet, a heavy-duty construction whose design range has been limited to solid colors, heathers, and tweeds, according to the manufacturer. This pattern availability may encourage the use of textured-loop carpeting in more design-sensitive interiors. Armstrong World Industries, Lancaster, Pa.

Circle 203 on reader service card

5. Mix and match

Conference tables designed by Alan Jay Paull come in square, racetrack, rectangular, and round shapes, up to 20-ft long. Base options include T-panel (shown), cross, drum, and cube. Taylor Desk Co., Lynwood, Calif.

Circle 204 on reader service card

6. Back to the box

The Interior Options Program now offers glazed ClearStory transom panels and workstation passage doors, to create a to-the-ceiling enclosed office that shares ambient light while establishing acoustical privacy. JG Furniture Systems, Inc., Quakertown, Pa.

Circle 205 on reader service card

Continued on page 156

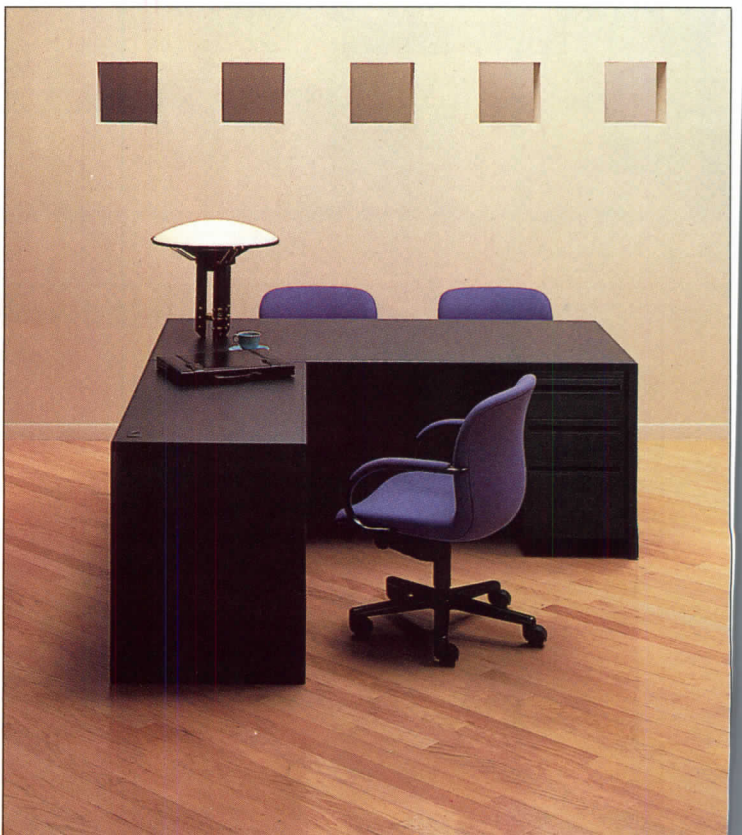

*For more information,
circle item numbers on
Reader Service Card*

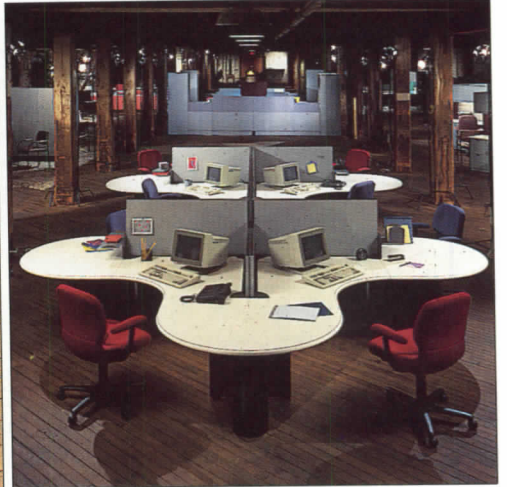

New products: NEOCON 21 *continued*

7. All-American

The Next Chair, designed by Richard Penney, is Interna's first American design/build commission, and will be shown at Deborah Ehlert Associates. A squared-off shape, Next stands just over 35 in. high; the seat can be maple or upholstered. The contoured cut-out plywood back flexes slightly for support. Back, arm, and frame finishes can match or contrast. Interna, Long Island City, N. Y.

Circle 206 on reader service card

8. Random effect

A new textile collection by Andrée Putman includes Varenne, a metallic-look blend of rayon and polyester that contrasts satiny boxes with random parallel lines. There are six colors, all combined with black. Stendig International, New York City.

Circle 207 on reader service card

9. Enclosure

Relocatable steel-framed Styline partitions come as complete floor-to-ceiling units, in panels from 6 to 60 in. wide by up to 12 ft high. Glazed panels and passage doors are options within the line. Adanlock Office

Environments, Jamestown, N. Y.

Circle 208 on reader service card

10, 11. Wall and floor

Artemide will show a white-glass and gray-metal bracket by Jeannot Cerutti for VeArt (10), as well as Ron Rezek's new Axis torchère (11). The upright comes in two finishes: black anodized and a brushed surface with brass details. Artemide, Inc., Long Island City, N. Y.

Circle 209 on reader service card

12. Occasional table

A compact maple table finished in dark red and black lacquer complements Davis Allen's Portico chair. Inset top has a beveled edge. Jack Lenor Larsen, New York City.

Circle 210 on reader service card

13. Factory fresh

Art Moderne chair designs by French architect René Herbst are being produced for the first time in the industrial materials specified 60 years ago: steel tubing and elastic cords.

Palazzetti, New York City.

Circle 211 on reader service card

14. Bauhaus textiles

Woven in bright colors of lilac, green, gold, blue, and orange tempered by black and gray, Dessau Woven Texture and Ontos Tapestry are reinterpretations of 50-year-old designs by Gunta Stolz.

Brunschwig & Fils, North White Plains, N. Y.

Circle 212 on reader service card

15. Up against the wall

Godley-Schwan's limited-production furniture, fresh from Brooklyn by way of Milan, will be shown at NEOCON. Pictured: a flat-footed steel display unit with lacquered ash shelves, which leans up against the wall for support. Similar pieces carry pier mirrors, towel racks, or coats. Godley-Schwan, Brooklyn, N. Y.

Circle 213 on reader service card

16. Cost-effective

The base is the same, but the backs of Toshiyuki Kita's new chair for ICF change: from Past to Present, then Future. Made of cast aluminum with padded seats, the chairs can be stacked, and are suggested for office and hospitality use. International Contract Furnishings, Inc., New York City.

Circle 214 on reader service card

More products on page 175



7

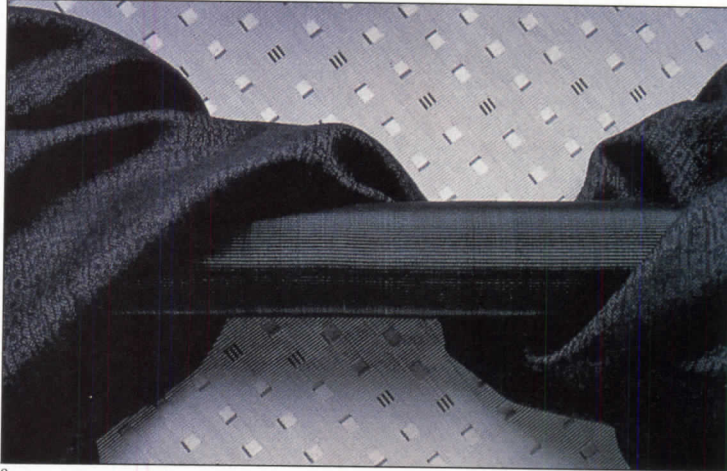

8



9

For more information,
circle item numbers on
Reader Service Card



10



13



15

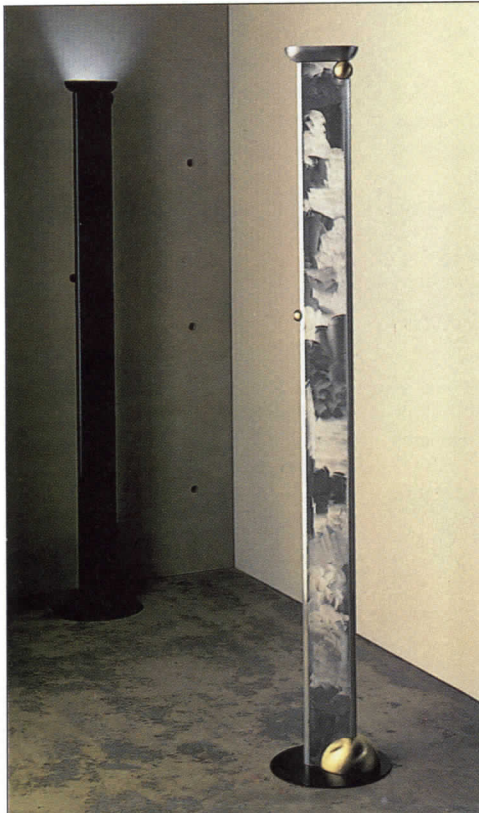

11



14



12



16

A/E/C Systems: Pre-meeting products preview

By Steven S. Ross

An early-bird survey of exhibits planned for this year's A/E/C Systems show in Anaheim, Calif., June 5-8 turned up plenty of new products to take advantage of new software and hardware platforms announced since last year.

On the software side, there are dozens of new add-ons for Autodesk's latest edition of AutoCAD, version 10. These enhancements do everything from laying out subdivisions to laying out ductwork.

Many software suppliers are also taking advantage of computers based on the powerful Intel 80386 chip. The effect is to make 80386-based computers as fast and full-featured in many respects as dedicated engineering workstations. Advances are particularly noticeable in surveying applications such as COGO (coordinate geometry) software, which make great demands on hardware.

Software for the Macintosh continues to evolve. The biggest news is that AutoCAD is about to release its Macintosh version, and will be showing it for the Mac II. Easy-to-use 2-D and fast 3-D packages are being introduced by a host of suppliers, but so much new add-on equipment is bringing complexity to Macintosh hardware and software integration. As with PC-DOS and MS-DOS equipment and software, Mac users now must often wade through setup menus to make sure everything works together.

Interest on the hardware side continues to focus on price. Plotters are cheaper than ever. One desktop 8-pen plotter is priced at less than \$1,300. Graphics cards are getting more standardized, cheaper (thanks to

memory prices, which are dropping), and ever-faster.

At presstime, the following manufacturers were able to supply us with material on new or improved products they will be showing in Anaheim. If you are not attending the show, you can request more information about the products described by using our convenient response card (page 221).

MS-DOS and Intergraph CAD software

VersaCAD, Huntington Beach, Calif., is introducing 386 software, which breaks the 640K memory barrier. Special graphics processing allows dynamic calculations on 3-D geometry. A QuickRender 3-D model viewer that provides fast shading and hidden-line removal is included with the package.

Circle 215 on reader service card

CADAM, Burbank, Calif., announces an improved AEC Design System capable of producing 3-D color shaded images. A particular strength is in the handling of piping and steel shapes from available catalogs.

Circle 216 on reader service card

A new 3-D version of FastCAD from Evolution Computing, Tempe, Ariz., will be demonstrated. The software's 3-D interface is unique, helping designers move easily in a third dimension while drawing.

Circle 217 on reader service card

TAP, Arlington, Tex., will be showing a full range of specialized information systems and TAPCAD, a facility-management software package that incorporates a CAD function.

Circle 218 on reader service card

Schroff Development Corp., Roeland Park, Kan., is demonstrating its SilverScreen 3-D modeling software with fast camera walk-through for MS-DOS and PC-DOS systems. A version for Sun UNIX workstations is expected soon.

Circle 219 on reader service card

SKOK's Drawbase 5000 is now compatible with the Nth Engine graphics card, the Cambridge, Mass., company says, for 2-second zooms and pans.

Circle 220 on reader service card

Omni-Pipe and Omni-ISO, the first piping application packages for the Intergraph MicroStation PC, will be shown by Applications Development, Inc., Metairie, La.

Circle 221 on reader service card

Macintosh CAD software

AutoCAD's Mac version for the II, IIx, and IIcx includes 3-D wireframe modeling, surface modeling, and the ability to display many views at once. The files are portable, so any information developed with the AutoCAD Mac version can be shared with any other platform running the software—including MS-DOS, Apollo, and Sun—without file conversion.

Circle 222 on reader service card

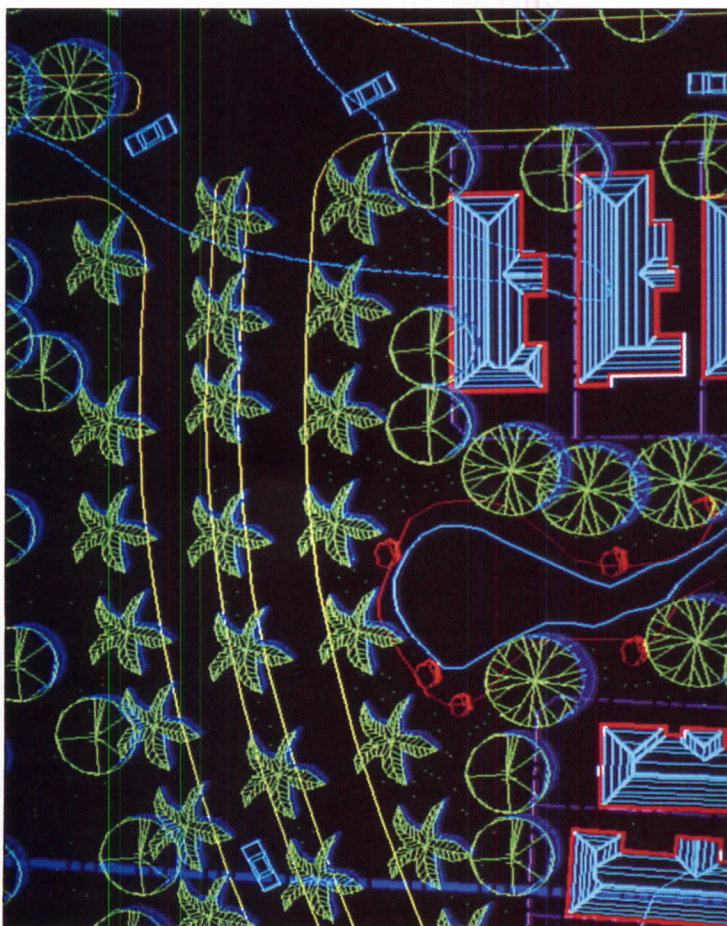

Courtesy Estrada Land Planning

1. LANDCADD's landscape design of West Las Vegas subdivision.
2. SilverScreen by Schroff Development.
3. MapInfo's desktop mapping system.
4. Engineered Data Products' Designer CAD stand.

Among the products on view: AutoCAD's new version for the Mac II; VersaCAD's new 386 with over 640K of memory; Electronic Sweet's SweetSearch and SweetSpec databases.

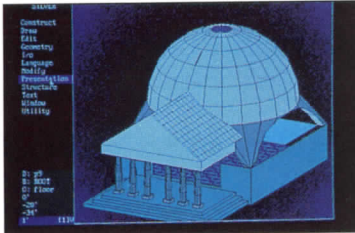

2
ArchitronII, from French software firm Gimeor (U. S. headquarters in Washington, D. C.), features new additions to this 3-D modeling package for the MAC SE or Mac II, including spherical, conical, or exploded views, selected hidden or visible-blocks rendering by layer, and color-surface or color-line perspective for axono and iso views.

Circle 223 on reader service card



3
FlexiCAD version 1.2, the newest release of this 2-D CAD software for the Macintosh from Amiable Technologies, will be announced at the show. The Philadelphia firm's software now includes the ability to draw multiple parallel lines, support digitizing tablets, and send data to files for bill-of-materials processing and other reports.

Circle 224 on reader service card

Graphisoft, South San Francisco, Calif., is displaying its comprehensive ArchiCAD 2-D

and 3-D software with takeoffs for bill-of-materials processing and other software for the Macintosh. Full-color renderings—solid, color-shaded, or wire-frame—and good plotter support are part of the package. Uses its own 3-D construction language, GDL, to allow user to create and store 3-D objects as macros.

Circle 225 on reader service card

Graphsoft, Ellicott City, Md., has new 2-D and 3-D CAD packages for the Macintosh. MiniCAD+ is a high-end package with 2-D, 3-D, a spreadsheet, and a command language. Blueprint is a 2-D package with built-in DXF translator.

Circle 226 on reader service card

IDD, Concord, Calif., is demonstrating its Dreams 2-D CAD package for the Macintosh, along with a new symbol library of more than 1,000 images for residential construction.

Circle 227 on reader service card

PowerDraw 3.0, the latest version of this 2-D CAD program for the Macintosh computer, will be introduced by Engineered Software, Greensboro, N. C.

Circle 228 on reader service card

Visual Information Development, LaPuente, Calif., is showing its new The Dimensions Presenter package, which adds 3-D capabilities to MacDraw from Claris (see page 167 for a review of Claris CAD).

Circle 229 on reader service card

MacNail, an integrated construction-management system from Turtle Creek Software, Spencer, N. Y., has added Hyper-Estimator, which sets project dimensions and material specifications using Apple's new Hypercard program.

Circle 230 on reader service card

AutoCAD add-ins
Applications Development, Inc., Metairie, La., will exhibit its Pro-

Pipe, Pro-Steel and Elec-Plan plant-oriented design packages to work with AutoCAD.

Circle 231 on reader service card

ARCHIBUS 4.0, to be announced at the show, can now handle mainframe and micro databases for space management, design, or furniture and equipment management. The software, from Jung/Brannen Research & Development Corp., Boston, moves data between AutoCAD, Lotus, and dBase IV files.

Circle 232 on reader service card

ARCHT2, an AEC substitute from KETIV Technologies, Portland, Ore., has four digitizing tablet overlays—for hvac, plumbing, power, and facilities.

Circle 233 on reader service card

AutoCAD developer Autodesk is marketing Pixar's Renderman photo-realistic imaging software on a nonexclusive basis, the Sausalito, Calif., company says.

Circle 234 on reader service card

CivilSoft's new CIVILCADD, a complete design and drafting program for civil engineers and surveyors running inside AutoCAD, is being demonstrated. The Orange, Calif., firm also markets its Site Design Program.

Circle 235 on reader service card

Slick! version 3.1 from CAD Systems Unlimited, Santa Clara, Calif., allows users to view AutoCAD drawings without AutoCAD.

Circle 236 on reader service card

Continued on next page



4

DuctLINK, the United Technologies Carrier link between AutoCAD and a microcomputer duct program, permits easy design of hvac systems. The software from this Syracuse, N. Y., company allows data to flow in either direction—to and from AutoCAD.

Circle 237 on reader service card

TopDUCT is an AutoCAD add-on that allows easy drafting of ductwork and fittings after the job has been sized and centerlines for ducts drawn. There's also direct conversion of drawings to pattern blanks for fabricating the actual ducts. From FastDuct Software, Charlotte, N. C.

Circle 238 on reader service card

Ever wish you could modify an old non-CAD "raster" image only where needed, instead of converting the entire image into something the CAD software can read? Now it is possible with CAD Overlay ESP from Image Systems Technology, Troy, N. Y. The hybrid images, combining the old scanned raster overlaid by CAD vector drawings where needed, can be zoomed and panned inside AutoCAD as if they were one.

Circle 239 on reader service card

Constructive Computing, Kansas City, will release its newest computer-assisted estimating system, QuickEST version 3. The package is modular, with modules for picking information off DXF drawing files such as produced by AutoCAD, and for doing quote analyses. Several cost databases are available, including the Berger Building Cost File, to work with QuickEST.

Circle 240 on reader service card

Landcadd, Inc., Franktown, Colo., will show enhancements to its LANDCADD line of design tools for AutoCAD. The newest releases include a Macintosh version and metrics.

Circle 241 on reader service card

Version 10.0 of the ASTEEL steel-drafting program (formerly called AutoSTEEL) from Holmes Manson A/E Services, Arvada, Colo., is being released at the show. This AutoCAD add-in



5

makes good use of AutoCAD's expanded programming capabilities; it uses 400 kilobytes of AutoLISP code. Different versions handle BS-4, ASTM A6-81b, and DIN 1045 shapes.

Circle 242 on reader service card

MAPMATE from Lietz, Overland Park, Kan., links AutoCAD drawings with SDRMAP and SDRLINK surveying software.

Circle 243 on reader service card

VS/Plot and VS/Render, two packages that transfer AutoCAD drawings to Neuendorf Systems' Videoshow, will be displayed at AutoCAD Expo by the Aurora, Ind., company.

Circle 244 on reader service card

Omniversal, Santa Monica, Calif., will demonstrate a link between AutoCAD and its Facility and Property Management System. The software runs on IBM PC computers and compatibles, and the new IBM AS/400 minicomputer.

Circle 245 on reader service card

VoiceCAD from Circle Computer Consultants, Orinda, Calif., is now available for AutoCAD 10. It handles about 200 voice commands directly, and another 250 using a command hierarchy.

Circle 246 on reader service card

The new BLOCK Librarian from SoftSource, Bellingham, Wash., allows users of AutoCAD 9 and 10 to store, view, and retrieve AutoCAD block files graphically. The new release includes REPORTER, a link to Lotus 1-2-3 and other software that can handle comma delimited ASCII files.

Circle 247 on reader service card

Other design software

The new 10CAD engineering data-management system by ACS Telecom, Lomita, Calif., allows numerous workstations to share drawing files, printers, and plotters. The software is compatible with Ethernet, Netbios, and Novell on IBM PCs and compatibles, as well as Sun, Apollo, and VAX computers. Version 10CAD Plus 2.2, being released at the show, is twice the speed of 2.0. The software is being displayed at the Autodesk Expo section, where it will be used to link several exhibits.

Circle 248 on reader service card

Byers Plot Station from Byers Engineering, Atlanta, links Intergraph and MicroStation users, UNIX or VAX machines to PC networks so that the cheaper PC can output to plotters without tying up the more expensive computers. The new version now supports 3-D plots.

Circle 249 on reader service card

5. TAPCAD facility-management package by TAP.
6. ArchiCAD by Graphisoft.
7. PowerDraw by Engineered Software.



6



7

data, is offering its new PULSAR microcomputer estimating and scheduling program; it is the first for directly accessing the Means database.

Circle 264 on reader service card

The Customer Profile System from Softouch Software, Portland, Ore., is a user-friendly front end to corporate Oracle databases. It uses the Macintosh HyperCard software. The firm's Cost Management System is an estimating and job-costing package. It offers links to many general ledger packages.

Circle 265 on reader service card

Specification writing

Electronic Sweet's will be using the A/E/C show as a platform to acquaint construction professionals with its recently introduced SweetSearch and SweetSpec [RECORD, March 1989, page 137]. SweetSearch is an electronic index to the Sweet's catalog allowing architects to search for products that meet design requirements. SweetSpec, an automated, interactive system based on Masterspec, produces specification documents from questions asked and answered in interchanges between user and system.

Circle 266 on reader service card

Furniture and facilities

CenterCore's new Trianon circular office furniture system can be customized to handle even high-level employees' workspaces in open-plan offices. The Plainfield, N. J., firm says the new system is a logical extension of its earlier Spacemaker line.

Circle 267 on reader service card

Engineered Data Products, Broomfield, Colo., is showing three new systems for architects. Designer CAD stand is cantilevered over the drafting table, so that CAD and manual drafting can be at the same location. CAD/2 offers room for computer and digitizing tablet. ADD-A-CAD accommodates monitors as large as 20 in.

Circle 268 on reader service card

Waldman Lighting, Wheeling, Ill., is introducing its new ZLL

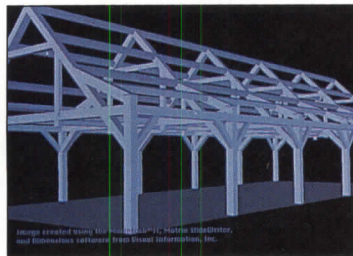

11

drafting-board light at the show. Two models fit boards 37 to 72 inches wide. The fixture attaches to the back of the board, not the side.

Circle 269 on reader service card

A keytouch electronic building directory system, the Touchcomm Electronic Directory, will be demonstrated by Digital Technologies, Inc., Burlington, Mass. New products include the touchscreen Wayfinder directory, specifically for hospitals, and a new security system.

Circle 270 on reader service card

Marvin Windows, Minneapolis, has released its Computer-Aided Design Program in a new version compatible with AutoCAD 10. The company says it will soon be available for all CAD software. The software not only provides a detail and specification manual on disk, but also a way to design and specify custom windows and doors.

Circle 271 on reader service card

Penn Ventilator's free FANCAD library of drawings and details for most CAD systems has been revised and expanded. The Philadelphia company includes FANSPEC, complete text specifications for its products.

Circle 272 on reader service card

Graphics cards and monitors Metheus, Beaverton, Ore., will be demonstrating its new Ultra Graphics Accelerator family of graphics cards with AutoCAD 10.

Circle 273 on reader service card

Data Translation, Marlboro, Mass., will be showing its new Arithmetic Frame Grabber, an IBM AT-compatible board that can capture and store images from standard devices and display them fast. The firm also is showing its new QuickCapture image capture and display

system with 256 levels of gray for IBM PS/2 computers and compatibles.

Circle 274 on reader service card

Nth Graphics' new Nth 3-D Engine board now comes with HYDRA, fast 3-D viewing software that converts VersaCAD or AutoCAD wireframe drawings to 3-D solid models in seconds. The Austin, Tex., company's boards are usable in AT-class personal computers.

Circle 275 on reader service card

The new Artist GT software driver, optimized for AutoCAD 10, will be demonstrated with Artist graphics boards from Control Systems, St. Paul, for IBM AT and PS/2 microchannel compatibles.

Circle 276 on reader service card

Plotters and printers

Bruning, Martinez, Calif., is featuring large 24- and 36-in.

plotters for as little as \$5,950. Plotting is truly continuous, not frame-to-frame—ideal for architects who need to output long drawings.

Circle 277 on reader service card

A D-size plotter for only \$2,395 and manufactured in America is being introduced by Gerard Research, Fremont, Calif. The plotter uses the DM/PL plotting command language.

Circle 278 on reader service card

Fast pencil plots are possible with the new F910A pen/pencil plotter from Mutoh America, Elk Grove Village, Ill.

Circle 279 on reader service card

A thermal plotter, the RY-T001, will produce plots of up to 46 by 33 in., with crisp lines and images that do not bleed, according to manufacturer RDK, Inc., Austin, Tex.

Circle 280 on reader service card

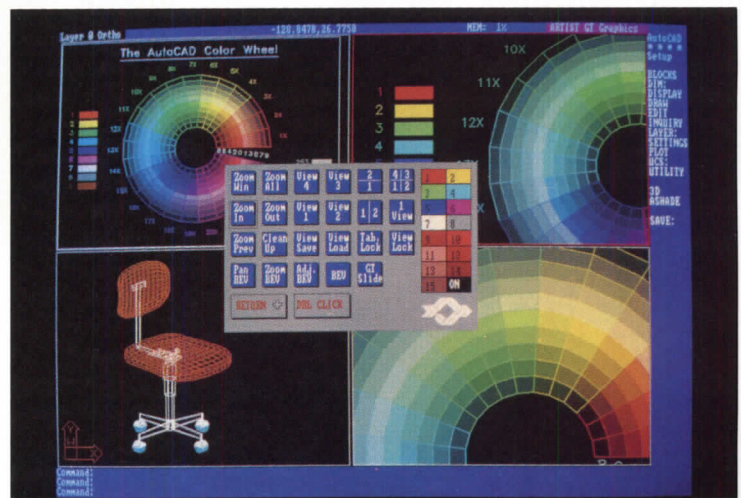

12

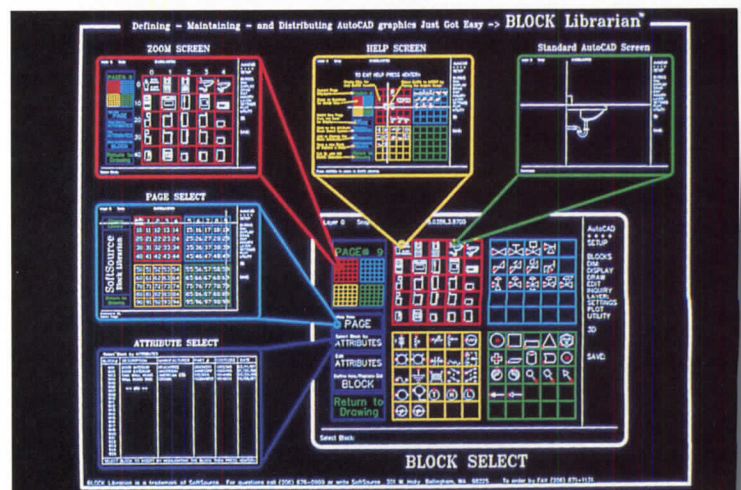

13

Roland, Los Angeles, will display a number of inexpensive plotters, including an 8-pen desktop model for \$1,295. It emulates the HP-GL plotting language.
Circle 281 on reader service card

The TPG-4300 thermal transfer video printer from Toyo Spectrum, Santa Clara, Calif., can print full-color A- or B-size images from any CRT monitor up to 1,280 by 1,024 pixels.
Circle 282 on reader service card

Buffer Plus from Applied Creative Technology, Dallas, is a modem-sized box with up to 1 megabyte of random-access memory. Placed between your computer and plotter, it can store the image to be plotted, freeing the computer for other tasks. It can handle serial or parallel communications. It can emulate the HP-GL plotting language, making it particularly useful for Hewlett Packard plotters.
Circle 283 on reader service card

Supplies

Graphic Controls, Buffalo, is releasing a new catalog of CalComp pen-plotter supplies.
Circle 284 on reader service card

A new vellum for electrostatic copiers is being demonstrated by Teledyne Post, Des Plaines, Ill. The image can be selectively erased, yet is very stable in normal use.
Circle 285 on reader service card

Digitizers and scanners

Kurta, Phoenix, Ariz., introduces the IS/THREE LTD line of large digitizing tablets. The tablets support Timberline's Estimating Plus construction-estimating software.
Circle 286 on reader service card

The new 1280 RSKB digitizer from Los Angeles Scientific Instrument Company can be used with almost any CAD program, because it emulates most popular tablet digitizers;

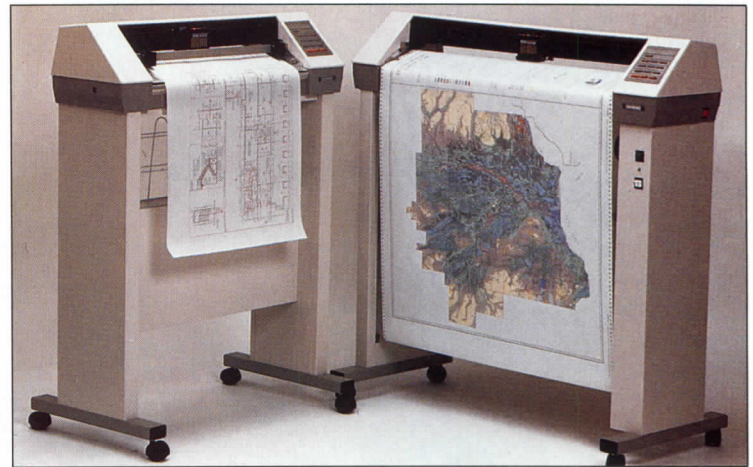

the CAD software thinks a tablet is communicating with it. The RSKB also emulates keyboard entry codes, so it can be used with non-CAD software, such as Lotus 1-2-3.
Circle 287 on reader service card

Calcomp of Anaheim will be demonstrating three recent large-format additions (D, E, and J size) to its DrawingBoard family. Resolution is up to 10,160 lines per inch. This new 9500 series replaces the 9100 models.
Circle 288 on reader service card

Altek's new digitizer for construction-estimating applications fits any DodgeScan machine and works with most estimating software. The Silver Spring, Md., company packages the digitizer with a keypad that handles length, area, and volume calculations without a computer attached.
Circle 289 on reader service card

Vemeo, San Dimas, Calif., offers its Multi-Scan multiple format scanner for transferring images as large as E-size into IBM PCs and compatibles.
Circle 290 on reader service card

Workstations

Silicon Graphics, Mountain View, Calif., is displaying its inexpensive Personal Iris 3-D workstation. The company has announced a pilot program to sell the workstation through Cadkey and Arris dealers.
Circle 291 on reader service card

The CEALStation engineering workstation combines COGO and other land use software from CLM/Systems, Inc., Tampa, Fla., with Intergraph's MicroStation software.
Circle 292 on reader service card

Services

K + CZL, specialists in helping firms configure IBM equipment, will be demonstrating its services. The San Jose, Calif., firm also offers training classes nationwide.
Circle 293 on reader service card

OCB Reprographics offers the C4 TelePlot system to convert PC-based drawings to plot files. The firm serves Orange, San Bernadino, and Los Angeles counties from its Irvine, Calif., offices.
Circle 294 on reader service card

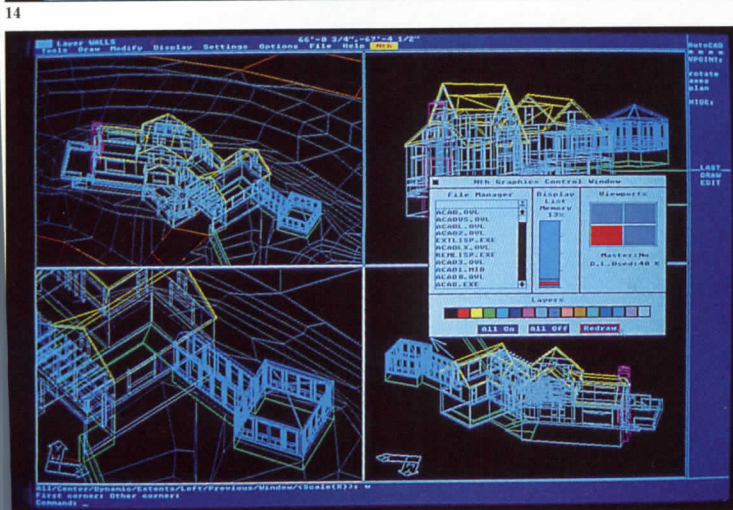
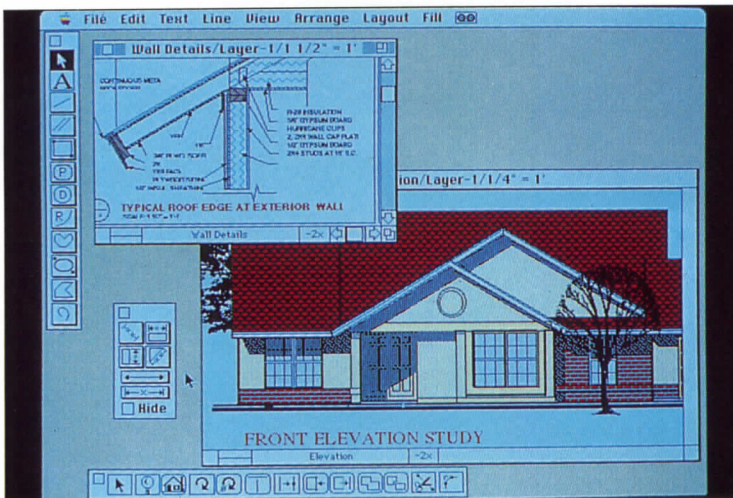

11. *Dimensions Presenter* by Visual Information Development.
12. *Artist GT* software driver by Control Systems.
13. *BLOCK Librarian* by SoftSource.
14. *Dreams* by IDI.
15. *HYDRA* by Nth Graphics.
16. *Bruning's Zeta 24-in. and 36-in. plotters.*

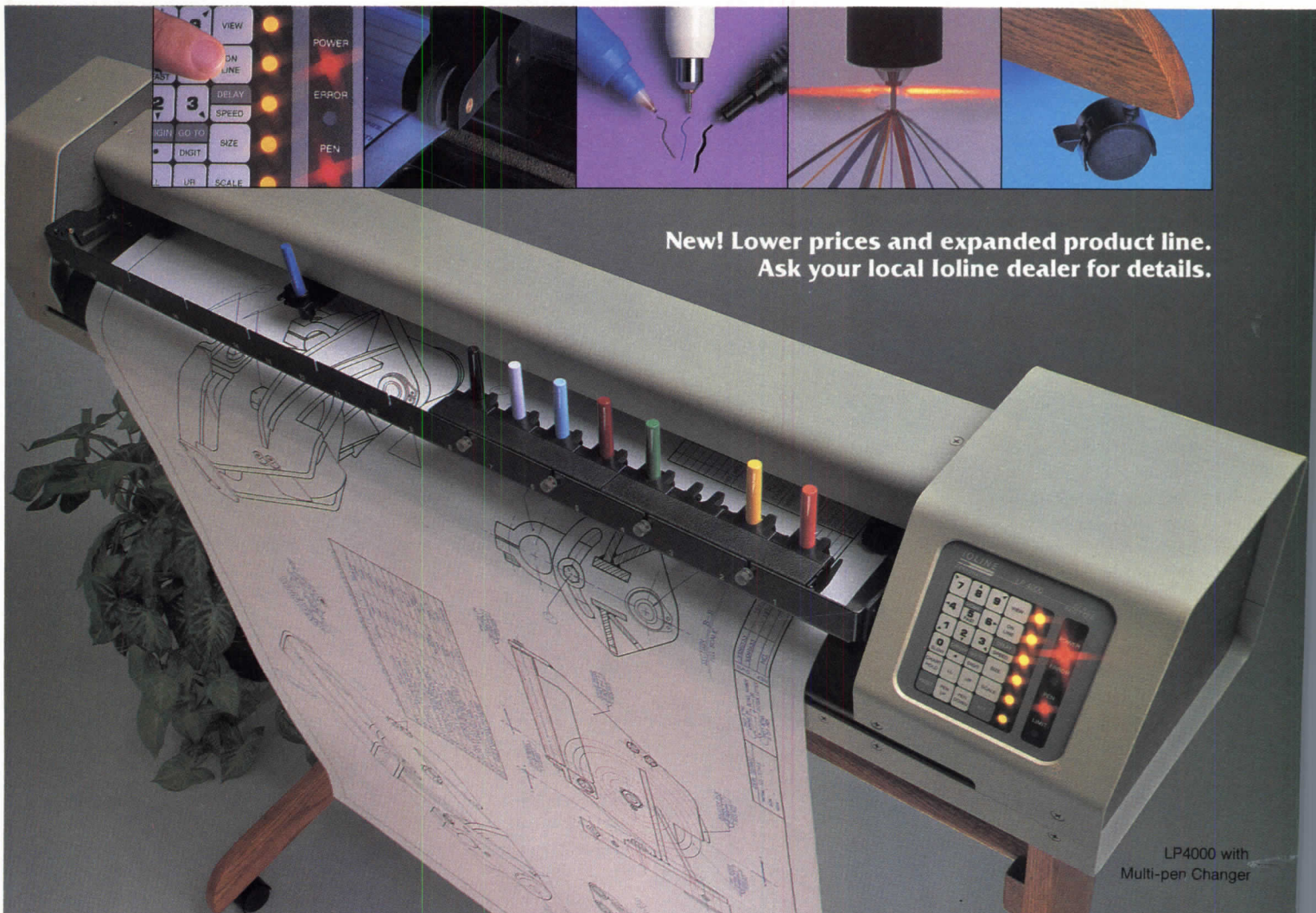

New! Lower prices and expanded product line.
Ask your local Ioline dealer for details.

LP4000 with
Multi-pen Changer

Here's what to look for when you want great value

Ioline plotters are designed to give you more flexibility and features for less cost than any other machine of their kind.

For example, our plotters draw not only on A through E sizes of media, but also plot on hundreds of in-between sizes from 1.5" x 1.5" up to 37" wide roll stock. This saves you time and money by allowing you to make "check plots" on small, low-cost paper before committing to full-size media for final work.

It's easy also to set paper size, pen speed, micro-calibration, plot rotation—everything exactly as you want—by just tapping a few keys on the plotter's intelligent keypad. Plus, up to 3 sets of personalized defaults can be saved in its non-volatile memory.

They're fast, too. Our high-

performance LP4000™ draws at speeds selectable up to 20 inches per second (ips) axially with .001" resolution. For less demanding applications, our economical LP3700™ plots up to 10 ips axially with .0025" resolution.

Another feature is compatibility. Ioline plotters emulate both HP-GL and DM/PL plotter languages so they work with a host of software like AutoCAD, VersaCAD, and CADKEY, to name a few.

Furthermore, our Multi-pen Changer™ option holds up to 20

pens and, with our hyper-BUFFER™ option, you can dramatically increase plotting throughput with intelligent vector sorting and compression buffering of up to 1MB of plot data.

Now here's the clincher: Our top-gun, servo-driven LP4000 costs just \$4,995.* And there are other models priced even lower!

Why wait? Call us now at **206-821-2140**. Or, circle our reader service number and we'll gladly send you our brochure.

Remember, getting your money's worth—that's what Ioline plotters are all about.

IOLINE™
LARGE-FORMAT PEN PLOTTERS

IOLINE CORPORATION 12020 - 113th AVE. NE KIRKLAND, WA 98034 (206) 821-2140 TELEX 4949856 IC UI FAX (206) 823-8898
LP4000, LP3700, Multi-pen Changer, and hyperBUFFER are trademarks of Ioline Corporation. AutoCAD is a registered trademark of Autodesk, Inc. VersaCAD is a registered trademark of T&W Systems. CADKEY is a registered trademark of MicroControl Systems, Inc. *Suggested U.S. List price.

Looking into CAD?

See how VersaCAD on the Macintosh stacks up . . .

When it comes to professional CAD on the Macintosh®, only VersaCAD® offers a complete solution. Now in its fourth release, this bestselling software gives you high-precision color graphics . . . plus unique design capabilities based on Apple Computer's HyperCard™ information management tool.

- 2D drafting rated "Best" at the National Computer Graphics Association shootout
- 3D color shading that's fast and easy, including multiple viewport display
- Exclusive HyperCard stacks for:
 - Bill of materials
 - Parametric design
 - Off-line plotting
 - Attribute database
 - CAD text processor
 - Drawing manager, and more.
- Proven two-way links to PC-CAD, workstations and thousands of productivity programs.

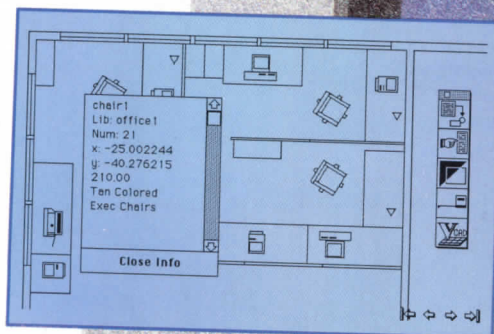
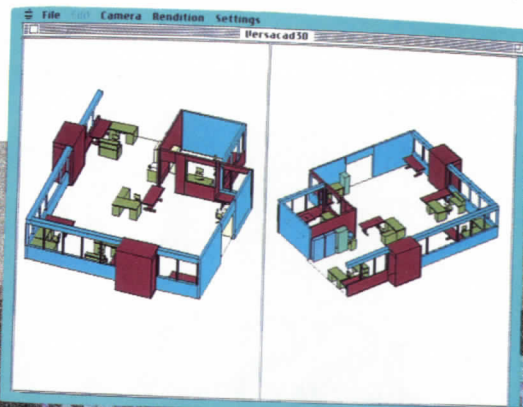

Labor Type	Labor	Ext Labor	Wage	Ext Wage	Total Cost	Unit Weight	Ext Weight
Construction	1.25	2.50	17.50	43.75	310.00	18.00	36.00
Construction	1.25	2.50	17.50	43.75	330.00	20.00	40.00
Construction	1.50	58.50	17.50	1023.75	5245.00	30.00	1170.00
Construction	0.50	6.00	17.50	105.00	900.00	20.00	240.00
Construction	1.00	9.00	17.50	157.50	1080.00	10.00	90.00
Construction	0.25	2.25	17.50	39.38	1395.00	10.00	160.00
Moving	0.25	4.00	19.85	79.40	2800.00	20.00	160.00
Moving	0.25	2.00	19.85	39.70	680.00	24.00	360.00
Utilities	0.25	3.75	19.85	74.44	1875.00	1.00	14.00
Technical	0.75	10.50	20.20	212.10	3360.00	30.00	60.00
Technical	2.00	4.00	28.50	114.00	7000.00	15.00	90.00
Technical	1.00	6.00	28.50	171.00	14970.00	35.00	245.00
Technical	2.25	15.75	28.50	448.88	4545.00	35.00	245.00
Technical	1.00	6.00	28.50	171.00	8970.00	15.00	90.00
				132.75	2723.68		2845.00
					94400.00		



See for yourself how VersaCAD stacks up. Return the coupon for a free demo disk or call (714) 960-7720 today.

VERSACAD®



Prime
Personal CAD/CAM

YES, send me a free demo disk (requires a Macintosh Plus or greater).

Name _____

Title _____

Company _____

Address _____

City/State/Zip _____

Phone _____

Please send to Demo Disk, Versacad Corporation, 2124 Main Street,
Huntington Beach, CA 92648. Record 5/89

See VersaCAD/Macintosh Edition demonstrated at A/E/C Systems, Booth # 1411.

How to cross your bridges 47% faster.

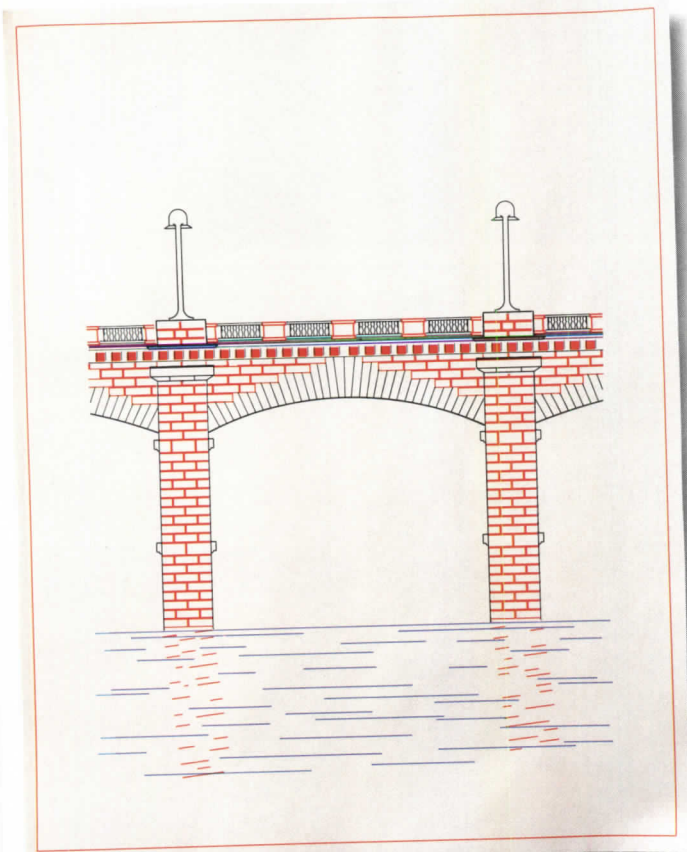

The HP DraftMaster plotter.

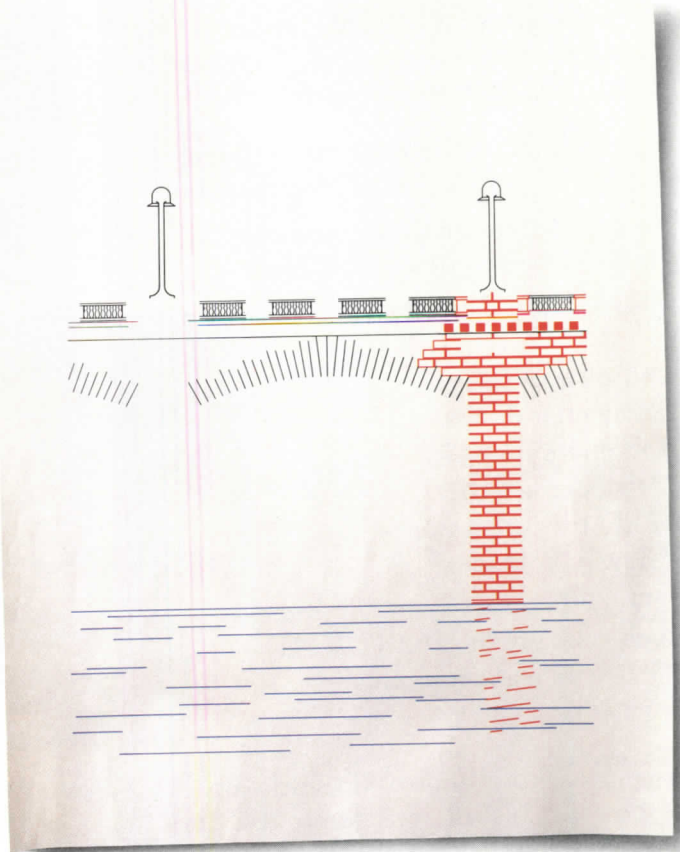

The other guy.

And not only faster. But with true lines, smooth curves and clean diagonals.

Only HP DraftMaster plotters can give you so much throughput with such high quality. In fact, we cross our bridges a full 47% faster than the 'closest' competitor.

At our acceleration of 5.7 g and pen speed of 24 ips, nobody can match our 0.0002 inch resolution and

0.004 inch repeatability. And our 'smooth curve generator' makes every arch a triumph.

And DraftMaster plotters are so reliable that we give them a one year *on-site* warranty. That's four times longer than the competition.

Small wonder we were PC Magazine's Editors Choice as tops in the large format field.* Yet our prices are very competitive. Just \$8495

for the DraftMaster I and \$10,995 for the roll-feed DraftMaster II.

So call **1-800-752-0900, Ext. 303B** for more details, a plot sample and your nearest dealer. Then get the plotter whose reputation keeps building faster and faster.



These plots were created using AutoCAD™ Rel. 90. An HP DraftMaster driver and HP-GL were used with the HP DraftMaster plotter. A CC 104X driver and PCI were used with the CalComp 1023 plotter. AutoCAD™ is a U.S. trademark of Autodesk, Inc. HP-GL is a trademark of Hewlett-Packard Company. * June 9, 1987.

Software reviews for architects

By Steven S. Ross

Clariss CAD

A fast, versatile 2-D drafting package for the Macintosh. Users of MacDraft or MacDraw II who have been looking for extra features—such as better control of tolerances and better accuracy—may find them here. Clariss CAD is also distinguished by its tutorials—including a tutorial on standard VHS videotape that comes in the package. In exchange for ease of use and good speed, users give up 3-D and the database capabilities of more advanced packages. Clariss is an Apple Computer Corp. spinoff that now operates independently.

Equipment required: Macintosh Plus, SE, II, or IIfx and 1 megabyte of random-access memory (at least 2 megabytes recommended), hard-disk drive, System 6.0 and Finder 6.1 (or later). Works with Hewlett Packard, Houston Instruments, and PC plotters, Postscript laser printers such as the LaserWriter, and the ImageWriter dot-matrix printer. Can be networked through AppleShare.

Vendor: Clariss Corp., 440 Clyde Ave., Mountain View, Calif. 94033. \$799. Upgrade for registered MacDraw II users, \$399. IGES and DXF translation package, \$299.

Summary

Tutorials: Excellent. Separate manuals include the tutorial and

Steven S. Ross is past president of CCM, an educational software company in New York City, and now teaches journalism at Columbia University, where he also runs a large computing laboratory for students. He is often consulted on quality-assurance matters; his 1984 book, *Construction Disasters: Design Failures, Causes and Prevention*, was published by Graw-Hill.

a user's guide. There's also a 10-page quick reference, a startup guide, and videotape tutorial. **Ease-of-use:** Good. Uses the Macintosh standard click-drag-click mouse interface. But menus do not go more than two levels deep, making the mouse an adequate command tool. Double lines for walls are automatic. There's a wide choice of fonts, line styles, and fill patterns. Tool palettes cannot be positioned for easy use in the drawing window itself; they stay off to the side. **Error-trapping:** Good. Users get only one chance to change their minds about saving files as they exit. We were unable to crash the system on a Mac II. There's no automatic-save feature; drawings should be manually saved to disk periodically, to avoid losing a great deal of work in case of a power failure. The "undo" command changes only the last action.

Review

There's something to be said for CAD software that, well, is easy to draw with. That is precisely what Clariss CAD is. It doesn't do 3-D. It cannot directly feed a database for producing a bill of materials, or for project scheduling. But it is easy, even intuitive, to use. And it comes with a good tutorial, particularly suited to the CAD novice, that covers all of the fundamental drawing techniques. The tutorial includes on-screen practice files and a videotape.

Users of MacDraw will have little trouble recognizing the controls for Clariss CAD. But the new features should attract many MacDraw users to switch. For instance, you can draw a circle by indicating its diameter, or by specifying three points through which the circumference should pass, rather than clicking at the center and dragging the mouse outward. You can specify three points as three corners of a
Continued on page 169

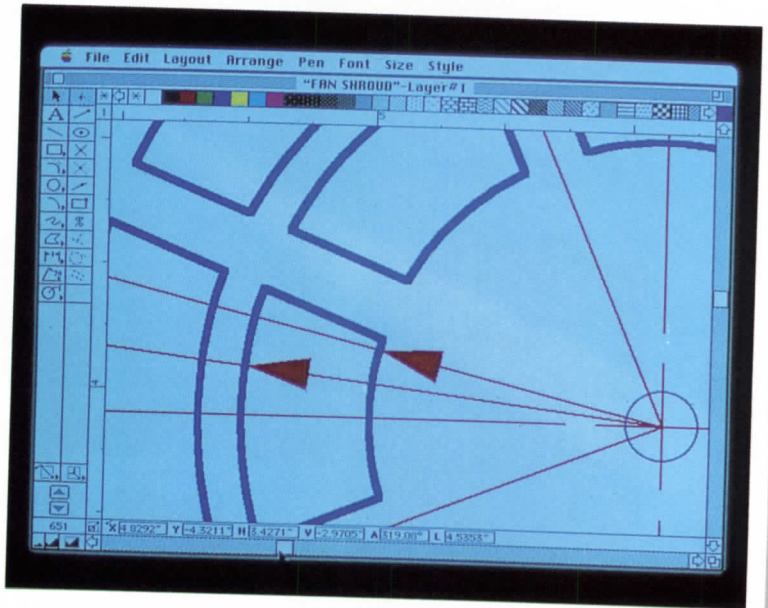

The Mac II screen that Clariss CAD runs on handles curves well, even at fairly high magnifications. But

on-screen fonts can appear sloppy as a view is zoomed inward to near-maximum magnification.

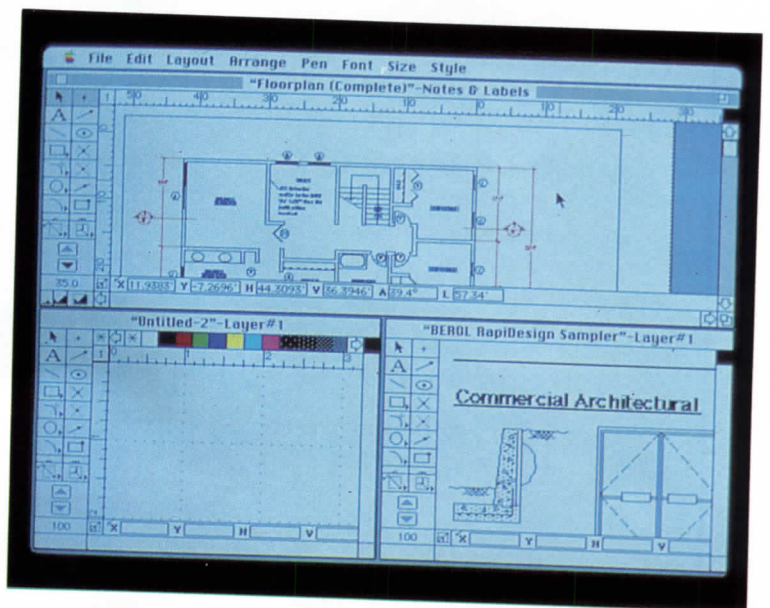

Multiple views can be displayed on-screen with Clariss CAD. In this view, they are tiled; the same views also can be stacked.

Notice that each view has its own set of drawing tools. A click of the mouse brings any view to the forefront.

THE CADVANCE/dBASE CONNECTION.

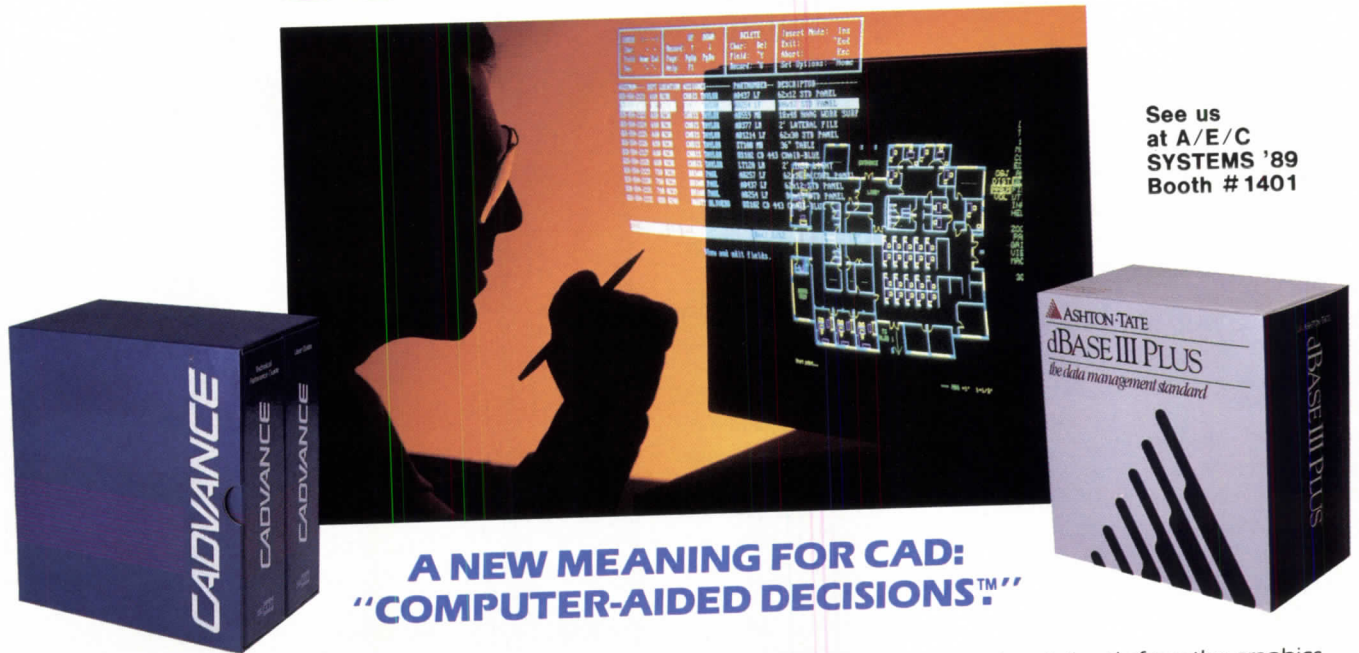

See us
at A/E/C
SYSTEMS '89
Booth # 1401

**A NEW MEANING FOR CAD:
"COMPUTER-AIDED DECISIONS™"**

Link Drawings to Data and Data to Drawings.

There's more to CAD than fast drawings. At least at ISICAD there is.

Now you can directly link CADVANCE® PC-CAD drawings with non-graphic information in dBASE® files for a total solution to information management.

CADVANCE Advances.

CADVANCE goes beyond ordinary computer-aided design and drafting on your PC. It allows you to manage the information behind the pictures, and puts you in total control of your project.

By linking drawings with data in a relational database, you increase the intelligence of your drawings. Keep track of inventories, estimates, costs, locations, schedules—and report on

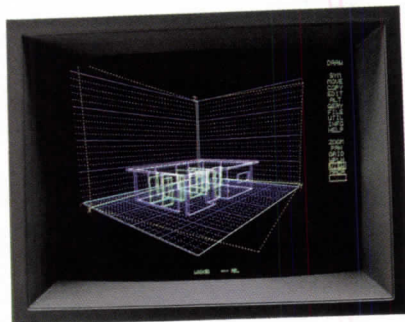

VGS—The new standard in 3D user interfaces.

them easily. Evaluate alternatives quickly, completely and economically. Gain control of project information so you can make better, faster management decisions: "Computer-Aided Decisions."

Instant Updates.

With the CADVANCE/dBASE connection, your database can be

updated directly from the graphics screen—without exporting, without delay, without repeating steps, and without complication. When you change information in the drawing, it is reflected in your database. And vice versa. Information is always consistent, so you avoid potentially costly errors.

The Latest in 3D.

In addition to advanced information management capabilities, CADVANCE Version 3.0 offers full 3D drawing and visualization capabilities, including an innovative user interface called the Visual Guidance System (VGS™). The VGS sets a new standard for 3D design and gives you the easiest, most intuitive interaction with 3D available today. See for yourself how easy 3D really can be.

	CADVANCE®	AutoCAD®	VersaCAD Design®
Direct two-way link to dBASE	Yes	No	No
3D VGS user interface	Yes	No	No
AE/FM application features	Built-In	+\$1,000	+\$1,000

CADVANCE, Computer Aided Decisions, and VGS are registered trademarks of ISICAD, Inc. dBASE is a registered trademark of Ashton-Tate. VersaCAD Design is a registered trademark of VersaCAD Corp. AutoCAD is a registered trademark of Autodesk, Inc.

TIME FOR DECISION

- Please have a dealer call me.
- Please send your free brochure that explains how successful companies are making the CADVANCE/dBASE connection.

For immediate response call **800-556-1234 Ext. 281** or **800-441-2345 Ext. 281** (in Calif. only). Or send in this coupon.

Name _____ Phone (____) _____
 Title _____
 Company _____
 Address _____
 City _____ State _____ Zip _____



ISICAD, Inc. P.O. Box 61022, Anaheim, CA 92803-6122

Circle 83 on inquiry card

rectangle, and so forth. At least four points define a spline curve.

You can duplicate objects in groups and arrange the duplicates in rows, columns, or along arcs. And there is precise, on-screen display of dimensions and control of zooms.

Drawings can be plotted as large as 100 by 100 inches. Up to seven documents can be on-screen at once. The easiest way to work on them is to overlap the windows (each window contains one document). Clicking on a window pulls it to the top of a pile of overlapping windows, almost immediately. Windows can also be placed next to one another (it's called "tiling" in the CAD world).

The number of layers in a drawing is essentially limited by the amount of memory you have. In a 2-megabyte monochrome system without Multifinder, we replicated a fairly complex drawing through 20 layers without the system slowing appreciably. In a 5-megabyte system with Multifinder and color monitor, we went 40 layers deep without hitting bottom. Layers can be numbered, or can carry a logical name such as "plumbing" or "chairs."

Double lines, for walls, are a breeze. The palette can be set to draw the lines so that the mouse click points are at the center of the line pair, or on the upper or lower of the two lines. The starting point of the double lines is capped with a line between them. You set the Preferences dialog box to leave the ending point of the lines open or closed. Rather than change the dialog box constantly, users found it easier to draw everything opened, then close all the ends of the double lines manually, and clean up extra lines at T intersections.

A location bar at the bottom of each window shows the X and Y location of your pointer on the drawing grid, horizontal and vertical distance from the last point specified, angle of rotation

from the last point, and linear distance from the last point.

As is common with Mac software, you will find it easiest to set most system defaults by creating empty documents with the defaults you want. You open the empty document—called a "stationery document" in Claris CAD—and begin drawing on it, then save it under a new file name. One default concerns whether or not you want on-screen color. If you have a color monitor, one of the first things you will do in Claris CAD is to change the name of the stationery document that contains color defaults, so the software will read it automatically at future startups.

Claris CAD can exchange files with other Mac software using the PICT format. An add-on package, not tested by us, will translate files to the DXF format (for exchange with AutoCAD and other packages), or to the IGES standard. Almost every serious CAD program in the DOS, UNIX, and Mac world will read either PICT, DFX or IGES, although the transferred files usually need a little touching up.

DXF, for instance, does not support complex curves. It converts them all to polylines—combinations of short-segment lines.

The Claris translator, called Transformer, is unusual in that it lets users view the drawing they are working with, and to selectively translate only certain objects or certain layers. To view them, Transformer first turns any file into a Claris CAD format. It can be saved to any format but the original one or MacDraw. Because Transformer can operate under the Macintosh MultiFinder, you can continue to draw with Claris CAD while translation takes place. Or, you can set a translation time and let Transformer work in off-hours.

Directory of Micro Engineering Software/Services

Vendor: Decision Graphics, Inc., 555 Sparkman Dr., Suite 652, Huntsville, Ala. 35816. 205-837-7710. Hard copy in 8 1/2 by 11 inch binder; \$189 for one year (includes one update and a "software locator" database on disk).

Review

No large architectural office can be without a guide to CAD software. Large CAD vendors like AutoDesk and VersaCAD will, of course, make available directories of software that runs with their own products. But this directory from DGI is the most comprehensive guide to the overall market. It lists more than 800 CAD packages and more than 235 companies that sell software, hardware, programming services, digitizing services (to convert hard copy to CAD), networks, and so forth.

Each product or service gets a small writeup, typically 100 to 200 words, discussing system capabilities, hardware requirements, number of systems installed, prices, addresses, and phone numbers. Placement of the writeups is a bit idiosyncratic, in part because the industry is the same way.

Sigma Design's ARRIS CAD, for instance, is in the chapter on "Architecture/Engineering/Construction" along with the AutoCAD AEC add-on. AutoCAD itself is listed in the chapter on "Computer-Aided Design & Drafting," along with other more generally used packages. But so is Drawbase from SKOK Systems—another CAD package that is used for product design but that clearly is optimized for A/E/C.

To make up for that, there is

an automated index on disk, and separate indexes in the directory itself that list entries alphabetically by product name and vendor name. The automated index allows users to enter the equipment they have and the function or functions they need. The computer screen then displays the software name, vendor, and directory reference for the items that meet the user's criteria. The disk can be used on an IBM PC or compatible.

Most of the material looks current, although we did notice two listings—for TK!Solver packs—that are about two years out of date.

(TK!Solver, an equation-solving program, was briefly owned by Lotus Development Corporation. But ownership long ago passed to Universal Technical Systems in Rockford, Ill.)

DGI itself does many of the custom software translators for converting one file format, such as DXF, to another. Some of the translators are marketed separately, while others are packaged with certain brands of CAD software.

It publishes a bimonthly newsletter, *Conversion Focus*, for the conversion "industry," for \$59 a year.

Versatec announces drastic reductions on electrostatic plotters.



Introducing a plotter that's half the usual size and weight.

And half the price you'd expect to pay for electrostatic performance.

Yet our 8500 Series gives you all the quality you've come to expect from Versatec. The leader in electrostatic technology for over two decades.

And while squeezing down the size of our plotters, we managed to squeeze out a lot more performance. The plot time is drastically reduced because the information is processed by the plotter, freeing your computer for other projects.

Also note that compared to pen plotters,



the 8500 has 6 to 20 times more throughput. Now that's fast. But the 8500 Series is easy

to handle as well. Media loading is up front. You simply plug in the system and it's ready to plot.

A unique user-friendly keypad takes anyone through the plotting process quickly, easily and in plain English. A built-in micro-floppy drive stores plotter setups and configurations on-disk. Which means no more time-consuming setups.

The 8500 Series is also the first plotter that's literally ready-to-roll. Its built-in casters let you move quickly to any location for sharing. You can also share the 8500 through networking with a plot server.

With optional features the 8500 also automatically cuts and winds plots. Up to 999 copies, overnight, completely unattended if you want. And it's available in both 400 and 200 ppi resolution, in either 24" or 36" formats.

You also get full support for 906/907 and HP-GL pen plotter data formats. So designers have the freedom to use virtually any major CAD package they choose.

Incidentally, the same technology that reduces the size of the 8500 also makes it three to four times more reliable than the industry standard. Which means you'll have

little need for the most comprehensive service and support organization in the world.

For more information on our 8500 Series, call our toll-free number now:
(800) 538-6477;



in California,
(800) 341-6060.

But do it now. Because choosing any other electrostatic plotter could have drastic consequences for your budget.

VERSATEC
A XEROX COMPANY
Engineering Systems Division

We deliver performance.

Versatec Inc.
2710 Walsh Avenue, Santa Clara, CA 95051
Versatec is a trademark of Versatec Inc. Xerox is a trademark of Xerox Corporation. HPGL is a trademark of Hewlett-Packard. 906/907 is a trademark of California Computer Associates.
© 1989, Versatec Inc.

Product literature

For more information,
circle item numbers on
Reader Service Card

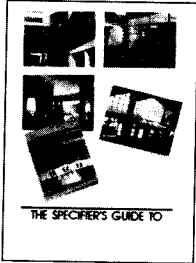

Steel window guide

A 20-page booklet supplies general specifications for various architectural windows made from hot-rolled steel sections, including commercial, residential, and fire-rated types. Steel Window Institute, Cleveland.

Circle 400 on reader service card



Textured marble

A color booklet introduces new slip-resistant bushhammered, striated, and sandblasted textures available in natural stone and marble for lobbies, stairs, and pool decks. Solnhofen Natural Stone, Inc., San Francisco.

Circle 406 on reader service card



Rubber flooring

Brochures and sample tiles are available for 15 colors and four profiles of commercial rubber flooring and stair treads. Colors include purple, burgundy, and sage green. Endura Flooring, Waltham, Mass.

Circle 401 on reader service card



Roof-deck renovation

A color brochure on the Terra System One precast concrete paver illustrates a retrofit installation step-by-step. Wausau Tile, Inc., Wausau, Wis.

Circle 407 on reader service card



Park and site furnishings

Wood play equipment, fitness courses, and benches and site furniture are illustrated in a full-line color catalog. New product features include bright-colored steel components. Natural Structures, Sherwood, Ore.

Circle 402 on reader service card

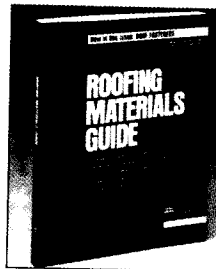

Roofing materials

A folder describes the Roofing Materials Guide, containing 400 pages of product and test data on all currently sold low-slope roof membranes, insulation, and fasteners. National Roofing Contractors Assn., Rosemont, Ill.

Circle 408 on reader service card

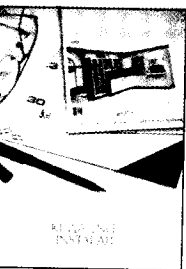

Laboratory furniture

An eight-page brochure highlights wood and metal cabinets, fume hoods, benches, and other laboratory equipment offered in the Instalab quick-ship program. Kewaunee Scientific Corp., Statesville, N. C.

Circle 403 on reader service card

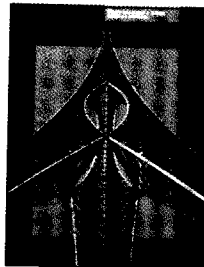

High towers

A color brochure explains the structural and materials-saving advantages of the Landmark three-legged tower, showing a 761-ft-high tower erected in Washington, D. C. Adelphon, Inc., Fort Worth, Tex.

Circle 409 on reader service card

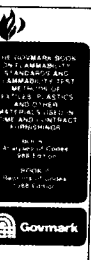

Flammability standards

A folder describes a two-volume set on flammability standards and tests for textiles, plastics, and other materials used in home and contract furnishings. The Govmark Organization, Inc., Bellmore, N. Y.

Circle 404 on reader service card



Plastic products

A 160-page catalog describes hundreds of retail, display, signage, molding, laminate, tambour, and hardware items. Outwater Plastics, Inc., Wood-ridge, N. J.

Circle 410 on reader service card



Nurse/patient communications

The ProCare 4000 system facilitates the most effective use of health-care staff without requiring hard-to-learn codes, according to a four-page brochure. Dukane Corp., St. Charles, Ill.

Circle 405 on reader service card



Architectural aluminum

Kawneer's 1989 design brochure features operable windows, overhead glazing, and six different curtainwall systems, illustrating each product with color photos of built projects.

Kawneer Co., Inc., Norcross, Ga.
Circle 411 on reader service card

Fabric Membranes

Today's Cutting Edge Building Technology



Glass gables are integrated into Sun Palace membrane roof.

Glue-laminated wood structure supports tensioned membrane roof at Sun Palace swimming facility.

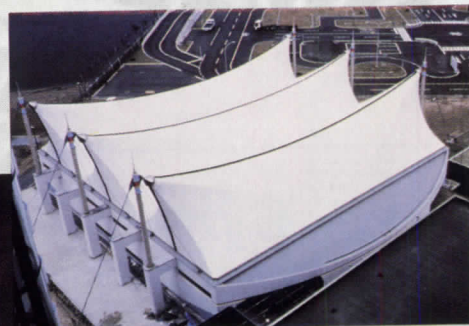

Point-hung tensioned membrane structure at Toyohashi.



Translucent membrane roof brings daylight to college gymnasium at Hiroshima.



Clustered tension membrane Modular Shelters, Pompano Beach, Florida.

Tensioned fabric membrane structures have become the technology of choice for an increasing range of building applications.

Their light weight and a nearly infinite variety of support structure systems allow architects extraordinary design freedom. Their ability to span large areas without interior support posts makes it feasible to bring many outdoor activities indoors, unhampered by weather. Above all, tensioned fabric membranes make possible delightful environments combining indoors and outdoors in new ways.

The magic of light-translucent membrane materials for an entire roof creates a naturalistic atmosphere as if one is outdoors in broad daylight. The light, however, has a softer, more diffused quality than actual daylight, with almost no shadows. Besides creating this delightful atmosphere, this translucency greatly reduces the need for supplementary lighting during daylight hours, a vital factor in applications such as skylight roofs for atriums, shopping malls, convention centers, and sports and entertainment arenas.

Helios Industries, Inc. has local representatives in the following countries:

Spain
Boetticher Y Navarro, S.A. (BYNSA)
C.T.R. (Comercial Tecnologias Recreativas)
Avda. De Andalucia, Km. 9
28021 Madrid, Spain
Facsimile: (1) 796-6892
Telex: 47964 BYNSAE
Telephone: (1) 797-8266

Hong Kong
L. F. Sam (H.K.) Ltd.
7/F First Commercial Bldg.
33-35 Leighton Road, Hong Kong
Facsimile: (5) 834-5283
Telex: 62872 SFSAM HX
Telephone: (5) 891-8448

Helios Industries, Inc., the International Operations Division of Taiyo Kogyo Corporation, has been at the forefront in developing new technologies in the design and utilization of fabric membrane structures all around the globe. Our technological expertise and experience in erecting membrane structures is ready and available to assist you.

For more information, or assistance with a specific project, call or write:

Helios Industries, Inc.
20303 Mack Street
Hayward, California 94545
U.S.A.
Facsimile (415) 887-0134
Telex 176226
Telephone (415) 887-4800



Helios Industries, Inc.
International Operations Division
Taiyo Kogyo Corporation

Circle 85 on inquiry card

For more information,
circle item numbers on
Reader Service Card

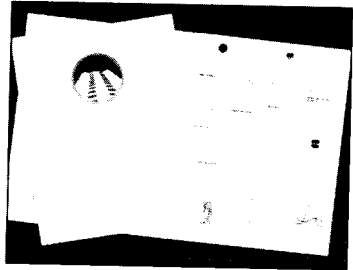

Cast-in-place concrete

A four-page brochure compares the materials-, time-, and space-saving benefits of cast-in-place reinforced concrete to other structural building materials.

Concrete Reinforcing Steel Institute, Schaumburg, Ill.

Circle 412 on reader service card



Architectural extrusions

Copper-alloy components for curtainwalls, entrances, frames, and moldings are profiled in a four-page design catalog. Recent applications include the Humana Building in Louisville.

MAC Metals Inc., Kearny, N. J.

Circle 418 on reader service card



Linoleum

A design guide on Marmoleum marbled sheet, available in 36 standard colors, shows the flooring installed with decorative and functional inlays.

Forbo North America, Richmond, Va.

Circle 413 on reader service card

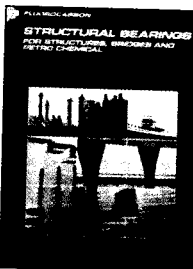

Structural bearings

A 16-page brochure provides design data and product information on rubber, Teflon, and other slide-bearing systems for buildings and bridges.

Fluorocarbon Co., Athens, Tex.

Circle 419 on reader service card

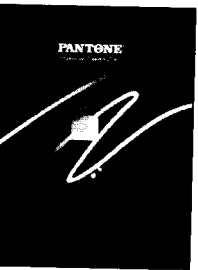

Color specification

A 16-page booklet describes how an industry-specific color matching and computer graphics system meets the needs of architects and designers of interior furnishings.

Pantone, Inc., Moonachie, N. J.

Circle 414 on reader service card

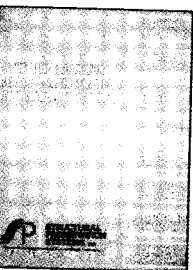

Parking-structure repair

A 72-page "Guidebook for Repair & Maintenance of Parking Structures" explains surface preparation, waterproofing, patching, and other concrete techniques.

Structural Preservation Systems, Baltimore.

Circle 420 on reader service card



Entrances

American Series aluminum doors, introduced in a four-page catalog, are said to have the carefully made, solid appearance of wood. Custom glazing patterns are offered.

Vistawall Architectural Products, Terrill, Tex.

Circle 415 on reader service card



Membrane structures

A colorful brochure shows tension-, air-, and space-frame-supported fabric structures used as temporary exhibition halls, permanent sports facilities, and shade screens.

Helios Industries, Hayward, Calif.

Circle 421 on reader service card

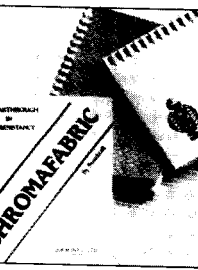

Fire-resistive fabric

A folder supplies samples of decorative, glass-based fabrics that will not ignite, melt, or drip, and have a soft, easy-to-work hand.

Joem Distributors, Inc., Island Park, N. Y.

Circle 416 on reader service card

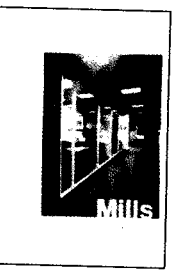

Movable walls

A brochure on Forecast Series partitions demonstrates how recessing the walls at both floor and ceiling creates a "floating panel" effect.

The Mills Co., Wickliffe, Ohio.

Circle 422 on reader service card

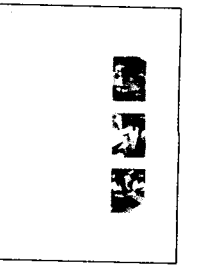

Healthcare furnishings

A 16-page capabilities brochure on Kineticare furniture shows patient and nurses chairs, group seating, and public area furniture in hospital settings.

Institutions specifying the line are listed. Kinetics, Dallas.

Circle 417 on reader service card

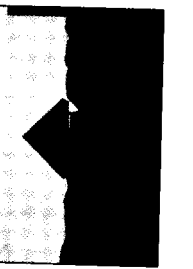

Decorative laminates

A 20-page Wilsonart brochure illustrates 26 new solids and patterns in the Design Group 1 line, highlighting stone-looks and leather textures in a variety of room settings.

Ralph Wilson Plastics Co., Temple, Tex.

Circle 423 on reader service card

AMERICA'S FIRST CHOICE IN MOBILE FILING AND STORAGE SYSTEMS.



S P A C E S A V E R

Double filing/storage capacity—or handle client needs in half the space.

Spacesaver systems can give you room for more offices, terraces, atriums—whatever.

And give your clients more efficiency, accuracy, security... with fewer steps and faster file retrieval.

From archives to active filing, the ideal choice.

You can customize systems to store virtually any type of material, and for the full range of business needs: massive records retention, central filing areas—or compact modules, handy for each department.

Exclusive Nationwide Local Area-Contractor Network.

And only Spacesaver brings you a coast-to-coast Area Contractor network.

Local installation.
Local service.

Two more reasons why we're America's first choice in Mobile storage systems. And why you can specify Spacesaver with confidence.

Meet us at Neocon
at space #804.

Spacesaver 

For more information, circle these Inquiry Card numbers:

Free Spacesaver Design Library Subscription 8

Spacesaver Systems for...

Business Offices 87 Libraries 92

Law Firms 88 Museums 93

Health Care Facilities 89

Government Facilities 90

Floor Loading Solutions 91

The Spacesaver Group, 1450 Janesville Ave., Ft. Atkinson, WI 53538
1-800-492-3434. In Wisconsin, call 414-563-5546



Wood side chair

Paul Haigh has incorporated a number of interesting details into his new Sash chair. Although the seat and back are fully upholstered, the outer edges of the frame are flat, enabling it to stack four high. The leg and arm connection is detailed with a polished aluminum bracket. Conde House, San Francisco.

Circle 300 on reader service card

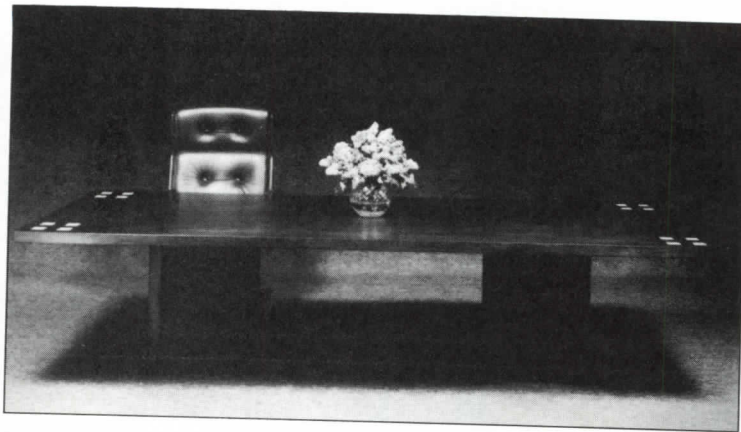

Conference table

Designer I. M. Rosen's signature detail for the Quad tables is a contrasting corner inlay. The

square or rectangular tops come in 10 sizes. Cumberland, Long Island City, N. Y.

Circle 302 on reader service card

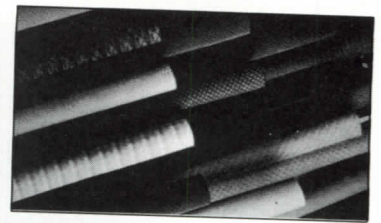

High-tech upholstery

A new polyamide fiber from Europe, Quintesse is said to provide both luxurious esthetics and easy maintenance. Suitable for contract weaves, jacquards, and velvets, the fiber comes in bright and subtle colors. ICI Fibres, Greensboro, N. C.

Circle 303 on reader service card
Continued on page 177

**WHY ARE
PC GLASSBLOCK®
products the choice of America's
leading architects?**

See us at the
CSI Show
Booth No. 980/982.

**Because there is a difference
in glass block quality . . .
and the service that comes with it.**

Superior-bond
edge-coating.
Pure, high
quality glass.

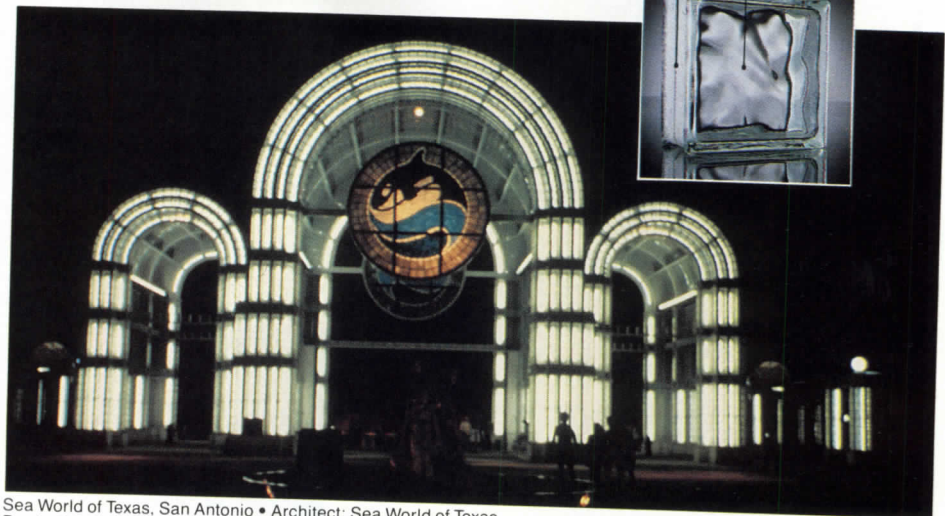
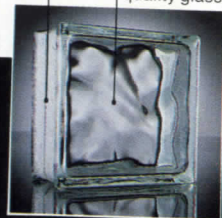

Sea World of Texas, San Antonio • Architect: Sea World of Texas
Production Architect: Jones & Kell, Inc. • DECORA™ Pattern

The clarity and brilliance of PC GlassBlock® products are unmatched, thanks to the exclusive use of low iron-content sand. No recycled glass is ever added because this affects color and clarity. And the unique edge coating on PC GlassBlock® products provides a superior bond with mortar, expediting installation. At Pittsburgh Corning we maintain strict quality control—for example, each block is visually inspected at least once before it's packed. The result: superior, consistent products.

Architects and designers have access to Pittsburgh Corning's drawing review and technical guidance . . . on-site assistance by trained, qualified Pittsburgh Corning representatives . . . full sample selection. And, even after

installation, we stand behind our products. The Difference—Pittsburgh Corning's quality and service. That's why American-made PC GlassBlock® products are your best choice. For more information, or details on our international distribution, call the PC GlassBlock® Products Hotline.

800-992-5769

or write, Pittsburgh Corning Corporation, 800 Presque Isle Drive, Department AGB-9, Pittsburgh, PA 15239. In Canada, call (416) 222-8084.



Circle 94 on inquiry card



Wool damask

An all-wool damask for contract upholstery and vertical use, Falling Leaves has a tone-on-tone pattern and is offered in five colors. Lee Jofa, Carlstadt, N. J.

Circle 301 on reader service card

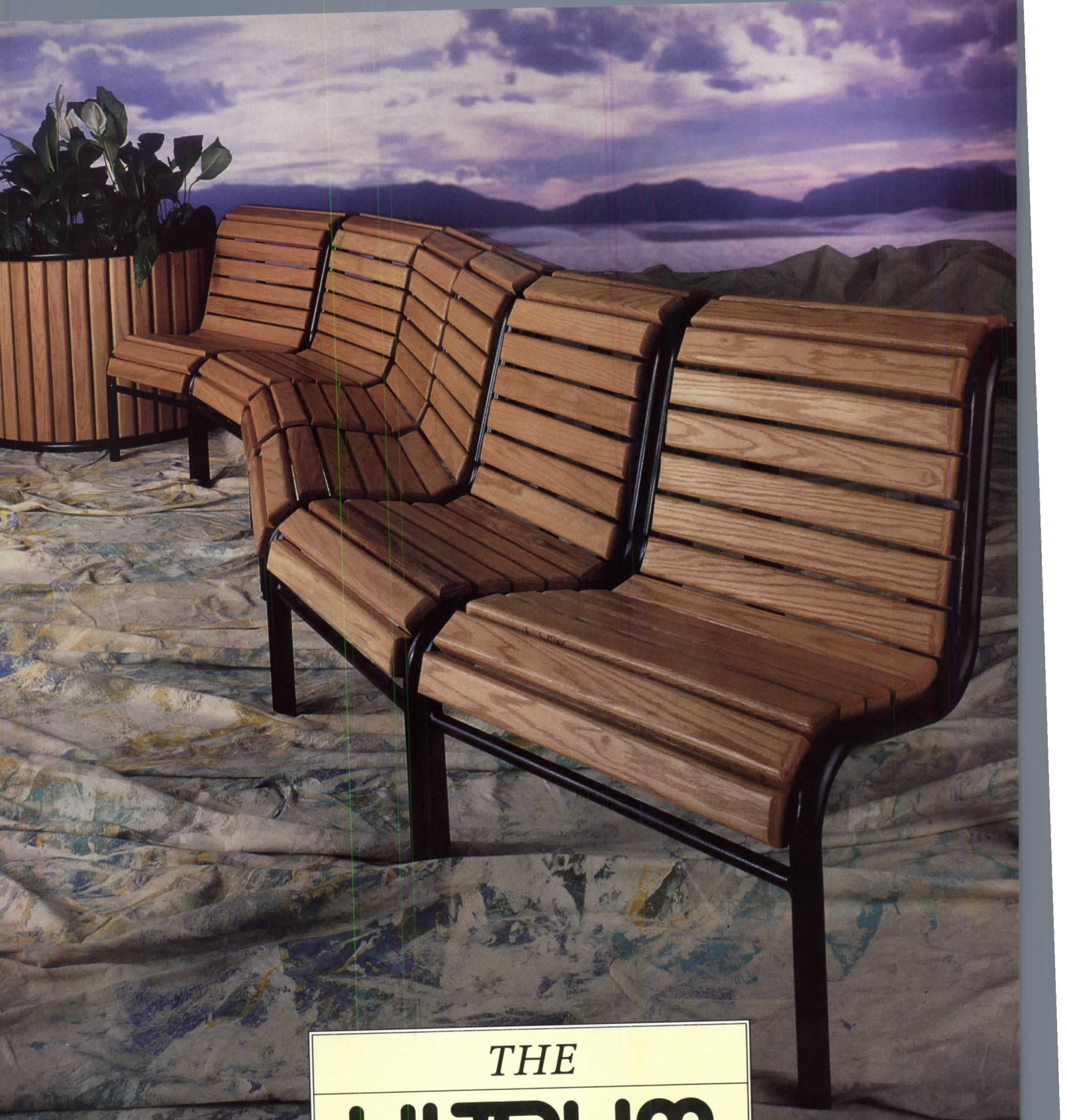

THE
•ULTRUM•
COLLECTION

© 1988 GameTime, Inc.

From beautiful hand-rubbed wood finishes to the contemporary and contour styles of our wood series line, Ultrum offers today's most exciting site furniture collection. For our new full-color catalog, contact your Ultrum sales representative or write GameTime, Inc., P.O. Box 121, Fort Payne, AL 35967. 205/845-5610, telex 782-534, FAX 205/845-2649.

Circle 95 on inquiry card



Side stacker

A compact side chair offered in dozens of matching or contrasting frame, Zytel plastic shell, and fabric color combinations, Parade is described as a safe, comfortable chair that needs only the barest maintenance. Steelcase, Inc., Grand Rapids, Mich.

Circle 304 on reader service card

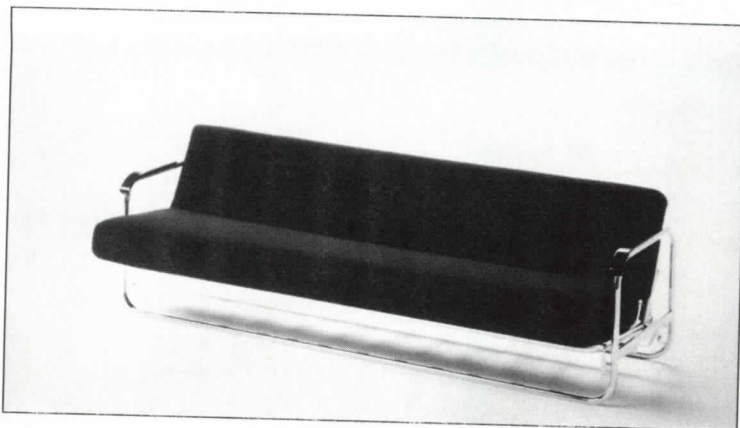

Early Aalto

From 1930, the architect's pre-bentwood, Functionalist phase, a daybed of steel tubing adjusts

flat to create a twin-size bed.

Offered in fabric or leather.

ICF, Inc., New York City.

Circle 306 on reader service card

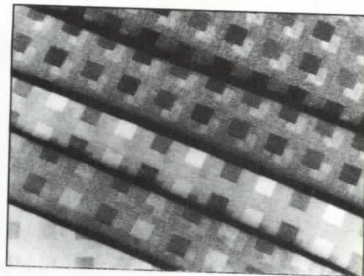

Wool-blend fabric

Shadowbox, offered in five colorways, is a half-and-half weave of wool and lenzing, a viscose fiber said to be naturally flame-retardant. Karl Mann Associates, New York City.

Circle 307 on reader service card

Continued on page 179

PPG Place, Pittsburgh, PA.
Architects:
Philip Johnson & John Burgee.



OASIS

Circle 96 on inquiry card

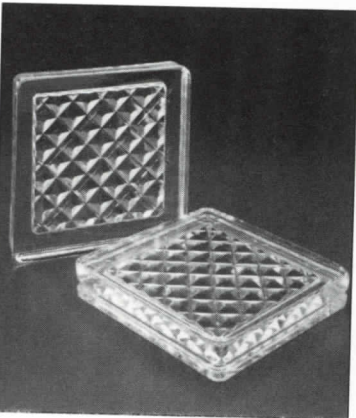

Glass-block pavers

Developed for use in horizontal applications such as stairways, walks, skylights, and between-floor partitions, this new GlassBlock Paver has been deadload-tested in frame systems for up to 200 lb per sq ft. The unit has a multitriangle Delphi pattern pressed into the bottom, and a skid-resistant raised-line design on the top surface. Pavers can be used in most flat, curved, horizontal, and vertical frame systems. Pittsburgh Corning Corp., Pittsburgh.

Circle 305 on reader service card



2000X[®]

THE SOLID THAT SHAPES THE FUTURE.

FORMICA[®] brand 2000X[®] building products invite you to let your imagination soar. These advanced solid products with color running through their entire thickness offer you unlimited design possibilities. Now you can create the look, as well as the feel, of stone and marble like never before.

FORMICA brand 2000X products also provide the kind of versatility that will greatly expand your design horizons. It represents a range of solid surfacing products unequalled by any manufacturer. The list includes vanities with integral backsplashes, bath and shower surrounds, bathtubs and shower basins, and sheets.

The look is stone, but the subtle palette is warm and welcoming. 2000X products from Formica Corporation are available in six colors, including Frost pictured here. All colors coordinate naturally with our entire line which offers our on-going tradition of quality and reliability.

2000X products will help your most creative designs take shape, because they're the solids that are the shape of the future.

For additional information, call 1-800-524-0159; in NJ call 1-800-624-1914.



Circle 97 on inquiry card

Continued from page 177



Passive ergonomic

Reflex is an international effort, with Italians Paolo Favaretto and Giancarlo Bisaglia, working for Estel, developing the ergonomic design for manufacture in Muskegon. The chair is built with elastic webbing over steel tubes, encapsulated in injection-molded foam. A steel flex mechanism between back sections allows unrestricted body movement and stretching. Shaw-Walker, Muskegon, Mich.

Circle 308 on reader service card

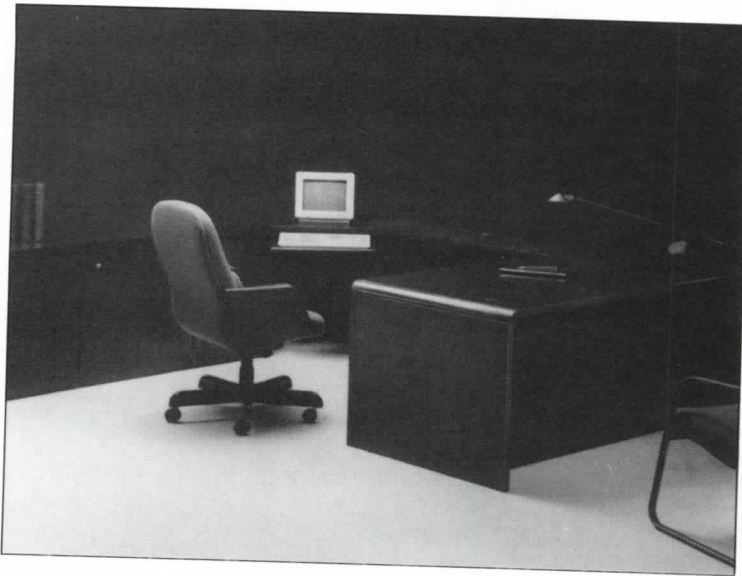

Computer support

The Concept Collection offers a large number of workstation, desk, and return options in hardwood furniture for the executive level. An articulating keyboard tray retracts for storage; the 45-deg corner unit can be added to standard U-shaped stations for additional computer space. Dar/Ran Furniture, High Point, N. C.

Circle 310 on reader service card
Continued on page 183

Entrance Exam.



Entrance exams leave little room for error. The questions are tough: Were your original design objectives supported by high quality door and entrance construction? Will the

Will the doors you choose stand up to the test?

doors stand up under traffic conditions and operate without problems day in, day out? Does the fabrication and finish represent the kind of craftsmanship you expected. Passing this kind of test over and over

means specifying a manufacturer with a reputation for producing beautifully crafted doors and entrances. Dawson is the company. Whether your concept calls for mirror



A Division of
Dawson Metal Co., Inc.
608 Allen Street
Jamestown, NY 14701
(716) 664-3811 Fax: 661-3722

Guest chair

Almost Grecian in detail, John Cladwell's new chair for the Manner Collection has an upholstered back, seat, and sides. Thonet/Madison Industries, Chicago.

Circle 309 on reader service card



TO CLOSE THE SALE OPEN THE DRAWER

When customers open these drawers this furniture literally sells itself. The drawers move with the smoothness and silence of a ride in an ultra-expensive luxury car. The reason is the Accuride® slides that suspend the drawers.

Furniture buyers physically experience a sudden and irresistible impression of overall quality. And it carries through to the entire piece of furniture, regardless of price.

The effect is exclusive. No other slides (even those that use a "copycat" design) come even close to the Accuride fine movement. And there's no way any other slide ever will.

More than 10,000 Accuride custom designs are now in use in fine furniture and file drawers, computer keyboards, disc drives, photocopiers, shipboard electronic enclosures and microfilm readers.

"Surprising" the steel into a precision movement

Ordinary slides are bent progressively by roll-forming, much the same way you crease a piece of paper with your thumbnail. And, like paper, the metal "wants" to return to its original shape, causing tiny dimensional variations in the slide raceway. That's why ordinary slides just don't move very smoothly.

The Accuride raceway is created simultaneously along its entire length in a fraction of a second. Immense forces in a precision die form the close tolerance ball raceways of extraordinary straightness and parallelism, and the fine Accuride movement that has never been duplicated.



Accuride controls virtually all elements in the manufacturing process

Accuride buys only steel and plating chemicals. Everything else (processes and components) that other slide manufacturers "job out" are done in-house at Accuride plants in California, North Carolina, England, West Germany and Japan. The result is unparalleled quality control.

Dozens of the world's largest and most demanding companies put Accuride to the test every year

Despite exhaustive vendor performance analyses, value engineering studies and

quality audits, over 95% of all Accuride customers choose to place 100% of their business with Accuride year after year.

The reasons are simple: excellent quality control, on-time deliveries, reasonable lead times, stable pricing, and superb emergency response.

Here's an offer that puts the proof into your own hands

Prove to yourself that Accuride slides are superior to every other slide in the world. Just send a request on your company letterhead

describing your interest in slides and Accuride will send you an actual slide.

The action is so smooth and precise, some people call it an "executive pacifier," but its

purpose is to demonstrate the value of the Accuride quality and movement.

Write to Accuride, 12311 Shoemaker Avenue, Santa Fe Springs, CA 90670. (213) 903-0373. Fax: (213) 903-0208.



Accuride®

NEOCON[®] 21

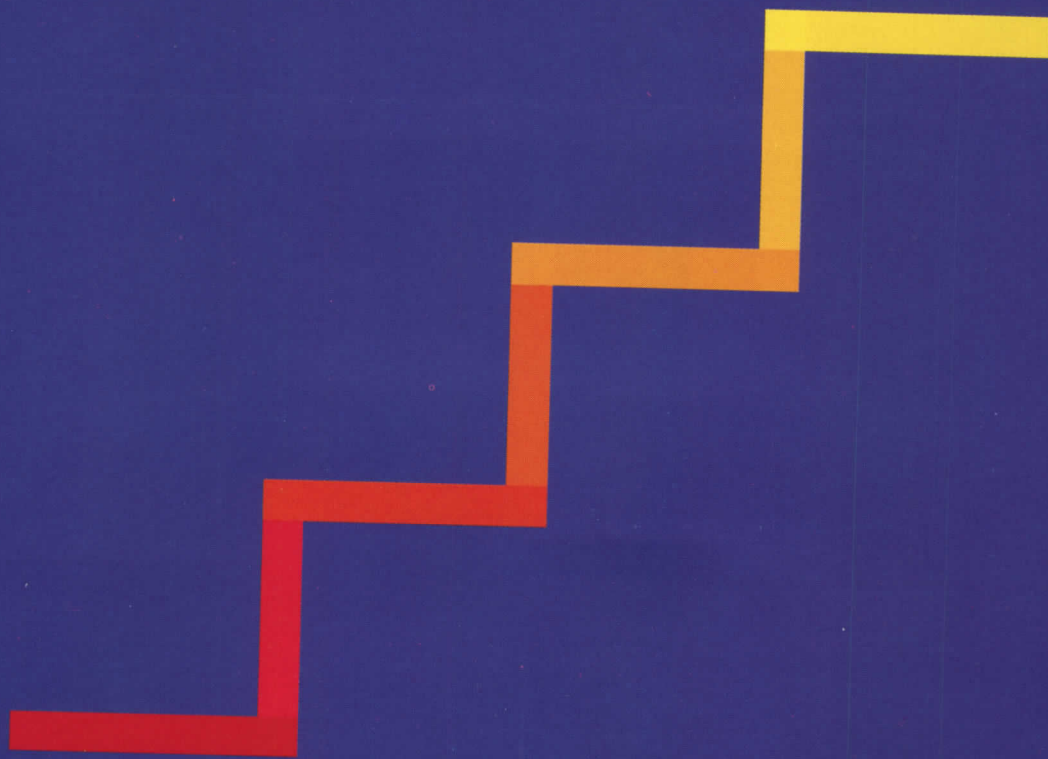

THE MERCHANDISE MART CHICAGO JUNE 13-16 1989

PORTRAIT *of the* GREAT AMERICAN INVESTOR

Jon Higuera began his journalism career as an eight-year-old, interviewing neighborhood kids and writing stories for a homemade newspaper. Today, he's one of the hottest young reporters around, with an even brighter future.

There's no doubt about it. Jon Higuera knows what he wants from the American dream, and how he's going to get it. He invests his time in a job well done, and his money in U.S. Savings Bonds. And that makes him one of the Great American Investors.

Like Jon, 30 million people invest in America while helping themselves. The Bonds they buy today pay competitive rates, like money-market accounts. They're free from state and local income tax, and federal tax can be deferred.

You can purchase Bonds through the Payroll Savings Plan at work, or where you bank. They're a great way to make the money you've worked for start working for you. For more information on U.S. Savings Bonds, call toll-free: 1-800-US-BONDS. For a free brochure, send a postcard to U.S. Savings Bonds, Dept. 891-M, Washington, D.C. 20226.

U.S. SAVINGS BONDS
THE GREAT AMERICAN INVESTMENT

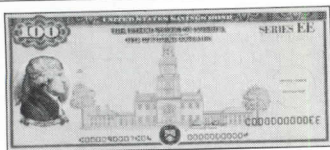

Bonds held less than five years earn a lower rate.
A public service of this publication.

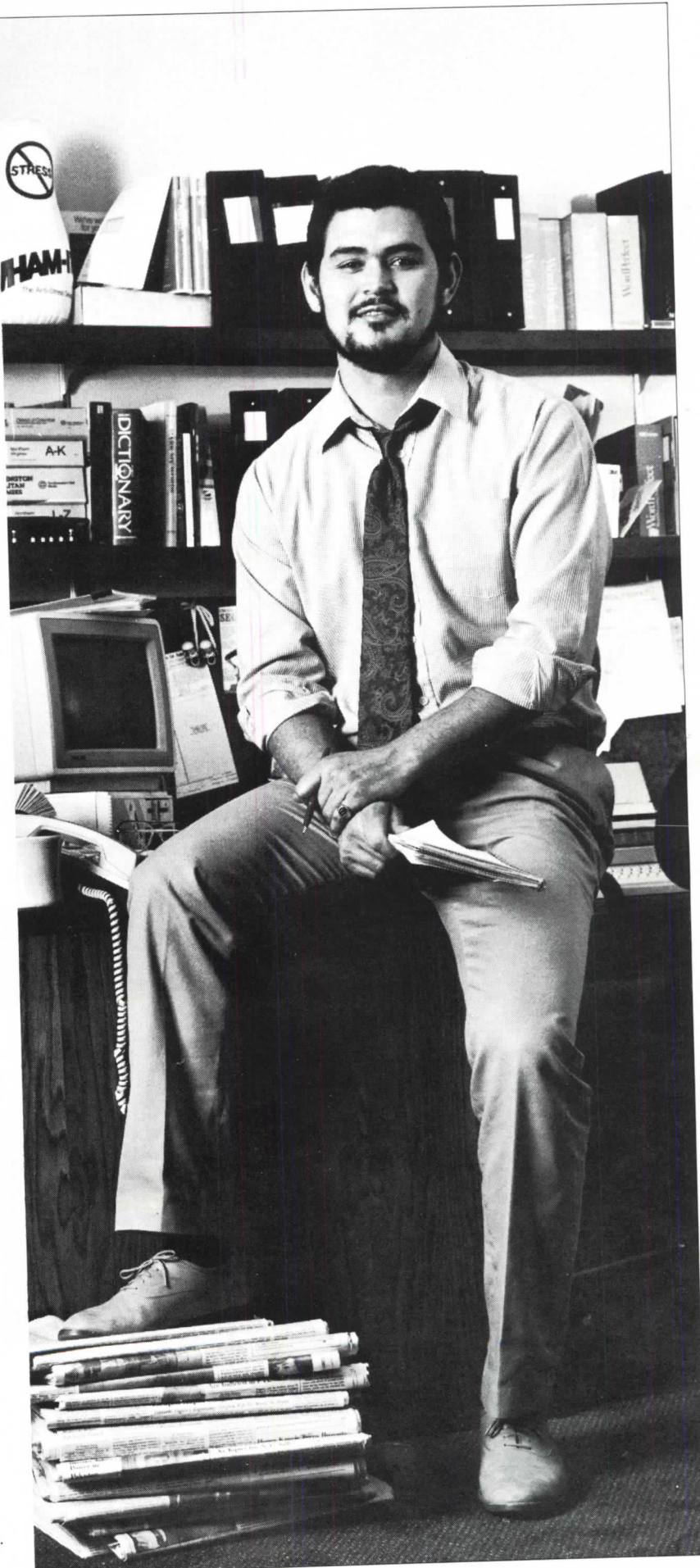

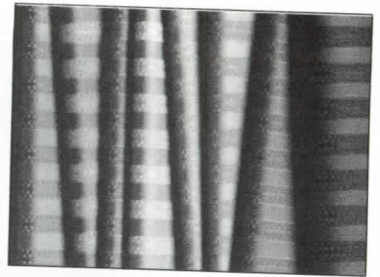
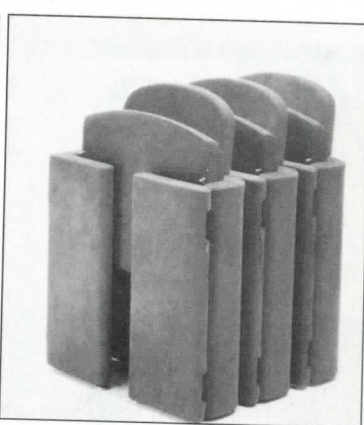

Multiple-use chair
The TreperUno chair has a light steel frame covered with cold-processed foam and removable

upholstery. It can be folded and ganged, as shown. GE Int'l., Long Island City, N. Y.
Circle 314 on reader service card

Striped wool upholstery
A new pattern, Biedermeier Stripe comes in 14 colorways, from black and white to more traditional reds and greens. Unika Vaev, Orangeburg, N. Y.
Circle 315 on reader service card
Continued on page 186

On commission

Based on designs the architectural firm of Rodrigo-Mazure executed for a client in Florida, the Bermont chair is offered on a limited-production basis. It is constructed of an intricate assembly of curved hardwood slats. R-M F, Miami.
Circle 311 reader service card



Contract tables

The Heraldic Collection includes the table shown, and a desk, game table, and cocktail-style table. The tables have intricate starburst veneer designs set into an ornate top. Dakota Jackson, Inc., New York City.
Circle 312 on reader service card



Ball-footed lounge

The Viola Club Chair comes in two sizes, 26- and 30-in. wide. Fully upholstered with dacron-covered foam, it is suggested for heavy-use lobby and hospitality areas. Monel Contract Furniture, Inc., Oakland Gardens, N. Y.
Circle 313 on reader service card



53rd and Horton Street, Emeryville, CA

The Munselle/Brown Partnership, Architect

KALCURVE™ The most highly insulating light transmitting curved material for skyroofs and curtainwall systems.

See Sweet's 08900/KAL and 07820/KAL.

Kalwall
CORPORATION

P.O. Box 237, Manchester, NH 03105, Phone 603-627-3861 or 800-258-9777

Kalwall: a High-Tech Building Systems Company. Always the leader!

U.S. Patent Number 4,557,090

Circle 101 on inquiry card

We're standard, bu

Intergraph Compliance with Standards

Standards	Intergraph	Sun	DEC	Apple	HP	IBM
UNIX-based os	X	X				
C, Fortran	X	X	X	X	X	X
X-Windows	X	X	X	X	X	X
PHIGS	X	X	X	X	X	X
GKS	X	X				
Ethernet	X	X				
TCP/IP	X	X				
DECnet	X	X				
NFS	X	X	X			
RS232	X	X	X			
SCSI	X	X				
VME	X					
Binary Compatible	X					

We stand apart...



With Integrated Application Solutions

Intergraph®, the leading total solutions company, offers the broadest range of integrated applications in the industry, including AEC, utilities, plant design, mechanical, industrial engineering, mapping, energy exploration, electronic publishing, and electronic design.

With Third-Party Software

Intergraph's RISC-based CLIPPER® platform allows us to offer hundreds of third-party software products. Additionally, a full suite of development tools provides an ideal platform for third-party vendors.

With Binary Compatibility

Intergraph goes beyond the source compatibility of other vendors. We offer binary compatibility. So software running on any CLIPPER system will run on all future CLIPPER systems without modification. This protects your investments in software, training, and databases.

With Number 1 Standing In Customer Satisfaction

We rank Number 1 in customer satisfaction. This is due to 20 years of commitment to total systems solutions and our worldwide sales, training, and support. To learn more about our workstations and systems solutions, call us today: 1-800-826-3515 in the United States, 31-2503-66333 in Europe, or 852-5-8661966 in Asia.

INTERGRAPH

Intergraph and CLIPPER are registered trademarks of Intergraph Corporation.

Continued from page 183

Designer-makers cross the pond

The whimsical yet functional pieces at right are produced by members of Britain's Crafts Council, who will represent the U. K. at the first International Contemporary Furniture Fair in New York City, May 21-24, at the Javits Center. A spin-off of the British Design Council, the Crafts Council assists in the marketing of work by designer-makers such as Danny Lane, Nigel Coates, and Helen Yardley. Many of this year's exhibitors have never before shown in this country, but some limited-production furnishings are available in American showrooms.

Information on all of these craft items will be supplied by the British Trade Development Office in New York City.

For those willing and able to cross the Atlantic in the other direction, the Interior Design International annual show will be held in London, May 14-18, at both Earls Court and Olympia halls.



Plates, tableware, and glasses are always ready on Tony Isseyegh's painted tilt-top table. The straight-back chair has a

design of slats and spaces. Tony Isseyegh, Hebden Bridge, West Yorkshire.

Circle 316 on reader service card



Twisted black forged steel forms a tripod supporting a glass top; Tim Sherburne also crafts dramatic candlesticks. Sherburne and Sherburne, London.

Circle 317 on reader service card

NORTHWEST

DOING BUSINESS IN SINGAPORE TAKES A BIT OF CULTIVATION.

Although the business world of Singapore is thriving, trying to deal with its three distinct cultures—Chinese, Malay and Indian—takes a certain delicate balance.

LET'S HAVE A MEAL, LET'S MAKE A DEAL. An essential tool of business is hospitality. Visitors are treated to lavish entertainment before and during negotiations. It's important to know that you're required to return the favor. An excellent choice for dinner would be the



Domus restaurant at the Sheraton Towers Hotel. Tel: 737-6888

EVERYONE'S A WINNER. Saving face is important. Singaporeans won't tolerate losing an argument, but they won't let you lose face either as they're very aware of the pride of others. A word of advice: call it a draw.

ARE YOU SINGLE?

Don't be surprised if people ask you very personal questions, just

answer politely but keep all of your own inquiries as objective and impersonal as possible.

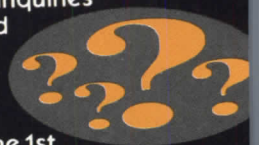

NORTHWEST NOTES. On June 1st we begin convenient connections to Singapore from over 200 U.S. cities. And, in addition to our all-747 fleet, we offer you something no other U.S. airline can—the knowledge and information that comes from over 40 years of helping people do business in Asia.

LOOK TO US  NORTHWEST AIRLINES

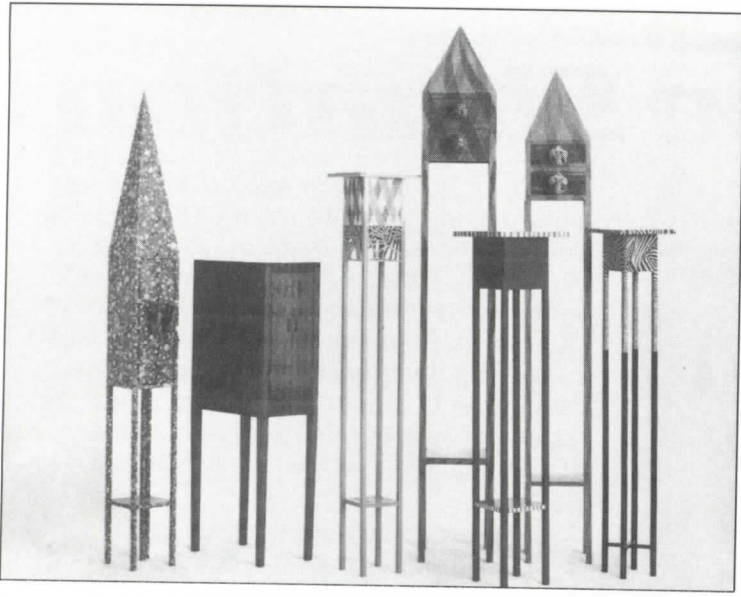

Brian James and David Davies collaborated on jewelbox-like cabinets fitted with tiny drawers and pointy tops. Paint, shellac,

and varnished finishes are gilded and french polished. The Imperial Workshops, Norfolk.
Circle 318 on reader service card

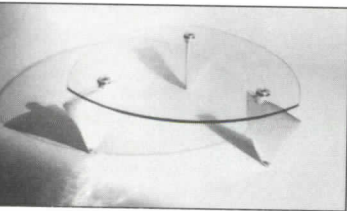

Though designer Matthew Hilton calls his assembly of glass and steel the Flipper Table, one could imagine the legs to be shark's teeth. SCP Ltd, London.
Circle 319 on reader service card

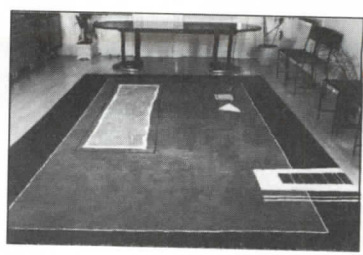

Helen Yardley's limited-edition wool rug comes in Egyptian colors. A-Z Studios, London.
Circle 320 on reader service card

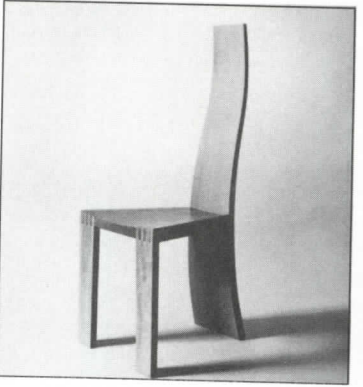

Already almost a classic, Robert Williams' plank-back chair is offered for contract use. Pearl Dot Workshops, London.
Circle 321 on reader service card

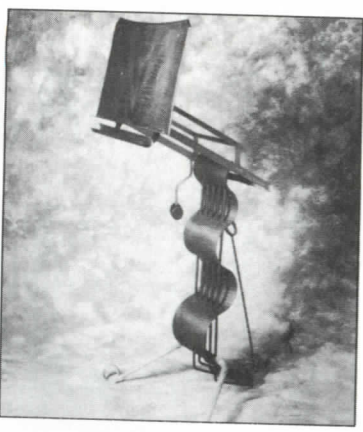

A lectern of curved, stained plywood. Fred Baier, London.
Circle 322 on reader service card

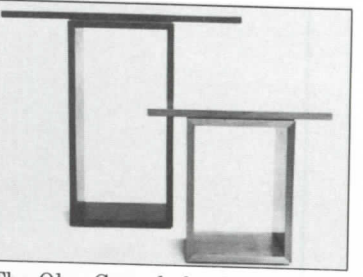

The Olso Console by John Coleman strives for geometric perfection. A-Z Studios, London.
Circle 323 on reader service card
More products on page 190



NORTHWEST ASIA SERIES

On Top of the Situation



Specify a Bilco scuttle and put your client on top of the situation. With a Bilco scuttle, rooftop access occurs from within the building itself, eliminating the hazards and inconveniences of outside ladders. No more worries about wet, slippery ladder rungs, the unattractive appearance of a fixed exterior ladder or the need to use an extension ladder. With an inside ladder, opportunities for vandalism are reduced as well.

Available in aluminum or steel, Bilco scuttles are designed and built to provide long, trouble-free service. The integral capflashing, fully welded corner joints and thermoplastic rubber gasketing ensure complete weathertightness.

For safety, convenience and easy one-hand cover operation, nothing can match a Bilco scuttle. See our catalog in Sweet's or send for a copy.

Bilco

DOORS FOR
SPECIAL SERVICES

The Bilco Company, P.O. Box 1203, New Haven, CT 06505

Circle 103 on inquiry card

Decorative Grilles in Color

Adds a new dimension to your designs. Unusual visual effects emerge when our grilles are used for area effects. Choose from an array of custom colors that will match or contrast your grilles. As an innovative industry leader we see beyond black and white.

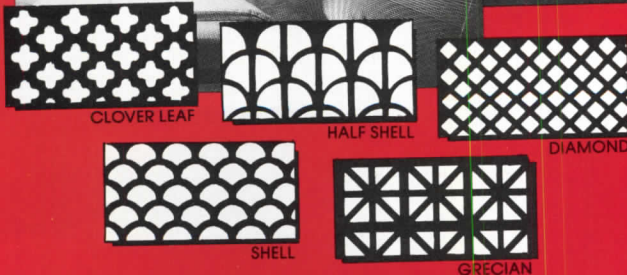

CLOVER LEAF

HALF SHELL

DIAMOND

SHELL

GRECIAN

Write for color catalog for ideas on the use of decorative grilles

REGISTER & GRILLE MANUFACTURING CO., INC.
202 NORMAN AVENUE, BROOKLYN, NY 11222 (718) 383-9090
CALL TOLL FREE 1-800-521-4895

Circle 104 on inquiry card

This is the child who can make the dollar strong.



Only a child.

But like all American kids, Randal Six, inventor of a solar heating device called *Le the Sun Shine*, is a very special child.

For our kids have a creative, inventive heritage second to none. And inventiveness, creativity, productivity; these are the things prosperity and growth are made of.

Now the inventive instincts of American school kids are being challenged by a very special education program and contest.

Invent America!

It's the only program that recognizes small genius. With more than half a million dollars in awards every year.

And the only program that knows small genius can grow up to become big genius—with the capacity to make a big difference in the world.

Just write Invent America!, 510 King Street, Suite 420, Alexandria, VA 22314, or call 703/684-1836.

Invent America!

Designed to make America a winner again.

**INVENT
AMERICA!**

Bringing bright ideas out of young minds

Ad Council

Invent America! is a nonprofit program in partnership with business, industry and education. Call or write today to join this vital national effort.

Circle 105 on inquiry card

United States Aluminum Corporation's Five Year Warranty on the corner construction of Entrance Doors is another first by number two.

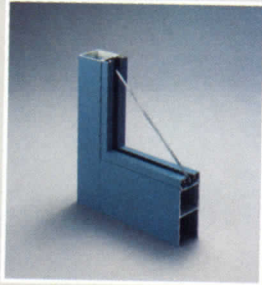

Yes, it is true that United States Aluminum Corporation is only the second largest manufacturer of aluminum entrance doors in the United States. But, we are the **first** to issue you a **five** year warranty against corner construction failure.

With this five year warranty, doesn't it make sense to specify entrance doors by United States Aluminum Corporation on all your projects?

We offer a complete line of entrance doors to meet your requirements: trim, narrow, medium and wide stiles, also flush panel, and mall sliders.

Available in clear, bronze or black anodized finish or custom painted to architect's specifications.

See us in Sweets 08400/UMV

For complete information call 1 (800) 527-6440, in Texas call 1 (800) 442-3247, or write:

United States Aluminum Corporation

Manufacturing Facilities

3663 Bandini Blvd.
Vernon, California 90023
Telephone (213) 268-4230

200 Singleton Drive
Waxahachie, Texas 75165
Telephone (214) 937-9651
or (214) 299-5397 metro

6969 West 73rd Street
Chicago, Illinois 60638
Telephone (312) 458-9070

720 Cel-River Road
Rock Hill, South Carolina 29730
Telephone (803) 366-8326

You're playing it safe with Elkay.

Introducing the Elkay Design 2000 Coolers. An extra-fine strainer, "The Filtrex System," helps keep out solid impurities. And, all components are lead-free. Trust Elkay for all your cooler needs...



© 1989 Elkay Manufacturing Company

just say **ELKAY**

Circle 107 on inquiry card

Elegant, not splashy.

Stylish SwirlFlo coolers from Elkay have a unique-contoured basin to minimize splashing. And the exclusive Flexi-Guard™ safety bubbler. For every cooler imaginable, there's only one name to know...

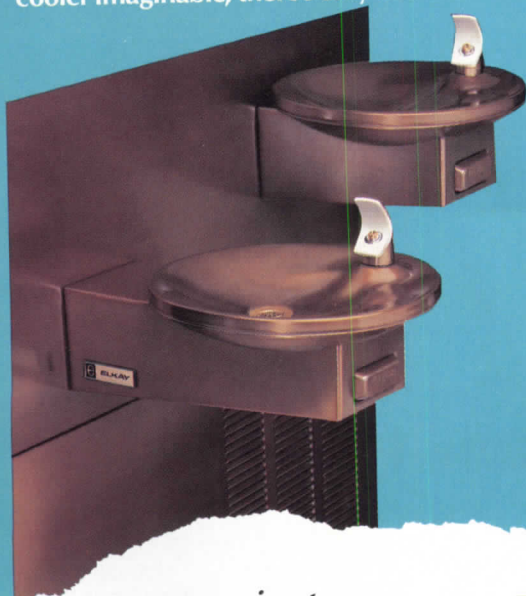

© 1989 Elkay Manufacturing Company

just say **ELKAY**

Circle 108 on inquiry card

Continued from page 187



Color in components

The Tinta System, interrelated wood casegoods, worksurfaces, and panels, come in many natural woodgrains, and 26 colors of two-step catalyzed urethane paint. Geiger International, Atlanta.

Circle 324 on reader service card

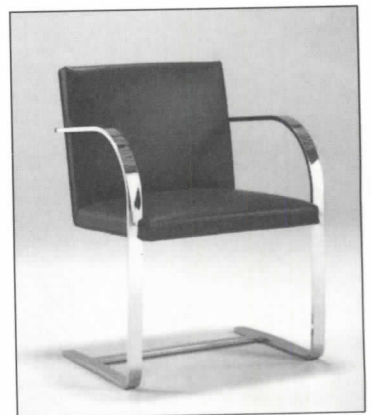

Modern classic

Brueton's new version of the Brno Chair can be ordered with a bronze finish on the solid stainless-steel flat bar or tube frame, as well as the standard mirror-polished steel. Brueton Industries, Inc., Rifton, N. Y.

Circle 325 on reader service card

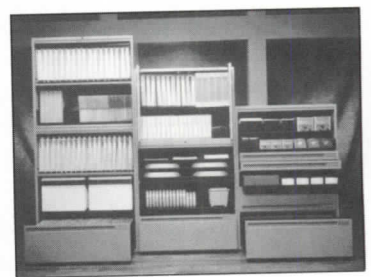

Media storage

A lateral file series, the Performance Group accommodates printouts, diskettes, reels, cartridges, etc., in 3- to 15-in. openings, receding or pull-out drawers, and binder hangers. Storwal International, Inc. Toronto.

Circle 326 on reader service card

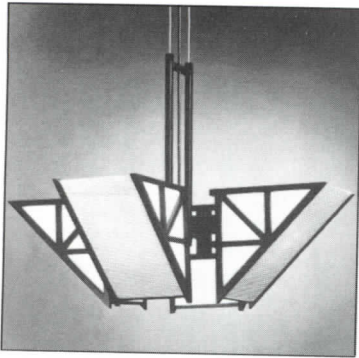

Architectural pendant

By Boston architects Cary Tamarkin and Tim Techler, designers of the Merns Lamp, the Struts fixture has perforated metal framing white glass; light takes standard incandescent bulbs. Also available as a bracket. George Kovacs, New York City.

Circle 327 on reader service card

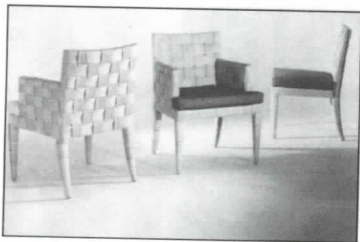

Block-woven wicker

A more robust version of the Victorian settee, the Block Island group includes an arm chair/side chair (pictured), sofa, club chair, and ottoman. Donghia Furniture, New York City.

Circle 328 on reader service card

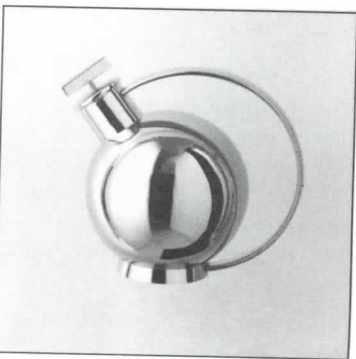

Across the bar

Alessi is offering a stainless-steel version of Marianne Brandt's 1925 silver cocktail shaker, originally created in the Bauhaus' metal workshop. The flask shape is very efficient: it really doesn't have to be shaken. The Markuse Corp., Woburn, Mass.

Circle 329 on reader service card

Style that knows no barriers.

Elkay Barrier Free coolers are unsurpassed for their stylish good looks. And the light-touch, wrap-around pressbar always makes access easy. For coolers for every situation imaginable, just say the word...



© 1989 Elkay Manufacturing Company

just say **ELKAY**

Circle 109 on inquiry card

The quality runs deep!

This wall hung economy cooler is no exception. It doesn't take up a lot of room. Or a lot of your budget. For high quality coolers for every setting, one word says it all...



© 1989 Elkay Manufacturing Company

just say **ELKAY**

Circle 110 on inquiry card

TCS and the Corporate Ediface

Procter & Gamble General Office
Cincinnati, Ohio
Architect: Kohn—Pedersen—
Fox Associates
New York, NY
Roofer: Imbus Roofing Company,
Cold Spring, KY

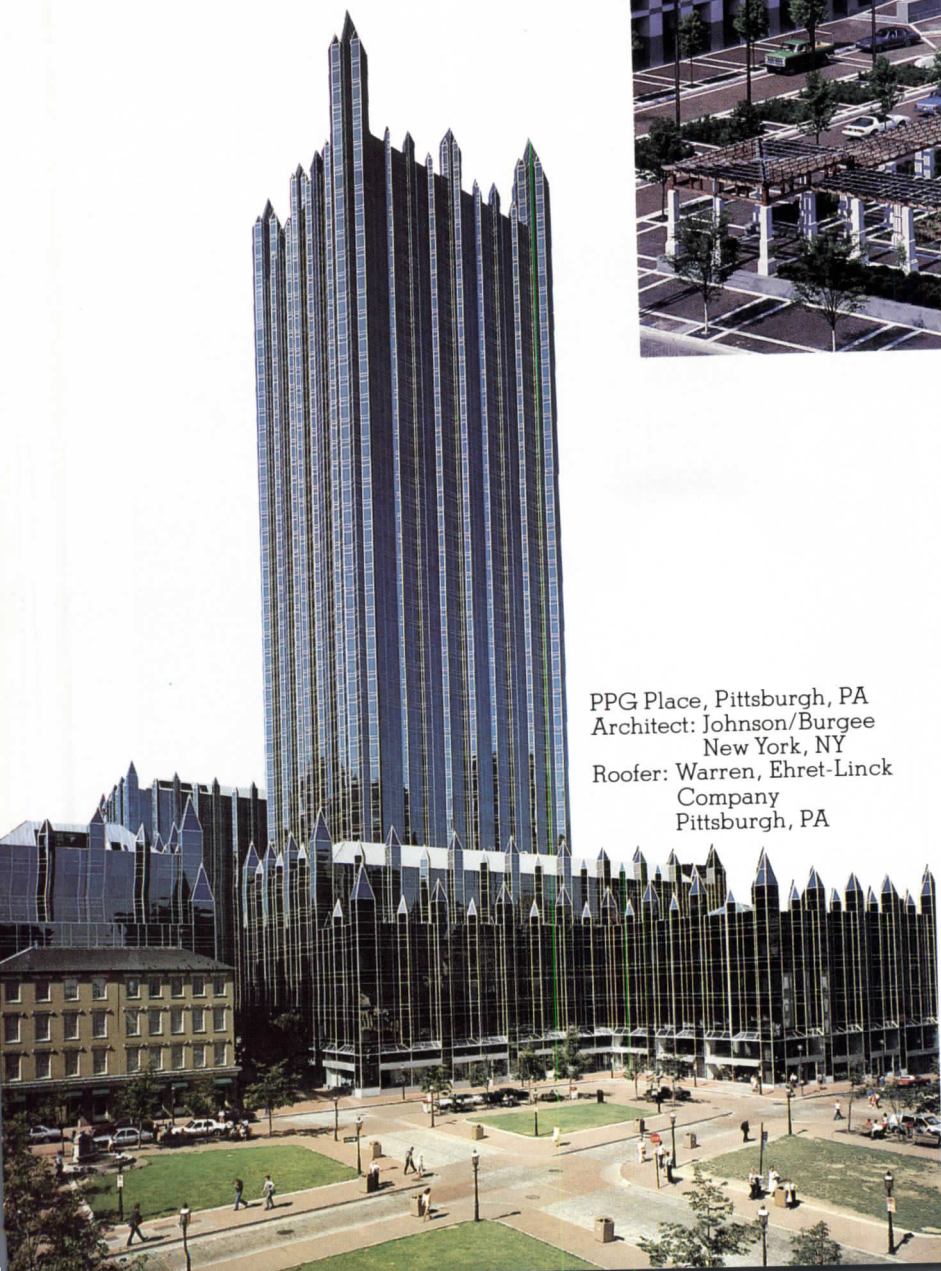

PPG Place, Pittsburgh, PA
Architect: Johnson/Burgee
New York, NY
Roofer: Warren, Ehret-Linck
Company
Pittsburgh, PA

There are many striking examples of how TCS (terne-coated stainless) has become an integral part of a total architectural concept...expressed so beautifully as roofs on the Procter & Gamble building and on the many roofs of PPG Place. Weathering to a predictable warm, natural glow, TCS blends quietly with the buildings' architectural expression.

Aesthetics aside, however, TCS has impressive functional credentials. Among them are great tensile strength combined with light weight, exceptional resistance to corrosive environments, complete freedom from maintenance thereby promising a durability measured in generations rather than years. We'll be happy to send you substantiating evidence. Call us toll free 800-624-6906.

FOLLANSBEE
FOLLANSBEE STEEL • FOLLANSBEE, WV 26031

Circle 111 on inquiry card

**THE VIRTUES OF QUALITY
AND CRAFTSMANSHIP
SINCE 1946.**



Woodfield Corp. Center, Chicago, IL

Arch: Holmberg-Root • Cont: Pepper Corst Co • Erector: Engineered Erection Co Inc

MARMET QUALITY.

DISCOVER IT.

When you've been making high performance aluminum windows as long as we have, quality and craftsmanship is no accident.

Marmet windows have withstood the most stringent test of all - the test of time. Architects have relied on Marmet's aluminum windows, curtainwall systems and detention/security windows because our experience pays off with distinction and style for your projects.

For 43 years, our design specialists have worked with architects creating standard and customized windows that are precision engineered. We've performed for new construction and for countless replacement projects.

For more information on aluminum windows and curtainwall systems made with the virtues of quality and craftsmanship call MARMET at

1-800-444-8881 or write

MARMET CORPORATION

P.O. Box 1008, Wausau, WI

54402-1008. Marmet quality. Discover it.



Aluminum Windows • Detention/Security Windows
Curtain Wall Systems • Replacement Windows

Circle 112 on inquiry card

Manufacturer sources

For your convenience in locating building materials and other products shown in this month's feature articles, RECORD has asked the architects to identify the products specified

Pages 116-121

American Museum of the Moving Image
Gwathmey Siegel & Associates, Architects

Pages 116-117—Stucco: U. S. Gypsum. Curtain wall and aluminum-framed windows: Modu-Line Windows. Glazing: PPG Industries (Solex). Entrances: Kawneer. Concrete coatings: Edison Chemical Systems. Roofing: Carlisle Syntec System. Rolling doors: Atlas Door.

Page 118—Auditorium seating: Irwin Seating. Lighting: Red Dot.

Pages 128-131

Delta Air Lines Reservations and Training Center
Lord & Sargent, Inc., and MHT Architects, Inc., architects
Brick: Interstate Brick. Precast coping and trim: Buchner Concrete. Revolving doors: Crane Fullview Door. Metal-framed windows: Kawneer. Glazing: PPG Industries (Solex Solar Green). Perforated aluminum acoustic panels: Kawneer. Window blinds: Hunter Douglas (Sunflex). Thermafiber insulation: USG. Roofing: Tamko Asphalt Products.
Page 131—Stainless-steel and oak railing: Niederhauser Metalworks. Carpet tile: Interface. Wood and glass doors: Weyerhaeuser. Lay-in troffer lighting: Metalux.

139-143

Finlandia Vodka
Anderson/Schwartz, Architects
Pages 139, 141—Desk and conference seating: Knoll International (Saarinen). Leather upholstery: Spinneybeck. Arm chairs: Artec (Aalto). Maple desk and wall cabinets: custom by architects, fabricated by Leinoff Woodworking. Pedestal files: Artec (Aalto). Pulls: Hafele.

Continued on page 196

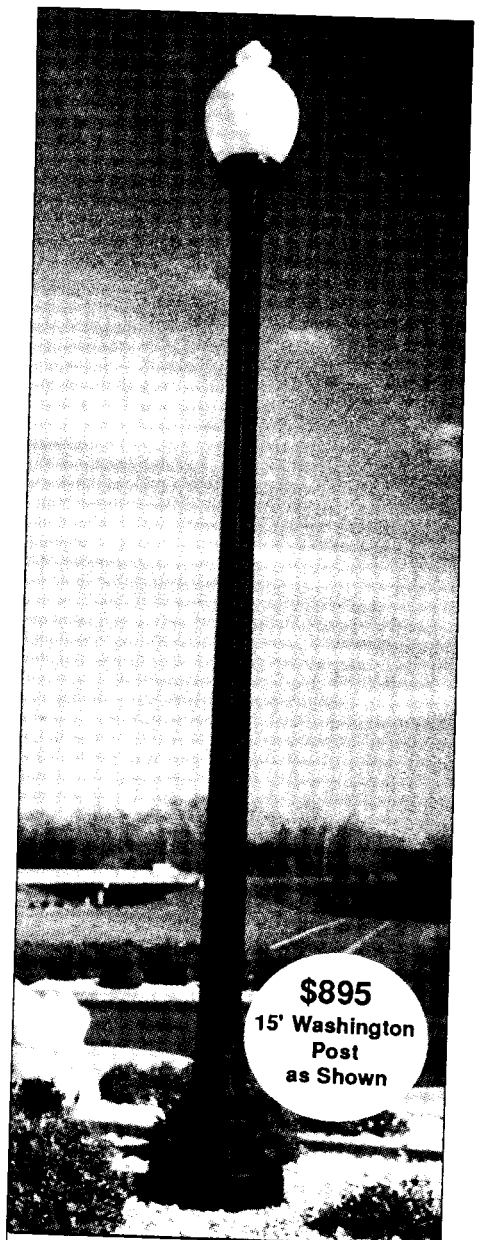

\$895
15' Washington Post as Shown

BUY FACTORY DIRECT & SAVE!

Classic Lamp Posts offers the highest quality, lowest cost lighting posts and luminaires for street lighting, parks and parking lots in America. These unique lamp posts are molded of a steel-reinforced outdoor polymer and urethane laminate that we call "Polysteel".

Our polysteel posts:

- Never Need Painting
- Easy to Install
- Available in qty's of 1 to 1,000
- Our Objective: 4 week delivery
- Designed for municipal use
- Available in 8' to 15' heights

FREE 12 PAGE COLOR CATALOG!

CALLTOLL FREE (800) 654-5852
IN FLORIDA (305) 696-1901

Classic Lamp Posts, Inc.

3645 N.W. 67 Street Miami, FL 33147

Circle 113 on inquiry card



Ordinary Paint.

After the equivalent of 3,000 hours
of 5% salt fog (AAMA 605.2).

Why Risk Tarnish



Introducing the Permacoat™ and Permacoat Plus™ system of high-performance premium finishes for Pella® aluminum-clad wood windows and doors. They offer unmatched durability even in the harshest environments: industrial emissions, acid rain,

temperature extremes, salt spray, high ozone and high altitude.

Unlike any paint, Permacoat exceeds AAMA 605 standards for hardness, color uniformity and film adhesion as well as resistance to impact, abrasion, detergents, solvents and chemical attack. It performs up to three times better than the AAMA 605

©1989 Rolscreen Company. Kynar is a registered trademark of Penwalt Corporation

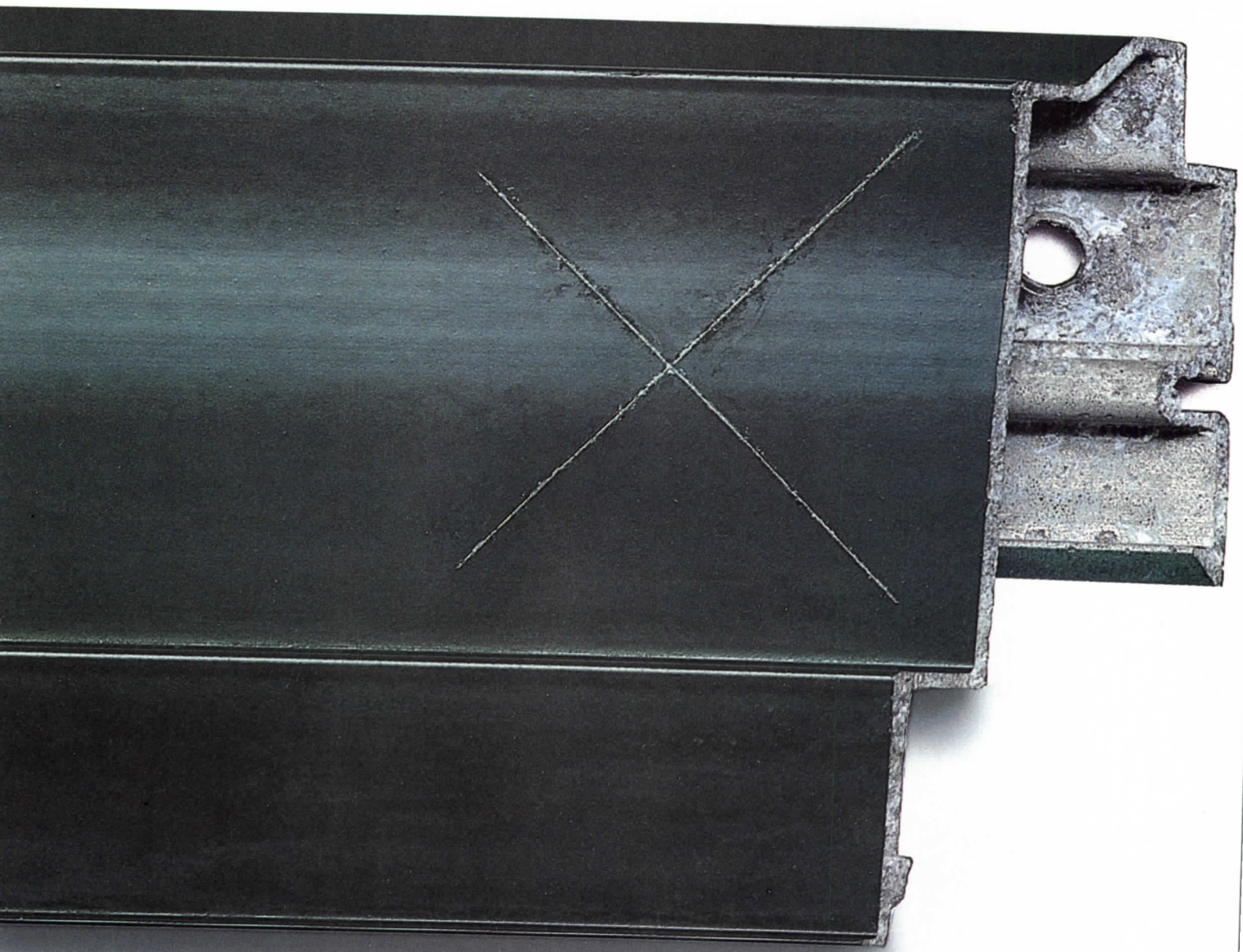

New Permacoat.™

After the equivalent of 10,000 hours
of 5% salt fog (AAMA 605.2).

Your Reputation?

standard for corrosion resistance.

Permacoat Plus is simply unbeatable. This tough, Kynar-500®-based fluorocarbon finish also exceeds AAMA 605 and resists fading, chalking, scuffing, marring and UV deterioration better than any other coating.

Thanks to our new Permacoat finishes, you can confidently recommend custom

color outside and Pella wood beauty inside, no matter what the environment.

For more information, or to see an informative video about our Permacoat system, see your Pella distributor or write to Commercial Department, T31E9A Rolscreen Company, 100 Main Street, Pella, IA 50219.



ROLSCREEN COMPANY
COMMERCIAL DIVISION
PELLA, IOWA 50219

Also available throughout Canada

Circle 114 on inquiry card

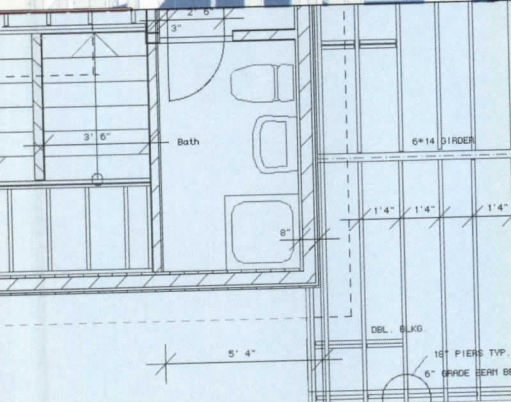
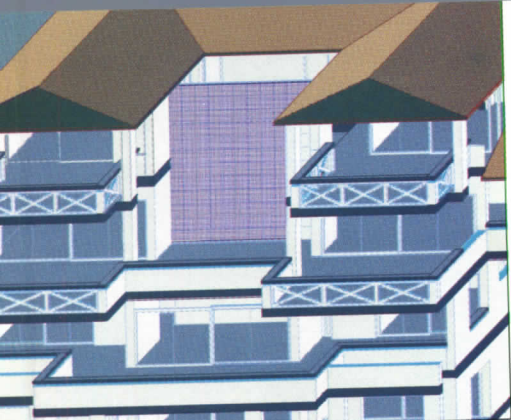

***** BILL OF MATERIAL OF Farrow Residence *****
by ArchiCAD

Name	Quantity	Pen	Layer	Size/Height	Pattern	Thickness
WALL	195.32+185.15sq ft	5	2	8"	frase+drywall	8"
- handhood	15.87cu ft					3/4"
- cavity	15.87cu ft					5"
- frame wall	79.37cu ft					1"
- siding	25.87sq ft					1"
WALL	90.51+90.51sq ft	5	2	8"	frase+dryw.1	4 1/2"
- plywood	33.98cu ft					1/2"
- frame wall	3.78cu ft					3 1/2"
- gypsum board	26.43cu ft					1/2"
WALL	40.35+40.35sq ft	5	2	8"	frase+dryw.1	4 1/2"
- plywood	15.18cu f					1/2"
- frame wall	1.68cu ft					3 1/2"
- gypsum board	11.77cu ft					1/2"
door_2'-6"	6	1	2	2'-6" * 6'-8"		4 1/2"
Beam	12	3	1	4" * 12"		
Additional parameters:	1'					

Graphisoft
ArchiCAD®
The Architect-Friendly CAD

Full solution CAD package to take projects through 2D and 3D modeling, from design development drawings to construction documents. Color Shaded Renderings, Perspectives, Elevations, Detailed Floor Plans, Bill of Materials, Plotter Support.

Graphisoft is located at 400 Oyster Point Blvd., Suite 520, South San Francisco, CA. 94080.
Phone: (415) 266-8720
(800) 344-3468
Fax: (415) 266-8176

ArchiCAD is available through authorized dealers. For your nearest dealer or for any info call 1-800-344-3468

See Graphisoft at the:

- AIA Show in St. Louis, Booth 1313 and
- A/E/C Systems 89 in Anaheim, Booth 1748

Continued from page 193

Hinges: Grass. Drawer glides: Accuride. Ceiling: Armstrong. Lamp: Poulsen. Casements: Gretchen Bellinger. (bottom) Conference table: Cumberland. Carpet: custom by owner.
Page 138—Reception desk: custom by architects, fabricated by Leinoff Woodworking. Office chairs: Knoll (Diffrient). Laminate surfaces: Formica. Paints: Benjamin Moore. Wall light: IPI. Recessed troffers: ICE. Dome fixtures: Lighting Solutions East. (bottom) Sauna lighting: Edison Price. Tile: American Olean.

Pages 138 (top), 142-143 Private Offices, New York City American Design Company, Designers
Pages 138, 142—Translucent screen: custom design; Kalwall. Hinges and locksets: Schlage. Custom cabinetwork: Karl Springer Woodworking. Ceiling: Armstrong. Paints: Benjamin Moore. Vinyl flooring: Vinyl Plastics, Inc. Incandescent lighting: Halo. Pedestal file, desk chair: Herman Miller. Granite-top table: Bieffeplast (D'Urso). Guest chair: DeLorenzo (Jean Prouve).

Page 143—Carpeting: custom design; Karastan. Window blinds: Levelor-Lorentzen. Track lighting: Halo. Workstation: Herman Miller (Burdick Group). Conference table and seating: Herman Miller (Eames Executive Table and Aluminum Group). Occasional chair: ICF (Eliel Saarinen).

Pages 144-145 Woodwork Corp. of America Powell/Kleinschmidt, Inc., Architects
Architectural woodwork, cabinetry, and doors: custom, fabricated by Woodwork Corp. Cabinet pulls: Chautauque Hardware. Coating on column and reception desk: Du Pont. (Imron). Paints: Benjamin Moore. Ceiling: Armstrong (Cirrus). Upholstered lounge seating: Sunar-Hauserman. Floor tile: Fiandre. Carpeting: Karastan. Recessed downlights: Halo.

Pages 146-147 National Shopping Centers Management Corp., Inc. Bausman Gill Associates, Architects
Steel-framed doors and window walls: A & S Windows. Flooring: Pennsylvania Black Slate. Railings: custom by architects.

1	Exxon
2	General Motors
3	Mobil
4	Ford Motor
5	IBM
6	Texaco
7	E.I. du Pont
8	Standard Oil (Ind.)
9	Standard Oil of Cal.
10	General Electric
11	Gulf Oil
12	Atlantic Richfield
13	Shell Oil
14	Occidental Petroleum
15	U.S. Steel
16	Phillips Petroleum
17	Sun

27 million Americans can't read. And guess who pays the price.

Every year, functional illiteracy costs American business billions.

But your company can fight back...by joining your local community's fight against illiteracy. Call the Coalition for Literacy at toll-free **1-800-228-8813** and find out how.

You may find it's the greatest cost-saving measure your company has ever taken.

A literate America is a good investment.

Ad Council Coalition for Literacy

Solana
Dallas, Texas
IBM/Maguire Thomas Partners
Joint Venture

Architects: Legoretta Arquitectos
Mitchell/Giurgola Associates
Associate Architects:
Leason Pomeroy Associates
Harwood K. Smith Partners



Technology you never thought possible with exterior insulation systems.

To create an architectural statement that reflects the image of a technological giant requires materials of exceptional integrity and performance.

STO Wall Systems and Coatings were selected for the impressive 900 acre, 15 building Solana complex. Pioneered and developed by STO in Europe and the U.S. for over 30 years, STO Systems form a protective shield that completely defies the elements while creating surfaces that will hold their beauty far into the future.

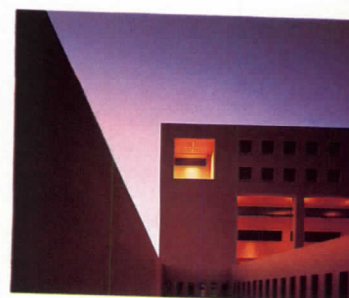

STO INDUSTRIES, INC.

Quality Lane, Box 219
Rutland, VT 05701
Toll Free: (800) 851-5533

A subsidiary of STO Corp.,
the Systems Technology Organization

Circle 116 on inquiry card

No Architect Throws Away Sweet's.



- 70% of loose catalogs end up in the circular file.*
But...
- 96% of architects use catalogs in Sweet's as their prime reference source.**
- Catalogs in Sweet's are referred to 10 times as much as any other source, including manufacturers' loose catalogs.**

Architects Use Sweet's

SWEET'S MCGRAW-HILL

Sweet's Group
McGraw-Hill Information Services Company
1221 Avenue of the Americas, New York, NY 10020

*Catalog Perspective, Smith Stanley & Co.
**Information Sources Used by Architects,
Glen Oaks Research & Statistical Services

ARCHITECTS' BOOK CLUB®

Membership Order Card

Please enroll me as a member and send me **Means Graphic Construction Standards**, (583786-2), billing me only \$14.95, plus local tax, postage, and handling. I agree to purchase a minimum of two additional books during my first year as outlined under the Club plan described in this ad. Membership in the club is cancellable by me any time after the two book purchase requirement has been fulfilled. A shipping and handling charge is added to all shipments.

Signature _____

Name _____

Address/Apt. # _____

City/State, Zip _____

This order subject to acceptance by McGraw-Hill. Offer good only to new members. Foreign member acceptance subject to special conditions.

ARCHITECTS' BOOK CLUB®

Membership Order Card

Please enroll me as a member and send me **Means Graphic Construction Standards**, (583786-2), billing me only \$14.95, plus local tax, postage, and handling. I agree to purchase a minimum of two additional books during my first year as outlined under the Club plan described in this ad. Membership in the club is cancellable by me any time after the two book purchase requirement has been fulfilled. A shipping and handling charge is added to all shipments.

Signature _____

Name _____

Address/Apt. # _____

City/State, Zip _____

This order subject to acceptance by McGraw-Hill. Offer good only to new members. Foreign member acceptance subject to special conditions.

**BUSINESS REPLY MAIL**

FIRST CLASS MAIL PERMIT NO. 42 HIGHTSTOWN, NJ

POSTAGE WILL BE PAID BY ADDRESSEE

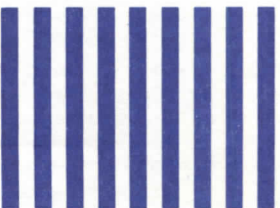
McGraw-Hill Book Clubs**P.O. BOX 582****Hightstown, NJ 08520-9959**NO POSTAGE
NECESSARY
IF MAILED
IN THE
UNITED STATES**BUSINESS REPLY MAIL**

FIRST CLASS MAIL PERMIT NO. 42 HIGHTSTOWN, NJ

POSTAGE WILL BE PAID BY ADDRESSEE

McGraw-Hill Book Clubs**P.O. BOX 582****Hightstown, NJ 08520-9959**NO POSTAGE
NECESSARY
IF MAILED
IN THE
UNITED STATES

Take this giant \$87.95 Handbook for just \$14.95...

when you join the
Architects' Book Club®

MEANS GRAPHIC CONSTRUCTION STANDARDS

F. WILLIAM HORSLEY, Senior Editor
515 pages, 1,000 illustrations, outsized 8½ x 11 format
Publisher's Price, \$87.95

Special features

- 1,000 illustrations
- brilliant graphic detail
- concise discussions of each assembly
- sizes, specs, functions
- man-hour data
- useful terminology

Here's how the club works to serve you
IMPORTANT INFORMATION... WE MAKE IT EASY TO GET!
For reliable, hands-on information, successful architects turn to the Architects' Book Club. Every 4 weeks members receive the Club Bulletin offering the best, newest, most important books from all publishers.

DEPENDABLE SERVICE... WE'RE HERE TO HELP! Whether you want information about a book or have a question about your membership, just call us toll-free or drop us a line. To get only the books you want, make your choice on the Reply Card and return it by the date specified. If you want the Main Selection, do nothing — it will be sent to you automatically. A small shipping and handling charge is added to each shipment.

CLUB CONVENIENCE... WE DO THE WORK! You get a wide choice of books that simply cannot be matched by any bookstore. And all your books are conveniently delivered right to your door. You also get 10 full days to decide whether you want the Main Selection. (If the Club Bulletin ever comes late and you receive a Main Selection you don't want, return it for credit at our expense.)

SUBSTANTIAL SAVINGS... AND A BONUS PROGRAM TOO!
You enjoy substantial discounts — up to 40% — on every Club book you buy. Plus, you're automatically eligible for our Bonus Book Plan which allows you savings up to 70% on a wide selection of professional and general interest books.

EASY MEMBERSHIP TERMS... IT'S WORTHWHILE TO BELONG! Your only obligation is to purchase 2 more books — at handsome discounts — during the next 12 months, after which you enjoy the benefits of membership with no further obligation. You or the Club may cancel membership anytime thereafter.

Fill out the coupon and mail today!

Or for faster service call toll-free

1-800-2-MCGRAW

ARCHITECTS' BOOK CLUB

P.O. Box 582,

Hightstown, NJ 08520-9959

This one master reference will give you the ability to analyze and select building assemblies visually. 1,000 assemblies are graphically detailed through the use of clear illustration, allowing for a complete overview of the assembly.

Helping you to make preliminary audits of designs, this valuable guide simplifies the review of building approaches, letting you sort out potential problems. You decide which elements are essential and which offer you the most cost-effective alternatives.

Because each construction assembly gives you extensive design data, you're able to leap from rough concepts to workable plans quickly — you won't waste time working backwards from costs to designs. The book gives you the freedom to maximize your creativity within time and budget constraints.

One of the book's most valuable features is the numerous man-hour charts which list man-hours per unit in place by component and by entire assembly. A brief review of these easy-to-use charts lets you make effective comparisons of assemblies by time and cost factors.

Means Graphic Construction Standards will help you prepare rough plans that meet your objectives, because they're grounded in standards that are easily compared. This in turn helps you be more original, see design solutions faster, and work more productively.

Order today!

McGraw-Hill Book Clubs
Architects' Book Club®
P.O. Box 582
Hightstown, NJ 08520-9959

Please enroll me as a member of the Architects' Book Club and send me **Means Graphic Construction Standards (583786-2)** for just \$14.95, plus local tax, postage, and handling. I agree to purchase a minimum of two additional books during my first year as outlined under the Club plan described in this ad. Membership in the Club is cancellable by me or McGraw-Hill any time after the two book purchase requirement has been met. A shipping and handling charge is added to all shipments.

Signature _____

Name _____

Address/Apt. # _____

City/State/Zip _____

This order subject to acceptance by McGraw-Hill. Offer good only to new members. Foreign member acceptance subject to special conditions.

A36622



This billboard brought fame, fortune and an award to a Florida bank.

Along the expressways of Jacksonville, Barnett Bank sponsored a series of billboards that showcased the talents of local Florida artists. This focused public attention on Barnett Bank, helping them win new depositors and a Business in the Arts Award—an accolade that comes complete with local and national recognition.

The competition is open to businesses of any size that contributed dollars, personnel, goods or services to the arts.

To nominate your business or someone else's, write the Business Committee for the Arts, Inc., 1775 Broadway, Suite 510, New York, New York 10019. Or call (212) 664-0600 for nomination information.

The deadline for entry is May 31, so enter soon. And perhaps you, too, can put your company on the road to fame and fortune.



BUSINESS COMMITTEE
FOR THE ARTS, INC.

This advertisement prepared as a public service by Ogilvy & Mather.

REDUCE YOUR

Wouldn't it be nice if there was a simpler, more accurate way to determine window glass thickness?

A method that not only reduced your chances of over or under specifying your glazing design, but also reduced your time and energy involved?

Well, now there is.

And you'll find it in our new publication and software program, *A Guide To The Structural Performance of Laminated Architectural Glass*.

You see, this guide—which is the result of five years of exhaustive research on the strength and behavior of laminated glass made with Saflex®

interlayer—offers a new, simplified way to accurately verify glazing designs.

Just follow the straightforward methodologies presented in the manual.

Or load the disk, run through our easy menu-driven program and—bingo!—your designs are verified.

Interested? If so, both our guide and disk are yours for free. Just fill in and mail the coupon.

And discover how you can make glazing design as simple as loading a floppy disk into a computer.

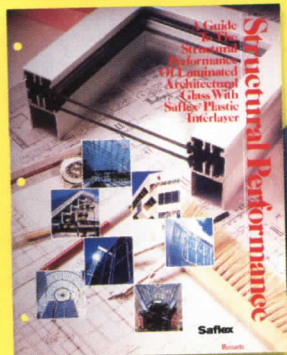

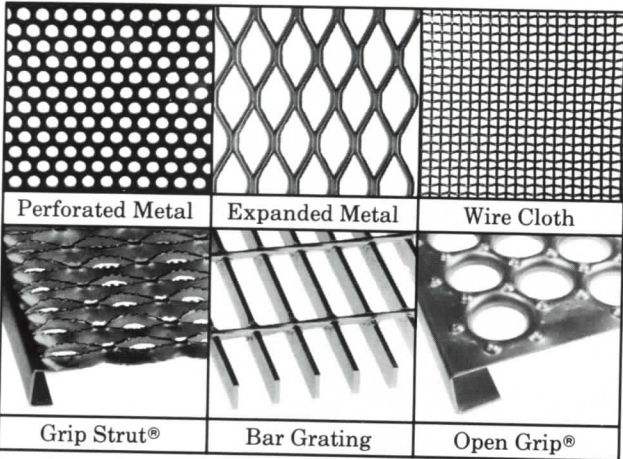

Perforated Metal

Expanded Metal

Wire Cloth

Grip Strut®

Bar Grating

Open Grip®

SHOPPING FOR METAL WITH "HOLES"?

Then Call the 'Hole Store®'!
Complete Stocks - Fast Shipment



National
Toll Free: **800-237-3820**

McNICHOLS CO.

FAX: 813-289-7884 Telex: 52706



Cleveland • Chicago • Dallas • Atlanta • Newark • Boston • Tampa

Circle 105 on inquiry card

Meet the Only Answering Machine You'll Swear By, Not At.



Dave Mahowald.

Every week, our team of experts gives hundreds of architects and spec writers answers to all types of coatings questions. Answers that save time and prevent costly mistakes.

So, when you need answers in a hurry, call

our toll-free Paint DataBank® 1-800-321-8194, in Ohio 1-800-362-0903, from 8:30 a.m. - 5 p.m. EST, Monday-Friday. No canned

messages. Just candid advice from experts like Dave Mahowald.



Circle 117 on inquiry card

WORK.LOAD.

Monsanto Company, Dept. 204, 800 N. Lindbergh Blvd., St. Louis, MO 63167

... please send me your free guide and IBM-compatible disk.

me _____
le _____
company _____
dress _____
y _____ State _____ Zip _____
phone () _____

AR589

any, 1989. © Registered trademark of Monsanto Company.

Circle 150 on inquiry card

Design Program To The Structural Performance Of Laminated Architectural Glass

WIND

This diskette for use with IBM-compatible equipment only.

Use DOS 2.1 or higher.

For assistance, call 1-800-325-4330.

Monsanto Chemical Company

A unit of Monsanto Company

800 N. Lindbergh Blvd.

St. Louis, MO 63167

*Registered trademark of Monsanto Company

©Monsanto Company 1989

Saflex

Plastic Interlayer By

Monsanto

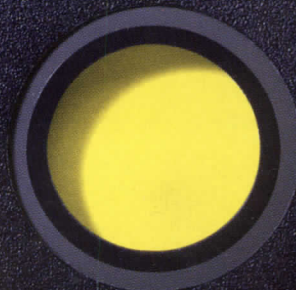

The classic Architects & Engineers Liability program.

How to identify coverage that will endure.



Continuity of quality coverage. Shand Morahan & Company has provided fairly priced, top quality liability coverage to the architectural design and engineering professions continuously for two decades.



Underwriting experience. With an in-depth staff of highly experienced underwriters that concentrates solely on this coverage, Shand Morahan offers an understanding of architectural liability second to none.



Claims experience and service. Our highly respected claims department offers claims specialists licensed in law *and* engineering or architecture. These on-staff pros will recommend the best claim resolution among available options.



Client partnership and service. We treat our insureds and their brokers as partners and encourage them to call upon us for advice and counsel regarding any aspect of our mutual concern. We are ready to help resolve any questions or risk problems.

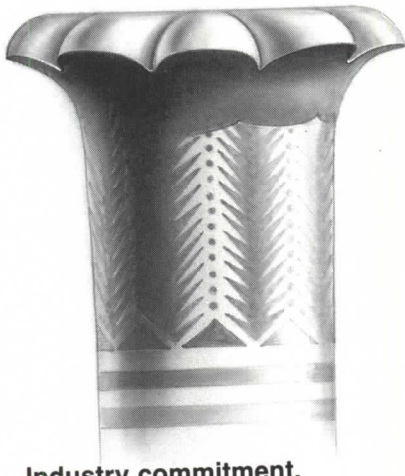

Industry commitment. Our long association and close partnership with the architectural and engineering communities is well known. We have conducted loss-prevention seminars and our experts are always available to discuss any aspect of architectural risk control and prevention.



Fast response time. Shand Morahan is proud of its record of responding to all questions and concerns promptly. We are particularly interested in underwriting for small- to medium-sized design firms. For an immediate response, ask your agent or broker to call Mike Welbel, Product Manager, at (312) 866-0845, today.

SM Shand Morahan
A member of the Shand Morahan Group

Shand Morahan & Company Inc.
Shand Morahan Plaza
Evanston IL 60201 312 866-2800

Professional Liability and Specialty Insurance

Can You Recall Any New Schools Without A Metal Roof?

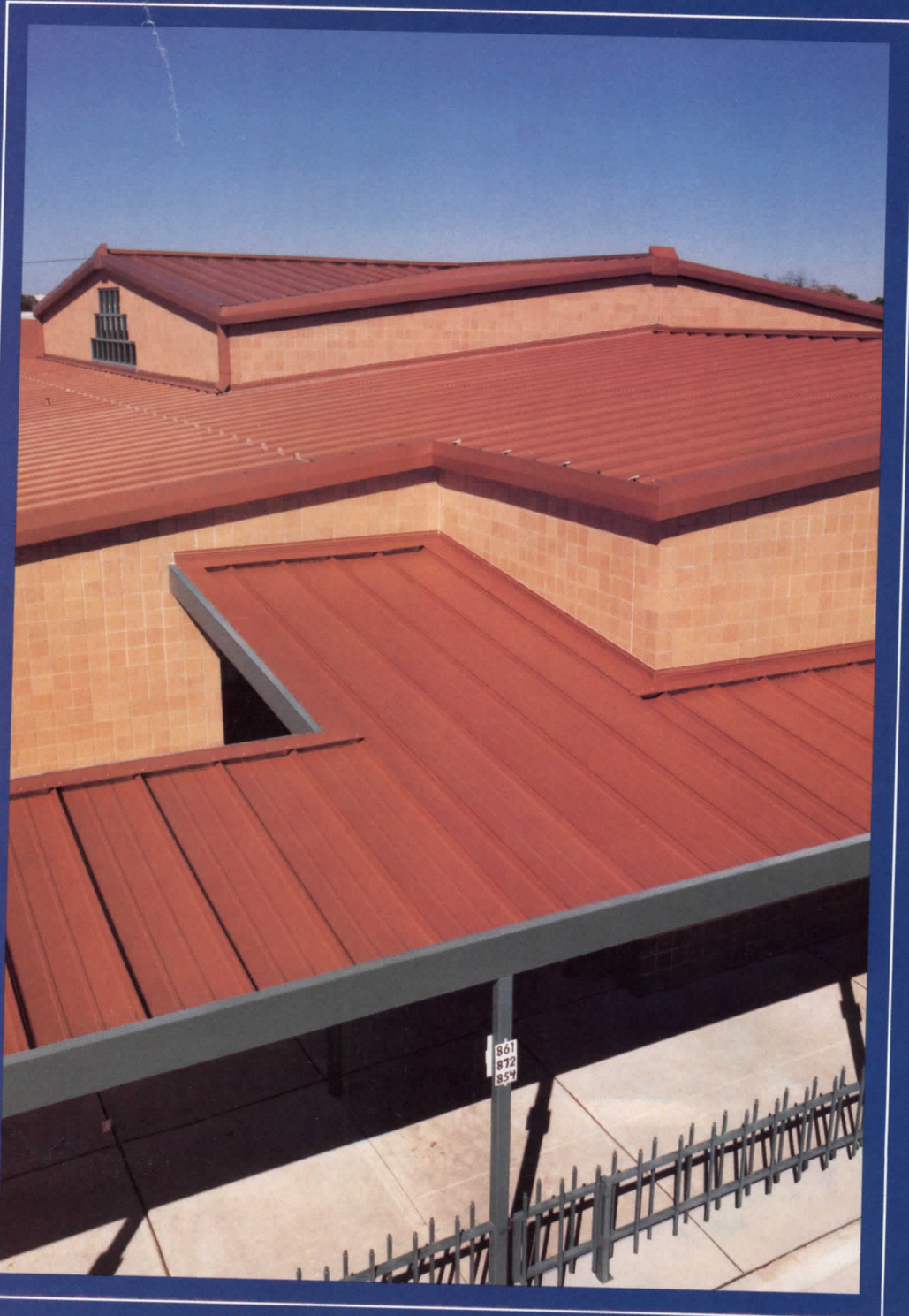

Chances are no. Metal is being specified and used on more and more school buildings today. Designers and school districts appreciate the low maintenance value in addition to the multitude of colors to work with the surrounding environs.

When you specify an MBCI roof system, we want you satisfied. We will work with your design team to insure the proper product selection for your project.

For a copy of the MBCI design manual, call or write the nearest MBCI plant. Metal is our only business and we want you satisfied.



Houston 713/445-8555
Lubbock 806/747-4291 Atlanta 404/948-7568
Oklahoma City 405/672-7676 Tampa 813/752-3474
San Antonio 512/661-2409 Richmond 804/526-3375
Dallas 214/988-3300 Indianapolis 317/398-4400

Architect: Cavitt McKnight Weymouth Inc.

Project: Brenbam Intermediate School
Brenbam, Texas

ABITARE The international magazine that deals with the home, town, and the environment.

ABITARE brings you the latest products, the freshest ideas, and the most creative applications of architectural and design techniques from Italy and around the world.

ABITARE's stylish, easy-to-read copy comes in both Italian and English. The paper is of the highest quality, thereby enhancing the full color photography.

ABITARE will keep you informed about the major exhibitions, meetings, fairs and shows you need to know about. As well as bringing you reviews of the latest books and catalogs on the market.

As a subscriber you will get it all by air mail hot off the press. Direct from our headquarters in Milan.

For information please call our toll free number (800) 238-8462. From California (818) 994-4462. To take out your subscription please mail this coupon to:
Virginia Gatti, 6725 Allott Ave. 91401 Van Nuys California.

- 1-year subscription (10 issues) \$75 instead of \$105
 2-year subscription (20 issues) \$130 instead of \$210

Mr Mrs

Name

Surname

Address

City

State

Zipcode

Enclosed is my check for \$

ABITARE

Save \$30 1-year subscription (10 issues) by air mail \$75 instead of \$105.

Save \$80 2-year subscription (20 issues) by air mail \$130 instead of \$210.

Why not go first class?

Go with BEST locks. Once you've seen and touched them, you'll agree that they reflect the quiet elegance, the uncompromising design and quality that you've come to expect from BEST. Each style has been meticulously designed with intelligent aesthetics and functional practicality for all types of architecture decor.

At Best Lock, our service team is also First Class. No other company in the world has the ability to provide such all-encompassing, comprehensive services. During design and construction, all your special needs will be quickly and effectively met by a BEST Contract Construction Representative. No questions will be left unanswered.

Once the building is occupied, everyone benefits from BEST's cost and time efficient Interchangeable Core. This customized masterkeyed security system can be easily expanded and altered to satisfy your present and future needs. To assure continued quality service, the building is assigned a permanent BEST Factory Authorized Representative to help monitor and control the system.

Go First Class. Go with the BEST team. Check the Sweet's Buyline for your Best Lock Representative, or contact Best Lock Corporation, P.O. Box 50444, Indianapolis, IN 46250, 317-849-2250.



From concept to completion, architects and owners have always appreciated the aesthetic quality, security and versatility of BEST locks, as well as the best service team in the business.



BEST LOCK CORPORATION

Circle 120 on inquiry card

MBT — Symbolizing Construction Chemicals for the Future — Today



In today's computer-driven world, rapid change and "technology" have become synonymous. And we at Master Builders Technologies examine each new technology to assess its potential application to our products or to new developments in the construction industry.

Upon initial evaluation, this seems a normal business procedure. However, it is the intense commitment we have in providing our customers with the leading technology in products, the service to assist or train them in employing these products, and the quality standards we set to assure the performance of them . . . which set MBT apart.

Worldwide, whether your application is industrial, commercial, transportation or living environment, Master Builders Technologies provides the appropriate construction chemicals, products and services for your new construction, renovation or maintenance project. Additionally, we supply appropriate field service or application support to make sure our products meet your specifications.

To MBT, the future is now. Whether you design, engineer, construct or own the construction project, assure yourself of the most advanced, highest quality products and services, and the best results by having the MBT symbol on your next job.

Construction chemicals for the future.



Master Builders, Inc.

23700 Chagrin Boulevard
Cleveland, Ohio 44122-5554
(216) 831-5500

Steel joists help turn on the speed at new ITT-TEVES, anti-lock brake-system assembly plant.

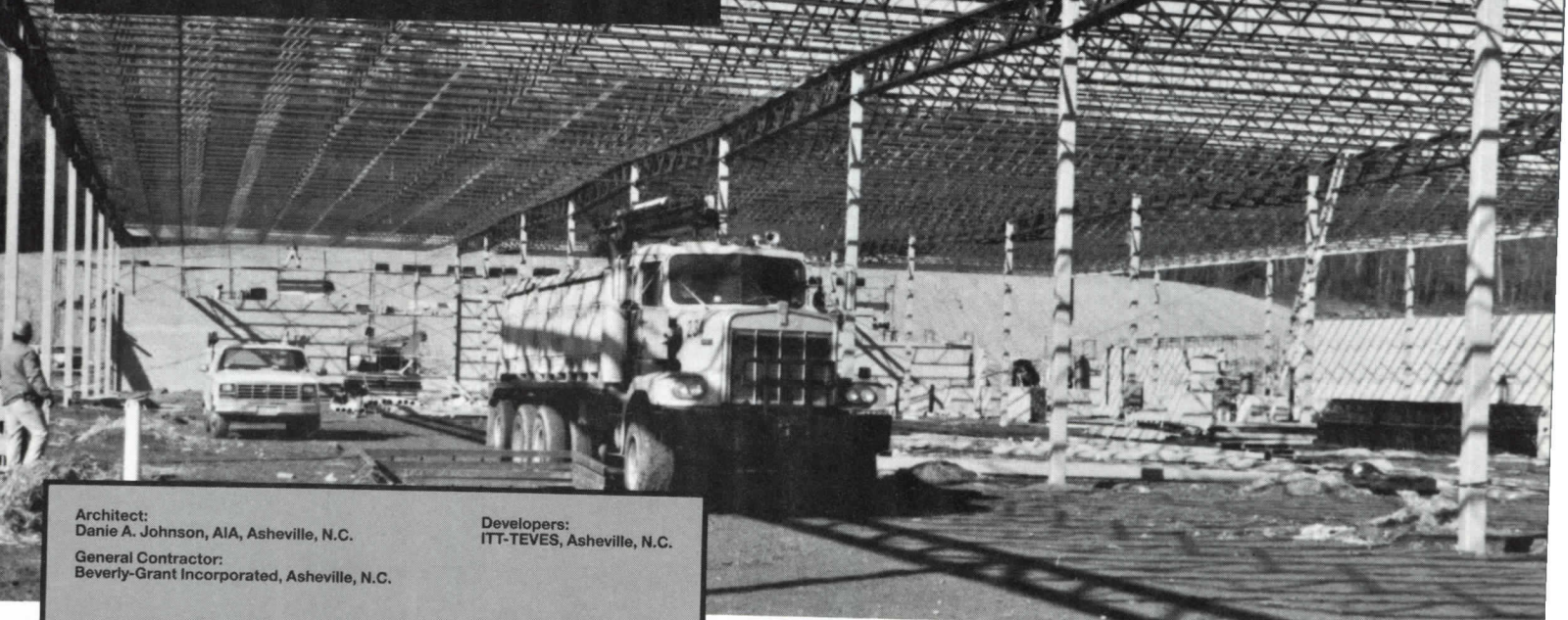

Architect:
Danie A. Johnson, AIA, Asheville, N.C.
General Contractor:
Beverly-Grant Incorporated, Asheville, N.C.

Developers:
ITT-TEVES, Asheville, N.C.

Requirements for ITT-TEVES' new antilock brake systems manufacturing facility in Asheville, N.C. were familiar to Beverly-Grant Construction Company. The client wanted a well-built plant — quickly and cost-effectively.

So steel joist construction was the natural selection.

According to Henry Watts, Beverly-Grant Project Manager, steel joist construction has been the choice for many of the company's clients.

A major reason is the fact that steel joists save 5% to 10% over beam type construction. Erection is more rapid, and steel joist construction allows for easier location and installation of joint-mounted conveyor systems and heating/cooling systems.

Send the coupon for your copy of New Specifications, Load Tables and Weight Tables and 50 Year Digest.



Managing Director
Steel Joist Institute
Chamber A
1205 48th Avenue North
Myrtle Beach, SC 29577

NEW! 60th ANNIVERSARY issue.
64 pages of facts and figures with new instructions for designating and specifying the new K-Series joists. \$8.50 (\$9.50 outside U.S.).

No. of copies _____

50 years of Steel Joists.
220 pages of specs and load tables from 1928 to 1978 to help you determine load capacities in **existing structures**; plus time saving tips. \$34.00 (\$44.00 outside U.S.).

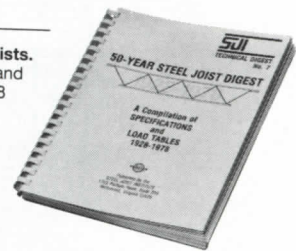

No. of copies _____

Total enclosed _____ (Remittance with order, please)

Name _____

Firm _____

Street _____

City _____

State _____ Zip _____

Circle 122 on inquiry card



ALPOLIC

**The Lightweight, Rigid, Bendable
Composite Material.**

ALPOLIC combines beauty with superior flatness and easy workability. Used for exterior sheathing, display panels, sign boards, and other applications, it resists weather and corrosion. Used for interior applications such as displays, it will enhance the beauty of your designs.

ALPOLIC is available in silver, light bronze, dark bronze, gold and black anodized and painted in a range of colors.

A-LOOK EX

**The Lightweight, Flexible, Unbreakable
Mirror For Exterior Use And Where
Humidity Is High.**

Indoors and Outdoors, A-LOOK EX supplies the reflective beauty of a mirror. You can bend it, cut it and hang it. It's ideal for store fronts, eaves, entrance areas and signs as well as for any variety of indoor applications including spas, bathrooms and other areas subject to humidity. The fluoride resin surface of A-LOOK EX provides outstanding weatherability and resistance to humidity.



MITSUBISHI KASEI AMERICA INC. (MKA)

800A Corporate Court, South Plainfield, NJ 07080
Phone: 201-757-6900/800-422-7270/FAX: 201-757-6690

Circle 123 on inquiry card



MACS II*

The communications system that's never too busy. Even if you are.

Let's face it. An intercommunications system is supposed to make work easier. And the staff more productive. Yet most school intercom systems aren't equipped to handle multiple stations in use simultaneously. And that means people are waiting to use the system, instead of communicating.

At Dukane, the lines are open.

The MACS II* was designed around the realities of school operation. The hardware package is amply equipped for multiple,

simultaneous communications and user-programmable functions. Because a communications system that makes people wait, ends up being a system that isn't used.

Add as many new stations as you need. Quickly and easily.

The Dukane MACS II features built-in flexibility that lets the system grow as quickly as your communications needs. Fire alarms, security systems, classroom emergency calls and up to 128 stations are all easily programmed into the system.

And with the MACS II Networking Option, you can have over 1,900 stations with 128 simultaneous communication paths.

Call your authorized Dukane distributor today.

***Modular Administrative Communications System**



DUKANE

312-584-2300
2900 Dukane Drive
St. Charles, IL 60174

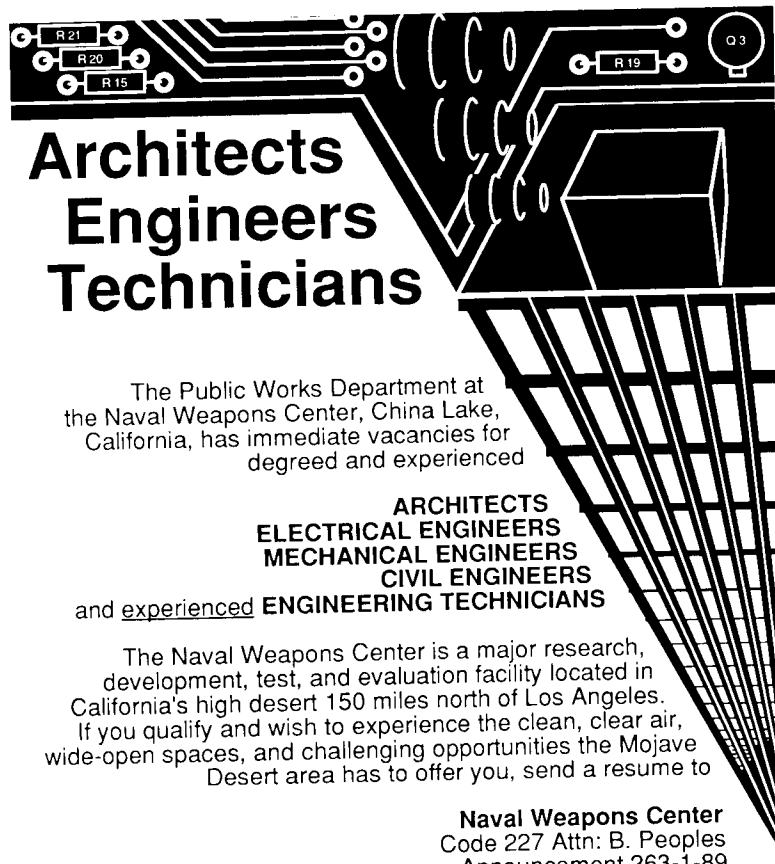

Architects Engineers Technicians

The Public Works Department at the Naval Weapons Center, China Lake, California, has immediate vacancies for degreed and experienced

**ARCHITECTS
ELECTRICAL ENGINEERS
MECHANICAL ENGINEERS
CIVIL ENGINEERS**
and experienced **ENGINEERING TECHNICIANS**

The Naval Weapons Center is a major research, development, test, and evaluation facility located in California's high desert 150 miles north of Los Angeles. If you qualify and wish to experience the clean, clear air, wide-open spaces, and challenging opportunities the Mojave Desert area has to offer you, send a resume to

Naval Weapons Center
Code 227 Attn: B. Peoples
Announcement 263-1-89
China Lake, California 93555-6001

An Equal Opportunity Employer/Us Citizenship Required

Architect/Studio Owner. Marshall Erdman and Associates, the designers and manufacturers of Techline, are adding new Techline Studios to those already established. Studio owners use Techline, a sophisticated systems of furniture and cabinetry, in the design of residential, medical and other institutional interiors. At least one Studio partner must be in the design profession. Successful applicants have management skills, enjoy client contact and a hands-on operation. We are an established architectural and building firm. Our goal is to develop mutually beneficial relationships with creative and ambitious individuals. Contact Marshall Erdman, Chairman, Marshall Erdman and Associates, 5117 University Avenue, Madison, WI 53705. (608) 238-0211.

Business Manager/Architect. To be responsible for administration/management of growing 20+ person firm. 10 years experience as Project Manager; 5 years experience as Business Manager, a minimum. Position requires well developed skills in personal relations, verbal and written communications, procedural organization, budgeting, scheduling and problem-solving. MBA preferred. Major career opportunity. Candidates not meeting the above requirements please do not apply. Salary open. Send resume and reply to: Brooks/Collier, 3131 Eastside, Suite 100, Houston, TX 77098. Attention: James T. Collier.

Director of Design — Equity opportunity with an award-winning, well established Design Collaborative in Cambridge, Massachusetts who is seeking an Architect with an advanced architectural degree, exceptional design skills and demonstrate ability to manage complex client groups and functional programs. Send resume, references and salary history to P-5726, Architectural Record.

ARCHITECTURAL RECORD:

The place to build your recruitment image.

Reach 74,000 architects and A/E firms through the pages of Architectural Record's Recruitment Advertising Section.

**Call (212) 512-2556
for rates and information**

TO ANSWER KEYED ADS:
Address separate envelopes (smaller than 11" x 5") for each reply to:
Key number from ad
Architectural Record
Post Office Box 900
NY NY 10108

Medical Programmer/Planner, Equipment Specialist. A major career opportunity for a licensed architect to work directly with clients in programming and planning of various scale medical facilities. Knowledge of functional requirements of hospital equipment a plus. Must have a minimum 10 years experience in health planning/architecture, and well developed skills in personal relations, verbal and written communications. In-depth knowledge of codes and regulations a must. Candidates not meeting the above requirements please do not apply. Salary open. Send resume and reply to: Brooks/Collier, 3131 Eastside, Suite 100, Houston, TX 77098. Attention: James T. Collier.

Michael Latas & Associates, Executive Search and Professional Recruiting Consultants, Specialists in the architectural and engineering fields. Operating nationally. Inquiries held in the strictest of confidence. 1311 Lindbergh Plaza Center, St. Louis, Missouri 63132; (314) 993-6500.

FACULTY POSITIONS VACANT

Instructor — Architectural Technology. One-year temporary full-time position to teach architectural design, architectural presentation and working drawings. Graduate of accredited architectural school and one year experience or licensed architect. Available September 1, 1989, salary, mid \$20's, comprehensive benefit package. Send letter of application and resume by May 31, 1989 to: Mr. Paul Higgins, Personnel Administrator, Dutchess Community College, Pendell Road, Poughkeepsie NY 12601.

FACULTY OPENINGS IN ARCHITECTURE

Advertise for faculty openings in Architectural Record's Faculty Positions Vacant Section.

**Call (212) 512-2556
for rates and information.**

SPECIAL SERVICES



**COMPLETE PREPARATION FOR
THE REGISTRATION EXAMS**

Architectural License Seminars (213) 208-7112
Box 64188 Los Angeles California 90064

Cost Estimating, Quantity Surveys, Computer Applications, Corp, DOD, GSA, VA. Construction Cost Systems, Chicago (312) 858-5441; Tampa — (813) 887-5600.

CHICAGO METALLIC CORPORATION

Introduces

NOVARA 3900 SYSTEM

Remember
when ceiling
grid used to
be flat?

For as long as there has been acoustical ceilings, the suspension grid has been flat and lifeless. Now, Chicago Metallic Corporation introduces a major innovation in exposed ceiling grid design ... Novara 3900. It is a revolutionary and refreshing new look in ceilings. Novara 3900 features a narrow $\frac{3}{4}$ " wide face which extends $\frac{3}{16}$ " below the ceiling plane and has a distinctive bevel on each side, creating a unique three dimensional appearance. Mitred intersections and a custom wall molding help create a geometric picture frame effect that incorporates shadow lines, contrast and texture into the overall ceiling design. Novara is available in over 100 designer colors and reflective finishes, including laminated wood veneers. Novara 3900... it will make flat grid nothing more than a memory.

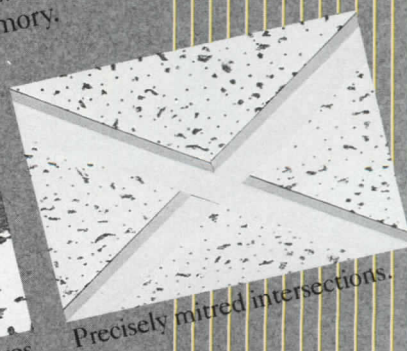
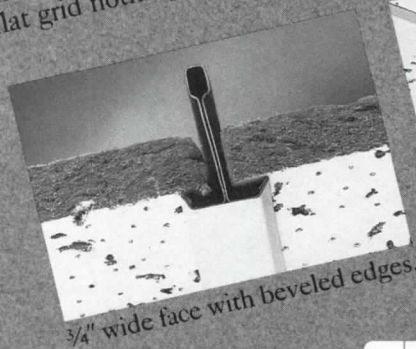

Chicago Metallic Corporation

Chicago (312) 563-4600 Baltimore (301) 796-8220 Los Angeles (213) 582-1100

Circle 125 on inquiry card



KYNAR 500[®]-BASED FINISH.
THE PERFECT COAT
FOR ANY WEATHER.

Specify a KYNAR 500[®]-based finish on your next project. In any weather, it's beautiful outside. For more information or a list of licensees, contact: Pennwalt Corporation, Fluorochemicals Division, Three Parkway, Philadelphia, PA 19102, U.S.A. (215) 587-7520.

KYNAR 500[®]. We build performance.



Circle 126 on inquiry card

The Marketplace

To Advertise Call
1-800-544-7929
Fax: 212-512-4256

THE VERY BEST

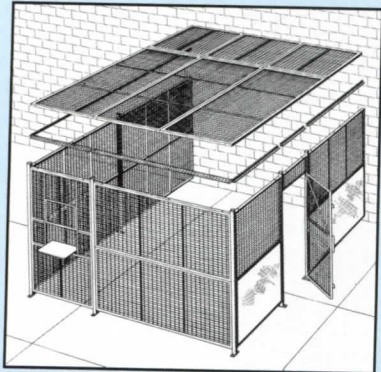

Woven Wire Partition
• Quality Product • Fast Delivery •
WireCrafters, Inc.
1-800-626-1816

6208 Strawberry Lane, Louisville, KY 40214

Circle 127 on inquiry card

Custom Colors and Wood Finish Now Options with SUNSHINE ROOMS!

Now you can custom match a Sunshine Room solarium to any decor. We can match the finish of our high-strength aluminum frames to any color in addition to standard bronze or white. Our new Wood-borough Edition offers a choice of wood veneers laminated by our exclusive Woodloc Bonding. Available in three designs and 60 different models. Free Spec and Tech catalog.



1-800-222-1598
In Kansas
1-316-838-0033

SUNSHINE ROOMS™, INC.
P.O. Box 4627
Wichita, KS 67204-4627



Circle 128 on inquiry card

BIRD BARRIER

- Humane and ecological
- Virtually maintenance free
- Inconspicuous stainless steel spikes
- Commercial, institutional or residential
- Proven reliable for 39 years



NIXALITE of AMERICA
1025 - 16th AVE • BOX 727
EAST MOLINE, IL 61244 • 308-755-8771
800-624-1189 • FAX 309-755-0077
SPECIALISTS IN BIRD CONTROL



For more info., see Sweet's section 10290/NIX

Circle 129 on inquiry card



Faster Plaster™ Renovates Ceilings in One Step. New Faster Plaster™ renovates problem ceilings in only one step. Covers over small holes, cracks or other damage. Heavy-duty gypsum-impregnated fabric can be painted or covered with textured or patterned wallcoverings. Class "A" fire rating. From *Flexi-Wall® Systems*, P.O. Box 88, Liberty, SC 29657, Phone 803-855-0500.

Circle 130 on inquiry card



Hubbell Quality comes to Down & Track Lighting. Everything you'll need to specify a top performing Downlighting or Track Lighting installation that fits within your budget is available in Hubbell's new Light Moods™ catalog. For your free personal copy write to *Hubbell Lighting*, 2000 Electric Way, Christiansburg, VA 24073.

Circle 131 on inquiry card

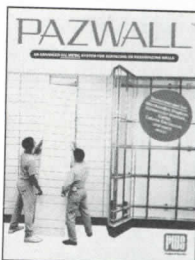

Discover The PAZWALL Advantage!

The most innovative wall system to date. Our system combines an erector-set technology with exceptional design flexibility.

PAZWALL utilizes any material in panelized form: marble, stone, glass, plastic laminate, vinyl, fabric, etc.

And **PAZWALL** does not stop at walls. Soffits, fascias, light coves, . . . are all easily achieved. Our technical staff is eager to assist.

Fast! Accurate! Strong! Clean! Versatile!

Ideal for retail and commercial use.

Call for informative brochure:

PAZ SYSTEMS INC. (800) 323-WALL

Circle 132 on inquiry card

CADD SOFTWARE FOR SALE?

Advertise your software to 74,000 architects and A/E firms in ARCHITECTURAL RECORD'S Computer Software Section.

Take advantage of advertising rates as low as \$162.45.

Call (212) 512-2984 for more information.

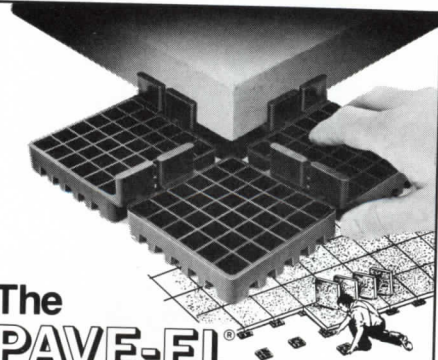

The PAVE-EL Pedestal System

A practical solution to roof paver applications

Write or call for specification brochure
ENVIROSPEC INCORPORATED
Ellicott Station Box 119, Buffalo, New York 14205
(416) 252-2090

Circle 133 on inquiry card

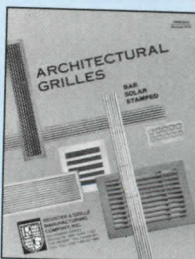

Decorative Grilles in Color.

Add a new dimension to your designs with these decorative grilles which can be used

to make striking unusual effects. Choose from an array of custom colors to match or contrast existing grilles. Designers can also create numerous metal forms for interior or exterior applications. Write for a catalog: *Register & Grille Mfg. Co.*, 202 Norman Avenue, Brooklyn, NY 11222. Call 718-383-9090 or 1-800-521-4895.

Circle 134 on inquiry card

The Marketplace

Greenwich Collection of Bathroom Designs by Paul Assoc.

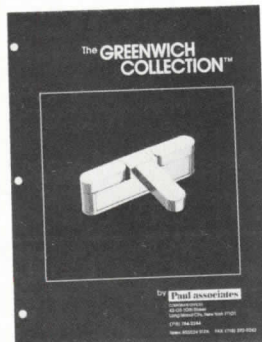

Many faucet designs come in a choice of handles in gold, chrome and colors. Also available — a coordinated collection of accessories including towel rings, bars shelves, and more. All from the most prestigious name in the industry: Paul Assoc. 42-05 10th Street, Long Island City, NY 11101 Tel. 1(718) 784-2244. Fax 1(718) 392-9242. Catalog Available.

Circle 135 on inquiry card

AMWELD

DOORS, FRAMES AND HARDWARE

AN OLD COMPANY... A NEW SPIRIT

Backed by 40 years of experience

- Masonry, Drywall and Remodeling Frames
- Full-Glass Entrance Doors
- Stile and Rail Doors
- Replacement Doors
- Security Doors and Lights
- Bullet Resistive Doors and Lights
- Builders Hardware
- Supercore™ Doors
- Acoustical Doors
- Embossed Doors
- Fab-A-Frame

AMWELD Building Products, Inc.

Industrial Park • 1500 Amweld Drive • Garrettsville, Ohio 44231
Phone: (216) 527-4385 • Telefax: (216) 527-5122 • TOLL FREE: 1-800-248-6116

Circle 136 on inquiry card

FACULTY OPENINGS IN ARCHITECTURE.

Advertise for faculty openings in ARCHITECTURAL RECORD'S Faculty Positions Vacant Section.

Call (212) 512-2556 for rates and information.

York Spiral Stairs.

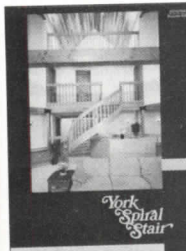

Catalog highlights the finest spiral stairs on the market. Our unequalled experience in design and construction has

created a stair system which is beautiful today. No unsightly center-post-and engineered to be durable for years to come. Straight stairs and balcony accessories also available. For information, write to York Spiral Stair, Rte 32, North Vassalboro, Maine 04962.

Circle 137 on inquiry card

Without a wind baffle, ridge vents don't work

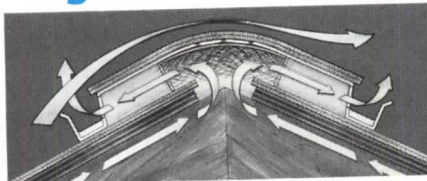

Specify Shinglevent, the only shingle-over ridge vent with a wind baffle. Research proves a wind baffle is essential for efficient ventilation. Combined with our patented weather filter, the baffle also helps stop infiltration of rain and snow. For our current product catalog, write: Air Vent Inc., A CertainTeed Company, 4801 N. Prospect Rd., Peoria Heights, IL 61614.



Circle 138 on inquiry card

HARDWORKING FIREPLACES

- All-Masonry construction adds value to your home.
- Heat Exchange section retains and radiates heat into your home.
- Modular Components are quickly and easily assembled.



For more information call 1-800-323-TESSI or write TESS, Inc., R.R. 1, Box 3, Dept 105 Randolph, VT 05060



Circle 139 on inquiry card

NEW! EUROWALL PANELING SYSTEM WOODEN INTERLOCKING PLANKS

IDEAL FOR: Commercial/Residential/Architectural/Ceilings
and Outwater's Got It!

Low cost... lightweight real wood veneer on MDF

No waste... easy to install

Available in 8 lengths, 6" wide, 3/8" thick.

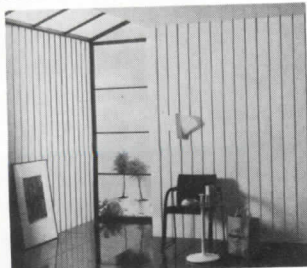

FREE samples, literature, price list
Call toll-free: 1-800-631-8375
In N.J.: (201) 340-1040 Fax: 201-916-1640

OUTWATER PLASTIC INDUSTRIES Inc.

4 Passaic Street/Wood-Ridge, NJ 07075/Telex 133-526

Circle 140 on inquiry card

ARCHITECTURAL RECORD:

The place to build your recruitment image.

Reach 74,000 architects and A/E firms through the pages of ARCHITECTURAL RECORD'S Recruitment Advertising Section.

Call (212) 512-2556 for rates and information.



Frank Lloyd Wright's Timeless Essays IN THE CAUSE OF ARCHITECTURE.

A collection of essays (until 1927) written by Wright, has retained the agelessness of his ideas. Edited by F. Gutheim and reprinted as a 246 page, high-quality paperback. \$12.95 (includes postage & handling.) Send to: ARCHITECTURAL RECORD BOOKS - 41ST FLOOR - 1221 Avenue of the Americas - New York, NY 10020.

To Advertise Call
1-800-544-7929
Fax: 212-512-4256



FRP products add beauty to any building

Fiberglass Reinforced Plastic (FRP), is dimensionally and environmentally stable, non-corrosive, light weight, and strong. MFG will design, engineer, manufacture, and deliver custom FRP products to meet your expectations. For more information, look us up in the 1989 Sweet's Catalog, or send today for a personal copy of our brochure.

MFG * MOLDED FIBER GLASS/UNION CITY
A DIVISION OF MCGRAW-HILL CONSTRUCTION
55 Fourth Avenue • Union City, PA 16438
Toll Free 800/458-0863 In PA 814/438-3841 FAX 814/438-2284
West Coast: 1130 Watson Center Road • Carson, CA 90745 • 213/549-5044
FAX 213/549-5056

Circle 141 on inquiry card

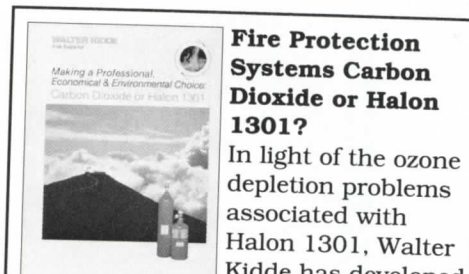

Fire Protection Systems Carbon Dioxide or Halon 1301?

In light of the ozone depletion problems associated with Halon 1301, Walter Kidde has developed a four page brochure outlining the pro's and con's of CO₂ and Halon 1301 for a wide variety of hazards. The brochure entitled "CO₂ or Halon 1301, Making a Professional, Economical and Environmental Choice" is now available free from Walter Kidde at P.O. Box 1147, Wake Forest, NC 27587, Phone: (919) 556-6811, Fax: (919) 556-7766.

Circle 142 on inquiry card



CUSTOM WALKWAYS & CANOPIES
...WITHOUT CUSTOM PRICES

Styles include roll-formed, extruded, acrylic, pyramid, or barrel vault. Standard designs can be used to create custom appearance at a fraction of custom price.

FREE CATALOG & DESIGN INFORMATION: 1-800-228-2391

The MAPES permanent solutions

Mapes Industries, Inc. / P.O. Box 80069
Lincoln, NE 68501 / (402) 466-1985
FAX: 1-402-466-2790

Circle 143 on inquiry card



THE REPORT
The monthly newsletter for building product sales reps and distributors.

News briefs and reports, building products, law, marketing, management, selling tips, news of companies and people, employment listings, new lines available...and sales leads on major construction projects...everything the successful rep or distributor needs to know...from McGraw-Hill. \$69/year (12 issues). Subscribe now and get 5 valuable sales manuals FREE. Call 212/512-3442.

Fenestration 2000. The complete transcript of the year's most important architectural roundtable.

On October 3, 1988, an international panel of architects and industry leaders met for an Architectural Record roundtable on curtain wall and fenestration. They discussed the best in current practice, developments in materials, performance-based engineering of components, and emerging technologies. The complete transcript of the roundtable can be yours for just \$399. Send your check for \$399, payable to Architectural Record. Send to: Marketing Director, Architectural Record, 1221 Ave. of the Americas, N.Y., N.Y. 10020.



Solve Roof Drain Problems with RetroDrain.

RetroDrain allows you to replace a broken existing drain entirely from the roof top. No access is required to the building's interior and installation is completed in minutes. Interior ceilings are not damaged and work inside the building is not disruptive. An easy cost effective method of replacing roof drains. Uflow Inc., Box 1470, Buffalo, NY 14240. Phone 716-854-1521.

Circle 144 on inquiry card



Make The Right Moves At The Right Time!

Subscribe to ENR, the only weekly information source in the construction industry. Late-breaking news on bids, market trends, government legislation and regulations, new products, employment opportunities...**PLUS** special reports — forecast issues, top contractors, design firms...and more. One year (U.S. & Canada) \$49. For additional rates write: ENR, Circulation Mgr., 1221 Ave. of the Americas, N.Y., NY 10020.



The Record Houses Collection.

A compilation from 1984/1985/1986. Everyone loves RECORD HOUSES! And we have put three years' worth into a single volume. Over 260 pages, in full color, with plans and text directly from the pages of ARCHITECTURAL RECORD's RECORD HOUSES issues. Just \$16.95 (includes postage and handling.) Send to: ARCHITECTURAL RECORD BOOKS - 41st FLOOR - 1221 Avenue of the Americas, N. Y., NY 10020.



Residential & Commercial LANDSCAPE LIGHTING
Wood - Metal - Ceramic

Complete selection of "architectural quality" contemporary outdoor residential and commercial lighting fixtures. Over 100 design variations of garden, driveway, post and wall-mount lights available in a choice of quality materials. Low-voltage, incandescent, fluorescent and high-pressure sodium options are offered direct from the factory. Call toll-free 1-800/458-2505 for catalog and prices.

LITEFORM DESIGNS
Dept. A, Post Office Box 3316 Portland, Oregon 97208 503/257-8464

Circle 145 on inquiry card

Advertising index

For detailed data, prefiled catalogs of the manufacturers listed below are available in your 1989 Sweet's Catalog File as follows:

(G) General Building & Renovation
(E) Engineering & Retrofit
(I) Industrial Construction & Renovation
(L) Homebuilding & Remodeling
(D) Contract Interiors

A

Abitare, 206
Accuride, 180; 99 [D]
(213) 944-0921
Advance Lifts, Inc., 48; 43 [G]
(312) 584-9881
American Gas Association, 38; 35
American Standard, 20-21; 11
(800) 821-7700
Amoco Chemical Co., 28-29; 18
(800) 292-6626
Andersen Corp., 102-103; 75 [G-L]
(800) 635-7500
Apple Computer, Inc., 12-13
(800) 446-3000
Architect's Book Club, 199 to 201
(800) 2-MCGRAW
Armstar, 18; 9 [G-D]
(615) 986-4040
Armstrong World Industries, Inc.,
Cov. II-1; 1, 2-3; 2 [G-E-D]
(800) 233-3823
Autodesk, Inc., 14-15; 7

B

BASF Corp. -Fibers Div., 98; 71
[G-E-L]
(704) 667-7713
Best Lock Corp., 207; 120 [G]
(317) 849-2250
Besteel Industries, 32Sa; 30
(800) BESTEEL
Big Show, The, 32Ed
(305) 477-0303
Bilco Co., 188; 103 [G-E-I-L]
(203) 934-6363

C

Carey-McFall (Bali), 76-77; 58, 59
[G-D]
(800) 433-7136
Charleston Carpets, 65 to 68; 53
(800) 241-4359
Chemstar, Inc., 32Wa; 28
(800) 523-8977
Chicago Metallic Corp., 213; 125
[G-D]
(312) 563-4600
Classic Lamp Posts, Inc., 193; 113
(800) 654-5852
Coyne & Delany Co., 56; 49 [E]
(804) 296-0166
Crown Metal Mfg. Co., 40; 37
(312) 873-3833
C/S Group, 27; 17 [G-E]
(800) 233-8493
Custom Building Products, 32Sc; 31
[G-L]
(213) 582-0846

D

Dawson Doors, Div. of Dawson Metal
Co., Inc., 179; 98 [G]
(716) 664-3811
Domtar Gypsum, 32Eb-32Ec; 22 [G]
(800) DOMTAR-4
Dover Elevator Systems, Inc.,
46-47; [G-I]
(601) 393-2110
Dow Chemical Co. -Styrofoam Brand
Products Div., 78; 60 [G-E-I]
DuPont Co. -Corian, 43, 45; 40
[G-D-L]
(800) 345-8601
DuPont Co. -Hypalon, 90-91; 67 [G]
(800) 441-7111

Dukane Corp., 211; 124
(312) 584-2300
Duro-Last Roofing, Inc., 63; 51
[G-E]
(800) 248-0280

E

Ebeo Mfg. Co., 177; 96 [G-E-I]
ECI Building Components, Inc., 101;
74 [G]
(713) 499-5611
Efco Corp., 16; 8 [G-I]
Elkay Mfg., Inc., 190, 191; 107 to
110 [G-E-I]
(312) 986-8484

F

Flexco International, 82; 62 [G]
(800) 633-3151
Follansbee Steel Corp., 192; 111 [G]
(800) 624-6906
Formica Corp., 6; 4, 178; 97
[G-L-D]
(800) 524-0159
Freudenberg Building Systems, Inc.,
Cov. III; 148 [G-I-D]
(800) 332-NORA

G

Gametime, Inc., 176; 95 [G]
(205) 845-5610
General Electric - C&I Lamps,
72-73; 56 [G-E-I-D]
(800) 523-5520
Gimeor, Inc., 34; 33
(202) 546-8775
Glen Raven Mills, Inc., 32; 20 [G]
(919) 227-6211
Gory Roof Tile, 32Eg; 25 [G-L]
(800) 223-8453
Graphisoft, 196; 115
(800) 344-3468

H

Helios Industries, Inc., 172; 85 [G]
(415) 887-4800
Hewlett-Packard, 166; 82
(800) 367-4772
HWH Corp., 32Ef; 24
(215) 661-2000

I

Innovative Marble and Tile, Inc.,
49; 45 [G]
(516) 752-0318
Intergraph Corp., 184-185; 102
(800) 826-3515
International Granite & Marble Co.,
Inc., 32Ca; 27 [G]
(201) 869-5200
Ioline Corp., 164; 80
(206) 821-2140
ISICAD, Inc., 168; 83
(800) 556-1234

J

Julius Blum & Co., Inc., 69; 54
[G-E-I-D]

K

Kalwall Corp., 183; 101 [G]
(603) 627-3861
Kawneer Co., Inc., 96-97; 70 [G]
Kimball Office Furniture Co., Div. of
Kimball International Marketing,
Inc., 92-93; 68
(800) 482-1616

Knoll International, 30-31; 19 [G-D]
(800) 633-0034
Koch + Lowy, 17, 19; 10
(718) 786-3520
Koh-I-Noor Rapidograph, Inc., 99; 62
(201) 479-4124
Kohler Co., 8; 5 [E]
Kroy, Inc., 64; 52
(800) 328-KROY

L

Lafaenza America, Inc., 74-75; 57,
100; 73
(800) 223-4982
Lees Commercial Carpet Co., 88-89;
66 [G-D]
(800) 523-5647

M

Marble Modes, Inc., 32Ea; 21
(718) 539-1334
Marmet Corp., 193; 112
(800) 444-8881
Maruhachi Ceramics of America, Inc.,
32Sd; 32 [G-L]
(714) 736-9590
Master Builders, Inc., 208; 121
(216) 831-5500
Matico, Div. CBA, 85; 64 [G-D]
(516) 864-4343
MBCI, 205; 119
McNichols Co., 203; 105 [E-I]
(800) 237-3820
Mercer Products Co., Inc., 219; 146
[G]
(407) 578-2900
Millikin & Co., 104-105; 76
(800) 241-2327
Mitsubishi Chemical Industries
America, Inc., 210; 123 [G-D]
(800) 422-7270
Mysten Industries, Inc., 32Eh; 26 [G]
(914) 739-8486

N

Norco Windows, Inc., 94-95; 69 [G]
(715) 585-6311
Northwest, 186-187
(800) 447-4747

O

Overly Mfg. Co., 48; 42 [G-I]

P

Pearce Structures, Inc., 5; 3 [G]
(818) 998-2811
Pella Rolscreen Co., 86-87; 65,
194-195; 114 [G-L]
(512) 628-1000
Pennwalt Corp., Fluorochemicals
Div., 214; 126 [G-E]
(215) 587-7520
Philips International BV, 48B-48C;
44
Pittsburgh Corning Corp., 175; 94
[G-E]
(800) 992-5769
Prestressed Concrete Institute, 40;
36 [G-E]
(312) 346-4071

R

Raceway Components, Inc., 80; 61
(201) 661-1116
Radio Shack, 26; 16
Register & Grille Mfg. Co., Inc.,
188; 104 [G-E-D]
(800) 521-4895

R.R. Brink Locking Systems, Inc.,
108; 79 [G]
(815) 744-7000

S

Sargent & Co., 25; 15 [G]
(203) 562-2151
Sarnafil, Inc., 24; 14 [G-I]
(800) 451-2504
Schnabel Foundation Co., 84; 63
(312) 866-2800
Sherwin-Williams Wholesale, 22; 12,
203; 117 [G-E-I]
(800) 321-8194
Sloan Valve Co. -Plumbing Div., Cov.
IV; 149 [G-E-I]
Solarium Systems International, 58;
50
(800) 225-6423
Southern California Edison, 32Wb; 29
(800) 952-5062
Spacesaver Corp., 174; 86 to 93
[G-I]
(800) 492-3434
Steel Joist Institute, 209; 122
Steelcase, Inc., 10-11; 6
(800) 447-4700
Sto-Industries, Inc., 197; 116 [G]
(800) 851-5533
Sweet's Div. -McGraw-Hill
Information Systems, 198
Sweetspec Seminar, Heery
International, Inc., 220; 147
(800) 523-1353

U

Ulrich Planfiling Equipment Corp.,
48; 41
(800) 346-2875
United States Aluminum Corp., 189;
106 [G]
(800) 527-6440
USG Interiors, Inc., 50-51; 46
[G-E-I-L-D]
USG Interiors, Inc., Access Floor,
36; 34 [G-E-I-L-D]
USG Interiors, Inc., Fabric/Tile,
52; 47 [G-E-I-L-D]
USG Interiors, Inc., Wall Div., 54;
48 [G-E-I-L-D]

V

Velux-America, Inc., 23; 13 [G-L]
VersaCAD Corp., 165; 81
(714) 960-7720
Versatec, a Xerox Co., 170; 84
(800) 538-6477
Vitricon Div., Polymer Plastics
Corp., 32Ee; 23 [G]
(800) 777-6596

W

Weather Shield Mfg., Inc., 70-71;
55 [G]
(715) 748-2100
Willamette Building Products, 106;
77
(503) 928-3341
Wind-2 Research, Inc., 40; 38
(303) 482-7145
Wiremold Co., 107; 78
(203) 233-6251

Z

Zero International, Inc., 41; 39 [G]
(800) 635-5335

Sales offices

Main Office

McGraw-Hill, Inc.
1221 Avenue of the Americas
New York, New York 10020

Publisher
Ted Meredith (212) 512-4685

Associate Publisher
Roscoe C. Smith III (212) 512-2841

Director of Business and
Production
Joseph R. Wunk (212) 512-2793

Director of Marketing
Camille Padula (212) 512-2858

Classified Advertising
(212) 512-2556

District Offices

Atlanta
4170 Ashford-Dunwoody Road
Atlanta, Georgia 30319
Gregory Bowerman (404) 252-0626

Boston
607 Boylston St.
Boston, Massachusetts 02116
Louis F. Kutscher (203) 968-7113

Chicago
645 N. Michigan Ave.
Chicago, Illinois 60611
Anthony Arnone, (312) 751-3765
Thomas P. Kavooras, Jr.,
(312) 751-3705

Cleveland
55 Public Square
Cleveland, Ohio 44113
George Gortz (216) 781-7000

Denver
7400 S. Alton Ct. Suite 111
Englewood, Colorado 80112
John J. Hernan (303) 740-4630

Houston
7600 W. Tidwell, Suite 500
Houston, Texas 77040
Lockwood Seegar (713) 462-0757

Los Angeles
Media Sales Associates
23232 Peralta Drive
Laguna Hills, Calif. 92653
William W. Hague (714) 859-4448
Richard Ayer

New York
1221 Avenue of the Americas
New York, New York 10020
Laura Viscusi (212) 512-3603

Philadelphia
777 Long Ridge Road
Stamford, Connecticut 06902
Frank Rose (203) 968-7112

Pittsburgh
6 Gateway Center, Suite 215
Pittsburgh, Pennsylvania 15222
George Gortz (412) 227-3640

San Francisco
Media Sales Associates
William W. Hague (415) 345-0522
Richard Ayer

Stamford
777 Long Ridge Road
Stamford, Connecticut 06902
Louis F. Kutscher, (203) 968-7113

The Marketplace

Darryl Hudson
Lou Ruvane
1-800-544-7929

Vice President Market
Development
Federal Government
Paul R. D'Armiento
1750 K Street NW
Suite 1170
Washington, D.C. 20006
(202) 463-1725

Overseas Offices

Frankfurt/Main
Liebigstraße 19
Frankfurt/Main, Germany

Sheffield
46 West St.
Sheffield S14ES, England

Milan
Via Baracchini No. 1
Milan, Italy

Paris
28, Faubourg St-Honoré
75008 Paris, France

Tokyo
2-5, 3-chrome
Kasumigaseki, Chiyoda-ku
Tokyo, Japan

South America
Empresa Internacional de
Comunicacoes Ltda.
Rua da Consolacao, 222
Conjunto 103
01302 Sao Paulo, S.P. Brasil

We produce wall base
in 25 colors
and 5 heights.
Just imagine the
design options.



High-profile commercial interiors deserve the decorative accents your palette calls for. That's why we offer the field's most dramatic vinyl wall base line. We make it easy for you to coordinate any tone, shade and pattern of carpet or resilient flooring. All 25 colors are available in cove and toeless, rolls or cut sections, with matching inside and outside pre-molded corners. What's more, our modern labs are equipped to critically match your custom color requirements.

For the Mercer Wall Base distributor in your area, call or write today.



mercer
PRODUCTS COMPANY, INC.
DIV. OF THE DEXTER CORPORATION

4455 Dardanelle Drive/Orlando, FL 32808/(407) 578-2900
Eustis, FL • Newark, NJ

Circle 146 on inquiry card

SEMINAR

EFFECTIVE USE OF SWEETSPEC

1 9 8 9

SweetSpec: (swēt' spēk') n. McGraw-Hill's new interactive, computerized construction specification writing system on compact disc from Electronic Sweet's.

Who should attend

This intensive one-day seminar will demonstrate both the basics of SweetSpec and sophisticated techniques for achieving maximum efficiency. Professionals who would benefit from participation include the following: architects, engineers, designers, facility managers, and others with the need to create correct, up-to-the-minute construction specifications.

Your instructors

All instructors are professionals who have participated in the actual development of SweetSpec. Classes will be limited in size, so early enrollment is advised.

Fees

One Registrant: \$345
Two or more registrants per firm: \$295 per person
Course binders are included in the price of the seminar, but they may be purchased separately at \$75 per copy.

Registration

You may register for a seminar and make all travel arrangements with a single telephone call to All-Around Travel, Inc. at **800-523-1353**. (In Georgia, call 404-263-9786 collect.) Or write to:

SweetSpec Seminar
Heery International, Inc.
999 Peachtree St., N.E.
Atlanta, GA 30367-5401

- ATLANTA** • Colony Square Hotel
- ORLANDO** • Wilson World Hotel
- CHICAGO** • Hilton (Michigan Ave.)
- ST. LOUIS** • Airport Hilton
- DALLAS** • Hilton (Central Expressway)
- LOS ANGELES** • Sheraton Santa Monica
- BOSTON** • Park Plaza & Towers
- NEW YORK** • Marriott Marquis
- SAN FRANCISCO** • Marriott Fisherman's Wharf
- SEATTLE** • Red Lion - Airport
- COLUMBUS, OH** • Marriott North

WASHINGTON, D.C. • Hilton (Towers)

Use your STAC number!

XXXXXXXXXX5-DIGIT 69699
6400 009876543 FEB90 S07
TERRY DOE, TD & ASSOCIATES
128 MAIN STREET
ANYTOWN IL 69699

Need product information fast? Your Architectural Record Subscription Telephone Access Card number can help speed information to you about any product or service (advertised or new products/manufacturers literature items) described in this issue.

Architectural Record's exclusive STAC number system enables you to call and key your "more information" requests directly into our computerized touch-tone telephone. Your personal STAC number is conveniently listed above your name on the mailing address label for each issue. **IMPORTANT!** Your STAC number starts *after* the first four numbers and is separated from them by a space. If your STAC number starts with one or more zeros, ignore them. (For example, the STAC number on the above label is 9876543.)

Soon after your call, advertisers can access your requests by phone from our computer, and start speeding information to you. So when you need information fast, free help is as close as your STAC number. And STAC service is available to you 24 hours a day, seven days a week.

BEFORE YOU DIAL:

1. Write your STAC number in the boxes in Step 4 below. Do not add leading zeros.
2. Write the Reader Service numbers for those items about which you want more information in the boxes in Step 6. Do not add leading zeros.

CALL STAC:

3. Using a standard touch-tone telephone, call 413/ 442-2668, and follow the computer-generated instructions.

ENTER YOUR STAC NUMBER AND ISSUE NUMBER:

4. When the recording says, "Enter your subscriber number..." enter your STAC number by pushing the numbers and symbols on your telephone keypad. Ignore blank boxes. Enter:

									#	#
--	--	--	--	--	--	--	--	--	---	---

5. When the recording says, "Enter magazine code and issue code..." enter these numbers and symbols:

2	5	#	5	9	#	#
---	---	---	---	---	---	---

ENTER YOUR INQUIRIES:

6. When the recording says, "Enter (next) inquiry number..." enter the first Inquiry Selection

#	#
---	---

Number, including symbols from your list below. Ignore blank boxes. Wait for the prompt before entering each subsequent number (maximum numbers).

1.					#	#
2.					#	#
3.					#	#
4.					#	#
5.					#	#
6.					#	#
7.					#	#
8.					#	#
9.					#	#
10.					#	#
11.					#	#
12.					#	#
13.					#	#
14.					#	#
15.					#	#
16.					#	#
17.					#	#

END STAC SESSION:

7. When you have entered all Inquiry Selection Numbers, the recording prompts, "Enter next inquiry number." Enter call by entering:

#	#
---	---

If you are a subscriber and need assistance, call 212/512-3442. If you are not a subscriber, fill out the subscription card in this issue, or call Architectural Record Subscription Services at (609) 426-7070.

A breakthrough in flooring. norament stone.

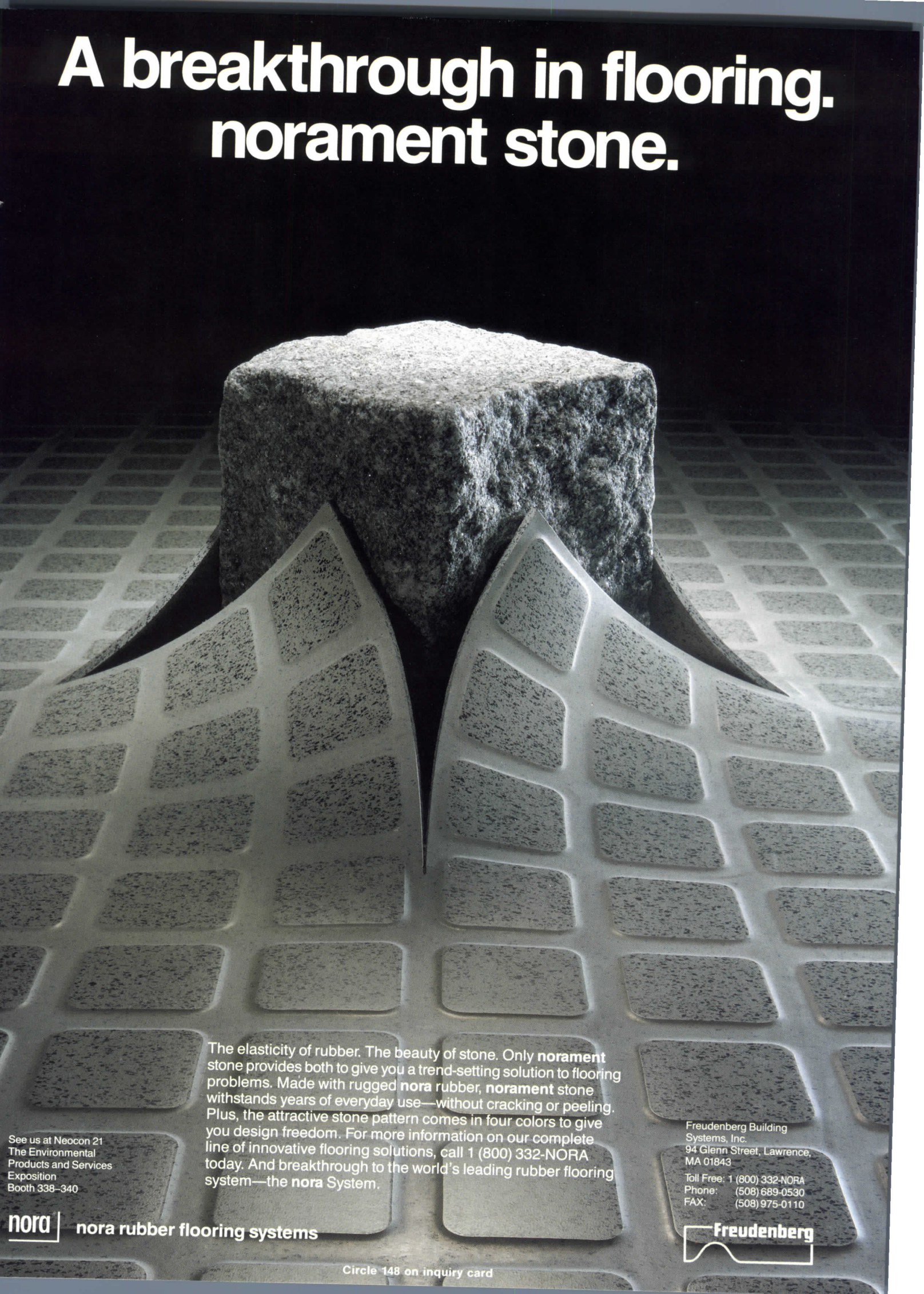

The elasticity of rubber. The beauty of stone. Only **norament** stone provides both to give you a trend-setting solution to flooring problems. Made with rugged **nora** rubber, **norament** stone withstands years of everyday use—without cracking or peeling. Plus, the attractive stone pattern comes in four colors to give you design freedom. For more information on our complete line of innovative flooring solutions, call 1 (800) 332-NORA today. And breakthrough to the world's leading rubber flooring system—the **nora** System.

See us at Neocon 21
The Environmental
Products and Services
Exposition
Booth 338-340

Freudenberg Building
Systems, Inc.
94 Glenn Street, Lawrence,
MA 01843

Toll Free: 1 (800) 332-NORA
Phone: (508) 689-0530
FAX: (508) 975-0110

nora | nora rubber flooring systems

Freudenberg

Circle 148 on inquiry card

Metamorphosis:

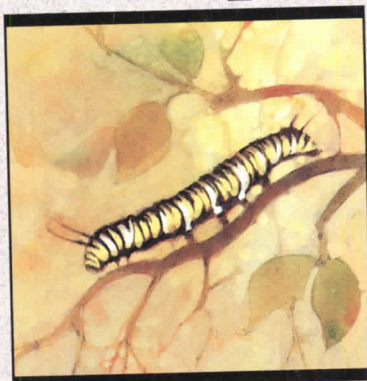

Some changes take only a few hours. Others continue for more than 80 years. In fact that's how long Sloan Valve Company has been a leader in the plumbing industry.

Today our new look is evidence of an evolution

from a single product supplier into a world

class company.

Sloan—a product of change but dedicated to those traditions which have been the foundation for our position of leadership.



SLOAN

SLOAN VALVE COMPANY
10500 SEYMOUR AVENUE • FRANKLIN PARK, IL 60131