

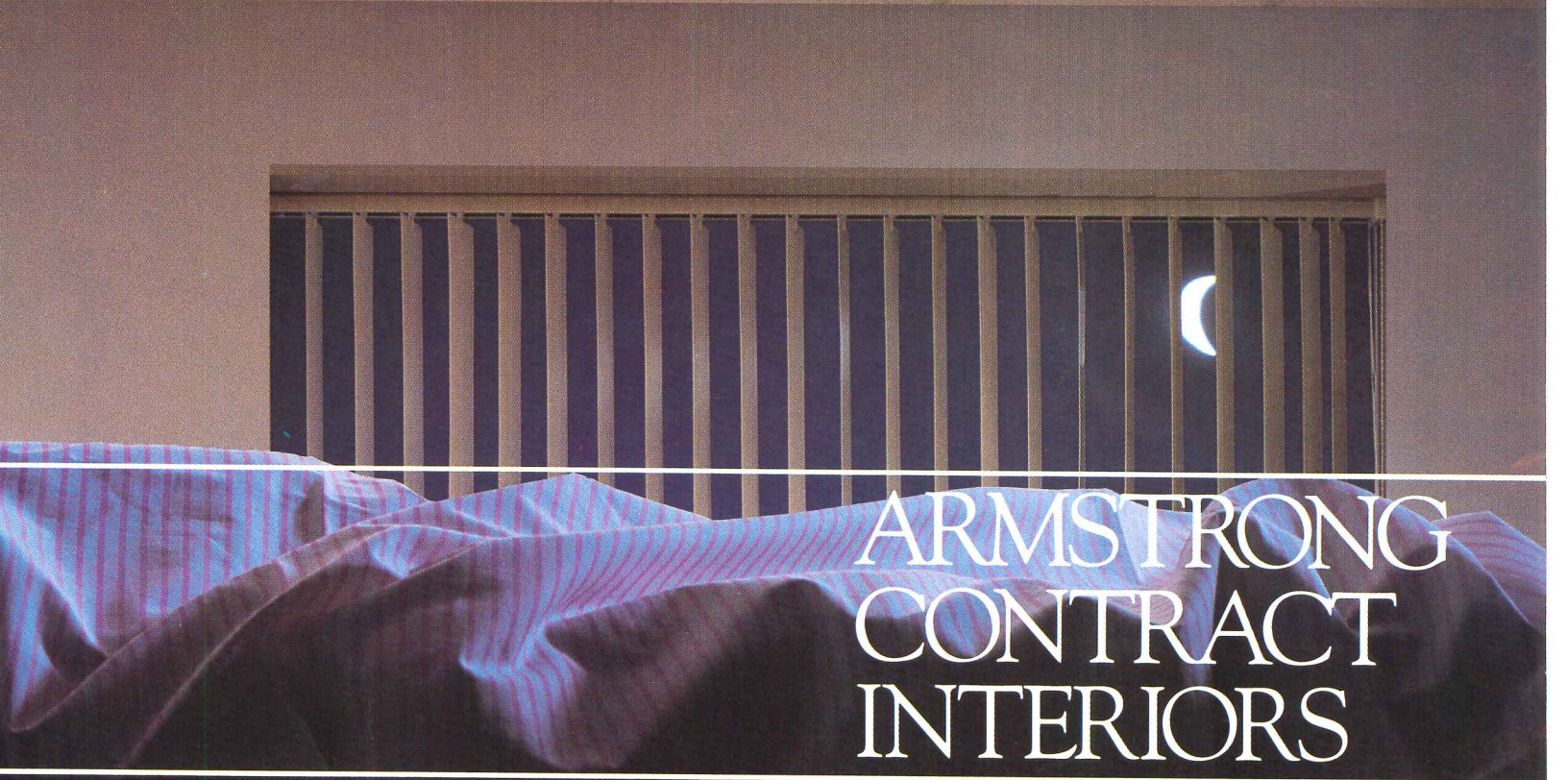



# HOW TO MAKE A ROOM SMILE.

New Cirrus® Themes™ bring a smile to any room. Five cheerful themes—Stars, Leaves, Primaries, Critters and Trains—each artistically carved to add character to any space. These Cirrus-textured acoustical panels are available for either  $\frac{1}{16}$ " or  $\frac{15}{16}$ " exposed tee grid, making them a great choice for new construction or renovation. For a free color brochure, call 1 800 233-3823 and ask for Cirrus Themes.





# ARMSTRONG CONTRACT INTERIORS

**Armstrong**  
Circle 1 on inquiry card





## CAN YOU

**Barton Myers Associates did.** The faint outline of a new performing arts center rising majestically from the landscape. Finding it took a remarkable group of architects.  And an equally remarkable computer. The Apple® Macintosh®. Why did they choose Macintosh?  Macintosh. They wanted computers with the power to work quickly, efficiently and, above all, intuitively. Perhaps it was because our systems run critical design applications, like AutoCAD, Adobe Photoshop and form•Z.  Or because ours are the only computers able to read from and write to a CD-ROM.

For the name of your nearest authorized Apple reseller, call 800-538-9696, ext. 205. \*Just add Macintosh PC Exchange software. ©1993 Apple Computer, Inc. All rights reserved. Apple, the Apple logo, Macintosh and "The power to be your best" are registered trademarks and Macintosh PC Exchange is a trademark of Apple Computer, Inc.



SEE IT?

Macintosh, DOS, OS/2 and Windows floppy disks, offering compatibility with most existing systems.\*  It could even have been our built-in networking and file-sharing systems, which let people tap into the same information, helping every one of their projects move quickly through the office.  Or maybe, just maybe, Barton Myers Associates chose Macintosh for the same reasons everyone else does.  for the power to explore new ideas. The power to chase your dreams. The power to be your best.® **Macintosh for Architects.**

Photoshop is a trademark of Adobe Systems Incorporated. AutoCAD is a registered trademark of Autodesk, Inc. form-Z is a trademark of auto-des-ys Incorporated. OS/2 is a registered trademark of International Business Machines Corporation.

### Discarding Modernist Ideology

Suzanne Stephens' article on Montgomery Schuyler's critique of Chicago's 1893 World's Fair [RECORD, June 1993, pages 36-38] was enjoyable reading. Her description of the critical tone at the time vis à vis the project in question sheds an interesting light on our own times.

Stephens posits several notions:

- The criteria to judge the worth of a piece of architecture changes with the times, i.e., modern times require modern criteria; past times used past or outdated criteria.
- Because our late-20th-century criteria are better, our buildings can and should dispense with outmoded notions of unity, coherence, and illusion. Modern criteria should be better and more all-encompassing.
- Modern critical thought should move towards the unideological, as Schuyler implied.

These notions, which exist in the realm of critical theory, have grave implications for those of us who practice architecture. While it's true that the translation of rhetoric to built form is not necessarily on a one-to-one [basis], it is also true that two divergent critical outlooks would yield two different design responses to the same problem. This is sometimes evident in competitions. Our late-20th-century society is so immersed in the Modernist philosophical trappings that we sometimes miss fundamentals.

The notions enumerated above belong to a clear set of Post-Enlightenment principles such as positivist notions of progress and evolution. These, in turn, stem from Descartes' reductionist views of the human being. It

seems to me that Schuyler's *unity, coherence, and illusion* should not be seen as inevitably the last twitches of the dead body of the past (as Stephens' article implies) but as what could be the celebration of humanness in architecture. Perhaps, after all, this was what the 1893 World's Fair was all about. Perhaps, 100 years after, architects will throw away Modernist ideology and do architecture again!  
*Manuel Mergal*  
*Hardy Holzman Pfeiffer*  
*New York City*

### Dangerous Duties?

I am appalled at the misleading idea that an architect performs "observation" duties during the construction-contract administration phase [RECORD, May 1993, pages 32-33]. The author, Ann Bayard Ketterer, confuses the duties of the observing architect (OA) with a project representative (PR). The PR's services are *additional* and paid by the client as an *additional* fee. The OA is only on site a short period of time, so it's impossible to perform all the "inspection" the author requires. The duties of an OA described in her article are *dangerous* since they can be used as evidence in court as the *standard of care* solely because it was printed in a respected architectural journal.

*William Krisel, Architect*  
*Los Angeles*

*Ketterer replies: Construction-contract administration, as described in my article, is a normal part of architectural services in almost all of the U. S. Outside project representatives are stepping in to compete for these duties and may be needed on unusually complex projects if the architect chooses not to be more involved in administration. ■*

### August 17-January 2

"Exploring Rome: Piranesi and His Contemporaries" exhibition on Rome and its history, Canadian Centre for Architecture, Montreal, 514/939-7000.

### August 21-September 12

Fourth Viennese Seminar on Architecture. Contact Architektur Zentrum Wien, Messepalast, Burggasse 1, A-1070 Vienna, 43/1/93-73-66, fax 43/1/408-71-33.

### Through September 30

The Municipal Art Society's walking tours of New York City. The fee is \$10. For more information contact Suzanne Ford/The Zeisler Group at 212/807-6480.

### September 5-9

*Design Renaissance: Designing for Regeneration*; Glasgow, United Kingdom. Write the International Design Congress, 29 Bedford Square, London WC1B 3EG or call 44/71/580-2338.

### September 8-12

"Frank Lloyd Wright and the Prairie School in Iowa," Building Conservancy annual conference, Mason City, Iowa. Contact Judith Trent, 708/848-1141 or Jeanette Fields, 708/366-9342.

### Competitions

- American Planning Association is accepting submissions until September 22 for its 1994 National Planning Awards. There are six entry categories, including outstanding planning; distinguished leadership; planning for economic development; and public education. Write APA at 1776 Massachusetts Ave., N. W., Washington, D. C., or call 202/872-0611 for entry form and details.

- Armed Forces Memorial design competition, San Jose, Calif. Winner receives \$25,000. Registration deadline, mid-August; \$50 fee (waived for students). Submissions deadline, mid-November. Call 408/277-2789 or fax 408/277-3160 for details. ■



ARCHITECTURAL RECORD (Combined with AMERICAN ARCHITECT, and WESTERN ARCHITECT AND ENGINEER) (ISSN0003-858X/93) August 1993, Vol. 181, No. 8. Title © reg. in U. S. Patent Office, copyright ©1993 by McGraw-Hill, Inc. All rights reserved. Indexed in Reader's Guide to Periodical Literature, Art Index, Applied Science and Technology Index, Engineering Index, The Architectural Index, the Architectural Periodicals Index, the Avery Index to Architectural Periodicals, and the Construction Index.

Every possible effort will be made to return material submitted for possible publication (if accompanied by stamped, addressed envelope), but the editors and the corporation will not be responsible for loss or damage.

*Executive, Editorial, Circulation and Advertising Offices:* 1221 Avenue of the Americas, New York, NY 10020.

*Officers of McGraw-Hill, Inc:* Chairman, President and Chief Executive Officer: Joseph L. Dionne. Executive Vice President: Harold W. McGraw III. Executive Vice President, General Counsel and Secretary: Robert N. Landes. Senior Vice President, Treasury Operations: Frank D. Penglase.

*Associated Services:* Sweet's Catalog Files (General Building, Engineering, Industrial Construction and Renovation, Light Residential Construction, Interiors), Dodge Reports and Bulletins, Dodge/SCAN Microfilm Systems, Dodge Construction Statistics, Dodge regional construction newspapers (Chicago, Denver, Los Angeles, San Francisco).

Subscription rates are as follows: U. S. Possessions and Canada \$54.00; all other Foreign (including Air): \$160.00. Single copy price \$7.00; For Foreign: \$10.00. For Subscriber Services: 609/426-7070.

*Change of Address:* Forward changes of address or service letters to Fulfillment Manager, ARCHITECTURAL RECORD, P. O. 566, Hightstown, NJ 08520. Provide both old and new address; include zip code; if possible attach issue address label.

*Guarantee:* Publisher agrees to refund that part of subscription price applying to unfiled part of subscription if service is unsatisfactory. Publisher reserves right to accept or reject any subscription.

*Copyright and Reprinting:* Title © reg. in U. S. Patent Office. Copyright ©1993 by McGraw-Hill, Inc. All rights reserved. Where necessary, permission is granted by the copyright owner for libraries and others registered with the Copyright Clearance Center (CCC) to photocopy any article herein for personal or internal reference use only for the base fee of \$1.50 per copy of the article plus ten cents per page. Payment should be sent directly to the CCC, 27 Congress Street, Salem, MA 01970. Include code with request: ISSN0003-858X/93 (\$1.50 + .10). Written permission must be secured for any other copying. Write Reprint Manager for such permission at address below, or to obtain quotations on bulk orders.

*Subscription List Usage:* Advertisers may use our list to mail information to readers. To be excluded from such mailings, send a request to ARCHITECTURAL RECORD, Mailing List Mgr., P. O. Box 555, Hightstown, NJ 08520.

ARCHITECTURAL RECORD (ISSN0003-858X/93) published monthly by McGraw-Hill, Inc. Second-class postage paid at New York, NY and additional mailing offices. Postage paid at Montreal, Quebec, Canada. Canada Post International Publications Mail Product Sales Agreement No. 246565. Registered for GST as McGraw-Hill, Inc. GST Number R123075673

*Postmaster:* Please send address changes to: ARCHITECTURAL RECORD, Attn: Fulfillment Manager, P. O. Box 566, Hightstown, NJ 08520.



**Gives you room to work.** Do you know what it's like working with your tool palette and design crammed on the same screen? You wouldn't if you used a Macintosh. Most models can run multiple monitors, regardless of which application you're using. And best of all, only Macintosh offers this feature.

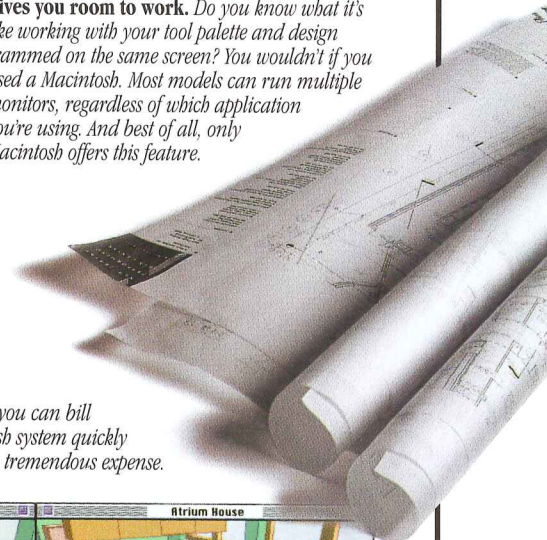

**Helps you make money.** Since you can bill clients for computer time, a Macintosh system quickly becomes a valuable revenue center, not a tremendous expense.

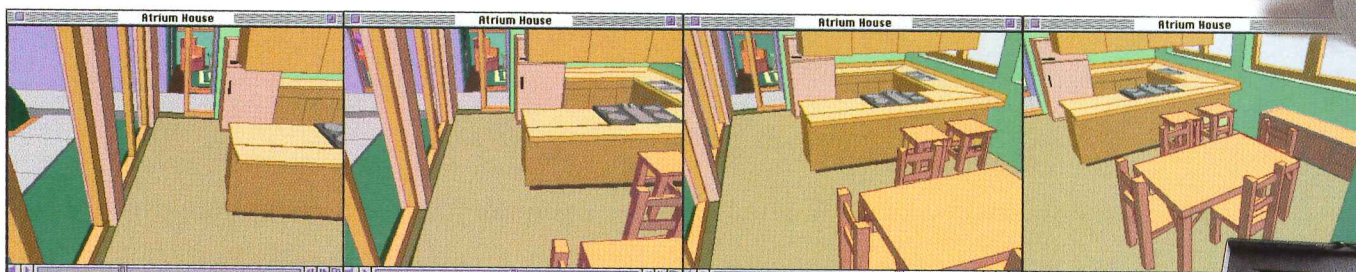

**Makes your presentations come to life.** Architecture is an extremely visual profession. That's why we created QuickTime® software for Macintosh and Windows environments. With it, you can create presentations so powerful, they actually come to life. These animated walk-throughs make it easier for clients to see your ideas. And, in turn, easier for you to sell them.

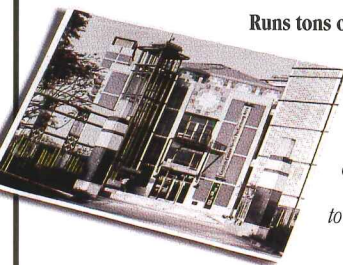

**Runs tons of software.** Whether you're sweating over a design or trying to whip out a memo, Macintosh has the applications you need to do your job quickly and easily. And Macintosh computers run powerful 3-D modeling programs that let you evaluate and modify your ideas immediately. Ultimately giving you more time to make your designs the best they can be.

- Alias upFRONT**
- ArchiCAD**
- AutoCAD**
- DesignWorkshop**
- form-Z**
- MicroStation Mac**
- MiniCad+**
- PowerDraw**
- Virtus WalkThrough**



**Follows you everywhere.** Once you know what our systems can do, you'll never want to be without one. Our PowerBook™ and PowerBook Duo™ systems give you the ability to take a powerful, portable computer with you anywhere you go.

**Helps you do more work more quickly.** By using Ethernet and Token-Ring technology, Macintosh easily integrates into existing DOS and UNIX® networks, helping work move more smoothly between people in your office and outside consultants.

Activity	Planned Start Date	Actual Start Date	Planned Finish Date	Actual Finish Date	1993		
					2	3	4
					JULY	AUGUST	SEPTEMBER
Planning							
Final Space Plan	6/26	7/2	7/31	8/20			
Port Authority Space Plan	8/5	8/20	8/26	9/10			
Final Preliminaries	9/8	9/14					
Design Development							
Procedure Design	6/29	7/16	9/29	10/23			
Estimates	7/23	8/24	9/30	10/26			
Construction Documents							
Structural Reinforcements	9/25	10/22	11/12	12/1			

**Produces memorable proposals.** Macintosh runs the layout and design software you need to make your proposals look their best. And, as you know, a proposal that looks impressive makes you look the same.

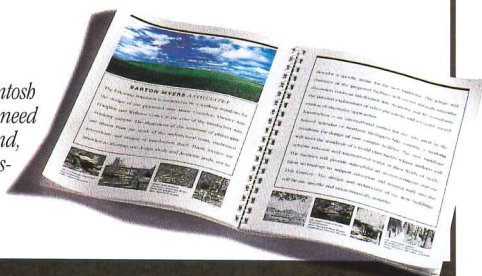

## SEE WHAT MACINTOSH CAN DO FOR YOU.

Having a great idea is hard enough. Why use a computer that makes it even harder? Apple® Macintosh® personal computers are powerful enough and versatile enough to handle the entire architectural process. Maybe that's why more architects use Macintosh than any other computer.\* For information about solutions seminars, call 1-800-438-1138, ext. 110. Attend one, and you'll learn about our powerful solutions, each one with a feature only Macintosh can offer: The power to be your best.®

**Macintosh for Architects.®**



\*DataQuest, March 15, 1993. © 1993 Apple Computer, Inc. All rights reserved. Apple, the Apple logo, Macintosh and "The power to be your best" are registered trademarks and PowerBook, PowerBook Duo and QuickTime are trademarks of Apple Computer, Inc. Alias upFRONT is a registered trademark of Alias Research Inc. ArchiCAD is a registered trademark of Graphisoft. AutoCAD is a registered trademark of Autodesk, Inc. DesignWorkshop is a trademark of Artifice, Inc. form-Z is a trademark of auto-desys Inc. MicroStation is a registered trademark of Intergraph Corp. MiniCad+ is a trademark of Diehl Graphisoft, Inc. PowerDraw is a trademark of Computer Shoppe. UNIX is a registered trademark of UNIX System Laboratories, Inc. Virtus WalkThrough is a registered trademark of Virtus Corp.

C L A S S 1 I S A R E S T R I C T I O N

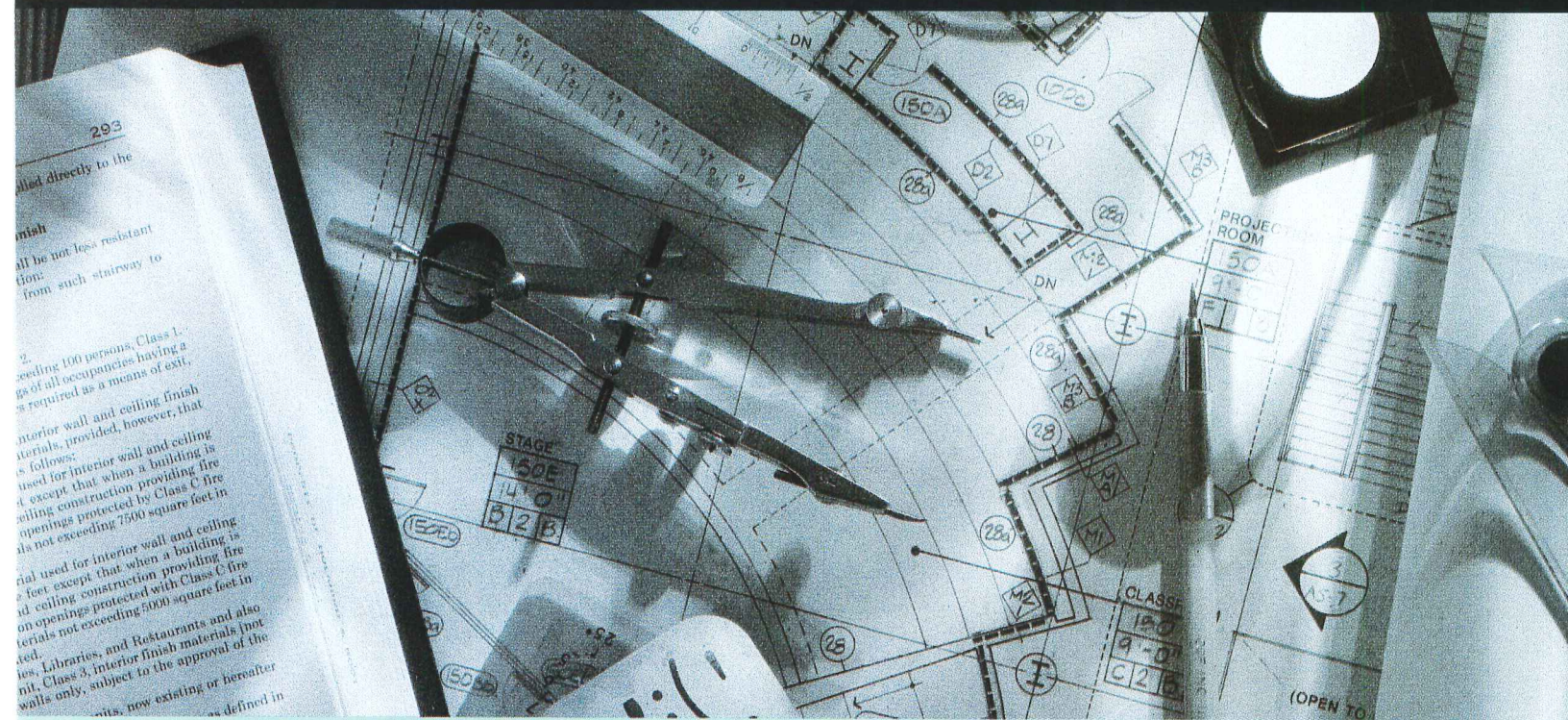

One look at the Chicago-Kent College of Law is proof positive. You don't have to compromise dramatic woodwork design in order to meet code. Not with Duraflake FR, the only Class 1 fire-rated particleboard in America. It's remarkably smooth, stable substrate ideal for laminating. And FR isn't just topically treated with chemicals. It's fire-retardant to the core. Not to mention more versatile and less expensive than fire-rated plywood. What it means is woodwork designed with Duraflake FR isn't just beautiful. It's smart.



Willamette Industries, Inc. • Duraflake Particleboard Plant • P.O. Box 428, Albany, OR 97321 • (503) 928-3341 • FAX (503) 928-4



N O T A L I M I T A T I O N .

Circle 2 on inquiry card



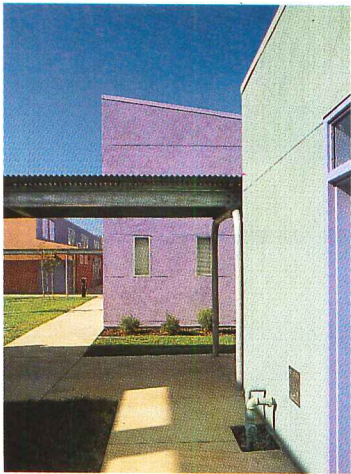

Chas McGrath

At Patwin Elementary School, The Steinberg Group took advantage of a benign climate to use covered walkways instead of indoor corridors. Page 110.

**Introduction 81**

**Overhauling Education 82**

Trends in School Design

**Fountain Hills Junior/Senior High School  
Fountain Hills, Arizona 84**

*HNTB Corporation, Architect*

**Seward Hedges Area School  
Chicago, Illinois 92**

*Ross Barney + Jankowski, Inc., Architect*

**Troy High School  
Troy, Michigan 96**

*Perkins & Will, Architect*

**Intermediate School 218  
New York City 104**

*Richard Dattner Architect*

**Rogers Elementary School  
Victoria, British Columbia 108**

*Hughes Baldwin Architects*

**Patwin Elementary School  
Davis, California 110**

*The Steinberg Group, Architect*

**Focus on:  
Refresher Courses For Schools 116**

*Projects in Truro, Massachusetts;  
New Territories, Hong Kong; Los Angeles;  
James Island, South Carolina;  
New Haven, Connecticut*

**Building Technology 32**

Engineering Arena Roofs;  
Beyond Wheelchairs: ADA's Design Potential

**Software Reviews 44**

Product reviews from A/E/C Systems

**Editorial 9**

Gold Medal: AIA Needs to  
Sort Out Process, Priorities

**Letters/Calendar 4**

**Design News 25**

**Practice News 28**

**Technology News 30**

**Product News 42**

**Observations 50**

**Product Literature 123**

**Classified Advertising 136**

**Manufacturers' Sources 139**

**Advertising Index 144**

**Reader Service Card 145**

Cover: *Seward Hedges Area School, Chicago, Illinois*  
*Ross Barney + Jankowski, Inc., Architect*  
©Steven Hall/Hedrich-Blessing photo

**SUPPLEMENT ON LIGHTING IS INCLUDED WITH THIS ISSUE**  
**(with U. S. and Canadian copies only)**

**Next month:**

**Building Types Study 709**  
**Record Interiors**

A theater, a warehouse renovated into an office, an apartment, a showroom, a shop, and an office are the editors' choices for next month's RECORD INTERIORS issue.

How to accommodate downsizing is covered in a feature on the planning and design of office space.

**Also in September:**

**Update on the nation's construction activity.**

**Specifying entrances and storefronts.**

**Furniture by young American designer Marc Ewing.**

## Pity the poor pedestal. . .

... so deserving, yet relegated to play the supporting role of faithful hero and selfless sidekick to monuments and mementi mori beyond count. It hardly seems fair.

Even by those who ought to know better, pedestals are often taken for granite (sorry). Mere footstools for the fabulous, ottomans for emperors, permanent soap boxes for once-windy orators, they are simply there. Like the best butlers in English novels, pedestals do their essential work without attracting attention to themselves, and thus their virtue is often measured by their invisibility.

But at Forms + Surfaces, the pedestrian pedestal is never a given. Witness four new variations of this oft-underwhelming theme, and rest assured . . .

*. . . there is poetry to be found in unexpected places.*

**FORMS+SURFACES**

800.451.0410 Fax 805.684.8620

Circle No. 3

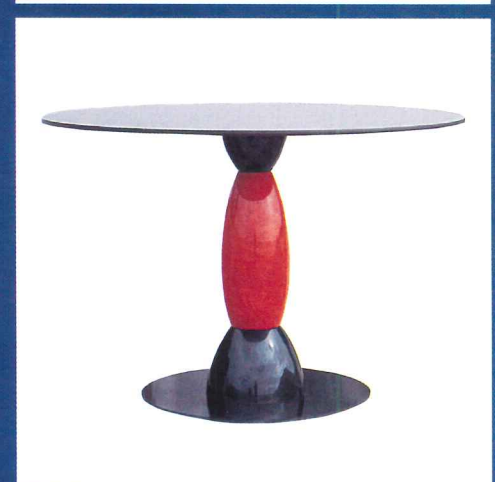
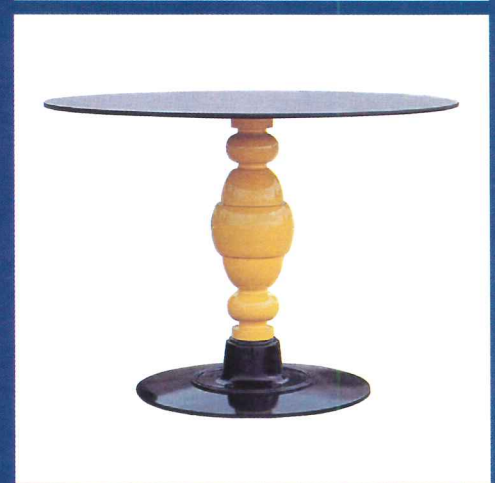

## Gold Medal: AIA Needs to Sort Out Process, Priorities

Editor  
*Stephen A. Kliment, FAIA*

Managing Editor  
*Carolyn Kerr De Witt*

Senior Editors  
*Charles K. Hoyt, FAIA*  
*Karen D. Stein*  
*James S. Russell, AIA*  
*Charles D. Linn, AIA*

Associate Editors  
*Joan F. Blatterman*  
*Clifford A. Pearson*

Design Director  
*Alberto Bucchianeri*

Senior Associate Design Director  
*Anna Egger-Schlesinger*

Editorial Production Manager  
*Annette K. Netburn*

Assistant Production Editor  
*Colleen M. Donohue*

Technical Illustrator  
*Muriel Cuttrell*

Design Consultant  
*Massimo Vignelli*

Editorial Advisory Panel  
*William J. Stanley, III, AIA*  
*Ivonne Love-Stanley, AIA*

Contributing Editors and Consultants  
*David Ballast, AIA*  
*Robert Campbell, FAIA*  
*Kristine Fallon, AIA*  
*Peter Hoffmann, Washington*  
*Phillip Kidd, Finance*  
*Robert Murray, Economics*  
*Peter Piven, FAIA*  
*Steven S. Ross, Computers*  
*Norma Sklarek, FAIA*

Correspondents  
*Aaron Betsky, Los Angeles*  
*David Cohn, Madrid*  
*Beth Dunlop, Miami*  
*Pam Kinzie, AIA, San Francisco*  
*Victoria S. Lautman, Chicago*  
*Nancy Levinson, New England*  
*Tracy Metz, Amsterdam*  
*Gerald Moorhead, FAIA, Houston*  
*Naomi R. Pollock, at Large*

Circulation Director  
*Pat Traylor*

Circulation Assistant  
*Cheryl Levy*

Director of Business and Production  
*Joseph R. Wunk*

Advertising Production Manager  
*Laura M. Blumin*

Business Manager  
*David Sandhusen*

Publisher  
*Roscoe C. Smith III*

*Inquiries and submissions of work for publication may be sent to the editors listed below who are responsible for the subject areas named:*

*Carolyn K. De Witt, design news*  
*Karen D. Stein, houses, interior design*  
*Clifford A. Pearson, observations, books*  
*Charles K. Hoyt, practice*  
*James S. Russell, technology*  
*Joan F. Blatterman, new products*  
*Charles D. Linn, RECORD LIGHTING*

PRINTED IN U. S. A.

The embarrassing debate at the June AIA convention over a possible joint award of the Gold Medal to Robert Venturi and Denise Scott Brown [RECORD, Practice News, page 28] highlights some real concern over the vision and mission of the entire Gold Medal program.

At a time when education, affordable housing and healthcare, and sustainable development are begging for design attention, it may seem specious to be worrying about a small round piece of metal attached to a red ribbon. But as a major voice for architecture in the U. S. and globally, the AIA must realize that its choice of Gold Medalist sends a signal to society, to the profession and students, serves as a beacon to the serious general public, and becomes a building block in the historical record of architecture for the ages.

Therefore there are standards such an award must meet. AIA's Gold Medal winner is chosen by its Board of Directors "in recognition of most distinguished service to the profession of architecture or the [AIA]." This command is so vague as to place virtually no limit on the candidates to consider and still meet the criteria. But with nearly 40 Board members, elected like members of Congress to represent a given number of constituents, the selection process becomes so cumbersome and politicized that the winner tends to be one about whom there is the least dissension, rather than a choice that could run into controversy. Once the choice is made, the AIA's public-relations apparatus goes into high gear, and each February puts on a mammoth media event centered on the Gold Medal and its winner.

All of this raises some serious questions:

- Jurors need total independence. Unlike the Pritzker Architectural Prize, where a small seven-person jury acts with zero involvement from the sponsor, the Gold Medal Board-jurors know they are always under scrutiny from their constituents. This tends to discourage the kind of bold choices that yielded Alvaro Siza for the Pritzker prize.
- It's patently absurd to limit the award to a single person. The standing of the architectural profession at the grass-roots client level continues to suffer from the unfortunate image of the single self-indulgent star along the lines of Howard Roark in *The Fountainhead*, rather than of hardworking teams doing their best to provide high-quality design on modest, often socially significant projects, for modest clients. What does the profession gain when two architects who have had a huge impact on the form and content of architecture are denied the Gold Medal? The Architecture Firm Award, which is supposed to recognize teams, is treated as a poor relation on the publicity scale. It must be given equal time if the February event is to echo the genuine values of the architectural profession.

When the AIA Board meets next month, it should take a whole new look at the Gold Medal and its premises. For one thing, the very real concerns of the profession are not only the domain of the individual architect; and if the AIA is to reflect this, then the symbols and icons it chooses to recognize must fit the times.

*Stephen A. Kliment*

# THIS BANK SELECTED US BECAUSE WE PAID HIGHE

It looks less like a bank and more like an English country manor. But the charm of the Investors Savings Bank belies the challenges its design and construction presented. Particularly to Marvin Windows and Doors.

For one thing, fast-track construction scheduling was necessary due to constantly evolving design constraints. For another, it wasn't until thermal efficiency, condensation resistance and aesthetics were factored in that wood was chosen over aluminum. Consequently, Marvin wasn't selected for the job until construction was underway, making manufacturing and delivery deadlines extremely tight.

But Marvin's biggest challenge proved to be the building's three massive window and door assemblies, the largest of which measures 28 feet wide by 30 feet high. Using a combination of sturdy Magnum Double-Hungs and French Doors, Marvin not only built them on schedule, but also engineered them prior to delivery to guarantee they would withstand the strong, prevailing winds off the lake. And, like all 177 of the bank's other made-to-fit windows and doors, they were built with features designed specifically for the project. Features such as authentic divided lites, interior windows and doors glazed to match those on the exterior and a durable, factory applied finish in two complementary colors; Midnight Teal for the sash

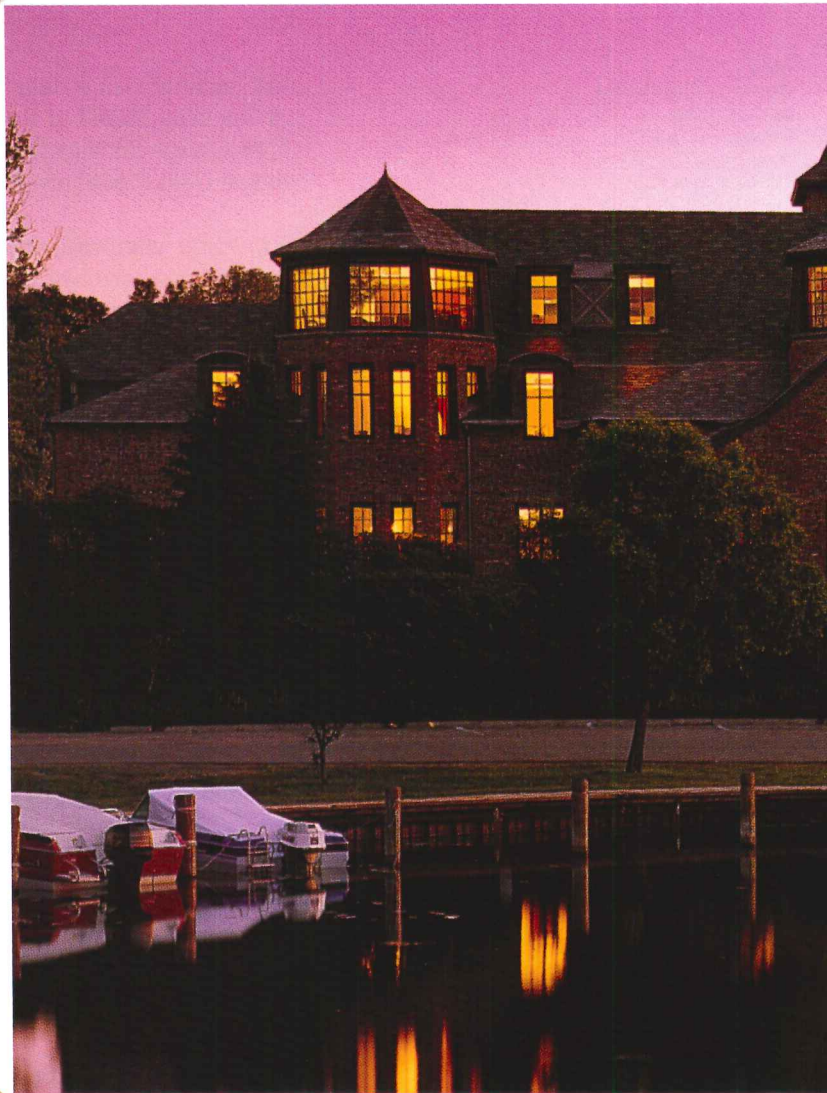

# INTEREST.

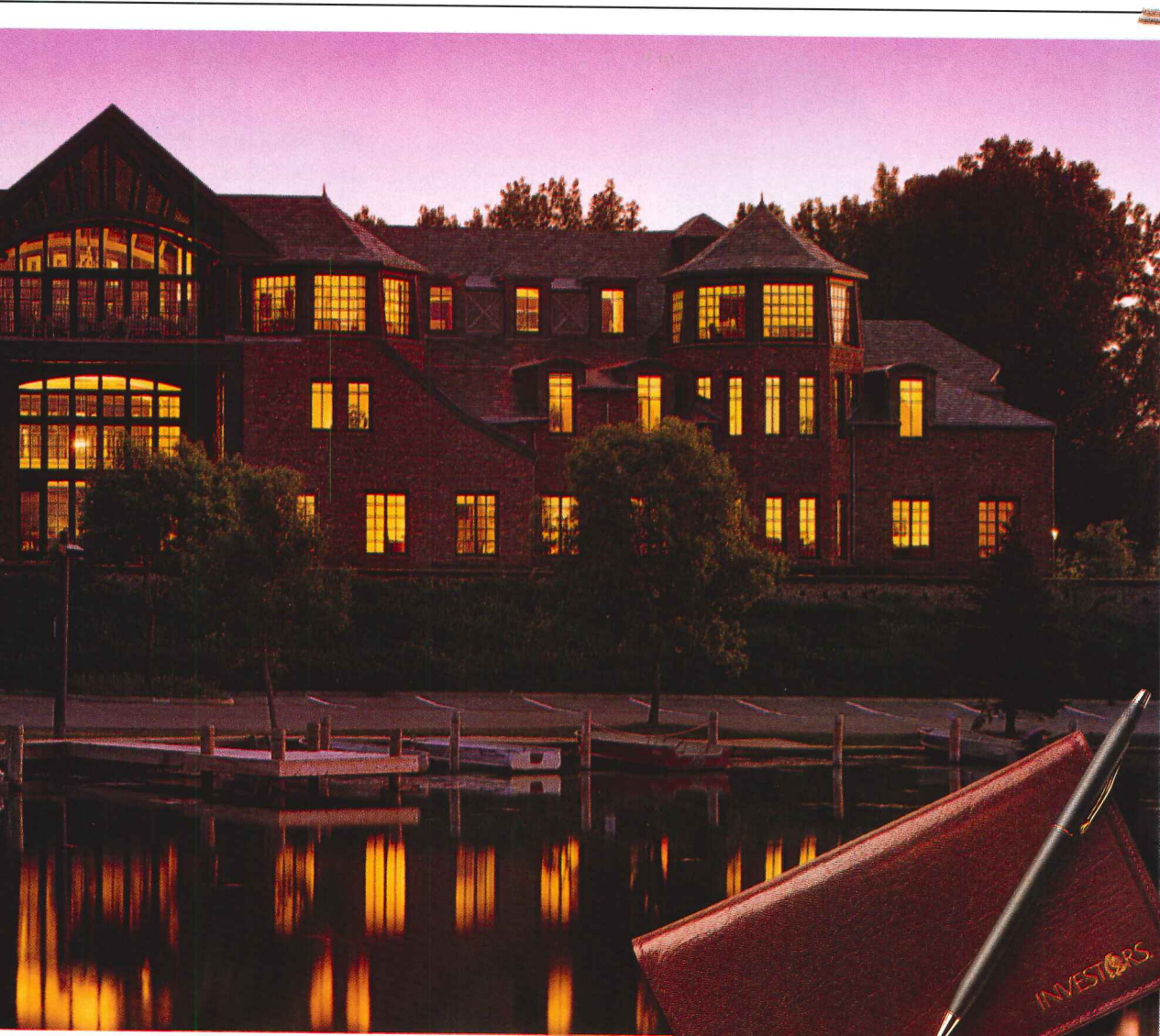

and Graphite Grey for the frames.

Shortly after its completion, Investors Savings Bank was named the NAIOP Build To Suit Building of the Year. Which just goes to show that paying extra interest can result in some handsome dividends.



**MAKE US YOUR FIRST CALL, NOT YOUR LAST RESORT.**

If your new construction project needs special attention or you've got a window design problem you just can't solve, call the one company you know will have the right solution. Call Marvin Windows and Doors at **1-800-346-5128** (1-800-263-6161 in Canada). Or mail the coupon for a free catalog featuring our entire line of made-to-order Marvin windows and doors.

Send to: Marvin Windows and Doors  
Warroad, MN 56763  
1209308A

Name \_\_\_\_\_

Company \_\_\_\_\_

Address \_\_\_\_\_

City \_\_\_\_\_ State \_\_\_\_\_

Zip \_\_\_\_\_ Phone \_\_\_\_\_

Please send me:  Residential Catalog  
 Commercial Catalog



Circle 4 on inquiry card

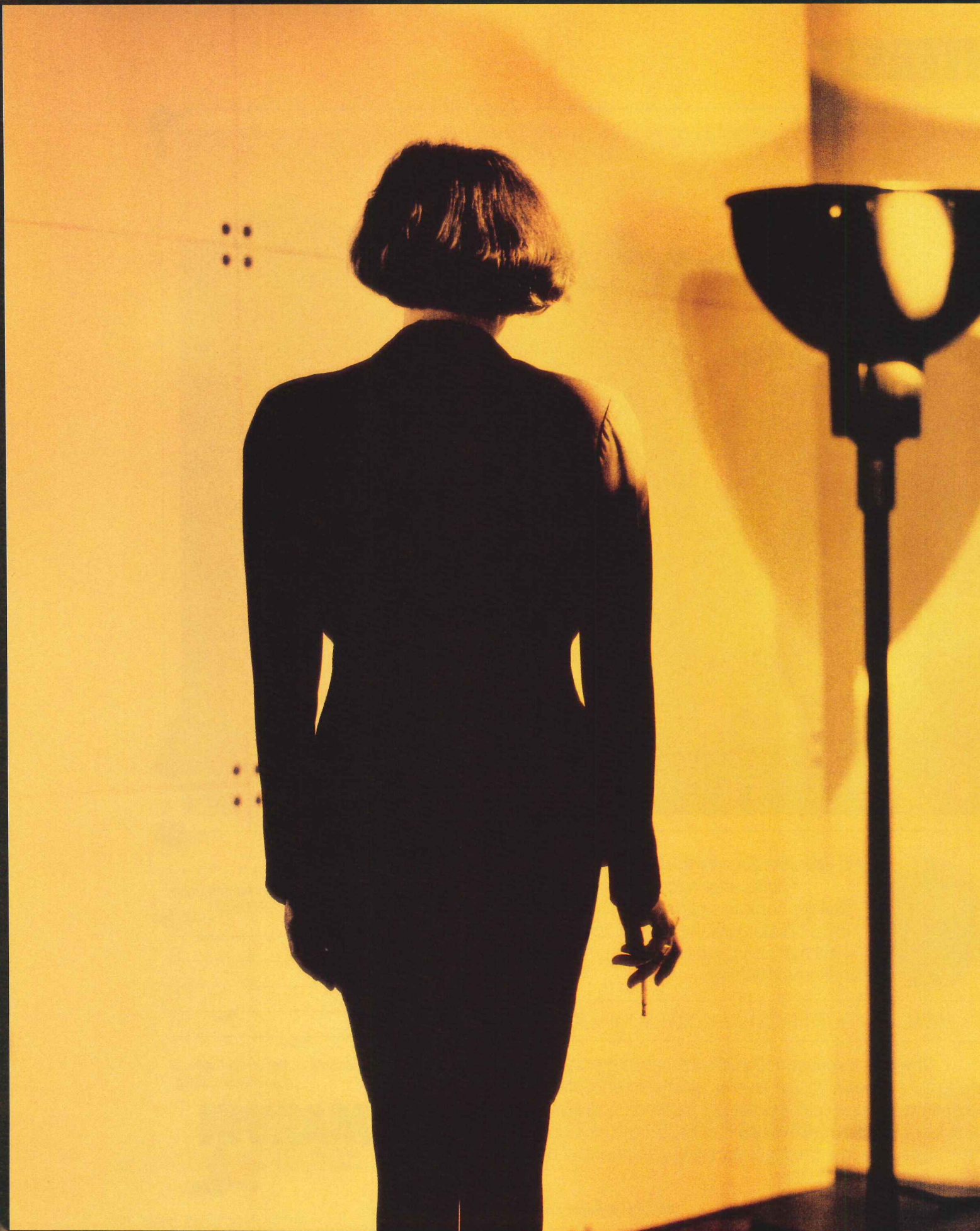

# ANDRÉE PUTMAN

*Andrée Putman, ASID, interior designer  
and founder of Ecart, a Paris-based architecture and design firm.  
Putman strongly adheres to following her own beliefs.*

## THE POWER OF DIFFERENCE.

"I believe in freedom. We should all have the strength and authority to think for ourselves, to turn against what is expected. To pick up something in the dust or in the worst condition. Maybe it's not miraculous for everyone, but certainly for you this object has immense charm. "I like mixing things.

Adding things that were never together before. Mixing rich materials with poor. Mixing something remarkably funny with a sad, boring material.

There is always balance, which is full of contradiction. But after all, life is full of contradiction. "Carpet is like the sand in the desert. It brings something very sensual that is not only visual. It has to do with sound. And the charm of walking barefoot. In so many places there's no other solution."

Innovators like Andrée Putman challenge us at DuPont to continue leading the way with ANTRON® nylon. The carpet fiber top professionals specify most.

For more information about Ecart design, call 1-800-4-DUPONT.



DU PONT ANTRON THERE IS NO EQUAL



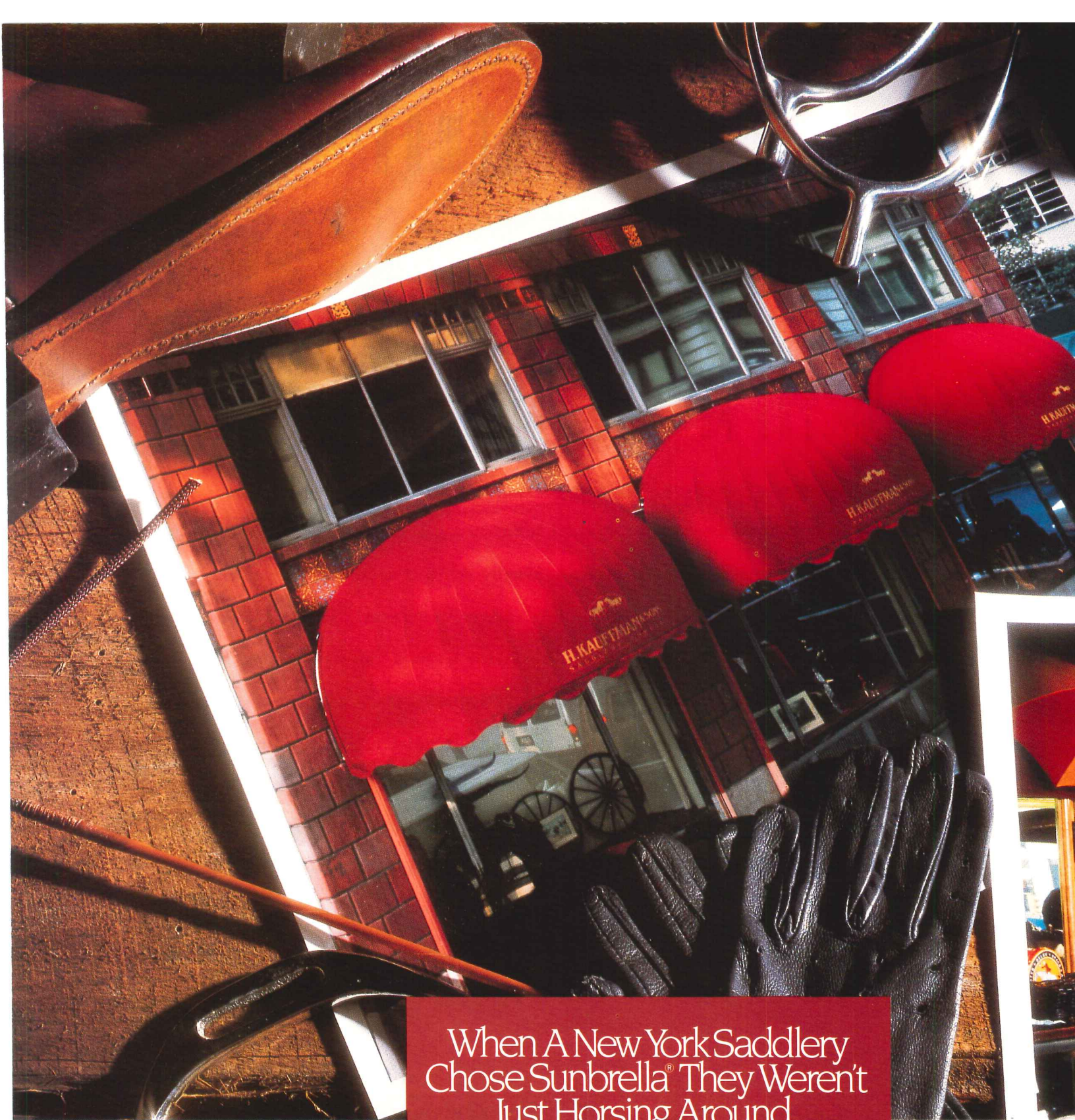

When A New York Saddlery  
Chose Sunbrella® They Weren't  
Just Horsing Around.

Not just any fabric would do

for H. Kauffman & Sons

Saddlery Company. They needed something that was versatile, beautiful and durable. Sunbrella solution-dyed acrylic fabric and Sunbrella Firesist® fabric are all those things.

The versatility of our fabric is evident all over the store. Inside and out creative uses of the fabric abound: in the beautiful awnings that grace the outside, in the canopies hanging over the showroom, in the door and window treatments, in the many accent pieces

The beauty of Sunbrella shines through in every Sunbrella fabric we offer. Regular Sunbrella is available in over 90 colors and styles.

Designer: Jane Victor Associates, New York, Fabricator: ABC Awning, New York, Location Photography: © 1991 Norman McGrath, Studio Photography: Gerin Choiniere



(ADVERTISEMENT)

# SAFTI BULLETIN

SAFETY AND FIRE TECHNOLOGY INFORMATION FROM O'KEEFFE'S INC.

## SCHOOL DISTRICT'S PYROSWISS™ TEST PROVES SUCCESSFUL

**San Francisco School District plans to reduce annual operating budget and provide enhanced safety for students.**

Until just a few months ago the San Francisco School District's glazing problems seemed insurmountable. Faced with continued escalating costs from recurring breakage of wired glass the District's in-house glazing operation was working overtime just to keep up. In some cases they replaced a pane of wired glass over five times in the same door or sidelite during the school year.

**San Francisco School District Sees its Way Clear**

O'Keeffe's introduced 20/30 min. PYROSWISS to the school representatives with claims of up to ten times the strength of wired glass, clear vision and safety certified. The District's representatives were a bit dubious. Although they reviewed the test reports and viewed performance videos they felt the final proof would be its field performance. Two test locations were chosen which were known to be "high replacement" locations. They felt that if PYROSWISS could stand up in the final two months of the school year, during the rigors of day to day school activities it would pass. While the cost of PYROSWISS is higher than wired glass the School District felt the overall annualized cost would be significantly less.



*San Francisco School District initiates program to end recurring breakage of wired glass using impact resistant PYROSWISS.*

*continued on page 2...*

## WIRED GLASS INJURIES CONTINUE UNABATED

Injuries from wired glass breakage continue to escalate. Students are proven to be at particular risk. One recent victim was a 16 year old Connecticut high school student who received severe lacerations on his hand and arm. Tragically, this resulted in loss of mobility and permanent damage.

The student's attorney stated that the teenage boy was pushing open a door which contained a wired glass pane. He missed the press plate and his hand and arm broke through the wired glass pane. The court recently settled this case finding the high school negligent.



Reports of other recent incidents of injury from wired glass breakage include a high school student in Michigan, a basketball player in North Carolina, and a middle school student in Wallingford, Connecticut. All of these involved serious, permanent injuries with lawsuits filed.

## CONTRACRIME™ 45

### PIONEERED AND SUCCESSFULLY TESTED FOR SECURITY APPLICATIONS

Over the past two years O'Keeffe's has been working with Vegla in Germany, the manufacturer of CONTRAFLAM™, to develop a fire and security rated glazing product specifically for security applications. The culmination of these efforts was a fire test conducted at the Warnock-Hersey laboratories in Pittsburgh, California in April of this year.

**Fire, Security and Safety All in One**

One facility which has CONTRACRIME

*continued on page 3...*

SAFTI

1

# PERFORMANCE AND AESTHETIC COMPARISON OF FIRE RATED GLAZING MATERIALS

	CONTRAFLAM™	PYROSWISS™	FIRELITE™	WIRED GLASS
<b>Safety Glazing<sup>1</sup></b>	<b>Yes</b>	<b>Yes</b>	No	No <sup>2</sup>
Meets Code Requirement for 1 Hour wall rating (limits temperature rise to <250° F per ASTM E119)	<b>Yes</b>	<b>No</b>	No	No
May Be Installed in Standard Frames	<b>Yes<sup>3</sup></b>	<b>Yes</b>	Yes	Yes
Security/Attack Options	<b>Yes</b>	<b>No</b>	No	No
High Wind Loading Resistance	<b>Yes</b>	<b>Yes</b>	No	No
Largest Listed Lites <sup>4</sup> (Area) <sup>4</sup>	<b>48"x102"</b> (4,896 sq. in.)	<b>50"x93"</b> (4,638 sq. in.)	<b>35"x95"</b> (3,326 sq. in.)	<b>24"x54"</b> (1,296 sq. in.)
Sound Transmission Ratings (STC)	<b>48db<sup>5</sup></b>	<b>28db</b>	26db	28db
Visible Appearance	<b>Clear/Colorless</b>	<b>Clear/Colorless</b>	Yellowish-Tinge	Visible Wire
Optical Quality	<b>Excellent</b>	<b>Excellent</b>	Fair <sup>6</sup>	Poor
Daylight Transmission	<b>85%<sup>5</sup></b>	<b>83%</b>	77%	83%
<p><b>1</b> Safety glazing is required of fire rated assemblies in all Hazardous Locations. <b>4</b> Or maximum area tested, may vary with rating period, check listing.  <b>2</b> Based on independent testing of wired glass from the four leading manufacturers. Wired glass failed to meet the minimum safety standards of ANSI Z97.1. <b>5</b> Based on 60 min. rating.  <b>3</b> For 20/45 min. applications only, 60/90 min. require GPX framing system. <b>6</b> Applies to "Premium" grade. Optical quality for non-polished is poor.</p>				
For additional information please use reader service #97.				

## SCHOOL'S PYROSWISS TEST SUCCESSFUL *continued from page 1...*

From 6, 8, 12, 10, 15 and 19mm available make-ups of PYROSWISS, 6 and 8mm were selected for the test.



*Wired glass prior to removal*

### **PYROSWISS stands up to the test**

After two months representatives from O'Keeffe's and the District met to review the results. None of the PYROSWISS panes were broken!



Not only is the School District delighted but now they can see their way clear to repair other areas that they previously could not have afforded due to budget constraints. As injuries from wired glass continue to escalate, the San Francisco School District is ensuring a higher level of safety for its students. The School District is planning on using PYROSWISS as a replacement glazing for wired glass in 20 and 30 minute applications as well as in new construction projects which require 20 and 30 minute draft and smoke control assemblies.

**Let O'Keeffe's representatives show you how to reduce your costs and provide a high level of safety to your students.**

Call or write us today. We will be happy to have our representatives show you the test reports and samples of PYROSWISS. Perhaps you too can make an adjustment to your budget next year. Or use reader service #95 for more information.

# CONTRACRIME 45

continued from page 1...

incorporated in its design is the Somers Correctional Facility in Somers, Connecticut. The intent for this project was to develop large, clear glazing units which would provide a more open atmosphere coupled with better visual security. The glazing had to meet all three criteria of a 45 minute fire test, an 18 minute security/attack rating and meet CPSC safety standards.

Pilot scale fire tests were completed and were followed by full scale California Department of Correction security and attack tests. Both with excellent results. The attack test included such implements as: a sledge hammer, a fire ax, a ball peen hammer and a propane torch.

(ADVERTISEMENT)

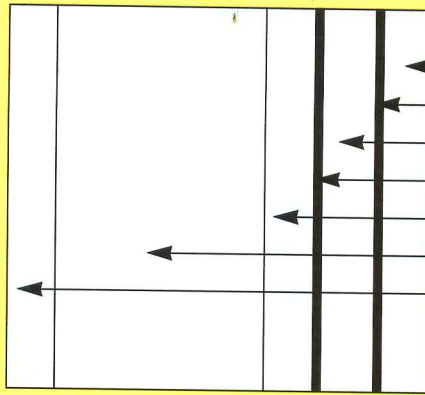

## CONTRACRIME Make-up

- 4mm Tempered Glass
- 1.2mm Urethane Interlayer
- 4mm polycarbonate
- 1.2mm Urethane Interlayer
- 4mm Tempered Glass
- 18.5mm Gel Layer
- 5mm Tempered Glass

---

- 37.9mm (1.5") Thick

## 4,896 Square Inches

The plans for the Somers Correctional facility incorporated several 48" x 102" horizontal lites. As these lite sizes exceeded the previously tested size of CONTRACRIME, it was required to test to the large size specified. O'Keeffe's built a hollow metal detention frame and the entire unit was subjected to a

45 minute fire endurance test. This was immediately followed by a hose stream test subjecting the entire glazing unit to 30 lbs. of cold water pressure. With the successful passage of the fire test and the hose stream test O'Keeffe's is able to offer a listed and labeled 45 minute fire rated glazing system close to four times the size of fire and safety rated products currently available.

## CONTRACRIME Make-up

The make-up of "CONTRACRIME 45" as illustrated above consists of an outer layer of 4mm tempered glass, a 4mm polycarbonate layer, and a 4mm inner layer of tempered glass. This is followed by an 18.5mm layer of protective gel and a 5mm outer layer of tempered glass. Because of polycarbonate's characteristics to be scratched and become obscure it is necessary to protect it with an outer layer of glass. Since the attack side is generally well defined only one side of the glazing unit typically needs to be protected for security/attack. However, in cases where the attack side cannot be determined the "CONTRACRIME" make-up can be applied to both sides.

## Security Applications

Since completing these tests architects, state correctional facilities, hospitals, school districts and various special building projects with requirements for a high level of security combined with fire protection and visual clarity have shown tremendous interest in this product. CONTRACRIME 45 is ideal where potential fire risks are coupled with a need for security/attack ratings.

For additional information on UL and WHI listed and labeled CONTRACRIME 45 or other special security make-ups please use reader service #96.

## AMERICAN HOME PRODUCTS INSTALLS GPX

### The Ultimate in Design Flexibility

For years architects and designers have felt the restriction of fire codes when it came to providing large vision areas. They were limited to wired glass, the 25% glazing limitation and small vision panels. With the introduction of GPX/CONTRAFLAM system and its successful passage of ASTM E-119, a fire test for walls, designers can now open up large vision areas previously boxed in by solid walls.



The Architects of the American Home Products building in New Jersey took full advantage of the design possibilities of GPX (GLASS-PROTEX). GPX/CONTRAFLAM systems were incorporated throughout the facility in 60, 90 and 120 min. applications. In one application the Architects were faced with providing the visual qualities of a typical curtain wall for a three story stairwell while meeting the code requirements for a 90 minute wall condition. GPX provided the solution with large multiple panels.

Other areas required 60 and 120 min. fire protection. 60 min. systems were incorporated in many of the interior corridor walls. The parking garage had a more stringent requirement for 120 min. fire protection. Vision panels of CONTRAFLAM CF-120 were used to meet this two hour condition. GPX systems allowed the Architect to supply a design that was visually exciting, cost effective, and in full compliance with code requirements. GPX 60 and 90 min. window/wall and door systems are listed by UL and WHI. Reader service #98.



## O'KEEFFE'S CUSTOM SKYLIGHT DIVISION'S GLAZING RESTORATION PROJECT

Como Park in Saint Paul, Minnesota is owned by the city of Saint Paul under the jurisdiction of the division of Parks and Recreation. In this park is a Victorian conservatory patterned from that of Kew Gardens in England.

Built in 1914 by the King Construction Company, New York, the structure is composed of a main circular area known as the Palm House, two wings opposite each other, the North House and the Sunken Garden, and the Vestibule wing or the entrance to the conservatory. The entire building was glazed with 1/8" thick shiplapped glass in a typical greenhouse fashion. This original glazing was demolished in a major hail storm in the early 60's. The roofs were temporarily covered with translucent fiberglass.

The restoration project called for a new glazing and framing system supported by the restored structural steel. O'Keeffe's Inc. was the successful bidder on all three phases of the restoration with a total contract amount of almost 3 million dollars. O'Keeffe's first contract was the reglazing of the 46' x 100' North House. The roof is radiused on both sides and peaks in the center to form a ridge. The whole length of this ridge is furnished with operable panels for ventilation. The second contract was the reglazing of the Sunken Garden. This structure is almost identical with that of the North House.

The final contract was the reglazing of the Palm House and Vestibule. This was the most challenging as it is the largest section and focal point of the structure. The main domed roof is 100' in diameter and is topped with another 42' diameter dome ornamented at the apex with a louvered cupola for ventilation.

The Conservatory restoration project was designed by Winsor/Faricy Architects, Inc. of Saint Paul with Mr. Bruce Tackman as the project Architect. O'Keeffe's custom designed a new extrusion system for the project. Since the aluminum rafters are supported by structural steel, it was designed to the minimum size of 1-1/2" wide x 2-1/2" deep. Snap-on anchor clips at the base of the rafters are mounted at steel lo-

cations. Rafters were rolled to radius to accommodate curved laminated glass composed of 2 pieces of 1/8" thick glass with a .030 clear P.V.B. interlayer, silicone glazed to the main rafters. Pressure cap clips are installed at the main rafter and cross-rafter intersections. A continuous rolled to radius snap-on cap cover is installed over the pressure cap clips and then "wet sealed" at both sides to the glass.

The most complicated aspect of the project is the intersection of the North House, Sunken Garden and Vestibule to the face of the main Dome of the Palm House. This detail calls for jamb rafters that are rolled to radius in two directions to follow the contours. For more information on custom skylights please use reader service #99.

### O'KEEFFE'S TRADE SHOW SCHEDULE

To obtain first hand information on PYROSWISS, CONTRAFLAM, and GPX framing systems stop by the O'Keeffe's booth at the following trade shows.

<i>Show</i>	<i>Location</i>	<i>Dates</i>
Southeast Glass Expo	Orlando, Florida	Aug. 19-21
International Conference of Building Officials	Sacramento, California	Sept. 12-14
Doors & Hardware Institute	Vancouver, British Columbia	Oct. 16-19

GPX GLASSPROTEX is a registered trademark of O'Keeffe's Inc.

CONTRACRIME is a trademark of O'Keeffe's Inc.

CONTRAFLAM is a registered trademark of Saint-Gobain

PYROSWISS is a registered trademark of Vetrotech Ltd.

FireLite is a registered trademark of Nippon Electric Glass Company, Ltd.

### O'Keeffe's Inc.

75 Williams Ave. • San Francisco, CA 94124

Phone (415) 822-4222

FAX (415) 822-5222

Toll Free (800) 227-3305



A Z R O C K

## THE MIRACLE OF NATURE.

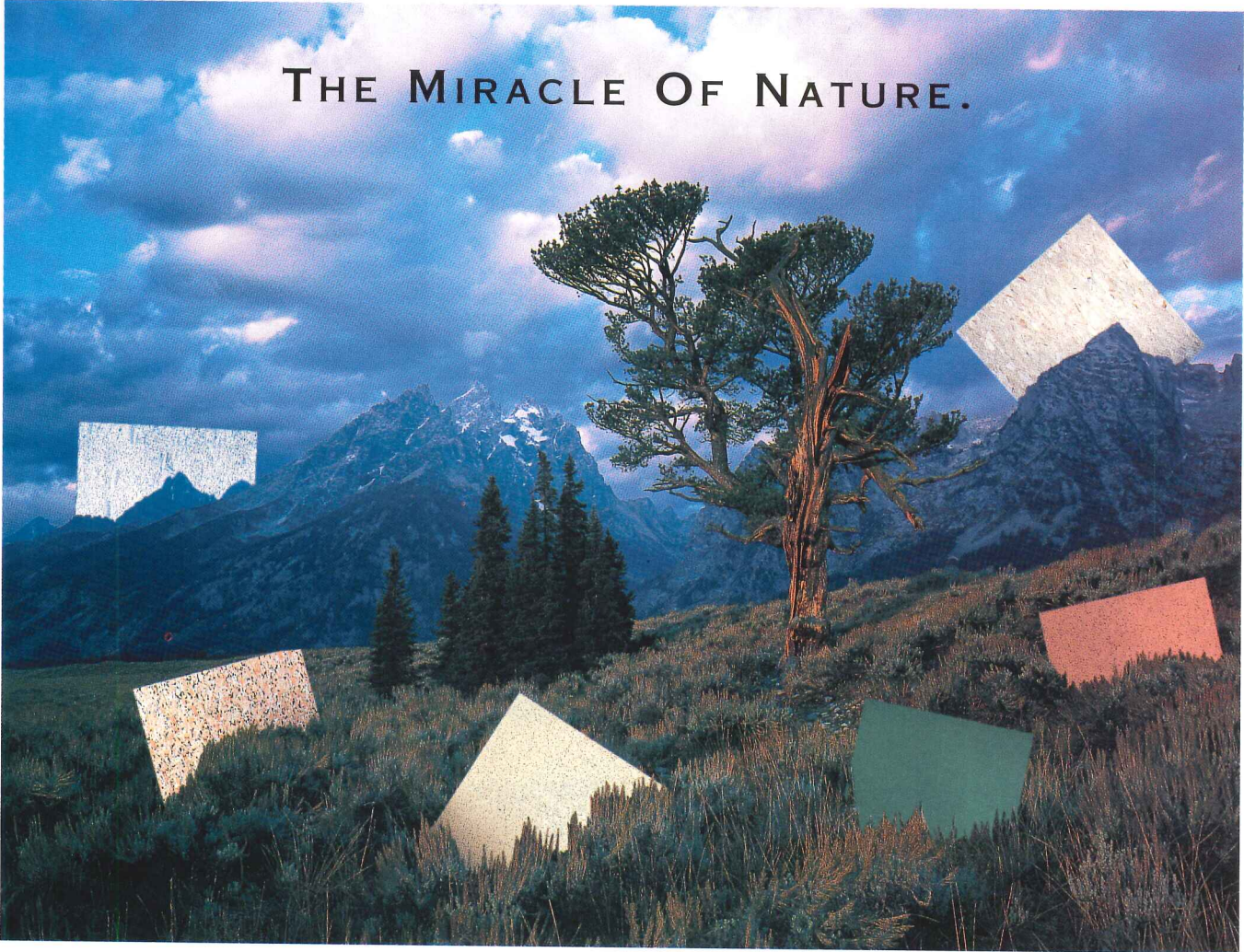

## THE COLORS OF AZROCK.

Nature works miracles with color every day. And now you can match her natural inspiration with our new palette of floor tiles, color-styled in harmony with nature. ♦ You see, we've expanded our entire range of premium patterns in Azrock Vinyl Composition Tile. So you can let your imagination roam freely through a world of inspired colors. From Bay Blue to Rio Red, from Mossrock to Forest Mist, we make it easy for you to create colorful, durable floors for commercial or residential interiors. And our new Color & Style Selector System chart simplifies the design process even more. ♦ For a chart and samples, see your Azrock contractor or write Azrock Industries Inc., Dept. 436A, P.O. Box 696060, San Antonio, Texas 78269.



©1993 Azrock Industries Inc.

◆ MORE THAN YOU EXPECT ◆

Circle 8 on inquiry card

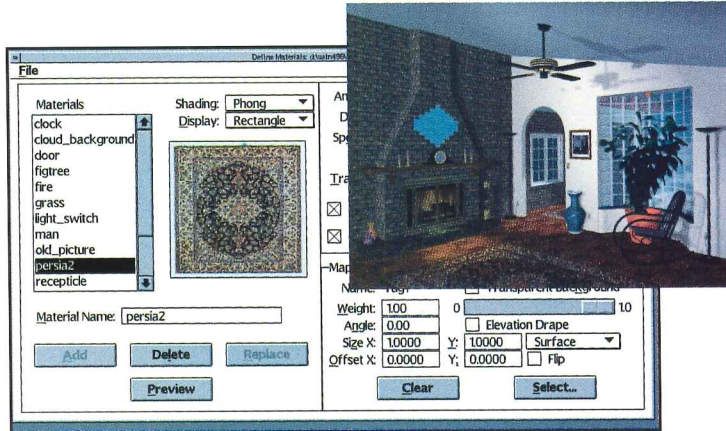

**Rendering.** Visualization and flythroughs – at your fingertips! MicroStation offers photo-realistic rendering to every designer, right in the software. It's easy to make your image reflect your imagination.

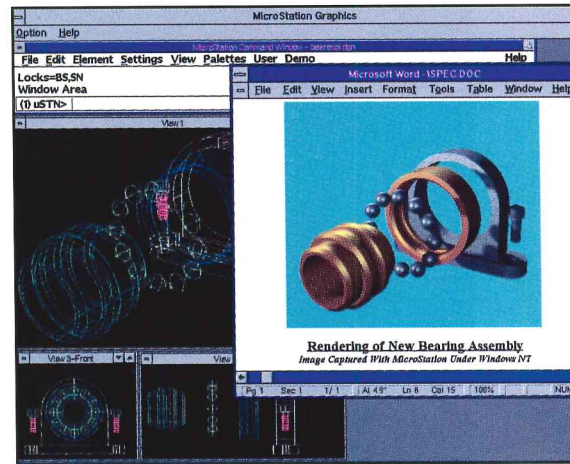

**Windows.** It walks and talks Windows. Behind MicroStation lies the user-responsive programming you look for in good Windows software. Version 5 gives you the ultimate in integration of CAD, engineering, and business applications.

# MORE POWER TO YOU.

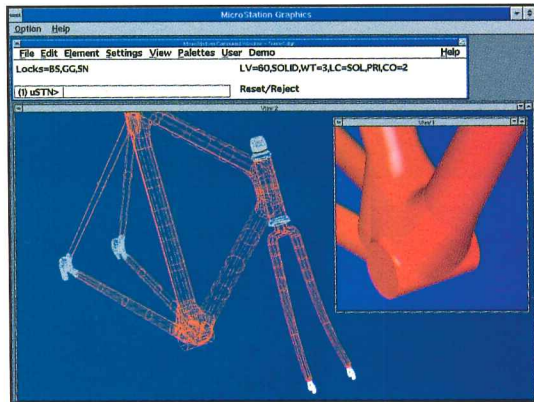

**Modeling.** Model any surface you can imagine in MicroStation. NURBS surface modeling combined with 3D Boolean operations gives you astounding flexibility in creating and modifying freeform models.

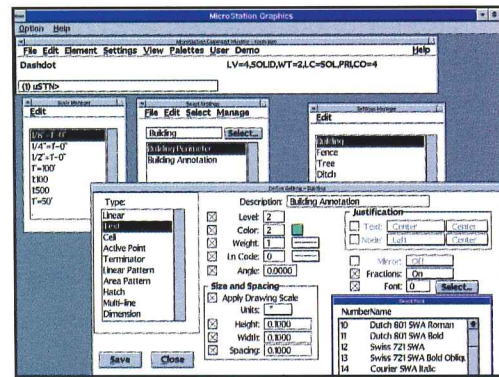

**Drafting.** MicroStation gives you first-rate drafting – without the limitations of traditional technology. Enjoy the advantage of contemporary features like associative patterning/batching, preview, standard text editors, fonts, and context-sensitive Hypertext help.

Read & write  
AutoCAD .dwg

**Workspaces.** Choose the design environment that matches your profession or your CAD expertise – even AutoCAD. Complete with custom interfaces, drafting styles, and design environment management. CAD has never been so streamlined!

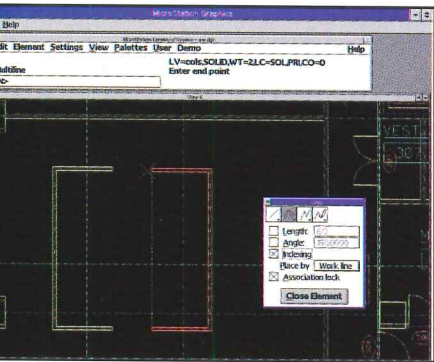

**Usability.** What does computer-aided drafting have to do with the way you think? Everything. MicroStation software works for you. It understands the drafting process so well that it infers what you'll do next.

## Graphical User Interface.

MicroStation's easy-

to-use interface includes pull-down menus, dialog boxes, tear-off tool palettes, and tool settings window. Choose your interface – Windows or Motif – on any platform. **Transparent Modeless Operation.**

The software supports the way you naturally work, maintaining command execution while you fine tune: change element attributes or command parameters, manipulate views, change the dimensioning system, and more.

**Powerful View Manipulation.** MicroStation supports up to eight active views that can be moved, sized, and overlapped to fit your design. Zoom and area at any scale. Move around your design fast with built-in dynamic panning.

**Workspace Editor.** Tailor pull-down menus, dialog boxes, and tool palettes – even disable commands – with a graphically oriented toolset for customizing your chosen interface. **Text Capabilities.**

A convenient text editor lets you easily edit single-line or paragraph text. Choose from TrueType, PostScript, AutoCAD SHX, and MicroStation fonts. ASCII text files can be imported and exported. **Multiple Undo/Redo Commands.**

Undo mistakes and perform “what-if” designs in a flash with unlimited undo and redo. **Plotting.**

Plot raster and vector information by view or defined areas, at any scale. Visually preview the plot before plotting, saving time and materials. **Online HELP.**

MicroStation's HELP remains active, tracking the command you're currently using, so there's no searching through manuals for assistance.

## Associative Patterning and Hatching.

Associate patterning with graphics. Change graphics and the patterning updates. Flood-fill hatching/patterning intelligently fills an area, detecting boundaries and holes with a single pick. **Associative Dimensioning.**

Dimensions are associated with the geometry, not with a point in space, so that when you change the geometry, the dimensions automatically update. **Custom Line Styles.**

Create space-saving custom line styles and place railroad tracks, trees, isobars – anything – just as you would place a line. **Multi-lines.**

Define line string elements comprising up to 16 parallel lines of varying symbology and store them in a style library for architects can use multi-lines for fast and easy placement and intersection cleanup of walls and partitions. **2D Boolean**

Quickly modify, measure, and hatch multiple 2D shapes with integrated Boolean operations. **Mass Properties.** Calculate area and your model: surface area, volume, mass, centroid, moments and products of inertia, principal moments and directions, and radii of gyration.

Define relationships among graphic entities with intuitive drawing modes such as tangent, parallel, perpendicular, midpoint, intersection, and end-

**Dimension-driven Symbols.** Based on established relationships, you can assign variables to dimensioned graphics and save the graphics as cells. Changes in dimensions automatically drive changes to graphics. Dimension-driven design saves valuable time in the design of families of



**Power.** Take your pick of popular environments: DOS, Mac, Windows, Windows NT, or UNIX. Have a look at MicroStation on Intergraph's Technical Desktop Series personal workstations.

# MicroStation Version 5 puts you in charge.

Call 800-345-4856 for a free brochure on MicroStation Version 5 and the name of an Intergraph representative in your area.



# MicroStation

## INTERGRAPH

Solutions for the Technical Desktop™

Circle 9 on inquiry card

What  
Trees  
Would  
Wear  
If  
They  
Didn't  
Have  
Bark.

Dare we say we've done one better than Mother Nature?

We've taken wood apart and put it back together to make Inner-Seal lap siding.

Miraculously, it has the appearance of sawn wood siding without many of its

drawbacks. So it looks, feels and sounds solid yet it resists warping and splitting. In

fact, it has such integrity that it allows you to top nail only.

Inner-Seal lap siding is made with a high-quality overlay that's designed to

resist moisture and hold paint remarkably well. Unlike sawn wood sidings, the

overlaid surface is free of knots and cracks and comes preprimed and ready to paint.

To top it all off, Inner-Seal lap siding is priced as competitively as vinyl and is

made from a renewable resource: small-diameter, fast-growing trees. So it answers

environmental concerns as well as economic ones. To find out more about our modest

improvement on nature, call us in Hayden Lake, Idaho at **208-772-6011**, in Chicago at

**708-517-8833**, or in Houston at **409-756-0541**.



**Louisiana-Pacific  
Inner-Seal Lap Siding**

*Doing something about it.™*

Circle 10 on inquiry card



San Francisco

Maki, Polshek, and Botta Buildings to Bloom At Yerba Buena Gardens



1



2

Peter Xiqués

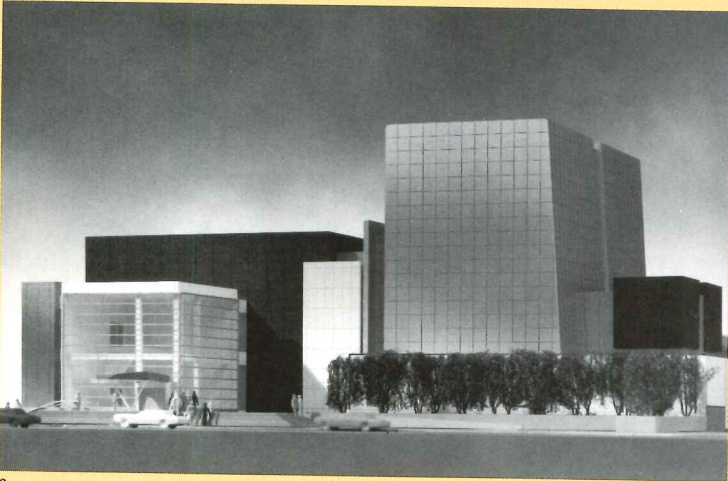

3

Peter Xiqués

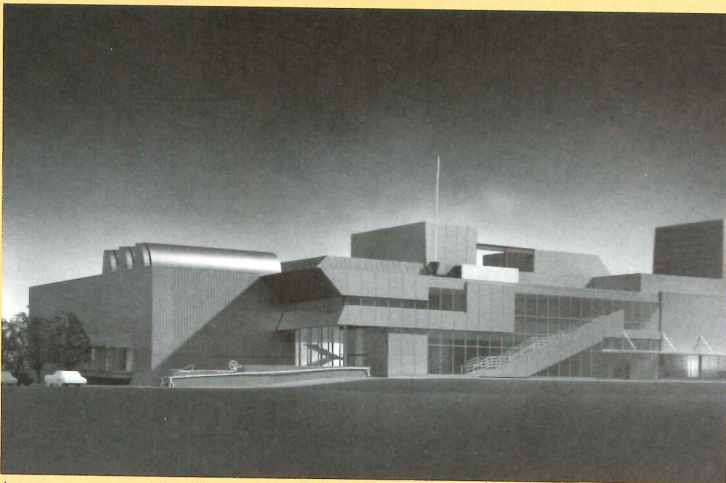

4

Peter Xiqués

San Francisco's 87-acre urban-renewal project, Yerba Buena Gardens, is about to become a cultural-arts center, with buildings by Fumihiko Maki, James Stewart Polshek and Todd Schiemann, and Mario Botta.

Maki compares his horizontal 55,000-sq-ft Center for the Arts (4) to a ship, evident in its mast-like pole. An aluminum-clad exterior, glass windows and entrances add to its light-handed structure and ensure, in Maki's words, "a large house" for performing-arts groups rather than a monumental cultural

institution. It will open in October. Associate architects are Robinson Mills + Williamson.

Botta's 225,000-sq-ft San Francisco Museum of Modern Art (2)—his first U. S. commission—features a steel-and-glass skylight, mounted at 45 deg. on a granite-banded cylindrical turret. The whole turret intersects the front facade's majestic stepped-back, brick-covered tiers, each providing skylit roofs for galleries. Daylight from the turret skylight will pour into the museum's public atrium.

Polshek's 46,800-square-foot Center for the Arts Theater (3), with its distinct volumes, is a 752-seat stepped-back mass echoing the Botta museum's receding tiers.

Other major parts of Yerba Buena (1) include a five-acre Esplanade park by MGA Partners and Romaldo Giurgola, and the Moscone Center convention facility (Moscone South). Moscone North, beneath the Esplanade, extends from the Center for the Arts Theater northward under the Center for the Arts. *Susannah Temko*

**Airports**

# Architects Design Airports That Capture the Meaning of Flight

High-design airports seem to be the rule these days. Seoul's new offshore airport (1) begins with a 56-gate radial terminal designed by Fentress Bradburn/McClier/Baum Hi-Lim Junglim Wondoshi to ease the earth-sky transition. Sweeping rooflines reflect aerodynamic forms and the rolling waves in the surrounding sea, as well as historical Korean structures. Skylights and open floors lead daylight to all levels. Landscaped interiors employ tiger and dragon myths. Long-range plans for traffic greater than O'Hare or LAX include two pairs of runways, 260 gates, remote concourses, a satellite transportation center, and a business building.

Holmes & Narver's 21-story LAX airport tower (2) embodies aircraft-derived geometries and metaphors of flight to address a city mandate for a monument to air safety.

Now that HOK is applying the parabolic arc symbol of air travel to New York City's long-demolished icon of rail travel, Penn Station [RECORD, June 1993, page 23], Cesar Pelli seems to be rebuilding the original as the new 35-gate, 1-million-sq-ft North Terminal at Washington National Airport (3). Pelli's design for an air gateway to the nation's capital relies on a series of 64 shallow handkerchief domes on soaring exposed steel columns, mullioned, arched curtain walls, and a system of 45-ft-sq structural bays. Leo A. Daly is architect-of-record; client is Metropolitan Washington Airports Authority.

HNTB's new 15-gate replacement terminal for T. F. Green Airport in Warwick, Rhode Island (4), will be a village-like mass of red brick and granite with a high central atrium. ■

Photo courtesy Fentress Bradburn

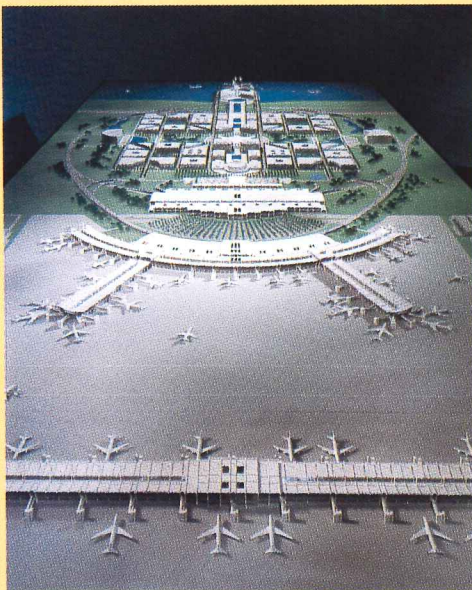

1



2

Maxwell McKenzie

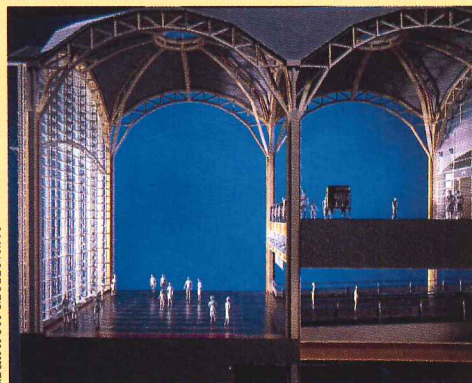

3

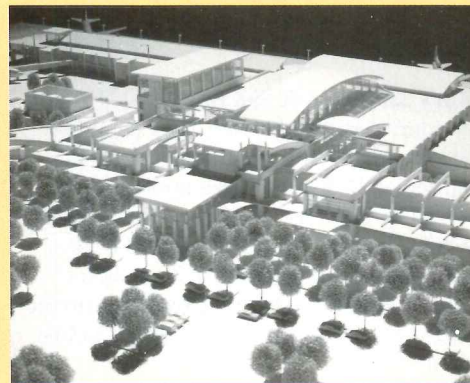

4

**New Jersey**

# Elementary Architecture



"Design helps my students communicate and think in English, and sparks their creative juices," says architect/teacher A. J. Gonzalez-Leonard (left in photo), who coordinates a bilingual program at Washington Elementary, Harrison, N. J. Every year 20 or so seventh- and eighth-graders participate. Inspired to enter a profession someday, some designed their own home/office. Others created context-sensitive schools, a project that challenged José Navarro so much (right, with school sketch) that he escaped gang life and went on to get his eighth-grade diploma. ■

**California**

# New Delay Tactic Hits Salk Institute

Opponents of a scheme, now under construction, to add lab and administrative space to Kahn's Salk Institute for Biological Sciences have uncovered an obscure clause in the National Historic Preservation Act which requires design review by the Federal Advisory Council on Historic Preservation of any project that has received federal assistance. Section 106 calls for such a review whenever action by a federal agency is likely to affect a historic property. The Institute did indeed receive funds from the National Institutes of Health, but claims none were being used for construction. Asked for his reaction to the FACHP move, Dr. Jonas Salk told RECORD with a note of exasperation that construction was proceeding on schedule and that he didn't expect the effort to derail completion. The addition replaces a eucalyptus grove. ■

## Briefs

## Winners

- Sir Norman Foster & Partners has won the first Benedictus laminated glass award, sponsored by the AIA/ACSA Research Council and DuPont, for the terminal at London's Stansted Airport, which features glass-lattice shell domes, glass walls, and fully glazed elevators. Daichi Amano of Washington State University won the student prize.
- Otis Elevator has honored architecture students Tomasz Rozwadowski of the Technical University of Gdansk, Morten Kirketerp of the Royal Danish Academy of Fine Arts in Copenhagen, and John Hreno and Ryan Smith of UCLA for their housing-design responses to problems in their home cities.

## Strategic Moves

- Jack Hartray of Nagle, Hartray & Associates is acting dean at the Illinois Institute of Technology College of Architecture until the search for a permanent dean is completed.
- RTKL and the Mexican firm of Gomez Vasquez Aldana have announced a "strategic alliance" to jointly pursue assignments throughout North and South America, with a focus on commercial, mixed-use, medical, high-tech, and planning and urban-design projects. RTKL chairman Harold Adams, a member of the Services Policy Advisory Committee of the U. S. Trade Representative, has been involved in discussions on the North American Free Trade Agreement's effect on the delivery of professional services.
- Richardson Nagy Martin has signed a joint-venture agreement with Thailand real-estate developer Tong Gween Co., Ltd. RNM Pacific has already completed planning and design for Tong Gween Estates, a resort of mansion-sized houses in Parkchong.

## Competitions

- Steel Institute of New York and Ornamental Metal Institute awards-competition entries must be postmarked by September 12. Contact SINY/OMI, 211 East 43 Street, #804, New York, NY 10017, 212/697-5553.
- National Organization of Minority Architects design-awards entries are due September 29. Call Cynthia Coe, 804/788-0338.
- November 15 is the deadline for the 98th American Academy in Rome fellowships. Write 667 Madison Avenue, New York, N. Y. 10021, 212/751-7200, fax 212/751-7220.

## Remembered

George Lewis, New York AIA director from 1969 to 1986, died on June 25 at age 77.

## Miami Beach

## Isozaki Competition-Winning Scheme Adds Sculpture Garden to Bass Museum

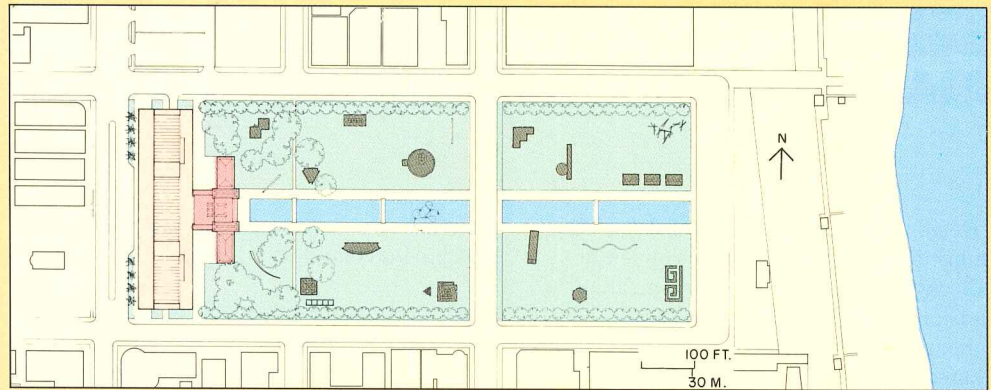

Arata Isozaki's planned \$18-million expansion and renovation of Miami Beach's Bass Museum will place a three-story stucco and Florida keystone addition behind the existing 1931 Art Deco structure and convert the park in front into a vast sculpture garden (done in

collaboration with landscape architect Martha Schwartz). Isozaki will also work with various artists on a series of pavilions for site-specific sculptures, and with Miami architects Spillis Candela & Partners, Zyscovich Inc., and Frankel & Miller. *Beth Dunlop*

## Chicago

## 70 Years of Sandburg's City

One of the most eye-popping exhibits to seduce this viewer in many years, *Chicago Architecture and Design, 1923-1993* virtually forces the visitor's immersion in the design paraphernalia of the past 70 years of Chicago, that most genuinely urban (and urbane), of American cities. Original drawings, architectural fragments and artifacts, paintings, models, photomurals are arranged in a series of eight wire-mesh-over-steel stud "tunnels" depicting planning, transportation, institutions, commerce, industry, shopping, houses, and recreation. In each tunnel visitors are greeted by appropriate sounds—fire engines, elevated trains click-clacketing across the Loop, a babel of street noises. Highlights include original working drawings of the Chicago Board of Trade (1928) by Holabird & Root, and early (1931) drawings for the Evanston lakefront scheme by the Burnham brothers. Stanley Tigerman (with Charles Smith) designed the exhibit and John Zukowsky of the Chicago Art Institute was curator. For those who won't make it before it closes August 29, it may be savored (in a way) through a 480-page book, available from the Art Institute. *S. A. K.*

## Korea

## Bridge Game



Tai Soo Kim Partners of Connecticut has won the competition to design the Tong Yang corporate headquarters, at 40 stories the tallest building in the Seoul city center. Curved structural ties top and bottom mirror nearby river and highway bridges. ■

## AIA Convention

### AIA Convention: Architecture at A Crossroads

"Designing for a sustainable future," the subtitle of this year's annual convention (Chicago, June 18-21) promised meaningful substance. Some 13,000 people showed up, of whom half were architects—a much better-than-average gathering, bolstered by 2,000 architects from abroad lured by the conjunction of the International Union of Architects.

A large crowd that came to hear a group of household-word architects discuss a topic labeled as "Architecture for the 21st Century" got their money's worth. Jean Nouvel made a case for a light, easy-to-transport building technology that is usable in any country, in order to achieve what he calls a "universally applicable architecture." Drawing a parallel from transportation, he cited motorbikes that are light and energy-efficient, capable of doing 1,200 miles to the gallon.

Much talked about later was the spirited difference of opinion between Helmut Jahn and environmental architect William McDonough over whether today's architects are really pushing the envelope enough in creating a sustainable architecture. McDonough, with more modest-sized buildings to his name and with amenable clients, claims he is meeting the goal, whereas most architects are still "designing steamships." Jahn, with a large body of work under his belt, including many megastructures, pointed out that he has had to work with available products to meet his clients' budgets and schedules. He also denied that energy conservation wasn't feasible with today's kit of tools.

Sir Richard Rogers declared we can easily save 50 percent of the energy consumed by a typical building by radically rethinking approaches to design. He had in mind foremost the idea of planning at the scale of neighborhoods, not individual buildings. This could lead to totally new forms, with more glass, more reliance on daylight and, as he later confided to RECORD, the willingness of occupants to add or shed both clothes and

convention as an acceptable component in the indoor comfort equation.

As a sign that architects are able to balance idealism with horse sense, two consecutive afternoon practice seminars—one on managing small projects successfully, the other on surviving as a sole practitioner—rivaled in attendance a star-studded seminar billed as "New Stars: Architects and Social Responsibility." Run by architect James Franklin, the two practice seminars offered a useful mix of solid information and the opportunity to discuss pressing problems and issues. A surprise to many was a long, spirited discussion about employee moonlighting. Some principals encourage moonlighters because it shows enthusiasm, improves the quality of their work, and sometimes brings in commissions; others oppose it on the ground that moonlighting shows lack of commitment and raises questions of liability.

The much-publicized "Call for Sustainable Community Solutions" yielded 406 entries from 50 countries. The results merit coverage in a subsequent issue. After a belated announcement, Cambridge Seven Associates Inc. received the 1993 Firm of the Year Award for its creation of "joyful" places such as museums, aquaria, transportation nodes, and convention centers. In the business sessions, sharp debate marked a proposal to make Robert Venturi and partner Denise Scott Brown eligible for the AIA Gold Medal, currently limited to individuals. The motion to discuss the matter formally failed to attract the required two-thirds vote (See Editorial, page 9). L. Bradford Perkins became the third generation of Perkins to be made a Fellow of the AIA. Perkins' father is founder of the Chicago firm of Perkins & Will. S. A. K.

#### The Kazakh connection

One morning, this reporter took some Kazakh and Bulgarian friends on a tour of the Loop. Walking up Dearborn Street toward

the river, Tohtar Eraliev was grinning. Ahead of us was the Marina Towers. "I saw these buildings in the [American] magazines when I was a student [at Moscow University]. The world has changed and now I can come here to see them for myself." Eraliev is the past president of the Union of Architects of Kazakhstan and the designer of many prominent buildings in the capital city of Alma-Ata. His delegation of four, led by current president Serjan Shimerdenov, came to Chicago to seek the admission of their union into the UIA, as have groups from other CIS countries. (They were accepted.) Membership will open the world of information and professional contact to them. For many, like the 210 Bulgarians who made it to Chicago from New York by bus, this was the first chance in decades to travel outside their country. The success of the Chicago turnout shows the importance of improved communications. *Gerald Moorhead*

*Kazakhstan Delegation: Serik J. Rustambekov, Tohtar Eraliev, Kaldibai Montahaev, Serjan Shimerdenov (President of Kazakhstan Union of Architects).*



Gerald Moorhead

## Judge's Bad Luck in Washington May Be Good Luck for Boston's Waterfront

By Robert Campbell

The recent failure of Boston judge Stephen Breyer to get appointed to the Supreme Court may turn out to have a silver lining. Breyer, along with fellow judge Douglas Woodlock, has been a key figure in a remarkable effort to create a major public building of true architectural and civic significance in Boston, where he would have been sorely missed. The building is the massive new Federal Courthouse. It is being designed by Henry N. Cobb, of Pei Cobb Freed & Partners in association with architects Jung/Brannen, for a waterfront site, which is almost as prominent in Boston as is that of the opera house in Sydney. And the building, with 27 courtrooms and nearly three quarters of a million square feet, will probably be the most important addition to Boston of the 1990s, public or private.

Early on, Breyer and Woodlock—acting pretty much on their own—decided to act like the clients for the building. They were the two youngest federal judges in town and figured they'd have to live with the new building the longest. So they would push the government to a new standard of civic excellence. They helped pick the architect, then spent six months introducing him to the mysteries of the judicial system. They helped pick the site, too, then followed through with an amazing commitment of time and energy. "They are the best clients I've ever had," says Cobb. "No other client has ever given me as much time."

"We looked for the best architect in the world," says Breyer. "We want to add a building to Boston that can take its place with Trinity Church and the Boston Public Library." Woodlock is a Louis Kahn fan who recently took his family to see the Salk Institute. Breyer loves the Royal Courts of Justice in London, by George Edmund Street. Woodlock is the author of a brief "Architectural History of the Federal Courts in Massachusetts." Breyer was so

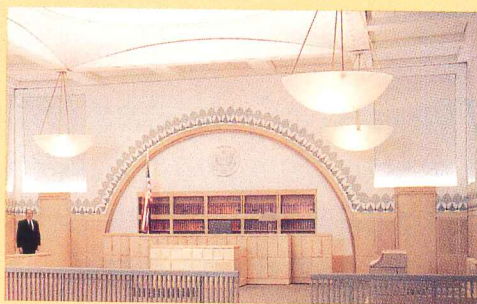

Federal courthouse and public space on Boston Harbor (top photo). Breyer in a courtroom mockup (bottom photo).

concerned to create an accessible populist building that, way back during the initial interviews of architects, he asked the test question: "Would you be willing to put birds and flowers on the beams in the courtrooms?" Flat abstracted stencils of natural forms are now in the works, as Cobb and his staff bone up on such works as G. R. Riegl's turn-of-the-century *Problems of Style*.

Woodlock occasionally gives talks to other judges on getting better courthouses, handing out a nine-page bibliography including William Faulkner: "Above all, the courthouse: the center, the focus, the hub . . . musing, brooding, symbolic and ponderable, tall as cloud, solid as rock, dominating all . . . The courthouse was theirs, bigger than any because it was the sum of all and being the sum of all, it must raise all of their hopes and aspira-

tions level with its own aspirant and soaring cupola." Both judges are eloquent about the role of the court as an institution. "We want to create a place of civic convergence, of civic enlightenment and entertainment," says Woodlock. "My mother comes to my court to watch human theater. The jury is the last direct democracy, where citizens can directly affect government."

As does Harry Cobb, Breyer and Woodlock relish the memory of early American one-room courthouses, places with front porches that symbolized interaction with the community. They were courtrooms from which judge, lawyers, jurors, claimants, and spectators could all retire, together, to the tavern next door—the "ordinary"—for ale and talk. Because the courthouse is a federal building, the designers could probably ignore local and state regulations and opinions. But the judges encouraged the General Services Administration to involve a more public process. The GSA agreed to pull the building back from the edge of the water to allow more public space, although not as far as would have been mandated by state law. Not everyone thought this pullback was a good idea. Opposed were the architect and the city's extremely capable design review board—the Boston Civic Design Commission, chaired by architect Joan Goody—both of whom thought the courthouse should interact with the water, rather than withdraw from it. They lost that argument.

The GSA also liked the idea of a task force, which would include representatives of all concerned groups, empowered to make recommendations for its public features—such as a proposed public park on the harbor side of the building, and the public spaces inside the building. The task force included members of the Boston Society of Architects and the Boston Society of Landscape architects, along with public officials and interest groups of all kinds. The judges sat in too. A *Continued on page 130*

## Tragedy of Andrew Rolls On

As the one-year anniversary of Hurricane Andrew nears (August 24), assessments by a wide range of experts paint a consistent if inevitably incomplete picture of why the storm wrought \$25 billion in damage and displaced some 80,000 from their homes. (The previous record holder for monetary damage was 1989's Hurricane Hugo, at \$7 billion.) While the reports tell us how a wide variety of construction techniques fared in an extraordinary event, they also say much about the efficacy of many systems under less severe conditions, such as aging. Reconstruction also uncovered an ominous pattern: the web of responsibility and accountability among designer, builder, and enforcement official broke down in Dade County. It has yet to be fixed.

### Systematic failure of some assemblies

Though experts still debate the storm's actual wind speeds, most engineering analysts have concluded that buildings complying with the strict South Florida Building Code consistently survived the storm structurally intact. An enormous proportion of destruction, researchers found, was due to noncompliant construction. Saving a few dollars, in some cases, cost the building.

While all kinds of buildings were damaged or destroyed, some assemblies and certain components performed particularly poorly. Such systems typically lacked innate redundancy, or, to be wind-resistant, the system required close attention to field craftsmanship. *Every* wind-resisting component needed to be properly attached to supports, analysts say, establishing an uninterrupted load path to ground. Clearly many designers and builders ignored or didn't understand this concept.

- **Wood-frame gable ends:** Thousands of houses were destroyed because builders had failed to nail sheathing according to code (6-in. o. c. at panel edges and 12-in. o. c. at intermediate supports—a simple requirement). Inspectors found panels tacked in place. Nailing at more than double allowable spacing was common among destroyed buildings. One or both legs of sheathing staples (which have lower pullout strength than nails) often missed underlying supports.
- **Metal-roof decking** was typically inadequately connected to bar joists, as were bar

joists to the supporting system.

- **Pre-engineered buildings:** Manufacturers constructed newer structures with fewer roof braces and wider spacing of purlins and girts. More conservative designs worked better. Large doors often collapsed.
- **Trailer homes** in the path of the storm were leveled. Though Dade has special tie-down requirements, manufacturers use less-restrictive HUD nationwide standards. Factory-built modular homes generally fared better than other wood-frame buildings.
- **Roof coverings:** Few types of roofs survived Andrew's onslaught. Asphalt shingles, especially when staple-attached, fared worst. Low-slope built-up roofs and other fully adhered systems performed best,

gineer and professor at the University of Miami, credited "greater mass and overall structural stiffness."

In structures such as warehouses and hangars, the loss of doors and windows created full internal pressurization which, according to Joseph E. Minor, a University of Missouri expert on wind effects, "effectively doubled the pressures acting to lift the roof and to push side and leeward walls outward." Many collapsed. In these cases, neither the designer nor the code likely allowed for the actual forces developed. In both residential and non-residential construction, unprotected doors and windows broke open, exposing the interior to total destruction, even when the envelope remained intact.

*The web of responsibility and accountability among designer, builder, and enforcement official has broken down in Dade County. It has yet to be fixed.*

though gravel embedded in the membrane frequently became airborne, damaging surrounding buildings.

- **Lightweight cladding:** Composite-wood cladding panels and Texture 111 panels showed premature rot and tore away from fasteners. Flanges of metal-stud systems supporting exterior non-loadbearing walls sheared off. (In one building only one screw attached each stud at top and bottom.) Properly framed wood-stud partitions did a better job of bracing exterior walls than did similar metal-stud walls. EIFS (synthetic stucco finish over insulating boards attached through sheathing to studs) failed at lower wind speeds than other systems, even where the stud-wall supporting system remained in place, according to a report by an interdisciplinary investigative team.

Heavy construction, such as reinforced concrete block with stucco finish (CBS—a commonly used combination in south Dade) performed well, according to Ronald F. Zollo, who prepared the report. Zollo, an en-

Proposed building-code changes will probably mandate missile-resistant glass or shutters.

The code will probably call for more lateral bracing of wood-frame gable ends and a system to add backup for wood-truss roofs (opposite). Dade county banned oriented-strandboard sheathing after the storm, but researchers found no difference in performance between structural-rated non-veneer panels and plywood.

### Code passed; enforcement failed

The major lesson of Andrew is that south Florida's strict code did not fail in the face of Andrew; rather it was builder indifference and a notoriously inadequate system of enforcement. "Damage followed the rigid lines of subdivisions, not the whimsy of the wind," reported Zollo. "Construction quality and design largely determined the degree of hurricane damage." Since then, efforts to augment Dade County's enforcement staff have lagged. Robert Barnes, an architect

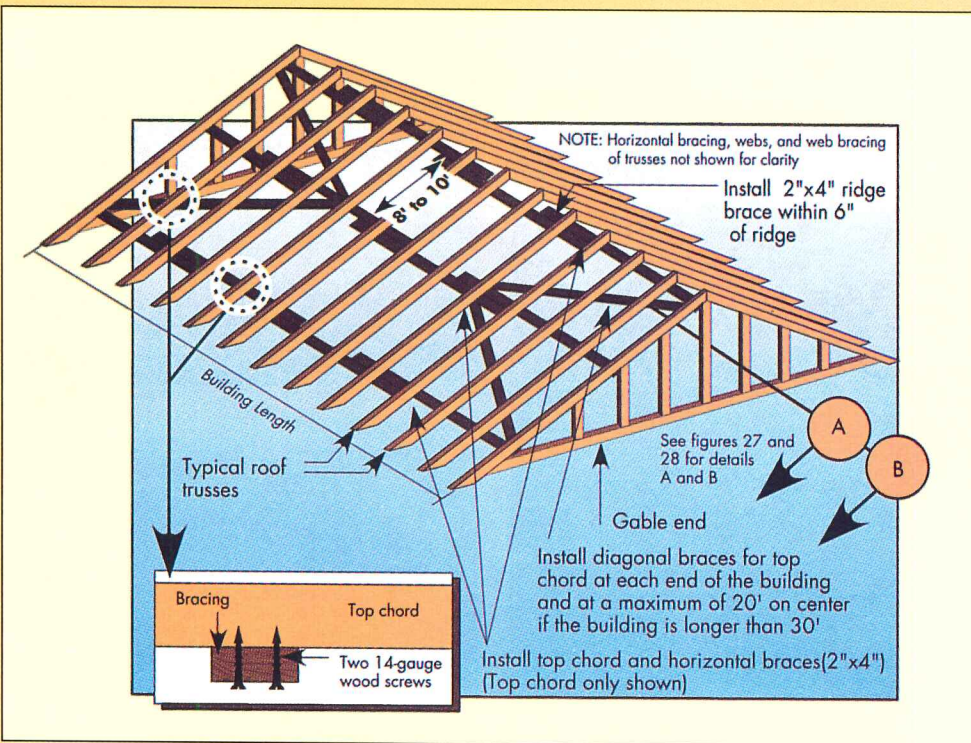

*A bracing assembly recommended by FEMA backs up the diaphragm action of sheathing attached to wood-truss roof framing.*

with his own firm in hard-hit Homestead, says that code officials' first response "was to blame all the developers and hide the fact that their inspection abilities were very poor. Then they tried to blame insurance companies."

Nearly all residential and non-residential structures in the affected area were spec-built with little or no architect/engineer involvement. Under these circumstances, the only one to assure adequate construction is the builder, an arrangement that clearly failed catastrophically.

#### **Engineers in, architects out**

Though construction deficiencies far outstripped design errors, Dade County's early reaction was to permit only an engineer—any kind of engineer—to seal drawings. "No one at the county will admit that there are not enough inspectors and they're not trained well enough," says Roney J. Mateu, president of the Miami Chapter/AIA and director of design for Harper, Carreno, Mateu Architects and Engineers. Under threat of a lawsuit, a memorandum amends the ordi-

nance for now to continue to permit architects to seal drawings. "The county is run by engineers," explains Mateu.

In the meantime, "inspection is worse than before," says Barnes. "Owner-builders can pull permits for up to \$50,000 without sealed drawings. Some take eight and a half by eleven sheets of paper, scribble wallboard, doors, and windows on them, and they are able to pull permits." Barnes, who has added inspection services, reports, "In one [ostensibly repaired] place . . . my inspector found a half-inch gap between the plywood truss and the plywood. There were no nails attached to the rafter. This house had a certificate saying it was inspected by some engineer in Palm Beach. In another case I saw an engineering form that said the house met all building codes. The name and address of the owner were blank. A builder could use this wherever he wanted." Incredibly, he says, "an engineer signed this."

#### **Planning to avert storm disasters**

Though reports of shoddy reconstruction are widespread, neither the insurance industry

(which is reeling under \$16.4 billion in covered losses, vastly in excess of prestorm assumptions), nor the Federal Emergency Management Administration (FEMA), have done much to push the county beyond its short-term, politicized focus. Insurers are considering whether to rate communities according to the strength of local codes and enforcement, says John Mulady, chairman of the building codes subcommittee of the insurance industry's Natural Disaster Loss Reduction Committee. Communities are required to adopt and enforce FEMA standards to be eligible for (privately unavailable) federally underwritten flood insurance. Though FEMA regards non-compliance with codes in the wake of Andrew as "a major problem," according to John Gambel, chief of the Technical Standards Division, he is not aware of any south Florida community that is currently on probation or has been dropped from the program.

A spring conference, sponsored by the University of Miami's architecture school and the Knight Foundation in Miami emphasized that disaster mitigation includes response, relief, and recovery. Aid programs too often ignore the latter. Recovery should include, for example, disaster-aid grants or insurance that picks up the added costs for reconstructing houses to meet updated standards. And predisaster plans usually ignore means to avoid the sloppiness of hurried rebuilding. Participants pointed out that disaster preparedness for earthquake regions is far more advanced, offering a model for the far greater number of communities that may lie in the path of major storms. *James S. Russell*

#### **Further information**

"Hurricane Andrew: August 24, 1992," by Ronald F. Zollo. Department of Civil and Architectural Engineering, University of Miami, Coral Gables, Fla. 33124 (305/285-9543).

"Building Performance: Hurricane Andrew in Florida," published by FEMA (FIA-22, 2/93). FEMA Publications, 500 C Street, S. W., Washington, D. C. 20742

Specialized reports: American Plywood Association (206/565-6600); American Wood Council (1250 Connecticut Avenue, N. W., Washington, D. C. 20036). ■

## Facilities Sport Athletic Engineering

Each decade spawns its own large-urban-facility fad. In the '70s it was domed stadiums; in the '80s, convention centers. Cities today are competing to erect specialized sports and entertainment facilities. This trend may stem from the widely publicized success of Camden Yards, in Baltimore, which combines sensitive urban design with a television-friendly image.

While huge multipurpose facilities were in vogue 20 years ago, today's fans want (and teams have the clout to demand) facilities oriented to individual sports. Hence, close to a dozen cities are planning, building, or have completed enclosed arenas. Though cities increasingly look for a unique image, and newer facilities feature dramatic architectural designs, the projects are at base engineering-driven. Further, clients demand fast schedules and strict cost controls, which keep designers focused on straightforward solutions.

To handle national tours and teams, arena criteria are quite similar: seating between 17,000 and 19,000 for basketball and hockey crowds, and sophisticated provision for the lighting, sets, and rigging required to stage events ranging from Bon Jovi to Barnum and Bailey's three-ring circus.

Arena roof structures in America eschew structural drama. "Larger spans may require more dramatic solutions—cables, masts, domes—but it is very reasonable to support the typical 350-ft span with trusses," says engineer William LeMessurier. (A retrofitted stadium is shown on page 34). Though a two-way space-frame system might use less material, says Charles Thornton, of structural engineer Thornton-Thomasetti, the shoring, staging, and connection complexities more than make up for the material's lower cost.

The following projects show that inventive spirit need not be sacrificed to meet tight tolerances of time, cost, and ease of construction. Older arenas are also ripe for attention. Seattle's handsome Coliseum, with a net of roof panels suspended by cables that dates from (and has leaked since) 1962, is getting a new, rigid roof that follows the existing profile. *James S. Russell*

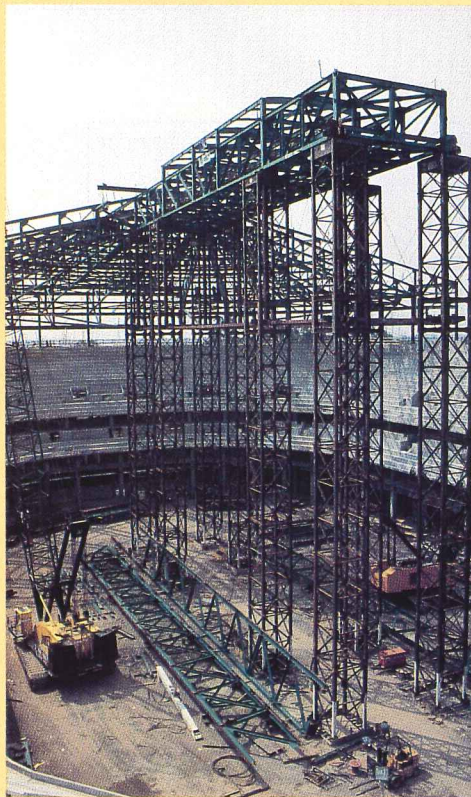

### Anaheim Stadium, California

Awaiting only finishing touches, this 19,000-seat arena, designed by HOK Sports Facilities Group, of Kansas City, departs from the norm in two ways. The design is intended to eliminate the need for expansion joints within the cast-in-place arena bowl. (These joints would be large because the facility is in seismic zone 4—the most severe exposure—and difficult to maintain.) More significantly, structural engineers Thornton-Thomasetti departed from the usual lineup

of identical one-way trusses in designing the 440- by 325-ft roof system by using a combination of radial and straight tied-arch trusses framed 150 ft into a central box. A one-way system, the 12.5-ft-deep straight trusses, which rise 28 ft from their spring point, are the compressive element of the arch. Queen posts extend 39-ft down from the box, connecting a wide-flange-section tension member from stands to the central box (opposite top and bottom). Though the effective depth of the truss is about 50 ft, the roof looks light and little encumbered by



*Time, cost, and construction constraints drive the design of long-span arena roofs.*

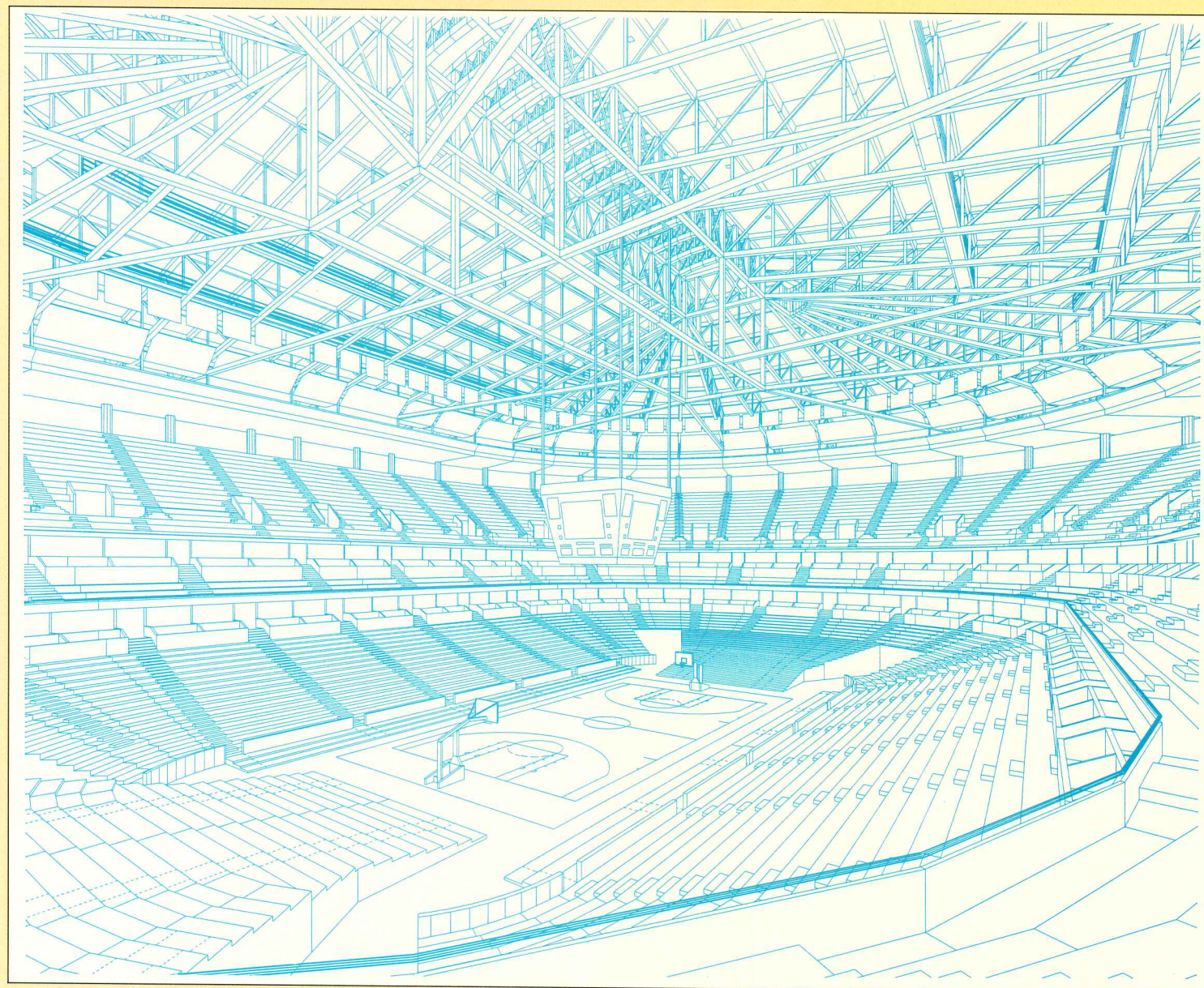

structure. The system also offered construction advantages. Eight erection towers at the center of the field simplified lifting the elements into place (sequence photos opposite). Erection followed completion of each section of the concrete bowl. The architects expressed the structural system on the metal roof by pushing up a monitor at the peak and creating recesses at the pie-shaped radial sections. (Reduced spans meant that these needed to be only 7.5-ft deep.) *J. S. R.*

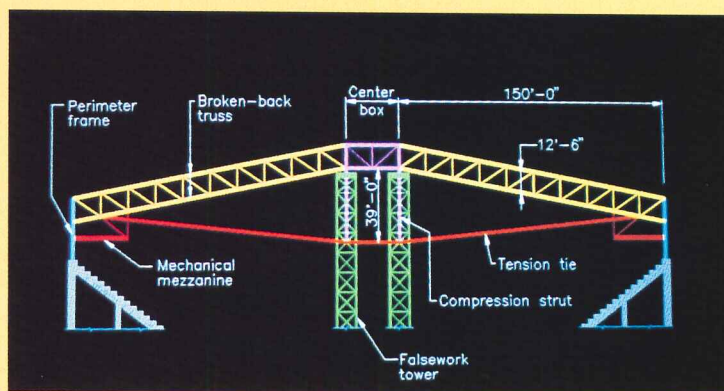

## Technology

Two arenas by Ellerbe Becket demonstrate how straightforward means can yield dramatic architectural form.

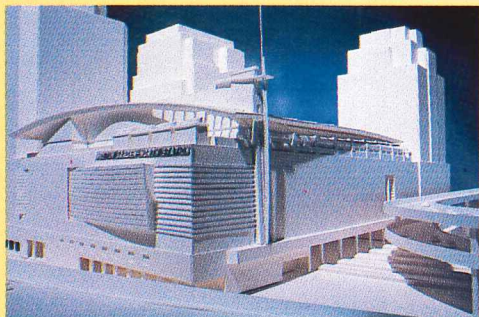
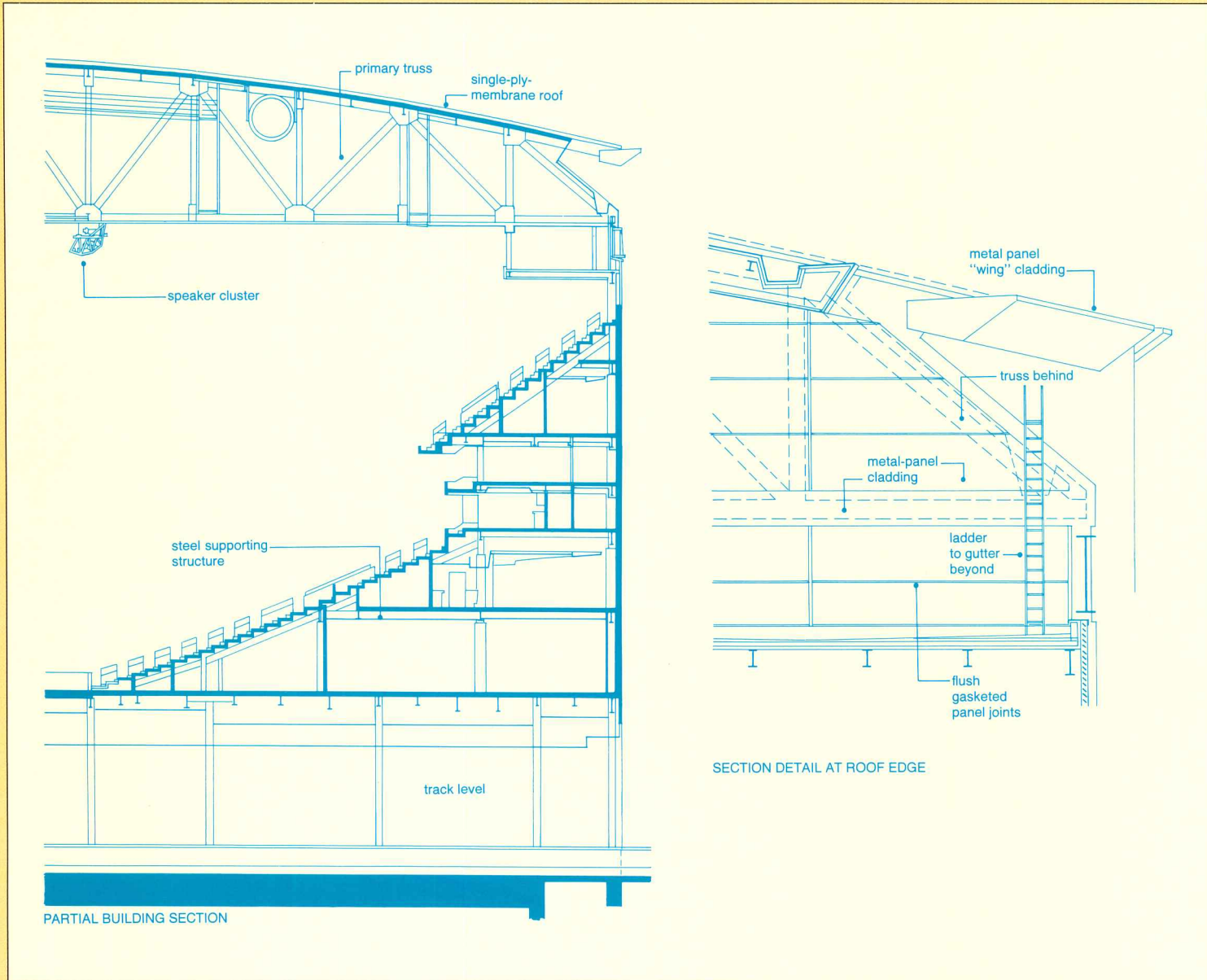

*Shawmut Center spans existing rapid-transit-system tracks.*

### Shawmut Center, Boston

Due for completion in September 1995, this steel-framed replacement for the Boston Garden is hemmed in by existing construction on all sides, which causes it to be "among the smaller arenas" in this category, says Tom Beckenbaugh, chief architect for Ellerbe Becket. The top chord of the one-way truss system (designed by LeMessurier Consultants) is curved to give the roof its signature form. The trusses range to 30 ft deep and span 309 feet. "It's a

practical proportion at a depth of about one-tenth the span," says William LeMessurier who feels the structure meets his criteria, being "elegantly frugal." The roofs on this project, as well as the Kiel arena (opposite), and a number of other recent projects are, according to Gary Harper, Ellerbe Becket's chief structural engineer, "influenced by the work of [New York partner] Peter Pran." He explains: "It's simple to do these sweeping curve shapes with one-way trusses. We've also found the pricing on trusses the most economical." *J. S. R.*

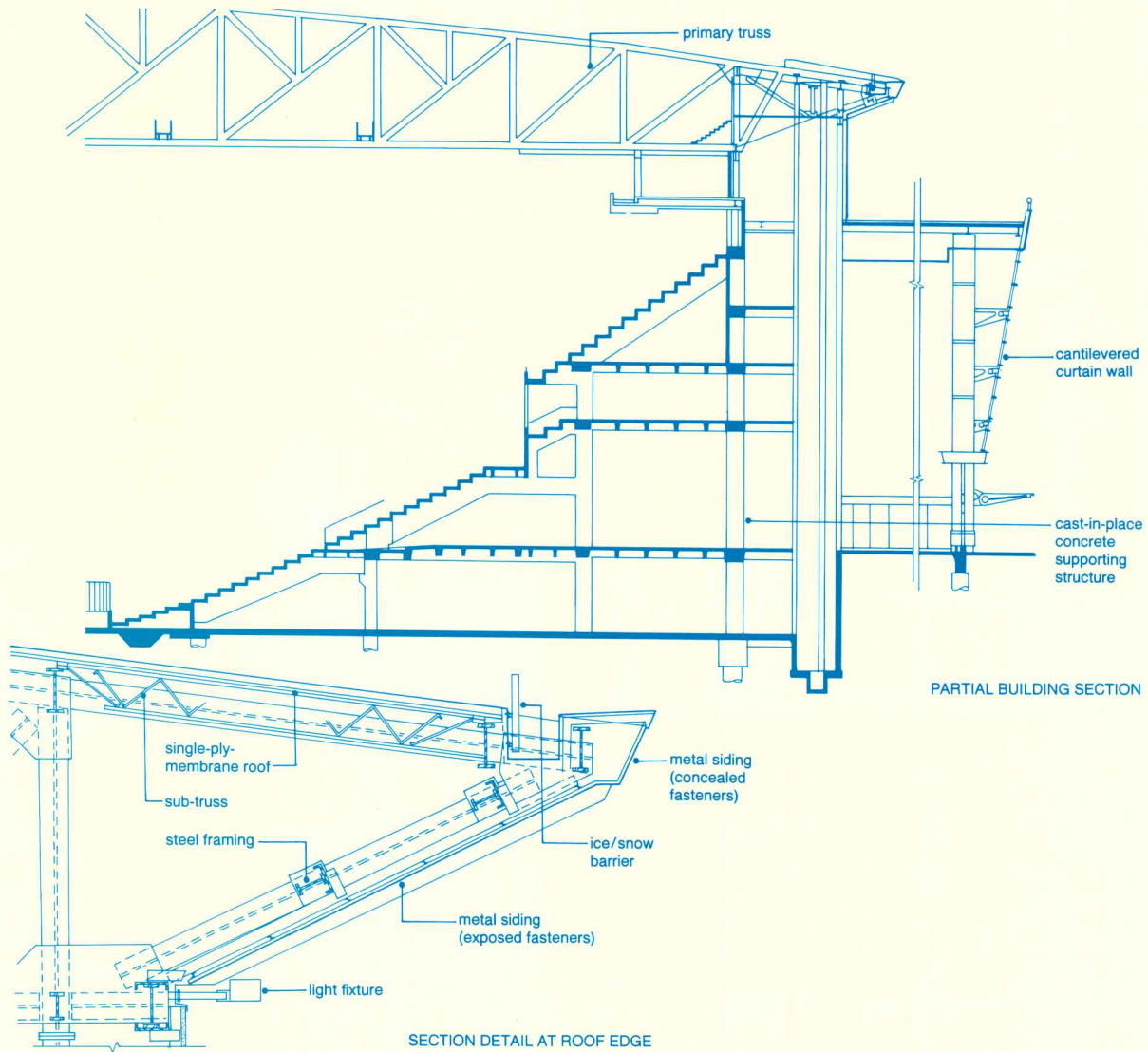

## Kiel Arena, St. Louis

The concept of this arena is much like Boston's, but Ellerbe Becket's Kansas City office, which specializes in sports facilities, engineered it using an in-house team assembled only a few years ago, and led by Gary Harper. Kiel also has a one-way truss system, though it is set on a poured-in-place arena-bowl structure. The 10 major trusses, spanning the 345-ft short direction, are braced by two trusses in the long direction. Subtrusses span between trusses and canti-

lever to support the building's dramatic overhangs (detail above.) In designing the trusses, computers analyzed 100 possible load combinations in three dimensions, taking into account the building's dead loads as well as live loads from wind, snow, and as much as 120,000 lb of concentrated load from assorted stage-rigging configurations. Since the truss fabricator's shop is only two miles from the site, the trusses will be shipped in quarters, and erected in halves using one erection tower per truss. The contractor will complete work in 1995. *J. S. R.*



*The Kiel Arena's generous overhangs cantilever from the main trusses.*

## Technology

*Rome's 1930s stadium was updated with a cantilevered, fabric-roof structure supported outside the existing bowl's perimeter.*



1



2

### Olympic Stadium, Rome

In 1987, Rome was chosen as site of the 1990 World Cup, but the city's stadium, dating from the 1930s, and twice enlarged, did not meet the organizers' standards. Discarding the idea of building a new facility out-of-town, the city elected to reconstruct the existing stadium, expanding its capacity from 54,000 to 85,000 and adding a roof.

The demands on the design and construction team were backbreaking: meet the short

schedule while making 60,000 seats available for play during construction. The engineering criteria included a desire for a very light roof, since it couldn't rest on any of the existing structure, and one with sufficient redundancy so that local failure of any component would not ripple throughout the system.

The scheme, by a design team comprising Studio Zucker (architecture) and engineers G. Caloisi, of Italprogetti, s. r. l., and Massimo Majowiecki, of Studio Tecnico



3

Majowiecki, placed the new roof's 16 195-ft-high concrete columns completely outside the seating envelope (photo 2). These support an oval external anchoring ring (1), which itself cantilevers over the stands. It ranges from a diameter of 1,020 ft to 715 ft. The external ring comprises a tubular truss that is triangular in section and nearly 20-ft-deep. From it, beam-and-tension-cable trusses cantilever in a radial pattern toward the center (5 opposite).

At the inner edge of the roof, a ring of 12

Robert Reck photos this page, courtesy Birdair

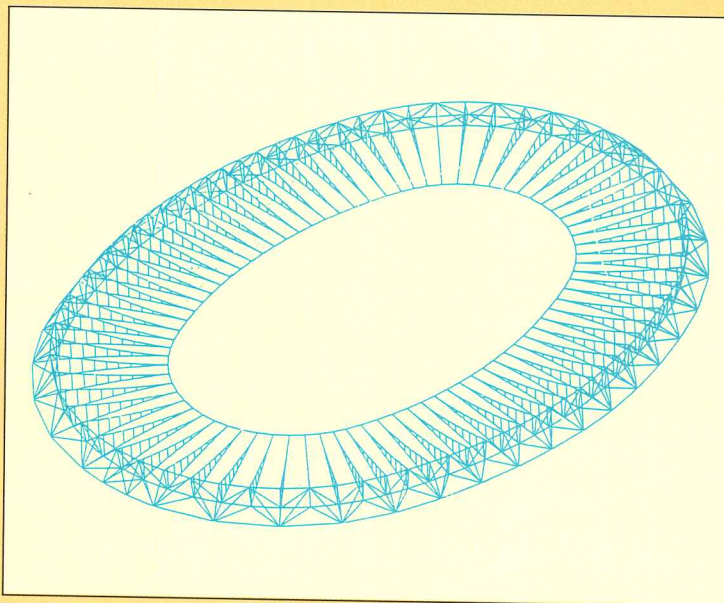
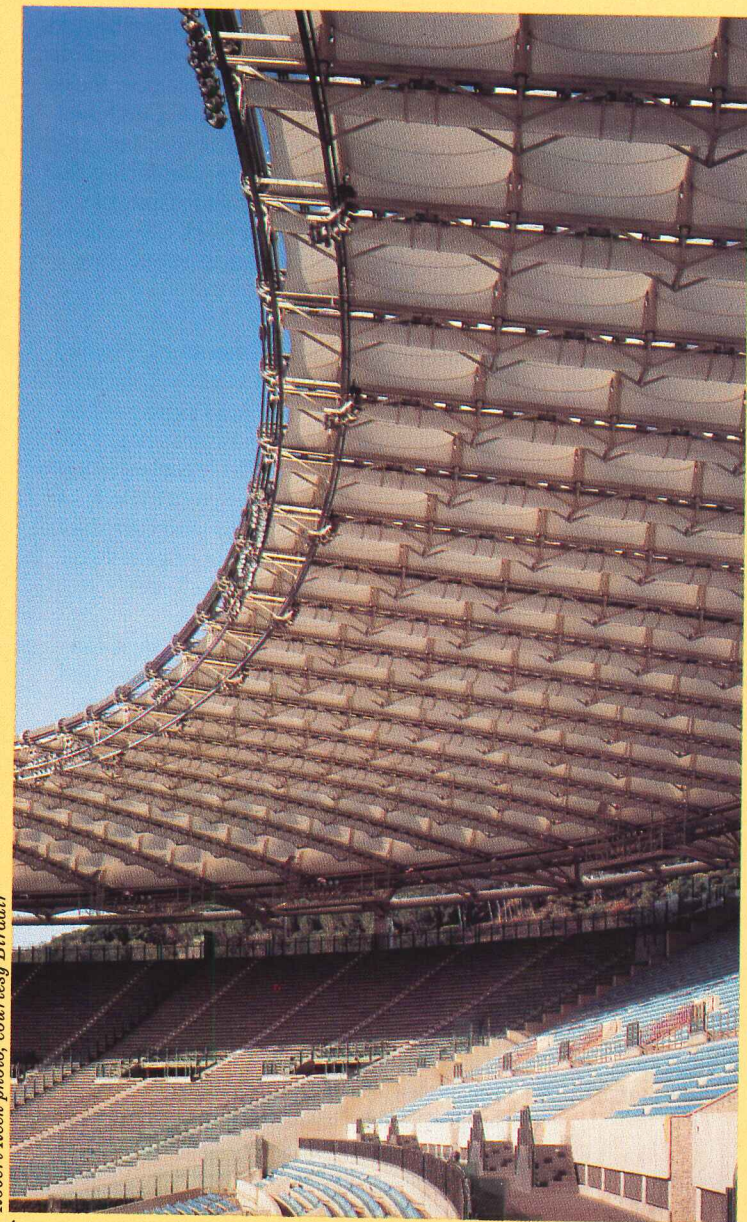

5

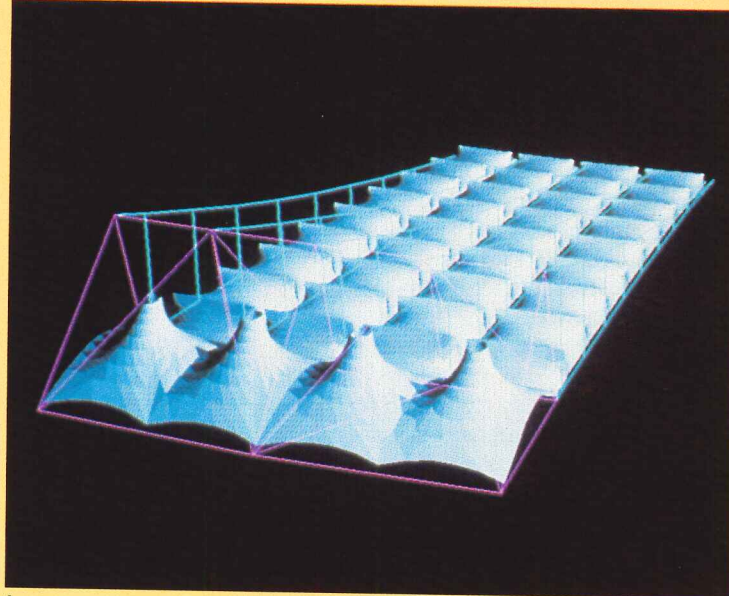

6

galvanized cables, each 3.4-in dia, balances the horizontal stresses transmitted by the radial trusses. Teflon-coated fiberglass roofing fabric (Sheerfill, made by the U. S. firm, Birdair), was stretched over frames to make shallow vaults between the radial trusses (4) and conelike sections within the external-ring truss (6).

The external truss was largely prefabricated, assembled into larger components onsite, and lifted into place. Erection teams laid out and preassembled the internal cable

ring and radial trusses on the stands. A temporary pulley and backstay system was attached, then eight teams lifted the entire ring and truss system into place. Cranes placed secondary trusses supporting the fabric panels, over which teams stretched the translucent fabric. External ring assembly took five months; the cable-truss system was assembled in five months and erected in five weeks. The fabric roof took one month to apply. *J. S. R.*

## Beyond Wheelchairs

By Peter Slatin

When it came into full force in 1991, the Americans With Disabilities Act (ADA) may have felt to architects like a big new brick in the load of regulations they are forced to haul to each project. To some, this load increasingly replaces the discretionary role of the architect in design with the aggravations of bureaucracy and the impersonal nature of code compliance. Though the ADA is presenting some sticky questions, it's still in the shakedown phase, and architects are learning to turn the regulations to their advantage, exploring new design possibilities.

### Making the ADA accessible

Critics say the ADA contains too much that overlaps or duplicates existing regulations. Disabled groups fought hard for the Act's passage, asserting that its federal status makes an enormous difference. John Del Colle, associate executive director of the Eastern Paralyzed Veterans Association, says disabled groups are pleased with the way ADA has worked. "If the regulations are properly used and put into effect, they cover most everything," says Del Colle. "Existing state barrier laws don't provide the total and complete access that they are supposed to." Weaknesses on the local level, he says, were due to "enforcement and whether professionals were aware of what's in the law and followed it. For some obscure reason," Del Colle adds, "when professionals look at state barrier codes, they don't pay as much attention as when it's a federal civil-rights statute."

Todd Harvey, an architect and principal at Beatty Harvey and Associates, in Manhattan, has followed the flow of disability legislation over the years. His firm performs ADA audits, mainly for public agencies and schools, and provides its clients with advice on how to comply with the regulations—and on whether compliance requires any changes at all. "Most of the solutions are simple," he reports. He says that public clients have responded to the ADA more quickly, a lead role they have taken since the first accessibility laws were passed.

*Peter Slatin, a writer in New York City, is a former associate editor of RECORD.*

### Grab bars, Braille signs—and civil rights

Drafters wrote ADA as civil-rights legislation. Its language is purposefully vague and wide open to interpretation. "The real problem is that it is so broad and the terms are so gray that it's difficult for people to nail down what definitions apply to them," explains Harvey. "What is 'readily achievable,' and what's an 'undue burden'?" Attorneys say a lot of this will be defined over the years as it gets litigated." Owners are not seeing the big lawsuits with far-reaching financial burdens that they feared when the legislation was first passed, however.

In the meantime, the reality of the ADA is compliance. How do you know when you comply? "The best defense is to make a good-faith effort, to be a little conservative," admonishes Harvey. "The law is written to encourage compliance." The nonspecific language can be turned to advantage, because it encourages clients and professionals to work out individualized solutions, and permits creative answers, especially in existing buildings. "Most of the solutions are simple," says Harvey.

Some examples: A low counter at library checkout stations eases the process for wheelchair-bound users (not to say small children). A cash-strapped public system may not be able to afford to rebuild all its counters. Hand out clipboards with forms attached, suggests Harvey. If it's not feasible to lower drinking fountains, install paper-cup dispensers at the appropriate height.

In working with a client, the architect needs to take the "publicness" of the facility into account. If you allow public access to a private facility, then you must make it accessible to all. Though not an official restroom, clerks at a New Jersey toll plaza often permitted the public to use men's and women's rooms located on the second floor. The New Jersey Turnpike Authority recognized that the facility must be made accessible. Harvey found it cheaper to build a separate, fully accessible public restroom rather than refit the existing building.

### Letting the blind lead themselves

For most buildings, whether retrofit or new,

accessibility is, if no longer an afterthought, simply one of many program considerations. It is, however, the main ingredient in the design of a 170,000-sq-ft Manhattan midtown headquarters for The Lighthouse, Inc., the country's largest private service facility for the visually impaired. Mitchell/Giurgola Associates' (MGA's) New York City office is designing this combination of renovation and new construction.

The project is a virtual laboratory, causing the architects to rethink surfaces, circulation patterns, lighting, color, and signage that must serve an extremely diverse population of impaired and able-bodied people, both professionals and clients. The population's visual abilities vary widely, with correspondingly different needs. People rely on dogs, canes, chairs, or other people to get around—or try on their own. "Issues of orientation are key," says Jan Keane, partner at MGA. She stresses that the process of wayfinding "is the same whether you can see or not. It's important not to cater in a helpmate way. This is a teaching institution, so you want people to be able to walk out into the world and function."

Keane found it easier to enhance accessibility by minimally modifying standard components rather than custom-designing new ones. One usually overlooked area that is greatly improved by a simple alteration: stairs. "Stairs normally have a solid tread and the same color riser," explains Steve Goldberg of Mitchell/Giurgola. Contrasting colors are very useful to those with limited vision. While contrasting-color strips are often used to denote a small change of level, Mitchell/Giurgola made treads and risers contrasting for the entire stair run (page 40). "The nosing of the stair is the same color as the riser and in contrast to the tread," adds Goldberg. Color will also differentiate landings, "so you know you've arrived someplace."

On the main floor, molding at the top of wainscoting is extended outward from the wall to serve as a guiderail. Notches denote wall openings or other transition points. Changes in terrazzo-floor texture delineate pathways and warn of turns and cross corridors.

*The Americans With Disabilities Act is also being tapped by architects for its design potential for the vision and hearing impaired.*

© Gregory Benson

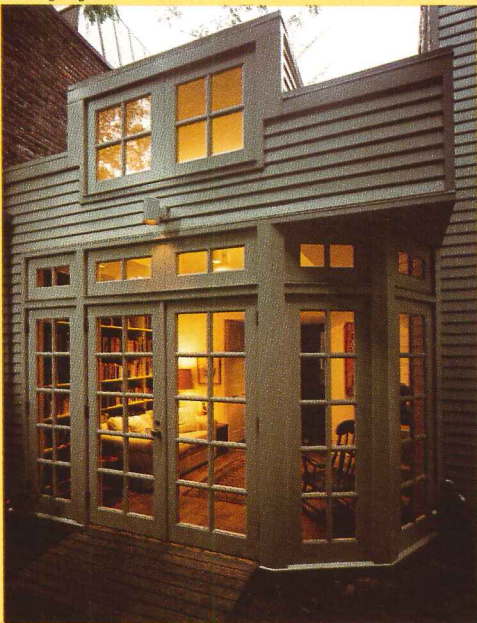

© Gregory Benson

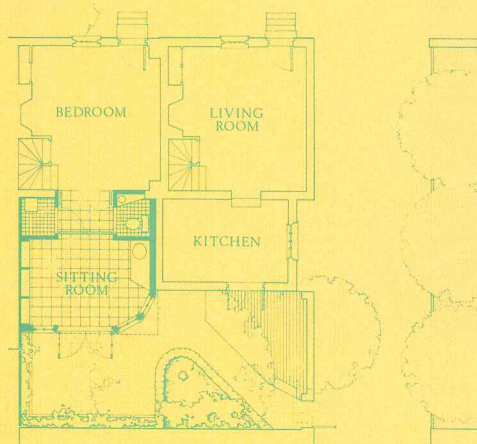
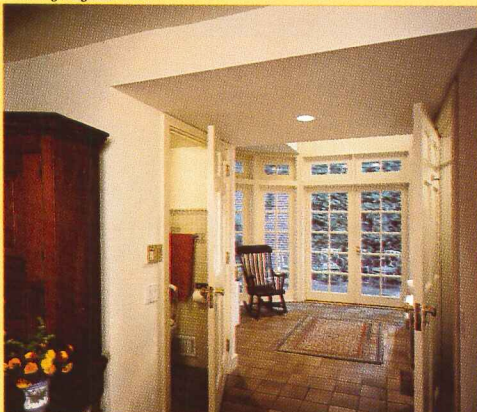

*Swinging doors in a tiny Philadelphia row house make an accessible bathroom (middle) out of a sitting room (top).*

The constant flow of new patrons means that the layout, especially at the main entrance, must be easily and quickly comprehended. Visitors find a reception desk, then move around it to a recessed elevator lobby. “We made sure the elevator lobbies are away from the general flow,” says Keane. Wide cabs and doors accommodate the tendency of the totally blind to stand at the front of the elevator. For the partially sighted, large, illuminated triangular hall lanterns announce the elevator; call buttons are beefy oblongs set into bright discs.

The client itself, a committee of Lighthouse staff and clients, included members with a range of impairments. MGA and its team, including design consultant Whitehouse Associates and lighting designer H. M. Brandston and Partners, recognized this, and presented an array of tactile maps indicating everything from floor textures to the presence of warning notches on wainscoting. (At completion, similar maps, including a building section, will be on permanent display at the front desk.) The main floor has the most complex layout. Common elements that recur on upper floors—reception areas, bathrooms, and doorways—have been standardized in form as much as possible, and located in constant positions.

Keane credits the committee experience with helping her to understand that “blind” is not a monolithic disability. The disabled population has abilities as widely varied—and as many ways of living—as the population at large. She says the experience has made her conscious of “trying to make reasonable choices.” She saw that clarity of circulation was not merely an esthetic issue. Color and light are important, especially as the aged become a higher percentage of the population. “You start out thinking a lot of rules are guaranteed to make things ugly,” she says. “I have a lot of respect for those rules now. It’s all in how you use the materials in ways that are still attractive.” The results will be clear to see when the building is completed next summer.

**Addressing a silent world**

Although making darkness visible is no easy task, it still dwells in the architect’s world of

tangibles. Rendering silence “audible” is a world where solutions are still emerging, and usually still expensive. In ADA terms, this means making public entertainment and information fully accessible to the hearing impaired. Today, strobe lights warn in case of emergency, and infrared transmitters and receivers allow more patrons to enjoy performances in public halls. (While many performers find sign-language translators distracting, many venues provide them on request as a matter of policy.) A trickier issue is voice announcements in public places.

The ADA appears to contain something of a loophole here: Because it requires only that services available to the general public be made universally accessible, performance or convention halls and other public spaces can get around the problem of paging the deaf by eliminating all paging. This was the case at one performing arts center now in design for a northeastern city when the budget had to be cut.

Artec Consultants are acousticians who do much of their work in theaters and other performance spaces. Paul Garrity, a principal consultant, notes that the firm’s work has long included the infrared systems for listening to performances that are common in Broadway theaters. “People are starting to desire [more-accessible] public-address systems wherever feasible, but nobody’s really thought about how to do that,” he says. “It’s a problem everyone agrees would be nice to solve, but no one can afford the solutions we’ve come up with. But once we solve these problems, it helps everybody, not just the disabled.”

Light-emitting diode (LED) display systems are in wide use for visual announcements, but are more useful for standardized, simple messages than for customized paging. Garrity points out that, at present, video monitors are more flexible and may be cheaper. Acousticians Lawrence Kirkegaard Consultants of Chicago apparently agreed, and opted for a video-monitor announcement system for the International Terminal at O’Hare Airport. Though the video-messaging system designed by Kirkegaard as consultants to architects Perkins & Will interfaces with a computerized system that

*"When professionals look at state barrier codes, they don't pay as much attention as when it's a federal civil-rights statute."—John Del Colle*

sends out both canned messages and standard flight-information messages, it still can't carry personal pages. Whether visual and audio paging will be required remains questionable. "The ADA is not very specific on this and I don't know how it's being enforced," says one acoustical consultant.

**Accessing emergency exits**

Though designers and regulators have paid plenty of attention to accessing buildings, they have not been able as readily to answer the question of emergency egress for the disabled. The February, 1993 bombing of New York City's World Trade Center blew this issue to the fore, with tales of wheelchair-bound workers carried down tens of flights of smoke-filled stairs by colleagues. Carefully graded ramps, wider doorways, and big, bright elevator buttons are worthless without operating elevators.

The ADA sets forth two major initiatives to ensure emergency evacuation for the disabled. "The glaring hole in all the codes based on the original ANSI standard (117.1) is that they require you to provide the hand-capped access into multistory buildings and then tell them not to use the elevators when there's an emergency," explains Tyler Donaldson, an architect with James Stewart Polshek & Partners, who is currently working on renovation of a museum in New York City.

Todd Harvey agrees, but feels that the ADA has addressed the problem. "One of the big improvements has been to mandate added areas for 'rescue assistance,'" says Harvey. These are offered as an alternative when accessible routes of entrance can't double as emergency egress. Areas for rescue assistance must accommodate two wheelchairs per floor, must have fire-rated enclosures, must be adjacent to fire stairs or other exitways, and be equipped with emergency lighting and communications systems. "It shouldn't mean rebuilding," says Harvey. "It will take some hallway space, but not an enormous amount."

**Scaling historic landmarks' steps**

ADA sounded alarms among historic preservationists, who feared defacement in the

name of accessibility. The act is flexible, even lenient, says Harvey. "You do not have to alter a historic building if to do so would change its character or significance," he cautions. "If you can't widen a door or change a room without doing that, that fact overrules the requirements." This is not to say that the designer should not make every effort. As a consultant to two historic-house museums in Oyster Bay on New York's Long Island, Harvey recommended that a temporary wooden ramp be stored in a closet and used as needed. Assistance provided by the caretaker counteracts the fact that the ramp's slope is steeper than would be permitted for the unassisted. Institutions with strict fund limits must look closely at the tradeoffs. If changes in the building are possible (even if costly), they can avoid an open-ended commitment to maintaining staff.

Even apparently poor candidates for upgrading can often be made rewardingly accessible. A wheelchair-bound client asked Philadelphia architect James Oleg Kruhly to create a fully accessible ground floor within a pair of narrow 18th-century three-story row houses (known as "trinities"—so named because they contain one room on each of three floors). The pair were joined by a small rear garden, with the client's able-bodied companion living in the other trinity. Not only was access between the two houses to be provided only through the garden, the owner asked Kruhly to subordinate the handicapped features of the renovation to the historic nature of the property. Leaving the two upper floors for storage and live-in help, Kruhly placed the bedroom and living room along the front of the house. He built a small sitting room with a double-height wood-framed glass wall that extends slightly into the garden and has a view toward the adjacent property. It seemed impossible to meet the space requirements of a wheelchair-accessible bathroom without destroying the scale and character of the residence. But Kruhly found that he could separate the bath into a toilet-and-sink component opposite a shower room. Normally the space between forms a wide passage between bedroom and sitting room. The shower and toilet compartment doors can be rotated to screen the sitting room, and then the space between the compartments be-

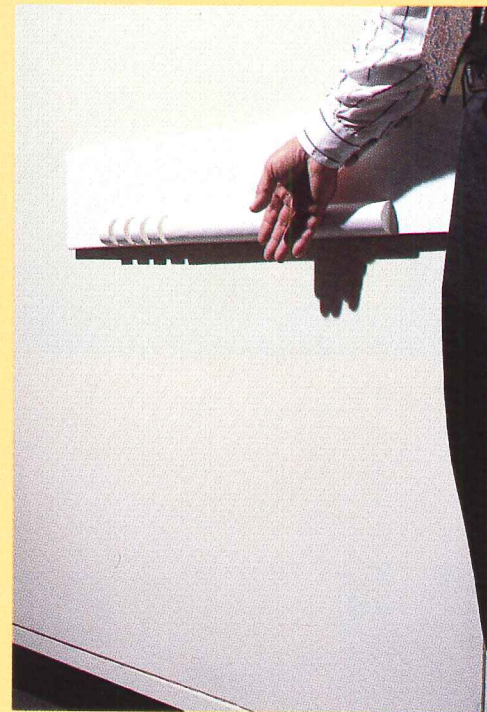
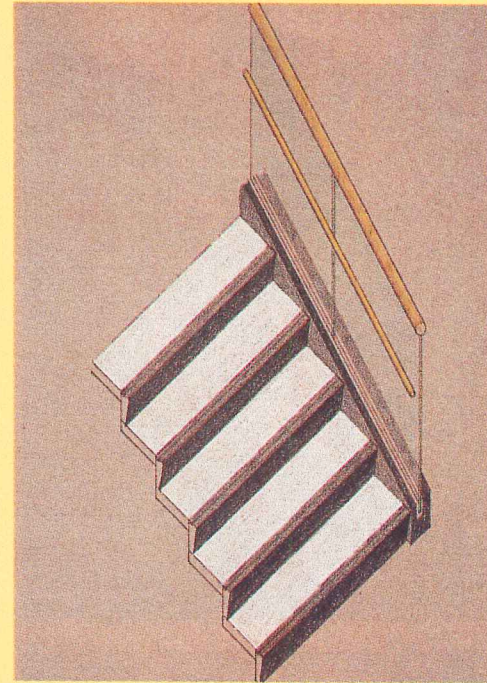

*At new headquarters for The Lighthouse, Inc. in New York City, stair treads and risers are done in contrasting colors (top). Notches at the end of a guiderail (above) cue the blind to direction changes, level changes, and cross halls.*



comes the bathroom's wheelchair turning radius (page 39).

Kruhly is proud of the result, which won an award from the National Trust for Historic Preservation, but he also gives credit to the client. "He wanted to keep the historic character, and he was prepared to sacrifice so that it didn't look clumsy."

Stairs have been a problem at the Cooper-Hewitt Museum of the Smithsonian Institution, located in the turn-of-the-century Andrew Carnegie Mansion in New York City. Converted to a museum in the 1970s, the main entrance of this National Historic Landmark is formidably inaccessible, with a flight of steps outside followed by a four-foot stair run within the lobby. Wheelchair entry is currently available through the service drive, and requires assistance. In addition, the museum needed to improve access to two townhouses on its southeastern side (now used for offices and storage) and link them to the main museum.

James Stewart Polshek & Partners, architects of the renovation, earlier faced similar difficulties reconciling floor levels in a restoration of Carnegie Hall. Thus, says Tyler Donaldson, "We sought a solution respectful of both building and people." The architects are converting a four-foot planting strip inside the mansion's iron fence into a ramped pathway to the exterior entrance level. Once inside, a small elevator will be available.

"Basically the procession into the museum is the same for wheelchair users and for those who use steps," says Donaldson.

The architects also had to devise access to the museum's large garden (down a flight of steps today) and to the townhouses. Because the museum is set in a difficult-to-bridge recessed moat, the architects proposed a scheme that required minimal alterations to the historic mansion. An upper level connection through the nearest, L-shaped rowhouse forges a new public sequence to the garden. Again, the design is inclusive, not just for the disabled. "It's the intention in all of our work to eliminate as much as possible any special or obviously different accessible routes," explains Donaldson. He points out the secondary benefit to the mu-

seum of having larger, smoother passages for moving collections. Along with communication devices (in places like bathrooms) to comply with the ADA's rescue-assistance requirements, the firm is designing visual and aural alarms systems, and providing corridor lighting brighter than "typical museum levels."

#### **Building on ADA**

Donaldson's accessibility solutions had to comply not only with the city's formidable landmark guidelines, but also the Smithsonian's own accessibility codes. He worked with Janice Majewski, the institution's Coordinator of Accessibility Programs, an office that provides technical assistance throughout the organization, reviewing construction documents with its internal design and construction office. Majewski is familiar, not only with the ADA, but with earlier guidelines for federal buildings such as the Architectural Barriers Act of 1968 and the Rehabilitation Act of 1973.

"These are minimum standards," says Majewski, who has been at the Smithsonian for 15 years, the last two creating and heading this department. "And if we find it appropriate, we go beyond them. Many people can't negotiate [barriers that remain even with] minimum standards, so we are working to develop a Smithsonian standard of uniform accessibility."

That the ADA doesn't go far enough in some instances is not its major difficulty, Majewski insists. "The challenge is not from the ADA but from the people I work with, who are trying to understand what accessibility means. People don't truly understand the audience for whom these regulations were designed, and so there may be resistance." Majewski is optimistic: "I've seen more turnaround in the past two years than in the prior 13, and the Americans with Disabilities Act has made the difference." ■

#### **ADA Resources**

- "ADA Handbook," published by the Equal Employment Opportunity Commission and the Department of Justice: 800/669-EEOC; the TDD number is 800/800-3302.
- The AIA offers "ADA: A Resource Guide," a \$30 looseleaf compendium of regulations and interpretive information issued by federal agencies.
- The Building Owners and Managers Association publishes the "Americans With Disabilities Act Compliance Guidebook," available from BOMA International, 1201 New York Avenue N. W., Washington, D. C. 20005; 202/408-2662.
- "The Americans with Disabilities Act Compliance Workbook," by Evan Terry Associates in association with Barrier-Free Environments Inc. (John Wiley & Sons, 1992, \$150) includes analysis of the ADA, a systematic method for surveying facilities, and suggests means to interpret the regulations. 2129 Montgomery Highway, Birmingham, Ala. 35209.
- An extensive list of publications is available from Barrier Free Environments, P. O. Box 30634, Raleigh, N. C. 27622; 919/782-7823.
- The Eastern Paralyzed Veterans Association also publishes a number of free compliance guidebooks. Write the EPVA at 75-20 Astoria Boulevard, Jackson Heights, New York 11370-1177, or call 800/444-0120.
- Vocational Studies Center at the University of Wisconsin/Madison offers videos and handbooks on working with the disabled. Write the VSC, University of Wisconsin/Madison, Dept. AF, 1025 W. Johnson Street, Madison, Wis. 53706, 608/263-2929.
- For specific questions, contact the U. S. Department of Justice, Civil Rights Division, Office on the Americans With Disabilities Act, P.O. Box 66118, Washington, D. C. 20035-6118, 202/514-0301; TDD number: 202/514-0383. ■

## Seen at CSI



200



203

*Computer-based specifications, natural disasters (and buildings that survive them), the ecological advantages of minimizing construction waste: all were dealt with in detail at the 37th Annual Convention and Exhibit of the Construction Specifications Institute. The product introductions selected for RECORD's spotlight reflect these industry-wide concerns, as well as the classic architectural appeal of color and subtle shape. J. F. B.*

### 200. Five-panel wood door

A Mission-influenced style of Douglas fir over a split-proof laminated core, this five-panel door can be used in exterior-entrance applications as well as indoors. Door leaves come in widths to 3 ft 6 in., and up to 8-ft high. Also available in Western hemlock. Simpson Door Co., Federal Way, Wash.

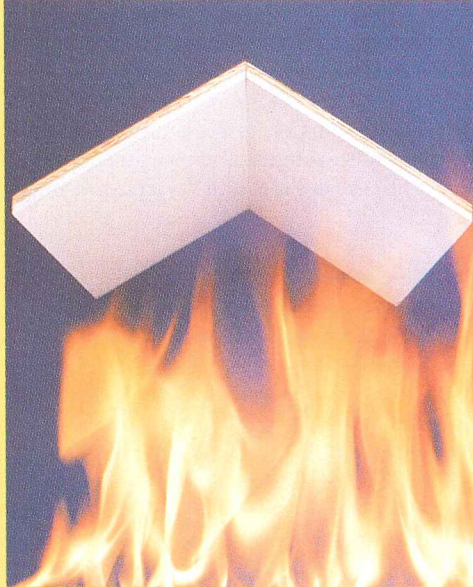

201

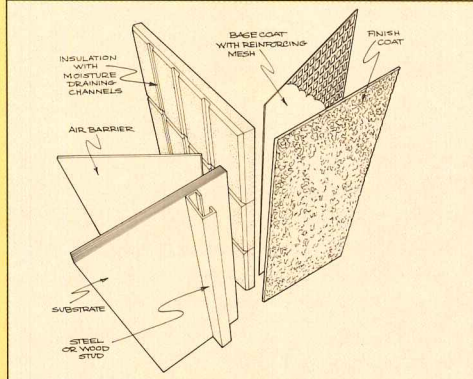

204

### 201. Fire-resistant roof decking

More of a time-saving assembly than a new technology, FlameBreak is a structural panel made of APA-rated plywood bonded to a 1/4-in.-thick layer of Dens-Glass, a proprietary fiberglass-faced gypsum panel. UL Fire classified as composite building units for roof-deck construction, panels achieve a UL 30-minute flamespread rating with no chemical treatment. Georgia-Pacific Corp., Atlanta.

### 202. Seismic-capable structural tile

A new design for horizontally cored ceramic-surfaced masonry units adds two large vertical holes, allowing placement of grout or steel bars to meet the security standards of the Federal Bureau of Prisons. The vertical-reinforcement capability is said to also resist earthquake damage in seismic areas. Stark Ceramics, Inc., Canton, Ohio.

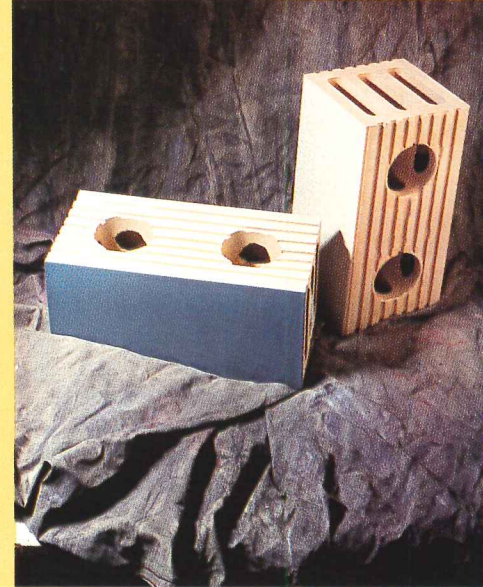

202

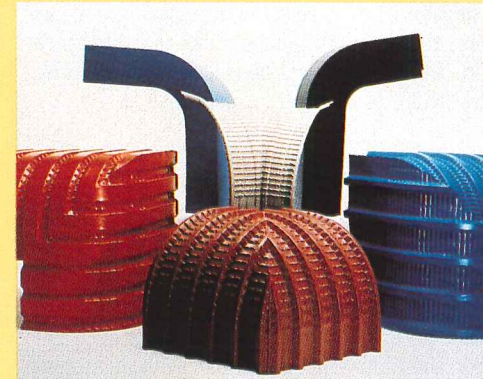

205

### 203. High-impact wallcovering

Made of a non-porous vinyl/acrylic material said to be highly resistant to common stains, integrally colored wall treatment is an almost tear-proof .022-in. thick. Fire-rated Class I, the wallcovering comes in nine stone patterns and 64 complementary solid colors. A fiber backing aids hanging with a water-based primer/adhesive. The C/S Group, Muncy, Pa.

### 204. Pressure-equalized EIFS wall

An installation system, developed to pre-empt possible defects in workmanship, applies rainscreen principles to exterior insulation and finish systems. Insulation board is supplied with drainage channels, wall sections are compartmentalized and vented, and a secondary weather barrier prevents deterioration of the substrate over the long term. Dryvit Systems, West Warwick, R. I.

Hot and humid Houston hosted '93's major architectural-materials trade show.



206

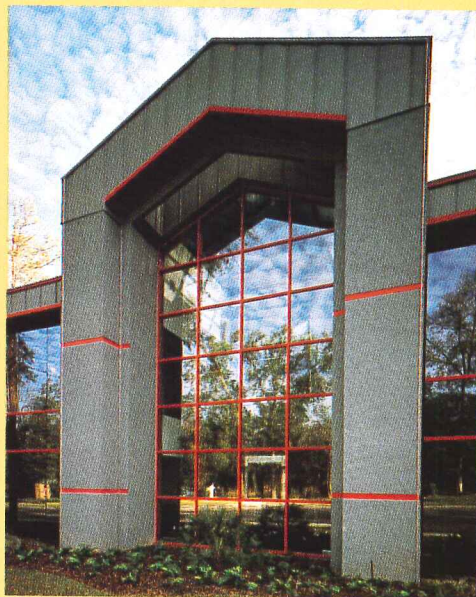

208



207

### 205. Curved sheet-metal trim

A proprietary curving process, said to be more economical than stretch forming, can now be applied to a wide range of prefinished sheet-metal trim and flashings, ridge caps, and 90-degree mitered corners. Fabricated to the specifier's radii and angles, simple or complex curves can be produced on 29- to 18-gauge panels in a range of substrates. Curveline, Inc. Ontario, Calif.

### 206. Fireproof coating for steel

A/D Firefilm, an intumescent coating about the thickness of a credit card, meets code requirements for 1- and 2-hour fire protection of structural steel, replacing bulkier methods. It permits use of architecturally exposed steel in locations such as a top-floor pedestrian bridge at the Hospital for Sick Children, Toronto (Zeidler Roberts Partners Archi-

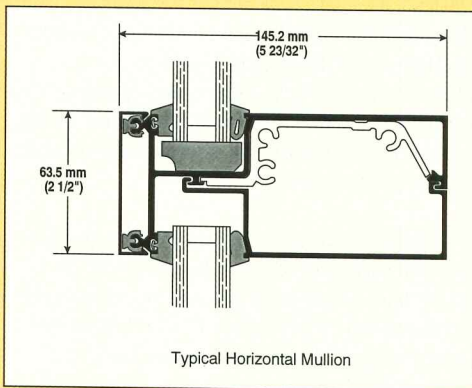

208

ects), where Firefilm is the white coating on the trusses. Developed in Canada, the system consists of an adhesion-promoting primer, the spray-applied, water-soluble Firefilm, and a decorative paint topcoat. FIPRO Corp. of America, San Diego, Calif.

### 207. Window design on Windows

Marvin Design System software works with Microsoft Windows as well as AutoCAD 12.0, supplying documentation in the form most usable to each member of the design team. It allows what-if planning of various window assemblies; an automatic Rulebase indicates when a design exceeds structural limitations. There is hotline support. Needs an IBM-compatible 386/486, 4Mb RAM, 5Mb free disk space; available without charge to holders of Marvin's current Architectural Detail Manual. Marvin Windows, Warroad, Minn.



209

### 208. Easy-in curtain wall

Described as thermally improved, the ICW-250 lowrise system is designed with square cuts and snap-on shear blocks that facilitate inside glazing. Weep valves are integral, and there are no exposed fasteners. Face dimension (detail) is a narrow 2 1/2 in.; a split horizontal accommodates large live and seismic loads. Vistawall Architectural Products, Terrell, Texas.

### 209. Stainless-steel curves

Subtly radiused edges, corners, and flanges create a new esthetic for all of this maker's recessed and surface-mounted accessories, from towel dispenser/receptacles (above) to tissue holders. Heavy-gauge steel components are made with imperceptible welds. Bobrick Washroom Equipment, Inc., North Hollywood, Calif. ■

## Windows Software Dominates at A/E/C Systems

*Fast Macintoshes, color output devices, and raster scanners draw lots of attention.*

By Steven S. Ross

The big news at this year's A/E/C Systems show revolved around Microsoft's new operating system, Windows NT. Most major CAD vendors are jumping on the NT bandwagon, promising NT versions of their software within the next 12 months or so.

The charge is being led by Intergraph, which has readied a new version of MicroStation, 5.0, for NT—and has adapted NT for its own Clipper 400 workstations. Intergraph demonstrated NT versions of MicroStation 5.0 and its MasterWorks series of architectural and civil-engineering applications at the show.

It's not hard to see why CAD vendors are excited. Windows NT (the NT stands for "New Technology") is a true 32-bit operating system. It will look like Windows 3.1, but unlike 3.1, which is really a sophisticated shell for DOS, NT stands alone. Software written especially for NT will have major speed advantages over most software written for MS-DOS. That's because NT processes data 32 bits at a time. DOS and Windows 3.1 process data only 16 bits at a time. (A bit is a zero or a one; a 16-bit number is approximately equal to a value with 10 decimal places, or two text characters).

NT is network-capable, out of the box.

There's also the promise of "inter-operability." NT's first release, due as RECORD went to press, will work not only with Intel 80386 DX and newer CPUs, but also with workstations based on the MIPS R4000 and R4400, Digital Equipment Corporation's new Alpha AXP, and the Intergraph C400.

Microsoft has been saying that this means a software application written for NT should be able to run on any of the listed machines, with more machines to come. But don't expect that level of full compatibility in the CAD world for a while. For one thing, the different machines have different peripherals that will require different "driver" software, particularly for graphics. For another, CAD vendors are nervous about certifying their software across different machines.

Indeed, NT's initial support for compressed

data disks will be non-existent and for removable disks (SyQuest, Bernoulli) will be limited. This reduces functionality that many architects need today. In addition, NT requires a big PC—16 MB of random-access memory and a 486 CPU running 33 MHz is recommended; operating-system files take 70 MB of disk space, all by themselves. The equipment costs came down considerably in the past six months (a solid NT-capable machine should cost under \$3,000, and upgrading from the 8 MB that is *de rigueur* now, to 16 MB, should cost only \$300), catching CAD vendors somewhat by surprise, however. They thought they would have until the end of 1994 to catch up with architects wanting to adapt to NT. But many offices can afford the upgrade now.

Intergraph, which seems furthest advanced in the process, insisted that it would not be offering its NT software on the DEC Alpha anytime soon. Reaching the code for it might only take a few days, but checking for minor incompatibilities and preparing extra documentation would be a painstaking and expensive process.

Intergraph's task is complicated by the fact that MicroStation 5.0 can be switched between the standard Windows interface and the standard "UNIX-Motif"-like interface. MicroStation 5.0 will also be available in DOS and Windows 3.1 versions. And 5.0 has many new features, including rendering and broad file compatibility with AutoCAD and other packages. **Circle 300**

Other CAD vendors have evolved similar schemes to get around the problems the Windows menu system poses for multi-command CAD software—floating on-screen palettes, toolbars, and so forth. It is ironic, therefore, that architects are among the few classes of computer users that crave the power of NT now, even though the interface is not quite up to their needs.

And one major vendor of UNIX CAD workstations, Sun Microsystems, has offered NT only lukewarm public support, saying it will eventually adapt NT for Sun computers but not providing any timetable. Sun did announce work with Fujitsu on the next generation of SPARC microprocessors.

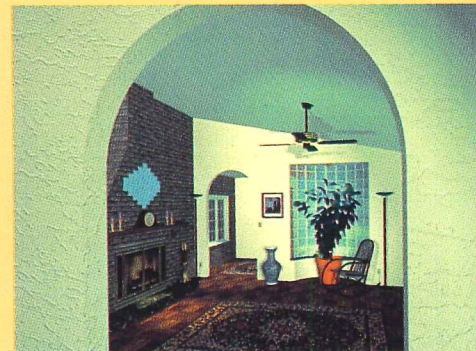

300a

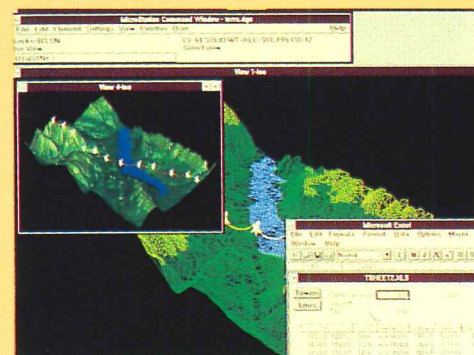

300b

Furthermore, some UNIX vendors have found NT's competitive threat among the new reasons to cooperate. Attendees at this show had to look closely, but the evidence was there. IBM, for instance, for the first time was demonstrating its Architecture & Engineering Series (A&ES) on a Hewlett-Packard HP Apollo 9000 Series 715/50 workstation. The normal platform is an IBM RISC System/6000. Both are UNIX computers. The demo was running at both the IBM and the HP booths.

**Circle 301**

ComputerVision announced that its CVaec for DIMENSION III plant-design software, which had been available on HP Apollo 9000 Series 400 workstations running under the Apollo DOMAIN operating system, was now available as a UNIX application for Series 700 workstations as well.

**Circle 302**

Also running on the Series 700 are AutoCAD Release 12, the ASG Architectural add-on, and KETIV Technologies and RenderStar's Advanced Rendering Extension (ARE-24).

**Circle 303**

**300a. Full-blown rendering in Intergraph MicroStation 5.0.**

**300b. Creating spreadsheet macro in Intergraph MicroStation 5.0.**

**301. Floor plan from IBM's A&ES showing highlighted area and furniture inventory.**

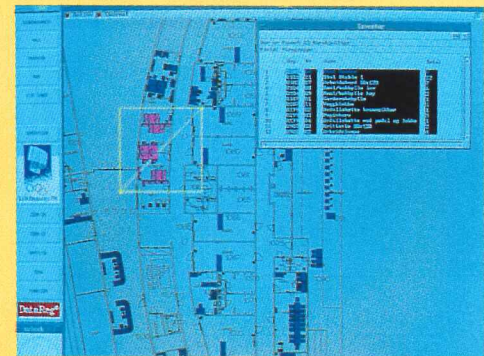

301



303

Indeed, KETIV and Softdesk are emerging as the major suppliers of AutoCAD add-ons, even as more firms enter the growing market. **Circle 304**

ASG and Softdesk completed their merger plans—essentially a merger of ASG into Softdesk. The two firms have been the leading suppliers of AutoCAD add-on software, with more than 100,000 systems in use. Last year, they had announced a common file format for AutoCAD details. At this year's conference, Softdesk unveiled a wide range of new products, including AutoCAD add-ons for Windows. Softdesk will also be distributing Sirlin's SirlinVIEW/Plus 2.5, a special version of this file viewer designed to work directly with Softdesk project files. **Circle 305**

NT is bringing many UNIX developers into the world of relatively inexpensive personal computers, too. For instance, Timeline Inc., a DEC VAX developer of financial-management and accounting software, showed NT versions of general-ledger and desktop-reporting packages. **Circle 306**

EDS unveiled MicroGDS CAD software for

**303. RenderStar Advanced Rendering Extension image**

**304a. Softdesk Architectural**

**304b. Softdesk Survey/Civil.**

**308. Office/residential building, Budapest. Graphisoft ArchiCAD.**



304a



304b

the DEC Alpha and NT at the show. GDS has been particularly strong in GIS software. **Circle 307**

CAD vendors that were already moving toward Windows anyway say NT is a logical step as well. Graphisoft introduced the Windows 3.1 version of its ArchiCAD modeling and CAD package, and said it would be released for NT as well; until recently, this software ran only on large Macintoshes. **Circle 308**

Autodesk privately showed a "developer's version" of AutoCAD Release 12 for Windows, compiled to run under Windows NT. It will not be sold to end-users, however. In a two-processor Pentium system, two copies ran simultaneously and exchanged data—each using one Pentium processor. The inside betting is that Release 13, the first end-user version due to run under NT, will be out by mid-1994—and maybe earlier in the spring.

The extra power of NT will be used, in part, for what Autodesk is calling the "Anaheim" add-ons—vastly improved links to databases, including geographical informa-

For more information, circle item numbers on Reader Service Card.



308

tion system (GIS) databases. The file structures will not be proprietary, Autodesk says. This means that other vendors can design their own file structures and file-translation programs to translate not only the graphical details of AutoCAD files, but also the underlying data.

Autodesk also announced that it has licensed the fast HOOPS Graphics System for 3-D graphics from Ithaca Software for future releases of AutoCAD. HOOPS should make AutoCAD faster, and files from AutoCAD add-on applications more portable. Also, Ithaca already has released an NT version. **Circle 309**

Cadkey announced that its next generation of CAD software would initially ship on NT as well. It will use the ObjectStore object database. The company also announced an advanced NURBS-based modeling package as an add-on to Cadkey 6.0, and an upgrade to DataCAD, dubbed 5.0. **Circle 310**

Isicad is also promising an NT version of its Cadvance CAD software. But the next upgrade, 6.0, due in September, will still be a standard Windows 3.1 product. It improves

313. GTW's project management system is modular; it connects to many Windows files.  
319. Cyco Automanager Classic is

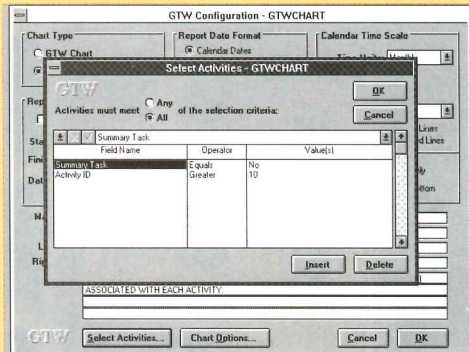

313

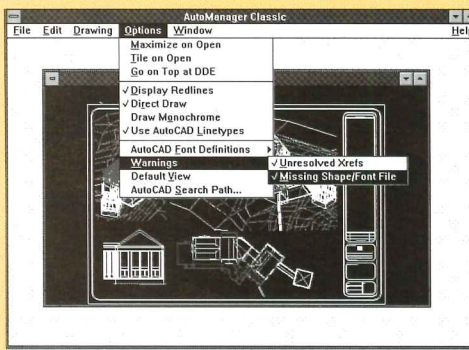

319

on the firm's first Windows version, 5.0, by adding TrueType font support, better text editing, better OLE and ODBC (Open Database Connectivity) support, and somewhat faster operation. **Circle 311**

Isicad was also showing AE Tools from A/E Technologies, a "smart symbol" library for automating the creation of architectural construction documents inside Cadvance 5.0. **Circle 312**

Like Windows 3.1 and Apple System 7.1, NT allows vendors to stitch together mature applications, to create special systems for architects. GTW Corporation, a project-management outfit, demonstrated a system that combined Microsoft Project for Windows, Excel, Word for Windows, and the Microsoft Access database with the GTW "Graphics That Work" package. **Circle 313**

Autodesk's Retail Products division released Generic CADD 6.1, with full 2-D DWG and DXF import and export. **Circle 314**

Macintosh users, who have been treated to new versions of AutoCAD and ArchiCAD in recent months, saw MiniCAD+ 4, version 3

particularly good at keeping track of AutoCAD files.  
321. CadmanView file viewer can search for any CAD files on your system.

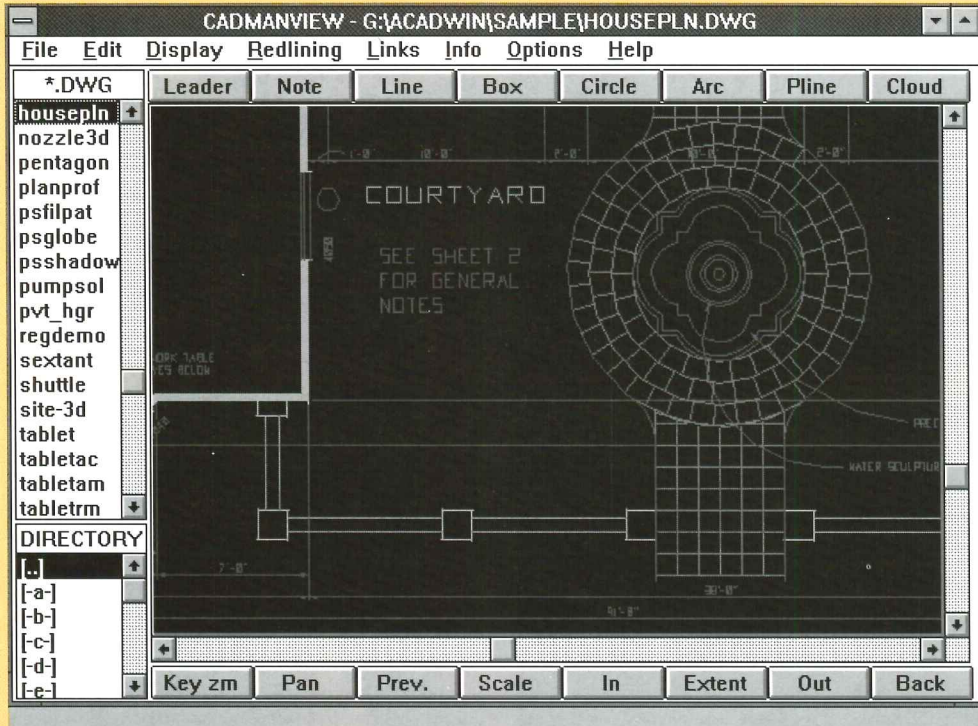

321

at the show. The new release has many new 3-D features, and the ability to import and export 3-D DXF and export RIB files for RenderMan rendering.

Graphsoft is taking full advantage of Claris's decision not to upgrade Claris CAD; Claris users can buy MiniCAD+ for \$495; the new release comes with a Claris CAD to MiniCAD+ converter. **Circle 315**

Innovative Data Design introduced a major upgrade, version 3.0, of MacDraft. It includes associative dimensioning, many new drawing tools, and some new presentation tools such as being able to create a slide show out of separate layers. IDD is discontinuing its Dreams CAD, however; most features are now in MacDraft. **Circle 316**

Auto.des.sys showed form-Z 2.2, an improved version of its excellent Macintosh modeling software. This package has excelled at producing intricate models of structures with fine detail and complex curves on any axis. **Circle 317**

## File Management

New approaches are emerging to keep track of CAD files on networks—even when the files themselves reference other files. At the high end, Micro Engineering Solutions is bundling Viewbase Tools 4.0 from Image Systems with its own IDoCS engineering document and revision-control software. The combo replaces the ViewBase system based on FoxPro; it handles viewing, multi-layer redlining, revision control, and "on-demand" document distribution. **Circle 318**

At the low end, Cyco International announced AutoManager Classic for Windows. For \$25, it allows zooming and panning, view of individual layers, blocks, or views, support of Windows multiple-document interface, and the ability to insert and Xref blocks. The firm's AutoManager WorkFlow is now in version 3.1 as well—with direct links to MicroStation and Generic CADD and the ability to read 15 different file formats. **Circle 319**

Covering high and low, SoftSource offered a "Lite" version of its AutoCAD Windows drawing viewer for \$10. It even tracks Xref and paperspace drawings from Release 12.

315. Graphsoft MiniCAD+.  
317. This is a model generated with  
form-Z 2.2 from Auto.des.sys.

330. Running JSpace facilities-  
management, Jacobus Technology.

For more information, circle  
item numbers on Reader Service Card.

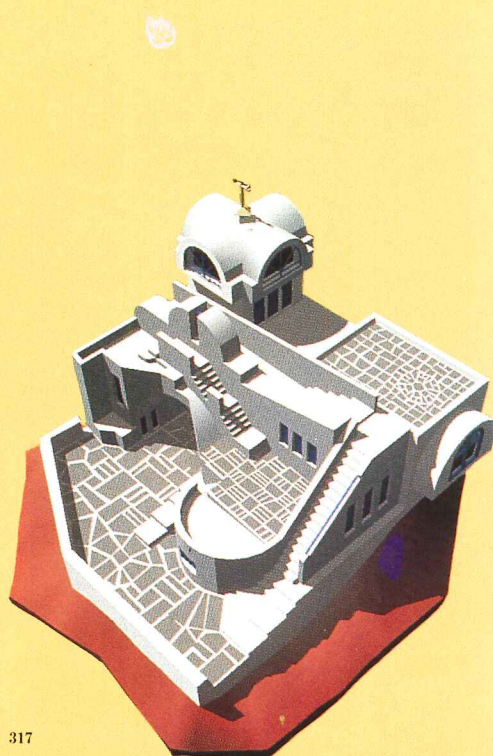
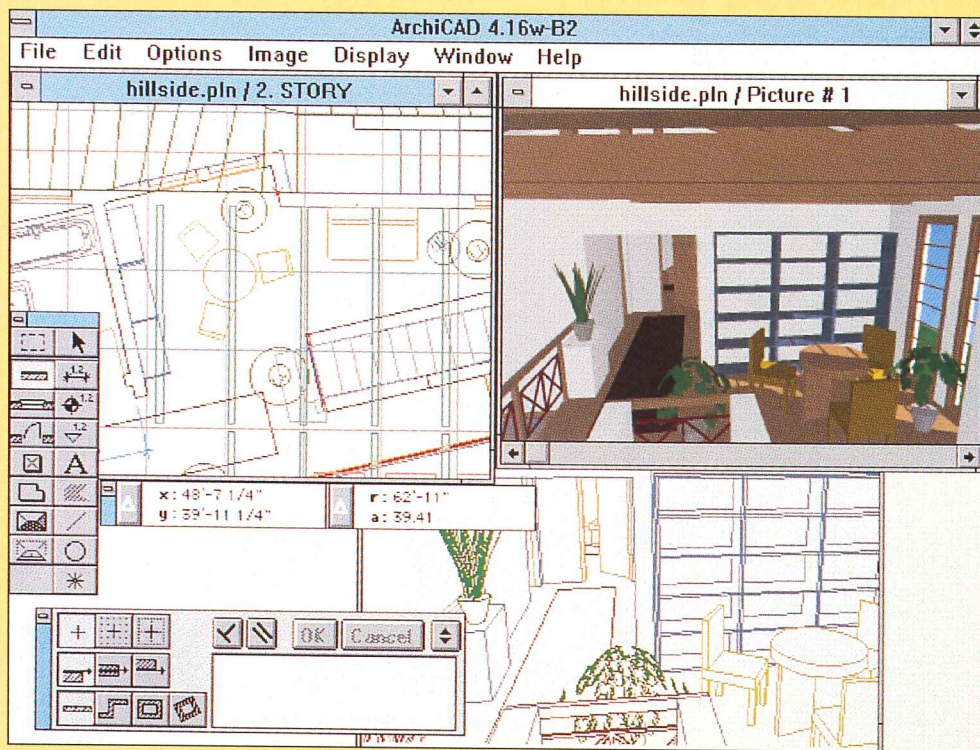

The full-blown Drawing Librarian is \$99; it can be customized for many different systems and needs. **Circle 320**

Baratek showed its Cadmanview file viewer as well. **Circle 321**

Cimmetry Systems, Inc., announced AutoVue 12.2, which allows viewing a wide variety of CAD, raster, and text files. There's a particularly powerful "compare" feature to help track revisions. There are UNIX, DOS, and Windows versions. **Circle 322**

CADWorks released its DecisionBase view-only product for Drawbase files. A Windows version of the parent product, Drawbase, is due this summer and an NT version is promised. This CAD package has been particularly popular for those doing facilities-management work. **Circle 323**

On the Macintosh side, Graphic Management Group announced a major upgrade to its Aperture "visual information management" software, version 4.0, and also announced a version for Windows. **Circle 324**

## Project Planning and Facilities Management

BEEDEE announced the first stand-alone Macintosh package for combined practice and project financial management. It is aimed directly at the architectural market, not for general accounting. **Circle 325**

Archibus showed its FM version 6.1 facilities-management package (for AutoCAD Release 12 for Windows). It allows viewing of a drawing and its database in separate windows on the same screen. **Circle 326**

Accugraph added new modules to its comprehensive facilities-management software as well. There's better asset management, with especially good graphics links. **Circle 327**

Primavera Systems previewed a Windows version of Primavera Project Planner. It includes all the functionality of the DOS version, along with the hourly scheduling features of its Finest Hour package. The final release should be out by summer's end. **Circle 328**

Harper and Shuman announced an addition



to its facilities-management/financial-management software—a package based on the popular Oracle database. It also announced its first DEC Alpha installation. **Circle 329**

Jacobus Technology showed its JSpace software for merging project databases, and JT/ID interference-detection software (based on JSpace). There are already versions for A&ES, MicroStation, and AutoCAD; it works with DXF or IGES files. **Circle 330**

331. Rendering of the Chrysler Building on Encad's Novajet II color ink-jet printer/plotter.

332. Plot done on the Hewlett-Packard

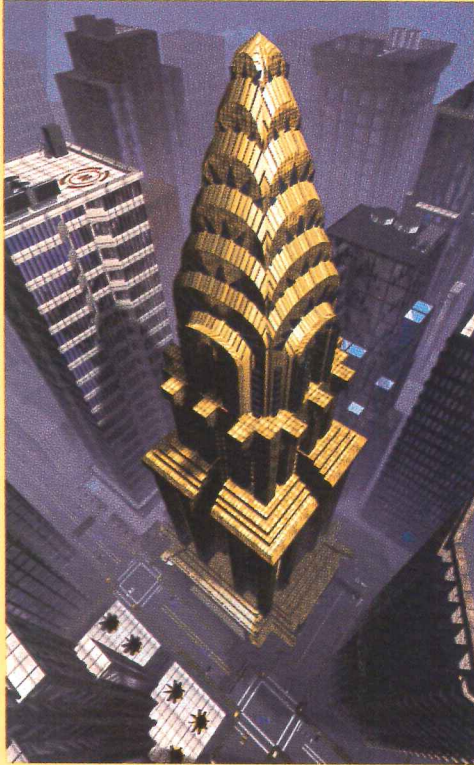

331

## Printers and Plotters

Large-format color inkjet printers improved enormously while prices came down considerably. Offerings from Encad and Hewlett-Packard handled even densely inked output with no noticeable color banding. And both firms offered a good range of network interfaces and add-on equipment such as PostScript interpreters.

Encad introduced its NOVAJET II E-size color ink jet printer/plotter. The unit is compatible with any software that handles HP-GL/2. At \$7,995 list, it is \$3,000 cheaper than last year's model, but offers more uniform color without noticeable "banding," and easier plot setups from memory or the front control panel. *Circle 331*

Hewlett-Packard introduced a direct competitor to the NOVAJET II, the HP DesignJet 650C, at \$9,995 for E-size and \$8,495 for D-size—and \$1,000 off either one if you trade in a D-size or larger plotter from any vendor. *Circle 332*

Indigo Graphic Systems added the 536-E to

DesignJet 650C.

335. CalComp dual-mode E-size pen plotter.

340a, 340b. Vermont Microsystems Auto-

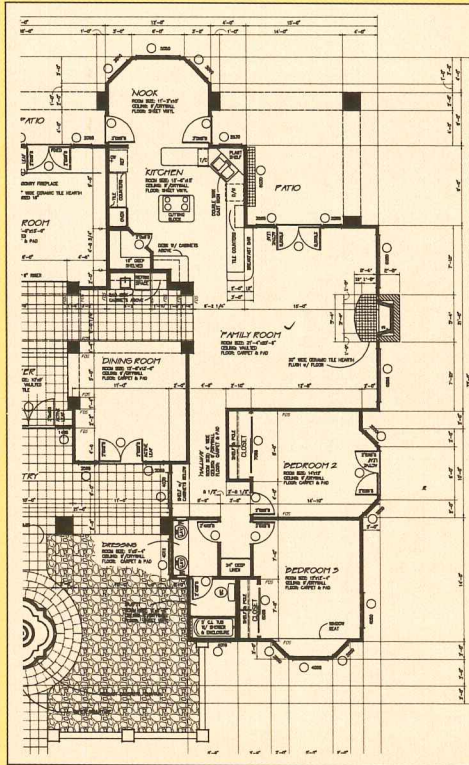

332

its line of electrostatic plotters. At about \$90,000, it is aimed at firms doing roughly 50,000 E-size plots a year. *Circle 333*

Shacoh USA showed an "all in one" E-size electrostatic copier, the model KIP 3800. With options it can be used as a plotter, fax machine, or scanner. The "full house" price with all options is \$59,000. *Circle 334*

CalComp introduced four large-format ScanPlus II scanners. With optional interfaces, they work on a wide range of workstations and personal computers. CalComp also announced across-the-board price cuts of up to \$3,000 on its DrawingMaster family of direct-imaging plotters. E-size units are now under \$20,000. The firm released several low-priced pen-plotters over the past year as well, and showed them at A/E/C Systems for the first time. *Circle 335*

Xerox Engineering Systems introduced four new electrostatic plotters in its 8770 series, featuring a new silicon-based imaging technology. The lowest-price unit, for 24-inch-wide media, lists for less than \$26,000 with 400 dpi resolution. *Circle 336*

Mate Pro for AutoCAD Windows release 12 allows quick view manipulation with its own display list.

344. SweetSource "snapshot" shows three

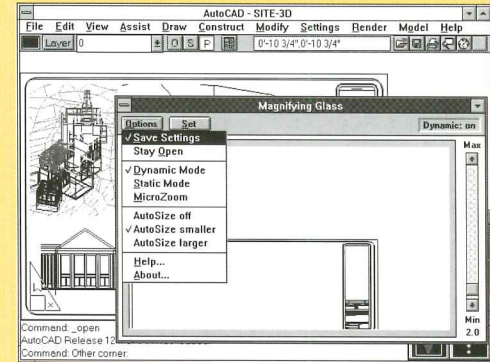

340



340a

## Video Drivers

Artist Graphics announced shipping of its Xj1000i family of graphics controllers, for 1600 by 1200 resolution on relatively inexpensive monitors. Software is included for real-time wireframe rotation in AutoCAD, and quick rendering. *Circle 337*

Matrox announced a super-fast 64-bit video-accelerator card that uses the Intel PCI local bus; deliveries are not expected until the end of 1993. It also showed its DynaView software for AutoCAD Release 11 and 12 DOS versions—with bird's eye view and the ability to switch screen resolutions without rebooting. *Circle 338*

Panacea released PanaIcon for AutoCAD 12 (DOS and Windows). It takes AutoCAD DWG files and converts them to menu icons. You display and access them through the AutoCAD Dialog Box Interface; icons can be resized to look good at any screen resolution, and the menus can be nested. One obvious use is to display a duplicate of the on-digitzed menu (a DWG file) on screen, and then modify it as needed. *Circle 339*



views of product—photo, CAD drawing, and text with technical data.  
**348. Summagraphics' SCAN-CAD 128P add-on cleans old blueprints.**

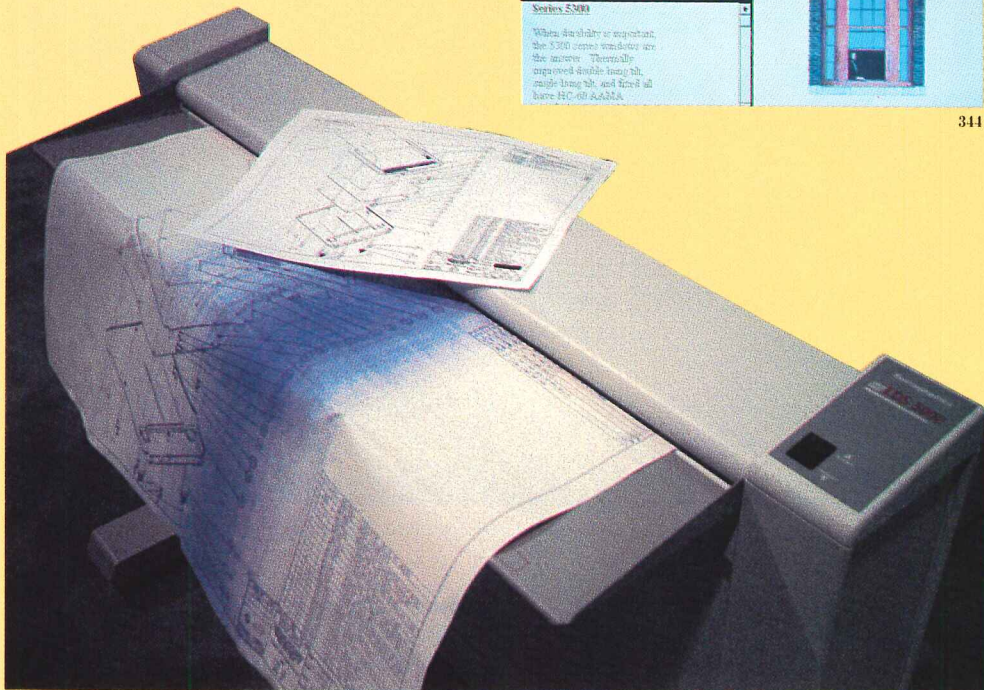

**348** Vermont Microsystems showed its AutoMate/Pro AutoCAD accelerator and on-screen menu software. The firm is concentrating more and more on software and less on hardware. **Circle 340**

Vibrant Graphics announced support of video boards based on the Weitek P9000 (Orchid P9000, Diamond Viper, Cardinal P9000) and the Western Digital W32 (Hercules Dynamite, Compaq ProLinea), and expanded support for graphics cards based on the S3 (9 GXE, Diamond Stealth Pro, etc.). Vibrant has accelerator software for AutoCAD, CADKey, and Intergraph MicroStation. **Circle 341**

Video Seven introduced a new display list driver for AutoCAD 12 running on Video Seven's graphic accelerator cards. It includes some nice ease-of-use features such as on-line help, and particularly speeds rendering. **Circle 342**

For more information, circle item numbers on Reader Service card.

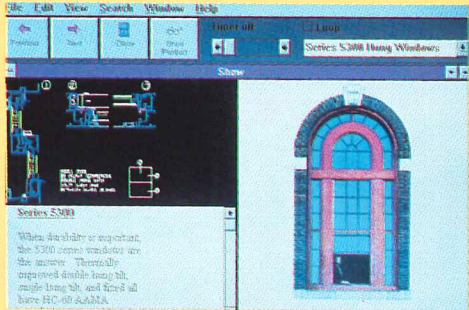

**344**

**Productivity Aids**

An inexpensive (as low as \$139) hood that fits over the monitor and allows 3-D viewing was introduced by Simsalabim Systems. You have to convert files to 3-D DXF first, but there are several vendors interested in improving the interface software. **Circle 343**

Sweet's Electronic Publishing showed the first "commercial" CD-ROM SweetSource disk. On it, dozens of companies have provided data that can be "pasted" into project files. Sweet's also showed its CadPLUS AE Design System, for automating facility-management chores. The report-writing feature is particularly flexible. **Circle 344**

Andersen Commercial Group released a DXF version of its Electronic Detail File of window and patio-door products; previously, it had only been available in AutoCAD DWG format. **Circle 345**

Decision Graphics showed the Windows version of its DGNLink software for moving files both ways between AutoCAD Release 12 and MicroStation. **Circle 346**



**335**

Insight Development is shipping PrintAPlot 3.0.3; it allows you to use a wide variety of printers in place of plotters. The software converts HP-GL to PostScript and most laser and dot-matrix formats. Drawings up to E-size can be printed by tiling smaller sheets. **Circle 347**

Summagraphics introduced a new pen-plotter line and showed large-format, backlit digitizer tablets. But perhaps the most amazing item was its SCAN-CAD 128P scanner add-on for the new HiPlot Series 7000 plotters; in tests at the booth, the scanner and software easily cleaned old, badly exposed blueprints to create files for further processing, or for use as a base for CAD. **Circle 348**

Axama introduced its DigiPlot 1000, a digitizer connected to a plotter for real-time output of the file you are tracing. The effect is something like a computerized "etch-a-sketch" machine, but the partial plots can be saved. It is a clever way to keep everything in one place, reducing the need to generate lots of paper ahead of time. **Circle 349**

Advanced Technology Center (ATC) released CADReview, a Windows 3.1 entry-level document viewer/markup package for AutoCAD, Generic CADD, DXF, SLD, and HPGL files. The firm upgraded its ForWare series as well. The ForWare series includes raster-document editing and viewing tools, and conversions. **Circle 350**

Image Systems showed a Windows version of its CAD Overlay ESP, for making revisions to scanned drawings inside AutoCAD. It is due to ship late this summer. **Circle 351**

Digest Software started marketing its raster scanning CleanScan software to end users. You can buy an evaluation copy for \$15; it will save a limited number of scanned images. You can then "buy" the right to *Continued on page 137*

## Berlin's IBA: A Critical Assessment

By Peter Blake

People have been building "ideal cities" for centuries—to memorialize popes and princes and other figures of authority or devotion. But in our century, ideal cities have usually been built to prove more prosaic points—political, social, sometimes esthetic. There have been new towns in Britain, the U. S. and elsewhere; there have been new capital cities like Brasilia and Chandigarh; and there have been experimental towns that explore new urban or architectural alternatives.

The three most interesting experiments in this century may have been conducted in Germany. There was the *Weissenhof Siedlung* of 1927 in Stuttgart, which was planned by Mies van der Rohe and contained an extraordinary collection of avant-garde structures by architects like Le Corbusier and Pierre Jeanneret, Walter Gropius, Hans Scharoun, Peter Behrens, J. J. P. Oud, and Mies himself. There was the large *Interbau* complex of 1957 in West Berlin—a realization in many ways of Le Corbusier's Radiant City concepts of the early 1920s, and containing impressive buildings by Aalto, Markelius, Niemeyer, Gropius, and many others. And then there was the most ambitious effort of all—the IBA (*Internationale Bau Ausstellung*, or International Building Exposition), which got under way in the late 1970s in West Berlin and is now finishing up.

In many ways, IBA is the most remarkable of the ideal cities built in this century. This is not because its components are exceptional works of architecture (though many are). It is because IBA is not a prototypical city at all, but a radically new urban approach.

Like many European cities, Berlin was a disaster area after World War II. Although much had been reconstructed in the 30 years since the war, by 1975 significant holes in its urban fabric remained: empty lots in the middle of city blocks and empty blocks in the middle of surviving neighborhoods.

These "infill sites," represented an entirely new problem. In East Berlin the commissars dealt with the challenge by wiping out what-

*Peter Blake's latest book, No Place Like Utopia, will be published this fall.*



Hertzberger's LiMa apartments overlook a central courtyard.

ever was left standing and starting with a *tabula rasa* on which to erect monumental boulevards honoring the new ruling elite. But in West Berlin, the complex ideals of participatory democracy demanded a different set of strategies: not a *tabula rasa*, but a kind of roundtable dialogue at which design solutions emerged from the interaction of all those most directly involved.

### Two heads for the program

By the late 1970s, Josef Paul Kleihues was appointed Director of Planning for the operation, with special responsibility for all the areas of new construction. Hardt-Waltherr Hamer, who had considerable experience in restoration, preservation, and community involvement, became head of those IBA operations that dealt primarily with existing structures. The Kleihues operation became known as "New IBA"; the Hamer operation, partly by default, was called "Old IBA."

The basic principle in both the New and the Old IBA was to mend the urban fabric—not by tearing out large pieces and replacing them with something dramatically different, but by inserting a little patch here and another there. A crucial principle established by Kleihues was that, if at all possible, infill sites and entire city blocks should be designed by several different architects to

assure a degree of variety very different from the uniformity that had characterized some Ideal City projects of the 1920s. To make sure that West Berlin would not suffer from too much unity, Kleihues selected architects of various persuasions and very different cultural backgrounds to design and build cheek by jowl in the areas of the New IBA. And Hamer, though less concerned with the problem of excessive uniformity, pursued similar strategies. By 1980 ground was broken on the first projects.

"What would you do differently if you had to do it over again?" I asked Kleihues recently. "Well, I'd do it on a much smaller scale," he replied. "We were too ambitious in those early days. We just did too many things. A few demonstration projects—that might have been a good way to start."

IBA's accomplishments have been little short of spectacular. The old IBA, to start with, has recycled or refitted some 10,000 apartments; constructed daycare centers, schools, and other educational facilities; inserted some of these into existing apartment buildings or courtyards behind them; provided space for family stores and other neighborhood facilities; and created pocket parks and public gardens. All this was planned and designed in conjunction with

Now that the decade-long International Building Exposition is mostly completed, Peter Blake examines its legacy of building and planning.



Moore's Tegel Harbor buildings stand on a small peninsula.

tenants, neighbors, and community groups. It was a laborious and often tense dialogue; but all those involved in it felt they had a personal stake in the final results.

#### Building the new

Meanwhile, the New IBA under Kleihues's direction has completed several thousand apartments and townhouses; it has built schools, daycare centers, a community library, a power station, a major scientific research institute, a water-purification plant, parks, gardens, and all sorts of ancillary structures. To get these structures designed, the New IBA selected architects from all over the world, sometimes directly, more often through competitions.

Because all of this has to do as much with process as with the final product, the ultimate results—the successes and failures of IBA—will have to be judged by future generations. But some of the results can be assessed even now, at least in part. To do this, I will discuss five projects (out of many dozens), not because these are necessarily the IBA's finest contributions to contemporary housing, but because they seem to be the most interesting experiments.

"There is more 'interaction' and 'participation' by the residents of this place than you'll

find in any other IBA project," says architectural historian Claus Baldus, in reference to the LiMa project, a 48-unit apartment complex in Southern Friedrichstadt. Designed by the Dutch architect Herman Hertzberger, the LiMa apartments (so named because it is located on a triangular site where Linden and Markgrafen Streets converge) are arranged in a semi-circle around a central playground. All 48 family apartments look onto this playground.

Throughout the project, Hertzberger involved the people who would live here in large and small design decisions. The playground in the center of the courtyard, for example, has been decorated with mosaics of colorful broken tiles contributed by the residents themselves. Hertzberger and his artist-wife showed the children and their parents pictures of how Antoni Gaudí had done it in the Parque Guell in Barcelona and then let everyone participate.

You can get into LiMa's court from all directions. "It's not like those traditional Berlin courtyards that are cut off from the outside world and are often quite depressing," says Hertzberger. Because people can look into the courtyard from their apartments and from the many balconies, there is no sense of insecurity among the children or their

parents. The apartment balconies are quite close together, but, at the same time, still private. Neighbors can chat from balcony to balcony if they want to. If not, they don't.

The second project is a set of eight new "urban villas" plus a ninth, existing building that used to house the Norwegian Embassy, and has been converted into an apartment house. Occupying an entire city block on the Rauchstrasse, in what used to be Berlin's Diplomatic Quarter, the project began with a competition won by the Luxembourg architect Rob Krier, who lives in Vienna.

The villas were designed by different architects from all over the globe. Krier himself did one of the villas and restored the former embassy, while Hans Hollein, Aldo Rossi, Giorgio Grassi, and others designed the other structures. The basic massing of the buildings was set in Krier's overall plan, so the entire block is a demonstration of how to achieve a degree of architectural variety without sacrificing urban unity.

Did they succeed? Yes and no. Clearly, the whole is considerably greater than the sum of its parts. The outdoor spaces between the villas are almost more pleasant than the villas themselves, most of which are boxy and finished in stucco painted a rather timid bureaucratic hue. Only Aldo Rossi's Villa has walls of bright red brick with dark-green steel lintels above doors and windows; all the others literally pale by comparison.

Still, the Rauchstrasse block was an important start. "I wish they had given more thought to the orientation of the apartments," a tenant told me. "When you have five apartments per floor, they don't have equally good views and you don't have sun in all of them." The tenant put her finger on something that plagues other IBA projects as well: they look good from the outside, but work less well for those who live inside.

#### Moore is more

"It's a sort of architectural zoo," the Berlin architecture critic Falk Jaeger says of the Tegeler Hafen (Tegel Harbor) project, a 350-unit apartment project in Northwest Berlin that is the work of architect Charles Moore and a group of American and European as-

© Richard Bryant/Arcaid

sociates [RECORD, July 1989, pages 82-95]. The Tegeler Hafen complex is the nearest thing to Postmodernism at IBA. The dearth of Postmodern buildings is not surprising. After all, Europeans have never felt driven to invent some sort of fantasy past; they can look at the real thing just down the street.

Moore's fantasy past is an intriguing exercise: it is a building complex located on a man-made peninsula that extends into one of Berlin's many canals. The buildings form a series of courtyards very much in the best Berlin tradition. And although the units are repetitive and modular in plan, the architects designed them to create an extraordinarily romantic composition of mansard roofs, turrets, and balconies—all rendered in the pastel shades of California's Bay Region!

The Tegeler Hafen is wonderfully klutzy, perfectly "contextual," and right on target—if what you are trying to hit is popular taste. And unlike other high-style works at IBA that have received much critical acclaim, Moore & Co.'s apartments are well planned, and their little peninsula will be quite charming once the greenery matures.

My fourth IBA project is about as different from the Tegeler Hafen as Jefferson's University of Virginia campus is from Disneyland. It is an extremely disciplined city block of about 100 townhouses designed by the Milan architect Vittorio Gregotti and several associates.

Gregotti's group designed the block that faces the street—the Lutzowstrasse in the Southern Tiergarten District—and a group of German architects designed a series of "fingers" that extend behind Gregotti's building and contain additional townhouses and apartments.

The entire affair is quite geometric in plan, but Gregotti's facades are colorful and full of elegant details including steel and glass bridges that link the long brick fronts facing the street. The spaces between the fingers are, alternately, access roads to the townhouses in the four wings and private gardens for those same townhouses. An underground garage provides parking and is topped by gardens and playgrounds at

street level. It is a convincing diagram for urban living—but not exactly what would pass for "low-cost housing" in the U. S.

#### **Eco Houses: designing your own nest**

"This is absolutely *"verruckt (crazy)!"* an elderly Berliner on his daily constitutional said to me. "This sort of thing really shouldn't be permitted!" The craziness in question is a set of three buildings, most commonly called the "Eco Houses," organized by Frei Otto next to the Rauchstrasse block. Containing 28 apartments (if that is the right term), the complex is as wildly experimental as anything that has been built anywhere in recent history.

First known for his innovative tensile structures (especially the Olympic stadium in Munich), Otto has expanded his interests in recent years to encompass all kinds of experimental ways of responding to environmental concerns. Otto's idea for the Eco Houses was to design a structural framework of reinforced concrete with two-story-high spaces between floor slabs and a complete network of pipes, ducts, and cables. This raw skeleton was then turned over to future residents who designed and built their own "nests" within the framework.

Each family was encouraged to pick an architect to help it plan and construct its future nest; most of them did, though some designed their own spaces. Many of the families, being of moderate means, did a great deal of construction themselves. All of the tenants were encouraged to provide outdoor spaces at various levels and were asked to "coordinate" their designs with those of neighbors and with the supervisory architect, a Berlin practitioner of superhuman patience named Herman Kendel, who had worked with Frei Otto in the past.

To anyone even remotely familiar with the process of designing "nests" for people and of getting them built, the Eco House method sounds like a sure-fire prescription for disaster. And, in the eyes of some, the three buildings may be just that. The houses are collages of brick, glass, canvas, plastics, steel, stone, wood, tile, fencing, siding, grass, rocks, plants, string, wire, plywood, copper, concrete, bird cages, pools, and at

least one beehive. There are, in addition, bay windows, greenhouses, mansard roofs, outside stairs and ramps, paved walkways, roof gardens, playgrounds, and bridges over the roots of existing trees.

What did the critics have to say about all this? Some were almost speechless. Kleihues who, I suspect, considers the Eco Houses non-architectural, prefers not to comment.

#### **Beyond habitat**

Some of the very best buildings commissioned and constructed by IBA are not housing at all. These include an elegant water purification plant in Tegel designed by Gustav Peichl, an electrical transformer on the Lützowstrasse, and a handsomely detailed work of industrial architecture designed by the Berlin architects Max and Karl Kudler. Above all, IBA has created some of the finest urban gardens and other outdoor spaces. The unsung heroes and heroines of the IBA experiment may turn out to have been its landscape architects.

There is no question in my mind that IBA has turned out to be a huge success. One need not approve of every building erected under its program (and I don't), or of every architectural assemblage on IBA's many sites. One need only compare the results with what has been constructed elsewhere in the name of Utopia, over the past hundred years or so, in dozens of different locations all over the world.

The most dramatic contrast, needless to say, can be found on the other side of what used to be the Berlin Wall. There the commissars over the past 40 years wiped out large areas of what was left of East Berlin and replaced its neighborhoods with monumental avenues lined with precast-concrete apartment blocks, perfectly aligned—row upon row of Communist prison cells all precisely identical, all miserably built, and all today rapidly falling apart. On the other side, a different pattern developed: a free, slightly chaotic collage of all the many factors that make life in cities so exciting, including, above all, the visible and audible presence of the arts. "Life," as Lewis Mumford liked to say, "is really more interesting than Utopia." He would have enjoyed the IBA. ■

# WOW!

*This is a CMU?*



Churchill Public School • Griffiths Rankin Cook Architects • Ottawa, Ontario



**astra-glaze<sup>®</sup>-sw**

glazed masonry units offer:

- Design flexibility, interior and exterior
- Color variety
- Fire safety
- Graffiti-proof cleansability
- A sanitary, low-maintenance surface
- Cost savings, short and long term
- Innovative shapes and sizes

*The Designer's Choice  
in Architectural Concrete Masonry.*

**TRENWYTH**

*Other quality products from TRENWYTH INDUSTRIES, INC.*

TRENDSTONE<sup>®</sup> ground face masonry units  
TRENDSTONE<sup>®</sup> PLUS filled and polished units  
ACOUSTA-WAL<sup>®</sup> sound absorbing masonry units  
AGGRE-BLOK<sup>®</sup> aggregate faced units

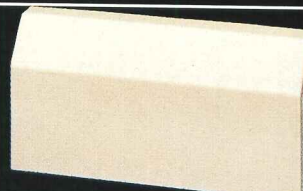
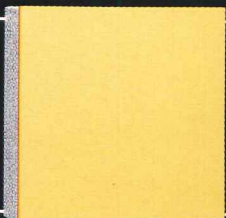

HEADQUARTERS PLANT:  
One Connelly Road, P. O. Box 438  
Emigsville, PA 17318  
(800) 233-1924 FAX (717) 764-6774  
(717) 767-6868

MANUFACTURING PLANT:  
South Beloit, IL  
(800) 358-3003  
FAX (815) 389-3214

SALES OFFICES:  
Rockford, IL (815) 389-3003  
Erie, PA (814) 452-6035  
Kansas City, MO (816) 229-6780

Detroit, MI (313) 588-3012  
New York, NY (914) 623-2539  
Northern, NJ (609) 291-8421  
Orlando, FL (904) 789-4050

Pittsburgh, PA (412) 921-0683  
Washington, DC (301) 986-1105  
Madison, WI (608) 274-4481  
Charlotte, NC (704) 642-0732  
York, PA (717) 767-6868

Circle 11 on inquiry card

**IF YOU'RE WONDERING  
ARE THE ANSWER, REMI**



*The 65,000-seat multi-purpose Alamodome, San Antonio, Texas.*

# WHETHER STEEL JOISTS REMEMBER THE ALAMODOME.



When San Antonio needed an economical structural system for the roof of their new Alamodome, Vulcraft had them covered.

Because they had a lofty construction goal: to build the most economical and flexible hard-roof stadium ever built. How economical did it need to be? Let's put it this way. The entire structure had to be paid for in five years with only the help of a one-half cent sales tax.

Which meant when it came to choosing partners, everyone had to sharpen their pencils and do their financial homework. When it was all over, everything pointed to a cable-suspended system using Vulcraft super long span steel joists.

A chief benefit of joists' high strength-to-weight ratio is that there's less tonnage to pay for, ship, and erect. And there's no more effective way

to save money than to keep these to the absolute minimum.

As for experience, no one has accomplished more with steel joists than Vulcraft. As the largest producer of steel joists and steel deck in the United States, we have more engineering background and know-how than any other joist company.

So our engineers were able to interact closely with the Alamodome's project designers right from the beginning. Bringing our many years of experience to the project at every stage, from early planning through erection of the entire job. Addressing the proper use of each component. Calculating loads. And helping determine requirements for attachments, and structural relationships.

As a result, we were able to supply 1,700 tons of problem-free steel joists for this job, 35 of them measuring 210 feet in length—extraordinary by any standards. Plus, we supplied nine acres of acoustical steel deck to cover them.

As you might have noticed, we're proud to have been a part of a project like this. We'd be no less proud to assist you. Call any one of our plants listed below, or consult Sweet's 05100/VUL and 05300/VUL, to see how we can make your next project a success.

Until then, when you think of the Alamodome, remember Vulcraft.

**VULCRAFT**  
A Division of Nucor Corporation

PO Box 637, Brigham City, UT 84302, 801/734-9433; PO Box 100520, Florence, SC 29501, 803/662-0381; PO Box 169, Fort Payne, AL 35967, 205/845-2460; PO Box 186, Grapeland, TX 75844, 409/687-4665; PO Box 59, Norfolk, NE 68702, 402/644-8500; PO Box 1000, St. Joe, IN 46785, 219/337-5411.

Architects: Marmon Barclay Souter Foster Hays and HOK Sports Facilities Group; Structural Engineer: W.E. Simpson Co. Inc.; Project Manager: Day & Zimmerman, Inc.; Structural Contractor: Lyda Incorporated; Steel Fabricators: Crown Steel Inc. and Industrial Mechanical Co.; Steel Erector: John F. Beasley Construction Co.



# A DOOR IS MORE THAN A SPECIFICATION IT IS A REFLECTION

WHEN PEOPLE LOOK AT ONE OF YOUR BUILDINGS, WHAT SHOULD THEY SEE? IDEALLY, YOU AND YOUR VISION. WHEN IT COMES TO HELPING YOU ACHIEVE THAT VISION, NO ONE DOES MORE FOR YOU THAN WEYERHAEUSER ARCHITECTURAL DOOR DIVISION. REPRESENTING THE WORLD'S FINEST SOLID WOOD INTERIOR DOORS, WEYERHAEUSER OFFERS ONE OF THE MOST EFFECTIVE AND LASTING WAYS TO PERSONALIZE YOUR BUILDINGS. OUR RANGE OF VENEERS, COLORS, STAINS AND SPECIFICATION OPTIONS IS UNRIVALED AND ASSURES THAT EACH PROJECT CARRIES YOUR INDIVIDUAL STAMP. BECAUSE AFTER ALL, IF IT DOESN'T LOOK LIKE YOU, WHY BOTHER? CALL {800} 869-DOOR.

WEYERHAEUSER ARCHITECTURAL DOOR DIVISION SALES CENTER 1401 EAST 4TH ST., MARSHFIELD, WI 54449-7780.



Weyerhaeuser

There Is No Equal.™



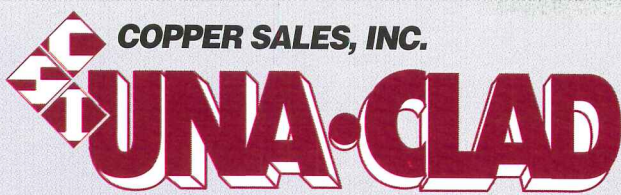

# Multiple Solutions for the Designer



## FLEXIBILITY

At Copper Sales, we are able to meet your project specification needs for metal roofing with four different preformed roofing systems; snap-on standing seam, snap-on batten, lock formed standing seam and the NEW UC System IV NO CLIP standing seam (the UC-IV carries a UL 90 rating both in 24 gauge steel and 16 and 20 ounce UNA-CLAD copper). Roofing systems are available in aluminum, steel, stainless and architectural grade copper.

## QUALITY

Every UNA-CLAD roofing system is fabricated under strict quality control criteria. Computer Aided Design and Computer Aided Manufacturing assure close tolerance and efficient manufacturing of every system component. Close attention is given to flatness, weather resistance and durability for every unit we produce.

## RELIABILITY

Each facet of our business has been built in response to market needs for quality, cost effective products. Through our metal roofing systems, panels systems, column covers and architectural flat sheet metal programs we have continued to expand by innovation, design and state-of-the-art production methods.

## SERVICE

Our professional representatives are located throughout the nation. They will provide you with an immediate link to obtain design and detail assistance, budget studies and specification guidance.

## RELATED PRODUCTS

Our UNA-CLAD roofing systems are complemented by our column cover and eight different panel systems. We are also a major source for pre-finished and pre-polished architectural metal sheets.

- See us in Sweets:*
- Panels — 07420/COP
  - Roofing — 07610/COP
  - Columns — 05600/COP

*Circle inquiry card, or if you are in a hurry, call toll free.*

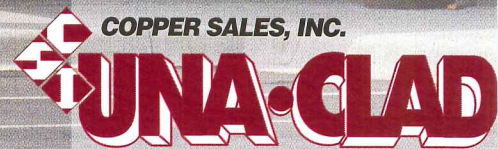

1405 North Highway 169  
Minneapolis, Minnesota 55441  
**Toll Free** (800) 426-7737  
**Local** (612) 545-1604  
**Fax** (612) 545-2762

JOB NAME: Park Square Rainbow Foods, Minneapolis, MN  
ARCHITECT: Weiss Architects  
GENERAL CONTRACTOR: Weiss Builders  
CONTRACTOR: Metal Systems, Inc., Bloomington, MN  
MATERIALS: 24 Gauge UNA-CLAD steel, UC-1, Sherwood Green

Circle 14 on inquiry card

# Custom Architectural Metal Systems



# 100% ACRYLIC EIFS

## What All The Best-Dressed Buildings Will Be Wearing

### Rohm and Haas 100% Acrylic Polymers Build In Lasting Beauty

The best fashions stand the test of time. And nothing dresses buildings with more enduring beauty than 100% Acrylic EIFS (Exterior Insulation and Finish Systems).

EIFS, when properly formulated with 100% acrylic polymers, provide long-lasting durability. Finish coats resist fading, cracking, and yellowing from UV exposure. Base coats deliver strong protection against impact and water infiltration from wind-driven rain. Plus adhesive layers bond securely to a variety of substrates. So you get 100% Acrylic EIFS that provide durable good looks, season after season.

That's the real beauty of 100% Acrylic EIFS: quality performance that outclasses non-100% Acrylic EIFS. Performance you can specify in an unlimited array of colors, and with greater design versatility than stucco, brick, or precast concrete.

For complete information on 100% acrylic polymers in EIFS, send for our brochure by writing Rohm and Haas Company, Marketing Services Dept., Independence Mall West, Philadelphia, PA 19105. Then dress your buildings in the best fashion with 100% Acrylic EIFS.

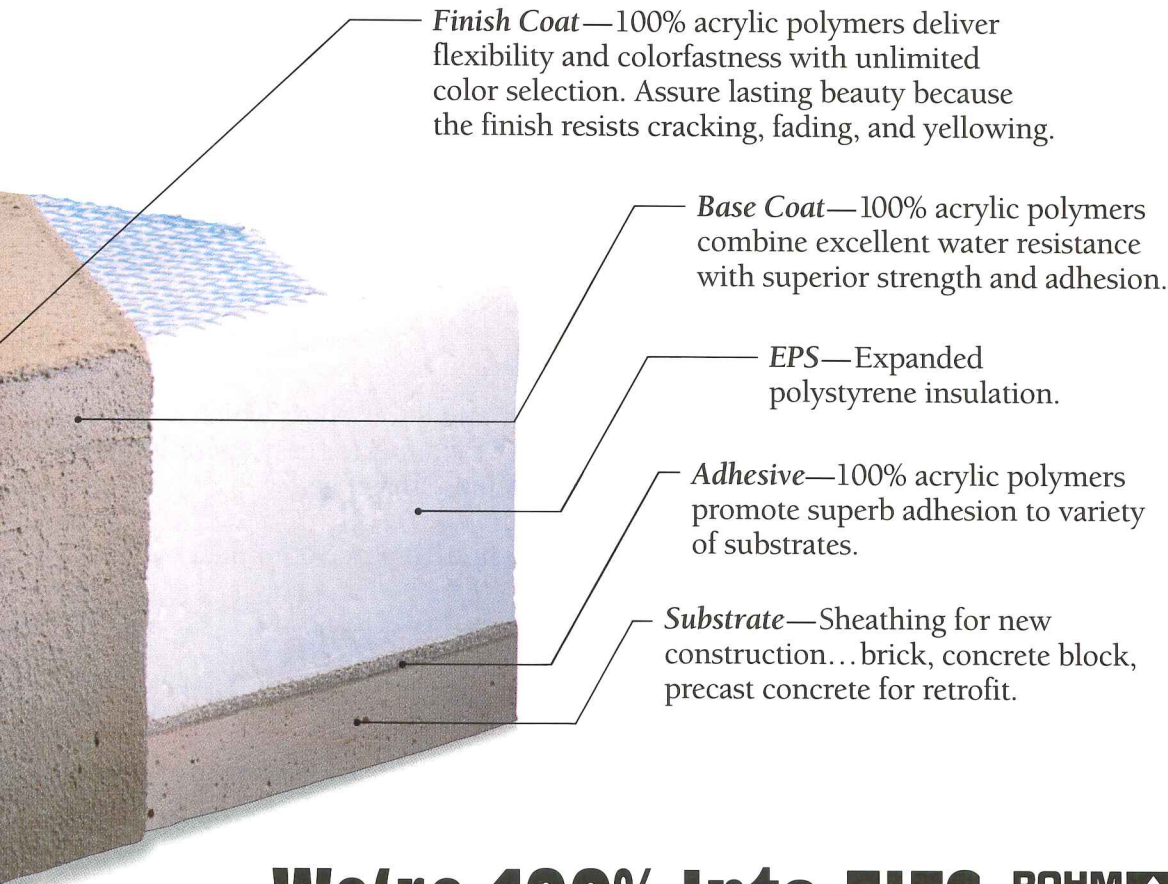

**We're 100% Into EIFS**

Circle 15 on inquiry card

**ROHM  
AND  
HAAS**  
PHILADELPHIA, PA. 19105



# Quiet Please



## Don't let outside noise intrude on the inside performance

When you require theatre ventilation, emergency fire venting, and...

- Acoustical Integrity
- Reliable Performance
- Long Product Life

Specify the fire vent that provides all three.

BILCO Acoustical Fire Vents are designed to provide a barrier against outside noise intrusion and at the same time provide necessary emergency automatic heat and smoke venting or manual ventilation. This unique design has gasketed and specially insulated upper and lower doors which open simultaneously when heat breaks the fusible link. The vents can be factory modified for easy operation from the stage area when you specify motorized or manual winch operation options shown below. These vents carry an STC rating of 45 and an OITC rating of 37.

The BILCO Acoustical Fire Vent's reliability and durability will provide you with peace of mind... and your client with peace and quiet.

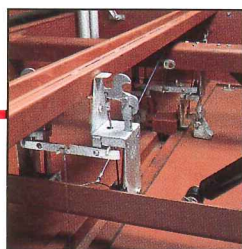
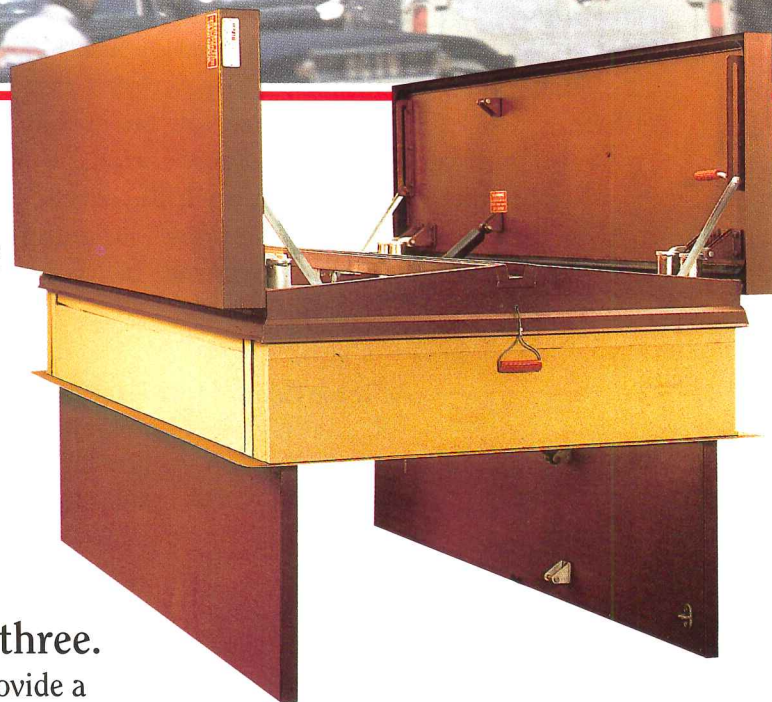

Standard BILCO Thermolatch®

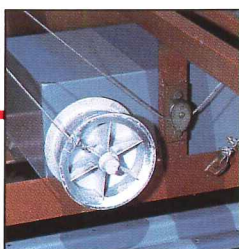

Optional motorized operation

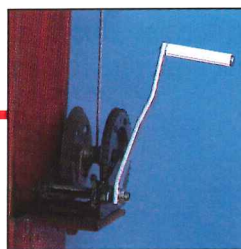

Optional manual winch operation

*Specify Bilco, a quality performer since 1926.*

**Bilco**®

DOORS FOR SPECIAL SERVICES

The BILCO Company, P. O. Box 1203, New Haven, CT 06505  
(203) 934-6363, FAX (203) 933-8478

# CATALOG FIFTEEN YOUR COMPLETE SOURCE

**JULIUS BLUM  
& CO., INC.**

CATALOG FIFTEEN

**STOCK  
COMPONENTS  
FOR  
ARCHITECTURAL  
METALWORKS**

**JB**

JULIUS BLUM & CO., INC.  
P.O. BOX 816, CARLSTADT, NEW JERSEY 07072-0816  
(800) 526-6293 • (201) 438-4600 • FAX (201) 438-6003  
© 1991 JULIUS BLUM & CO., INC.

Since 1910, Julius Blum & Co. has provided ornamental metal components of high quality to the architectural trades. Today, Julius Blum & Co. is the industry's most complete source for architectural metals. Our latest publication, **Catalog 15**, describes our full line of architectural metal components: JB® Glass Rail; Connectorail®; Colorail®; Carlstadt® Railing Systems; Traditional Railings; Elevator Cab Components; Handrail Brackets; Expansion Joints, Thresholds and Mouldings; Tubing, Bars and Shapes in Bronze, Aluminum, Steel and Stainless Steel.

**Catalog 15** also includes a complete Engineering Data section to assist in the proper structural design of various handrail systems.

**Julius Blum & Co., Inc.**  
P.O. Box 816, Carlstadt, New Jersey 07072-0816  
800-526-6293 • 201-438-4600 • Fax: 201-438-6003

Circle 17 on inquiry card

DECIDING WHICH MORTAR TO SPECIFY DOESN'T HAVE TO BE PUZZLING

---



## For superior uniformity, Masonry Cement is the answer.

No one likes surprises. You get used to the specific characteristics of the tools and materials you work with, and you expect them to operate with consistency. Specifying and using mortars is no different. You need a product that sets up and works with as little variation as possible, it saves you time and it saves you money. This is a point on which architects and contractors agree, when there's a demand for superior uniformity...masonry cement is the answer.

We invite you to write or call today for our latest technical update and list of material suppliers.

PORTLAND CEMENT  ASSOCIATION

5420 Old Orchard Road Skokie, Illinois 60077-1083 (708) 966-6200

F L O O R I N G  
GO WILD WITH COLOR!  
ENOUGH OPTIONS TO  
CONFOUND A CHAMELEON.

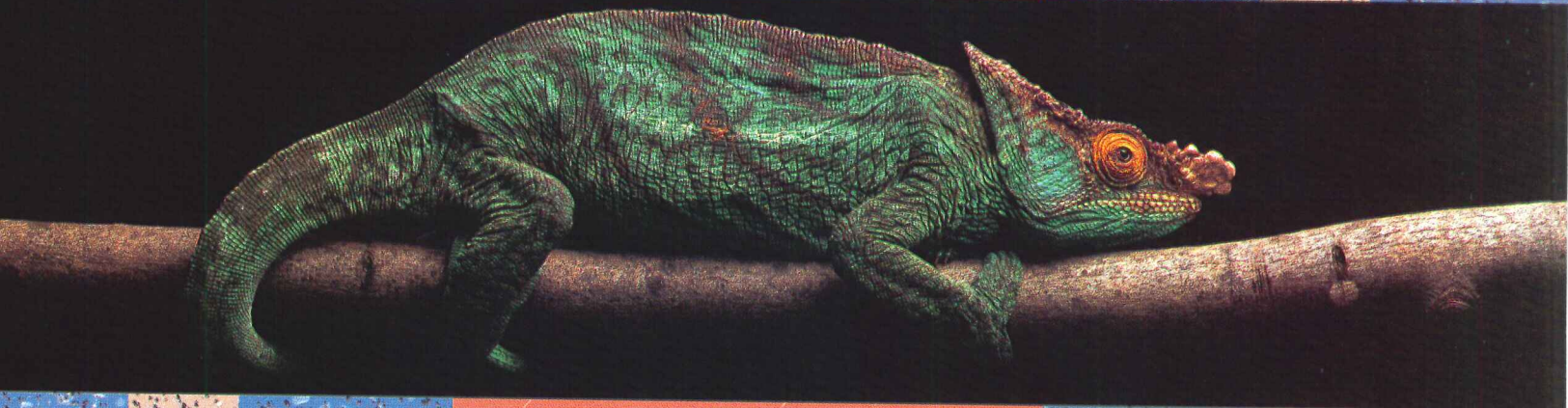

Forbo's vinyl flooring offers so many colors, even nature's best quick-change artist can't adapt. But what an opportunity for you to go wild with design! MultiStep\*, ColourStep and TractionStep share similar palettes, but mix the colors as solids and complementary chips for a nearly inexhaustible source of coordinated designs. New Colorstyle gives you swirls of marbled color. Rugged Smaragd lets you combine a strong design statement with the easy maintenance and great durability necessary in hospitals and labs. Ask us about the higher vinyl content in Forbo vinyls. It's your assurance of finer quality flooring that lasts longer and performs better.

Go wild with  
**FORBO VINYL  
FLOORING.**

The new standard in vinyl.  
Forbo Industries Incorporated  
Hazleton, Pennsylvania

\*1993 Neocon Gold Award Winner

**FORBO**  
VICRTEX WALLCOVERINGS  
**CONTRACT**  
FORBO FLOOR COVERINGS  
**SURFACES**

Circle 19 on inquiry card

**forbo**

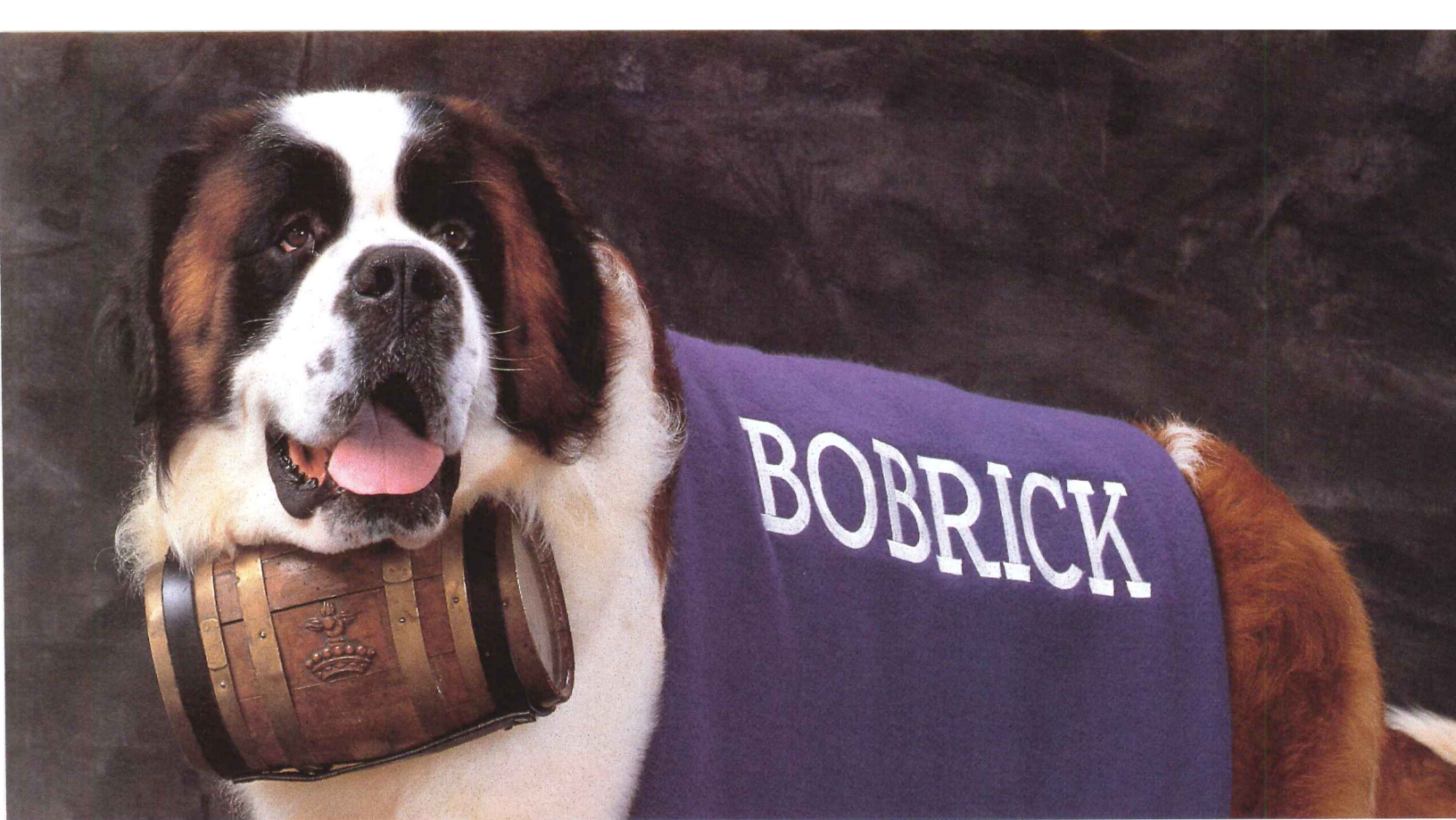

# GETTING LOST IN THE TRANSLATION OF ADA? HELP IS ON THE WAY.



*New Barrier-Free Washroom Planning Guide.*

Specify Bobrick; the only complete line of washroom accessories that meets the new ADA Accessibility Guidelines. With Bobrick, you're never stranded in ADAAG, risking fines and unhappy clients and patrons. Only Bobrick has the products and the experience to help you comply throughout the washroom.

Soap dispensers, vendors, and toilet compartment hardware need only one hand and less than five pounds of force to operate. Grab bars meet dimension, configuration and strength criteria.

Every accessory has been designed to meet the proper mounting heights, clearances, and functions required by ADAAG.

And your Bobrick Representative is prepared to help with product selection, placement and specifications. In fact, Bobrick has published the industry's most comprehensive Barrier-Free Washroom Planning Guide with the assistance of Ronald L. Mace, FAIA. No professional library is complete without it.

For a complimentary copy, and a Wheelchair Maneuverability Drawing Template, contact Bobrick, 11611 Hart Street, North Hollywood, CA 91605. Telephone: 800/553-1600, in CA call 818/503-1630. © 1993 Bobrick Washroom Equipment, Inc.

*All Bobrick soap dispensers meet ADAAG 5 lbf requirements.*

*Only Bobrick vendors meet ADAAG operation standards.*



## BOBRICK Washroom Equipment

New York Los Angeles Jackson, TN Toronto



**Judging  
from  
the  
sidelines,  
are  
these  
fixed  
or  
operable  
windows?**

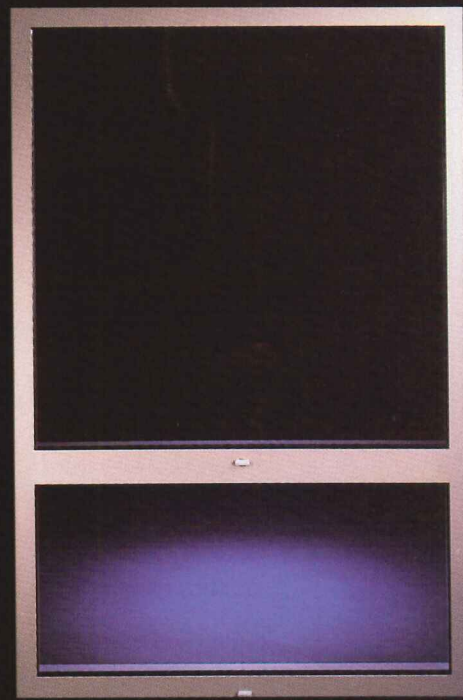
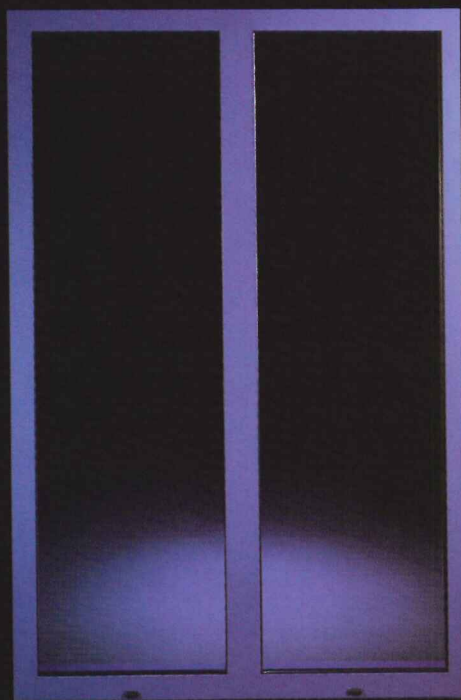
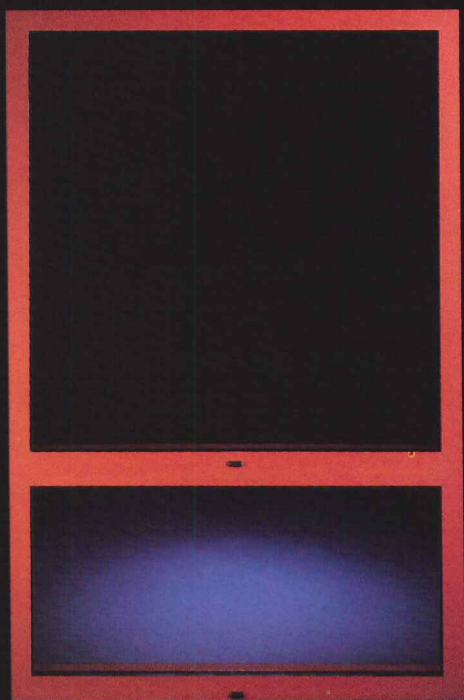

**CALL FOR ENTRIES**

# **RECORD HOUSES 1994**

The editors of ARCHITECTURAL RECORD announce the 39th annual RECORD HOUSES awards program. This program is open to any registered architect; work previously published in other national design magazines is disqualified. There are no entry forms or fees, although submissions must include plan(s), photographs (transparencies, slides, or prints), and a brief project description—bound firmly in an 8½ by 11 in. folder—and be postmarked no later than October 30, 1993. Winning entries will be featured in the 1994 RECORD HOUSES. Other submissions will either be returned or scheduled for a future issue. If you would like your entry returned, please include a self-addressed envelope with appropriate postage.

Submissions should be mailed to:

Karen D. Stein

**RECORD HOUSES**

**ARCHITECTURAL RECORD**

1221 Avenue of the Americas

New York, New York 10020

**Yes.**

Sometimes the obvious is not so obvious.

Equiline™ is a high performance operable and fixed window system providing no build-up of sitalines between fixed and operable units.

It's available in both thermal and non-thermal options, a variety of sizes and finishes that accommodate nearly every design need, and glazing choices that reduce on-site labor.

Engineered, structural integrity and a clean, uninterrupted siteline, from the company that pioneered high performance windows.

Equiline. The obvious choice.



*The 8350 T-L EQUILINE™ window employs the Pour and Debridge thermal break utilizing the Iso-Lock® process to eliminate expansion and contraction of the urethane.*



**The Mark of Responsibility**

Technology Park—Atlanta 555 Guthridge Court Norcross, GA 30092 404-449-5555

Circle 21 on inquiry card



# "YOU FIND A WINNING GAME PLAN TO INCREASE COPIER PRODUCTIVITY AND REDUCE OPERATING EXPENSES, YOU GO FOR IT."

CHUCK DALY  
CHAMPIONSHIP COACH

Business is like sports.

To win, you've got to make sure your team is performing to the maximum.

That's why Sharp has developed a Winning Game Plan for copiers.

This booklet can help you find the right Sharp Copier that's going to give you a big jump in productivity and reduce operating expenses.

Copiers like Sharp's SD-3075 high-volume duplicating system—a phenomenal player that gets the job done at 75 copies-per-minute. It has every advanced feature as standard. It collates, staples, handles 2-sided copies, report covers, inserts and computer fanfolds.

In fact, this powerful, reliable workhorse does it all. So call for your Winning Game Plan today. Or fax 1-800-3-SHARP-3.

We guarantee it: with performance like this, there's no way you're not going to come out ahead.

**CALL 1-800-BE-SHARP FOR YOUR  
WINNING GAME PLAN FOR COPIERS.**

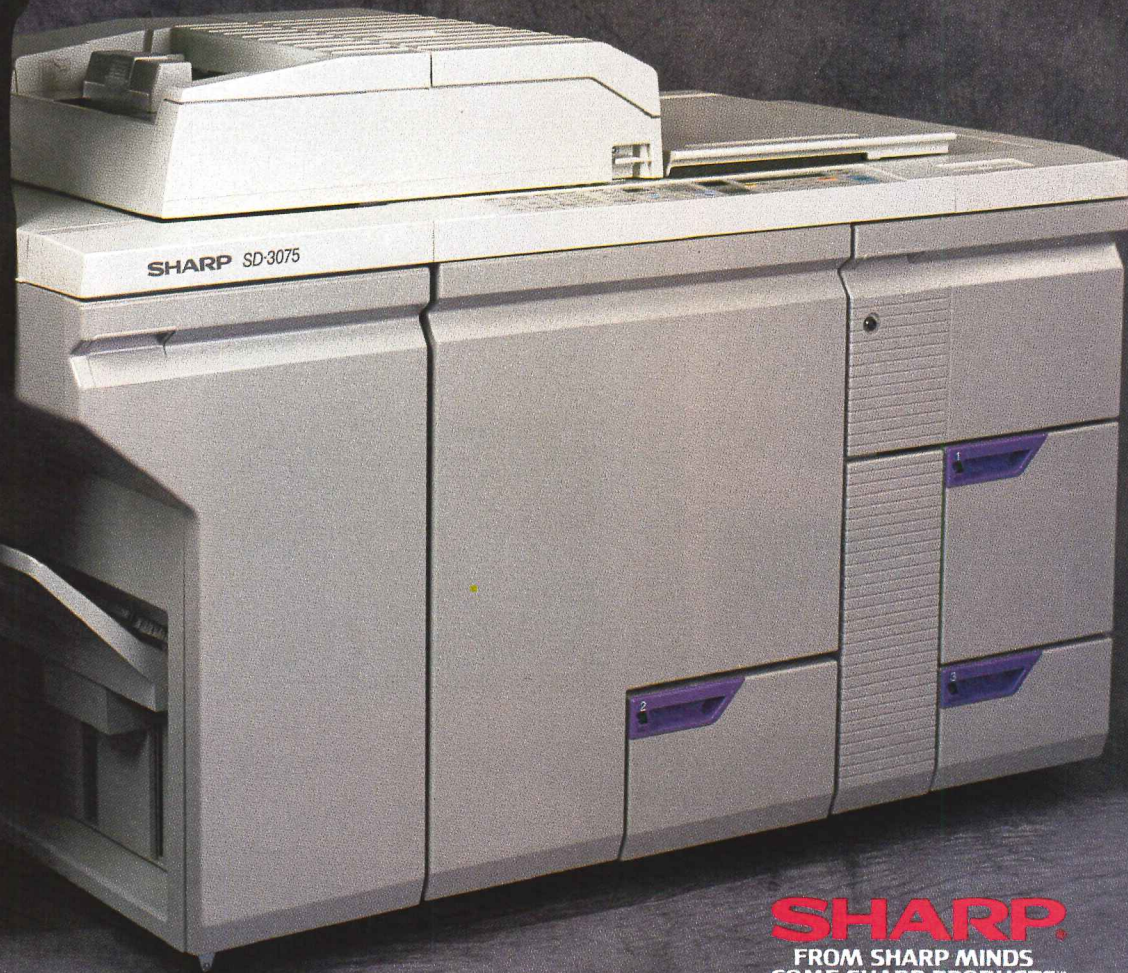
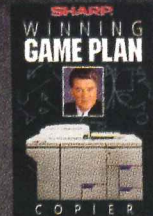

LCD

BANKING SYSTEMS • CALCULATORS • CASH REGISTERS • COLOR SCANNERS • COMPUTERS • COPIERS • FACSIMILE • LASER PRINTERS • TYPEWRITERS • WIZARD® ORGANIZERS

© 1993 Sharp Electronics Corporation.

**SHARP.**  
FROM SHARP MINDS  
COME SHARP PRODUCTS™

ANOTHER REASON TO USE PELLA® WINDOWS

Call for free design solutions,  
and you won't have to go buy the book.



The 1993 Pella® Architectural Design Manual has complete information on all our products and our unmatched custom capabilities, to help you find a unique solution for virtually any design challenge. And it's *free* to qualified architects and designers. Call 1-800-54-PELLA (mention code A223Z3AA) or send for your free copy today.

*Quality like this only comes from Pella.*

Circle 22 on inquiry card

Call or write for a free Pella® Architectural Design Manual.

NAME \_\_\_\_\_

TITLE \_\_\_\_\_

COMPANY \_\_\_\_\_

ADDRESS \_\_\_\_\_

CITY \_\_\_\_\_

STATE \_\_\_\_\_ ZIP \_\_\_\_\_

PHONE ( ) \_\_\_\_\_

**1-800-54-PELLA**

Pella Information Center  
P.O. Box 308, Moline, IL 61265-0308

CODE: A223H3AA



# THE SIMPLE SOLUTION FOR SAGGING SCHOOL CEILING PANELS

WHEN SCHOOLS CLOSE FOR SUMMER VACATIONS, THE INTERIORS CAN BECOME HOT, HUMID OVENS, AND ORDINARY CEILING PANELS SOMETIMES SAG, AND LOOK UNSIGHTLY.

TO COMBAT SAG, CELOTEX DEVELOPED VANTAGE 10,<sup>TM</sup> A MINERAL-FIBER, SAG-RESISTANT CEILING PANEL. SINCE 1986, VANTAGE 10 HAS CONCLUSIVELY PASSED THE TEST OF SAG RESISTANCE IN TEMPERATURE AND HUMIDITY CONDITIONS FAR BEYOND THE INDUSTRY STANDARD TOLERANCE FOR MINERAL CEILING PANELS. NOT JUST IN SCHOOLS, BUT SHOPPING CENTERS AND PUBLIC INSTITUTIONS, AS WELL. AND WE SUPPORT VANTAGE 10 WITH A **TEN-YEAR LIMITED WARRANTY AGAINST SAGGING...IN** TEMPERATURE AND HUMIDITY CONDITIONS UP TO **90°F/90%RH**. THERE'S MORE GOOD NEWS TO THIS STORY. VANTAGE 10 HAS A DURABLE MINERAL FIBER SURFACE. IT WILL NOT TEAR, WRINKLE, OR PEEL LIKE A HUMIDITY-RESISTANT, LAMINATED PANEL. IN ADDITION, VANTAGE 10 OFFERS A STANDARD **40-44 STC RANGE** DESIGNED TO **ABATE NOISE BETWEEN CLASSROOMS**. SO, WHEN YOU'RE TALKING ABOUT UNCONTROLLED SCHOOL ENVIRONMENTS, YOU SHOULD CONSIDER BOTH SAG AND SOUND BEFORE SPECIFYING STANDARD CEILING PANELS. CELOTEX VANTAGE 10 MAKES THE HIGHEST GRADES IN BOTH.

VANTAGE 10<sup>TM</sup>  
Mineral Fiber Lay-in Panels

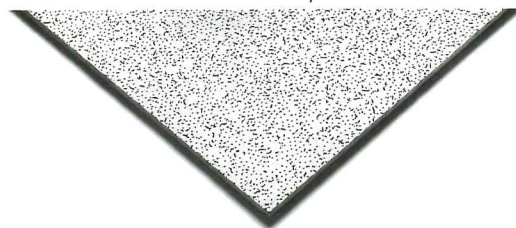

**The Original**

**Celotex**

THE FIRST NAME IN CEILINGS  
(813) 873-4498 or FAX (813) 873-4103

**Coloright**  
Flooring System

**Problem:**  
Integrity of design.

**Solution:**  
Specify Johnsonite.

The only single source for the most complete line of designer color-matched vinyl and rubber flooring products and accessories. Johnsonite's Coloright system is styled to aesthetically enhance interior environments.

We understand the problem, that's why we provide a system of wall base, stair treads, risers and stringers, reducers, edge guards, nosings, transitions, rubber tile and the industry's broadest range of mouldings — all color-matched for design flexibility!

Call Johnsonite today  
(800) 899-8916 or in  
Canada (800) 445-2162 to  
request samples, or for your  
nearest distributor.



**Johnsonite**<sup>®</sup>

Quality products since 1895  
Chagrin Falls, Ohio  
Waterloo, Ontario Canada

Sweets-Section 09650, Buy-Line 0822

© 1992 Johnsonite, Division of Duramax, Inc.

**Circle 24 on inquiry card**

# The Dome Wasn't Built In A Day.



Georgia Dome rendering supplied by joint venture: Heery/RFI/TVS, Atlanta, GA.

## Our Reputation Wasn't Either.

Sweet's  
08400/08900 YKK

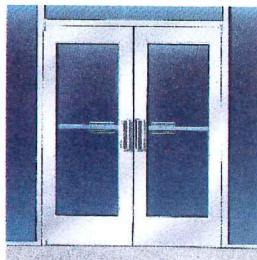

YES 45F-I Storefront Framing System

In fact, we've been working on it for over thirty years. Our continued investment in the highest quality production facilities combined with Total Quality Control and advanced Research & Development has put us at the forefront of architectural aluminum manufacturing. And we've stayed there by offering a level of service that matches our framing systems. Performance testing assures the absolute highest quality at every phase of production, from casting and extruding to finished products. Fast turnaround assures rapid delivery to meet the demands of today's fast-track projects. Like the Georgia Dome. As a result, we're proud to say that millions of people will beat a path to our doors. Walk through our YES 45F-I storefront framing. And gaze through our YSG 50 structural silicone glazed ribbon window and our YCW 752 curtain wall framing systems. So for your next project, specify YKK. You can be sure of what you're getting. Our reputation was built on it.

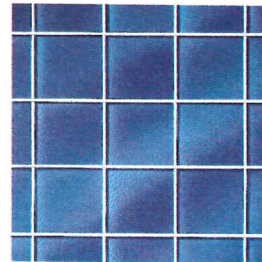

YCW 752 Curtain Wall Framing System

**YKK**<sup>®</sup>  
AP America, Inc.

Framing Systems for Innovative Designs  
5610 Gwaltney Drive, Atlanta, GA 30336  
(404) 344-2981

YKK, AP International: Tokyo, Singapore, Taipei, Hong Kong, Jakarta, Melbourne and Sao Paulo



# Performance That Dominates The Skyline.

Now there is a glass of such striking beauty that it draws the eye like a magnet. A glass whose unique aquamarine color transforms buildings glazed with it from mere architectural objects into performances of visual artistry. *Azurlite*® glass from PPG.

But while *Azurlite* glass is perhaps the most beautiful float glass available for architectural glazing, its stunning visual performance is only half of its story. *Azurlite* glass is also a solar control glass of unsurpassed performance.

With a full 71% light transmission in 6 mm thickness, spectrally selective *Azurlite* glass allows designers to realize all the openness, aesthetics, and efficiencies of daylighting. Yet its outstanding 0.58 shading coefficient provides solar heat gain management that delivers coolness and comfort. An unmatched performance ratio of  $0.71/0.58=1.22$ .

See for yourself how the performance of *Azurlite* glass can help your designs dominate the skyline. Contact your glass supplier or glazing contractor.

Or call 1-800-2-GET-PPG for more information and a free sample.

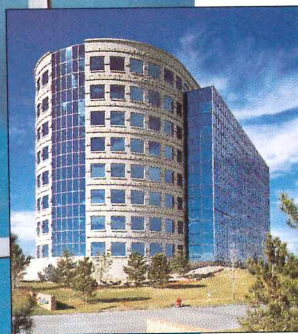

*Azurlite* is a registered trademark of PPG Industries, Inc.



Circle 26 on inquiry card

**Problem:** Your client wants lots of windows—non-tinted windows—facing west. How do you control heat gain?

**Solution:** Hurd Heat Mirror™ 66 windows are designed to reflect heat out—without using tinted glass, blinds or shades.

Hurd windows provide your clients extra comfort when it's hot by acting as a barrier to reflect heat out without obstructing the view. The result? You can create a much more comfortable environment for your clients.

And Hurd gives you a choice of beautiful, durable windows in hundreds of sizes and shapes that offer you the option to fine tune a building for the most energy efficiency possible.

Shading Coefficient Comparisons

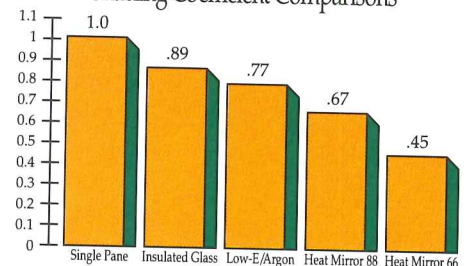

You can even reduce the HVAC investment without compromising comfort and design.

Find out more. See your Hurd distributor or call 1-800-2BE-HURD. Or write Hurd Millwork Co., 575 South Whelen Ave., Medford, Wisconsin 54451.



# Take your large document copying to new heights.



Is your current diazo printer or engineering copier letting you down? Then set your sights on the Océ 7000. Compact and affordable, it towers over the competition, offering extremely high quality copies up to 36" wide.

With the Océ 7000 you can produce high quality copies from blueprints, sepia's, plots and other large originals onto a wide variety of media.

Copy solid fills consistently, faithfully reproduce pencil marks, ink lines and halftones, and generate sharp images with high contrast. You can also replace damaged and faded originals with clear, high quality copies at the touch of a button.

So take a higher view on low volume plain paper copying. Mail in the attached coupon, and arrange for a free trial of the Océ 7000. Or call us directly at 1-800-445-3526 ext. 7000.

Yes, I want better quality copies!

Please tell me more about the free trial.

Please send me more information on the Océ 7000.

Please have a sales representative call me for a demo.

*Océ-Bruning offers full line of large document copiers, diazo printers, plotters, microfilm reader/printers and reprographic supplies.*

Name: \_\_\_\_\_ ARC8/93

Title: \_\_\_\_\_

Company: \_\_\_\_\_

Address: \_\_\_\_\_

City: \_\_\_\_\_ Stat: \_\_\_\_\_

Zip: \_\_\_\_\_ Telephone: \_\_\_\_\_

Mail to: Océ-Bruning  
1800 Bruning Drive W. Itasca, IL 60143.

Attn: Marketing Dept.

Fax to: 708-351-7549.

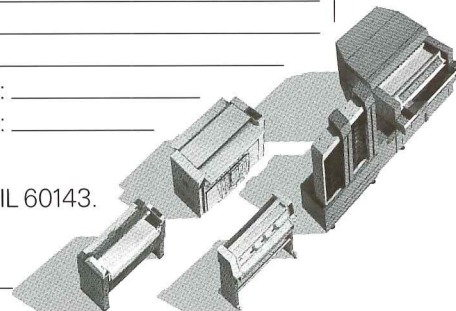

Circle 28 on inquiry card



Copying and printing with the simple touch of genius.

Océ-Bruning, Inc., 1800 Bruning Drive West, Itasca, Illinois 60143.

LEGENDARY PERFORMANCE.

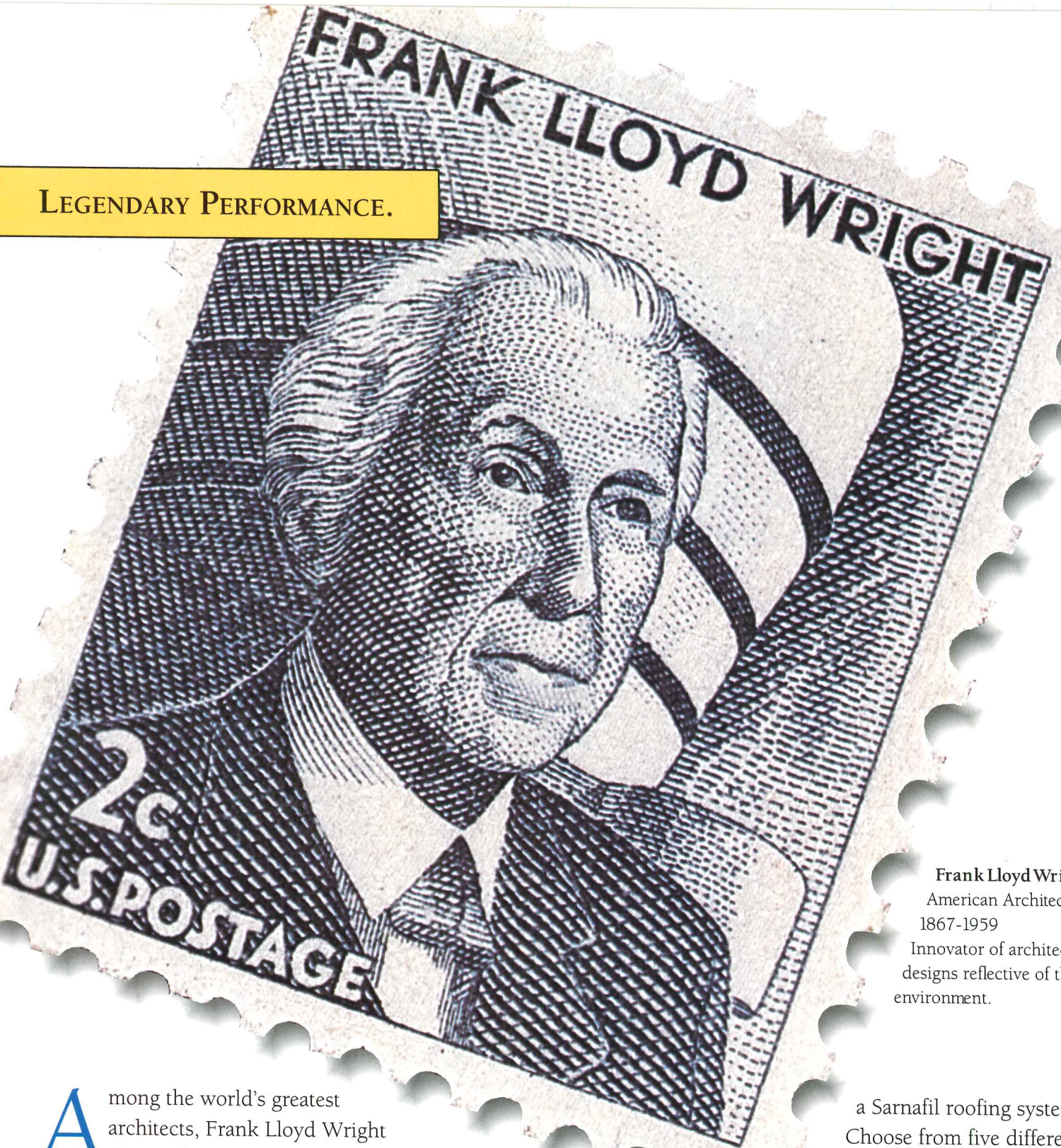

Frank Lloyd Wright  
American Architect,  
1867-1959  
Innovator of architectural  
designs reflective of their  
environment.

Among the world's greatest architects, Frank Lloyd Wright designed masterpieces that have influenced contemporary architecture. He confirmed that while greatness is often measured by beauty of form, the requirements of function are equally compelling.

That's why every Sarnafil roofing system is designed to not only look good but to perform. Only Sarnafil

offers you design possibilities that are backed by an undeniable record of performance. For nearly 30 years, we have provided not only aesthetically pleasing products, but also unmatched peace of mind to architects and specifiers around the world.

So, for your next project, specify

a Sarnafil roofing system. Choose from five different attachment systems, in unlimited custom colors, from 48 to 96 mil thicknesses.

**Sarnafil**  
Roofing and Waterproofing Systems

**Top Performance Every Time**

100 Dan Road, Canton, MA 02021  
1-800-451-2504 or fax 617-828-5365

*Building Types Study 708/Schools*

The last time the United States took such a long hard look at its educational system the Russians had just launched *Sputnik* and were about to send a few faithful Soviet dogs into space. This conspicuous display of technological prowess set off a bout of American soul-searching followed by a frenzy of school construction that lasted through the 1960s. New Math, language labs, open plans, and team teaching were all legacies of the national effort to revamp education. Today, the Soviet Union is gone, but a wave of school construction is once again sweeping over North America. Fast-growing areas such as the Southwest require large new facilities, as seen in HNTB's Fountain Hills Junior/Senior High School outside Phoenix (page 84). In older urban areas, the role of the school is changing. In Chicago, the Seward Hedges Area School designed by Ross Barney + Jankowski provides a safe haven for learning (page 92), while in New York City Richard Dattner's Intermediate School 218 offers a broad range of community services (page 104). Suburban Troy, Michigan, posed a different set of challenges and Perkins & Will responded with a generous campus design for Troy High School (page 96). For a smaller community in British Columbia, Hughes Baldwin Architects created an inspired solution for the Rogers Elementary School that can be easily expanded (page 108). Taking advantage of the climate in Davis, California, the Steinberg Group Architects organized Patwin Elementary School around outdoor spaces (page 110). Since much construction today involves renovating or adding to existing facilities, our Focus On section looks at five innovative school additions. *C. A. P.*

*Manufacturers' Sources  
listed on page 139*

# Overhauling Education

Not since the 1960s have schools attracted so much attention from architects and educators. While the demographics of the so-called Baby Boomlet are the most obvious reason for all the fuss, a number of other factors are contributing to a movement that may very well overhaul the programming and design of elementary through senior high schools. The emergence of new computer and video technology, the changing ethnic makeup of the school-age population, the realization that many existing schools are failing to educate, and the appearance of major private developers are all key factors in the recent burst of school construction. As a result, architects are being asked to rethink everything from the design of the individual classroom to the relationship between the school and its community.

The driving force behind the latest generation of schools is the growing number of children. For the fourth year in a row, more than 4 million births were recorded in the U. S. While this doesn't match the original Baby Boom when births topped 4 million a year for 11 years in a row (ending in 1964), it's up from the mid-1970s when births declined to 3.1 million a year. Nationwide 47.5 million kids are now attending primary or secondary school and this will grow to 49.9 million by the year 2000, says Paul Abramson, president of Stanton Leggett Associates, an educational consulting firm. That prediction, however, is low, says Abramson, because it doesn't account for new Census data that shows higher birth rates for Hispanics and Asians.

In a period when construction for many building types is decreasing, the numbers for schools are brighter. In 1992, \$10.7 billion was spent on building schools (kindergarten through high school, including vocational schools), up 56 percent from five years before, according to the F. W. Dodge Division of McGraw-Hill. Although the total figure for 1992 was down 5 percent from 1991, new-school construction was up 8.7 percent. Accounting for the overall drop was a downturn in renovations and additions, which were casualties of tighter government spending. "There's no question about continued demand for more schools," says Abramson. "Whether the public comes up with the necessary money is another matter."

Without a doubt, the role of the school is changing radically. No longer is it an institution isolated from the rest of society and open

only six hours a day, nine months a year. Today some schools are open 14 hours a day—offering adult-education classes in the evening, library and meeting facilities for the entire community, and recreational activities year-round. "Involving the community is the key to schools of the future," states Selim Iltus, an architect who is co-director of the Children's Environments Research Group at the City University of New York Graduate Center. "The school has to be seen as a resource for everyone."

The incidence of crack babies, broken families, and violent crime, though, remind us that the outside world brings many problems into the school arena. Special-education classes for children with learning disabilities, social services for those with weak family-support structures, and language programs for recent immigrants are added elements transforming schools. Many children today receive most of their meals and primary health care at school. "A lot of children require tremendous support services that just weren't part of the traditional set of services provided by schools," explains Abramson.

In poor urban areas in particular, schools have become key tools in fighting social ills. In the Watts section of Los Angeles, for example, the private Sheenway School has been a force in knitting a troubled community together since 1971. Now Dolores Sheen, one of the school's founders, is hoping to build a larger facility to include 23 elderly-housing units, an infant-care center, a pre-school, a community center, a health clinic, a food cooperative, a few stores, a garden, and a K-12 school. The idea is to surround the school with "the integral components of a community," says Ron Radziner, a partner in Marmol, Radziner & Welsh Architecture, the architects for what Sheen calls "the Integral Urban School." MRW has accommodated Sheen's program by designing a village of buildings climbing a sloping site and surrounding a landscaped plaza (opposite right).

As the role of the school has grown, so has its size. With expanded social services, larger science facilities, and equal recreational areas for boys and girls, the amount of space per student has increased from about 150 to 180 square feet over the last 20 years in northeastern high schools, says architect C. William Brubaker, of Perkins & Will. (Warm-weather schools need less indoor space.) But at the

*The Victor Valley High School in Ontario, California, will be a \$35-million facility organized into academic villages (right). The Sheenway School in Los Angeles is to include elderly housing, retail, and a cultural center (far right).*

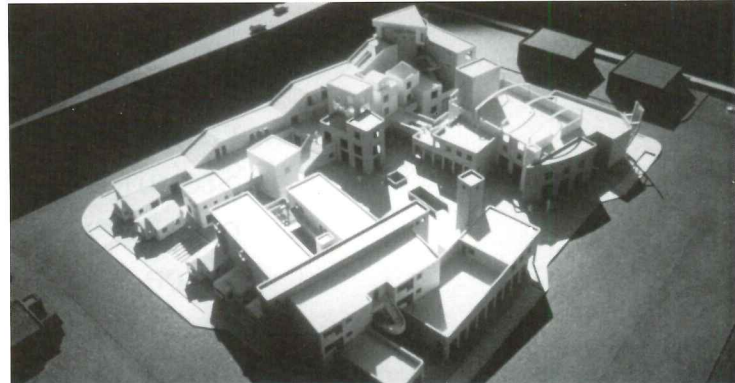
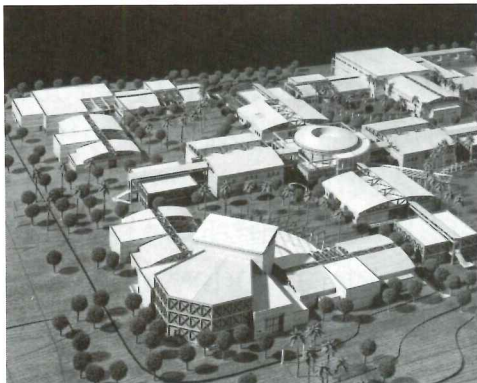

# As schools provide expanded services for adults as well as children, architects and educators are changing the way educational facilities are organized and designed.

same time, educators have recognized that many students get lost in large schools. "All of the research shows that smaller schools are better," says Iltus. "But it's not always financially possible to build smaller schools. So it becomes a design and programming problem: How do you create small schools within larger ones?"

To accomplish that task, some schools organize themselves into several "academies" or clusters—often with one academy on each floor or in each wing. One such school is the Victor Valley High School in Ontario, California, designed by the HMC Group (opposite left). Set to begin construction in 1994 on a 60-acre site, the 3,000-student facility groups buildings around three interdisciplinary clusters rather than various academic departments. Each cluster surrounds its own courtyard and operates as an semi-autonomous academic village. "We wanted to get away from the one large quad scheme," says John Nichols, the HMC partner-in-charge of the project. Separate courtyards also allow the school to secure certain parts of the campus, while other parts are open at night or during the weekend.

Some cities are experimenting with theme high schools and other non-traditional educational approaches. New York City, for example, opens 37 such high schools this fall with themes ranging from economics to social change and the health professions. Instead of several thousand students, each theme school is to have only 500 to 600. Most of the new schools will be housed in existing buildings, but are being programmed by outside organizations—including Outward Bound and the Pratt Center for Community and Environmental Development. Ron Shiffman, director of the Pratt Center, is helping to organize the Benjamin Banneker School, which will focus on community development and architecture and which will be linked to a community development corporation (CDC) involved in rebuilding and redevelopment projects in the neighborhood. The CDC will provide hands-on training for students in planning, design, and construction, says Shiffman.

One of the most talked about trends in education today is the growing impact of the private sector. Encouraged by then President George Bush, a nonprofit foundation called the New American Schools Development Corporation began raising money for "a new

generation" of experimental schools in 1991. Shortly thereafter entrepreneur Chris Whittle announced he would build and operate a national chain of 1,000 schools. Called the Edison Project, the for-profit venture is headed by former Yale president Benno Schmidt, Jr. and recently hired Venturi Scott Brown & Associates, Frank O. Gehry Associates, William Rawn Associates, and Billes/Manning Architects to work on the design of its schools. In an article in *Tennessee Illustrated*, Whittle stated his goal is "a complete redesign of the way we teach our children."

Benno Schmidt sees Edison schools experimenting with new methods of teaching in addition to traditional classroom instruction. Since all children don't learn at the same pace and in the same way, "we must provide more flexible, individual learning," says Schmidt. "This means you will need a different kind of architecture," he adds. "A repetitive and closed architecture won't provide the right learning environment for this program." Schmidt also states new electronic technology will have a great impact on the way children learn and how schools are laid out. "The electronic classroom will most certainly not be set up with rows of desks," says Schmidt. Although the design stage has yet to begin, the architects and educators involved in the project believe it is important to break the schools into various "houses" or academies, says Denise Scott Brown. The schools, which are to be built at the same cost-per-pupil as public schools, will emphasize interdisciplinary teaching and a variety of learning styles, explains Scott Brown.

A four-year research and design project at the Massachusetts Institute of Technology is investigating some of the same territory as the Edison Project. Headed by Roy Strickland, the MIT project will develop prototype designs for urban, suburban, and exurban schools. After one year, the group has come up with some innovative designs for a K-12 school in an urban setting, examining issues such as the school's ties to its community and ways to design classrooms for more flexible teaching methods (diagrams below).

No one knows whether any of these new directions will pass the test of time. What *is* clear is that a growing number of people are re-examining the basics of education in America. *Clifford A. Pearson*

1. Stair hall
2. Teachers' office
3. Lounge
4. Lavatories
5. Classroom
6. Shared space/seminar
7. Study/computer
8. Balcony
9. Greenhouse

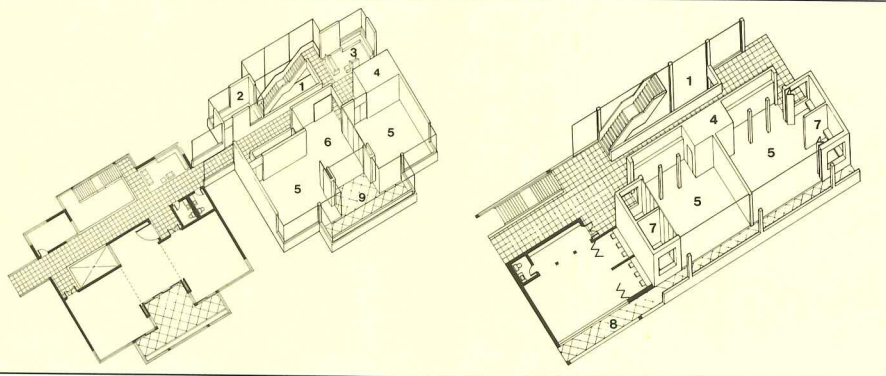

*Designs developed for MIT's New American School Design Project: scheme by Anne Townes has shared space between classrooms and a lounge across the hall (far left); scheme by Veronica Pedrini has study areas in each classroom (left).*

Drawings by Jennifer Mecca

# Open Minded

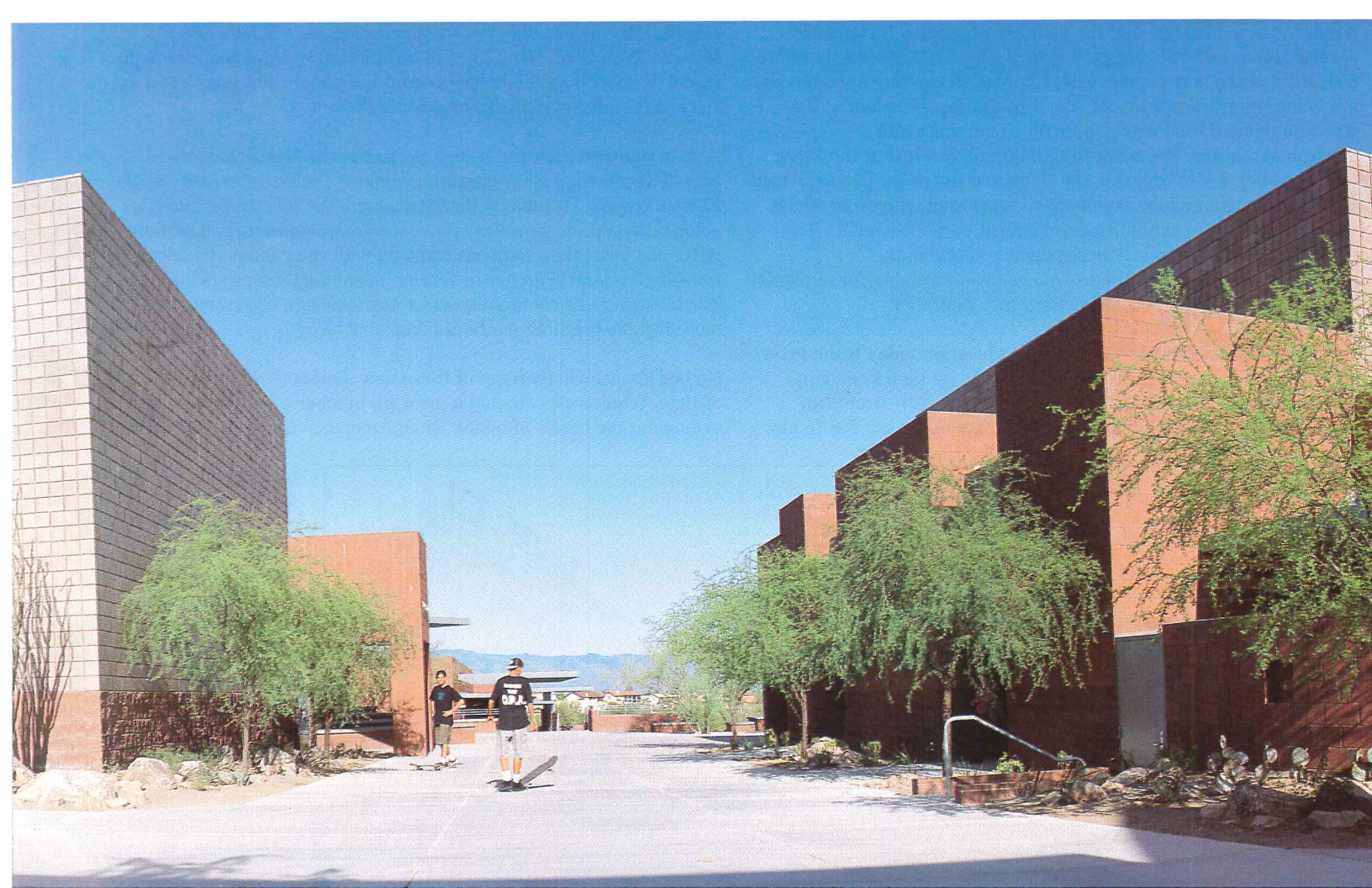
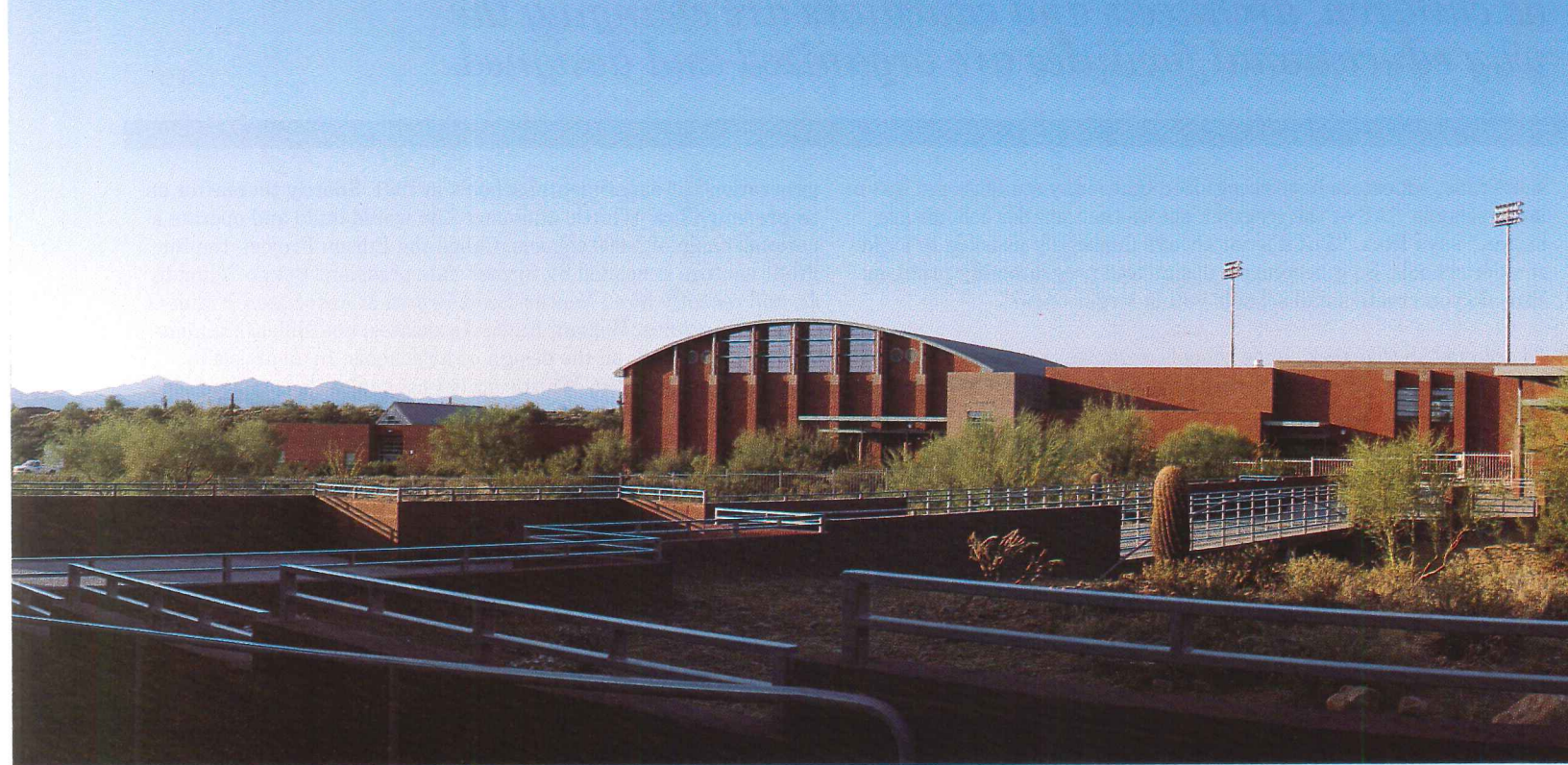



*Windows bring the desert landscape to students in an innovative junior/senior high school that combines teaching functions and saves energy as well.*

*Fountain Hills Junior/Senior High School  
Fountain Hills, Arizona  
HNTB Corporation, Architect*



**S**chool boards across the nation spurn windows because they supposedly distract students' attention and need constant maintenance, thus sacrificing daylight and fresh air. An exception is Fountain Hills outside Phoenix where harsh sun and temperature extremes are the norm. The local school board asked architects HNTB for buildings that would minimally disturb 52 acres creased by arroyos, locally known as "washes" because they fill with streams after rains. And the board wanted windows so students could appreciate the beauty of the site.

HNTB gave them what they wanted and more—skylit interior corridors, saving on electric lighting, windows that open on pleasant days, saving on cooling, and outdoor corridors that bring people in close contact with the desert. Project architect William Waldrom describes the desert not as arid sand but as a "living forest" filled with native plant life and animals, a schoolyard that educates students in desert ecology. Plants displaced during construction were transplanted elsewhere on the site.

Has this open solution paid off? It has made the 900 students appreciate their school, says Waldrom. Not only are the windows untouched, but walls are graffiti-free. The community is highly civic-minded, he adds, noting that the school's evening use by adult organizations, such as the local Kiwanis, may further deter graffiti-minded vandals.

A second innovation for the region is the combining of junior and senior high schools into one 198,000-square-foot facility. To allay parental fears that younger students would be exposed to older students' more worldly ways, classroom groups are separated. The junior component, in three classroom clusters (left in plan, this page), is separated from the five-cluster senior high (right in plan) by a common auditorium, cafeteria, music facilities, media center, and library. These facilities, along with the gymnasium, technology laboratory, and football field, are the most expensive elements in a school to build and maintain. It was the economy of sharing these facilities that overrode parental objections to combining junior and senior high schools in this small community of 10,000. While common facilities are used in shifts, junior and senior high students do intermingle when younger students attend advanced courses, another advantage of the joint arrangement. Other communities in the area are studying the project and considering whether a similar scheme might work for them.

Though the facility's architecture underscores its natural surroundings, electronics are an acknowledged presence inside classrooms. Announcements that students once trooped into an auditorium to hear are now viewed in closed-circuit television-linked classrooms. School-election campaigns are also conducted on the system, and excess conduit is in place for future high-tech additions. "Shop," as it was once known, where students received vocational training in wood- and metal-craft, has been largely superseded by technology labs, where students use robotics to hone 20th-century skills.

Despite special construction (see caption, page 89), costs for the buildings were held to \$13.9-million or slightly over \$70 per square foot. A 250,000-gallon buried thermal-storage tank supplies fan-coil units with water chilled during the night, when the off-peak rates for electricity from the local utility company are one-third of the day rate, yielding a major saving in operations costs. This complements the use of daylighting, fresh air, and sun-shading devices (see Up Close, page 89) to reduce energy consumption. *Charles K. Hoyt*

*To keep the site as undisturbed as possible, the architects had to cope with up-and-down grade changes and an overall elevation change of 50 feet from the north to the south boundaries—a challenge to new ADA requirements. Not only did they have to position buildings to avoid internal grade changes, they also had to lay out walkways of exposed-aggregate and salt-finished concrete in gentle slopes. The exposed, integrally colored masonry units used for walls not only recall a locally favored Frank Lloyd Wright tradition, but—compared with the stucco-covered concrete block often used here—reduce the number of trades needed for construction and maintenance. A clear masonry sealer that prevents water absorption will be renewed every five years. Local stone, used as a base under the units, visually ties buildings to landscape.*

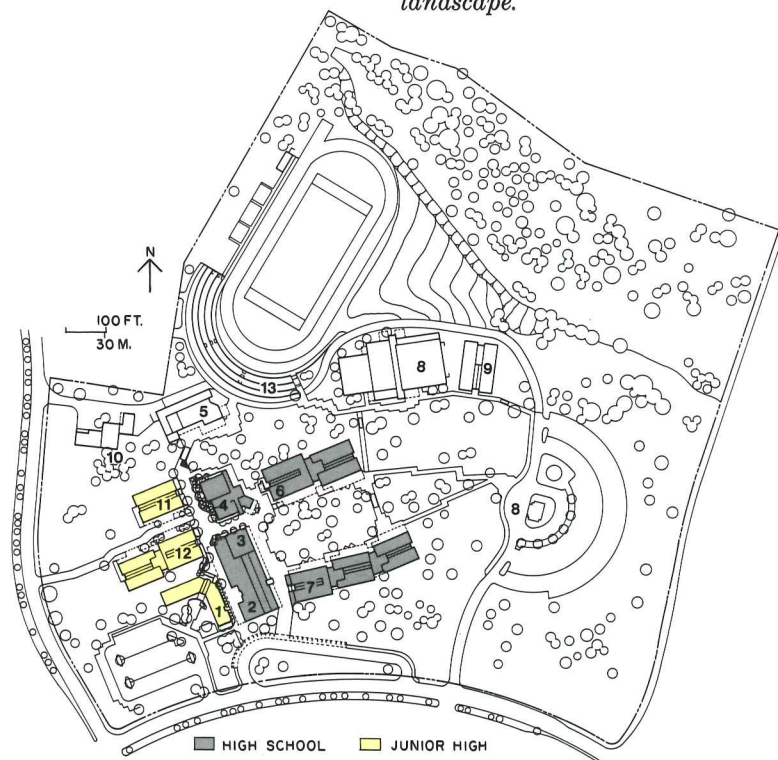

- |                      |                                 |                                  |
|----------------------|---------------------------------|----------------------------------|
| 1. Administration    | 6. High school north classrooms | 10. Central plant                |
| 2. Media center      | 7. High school south classrooms | 11. Junior high north classrooms |
| 3. Lecture hall      | 8. Gymnasium                    | 12. Junior high south classrooms |
| 4. Music-band/choral | 9. Technology lab               | 13. Amphitheater                 |
| 5. Cafeteria         |                                 |                                  |

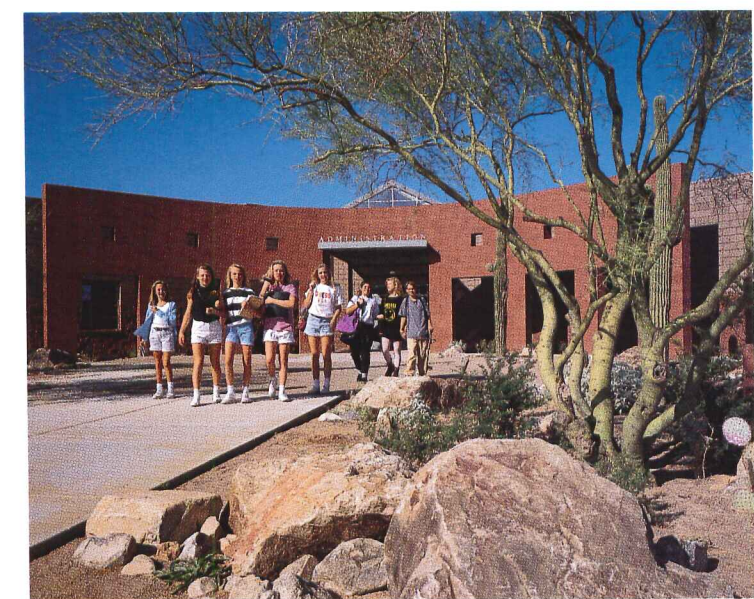
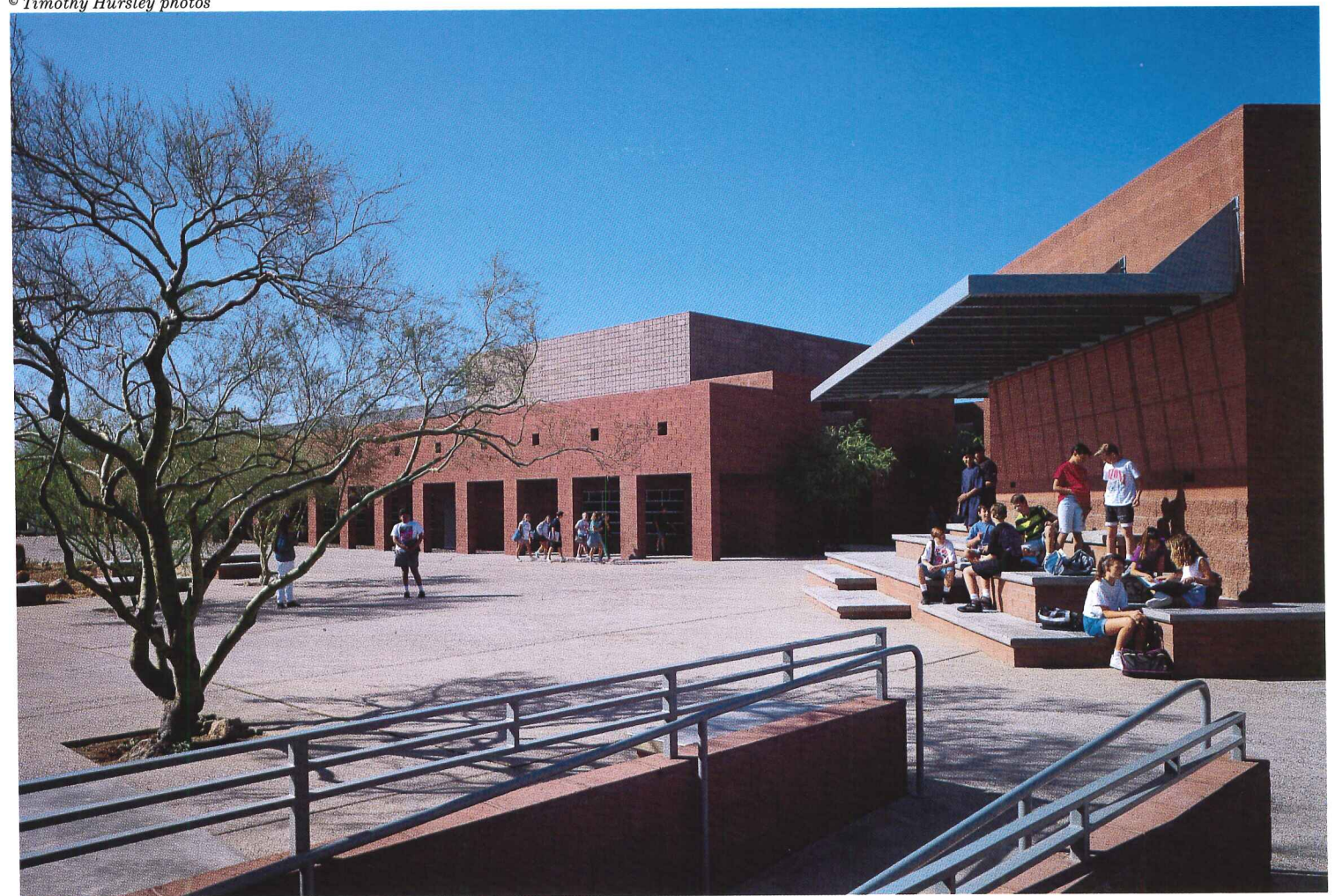



**Up Close**

*Making the sun a friend.* "Sun is the biggest factor," says HNTB project architect William Waldrom in talking about design in Arizona. Nonetheless, local residents are so used to it that their tradition is to put student lockers on the outside of buildings. To accommodate this practice, prevent walls and sidewalks from absorbing heat, and provide pleasant passage around and between buildings, the architects devised relatively inexpensive and maintenance-free canopies. There are two types. One provides solid cover over the lockers (left in sections below). The second is higher, cantilevered, and covered with corrugated, rolled, perforated aluminum (right in section.) When the sun is out, the perforated metal provides dappled shade much like that of the local small-leaved palo verde tree. During rainy conditions, the water runs through the perforations and down across the sloped paving, cooling it as it goes and feeding the site's natural drainage and irrigation system, the arroyos. Even in very hot weather (the recent local record is 122 degrees), the combination of canopies and the area's low humidity make the outside areas bearable, if not always comfortable.

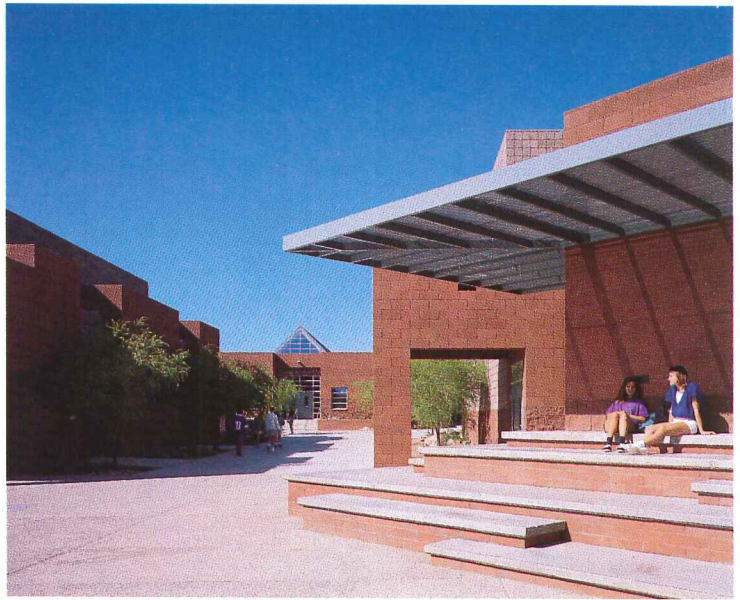

*Basic construction of the buildings is economical: poured-concrete floor slabs and masonry-block walls spanned by steel joists and steel decking covered with concrete. Roofing is elastomeric foam and standing-seam metal. Termite shielding is required under floor slabs in the desert to protect wood cabinets. Despite moderate temperatures during parts of the school year, thermal-glazed windows not only had to be screened from the sun, but thoroughly insulated because summer temperatures often soar into the 100s.*

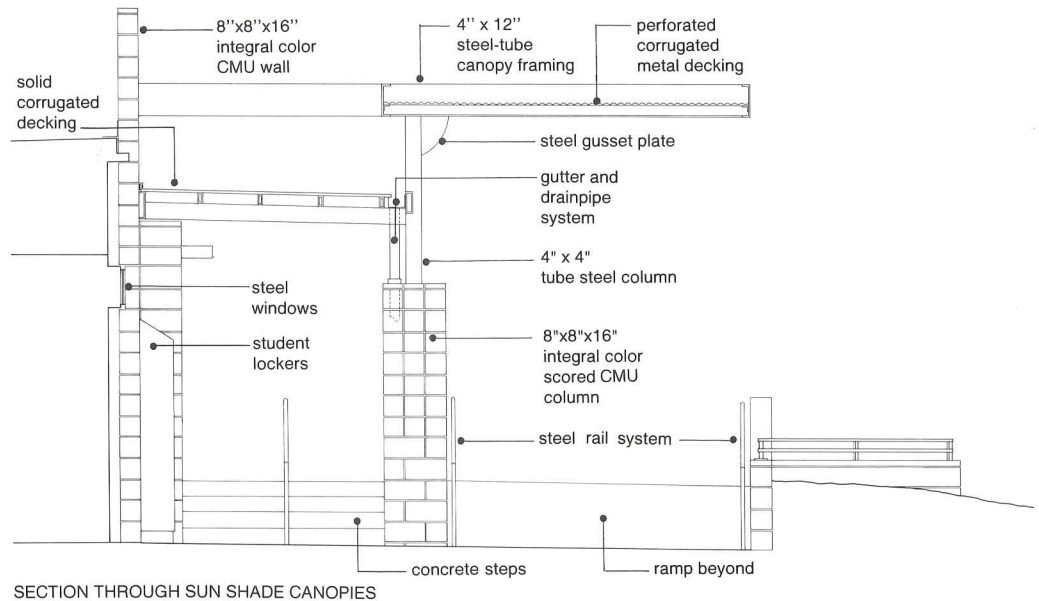

1. Junior-high stacks
2. Senior-high stacks
3. Reading niches
4. Computer lab
5. Lecture hall
6. Art studio
7. Lab
8. Classroom
9. Music

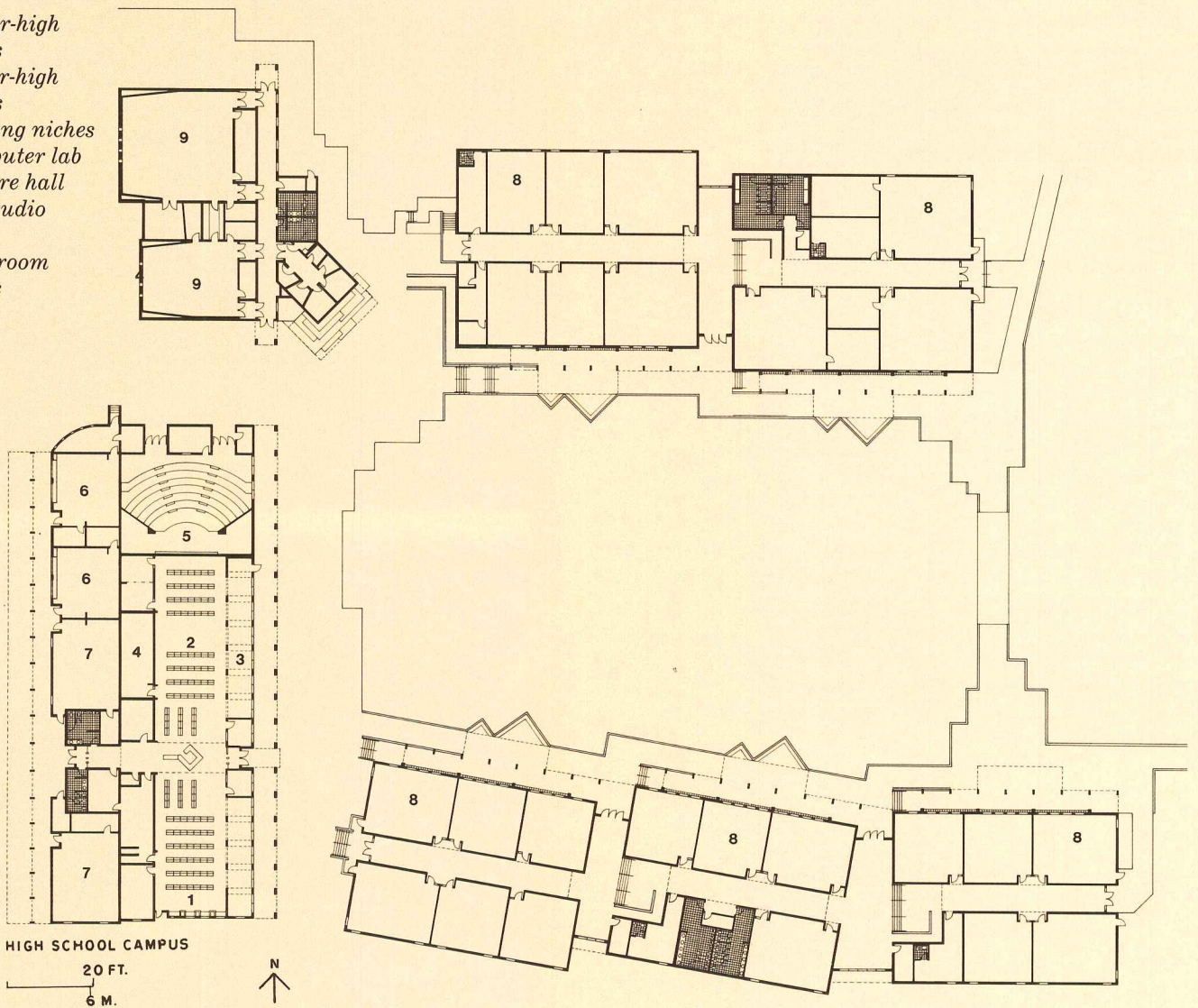

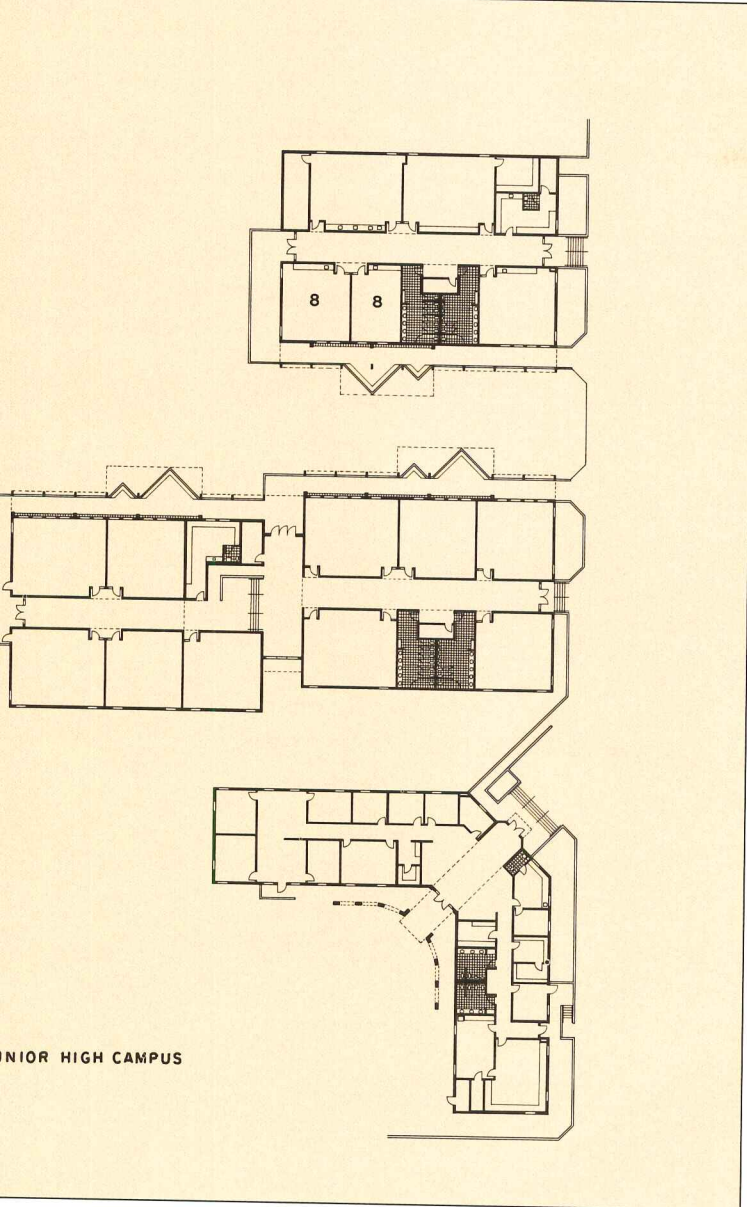

JUNIOR HIGH CAMPUS



*Classrooms are square in plan for flexibility in arranging furniture to suit an individual teacher's preferred teaching method. Square classrooms also produce shorter corridors than the more usual long-side-to-the-outside-wall arrangement—a distinct advantage on the sloping terrain, where otherwise there would be level changes within individual corridor runs. (Note that local fire codes require two exit-entries in each space.) Future expansion will add six-classroom units to the ends of existing wings. Courtyards are designed to allow classes to move outdoors during good weather.*

**Credits**

*Fountain Hills Junior/Senior High School*

**Owner:** *Fountain Hills Unified School District Number 97*

**Architect:** *HNTB Corporation—Donald P. Keuth, vice-president-in-charge; Scott T. Ebert, director of architectural services; Trudi G. Hummel, project director; Jay R. Silverberg, senior project designer; Paula M. Tingleff, project manager; William X. Waldrom, project architect/construction administration; Jackie M. Keller, landscape architect*

**Engineers:** *HNTB Corporation, civil and structural; Lowry-Sorensen-Willcoxson, mechanical/electrical*

**General Contractor:** *D. L. Withers*

# Beacon of Learning

*Seward Hedges Area School  
Chicago, Illinois  
Ross Barney + Jankowski, Inc.,  
Architect*





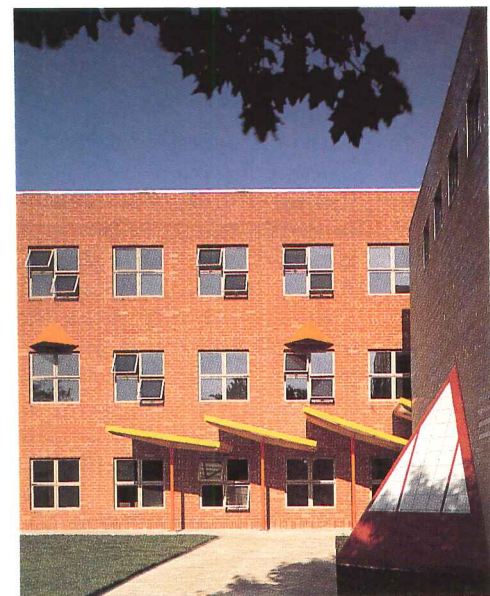
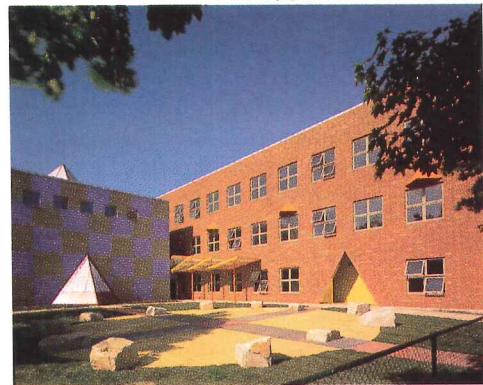

*Providing color on the building (left and above) in the form of bright masonry units, was a priority for architect Carol Ross Barney, who notes that many shopping mall exteriors provide a better model of what makes the exterior of a school appeal to children than do most school buildings. Translucent-fiberglass insulating panels form the corners of a pyramid that intersects the cube-shaped activity-center wing (left and above). The apex of the pyramid is illuminated from inside, so it can function as a nighttime beacon.*

**T**he Seward Hedges Area School sits on a lot that wouldn't be anyone's first choice. Located on a partial city block in the Back of the Yards neighborhood, adjacent to the former Chicago stockyards, the 121- by 456-foot site was the only land available in the area. It backs up to an alley that provides access to the service entries of several light commercial buildings. "Our first priority was to make the building a good neighbor," says architect Carol Ross Barney, referring to the way the new school would mesh with these buildings and the two-story, wood-frame, single-family houses typical of the neighborhood. Instead of pushing the pre-kindergarten through eighth-grade school tight against the street and putting the playground behind, the architects did the opposite. The playground was built in front of the building, so children could play within view of both classrooms and nearby homes, providing at least a visual sense of security in an area plagued by gang activity.

This decision and, in turn, the long, shallow shape of the site, influenced the building's floor plan. "We had to give up double-loaded corridors and go to three floors, which we normally would not have done. We wound up with very long corridors too," says Ross Barney. "But it does work out in terms of the structural system." Standard-sized, 12-inch-thick, 40-foot-long precast concrete floor slabs were chosen, supported by 14-inch-thick, insulated masonry bearing walls. Gypsum board on metal studs was used for interior partitions. Normally, more indestructible masonry units would have been specified here but, according to Ross Barney, "the dead-load was such that we would have had to go with a 14-inch-thick slab, which was a custom thickness. We went with the lighter partitions." In abuse-prone areas, such as corridors, the gypsum board is covered by painted, 1/2-inch-thick particle board wainscoting to protect it against impact and provide an easily repaired wearing surface.

Ross Barney is adamant about the importance of introducing secondary colors to the exterior and interior of the building. This not only provides relief from the neutral backdrop of the city but also sends a signal to children that the school is a place of significance. "If you want to see a building whose importance is stated by the architecture, look at a shopping mall. That speaks to children. Too often, schools take on sort of a 'brown brick governmental building' sort of appearance," says Ross Barney. "Who wants to go there? We're making this a significant place by using color [opposite, left]. We also toned down the color as the spaces get closer to the classrooms, which are supposed to be undistracting, like a plain canvas."

The school's library is stacked on top of a multipurpose display space inside a checkerboard-hatched cube that intersects a pyramid made of insulated fibreglass panels. The activity wing is connected to the classroom wing through a vestibule (see plan, page 94). This allows the classrooms to be secured separately, so the multipurpose space may be used for public activities at night. This flexibility was insisted upon by the client, says Ross Barney. "We wanted the school to operate as a beacon in the neighborhood, so we've illuminated the apex of the pyramid from the inside," she adds. For the Back of the Yards, it's a beautiful symbol. *Charles D. Linn*

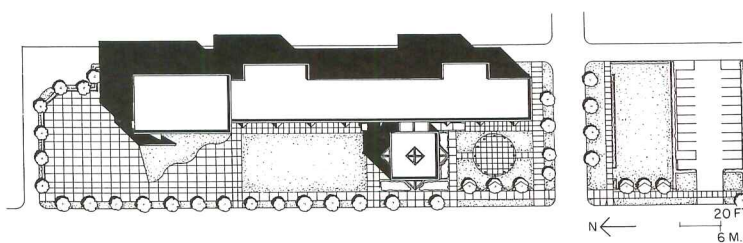



One of the single-loaded corridors in the Seward Hedges School (left) displays utilitarian finishes: concrete masonry, and particle-board paneling, tempered with colored daylight and bright vinyl composition tile. The school was built for about \$82 per square foot. The daylit-filled vestibule (opposite) constructed of translucent fiberglass panels, links the classroom wing to the display room. The bridge connects the classroom wing to the second floor of the library.

**Credits**

*Seward Hedges Area School  
Chicago, Illinois*

**Owner:** *Chicago Public Schools*

**Architect:** *Ross Barney + Jankowski, Inc.—Carol Ross Barney, principal-in-charge; James C. Jankowski, Daniel J. Miller, Wesley Hoover, project team*

**Engineers:** *Martin/Lam (structural); Beling Consultants (mechanical/electrical)*

**General Contractor:** *UBM, Inc.*

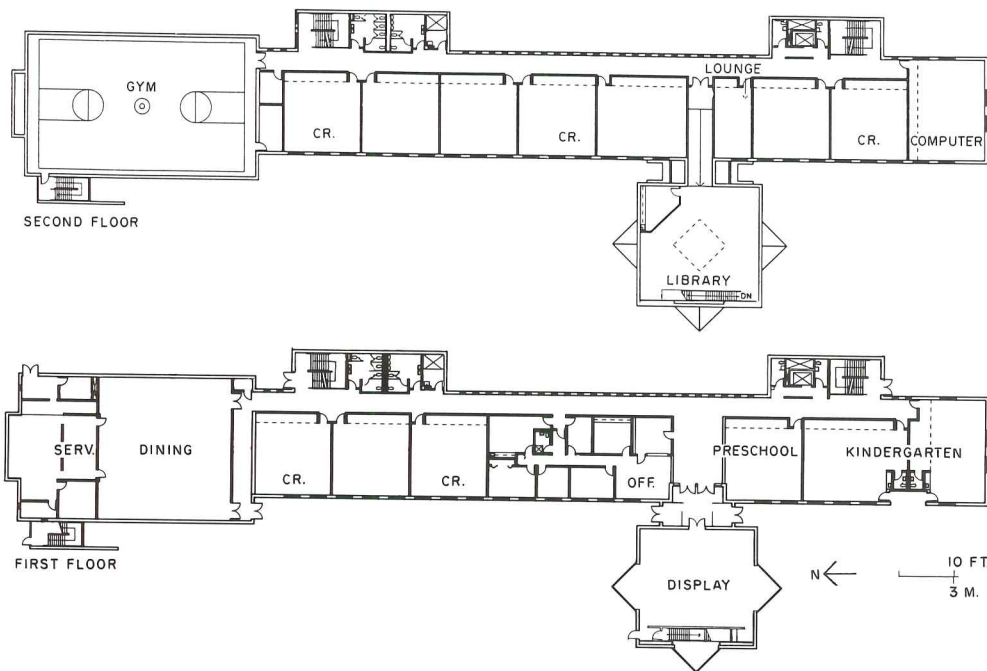



# School Spirit



*Perkins & Will gives a  
growing suburb a lesson in  
civic-minded design.*

*Troy High School  
Troy, Michigan  
Perkins & Will, Architect*



The trend is toward creating educational parks on larger sites and using the facilities as cultural and recreational centers," observes C. William Brubaker, a longtime Perkins & Will principal and a recognized expert on school design. Together, these issues led to the rejection of an early scheme by Brubaker and partner Ralph Johnson to renovate an existing high school in downtown Troy, Michigan, where the cost of correcting outdated exiting conditions and upgrading derelict mechanical and electrical systems proved less cost-effective, and far less fetching, than a \$36-million new building.

The new Troy High School's seemingly effortless union of complex program and imaginative design stems from the unique collaboration of Brubaker and Johnson. Johnson is an anomaly on the current architectural scene—a name "designer" in a corporate firm; a stylistic renegade in the mainstream Modernism course charted by the Chicago office of Perkins & Will. His success, however, comes from his unwillingness to sacrifice function for form. Architect Joe Valerio, fellow member of the Chicago 8, an informal critique group, says of Johnson's work: "It's some of the most beautiful stuff being built today, but Ralph talks about it in planning and functional terms and not specifically about its beauty and cultural impact."

Located at the edge of a booming Detroit, Michigan, suburb, Troy High School is the most recent in the architects' series of completed school commissions [RECORD, January 1991, pages 91-97]. Although the town offered no obvious architectural heritage for the duo to draw upon, its proximity to Bloomfield Hills and Eliel Saarinen's Cranbrook Academy was "a mild influence," according to Johnson, who terms the overall esthetic of the 1,800-student facility "loose Prairie style." The composition of horizontal load-bearing brick blocks of classrooms, punctuated by the more sculptural forms of the library and theater, responds as much to the characteristics of the sprawling 72-acre site as to any notion of regional style.

The classroom wings form U-shaped courtyards, which open toward a 10-acre wooded grove at the edge of the site (plan page 100). The more public elements, the theater and main entrance (the latter marked by a dramatic glass-encased stair tower—opposite), face the town. Salmon-, rust-, and white-colored brick create a series of bands overlaid by horizontal and vertical strips of windows. The use of brick was also a response to local market conditions: a surfeit of unemployed Detroit bricklayers made the design cost-effective. In addition to low-maintenance, insulated concrete-block cavity walls have low thermal conductivity, an important concern in the Great Lakes region.

Whereas the firm's famed Crow Island School in Winnetka, Illinois, marked a revolution in teaching philosophies in 1940 (see Up Close), more recent curriculum changes incorporated into the design of Troy High School—such as the use of technical equipment as educational tools—are more gradual. All classrooms are equipped with telephones and video monitors. Indirect fluorescent lighting accommodates computer work. "The change is largely invisible," Johnson says of cable trays in corridor ceilings, the most extensive architectural impact of new teaching methods.

More visible is the need to address the requirements of users with physical disabilities (elevators connect the three academic floors), the increased presence of women's athletics (equal-sized playing fields for male and female sports are now accepted policy), and the growing symbolic role of the school within the community, particularly in a town expanding as rapidly as Troy. *Karen D. Stein*

### Up Close

*Redefining a building type.* Perkins & Will established its reputation as specialists in school design with the Crow Island Elementary School in Winnetka, Illinois (Perkins, Wheeler & Will with Eliel and Eero Saarinen) in 1940. Some 50 years later, the residential scale, informal yet organized plan, and interweaving of exterior and interior spaces of Crow Island—the physical embodiment of a relaxed educational atmosphere—still guides partners C. William Brubaker and Ralph Johnson. Recent Brubaker and Johnson projects elaborate on the theme of school-as-miniature-village. Forces outside the architectural profession continue to influence design decisions: demographics of new towns, with schools acting as community centers (school theaters, gyms, and classrooms are increasingly used after-hours for community events and continuing education programs); a growing interest in energy conservation through the use of insulated surfaces and well-placed windows that limit solar heat gain; and the use of computers and video as educational tools. Brubaker likens the need for a flexible solution, which adapts to changes in technology and curricula, to the demands of speculative office building design: "A good school is never 'finished,'" he comments in a recent essay. "It evolves and adapts as people and programs evolve."



© Balthazar Korab Photography

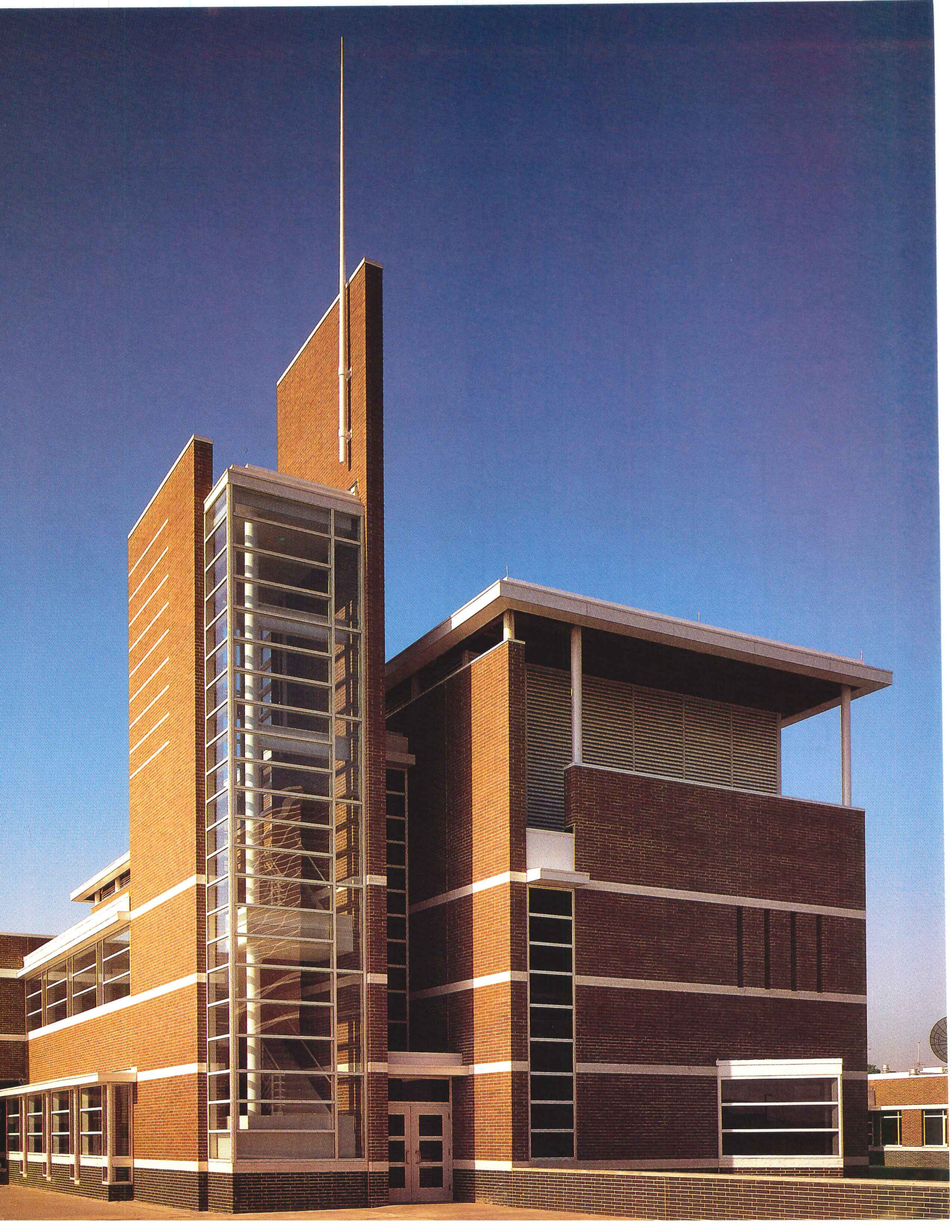

- 1. Pool
- 2. Gym
- 3. Auxiliary gym
- 4. Dining
- 5. Kitchen
- 6. Library
- 7. Industrial arts
- 8. Music
- 9. Theater
- 10. Classroom
- 11. Administration

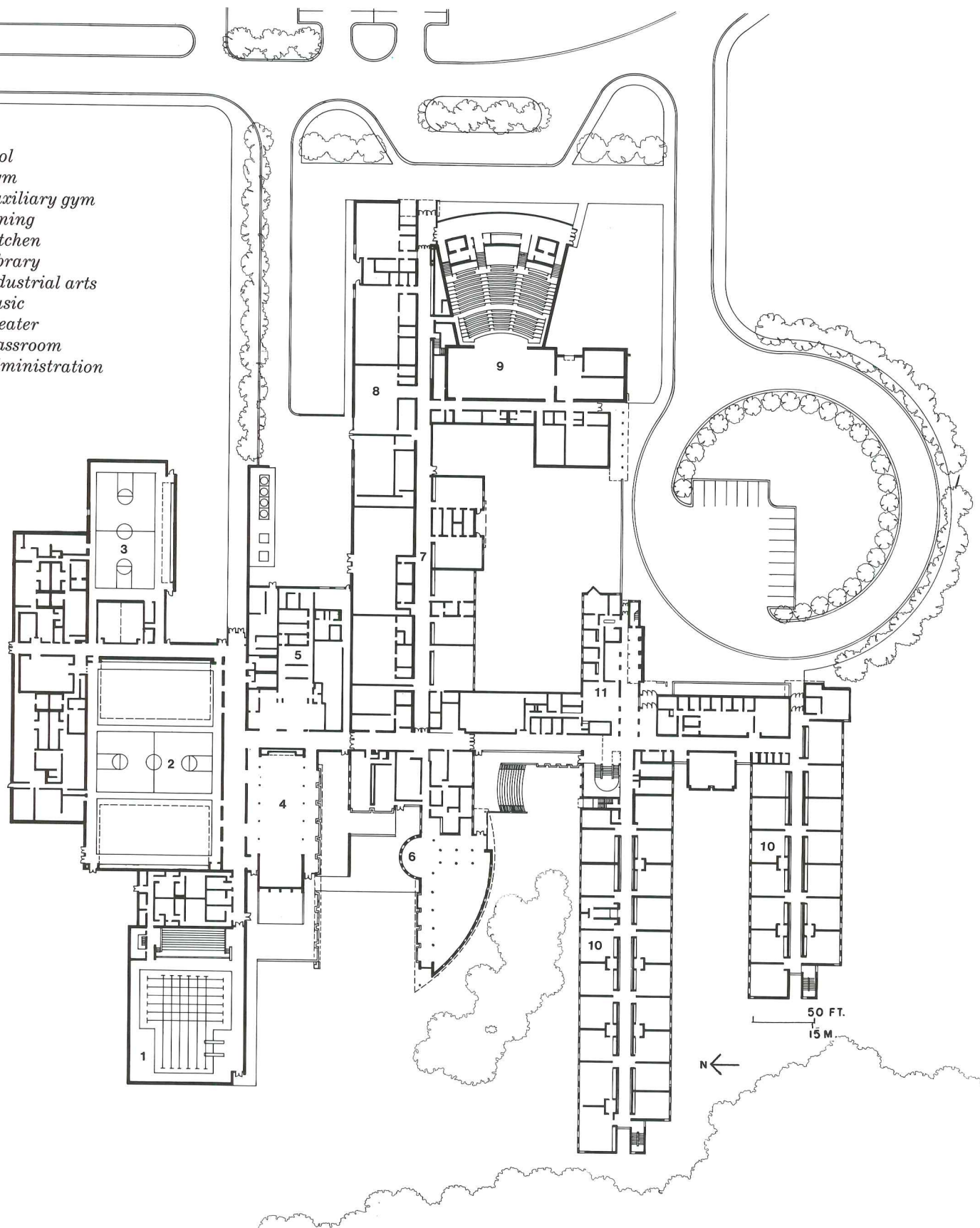





To avoid an intimidating institutional appearance, Perkins & Will broke the 300,000-square-foot Troy High School into linear classroom blocks arranged around communal spaces and administration offices, creating a village-like setting (plan opposite). The architects placed the school in the southwest corner of a 72-acre site, adjacent to a 10-acre wooded grove, in order to take advantage of views and to screen portions of the structure from the neighborhood. A circular drop-off courtyard and a brick, glass, and aluminum stair tower—a “campanile,” according to the architects—mark the main entrance (above and top right).

The barlike parallel classroom wings, which run east to west, are arranged to form courtyards, allowing daylight to enter classrooms on both sides of double-loaded corridors. Contrasting with the recurring elements are the more sculptural forms of the library (a rotunda) and theater (a pie wedge), which fans out toward downtown. Like the theater, the gym is often used for community events and has a separate entrance and nearby parking.

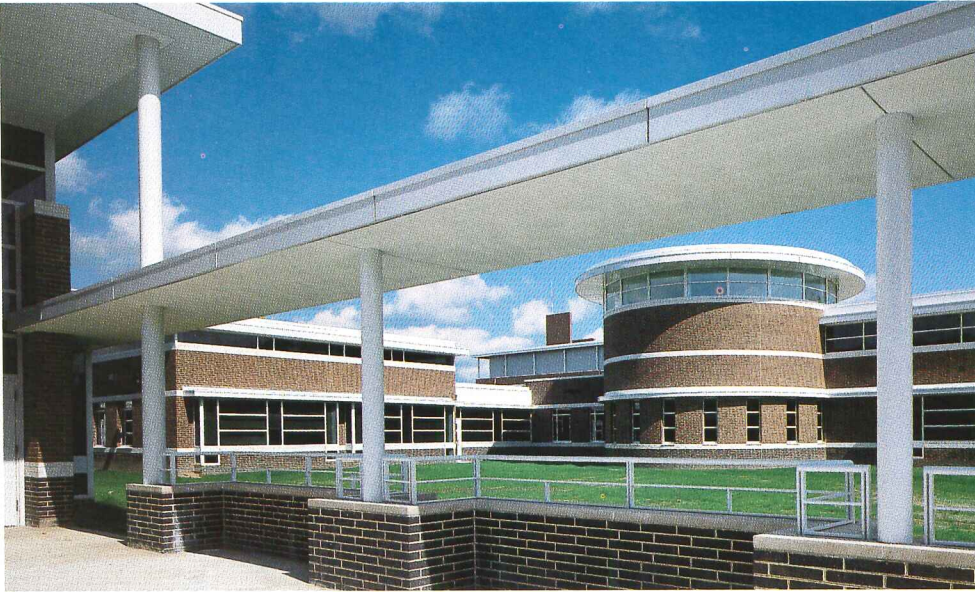

© Baltazar Korab Photography





*Perkins & Will met the faculty's request for daylit spaces with an extensive use of windows, clerestories, and skylights. Each classroom has three operable windows, but for security reasons, windows on the ground floor are smaller than those on upper floors. The south and east-facing cafeteria has larger openings (bottom left). A toplit rotunda contains the periodical room (below).*

**Credits**

*Troy High School  
Troy, Michigan*

**Owner:** *Troy Public Schools*

**Architect:** *Perkins & Will—  
Ralph Johnson, design principal; C. William Brubaker, managing principal; John Arzarian, Jr., senior designer; James Toya, project manager; Carlos Parrilla, senior technical coordinator; Randy Takahashi, structural engineer; Jack Ramm and Michael Michalski, mechanical engineers; Elizabeth Fakatselis, Susan Stevens, George Witaszek, Eric Spielman, and Robin Randall, project team*

**Consultants:** *Schuler & Shook, Inc. (theater); Stan Roller, Inc. (acoustic); E. F. Whitney (kitchen equipment)*

**General Contractor:** *Barton Malow*

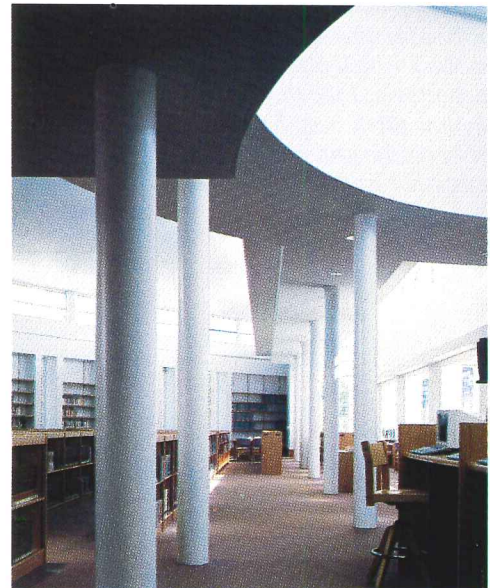



# Community Service

*Intermediate School 218  
New York City  
Richard Dattner Architect*

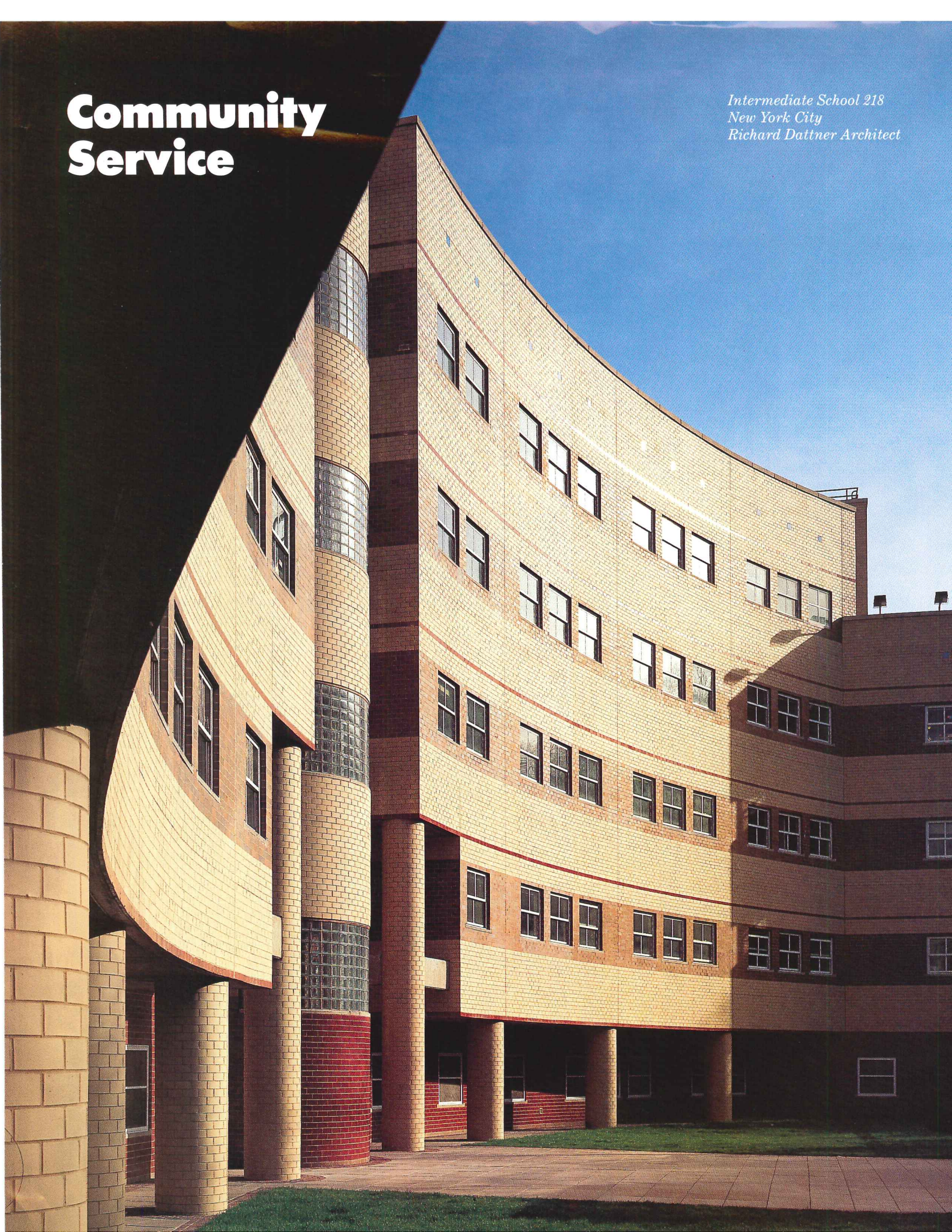

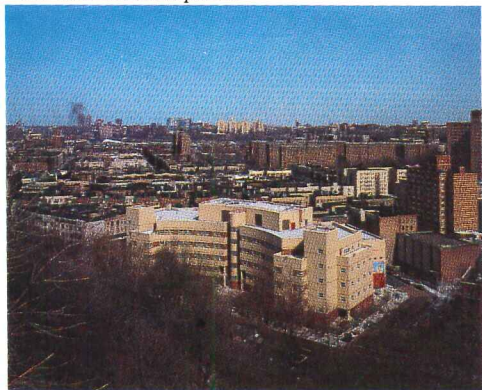

*The west facade (opposite) curves away from Broadway to keep classrooms from the noise of the street. The school looks onto Fort Tryon Park in northern Manhattan (top). Most students enter the school from the south, where a playground sits across the street (above).*

Former New York City School Chancellor Joseph Fernandez called it “the school of the future” when it was dedicated last year. But I. S. 218 looks like it has been around since the 1930s—a neighborhood landmark with Art Deco touches similar to those found on nearby apartment buildings. What makes this school progressive is not any superficial styling—no space-age pods or high-tech light fixtures—but the services it provides and how it is organized.

I. S. 218 is a real community school, where children *and* parents come to learn. Serving the predominantly Hispanic neighborhood of Washington Heights near the northern end of Manhattan, it is an intermediate school for 1,200 students, as well as a satellite college operated by Mercy College, and a health center run by the Children’s Aid Society. The building stays open 15 hours a day, six days a week, and principal Mark Kavarskey wants to keep it open on Sundays too. “We call this a ‘seamless’ program,” says Kavarskey, “because there’s no separation between daytime and evening activities.”

Spaces for community programs and administrative functions occupy the first floor, while classrooms and other educational spaces are on the four floors above. To prevent students from getting lost in the crowd, the school is divided into four “academies” of 300 students, each with a focus and core curriculum. Although the academy program was developed after the school was designed, Kavarskey says “there was an easy marriage between the educational program and the building’s architecture.”

A steel-frame structure with concrete-and-metal-deck floors, I. S. 218 presents two faces to the city: a great curving facade on Broadway that serves as the main entrance to the school and a less formal side entry enlivened by a colorful mosaic mural where most students arrive. The Broadway elevation embraces a somewhat austere semi-circular courtyard that looks across the street toward Fort Tryon Park. To capture views of the park, architect Richard Dattner placed classrooms along the Broadway side of the school and put special-purpose spaces, such as laboratories and computer rooms, in the back of the building. Attached to the back of the classroom wing of the building is a structure with a 600-seat auditorium on the first two levels and a 26-foot-high gym above. Although air conditioning is provided (from variable-air boxes set in hung ceilings), windows in classrooms are operable. Heat is distributed via a perimeter steam system.

By curving the Broadway facade, Dattner was able to place more classrooms along this edge of the building and give them views of the park. “At MIT I lived at Baker House,” says Dattner, “and I remember being impressed by the way [Alvar] Aalto used a curving edge to give all rooms a view of the river.” At its two ends and where it meets the auditorium and gym structure, the curving corridor expands to create informal social areas. According to Kavarskey, these areas have been well used for student art displays, parent meetings, and chance gatherings.

Because I. S. 218 is a community school, the people of Washington Heights were very involved in planning it and even in selecting the architect. Working in Dattner’s favor were his long residence in the area and his experience designing other New York schools (his P. S. 234, see RECORD March 1989, page 108, was a big hit with both kids and adults). Like many of the students at I. S. 218, Dattner came to this country as a child, speaking Spanish but no English. Sharing the immigrant experience, the architect and community together created a school that gets its strength from multicultural roots.

*Clifford A. Pearson*

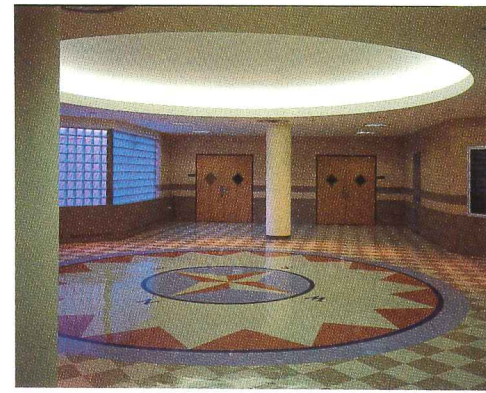
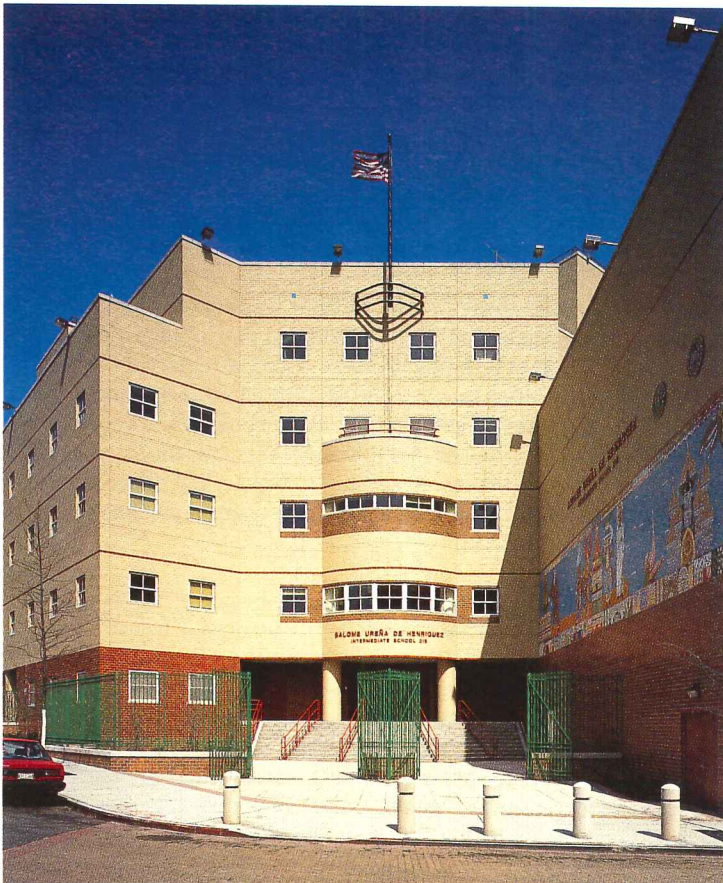
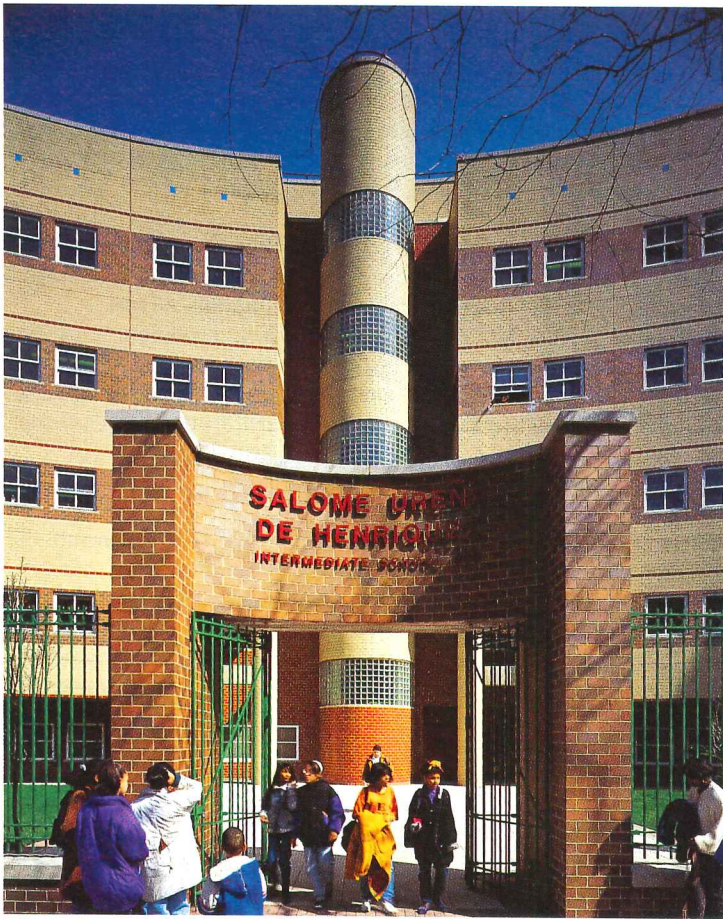

The curving facade and main entry gate form a protected courtyard in which kids can play or gather (left top). The bands of different colored brick recall the Art Deco styling of some apartment buildings in the area. Glass block brings daylight into the main stairway tower in the center of the elevation. A mosaic mural at the south entrance (left bottom) reflects the Hispanic culture of the local community. A shallow dome ringed with a fluorescent cove tops an informal gathering area just off the classroom corridor (above). Community facilities and shared spaces such as a cafeteria and an auditorium are on the ground floor (plans opposite). On upper floors, classrooms are placed around the front of the school, while special-purpose spaces, such as computer rooms and laboratories, are along the back.

#### Credits

*Intermediate School 218  
New York City*

**Owner:** *New York City  
Board of Education*

**Architect:** *Richard Dattner  
Architect—Richard Dattner,  
partner-in-charge; William  
Stein, Jaime Ortega,  
associates-in-charge; Michael  
Daniels, project architect*

**Engineers:** *Goldreich, Page &  
Thropp (structural); Robert  
Derector Associates  
(mechanical)*

**Landscape Architect:** *Miceli,  
Kulik, Williams*

**General Contractor:** *Arnell  
Construction*

1. Courtyard
2. Rotunda
3. Auditorium
4. Dining
5. Kitchen
6. Staff dining
7. Office
8. Medical suite
9. Community room
10. Classroom
11. Computer
12. Word processing
13. Dance
14. Lockers
15. Gymnasium

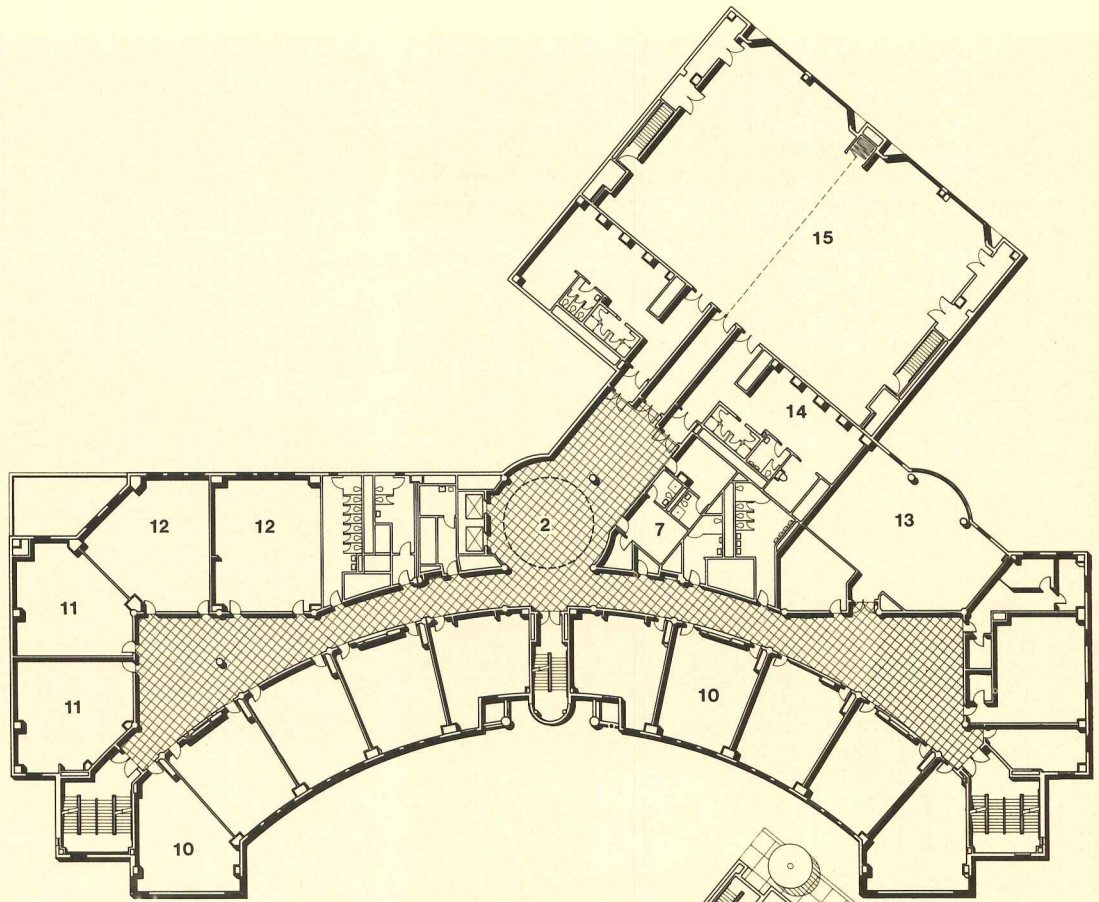

SECOND FLOOR

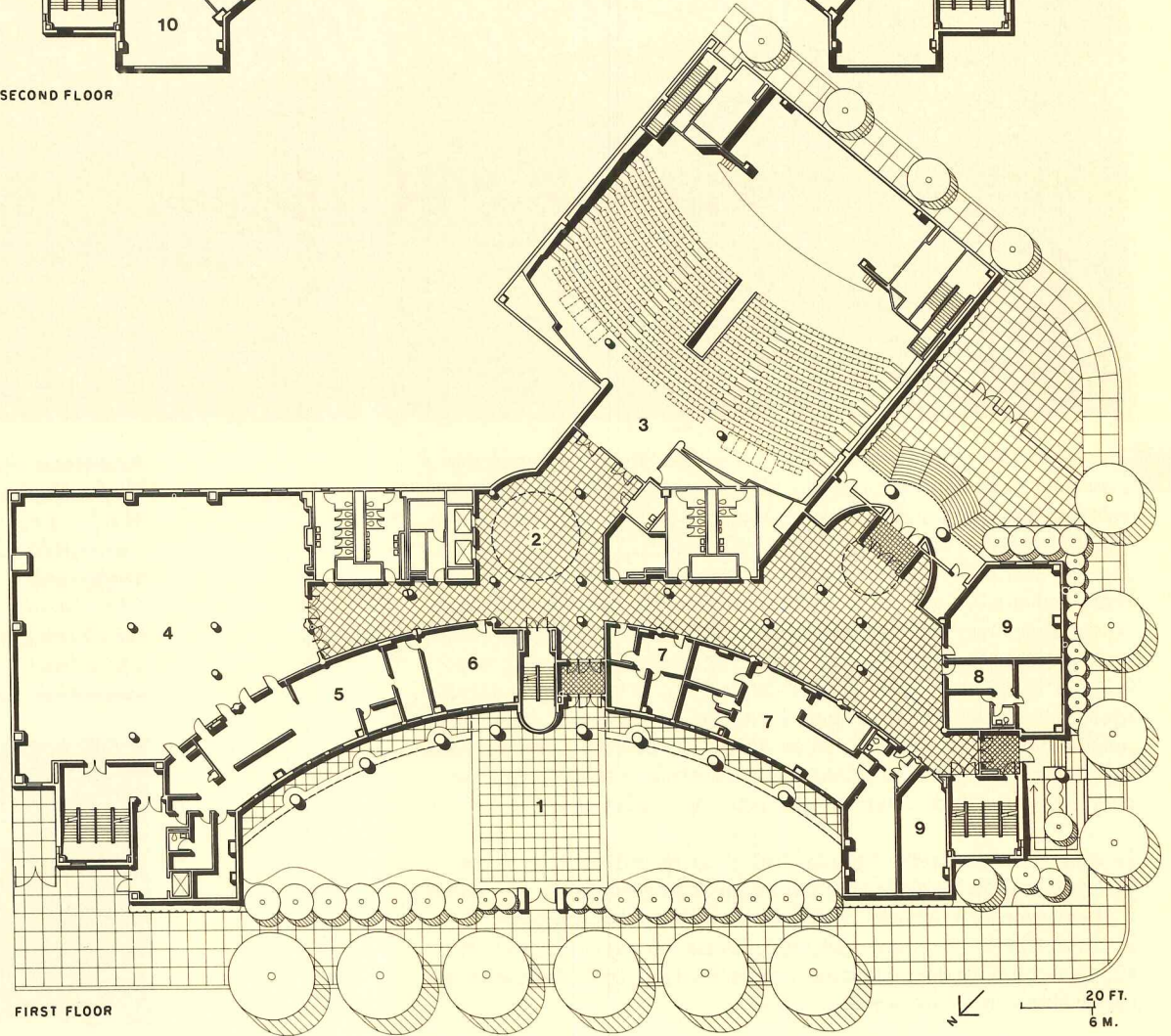

FIRST FLOOR

20 FT.  
6 M.

# Reaching for the Sky



**W**ith a V-shaped roof hovering above its main spine and an angled roof over its gymnasium (foreground, photo above), the 23,000-square-foot Rogers Elementary School in Victoria, British Columbia, seems ready to take to the air. But the school's innovative design is no flight of fancy. By supporting the central roof on freestanding concrete-and-steel columns and raising it above load-bearing masonry walls, Vancouver-based Hughes Baldwin Architects was able to insert clerestory windows that bring daylight deep into the school's interior. To emphasize the school's strong ties to its community, the architects located facilities shared with the public—such as the gymnasium and a multipurpose room—closest to the street. A courtyard separates the academic portion of the 250-student school from the community facilities and lets each sector operate independently.

In wings on either side of the central spine, paired classrooms are grouped around cores that include small quiet areas and a shared activities space—an arrangement that allows for team teaching. Future growth for another 200 students can be accommodated by simply extending the main axis of the school and the classrooms on either side of it. *Clifford A. Pearson*

**Architect:** *Hughes Baldwin Architects—Roger Hughes, partner-in-charge; Karen Marler, project architect; Bruce Carscadden, Marc Boutin, design team*  
**Engineers:** *C. Y. Loh Associates (structural); Keen Engineering (mechanical); D. Valeri & Associates (electrical)*

**Landscape Architect:** *Christopher Phillips*

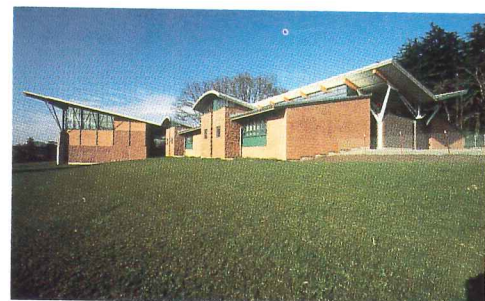

© Bob Matheson photos



*An elementary school in western Canada  
by Hughes Baldwin Architects reaches out  
to serve a growing community.*

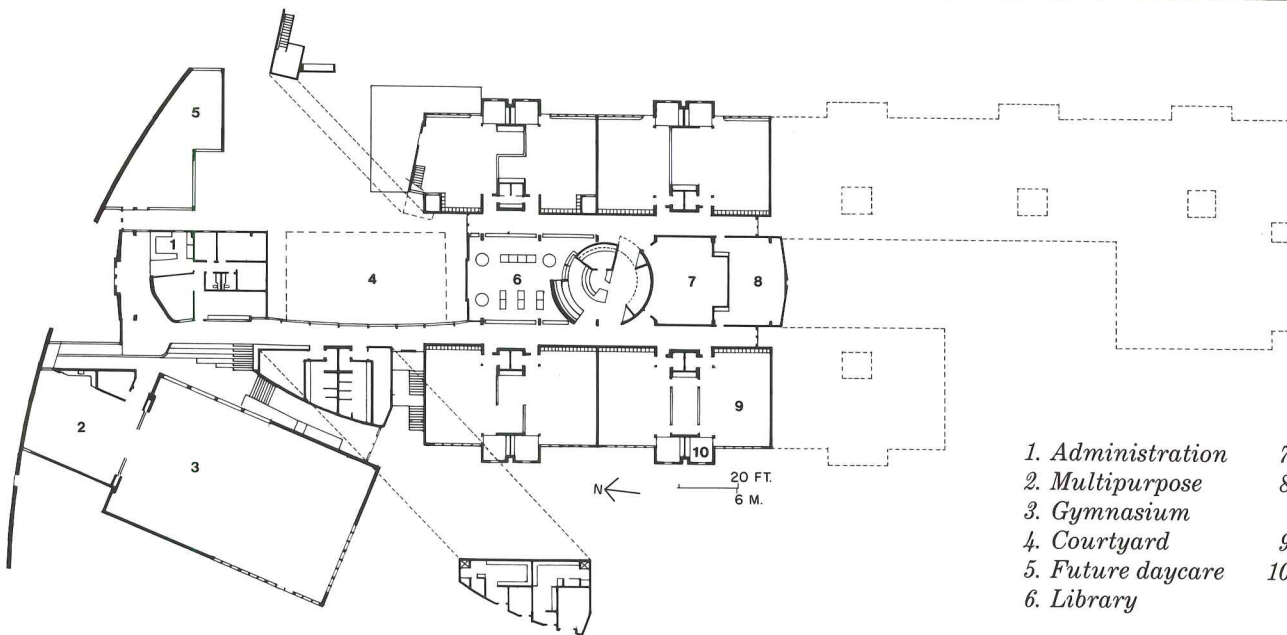
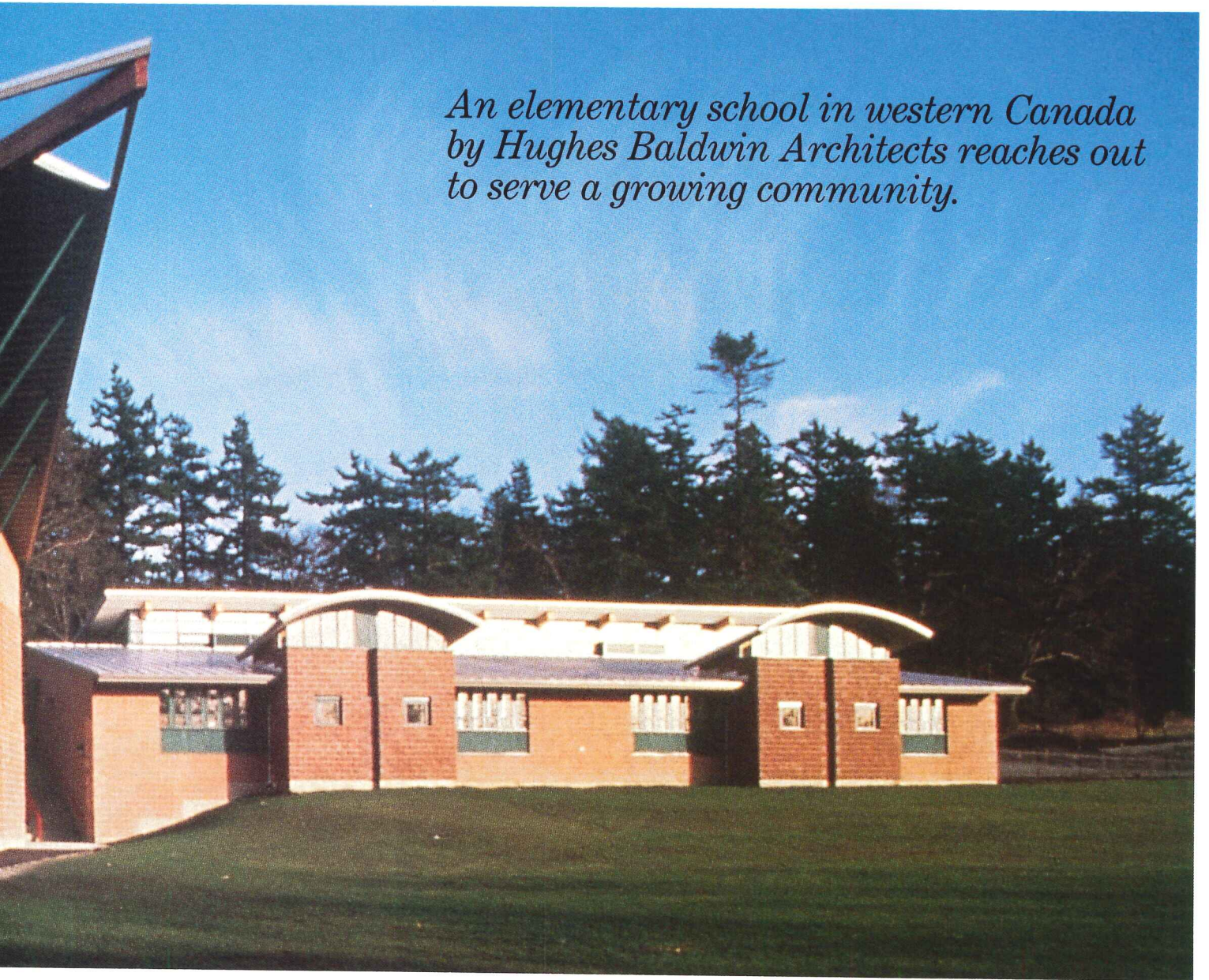

- 1. Administration
- 2. Multipurpose
- 3. Gymnasium
- 4. Courtyard
- 5. Future daycare
- 6. Library
- 7. Computer lab
- 8. Special education
- 9. Classroom
- 10. Quiet area

**User Friendly**



*These architects show that listening  
to clients can produce a school for  
use by the whole community.*

*Patwin Elementary School  
Davis, California  
The Steinberg Group, Architect*



ur climate is paradise," says architect Robert Steinberg about Davis, the north central California town where this new kindergarten-through-grade-six school is located. Given the community's early active response to progressive environmental causes (such as solar heating in local buildings and a system of bicycle paths), the decision was not surprising to make classroom and clerestory windows operable so they could catch prevailing southerly breezes during much of the spring and fall. The students benefit by getting fresh air; less energy is expended on air conditioning, and the windows bring in daylight.

The use of passive cooling here was only one of the results of an intensive user-input design process in which The Steinberg Group attempts to get "into the mindset of the user." The technique has worked well on many projects, which have included housing for homeless persons and schools for disadvantaged learners. As Steinberg puts it: "Architects aren't the only ones who contribute to a project." And the community, students, parents, and teachers all contributed.

The firm got input from the community on facilities that parents as well as children could use. One result was the multipurpose building that faces an outdoor amphitheater on one side (photo, previous pages) and the street on the other. Here the community can come to hear concerts or play basketball indoors when "paradise" becomes a little fogged in and chilly during midwinter, even while the rest of the school is closed. Another solution answered concerns about security for the kindergarteners. A special parking lot and entry (site plan, bottom right, page 115) allow parents to drive up, park, and place their youngsters directly into a teacher's care.

Teachers instructed the architects on their preferred teaching methods, which include working with small groups in contained classrooms and combining classes in larger sessions similar to team-teaching. The teachers' belief in student interaction resulted in classroom windows that look into central triangular outdoor courtyards between each classroom cluster where several classes can be combined. Teachers also were concerned that children with learning disabilities, who in other schools would be sent to a central building for remedial training, would be stigmatized by classmates. The result is small classrooms in each cluster where special teachers can work with students inconspicuously.

It was from the students that the architects took their cues on how the eight buildings would look—like playful blocks culminating in the central library (top photo, page 114) that resembles a whale. Steinberg takes pride in the seemingly casual resulting character, despite a formal overall plan that lets people know where they are—"like a village built over time," he describes it, "holding the edge between order and childlike chaos." *Charles K. Hoyt*



Chas McGrath photos

### Up Close

*Color Code.* The Steinberg Group wanted to emphasize these buildings' playful building-block character by using a colorful palette to enhance their basic geometries. The community voted on three choices offered by the architects—combinations of earth tones, primary colors, and the muted scheme that the residents chose. Color was integrated into the stucco topcoat and matching paint was applied over that. "Integral color in stucco is not even," notes Robert Steinberg, "but it keeps the surface from looking unsightly when the paint chips off." He is pleased with the contrast between the painted walls and the unpainted-steel walkway covers: "The steel and painted surfaces heighten the intensity of each other." And, of course, the unpainted steel has its functional purpose as well: "No finish will stand up long under the close attentions of young children." Of course, color adds character to basic materials and surfaces, such as asphalt roofs and modest commercial-grade windows on classrooms, as well as to central design elements.

Inside, the architects have taken the opposite approach. Everything is white (see small photos, overleaf). In the classrooms, "teachers and children produce paintings and graphics that are far more colorful than anything architects can come up with," says Steinberg. "I know when I'm outmatched." In the library's main reading room, the stark effect is one that he describes as "spiritual."

*One triangle of buildings at the back of the site (far left, photo, left) is temporary construction, awaiting a decision on whether these will be made permanent or torn down as classes grow or shrink.*







The multipurpose building (bottom of plan) faces the main road so that it, the administration building, and kindergarten are accessible by car. Behind it is a paved amphitheater. The "whale" (top photo, opposite) or library, is placed on axis to make it central to campus traffic and shaped to make it inviting. The green "fins" hold remedial classrooms and the "tail" holds the computer center. Thirty-student classrooms are arranged by age group around three triangular courtyards (bottom photo) where joint classes can be held. Outdoor covered walkways are used in lieu of interior corridors. Total square footage is approximately 33,000 square feet.

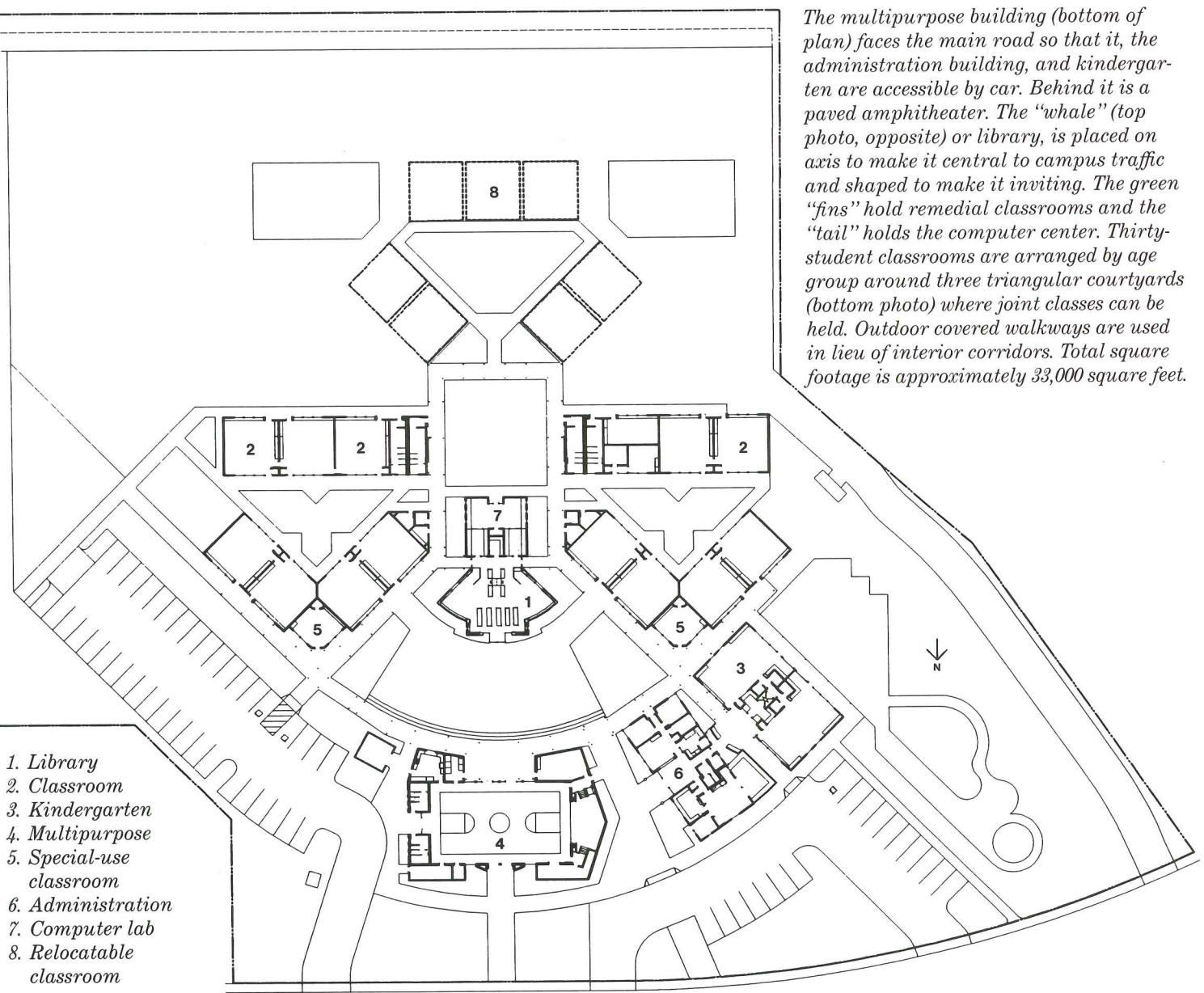

- 1. Library
- 2. Classroom
- 3. Kindergarten
- 4. Multipurpose
- 5. Special-use classroom
- 6. Administration
- 7. Computer lab
- 8. Relocatable classroom

**Credits**

*Patwin Elementary School  
Davis, California*  
**Architect:** The Steinberg Group—Robert T. Steinberg, principal-in-charge; Vladimir Frank, project designer; Gregory Hepp, project manager; Jacob Sofer, Alida M. Guerrero, Lee Salin, Robert Dolton, project team  
**Engineers:** Hrach Kouyoumdjian & Associates (structural); Capital Engineering Consultants (mechanical); Jack Todd, Inc. (electrical); Cunningham Engineering (civil); Raney Geotechnical (soils); Charles M. Salter Associates (acoustical)  
**Consultant:** Gates & Associates (landscape)  
**Construction manager and cost estimator:** Vanir/3DI



# Focus on: Refresher Courses For Schools

*Although schools in some parts of the country face declining enrollment, those in other areas have gained so many pupils that expansion is of the essence. Of course, all school additions must be pleasant places for learning, but there are other issues that must be addressed. Urban schools, such as the Hong Lok Yuen International School in Hong Kong, the Center for Early Education in Los Angeles, and Saint Thomas's Day School in New Haven, must make the most of the available site while being appropriately scaled and in context with the neighborhood.*

## Truro Central School

*Truro, Massachusetts  
HMFH Architects*

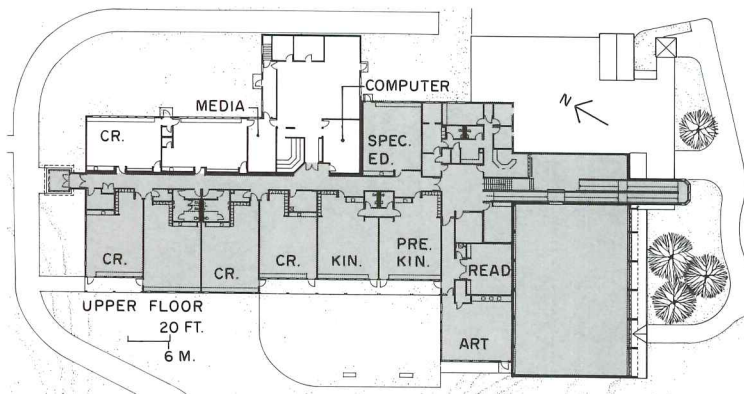

*Waame Sovereigns, Jr. photos*

## Hong Lok Yuen School

*New Territories, Hong Kong  
Wong Chen Associates, Architect*

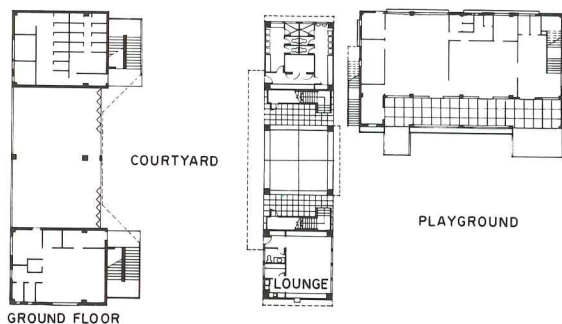

*Li Bun Photography & Associates photos*



*At the Truro Central School, context and appropriateness issues are still at work, yet the school's function as a community meeting hall influenced its street-like circulation spaces. At Murray-Lasaine Elementary School, flexibility with an eye toward future expansion was the rule.*  
*Charles D. Linn*



#### **Elementary school serves as town square**

Education is a matter of pride with the citizens of Truro, Massachusetts. Faced with the choice of busing their children to grade school in another town, or school construction, they built. HMFH Architects' scope of work included feasibility studies to help determine whether several school buildings should be remodeled, or whether a new structure should be built. The town opted to reuse only one of the existing buildings. The rest were demolished, and a new L-shaped structure added to two sides of the existing building (plan opposite). The stained, gray wooden shingles (photo opposite), trimmed in white, along with the hip roof, cupolas, and over-scaled bay and two-over-two window treatments, are in keeping with the local Cape Cod vernacular. Inside, HMFH Architects took what might have been an ordinary hallway and gave it a street-like quality, (left) with the use of tile on floors and walls, wooden pilasters and pediments around the cafeteria doors, and exterior lighting fixtures. The gymnasium, reached via the ramp at the right of the photo, and the cafeteria, are the only large meeting places in town and are in constant use. Thus when the citizens of Truro fill up this space it really does act as a "main street." *C. D. L.*



#### **Primary in pastels**

The Hong Lok Yeun International School's 6,000-square-foot new wing (photo opposite) fills in a site between a two-story kindergarten and a four-story primary school. New York-born architect Nelson Chen scaled down the stucco-finished, reinforced-concrete structure for compatibility with the surrounding residential community's, using deep frames and treehouse-like balconies to subdivide what would otherwise be plain, expansive elevations. The framed balconies also block the sun, yet give classrooms plenty of light as well as views uninterrupted by window coverings. Skylights and a sun scoop flood the stairways and an upper-level classroom with daylight. Chen pastel-color-coded services in a manner that will appeal to a child's sense of whimsy: the water tank and piping are blue, the sun scoop yellow, and fire-protection equipment is red. The school's textures of glass and stucco, pastels, and deceptively complex patterns of planes and grids make attending the school a rich experience for a child. *C. D. L.*

# Center for Early Education

Los Angeles, California  
 Goldman Firth Boccato,  
 Architect

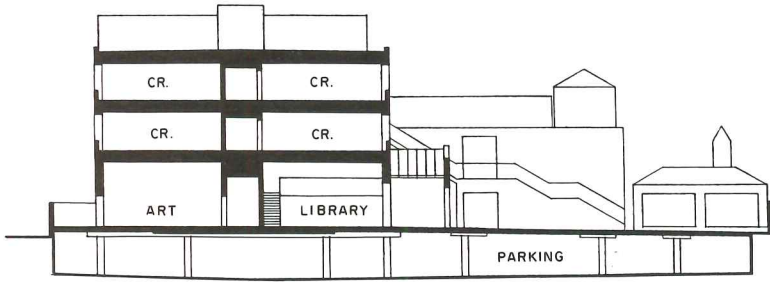

# Murray-Lasaine Elementary School

James Island, South Carolina  
 Ray Huff, Architect

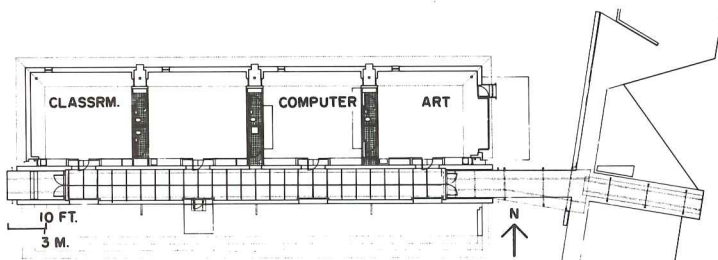

# Saint Thomas's Day School

New Haven, Connecticut  
 Office of Michael Rosenfield, Architect

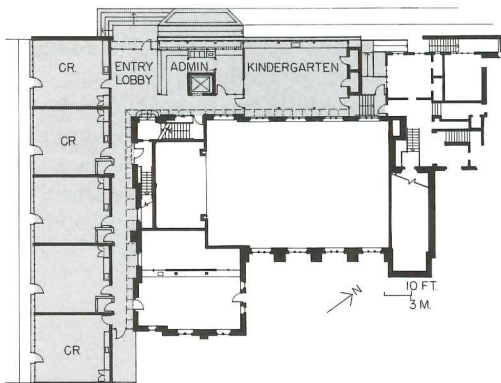

Paul Ferrino photos

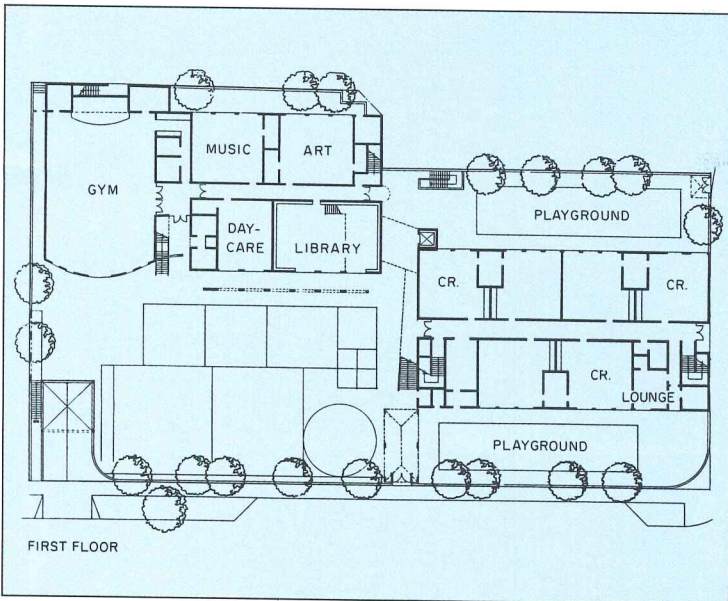

### Rooftop playgrounds get top billing

The Center for Early Education occupies a tight 40,175-square-foot site (about one acre) in west Los Angeles. The learning-laboratory complex serves 475 students, as well as being a fully-accredited teachers college. Smart budgeting of \$3.5 million bought a new 25,000-square-foot classroom building, renovation of an existing 16,000-square-foot brick building, and an 88-car parking garage. Two 8,000-square-foot rooftop play areas were added to three existing playgrounds, allowing almost 100 percent of the site's gross area to be used for recreational purposes. The new play areas double as outdoor classrooms for astronomy, hydroponics, and urban geography. The new buildings' outdoor pavilions (section opposite), colors, and stepped massing help establish a scale that children find friendly. Some of the building forms are symbolic: a bus-stop shelter built of red brick invokes the image of a traditional schoolhouse, while a clocktower anchors a multi-level outdoor streetscape connecting classroom and playground levels. *C. D. L.*

### A four-classroom addition poised for future expansion

This modest addition to a 1960s structure, itself a massive addition to a 1920s building, is the part of the school most visible from the street, so Ray Huff expressed the addition's components. He placed toilet rooms and other services in a recessed zone separating the classrooms (plan opposite). The corridor, visually pulled away from the classrooms, is set between parallel cementitious synthetic stucco-on-block walls (photo opposite). Site conditions precluded a straight-line addition to the earlier structure, so the inverted curve of Huff's metal canopy sweeps up, covering a skewed junction to a canopy leading to the main building. In Charleston's hot, humid climate, air conditioning is standard these days, but windows, seen mainly as inconvenient heat-gain devices and an invitation to vandals, are only grudgingly tolerated. With butt glazing, Huff floated the roof of the addition over the concrete-brick walls, and further animated the rooms with glass-block panels and slim vertical lights which face the recesses between each classroom (left). The corridor is single-loaded, but large cutouts in the exposed stucco wall (on wall not visible in photos) will one day permit easy placement of doors and mechanical ductwork for added classrooms. *J. S. R.*

### Addition keeps low profile

Saint Thomas's Day School's pre-kindergarten through sixth grade classes had occupied a converted parish house for over 30 years. The school commissioned the Office of Michael Rosenfield to design an addition and prepare plans for other necessary renovation work in the late 1980s, when the student population finally outgrew existing facilities. Rosenfield's design had to respond not only to the site conditions and the expansion program, but also to neighbors' concerns that the addition, located on a prominent neighborhood corner, maintain a residential scale. The resulting single-story, L-shaped classroom wing and administration wing (plan opposite) wraps around the back and sides of the parish house. A flat roof and matching granite walls, as well as judiciously selected plant materials, help diminish the bulk at the remaining street side (photo opposite). The addition is knit to the parish house by a skylit corridor. Clerestories admit daylight to classrooms from the corridor and from a curtain wall on the exterior elevations. Improvements for disabled access were also made during the expansion. *C. D. L.*

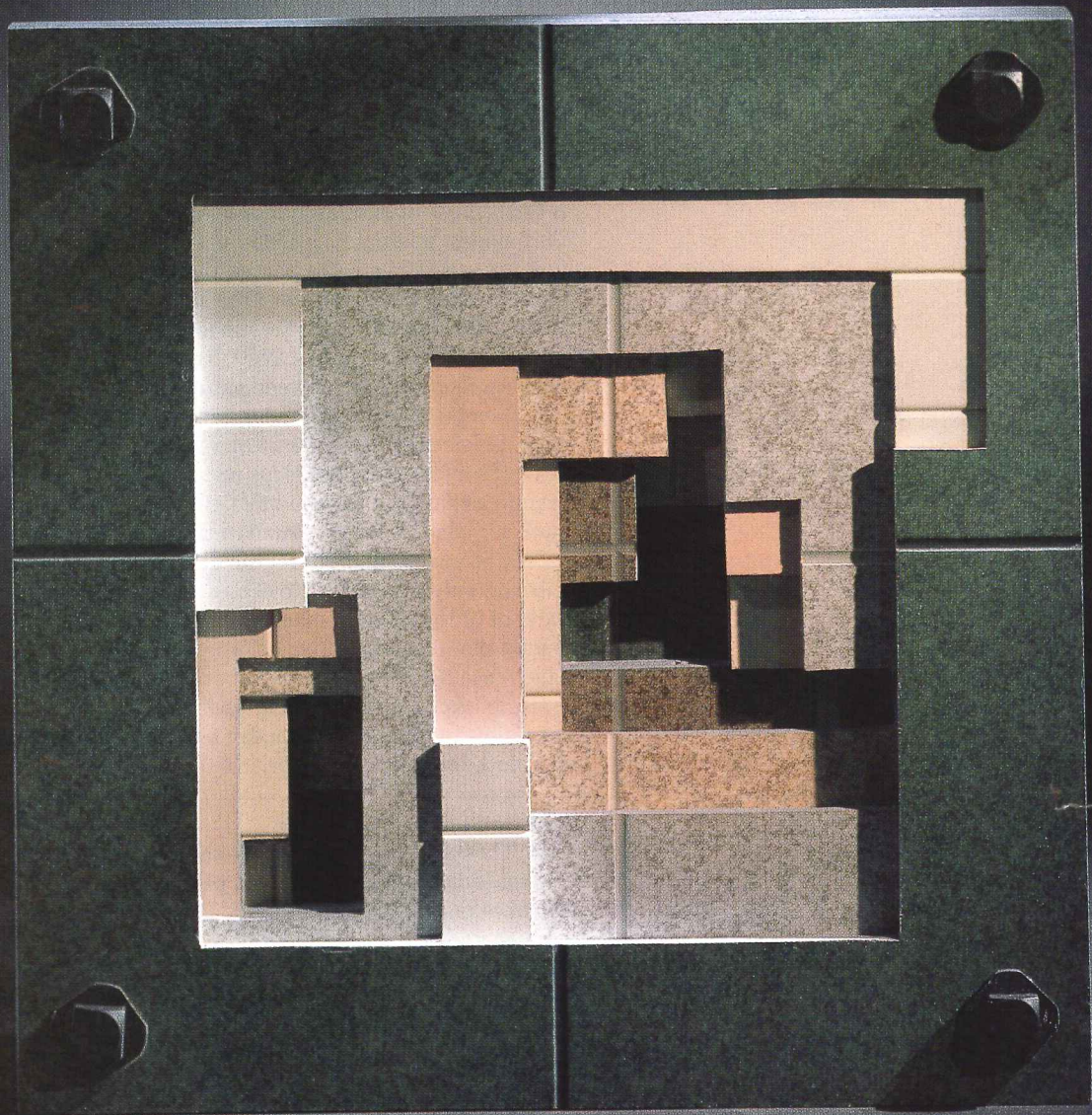

**Shadow Box.** Inspired by the richly detailed surfaces of *Marlite*® Plank. A winning entry in the *Marlite Student Art Contest* by Nadine Dross from Kent State University. This contest allowed college students to exercise their creativity using *Marlite* products as a medium. Our hope is to inspire your creativity as well.

*Marlite* Plank offers you the freedom to design beauty into areas where the need for durability and aesthetics often conflict. Explore the entire palette of exclusive patterns, solids and woodgrains. All in an easy-to-install, easy-to-maintain 16" wide, tongue and groove module. 202 Harger St., Dover, Ohio 44622. (216) 343-6621. Fax: (216) 343-7561.

 **Marlite**

Circle 30 on inquiry card

## New Products



### 210. Children's suite

Made of maple-faced plywood set on solid legs, Christopher Murray's Leaf chairs and tables (above) are sturdy enough for kindergarten use. Backs come in five "species": acorn, clover, poplar, currant, and ginko, in a choice of bright stain colors. Seat height can be ordered 10-, 12-, or 14-in. high. Harry Loucks designed the magnetic sand table (top) for pediatric waiting rooms. Magnets move toy cars and trucks through sand enclosed in a vacuformed plastic tray. The Children's Furniture Co., Baltimore.

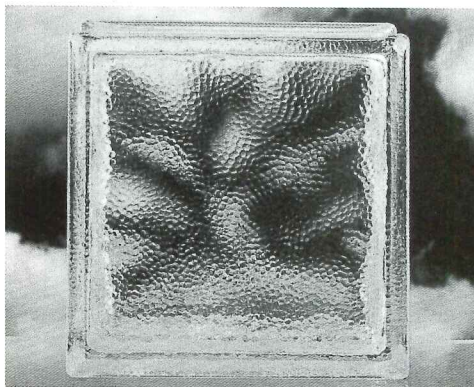

### 211. Dual-pattern glass block

Cirrus, the newest of eight block designs, combines a wave-patterned interior face with a privacy-enhancing stippled exterior. At 3 1/8-in. thick, it offers good light transmission. Pittsburgh Corning, Pittsburgh. ■

For more information, circle item numbers on Reader Service Cards.

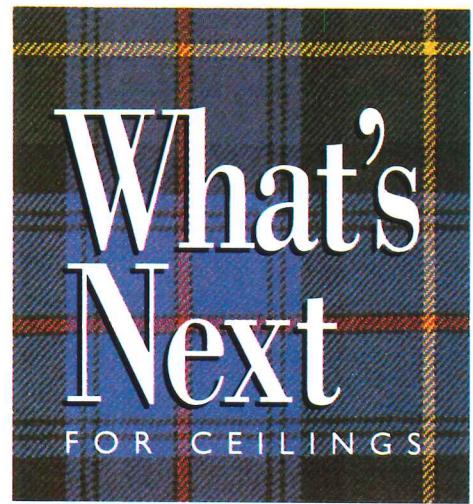

Introducing Tartan™ Ceilings. In Fine Fissured or Cirrus® textures, these exclusive designs are available in white and colors and fit 5/8" or 15/16" exposed tee grid. Call 1 800 233-3823 and ask for Tartan.

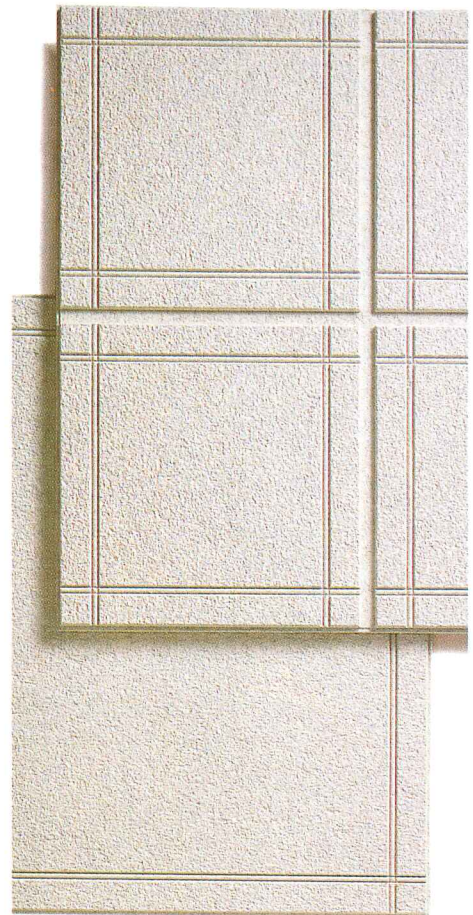

**ARMSTRONG  
CONTRACT  
INTERIORS**

**Armstrong**

Ceiling designs copyrighted by Armstrong.

Circle 31 on inquiry card

Architectural Record August 1993 121



It's about time.

Specifying a roofing system used to take days. But now it takes just minutes.

Tam-CADD® from Tamko generates CSI-formatted specifications, drawings, construction details, even multiple roofs with electronic speed and total accuracy.

All you need to operate Tam-CADD is an IBM PC or compatible computer with MS-DOS as the operating system, a minimum 640K RAM, a 30 megabyte hard drive, AutoCAD Release 10 or higher and word processing software capable of importing ASCII files.

If you're an architect, Tam-CADD will help you create a better specification in less time and with fewer associated costs. If you're a contractor, Tam-CADD can give your bids more credibility.

Call 1-800-641-4691 today for a copy of our free brochure. Tam-CADD. Isn't it about time?



**TAM**   
ROOFING DETAIL & SPECIFICATION SYSTEM

Tam-CADD is a product of TAMKO Asphalt Products, Inc.  
© 1990 TAMKO Asphalt Products, Inc.  
System developed by Architectural Synthesis Inc., Nashville, TN.

Circle 32 on inquiry card

**Product Literature/Schools**

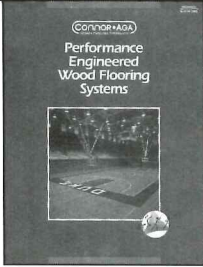
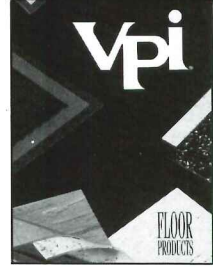

**400. Solid-vinyl tile**  
A 32-page catalog covers resilient flooring for educational, healthcare, and retail applications, including a new line of composition tile as well as solid-color and patterned vinyl and slip-resistant rubber flooring. Illustrates an expanded color range. VPI, Sheboygan, Wis.

**401. Sports flooring**  
Architectural guides are offered on an international line of athletic surfaces for both indoors and out. Special floors include wood-plank and parquet systems for specific use such as ballet, aerobics, or basketball; general-purpose synthetic surfaces; and ElastiTrac running tracks. Connor.AGA, Balsam Corp., Amasa, Mich.



**402. Demanding-use plumbing**  
Bradmax stainless-steel fixtures and accessories are said to withstand the abuse possible in unsupervised washrooms. A 12-page catalog covers lavatories, water closets, sinks, fountains, shelves, and dispensers; a chart displays color-glaze options. Bradley Corp., Menomonee Falls, Wis.

**403. Playground equipment**  
A 108-page catalog features products for playgrounds, parks, recreation, fitness, and sports, including items made of recycled plastics. Illustrated specifications demonstrate ground-space requirements and fall-zone dimensions. Quality Industries, Hillsdale, Mich.

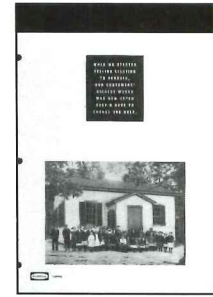

**404. Lighting for schools**  
A capabilities brochure describes energy-efficient equipment for any educational-lighting requirement, from classrooms to parking lots and athletic fields. Using a single source for lighting is said to reduce costs, expedite purchasing, and simplify maintenance. Hubbell Lighting, Christiansburg, Va.

**405. Acoustical products**  
Decorative and durable wall and ceiling materials, such as lay-in or full-span corridor panels, are illustrated as used in recent school, recreational, and institutional projects. Finish options include fabric wrap, nubby fiberglass, and paint. Tectum, Inc., Newark, Ohio.  
*Continued on page 125*

For more information, circle item numbers on Reader Service Cards.

# A NEW ANGLE TO THE HEALTH CARE ENVIRONMENT

# VPI®

**SHEET VINYL FLOORING**

Providing outstanding durability for heavy traffic areas, the VPI Sheet Vinyl Flooring line offers:

- CUSTOM ROYALE™ – a monolithic floor in the classic tradition
- BRIO™ – create a new look with this non-directional pattern
- SURE-TRAC™ – when slip resistance matters most

We're paving the way for today's commercial environments.

1-800-874-4240

Extension A150

Circle 33 on inquiry card

Circle 34 on inquiry card

# With Star Building Systems, architect designs appear as good in reality as on the rendering.

Over 50 percent of Star building orders involve custom manufacturing to meet special architectural design requirements. For custom fabrication, Star offers a complete line of long-lasting, attractive, weather-resistant structures and exterior coverings. Star also provides detailed specifications.

Star Building Systems has broad experience in exporting buildings throughout the world. We have been exporting our product since 1963 and have hundreds of international buildings in service.

Star has developed cooperative, working relationships with architects spanning 25 years. Our custom fabrication experience, combined with the versatility of Star Building Systems, means you can count on Star to meet or exceed your aesthetic expectations.

**Write, call or FAX today for informative free literature!**

- Star Product Design Guide
- Custom Details Product Digest
- Star Specifications Guide on diskette

**800-654-3921**

(405) 636-2549 Outside U.S.

FAX (405) 636-2037 • In Canada, call Norm Crumpton at (800) 387-5335



**Northmore Elementary School**  
Lantana, Florida



**Turner Elementary/Middle School**  
Shreveport, Louisiana



**Robertsdale High School**  
Robertsdale, Alabama

**PARTNERS IN TECHNOLOGY**



**STAR BUILDING SYSTEMS**

8600 S. I-35, Box 94910  
Oklahoma City, OK 73143

Circle 35 on inquiry card



**DIM IT ALL!**

Express yourself. Use dimmable compact fluorescents wherever you'd like. Choose from the largest selection of controllable, energy saving fixtures. Downlights or wallwashers. Open reflectors, cross-baffles or lenses. 7" or 8" apertures. One-lamp or two-lamp models, for 18 or 26 watt lamps. All dimmable, and all shipping now. Eleven Standards help you get your way. For information and the name of your local representative, please call 212-838-5212 or fax 212-888-7981.



DTT



DUPLUX



SUPER BAFLUX



WASHLUX

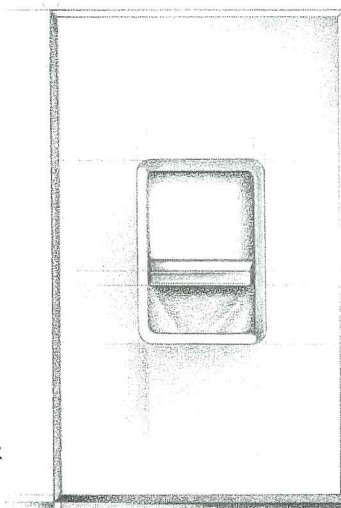

ARCHITECTURAL LIGHTING AT ITS BEST

Circle 36 on inquiry card

**Product Literature/Schools**

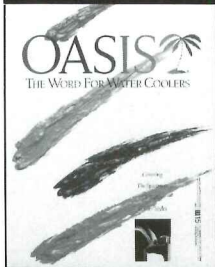

**406. Water coolers**

A new 28-page Oasis catalog highlights pressure water coolers, fountains, and accessories. Format places on-site color photos, dimensional data, and design criteria on the same page for easier use by architects and specifiers. EBCO Manufacturing Co., Columbus, Ohio.



**407. Security equipment**

CCTV cameras and other surveillance components have been constructed with protective housings for use in vandal-prone and remote environments such as stairwells and ATM enclosures. A six-page data sheet illustrates housings and gives dimensions; CAD specification help is offered. PELCO, Clovis, Calif.

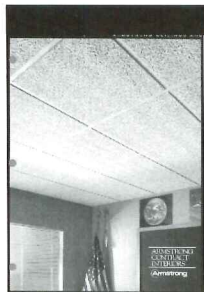

**408. School ceilings**

A handsome brochure illustrates ceilings and wall treatments suitable for the specific needs of every school area, from high-humidity locker rooms and must-be-scrubbed cafeterias to fire-rated corridors. Charts match areas and requirements with suggested acoustic products. Armstrong World Industries, Inc., Lancaster, Pa.



**409. Radiant floor heating**

Its low-draft, low-maintenance performance is said to make in-floor radiant heating particularly effective in school settings. A technical flyer describes new high-capacity systems suitable for educational, institutional, and factory applications. Gyp-Crete Corp., Hamel, Minn.

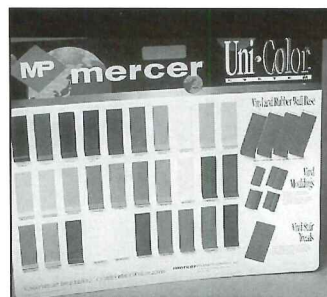

**410. Wall base**

Uni-Color is a system for color-coordinating wall base and flooring accessories across four rubber and vinyl product lines. A specification-assistance program supplies samples of all colors available in both matte and glossy finishes. Mercer Products Co., Inc. Eustis, Fla.

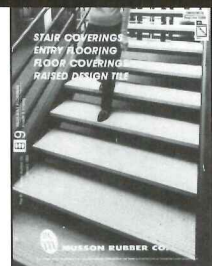

**411. Safety flooring/stair treads**

An architectural catalog covers key points in floor and stair safety, including products that meet visual impairment and fire-safety standards. Offered in marbled or solid colors, rubber flooring and treads come in low- and high-profile disc, square, and diamond patterns. Musson Rubber Co., Akron, Ohio.

Continued on page 127

For more information, circle item numbers on Reader Service Cards.

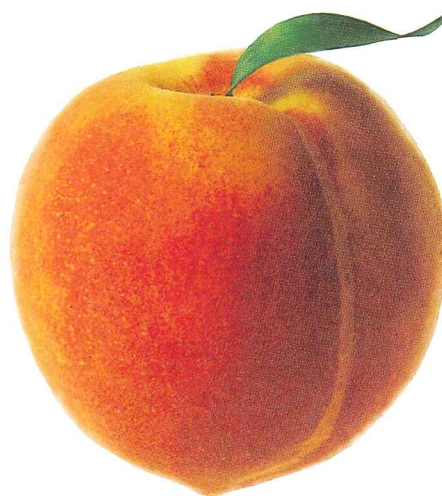

Plastic Interlayer

By Monsanto

Circle 34 on inquiry card

## Inspiration.

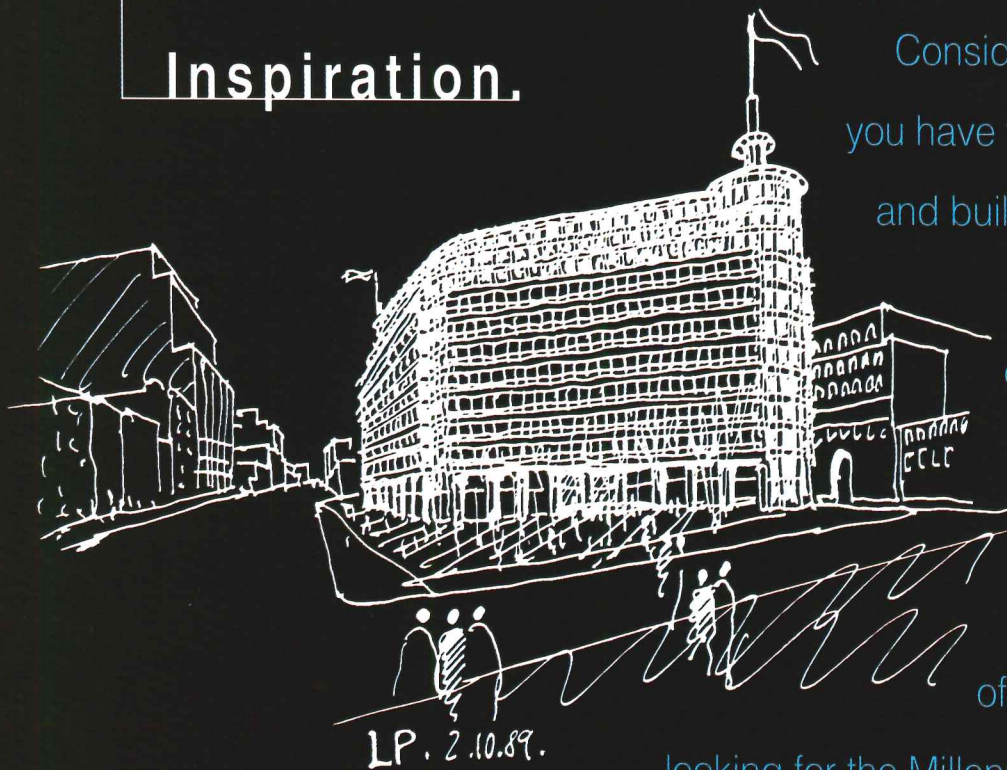

Considering the 10,001 details you have to worry about in designing and building a project, the least we can do is simplify part of the process. If you're looking for a wall material that will both inspire you and withstand the tests of time and nature, you're

looking for the Millennium Collection from

Stark Ceramics. For complete details, send for your free Millennium portfolio and information guide and see how several companies like Murphy/Jahn have taken projects from sketches to structures with Stark's Millennium Collection.

Stark, P.O. Box 8880, Canton, OH 44711

## Execution.

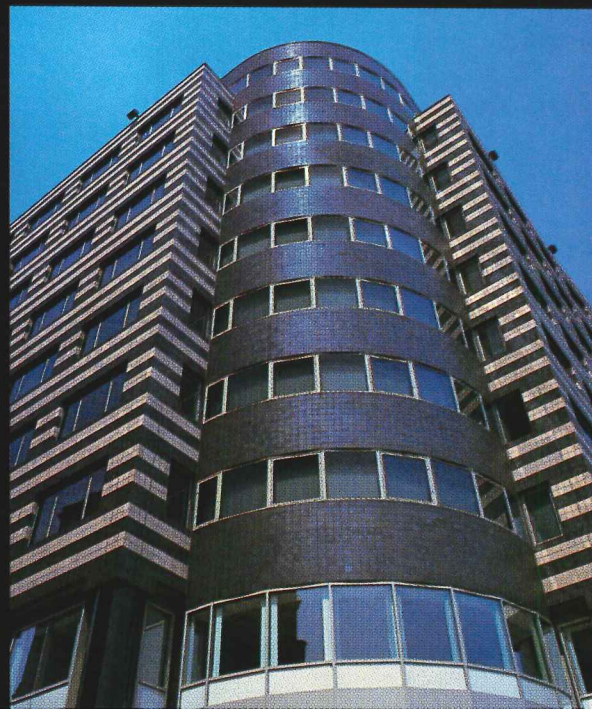

**stark**

1 800 321 0662

Circle 37 on inquiry card

**Product Literature/Schools**

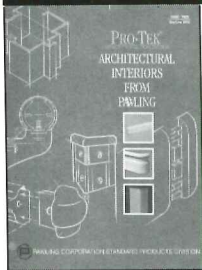

**412. Wall protection**

A 24-page color catalog explains the design potential and ergonomic principles incorporated in Pro-Tek handrails. It also illustrates the full rail and impact-protection line, including specialty wall and door protectors. Products are Class I fire rated and meet ADA standards. Pawling Corp., Wassauc, N. Y.

**413. Music-practice rooms**

Modular sound-isolation rooms are supplied in sizes suitable for solo, ensemble, band, and other school music program requirements. Installed on site, units save space, and are said to offer a superior level of acoustic control over built-in practice rooms. Risers, band shells, and instrument-storage lockers also offered. Wenger Corp., Owatonna, Minn.



**414. Classic school blinds**

Catalog inserts detail window coverings long used in educational settings: 2-in. horizontal aluminum blinds, and roller shades of fire-retardant vinyl, fiberglass, and woven cotton. Swatch cards sample color choices for tapes and slats, as well as FR verticals made of perforated PVC. Springs Window Fashions Div., Middleton, Wis.

**415. Abuse-resistant washrooms**

Washfountains and lavatories are operated by an electronic passive-infrared detection system said to permit hands-off use for over five years on a single battery. Described as insensitive to ambient influences, automatic stainless-steel faucets save water and energy. Intersan Mfg. Co., Phoenix.

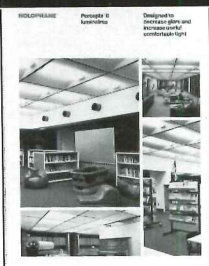

**416. Classroom lighting**

A brochure on Percepta II luminaires demonstrates how the fixtures reduce veiling luminance and increase useful, comfortable light. Illustrations depict several classroom-lighting applications, using totally enclosed as well as surface-, pendant-, and coffer-mount fixtures. Holophane Co., Inc., Newark, Ohio.

**417. Drinking fountains**

A colorful 20-page catalog shows fountains and coolers in finishes that meet very different design and performance requirements, from reinforced fiberglass and exposed aggregate to satin-finish stainless steel, colored enamels, and polished brass. Haws Drinking Faucet Co., Berkeley, Calif. ■

For more information, circle item numbers on Reader Service Cards.

**ROUND ALUMINIUM WINDOW**

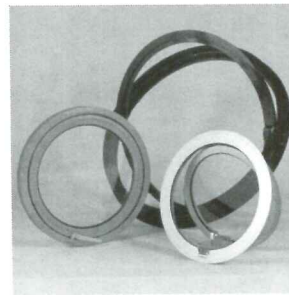
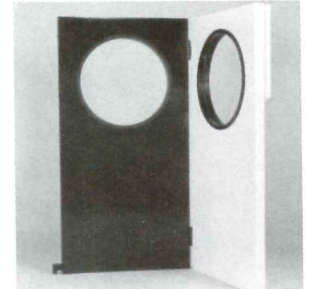

baudisson concept window corp.  
979 bennington st. • east boston, ma 02128  
telephone: (617) 569-2927 • fax: (617) 569-3381

Circle 38 on inquiry card



**Saflex**<sup>®</sup>  
Plastic Interlayer  
By **Monsanto**

Circle 34 on inquiry card

# Birdair. Covering Sports Around The World.

Striving for architectural excellence is no kid's game. It's serious team play. And what contest could be tougher than creating a major sports arena? Birdair knows that keeping the lead in tensioned membrane sports domes and structures means fighting for goals through technical innovation and manufacturing excellence. Extra effort wins. The World Cup Championship, World Series Baseball, The Superbowl, NCAA Final Four Basketball, Pan American and Asian Games have all appeared in world class sports facilities covered by Birdair.

Rome's Olympic Stadium is covered with a 50,000 sq. meter Birdair shade roof dramatically extending 55 meters from an externally supported structure. St. Petersburg, Florida's cable supported Birdair dome is the second of its type in the U.S. and the largest of its design in the world (34,385 sq. meters of membrane are tensioned to form a 210 meter clear span cable dome weighing less than 30 kilograms per sq. meter). Ravenna's Flammini Group project is configured for basketball and tennis. Its 2,920 sq. meter Birdair dome is supported with an exposed steel pipe lattice framework in a four sided cylindrical shape.

These are just a few examples of how the Birdair team can meet the challenge of your next tensioned membrane project with skills that compete with anyone in the field. Contact us for additional information. We will send you a free brochure featuring eighteen of our most recent and exciting installations.



Birdair, Inc. • 65 Lawrence Bell Drive  
Amherst, New York 14221 USA  
716-633-9500 • 800-622-2246  
FAX: 716-633-9850

Top: Olympic Stadium, Rome, Italy. Architect: Italprogetti S.r.l. Roof Consultant: Studio Technico Majowiecki. Middle: Florida Suncoast Dome, St. Petersburg, Florida. Architect: Hellmuth, Obata & Kassabaum, Inc. Engineer: Geiger/KKBNA. Bottom: Ravenna Sports Palace, Ravenna, Italy. General Contractor: Flammini Engineering. Roof Consultant: Studio Technico Majowiecki.

Circle 39 on inquiry card

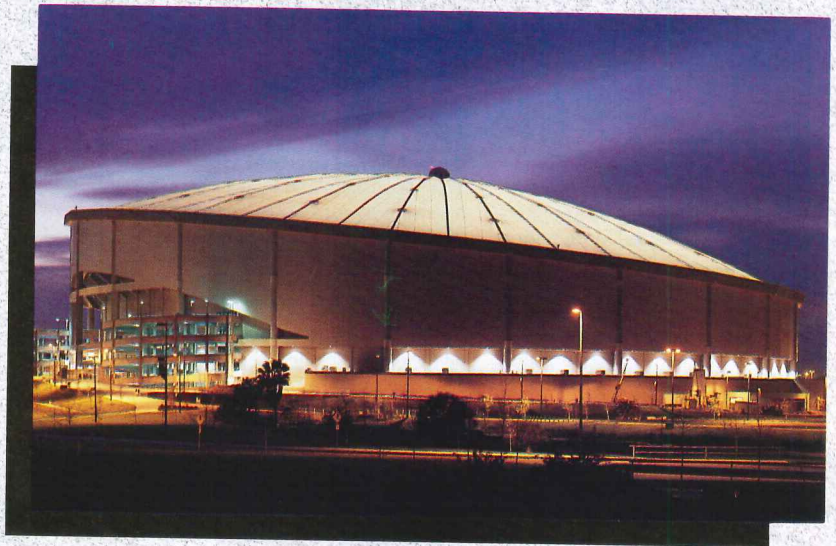

# WE'RE CHANGING THE WAY YOU'LL LOOK AT THE WORLD OF COLORED GLASS.

You'll look at the world through rose-colored glasses. Or peach-colored. Or emerald-colored. As a matter of fact, you'll look at the world through just about any color you can imagine when you specify laminated glass made with the Saflex OptiColor® System by Monsanto.

Choose from hundreds of transparent and translucent colors for curtain walls, spandrels, skylights, balustrades, elevator enclosures, atriums and more.

Since the glass is laminated, it can meet virtually any building code for safety, sloped and overhead applica-

tions. It goes where ordinary glass can't.

You don't have to buy a huge volume to make it economically feasible, so you can use it for small projects as well as big ones. You don't have to allow for a ridiculous lead time. And when you need replacement glass,

you can get it quickly in the exact color you need.

If that weren't enough, the interlayer also reduces light transmittance and solar heat gain. It provides added security. And it helps control noise.

To receive your free design kit, call us at 1-800-24-TOUGH. Or send or FAX the coupon to Dept. 204, 800 N. Lindbergh Blvd., St. Louis, MO 63167. FAX 314-694-7021.

Once you see the Saflex OptiColor system, the whole world of glass will look a whole lot rosier.

Please send me the free design kit for the Saflex OptiColor system.

Name \_\_\_\_\_

Title \_\_\_\_\_

Company \_\_\_\_\_

Address \_\_\_\_\_

City \_\_\_\_\_ State \_\_\_\_\_ Zip \_\_\_\_\_

Telephone \_\_\_\_\_

MONA-0004 AR

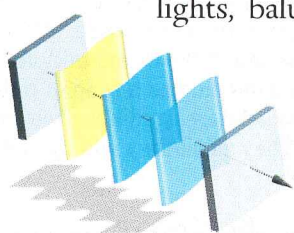
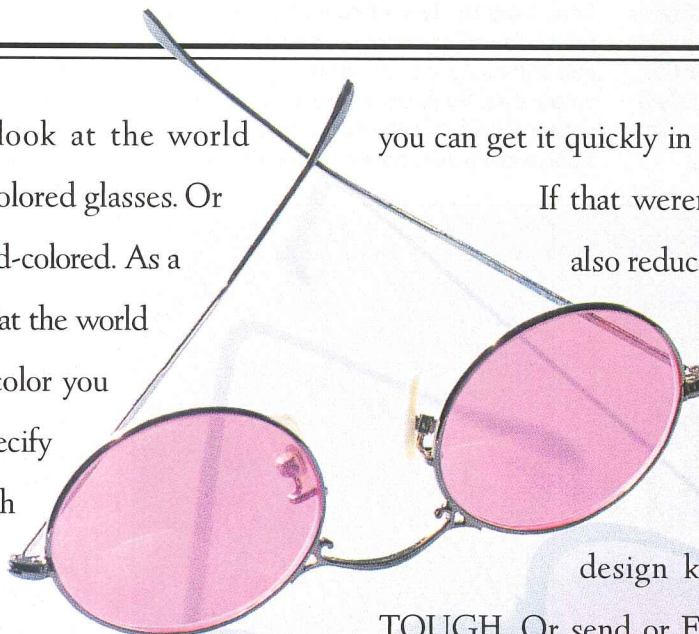

One to four interlayers are combined to create hundreds of color options.

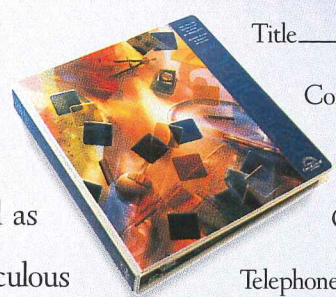

The new Circus Circus Grand Slam Canyon in Las Vegas.

**Boston** continued from page 29

draft report came out in May, with a final document late June. In some ways the task force was bold. It simply erased the proposed park, the joint creation of Cobb and the landscape firms of Hanna-Olin and Carol Johnson. The park had been a rigorous exercise in geometry, a kind of projection of the building itself. Working with the original designers, especially Laurie Olin, the task force changed it into a gentle, wandering English landscape garden that became a foil for the architecture. The task force also established the principle that the water's edge must not be dead, but alive with docks and boats.

In other ways the task force was timid. It failed to make any real dent on the building itself, despite what it perceived as problems. The problems included a rather tortuous public route through the building from the city side to the water side, a route much less generous than its model, the interior gallery of the Royal Courts in London. Other problems were the lack of retail frontage along the major adjacent street and an inconspicuous and inconvenient public entrance on the water side. Such issues were mitigated rather than truly solved. Helpful suggestions were made, however, for Cobb's

already generous public hallways, including the appointment of a kind of "social director" to create activities for them.

At the eleventh hour, yet another vigilante galloped onto the scene. The Boston Chamber of Commerce, prodded by the owners of Rowes Wharf—a waterfront complex that will face the courthouse across a narrow band of water—hired four prominent local urban designers, Gary Hack, William Porter, Alex Krieger, and Anthony diMambro, to think not so much about the courthouse as about its future urban context. Like the Yuppie cartoon woman who forgot to have children, the city's own planners neglected to lay out a street plan for the large new neighborhood that will eventually surround the courthouse. The four designers made a number of informal recommendations, the strongest being that a historic bridge, slated for demolition, instead be kept open as a pedestrian route from the downtown to the courthouse. Saving the bridge was a hope often voiced before, but never by anyone with comparable clout.

Looking back on all this happy democracy, one feels some hope, but also some depression—depression that after three decades of intense public participation in Boston, the sponsors of the courthouse were slow to realize they were going to have to get the community invested in the design process rather than merely its review. Says Woodlock: "We didn't reach out to the community enough in the early stage." On the other hand, he faults the community for treating a civic building as a fund of public benefits. "Single-interest groups each want a piece of it. They think they win by how much they get."

The next step—after all the proposed improvements are agreed on—is to appoint a committee to go to Washington to find a way to fund them. Most are not in the GSA's budget, nor are they likely to be. In his paper on courthouses, Woodlock quoted Oliver Wendell Holmes, Jr., to the effect that "the law is the government of the living by the dead." So too, he might well have added, is architecture. And the rest of Holmes's quote is just as applicable to architecture: "The past gives us our vocabulary and fixes the limits of our imagination; we cannot get away from it . . . But the present has a right to govern itself so far as it can, and it ought always to be remembered that historic continuity with the past is not a duty, it is only a necessity." ■

**Haws**

# Designed to meet Americans With Disabilities Act.

**THE  
HEIGHT OF  
ACCESSIBILITY**

Model 1114 HPB  
in high polish  
bronze

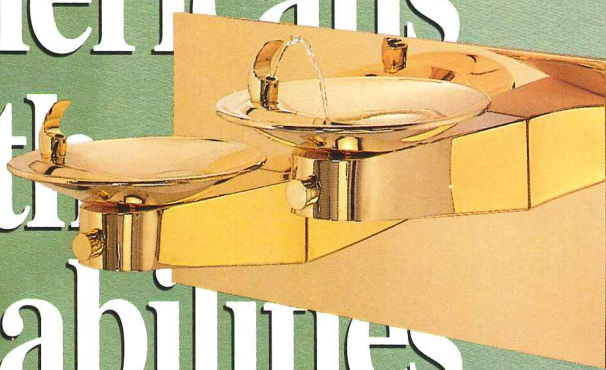

Haws new Hi-Lo drinking fountains help you meet ADA requirements. Also, being 0.0% lead-free, they exceed the standards of the Safe Drinking Water Act. Call your Haws representative and see exactly how attractive accessibility can be.

P.O. Box 1999 • Berkeley, CA • 94701 • (510) 525-5801 • FAX: 510-528-2812

Circle 40 on inquiry card

## HAC Water Cooler In Room Setting

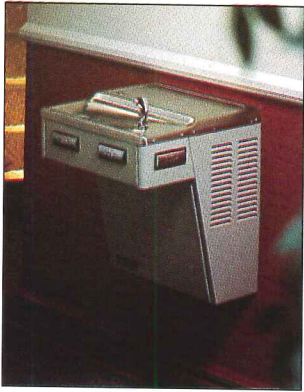

The Halsey Taylor HAC Barrier-Free Water Cooler **meets all ADA requirements** and has **no lead-bearing components** in the water system, making it ideal for new and renovated educational facilities. Features an attractive contemporary design and a standard platinum vinyl finish. Optional designer finishes available.

Halsey Taylor ... Satisfying Thirsts Since 1912.

### Halsey Taylor

Circle 41 on Inquiry card

## Adapta-Curb

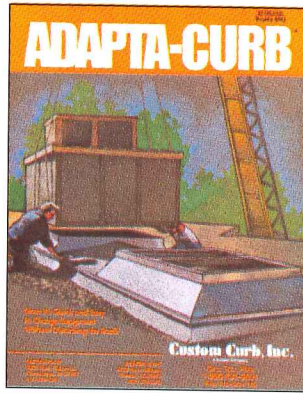

Informative color brochure illustrates the many configurations and options available with Adapta-Curb System that allows easy addition or replacement of rooftop equipment without disturbing the roof. It's designed for retrofit as well as new construction applications. The brochure outlines features & methods possible for easy addition or replacement of HVAC units & other rooftop equipment. 1-800-251-3001

### Custom Curb, Inc.

Circle 42 on Inquiry card

## Athletic Flooring

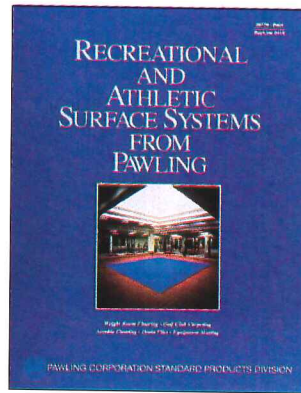

Full color catalog features photos, diagrams and specifications for many styles of specialty tile and carpet flooring including: Pawling's Inter-Lok® tile floor systems ideally suited for club, school and college sports and recreation facilities including weight rooms, court floors, work out areas, aerobic floors, exercise equipment areas, and wet areas (showers, saunas, pools).

### Pawling Corporation

Circle 43 on Inquiry card

## Revere Copper Shingles

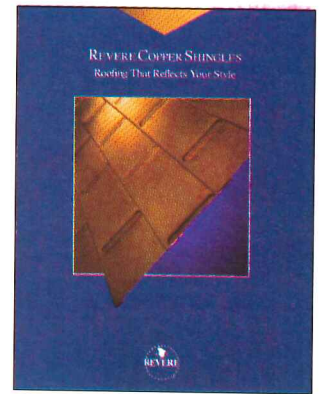

Revere Copper Shingles are quicker and easier to install than ordinary asphalt shingles. There are no special skills required and no special tools. Because Revere shingles are manufactured from solid copper, not a foil laminate, they will likely last as long as the building they protect. To learn more about our copper shingles, or any of our other copper roofing products, call us toll-free at (800) 448-1776.

### Revere Copper Products

Circle 44 on Inquiry card

## Synthetic Flooring Systems

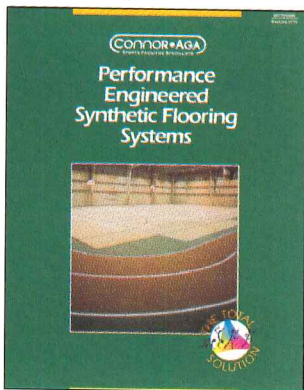

As part of the worldwide Balsam Family, Connor-AGA is the premier manufacturer of environmentally safe wood and synthetic sports flooring systems throughout the U.S. New, innovative and performance driven synthetic systems are available for virtually every educational and sports application. For catalogs and more information, call: 800-833-7144.

### Connor •AGA

Circle 45 on Inquiry card

## New Custom Lamp For Your Lounge



New lounge lamp is ideal for the educational environment. Heavy-duty, tamper-resistant construction provides security and low-cost maintenance while handsome Brass'n Color® design compliments a variety of interiors. Plus you can Perma-Mount™ to any end table to prevent theft. Available in 7 design colors. UL and CSA listed. Free 30-day trial sample.

### Adjustable Fixture Co.

Circle 46 on Inquiry card

## Floor and Stair Safety

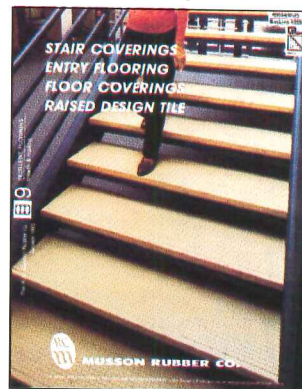

Learn more about VI (Visually Impaired), Fire Safety & other rubber floor and stair tread systems featuring marbled or plain, raised and surface designs in new popular colors. Also included is the latest entry flooring such as Disco, Low Disc, Square, Diamond, Fluff Cord and Traffic Tiles along with colorful illustrations & helpful specifications. P.O. Box 7038, Akron, OH 44306. Call: 216-773-7651

### Musson Rubber Co.

Circle 47 on Inquiry card

## Advanced Training System

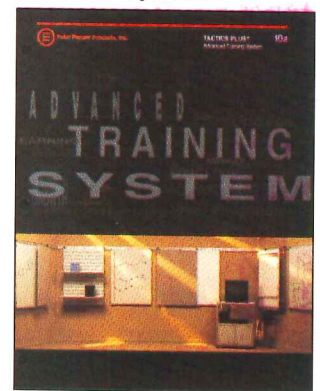

Tactics PLUS™, Advanced Training System is a versatile, space saving, modular system to help train, demonstrate, educate, inform & much more - all to increase productivity & efficiency. The 2 level wall mounted track allows interchangeable components to be arranged in any combination. Porcelain writing surfaces, fabric tackboards, projection screens, flip charts, conference centers & shelving bi-pass one another nearly doubling the capacity of your visual presentations. Call: 310-639-0390

### Peter Pepper Products

Circle 48 on Inquiry card

# Product Literature Showcase

## Acoustical Glazing Panel Integrated Blinds

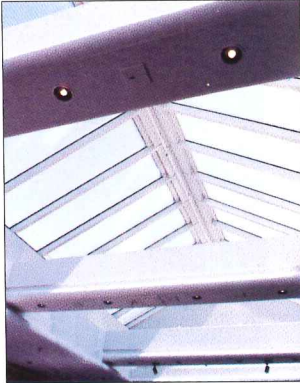

Custom designed **Vision Control** consists of pivoting louvers, manually operated or motorized. **Hermetically** sealed between glass of various shapes and types. **Dust-free, cord-free, Maintenance free.** Provides privacy, hygiene, control of light & sound. Ideally suited for sloped glazing, interior partitions, windows and doors in classrooms, laboratories, conference and computer rooms, libraries & auditoriums. Remote control available.

**Unicel, Inc.**

Circle 49 on Inquiry card

## PLASTRGLAS Glass Fiber Reinforced Gypsum

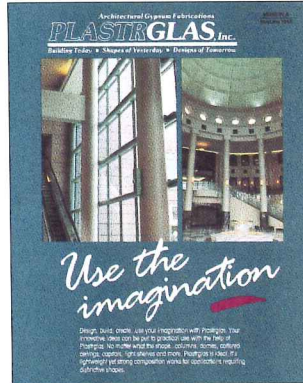

Innovative designs are made simply, economically and easy to install with PLASTRGLAS Glass Fiber Reinforced Gypsum. A complete line of columns, domes, coffered ceilings, capitals, and light shelves are offered and are engineered to meet the most exacting architectural specifications. Products are shipped in special crating to avoid handling problems. Architectural fabrications are available for interior as well as exterior use. Call (402) 455-0652

**PLASTRGLAS, Inc.**

Circle 50 on Inquiry card

## PowerGuard™ from Atlas Roll-lite

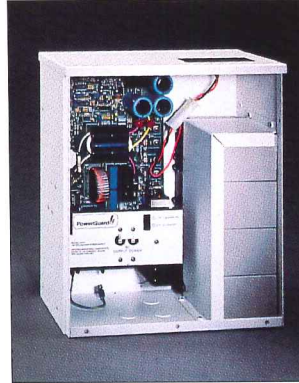

Atlas Roll-lite's PowerGuard back-up power supply activates your grille door or gate in the event of a power outage. It is easy to install and compatible with 1/3 and 1/2 HP, 110V motor driven operators. PowerGuard is ideal for installation in freight facilities, hospitals, and schools. PowerGuard is tested & approved by Underwriters' Laboratories, Factory Mutual, & others. P.O. Box 593949, Orlando, FL 32859-3949.

**Atlas Roll-lite Door Corp.**

Circle 51 on Inquiry card

## Space Master International, Inc.



Extensive portable classroom & modular building experience has positioned Space Master Buildings to creatively respond to today's Educational Facilities Planners requirements. Capabilities include: feasibility studies, site development, facility design, building fabrication, & construction management. From the classic portable classroom to state-of-the-art modular schools call 1-800-241-1126

**Space Master**

Circle 52 on Inquiry card

## Premier-Grade Fire Sprinkler System



The DecoShield® Modular System by **Creative Systems Engineering, Inc.** Produced from high-impact, low flame spread, low smoke generation BF Goodrich engineered resin, this system is UL tested & listed for use with listed CPVC sprinkler piping, & metal piping. Snap-fit cover support system is designed to be installed by a piping contractor & can be utilized with hot water heating, communications, plumbing & air conditioning systems. Call: 608-757-0717; fax: 608-757-0721.

**Creative Systems Engineering, Inc.**

Circle 53 on Inquiry card

## Wheelchair Platform Lift

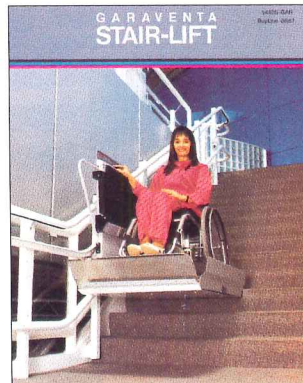

When stairs represent the barrier, the Garaventa Stair-Lift answers your client's needs, economically and in-style. With thousands installed worldwide, including the White House and Harvard, Stair-Lift is the first choice of accessibility planners like you. Call today for your information package and get a free 40-page Design and Planning Guide: 800-663-6556.

**Garaventa**

Circle 54 on Inquiry card

## ADA Compliance Signage

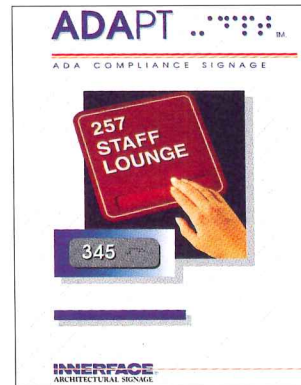

INNERFACE makes it easier for you to meet the new Americans With Disabilities Act (ADA) signage standards. INNERFACE offers (1) A variety of compliance signage, (2) National distribution, (3) Solid 21 year history and (4) Economical, attractive, & highly functional interior and exterior signage. INNERFACE also offers a complete line of interior and exterior signage. For free literature Please call: (800) 445-4796.

**INNERFACE**

Circle 55 on Inquiry card

## POMEROY

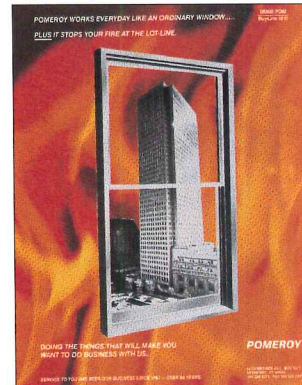

PomeroY features its line of automatic closing steel fire rated hollow metal windows. UL listed.

Call: 203-324-6775  
or fax: 203-325-3397 for more product information.

PomeroY, 64 Sunnyside Avenue, Box 1377, Stamford, CT 06904.

**PomeroY**

Circle 56 on Inquiry card



### Metl-Span Building Panels

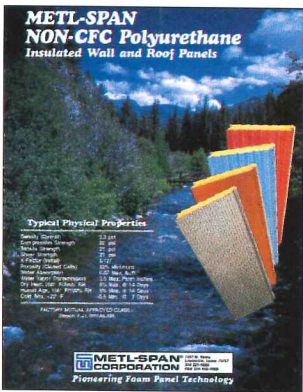

Metl-Span NON-CFC Polyurethane Insulated Building Panels. Metl-Span makes a complete line of concealed fastened insulated metal wall and roof panels. The NON-CFC polyurethane core building panels are made by a fully automated continuous line process, assuring uniform quality. Factory Mutual Class I approved panels are pre-painted with Kynar 500 or siliconized polyester coatings.

**METL-SPAN Corp.**

Circle 57 on Inquiry card

### Concrete Construction for Building Owners/Developers

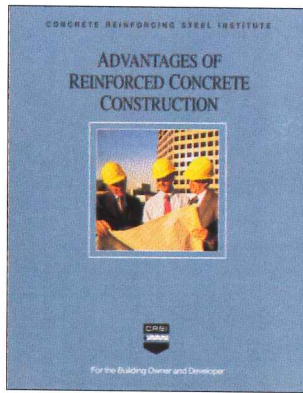

Produced by CRSI, this 4-page, 4-color brochure discusses the aesthetics and cost effectiveness of cast-in-place reinforced concrete in structures from one-story to skyscrapers. Seven areas of cost-savings are discussed. Four dramatically different structures are described to demonstrate the versatility of cast-in-place reinforced concrete.

**CRSI**

Circle 58 on Inquiry card

### Renovation Stair Treads

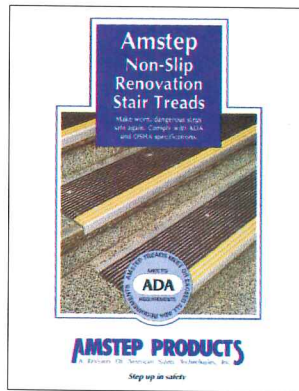

Amstep renovation stair treads are the economical way to repair worn, dangerous stairways both indoors and outdoors. Easily installed over stairs of virtually any material, these long-lasting treads will provide a safe, non-slip surface which exceeds the Americans With Disabilities Act (ADA) and OSHA requirements for slip resistance. Call toll free at (800) 631-7841.

**Amstep Products**

Circle 59 on Inquiry card

### TOUCHBAR EXIT DEVICES

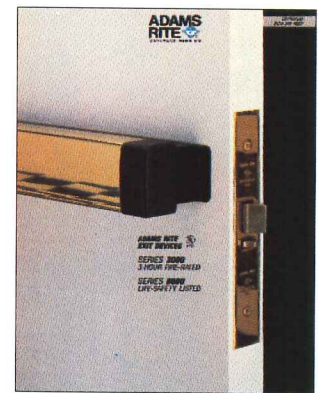

Catalog of UL listed (for life safety only or fire-rated for up to 3 hrs.) exit devices. All have matching 1-piece touchbar. Available in bright or satin brass; bright, satin or oil-rubbed bronze; bright or satin stainless steel & aluminum anodized clear, dark bronze or black. Catalog also includes choice of entry trim; pullers, levers, knobs, thumbturns or key-only functions. Electric operation, monitoring, mullions & other accessories are shown. Call: 310-699-0511

**Adams Rite Mfg. Co.**

Circle 60 on Inquiry card

### The Future of Cedar Shingle Siding

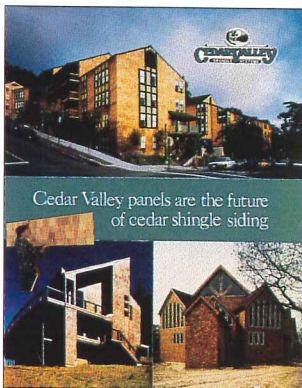

Cedar Valley's new 8-page color brochure details the panelized exterior siding system. Included are specifications, product descriptions & illustrations, finishing & application information and nearly four pages of color photos of significant projects by leading architects throughout the U.S. who used conventional & Decorator shingle panels. Cedar Valley. Call: 800-521-9523. Fax: 408-636-9035.

**Cedar Valley Shingle Systems**

Circle 61 on Inquiry card

### Ceco Building Systems

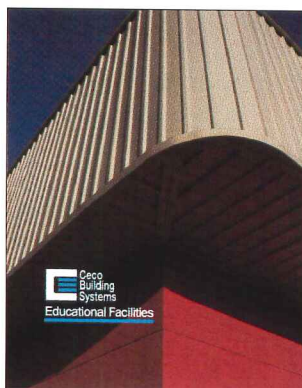

Ceco Building Systems designs and fabricates attractive, energy efficient, "function-oriented" pre-engineered metal buildings and standing seam roof systems for schools. Ceco is well known for its "non-standard is standard" design philosophy, allowing each project to be designed and manufactured to meet specific space and function requirements.

**Ceco Building Systems**

Circle 62 on Inquiry card

### Acoustical Wall & Ceiling Panels

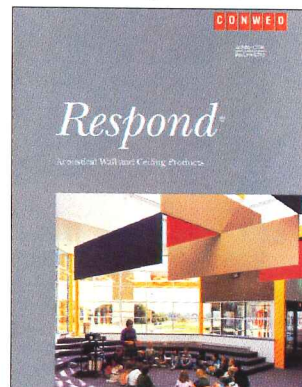

Conwed, the industry's acoustical expert for over 70 years, offers Respond, a custom acoustical products line. The innovative & coordinated array of acoustical products - wall & ceiling panels, baffles, ceiling clouds, absorbers, & diffusers - can be combined to solve any noise problem, whether it's in a music or practice room, gymnasium, cafeteria, or multi-purpose room. Conwed, 1205 Worden Ave. East, Ladysmith, WI 54848; 800-932-2383, Fax: 800-833-4798

**Conwed Designscape**

Circle 63 on Inquiry card

### Thorocoat® 200



Designed with safety and energy efficiency in mind, Thorocoat 200 adds improved light reflectivity to non traffic-bearing surfaces in dormitories, parking areas, gymnasiums, hallways, etc. A two-man crew can cover 20,000 feet a day with a standard electric airless sprayer as easily as they would apply latex-based paint. Call: (305) 597-8100 Fax: (305) 592-9760

**Thoro System Products**

Circle 64 on Inquiry card

# Product Literature Showcase

## Total Opening Systems



Absolutely everything you need to finish an opening securely in the widest variety of materials is explained in detail in this comprehensive catalog from ESSEX Industries. SARGENT architectural hardware, CURRIES hollow metal doors and frames, GRAHAM wooden doors, MCKINNEY hinges and MCKINNEY PARKER washroom accessories come together in this comprehensive reference work from the quality single source of total opening systems. Call: 1-800-945-0536

### ESSEX Industries, Inc.

Circle 65 on Inquiry card

## Expanded Line of Recycled Rubber Flooring

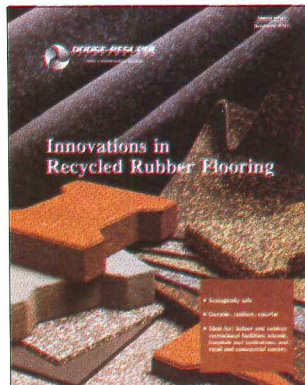

Dodge-Regupol, Inc. recently expanded its durable & resilient rubber flooring to include **EVERLAST™** tile, **EVERROLL™**, & **REGUPOL™ Pavers & Elastic Tiles**. Dodge-Regupol's line of rubber flooring, made from 100% recycled tire rubber, is renowned for its sound & impact absorption properties & has been chosen by innovators for over 30 years to provide a means for noise reduction, shock absorption & overall pedestrian comfort.

### Dodge-Regupol, Inc.

Circle 66 on Inquiry card

## Quarriers & Fabricators

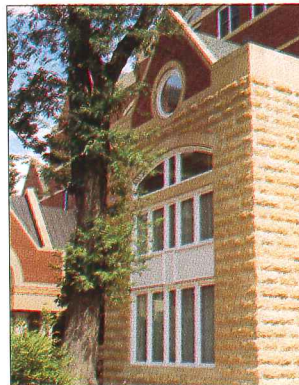

Going to school and getting straight A's. Mankato-Kasota Stone can be found on the walls of higher education from Yale to Princeton, from Notre Dame to Stanford, as well as St. Olaf, St. Thomas, &, of course, Mankato State University. Mankato-Kasota Stone quarriers & fabricators of Minnesota dolomitic limestone. Four generations dedicated to service, quality, & on-time delivery of dimension stone. Test us.

Call: 507-625-2746

### Mankato-Kasota Stone

Circle 67 on Inquiry card

## Unbreakable Low Maintenance

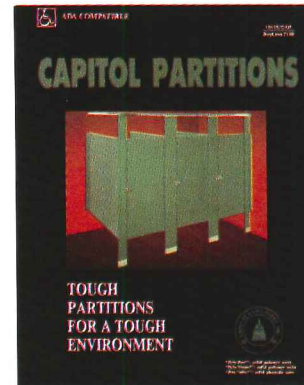

Capitol Partitions solid "Poly Pro" & "Pro Nolic" partitions offer years of low maintenance performance. All the materials & hardware are designed to be virtually unbreakable & to perform in the toughest environment. Optional continuous brackets & hinges enhance the durability & appearance of the product. Design assistance for ADA compliance is available.

### Capitol Partitions, Inc.

Circle 68 on Inquiry card

## Silentspace



This full-color brochure describes a wide range of interior acoustical products for applications from administrative offices to gymnasiums. Included is the entire silentspace products line of wall panels, baffles, banners, ceiling panels and encapsulated masks and pads. **Essi Acoustical Products**, P.O. Box 643, Cleveland, OH 44107-0643. Call: 216-251-7888

### Essi Acoustical Products

Circle 69 on Inquiry card

## Kroy ADA Signage

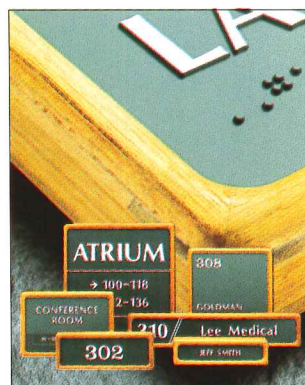

For more than a decade, Kroy Sign Systems has been working with architects & designers to specify professional, cost-effective signage. Let us worry about ADA signage compliance for your next project while you concentrate on the rest. Whether you're bringing a facility up to code, renovating or designing for new construction, it's imperative to know how to comply - before you begin. Call: 800-733-5769 or Fax: 602-951-7033

### Kroy, Inc.

Circle 70 on Inquiry card

## New Single-ply Roofing Video



New video shows architects, consultants, owners and roofers responding to commercial challenges using white BondCote fabric-reinforced single-ply roofing systems on schools, churches, municipal buildings, plants, warehouses. You'll see manufacturing, quality-control, testing, inspection, code approvals, application procedures and warranties, all in less than 10 minutes. Call: 1-800-368-2160

### BondCote Roofing Systems

Circle 71 on Inquiry card

## Protective Wallcovering

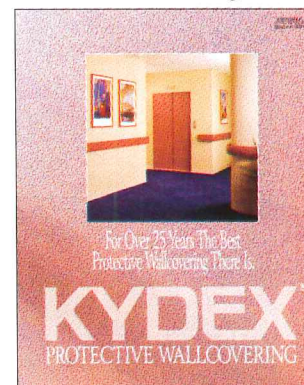

For Over 25 Years The Best Protective Wallcovering There Is. **KYDEX®** Protective Wallcovering is a semi-rigid, fire-rated, acrylic/PVC sheet that protects interior walls against high impact, scuffs, gouges, abrasion, & harsh chemicals/cleaners. Looks new after many years of abuse. Available in 33 standard & 200 designer colors, 4 textures, & 8 thicknesses (.028 - .250") with color matched moldings & caulking. 100 Gaither Dr., Suite B, Mount Laurel, NJ 08054, 800-626-2181.

### Kleerdex Company

Circle 72 on Inquiry card

### EFCO 1993 Product Catalog



The 1993 EFCO Product Catalog is an invaluable tool for selecting Division 8 products. It features photographs of completed new construction and retrofit projects, detail drawings, product information & descriptions, specifications, performance ratings, lab test results, and options for the entire line. EFCO offers a complete line of Division 8 products plus custom designs & historical replications. Call: 1-800-221-4169.

**EFCO Corp.**

Circle 73 on Inquiry card

### Telecenter® System



Rauland-Borg, an innovative leader of educational & institutional communication systems, introduces the Telecenter V System. It delivers seamless operation from classroom communication to media retrieval & back. It also increases interconnect capacity, doubling throughout traffic, & reducing service response time. Released with a feature set that is unmatched by other integrated systems, Telecenter V provides; standard progress tones, message waiting indication & call forwarding.

**Rauland-Borg Corp.**

Circle 74 on Inquiry card

### Glass Block Panels



Circle Redmont offers prefabricated glass block panels for installation as skylights, barrel vaults, skybridges, floor and deck lights, stairtreads and landings, sidewalks, wall panels and complete structures. Structurally engineered, preglazed and fully waterproof, these panels are available in many standard and custom sizes and in a variety of glass block designs. Call: 1-800-358-3888

**Circle Redmont, Inc.**

Circle 75 on Inquiry card

### Graffiti Wipes Off High Impact Wall Panels

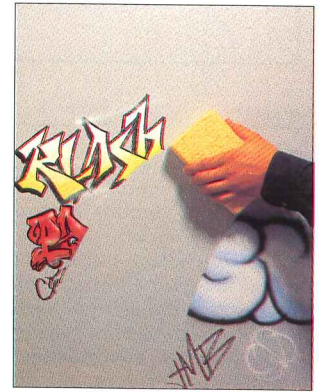

Acrovyn is impervious to common stains such as lipstick, markers & paint - they clean off quickly & easily. Acrovyn Wall Panels withstand abuse because they're five times more impact resistant than drywall. They also install easily & economically over damaged & uneven surfaces & offer 784 texture, color & design options. For literature, call: The C/S Group 800-233-8493. Fax: 717-546-5169

ACROVYN® INTERIORS

**C/S Group**

Circle 77 on Inquiry card

### Architectural Achievement

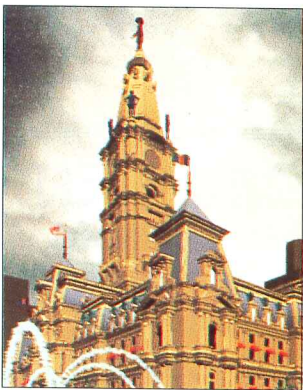

ARRIS is the AEC CAD system of choice by leading architects in 30 countries. Create photo-realistic 3D models; generate drawings in record time. No project too complicated. Send for **FREE** product catalog: How ARRIS helps you win more business and be more productive on the business you win. Call: 1-800-848-4400, Ext. 110

**Sigma Design, Inc.**

Circle 78 on Inquiry card

### Clutch System Key-In-Lever Lock



When locked, the "CLUTCH" releases the outside lever to turn freely without opening the latch. This eliminates the rigid lever; a cause of other lock failures. The "Survivor" satisfies all Federal ADA & State disability codes, is UL listed, meets ANSI grade 1 & is made in U.S.A. After 1 million cycles, support springs continue to prevent lever droop. IC core models available. Call: 800-225-6136

**Marks USA**

Circle 79 on Inquiry card

### FiberBond® Sheathing



FiberBond Sheathing is designed for use on outside or sidewall framing. It provides a water-resistant backing for various exterior siding materials. They are exceptionally strong & fire-resistant with superior fastener-holding ability. Sheathing can be used in E.I.F.S. construction & meets or exceeds ASTM c79 requirements. Underlayment & wallboard also available.

**Louisiana-Pacific**

Circle 80 on Inquiry card

### NEW from Brefford LEGACY Library Shelving

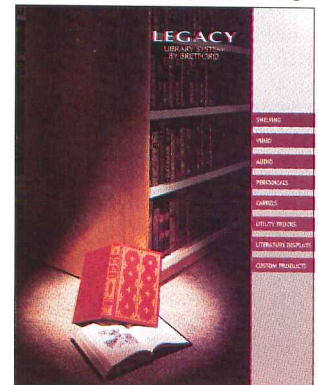

Beauty & practicality combined. Brefford's new library shelving system offers the most comprehensive storage & display options for today's libraries. With Legacy, shelving alternatives for all media formats are endless. The contemporary but simple lines of Legacy's wood & steel construction coordinate with any setting; school media centers, universities, & public libraries. For free brochure call: 708-678-2545 or Fax: 800-343-1779.

**Brefford Manufacturing**

Circle 81 on Inquiry card

# Classified Advertising

To Advertise Call  
801-974-2843 or  
Fax 801-972-9409

## POSITIONS VACANT

**Exhibit Designers & Producer/Developers.** Unprecedented opportunity for visionary design & production professionals to participate in the creation and execution of major new interactive exhibitions for a groundbreaking 21st Century science-technology center. Producer/Developers will manage a series of exhibition projects from conception to installation, coordinating all aspects of the exhibition development process. Designers will challenge the limitations of traditional museum exhibit design by integrating building architecture with design strategies from the theater and theme park. Send resume, professional references, and salary history to: COSI, Ohio's Center Of Science & Industry, Attn: Human Resources, 280 E. Broad Street, Columbus, Ohio 43215-3773. For more information, call (614) 228-2674, ext. 563.

**A leading multi-disciplinary Architectural & Engineering firm in Saudi Arabia is seeking qualified persons for the following positions:** 1) Design Architects: Candidates must have exceptional design talents and presentation capabilities with min. of 10 years design experience on residential, commercial and hospitality projects, preferably with Middle East Exposure. Strong interpersonal skills are necessary along with the ability to communicate design concepts to others. 2) Project Managers/Project Architects: Candidates must have proven record of managing design projects of various sizes in a multi-disciplinary A/E environment with min. 12 years in similar position. Strong communication skill is required to properly manage a team of multi ethnic background. Exposure to Middle East working environment is a plus. Candidates are required to submit their resume (CV) to the address shown below for interviews. Successful candidates would receive a generous package commensurate with their experience. Please send your CV to: Diyar USA Inc., 3186 Pine Tree Rd., Lansing, MI 48911 or fax it direct to: Saudi Diyar Consultants, P.O. Box 19413, Jeddah 21435, Saudi Arabia, Fax # (+9662) 631-7904.

**Architect: Researches, plans, designs & administers building projects for clients, applying knowledge of design, construction procedures, zoning & building codes, & building materials with emphasis on German projects.** MA on Architecture. 5 yrs. job offered exp. & fluency in German required. 40 hrs./wk. (9:00 A.M. to 5:00 P.M.). Needs to be available to complete projects. \$40,000.00 yrly. Must have proof of legal authority to work permanently in the U.S. Send resumes to: Illinois Department of Employment Security, 401 South State Street - 3 South, Chicago, Illinois 60605, Attention: Arlene Thrower, Reference #V-IL 10470T, No Calls, An Employer Paid Ad-Send two copies of resume.

**Architectural Consultant/Mid-East:** Work w/U.S. bus. having ofcs. or clients in Mid-East. Advise re: regulations on architect. & con-

strctn. in Mid-East & obtaining req'd permits & licenses; Assist w/contract negotiations & monitor projects in Mid-East. Must have B.Sc. Arch. & 1 yr. exp. in job offr'd or as Architect. Exp. must be in Mid-East firms having branches or doing work in Mid-East to give kwldg. of archt/urban codes in Saudi Arabia, Jordan & Iraq; Must speak, read & write fluent Arabic & be able/willing to travel freely in Mid-East as req'd, 5-6 times per yr. or approx. 30% of time. 40 hrs/wk; 8am-5pm Mon-Fri; \$40,000/yr. Employer paid ad. Send this ad & resume to: 7310 Woodward Ave., Room 415, Detroit, MI 48202, ref.#44593.

## POSITIONS WANTED

**Grad. Architect - M. Arch. three years of design/construction experience.** Seeks employment in a design oriented office. Excellent presentation, communication, and 3-D computer skills. Will relocate. 713-896-6152.

## BUSINESS OPPORTUNITIES

**Wanted: Architectural Practice.** Seeking ownership transition/purchase or association. Upper midwest location. Reply to BO-7153, AR.

## SPECIAL SERVICES

**ENVISION** San Francisco  
Los Angeles  
DESIGN CENTERS New York

**CAD-DRIVEN  
LASER CUTTING  
& MODELING  
SERVICES**

Complete Modeling Services  
Fast Track—  
24 hr. Turn-around  
Laser Cutting

3D CAD & Digital Rendering

For estimates and samples call **1-(800)-466-8811**

**Full-Color post cards are an effective way to promote your services!** At Mitchell Graphics we specialize in printing affordable full-color post card and direct mail products. All our quality reproductions are 100% guaranteed to meet your satisfaction. To receive your free sample package and product catalog, please call toll-free 1-800-841-6793. Mitchell Graphics, 2230 E. Mitchell, Petoskey, MI 49770-9604.

## BOOKS FOR SALE

**Old are rare books. Architecture and Decorative Arts.** Send for free illustrated catalog to: James Beattie, 105 North Wayne Ave., Dept. R, Wayne, PA 19087 or call 1-800-441-6705.

## MISCELLANEOUS

### — \$500 REWARD —

For Square D Smoke Detector Model EGD-51LR  
Manufactured Before March, 1986. Contact  
Tom Gallo at 312/861-2147.

**REACH and SELL**  
your services to over  
**155,000 active registered**  
architects for as  
little as \$300.

+ + + + +

Be a part of Architectural  
Record's monthly  
**"Consultant's Directory"**

+ + + + +

• Call 800.544.7929  
• Fax 212.512.2074

**Computers** continued from page 49 scan more images, at \$15 each (minimum order \$750) or rent the software for \$1,250 a month (minimum six months). **Circle 352**

Taylor Made Software introduced Hp2Design LFV, a simplified \$99 package to turn HP-GL/2 plots into DXF files, and another package, CadDesign (\$395 to \$595), that transforms CAD raster images into file formats used in desktop publishing (TIFF, PCX, GIF, PostScript). **Circle 353**

Tracer 1.0 for AutoCAD 12 does raster-to-vector conversions. The two modules, one for text and one for graphics, are from Information+Graphics Systems, Inc. **Circle 354**

## Cost Estimating

Joint ventures were the order of the day. WareCon Systems, Timberline Software, and North American MICA BidFax will, by the end of 1993, allow construction estimators to import vendor and subcontractor records from a Timberline Precision database to update a BidFax master database—simply by opening a menu option. **Circle 355**

R.S. Means introduced a new Windows-based spreadsheet estimating program with pre-loaded data. The firm also showed a “demo kit” with estimating software from Software Shop Systems, G2, Computerized Micro Solutions, WinEstimator, and others. It costs \$19.95. **Circle 356**

## Structural Analysis

Analysis of structures too unusual to be covered by standard codes is usually the domain of a specialized engineering firm, even when there is engineering expertise in-house. Many vendors showed basic analytical software, based on the Finite Element Method, however, at low prices. They handle a limited number of nodes, and static (not dynamic) loads. But they are a cheap way to do preliminary work.

Avanessa showed its basic 150-node version for \$250. Plate analysis adds \$10 and dynamic analysis adds another \$150. The full 1360-node version with all add-ons is under \$1,100. The program was developed for the South American market; documentation is available in Spanish as well as English. **Circle 357**

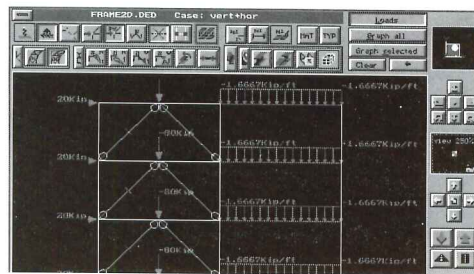

357

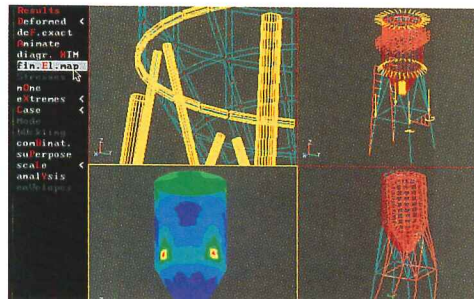

358

357. Avanessa structural finite-element analysis is graphical.

358. Metrosoft Robot V6 structural design.

Metrosoft has many Robot V6 finite-element analysis packages. An entry-level version, statics only, for 150 nodes, elements, loads, and combinations, is \$495. **Circle 358**



THE ANSWER IS—

**Danpalon®**  
Insulating Skylighting Systems

THE QUESTION IS —

Which translucent daylighting system is the only one with a cutting-edge technology, is **leak proof** by design, and is **revolutionizing** the industry?

That's a question you need to ask before you specify any skylighting/daylighting project.

**There's only one right answer—Danpalon from CPI International.**

There are many good reasons why Danpalon is the most versatile, most cost-effective high performing translucent insulating daylight system.

But if you don't ask the right people the right questions, you'll never get the right answers. You **COULD** be putting your project in **JEOPARDY!**

**Phone or fax CPI today.**

Get factual, fully documented answers to all your daylighting system questions...Ask for a personal Video Viewing...For a hands-on demonstration in your office. For immediate assistance with a project call (800) 759-6985 (outside of Illinois).



**CPI**  
INTERNATIONAL

Excellence in Translucent Daylighting  
See us in Sweets 07820/CPI Use our Sweets BuyLine 4424

**CPI International, Inc.**  
1371 Wilhelm Road  
Mundelein, IL 60060  
TEL: (708) 816-1060  
FAX: (708) 816-0425

Circle 82 on inquiry card

Excellence in Translucent Daylighting

# WE WANTED A WINDOW COMPANY THAT COULD ADD WITHOUT SUBTRACTING.



Portland High School, Portland, ME. Architect: Portland Design Team.  
Products: Series 670 Double-Hung, 660 Single-Hung, and 550 Projected Windows, Series 5600 Curtain Wall.

*The enrollment in America's second oldest high school had multiplied beyond capacity. We were asked to add room for students without taking anything away from the school's historic personality.*

*We had to find a company that could replicate existing windows, plus fulfill additional design needs for windows and curtain wall.*

*We awarded the job to EFCO.*



1-800-221-4169

## Manufacturer Sources

For your convenience in locating building materials and other products shown in this month's feature articles, RECORD has asked the architects to identify the products specified.

### Pages 84-91

Fountain Hills Junior/Senior High School  
Fountain Hills, Arizona  
HNTB Corporation, Architect  
Sheet-metal and foamed-in-place roof: Duraguard; AARA. Steel windows: Hope's Architectural Products.  
Direct/indirect lighting in library: Litecontrol. Fence: Lee Fabrication.  
Multiple glazed glass: Labglas.  
Locksets: Best Lock Corp. Hinges: Lawrence. Closers: LCN. Exit devices: Corbin. Surface ceilings and VCT flooring: Armstrong. Suspended ceilings: Chicago Metallic. Paints and stains: Dunn Edwards. Ceramic tile: American Olean. Indoor lighting: Lithonia. Outdoor lighting: Kim Lighting.

### Pages 92-95

Seward/Hedges Area School  
Chicago  
Ross Barney + Jankowski, Inc., Architect  
Brick-masonry curtain wall: Glen-Gery. Concrete: Hanley. Caulking, sealants, gaskets: Sonneborn. Built-up roofing: Manville. Skylights: Kalwall. Doors: Kewaunee. Wood windows: Eagle. Suspended system ceiling: Chicago Metallic. Paints and stains: Glidden. Tile: Dal-Tile Corp.; Metropolitan Ceramics. VCT flooring: Azrock. Indoor lighting: Lithonia.

### Pages 96-103

Troy High School  
Troy, Michigan  
Perkins & Will, Architect  
Lunch-room seating: Sico. Library casework: Nelson Mills. Skylights: Wasco. Masonry: Stone Creek; Yankee Hill; Cloud Ceramic. Quarry tile: American Olean. Ceramic tile: Dal-Tile. Glass and aluminum curtain walls, aluminum windows and doors: U. S. Aluminum. Built-up roof: Firestone Bldg. Prod. Suspended ceiling system: Armstrong. Paints and stains: Pittsburgh Paints. Floor treatment: H. B. Fuller. Carpet: Bigelow. Indoor lighting: Lightolier, Inc. Elevators: Dover.

### Pages 104-107

I. S. 218, New York City  
Richard Dattner Architect  
Glazed block: Stark Ceramics. Fence: North Shore Metal Fabricators. Exte-

rior flood lighting: Crouse-Hinds Lighting. Floor mosaic in rotunda: Armstrong. Built-up roofing: Manville. Metal and glass doors: Bilt-Rite. Aluminum windows: EFCO. Window guards: Kane. Tinted and laminated glass: Viracon. Paints: Pittsburgh Paints. Elevators: Westinghouse. Lifts: American Stair Glide.

### Pages 108-109

Rogers Elementary School  
Victoria, British Columbia, Canada  
Hughes Baldwin Architects  
Aluminum windows: Inolite Glass Co. Glass: Debonair Ind.

### Pages 110-115

Patwin Elementary School  
Davis, Calif.  
The Steinberg Group, Architect  
Portland-cement plaster-stucco colorant: California Stucco Supply. Single-ply PVC roofing: Trocal Roofing Systems. Sheet-metal roof: Valley Sheet Metal. Shingles: Elk Corp. Corrugated sheet-metal roof: Corrugated Metals, Inc. Aluminum doors: Kawneer. Special protective doors: Overly Mfg. Co. Aluminum projecting and vertical sliding windows: Bonelli Enterprises. Tempered glass: L.O.F. Locksets: Schlage. Hinges: McKinney. Closers: Norton. Exit devices: Von Duprin. Suspended system ceiling: Chicago Metallic. Surface ceiling: Armstrong (Second Look). Chalkboards and marker boards: Greensteel. Paints and stains: Fuller-O'Brien. Vinyl-coated wallcoverings: Columbus Coated Fabrics. Air grilles: Anemostat. Recessed lighting fixtures: Columbia. Indoor lighting: Ledalite. Outdoor lighting: Sterner. Wheelchair lift: The Cheney Co.

For more information, circle item numbers on Reader Service Cards.

### Corrections

The design credits for the U. S. Embassy, Amman, Jordan [RECORD, May 1993, pages. 66-73] should have included Ms. Meredith Robbins Basque, Design Team Member.

Mark Price was incorrectly described as a lobbyist [RECORD February 1993, page 31]. He is head of the Development Building Counsel in Washington, D. C., a consulting firm that helps design professionals procure federal work. He describes his role with COFPAES as "working in concert."

### Amplification

The manufacturer of the curtainwall specified by Nicholas Grimshaw & Partners, Architect, for Pier 4/4a, Heathrow Airport [RECORD, June 1993, pages 108-111] has representation in the U. S.: Don Reynolds USA, Inc., St. Louis, Mo.

## EXIT DEVICE FOR THE 21st CENTURY

The 2100 Series from Jackson is the perfect mating of form and function. These are the only ADA compliant exit devices available with such a narrow profile.

The 2100 Series models include rim, concealed and exposed vertical rod devices. The concealed rod is also available in an electrified version.

Enduring beauty for the next millennium. For more information call 800-533-6229 - 800-585-6533 in CA.

Patent Pending

THOMAS INDUSTRIES INC.

  
**jackson**  
EXIT DEVICE

Circle 84 on inquiry card

## Consultants Directory

### Modelmaking

#### Scale Models Unlimited SERVING CLIENTS NATIONWIDE SINCE 1962

Our staff of 35 professionals can produce your design studios and topo models within 3 - 5 days or a complete marketing display model within 2 - 3 weeks. With immediate attention to your model requirements, we use the latest technology, including LaserCAMM, our own CAD-driven laser cutter. Please call for a quotation!

111 Independence Drive, Menlo Park, CA 94025

415-324-2515 FAX 415-324-2111

Circle 105 on inquiry card

### Construction Consultants

#### LEONARD SMITH & ASSOCIATES INC. Construction Consultants

Construction Oriented Professionals Providing:

- Design Phase Cost Planning & Estimating
- Quantity Surveying
- CPM Scheduling
- Litigation Support and Expert Testimony
- Claims Evaluation
- Contract Administration
- Cost & Schedule Monitoring

Since 1970

6383 Little River Turnpike,  
Alexandria, Virginia 22312

Telephone: (703) 658-0041 Fax: (703) 658-0045

ASSOCIATED INTERNATIONAL OFFICES

Circle 106 on inquiry card

### Acoustical Consultants



Cavanaugh Tocci Associates, Inc.  
327 F Boston Post Road  
Sudbury, MA 01776

Specialized consulting services in architectural, industrial, and environmental acoustics.

Greg Tocci  
508-443-7871 FAX 508-443-7873

Circle 107 on inquiry card

### Architecture Consultant

Commerce Business  
Daily Reviews  
\$129/Year Complete

Designed By  
Architects/Engineers  
For Architects/Engineers!  
Convenient Index!  
Easy To Scan Abstracts!  
Complete Full Text!  
On-line Computer Access!

1-800-880-0190

Circle 108 on inquiry card

## ESSENTIAL MARKETING TOOLS

# ARCHITECTURAL RECORD REPRINTS

Get your message across with reprints of articles from ARCHITECTURAL RECORD.

Promote your firm. Reprints of RECORD articles featuring your work are an ideal way to remind clients and prospects of your firm's accomplishments and high standards of design.

You can order reprints of articles that have appeared in RECORD within the past two years, in any quantity (minimum: 500).

For more information, price quotes, and help with layout on building project reprints, write or call:

Janice Austin  
**ARCHITECTURAL RECORD**  
Princeton Road  
Hightstown, NJ 08520  
(609) 426-5494



# Everybody's Happy.

Everybody's happy at Ocean Palms, Port Royal Plantation. This unique and successful interval ownership development on Hilton Head Island was begun in 1989 and continues today, with each successive eight-unit building sold out before construction ends.

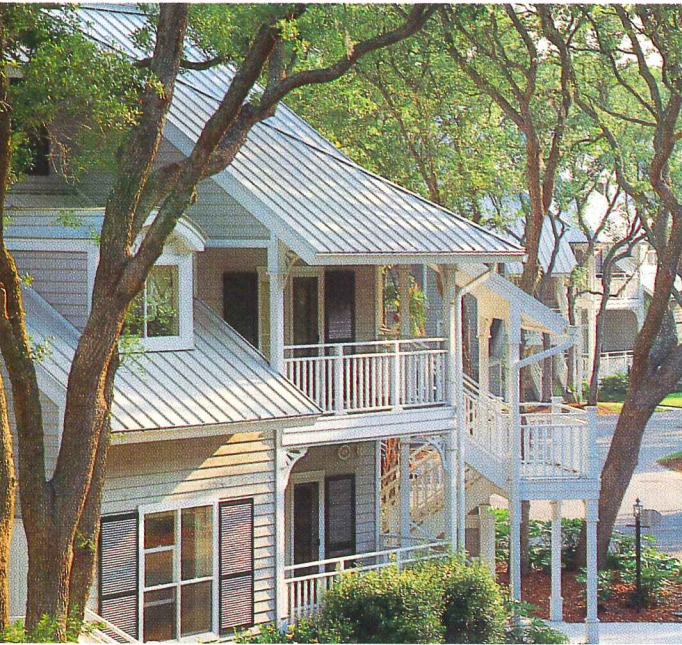

The innovative design of Ocean Palms is enhanced by MBCI's popular Craftsman SB-12 pre-formed metal roofing system. Small ribs and narrow spacing provide strong aesthetic appeal, while tough pre-painted Galvalume® panels provide long life and easy maintenance. The system's UL90 rating provides roof integrity and ease of mind for unit owners, even with the strong winds of Hilton Head.

MBCI is proud to be associated with this project. It's a good example of what can happen when everybody contributes their very best... from developer to architect, contractor to system manufacturer.

We invite you to find out more about us, more about the many advantages of our top-quality, competitively priced pre-formed metal roofing systems. Take a look at your Sweet's Catalog: 07410/MBC and 07610/MBC. Then call the MBCI office nearest you.



Houston 713/445-8555

Lubbock 806/747-4291

Atlanta 404/948-7568

Oklahoma City 405/672-7676

Tampa 813/752-3474

San Antonio 210/661-2409

Richmond 804/526-3375

Dallas 214/988-3300

Indianapolis 317/398-4400

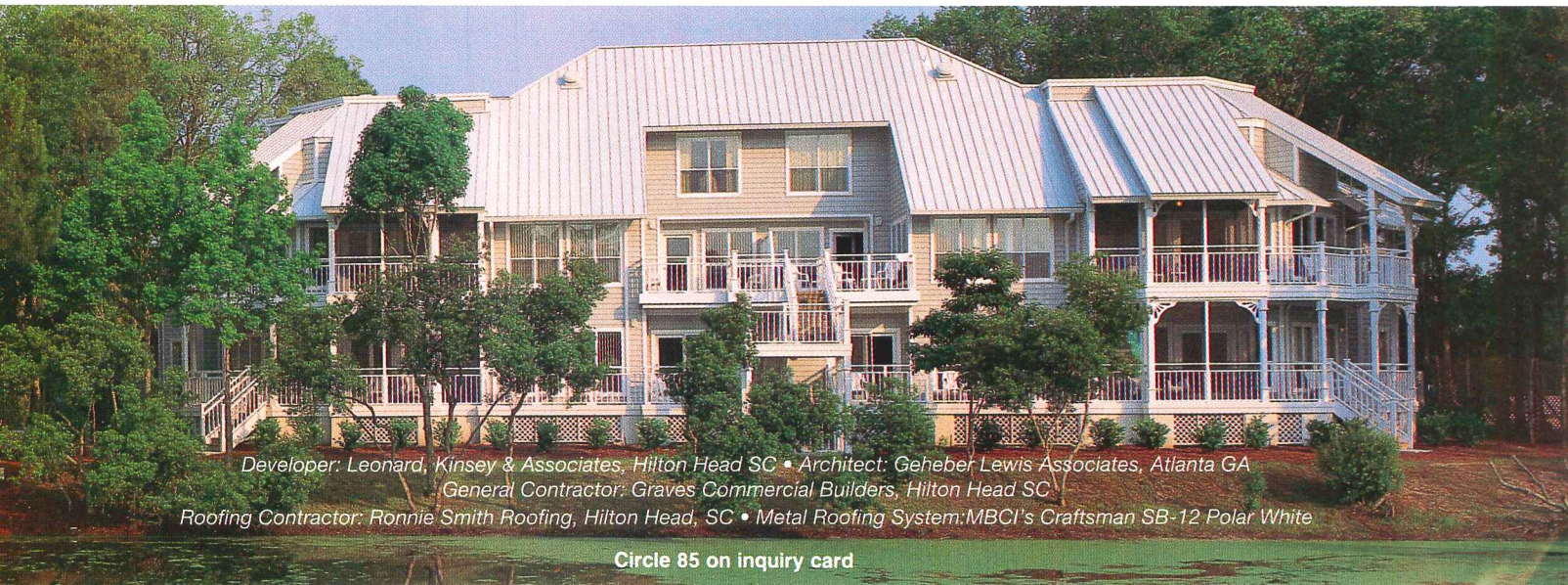
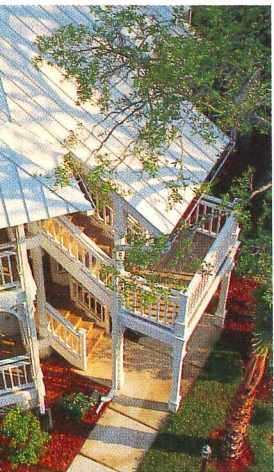

Developer: Leonard, Kinsey & Associates, Hilton Head SC • Architect: Geheber Lewis Associates, Atlanta GA

General Contractor: Graves Commercial Builders, Hilton Head SC

Roofing Contractor: Ronnie Smith Roofing, Hilton Head, SC • Metal Roofing System: MBCI's Craftsman SB-12 Polar White

Circle 85 on inquiry card

# THE MARKETPLACE

## HANDY-SHIELD™ by PLUMBEREX PRODUCTS

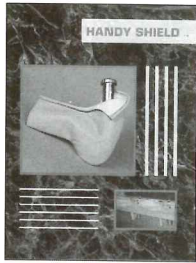

HANDY-SHIELD safety covers conform to the Americans Disability Act (ADA) whenever insulation of drain & supply lines are required to protect individuals in wheelchairs from burns or injury, under wash basins. HANDY-SHIELD features a unique conforming style with interior foam lining & exterior vinyl texture in an array of colors, resulting in an appealing finished product. Please call (619) 322-1772 for more information.

Circle 86 on inquiry card

## FREE X-Ray Room Planning Guide

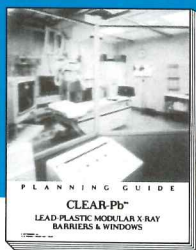

Made of lead-impregnated, transparent plastic, CLEAR-Pb® X-Ray Room Shielding provides complete radiation protection with panoramic viewing. Features include prefabrication for quick on-site assembly, attractive, space-saving decorator look and shatter resistance with a choice of lead equivalencies. Free CLEAR-Pb X-Ray Room Planning Guide is available.

### NUCLEAR ASSOCIATES



A Division of VICTOREEN, INC.  
100 VOICE ROAD  
CARLE PLACE, NY 11514-1593 U.S.A.  
(516) 741-6360  
FAX (516) 741-5414

Circle 89 on inquiry card



### Impressions Are Important !!!

Insure you make a professional one by carrying your blueprints in a THOMAS CASE. Each case is meticulously handcrafted and only the finest materials are used. Makes the carrying of your prints easy and convenient while it also protects them.

Leather covered:	4" dia. x 32" length	\$190.00
	3" dia. x 32" length	\$175.00
Vinyl covered:	4" dia. x 32" length	\$95.00
	3" dia. x 32" length	\$85.00

(Available in Burgandy, Black & Tan)  
Custom sizes available. Allow 3 weeks for delivery.  
To order call 1-800-544-7929.

Circle 91 on inquiry card

## HID-N-LOK® Pawling's Premier Interlocking Athletic Tile

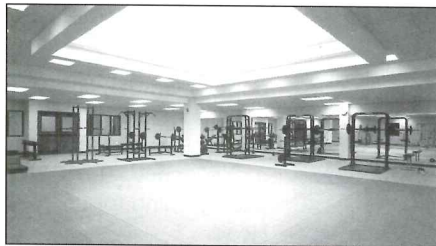

Call 1-800-431-3456

Circle 87 on inquiry card

## Animation

WE USE YOUR DATABASE

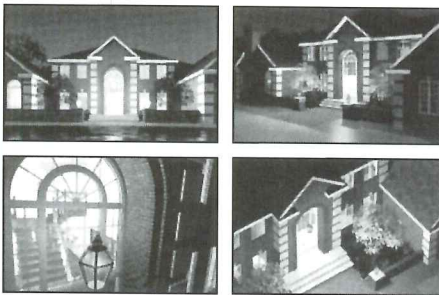

We produce state of the art computer animation using your database.

Howard Associates, Animation OutSource  
5800 Monroe St. Sylvania, OH 43560 Call (419) 882 7131 Fax (419) 882 8710

## OutSource

Call 419-882-7131 for more information

## Lap-Joint PLYCEM Offers Greater Strength, Lower Costs!

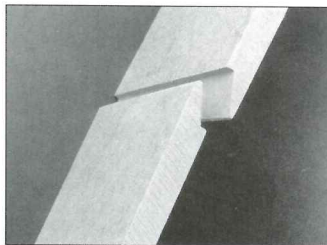

PLYCEM® Fiber-Reinforced Cement Board with lap-point edges eliminates the need for T-splines in roof & floor assemblies. PLYCEM is non-combustible & moisture-resistant, & it is installed using conventional carpentry tools. Call 800-243-6677.

Circle 92 on inquiry card



## Architectural Record Review

A collection of the best Shopping Centers, Healthcare Facilities, Office Buildings, and Educational Buildings from the pages of Architectural Record.

Reviewed and updated...tracking reports on regional construction trends. For more information about these issues write:

*Architectural Record Review, 1221 Ave. of the Americas, 41st Floor, New York, N.Y. 10020.*

Circle 88 on inquiry card

## Architectural Record Subscriber Service

For subscription inquiries and address changes call toll free  
**1-800-525-5003\***  
(Monday thru Friday 9 a.m. to 4 p.m. EST)

Call 1-800-257-9402\*  
for the following services

- Order a new subscription
- Renew your subscription
- Give a gift subscription

\*Outside U.S. call 609-426-7070 or write:  
**Architectural Record**  
P.O. Box 564  
Hightstown, NJ 08520

Circle 90 on inquiry card

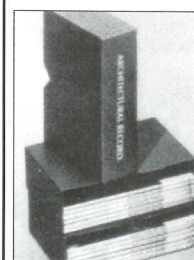

## Architectural Record File Cases

Preserve and protect your valuable copies of Architectural Record with sturdy and durable file cases. These cases have a garnet red finish with embossed gold lettering. They leave the magazine spines visible and keep your copies free from dust and tearing. Each cases holds 8-10 issues. Only **\$6.95** each ...or 4 cases for **\$25**.

Send check payable to:  
Architectural Record  
1221 Avenue of the Americas  
New York, NY 10020  
Attn: Cheryl Levy

Circle 93 on inquiry card

### Limited Numbered Edition

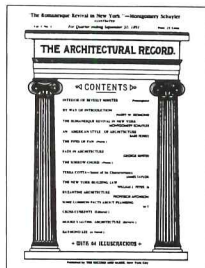

**ARCHITECTURAL RECORD'S** first issue (1891) is reprinted to celebrate our centennial. 150 pages & 64 illustrations. Every architect should have this collector's issue. Only \$16.95 postage paid. For more information call 212-512-3443.

Architectural Record, Circulation Dept.  
1221 Ave. of the Americas, NY, N.Y. 10020

Circle 94 on inquiry card



### Site Complements Catalog

The **TimberForm Site Complements** catalog presents matching benches, ash receptacles, litter containers, planters, bollards and bike racks in traditional through contemporary designs. Over 350 cast iron, steel and wood products are offered in more than 170 colors.

Call toll-free 1-800/547-1940, Ext. 507  
**Columbia Cascade**

Circle 101 on inquiry card

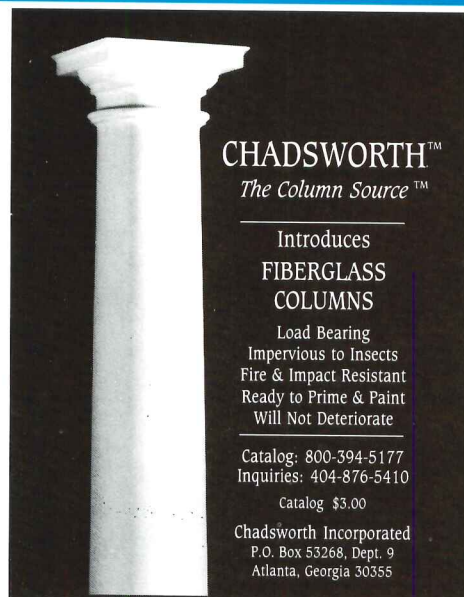

### CHADSWORTH™ The Column Source™

Introduces  
**FIBERGLASS  
COLUMNS**

Load Bearing  
Impervious to Insects  
Fire & Impact Resistant  
Ready to Prime & Paint  
Will Not Deteriorate

Catalog: 800-394-5177  
Inquiries: 404-876-5410

Catalog \$3.00

Chadsworth Incorporated  
P.O. Box 53268, Dept. 9  
Atlanta, Georgia 30355

Circle 102 on inquiry card

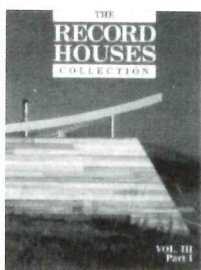

### The Record Houses Collection.

A Compilation from  
**1990/1991/1992.**

Everyone loves  
**Record Houses!** And  
we put 3 yrs. worth  
into a 2 volume set.

Over 290 pages, in  
full color, with plans and text directly  
from the pages of Architectural Record's  
**Record Houses** issues. Just \$19.95  
(including postage and handling). A  
single volume compilation 1987/88/89  
is also available for \$19.95. Send check  
or money order to Architectural Record,  
1221 Ave. of the Americas, New York,  
N.Y. 10020. Attn: Back Issue Dept.

Circle 103 on inquiry card

### Classic Custom Casting

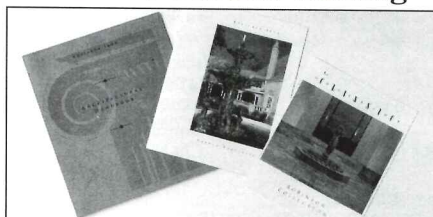

Discover Robinson Iron's products & capabilities. Our Architectural Handbook provides scaled line drawings of our cast building components, monumental fountains and site amenities. The Garden Portfolio showcases exterior ornaments cast from historic patterns. The Classic Collection features unique pieces in interior applications. \$10. To order, call 1-800-824-2157.



Robinson Road, P.O. Box 1119  
Alexander City, Alabama 35010

Circle 104 on inquiry card



### Decorative Grilles in Color

Add a new  
dimension to your  
designs with these  
decorative grilles  
which can be used

to make striking unusual effects.

Choose from an array of custom colors  
to match or contrast existing grilles.

Designers can create numerous metal  
forms for interior or exterior applications.

Write for a catalog:

Register & Grille Mfg. Co.

202 Norman Avenue, Bklyn., N.Y. 11222.

Call 718-383-9090 or 1-800-521-4895

Fax# 718-349-2611

Circle 105 on inquiry card

### "The Consultants Directory"

Architectural Record announces an exciting new ad section: The Consultants Directory. The key to business success is a matter of getting your foot in the door.

Each month Architectural Record reaches over 153,000 architectural, design, and landscape design professionals. Architectural Record is read by over 97% of the nation's architects who account for over 95% of the nation's non-residential and large-residential buildings.

Don't miss out. . . act FAST!

For more information call:  
**1-800-544-7929**

Circle 106 on inquiry card

### Keep Dodge In Your Plans!

Don't forget to provide your local Dodge Reporter with the details and plans for your next job. Thousands of Dodge Report and SCAN customers count on Dodge for leads. And you don't want them to miss out on the best bid for your next job. Contractors can't bid on jobs they don't know about. Thank you for your input. We appreciate your cooperation.

- ■ ■ F.W. Dodge
- ■ ■ McGraw-Hill Construction
- ■ ■ Information Group

Circle 107 on inquiry card

### WORTHINGTON COLUMNS • BALUSTRADING MUCH MORE



44-Page Catalog  
**1-800-872-1608**  
FAX 404-872-8501

Circle 108 on inquiry card

# Advertising Index

For detailed data, prefiled catalogs of the manufacturers listed below are available in your 1993 Sweet's Catalog File as follows:

(G) General Building & Renovation  
(E) Engineering & Retrofit  
(I) Industrial Construction & Renovation  
(L) Homebuilding & Remodeling  
(D) Contract Interiors

**Bold Face** - page number  
*Italics* - Reader Service number

- A**  
Apple Computer, **2-3, 5**  
(800) 441-3001  
Armstrong World Industries, Inc.,  
**Cov.II-1 ; 1, 121 ; 31** [G-E]  
(800) 233-3823  
Artimed, **Cov. IIIS ; 150**  
(800) 359-7040  
Azrock Industries, Inc., **21 ; 8**
- B**  
Baudisson Concept Window Corp.,  
**127 ; 38**  
(617) 569-2927  
BEGA, **10S ; 119**  
(805) 684-0533  
Bilco Co., **62 ; 16** [G-E-L]  
(203) 934-6363  
Birdair, Inc., **128 ; 39**  
(800) 622-2246  
Bobrick Washroom Equipment, Inc.,  
**66 ; 20** [G]  
(800) 553-1600  
Builders Brass Works, Jackson Exit  
Device, **139 ; 84**  
(800)533-6229
- C**  
Celotex Corp.,**74 ; 23** [G-E-I-L-D]  
(813) 873-4498  
Clear Plastics International, Inc.,  
**137 ; 82** [G]  
(800) 759-6985  
Columbia, USI Lighting, **42S ; 126**  
Compaq Computer Corp., **16 ; 7**  
(800) 345-1518  
Consultant's Directory, **140**  
Copper Sales, Inc., **59 ; 14** [G]  
(800) 426-7737  
CSL Lighting Mfg., Inc., **44S ; 151**  
(805) 257-4155
- D**  
DuPont Co. - Textile Fibers, **12-13 ; 5**  
[D]  
(800) 4-DUPONT  
Duraflake Div., Willamette Ind., Inc.,  
**6 ; 2** [G]  
(503)928-3341
- E**  
Edison Price, Inc., **125 ; 36**  
(212) 838-5212  
Efco Corp., **138 ; 83** [G]  
(800) 221-4169  
Elliptipar, Inc., **20S,45S,47S,49S ; 121,**  
**130,133,137**  
(203) 932-2266
- F**  
Forms + Surfaces, **8 ; 3**  
(805) 684-8626  
Forbo Industries, **65 ; 19** [G-D]  
(800) 233-0475
- G**  
Glen Raven Mills, Inc., **14-15 ; 6** [G]  
(919) 227-6211
- H**  
Haws Company, **130 ; 40** [G-E]  
(510) 525-5801  
Hurd Millwork Co., **78 ; 27** [G-L]  
(800) 2BE-HURD  
Hydrel, **46S ; 131**  
(818) 362-9465
- I**  
Intergraph, **22-23 ; 9**  
(800) 345-4856
- J**  
Johnsonite, **75 ; 24** [G-D]  
(800) 899-8916  
Julius Blum & Co., Inc., **63 ; 17**  
[G-E-I-D]  
(800) 526-6293
- K**  
Kawneer Co., Inc., **67,69 ; 21** [G]  
Kim Lighting, **24S ; 125**  
(818) 968-5666
- L**  
Louisiana-Pacific,**24 ; 10** [G-I-L]  
(800) 223-5647  
Leucos USA, Inc., **2S ; 114**  
(800) 832-3360  
Lighting Services, Inc., **43S ; 127**  
Lightolier, A Genlyte Co., **21S ; 122**  
(201) 864-3000
- M**  
Marlite, **120-121 ; 30** [G]  
Marvin Windows, **10-11 ; 4** [G]  
(800) 346-5128  
MBCI, **141 ; 85** [G]  
(713) 445-8555  
Monsanto Chemical Co. - Saflex Sound  
Control, **123,125,127,129 ; 34** [G-E-I]
- N**  
Neo-Ray Lighting, **48S ; 135**  
(718) 445-5492  
Nucor Corp., **56-57 ; 12** [G-E]
- O**  
Oce-Bruning, Inc., **79 ; 28**  
(800) 445-3526  
O'Keeffe's, Inc., **17 to 20 ; 95 to 100** [G]  
OSRAM SYLVANIA, **Cov.II-1S ; 113**  
(800) 338-2542
- P**  
Pella Rolscreen Co., **71 to 73 ; 22** [G-L]  
(800) 524-3700  
Philips Lighting, **8-9S ; 118** [E]  
(800) 631-1259  
Portland Cement Association, **64 ; 18**  
(708) 966-6200  
Poulsen Lighting, Inc.,**23S ; 124**  
(800) 342-2310  
PPG Industries, Inc., Glass Div., **77 ;**  
**26** [G]  
Product / Literature Showcase,
- R**  
Rambusch, **4S ; 115**  
(212) 675-0400  
Reggiani USA, **Cov.IVS ; 128**  
(914) 565-8500  
Rejuvenation Lamp & Fixture Co., **48S ;**  
**134** [G]  
(503) 231-1900  
Rohm & Haas Co., **60-61 ; 15** [G-I]
- S**  
Sarnafil, Inc., **80 ; 29** [G-I]  
(800) 451-2504  
Sharp, **70**  
(800) BE-SHARP  
SPI Lighting, Inc., **22S ; 123**  
(414) 242-1420  
Spring City Electrical Mfg. Co., **19S ;**  
**120** [G-E]  
(215) 948-4000  
STAFF Sales, Inc., **6-7S ; 117**  
(800) 932-0633  
Star Building Systems, **124 ; 35**  
(800) 654-3921  
Stark Ceramics, Inc., **126 ; 37** [G-E-I]  
(800) 321-0662  
Stern Lighting Systems, Inc., **45S,**  
**47S, 49S ; 129, 132, 136**  
(800) 328-7480  
Summitville Tiles, Inc., **Cov.III ;**  
**111** [G]
- T**  
Tamko Asphalt Products, **122 ; 32**  
[G-I]  
(800) 641-4691  
Technical Glass Products, **53-54 ; 76**  
(800) 426-0279  
The Marketplace, **142-143**  
Trenwyth Industries, Inc., **55 ; 11**  
[G-E-I]  
(800) 233-1924
- U**  
USG Interiors, Inc., **Cov.IV ; 112**  
[G-E-L-D]  
(800) 950-3859
- V**  
Vinyl Plastics, Inc.,**123 ; 33** [G]  
(800) 874-4240
- W**  
Weyerhaeuser Architectural Door Div.,  
**58 ; 13**  
(800) 869-DOOR
- Y**  
YKK AP America, Inc., **76 ; 25** [G]  
(404) 344-2981
- Z**  
Zumtobel Lighting, **5S ; 116**

# Sales Offices

## Main Office

Mc Graw-Hill, Inc.  
1221 Avenue of the Americas  
New York, NY 10020

Publisher  
Roscoe C. Smith III (212) 512-2841

Administrative Assistant  
Anne Mullen (212) 512-4686

Director of Business and Production  
Joseph R. Wunk (212) 512-2793  
Fax: (212) 512-4256

Assistant Promotion Manager  
Sheryl Berger (212) 512-2234

Classified Advertising  
(801) 972-4400

Editorial  
(212) 512-2594

## District Offices

**Atlanta**  
4170 Ashford-Dunwoody Road  
Atlanta, GA 30319  
Ollie Bieniemy  
(404) 843-4781  
Fax: (404) 252-4056

**Chicago / Dallas / Houston**  
2 Prudential Plaza  
180 North Stetson Avenue  
Chicago, IL 60601  
Thomas P. Kavooras Jr.  
(312) 616-3338  
Fax: (312) 616-3323

**Philadelphia**  
1700 Market Street  
Suite 1520  
Philadelphia, PA 19103  
Tom Esposito  
(215) 496-3834  
Fax: (215) 496-3828

**Arizona**  
Media Sales Associates  
7119 East Shea Blvd., Suite 106-28  
Scottsdale, AZ 85254  
William Hague  
Sherylen Young  
(602) 991-2889

**New England / New York**  
1221 Avenue of the Americas  
New York, NY 10020  
Louis Kutscher  
(212) 512-2814  
Fax: (212) 512-4256

**New York**  
1221 Avenue of the Americas  
New York, NY 10020  
Laura Viscusi  
(212) 512-3603  
Fax: (212) 512-4256

**San Francisco / Seattle**  
Media Sales Associates  
9017 Peacock Hill  
Gig Harbor, WA 98332  
William Hague  
(206) 858-7575  
Fax: (206) 858-7576

**Canada**  
Frank B. Spangenberg  
(416) 898-3911  
Donald R. Wall  
(416) 967-4314

## The Marketplace / Product Literature Showcase

Eve DeCarlo  
Kevin Beatty  
John Haddock  
1221 Avenue of the Americas  
New York, NY 10020  
1-800-544-7929  
Fax: (212) 512-2074

"S" after number indicates supplement advertising location

Q U A R R Y



## A New Look At American Durability.



Quarry tile from Summitville.

Always durable, now more versatile than ever with new colors and sizes.

All across America, Summitville quarry tiles mean performance.

In hotels, restaurants, airports and shopping centers: wherever high-traffic, low-maintenance flooring is essential.

Wherever quality is in demand, Summitville tiles are specified.

Evolving through research and testing to meet market demands.

To learn more about Summitville's products, complete the reader service card for full-color product information.

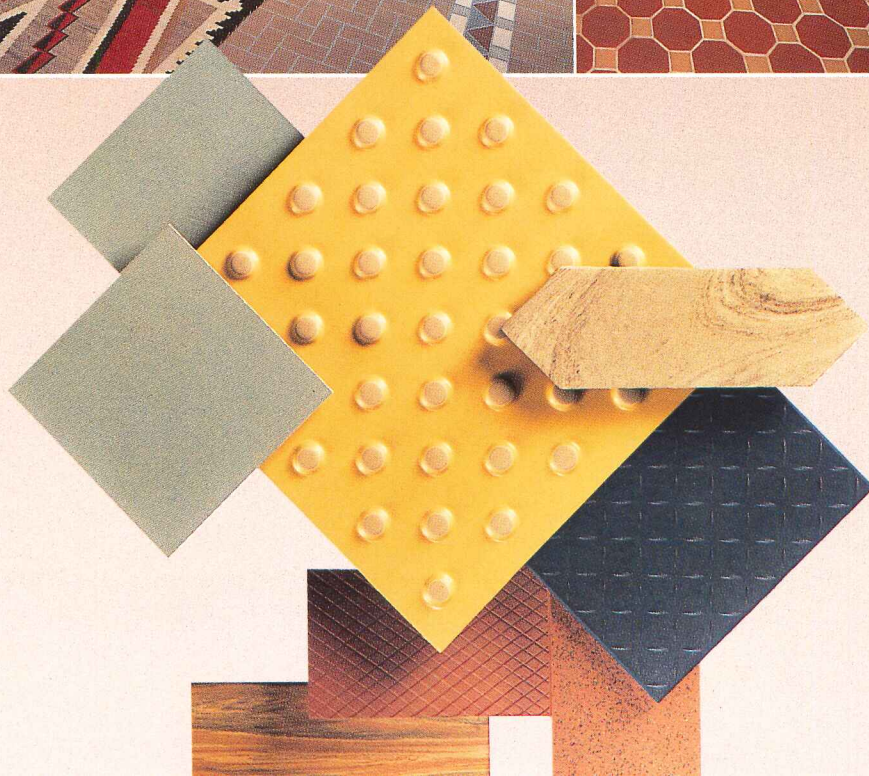

**Summitville**<sup>®</sup>

Summitville Tiles, Inc., Summitville, Ohio 43962  
FAX 1-216-223-1414

Circle 111 on inquiry card



**INTRODUCING  
THE FIRST  
SINGLE-LAYER  
TWO-HOUR  
FIRE-RATED  
U.L. CLASSIFIED  
LABOR-SAVING  
COST-CUTTING  
PROFIT-MAKING  
SYSTEMS  
FROM U.S. GYPSUM.**

Getting a two-hour fire rating used to mean you had to specify double-layer wall systems. But with new 3/4" ULTRACODE™ Core SHEETROCK® brand Gypsum Panels, you can get that same rating with a single-layer system.

That means the extra fasteners and panels used for standard two-hour rated double-layer systems are eliminated, as are the labor costs that go with them. Which means time and cost savings for you.

All new fire-rated systems using ULTRACODE™ Core Gypsum Panels have been tested and classified by Underwriter's Laboratories. Consult the 1992 U.L. Fire Resistance Directory for assembly designs U490, U491, & U492.

*For More Information, write:*

**United States Gypsum Company**

Department #147-4  
101 S. Wacker Drive  
Chicago, IL 60606-4385  
or call:

1(800)USG•4YOU  
and request publications  
SA-923-A and WB-1893

**ULTRACODE™ Core**



Circle 112 on inquiry card

©1992, United States Gypsum Company

**USG**