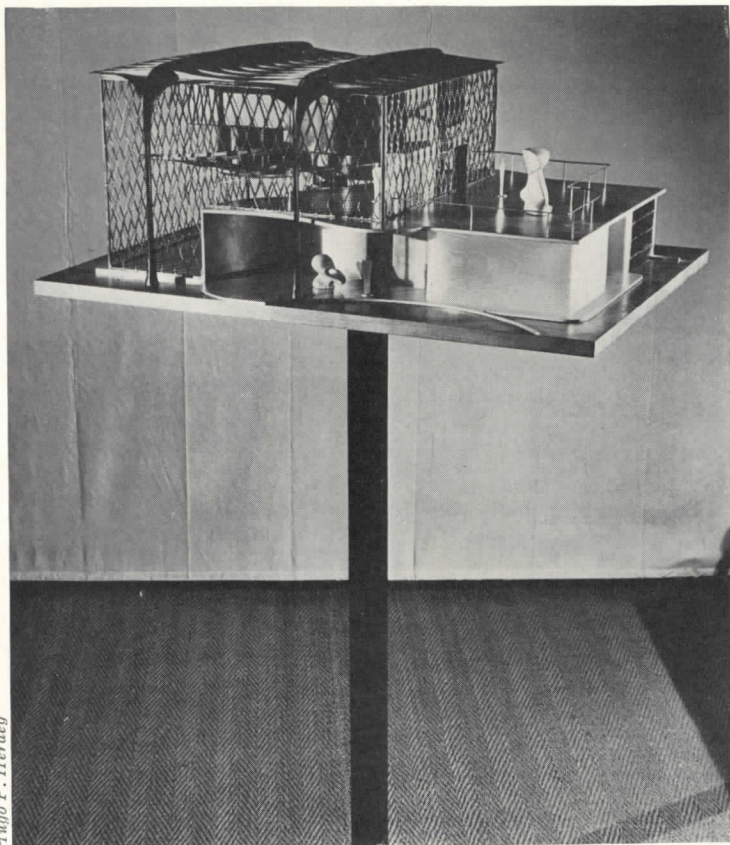


# BUILDING NEWS



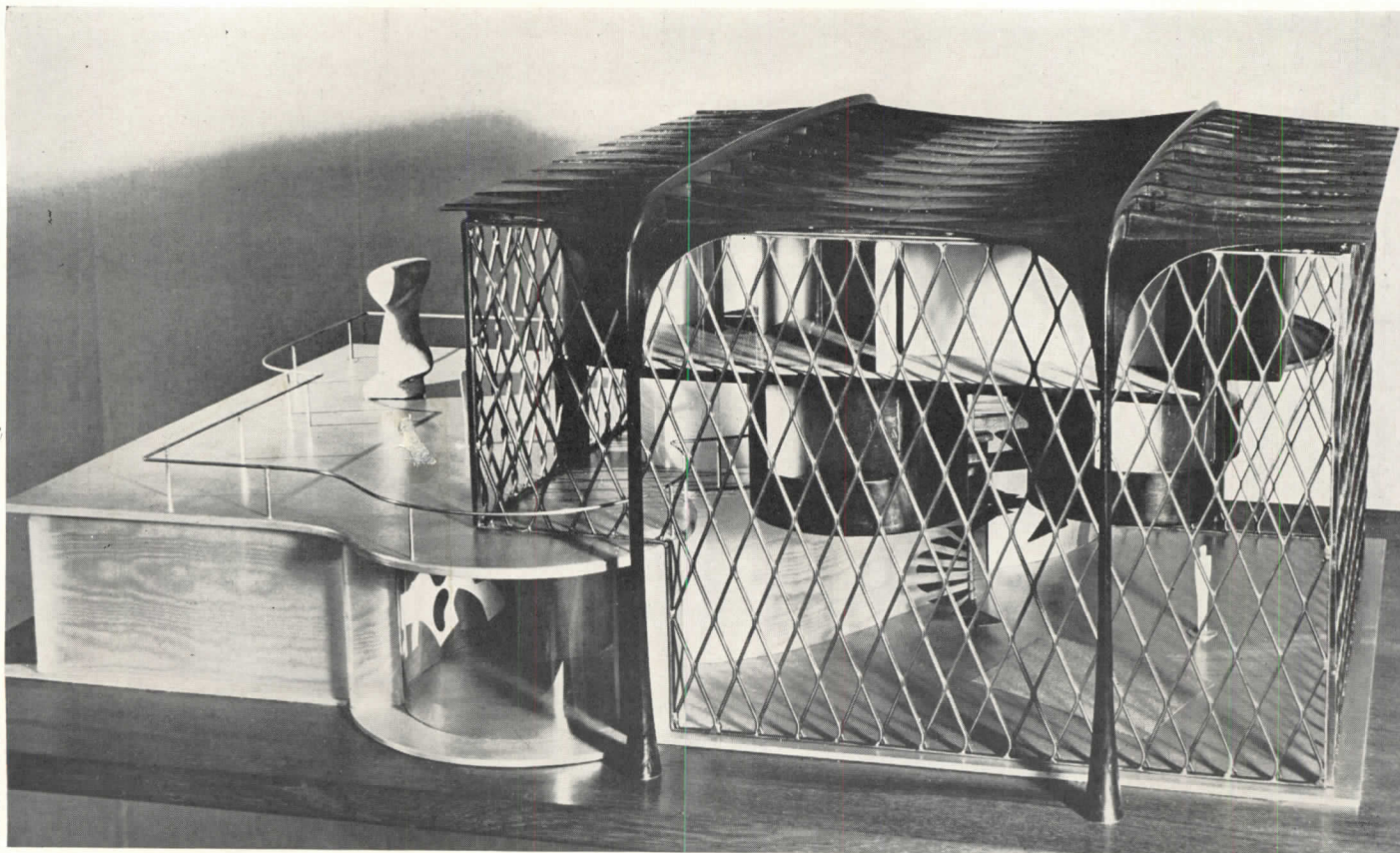
*Eugene P. Herdeg*

**A HOUSE FOR TOMORROW? . . .**

ARCHITECTURAL  
RECORD

CONSIDER WITH  
AMERICAN ARCHITECT AND ARCHITECTURE

Photos by Hugo P. Herdeg



The Suspended House has three levels: at ground level, a service group, partly within and partly outside closed form; at the top of the house, a habitation level; leisure space between and around the other two groups.



Elements of the leisure space are connected by a ramp, in itself a leisure-use form; contrast this with the direct and rapid connection between service and habitation groups provided by the main stairway.

# HOW USE OF SPACE DETERMINES DESIGN OF PROPOSED HOUSE

JUL NELSON, Architect

THIS, THE SUSPENDED HOUSE, has been designed "as a hypothetical research in architecture."

One consequence of this research is a new conception for the use of space. In the design of the Suspended House space is not conceived *primarily* as a function of the materials and labor-time used in the fabrication of an enclosing structure, therefore to be carefully economized. Neither is adaptability to industrialized production the driving consideration. Space—more specifically dwelling space—is, before all, conceived as the scene of human regeneration, for rest, for study, for leisure.

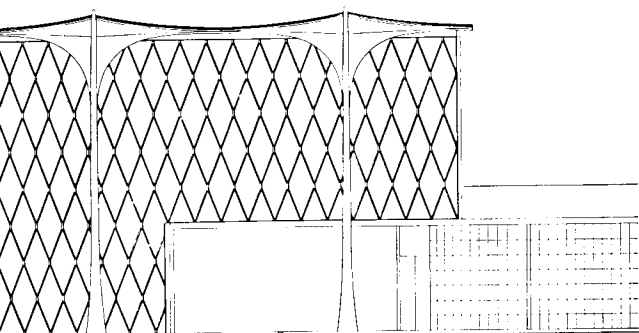
In this house, there is space to permit various degrees of intimacy and seclusion; to provide, within wider limits, a choice among alternatives; to allow greater flexibility for future changes; space in which the play and contrast of volumes and forms stimulate the senses. Nor does this mean that space is "wasted": on the contrary, in the service block and in other parts of the house which serve the basic human functions, there is a high concentration of useful space—through the use, for instance, of the Dymaxion bathroom. This concentration serves to release space for leisure activity.

To satisfy the need for privacy, the form of the house is closed; the design of the building develops within. Suspension permits a freedom of form and volume which contrasts sharply with the restrictions imposed by the traditional cubic room or by the usual arbitrary division of a house into "floors." In the Suspended House, there are no "floors"—there are levels: on the ground level, a service group, partly within and partly outside the closed form; at the top of the house, a habitation level suspended from the roof; recreation and study spaces between and around the service and habitation groups. On the upper levels, suspension in space heightens the sense of isolation from the outside world. Contrary to traditional practice, bathing, sleeping, dressing, and calisthenics are performed in distinct rooms on the habitation level, each specifically designed for the function it serves. A separate bedroom with bath and porch permits an alternative choice with the suspended sleeping cabin as well as for the use of guests and for use in the event of illness.

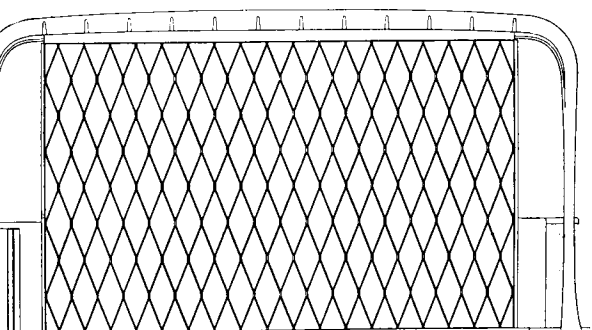
The suspension construction is of arc-welded tubular metal. Materials proposed for the service block are reinforced concrete and glass brick. On this level interior rooms are to be lighted from the terrace above. All other exterior walls are to be made up of diamond-shaped glass panes, each slightly inclined, giving to the whole an appearance of opacity; diagonal, rather than vertical or horizontal framing has been used, so that the walls, which are non-supporting, may not seem to be bearing walls. Suspended rooms are of continuous metal sheeting. The entire house is to be air-conditioned.

An attempt has been made to use painting and sculpture as an integral part of the design. Miro and Leger have painted abstract mural sketches for the reception room and dining room, and Arp has designed sculpture for the entrance and terrace.

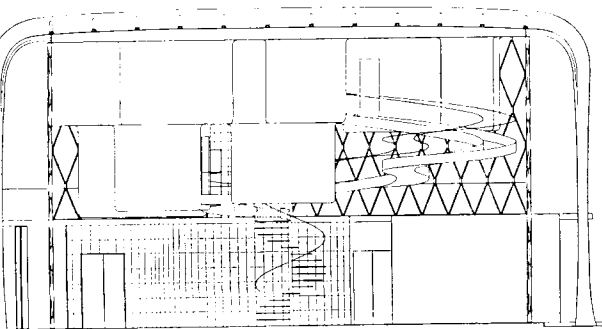
The Suspended House, says Mr. Nelson, is "primarily a work of anticipation . . . (although) its design is such that it could be realized today."



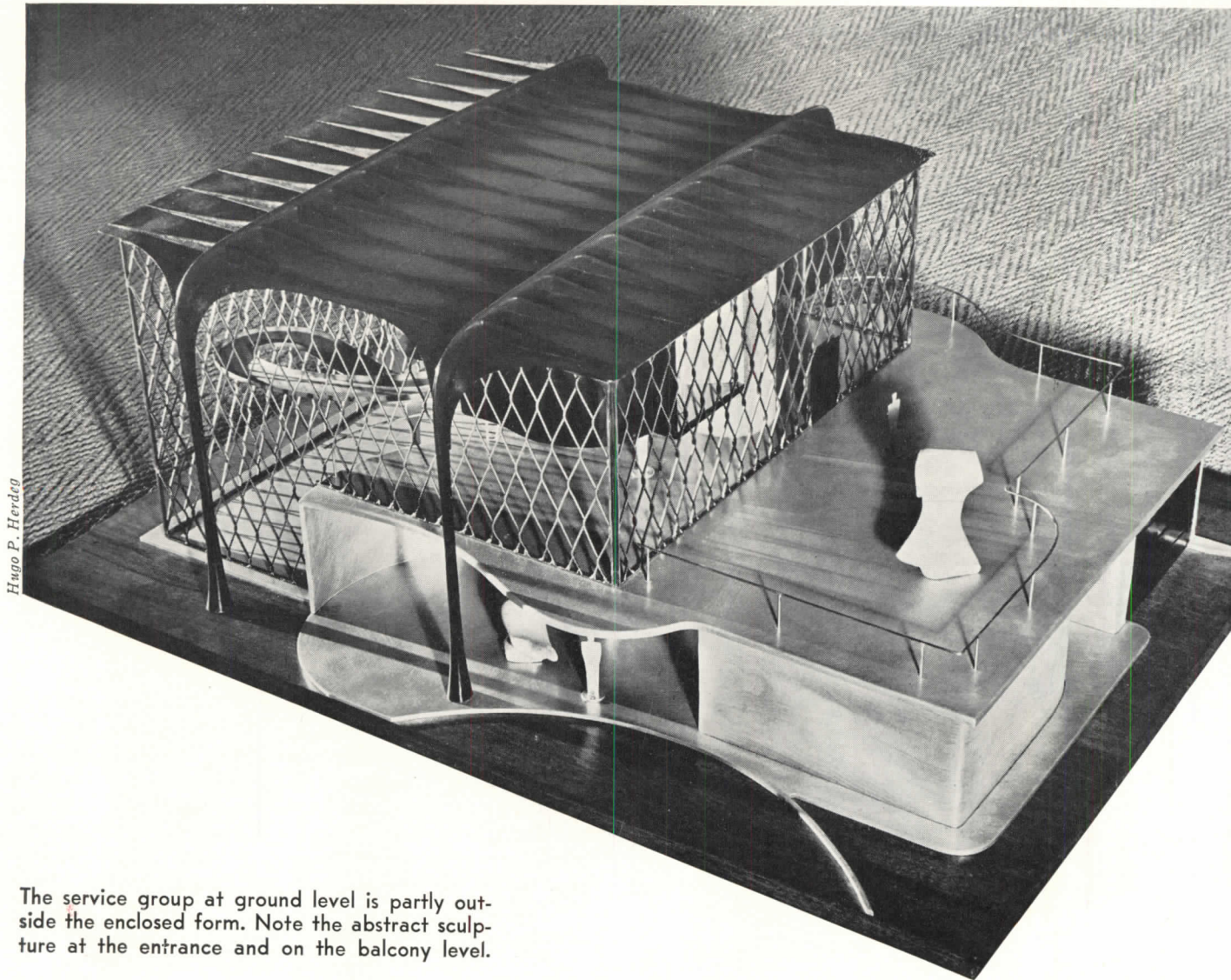
North elevation



East elevation

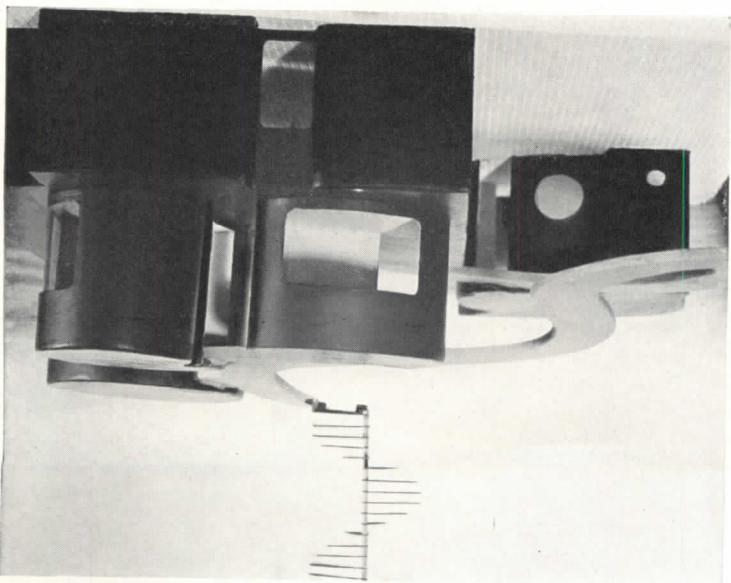


Cross section



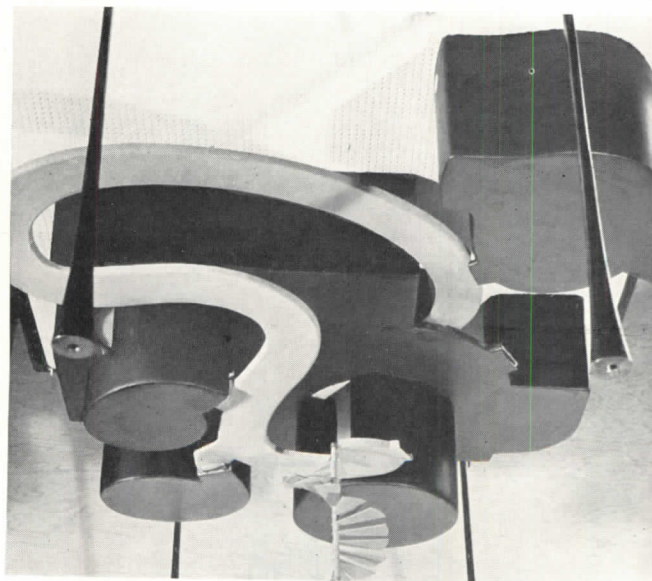
Hugo P. Herdeg

The service group at ground level is partly outside the enclosed form. Note the abstract sculpture at the entrance and on the balcony level.



St. Thomas

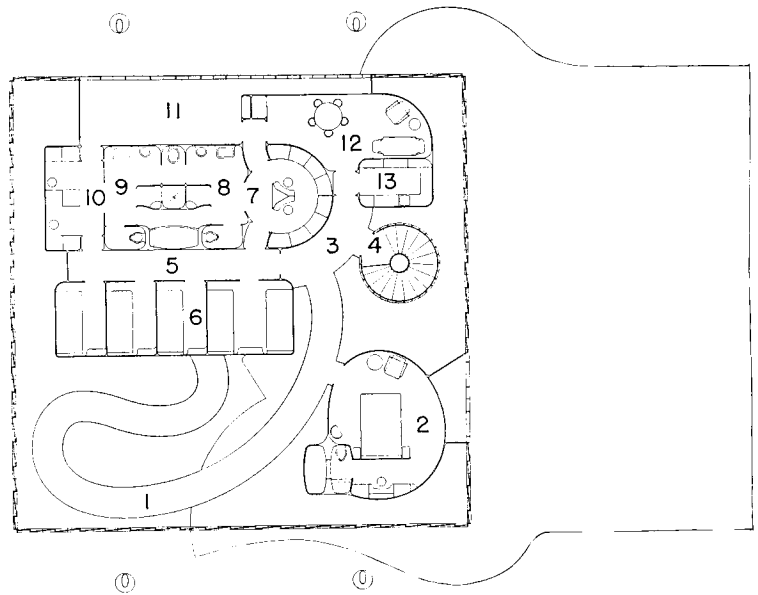
Suspension in space heightens the sense of privacy.



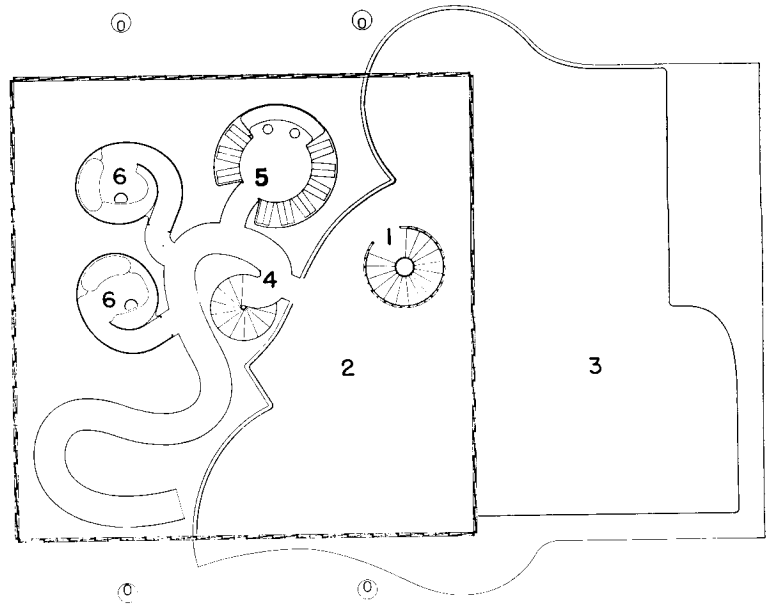
Continuous metal sheeting implies curved surfaces.

# PROPOSED SUSPENDED HOUSE

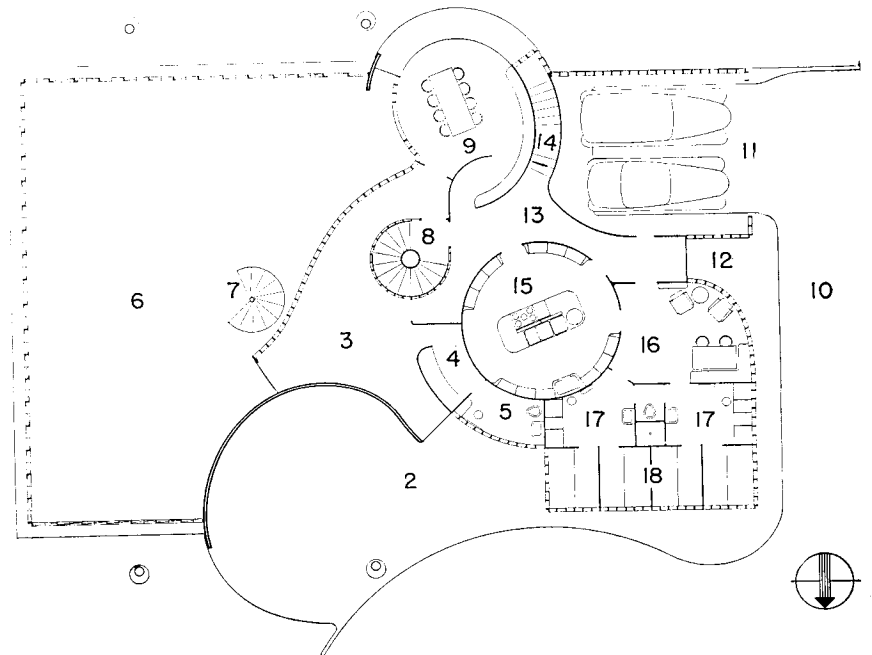
**Top level:** 1. Ramp. 2. Bedroom with dressing space, bath (Fuller), and porch. 3. Landing. 4. Main stairway. 5. Passageway. 6. One double and three single sleeping cabins. 7. Dressing room (women). 8. Toilet and bath (women). 9. Toilet and bath (men). 10. Dressing room (men). 11. Porch for calisthenics and sun-bathing. 12. Children's playroom. 13. Linen and cleaning utensils.

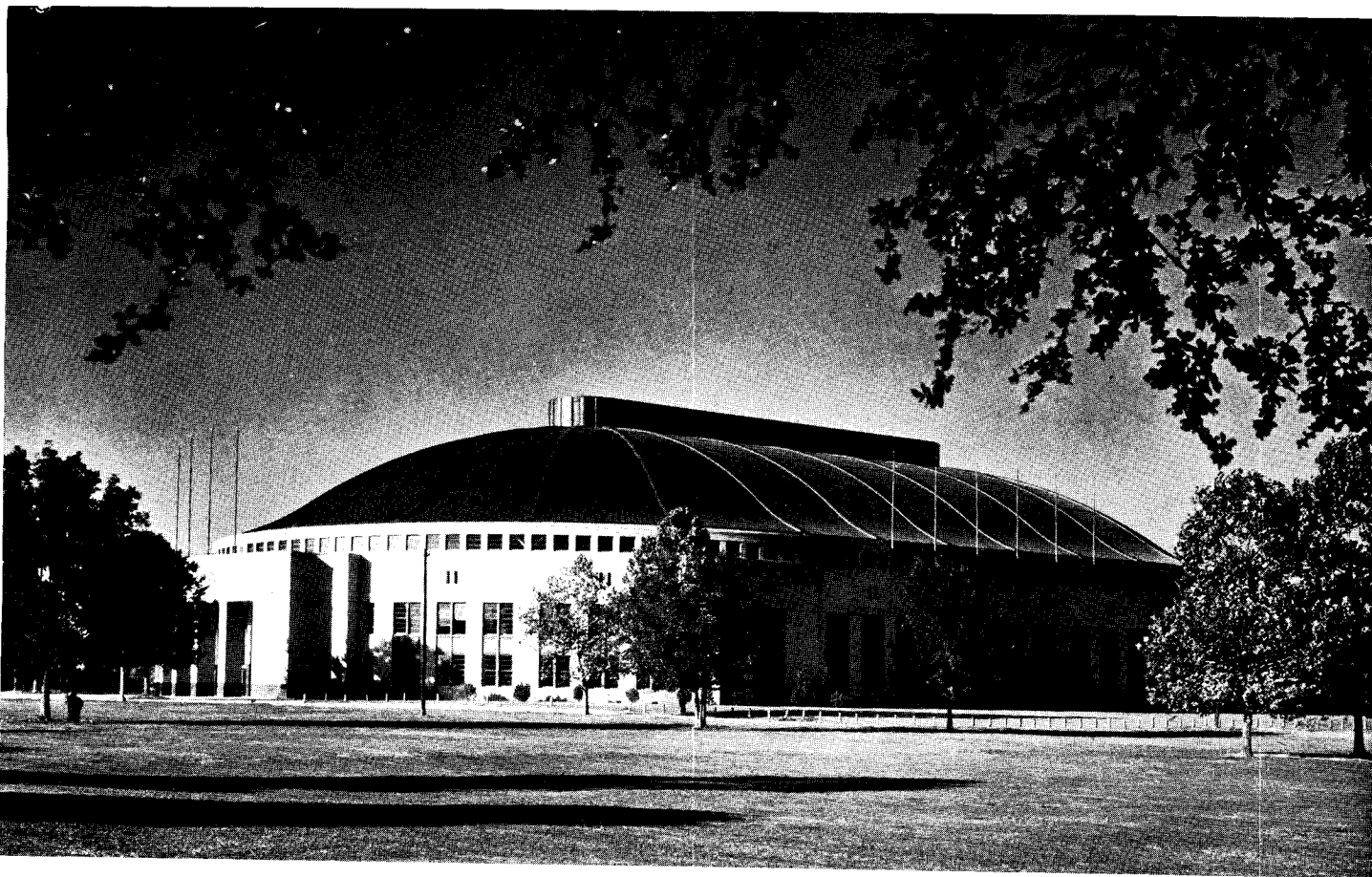


**Intermediate level:** 1. Main stairway. 2. Balcony for leisure and recreation, music, radio, television, games, etc. 3. Terrace. 4. Ramp. 5. Suspended library and writing room. 6. Suspended individual studies.

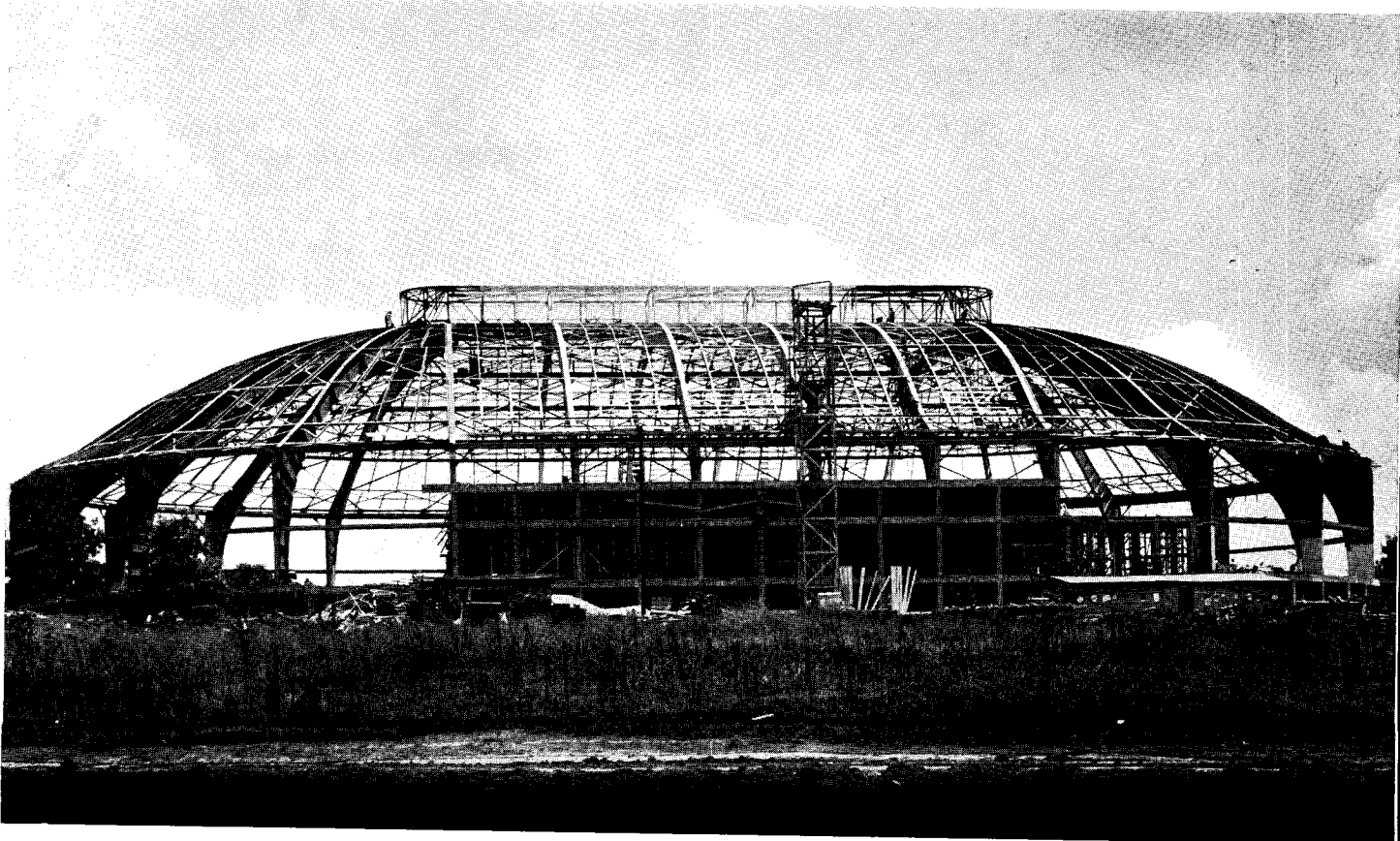


**Ground level:** 1. Main driveway. 2. Entrance porch. 3. Vestibule. 4. Coatroom. 5. Toilet. 6. Space for reception and family reunion. 7. Stairs to ramp. 8. Main stairway. 9. Dining room opening on reception and on garden. 10. Service driveway. 11. Garage. 12. Service entrance. 13. Service corridor. 14. Stairs to basement. 15. Kitchen. 16. Servants' dining room. 17. Dressing rooms, toilet, and shower. 18. Individual sleeping cabins.





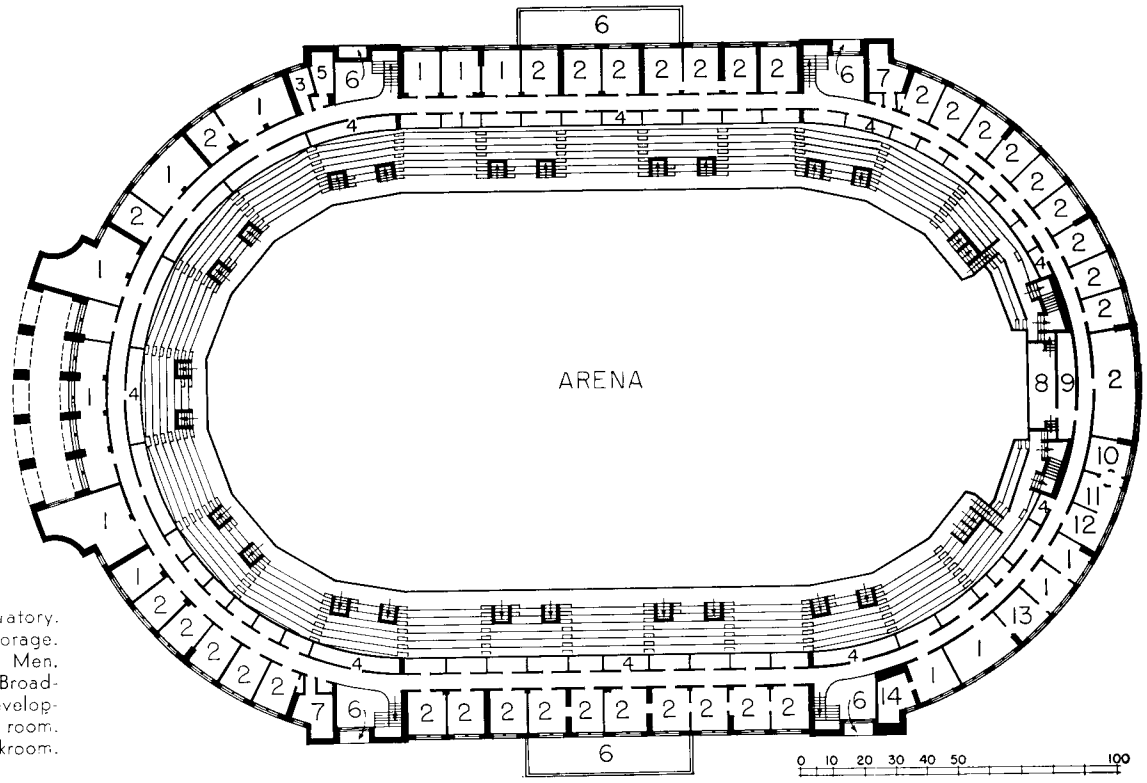
Agricultural Center Building, Baton Rouge, Louisiana. Laboratories and offices on the second floor enclose a clear-span arena.



Steel rigid-frames, braced by six continuous truss-type cross frames, are used. Fan room is placed above the roof.

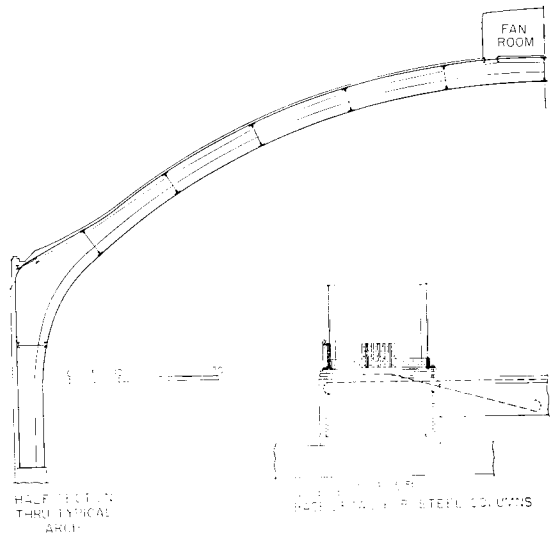
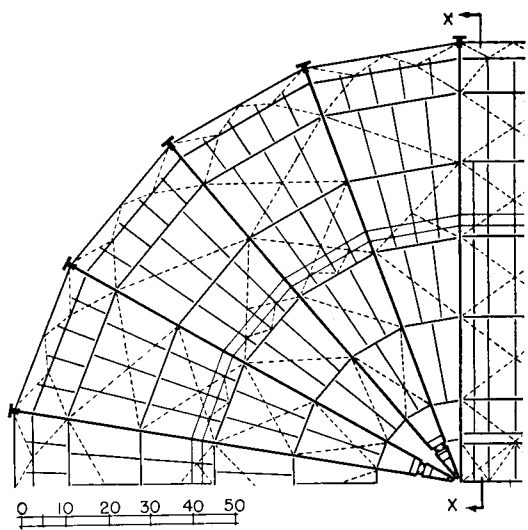
# RIGID-FRAME CONSTRUCTION USED IN CLEAR-SPAN AUDITORIUM

WARD F. NEILD, Architect



**Second-floor plan:** 1. Laboratory. Office. 3. Women. 4. Storage. Darkroom. 6. Marquise. 7. Men. Observation platform. 9. Broadcasting control room. 10. Development room. 11. Enlarging room. Copying room. 13. Stockroom. Cold storage.

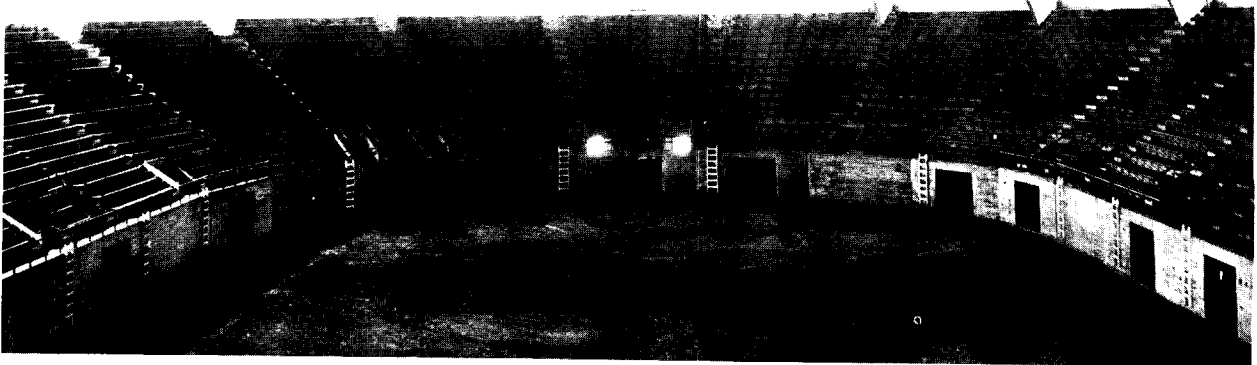
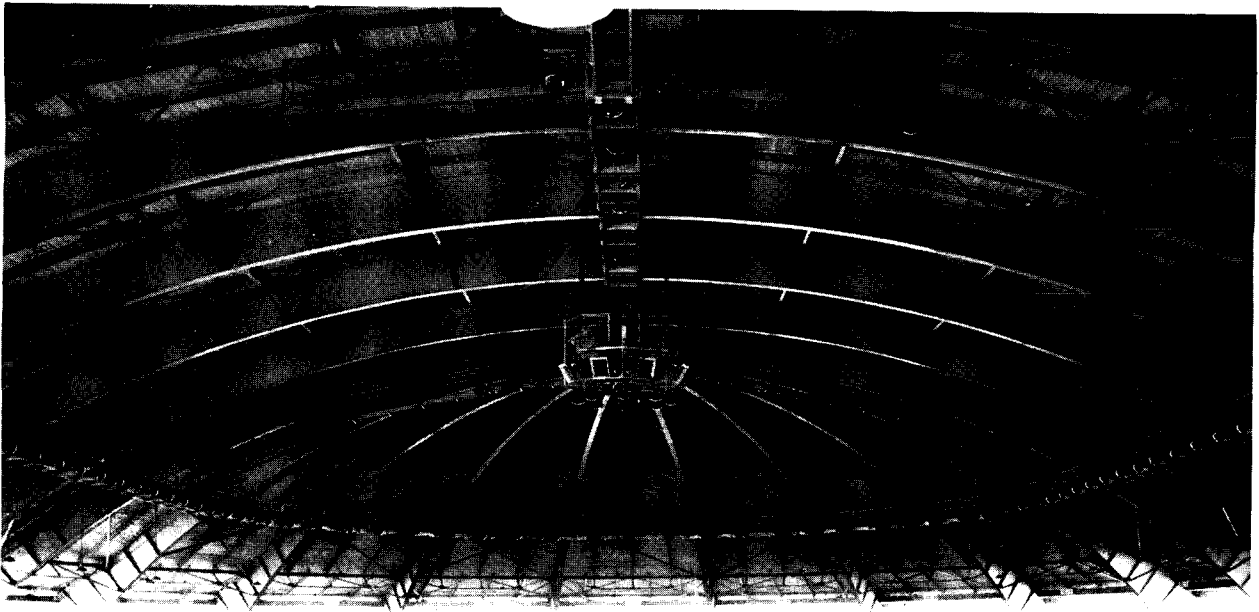
There are six lines of truss-type cross frames, spaced 20 ft. on centers. Each of the rigid frames is an arch with five centers; reinforcing bars extending from base plates into floor system aid in taking horizontal arch thrust.



THE Agricultural Center Building of Louisiana State University at Baton Rouge is one of a new type of clear-span auditoriums using rigid frames of steel. The building has over-all dimensions of 349 ft. 4 in. by 199 ft. 4 in.; its height from the finished floor level to the bottom chord of the rigid frames supporting the roof is 76 ft. 8 in. Excepting catwalks, which are suspended directly from the steel, the building is completely clear of all bracing or obstruction below the bottom flanges. There are six transverse frames, each in the form of

an arch with five centers. The column and arched sections are in the form of a plate girder 5 ft. deep. The knees of the frames are increased in depth to approximately 11 ft. deep. At either end of the building, eight radial half-frames of similar design connect to the last transverse arches and are spaced equally on a semicircle to form the half-dome end of the building. The horizontal thrust of the arches is carried by bars welded to the base plates and extended down into the reinforced-concrete floor. The rigid frames are braced by truss-type cross frames.

# AGRICULTURAL CENTER BUILDING

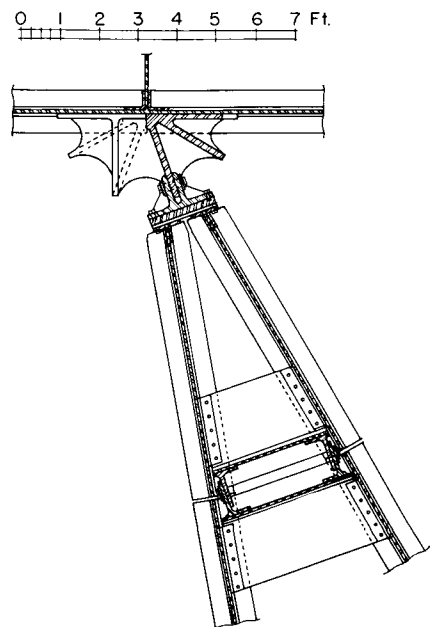


Photos by Rembrandt Studios

Interior view of auditorium. Behind the seats at the second-floor level are offices and laboratories.

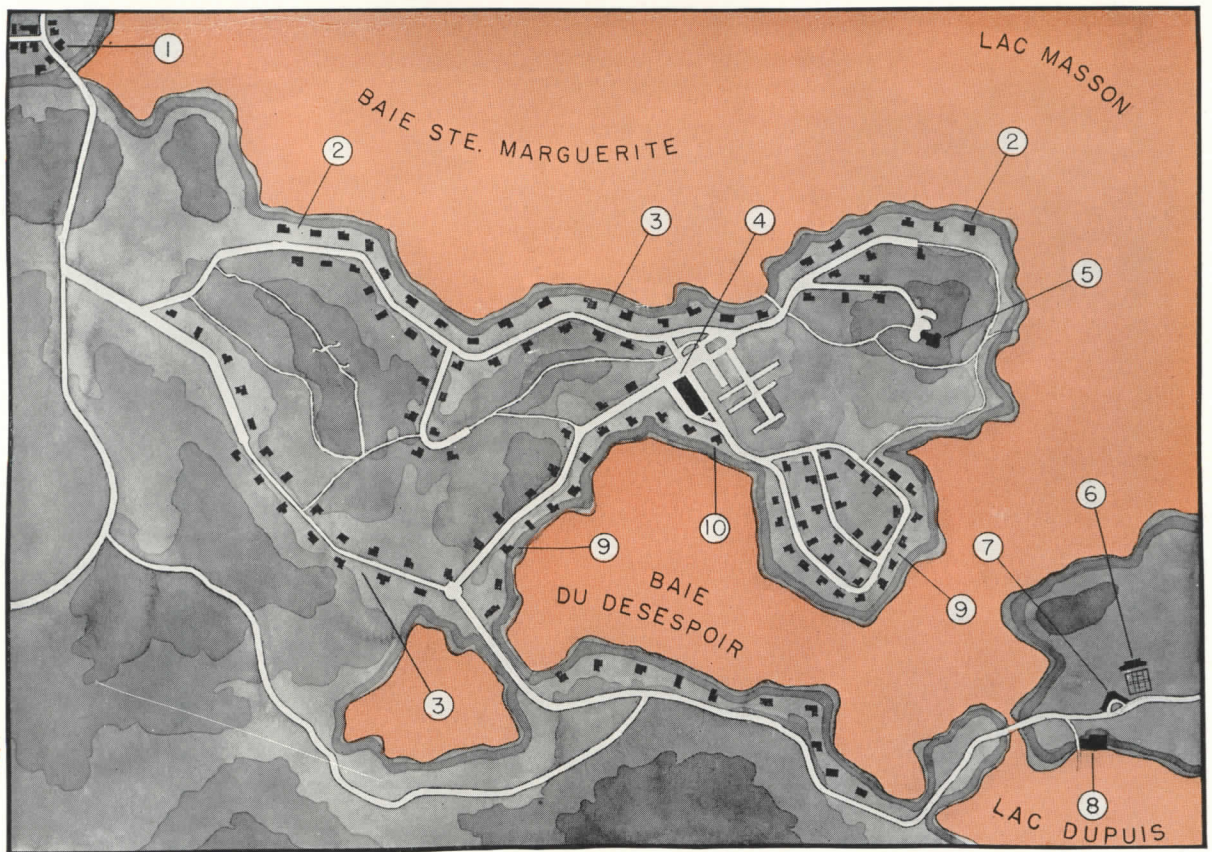


View of construction showing the rigid frames and the systems of purlins and bracing used.



Detail plan showing connection of transverse and radial arches.





1. Village of Ste. Marguerite. 2. Log cabin area. 3. Modern cottage area. 4. Commercial center. 5. Hotel. 6. Tennis courts. 7. Riding school. 8. Clubhouse. 9. Rustic cottage area. 10. Air service.

## 7,000-ACRE RESORT BUILT IN CANADIAN WOODS

ANTOINE COURTENS and LOUIS NICOLAS, Architects

MONTREAL

THE TOURIST TRADE is Canada's fourth largest industry. Until quite recently, however, the Laurentian country north of Montreal had no adequate tourist resort adapted to year-round activity and equipped for contemporary usage.

In 1935, a Belgian philanthropist, Baron Louis Empain, procured a vast territory some 60 miles northwest of Montreal. Here within the last three years has been built a sportsman's resort, the *Domaine d'Esterel*.

The *Domaine* occupies some 7,000 acres, bordering on Lac Masson; this is exclusive of sections reserved for hunting and fishing. In summer the lakes provide a wide range of water sports and beach games. For skiing, more than one hundred miles of trails have been mapped out and broken through the woods. The resort includes a community center, clubhouse with tennis courts and stables, a hotel, an airport, dwelling facilities for employees, and a number of log cabins built on the lakeshore: in brief, an integrated community in the heart of the Canadian woods. The resort can be reached from Montreal by train, bus, automobile or plane.

With minor exceptions, the larger structures are of reinforced concrete, with exterior walls

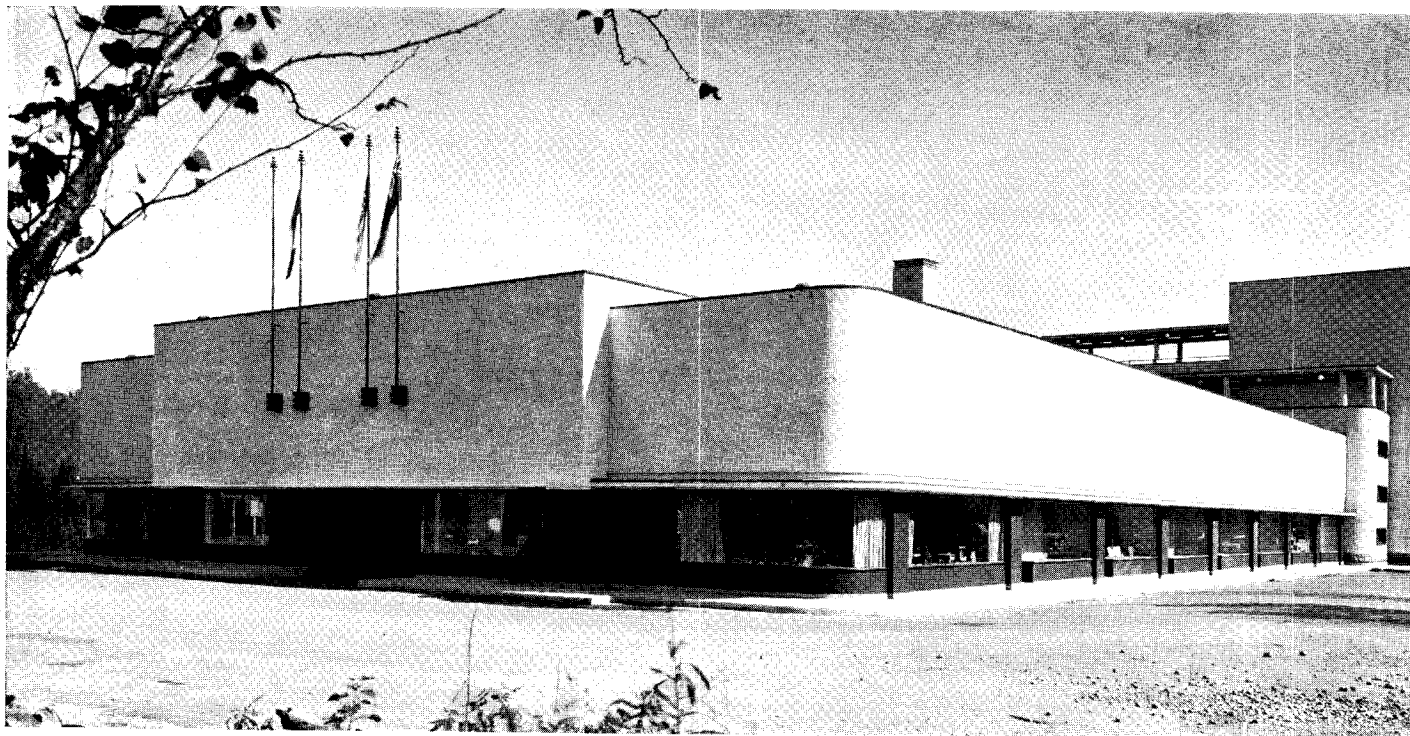
of steel-stud framing, covered with stucco on metal mesh.

The community center is located in the approximate middle of the district, conveniently near the hotel. The main floor of this building includes some 30 shops, which enclose a garage with repair shop and other necessary services. Enlargement of the community center by the erection of additional buildings is projected for the future.

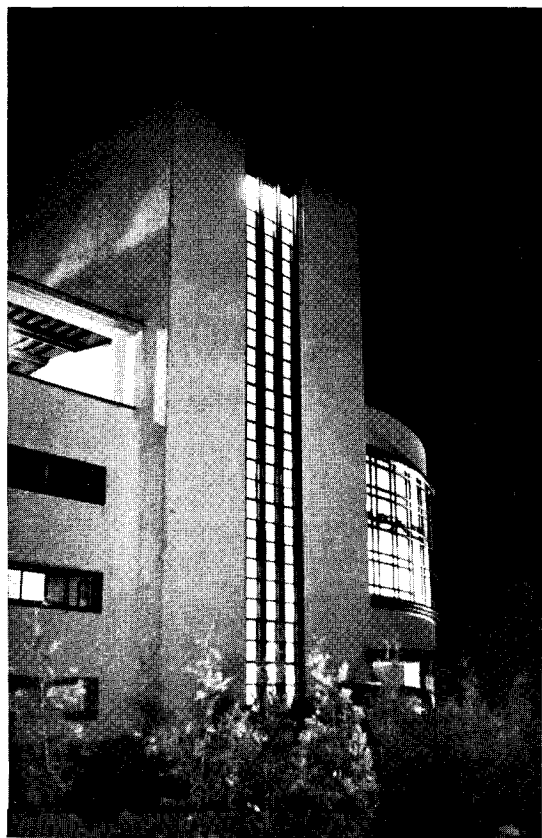
The clubhouse is constructed on piles which extend into Lac Dupuis. Its dressing rooms can be used by 1,500 to 2,000 bathers daily. Two solarium balconies, connected by outside stairways, accommodate 300 to 400 people. From one of these balconies, guests can reach the diving boards and towers on the pier, which extends out into the lake. Tennis courts and public grandstands have been built near the clubhouse. And not far away are stables, riding school, and bridle paths into the enclosing forest.

The hotel is located on a rocky promontory which juts out into the lake; it is surrounded by terraces which command a spectacular view of the lakes and the Laurentian woods which stretch for miles in every direction.

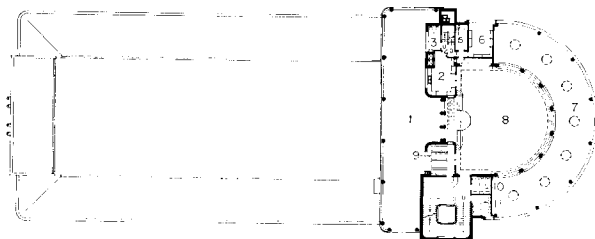
**COMMUNITY CENTER AT DOMAINE D'ESTEREL**



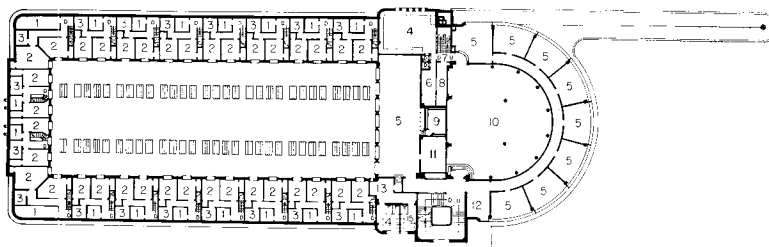
E. W. Bennett



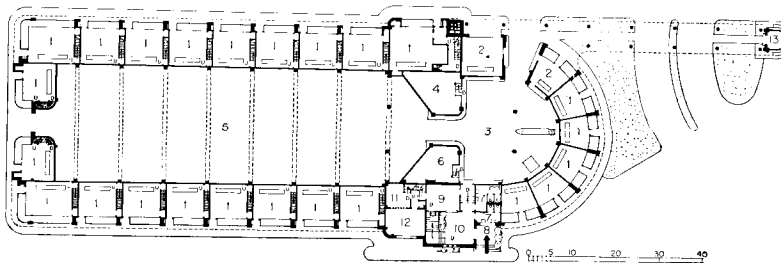
Behind the continuous vertical glass is a stairway leading to a cinema on the second floor and a restaurant on the third. The restaurant windows and the terrace opposite command a view of the surrounding woods and lakes.



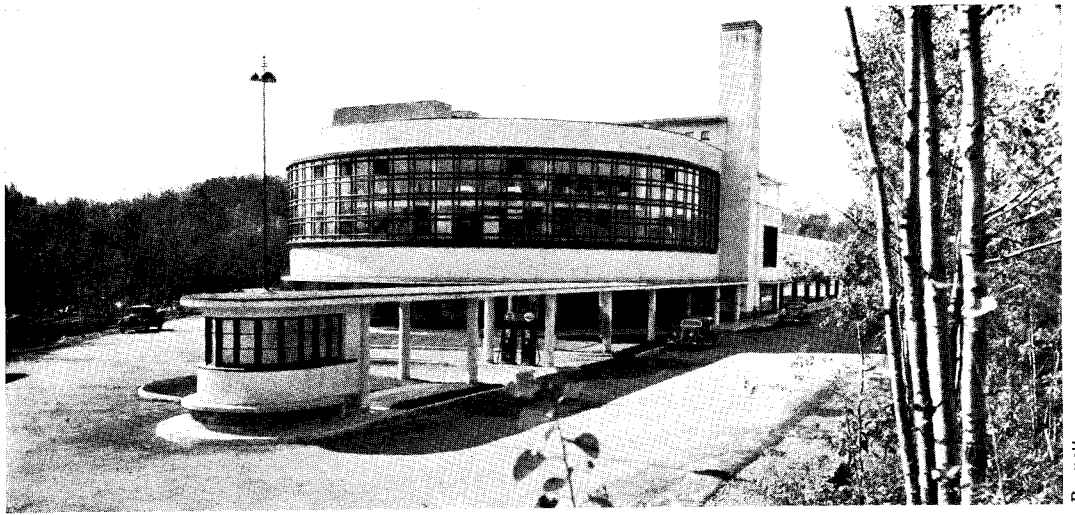
**Third floor:** 1. Terrace. 2. Pantry. 3. Servants' toilet. 4. Service stair. 5. Servants' lockers. 6. Storeroom. 7. Blue Room. 8. Restaurant. 9. Coatroom. 10, 11. Toilet.



**Second floor:** 1. Storeroom. 2. Bedroom. 3. Bathroom. 4. Kitchen. 5. Office. 6. Cold storage. 7. Service stair. 8. Storage. 9. Projection booth. 10. Theatre. 11. Film room. 12. Waiting room. 13. Coatroom. 14. Women's room. 15. Men's room.



**First floor:** 1. Store. 2. Garage store. 3. Auto repair. 4. Auto parts. 5. Garage. 6. Electrical materials. 7. Toilet. 8. Porch. 9, 10. Halls. 11. Kitchen. 12. Supt. 13. Garage.



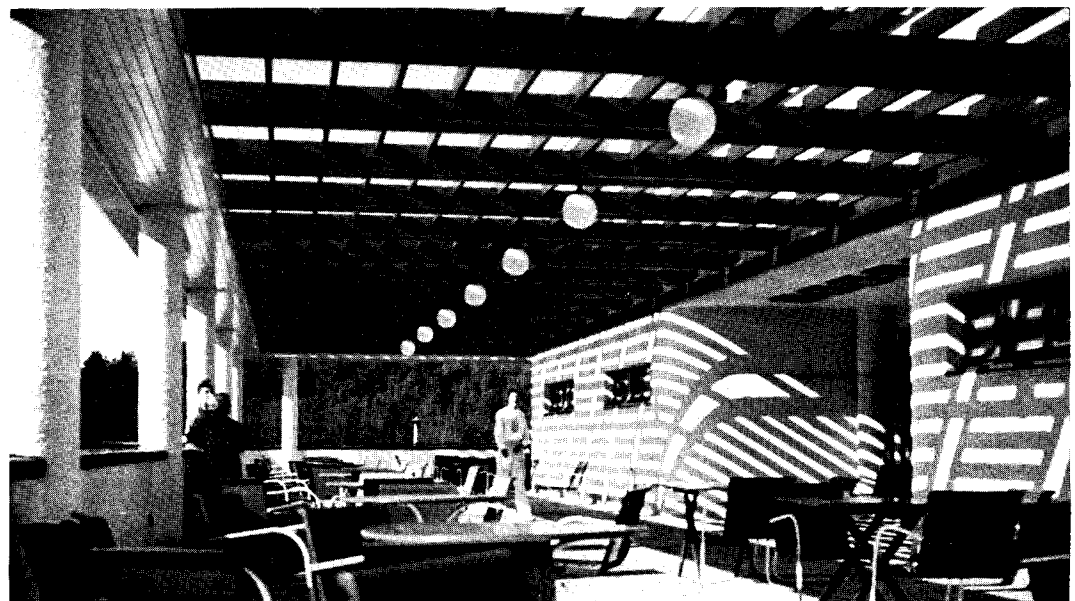
Bennett

Northeast end: Offices on second floor with cinema behind; restaurant and ballroom on third.



Bennett

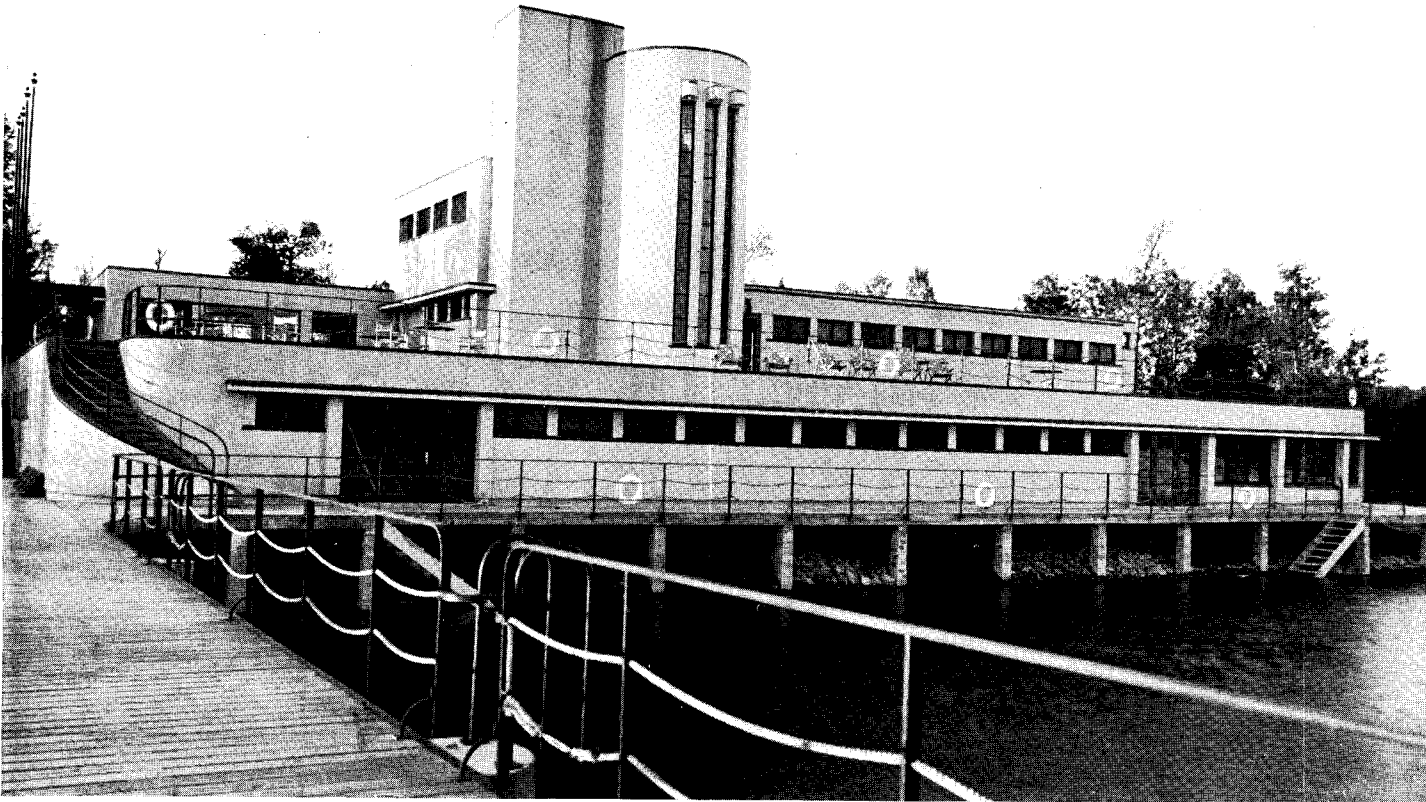
Restaurant, third floor; note orchestra stand at left and clear space for dancing.



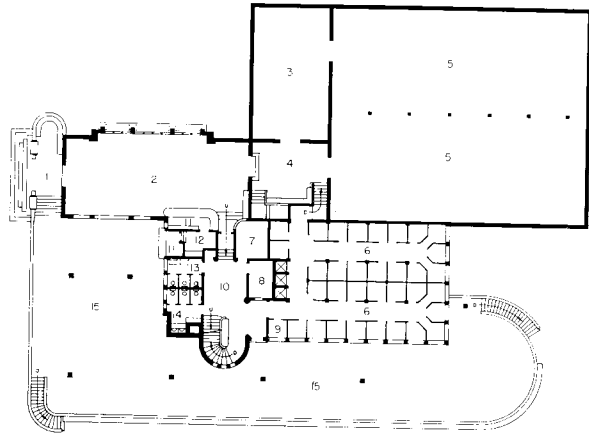
Third-floor terrace; the restaurant and dance floor are accessible through entrance at right.

# CLUBHOUSE AT DOMAINE D'ESTEREL

Photos by Bennett



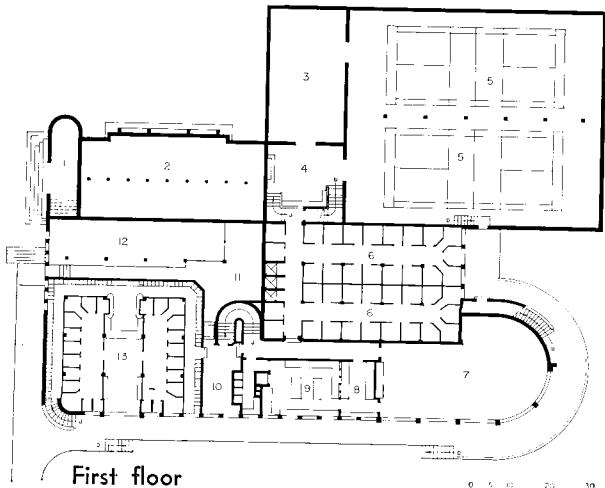
The structure is built on solid rock. Entrance opens on a lounge, with gymnasium, badminton courts, and dressing rooms beyond; the latter can accommodate 1,500 to 2,000 persons daily.



Second floor

### Second floor

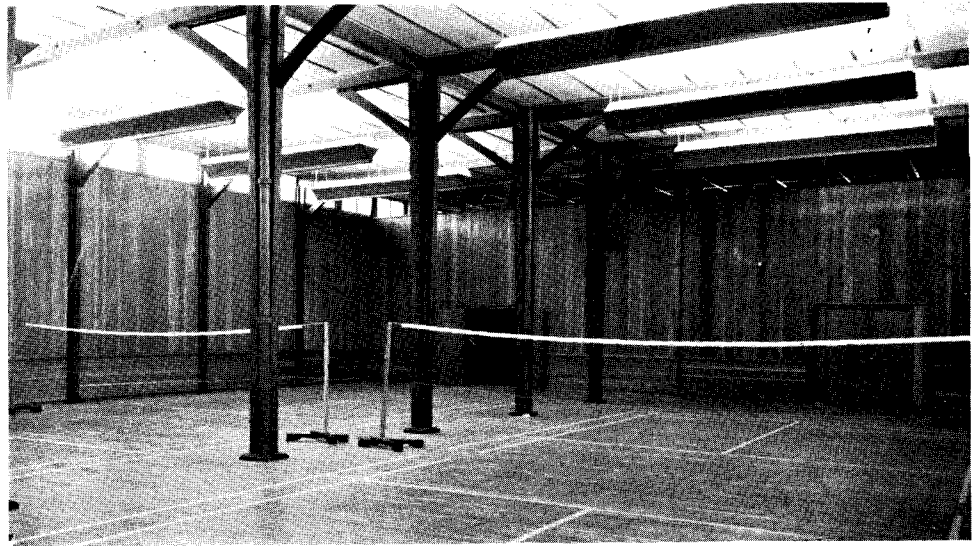
1. Porch
2. Lounge
3. Gymnasium
4. Hall
5. Badminton court
6. Dressing rooms
7. Office
8. Coatroom
9. Linen room
10. Stair hall
11. Bar
12. Pantry
13. Women's room
14. Men's room
15. Terrace



First floor

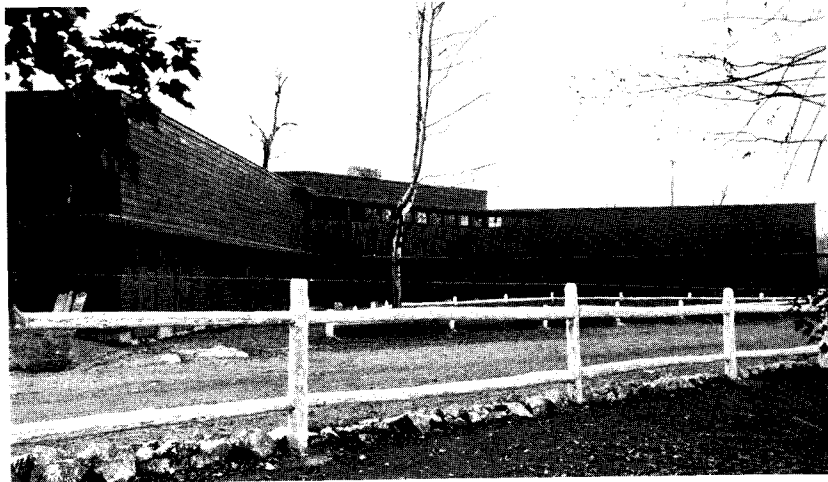
### First floor

1. Porch
2. Unexcavated
3. Gymnasium
4. Hall
5. Badminton court
6. Dressing rooms
7. Dining room
8. Pantry
9. Kitchen
10. Pumping station and filters
11. Heating
12. Fuel room
13. Locker room

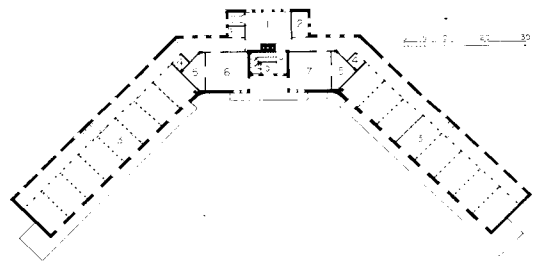


Above, right: Bar in lounge just inside the entrance. Beyond this lounge are gymnasium, badminton courts, and dressing rooms. Lower, right: Badminton courts are two floors in height.

## RIDING SCHOOL AT DOMAINE D'ESTEREL

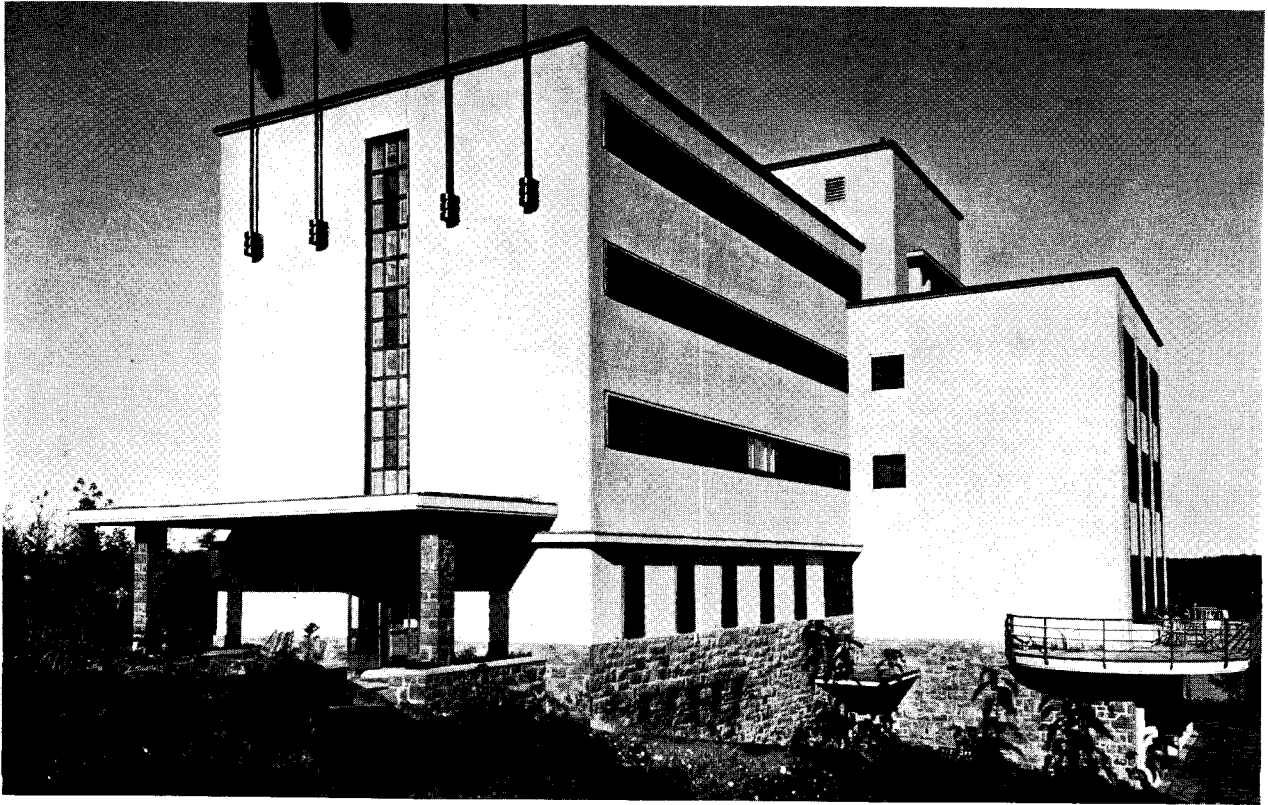


Riding school, stables, and bridle paths are located near clubhouse.



Ground floor: 1. Kitchen. 2. Fodder. 3. Stall. 4. Chute for oats. 5. Storage. 6. Stable boys. 7. Saddle room.

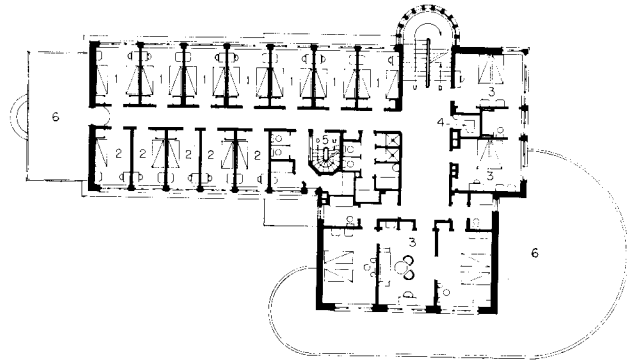
**HOTEL AT DOMAINE D'ESTEREL**



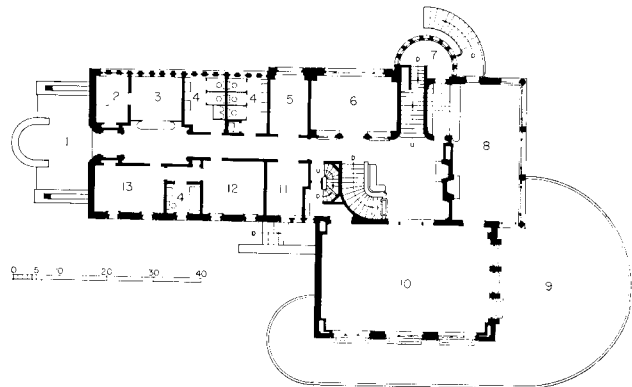
Bennett



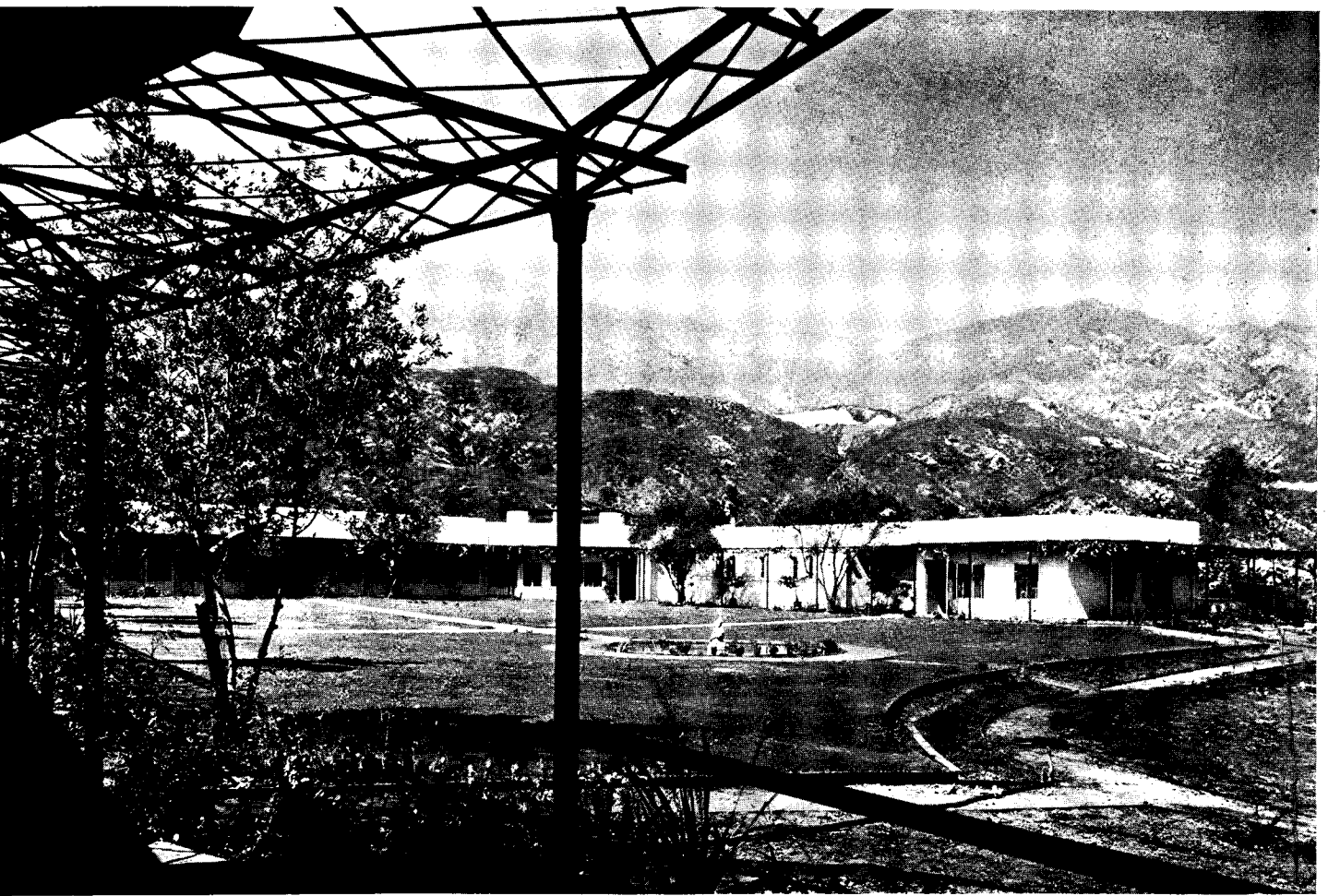
The hotel is built on a rise of ground, and its terraces command panoramic views of the forest and lakes. It is situated on a rocky promontory which juts out into a lake. The hotel is within easy access of the commercial center and of the other community buildings.



**Third floor:** 1. Double bedroom. 2. Single bedroom. 3. Double bedroom suite. 4. Linen closet. 5. Service stair. 6. Roof.



**First floor:** 1. Porch. 2. Bedroom. 3. Supt. 4. Washroom. 5. Reading. 6. Games. 7. Bar storage. 8. Bar. 9. Terrace. 10. Lounge. 11. Coatroom. 12. Mgr.'s office. 13, 14. Mgr.'s bedroom and bath.



## SANATORIUM DESIGNED FOR HILL SLOPE IN EARTHQUAKE COUNTRY

MYRON HUNT and H. C. CHAMBERS, Architects

THE LA VIÑA TUBERCULAR SANATORIUM near Altadena, California, is situated on one of the foothills of the Sierra Madre Mountains, overlooking a broad plain.

The structure has been designed in the form of a modified U, the arms extending southward. All patients' rooms are on the east end of corridors, facing the morning sun; men's and women's wings do not face each other. Terrain for a mile or so south of the site is an alluvial fan with a gentle slope away from the mountains, the arms of the building extending in the direction of the slope. But the length and evenness of this slope, in combination with the rugged mountains behind, create the illusion that the terrain is level; so that level structures of considerable length appear to be tilted backward toward the mountains. To mitigate this distortion, the sanatorium floors are made to follow the contour of the ground: each successive room is two inches lower than its neighbor to the north; corridors drop two inches between each room door. Despite the marked difference in elevation of the wing ends, however, the building appears level from the outside and within.

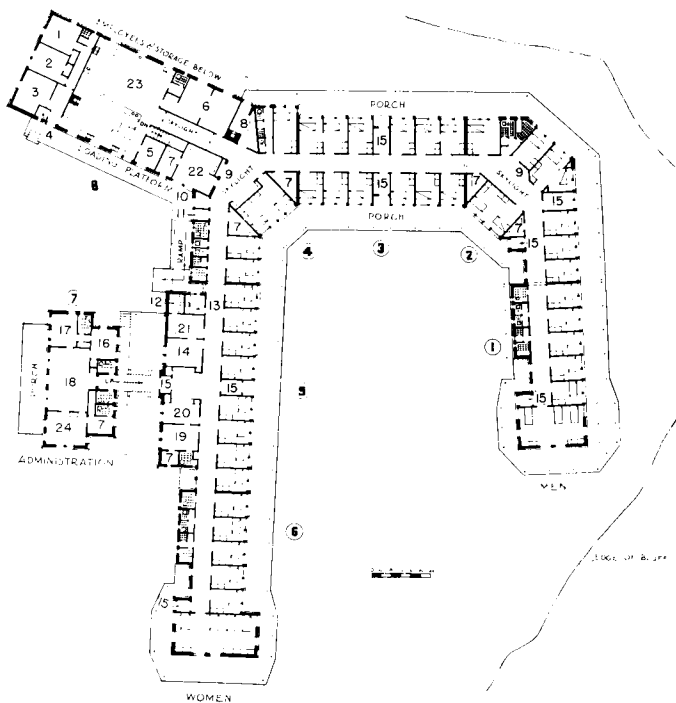
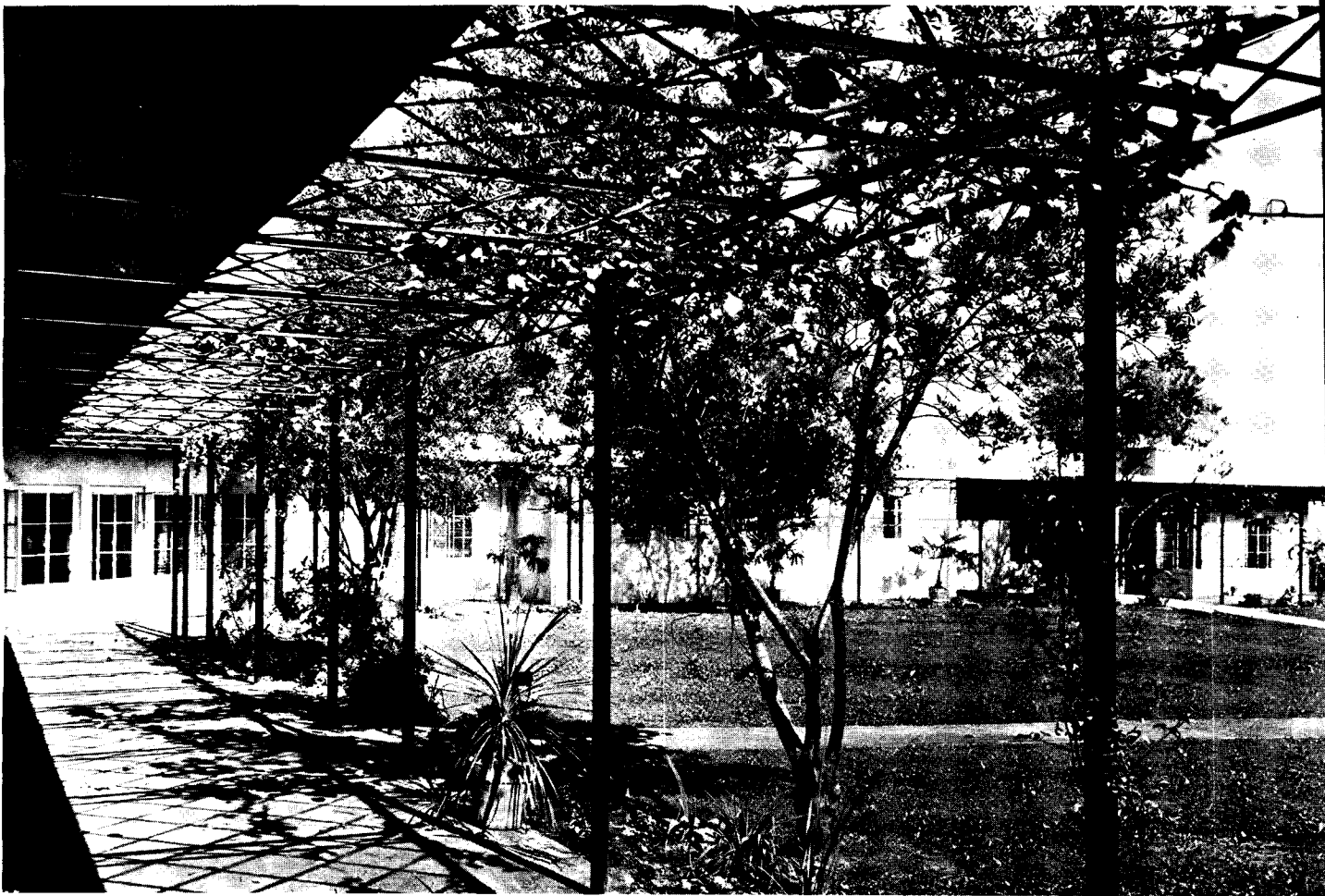
This moulding of the structure to the terrain is carried farther in the design of the parapets: these not only step downward to conform to the sloping foundations, but exceed this pitch, being considerably higher above roof level

at the north than at the south end of the arms. This sloping of corridor and parapets permits occupants of rooms deep in the courtyard of the U to enjoy virtually as much view of the valley as those in rooms near the wing extremes.

Earthquake resistance is essential: the sanatorium site is close to one and between two other important earthquake faults; further, quake undulations are particularly severe on long structures. The wings, therefore, are broken into units, each separate from those adjoining; space between units is about three inches, but continuity of walls and ceilings is maintained by slip-joint connections; each unit has its own foundation. In an earthquake, each unit will rock independently of the others, like one of a string of barges in a heavy sea. A concrete-beam foundation system is used. Floors are laid directly on the ground.

Each patient's room opens onto a trellis-shaded porch with macadam floor. Doorways are 4 ft. wide, so that beds may be moved easily to the porch. The pergola is formed by a continuation of the structural skeleton of the building beyond the exterior walls.

In conformity with the quiet background desired, colors are inconspicuous. Exterior walls are painted egg-shell white; exposed steel work in the pergolas is deep blue; interior walls are an English gray.



**Floor plan:** 1. Cook's room. 2. Asst. cook's room. 3. Kitchen storage. 4. Janitor's closet. 5. Men's dining room. 6. Nurses' and women patients' dining room. 7. Stores. 8. Janitor's room. 9. Nurse's station. 10. Ambulance vestibule. 11. Stretcher. 12. Darkroom. 13. Laboratory. 14. Surgery. 15. Vestibule. 16. Examination room. 17. Doctor's room. 18. Reception room. 19. Head nurse. 20. Office of head nurse. 21. X-ray room. 22. Linen. 23. Kitchen. 24. Office.

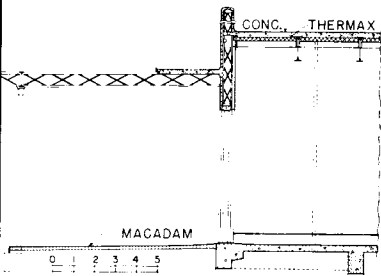
The circled numbers indicate the units of the building, separated for earthquake resistance; units are connected by three-inch slip-joints.

THE LAYOUT is determined by requirements peculiar to sanatorium. Corners of the U are broken so that no more than two nurses' stations, properly placed, are needed to cover every room. Floor areas are so articulated that administrative and other work areas are removed from the patients' attention. These areas are placed on the west side of corridors, and no patient's room faces in that direction. All entrances are hidden not only from patients' rooms but from the exercise areas for ambulatory patients as well; visitors enter through the reception room in the administration building; ambulance entrance and merchandise delivery loading platform are in the motor courtyard formed by administration building and kitchen wing. Thus the plan can be operated without disturbance of patients.

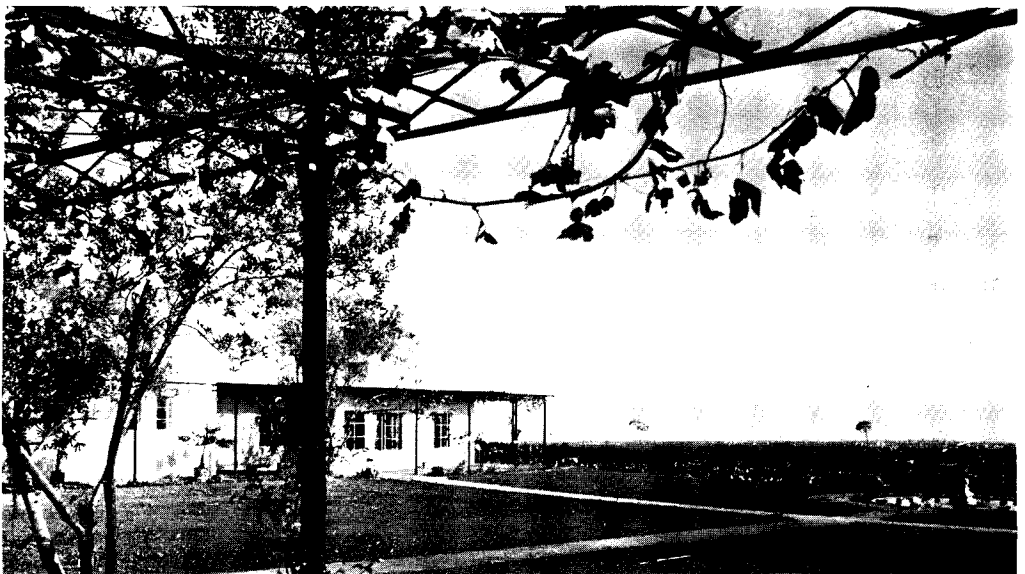
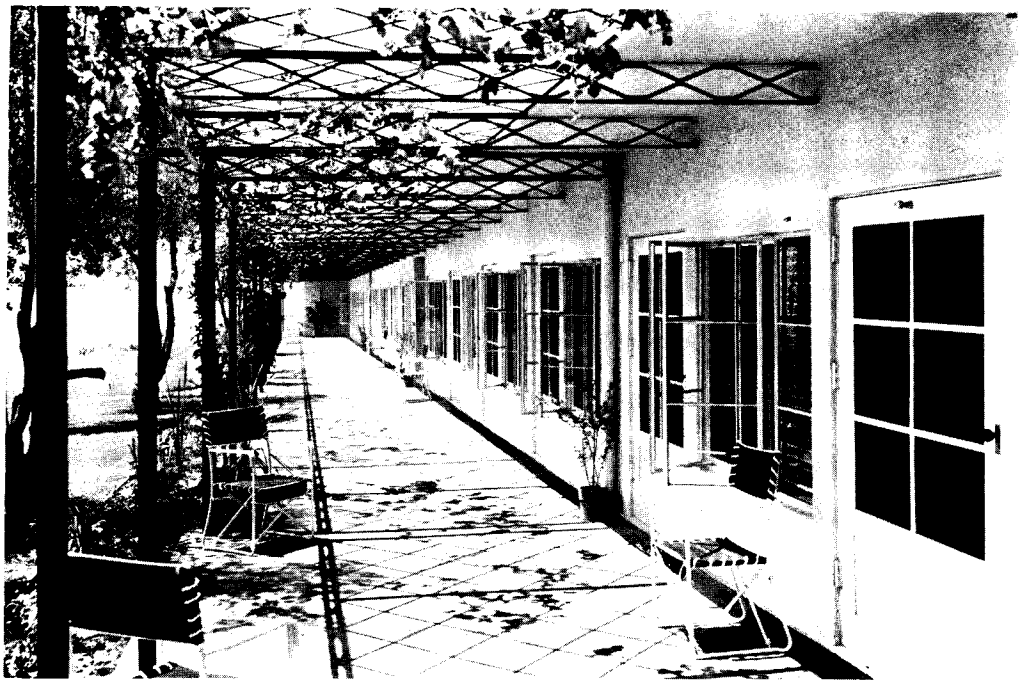
Almost all rooms contain but a single bed; only patients well advanced toward recovery occupy multiple-bed wards in company with others. This need for seclusion has encouraged several aspects of plan that are ordinarily considered disadvantages: the long corridors with rooms uneconomically placed along only one side; the small, rarely used dining rooms; the remotely situated toilets. Since 85% of the patients are bedridden, eating, bathing, and other functions must be performed in bed, so that adjoining toilets are unnecessary. Centralization of toilets permits centralization of plumbing, and leaves the entire eastern face of the wings available for patients' rooms.

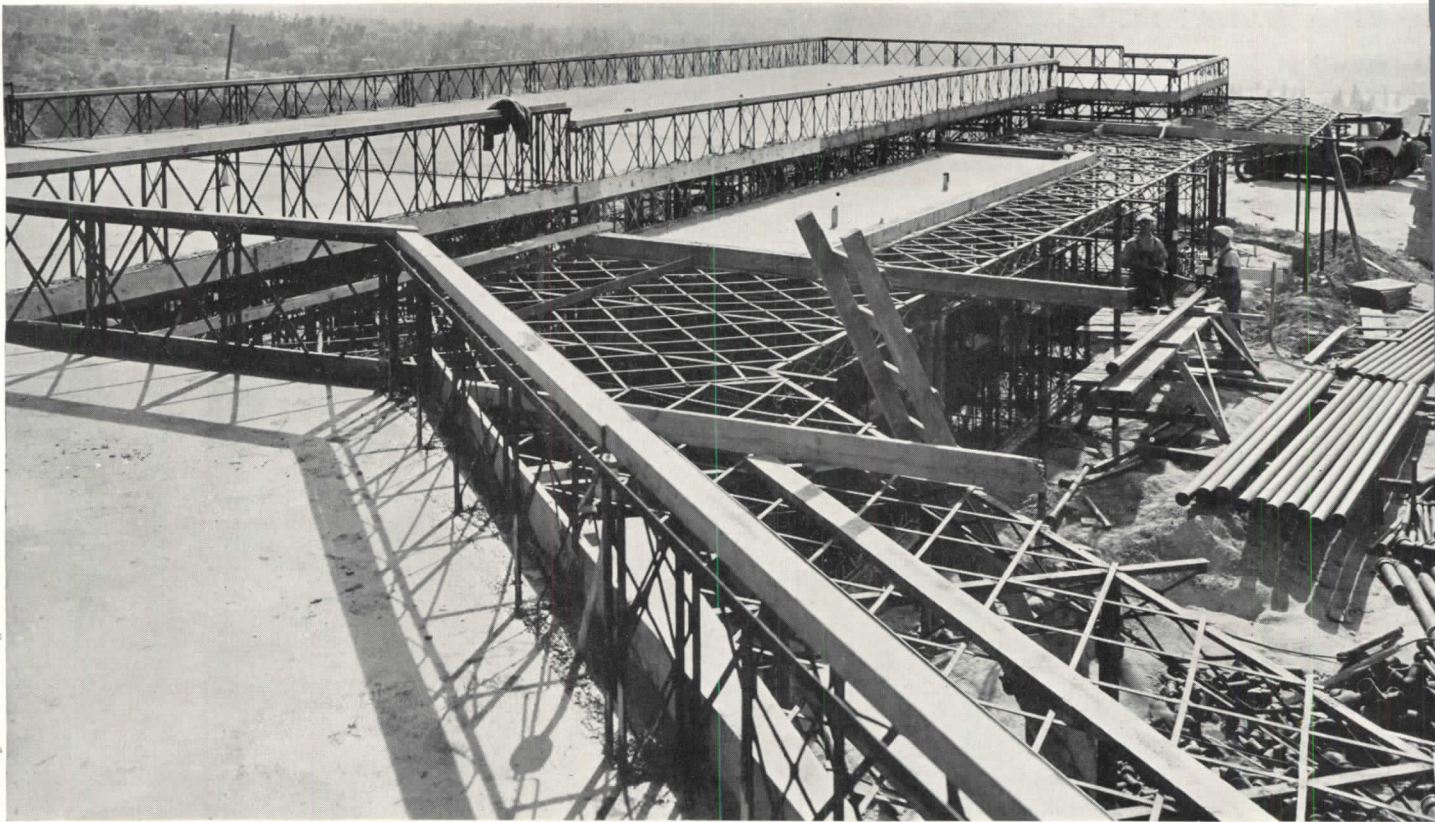


# A VIÑA SANATORIUM

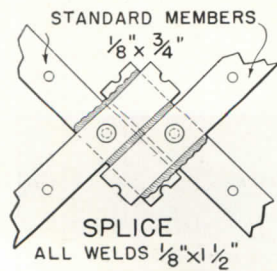
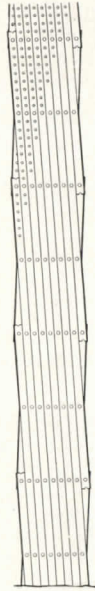
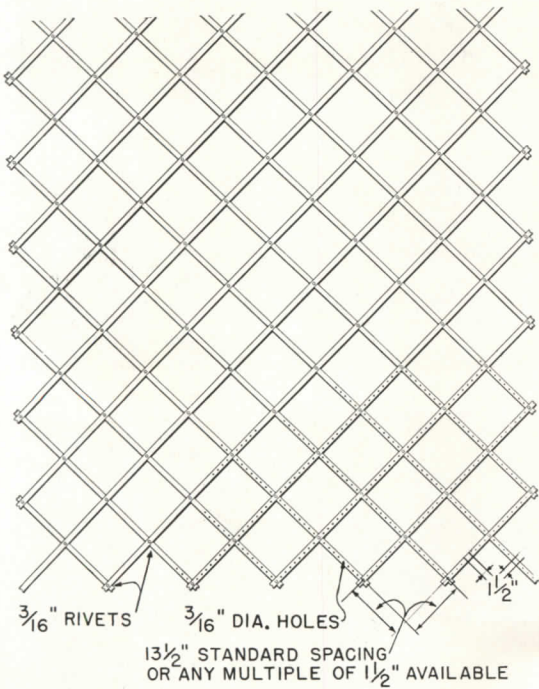


The pergola is a continuation of the structural skeleton beyond the exterior walls of the sanatorium.





The flat roof is laid on Latisteel rafters. A continuous air chamber between ceiling and roof affords insulation

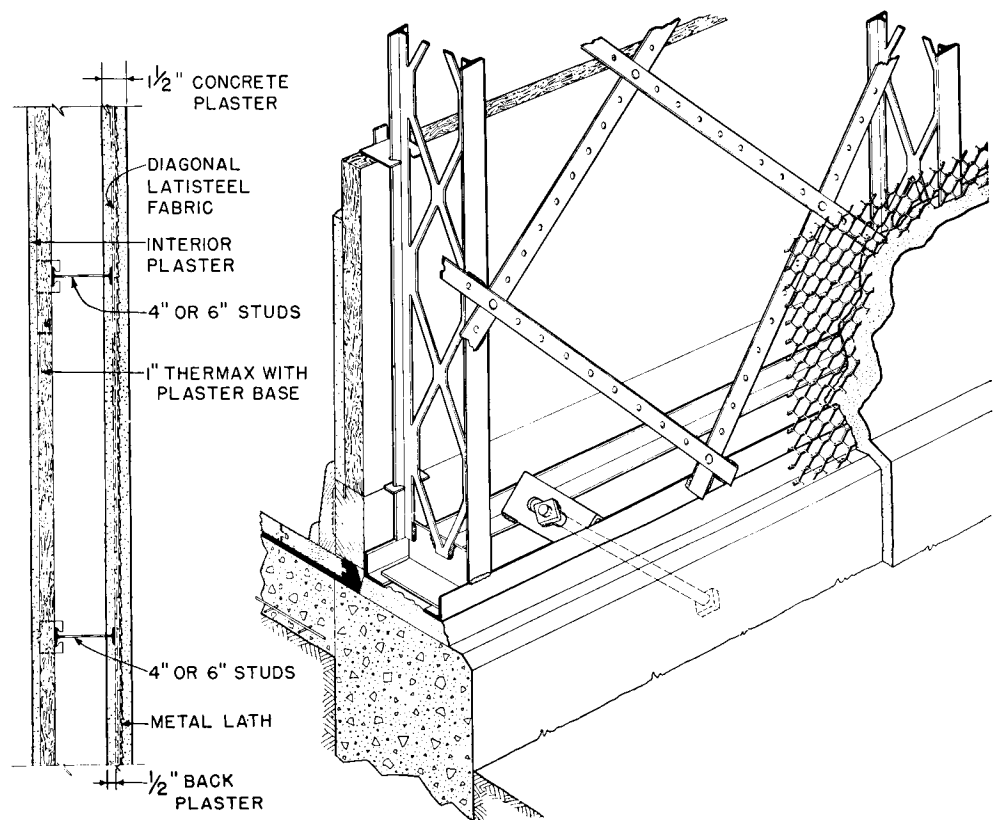


The diagonal steel-strip latticing can be "expanded" like metal lath; all joints and connections are welded. In this way the wall framing is trussed and made relatively rigid and integral with the other materials.

THE BUILDING is of Latisteel frame construction: light in weight, relatively inexpensive, fireproof, termite-proof, and easily adapted to thermal and acoustic insulation. The light weight simplifies foundation problems and aids earthquake resistance. The system consists essentially of one piece "hot expanded" webbed steel studs, braced with diagonal steel-strip latticing which can be "expanded" like metal lath; all joints and connections are welded. Thus the wall framing is trussed and made rigid.

Metal lath is wired to the exterior face of the steel latticing, covered front and back with cement plaster, and finished with a brush coat of stucco. Thermax insulating plaster base is applied across the interior face of studs then plastered. The flat roof is laid on Latisteel rafters. Above the rafters is a layer of Thermax insulation covered with "lightweight" aggregate three-inch cast-concrete slab topped with tar and gravel. Ceilings are suspended from the rafters and are faced with acoustic plaster. The continuous air chamber between interior and exterior wall surfaces and between ceiling and roof, together with Thermax and acoustic plaster, afford relatively high sound and heat insulation. All utilities are carried in the wall spaces afforded by the expanded studs and joists.

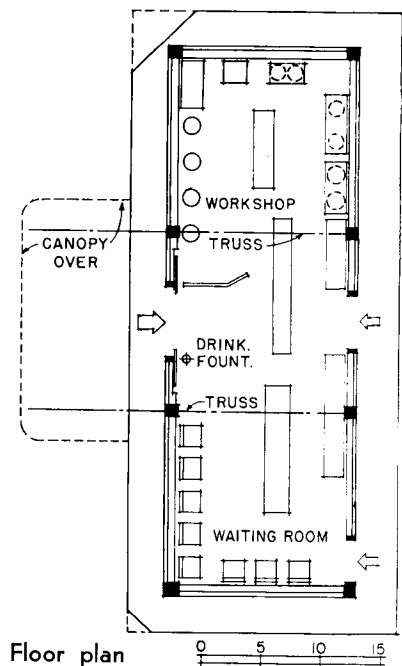
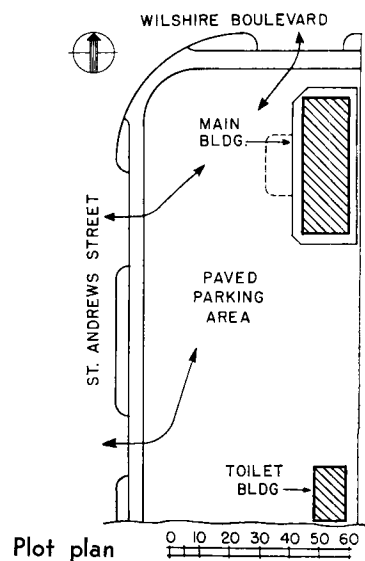
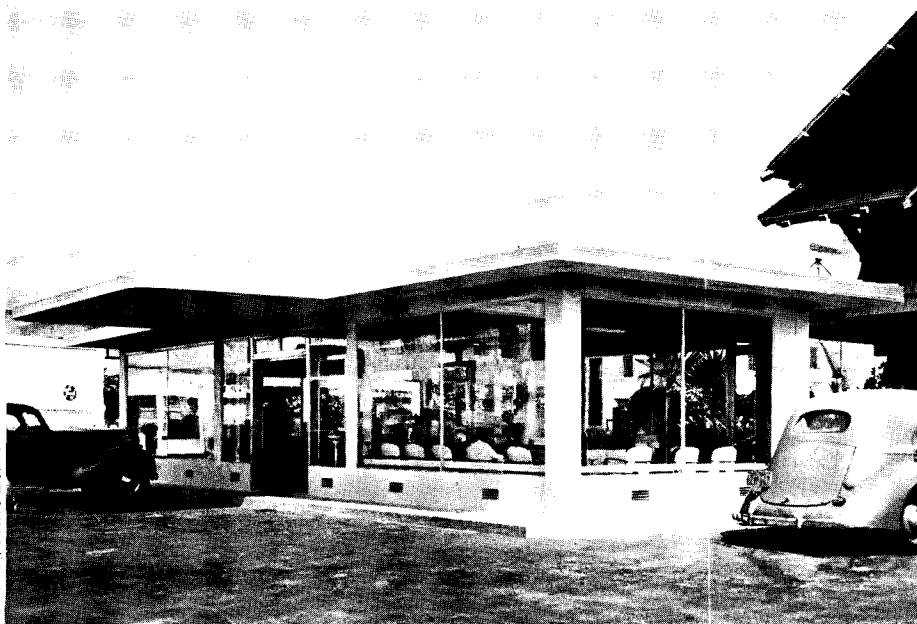
No inflammable materials are used on the exterior: the pergola is steel, and the door and window sash are metal. This is an important consideration because brush fires have been common in these foothills; the present structure replaces one destroyed by a brush fire two years ago. As an added precaution, steel windows and exterior doors nearest the brush-covered slopes are glazed with wired plate glass.



# COMBINED SHOWROOM AND WORKSHOP FOR MOTORIST PATRONS

HAROLD O. SEXSMITH, Architect

Photos by Miles Berne



ALONG WILSHIRE BOULEVARD in Los Angeles (see AR, 11/38, p. 43) there has recently been built a "drive-in" shoe-repair shop. Here customers can motor in, sound their horns for service, and wait in their cars while worn footwear is repaired. A small waiting room is provided inside the structure.

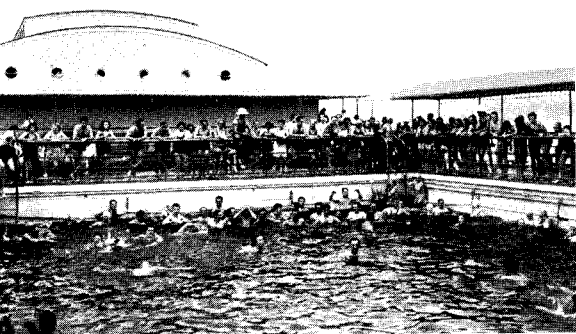
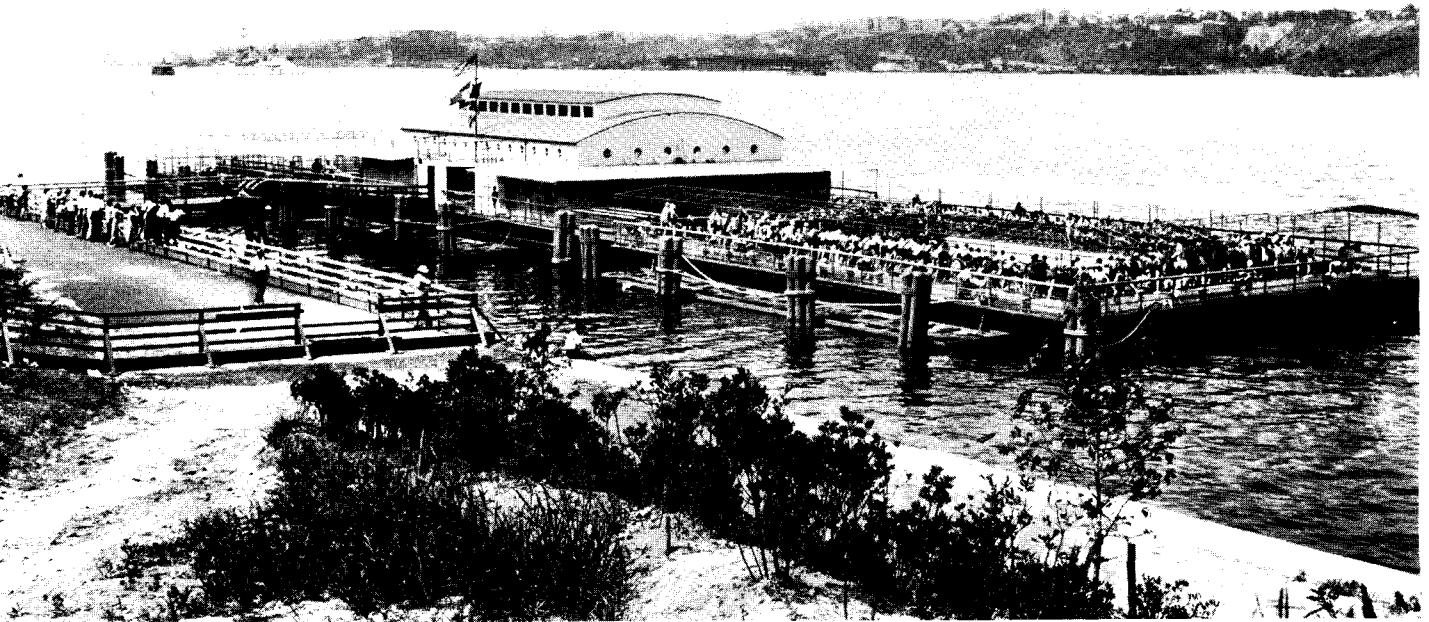
For reasons of showmanship, the workshop is in plain view of passersby and customers: all walls are glassed, with work benches facing the boulevard and

parking area. To keep the showroom-workshop clean, a 2-hp. rotary fan is installed in the basement, drawing leather dust and particles from the machines, collecting it in a cloth bag. The building is a steel-frame structure, faced with concrete. The interior is faced with plywood. Ventilation is provided through louvers close under the roof overhang.

The owner of this drive-in shop, a chain shoe-repair organization, is planning additional units.

# ANTIQUATED BARGES BECOME FLOATING POOLS AND BATHHOUSE

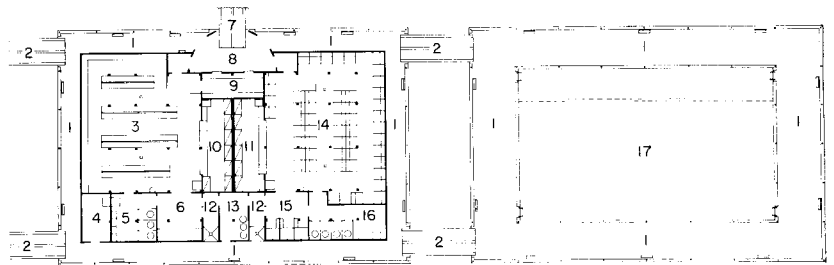
MADIGAN & HYLAND, Engineers



...one of the floating pools which flank the bathhouse ...



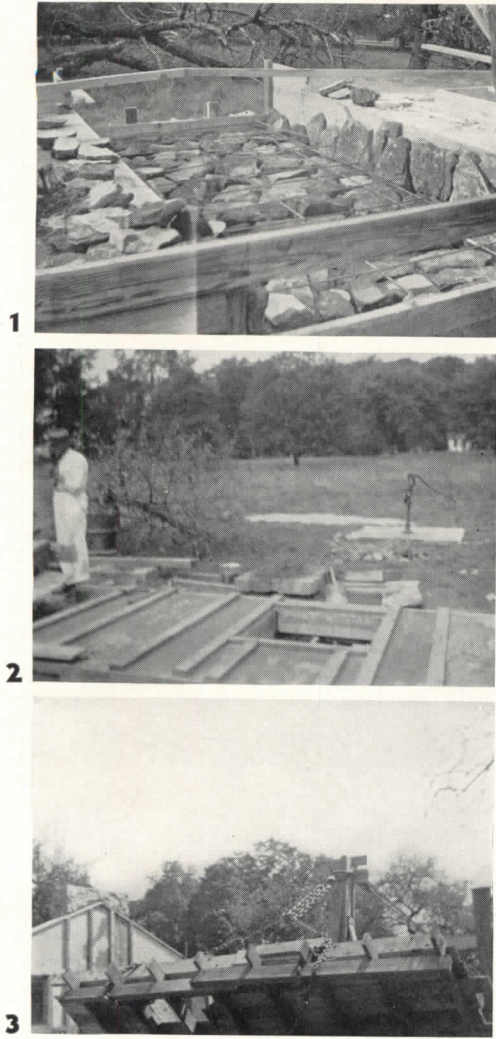
...one of the barges before modernization began . . .



1. Promenade. 2. Gangplank. 3. Men's dressing room. 4. First-aid room. 5. Men's toilet. 6. Men's shower. 7. Gangplank to dock. 8. Entry. 9. Office. 10. Men's basket room. 11. Women's basket room. 12. Shower passage. 13. Chlorination room. 14. Women's dressing room. 15. Women's shower. 16. Women's toilet. 17. Bathing area.

THREE ANTIQUATED barge-pools owned by New York City's Park Department have been redesigned: two of them, superstructures removed, have become outdoor pools, joined by gangplanks to a third barge between them; the latter—rebuilt—is now a floating bathhouse. pontoons support all three structures—wooden pontoons under the pools, thousand-gallon steel ones under the bathhouse. Copper paint is applied to the wooden walls and floor of each pool, and—below water level—to the outside surface of the barges; this paint reacts with water to form an acidic coating which prevents the adherence of barnacles. Because of the pressure of the river, the pools are never emptied during the swimming season; they are vacuum-cleaned. Bathhouse flooring is plastic magnesia—non-slippery, waterproof, and easily cleaned. The cost of this project was \$50,000.

# NEW SYSTEMS



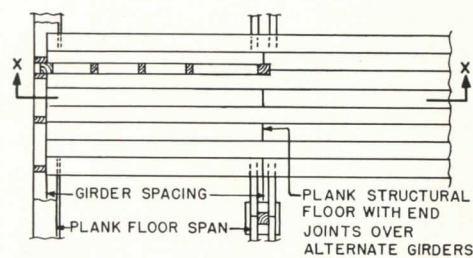
## Walls built in horizontal form and raised to position

A SYSTEM for the construction of masonry walls, claimed by its sponsor to result in savings of 10 to 15%, has been developed by Form-U-L Homes, Inc., of Cleveland, Ohio. In this system both foundation walls and walls above foundations are built in forms on the ground and raised to position by cranes.

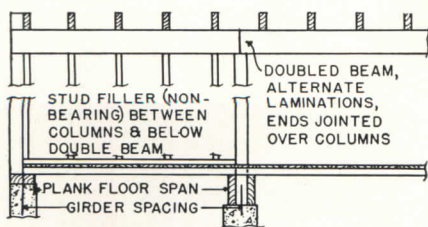
First, a horizontal concrete form is placed adjacent to the foundation footing; reinforcing bars are laid and concrete poured. After hardening, the wall is tilted vertically into position against the foundation footing. Then, concrete is poured in the corners to lock the ends. Side walls are fabricated the same way.

Other masonry materials may be used: stone was used, for instance, in the house illustrated at left. The mason laid the stones flat face down, leaving space for deep wide joints when the concrete was poured. Four inches of stone and four inches of concrete give a total wall thickness of eight inches. Furring strips are bolted to the inside face of the form. The projecting chimney of the house was cast in one piece with the wall. Corners are fabricated separately to seal the ends.

1. Stones are laid in form, flat face down; reinforcing bars are laid over.
2. After concrete is poured into the form, furring strips are bolted to the inside face of the wall section.
3. Wall is raised into position by crane.
4. Projecting chimney and wall cast in one piece are now in position.
5. The assembly is now complete.



Plan



Section XX

## Tests prove tank subfloors are more economical than joist

A CONSTRUCTION employing a plank subfloor over beams spaced wider apart than they are usually spaced for joists was recently investigated by technicians of the National Lumber Manufacturers Association. Exact comparisons of this system with the more usual joist construction have seldom been made; now a comparison of buildings erected by the same contractor on adjoining sites gives these results:

### PER SQ. FT. OF FLOOR CONSTRUCTION

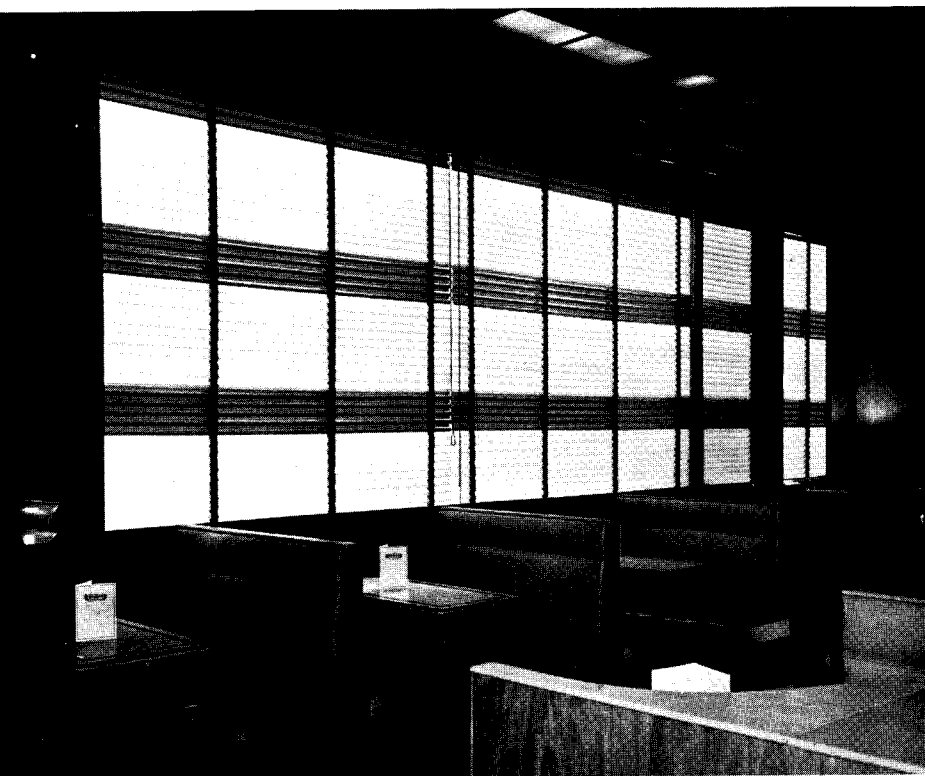
	Saving by Use of Plank Floor
Labor time .....	26.3%*
Lumber required .....	14.7%
Lumber cost .....	24.8%
Total cost .....	22.6%

	Increase in Resistance to Heat Loss
Heat loss rate .....	24.8%

\*Labor-time saved per M.B.F. of lumber, 13.6%.

The plank floor was of 2 x 6 D&S plank placed flatwise over girders spaced 6 ft. on centers (5 ft. 6 in. clear span). Planks were 12 ft. long with end joints of adjoining planks occurring over alternate beams. With a maximum deflection fixed at L/360 the 2-in. plank floor, of lumber qualifying for a modulus of elasticity of 1,400,000 lbs. per sq. in., will take a load of 52 lbs. per sq. ft.; for an E value of 1,600,000 lbs., it will take a load of 59 lbs. per sq. ft.; the former is 5 lb. and the latter 12 lbs. more than is required for dwelling design. In fact it is claimed that, mainly because of the greater continuity of this construction, a material with an E value of 1,200,000 lbs., which rates a load of 44 lbs. on a simple span of 5 ft. 6 in. would probably be stiff enough.

## NEW EQUIPMENT

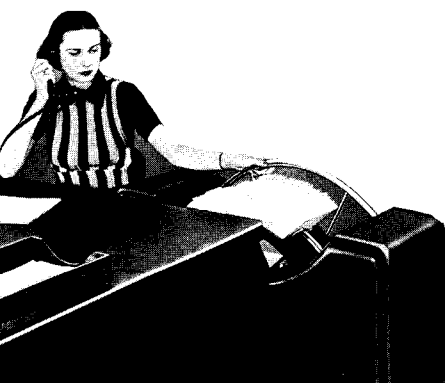


### Translucent Bakelite Venetian blinds now made available

VENETIAN BLINDS of translucent Bakelite laminated slats are manufactured by Rex Company, Inc. Slats are of S-curve construction to prevent sagging and to afford compact nesting when the blind is lifted. The S-curve is said to permit better ventilation than flat slats. The blinds are available in eight colors—white, cream, amber, scarlet, dark red, dark blue, turquoise

blue, and green; interiors can be tinted by diffused light with any one of these colors. The laminated material admits from 10 to 40% of the light, depending upon the color used. The slats clean easily and are not damaged by water, alcohol, or household cleaning fluids. These blinds, made of a special phenolic laminating compound, are insulation against summer heat and winter cold.

### Office filing equipment based on "wheel principle" announced



OFFICE FILING equipment based on the "wheel principle" has just been announced by the Diebold Safe & Lock Company of Canton, Ohio. Two types

of filing wheels are manufactured—one revolving in a vertical plane and another revolving in a horizontal plane. Among the advantages claimed for this equipment are:

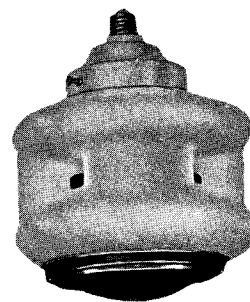
1. Greater flexibility of design is permitted: portable cabinets make it easier to move records to any desirable location, from office to office or, by elevator, from floor to floor.

2. Greater capacity per square foot of floor space.

3. Eye strain is reduced: records can be read and posted from normal positions under identical lighting.

4. Posting and filing are speeded: finding, removal, and replacement of records are easy one-hand operations, from normal working positions.

### Light trap captures nocturnal moths and other night pests



A LIGHT TRAP designed for catching nocturnal moths and other night-flying insects is manufactured by The Miller Company, Meriden, Connecticut. The trap is a globe made of Genco diffusing glass, its sides pierced with three funneled slots leading to the light bulb. The light attracts the insects into the globe where the heated air kills them; on a warm night the "catch" may range from 1,000 to 1,500 insects. First developed for porch and kitchen use, and to rid truck gardens of pests, these traps are also used in hotels, summer resorts, and roadside stands.

The trap uses a 100-watt or 150-watt lamp. It is made with and without removable bottoms for dumping accumulations of dried insects.

### Reservoir for wet concrete saves on truck mixers

A NEW STEEL hopper for receiving truck-mixed concrete and dispensing it into barrows and carts as needed is manufactured by the Ransome Concrete Machinery Company, Dunellen, New Jersey. The use of this hopper allows the truck mixer to be dismissed without delay. A bottom discharge, equipped with lever-operated double-clamshell gates, controls the flow of concrete into wheelbarrows and carts; it is claimed that better control of the discharge is possible, preventing segregation of aggregate and assuring a more uniform mixture. The hopper may be towed to the job behind any truck; it rides on a special pneumatic-tired trailer undercarriage, which, on arrival at the job, can be quickly detached from the hopper. The total height of the hopper and its frame is 10 ft.; the width, when it is in carrying position, is less than 8 ft. Two lines of barrows or carts may be operated simultaneously from the hopper.

## NEW MATERIALS



### New material obtained from waste liquor out of steel mill vats

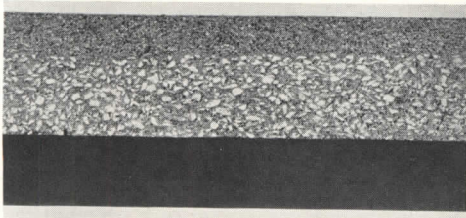
A NEW MATERIAL obtained from waste liquor out of the "pickling vats" of steel mills has been announced by the Allied Development Corporation, 1700 Standard Building, Cleveland, Ohio.

The material, which is called "Ferron", is said to have remarkable insulating properties: it is stated that 1 in. of the material affords the same insulation as 15 in. of brickwork. Ferron is further reported to be fireproof, termite-proof, and nonwarpable. It is about one-third the weight of brick and can be cut, sawed, and machined. It is extremely porous: under the microscope Ferron reveals a great number

of air spaces; these give to the material its high insulating value. (A brick made of Ferron will bubble for several minutes when dropped into water, and the air spaces can be calculated from the difference in weight of the wet brick and the dry brick.)

Lightweight building block can be made by mixing the material with cement, sand, lime, and other building materials. Ferron is also made in the form of a powder, which can be mixed with water and sprayed on boiler settings, between house walls, under eaves, and in other places where fireproof insulating material is required.

### Plastic, nonslip, water-resistant flooring material announced



A PLASTIC, nonslip, water-resistant flooring material called "Monocork" has been announced by the Armstrong Cork Products Company of Lancaster, Pennsylvania. Monocork is composed of rubber latex, a dehydrating powder, granulated cork, and various types of fillers. Latex sets by the loss of water, while the dehydrating agent sets by the absorption of water; when these two materials are in one mixture, the setting action of each ingredient is complementary to the other.

Monocork is applied in plastic form, giving a monolithic surface. For special applications the percentage of

cork granules is increased, making the floor lighter in weight and relatively nonslippery either wet or dry. According to the manufacturer, the rubber content of the composition is high enough to make the product flexible, so that it can withstand considerable distortion before cracking or breaking. It is claimed that the combination of cork and rubber results in a surface which is resilient and quiet underfoot and resistant to wear and moisture. Monocork adheres to clean steel, concrete, masonry, composition boards, or wood surfaces.

Ingredients of the material are generally shipped to a job in three containers: one for the rubber latex and all other liquid ingredients; the second contains dehydrating agents and mineral fillers; the cork filler is shipped in a third container. When combined in a mechanical mixer on the job, these materials result in a plastic mixture which is trowelled over the sub-base.

### Precision control results in "practically a new material"

PRECISION control of concrete manufacture, said to result in "practically a new material", is now made available by Scientific Concrete Service Corporation, Washington, D. C., under patent licenses from the Toledo Scale Company. This control is effected by specially-designed, precision weighing instruments which assure the specific proportions of ingredients in the concrete mixture. In addition, "The Toledo Method" includes: moisture determination, moisture compensation, complete graphic record, specific gravity and absorption determination, sieve analysis, and the analysis of fresh concrete. The resulting material is said to be homogeneous within relatively close limits: strength, durability, resistance to wear, volume change, and workability are controlled with a precision comparable to that maintained in the manufacture of steel.

Variations in properties of supposedly identical specimens of concrete fabricated with the usual proportioning methods, are reported as high as 100%; this lack of precision has heretofore necessitated a corresponding high factor of safety. Scientific Concrete Service Corporation claims that precision control of concrete manufacture reduces cement costs 10 to 25% and insures concrete which is relatively uniform and less liable to crack.

According to its sponsors, this engineering service is available to the concrete manufacturer without cost. Scientific Concrete Service Corporation receives as compensation a percentage of the value of the cement saved by use of the service.

### New material combines Micarta and natural woods

DURAWOOD, a new material combining Micarta and natural woods, is manufactured by the Westinghouse Electric & Manufacturing Company. The product is not an imitation: the natural wood itself is impregnated and treated so that, according to the manufacturer, its glass-like surface is impervious to liquids, yet will not chip, break or crack. It does not require resurfacing.

Durawood is furnished in sheets 48 x 96 in. It can be cut with a carpenter's saw or drilled for attaching.



# DESIGN TRENDS



ARCHITECTURAL  
RECORD

COMBINED WITH  
AMERICAN ARCHITECT AND ARCHITECTURE

# WELDING—NEW AID TO BUILDING

By DOUGLAS HASKELL

Few subjects have been as dramatically spotlighted as was that of welding by the recent \$200,000 Contest of the Lincoln Arc Welding Foundation. For the 328 prize-winning papers covered in great detail the application of welding to almost every field of production—with considerable emphasis on building. Always intent on pointing out new potentialities in building design, ARCHITECTURAL RECORD asked Douglas Haskell to analyze some of the most significant papers in this category: herewith Mr. Haskell's survey.

## No. 1: English Engineers Use Welding to Achieve New System for Long Spans

WELDED STRUCTURES should of course not be designed on riveted precedents at all, but redesigned not only as to individual joints and sections, but as to the entire structure, in accordance with the new nature of the welded connection. What is the chief peculiarity of a weld? It is the so-called "monolithic" or continuous, cooperative action among the various parts, once they have been made into one continuous whole. Such systems are "hyperstatic" or "fully indeterminate". It was by taking full advantage of this new resource available through welding that Engineers Anant H. Pandya and R. J. Fowler of London designed the "Dia-Grid" system of floors and roofs that won the Grand Prize in the structural division of the Contest.

In appearance the basic grids are simple, consisting of a grid-work of equally spaced beams set diagonally within an enclosing rectangular frame. Photographs of buildings in

which they have been used instantly reveal their advantage. Here we see vast roof spans, economically framed in steel, which not only leave the floor entirely free but consume no space whatever below the roof-plane itself. Again, there are shown floors or flat roofs widely cantilevered beyond slender supporting columns with an ease comparable to concrete.

The analogy with concrete is important. The crossed beams resemble two-way concrete slab reinforcement vastly enlarged (see Fig. 1), and the radiating pattern above the internal columns is like the reinforcement of drop-slabs and mushroom construction in concrete (see the front column in the same illustration). It is in comparison with concrete that the authors feel that they have achieved revolutionary results: "All-welded steel diagonal grids," they say, "have proved to have all the advantages of two-way slab construction, with none of its disadvantages. The common practise in the design of the latter is to follow certain empirical regulations which place many limitations on the layout of panels in plan. The grids under consideration are entirely free from these restrictive rules, and are more adaptable to practical requirements. They exploit the two-way reinforcement and drop-panels ideas in the most economical manner, and all moments and shear forces are analyzed with great accuracy."

As the illustrations reveal, the diagonal beams are always of unequal length and would therefore be of varying rigidity if acting alone. The strength of the grid derives from the equalizing forces due to the continuous elastic nature of the welded structure, which brings about cooperation

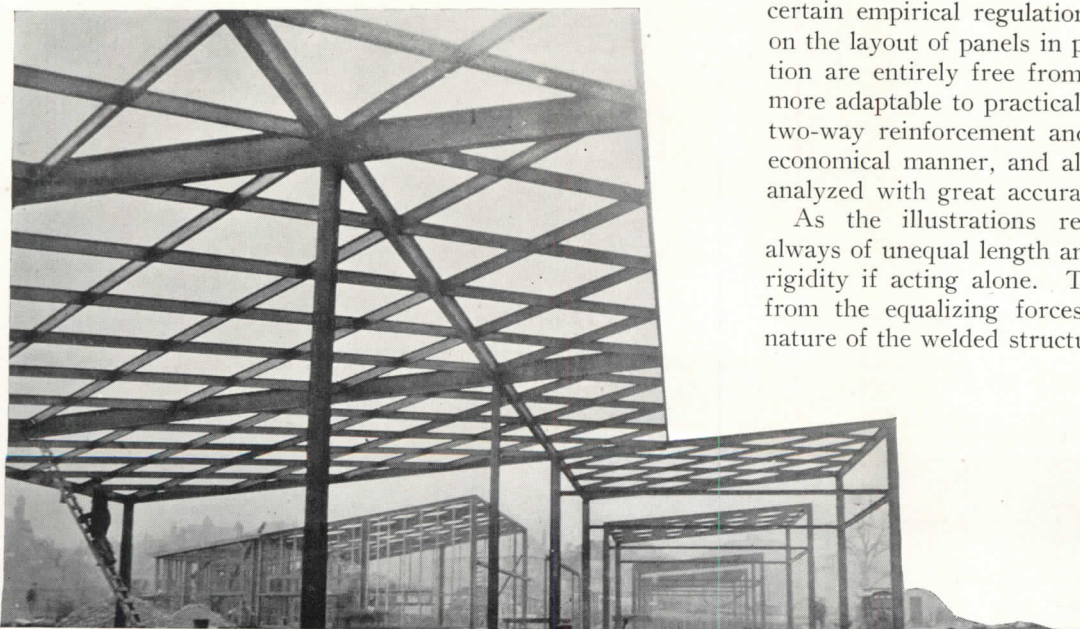


Fig. 1. Structures framed with the "Dia-Grid" system

between the members. Of importance is the fact that all the grid beams are subjected to moments and forces which tend to attain a *uniform maximum value*." Hence, for any given layout the actual spans and loading can be varied without the necessity of a new calculation. This leads directly to the possibility of achieving *standardized calculations* which are independent of the variables, load and span, and which once made can be applied to a variety of conditions. Furthermore, the selection of the size of the grid beams can be made in a few minutes from the maximum factor for a given layout."

In laying out the plane grid, the sides of the rectangular bay can be divided into 2, 3, 4, 5 or even 6 equal parts. Square bays, however, are best divided into 3 equal parts, this number being most economical in operation. "The aim is always to provide a short corner beam and an angle of intersection as near to 90° as possible."

For the larger spans, beyond 50 ft., it is possible to fold the plane grid into the shape of a gabled roof, with a ridge along the center line and horizontal ties at the gable ends. The grid, instead of being made up of interlacing straight beams, now consists of a number of cranked beams which are fully continuous at the cranking points and are capable of transmitting moments from one side of the crank to the other." The cranking introduces virtual elastic supports or grid members at the ridge nodes.

With such folded or gabled grids it is possible to span distances up to 300 ft. in the shorter direction—parallel to ridge and valley lines—and *almost unlimited distances* in the other direction (Fig. 2).

Erection of the grids, like their design, had to be freed from riveted precedents before real efficiency could be obtained. Making use of the stiffness of the grid, the engi-

neers devised ways of welding whole bays on the ground and then lifting them intact into place, thus saving greatly on field welding. Lifting in one piece is done even with the gabled grids, this being easier than propping one slope after another.

Summarizing the advantages, the engineers pointed out: 1.) the complete absence of bracings, tie-rods, trusses or other similar members below the roof-plane, making usable space available to the very top of the room. 2.) The enlarged size of individual members compared to truss members, reducing the area for painting up to 40%. 3.) The spanning of large areas with entirely standard rolled sections. 4.) The intrinsic wind resistance. 5.) The new note for 1938: Such a structure would localize the damage of an air attack.

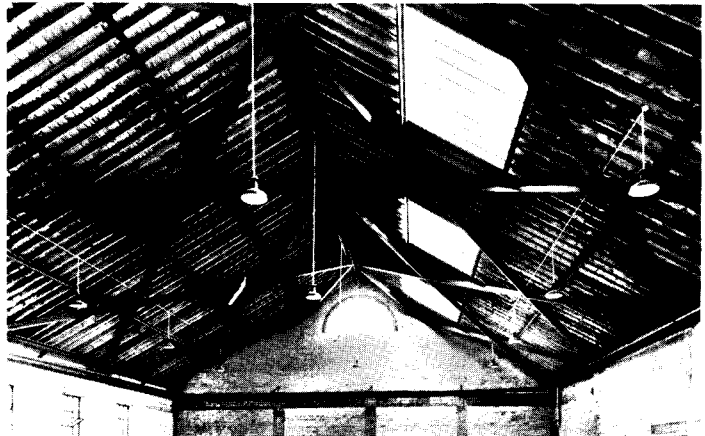


Fig. 2. Folded, the effective span of the "Dia-Grid" system can be enormously extended.

## o. 2: Accessory Welding in Riveted Trusses Gives Greater Precision, 35.2% Economy

ENGINEER WM. J. DUTHIE was in charge of fabrication methods for the erector of the hangar for the U. S. Naval Station at Sunnyvale, California. With an unobstructed floor area of 300,000 sq. ft., this hangar when built covered the largest free interior space in the world. The contract had been let on a riveted design, and a riveted design it remained, but with great fabrication savings through the accessory use of arc welding.

The engineer's attention was chiefly focussed on 28 large similar half-trusses, offering a chance for rapid assembly if only the parts could be made interchangeable. Ordinary riveting procedure does not permit this. Parts are first milled to accurate shape, then punched for rivets, then preassembled, checked, and if necessary corrected. Between steps there intervenes the great enemy of riveting accuracy, which is *creepage*. Because of the inaccuracies it introduces, each truss must undergo preliminary assembly and checking in the shop and be match-marked before shipment to the site. Mr. Duthie decided that he could eliminate creepage, by simply reversing the steps in fabrication. He would assem-

ble first, not last—by means of arc welding. Having assembled and welded the individual truss chords, he would next mill them accurately to template. Not until the chords, laid in position, made an accurate butt joint at each connection, were any holes laid out for riveting. Since the brackets were already tackwelded in place, a single hole, drilled through the complete member, served for every rivet.

The results were splendid. Only one truss was completely assembled in the shop. It fit so perfectly that all other trusses were shipped to the site without preliminary assembly and match-marking. "As the different members were unloaded on the job site, it was only necessary to keep members of the same mark and location together. Then as each truss was erected, the top member of each pile was taken and placed in position. This eliminated the sorting and turning over of the material to get the proper member for a given truss." The saving in the shop, according to Mr. Duthie, was 35.2% on this part of the job. He did not estimate the added savings in the field, which, because of lessened handling, were correspondingly large.

### No. 3: Welding Yields Defense Against Sea, Simpler Framing, Lower Maintenance

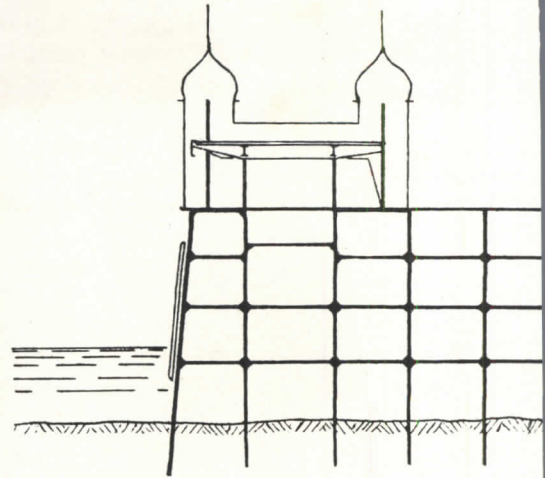
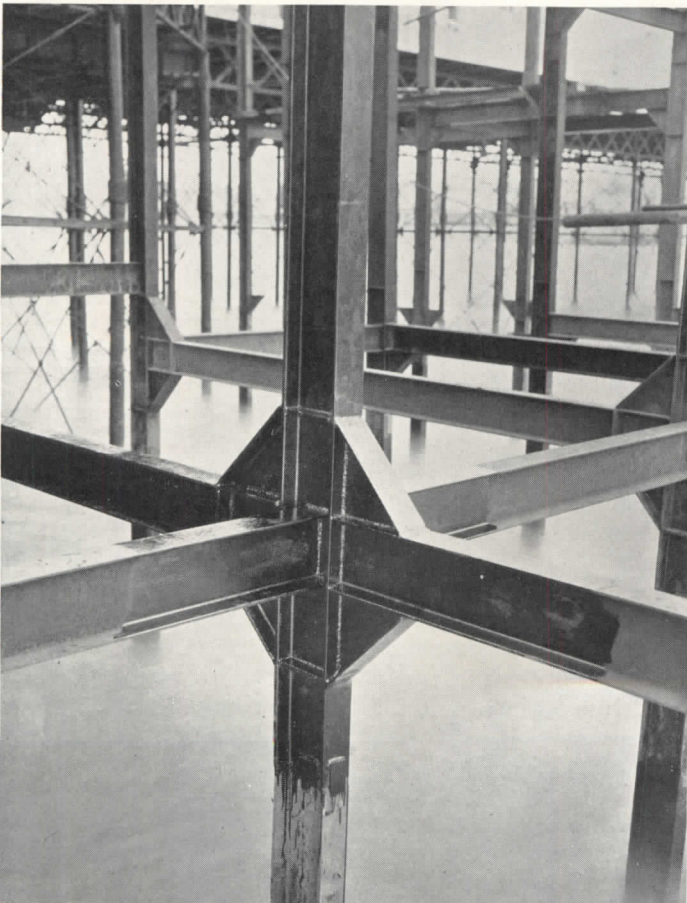
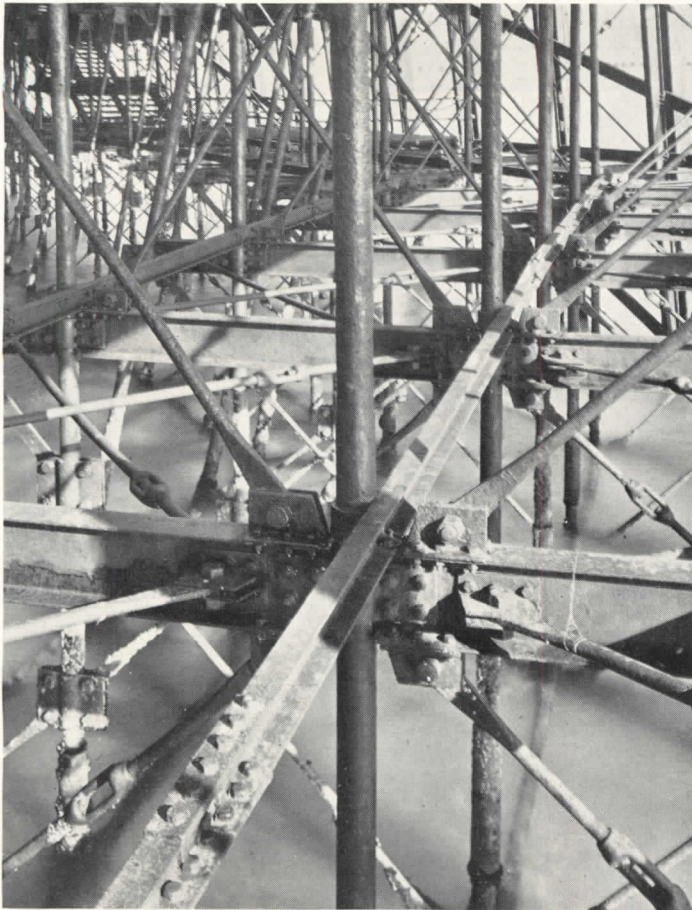


Fig. 3. Framing diagram of reconstructed pier. General design was essentially unchanged.

FEW STRUCTURES are subject to attack so severe as the attack on a pier by the sea. So, looking for a method of sealing up every crack and fissure, Engineer C. Helsby of London, charged with enlarging and extending a steel pier (Fig. 3), turned naturally to welding.

The greatest problem, in the original, riveted pier, had been to keep out the water. In a structure shaken by storm and bumped by steamers, not even a tight bolt or rivet joint is wholly immune to the entry of water, which, once entered, rapidly spreads by capillarity. "Every year bolts and rivets have to be replaced because they burst off under the pressure exerted by rust within the joint, where, after assembly, paint cannot be reintroduced."

Moreover a second characteristic of the riveted structure offers the water a direct invitation. The riveted joint with its superposed plates does not easily transfer bending stresses, therefore diagonal tie-rods are needed to transmit the tensional components of induced stresses. Unless these tie-rods are kept taut, they fail to function; but the manifold impacts upon the pier inevitably cause shackle eyes and pins to wear oval, slackening the tie. Meanwhile rust attacks the turnbuckles as well, making adjustment always difficult, sometimes impossible. Ties must frequently be replaced.

A storm aggravates the situation, much damage being caused by the loosened parts acting as battering rams against the remainder.

The photographs (Fig. 4) show clearly how the engineer was able by welding to clean up the job, once he had persuaded the owners to accept arc welding.

The first effect was to present to the water a *continuous, hermetically sealed surface*. The second was to eliminate 64% of the steel work, representing the tie-rods and their fittings. Since the cost of such items equals 240% of the cost of ordinary rolled sections, it becomes understandable that there was a 31% saving on the cost of the structure as a whole.

Fig. 4. Before and after views of substructure, showing how use of welding eliminated maze of tie-rods and fittings.

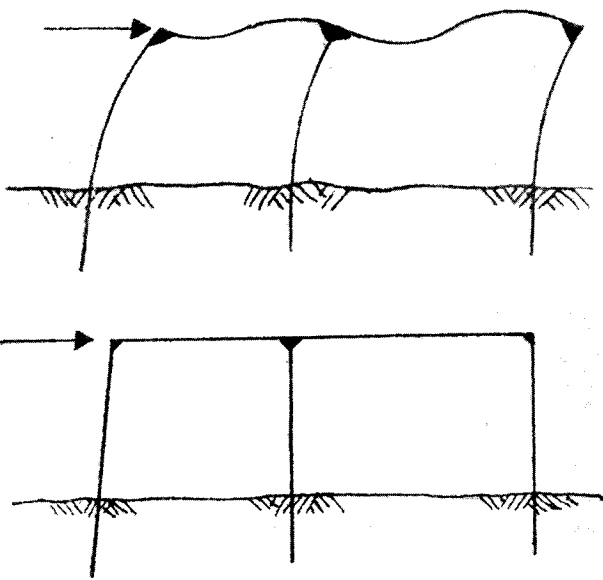


Fig. 5. Impact on welded and non-welded frames.

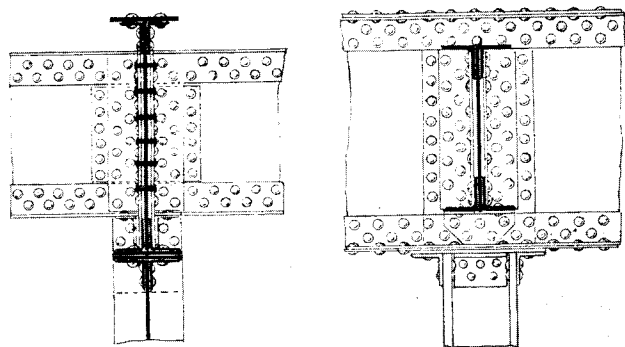
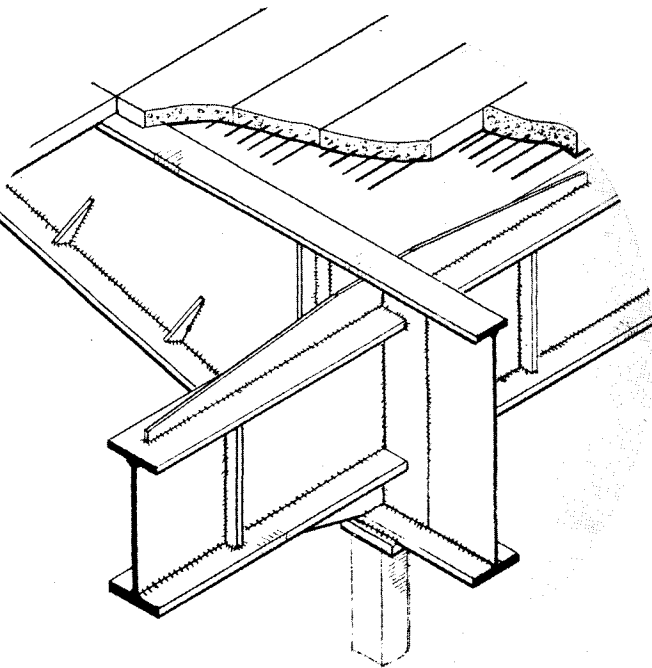


Fig. 6. Compare design as executed with welding (top) with same design problem done with riveting (bottom).

These structural economies, however, are not the end of the story, since the new, simple, and continuous surface will be so much easier to paint and to maintain that the owners will earn substantial savings throughout the entire life of the structure.

The elimination of the tie-rods was possible because of the intrinsic elasticity of the welded connection. "Portal type construction of perfect elasticity can be used, allowing impacts to be absorbed with a smoothly increasing passive resistance, due to the perfect joining medium, arc welding, which gives continuity of stress without slip or uncontrollable contraction" (Fig. 5).

Although the simple, elastic, continuous character of the frame was the chief advantage to be derived from the welding process, the engineer gathered up many incidental advantages along the way. There was for example the ease of building up complicated frame members, where riveting would have demanded a multiplicity of plates and often the modification of the design itself because of inaccessibility for rivets. Since the front piers were raking ones, irregular angles were frequent here, as also in the wind-bracing of the superstructure.

In the connection illustrated (Fig. 6) part of the wind-braced superstructure, not only was the assembly simpler, but it was possible to treat the crossing beam as continuous—a design prohibitive with riveting.

Between the front piers and the next row back there were horizontal diagonal ties, in which it was desired to obtain an initial stress of 2 tons per sq. in. This being the equivalent of 0.034 in. of elongation, the bars, after one end had been welded to its gusset, were warmed by means of a blow-pipe and the free end welded to its plate at the moment when a simple lever and easy reading scale showed that it had reached the correct extension. In this quick way the diagonals were correctly tensioned and fixed. No such simple procedure could have been used to line up the plates for riveting.

To prevent shock to promenaders if a steamer should hit the pier when out of control, and to prevent breakage of glass in the superstructure, it was desired to let the promenade deck slide freely on its supports at right angles to the front of the pier. This was achieved by simple slotted, bolted connections which, translated into riveting methods, would have required no less than 14 rivets apiece. A similar simplicity attended the affixing of a housing for the timber fenders to the front piers; also, the absence of complicated plates and shackles permitted the floor to be fitted around the upright members simply, neatly, and cheaply. Simple box columns, built by toe-welding two L's into a square, were reported by other contestants as well as Mr. Helsby.

As contrasted with the Sunnyvale hangar, reported above, the pier represents a decisive step forward in welding progress. No longer an accessory to field riveting, welding creates a new product, since the indivisible continuity of the frame is a wholly new characteristic. At its best in extreme conditions of abuse, the continuous welded frame is still superior, if properly made, under conditions more nearly average.

## No. 4: Use of Welding and Folded Steel Sections Give Novel Structural System

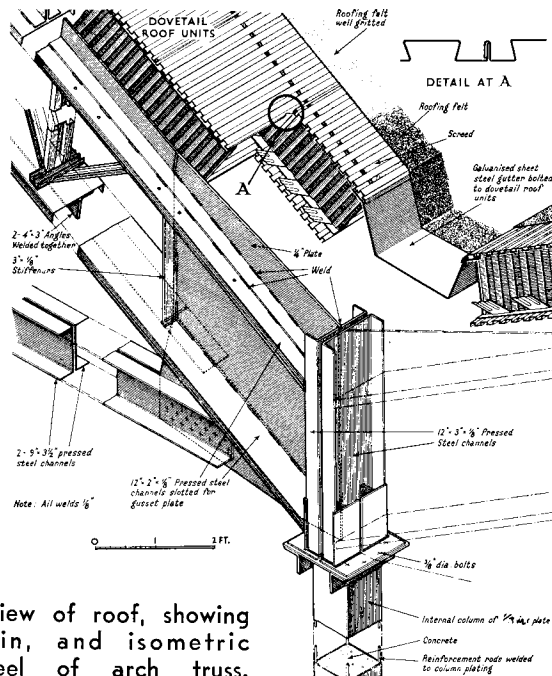
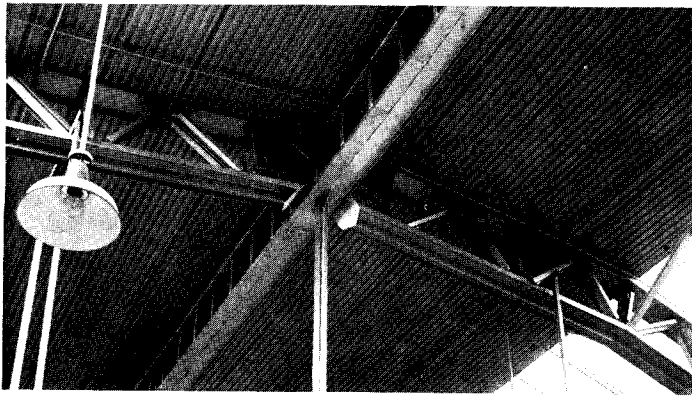


Fig. 7. View of roof, showing top purlin, and isometric detail, heel of arch truss.

THE FACTORY ROOF to be described in the next report was a veritable exhibition piece of *folding*. The roof units were folded and so were the supporting columns and trusses. The roof units were parallel "Lewis" sheets, corrugated into a series of dovetails and spaced 15 in. apart by diagonal braces of the same dovetail section, thus making up into continuous trusses in lengths of 30 ft. and in 2-ft. widths. The wall was of the same dovetail sheets but spaced 6 in. apart instead of 15 in. (Fig. 7). The supporting 3-hinged arches were made up of trusses whose top and bottom chords were a combination of channels and L's, both folded out of mild flat steel and welded together; the diagonals were of 16-gauge sheet again folded into a dovetail section. The columns were also folded.

The author, Engineer R. Sherman of London, declared that he rejected the usual rolled steel sections as being "unwieldy, unsuitable, and uneconomical." He proposed to substitute sections of  $\frac{1}{8}$ -in. thick mild steel plate, folded to shape as required, and then to use arcwelding both to build up the sections and to unite them into the finished structure.

The finish on the roof was 2 in. of concrete screed, one layer of bitumen felt, one layer of bitumen, and a top dress-

ing of pebble. The walls were finished with 1 in. of plaster internally and 2 in. externally.

The isometric view shows that this roof, though firm and highly insulated both for heat and sound, was not light in weight. Its dead weight was 35 lbs. per sq. ft., exclusive of arches, purlins, and other steelwork. "Although this is high compared to the usual roofing materials (e. g., corrugated iron or asbestos), the weight of the steelwork in the roof proved to be about 20% to 40% lighter than would have been required for a roof of asbestos or iron sheet supported by ordinary rolled steel members."

There was a corresponding reduction in cost. The engineer's calculations yielded him a percentage of saving in favor of the new design of 38.3% as against a similar dovetail roof of normal riveted design, or 38.4% as against even a light-weight corrugated steel or asbestos roof of normal design. Allowing for a turn in steel prices, he still felt that there would be a differential of 20% and 12%, respectively, in favor of welding.

In common with the other reporting engineers, Mr. Sherman found many contributory advantages in welding as it went along. The main one was that, folding his own sheets as required, he was able to use shapes such as flanges at their highest efficiency as compared to roofs made of rolled steel sections for which, "a design having been taken out, is often only possible to use a section much heavier than required, owing to the limitations of the section rolled."

A neat trick was the construction of internal columns kept down in weight and size by using concrete in a steel box. "The  $\frac{1}{8}$ -in. walls were considered as hoop reinforcement to the concrete, thus increasing the allowable concrete stress. The reinforcing bars (at the corners of the column) were tack-welded to the 8 by 8 in. angles, which were then welded together continuously along their edges."

The author concludes that the method of roofing could well be extended to still larger structures, eliminating tie bars, by replacing the 3-hinged arches with 2-hinged ones supported on columns designed to take bending stresses. Other types of roof support could also profitably be carried out in thin plate construction, for example N-trusses, Warren girders, French and other pitched trusses.

Advantages of welding folded sections, as claimed by Mr. Sherman, are as follows: (1) "Flexibility" of sections, "which is meant the ability to use sections which approximate closely to the theoretical minimum." (2.) On tension flanges, there are no reductions for rivet and bolt holes. (3.) On compression chords and flanges, greater width can be given to members without a large increase in weight, making it possible to use stresses nearer to the maximum allowable. (4.) On compression members generally, the metal in the section can be arranged so that the ratio of effective length to least radius of gyration is relatively low, so that decreased working stresses have to be considered less often. (5.) Less metal goes into scrap.

Whereas the engineer of the bridge pier previously described was able by welding to change an old material into a new form, that is, to convert rolled steel sections into a single, continuous, articulated structure, the engineer of the roof herein reported was able by virtue of welding to bring into use a new and cheaper material to begin with, namely mild plate steel.

## Fig. 5: Lightweight Welded Structural System Achieves New Insulation Values

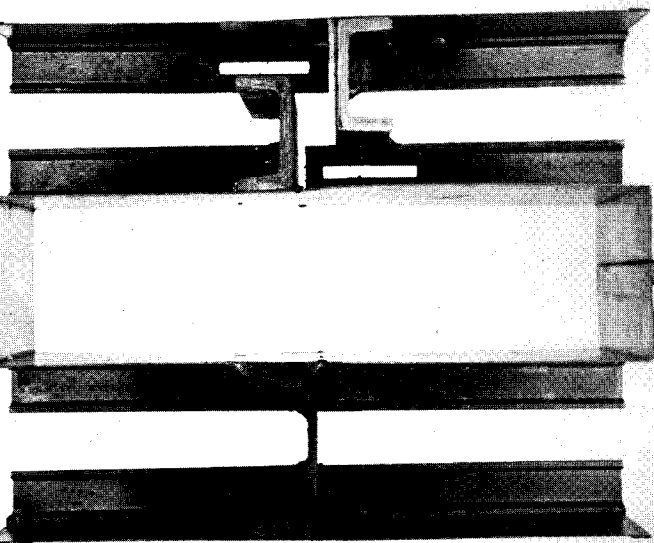


Fig. 8. Comparative cross-sections of McClintock insulated wall system (top) and standard system (bottom).

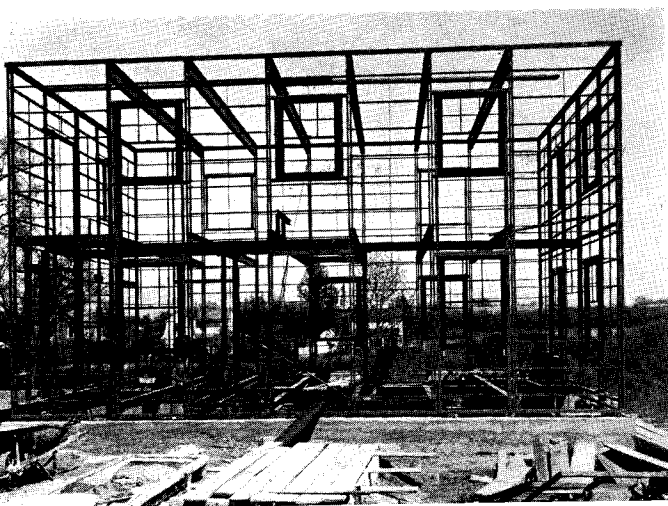


Fig. 9. Completed framing for two-story residence, made up of house-height shop-fabricated wall panels welded on site.

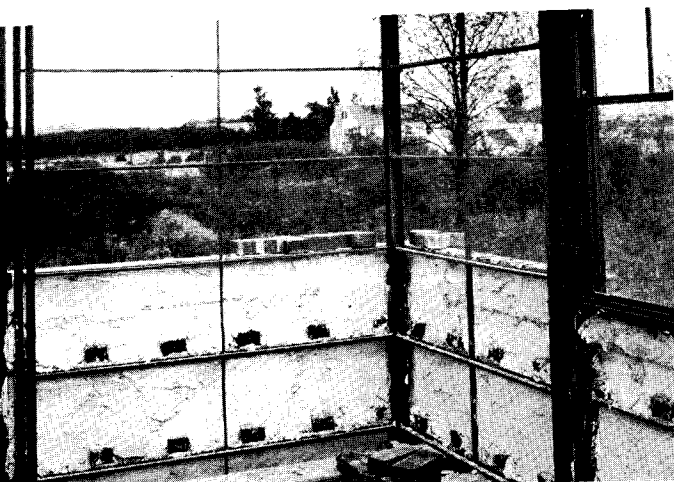


Fig. 10. Cross-girts are spaced for keying in with every sixth course of standard brick-veneer.

INVENTOR E. H. McCLINTOCK of Springfield, Mass., was not satisfied with existing structural systems; he was intent upon devising a light-weight, rigid, fireproof steel frame with a higher standard of insulation. Taking advantage of the opportunity that welding gives to attach steel members in contact with each other over a minimal area, he devised a light steel panel with "absolutely no through-planes of conductivity."

The panel consists essentially of a double set of horizontal members, one flush to the inside and one to the outside face of the wall, supported by an intermediate set of studs so staggered as not to carry through the whole thickness of the wall. The photograph of a cross-section (Fig. 8) clearly indicates how the through-planes are broken at the connections. The only contacts between the vertical studs and the double horizontal girts are between the crossed flanges; and even where such isolated contacts appear, the horizontal member is *slotted*, retarding conduction by breaking the through-plane.

Tests were made of insulated and uninsulated frames otherwise similar by attaching them (as shown in Fig. 8) to opposite sides of a tank in which was placed dry ice (temperature  $-38^{\circ}$  F.). In one hour condensation appeared at the bottom of the sheet lining on the uninsulated frame, and spread upward in parabolic form, continuing to show throughout the seven hours of the test. No condensation appeared at any time on the sheet attached to the insulated frame.

For residential construction, the panels are 4 ft. wide, full house-height, and only 3 in. in cross-section, weighing  $2\frac{1}{2}$  lbs. per sq. ft., so that one panel for the usual 2-story house weighs not over 200 lbs. The studs are staggered pairs of 1.78-lb. two-inch hot-rolled channels, and the double girts, spaced at  $15\frac{3}{4}$  in. vertical intervals, are .75-lb. one by seven-sixteenth-inch channels.

The  $15\frac{3}{4}$ -in. spacing of cross-girts—which incidentally provide wind-bracing—is adapted to keying in every sixth course of brick-veneer, if this is to be used as wall-facing (Fig. 10), and every fourth course in the "Ideal" method of using brick on edge; this spacing also adapts itself to wire lath, obviating the use of wood furring.

Such frames are said not to depend on the envelope, either during construction or afterwards, and need no temporary support; on the contrary the steel lends support to such types of covering as "Ideal" brick veneer, which are weak in themselves. Design is as free as design for wooden frames; but the method uses savings inherent in predominantly shop construction.

Computing the cost of a 4-in. brick wall at 37 cents a sq. ft. including furring, and the erected cost of his steel frame at 20 cents a sq. ft., he estimates the saving at over 15 cents per sq. ft. of wall.

Mr. McClintock's design can be covered with brick, stone, plaster or metal; it is not especially fitted for direct application of wood or composition sheets, the strong point of the design to follow.

# No. 6: Steel and Wood, Integrated in New System, Give New Flexibility

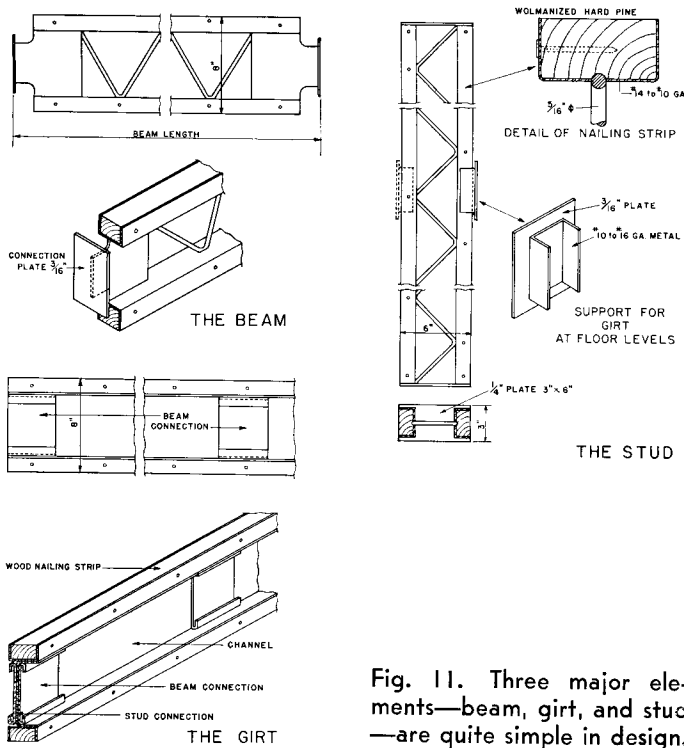


Fig. 11. Three major elements—beam, girt, and stud—are quite simple in design.

ARCHITECTS have had a standing quarrel with those inventors of new structural or insulating systems who have sought to stretch the good qualities of a single material to cover all the complex needs of a house. The first-prize winner in the Structural Houses classification was guilty of no such error. His contribution lay in a close and economical marriage of steel and wood: steel for fireproofing and support, wolmanized hard pine for the easy attachment of finish.

The outstanding merit of the design described by S. Fraser McIntosh of Insulated Steelbilt Structures, Inc., lies in its utter simplicity. The components are an open stud, a light nonbearing partition stud, an open beam, and a girt with handy connection plates. The drawings serve as a complete description (Fig. 11). After a trial of various methods, it was decided to employ arc welding; some of the operations could in fact be done only by arc welding.

Although adaptable to usual random methods of design, such a frame is most economically fabricated on a module planning basis. "By using a module system . . . shop detailing is eliminated almost entirely, since most of the required shop information is covered in listing by numbers. For example, 'B-12-8-16' is an order for 12 standard beams 8 in. deep for a 16-ft. room. The order for 2-standard girts 8 in. deep for a 14-ft. room was by this designation G-2-8-14. SS-40-6-9-9-9 ft. 6 in. is the order for 40 single studs 6 in. standard for a building with a first-story height of 9 ft., second story 9 ft., third story 9 ft. 6 in. Had the order read DS instead of SS it would have called for interior studs with double beam supports."

"No comparison between various steel frames can be made," asserts the author, "without considering what has to be done after the steel is erected to take care of enclosing materials and other things such as installation of door bucks, grounds for plastering, fastening for wood trim, and nailing strips for finish floors. . . . The frame described does not require temporary bracing, connections keeping the frame true and plumb. Also furnished as part of the frame proper are all necessary requirements for fastening windows, doors, flooring, plaster grounds, interior trim, and insulation."

Also appended to this paper is the most complete list of the advantages for the house and apartment builder of the general type of light construction in steel made possible by welding:

- (1) Nonshrinking structural members
- (2) Elimination of plaster cracks
- (3) Ease in fastening materials to the frame
- (4) Simplicity of design
- (5) Elimination of rot and vermin
- (6) Use of standard finishing materials
- (7) Simplification in the installation of heating, plumbing, and electrical equipment
- (8) Rapidity of construction
- (9) Adaptability to any architectural "style"
- (10) Transfer of work from field to shop
- (11) Simplified shop detailing
- (12) Low shop equipment cost

COMPARATIVE COSTS	
<b>COST OF OLD TYPE WALL, NO FIREPROOFING FEATURES</b>	
Face brick . . . . .	\$ .42 sq. ft.
Backup brick . . . . .	.58 " "
Waterproof coating . . . . .	.03 " "
Wooden wall furring . . . . .	.03 " "
Wire lath and plaster . . . . .	.13 " "
	\$1.19 " "
<b>COST OF NEW TYPE WALL, 3-HOUR RATING, FIREPROOF</b>	
Face brick . . . . .	\$ .42 sq. ft.
Waterproofing . . . . .	.02 " "
Wall ties, special . . . . .	.03 " "
Insulation, fireproof . . . . .	.12 " "
Steel . . . . .	.16 " "
Lath and plaster . . . . .	.13 " "
Reflective insulation . . . . .	.03 " "
	\$ .91 " "
<b>COST OF OLD TYPE FLOOR CONSTRUCTION, WOOD</b>	
Finish flooring . . . . .	\$ .16 sq. ft.
Sub-floor . . . . .	.06 " "
Wood floor beams . . . . .	.08 " "
Bridging . . . . .	.02 " "
Furring . . . . .	.03 " "
Wire lath and plaster . . . . .	.13 " "
	\$ .48 " "
<b>COST OF NEW TYPE FLOOR, FOUR-HOUR RATING</b>	
Finish flooring . . . . .	.16 sq. ft.
Sub-floor . . . . .	.06 " "
Fireproofing . . . . .	.14 " "
Steel . . . . .	.15 " "
Wire lath and plaster . . . . .	.13 " "
	\$ .64 " "

Fig. 12. Comparative cost data, part of the McIntosh paper, indicate economies and higher fire-resisting values.



## No. 7: Architect Uses Welding to Achieve Fire- and Verminproof House

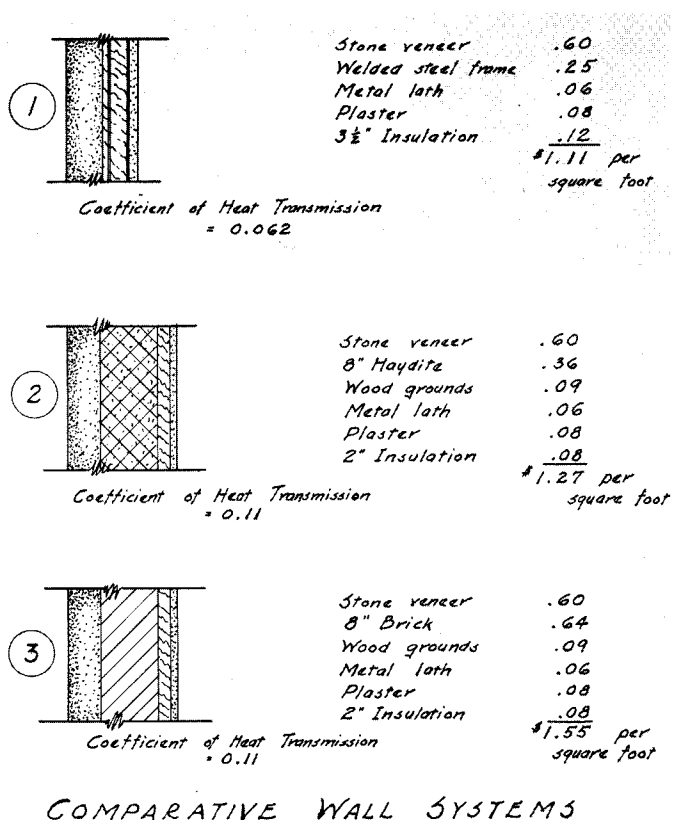


Fig. 13. Comparative data on three types of wall construction

"HEARTHSTONE" is an unusually large country house; each leg of the L has a length of over 100 ft. What chiefly concerned Architect Myron T. Hill was the remoteness of Hearthstone, set in the Ottawa Hills, from efficient fire protection. So he set up three highly fire-resistant types of wall construction, to calculate the relative cost. His results are expressed in the diagram:

Choosing the welded steel frame, the architect made no attempt at module design, steered clear for the sake of easy contracting from any patented type of erection. Essentially his frame was like the wooden "braced-frame" type. It was made up of large shop-welded panels of one-story height, using 3-in. channels as studs, all panels being held down to dimensions less than 10 by 18 ft. for trucks to haul; the largest weighed less than 500 lbs. The 45 tons of structural steel were erected by four structural iron workers and a foreman in ten working days, with the necessarily intermittent help of a field welder throughout the whole period. A plate was laid on the foundation, then first-floor beams and panels; then the whole first story was aligned and welded with the aid of gas-driven welder using coated electrodes and making ¼-in. fillet welds throughout. Field welds were held to a minimum, since their cost was found to be 3½ times the shop welding cost. The architect was pleased with his girt system for supporting second-floor beams, which left the full vertical spaces between studs free for continuous runs of pipe and ducts; he liked the low cost, and rested easy because his fireproof and verminproof structure would never shrink and crack the plaster.

## No. 8: Open-web Welded Frame Gives Flexibility in Duct Layouts

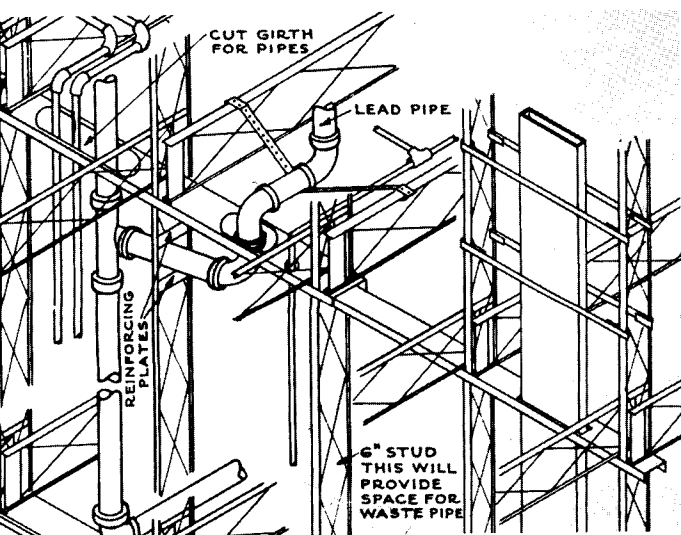


Fig. 14. Open framing permits flexibility in ductwork.

LIKE THE FRAME used by Myron Hill, that used by Architect Waldron Faulkner, for his own house, offered no important structural novelties. The layout was made—of course under the architect's supervision—by Bethlehem Steel, and employed open members for joists as well as studs. The chief added advantage of the light frame, procurable only by welding, was in relation to the air conditioning. It was possible to carry the whole complicated system of space-consuming ducts *through* the floor framing instead of destroying the spaciousness of the basement underneath. This was done by cutting through the bars of the open joists at the appropriate place, and welding in position a stiffening plate with an opening in the center fitted to the duct. Only welding would permit the use of this easy procedure. Plumbing pipes and electric cable also passed right through the frame in any direction, and could therefore be considerably shortened.

## 9. Summary



Fig. 15. A welded-frame apartment house recently completed in New York—first American city to amend its building code to permit welding.

ONLY TWO or three of the many classifications in the Lincoln Foundation's contest were of direct concern to the building designer; and, in the foregoing, we have already briefed the prize winning papers in these classifications. But taken together, the 328 papers in this competition have a wider—if less direct—significance for building production which cannot be ignored. They indicate rapidly rising standards in the field of industrial production which must inevitably affect building and the building designer. They represent every kind of industry and occupation, from all over the world. More important, *they are documented records of the direct personal experience of designers and fabricators in these varied fields.* The authors are aircraft, automotive, and boat designers; railroad equipment designers and railroad operators; they have designed tools and built them, acted as superintendents of machine production in a dozen industries, were foundrymen, metallurgists, structural engineers, and architects.

Adding the sum of evidence brought in by contestants the jury concluded that the general adoption of the methods proposed might be expected to save industry in general the sum of \$1,600,000,000 a year. Were even a part of this prediction to be realized, it would justify the \$200,000 outlay, and would also justify study of the conclusions by every professional concerned with production.

Even a cursory examination of the architectural and structural papers in the Lincoln Arc Welding Contest re-

veals the sweeping progress made since the time when architects first became aware of welding as an expedient against noise. Progress in this country has unfortunately been slower and less even than in Europe—due perhaps to anachronistic building codes, regulations, etc. Many of the prize-winners in the present contest were English, but their application to this country are obvious. In any event a rough tabulation of the different degrees of use to which welding can be put is possible:

### 1. Old methods expedited

The Sunnyvale Hangar was an example of welding, the "carpentry of steel" in use simply to tack pieces together to make punching more accurate and the riveting process quicker. The advantage was confined to a considerable reduction in cost.

### 2. Design refinement

Welded structures generally speaking have come to show a remarkable simplicity and cleanliness of profile, especially in large girders. A part of this refinement is due to the greater *flexibility* of the process: reinforcing strips are easily cut to special shapes as required and attached without difficulty in fairly tight places. A second element in the refinement lies in design *translation*, for example the translation in Sherman's roof from rolled sections into mild plate steel easily folded to precise requirements. The result was not only the employment of a cheaper material but the use of shapes such as flanges to higher efficiency. This brings us straight to the next stage.

### 3. Diversification of materials

Here we still stand only at the threshold of the possibilities. Arc welding is only one of three forms; resistance welding has already extended the welding field through the difficult field of stainless steel and into non-ferrous metals such as brass and aluminum. An important aspect of diversification is the *coupling of materials*, our example being the use made by MacIntosh in his light house-frame of steel in combination with wood, to make up a combination joist or beam with qualities not available in either material alone. The age of single-material worship is past. Diversity of materials permits wider choice in working to exact, predetermined standards.

### 4. Securing new qualities in the product

The result of several such welding developments working on one another has been the evolution of new qualities in the finished product. Thus the use of elasticity in the steel recreation pier eliminated shock and breakage by simple means. New qualities are introduced into the structure of the house when it becomes possible, as recounted by two of the contest architects, to pass pipes and air-conditioning ducts almost at liberty *through* the frame.

Full exploitation of new possibilities will occur only when there is free choice among all three types of welding for different parts of the same job. Stainless steel, for example, can as yet be handled satisfactorily only by resistance welding; yet its corrosion-resisting qualities, which have caused wide use in the food-container industry and

the railroad equipment industry, are important to shelter as well. Incidentally, welding control and accuracy have made the process an entirely different one than it was ten years ago; stainless steel welding time is held to  $\frac{1}{2}$  cycle, or  $\frac{1}{120}$ th second.

### 5. Radical redesign

Old habits of thought must be completely dropped if a new process is to be used with real efficiency in accordance with its own nature. Quite appropriately, the grand prize in the structural division went to a new type of floor and roof evolved entirely with reference to the properties of welded joints. This was Robertson and Pandya's "dia-grid" roof and floor system.

A few other innovations not mentioned in the contest papers under review are briefly listed:

**Rods:** Not in the contest, the Church in Culver City, California, reported in the last issue of the Architectural Record (page 60), is an example of a skeleton arc-welded out of  $\frac{1}{4}$ -inch to  $\frac{3}{4}$ -inch steel rods. It was virtually the erection of a reinforcing frame first, to be sprayed with concrete afterwards.

**Pipes:** Used in bicycles for over fifty years, but first thought of by many architects as merely decorative adjuncts, or as something inevitable in a heating system, are pipes. They now show themselves suitable as structural material not only for bus-seats and modish chairs but for scaffoldings and finally for buildings. Under appropriate conditions a tubular section has greater strength in relation to its weight than any other section. A striking tubular structure was a water conduit in Switzerland spanning an arch of 140 ft. with no intermediate support. Pipe framing has been used in industrial structures with a saving as high as 3 cents per cu. ft. of finished structure.

Steel tube construction is rapidly being developed in the airplane, automobile, and trailer field. The well-known "Scarab" car engineered by Stout Laboratories provided seating capacity beyond that of luxury cars with a tubular, chassis-less frame weighing approximately 25% less than the average standard of low-cost car construction. A tubular-frame bus, involved in a collision while travelling 60 miles an hour, cracked only its windshield and one windshield side-glass; on examination engineers imputed this to the shock-localizing properties of its frame. Pipe or tube framing is economical only when welded.

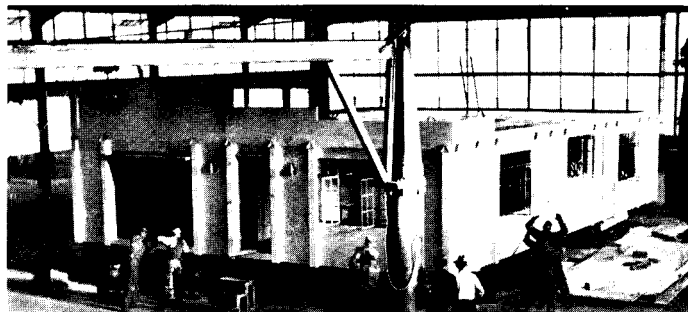
### 6. Erection methods simplified

Prominent in every efficiency endeavor is the effort to design for maximum production in the shop, minimum in the field. This is true even when modern flexibility carries the shop to the field, as welding jigs can be set up at the site. Not the least important innovation reported in the paper on "dia-grid" structures was the possibility of completing the whole structure on the ground under conditions approaching shop-work, and erecting it in a single operation.

The rapidly increasing scope and diversity of welding within the past ten years has brought the necessity of concentrated study. Within the last month Ohio State University has announced a new course leading to a degree in welding engineering; and other universities may be expected rapidly to follow suit.

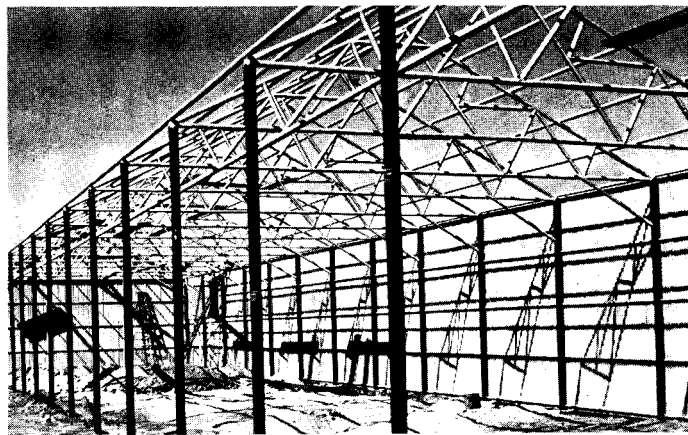


Fig. 16. One of a line of all-steel, shop-welded houses recently introduced in the South by United States Steel.



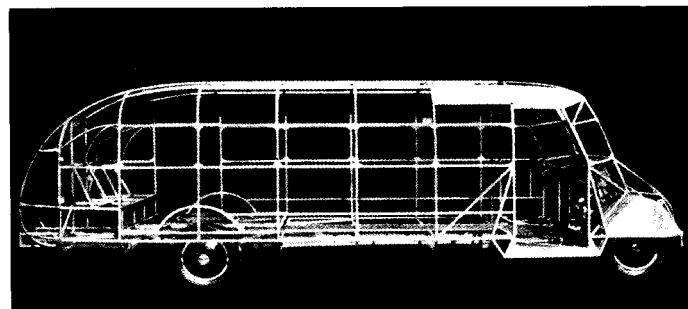
Courtesy Lincoln Electric Co.

Fig. 17. The now-famous Le Tourneau "floating house" was completely shop-fabricated, floated to its site.



Courtesy Linde Air Products Co.

Fig. 18. Welded steel tube construction in a warehouse in Denver, Colorado.



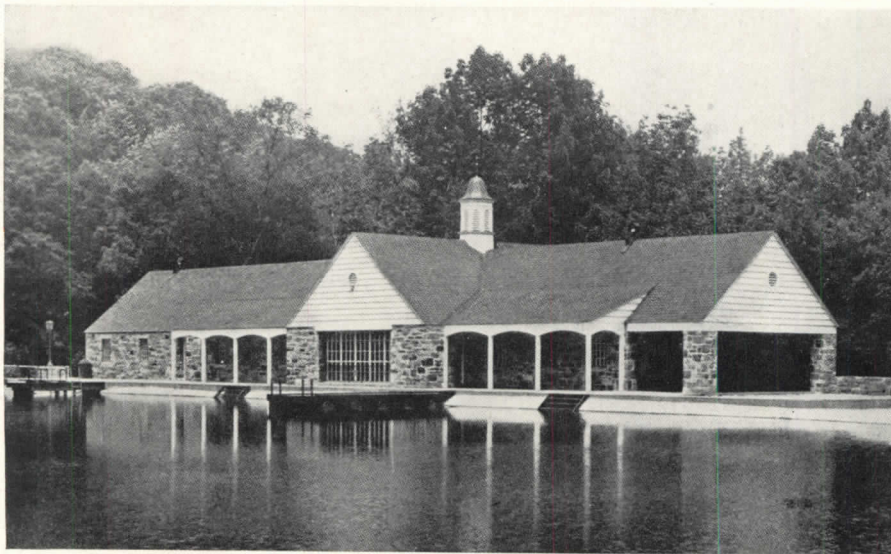
Courtesy "Product Engineering"

Fig. 19. Welded steel tube construction has reached its highest development in the automotive and aeronautics field.

# Review of New Books



"Free and rugged masonry and a vigorous log construction . . ."



"A bathhouse of sophisticated appearance in streamlined Colonial . . ."



"Commemorative of some circuitous route between the Congo and the Emerald Isle . . ."

## MAN IN THE WILDERNESS

THESE THREE volumes\* are a very valuable addition to park and recreation literature. The park and recreation movement has grown enormously in recent years, and here we have an expression of its widespread achievements. As a summary of policy trends and a directional pointer for many problems of function, the books are very good. But as an index of the American park designer's sense of form, they are very disappointing. Among the cute and the ingenious, the rustic and the picturesque, there are a few structures whose handling of material, relation to site, and general form conception, have true design distinction. But so much preoccupation with "precedent," such rustic inhibitions and inferiority complexes, are exasperating and stifling to one who considers things to come more important than things that have been.

In spite of rustic charm and backwoods handicraft handling of material, in spite of "organic integration"—which seems to mean a very obvious "growth" from natural rock outcrop to finished masonry—one is inclined to wonder whether a frank avowal of 20th century thought and technique might not have produced something equally delightful and equally organic. Only in extreme cases would lack of transportation and technical facilities, or availability of materials, make this completely impossible. Light, refined, carefully finished structures of wood, steel, concrete, set in the wilderness, might emphasize more effectively Man's inevitable return to Nature, than this very labored, rather clumsy, extremely inhibited rusticity. One is led to wonder what the ancient Greeks, with their painstakingly refined and elegant stone temples set among rocky wildernesses, could have produced if affected with this rustic inferiority complex.

In Europe, where precedent is piled high at every turn, designers produce startling innovations; in America, still

(Continued on page 81)

**\*PARK AND RECREATION STRUCTURES.** By Albert H. Good, Architectural Consultant, National Park Service. U. S. Government Printing Office, Washington, 1938. Illustrated. Three Volumes. 200, 212, and 192 pages respectively. 8¾ x 11¾ in. Price, 75¢ each.

# WINDOW TREATMENTS

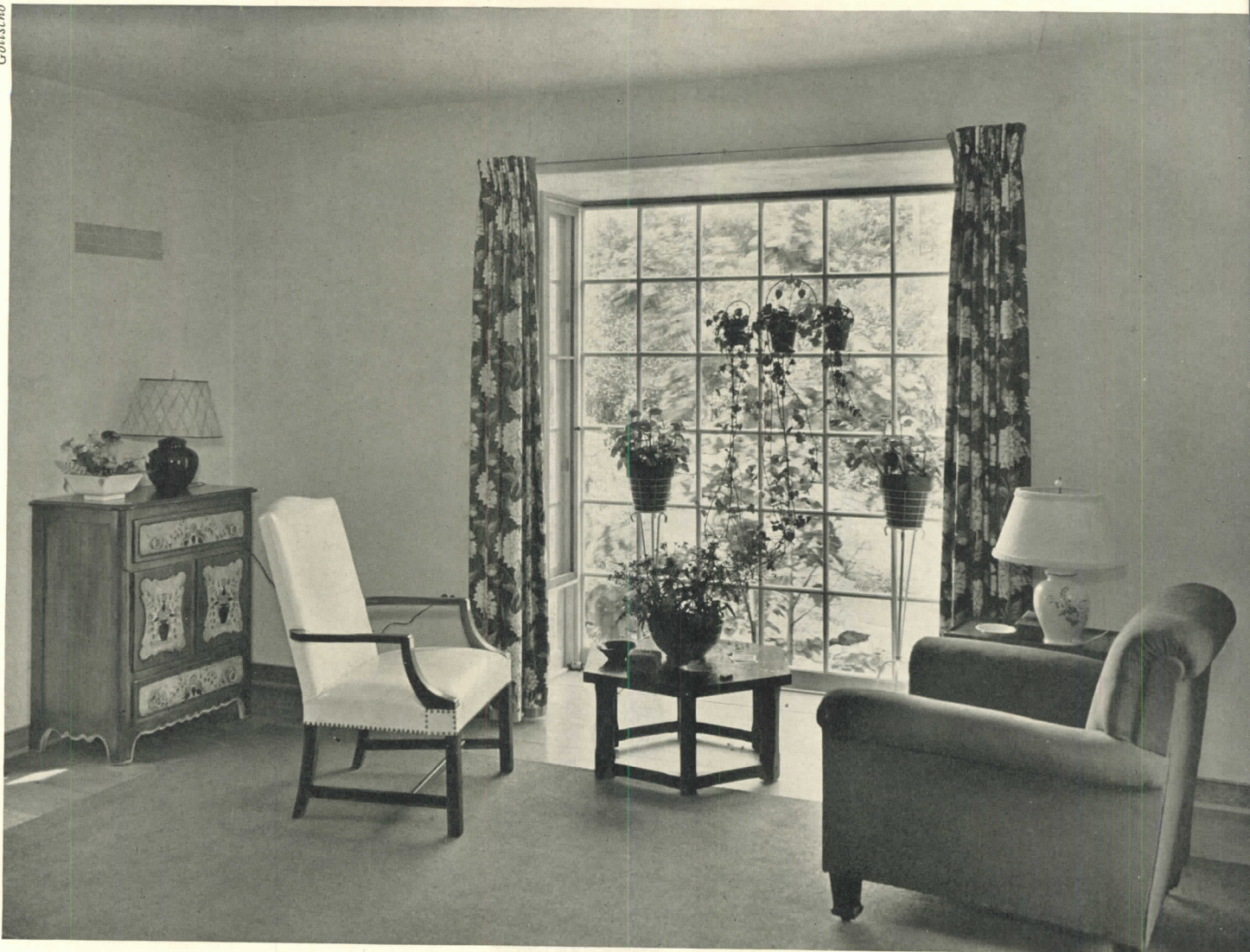


Gottschko

Residence in New York City, Mott B. Schmidt, architect

## WINDOWS... in the Living Room

Goettscho



1

Goettscho



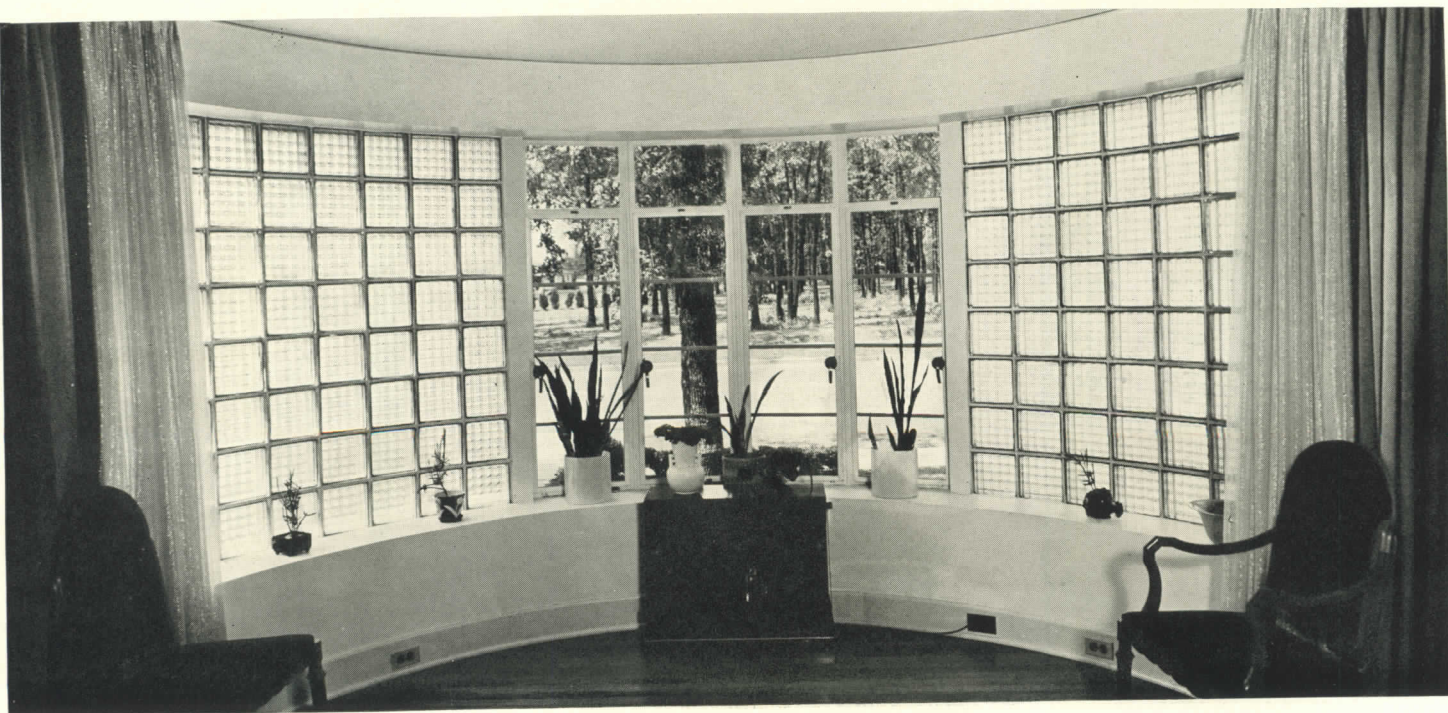
2

ON THIS PAGE: 1 treats a bay window both as light source and as conservatory: residence in Norwalk, Conn., Robertson Ward, architect. 2 is a rounded bay with window seats in a Palm Beach, Fla., residence, Treanor and Fatio, architects.

ON OPPOSITE PAGE: 3, a tall window with seat in a residence in South Miami, Fla., designed by Howard Knight, architect. 4 is in a New York City apartment, and combines cabinets and built-in seat over radiators with the window treatment; Joseph Mullen, designer. 5 uses glass brick for light and privacy, plate glass casements for ventilation in a residence at Tyler, Tex., Hobart Plunkett, architect.



4



5

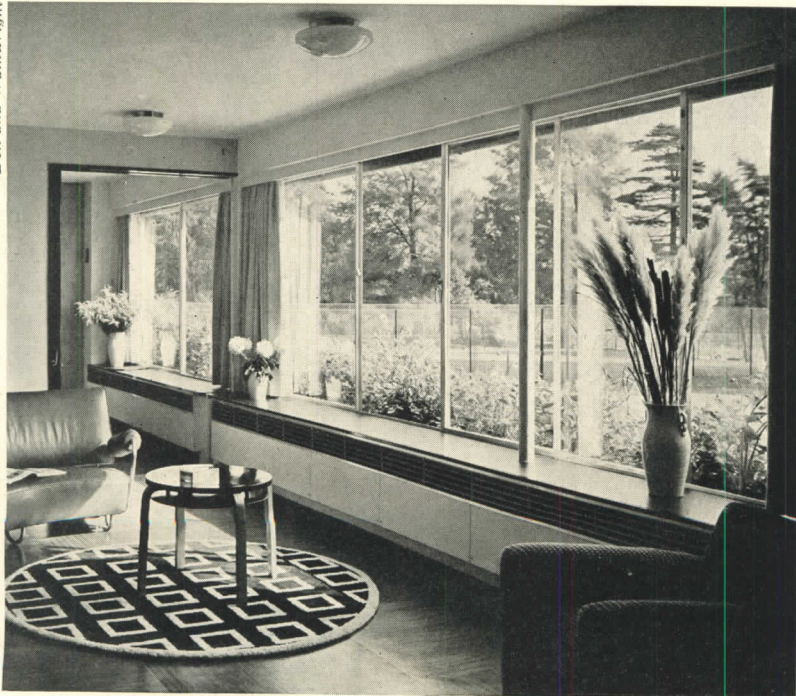
# WINDOWS ... in the Living Room

Gottsch



6

Dell and Wainwright



7

ON THIS PAGE: 6 shows treatment of living room window in a residence in Moncks Corners, S. C., Edward D. Stone, architect. In 7, sliding windows extend the length of the living-room wall in a house at Kingston, Surrey, England, E. Maxwell Fry, architect.

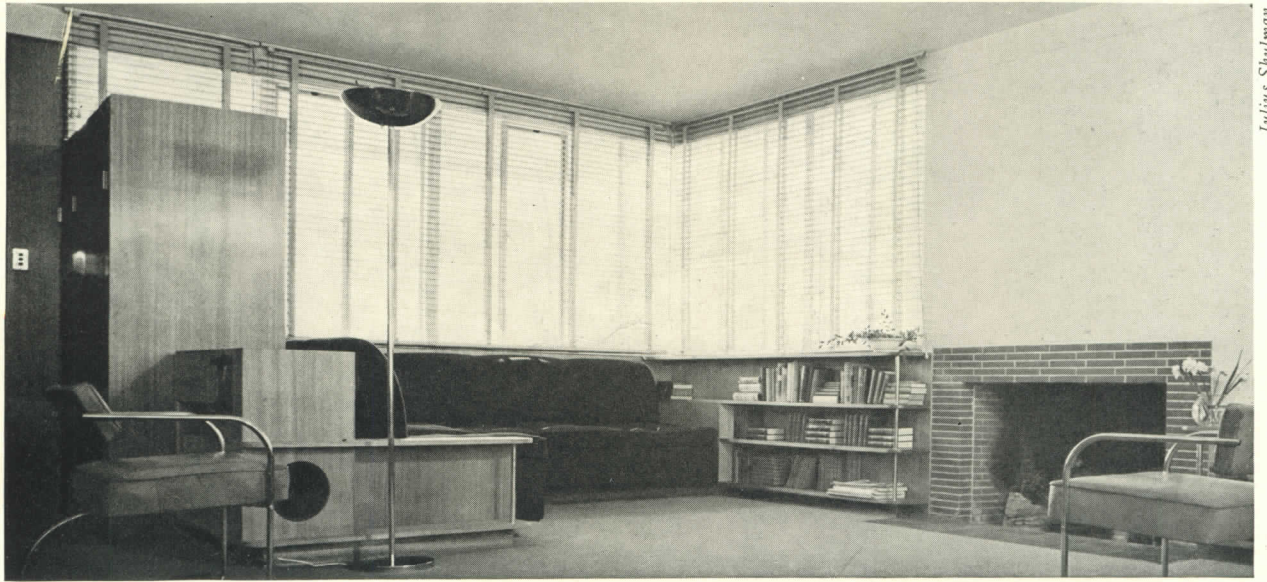
ON OPPOSITE PAGE: 8 features a built-in flower box in a residence at Brookline, Mass., Samuel Glaser, architect. 9, built-in book shelves are combined with the window treatment in a residence at Bakersfield, Cal., Richard J. Neutra, architect, and Peter Pfisterer, associate, and, 10, designed by Joseph Aronson for a residence at St. George, Staten Island, N. Y.





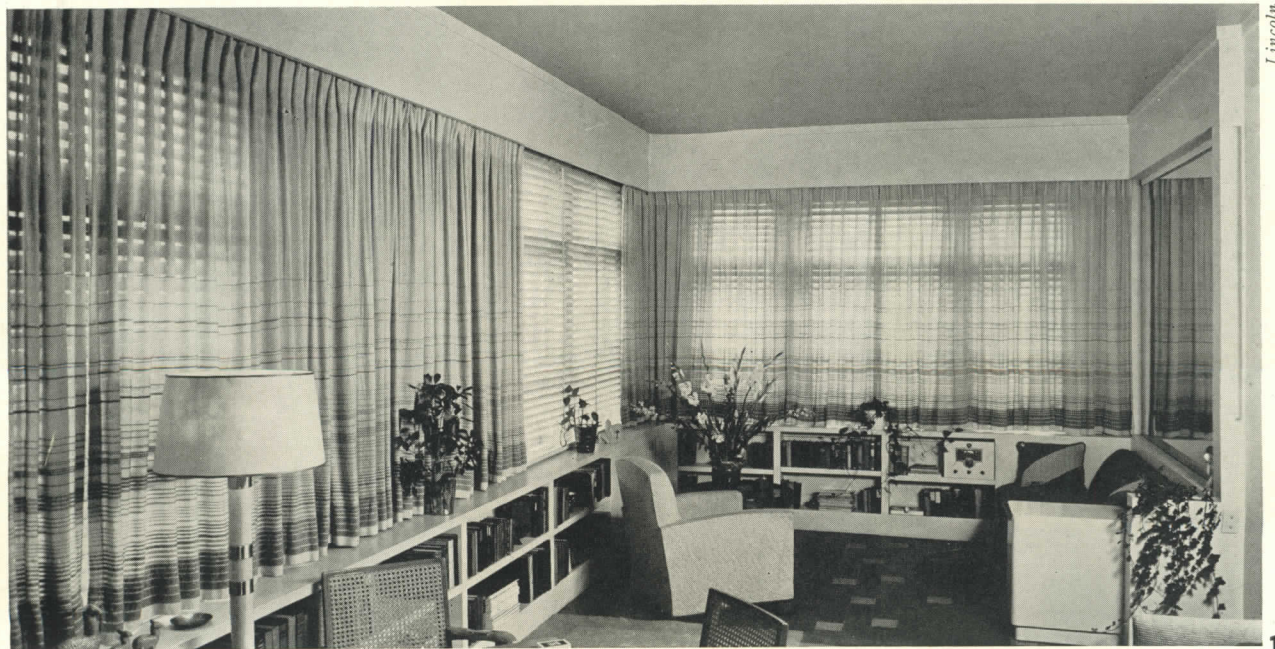
*Rollin W. Batley*

8



*Julius Shulman*

9



*Lincoln*

10

**WINDOWS . . . with built-in shelving**

Lincoln



11



Gottischo



14



... and in the Bedroom

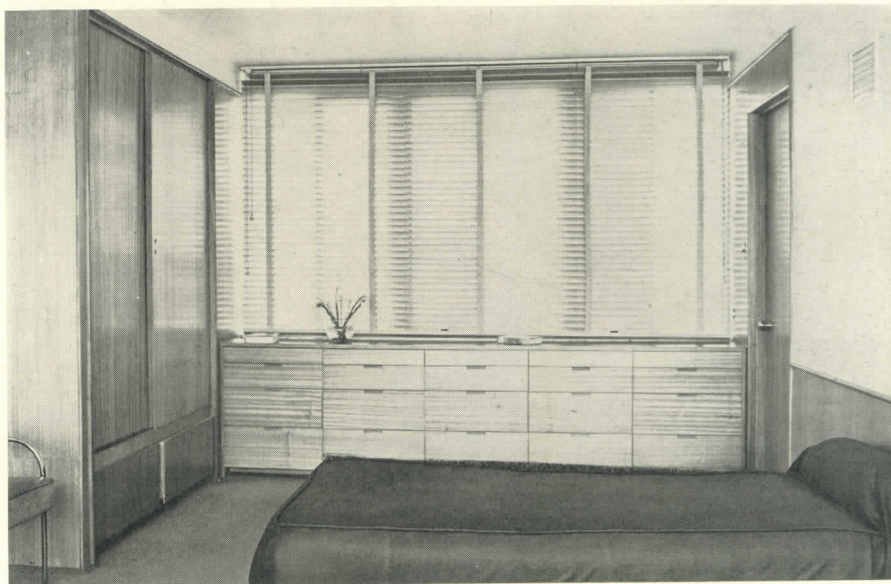


Mott Studios

17

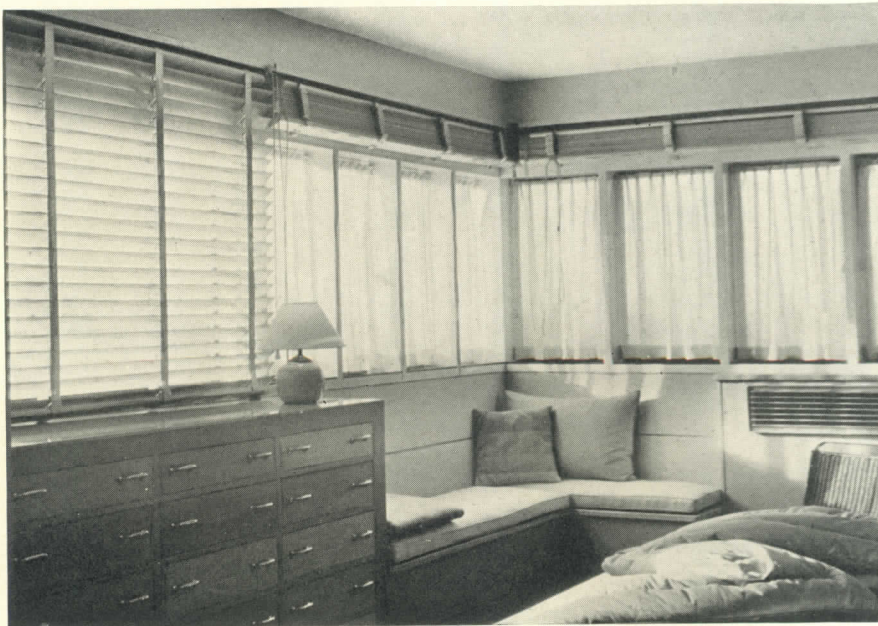
ON OPPOSITE PAGE: 11 is in a Brooklyn, N. Y., dwelling, Joseph Aronson, designer. 12 is in a residence at Westwood, Cal., Leo F. Bachman, architect. 13 combines book shelves and desk in a New Milford, Conn., residence for which H. P. Staats was architect. 14 was designed by Richard Henry Davis for a residence in Greenwich, Conn. 15 shows built-in shelving in the dining room of a Detroit, Mich., residence, Earl L. Conner, architect.

ON THIS PAGE: 16 is a dressing room designed by Pierre Dutell. In 17, closets flank the bedroom window in a residence at Palm Springs, Fla., Charles O. Matcham, architect. 18 is the bedroom of a residence in Bakersfield, Cal., Richard J. Neutra, architect, and Peter Pfisterer, associate. 20 was designed by Robert M. Brown for his Philadelphia home.



Julius Shulman

18



Lincoln

19

# WINDOWS ... in the Kitchen

Chicago Arch. Photo. Co.

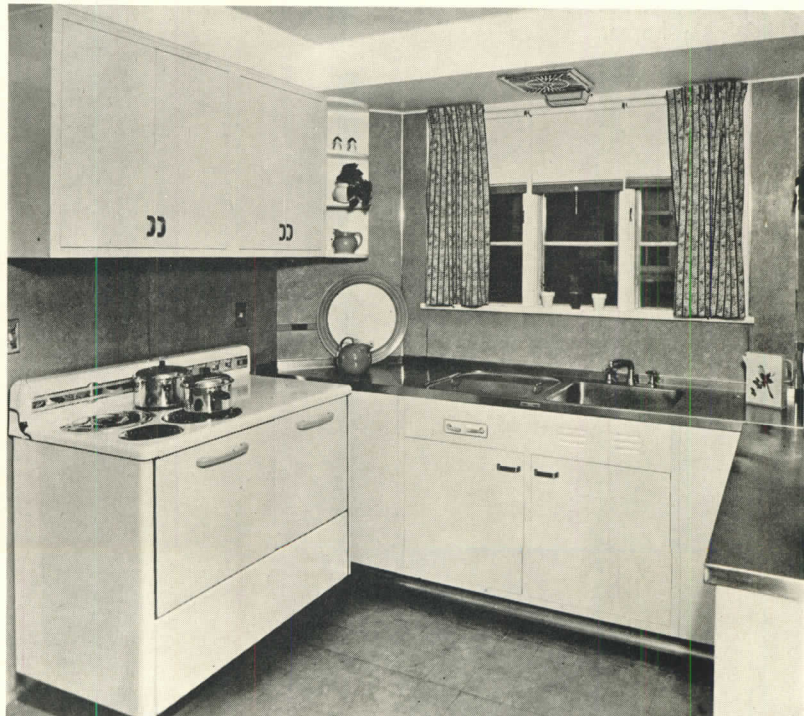


20

Shown here are "model" kitchen and breakfast room arrangements. 20 was designed by General Electric's Home Bureau for a model house in Chicago. 21 and 22 are Detroit versions by Ditchey-Farley-Perry, architects.



21



a relatively new country, one finds designers searching feverishly for precedent in the vast open spaces. One wonders again at the Greeks: how did they manage to do so well with only a few Egyptian temples behind them?

The thesis of the "natural" park designer—*Man Mars Nature*—is in reality a negation of our 20th century civilization. A nation can scarcely be considered civilized unless it lives in harmony with Nature, and this is impossible where there is a feeling of opposition between the two. The primary problem of park design is *Man plus Nature*, not *Man versus Nature*. Man is a part of the whole of nature, not something outside of it; he came from nature, and everything he produces comes from a natural source through the refinements evolved by his imagination. The park department endeavors to preserve Nature from Man, yet its basic aim is recreation—the re-creation of Man. Perhaps it is from this ambiguity of philosophy that the ambiguity of its work arises. Nature and Man are two parts of the whole: neither has meaning without the other. The question of opposition between them is an arbitrary issue.

Of course the basic difficulty is that because our cities suffer from a complete over-emphasis on building, we are forced to flee to the opposite extreme. This is a fundamental social derangement which cannot be corrected by any single governmental agency. The second supposition, that Nature is a better gardener than Man, is a completely romantic fallacy, but doubtless beyond the scope of this review.

The quality of the text deserves a word. In a publication of such potential dullness, it is indeed surprising to find the material presented with so much elegance and wit: all degrees of clarity and fogginess of thought alike receive a sugar-coating. Perhaps here we find the very core of the Beaux Arts principle—a good facade conceals any number of sins:

"This structure shelters a bromide spring." Vol. I, p. 121.

"For the pleasantly dishonest authenticity of this new-old blockhouse we are indebted to the salvaged timbers of a wrecked lake vessel." Vol. II, p. 109.

"Interpretation of the Indian tepee

in wooden architecture is the theme. . . By the ultra practical among camp planners, the windows will be held to be of insufficient size. To these, architects will willingly stand up in debate; larger windows would obscure the provenance of this interesting adaptation." Vol. III, p. 171.

"Here is a novel departure from the stereotyped T-shaped dining lodge plan. Substituting an octagon for the crossing of the T produces a structure of refreshing individuality. . ." Vol. III, p. 170.

GARRETT ECKBO.

**THE DESIGN OF NURSERY AND ELEMENTARY SCHOOLS.** H. Myles Wright and R. Gardner-Medwin. Architectural Press, London, 1938. Liberally illustrated, with bibliography and index. 120 pages. 9 x 12 $\frac{3}{4}$  in. Price, \$4.

ALTHOUGH COMPILED for British architects and drawing almost exclusively upon European experience, this book should nevertheless prove to be of great interest to American school designers. In the first place, the authors face a problem with which American school specialists are increasingly familiar—that of an educational system whose social responsibility is rapidly expanding in both size and complexity. And, flowing out of this fact, there is the further one that educational standards are not only in flux but are being constantly raised.

This trend the authors see as imposing new demands on the architect. He must have a more dynamic definition of education—"the process by which each child is helped to prepare itself for adult life." His schools must provide more facilities than hitherto, since "all but a trivial number of elementary school children have no opportunities for cultural and physical development outside those provided by their school." Finally, his schools must be flexible, subject to economical modification, alteration or demolition.

"It seems quite clear that the solid stereotyped buildings of fifty years ago are entirely out of place in this connection. The demand is for light buildings, with little of the classroom about them, arranged with a view to freedom and variety of use, to pos-

sible enlargement and even replacement in the not too far future."

The book is well-organized and well-documented. A general introduction interprets the policies of the (national) Board of Education and analyzes the structure of the British educational system. Each sub-type—nursery-infant, elementary, junior high—is then subjected to a standard analysis. A general summary and bibliography complete the study.

**STEEL CONSTRUCTION.** By Henry J. Burt; revised by C. H. Sandberg. American Technical Society, 1939. Illustrated with photographs and drawings. 437 pages. 5 $\frac{3}{4}$  x 8 $\frac{1}{2}$  in. Price, \$3.50.

A THOROUGHLY revised and enlarged edition of "Steel Construction" to bring it up to the present in steel construction practice; rearranged into chapter form for a more convenient use. Additional chapters have been written to cover present steel building design more completely.

The book deals with facts and formulas necessary for transforming proposed designs into tangible structures. All necessary data needed in designing the structural steel framework for buildings are conveyed to the student by illustrations of a practical nature which serve not only to teach the proper application, but to illustrate current practice in this form of construction. It is a book to be used as a text book by students and as a reference by designers.

**AIR CONDITIONING FOR COMFORT.** By Samuel R. Lewis. Keeney Publishing Co., Inc., Chicago. Third Edition, 1938. Diagrammatic explanations included. 285 pages. 6 x 9 in. Price, \$2.50.

THIS NEW edition of Lewis' well-known book on "Air Conditioning for Comfort" has been completely rewritten, revised, and enlarged and embodies the experience resulting from use of the two earlier editions in almost daily practice. It will be found valuable as a text for school and home study use, as well as a reference for contractor, engineer, architect, and owner or prospective owner of an air-conditioning system. The author is recognized as an authority on the subject.

(Continued on page 122)

# Current Trends of Building Costs

Compiled by Clyde Shute, Manager, Statistical and Research Division, F. W. Dodge Corporation, from data collected by E. H. Boeckh & Associates, Inc.

CURVES INDICATE control trends in the combined material and labor costs in the field of residential frame construction, the monthly curves being an extension of the local cost averages during the years 1935, 1936, and 1937. The base line, 100, represents the U. S. average for 1926-1929.

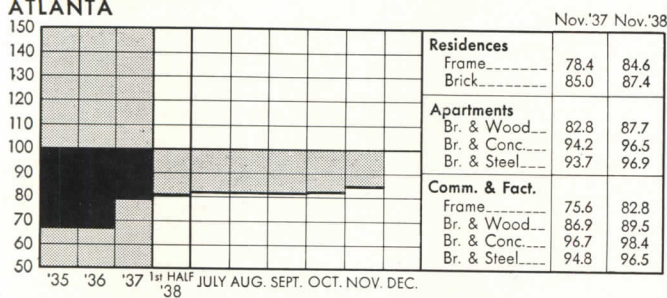
Tabular information gives cost index numbers relative to the 100 base for nine common classes of construction, thus showing relative differences as to construction types for this year and last.

Cost comparisons or percentages involving two localities can easily be

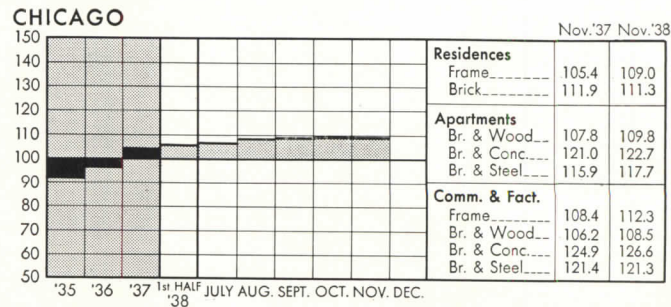
found by dividing one of the index numbers into the difference between the two. For example: if index A is 110 and index B, 95,  $(110-95) \div 95 = .16$ . Thus costs in A are 16% higher than in B. Also costs in B are approximately 14% lower than in A:  $(110-95) \div 110 = .14$ .

## CONSTRUCTION COST INDEX U. S. average, including materials and labor, for 1926-1929 equals 100.

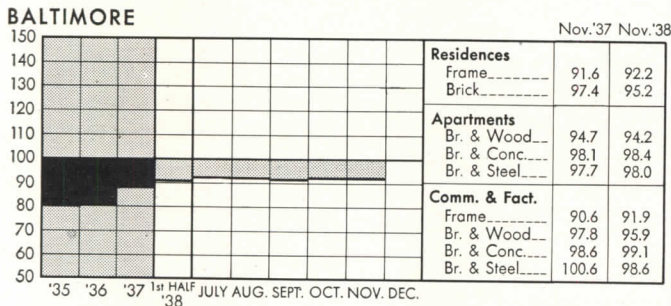
### ATLANTA



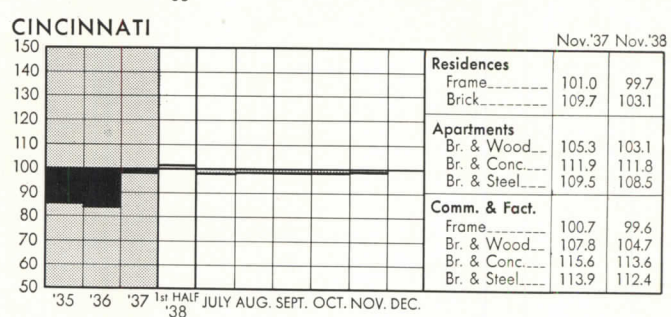
### CHICAGO



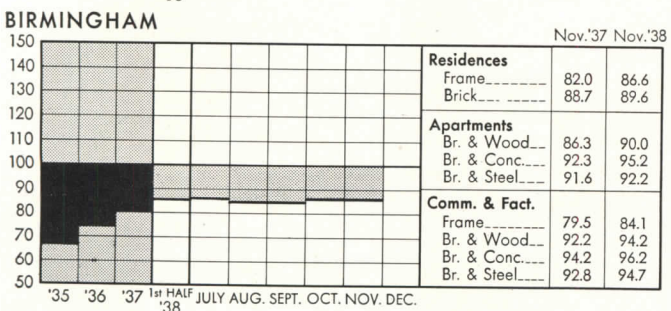
### BALTIMORE



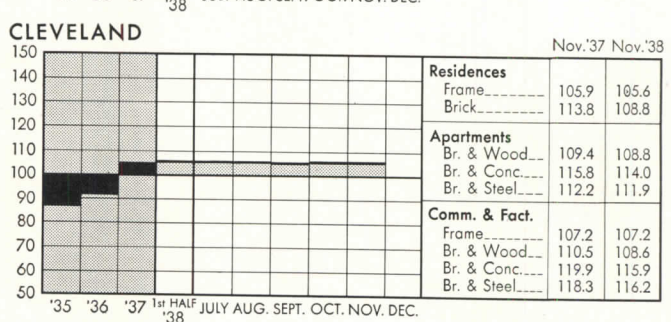
### CINCINNATI



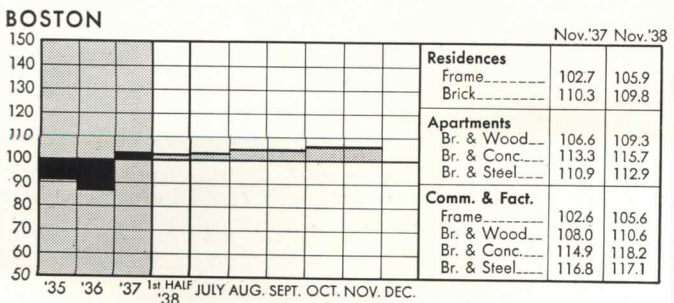
### BIRMINGHAM



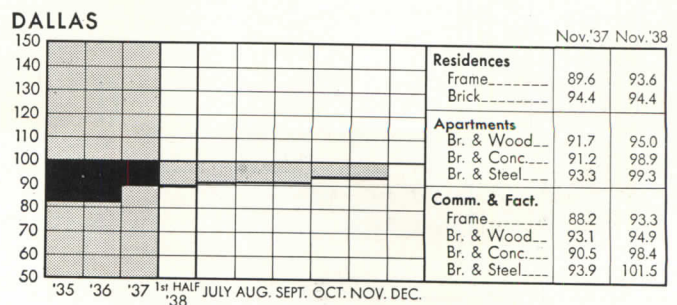
### CLEVELAND

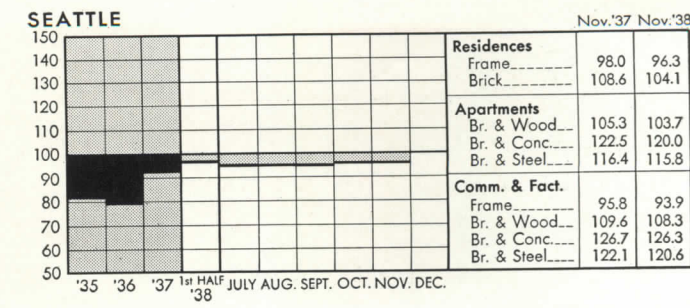
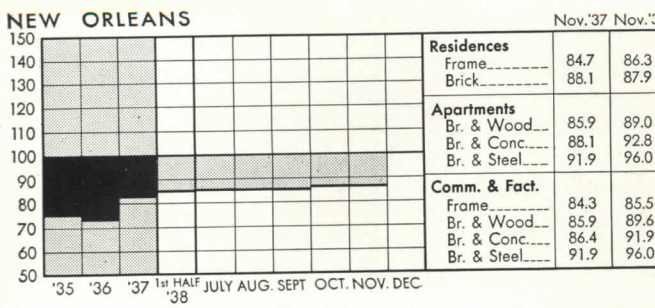
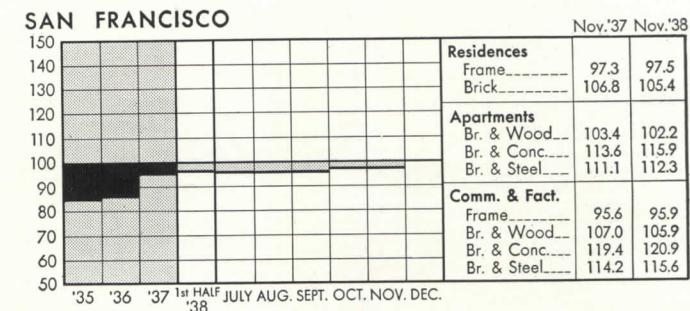
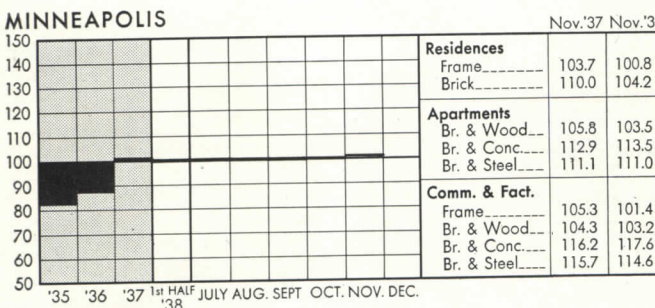
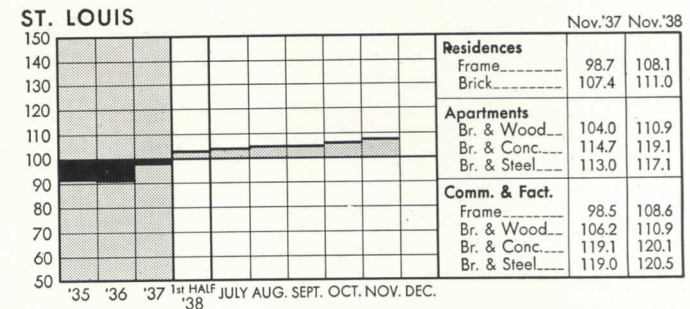
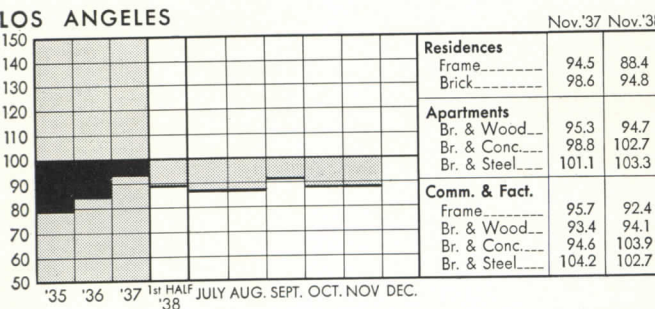
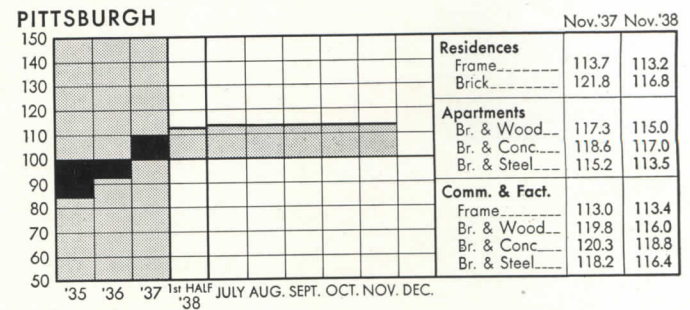
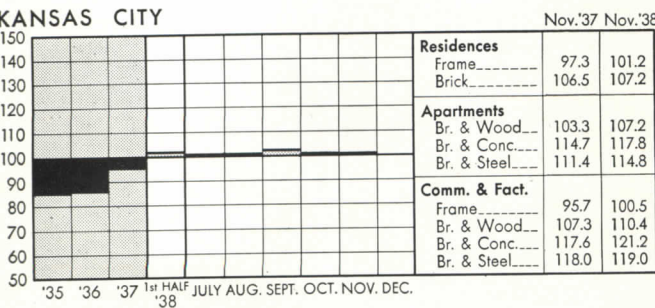
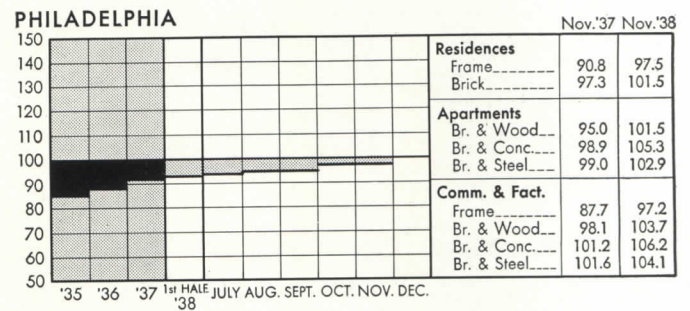
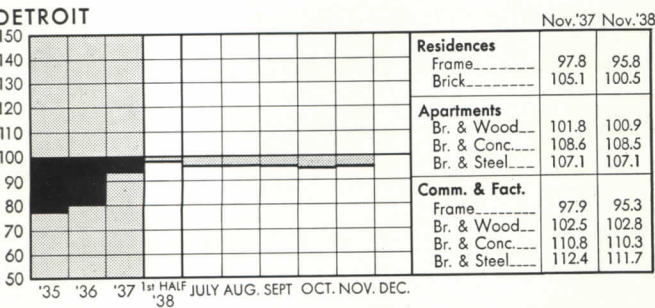
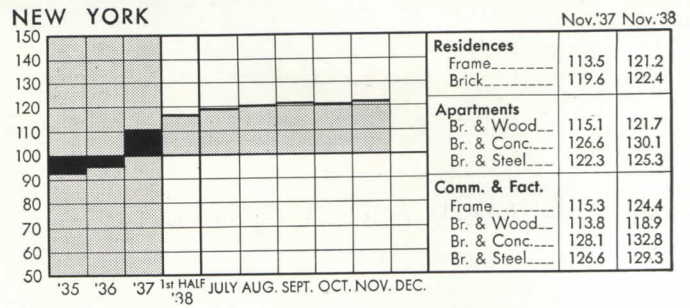
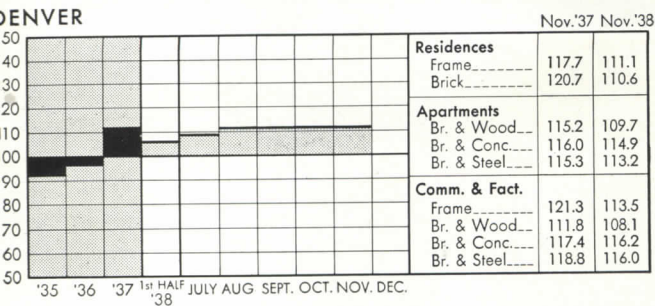


### BOSTON



### DALLAS





# An Air Conditioned School.

WITH A COMPLETE  
**MINNEAPOLIS-HONEYWELL**  
PNEUMATIC CONTROL SYSTEM

*T*HE first unit of the new Municipal University of Omaha is one of America's first air conditioned schools. In every respect, this new building represents the last word in school design and construction. It is, therefore, significant that both the winter heating cycle and the summer cooling cycle are completely controlled by a Minneapolis-Honeywell Pneumatic Control System. Each Minneapolis-Honeywell Control System is engineered for its individual installation. Only Minneapolis-Honeywell offers a complete line of controls—Pneumatic, Electric or a combination of both. M-H Engineers can therefore give you unbiased advice in the selection of a control system for your school building. Minneapolis-Honeywell Regulator Co., 2804 Fourth Avenue South, Minneapolis, Minnesota. Branches everywhere.

The First Unit of the New  
Municipal University of  
Omaha . . . Architects:  
John Latenser & Sons,  
Inc., Omaha, Nebraska



**MINNEAPOLIS-HONEYWELL**

BROWN INDUSTRIAL INSTRUMENTS

NATIONAL PNEUMATIC CONTROLS

*Control Systems*





# BUILDING TYPES



**OFFICE BUILDINGS**

**FORTHCOMING STUDIES:** Restaurants — January; Schools — February.  
**PRECEDING 1938 STUDIES:** Houses (\$25,000 and Up) — November; Houses (\$15,000-\$25,000) — October; Apartments — September; Hospitals — August; Theatres — July; Factories — June; Schools — May; Houses (\$7,500-\$15,000) — April; Houses (\$7,500 and Under) — March; Retail Stores — February; Hotels — January.

ARCHITECTURAL  
RECORD

CONDUCTED WITH  
AMERICAN ARCHITECT AND ARCHITECTURE

# Design Reference on Office Buildings

**MATERIAL IN THIS REFERENCE STUDY** has been compiled from a variety of sources toward the end of reporting certain standards of good practice in office building design. The subjects treated represent those phases of design which are most generally subject to a variety of solutions because of differences of technical opinion, rapid changes in the means of construction and equipment, or the force of local conditions and technical custom. Limitation of subject matter was, therefore, a self-explained necessity.

In each case an effort has been made to report performance standards in each field covered—the objective being the compilation of facts to which designers might refer in developing a specification for individual design conditions. To this end, each section of this study represents editorial research beyond the personal opinion of a single individual. From six to twelve or more individuals—each a specialist in his particular field—contributed information based on his technical experience. Statements of individuals were analyzed, edited to eliminate duplication and developed in their present form by technical members of the Record's editorial staff.

As presented, each section lists—where possible to do so—performance standards that represent the median, or the average, of currently accepted practice according to statements of the specialists who were consulted. Variations above or below this average—which might be called a basic performance value—are reflected in individual reports as published. Some represent the opinion of individuals or of groups; others indicate the force of locality or custom. All statements that relate to performance standards were either deduced or derived directly from an able body of technical opinion. Therefore readers are particularly cautioned not to regard this reference material as either blanket or specific recommendations on the part of the Record's editorial staff.

**THE OBJECTIVE** of any research activity is—or should be—confined to a compilation of facts. Conclusions touching on any phase of a subject cannot properly be made until facts on that subject are at hand and its condition thus exposed. So far as this Building Types Reference Study has involved collection of factual information of many sorts, it constitutes a research activity. And from it two conclusions can be drawn.

The more obvious is the startling lack of standardization in the design—planning, construction, and equipment—of structures to house highly standardized activities. Functions of office buildings are generally similar throughout the country. But provisions for these functions appear to be largely the result of designing whims, commercial fancies or the arbitrary imposition of technical experience simply because of habit or customs.

The second conclusion is the more basic in that it furnishes a reason for the wide variations that exist in the fields of technical opinion and practices. There exists an amazing scarcity of scientific data regarding the environmental needs of people who tenant office buildings. Merely as a consumer of rentable space, an office worker's physical and psychological requirements have received scant attention. As a human organism he has been all but ignored. The deduction seems inescapable that science must furnish, through research, more explicit standards of environment based upon human actions and reactions before office building design can show marked improvement from current policies and practices.

## ALPHABETICAL INDEX

TIME-SAVER STANDARDS DATA	
Acoustics .....	94
Air Conditioning—	
Performance standards.....	92
Color .....	98
Lighting—	
Characteristics .....	96
Equipment, location, and types.....	97
Methods .....	95
Planning .....	87
Clearances (furniture).....	90
Layout	
(bays, columns, corridors, windows)	88
GENERAL DESIGN INFORMATION	
Design Elements Affecting Rentability. A report of maintenance and management recommendations, developed by the Editors of "Real Estate Record"...	99
ILLUSTRATED CASE STUDIES	
Air Line's Headquarters—	
United Air Lines Transport Corp., Chicago.....	110
General Purpose Office Building—	
Associated Press Building, Rockefeller Center, N. Y.....	103
Home Office Building—	
Liberty Mutual Insurance Co., Boston..	106
One-Story Offices Around a Patio—	
O. C. Field Gasoline Corp., Los Angeles.	114
Plant Administration Offices—	
Standard Register Co., Dayton, Ohio..	116
Statistical Research Organization—	
Offices for A. C. Nielsen Co., Chicago..	112



## Planning, Layout, and Clearances

IN PLANNING a commercial office building, whose success is measured in dollars and cents, the designer must analyze the site, the type of plan and structure proposed, proportions of rentable public and service areas, and code or other restrictions, so that the owner may have an understandable approximation of building costs and potential returns. These analyses are equally applicable (1) to offices for multiple tenancy and (2) to those for single company tenancy. While the following data is related principally to multiple-tenancy buildings, much of it is equally valuable in planning single-tenant structures. Considerable variation as to common practice prevents setting rigid "standards." Data presented should be regarded as a report of current trends from which a basis can be evolved for solving a particular problem.

Site coverage, according to opinions surveyed\*, is almost always 100% for lowest stories; above the first floor or floors coverage is determined by the availability of light and air for rentable spaces; by code restrictions (based generally on the same factors); and by the economic relation, based on studies and analyses, between building costs and potential income from rentable area. Building height varies similarly with land values, code restrictions, and the building-cost-to-rent-

able-area relationship, the latter modified by the potential demand for office space.

### Location and proportioning of areas

In general, according to the architectural department of Rockefeller Center, Inc., building service areas should be as close to the center lines of the building as possible. Basements usually contain the principal items of equipment: heating, ventilating, fan, electrical. Roofs may be used for air-conditioning and exhaust equipment, water storage and pressure tanks. At intermediate levels in buildings of more than 15 stories, auxiliary pumps and heaters are usually required at 15-floor intervals (Rock. Center, Inc.).

Building entrances, the consensus of opinion seems to be, should be so located that they are in the average pedestrian's instinctive line of approach. If more than one building entrance is considered, its value should be weighed against income from the displaced rentable area. W. H. Tusler gives the following figures for approximating first floor area proportions: Lobbies, stairs, foyers, 12%; rentable, 88%.

On typical rental floors, average recommendations are: Service, 31.6% (low, 15 to 25%; high, 40-50%); rentable, 68.4% (low, 50%; high, 85%). Rockefeller Center's architec-

tural department states that building perimeter multiplied by 1.5 produces the net wall area to be deducted from gross area, and that column area is included in computing rentable area. (See also "Design Elements Affecting Rentability," page 99).

### Toilets

Two opinions consulted advised, for men, 1 toilet per 5000 sq. ft., 1 urinal per 10,000 sq. ft. (rentable area). The recommendations for women were, 1 toilet per 1000 to 10,000 sq. ft.—a range which cannot be averaged. Building managers (page 99) recommend, for men, 10 toilets, 4 urinals, and 2 lavatories per 30,000 sq. ft.; for women, 9 toilets, 2 lavatories per 30,000 sq. ft. Rockefeller Center supplies 1 toilet for every 10 or 15 persons; executive areas require the smaller ratio. Slop sinks, according to E. E. Probst, of Graham, Anderson, Probst and White, should average 1 per 7500 sq. ft. (rentable area). Consult sanitary and labor codes also.

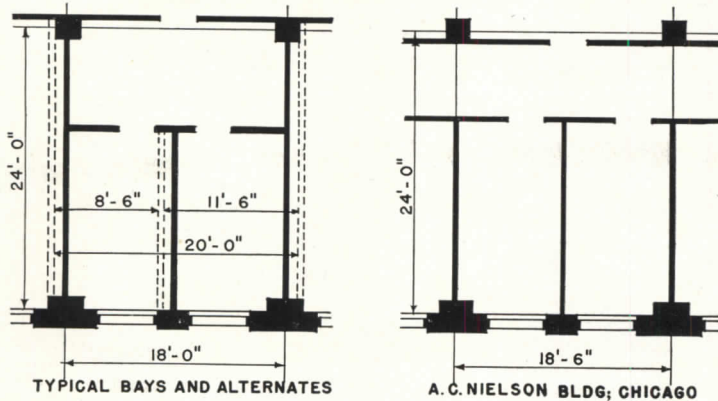
Information on office building layouts, bays, courts, corridors, etc., is given in the following four pages.

\*The Editors wish to acknowledge the assistance of the following in preparing the above information: Earl H. Lundin (Architectural Dept., Rockefeller Center, Inc.); Edward E. Probst (Graham, Anderson, Probst & White, Architects); W. H. Tusler (Magney, Tusler and Setter, Architects); J. D. Sandham (Kimball, Steele and Sandham, Architects).

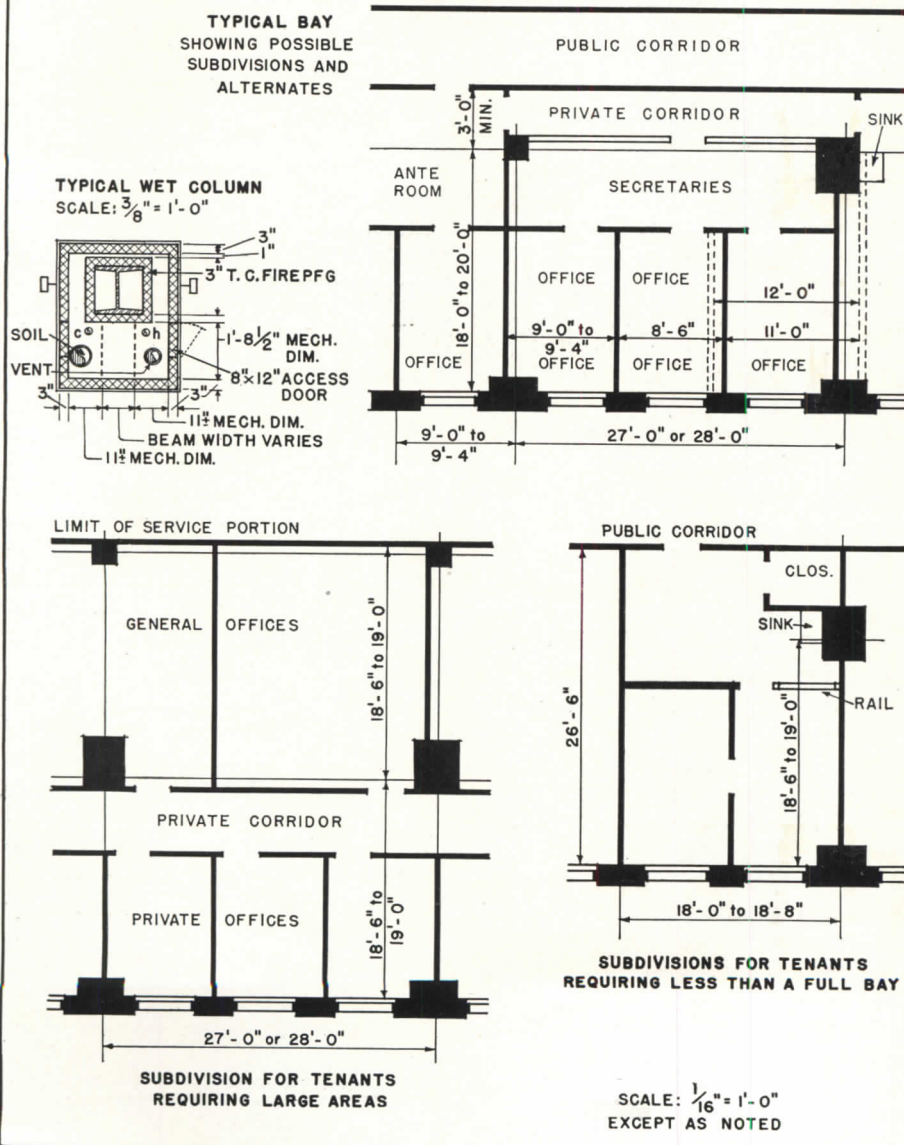
# LAYOUT

## Bays, Courts, Heights, Fenestration, Corridors

### AVERAGE BAYS based on COMMON PRACTICE



### ROCKEFELLER CENTER STANDARDS



The accompanying drawings have been developed from data on common practice as to bay sizes, modified by recommendations made by building managers as reported in another portion of this study. Data should not be considered mandatory standards; all should be studied in relation to the particular problem at hand. Local codes, costs, type of occupancy, and similar factors should govern.

#### Typical bays

Bay width termed "ideal" by Rockefeller Center, Inc., is approximately 50% larger than the average of common practice, thus eliminating 1 column in every 3 on the building's perimeter.

Bay depth, from center of outer columns to face of public corridor, averages 25 ft. to 25 ft. 6 in. on street frontages, with one consultant recommending 20 ft. depth for court or alley frontage. Rockefeller Center practice places interior columns far enough from corridor walls to permit of a private corridor between, serving suites of offices; and sets maximum rental area depth at 30 ft.

"Wet" columns, carrying hot and cold water, soil and vent stacks, are so placed in Rockefeller Center buildings that every tenant may have a lavatory within his office; in some cases, complete bathrooms are installed. Generally speaking, every alternate column is "wet."

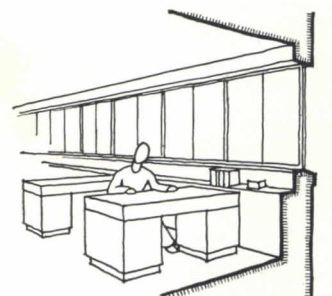
#### Courts

Shallow courts seem to be more generally desirable than deep ones, courts one-half as deep as they are wide being preferred. Layouts of good rentable area, considered in conjunction with code requirements as to corridor length in relation to fire stairs, elevators, etc., govern court sizes and disposition. Their prime purpose is to assure permanently good light and air to all stories.

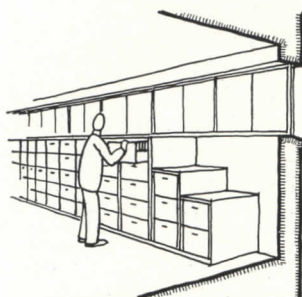
#### Floor heights

Average floor heights are as follows: First story, no mezzanine, 18 ft. to 21 ft. Loft floors, average 12 ft. floor to floor; general office floors,

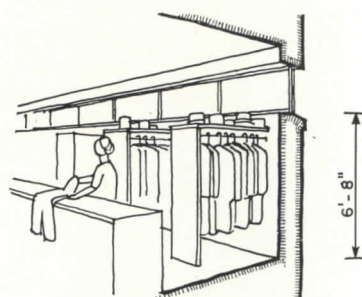
WINDOW SILL HEIGHTS, DETERMINED BY FURNITURE AND EQUIPMENT HEIGHTS



DESK, PLUS BOOK SHELF  
(POSSIBLY CONCEALED RADIATION)

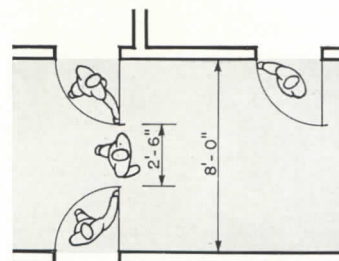
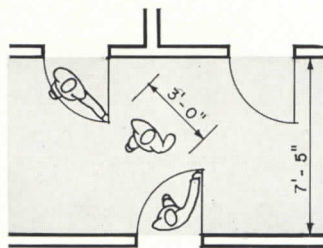
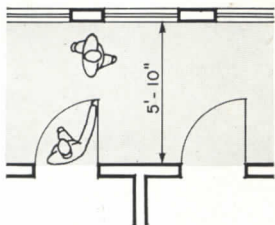
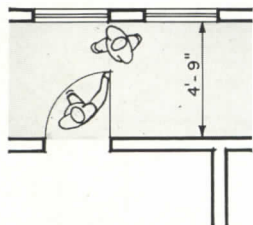
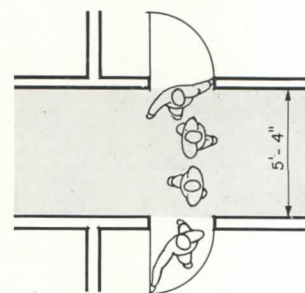
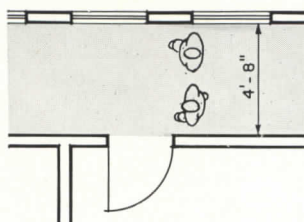
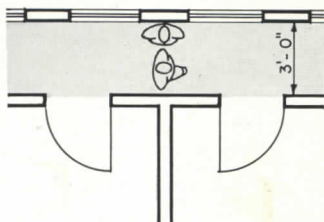


FILES, VARYING HEIGHTS  
CORRESPONDING TO STANDARD  
FILE DIMENSIONS



CLOAK ROOM, HANGING  
ROD PLUS HAT SHELF

CORRIDORS,  
MINIMUM CLEARANCE  
BASED ON HUMAN  
FIGURE DIMENSIONS



SCALE FOR ALL DRAWINGS  $\frac{1}{8}'' = 1'-0''$

9 ft. 6 in. to 11 ft. 6 in., 9-ft. clear height being the minimum recommended. Interior doors are usually 7 ft. high; door plus transom, 8 ft. 6 in.

Penetration

Great variation exists in window size and area recommendations. Individual window width apparently varies from 4 ft. to 5 ft. 3 in.; height, from 6 ft. 6 in. to 8 ft. Height is most often controlled by floor to floor height, one recommendation being that window heads be within 6 in. of the underside of the spandrel beam, another that heads be 2 ft. 6 in. from the finish floor above. Sill heights are relatively standardized at approximately 2

ft. 6 in., although some are as high as 3 ft. The accompanying sketches illustrate methods of determining sill heights in special cases where furniture or equipment can govern.

Window area recommendations range from 10% of rentable floor area to 50% of the building's perimeter. "Light shafts" are not normally recommended.

Corridors and lobbies

Elevator lobbies serving 4 cars are considered satisfactory if 6 ft. wide, according to one opinion; others state that lobbies with elevators on 1 side should be 9 ft. wide; with cars on 2 sides 11 or 12 ft. wide. In Rockefeller

Center, 10-ft. width is standard. In general the desirable maximum length of an elevator bank is 6 cars.

Corridors on typical floors show the same variation. The average, outside New York, seems to be 6 ft. in width, with widths for short corridors (1 or 2 bays) ranging from 4 ft. to 5 ft. 6 in.; for medium-length corridors, 5 ft. to 6 ft. 6 in.; for long corridors, 6 ft. to 7 ft. Rockefeller Center corridors average 5 to 6 ft. Minimum corridor width is set by some codes, in which case it must equal the minimum exit door width. Methods for determining corridor width in accordance with human figure dimensions are shown in the drawings.

# CLEARANCES

## Minima for Private Offices

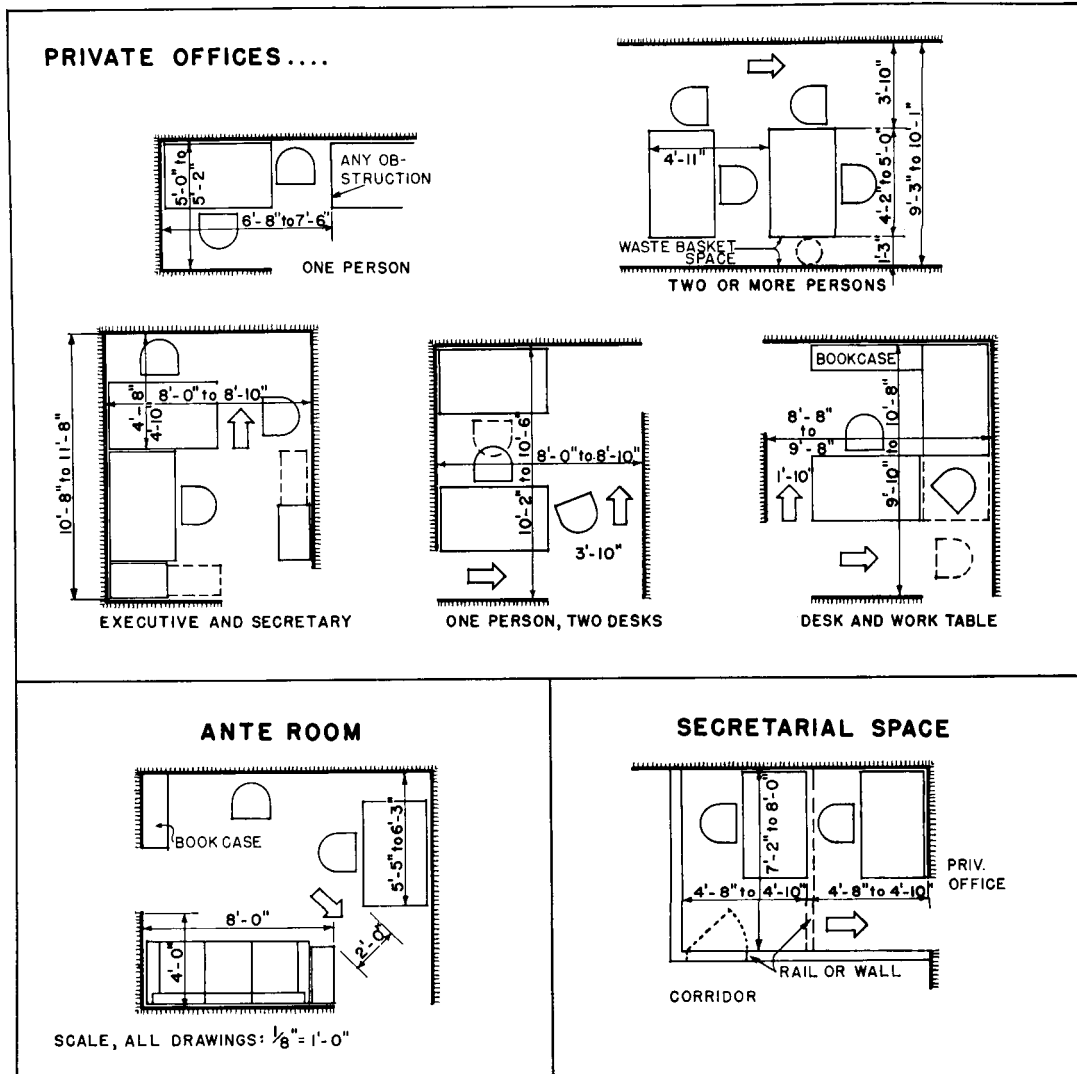
THESE TWO pages contain information on average minimum clearances necessary around typical units of office furniture under various typical conditions.

Use of this type of data will enable building designers to lay out interior portions of office buildings economically and to determine spans or bay dimensions which will most efficiently serve various departments or types of office space. In the case of buildings for general occupancy, tenant layout designers may find the data useful in setting up standards applying to their particular needs.

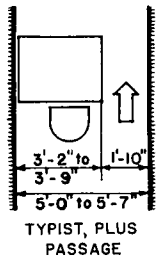
Data are based on standard office furniture and equipment sizes plus dimensions of the human figure, and were in part adapted from "Bau-Entwurfslehre" (Architectural Design) by Prof. Ernst Neufert. Minima for reasonably comfortable human

occupancy, passage, etc., are given, rather than absolute minima; and the high valuation per square foot of office space was carefully considered in their development. Variations in dimensions are principally due to variations in furniture sizes. Dimensions read to obstructions, usually walls, partitions, columns, files, etc.; but in certain cases low obstructions such as desks, rails etc., will require less clearance than high obstructions. In such cases, from 6 in. to 1 ft. should be added to given clearances if high obstructions exist.

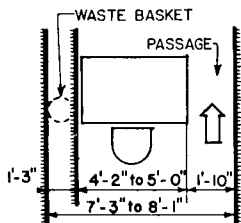
Drawings for executives' offices, ante rooms, and secretarial spaces are similarly developed. Space or room limitations indicated are not to be considered the only typical conditions. They are intended to serve as guides in the development of plans suited to the particular conditions at hand.



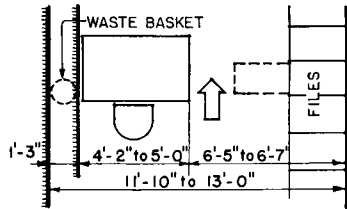
**DESKS....**



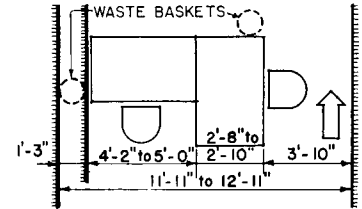
TYPIST, PLUS PASSAGE



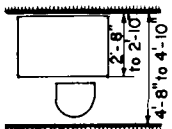
STANDARD DESK, PLUS PASSAGE



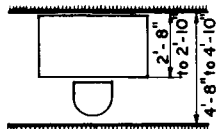
STANDARD DESK, FILES, PLUS PASSAGE



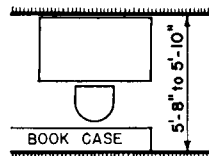
STANDARD DESKS, PLUS PASSAGE



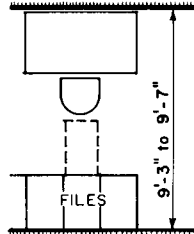
TYPIST, NO PASSAGE



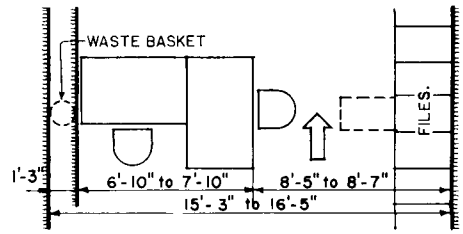
STANDARD DESK, NO PASSAGE



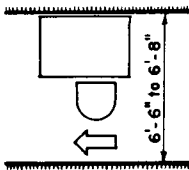
STANDARD DESK, PLUS BOOKCASE



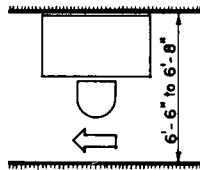
STANDARD DESK, PLUS FILES



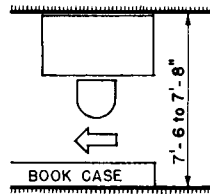
STANDARD DESKS, PLUS FILES, AND PASSAGE



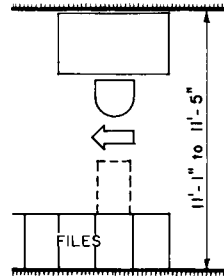
TYPIST, PLUS PASSAGE



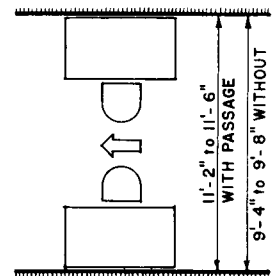
STANDARD DESK, PLUS PASSAGE



STANDARD DESK, PLUS BOOKCASE, AND PASSAGE

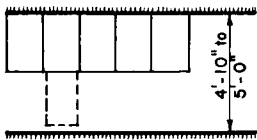


STANDARD DESK, PLUS FILES AND PASS.

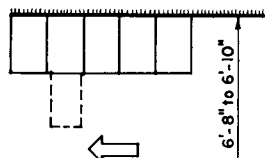


STANDARD DESKS, BACK TO BACK, PLUS PASSAGE

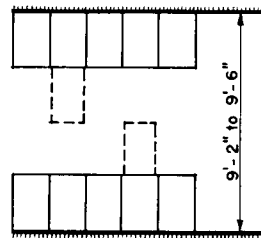
**FILES....**  
STANDARD CLEARANCES FOR BOTH LEGAL AND LETTER SIZES



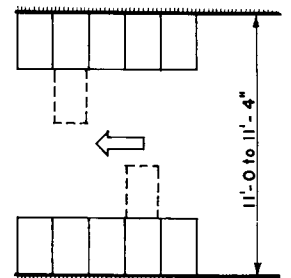
PASSAGE, DRAWERS CLOSED ONLY



PASSAGE, DRAWER OPEN

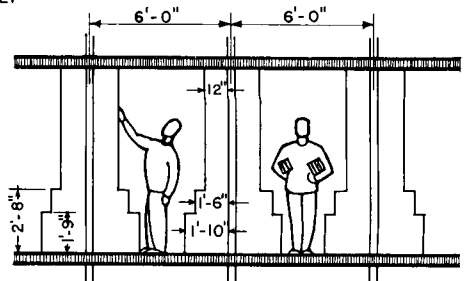
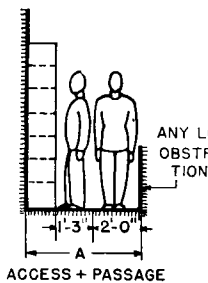
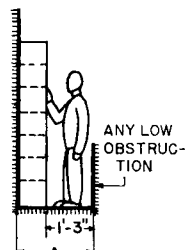


FILES, FACE-TO-FACE PASSAGE WITH DRAWERS CLOSED ONLY



FILES, FACE-TO-FACE PASSAGE, DRAWERS OPEN

**SHELVING....**  
MANY DEPTHS ARE AVAILABLE; USUAL MINIMUM FOR A, EQUALS TWICE SHELF DEPTH, TO PERMIT EASY REMOVAL OF CONTENTS



SCALE FOR ALL DRAWINGS  
1/8" = 1'-0"

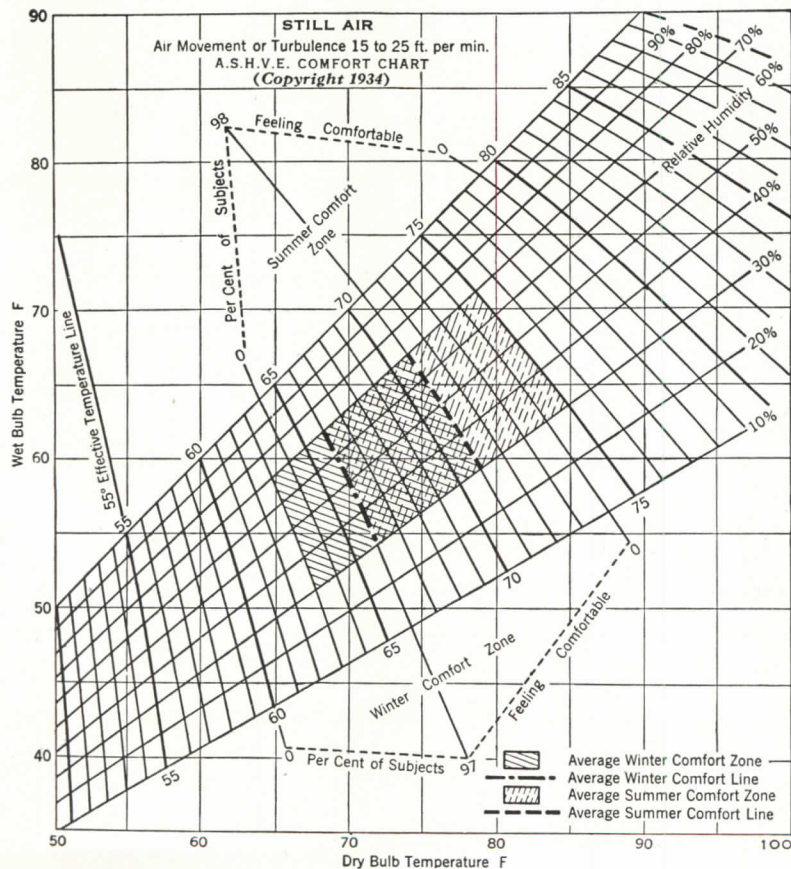
# SUMMER AIR CONDITIONING

## Acceptable Performance Standards

### INSIDE DESIGN CONDITIONS FOR COMFORT COOLING

Outside Design Dry Bulb	CLASS AA SPECIAL APPLICATION OCCUPANCY OVER 40 MIN.			CLASS A AVERAGE APPLICATION OCCUPANCY OVER 40 MIN.			CLASS B OCCUPANCY UNDER 40 MIN.		
	Dry Bulb	Wet Bulb	R.H.%	Dry Bulb	Wet Bulb	R.H.%	Dry Bulb	Wet Bulb	R.H.%
85	73	64	64	74	64	60	75	64	57
	74	62	53	75	62	50	76	63	48
	75	61	45	76	61	43	77	61	41
	76	59	38	77	59	35	78	59	32
90	75	66	65	77	67	62	78	68	60
	76	65	57	78	66	53	79	66	53
	77	63	48	79	65	48	80	65	45
	78	62	41	80	63	40	81	64	40
95	77	67	60	79	68	58	81	69	55
	78	66	54	80	67	51	82	68	49
	79	65	47	81	66	45	83	67	44
	80	64	42	82	65	40	84	66	38
100	78	69	65	80	69	58	82	70	57
	79	68	57	81	68	52	83	69	51
	80	66	50	82	66	44	84	68	45
	81	65	43	83	65	38	85	67	38
105	79	69	63	81	70	58	83	71	57
	80	68	57	82	68	51	84	70	50
	81	67	49	83	67	45	85	69	45
	82	66	43	84	66	39	86	68	40

From the Interim Code (1936) of the Air Conditioning Manufacturers' Association



A.S.H.V.E. COMFORT CHART FOR AIR VELOCITIES OF 15 TO 25 FPM

Note.—Both summer and winter comfort zones apply to inhabitants of the United States only. Application of winter comfort line is further limited to rooms heated by central station systems of the convection type. The line does not apply to rooms heated by radiant methods. Application

of summer comfort line is limited to homes, offices, and the like, where the occupants become fully adapted to the artificial air conditions. The line does not apply to theaters, department stores, and the like where the exposure is less than 3 hours. (From A.S.H.V.E. Transactions, Volume 38, 1932.)

SUMMER AIR CONDITIONING in office buildings is still a matter of controversy; scientifically, technically, and commercially. Scientifically there exists no set of conclusive physiological standards that can be used as a general basis for performance specifications.

A start has been made toward establishing such standards. Experiments are now being made in an attempt to establish more definite comfort and health limits for air velocity, air purity, temperature, and humidity than now exists. The American Society of Heating and Ventilating Engineers are conducting tests in Canada, Pittsburgh, and Texas to supplement information already compiled. Prominent among university scientists who are studying the same subjects are Dr. C. E. A. Winslow, Professor of Public Health at Yale and Dr. C. P. Yaglou, Assistant Professor of Industrial Hygiene of the Harvard University School of Public Health. In addition, a Committee on Air Conditioning of the American Medical Association, chaired by Dr. Carey P. McCloud of the Detroit City Bureau of Hygiene, has been studying various aspects of the problem but so far has withheld its findings.

Because of this compound situation, the building designer has no choice but to exercise his judgment and adjust the experience and recommendations of others to the set of conditions peculiar to his locality and building problems.

To provide an outline basis for this, the following paragraphs list commonly accepted limits of temperature, relative humidity, and air motion and reflect variation of opinion and practice where it is known to exist.

#### Temperature and relative humidity

Temperature cannot be arbitrarily set, for its effect on human beings varies materially with the percentage of relative humidity and degree of air motion. The A.S.H.V.E. "Comfort Chart" suggests a range of temperatures and humidities based on laboratory experiments. Though it may serve as a basis for adjustment to local conditions, it takes no account of significant factors invariably encountered in practice—costs, prevailing conditions of outdoor air, and the varied effects of temperature-changes upon people.

Opinion on the value of such practical matters as they may affect per-



formance specification can be classed, generally, in three groups: The *first* advocates maintenance of nearly optimum conditions (approximately 71 F and 50% R.H.) inside with little or no regard for temperature differences between out- and indoors. The *second* favors a comparatively low temperature (dry bulb) and high humidity (70 F to 75 F with 70 to 80% R.H.) also with little regard to outdoor conditions; and the *third* a higher temperature, varying with the range of outdoor temperatures, with a comparatively low and fairly constant humidity (30 to 45% R.H.).

There exists considerable engineering opinion that the A.S.H.V.E. summer comfort zone is a compromise, influenced by what has been economically practical to attain, and that a range between 70 F with 50% R.H. and 85 F with 30% R.H. comes closer to reflecting generally desirable conditions. In adjusting any recommendation to local conditions it should be borne in mind that these are expressed in terms of Northern practice. In warmer climates higher temperatures can be tolerated; and the comfort range can therefore be considered as from 1 to 10 degrees above figures cited here.

It has been established that both comfort and health are aided by avoiding shock resulting from wide and sudden changes of temperature. Corresponding variations in humidity appear relatively unimportant as they concern health, although they have a marked effect on comfort. Adoption in principle of any one of the three relationships, therefore, depends largely upon prevailing outdoor conditions and the local average tolerance of people to these conditions.

No general agreement appears to exist regarding temperature differentials to avoid shock—probably because physiological tolerances have not yet been completely charted and also because of the varying effects of humidity and air motion. A large body of opinion regards 15 degrees as the desirable maximum without regard to relative humidity or air motion. Another group sets a much lower differential—from 5 to 8 degrees—coupled with comparatively low relative humidity and above-normal air motion.

The accompanying tabulation repre-

sents the design conditions recommended for summer air conditioning as part of the Interim Code of the Air Conditioning Manufacturers' Association.

#### Air motion

A range of 15 to 25 fpm is considered calm air and is generally regarded as desirable during the heating season in rooms of ordinary temperature (68 to 71 F dry bulb). With temperature 2 or more degrees lower, drafts are likely to occur when air motion is 40 fpm or over. At higher temperatures—80 F or above—velocities can be considerably increased.

Regarding practical limits of air velocity a variety of opinion exists. As with temperature and relative humidity, air motion has varying effects on people. Few of these effects have been sufficiently researched to provide a scientific basis for setting velocity limits for commonly encountered conditions.

It is probably a fact that persons of sedentary occupation are most generally susceptible to draft effects and, therefore, the desirable air motion for summer air conditioning in office spaces should not usually be greater than 50 fpm within the room. However, Samuel P. Brown states as an opinion based on experience, "in summer, so long as the cool air supplied is well mixed with room air before contacting occupants, velocities as high as 125 fpm. have been satisfactorily used. Such higher velocities decrease the effective temperature because of the velocity effect alone, thus relaxing requirements on dry bulb temperature and humidity."

General practice allows 6 to 8 air changes per hour as satisfactory. It is common practice to recirculate from one-third to three-quarters of inside air depending on requirements and the type of mechanical means employed. Therefore 6 air changes per hour *through the machines* would mean replacement of inside air from 2 to 4 times per hour.

Provided outside air is adequately conditioned, the higher figure reflects the more generally desirable condition from a health point of view.

#### Air purity

This is still a subject for research as

it refers to a scientifically desirable standard for office spaces. Some form of air cleaning device is generally regarded as an essential part of air-conditioning equipment. But choice of the three principal types—filters, air washers, and electrical precipitation devices—depends largely upon the relative purity of local air. Also the efficiency of air washers and filters varies widely. Electrical precipitation of dust particles is basically the most efficient; but it is a relatively new method for cleaning air and still comparatively expensive.

Removal of odors necessitates a sufficiently large proportion of outside air to overcome the odor by dilution. Odor tolerances are not standardized and for office buildings are regarded as relatively unimportant if other functions of summer air conditioning operate satisfactorily.

#### References

The foregoing report was compiled from a number of sources. Acknowledgment is given to the following individuals, but readers are cautioned not to ascribe statements to any one person unless otherwise noted: Samuel P. Brown, Research Corporation; R. E. Cherne, Carrier Corporation; A. R. Mumford, Research Engineer, the New York Steam Corporation; Clifford F. Holske, American Ice Company; F. O. Urban, General Electrical Company; C. H. B. Hotchkiss, Editor, and Clifford Stroock, Associate Editor, Heating and Ventilating Magazine.

#### Bibliography

For reports on current progress toward scientific development of health and comfort standards refer to: Bulletins of the U. S. Public Health Service, Washington, D. C.; Transactions of the American Society of Heating and Ventilating Engineers and issues of the American Journal of Public Health, New York, N. Y.; Heating and Ventilating, New York, N. Y.; and Heating, Piping and Air Conditioning, New York, N. Y.

Recently published technical books on installation standards and methods include: Air Conditioning for Comfort, by Samuel R. Lewis, Keeney Publishing Co., Inc., Chicago, 1938; Air Conditioning in Summer and Winter, by Richard E. Holmes, McGraw Hill Book Co., Inc., New York, 1938; Air Conditioning by Charles E. Fuller and David Snow, The Norman W. Henley Publishing Co., New York, 1938; Heating, Ventilating and Air Conditioning Fundamentals by William H. Severns, John Wiley & Sons, Ltd., New York, 1937; Heating and Air Conditioning of Buildings by Oscar Faber and J. R. Kell, The Architectural Press, London, England, 1936.

NOISE IN BUILDINGS			
From Joint D. & R. Subcommittee Survey—New York Data	Noise Level	Data From Other Sources	Source
	100		
		Boiler Factory	1
Subway—Local station with Express passing	95		
	90		
	85	Some factories are as high as this	2
	80	Very loud radio music in home	4
	75		
Noisiest non-residential Bldg. Location measured	70	Stenographic room	3
Average of 6 factory locations	65	Very noisy restaurant	4
	60		
Information booth in large railway station	55	Noisy office or department store	1
Average non-residential location	50	Moderate restaurant clutter	4
		Few places where people work are	2
Noisiest residence measured	45	Average office below this	1
	40	Very quiet radio in home	4
	35	Quiet office	1
Quietest non-residential location measured	30	Soft radio music in apartment	3
Average residence	25	Country residence	1
	20	County Court, Chicago, room empty, windows closed	2
Quietest residence measured		Quiet garden, London	4

SOURCES:

1. H. Fletcher, "Speech and Hearing," p. 187, Marginal Audibility Method with 3A audiometer and offset receiver. 17 Db. added as approximate figure to convert to noise level.
2. D. A. Laird, Scientific American, Dec. 1928, p. 509. Balance Method with 3A audiometer and receiver with flat cap. Approximately equal to noise level.
3. W. Waterfall, Engineering News Record, Jan. 10, 1927, p. 60. Same method as (2) above.
4. A. H. Davis, Nature, Jan. 11, 1930, p. 48. Balance or marginal audibility method with 640-cycle tuning-fork. Figures given in terms of sensation level, estimated equal to noise level.

From "City Noise", courtesy New York City Department of Health.

SOUND is vibrational energy identified as to pitch by frequency of vibration (cycles) and as to loudness by intensities—the amount of vibrational energy transmitted per second per cycle—measured in decibels.

Noise is a combination of sounds, each of which may vary in pitch and intensity, and depending upon character and volume may be unnoticed by, or irritating to, office workers.

### Effect of noise on people

Human reactions to noise have not yet been completely charted. Tests at Northwestern University and at Bellevue Hospital in New York have shown that noise changes pulse and breathing rates, increases blood pressure, causes bodily fatigue and a lowering of efficiency. Other tests showed "an increase of about 9 per cent in overall efficiency as measured by the output per worker-hour resulting from a reduction of about 6 decibels in the general noise level" (Sabine).

Such tests, however, give no conclusive facts regarding the type and character of noise most irritating to the average office worker. Acoustical engineers hold various opinions as a result of experience. Most, however, think that high pitched and intermit-

tent sounds are more generally annoying. Constant noise seems most disturbing to average office workers. (Pearce). Nearby inside noise is thought to be most irritating.

### Acoustical "Comfort Zone"

Individuals differ as to their ability to tolerate noise without annoyance and as to the extent of mental and nervous accommodation to noisy conditions. There exists, also, a wide variety in the character of noise to which office workers are subjected.

Because of such variations, few scientific data are available which define limits of acoustic comfort for office workers. The matter is further complicated by the fact that a constant noise lessens the *apparent* intensity of individual sounds that might otherwise be loud to the point of annoyance. Therefore an acoustical "comfort zone"—limits of easily-tolerated pitch and intensity requiring a practical minimum of individual accommodation—can be stated only in terms of engineering opinion and experience.

Satisfactory pitches (those that are apparently least generally annoying) depend to a great extent upon intensity or loudness, but range practically between 256 and 2048 cycles. Given extremes of pitch, a room can be relatively quiet but still annoying.

Intensities can be marked only by average or upper limits relative to an average of the pitches noted above.

Following are averages of engineering opinion relative to satisfactory noise levels in various types of office spaces. The range indicates upper limits only.

*Executive offices:* Below 45 decibels. With a noise level of 25 to 40 decibels "comfort conditions for work would be considered ideal" (Pearce). Recommendations ranged from 40 to 55 decibels.

*Secretarial and Reception spaces:* Below 50 decibels. Recommendations ranged from 40 to 60 decibels.

*Switchboard operating areas:* Below 55 decibels. Recommendations ranged from 35 to 70 decibels.

*General office space for typing, operating, clerical & accounting machines, etc.:* Below 65 decibels. Recommendations ranged from 50 to 75 decibels.

These figures are regarded as reasonable standards commercially attainable. Preferred noise levels would be

from 10 to 15 decibels lower in each case. In general the less noise present, the better working conditions become (Parkinson).

### Methods of controlling sound

Construction to exclude noises outside the building involves a relatively massive structure (sound transmission in general is proportional to the mass of the transmitting substance) fixed windows, double membrane windows or the omission of all windows as the most effective means currently known.

Vibrations from machinery can be damped through use of resilient devices and materials. Choice of a particular type involves analysis of frequencies and intensities of the sounds to be isolated and usually calls for services of an acoustical engineer.

In air-conditioning systems flexible connections between ducts and blower units will damp vibration. Noise of fans, air-borne through supply ducts, can be practically eliminated by lining the room end with sound-absorbent material for an area approximately ten times the average opening.

Equipment and structure-borne noises may be annoying in a quiet office and not noticeable in general working areas. They will be completely masked if reduced to a loudness 5 decibels less than the average noise levels of spaces under consideration.

Noise generated in a room can be reduced by sound absorbing materials, usually applied to ceilings, rarely—in severe cases—to walls. A maximum reduction of 10 decibels can be obtained by this means—about a 50% loudness reduction judged by ear.

Selection of such material depends upon its appearance, ease of maintenance, etc., as well as its sound-absorbing efficiency. Rating should be the average value of co-efficients from 256 to 2048 cycles.

### References:

The foregoing material was compiled from information furnished by Paul E. Sabine, Riverbank Laboratories; John S. Parkinson, Johns-Manville; S. P. Walker, United States Gypsum Co.; L. S. Ayars, Jr., The Celotex Corporation; Allen E. Pearce, Armstrong Cork Products Co., and various published sources including the Journal of the Acoustical Society of America, Circulars of the National Bureau of Standards, and "City Noise," Report of the New York City Noise Abatement Commission.



Semi-indirect fixtures 9 ft. on centers, bookkeeping department, Crocker First National Bank, San Francisco

### LIGHTING METHODS

#### General illumination

All types of areas require some degree of general illumination. Recommendations as to quantity within each area vary, one consultant suggesting the use of approximately 3 footcandles of general illumination for most office building spaces (supplemented by local lighting); others range from 5 to 10 or 20 footcandles.

#### Local illumination

This can be supplied by portions of installed lighting systems by increasing wattages locally, by using portable fixtures, or by equipping machines or desks with individual lighting units. The first method may overload wiring systems; the second and third are commonly used. Local illumination is seldom, if ever, recommended as the only source of light; general lighting should supplement it to avoid excessive eye-strain and consequent fatigue.

Proportions of local to general lighting are variously recommended as 5 to 1 (General Electric Co.), 100 to 1

(Sweet), and other ratios between. Mr. Sweet foresees the eventual use, to a very great degree, of local lighting in office buildings, as knowledge and appreciation increases of material benefits to be obtained from, and flexibility desirable in, lighting systems.

Recommendations as to methods of supplying both types of lighting also vary. The General Electric Co. states that: "Illumination values up to 50 footcandles can be obtained from a general lighting system. For those tasks requiring more than 50 footcandles it will be found more economical to provide a combination of general lighting plus supplementary."<sup>(1)</sup>

### LIGHTING CHARACTERISTICS

Attributes of lighting quality have been defined as: (a) *intensity*; (b) *uniformity*; (c) *exposed brightness*; (d) *direction*; (e) *distribution of brightness*. Similar terms such as "glare," which may be the result of exposed or reflected brightness, and "dif-

(1) "Lighting for Seeing in the Office," General Elec. Co., Cleveland, Ohio.

fusion" are used by many authorities.

#### Intensity

Recommendations for intensities for various types of work have been made by several authorities, some based on laboratory tests, some on practical experience. These are tabulated on the following page. A wide range will be noted in some instances; this is due partly to variable conditions covered by the general classifications listed. Exact limits are difficult to assign since intensities are in all cases relative. Many factors affect the subject besides the number of footcandles delivered.

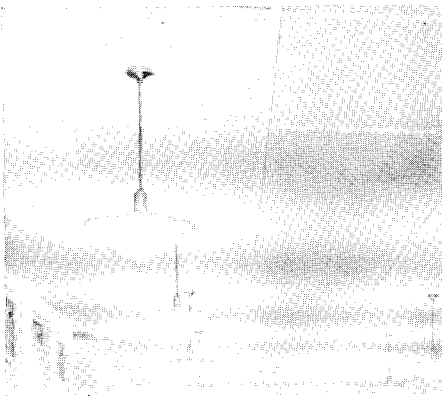
The psychological effect of increased intensities has been stated by some authorities to be an increase in cheerfulness, mental perception, expenditure of nervous energy, etc. However, Arthur J. Sweet, consulting engineer,

The Editors wish to acknowledge help from the following sources: Thos. A. Carter (Curtis Lighting, Inc.); A. L. Powell, J. L. Tugman, F. O. Urban (General Electric Co.); W. H. Kahler (Westinghouse Elec. & Mfg. Co.); H. L. Logan (Holophane Co., Inc.); F. E. Guth (Edwin F. Guth Co.); Henry H. Dean (George Ainsworth); Arthur J. Wilde (Pittsburgh Reflector Co.); Stanley McCandless, consulting engineer; Arthur J. Sweet, consulting engineer.



Courtesy General Electric

Direct lighting units, with direction and diffusion control; Nela Park branch, Cleveland Trust Company.



Courtesy Westinghouse

Semi-indirect units here furnish 30 footcandles at desks; Crocker First National Bank, San Francisco, Calif.



Courtesy Westinghouse

Totally indirect units in the Remington-Rand Building, Chicago, Ill.

## LIGHTING INTENSITIES IN FOOTCANDLES

Type of Work or Space	Range	Type of Work or Space	Range
Lobby—public	3-15***	Filing	10- 30*
Lobby—elev.	5-15	Bookkeeping	20- 50*
Corridors, stairs	3- 5	Accounting machines	20-100*
Reception	5-20**	Sorting	10- 50*
General office	10-30**	Addressing	10- 30*
Reception	10	Drafting	30- 50*
Switchboard	10-30	Vault	5- 10
Executive	15-50*	Stores, janitor	5
Secretary	15-50*	Toilets	5
Typing	25-50		

\* Wide range due to inclusion by 1 consultant of age factor, or to consideration of more difficult types of visual tasks—see text.  
 \*\* Several consultants recommend for general office spaces and particularly reception rooms the use of comparatively low general intensities and high intensity local lighting—see text.  
 \*\*\* Wide range due to consideration of display or decorative lighting.

suggests that high general intensities may result in lack of concentration and consequent inefficiency in offices. He recommends, "for areas where close visual work is seldom or never performed, relatively low intensities"; and for general areas where exacting work is more or less frequently performed, general illumination of about 3 footcandles, plus properly designed local illumination. There are two difficulties: Portable fixtures, etc. are usually tenant-supplied, and the average tenant recognizes neither good lighting standards nor their value; and provision of sufficient outlets to permit good local lighting is difficult. A reasonable recommendation would seem to be provision for both high intensity general lighting and a multiplicity of outlets for portable fixtures.

Few persons or organizations consulted reported consideration of natural lighting (source or amount) as affecting artificial lighting recommendations. Mr. Sweet states, "Where artificial lighting is used to supplement daylight (the usual case in offices), intensities should be double those adequate where artificial lighting is exclusively employed. This arises because the day-adapted eye is less sensitive to light stimuli than night-adapted eye."

Desirability of flexible installations to meet the requirements of workers of varying ages was emphasized by H. L. Logan, consulting with the Holophane Company. He calls attention to the fact that light intensity recommendations generally apply to young workers, and as workers age, "the amount of light required for a visual task increases, slowly at first but swiftly in upper brackets." Consequently, his recommendations for executives' offices are

high. "Middle aged men need on the average five times as much light . . . as men in their twenties."

### Uniformity

Absence of "spotty" installations, in which light sources are unduly obtrusive against their backgrounds, is generally considered desirable. Several opinions recommend moderately high levels of general illumination, coupled with judicious choice of fixtures and location, as the means for avoiding this defect. On the other hand, Mr. Sweet says: "Where (as in corridors or in general offices where no local lighting is employed) a like intensity may be required at any and all points, uniformity of lighting makes for low operating costs and should therefore be approximated. Where . . . close visual work is . . . (permanently) associated with particular locations, non-uniformity of proper character becomes a positive virtue . . ."

### Exposed brightness

High exposed brightnesses are universally termed undesirable except for display or "festive" lighting and then only if not extreme. Direct glare is the usual result, with consequent fatigue and inefficiency of the workers.

### Direction

Certain types of spaces demand direct lighting; precautions taken to control direction and diffusion of direct light result in high efficiency and absence of surface reflections, glare, etc. Means employed to avoid high brightness toward the floor generally result in lighting by reflection from ceilings or by extended "architectural" sources, panels, etc. These should diffuse light

SPACING OF LIGHTING OUTLETS

Ceiling Height (Or Height in the Clear) (Feet)	Between Outlets		Between Outside Outlets and Wall		Approx. Area Per Outlet (Sq. Ft.)
	Usual (Feet)	Max. (Units at Ceiling) Not more than*	Aisles, Storage	Desks Not more than*	
9	8	8	Usually one-half actual spacing between units	3	60- 70
10	9	9		3 1/2	70- 85
11	10	10 1/2		3 1/2	85-100
12	10-12	12		3 1/2-4	100-150

\* For totally indirect lighting, maximum between units may be increased approximately 2 ft.; between units and wall, 1 ft. From "Lighting for Seeing in the Office", General Electric Co.

sufficiently to avoid objectionable shadows and high brightness (or "glare"). Portable fixtures, producing local lighting satisfactory for particular tasks, may throw strong shadows which, if properly controlled, may be rendered harmless.

Research by the Illuminating Engineering Society tended to show that: "Reading tasks, placed flat on a desk, seem to be more visible under unidirectional (controlled direct) lighting than under the indirect lighting; that, for all seeing tasks considered, lower levels of unidirectional illumination are required than of indirect (76%); that visibility (of such tasks) is materially higher per footcandle when lighted by unidirectional lighting from over the left shoulder as compared to diffuse illumination from an indirect system."<sup>(2)</sup>

Importance of avoiding high brightness and providing proper direction respecting both the eye and the object viewed "preclude use of direct lighting in working areas unless, (1) points at which work will be performed can be definitely established, (2) direct sources are of a size approximating 1/4 floor area, certainly not smaller than 1/10 floor area" (Sweet).

Distribution of brightness

Psychological effects as well as physical are here important, as noted under "Intensity" and "Exposed brightness." In addition . . . "Where the ceiling of a small office is very much brighter than lower walls or objects in the normal field of vision, a strong unpleasant sense of being in a pit . . ." may be

(2) "Visibility of Various Reading Tasks Under Combinations of Diffuse and Unidirectional Lighting," report by Brown, Robinson (Stanford Univ.) and Gianini (General Electric Co.) Illuminating Eng. Soc.

produced. "Such lighting . . . tends to make the room seem smaller, the ceiling higher . . ." (Sweet).

Natural inside lighting falls off rapidly as distance from windows increases, in some instances dropping from 100 footcandles to 5 in a distance of 20 ft. One means of overcoming this is to provide separate controls for lights, using those farthest from natural light sources more constantly than those close. Photo-electrically operated automatic controls are also available.

EQUIPMENT

Types of fixtures vary according to the manner in which they distribute light. Brief descriptions of the main classifications are given in the accompanying tabulation. Those usually recommended for general illumination and for special effects include semi-indirect and totally indirect types. For local lighting, semi-direct and semi-indirect fixtures are commonly used, as well as direct types. Means of determining desirability of specific types may be found under "Lighting Characteristics."

TYPES OF FIXTURES OR SYSTEMS

**Direct fixtures** concentrate all or most of their light downward. Kinds of fixtures range from factory-type reflectors, to fixtures of large area, such as enclosing globes, panels, etc. High-brightness direct fixtures generally produce fatigue; controls such as diffusing glass, lenses, etc., minimize this defect. One consultant recommends highly the use of direct fixtures whose light can be controlled as to direction by louvers, shades, etc. Nearly all recommend concealing the light source.

**Semi-direct** systems comprise those where predominant light on working surfaces comes direct from the lighting units, but where considerable light comes also from reflection. Typical fixture has white glass enclosing globe.

**Semi-indirect** lighting supplies some light directly, but the major portion is transmitted indirectly. Fixtures generally have translucent lower portion of shade or globe, transparent (or omitted) upper portion. Correctly designed semi-indirect fixtures eliminate glare.

**Indirect** lighting supplies all working light by reflection from ceilings and upper portions of walls. Sources may range from simple pendant fixtures to elaborate built-in units, provided no light is transmitted directly downward. Wattage required is usually greater than for other types; source is always concealed; glare usually eliminated.

TYPES OF LAMPS

While tungsten lamps are at present the predominant type, others are being developed, of which two kinds seem to be suitable for offices.

Forms of Mercury lamps supply a close approximation of daylight and are used together with tungsten lamps. Installation costs are at present high, since special transformers are required; operating costs are somewhat lower; replacement cost per lamp is high. Fixtures are available for combinations of mercury and tungsten lamps.

Mazda fluorescent lamps are available for supplying a wide range of colors in light, but here again, the "daylight" type, or those which emit a bluish light, seem most applicable to office buildings. These are similar in shape to "Lumiline" lamps but require special equipment and wiring. A 15-w., 18-in. white fluorescent lamp is approximately equivalent to a 40-w. regular or 60-w. "Lumiline" lamp.

Use of "Polaroid" glass in fixtures is at present limited to a few portable types. Use of these will eliminate reflected glare from high intensity direct local sources; this effect is most noticeable when light rays strike and are reflected from a surface at approximately 35° angles.

# COLOR FOR INTERIORS

## A Guide to Color Selection

## TIME-SAVER STANDARDS

RESEARCH on the mechanics of producing colors, also the classification and standardization of color samples has been extensive. But *use* of color is not yet a science. Research has produced comparatively few facts indicating the effect of color on human beings that can be generally applied to meet a scientific standard of environment.

### Psychological aspects

Experience has shown that men prefer cool colors, women warm ones. Warm colors generally stimulate; cool ones produce a quieting effect. Also, colors seem actually to enhance sensations of temperature (Birren).

Various tests, though not conclusive, show other reactions to color. Birren states: "Under influence of red, time is overestimated, weights seem relatively heavier. Under influence of green, conditions are reversed." Experiments on students showed the following effects of colors (From "National Safety News," March, 1937): *Black*; Melancholia. Decreased work. *Red*; Temporary stimulation followed by recreation, nervousness, and headache. *Blue*; Calmness and seriousness. *Green*; Increased vitality, happiness. *Yellow*; Increased vitality, amiability. Yellow is conducive to greatest mental efficiency. Green has therapeutic worth in combatting nervous irritation (Ketcham).

Relatively large areas of strong colors repel. Grayed or partially neutralized shades are relatively less tiring and least so if accompanied or "accented" with small areas of contrast.

Dark shades produce underestimation of space; light colors the opposite. Also, assuming proper interior lighting, deep tones tend to enhance concentration, light tones to dissipate attention. Light, clean tints of any color promote neatness (Hookway). In general, colors with high reflectivities—light blue, green, gray-blue, green-yellow, buff, etc.—are conducive to a sense of cheerful well-being and stability in people. The reds, dark browns, dark blues, etc.—colors with low reflectivities that require high lighting intensities for equivalent illumination levels—have adverse effects. (Ketcham)

### Physical aspects

Reflection values for flat paint colors based upon a comparison with mag-

nesium carbonate as the standard of reflection at 98 per cent are:

COLOR	VALUE
White	84.0
Cream	70.4
Light pink	69.4
Ivory	64.3
Yellow	60.5
Flesh	56.0
Buff	55.4
Light green	54.1
Light gray	53.6
Light blue	45.5
Aluminum gray	41.9
Sage green	41.0
Brown	23.6
Dark red	14.4
Dark green	9.8
Dark blue	9.3
Black	2.9

Readings made by the Munsell Color Co., Inc., for the New Jersey Zinc Co.

Black absorbs heat, light, and sound, and white is the opposite in all respects. White, however, as the strongest of all colors, can cause aberration in the eye; and all strong light-reflecting colors tend to tire the eyes and cause a physical and nervous strain.

Color effects are dependent not only on the type, shade, and extent of color, but also on location of color areas, the relative positions of contrasting colors, and the quantity and quality of illumination employed. In addition, tints, or mixtures, of colors can be adjusted to provide a 10 to 15 percent varia-

tion in light reflecting value without materially affecting visual character.

Reflection values are also influenced by the type of light used. Westinghouse lighting engineers tested 21 color specimens and found that the co-efficient of reflection under ordinary Mazda illumination is about 2 percent less than under illumination from a mercury vapor lamp.

### Color application

Colors that are too warm or too cool will lower efficiencies of office workers. A light green midway between yellow and blue is considered the best all-season color for any exposure and probably the best color for general office space (Hookway). Blue is too cool a color for high efficiency.

For office interiors with indirect, semi-indirect lighting fixtures, or direct lights from large panels, a reflection value of 80 to 85 percent (white) is regarded as desirable for ceilings; from 50 to 60 percent is generally adequate for walls. Light wall colors tend to enlarge spaces, make detail subordinate. Deeper wall colors enhance visual efficiency as to details. (Birren).

The following table gives color schemes suggested by Howard Ketcham, color engineer, for private offices.

	WALL	LIGHT REFLECTION %	RUG	UPHOLSTERY	CURTAIN
A.	Very Pale or Pale Gray	73	Cedar or Mulberry	Old Red	Old Red
B.	Faint Buff	71.5	Deep Adam's Green	Pigskin (light tan)	Medium Adam's Green
C.	Pale Buff	65	Rust	Deep Adam's Green	Rust—Lighter value than rug
D.	Yellow Pale Green-	64.5	Pure hue of Green (no yellow or blue content)	Pigskin (light tan)	Combining 2 greens already used and beige
E.	Faint, Gray Blue-Green	69	Deep Gobelin Brown	Brown or Reddish Brown	Tan
F.	Pale Gray Blue	65	Delft Blue	Reddish hue of Brown	Reddish hue of tan

### References:

The foregoing information has been compiled from a number of sources, including: Howard Ketcham, Color Engineer; Faber Birren; Dr. Forrest Lee Dimmick of Hobart College Psychology Laboratory; Raymond H. Hookway of The Sherwin-Williams Co.; Allen J. Burdette; and S. G. Hibben, Westinghouse Electric and Manufacturing Co.

### Bibliography:

**A Dictionary of Color**, by A. Maery and M. Rea Paul; McGraw-Hill Book Co., Inc., New York. Contains approximately

7,000 different color samples arranged for use as practical color standards.

**Munsell Book of Color**, by The Munsell Color Co., Baltimore, Md., 1929. Standard and abridged editions, each containing approximately 400 different color samples, each identified as to hue, lightness, and saturation, according to the Munsell system of color nomenclature.

**Color and Design in the Decorative Arts**, by Elizabeth Burris-Meyer, Prentice Hall, New York, 1933.

**Functional Color**, by Faber Birren, The Crimson Press, New York, 1937.



# Design Elements that Affect Rentability

## General observations

CHANGING DESIGN fashions and technical advances tend to hasten obsolescence in many parts of the building. Among the items especially subject to these influences are lighting fixtures, elevators, air-conditioning equipment, and wall finishes. Building managers as a group are strongly opposed to designs embodying garish effects or extreme styles.

Lighting that draws attention to the location is considered a prime factor in the design of the ground floor. There is a trend toward giving storefronts a full story's height to permit maximum display of the tenant's name. Another growing practice is that of placing the entrance at the side of the storefront rather than in the middle in order to provide more display space. There should be no steps, either up or down, at the store entrance, and columns should be as small as possible in the interest of greater window area. A freight entrance is recommended at rear or through basement. Good ventilation, with provisions for air conditioning, is considered essential.

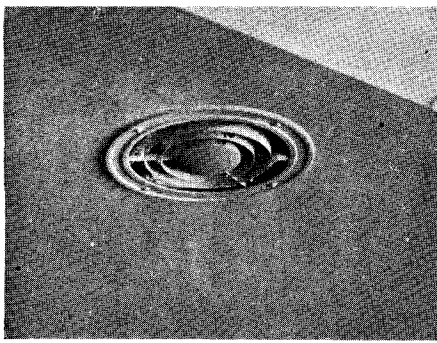
On the first floor of the building, and possibly in part of the basement, there should be at least enough service shops to meet the needs of tenants. Conference rooms, law libraries, and similar facilities for use of tenants are desirable. Few managers think recrea-

tional space is necessary for tenants.

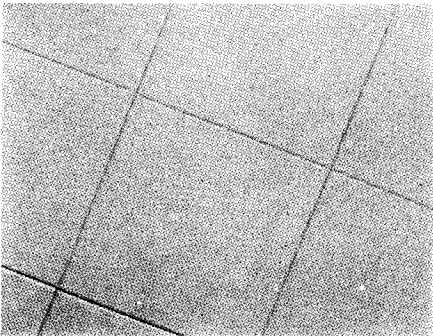
There is a long list of equipment, some of it essential, which managers consider costly to maintain, including double-hung, non-reversible windows; wood and travertine floors; fixtures of highly polished bronze, aluminum, and the so-called stainless metals; fully automatic elevators; self-contained radiator valves; highly polished wood paneling; porous stone, either exterior or interior; veneered elevator cabs; venetian blinds with taped wood slats; totally and semi-indirect lighting fixtures of the open type; flat and semi-gloss wall and ceiling finishes; prismatic glass; steel sash; floor covering in elevator cabs; collapsible elevator gates and doors, and elevator guide rails. One manager, contending that both marble and terrazzo floors are expensive to maintain, says that the ideal floor for the entire building is concrete slab covered with  $\frac{1}{4}$ -inch battleship linoleum.

From the manager's point of view, some of the most troublesome elements of building design are improper relation between window area and floor area, bays of incorrect size, penthouses that are too small, excess radiation, insufficient capacity in the electrical system, wrongly designed elevator shafts, lack of zoning or improper zoning of the heating system, exposed steam risers, insufficient space for ma-

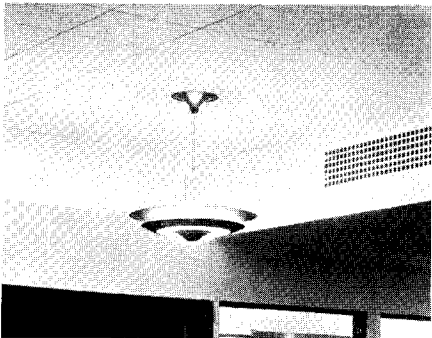
Because the building manager has special knowledge of tenant needs and preferences, he is particularly able to discuss elements of construction and equipment that may add to or decrease the earnings of a modern office building. This report, developed by Norbert Brown, Editor of the Real Estate Record, in collaboration with Robert F. Marshall, Managing Editor of the same publication, represents an expression of professional building management. Statements may not be applicable in all cases; and care has been exercised to divorce expressed opinions from application to unusual situations. . . . Acknowledgment is given for valuable assistance in preparation of this report to the following building management executives, but readers are cautioned not to ascribe specific assertions to any one person: Jeremiah K. Cronin, manager, Mortgage and Real Estate Department, Bankers Trust Company, New York; Herbert A. Fisher, manager, Fisher Building Division, Fisher & Company, Inc., Detroit; W. E. Malm, president, Wm. E. Malm & Co., Cleveland; Fred B. Moore, manager, Rhodes-Haverty Investment Co., Atlanta; and E. J. Smith, operating manager, Sixty Wall Tower, Inc., New York.



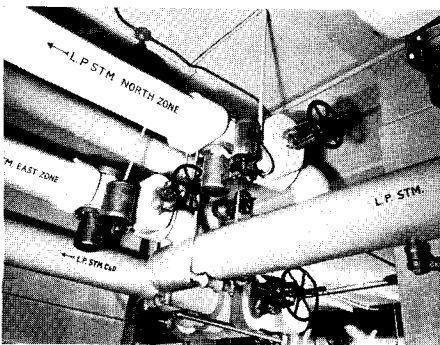
Air conditioning is an aid to renting; the type of system a matter of controversy.



Acoustic control is generally endorsed; necessary on lower floors, desirable elsewhere.



Good lighting is essential; concealed light sources, intensities from 10 to 20 footcandles.



Steam and power can be purchased; the private plant may soon be a thing of the past.

chinery, deficient toilet facilities in the basement, and inadequate and badly located janitors' closets, employees' locker rooms, and workshops.

There also are certain pieces of building equipment that are likely to depreciate rapidly with use, such as steam return lines carrying steam with a high CO<sub>2</sub> content, and hot-water lines. It usually is regarded as poor economy to use materials for pipe and flashing that are locally subject to corrosion and otherwise to sacrifice durability for a small initial saving. One manager stresses the need for constructing mortar joints in exterior walls so that they are watertight, as follows: "Ninety per cent of the buildings erected since 1927 have had to spend substantial sums of money because of outside walls leaking and ruining the plaster."

#### Renting aids

Among the structural and mechanical features which stand highest in the estimation of managers as renting aids are high-speed elevators, properly proportioned bays, conveniently situated and amply large washrooms, sound-proofed walls and ceilings, adequate plumbing and electrical connections, floors finished so that they are ready for use, indirect lighting, concealed radiation, air conditioning, efficient natural and artificial lighting, and good ventilation, possibly with window ventilators supplying filtered air.

#### Maintenance aids

Equipment recommended for lower operating and maintenance costs includes static condensers for electric current to increase the power factor credit, zone controls on steam risers, modern tool shops for electricians and mechanics, and modern scrubbing and cleaning machines. Among the suggested shop equipment are electrically operated pipe-cutting and threading devices, portable electric drills, welding tools, and portable paint sprayers.

#### Parking facilities

Parking facilities in connection with the building, and preferably in the basement, add to the rentability of both store and office space.

#### Lobbies

The lobby of the building should be impressive in design, but in no sense gaudy. At the same time, it should be cheerful and businesslike. Marble and bronze still are favored materials. There is great emphasis on service fa-

cilities, despite some disagreement as to what should be included. Some managers, for example, approve cigar and news stands in the lobby proper. Others, believing them undignified, contend that they should be included in the provisions for service shops such as lunch rooms, telegraph offices, drug-stores, and haberdasheries. Among the indispensable items are directory boards and, in large buildings, information desks. Both should be near, but not in front of, the elevators. One manager suggests that a large clock be mounted over the information desk. Another cautions that if this is done the clock must be worked into the general design of the lobby. Few managers encourage installation of vending machines or drinking fountains.

The modern building manager wants a functional rather than a monumental lobby, one that is large enough to accommodate traffic in peak periods but not large enough to foster loitering. It also is felt that a large empty lobby gives the impression that the building has few tenants, which leads to a suspicion that something is wrong with the offices. Adequate lighting is particularly important in the lobby.

It is recommended that elevator banks face one another, that there be a double bank of building entrance doors with heat introduced between them in winter, and that a recessed storm mat be installed.

#### Rentable areas

It is commonly thought that net rentable area should represent from 70 to 85 per cent of the gross area, depending on the height of the structure. The higher the building, the lower the net rentable area per foot of gross area. A gauge of planning skill is the general rule that every twenty to twenty-two rule that every 20 to 22 cu. ft. of construction should produce one square foot of rentable area.

#### Elevators

Elevators, like other utilities, should be as near the center of the building as the structure's size and shape permit, and convenient to the main entrance. At the same time, the location should be adjacent to the flow of traffic but not at a point where elevator traffic will cross traffic to other portions of the building, such as a bank or interior shops on the ground floor. Recommended speeds range from 400 ft. per minute for local service to 1,200 ft. per minute for express cars. The



following schedule might be taken as a median of current requirements: local service to the fifteenth floor, 600 F.P.M.; express service above the fifteenth floor, 700 F.P.M.; tower service, 800 F.P.M. Service is considered excellent at intervals of 30 seconds, good at 35 seconds, fair at 40 seconds, and unsatisfactory at longer intervals.

It is suggested that elevator capacity be calculated on the basis of 25,000 sq. ft. of gross area per car, and a building population of one person for each 100 sq. ft. of gross area. Another proposal is that one passenger elevator be provided for each 20,000 sq. ft. of rentable area. These rules of thumb are, of course, subject to revision in actual application. One manager makes the specific recommendation that a twenty-story building with a gross area of 100,000 sq. ft. and a population of 800 persons be equipped with four elevators traveling 700 F.P.M., each capable of carrying twenty passengers.

Managers seem to agree that elevators should accommodate fifteen to eighteen persons, that all cars should serve the basement, and that they should be arranged in banks of four or five units. In general, it is felt that the total capacity should be sufficient to empty the building in thirty minutes.

The gearless traction, variable voltage, self-leveling type of elevator with automatic signal control is considered the most efficient. With such features as "selective automatic control" and full "quota control", such installations approximate the present ideal. There are instances in which cost restrictions rule out equipment with these refinements, but in any case the installation should include flash lanterns with gongs at each landing, synchronized with flash signals in the cabs. In larger installations, an automatic or manual dispatching system, with a position indicator in the lobby, should be provided. It also is recommended that a position indicator, either mechanical or illuminated, be installed above the entrance to each car at the ground floor.

#### **Freight entrances**

The freight entrance should be at the rear of the building, facing a wide alley or receiving lot if possible. In any event, it should be off the principal thoroughfare in a location where traffic congestion and handling of freight will be at a minimum. A basement receiving room with a ramp approach is one solution. The location of the freight entrance should not be considered in

terms of convenience to passenger elevators. Special freight elevators should be provided.

#### **Bays**

The 18 x 24 ft. bay, with some variations permissible in both dimensions, is considered the most efficient unit of rentable space. A T-shaped partition divides the 18 ft. width into two 8 ft. 9 in. offices—an arrangement which, with a reception room on the corridor, usually commands the maximum squarefoot rental. A bay less than 17 ft. wide cannot be divided satisfactorily in this fashion. The latitude allowable in modifying the 18 x 24 ft. bay is indicated by these specific recommendations as to size: 18 ft. 6 in. x 22 ft., 20 x 22 ft., and 17 ft. 6 in. x 20 ft. to 25 ft. All of this applies to outside bays. Inside bays should be of a size which permits symmetrical and efficient arrangement of lighting fixtures.

#### **Windows**

Two 4 x 7 ft. windows in an 18 x 24 ft. bay constitute the most desirable arrangement. The window height may be varied slightly either way, but the 4 ft. width usually is regarded as the minimum. One manager contends that the area of glass exposed to the weather should amount to about 7 per cent of the total floor area. Another points out that under the widely used Sheridan-Karkow formula for pricing office space, rent is directly affected by relation of window area to floor area. Within practical limits, the greater the window area, the higher the rent.

#### **Partitions**

As a precaution, it is urged that not over 50 per cent of the dividing partitions be installed in a new building, and except for display purposes, no T-shaped partitions be erected until the space is rented. One manager suggests temporary partitions for large tenants, and permanent partitions for small offices and professional quarters. Of course, permanent partitions are necessary between suites. Among the permanent partitions recommended are hollow tile and plaster, gypsum block and plaster, and glass block. Because of the relatively low cost of the first two and the flexibility of the last, they also can be employed as temporary partitions. The usual alternatives where clear glass is needed are wood and steel sectional partitions. Building codes and insurance regulations restrict use of the latter in some cities.

#### **Corridors**

Preference as to corridor width varies considerably, but the 6-ft. corridor has gained general acceptance. One manager who recommends this size for secondary or extension corridors specifies 8 ft. for elevator corridors. Another suggests 6 to 15 ft. for main corridors and 5 to 8 ft. for secondary corridors. Still another believes that corridors more than 100 ft. long should be 5 ft. wide, with a width of 4 ft. in shorter corridors. Ceiling height is one of the governing factors, for lower ceilings require wider corridors.

#### **Floors**

Marble, terrazzo, and rubber tile are the most popular materials for corridor floors, with no preponderant preference for any one of the three. A 5-ft. marble wainscot set on a dark base is recommended for the walls, with smooth plaster on the upper walls and ceilings. The treatment of toilets and washrooms should be much the same, with the possible exceptions of higher wainscoting and the substitution of ceramic tile for marble walls and floors. Stall dividers should be of a non-absorbent material such as marble.

#### **Toilet rooms**

It is held generally that toilet rooms should be as near the center of the building as possible. However, this is somewhat contingent on the cost of adequate ventilation. A central location is especially feasible where the necessary ducts can be combined with ducts serving other space. If outside space must be used for toilets—and there are some managers who believe that light, airy toilets are a renting aid—they should be adjacent to or at least near other service space. In addition, they should be on the north side of the building so that the more desirable exposures will not be sacrificed.

The inside "L" spaces in buildings with two or more wings are considered good toilet locations. Although both the location and number of toilets are dependent on the size and shape of the building, most managers believe that there should be toilet rooms for both men and women on each floor. It is suggested, as a general rule, that for every 30,000 sq. ft. of office space, the following facilities be provided: ten toilets, four urinals, and two lavatories for men; and nine toilets and two lavatories for women. With central toilets, there should be at least one urinal on each floor.

### **Workshops and storerooms**

Architects sometimes are criticized for failing to provide enough space for workshops and rooms for storing partitions, lumber, and other bulky supplies. The basement is the preferred location for workshops. In a building with a bank on the ground floor, they can be located on the truss floor. They should be grouped, rather than scattered through the basement, and properly ventilated.

### **Waste paper storage**

Storage rooms for waste paper should be fireproof and large enough to handle a 24-hour accumulation. A basement location convenient to the freight entrance is best. Installation of sprinklers and a steam line controlled from the outside is recommended for fire protection.

### **Ash hoists and incinerators**

Fewer ash hoists and incinerators are installed today than formerly. There is no need of an ash hoist in a building using purchased steam, or oil, or natural gas as fuel. Instead of operating an incinerator, many managers have waste removed. Where an incinerator is needed, a 3 x 6 ft. firebox is recommended for buildings with less than 200,000 sq. ft. of floor area. In larger buildings, the size of the firebox should be increased in proportion. It is suggested that the incinerator be equipped with a pipe coil connected to the hot-water lines, adding to the capacity of the hot-water system.

### **Pipe shafts**

Pipe shafts should be of sufficient size to allow easy access to all lines for inspection and repair, and there should be access panels on all floors. In particular, cut-off valves and similar devices should be readily accessible. It is conceded to be impractical to attempt such provisions in the case of pipe and conduits that are concealed in floors, walls, and ceilings. However, trouble in these lines is rare, and heating risers and conduits usually last the life of the building. There is no way to avoid tearing out plaster when plumbing lines must be replaced.

### **Floor loads**

There is some demand for larger floor loading capacities. Recommendations range roughly from 100 to 200 pounds per sq. ft., 150 pounds ordinarily being considered ample. A 10-ft. ceiling height in the clear, which per-

mits use of high shelves and cabinets, allows installation of ducts for air conditioning, and makes for efficient lighting and ventilating, is regarded as ideal. In general, ceilings are higher in the South than in the North.

### **Boiler plants**

Few managers believe it is necessary to reserve space for private boiler plants in buildings using purchased steam and power. One goes so far as to call the private plant a thing of the past. Another points out that in a tall building the stack would usurp too much rentable area, while in a large low building this might not be the case.

### **Air conditioning**

Some managers believe that the designer of a building need make no special provision for air conditioning in the office space itself. They maintain that unit conditioners can be installed with little inconvenience to either tenants or management. In the case of large lower-floor tenants who contract for specific space in advance of construction, it is suggested that ventilating equipment adaptable to air conditioning be supplied.

There are other managers, however, who believe that definite provisions should be made for air conditioning when a building is planned. They offer a variety of recommendations: ventilating ducts arranged so that they can be used for sectional air conditioning; base plugs in exterior walls for connecting individual units; waste and water lines in the wall at the window side of the units (not necessary for conditioners of the evaporative condenser type); a 220-volt three-phase line on every floor into which unit conditioners can be plugged; doors designed for easy installation of return ventilators, and general provisions for concealment of ductwork.

### **Cleaning systems**

Opinion is divided as to the advisability of installing a central vacuum cleaning system, but managers of buildings so equipped assert that the central system is more economical than portable equipment. With the former, vacuum outlets at every second column are recommended. Where portable cleaners and scrubbing machines are to be used, electrical outlets must be provided in the corridors. There should be a janitors' closet on each floor containing a slop sink, preferably at floor level to facilitate dumping of

portable scrubbing tanks. The closet should be large enough to hold cleaning machines and janitors' supplies.

### **Wiring and plumbing systems**

Wiring and plumbing systems should anticipate increases in demand, with pipe shafts and conduits allowing for expansion by as much as 100 percent. Wiring in feeder and room distribution systems should provide for 50 percent more than the capacity of the initial installation. Further recommendations: a plumbing outlet on every other column; one electrical outlet on each face of interior columns, and one on each outside column; one fan outlet and a power outlet for an air-conditioning unit in each bay; under-floor ducts on 5-ft. centers; additional outlets for telephones, desk lamps, clocks, office machines, and other equipment if under-floor ducts are not installed.

### **Illumination**

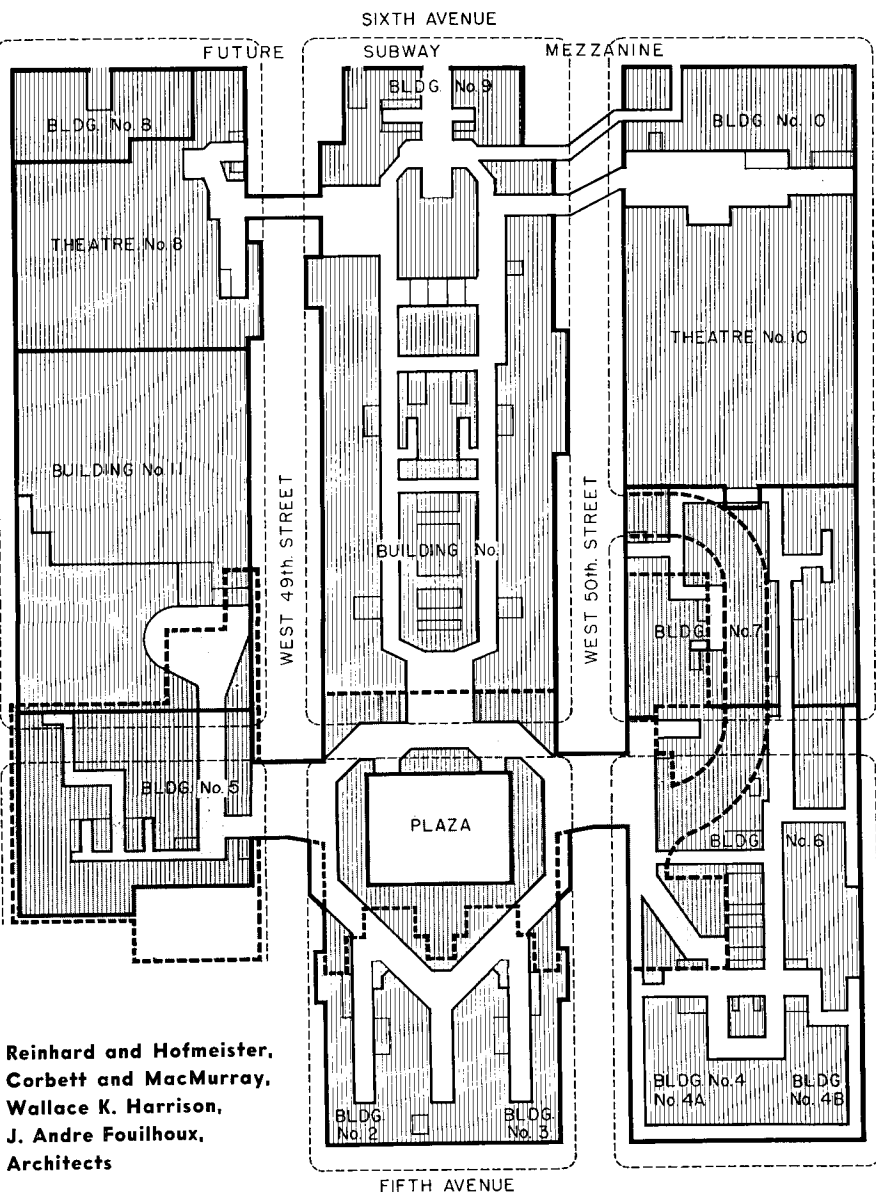
Semi-indirect illumination with an intensity of ten to twelve footcandles ordinarily is considered adequate in office space. One manager, however, expresses the opinion that in the future it will be necessary to make provision for at least twenty footcandles. Using 300-watt bulbs, this intensity can be obtained with ceiling fixtures spaced 9 ft. on centers. The lower level of illumination now considered acceptable is provided by four 200-watt fixtures in an 18 x 24 ft. bay. One manager recommends that arrangements be made to supply 4 K. W. per bay for business offices, and not less than 6 K. W. for medical offices. He also suggests that separate fuse boxes be installed in medical bays. In calculating the electric load, the present practice is to allow 4 or 4½ watts per sq. ft., but there is some tendency toward a higher standard.

### **Soundproofing**

Managers are practically unanimous in the opinion that soundproofing is necessary, particularly in the first three to five floors. Some prefer soundproof ceilings only; others would apply the principle to the design of walls, floors, and ceilings throughout the building. It is pointed out that soundproof partitions give the occupant of a room in an office divided by a T-shaped partition far more privacy than he ordinarily has, while soundproofing is needed in large offices to deaden the sound of typewriters and business machines.

# GARAGE, SHOPPING CENTER, AND BONDED WAREHOUSE

**New parking facilities and a system of underground trafficways will link the eleven office buildings of Rockefeller Center into one huge unit.**



**Reinhard and Hofmeister,  
Corbett and MacMurray,  
Wallace K. Harrison,  
J. Andre Foulhoux,  
Architects**



*Necessities, Inc.*

Above: An air view rendering of Rockefeller Center, New York, as it will appear upon completion. The parking garage and the new Associated Press building flank the tall R.C.A. building on the left and right respectively. Left: Underground traffic diagram of the development. White areas are circulation spaces at the concourse level; shaded area enclosed by dotted lines indicates extent of warehouse and trucking facilities.

WITH COMPLETION of the Associated Press Building, Rockefeller Center nears its final stage of development as the world's largest group of related office buildings under one management. The group already contains nearly four million sq. ft. of net rentable area as a result of building which has been nearly continuous since 1930. Completion of the two final buildings now under construction—Nos. 8 and 11 on the diagram above—will swell this total by nearly half a million sq. ft.

Significant among elements of planning and design that contributed to the success of Rockefeller Center is the

integration of its thirteen buildings (two theatres, eleven office buildings) into a single compact operating unit. Centralized control and management of a three-block area have made possible the development of pedestrian trafficways below the street level and creation of an extensive shopping center on the concourse level. This under-surface street system will be linked to the new subway at Sixth Avenue and has already proved a means of reducing surface congestion during rush hours.

Automobile parking will become—for the first time in New York—an integral part of office building design

when Building No. 11 is completed to house 800 cars and over 200,000 sq. ft. of net rentable area.

Commercial storage space as part of an office building is a comparatively new idea that has proved to be a profitable addition to Rockefeller Center facilities. A bonded warehouse is located in the service basement reached by a ramp that enters the new Associated Press Building (No. 7) at 50th Street. It provides convenient storage and trucking areas for importers and prevents street congestion which would otherwise be caused by delivery trucks.



**GENERAL PURPOSE OFFICE BUILDING**  
**ASSOCIATED PRESS BUILDING**  
**ROCKEFELLER CENTER, NEW YORK**

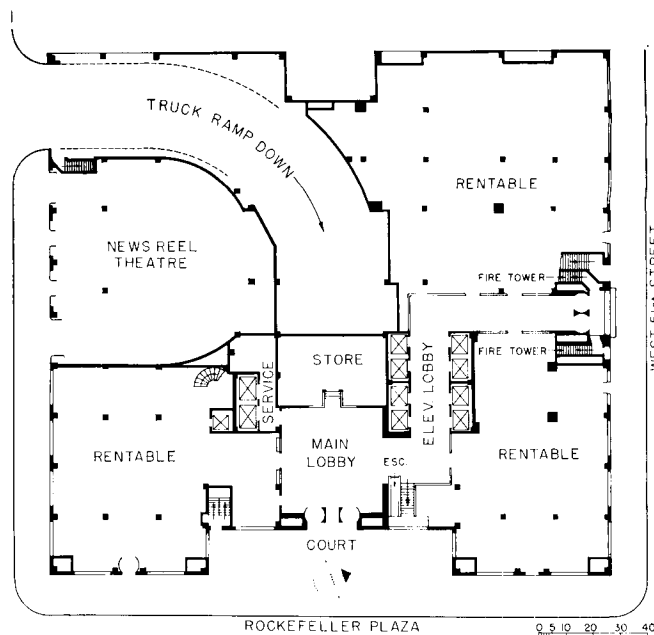
PLANNING and construction of the building were complicated by the presence of the truck ramp which runs through the first floor and concourse down to the service level. The ramp structure is entirely independent of the building which surrounds it. Column spacings throughout the building's height had to be modified from the ideal established for Rockefeller Center as a whole; so did elevator and other service locations.

In the service basement, ramp columns are clearly identifiable. Storage space is used partly in conjunction with the bonded warehouse which serves all the buildings, partly for usual building requirements.

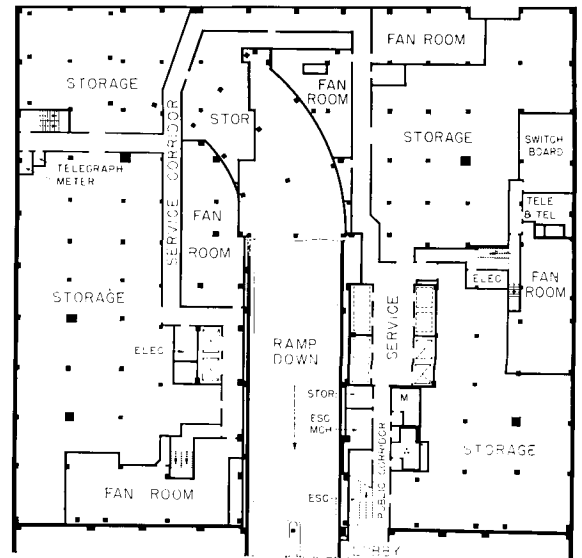
At concourse level, the connection to the public lobby in the adjacent building (No. 6) gives access to an escalator and stairs connecting with the lobby above.

On the first floor the newsreel theater fitted naturally into the ramp's curve; at least one rentable space is to be occupied by a business firm for public showrooms, with office space on the floor above. Notice that between the first and third floors the fire tower and other stairs cross over from exterior wall locations to the core of the building. The third floor is occupied by the administrative offices of Rockefeller Center. The fourth to seventh floors have been leased to the Associated Press. The larger columns shown in the plan are "wet" and carry hot and cold water, and soil stacks.

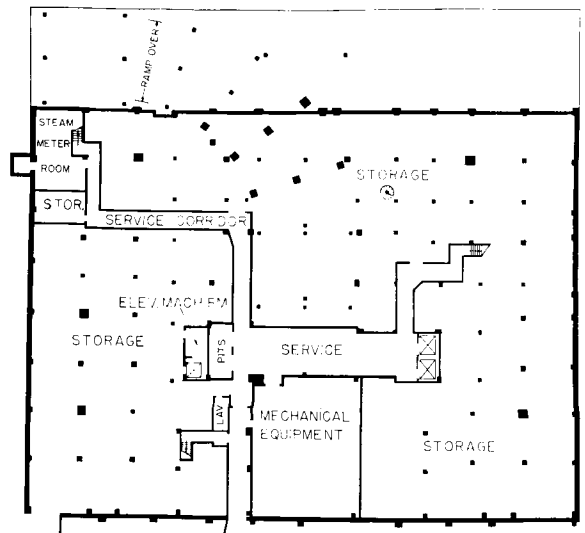
Effects of the truck ramp on typical floors are clearly visible on the upper floor plans. Notice the location of the elevators with respect to rentable floor area, which results in extremely shallow rentable space between the rear of the service core and the setback walls. As with most Rockefeller Center buildings, setback roofs are used for gardens. Sixteenth and seventeenth tiers, not shown, contain cooling towers, elevator machinery, fan rooms, and exhaust chambers.



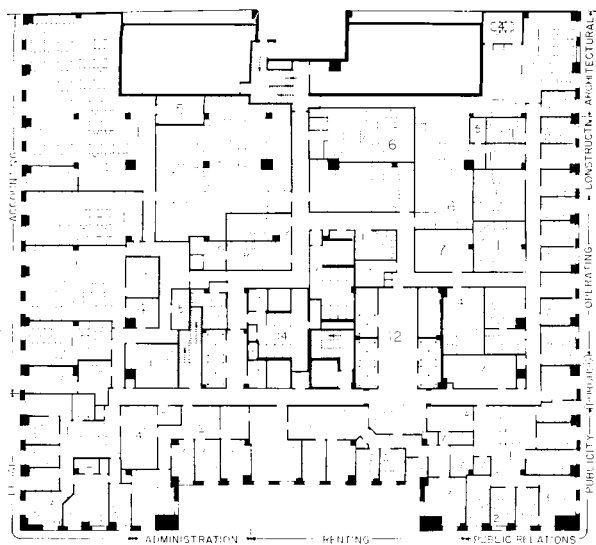
First floor



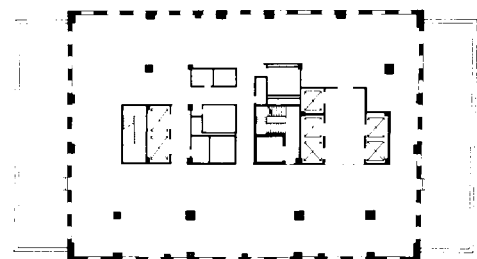
Concourse



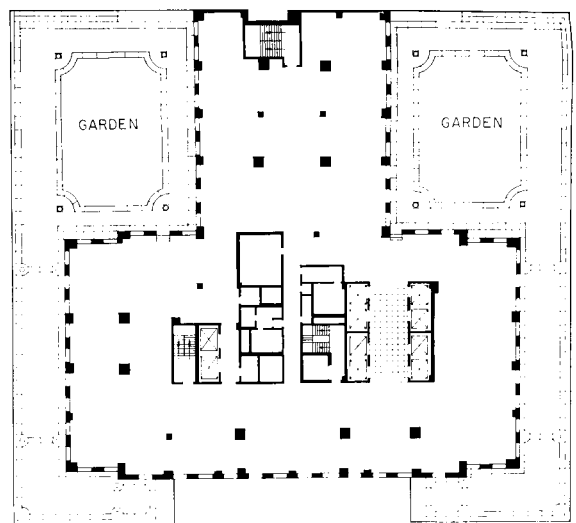
Service basement



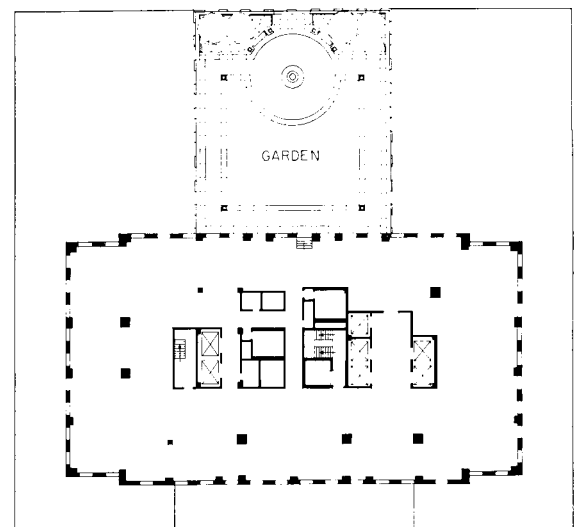
**Third floor, occupied by administrative offices of Rockefeller Center, Inc.** 1, general office. 2, private office. 3, executive office. 4, conference. 5, coatroom. 6, plan room. 7, storage. 8, waiting room. 9, duplicraph room. 10, consolidated stockroom. 11, switchboard. 12, reception. 13, women. 14, men. 15, vault. 16, consolidated file room. 17, mailing. 18, rest room. 19, quiet room. 20, executive's toilet.



**Fifteenth floor**



**Fifth to eighth floors**



**Thirteenth and fourteenth floors**

Reinhard and Hofmeister, Corbett and MacMurray, Wallace K. Harrison, J. André Fouilhoux, Architects

## MATERIALS AND EQUIPMENT

### FOUNDATION

Reinforced concrete

### STRUCTURE

Steel frame

### FLOORS

Floors cement generally; abrasive and hardener in trucking and shipping spaces; hydrolithic finish in storage spaces; terrazzo in public lobbies, elevator corridors, etc.; tile in toilets and washrooms

### WALLS

**Base:** Cement in shops; tile in toilets; terrazzo in main lobby; marble in elevator corridors; removable metal base at exterior walls of rentable areas

**Wainscot:** Steel in trucking and shipping areas; cement plaster in service basement washrooms; tile in toilets; bronze in escalator and stair hall

**Wall:** Smooth cinder block and brick in shipping platform, ramp, and service areas; enameled brick in shipping and trucking

areas; plaster and marble in public areas; face brick, common brick, sandlime brick, and smooth concrete block in sixteenth and seventeenth tiers; sandlime brick in fire tower

### CEILINGS

Plaster generally; unfinished in service and storage areas; hung plaster ceiling with asbestos insulation above, in steam-meter room; suspended metal lath and plaster in shop areas, public spaces, toilets, and in rentable space as required



**INSURANCE COMPANY'S HOME OFFICE, BOSTON, MASSACHUSETTS**  
**Chester Lindsay Churchill, Architect**

**LIBERTY MUTUAL INSURANCE COMPANY**

THE SITE was selected with a view to reducing traffic congestion and parking difficulties, convenient transportation, and permanently satisfactory light and air on at least three sides. The neighborhood is noisy, but methods of construction and the fact that the upper stories are set back from the building line minimize this defect.

**Plan features**

Perhaps the most notable feature is the column spacing, which was fixed to give maximum amounts of usable floor space in upper stories, eliminating columns in working bays.

Addition of future upper stories over wings is provided for in existing framing. Incorporating a large central fire tower, and centralizing circulation about it, permitted the omission of two stairways. Flexibility and convenience

of floor areas were enhanced by using movable partitions.

**Construction**

Dead loads were reduced by: Placing concrete floor slabs on top of beams, saving 4 in. fill; using gypsum block fireproofing generally around beams, saving also on cost; constructing tower roof of gypsum plank. These measures reduced foundation loadings, which were otherwise complicated by at least three factors.

First was the unusual column spacing referred to before. Consideration of spans together with results of test borings (bearing soil was soft blue clay in a stratum 90 ft. thick) resulted in selecting a system of clustered caissons, each supporting two or more columns. Second, lower portions of exterior walls were carried on the basement

walls, which were cantilevered from the same clusters of caissons. Basement walls thus became in essence a reinforced, continuous, concrete beam, containing positive and negative steel. Third, a very high retaining wall at the rear driveway, extending from sub-basement to grade, was supported at driveway level by horizontal concrete beams which also formed the driveway floor. These beams developed a horizontal thrust which was also carried into the basement.

**Heating and air conditioning**

Heating and air conditioning were combined into a "split" system, with six zones of steam heating and eight of air conditioning. Steam is purchased. All controls are automatic, and are brought together in the sub-basement, from which point manual re-

mote control is also possible.

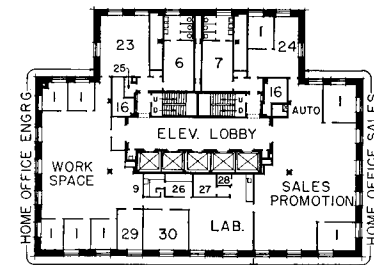
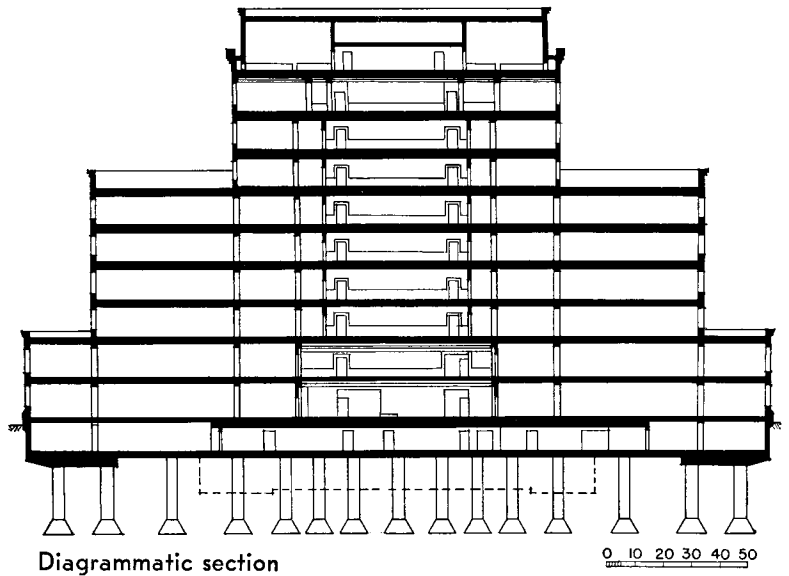
The steam-heating system comprises four exposure zones, one to each compass point, and two zones of "hot-blast" heating for the lobby. Automatic controls for exposure zones are placed in the building walls, and are sensitive to outside temperatures, sun, shadows, and wind infiltration. Lobby zone controls are similar, operating by pressure modulation. Radiators are cast iron convectors, with precision metered orifices, return traps being omitted. This permits radiators to be sealed without anticipation of repairs.

The eight winter air-conditioned zones are served by four groups of apparatus. Possible expansion of equipment and controls, for future summer conditioning, was considered and provision made for it. One shaft is used for the common exhaust from all floors. Exhaust inlets are located near floors at the center of the building. Supply outlets are in general at ceiling levels, in the faces of beams. Supply ducts at present extend to the 6th floor and are designed for future extension to all floors. The 9th floor is supplied with conditioned air from individual cabinets under each window, and air is exhausted through individual room inlets.

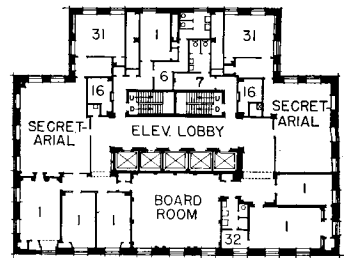
This combination of heating and conditioning was chosen to provide maximum flexibility in control and uninterrupted service and a minimum of steam consumption, maintenance, and repair. Flexibility was extremely important because portions of the building might be occupied at odd hours, and the system had to be capable of heating such portions without heating the entire structure.

#### Electrical systems

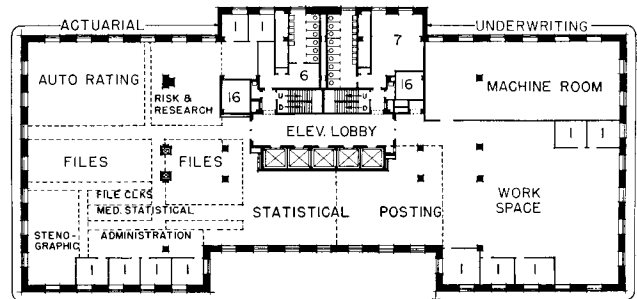
The wiring system is 3-phase, 4-wire, 120-208 volts, designed for a maximum of economy, flexibility for power and lighting, and minimum installation expense. The under-floor ducts are laid in a checkerboard system, with parallel ducts, one for telephone, bells, and buzzers, the other for machines. Lighting outlets are somewhat widely spaced and use high wattages. Lighting fixtures in all areas were chosen after exhaustive tests, made when the building had been completed, but before occupancy. Fixtures were rated for appearance, foot-candles delivered at certain wattages, cost, ease of maintenance and similar pertinent features. The average light intensity delivered is 17 footcandles at desk level.



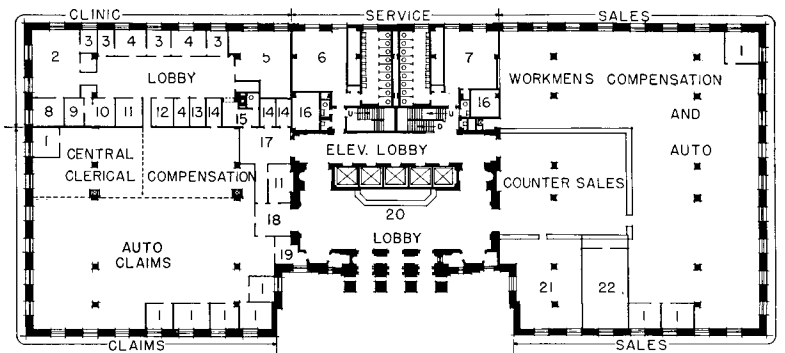
Eighth floor



Ninth floor



Fifth floor



First floor

**Legend:** 1, private office. 2, clinic. 3, examination room. 4, doctor's room. 5, baking and massage. 6, men's lockers. 7, women's lockers. 8, operating room. 9, darkroom. 10, X-ray room. 11, storage. 12, sterilizing. 13, nurses' room. 14, conference. 15, clinic waiting space. 16, duct shaft. 17, waiting space. 18, public space. 19, attorney waiting space. 20, information. 21, collections. 22, cashier. 23, projection room, drivers' tests. 24, general service. 25, projection booth. 26, microscope room. 27, dust room. 28, balance room. 29, engineering library. 30, laboratory office. 31, executive office. 32, anteroom.

# INSURANCE BUILDING BOSTON, MASSACHUSETTS

## MATERIALS AND EQUIPMENT

### FOUNDATION

Reinforced concrete; test borings, Raymond Concrete Pile Co.

### STRUCTURE

Steel, American Bridge Co.; sand-lime brick interior partitions, Parry Brick Co.; reinforced concrete slab floors

### EXTERIOR

**Walls:** Brick; limestone facing, Indiana Limestone Corp.; base, pink granite, Swenson Granite Co.; main entrance, glass block, Corning Glass Works. **Sash:** Steel casement, Detroit Steel Products Co. **Roof:** Tar and gravel on structural gypsum, concrete slab.

**Insulation:** Cork, at all roof levels; sectional partitions packed with Rock-Wool.

### INTERIOR

**Floors:** Basement, granolithic; lobby and vestibules, rubber mats, American Mat Co.; terrazzo, De Paoli Mosaic Co.; asphalt tile, David E. Kennedy Co.; linoleum, Sloane-Blabon and Congoleum-Nairn ("Sealex"); rubber, "Air pad" sheet rubber, Voorhees Rubber Mfg. Co.; ceramic tile, Galassi Co. **Walls:** Gypsum plaster; tile; travertine; main lobbies, Italian travertine, Vermont Marble Co.; office partitions, painted and glazed, 3 $\frac{7}{8}$ -in. "Transite", Johns-Manville Corp.; machine, tabulating and addressograph rooms, Acousti-Celotex tile, 1 $\frac{1}{4}$ -in. Type BBB. **Doors:** Main entrance, bronze, General Bronze Corp.; hollow metal, Jamestown Metal Corp.; vault, York Safe & Lock Co. **Ceilings:** Corridors and lobbies, plaster; 8th and 9th floors, acoustic plaster; other floors, "Sanacoustic" tile, Johns-Manville Corp.

### EQUIPMENT

**Elevators:** Otis Elevator Co.; cabs, W. S. Tyler Co.—speed, 500 ft.-min., 3,000-lb. capacity, full automatic floor control in lobbies and cars.

**Hardware:** Yale & Towne. **Plumbing:** Brass pipe, Anaconda Wire & Cable Co., American Brass Co.; "Duriron" acid-resisting pipe; steel, National Tube Co.; wrought-iron, Byers Co.; brass fittings, Walworth Co.; pumping equipment, Dayton-Dowd; sprinkler heads, Reliable Automatic Sprinkler Co.; fixtures, Crane Co.

**Heating and Ventilating:** American Radiator convectors; exposed radiation, Shaw-Perkins; heating specialties, Hoffman Specialty Co.; temperature indicating system, American Temp. Indicating Co.; pipe, copper-bearing steel, National Tube Co.; zone control system, Tallmadge Co.; primary and secondary heaters, Aerofin Corp.; valves, Walworth Co.; motors and controllers, G.E.; air-conditioning cabinets, 9th floor, Carrier. **Electrical:** Switches, Hart & Hegeman, Automatic Switch Co., Trumbull Elec. Co.; circuit breakers, Westinghouse; motor starters, G.E.; receptacles, Bryant; duct, steel, Walker Bros.; outlet boxes, National Electric; cable, "Simplex", and American Steel & Wire Co.; switchboard, Westinghouse.

**Waterproofing:** Basement, plaster coat, "Ironite"; spandrel beams, membrane, through walls; forecourt and rear ramp, three-ply membrane; expansion joints in all copings. **Toilets:** Partitions, Henry Weis Mfg. Co.; soap dispensers, West Disinfecting Co. **Storage:** Shelving, steel, adjustable, Berger Mfg. Co.; lockers, steel, Metal Office Furniture Co. **Dust Room:** A. O. Wilson Structural Co. **Office equipment:** Furniture, Stow-Davis Furniture Co., Daten-Dunton Desk Co., Paine Furniture Co.; mailing room, General Fireproofing Corp.

Cost, not including architect's fees, approximately 57¢ per cu. ft.

Photos by Ben Schnall



Main lobby is 22 by 72 ft., 27 ft. 6 in. high. Lighting is provided by 14 down-light projectors, 300 watts each. Floors are terrazzo; walls travertine with plaster panels for murals. Ceiling is painted medium blue.



Elevator lobby, third floor, is 12 by 5 with a linoleum floor in terra cotta, and black. Base and dado are marble; and ceiling, plaster. Lighting is furnished 3 semi-indirect fixtures.



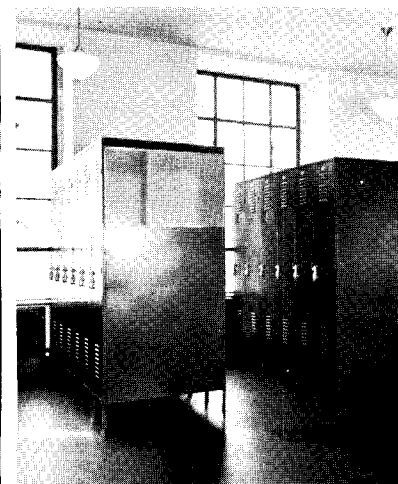
General office spaces have air-conditioning outlets at the faces of beams and are acoustically treated. Lighting is semi-indirect; colors having high reflectivities are used on walls and ceilings.



Typical work space. Number of persons employed varies through the year, but averages as follows: Basement, 50; 1st floor, 160; 206; 3rd, 167; 4th, 140; 5th 220; 6th, 96; 52; 8th, 35; 9th, 28; total, 1,154.

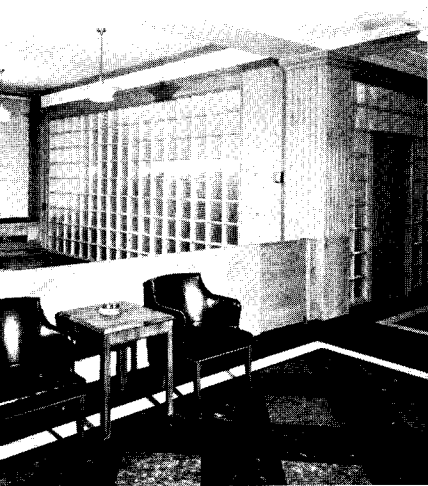


Basement supply space is equipped with 1,020 units of shelving in depths varying from 18 to 42 in. Shelving height is usually 8 ft. 3 in., sometimes 6 ft. 8 in. or 7 ft. 3 in. Lighting is of the direct type.

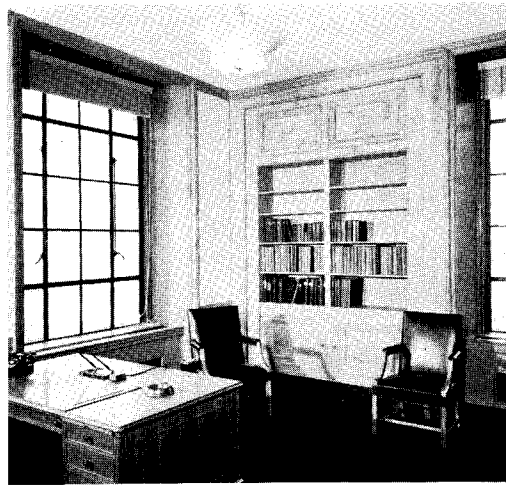


Typical locker room. These vary in size capacity; the largest contains 93 lockers in sq. ft. There are 18 such rooms. Lighting is standard direct, diffused.

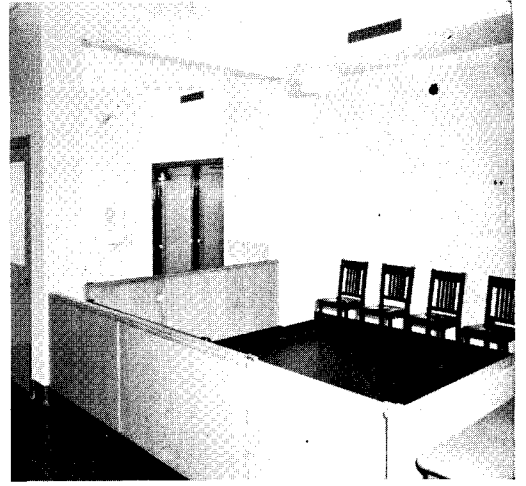




President's office and waiting space, 9th floor. Floor is of linoleum; base is marble; walls of wood, brick, wood, and plaster. Ceilings are of acoustical plaster; lighting by semi-indirect fixtures.



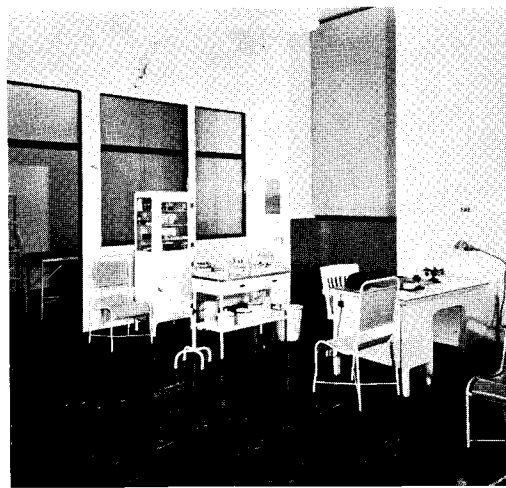
Vice-president's office, 9th floor. Floor is of linoleum; base is marble; walls are wood paneled; and ceiling is of acoustical plaster. Lighting is furnished by two semi-indirect fixtures.



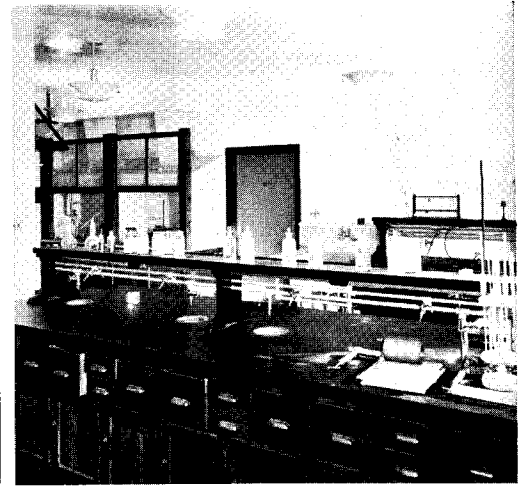
Purchasing dept. waiting space on 2nd floor is 11 ft. 6 in. by 12 ft. Floor is linoleum; base, slate; walls, plaster. Ceiling is of acoustical tile set in panels between the beams.



Tabulating machine space. These have well as ceilings acoustically treated, using "Acusti-Celotex" perforated or is linoleum; base, slate; and lighting indirect.



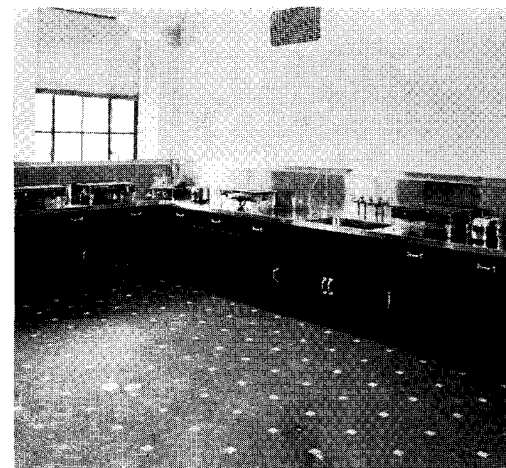
Clinic on first floor is an important unit containing 20 rooms. Floor is rubber; base, slate; sectional partitions are painted. Lighting is in general indirect, although the unit here shown is semi-indirect.



Chemistry laboratory on 8th floor contains 600 sq. ft. Floor is asphalt tile; otherwise finish is similar to other areas. Among several rooms served is a dust-testing room, built airtight, for air-supply and exhaust calibration.



Washroom. These vary from 120 sq. ft. to 150 sq. ft. in size. Lighting is standard direct, diffused. Walls, floor, base, and dado are ceramic tile in shades of tan with white trim.



Kitchen floor and base are tile; walls and ceiling, acoustic plaster; lighting direct, diffused. Equipment includes hot plates, toasters, sinks, refrigerators, incinerator, dishwasher, cabinets, and glass and plate tables.



Lunch room is 39 ft. 6 in. by 53 ft.; contains 43 tables, 171 seats. Lighting is standard direct, diffused. Floor is rubber; base, slate; walls and ceilings, acoustic plaster.



## AIR LINE'S HEADQUARTERS CHICAGO, ILLINOIS

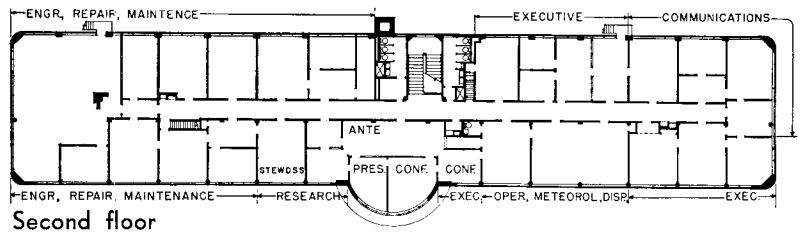
**Albert Kahn, Architect**

### UNITED AIR LINES TRANSPORT CORP.

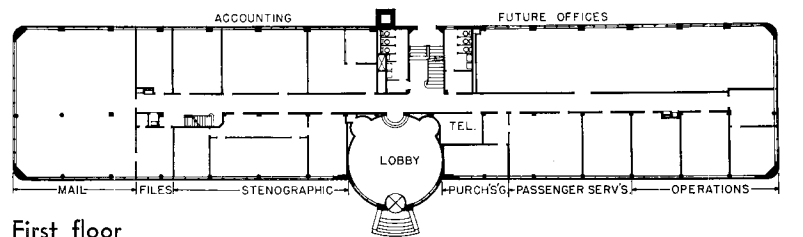
ALL OFFICE AREAS are lighted by 300-500 watt indirect fixtures. The average per square foot is 4 watts, furnishing 25 footcandles in offices, 40 footcandles in drafting rooms.

Large areas are surfaced with "Acoustone-W" Mineral Tile, which has a sound reduction coefficient of .60 and a light reflection coefficient of .70. Paint on the walls has a reflectivity of 60 percent; ceilings, 80 percent.

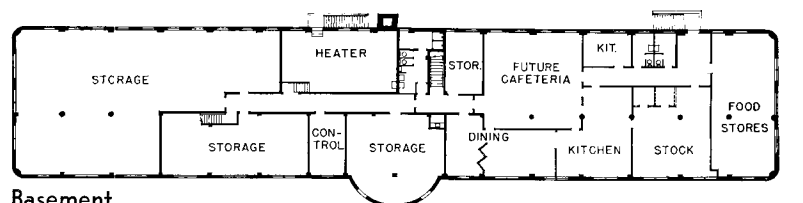
Most of the ventilating equipment is located in a penthouse. Air is partially recirculated and partially fresh. The ventilating system supplies about 10 percent of the maximum heating load. The remainder is supplied by a 2-pipe, forced circulation, hot-water system with concealed copper fin radiators. The entire heating system is thermostatically controlled for all variations of outside temperature with automatic valves controlling various portions.



Second floor



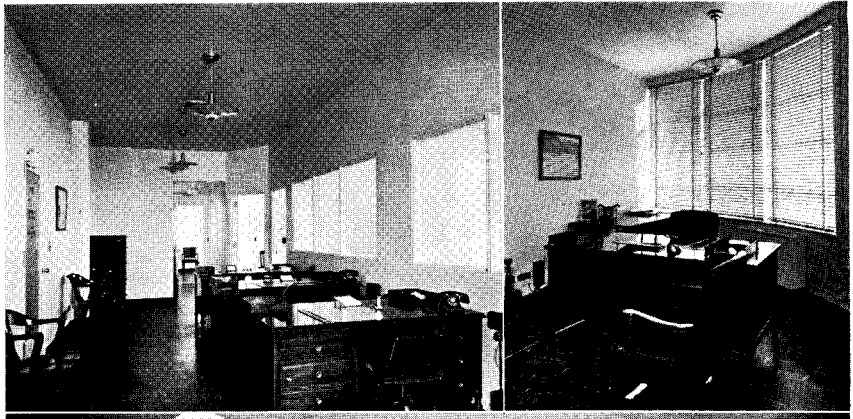
First floor



Basement

Photos at right: 1, typical office; 2, president's office; 3, basement kitchen; 4, entrance lobby; 5, exterior.

1, 2



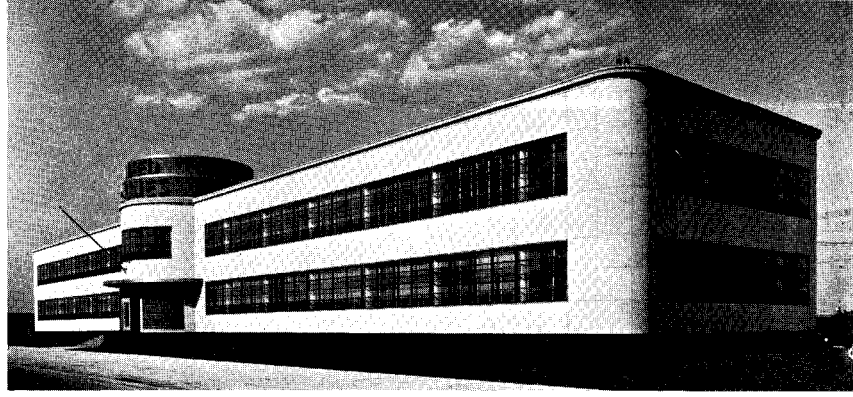
3



4



5



**MATERIALS AND EQUIPMENT**

**FOUNDATION**

Concrete

**STRUCTURE**

Reinforced concrete frame

**EXTERIOR**

**Walls:** Black granite base and entrance, American Black Granite Co.; Indiana limestone, Ingalls Stone Co.; glass brick, Owens-Illinois Glass Co.; face brick, Moulding-Brownell Co.  
**Sash and doors:** Architectural projected steel sash and screens, Hope's Windows, Inc.; sills, aluminum; doors, main entrance, metal (revolving), others, wood and hollow metal, Trussbuilt Co.

**Roof:** Tar and gravel roofing; copper flashings

**Insulation:** Cork, United Cork Co.

**INTERIOR**

**Floors:** Concrete with linoleum generally; terrazzo in toilets, stair hall; quarry tile in kitchens, commissary; rubber tile in executive offices

**Partitions:** Gypsum block generally; hollow tile in kitchens, commissary; glazed tile in toilets; metal partitions, Henry Weiss Mfg. Co.; marble, Vermont Marble Co.

**Trim:** Hollow metal and wood, Trussbuilt Co.

**Ceilings:** Plaster, painted; acoustic ceilings in lobby and special offices, Celotex Corp.

**EQUIPMENT**

**Electrical:** Mild steel tube conduits, Clayton Mark Co.; clock system; tower floodlighting, Westinghouse Electric & Mfg. Co.; power panels, C. J. Petersen Co.; light panels, Major Equipment Co.; circuit breakers, I.T.E.; wire and cable, Rome Cable Corp.; intercommunicating telephone system

**Plumbing:** Hot-water and recirculating lines, copper tubing; fixtures, vitreous china, Standard Sanitary Mfg. Co.; floor drains, Boosev Mfg. Co.; soil pipe and fittings, Sommerville Iron Wks.; valves and fittings, Walworth Co.; faucets, Chicago Faucet Co.; vitrified tile pipe, N. A. Williams; flush valves, Sloan Valve Co.

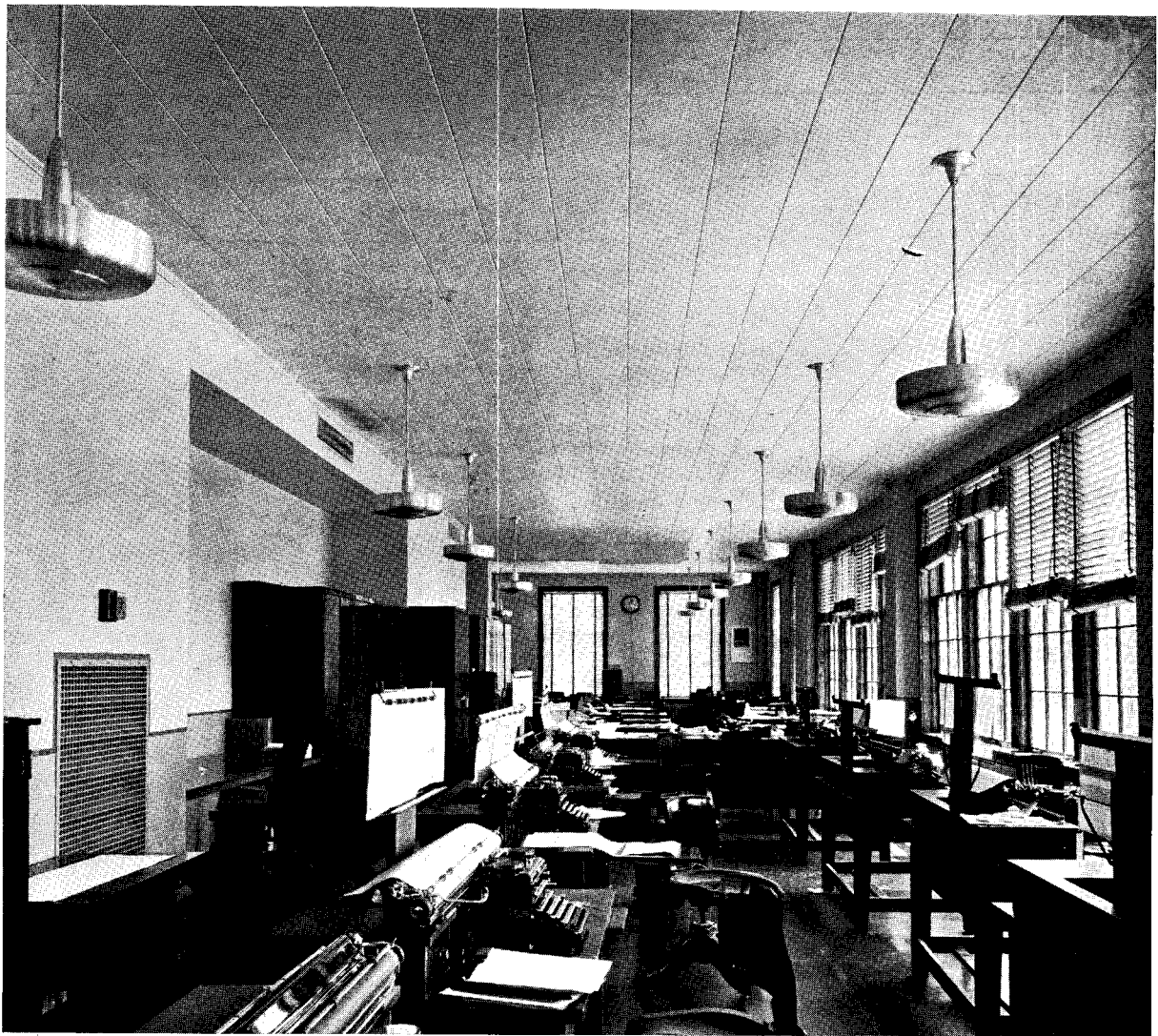
**Heating:** Forced circulation two-pipe hot-water system, concealed radiation, copper; radiator valves, J. P. Marsh Corp.; oil burners, Todd Combustion Equipment Co.; unit heaters, Perfex Corp.

**Air Conditioning:** Installed as designed by architect

**Hardware:** Russell & Erwin Co.

Cost of building: 51.6¢ per cu. ft.

Photos by Chicago Architectural Photo. Co.



## OFFICES FOR A STATISTICAL RESEARCH ORGANIZATION, CHICAGO, ILLINOIS The Benjamin H. Marshall Co., Architects

A. C. NIELSEN COMPANY

### MATERIALS AND EQUIPMENT

#### FOUNDATION

Reinforced concrete

#### STRUCTURE

Reinforced concrete

#### EXTERIOR

**Walls:** Red brick, Western Brick Co.

**Sash:** Wood, double-hung

**Roof:** Two-inch cork insulation, quarry tile deck on main roof; penthouse, roofing composition; sheet metal, lead-coated copper

**Insulation:** Sprayed-on rock wool on all exterior walls with two layers "Fibrewole" insulating paper No. 7, saturated and coated. Philip Carey Co.

#### INTERIOR

**Walls:** Hollow tile plastered and painted; wainscot in offices, Flexwood, U. S. Plywood Corp.; wainscot in reception hall and stair hall, walnut

**Floors:** Work spaces and offices, asphalt tile; public corridors, stair hall, reception hall and toilet rooms, terrazzo; stairs, Chicago Art Marble Co.

**Ceilings:** Lobby, stair hall and public corridors, plastered; private offices, more

Cost for building only: \$219,574.27

important and noisier work spaces, "Perfatile," U. S. Gypsum Co.; remainder of spaces, "Acoustone," U. S. Gypsum Co.

**Doors and trim:** Reception hall, stair hall, public corridors and private offices, walnut and maple; secondary private offices and work spaces, birch, stained walnut

**Painting:** Public corridors, light buff; work spaces, light grey with greenish touch; wainscot, medium grey-green

#### EQUIPMENT

**Heating and air conditioning:** "Moderator" heating system with vacuum pump, Warren Webster Co.; temperature controls, Johnson Service Co.; air-conditioning compressors, Westinghouse Elec. & Mfg. Co.

**Plumbing:** Fixtures, Kohler Co.

**Incinerator:** Kerner Incinerator Co.

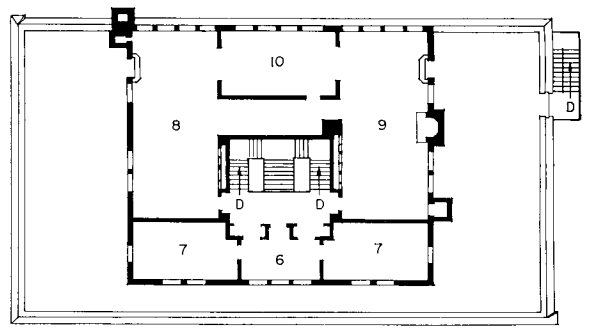
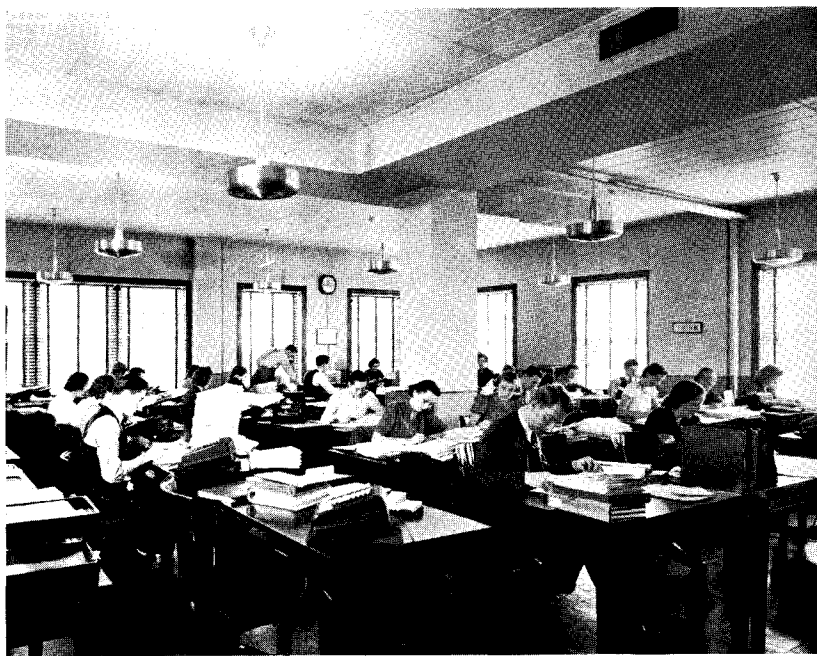
**Vault:** Mosler Safe Co.

**Electrical:** Full indirect lighting; fixtures, Curtis Lighting, Inc.; electric dumbwaiter, Otis Elevator Company

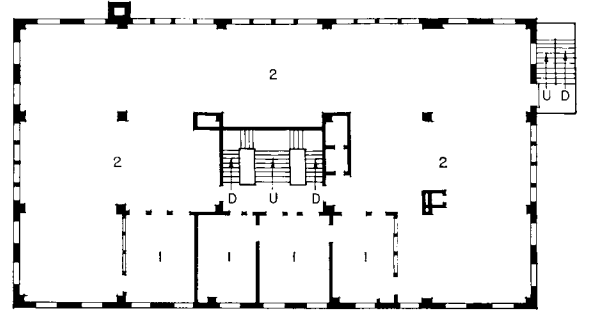
**Toilet rooms:** Stalls, Fiat Metal Mfg. Co.

**Service kitchen:** Albert Pick Co.

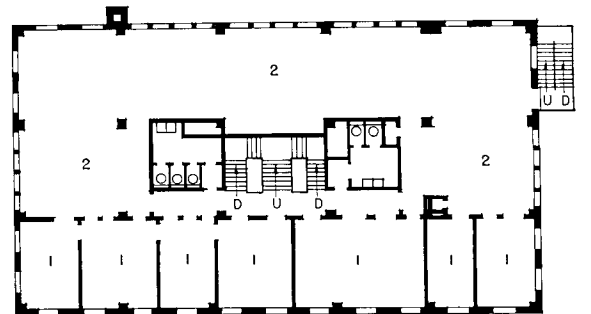




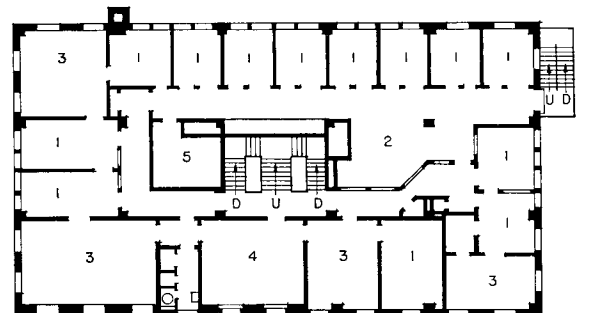
Fifth floor



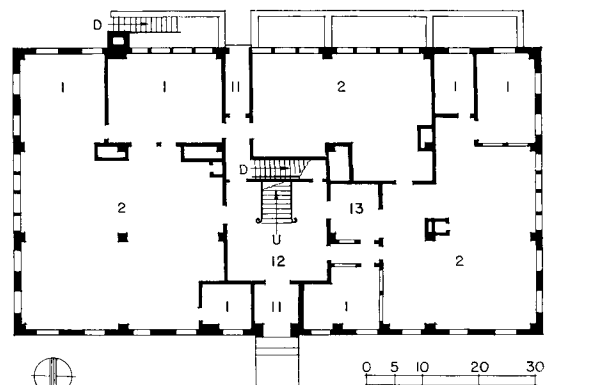
Fourth floor



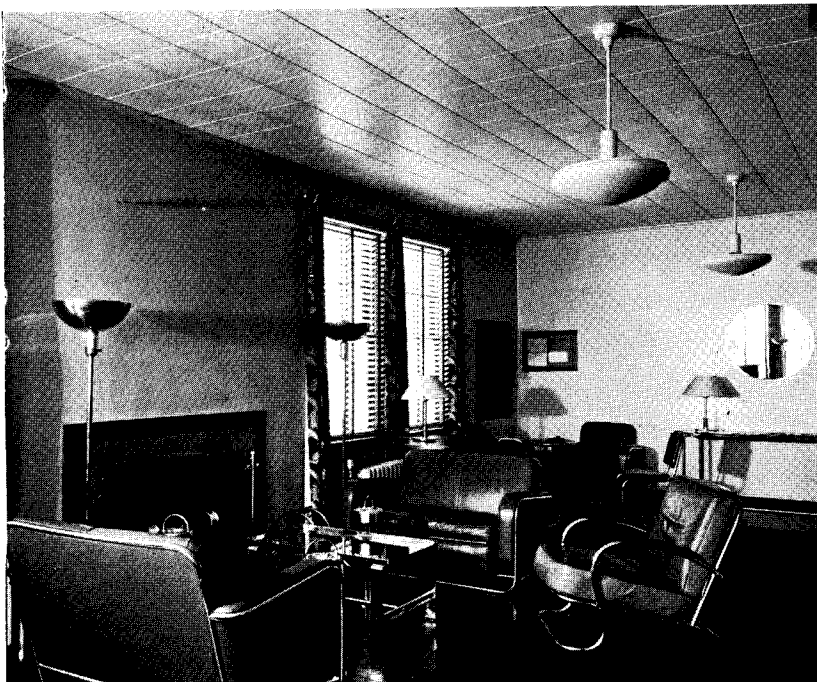
Third floor



Second floor



First floor



Top photograph, typical work space; lower, employees' recreation room. This building is a modernized structure. The principal problem was laying out floor space to fit special requirements of the business. Many private offices are necessary for report writers. Large working spaces are used by checkers, Comptometer operators, typists, etc. The second floor library is in effect a vault for filing official reports. Another vault is provided in the basement. Sample rooms in the penthouse are set up as a drugstore and grocery store and are used for training the field staff. Mechanically, the building is completely air conditioned, insulated, has acoustically treated ceilings and indirect lighting.

1, private offices. 2, general work space. 3, executive offices. 4, conference room. 5, library. 6, anteroom. 7, sample room. 8, recreation room. 9, clubroom. 10, executives' room. 11, vestibule. 12, lobby. 13, switchboard.

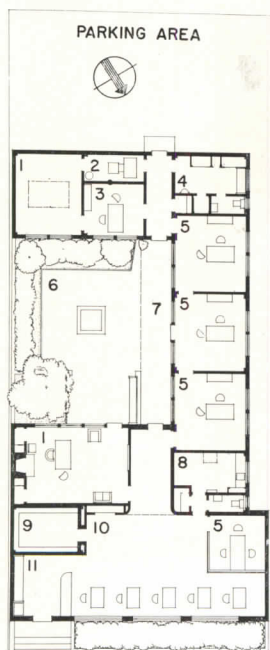
Photos by Miles Berne



**ONE-STORY OFFICE BUILDING  
LOS ANGELES, CALIFORNIA**  
**Winchton Leamon Risley, Architect**



**THE O. C. FIELD GASOLINE CO.**

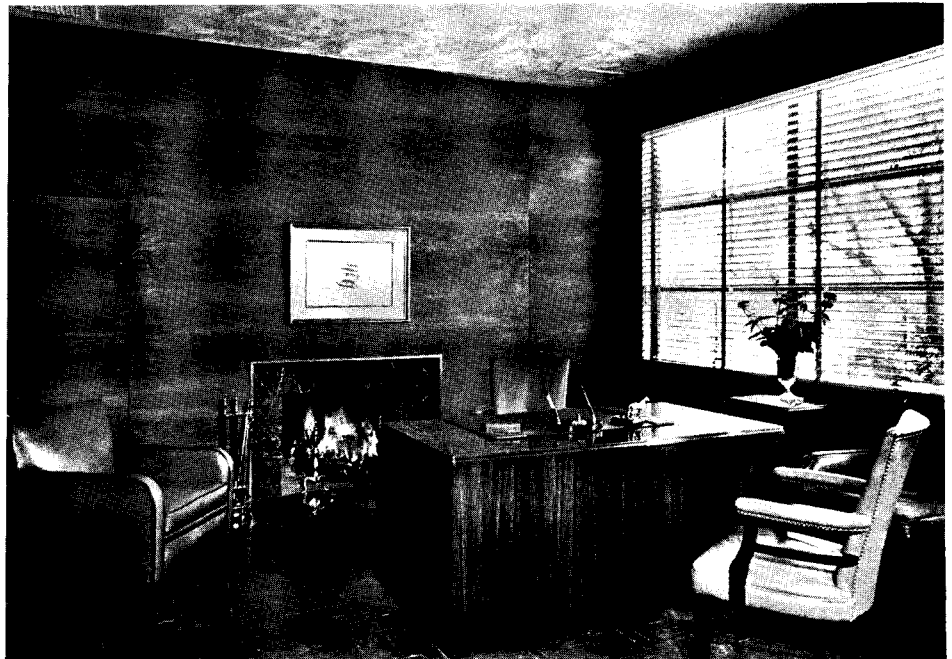


- 1, executives. 2, heater.
- 3, conference. 4, men.
- 5, private offices. 6, patio.
- 7, roofed gallery.
- 8, women. 9, vault. 10, work space.
- 11, entry.

STREET 0 5 10 20 30

IN KEEPING with what has become traditional "California" residence planning, the patio is used in this one-story office building and serves to provide economical circulation and outdoor conference space. It also affords natural light and a pleasant outlook for all private offices, and provides pleasant surroundings for both employees and business visitors. The parking area in the rear of the building is reached from an adjacent street.

The heater room was located in the rear of the first floor in order to eliminate any necessity for a cellar, thus aiding in reducing costs to a minimum.



At top, general office space; below, executive's office. Use of parchment-colored stucco and henna-colored doors relieves the simplicity of the interiors; executive's office is in natural walnut-faced plywood.

## MATERIALS AND EQUIPMENT

### FOUNDATION

Concrete

### STRUCTURE

Reinforced concrete

### EXTERIOR

**Walls:** Poured concrete; stucco on brick chimney; painted light green with rust-colored dado and cornice, "Semolith"

**Roof:** Five-ply, built up with gravel

**Insulation:** "Silvercote" insulation fabric between roof joists and furred-down ceiling, Specialty Converters, Inc.

**Sash:** Side-hinged steel, Druwhit Metal Products Co.; bronze screens

**Waterproofing:** All concrete walls, "Suconem", Super Concrete Emulsions, Ltd.

### INTERIOR

**Walls:** Parchment-colored stucco; Office No. 2, natural walnut finish plywood panels, "Ailon", U. S. Plywood Co.

**Ceilings:** Parchment-colored stucco

**Floors:** Reinforced concrete slabs; asphalt tile finish, Seaside Products Corp.

### EQUIPMENT

**Heating:** Hot-air and air-circulation systems, Payne Furnace & Supply Co.

**Plumbing:** Galvanized steel pipe; fixtures, gas hot-water heater, Crane Co.

**Lighting:** Semi-indirect, General Electric Co.

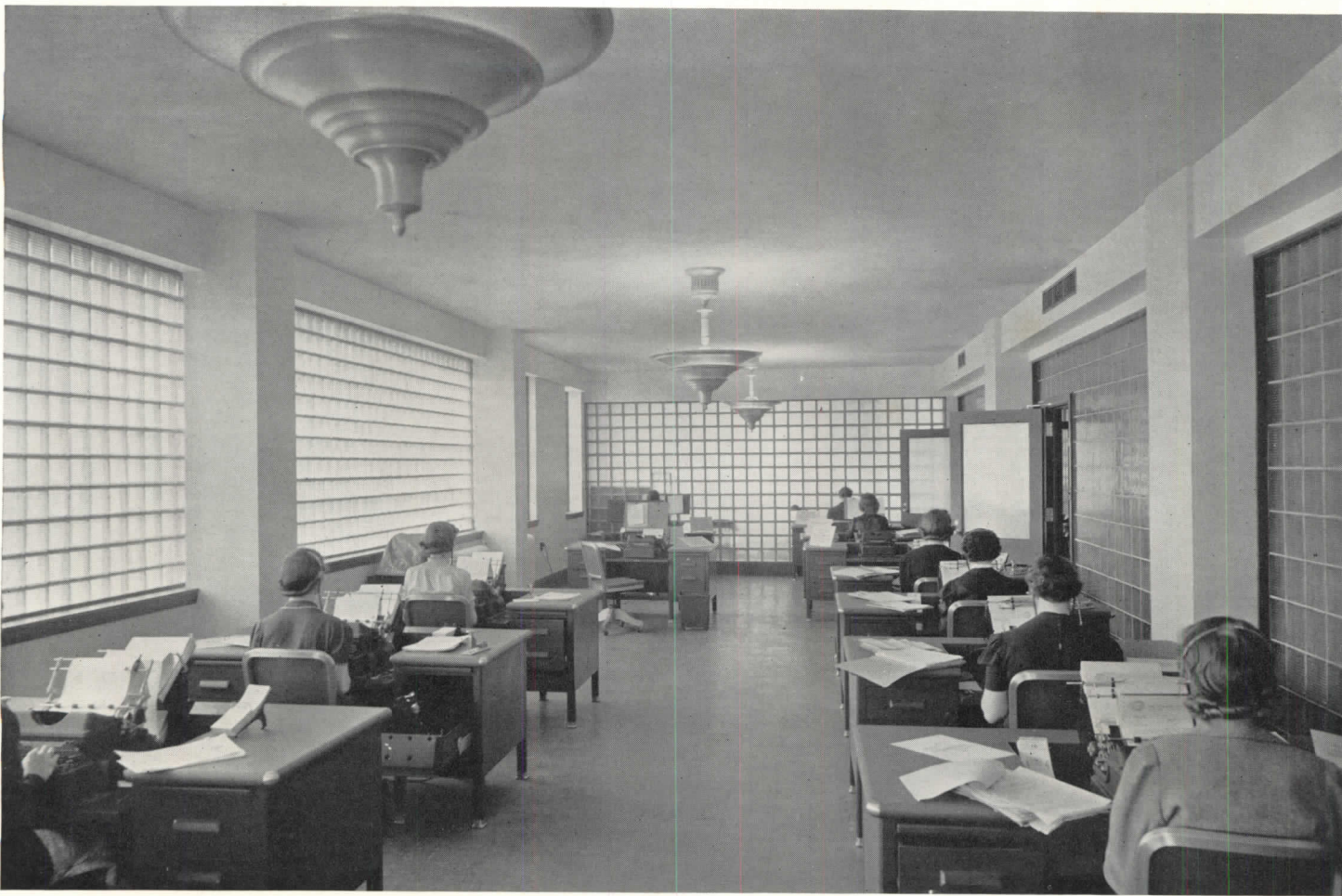
**Hardware:** P. & F. Corbin

**Glass:** Standard, American Sheet Glass; glass block over front door, "Insulux", Libby-Owens-Ford Glass Co.

**Decorative tile:** Gladding, McBean & Co.

**Acoustical treatment:** Ceilings of offices 1, 2, 3, 4, 5, and 6 have acoustical plaster on metal lath. Plaster, Blue Diamond Corp., Ltd.

Cost, including interior finish, excluding fees: 32¢ per cu. ft.



## PLANT ADMINISTRATION OFFICES

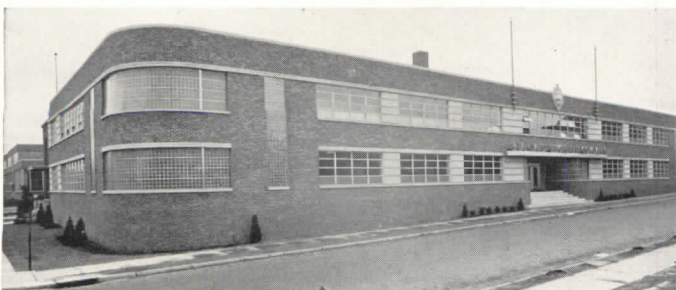
DAYTON, OHIO

The Austin Company, Engineers

### THE STANDARD REGISTER COMPANY

SINCE THIS company's business is the manufacture of precision forms to eliminate waste motion in offices, it is natural that its new administration building should be designed with the same end in view. It is all-year air conditioned, acoustically treated, and lighting is General Electric engineered.

The air-conditioning system will maintain an average temperature of 80° with 50% relative humidity when the outside temperature goes to 90° in summer. The system operates in combination with direct radiation and is under thermostatic control with 7 zones. Cooling is provided by a combination of well water and mechanical refrigeration.

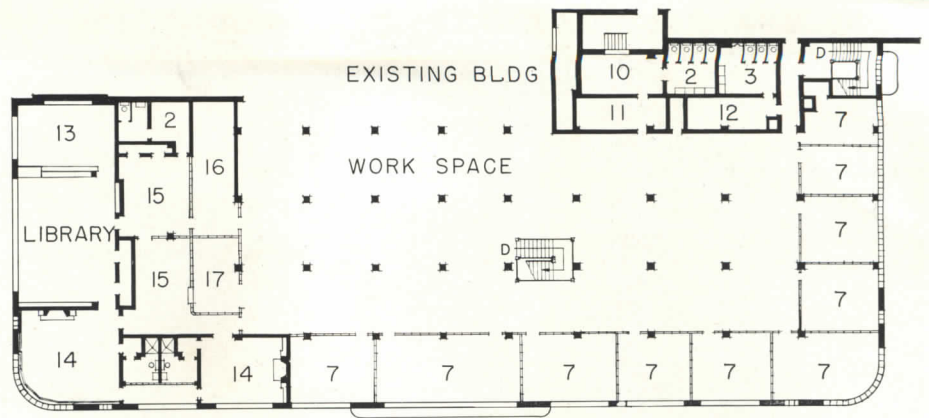


In addition, well water is sprayed on the office roof to minimize heat absorption.

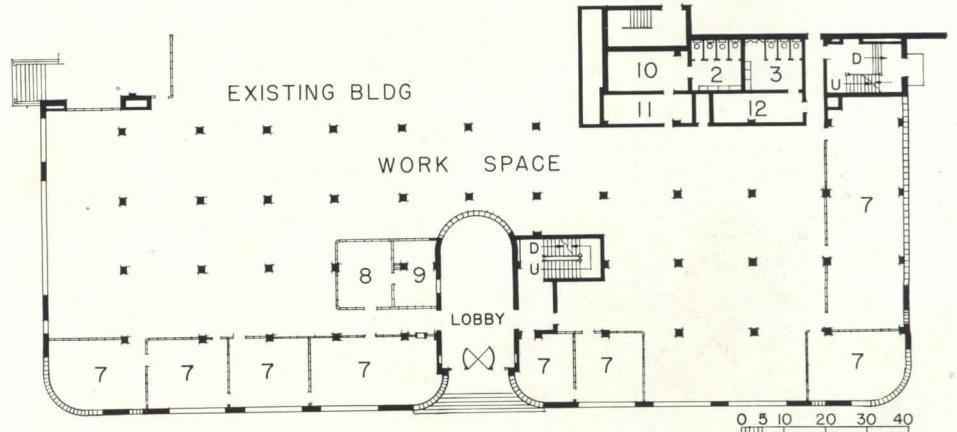
The office shown at the top of the page is a transcribing room. Directly outside this runs the main line of the Big Four Railroad, yet by use of glass block exterior walls and acoustical ceiling treatment, the noise level is sufficiently reduced so that it does not disturb the workers. All interior glass block partitions are set upon special rolled steel channel bases which provide raceways for electrical conduits. These, together with the hollow door jambs which function similarly, permit the concealment of all wiring which would otherwise have been rendered difficult or unsightly. The lighting is accomplished by a combination of Mazda lamps and mercury vapor lamps in spun aluminum reflectors. Twenty footcandles are delivered on working planes. Assembly hall, shown on the plans on facing page, is necessary for salesmen's conferences, and the kitchen and cafeteria will be used in the same connection.

On the second floor, the principal portion is devoted to a general office with a ceiling height of 25 ft. and surrounded by glass block walls. The upper portion of these is a monitor, providing natural lighting which is sufficient for all but the darkest days.

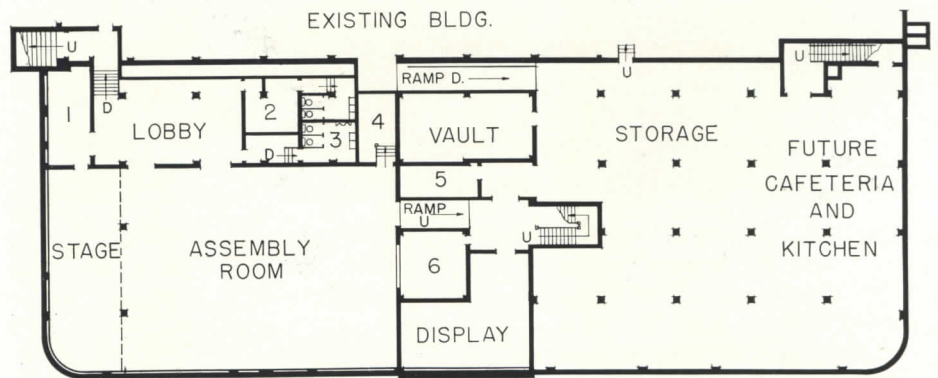




Second floor



First floor



Basement

**Legend for plans:** 1, checkroom; 2, women; 3, men; 4, chair storage; 5, telephone equipment; 6, projection room; 7, offices; 8, teletype; 9, telephone and information; 10, rest room; 11 & 12, coatroom; 13, conference room; 14, private office; 15, secretary; 16, records; 17, waiting room.

**MATERIALS AND EQUIPMENT**

**FOUNDATION**  
12-in. concrete to grade

**STRUCTURE**  
Steel frame

**EXTERIOR**  
**Walls:** Grade to first floor, face brick, concrete wall backing; first floor to roof, face brick, clay tile backing, Alliance Brick Co.  
**Roof:** Tar and gravel, 15-year-guaranty bond, Philip Carey Co.; sheet metal, 15-year-guaranty bond flashing system

**Insulation:** One-inch cork insulation nailed to wood roof sheathing, Armstrong Cork Prod. Co.  
**Sash:** Monumental windows, Truscon Steel Co.  
**Trim:** Art stone sills, heads, coping, George Rackle & Sons

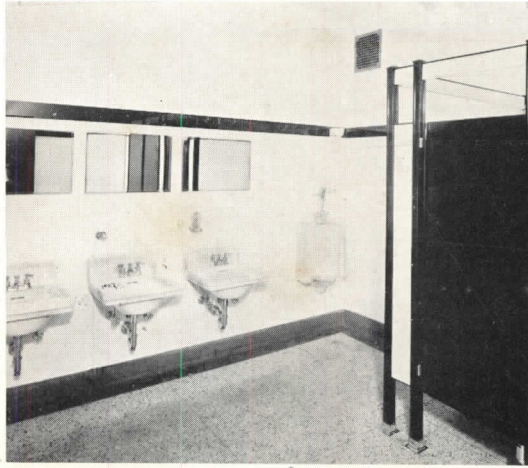
**INTERIOR**  
**Walls:** Glass block, Owens-Illinois Glass Co.; clay tile plaster; executive offices, oak panels  
**Floors:** Concrete ribbed type, metal forms; asphalt tile; lobby, terrazzo  
**Doors:** Wood with metal frames  
**Stairs:** Metal pan type; terrazzo filled treads and landing

**EQUIPMENT**

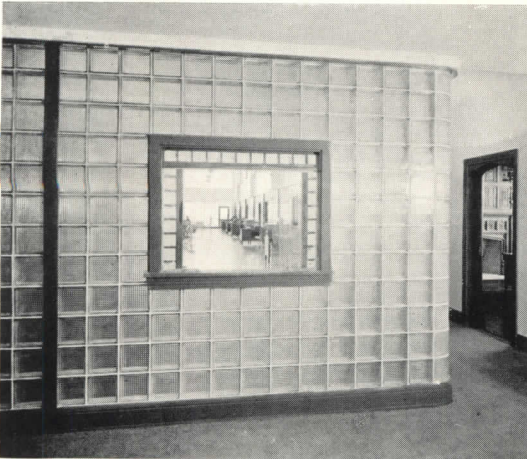
**Air Conditioning:** Delco Frigidaire; fans, American Blower Co.; filters, American Air Filter Co.; automatic control, Minneapolis-Honeywell Regulator Co.; motors, Delco, General Motors Corp.; sheet metal, American Rolling Mill  
**Electrical:** Combination Mazda and high intensity indirect fixtures providing 20 foot-candles; fixtures, Miller Co. and Curtis Lighting; lighting panels, "no fuse" type, Trumbull Electric Co.  
**Plumbing:** Fixtures, china, The H. J. Osterfeld Co.; toilet ventilators, Allen Turbo-Ventilors



General office, second floor. Note that air-conditioning ducts are treated as ceiling beams.



First floor lavatory and toilet. Conditioned air is not recirculated from this zone.



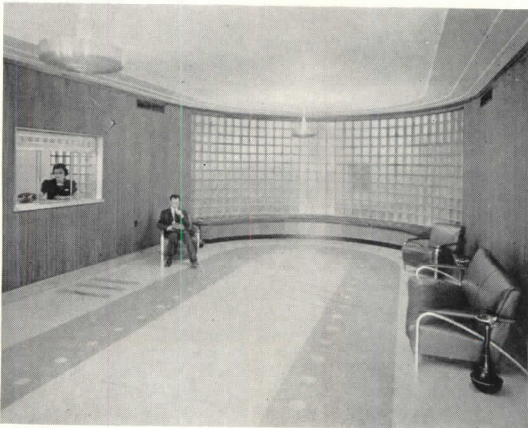
Looking from private secretary's office, second floor, toward general office.



General manager's office. Notice that this office is in a radiator-heated zone.



Basement assembly room seats 500 persons and is used for conventions, etc.



Entrance lobby. In all interiors, lighting fixtures are totally indirect.