

# BUILDING NEWS



*J. A. Fraser*

**Show window inside store...see pp. 34-37**

ARCHITECTURAL  
RECORD

# RESTAURANT AT DUDLEY ZOO

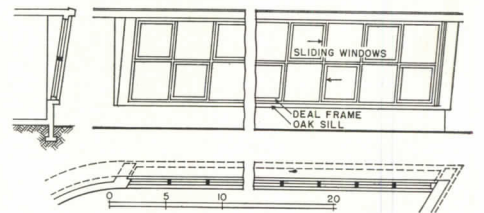
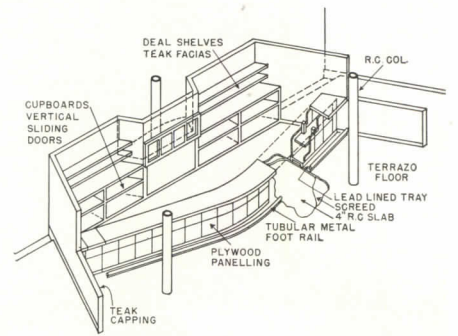
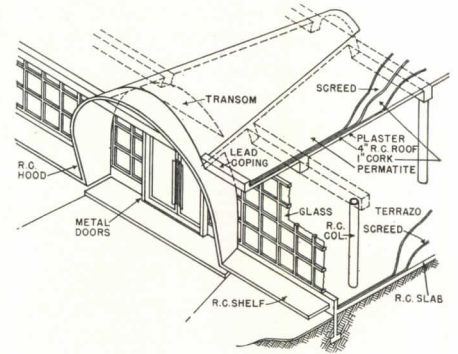
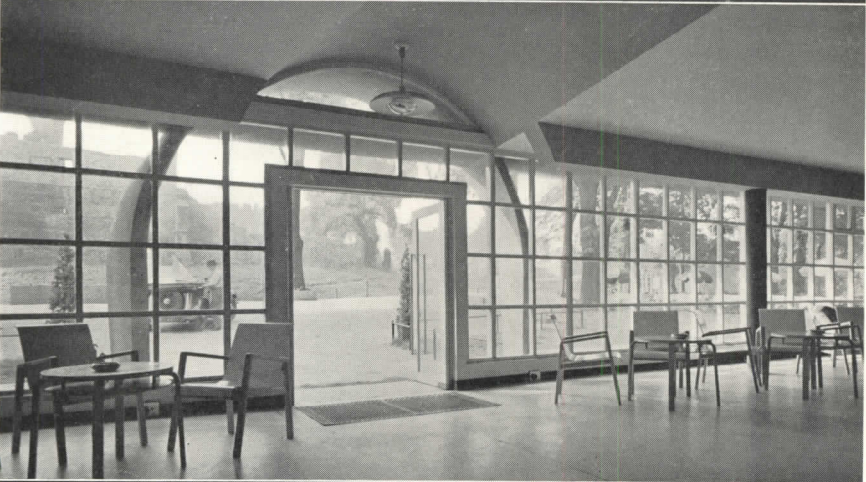
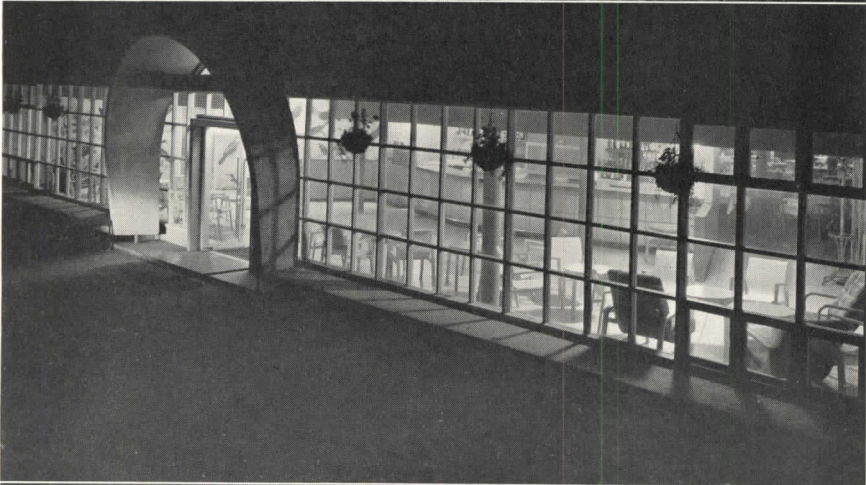
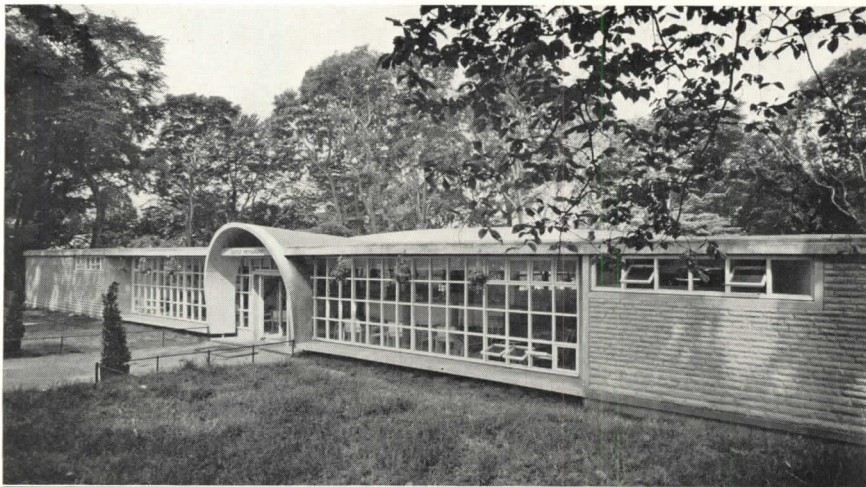

Isometrics and details of sliding windows of restaurant. This structure, triangular in plan, is located about midway to the top of the hill. The central part of the roof has been given a conic surface, coinciding at center of span with the top of the beam.

Photos by Herbert Felton

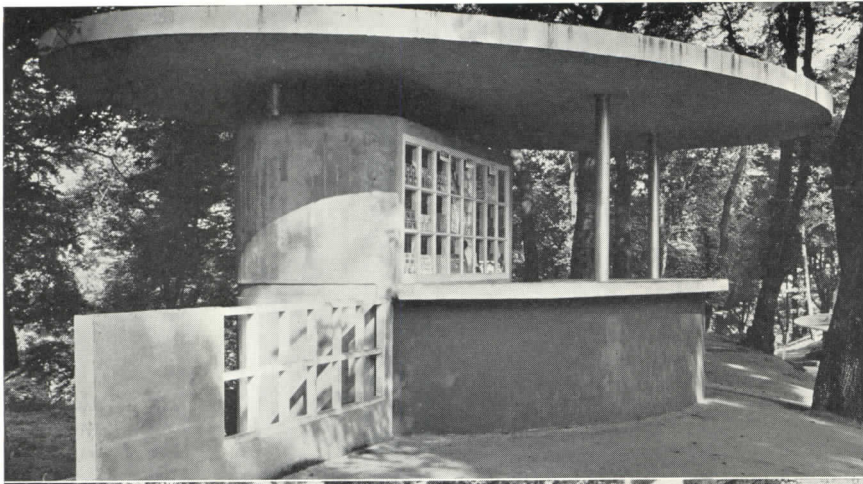

**OTHER ZOO BUILDINGS**

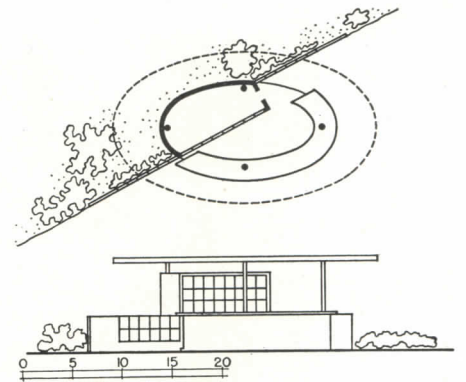

Kiosk

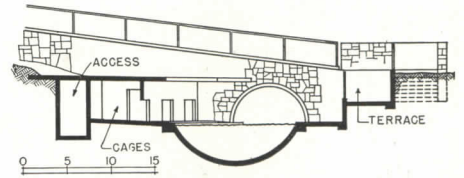
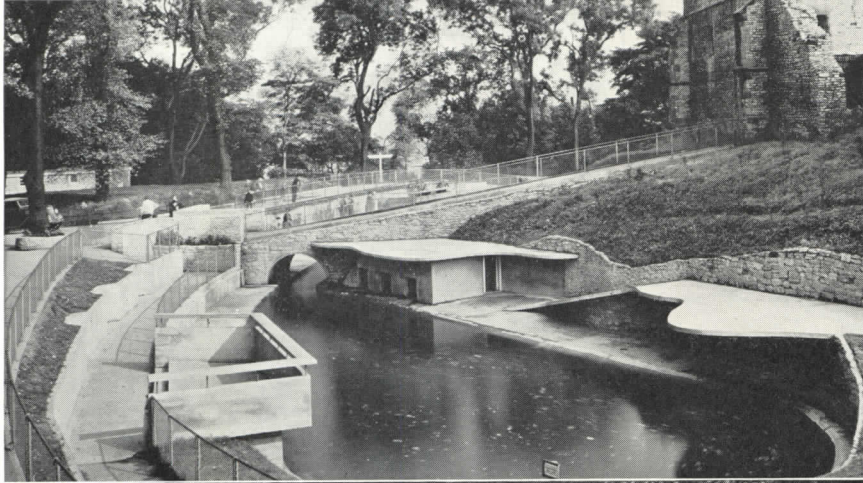

Sea-lion pool in castle moat

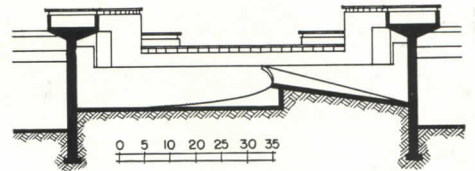
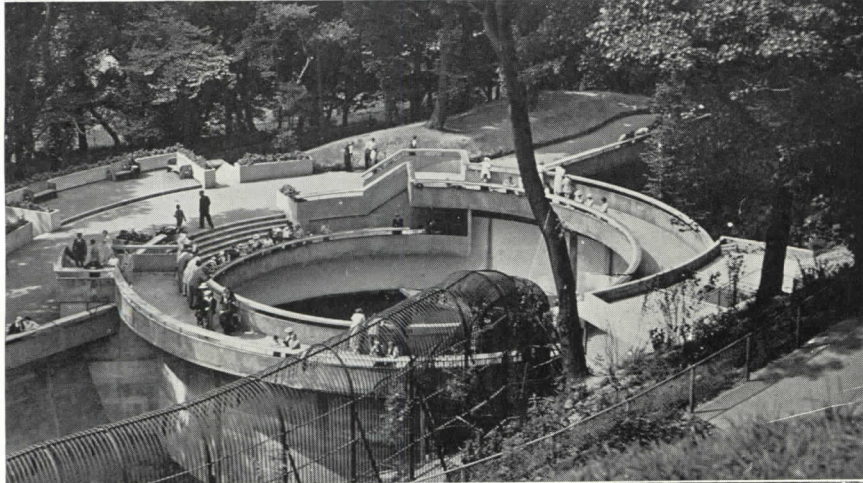

Polar-bear pit

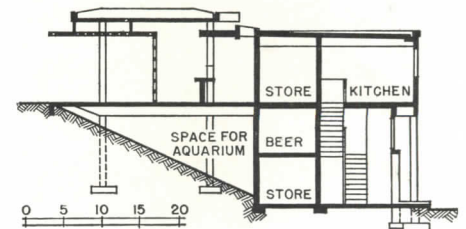
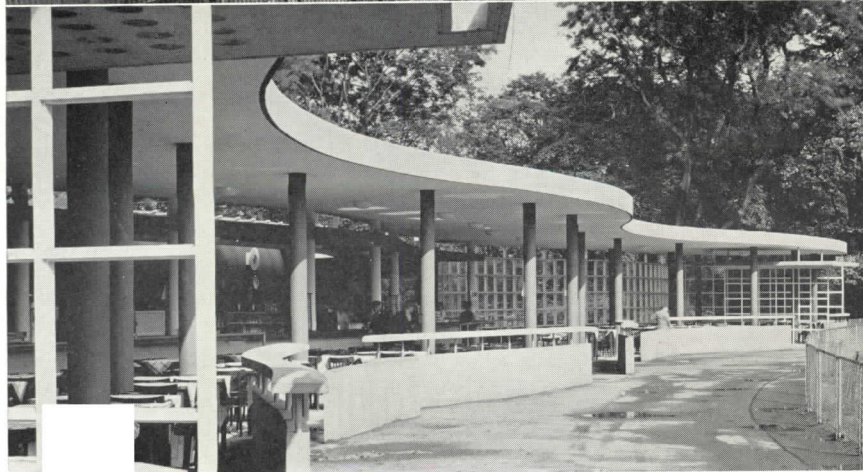

Castle cafe



Photos by J. A. Fraser

Counter near entrance, seen from shoe department; louvered catwalk behind counter, offices above entrance at left.

# LOS ANGELES: SALON-TYPE SHOE STORE FOR MIDDLE-CLASS TRADE

THE KLASSEN COMPANY, Designers

SEVERAL INNOVATIONS in store design have been made in a Los Angeles shop, remodeled without interruption of business.

Front show windows are designed not only to attract attention but also to lead the shopper into the store. To this end, the windows are carried back into the store proper. The existence of a structural column near the entrance suggested a vestibule narrowing around the obstructing column, so that the entrance is not perpendicular to the street.

The windows are designed for flexibility in merchandise display, with backgrounds composed of panels slid into permanent frames, staggered and set at an angle to the walls. Each frame slightly overlaps its neighbor and the niches so formed are a source of concealed illumination. The panels can be slid easily in and out of their frames, thus facilitating changing backgrounds. Within the store, the glass is carried around the back of the windows, so that merchandise in the windows is visible from the store, too. The terrazzo vestibule floor is carried into the store and swings around the curved rear of the display window to the mezzanine stairway. This also tends to draw window shoppers into the store.

In the design of the interior, a compromise was sought between the salon type in which no merchandise is displayed and the more usual store type with its exposed shelves. Exposed shelving holds about half the stock on the ground level. The rest of the stock at this level is divided into four groups in alcoves behind partitions, yet accessible to salespeople. Additional merchandise is at the rear of the store and on shelving along both walls at mezzanine level, accessible from enclosed catwalks.

The sales floor is arranged in three sections: for men's shoes, for women's shoes, and for accessories and hosiery. The men's section is nearest the entrance, accessible without passing through any other part of the store and enclosed by a waist-high partition; this because men are notoriously shy shoppers in stores which also cater to women. The rear of the store is the women's shoe section; hosiery and accessories, bought largely on "impulse", are placed adjacent to the wrapping counter and entrance. A hosiery counter of serrated design serves to make merchandise more easily visible and provides niches for salespeople, so that other salespeople can pass more freely in the aisle behind them.

Originally, both walls of this store were shelved for stock clear to the ceiling; exposed catwalks ran the full length of the store making the top shelves accessible. Down the center were two rows of seats, back to back. In the rear a central stairway led to the children's department.

In remodeling the interior, knockdown scaffolding in sections, mounted on rollers, was used to build the partitions enclosing the catwalks. After these were furred and plastered, the shoe-stock shelving on one wall was pulled out to permit rebuilding of one half the store. The same procedure was followed on the other side. Ceilings on each side were handled at the same time. Installation of carpeting, seats, and display cases was the final step.

In remodeling the exterior, a deck was built above the display windows and the upper portion of the front installed. This completed remodeling of the show windows—one at a time, so that at least one window was available for display purposes all the time. Working hours were so scheduled that, as a matter of fact, the store was not without full window display for more than 48 hours.

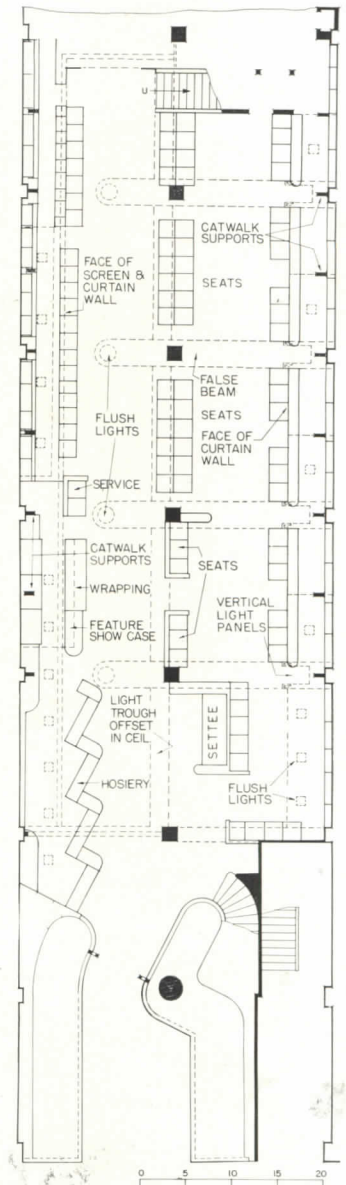

Floor plan



View of remodeled entrance



Interior from left of entrance: serrated hosiery counter in left foreground, enclosed catwalks on either side. View shows effect of concealed lighting in lip of lower plane of the two-level ceiling and in mezzanine window sills.



Photos by I. A. Fraser

View of men's section enclosed by waist-high partitions. Stairway in the rear leads to children's department.

# SHOE STORE IN LOS ANGELES

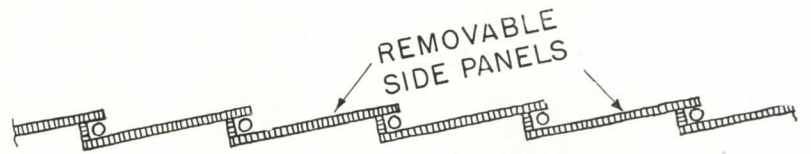
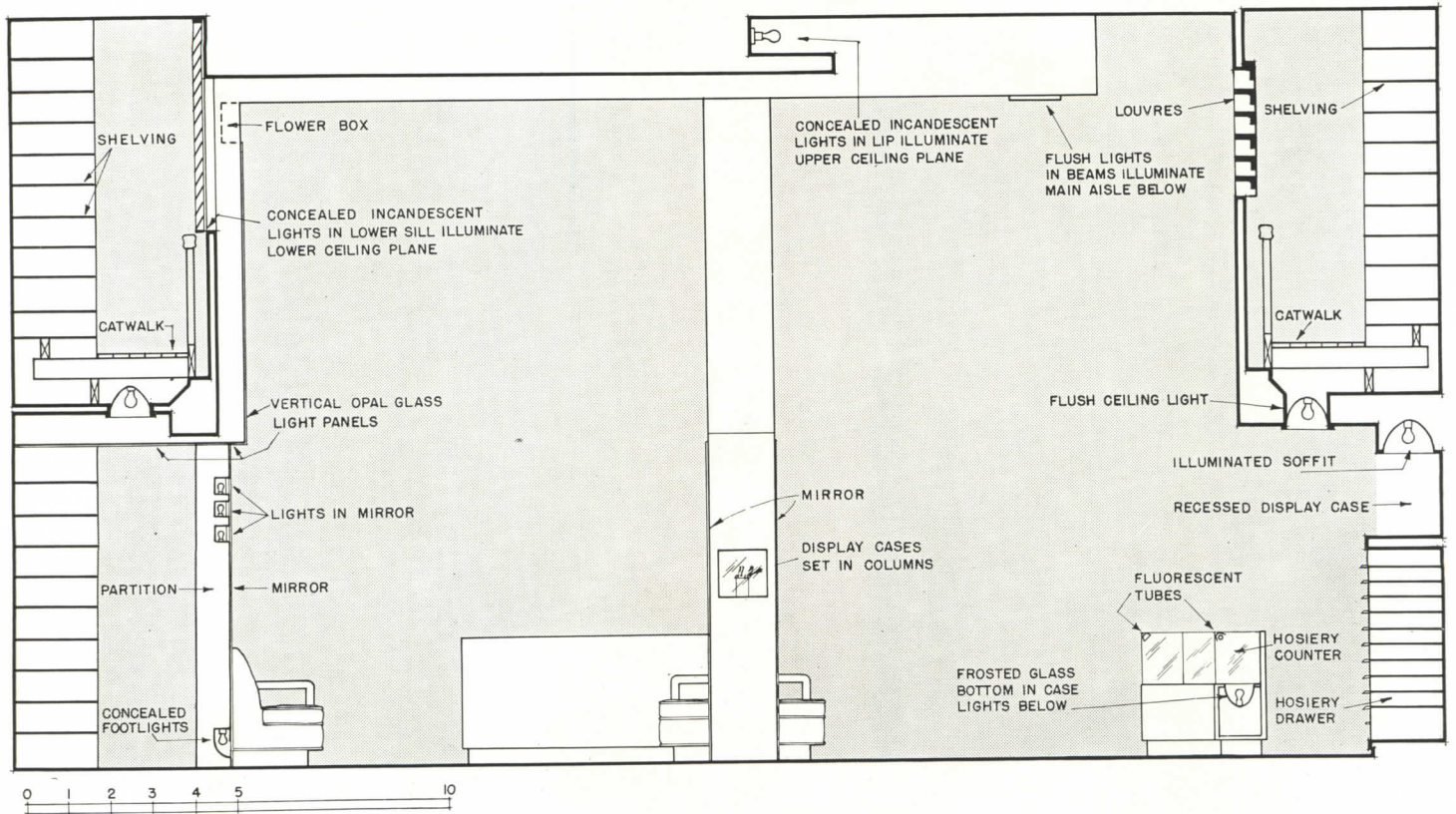

Show windows are designed for flexibility; backgrounds are composed of panels slid into permanent frames, staggered and set at an angle.

CEILING LIGHTS are countersunk into ends of the falsework beams above the main aisle. In addition to these, there is indirect illumination from the lip at the edge of the lower ceiling plane. Other indirect lighting is concealed in the lower sill of windows in the north mezzanine wall. Vertical flash-opal glass illumination panels extend down from near the ceiling to the bottom of the mezzanine wall on the north side, then turn under so that light is thrown both horizontally into the store and downward into merchandise; there are flower boxes atop these panels. Vertical fitting mirrors are raised a few inches from the floor and the niche so formed conceals lights for customers' footwear. Concealed lighting floods the small wall cases for featured merchandise making them stand out prominently.

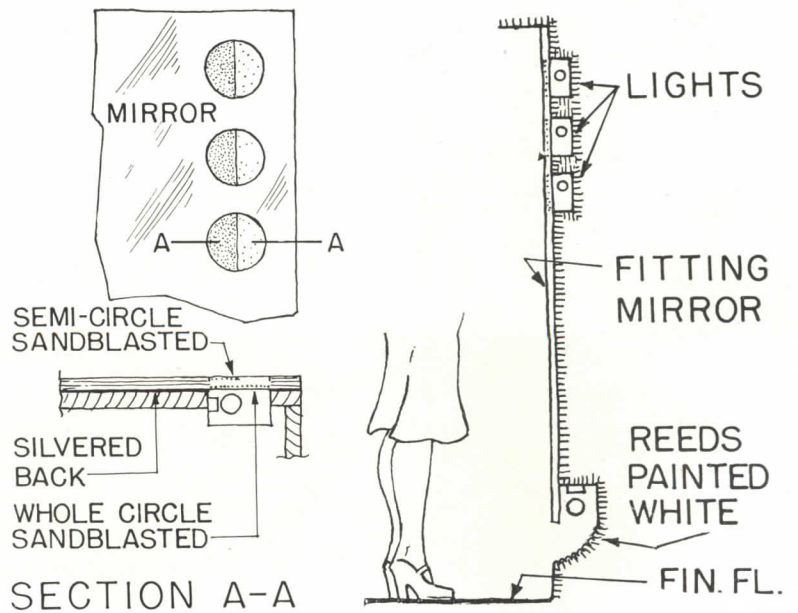

Photos by D. F. Dazis



The marks of the form boards are left as a surface texture. All the sash are Soulé steel with felt weatherstrip.

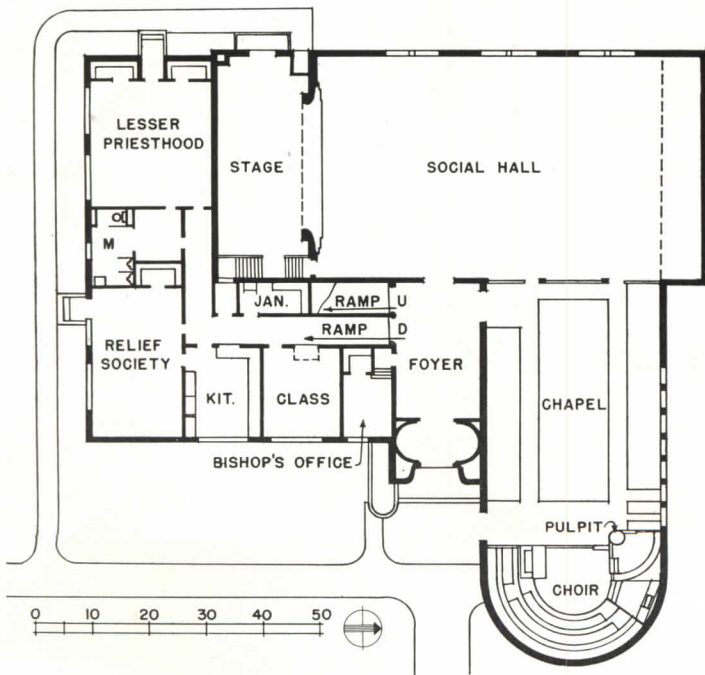

First floor

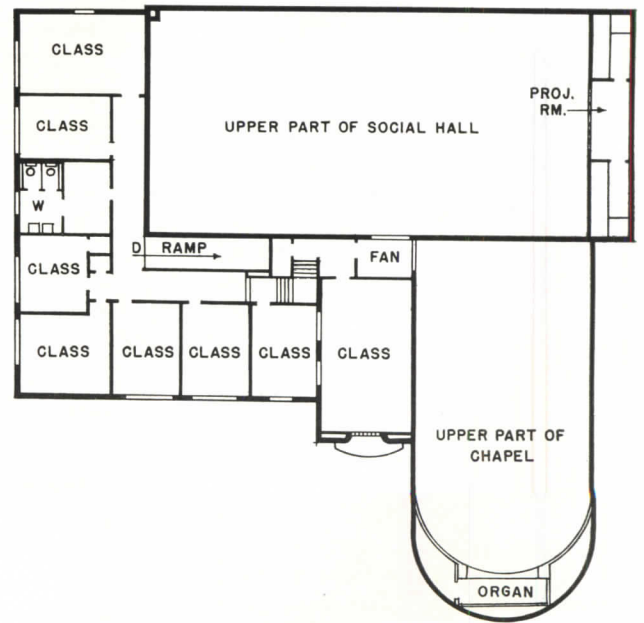

Second floor



# ALL RELIGIOUS AND SOCIAL FUNCTIONS COMBINED IN ONE STRUCTURE

LOWELL E. PARRISH

Architect

MORE AND MORE, designers of church buildings and their dependencies find it necessary to include provision for various social activities other than those of a purely religious nature. This new, reinforced-concrete chapel and social unit, designed for the Church of Jesus Christ of the Latter-day Saints near Salt Lake City, Utah, is a good example. Typical of the church buildings for this religious group, this one is planned to care for all the neighborhood's social activities except those of school, work, and home. Especially noteworthy are the relation of the various services and an unusual consideration for the convenience of the individuals and groups who use the several services of this multipurpose structure.

The juxtaposition of chapel and large social hall accomplishes two desirable purposes: 1. Either of these assembly rooms is equally accessible from the building's main entrance. 2. At holidays or conference times, large lift-up doors at the rear of the chapel can be opened. By utilizing one end of the social hall, the chapel's seating capacity is more than doubled.

For ease of circulation—particularly for the very old or very young—the architect uses ramps in place of stairways to connect the different levels. Headquarters for the Relief Society and another large room, used jointly by the Boy Scouts and the Lesser Priesthood, have separate outside access, as these activities take place at their own times.



The two-story entrance tower dominates the design and separates the public and semi-public functions of the building. The vertical panel over the entrance is Insulux glass block.

## CHAPEL AND SOCIAL UNIT

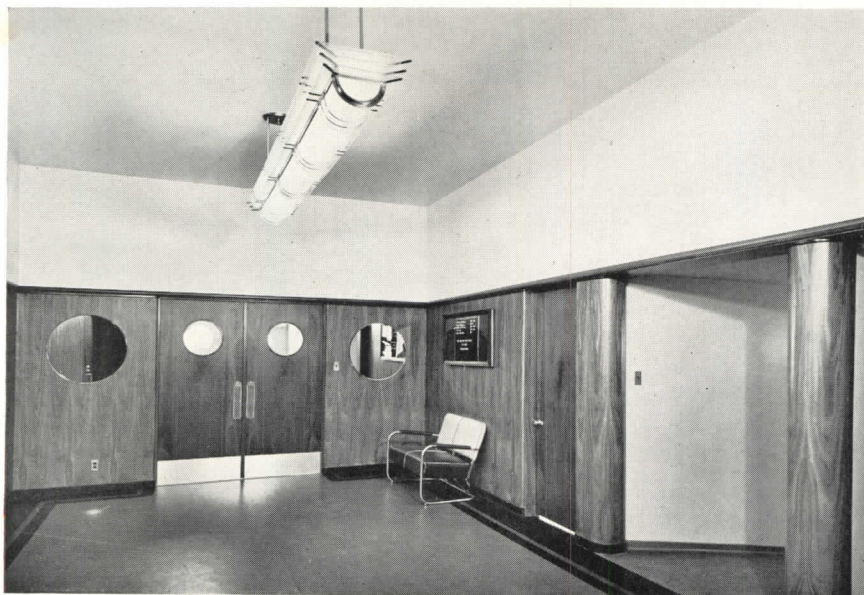

Foyer, looking toward main entrance. Walls are of wood veneer and smooth plaster. The floor is covered with battleship linoleum.



The chapel is semicircular at one end; this provides seating for the choir, each member of which has at least a side view of the speaker. For economy the organ is located in the slight overhang, with a grilled opening in the wall above the choir. Walls are of smooth plaster painted pale lime yellow.

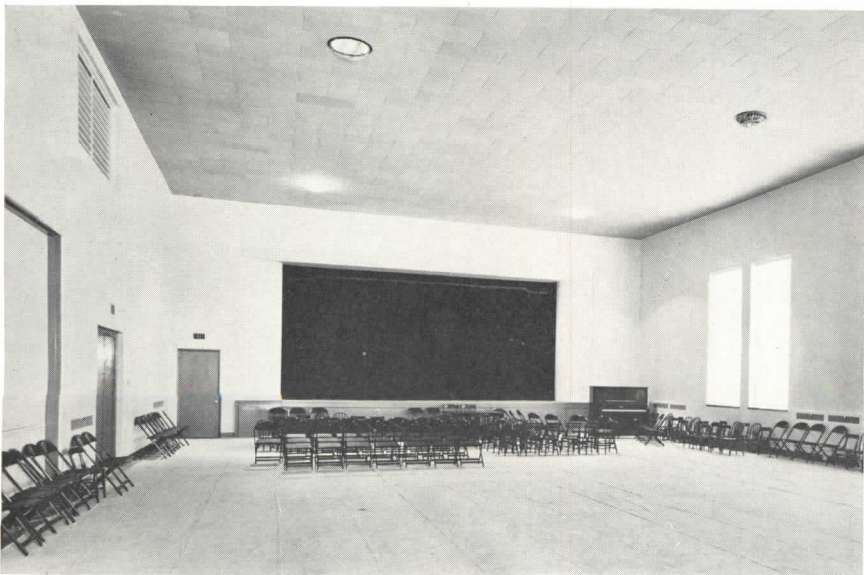

The social hall is equipped with a stage at one end and is used for all types of functions. Lift-up doors between chapel and social hall make possible extra seating at holiday and conference times.

Photos by D. F. Davis

## PROPOSED BUILDINGS

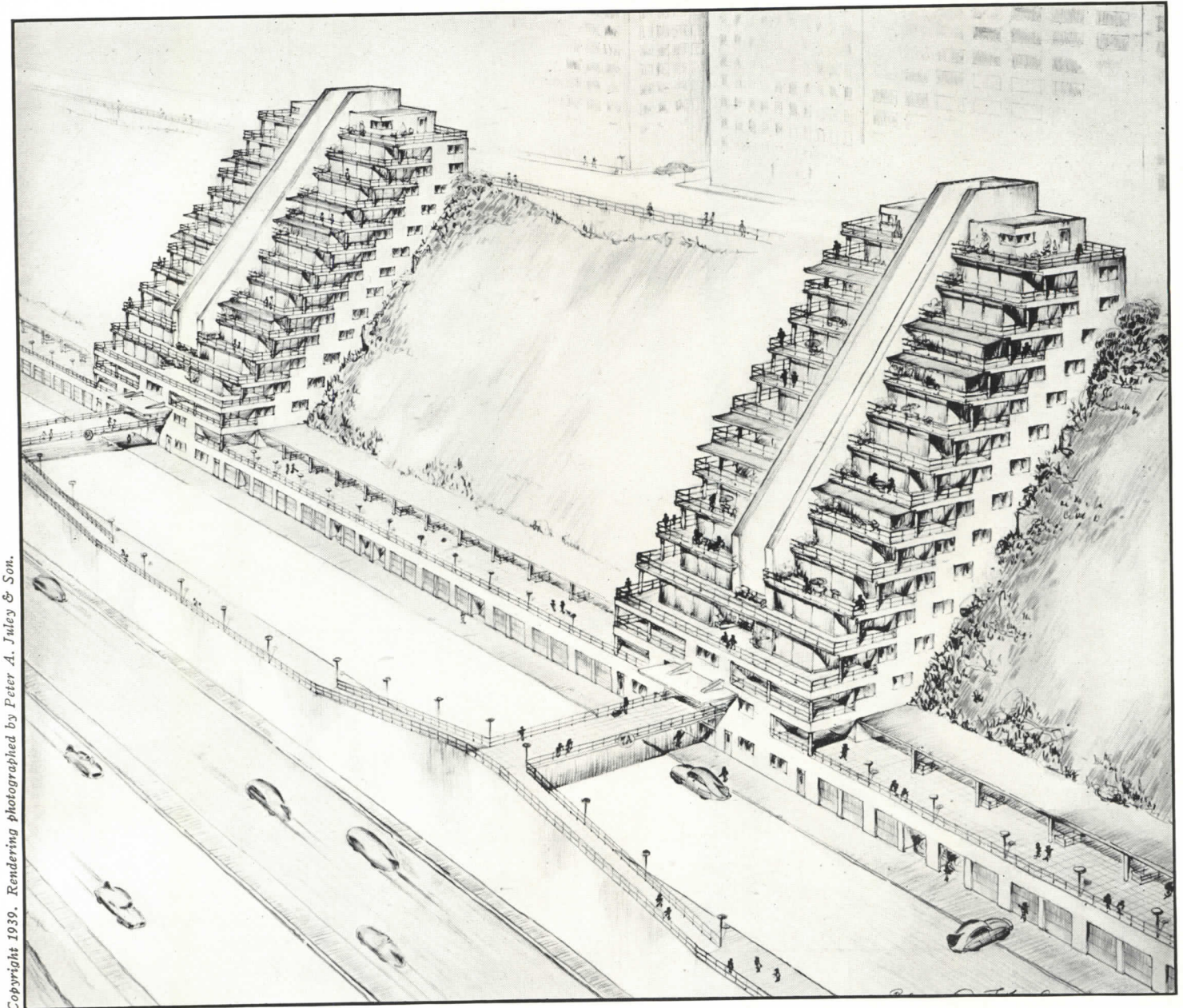

Copyright 1939. Rendering photographed by Peter A. Juley & Son.

### HILLSIDE APARTMENT GROUP SERVICED BY A FUNICULAR-ELEVATOR

EDWIN A. KOCH, Designer

IN SPITE OF noteworthy advances in recent years in both elevator and escalator equipments, the problem of transportation that follows the angle of a steep-sloping site on which a structure is built has not been widely explored. Here is an arresting proposal for such a scheme, designed by Edwin A. Koch for an apartment-house group on the New York City river front. Both elevator and setbacks follow the slope of the site.

For optimum efficiency, Mr. Koch's funicular-elevator scheme seems most desirable on a 45° slope, as suggested. However, within a limited range, it would be practical on slopes of greater or less pitch. For other sites or in other building types, the system has design potentialities—either within the framework of a typical rectangular-shaped building, or, perhaps, in a structure on a sloping site that rounds a turn, as at the end of a hill.

HILLSIDE APARTMENT GROUP

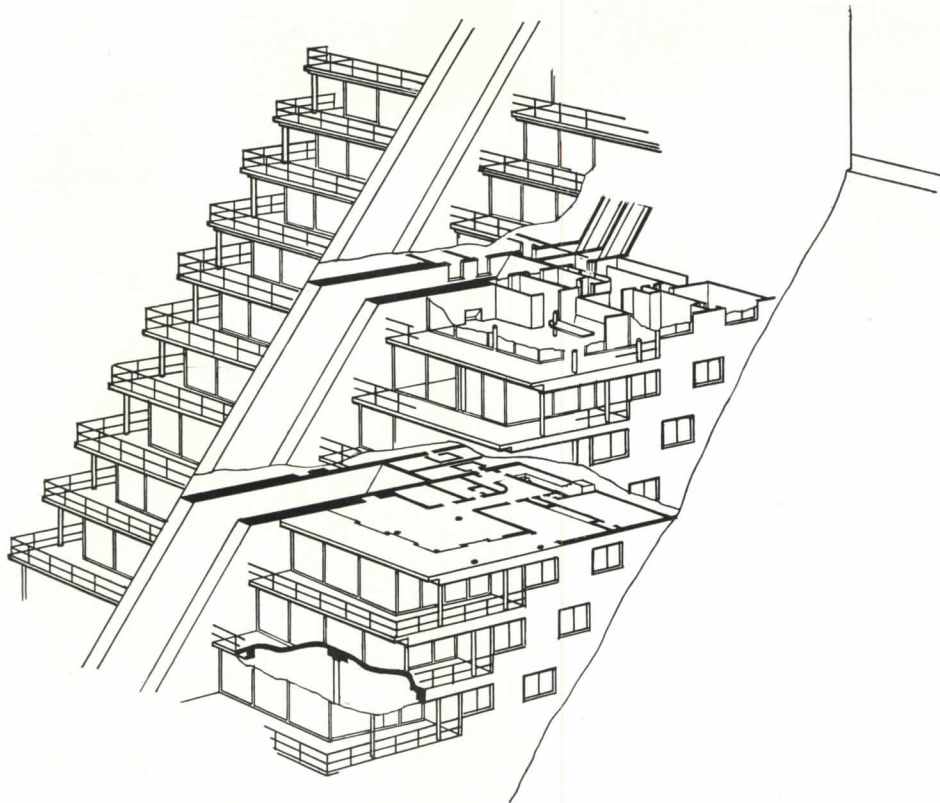

Cut-away sectional view showing relation of typical setback apartment units and the funicular-elevator

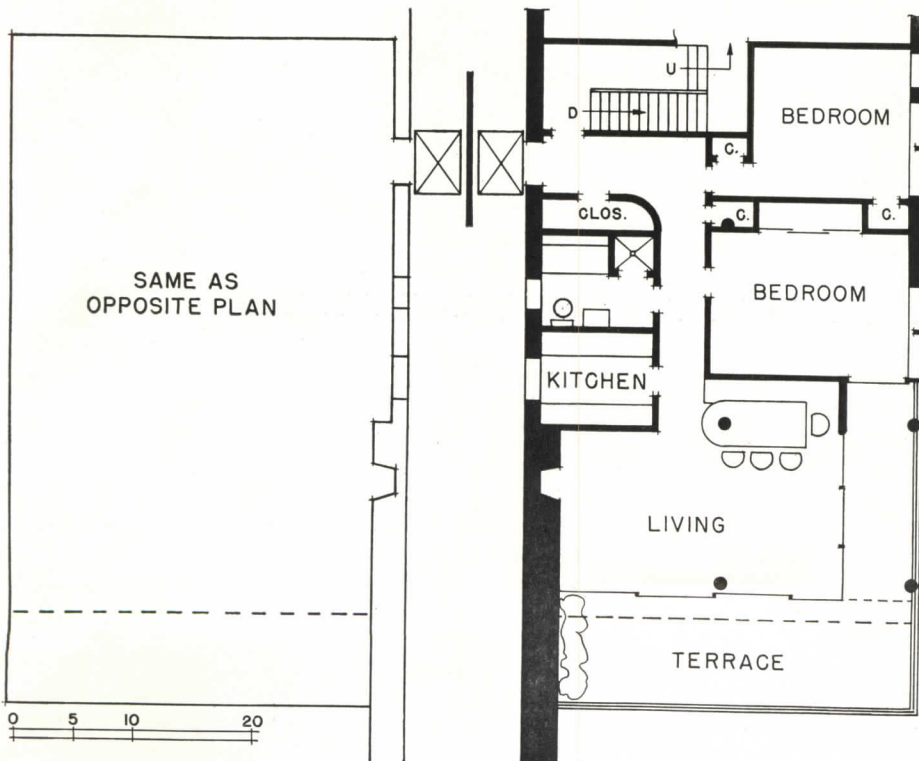

Typical floor plan

THE ANGULAR ELEVATOR shaft comes in the middle of each of the apartment blocks. Placed thus, the elevator cab stops at the same point in all of the apartments, allowing exact duplication of a desirable unit plan at each level. The setback construction has other important advantages. Savings in construction requirements, time, and labor are gained by the fact that at any one point, the building is only 4 to 4½ stories in height.

At left is the typical apartment plan, two units at each level. From the elevator door a central hallway communicates with service, sleeping, and living portions. With the entrance located near the rear of the unit, the living room has greater privacy than most city apartments. A light and airy terrace offers unusual opportunities for outdoor living. Furthermore, all rooms are "outside" rooms.

SCHEME 1

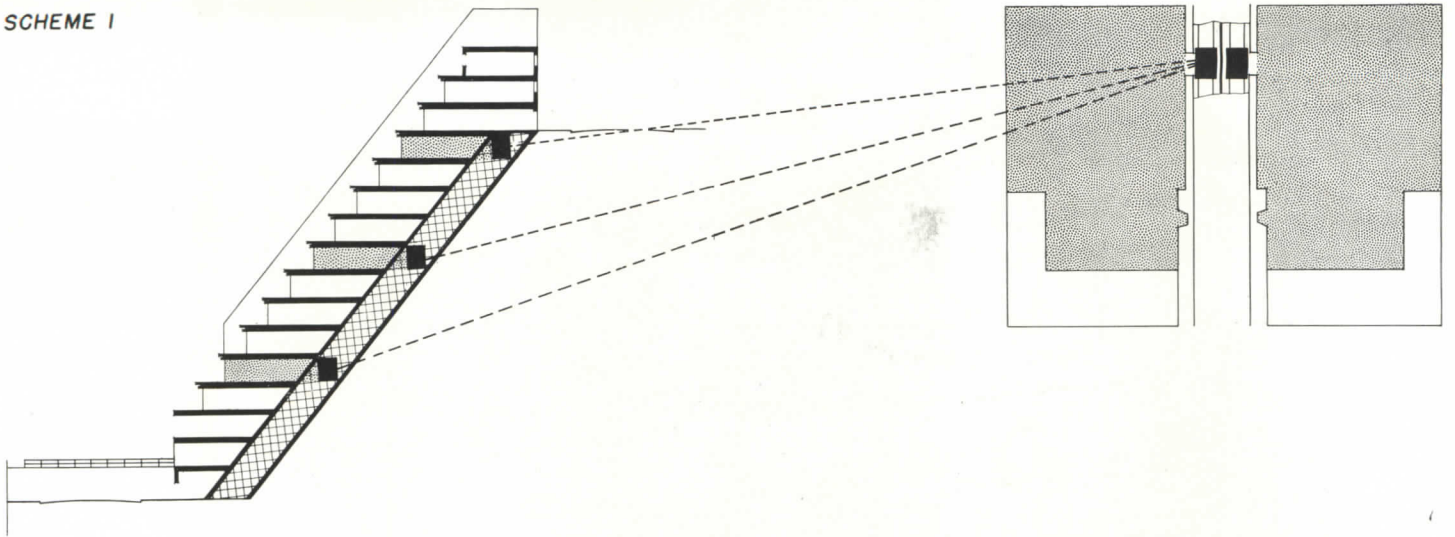

SCHEME 2

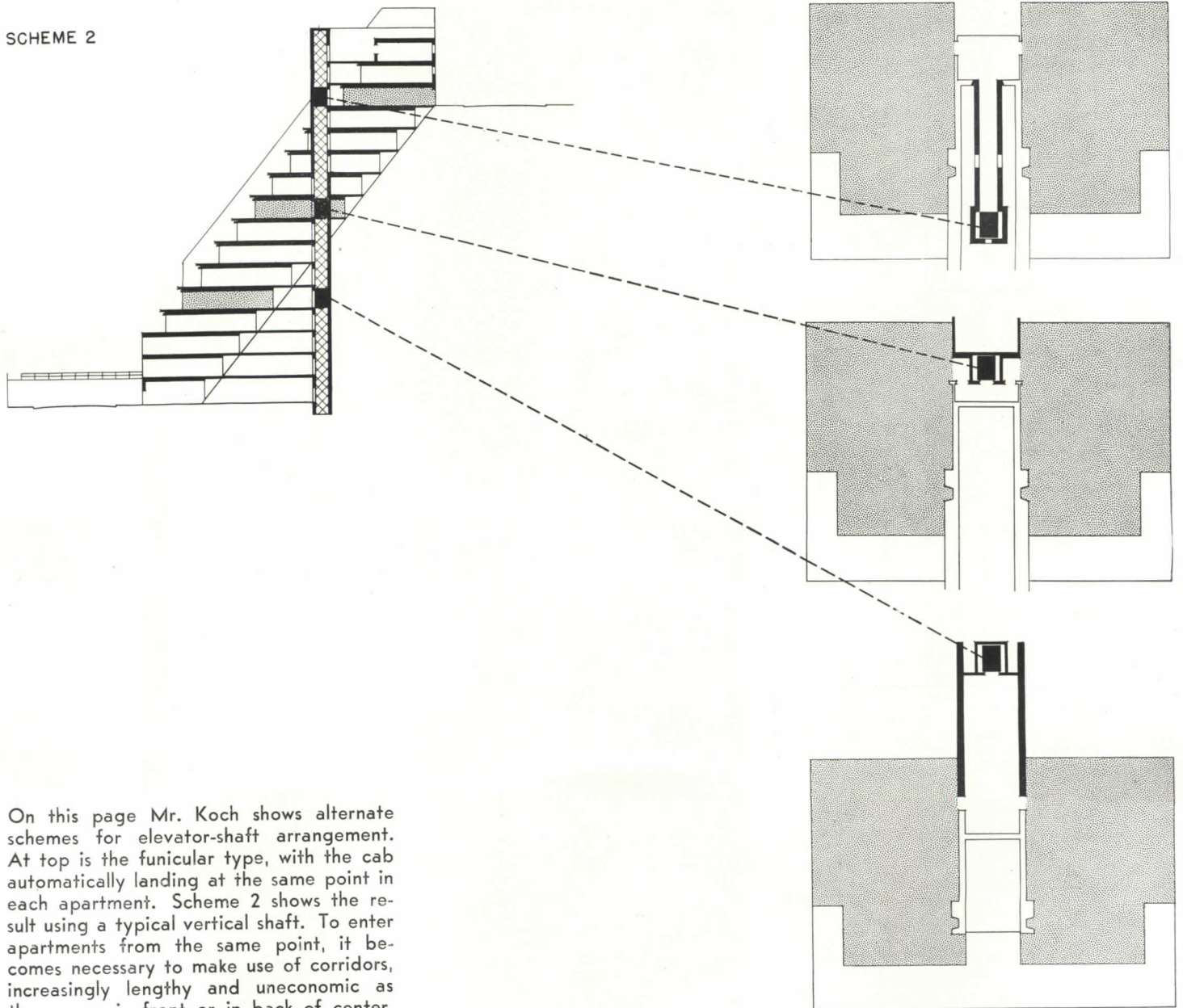

On this page Mr. Koch shows alternate schemes for elevator-shaft arrangement. At top is the funicular type, with the cab automatically landing at the same point in each apartment. Scheme 2 shows the result using a typical vertical shaft. To enter apartments from the same point, it becomes necessary to make use of corridors, increasingly lengthy and uneconomic as they occur in front or in back of center.

$3\frac{5}{8}$ " AIR SPACE

$\frac{1}{4}$ " MAHOGANY  
"WELDBORD"

$\frac{1}{4}$ " BAYOTT WOOD  
"WELDBORD"  
KEYSTONE FLAT  
VARNISH

4" x 4" STUDS  
4'-0" O.C.

2" x 4" GIRT

$\frac{1}{4}$ " PLYWOOD  
FURRING STRIP

ARMSTRONG  
LINOLEUM  
FINISH FLOOR

$\frac{5}{8}$ " "PLYSCORD"  
SUB-FLOOR



# HOUSE IN CONNECTICUT USES PLYWOOD BOTH INSIDE AND OUT

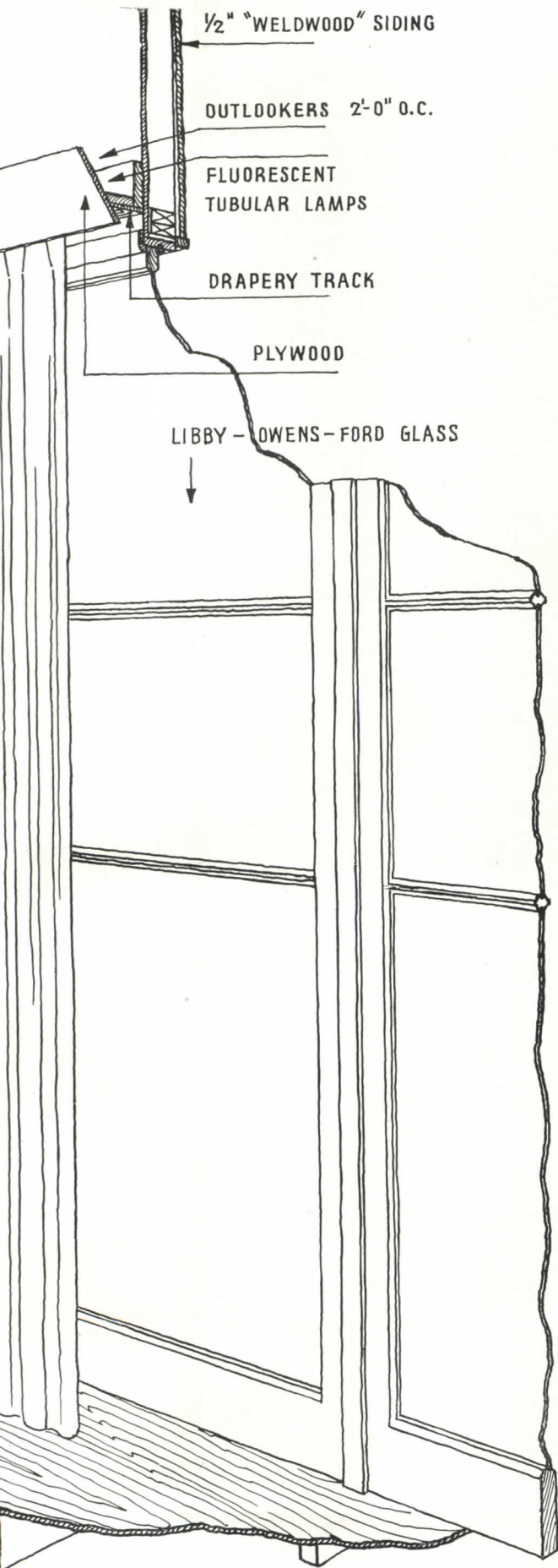

OSCAR FISHER,  
Designer

IN THIS Redding, Conn., home designed by Oscar Fisher for Mr. and Mrs. S. Poliak, plywood is used on floors, both interior and exterior walls, ceilings, and roof (See plan and details, pages 46, 47). Most of these applications are clearly defined in the cut-away sectional drawing at left. What doesn't show are some of the economies Mr. Fisher achieved by working with a 4-ft. module.

Before interior non-bearing partitions were constructed, the inside-finish plywood panels were applied without cutting or waste directly to the 4-ft.-on-center studs. Ceiling panels of 1/4-in. plywood were similarly installed without cutting. Then—and only then—non-bearing partitions were constructed up against the plywood surfaces. Roof construction consists of 5/16-in. "Plyscord" sheathing, 15-lb. asphalt felt, and 220-lb. J-M asphalt strip shingles. Note the double-duty device of light cove and drapery track combined in a single decorative horizontal band.



Front and rear views. A modern scheme respects tradition.

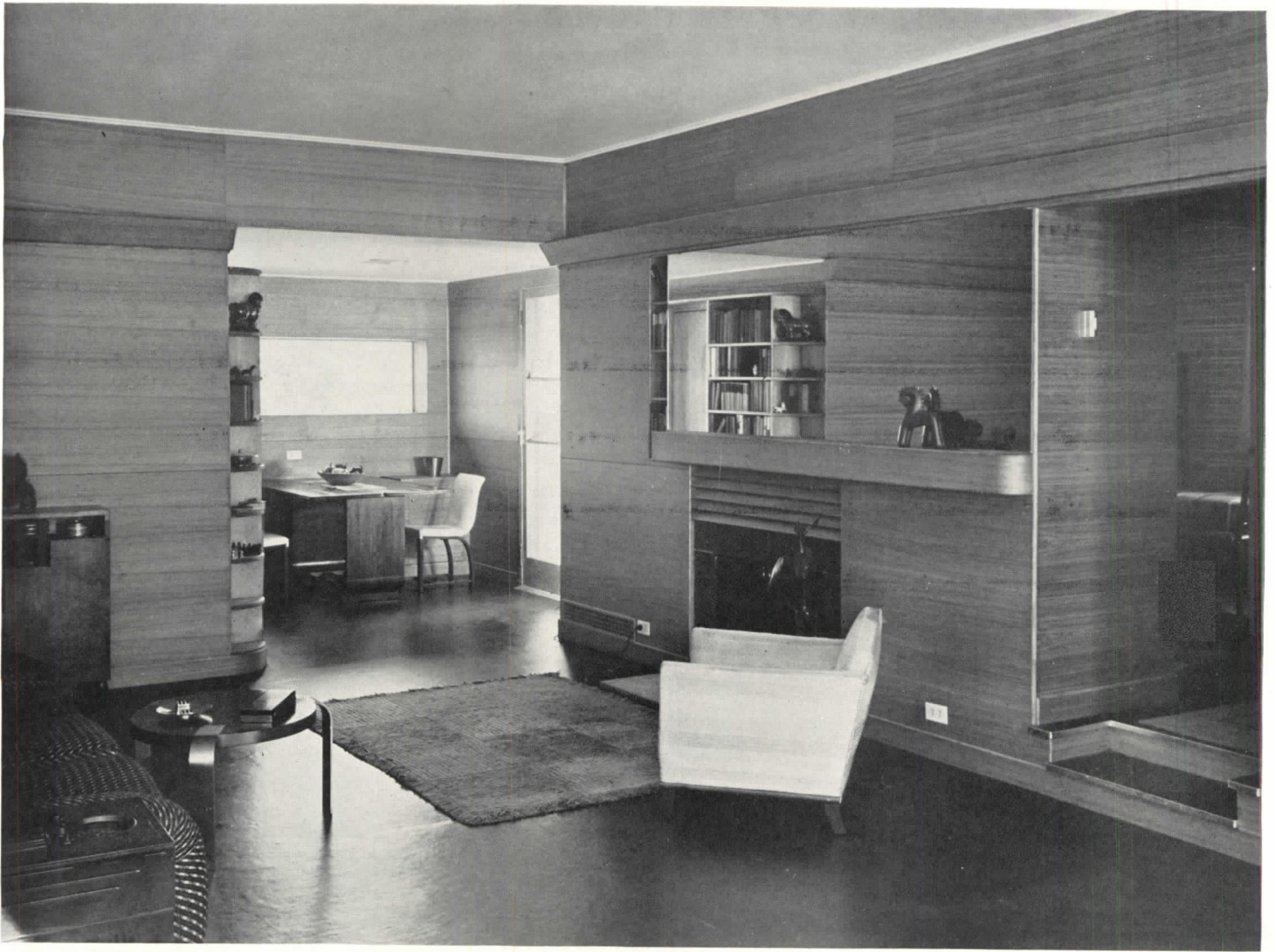

View from Arrow No. 1 on plan

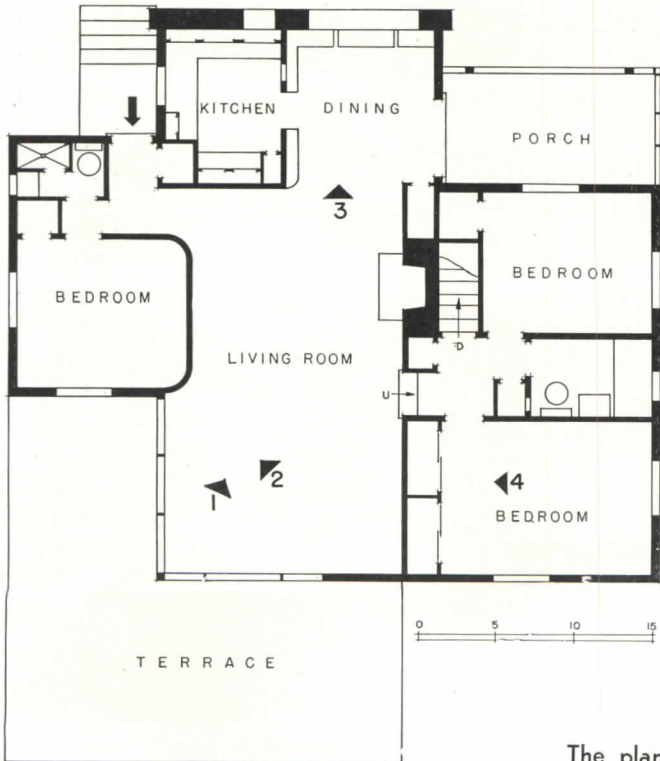

The plan

FOR SO SMALL a plan, the Poliak home has a surprising amount of storage space and service equipments. Yet partitioning is kept to a minimum. To form the pair of storage units at the end of the master bedroom, the partition between living and sleeping areas is utilized. The closet of the second bedroom uses the end of an area already defined by the stairs to the basement. The wood-storage compartment is formed simply by extending the fireplace wall.

Perhaps the most interesting plan feature of all is the useful and ingeniously placed third bedroom, with its private bath. Entirely separate from the family bedrooms, this room is potentially a convertible living unit. Its isolation suggests its use as a study or den, a guest suite, a living unit for a close relative, or as servant's quarters. Furthermore, its placement in plan automatically creates a protected entrance hallway desirably separated from the main living area of the house.



**PLYWOOD HOUSE**

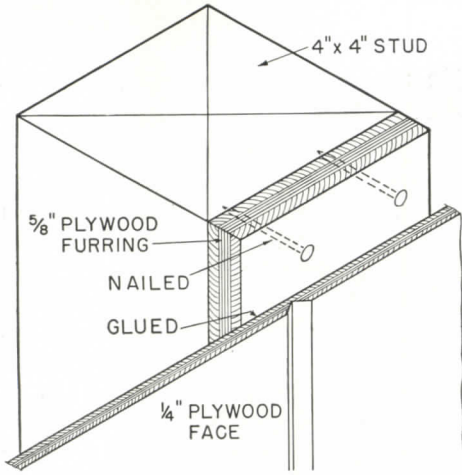

The wall and framing system are integrally welded

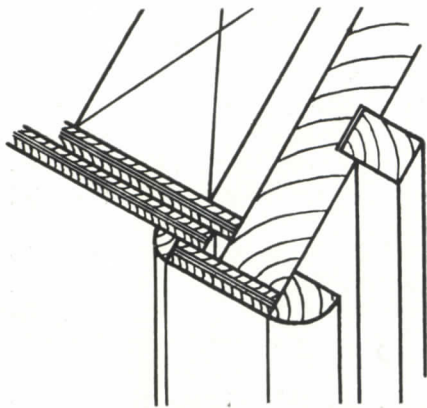

Behind trim, at end of panel, is an expansion joint

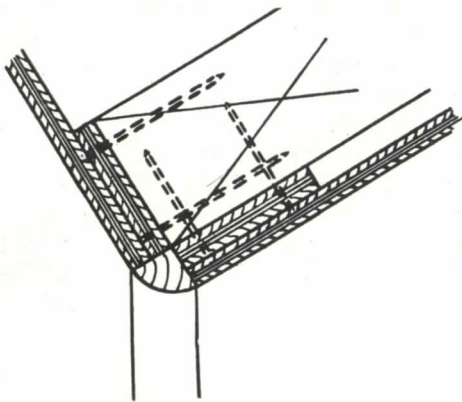

Construction detail of an outside corner

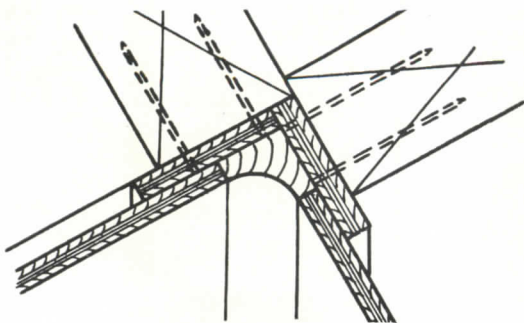

Construction detail of an inside corner

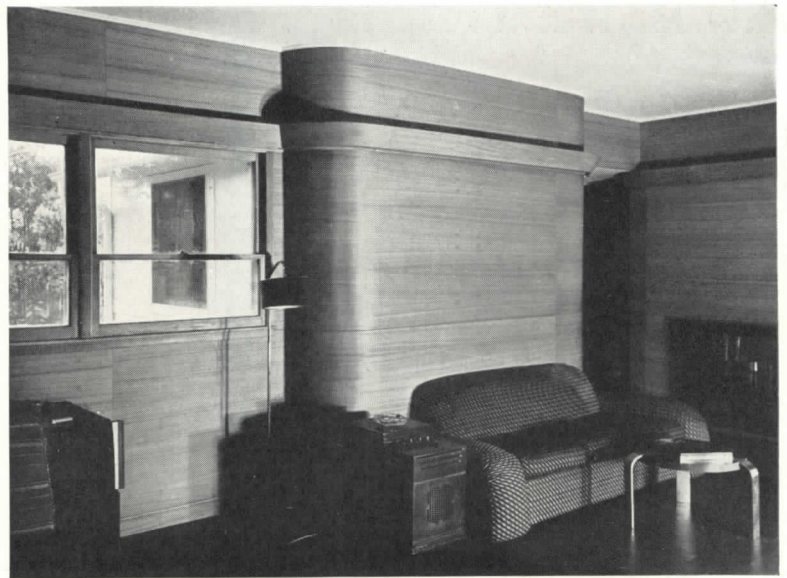

From Arrow 2: the walls are surfaced in veneer of Philippine bayott



Arrow 3: built-in storage. A pass window opens into the kitchen



Arrow 4: mahogany-surfaced sliding doors in bedroom storage wall

## NEW MATERIALS

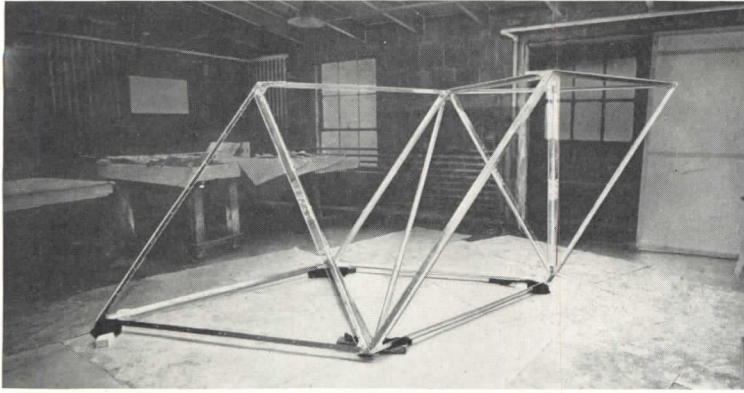

1. The structural framework for the crystal is lightweight metal.

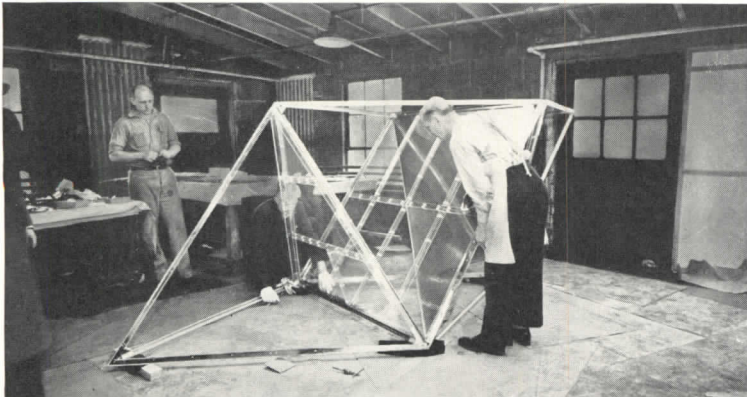

2. After the first facets are placed, stresses are carefully tested.

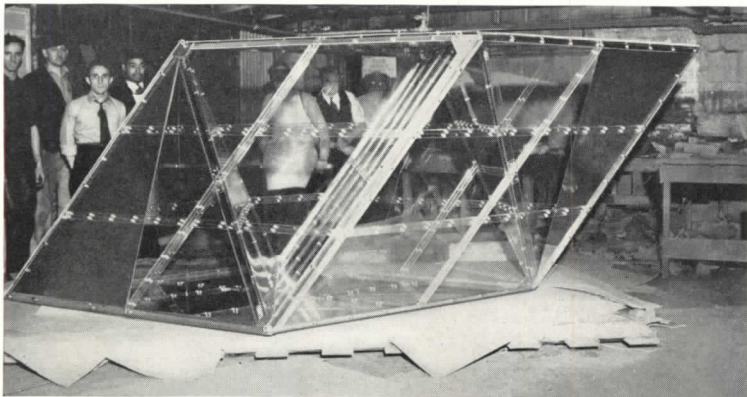

3. Besides the covering facets, the interior baffles are of plastic.

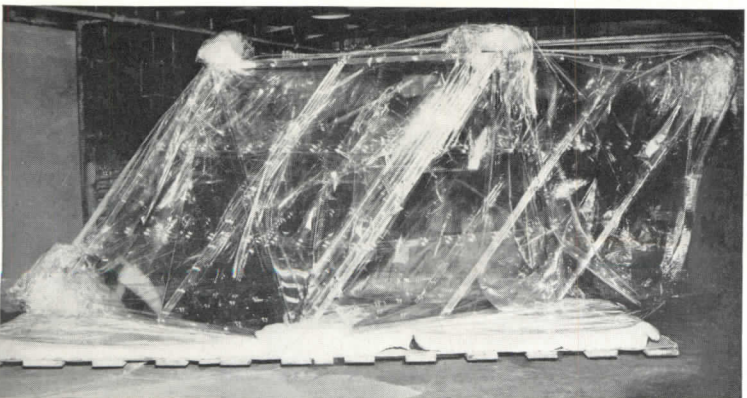

4. The finished crystal is wrapped in protective transparent foil.

### Plastic makes first appearance as semi-structural material

ALTHOUGH PLASTICS are widely used in a variety of ways, the possibilities of their use as structural or semi-structural materials have just begun to be exploited. The first such use was in this 600-lb. transparent rhomboid crystal, designed by Xanti Shawinsky with the assistance of engineers of the Celluloid Corporation. The crystal was a part of the Pennsylvania State exhibit at the New York World's Fair.

Transparent, lightweight, easily machined  $\frac{1}{4}$ -in. sheets of a special formulation of Celluloid Corporation's *Lumarith* form the covering facets and interior baffles which span the members of a light structural framework of Dow metal. Each facet consists of six sheets loosely assembled with butt-strap splices of *Lumarith* and fastened with  $\frac{5}{16}$ -in. transparent plastic screws through  $\frac{7}{8}$ -in. holes to allow for expansion and contraction. Some of the interior planes are partially covered with a thin lamination of polished metal to emphasize the third dimension by reflected light.

The special *Lumarith* used is similar to the airplane type formulated for cockpit enclosures, bomber's turrets, and running-light covers. Its special characteristics are transparency, toughness, and resistance to weathering and temperature changes. In this display the possible temperature range was estimated at  $-10^{\circ}$  F. to  $+120^{\circ}$  F., since the crystal is suspended, by two airplane cables, in the upper part of the unheated pavilion. This type of *Lumarith* will stand fastening with 8-penny nails,  $\frac{1}{2}$  in. on centers, at room temperature—a severe test for a plastic material. In order to compare various plastic materials for this toughness and the shock resistance for which *Lumarith* is noted, plastic engineers have developed an index known as "tensile product" which is not used for other materials. It is the product of the ultimate load in kilograms per sq. mm. times the per cent of elongation.

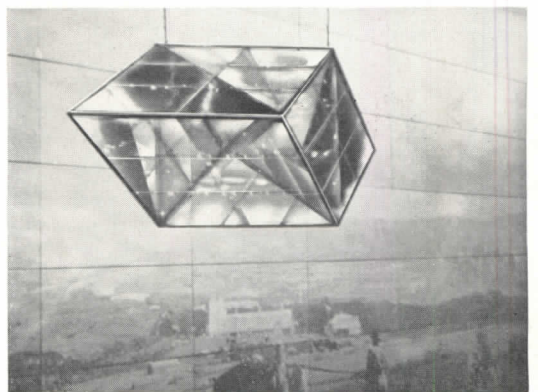

5. The crystal is suspended by airplane cables.



Rollin Bailey

## 1. SAMUEL GLASER

Architect

SITUATED ON THE ground floor of the house, this recreation room opens onto a porch, and thence to the garden, by means of folding and sliding doors. The room is large enough to accommodate a ping-pong table with ample space for playing. The floor is of concrete, colored red. Walls and ceiling are of plaster painted gray, except around the fireplace where the wall is of gray-blue concrete. Lighting is semi-indirect, with the ceiling fixture centered.

### Materials and equipment

Walls and ceiling: plaster, U. S. Gypsum. Doors: wood; hardware, Richard Wilcox. Windows: wood sash; glazing, Libbey-Owens-Ford. Lighting: Georgian Bronze Co.

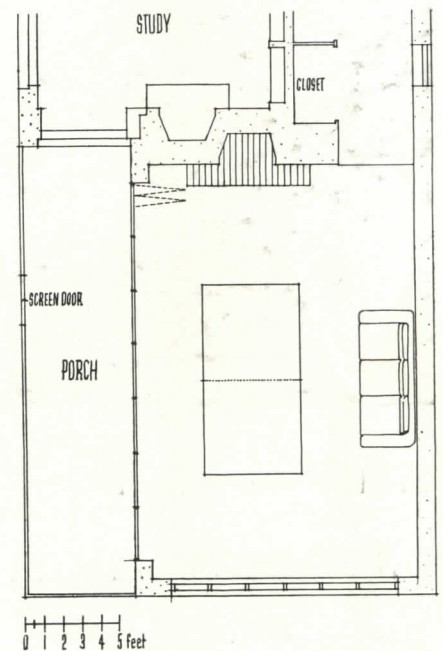

NEW DWELLING UNITS  
RECREATION

*Drawings by Torben Muller*

## NEW DWELLING UNITS: RECREATION



### 2. RICHARD KOCH

#### Architect

THIS GAME HOUSE on a southern estate resulted from the fact that the main house was too small for a growing family and its guests. A building such as this was needed not only for a gathering place but as a dressing place for the adjacent swimming pool; hence the showers and dressing rooms. A small but completely equipped kitchen makes the game house independent of the main house. Structure and materials are simple and suitable to the building's purpose: exterior walls are of stucco on wire lath; the roof is tile; interior walls are of cypress boards, stained with a natural finish. The ceiling is of pine painted with white casein. The floor is of brick laid on concrete.

#### Materials and equipment

Roof: tile, Schneider Brick and Tile Co. Plumbing: Standard Sanitary Mfg. Co. Hardware: Russell and Erwin Mfg. Co.

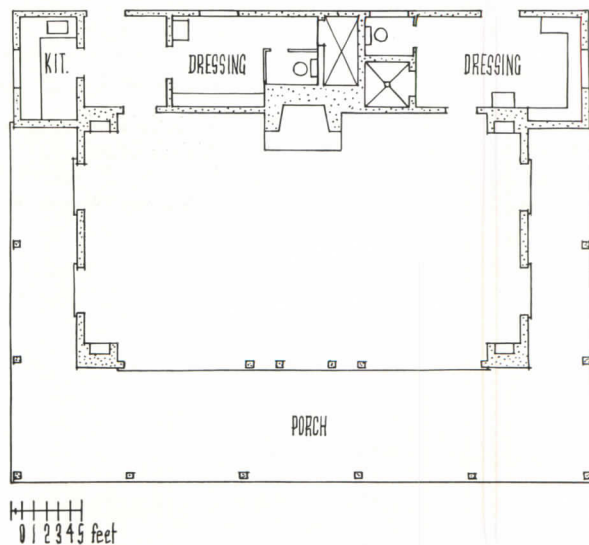



### 3. EUGENE SCHOEN & SONS

#### Architects

DESIGNED FOR gaming and dancing, this unit reverses ordinary procedure and obtains all its artificial light from below. Lamps are installed 25 in. o. c. on two sides of the glass panel in the center of the floor. This panel is made up of 2-ft. squares of unpolished glass, 1 in. thick; the rest of the floor is brown linoleum, with an inset of blue linoleum immediately adjacent to the glass panel. The walls have a cobalt blue background; the Tyrolian scenes are done in bright colors; ceiling is lemon yellow. Built-in benches are upholstered in royal blue leather, and chairs in gray green leather; tables have Micarta tops. The room is air conditioned.

#### Materials and equipment

Floor: Asphalt Tile, Armstrong Cork Co.; Glass panel: Pittsburgh Plate Glass Co. Air conditioning: Anemostat Corp. of America. Furniture: specially designed, executed by Schmieg and Kotzian.

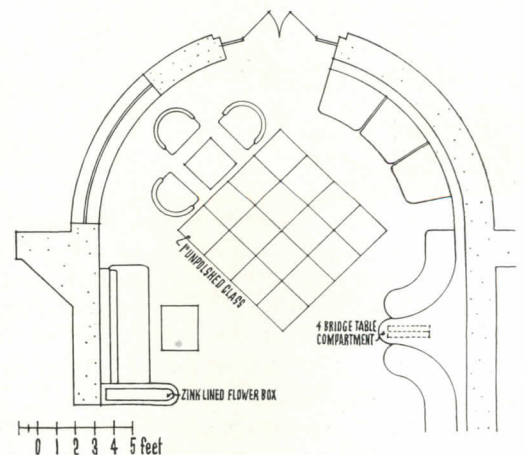

## NEW DWELLING UNITS: RECREATION



Elmer L. Astleford

### 4. ALDEN B. DOW

#### Architect

THIS GAME ROOM is located in the basement; its ceiling (and one wall also) are acoustically treated to prevent noise conduction to main rooms of the house. Access to the recreation unit is by a stairway concealed behind a brick panel at one end of the room. Walls are of common pink brick, except over the mantel where white acoustical wall board is used; the mantel is of wood. The ceiling is white; floor is blue asphalt tile.

#### Materials and equipment

Ceiling and wall: Acoustex, Johns Manville. Walls: brick, Wyandotte Clay Products Co. Floor: asphalt tile, Armstrong Cork Co.

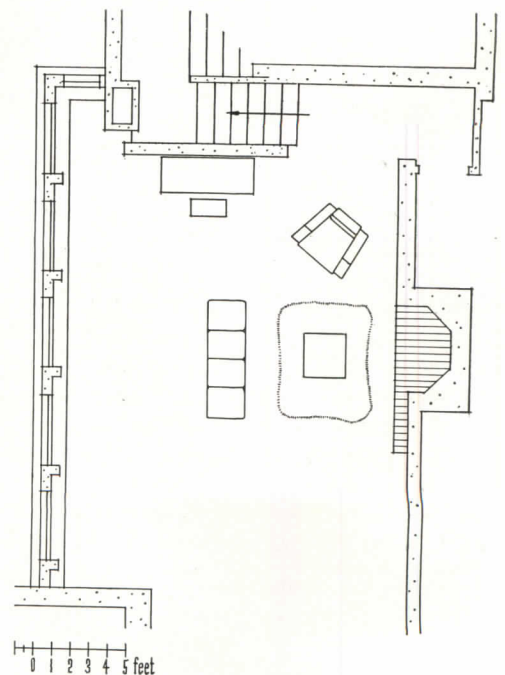

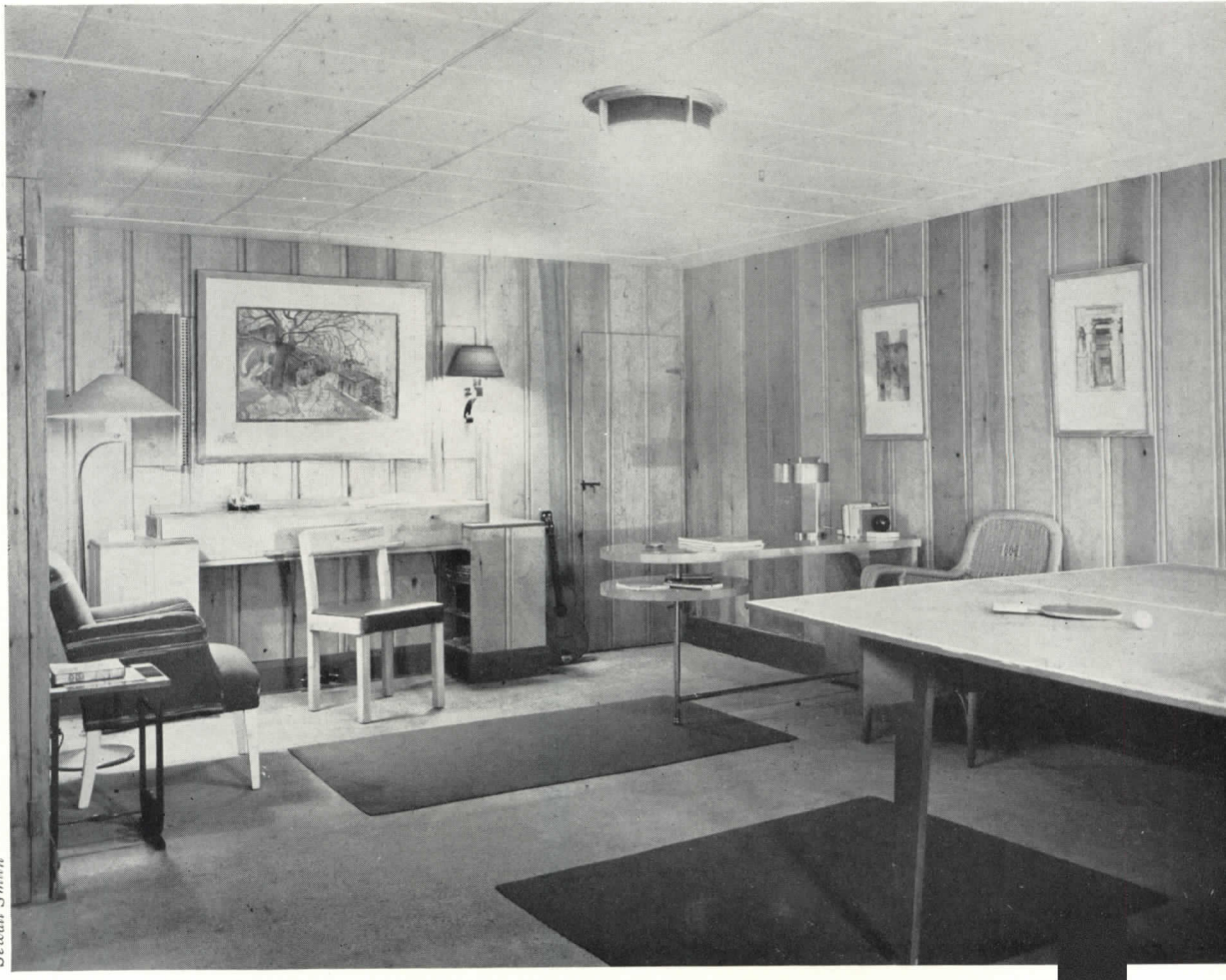

Sewall Smith

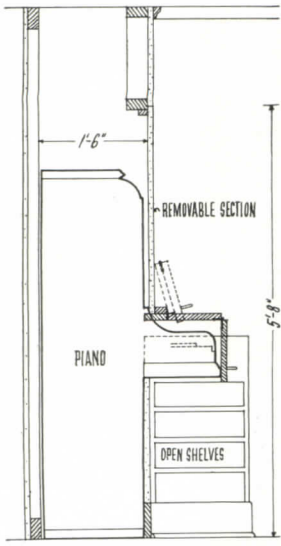

Detail of built-in piano

## 5. SEWALL SMITH Architect

THIS RECREATION ROOM is a music room as well, but is not readily recognized as such because the piano is built into one wall. This ingenious solution makes possible the use of an obsolete model piano in a room of contemporary design. Shelves at either side of the keyboard hold sheet music. The desk has a revolving magazine shelf below its table top. A built-in closet holds the ping-pong table when not in use. The floor is concrete, painted orange; walls are natural-finish pine; ceiling is ivory wallboard. Upholstery colors recall those of floor and ceiling.

### Materials and equipment

Ceiling: Art Ply. Lighting: Air-Lite.

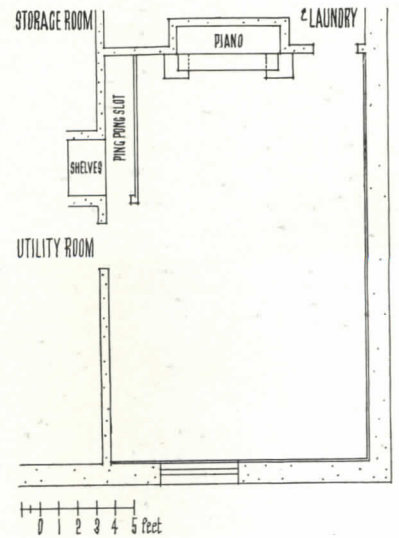

## NEW DWELLING UNITS: RECREATION

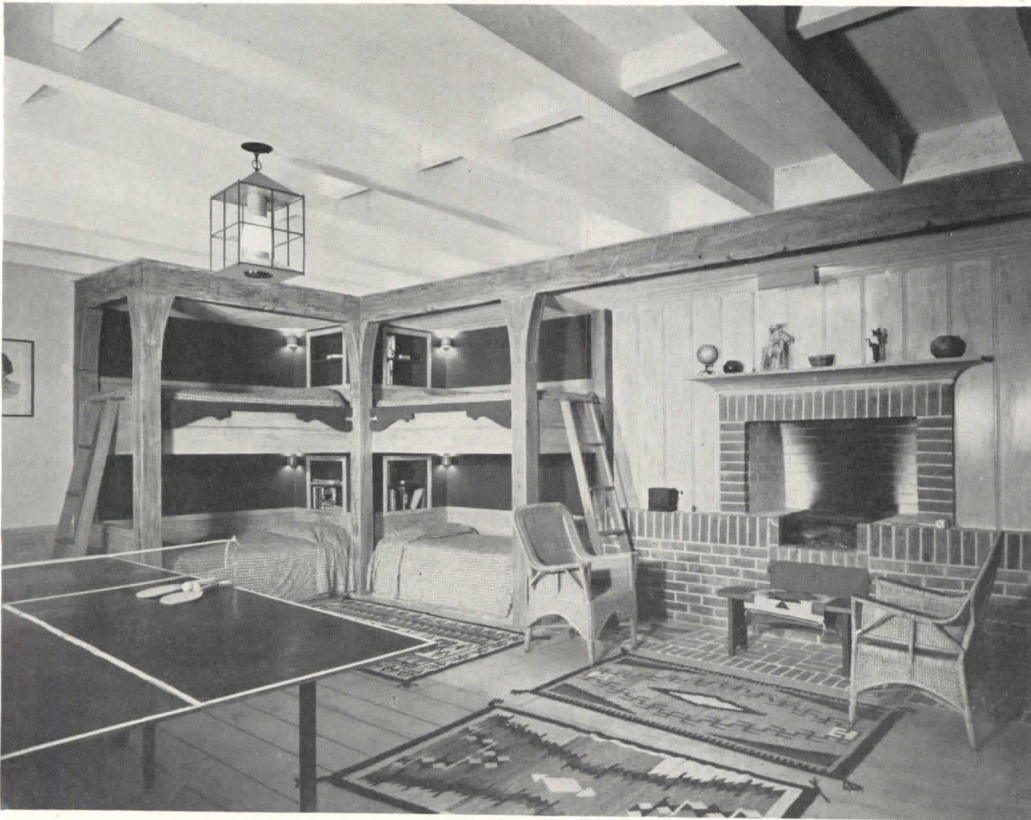

John H. Lohman

### 6. ROBERT STANTON Architect

ALTHOUGH PRIMARILY a recreation unit, this room has four bunks in one of its corners which provide extra accommodations for overnight guests. The common brick fireplace is designed for use as a barbecue. Since this room is in the basement, a dumbwaiter serves as communication between it and the kitchen on the floor above. The floor is of concrete, with the cement finish marked off to simulate plank flooring.



Hedrick-Blessing

### 7. JAMES F. EPPENSTEIN Architect

SWINGING DOORS between this game room and butler's pantry facilitate refreshment serving. The counter acts as a bar; beneath it is a liquor storage cabinet which is accessible from both rooms. The game room is paneled in natural finish mahogany; the furniture is also mahogany.



# DESIGN TRENDS



ARCHITECTURAL  
RECORD



**ORIGINALLY** planned for presentation at the Fifteenth International Congress of Architects, which was to have been held in Washington concurrently with the recent AIA convention, this exhibit was executed by the City Planning and Housing Committee of the Washington Chapter, AIA and hung in Washington during the Convention.

Subsequent to the showing and attendant discussion in local papers, the Chapter passed a resolution which states in part: "whereas, articles appearing in the public press have given the impression that the Washington, D. C., Chapter of the AIA had adopted an attitude critical of the commission and of its work and at variance with the policy of the AIA national body . . . be it resolved, that the Washington, D. C., Chapter commends and approves the work of the National Capital Park and Planning Commission and offers no criticism of the composition of this body, its methods of procedure, or the results obtained by it."

Although the exhibit will be circulated by the American Federation of Arts, the RECORD herewith presents it—with an abstract of the paper which accompanied it—to those readers who did not see it in Washington, and may not see it as it makes the rounds.

## THE CITY OF WASHINGTON D. C.

BY ARCHITECTS:

- HANSEN
- JACOBS
- KASTNER
- ORMSTON
- PALMS
- REESE
- RIEHL
- SQUIRE
- STEVENS
- WOODBARD

"THE ELEMENTAL UNIT OF PLANNING IS NO LONGER THE HOUSE OR THE HOUSEBLOCK . . . . THE UNIT IS THE CITY, BECAUSE IT IS ONLY IN TERMS OF THIS MORE COMPLEX SOCIAL FORMATION . . . . THAT ANY PARTICULAR TYPE OF ACTIVITY OR BUILDING HAS SIGNIFICANCE"

LEWIS WUMFORD

MATERIALS COURTESY USNA

## WASHINGTON: THE PLANNED CITY WITHOUT A PLAN

OBSOLETE IMPERIAL PLAN

"DONES'T COME UP TO STANDARDS OF CURRENT THOUGHT"

. . . "THE BOOTLEG TOMORROW"

**NEITHER IS THE CRITERION FOR THE CITY FOR PEOPLE OF TODAY**

14

TRAFFIC : AN INTEGRAL PART OF THE CITY PLAN

MONUMENTAL PLANNING CONCENTRATES ON STREETS

MODERN PLANNING CONSIDERS STREETS A NECESSARY EVIL

13

SERVICES : AN INTEGRAL PART OF THE CITY PLAN

DISORGANISED SERVICES DISORGANISE THE CITY PLAN

12

RECREATION: AN INTEGRAL PART OF THE CITY PLAN

WASHINGTON HAS MONUMENTAL PARKS

BUT LACKS NEIGHBORHOOD PLAY AREAS

11

EDUCATION: AN INTEGRAL PART OF THE CITY PLAN

SCHOOLS FOR YOUNG AND OLD SHOULD BE VITAL CENTERS FOR NEIGHBORHOOD ACTIVITIES

10

HEALTH : AN INTEGRAL PART OF THE CITY PLAN

HEALTH - THE CRITERION OF CITY PLANNING

WASHINGTON HAS A HEALTH PLAN WHICH IS STYMIED POLITICALLY

9

HOUSING: AN INTEGRAL PART OF THE CITY PLAN

NO HOUSING SURVEY

NO CITY WIDE PLAN

NO NEIGHBORHOOD PLAN

\*In certain respects the influence of the (McWilliam) Commission was altogether fortunate and salutary. Above all it developed the magnificent system of parks that have added charm and distinction to Washington. Another quarter of a century, however, sufficed to reveal the weakness and inadequacy of its approach. Even the restoration of the Mall to something like L'Enfant's conception, and the insistence upon large-scale planning in the development of the city, could not save the Capital from the grievous effects of a hidden conflict between public and private interests that, from the beginning, destroyed the organic unit of the whole." Washington: City and Capital, American Guide Series, WPA.

†"whenever the culture of a people loses contact with the common life of mankind and becomes exclusively the plaything of a leisure class, it is becoming a priestcraft. It is destined to end, as does all priestcraft, in supersession." Lancelot Hogben, F.R.S.

\*Henry Adams, for his pertinent writings on architecture, was made an honorary member of the American Institute of Architects.

†Washington: City and Capital, American Guide Series, WPA.

This does not imply another "plan"; on the contrary, cities cannot be leveled and rebuilt every decade. Most plans which require this cannot be achieved. It should be possible to keep the city plan in a constant state of change, so that every attempt could be made to meet contemporary requirements. If Washington had been restudied 15 or 20 times since L'Enfant's first plan, it would probably approach more closely our ideas of an appropriate modern city than it does today. If, at the first sign of changed requirements, the most competent planners were given an opportunity to develop schemes which would recognize the new requirements, the chances for rational city development would, at the least, be increased. A system which anticipates change, instead of ignoring it until the changed condition has produced complete chaos, should be the core of any city planning program.

In 1893, the Chicago World's Fair channeled popular taste into a Beaux Arts version of the Classic. This was directly responsible for the aesthetic movement known now as the "City Beautiful." Its outstanding examples are the Mc-

To the average citizen, a city is an entity almost as natural as a mountain and as difficult to change. Seldom does he consider that men make cities and that he is a vital part of this process. To him cities simply are. It is not surprising that the citizens of American cities have no understanding of modern city planning. They have no leaders. If the architect has lost his direct relation to the primary forces which determine the execution of his plans, he has lost more than his place in society, he has lost the foundations for his art.† It is mandatory that the architect search for methods which will make him a potent factor in society.

In 1867 Noyes, a prominent political figure, acquired control of a newspaper—the *Star*—and laid the basis for a coordinated public works program.† With Noyes was associated Alexander (Boss) Shephard, a progressive politician and builder. These two men decided to modernize Washington and when the time ripened in 1871, Shephard, then governor of the district, "openly, courageously, and with dictatorial abandon" constructed the many miles of sewers, streets, sidewalks, and street lighting, developed the spacious parks, and all over Washington planted trees that are today its pride. These major changes to the city were not made by architects. In 1893 Henry Adams (after the improvements by Shephard) . . . "found himself again in Washington. . . . Changes had taken place there; improvements had been made; with time—much time—the city might become habitable according to some fashionable standard."

Unfortunately, present day Washington is still known as "the planned city" and is still considered a model by many communities. The word "planned" carries a connotation implying "well-planned." The fact that plans can be good or bad, obsolete or inappropriate, is ignored. The plan of Washington in 1939 is obsolete and inappropriate. The student of cities who walks through the capital city is disillusioned by glimpses—behind the monumental facade—of a planlessness quite as apparent as that of most American cities. L'Enfant's plan in 1791 was a bold scheme which, if studied relative to the aims and ideals of the times, must have appeared to be a "good" plan. Viewed from the distance of a century and a half it lacks the elements of what we would define today as the basic physical requirements for a democratic city.

What the founding gentry could not suspect were the changed requirements which time had in store. By 1835, the railroads came into town to stay—the B & P built a permanent station on the Mall. By 1844, the telegraph came. Both were favorable to the Federal City which, with western expansion, was increasingly isolated. By 1865, a few streets were paved; the water supply was brought down from Great Falls; some horse-drawn streetcars appeared; a primitive sewerage system remained a menace to health and an affront to the nostrils. Yet it was during this time that the form of present day Washington was cast. This was done without broad new plans to solve the problems which the changes had created.

The scale on which L'Enfant conceived the Plan and which—if the traditional approach had been feasible—should at least have been quadrupled in scope by 1900, was reduced to some achievable minimum by the McWilliam Commission. The minor axis, which, counterpointlike, the early planners had made the object of the major axis, the Potomac Valley, became the primary object of lavish care. The public office buildings were placed along the Mall—little allowance being made for the greatly increased transportation and housing facilities required by the rapidly increasing number of Federal office workers.

Here and there wooden houses were deserted Syrian city. Here and there wooden houses were scattered along the streets, as in other southern villages, but he was chiefly attracted by an unfinished square marble shaft, half a mile below . . . even the effort to build Washington a monument . . . had failed."

The embarrasment, wrought by a city plan so grand as to make hopeless the prospect of ever filling the empty squares with inhabitants, stands in marked contrast with the congestion which overcame the city in less than sixty years. The inadequacy of traditional planning approaches, which permit a city to suffer both from the utter lack of population and from hopeless congestion in so short a time, poses the question as to the validity of these approaches.

In 1868 Henry Adams found " . . . the village unchanged . . . nothing betrayed growth. As of old, houses were few; rooms fewer. . . . No one seemed to miss the usual comforts of civilization. . . . Washington was a mere political camp, as transient and temporary as a camp-meeting for religious revival . . . the life belonged to the eighteenth century, and in no way concerned education for the twentieth."\*

\*... in short, the Town of Tomorrow at the Fair, which might have topped the Fair and sent people away with a vision of the future, doesn't even actually come up to the standards of current thought and current design. It remains the boogie tomorrow that used to be sold as genuine Scotch before October, 1929." —Lewis Mumford.

In 1850 Henry Adams "... found himself on an earth road or village street, with wheel tracks meandering from the colonnade of the Treasury hardly, to the white marble columns and fronts of the Post Office and Patent Office which faced each other in the distance, like white Greek temples in the abandoned graveyards of a

wake ruined speculators and a blighted area. had become a dismal failure, leaving in its (through which the City was to be financed) London idea had been forgotten. The real-estate venture, too, was forgotten, the canals had not progressed, and the super-had died in obscurity, the majestic approach near the Potomac But by the time L'Enfant, impoverished and embittered, job of planning, was selected as planner.

The site for the Federal City had potentialities. In George Washington's time the Potomac River as seen from Mount Vernon was a great shipping avenue to a strategic position acceptable both to the North and South, and a connection to a projected canal system to the then opening West. Here, George Washington and his contemporaries readily conceived a great harbor, a seat of learning, a super-London, as the center of government for the Republic. The prototypes for such vision were the perfected aristocratic plans of 18th century Europe. L'Enfant, who had made a strong plea for the

And how much of the first plan remains useful today? original plan withstood the assaults of later improvement? changes and a predetermined plan. To what extent has the relatively short time, the interaction between contemporary City is therefore a good example in which to observe, over a more obvious features into their home towns. The Federal and eagerly have they attempted to transplant some of its the cousins from the States looked upon the great White City has become a tangible symbol of the Republic. With awe have the United States. As the seat of the Federal Government it WASHINGTON, D. C. is well known as "the planned city" of

II

The plans are only part of the city building process—the process requires direction which will inspire citizens to act. Here the architect must clear the vision. In this light, the "dream cities" which lately have appeared on the American scene can have little influence on city building. None of these "cities of the future" are tied to realities. Most of them are not even bold conceptions. \* Even if they were, they would be insufficient. It is not enough that men can conceive fine cities—they must be able also to create them.

is the substance of contemporary planning. requirements of the greatest number of citizens. This timing The social potentialities of the city, therefore, depend on whole, are in the nature of a continuous remodeling job. required alterations, which, if one looks at the city as a change, one cannot simply throw the city away. On the contrary, it takes time, effort, and capital to make even the a city at a given time could articulate demands for drastic

### WASHINGTON 1939 IS A CONGESTED CITY

PER CAPITA — IN U.S.

MOST CABS AND BUSES  
LIVING COST AMONG HIGHEST  
HIGHEST MEDIAN RENTAL AND HOME VALUE  
LARGEST NUMBER OF HOUSES OVER \$5,000  
HIGHEST ANNUAL RETAIL SALES

IN 1939: 112,000 PLUS FAMILIES EQUAL  
OVER HALF OF POPULATION

IN 1800: 130  
FEDERAL EMPLOYEES—

2,000,000 TOURISTS ANNUALLY  
FOURTEENTH LARGEST CITY IN U.S.  
800,000 PEOPLE IN METROPOLITAN AREA  
70 SQUARE MILES OF LAND

### NOW: THE CITY OF MONUMENTS

EMPHASIS ON "THE GRAND PLAN"

FOR TOURISTS  
FOR RESIDENTS

THE MACMILLAN PLAN STRESSED PARKS AND THE MALL  
"WASHINGTON'S AESTHETIC REGENERATION"

1901

### A WAR - A BOOM - A BUILDER

1880  
1880

"BOSS" SHEPHERD  
PLANTS 60,000 TREES  
BUILDS STREETS SEWERS SIDEWALKS

"The elemental unit of planning is no longer the house or the household; the elemental unit is the city, because it is only in terms of this more complex social formation that any particular type of activity or building has significance."  
—Lewis Mumford.

1

Architecture is defined by Webster as "the art or science of building, especially for the purpose of civil life"; *civil* is defined as "characteristic of or befitting a developed social community: civilized"; and *civilization* as "denoting an advanced state of material and social well-being." Thus, it will be seen that implicit in the very terms is a recognition of the social function of the architect in the community as a whole. Whether architecture is rapidly becoming a discipline of the emerging science, "city planning," or whether city planning remains a phase of "architecture," is not the point in question here. What is important is whether the architect can, and will, utilize his unique position today to play a decisive role in the city planning of the future.

What are the criteria by which the functions of cities are determined and what are the objectives of city planning? Obviously, cities are institutions made by and for citizens. This must be understood: the inanimate thing called city exists only because of and for citizens.

In any discussion of city planning, differentiation must be made between the traditional connotation of the term and its contemporary usage. Thus, the meaning of city planning in terms of an eighteenth century baroque city is changed by the requirements of a twentieth-century democratic society. In general, the requirements are as follows:

1. The modern democratic city is the place for all citizens to live, work, play, etc. The baroque city was planned by and for the aristocratic minority. There can therefore be little similarity between a city planned for a minority and that planned for all the residents of the city.

2. All elements in the democratic city must be integrated. Since the democratic city exists to fulfill all the requirements of its citizens, planning for the democratic city must integrate all elements in the city. \* Unless all the fields are brought into proper relation to one another, there can only be partial solution of any one.

3. The modern democratic city demands a workable relationship between people and their environment. This must be in human scale. Traditionally a city, which itself grew out of a village, has been conceived as a center which could be enlarged as the population increased. The traffic expansion of cities which came about after the industrial civilization of the nineteenth century has shown that this concept is in error. It resulted in an unwieldy pattern which must be reexamined and revised.

4. A city plan, once formulated, must be kept flexible in order to serve successive generations. The plan of the city has been relatively static compared to its population, which has definite dynamic qualities. But even if the population of

\*For example, an excellent traffic plan may serve an irrational development of housing and commercial centers. In itself, the traffic plan may function properly for the moment, but if any rational housing plan were inaugurated, the traffic plan might prove to have been a program in direct opposition to one which would fit into the housing plan.

Aerial Photo by McLaughlin Aerial Surveys, Inc.



WHAT SEEMS to be required for the Capital, as for many other cities, is not *one new plan*, but a *new method of city planning* which will yield a better timing between the physical city and constantly changing human needs. One method for accomplishing this lies in a system of periodic public competitions. Such a system could be so devised as to provide in all fields of city planning dramatic public concentration on all issues of civic importance. Specifically, it could provide:

- a) Plans which would not become obsolete because they would change as the problems changed
- b) Coordinated planning activities
- c) Competent city planners
- d) Active programs which would force the adoption of rational city plans.
- e) Participation by all planners in the job which is their social responsibility

For the purpose of discussion of the feasibility of a professional approach through public competitions for city planning, one specific method—there are undoubtedly other ways of utilizing competitions as a method—is proposed in this article. This method proposes divisions as follows:

1. Master Plan
2. Sectional Plans
3. Collaborative Plans
4. City Planning Institute
5. City Planning "Museum"

1. The function of the PERIODICAL MASTER PLAN (perhaps six years might be an appropriate time to instigate anew an analysis into the broad aspects of the city) would be to produce a plan which would integrate all components of the city. The program for this plan would be so framed as to invite the participation of national, if not international, authorities on the subject. The programming of the competition into preconceived solutions would be carefully avoided.

The winner of the Master Plan Competition would become the leading member of the city planning commission. This would eliminate the tendencies of appointive commissions towards the perpetuation of a single school of thought. Further, it would place in the leading position a man who would be a civil servant in the best sense of the term—that is, a man demonstratively competent to perform the job.

The city planning commission would be made up of the first three winners in the competition. All participants of the Master Plan Competition would form an advisory committee for the purpose of meeting at stated intervals with the commission for discussion and criticism of its program.

2. The SECTIONAL COMPETITIONS would be held to secure solutions of special problems in the city—housing, health centers, recreation centers, etc., or the revision of any particular section of the city—specific neighborhoods, waterfronts, commercial areas, etc.

This series of competitions would be important from several standpoints. It would bring to the front specialists with a variety of ideas which would assist in the detailed development of the winning master plan. The fields covered by these competitions would include all the component parts of the city. This would relate all the elements in the city to the master plan and would eliminate the confusion which exists today in the isolation of many planning agencies.

The Sectional Competitions might be held twice during the life of a master plan so that during the term of office of the planning commission two groups of staff members would be

## BUSINESS: AN INTEGRAL PART OF THE CITY PLAN



PLANNED  
BUSINESS CENTERS  
SHOULD REPLACE COMMERCIAL CHAOS

## INDUSTRY: AN INTEGRAL PART OF THE CITY PLAN



GOVERNMENT IS THE CAPITAL'S CHIEF INDUSTRY

CONCENTRATION OF THIS INDUSTRY INTO A FEDERAL ISLAND CREATES CONGESTION

## INTEGRATION: ESSENCE OF A CITY PLAN

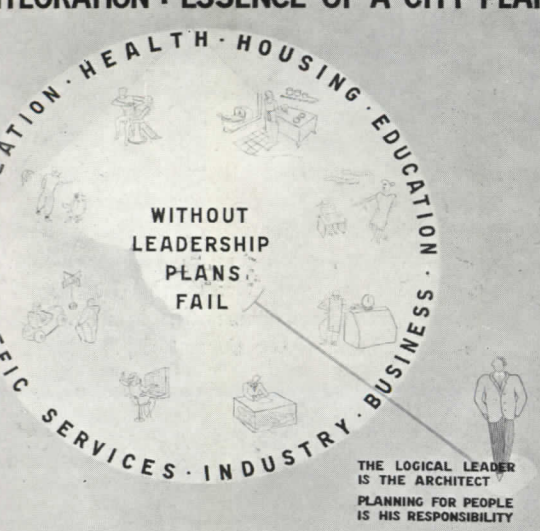

RECREATION · HEALTH · HOUSING · EDUCATION · BUSINESS · INDUSTRY · SERVICES · TRAFFIC

WITHOUT LEADERSHIP PLANS FAIL

THE LOGICAL LEADER IS THE ARCHITECT  
PLANNING FOR PEOPLE IS HIS RESPONSIBILITY

## PERIODICAL COMPETITIONS FOR THE CITY PLAN

A CITY PLAN CANNOT BE MADE ONCE: IT MUST BE REVISED AND REMADE FOR SUCCEEDING GENERATIONS: THIS IS A CONTINUING PROCESS



CHANGES IN THE PHYSICAL CITY  
TIMED  
WITH CHANGES IN HUMAN NEEDS  
EQUAL  
A MODERN CITY

THE NEED: PERIODIC SURVEY AND DEVELOPMENT OF THE CITY  
THE METHOD: OPEN COMPETITIONS AT REGULAR INTERVALS

18

## A CITY PLANNING MUSEUM

FOCAL POINT FOR ACTION

THE PEOPLE'S FORUM

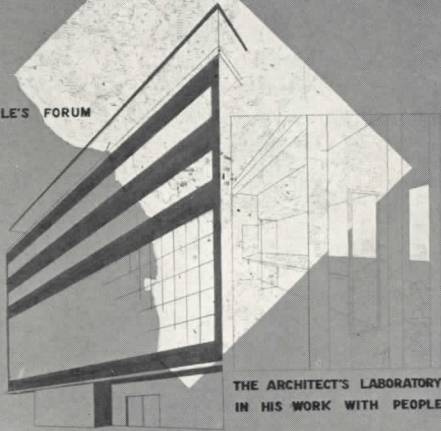

THE ARCHITECT'S LABORATORY  
IN HIS WORK WITH PEOPLE

19

## PLANS ARE POINTLESS UNLESS REALIZED THIS CALLS FOR BOLD ACTION

BY CITIZENS  
BY ARCHITECTS



A CITY FOR CITIZENS

DEMANDS:

THEIR VOICE  
THEIR VOTE  
THEIR COOPERATION

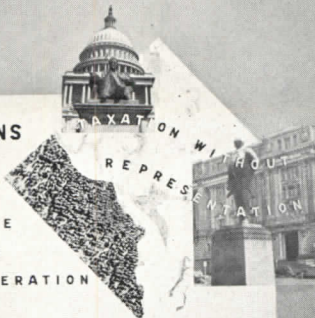

available. This would tend to stimulate the commission's activities.

3. The COLLABORATIVE COMPETITION would bring into the picture all the vital forces in city planning other than architects. Doctors, sociologists, political scientists, etc., would present schemes for any of the component parts of the city. These would give opportunity to those in all fields to bring out schemes which today are too frequently buried in the notes or minds of the individuals.

Whenever feasible, these schemes will accompany the planning submissions by architects in either of the other two competitions, and, worked out with the architects, will include drawings illustrating the physical expression of the scheme. For example, a doctor, presenting a paper on a city-wide program for health centers, would work with an architect who would present a city plan showing the location of the centers, and drawings indicating the type of building and its relationship to a specific neighborhood.

One participant might present a scheme for a valuable type of housing survey. This would not require plans, but would be important in the development of the city plan. The tendency would be to bring together the planner and all others whose work is a vital part of the city plan. The architect would learn to revise his thinking in terms of human requirements brought out by students of cities in other fields, and the doctor, sociologist, etc., would become familiar with the physical expression of their ideas.

4. CITY PLANNING INSTITUTE. All members of the planning commission and its staff, and all participants in any of the competitions at any time, would automatically be members of the City Planning Institute. This Institute, with a membership made up of those who had, by participation in the competitions, displayed an active interest in city planning would provide the core for leadership in the entire city. Its job would be to serve as an educational and political body which would stimulate the average citizen to active participation in the rational development of the city. Gradually such an Institute would become the coordinating body of citizen representatives of all neighborhoods. The Institute would thus be a public interprofessional clearing house for discussions of planning problems.

5. The CITY PLANNING "MUSEUM." In order to create a focal point, something more dramatic than competitions must be found. This instrument might be what, for want of a better word, can be called a City Planning "Museum." The word "Museum" is defined as "a building in which are preserved and exhibited objects of permanent interest in one or more of the arts and sciences." This is only a partial picture of the functions of the museum. It would be a meeting place and a workshop as well as a place for study. It would be an institution which would educate the citizen, the architect, and all others professionally interested in city planning. It would bring together all forces which are necessary to develop political action for city planning.

Citizens should be educated by exhibits, films, books, lectures, etc. The aim of all such activity would be to remove the popular suspicion of the planner as a meddler and a destroyer of individual rights. This would have to be replaced by the idea that cities are group enterprises and that city planning which recognizes this is a benefit to all members of the community.

ARCHITECTURAL RECORD

20



# REVIVAL OF WOOD AS A BUILDING MATERIAL



J. B. Guss, Black Star

Ironically enough, it has remained for modern scientific analysis to make possible the full exploitation of one of man's oldest and most familiar building materials—wood. The greatest advances in its use in recent years have been almost exclusively due to increasing knowledge—and hence control—of its properties. Much of this knowledge has come from other fields—chemistry, metallurgy, etc.—and is only now being applied to the re-creation of wood as a modern material. Mr. Don Taylor, of Los Angeles, is the author of the following study—fifth of a series in the RECORD'S survey of trends in building materials.

WOOD POSSESSES a greater variety of inherently desirable qualities than any other building material; but, as in any raw product, these qualities require intelligent exploitation. Produced by nature on her own terms, it is a nonhomogeneous and nonuniform substance whose strength and dimensions are sensitive to many influences. Little was done to refine this product and extend the horizon of its uses until recently, because it was so versatile in a mediocre all-around way in the raw state, and because centuries of tradition had defined the scope and manner of its use . . . and misuse! It took the impact of the engineering age in architecture, with its emphasis on standards of extreme exactitude and its demand for efficiency, to jolt the lumber products industry from its state of tolerant complacency.

In the past 25 years belated research\* has been made in many directions: (1) better control of inherent properties; (2) development of greater uniformity in the raw product; (3) formulation of more exact and more satisfactory data on standards of strength, deflection, etc.; (4) reconstruction into new physical forms; (5) improvement in methods of distribution. Remarkable progress has resulted from this many-sided research—developments which afford architects new latitude in design, new breadth of concept . . . and which make imperative fundamentally new archetypes both in design and construction.

\*One of the most important lines of research was conducted by the U. S. Forest Products Laboratory in Madison, Wis., which compiled data on the strength of small, clear specimens of American timber. Approximately 130,000 tests were made. Although these were valuable as a foundation for further research, their immediate practical value was debatable because small, clear specimens of timber are not used in construction. However, in 1925, Secretary of Commerce Herbert Hoover established the National Committee on Wood Utilization, with which the Forest Products Laboratory and the National Lumber Manufacturers' Assn. cooperated in establishing a body of unified knowledge and accurate standards comparable to those of steel and reinforced concrete. Definite working stresses were established; tests of full-sized timbers up to 50 ft. long demonstrated in quantitative fashion the influence of common defects, such as knots and checks, on strength, with the result that structural designers have been supplied with more efficient working-stress values, building codes are being modernized, and timbers are bought and sold on a basis of strength grades by which they can be rationally and economically selected for their intended loadings.

When it comes to canny exploitation of its potentialities, many designers besides architects have excelled with wood.



Metropolitan Museum of Art

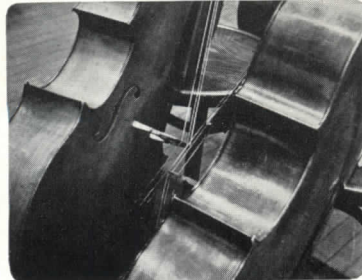

Goro from Black Star



Arthur E. Nelson from Black Star



Courtesy: Aero Digest, Boeing Airplane Co.

## WOOD—APPLICATIONS

Wood as a building material has long been used for everything from framing to surface finish. The photographs on this page indicate the range of these uses in some of their newest aspects. In the accompanying study, the present-day development of stronger, more precise, useful, and reliable forms of this age-old material is explored.

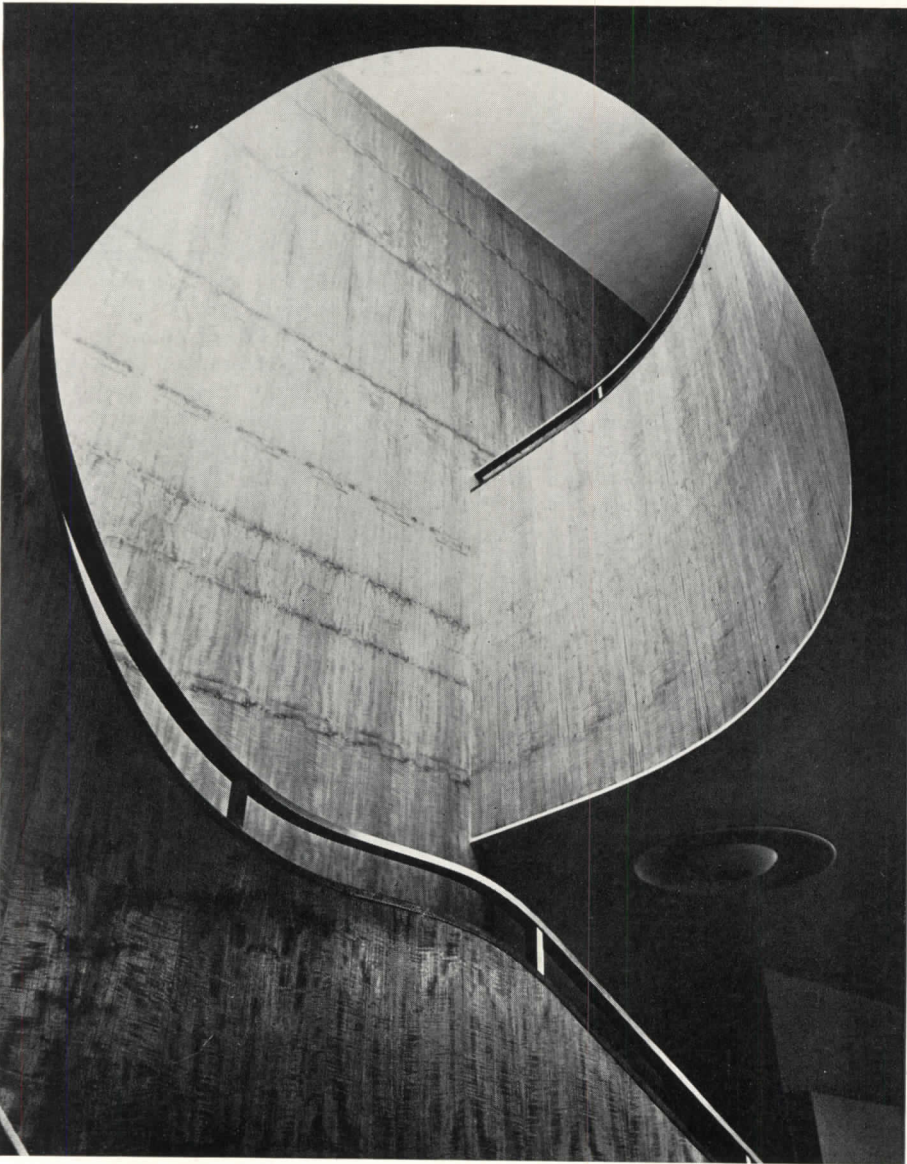

Gottschalk. Courtesy U. S. Plywood

Fig. 1. As a surface finish—rare veneer.



Chicago Architectural Photographing Co.

Fig. 2. As framing—all timber.

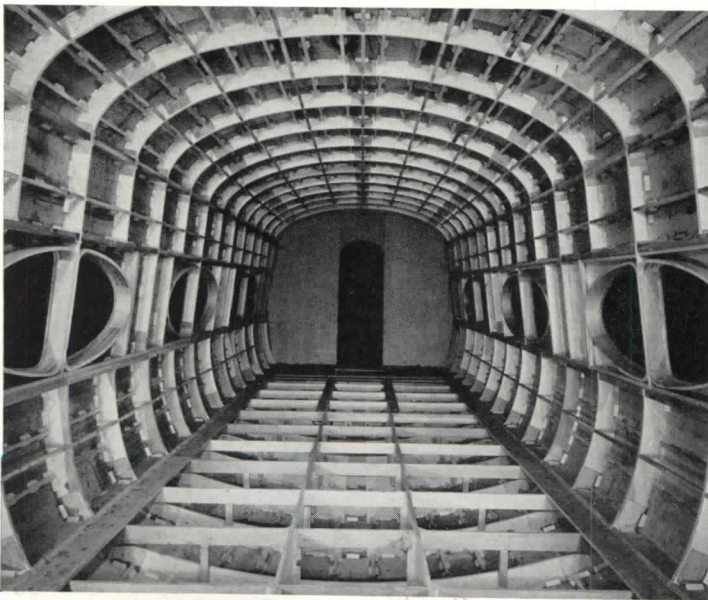

Courtesy Pacific Railway Equipment Co.

Fig. 3. As structure—wood and plywood.

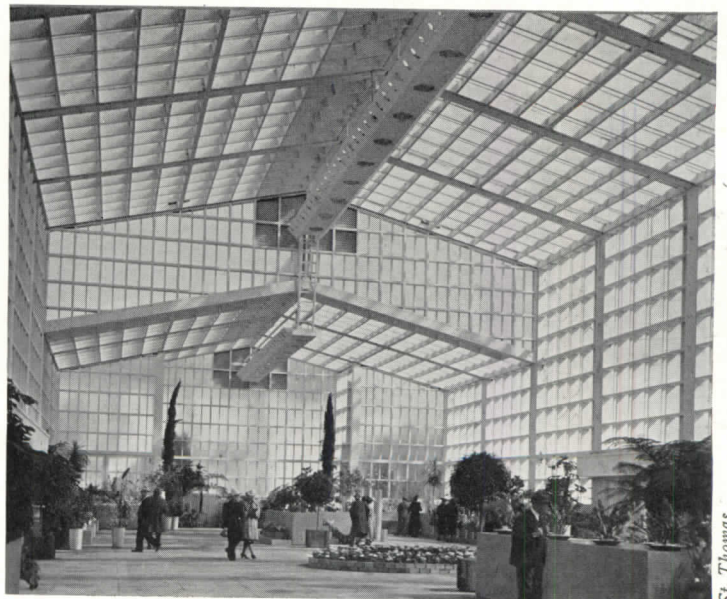

St. Thomas

Fig. 4. As framing—all plywood.

## Properties of wood

The properties of wood differ widely in the various directions relative to the grain. If its strength parallel to the grain were characteristic in all directions, it would be unexcelled for all structural uses where strength per unit weight is of importance.\* The tensile strength along the grain is from 3 to 5 times its compressive strength in the same direction, and may be 20 or more times the tensile strength in a perpendicular direction. Resistance to compression along the grain is 5 to 9 times greater than perpendicular to it. Similarly the modulus of elasticity along the grain is from 15 to 80 times that across the grain. Resistance to shear is greatest along planes perpendicular to the grain.

Wood is easily workable, requiring only simple craftsmanship and tools; it is strong in relation to its weight, of light weight in relation to volume, possesses high thermal and sound insulation value. It has the advantage of being almost universally available, relatively inexpensive, resistant to fatigue, and easy to finish. These qualities make it the most universally accepted material for experimentation in lower-cost home design. It has, however, many undesirable quali-

ties which, until recently, have greatly restricted its use. It is susceptible to extreme shrinkage, expansion, and warping; it is limited as to unit sizes; it absorbs water; its strength is not uniform in all directions; it is susceptible to decay and prey to many common insects; it cleaves easily, cannot be flexed and fixed, cannot be molded to desired shapes except within extremely close limits. Each of these undesirable properties of the *raw product* can be eliminated by special manufacturing and processing technics.

Latest data on strength and related properties of wood as determined at Forest Products Laboratory are given in U. S. Dept. of Agriculture Technical Bulletin No. 479, Table 1, page 4, obtainable from the Superintendent of Documents, Washington, D. C.

Complete data on safe working stresses are given in U.S.D.A. Technical Bulletin No. 167. (15 cents.)

Latest data, graphs, etc., on strength-moisture relations in wood are given in U.S.D.A. Technical Bulletin No. 282, obtainable from the Supt. of Documents. (20 cents.)

## Trends in processing

Modern structural materials must be efficient, hence predictable, hence uniform. Efforts are being made through silviculture to produce wood of greater uniformity and desirability, but, to date, improvements in lumber as a product still must be made after the log is cut, through new processes in manufacture and treatment, and through better methods of use. Wood-processing technics have two fundamental purposes: (1) to create a product of greater efficiency, dependability, and uniformity; (2) to develop specific latent properties. Frequently the development of one characteristic results in sacrifice of other desirable qualities—thus, in certain types of resin-impregnated plywoods, water absorption is virtually eliminated but with loss of the normal high strength-weight ratio advantage.

### Chemical processes

By forcing substances inhibitive to bacteria into its fibrous tubes, wood can be made to resist decay and fungus growths for apparently unlimited periods of time. The synthetic resin with which many plywoods are now bonded also assists in preventing decay by releasing vapors which impregnate the wood and are obnoxious to fungi.† (See AR 3/38, p. 76.)

One of the greatest objections to wood as a building material is its tendency to swell, shrink, and warp due to atmospheric conditions and to working conditions of extreme humidity. Fixed dimensions are assured by deep impregnation with chemicals which make the wood structure practically impenetrable to the movement of moisture vapor.

Lumber can also be made to resist combustion by impreg-

nation with chemical salts which fill the hollow cell structure, leaving no space for oxygen. (See AR 11/37, p. 37.) Some types of lumber, notably redwood, have high natural resistance to combustion, and almost any variety of wood of more than a specified minimum size (4 by 4 in.) resists fire better than exposed steel and commands a lower insurance rate.††

Within the last year a salt process has been developed to eliminate checking and warping of large timbers during seasoning. The treatment brings about a state of moisture equilibrium in which the wood dries from the center outward, reversing the usual direction, and in the final dry condition, the salts absorbed act in a way to hold the wood against shrinkage and change of shape. By this method large timbers are dried practically without checking.

The purpose of seasoning is to fit wood for moisture conditions it will meet in service. The importance of proper seasoning is aggravated by air conditioning which introduces serious problems of moisture transfusion, sweating, and ice formation in walls. The government is investigating moisture tolerances for lumber according to localities and uses.

### Plywood

It seems apparent that plywood will serve as the integrating factor in the architecture of tomorrow. Currently, the depth of a 2 by 4-in. stud, 16-in. spacing of joists and studs, are the modules which affect more items in a house than any others. In larger elements, 4 ft. and 8 ft. (multiples of 2, 4, and 16 in.) are most logical, practical, and economical. Hence plywood sheets are standardized at 4 by 8 ft., a unit of integration around which future buildings must be planned. The

††In fires of short duration but enormous heat, unprotected steel trusses will expand, damage the walls, soon collapse without warning from loss of strength due to the rise in temperature. Timber trusses are less affected by the intensity of the fire than by its duration because their strength diminishes only in proportion to the loss of cross-section, with the charred surface acting as an insulator. In case of collapse they give ample warning and their removal is much less costly. The fire hazard of a building is determined more by the contents than the structure itself. (Source—"Modern Timber Construction" by C. Pantke, presented before A.S.M.E., Wood Industries Division Meeting, Oct. 12, 13, 1939.)

†Scientific American, July, 1939, p. 46.

\*In his article on glass (AR 2/39, p. 66), Dr. Jaroslav Polivka declares that glass is the most efficient structural material in relation to its weight. He quotes ultimate compressive strengths of 65,000 to 85,000 lb./sq. in. But the limitations of glass as a load-bearing material are indicated in his Table 3, in which compressive strength of a glass prism, 2 by 2 by 2 in., is quoted at 80,000 lb./sq. in., but increasing the length to 10 in. reduces the strength 75%, to 20,000 lb./sq. in. Presumably this rapid loss of ultimate strength continues as length increases. Glass may be efficient as a structural material in theory, but the day of glass beams, column- and load-bearing panels, etc., has not yet arrived.

# TIMBER-STRUCTURAL

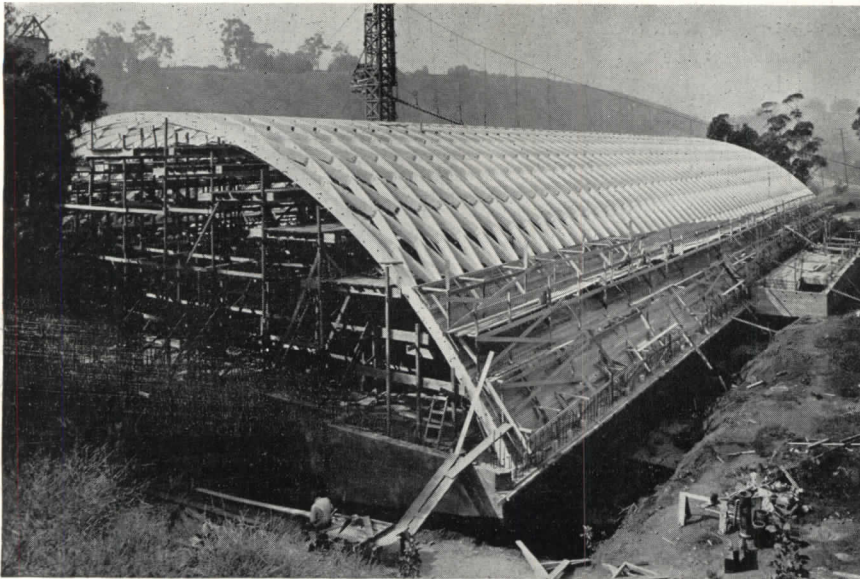
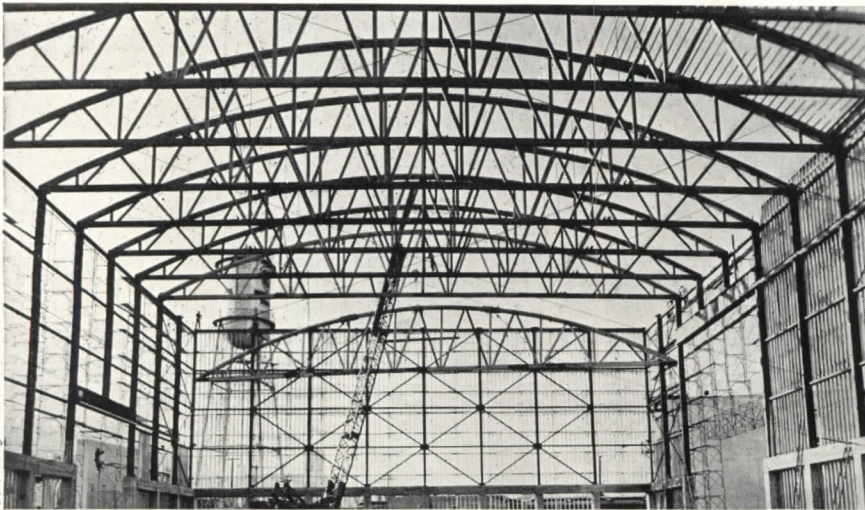

Fig. 5. The Lamella-type roof truss distributes loads over the whole structure.



Fig. 6. A timber frame for a monumental arch.

Courtesy Lamella



Courtesy National Lumber Manufacturers' Assn.

Fig. 7. All of the members of these broad-arched trusses are framed in timber.

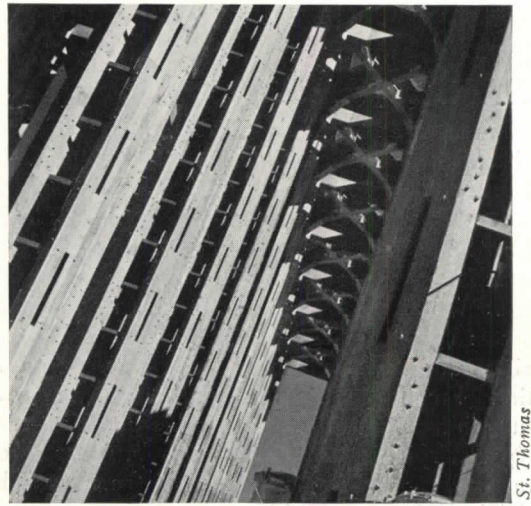

St. Thomas

Fig. 8. Columns built up of timber and plywood.

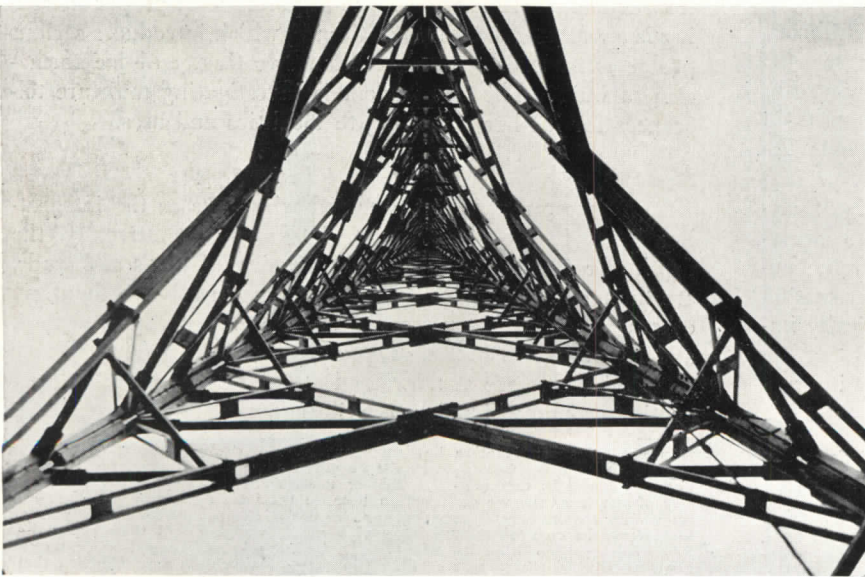
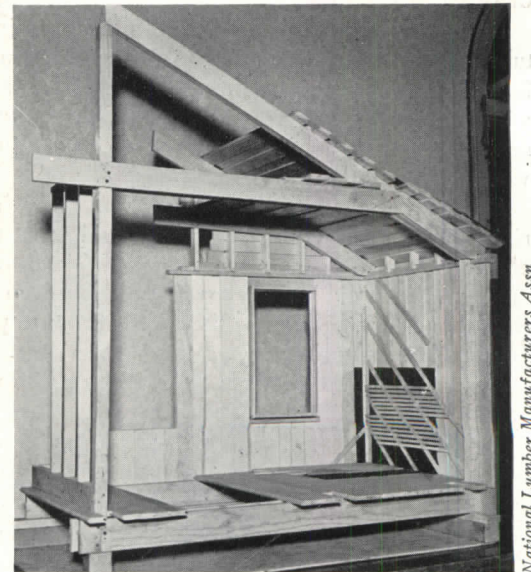

Fig. 9. Looking up into a radio tower. It is timber as far as the eye can see.



National Lumber Manufacturers Assn.

Fig. 10. Plank floor over wide-spaced joists.

Japanese floor mat, controlling modular area which governs planning, developed over hundreds of years, is approximately 6 by 6 ft. (AR 9/37, p. 32.) Plywood is a development of veneering, an art known to the early Egyptians. It consists of layers of veneer (thin-cut wood) usually placed with the grain of adjoining layers perpendicular to each other and bonded with glue or cement. The glue acts not only as a binder between surfaces, but insofar as it penetrates the wood fibers, it acts as a binder between the fibers themselves. The perpendicular arrangement of layers with respect to the grain balances internal stresses and strains, resulting in permanence of dimension and shape, and equalization of stress resistance.\* Plywood, stronger per unit of weight than solid steel, has the highest strength-weight ratio of any building material. It can be fabricated to give amazingly diverse predetermined characteristics, through judicious selection and proportioning of the component veneers. It can be produced in much larger unit sizes than unprocessed wood.

Many types of glues have been used as binders—animal, vegetable, casein, albumen, and silicate—but the newest and seemingly most satisfactory type is phenolformaldehyde resin which has greater water resistance, is non-toxic, and is not attacked by fungus growths or bacteria. (See AR 11/37, p. 38 and 11/38, p. 60). It is reported† that in the case of such synthetic resin plywoods, their waterproofness is so complete that after four years of exposure to Florida weather, no evidence of solubility or weakness was found in the adhesive, although the wood showed signs of decay.

The particular use to which a plywood panel will be put usually determines the number of plies. If the same bending or tensile stress is anticipated in all directions of the plane of the panel, the greater the number of plies the better. However, it is pertinent to note that a 3-ply panel is stronger in the direction of the grain of its faces than plywood of more multiple ply.

The advent of waterproof resin adhesives permits manufacture of special plywood for exterior use. Extensive use of exterior plywood was made at the Golden Gate International Exposition, San Francisco, where it showed its mettle under high wind pressures and constant humidity. Sharply curved plywood may be obtained in any radius down to 6 in. It is usually made to order and is considerably more expensive than flat pieces. Ordinary dry plywood will take a radius of 16 in. Fire-resistant plywood, required by some city building codes, has a core impregnated with salts.

#### Super-pressed plywood

“Super-pressed” plywood, a very recent development, makes use of hot pressing technique and extremely high pressures. This produces a plywood of much higher strengths, “which can be predetermined with a fair degree of accuracy. Just as metals can be alloyed, tempered, treated, and strengthened, so can wood be improved by this process.”†† The abnormally high pressures used increase the density of the wood layers.

\*Although resistance to bending is more equalized in all directions, it is not exactly equal. The outer layer will resist bending (in the direction of its grain) better than any of the inner layers (relative to the direction of their grains) because it is farther removed from the neutral axis; that is, it has a more favorable bending moment. (Source—“Engineering Characteristics of Plywood” by Thomas D. Perry, A.S.M.E. Transactions, Vol. 50, WID-50-13.) Also, since the strength of wood across the grain is much less than with the grain, the gain in strength (compressive or tensile) in one direction is offset by a decrease in strength in the other direction below that of solid wood. Thus solid wood is to be preferred where longitudinal strength and stiffness are important considerations.

†“Super-Pressed Plywoods” by R. K. Bernhard, Thos. D. Perry & E. G. Stern, read before A.S.M.E., Wood Industries Division Meeting, Boston Oct. 12-13, 1939.

††“Super-pressed Plywoods” (see R. K. Bernard et al reference bottom of page 6).

Tests made on yellow poplar veneer subjected to pressure of 1500 lb./sq. in. indicated comparative strengths with solid poplar as follows: Compression, 310%; tension, 286%; shear, 139%. Tests made on birch veneers indicated that although strength increased rapidly with pressures up to 1000 lb./sq. in., little advantage was gained by subjection to pressures exceeding 1000 lb./sq. in.

Super-pressed plywood may replace certain extra-dense solid woods which are available only in small sizes and are difficult to obtain. Such plywood, made to predetermined specifications paralleling those of the rare woods, could be made in large sheets as ordered. The new material also will be valuable for gusset plates in timber construction and for webs for plate girders.

#### Compound wood beams

Although compound wood beams have long been in use to circumvent limitations in unit sizes of timbers, it is only recently that beams have been compounded of various species of wood to create structural members with characteristics comparable to steel and other metals. Wooden beams, thus, can be fabricated to possess any specific density, elastic strength, and other properties. They are laminated in proportions and varieties of wood to create the characteristics desired. Phenolic resins are used as the binding agent.

#### Veneer combinations with other materials

Veneers used in combination with other materials are generally to be classed as specialties whose functions are essentially decorative. A strong bond can be made between wood veneer and metal by the use of cloth which adheres to the metal through a cloth-and-metal adhesive and to the wood by a phenolic resin adhesive. (See AR 12/37, p. 33.)

The metal adhesive penetrates the cloth fibers from one side, interlocking with them, and the phenolic resin penetrates the fibers in a similar manner from the other side. The cloth also helps equalize the differences in expansion and contraction of the two materials. The resin provides protection against rot, fungi, mold, etc, and prevents moisture absorption by the cloth.

The bonded wood-metal can be bent to a ¼-in. radius across the grain, 1-in. radius with the grain. In a similar manner, metal facing is applied to both sides of wood veneer to form panels of great strength and lightness. Such veneers are used in modern railroad equipment.

Plywoods with cores of Bakelite and other plastics, corrugated steel, asbestos, or faced with plastic, linoleum, cork, or marble indicate the almost limitless combinations of materials available for building uses.

A novel variety of plastic-wood plywood is formed of woven strips of thin wood veneer treated with plastics to produce a finishing material which combines durability with beauty. This surfacing material is unaffected by moisture, alcohol, common acids, and even resists cigarette burns. With a thickness of but .02 in., it can be stitched, stapled, or cut with shears. The surface is smooth as glass. Rare woods are often used in its manufacture. (AR 3/38, p. 76.)

Wood veneers, cut to 1/85-in. thickness, are bonded to cloth for use where extreme flexibility is desired. A special operation breaks down the cell unity of the wood to provide a limp, pliable sheet which may be applied by hand to any smooth surface, flat or curved. The cloth prevents tearing.

Veneers of rare woods have long been made to save expense and to provide surface areas which are larger than solid wood allows.

# PLYWOOD-STRUCTURAL

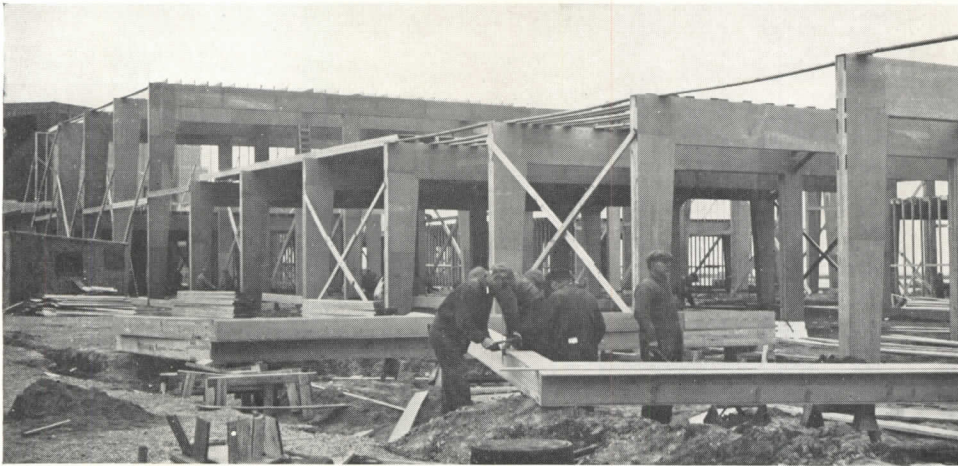

Fig. 11. Plywood nailed to a rigid frame forms extremely strong, lightweight members.

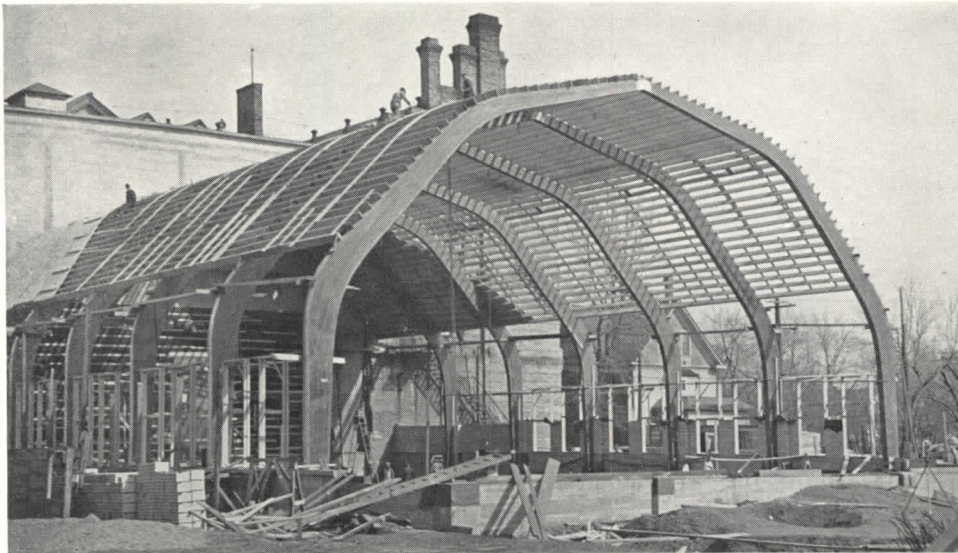

Fig. 12. Hinged arches of laminated wood are employed to span this large auditorium.

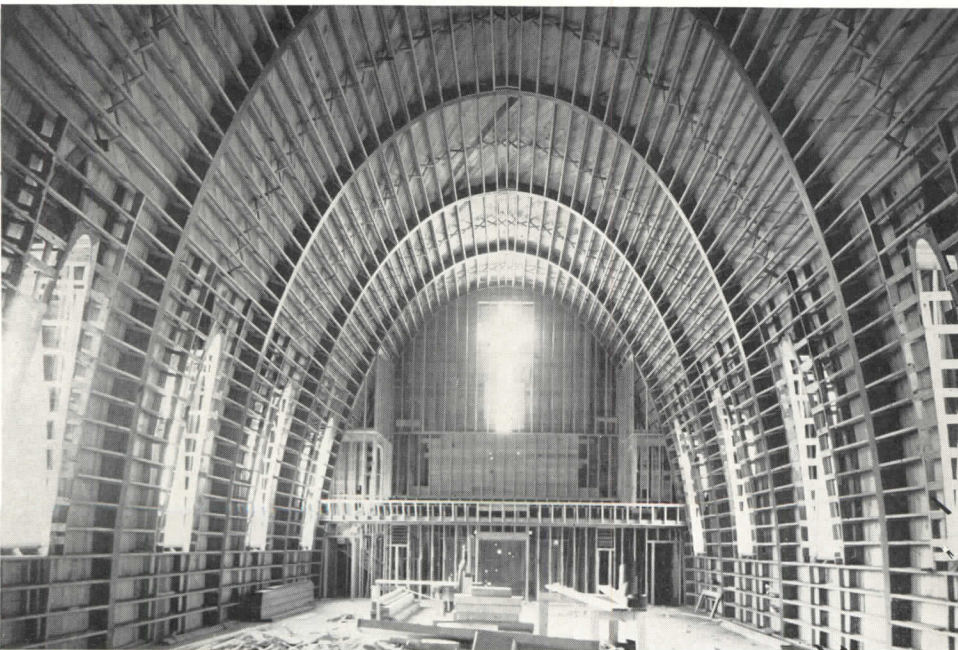

Fig. 13. Laminated parabolic arches are a striking expression of wood's renaissance.

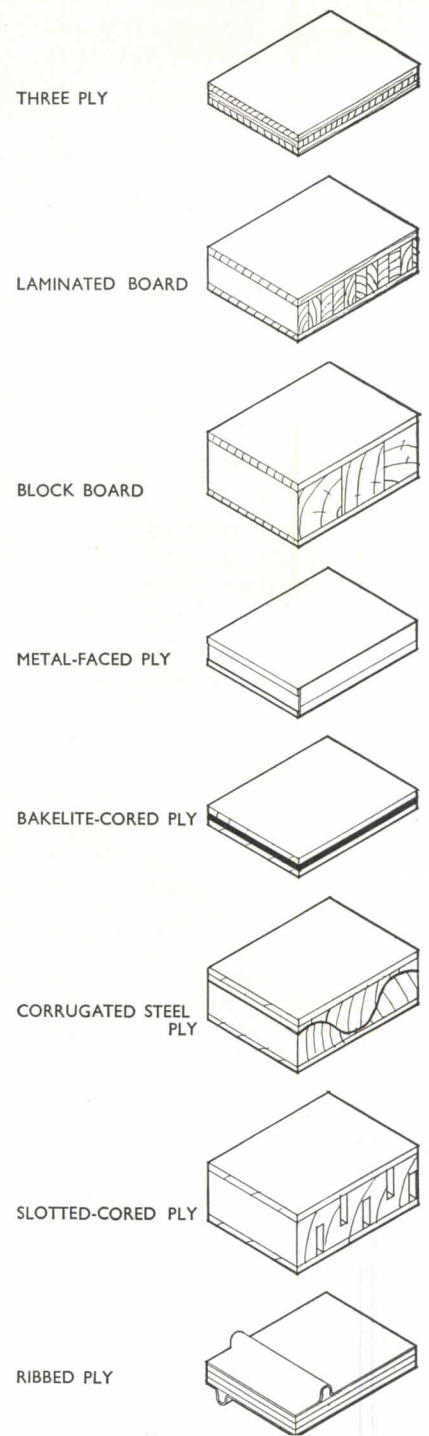

Fig. 14.

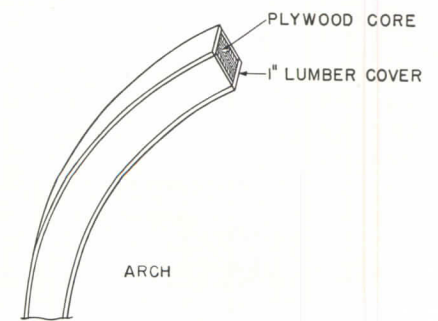

Fig. 15.

## Trends in the uses of wood

Coincident with the trend toward greater flexibility and the multiform improvements of wood as a building material, through the various forms of processing and reconstruction, has been a revolution in the use of wood in building. It has been inevitable that fundamentally new concepts of design and construction should spring from this flow of essentially new materials, that designers should seek to free themselves of fetters of traditional practices and re-examine thoughtfully the fetishes which followed the introduction of steel, reinforced concrete, and the resultant structural systems. In the course of this revolution, wood regained much of its lost prestige and earned respectful consideration for a host of purposes for which it had long been deemed inadequate.

### Structural uses

At this early stage of its renaissance, wood is still most favored for small load-bearing duties, a multitude of highly specialized functions, and for decorative uses; but it is also rapidly gaining favor as a structural load-bearing material, a movement that originated in Europe as a result of the scarcity of raw materials required for steel and concrete.

As evidence of this trend toward timber construction, we see at the Golden Gate International Exposition 200-ft.-span timber arches enclosed by prefabricated wood roof and wall panels, and 106-ft. structural wooden columns whose 3-in. webs are formed of 29 plies (see Fig. 8), hot-pressed and resin-bonded; we see increasing use of all-timber radio towers (see Fig. 9), one in Europe being more than 600 ft. high; we see widespread use abroad of timber-framed auditoriums, railway stations, industrial buildings, exhibit halls, and churches; and here in America, motion-picture sound stages, warehouses, airplane hangars, stadiums, and schools of timber-frame construction (see Figs. 5, 7).

This revival of timber construction has been hastened by the development of more exact standards of strength, better grading, better preservative treatments, and more efficient connecting devices and joints, coupled with the introduction of laminated construction and the increasing use of structural plywood and plywood box beams.

### Timber connectors

Modern mechanical connecting devices were developed in Europe. They assume the same function as rivets in steel construction—shear resistance—and they must be used in combination with bolts which may be of much smaller diameter than normally required. There are two general types of connectors: (1) those forced into the timbers under high pressure such as toothed rings, grids, and clamping plates; (2) those inserted into precut grooves such as split rings, shear plates, and claw plates. The first group is best suited for timber to timber connections, the second can also be used for joining timber to steel. The very latest type of connector, not yet introduced into America, overcomes the necessity to force connector teeth into the timber. It is a ribbon, 3½ in. wide, 3½ to 35 in. long; 18 teeth in an area 3½ by 3½ in. afford a safe shear value of 135 lb./sq. in. at any angle to the grain. The teeth, being small, may be driven into the timber with ordinary hammers, eliminating the need for clamping devices. By distributing the shear load over a greater area than bolts, these various connectors overcome bending of the bolts and deformation of the timber.

In addition to improved connecting devices, foreign countries have developed nailing standards for large lumber which make nails safe and accurately predictable connectors.\* Nailed girders were tested in Europe under loads repeated 20,000 times, and nailed trusses of 82-ft. span on 13-ft. spacing are in use. Nails have the advantage of forming an intimate contact of comparatively large surface area with the timber, and distribute the forces uniformly over the whole joint. For instance, 32 twenty-penny nails weigh not more than one ¾-in. bolt, but they will form a more rigid and stronger connection. Limiting factors are: (1) they must be driven by hand, and (2) they must be at least twice as long as the thickness of the timber. The largest nail (60-penny) is only 6 in. long, hence suitable for a timber only 2¾ in. thick. Drift bolts inserted into prebored holes of slightly smaller diameter maintain the advantages of nails for several layers of thin timbers. (See AR 12/37, p. 31.)

Glue, which is undependable for small areas of contact, gives efficient bond for large areas as between flanges and web of girders. It acts on the principle of numerous small contacts over a large area. Glue makes possible timbers of almost any size and shape. Its value is comparable to that of welding in steel construction. Glued laminated members check very little and have more uniform strength than solid timbers. They can be formed to any desired curves to provide rigid structures of dependable and permanent strength. Timber and plywood are combined, through chemical adhesives, into the efficient and economical shapes characteristic of steel construction. They are frequently used in manufacturing long curved members as in arches, flanges of curved girders, or chords of trussed arches (see Figs. 6, 7, 12, 13). The arch is the most important type of laminated wooden member from an architectural standpoint. Its strength makes trussing or bracing unnecessary, permitting high, wide, unobstructed interiors, lending dignity and impressiveness. These wooden arches are preferred abroad for railroad and chemical-industries structures because of their immunity to fumes.

Advantage, too, is being taken of the high compressive strength of short pieces of lumber in patterns which distribute loads over the whole structure. The familiar Lamella type of roof truss makes use of this principle (see Fig. 5).

### Timber-plywood members

Gusset plates of structural plywood with metal ring-dowel connectors are used to join timbers, especially in trusses. Heavy plywood, 4 to 6 in. thick, serves as gusset and spacer at the same time, and members can be connected to its edges as well as to its faces. The recently developed "super-pressed" plywoods will probably prove even more desirable for gusset functions.

Plywood is being used with timber to form members of remarkable strength in relation to weight. Plywood "stressed coverings" were so used in the Hall of Progress at the Great Lakes Exposition, Cleveland (see Fig. 11). The frames consisted of built-up timber columns, about 30 ft. apart and 16 to 20 ft. high, connected at the top by a skeleton wood frame or truss. The two columns and the connecting truss formed the rigid frames which were completely enclosed in plywood. The plywood was heavily nailed to the frame, and functioned

\*Diameter of nails must not be more than 1/7 thickness of the timber. Nails are arranged in a predetermined pattern so that the gage lines form an angle of about 1:10 with the wood fibers. Length, spacing, distance from edges are also calculated.

# WOOD—SURFACING



Roger Sturtevant

Fig. 16. Modern shiplap siding produces a flush exterior wall surface.

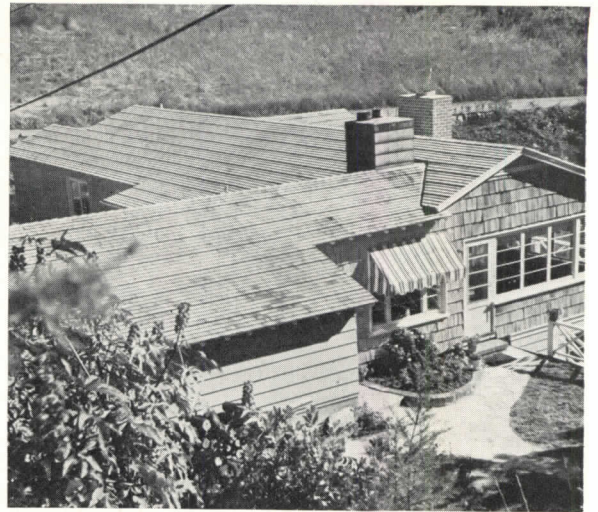
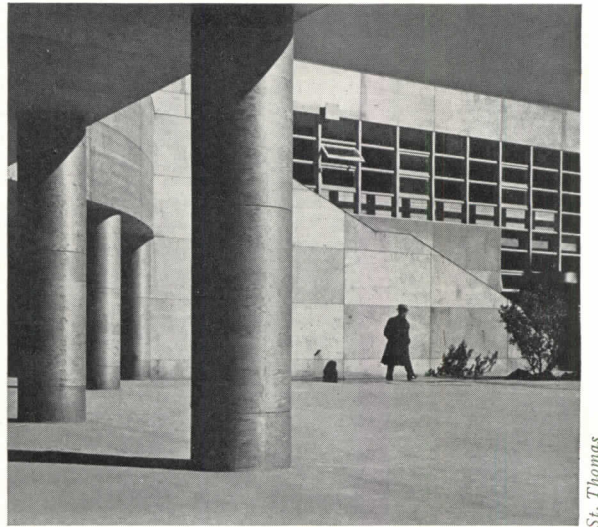
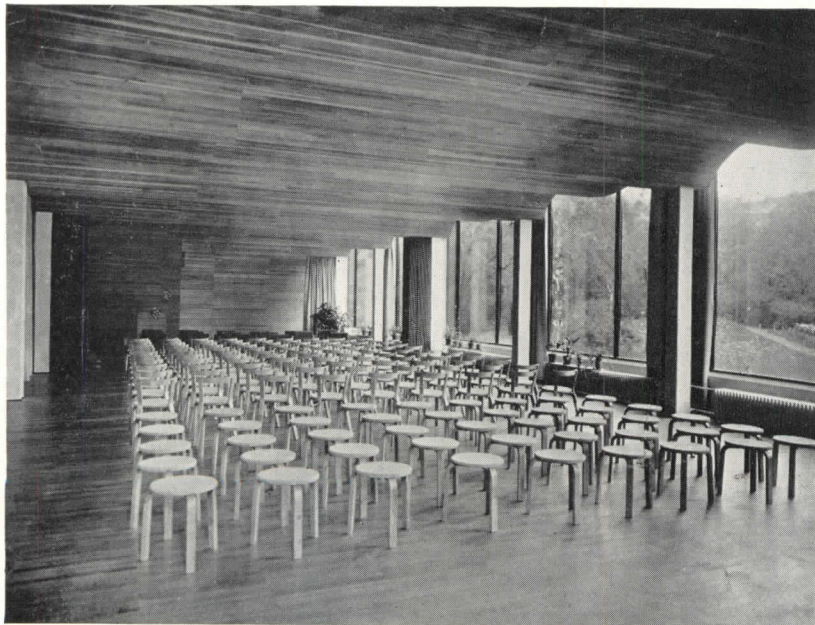

Fig. 17. Another wood form—shingles and shakes.



St. Thomas

Fig. 18. Bold columns express plywood's versatility.



Courtesy Museum of Modern Art

Fig. 19. In Europe, this wave-like ceiling is used to correct acoustics.



Hedrich-Blessing

Fig. 20. Rare-wood veneer for a colorful interior.



like steel cover plates on fabricated steel columns and girders.

Laminated wooden arches with exterior-type plywood envelope are being used for auditoriums, gymnasiums, and similar large-span structures (see AR 2/38, p. 48). The laminated arches consist of a core formed of plywood panels shaped to the curve of the arch, glued sideways and lengthwise with staggered or dovetail joints, the core being covered with 1-in. lumber (see Fig. 15).

#### Plywood panels

Weatherproof exterior plywood came into the building picture about five years ago and is gaining favor for use in large as well as small structures. It increases structural rigidity, can be erected quickly, permits large unbroken surfaces through use of shiplapped or tightly-butted joints, and is adaptable to many graceful effects and a variety of finishes. Plywood panels are being used on residence roofs, too, as a base for shingles—an added advantage being ability to hold nails tightly.

Used as wall sheathing and siding, commercial plywood imparts exceptional rigidity to frames. Tests at the Forest Products Laboratory show that even  $\frac{1}{4}$ -in. plywood nailed to a wood frame furnishes 5.9 times the rigidity provided by ordinary 25/32-in. (1 in. nominal) horizontal sheathing, and 40% more rigidity than 25/32-in. lumber applied diagonally. With plywood glued to frame, rigidity increases to 14.4 times that of 25/32-in. horizontal lumber sheathing. Such rigidity increases resistance to seismic loads, hurricane stresses, ground settlement stress, etc. The panels are puncture- and crack-proof, prevent infiltration of air, have heat insulation value about the same as lumber of corresponding thickness, and practically the same sound transmission coefficient as ordinary lath and plaster construction. From the standpoint of sound absorption, that is, the deadening of sounds originating within a room, plywood is from 4 to 6 times superior to lath and plaster. If a deadening felt ( $\frac{3}{4}$ -lb. building felt) is applied over the plywood as a base for wallpaper, the sound deadening properties are still further increased. Relative coefficients of absorption are: .03 for lath and plaster; .10 to .35 for plywood depending upon the pitch of the sound. The average for plywood is .15. Plywood sheathing is sometimes covered with conventional siding, shingles or masonry veneer, or with exterior plywood. The United States Army Air Corps selected Douglas fir plywood in lieu of siding in its current building program involving about 180 new barracks and accessory buildings at 14 air fields.

"Stressed skin" plywood construction, embracing the same principle used in airplane wings, is used with considerable success in wall panels, floors, and ceilings (see Fig. 3). This consists of plywood panels fastened (preferably with glue) to both sides of a lumber frame. The assembled unit then becomes, in effect, a box girder, the plywood functioning as webs, the lumber as flanges (see AR 6/38, pp. 74, 77). Load is distributed through the heavier members to the plywood faces relieving the studs or floor joists, as the case may be, of approximately 75% of the load they normally would carry.\* This, in turn, permits use of much smaller studs and floor joists. The units are easy to handle, save erection labor. In practice it is found that a stress-covered panel built over 2 by 6-in. structural members can be substituted for the conventional 2 by 10-in. joist. The upper face (in floor panels) consists of  $\frac{5}{8}$ -in. plywood in 5 plies, lower face is  $\frac{3}{8}$ -in. 3-ply stock. Forest Products Laboratory has used

\*This efficiency can be obtained only by gluing.

$1\frac{5}{8}$ -in. and  $2\frac{5}{8}$ -in. studs in lieu of the customary  $3\frac{5}{8}$ -in. (4 in. nominal) wall studs.

Plywood subflooring grips flooring nails tenaciously and prevents open joints and squeaks because it cannot move, due to its cross-grained construction. It can be laid twice as fast as board sheathing and is excellent for linoleum coverings because no board marks will show through. It creates warmer, dustproof floors. Plywood is also used for temporary floors because of its light weight and ease of handling.

In localities where condensation in walls may be a factor due to high room temperatures and low outside temperatures, plywood coated with asphalt paint (two coats), or a layer of 50-lb. asphalt-coated and impregnated paper, is effective as a vapor barrier. The barrier should be placed on the warm side of the wall to permit exit of moisture from wall cavities.

#### Plank construction

Another new development in flooring practice, directly the result of the current interest in low-cost housing, is the so-called plank construction in which heavy ( $1\frac{5}{8}$ -in) tongue-and-groove plank flooring is laid over beams spaced 6 ft. 9 in. to 7 ft., instead of closely spaced joists, with finish flooring laid above (see Fig. 10). This method has been found satisfactory for low-cost homes and reduces material cost because of lower grade lumber which can be used, and labor cost because of reduced handling.† Load necessary to produce a tolerable deflection of  $1/360$  is safely in excess of probable loads assumed in standard dwelling design. Higher insulation efficiency is also claimed due to the thicker flooring used.

#### Special plywood uses

One of the most important developments of recent years in concrete form construction is the use of plywood panels. The architect is afforded new freedom of design, the builder provided with new economy and convenience. Savings on carpentry labor are estimated at 40 to 75%. An endless variety of impressive architectural effects stems from the broad plane surfaces of plaster-like smoothness, and the smooth curves of sharp radius obtainable with this type of form. The large, smooth panels reduce the number of joints and fins, diminishing leakage of cement and water and lessening the cost of finishing.‡ Construction costs are also minimized through multiple re-use of forms which strip easily from the concrete. Fifteen re-uses are common in the hands of experienced form men. As many as 55 have been reported. Plywood for concrete forms is especially manufactured to withstand conditions of extreme humidity, and its contact faces are coated with oil.

#### Temporary construction

New uses for plywood are being continually brought to light as the ingenuity of architect and builder submerges the dictates of tradition. Thus, in Los Angeles, we see plywood used as a protective covering enclosing scaffolding while the face of an old building was modernized (see also AR 12/37, p. 33); we see excavation walls shored with plywood panels, and the panels salvaged and re-used many times; we see plywood used under linoleum drainboards, counters, and table tops; for baseboards and trims around doors and windows.

†Labor time is reduced 26.4% of cost for standard joisted floor. (N.L.M.A.)

‡Saving in rubbing costs runs 5 to 12 cents/sq. ft. Frequently the fins are not rubbed at all, forms being made so that joint markings add interest to the surface. (Example—Columbia Broadcasting System headquarters in Hollywood.)

## Trends in distribution

An unspectacular but vital role in the return to favor of wood as a building material is the system of grade marks now in use throughout the country and still in the process of development. Grade-marked lumber assures a uniformity in the raw product which permits use of more precise coefficients by architects and engineers. Lumber is marked to indicate its origin within the log, its condition regarding knots and imperfections, its degree of dryness, and many other factors pertinent to its specific ultimate use. Douglas fir plywood is graded according to moisture-resisting properties.

The last ten years have witnessed the development of precision-formed lumber, the manufacture of which is spreading rapidly among the mills. This is structural lumber delivered with accurately squared ends in lengths suitable for use in the average stud wall and for the average floor joist span. Such precutting has not been an unqualified success because of lack of cost saving and frequent necessity for further cutting on the job (see also AR 4/38, p. 75).

However, Los Angeles is the testing ground for a new system in which shop-cut framing is delivered to the job in bundle form. The new system is conceived with the faults of its predecessors in mind. Every wall frame member is pre-cut. The system is based on standards of dimensions most common in Southern California. The length of the stud (7 ft. 9 in.) is the key to vertical dimensions. It provides a mini-

mum of 8-ft. clear ceiling height and is adapted to 8-ft. wall coverings. (Plywood panels are 4 by 8 ft.) The header is the key to horizontal dimensions. It occupies the minimum number of stud spaces which will admit the intended window or door. By this system the position of door or window can be at the exact point indicated in the design; trimmers can be moved as desired.

It is claimed for this system that every piece is accounted for which means 100% accuracy in estimating. Pieces are sorted into bundles so that they can be laid down where they are to be used, saving confusion, trips to the material pile, job measuring, and cutting. Labor cost saving is declared to be \$10 per thousand board feet.

An extension of this trend toward less wood working on the job is seen in factory-finished flooring. Originally adopted for use in connection with parquet blocks, factory finish is now available in other styles—strip and plank flooring. It is pre-sanded, filled, waxed, and polished at the factory and is said to cut floor costs by almost 50%.

Hardwoods are being produced and packaged in stock lengths for use in the same market which has taken so much knotty pine in the past. "Character-marked" hardwoods are a grade which corresponds to the knotty grade used for pine paneling. They are sanded and finely finished at the mills and supplied in packaged form in lengths usually required for room paneling.

### DATA ON PLYWOOD

Four kinds of veneer are used in plywood: ROTARY CUT from logs revolved in a veneer lathe; SLICE CUT from log flitches moved angularly against the slicing knife; SAWED on a segment saw; and HALF ROUND CUT from flitches mounted in a wide-swing or eccentric lathe. Rotary cut is the most common type but is frequently characterized (in veneers of more than 1/16 in.) by checking. Rotary cut veneers are often twice as hard as the timber from which they are cut because the annular rings are left largely intact in the surface (source—Architectural Review Supplement, Sept. 1939).

Although any type of wood can be used as a facing veneer, selection of timber for plywood is restricted. The wood must have firm and even grain, be pliable and reasonably free from knots, and obtainable in suitable sizes.

Face veneers largely determine the characteristics of plywood because resistance to bending is essentially the function of the layer farthest from the neutral axis, and because surface wood obviously determines surface qualities. Facing veneers may roughly be grouped as follows:

Group 1—Beech, birch, hard maple, black walnut—desirable for hardness, resistance to abrasion, strength of fastening and finish.

Group 2—Soft elm, red gum (heart), soft maple, mahogany, African mahogany, sycamore—for attractive finish.

Group 3—Basswood, Douglas fir, Port Orford or Spanish cedar, West Coast hemlock, pine (white, sugar, Ponderosa, or California white), yellow poplar, redwood, spruce (red, white, or Sitka), tupelo gum, and fir (lowland white, noble, or silver)—for flat panels with high bending or compressive resistance with minimum of weight.

Practically all of the fine woods such as walnut, evodire, satinwood, etc., are sliced 1/20 in. in thickness. Birch, maple, oak, and ash are usually cut 1/20 in. Thin face veneers are technically and practically better than thick, because internal stress is practically eliminated, and more thorough glue impregnation holds the fibres together. Veneer can be sliced as thin as 1/150 in.

## Bibliography

- U. S. Dept. of Agriculture Technical Bulletin, Nos. 158, 167, 282, 479, 552.
- "Products of American Forests," Forest Products Laboratory publication, Aug. 1939.
- "Recent Progress on Housing Research," Forest Products Laboratory publication, 1938.
- "Condensation Problems in Modern Buildings," Forest Products Laboratory publication, by L. V. Teesdale.
- "The Forest Products Laboratory," U. S. Dept. of Agriculture Miscellaneous Publication No. 306.
- "Plywood and Its Uses," U. S. Dept. of Commerce publication, 1937.
- "Engineering Characteristics of Plywood," by Thos. D. Perry, Transactions of the A.S.M.E., Vol. 50, pp. 1-11.
- "Hot Pressing Technique for Plywood," by Thos. D. Perry, Transactions of A.S.M.E., Vol. 60, p. 59.
- "Super-pressed Plywood," by R. K. Bernhard, Thos. D. Perry, and E. G. Stern, contributed by A.S.M.E. Wood Industries Division Meeting at Boston, Oct. 12-13, 1939.
- "Plywood," by U. S. Plywood Co.
- "Plywood in Building Construction," by N. S. Perkins, Building Standards Monthly, Dec. 1938.
- "Influence of Douglas Fir Plywood on Modern Architecture,"—Architect & Engineer, Sept. 1938.
- "Plywood," by Bryan Westwood, Architectural Review Supplement, Sept. 1939.
- "Modern Timber Construction," by C. Pantke, contributed by Wood Industries Division, A.S.M.E., Oct. 12-13, at Boston.
- "Engineering in Timber," Timber Engineering Co. (subsidiary of National Lumber Manufacturers Association).
- "Manual of Timber Connector Construction," Timber Engineering Co.
- "Lowering the Cost of Low Cost Houses," Southern Lumberman, Dec. 15, 1938.

# NO IS ON NEW BOOKS

**PLAY SPACE IN NEW NEIGHBORHOODS**, *A Committee Report on Standards of Outdoor Recreation Areas in Housing Developments*. Published by the National Recreation Association, New York City. 23 pp. 5½ by 8½ in. Price 25¢.

AS A RESULT of the appointment, at the 1938 National Recreation Congress, of a "committee . . . for the purpose of determining reasonable standards of size, location, and type of outdoor recreation areas which should be permanently reserved near or within new housing units," this timely brochure is offered as one of the first attempts at codified information on this increasingly important subject.

From a platform of general recommendations intended to obviate the duplication of past mistakes, the committee report proceeds with explicit examination of essential principles—play lots, children's playgrounds, playfields. Consideration is given to special recreation areas, such as golf courses, bathing beaches, etc., only from the standpoint of locating new housing developments with respect to the accessibility of such areas through existing transportation facilities.

The report is concerned primarily with setting up acceptable ratios of play-space frequency and extent to population to be served, and standards for site location, apparatus and equipment, maintenance and supervision, restrictions of usage, etc.

Suggestions are advanced as to finance and administration, and in conclusion a few examples are cited where effective planning and cooperation have been present, and a few others where they have been lacking.

**ELEMENTARY DESIGN OF STRUCTURAL STEEL AND REINFORCED CONCRETE**, *with solutions of structural design problems given in examinations for licensed professional engineer in N. Y. State*. Second edition. By Charles Kandall, P.E., Instructor of Structural Design, Federation Technical School. Sponsored by the Federation of Architects, Engineers, Chemists, and Technicians, New York City. 162 pp. 5¼ by 8¼ in. Price \$2.00.

BASED ON A REVIEW course in structural design, given by the author at the Federation Technical School to students preparing for the New York State licen-

ing examinations for registered architect and professional engineer, this book is intended to provide both the practicing architect or engineer and the student with a reference and review text which is authoritative in character and which covers accepted methods employed in structural design. Fundamental theories of elementary structural design are briefly reviewed and illustrated by solutions of problems. In addition to these illustrative examples, solutions are also presented of various numerical problems given in past examinations for license by the University of the State of New York.

**MODERN PLASTICS: SPECIAL ISSUE FOR OCTOBER, 1939**. E. F. Lougee, Editor. Published by Breskin Publishing Corp., New York City. 454 pp. 8¾ by 11¾ in. Price \$2.00.

IN THIS SPECIAL October issue, the fourth annual Catalog-Directory number, the editors of *Modern Plastics* have succeeded in arranging the contents so that each descriptive article on plastic materials follows a preplanned pattern for easy reference. The first of the seven divisions exhibits the current phases of product development, with illustrations of plastic uses in industry, transportation, office, home, etc. Specific materials—composition, chemistry of formation, general characteristics and properties—are next discussed in a series of papers prepared by representatives of the various manufacturing companies concerned.

Similarly the processes of molding and fabricating are described, and the section following this exposition deals with the machinery and equipment involved. An entire section is devoted to a discussion of laminates.

An important inclusion is a plastics comparative-properties chart, the values of which are based on maximum and minimum figures submitted by a number of manufacturers of each type of plastic material. Also a directory of trade names and manufacturers is provided. Of additional value to readers is a glossary of nomenclature and a bibliography of books and magazines on the subject of plastics.

**ENGINEERING TERMINOLOGY**, *Definitions of Technical Words and Phrases*. By Victor J. Brown, C.E., and Delmar G.

Runner, A.B., A.M. Second Edition. Published by Gillette Publishing Co., Chicago, Ill. 439 pp. 5⅞ by 9 in. Price \$4.00.

BECAUSE INDIVIDUALS in one part of the engineering field often lose touch with essential nomenclature in other branches, the first edition of this book filled a great need in bringing all the assorted terms together in one handy comprehensive reference source. Fields covered included architecture, air conditioning, aggregates, highways, streets, investment, waterworks, sewerage, geology, engineering economics, railways, steel marine—to list but a few of the particular engineering phases represented.

In the second edition, all of the original material has been revised and amplified in respect of suggestions and criticism advanced by authoritative agencies and institutions in the various engineering branches concerned. In addition appendices have been added on map standard symbols, English-Spanish, English-German terms, aeronautics, standard conversion units, etc.—all invaluable to architects, engineers, and others directly or indirectly concerned with the field.

**SYMPOSIUM ON THERMAL INSULATING MATERIALS**. Published by the American Society for Testing Materials, Philadelphia. 125 pp. 6 by 9 in. Price \$1.25, paper bound; cloth, \$1.50.

FOUR TECHNICAL papers comprise the Symposium; the first, by J. B. Austin discussing the "Factors Influencing the Thermal Conductivity of Non-Metallic Materials," is intended to summarize the established principles of physics and chemistry bearing on the subject, collate the data recorded in previous literature, and supplement these with new measurements.

The paper by H. H. Rinehart on "A Discussion of Test Methods for Determining the Physical Properties of Thermal Insulation" deals with a number of the problems being studied currently in an effort to develop proper standards for gaging the acceptability of materials. Appropriately following this study is a paper by representatives of a consumer. E. T. Cope and W. F. Kinney write on "One Consumer's Problems in Selecting Thermal Insulation."

The final treatise by F. C. Houghten,

(Continued on page 124)

# What more can you ask?

## Woodmen of the World Building

OFFICE OF  
R. A. AHLSTRAND  
VICE PRESIDENT

Omaha, Neb.

OPERATED BY  
WOODMEN BUILDING  
CORPORATION

May 18, 1938



Minneapolis Honeywell Regulator Company  
378 Saunders Kennedy Building  
Omaha, Nebraska

Attention: Mr. S. L. Furber

Gentlemen:-

Your National Regulator Thermostats and Radiator Valves have now been in use in the W. O. W. Building for twenty-six years. The system performs today with the same efficiency and accuracy that it did in 1912. The thermostats contain the original elements and we find that these thermostats are today just as responsive to temperature changes as the latest thermostats obtainable.

The maintenance cost of our temperature control equipment is very nominal. The repair parts and upkeep has not amounted to \$10.00 in any one year. My experience in the building management field has brought me to appreciate the value of a thermostat that is ruggedly constructed and cannot be tampered with by tenants. The National equipment has served us well and I would be glad to recommend this equipment to any of my friends and co-building managers.

Very Sincerely,

WOODMEN BUILDING CORPORATION

*R. A. Ahlstrand*  
R. A. AHLSTRAND, VICE PRES.

RAA:EK

The above building has:

424 Room Thermostats controlling  
620 Radiator Valves



WOODMEN OF THE WORLD  
BUILDING., OMAHA, NEBRASKA.  
HOLABIRD & ROCHE, ARCHITECTS

## TODAY IT'S THE GRADUTROL SYSTEM

Thank you Mr. R. A. Ahlstrand. Your experience with the National Pneumatic Control System installed in the WOW Building 26 years ago is typical of reports we often receive. However, today the New M-H Gradutrol System offers distinct improvements, but at the same time retains the time proven features that have made your installation so satisfactory. National Regulator Division, Minneapolis-Honeywell Regulator Co., 2804 4th Ave. So., Minneapolis, Minnesota.



# MINNEAPOLIS-HONEYWELL

BROWN INDUSTRIAL INSTRUMENTS  
NATIONAL PNEUMATIC CONTROLS

*Control Systems*

# BUILDING TYPES



*William M. Rittase*

## HOSPITALS

**PRECEDING ISSUES:** 1939—November, Houses; October, Theaters; September, Apartment Houses; August, High Schools; July, Houses; June, Factories; May, Houses; April, Retail Stores. **FORTHCOMING ISSUES:** 1940—January, Restaurants and Bars; February, Factories; March, Houses; April, Schools (Vocational).

ARCHITECTURAL  
RECORD



William M. Ketrace

# PLANNING THE SMALL GENERAL HOSPITAL

INDEX	Page
General Requirements	77-78
Time-Saver Standards Data	79-106
Administrative areas	79-81
Service areas	82-86
General planning	82-83
Food service	84-85
Laundry, housekeeping	86
Nursing units	87-95
General planning	87-89
Bed accommodations	90-91
Nursing and service facilities	92-95
Clinical services	96-104
General planning	96-97
Maternity department	98-99
Operating suite	100-101
X-ray department	102
Laboratory, pharmacy, morgue	103
Physical Therapy department	104
Outpatient department	105-106

In this study, *Architectural Record* presents information which may be used as a basis for designing the small voluntary general hospital—a category which is rapidly expanding, in both number and scope of facilities.

This reference material has been largely compiled and developed for publication by Charles F. Neergaard, who for many years has maintained a professional practice as consultant in hospital planning, organization, and management. For several terms Mr. Neergaard has been Chairman of the Committee on Hospital Planning and Equipment of the American Hospital Association.

In addition, substantial contributions to the completeness of this study have been made by W. H. Walsh, M.D., F.A.C.P.; by the editors of "Modern Hospital"; and by H. A. Bliss, I. D. Bennett, Arnold Erlanger, Charles E. Daniel, Edgar Hayhow, and George A. Dudley.

THE VOLUNTARY general hospital of today must be organized and equipped to care for some 36 different types of patients requiring medical, surgical, maternity, or pediatric service within private, semiprivate, ward-private, and ward classifications. It is a far cry from the comparatively simple structures that, a few decades ago, cared for "charity cases" in large wards. Today, nearly two-thirds of the hospital's floor area is devoted to services and one-third to patients. Areas required for administration and refinements of service, for diagnosis, therapy, surgical, and delivery facilities, are so extensive that spaces for patients' beds—rooms, wards, and solaria—although equal in importance, are decreased in comparative extent.

The patient's bed, however, is still the focal point of the hospital designer's problem. It is the unit about which hospital functions revolve; and cost per bed constitutes a practical—though not a precise—measure of hospital valuation. Surveys have disclosed that costs per bed range from \$6,000 to \$8,000 in congested urban areas; from \$3,000 to \$5,000 elsewhere. Hospital operating expenses—based on a survey of 50 voluntary urban hospitals—have risen from an average of \$2.11 per patient day in 1922 to more than \$6.00 in 1938.

These figures clarify one important reason why the hospital design must be—above all else—practical and economical. In the successful hospital plan, space and service facilities must be ad-

justed to provide a balance between the many—and often conflicting—technical, professional, and administrative requirements. And in all details, provisions of the plan must be particularly related to the medical, economic, and social needs of a given locality and situation.

Such primary requirements can be ascertained only on the basis of a detailed survey which will disclose the hospital needs of a community, and will thus establish a practical program for development of a building. The survey can best be made and the program written by a consultant with specialized knowledge of hospital problems. And the architect's job then becomes that of translating the general principles established into a building design that is at once adequate in provisions for patients; convenient in terms of services; flexible in relation to fluctuating demands; economical to build, operate, and maintain; and, finally, attractive in relation to its function and to characteristics of the community environment.

Economy of operation and provision for flexibility in use are two of the most vital hospital design criteria. With high per bed costs, the hospital must be designed to house the maximum practical number of patients in the area. Wide variety of patient types; fluctuating demands for accommodations (in good times private room demands increase; in bad times hospital needs increase but demand is for less costly service); and seasonal variations in a hospital's daily

census—which may range from 20% to 50% between minimum and peak loads—necessitate arrangement and dimensions of rooms, wards, and related facilities for service, nursing, and treatment that will conserve space in terms of building bulk per bed, minimize waste motion and confusion, and promote convenience in service even at peak load periods.

**Planning principles.** Fundamental requirements include orientation of bed accommodations for air and sunlight; location for quietness; and general planning for economy of maintenance.

In principle, hospital designers have discarded that type of extended plan—the "pavilion" or "continental" type—which results in one- or two-story buildings with their various departments strung along corridors. The trend of hospital design is toward a compact, multistory plan, which is at once less expensive and more elastic to operate.

The survey of community needs, previously referred to, should include analyses of many conditions, involving: size, racial composition, and rate of growth of population; its economic status and its intelligence; the character of its housing and industries; its transient visitors and dependent districts; its present hospital facilities and the extent of their use; its morbidity levels; and the number and caliber of its doctors.

In large cities whose medical centers and specialists draw patients from great

## GENERAL PROVISIONS (continued)

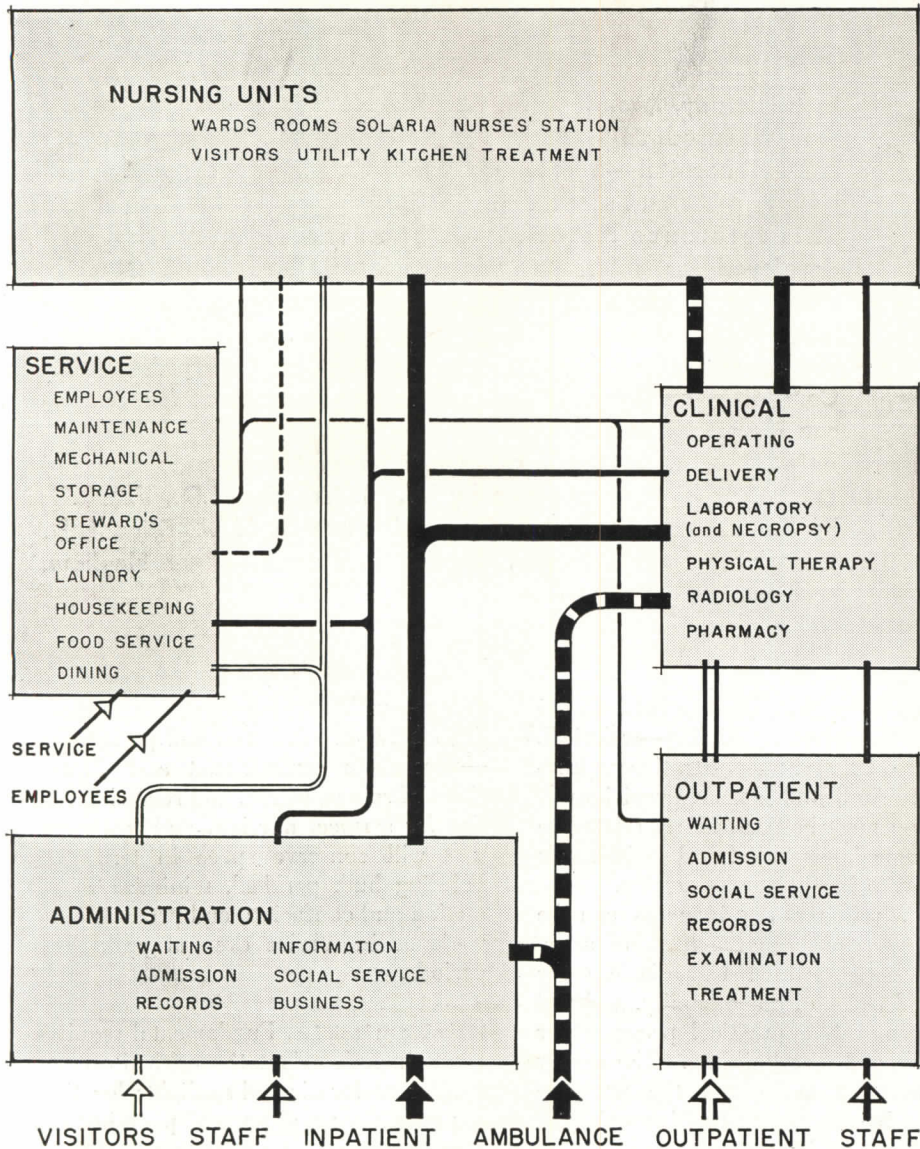

The chart above, which indicates the broad, general pattern of organization of space and circulation within the average voluntary general hospital, reflects the increasing trend toward departmentalization in such institutions.

Of the five general divisions shown, the Outpatient Department is occasionally omitted; but with increasing development of social consciousness and recognition of social needs, facilities for outpatients are being incorporated in more and more hospitals.

The other four general types of hospital departments are universally necessary in modern voluntary general hospitals. The extent to which these are developed, and the number of subdivisions included, depend upon local needs, upon the requirements of the staff, and upon the existence or nonexistence of similar hospital facilities in the locality.

Circulation shown above does not include all the minor traffic which passes through the hospital. Only the principal arteries of human travel are indicated; these serve to demonstrate the great degree to which hospital departments are interdependent. Supplementary diagrams that similarly indicate relationships within each general area will be found under each of the five main headings.

In the following pages the main divisions, and departments contained in each, are discussed in turn. The tabulations of spaces and equipment, together with the brief descriptive comments, are pointed toward solving problems which arise in the design of small hospitals—those which contain from 50 to 200 beds. In no case are the data intended to become rigid specifications. Rather, all information is presented as constituting a useful guide to planning.

distances as well as from suburban communities, each of which may have its own hospital facilities, the determination is particularly complex. However, the Committee on Hospital Planning and Equipment of the American Hospital Association has recommended the following criteria: For large metropolitan centers with general multiple housing, extensive suburbs, and nationwide medical prestige—5 beds per 1,000 of population. For cities which serve as medical centers for extensive districts and suburbs not adequately self-hospitalized—4 to 5 beds per 1,000. For smaller cities—3 to 4 beds per 1,000. For rural districts—up to 1 bed per 1,000.

It is of course essential that these ratios be subject to modification as the needs of specific communities dictate.

There are several methods by which flexibility of planning may be achieved and the number of beds decreased. Accommodations provided by the use of small, modern wards designed primarily for four but large enough for five beds each, and private rooms sufficiently large to accommodate two beds, make it possible to expand capacity when needed, and to pool reserve beds among several departments.

It is necessary to maintain a certain proportion of reserve beds over and above those needed for normal use. These are for use in times of epidemics, emergencies, necessary repairs and maintenance, and seasonal or other peak loads. However, these peaks occur on an average of but 17.4 days per year. By pooling reserves, as noted in the preceding paragraph, provisions for peak loads may be held to a minimum of 25% of the normal hospital census; i.e., five beds may be maintained for every four patients in the average daily census. Otherwise, reserves may amount to 50% of the expected average occupancy.

Chronic and convalescent cases are preferably not cared for in voluntary general hospitals. The principal difference between provisions for recovery cases and for those who are acutely ill is in service. Recent trends indicate the desirability of providing special "acute" wards and rooms, grouped in one section, and equipped with special resources for intensive nursing, such as piped oxygen, suction outlets, acoustical treatment, numerous electric outlets, and air conditioning. Floor plans are not substantially affected by this arrangement.





## ADMINISTRATIVE AREAS

IN ANY HOSPITAL, the administrative areas perform a double function. First they provide for an efficient control of hospital plant and activities through which business contacts are established and from which matters of policy and service operations are directed. In addition the administrative department serves as the hospital's introduction to the visitor or patient. Thus, from two points of view it must be considered an important point of the hospital design.

In a small hospital—particularly one in which the outpatient department is of minor importance—administrative activities are closely interrelated; the executive and business staff is small; and, therefore, centralized facilities are usually most efficient and economical. For example, private offices for superintendent, directress of nursing, staff director, general business and cashier's offices, and secretarial spaces, may be combined in a single section. Another may include public areas (lobbies, wait-

ing rooms, etc.) and information desk. Admissions and records may often be advantageously related to the administrative requirements of an outpatient department, from which access to the staff room, for consultation, is necessary. Staff and locker rooms, library, conference and board rooms form a fourth type of grouping within the administrative area. Rest and locker rooms for special nurses, technicians, clerks, male and female employees, are required and may be located either in administrative or service areas. Offices for purchasing agent, housekeeper, and plant engineer may be most efficiently located in close relation to areas and activities within their jurisdiction.

Whether administrative functions are housed on the main floor or in the service area, patients, visitors, and hospital personnel must be routed throughout the hospital without confusion or cross-traffic. The creation of an atmosphere

*(Continued on page 81)*

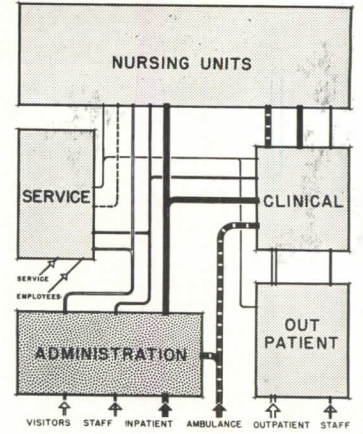
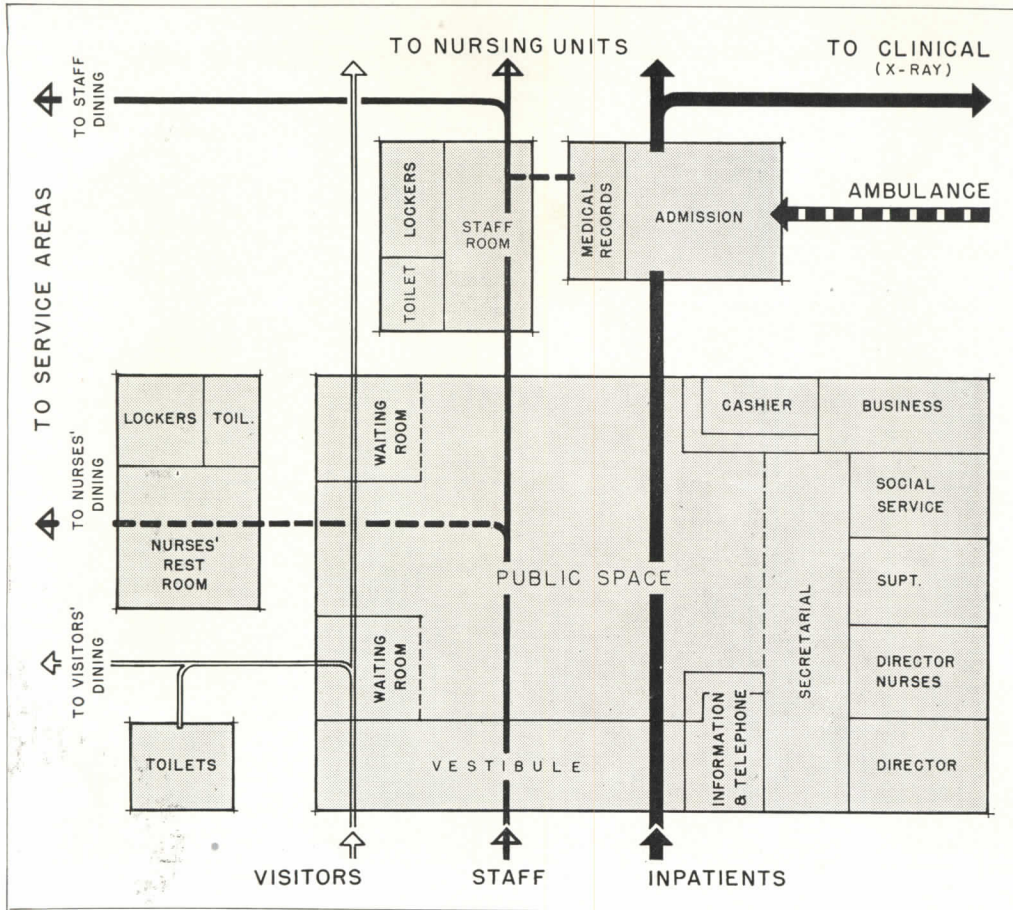
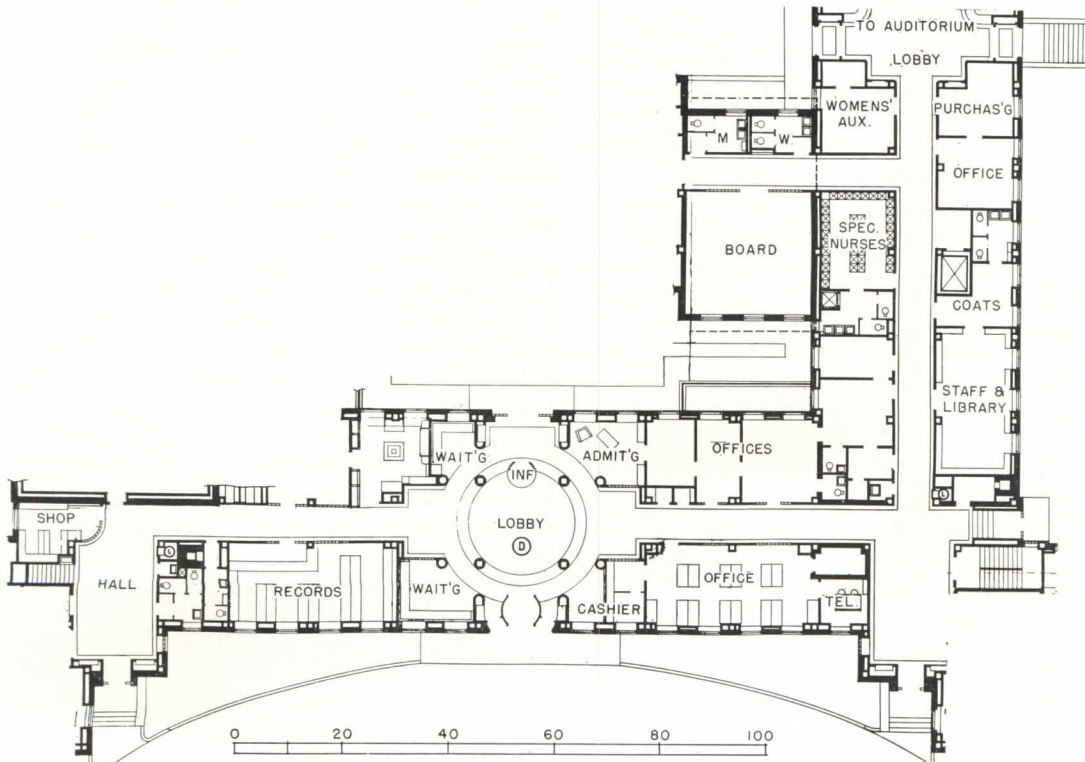

Chart at left details arrangement of necessary administrative spaces. As indicated, dining areas for visitors, nurses, and staff are closely associated. Above, key diagram which relates administrative space to remainder of hospital.



Administrative areas, first floor, White Plains Hospital, White Plains, N. Y.; Schultze and Weaver, architects.

ADMINISTRATIVE SPACES ON MAIN FLOOR (areas in sq. ft.)				
Type of Space	50-bed Hosp.	100-bed Hosp.	200-bed Hosp.	Special Structure, Finish, Equipment
Lobby and waiting.	225	350	1200	With 2 or 3 120-ft. waiting alcoves partitioned off; acoustical treatment
Ward waiting* . . .	150	300	300	Acoustical treatment
Information . . . . .	100	100	150	Acoustical treatment; doctors' in-and-out register; telephone
Business office . . . .	200	250	500	Desks; vault (24 sq. ft.); business equipment
Cashier . . . . .	150	150	150	Acoustical treatment; counter; desk; safe
Superintendent's office and committee room . . . . .	180	300	450	Acoustical treatment; desk; files (long table; 8 chairs in 200-bed hosp.)
Secretary . . . . .	150	150	150	Office furniture
Supt. nurses . . . . .	150	150	150	Office furniture
Asst. supt. nurses . . . .	150	150	150	Office furniture
Purchasing agent . . . . .	150	150	300	Office furniture
Registrar . . . . .	150	150	150	Office furniture; acoustical treatment
Records . . . . .	225	300	450	Office furniture; files
Record research . . . . .	150	150	150	Office furniture
Social service . . . . .	150	300	450	1 to 3 offices, each 150 sq. ft.; acoustical treatment
Staff lockers . . . . .	180	225	300	Coat closet; toilet; lavatory; large table; 12 chairs; lockers

\*Sometimes included with other waiting space in small hospitals; preferably separate in larger institutions (200 or more beds).

ADMINISTRATIVE SPACES ON MAIN FLOOR (areas in sq. ft.)				
Type of Space	50-bed Hosp.	100-bed Hosp.	200-bed Hosp.	Special Structure, Finish, Equipment
Staff lounge, library, board room . . . . .	225	300	450	Coat closet; toilet; lavatory; large table; chairs; bookshelves; acoustical treatment
Patients' library . . . . .	150	250	250	Bookshelves; table; easy chairs
Consultation . . . . .	180	360	360	1 to 2 rooms, each 180 sq. ft.; scales; desk; 2 chairs; exam. table; storage cabinet; instrument sterilizer
Total sq. ft. . . . .	2235	3505	6060	

ADMINISTRATIVE SPACES NOT ON MAIN FLOOR (areas in sq. ft.)				
Type of Space	50-bed Hosp.	100-bed Hosp.	200-bed Hosp.	Special Structure, Finish, Equipment
Special nurses' lockers . . . . .	225	300	400	Lockers; toilet; shower; lavatory
Special nurses' lounge . . . . .	150	150	300	Easy chairs; couches; bookshelves
Technicians' lockers, lounge . . . . .	225	300	300	Lockers; toilet; lavatory; easy chairs
History storage . . . . .	180	300	450	Files
Central storeroom . . . . .	1500	2500	4000	Shelves; bins; cabinets
Steward's office . . . . .	150	150	250	Office furniture; files
Total sq. ft. . . . .	2055	3475	5700	

(Continued from page 79)

of quiet and orderliness is paramount. This implies generous lobby spaces; main corridors 7 or 8 ft. wide—never less than 7; centrally placed information counters; and easy accessibility to cheerful, comfortable waiting rooms, toilets, telephone booths, and to whatever facilities for purchasing gifts or flowers may be established. Since these constitute public areas, some segregation from hospital traffic is desirable.

Provision of adequate parking space conveniently adjacent to the hospital cannot be ignored. Unless such provision is made, the institution will suffer from congestion and noise resulting from automobiles parked in undesirable locations. It is advantageous to locate the doctors' entrance in a spot accessible to both the parking space and the staff room. Separate parking spaces for staff and employees are advisable where land

costs permit or the size of the hospital demands.

*Finishes and equipment.* Wall, floor, and ceiling finishes in administrative areas should be of types which reduce noise and fatigue, and which impart a pleasant first impression to visitors and patients. Acoustic treatment, at least of ceilings, is imperative in all public spaces—particularly the corridors and lobbies. Colors and furnishings are preferably cheerful and reassuring.

Lighting of comparatively low intensities, from attractive sources, is suitable for all administrative spaces except those in which concentrated desk work, etc., demand high-intensity local lighting.

Some hospitals have public spaces which are designed to achieve a domestic atmosphere; this practice is in accord with the growing tendency to consider the patients' psychological well-being in addition to their physical condition.



## SERVICE AREAS

THERE IS A definite trend toward centralization of service areas; few hospitals are built today with separate services for various departments. The mechanical plant accounts for about 30% of the total initial building cost, and 8½ to 16½% of the operating budget.

In providing spaces and equipment for these services, a balance has to be maintained between budgetary restrictions; the necessity for adequate provisions and elimination of nonessentials; and requirements for economical operation and maintenance.

**Boiler plants** serve two purposes in hospitals: first, to supply heat; second, to supply steam for sterilizing, laundry, heating domestic hot water, and cooking. Heating load is approximately 2/3 of the total, but due to varying seasonal requirements, consumes only 1/2 the total yearly fuel. A reserve boiler is essential to insure uninterrupted service. Choice of fuel depends on costs and

other local conditions. Average space required for the boiler and pump room is approximately 900 sq. ft. for a 50-bed hospital, 1200 sq. ft. for 100 beds, and 1500 sq. ft. for a 200-bed institution.

AVG. STEAM REQUIREMENTS  
(100-Bed Hospital)

Use	H.P. Needed	Steam Pressure Needed, Lbs.	Daily Hours at Full Load
General heating . . . .	90	5	24
Special heating (operating, delivery)	3	5	8
Domestic hot water . . . .	20	5	16
Laundry . . . . .	15	100	6
Kitchen, dishwashing . . . .	10	20	6
Sterilizing . . . . .	15	40	5
Total . . . . .	153	.....	.....

**Heating system.** Forced circulating hot water systems have been found satisfactory for general heating in most cases. In specific locations, such as operating or delivery rooms, etc., unit air conditioners are desirable. Simplified local control systems have been found desirable; but such refinements as room thermostats are ordinarily inadvisable.

**Piping and plumbing.** Piping for all pur-

poses is preferably corrosion resistant, and carefully installed to prevent water-flow noises or leaks. An important requisite for plumbing fixtures is quiet operation. Operating and maintenance economies to be derived from the use of the highest quality fittings, particularly valves and faucets, more than justify their initial cost.

**Elevator** requirements are determined by the hospital's geographical location; the estimated number of visitors per day, and the institution's policies as regards the number, age, and time regulation of visitors; as well as patient, staff, and service requirements. Visitors, as an average rule, number six per inpatient; but suburban hospitals ordinarily have more visitors than urban ones. At least one passenger and one service elevator, with automatic floor-leveling devices, and with manually operating or selective-control cars, not less than 5½ by 8 ft. in size, are required in the average 100-bed hospital.

These two diagrams serve to indicate the organization and circulation of service facilities in the average hospital, and relate the service areas to other hospital departments. With increasing development of centralized linen, food, and other services, close association with all other sections of the hospital is essential.

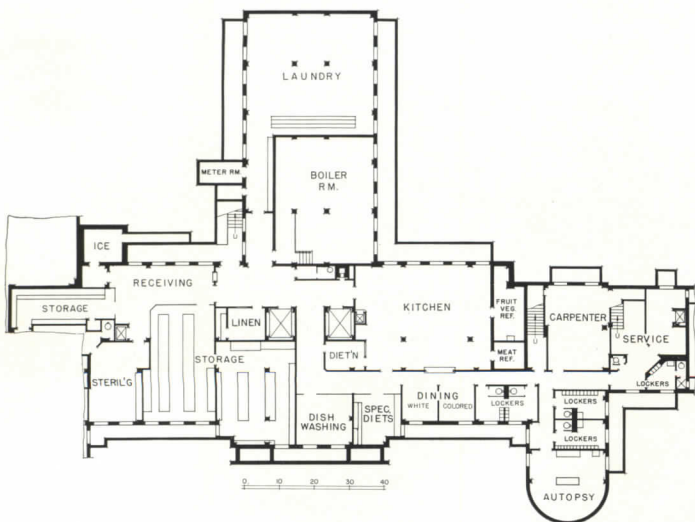
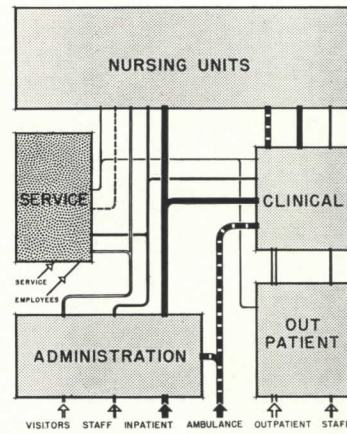
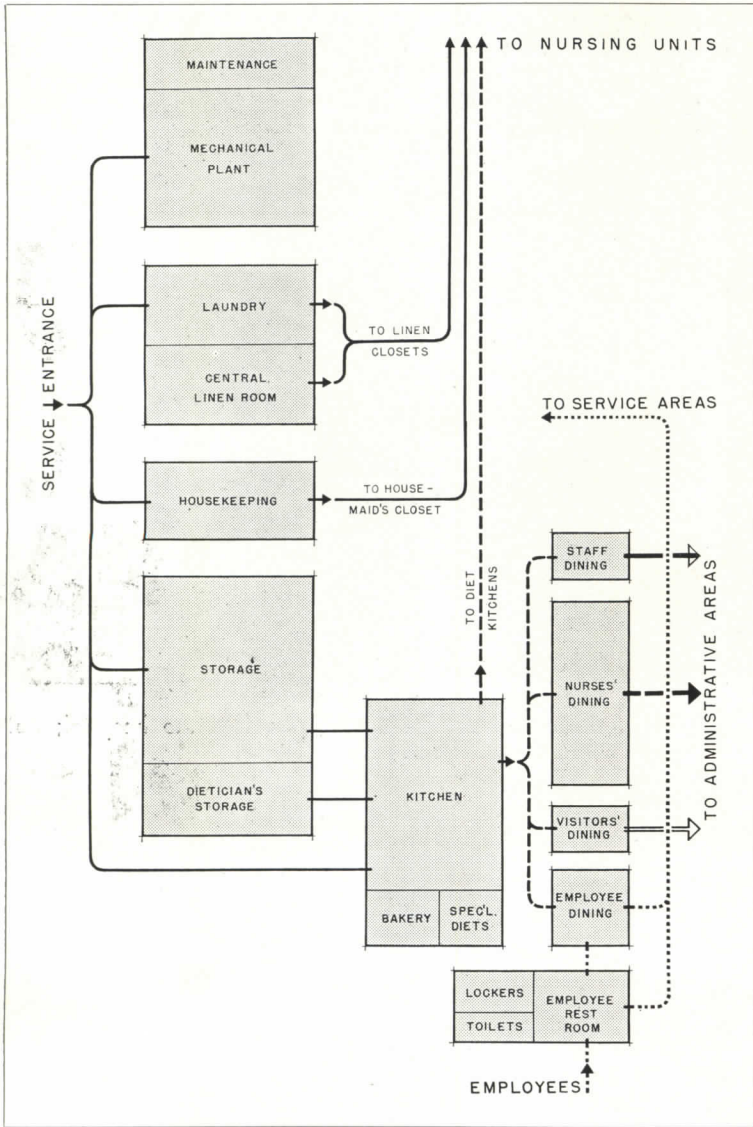

Service basement, City-County Hospital, Fort Worth, Tex.; W. G. Clarkson and Co., architects. Notice that morgue and autopsy rooms are located in service areas of this institution.

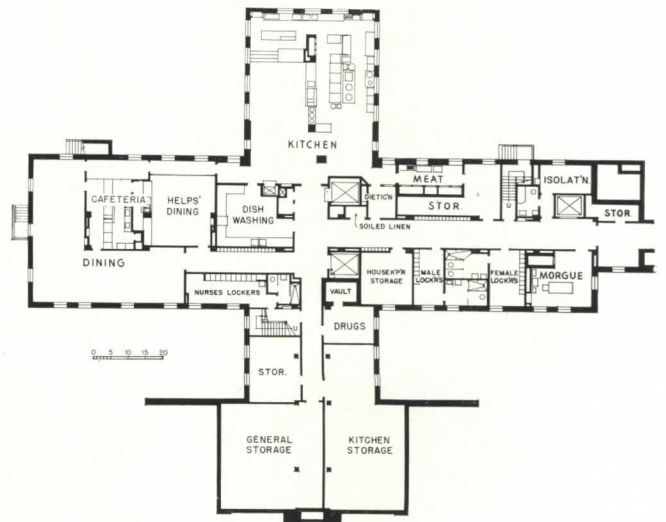

Service basement, Sheboygan Memorial Hospital, Sheboygan, Wis.; Schmidt, Garden, and Erikson, architects; E. A. Stubenranch, associate architect. In this case, laundry is done outside the building.

SERVICE AREAS **FOOD SERVICE**

Frank Oberkoetter Studios

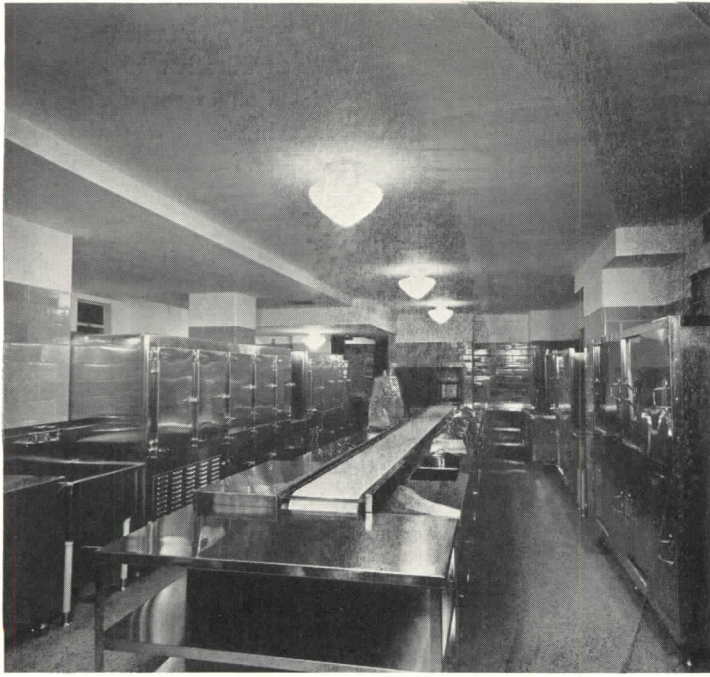

Serving counter, kitchen, St. John's Hospital, Springfield, Ill.; Henry R. Helmle, architect.



Coffee shop, or public dining space, in same hospital; note acoustic treatment of ceiling.

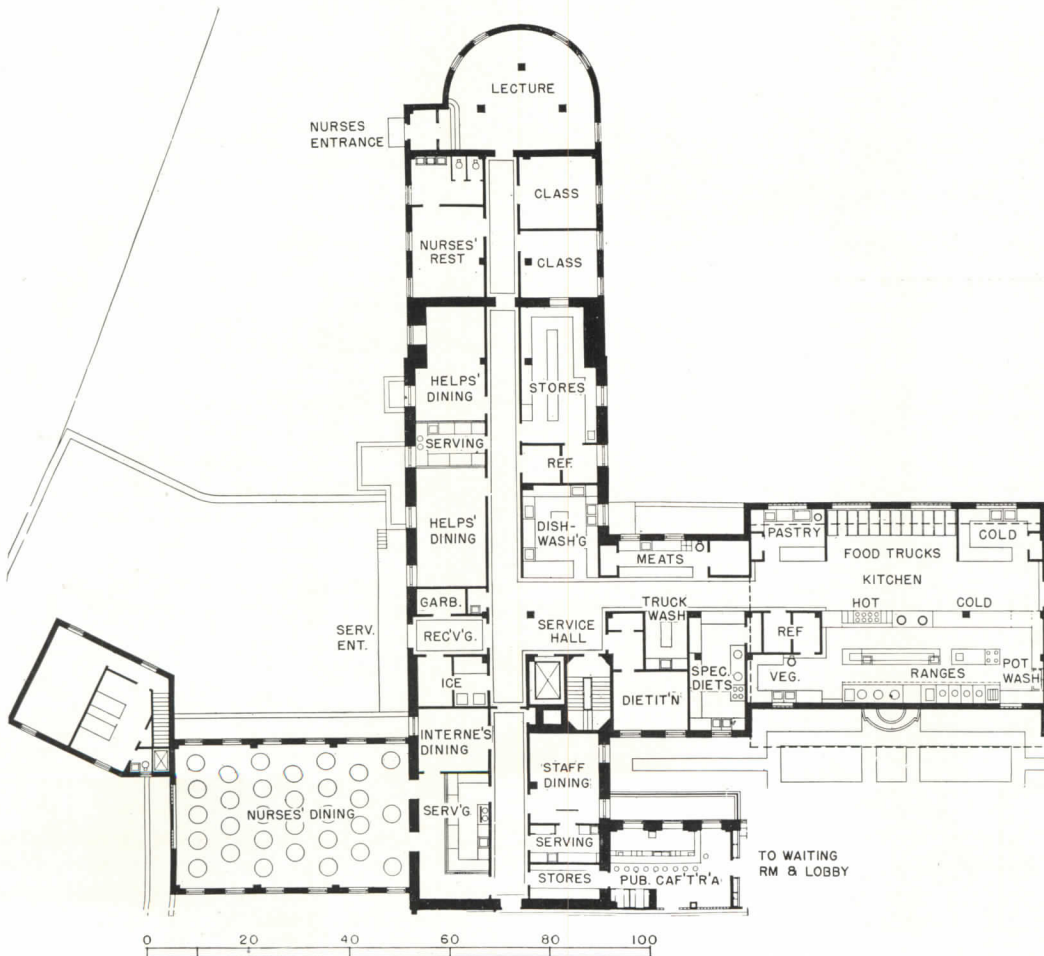

Kitchen and dining areas, first floor, White Plains Hospital, White Plains, N. Y.; Shultze and Weaver, architects; Chas. F. Neergaard, consultant.

CENTRAL FOOD SERVICE is common in smaller hospitals. Kitchen plans shown, therefore, provide for complete food preparation and tray set-up within the kitchen. Food is served on trays, which are either placed on closed tray trucks and transported to the nursing units by elevator, or are carried by conveyors.

Arrangement of spaces and equipment is preferably planned to permit a routine similar to the production line of a modern factory. At one end of this "line", goods are received at the service entrance, separate from the ambulance entrance except possibly in small hospitals (50 beds or less); at the other end is the service elevator or conveyor. In between, raw foods pass to storage spaces (both "dry" and "refrigerated"), or directly to preparation spaces, or to both. From there, foods go to the cooking or other final preparation areas, then to serving counters, and thence to trays. Trays returning from nursing units carry soiled dishes to the central dishwashing space. All of this circulation is most efficiently served by a plan which requires little or no cross-traffic.

In addition to the main kitchen, there is need for a segregated special diet kitchen in which special dietary requirements are filled. Also, the administration of the kitchen requires an office for the dietician; and an office for the steward, near the service entrance, where all supplies are received.

Although kitchens can operate with varying degrees of satisfactory service in spaces which vary greatly in area, the average space requirements for central tray service with truck delivery can be stated as follows: for a 50-bed hospital, 2100 sq. ft.; for 100 beds, 3000 sq. ft.; for 150 beds, 3800 sq. ft. These allowances include food-storage rooms and refrigerator boxes.

Equipment for the average hospital kitchen remains fairly constant in number and kind of units, but changes in sizes or capacities as the hospital varies in size. A comprehensive list will be found in a previous hospital study (AR, 8/38).

Beyond considerations for patient-service as outlined above, there are required service pantries for dining areas or cafeterias for the staff, nurses, internes, employees, and public. It is desirable to group these closely about the kitchen proper, for efficient operation.

Data from C. E. Daniel, Daniel & Wallen, Consulting Engineers.



M. Rittase

Kitchen, North Hudson Hospital, Weehawken, N. J.

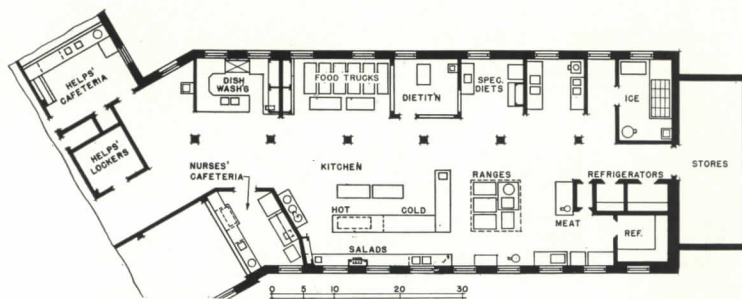

Kitchen, So. Nassau Community Hospital, Rockville Center, N. Y.; Wm. T. McCarthy, architect.

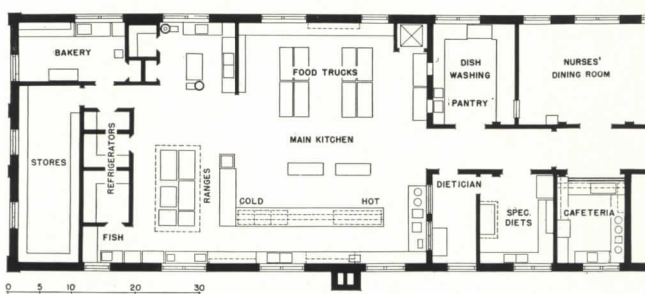

Kitchen, King Edward VIII Memorial Hospital (100 beds), Hamilton, Bermuda; George Hutchins, architect.

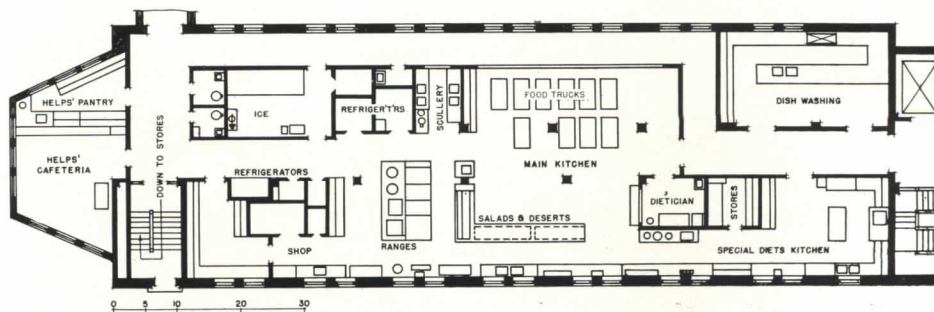

Kitchen, Washington Co. Hospital (200 beds), Hagerstown, Md.; Buckler and Fenhagen, architects.

SERVICE  
AREAS **LAUNDRY, HOUSEKEEPING**

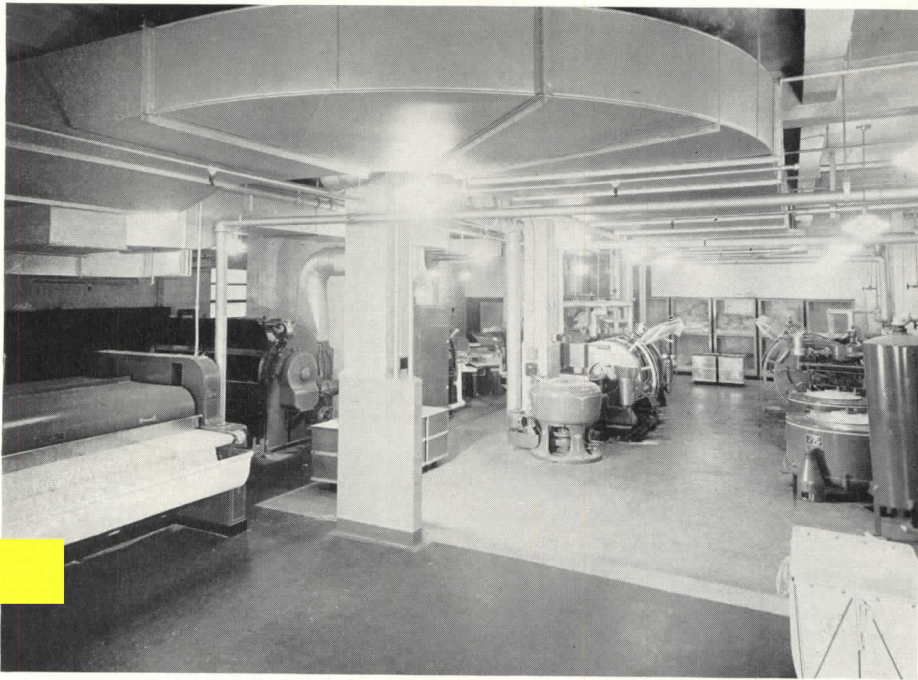

Typical laundry for a large hospital.

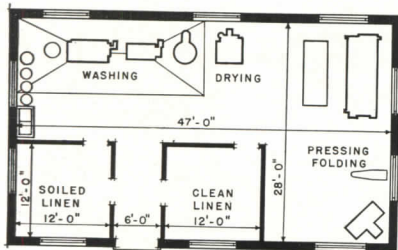

Plan of typical laundry for a 50-bed hospital.

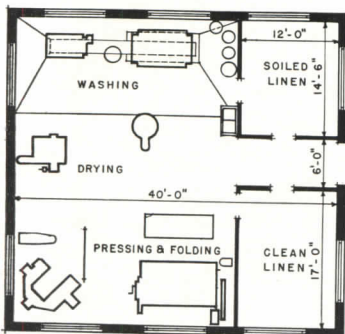

Plan of typical laundry for a 100-bed hospital.

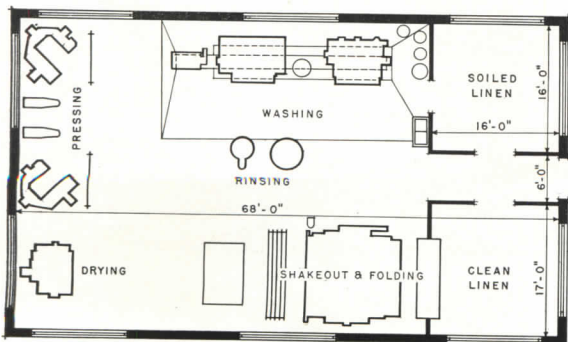

Laundry for a 200-bed hospital: note that equipment remains constant in amount, increases in size and capacity of units as hospital size increases.

HOSPITAL LAUNDRIES are commonly designed in consultation with experienced laundry engineers. Laundry design proceeds from a number of very definite and important factors concerning the institution, in order that the laundry may adequately supply clean linen for every need of every department at the time of the requirement, with a minimum of labor.

The following data are needed:

- (1) Number of beds in the hospital
- (2) Type of hospital (general, maternity, tubercular, etc.)
- (3) Whether it is a private or public institution (character of work being done for the geographical location)

The quantity of linen used per patient per day varies according to the type of hospital. A general hospital may consume anywhere from 10 to 15 pounds; maternity somewhat above this figure; tubercular somewhat below. These figures include that linen which is used directly for the patient, and "indirect" linen which is used by nurses and doctors and for general utility in the hospital. The laundry layout must take into consideration the quantity of linen in circulation—that is, the number of changes of linen in use per bed as well as the fact that the hospital operates and uses linen seven days a week while the laundry operates five and one-half days.

Laundry planning is preferably arranged so that the flow of work from the soiled-linen room to the clean-linen room has no back- or cross-tracking, also so that fresh linen is not contaminated by soiled linen.

Subdivisions by classifications of work in the normal way would show 65 to 70% to be flat work requiring ironing. The flatwork ironer may be located in such position that finished linen passes directly from folding table to clean-linen room. This obviates extra handling of approximately 70% of the total linen.

Tumbled work approximates 25 to 28% (bath towels, robes, etc.); and starched or pressed work (nurses' uniforms, doctors' coats, etc.), 5 to 8%.

With tap water averaging 55° F., the necessity of heating it to 180° F. requires 30 boiler-horsepower per 1000 gallons.

**Housekeeping.** The housekeeper needs an administrative office, and usually supervises the central storage room, where all reserve supplies are kept and issued to the various departments on requisition.

Laundry data from Arnold Erlanger, U. S. Hoffman Machinery Co.





## NURSING UNITS

EACH FLOOR OR portion of a floor devoted to care of patients is composed of easily definable units, which are repeated as required. Certain *nursing units* may be devoted, in whole or part, to specific purposes (isolation, acute, etc.); or the type of accommodation (ward, private, etc.) may vary. The optimum number of beds per nursing unit given in the table on the following page represents an economical nursing set-up, considering use of elevators, stairs, toilets, etc. In 50- to 100-bed hospitals there is usually one nursing unit per floor; in larger hospitals, two or three.

The nursing unit contains patients' (or "bed") accommodations and auxiliary services necessary for its efficient functioning. Types of patient accommodations, and methods of allocating them to specific requirements, are discussed under "Bed Accommodations." The number of beds for each type, and

possibilities for making reserve beds available for more than one purpose, are important to hospital design. Likewise, trends in design of nursing facilities—utility rooms, bedpan services, etc.—discussed on pages 93 and 95, tend toward efficiency and economy of space and equipment, as well as consideration for the patients' comfort.

**Arrangement.** The general criterion for nursing-unit planning may be stated as follows: nursing and service spaces and equipment should be so located with reference to bed accommodations, corridors, etc., as to require the minimum of travel in doing all types of work.

**Finish and equipment.** In the tabulation on the following page, acoustic treatment is indicated as being desirable in certain locations. Installation of sound-absorbing finishing materials on ceilings,

to provide 75% absorption, is desirable in the noisiest areas. Due to restricted budgets, it may not be possible to treat all the spaces listed. Of those shown, treatment of corridors, quiet rooms, diet kitchens, nurses' stations, and toilets is most needed.

Other valuable methods of sound and vibration control include sound isolation of all machines likely to transmit noise; selection of such machines, as well as plumbing and other equipment, for quiet operation (noiseless flush valves, noiseless toggle switches, etc.); and use of structural methods which tend to eliminate sound transmission through walls and floors.

Other types of equipment include small unit fans for mechanically ventilating the toilet and utility rooms. These are controlled by automatic switches which start the fan, and thus cause a complete change of air, after each operation of a flush valve.

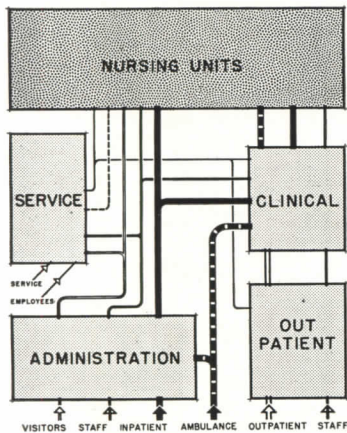
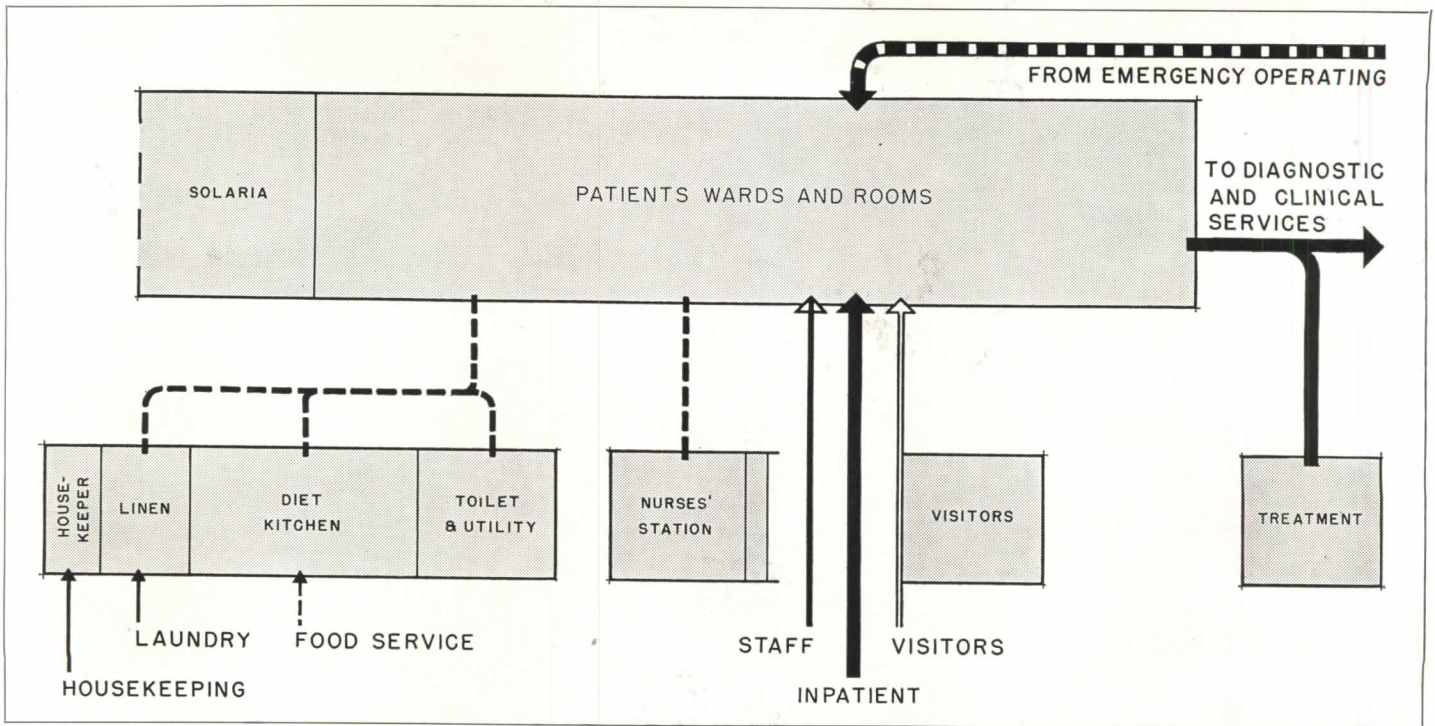

NURSING-UNIT SPACE REQUIREMENT (sq. ft. areas unless noted)

Type of Unit	Private	Semi-private	Ward	Special Structure, Finish, Equipment
Beds per unit.....	18 to 20	25 to 30	35 to 40	
Beds per room or ward.....	1	2	3 to 6	
Avg. sq. ft. per bed....	For fixed capacities, 304; for variable capacities, 228 to 315; all figures include allowance for nursing services averaged in with bed spaces. See text.			
Nurses' station.....	150	180	180	Counter and history racks; lavatory; 2 medicine cabinets; locked compartment for narcotics; acoustical treatment
Stretcher clos.....	45	45	45	Stretchers; wheel-chair and dressing cart; shelves over
Supply clos.....	35	35	35	Storage cabinet and shelves
Linen clos.*.....	50	50	50	Shelves
Housemaid's clos.....	20	20	20	Hopper sink; equipment hooks; floor drain; marble shelves; tile floor; tile wainscot 4 ft. 6 in. high
Toilet, bath, bedpan....	270	270	270	2 rooms, each 135 sq. ft., with toilet, bath, lavatory, bedpan washer, sterilizer, rack, hopper sink, acoustical treatment
Utility.....	135	150	150	Hopper sink; utensil sterilizer; blanket warmer; storage cabinet; work table; ice cabinet; tile floor; tile wainscot 4 ft. 6 in. high; acoustical treatment
Diet kitchen†.....	180	180	180	Storage cabinet; double drainboard sink; short-order range; refrigerator; tile floor; tile wainscot 4 ft. 6 in. high; acoustical treatment
Treatment‡.....	180	180	180	Storage cabinet; surgeons' scrub-up sink; hopper sink; instrument sterilizer
Visitors.....	135	135	135	Acoustical treatment
Laboratory.....	...	...	135	Counter; hopper sink; storage cabinet
Flower†.....	100	100	100	Sink and shelves
Corridors.....	7'	7'6"	7'6"-8'	Acoustical treatment; well-lighted; max. glass area.

\*Where central linen control is used only the minimum area as listed is needed in nursing unit.

†Where central tray service is used little work is done in diet kitchens, and they are frequently used as flower rooms. With decentralized service, diet kitchens should have 225 to 300 sq. ft.

‡As a rule 50-bed hospitals do not have separate treatment rooms or flower rooms.

Detailed diagram showing types of spaces and circulation in the typical nursing unit is at top of page; it must be related to the entire hospital plan as indicated in the key diagram immediately above. Wards, rooms, and solaria occupy only about 1/2 the nursing unit, preferably the sunniest, most quiet side. Storage for stretchers and similar supplies ought to be provided near the nurses' station.

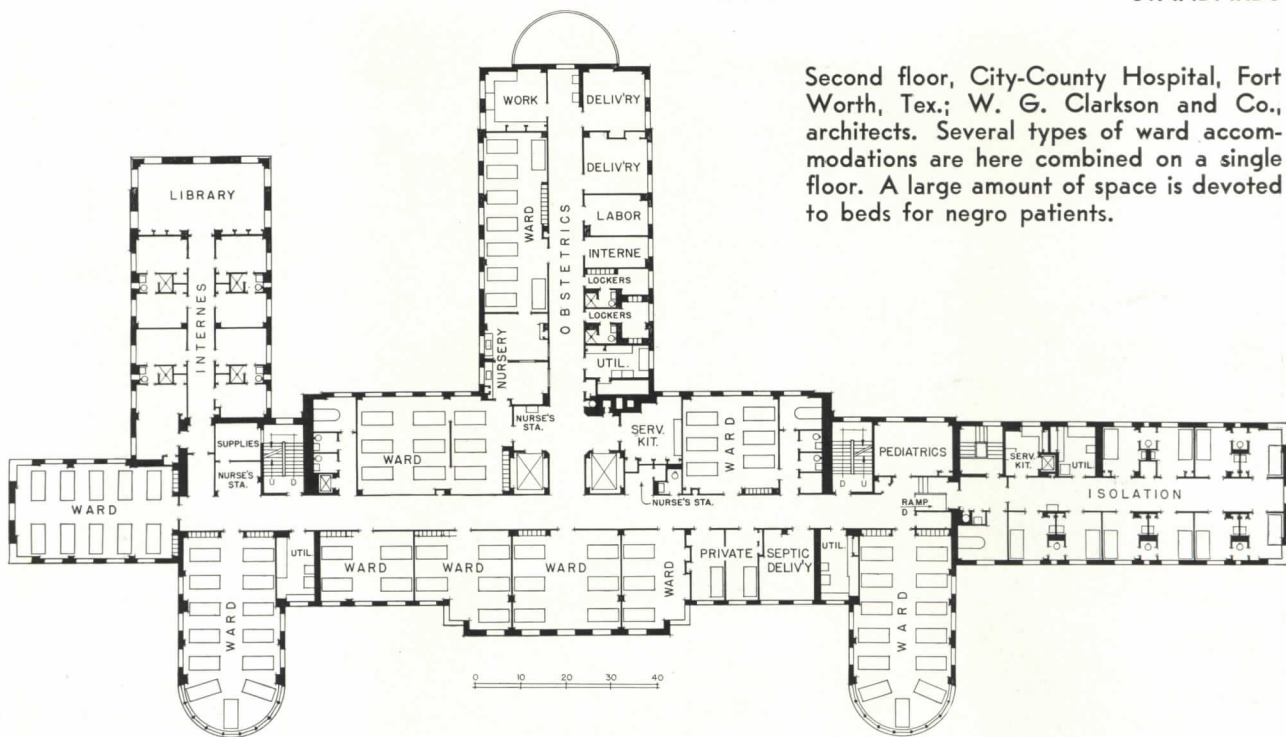

Second floor, City-County Hospital, Fort Worth, Tex.; W. G. Clarkson and Co., architects. Several types of ward accommodations are here combined on a single floor. A large amount of space is devoted to beds for negro patients.

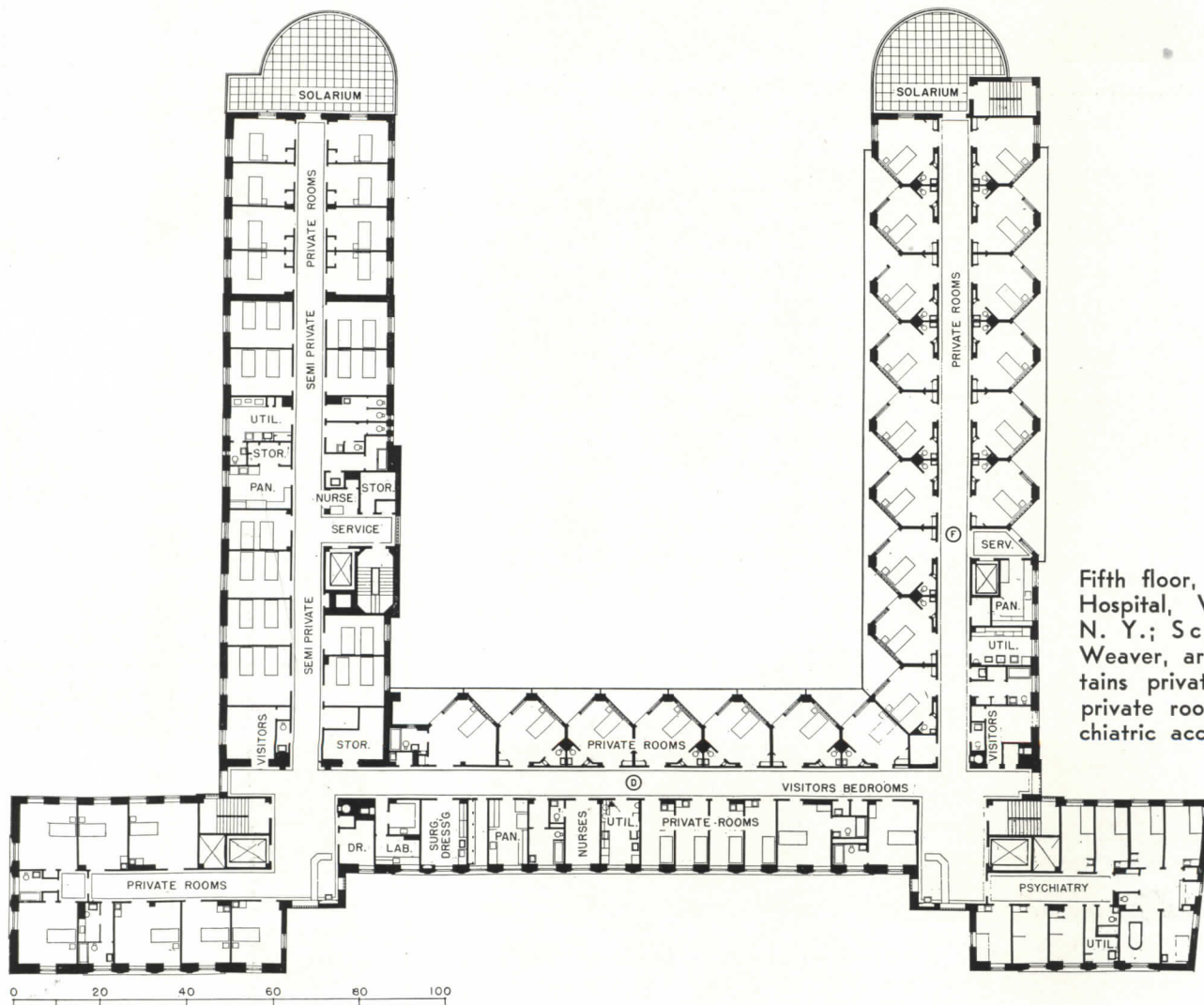

Fifth floor, White Plains Hospital, White Plains, N. Y.; Schultze and Weaver, architects; contains private and semi-private rooms, and psychiatric accommodations.

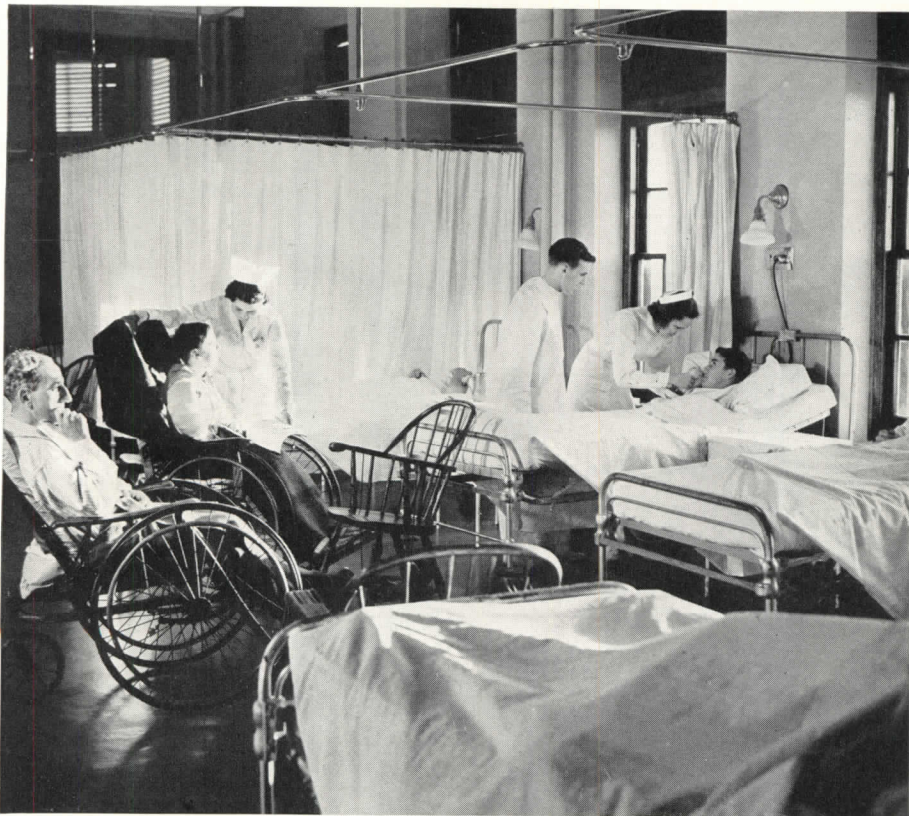

William M. Rittase

Typical ward, showing use of curtains to partition off beds for privacy. Occasionally fixed partitions are used to afford "ward-private" accommodations.

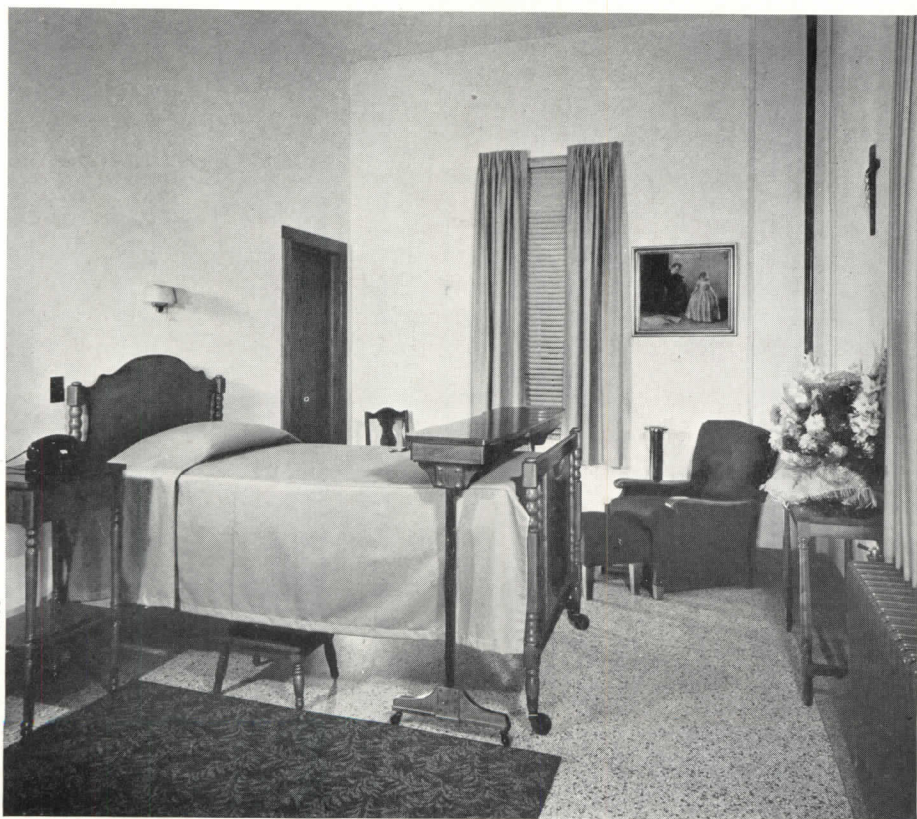

Frank Oberkattler Studios

Typical bedroom, St. John's Hospital, Springfield, Ill., Henry R. Helmle, architect. Semiprivate rooms are larger; may be sized to accommodate three beds if needed.

WARDS AND ROOMS on typical plans occupy approximately  $\frac{1}{2}$  the nursing unit's area. They require pleasant, sunny, quiet locations. Separate sections are usually assigned to medical, surgical, obstetric, and pediatric cases. A separate isolation unit is desirable. Larger hospitals (200 or more beds), which are more specialized, may require units for orthopedic departments, for nose-and-throat cases, and for psychiatry.

In the average general hospital, 60 to 75% of the patients are surgical. In modern planning, it has been found desirable to group the acutely ill—approximately 30% of the beds—together, for convenience in nursing, and to avoid disturbing convalescent patients. The pediatric department is desirably located on the ground floor, and usually contains not over 10% of the total beds.

*Arrangement:* It is desirable to arrange wards and rooms so that there will be a maximum of elasticity in the plan, and so that, in emergencies, the number of beds per unit may be expanded without undue crowding. Thus, a four-bed ward 26 by 15 ft. (slightly larger than is required for a fixed capacity of four beds) may accommodate five beds; a 12 by 15 private room may take two beds, etc. Use of wards and rooms of small bed capacities facilitates the segregation of patients, by race, sex, or degree or type of illness.

*Plan types:* Illustrated are two distinct planning principles which have often been the subject of controversy. In one, beds are placed at right angles to the exterior wall, so that the patient looks at a blank partition; and in the other, parallel to it, so that he can look out the window. In one, low-cost accommodations (semiprivate) are in small single rooms; in another, in double rooms. In one, bedpans are emptied in a sub-utility opening into the ward; in the other, they are removed at once from the patient's room and carried to a utility across the corridor.

*Desirable equipment includes:* two large windows per room, spaced to admit maximum light and air (four windows per four-bed ward); 3 ft. 10 in.-wide door, hung to conceal beds, with friction hinges which prevent slamming; glareless artificial light (not ceiling fixtures); electric receptacles, night light, nurses' call; small clothes closets; and satin-finished hardware (to eliminate reflected glare).

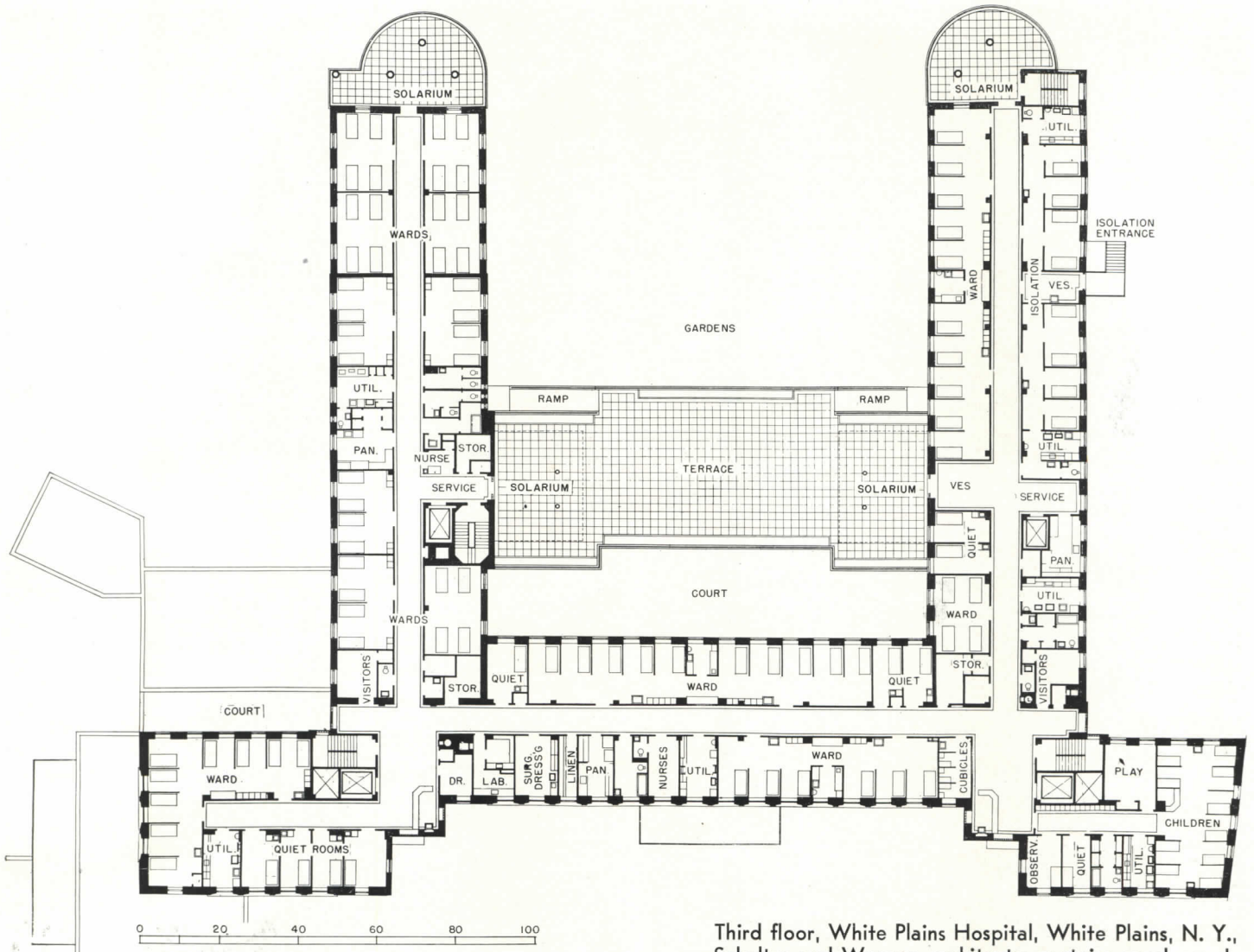

Third floor, White Plains Hospital, White Plains, N. Y., Schultze and Weaver, architects; contains ward, ward-private, isolation, children's, and quiet accommodations. Beds are mostly at right angles to outside walls; semi-private (low-cost) accommodations on other floors are similar to quiet rooms shown here; note utilities in centers of wards.

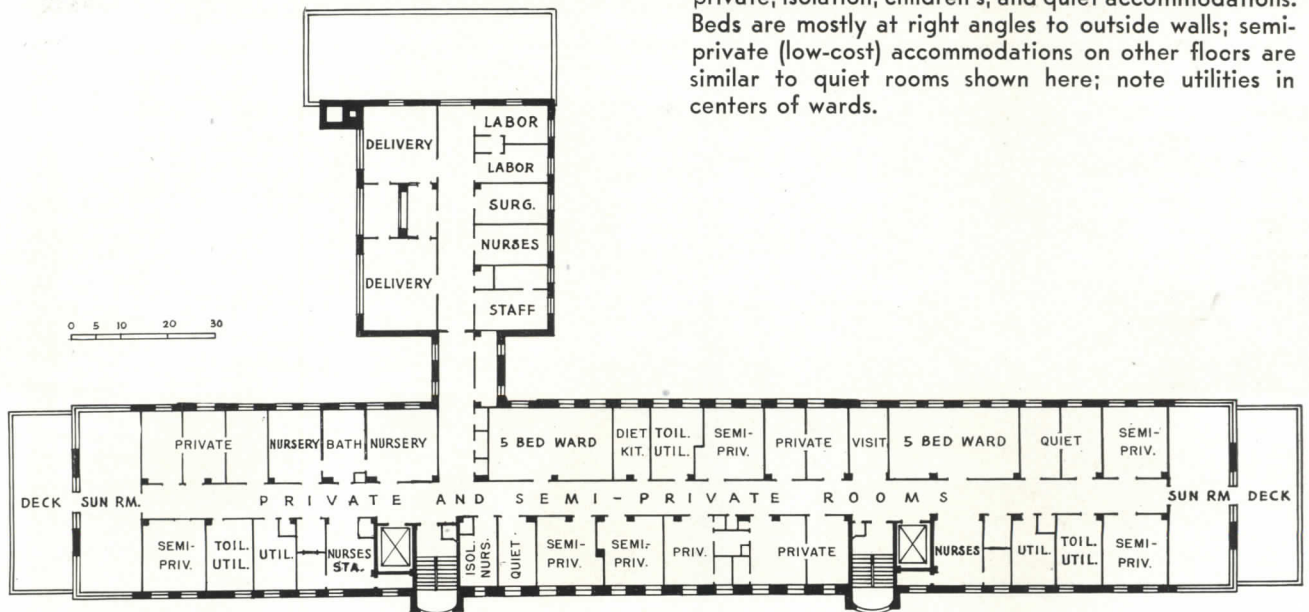

Second floor, Rome Hospital, Rome, N. Y.; Bagg and Newkirk, architects; contains a combination of ward, semi-private, and private facilities. Beds are mostly parallel to outside walls; one bed in each ward is at right angles.



View from visitors' room through corridor to nurses' station, Chicago Lying In Hospital.



Nurses' station, St. Vincent's Maternity Hospital, Little Rock, Ark.; Brueggeman, Swaim & Allen, architects.

*Wm. Hughes*



Utility room, St. Vincent's Maternity Hospital. Note bed-pan unit.

*Wm. Hughes*



Service room for two four-bed wards, Chicago Lying In Hospital.



Service room, four-bed ward, St. John's Hospital, Springfield, Ill.; Henry R. Helmle, architect.

*Frank Oberhoetter Studios*

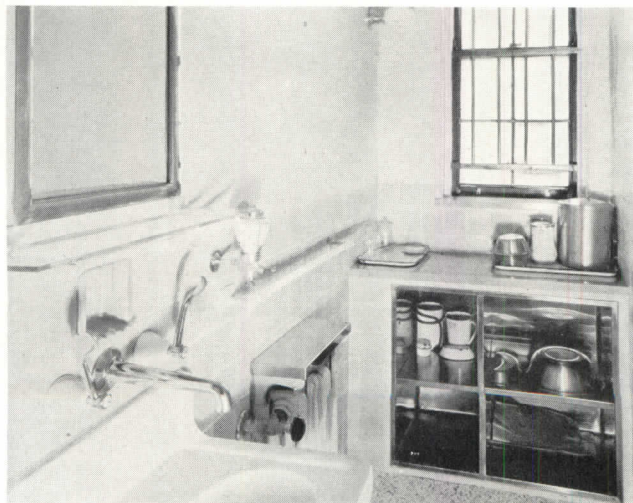

Toilet (service room), Chicago Lying In Hospital; Schmidt, Garden & Erikson, architects.

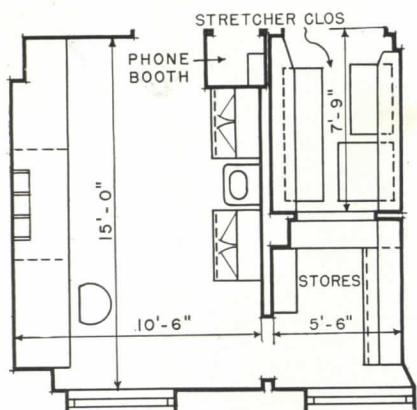

Standard plan for nurses' station and adjoining closets for stores, stretchers, wheel chair, and dressing carriage.

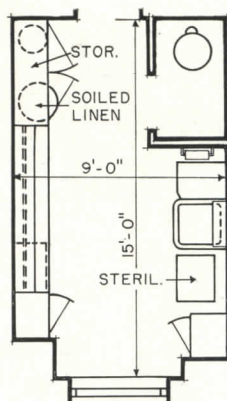

Standard plan for utility room, with toilet alcove; soiled-linen hopper may be included here.

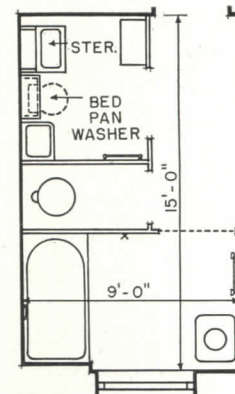

Standard plan, bedpan-bath unit, makes the seldom-used patients' bath do double duty.

**Patients' services.** Private toilets and baths have largely a sentimental value for the majority of patients, as on the average day only one patient in nine is able to get out of bed. On a private-room floor, an ample quota for a medical or surgical unit of 20 beds is one suite of two rooms with connecting bath, from two to four private rooms with individual toilets, and general toilets for the remainder.

However, on private maternity floors, or in the event that the hospital has a wealthy clientele, these proportions may be increased.

**Nursing service facilities.** One *nurses' station* is needed for each nursing unit. The nurses' station should be located at the entrance to the nursing unit, facing elevators and stairs so arrival of staff members and visitors can be controlled. Outside light and air, and acoustical treatment, are desirable.

*Closets* for stores, linen, stretchers, and wheel chairs are best located for convenient access from the nurses' station and from the corridor. On private floors, there should be a separate *rest room* for special nurses. Bedpans may be emptied in private toilets or utility rooms; most convenient, and common practice, is disposal in a mechanical

washer, followed by direct steam sterilization. *Bedpan units* properly spaced for each 10 or 12 beds may be in alcoves combined with the general patient toilet and bath.

One *utility room*, located centrally with respect to beds served, is required per nursing unit. In the main utility room, blankets are warmed, sterile supplies and medications are prepared for use, etc. It is no longer considered good practice to include the bedpan washer in this unit, which is used for "clean" technique.

A *treatment room* for surgical dressings and other special treatments is desirable in each nursing unit, particularly on the ward floors in hospitals having 100 or more beds. If teaching demonstrations take place here, a larger room than that shown in the preceding tabulation may be provided.

A *clinical, or internes', laboratory* is desirable in hospitals of 100 and 200 beds; here, for convenience, routine blood, urine, and similar examinations are made. In hospitals of 50 beds or less, this laboratory is often omitted, and the work is done in the main laboratory.

*Diet kitchen:* With food distributed from a central tray service—which most

(Continued on page 95)

Reference is also made to standard details developed by the New York City Department of Hospitals and published in the August 1938 Building Types study on Hospitals. A comprehensive bibliography was included in another Building Types study, AR 7/37.



Wm. Rittase

Tray preparation in a diet kitchen.



Floor pantry, Chicago Lying In Hospital.

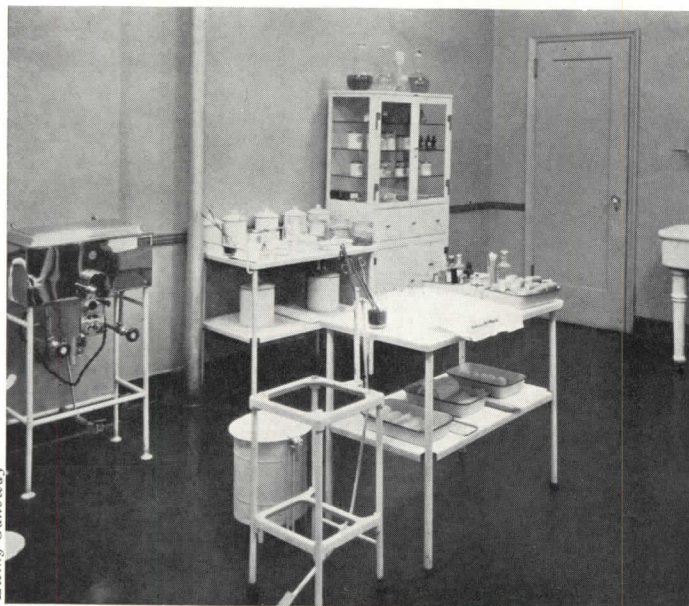

Erving Galloway

Treatment room, Beekman Street Hospital, New York City.



Courtesy Celotex Corp.

Acoustically treated corridor, Ellis Hospital, Schenectady, N. Y.

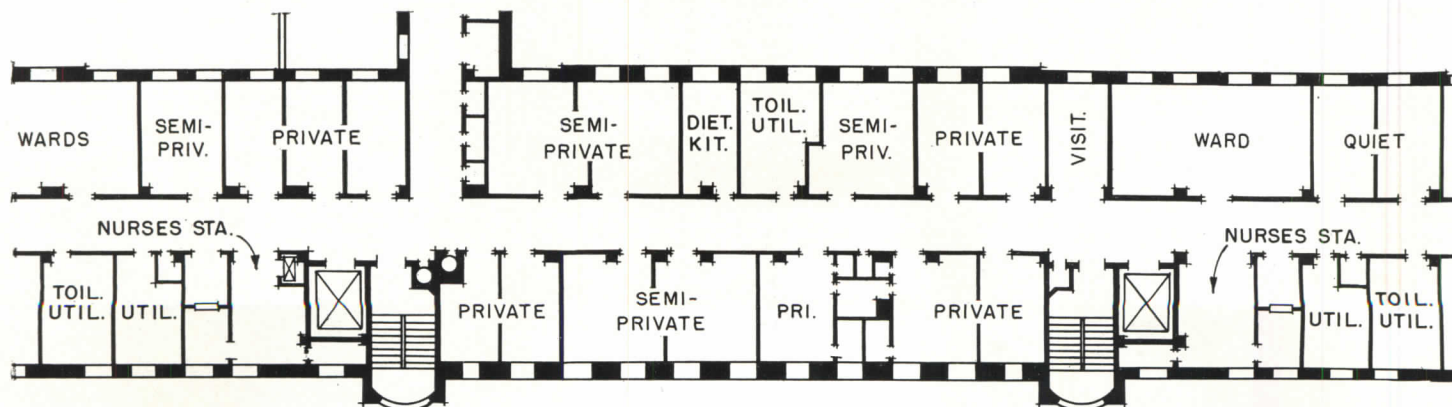

Method of combining wards, rooms, and service rooms in Rome Hospital, Rome, N. Y.



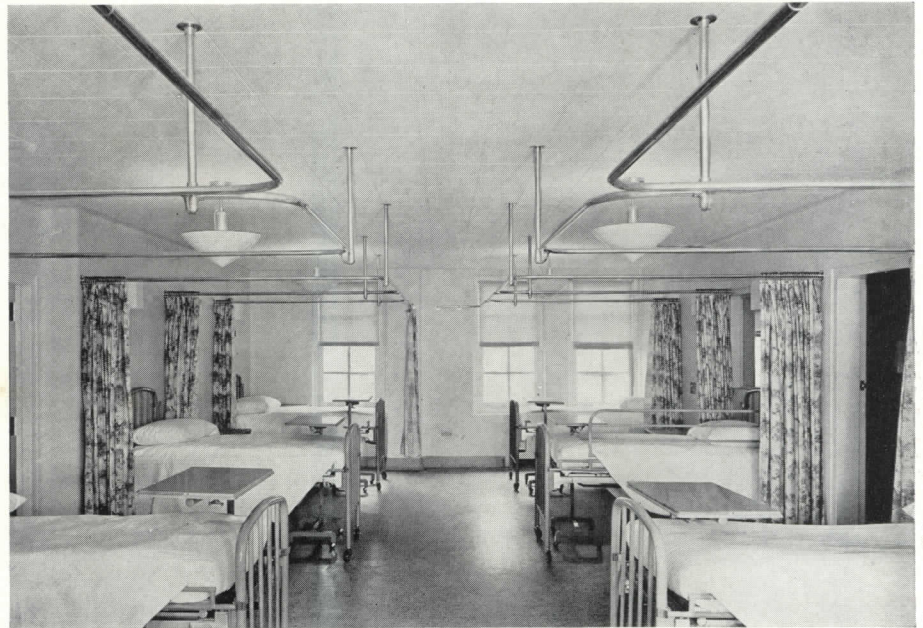

Courtesy Calotex Acoustical Products

Acoustically treated ward, Ellis Hospital, Schenectady, N. Y.; Heacock, Hokanson, and Scheuringer, architects.

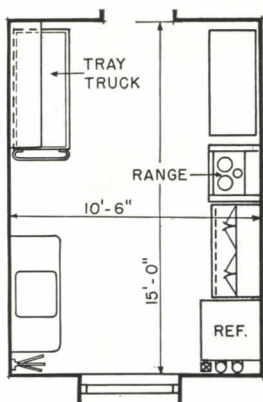

Standard plan, diet kitchen or floor pantry.

Standard details on pages 93, 95 and 99 were developed by Charles F. Neergaard.

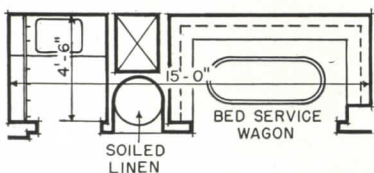

Standard plan, housemaids' closet, includes a soiled-linen chute.

(Continued from page 93)

small hospitals are adopting—the floor diet kitchen becomes of secondary importance, and may be decreased in size and amount of equipment to the minima shown in the preceding tabulation.

The chief advantages of central service are reduction of food waste, and freedom from noise, confusion, and odors on the patients' floor. Acoustic treatment is highly desirable.

Since its use is thus limited, the diet kitchen is frequently used as a *flower room*.

*Visitors' room.* One or more visitors' rooms are required per nursing unit. Occasionally, limited budgets cause the omission of all but one visitors' room per floor; but since visitors average six per patient per day, and since both the number of visitors admitted to see a patient at one time, and visiting hours—particularly for ward patients—are usually limited, the need for more space is apparent.

The visitors' room is preferably located near the nurses' station, adjacent to elevators and stairs, and is frequently an alcove off the main corridor, where acoustic treatment is needed.

*Supplies, storage, linen control.* Only when an "exchange" system of linen supply is used, is a large nursing unit or floor linen room required. With a

central linen control, all linen is used in common, and sorted and graded for private or ward patients. The supply is replenished daily, by requisition, sent to the floors, and placed on the chair by the bedside. With this system, nursing labor is minimized, waste in use is controlled, and the active linen inventory is held to a minimum.

Only a small linen closet containing an emergency reserve quota, over and above the changes actually used for occupied beds, is then needed in each nursing unit.

An entirely separate linen supply for the maternity department is justified if proper laundry sterilization cannot be assured. However, with modern equipment and washing technique, it should not be necessary.

One *soiled-linen* chute is needed per nursing unit.

The *janitor's or housemaid's closet* is preferably centrally located with respect to the area it serves, and is shown in bottom plan on this page.

Storage space for stretchers, dressing carriages, and wheel chairs is shown in plan on page 93, in conjunction with the nurses' station. One such room, located as on the plan, is needed per nursing unit.

*Main corridors* in nursing floors should be at least 7 ft. wide, sometimes 8 ft. in large hospitals.

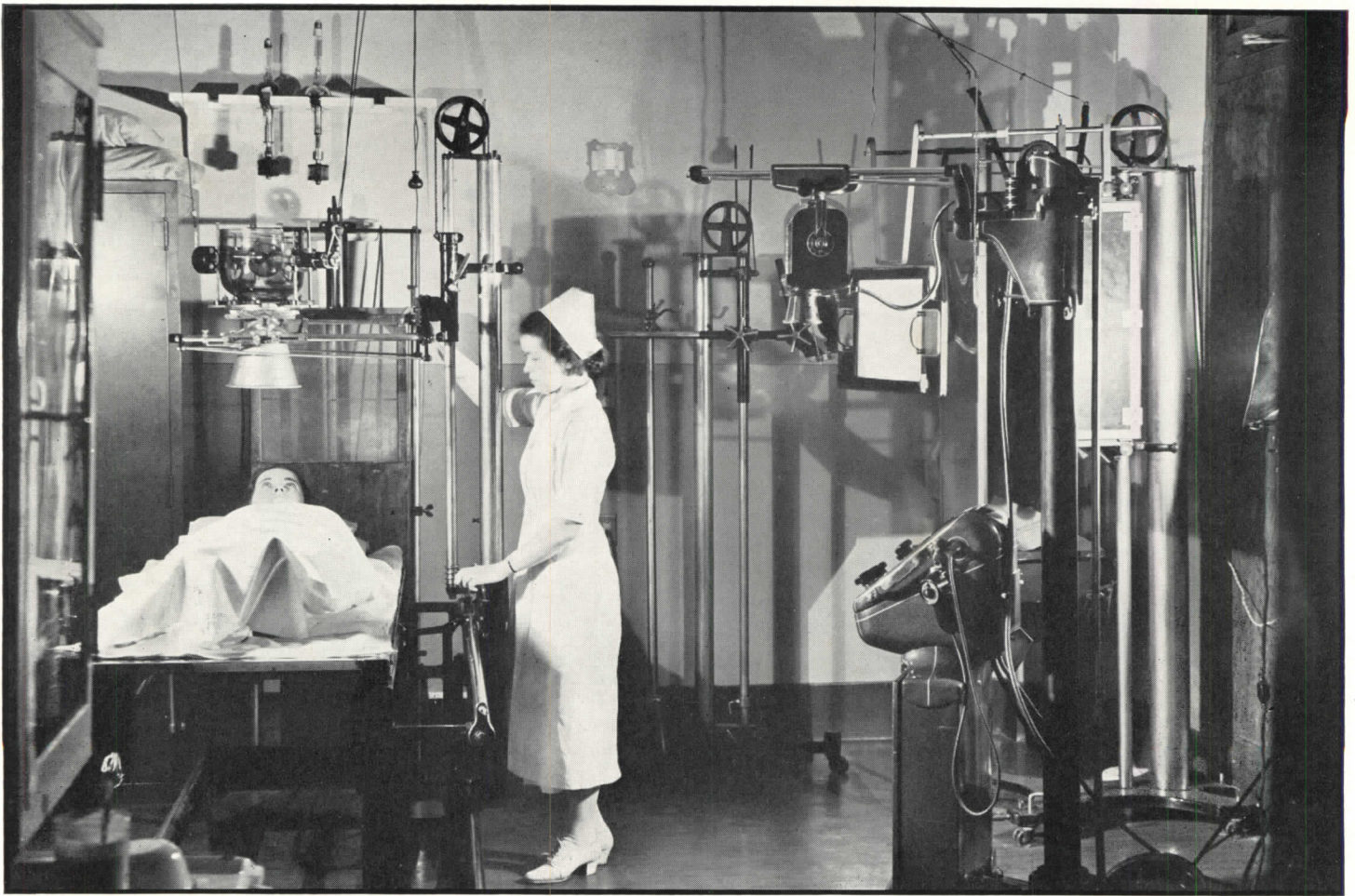

## CLINICAL SERVICE AREAS

CLINICAL FACILITIES for the average small voluntary general hospital may include all the areas shown in the chart on the opposite page. The facilities are preferably so located that they are accessible to both inpatient and outpatient departments.

Depending upon the type of services which the institution is intended to furnish and the requirements of the staff, certain of the clinical areas may be expanded or contracted.

The average 50- to 100-bed hospital contains a *prenatal clinic*, *babies' clinic*, and *emergency clinic* (for cuts, bruises, etc.). The *dental clinic* is usually in the outpatient department. *X-ray and fluoroscopy facilities*, used in several hospital departments, are commonly housed in an independent X-ray suite, convenient for both inpatients and outpatients. In small hospitals, the X-ray unit may be grouped with an adequate *laboratory*, to

facilitate diagnosis.

Indispensable clinical facilities include a *surgical suite* of at least two operating rooms and the necessary auxiliary spaces. In 50-bed hospitals two operating rooms en suite cannot ordinarily be afforded. The best such hospitals can usually do is to have one operating room and one emergency room at the ambulance entrance. This casualty department may be used for minor surgery, but is preferably a distinct unit.

It is considered essential that the *maternity service* be a separate, self-contained unit, as maternity is a "healthy" process and therefore should be so located as to avoid possible contagion. Maternity surgery is sometimes handled in the operating room. Postdelivery work is usually a surgical procedure. Nurseries and recovery wards are sometimes included with the obstetrical suite.

Since its facilities are to some extent used independently of the rest of the hospital, the obstetrical division is segregated within a floor or wing.

The *necropsy room*—mortuary and autopsy facilities—is commonly located in the basement.

The *pharmacy* commonly serves all departments of the hospital and should be accessible from all. Hospitals containing 50 beds or less often do not operate their own pharmacies, but require at least a drug room.

*Physical therapy* departments, with facilities for various forms of treatments, are not included in all small hospitals, but are growing rapidly in larger hospitals, with the development of new types of treatment by heat, electricity, exercise, and water. This is a highly specialized department and should be developed in consultation with a professional staff.

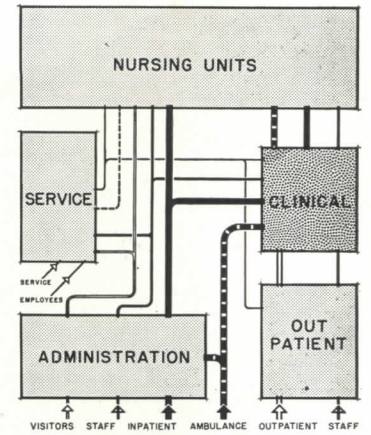
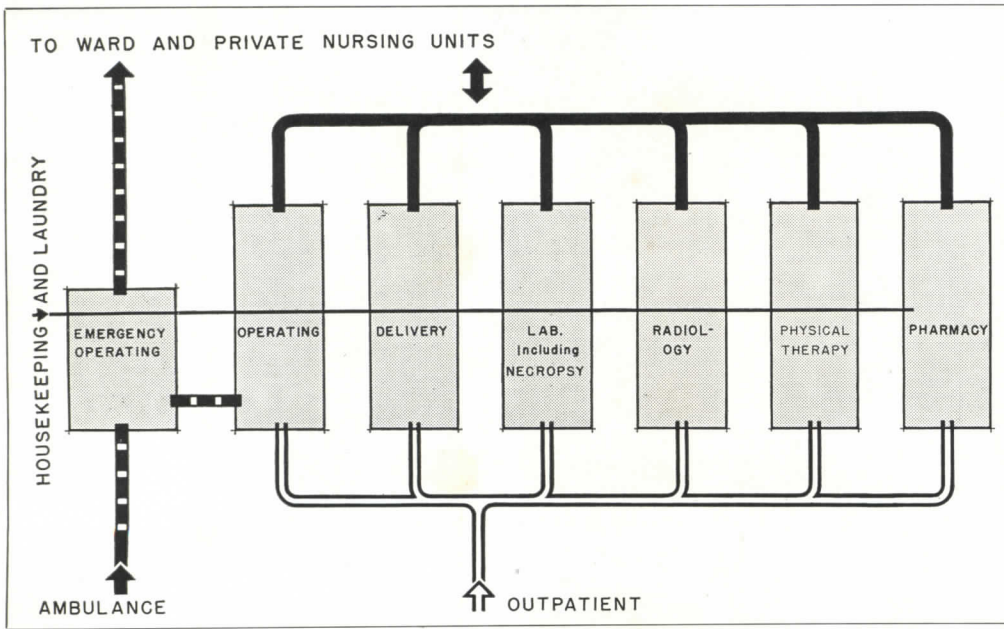
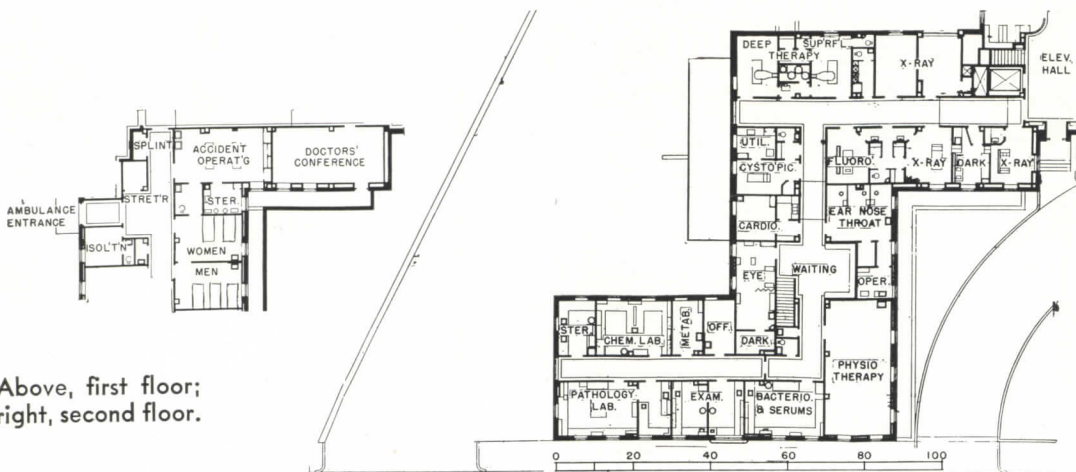
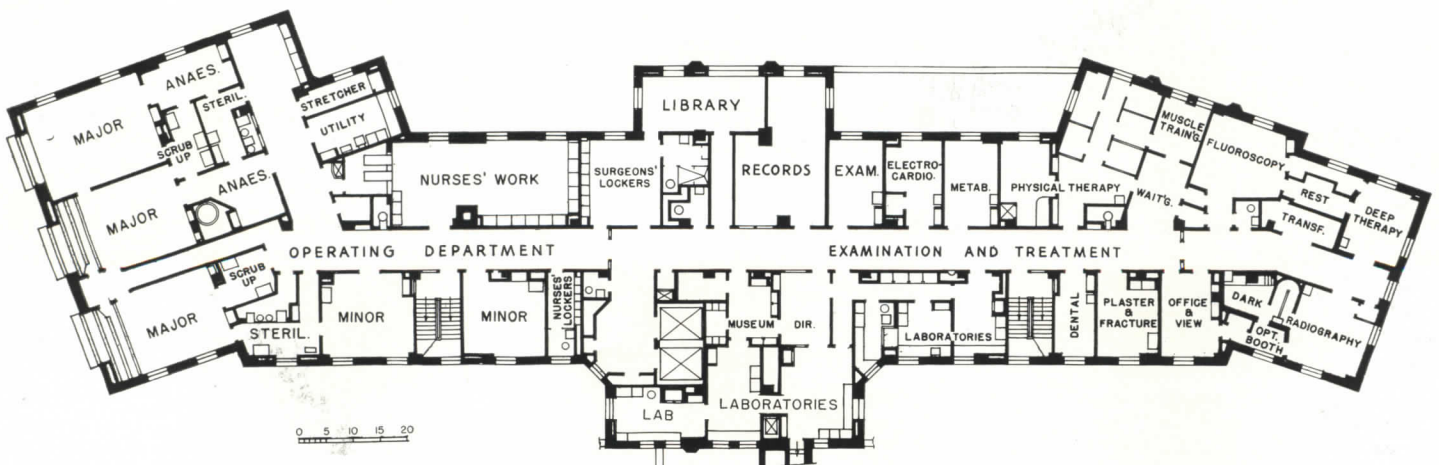

Diagram at left shows spaces and circulation necessary for clinical services; key above relates clinical departments to remainder of hospital.



Above, first floor;  
right, second floor.

Part of the clinical facilities at White Plains Hospital, White Plains, N. Y.; Schultze and Weaver, architects. Included here are emergency, or casualty, unit; laboratories; physiotherapy room; X-ray department; and several specialized treatment rooms. Operating, delivery, pharmacy, and morgue provisions are elsewhere in the building.



Clinical floor, Menorah Hospital, Kansas City, Mo.; Schmidt, Garden, and Erikson, architects; Greenbaum, Hardy, and Schumacher, consulting architects; contains operating, laboratory, X-ray, and physical therapy departments.

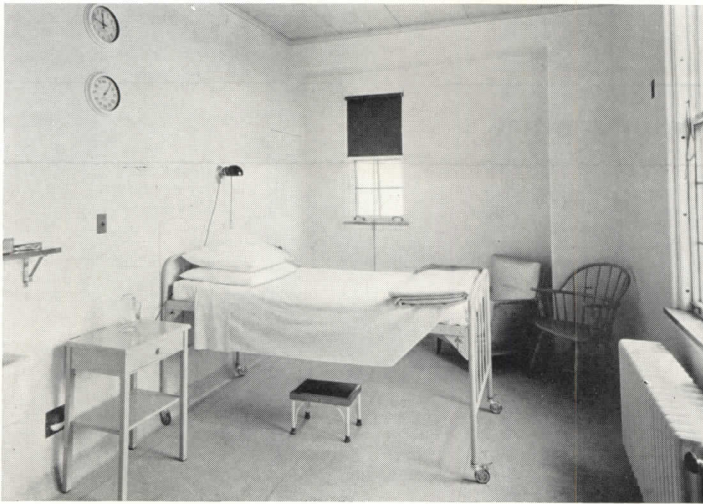

Labor room, Chicago Lying In Hospital; Schmidt, Garden & Erikson, architects.



Delivery room, Alleghany General Hospital; York & Sawyer architects. Note scrub-up sinks.

Trinity Court Studio

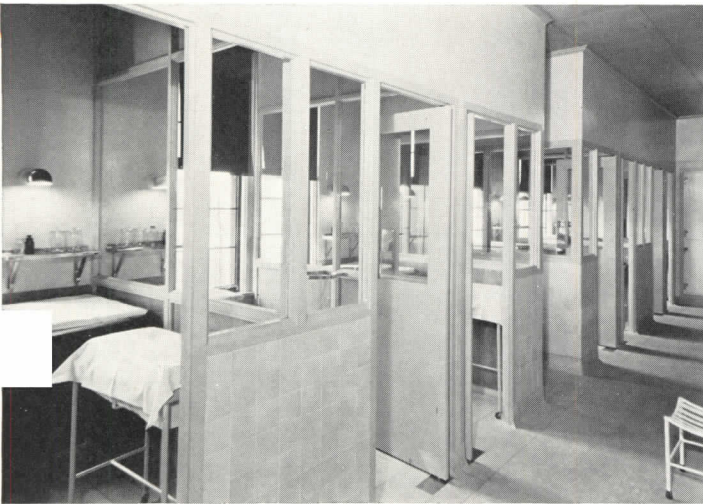

Individual isolation nurseries in the Chicago Lying In Hospital.



Prefabricated isolation nursery cubicles, Presbyterian Hospital, Chicago, Ill.

Kaufman & Fabry

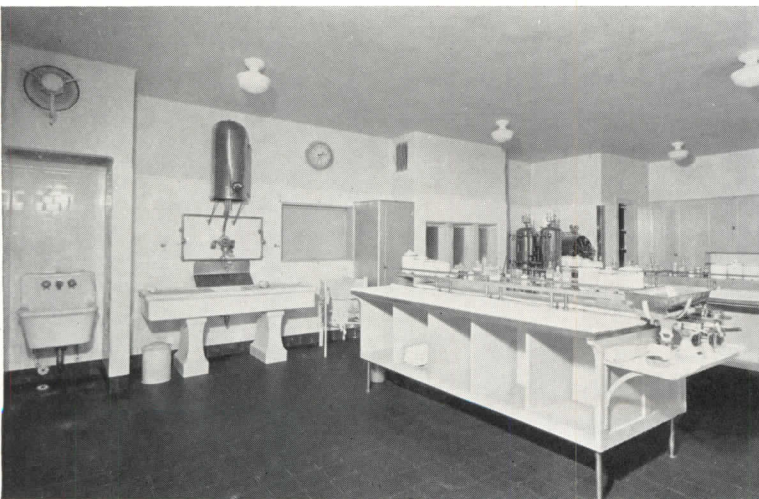

Nursery service room, West Suburban Hospital, Oak Park, Ill. Notice specialized equipment.



Nursery formula room, West Suburban Hospital, showing refrigerator, stove, sterilizers, cabinets.

DELIVERY SUITE SPACE REQUIREMENTS (areas in sq. ft.)

Type of Space	50-bed Hosp.	100-bed Hosp.	200-bed Hosp.	Special Structure, Finish, Equipment
Delivery room*	225	450	675	1 to 3, at 225 sq. ft. each, with acoustical treatment; air conditioning; tile floor; tile wainscot, 5 ft. 6 in. high
Sterilizing		135	135	Instrument sterilizer; utensil sterilizer; water sterilizer; double drainboard sink; storage cabinet; tile floor; tile wainscot, 4 ft. 6 in. high
Scrub-up		135	135	3 surgeons' scrub-up sinks
Sterilizing and scrub-up.	120	...	120	Instrument sterilizer; utensil sterilizer; 2 surgeons' scrub-up sinks; double drainboard sink; storage cabinet; tile floor; tile wainscot, 4 ft. 6 in. high
Labor room	150	300	600	1 to 4 at 150 sq. ft. each, with air conditioning; acoustical treatment
Utility room	135	150	150	Blanket and solution warmer; hopper sink; double drainboard sink; storage cabinet; tile floor; tile wainscot, 4 ft. 6 in. high
Preparation room		...	150	Bath slab; toilet; storage cabinet; tile floor; tile wainscot, 4 ft. 6 in. high
Nurses' work room†	150	225	300	Storage cabinet; work table; double drainboard sink; autoclave
Staff locker	150	225	300	Toilet; shower; lavatory; chairs; couch; lockers
Nurses' locker		120	120	Toilet; lavatory; chairs; lockers
Stores	40	60	100	
Total sq. ft.	970	1,800	2,785	

\*Similar to operating room but not identical; where operative cases are performed in delivery suite, one delivery room should have 290 sq. ft. area, operating equipment, etc.  
†If central sterilizing and supply room is used, these rooms may be smaller.

**Nursery:** Approximately 20 sq. ft. per bed, including bassinets and incubator spaces  
**Isolation nursery:** 130 sq. ft.; cubicled bassinets; hopper sink; blanket warmer  
**Infants' bath:** 100 sq. ft.; bath slab and mixing tank; hopper sink; blanket- and linen-warming closet; soiled linen hamper; examination table; dressing table  
**Formula room:** 130 sq. ft.; refrigerator; bottle pasteurizer; double drainboard sink; hot plate

THE MATERNITY DEPARTMENT and delivery suite are preferably located apart from other units in the hospital, to avoid possibility of infection. Labor and delivery rooms, together with their supplementary spaces, are similar to the operating suite discussed on the following page. Finishes of floors and walls and, to an extent, lighting facilities, are treated as in the operating room. Acoustic treatment is essential.

Nurseries for both normal and premature infants, with bath and examining rooms, are usually provided with vestibules opening from the main corridors (to insure quiet). They are equipped with corridor windows to permit visitors to see the infants. A special room is required for preparing babies' formulae and is equipped with a bottle sterilizer, washer, refrigerator, and hot plate.

Floor of the nursery is preferably of a resilient material with a coved base and border; ceilings are acoustically treated and walls should be finished so as to minimize reflected glare. Indirect lighting is highly desirable.

It is now common practice to place physical barriers between infants and to use individual bassinets equipped with a shelf for linen supplies and for bathing the infant. These are frequently used for both general and isolation nurseries. Air conditioning is desirable (though rarely with summer cooling) and should permit the maintaining of constant temperature of not less than 78° and control of humidity, together with a constant, controlled supply of filtered air. For premature infants, both temperature and humidity may be increased, the latter to 50 to 75% relative.

For these purposes, there have recently been developed completely enclosed cubicles, in each of which, atmospheric conditions can be independently controlled. Each cubicle is planned for one child and is completely prefabricated so that it can be installed as a unit.

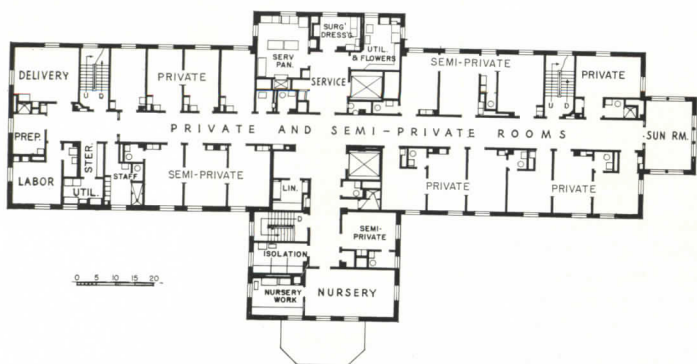
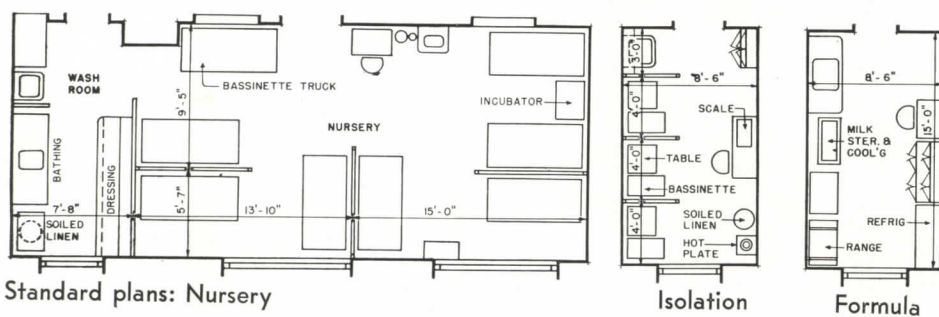

Left, maternity and nursery floor, Sheboygan Memorial Hospital, Sheboygan, Wis. Schmidt, Garden and Erikson, architects.

CLINICAL SERVICES OPERATING SUITE

Steward Photo

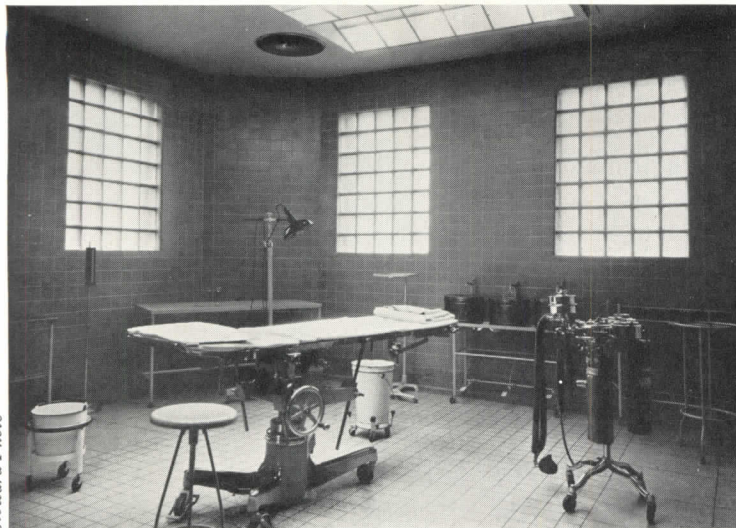

Operating room, Dover General Hospital, Dover, N. Y., has multiple-spot-lens artificial lighting.

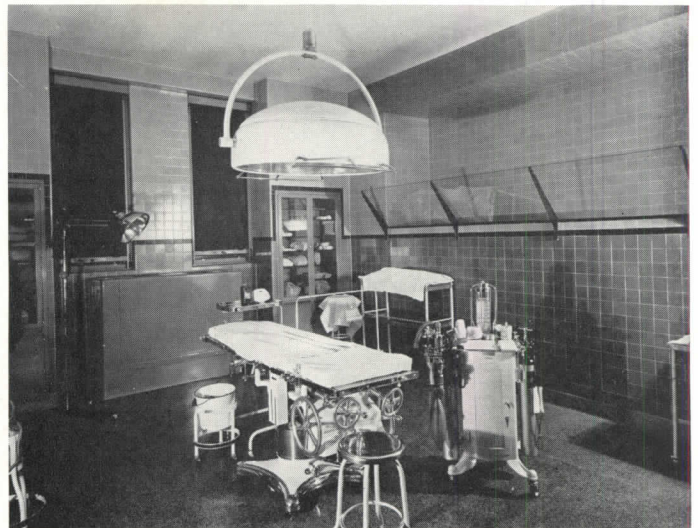

Operating room, Worcester City Hospital, Worcester, Mass.; Stevens, Curtin, and Mason, architects.

Photos: Frank Oberkoetter Studios

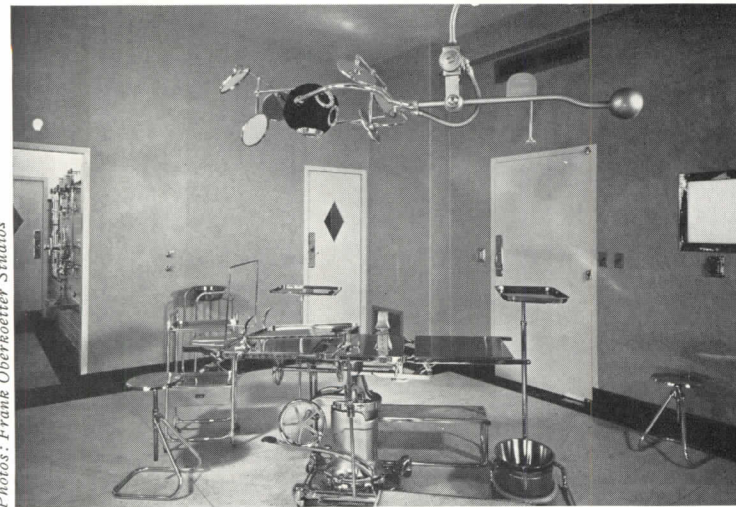

Orthopedic surgery, St. John's Hospital, Springfield, Ill.; Henry R. Helmle, architect. At left, sterilizing room; right, X-ray panel.



Scrub-up room, adjoining operating room at left; note knee-operated faucets and "explosion-proof" lights.

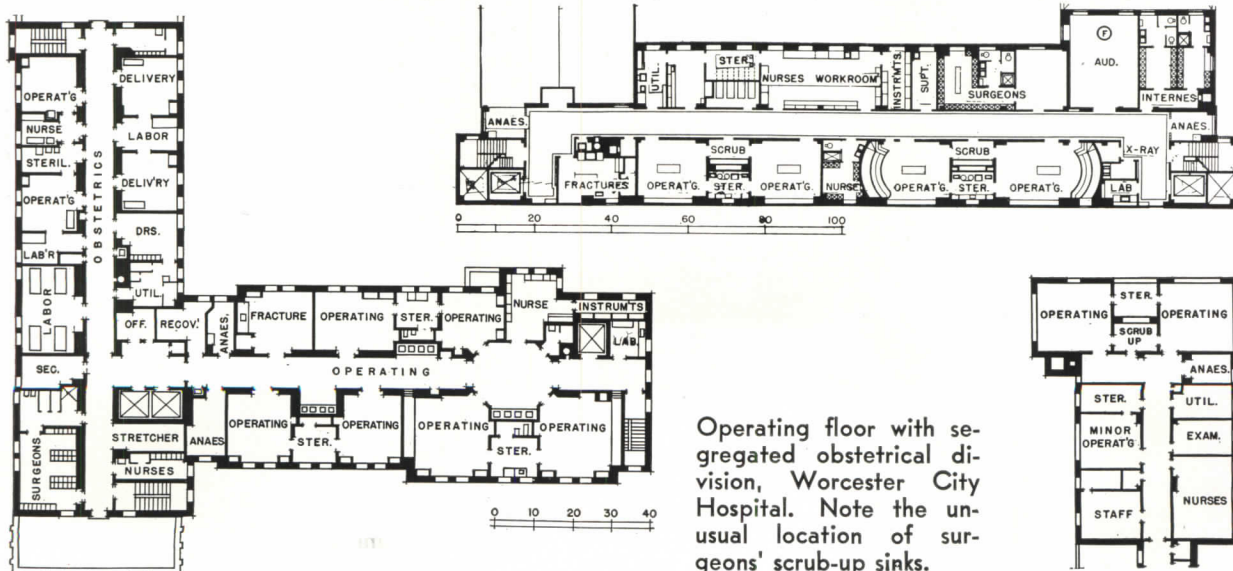

Operating suite on sixth floor, White Plains Hospital; Schultz and Weaver, architects.

Operating floor with segregated obstetrical division, Worcester City Hospital. Note the unusual location of surgeons' scrub-up sinks.

Operating suite, Rome Hospital, Rome, N. Y.; Bagg & Newkirk, architects.

OPERATING SUITE (areas in sq. ft.)

Type of Space	50-bed Hosp.	100-bed Hosp.	200-bed Hosp.	Special Structure, Finish, Equipment
Major operating	290	580	1,160	1 to 4, at 290 sq. ft. each, with X-Ray viewing cabinet; instrument cabinet; storage cabinet; air conditioning; tile floor; tile wainscot, 5 ft. 6 in.
Minor operating	225	225	225	Cabinets; air conditioning; tile floor; tile wainscot, 5 ft. 6 in.
Sterilizing	135	135	270	1 to 2, at 135 each, with utensil cabinet; blanket and solution warmer; tile floor; tile wainscot; double drainboard sink; sterilizers
Scrub-up	135	135	270	1 to 2, at 135 sq. ft. each, with 3 surgeons' scrub-up sinks; tile floor; tile wainscot, 4 ft. 6 in.
Sterilizing and scrub-up	120	120	120	Sterilizers; tile floor; tile wainscot; double drainboard sink; storage cabinet; 2 surgeons' scrub-up sinks
Surgical utility	150	150	150	Hopper sink; storage cabinet; double drainboard sink; tile floor; tile wainscot, 4 ft. 6 in.
Glove and gown	...	...	150	Double drainboard sink; storage cabinet
Instrument library	...	120	120	Cabinets
Nurses' work*	225	300	400	Cabinets; double drainboard sink; work tables; autoclaves
Anesthetizing	135	270	405	1 to 3, at 135 sq. ft. each; cabinet
Staff lockers	135	225	360	Lockers; chairs; toilet; lavatory; shower; acoustical treatment
Chief surgeon	...	...	135	Office furniture
Nurses' lockers	...	120	120	Toilet; lavatory
Supervising nurse	...	135	135	Office furniture; medicine cabinet
Equipment storage	80	120	150	Portable X-ray; oxygen tanks; etc.
Cystoscopy	...	180	180	Storage cabinet; surgeons' scrub-up sink; tile floor; tile wainscot, 4 ft. 6 in.
Dark room	...	50	50	Developing sink, etc.
Plaster room	...	180	225	Plaster sink; ceiling hook; tile floor; tile wainscot, 5 ft. 6 in.
Splint closet	...	80	80	Splint racks
Laboratory	...	80	80	Counter; microscope cabinet
Total sq. ft.	1,630	3,205	4,785	

\*Where central nurses work and sterilizing room is used to supply all departments, surgical work room is smaller and autoclaves are omitted.

EMERGENCY (ACCIDENT) DEPARTMENT (areas in sq. ft.)

Type of Space	50-bed Hosp.	100-bed Hosp.	200-bed Hosp.	Special Structure, Finish, Equipment
Visitors	120	120	180	
Accident operating	225	300	350	Tile floor; tile wainscot, 4 ft. 6 in.; cabinets; 2 or 3 tables; surgeons' scrub-up sink
Utility	80	150	150	Sterilizers; blanket warmer; hopper sink; storage cabinet; tile floor; tile wainscot, 4 ft. 6 in.
Bath and toilet	70	70	70	Toilet; lavatory; bedpan washer
Emergency ward	120	180	360	1 to 2 at 120 to 180 sq. ft. each
Plaster room*	...	180	225	Plaster sink; ceiling hook; tile floor; tile wainscot, 4 ft. 6 in.
Splint closet	50	70	100	Splint racks
Central ster. and supply	225	375	450	Storage cabinet; autoclaves; dumb-waiter; double drainboard sink
Total sq. ft.	890	1,445	1,885	

\*Plaster room may be in operating suite or accident department. Where hospitals have a large accident service, 2 or 3 examining tables are used in accident operating room, and beds are provided in emergency wards for shock cases. Where a central work room is used to prepare and sterilize trays and supplies for all departments, it may be located near the accident room to care for emergencies also.

THE TYPICAL surgical unit consists of two operating rooms, with a surgeons' scrub-up room and a sterilizing room for each pair. There may be one or more units, depending on the hospital's size. In addition, there are needed one or more anesthetizing rooms, a nurses' work room, instrument room, and a utility room. The suite is preferably located on the top floor. North light was formerly considered essential, but with present-day artificial illumination, orientation is of little importance.

In hospitals of 200 beds or more, special orthopedic, and eye-ear-nose-throat rooms may be provided.

Observation galleries, when required, may be on the operating-room floor level, in order to avoid wasting cubage (as in two-story galleries); a separate entrance and impervious screen between operating room and gallery are required.

*Sterilizing and work space.* In hospitals with central sterilizing facilities, size of the nurses' work room is reduced and equipment simplified, and the room is preferably centralized in the suite.

*Equipment and finishes.* Air conditioning is becoming recognized as essential to the operating suite. Desirable conditions include: 10 air changes per hr. (min.); temperature, 78-82F; relative humidity, 55-60%. Recirculation of air is not permissible. For summer cooling, two to three tons of refrigeration are needed per operating room. A supplementary radiator may be connected to medium pressure steam lines for late spring and early autumn use. Unit air conditioners are frequently used in the operating rooms. Protection against anesthetic gas explosions is provided to an extent by maintaining relative humidity at 55-60%. Lighting fixtures, switches, and receptacles are preferably "explosion-proof."

Walls and floors are preferably of colors and materials which do not reflect glare from lighting fixtures. Soft grays and greens have been found advisable. The floor is preferably of non-slip, water-resistant material.

*Lighting* for operating tables must be shadowless and free from excessive heat. There are several types of systems, of which three are illustrated. General illumination is also necessary.

Photos courtesy Picker X-Ray Corp.

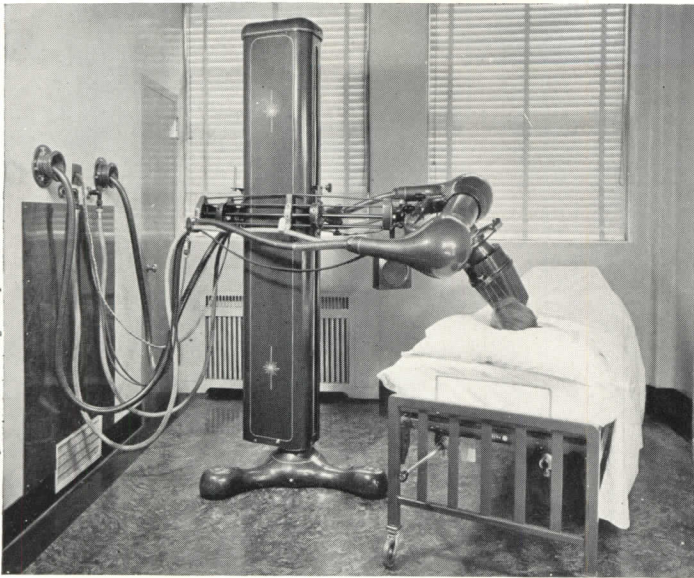

Typical modern shockproof 200,000-volt deep-therapy room with shockproof cables connecting through sleeves in wall to equipment room.

Control alcove with equipment room behind serves a pair of radio-therapy rooms. This unit is shown in the plan of the Carson C. Peck Memorial Hospital.

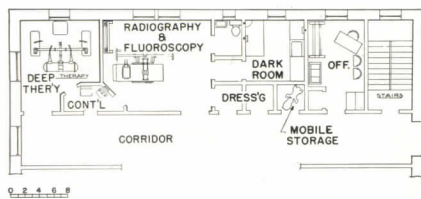

Typical provisions for X-ray department in a 50-bed hospital.

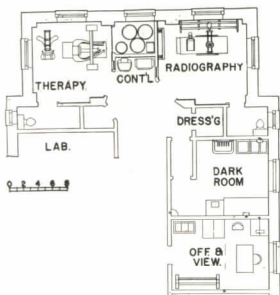

Layout of the X-ray department of the Carson C. Peck Memorial Hospital, Brooklyn, N. Y., which contains 100 beds.

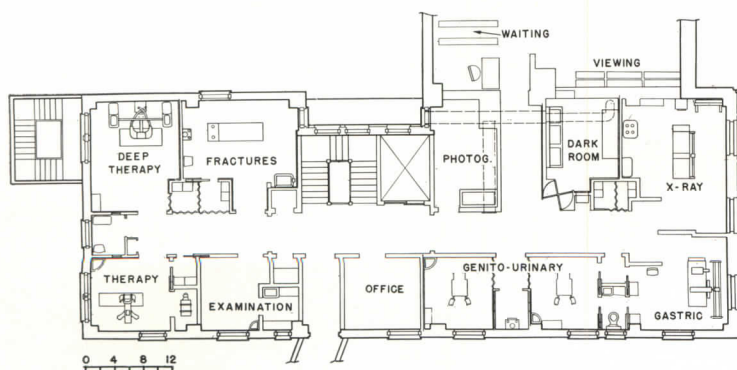

X-ray department, Hospital for Joint Diseases, New York, N. Y., (350 beds) contains more elaborate and extensive layout.

THE X-RAY DEPARTMENT should be located within easy access of wards and private rooms, and yet should also be available to the outpatient department and to other clinical areas with which its work is allied. The size of the department varies considerably as the radiographic sciences are constantly expanding in use and importance. Sizes shown in the accompanying plans are fair averages, judged by present standards.

Extent of the department and scope of services to be rendered can be determined only through conferences with the roentgenologist and consultants. Several special structural provisions are needed: complete lightproofing in darkrooms and treatment rooms; and lead protection to prevent transmission of secondary rays through walls, floors, and occasionally ceilings. The darkroom is usually entered through a light trap, and requires mechanical ventilation; adequate supplies of hot, cold, and, if possible, ice water; and a floor drain.

Almost all X-ray generators operate at 220 volts. The power line is preferably separated from the rest of the hospital service and should be so designed that voltage drop is minimized. Further data may be obtained from the Bureau of Standards, Department of Commerce, Washington, D. C.

Data by I. D. Bennett, Picker X-Ray Corp.



**Pharmacy.** Preliminary planning considerations include type and size of hospital, hospital census, number of outpatients served, and type of work.

Operations carried on include storing of all supplies (divided into active and reserve storage, and special storage for drugs and poisons) and compounding or manufacturing and dispensing of solutions and of prescriptions. The pharmacy sometimes serves as a central supply service, for distributing surgical and other hospital supplies.

A first-floor location is considered desirable. If the hospital includes an outpatient department, a dispensing room and waiting facilities are required. *Prescription department* must be adequate to contain equipment specified by the National Association of Boards of Pharmacy. *Storage space* is preferably directly connected to the manufacturing and dispensing areas.

Floors in prescription, manufacturing, and storage areas are subject to staining and severe wear and tear. Floor drains are required. Adequate natural light is preferred; artificial light, if used, should be glareless. High intensities are required. Electrical outlets are required for mixing machines and, if internes frequent the pharmacy, for call stations.

**PHARMACY AREAS (sq. ft.)**

50-bed hosp. (drug storage).....	200
100-200-bed hosp. (heavy stocks kept in gen'l store room):	
Total area .....	300
Add'l for solution rm.....	250
200-bed hosp. (or larger):	
Prescription (incl. office and mixing)...	300
Manufacturing .....	300
Reserve stock .....	150
General stock .....	300
Total area .....	1050

**Laboratory.** Space allotted bears a direct ratio to the bed capacity of the institution. For very small hospitals (less than 50 beds), one room not less than 12 by 14 ft. is required. Beyond this, laboratory services may be expanded to include separate provisions for pathology, serology, bacteriology, chemistry, hematology, urinalysis, metabolism, etc. Design requires professional guidance.

**LABORATORY SPACE**

No. Beds	No. Lab. Rms.	Lab. Area (sq. ft.)
100	1-2	350-450
200	4-6	900-1200
300	6-7	1200-1500
400	6-8	1400-1800

Data on laboratories obtained through cooperation of H. A. Bliss of the Kewaunee Mfg. Co. Pharmacy data from E. C. Hayhow, Paterson General Hospital, Paterson, N. J.

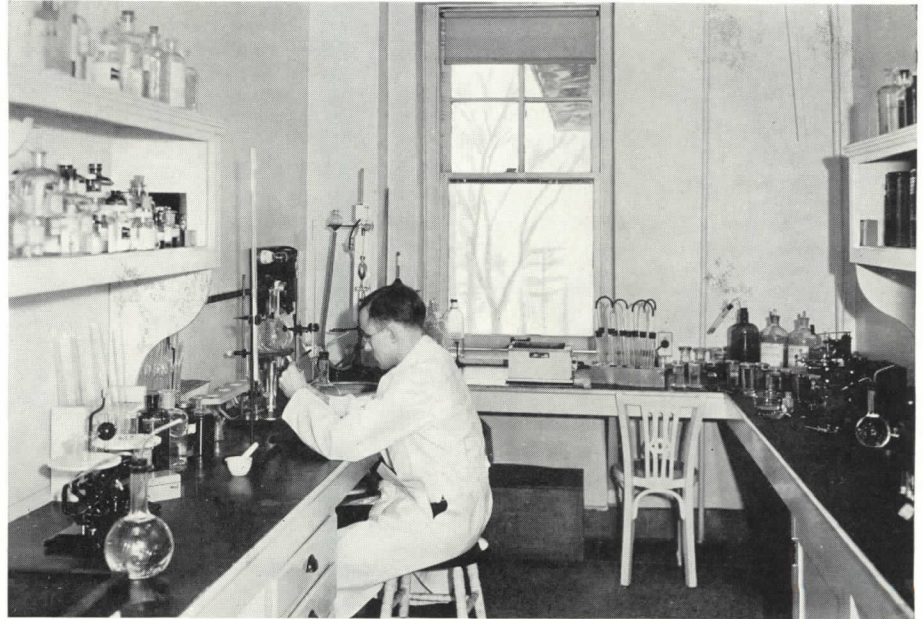

Typical laboratory, for diagnosis and research.

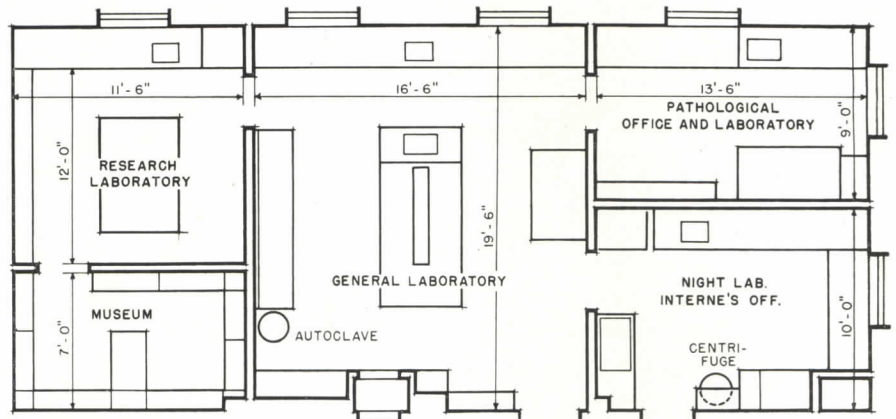

Above, typical laboratory developed for a 200-bed hospital, and, at right, similar provisions for a 50-bed hospital. Both plans were developed from sketches prepared by H. A. Bliss.

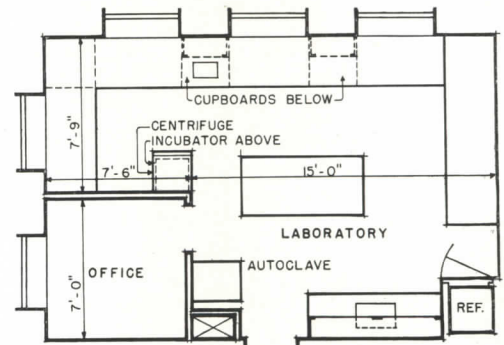

**Morgue.** A morgue and autopsy room is always required. In a 50-bed hospital this may be a 12 by 16 ft. room, so located that bodies may be taken from hospital floors, and out of the building, inconspicuously — usually in the basement. Minimum equipment includes an autopsy table with hot and cold running water and drain, clinic

sink, lavatory, work table with scales, instrument closet, instrument sterilizer. Walls are preferably tiled up to 5 ft. 6 in., and water-resistant floors with drains are required. In addition, one or more refrigerated compartments for corpses are needed. Mechanical refrigeration equipment is an essential for this department.

CLINICAL SERVICES **PHYSICAL THERAPY**

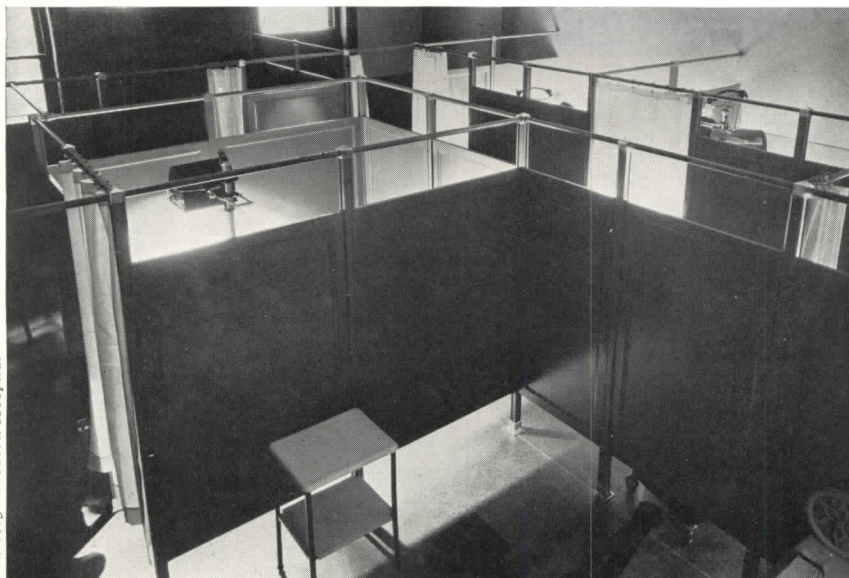

Courtesy "Modern Hospital"

Cubicles in the physical therapy department of Northwestern University Medical School, Chicago, showing the use of steel partitions to divide a 30 by 24-ft. room into suitable therapy spaces.

IN THE VOLUNTARY general hospital, physical therapy provisions are increasingly important. Means of treatment include heat, massage, electricity, exercise, and hydrotherapy. Type of hospital, types of patients treated, and requirements of the staff determine size of the department.

*Preferred location* is on the ground floor to enable outpatients to receive treatment without going through hospital corridors or elevators. A location which will permit good ventilation and a maximum of natural light is desirable.

*Types of plans* range from a single large room which includes all equipment, office space, and treatment cubicles, to a large number of separate rooms for each therapeutic measure. In the former case, sufficient privacy may be achieved by the use of cubicles with 7 ft. high partitions, or cubicle curtains. Cubicle sizes given in the tabulation are minima.

**Structure and finish.** Floor finishes are preferably of types which reduce fatigue. In hydrotherapy spaces, water-resistant floors and floor drains are required. If a pool is installed, the great weight causes the hydrotherapy room to become a structural problem which may be solved by placing this room in the basement, or by making suitable structural provisions.

The use of diathermy, X-ray, and other electrical apparatus may require the screening of treatment rooms, or the entire department, with lead lining.

*Special equipment.* It is preferable to have numerous electrical convenience outlets, with special receptacles such as polarity outlets, etc., for connecting treatment machines. Outlets are preferably 3 or 4 ft. from the floor to facilitate their use and movement of apparatus.

In a small physical therapy department for a 50-bed hospital, equipment is preferably movable, even including the tank for underwater exercise. Special electrical provisions are necessary for 1000-watt lamp installations, infrared lamps, diathermy units, ultraviolet mercury arc lamps, and galvanic-sinusoidal outfits. As the size of the department increases, it includes additional equipment, such as a whirlpool bath, ultraviolet generators; and, for neurological cases, a faradic coil is required.

Only in the largest of the general hospitals here discussed is a curative workshop necessary.

MINIMUM PHYSICAL THERAPY AREAS (sq. ft.)			
Type of Space	50-Bed Hosp.	100 or More Beds	Special Structure, Finish Equipment
Exercise .....	...	315	Exercise table; steps; stall bars; posture mirror; shoulder wheel; lockers; office furniture; whirlpool bath
Office and exercise.....	450	...	
Treatment .....	280	520	4 to 6 cubicles, each with table, each 45 to 90 sq. ft.; also lavatory; toilet
Office and special treatment...	...	240	Office furniture; lockers; treatment table
Curative workshop .....	...	385	Work tables; chairs
Hydrotherapy .....	...	435	Pool; showers; dressing booths
<b>Total sq. ft.</b> .....	<b>730</b>	<b>1,895</b>	

Corridors 7 ft. wide (minimum)

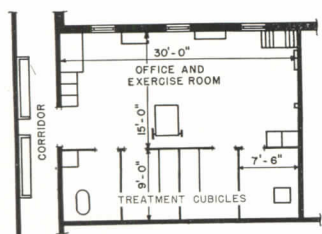

Above, physical therapy room for a 50-bed hospital, developed by Dr. F. H. Krusen (both plans from "Reports of Council on Physical Therapy," A. M. A. Journal).

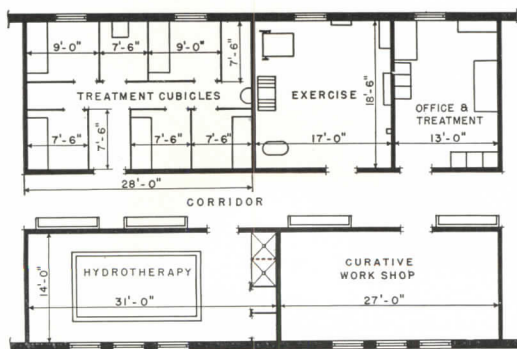

Typical physical therapy unit for a 200-bed hospital, also developed by Dr. Krusen.



## OUTPATIENT DEPARTMENT

OUTPATIENT REQUIREMENTS are subject to such wide variations that detailed clinical and administrative facilities can be established only upon the basis of local conditions. Outpatient departments of large urban hospitals have been operated primarily for treatment of the sick poor. Necessity for this has increased in late years; and the rapid growth of measures to prevent the inception and spread of illness has emphasized the outpatient clinic and dispensary as an important factor in the successful development and maintenance of public health programs.

Economically, such hospital departments are not self-supporting; but in relation to structure and necessary equipment they assume equal importance with other parts of the hospital. Use of outpatient spaces is naturally dependent on location and clinical facilities. A study of six New York City hospitals showed a daily average use which

varied from 2 outpatients down to .4 outpatients for each ward-bed inpatient.

Space requirements on the basis of experience allow 44 sq. ft. gross area per patient. In administrative areas the waiting room should provide sitting space for 85% of the expected attendance. Usually each outpatient is accompanied by a mother, father, uncle, etc., so that 15 sq. ft. per patient is required in the waiting room.

These figures are, of course, subject to radical changes depending upon the type of hospital, the type of plan, and the extent to which its location involves public health or sick poor services.

There are so many variables in connection with planning outpatient departments that design should be undertaken only after the most detailed study. Variables include, for example, whether state tuberculosis and venereal clinics are to be included, whether a psychiatric clinic is to be housed, whether a diagnostic

clinic and a preventive health clinic are to be provided, whether school clinics are taken care of in outpatient departments, the necessity for rendering dental service, etc.

Many clinics operate from 2 to 4 o'clock in the afternoon, whereas others hold hours from 9 a.m. to 9 p.m. The spread of hours during which services are rendered affects space to be provided. A clinic operating from 2 to 4 p.m., and expecting the same number of visitors as a clinic operating from 9 to 9, naturally will require greater waiting-room space per person.

Within the hospital, location of the outpatient department ought to provide a segregation from other parts of the hospital, with entirely separate entrances directly accessible to streets. However, it must be so integrated with administrative and clinical areas that admission to wards or treatment rooms can be accomplished without confusion.

**OUTPATIENT DEPARTMENT**

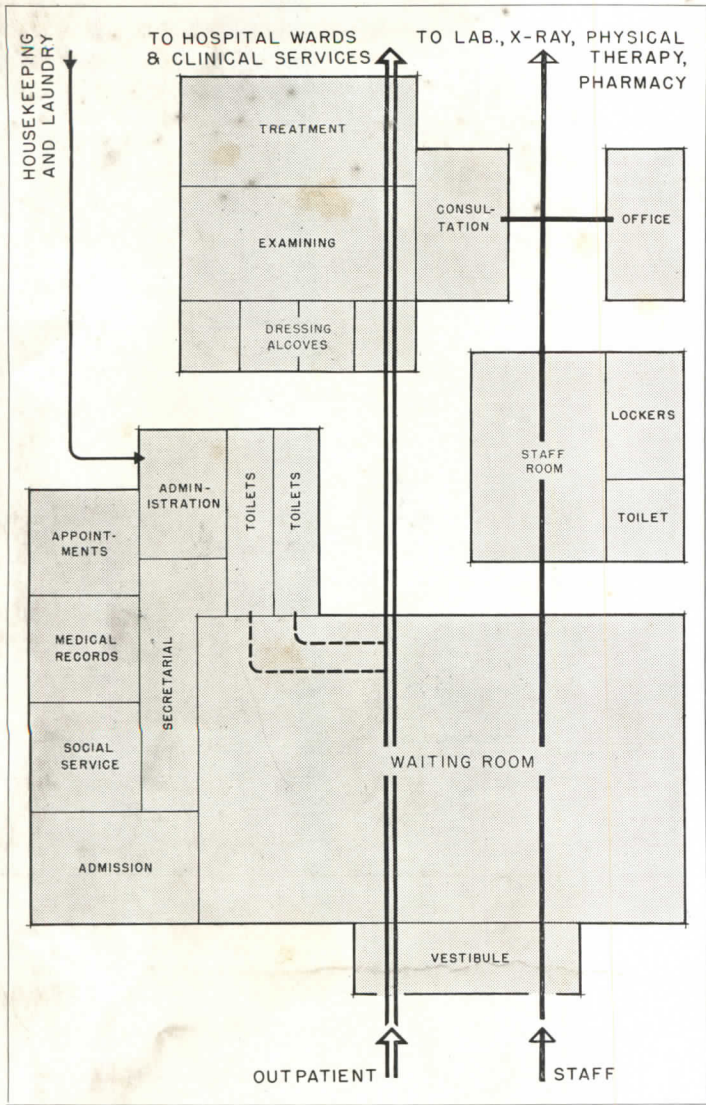

**TIME-SAVER STANDARDS**

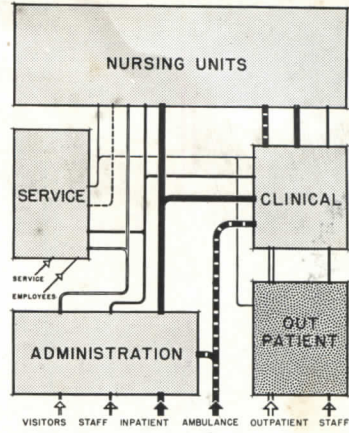

Above, key diagram showing relation of outpatient department to remainder of the hospital. At left, detailed chart of the relationships and circulation in a complete outpatient department.

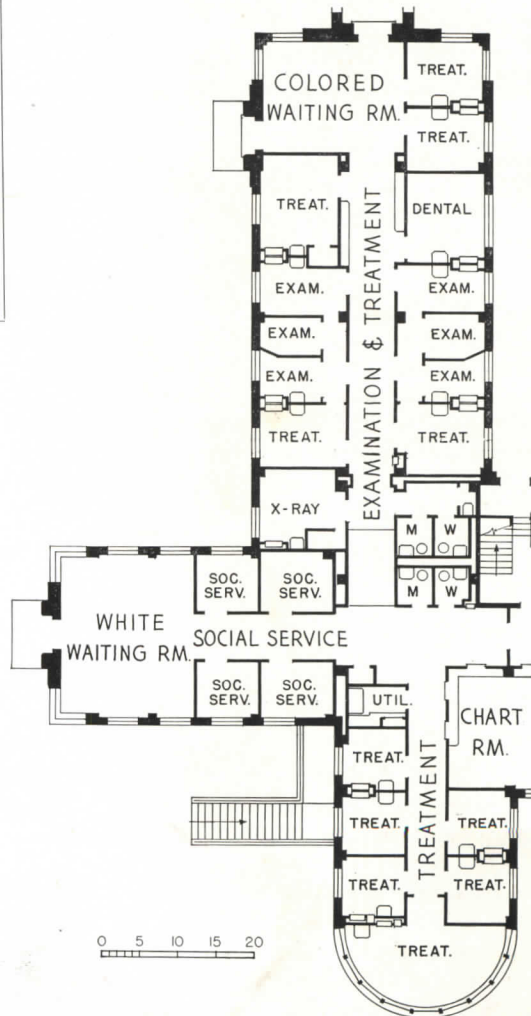
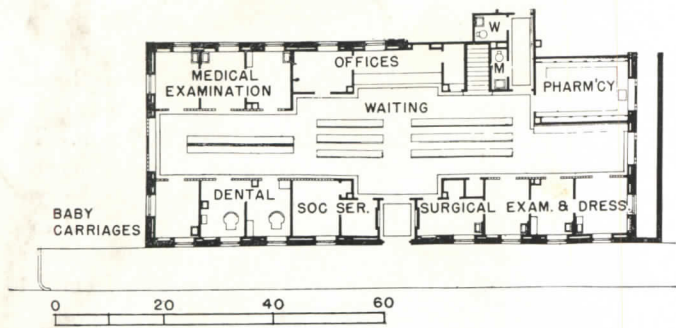

Above, one floor of outpatient department at White Plains Hospital, White Plains, N. Y.; Schultz & Weaver, architects. Clinical facilities adjoin this unit. At right, outpatient wing, first floor, City County Hospital, Fort Worth, Tex.; W. G. Clarkson & Co., architects. This hospital has to care for a great proportion of the community's outpatient cases. In addition, provisions must be made for segregation of patients by race.