

MUNICIPAL AIRPORT



ARCHITECTURAL

FEBRUARY 1953

RECORD

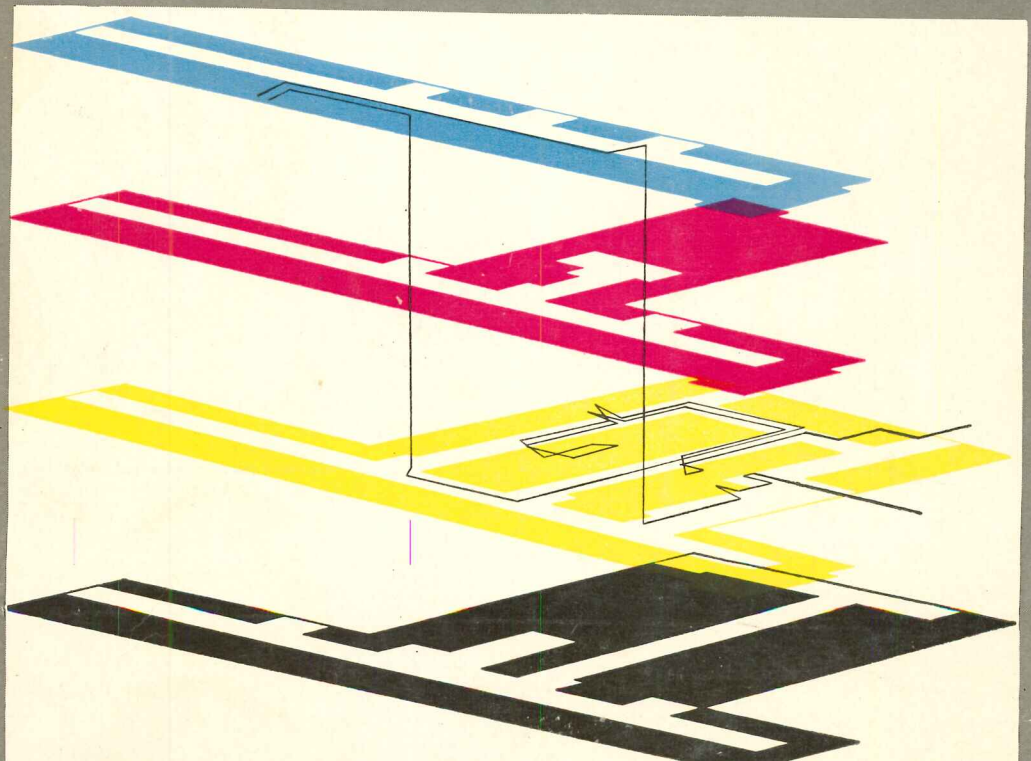

195

NUMBER
HOSPITALS



FOR CLASSY SHOPS

... OR BUSY PLANTS



THERMOLIER UNIT HEATERS

The condensed table below is a quick guide to the selection of the correct Thermolier for specific conditions. The capacities, when motors are operating at normal speeds, are based on Standard Basis of Rating: 2 lb. steam pressure and 60° F entering air temperature.

Grinnell Thermoliers are tested and they are rated in strict accordance with rules of the Industrial Unit Heaters Association.

All Thermoliers can be operated at working steam pressures up to 125 psi and steam temp. up to 406° F.

A MODEL AND SIZE FOR EVERY PURPOSE

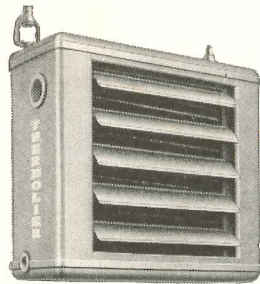

horizontal delivery



textile (horizontal delivery)

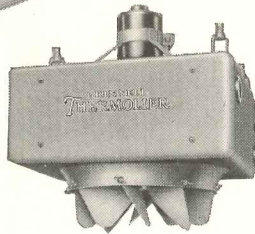

vertical delivery

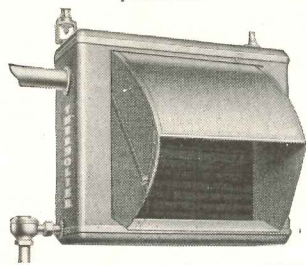

velocity nozzle (horizontal delivery)

model	total heat delivered, Btu per hr	sq ft edr (nominal)	air velocity at exit, louvers open, lin. ft. per min.
horizontal delivery			
D21	35,600	148	786
D31	48,700	203	851
D37	62,200	259	753
D41	71,000	295	901
D44	84,100	350	887
D57	101,300	422	1016
D66	128,700	536	779
D71	151,700	632	977
D91	196,000	817	985
D111	275,300	1147	1048

Textile

TX70	69,800	291	826
TX110	113,700	474	877

vertical delivery

VA1042	50,800	212	1399
VA1045	73,600	307	1287
VA1065	109,400	456	1354
VA1075	145,600	607	1231
VA1101	185,000	770	1495
VA1111	257,000	1071	1631

performance with velocity nozzle

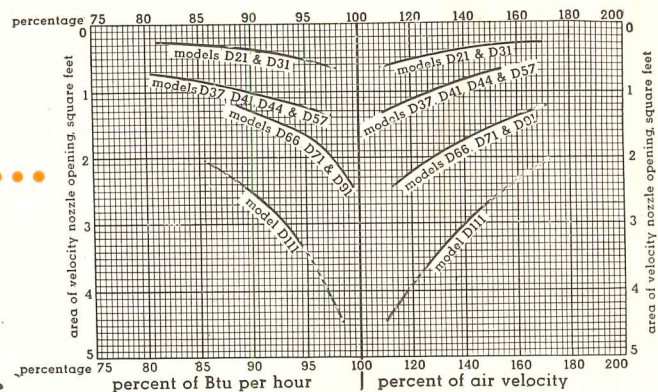

GRINNELL THERMOLIER UNIT HEATERS

CALL YOUR LOCAL GRINNELL DISTRIBUTOR



Grinnell Company, Inc., Providence, Rhode Island

Coast-to-Coast Network of Branch Warehouses and Distributors

Manufacturer of: pipe fittings • welding fittings • forged steel flanges • steel nipples • engineered pipe hangers and supports
Thermolier unit heaters • Grinnell-Saunders diaphragm valves • prefabricated piping • Grinnell automatic fire protection systems

ARCHITECTURAL RECORD (Vol. 113, No. 2, February, 1953) is published monthly by F. W. Dodge Corp., 10 Ferry Street, Concord, N. H., with editorial and executive offices at 119 W. 40th St., New York 18, N. Y. \$4.50 per year; Foreign, \$6.50.

Entered as second-class matter at the Post Office, Concord, N. H., March 16, 1946, under the Act of March 3, 1879.

ARCHITECTURAL RECORD



Copyright 1953 by F. W. DODGE CORPORATION, with all rights reserved • Publishing Director, Magazine Division, H. Judd Payne • Business Manager, Robert F. Marshall • EDITORS: Executive Editor, Joseph B. Mason; Managing Editor, Emerson Goble; Senior Associate Editor, Frank G. Lopez, A.I.A.; Associate Editors: James S.

Hornbeck, A.I.A., Robert E. Fischer (Engineering), Florence A. van Wyck, Herbert L. Smith, Jr., A.I.A., Jeanne M. Davern (News), Elisabeth Kendall Thompson (Western); Contributing Editors: Ernest Mickel (Washington), John Caulfield Smith, M.R.A.I.C. (Canada); Assistant Editors: Mary Lou Mullan (Copy), Jeanne G. Whitbeck (Reader Service) and Belding (Books), Carl Scarenco (News) • DESIGN: Consultant, M. Peter Piening; Director, Alfred Petersen; Assistants: Donald Ervin, Joseph D'Amato; Drafting, Sigman-Ward • CONSULTANTS: Industry Relations Consultant, Thomas S. Holden; Statistical Consultant, Clyde Shute; Field Research Consultant, Clifford Dunnells, Jr.; Public Relations Consultant, Samuel C. Pace.

Architectural Record (combined with American Architect and Architecture) is published monthly by F. W. Dodge Corporation, 10 Ferry Street, Concord, N. H., with editorial and executive offices at 119 West 40th Street, New York 18, N. Y. Western editorial office, 2877 Shasta Road, Berkeley 8, Calif.

Chairman of the board, James McV. Breed; vice chairman of the board, Paul Abbott; president, Thomas S. Holden; vice president and treasurer, Howard Barringer; secretary, Sanford D. Stockton, Jr.; vice presidents: Irving W. Hadsell, Chauncey L. Williams, H. Judd Payne, T. Oliver Morgan; assistant secretaries: George W. Morgan, Jr., William C. Breed, Jr.; assistant vice presidents: Clyde Shute, Clifford G. Dunnells, Jr., Howard M. Thompson, Marc Wayne, Robert F. Marshall; assistant treasurers: Walter F. DeSaix, Edwin H. Freed, Irving B. Satin; regional vice presidents: Carl S. Bennett, Ralph M. Hairston, Julius T. Little, Richard H. Ray.

Subscription rates: United States and possessions, Canada, Cuba, Mexico, Central and South America, and Spain, \$4.50 a year, \$7.50 for two years, \$9 for three years; elsewhere, \$6.50 a year, \$11.50 for two years, \$15 for three years. Single copy \$2. Circulation manager, Marshall T. Ginn.

Member of Audit Bureau of Circulations and Associated Business Publications. Architectural Record is indexed in Readers' Guide to Periodical Literature, Art Index, Industrial Arts Index and Engineering Index.

Every effort will be made to return material submitted for possible publication (if accompanied by stamped, addressed envelope), but the editors and the corporation will not be responsible for loss or damage.

Other Dodge services: Dodge Reports and Dodge Statistical Research Service; Sweet's Files, Home Owners' Catalogs, Chicago Construction News, Daily Pacific Builder, Denver Daily Journal, Real Estate Record & Builders' Guide.

Cover: Municipal Airport, Shreveport, La. Samuel G. Wiener, E. M. Freeman & Associates, Architects and Engineers. Ulric Meisel photo

THE RECORD REPORTS	9
Perspectives	9
Periodical Report	20
News from Canada. By John Caulfield Smith	24
News from Washington. By Ernest Mickel	36
Construction Cost Indexes	42
Current Trends in Construction	364
REQUIRED READING	46
ENTIRELY ARCHITECT-DESIGNED	123
Municipal Airport, Shreveport, La. Samuel G. Wiener, E. M. Freeman & Associates, Architects and Engineers	
AWARD-WINNING PROTESTANT CHURCH IN NORTH LITTLE ROCK, ARK	132
First Methodist Church. Brueggeman, Swaim & Allen, Architects	
ASSOCIATED GROCERS CO-OP, SEATTLE, WASH.	140
Robert Hugh Ross, Architect	
NEW BUILDING FOR CONSOLIDATED SCHOOL	146
Winecoff High School, Cabbarus County, N. C. A. G. Odell, Jr., & Associates, Architects	
PLANNED FOR ADULT PRIVACY AND SUPERVISION OF CHILDREN	152
French Residence, Fillmore, Calif. Chalfant Head, Architect	
CANTILEVERED DECK ADDS LIVING SPACE	156
Residence for Mr. and Mrs. H. E. Lunken, Cincinnati, Ohio. Carl A. Strauss, Architect	
HOW ONE SPACE BECAME FOUR	159
Showroom and Offices for "Scarves by Vera," New York, N. Y. Marcel Breuer, Architect	
BUILDING TYPES STUDY NO. 195 . . . HOSPITALS	165
OPPORTUNITIES FOR ARCHITECTS IN HOSPITAL DESIGN	166
PLANNING THE HOSPITAL STARTS WITH CIRCULATION	168
By Emerson Goble	
ONE-STORY HOSPITAL	174
West Calcasieu-Cameron Hospital, Sulphur, La. Ricciuti, Stoffle and Associates, Architects	
HOSPITAL PLANNED FOR LOW OPERATING COSTS	176
West Contra Costa Hospital, Richmond, Calif. Stone & Mulloy, Architects, and S. P. Marraccini, Architect	
CONVENTIONAL T PLAN FOR A LARGE HOSPITAL	179
Marion General Hospital, Marion, Ohio. Dan A. Carmichael, Jr., Architect	
DOUBLE-CORRIDOR VARIATION ISOLATES IMPORTANT AREAS ..	182
Magic Valley Memorial Hospital, Twin Falls, Idaho. Fisher & Fisher, Architects	
T-FORM HOSPITAL WITH TRIPLE CORRIDOR PLAN	186
Riley County Hospital, Manhattan, Kan. F. O. Wolfenbarger & Associates, Architects	
ARCHITECTURAL ENGINEERING	
TECHNICAL NEWS AND RESEARCH	
INDUSTRIAL LIGHTING SYSTEMS APPRAISED FOR COMFORT AND ECONOMY	189
By George J. Taylor	
PIPING PROBLEMS SIMPLIFIED WITH HIGH-TEMPERATURE HOT WATER DISTRIBUTION	192
By Fred L. Moesel, Fred L. Moesel Associates, Consulting Engineers	
PRODUCTS FOR BETTER BUILDING	195
LITERATURE FOR THE OFFICE	196
TIME-SAVER STANDARDS	199
Metal Lath Membrane Fireproofing — 6. Presented through the Cooperation of Metal Lath Manufacturers' Association	
Stainless Steel — 5, 6. Presented through the Courtesy of the Committee of Stainless Steel Producers, American Iron and Steel Institute	
INDEX TO ADVERTISING	366

In New York's newest

260

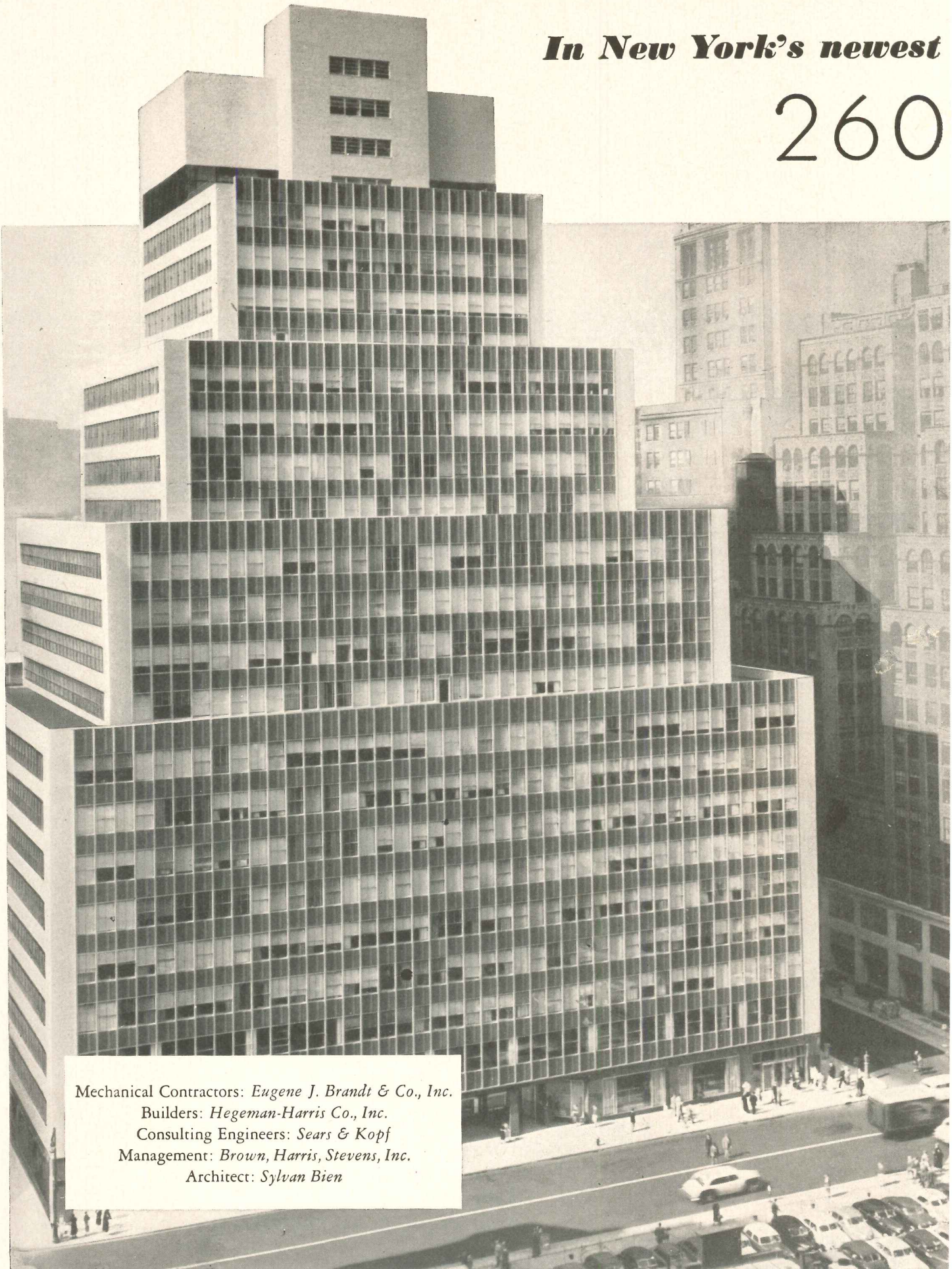

Mechanical Contractors: *Eugene J. Brandt & Co., Inc.*
Builders: *Hegeman-Harris Co., Inc.*
Consulting Engineers: *Sears & Kopf*
Management: *Brown, Harris, Stevens, Inc.*
Architect: *Sylvan Bien*

THE RECORD REPORTS

P E R S P E C T I V E S

DESIGNED FOR IKE: The big architect on Inauguration Day was Robert A. Weppner, Jr., who designed the Presidential reviewing stand from which President Eisenhower and his new official family and their guests reviewed the Inaugural parade. Mr. Weppner won a competition sponsored by the Washington Metropolitan Chapter of the American Institute of Architects. The 48 competitors were required to complete their preliminary sketches within an hour; only 32 made it.

MIES LLOYD GROPIUS DEPARTMENT: Instituto Tecnico de la Construcción y del Cemento of Madrid sent holiday greetings — somewhat delayed — to several American architects in care of the RECORD. The addressees included (*sic*): Mr. Holabrid Root, Ingeniero; Mr. Burge; Mr. Wuster Bernardi, Architect; Mr. Emmons, Architect; Mayer & Whittlesey-Skidmore; Owings & Merrill.

NEW COUNTRY — NEW ARCHITECTURE: The theme of the 1953 convention of the American Institute of Architects June 16–19 in Seattle appears to have influenced the choice of seminar topics. The northwest architecture slant is sure also to stimulate discussion about regionalism in American architecture; a subject, by the way, which gets some mention in Henry-Russell Hitchcock's introductory essay for *Built in USA: Postwar Architecture*, the new book from the Museum of Modern Art. Hitchcock says ". . . the ablest architects, like Wright from his earliest days, know how to be successful regionalists of all the regions they are called upon to work in . . . But in many ways, considering — as compared to European countries — the enormous distances between one region and another and their disparate climates and available building materials — it is the homogeneity of American pro-

duction that is surprising." The convention seminars will include three on the future of wood as a building material; one on condensation in buildings; and one entitled "The Oriental Influence in Art and Architecture in the United States."

JOSE LUIS SERT, who will succeed Joseph Hudnut as dean of Harvard's Graduate School of Design next September, is a man who believes there are too many words in the world today; the image, he says, is an important and neglected medium of communication. Even the techniques which are too new to be neglected are badly used — television is like radio with a camera, Cinerama in its first feature devotes too much footage to subjects which do not realize its potentialities. In whatever field, Sert wants artists to *use* the new techniques to do new things and old.

LE CORBUSIER TRIUMPHANT: The Society for Protection of Esthetic Beauty in France has lost its suit and Corbu's *Radiant City* is safe even if, in the Society's view, the "esthetic aspect" of the waterfront of Marseilles has been destroyed. The newspapers, which do not always seem to architects to be alert to architectural news, were not caught napping on this item — even the *New York Daily News* had a story and *The New York Times* gave it an editorial, winding up with a comment that rather put architectural controversy in its place: "With all the dreadful things that are happening in the world today, there's something pleasant and relaxing about a good old-fashioned fight over the esthetics of the skyline of Marseilles."

GOVERNMENT MONEY FOR ART: The report by A.I.A. Past President Ralph Walker on the UNESCO Conference of Artists in Venice, to which he was a delegate last October, includes a

suggestion that might be the basis for some architectural crusading in this country. The Danish delegation at the Conference proposed an effort to have included in every government building budget a definite percentage to be used in enriching the building through ornament, sculpture, painting and better designed furnishings. The idea has been tried in Copenhagen, where the annual civic budget also carries an item devoted wholly to art purposes and to furthering the development of the city as a cultural center, including even the adornment of private commercial buildings when they occupy a dominant position within the city. "This type of budget in every city," says Mr. Walker, "might well be considered as a goal — to be achieved by the combined action of the artists and architects who live in them."

T. S. ELIOT AND UNESCO: The esthetics of the Paris skyline, with a side glance at New York's, was the concern of T. S. Eliot in a recent letter to the Editor of *The Times* of London. Expressing himself in no obscure phrases, Eliot wrote: "In your issue of November 1, your Architectural Correspondent refers to 'faults of planning and lighting that have made the United Nations secretariat the target for so much criticism.' The building is also open to the criticism that its shape is quite incongruous with those of the skyscrapers which have made the skyline of New York famous. It would be still more incongruous with the architecture of Paris; and if a similar honeycomb-on-end were to be erected on the edge of the Bois de Boulogne it should be as unwelcome to lovers of Paris, the world over, as the model is stated to have been to the Sites Committee of the prefecture of the Seine." Have Harrison, Breuer, Zehr-fuss or Nervi any comments on *The Wasteland*?

"BUILT IN USA: POSTWAR ARCHITECTURE"

All photos: courtesy Museum of Modern Art

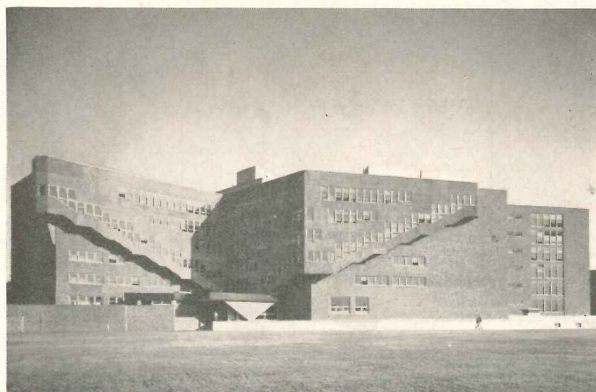

Pictor: Ezra Stoller

Alvar Aalto & Co.: senior dormitory, Massachusetts Institute of Technology, Cambridge, Mass., 1948; "perhaps the most strikingly mannered building of recent years"

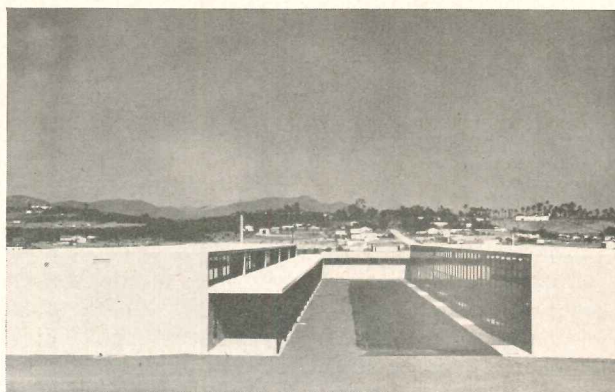

Merge Studios

Maynard Lyndon: Vista Elementary School, Vista, Calif., 1950; "the school buildings of Maynard Lyndon recall phases of Italian architecture during the 1920's and 1930's"

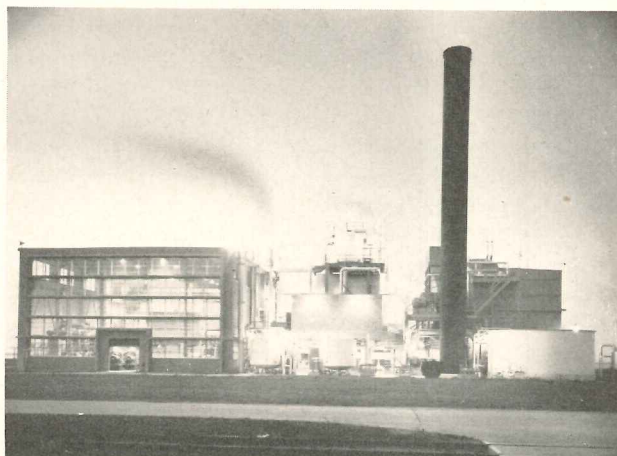

Frank R. Whitney of the H. K. Ferguson Company: Bluebonnet Plant, Corpus Christi, Tex., 1949; "the buildings are concrete cages in which machines are freely arranged like books on a shelf"

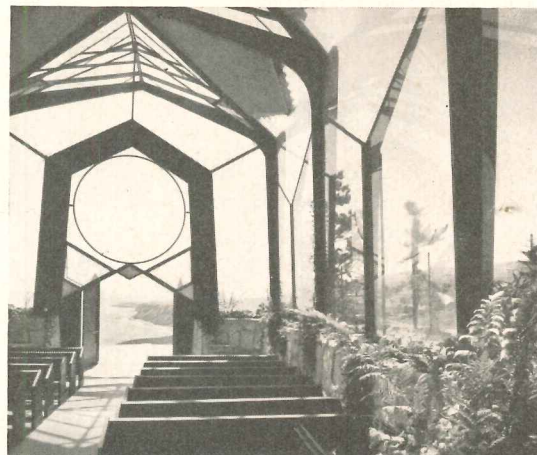

Julius Shulman

Lloyd Wright: Wayfarers' Chapel, Palos Verdes, Calif., 1951; "one of the very few modern buildings for religious celebrations that can be distinguished from . . . a gymnasium"

NEW YORK'S MUSEUM OF MODERN ART last month opened the third in its series of major exhibitions of architecture. The first, in 1932, launched the Museum's Department of Architecture with the famous "International Exhibition of Modern Architecture," prepared by Philip Johnson and Henry-Russell Hitchcock; the second, in 1944, spanned the intervening years with "Built in USA: 1932-1944." Now 43 buildings have been selected by Henry-Russell Hitchcock from the nominations of a large advisory committee as the most significant examples of modern architecture

built in this country since 1945; the criteria, in Mr. Hitchcock's own words, were "quality and significance of the moment."

Of the 32 architects represented in the show, 15 are "new" in the Museum's series; that is, they were not represented in either the 1932 or 1944 exhibitions. The examples of their work selected by Mr. Hitchcock are shown on these three pages.

Other statistics: the selection includes 18 houses, several school buildings, a hospital, a retail store, a chapel and a stadium. Eight firms are represented by

more than one building; only Frank Lloyd Wright (four) and Ludwig Mies van der Rohe (three) with more than two.

The selected buildings are presented both in the exhibition, which includes 10 models and photographic enlargements and three-dimensional color slides of every building, and in a new book of the same title. The 128-page book contains more than 100 plates; a preface by Philip Johnson, director of the Museum's Department of Architecture and Design; text by Arthur Drexler, its curator; and an introductory essay by Mr. Hitchcock.



Gabriel Benzur



Dean Stone, Hugo Steccat

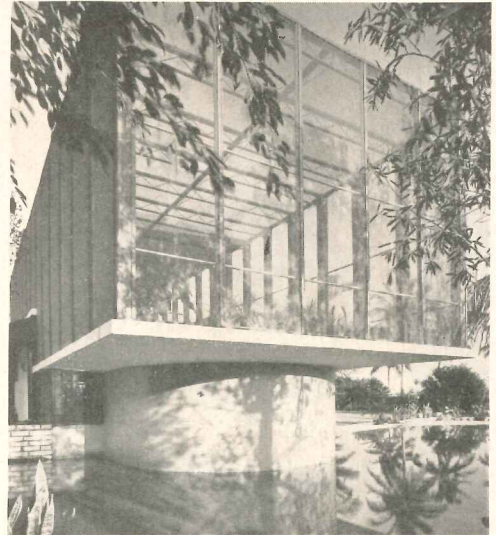

Pictor: Ezra Stoller

Above, left: R. L. Aeck & Associates: football stadium, Henry Grady High School, Atlanta, Ga., 1948; right: Eric Mendelsohn: Maimonides Health Center, San Francisco, 1950; "It is true that the balconies are rather like embroidery on an otherwise stolid architectural cloth. But they are an engaging diversion of obvious utility"

Above: Igor Polevitsky: Heller house, Miami, Fla., 1949; below: Charles Eames: Case Study House, Santa Monica, Calif., 1949; "unexpectedly draws out of industrial techniques a Japanese delicacy and decorativeness"

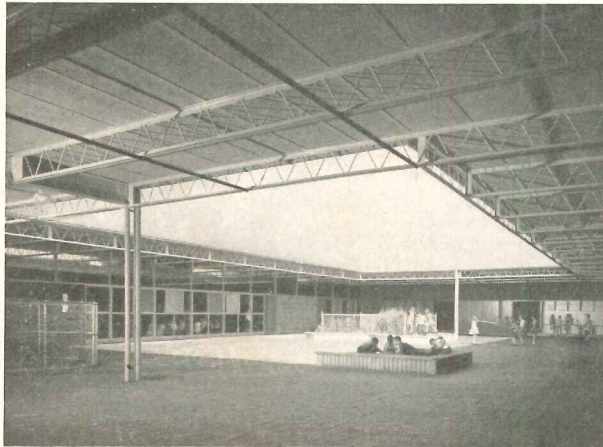

Donald Barthelme & Associates: West Columbia, Tex., Elementary School, 1952



Julius Shulman

In addition to the 15 buildings shown on these pages, the exhibit and book include:

Gregory Ain — Wilfong house, Los Angeles, 1952; Pietro Belluschi — Equitable Building, Portland, Ore., 1948; Marcel Breuer — Co-operative Dormitory, Vassar College, Poughkeepsie, N. Y., 1951; Gardner Daily & Associates — Red Cross Building, San Francisco, 1948; Walter Gropius — Harvard Graduate Center, Cambridge, Mass., 1950.

Harwell H. Harris — Johnson house, Los Angeles, 1951; Wallace K. Harrison etc. — Alcoa Building, Pittsburgh, Pa., 1952, and United Nations Secretariat, New York City, 1950; Philip Johnson, own house (glass house), New Canaan, Conn., 1949, and Hodgson house, New Canaan, Conn., 1952; Kennedy, Koch, Rapson, DeMars & Brown — 100 Memorial Drive apartment house, Cambridge, Mass., 1950; Ernest J. Kump — San Jose High School, San Jose, Calif., 1952.

Ludwig Mies van der Rohe — Farnsworth

house, Plano, Ill., 1950; 860 Lake Shore Drive apartment house, Chicago, Ill., 1951; Boiler Plant, Illinois Institute of Technology, Chicago, 1950.

Richard J. Neutra — Tremaine house, Montecito, Calif., 1949; Saarinen, Saarinen & Associates — General Motors Technical Center, Detroit, 1951; Saarinen, Swanson & Saarinen — Berkshire Music Center opera shed, Stockbridge, Mass., 1947; Skidmore, Owings & Merrill — Lever House, New York City, 1952, and Garden Apartments, Oak Ridge, Tenn., 1950.

Raphael Soriano — Case Study House for Arts & Architecture, Los Angeles, 1950; Twitchell & Rudolph — Siegrist house, Venice, Fla., 1949; Frank Lloyd Wright — Helio-laboratory for Johnson Wax Co., Racine, Wis., 1949, V. C. Morris store, San Francisco, 1949; Jacobs house, Madison, Wis., 1948, and Friedman house, Pleasantville, N. Y., 1949; Yeon, John — Visitors' Information Center, Portland, Ore., 1949.

Below: Soleri & Mills: desert house, Cave Creek, Ariz., 1951; "amusing glass and aluminum dome in the Arizona desert"

Julius Shulman

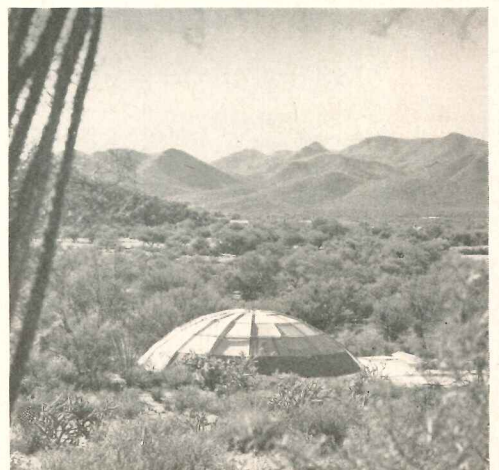

THE RECORD REPORTS

**BUILT IN USA:
POSTWAR ARCHITECTURE**

(Continued from preceding page)

Right: Edward Larrabee Barnes: house for Ted Weiner, Fort Worth, Tex., 1952

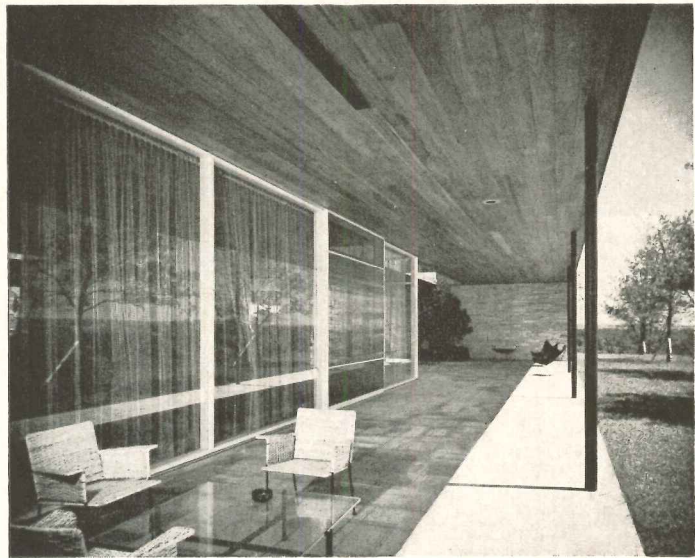

Ulric Meisel—Dallas

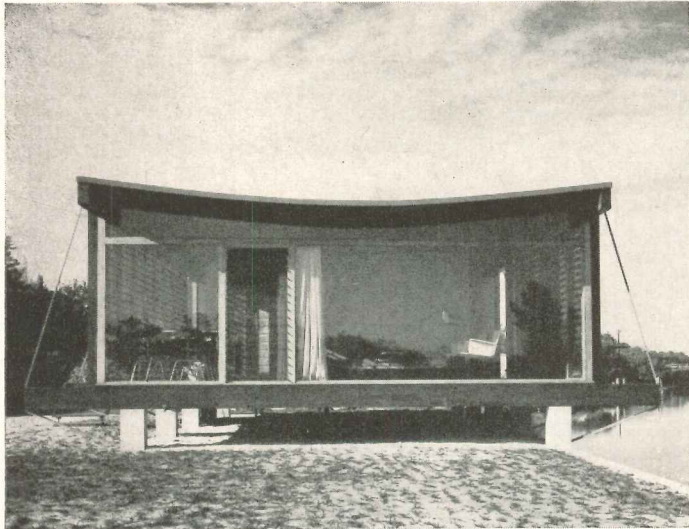

Ezra Stoller

Twitchell & Rudolph: house for W. R. Healy, Sarasota, Fla., 1950

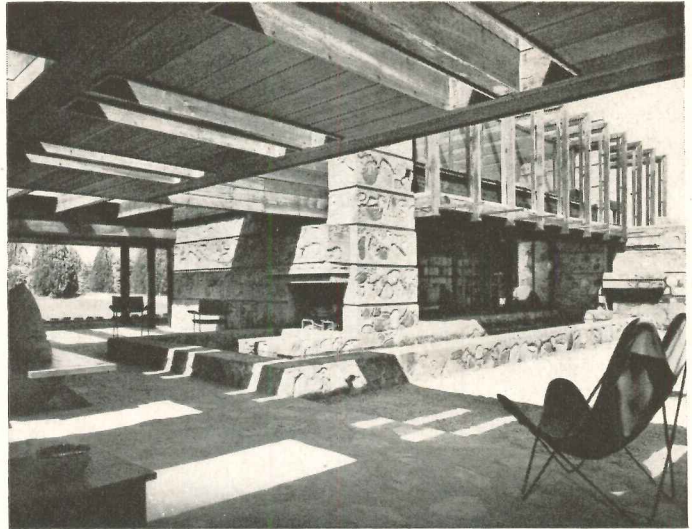

Julius Shulman

Schweikher & Elting: house for Louis C. Upton, Paradise Valley, Ariz., 1950

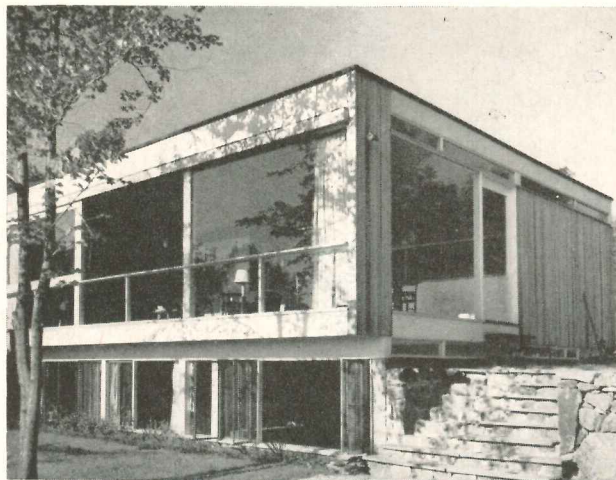

John Johansen: own house, New Canaan, Conn., 1949

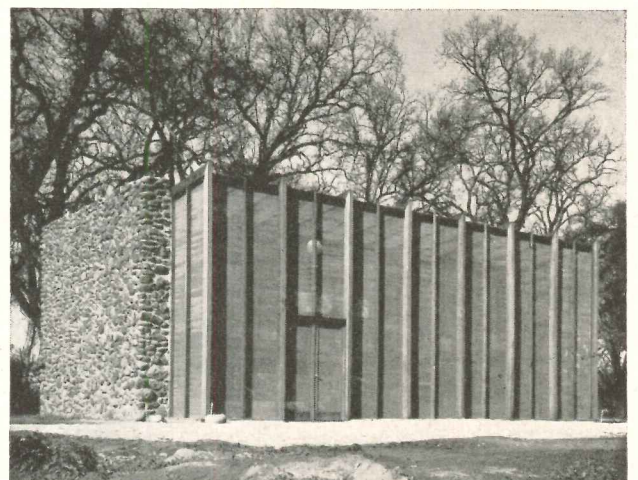

Dean Stone, Hugo Steccat

Mario Corbett: house for Moritz Thomsen, Vina, Calif., 1952

THE RECORD REPORTS

A.I.A. MEMBERS ENTER PUBLIC RELATIONS ERA

THE \$100,000 THREE-YEAR PUBLIC RELATIONS program approved by the 1952 convention of the American Institute of Architects was officially launched last month with the signing of a contract with Ketchum, Inc., Pittsburgh public relations firm, to run the program. Anson Campbell is the firm's account executive for the A.I.A.

The public relations counsel will work with A.I.A. chapters, in consultation with the A.I.A. Public Relations Committee headed by John Root, to lay the foundation for a program "to help architects become more articulate," according to the Institute's announcement.

Tools for chapter public relations committees to work with are first on the Ketchum agenda. The tools will be developed in four projects; 1) a "facts package" of background material on architects, architecture and the A.I.A. for the information of editors of newspapers and selected consumer magazines; 2) public relations workshops at regional level to explain public relations tools, techniques and opportunities to architects; 3) beginning in April, a periodic letter to all members of the A.I.A.; 4) a promotional "handbook" for architects, summarizing the most successful promotion ideas of architects.

"CONVENTION SECRETARY" ADDED TO A.I.A. STAFF

ARTHUR B. HOLMES, former executive director of the New Jersey Society and the New Jersey Chapter of the American Institute of Architects, has joined the Institute's headquarters staff as convention secretary.

Announcing the appointment, Executive Director Edmund R. Purves explained that the expanding scope of A.I.A. conventions has developed an urgent need for a full-time headquarters staff aide to help with organization of the meetings.

Mr. Holmes, who is also a former president of the New Jersey groups, met at the end of January with Washington State Chapter committees to discuss the developing plans for the 1953 convention June 15-19 in Seattle.

DESIGN COMPETITION FOR STORES OF THE FUTURE

A \$10,000 NATIONAL COMPETITION for "The Best Architect-designed Retail Stores of the Future" will be held in connection with the Fourth National Store Modernization, Building and Maintenance Show June 9-12, in Madison Square Garden, New York.

John W. H. Evans, managing director of the Store Modernization Institute, sponsors of the exposition, has announced that the contest will comply with the code for secondary competitions of the American Institute of Architects. The professional advisor is Caleb Hornbostel, A.I.A., 80 West 40th Street, New York.

The program for the competition requires the shopping center design to include at least 16 types of stores — suburban branch department store; apparel specialty shop (women's); apparel specialty shop (men's); bakery; books and records; drug; independent food; hardware; jewelry; liquor or package goods; florist; furniture and appliance; gift; shoe; stationery and office equipment; supermarket; variety store.

Awards will include a first prize of \$8000 and 10 honorable mentions of \$200 each. A jury of nationally known architects will be announced later.

The competition will be co-sponsored

by invited manufacturers from among the following fields: lighting, fluorescent and incandescent; air conditioning; floor coverings; wall coverings; store fronts and awnings; signs; vertical transportation; store fixturing and self-service equipment; structural materials; acoustical ceilings; washroom fixtures; electronic doors and others.

The competition is open to all registered architects. Information about the rules governing entries is available from Mr. Hornbostel.

LAUNCH NEW PROGRAM OF NEW YORK HONOR AWARDS

SCHOOL BUILDINGS are the subject of the first annual program of Honor Awards for current work sponsored by the New York Chapter of the American Institute of Architects. To be eligible, buildings must be for age groups below the college level; in or within 50 miles of New York City; completed since January 1948; and designed by a registered architect practicing anywhere in the U. S.

Closing date for registration, originally set for February 15, has been moved up to March 1. Entries must be received by March 16. Details from: Committee on Honor Awards, New York Chapter, A.I.A., 115 East 40th Street, New York 17, N. Y.

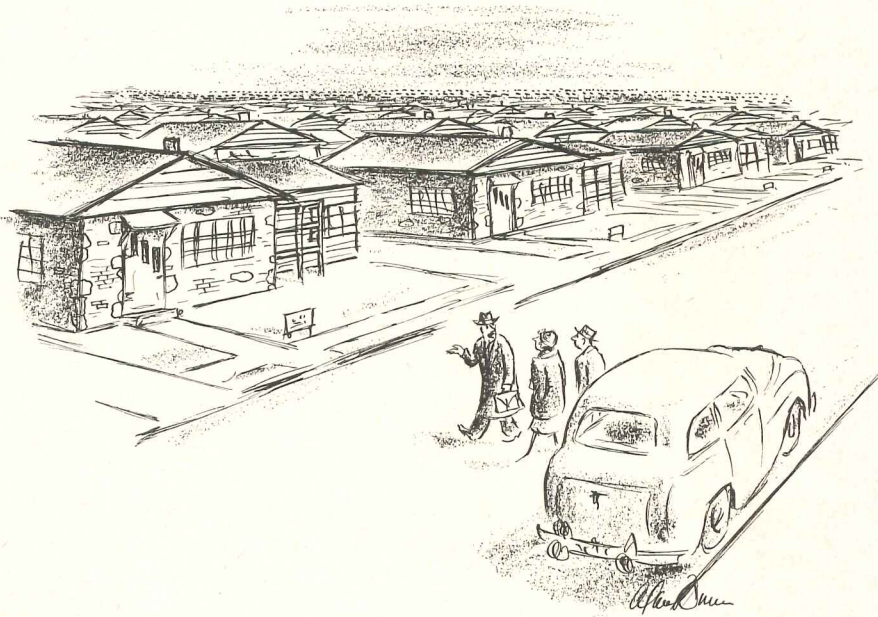

—Drawn for the RECORD by Alan Dunn

"Only six months ago this was a 'Blighted Area' —"

CIVIL DEFENSE CALLED FEASIBLE AND URGENT

Project East River Calls for Vast Program of Urban Planning and Structural Protection

A TEN-VOLUME REPORT on civil defense which could be the herald of a new era in urban construction — or so many pieces of paper — was submitted early last month to the Federal Civil Defense Administration, the National Security Resources Board and the Department of Defense. The decision is now up to President Eisenhower and the new Republican Administration.

Major conclusions of the report: defense against air attack is both possible and feasible; reduction of urban vulnerability by (1) space and (2) structural protection is the logical approach to such a defense; and the Federal Government has an urgent obligation to assume decisive leadership in the launching of the required programs.

The report came out of "Project East River," an 18-month study for the government agencies by more than 100 leading scientists, educators, businessmen and government officials under the aegis of Associated Universities, Inc., the association of nine eastern universities formed seven years ago to operate Brookhaven National Laboratory for the Atomic Energy Commission. A number of architects and engineers were among the participants, one of them, Stephen S. Voorhees of Voorhees, Walker, Foley & Smith of New York, on the eight-member steering committee.

Architects and engineers will be most concerned with Part IIB and Part V of the report — the sections which deal with reduction of urban vulnerability. Desirable standards are summarized as follows:

1. Urban areas should be grouped in Class I and Class II Vulnerable Urban Districts by NSRB or a Federal agency it designates.
2. No new defense-supporting industry should be located in any VUD or within 10 miles of Class I or six miles of Class II VUDs.
3. Housing, commercial and non-defense industrial densities should be

reduced in Class I and all new construction in Class I should be blast- and fire-resistant.

5. Public and institutional buildings in any metropolitan area (as defined by the Census Bureau) which contains a VUD should be built to blast- and fire-resistant standards.

6. Federal, state and municipal spending, financing and construction activities in urban areas should be brought into line with minimum standards for urban development and redevelopment on a metropolitan area basis.

7. Urban land use and building controls should be exercised on a metropolitan basis and brought in line with minimum standards for urban development and redevelopment.

8. The FCDA survey for shelter in existing structures, modified where indicated by local conditions, should be completed as soon as possible in the VUDs, if necessary by Federal funds.

9. As the survey proceeds, the best available shelter space in existing structures should be designated (with minor alterations made where necessary) for VUD residents.

10. After completion of the survey, a study should be made of the cost and feasibility of a comprehensive shelter program to provide a reasonable level of protection.

Parts IIB and V are not among the classified portions of the report, but no copies were available for distribution. The first printing was only 300 copies.

SCHEMATIC SUMMARY OF URBAN DEFENSE STANDARDS

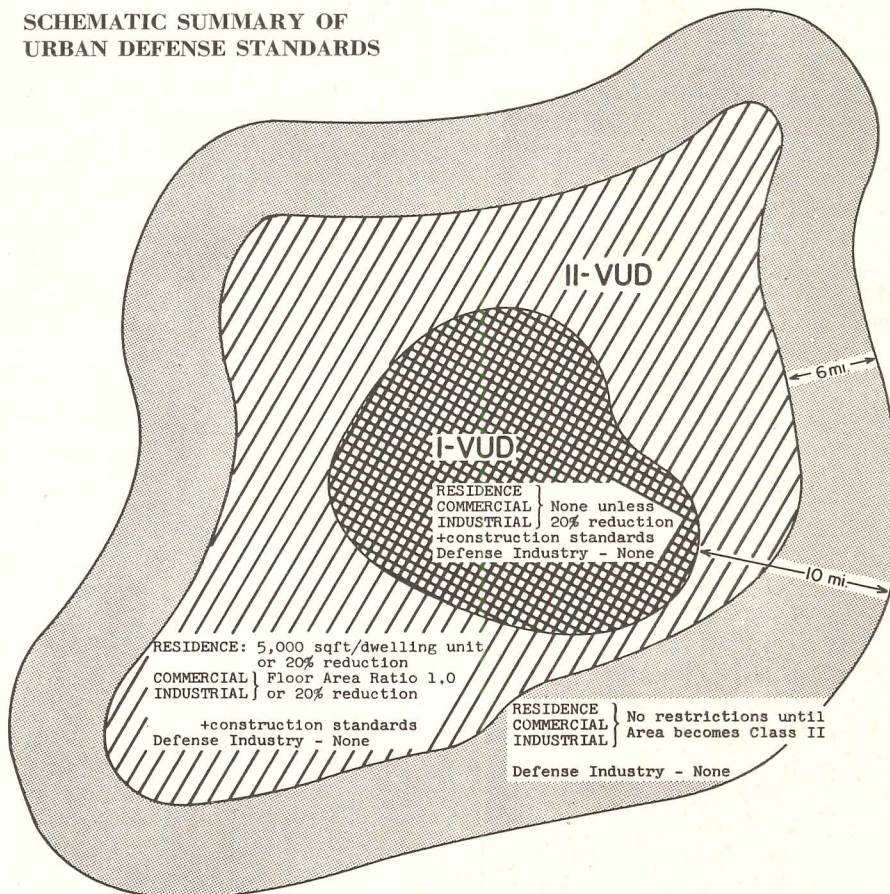

A wall-and-finish in one

glazed facing tile

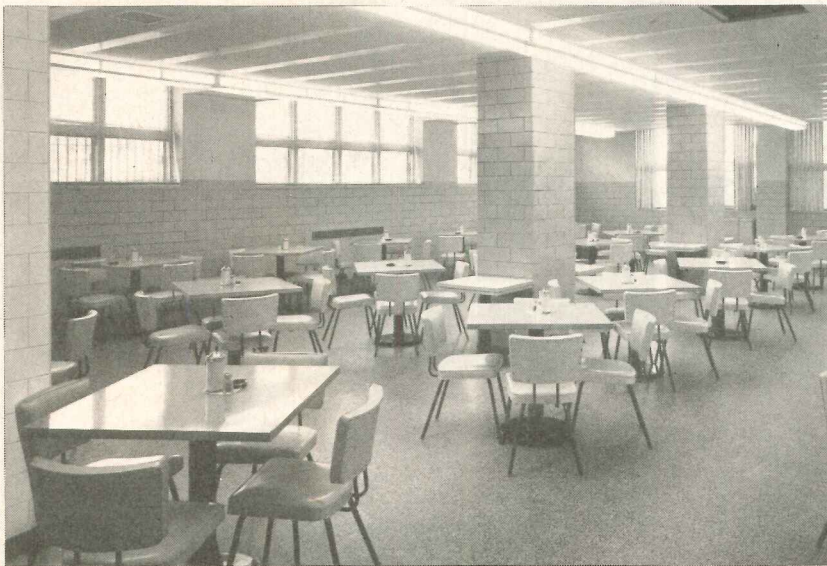

Stark's green mottle shade provides a combination of utility and beauty in the staff cafeteria (above).

Stark Glazed Facing Tile in clear glaze shade makes Beth-El's serving pantries bright, cheerful, easy to keep sparkling clean (right).

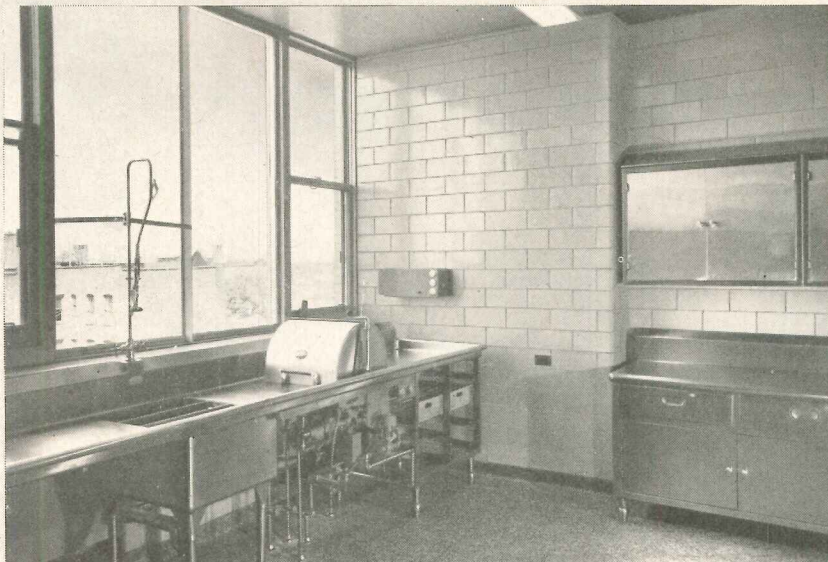

BETH-EL HOSPITAL, NEW YORK, N. Y.
ISADORE ROSENFELD, ARCHITECT
WILLIAM I. HOHAUSER, ASSOCIATE ARCHITECT

THE RECORD REPORTS

NEWS FROM CANADA by John Caulfield Smith

Architects Turn Critics: Another Look at the UN

IN THE FIRST of a new series of critical discussions of well-known recent buildings being held in conjunction with meetings of the Toronto Chapter of the Ontario Association of Architects, the United Nations Secretariat Building in New York was evaluated pro and con.

A panel consisting of Gordon S. Adamson (moderator), Basil Ludlow, F. H. Marani, Norman H. McMurrich, Robert R. Moffat and E. Sherrer, led the discussion, aided, abetted — and challenged — by speakers from the floor.

Not unexpectedly, the discussion evoked variant “traditionalist” and “modernist” points of view. F. H. Marani, for example, said that the Secretariat Building relies on “the sheen of glass and aluminum, like any box wrapped in cellophane”; and John Layng countered, “It is a mighty building, built in a mighty way, and we should be thankful that it has been built.” John C. Parkin expressed the opinion that “form follows function” was an outmoded battle cry for contemporary design, and suggested as a more accurate substitute, “Form blends with function.”

Swedish Architect Arrives To Study Canadian Building

NILS v. LINDQUIST, an architect who is secretary of the Swedish State Committee for Building Research, has arrived in Ottawa for a year's study of building in Canada. He will be attached to the staff of the Division of Building Research, National Research Council, and will travel widely throughout the country in the course of his work.

Established in 1942 to conduct and promote technical and scientific research in building, the Swedish State Committee is representative of technical

(Continued on page 26)

NEW BUILDINGS

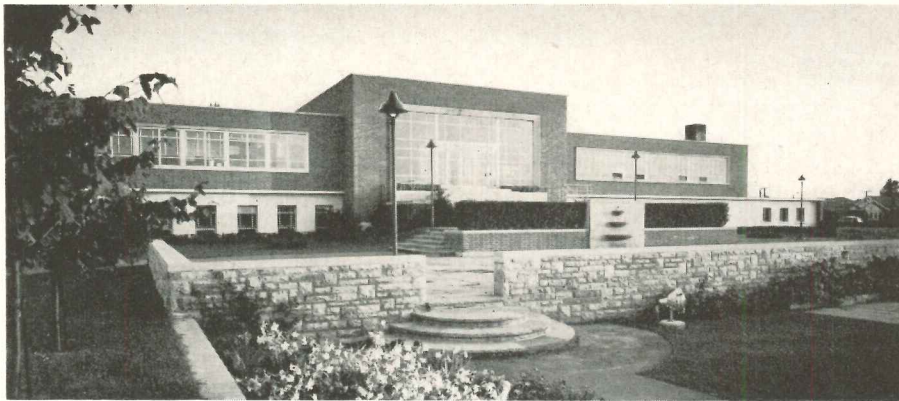

Above: municipal hall for township of East York, Ont. Architects for the structure are Shore & Moffat, Toronto, Ont.

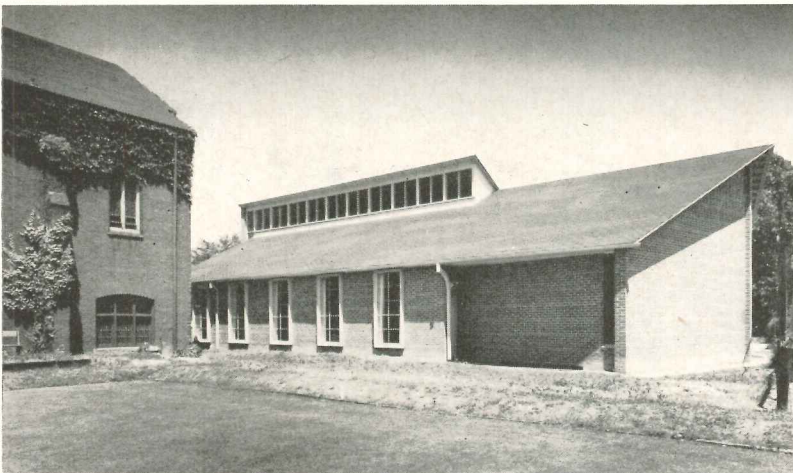

Exterior, left, interior, above, of parish hall for St. Cuthbert's Anglican Church, Leaside, Ont.; Fleury & Arthur, archts.

Pella® WOOD CASEMENT WINDOWS



WILLIAM J. WAGNER, ARCHITECT. (WETHERILL & HARRISON, DES MOINES, IOWA)

Achieve Exciting Interior Effects



All Pella Casements come with Inconspicuous Pella Rolsscreens — the original inside screens that roll up and down like window shades.



Pella Casement Windows have Dual Glazing that protects against winter cold and summer heat . . . the year-round storm window.

You can create countless custom window effects by combining stock-size Pella Wood Casement Windows. Pella Windows also save money on the job because they are completely assembled and pre-fitted at the factory. Your clients appreciate Pella beauty and convenience. Only Pella gives you all 3 — Rolsscreens, Dual Glazing and stainless steel weatherstripping. Available with vertical and horizontal muntins, horizontal muntins or without muntins. Glass openings up to 60" high. Patented hinge design, stronger 1 3/4" wood sash and steel inner frame. Low air infiltration factor permits use of more glass, yet saves more heat. More standard Thermopane sizes available for Pella than any other wood casement window. Investigate Pella Casement units today.

see our catalog in
ARCHITECTURAL
FILE
or write for copy

AND ELIMINATE THESE 6 WINDOW CHORES

- 1 PUTTING UP AND TAKING DOWN SCREENS
- 2 PAINTING AND REPAIRING SCREENS
- 3 STORING SCREENS
- 4 PUTTING UP AND TAKING DOWN "STORMS"
- 5 PAINTING AND REPAIRING "STORMS"
- 6 STORING "STORMS"

Write:
Rolsscreen Company,
Dept. E-6,
Pella, Iowa.



PLAN WITH *Pella* PRODUCTS MADE BY ROLSSCREEN COMPANY, PELLA, IOWA

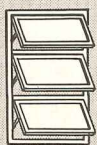

Pella
MULTI-PURPOSE WINDOWS



Pella
ROLSSCREENS



Pella
LITE-PROOF SHADES



Pella
WOOD FOLDING DOORS



Pella
VENETIAN BLINDS

THE RECORD REPORTS

CANADA

(Continued from page 24)

institutions, builders and trade unions. Its activities to date have been directed chiefly toward assisting research by making grants of money for the purpose.

Mr. Lindquist is the latest in a series of foreign experts who have visited the country on an exchange basis. From its inception in 1947, the Canadian Divi-

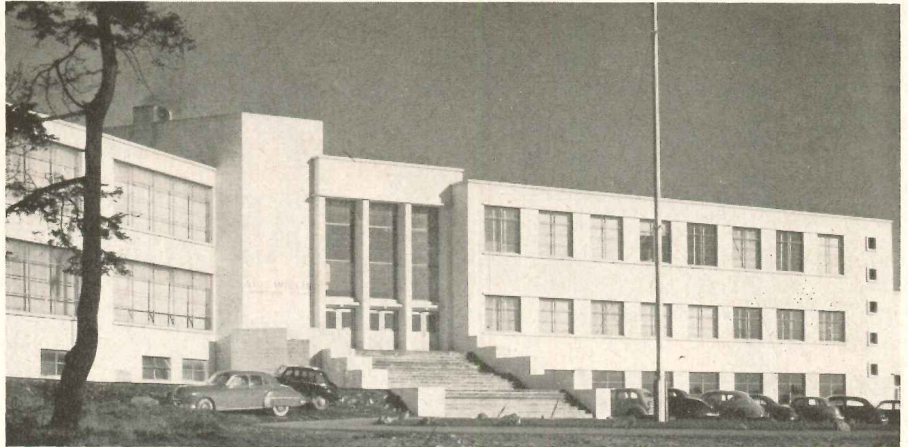

Above: new building for S. J. Willis Jr. High School, Victoria, B. C. Architect: C. D. Stockdill of Birley, Wade and Stockdill

"we discovered SEAL-O-SAN
and are we pleased!"

SAYS *Bill Moore*



Basketball Coach
Shepherd College
Shepherdstown, W. Va.



"WE CONDUCTED OUR OWN FLOOR FINISH SURVEY . . . and even though the architect specified another finish for the hardwood floors in our new fieldhouse, we picked SEAL-O-SAN! And we are glad we did! At such leading schools as the universities of Michigan and Kentucky, we found that SEAL-O-SAN was recommended above all other gym floor finishes. Why? We learned that SEAL-O-SAN GYM FLOOR FINISH does a double-duty job . . . assures safe, sure footing for all sports, plus extra protection from careless abuse. It's ideal on our multi-purpose floors."

What are you doing to protect your expensive hardwood gym floor from abuse? There is an answer that thousands of schoolmen know and use . . . SEAL-O-SAN GYM FLOOR FINISH.

HUNTINGTON LABORATORIES, INC. • Huntington, Indiana • Toronto, Canada



Send the names of Seal-O-San users in my neighborhood, and send me more information on Seal-O-San.

NAME _____

SCHOOL _____

ADDRESS _____

CITY _____

STATE _____

SEAL-O-SAN[®]
GYM FLOOR FINISH

sion of Building Research has maintained contact with building research organizations in many countries. Building scientists from Switzerland, the British Isles and Sweden have all worked in the country in recent years, with Canadians visiting and working in many European countries.

The liaison has been valued for its encouragement of the free exchange of information. Mr. Lindquist's year is expected to be one more addition to the program being pursued by the Division of Building Research as it develops a research service for the Canadian construction industry.

Final 1952 Building Figures Not Expected to Set Record

The bright forecasts made last January for a record-breaking year for construction activity now seem to have no chance for fulfillment. Substantial decreases in industrial and engineering projects kept the value of November construction contract awards below the corresponding figure for 1951, even though residential and business construction awards were ahead for the month.

According to MacLean Building Reports Ltd., November's total awards of \$152,975,000 were \$4,893,100 below those for the same month a year ago. They brought the total for the first 11 months of this year to \$1,714,175,400 for a decline of \$480,871,700 from the \$2,175,047,100 total of the first 11 months of 1951.

Only eight projects were listed in the big jobs for the month, the largest being a \$6,000,000 hospital in Montreal, and \$3,912,431 and \$4,000,000 hangars in Comox, B. C., and Cold Lake, Alta.

(Continued on page 30)

How Pittsburgh Glass

serves contemporary architecture

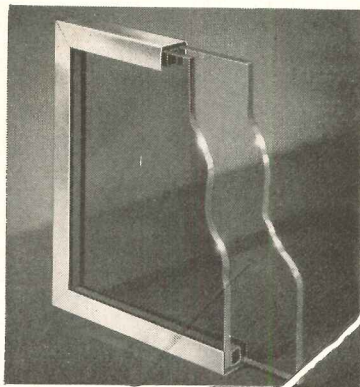
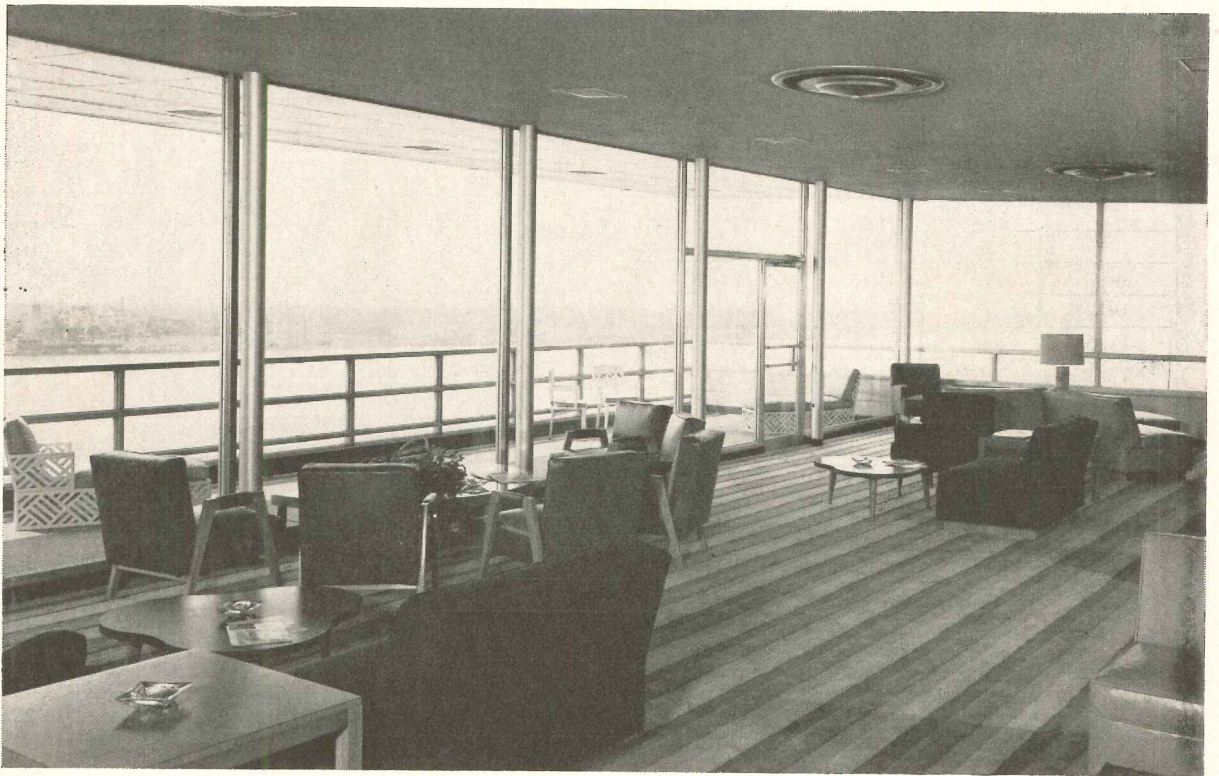

FOR THE VETERANS MEMORIAL BUILDING, Detroit, Michigan, Pittsburgh products were selected as a part of the basic design scheme. Included in these products are 6,589 square feet of Polished Plate Glass, 326 square feet of Mirrors, twenty-four Herculite Doors, Pittco De Luxe Metal. Illustrated here is the commodious and comfortable lounge, with its large expanse of Plate Glass giving a commanding view of the outside surroundings. Architects: Harley, Ellington and Day, Inc., Detroit, Michigan.

SOLEX-TWINDOW gives all the advantages of Pittsburgh's Twindow—"the window with built-in insulation"—plus the heat-absorbing, glare-reducing properties of Solex—"the best glass under the sun!" This cutaway shows the construction of such a unit. The outer pane is Solex—the inner light is clear Plate Glass. Between them is a sealed-in air space. A stainless steel frame protects the seal and glass edges; makes handling safe and easy.

Design it better with **Pittsburgh Glass**



Your Sweet's Catalog File contains detailed information on all Pittsburgh Plate Glass Company products . . . Sections 7a, 13e, 15, 16b, 21.

PAINTS • GLASS • CHEMICALS • BRUSHES • PLASTICS • FIBER GLASS

PITTSBURGH PLATE GLASS COMPANY

THE RECORD REPORTS

CONSTRUCTION COST INDEXES

Labor and Materials

United States average 1926-1929 = 100

Presented by Clyde Shute, manager, Statistical and Research Division, F. W. Dodge Corp., from data compiled by E. H. Boeckh & Assocs., Inc.

NEW YORK

ATLANTA

Period	Residential		Apts., Hotels Office Bldgs. Brick and Concr.	Commercial and Factory Bldgs. Brick and Concr.		Brick and Steel	Residential		Apts., Hotels Office Bldgs. Brick and Concr.	Commercial and Factory Bldgs. Brick and Concr.		Brick and Steel
	Brick	Frame		Brick	Frame		Brick	Frame				
1925	121.5	122.8	111.4	113.3	110.3		86.4	85.0	88.6	92.5	83.4	
1930	127.0	126.7	124.1	128.0	123.6		82.1	80.9	84.5	86.1	83.6	
1935	93.8	91.3	104.7	108.5	105.5		72.3	67.9	84.0	87.1	85.1	
1939	123.5	122.4	130.7	133.4	130.1		86.3	83.1	95.1	97.4	94.7	
1940	126.3	125.1	132.2	135.1	131.4		91.0	89.0	96.9	98.5	97.5	
1946	181.8	182.4	177.2	179.0	174.8		148.1	149.2	136.8	136.4	135.1	
1947	219.3	222.0	207.6	207.5	203.8		180.4	184.0	158.1	157.1	158.0	
1948	250.1	251.6	239.4	242.2	235.6		199.2	202.5	178.8	178.8	178.8	
1949	243.7	240.8	242.8	246.4	240.0		189.3	189.9	180.6	180.8	177.5	
1950	256.2	254.5	249.5	251.5	248.0		194.3	196.2	185.4	183.7	185.0	
1951	273.2	271.3	263.7	265.2	262.2		212.8	214.6	204.2	202.8	205.0	
Sept. 1952	279.7	276.6	274.4	276.5	274.3		219.1	220.7	214.2	211.9	216.8	
Oct. 1952	279.0	275.7	274.3	276.4	274.1		221.1	223.7	216.2	212.7	218.0	
Nov. 1952	277.9	274.3	274.1	276.3	273.8		220.4	222.8	216.1	212.6	217.8	
Nov. 1952	125.0	124.1	% increase over 1939				% increase over 1939			118.3	130.0	

ST. LOUIS

SAN FRANCISCO

1925	118.6	118.4	116.3	118.1	114.4	91.0	86.5	99.5	102.1	98.0
1930	108.9	108.3	112.4	115.3	111.3	90.8	86.8	100.4	104.9	100.4
1935	95.1	90.1	104.1	108.3	105.4	89.5	84.5	96.4	103.7	99.7
1939	110.2	107.0	118.7	119.8	119.0	105.6	99.3	117.4	121.9	116.5
1940	112.6	110.1	119.3	120.3	119.4	106.4	101.2	116.3	120.1	115.5
1946	167.1	167.4	159.1	161.1	158.1	159.7	157.5	157.9	159.3	160.0
1947	202.4	203.8	183.9	184.2	184.0	193.1	191.6	183.7	186.8	186.9
1948	227.9	231.2	207.7	210.0	208.1	218.9	216.6	208.3	214.7	211.1
1949	221.4	220.7	212.8	215.7	213.6	213.0	207.1	214.0	219.8	216.1
1950	232.8	230.7	221.9	225.3	222.8	227.0	223.1	222.4	224.5	222.6
1951	252.0	248.3	238.5	240.9	239.0	245.2	240.4	239.6	243.1	243.1
Sept. 1952	260.9	254.1	253.5	259.7	254.0	252.6	247.8	248.5	251.6	253.2
Oct. 1952	260.2	253.2	253.4	259.6	253.8	251.3	246.2	248.3	251.4	252.8
Nov. 1952	259.5	252.3	253.7	259.5	253.6	249.9	244.4	248.0	251.2	252.4
Nov. 1952	135.5	135.8	% increase over 1939			% increase over 1939			106.1	116.7

The index numbers shown are for combined material and labor costs. The indexes for each separate type of construction relate to the United States average for 1926-29 for that particular type — considered 100.

Cost comparisons, as percentage differences for any particular type of construction, are possible between localities, or periods of time within the same city, by dividing the difference between the two index numbers by one of them; i.e.:

index for city A = 110
index for city B = 95
(both indexes must be for the same type of construction).

Then: costs in A are approximately 16 per cent higher than in B.

$$\frac{110-95}{95} = 0.158$$

Conversely: costs in B are approximately 14 per cent lower than in A.

$$\frac{110-95}{110} = 0.136$$

Cost comparisons cannot be made between different types of construction because the index numbers for each type relate to a different U. S. average for 1926-29.

Material prices and wage rates used in the current indexes make no allowance for payments in excess of published list prices, thus indexes reflect minimum costs and not necessarily actual costs.

These index numbers will appear regularly on this page.

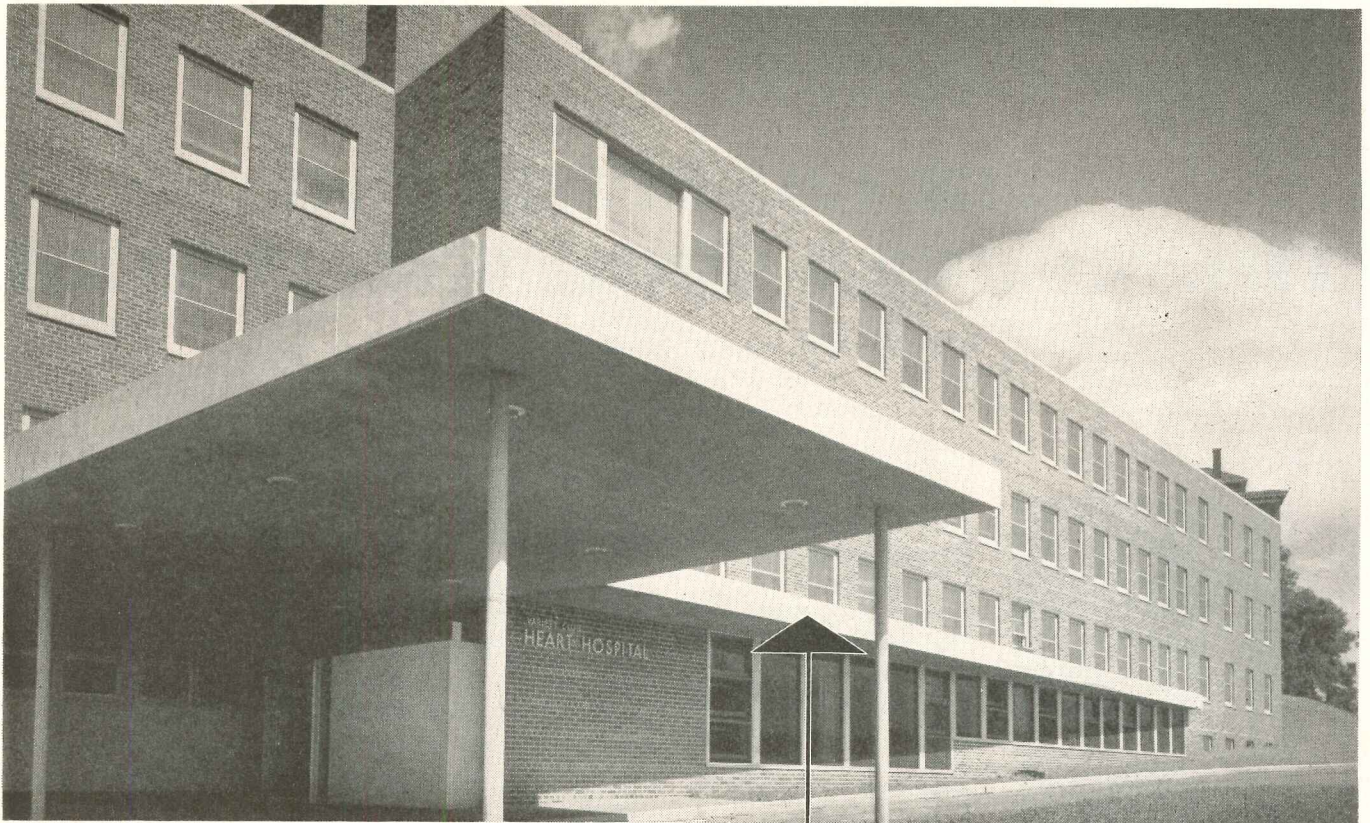

Architects and Engineers: Magney, Tusler & Selter
 University Advisory Architects: Roy Jones and Winston Close

ALL THESE DECORATIVE AND MECHANICAL FEATURES FOR LASTING SERVICE AND LOW MAINTENANCE

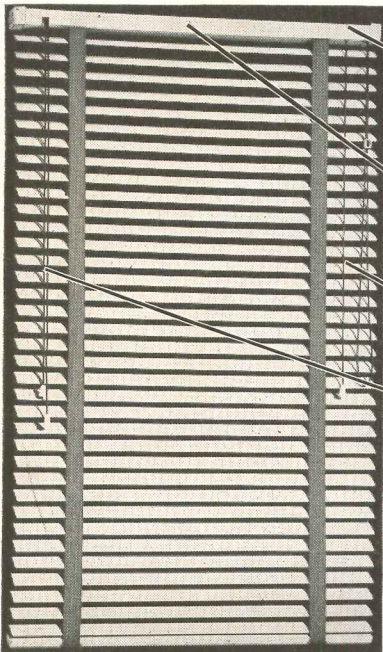

EXTRA LARGE PULLEYS

Pella pulleys are one whole inch in diameter. Made of self-lubricating Lignum-vitae wood, they always roll smoothly. This feature reduces cord wear to absolute minimum.

10 YEAR GUARANTEE

Pella's neat metal headmember and the enclosed operating mechanism are guaranteed for 10 years against operating defects.

SEPARATE LOCKING CORD

Separate locking cord holds blind at any height, minimizes frictional wear on nylon operating cords.

SLIP-PROOF TILTING

Tilt cords never slip out of reach. Tilting mechanism of silent positive gear action outwears life of the blind.

NO JERKING OF CORDS

Pella's separate locking cord eliminates jerking of the operating cord from side to side to lock and unlock blind position. Another exclusive Pella feature.

Pella[®]

VENETIAN BLINDS

specified throughout

VARIETY CLUB HEART HOSPITAL

University of Minnesota, Minneapolis

Pella Venetian Blinds are the logical choice for commercial and institutional use because their many quality features minimize maintenance problems. Specify Pella in either metal or wood slats . . . choose from a wide range of decorator colors . . . get Nylon operating cords . . . select either cloth or plastic tape. When you specify Pella, your client is assured of the finest in material, design and workmanship.

see our catalog in
**ARCHITECTURAL
 FILE**
 or write for copy

Free CATALOG ON VENETIAN
 BLINDS—WRITE DEPT. E-7
 KOLSCREEN CO., PELLA, IOWA



PLAN WITH *Pella* PRODUCTS MADE BY ROLSCREEN COMPANY, PELLA, IOWA

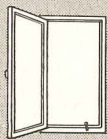

Pella
CASEMENT WINDOWS

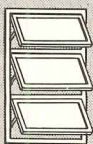

Pella
MULTI-PURPOSE WINDOWS



Pella
ROLSCREENS



Pella
LITE-PROOF SHADES



Pella
WOOD FOLDING DOORS

One of a series of papers prepared by leading authorities on air conditioning. The opinions and methods presented are those of the authors and are not necessarily endorsed by the Du Pont Company. Reprints of this article, and others in the series, may be had free upon request.

AIR CONDITIONING THE MODERN SHOPPING CENTER

by Geoffrey Baker and Bruno Funaro, A. I. A.



GEOFFREY BAKER and **BRUNO FUNARO** are authors of the well-known reference book, *Shopping Centers—Design and Operation*. They are members of Howard T. Fisher & Associates, architects and engineers of New York and Chicago. This firm is actively engaged in the design of shopping centers.

SHOPPING SHIFTS TO SUBURBS

Today the interest of store developers has shifted from the individual downtown store to the suburban shopping center. In these new centers, a balanced grouping of stores under single ownership, it is possible to offer conveniences (especially, of course, ample parking) which only the very largest of the stores in the group could otherwise afford. As the focus of competition changes from rivalry between individual stores to a rivalry between shopping centers, shoppers who are already accustomed to look for the sign "This store is completely air conditioned" will now go searching in their automobiles for the new group of stores which, in addition to ample parking space, can also proclaim, "This center is completely air conditioned for your comfort."

With the whole group of stores under single ownership the shopping center designer can often lighten the air conditioning load by careful orientation and landscaping. As the new type of shopping center is not dependent for success upon extensive highway coverage, the stores are usually set back from the road; and they can often be oriented and placed in a pattern quite independent of the road frontage line, without damage to their primary function of efficient selling.

INDIVIDUAL UNITS OR CENTRAL PLANT

In broad terms, there are two alternative methods of

air conditioning the new type of shopping center: 1) the use of individual units for each store, or 2) serving all the stores from a single central plant.

The system of individual units is one to which the tenants are already accustomed by experience in downtown stores. Such units are available in 3, 5, 7½ and 10-ton capacity. All are small enough to be easily moved through a 36"-wide doorway. The architect should provide suitable space and service connections at the time the building is planned, so that his nicely calculated façades and roof lines will not be later marred by unplanned towers, stacks and grills.

The tonnage per square foot required by the small store cannot be satisfactorily determined by any rule-of-thumb method. The number of units required in any given store will depend upon economics, the area to be conditioned, special conditions of smoke or odors, type of merchandise, importance of comfort cooling for customers and employees.

CENTRAL PLANT MOST EFFICIENT

Equipment and installation costs do not remain in direct proportion to tonnage. For example, two 3-ton units, costing approximately \$3,000, although they may give slightly better air distribution than a single 5-ton unit, will cost almost twice as much, because the electrical, water and drainage connections must be doubled. Ducts are not usually fitted to any package unit smaller than 10-ton, for their cost is out of proportion to that of the unit.

Uniform equipment throughout the center will mean economy in purchase, maintenance and repair. However, this would practically force the landlord into assuming all the costs of air conditioning. The landlord in turn would have to transform this added cost into a rent increase, which might add to his difficulties when looking for tenants. It would also increase his capital costs; and the small promoter already finds this discouragingly high.

Theoretically, at least, if the landlord is to pay for the installation of air conditioning, it should be cheaper and more satisfactory for him to provide heating and cooling from a central plant, rather than by a series of individual store units. Technically, such a plant should be more

efficient, provided that the center is large enough, and planned compactly enough to avoid long and expensive lines of distribution between the power plant and the individual stores. For short runs, the conditioned air may be circulated in ducts; for longer runs it may be more efficient to circulate chilled water between the central power house and air-handling units in the stores. Technical difficulties of metering have already been overcome.

It is probably significant that the existing and proposed shopping centers with central air conditioning plants are all sponsored by large investors with ample capital. Moreover, each of these centers contains one or more large department stores; and it is such large users who can benefit most from a central plant.

A 1200-TON INSTALLATION

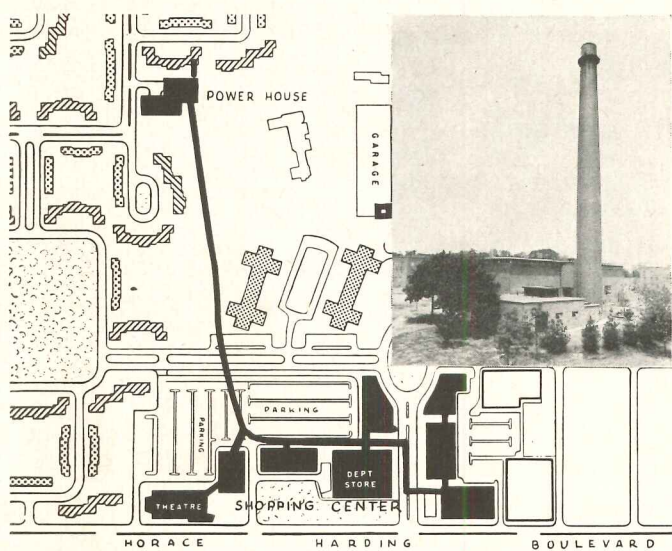

Diagram shows layout of modern shopping center at Fresh Meadows, Long Island, N. Y. Note location of power house (inset) and chilled-water lines from central plant to group of buildings in foreground.

The main shopping center at Fresh Meadows, the 3000-family community owned and managed by the New York Life Insurance Co. in Queens, N. Y., is among the first of the big centers to be served from a central air conditioning plant (of 1200-ton capacity). Chilled water circulated from this plant is metered and was made available to all commercial tenants who desired air conditioning. Almost all of the tenants took advantage of this offer and installed suitable air-handling equipment. As the central plant was put in as an extension to the main boiler house (which serves the residential buildings as well as the stores), operators were available to handle the chilled-water equipment.

Local regulations designed to conserve water made the central plant far more efficient and economical than a smaller number of units, each with its own diffusion well. Water for condensing purposes at the central plant is supplied from two wells, each of 500 gallons-per-minute capacity, and then returned to the ground by two diffusion wells.

NOVEL METER SYSTEM DETERMINES CHARGE

One of the problems was how to determine the charge to the tenant for the chilled water used. For the smaller tenants, the usage was estimated, and a charge based on an agreed rate for chilled water was included in the rent. For the department store and the theatre, for which the usage was large in amount and impossible to estimate closely, a unique metering system was evolved. The meters provided measure continuously the water flow in gallons and the temperature rise in degrees F., and integrate and record this in terms of BTU's. The charge to the tenant is based upon an agreed rate per million BTU of refrigeration as indicated by the meter. This is believed to be the first application of its kind.

FUTURE OF SHOPPING CENTER REFRIGERATION AND DESIGN

Ultimate development of the shopping center plan would seem, logically, to be a completely air conditioned enclosure of great size within which the individual stores would be set like different departments in a vast department store. This would transfer into terms of structure and mechanical engineering the merchandising advantages which have already been realized in the new shopping centers.



The shopping center of the future will almost certainly be air conditioned, either by central-plant or individual-unit system.

As Messrs. Baker and Funaro have explained, many shoppers today will actually go out of their way to trade in stores that provide for their comfort. The air conditioned place of business consequently has a decided advantage over the non-air conditioned store. It has already been proved many times that air conditioning is an excellent sales stimulator and merchants generally look upon it as a paying investment.

In considering various makes of machines now available, architects and consulting engineers heartily approve units charged with "Freon" refrigerants. These machines are compact . . . provide efficient, economical refrigeration . . . meet every air conditioning need of modern shopping centers.

"Freon" refrigerants are safe . . . nonflammable, non-explosive, virtually nontoxic . . . fully comply with building-code requirements everywhere. Their chemical purity and uniformity insure trouble-free performance of the equipment over a long period of time. You can always recommend "Freon"-operated machines with confidence. E. I. du Pont de Nemours & Co. (Inc.), "Kinetic" Chemicals Division, Wilmington 98, Del.



BETTER THINGS FOR BETTER LIVING . . . THROUGH CHEMISTRY

"FREON" SAFE REFRIGERANTS



"Freon" is Du Pont's registered trade-mark for its fluorinated hydrocarbon refrigerants

REQUIRED READING

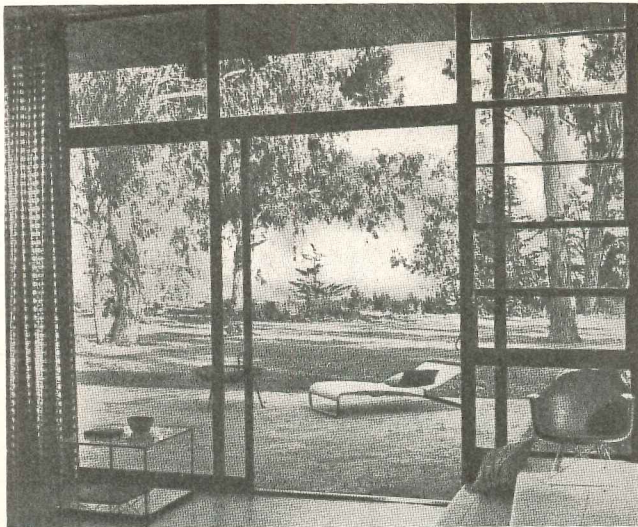

"The feeling about space which typifies our period. . . .": above—West Coast house by Eero Saarinen and Charles Eames; top right—house in Phoenix, Ariz., by Wright; bottom right—New York town house by Phillip Johnson. (Illustrations from "Living Spaces")

A SURVEY OF TODAY'S LIVING SPACES

Living Spaces. Interiors Library No. 1. Edited by George Nelson. Whitney Publications, Inc. (18 East 50th St., New York 22, N. Y.) 1952. 9 by 12 in. 148 pp., illus. \$7.50.

REVIEWED BY
HERBERT L. SMITH, JR., A.I.A.

Interiors has launched a projected series of books on various aspects of design with this handsome volume on contemporary living and dining areas. In many respects the book is quite remarkable. Unlike the too familiar be-all and end-all books on "decoration," the work quietly yet attractively presents a thoughtful selection of interiors done in the past few years. There is nothing startling or violently new, but all is of a high standard of design. Perhaps the basic and encouraging approach of the book is best summed up in George Nelson's concluding lines—"Contemporary design is here to stay for a while, and the pressure to prove one's orthodoxy has diminished. With this more mature outlook there should come more good interiors."

The work of 81 designers, a large proportion of them architects, is included. Among the more recent designs, some of the early interiors by such men as

Wright, Mies van der Rohe and Le Corbusier have been inserted to show their influence. Each of the interiors presented is accompanied by a concise description stating the problem and how it was met. The text throughout is written in an extremely readable style.

Nelson's introduction sets up a rather provocative chain of thought on the subject of orthodoxy in design. Starting from an observation, made in the early '40s, that "radicals and conservatives appear to be alike in their strong insistence on absolute conformity," he goes on to note that, although this is no longer strictly true of the modernists, "we now have something which has been fairly generally accepted as a 'style,' a word which less than a decade back caused serious designers to tear out what was left of their hair."

A quick leafing through the book certainly reveals this to be true. Some of the interiors are sleek, some heavy textured, some bear the undeniable mark of a particular architect or designer. But most, if not all, have a faint underlying similarity—which is probably as it should be if one concurs with Nelson when he states, "Once the basis

of a style has been established . . . there is no further room for drastic change until the development has run its course. This is the period in which we are now working, and it will be quite a while before the vitality of the present movement has exhausted itself." All of which leads one to hope that the remaining vestiges of the militant effect-for-effect's-sake attitude will disappear and that the current style will develop—and flower—on a sounder basis than has sometimes been the case.

Nelson singles out the "preoccupation with space" as the most significant development of the past few years. "The contemporary demand," he says, ". . . is really a double one: the freedom which comes only with space, and the freedom to do with the space whatever one chooses. If this is today's major trend, we could do a lot worse." It is decidedly more important than a preoccupation with the meticulous placement of ash-trays!

The new book should have a wide appeal: it should be of great interest to the layman, be an excellent reference to historians, and serve as a stimulating review for active practitioners.

(Continued on page 48)

Architects, Builders— Strong, Durable, Lightweight J&L Junior Beams

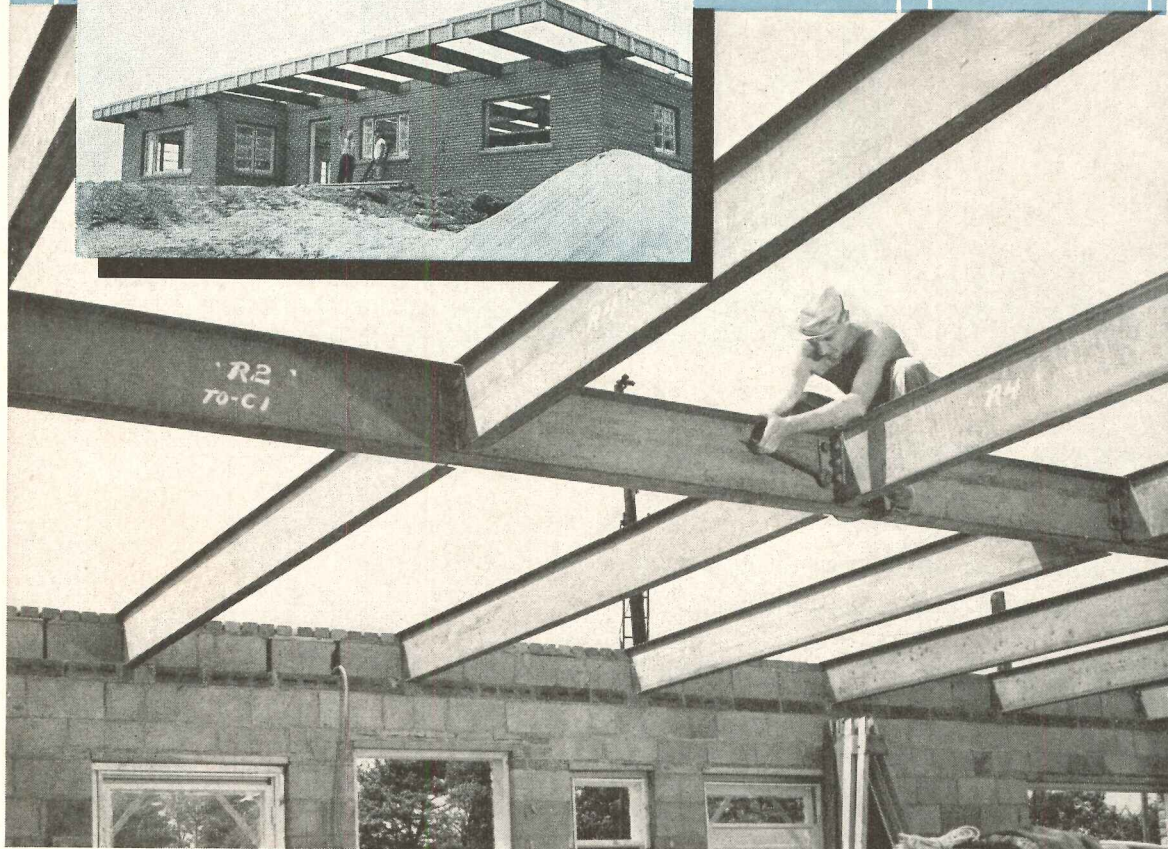

*Save Time, Save Costs, and
Help Solve Design Problems*

Modern building needs stress the importance of saving construction time, holding down over-all costs *without* sacrificing permanence, safety or beauty in design.

Because of their versatility and adaptability, J&L Junior Beams go far toward meeting the demands of today's builders. They cost less to buy and less to erect. Lightweight Junior beams may be easily raised, placed and bolted directly into position with a minimum of labor and manpower. This fast, economical construction helps hold building costs low.

In addition to their EASE OF INSTALLATION, you'll be interested in other important design

and construction features of J&L Junior Beams: They are RIGID, VIBRATION RESISTANT, SHRINK PROOF, FIREPROOF, VERMIN PROOF, and have the LOWEST DEFLECTION FACTOR OF ANY STRUCTURAL SECTION OF EQUIVALENT WEIGHT.

Why not write today for our new booklet covering J&L Junior Beams and Channels? It shows how Junior Beams are used as floor joists and roof purlins, with loading and spacing tables for various spans.

J&L STEEL

Jones & Laughlin Steel Corporation
492 Gateway Center
Pittsburgh, Pennsylvania

Please send me a copy of the booklet covering J&L Junior Beams and Channels.

NAME _____

COMPANY _____

ADDRESS _____

JONES & LAUGHLIN STEEL CORPORATION
PITTSBURGH, PENNSYLVANIA

**ACOUSTICAL
MATERIALS
AT WORK**

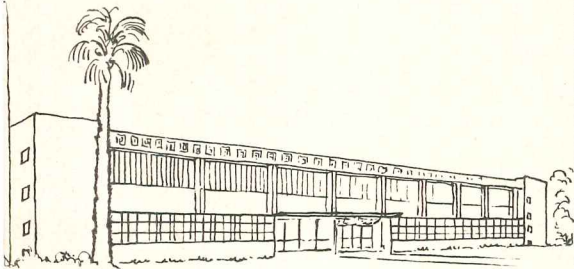

ARIZONA STATE TEACHERS COLLEGE, Tempe, Arizona

Architect: Edward Varney

General Contractor: Daum-Donaldson Construction Co.

Acoustical Contractor: Barrett & Homes

Low-cost, functional design characterizes the new Administration Building at Arizona State Teachers College. In the lobby, the open architectural plan is made more practical by the sound-absorbing ceiling of Armstrong's Cushiontone.

Cushiontone, a perforated wood fiber tile, has also been installed throughout the classrooms, laboratories, and hallways of the building. Its high acoustical efficiency and low cost made it a logical selection for the architect. Other important features of Cushiontone are its repaintability, high light reflectivity, and ease of installation and maintenance.

Armstrong offers the most complete line of acoustical materials available. Your Armstrong Acoustical Contractor will be glad to give you free, expert assistance with any of your sound-conditioning problems. For the free booklet, "How to Select an Acoustical Material," write to Armstrong Cork Company, 2402 Stevens Street, Lancaster, Pennsylvania.



Noisy footsteps and voices were quieted in Cushiontone-treated corridors like this.



For extra beauty, a ceiling of Armstrong's Travertone was selected for the Board of Regents Conference Room.

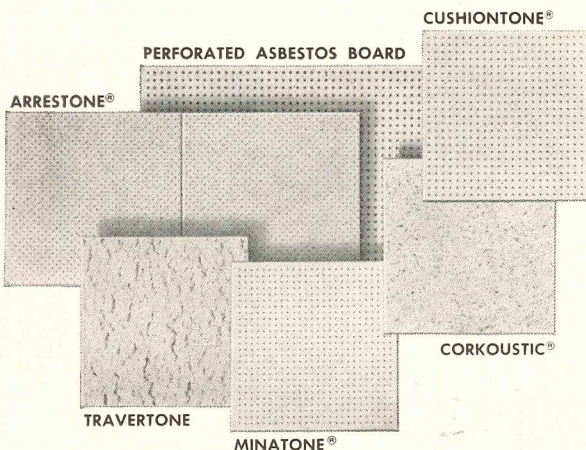

ENTIRELY ARCHITECT-DESIGNED

Municipal Airport, Shreveport, La.

*Samuel G. Wiener, E. M. Freeman & Associates
Architects and Engineers*



A R C H I T E C T U R A L
R E C O R D

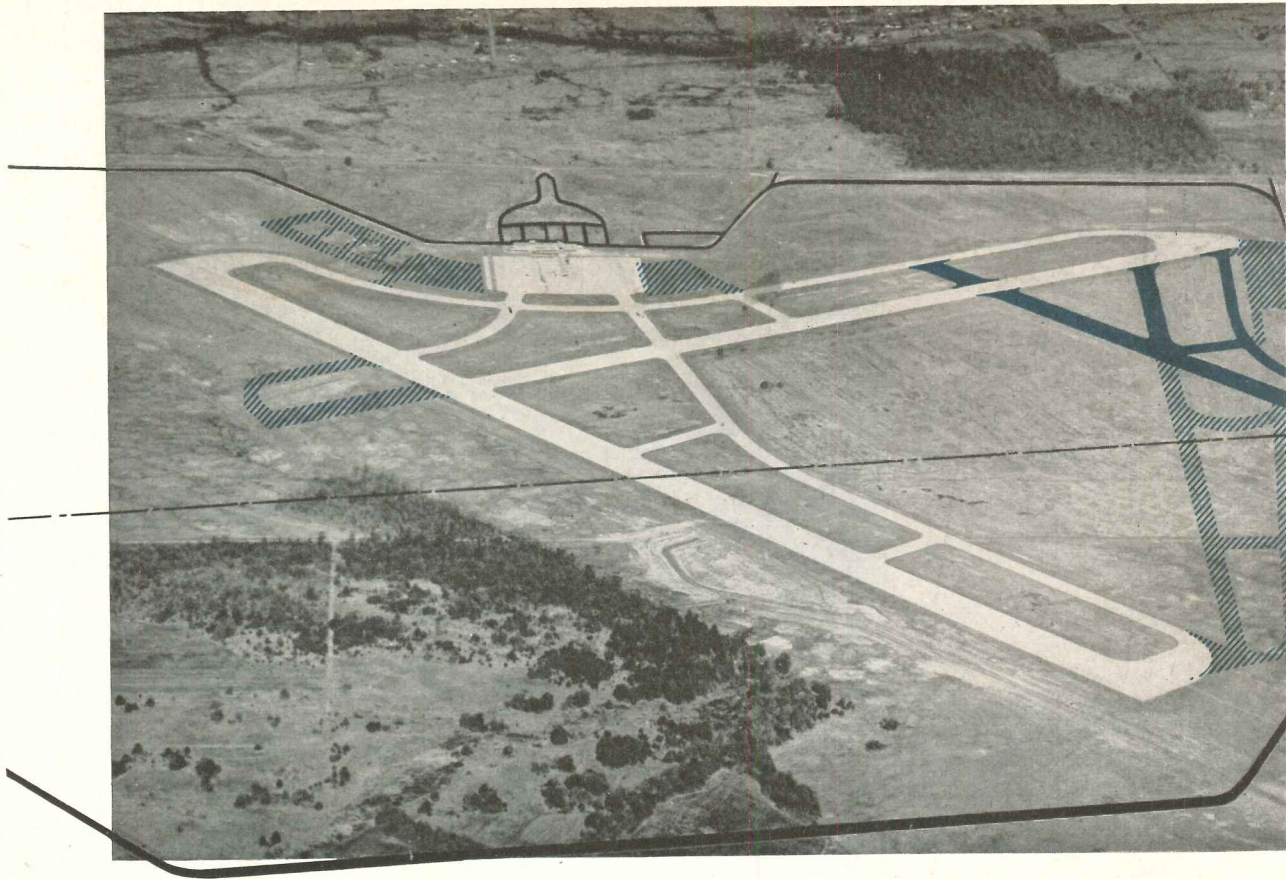

**SHREVEPORT
AIRPORT**

Shreveport's new airport was designed in its entirety—including runway layout and all buildings—by one firm of architects and engineers. Old airfield could not be expanded, was dangerously close to a military field; increasing commercial traffic necessitated move to a safer field where facilities could grow. Photograph shows present stage; black lines are relocated highway (bottom of photo), co-axial cable (across center of field), and service roads. Solid blue indicates next stage; shaded blue, final stage; potential hangar sites at upper left and right



H. O. Wiseman

SHREVEPORT'S MUNICIPAL AIRPORT, built under the authority of the city's Department of Public Works, of which H. Lane Mitchell is Commissioner, cost approximately five million dollars. Financed by a municipal bond issue and by a grant from the Civil Aeronautics Administration, it was entirely designed by one architect-engineer firm. Between its conception and its recent opening there were not only many months of work; it was also somewhat of a *cause célèbre* locally, though discussion has now given way to pride in the city's new transportation facility.

Due to increasing air traffic at Shreveport, it became necessary to either enlarge the old airport or build a new one. The old one had a decided advantage; it was within one mile of the city's business center. But it was also on the concave side of a curve in the Red River, which made expansion somewhat of a problem, and military traffic at Barksdale Air Force Base only 3 miles away was a source of annoyance if not of danger. Enlargement versus building anew became a heated issue, involving civic societies, newspapers and individuals. At a referendum, Shreveport voted to build a new airport; a bond issue was passed; and a more distant 1600-acre site, mostly hilly wooded land with some cultivated fields, in several privately owned parcels, was purchased.

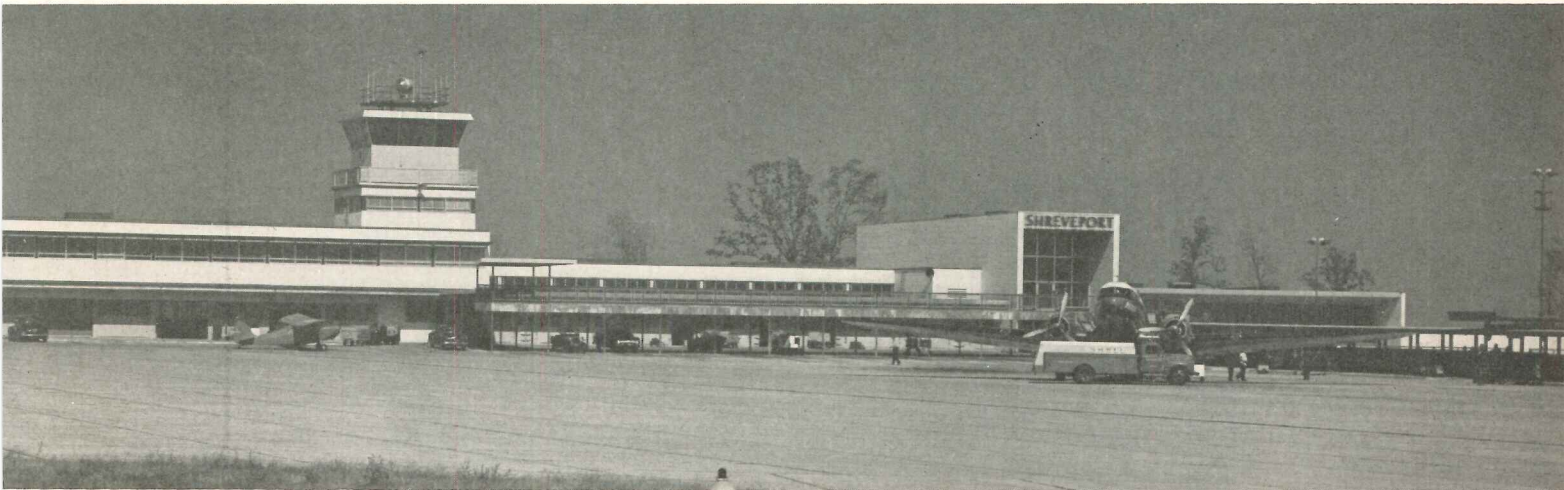

As terminal building looks to arriving passengers: facing page, from air; above, when taxiing up; below, from concourse after de-planing

Ulric Meisel



Main Entrance

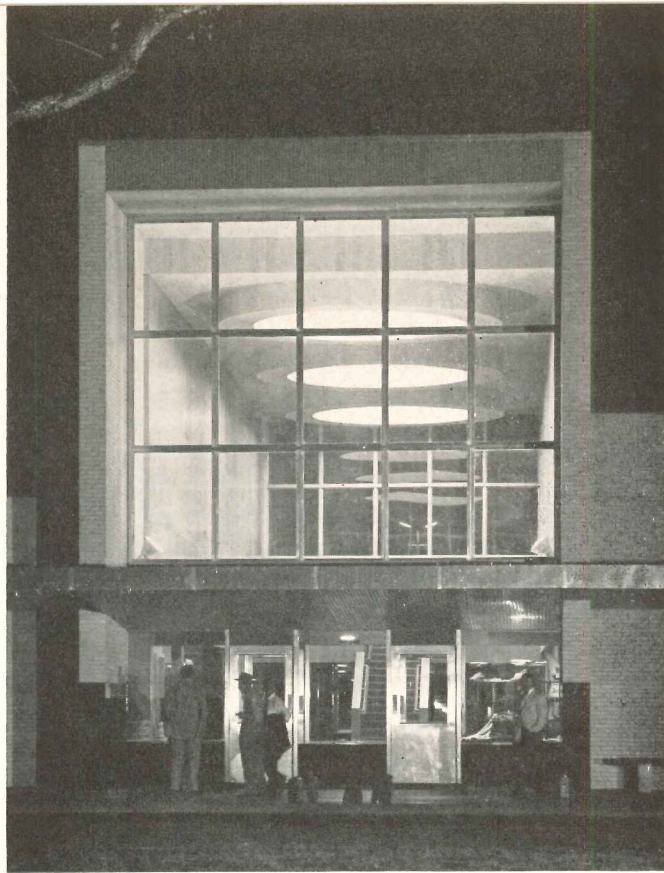

SHREVEPORT
AIRPORT

Inside Lobby



Airline Counters

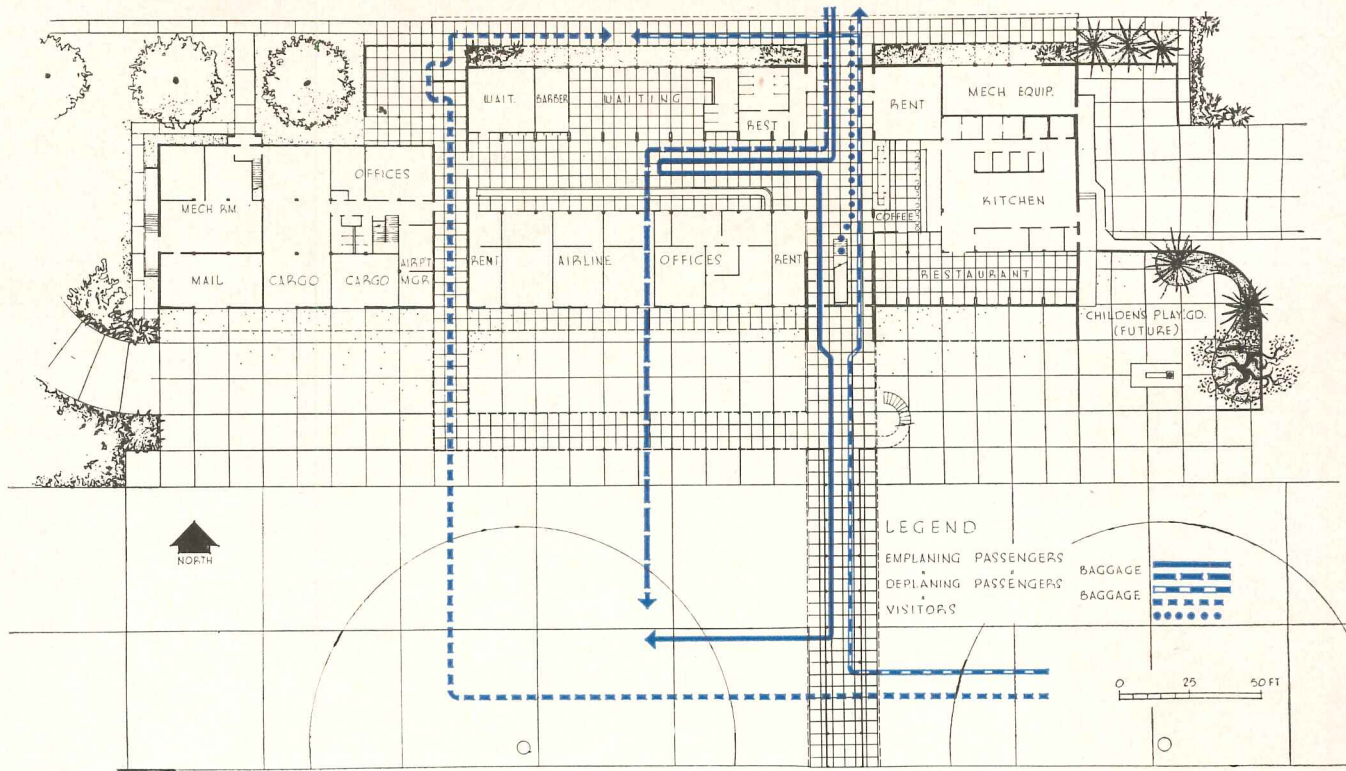

Passengers use lower doors to field; visitors, stairs to observation level above

Site preparation consisted of a substantial amount of clearing, grading, filling and compacting. A highway was re-routed; a co-axial cable had to be protected; some pipelines and utilities were relocated. Roads were extended, water wells drilled, power and gas brought in, and subsurface drainage installed. Now built are two runways, one, instrument-controlled, 6400 by 200 ft; the other 4800 by 150 ft. Locations for two more runways have been determined. Taxiways are 175 ft wide. Concrete runways and plane parking areas are 8 to 10 in. thick. In addition to the Terminal Building there are buildings for Maintenance, Remote Communications, Gasoline Fueling facilities and Water Pump House. Spots for future buildings and hangars have been determined. The entire airport and its facilities can grow in orderly fashion as needs arise.

The Terminal Building is primarily a transportation

Pedestrian and baggage traffic are not mixed

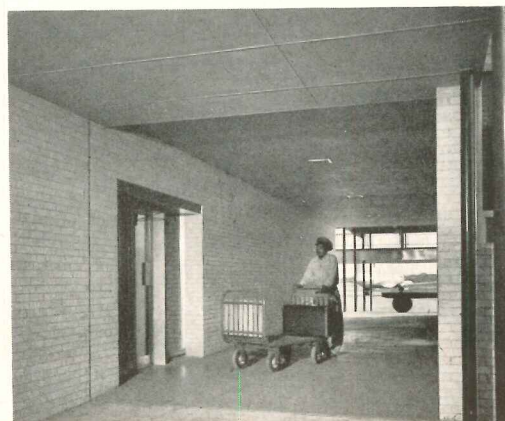

Ulric Meisel

SHREVEPORT AIRPORT



depot, with circulation of passengers, personnel, visitors, baggage and service equipment carefully organized on a one-level scheme to minimize interference. The architects decided to separate the administration and operation unit from the passenger unit by a breezeway. It was early decided not to bring deplaned baggage into the building or to handle it unnecessarily; the breezeway facilitates this. The structure, of reinforced concrete and steel frame faced with brick, has no basement; a crawl space continuous under both units and breezeway will permit future changes in wiring and services as tenants and equipment change. Public, rental and office spaces are air conditioned; the two mechanical rooms are at a slightly lower floor level.

Special features, some now completed, include the 350-ft-long "finger" concourse, 200-ft-long observation deck, and space reserved between building and ramp for a future planted, equipped children's playground. The project was conceived as a show-place for the city as well as a smoothly functioning airport.

Left, observation platform on south (field) side of structure; center . . .



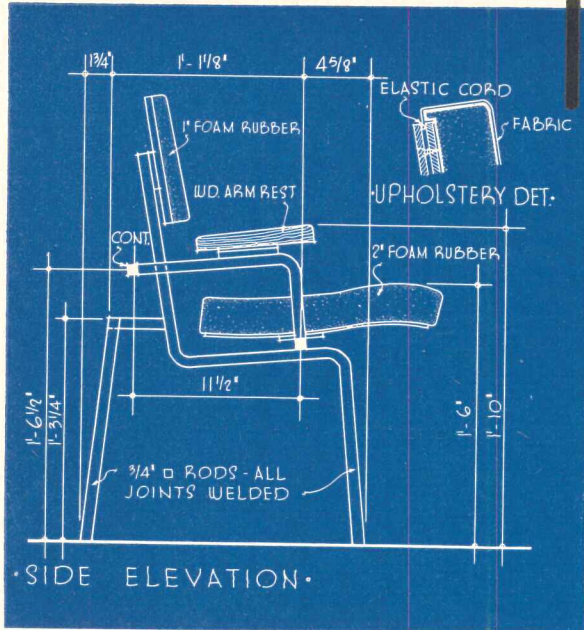
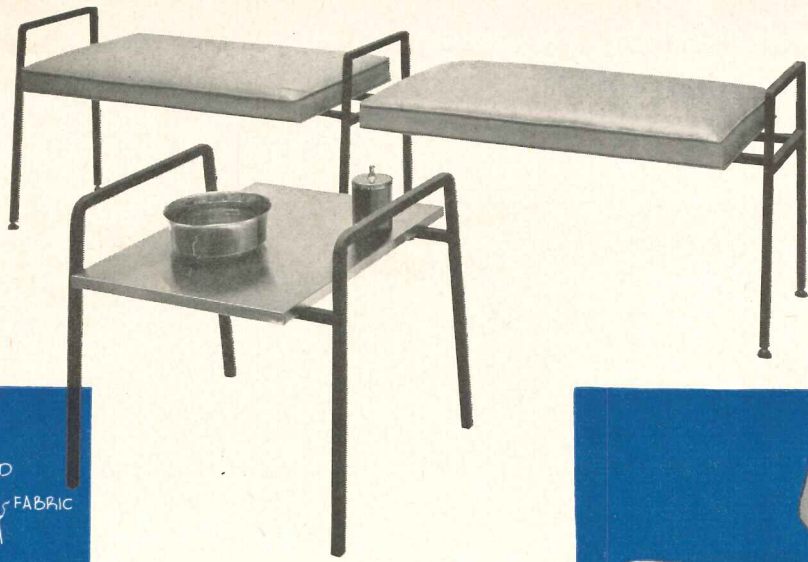

Furniture in main waiting room, specially designed by architect-designer James R. Lamantia of New Orleans, is of height suitable for waiting passengers but not comfortable enough to encourage lounging. Benches are convenient height for depositing baggage. All pieces are heavier than strength alone demands, to prevent pushing them around. Removable plywood panels permit taking off fabric for cleaning. Floor is terrazzo, walls marble, ceiling acoustical tile



Furniture photos: Frank L. Miller

... stair to concourse level; right, restaurant

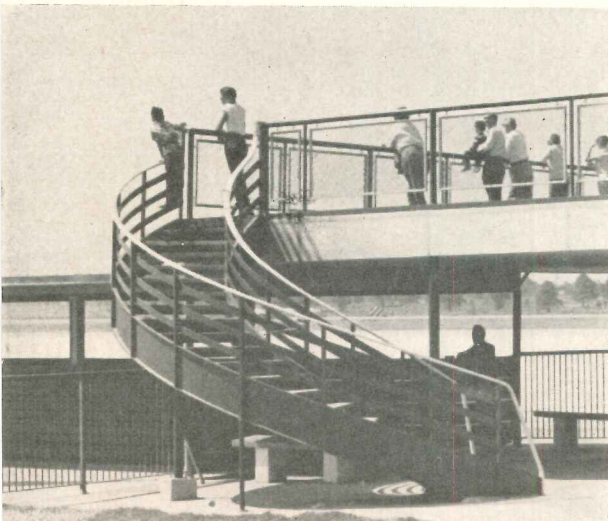

Ulric Meisel

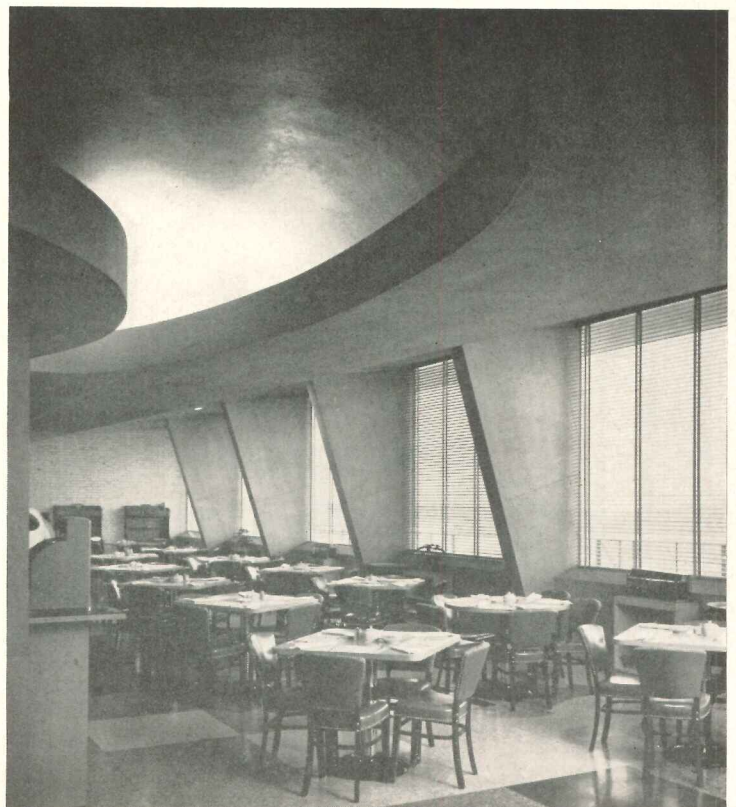



SHREVEPORT AIRPORT

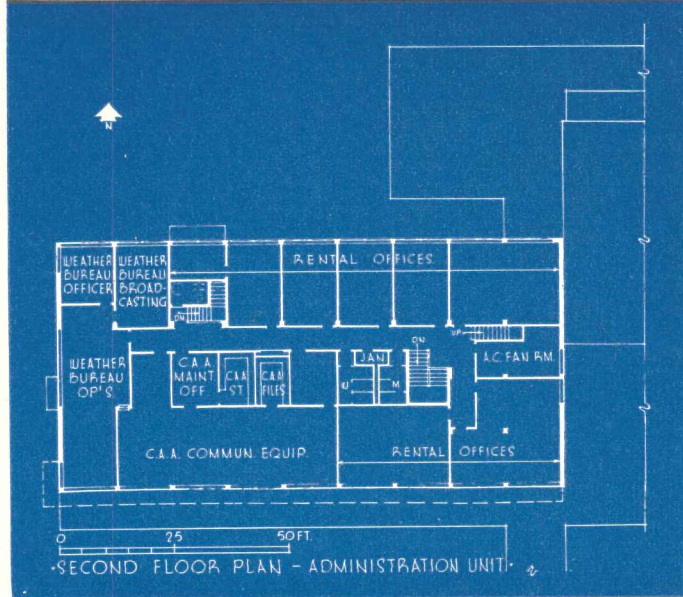

Second floor of administration unit (plan at left) contains weather bureau, CAA offices, rental space. As in all air terminals, official spaces here and in control tower floors (controller offices, radar room, control cab) contain much special equipment required by regulations, with provision for more and different future equipment



H. O. Wiseman





H. O. Wiseman

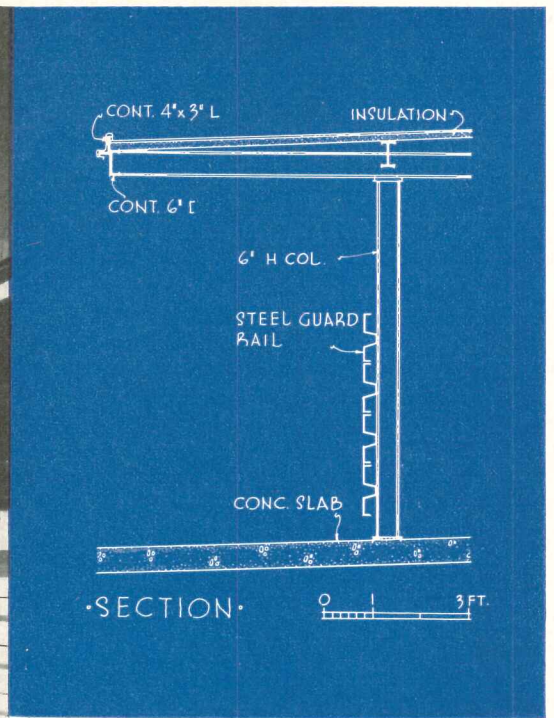

Steel guard rail at concourse and stair to observation deck are painted fire-engine red; copings and signs are porcelain enamel. Below: de-planed passengers and baggage meet under cover on north side

Ulric Meise



AWARD-WINNING PROTESTANT

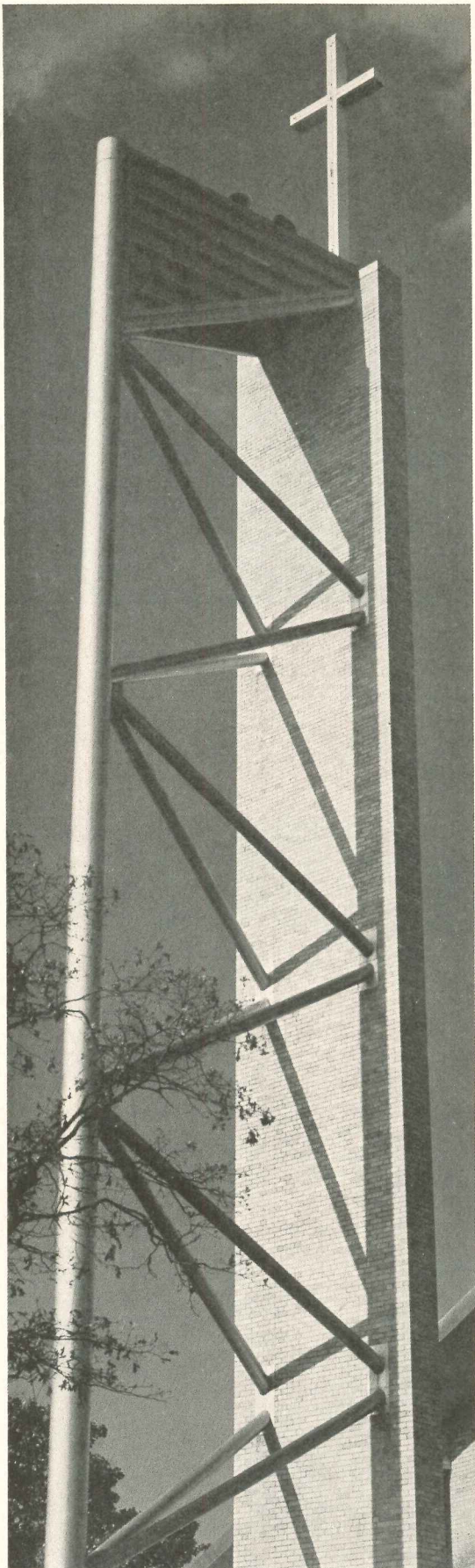

Earl Saunders

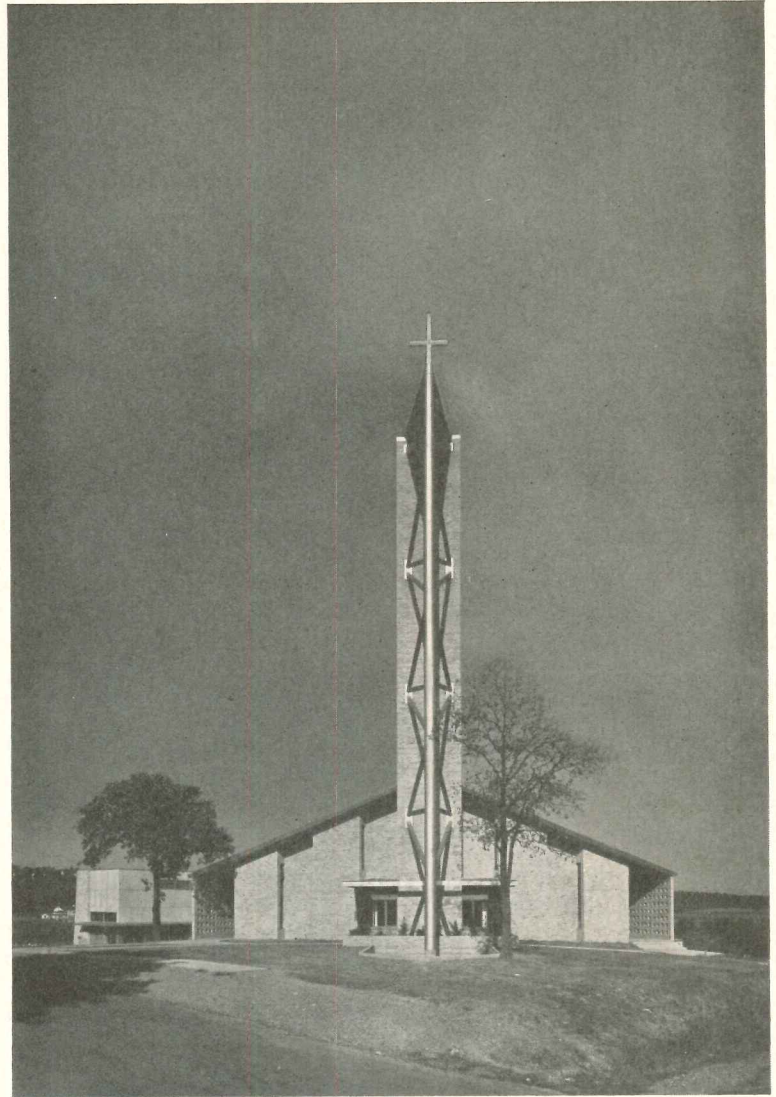

Given an Award of Merit at the Gulf States Regional A.I.A. Conference last October, North Little Rock's new First Methodist Church has a commanding site in a residential area where many of its congregation live. The site slopes sharply, a fact which was turned to advantage in designing the building

CHURCH IN NORTH LITTLE ROCK, ARKANSAS

*First Methodist Church
Brueggeman, Swaim & Allen
Architects*

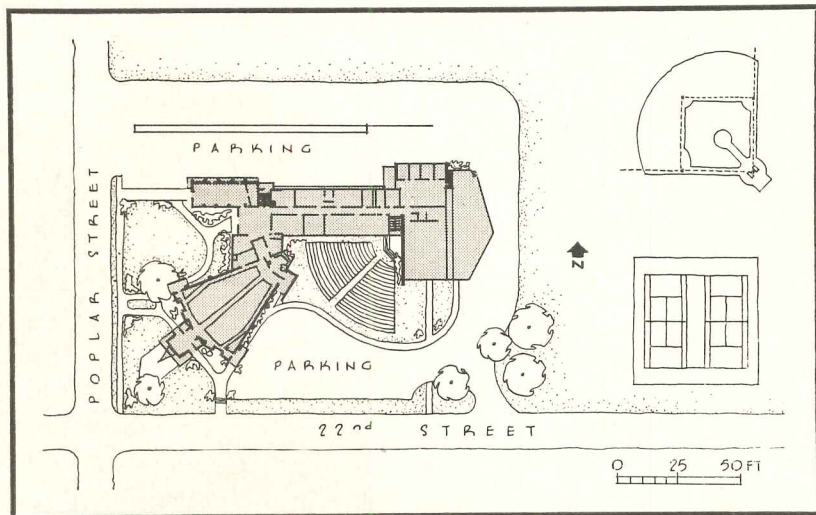
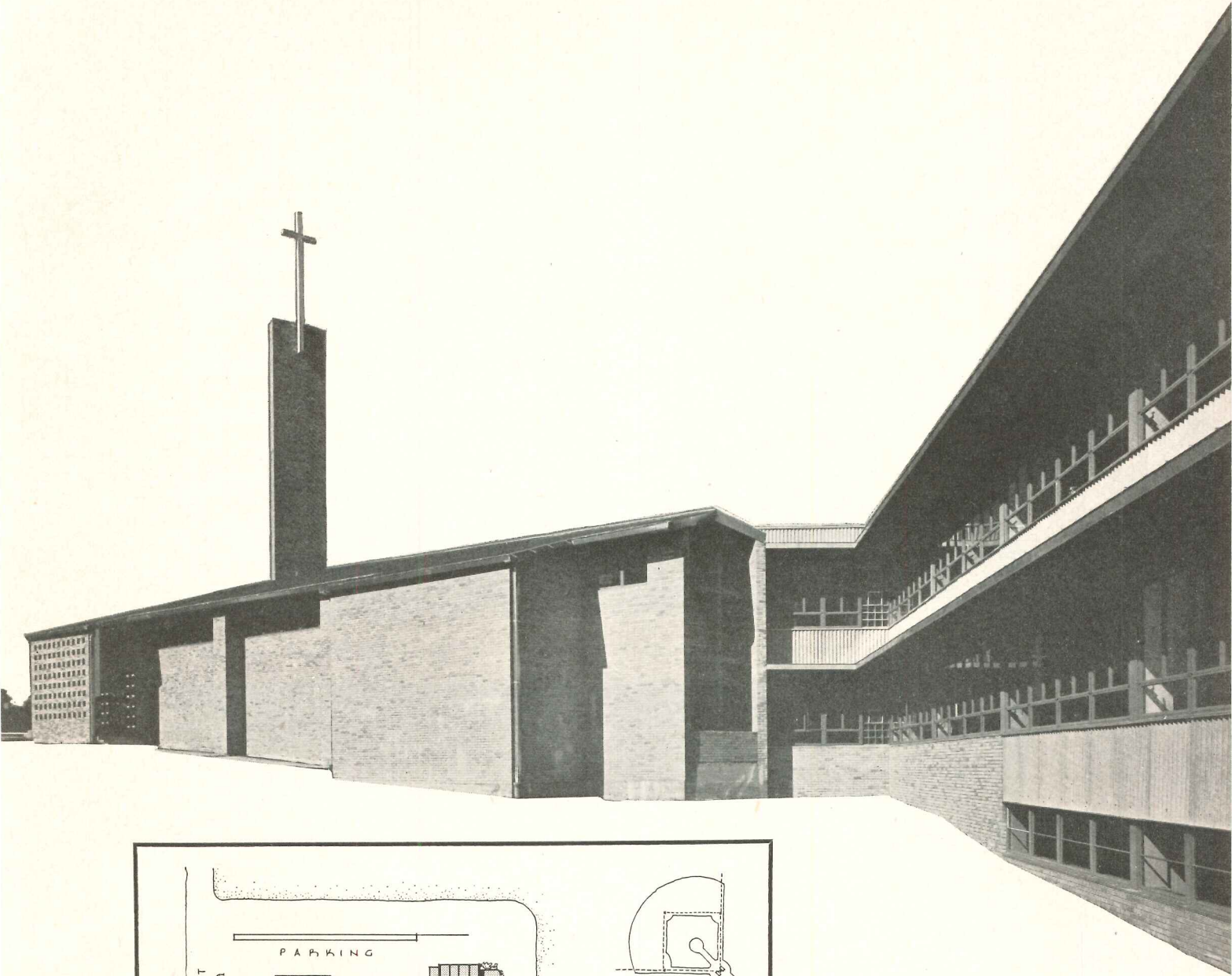

AWARD-WINNING CHURCH



THE FIRST METHODIST CHURCH of North Little Rock, Ark., formerly occupied a building on a small but valuable downtown corner with no parking facilities. Its new building is on a large site in a residential area, where most of its members live — a plot bought for a fraction of the price at which the old one was sold. The congregation is not wealthy, so despite this financial profit the buildings had to be designed with economy continually in mind if the full program — sanctuary, chapel, educational building, community facilities, outdoor chapel and parking space for 100 cars — was to be realized. As it is, the east wing of the educational unit is at present not built above the ground floor, and until it is completed the outdoor sanctuary cannot be finished. All other requirements were met, however, though only after the membership had agreed to accept contemporary rather than traditional design.

Even so, the architects' utmost ingenuity was called for. The site drops 35 ft from northwest to southeast, a fact which was turned to distinct advantage; every possible cubic foot of excavation was eliminated by placement and design of the units. The carillon tower, factory-fabricated of aluminum, was erected in one piece and attached to the vertical brick slab which braces the metal. The sanctuary, fan-shaped because that was the economical en-

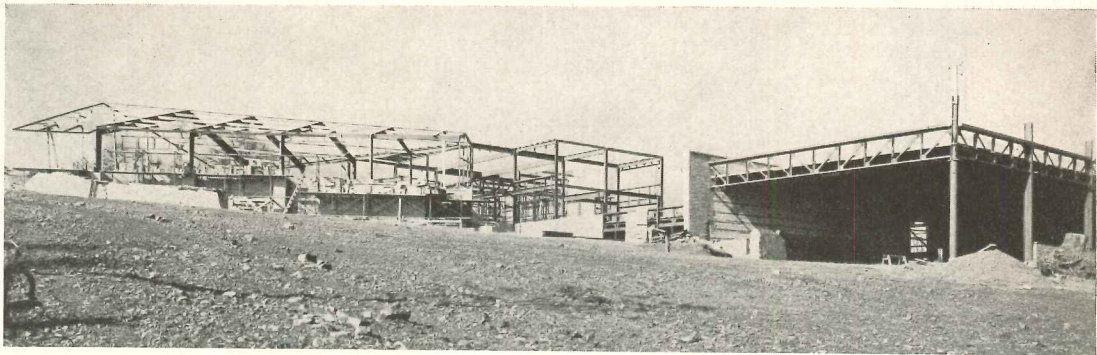

Structure follows slope with minimum excavation. Photo below: at left is chapel; right, side entrance to narthex

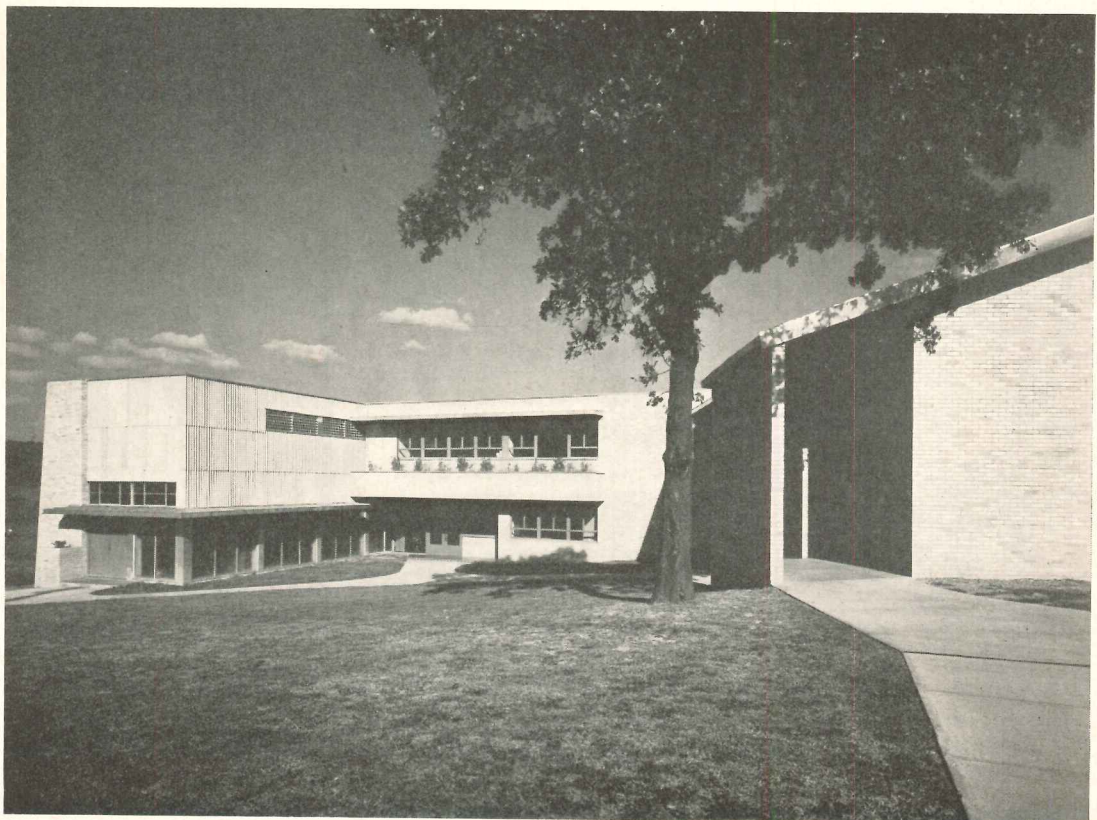

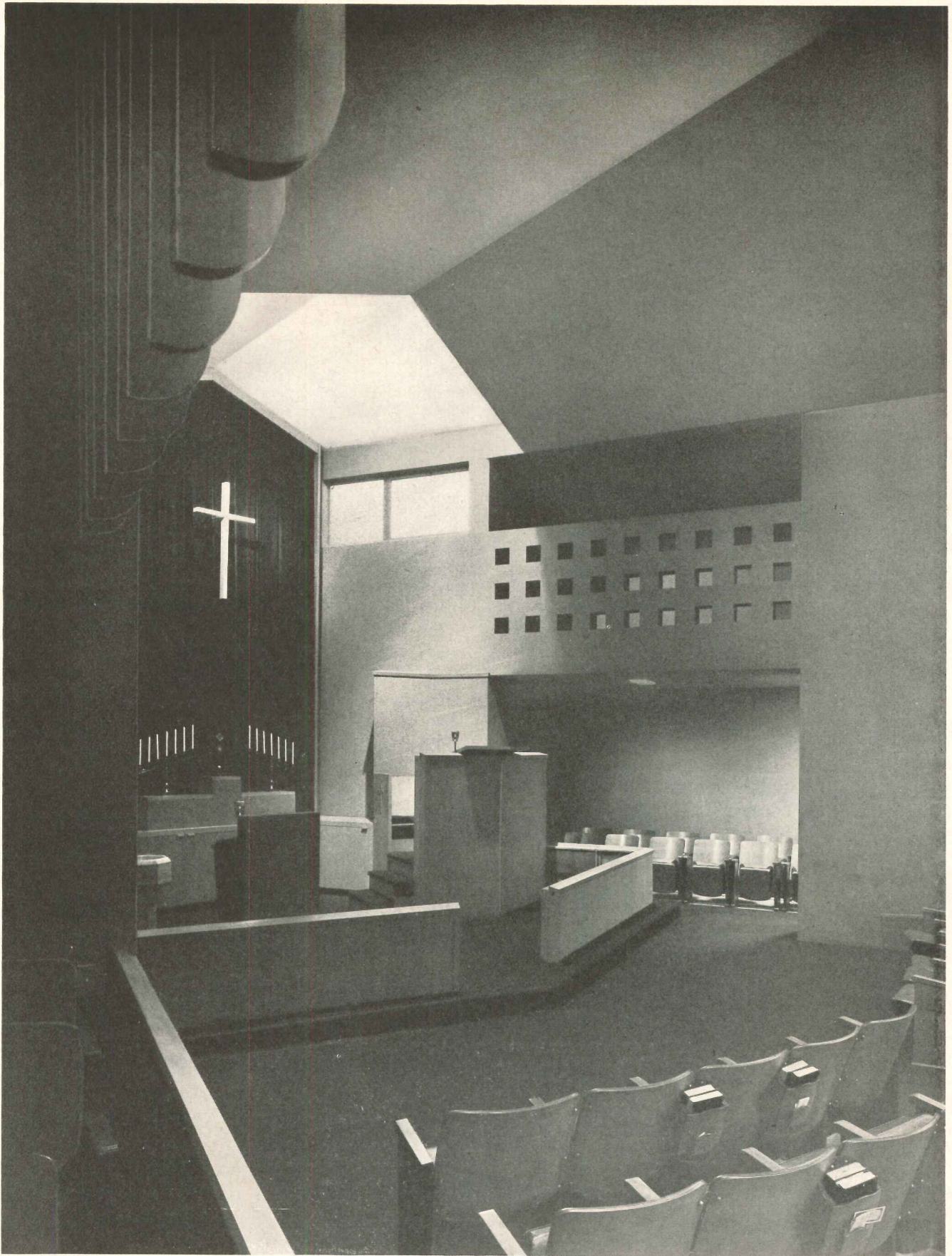

Earl Saunders

Sanctuary, megaphone-shaped, has walls converging toward chancel. Concrete floor slab was laid directly on slope with little more than simple grading operations

**AWARD-WINNING
CHURCH**

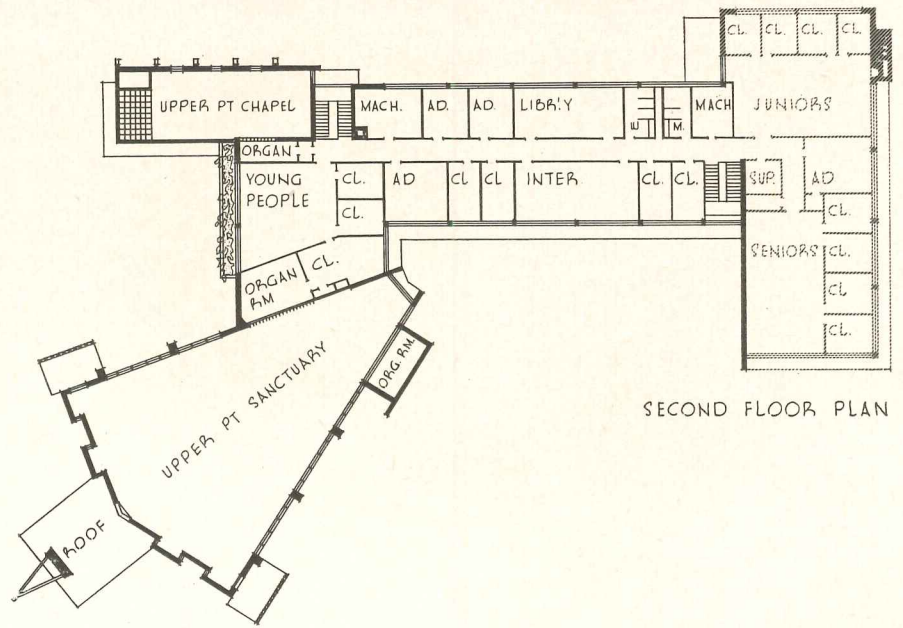

SECOND FLOOR PLAN

Earl Saunders

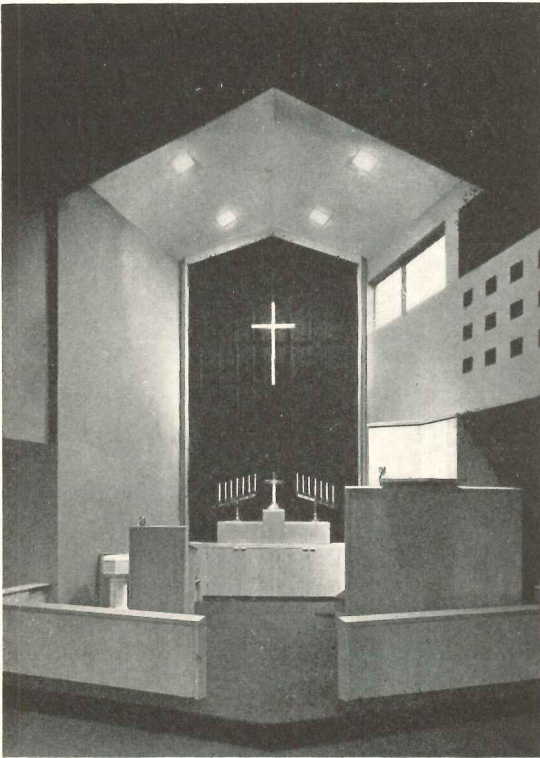

closure for the desired number and arrangement of seats and for acoustical reasons, has its sloping floor slab laid directly on existing grade. Sanctuary framing is a series of rigid steel bents of diminishing spans, fire-proofed with vermiculite. Weight is saved in the educational unit by using steel trusses for spandrels, fire-proofed and covered with corrugated asbestos-cement sheets.

In relationship and circulation the various units function well. The family room for funerals is so located that it has a direct entrance, maximum privacy and immediate access to the chapel. Except for the top floor of the educational building, every level can be entered directly from natural grade. Construction is concrete and steel, with brick, glass and asbestos-cement sheets on exterior walls, steel windows, aluminum and built-up roofs; interiors are plaster, exposed brick, glass, tile, asphalt tile and carpeting. Lighting is both incandescent and fluorescent, with sanctuary lights on rheostats. Sanctuary windows are green glass with symbols sandblasted in them. The whole church has year-round air conditioning. Cost was \$372,000, or \$10.50 per sq ft, \$.76 per cu ft.

Although sanctuary walls average only 16 ft in height, their convergence and the sloped floor afford extra height—24 ft—desired for design of chancel. In first educational building, areas shown gray on first and second floors will be built in future; present building terminates at stair hall

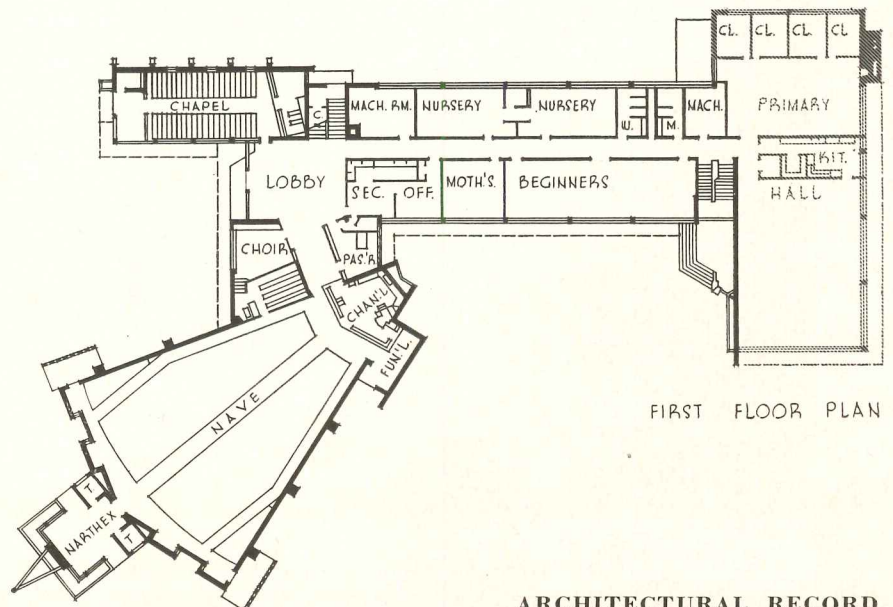

FIRST FLOOR PLAN

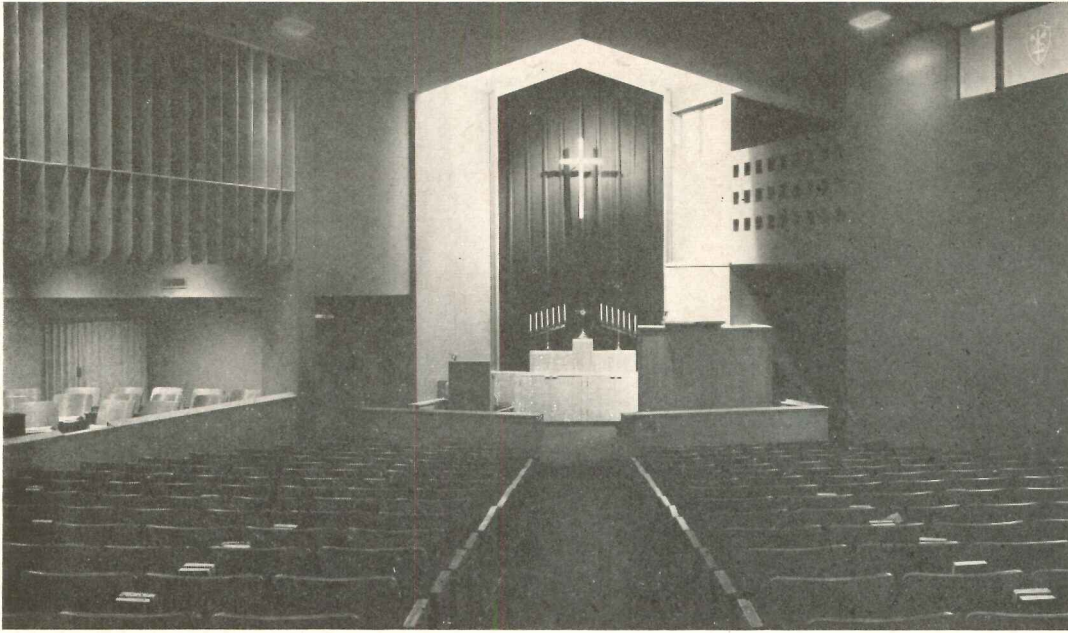

Non-parallel enclosing surfaces produce desirable acoustic properties in sanctuary. Only acoustic treatment is absorbent plaster in center ceiling panel. Although choir (below) is at one side, no noticeable variation in intensity or quality of sound has been reported

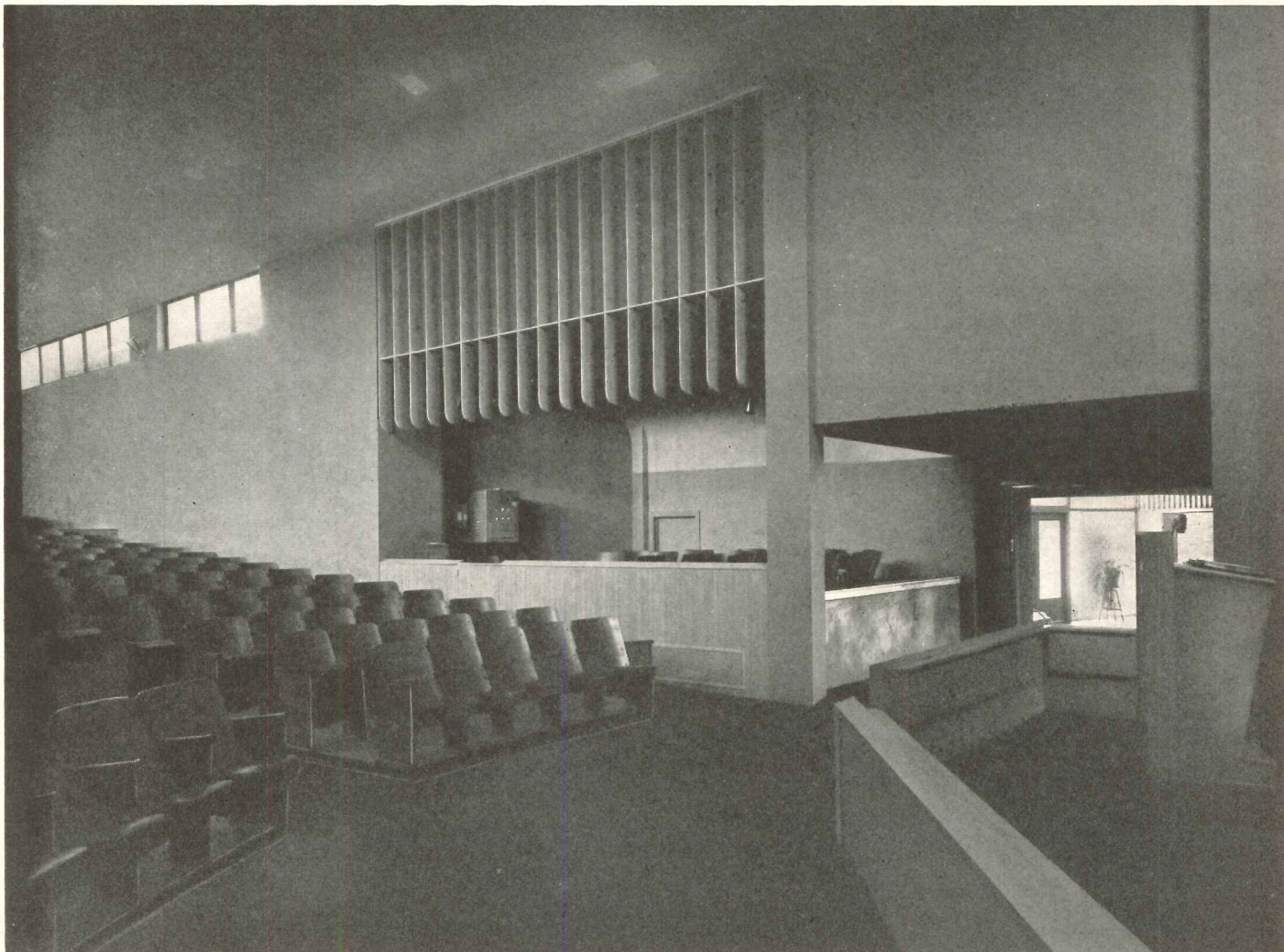

AWARD-WINNING CHURCH

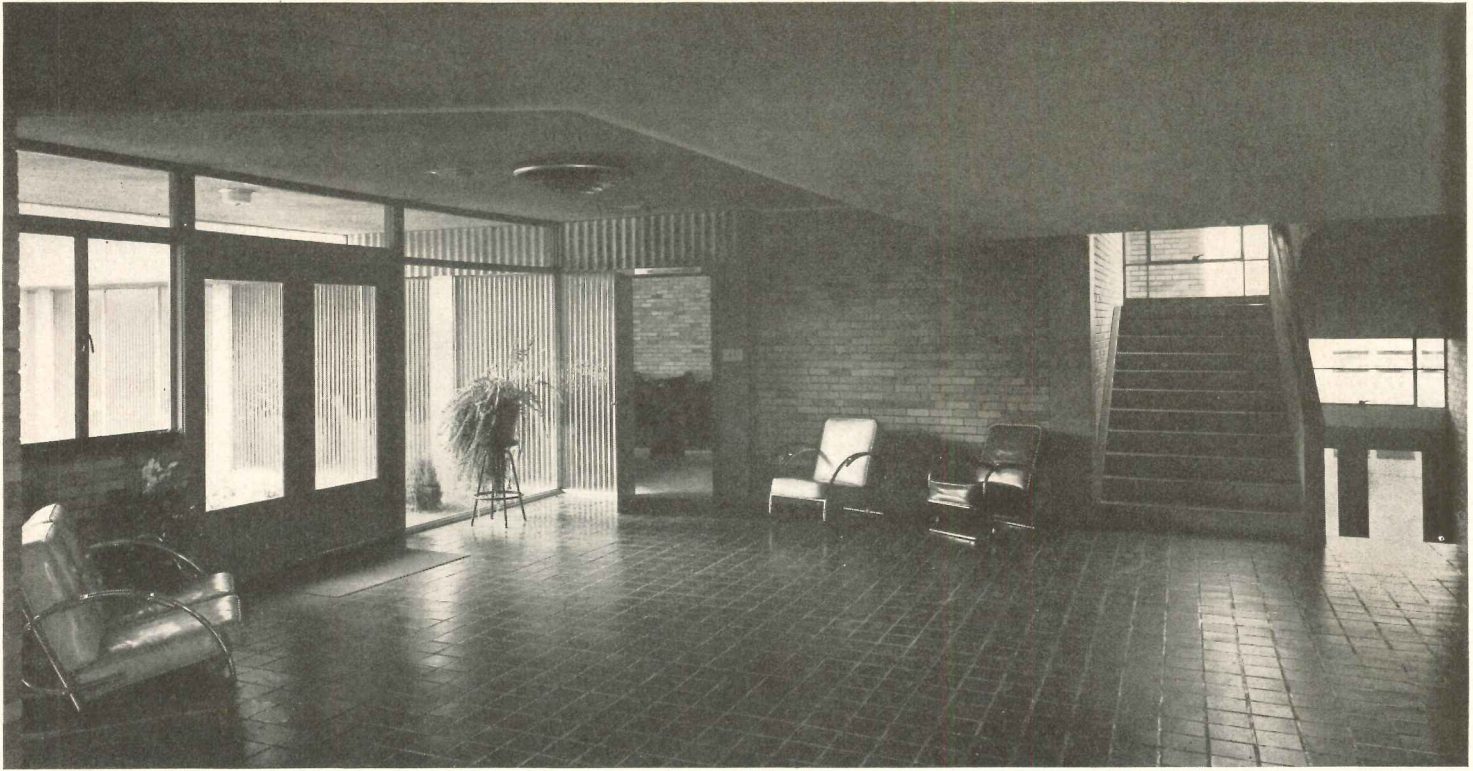

Above, lobby between sanctuary and educational building; chapel is accessible through door in center of photo. Bottom of page, model shows eventual appearance of educational unit when two-story wing at right is added. Between sanctuary and educational building is to be an outdoor sanctuary fitting the natural contours. At right, typical classrooms

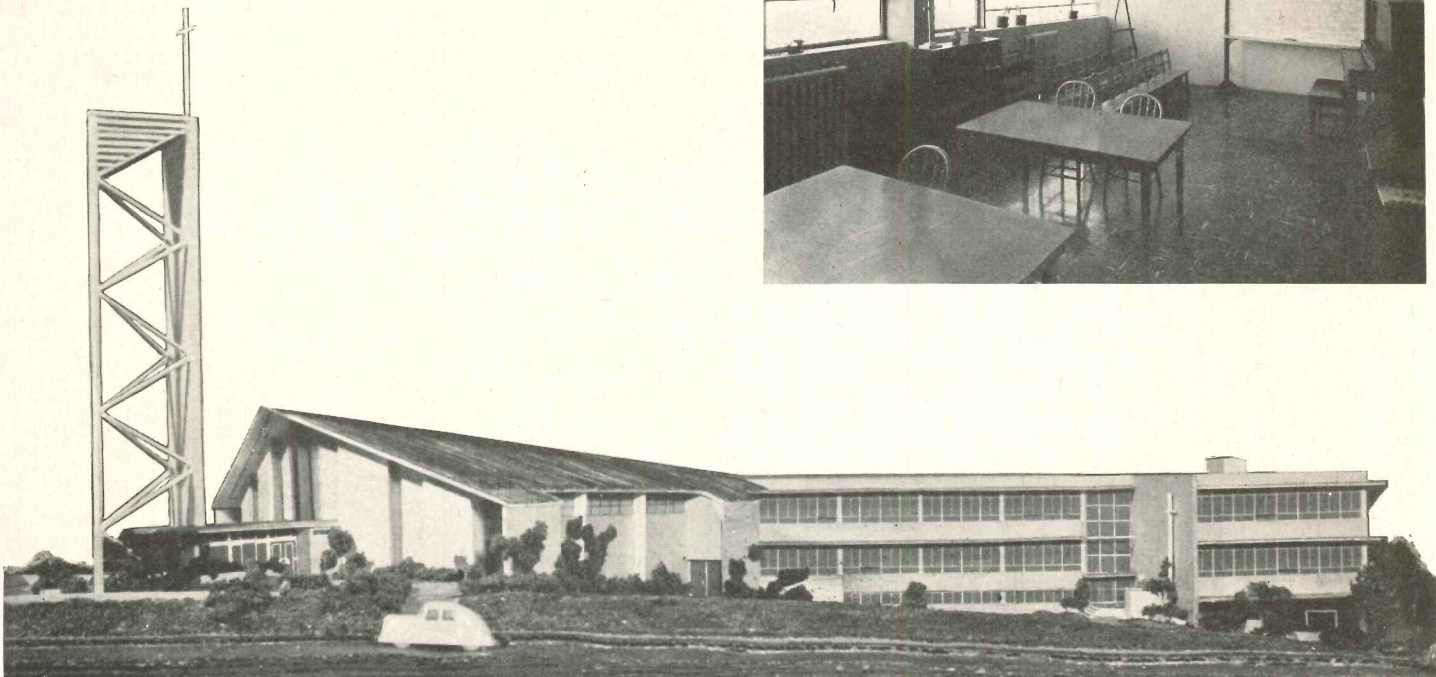
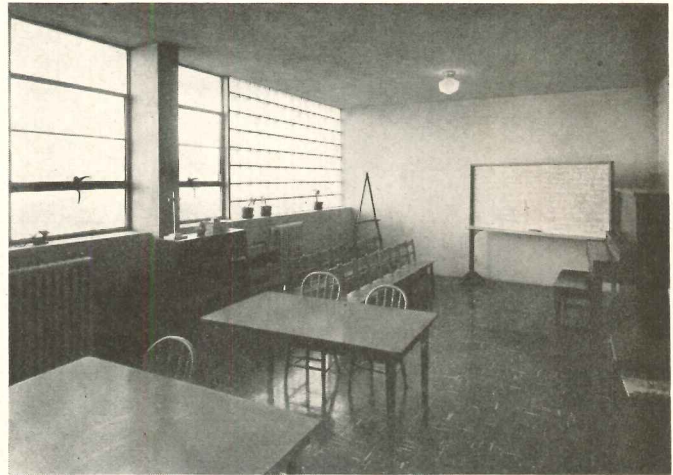



Banquet room on ground floor (photo above) is only portion of east wing of educational unit now built. Adjacent outdoors is Interchurch League softball field, lighted for night use. Tennis courts have been proposed

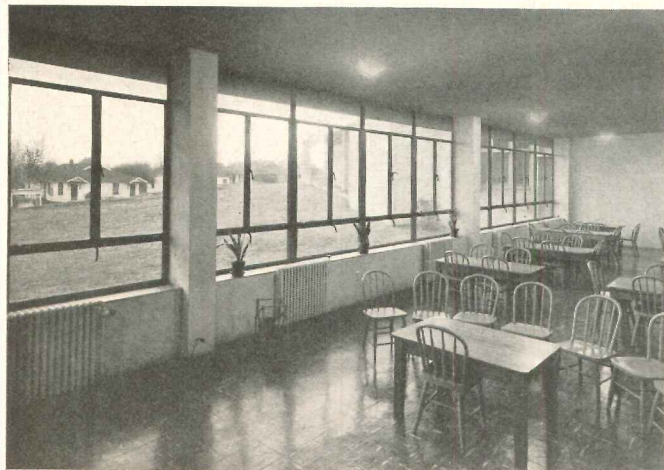
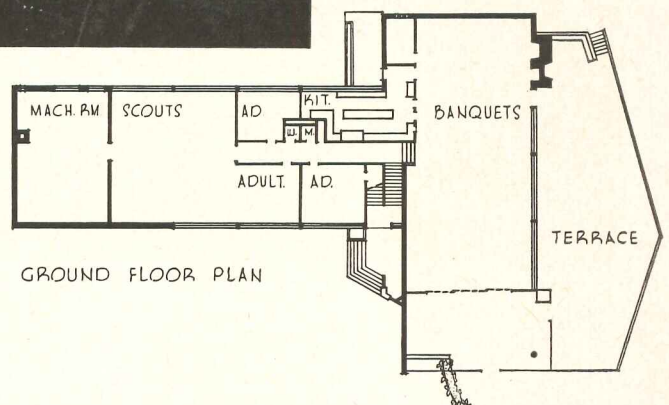

Earl Saunders

Photo, right: end of educational unit now built. Platform at grade entrance to ground floor has brick pulpit for use when outdoor sanctuary is completed, as shown in model photo on facing page. Buildings shade this area from late afternoon sun

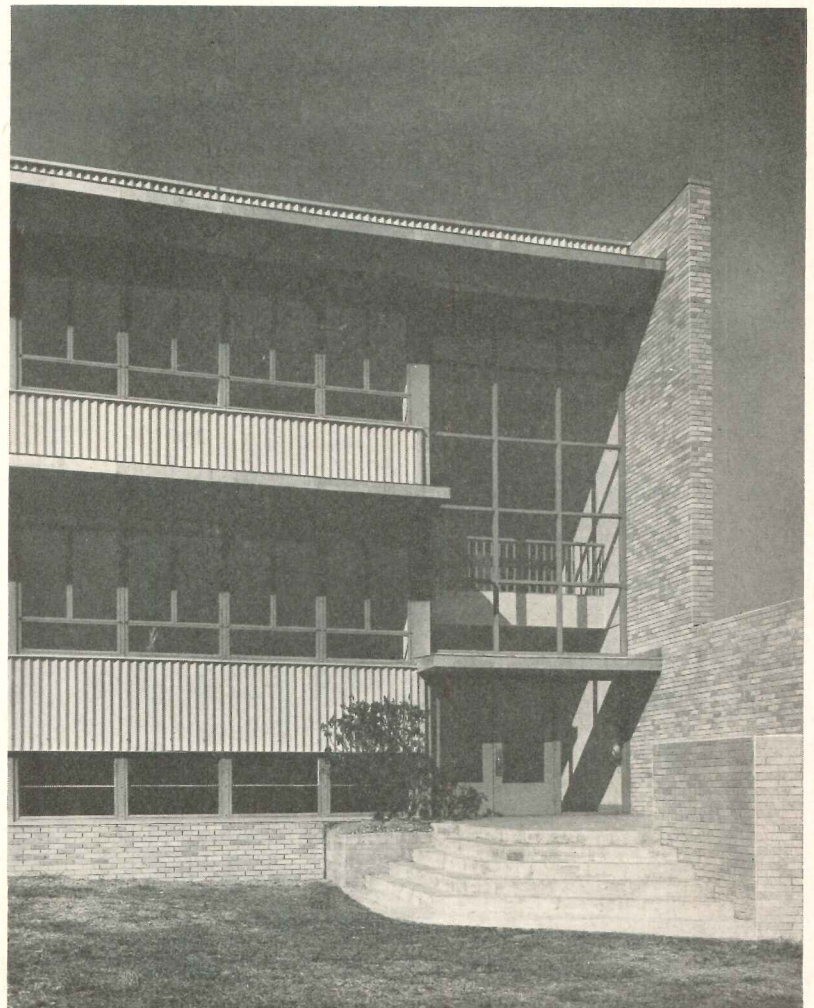

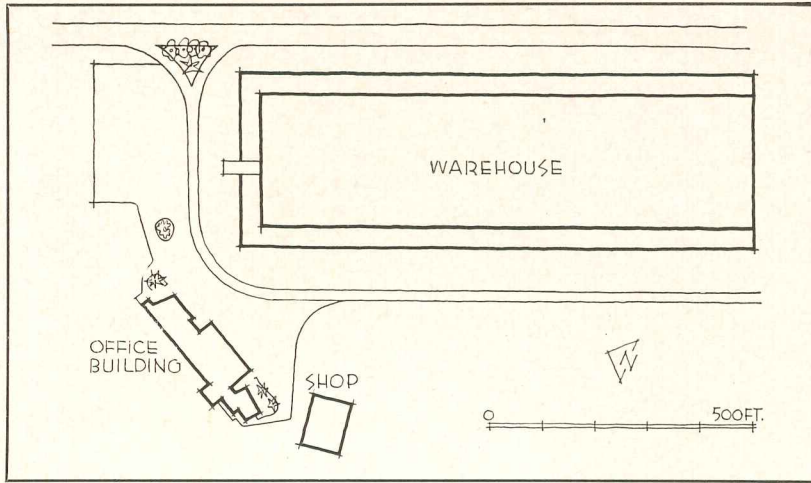

ASSOCIATED GROCERS CO-OP,

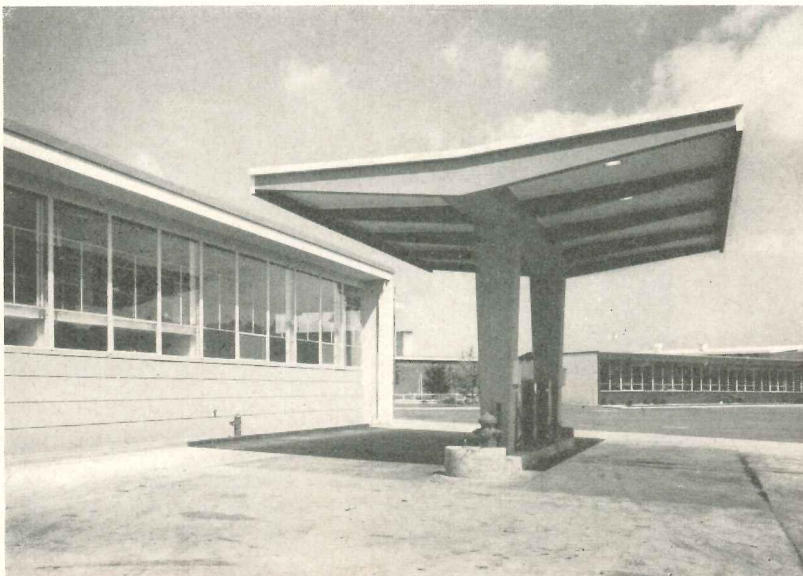
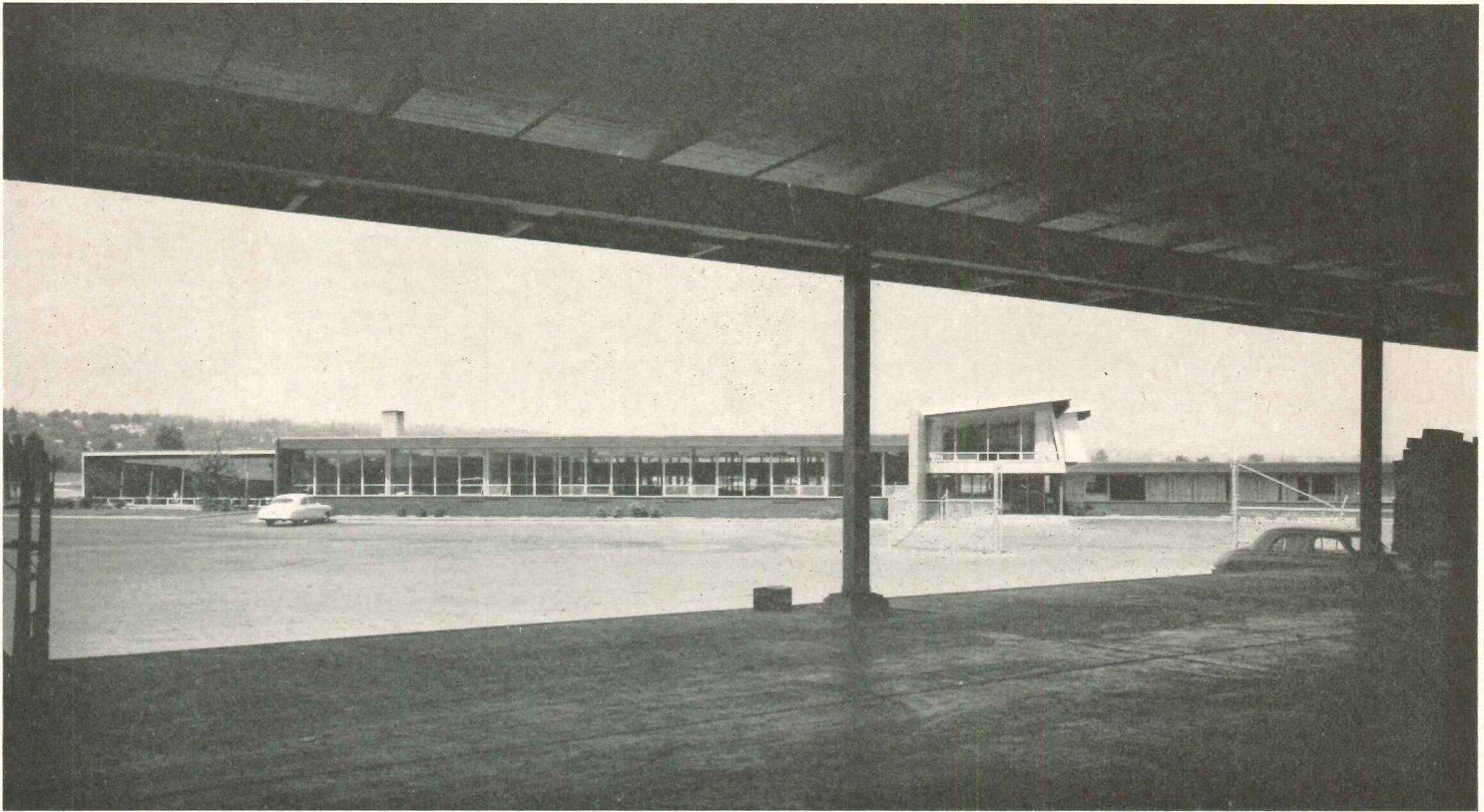

Robert Hugh Ross, Architect
George M. Anderson and
William C. Bunch,
Structural Engineers
George S. Troberg,
Mechanical Engineer
Morrison Knudsen Co.,
Contractor

**Crisp new headquarters combine
efficient, low-overhead facilities
for mass purchase and distribution
of supplies for 600 member stores**

SEATTLE, WASHINGTON

Dearborn-Massar

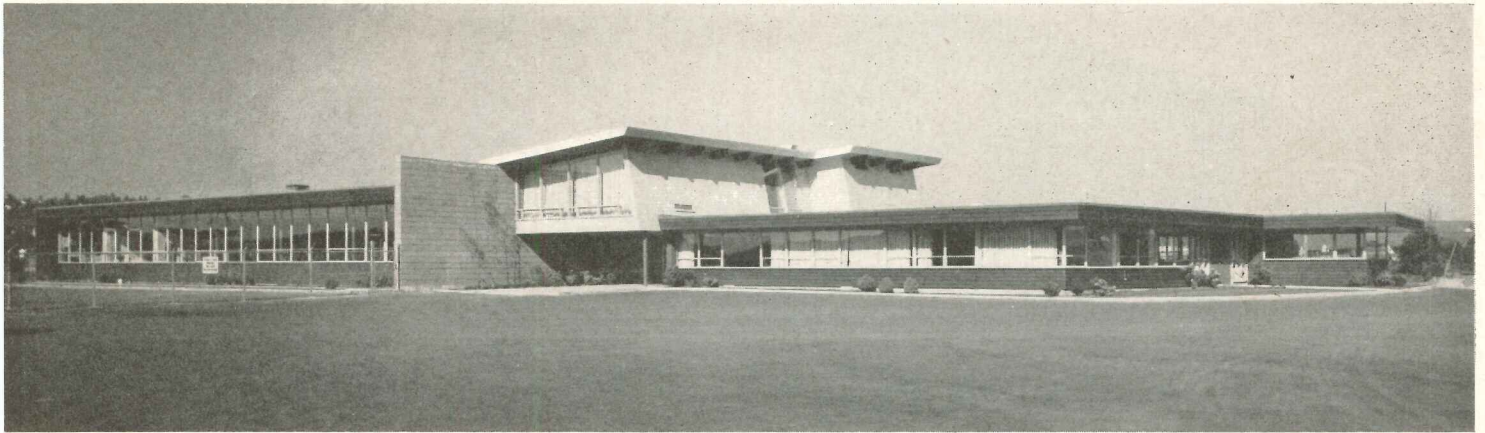

IN RATHER STRIKING CONTRAST to the drab conditions usually associated with warehouse operations, these clean-cut buildings provide pleasant, efficient accommodations for Associated Grocers Co-Op. The organization, associated for some 18 years, has grown steadily since its beginning; membership today totals some 600 stores in Washington, Oregon, Alaska and the Hawaiian Islands. The expansion in size and in volume of business (sales for 1951 were around \$33 million) created a severe strain on operations and efficiency,

made it difficult to keep costs down in the original buildings. This overhead has been considerably reduced in the new center, and a good working environment provided, by careful plan organization and selection of materials and equipment.

The buildings are located on a 26-acre suburban site in Seattle's South End. The group includes an administration office building, a large warehouse, a maintenance shop for trucks and ample parking space. All buildings are related by color: gray, coral trim.



IN PLAN, THE OFFICE BUILDING is divided into two distinct parts by a fire wall with fusible link fire doors; one section contains executive and buyers' offices, the other is devoted to general office space and a cafeteria-auditorium for employees. The general office is connected to the warehouse by an underground pneumatic tube system to expedite orders.

THE WAREHOUSE is a tip-up slab structure and contains: canned goods storage area, frozen foods storage area, special banana rooms and an assembly line for orders. The grounds are landscaped with simplicity for easy upkeep.

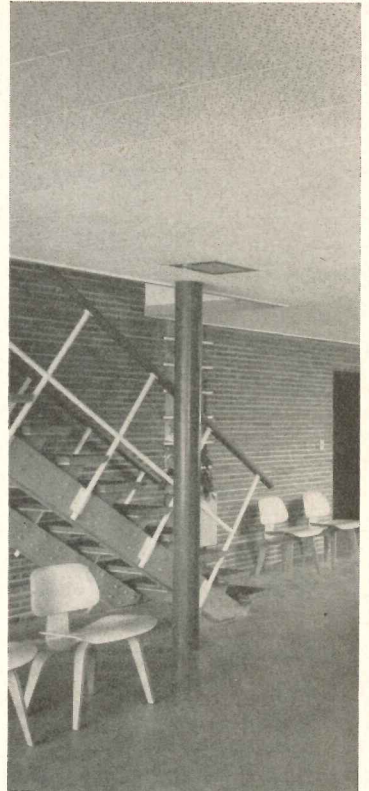

Dearborn-Massar

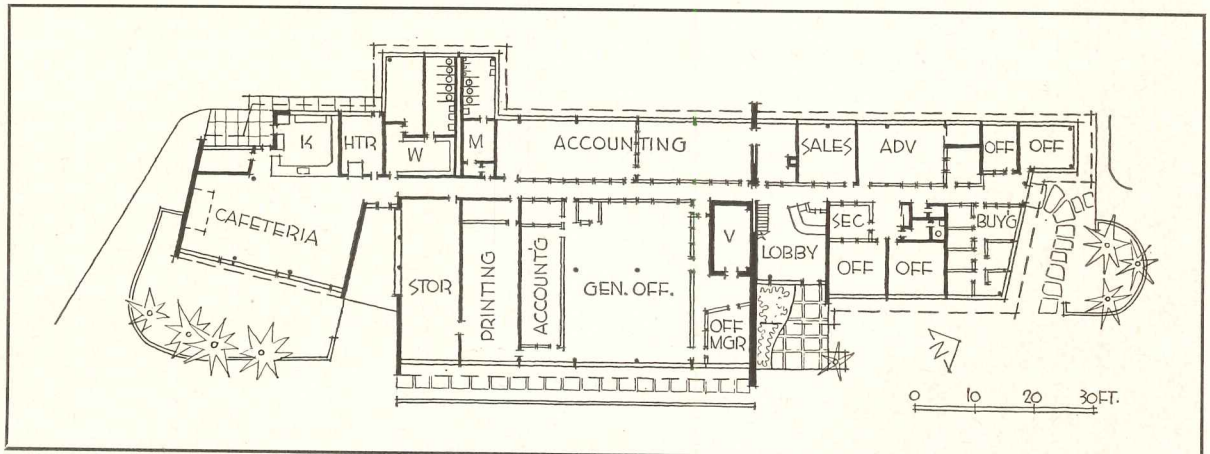

**Clean lines and durable materials
minimize Co-Op maintenance costs**

THE STRUCTURE of the office building is steel frame. Exterior walls are brick and frame surfaced with creosote-stained cedar siding. Interiors have similar finishes, plus painted plaster board with taped joints (see lobby photo, center). The roof is built-up, with asphalt and aluminum coat finish. Floors are oxy-chloride cement on reinforced concrete slabs, pegged random oak in board room (below). Thermal insulation is rock wool batts, acoustical is random perforated acoustical tile. Considerable saving was made by using a split heating system: radiant floor panels with pipes 48-in. o.c. in slab, augmented by baseboard heaters on outside walls.

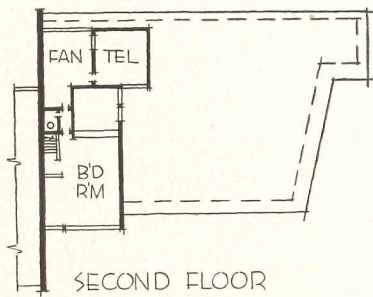
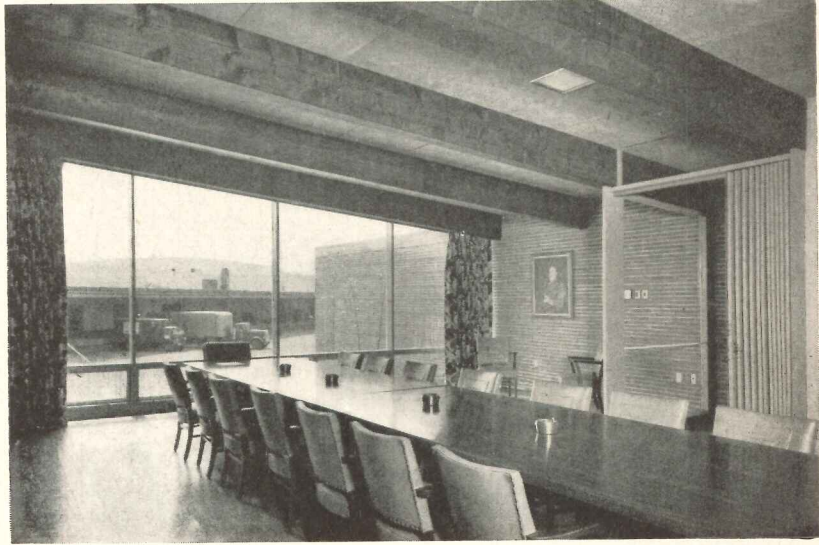

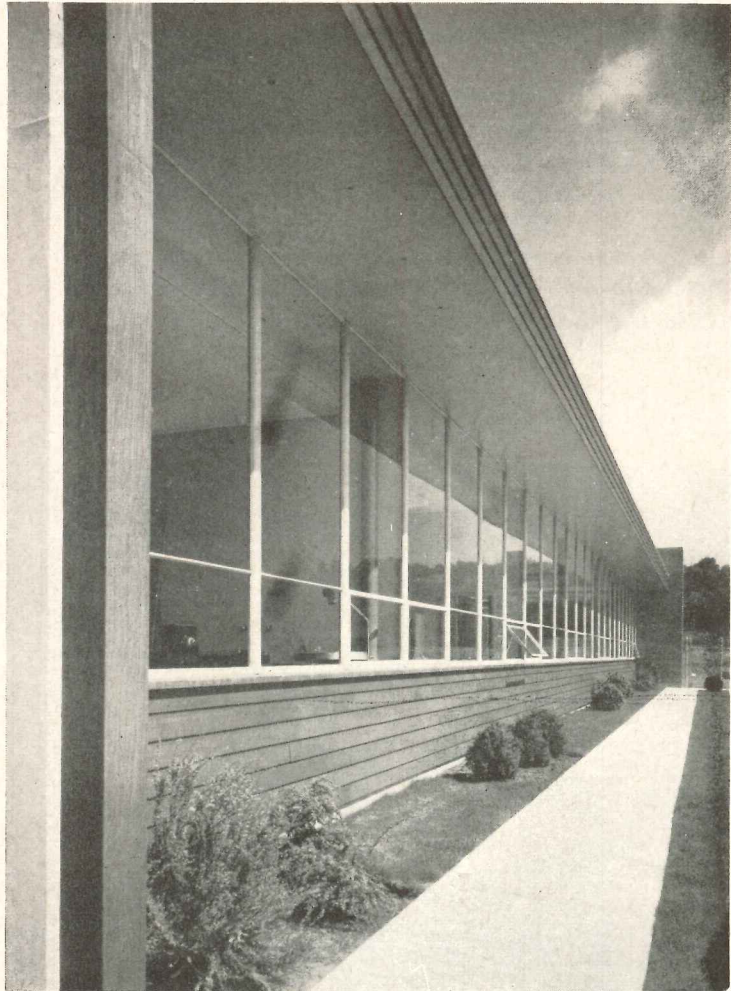

1

Office efficiency in the Co-Op is increased by a number of features as illustrated:

- 1 Good daylighting from windows to ceiling, wide overhangs for sun protection
- 2 Good corridor lighting from clerestory and glass partitions; double glazing and acoustical wall panels reduce noise
- 3 Pleasant working environment provided by gray and coral color scheme; ventilation system and vent sash keep air fresh; heating by radiant floors, baseboards
- 4 Comfortable artificial lighting level by fluorescent fixtures. Pneumatic tubes to warehouse; orderly equipment layout
- 5 Separate entrance to cafeteria and offices forms outdoor patio
- 6 Cafeteria serves 100 employees, doubles as auditorium for 300. Slanted glass is green, glare-reducing. Fibrous acoustical material between beams reduces noise

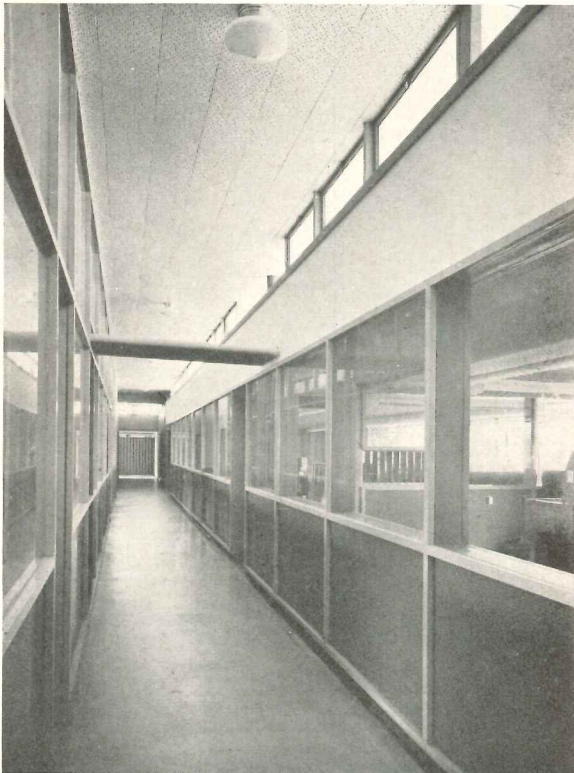

2

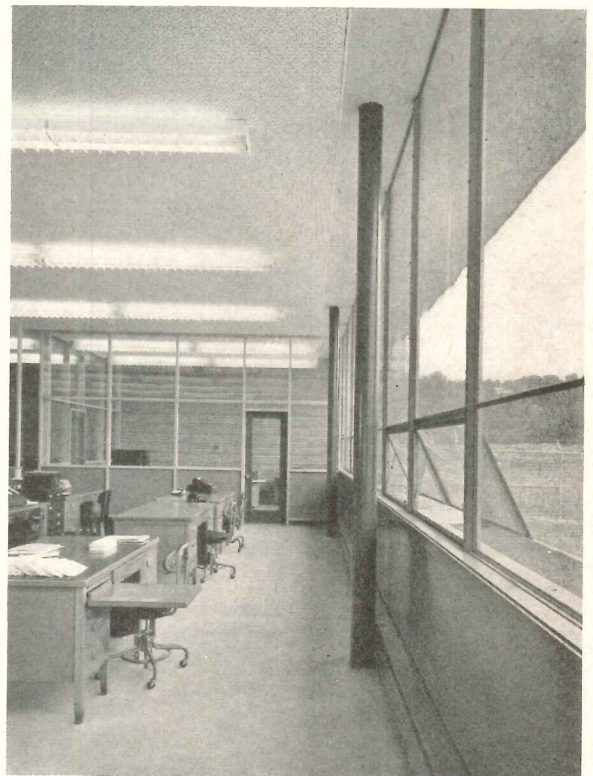

3

5

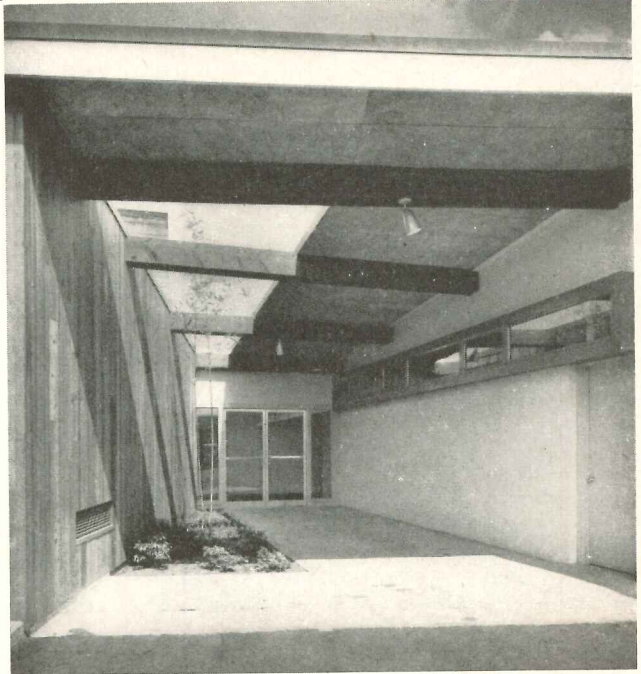

4

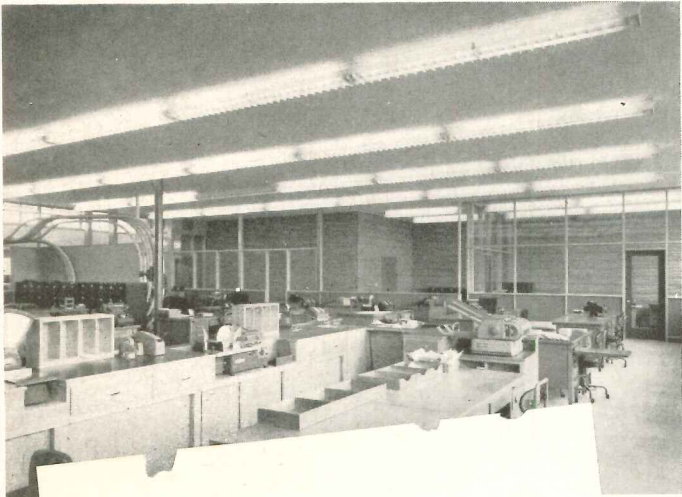

6



NEW BUILDING FOR CONSOLIDATED SCHOOL

Winecoff High School, Cabarrus County, North Carolina

A. G. Odell, Jr., & Associates, Architects

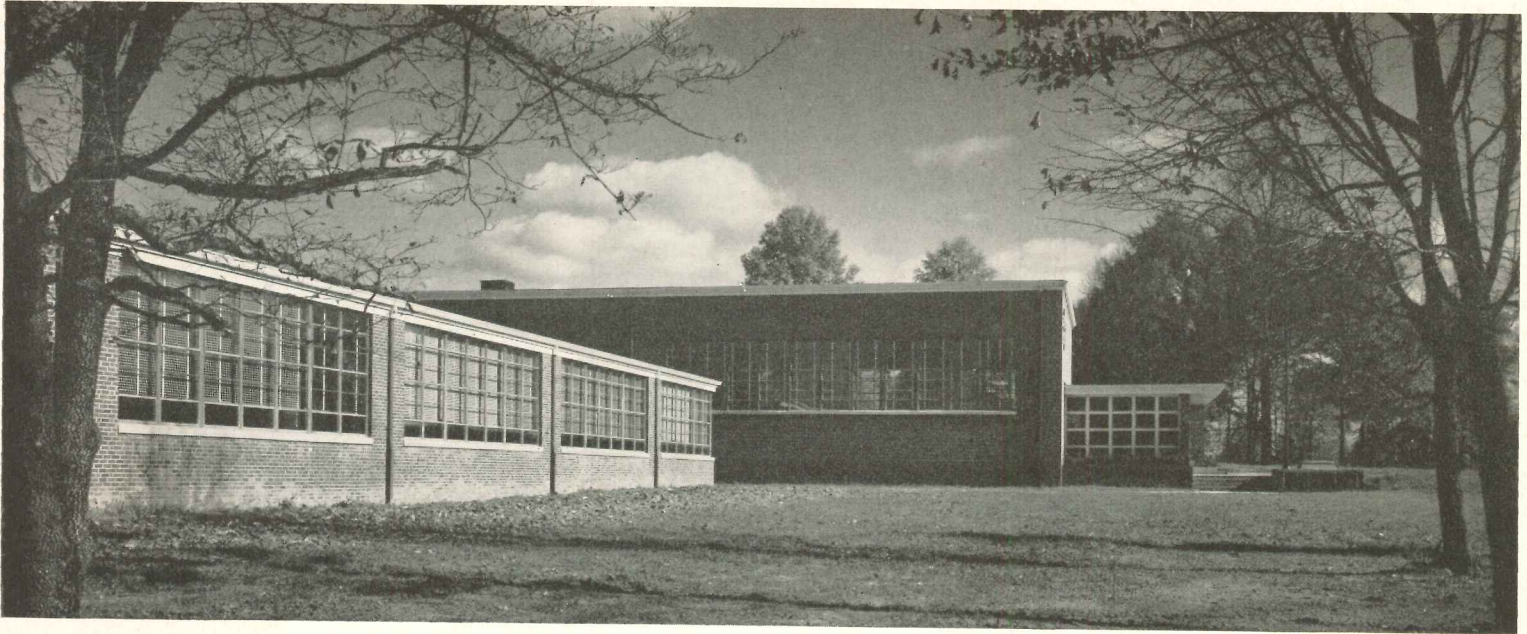

Joseph W. Molitor

WINECOFF'S NEW HIGH SCHOOL BUILDING is the first step in a long-range expansion program which eventually will give the school an integrated and unusually complete plant.

Before the program got under way, the plant consisted of one main classroom and cafeteria building serving all 12 grades (Winecoff is a consolidated county school, located about half-way between the towns of Concord and Kannapolis). The first decision made was to use the existing building for the elementary grades, and to erect new facilities for the high school. The second decision was to place the new building well toward the rear of the property, at a 90 deg angle to the cafeteria. This location offered several important advantages: (1) it provided direct community access to the auditorium and library from a newly-opened road at the rear of the school site; (2) it centered the existing cafeteria between the upper and lower schools; and (3) it formed the basis of the projected quadrangle which is part of the school's long-range plan. At present the eventual quadrangle is occupied in part by the old gymnasium and an agriculture-canning building, both of which are to be razed; a new gymnasium and a vocational building are planned for the western end of the site, to complete the quadrangle now edged on east and south by the original school building and the new high school.

Site plan below shows eventual school plant. Quadrangle at present contains old gymnasium and agriculture-canning building, both of which are to be removed; new vocational building (4) and gym (5) will close in west end

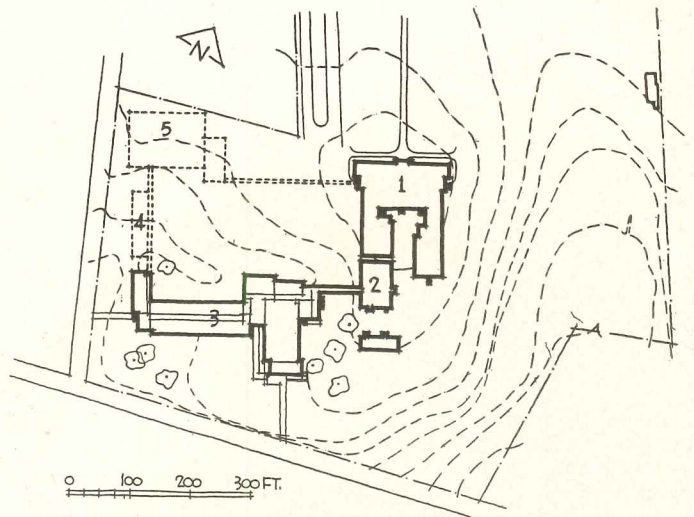

1. ORIGINAL MAIN SCHOOL (PRESENT ELEMENTARY)
2. CAFETERIA
3. NEW HIGH SCHOOL
4. FUTURE VOCATIONAL BUILDING
5. FUTURE GYMNASIUM

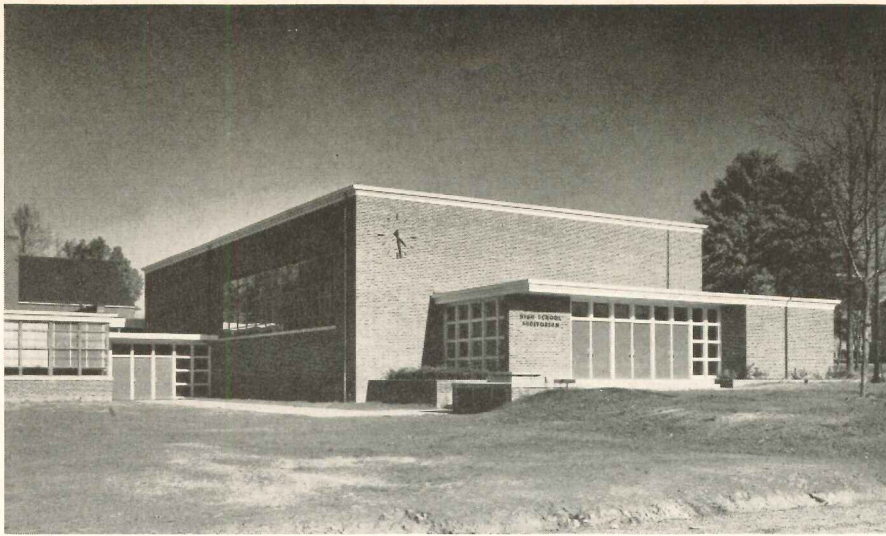

Auditorium of new high school building (above and below) has direct access from road at rear of site to facilitate community use. Wing includes also library and teachers' quarters



Below: stairs and covered walk connect one-story high school building (left) with lower-level cafeteria and original two-story classroom building. The two buildings harmonize unusually well

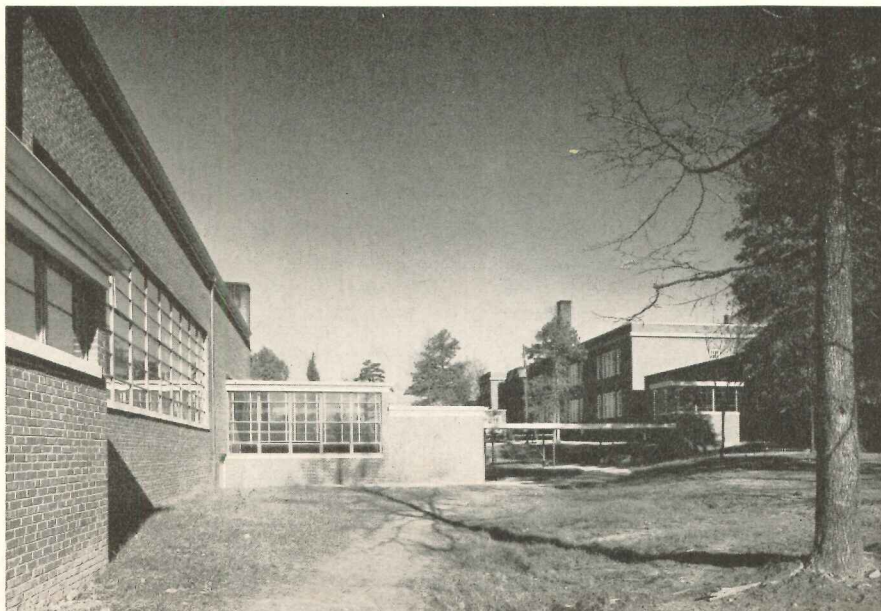

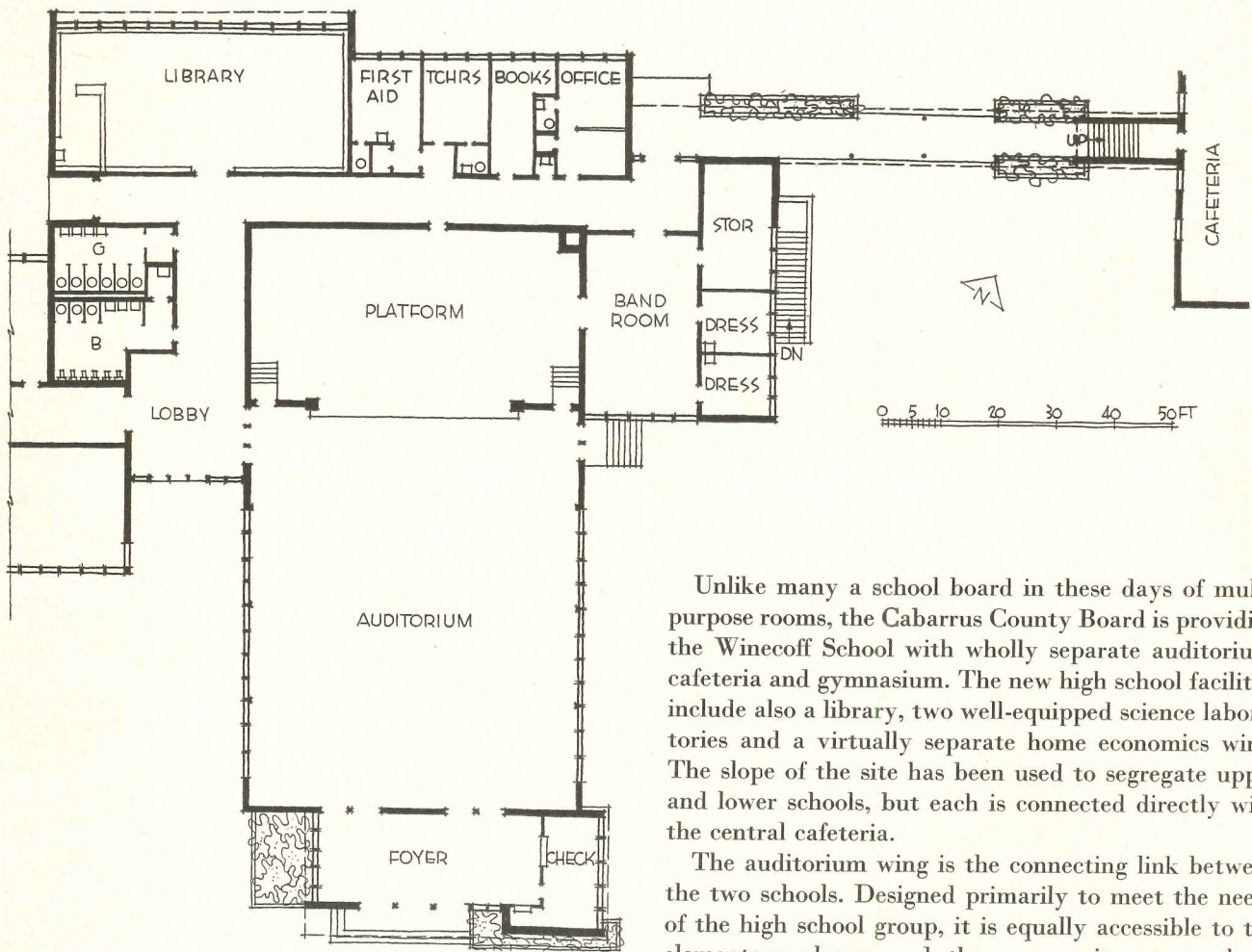
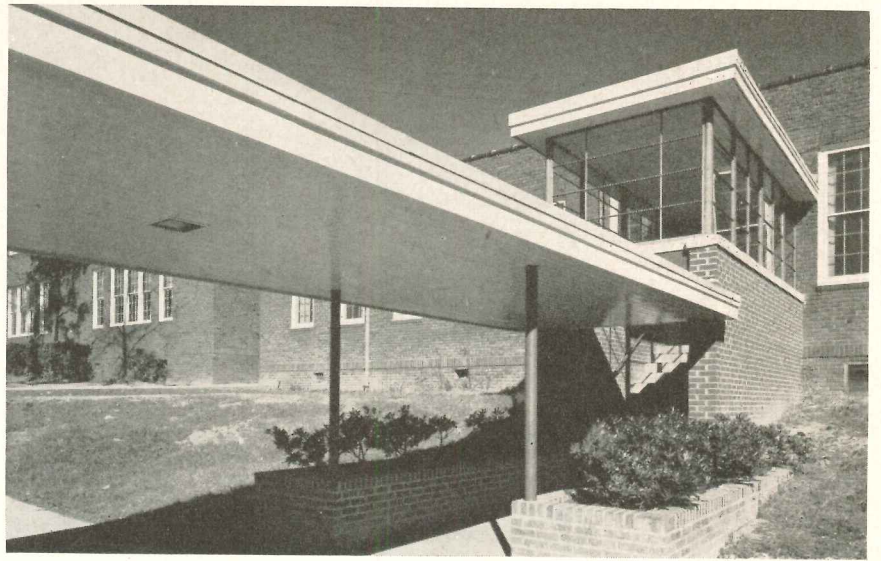

Unlike many a school board in these days of multi-purpose rooms, the Cabarrus County Board is providing the Winecoff School with wholly separate auditorium, cafeteria and gymnasium. The new high school facilities include also a library, two well-equipped science laboratories and a virtually separate home economics wing. The slope of the site has been used to segregate upper and lower schools, but each is connected directly with the central cafeteria.

The auditorium wing is the connecting link between the two schools. Designed primarily to meet the needs of the high school group, it is equally accessible to the elementary classes and the community as a whole. A single walk connects the rear road with both auditorium and library, as well as with high school classrooms.



WINECOFF HIGH SCHOOL

Across-page: far left, high school classroom wing from auditorium terrace; center, covered walk, looking toward high school wing from cafeteria. Left: band room is well silenced by perforated asbestos tile over blanket insulation. Immediately below: auditorium has permanent seats, generous platform. Bottom of page: library has windows along whole north side, clerestories on south; double door faces lobby at rear (south) side of school site



Joseph W. Mollitor

WINECOFF HIGH SCHOOL



Joseph W. Molitor

Home economics room, like all other classrooms in new high school building, has windows along one side, clerestory on other; storage and display space is noteworthy. Below: left, lockers line entire corridor of high school wing; center, typing classroom has equipment easily shifted from room to room

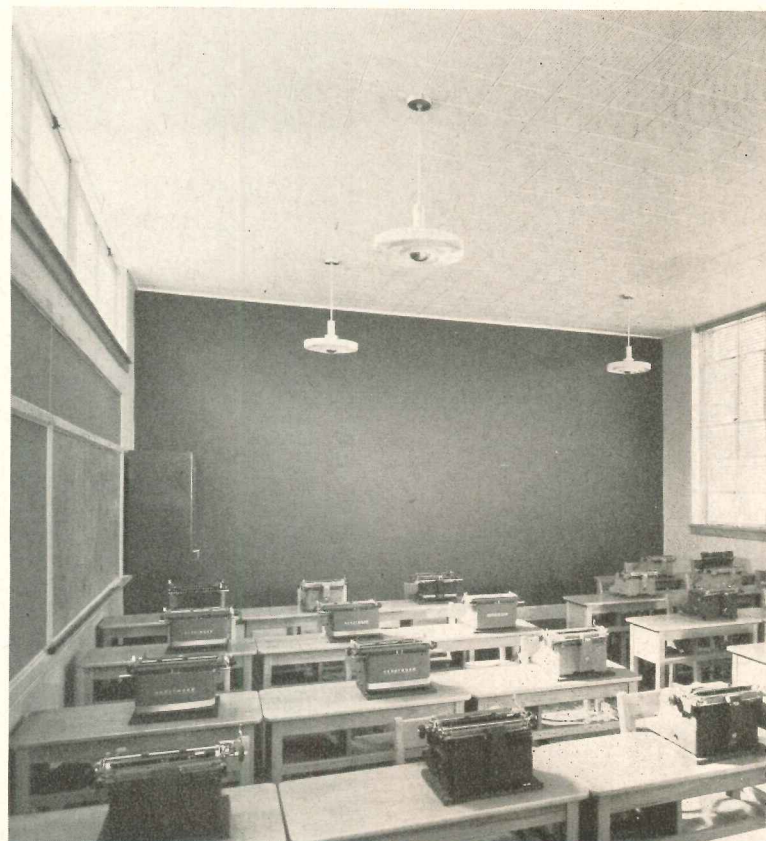

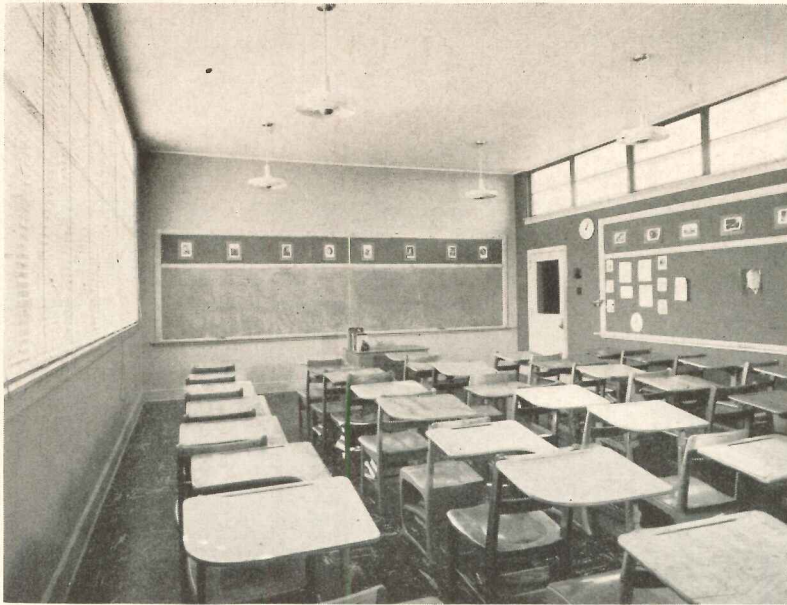

Left: typical classroom has good blackboard and bulletin board space, movable furniture, bi-lateral lighting. Bottom of page: the two science laboratories share hood space, but each is fully equipped otherwise

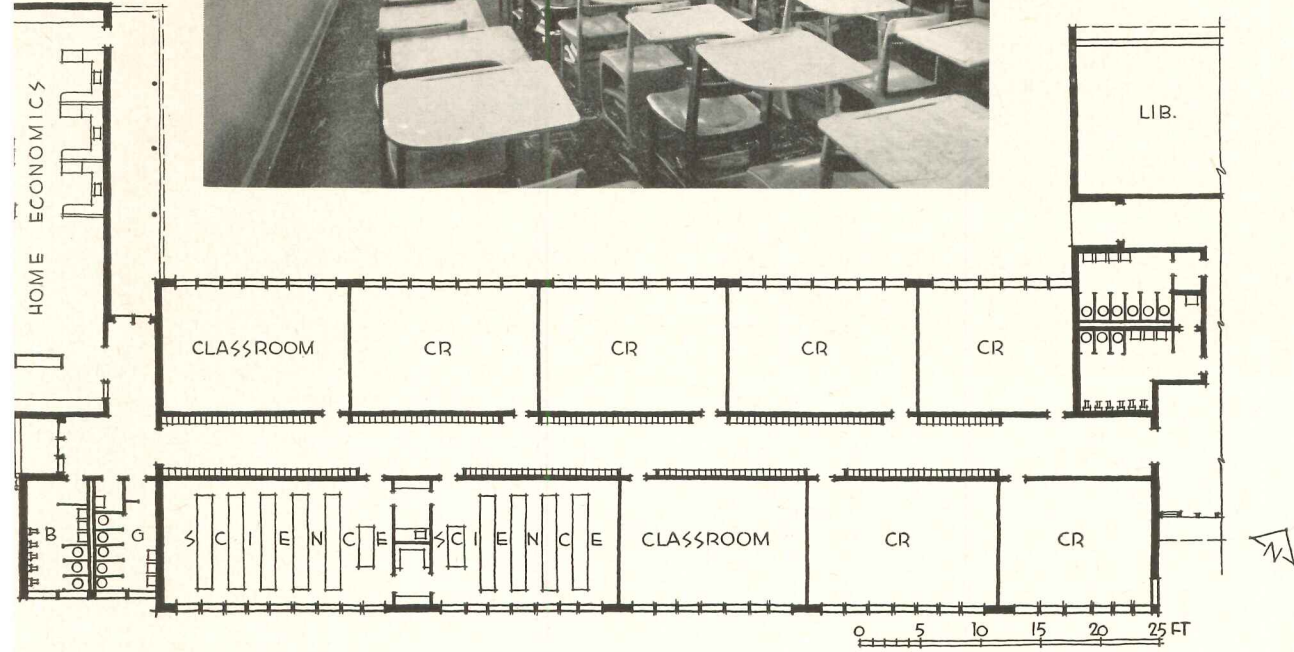

PLANNED FOR ADULT PRIVACY AND

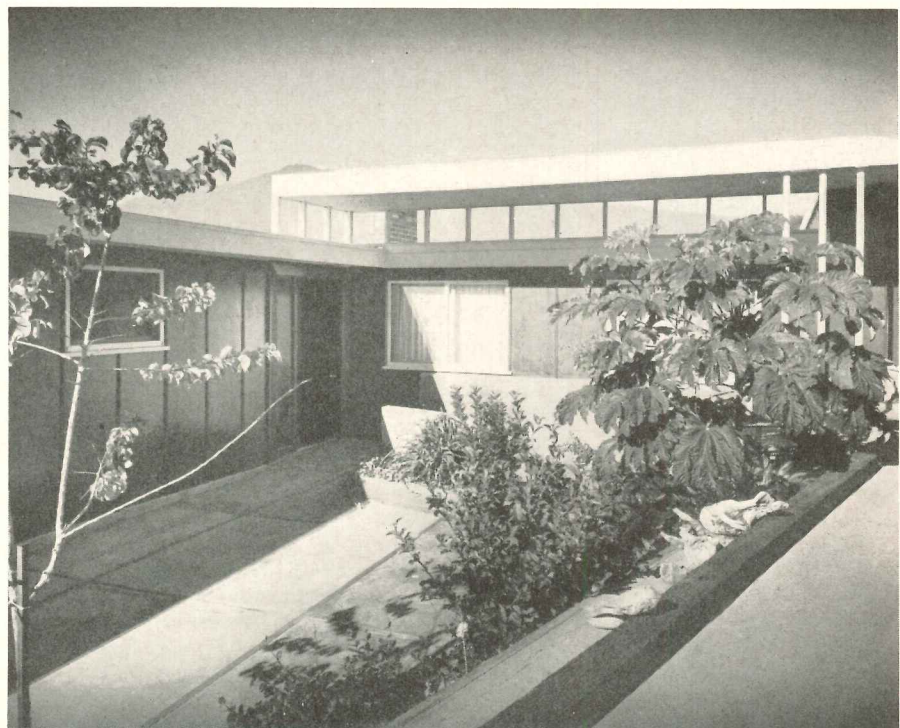

Robert C. Cleveland

SUPERVISION OF CHILDREN

French Residence, Fillmore, Calif.; Chalfant Head, Architect

THE BASIC REQUIREMENT in the design of this house was to incorporate two separate living areas into the interior plan — one for the adults and one for the children. This need was met by placing a combination family dining and play room between the adult living room and the kitchen. Supervision of the play area from both kitchen and living room is possible due to wall openings between the rooms, as seen in photos on following pages.

The house is set on a sloping plot in mountain foothills, and entry is made from a paved ramp leading from the motor court, which is slightly higher in level. A patio in the front at floor level is afforded privacy from the road through various high plantings along a low wall. Built on a modular system, the house rests on a concrete slab foundation. Exterior finish is natural finished redwood with yellow trim. Roof is built-up composition topped with heat-deflecting white gravel. Heating is by radiant panel system with copper tubes embedded in slab. Photos on these pages depict slanting driveway from the road above, sheltered ramp to entry and various other exterior views of house. Relation of house to irregular shaped plot is indicated at right.

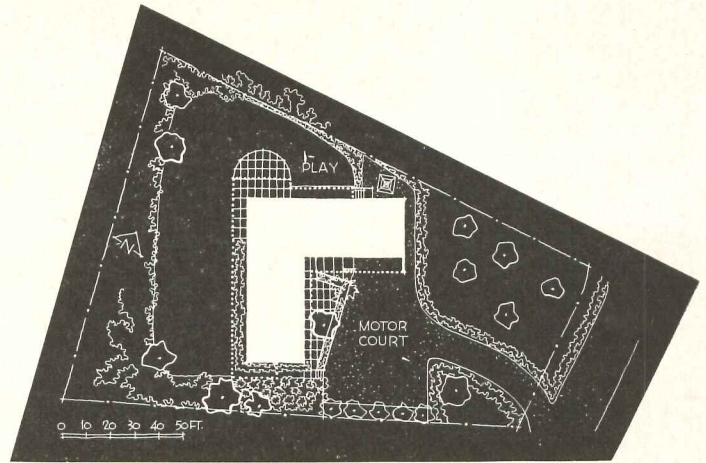

How harmonious living for families with children can be achieved through careful planning. Such an example is this house with a centrally located "family room" for supervised play and dining

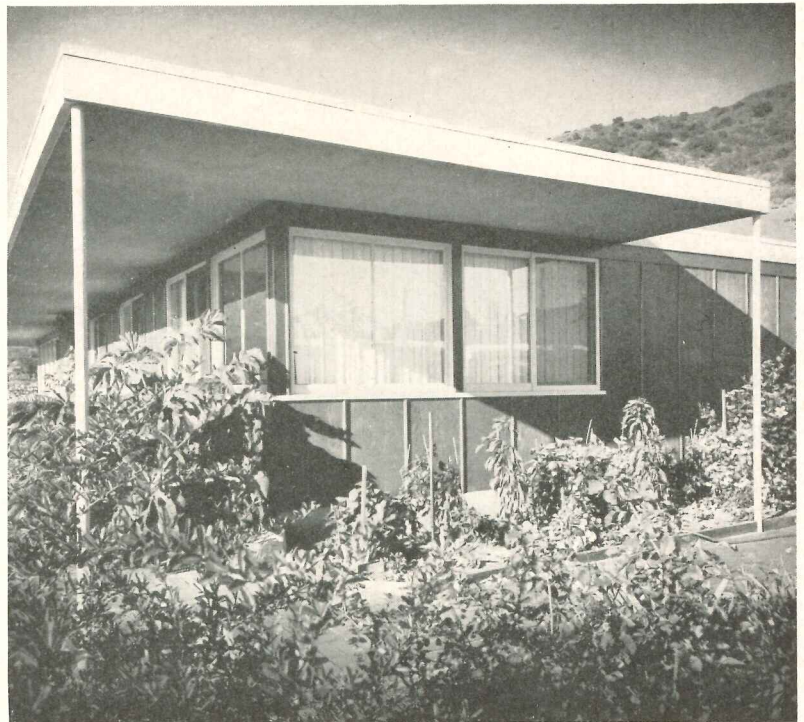
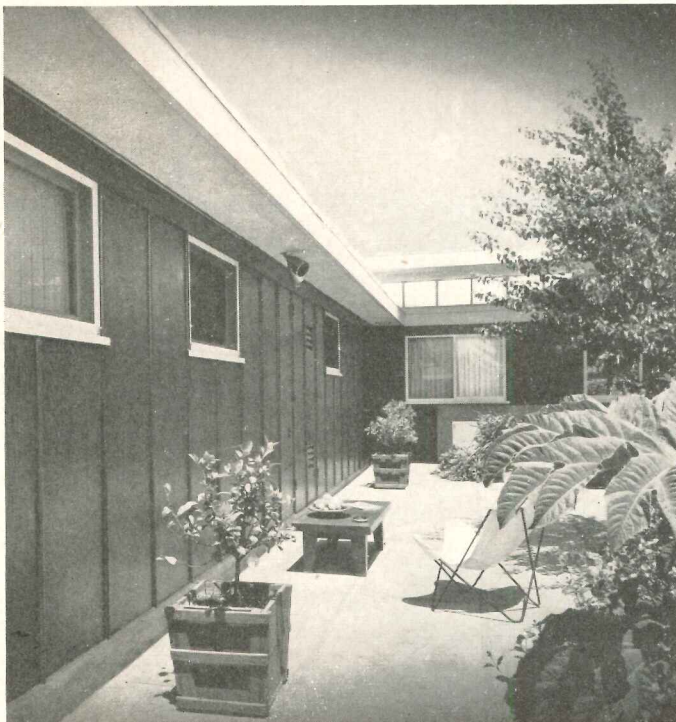

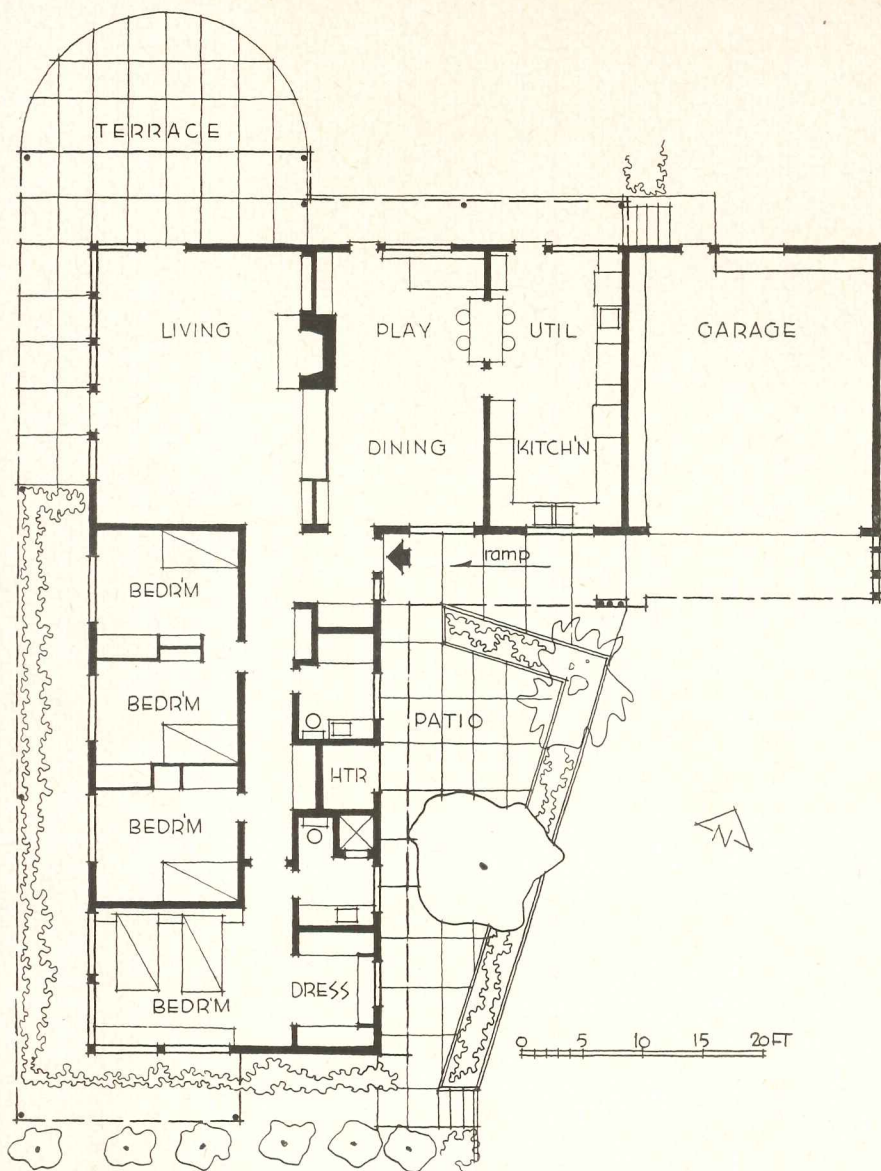

FRENCH RESIDENCE

A house need not be large and portentous to accommodate both adults and children in peaceful and uncluttered surroundings.

A) Adult living room with pass-through to "family room" for simplified entertaining has built-in cabinet wall containing radio-phonograph and loudspeaker above. **B)** Master bedroom is at far end of bedroom wing, affording privacy and quiet to adult members of family; has built-in desk, book-cases and trays below sliding wood casements, found throughout house. **C)** Kitchen is adjacent to children's play area and is well lighted—both naturally and artificially. **D)** Snack center is conveniently located between kitchen and play area. **E)** View of play space and main dining area from snack bar shows spaciousness of "family room." Section of living room seen at pass-through on opposite cabinet wall

A

B



C

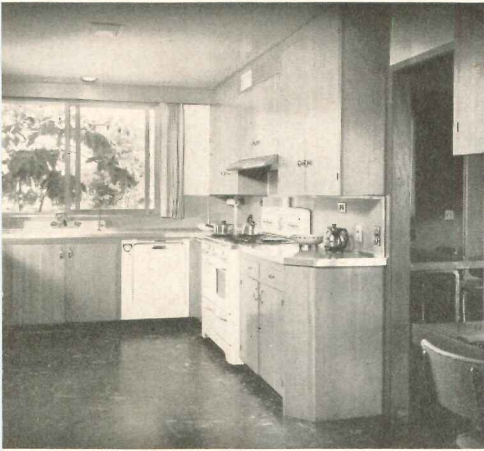

Robert C. Cleveland

D



E



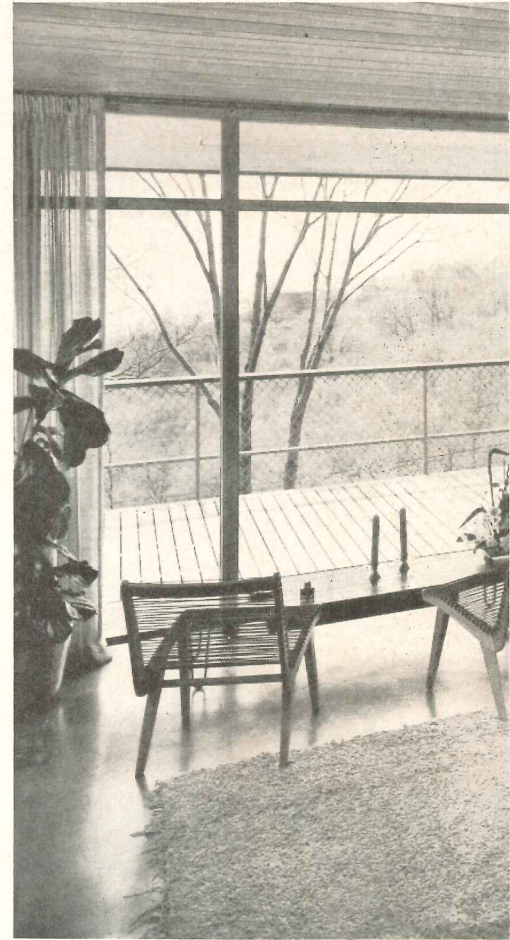
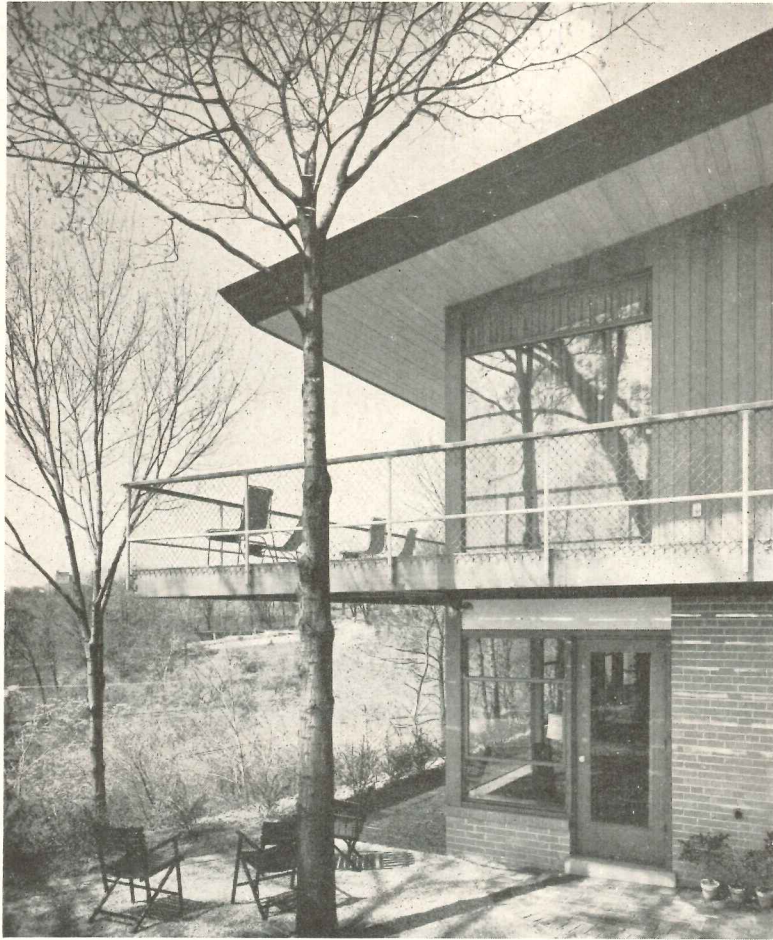

CANTILEVERED DECK ADDS LIVING SPACE

Residence for Mr. and Mrs. H. E. Lunken

Cincinnati, Ohio

Carl A. Strauss, Architect

Henry Fletcher Kenney, Landscape Architect

WHILE this site's sharp hillside slope presented building difficulties, a view of the Ohio River and convenience to downtown Cincinnati determined its selection. Maximum advantage of the view is taken by the living and dining rooms' south wall of glass and by the cantilevered deck which runs the entire length of the house. To avoid a steeply-graded driveway, the carport was built at a higher level than the house; a flight of steps from the carport leads down to the main living floor. (See plan on page 158.)

In the living-dining area, walls and ceilings are $\frac{3}{8}$ -in. ash panelling, fireplace is painted brick, and floors are cork. The screened-in porch has a canvas-deck floor, while asphalt tile is used for floors throughout the service

area. The maid's room and bath in this section are also cantilevered, since a sewer directly beneath made the use of footing walls impossible.

On the lower floor, deck acts as a sunshade for the south side of the house; master bedroom opens to terrace. Floors on this level are also cork; walls are painted plaster. Ceilings of acoustic tile are used in the hall, children's rooms and baths.

House is steel frame and wood joist construction; upper floor covered with vertical, gray-stained redwood boards. Rear walls, which act as retaining walls, are reinforced concrete, while front wall is brick and glass. Roof is built-up tongue and groove. A $7\frac{1}{2}$ -ton unit provides air conditioning.



Bill Hedrich, Hedrich-Blessing



Left: sliding steel frame doors form part of glass wall, open on 10-ft deck. Below, left: radio-record-book cabinet also acts as stair railing. Below, right: two-way fireplace separates living and dining areas

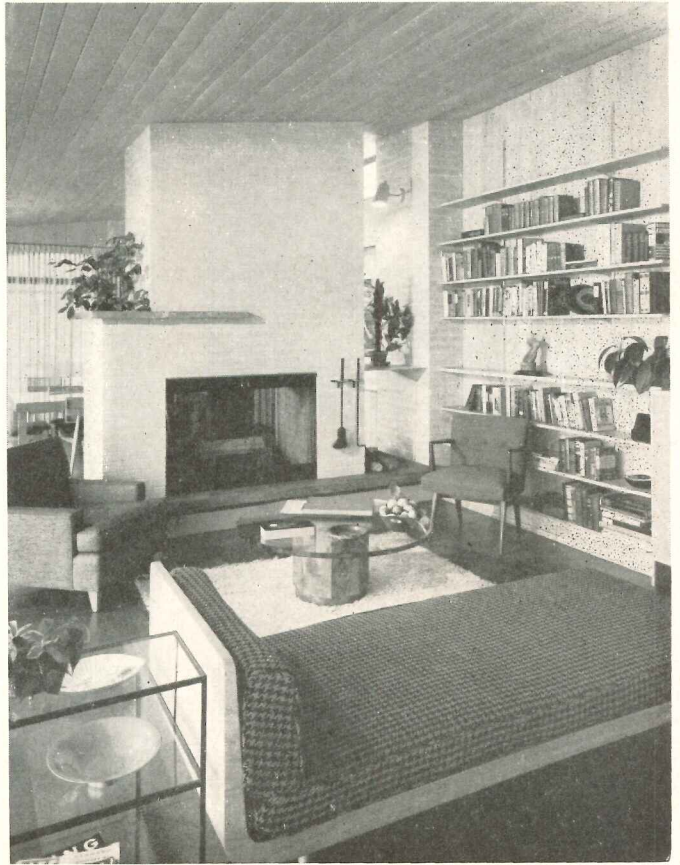

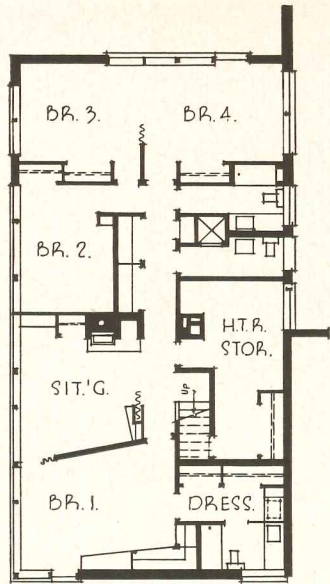

FIRST FLOOR

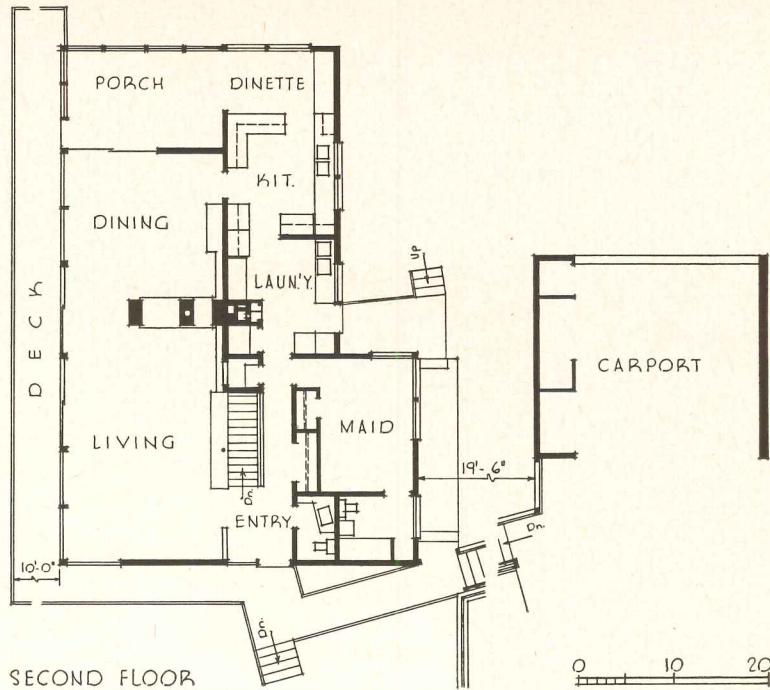

SECOND FLOOR

LUNKEN HOUSE

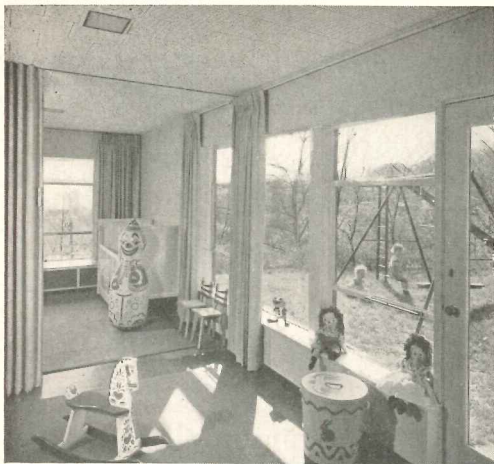

Above: children's rooms are divided by folding wall, have outside door to play yard. Above, right: sitting room has folding partitions to hall and master bedroom, can be used as a guest room. Right: kitchen cabinets are stained birch; pass-through counter serves dinette

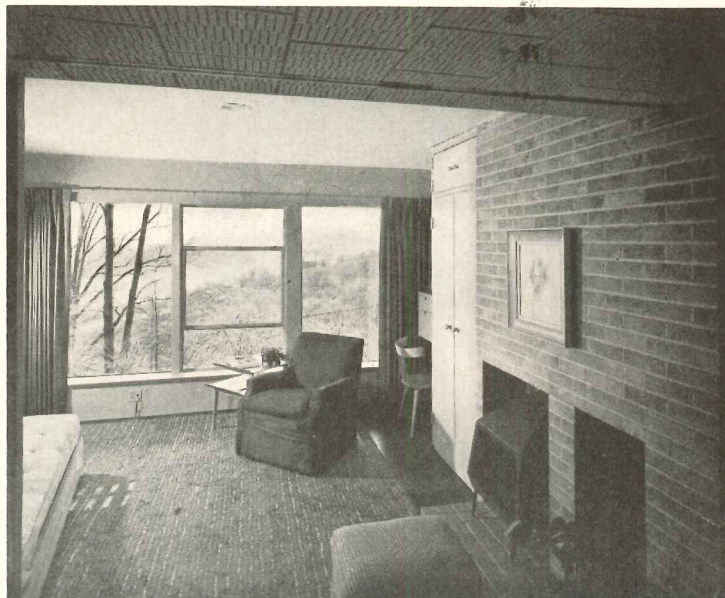

Bill Hedrich, Hedrich-Blessing





Gottschö-Schleisner

HOW ONE SPACE BECAME FOUR

Showroom and Offices for "Scarves by Vera," New York

Marcel Breuer, Architect

IN THIS DEFTLY HANDLED ALTERATION, a central problem was to provide a showroom for women's scarves where buyers from rival stores could be accommodated simultaneously with the proper degree of privacy. In addition, the program called for two private offices and a general office — all to be crammed into an area 37 by 42 and to be ready for business within two months!

A major design question was how to handle the bulky existing column poised slightly off center in the main

space. This difficulty was transformed into an asset by girding the shaft with the showroom's most unusual and attractive feature: a display case unit that reaches out four fins to define four separate sales areas. This is accomplished without destroying the unity of the showroom volume. (Detail on page 164.) The four-part division is further augmented by treating each of the enclosing walls in a different fashion: one is draped in gray flannel, another painted electric blue, a third



covered by a photo mural, while the fourth is faced with sheet cork upon which ordinary bottle corks are cemented in a regular pattern which sets up an interesting decorative shadow rhythm. (Detail on page 163.)

Each sales station contains a table and chairs: the tables, architect-designed, consist of a black lacquered $1\frac{1}{8}$ -in. plywood top supported by a welded frame of $\frac{5}{8}$ -in. square steel bars painted gray; the chairs are the newest Eames design, leather covered.

The acoustical ceiling is suspended 3 ft below the existing one to bring it down to an 8 ft 6 in. height for good scale, and at the same time provide room for ducts and recessed lighting fixtures. The ceiling terminates

14 in. away from the walls, both for visual separation and to yield space for concealed peripheral lighting. The architect's conception for lighting, i.e., the strong texture light on all walls which spills enough into the room for a soft over-all effect, supplemented by downlights above the tables, has proved to be extremely successful. (Detail on page 163.)

In the office spaces, an economical and attractive new ceiling consists of an open framework of 2 by 6s painted white which contains standard fluorescent troffers arranged in a staggered pattern. Ducts, pipes and the old ceiling over are painted dark gray, creating the illusion of a void above. (Detail on page 163.)

ARCHITECTURAL INTERIORS

Design | Details | Materials | Equipment

SHOWROOM FOR "SCARVES BY VERA" MARCEL BREUER, ARCHITECT

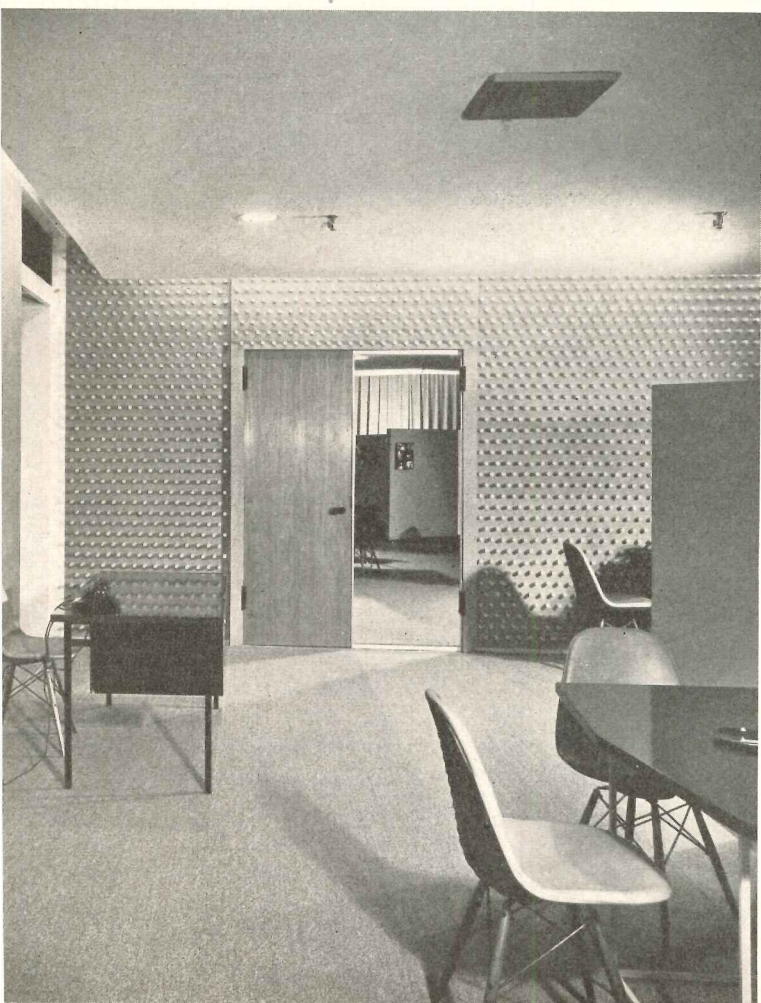
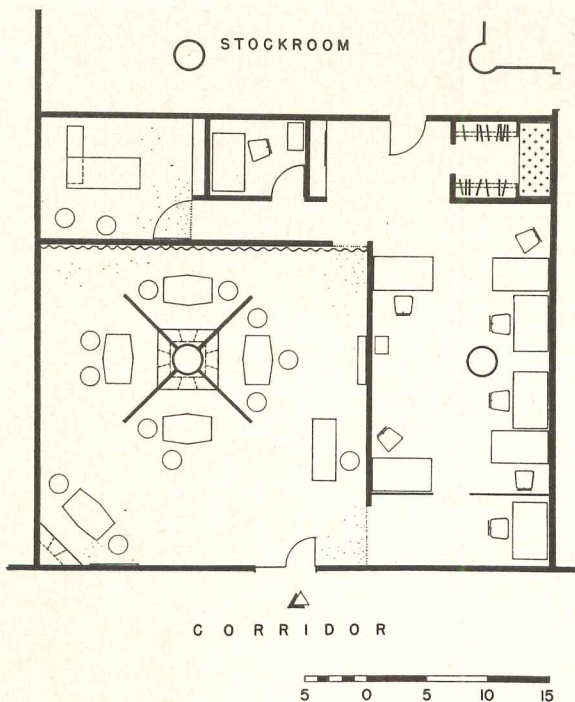

General view as one enters, left page, shows how four comparatively private sales stations have been created without sacrificing the spatial unity of the room. Entrance wall, next left, is cork covered—mirror on fixed door leaf adds depth and glitter. Rear wall, above, is draped with a medium gray wool flannel of the sort widely used for men's business suits

ARCHITECTURAL INTERIORS

Design | Details | Materials | Equipment

SHOWROOM FOR "SCARVES BY VERA"
MARCEL BREUER, ARCHITECT



Gottscho-Schleisner



The photo-mural wall was designed by Herbert Matter, who determined that black and white would be most effective in relation to the other wall treatments. The view above reveals its scale and effect in the room; the montage at left shows the entire panel. The leaf is a favorite design motif of the owner-designer, Vera, and her leaf designs have been perennial best sellers

Drawing by Tom Ballenger

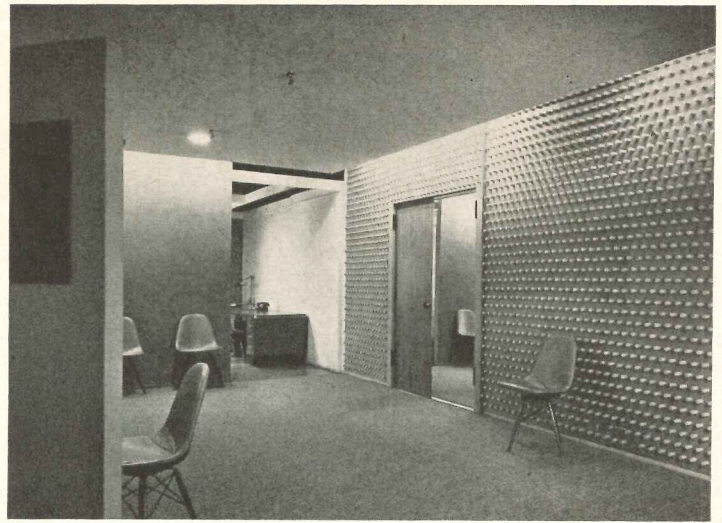
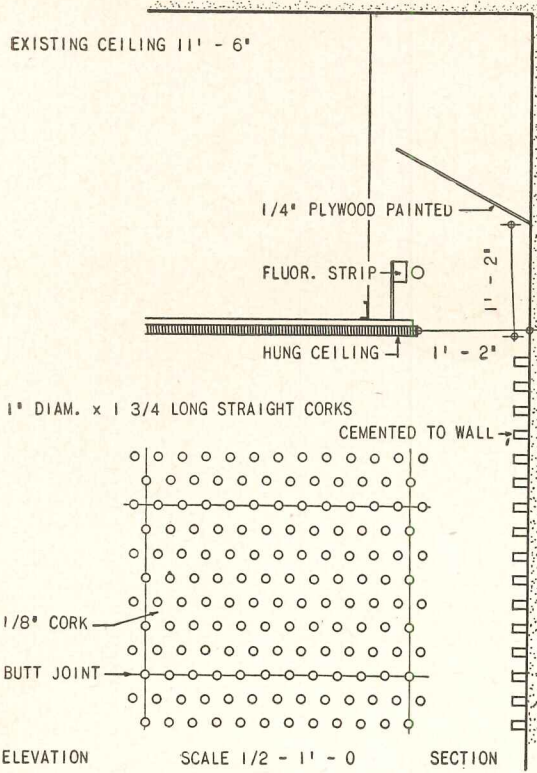

DETAIL OF CORK WALL TREATMENT AND CONCEALED PERIMETER LIGHTING

Drafting by Mogens Leth

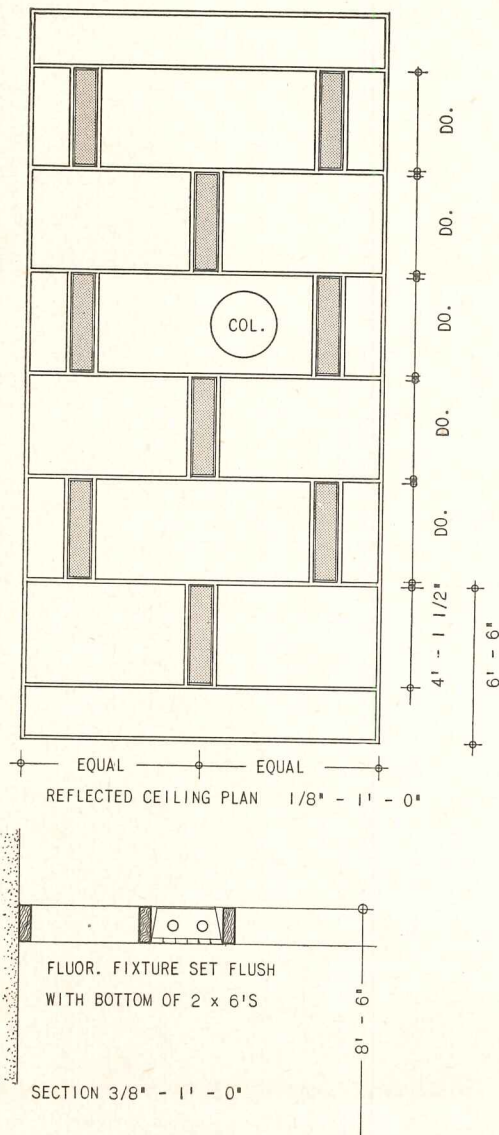

DETAIL OF OPEN CEILING AND LIGHTING PLAN FOR OFFICE AREA

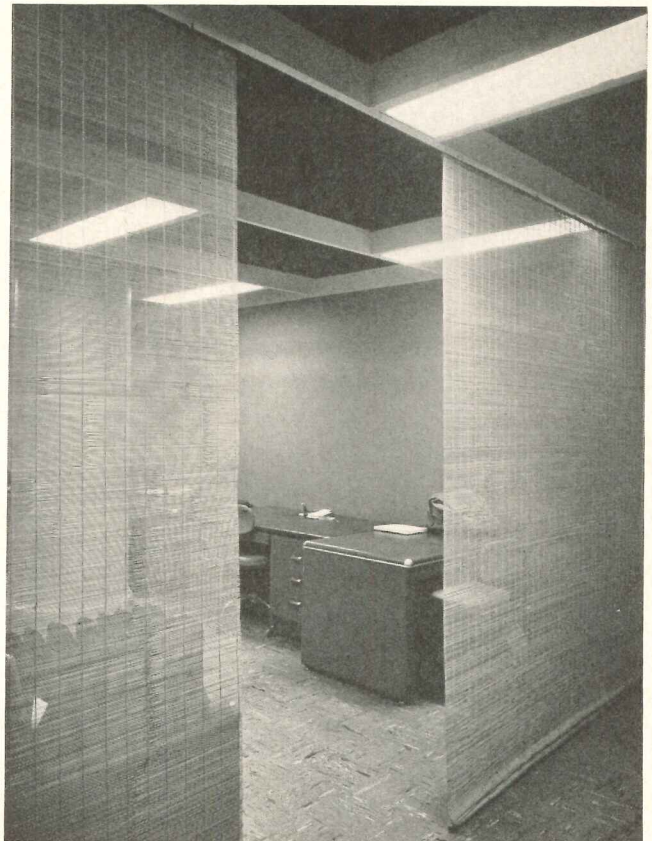

SHOWROOM FOR "SCARVES BY VERA"
 MARCEL BREUER, ARCHITECT



Gottschalk-Schleisner

DETAIL OF FOUR PART DISPLAY CASE UNIT

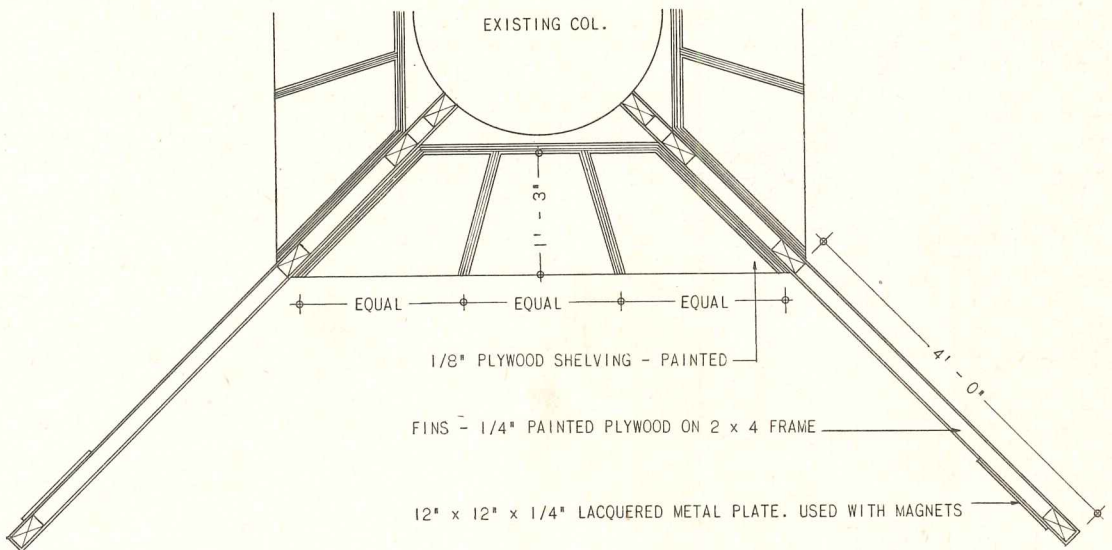

PLAN

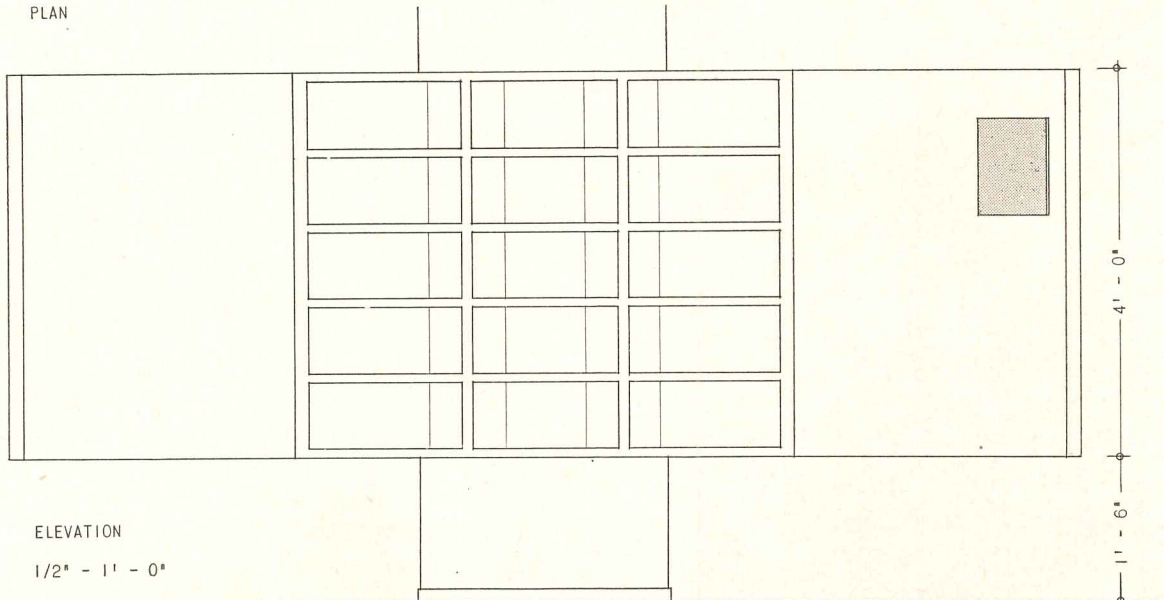

ELEVATION

1/2" - 1' - 0"

Drafting by Mogens Leth

HOSPITAL BUILDING TYPES STUDIES IN ARCHITECTURAL RECORD

Hospitals	July 1937	Elements of the General Hospital	June, July, Aug. 1946
Chronic Hospitals	Aug. 1938	Hospitals	June 1947
Hospitals	Dec. 1939	Type Plans for the General Hospital	Jan. 1948
Health Centers	Sept. 1940	Hospitals	May 1949
Hospitals	Aug. 1941	Hospitals	Feb. 1950
Hospitals in Wartime	Aug. 1942	Mental Hospitals	Oct. 1950
Hospitals	May 1943	Tuberculosis Hospitals	Apr. 1951
The General Hospital	Aug. 1944	Hospitals and Health Centers	Oct. 1951
Coordinated Hospital Service Plan	Aug. 1945	Revised Elements of the General Hospital	Apr. 1952
Hill-Burton Hospitals			Oct. 1952

BOOKS: "Psychiatric Sections in General Hospitals," by Paul Haun, M.D.

FORTHCOMING: "Design and Construction of General Hospitals," by U.S. Public Health Service, published jointly by ARCHITECTURAL RECORD and *The Modern Hospital*.

H O S P I T A L S

ARCHITECTS who have not planned a hospital in the last half dozen years will find that the general hospital is almost a new type of building. So many forward strides have been made in concepts and functions and equipment of hospitals, so much new study has been given to hospital problems, that it might add up to something frightening.

This particular Building Types Study is especially addressed to architects starting afresh in today's world of hospital design, though the study includes five hospital projects worthy of study by the most hardened of old regulars. It begins (next page) with an article on the opportunities in the field, with counsel for the architect who has not followed developments but is anxious to start.

Then follows a discussion of what amounts to the central problem of hospital planning — circulation. It is the relationships of departments to each other, the traffic routes for patients, doctors, nurses, service workers, for supplies, bedpans, food and medicines, that make an efficient, workable hospital, or a costly tangle of confusion. It is these matters which, largely, make a hospital a different assignment for the architect. It is here that he can stub his toe most painfully, or build a reputation.

Then follow five hospital projects especially selected for study of circulation problems. They are exceptionally good examples of planning for functions. They differ in size and locale, also in theory. They follow no pattern previously established, in fact they show some pioneering with respect to putting the several departments together. Among them they constitute an excellent demonstration of the theories of circulation stated more generally in the article mentioned above.

OPPORTUNITIES FOR ARCHITECTS IN HOSPITAL DESIGN

TEN YEARS AGO a new hospital, if it was well planned for its functions, was likely to be the work of a specialist in hospital design. A few dozen architectural firms did the important projects. It was difficult for the typical architectural office to plan a good hospital; there was so much specialized study to be done, very little literature to help. The architect new to the work had to undertake an individual research project, or else merely accept the program and recommendations of the administrator or the hospital consultant, and limit his own work to making the drawings.

Today it is feasible for any good architectural office to undertake a hospital commission; it is being done all over the land. The "hospital specialists" are still doing big business, but there are a great many more offices in that category than there were even five years ago, and scores of hospitals are being done by offices which never planned one before. Designing a workable hospital is still as complicated as it ever was; what is different now is that good planning information is readily available to all architects. The research study has not exactly been eliminated, but it has been greatly simplified. It is no longer in the realm of black magic.

In the last half dozen years many architects have built up an imposing practice in hospitals. They were the ones who early realized the potentials in the Hill-Burton program, who dug assiduously into the mine of information built up by the Public Health Service

Architectural Section and its regional offices, who developed contacts with state agencies administering the program, who made their hospitals demonstrations of good planning, and who profited therefrom.

There are still important opportunities. The great hospital program in this country, though it has been slowed somewhat by rising costs and limited federal funds, will go forward, is really only started. Late figures indicate that the hospital situation is roughly this: there are now 1,000,000 acceptable hospital beds in this country. Under the Hill-Burton program 90,000 have been put into service. But there is still a deficit of 950,000 beds.

In short, the country still has only about half the hospital beds that studies indicate it should have. And to date the Hill-Burton program has concentrated largely on general hospital beds, with first attention on rural communities; there are great areas of need still almost untouched — neuro-psychiatric, chronic, tuberculosis and public health centers.

The significant fact is that the country has started on a planned program of providing adequate health facilities and the end is not near. For the first time the need has been measured. The people have become conscious of the need; they have had some encouragement toward realization of the stated goals; they are going to get their hospitals. When such a snowball gets started one might even mistrust the measuring instruments used in totaling up the lack of beds. They are really based on rather arbitrary assumptions, such as one general hospital bed for each 220 persons, and may not

Dollar value of non-military hospital construction, 1947-52

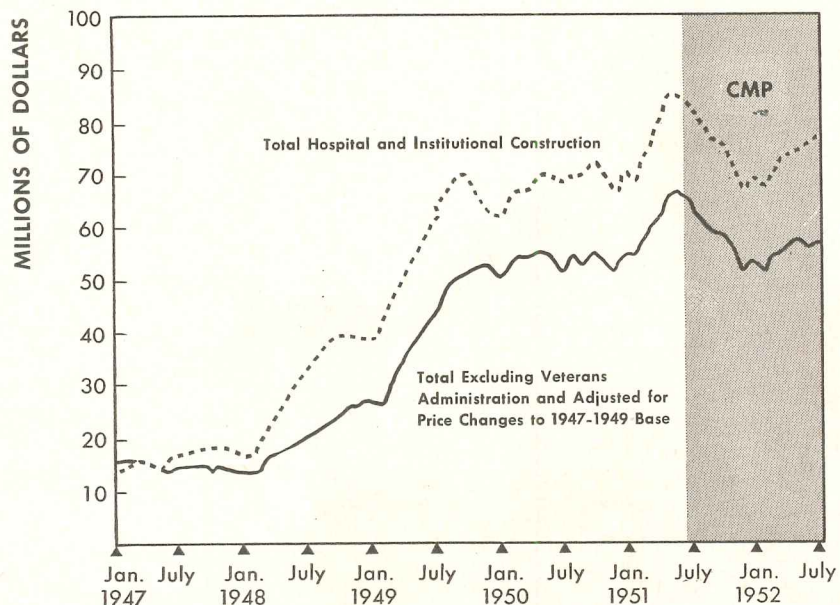

prove too reliable as the country gets interested in good hospital care. In the mental field, for a single example, nobody would argue very loudly for older standards of numbers of beds needed. Who can say now what would constitute adequate hospital facilities?

The opportunities and informational aids for architects were not merely a casual result of this hospital boom. They were projected from the beginning and have been skillfully nursed. Marshall Shaffer and his staff in the Architectural Section, Hospital Facilities Division, U. S. Public Health Service, did missionary work of a high order. Sometimes it required some whipping of the architects themselves, in the early days, to push them into their share of organizational efforts in state agencies, to initiate hospital seminars, to bring about collaboration with hospital administration groups, to forward research and education.

It began actually during the war years, in those days of "postwar planning." The wartime Lanham Act developed some facts as to hospital needs in war-worker areas, showed the sad lack of system in the initiation of hospital construction. The American Hospital Association decided there should be a better way than to wait for some philanthropist to help start a hospital. It established the Commission on Hospital Care, which began the fact-gathering and started the move toward federal legislation. Their studies showed three facts: 1. the shortage of hospital beds, 2. the poor physical condition of the existing hospital plant, 3. the maldistribution of hospitals especially with respect to rural areas.

The culmination of it all was the passage of Public Law 725 (Hill-Burton Act) on August 13, 1946. For the first time the country was embarked on a systematic, nation-wide hospital construction program with financial aid from the federal government.

The act, drawn by Senators Taft and Hill, put the initiation of individual projects up to the states and territories. They are to study needs, plan an overall program for their area, raise two-thirds of the funds. This decentralization blocked the possibility of an operation by federal bureaucracy, put the planning in the hands of private architects. The federal part was essentially to put some minimum standards of hospital design under all the work, to assure wise spending of federal funds. The legislation has been so successful that it is being copied in other countries.

The architectural profession was active in the program from the start. The A.I.A. and its state and local chapters offered substantial help in the setting up of state agencies and starting the surveys of need. A.I.A. representatives shared in the work of establishing the standards of hospital planning and equipment, and have served on federal and state advisory councils. Architects generally have joined with the Public Health

Service and the A.H.A. in sharing views and secrets in conventions and seminars. The years since the passage of the Act have witnessed a great educational movement in the interest of improved hospital design and the accommodation of rapidly changing medical techniques.

It has been the function of the Architectural Section of the Public Health Service to focus all of these educational efforts, to study with the medical and architectural professions all of the intricate parts of hospital design, to document the basic information, and to make it available to architects through several Building Types Studies in ARCHITECTURAL RECORD (see page 165) and in hospital magazines. It cannot be too frequently emphasized that this assembling and issuing of information is never arbitrary or forced. It is research data for architects, to be applied to individual designs in individual ways. No architect will find his building planned for him, neither will he have to conform to frozen patterns. He will be expected to submit his plans for examination against established standards, and he will find plenty of help available to him in any problems he may encounter along the way.

Such help is available first in the state agencies, which have technical men working for better planning. It will be found also in the regional offices of the U. S. Public Health Service, and in Washington where a large architectural and engineering staff is constantly reviewing plans and assembling every new data. The architect will find similar aid in the Octagon, or in the home office of the American Hospital Association in Chicago.

Hospital consultants have shared in the studies all along the way, and are available severally or individually for the planning of hospitals.

Architects still complain, and not without justice, that it is difficult to break into the hospital field. It is difficult; it is difficult to break into the school field; it is difficult to break into practice, period. Many cite, with sharp language, the list of hospital architects of the A.H.A. as a closed corporation of specialists who grab all the jobs. How does one become a hospital specialist, when you can't even join the fraternity without already being a specialist?

Well, they have a point there, but it is not as bad, or as closed, as it seems. Since the program started it has encompassed 1800 projects totaling \$1,500,000,000. These buildings were not planned by a closed corporation of specialists. Many, in fact most, were small jobs done by local architects. Many more will be. The central fact is that it does not now require years of specialization to plan a good hospital (although the point is still argued).

There are opportunities ahead for any good architectural office willing to learn about hospital planning, to join in a really great movement to improve hospital design.

PLANNING THE HOSPITAL STARTS WITH CIRCULATION

Separate all departments, yet keep them all close together; separate types of traffic, yet save steps for everybody: that's all there is to hospital planning

By Emerson Goble

FOR THE ARCHITECT not already familiar with modern hospital planning, the principal subject for study will be circulation—the proper integration of the many departments so that different types of traffic through the building will be separated as much as possible, traffic routes will be short, and important functions protected against intrusion. Needless to say, the skill with which circulation is handled will determine the efficiency of the hospital for all of the years of its use. If nurses have to walk too far (according to hospital administrators all nurses are old and have varicose veins) curses will be heaped on the architect's name, day and night, for fifty years.

Principles of Planning

Protection of the patient (despite the nurses' beefing) is the primary principle of circulation schemes. Too much traffic in the nursing unit corridor will disturb the patient, will involve excessive risk of contamination, or at least of confused and inefficient care. Any unwanted traffic in the surgical suite means dilution of the effectiveness of aseptic technique. Assured protection against contamination is the very heart of good patient care, and is the basis of hospital planning.

Short traffic routes, with as much separation as is feasible, assist in assurance of asepsis. For another reason, however, they become the second principle of circulation; obviously short routes save steps for everybody concerned with hospital care. Nurses, doctors, patients, service and office personnel—all have a share in the patient's welfare. All must work fast at times, and all are subject to fatigue. Their steps take time and cost money, more money each year. Hospital planning is increasingly concerned with labor saving in all possible ramifications.

Separation of dissimilar activities is another principle, for the reasons stated and for other reasons. Separate the "clean" and "dirty" operations. Separate different types of patients. Separate quiet and noisy operations. Separate different types of traffic outside the building as well as inside. Separate pleasant and

unpleasant functions. Separate types of workers.

Control is a fourth general objective. No matter how much control may be inherent in good separation, in good disposition of functions, there are places where control must be still more positive. So the nurses' station must involve some supervision of patients' corridors; the infants must be protected against germs brought in by visitors, or even by doctors; the surgical suite must be protected similarly. And so it goes.

Separate everything. Yet have everything close together. That's all there is to it.

If it begins to sound impossible, well, it is. Yet it is still possible to do very well or very poorly. Accordingly is the architect's reputation established. This article will state, as quickly as possible, the major factors in circulation, with reasons for the most urgent requirements. The individual hospital plans presented in the following pages will give practical demonstrations of the theories.

Separate Exterior Traffic

It is customary to start separating traffic before it even gets within the building; in fact it is necessary to separate it outside in order to do it inside. The key flow chart, Figure 1, offers a general guide to circulation lines in the building, and thus also to exterior traffic.

Usually there are separate entrances for these main traffic lines: 1) Inpatients and visitors; 2) Outpatients; 3) Emergency patients (or ambulance cases); 4) Supplies and fuel.

The main entrance would usually serve for ambulant inpatients arriving for admission, or leaving after their stay. They would proceed through main lobby to admitting desk, possibly with a stop at a social service office. Visitors would also use the main entrance, largely for reason of control of visitor traffic by the receptionist.

The main entrance can also be used by doctors, so that they may be clocked in or out, or possibly so that the records clerk may catch them for a task the doctors always seem to find onerous. On the other hand, doctors frequently prefer a separate entrance, so that they will

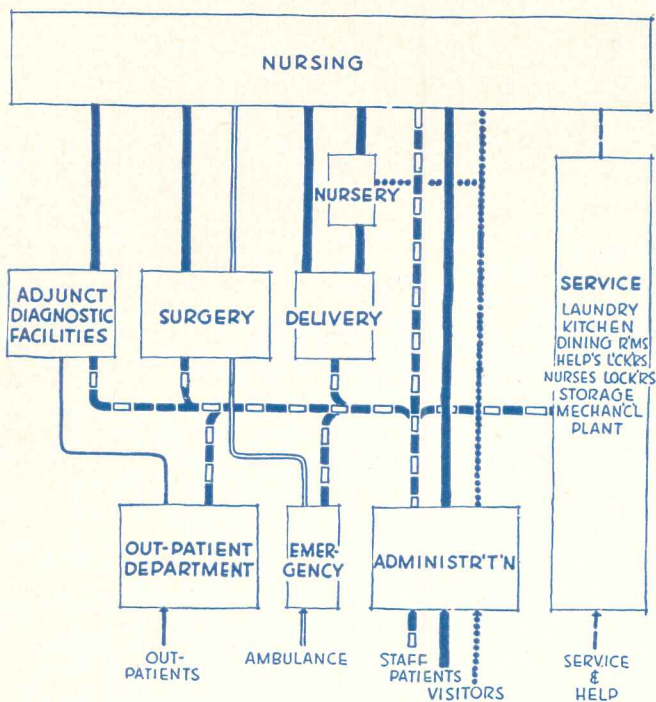

Figure 1: Key Flow Chart, Acute General Hospital

not be button-holed by visitors or relatives or just friends. Another consideration is that usually the doctors have a separate parking area, and another entrance may be much more convenient.

The ambulance or emergency entrance is presumed to be convenient to elevators for inpatients who must be brought in by ambulance or private car. The emergency entrance is principally intended, however, for real emergency cases, who might arrive in some unsightly condition and who would require instant attention in the emergency suite. The "emergency" patient might even be a drunk, or a criminal arriving with full escort. Also the emergency case might be a medically "dirty" patient, not to be taken any farther than necessary until he can be given some preparation.

This same entrance is usually designed also to offer an unobtrusive means of removing the dead.

A separate entrance is desirable for outpatients since any volume of them would soon confuse the main entrance and the departments nearby. Moreover, there is the need to control the movements of outpatients, to keep them out of principal corridors, to confine them to certain areas. Merely from the standpoint of unpleasantness it is desirable to shield the main hospital from a constant parade of sufferers coming and going.

Separate entrance for service and employees seems to have obvious advantages. An especial point is that deliveries are usually a fairly noisy operation, sometimes unpleasant in other respects, and should be iso-

lated and screened as much as practicably possible.

Parking space is usually grouped roughly according to entrances. At the least there should be separate and convenient parking space for doctors, who should not be expected to fight a traffic jam at each visit. Perhaps hospital workers should have a separate parking area. Clearly any separation that can be arranged for parking areas will help to maintain separations of types of traffic both within and without the building.

Interior Traffic Streams

Figure 1, the key flow chart, shows the main streams of traffic within the hospital to and from principal departments. It does not, of course, show all of the comings and goings up and down these lanes; these are indicated in more detail in departmental charts. The key chart is reliable for indicating the major departmental separations, nevertheless, and this is of course the first step in traffic control.

Architects have developed notable ingenuity in schematics designed to control traffic. The cruciform plan is an old favorite, providing a central traffic and service core and a goodly number of cul de sac locations in the wings.

The T form is another favorite. Again there is a central core, with various medical departments isolated in bases of the T, floor by floor, and nursing units facing south in the top of the T.

Variations are found, literally by the dozen, with wings added on to isolate departments, particularly on the lower floors. Sometimes a wing is sent out, only to be folded back again against the building.

Double corridors have been extensively used, and often they serve to shorten horizontal travel in ingenious ways. There is one plan included in this study, page 187, with a triple corridor scheme, with the same objective.

Always the intent is to separate departments yet keep horizontal travel to a minimum. It is worth noting, and quite healthful, that "standard" schemes do not seem to do very well against the wide variety of individual conditions and sites. And against the ever-changing display of originality that architects have exhibited.

Nursing Department

As seen in Figure 2, the nursing unit corridor is really a traffic highway. The main streams indicated are endlessly repeated throughout the day and possibly the night. Obviously, then, any possible saving in steps can be multiplied many times over, especially for the nursing staff.

The first point, then, is the location of the nurses' station, as this is the starting and finishing line for

HOSPITALS

all their little foottraces. Modern practice usually puts their station roughly in the center of their group of patients. It is generally assumed that the maximum travel distance should be about 80 ft. This almost automatically places a reasonable limit of 25 to 30 patients in one nursing unit, though practice varies in this respect.

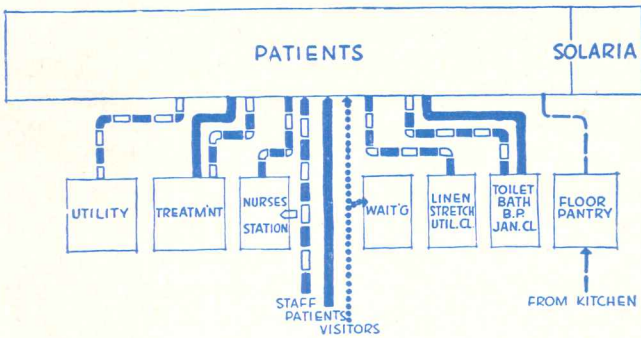

Figure 2: Nursing Department Flow Chart

There is some clash of objectives in the placing of the nurses' station, as the central location, it is argued, might weaken the element of control. The central location within the nursing unit might not be quite so good, as to control, as some other location nearer the elevators or stairs where the nurse can keep a weather eye out for the unauthorized visitor or the wandering employee, or can assume the role of policeman as may be required.

Present thinking nevertheless tends in the direction of the central location, where nurses' patient duties are most readily and most quickly performed. The control, it is said, is tenuous at best, for the nurses are usually busy with running for the patients, and cannot always stand with a billy club in their hand. That is, control of the exceptional incident would be tenuous — control of most matters, such as visitors, would be almost automatic anyway, since there is so much going on through most hours that anything untoward would be quickly spotted.

Where the control argument takes on more substance is in the matter of night hours. Then there might be but a single nurse, and she might even have to handle two different nursing units. This consideration might be the prevailing one, depending on such factors as size of nursing units, their relation to each other, or any of many layout factors affecting the need for control.

Elements that group themselves around the nurses' station are utility rooms, baths, floor pantries, drug cabinets, possibly a flower room, maybe also a treatment room. The location and convenience of these facilities can make the nurses' tasks relatively easy or very

difficult. If there is one bedpan closet poorly located, this error alone can drive the nurses to distraction. Good practice puts two bedpan closets in each nursing unit, each centrally located in one half of the unit.

Recent practice also is to put private toilets in as many patient rooms as possible. When the patient is confined to bed, the nurse need go no farther than the private toilet with the bedpan. Or, with early ambulation so much stressed, the nurse may be needed much less frequently.

There are other step-saving devices coming into more general use. An important one is two-way communication between patient and nurse, so that the nurse is at least saved the trip down the hall just to learn the patient's want — maybe she can bring the aspirin tablet with her on the first trip. Many times she will not have to make the trip at all.

Surgical Suite

It is important that the operating suite be completely isolated from the rest of the hospital, and so located that there will be no traffic through it. In a large hospital it might occupy a separate floor; in a smaller one it is usually placed at the end of a wing. Operating rooms and associated areas must, of course, be protected against unwanted persons, mostly to minimize the risk of contamination, but also to prevent interruptions and confusion.

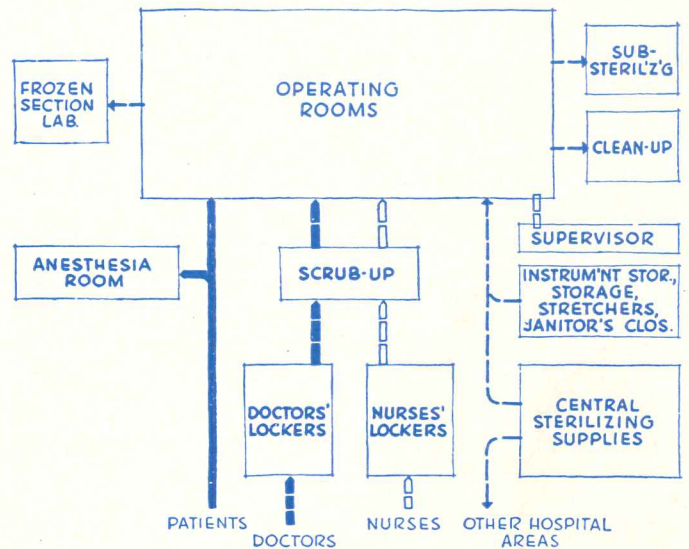

Figure 3: Surgery Flow Chart

The suite ought to be close to elevators, or to the surgical nursing unit. It has some relationship also to the emergency department, as emergency cases might require major operating procedures. Or, in case of a general emergency (railroad wreck or fire) the whole

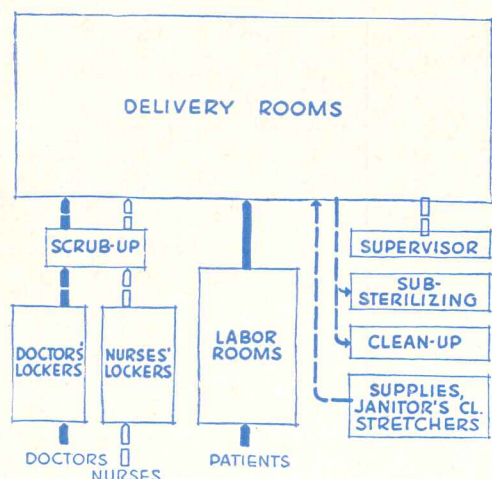

Figure 4: Obstetrics Department

operating department might be taken over temporarily for emergency use.

The surgical suite also has an obvious relationship to the x-ray department. The fracture room-x-ray relationship is especially close, and radiographic work is done also in cystoscopy, though portable x-ray equipment might solve this problem. The fracture room, incidentally, is sometimes placed in the emergency suite, especially if a large volume of accident cases may be expected, but it is usually considered part of the operating department and so placed.

Modern practice tries to put the central sterilizing department either adjacent to or within the surgical suite. This arrangement naturally makes it convenient to supply the sterile packs and so on needed in the operating rooms with minimum risk of contamination after sterilizing. It also puts the sterilizing operation more or less under control of the surgical nursing staff. In many hospitals this staff actually does the sterilizing in free time when operations are not in progress. The sterilizing department would be arranged also, of course, to dispense supplies to the rest of the hospital without involving outside traffic within the surgical department itself.

Figure 3 is useful in showing the main elements of the operating department and their relationships to each other.

Obstetrics Department

The delivery suite is very much like the operating department, and the same general considerations of location and control hold here. The obstetrical suite is given a similar location, though its primary relationship is to the maternity nursing unit, not to emergency or x-ray facilities.

Special consideration should be given to separating

the suite from the nursery itself, since the newborn infants attract a great deal of visitor traffic. On the contrary, however, a long distance means that much more risk in the moving of newborn from delivery suite to nursery. The separation, then, should ideally be a matter of control, not distance.

Some of the newer hospital plans show the delivery suite actually adjacent to the surgical department, especially in small buildings. There are obvious advantages, and some disadvantages. The two departments require the same isolation, the same type of nursing service, same cleaning, air conditioning, sterile supplies and so on. Nevertheless, intertraffic between the two is undesirable, and the possibility of cross-contamination is ever-present. If the two departments are nearby, then, especially good control is required.

Figure 4 shows the units of the delivery department and their interrelationships.

Nurseries

The nursery is designed to keep traffic to an absolute minimum, for nothing worries the hospital administrator quite as much as the possibility of an epidemic in the nursery, especially the dread infant diarrhea. The nursery is closed off from the corridor, entered only through the nurse's work room. The usual arrangement permits only the nurse — not even the doctor — to enter the nursery itself. The baby is taken by the nurse to the examination room, off the work room, for the doctor.

Frequently each nursery is limited to eight bassinets, representing the number of babies a single nurse can handle. Thus each infant is normally in contact with only one person; that is, in the nursery. The baby is taken to the mother, of course, and that necessity imposes some requirements on the location of the nursery.

It should be centrally located within the maternity nursing unit, to keep distances as short as possible and again minimize risk of infection. The central location is good also to keep down delivery routes for linen, bottles and medication.

Adjunct Diagnostic and Treatment Facilities

In general all of adjunct diagnostic facilities have about the same traffic conditions, and the same type of uses. So they are grouped together.

From the circulation standpoint the main point is that diagnostic facilities are used both by inpatients and outpatients. The natural location, then, is on the street floor, for convenience of outpatients, but near elevators or main corridor for convenience of inpatients and staff (see Figures 5 and 6).

As previously mentioned, the outpatient department

HOSPITALS

usually has a separate entrance and waiting room, to keep the department self-contained, and to keep outpatients from wandering about the hospital. Thus it is desirable, on the inside, to maintain some isolation of the diagnostic facilities. Access to the department by inpatients, therefore, while it should be convenient, should be susceptible to positive control, not for the hospital patients themselves but for the outpatients.

In some hospitals there may be a public health department, which will have use for the diagnostic facilities, for their own patients, and this relationship may

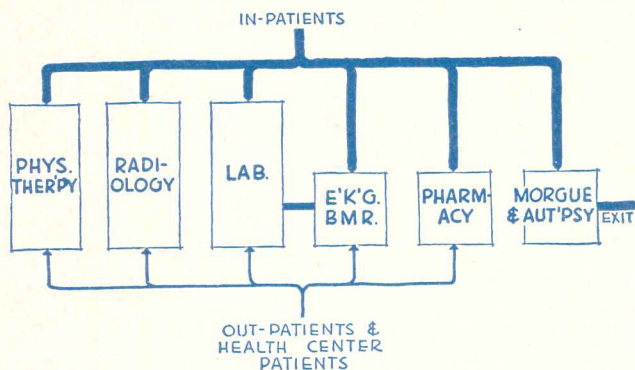

Figure 5: Adjunct Diagnostic Facilities

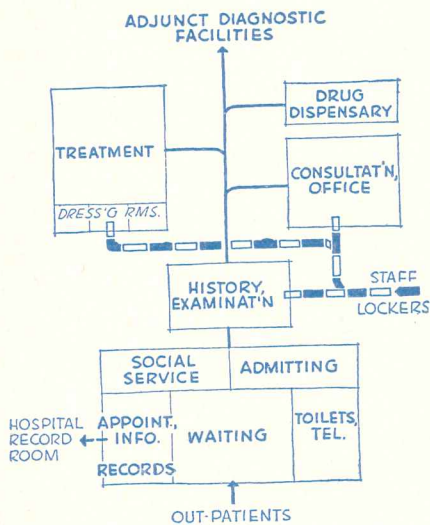

Figure 6: Outpatient Department

have to be separately planned. There may occasionally also be doctors' offices in connection with the hospital, and the doctors will have use for diagnostic facilities. Even if the hospital does not maintain a normal outpatient department, there will be some use of these facilities by doctors attached to the hospital and by their patients needing x-ray diagnosis or treatment.

It is worth noting that modern medicine places increasing reliance on diagnostic and laboratory procedures. There are some staffing problems in these depart-

ments, and some hospital administrators don't particularly like them, especially in rural areas. But in just those areas the diagnostic facilities may be most appreciated; they might be necessary to induce young doctors to practice there, and thus they are very important to the hospital's community service. The point is that it is not safe to plan on the basis of having no outpatient department, or of keeping the diagnostic facilities to a minimum.

Administration Department

The administrative offices are grouped in the area adjoining the main lobby and main entrance (see Figure 7). Certain sub-groupings should be considered, so that each unit within a sub-group will be conveniently located with reference to each other unit in that sub-group.

For example, the administrator's office, the director of nurses' office, the general business offices, the secretary's office and the toilet facilities for the administrative staff form one sub-group of the administrative facilities, each unit of which should be convenient to each other unit.

Other sub-groups include: the main lobby and waiting room, the information desk, the cashier's window alcove and the public toilets; the admitting office, the social service office; the medical record room and that section of the staff room intended for the record study; and the staff room, locker room, library and conference or board room.

Many hospitals have found it desirable to provide a separate small retiring room in this area for the use of distraught relatives.

The medical record room should be accessible from the admitting office and the outpatient department. It may well adjoin and control the entrance to the staff locker room, and should have convenient access to the inactive record storage room below, possibly by a spiral staircase. Space should be available either in the record room or in the staff room for staff members to use while completing their medical records and for reviewing microfilmed records if that system is contemplated. In larger hospitals it may be necessary to provide a pneumatic tube or other device to convey records to and from the nurses' stations, admitting room, outpatient department and emergency room.

In the larger hospitals, a separate library and conference room should be provided. It is advantageous if this can adjoin the medical record room, thus serving the double purpose of furnishing a control for the library books and space for staff members to consult records without removing them from the control of the medical record librarian. If interns are to be trained at the hospi-

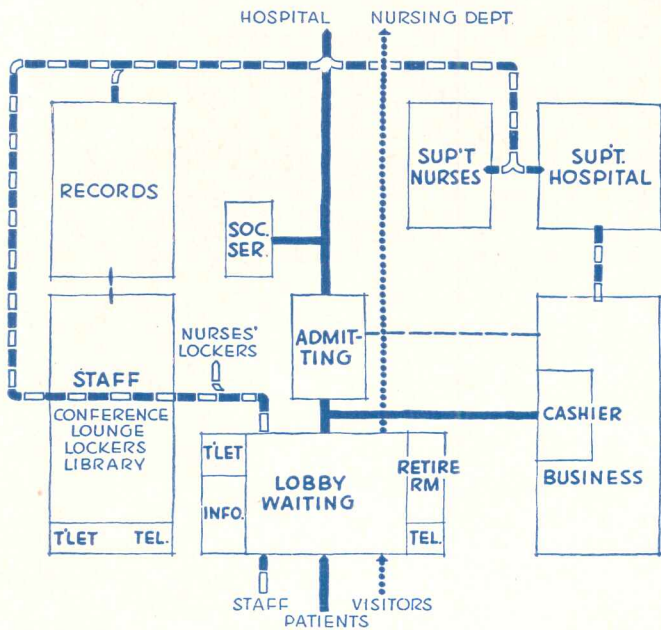

Figure 7: Administration Department

tal, a library is required. The library should have adequate shelving and provisions for unbound periodicals. In smaller hospitals a combination board room, staff conference room and medical library may be arranged in conjunction with the administrator's office by the use of accordion doors, thus enabling the total space to be made available for large meetings.

Service Departments

Figure 8 outlines the flow of activities in the kitchen and other service departments. These are not too different from similar facilities in other types of buildings, but there are a few notable points in hospital operation.

One is to maintain if possible a more than normal isolation of these areas, largely because there is much noisy bustle about them which would disturb the quiet of a hospital or weaken the concentration of certain departments which at times do critical things. A basement location is frequently given them, yet it is often pointed out that a great many people work in these departments, or eat in staff dining rooms, and these busy and underpaid souls should not be asked to struggle in basement space. A change of grade is useful in this problem, giving ground level delivery access and windows for dining rooms. A principle is to point delivery entrances, say, to the rear — at any rate in the opposite direction from the patients' rooms — to screen the less pleasant, noisier activities.

A complicating factor as to kitchens is that food must be delivered to patients in their rooms, so that the food operation must reach into most corners of the building. This is usually accomplished by a tray

service system, with individually prepared trays or bulk food sent from kitchen to nursing units. Floor pantries may or may not enter into the operation, usually not for regular meals. But they serve for bed-time or between-meal snacks or for certain peculiar dietary situations.

Storage problems are always harassing in a hospital. It's a chronic complaint that there is never enough storage area, and that it's never in the right place. Just the same, the central storage system is preferred, for reasons of control. A hospital stores an infinite variety of commodities, from foods to furniture. Some of it is quite valuable, or at least very subject to disappearance, so control is a strong need. Storage problems might be said to compare with those of a hotel, and so require more than ordinary attention in planning.

More Detail

This has been the quickest possible introduction to the circulation problems involved in hospital schematics.

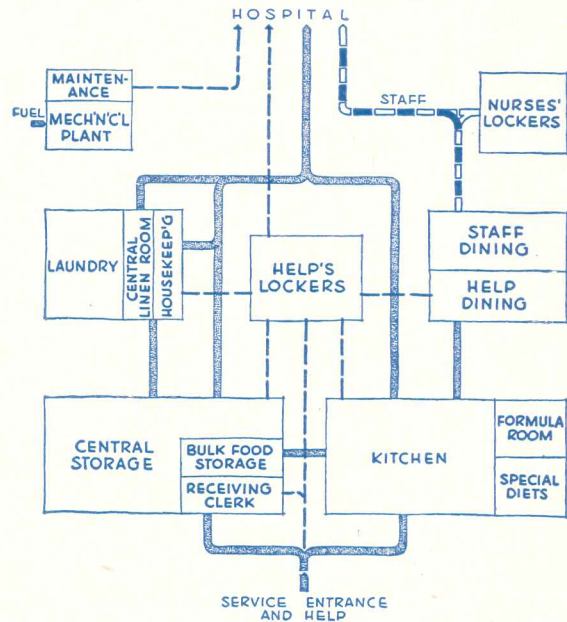
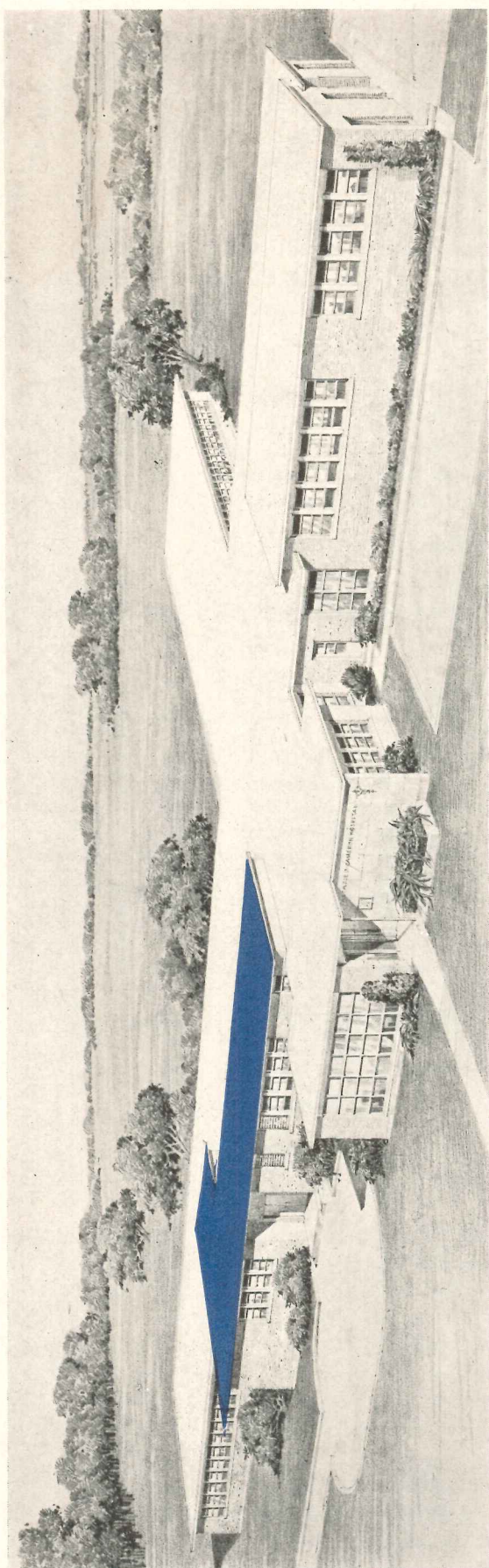

Figure 8: Service Department

If the review seems to deal mainly in principles, they are principles most frequently neglected. Those who have studied hundreds of hospital plans say they are violated by experts as well as beginners, and that when you find a bad hospital scheme the trouble usually goes back to these basic worries about circulation.

They have been treated in considerably more detail in various publications of the U. S. Public Health Service. The more or less official Health Service text has been revised and will be issued soon in book form published jointly by ARCHITECTURAL RECORD and *The Modern Hospital*.



ONE-STORY HOSPITAL

New cruciform scheme relates surgical to emergency to obstetrical, yet separates all. Nurses' stations both for step-saving and control. Good location for sterilizing

West Calcasieu-Cameron Hospital, Sulphur, La.
Ricciuti, Stoffle and Associates, Architects

A NOVEL VARIATION of the cruciform plan, this hospital is an excellent demonstration of the principle of having everything separated yet close together. Perhaps most interesting is the placement of surgical suite, obstetrical department and emergency together in one protected location. X-ray is also in this portion, and the arrangement of central sterilizing is particularly convenient, both to these three departments and to the rest of the hospital. Operating is closely related to emergency, which is always good, but especially desired here since industrial accidents are anticipated. Yet operating can be closed off against contamination from emergency suite. Emergency bears a similar relationship to obstetrical suite. Notice that x-ray is placed with emergency and operating, rather than, as usually, with adjunct facilities; any really critical need for x-ray is more likely to arise in connection with emergency or operating than with adjunct facilities.

The nurses' stations are also interesting. Main nurses' stations are placed centrally within each nursing unit, to keep the nurses' traffic routes as short as possible. For the problem of control during night hours there is an auxiliary nurses' station at the center of the cross, so that one night nurse can control both units.

Adjunct facilities (blood bank, pharmacy, laboratory, etc.) are placed for convenient use as an out-patient department, but are also central as far as the rest of the hospital.

In general, the principle of the scheme is short routes for highly paid personnel, less convenience for others.

HOSPITAL PLANNED FOR LOW OPERATING COSTS

*Exceptionally good schematics—logical
grouping of departments—short travel
distances—two-direction expansibility*

West Contra Costa Hospital, Richmond, Calif. Stone
& Mulloy, Architects, and S. P. Marraccini, Architect

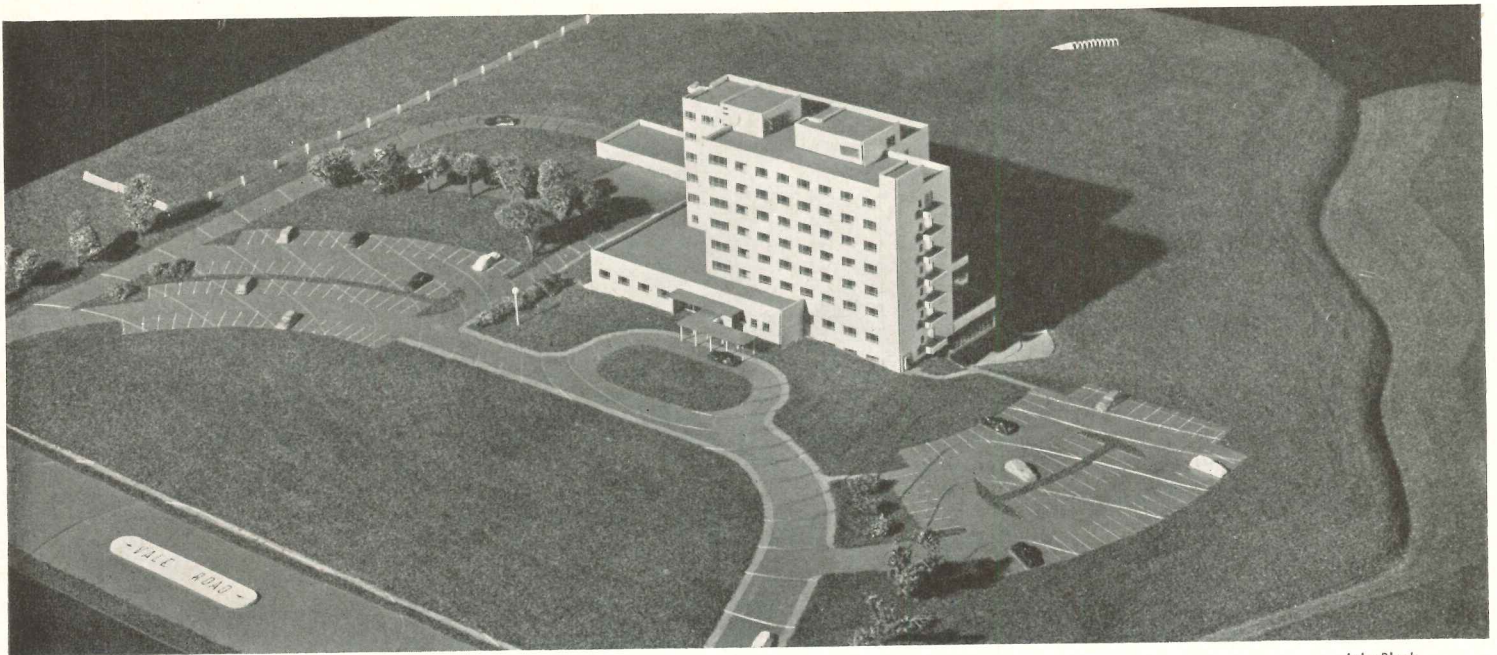

John Black

ALTHOUGH THIS GROUP OF ARCHITECTS has done many hospitals under the Hill-Burton program, they cite this one as their best with respect to circulation problems. Lower floors, heavy with facilities, are basically in the cruciform scheme, though the cross is so fattened as to be hardly recognizable. Upper floors use a sort of squashed Z form, with wings offset to shorten nurses' walking distances. Medical facilities on the first floor can expand horizontally; additional nursing units can be added by vertical expansion. With a rated capacity of 165 beds now, the hospital has operating and medical departments ready for addition of 100 beds before other changes need be contemplated.

First floor is especially worthy of study for its realization of the objective of separating everything yet keeping it all close together. Notice how well the several departments — administration, central sterilizing and supply, surgery, emergency, x-ray and adjunct facilities (including physical therapy) — are separately defined and isolated. Still, following the theory of the cruciform scheme, all gather closely about the center.

Especially good is the enlarged arm of the cross including emergency, x-ray and adjunct facilities. The connected double corridor permits each department to be closely controlled while giving access from, say, adjunct

facilities to x-ray, or from x-ray to emergency. X-ray is also close to the operating department, and all facilities are within easy reach of elevators to upper floors for inpatient use. Emergency is nicely developed — across the corridor from x-ray and adjacent to surgery, yet with plenty of barriers against contamination.

The same trick of the connected double corridor, in H form, keeps the operating department compact, with short distances and complete isolation. Surgery connects directly with central sterilizing, also with elevators.

Obstetrical is deliberately underplayed here, but can be expanded outward if the need develops. Delivery rooms, at the far location of the Z, are directly on the maternity floor but well isolated. The nursery, at the other far location, is similarly isolated, yet still very close to the nurses' station.

The same offset wing scheme is used for typical nursing unit floors. This places nurses' station directly opposite elevators, also central with respect to the patients' rooms. The nurses have all their utilities grouped in the center, with again a connecting corridor saving steps.

The architects were asked to plan this hospital for low operating costs, and nothing could contribute to this end like the circulation scheme here developed, to save time for critically busy personnel.

Surgery adjacent to central sterilizing

Also near emergency

Emergency near x-ray

X-ray near outpatient

All close to elevators

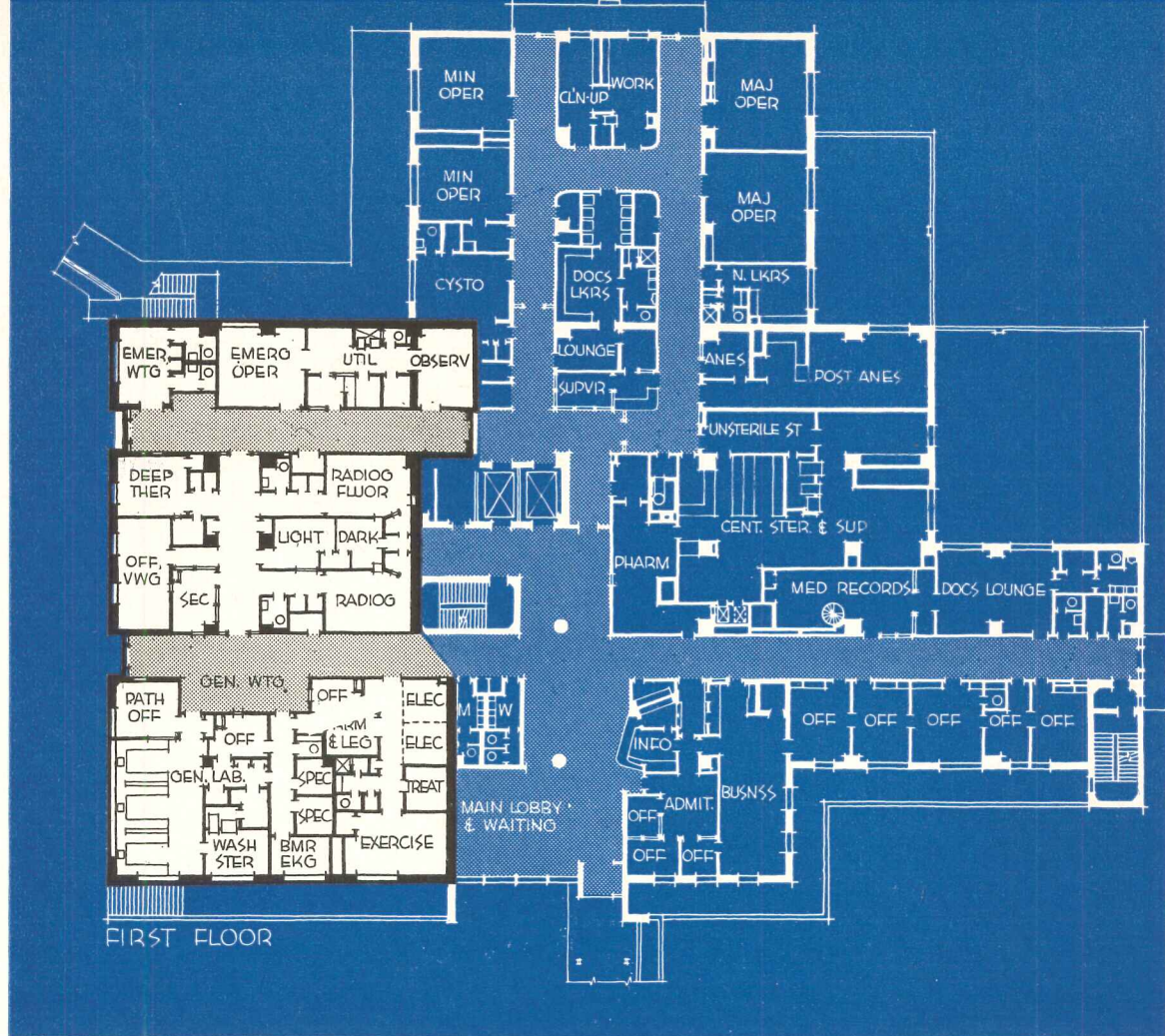

Basement departments focus toward unloading

Modified cross plan shortens distances

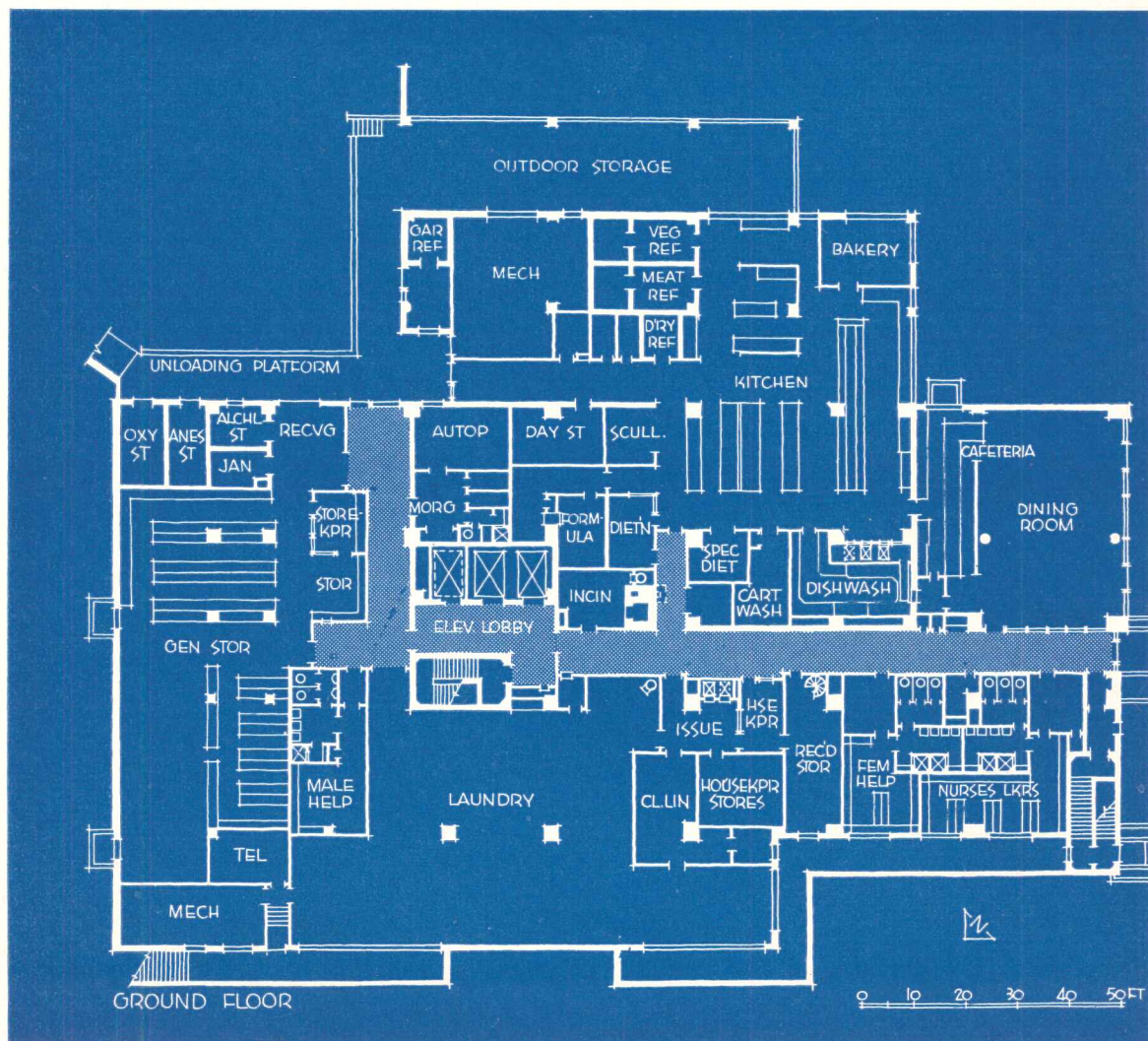

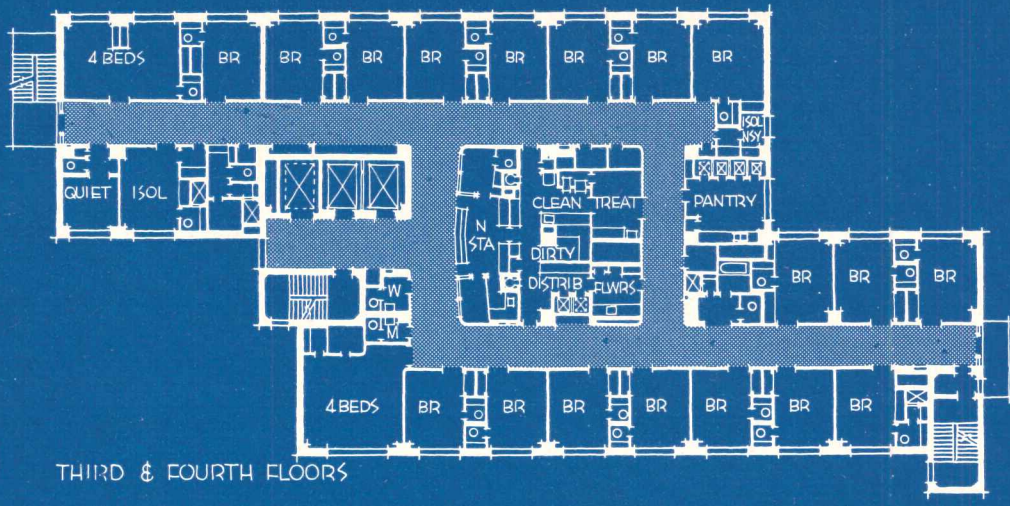

THIRD & FOURTH FLOORS

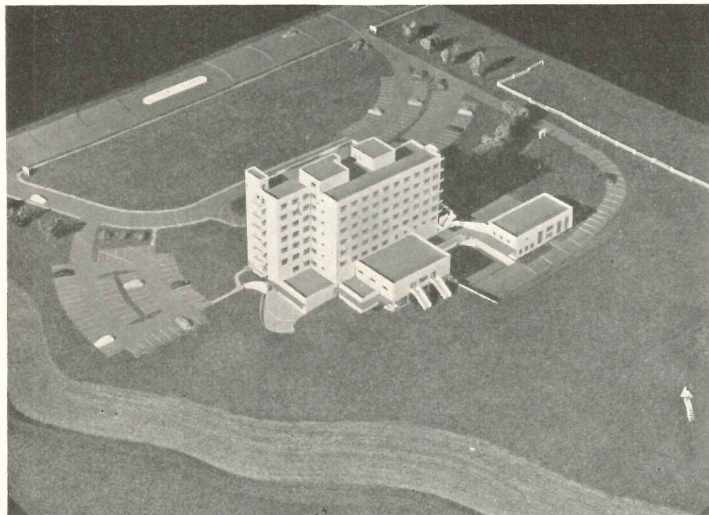

Typical nursing floor, above, divides patient rooms in a fat Z plan, keeping nurses' station at best location for control, also keeping walking to a minimum. Maternity floor, below, uses far points of the Z to isolate delivery suite and nurseries

John Black

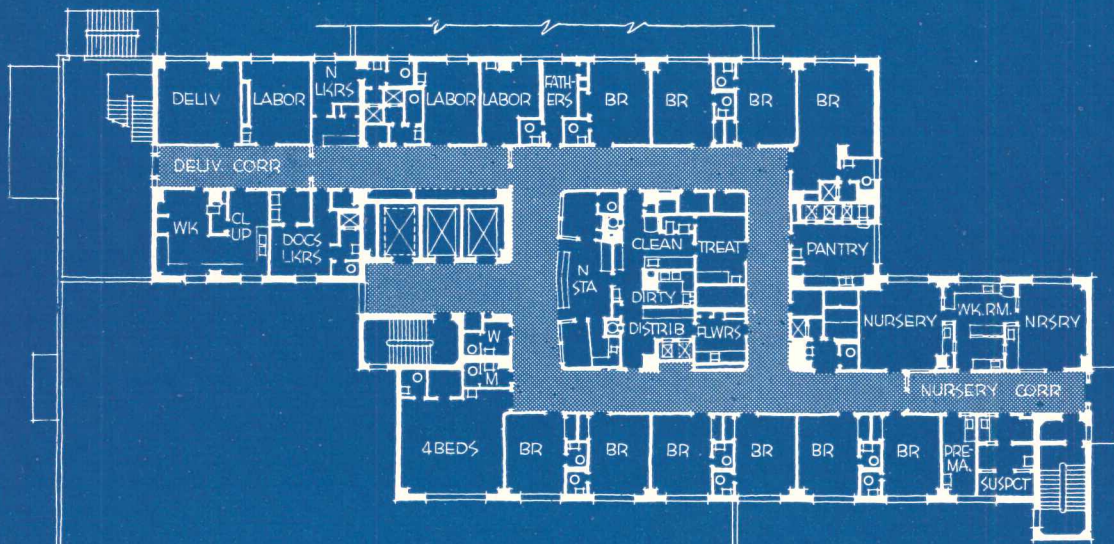

SECOND FLOOR

*A good illustration of the advantage of the T form
in separating traffic and isolating departments*

CONVENTIONAL T PLAN FOR A LARGE HOSPITAL

Marion General Hospital, Marion, Ohio
Dan A. Carmichael, Jr., Architect

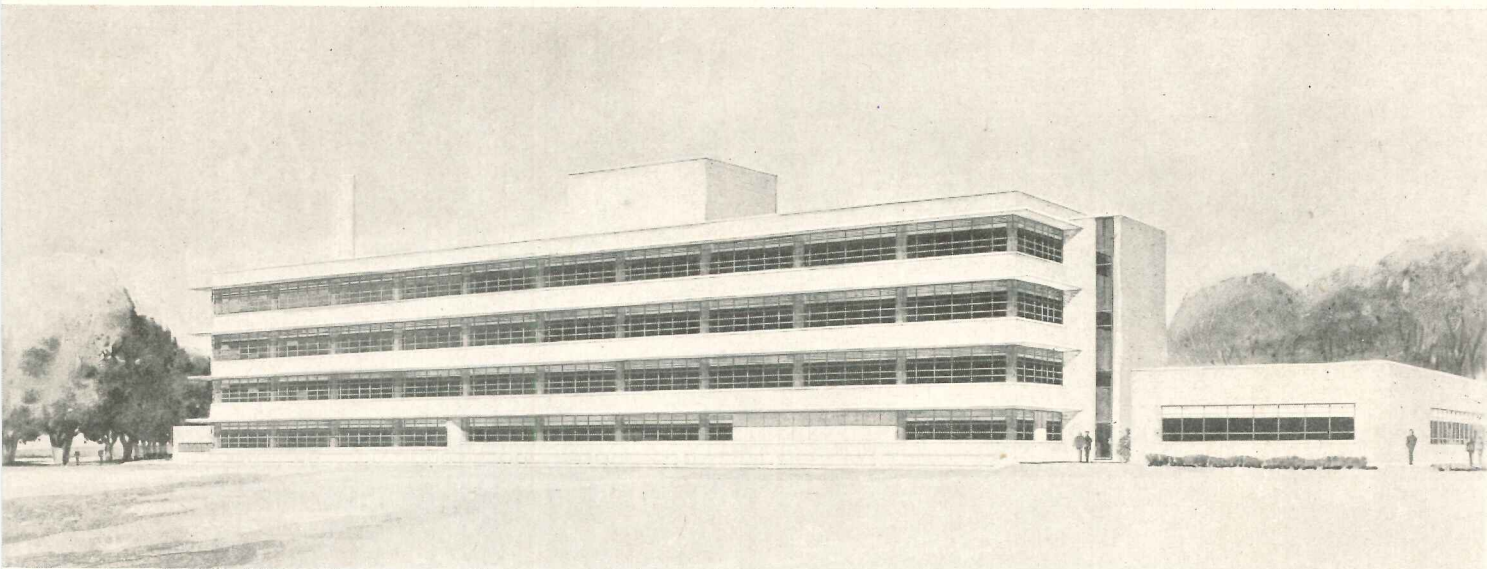

A MORE CONVENTIONAL SCHEME than others in this study, this hospital is an excellent example of the typical advantages of the T plan for a large hospital. Good separation of different traffic streams, good shielding of individual departments, positive control of visiting public, best orientation for patient rooms, isolation of noisier activities and deliveries — these are important merits of the T form.

In evaluation of these schematics it is important to remember that this is a large hospital. It has at present a nominal capacity of 158 beds, in three large nursing units on second, third and fourth (not shown) floors, with sufficient medical and service facilities for the addition of a fifth-floor nursing unit of some 50 beds. The unusual size of the nursing units was a careful decision here, based on shortage of well trained nurses. Horizontal travel distances are accordingly somewhat longer than is customary.

In the early stages the architect submitted several designs for the nursing units, ranging from 35 to 50 beds and including one of present size with two nurses' stations at the quarter points. The final scheme puts the nurses' station at the central control point, but cuts nurses' walking distances by duplicating utilities at the quarter points.

Public circulation (first floor) is confined to the north-east section, with visitors and inpatient entrance in the

stem of the T, outpatient at the end of a wing. Emergency and general service entrances are from a court at basement level, on the opposite side from public entrances. The staff entrance is at the north end of the stem; this location brings the doctors in past the switchboard operator (who keeps in and out register), then past doctors' lounge and medical records, a good routing of the staff. There was some discussion of the desirability of doctors having to pass through the waiting room, but the staff voiced no objection. Doctors have a separate parking area close to this entrance.

The surgery, located in the usual horizontally contiguous relation to the nursing wing, has typical longitudinal circulation. The stairwell is a mandatory requirement of Ohio laws, but it will be equipped with exit hardware only on all floors, so that it cannot be used for interfloor circulation. Central sterilizing and supply is in the surgical suite, connected by dumbwaiter to obstetrical above, and to the floors below to serve emergency department and the rest of the hospital. The pharmacy is similarly connected with other floors by dumbwaiter, a particular request of the staff.

The obstetrical department takes the usual position in the T plan — in the stem opposite the maternity nursing unit. This department is a little larger than normally, with a few extra labor rooms, again at the special request of the hospital staff.

HOSPITALS

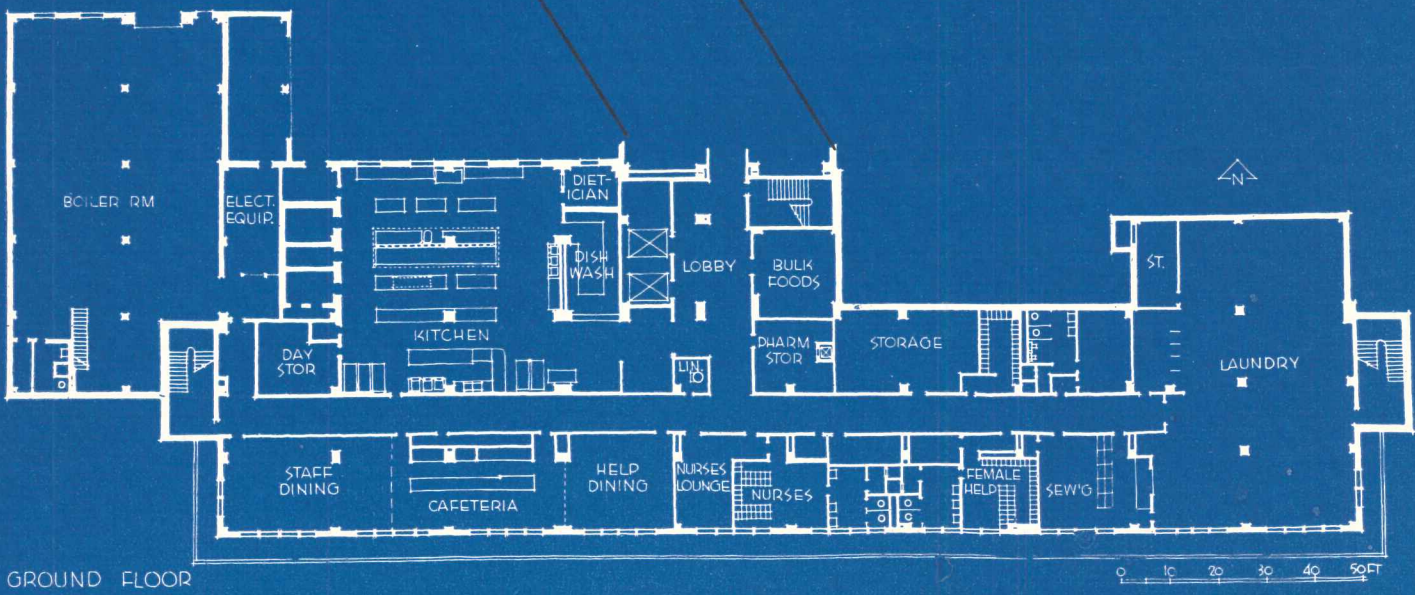
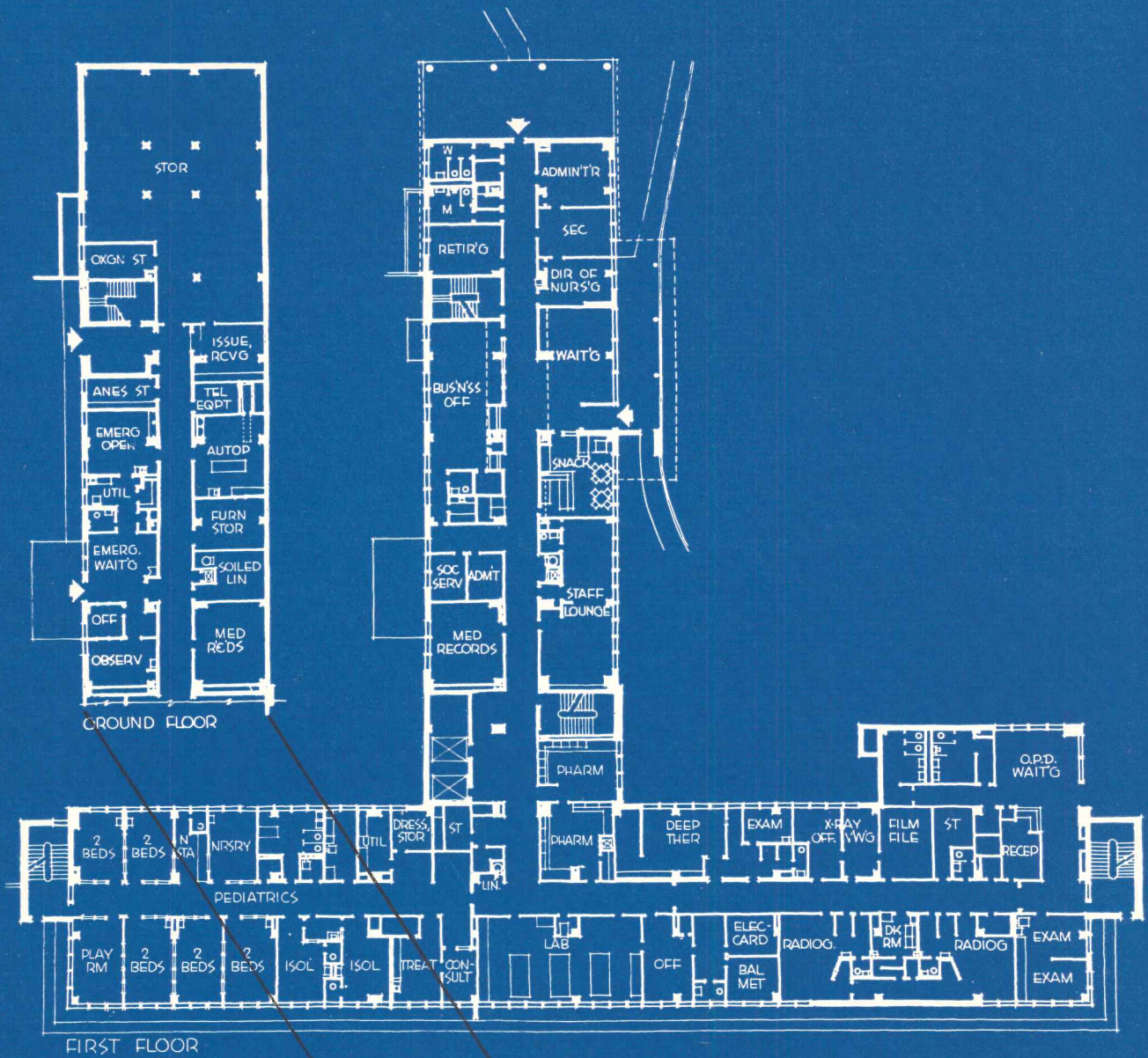

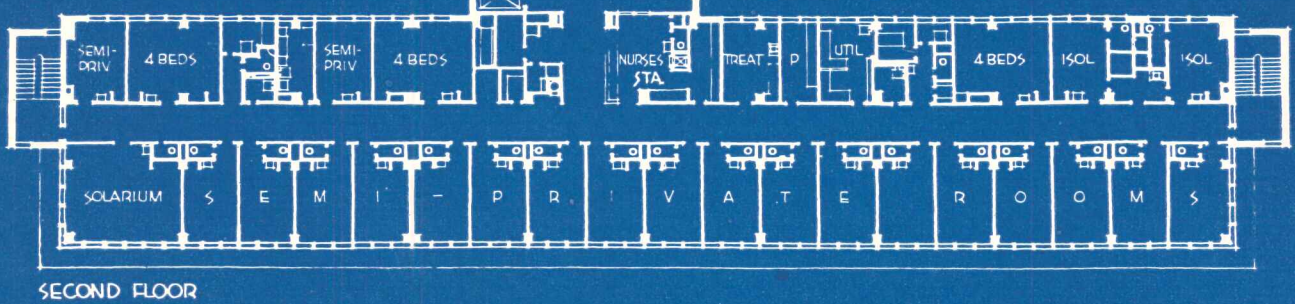
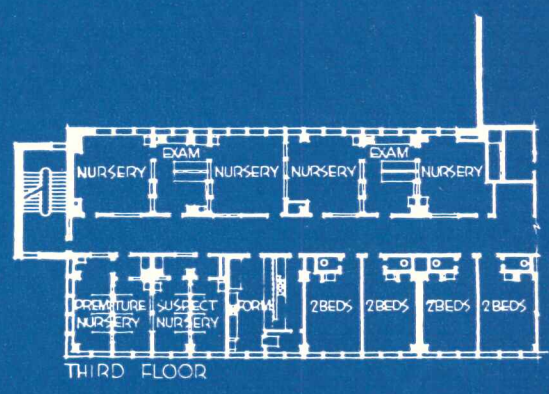
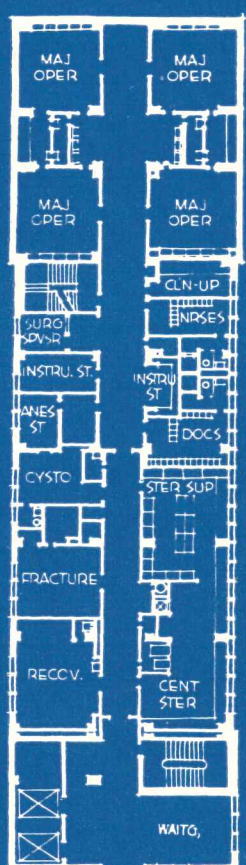
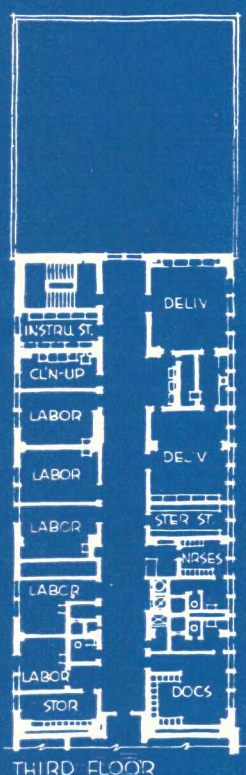
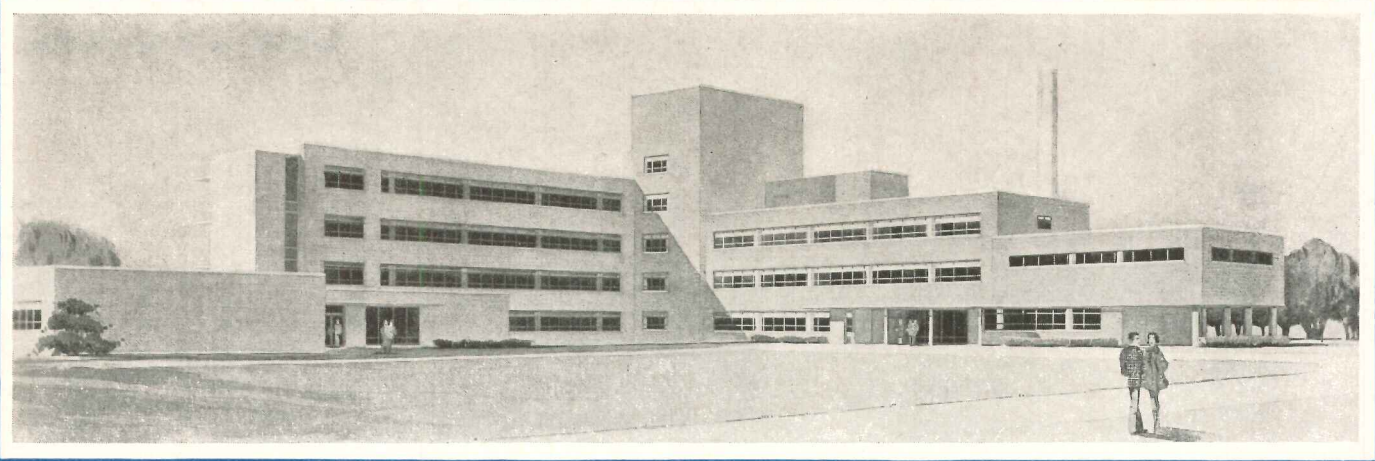

HOSPITALS

DOUBLE-CORRIDOR VARIATION ISOLATES IMPORTANT AREAS

*Surgery on one corridor, x-ray on other
can be joined or isolated as needs dictate*

Magic Valley Memorial, Hospital, Twin Falls, Idaho
Fisher & Fisher, Architects

Milo Ketchum, Structural Engineer
Marshall & Johnson, Mechanical Engineers

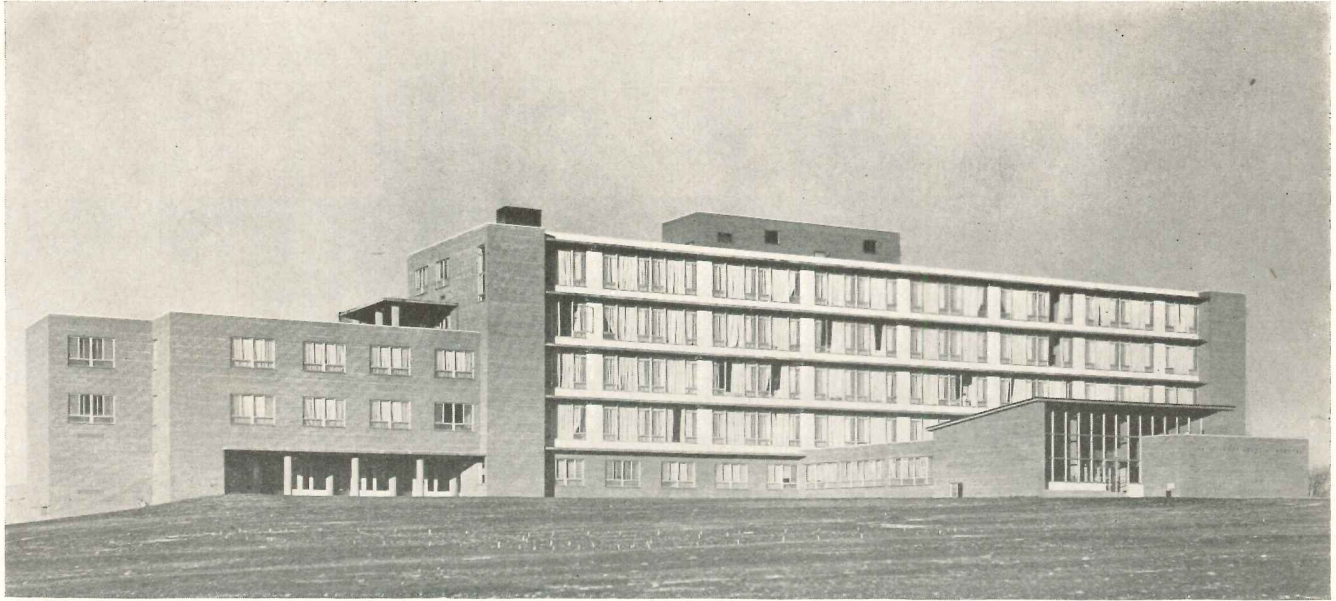

Williams Photo

BASEMENT FLOOR

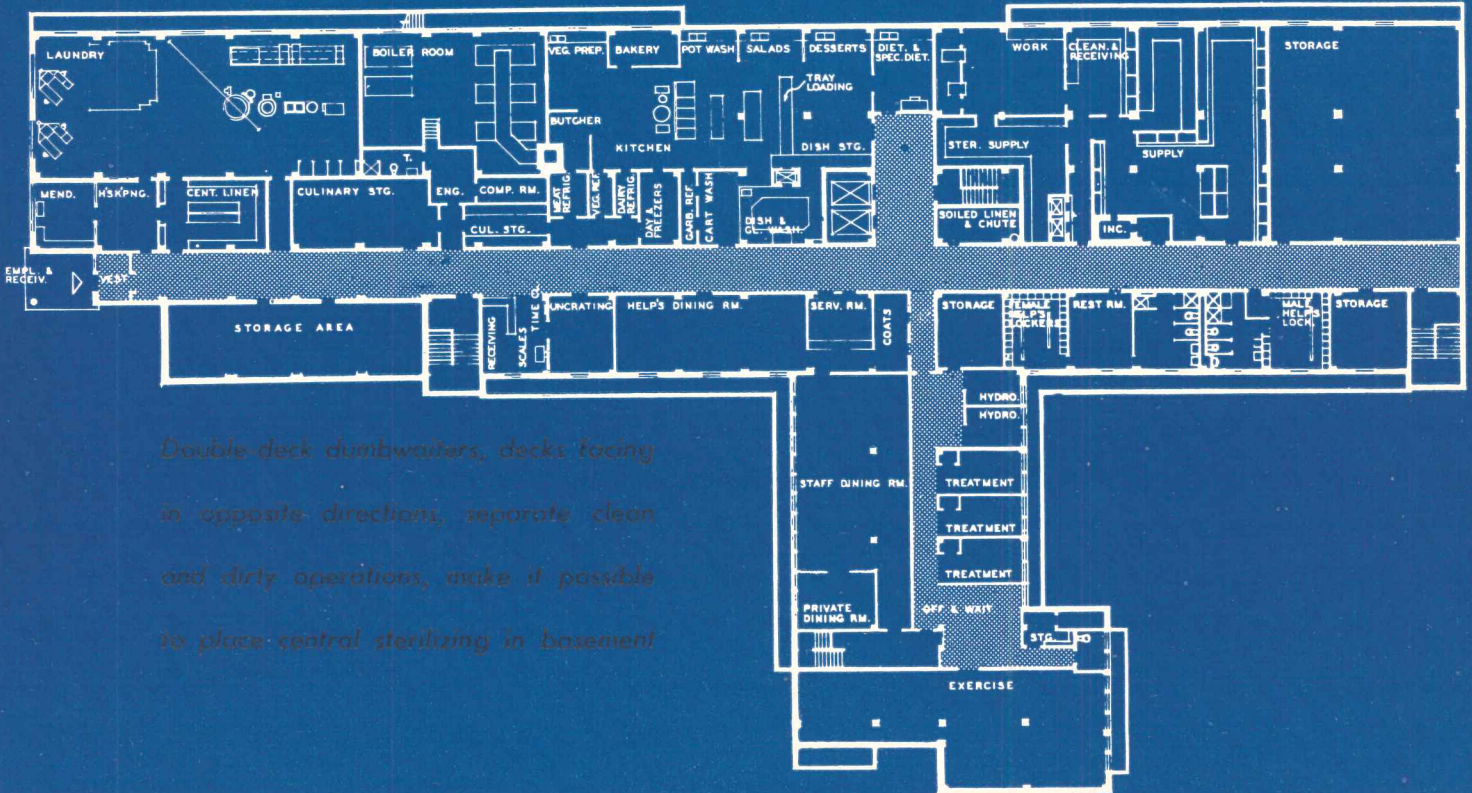

*Double-deck dumbwaiters, decks facing
in opposite directions, separate clean
and dirty operations, make it possible
to place central sterilizing in basement*

SELECTION OF THIS HOSPITAL for this Building Types Study, thus rushing its publication somewhat, is based on the ingenuity with which the relationships of the various departments are developed. A novel variation of the double-corridor scheme gives isolated locations to critical departments, yet maintains good communication and circulation.

The surgery (first floor) places its four major operating rooms in a line along an isolated corridor at the rear. This section is closely related to emergency and ambulance entrance, so that emergency patients requiring major surgery can be taken quickly to the operating department. In case of disaster, the surgical department can become part of the emergency operation. Note also the convenient accessibility of the tissue section of pathology, in case laboratory work is indicated in connection with surgery.

The double-corridor scheme relates surgery to x-ray in unusually convenient ways. The radiology corridor provides access to nurses' and doctors' surgery locker rooms, so that medical personnel can prepare for operating and never need enter the surgical corridor in street clothes. Routes can be opened from surgery to x-ray, or can be closed off positively to protect the operating rooms. Either the cystoscopy room or fracture room serves in this respect, and either room can be

opened in either direction depending on its immediate relationship to operating or outpatient department. Central sterilizing and supply is directly underneath surgery, and works through ingenious double-deck dumbwaiters — one deck for sterile supplies opens in one direction, the other deck for soiled things opens into another corridor. The same isolation of dirty and sterile operates also for the obstetrical department.

The outpatient department is exceptionally large (so are some other departments) because the hospital is virtually alone in fabulous and picturesque Magic Valley, an area that has developed rapidly as irrigation brought prosperity. Outpatient department, with all adjunct facilities, can be closed off completely from the rest of the hospital, and yet is convenient for inpatients. Only persons needing x-ray need go beyond the barrier.

Obstetrical department uses the same double-corridor idea on the second floor to isolate the delivery corridor and yet give short routes for authorized personnel. This department, with its nurseries, is quite large, again because of the growth of the area. There is one unusual room in the delivery suite, one labelled obstetrical surgery, for caesarian deliveries, a special request of the hospital staff.

The administration department, in its own wing, is well planned for functioning of its sub-groups.

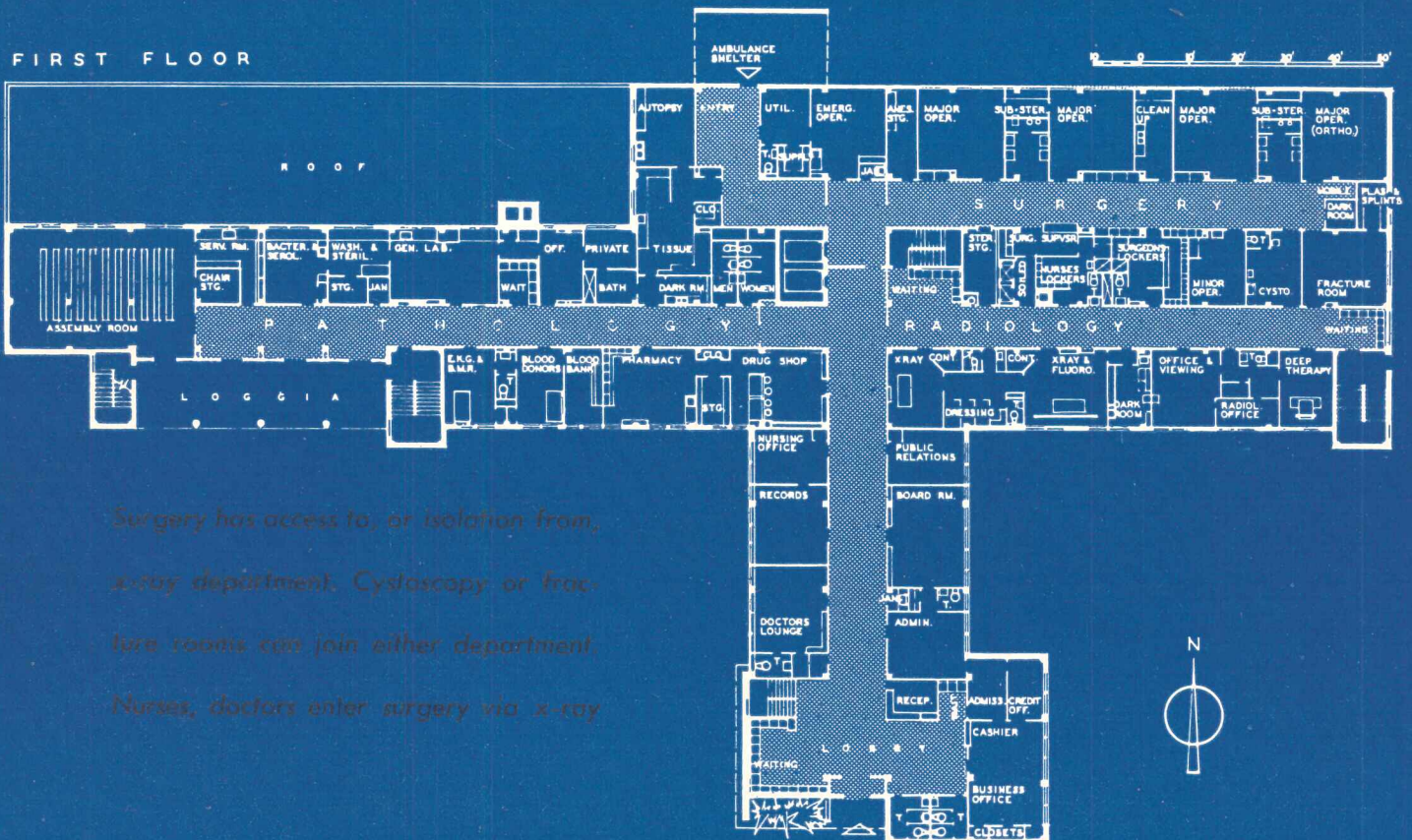

Surgery has access to, or isolation from, x-ray department. Cystoscopy or fracture rooms can join either department. Nurses, doctors enter surgery via x-ray



Nurses' station, third floor



Main kitchen, in basement

Williams Photo

Typical major operating room, first floor

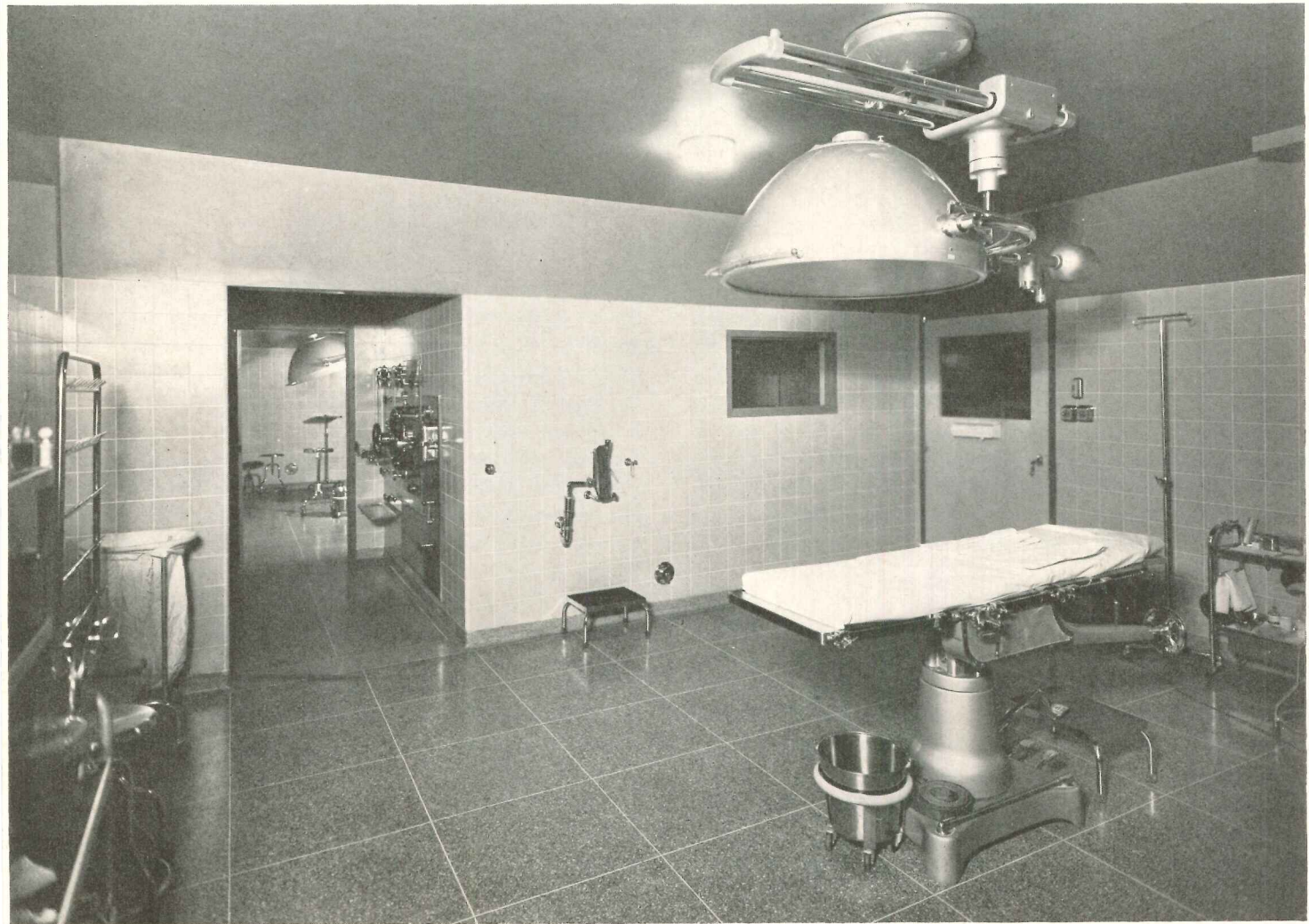

T-FORM HOSPITAL WITH TRIPLE CORRIDOR PLAN

Ingenious scheme permits double-size medical facilities without sacrifice of T-plan merits

Riley County Hospital, Manhattan, Kansas
F. O. Wolfenbarger & Associates, Architects

Finney & Turnipseed, Structural Engineers
Howarth, Scott & Kinney, Mechanical Engineers

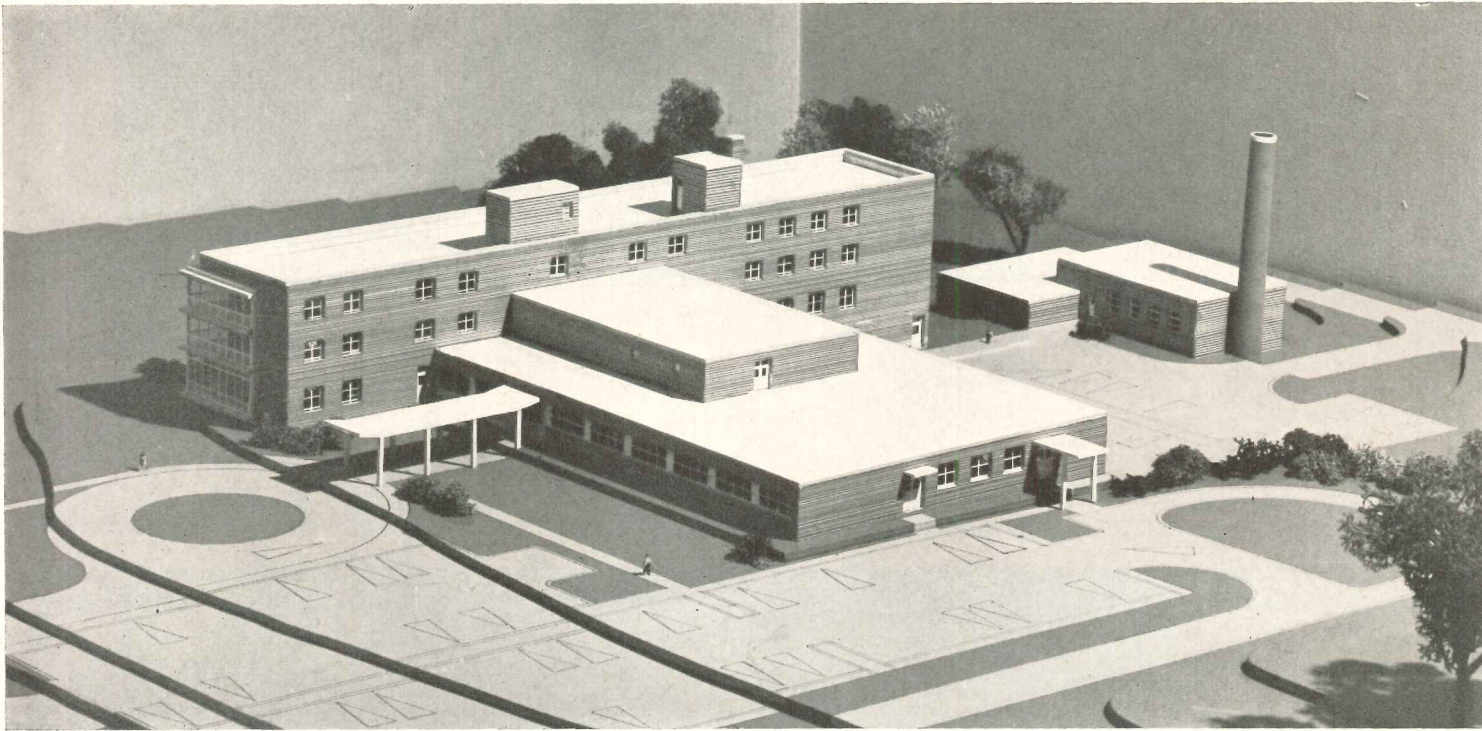

Blakes Studio

A THICKENED T PLAN with a triple corridor scheme is the most interesting circulation idea in this hospital. It makes possible a good grouping of administration, adjunct facilities, emergency and operating departments, each well isolated from each other and from the rest of the hospital. All of these departments are at present oversize, for the nominal bed capacity of 95 beds can be enlarged by the addition of three nursing floors.

The scheme preserves all of the normal advantages of the T form, and avoids some of the distortions often produced in the effort to enlarge basic departments in anticipation of expansion. The top of the T is, as usual, reserved for nursing units, with all extraneous traffic kept out of nursing corridors. In this plan the nursing wings are so fully protected that there is not even one entrance on this side of the building; even the lowest floor (first) becomes available for patients' rooms. This level becomes a basement at one side of the stem of the T, but has full window height for patients' rooms and for dining rooms and kitchen.

The center of activity then becomes the second floor,

and it is here that the triple-corridor plan keeps departments separated but close together, and keeps traffic un-snarled. Main entrance leads quickly past admitting office to patients' rooms or to elevators. Administration department is to the other side of the main entrance.

Doctors have a separate entrance, leading to administration, adjunct facilities, emergency or operating departments. It should be explained that this hospital does not contemplate operation of an outpatient department, so very little public traffic is anticipated to adjunct facilities; they are naturally placed for relationship to other medical facilities.

The emergency entrance leads quickly, beyond the emergency operating room, to x-ray or to surgery.

The operating department is centrally located, but still isolated. The central corridor offers a protected by-pass around the operating department; also makes for quick access from this department of x-ray facilities in the interior space.

On the third floor the stem of the T is much reduced; it need accommodate only the obstetrical department,

Emergency close to surgery

*X-ray close to emergency,
cystoscopy and surgery*

*Operating suite central, but
still well isolated*

*Central corridor shortens
routes, separates traffic*

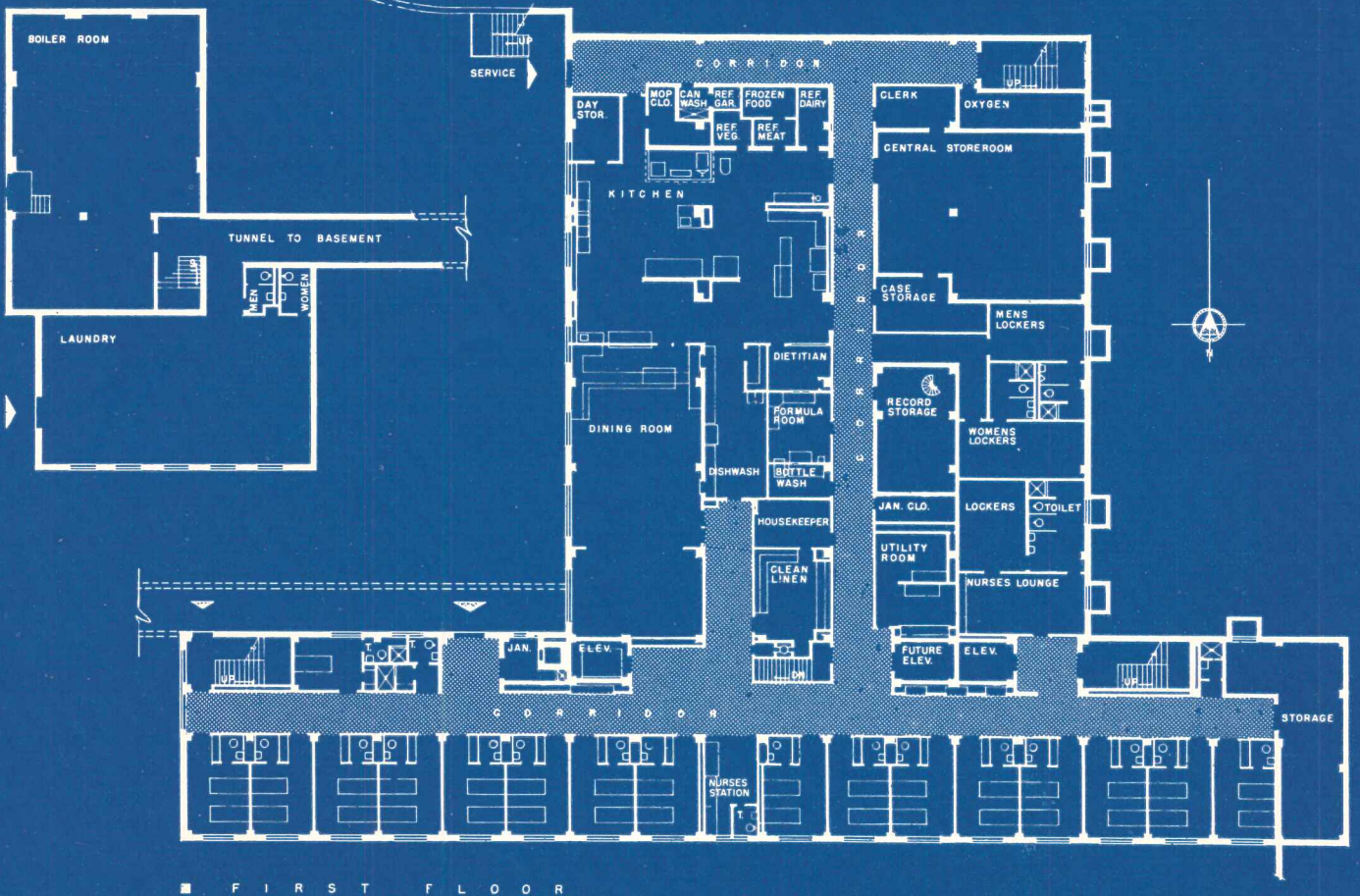
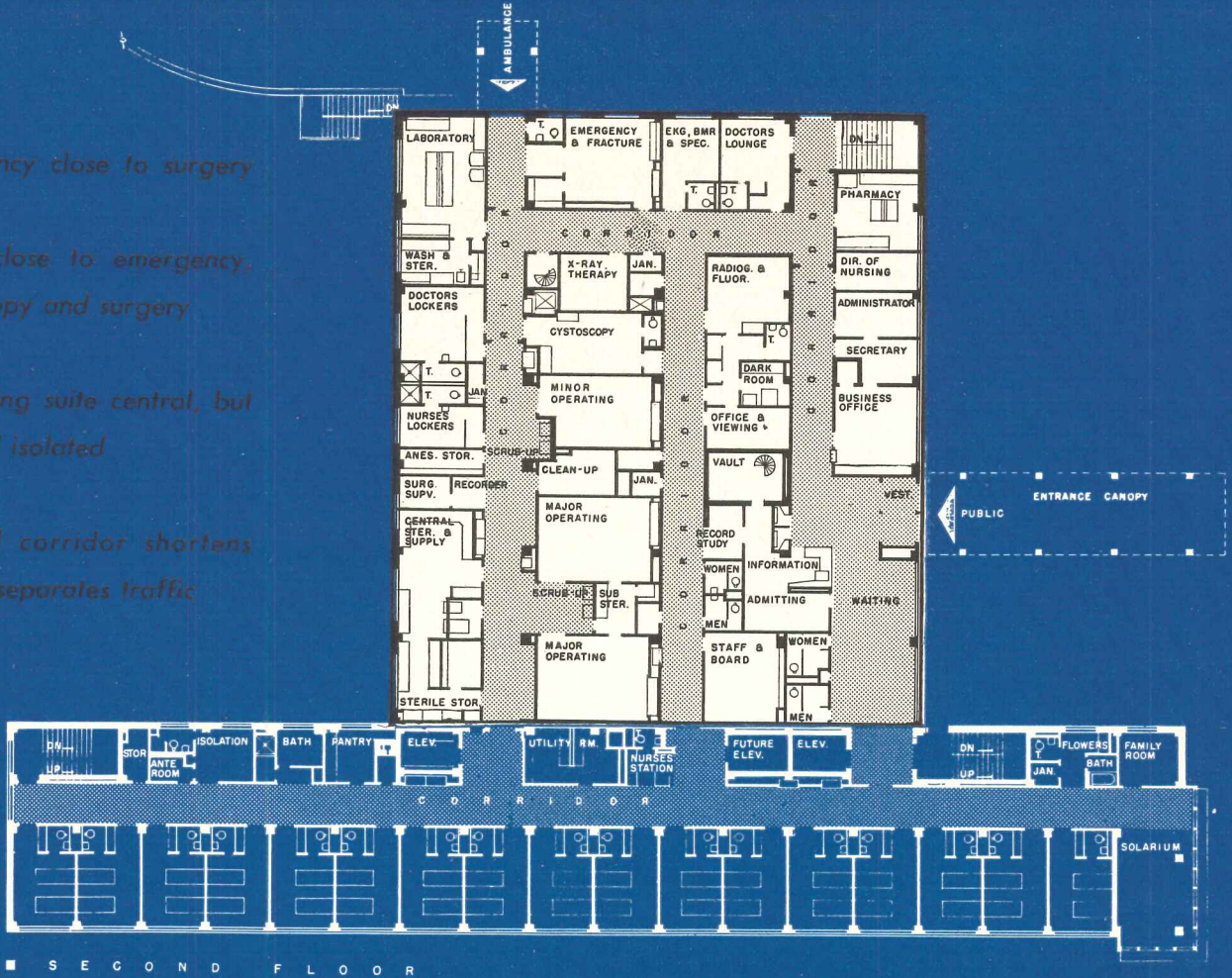

0 5 10 20 30 40 50

INDUSTRIAL LIGHTING SYSTEMS APPRAISED FOR COMFORT AND ECONOMY*

This evaluation of typical fluorescent industrial luminaires compares visual comfort, operating and first costs and maintenance. It describes recently developed fixtures with openings in the top which cast a portion of their light upward to avoid ceiling gloom and reduce brightness ratios, and which maintain better than closed-top fixtures

IN THE PAST industrial lighting has been applied with less attention to the virtues of seeing comfort than in offices. Yet, many visual tasks are much more critical and difficult in factories. Industrial luminaires which cast all light downward account for dark gloomy ceilings, resulting in poor brightness ratios and discomfort.

Perhaps the very diversity of conditions found in all types of industrial areas, from foundries to laboratories, has been partly responsible for this situation. Today, however, the lighting industry is making equally diversified fixtures for what might best be called "production lighting" — lighting for all areas where production is the important factor. And now the concept that comfort levels for industrial lighting systems should approach those employed in offices is agreed upon in most lighting circles, although in practice this concept still has a long way to go.

Actually, the steps to quality lighting are simple: 1. Provide an adequate level of illumination for a given visual task. 2. Lighten all surfaces — ceiling, walls, floor, bench tops and machinery in colors as light as practicable for the area involved. 3. Give more — much more — consideration to improved shielding of light sources and a greater upward component of light: *the recently developed luminaires with openings in the reflector tops have been designed to furnish this upward light.* Not only do these fixtures improve seeing conditions, but they accumulate less dirt, as shown by tests.

Industrial Luminaire Analysis

To aid in the application of quality factors to industrial lighting installations, an analysis was made of typical fluorescent industrial luminaires, appraising their characteristics in relation to comfort of seeing, economics and maintenance. A summary of this anal-

ysis is given in Table 1.

Types of luminaires included in the analysis are for regular industrial applications, are all-metal, sturdily constructed, using channels to house ballasts, and lampholders, with detachable closed end all-white all-porcelain reflectors. Some luminaires have longitudinal baffles, some have egg-crate louvers, and some have no shielding other than the reflector.

The comparative analysis of fluorescent luminaires is divided into three categories:

(A) Group I — Solid top reflectors with all light directed downward.

(B) Group II — Slotted top reflectors with 10 to 15 per cent uplight and the remaining light directed downward.

(C) Group III — Open top reflectors with 30 to 50 per cent uplight and the remaining directed downward.

Factory Area Assumed

In order to analyze each luminaire type in relation to comfort and economics, a typical factory area representing average construction features was assumed. The room size is 60 by 120 ft. Luminaires are mounted 10 ft above the floor. The height of the ceiling is considered to be 14 ft and of concrete slab construction.

To study and compare the various types of luminaires under varied conditions, four factory finishes with reflection factors as follows were considered:

















	Ceiling	Walls
1.	75%	50%
2.	50	30
3.	30	30
4.	30	10

* This article is an abstract from a paper by George J. Taylor and R. D. Bradley (Day-Brite Lighting, Inc., St. Louis) presented at the National Technical Conference of the Illuminating Engineering Society, September 8-12, 1952, Chicago, Illinois.



Fixtures in the foreground direct 10 per cent of their light onto the ceiling to help reduce brightness contrasts. Note, in comparison, the spotty effect of the fixtures in the inset section of the photo where all light is directed downward

Table I

	1	2	3	4	5	6	7	8	9	10	11	12	13	14	15	16
General Data																
	3/40	2/85	2/75	2/40	2/40	3/40	3/40	2/85	2/75	2/40	2/85	2/40	3/40	2/40	2/75	2/40
Lamps per section	6-40	4-85	2-75	4-40	4-40	6-40	6-40	4-85	2-75	4-40	4-85	4-40	6-40	4-40	2-75	2-40
Luminaire shielding *	14° x 2°	14° x 2°	14° x 0°	14° x 2°	28° x 2°	26° x 28°	13° x 2°	14° x 2°	14° x 0°	13° x 2°	25° x 28°	27° x 2°	26° x 28°	26° x 28°	35° x 24°	35° x 3°
Luminaire distribution																
Uplight—%	0	0	0	0	0	0	9	10	10	10	13	12	11	14	47	30
Downlight—%	100	100	100	100	100	100	91	90	90	90	87	88	89	86	53	70
Overall efficiency—%	77.0%	78.5%	79.0%	78.0%	71.0%	63.8%	77.2%	83.2%	81.4%	82.0%	72.5%	70.5%	64.4%	69.1%	81.0%	79.5%
Maintenance factor **	.65	.65	.65	.65	.65	.60	.70	.70	.70	.70	.65	.70	.65	.65	.70	.70
Coeff. of utilization †																
Room reflectances ††75/50	.70	.73	.72	.72	.65	.60	.68	.73	.70	.72	.63	.63	.58	.61	.62	.65
Room reflectances 50/30	.67	.68	.68	.68	.62	.57	.64	.68	.65	.67	.59	.58	.53	.56	.52	.57
Number luminaire sections																
Room reflectances 75/50	58	41	80	84	93	73	55	39	77	78	48	89	69	99	86	172
Room reflectances 50/30	60	44	95	89	98	77	58	42	83	84	52	97	75	108	103	196
Cost Data (75/50)																
First cost including lamps Per cent (of Type 1)	100%	101%	108%	123%	142%	144%	95%	97%	104%	115%	134%	136%	136%	169%	143%	149%
Annual operating cost Per cent (of Type 1)	100%	100%	102%	105%	119%	136%	95%	94%	97%	97%	122%	113%	127%	135%	118%	114%
Cost per sq ft																
First cost/sq ft	\$.63	\$.64	\$.69	\$.78	\$.90	\$.91	\$.60	\$.61	\$.66	\$.73	\$.85	\$.86	\$.86	\$1.07	\$.91	\$.95
Annual operating cost/sq ft	\$.23	\$.23	\$.24	\$.24	\$.27	\$.31	\$.22	\$.22	\$.22	\$.22	\$.28	\$.26	\$.29	\$.31	\$.27	\$.26
Comfort Data (75/50)																
Glare factors																
Crosswise	234	157	140	146	75	138	121	112	98	97	77	47	68	48	14	8
Lengthwise	276	152	125	130	92	122	131	140	95	94	62	56	64	41	15	31

* Luminaire shielding: first figure denotes crosswise shielding; second figure lengthwise shielding.
 † Coeff. of utilization = total light received by working plane/total lamp output.

** Indicates fraction of initial output maintained in service.
 †† Room reflectance: First figure denotes ceiling reflectance; second figure wall reflectance.

While all sorts of conditions for room finishes are still prevalent in many industrial interiors, it is not the intent to encourage the use of low reflectances of room finishes. Later it will be shown that low reflectances are undesirable for many reasons.

Basis for Computations

Illumination computations were made for the 16 types of lighting systems to provide 50 ft-candles maintained. The conditions and general factors applying to these computations are shown in Table I.

The assignment of maintenance factors for various luminaires favors slotted and open top reflectors over solid top reflectors. Tests have been conducted showing that a draft action takes place through reflector openings which reduces the rate of depreciation of light due to dust and dirt accumulation.

In a 10-month test by the Detroit Edison Co., a reflector with circular openings depreciated only eight per cent in light output, while a closed-topped fixture depreciated 21 per cent during the same period.

It is possible that completely open top reflectors with high upward light components may have some advantage over

slotted top reflectors with lower upward light. However, this condition has not been established and maintenance factors for both these classifications were assigned the same values for similar type luminaires.

Computed costs are based upon an in-service level of 50 ft-candles. Included in the wiring costs are the cost and installation of lighting panel boards, branch circuit wiring in conduit to luminaire channels and wiring connections to each luminaire.

The installation of luminaires in their proper location includes cost and installation of mounting anchorage points in the ceiling from which luminaires and suspension members are supported.

The installation costs of luminaires are based upon an unoccupied room area. Such costs may be materially higher if machines or other equipment are in place making it difficult or impossible to use and move scaffolding in the room.

Appraisal of Lighting Systems

Comparisons of first costs for the luminaires analyzed for room finishes are shown in Table I. However, the first cost and operating cost of a lighting system are by no means the only criteria

upon which a lighting installation is selected. Other important factors besides cost may be the determining factor in the final selection of the system to use. These factors, not necessarily in order of their importance, may be listed as follows:

1. Comfort — quality of illumination
2. Appearance — esthetic effect
3. Maintenance — lasting qualities
4. First cost — initial investment
5. Operating cost — annual investment

Whatever weight or importance is assigned to any of the above factors will determine the type of lighting system to use.

If high comfort and good overall room appearance is desired, System 15 might be considered. If low maintenance is coupled with reasonably good comfort, System 12 may be the answer. If cost is a consideration with a fair degree of comfort, System 9 might be considered. The point is, the five factors just listed do have a direct bearing on the final selection of a lighting system.

Seeing Comfort. The comfort, or quality, of the illumination provided by a lighting system takes the following factors into consideration:

1. Brightness and area of the source.
2. Luminaire light distribution and proper brightness ratios and contrasts.
3. Proper shielding of the source.
4. Overall room conditions, such as proper brightness patterns and ratios between visually adjacent surfaces, as well as between work, and work surfaces and other room areas or background.

To correlate all these features into one comprehensible condition to produce the desired result in terms of comfort has always been a difficult thing to achieve, even by the experienced lighting engineer.

In appraising the comfort of the lighting systems analyzed here, the Harrison-Meaker method of glare rating has been used, the significance of which is explained later. It was felt that this method provided a relatively valid figure of merit from the standpoint of comfort. It applies widely to varying types of luminaires under given room conditions.

Glare factor values for the 16 lighting systems are shown in Table I. Only one room size, ceiling height and room finish condition is given for the sake of simplicity. This study, however, indicates the importance of carefully selecting a lighting system if comfort of seeing is to be obtained.

This glare factor can be interpreted as follows for industrial lighting:

<i>Range</i>	<i>Occupant Reaction</i>
0-25	Few or no complaints. Comfortable for all

Here we see the comfortable lighting environment provided by fixtures with a 50 per cent upward light component, together with the use of light-colored machinery, walls and floor

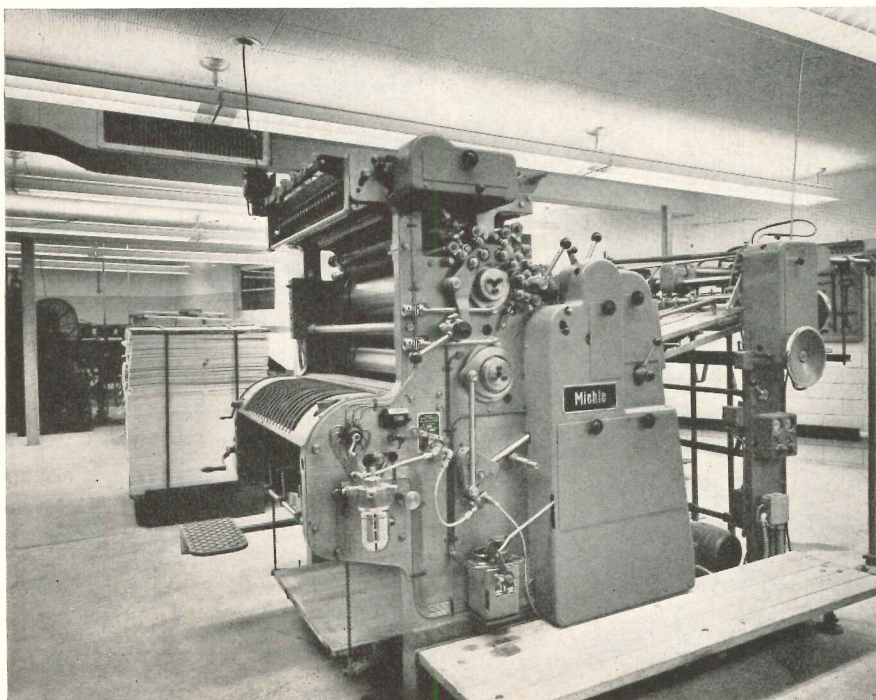

- | | |
|---------|---|
| 25-50 | Practical average. Comfortable for most occupants |
| 50-75 | Average borderline of discomfort |
| 75-115 | Approximately one-half of the occupants may complain of discomfort |
| 115-225 | Approximately three-fourths of the occupants may complain of discomfort |

Based on this comfort range it is observed that highest comfort is obtained with Group III luminaires having 30 to 50 per cent upward light component. Attention again is called to the fact that all room finishes must conform to conditions previously given to obtain the best results of quality lighting and "brightness engineering" to achieve comfort of seeing. For instance, if machinery or floors or bench tops are dark in color (of low reflectance value) while ceilings are bright by comparison, discomfort may result.

Next in line in consideration of employee comfort are Group II luminaires with 10 to 15 per cent upward light component. Systems 12 and 13 fall well within the comfort range of glare factors for industrial type applications. So does System 14, but for comparable range of comfort, the costs are high. System 11 fares well from the standpoint of comfort and cost. It is interesting to note that all these systems have better than normal shielding.

It will be seen that glare factors are about the same for System 9 (two 75-w

slimline) as System 10 (two 40-w fluorescent). This close proximity of results will apply to slimline vs. fluorescent in other instances also. For example, System 12 with two 40-w fluorescent as shown would give reasonably close results with the same type of luminaire for two 75-w slimline.

Group I luminaires have glare factors out of the normal comfort range in the higher ft-candle brackets, and for this reason they are not as suitable for industrial applications where comfort is a criterion.

The glare factor values shown in Table I are computed for a lighting level of 50 ft-candles. Since comfort is a measure of projected and accumulated glare sources (luminaires and ceiling brightness) its range in terms of glare factors will increase with higher ft-candle levels and decrease with lower levels. So in determining a lighting system for comfort, it must first be established what level of illumination is required for the specific seeing task. If "ordinary seeing tasks" are involved and 30 ft-candles are recommended, glare factors for System 12 would be around 35 crosswise and 40 lengthwise as compared with 47 and 56 respectively when 50 ft-candles are required for "difficult or critical seeing tasks." At 60 ft-candles the respective values would be around 53 and 63. Similar comparative reasoning applies to other systems presented in Table I.

Attention is called to the fact that glare factors for any given level of illumination decrease when mounting heights of luminaires increase. Also as room sizes become smaller glare factors become lower.

Maintenance. In the analysis, maintenance costs are based principally upon the type and number of luminaires used in the installation. The costs include only cleaning or washing costs and labor to replace burned out lamps. The two 85-w units (System 2, Group I, and System 8, Group II) are the cheapest to maintain in their respective groups. Next in line in maintenance economy are the two 75-w units (System 3, Group I, and System 9, Group II).

It should be pointed out that maintenance is more than just the cost relation indicated above. Construction of a luminaire is of vital importance. In factories, machinery and operating equipment is of a heavy duty type to withstand hard production usage.

First Cost. It is to be expected that good room finishes (75/50) have good
(Continued on page 206)

PIPING PROBLEMS SIMPLIFIED WITH HIGH-

1. Characteristics of high-temperature hot water distribution and its advantages
2. Development of a high-temperature system for Rutgers University

By Fred L. Moesel, Fred L. Moesel Associates, Consulting Engineers

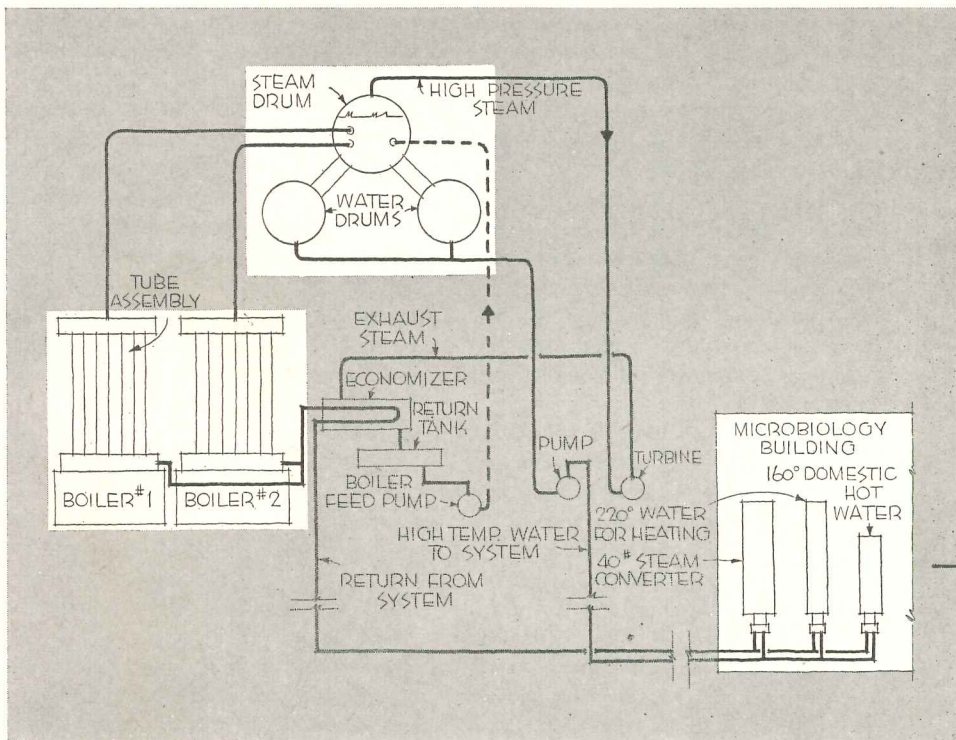

Schematic diagram of the high-temperature hot water system for Rutgers University. High-temperature water flows from drums to steam or medium-temperature hot water converters in each building. High-pressure steam operates the turbine-driven circulating pumps. The return water is preheated by the exhaust steam.

MOST OF US are familiar with gravity and forced hot water heating systems for buildings using temperatures up to approximately 220 F, but now we are hearing about high-pressure, high-temperature hot water systems in the neighborhood of 400 F which make possible a wide range of hot water temperatures, and can produce steam as well. In other words, high-temperature hot water systems are designed to supply heat over long distances using water as the heating medium instead of steam, and as such are applicable to district heating, hospitals, airports, industrial buildings, college buildings, etc. The water is in a closed circuit and is kept under pressure corresponding to the desired temperature. For example, water at 375 F would have a pressure of 185 psia. It is only recently that high-temperature water distribution systems have been given serious consideration in this country, although they have been used in Europe for many years.

1. Characteristics and Advantages

There are many advantages inherent in all types of forced hot water distribution systems. Two of the important ones which probably will be of most interest to the architect are: (1) internal corrosion is virtually eliminated; (2) variation in levels of any terrain does not offer obstacles, since the water is pumped up or down as required; whereas with steam, lines must be pitched down in the direction of flow to drain properly, and must be dripped at all low points and when pipes rise.

Other advantages of high-temperature hot water distribution include:

1. No condensate handling equipment, eliminating steam traps, drip mains, condensate pumps, etc.
2. Flexible, close temperature control.
3. Reduction in number of licensed steam plant operators required.
4. Low maintenance cost.
5. Large heat storage capacity of water as compared with steam.

6. Fuel savings up to 20 per cent, due to even operation of boilers.

In a steam system the drips and the drip system are the weak links which often require the opening of conduits for expensive repairs and replacement. The condensate or water running in the bottom of steam pipes to the drip points in the presence of steam erode the bottom of the pipe and ultimately wear the pipe to the point where replacement is required. After installation of a high-temperature water system, changes affecting carrying capacity of the water mains are easily handled, and if the existing pumps cannot handle the pressure required for the change in resistance, the pump can be replaced or in some instances just the impeller is changed.

The first cost of a complete system including the boilers, distribution system, converters and appurtenances is usually about 20 per cent below the cost of the corresponding steam system, depending on design. Operating cost saving can approach the same figure.

TEMPERATURE HOT WATER DISTRIBUTION

We feel that the high-temperature hot water mains will outlast at least two replacements of steam mains which have been destroyed as described above, and will have a life equal to the buildings connected to them. As long as the conduit remains watertight, outside deterioration of the mains is eliminated, and the remaining destructive force would be friction or the wear incurred by the

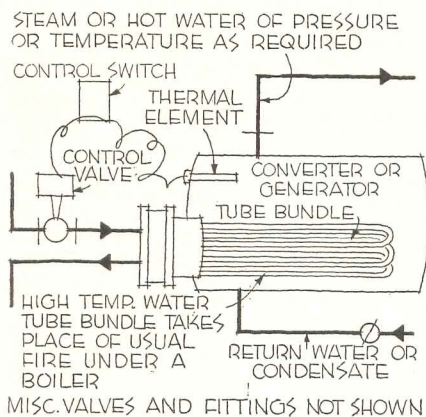

continuous circulation of water over many years' time.

A water distribution system permits selection of temperature levels to accommodate the particular problem. If the requirements call for space heating only, moderate temperatures to approximately 240 F may be used, and these can be standard low pressure boilers where the pressure limitation is 10 to 15 lbs (psig) for non-licensed engineers. In New York City where the limit is now 10 lbs, the water would be limited to approximately 230 F. Where requirements call for steam supply in any building on the circuit for purposes such as laundry, kitchen or laboratory equipment, a temperature sufficiently high to generate steam at the desired pressure can be selected.

The generation of steam from high-temperature hot water through an unfired heat exchanger eliminates the need of licensed steam plant operators and thereby reduces operating costs. Assume 40-lb steam (psig) is required for a kitch-

en; to generate it, it would be necessary to have a minimum flow temperature in the system of 315 F; to generate 15 lbs (psig) for laboratory service, 275 F minimum flow temperature would be required.

Hot water heating systems, with modern controls, are the most economical in fuel consumption, since by varying the water temperature circulated, the heating demands can be very closely met and practically all overheating is eliminated. Also, the water has a high heat storage capacity, so that boilers can be fired evenly.

It is of utmost importance to select the proper conduit to house these lines. The piping itself has a life which will be limited internally only by water wear in the pipe and will probably outlast several mediocre conduit replacements. The replacement of the conduit when required should not be delayed to the extent of permitting outside corrosion to destroy the pipe.

In some localities high-temperature water up to 400 F at 235 lbs pressure or more can be used without licensed engineers.

By using special boilers filled with chemicals, flow temperatures to 550 F or more can be attained without develop-

ing any pressure, since the boiler is actually vented to outdoors. A convertor is used wherein this heated chemical is circulated in the coils by a pump, which then heats the water in the storage part of the convertor to the desired temperature of 400 F, or as required, which is then under a pressure of 235 psia or another corresponding pressure for the selected water temperature. However, the convertor being a so-called "unfired vessel" should take that classification, for which codes do not require a licensed operator, although some building or other inspectors may be hesitant on the approval. These are designs for which specialized knowledge is required.

2. The Distribution System at Rutgers

Several years ago Rutgers University started the planning and development of a new campus across the Raritan River from the main campus. The architects are York & Sawyer of New York City, and approximately 14 major buildings are included.

The first permanent structure was the chemistry building. Included in the plans was provision for a conventional steam distribution system with a connection from our original boiler house. Contracts for the chemistry building

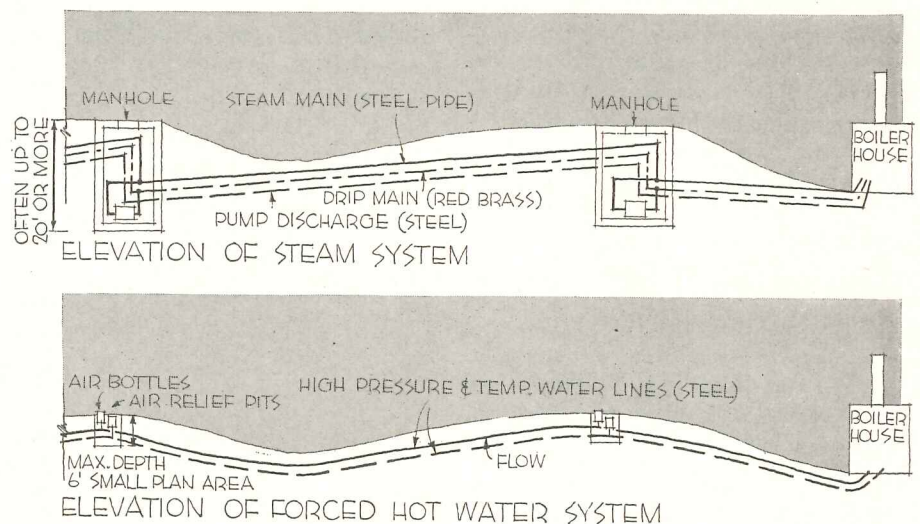

Hot water system piping can easily follow the contour of the land—the circulating pump takes care of any changes in elevation. With steam systems, pipe lines must be pitched down in the direction of flow to drain properly, and must be dripped at all low points. Red brass is usually used for drip mains to cut down on the amount of erosion. Red brass for the large steam main would be too expensive

construction were awarded, but installation of any steam provisions was omitted until actually required for the finished building.

During 1948, we became interested in the use of high-temperature hot water for distribution of heat in other than industrial buildings. There seemed to be no reasons why the high-temperature hot water system should not be substituted for our steam system since it would give large savings in first cost, provide maximum flexibility and a life possibly exceeding that of several steam systems or the buildings themselves. The life of a campus being long, these savings can be compounded into tremendous figures, especially if consideration is given to a price index which is constantly increasing.

It became necessary to install a connection from the original boiler house to the chemistry building for heating and for some steam process work. Since we were fully sold on the idea of high-temperature water, one section of the future high-temperature water system was installed between the boiler house and the chemistry building. This section consisted of two 12-in. lines for the high-temperature hot water system and one 3-in. line for a future central compressed air system. One of the 12-in. lines was used temporarily for steam from our existing boilers and the 3-in. compressed air line was used as a temporary pump discharge line returning the condensate to the boiler house.

A convertor, which might be visualized as a boiler without a fire, will be used in the chemistry building. A bundle of tubes containing high-temperature hot water installed near the bottom of the convertor take the place of the usual coal or oil fire. A convertor does not require a fireman, it being entirely automatic but having a trouble alarm line to the boiler house to warn of failure of any control devices. All buildings on the circuit will be equipped with a steam or medium-temperature hot water convertor for each different requirement, which cannot be a subdivision of another requirement.*

The high-temperature water for our project is secured from specially designed, forced circulation hot water boilers using orifices for control of circulation therein. Two forced recirculation boilers, with a maximum output of 750 boiler hp, are being installed in this plant. They are primarily bundles of tubes tied to headers which are connected to expansion

tanks remote from these bundles. The tops of these expansion tanks are connected to a central drum above, in which steam is released from the water surface into a space above. The steam feature was added to permit the use of steam turbines for driving the circulating pumps for the boilers and the system which will operate 24 hours every day of the year.

The initial pressure on these turbines is the full system pressure to permit back pressure steam on the turbine exhaust having a temperature sufficiently high to permit preheating the return water from the system. Electric, motor driven units are provided for breakdown service for the turbines. This indicates also that power production is economically possible using this type of system.

The idea of a leak in a high-temperature hot water system has caused some consternation among inquirers. However, accident records seem to indicate that such leaks are more harmless than a leak in a steam line of equal pressure. To flash one lb of steam at atmospheric pressure at a leak point requires roughly 1000 Btu, which must be extracted from the adjoining hot water or the atmosphere which then produces a cooling effect in the immediate vicinity of the break, rather than a terrific scalding effect as it would seem without due consideration. Should a line break somewhere in the field for any reason, the operating engineer in the central plant will know almost immediately, because the lines will begin to thump with any appreciable loss of water.

As this article is written, a second major building, the Institute of Microbiology, is nearing completion. This building will be heated by forced low-

temperature hot water with three heating zones off a convertor for 220 F water; a convertor is also provided for 40 lb (psig) steam and another for domestic hot water service.

Along with our outside distribution system is a conduit containing wires for an alarm system. Safety devices in each building have connections wired in parallel to one pair of lines from each building going back to the boiler house and connecting to an annunciator. Should any failure occur, the annunciator in the boiler house will indicate some sort of trouble exists in that building. By telephone, an employee can be dispatched to the building to ascertain the trouble.

The mechanical engineering and chemical engineering buildings are already planned, awaiting funds to start construction. Each will contain several convertors to handle a variety of services.

Present plans indicate that our ultimate long circuit supplying the buildings located to the west of the boiler house will be approximately 5600 ft (see sketch). The shorter branch circuit which supplies buildings to the southeast of the boiler house will be approximately 3000 ft.

Our underground system consists mainly of two 14-in. lines while the original short section installed for the chemistry building service is only 12 in. With a steam system, the corresponding line having the same heat capacity as our 14-in. water line, would probably have been 24 or 30 in. because of length of run. These high-temperature water lines along with a 3-in. compressed air line are encased in a casting of insulated concrete on a poured concrete base. The insulated concrete casting is covered with a built-up felt waterproofing.

Plot plan of the new University Heights campus of Rutgers University showing the high-temperature hot water piping: the solid line indicates that part of the system already designed; dotted line, proposed extension for future buildings

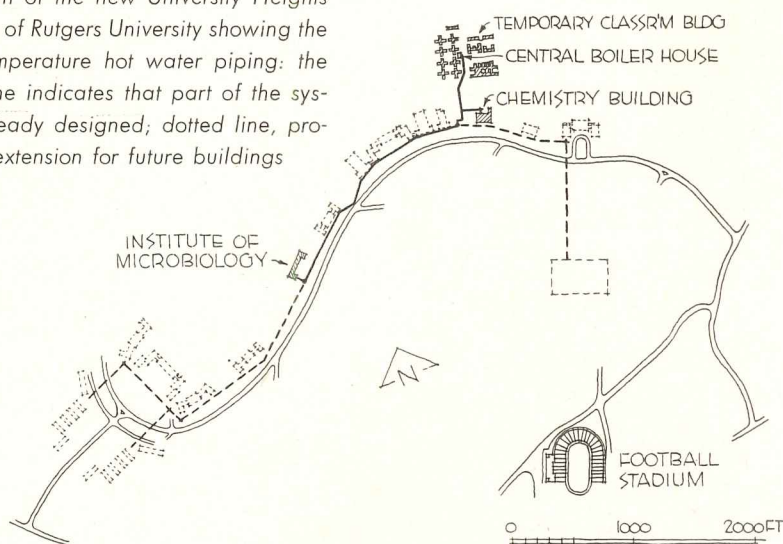

*Design features proposed by the American Hydrotherm Corp. were incorporated in this distribution system, and the boilers were designed according to their specifications.

**Color Television
In Medical Education**

A system of color television developed by the Laboratories Division of Columbia Broadcasting System, Inc. now permits direct, full-color telecasting of surgical operations from operating rooms to teaching rooms and private offices over closed circuits. Distribution of the system in its medical and surgical applications will be handled by the Wilmot Castle Co., which also furnishes special color-balanced operating room lights for the unit.

The color television camera is mounted in the center of a cluster of four of the special lights, suspended over the operating table and focused directly on the operating field. It is operated by remote controls from a booth overlooking the operating room. A technician operates special electronic controls which turn the camera in any direction, narrow or widen the field of view through three separate lenses, and keep the picture in focus. Through the audio portion of the system the operating surgeon can describe the procedure to the audience, which can in turn ask questions. This is made possible by a small microphone and headphone fastened under the surgeon's mask. A separate "silent" audio system permits supervision of an operation being performed by a junior surgeon. The supervising senior surgeon can speak directly to the operating surgeon without anyone else being aware of the conversation.

The scene picked up by the television camera is carried over closed circuits to teaching rooms and doctors' offices in other parts of the hospital where it

(Continued on page 218)



Above: special television receiver designed for use with the new system

PRODUCTS for Better Building

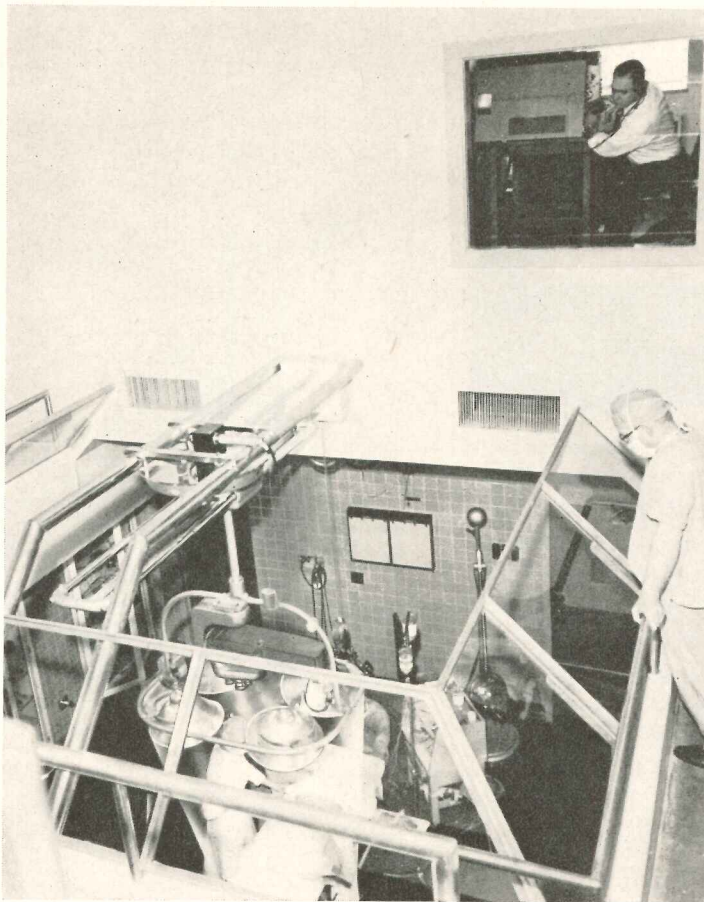

Above: camera, mounted in cluster of lights, photographs operation as directed by technician in booth, who selects lenses, controls color values

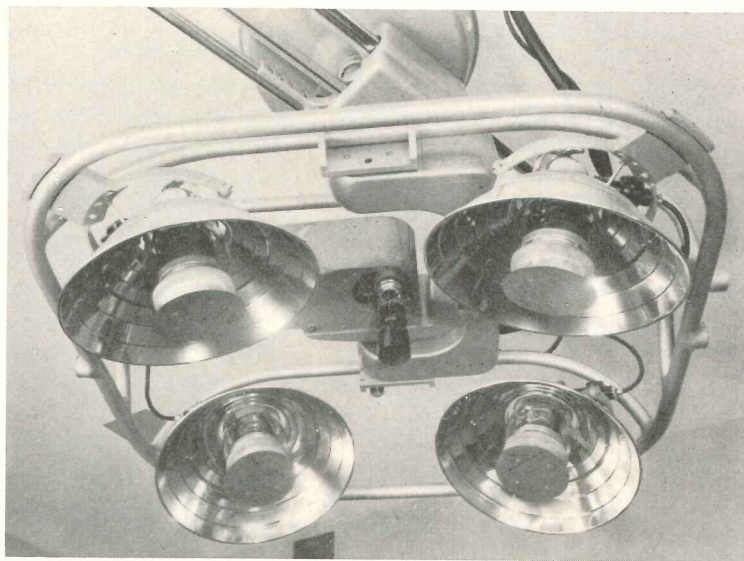

Closeup of fixture shows how camera is mounted in light frame. Lamps are special color-balanced units, designed to permit best possible color

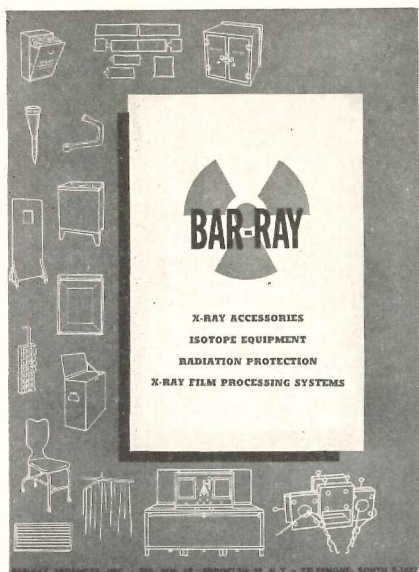

Above: cover of new X-ray accessories catalog. Right, room equipped with X-ray protective materials: A, lead insulated furring bars; B, lead insulated blocks; C, lead insulated lath; D, lead insulated frame; E, lead insulated door; F, cast lead fasteners; G, face veneer; H, lead overlap; I, lead insulated film cabinet with lead insulated flange; J, operators' window with lead frame and speaking opening

LITERATURE FOR THE OFFICE

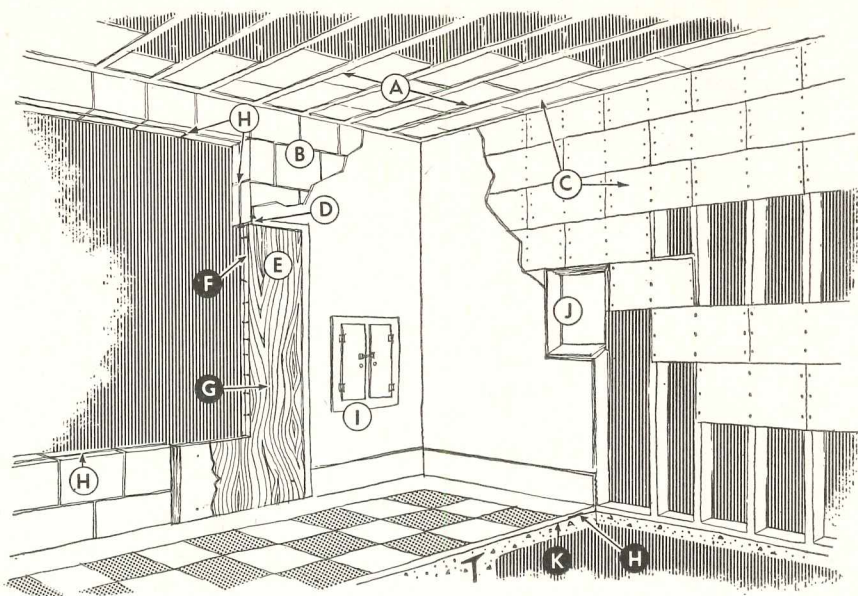

X-Ray Accessories and Radiation Protection

Bar-Ray Catalogue W-52. Comprehensive catalog of the manufacturer's X-ray accessories, isotope equipment, radiation protection and X-ray film processing systems. Includes sections on processing tanks and combination systems, through-the-wall processing systems, special tanks, water coolers, dark-room accessories, temperature controls, shades and special accessories. Also contains information on X-ray and nuclear radiation protective devices, including garments of lead glass fabric, industrial inspection units, radioisotope fume hoods, conveyors and the like. 72 pp., illus. Bar-Ray Products, Inc., 209-25th St., Brooklyn 32, N. Y.*

Stainless Steel Equipment

Just Line Quality Stainless Steel Products. Brochure describes and illustrates various operations in manufacture and fabrication of steel for Government atomic laboratories, hospitals, schools and universities, institutions, industrial

*Other product information in *Sweet's Architectural File, 1953.*

plants and home kitchens. Description and photographs of the manufacturer's new plant facilities are included. 20 pp., illus. Just Mfg. Co., 9233 King Ave., Franklin Park, Ill.*

Stainless Steel

Sharon 430 Stainless Steel. Brochure gives data on stainless steel, presenting chemical analysis and typical mechanical and physical properties. Information on fabricating, including forming and bending, spinning, drawing, soldering and cutting, is also included, along with data on polishing, annealing and welding. A list of typical applications is given with accompanying illustrations. 12 pp., illus. Sharon Steel Corp., Sharon, Pa.

Television Installation

Low Loss TV Antenna Accessories, Mosley Catalog 52-53. Catalog contains information on television accessories, with reference to better pictures through more efficient installation. Helpful to architects who wish to specify such equipment for new homes, the brochure gives data on TV lead-ins, couplers,

sockets, switches, etc. 8 pp., illus. Mosley Electronics, 2125 Lackland Rd., Overland, Mo.

Electronic Air Cleaners

Trion Electronic Air Cleaners. Brochure describes and illustrates construction and operational features of the manufacturer's electronic air cleaners. Engineering data is furnished and includes capacity cfm efficiency, approximate overall dimensions and approximate shipping weight, together with other information. Suggested specifications are also included. 12 pp., illus. Trion, Inc., 1000 Island Ave., McKees Rocks, Pa.*

Sweet's Issues New Improved Architectural File for '53

Sweet's Catalog Service is currently distributing its 1953 Architectural File. Architects, engineers and contractors in the general building field will find that the new File contains almost a thousand more catalog pages than the '52 issue.

(Continued on page 266)

NEW
Anemostat
Selection
Manual 45

*features for
the first time . . .*

*duct take-off
design data*

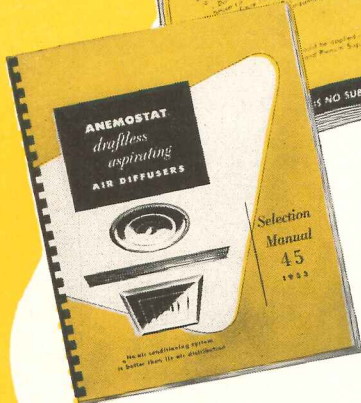
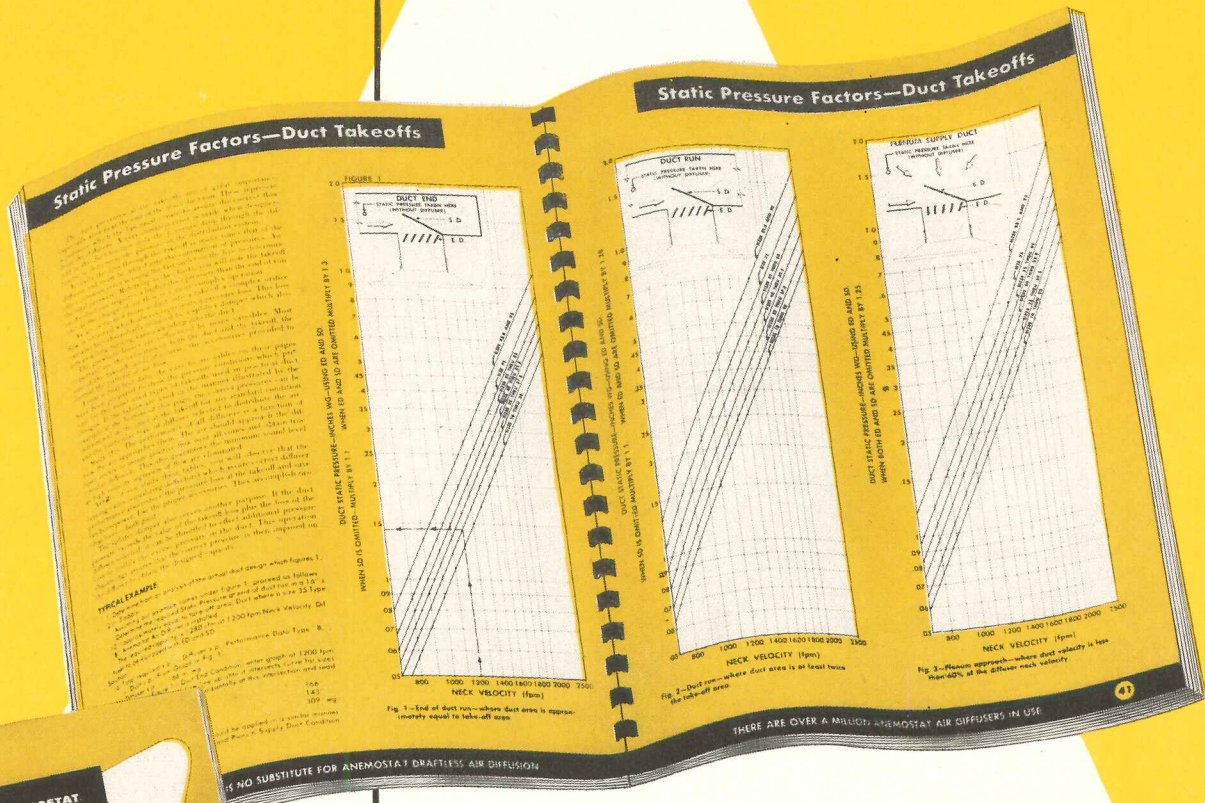

For the first time data is available to Architects, Engineers and Contractors on static pressure factors for Duct Take-Off Designs. Send for your copy today and save engineering hours and avoid design changes.

ANEMOSTAT®

DRAFTLESS Aspirating AIR DIFFUSERS

ANEMOSTAT CORPORATION OF AMERICA

10 EAST 39th STREET, NEW YORK 16, N. Y.

REPRESENTATIVES IN PRINCIPAL CITIES

"No Air Conditioning System Is Better Than Its Air Distribution"

**“Mr. FITZGIBBONS...
I hear you are starting
a boiler business”**

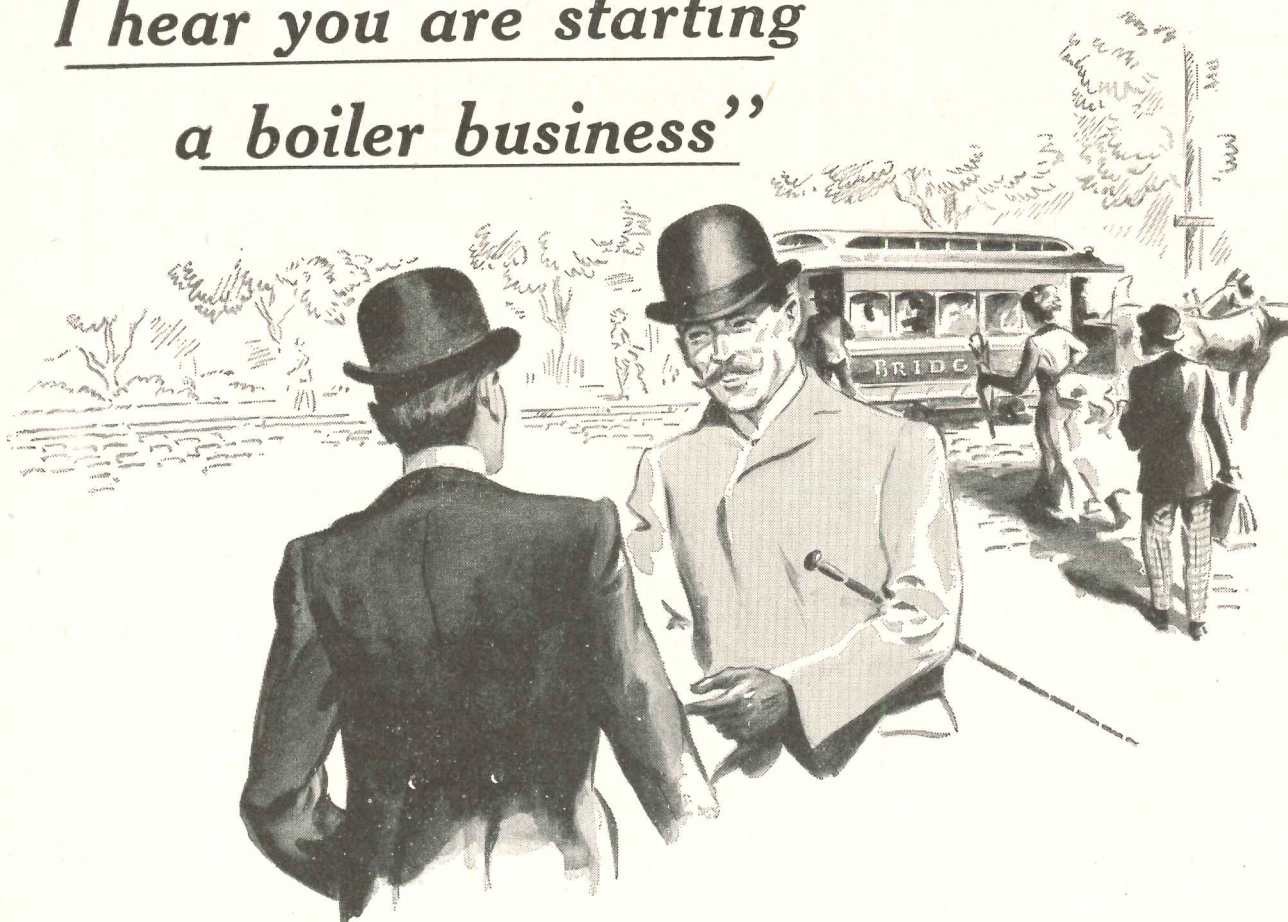

The year was 1886 when a million people hailed the unveiling of the Statue of Liberty on Bedloe's Island in New York harbor. That was the year Patrick Fitzgibbons, experienced journeyman boiler builder, announced the formation of the Fitzgibbons Boiler Company.

Sixty-seven years have seen much history — wars, booms, depressions — and the rise and fall of many industrial organizations. In the case of Fitzgibbons, these years have meant steady growth in plant facilities and boiler making experience, new, improved and highly regarded products. And now —

THE YEAR IS 1953 and Fitzgibbons is starting not only with a modernly equipped plant, but also with a larger, more highly specialized organization dedicated to renewed attention to the “little things” of boiler building and service to customers, as well as to the broad tradition of quality which has always been the most notable Fitzgibbons characteristic.

The selection of a Fitzgibbons Steel Boiler has always been a wise choice — and will continue to be.



For complete details and specifications on the Fitzgibbons Steel Boiler for every heating need, contact your nearest Fitzgibbons representative or write Fitzgibbons Boiler Company, Inc., 101 Park Avenue, New York 17, N. Y.



THE FITZGIBBONS BOILER®

METAL LATH MEMBRANE FIREPROOFING-6

Presented through the Cooperation of Metal Lath Manufacturers' Association

Metal Lath Membrane Fireproofing for Cellular Steel Floors

Constructions listed below are described as tested, including the exact distance of suspended ceilings from beams or floors. However, if the ceiling construction listed below is the equivalent of a ceiling listed with an equal rating for beams, girders and trusses, then, logically, furring channels may be fastened directly to the primary members. Although no tests have been conducted with ceiling furred 3/4 in. from beams supporting cellular steel floors, there are several successful tests on attached and furred ceilings protecting beams and joists in other types of floors.

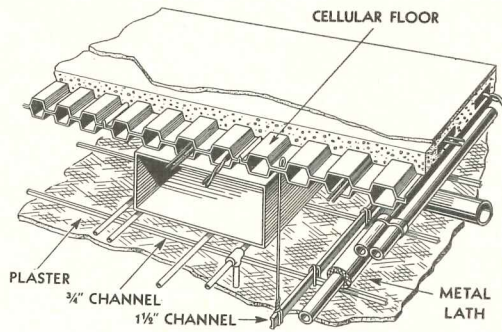

TYPICAL CELLULAR STEEL FLOOR

TABLE F — FIREPROOFING FOR CELLULAR STEEL FLOORS

CONSTRUCTION	DESCRIPTION	FLOOR RATING	BEAM RATING	AUTHORITY
	Floor: 2" concrete (minimum thickness over cells) Ceiling: 7/8" gypsum-vermiculite plaster 100:2 1/2, 100:2 1/2 Y = 2 1/4" minimum	4-hours		Underwriters' Laboratories Retardant 2689 dated 12/18/39
	Floor: 2" concrete (minimum thickness over cells) Ceiling: 1" gypsum-vermiculite plaster 100:2, 100:3 Y = 2" minimum	4-hours		BMS-92 Table 45 National Bureau of Standards
	Floor: 2" concrete (minimum thickness over cells) Ceiling: 1" neat wood-fibered gypsum plaster Y = 9" minimum	4-hours		
	Floor: 2" concrete (minimum thickness over cells) Ceiling: 1" neat wood-fibered gypsum plaster Y = 2" minimum	3-hours		
	Floor: 2" perlite concrete Ceiling: 1" gypsum-perlite plaster 100:3, 100:3 X = 3" Y = 3"	4-hours	4-hours	Underwriters' Laboratories Retardant 2993 dated 12/9/48
	Floor: 2 1/2" concrete (minimum thickness over cells) Ceiling: 3/8" gypsum-vermiculite base 100:2, 100:3 plus 1/2" vermiculite acoustical plaster X = 2 1/2" Y = 7 1/4"	4-hours	4-hours	Underwriters' Laboratories Retardant 2773 dated 11/29/50
	Floor: 2" concrete (minimum thickness over cells) Ceiling: 1 1/8" sprayed fiber with beam individually sprayed 3/4" thick X = 2 1/2" Y = 4 1/2"	4-hours	4-hours	Underwriters' Laboratories Retardant 3431-1 dated 9/14/51
	Floor: 2" concrete (minimum thickness over cells) Ceiling: 7/8" gypsum-perlite plaster 100:2, 100:3. Tested with openings for non-combustible ducts and electrical outlets, not exceeding 100 sq in. of openings per 100 sq ft of ceiling X = 3 1/2" Y = 15 1/2"	4-hours	4-hours	Underwriters' Laboratories Retardant 3355 dated 4/30/51
	Floor: 2" concrete (minimum thickness over cells) Ceiling: 7/8" gypsum-vermiculite plaster 100:2, 100:3. Tested with openings for non-combustible ducts and electrical outlets, not exceeding 100 sq in. of openings per 100 sq ft of ceiling. This test was arbitrarily stopped at 3-hours, long before failure X = 3 1/2" Y = 15 3/8"	3-hours	3-hours	Underwriters' Laboratories Retardant 2689 dated 12/13/49

**TO
KEEP
HEAT
AWAY
FROM COLD—and the reverse**

In every plant, office building, institution and the like . . . on every ship—there is an unseen labyrinth of pipes and ducts. These lines carry ice water, steam, cold air, hot water, gases and liquids of many types—drawn from furnaces, boilers, condensers or tanks. Every unit in such a system requires *insulation*—to keep cold away from heat or heat away from cold.

A major development of recent years is a new method of holding the insulating materials securely and lastingly in place—a *lagging adhesive*—a time- and money-saving substitute for the over-sewing of the covering material. Such an adhesive must be fire-retardant, must resist repeated heating and cooling, humidity, steam and water.

Developed to meet certain shipbuilding specifications during World War II, Arabol Lagging Adhesive is today the primary specification in major shipbuilding yards—as it is in major factories, power plants, office buildings, institutions, hotels and apartment houses. (Let us send you illustrated Booklet LR.)

This important type of adhesive is but one of 10,000 adhesives formulas developed in Arabol Laboratories over the past 68 years. We operate on the belief that, *for each particular adhesives application, there is one adhesives formula that can serve you best.*

We invite the opportunity to submit samples for you to test in your own plant—under your particular working conditions—for your specific requirements, whatever their nature. That is the one kind of testing that assures you of satisfactory results. Your inquiry to Department 68 will bring a prompt response.

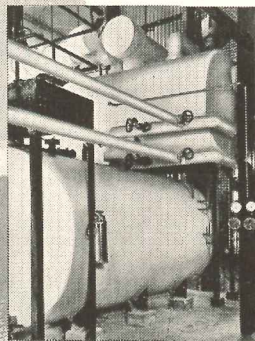

Adhesives? **ARABOL!**

68 Years of Pioneering



THE ARABOL MANUFACTURING CO. . . . a nationwide organization serving major users of industrial adhesives

EXECUTIVE OFFICES: 110 E. 42nd ST., NEW YORK 17, N. Y.

CHICAGO • SAN FRANCISCO • LOS ANGELES • ST. LOUIS • ATLANTA • PHILADELPHIA • BOSTON • PORTLAND, ORE. • ITASCA, TEX. • LONDON, ENG.

STAINLESS STEEL-5

Presented through the Courtesy of the Committee of Stainless Steel Producers,
American Iron and Steel Institute

Effects of Weather on Exterior Surfaces

Like glass, stainless steel, when it gets dirty, shows the dirt, but its smooth surface is easy to clean. Designs should include precautions against accumulation of unsightly dirt, as well as take advantage of natural rain washing in most climates. When relatively clean water, uncontaminated by rusty iron drippings, flows over stainless steel it does not increase maintenance requirements, but may aid appearance.

Rusty dirt-laden water should be diverted before it reaches important visible areas. Internal drains like the one sketched here will help assure cleanliness.

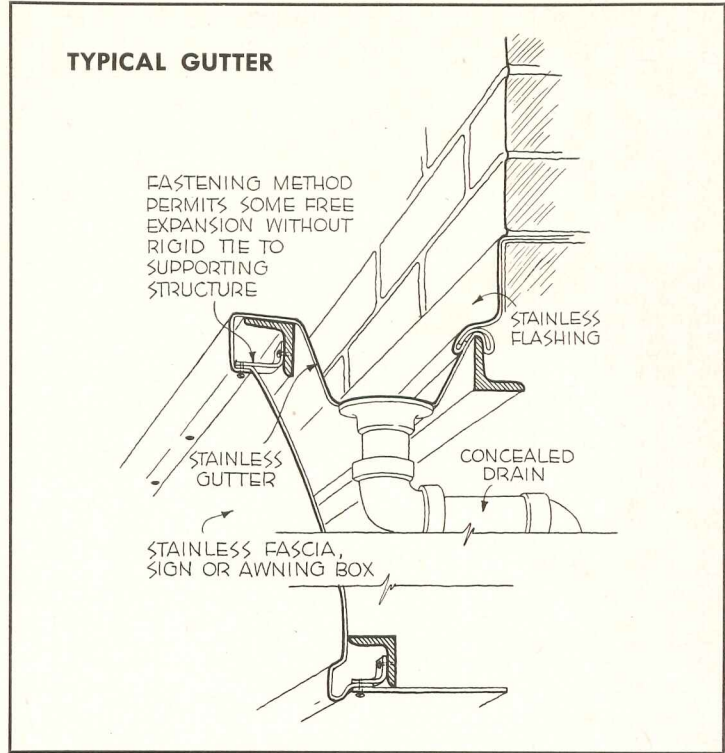

Display Window Glass Framing

Architectural metal work derives many antecedents from carpentry. These historical ties have too tight a hold when solid bars of stainless steel (as big as 1 by 5 in.) are assembled like wooden boards to make a window sash. This has actually been done, and incidentally, looks fine.

Adopting traditions of the cabinet-maker but working out the details more economically, many designers assemble brake-bent sections of stain-

less steel to build simple, rectangular sash and mullions. More resilient construction results from the use of sheet metal. This has an advantage in that the glass is cradled somewhat against shock, vibration, thermal strain, etc.

It is possible, if desired, to retain the conventional spirit of milled woodwork (which has been copied for some time in the non-ferrous metal trim), and yet employ an efficient, economical, functional component. Modern stock store-front sections in stainless steel are available in

many designs. Cross-sections range from simple rectangles to beaded moulding shapes. Units are designed for convenience of installation and glass setting as well as for resilient support.

Future design developments may be anticipated: using stainless steel for its mechanical properties, without regard for historic customs, designers will certainly evolve some improved components. Greatest advantages may grow out of designs that require more work of a mass-production nature in factories and less hand work at site.

Internal designs of type at right vary among manufacturers

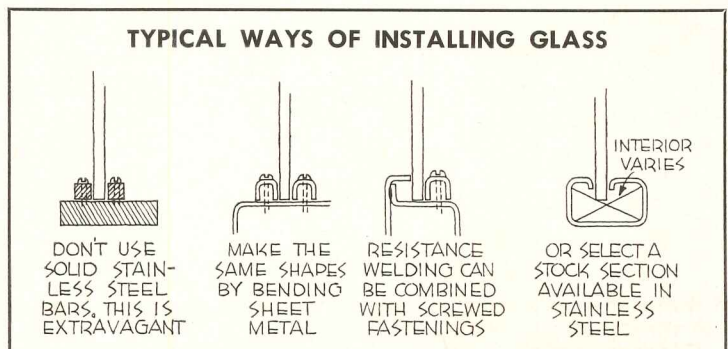

- ✓ **Super-Ex** — provides strong, straight nose held true by two semi-solid flanges.
- ✓ **Super-Ex** — combines expanded wing with solid sections. Note alternate perforations in solid portion — for better plaster key.
- ✓ **Super-Ex**—requires little or no plumbing; corrugations assure rigidity.
- ✓ **Super-Ex** — can be wired, stapled, spotted, or nailed to wall—no clips necessary.

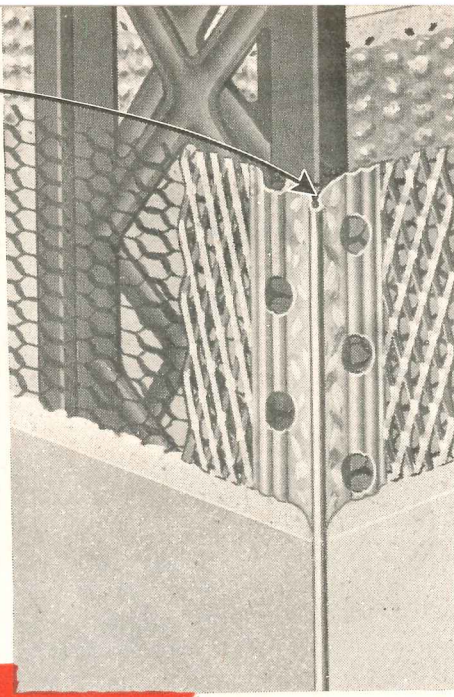

Firesafe construction at best: improved Milcor Super-Ex Corner Bead, Milcor Mesh Lath, and Milcor Steel

Improved **MILCOR**^{*} *Super-Ex Corner Bead*

for longer plaster life, lasting plaster beauty

— now provides for greater depth of plaster adjacent to the bead — regardless of the plaster grounds!

Improved Super-Ex Corner Bead, with its exclusive design, combines the rigidity of a solid wing with the added plaster reinforcement of expanded metal.

Super-Ex wings are formed at a minimum angle of 60° (max. 70°) for spring fit on a 90° corner, and easy adaptability to specified plaster grounds,

whether 3/4", 5/8", or 1/2".

Milcor Super-Ex goes on fast . . . reduces erection costs . . . protects corners against cracking, chipping . . . assures straight, true-edge beauty.

Standardize on Super-Ex in your specifications.

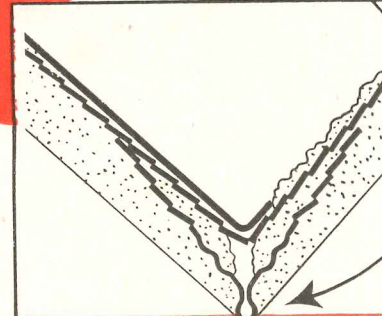

Here's why Super-Ex corners are so long-lasting: note greater depth of plaster adjacent to bead area . . . spring fit adapts easily to any specified depth plaster ground — whether it be 3/4", or 1/2" . . . and solid metal that protects corner at point of greatest strain.

Write for Catalog No. 252 today

*Reg. U. S. Pat. Off.

INLAND STEEL PRODUCTS COMPANY

4035 WEST BURNHAM STREET • MILWAUKEE 1, WISCONSIN

BALTIMORE 24, MD. — 5300 Pulaski Highway • BUFFALO 11, N. Y. — 64 Rapin St. • CHICAGO 9, ILL. — 4301 S. Western Avenue Blvd. • CINCINNATI 25, OHIO — 3240 Spring Grove Ave. • CLEVELAND 14, OHIO — 1541 E. 38th St. • DETROIT 2, MICH. — 690 Amsterdam Ave. • KANSAS CITY 8, MO. — S. W. Boulevard and State Line • LOS ANGELES 58, CALIF. — 4807 E. 49th St. • NEW YORK 22, N. Y. — 230 Park Ave. • ST. LOUIS 10, MO. — 4215 Clayton Ave.

STAINLESS STEEL-6

Presented through the Courtesy of the Committee of Stainless Steel Producers, American Iron and Steel Institute

Formed Tubing

It would be uneconomical to specify solid stainless steel members for railings, struts, built-in furniture and the like. Parts of this kind, designed to look solid, are usually made from stainless tubing shaped into the desired cross section. Suppliers of stainless steel architectural tubing have tools for producing a tremendous variety of special-purpose cross-sectional shapes.

Joining methods that can be used with this tubing include spot welding, fusion welds (ground smooth and polished), nuts and bolts, sheet metal screws, etc.

TYPICAL TREATMENT FOR LIGHTWEIGHT RAILING

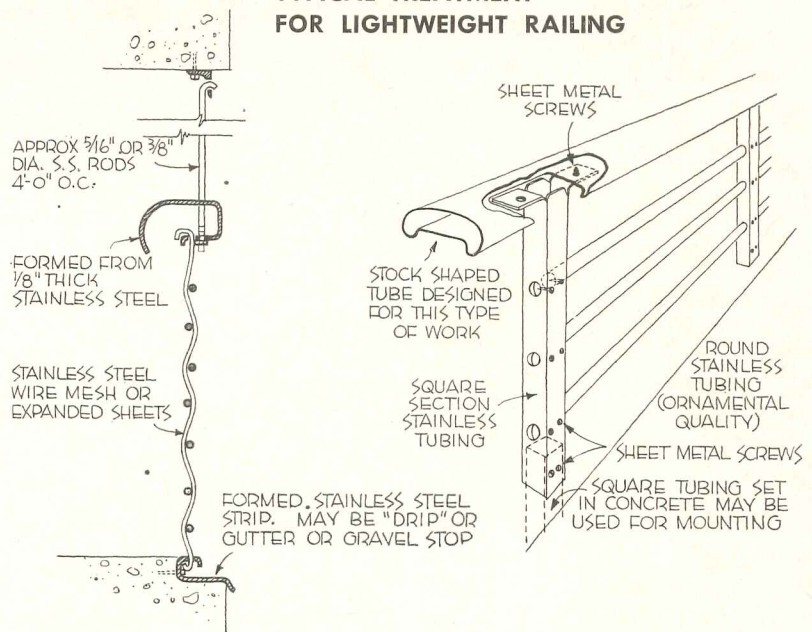

TYPICAL COLUMN COVER WITHOUT VISIBLE FASTENERS

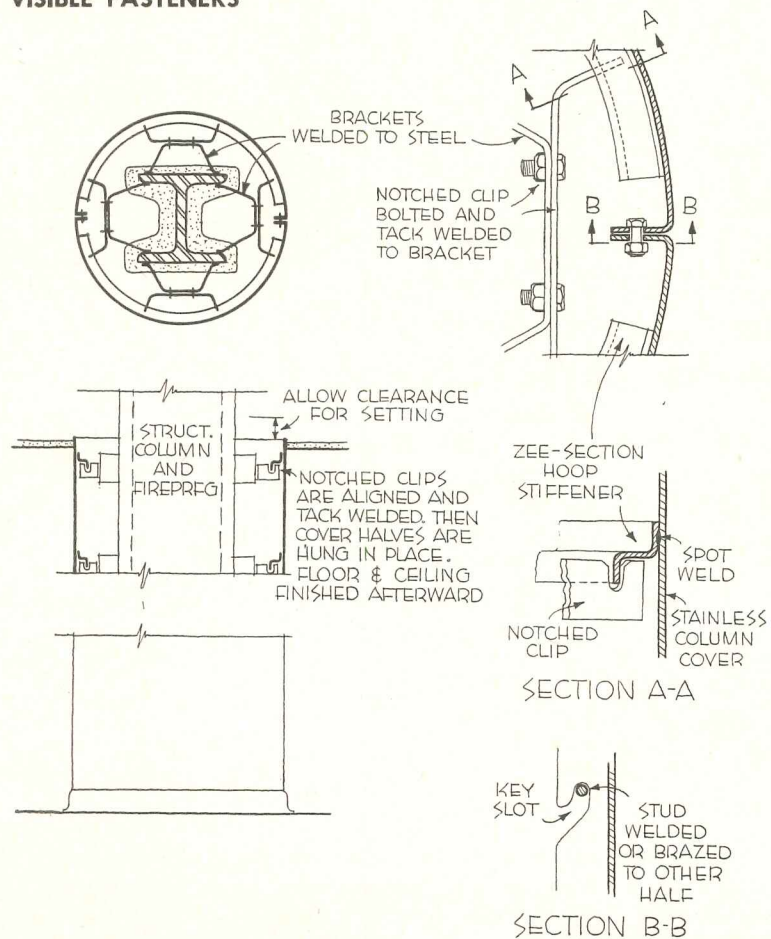

Column Covers With Invisible Fasteners

Structural columns that encroach on pedestrian traffic are frequently given stainless steel sheathings. At building entrances or set-back storefronts, in lobbies and in public rooms, the stainless cover can give a neat appearance, and eliminate painting or other periodic refinishing problems.

Sometimes column covers show exposed screw heads; sometimes screws are concealed by snap-in moulding strips. Jobs are also frequently designed with a hairline joint, with no visible indication of how it is secured.

Most of the concealed fasteners for such members are variations of a wedging or "keyhole" slot. If the sheathing consists of several separate panels, the accessible panels may first be screwed or bolted to a suitable framework. However, the pieces that "go on last" are treated differently. During installation they are lifted slightly, then lowered into place over hooks or studs of some kind. Finish plastering of ceiling and floor occurs after this operation. Because of this, the stainless cover cannot be removed without destroying enough plaster to free it.



Andersen Casements now also available in sash width 4½" wider than illustrated here

For built-in
beauty and comfort...

ANDERSEN
*Windowalls**

Four Basic Books on House Construction

Everyone who supervises or directs building or other construction projects must have a basic working knowledge of the various trades engaged in the project, in order to direct operations intelligently.

In the books described here you will find a wealth of information on building trades. Each book is a working tool and ready reference. They will greatly assist you in supervising building construction work. Order yours now.

Simplified Carpentry Estimating

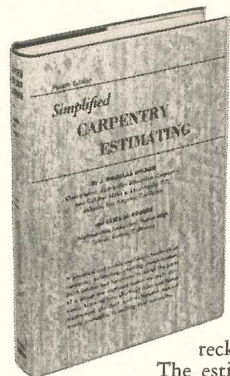

An easy to use reference handbook that will save time and money in figuring house carpentry jobs, offering a step-by-step analysis on how to figure materials needed for (1) foundation, (2) framing, (3) exterior finish, (4) interior finish, (5) hardware, and (6) stairs.

Included are such features as: lumber hardware and millwork checking list; quick-figuring tables for estimating concrete footings and walls, concrete piers, window frames, door and window areas, sash weights, nail quantities; how to figure labor hours per unit of work; rules for linear, area and volume measurement; lumber reckoner; conversion of weights and measures, etc.

The estimating short-cuts in figuring the amount of lumber needed for floors, walls, ceilings, roof, door, frames, drawers and cabinets, are alone worth the price of the book. Price \$3.75

Practical Job Pointers

More than 800 "practical job pointers" that save time, expense and labor on home-building jobs, are offered in this home builders' guide.

Here are brilliant short-cuts to many, intriguing, every-day home building problems: suggestions on excavations, foundations and forms; methods for making sills, girders, joists and sub-flooring; hints on exterior and interior wall construction; short-cuts in roof and bay construction; tips on making cornices and porches; ideas for interior wall covering and trim; helps on stair construction; window suggestions; ideas for hanging doors; tips on closets, shelves and built-in equipment; flooring pointers; aids in installing sanitary equipment. Detailed throughout with more than 700 how-to-do-it illustrations! 211 pages.

Price \$4.49

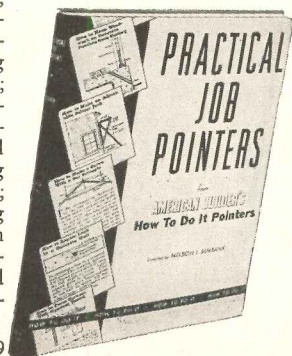

House Construction Details

This book is an exact working guide on every detail of house construction from foundation to finish. Gives dimensions, materials, processes and point-by-point working methods through hundreds of scale drawings and photographs.

Can be used for making additions or changes in a building, or for complete construction of a dwelling. Conforms with modern practice and building regulations in all parts of the country. Gives latest ideas on painting, wiring, heating, air conditioning, insulation and soundproofing. Every step explained and illustrated:

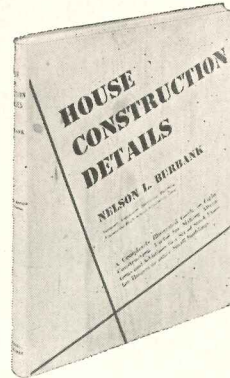

Excavations, Footings and Drainage, Foundation Forms, Sills, Girders, Joists, Sub-flooring, Exterior Wall Framing, Ceiling Joists, Gable Roof, Dormers, Siding and Shingling, Cornices, Porches, Exterior Walls of Wood and Brick, Interior Walls Finished in Plywood, in Plaster, Wall Panels, Stair Construction, Windows, Sash Details, Doors and Trim, Hardware, Closets, Shelves, Built-in Equipment, Flooring, Chimneys and Fireplaces, Outdoor Fireplaces, Garages, Electric Wiring, Insulation, Septic Tank, Painting and Finishing, Heating Systems, and many others.

A quick reference index enables one to instantly find any construction detail on which guidance is needed. More than 41,000 are regularly using this helpful volume. 313 pages, 1,500 illustrations. \$4.75

House Carpentry and Joinery

Here is one of the most practical books on house carpentry work ever published . . . packed to the brim with the know-how of a leading teacher who is also a professional carpenter. 32 chapters on house-building, from excavation and foundation to roof, flooring and finish!

"House Carpentry and Joinery" is essentially a how-to-do-it type of work. Over 600 plans, diagrams, detail drawings and photographs show how to:

build forms for foundations, footings, walls, steps, walks; build sills, girder supporting posts and girders; figure loads for house framing; layout, cut, and erect floor joists; frame around a chimney and stair well; lay out rafters for a gable roof, dormer roof and porch roof; lay floors and sub-flooring; frame outside and inside walls, allowing for openings; brace and sheathe up outside walls; erect ceiling joists; sheathe gable ends and rafters; build cornices; lay shingles; build porches and bays; apply siding; frame up inside walls; construct stairs; place trim around windows and doors; fit and hang sash and doors; make closets, shelving and built-in equipment; hang garage doors.

The how-to-solutions given are alone worth many times the price. Price \$4.49

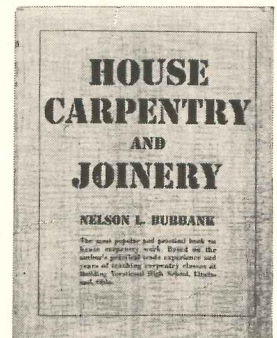

USE THIS HANDY COUPON!

Book Dept., Architectural Record, 119 W. 40th St., New York 18, N. Y.

Please send me the books checked below:

- | | |
|---|------------------------------------|
| <input type="checkbox"/> "Simplified Carpentry Estimating" \$3.75 | <input type="checkbox"/> I enclose |
| <input type="checkbox"/> "Practical Job Pointers" \$4.49 | \$ |
| <input type="checkbox"/> "House Construction Details" \$4.75 | |
| <input type="checkbox"/> "House Carpentry and Joinery" \$4.49 | <input type="checkbox"/> Bill me |
- (For N.Y.C. delivery, add 3% for Sales Tax.)

Name

Address

City Zone State

Save Mailing Costs:

Send payment in full and books will be mailed postpaid.

THE RECORD REPORTS

(Continued from page 336)

National Bureau of Standards Central Radio Propagation Laboratory near Boulder: one-story wings from central spine

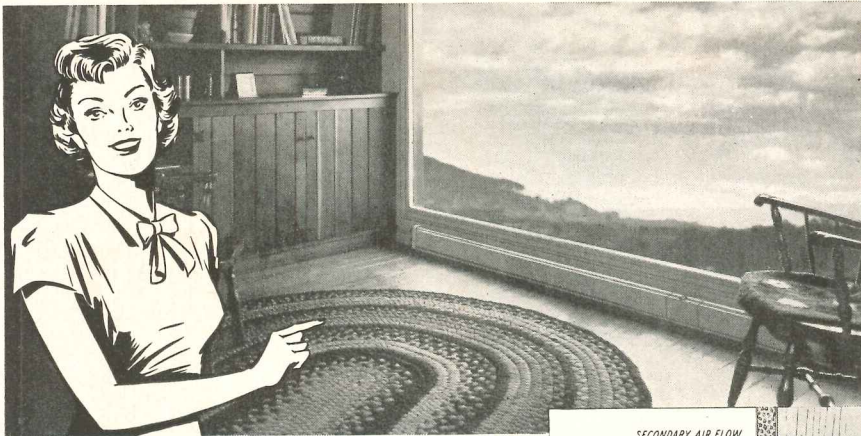
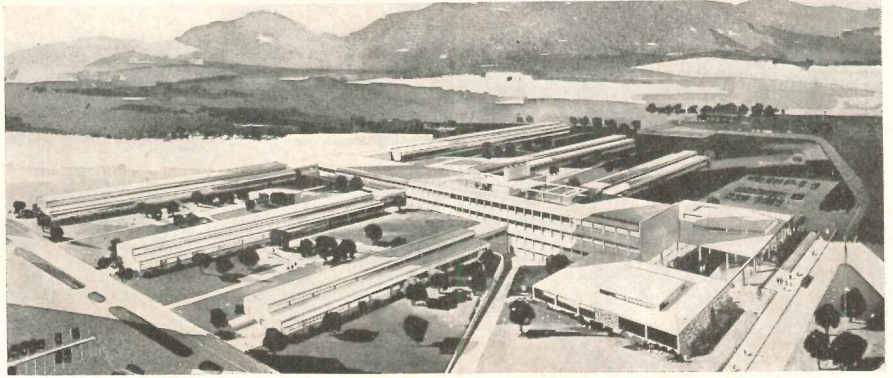

NEW WESIX BASEBOARD PANELS Luxury Heat at Low Cost!

Here's the perfect answer for new or remodeled homes where larger window area or changeable outside temperatures create heating problems only modern perimeter heating can solve. With new Wesix Automatic Electric Baseboard there is *no* time-lag from excessive thermal storage, *no* heat loss from transmission or distribution — a temperature difference of less than 2 degrees floor to ceiling can be expected in a well engineered installation.

Easily Installed . . . ANYWHERE!

Since Wesix Baseboards are completely pre-fabricated with no metal cutting or external controls required, you can be sure of perfect installation. Panels may be installed recessed or on wall surface without alteration and are available in standard lengths of 32 and 48 inches at a watt density of 157 watts (536 B.T.U.) per lineal foot with a maximum surface temperature of 140 degrees Fahrenheit. Overall height of six inches allows installation under windows with sill mold only seven inches from finished floor.

Specify Wesix for complete home heating or as economically installed and operated auxiliary heat and you specify perfect comfort! Send floor plans and insulation specifications to your nearest Wesix office for free engineering layout.

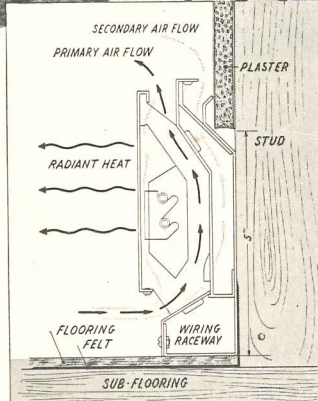

Details of all Wesix Wireheat products prefired in Sweets Architectural Catalog

WESIX
Wireheat

AUTOMATIC Electric HEAT

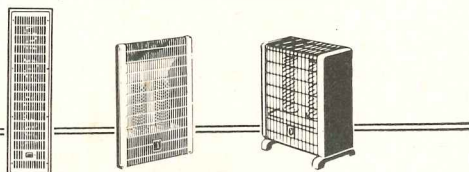

WESIX ELECTRIC HEATER CO. Dept. AR-2
390 FIRST STREET, SAN FRANCISCO, CALIF.
Seattle · Portland · Los Angeles · Detroit
Chicago · Dallas · Huntsville, Ala.

LOOK FOR THIS SIGN AT YOUR WESIX DEALERS

STANDARDS BUREAU STARTS RADIO LAB IN COLORADO

The Central Radio Propagation Laboratory of the National Bureau of Standards will be housed in a new building now going up on a 210-acre site near the campus of the University of Colorado south of Boulder. Pereira and Luckman and J. E. Stanton of Los Angeles are architects and engineers, with Robert W. Ditzen of Boulder, associate architect.

To Cost \$4,500,000

The building, which is expected to cost \$4,500,000, will provide facilities for research on the propagation of radio waves and on the expanded utilization of the radio spectrum now being used for FM, television, facsimile and radar.

The laboratory will be constructed of reinforced concrete with stone facing at the main entrance and at other portions of the exterior. It will have a central spine and one-story wings extending outward from either side of it. The front of the building is four stories high, reducing to one story at the rear of the central spine, thus taking advantage of the sloping terrain that rises toward the mountains to the west. A pair of wings join the spine at different floor levels. The central spine is designed so that wings may be added to meet future laboratory requirements.

PBS Directs Construction

Construction is under the direction of the Public Buildings Service of the General Services Administration, Washington, D. C. Completion is scheduled for early 1954. About 500 employees — including scientific and clerical personnel — are expected to be on the staff of the new laboratory by mid-1954.

(More news on page 340)