

# ARCHITECTURAL RECORD

NOVEMBER 1953

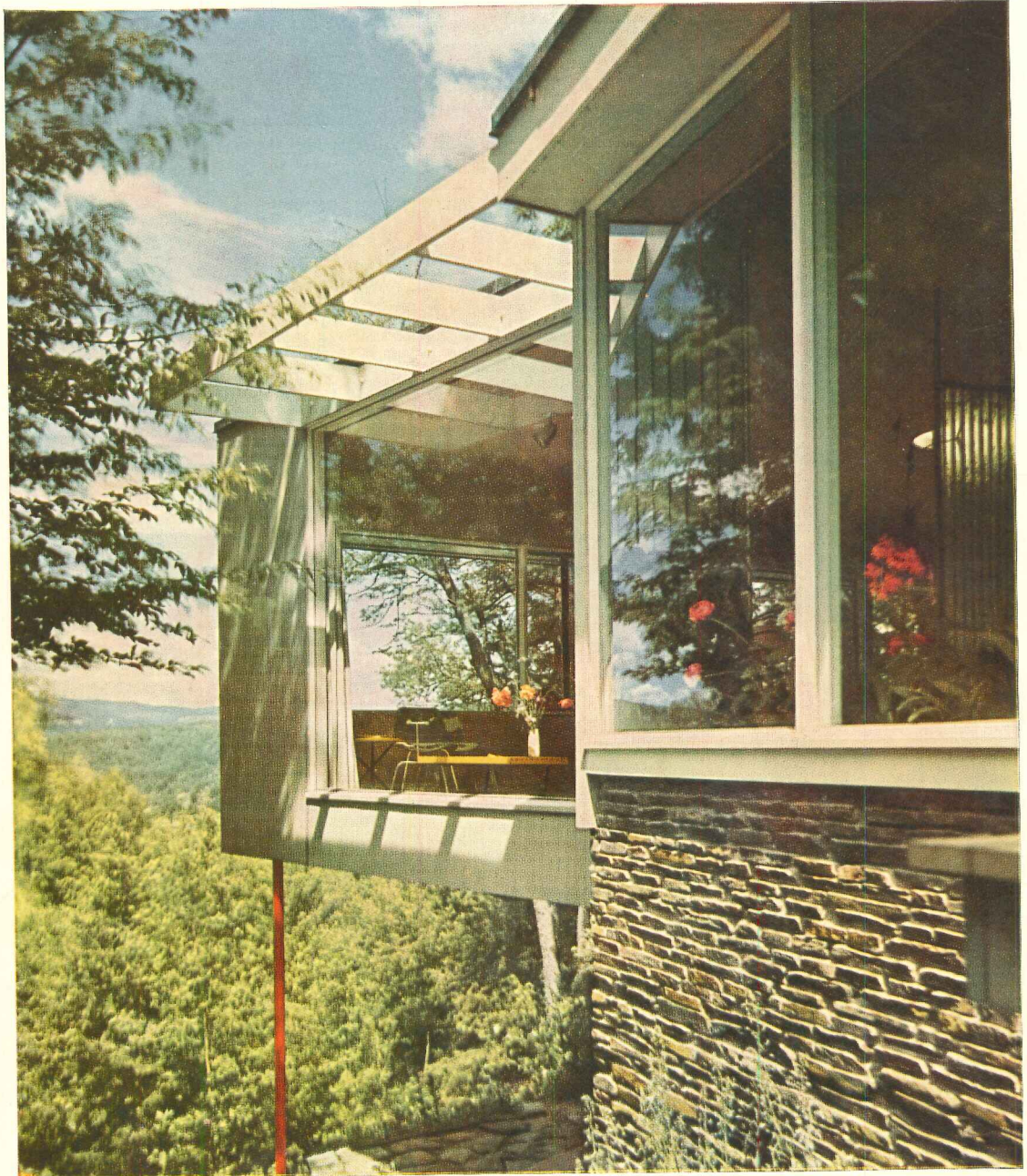

House, Hanover, N. H., E. H. & M. K. Hunter, Architects

BUILDING TYPES STUDY NUMBER **204** MENTAL HOSPITALS

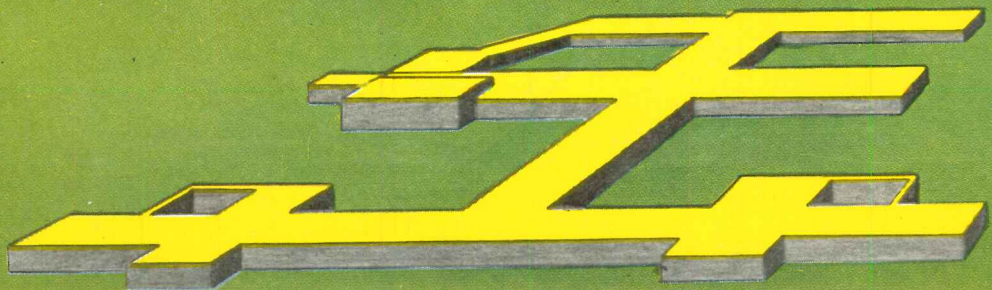



**THIS IDENTIFICATION  
APPEARS ON EVERY FORMICA PRODUCT**

*This mark certifies genuine*  
REMOVE WITH SOAP AND WATER



**IT CAN BE WASHED OFF, BUT DON'T DO IT**  
*and here's why...*

You'll want to leave this marking on Formica sink tops and Vanitory® units for the simple reason that it sells houses. When the new owner is allowed to remove this sure-fire identification personally, she knows she is getting genuine Beauty Bonded Formica. The material she knows, trusts, and asks for.

It's protection for you, too. The market is being flooded with inferior unbranded materials which copy Formica colors and patterns. Demand proof.

You can bet if it's not identified it's not Formica.

Kitchen by R. A. Nelson & Co.  
Roselle Park, N. J.





# ARCHITECTURAL RECORD

November 1953 Vol. 114 No. 5

Copyright 1953 by F. W. Dodge Corporation, with all rights reserved. ARCHITECTURAL RECORD (combined with AMERICAN ARCHITECT and ARCHITECTURE) is published monthly by F. W. Dodge Corporation, 10 Ferry Street, Concord, New Hampshire, with editorial and executive offices at 119 West 40th Street, New York 18, New York. Western editorial office, 2877 Shasta Road, Berkeley 8, California.

## STAFF OF ARCHITECTURAL RECORD



H. Judd Payne, *Publishing Director*; Robert F. Marshall, *General Manager*; Marshall T. Ginn, *Circulation Manager*. . . Joseph B. Mason, *Executive Editor*; Emerson Goble, *Managing Editor*; James S. Hornbeck, A.I.A., Frank G. Lopez, A.I.A., *Senior Associate Editors*; Elisabeth Kendall Thompson, *Associate Editor and Western Section Editor (Berkeley, California Office)*; Robert E. Fischer (*Engineering*), Florence A. van Wyck, Herbert L. Smith, Jr., A.I.A., Jeanne M. Davern (*News*): *Associate Editors*; Ernest Mickel, Dan Street (*Washington*), John Caulfield Smith, M.R.A.I.C. (*Canada*): *Contributing Editors*; Jeanne G. Whitbeck, Enid Belding, Carl Scarenco: *Assistant Editors*; Marjorie Blake, *Editorial Assistant*; Peter Piening, *Consulting Design Director*; Eugene H. Hawley, Alfred Petersen, *Design*; Sigman-Ward, *Drafting Consultants*; Thomas S. Holden, *Industry Relations Consultant*; Clyde Shute, *Statistical Consultant*; Clifford Dunnells, Jr., *Field Research Consultant*; Samuel C. Pace, *Public Relations Consultant*.

## OFFICERS OF THE F. W. DODGE CORPORATION

James McV. Breed, *Chairman of the Board*; Paul Abbott and Thomas S. Holden: *Vice Chairmen of the Board*; Howard Barringer, *President*; Irving W. Hadsell, Chauncey L. Williams: *Executive Vice Presidents*; Howard M. Thompson, *Vice President and Treasurer*; Julius T. Little, Robert F. Marshall, T. Oliver Morgan, H. Judd Payne: *Vice Presidents*; Carl S. Bennett, Ralph M. Hairston, O. O. Paulsell, Richard H. Ray: *Regional Vice Presidents*; Edwin H. Freed, *Assistant Vice President and Comptroller*; Walter F. DeSaix, Clifford G. Dunnells, Jr., Clyde Shute, Marc Wayne: *Assistant Vice Presidents*; Sanford D. Stockton, Jr., *Secretary*; William C. Breed, Jr., George W. Morgan, Jr.: *Assistant Secretaries*; Irving B. Satin, *Assistant Treasurer*.

## OTHER F. W. DODGE SERVICES:

Dodge Reports and Dodge Statistical Research Service — Sweet's Files — "Planning Kit for Our New Home" — Chicago Construction News — Daily Pacific Builder — Denver Daily Journal — Real Estate Record & Builders' Guide.

## TABLE OF CONTENTS

### How Much Construction for '54?

Thomas S. Holden's annual analysis of factors determining the health and prospects of building, including his survey of the analyses of economic prospects in general, by 138 of the country's leading economists. A 12-page insert following page 8

### The Record Reports

Perspectives	9
News from Canada. By John Caulfield Smith	24
News from Washington. By Ernest Mickel	38
Construction Cost Indexes	42
Required Reading	46
Current Trends in Construction	380

### Seven Houses

For the many architects interested in individual houses here is a report on the professional opportunities found in houses done for "professional people" . . . sympathetic to the rationale of contemporary design.

1, 2, 3 and 4. Four small houses by E. H. and M. K. Hunter, Hemlock Hill, Hanover, N. H. 154

*Continued on next page*



# ARCHITECTURAL RECORD

Continued from page 5

5. House for Russell Day, Everett, Wash., Harold W. Hall, architect, Arthur A. Graves and David W. Dykeman, associates	166
6. House for Hamilton Wolf, Oakland, Cal., Campbell & Wong, architects	168
7. House for George W. Wimberly, Honolulu, Wimberly & Cook, architects	171

## Office Building That Lost Its First Floor

The Remington Rand Building slid out from under the Massachusetts Mutual Life Insurance Building (Los Angeles) to maintain the separate identities of the two — the parking lot then went under the latter building. Kahn and Jacobs and Welton Becket, associate architects

175

## Architectural Interiors

Menswear Store, Eddy Harth, Statler Center, Los Angeles; Victor Gruen, architect; R. L. Baumfeld, associate in charge

177

## Building Types Study Number 204 — Mental Hospitals 181

First presentation of research material on the design of mental hospital building from the architectural staff of the U. S. Public Health Service, devoted especially to two most important facilities in the campaign for buildings designed for cure, not incarceration, of mental patients.

Mental Patients Can Be Cured, by Daniel Blain, M.D. 181

History Points Up the New Programs, by P. H. Felix, M.D. 182

Coordinated Hospital System for Nervous and Mental Patients, by John W. Cronin, M.D. 183

Coordinated Hospital System for Mental Patients (chart) 184

Humanization of the Mental Hospital, by Kenneth E. Appel, M.D. 185

Functional Areas of State Mental Hospitals (chart) 188

▶ Design of Intensive Treatment Buildings, by Alston G. Gutterson 189

Type Plans for Intensive Treatment Buildings 196, 199

▶ Psychiatric Service in the General Hospital, by Alston G. Gutterson 204

Out-Patient Facilities for Mental Hospital System 211

Bibliography 212

## Architectural Engineering 213

Space Requirements for Electrical Equipment in Office Buildings, by G. B. Gusrae 213

First of a number of articles on electrical systems in buildings, dealing with flexibility, safety, reliability, costs, and so on, in an area of ever-growing complexity.

Porcelain Enameled Panels for Interior Walls 219

Product Reports 221

Office Literature 222

Time-Saver Standards

1. Concrete Structural Forms 225

2. Gypsum Plaster 227, 229

## Index to Advertising 376

Member of Audit Bureau of Circulations and Associated Business Publications. Architectural Record is indexed in Readers' Guide to Periodical Literature, Art Index, Industrial Arts Index and Engineering Index.

Every effort will be made to return material submitted for possible publication (if accompanied by stamped, addressed envelope), but the editors and the corporation will not be responsible for loss or damage.



Subscription rates in U. S., U. S. Possessions, and Canada: \$5.50 for one year, \$9.00 for two years, \$11.00 for three years. Elsewhere, subscriptions from those who by title are architects or engineers, \$6.50 for one year, \$11.50 for two years, \$15.00 for three years; subscriptions from all others outside U. S., U. S. Possessions and Canada, \$20.00 a year. Single copy price, \$2.00. Circulation Manager: Marshall T. Ginn.



# THE RECORD REPORTS

## P E R S P E C T I V E S

ERIC MENDELSON asked in his will that the eulogy at his memorial service be delivered by Dean William Wurster of the School of Architecture of the University of California. Dean Wurster said in part:

"We are here today to honor a great spirit. This spirit ever turned to youth; and I speak for his students at the University of California, in fact, for all the students who have been inspired and freed by his genius.

"I think of his vitality, which swept aside all the usual material and psychological props, not with disdain, for he knew and used their value; but he also knew the greater needs of the spirit of man. He was ever ready to rebuild his life; and this has been necessary, for the framework of his existence has been constantly changing — the reasons for his move from Germany in 1933 would have embittered most of us.

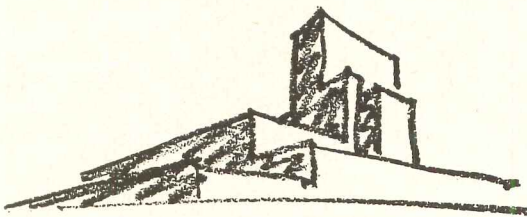

But Eric Mendelsohn always had a deep faith in the dignity of man which could not be weakened or corroded by exterior forces. . . . He always tried for the creative thought which did not set limits. He would not accept the things we call practical facts if in his opinion the greater good was served by ignoring them. . . .

"In a day when narrow proprietary dogmas threaten to stifle and dehumanize the modern movement in architecture even before it has come to its maturity, Eric Mendelsohn

stood for freedom, imagination and creative individual leadership. As an artist he always sought to make his life richer. He had a large scale vitality and exuberant optimism which made him, perhaps more than any other modern architect, akin to the great personalities of the baroque cities. . . ."

NEW YORK's fiery Robert Moses has written a rather fiery treatise entitled "The Influence of Public Improvements on Property Values." It might have been called "In Defense of Public Works" or even "The Case Against (Indiscriminate) Retrenchment." Mr. Moses not unexpectedly considers the influence of public improvements on property values to be highly salutary and cites — in ringing prose accompanied by numerous photos and elaborate charts — the multifarious activities of the multifarious city commissions he heads as local evidence. But he makes his most daring sally — quite undocumented — into the mind of that contemporary object of universal solicitude, the taxpayer, and finds him anxious not after his taxes but after — *architecture!* "When the taxpayer has to transact business with a city bureau or attend court, and finds these activities housed in obsolete, disgraceful rat traps which drag down all the surroundings," Mr. Moses reports, "he begins to think that substantial buildings reflecting good architecture as well as adequacy are essential to the dignity of government, lift it above contemptibility and inspire public respect for it. . . ."

THIS EXPLAINS SOME CLIENTS (maybe). A recent news release of the National Lumber Manufacturers Association begins as follows: "Design-

ers are re-thinking kitchens — just in the nick of time. The vague dissatisfaction of housewives who aren't supposed to get tired or depressed in some of today's kitchens — but do anyway — has become sharply vocal of late. (A sample: 'Ever since I had to lie flat on my stomach on the kitchen floor to see if the broiler was lighted in our new stove, I've brooded about the modern kitchen.' — Sylvia Wright, writing in Harper's Magazine, August 1953.)"

THE MYSTERIOUS EAST: When Architect Takesha Nishikawa designed a house for Client Sh'geru Hatsuyama "the only request ever made by Mr. Hatsuyama is, it may sound funny, that the house should be built as the designer felt pleased" — or so the editors of the Japanese architectural magazine *Kenchiku Bunka* report in their summary in English of an article on the house in their September issue. The house doesn't *look* funny.

NEW LOOK for B.A.I.D.: New York's Beaux-Arts Institute of Design, widely criticized in recent years for its "inflexibility," has announced some changes in its program service to schools, colleges and independent architectural students. The major items: fewer problems (only two in each class) with more emphasis on each; elimination of any program service charge to schools; maximum student freedom in development and presentation of solutions; submissions not to be graded for awards other than being selected for prizes.

THE EDITORIAL LIFE: Postscript to a recent letter from Alonzo Harriman, who has agreed to write for a forthcoming study on schools — "At Moosehead next week, if fishing poor will think about article."





**ERIC MENDELSON'S BUILDINGS**

- 1919-20 Hat Factory, Hermann & Co., Luckenwalde
- Einstein Tower (Astrophysical Institute), Potsdam
- New Hat Factory, Steinberg, Hermann & Co., Luckenwalde
- 1921-22 Administration Building, Berliner Tageblatt
- Twin Residences, Charlottenberg
- Silk Store, Gleiwitz (Silesia)
- Power Station, Wuestegiersdorf (Silesia)
- 1924 Residence Dr. Sternfeld, Heer Str., Berlin
- Fur Store Herpich, Leipziger Str., Berlin
- 1925 Lodge "Three Patriarchs" Tilsit, East Prussia
- Textile Factory, Leningrad
- 1926-27 Department Store Schocken, Nuremberg
- Department Store Schocken, Stuttgart
- Cemetery, Koenigsberg
- Department Store Petersdorf, Breslau
- Department Store Epstein, Duisburg
- 1927-28 "Deukon House," Berlin
- Power Station, Berliner Tageblatt
- Mosse Pavilion, Presse Exhibition, Cologne
- Universum Cinema, Berlin
- Block of Flats, Berlin
- 1928-29 Department Store Schocken, Chemnitz
- Metalworkers Union Administration Building, Berlin
- 1929-30 Columbus House, Berlin
- Youth Center, Essen
- Own residence, "Am Rupenhorn," Charlottenberg
- 1931-32 Department Store Bachner, Ostrowa, Czechoslovakia
- Department Store, Broederne Dublough, Oslo, Norway
- Power Station, General Electric Co., Magdeburg
- Zinc Factory, Giesche's Erben, Magdeburg
- 1933-40 Residence Nimmo, Chalfont St. Giles
- Residence Dennis Cohen, Chelsea
- De La Warr Pavilion, Bexhill on Sea — Competition 1st Prize
- Residence, Prof. Weizman, Rehoboth
- Residence, Salman Schocken, Jerusalem
- Private Library, Salman Schocken, Jerusalem
- Hadassah University Medical Center, Jerusalem
- Anglo-Palestine Bank, Jerusalem
- Trade School, Yaguri
- Hebrew University Agricultural College, Rehoboth
- Daniel Wolff Pharmaceutical Institute, Rehoboth
- Government Hospital, Haifa
- 1945-53 Temple and Community Center, St. Louis, Mo.
- Temple and Community Center, Cleveland, Ohio
- Temple and Community Center, Baltimore, Md.
- Temple and Community Center, Grand Rapids, Mich.
- Temple and Community Center, St. Paul, Minn.
- Temple and Community Center, Dallas, Texas
- Maimonides Health Center, San Francisco, Calif.
- Residence Russell, San Francisco, Calif.
- Electronic Plant, Palo Alto, Calif.
- Radiation Laboratory Building, University of California, Berkeley

Einstein Tower

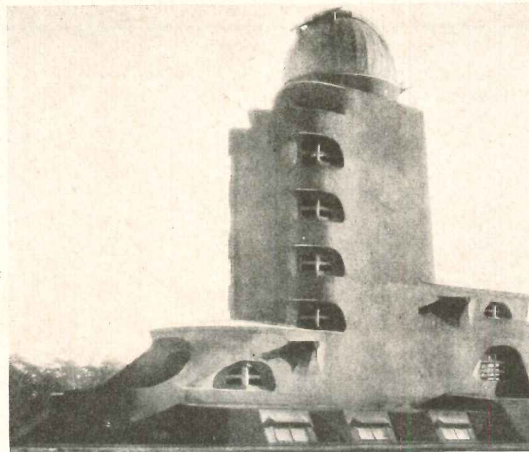

Schocken Department Store (Chemnitz)

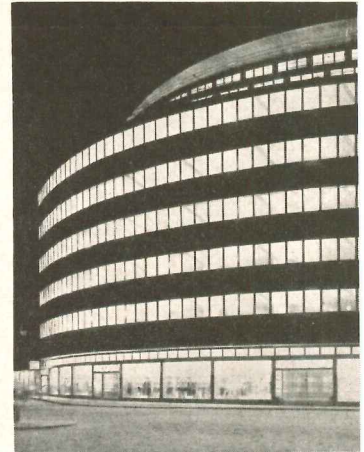

**ERIC MENDELSON DIES**

HE WAS BORN in Allenstein, Germany, in 1887; died in San Francisco, U. S. A., in 1953. The architectural record of his life spans three continents, eight countries, 35 years: his formal architectural education was completed in 1912, but he spent two years at painting and stage designing and sketching — the first of those distinctive sketch designs of various building types; and then came the war, and more than three years of army service; it was not until Nov. 9, 1918 that he began the practice of architecture. Not long afterward he held an exhibition of his sketch designs at Paul Cassirer's Galleries in Berlin: he called it "Architecture in Steel and Reinforced Concrete" and it became a milestone in architectural history. Nearly 15 years of practice in Germany — 44 projects and an international reputation: then Hitler: then England — lecturing and 13 projects, there and in Palestine: then, in 1941, the United States — consulting for the War Department, lecturing, teaching at the University of California, and 10 projects. The catch phrase for Eric Mendelsohn's architectural ideal — he used it himself — was "elastic continuity"; at Potsdam in 1921 Einstein's benediction on his tower was "organic"; in one of his early lectures in this country Mendelsohn put it like this: "Architectural beauty . . . is based on fundamentals which, being in themselves age old, must express in plan and appearance our own time's requirements and perceptions."

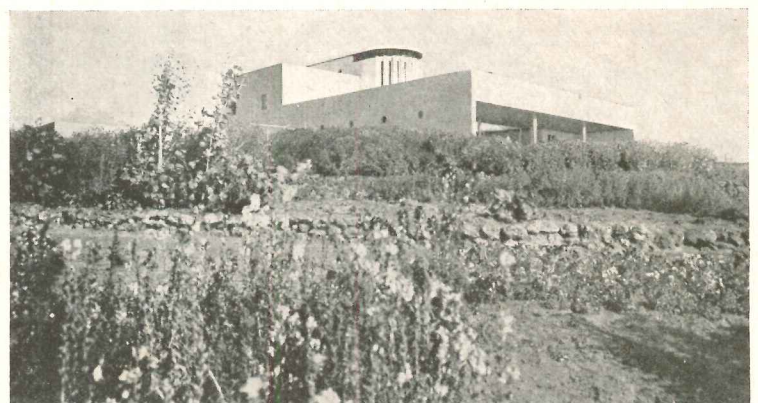

Chaim Weizman House



Universum Cinema

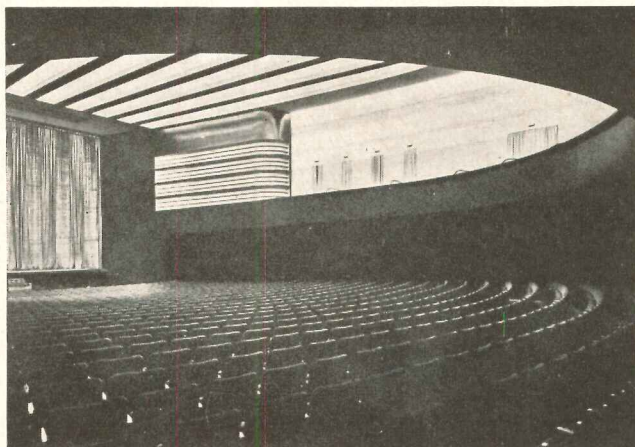
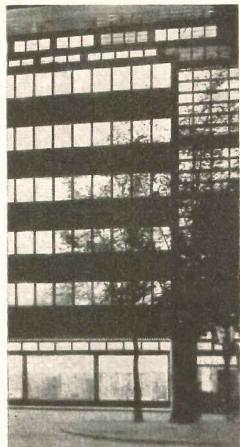

Bexhill Pavilion

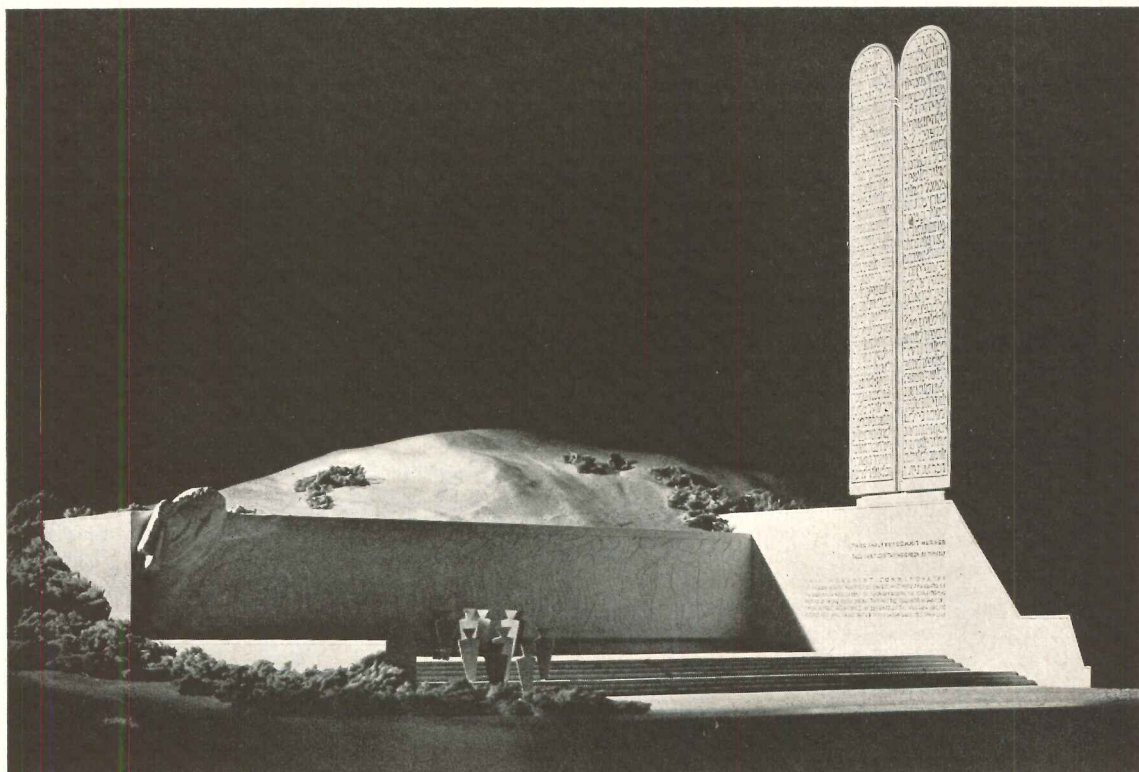
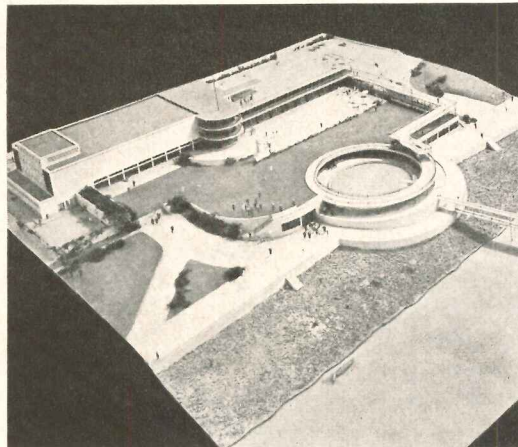

American Memorial to Six Million Jews—project to be built in New York City; sculpture by Ivan Mestrovic

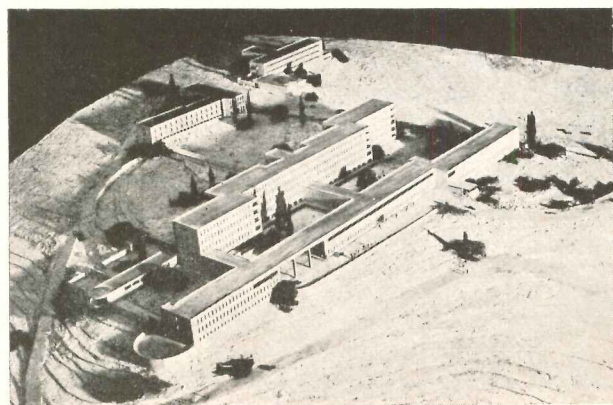

Hadassah University Medical Center

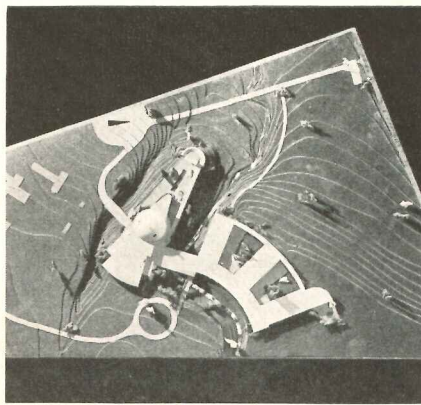

Cleveland Jewish Center



Maimonides Health Center



## THE RECORD REPORTS

# O P I N I O N

Editor, ARCHITECTURAL RECORD:

In your September issue you report that Congress restricted variations in cost between stations for military construction to five per cent in the United States. In the same issue you report variations in cost between cities in the United States from a survey of the FHA which run to over 30 per cent. Whether the FHA figures are perfect or not, it is obvious that the Congressional limitation is extremely unrealistic. As a matter of fact cost variations are greater at military installations than they are in the cities listed by FHA, due to exceptional labor and transportation problems at isolated locations, compared with installations adjacent to low-cost cities.

During 1951 and 1952 I was on duty at the Pentagon in the Air Force Installations H.Q. as a Colonel and filled assignments as Chief of the Analysis and Estimates Branch and as Chief of the Operations Branch, Construction Division, as well as several task force, committee and consulting jobs. I helped prepare two budgets and execute three. These unrealistic restrictions, placed by Congressional action on the Department of Defense building program, are often in reality the action of the Bureau of the Budget which approves the program for the President before it is submitted to Congress. The fact that the Air Force had \$1941 million of unobligated funds is partially due to the control of the Bureau of the Budget both before and after authorizations and appropriations are made. Resulting delays and bottlenecks often make it impossible to let contracts and thus obligate funds.

Yours very truly,

Harrison Gill, Architect  
(Colonel, USAF Reserve)

*In response to a request from the RECORD, Arthur Fehr of the Austin, Tex., architectural firm of Fehr and Granger, has set down some observations on a month's tour of Germany as leader of a group of eight American architects invited by the West German government*

*to inspect the progress of the postwar reconstruction program. Regional directors of the American Institute of Architects selected tour members, who also included Frederic A. Pawley, C. M. Deasy, C. Curtiss Inchow, Angus McCallum, A. G. O'Dell Jr., Richard W. E. Perrin and Thomas S. Hargis Jr. The group returned to this country in mid-September. Mr. Fehr's comments follow:*

There were things that surprised us as architectural visitors from the United States and there were situations that still surprised the Germans. The Germans were amazed that eight architects from eight different sections of the United States and eight men who had never seen each other could meet on a tour like this and get along with one another.

The Germans marveled and yet were most thankful for the aid the United States Government had given them in order to get a new start. Never in their history had a victor come to them, the defeated nation, and offered aid for recovery. They are making the most of this assistance.

Then we were astonished at how earnestly and hard the German is working to correct bombed cities into better planned — into better built communities. They work around the clock. The misery and despair before the reform of 1948 is growing into a solid prosperity. Germany will soon be the leading nation of Europe, if the present recovery program remains in full swing.

Each town has its problem of debris. In Berlin (West, that is) debris is piled into huge mounds and called "Mont Klamotten." Several of these areas have been built into large sports arenas with seating up to 30,000. Next to such a playing field there may be a huge swimming pool with necessary bath houses, green area, and concessions. Every part of such a mound is beautifully landscaped.

The most difficult thing to find in all Germany is ice water. There is plenty of excellent beer or wine. Food is plentiful and there is no rationing.

Just before we left Germany, politics was nearing a fever pitch. Similar to the American scene. Speeches, posters, radios, loudspeakers, etc. This election was important to all of Germany. It was to be an approval or a disapproval of the direction that Germany had taken. With 86 per cent of 33 million possible voters going to the polls by their free will, we can safely say that democracy is at work.

The German is not as fortunate as the American in an easy choice of building materials. One cannot enjoy the real value of a Sweet's Catalog until he is in a country where such a publication would be a rather thin book. The architects of Germany are making extensive use of reinforced concrete. Since they are short on clay products, concrete block with coarse aggregate, chiefly crushed rubble, is used both on exterior and interior walls. This construction is normally plastered. When the job budget permits, this rough surface may be faced with a thin sheet of stone, tile, or marble.

In commercial construction and in public building, the German makes elaborate use of glass set in metal store front sections.

Such an exchange program in which we eight American architects participated is a grand method of having two peoples learn to understand one another. It was our good fortune not only to have formal meetings and conducted tours, but also to visit Germans in their offices, in their drafting rooms, and in their homes. Here we were able to let down our hair and learn each other's problems, learn how each attacks such a proposition, learn how each prepares the documents, and learn how the work is carried to completion. Even though there were times when our language limitations kept us from conveying the full meaning of our thoughts, we did learn that the architects of Germany and the architects of the United States speak the same language architecturally.

I could go on and on, but I will close by saying I am very proud that I was one of the fortunate eight.

Cordially,

Arthur Fehr

(More news on page 15)



**All About Porcelain Enamel**

THE BUILDING RESEARCH ADVISORY BOARD is planning a conference around one specific building material for the first time in sessions scheduled November 12-13 in Washington. Porcelain enamel is the material; and the conference, co-sponsored by the Porcelain Enamel Institute, will be conducted by BRAB's affiliate, the BRAB Institute. The four sessions will cover fundamental properties of porcelain enamel; uses of porcelain enamel in building design; porcelain enamel as an engineering material; and building experience with porcelain enamel. The first session includes a talk on its radiochemical decontamination characteristics.

**Kentucky Dean Heads A.S.C.E.**

DANIEL V. TERRELL of Lexington, Ky., dean of the University of Kentucky's College of Engineering, has been elected president of the American Society of Civil Engineers. Dean Terrell, who was to be installed October 21 at the Society's annual meeting in New York, succeeds Walter L. Huber of San Francisco.

**Imagination at Play**

A COMPETITION for the design of "sculptural" playground equipment which encourages children to exercise their imaginations as well as their bodies is being co-sponsored by Parents' Magazine, the Museum of Modern Art and



Nebraska competition winners (story on page 340). Front row, left to right: Burkett Graf and Woodrow Hull, Lincoln; James A. Lynch, John H. Aylor and James W. Nicas, Omaha; Hedy Neumann, Lincoln; Mrs. Blanche Plunkett, Hastings. Back row, left to right: Reginald Davies, Lincoln; Alex Weinstein, Omaha; Kenneth Clark, Lawrence Enersen, Dale L. Gibbs and Roy C. Neumann, Lincoln; Clyde Bourgeois, Omaha; Ed C. Gross, Lincoln. Awards were presented at a Nebraska Architects Association Meeting

Creative Playthings Inc. Prizes totaling \$2000, plus additional royalties, will be awarded to the winning designs, to be exhibited at the Museum next June. Entries must be postmarked not later than January 15. Entry blanks and official programs from: Miss Greta Daniel, Assistant Curator, Museum of Modern Art, 11 West 53rd Street, New York.

**A Vote for Modular**

ADOPTION BY PRODUCERS of the modular coordination method was urged by building contractors at their round table

session at the midyear meeting in Chicago of the governing and advisory boards of the Associated General Contractors of America. Also recommended by the round table: more local joint cooperative committees of the American Institute of Architects and A.G.C.; wider distribution among architects and owners of the jointly-developed document, "A Suggested Guide to Bidding Procedure"; further study by both organizations of insurance provisions of A.I.A. standard contract forms; and wider distribution of plans and specifications to widen competition.

**For Better Lighting**

MASSACHUSETTS INSTITUTE of Technology has established a Laboratory of Lighting Design in the School of Architecture and Planning to study "all factors of environment which contribute to the process of seeing." The laboratory was inaugurated by an initial grant from the F. W. Wakefield Brass Company, Prof. Lawrence B. Anderson, head of M.I.T.'s Department of Architecture and chairman of the project's advisory committee, says the project will "draw upon and coordinate studies in psychology, ophthalmology and optometrics. It is our conviction and that of the Wakefield Brass Company that lighting problems cannot be separated from consideration of the entire architectural envelope. These problems are also closely related to acoustic and thermal controls; physiology, psychology and engineering are deeply involved."

(Continued on page 16)

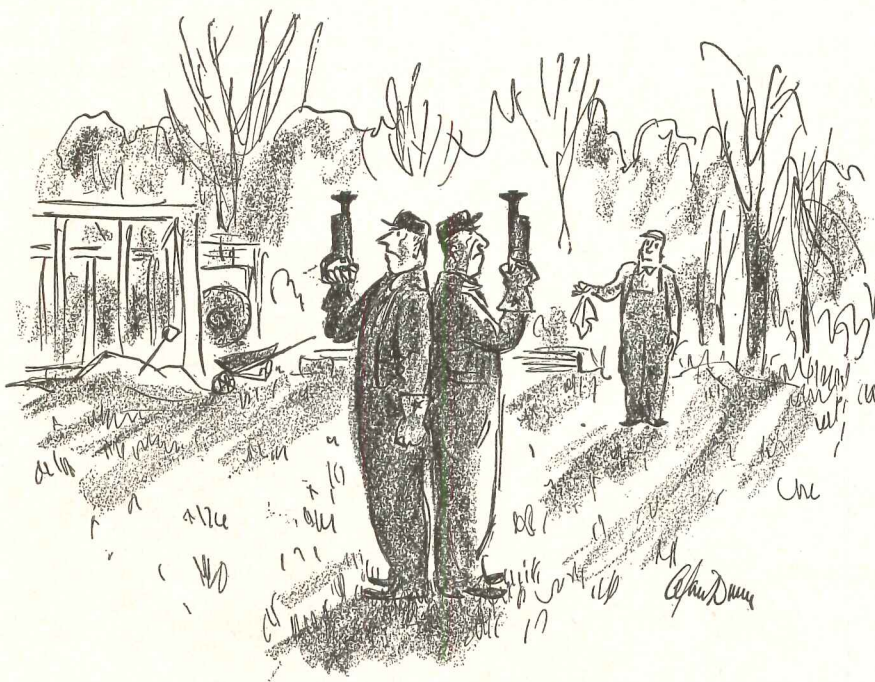

—Drawn for the RECORD by Alan Dunn



## THE RECORD REPORTS

(Continued from page 15)

A two-day seminar on Vision, Brightness and Design held September 23-24 at M.I.T. launched the new laboratory.

### "Not Only an Architect"

THE NATIONAL SCULPTURE SOCIETY presented its medal of honor to New York City's Commissioner of Public Works, Frederick H. Zurmuhlen, for "vision and achievements in the cause of re-integrating sculpture and mural painting with civic architecture of today." Commissioner Zurmuhlen, sixteenth recipient of the medal since the award was instituted in 1929, has been able in a good many cases during a six-year tenure encompassing direction of some \$280 million worth of construction to persuade the city fathers that sculpture and mural painting ought to be included in a number of city buildings — among them the Domestic Relations Court Building (Henry V. Murphy, architect) in the Brooklyn Civic Center, for which Joseph E. Renies was recently chosen in an invitation competition to execute sculpture, and the new Bellevue Hospital Nurses' School and Residence (Alfred Hopkins & Associates, architects), for which Ivan Mestrovic has been commissioned to do a series of panels. Accepting the award at a dinner in New York



Presidents get together (left) between sessions at Producers' Council annual meeting at Pittsburgh: Elliott C. Spratt, P.C.; Roy G. Warner, Pittsburgh P.C.; Clair Ditchy, A.I.A.; C. F. Williams, Pittsburgh Architectural Association; John N. Franklin, Pittsburgh A.I.A.; and Emanuel Spiegel, N.A.H.B. Below: Armstrong Cork president C. J. Backstrand welcomes architects to Armstrong auditorium for Pennsylvania Society's Annual Meeting

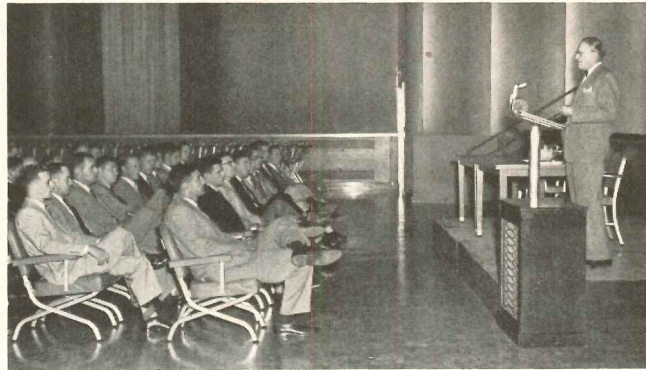

last month, Commissioner Zurmuhlen said he thought he had been winning "cases" rather than the basic argument that beauty as well as utility ought to be a function of civic architecture and that sculpture and mural painting can be an integral part of such an architecture. Introducing the Commissioner, Society President Wheeler Williams got close to another argument by describing the medallist as "not only an engineer but an architect; not only an architect but — if not an artist — a lover of the arts."

### " . . . Things to Come"

PENNSYLVANIA SOCIETY OF ARCHITECTS' 18-member Lancaster Branch, serving as a committee of the whole under the chairmanship of James Todd Baldwin to plan the annual convention of the Society in their town, got wholehearted cooperation from local newspapers and from Mayor Kendig C. Bare, who proclaimed it Pennsylvania Architects Week in Lancaster. The convention, held at the Hotel Brunswick and the Armstrong Cork Company Auditorium, took local flavor from such events as a "Pennsylvania Dutch Set-Out" and a tour of the surrounding Amish country

but looked to more distant horizons in its working sessions, notably its major panel discussion, "Research — and Things to Come," moderated by E. Claxton, director of research for Armstrong Cork Company. Speakers William H. Scheick, executive director of the Building Research Advisory Board, James T. Lendrum, director of the University of Illinois' Small Homes Council, Leonard C. Haeger, technical director of the National Association of Home Builders, and Walter A. Taylor, American Institute of Architects education and research director, discussed the probabilities and possibilities.

### Building Teamwork Stressed

THE IMPORTANCE TO BUILDING OF teamwork among its various elements was a dominant theme at the 1953 conference of the Producers' Council held at the William Penn Hotel in Pittsburgh September 16-17. Clair Ditchy, president of the American Institute of Architects, pledged the continued cooperation of architects in the joint effort to make ever better buildings; and the same note was sounded in his speech by Emanuel Spiegel, president of the National Association of Home Builders. The meeting also heard a call for cooperation between producers and builders from Housing and Home Finance Agency Administrator Albert M. Cole, who said he expected the housing industry would produce a million units in 1954, but only if builders and producers make a "sound market analysis" and produce the shelter needed. Elliott C. Spratt of the Hillyard Chemical Company, St. Louis, was reelected president for 1954.

(More news on page 20)

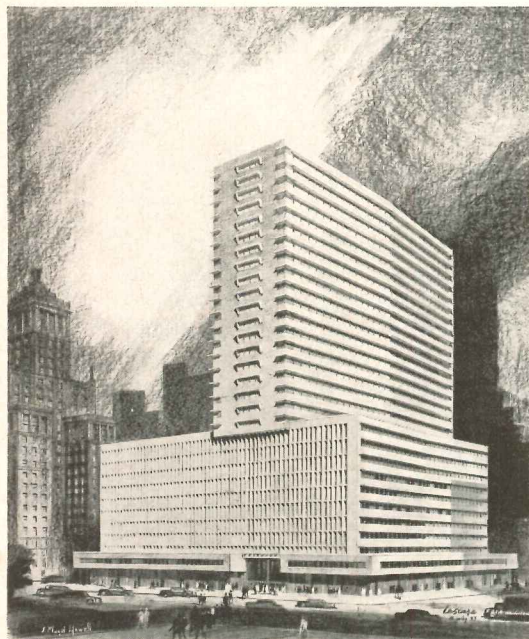

William Lescaze, architect with George Howe of a major landmark of modern office building architecture, the Philadelphia Savings Fund Society Building, has designed a \$25 million skyscraper (above) to replace an 1884 building designed by George B. Post and later enlarged, the New York Produce Exchange Building (right) at No. 2 Broadway in the midst of New York's financial canyons. Site has been leased by Jack D. Weiler, New York, and Benjamin H. Swig, San Francisco





# CONSTRUCTION METHODS?

## COMPLETELY ENCLOSED IN 6½ DAYS.....

### New construction technique revolutionizes building erection

At 10 A.M., Wednesday, August 5th, 1953, a new record was established that is of vital importance to everybody connected with the construction industry. At that precise time — only 6½ days after work had begun on enclosing the new skyscraper office building at 99 Park Avenue — the last prefabricated aluminum panel was set in place and bolted fast, and the 26 story skyscraper was enclosed.

Just imagine — 98,363 sq. ft. of exterior building surface set in place in only 6½ working days. This not only establishes a new construction record, but it marks the beginning of a new era in building methods.

GENERAL BRONZE CORPORATION, as designers, fabricators, and erectors of these giant two-story-high prefabricated aluminum panels, is one of the leading authorities and pioneers in the field of curtain wall construction. Their extensive experience and performance in this field includes the fabrication of windows, spandrels, spandrel frames, and exterior wall panels for such well-known structures as the U.N. Building, Lever House, 100 Park Avenue Bldg., the Alcoa Bldg., the Los Angeles Statler Hotel and others.

Working closely with architects Emery Roth & Sons and owner-contractor, Tishman Realty & Construction Co., Inc., General Bronze engineered and prefabricated the 4'8" x 21'3" aluminum panels, and erected the entire facade in the record time of 6½ days. This resulted in a considerable saving of construction time and with a cost per sq. ft. of exterior wall that compares favorably with other types of quality construction.

The drastic saving in construction time, dramatized by this building, is, of course, only one of the dividends offered by metal curtain wall construction. In addition to obtaining much earlier rent returns, owners benefit from the increased floor area made available for rental by the thinner exterior wall. The durable aluminum skin also cuts maintenance costs to a minimum, is more weather-tight and less subject to deterioration than other types of construction. Six-foot high, vertically pivoted, reversible aluminum windows, with stainless steel weatherstripping, are incorporated in the building panels to greatly reduce the expense and danger of window cleaning — they can be cleaned easily from inside the building.

With a background of more than 40 years' practical experience in solving problems as they pertain to windows, spandrels, exterior curtain walls and architectural metalwork, General Bronze is well qualified to serve you, especially when your requirements are great, difficult or unusual. We will be glad to discuss your problems with you at any time. An interesting brochure, explaining this new construction technique, is available to accredited inquirers. For your copy, please address Dept. AR-11.



Workmen operating from inside of building, putting aluminum panel into position ready for bolting to steel brackets on framework.

.....

Extensive testing by General Bronze proves weathertightness of prefabricated panels and windows before production begins:

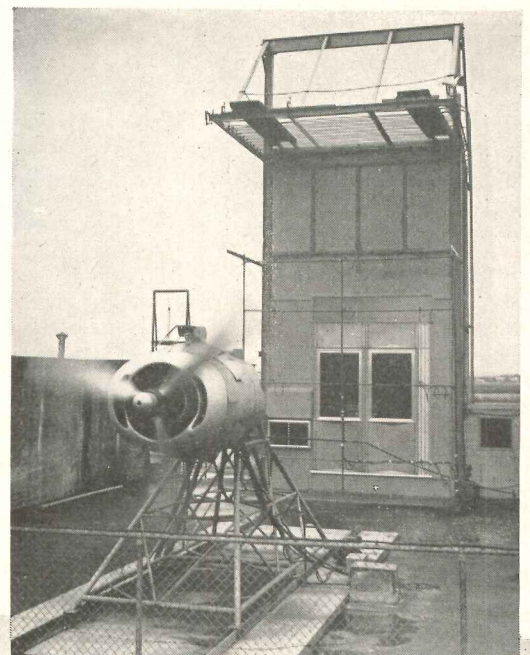

## GENERAL BRONZE CORPORATION

GARDEN CITY, N. Y.



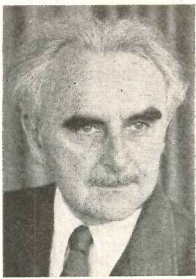

Richard Neutra



Paul Rudolph



Walter Creese



Hodding Carter



Buford Pickens



Christopher Tunnard

## FOCUS ON REGIONALISM AT GULF STATES CONFERENCE

ARCHITECTS OF THE NEW SOUTH took a searching look at social, economic and architectural history as well as contemporary development of their region at a three-day conference of the Gulf States Region of the American Institute of Architects whose theme was regionalism — parlayed for public relations purposes into the title "Serving the People of the New South through Architectural Progress."

The fourth annual Gulf States regional meeting, held September 17-19 at Biloxi, Miss., was dedicated to A.I.A. Second Vice President Howard Eichenbaum of Little Rock, "the man who conceived the idea of regionalism in the American Institute of Architects and made it work." As Gulf States Regional Director five years ago, Mr. Eichenbaum founded the first regional council in the Institute and initiated the regional conference idea which has since become an Institute-wide force.

With Dean Buford Pickens of the School of Architecture, Washington Uni-

versity, St. Louis, as moderator for all the panel sessions, the theme was developed in five major speeches — "The Social, Spiritual and Economic Background of the Region," by Hodding Carter, editor and publisher of the *Della-Democrat Times*; "The History of Regional Architectural Expression," by Walter Creese, professor of art history at the University of Louisville; "The Challenge of Regionalism," by Architect Richard Neutra of Los Angeles; "Regional Planning and the Landscape," by Christopher Tunnard, associate professor of city planning and director of the graduate program in city planning at Yale; and "Potential of Regional Architecture," by Architect Paul Rudolph of Sarasota, Fla.

Mr. Carter set the stage with a penetrating analysis of the impact of rapid industrial and economic development on a social and cultural complex quite unprepared to receive it. Mr. Neutra's talk emphasized the importance in the history of man's development of sub-

tropical climate and Mr. Creese dealt with the development in the South of common forms — like the "dogtrot house" — which answered regional — mostly climatic — problems. Mr. Tunnard warned against the "monumental anonymity" which can result when indiscriminate exploitation of areas never subjected to intensive development before is allowed to destroy their character. Regional characteristics are a part of all good architecture, Mr. Rudolph said, and should be accepted without either resistance or overemphasis.

Honor awards were given as follows:

**Industrial.** Award of Merit—Tank Repair Plant, Anniston, Ala. (ARCHITECTURAL RECORD, October 1953, pages 156-161); Sherlock, Smith & Adams, Montgomery, architects.

**Institutional.** Honor Award—Elementary School, New Orleans, Curtis & Davis, New Orleans, architects; Award of Merit—Colosseum, Montgomery, Sherlock, Smith & Adams, architects.

**Housing developments.** Honor Award—New Orleans Housing; Curtis & Davis, architects.

**Residential.** Award of Merit—House in Tennessee, Alfred Aydelott & Associates, architects.

**Commercial.** Honor Award—Architect's Office, Memphis; Alfred Aydelott & Associates, architects.

Depew Meredith

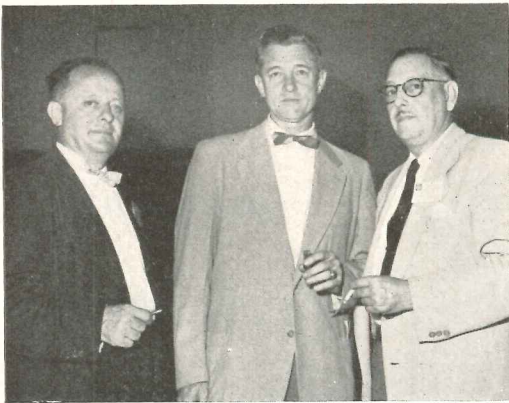

1

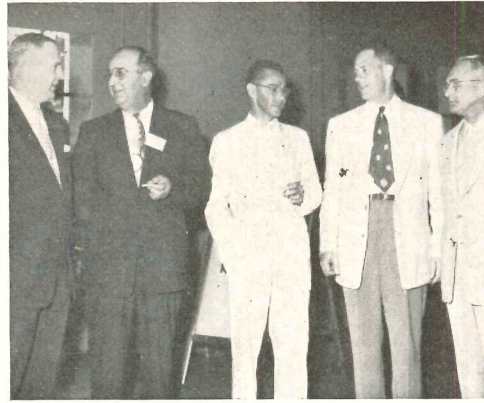

2



3

### CONFERENCE SNAPSHOTS

Extra-curricular scenes at Biloxi: 1. Program Chairman Jack Canizaro, Gulf States Regional Director Clyde Pearson and the honor man, A.I.A. Second Vice President Howard Eichenbaum. 2. Bevy of state chapter officials: Lawrence Whitten, Alabama president; Elmer Stucks, Arkansas vice president; Harry Haas, Mississippi president. 3. Honor Awards jury: Paul Rudolph, Sarasota,

Fla.; Douglas Haskell, *The Magazine of Building*; Sam Hurst, Georgia Institute of Technology; Dean Buford Pickens, Washington University School of Architecture, St. Louis; Frank Lopez, ARCHITECTURAL RECORD, 4, 5, and 6. Some of the award winners (left to right): Richard Adams, Sherlock, Smith & Adams; Al Aydelott, Ben I. Brown and Charles Jen, Aydelott and Associates; Arthur Q. Davis and Nathaniel C. Curtis, Curtis & Davis



4

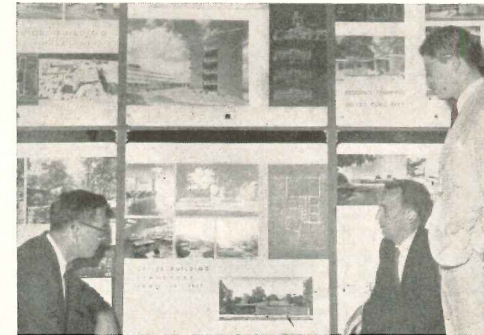

5

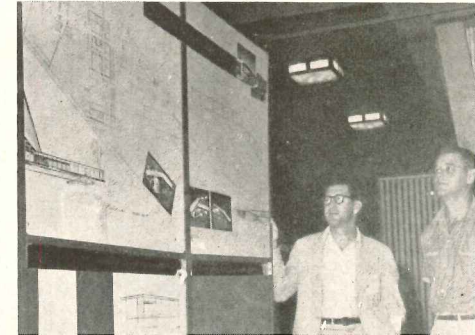

6



**WERE QUICK TO SEE ITS POSSIBILITIES—**

# Wheeling Tri-Rib Steel Roof Deck!

Imagine a roof deck so *light*, so *strong*, it actually saves up to 22 lbs. per sq. ft. of dead weight. Imagine it *saving steel*: not only does it *weigh* less, but it results in lighter supporting structure as well. Imagine it installed so *fast* that a 4-man crew can lay up to 4,000 sq. ft. a day. Then think of it *costing less* than comparable types of roofing. This is Wheeling Tri-Rib Steel Roof Deck — one of the most versatile

building products available today. No wonder it has captured the imagination of architects and builders.

*The Wheeling line of building materials* includes Expanded Metal, Metal Lath and Metal Lath Accessories, Steelcrete Reinforcing Mesh, Tri-Rib Steel Roof Deck, ExM Angle Frame Partitions, Steelcrete Vault Reinforcing.

**WHEELING CORRUGATING COMPANY, WHEELING, WEST VIRGINIA**  
**BUILDING MATERIAL DIVISION**

ATLANTA BOSTON BUFFALO CHICAGO COLUMBUS DETROIT HOUSTON KANSAS CITY  
LOUISVILLE MINNEAPOLIS NEW ORLEANS NEW YORK PHILADELPHIA RICHMOND ST. LOUIS

*Also when you build specify Wheeling Metal Lath,  
choice of leading builders for over 60 years!*



**WHEN YOU BUILD WITH WHEELING TRI-RIB STEEL ROOF DECK!**

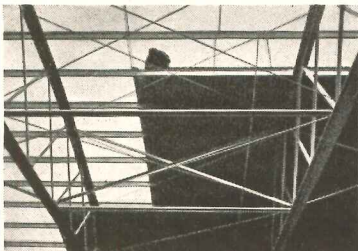

Strength plus lightness permit use of fewer columns, shallower footings, eliminate need for sub-purlins.

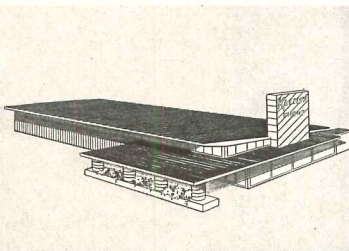

Roofs last longer because Tri-Rib is made of Cop-R-Loy, the Copper Alloyed Steel, protected by a baked-on coat of primer.



Its pleasing appearance often allows using the deck sheets as a "ceiling" without underfinishing, attaching fixtures to roof.

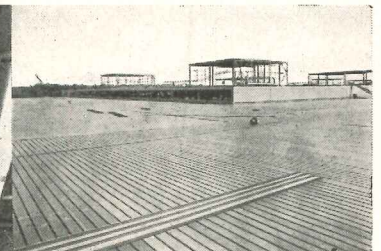

Designed in accordance with specifications adopted by A. I. S. I. for light gauge structures, dated Jan., 1941.



Below: Standard Regional Ordnance Depot Warehouse—Department of Defense. Architect: Robert D. Schoales

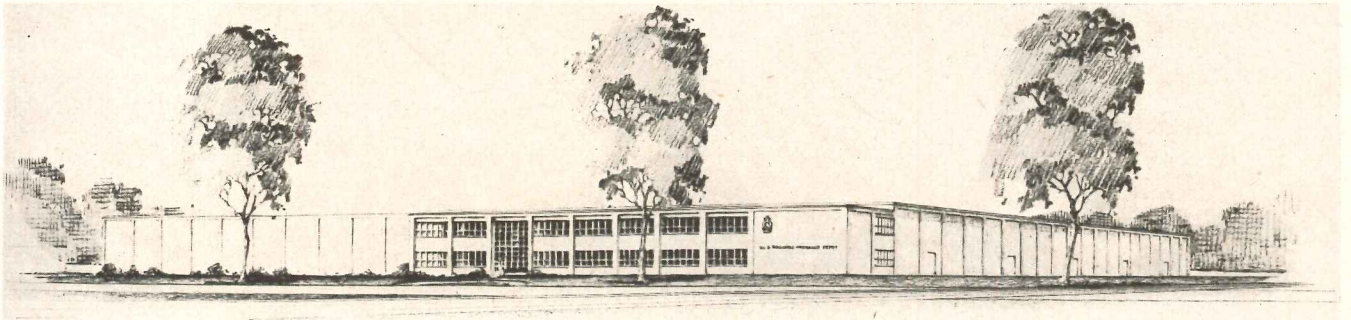

**GLOBE  
SPRINKLERS**

**FIREMEN EVERY 10 FEET**

**TAP THIS SOURCE OF NEW PROFIT**

The annual savings in insurance premiums after you install GLOBE Automatic Sprinklers often pay for the system in 4 to 8 years. Thereafter, the saving accrues to you. Ask our nearby office how much GLOBE protection can save you.

**GLOBE AUTOMATIC SPRINKLER CO.**  
NEW YORK . . . CHICAGO . . . PHILADELPHIA  
*Offices in nearly all principal cities*

**THEY PAY FOR THEMSELVES**

*Basil Spence* (Continued)

Assuring his audience that he considered himself no revolutionary, but rather a traditionalist, Mr. Spence said that he prized honesty and sincerity above all else in architecture, regardless of its period. It is not enough, he said, for a cathedral to be traditional, practical or economical. In addition, it must have a spiritual quality, to be able to speak of its own accord. This was the quality he had sought in his own design.

**BUILDERS HAIL BOOST TO MORTGAGE MONEY SUPPLY**

Canada's home builders hail the decision of the federal government to permit chartered banks to enter the mortgage lending field, declares Gordon S. Shipp, president of the National House Builders Association.

The Association has 1500 members located in principal cities in Canada.

Mortgage lending by banks is something his organization has been campaigning for for many months, Mr. Shipp said. Inadequate mortgage finance has stymied much needed housing development in many areas, he pointed out. Builders, he said, have been unable to get sufficient forward commitments from existing lending institutions to enable them to plan their operations on the scale necessary for maximum efficiency and economy.

"There is no reason," Mr. Shipp commented, "why 125,000 housing units cannot be built each year as a result of the government's action. That's a one-third increase over the 80,000 or 90,000 we've been building each year since the war. Production on the higher level will enable us to not only supply current demand but to catch up on the present backlog of 500,000 unbuilt units."

(Continued on page 32)



# Insulite meets requirements for Lamella roof construction

The roof insulation for this Lamella roof structure had to meet these requirements. 1) Serve as a roof deck and withstand traffic.

2) Stand up under rough on-the-job handling.

3) Provide an interior ceiling finish as well as

4) insulation value and 5) sound absorption.

Here's why MacKie and Kamrath, A.I.A., specified Insulite Roof Insulation.

**Strong, rigid roof deck.** The big, firm sheets provide a solid roof deck that withstands traffic with ease. Hardy Northern wood fibers are felted to create a board of exceptional transverse strength. Ask your Insulite representative for a sample. See for yourself.

**Interior ceiling finish.** At the same time that Insulite provides roof decking, insulation and efficient sound absorption, the exposed underside creates an attractive ceiling. What's more, it stands up for years. Many Insulite jobs are now more than 30 years old and still in sound condition.

**Cuts easily, handles without breaking.** Here is one of the big reasons roofers like Insulite. The strong, rigid sheets are built to stand up under the rough treatment they are subjected to under actual job conditions. Eliminates handling problems. Cuts loss due to breakage.

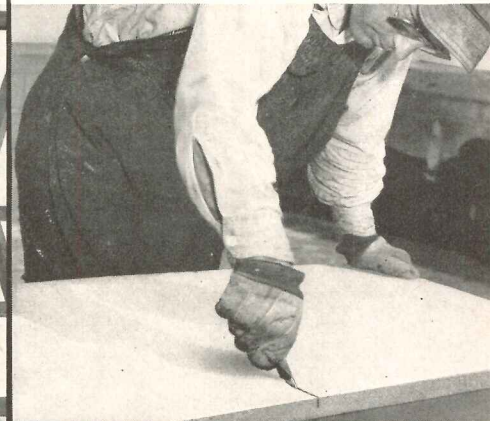
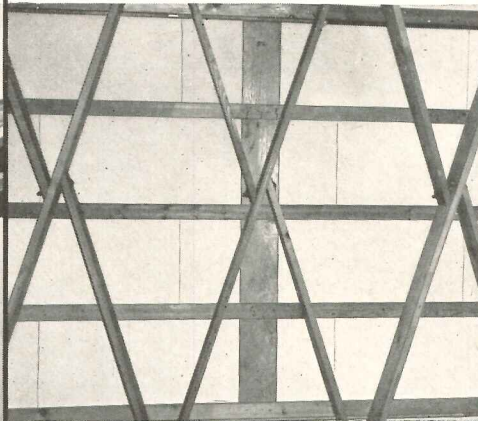
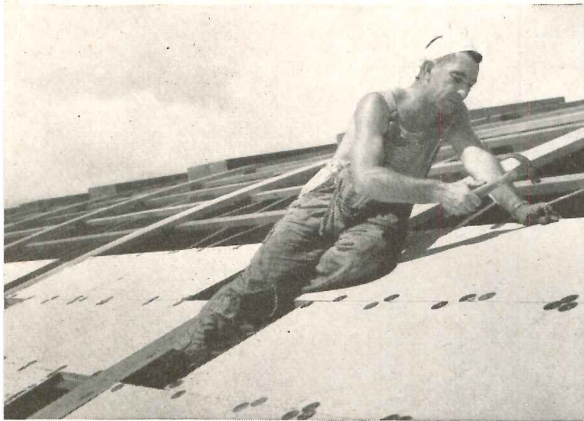

INSULITE IS A REGISTERED TRADE MARK

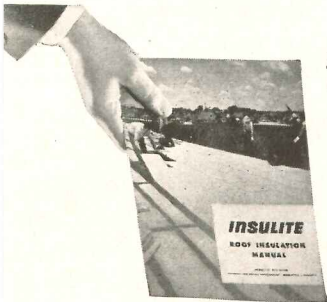

**A valuable addition to your files.** Contents include: (1) Coefficients of Heat Transmission and Thermal Resistance of Various Types of Flat Roofs Covered with Built-up Roofing, (2) Condensation Chart and (3) Fuel and Radiation Requirements Chart—plus product specifications and performance data. Write Insulite, Minneapolis 2, Minnesota for your free copy.

INSULITE DIVISION, Minnesota and Ontario Paper Company, Minneapolis 2, Minn.

**Build and insulate with double-duty**

# INSULITE

Made of hardy Northern wood





CONSTRUCTION COST INDEXES

Labor and Materials

United States average 1926-1929 = 100

Presented by Clyde Shute, manager, Statistical and Research Division, F. W. Dodge Corp., from data compiled by E. H. Boeckh & Assocs., Inc.

NEW YORK

ATLANTA

Period	Residential		Apts., Hotels Office Bldgs. Brick and Concr.	Commercial and Factory Bldgs. Brick and Concr.		Brick and Steel	Residential		Apts., Hotels Office Bldgs. Brick and Concr.	Commercial and Factory Bldgs. Brick and Concr.		Brick and Steel
	Brick	Frame		Brick	Steel		Brick	Frame		Brick	Steel	
1930	127.0	126.7	124.1	128.0	123.6		82.1	80.9	84.5	86.1	83.6	
1935	93.8	91.3	104.7	108.5	105.5		72.3	67.9	84.0	87.1	85.1	
1939	123.5	122.4	130.7	133.4	130.1		86.3	83.1	95.1	97.4	94.7	
1940	126.3	125.1	132.2	135.1	131.4		91.0	89.0	96.9	98.5	97.5	
1946	181.8	182.4	177.2	179.0	174.8		148.1	149.2	136.8	136.4	135.1	
1947	219.3	222.0	207.6	207.5	203.8		180.4	184.0	159.1	157.1	158.0	
1948	250.1	251.6	239.4	242.2	235.6		199.2	202.5	178.8	178.8	178.8	
1949	243.7	240.8	242.8	246.4	240.0		189.3	189.9	180.6	180.8	177.5	
1950	256.2	254.5	249.5	251.5	248.0		194.3	196.2	185.4	183.7	185.0	
1951	273.2	271.3	263.7	265.2	262.2		212.8	214.6	204.2	202.8	205.0	
1952	278.2	274.8	271.9	274.9	271.8		218.8	221.0	212.8	210.1	214.3	
June 1953	279.6	277.6	275.9	279.6	276.4		221.9	223.5	218.2	218.6	220.2	
July 1953	283.6	280.0	282.8	288.3	284.9		226.5	227.8	224.3	226.0	226.0	
Aug. 1953	283.1	279.2	283.4	288.7	285.2		225.7	226.6	224.8	226.4	226.2	
Aug. 1953	% increase over 1939			% increase over 1939			% increase over 1939			% increase over 1939		
Aug. 1953	129.2	128.1	116.8	116.4	119.2		161.5	172.7	136.4	132.4	138.9	

ST. LOUIS

SAN FRANCISCO

1930	108.9	108.3	112.4	115.3	111.3	90.8	86.8	100.4	104.9	100.4	
1935	95.1	90.1	104.1	108.3	105.4	89.5	84.5	96.4	103.7	99.7	
1939	110.2	107.0	118.7	119.8	119.0	105.6	99.3	117.4	121.9	116.5	
1940	112.6	110.1	119.3	120.3	119.4	106.4	101.2	116.3	120.1	115.5	
1946	167.1	167.4	159.1	161.1	158.1	159.7	157.5	157.9	159.3	160.0	
1947	202.4	203.8	183.9	184.2	184.0	193.1	191.6	183.7	186.8	186.9	
1948	227.9	231.2	207.7	210.0	208.1	218.9	216.6	208.3	214.7	211.1	
1949	221.4	220.7	212.8	215.7	213.6	213.0	207.1	214.0	219.8	216.1	
1950	232.8	230.7	221.9	225.3	222.8	227.0	223.1	222.4	224.5	222.6	
1951	252.0	248.3	238.5	240.9	239.0	245.2	240.4	239.6	243.1	243.1	
1952	259.1	253.2	249.7	255.0	249.6	250.2	245.0	245.6	248.7	249.6	
June 1953	262.4	254.3	258.9	268.4	261.6	253.7	248.5	252.7	256.0	255.0	
July 1953	264.2	257.0	260.7	269.3	263.2	257.2	250.8	258.3	263.1	261.8	
Aug. 1953	264.9	257.5	261.9	271.0	263.9	256.6	249.8	259.0	263.7	262.2	
Aug. 1953	% increase over 1939			% increase over 1939			% increase over 1939			% increase over 1939	
Aug. 1953	140.4	140.7	120.6	126.2	121.8	143.0	151.6	120.6	116.3	125.1	

The index numbers shown are for combined material and labor costs. The indexes for each separate type of construction relate to the United States average for 1926-29 for that particular type — considered 100.

Cost comparisons, as percentage differences for any particular type of construction, are possible between localities, or periods of time within the same city, by dividing the difference between the two index numbers by one of them; i.e.:

index for city A = 110  
 index for city B = 95  
 (both indexes must be for the same type of construction).  
 Then: costs in A are approximately 16 per cent higher than in B.

$$\frac{110-95}{95} = 0.158$$

Conversely: costs in B are approximately 14 per cent lower than in A.

$$\frac{110-95}{110} = 0.136$$

Cost comparisons cannot be made between different types of construction because the index numbers for each type relate to a different U. S. average for 1926-29.

Material prices and wage rates used in the current indexes make no allowance for payments in excess of published list prices, thus indexes reflect minimum costs and not necessarily actual costs.

These index numbers will appear regularly on this page.



# Leads in Design

The fact that Herman Nelson leads the unit ventilator industry in design is no accident. Herman Nelson products have forged into leadership position simply because they are *better made, better engineered* and *better designed* than any other heating and ventilating products in the market.

From the earliest days, under the direction of its founder, Mr. Herman Nelson, the Company has never lost sight of the value of the old-fashioned ideals of quality. Often copied . . . but never equalled, the Company's products have set new standards of quality year after year.

The streamlined exterior appearance of the products . . . with their color-engineered beauty . . . has not been the only factor in design. The job to be done, the ease of servicing the products, the simplicity of assembly and all other elements have been **DESIGNED** for maximum efficiency and greater economy of operation.

The success of these principles has been demonstrated year after year as leading Architects and Engineers have specified Herman Nelson unit ventilators for schools in every State of the Union.

If you are planning a new school or a modernization program—write for experience reports and factual information. Please ask for Bulletin number 3500—Dept. AR-11, Herman Nelson Unit Ventilator Products, American Air Filter Company, Inc., Louisville 8, Ky.



FOREST GLEN SCHOOL, GLEN ELLYN, ILLINOIS, *Superintendent of Schools*, MARK T. RIEDEL; *Architect*, CHILDS AND SMITH.

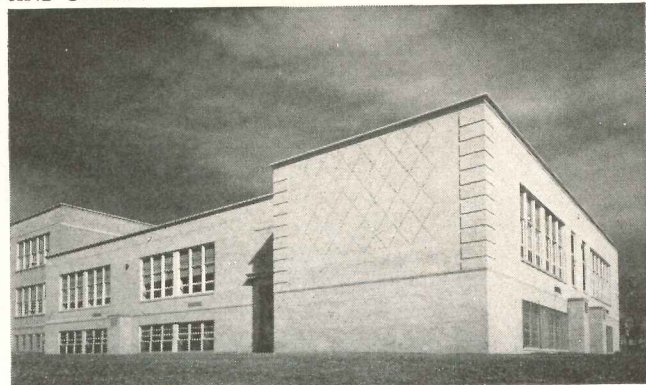

FAIRVIEW SCHOOL ADDITION, DENVER, COLORADO, *Architect*, R. EWING STIFFLER.



Typical Design Conference—where Herman Nelson design engineers plan a new product or refinements to products already being manufactured.

BEAUTIFULLY  
DESIGNED  
FUNCTIONAL  
EXTERIOR

DESIGNED  
ACCESSIBILITY  
FOR  
SERVICING

COLOR  
ENGINEERED  
FOR MODERN  
CLASSROOMS

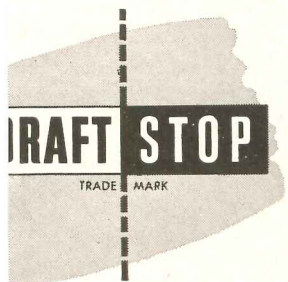
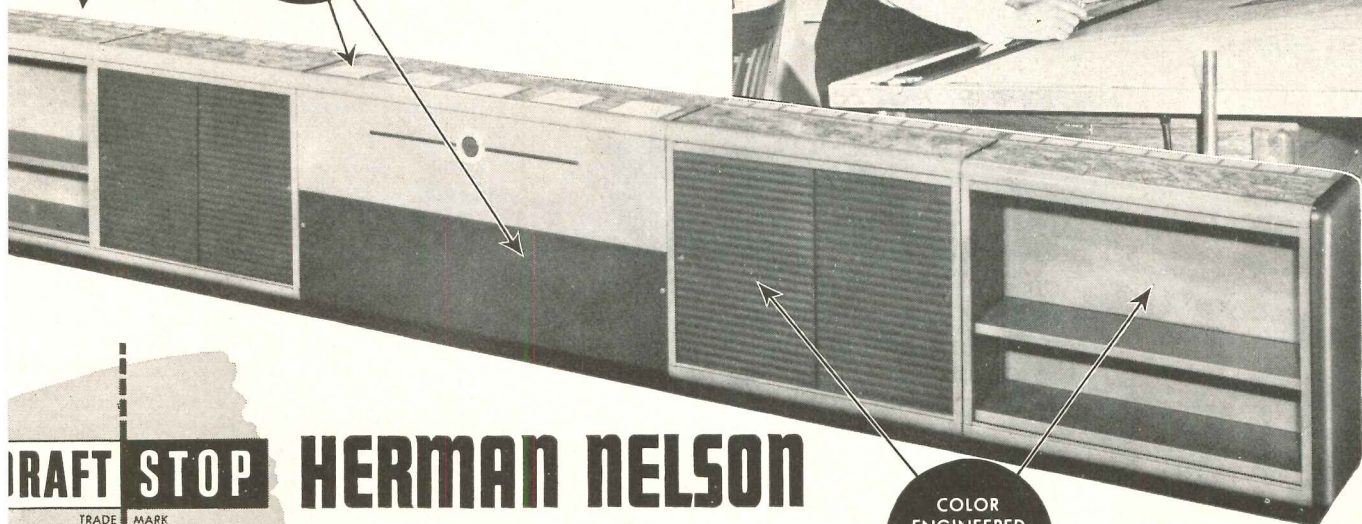

## HERMAN NELSON

SYSTEM OF CLASSROOM  
HEATING AND VENTILATING



# REQUIRED READING

## MOTELS, HOTELS, RESTAURANTS AND BARS

*Motels, Hotels, Restaurants and Bars.* By Editors of ARCHITECTURAL RECORD. F. W. Dodge Corp. (119 W. 40 St., New York, N. Y.) 1953. 8¾ by 11½ in. 216 pp., illus. \$6.95

REVIEWED BY CALEB HORNBOSTEL

TRAVEL AND SPEED are keynotes of our times. During the past 15 years America has gone on wheels and into the air at an accelerated rate. How fast is shown by these figures: from 1935 to 1949 automobile registration in this country jumped from approximately 24,000,000 to 36,000,000 and in the three years from 1949 to 1952 this figure rose by roughly more than another 7½ million.

The impact of this phenomenon on building types along travel routes has been tremendous and it is about time that somebody took the architectural problems in connection with travel, be it tourist, vacation or business, and condensed into a book what is going on in these exciting, really new fields.

This book, based on text and illustrations first published in ARCHITECTURAL RECORD, does just that. It makes available to both the general public and the design professions some of the best in recently built motels, hotels, restaurants and bars. The term "general public" here might be limited more to those in some way involved in these building types. Thus the material should be of value not only to architecture and designers, but also to owners of motels, hotels, restaurants and bars. It should also help make prospective investors — and for the architect, this is an important group to be reckoned with — it should make investors realize the business wisdom of engaging professional architectural talent early in the game.

Presentation of the material is based on photographs, and floor plans and general layouts. The emphasis is on over-all planning and design. The format as well as the presentation is visually handsome.

The motel is given the predominant

weight of the book and rightly so, since it is the newest of the types included. In fact, the motel and hotel are no longer distinct and separate entities. The motel has become more and more of a hotel, with most of a hotel's services, but placed along the highway, often at a strategic vacation spot and increasingly in conscious relation to airports as well as neighboring cities. All variations on the motel theme are included, from design from an economy basis, slanted for the budget-minded over-night stay, to designs for the luxury trade as exemplified by the resort hotel apartment type of motel.

The study by Frederick Arden Pawley of the changing conditions encountered in the motel field and the basic requirements in design, right down to the necessary amounts of storage space and linen is an especially valuable source of information to architects and designers engaged in such projects. The comprehensive bibliography must be mentioned as an invaluable mine of information.

The section on hotels contains the least factual data, but it shows by example how the hotel is changing in its basic character as a result of technological improvements and as a result of air travel which makes it possible to build a hotel, primarily for vacation purposes or as an air travellers' stopover in locations that once were relatively inaccessible. The Hilton Hotel in Istanbul is an obvious example of this. Since the hotels shown are primarily of this type, the emphasis is on leisure, luxury, everything for the comfort and amusement of its guests. Inasmuch as the motel and the hotel are actually competitors to a degree, hotel design is also going through a transitional stage. An example of unconventional thinking in design is a hotel in Florida by Polevitsky which is a combination of the usual vertical hotel with horizontal motel units to supplement each other.

The last part of the book deals with bars and restaurants and again endeavors to cover all types — those for pedestrian which can be reached by walking, and those for the automobile trade exclusively. Here again is some good basic information — general layouts, seating requirements, materials and other similar data. However, this

(Continued on page 48)



*The Istanbul Hilton Hotel by Skidmore, Owings and Merrill and their Turkish associate Sedad H. Eldem. Lower photograph: Carl's Sea Air, multi-service motel on Roosevelt Highway, Santa Monica, Calif., Burton A. Schutt, architect. From "Motels, Hotels, Restaurants and Bars"*

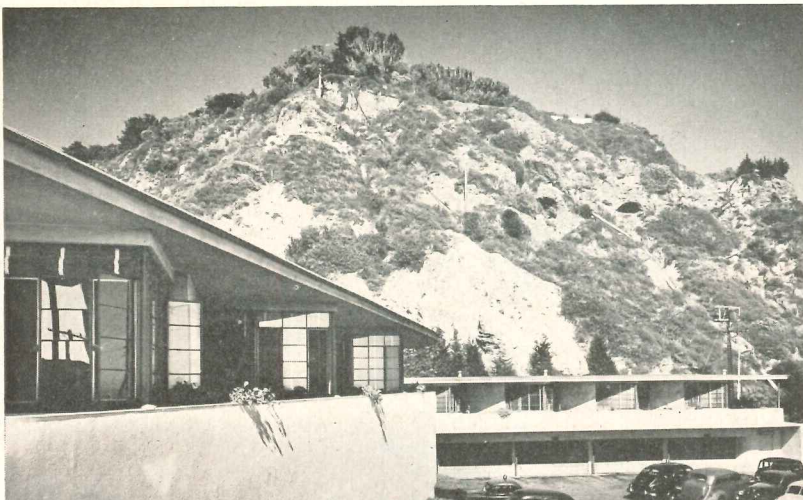



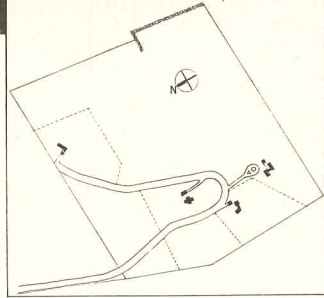
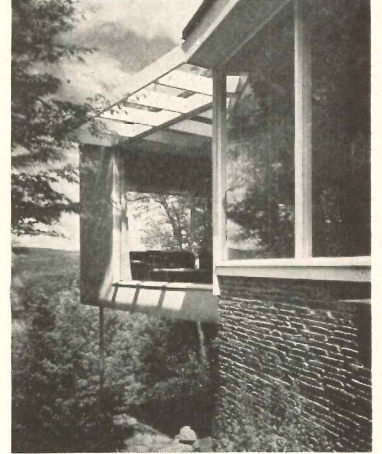
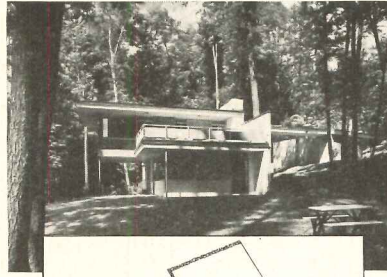
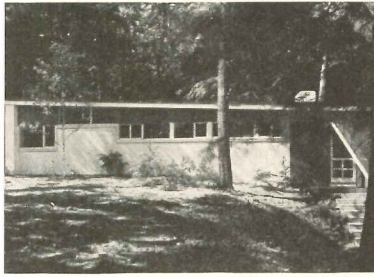

itor

## THE HOUSE AS ARCHITECTURE

TO SOME ARCHITECTS the house is today the best opportunity for individual expression, a fascinating problem of comprehensible size. Again, it may be a burden to be avoided if possible, or an acceptable commission only *en masse*. These seven custom-designed houses, considered together, encompass many problems typical of the field. For simplicity we have selected examples done for owners who are all professional people and hence sympathetic to the rationale of contemporary design; two are the architects' own houses. All are relatively small; all show the effects of locale, site, materials and labor; all were normally financed and most were designed with resale possibilities in mind. While all the architects concerned have indicated that in such houses there are intangible professional satisfactions, adequacy of fees, as one put it, is "debatable." Below are three houses on individual plots. Above are four designed as a group on a jointly owned jointly developed, 33-acre hillside site. All are presented in the following twenty pages both as architecture conditioned by specific locale, today's technology and owners' needs; and as instances of the professional problems that arise even in favorable circumstances.

Top: four houses, Hanover,

N. H., by E. H. & M. K. Hunter.

Bottom, l. to r.: Day house,

Everett, Wash., by Harold

Hall; Wolf house, Oakland,

Calif., by Campbell & Wong;

Wimberly house, Honolulu,

T. H., by Wimberly & Cook

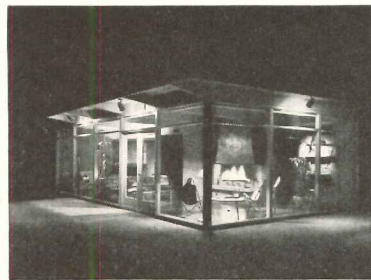

Chas. R. Pearson

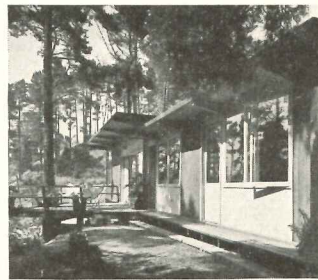

Morley Baer

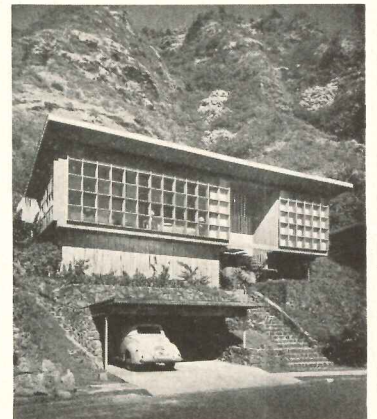

R. Wenkam



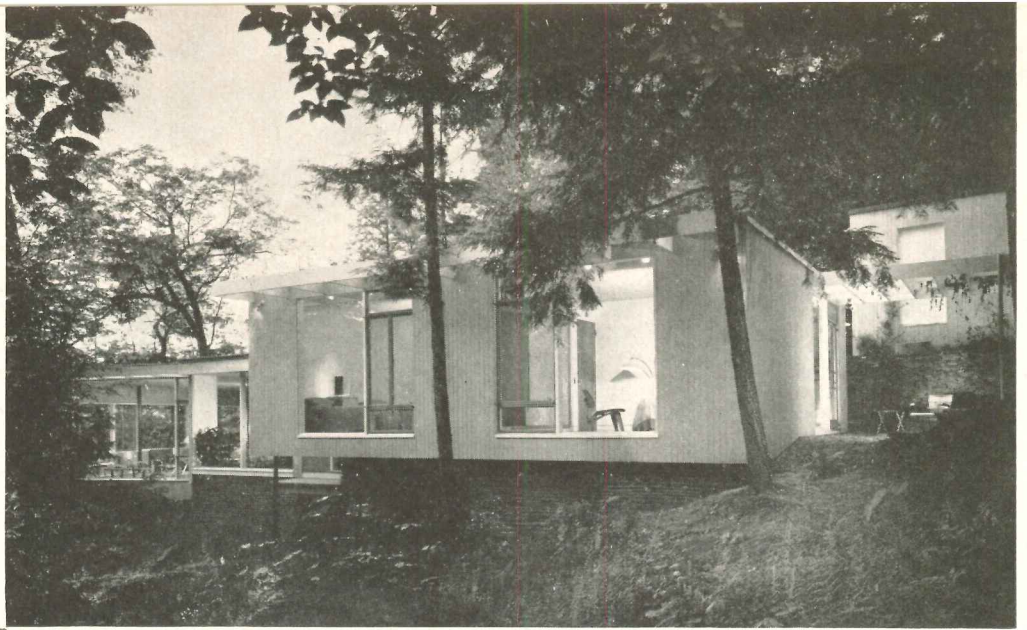

*HEMLOCK HILL,  
HANOVER, N. H.*

THE ARCHITECTS

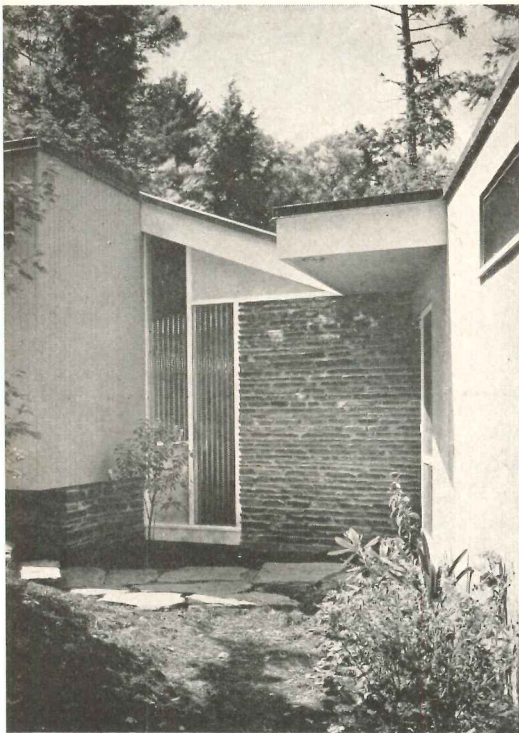

The House as Architecture





E. H. and M. K. Hunter House

E. H. and M. K. Hunter, Architects

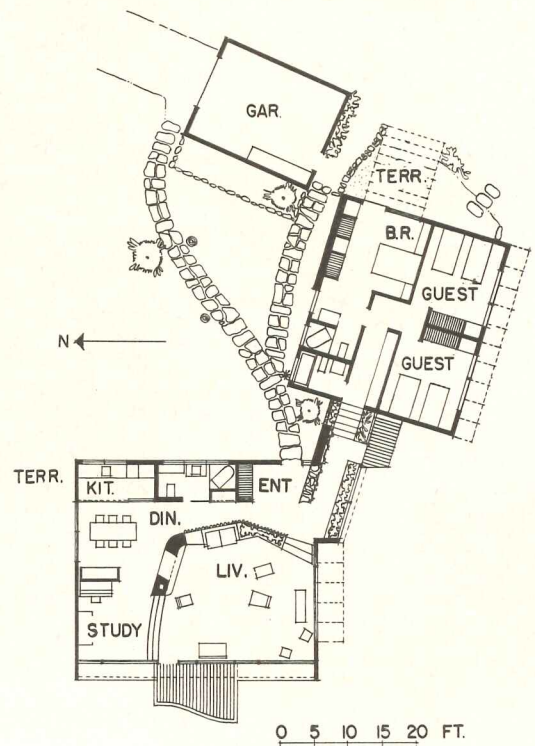

## DESIGN FOR THEMSELVES

### Clients and Architects

The Hunters try to work so closely with all their clients that seldom is there a fundamental conflict. This means long conferences, mutually educational, covering not only requirements but also personalities, living habits and wishes not always easily defined. In this house of their own, though they did not face the same problems of explaining esthetic and practical matters that they naturally encountered in designing the three other houses in the group, the architects did do the same exhaustive research into their own needs. Their budget was limited, so for some time the study area served as a bedroom, partitioned off with closets which have been removed; the bedroom wing was added recently.

Joseph W. Molitor

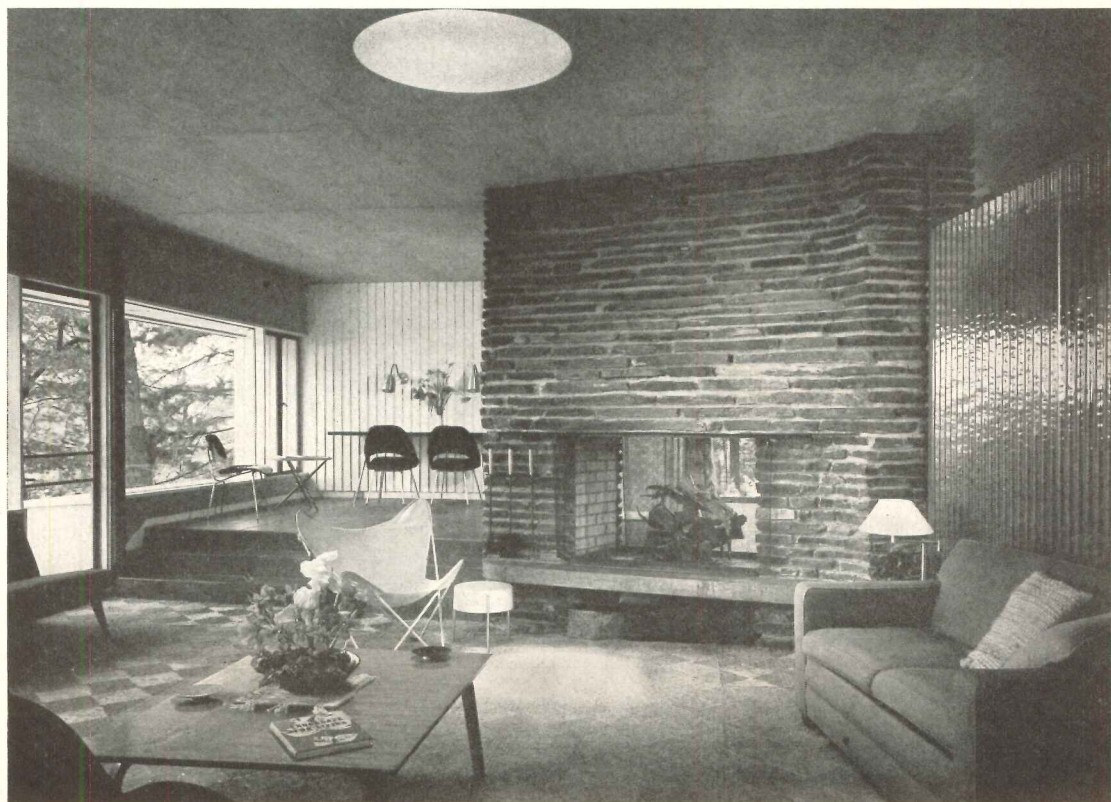



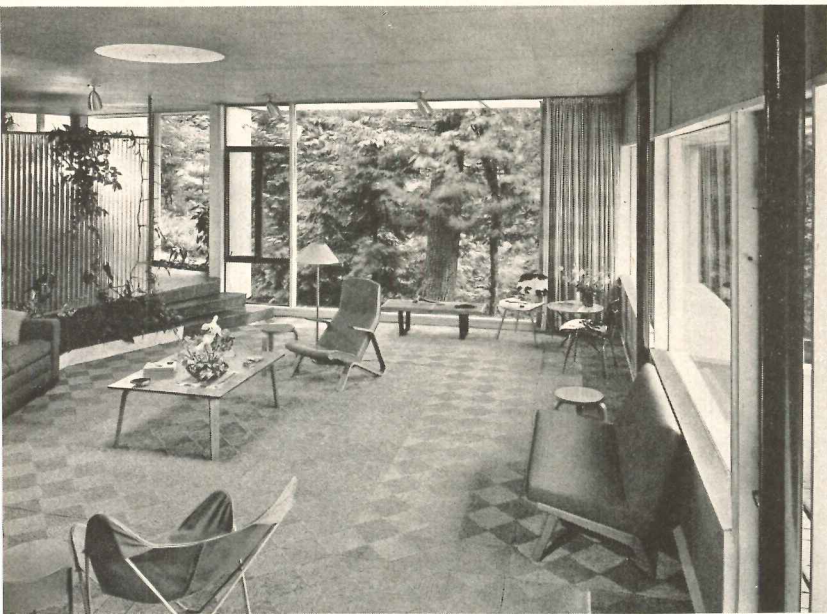

*The architects realized that their own house would be critically regarded by clients, friends and visitors. The graciously large living area, unified by a continuous ceiling yet subdivided by stone chimney, corrugated glass and changes in floor level, makes the most of intimate views to the south and north and of the western panorama of the Green Mountains*

House Architecture: E. H. and M. K. Hunter



Joseph W. Molitor



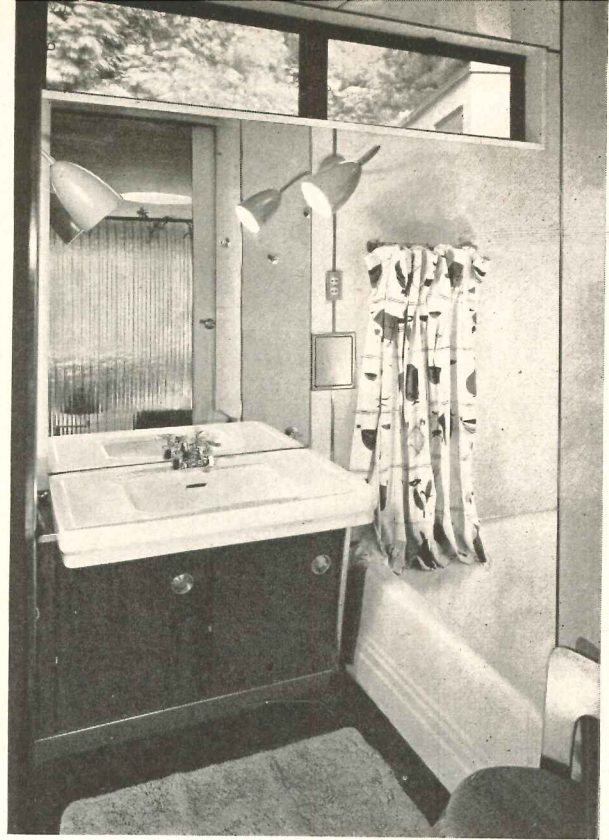

### **Local Factors**

In all four Hemlock Hill houses it was understood that local customs, not much changed since the days of carriages and long skirts, carried little weight. On the other hand, the demands of the region were met in careful planning for the trying climate, in large glass areas oriented south for natural heating, in liberal use of thermal insulation, and in use of flat or low-pitched roofs to hold snow and gain "free" insulation value. In these practical and esthetic effects of climate on design, the architects believe, lies true regional expression.

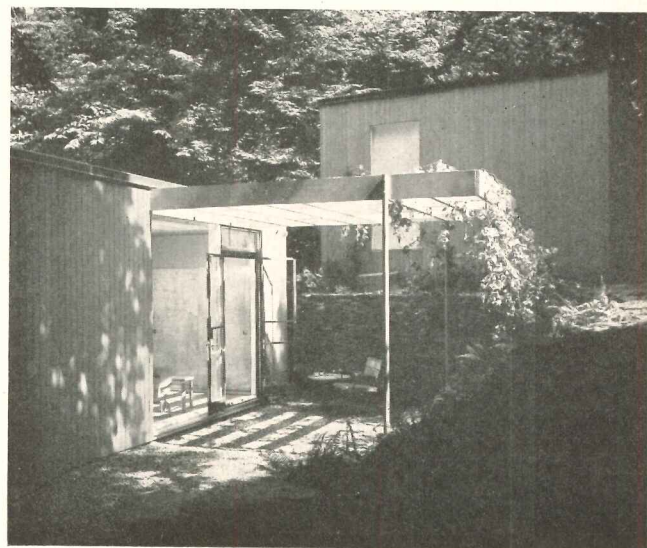



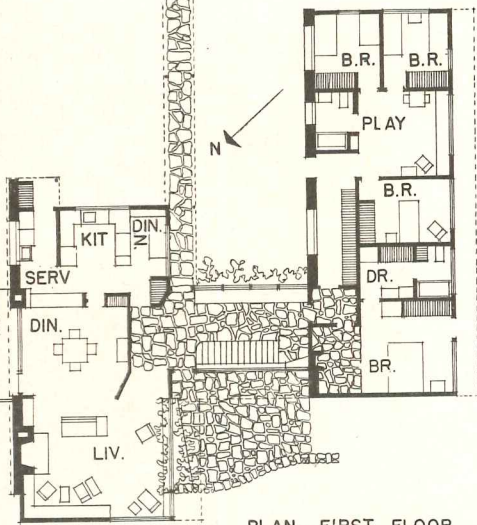
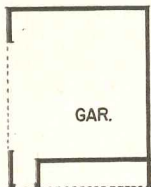

PLAN - FIRST FLOOR  
0 5 10 15 20 25 FT.

*Like the preceding house, this one was built in two stages. At first the downstairs study and guest room were subdivided into bedrooms; later the bedroom wing was added*

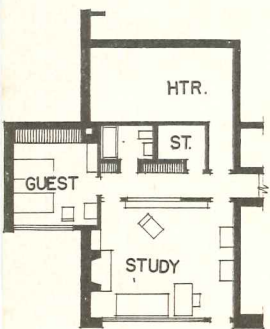

PLAN - LOWER LEVEL





*E. H. and M. K. Hunter, Architects*

### **Clients and Architects**

All the clients on Hemlock Hill had some strong traditional architectural contact, some in the south, some in New England. Before the designing of these houses started, while the clients had a fair understanding of contemporary architecture, they recognized more fully the potentialities for improved living in a contemporary home. At the same time, each approached such matters as raising children quite differently; in this case a play-room and separate entrance were required, so toys and outdoor clothing could be kept out of other areas.



### **Materials and Labor**

Other than local stone and concrete block, almost no local materials were available. Despite the region's reputation as "lumber" country, good lumber comes from the far west. Consequently, three of these houses have light steel framing; and this was also found to cut costs by reducing the inefficiency of cutting and fitting wood members. Local labor is familiar with steel joists, etc., so there was no difficulty here.

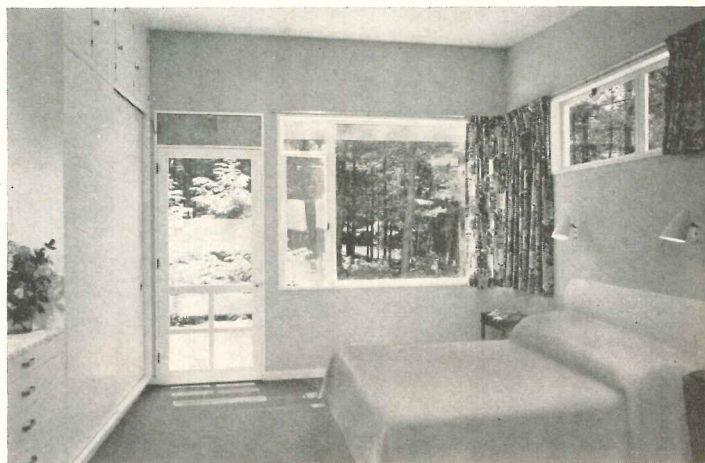

Joseph W. Molitor



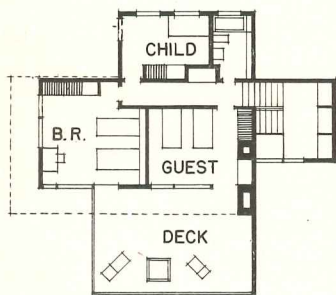
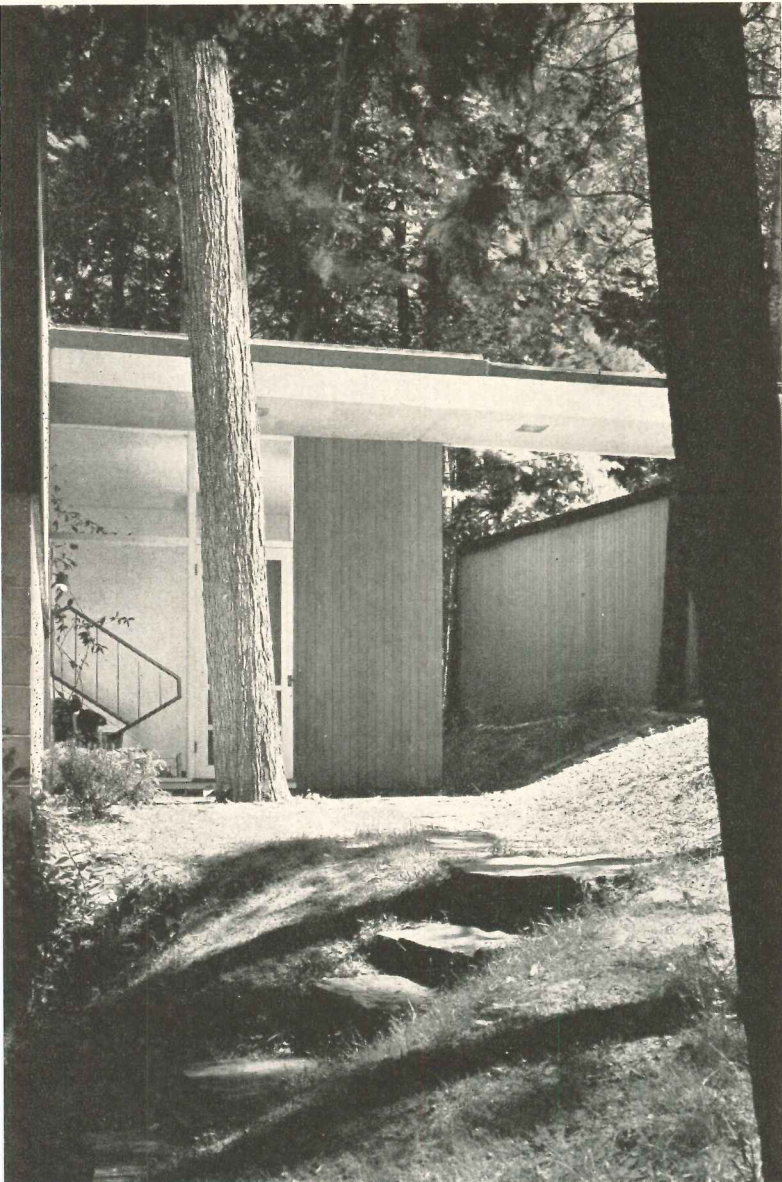

SECOND FLOOR

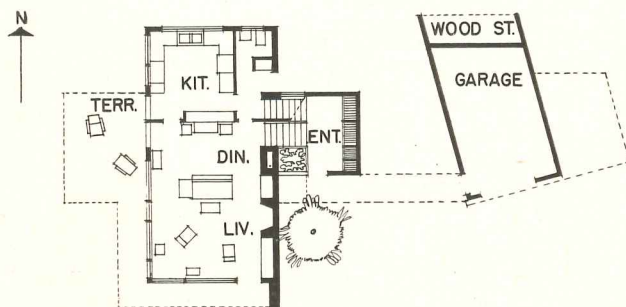

FIRST FLOOR

0 5 10 15 20 25 FT.

HEMLOCK HILL HOUSE FOR





Joseph W. Molitor

## DR. O. SHERWIN STAPLES

*E. H. and M. K. Hunter, Architects*

### *Clients and Architects*

---

In most cases, when clients on Hemlock Hill questioned unusual esthetic elements, when sound practical reasons could be advanced in their support, they were accepted. Individual preferences, however, were often the governing factor. For instance, Mrs. Staples preferred bedrooms on a second floor — and thus the house was designed; while all the others wanted direct access outdoors from master bedrooms. Again, the individual budget had dictated that the two preceding houses be built in successive stages (or else such materials as stone and acoustic plaster might have been eliminated); this and the next house were completed in one stage, though this necessitated using concrete block in the Staples house.

In none, thanks to careful programming and completely honest presentation, was design changed in fundamentals. There were, of course, some minor changes in plan which were not serious. This was the more remarkable since there was little opportunity for any of the clients to “feel out” contemporary design except in a few local houses.





**Local Factors**

The four occupied sites and a potential fifth were selected and laid out by the architects, with most of the owners participating as fully as possible in determining them. All liked the land, its slopes, the large trees, the woodland character. Thus the sites, several of them steeply sloping, had a substantial effect on design. All were agreed that it was important to fit these houses to their land, to work with it to make a whole picture in use and appearance.





E. H. and M. K. Hunter, Architects

**Materials and Labor**

This is the most recently built of the four houses. At the time of its construction, the Korean war, strikes and high cost per pound made the use of steel out of the question; it is the only one in the community that is completely wood-framed.

**Clients and Architects**

This family needed four bedrooms and a study, and more conventional living, dining, kitchen and breakfast space. Furthermore, the view to the west was also to be made visible from the kitchen.

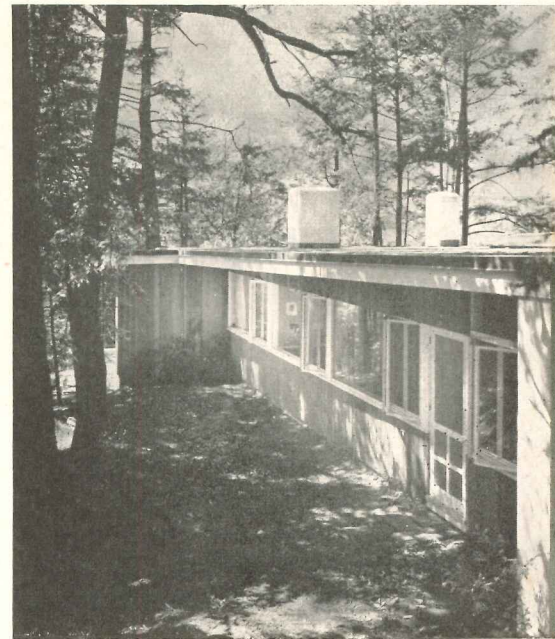

Joseph W. Molitor

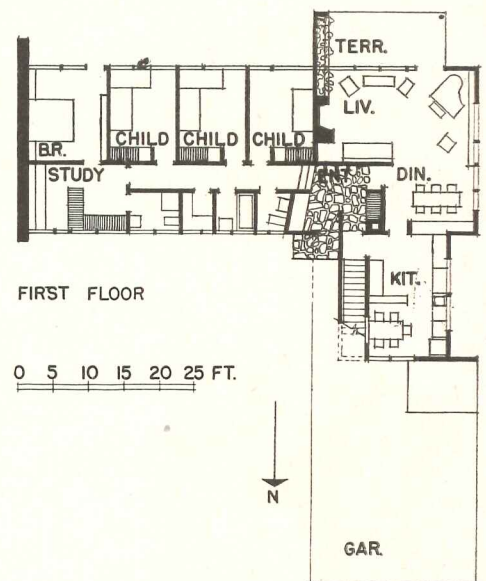
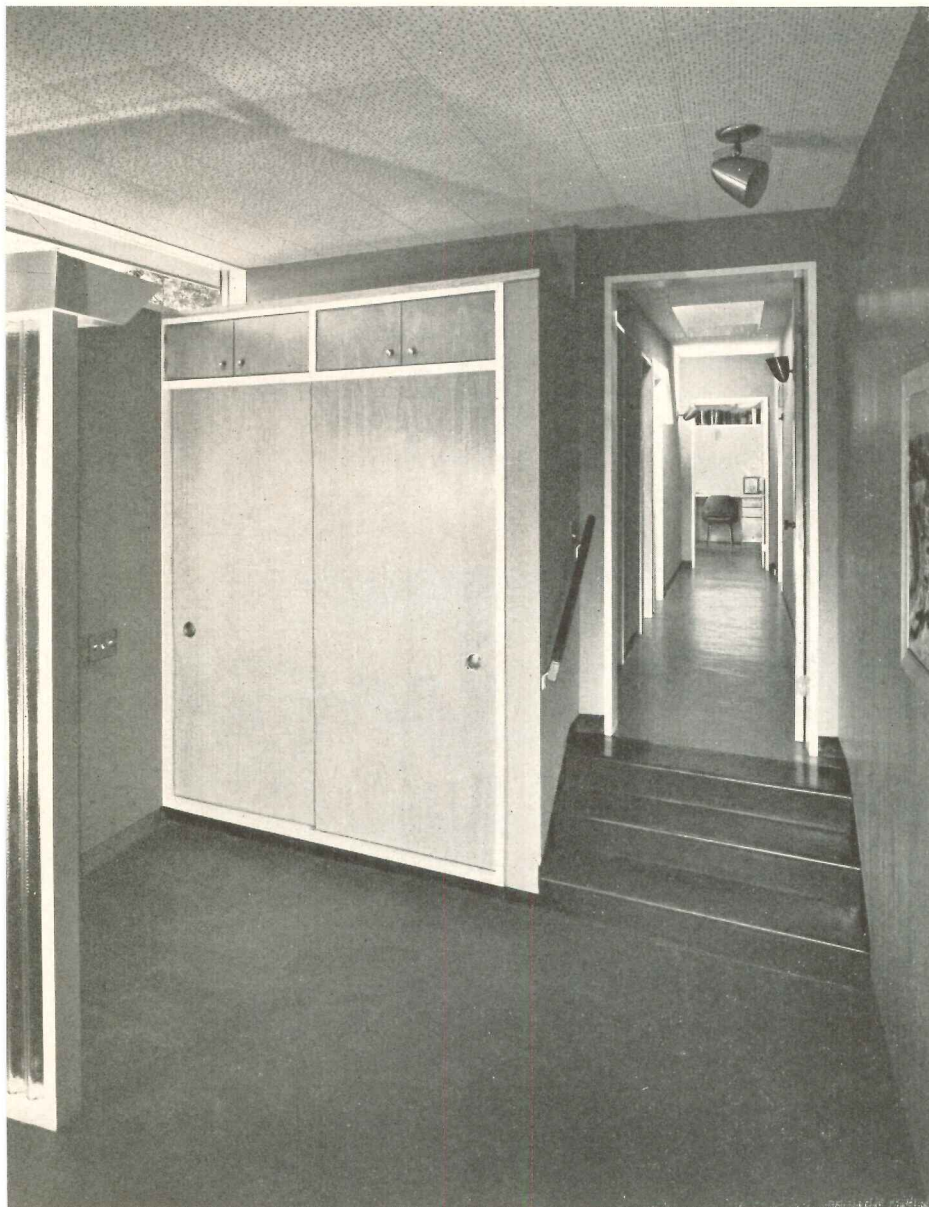



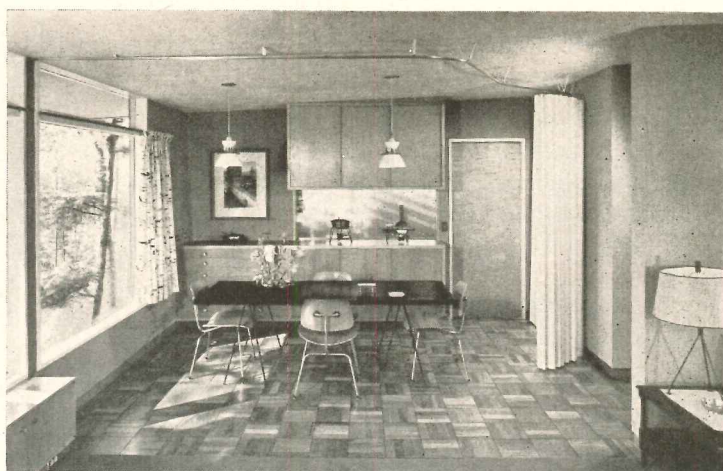
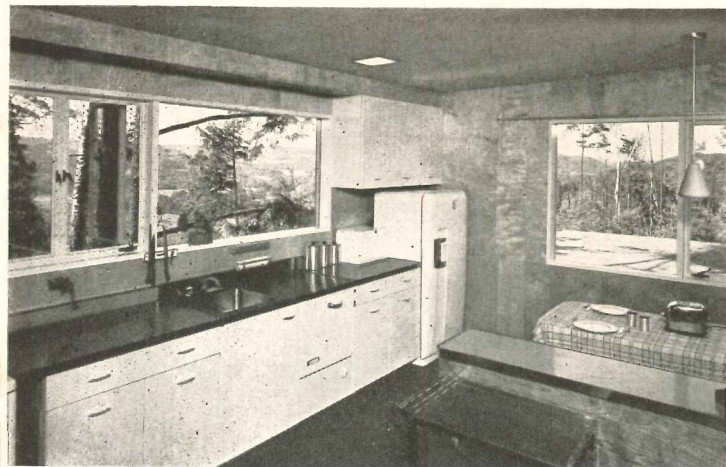

### *Financial Matters*

The architects believe that any house should be designed with resale possibilities in mind, since the owner's situation may change. At the same time, each of the four houses was custom-designed for its owners (a paradox which all architects face) and all four were financed with local savings bank mortgages. All these factors complicated design to some extent, increasing the countless hours of conferences required to bring design to the desired point of perfection. The standard percentage fee was felt to be a fair return, although the architects say: "This is not a field in which one can make a comfortable living; yet it is the field that affords the deepest satisfaction."

House Architecture: E. H. and M. K. Hunter

Joseph W. Molitor

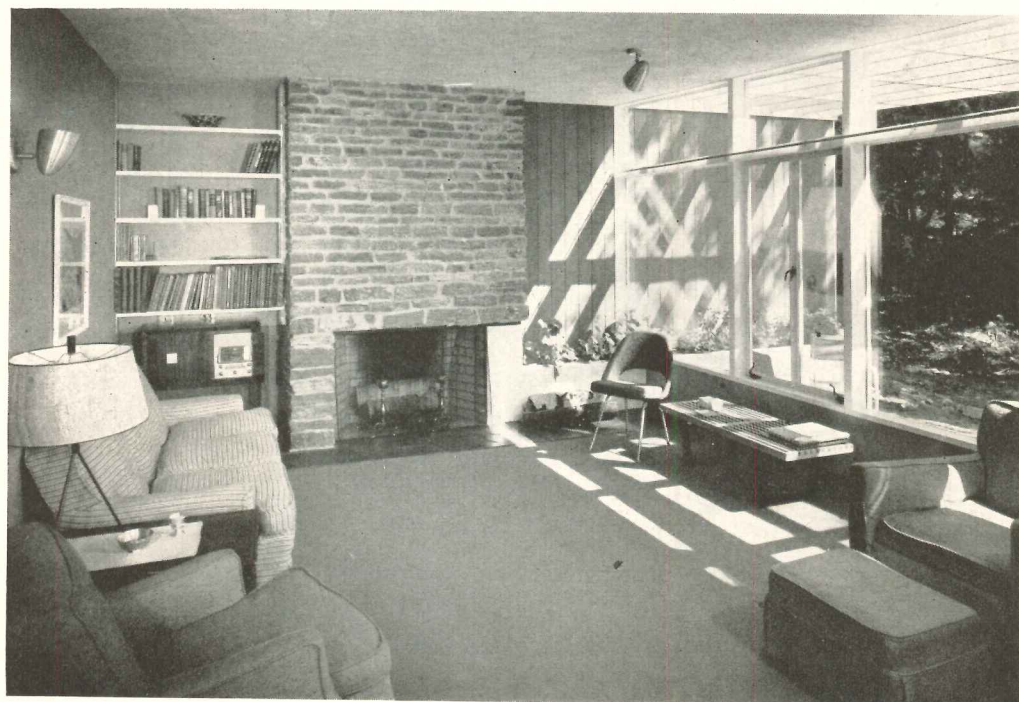



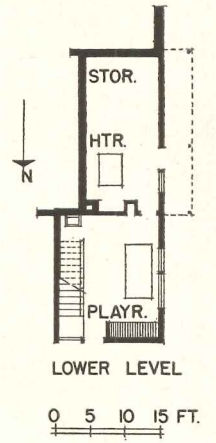
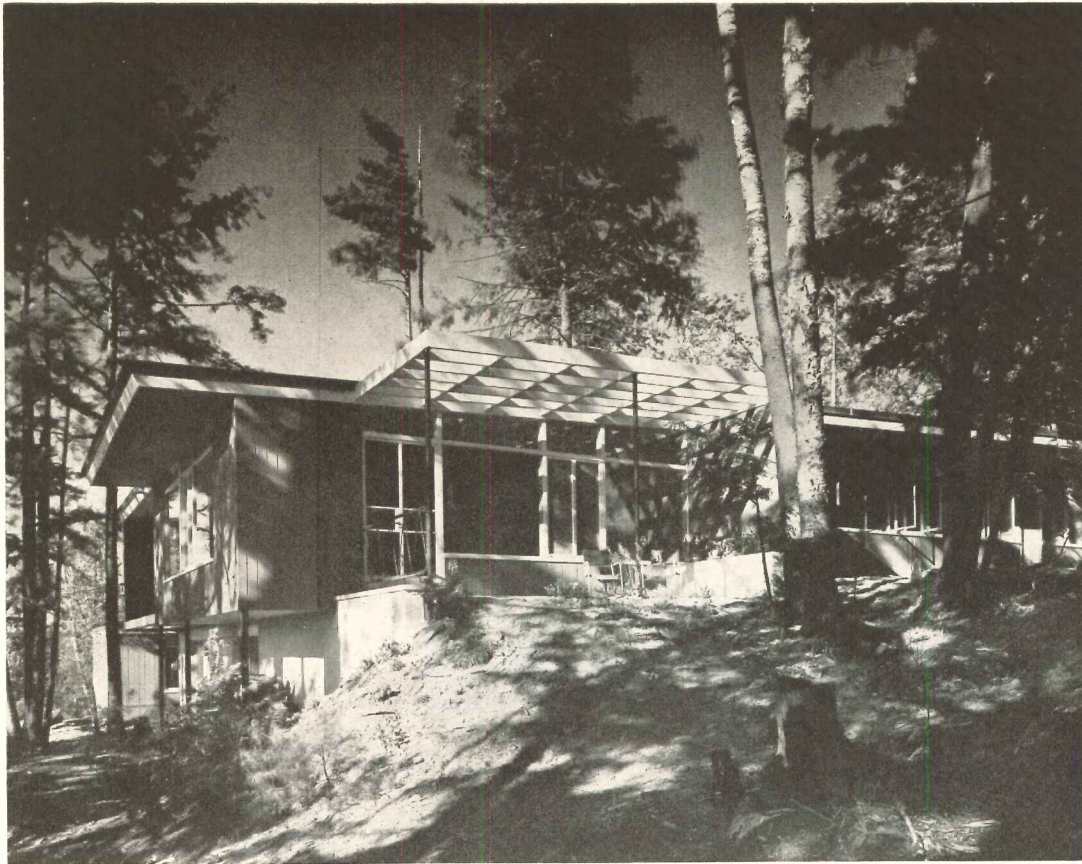

*All four of the houses on Hemlock Hill have wood studs, built-up roofing, copper flashing, steel casements and projected sash, flush doors. All baths have plastic-surfaced hardboard on the walls. Floors are concrete slabs with little or no excavation, contain copper tube radiant panels and are surfaced with a variety of materials— asphalt tile, slate, flagstone, wood, carpet, or matting*

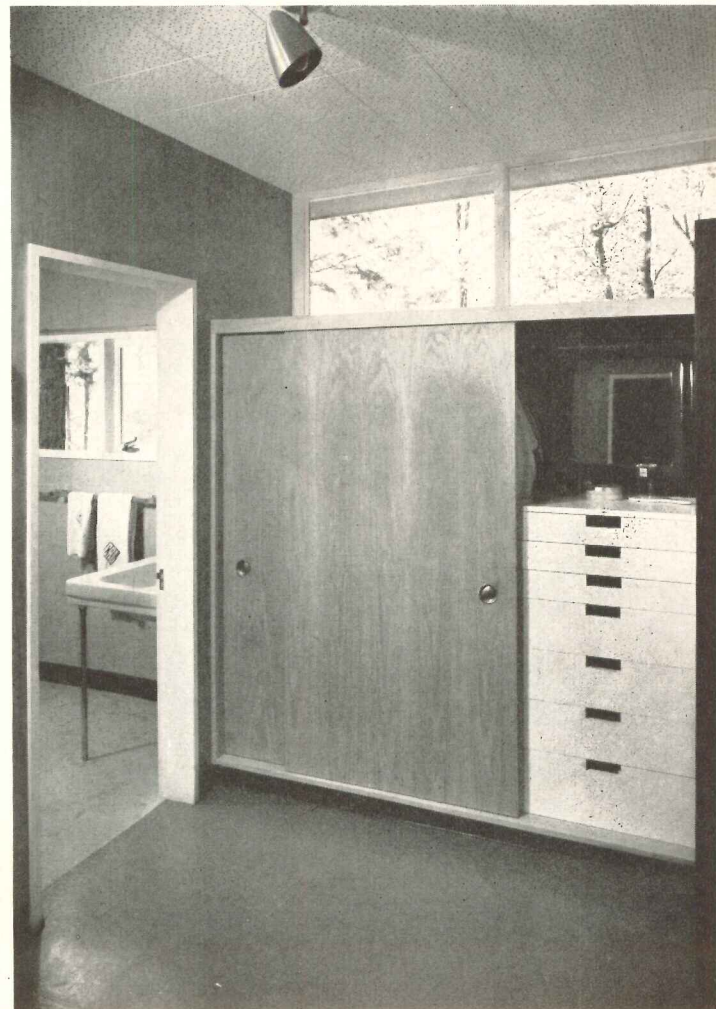
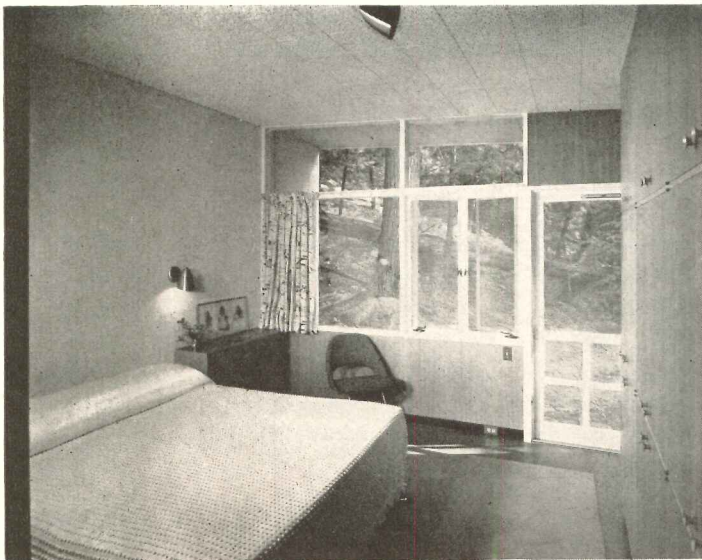





EVERETT, WASH.

## HOUSE FOR RUSSELL DAY

Harold W. Hall, Architect  
Arthur A. Graves and  
David W. Dykeman, Associates

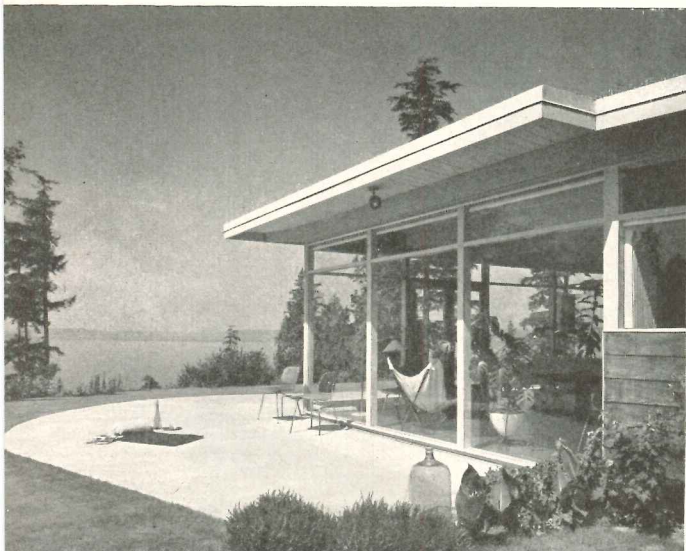

Charles R. Pearson

### Clients and Architects

This very small house was designed for the head of the Junior College Art Department and his wife, who, as one would expect, highly appreciated architectural values and gave the architects utmost freedom. It was designed, on a tight budget, for a family with no children, although bedrooms can be added to the south. The clients wished to live informally, but to provide for large gatherings of friends.



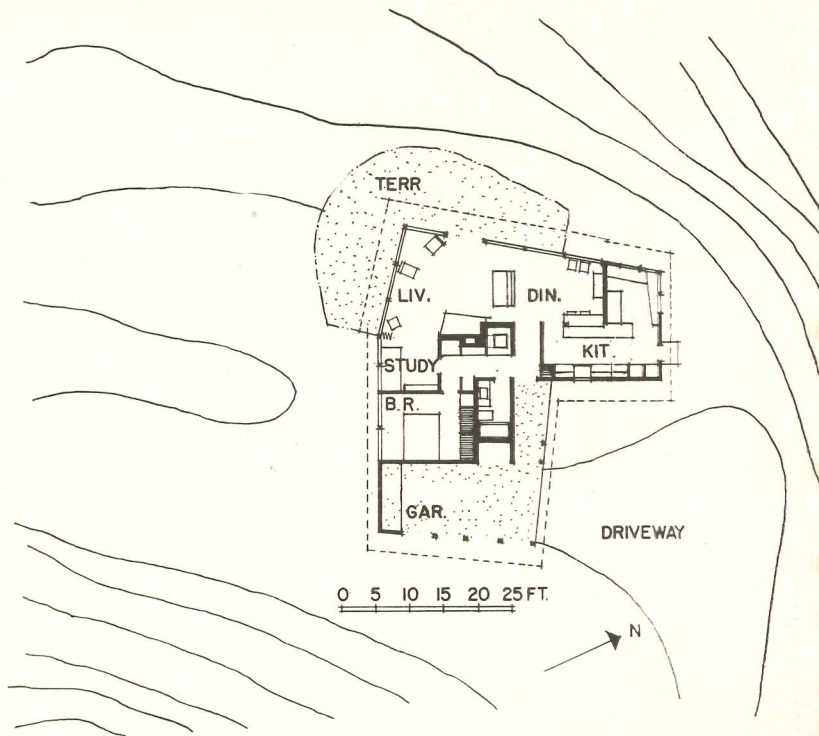
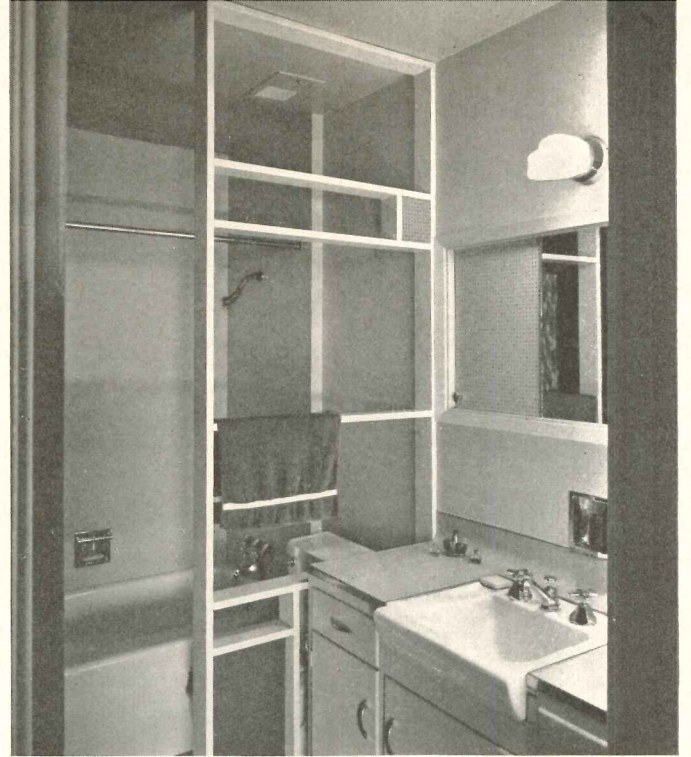
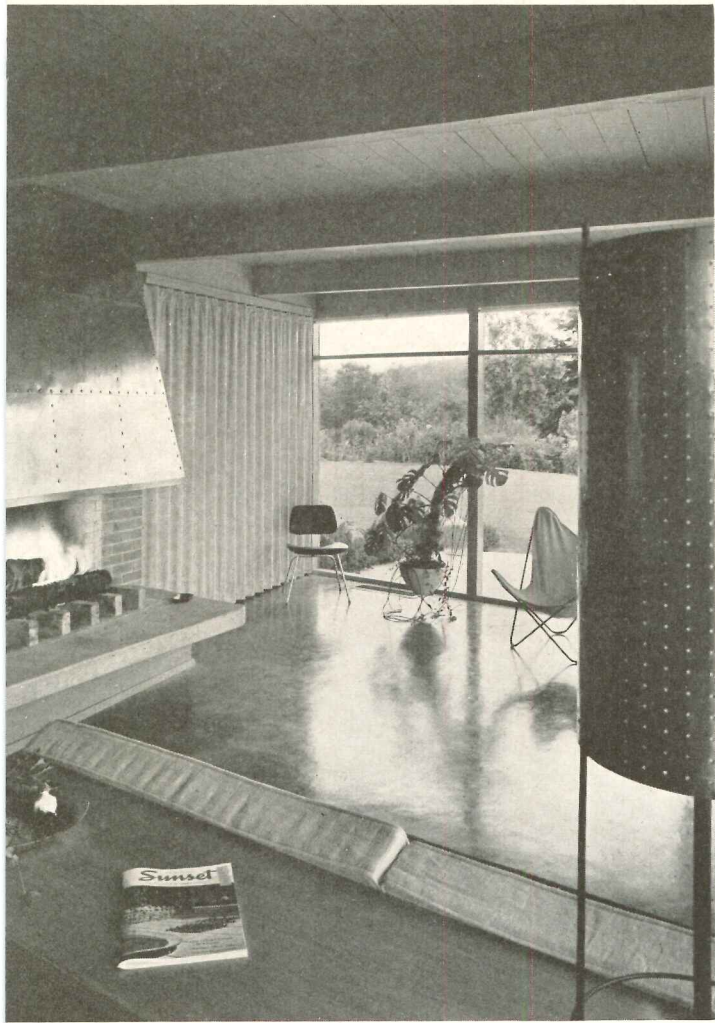

### **Local Factors**

There were no local customs strong enough to become design determinants, but the site is a knoll overlooking Puget Sound, which did strongly influence design. Local materials, chiefly wood, were employed, as they have been in several neighboring contemporary houses, following a recognizable regional pattern.

### **Finances**

The house was definitely designed with resale possibilities in mind; the possible extra bedroom was part of the original scheme. Although the architect says the owners were ideal clients and consequently matters went smoothly, he further states that a "normal" 10 percent fee did not produce an adequate return.





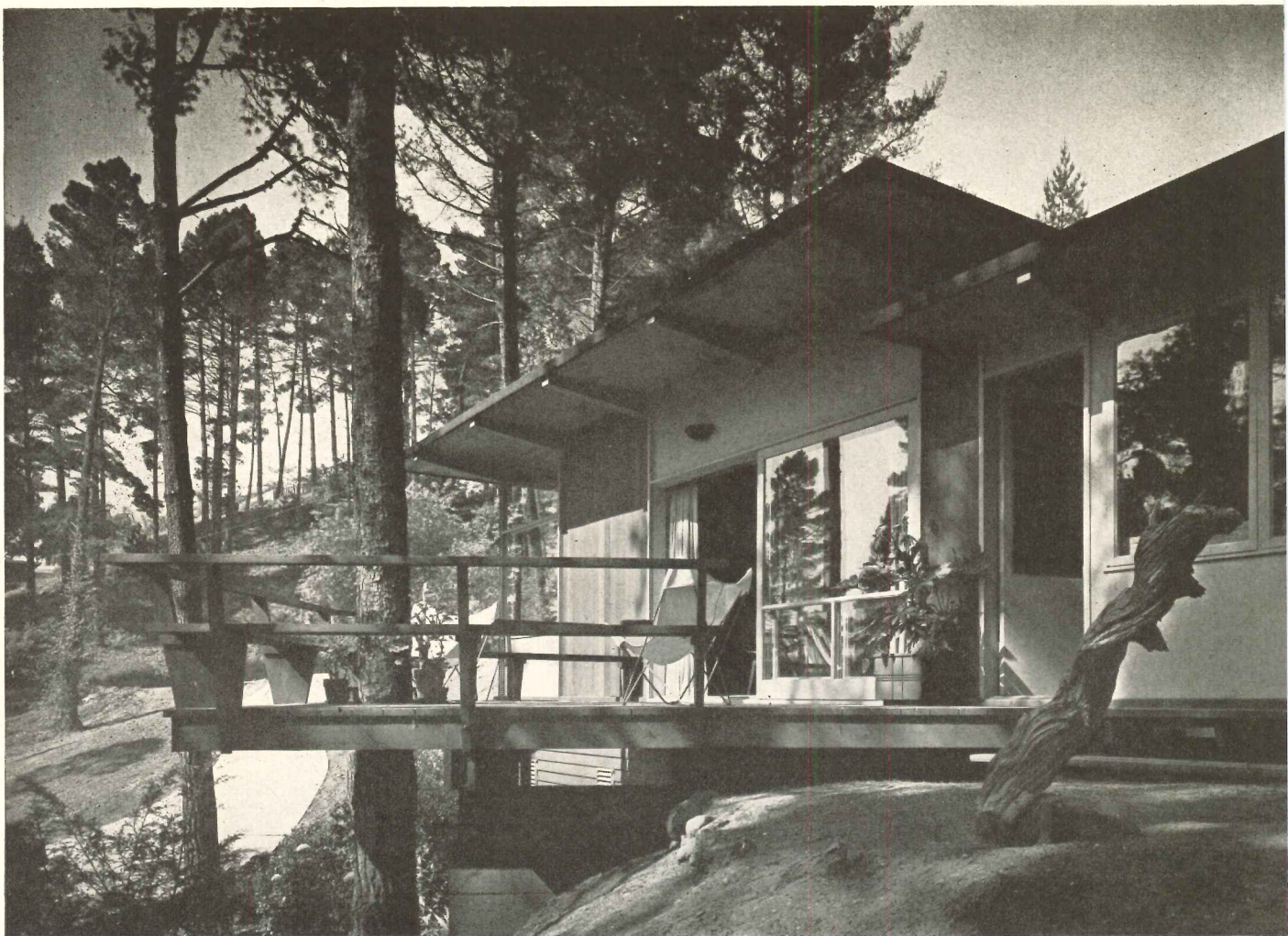

OAKLAND, CALIF.

## HOUSE FOR HAMILTON WOLF

### *Clients and Architects*

The owners — Mr. Wolf is an art teacher and his wife, curator of an art gallery — have an unusually high understanding of architectural matters. Both wanted a fitting modern house, and while they had a definite program they did not dictate design. Their budget was quite limited, so inexpensive materials were used and, since they needed both a working studio and a fairly spacious living room (for quite a bit of entertaining), some items of equipment have been omitted and more cubage added.

### *Local Factors*

The surrounding houses are mostly local "Spanish," the neighbors typically suburban. The Wolf house was designed to fit its site and, the architects say, "to blend with the pines." It is built principally of redwood.

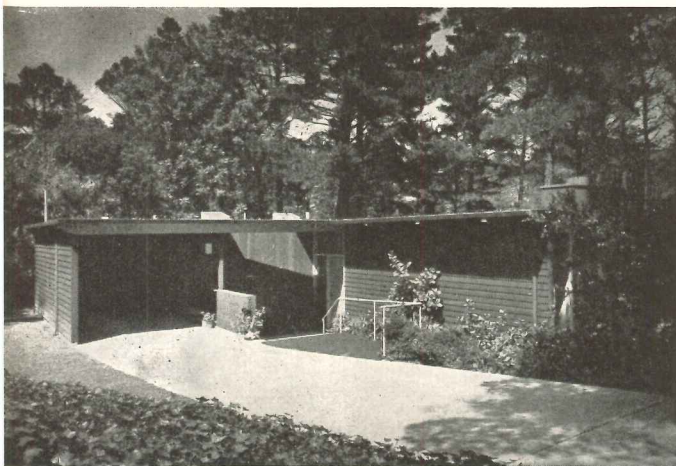

Morley Baer



## Finances

The house was designed not only with resale possibilities in mind (the studio can easily become a bedroom) but also with the knowledge that an F.H.A. mortgage was to be obtained. When we asked the architects if this job represented a sound use of their time and effort, the answer was: "Yes — subject for much discussion." To the question, "Did the fee represent an adequate return?" They replied: "Yes — but debatable; subject for long discussion."

*Campbell & Wong, Architects*

*Eckbo, Royston & Williams, Landscape Architects*

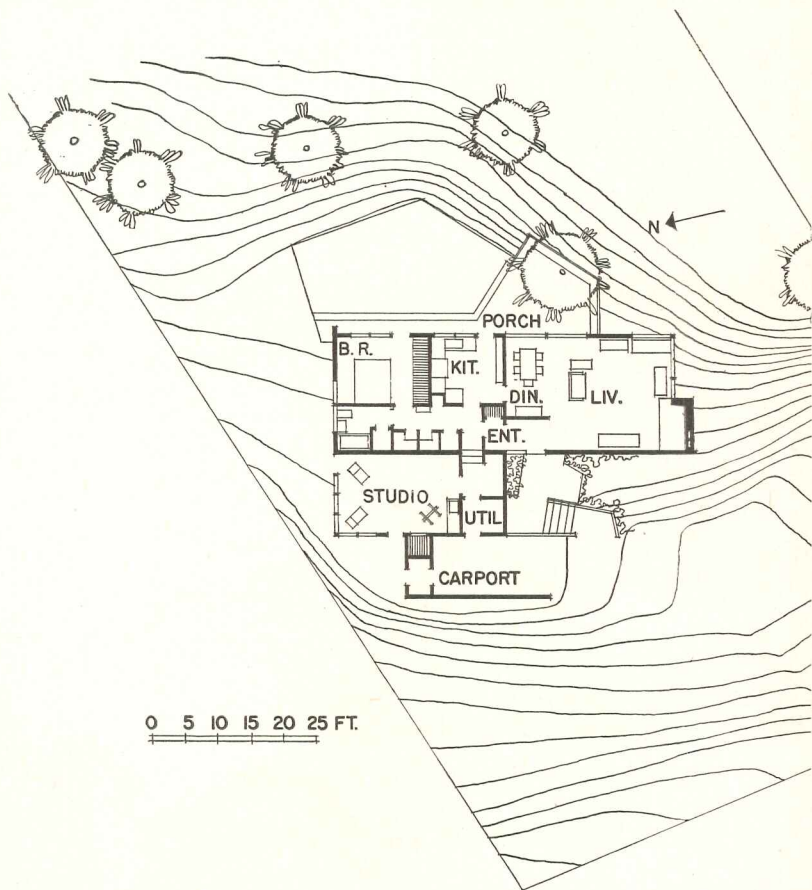
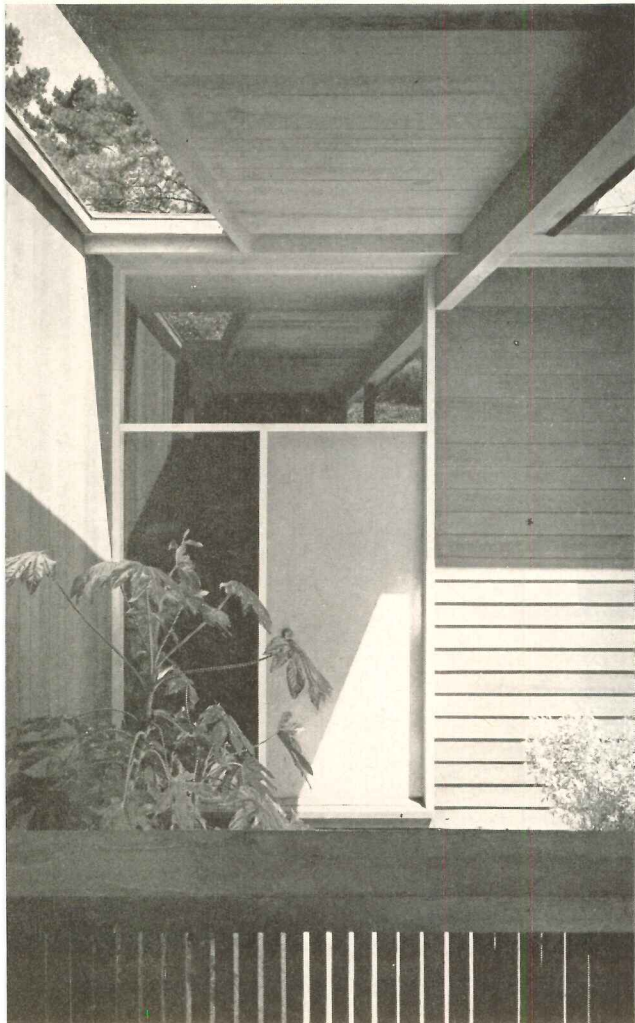



*The Hamilton Wolf house is quite small and simple; its proportions were carefully studied. In particular, the relation of openings to wall areas merits inspection, and such devices as the porch or deck extending to the east increase the feeling of spaciousness*

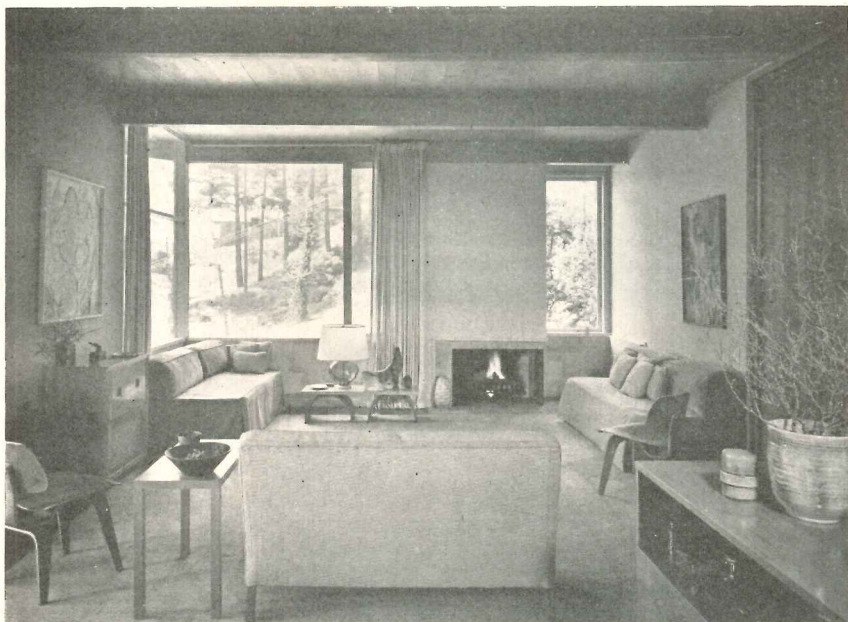

**House Architecture: Campbell & Wong**

Morley Baer



Wimberly & Cook, Architects

Paul Jones, Associate

*Client, Architect, Locale*

---

George Wimberly, again, designed his own house; it took him eighteen months to fit it to his hillside, to devise baffles to prevent sun glare, to get the ceilings high and the windows low. He is impatient with mainland customs transplanted bodily, as they so often are, to Hawaii. He wants the climate and the local brilliance of color to be reflected in his work.

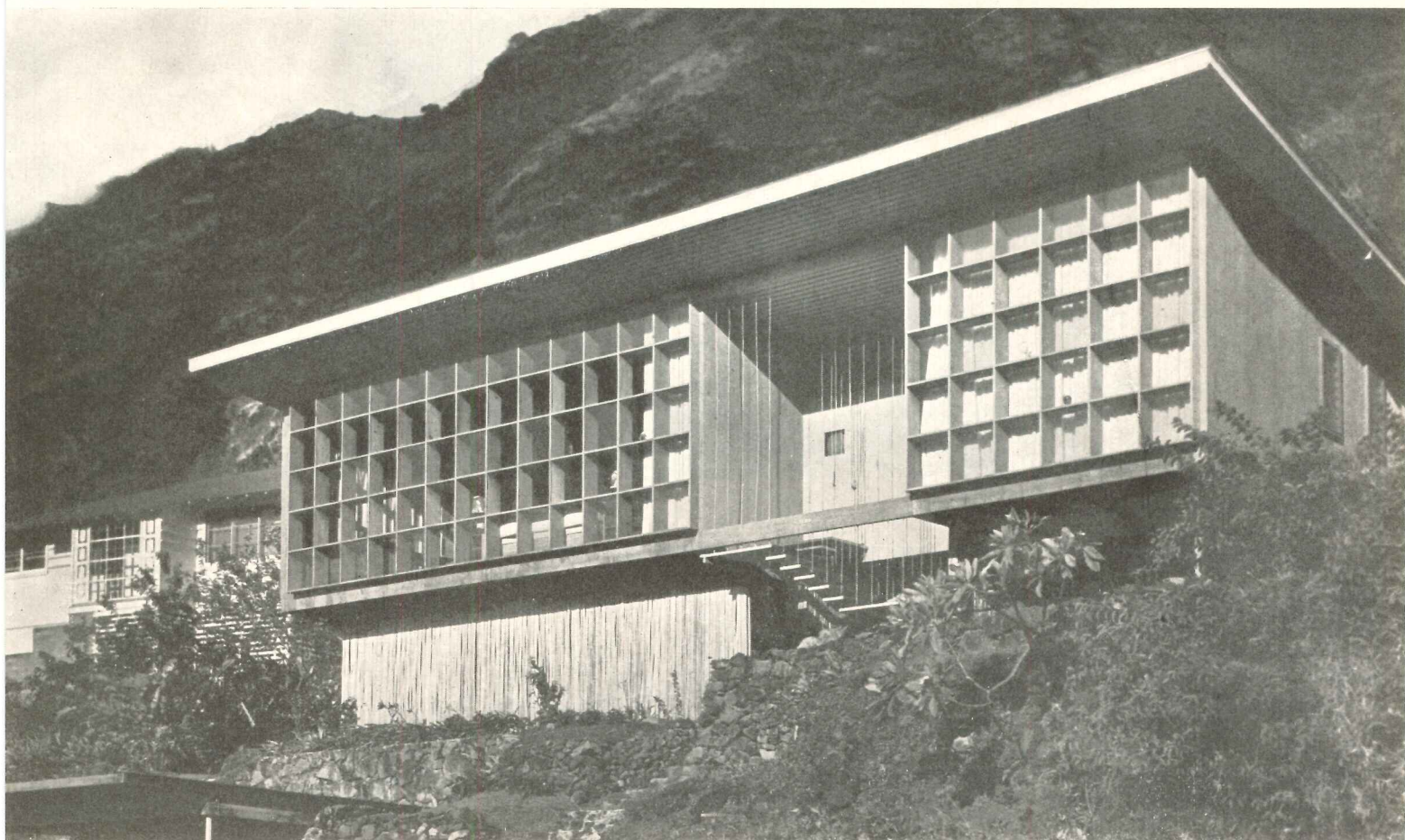

.Wenkam

Although the mean average temperature locally is quite comfortable, there are times when heat builds up and the ground-level breeze could be used to advantage; hence the ceiling height, window location and sun baffles. He has also tried to make the lanai not just a concession to a quaint native idea, but an integral part of the scheme.



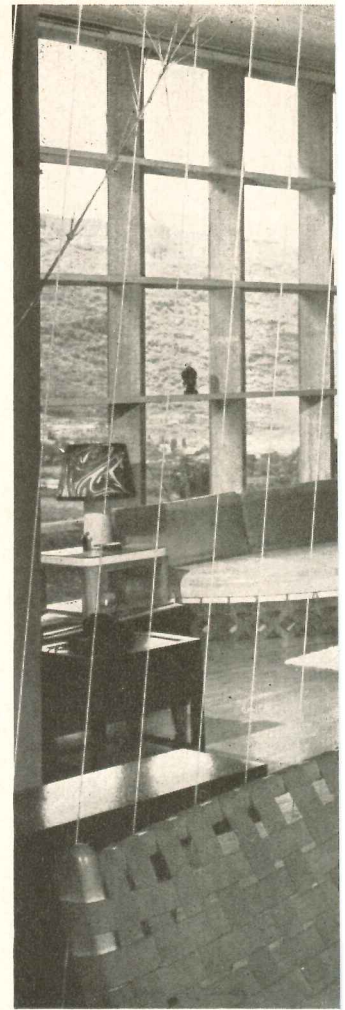
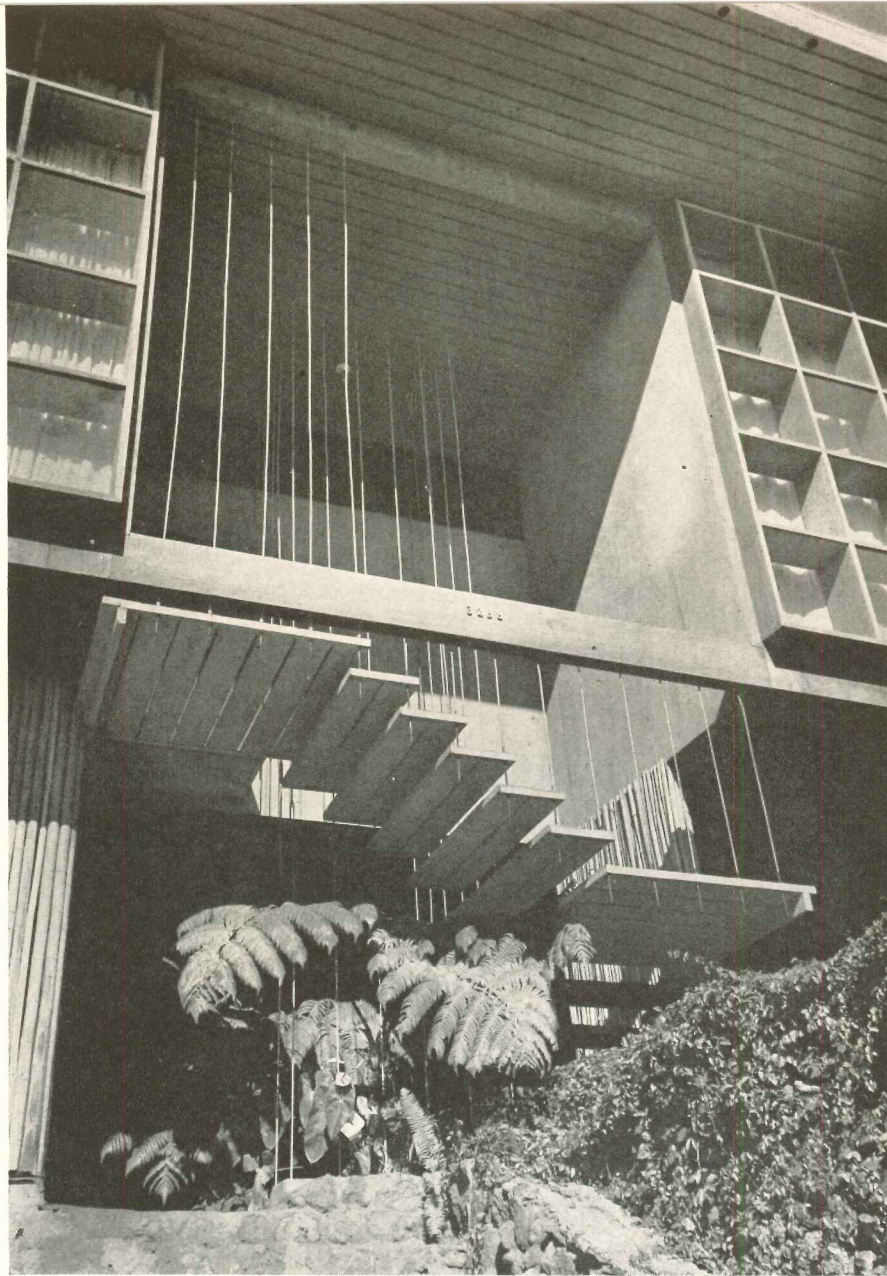

R. Wenckm

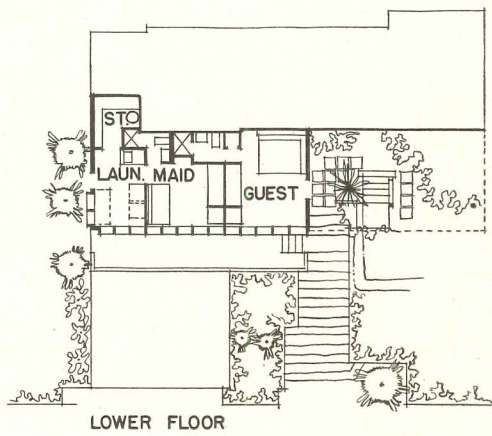
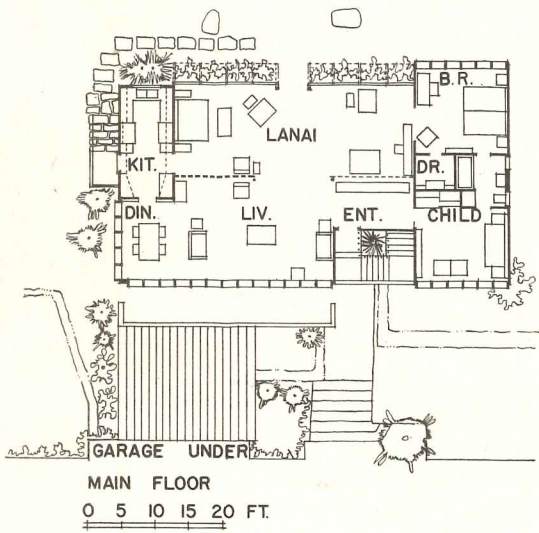





*Wimberly house in Hawaii has walls of a single thickness of 1¼-in. T & G fir, like most Hawaiian houses. Floors are maple, ohia wood, and waxed green concrete. Living room and lanai (above) have a coral ceiling*

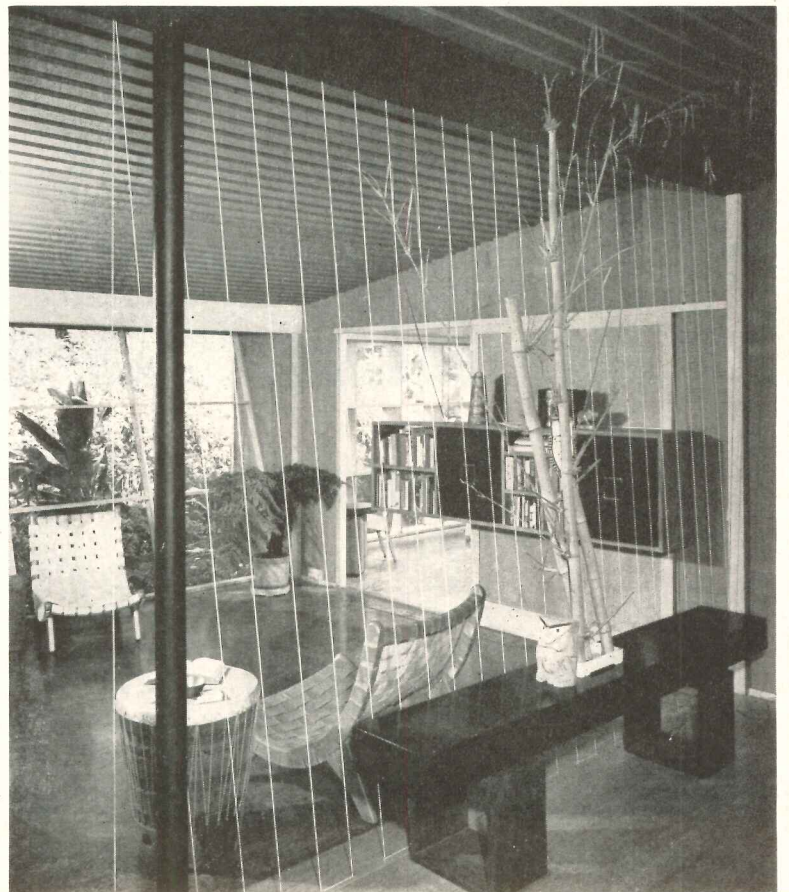





Douglas M. Simmonds

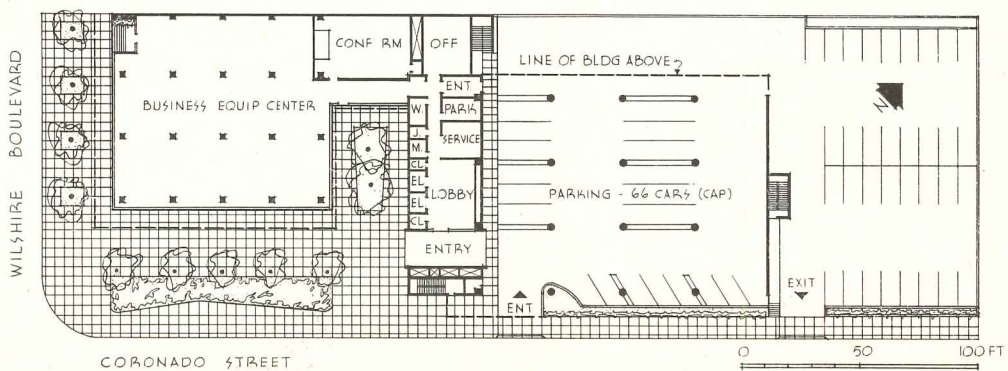



*Remington Rand Building  
Los Angeles, California*

*Massachusetts Mutual Life  
Insurance Company, Owners*

*Kahn and Jacobs, and Welton  
Becket, Associated Architects*

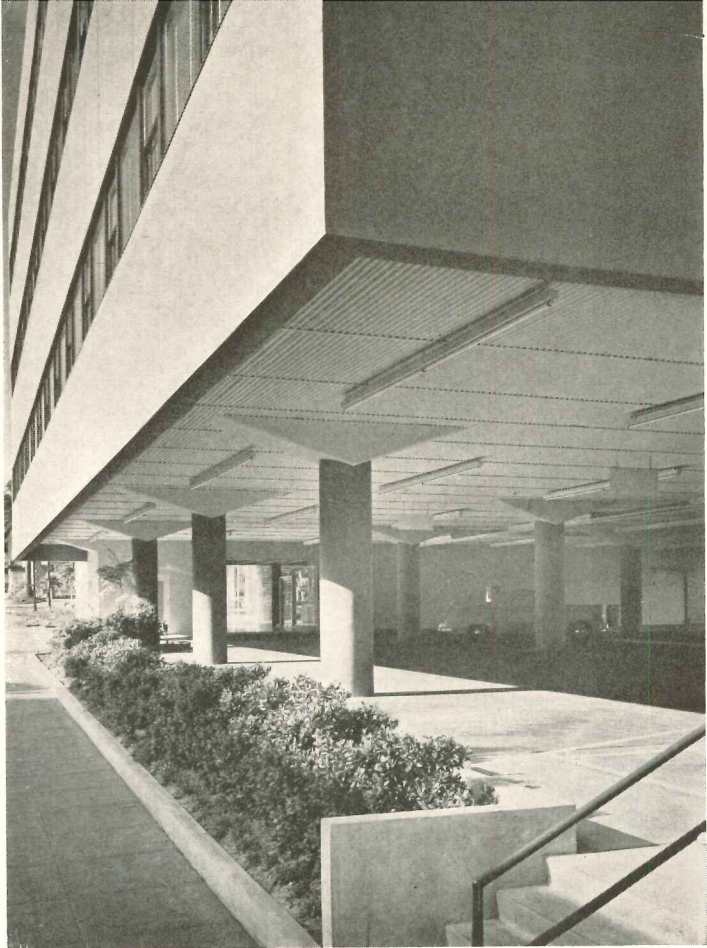

## A NEW APPROACH TO FAMILIAR PROBLEMS

A FRESH APPROACH has been taken in this trim design to reconcile three problems common to many office buildings: to establish the identity of two clients; to provide an inviting ground floor display area; and to incorporate required off-street parking without a bleak parking-lot look.

The structure was originally designed as a more conventional office block, with first floor show rooms and parking space to the rear. Subsequent studies led the architects to slide the display area to the front to form a glass pavilion bearing the Remington Rand name, and to contrast it with a larger solid block identifying Massachusetts Mutual. The open area beneath the building was then used as a covered parking area for a portion of the cars, and as a motorists' entrance.

*The completed building (left center) faithfully follows the original rendering (top left). Building is cantilevered over parking area for lightness (top right). The connecting entry is shown at right*

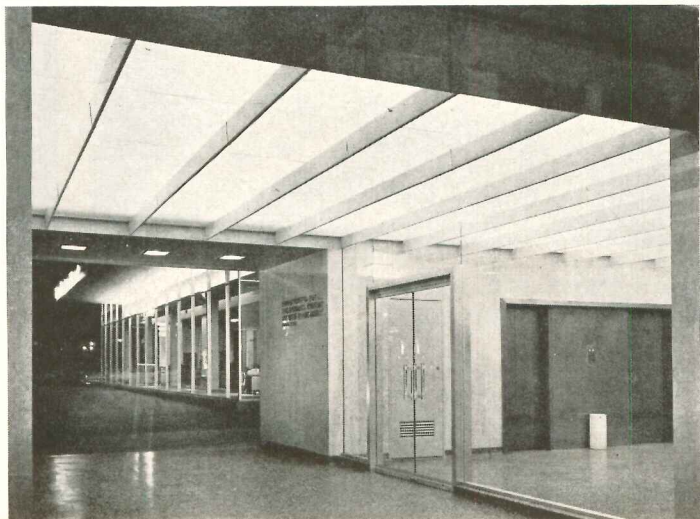



**REMINGTON RAND BUILDING**

*In plan*, the low display pavilion is connected to the main building by an auditorium and conference room, with a patio extending to the street. The upper floors (plan right) provide a service core and large open areas to be subdivided by the clients. The first three floors are devoted to Remington Rand facilities, and the fourth is occupied by an insurance agency representing Massachusetts Mutual. An employees' lunchroom, the business' machine service department, and the Remington Rand switchboard are in the basement.

The structure of the pavilion is steel and glass, while that of the main block is concrete with a windowless scored-concrete façade painted an off-white. The cantilevered portion is painted a darker buff, and columns and soffits are blue. Interior walls are plaster, ceilings are acoustic tile, and floors are asphalt tile or terrazzo. The entire building is air conditioned, and is serviced by automatic elevators.

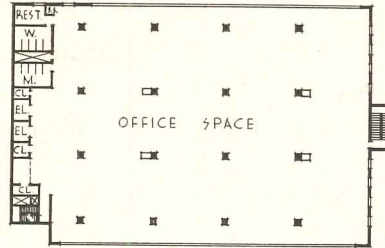

*Typical Upper Floor Plan*

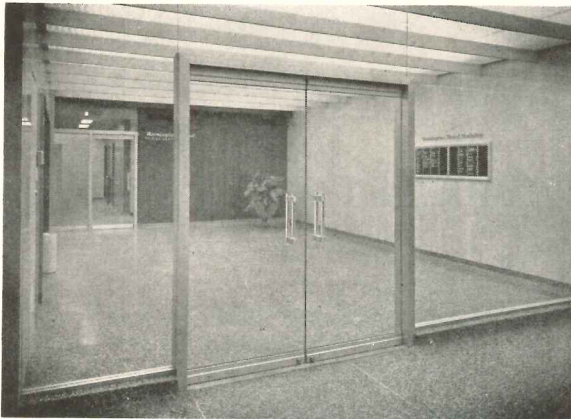

*Above: entrance lobby, finished in marble and rosewood.*  
*Above right: interior of business equipment display room*

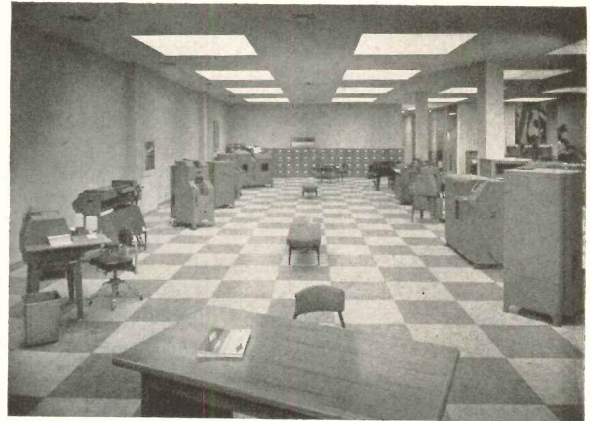

Douglas M. Simmonds



*Above: reception and elevator lobbies on two of the upper floors of the main building*





# ARCHITECTURAL INTERIORS

*Design* | *Details* | *Materials* | *Equipment*

Harry H. Baskerville, Jr.



**T**HE MOST NOTICEABLE feature of this new store in the Statler Center is its openness: each of its two levels is a single large sales area, departmentalized only by the placement of display cases and the use of color. Show windows are continuous and full-height on the two street sides, with the mezzanine cutting diagonally across the rear of the store between them. There are two entrances (see plans, page 179), one from the street to the lower level, and the other from the hotel lobby to the mezzanine.

*Eddy Harth, Statler Center*

*Los Angeles, California*

## OPEN PLAN FOR MENSWEAR STORE

*Victor Gruen, Architect*

*R. L. Baumfeld, Associate in Charge*





Harry H. Baskerville, Jr.

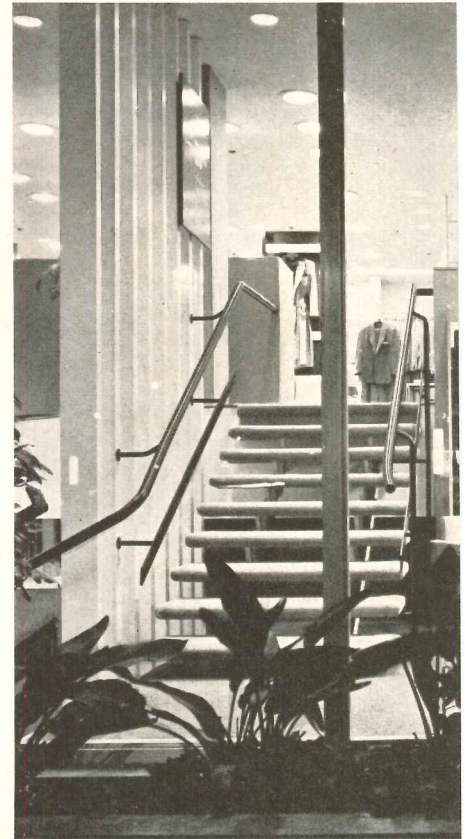

## ARCHITECTURAL INTERIORS

Design | Details | Materials | Equipment

*White ceilings and predominantly white walls are enlivened by frequent touches of bright color. Open stairway to mezzanine is carpeted in lemon yellow; steel rail is finished in black*





*All fixtures and furniture were designed by architect. Show cases are birch, some with glass, others with lacquered panels in yellow, gray or white; all are raised from floor on brass legs to facilitate cleaning. Light fixtures are enameled in colors corresponding to the colors used on panels*

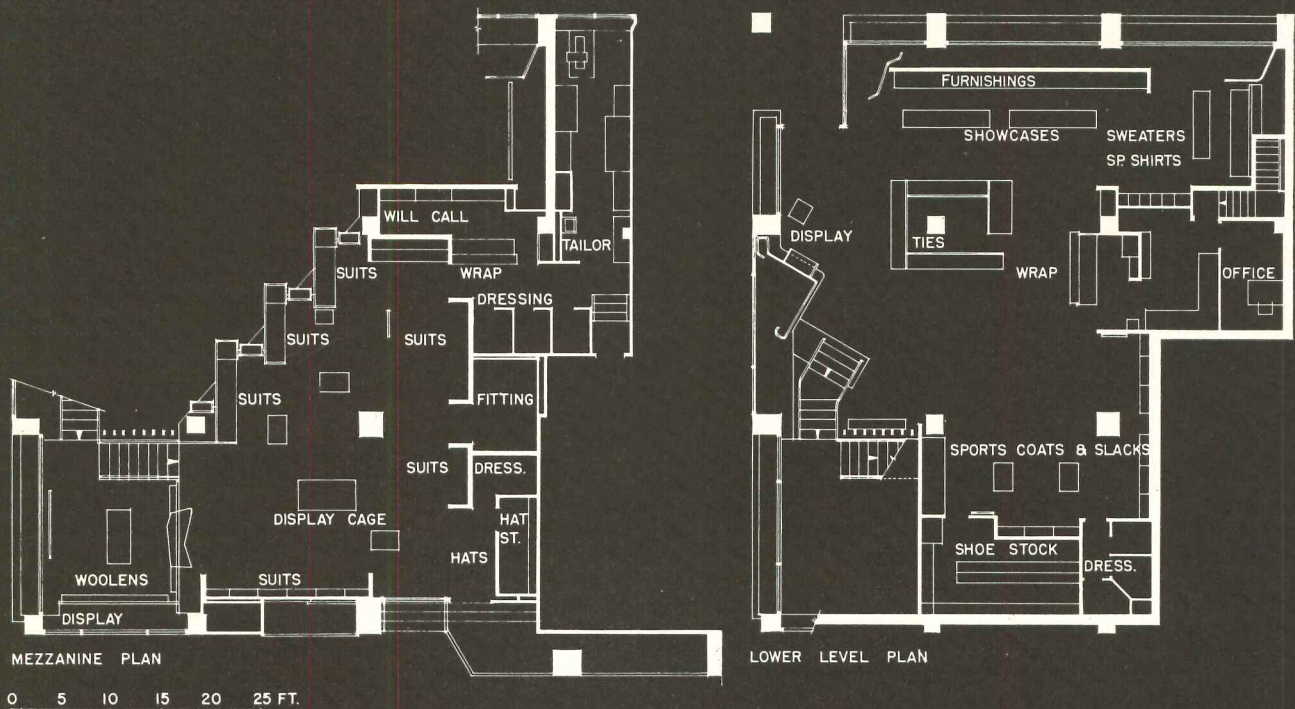

*Floor covering on lower level is bold-patterned vinyl in blue, green, gray and white. Columns are gray, blue, yellow*







## ARCHITECTURAL INTERIORS

*Design* | *Details* | *Materials* | *Equipment*

*Suit department occupies most of upper level. Hang-rod cases are conventionally peripheral except for three low ones which, alternating with planting boxes, zig-zag across diagonal of mezzanine face at 45 deg angle. Main display case is large cage of silver-gray birch, prominently placed and well-mirrored; its horizontal members can be used for showing of ties and accessories. Carpeting is again lemon yellow, and color accents same as below*

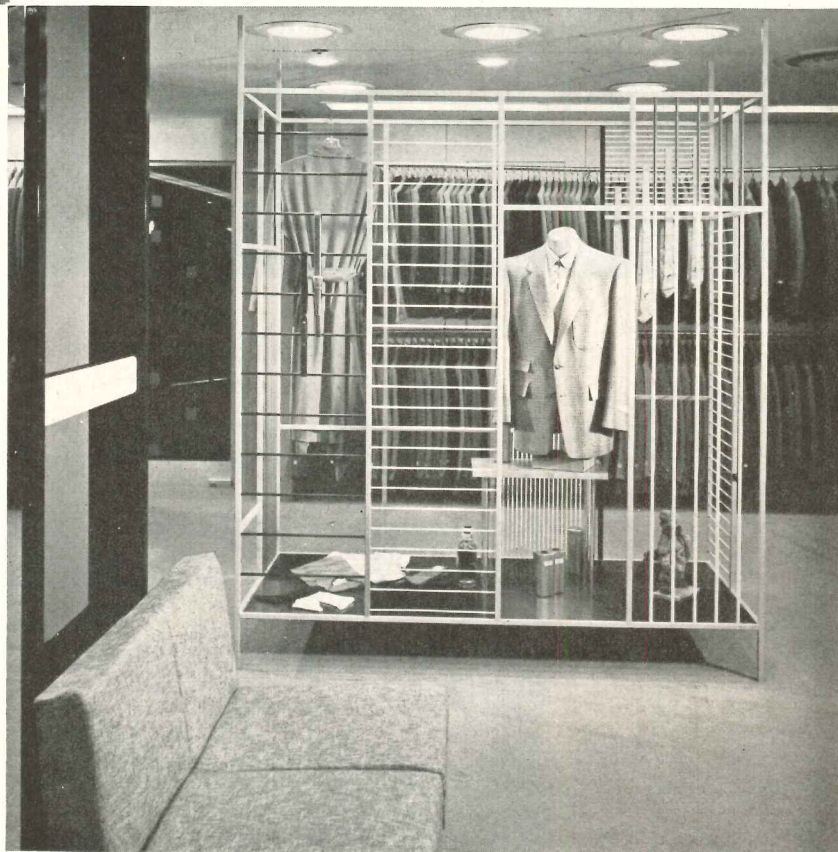

Harry H. Baskerville, Jr.



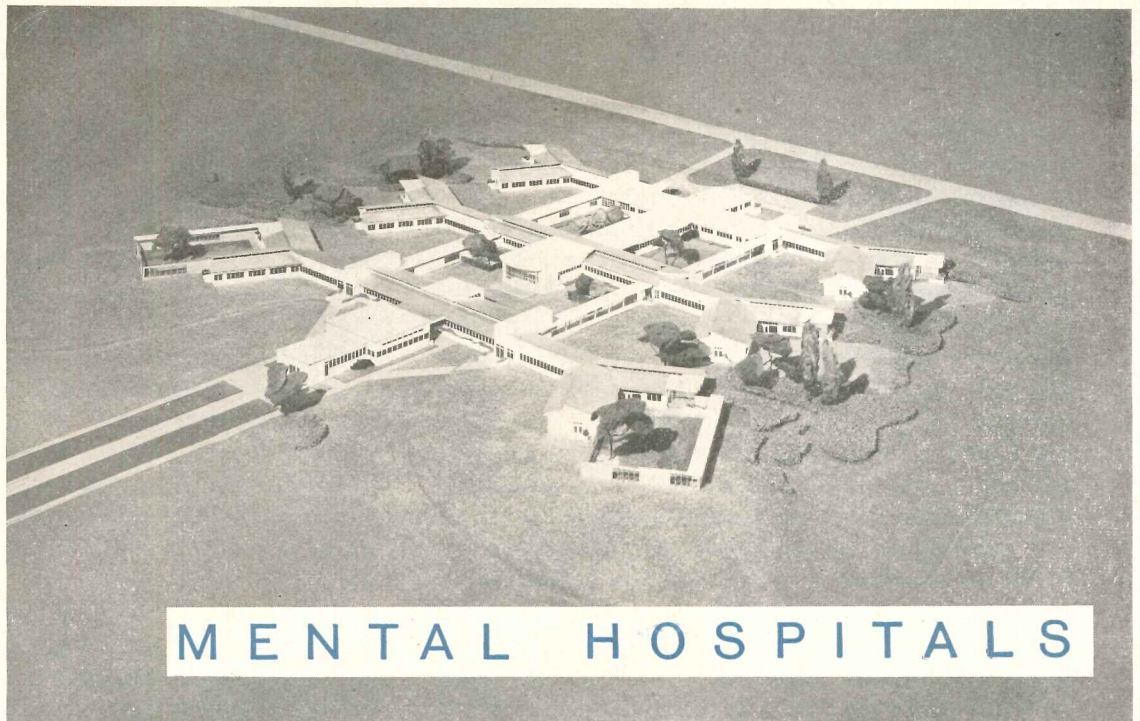

# MENTAL HOSPITALS

ARCHITECTURAL RECORD'S BUILDING TYPES STUDY NUMBER

204

®

## MENTAL PATIENTS CAN BE CURED

By Daniel Blain, M.D.

Medical Director  
American Psychiatric  
Association

### HOSPITAL BUILDING TYPES STUDIES IN ARCHITECTURAL RECORD

Hospitals.....	July	1937
Chronic Hospitals.....	Aug.	1938
Hospitals.....	Dec.	1939
Health Centers.....	Sept.	1940
Hospitals.....	Aug.	1941
Hospitals in Wartime.....	Aug.	1942
Hospitals.....	May	1943
The General Hospital.....	Aug.	1944
Coordinated Hospital Service Plan.....	Aug.	1945
Elements of the General Hospital ..	June, July, Aug.	1946
Hospitals.....	June	1947
Type Plans for the General Hospital.....	Jan.	1948
Hospitals.....	May	1949
Hospitals.....	Feb.	1950
Mental Hospitals.....	Oct.	1950
Tuberculosis Hospitals.....	Apr.	1951
Hospitals and Health Centers.....	Oct.	1951
Revised Elements of the General Hospital.....	Apr.	1952
Hill-Burton Hospitals.....	Oct.	1952
Hospital Planning Studies.....	Feb.	1953

#### BOOKS:

"Psychiatric Sections in General Hospitals,"  
by Paul Haun, M.D.

"Design and Construction of General Hos-  
pitals," by U. S. Public Health Service, pub-  
lished jointly by ARCHITECTURAL RECORD and  
*The Modern Hospital*.

THE SIGNS ARE UNMISTAKABLE. Modern society is casting aside the outmoded concept of the mental hospital as a custodial residence for patients who never or seldom get well. The view that has prevailed for some time among the enlightened is rapidly capturing the imagination of the rank and file, namely: that most mental patients, given active treatment in a properly staffed and equipped hospital, will get well.

The new view is not just a matter of faith. I know of a mental hospital in the South—not one of the best by any means—whose records show that in 1941 about 25 per cent of its newly admitted patients left the hospital in three months. By 1952 the treatment program had so improved that 50 per cent left in the same period of time. It is not at all uncommon these days for a public mental hospital to claim a 50–60 per cent discharge rate within a year after admission. Some leading authorities state categorically that the rate could easily rise to 80 per cent if mental hospitals could be brought up to the approved standards of the American Psychiatric Association.

How explain this progress? In part it is due to



the development of shock therapies which have proved enormously effective in certain cases, particularly involuntional melancholia; but, in general, these therapies appear to be effective in a narrower number of mental cases than was formerly anticipated. Skills in psychotherapy — particularly group psychotherapy, and “brief” psychotherapy — undergo a sharpening process as experience is gained from year to year. Research projects now in progress — physiological, bio-chemical, pathological, psychological, etc. — hold some promise of eliciting new treatment techniques; but these can probably not be validated for some time. A treatment for schizophrenia remains to be found.

In general it seems more likely that recent progress is due to the changed attitude of the public toward the mentally ill. This new attitude reflects itself *within the hospital* and leads the hospital to establish a therapeutic regime that carries with it group and social pressures that encourage a patient to recover. Such a hospital is characterized by an atmosphere of expectancy and determination that its patients are going to get well.

To be more precise, Dr. Abraham Myerson coined the phrase “total push”, which he used to refer to combining and focussing on a patient or group of patients all of the influences the hospital could muster that would tend to “push” the patient toward recovery. Such “push” might include individual or group psychotherapy, shock therapy, recreation, physical rehabilitation, job training, educational classes, trial visits at homes, etc. It may also be called environmental therapy. In a modern mental hospital it takes a score or more of different types of professional personnel to administer it. Barring a sudden stroke of good fortune in uncovering new specific treatments for various types of illnesses — especially schizophrenia — our best bet lies in improving environmental therapy.

Such therapy calls for a new way of looking at the mental hospital. Beyond usual hospital facilities, it means having rooms and grounds where patients can paint, sculpt, weave, listen to music, attend classes, attend private and group therapy sessions, see movies, dance, buy refreshments, go to the beauty parlor, read a book, etc. This is not to suggest that mental hospitals should be vacation centers. On the contrary, environmental therapies are carefully prescribed by physicians in a protective setting. It merely means that unlike general hospitals, these facilities must be viewed as an essential part of the treatment program.

One major task we can come to grips with immediately; and that is to do a better job of designing our mental hospitals.

Surveys show that hundreds of millions of dollars will be spent on new mental hospital construction in the next decade. The public demands that obsolete, custodial types of mental hospital buildings be replaced by modern treatment facilities.

What a tragedy if this opportunity were to be used to perpetuate the architectural stereotypes of the past into the future! Architects and psychiatrists must lose no time in collaborating to ensure that the new buildings they construct for the mentally ill will truly reflect the new attitude towards the patients who will reside in them temporarily.

By good fortune, the American Psychiatric Association has received grants from two foundations to finance a two-year study of mental hospital architecture and design. The project will be carried out in cooperation with the American Institute of Architects. The findings of this project should go far to help physicians and architects create the kind of buildings that will make possible the maximum application of “total push” at the same time that they serve the functions of any good hospital.

## HISTORY POINTS UP THE NEW PROGRAMS

By P. H. Felix, M.D.

Director, National Institute of Mental Health  
National Institutes of Health  
U. S. Public Health Service

**T**HE FACILITIES that a community provides for its mentally ill and the kind of treatment afforded by these facilities have usually reflected the current level of knowledge about mental illness.

Even as late as the first half of the 18th century, brutally repressive confinement characterized treatment of the mentally ill. In Europe, the asylums were worse than the jails and workhouses of the earlier period. In America, the mentally ill were boarded out, or auctioned off to the lowest bidder who would undertake their care at public expense, or unceremoniously dumped into institutions which were combination workhouse, poor-house, house of correction, and asylum.

The second half of the 18th century witnessed re-

forms both here and abroad. The work of Philippe Pinel in France, William Tuke in England, and Benjamin Rush in Pennsylvania in promoting “moral” or humane treatment laid the basis for a scientific approach to mental disease. Innovations introduced during this period included removal of many of the physical restraints, proper heating of hospital wards, separate facilities for men and women, occupational therapy, kind treatment, and the employment of proper attendants. Several centers for such enlightened treatment were opened both in England and this country.

By 1825, special institutions for the mentally ill had been established in nine different states, with two in Virginia. The mentally ill who were paupers or wards of



the community, however, rarely were supported in these hospitals. They were committed to the poorhouse, boarded out, or "dumped" in the next county.

The years between 1825 and 1850 saw the rise of the large state institutions which have characterized treatment of the mentally ill in this country up to the present time. Stimulated by an over optimistic belief in the easy curability of mental disease, proponents of these institutions emphasized their economy. Inadequately built, and without the necessary facilities for proper care, much less proper treatment, these state hospitals soon developed shocking abuses. It was largely due to the monumental work of Dorothea Lynde Dix that humanitarian custody was accepted as the basic minimum.

During the late 19th and early 20th centuries, advances in psychiatric knowledge were accompanied by the establishment of hospitals for psychopathic patients and of out-patient departments in mental hospitals, together with an emphasis on aftercare programs. The past 50 years have been marked by rapid improvements in institutional care. New and more effective therapies have been developed and there is greater understanding of the role of the hospital milieu in treatment.

Because of these advances, we are today at a crossroads in development of programs for the treatment of the mentally ill. We must continue to build adequate facilities. But, to make effective use of them, we must also provide the trained personnel to apply the treatment that modern science has developed. We need to make the necessary funds available to conduct more research into the cause, treatment, and prevention of mental illness; and to train the psychiatrists, psychologists, social workers, and nurses who can carry out the treatment on an intensified basis.

We need constant reassessment of the architectural design of our hospitals. We have learned that mental hospital buildings have been constructed to last too long and have been too inflexible in their use. Progress in therapy has demanded new design and new architecture to meet changing functional needs every 20 to 30 years. It is hoped that through such channels as the ARCHITECTURAL RECORD and through the presentation of plans and specifications in articles such as the one by Mr. Gutteresen (page 189), sufficient stimulus will be provided to encourage the development of better and more modern facilities for care and treatment.

---

## COORDINATED HOSPITAL SYSTEM FOR NERVOUS AND MENTAL PATIENTS

By John W. Cronin, M.D., F.A.P.A.

Chief, Division of Hospital Facilities  
U. S. Public Health Service

FOR THE FIRST TIME in the history of our country, we have had, on a nationwide basis, an analysis of the adequacy of our hospitals and an estimate of our total hospital needs. This has become possible through the Hospital Survey and Construction (Hill-Burton) Act. The purpose of this act was to provide federal funds to assist in the construction of private, non-profit; municipal; county and state hospitals. To become eligible for funds for improvements to existing hospitals, or the construction of new hospital facilities, each state was required, by the law, to survey and analyze all its existing hospitals in order to determine their adequacy to serve the community in which they were located. Also, on the basis of this analysis, the state had to provide a state plan which described facilities which were necessary before adequate medical services could be supplied to each community.

Mental and chronic disease hospitals present, in general, a picture of the most obsolete of all our hospital facilities. General hospital and tuberculosis hospital design have developed acceptable and functional patterns which are based on present day medical concepts and practices. In the field of mental hospital design, in too many instances, the obsolete patterns of design which were based solely on removing the patient from society and providing custodial care are repeated. In such facilities, medical staffs cannot provide treatment

programs in accordance with their modern procedures.

Moreover, adequate facilities for treatment of nervous and mental patients are not located where people in need can obtain treatment in the early stages of their illness, when the treatment can be most effective. A study of patients in general hospitals, and particularly in out-patient clinics, discloses a large percentage of patients who are suffering from nervous or emotional illnesses. Many of these people can be treated in out-patient clinics, in day-care programs and in appropriate services in general hospitals; but, under present conditions, many of these patients must wait until their illness is long established, until treatment can no longer be delayed, and they must be committed to a mental hospital.

It is impossible to conceive of a single hospital that could furnish adequate and appropriate facilities to meet the total community need for nervous and mental patients; the problems are too varied so that varied resources are required to meet them. It is for this reason that a Coordinated Hospital System for Nervous and Mental Patients is suggested as a basis on which this problem is being, and must be, attacked. State mental hospitals will always be required; they can offer excellent facilities for the treatment and rehabilitation of patients, but treatment programs should be expanded more rapidly into all our communities for the patient.



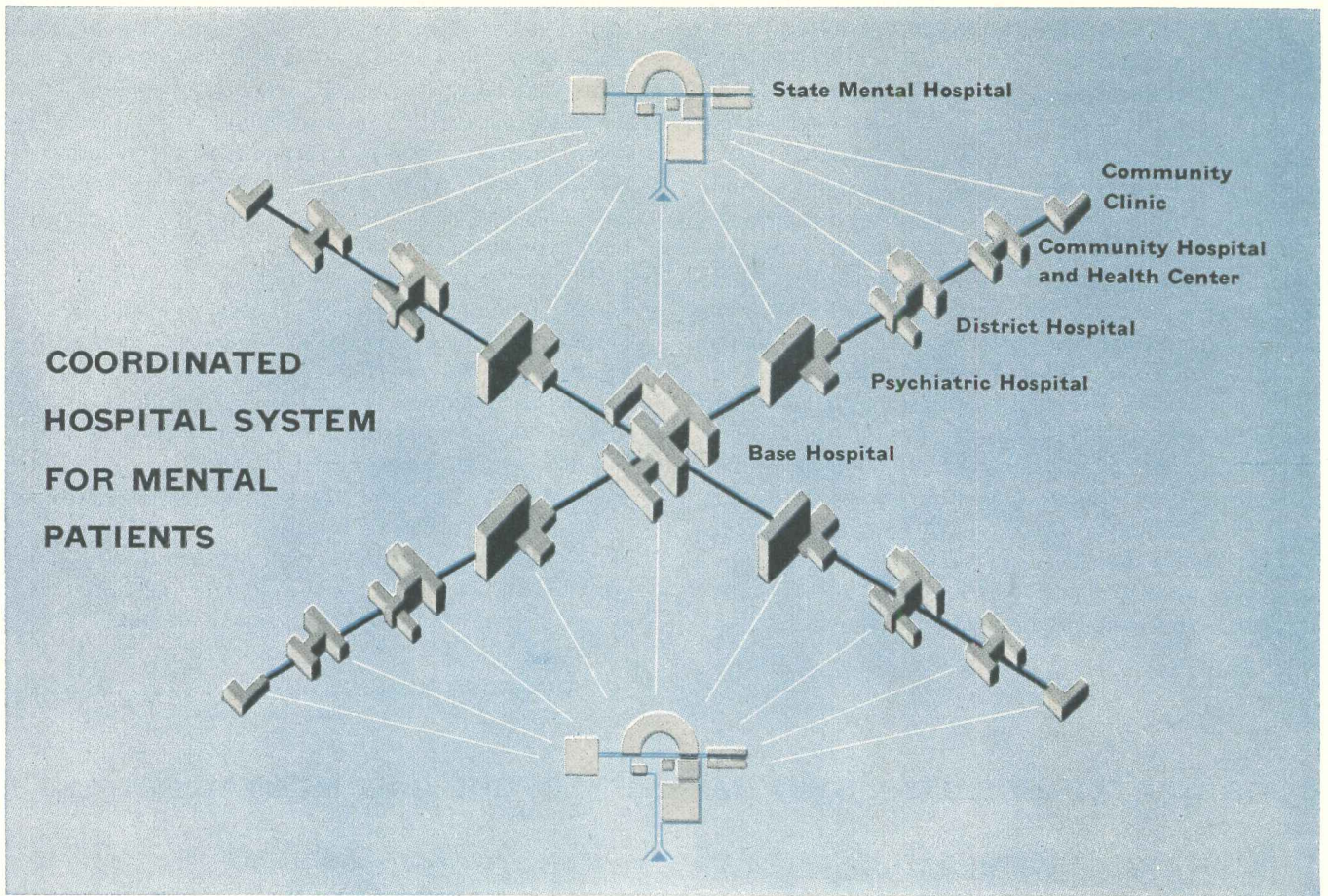

MODERN PROGRAMS of hospital construction and operation have as their aim a type of hospital service that combines and coordinates the two major aspects of medical care: preventive and curative. Both require diagnostic and therapeutic facilities and apply to nervous and mental patients as well as to all other types of patients.

On the basis of these requirements, the Division of Hospital Facilities of the Public Health Service has suggested a hospital system, charted above, to provide these services for nervous and mental patients through a network of hospitals and health centers which are located and programmed to meet the needs and staff qualifications of communities.

The teaching and research hospital is shown as the base of the general hospital system. It provides a more complete diagnostic and treatment service for all patients including nervous and mental patients than the smaller general hospitals of the area.

State mental hospitals are also shown as base areas having teaching and research particularly in the diagnosis and treatment of nervous and mental patients. Mental patients from any community or from any general hospital having a psychiatric service may be transferred to these hospitals. These hospitals would

have receiving and intensive treatment, out-patient and rehabilitation services as well as continued treatment of patients when indicated.

Next in extent of service is the large general hospital in the urban area and called the district hospital. This may have a 20- to 50-bed psychiatric in-patient service, an out-patient service and day-care program.

The smaller general hospital or community hospital and health center, being of only the minimum size for efficient operation, is not shown with a psychiatric service. This, and the community clinic, which is chiefly for obstetrical and emergency cases, may have a room or suite of rooms for the temporary housing of a nervous and mental patient until transfer to a psychiatric service can be effected. Diagnosis and screening may be accomplished in these facilities with the aid of traveling staff from a psychiatric service.

*Consultative services to aid in the preparation of programming and planning of statewide or community mental health services are available from two sources:*

1. *Mental Health Service of the American Psychiatric Association, Ralph W. Chambers, M.D., Chief Inspector 1785 Massachusetts Ave., N. W., Washington, D. C.*
2. *National Institute of Mental Health, Community Services Branch, Riley H. Gulhrrie, M.D., Mental Hospital Advisor*



# HUMANIZATION OF THE MENTAL HOSPITAL

By Kenneth E. Appel

*Institute of the Pennsylvania Hospital, Philadelphia  
Professor of Psychiatry, University of Pennsylvania  
President, American Psychiatric Association*

STRUCTURES, we are told, should be functional. The purposes for which mental hospitals are built — the care and treatment of the patient — need consideration and elaboration. Architecture, in its broadest sense, should reflect, should breathe, modern ideals of patient care, understanding and treatment.

The following thoughts may come, perhaps, under the heading of star-gazing. This does not appear inappropriate. The lines of the cathedrals direct us to the heavens. In order to obtain a comprehensive perspective of our problems, it is necessary to consider apparently tangential things. We should think of the psychological and social implications of buildings and facilities to be constructed, which are relevant to this problem and important for society as a whole.

Psychiatry is not only a science. It is humanitarianism, and it seems to me the lessons we learn from psychiatry have great significance for the civilization in which we are all living. So I would like to share with you some of my ideas and dreams about these matters, with no finality, with no dogmatism, just some relevant thoughts which seem important for psychiatry, for architecture and for our common situations in life.

What can architects do, what can psychiatrists do, in collaborative endeavor, to facilitate the recovery of people who are ill, and, when recovery is not possible, help patients bear their burdens and live more comfortably and constructively under the circumstances in which their condition places them? I believe architects have a therapeutic, an emotional and social job, in addition to a utilitarian function, when they are designing mental hospitals.

## Prescription: Beauty

There comes to mind the Moorish cloisters at the Museum of Fine Arts in Philadelphia — a small courtyard, a little patio. It could not have been very expensive to build, but it had vision and beauty in it. Why can't such a patio, why can't such cloisters, such beauty be available for our older people especially, and for our patients in mental hospitals, so that they can walk out of their rooms to a porch, then to grounds, then to a fountain; so they can see across the patio the beauty of lovely lines? Why can't our extremely ill

patients, our acutely disturbed patients, have some beautiful place like that to go, where they would not have the feeling of being fenced in and restricted, but a sense of freedom? Acutely ill mental patients cannot always go to a gymnasium without supervision. They need a place where they can be active in their own way or where they can sit and contemplate. Surely the sensing, the drinking in, the contemplation of beauty can have healing value in it.

In treatment of disturbed children we have seen the healing value of play and free artistic expression, not under the eye of a restricting or controlling adult, but with a sympathetic therapist who allows them to draw, to paint, to model, to play, in fact to do nearly anything they want to except injure themselves or others or destroy furniture and basic structures. How lacking are our mental hospitals in facilities for free play and artistic activity which are as much needed for sick adult patients as for children.

## Freedom of Expression

I remember a terribly ill patient who illustrates this need vividly. He was in a room which had just been redecorated and repainted. Somehow or other, this patient got hold of chalk. He took this chalk and drew the most hideous, bizarre things on this new wall of the hospital, with a lot of derogatory remarks about doctors and psychiatrists in hospitals. I said to myself, "What will the young administrator of the hospital do? Will he move the patient to another section of the hospital?" He did not. He left the drawings there. This freedom of expression was one of the bases of this patient's recovery. Although it looked as if he would never get well, he did. In this case it was not the prolonged search for psychodynamics or profundity of psychopathology which accounted for his recovery.

We are not going to be able to rely, except for experimental purposes, except for insights, on psychoanalysis. Psychoanalysis is one of the most penetrating and important discoveries which has been made in our field. Yet how many patients can a psychoanalyst see in the course of his life? Even if he is a hard worker, he probably can treat not more than 200 patients in his professional lifetime. I am not saying this is not proper. Maybe psychoanalysis will be a lever; perhaps it is going to be the means by which something new will be added to psychotherapy which will make it more effective. But psychoanalysis

---

*An address by the author before the Conference on Mental Hospital Design, sponsored by American Psychiatric Association*





"Devil"

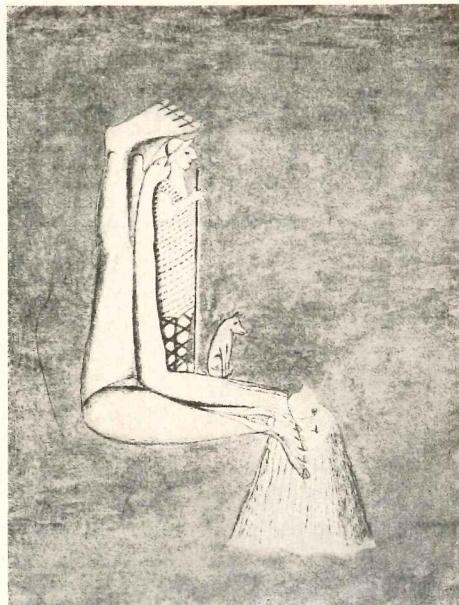

"Wondershepherd"



"Two Heads"

*Patients of mental hospitals have long been encouraged to find release in artistic expression; here are three examples from Bildnerie der Geisteskranken (art of the insane), written many years ago by Hans Prinzhorn*

is not directly going to help the 600,000 patients in the state and public mental hospitals at the present time. Our biggest and most immediate job is to pay more attention to the living experience, the activities, the social and recreational opportunities, the guidance and personal contacts provided for patients.

Let us turn now to the immediate consideration of our present buildings for the mentally ill. An enormous amount of construction has been going on in recent years. And there is much that is depressing in facades, and more that is depressing and ugly behind facades. I go in front of one building — it must have cost millions of dollars — and I say to myself, "Is that what man must do to man? Must he put his fellow man in that kind of building when he is sick? Is that what his family must see when they come to visit?" Architecture is often cheerless and depressing to the healthy, normal person, to the doctor, to the patient's relatives; how can it help but exert an adverse therapeutic effect upon the emotionally ill?

In spite of handicaps there is heroism inside these hospitals; there is devotion; there is vision; and there are beneficial results. With very poor facilities, it is possible for a superintendent, a director, with fine morale and vision, to inspire his staff to do a good job. But we need, in addition to that, the help of architects; we need planned space where health-restoring activities can take place. We need art and beauty introduced into our hospitals, not only in the facades and hedges, but inside, as well.

Our present structures seem unfamiliar and strange to the patient when he enters the hospital, and anything which is strange awakens apprehension and fear. In addition to whatever is going on within him, he

receives an impression of something which is depressing, a feeling of aversion, a wish to move away. Relatives go to this place from a sense of duty. Patients have no choice.

It is all so much the opposite of what is familiar, and the word "familiar" comes from the word "family", as you know. Where there is "home-i-ness", where there are warm feelings associated with structures, there are feelings and emotions, intangibles, which are terribly important for the individual, for the family, for social relationships and for healing. But the mental hospital building is usually so different from the home; it is different from athletic fields, entertainment halls, from the movies, the gymnasiums, from churches, from the places towards which so many people feel well disposed and towards which they normally move and feel that the experience is interesting, worthwhile, comforting, lifegiving and expanding. It seems to me we can do something to incorporate positive, constructive associations and suggestions into the structure, the organization, and approach to these places which house the largest proportion of sick people in our country.

Most mental hospitals today show crude form, block structures, squares, straight lines, box-like designs. There is a roof; there are four walls; there are long walls; there is protection from the weather. But there is mystery; there is the impression of herding, of bold strength, of power and mass and the force of matter arranged on restraining scale. One gets the suggestion often, of a factory or a jail. There are few curves; there are few lines of beauty; there is minimal suggestion of attractiveness, comfort, warmth, consolation, compassion, benevolence, health. These are the qualities



the psychiatrist has to have if he is going to do a good job therapeutically for his patients.

This is not just a problem of mental hospitals. It is a broader problem. What kind of civilization are we living in? What is the contrast between this civilization — and where we are going — and past civilizations man has lived in? Henry Adams speaks of the symbol of the Middle Ages as the statue of the Virgin, and the symbol of modern life as the dynamo. I suppose, if he were living now, he might speak of the atomic bomb as being the symbol of modern civilization. We do not have to think of the Virgin literally; but we can think of her as the symbol of kindness, of warmth, of maternity, of compassion and helpfulness, of what is fine in human nature, as opposed to what is mechanical and destructive in human nature, as emphasized by so much of our present civilization.

The medieval synthesis was the unity of man and the sovereignty of God through the mediation of the church. The church guided the whole of life, and the cathedral dominated the community. There was unity and devotion beyond nationality and beyond individuality.

In the heart of Gheel, in Belgium, there is a lovely cathedral. The mental patients are living in this village around the cathedral, living in homes. There is little treatment on the basis of psychopathology there. When I was there, there was no electric-shock and insulin therapy. But there certainly was kindness, warmth and beauty.

### Too Much Individualism

Following this medieval synthesis, in the sixteenth century came much emphasis on individuality, and the gradual development of science. There was increasing secularization of institutions of the family, the state, and science. This led to the atomization of society, overemphasis on the individual and the separation of the individual from common roots. Where are we now? There is a great tendency toward chaos and anarchy, with little deference to authority, to standards, and lack of reverence for anything. There is not so much feeling of reverence of children for their parents, or mates for their spouses, of citizens for the state, of people for a church, of workers for management, and vice versa. So there is an undue emphasis on individualism and pluralism and self, without relation to others. The result is a greater feeling of isolation and a lessened feeling of fellowship, relatedness, friendliness, and security.

Science has created undreamt of control of the forces of nature, changed time and space, given us leisure. But it has contributed to this great secularization, and it has only made a small beginning in the study of man and his relation to his fellows.

That is why I say this is a broader problem than just architecture and psychiatry. It is a social problem, and it is an educational and religious problem. The great need today is humanization of science, to develop new units of some kind to replace the old medieval

units, new relationships, new friendlinesses, new co-operations, based on something other than the intellectual formulae such as Marx and Pareto have invented.

### A Few Suggestions

Some of the general principles which we ought to bear in mind in the humanization of mental hospitals are the following:

Avoidance of impersonality

Emphasis on integration with regional culture and geography

The maximum use of occupation and recreation including artistic activities

Work is valuable for patients and gives release, drains energy, provides discipline, affords an opportunity for cooperation with others, helps in self-realization, and fosters a feeling of worth and capability.

Then as to art and games. Games are related to art and recreation, and are tremendously important. Play is the free, spontaneous expression of energy. There is some relation here to mental disease, to the uncontrolled expression of impulses in mental disturbances. In our acute wards, in our reception wards, we should not just have a parlor, rooms, beds, toilets, washroom facilities. We should have facilities and space, both indoor and outdoor, for the free, uncontrolled expression of energy. Certainly we can use electroshock sometimes, or sometimes we can use physical or chemical restraint. But that is not dealing with the basic problems. Some of these people are under such tension that they need to run; they need to bang; they need to throw; they need to be unsocial. They need to play with water. We provide this for children, but we have not yet provided it for adults in our mental hospitals. Small pools of water would be most helpful for many disturbed patients. Sections for the acutely disturbed should have facilities so that patients can release their energies and externalize their anxieties and hostilities in physical activity.

Then we need opportunities for art expression, for the relief which comes through artistic activities, through the free use of paint and clay and through musical experience. Through these channels (energetic, artistic, recreational) can come self-discovery and self-realization. By means of these various forms of activity, a hospital can do a tremendous therapeutic job in the rehabilitation of people who are emotionally and mentally ill.

Health depends in part on what we receive, what we take in, what impressions are made on us. Psychiatric patients are ill often because of what they have received in life. Therapy and reconstruction depend very much on what patients are given, what they receive, in opportunities for emotional growth and personal development. Lines, color, shape, form are things we receive — perceptions we are given. They can afford an artistic experience of beauty, warmth, constructiveness, expansion of life and health, or the reverse. This is a common challenge both to psychiatrists and architects.



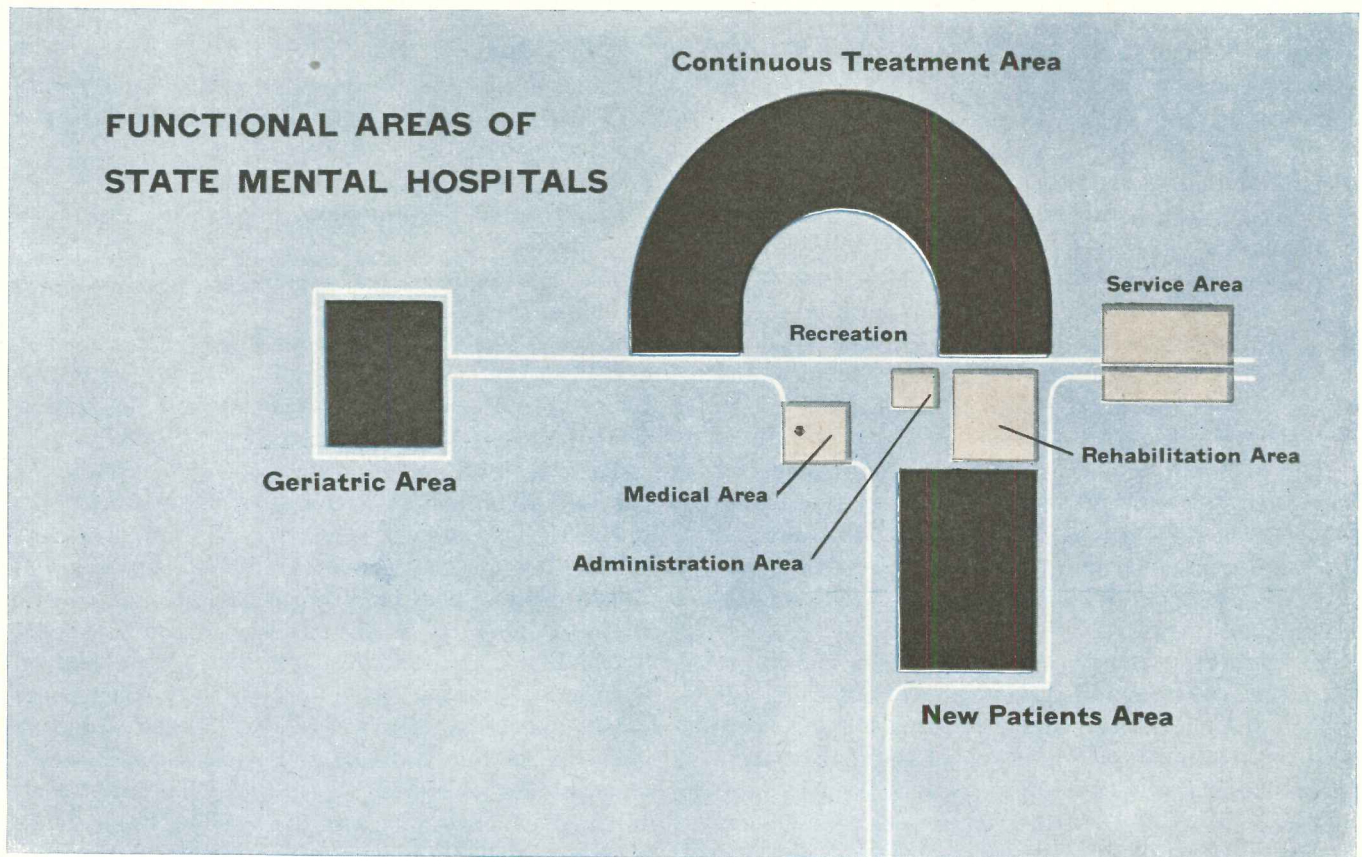

**T**HE MENTAL HOSPITAL is divided into three main parts: 1. receiving, diagnostic and intensive treatment, 2. continued treatment, 3. geriatric service.

Each becomes ideally a separate community and the three are separated by facilities and areas which are common requirements of each.

All patient buildings, except medical and surgical, are recommended to be designed as small one- or two-story buildings arranged to insure convenient and immediate access to easily supervised outdoor areas. Where patients must be carefully supervised and where restraint may be necessary, outdoor areas are designed as courts enclosed by structures. Small buildings provide for more satisfactory treatment, as patients of different personalities or dissimilar treatment programs should not be together.

Facilities which are common requirements of each group are: administration, medical and surgical, rehabilitation and service. The recreational and occupational facilities of the rehabilitation area should be grouped together into an interesting and stimulating community square. Visitors may mix with convalescing patients in this square, and it becomes an attractive area in which to promote public interest in the hospital.

*Receiving and intensive treatment service*, with its varied functions and activities, represents the true mental health clinic; it is described in detail beginning on page 189.

The larger receiving service will include separate small cottages for patients on intensive treatment who may profit

from the atmosphere of group living, or for patients on convalescent status. Only survey of need will establish the size of this service. A preliminary average estimate may be 6.5 per cent of the total mental hospital population for the receiving and intensive treatment service, and 13 per cent for the convalescent cottage area. These facilities should be set well apart from the continued treatment patient areas.

*Continued Treatment Service* is for patients who have failed to recover during their course of intensive treatment. Patient classifications vary; only a careful survey of need will establish accurate requirements. The following percentages of each classification within the total mental hospital population are estimates: Inactive, 8.0 per cent; Chronic Disturbed, 7.5; Industrial, 22.5; Medical and Surgical, 3.5; Chronic Disease, 13.0; Tuberculosis, 4.0.

*Geriatric Service.* Where facilities are not available for older patients in communities in which they have been living and it becomes necessary to care for them in the state mental hospital, it is desirable to provide a separate colony of small cottages outside the continued treatment and intensive treatment areas. These older patients would then be removed from the more strenuous treatment program required for continued treatment patients to the advantage of both groups. Patients from the colony would use the facilities of the medical and surgical building as required. Separate special recreational and occupational therapy facilities should be provided for these patients in addition to the central facilities for scheduled use by all patients.



# HOSPITAL BUILDINGS FOR MODERN THERAPY

THIS BUILDING TYPES STUDY is the first to present the researches of the architectural staff of the Public Health Service in mental hospital planning. The need has been urgent. The concept of quick cure, instead of permanent care, calls for entirely new types of mental hospital buildings. Architects must assimilate new treatment programs, and plan hospitals that will inspire patients to pick up again the threads of their shattered lives.

It is not easy — the new hospitals are great agglomerations of small-scale units, with an imposing variety of facilities, all disposed over the landscape in intricate patterns of buildings, courtyards, recreational areas. Esthetic considerations are of great importance; beauty becomes a functional requirement. Nowhere else will the architect be so tried, in his efforts to put a thousand little pieces together. But nothing else will be so rewarding, for nowhere else are human tragedies so apparent, or ministrations so appreciated.

This Study concentrates on two vital areas — the "receiving, diagnostic and intensive treatment" building of the mental hospital, and psychiatric facilities in the general hospital. The whole effort is to catch the patient early, give him quick help, or, that failing, give him the "total push" and return him quickly to out-patient status, then to final discharge. If the new array of facilities suggested in these pages sounds expensive, translate the costs in terms of, say, six months treatment vs. custodial care for the rest of his life. So Marshall Shaffer and his staff of architects in the Public Health Service have bent their first efforts (over several years by now) to these two types of facilities, which are presented in detail in following pages. Basic information on planning is available for other types of mental hospital buildings, will be presented in later studies. — Emerson Goble



The following material prepared under the direction of John W. Cronin, M.D., F.A.P.A. Chief, Division of Hospital Facilities Public Health Service U. S. Department of Health, Education and Welfare

## DESIGN OF INTENSIVE TREATMENT BUILDINGS

By Alston G. Gutfersen

Hospital Architect  
U. S. Public Health Service

IT IS THE RECEIVING AND INTENSIVE TREATMENT building, more than any other building of the modern mental hospital, that offers the best opportunity for a discussion of the facilities required in modern treatment programs for nervous and mental patients. It is to this building that all new patients will come for their initial diagnosis, and, in the majority of cases, will remain for treatment until return to the community can be effected.

Other patient buildings are simple by comparison. Each of these — excepting those designed for the physically ill bed patients, in the medical-surgical unit, the chronically ill unit and the tuberculosis unit — are designed for small groups of individuals of a particular classification. These classifications will be determined, for design purposes, by such characteristics as behavior, age, illness, etc., each of which may require special treatment techniques. The design of units for the medical and surgical, the chronic physically ill and the tu-

bercular patient differs widely with the design of other patient buildings as in these units the bed is the place of treatment. In all other patient buildings the medical treatment program must be supported by a wide variety of occupations, recreations, exercises and other constructive activities in accordance with the requirements of the individual and the group. Buildings for these patients, then, will require a large percentage of their area for these activities rather than for bedroom or dormitory areas.

The receiving and intensive treatment facility, more than any other service of the modern mental hospital, reflects the changing attitude and treatment of nervous and mental patients. It, together with the convalescing cottages, which are considered a part of this facility, is almost a complete mental hospital in itself. It has facilities for the segregate housing and treatment, in small groups, of all types of patients; for their diagnosis, for their occupation and recreation. This modern service



encourages, also, a greater freedom for a greater percentage of patients. The modern mental hospital does not reflect secure custody, but rather a simplified and controlled community in which constructive activity has been substituted for deteriorating inactivity or destructive behavior.

**Patient Programs**

The receiving and intensive treatment service may have facilities for out-patients and day-care patients as well as for in-patients.

Out-patients may be new patients on a program of interview treatment or they may be patients on follow-up care, after having received treatment as an in-patient of the hospital.

Day-care patients are those who require all of the facilities of the psychiatric hospital except its safety and security. They may be on full-day programs of group activities in occupation, recreation, socialization, group therapy, private interviews, etc. Where the men-

of segregation of different types of patients into small groups cannot be overstressed. Some patients of the receiving service will be on convalescent status and will live in nursing units that are open or unlocked. Some of these may also be in the adjacent convalescent cottages. Other patients may be quiet-cooperative, depressed or mildly overactive patients in nursing units which may be locked only part of the time. A few will be disturbed and these will be housed in nursing units, in whole or in part, of maximum security and safety for the patient. All should have access to living rooms and outdoor recreation areas immediately adjacent to their living areas for activities of their own as well as the therapist's choice, and to central recreational and occupational therapy areas for more organized group activities.

New patients whose prognosis is unfavorable for intensive treatment will be transferred to the continued treatment or other service after their initial work-up of from four to six weeks. Those new patients who fail

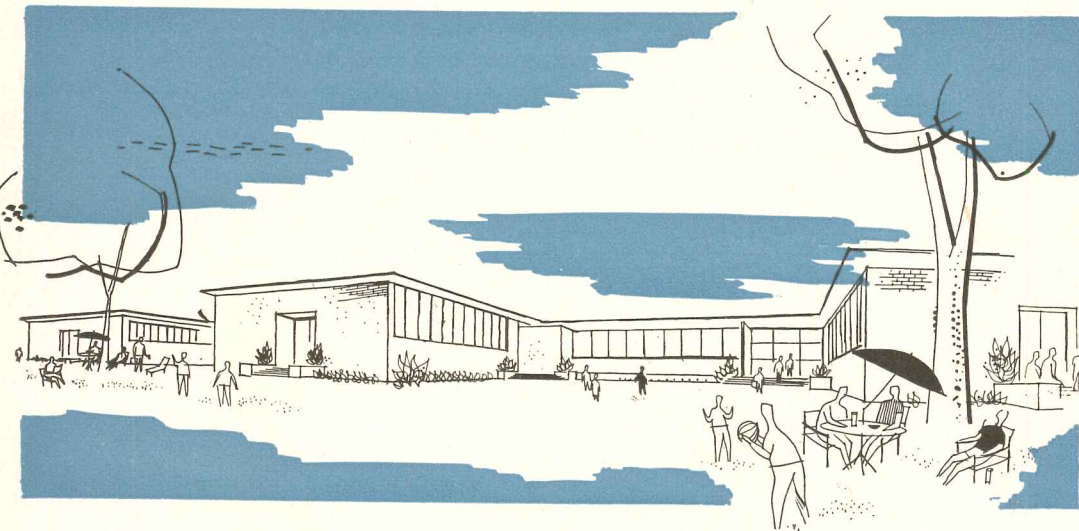

*"Psychiatric hospital care and treatment begins with admission procedures. All the patient's experiences, which are associated with commitment, detention, transportation and admission have an effect upon him — either good or bad. Mental patients often are more sensitive to environmental influences than a healthy person. Events and persons surrounding the admission of patients are important environmental influences." Riley H. Guthrie, M.D.*

tal hospital is in or near an urban area, the receiving and intensive treatment service may develop a large out-patient and day-care program. Most mental hospitals have been too far removed from population centers to provide this service.

In-patients of the receiving and intensive treatment service may be similar to day-care patients in treatment requirements or they may need, in addition, the safety or security of the hospital. Since they are new patients, in need of very careful treatment, contact between patients of different behavior or illness, should be controlled or prohibited.

There has been, in previous building programs, a tendency to group all types of patients together regardless of behavior, age, personality, etc., so that a wide variety of illnesses had to be treated in the same situation. Under such conditions the medical staff cannot create the therapeutic environment and the organized program of activities which is required by each individual. The environment and treatment of each individual must be carefully controlled. The importance

to recover in intensive treatment within a period up to six months also will be transferred to the continued treatment or the geriatric service, as is indicated in each case. Criminally insane, alcoholics, psychopathic personality disorders, etc., will also be treated in separate buildings or areas specially designed for the particular problem. The effort in the receiving building is directed toward maintaining a facility for the immediate, intensive treatment of patients whose prognosis is favorable, in the early stages of their illness when treatment will do the most good.

A new pattern of facilities for nervous and mental patients may be evolving from the more recent experiences in intensive treatment programs for out-patients and in-patients. The problem for the hospital board and the architect in programming and planning new facilities is to assist in the analysis of requirements for new treatment programs. In doing this it must be kept in mind that the architectural precedent for the most part is for custodial care only; that modern treatment techniques are extremely new and may, therefore, be



exercised, if they can be used, in facilities which are inefficient, unwieldy and generally unsatisfactory for the staff and injurious to the patient; that the patient can do much for himself if given the opportunity, the proper environment and the necessary assistance. The problems in the treatment of nervous and mental patients are varied and varied resources are required to cope with them.

The modern intensive treatment facility will strive to provide a friendly, encouraging atmosphere and a program of activities, from the time of initial admitting discussions to discharge, for each individual patient. To accomplish this will require facilities arranged for great flexibility in the placing of patients for diagnosis and treatment and for self-expression in work, recreation and relaxation.

### Organization

The main elements of the receiving service are: administration department; out-patient department; receiving and adjunct diagnostic facilities; occupational and recreational therapy facilities, both indoor and outdoor; dietary facilities; service facilities and in-patient nursing unit facilities. In-patient nursing unit facilities include those in the adjacent convalescent cottages.

Where there is to be a large day-care program, the occupational and recreational therapy facilities, the dietary facilities and adjunct diagnostic facilities should be located between the out-patient and in-patient departments in order that cross traffic of in-patients and out-patients to these departments may be avoided as desired. Such an arrangement is illustrated in the accompanying 40- to 50-bed plan.

Since the intensive treatment facility is the most active service of the entire mental hospital and may in fact treat more patients during the year than the other services, it is the recommendation of some hospital administrators that offices be provided in this building, rather than the main administration building, for the chief psychiatrist, chief psychologist, chief of psychiatric social service and chief of nursing services of the total hospital. The main administration building then would retain offices for the superintendent, central and inactive records, business and public contact functions.

### Size

The number of beds and the kind and amount of treatment facilities can only be determined by a study of requirements for the particular community. The requirements for the particular building will be affected by existing facilities, such as psychiatric services in general hospitals, special psychiatric hospitals and community health clinics in the area. It may also be affected by the presence of a recognized specialist on the staff of the proposed hospital and by the type of facility which it is proposed to construct.

An estimate of size in relation to the total mental hospital, for study purposes, is approximately 6½ percent of the total mental hospital population. The

patients of the convalescent cottage group are then estimated to be twice that amount or approximately 13 percent of the total mental hospital population. Where additional beds are required, it is recommended that duplicate receiving and intensive treatment services be constructed.

It is important to keep the receiving building small. The controlled, therapeutic environment, with opportunities to encourage the new patient in self direction, can only be accomplished with segregated, small group conditions. Additional nursing units, again small, can be furnished in the convalescent cottages which are a part of the receiving service. These cottages may be used by all patients of the intensive treatment service excepting those requiring maximum safety and security

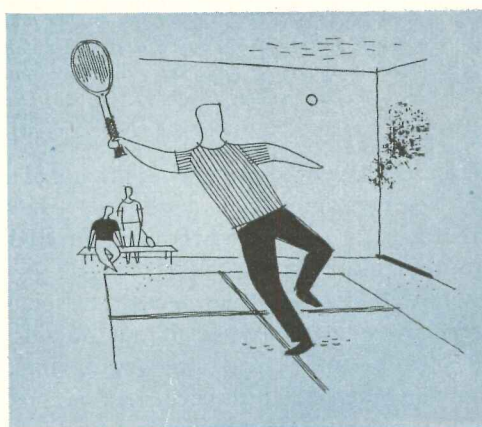

*"In our acute wards, in our reception wards, we should not have just a parlor, rooms, beds, toilets, washroom facilities. We should have facilities and space, both in-door and out-door, for the free, uncontrolled expression of energy. Some of these people are under such tension they need to run, to bang, to throw, to be unsocial." From "Emotional Impacts" — p. 17, by Kenneth E. Appel, M.D., in "Design for Therapy," Mental Hospital Service, American Psychiatric Association.*

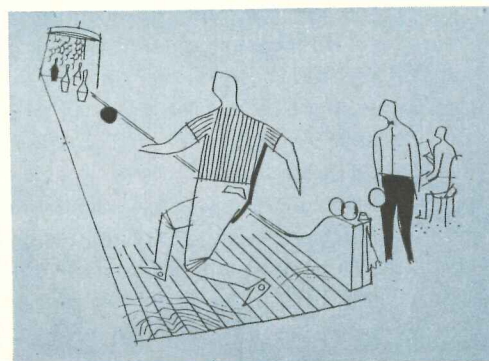





*"One unit should be designed especially for disturbed patients, and space enough in-doors and out-doors for plenty of exercise by restless patients without their being observed or observing quieter patients in other wings." From "Planning a Mental Hospital of 1500 Beds," by Samuel W. Hamilton, M.D., and Mary E. Corcoran, N.O., in "Diseases of the Nervous System," Vol. XI, No. 12, Dec. 1950.*

They offer flexibility in the placing of patients of similar behavior, age, personality, etc., who may be under similar treatment programs or who may profit by the particular group situation.

A receiving and intensive treatment service consisting of a 100-bed receiving building of four nursing units and small convalescent cottages, together having a total of eight nursing units of 25 beds each, may be considered a maximum desirable size. Large services tend to restrict the patient and reduce opportunities for self-expression in constructive activities.

### Location

The receiving and intensive treatment service of the state mental hospital should be located near the main entrance to the hospital, removed from the continued treatment patient and geriatric patient area, and conveniently located with respect to the medical and surgical building. While some new patients may be required to go to the medical and surgical building for special diagnostic or treatment procedures, and others may go to central occupational and recreational therapy facilities, nevertheless, this service should be sufficiently complete in diagnostic and supporting therapeutic facilities to provide treatment of new ambulant patients without contact with the main mental hospital population. This requires a duplication of some facilities of the complete mental hospital, but it permits a control of the therapeutic environment and a program of activities which is not possible when contact with chronic mentally or physically ill patients is made.

Under modern treatment programs, rapid improvement of patients is frequent, so that a greater percentage may be permitted greater freedom and choice of activities. Care should be taken in the location and design of this facility to provide sufficient outdoor space

for recreation with sufficient isolation from chronically ill patients to insure an encouraging atmosphere of recovery.

### Administration

The administrative offices are grouped together in a separate area near the main entrance, convenient to the public and away from diagnostic and treatment areas and in-patient areas. The main elements of this administrative group are: main entrance lobby and waiting room, information counter, public toilets, public telephone, business office, medical record room, library and conference room, offices for chief psychiatrist, chief psychologist, chief psychiatric social worker, chief nurse, secretaries and admitting, personnel lockers and toilets, and janitor's closet. Additional offices for staff interview and treatment of patients are located near patient areas of the nursing units.

Where an out-patient service and/or day-care program are to be included in the service, the chief psychologist, chief psychiatric social worker and their staffs would be located in the out-patient area together with the offices for the psychiatrists of this service.

The main entrance lobby and waiting room should be convenient to corridors leading to the out-patient department and the diagnostic facilities. Access to these facilities by the public should be easily observed and controlled from the information counter. The lobby and waiting areas should have adequate space for seating as well as circulation to the various departments. It should have direct access to the cashier's counter or office and to the corridor leading to the chief psychiatrist's office. This corridor should also be under control of the information counter.

The information counter should be located to provide observation of the lobby, waiting area and corridors to administration, diagnostic and out-patient areas. In the small hospital the telephone and information facilities may be combined. In the larger hospitals, where these services are separate, it is desirable to locate the communication services and information counter adjacent to each other in order that the telephone operator may also serve the information counter during the night. The intercommunicating telephone system should connect all staff areas and may be automatic. The system may serve also as a general fire signal.

Public toilets and public telephone booths should be provided in a convenient location in or near the main lobby. Both should be under supervision of the information counter.

The business office will contain the general office space for clerical staff and equipment, a vault for business records and a safe for patients' valuables. The office should be arranged with convenient access to the cashier facilities, which should be convenient to the lobby area. In the larger hospitals, it is desirable to furnish small separate offices for the directors, audit, purchasing and credit.

The medical record room should be accessible to the admitting room and out-patient department. It should



be convenient also to the administration area. Space should be available in the room, or in an adjacent staff room, for work on, or viewing of, medical records. In larger hospitals a pneumatic tube system for transportation of records to the various departments may be desirable.

A library and conference room should be provided and it is desirable to locate it adjacent to the medical record room. Where an out-patient service is included in the hospital, it may be located in the out-patient department. For details see section on Out-Patient Facilities, page 211.

The chief psychiatrist's office should be accessible to all other offices, but located to insure privacy. Access to the room should be provided both from the corridor and from the secretaries' office. It should be large enough to serve as conference area for a small group. The secretaries' office should be large enough to serve as entrance to the psychiatrist's office with sufficient waiting space for a small group of people.

Offices for the chief psychologist and chief psychiatric social worker may be located in the out-patient department when that service is provided.

The chief nurse will be in charge of all nursing personnel. The office should be near the administrator's, or chief psychiatrist's office, and large enough for conferences with three or four people. Larger conferences with nursing personnel will be held in the conference room. In the larger hospitals there would be a separate office for an assistant and an office for secretaries.

### Out-Patient Department

See section on Out-Patient Facilities, page 211.

### Diagnostic Facilities

The intent in the receiving building is that it furnish diagnosis and treatment of new patients for return to the community without their having been a part of the main mental hospital population. Since receiving buildings having this service are relatively new, their pattern of requirements has not been clearly established. This is particularly true regarding the amount of diagnostic equipment which is to be included in this facility.

Analysis of the treatment program establishes the fact that duplication of routine diagnostic equipment in the total hospital is justified in many instances. The medical and surgical facility serves the entire hospital community in the same manner that a general hospital serves any community. As such it serves the physically ill bed patients. It also furnishes out-patient medical services to the hospital community. It serves only those new patients who are physically ill or who may need more complete examination as indicated in the routine diagnosis.

In the receiving service an active program of therapy is begun with each individual upon his entering the hospital, and diagnosis is continually being made during the course of his treatment. Areas for programs in work, in recreation, in socialization and, at times, for

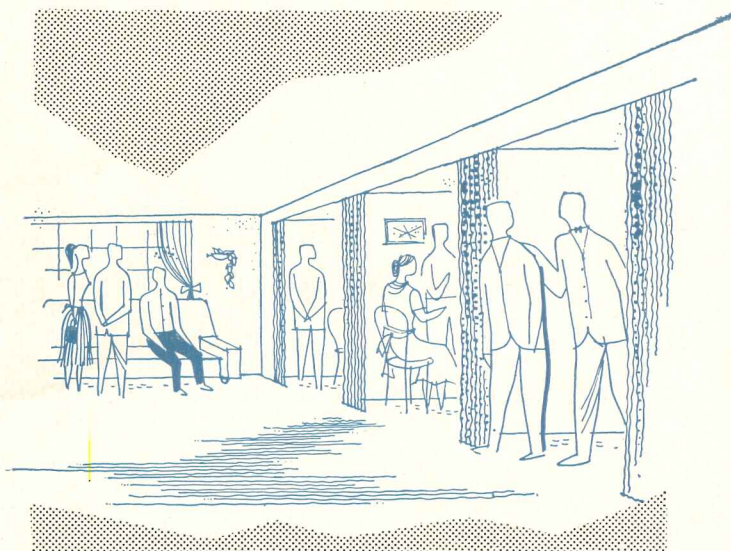

*"To render asylum life more like the outside world, something else is needed, however, besides attached residences: a greater variety of amusement, more frequent assembling together of the insane and the sane, more extended intercourse between patients and their friends. . . ." Dr. James R. DeWolf, N.S., from notes on Conference of Illinois State Board of Public Charities, Nov. 1869.*

uncontrolled self-expression in activity are required. These programs cannot conveniently or therapeutically be accomplished within the general hospital setting where the bed is the place of treatment and quiet surroundings are required.

New facilities are being constructed in which the receiving building is entirely separate from the main mental hospital population and in which, in some cases, routine diagnostic equipment is included. Also, new facilities are being constructed in which new patients are being admitted to the same building in which the general hospital facilities are located. This is being done for the convenience of having new patients, who require routine diagnosis, near the diagnostic facility to avoid duplication of facilities. Also for convenience, then, the convalescing patients, who are part of the receiving service, are located here; in addition, and for the same reason, the chronic physically ill patients who need careful nursing and considerable medical attention are in nursing units in this building. The result, in some cases, has been that, again, large buildings, housing 400 to 500 patients of these four classifications of both ambulant and non-ambulant patients, are housed in close proximity with less opportunity to provide an acceptable situation in which the individual may find means for self-expression.

In planning new facilities there is sufficient evidence to support the program of intensive treatment of new patients separate from the other services of the hospital. In order to accomplish this, equipment for the initial diagnosis of a routine measure should be included. These are doctor's office and admitting room, medical examination and treatment room, x-ray room, laboratory or specimen room, EKG, BMR, E.E.N.T. rooms, and dental facilities. Should more exhaustive diagnosis be required for some patients, these can be transferred



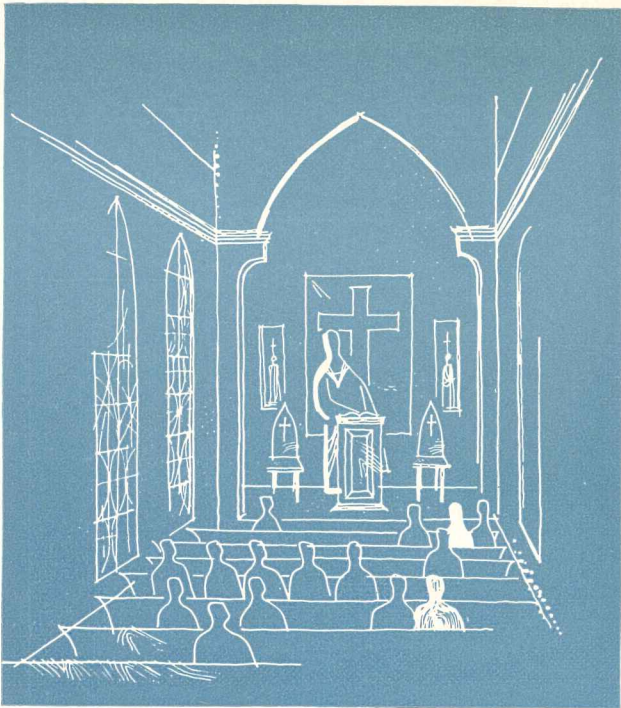

*"It has come to be recognized by such standard-making organizations as the Council for Clinical Training and the Association of Mental Hospital Chaplains that the ministry of a chaplain to the mentally ill is a specialized vocation . . . requires intensive preparation . . . to develop skills in observation . . . to create some awareness and understanding of the meaning and problems of mental illness. . . ." From "The Mental Hospital Trains the Minister," by The Reverend Ernest Bruder, Protestant Chaplain, St. Elizabeth's Hospitals, p. 8, Mental Hospitals, June 1952.*

*"Work gives us release, drains energy, gives us discipline, affords us cooperation with others, helps in self-realization, gives us a feeling of worth and capacity. Provision for art and games is terribly important. Play is the free, spontaneous expression of energy." From "Emotional Impacts" — p. 17, by Kenneth E. Appel, M.D., in "Design for Therapy," Mental Hospital Service, American Psychiatric Association.*



temporarily, or conducted, to the general hospital.

These diagnostic facilities should be grouped together and away from areas of patient activities and located between the out-patient department and the in-patient areas. The requirements for each of these facilities will be similar to those of general hospital facilities. The admitting room should be located adjacent to this suite, near the medical examination room. For requirements for the admitting room, see section on Out-Patient Facilities, page 211.

In addition, facilities for insulin and electric shock treatment will be required in the receiving building. The amount of insulin and electric shock treatment given varies in different hospitals. Therefore, in programming requirements for this facility, regard should be taken not only of proposed immediate requirements, but also of possible future requirements as operated under a different staff. Insulin may be given, as is preferred by some, in the single room of the patient. It usually is given in a larger room where several patients may receive the treatment at some saving in staff. It may be desirable to plan for the latter, in which case the recommended facilities are as follows: waiting room or space; insulin treatment room, for each sex; single bed room with each insulin treatment room; nurses' work room; linen and blanket storage and patients' shower and toilet rooms. This arrangement is shown on the 40- to 50-bed plan.

The waiting space should be located to provide good observation from the nurses' station or work area, but in a manner that will not permit patients who are waiting for treatment to observe or hear patients who are receiving treatment or who are in recovery from electric shock. This waiting space would be used chiefly by patients who are to receive electric shock. Patients should be conducted to this area in small groups. It may be used by out-patients as well as in-patients.

The insulin treatment room should have beds spaced so that they are easily wheeled in or out of the room. Space for treatment tables will also be required. The room should be arranged for good observation of all patients and for convenience in traffic to any bed. Patients who are receiving treatment will occupy the room for approximately four hours. In hot, humid climates, air-conditioning of the room is desirable. If electric shock treatment is to be given in this suite, the insulin treatment room may be used as the recovery room. The recovery period from electric shock treatment is approximately 30 minutes.

The single room may be used for preparation of patient before insulin treatment is started; for emergency treatment of difficult recovery cases and for electric shock treatment. It should be similar in size and equipment to a general hospital single bed room.

The nurses' work room should be located with good observation of the waiting area, the insulin treatment rooms and the single bed rooms. Its facilities should include an area for record keeping and a work area containing a sink with cabinets above and below for storage of treatment trays, utensils, etc.; refrigerator



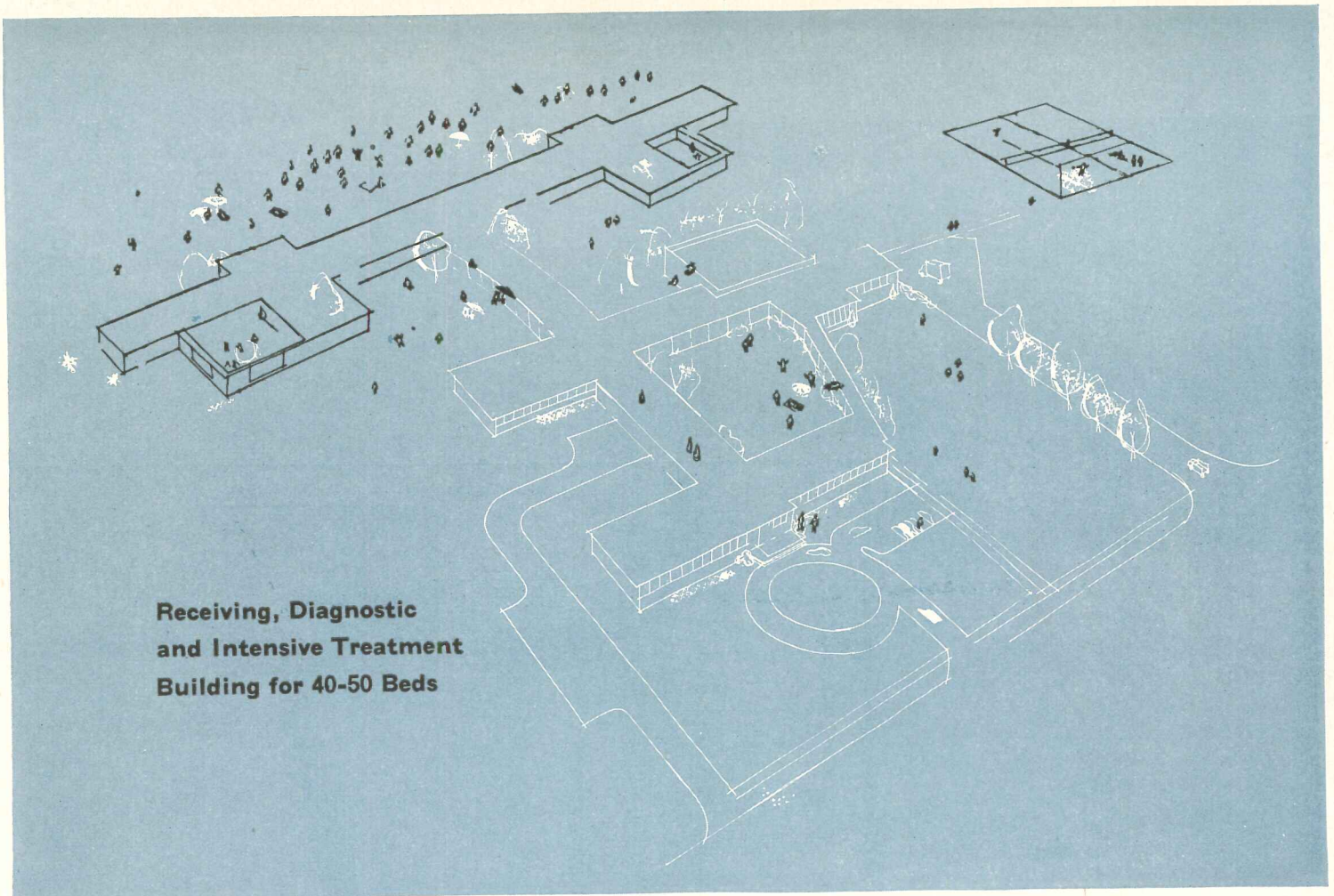

**Receiving, Diagnostic  
and Intensive Treatment  
Building for 40-50 Beds**

for storage of drugs and food; a counter for preparation of toast, orange juice, etc. and a double element hot plate. Food must be served to the patient during the recovery period from insulin shock therapy.

Linen and blanket storage areas should be convenient to both suites.

Emergency receiving facilities are desirable for the occasional disturbed patient who will be received. They will consist of a receiving bed room with bath and toilet and a sub-utility. Temporary isolation for observation of new patients may sometimes be necessary, also. This may be accomplished in the special facilities of the emergency receiving room or in special receiving and treatment rooms of each nursing unit. The latter is preferred. (See facilities of the nursing unit.)

#### **Recreational and Occupational Therapy**

Recreational and occupational programs are not new in mental hospitals. Today's programs of activities are, however, more scientific; they are no longer used solely for the amusement of the patient. All human beings and particularly those with emotional or mental illness need to achieve "something in the way of balanced activities." "In a sense, the whole function of a mental hospital is to assist the patients to live leisurely rather than compulsively." Doctors have long "... urged the development of work-play, exercise-rest relationships in the regular day's living program."

Occupational and recreational therapy programs will be organized into activities on the nursing units, and in the central facilities. Additional occupational activi-

ties may be provided in useful work in the hospital, on the hospital grounds, and in the service shops.

For programs on the nursing units the living rooms, screened porches and adjacent outdoor areas will be used. Closets, in or near these facilities, for the storage of equipment will be required. Chiefly those activities, such as sewing, typing, painting, card games, which require light equipment will be organized in the nursing units. For those activities requiring space or equipment of a special nature, central occupational and recreational therapy facilities will be used. These generally consist of occupational shop, with office for therapist and storerooms for storage of supplies; exercise gymnasium with locker and shower rooms for both men and women patients, office for therapist and equipment storage room; a canteen; and a hand laundry for women patients. The barber shop and beauty shop are generally located in this area. A library and reading room and a conference room for teaching purposes are desirable.

The exercise gymnasium should be a minimum of approximately one half of a basketball court for installation of a basketball backboard and basket. In general the least competitive activities will be used, though volleyball, badminton, shuffleboard, ping-pong, may be among the activities scheduled. Punching bags, tumbling mats, parallel bars, exercise pulleys, etc., are some of the equipment that will be used. The space should be arranged so that it may be used for motion pictures, plays, and dances. The gymnasium should open to outdoor exercise areas where tennis and ball games may be organized. Activities which



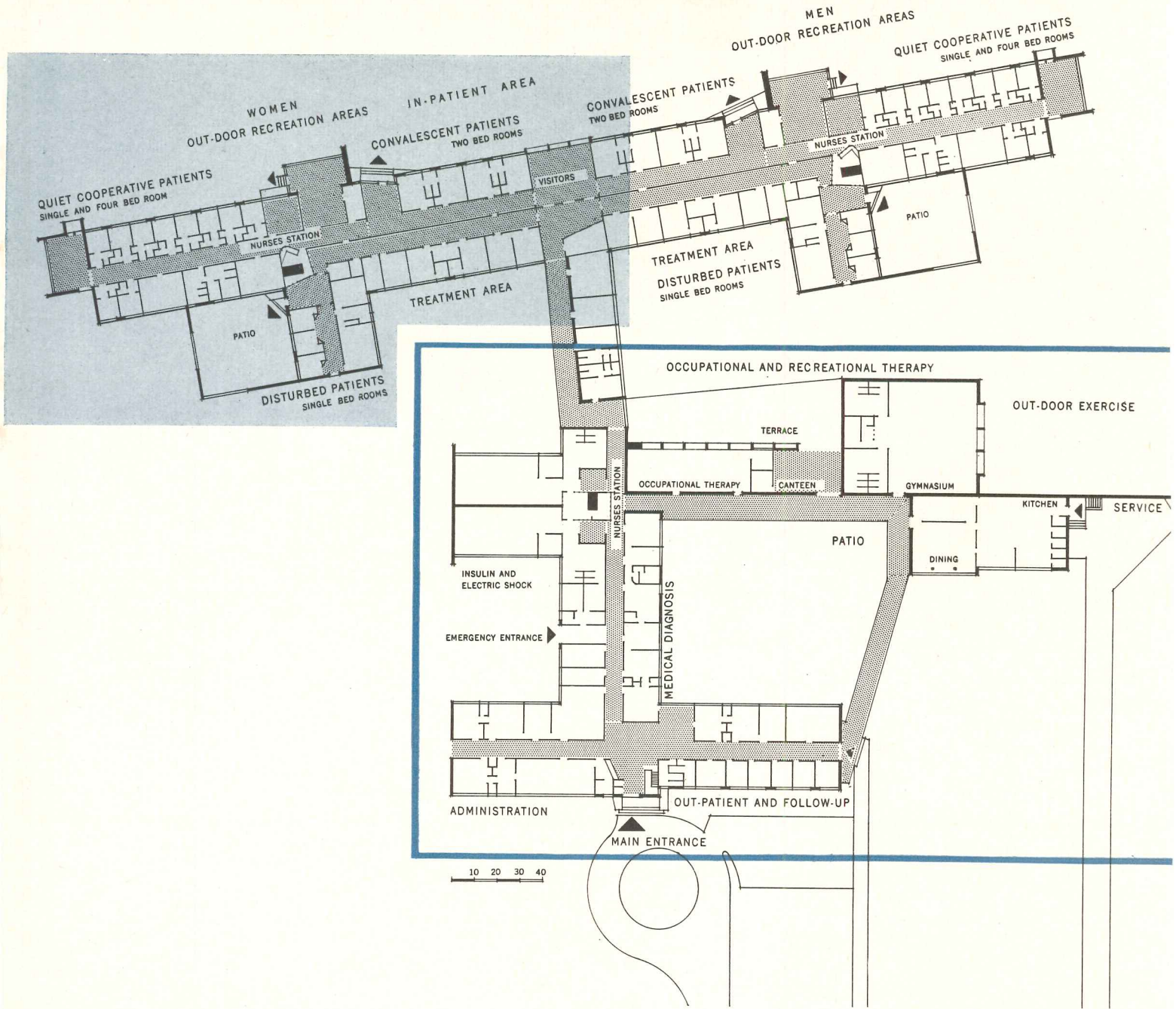

SUGGESTED TYPE PLAN OF  
A 40- TO 50-BED RECEIVING AND  
INTENSIVE TREATMENT BUILDING

TREATMENT FACILITIES in this small receiving and intensive treatment unit for a state type mental hospital were expanded to provide a large out-patient service of early care, follow-up care and day care programs, and are located between the out-patient and in-patient areas.

Since approximately twice as many patients under the intensive treatment program will be housed in adjacent "convalescent" cottages, facilities, such as insulin and electric shock, are larger than required for the in-patients of this particular building.

Several subdivisions of the nursing unit can be made with each having its own living room and adjacent outdoor areas for ward day activities. All service and medical facilities of the ward, excepting the pantry, are on a separate corridor of the nursing unit. The nurses' station is located near the center of the unit, near the entrance of the locked unit and has good observation of corridors and day activity areas.



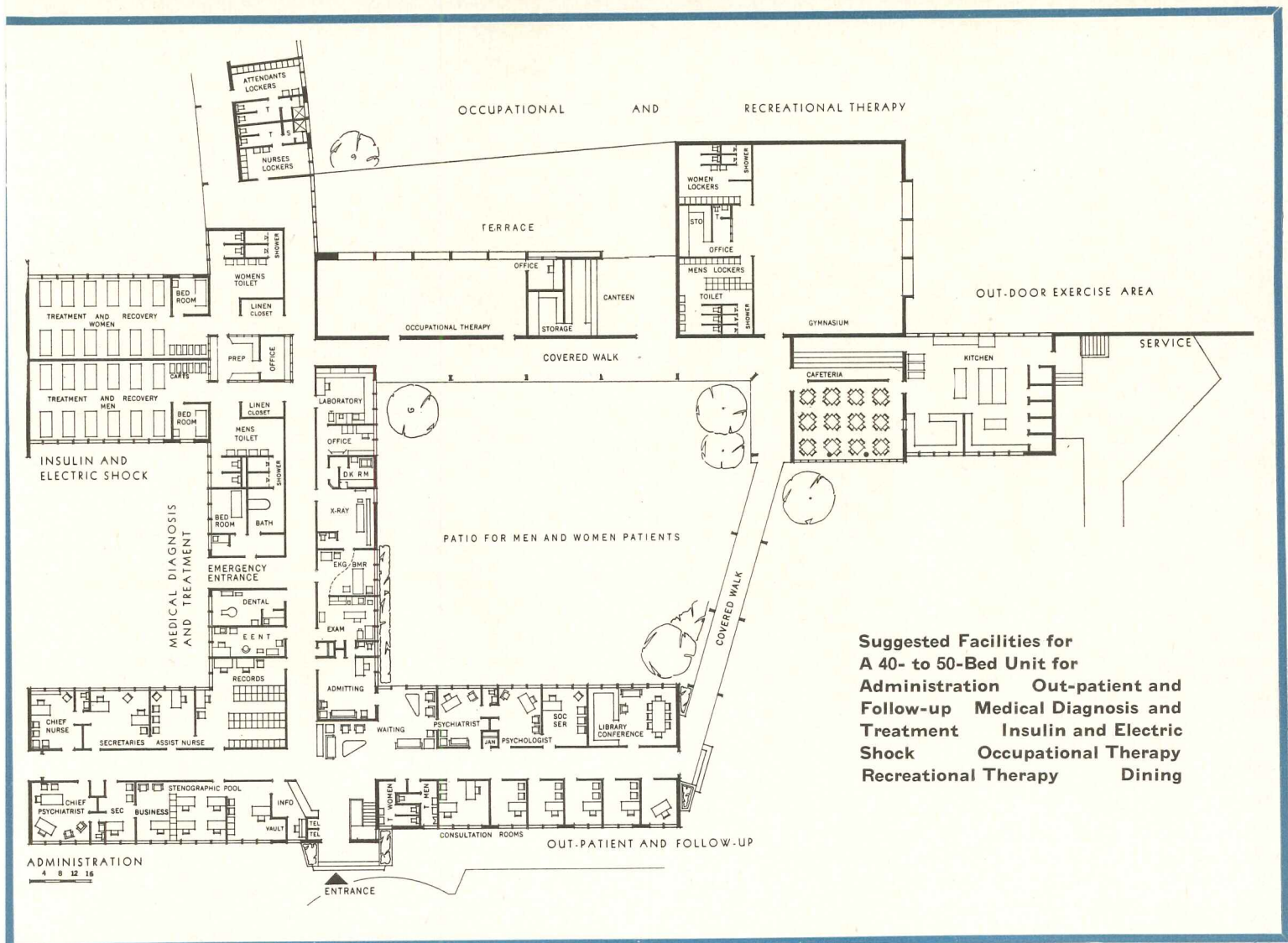

**Suggested Facilities for  
A 40- to 50-Bed Unit for  
Administration Out-patient and  
Follow-up Medical Diagnosis and  
Treatment Insulin and Electric  
Shock Occupational Therapy  
Recreational Therapy Dining**

**ELEMENTS OF THE RECEIVING AND INTENSIVE TREATMENT BUILDING**

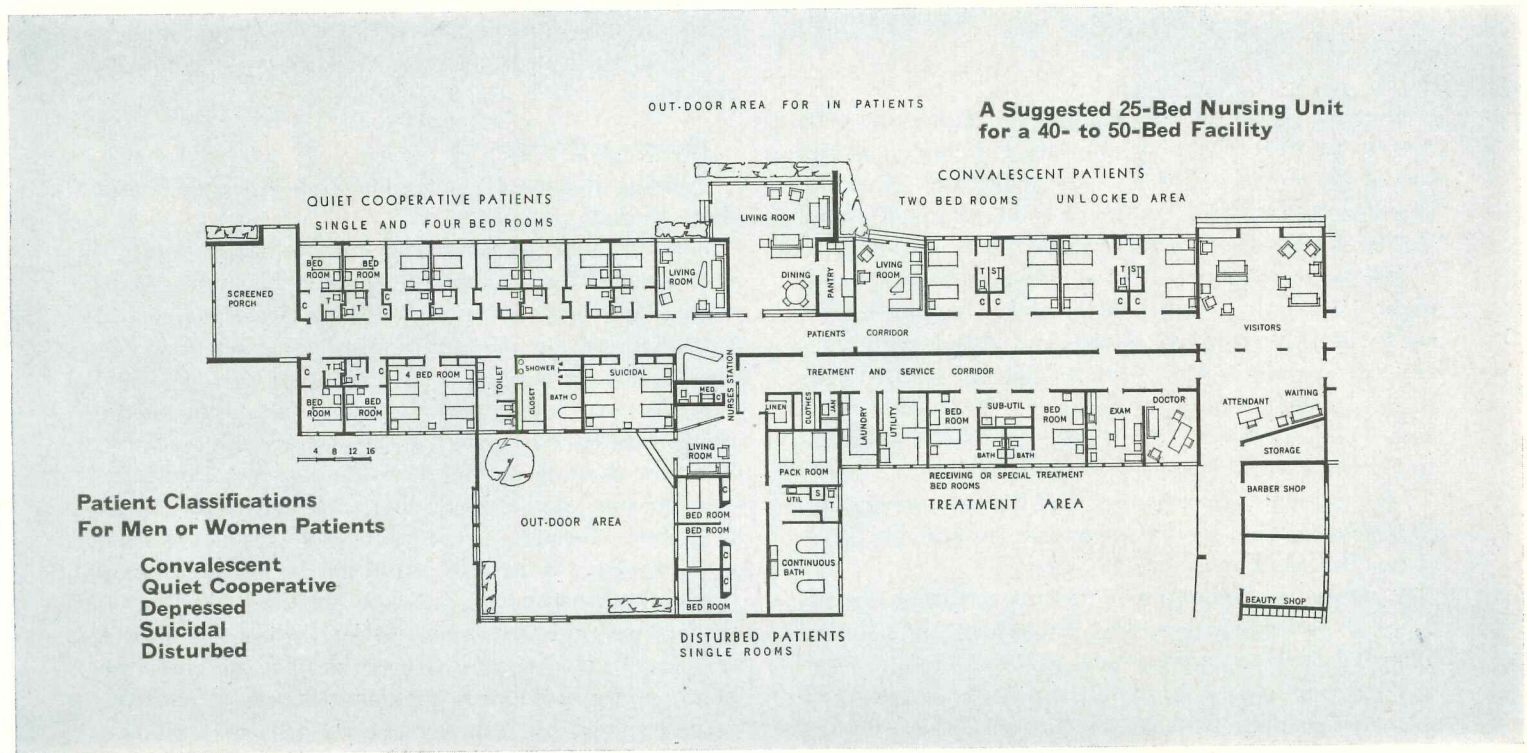

**A Suggested 25-Bed Nursing Unit  
for a 40- to 50-Bed Facility**

**Patient Classifications  
For Men or Women Patients**

- Convalescent
- Quiet
- Cooperative
- Depressed
- Suicidal
- Disturbed



require a larger or special space, such as bowling or billiards, will be located in the central recreational facility of the total mental hospital.

Locker and dressing, shower and toilet rooms for men and women patients should be located, when possible, so as to serve the occupational therapy shop also.

The office for the therapist should be located with observation of the gym floor and supervision of the locker rooms and equipment storage area. A coat closet and shower and toilet room should be provided adjacent to the office.



*"Some excellent mental hospitals have been built — many multi-million dollar projects are lacking in the one indispensable requirement of a mental hospital — the atmosphere of peace and comfort so important for the recovery of a mentally ill person. Why?" From "Heart of the Matter" by Daniel Blain, M.D. in Design for Therapy — Mental Hospital Service — A.P.A.*

Storage space for all equipment which may be moved to clear the floor for larger group activities should be provided. Where motion pictures are to be included as activities in the gymnasium, additional storage facilities for movable seats will be required.

The canteen, equipped to supply soft drinks, sandwiches, ice cream, coffee and possibly short orders for use by patients, relatives, friends and staff, is preferably located near the central recreational and occupational areas. It should be a well lighted, attractive room, large enough for several groups of tables and chairs and provide an atmosphere of relaxation.

For equipment in patients' hand laundry, see section on Psychiatric Service in the General Hospital, Facilities of the Nursing Unit, page 205.

A survey of occupational therapy activities for all types of patients in hospitals throughout the country indicated that approximately seventy different activities were in use. A complete program of proposed activities should, therefore, be furnished the architect

before sketches are started for this important facility.

The central occupational area will include office for therapist, preparation area for activities for nursing units, occupational therapy shops and storage.

The shops will be organized into the general activity areas or rooms for bench work, equipment work, table work, loom work, painting and finishing space. Loom work will include weaving and braiding of several types of materials. Bench work will include work in carpentry, plastics and metal. Equipment space for saws and lathes should be in this area. Table work will include activities in leather work, sewing, typing, painting, sketching, modelling, block printing and ceramics. Water, gas and electric outlets should be provided.

Areas or rooms should be organized with ample space around equipment and for storage of work in process or of waste material. The larger service will have separate rooms for bench work, table and loom work, ceramics and printing and painting.

Storage space will be in the form of shelves, cupboards and bins, above and below work areas or in special cabinets in the work area, and in a special storage room. Material to be stored will include both equipment and material for work in process and for general supply. Areas for the storage of paint should be constructed in accordance with the requirements of the local fire marshal.

The occupational therapist's office should preferably be near the entrance to the shop areas with good observation of the shop and storage areas. It should include a desk, work table, bookcase, filing cabinets, and two chairs. A clothes closet and toilet room should be adjacent.

For activities on the nursing units, mobile cabinets, containing materials and equipment, will be required. Space, near the therapist's office, should be available for the preparation and storage of these carts. The carts may be approximately 24 by 42 by 36 in. high.

A bulletin board, near the entrance door, should be provided.

### Nursing Units

Nursing units are recommended to be designed for not more than 25 patients.

They should be arranged for the segregation of patients of different classifications. In the larger service segregation for the various classification is accomplished by having a nursing unit for each classification. In the smaller service, it is necessary to provide these separate areas in the same nursing unit. The nursing units of the smaller service are, therefore, more complex in arrangement as contact between patients of different classifications should be prohibited or controlled. Great flexibility is needed in the placing of patients as each must have an acceptable situation in which he may express his personality as it is in his illness, and under modern treatment programs, patient behavior improves rapidly. It is desirable to provide, in the receiving building, segregate areas for classifications of patients, as determined by behavior characteristics as follows:



GGESTED TYPE PLAN OF AN 80- TO 100-BED RECEIVING AND INTENSIVE TREATMENT BUILDING

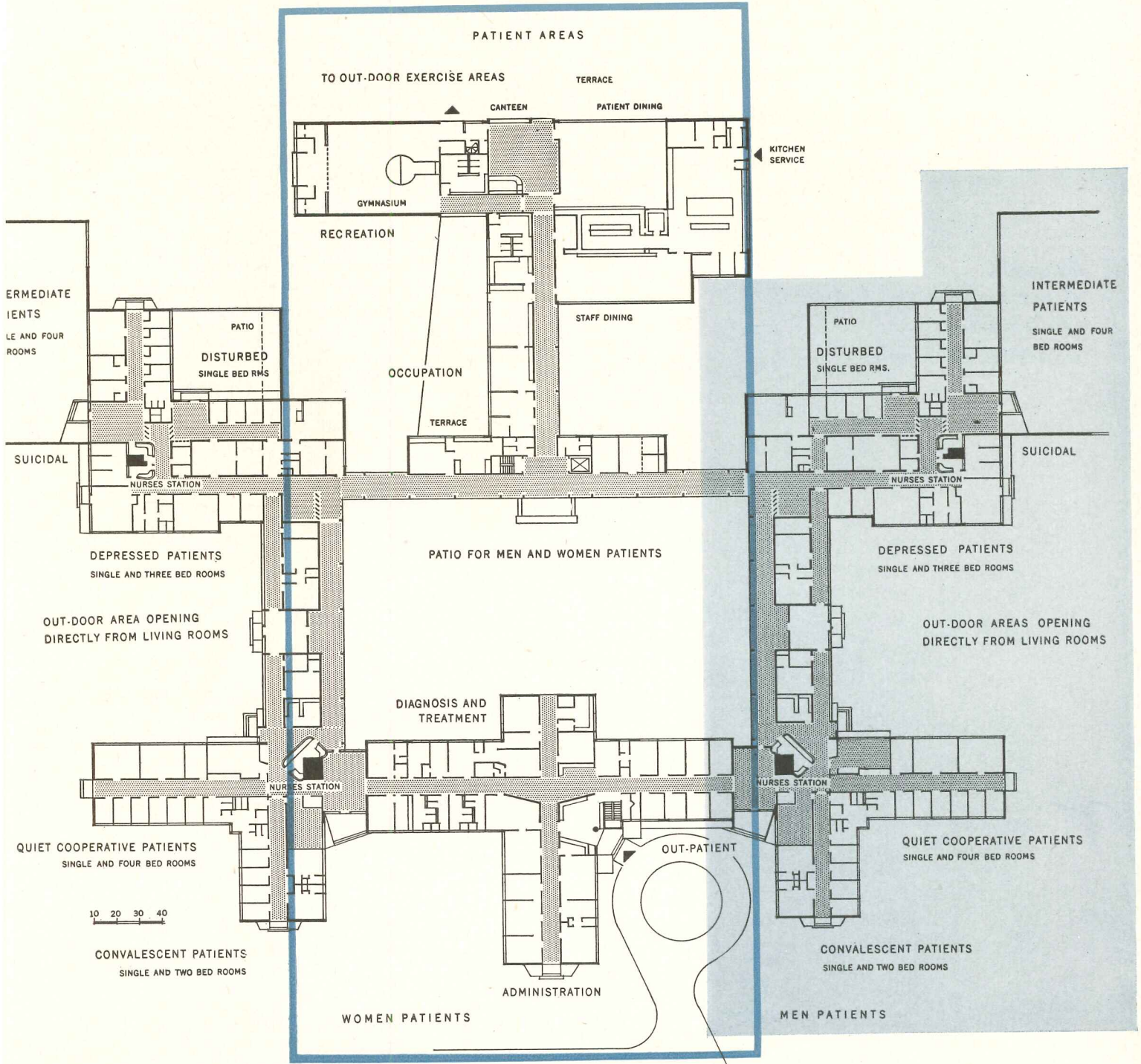

*Convalescent and quiet patients are located in nursing units near the front of the building and have access to front yard areas. Nurses' stations of the front wards have observation of front and side yards as well as the partially enclosed patio where men and women patients may be together. (Enclosed areas are detailed on succeeding pages.)*







**ELEMENTS OF THE RECEIVING AND INTENSIVE TREATMENT BUILDING**

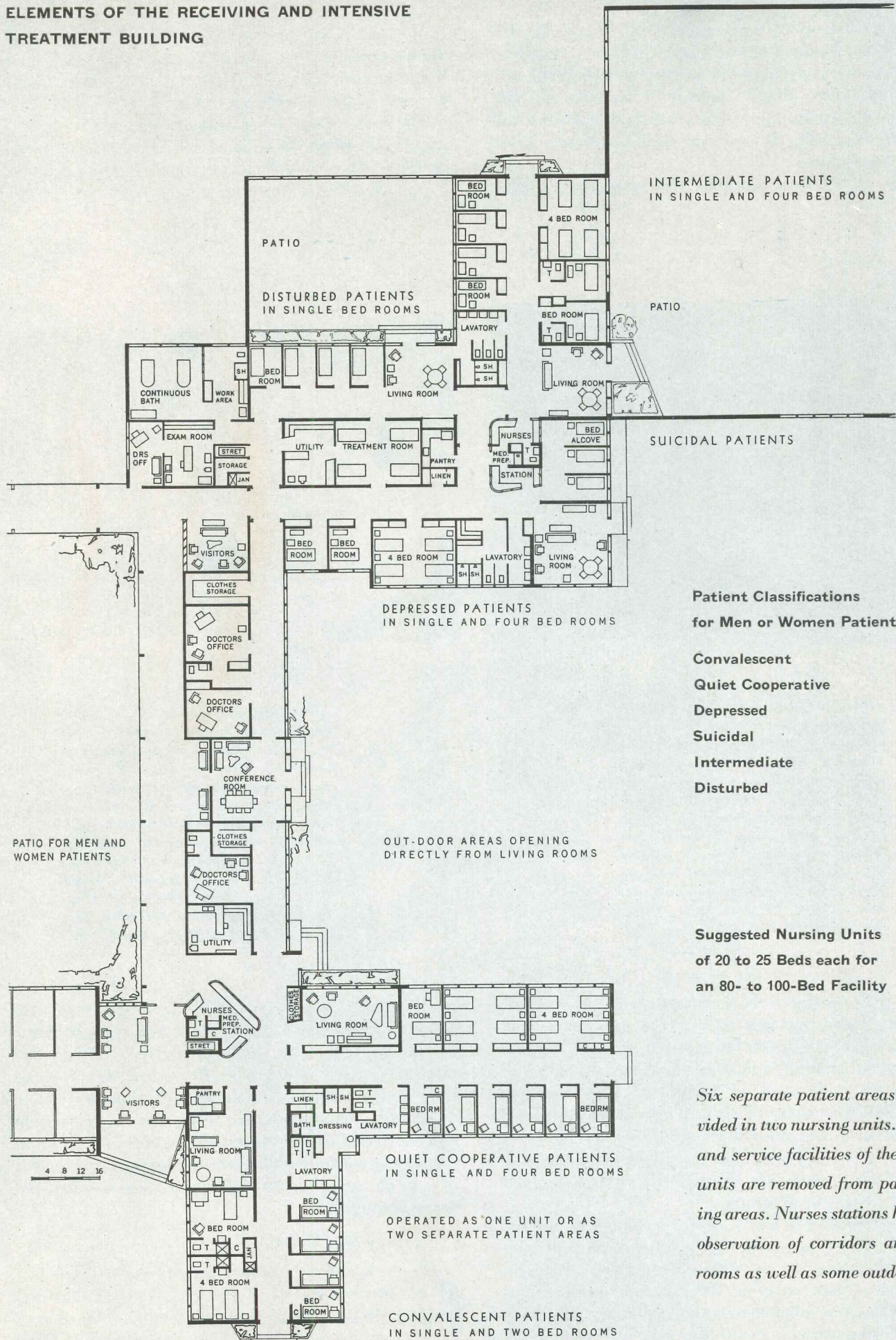

**Patient Classifications for Men or Women Patients**

- Convallescent
- Quiet Cooperative
- Depressed
- Suicidal
- Intermediate
- Disturbed

**Suggested Nursing Units of 20 to 25 Beds each for an 80- to 100-Bed Facility**

*Six separate patient areas are provided in two nursing units. Medical and service facilities of the nursing units are removed from patient living areas. Nurses stations have good observation of corridors and living rooms as well as some outdoor areas*



convalescent, quiet and cooperative, depressed, disturbed, suicidal and intermediate. Additional classifications, such as senile and arterio-sclerotic patients, are required. These may be housed in the adjacent convalescent cottages since their program of activities will be different from that of more active patients of the receiving service.

The convalescent cottages, also containing nursing

cation area from the nurses' station. With the use of double corridors, nursing units of 25 beds each have been devised with five separate areas each having access to separate outdoor recreation areas.

The major divisions of patient areas in the nursing unit for the receiving building will, then, be determined by the number of nursing units which are to be planned.

For facilities within the nursing unit see section

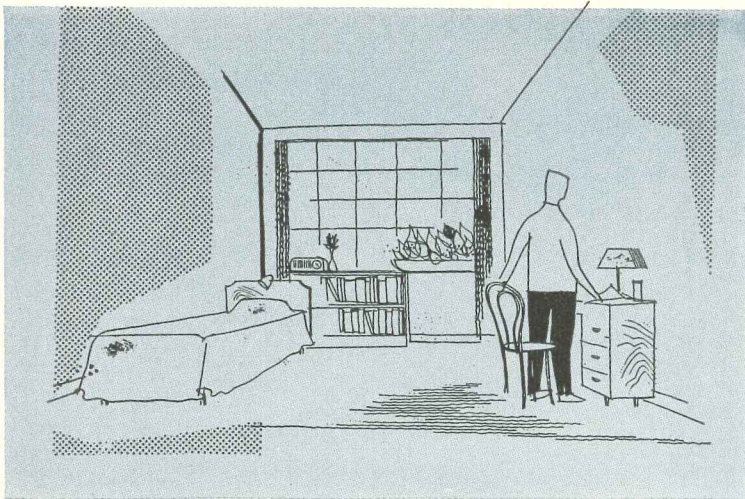

*"Psychiatric patients generally have been non-assertive, sensitive people who have difficulty in finding a life and place in group living. As they have much difficulty in relating to a group, and even trouble in individual relationships, it is advantageous to have single sleeping units where they can have privacy and a place they can consider their own." From "Functional Design of Psychiatric Hospitals," by Leslie A. Osborn, M.D., Vol. 109, No. 2, American Journal of Psychiatry, Aug. 1952.*



*"The gentle influences of environmental manipulation, emotional education, and step by step resocialization are brought to bear in the theatre, on the playing field, in the gymnasium, and within the structured society of the nursing unit where every identifiable stress is regulated and where the patient who may have returned to the behavior patterns of childhood can be helped to rebuild a personality." From "The Modern Mental Hospital," by Paul Haun, M.D., American Journal of Psychiatry, p. 165, Vol. 109, No. 3, Sept. 1952.*

units of 25 beds are considered a part of the receiving service. These cottages may house the senile and arterio-sclerotic patients for a period of approximately four weeks while their diagnosis is being completed or during the full course of treatment of those whose prognosis is favorable. They will also house additional patients of a convalescent classification who may live in an open situation, and groups of patients of a similar age, personality, illness, etc., who are under similar treatment programs.

In the small service of only two nursing units of 25 beds each it is possible to have separate bed room and living room areas with each having access to separate outdoor areas for the principal classifications of convalescent, quiet-cooperative and disturbed. These can be arranged with good observation of each classifi-

on Psychiatric Service in the General Hospital, page 152. The requirements will be similar except that many advantages are to be obtained in the receiving and intensive treatment hospital. These are: direct access from living rooms of each patient classification to separate outdoor areas for recreation or relaxation; greater freedom for patients and greater opportunities for self-expression; greater possibilities for development of suitable occupational and recreational therapy and group activities.

#### Dietary Facilities

Many state mental hospitals have a central kitchen for the preparation and cooking of food for the total hospital. Many have a central dining room for all patients who may leave their cottage. For those



patients who cannot leave their cottage, food is brought in bulk to a serving and dining facility in the particular cottage. In mental hospitals, where food must be transported over long distances, a most serious complaint is that it becomes unpalatable by the time it reaches the patient. Inasmuch as food is most important in patient welfare and good will, serious study must be given to the method of food service to the various patient classifications.

The receiving and intensive treatment facility should have a food service, insofar as cooking and serving is concerned, which is separate from the central food service. Supplies, prepared as required, should be obtained from the central storage and preparation facility, but cooking and final preparation for serving should be done at the receiving building. A dining room, or dining rooms, having cafeteria service would then serve all cooperative ambulant patients from the receiving building and convalescent cottages. Where a day-care program is included, patients of this service would also be served here. For patients remaining in the nursing units of the receiving building and convalescent cottages, bulk food carts, insulated and heated, may be used to transfer food to the serving pantries of each nursing unit. Patients remaining in the nursing unit may be served in small dining rooms, or on facilities in a day room, or in their bed rooms.

The dining room and kitchen should be located for convenience in traffic flow of patients, of prepared bulk food to nursing units and of service roads to the kitchen. The service roads to kitchen should not interfere in the development of patient outdoor exercise and relaxation areas. These outdoor areas, to be most successful, should be located immediately adjacent to the nursing units. Improper location of service areas may prohibit their successful development. Where day-care programs are a part of the hospital services, it is desirable to have the kitchen and dining facilities between in-patient and out-patient areas.

Dining rooms should be quiet, uncrowded, well lighted and well ventilated. Cafeteria service, offering a choice of food is recommended. Dining is an important item of therapy for the ambulant patient and every effort should be made to provide for this activity in an attractive, relaxed atmosphere. In planning the dining space some allowance for dining of staff with patients or groups of patients should be made as this may be desirable, particularly with the new patient. Most of the staff, however, may dine in the central staff dining facilities of the hospital.

Efficient kitchen design is a highly specialized subject and employment of a competent kitchen engineer is desirable for detailed preparation of plans and equipment. For preliminary programming and planning suggestions reference may be made to material prepared for the general hospital.

### Materials and Finishes

The degree of safety and security required throughout the receiving and intensive treatment building and the

adjacent convalescent cottages may be determined by many factors which will vary with each institution. A modern service providing an active medical program with adequate staff and supported with a variety of therapies in occupation, recreation, etc., will require much less security than will the custodial service. Also, the type of buildings which are provided will have their effect on patient reactions; those designs

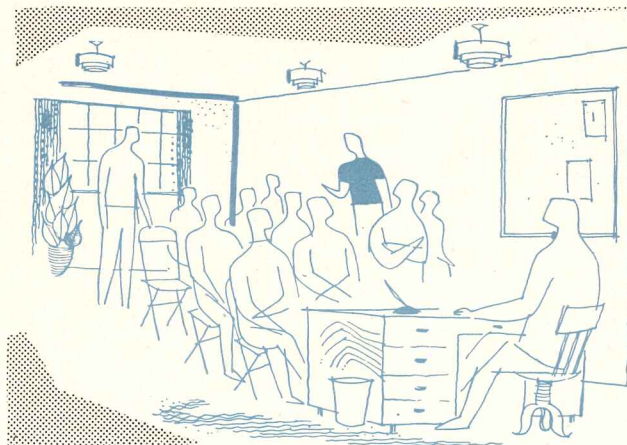

*"But today we are on the verge of a new and even more exciting adventure in the treatment of mental illness. We are discovering how to loosen and manipulate the powers of the group. This power has been known for years in terms of morale, but it is only now that the structured group is being brought into play to help the patient in the mental hospital." In "Design for Health," by D. Ewen Cameron, p. 5, Mental Hospitals, Nov. 1952.*

which provide for easy segregation of patients of different age, personalities, behavior, etc., and for flexibility in the placing of patients; those which provide patients with some freedom of choice of activity in living rooms, porches and outdoor exercise areas, as parts of each nursing unit, will require less safety and security than, for instance, the multi-story building in which, generally, the patient must be conducted to different areas for the various activities.

Requirements of materials and finishes for the various facilities of nursing units are discussed in the section on the Psychiatric Service in the General Hospital. While the requirements for nursing units in the receiving building and convalescent cottages may vary from those, the schedule may be used as guide material in programming for new facilities.



# PSYCHIATRIC SERVICE IN THE GENERAL HOSPITAL

By Alston G. Gutfersen

Hospital Architect  
U. S. Public Health Service

THE comparatively rapid growth, in recent years, of the psychiatric service in the general hospitals, and the changing attitudes toward nervous and mental patients, are responsible for the development of nursing units which are becoming increasingly simpler. Facilities for a large percentage of these patients, except for day living and recreational areas, are becoming more like those of medical nursing units of the general hospital. In at least one instance, 75 per cent of the patients who were received, without screening, during a three-year period were treated entirely on open medical nursing units, and the remaining 25 per cent were in the locked section, or units, only part of the time.

psychiatric conditions during the course of their treatment for another illness. Out-patient services will provide for follow-up care of patients who have been on intensive treatment and for early care of those who may continue to live and work in the community. It may also provide a child guidance clinic.

Many psychiatric services in general hospitals will not include all of the above services. Also the services may vary as to the patient classifications, by behavior characteristics, which the general hospital will accept for treatment. It is only after a careful survey of community needs and an evaluation of the diagnostic and treatment services which the particular general

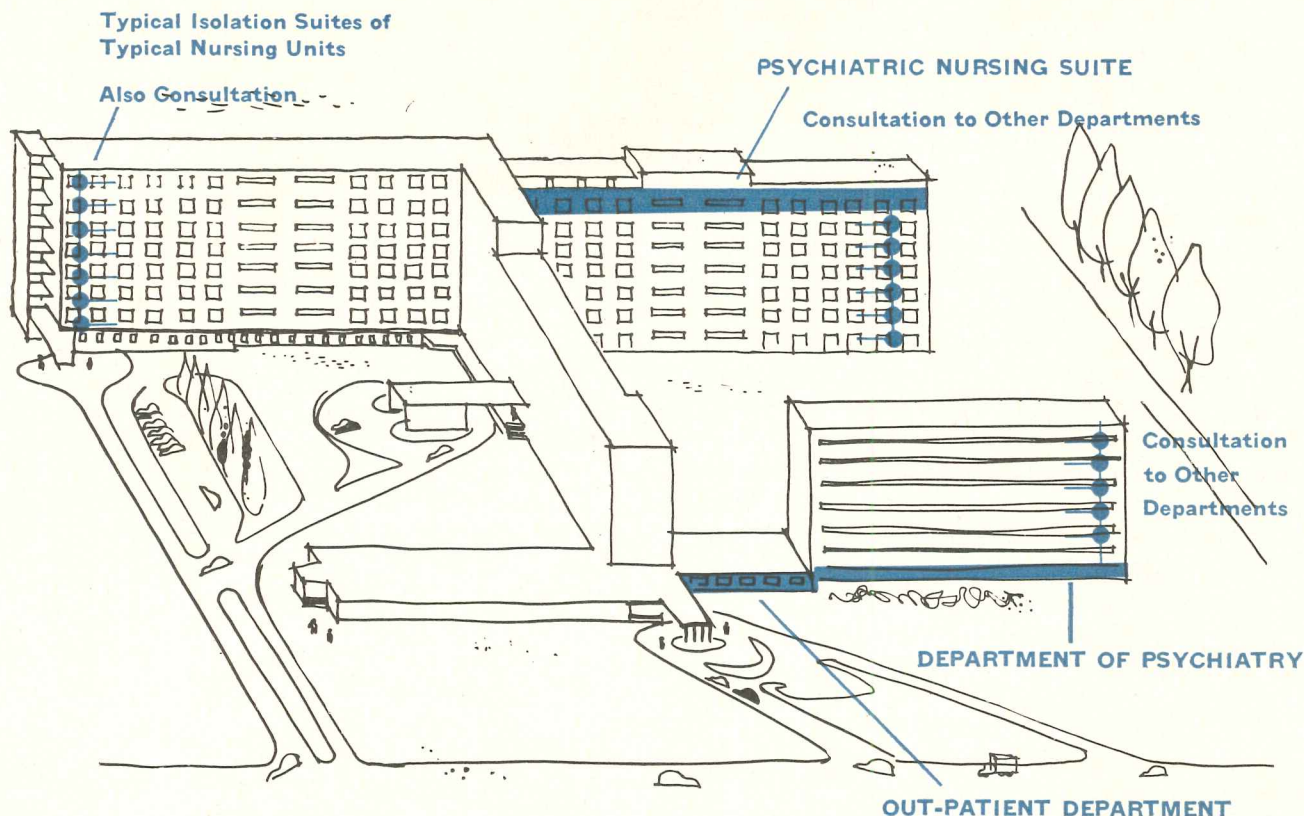

A complete psychiatric service will provide for the receiving and diagnosis of all types of patients and for the treatment of patients of favorable prognosis on a short term basis. Facilities will be provided in both the in-patient and out-patient areas of the hospital.

In-patient services may include living and treatment facilities in: a locked section for patients having periods of confusion and excitement; an open, or unlocked, section for convalescing and for day- or night-care patients. Provision may also be made for short-term treatment on medical nursing units without transfer to the psychiatric facility of those patients exhibiting

hospital can support that the number of beds and the types of services to be rendered can be determined.

### The Program

When the number of beds and types of mental health services to be offered have been determined, a program should be developed. This program should state the patient classifications, by behavior characteristics, for whom treatment is to be given, the number of each and the facilities, areas, equipment and personnel each group will require in the treatment program. It should clearly state the requirements of each depart-



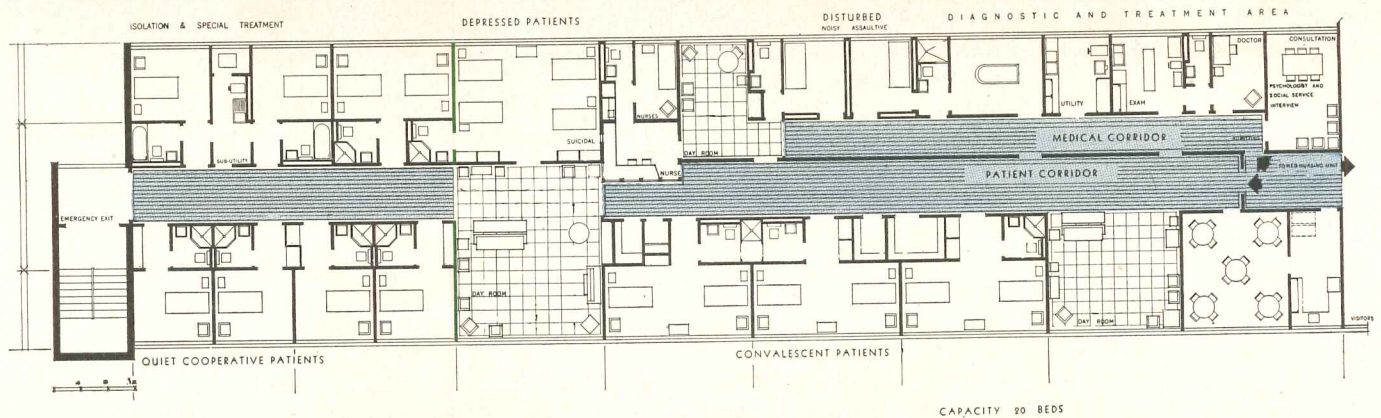

**SUGGESTED PLAN OF PSYCHIATRIC WARD FOR THE GENERAL HOSPITAL**

The plan shown above was developed for use with a new type and structure of medical nursing unit which has had much favorable comment. This is shown on page 18 of the "Elements of the General Hospital" and provides greater privacy, more uniform lighting and ventilation and greater convenience for the patient. In the plan shown here, a desirable separation of patient living areas and medical treatment areas is illus-

trated. Separate living areas, including bed rooms and living rooms, are then provided for "convalescent," "quiet" and "disturbed" patients. An additional separate special treatment area, complete with sub-utility facilities to be used for prolonged isolation or medical treatment, is also included. The four bed room, adjacent to the nurses' station, is provided for those patients who should not be isolated or who may need constant ob-

servation. It may also be used for insulin treatment where the treatment is not given in single rooms. Effort was made to provide flexibility in the placing of patients according to differences in treatment programs, behavior, age, personality, etc. Disturbed patients are isolated beyond the medical corridor, but are under observation of the nurses' station and may be transferred easily to other areas for day programs if desirable

ment, each service and each activity in terms of desirable arrangement, major items of equipment and personnel to be employed. Too much importance cannot be placed on this preparatory work as the architect cannot satisfactorily design and specify areas, traffic patterns, equipment and materials unless he has a complete understanding of the requirements of each of the activities and their interrelation. After the program is complete, the architect will translate the information into preliminary sketches. During this period there will be much discussion of the program and the sketches. Changes may occur in both in order to more nearly satisfy the total requirements. After approval of the preliminary sketches, the architect can proceed with the preparation of working drawings and specifications.

### In-Patient Facilities

*Open and Locked Sections.* In the design of nursing units for general hospitals, two major divisions are recommended: (a) an open section for convalescing and day patients and (b) a locked, or closed, section for patients having periods of confusion or excitement. Both divisions will require provision of living and recreation rooms for daytime activities, though in other respects the open unit may be similar to medical nursing units. The locked section should have separate bedroom and living rooms areas for the segregation of patients of different behavior characteristics. The desirable minimum number, for planning purposes, of patient classifications in the closed section are: quiet, depressed and disturbed. In the large service, separate nursing units may be provided for each classification. In the small service, which must have

both the open and locked sections provided in a single 25-bed unit, it may be necessary to provide only two separate areas in the locked section. The arrangement should be flexible in order that full use of all facilities may be made at all times, as patient behavior and classifications change during the treatment program. The recommended maximum size of nursing units for the closed section is 25 beds. The open section may have nursing units up to 40 beds.

The percentages for each classification vary greatly in different localities and with the services to be rendered by the hospital. Preliminary average estimates for each group for discussion purposes may be approximately: (1) Convalescing patients 30 to 40 per cent; (2) day patients 5 to 10 per cent; (3) quiet patients 30 to 40 per cent; (4) depressed patients 20 to 25 per cent; (5) disturbed patients 5 to 10 per cent.

### Facilities of the Nursing Units

Facilities within the nursing unit<sup>1</sup> may be divided into (1) patient accommodations and (2) treatment facilities. It is desirable to separate treatment facilities from patient accommodations in order to provide an appropriate environment in the patient area, as patients who are engaged in recreational or occupational therapy, or relaxation, should not be distracted by patients receiving special medical treatment. Comfortable and attractive surroundings in the patient area will encour-

<sup>1</sup> Nursing units for the psychiatric service in the general hospital will most likely vary from those in the receiving building, though the same principles will apply. The above, written for units in the general hospital, is amended, by notes, to apply to units for receiving buildings.



age informal group discussions, occupational activities, reading and social activities with participation of families.

Facilities of the patient area include: bedrooms, living rooms with closets for occupational and recreational therapy equipment, toilet rooms, bath and shower rooms, a patients' laundry for women patients of the locked section, pantry, dining room or space, and a nurses' station.

Facilities of the treatment area of the small service include: psychiatrist's office and interview room, medical examination room, psychologists' office and a visitors' room.<sup>2</sup> A room for continuous bath and pack treatments may also be included though neither treatment is used as much as formerly and opinions vary as to the need for these facilities in the small unit.<sup>3</sup> In the larger service the additional facilities which are required may serve more than one nursing unit. Interview rooms for use by psychiatrists, psychologists and psychiatric social workers should be provided in the

<sup>2</sup> In the receiving building, visitors' rooms may be in areas adjacent to the nursing units.

<sup>3</sup> In the receiving building, continuous bath tubs are recommended to be in the disturbed patients' area or nursing unit.

## DETAILS OF FACILITIES AND EQUIPMENT

### Toilet and Bathroom Units

Toilet and bathroom facilities for the open section and for quiet, cooperative patients can be as specified for medical and surgical nursing units.<sup>1</sup> Toilet and bathroom facilities for the closed section should be designed in accordance with the principals of psychiatric safety.

Toilet spaces for the disturbed and depressed patients area should be larger than for less confused or excited patients. Water closet stalls should be of sturdy construction. The top of doors to water closet stalls should be approximately 4 ft 6 in. from the floor and the bottom approximately 18 in. from the floor.<sup>2</sup> They should swing out and have no provision for locking. Water closets should be of the flush valve type with automatic flushing. The seat for the water closet should be reinforced.

Lavatories in the disturbed and depressed patients area may be of the institutional type and preferably having concealed supplies and trap though they may have exposed trap and keyed supplies. The faucets should be sturdy. Mirrors should be of heat tempered glass. Shelves, rather than hooks, for towels, soap containers, etc. should be provided, and recessed into the tile walls.

Water closet and lavatory rooms should

<sup>1</sup> In the receiving building, toilet facilities for convalescent and quiet, cooperative patients may be furnished with the bedrooms, or may be central in the nursing unit, though facilities should be arranged for privacy.

<sup>2</sup> In the receiving building, particularly the larger service, the hospital administrator may prefer that stall doors not be used.

be arranged for ease of observation while still affording the patient as much privacy as is possible with safety.

Showers, for the closed section, are recommended to be approximately 3 ft wide by 5 ft long. Institutional type shower heads are recommended and it is desirable to place these in the entrance lintel to the shower stall. The controls should be placed outside the shower stall. The lintel over the entrance should extend to the ceiling. A hand grip, recessed into the wall is desirable. Dressing areas should be provided.

### Food Service<sup>3</sup>

A serving pantry and small dining room should be furnished on both the open and closed nursing units. In the small nursing unit, treating all classifications of patients, one dining room is sufficient. In the large service, having several nursing units, a central dining room or rooms may be used for all patients of the open units and some patients of the closed units. In the small service, plates may be made up from hot food carts in the pantry and placed on the table for each patient. In the larger central dining area, a cafeteria service may be desirable. Provision should be made in the pantry for tray service to the rooms of those patients who are unable to go to the dining room.

Drinking water fountains should be

<sup>3</sup> For the receiving service, see "Dietary Facilities" of the *Receiving and Intensive Treatment Service*, page 202.

<sup>4</sup> For the receiving building, this may be in the occupational therapy area, and not in the nursing unit.

ratio of a minimum of one room to each ten patients. Receiving and special treatment bedrooms, insulin treatment suites and a staff conference room are desirable in the larger service.

Facilities in the nursing units which should be convenient to both the patient area and the treatment area are: utility room, linen closet, supply closet, janitor's closet, stretcher closet, patients' clothes room and attendant's toilet.

### Bed Rooms

Two-bed rooms may be used in the open section for the convalescing patients, and some may be specified for quiet patients of the closed section, though approximately 60 per cent of the beds of the closed section should be in single rooms. Single rooms are required for disturbed patients.<sup>4</sup> Single- and four-bed rooms are desirable for depressed patients. In general, two-bed rooms are unsatisfactory on the psychiatric service, except for convalescing patients.

One-bed rooms, two-bed rooms and four-bed rooms

<sup>4</sup> In the receiving building, single rooms are required in the disturbed patients' area, though in the large service some four-bed rooms may be used.

available to all patients. These should be recessed into corridor walls and be foot-operated.

### Patients' Laundry

Women patients will require a facility for the handwashing of personal garments. A small room in the nursing unit, near the day activity areas, should be equipped with laundry tubs, drying cabinets and ironing boards.<sup>4</sup>

### Patients' Clothes Locker Room

Patients of the psychiatric service will require a large wardrobe. Their stay in the hospital is longer than patients of the other services, and recreational and occupational therapy, requiring a variety of clothing, is a large part of their treatment program. Therefore, a clothes locker room will be necessary on each nursing unit for those articles which cannot be kept in the closets of the patients' bedrooms. The locker should be located near the entrance to the nursing unit. In addition to lockers for each patient, there should be luggage space and a table with equipment for the careful marking of all clothes and personal articles.

### Miscellaneous

Examination and treatment rooms, interview rooms, utility rooms, floor pantry, flower room, linen and supply closets, stretcher closet, janitor's closet may be as specified for medical and surgical nursing units, except that the principles of psychiatric safety must be observed as to locks, door swings, window protection, etc. in the closed section. If linen chutes are provided, they should be located within a



room off of the corridor. No areas, such as the stretcher closet, shall be left open, but shall have doors which swing into the corridor, and be capable of being locked from the outside only.

#### Materials and Finishes

In the open section, materials and finishes can be as specified for medical and surgical nursing units.

In the locked section, maximum security and safety should be provided in an unobtrusive manner. Care should be taken to avoid projections of structure, sharp corners, exposed piping, and no design should be accepted which could encourage attempts at hiding, suicide or escape. Simplicity of room arrangement and details is desired. The following discussion applies to the locked section.

In the closed section where rooms may be locked at times, local fire authorities should be consulted for the extent of precaution necessary for locked rooms. All structural members should be of non-combustible material. A two-hour fire resistive rating is desirable.

The construction of bedrooms for disturbed patients presents a special problem of noise. Bedroom wall construction is usually of four-in. hollow masonry block plastered both sides, and this does not always achieve the desired noise reduction. It is obvious that rooms for disturbed patients require an even greater reduction, because of noise transmission generated by impact on wall and floors.

To reduce the transmission of noise caused by impact, into rooms or corridors where it would be objectionable, double-wall construction may be used. A four-in. hollow block wall completely separated from a wall construction consisting of metal studding and metal lath may be used. The block construction should be on the disturbed patient side in order to reduce breakage of plaster surfaces. Where rooms for disturbed patients are adjacent, two completely separated walls of hollow block may be used.

Floors for disturbed patients' bedrooms also may need special consideration. In new construction, the structural slab may be depressed and a second slab poured over a one-in. thickness of wood or glass fibre, cork board, or similar cushion.

Ceilings do not present a tapping problem, but noise transmission may need to be considered. A suspended ceiling having blanket insulation may be sufficient.

The use of combustible material for finishes should be severely limited. Materials which have low smoke or flame producing characteristics should be used.

Most installations do not include construction in accordance with the above recommendations for floors, walls and ceilings. This may be due to the fact that there will be only a few instances in which such a room will be necessary, as modern treatment programs are effective in rapidly decreasing degree and length of disturb-

ances. The medical staff should assist by determining the extent of the problem as only they will be familiar with the type of patients who may be treated and the treatment program.

Ceilings should be of acoustical material except in rooms exposed to moisture where they should be of non-absorbent material.

Floors for patient areas can be of the same materials as issued in other patient rooms. Any type of resilient floor material which is reasonably resistive to indentation is probably the most satisfactory, except for one or two bedrooms for disturbed patients which should have non-absorbent, easy cleaning surfaces.

#### Protective Measures

When detention screens are used at window openings, any type of sash or glass may be used. The screen should be mounted flush with the wall surfaces at window head, jambs and sill to eliminate projections on which a patient may be injured. The best installation will provide operation of the sash by a removable crank without opening the screen. Provision should be made for release of the screen from the outside in case of emergency.

When detention screens are not used, windows of sturdy design, operated by removable crank, are recommended. These should be of such design that no opening large enough to permit exit is possible, while providing sufficient ventilation. Heat tempered glass should be used to reduce breakage. No window should swing into a room.

Since light may be too stimulating to some patients, it should be possible to darken the room easily. Shutters or venetian blinds should be installed between the detention screen and the sash. Sufficient space should be allowed between the screen and blinds or sash for movement of the screen under stress.

In the open section, doors can be as specified for medical and surgical nursing units.

In the closed section, all doors to patient bedrooms should have vision panels. Doors for quiet and depressed patients may be similar in construction to those in the open section. For disturbed patients, doors should be of sturdy design to resist damage and avoid noise disturbance. Special doors, having insulated wood panels set into solid wood frames, are available, as are metal clad solid core doors. Solid wood doors are probably the most satisfactory from the point of view of appearance and utility and where disturbed patients rooms are reached from sub-corridors, are satisfactory for noise resistance. Doors to patient bedrooms should be 3 ft 10 in. wide.

View panels in patients' bed room doors should be of heat tempered glass and approximately 8 in. wide by 12 in. long. They should be approximately 4 ft 6 in. from the floor for ease of observation. Shutters, on the corridor side, should be installed over the view panels.

Doors to the bedrooms may swing in or out. However, while it is true that a patient may barricade a door which swings into a room, the opinion of many is that there is better control of the patient with the in-swinging door. There is danger of injury to patients or personnel or damage to structure or equipment from an out-swinging door which may be thrown open too quickly. Out-swinging doors are more difficult to secure adequately, and where a number of rooms occur along a corridor, diminish ease of observation of the corridor from a nurses' station.

Doors to bathrooms, closets, patients' laundry room, should swing out and be capable of being locked from the outside only. The patients' laundry, utility room, pantry room, entrance and corridor doors should have view panels.

Local fire authorities should be consulted on door swings to rooms which are to be locked. All nursing unit exit doors should swing out.

In the open section, heating may be as specified for the medical and surgical patients. In the closed section, radiant panel heating from floors, walls or ceiling may be used. In disturbed patient bedrooms, radiant heating in the floor is desirable.

Air conditioning in the disturbed patients' area is recommended, both for patient comfort and in order that windows may be closed to prevent noise disturbances to street or adjacent patient areas.

If radiators are used for heating, they should be recessed into the walls and covered with metal grilles placed flush with wall surfaces. A cove at the interior corner of the jambs, head and sill of the recess will facilitate cleaning.

In the disturbed patients' area, recessed lighting fixtures with heat tempered glass covers are recommended. Outlets for floor or desk lamps should be placed 7 ft 6 in. from the floor. Night lights should have heat tempered glass covers. Nurses' call systems, especially designed for disturbed patients areas, are being manufactured. Convenience outlets for electric shavers may be provided in the toilet rooms.

For plumbing fixtures, see section on Toilet and Bathroom Units.

In the closed section, doors should have hospital type hinges and roller latches. Single-seated hospital arm pulls, turned down, may be used in the quiet and depressed patients area. In the disturbed patient area, these pulls may be used on the corridor side of the patients' room and flush cup pulls on the room side. Locks should be dead bolt operated by key only, and it should be possible to lock the patient rooms, bathrooms, storage closets, etc., from the outside only. Interview offices, examination, conference, treatment rooms, etc. should be capable of being locked from both sides and by key only. It is recommended to key all locks, excepting drug cabinet, within the closed section, to one key. Entrance and exit doors to the unit should be on a separate key.



for the open section should be similar to those for medical and surgical nursing units for reasons of flexibility of use, except that cubicle curtains should not be used.<sup>5</sup>

Bed rooms for the closed section should be designed in accordance with the principles of psychiatric safety. There should be no projections of structure, piping, sharp corners, etc., on which an excited patient may injure himself. A simple room, all of which can be seen at a glance, is desirable. Details of these conditions are discussed under "Materials and Finishes."

Eighty sq ft per bed in two-bed and four-bed rooms and 100 sq ft in single rooms is the minimum desirable size for bed rooms.<sup>6</sup>

Approximately 10 per cent of the bed rooms for quiet patients should have private bath with tub, as these will be required in the treatment program for some patients.

Clothes closets should be furnished in all bed rooms of the open section and for the quiet patients of the closed section. They are desirable in rooms for depressed and disturbed patients, though the closet doors should open into the corridor rather than the room. The nurse would retain the key for depressed and disturbed patients' closets.

**Living Rooms**

Living rooms should be comfortable and attractively furnished for informal activities of relaxation, reading, group discussion, writing, etc. There should be at least two, one small and one large, for each nursing unit, except where more than one classification of patient is

to be in a single nursing unit, there should be a living room for each classification.<sup>7</sup> This will provide the necessary flexibility of use by patients of different sex,<sup>8</sup> behavior, age, activities, etc. The larger living rooms should have large closets for storage of occupational and recreational therapy equipment for the more organized activities.

Living room area for nursing units is recommended to be from 40 to 50 sq ft per patient.

**Nurses' Station**

The nurses' station for open sections can be as specified for medical or surgical nursing units.<sup>9</sup>

Nurses' stations in the closed section should be enclosed and located to provide good observation of corridors and living rooms. Most designs show these enclosed with glass to provide unobstructed observation. This design has the added advantage that many patients will be reassured if they are able to see a nurse at all times. It should be remembered, however, that privacy for the nursing staff is required in the medical preparation area and in the area for record making, conferences, telephone, etc. An ideal arrangement for a nurses' station would include the charting counter area, glazed and projecting into the corridor and adjacent to a living room for good observation, a separate small medical preparation area and an adjacent interview room for use by the staff only. The nurses' toilet should be nearby.

<sup>5</sup> In the receiving building, where use by medical or surgical patients is not a consideration and where only ambulant patients are treated, the rooms may be smaller (see 6) and furnished with studio type (or low) beds.

<sup>6</sup> In receiving buildings, 70 sq ft per bed in alcoves and four- (or more) bed rooms; and 80 sq ft in single rooms is noted as a minimum requirement in Public Health Service Regulations.

<sup>7</sup> In the receiving building, where one-story construction is more likely to be used, living rooms should open directly to separate outdoor areas for recreation and relaxation. This is an important difference and influences greatly the type of service which can be furnished.

<sup>8</sup> In the receiving building, there would be separate nursing units for men and women patients.

<sup>9</sup> Privacy of records must always be insured.

**SUGGESTED PLAN OF PSYCHIATRIC WARD FOR THE GENERAL HOSPITAL**

**For Disturbed, Quiet and Depressed (Men and Women) Capacity 30 Patients**

*This plan provides possibilities for an "open" section and a "closed" section; separation of medical treatment areas from patient living areas, and an area for disturbed patients separate from that for "quiet" and "depressed" patients. The receiving or special treatment*

*bed rooms are conveniently located with reference to the medical area and the entrance to the unit. A single or four-bed room adjacent to the nurses' station may be a more desirable arrangement for patients requiring constant observation than the two-bed alcove which is shown.*

*Where a larger service is to be operated, the unit shown would be operated as the closed unit, with a typical medical unit operated as the open unit*

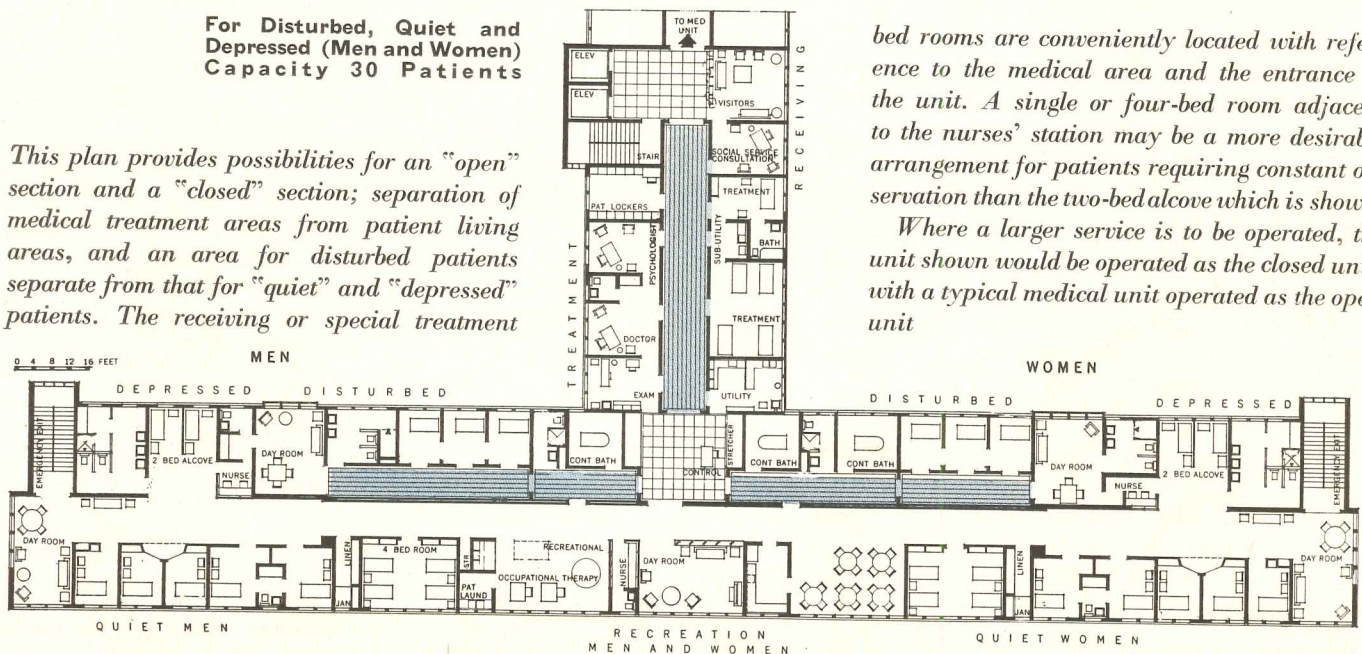



It is also desirable to provide a single- or four-bed room adjacent to the nurses' station for continuous observation of patients, when necessary.

Glass used for enclosing the nurses' station or for observation panels should be heat tempered.

### Recreation Facilities

Areas for outdoor exercise and relaxation should be provided. These are preferably located on the grounds of the hospital, but where this cannot be accomplished, roof areas may be developed. Roof areas should be carefully protected.

The hospital having a large psychiatric service will require an exercise gymnasium. The types of exercise provided may include handball, ping-pong, shuffleboard, gymnasium exercise equipment, etc.

### Occupational Therapy Facilities

In the large psychiatric service of the large general hospital, there should be a central occupational therapy department to provide a diversity of programs to meet the needs of the individual patient. Part of the lighter occupations such as sewing, typing, reading, music and painting, will be supervised on the nursing units in the living rooms. Those occupations requiring more or heavier equipment will be conducted in the central department. These may be woodcarving, model making, block printing, painting, weaving, typing, leatherwork, etc. In the small service of only one nursing unit, a room in addition to living rooms should be provided for some of the heavier and noisier activities.

### Receiving and Special Treatment Bedrooms

Some new quiet patients may have difficulty in adjusting to the hospital atmosphere. Also, some patients may be in need of special treatment or observation which may be better conducted out of the patients' living area. For this reason, one or two bed rooms with private bath and sub-utility are advisable in the treatment area of each nursing unit. They will be used in administering many treatments requiring isolation such as: fever treatment, narcosis, electric shock, etc.

If one of these rooms is enlarged to four or more bed capacity, it may be used for insulin treatment. The amount of insulin treatment varies in hospitals. It is best administered in the patient's bedroom, but since it requires constant and careful nursing for approximately a four-hour period, some hospitals provide a special large treatment room. If this is done, a small utility room for preparation and a room for difficult recoveries should be included nearby.

The small service will probably not be able to provide a special insulin treatment room and may use a four-bed room for this purpose.

If hydrotherapy is to be included, two tubs may be sufficient in the small unit. Since continuous flow bath treatments cannot be scheduled, there must be two separate tub rooms where men and women patients are being treated.<sup>10</sup> Tubs should be placed a minimum of three ft six in. from the wall. Where more than one tub

is to be in a room, the tubs should be placed a minimum of eight ft on center. In the large service which has several tubs, some single tub rooms, for use by noisy patients, should be provided.

Pack treatment may be given on movable or fixed tables. Tables should be a minimum of eight ft on center and three ft six in. from the wall. In the small unit pack treatment may be given in the tub room, on a wheel treatment stretcher with wheel locks, or in a single-bed room.

Linen and blanket closets, laundry tub, ice bin for compresses and blanket warmer should be included in the area for continuous flow bath and pack treatment. Where stimulative salt rub treatments are given a hydrotherapy shower would also be required. Water closets and dressing rooms should also be provided.

Continuous flow bath and pack treatment rooms should be adjacent to disturbed patients' bed room areas, and accessible to patients of other classifications.

### Entrance Halls

Main stair or elevator lobbies should be convenient to, but not within, the nursing unit. They should be accessible from patient areas only through locked doors. Stair halls should be completely enclosed and be capable of being locked. Stair walls, or balusters, should be continuous from stair to stair and not stop at the hand-rail. While all security and safety measures should be observed in entrance and stair lobbies, they should be unobtrusive. The area should be attractive and reassuring as first impressions of the in-patient units may be formed at this point.

Visitors' rooms should be adjacent to, but outside the nursing unit. They should be attractive rooms, comfortably furnished and arranged to provide privacy for two or three groups of patients and visitors.

### General Arrangement of Facilities in a Small Nursing Unit

The larger psychiatric services, having several nursing units, each one of which is designed for a particular patient classification, can be comparatively simple in arrangement. Patient living areas can be easily separated from treatment areas. It is the small service of 20 to 25 beds having facilities for several patient classifications that is difficult to design.

In planning the layout of the small service, it is desirable that the staff, upon entering the nursing unit, be able to go to the area of treatment facilities without entering the patient areas. Where the entrance is near the center, as in Tee or Cross-form plans, this is simple, as from this central point one may go to any separate patient area or to the treatment area. Nurses' stations near the converging corridors may have supervision of

<sup>10</sup> Separate suites will be provided for men and women patients of the receiving service. Approximately 50 per cent of the nursing units of the convalescent cottages are recommended to have a continuous flow bathtub. Those will not be used by disturbed patients, but by neurotic patients who may benefit by this relaxing, sedative hydrotherapy.



each corridor and be near the treatment area. Such a layout can be very flexible in operation as each wing may be operated separately for a special group or treatment program or all wings may be operated together. In the straight line plan, double corridors may be used to advantage in providing access to separate patient areas or the treatment area.

In the small units where disturbed patients' living room and bedroom areas are completely separated from other patient areas, as is desirable, a sub-nurses' station will be required. No patient should be left unobserved except for very short periods.

All diagnostic and treatment facilities of the general

hospital will be available, without change, for use by the patients of the psychiatric service as required. If an electro-encephalograph is added to these facilities in the small hospital, it may best be located with the laboratory suite or in the same room with the basal-metabolism equipment. In the large hospital, it may be desirable to locate the electro-encephalograph adjacent to the neurological nursing unit, in order to reduce, as much as possible, anxiety or excitement which may occur in travel to the examining room.

Out-Patient Facilities

See section on Out-Patient Facilities, page 211.

EQUIPMENT LIST

1. Built-In Lockers
  2. Bedside Cabinet
  3. Adjustable Hospital Bed
  4. Straight Chair
  - 5-R Nurses Calling Station with Duplex Receptacle, Contagious Type
  - 6-R Sliding Window Curtain
  7. Waste Paper Receptacle
  8. Lavatory with Goose Neck Spout and Knee or Elbow Control
  9. Wall Bracket, Switch Controlled
  - 10-R Bed Light
  11. Corridor Dome Light
  12. Night Light, Switch Controlled
  13. Over Bed Table
  14. Utensil Sterilizer 20" x 20" x 24"
  15. Sink and Drainboard
  16. Linen Hamper
  17. Nurses Calling Station (Push Button Type)
  18. Grab Rail
  19. Water Closet with Bed Pan Lugs and Bed Pan Flushing Attachment
  20. Hook Strip
  21. Dome Light and Buzzer, 5'6" Above Floor
  22. View Panel with Heat Tempered Glass Approx. 8" x 12" x 12" and 4'6" from floor
  23. Obscure Glass
  24. Coat Hook
  25. Sanitary Waste Receptacle
  26. Shower
  27. Ceiling Light
  28. Detention Screen
  29. Shutter
  30. Duplex Receptacle
  31. Easy Chair
  32. Desk
  33. Desk Lamp
  - 34-R Mirror
  35. Night Light with Heat Tempered Glass and Switch Controlled from Sub-Utility
  36. Air Conditioning Unit
  37. Supply and Exhaust Openings with Grille
  38. Telephone Outlet and Duplex Receptacle
- Note: All numbers noted with an "R" denote that the item is removable.

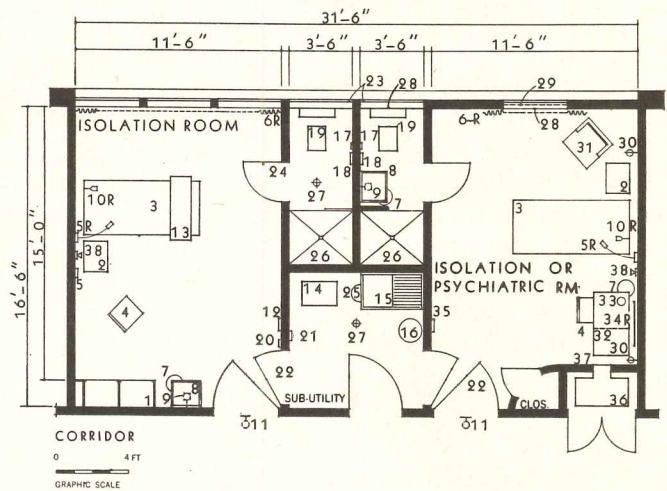

Plan No. 1. ISOLATION AND PSYCHIATRIC ROOMS

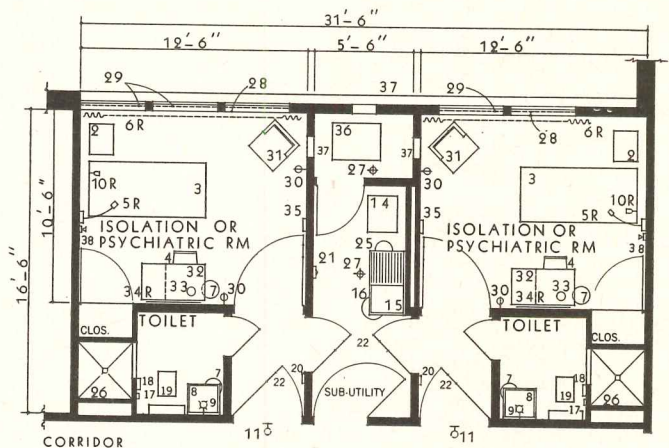

Plan No. 2. ISOLATION AND PSYCHIATRIC ROOMS

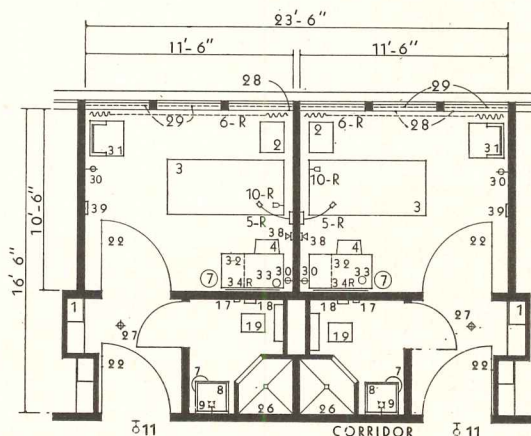

Plan No. 3. PRIVATE SPECIAL TREATMENT ROOMS



### Isolation Suites

Small community hospitals, in increasing numbers, have been providing a room, or a suite of rooms, within the medical nursing unit for the temporary housing of nervous and mental patients. These facilities are not intended to provide diagnosis and treatment of patients but only temporary housing, with medical attention, until their transfer to a psychiatric service can be effected.

Provision of this facility does not alter the desirability of including, in medical services to the community, psychiatric in-patient and out-patient services for diagnosis and intensive treatment in those general hospitals which are large enough to support the required staff and treatment facilities.

Rooms for the temporary housing of a nervous and mental patient should not be isolated, but should be in the nursing unit. The typical isolation suite, recommended for general hospital nursing units and consisting of two bed rooms, separated by private baths and sub-utility, may be used after some alteration to provide safety and security measures necessary for the protection of the hospital and the patient.

In the larger general hospital, which has a psychiatric in-patient service, these rooms would be necessary on every nursing unit of the hospital when the psychiatric service is expanded to include consultation to the other services. Patients who need special care may then receive short-term psychiatric treatment (possibly up to one week) without actual transfer to the more elaborate psychiatric in-patient nursing unit.

Plan Number I shows one room, altered so as to provide facilities for the care of an excited or confused patient. The lavatory has been moved from the bedroom to the bathroom. All equipment can be removed from the bedroom. In order that windows may be closed to prevent noise or other disturbances from reaching the street, air conditioning equipment has been shown in the location formerly occupied by clothes lockers.

Plan Number II, an alternate plan for an isolation suite, shows a relocation of the bathroom. In this new location an additional barrier against noise entering the corridor is provided. The entry accords good observation of the patient without disturbance to corridor traffic.

Both rooms have air conditioning. Care should be taken to avoid recirculation of air because of the possibility of cross infection, bad odors, etc. The air should be individually exhausted from each room without cross circulation through the entries.

Plan Number III retains the location of the bathroom as shown in Plan Number II, and thus insures complete privacy to the patients. It is assumed, where several rooms would be used, that central air conditioning from the corridor would be installed.

In the design of details and selection of materials, it should be kept in mind that these rooms will be used for the temporary housing only of nervous and mental patients; that perhaps only 10 per cent of these patients may be sufficiently excited to be termed disturbed, and that the room will be used by other than nervous and mental patients most of the time.

## OUT-PATIENT FACILITIES FOR MENTAL HOSPITAL SYSTEM

Out-patient facilities must be provided within the mental hospital system if it is to fully meet its community responsibilities. A large percentage of admissions to mental hospitals are readmissions. Mental health authorities agree that this readmission rate could be reduced if proper follow-up care could be provided.

In addition to providing follow-up care, it is desirable to provide care for new patients, in the early stages of their illness, when treatment will be most effective in forestalling long and costly hospitalization.

Out-patient mental health services may be in separate mental health clinics; in public health centers; in out-patient departments of general and psychiatric hospitals and in the receiving and intensive treatment buildings of state mental hospitals. Where they are in connection with receiving and intensive treatment facilities, the service can be enlarged to include day-care program.

In determining the size of the out-patient department, the number of interview offices which will be required

will be determined by the patient load and, or, the number of psychiatric teams which will be used in this service. The psychiatric team consists of one psychiatrist, one psychologist to each one or two psychiatrists, two to three psychiatric social workers, one nurse and two secretaries. Each team can be scheduled for 20 patient hours per week with the average patient interview being one hour.

The out-patient department of a complete hospital service is usually on the ground floor near the administrative area, convenient to diagnostic and treatment facilities and removed from in-patient areas. In health centers they will be located with other patient areas, except that in large health centers, separate areas with separate waiting rooms may be desirable. The usual arrangement will require: a receptionist's counter; facilities for records, appointments and cashier; a waiting room; admitting room; medical examination room; men and women's toilet rooms; interview offices for use by psychiatrists, psychologists and psychiatric social workers;

staff lounge and locker room; storage closet; and janitor's closet. A library and conference room for general staff review of patient's record, and for interview of family groups or for group therapy is desirable. Clerical office space will usually be required. If a child guidance clinic is to be included, additional waiting rooms, play areas, both in-door and out-door, and facilities for one way observation into both a large play room and small interview or playroom are required.

The waiting room, near the information counter, should be well lighted and ventilated, ample in size and attractively furnished to promote the psychological aspects so necessary to the treatment and care of any patient. If the mental health clinic is in a small general out-patient service, a separate waiting room is not required; in the large service a separate waiting room with separate entrance is desired. Furnishings should be comfortable and pleasant.

The medical examination room for the small general hospital out-patient service, mental health clinic or the re-



## MENTAL HOSPITALS

ceiving building of a state mental hospital may be placed with the other diagnostic and treatment services. In the large service a separate facility would be required. Requirements for this room are standard and will be similar to those in the general hospital.

Patients are generally referred first to the admitting room for consultation. It is desirable to have a waiting area near this room. The admitting room in the out-patient service of a receiving and intensive treatment service may be the same admitting room as is used for in-patients. In all other services a separate room will be required.

Interview offices for use by psychiatrists, psychologists and psychiatric social workers should be similar to the admitting room except that they may be smaller. In these offices complete privacy of interview or examination must be maintained during psychiatric or other interviews. It is desirable that

these offices be small, friendly and quiet in atmosphere. They should be sound-proof for privacy during interview. Offices for psychologists should have closets for equipment required for patient examination.

Play rooms for children's out-patient services should be furnished for both large group activities and for children at play alone. The large group room and at least one small room should have adjacent rooms for one way observation for both sight and sound. For children at play alone a standard interview room may be used. For the large group a special room should be furnished, and this should have direct access to an out-door play area. Movable chairs and tables and ample closet space for play equipment should be provided.

The conference room may include a small library in the small hospital. In the large hospital, and when a training program is included, a separate library

is necessary. In the small hospital it is desirable to have this combined facility near the medical record room in order to provide control of library books, and space for staff to consult records without removing them from the control of the record room. The room should have adequate shelving for unbound periodicals and space for motion pictures.

Staff lounge and locker space should be provided for the comfort of the visiting staff. The facilities should include a sitting room, lockers, telephone, bulletin board, paging outlet, clock and lavatories. The location of the physicians' parking space will usually determine which entrance is used. It is preferable that physicians, in order to reach the lounge, should pass the information desk and the door of the medical record room. This permits efficient in and out registration and enables the record librarian to check on case records.

## BIBLIOGRAPHY ON MENTAL HOSPITAL DESIGN

### Standards

Standards for Psychiatric Hospitals and Out-Patient Clinics Approved by the American Psychiatric Association\*  
Public Health Service Regulations  
B-3 Mental Hospitals  
B-4 Psychiatric Hospitals  
Public Health Service, Washington, D. C.

### Mental Hospitals

The Modern Mental Hospital  
Paul Haun, M.D.  
American Journal of Psychiatry, Vol. 109, Sept. 1952

Planning a Mental Hospital of Fifteen Hundred Beds  
Samuel W. Hamilton, M.D., and Mary E. Corcoran, N.O.  
Diseases of the Nervous System\*, Vol. XI, Dec. 1950

Design for Therapy  
American Psychiatric Association\*

Care of the Geriatric Patient  
Group for Advancement of Psychiatry, 3617 West Sixth St., Topeka, Kansas

Hospital Planning  
Butler and Erdman  
F. W. Dodge Corporation, New York, N. Y.

Hospitals—Integrated Design, Second Edition

\*Mental Hospital Service, American Psychiatric Association, 1785 Massachusetts Ave., N. W., Washington, D. C.

Isadore Rosenfield  
Reinhold Publishing Corporation, New York, N. Y.

### Psychiatric Service in General Hospitals

Bacon Library  
American Hospital Association  
Chicago, Illinois

Psychiatric Sections in General Hospitals  
Paul Haun, M.D.  
F. W. Dodge Corporation, New York, N. Y.

Psychiatric Nursing Units in General Hospitals  
Isolation Suites Detailed for Use by Nervous and Mental Patients  
Public Health Service, Washington, D. C.

### General Planning and Background Information

Psychiatric Service in the General Hospital  
A three year report of Services in the Barnes Hospital of the Washington University Clinics in St. Louis Hospital—Jan. 1947

Psychiatric Treatment in General Hospitals  
A. E. Bennett, M.D., and Eugene A. Hargrove, M.D.  
Journal of the American Medical Association, Vol. 147, Nov. 10, 1951

On the Positive Side  
2 articles

a. Physical and Chemical Restraint Reduced  
E. W. Miller, M.D.

b. More Can Be Done With Existing Facilities  
Sidney J. Tillum, M.D.  
American Psychiatric Association\*  
Mental Hygiene of the Aging  
Public Health Reports, Vol. 67, March 1952

Psychiatric Facilities in General Hospitals  
Jack R. Ewalt, M.D., and W. A. Cantrell, M.D.  
Texas Hospitals, Dec. 1949

Annual Proceedings  
Mental Hospital Institute  
American Psychiatric Association\*  
General Hospital Provision for Psychiatric Indicated  
Harold D. Williams, M.D.  
Also eleven other articles; Hospital Management, Jan. 1952

Planning Complete Occupational Therapy Service  
Wilma L. West and Alonzo W. Clark  
Hospitals, Oct. 1951

### Architectural Publications

Architectural Record—Oct. 1950  
Building Types Study No. 166—Mental Hospitals  
Ten New Mental Facilities  
Magazine of Building Architectural Forum Edition—Sept. 1951  
Occupational Therapy Building  
Magazine of Building Architectural Forum Edition—Sept. 1951  
Residence School for Boys



## SPACE REQUIREMENTS FOR ELECTRICAL EQUIPMENT IN OFFICE BUILDINGS

By G. B. Gusrae, Consulting Electrical Engineer

This is the first of a number of articles on planning for electrical systems in buildings. Provision of adequate space for electrical equipment is the primary concern here, since the extent and complexity of distribution systems in office buildings has increased considerably in recent years. Contributing toward this are acceptance of higher lighting levels and increased use of air conditioning.

There are many other considerations, though, and in succeeding articles, the relative importance of flexibility, safety, reliability, cost, maintenance and appearance will be analyzed for all types of buildings.

**T**HE ARCHITECT who designs a commercial building is, of course, vitally interested in obtaining the largest possible rentable area. He is generally aware that a reasonable amount of building space must be sacrificed to provide for mandatory mechanical and electrical equipment. It is, nevertheless, natural for him to tend to limit this space to the minimum.

The inconspicuousness of a well designed electrical distribution system in a building — the invisibility of the maze of ducts, conduits, cables and wires skillfully buried in the floor slabs, walls and

riser shafts — contributes to the architect's tendency to minimize the space requirements for the electrical equipment.

The overlooking or improper treatment of required spaces, however, will always result in unnecessary limitations and inconveniences, and may often cause a considerable increase in the cost of the equipment. It will reflect itself in an unsatisfactory utilization of the equipment and will prevent adequate planning for anticipated future needs. Lack of proper space for the equipment will contribute towards a premature obsolescence of the building.

### LIMITATIONS AND ASSUMPTIONS

Any attempt at a general discussion of adequate space requirements for electrical equipment in commercial buildings requires certain limitations and some generalized assumptions. Admittedly, these might be regarded as either arbitrary or too general. On the other hand, if such a discussion is regarded simply as a reminder of the space requirements necessary for adequacy — as a method and a check list rather than a compilation of inviolable design data applicable in all instances without discrimination — the arbitrary assumptions assume validity, subject, of course, to proper adjustment in relation to the actual conditions. The latter is the task of the electrical engineer.

For the purposes of this article, the types of buildings under discussion will

### TRANSFORMERS AND DISTRIBUTION SWITCHBOARDS

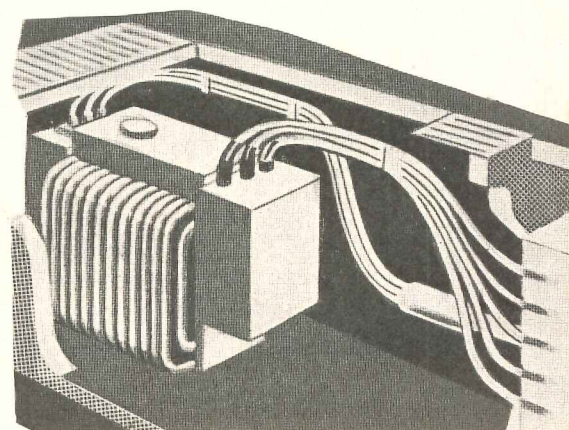
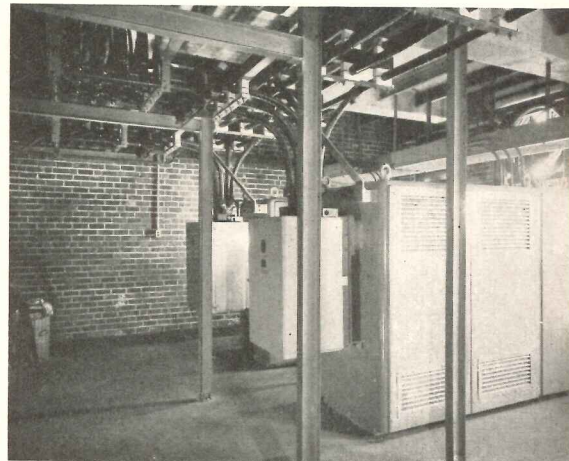
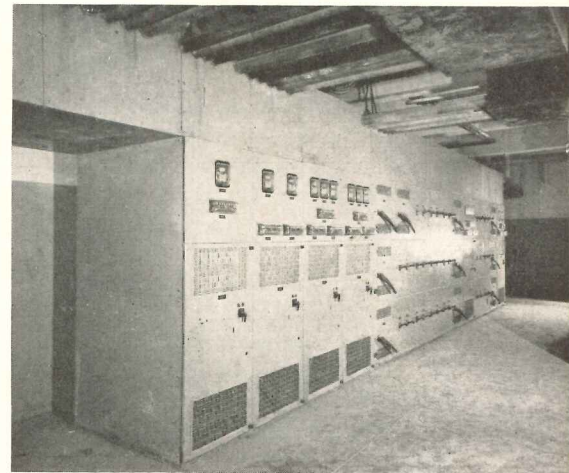

Top: main switchboard in a Pittsburgh office building

Center: air-cooled transformers in the same building

Bottom: an oil-filled transformer in a protective vault



be limited to: (a) the tall office building and (b) the large office building (less than about 12 stories).

Furthermore, it will be assumed that the total electrical power requirements for these types of office buildings will average 14 watts per sq ft of gross area. This has been determined in the following manner:

Experience indicates that an area lighted by fluorescent lamps will use an average of 2 to 3 w per sq ft. However, the average for the entire building area will be higher because of some incandescent lighting in the service, equipment, corridor, stair, closet and similar areas. The average will probably reach a value  $3\frac{1}{2}$  or even 4 w per sq ft.

An area lighted by incandescent lamps will average 5 w per sq ft. Here, the average for the entire building area will be lower because of the less intense lighting in the service, equipment, and other areas and probably will have a value of 4 to  $4\frac{1}{2}$  w per sq ft.

On the basis of these figures, it can be generally assumed that the lighting in a commercial building of the types considered will use the electricity at an average of 4 w per sq ft. The electric power necessary for the operation of boilers, elevators, ventilating fans, pumps, compressors, signalling systems and similar equipment will more than double the average to a value of 10 w. Air conditioning equipment will contribute another 4 w. When the entire electric power likely to be used in the building is totaled, the average may have a value of some 14 w per sq ft.

#### POWER SOURCE

A building may obtain its electric power in two ways:

1. The owner may manufacture his own power by driving suitable generators with Diesel motors, steam turbines or other similar primary movers. He is then responsible for the operation and maintenance of all components of the entire electric plant. This method has been largely abandoned in office buildings, for reasons of economy and convenience, in favor of the second method.

2. The owner may purchase the power from the local utility, which installs, owns and maintains the electric service components up to the building property line. The components within the property line usually are installed and maintained by the owner.

In congested areas, the second method is used almost exclusively for all commercial-type office buildings. The power is furnished to the buildings by the local utility either from secondary networks at a voltage suitable for direct use or from primary distribution systems requiring transformation of the utility's voltage into voltage suitable for building use.

A typical electric power supply chain for a building is something like this:

- (a) The utility furnishes the power to the transformer vault.
- (b) Power from the transformer vault is delivered to the building switchboard.
- (c) Power from the switchboard is distributed to a number of panelboards throughout the building.
- (d) Power from the panelboards is delivered to the various appliances served by the respective panelboards.

#### TRANSFORMER VAULT SPACE

Buildings requiring electric power in the range of less than 200 kw (i.e. structures of less than 15,000 sq ft gross area)

usually obtain the power from the local utility at a voltage value suitable for direct use. Where the power demand exceeds 200 kw, the electricity is usually delivered to the building at a very high voltage, and must be transformed into a lower voltage for utilization. This is accomplished by means of transformers generally located in a transformer vault. The commercial buildings under consideration will always have transformer vaults in one form or another.

The basic requirements to be satisfied in providing the space for a transformer vault are as follows:

1. The vault should be so located that it can be naturally ventilated to the outside air without the use of flues or ducts. Forced ventilation is sometimes employed.
2. The construction should be explosion-proof, with at least 8-in. thick reinforced concrete walls and roof, and a 4-in. concrete floor, a tight fitting class "A" door and a sill high enough to confine within the vault the oil from the largest transformer. Non-explosion-proof vaults with 6-in. reinforced concrete or 8-in. brick walls and roof and 4-in. concrete floor are permitted however.
3. Direct access to the vault at all times should be provided for the utility's maintenance crews.
4. Means should be provided for the removal of the vault components for maintenance and repair.
5. Drainage should be provided for carrying off any accumulation of oil or water that may collect in the vault.
6. The vault is normally located close to the building line either under the sidewalk or inside the building at the first basement or at street grade level. When it is located wholly or partly out-

#### • BUS DUCT AND CONDUIT

#### • PANELBOARDS

Right: panelboards for switching high intensity lighting in the Ford Motor Company's new Styling Building. Across Page: vertical run of bus duct between two panelboards in the General Accounting Office, Washington, D. C.

All photos with the exception of the telephone equipment room on page 216 were furnished through the courtesy of *Electrical Construction and Maintenance*

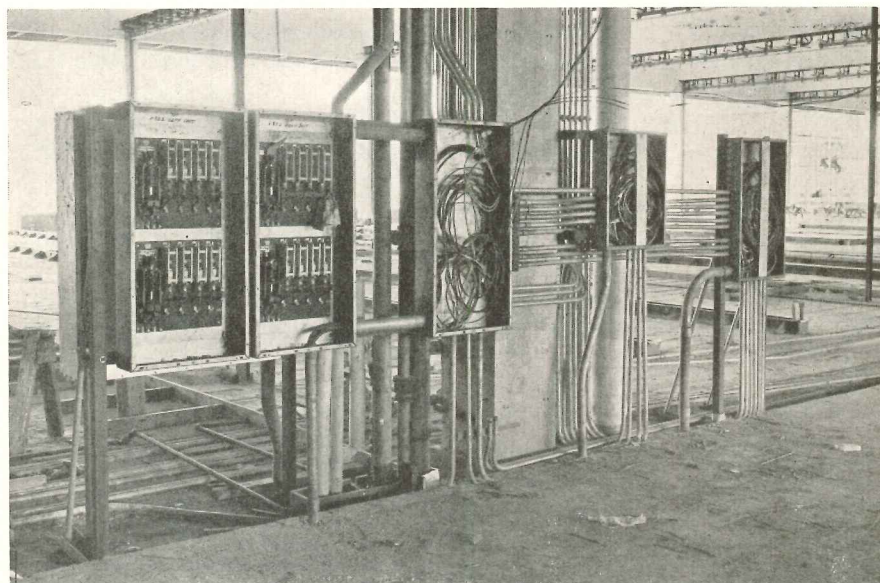



side the building line, or when it is located wholly within the building with any one of its sides touching the building line, the utility may bear the cost of vault construction, of the transformer equipment and of all electrical connections within the vault.

7. When the vault is located wholly within the building with none of its sides touching the building line, the owner may be required to bear the cost of vault and of all electrical connections within the vault. The utility generally furnishes the transformer equipment.

8. The space required for the vault will vary depending upon local conditions. In general, the following dimensions will probably be followed within reasonable limits, but actual dimensions should be obtained from the local utility. The inside height of the vault should be approximately 10 ft. The inside width should be about 9 ft. The inside length should be in the range of:

- 12 ft for 1000 kw or up to 70,000 sq ft gross area.
- 24 ft for 2000 kw or up to 140,000 sq ft gross area.
- 40 ft for 3000 kw or up to 210,000 sq ft gross area (max. vault area-600 sq ft).
- 61 ft for 4000 kw or up to 280,000 sq ft gross area (max. vault area-800 sq ft).
- 90 ft for 5000 kw or up to 350,000 sq ft gross area (max. vault area-1000 sq ft).

Generally, the smallest vault ever provided is for 3000-kw size even though the building demand is considerably below that. Where the building demand is from 1000 to 2000 kw usually the 4000 kw vault is provided. For higher demands up to 3000 kw, the 5000 kw is used. This is done by the utilities to allow for emergencies and future growth.

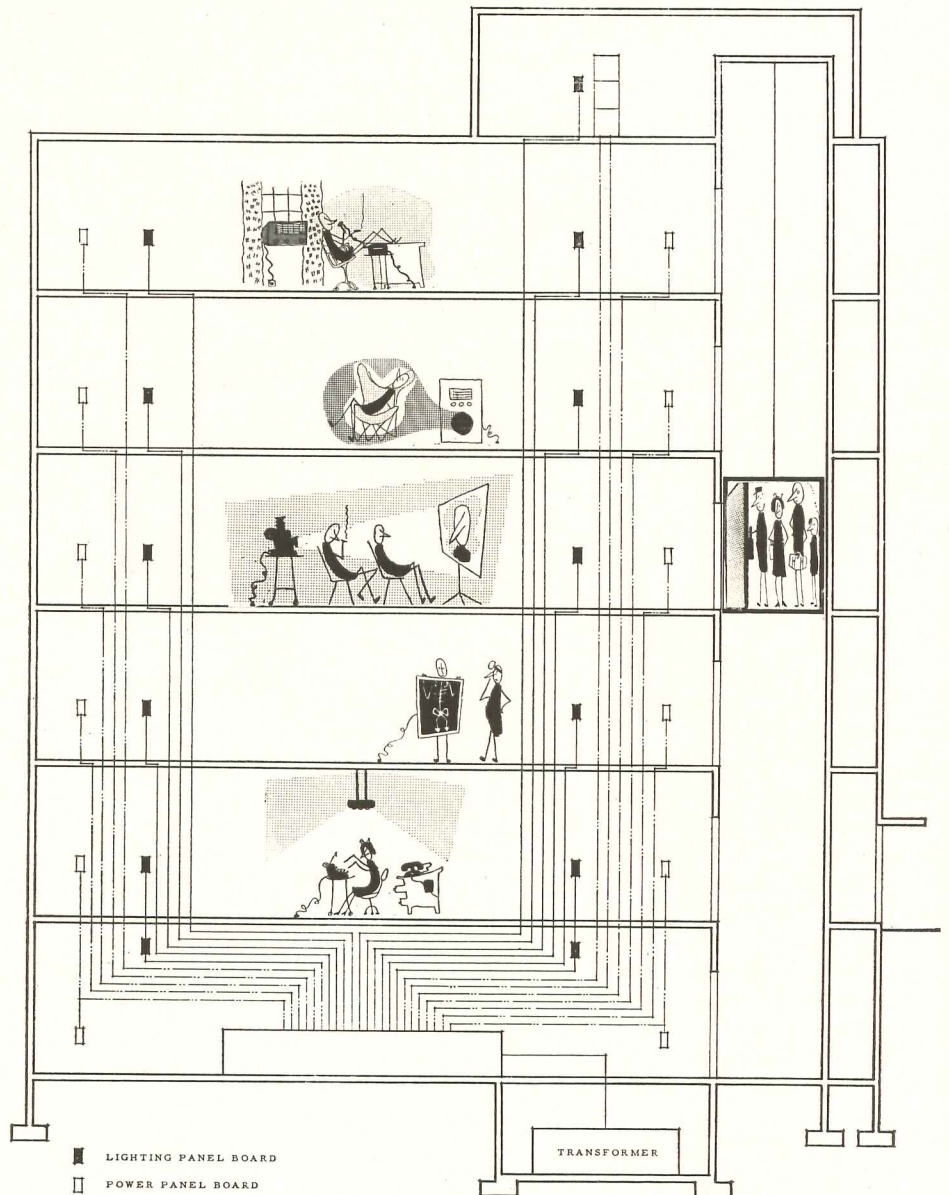
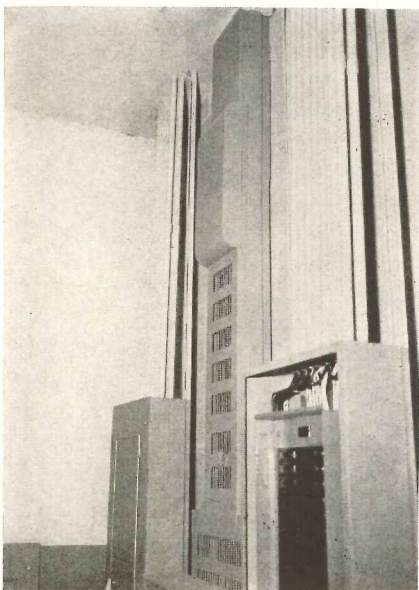

9. The large office building, less than about 12 stories, may be served by one transformer vault located in the basement or at grade level. The tall office building is usually served by several transformer vaults located either in the basement alone or on the upper floors in addition to the basement vault. The capacity of each vault will depend, of course, upon the number of square feet to be served by it.

10. Since practices vary among the utilities, the local utility should be consulted to determine actual conditions.

#### ELECTRIC ROOM SPACE

After transformation to proper voltage, the electric power is delivered from the vault to the electric room for distribution.

The distributing equipment in the electric room — a low voltage distribu-

tion switchboard containing a number of switches or circuit breakers — is bulky and requires a reasonable amount of space for installation and operation. Sufficient space should also be provided for the future growth of the switchboard.

Tall buildings equipped with several transformer vaults should have an electric room associated with each vault.

The general requirements to be considered in providing an electric room are as follows:

1. The height of the room should be at least 12 ft. This is based on a 7½ to 9 ft height of the switchboard and a minimum 3 ft clearance between top of switchboard and ceiling.

2. The width of the room should be at least 14 ft. This will provide a 3 ft clearance back of the switchboard and about a 5 ft clearance in front of it



(this is based on a 4 to 6 ft depth of the switchboard).

3. The length of the room should be at least 6 ft longer than the total of the switchboard. In general, the length of the room should be in the range of at least 18 ft for a power demand of 1000 kw (or up to about 70,000 sq ft gross area) and should increase about 2½ ft for every additional 500 kw or every additional 35,000 sq ft gross area.

4. The electric room should be fully enclosed to prevent access by unauthorized personnel. The entrance into the room should be 6 ft wide and 10 ft high, to permit passage of the equipment through the doorway. A double swing door is usually provided.

5. The room should be properly lighted and ventilated (natural ventilation, if possible).

6. The room should be located as near the transformer vault as possible, to keep the length of the costly cables or ducts between the two at a minimum.

#### TELEPHONE EQUIPMENT SPACE

Telephone entrance cables usually are brought into the building from a manhole in the street, through the foundation wall, to cross connecting terminals located in a terminal room.

The terminal room is usually placed in the basement of the building where space is least valuable, but if this area is subject to dampness or flooding, the room is placed higher in the building. In buildings equipped with private branch exchanges, the terminal room may be located adjacent to the exchange switchboard room or may be placed at some remote location.

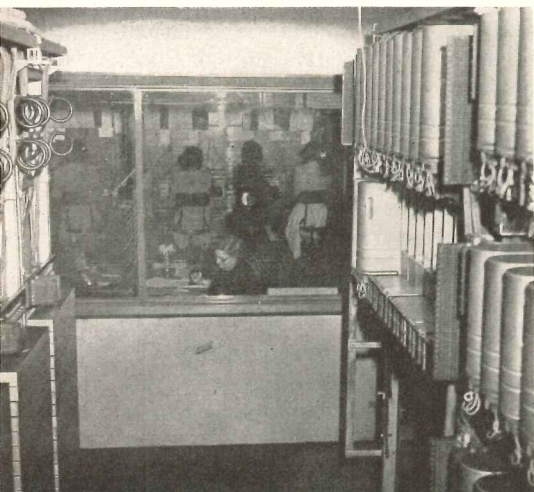

**TELEPHONE EQUIPMENT**

View of telephone switchboard (beyond glass partition) and equipment room

Private branch exchanges are of several types:

- (a) Small manual private branch exchanges requiring one or two attendants and generally placed in the tenant's rented space.

- (b) Dial private branch exchanges requiring more than two attendants and also usually located in the tenant's rented space.

- (c) Large dial private branch exchanges serving an entire single-occupancy building or its major part.

- (d) Order-receiving equipment designed for tenants who receive large volumes of telephone orders (such as brokerage houses, newspaper offices, and ticket reservation bureaus).

Definitely planned floor spaces must be provided for such equipment. To arrange for these spaces, the recommendations of the telephone company's engineers should be obtained and followed.

In addition to the foregoing, telephone booths are usually provided in the lobbies for public use, and, where warranted, attended public telephone stations are provided.

The following general rules apply for telephone equipment space:

1. Buildings from 60,000 to 70,000 sq ft of net area generally use wall-type cable terminals. The terminal room should have 1 sq ft of floor space for every 6000 sq ft of net floor area of the building for the terminals, plus 3 to 4 ft of working space in front of the terminals.

2. Buildings over 60,000 to 70,000 sq ft of net area generally use floor-frame-type cable terminals. The terminal room should be at least 11 ft long, 11 ft wide and 9 ft-6 in. high for a building of net area up to 100,000 sq ft. For larger buildings 1 ft should be added to the length of the room for each additional 25,000 sq ft of building net area.

3. Private dial branch exchanges require, in general, space as tabulated below:

Building Net Area	Line Capacity	Room Space Required
40,000 plus sq ft	400	600 sq ft
60,000 plus sq ft	600	700 sq ft
80,000 plus sq ft	800	900 sq ft
100,000 plus sq ft	1000	1100 sq ft
120,000 plus sq ft	1200	1200 sq ft

4. Rooms containing telephone equipment should be as dust-proof as possible and properly lighted. These rooms also should be ventilated because they frequently house storage batteries which discharge fine sprays of various gases into the air during the charging and discharging periods.

5. Consideration should be given to the

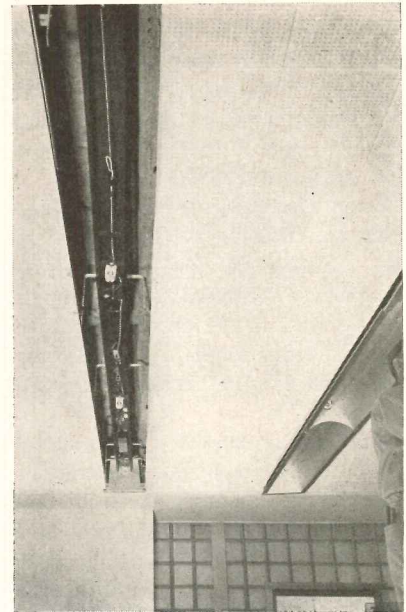

**RECESSED LIGHTING FIXTURES**

Recommended space for recessed troffers is 12 in. above ceiling

increase of the minimum spaces to allow for future growth.

6. A sufficient number of pipe sleeves should be placed in the foundation walls to provide means for the entrance of the ultimate number of telephone cables from the street manhole.

#### SIGNAL CONTROL ROOM SPACE

A number of electric signal systems are usually installed in commercial buildings. These may be a combination of any of the following:

- Fire Alarm System
- Electric Clock System
- Teletypewriter and Messenger Call System
- Stand Pipe Telephone System
- Stand Pipe Tank Alarm System
- Sprinkler Alarm System
- Watchman's System
- Burglar Alarm System
- Paging and Announcing System
- Doorbell System
- Radio and Television System
- Employees Time Recorder Clock System
- Public Address System
- Interior Telephone Intercommunication System
- Program Bell System

Many of these systems require central control apparatus where the system is set and adjusted, and where the indicators and alarm equipment operate.

Usually one or more signal control rooms are provided to contain all the



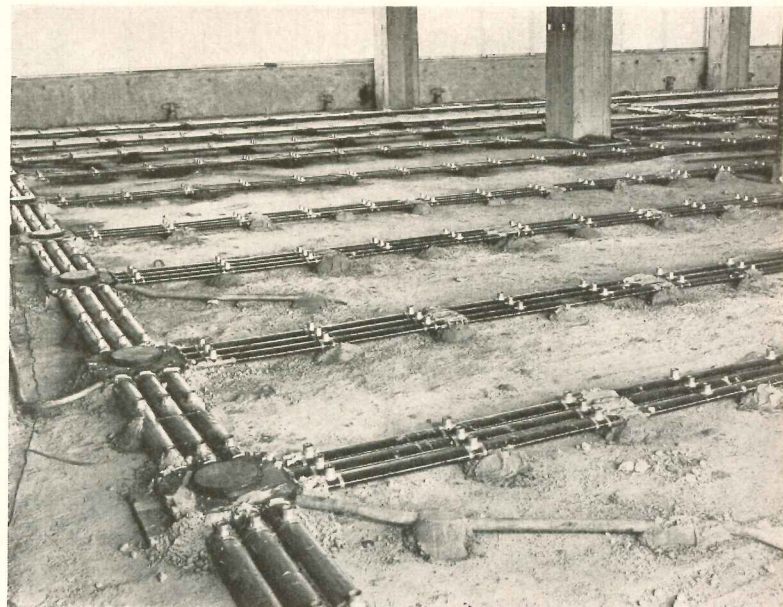
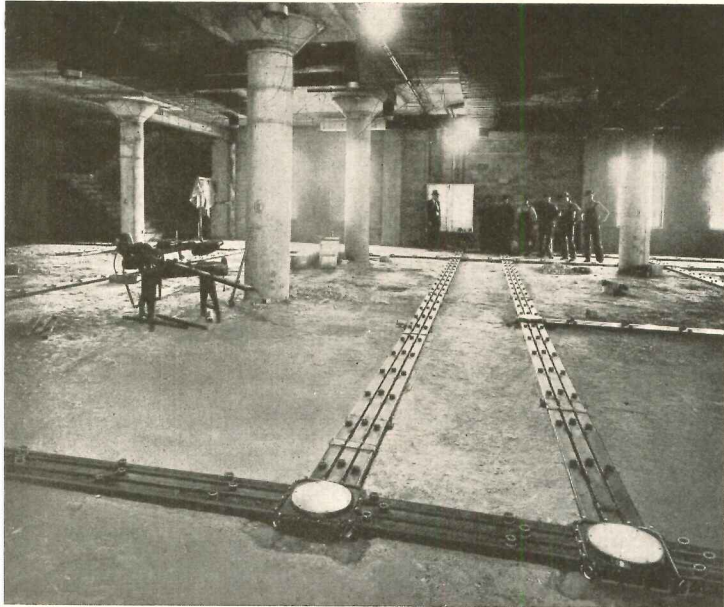

### UNDERFLOOR DISTRIBUTION

One type of underfloor duct distribution system consists of a network of steel (left) or fiber (right) ducts laid in

the concrete fill and finish. The depth of fill and finish will be about 3½ in. since terminal boxes are that high

central control apparatus. These include supervisory fire alarm panels, master time controls, interior telephone equipment, sound systems control, etc.

The general requirements to be considered in providing a signal control room are the same as those for providing an electric and telephone equipment room, except for the size of floor space.

The size of the room will depend on the number and types of signal systems employed in the building. Usually, a signal control room about 10 by 12 ft is large enough to contain most of the equipment. The size of the room should, of course, be adjusted when more elaborate controls are employed.

A separate room is often provided for the interior telephone system equipment. The size of this room should be the same as that required for the telephone terminal room.

### ELECTRIC AND SIGNAL RISER SHAFT SPACE

The electric cables originating in the electric and signal rooms must be distributed throughout the building to suitable lighting panelboards, power panelboards and signal terminal boxes located at the various floors and serving as centers for further distribution.

The most convenient and economical method for the cable distribution is to provide vertical riser shafts which penetrate all the floors of the building and terminate at each floor in electric closets. These closets contain all the necessary electric equipment relating

to the respective floor, such as the panelboards, meters and signal systems terminal boxes.

In tall buildings where several transformer vaults are provided on the upper floors, a separate high tension vertical riser shaft must be provided for the primary cables which serve the vaults. Conduits in such a riser shaft must be covered with at least 2 in. of concrete.

The general requirements to be considered in providing for the electric vertical riser shafts are as follows:

1. The riser shafts should be of fire-proof construction.

2. One riser shaft should serve no floor area larger than that in which the maximum distance from the riser shaft to the outer limits of the area does not exceed 100 ft. The reason for this is that the standard size of wire for lighting offers too much resistance when it exceeds 100 ft in length. Wiring runs longer than 100 ft must be made with wire of larger size. Furthermore, longer wire runs are more difficult and expensive to install. Generally, it is more economical and advantageous to provide two or more vertical riser shafts than to attempt to extend the floor wiring beyond the nominal 100-ft limit. The cross section of each riser shaft should be in the range of 12-in. deep and at least 12-in. wide, with an increase of 6-in. in width for every three floors of the building. Thus, a 30 story building would have a riser shaft about 12-in. deep and 6 ft wide.

The shallow, 12-in. depth of the shaft

is preferable because it permits placing of electrical conduits in a single line, thus simplifying the access to any one of the conduits during installation and maintenance.

4. In some buildings, bus ducts are employed instead of standard cables in conduits. Riser shafts for feeder busways should be about 2 ft deep instead of the 12 in. required for cable wiring. The width of the shaft may be decreased to three fourths of that required in the case of cable wiring.

### TELEPHONE RISER SHAFT SPACE

The telephone cables originating in the terminal room are distributed throughout the building by means of vertical riser shafts similar to the electric riser shafts. Usually, the cables are installed without conduits, to simplify the cable supporting means and to permit the complicated wire splicing in the telephone closets.

The use of joint electric and telephone riser shafts is acceptable, provided that at least a 2-ft separation between the telephone cables and any other cables or bus ducts is maintained. Since this would obviously result in a loss of space, separate telephone riser shafts will result in a more satisfactory installation.

The general requirements to be considered in providing the telephone vertical riser shafts are as follows:

1. The riser shafts should be of fire-proof construction.

2. One riser shaft should serve a floor area no larger than that in which the



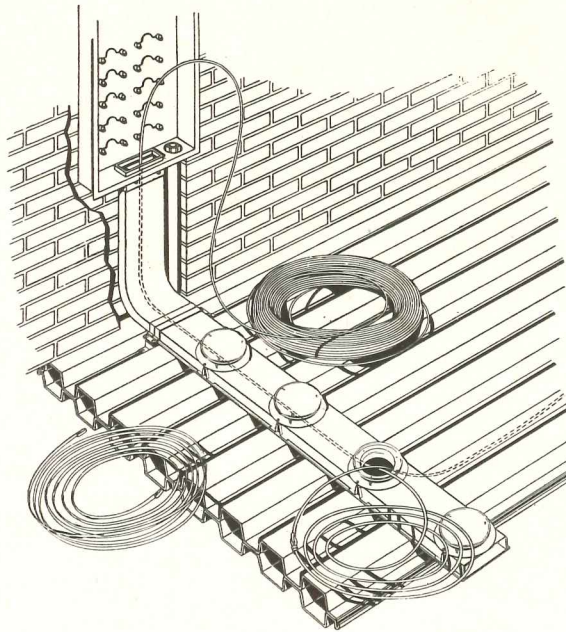

#### UNDERFLOOR DISTRIBUTION

Cellular steel floor provides convenient raceways for wiring. Power, telephone and signal wires are carried in separate cells fed by crossovers which are attached to panel boxes

maximum distance from the riser shaft to the outer limits of the area would not exceed 75 ft.

3. The cross section of each riser shaft should be at least 8-in. deep and 2-ft wide.

4. Where more than one riser shaft is required to serve a building, tie conduits should be provided at each floor between the riser shafts.

#### ELECTRIC CLOSET SPACES

The vertical electric riser shaft, as it penetrates the successive floors of the building, terminates at each floor in an electric closet. The closet contains all the electric and signalling equipment necessary at this point for serving each respective floor area.

This equipment includes the conduits or busways, the lighting panelboard, the meter panelboard (if used), the tenant meters (if used) and the signal systems terminal boxes.

The general requirements to be considered in providing electric closets are as follows:

1. The depth of the closets should be at least 3 ft.
2. The height of the closets should be at least 8 ft.
3. The width of the closet will depend on the amount of equipment it contains. The least width will, of course, be equal to the width of the vertical riser shaft passing through it. Generally, the width of the closet is in the range of 5 to 8 ft. It seldom exceeds 10 ft.
4. The vertical riser shaft should pass through the rear portion of the closet, i.e. the rear walls of the shaft and the

electric closets should be in line.

5. The front portion of each closet should be provided at the respective floor level with a concrete floor extending from the sill line to the vertical conduits or busways running along the rear wall of each closet.

6. Each closet should be provided with swing door or doors designed to provide full access to the closet. The door or doors should be equipped with a lock.

#### TELEPHONE CLOSET SPACES

The vertical telephone riser shaft, as it penetrates the successive floors of the building, terminates at each floor in a telephone closet.

Each closet contains the telephone cables, the cable splices and the terminal boxes necessary for serving each respective floor area at the riser shaft.

The general requirements to be considered in providing telephone closets are as follows:

1. The depth of the closets should be at least 2 ft.
2. The height of the closets should be at least 8 ft.
3. The width of the closets should be 3 ft for each 10,000 sq ft of net area served from the closet.
4. The vertical riser shaft should pass through the rear portion of the closet, i.e., the rear walls of shaft and closets should be in line.
5. The front portion of each closet should be provided at the respective floor level with a concrete floor extending from the sill line to the telephone cable slot in the rear of the closet. Instead of a slot, a sufficient number

of 3½ in. pipe sleeves may be provided in each closet floor for the passage of the telephone cables from the riser shaft into each closet.

6. Each closet should be provided with a swing door designed to provide full access to the closet. The door should be equipped with a lock.

7. The joint use of electric and telephone closets is acceptable provided a separation of at least 2 ft is maintained between the telephone equipment and any other equipment.

#### LIGHTING PANELBOARD SPACE

The lighting panelboards distribute the electric power to the lighting fixtures within the respective areas they serve.

The panelboards are rectangular in shape and vary in depth from 4 in. to 6 in.; in width from 1 to 2 ft; and in height from 2 to 5 ft.

The space to be provided for the panelboards should be the maximum, that is, the depth 6 in., the height 5 ft and the width 3 ft (this includes the panelboard width of 2 ft, plus 6 in. on each side for necessary clearance).

This space should be assigned to the lighting panelboard regardless of whether it is recessed into the wall, surface-mounted on the wall, or located in an electric closet.

#### TENANT METERING EQUIPMENT SPACE

The total electric power delivered to the building is measured by an instrument located in the electric room. This determines the financial charges by the utility for the purchased power required for building use.

In some buildings the owner resells the power to the tenants. The practice is being gradually abandoned, particularly since electric power rates have been readjusted to remove the profit incentive in private resales of power.

Where the resale practice is followed, it is necessary to provide adequate space at each tenanted floor for the individual metering instruments. These include a metering board combined with or located near the lighting panelboard at each tenanted floor, and a separate meter unit for each tenant.

#### POWER PANELBOARD SPACE

The power panelboards distribute electricity to the various electric motors and heating units operating the boilers, heating and ventilating units, pumps and elevators.

These units are usually located on  
(Continued on page 232)



# PORCELAIN ENAMELED PANELS FOR INTERIOR WALLS

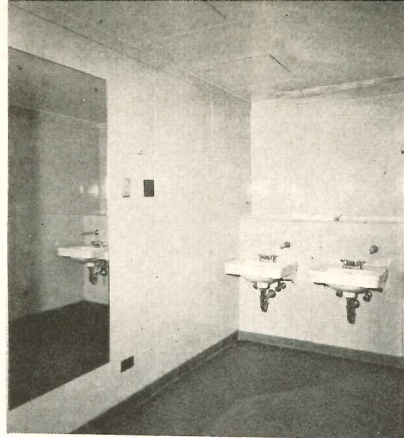

525 William Penn Place, Pittsburgh

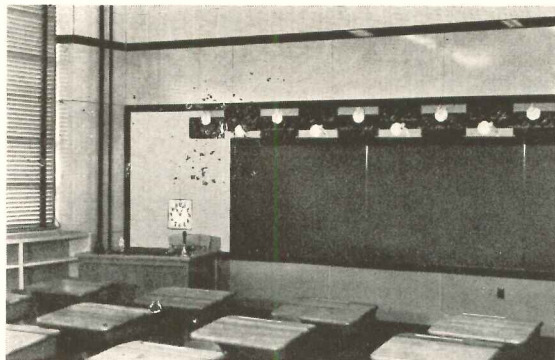

St. John's School, Monaca, Pa.

*Two new attachment methods help  
increase their practicality*

By Carl F. Block  
United States Steel Corporation

**P**ORCELAIN ENAMELED STEEL panels offer a number of unique advantages for both interior and exterior applications. For one thing, porcelain enameling is the only practical method of fusing a permanent inorganic protective color coat into the surface of a steel sheet. Since it is inorganic, this color will never fade, and since porcelain enamel is a glass-like material, it furnishes an easily maintained surface which never requires painting. Moreover, the panels are reasonable in cost, acid and abrasion resistant, strong, rigid, and available in a variety of shapes and sizes.

For all these reasons, the panels have been very popular for exterior applications as curtain walls, store fronts and the like. The same factors likewise make them suitable for interior applications, but these have for the most part lagged behind. Recently, however, a number of interesting applications have stimulated interest in the employment of the panels for interior work. Two of these will be examined here.

## PANELS FOR WASHROOM WALLS

A recent example of large-scale application of porcelain enamel panel walls occurred in the 525 William Penn Place

Building in Pittsburgh, where the wash-room walls were covered with panels approximately 3 by 4 ft. The building contains 64 toilet rooms. Fifty panels were needed in each of the men's rooms and 65 in each women's room. This involved in all about 35,000 sq ft of panel area.

All panels were applied to the wall by supporting them on welded hook clips at the top and bottom of each side. The horizontal supporting member consisted of cold-formed lipped channel section which was applied to a slag concrete block back-up wall by firing a 22 gage powder-activated shot attachment through the channel into the wall. Care was required in the placement of the toilets and lavatories, and holes had to be located in each panel by template in order to be certain that the panel would match the utility, water and support lines of the unit (see Fig. 1). The units were supported on conventional chairs and cemented into position. The plumbers who installed these positioning chairs were quite cooperative in setting them considerably closer than would be expected ordinarily, but even this was not close enough to avoid the necessity for measuring each individual panel before it was porcelain enameled.

The panels were fabricated for the job in the following manner; first a panel was formed with 90 deg flanges. Plumbing unit holes were located and punched to fit, in accordance with the pre-established measurements for the panel. Next the flange corners were welded and side clip attachments were welded in place. The panel was then cleaned, the porcelain enameling "frit" was applied by dipping or spraying as a ground coat, and then the panel was fired at about 1600 deg F, to protect the steel in both sides. A finish color coat was next sprayed on, dried, and fused into the panel. Each panel was then paper protected and crated for shipment to the job site, where they were erected. A specially prepared cornice piece was applied, and the joints were finish-calked with a compound to match the panel color.

In striking a level line for attaching the channel supports, measurements were taken from an established level of the toilet room and building floor. No difficulties were encountered, since all the workmen executed the job well within the prescribed tolerances. Although the usual irregularities were encountered in the location of the utility

1

2

3

## 525 WILLIAM PENN PLACE

Fig. 1: original installation with panels attached directly to concrete block wall. Note template holes in panels. Fig. 2: steel framework developed in second scheme. Fig. 3: close up of framework showing panel stiffener and sound deadener

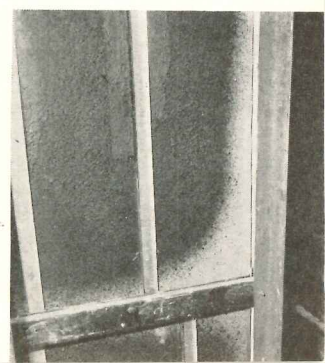
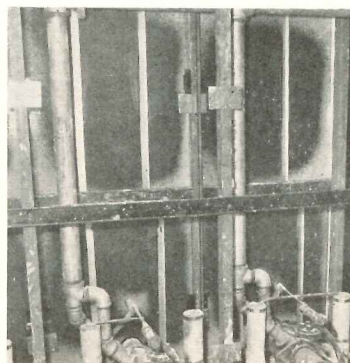
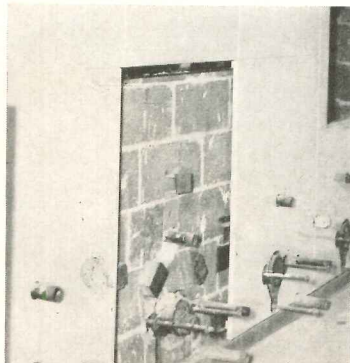



**ST. JOHN'S SCHOOL, MONACA, PA.**

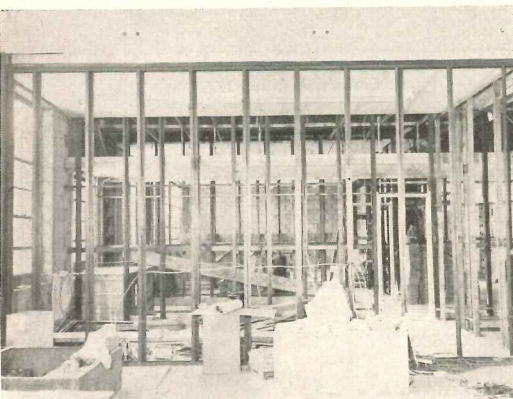

4

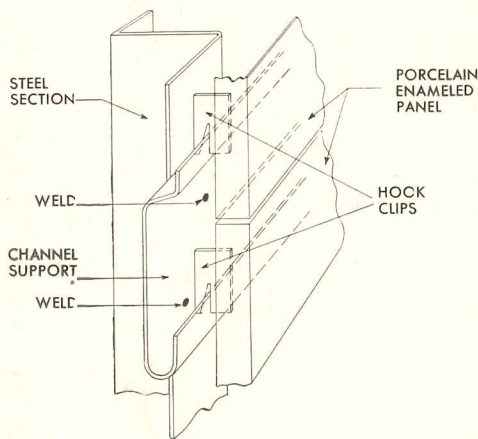

5

Fig. 4: steel framework for partition walls, attachment detail of which is shown in sketch, Fig. 5. Corridor partitions are shown before application of panels, Fig. 6 (note fibrous glass insulation pads) and in finished state, Fig. 7.

pipe connections, these were remedied by using half round escutcheons to compensate for any irregular space.

The erection of the toilet units, partitions, mirrors and towel cabinets proceeded with no serious damage to the enameled surfaces. All workers who applied these additional units were cautioned that they were working with panels of glass-fused-to-steel and were advised to handle them with care.

**Steel Framework Developed**

The above description gives a general outline of the application as it was originally proposed and installed. After the initial installations, however, it was generally conceded that there had to be found a better way of applying the panels than this method of attaching the supporting channels to concrete blocks. Estimates were made of the cost of the back-up concrete block wall, and a steel angle-and-channel framework was developed at about the same cost (Fig. 2). One of the sixteenth floor toilet rooms was utilized to work out the details of this framework. When the panels were attached to the complete frames, the assembly went up at a considerably faster rate. The walls were tighter and of improved appearance, since it was easy to keep the steel panels straight and plumb.

The experiment was so satisfactory that the building management arranged to have the barber shop finished in the same way. Here the walls between a small toilet room and the barber shop were sound deadened by using fibrous glass insulation (Fig. 3).

Still another innovation was tried in this room. The supporting frame was prefabricated from cold formed Z sections, angles and channels. These proved to be easier to handle on the job, provided very satisfactory support and supplied an easy method of supporting sound deadening insulation. These were erected by the same building trade that applied the panels, and the panel attachment was performed with exceptional smoothness.

**PANELS FOR SCHOOL INTERIORS**

Another, and quite different application, was the commercial installation of a complete school interior for the St. John's School in Monaca, Pa., Byron McCantless, Architect. Here, the building was constructed with a structural steel frame, steel windows, floors, ceiling joists, roofs and stairways. The same porcelain enamel panel fabricator who did the experimental support work on the 525 William Penn Place Building installed the porcelain enameled steel walls here.

Cold formed steel frames were erected as partitions between the classrooms and the halls (Fig. 4). These were formed from carbon steel sheets or strip, press formed into small angles, channels, Z's or hat sections. The frames were erected by shot fastening to the floor, bolting, welding and riveting to form the supporting wall for the porcelain enameled panels. The supporting channel to which the panels are attached was specially formed to receive the attachment clips which were welded to the top and bottom of the panel side flanges (Fig. 5).

Both interior room and corridor walls were covered with colored porcelain enameled steel panels in a neutral cream shade. Before the panels were applied, a two-inch fibrous glass insulation and sound deadener pad was inserted into the steel frame to insure silent rooms (Fig. 6). A colored porcelain enameled moulding closure at the top of the wall panels finished the walls (Fig. 7) and porcelain enameled steel chalkboards in a green shade were employed. Recessed doors opening outward into the corridor facilitated easy exit from the classroom without having doors jutting into the corridor in case of fire. Since the floors, walls, windows, doors and roof of this school are all steel, there is little danger of destruction by fire. An ordinary fire will not even harm the finish of the panels since this is fired into the steel at about 1600 deg F. Steel panels also insure the localizing to a single room of any small fire in wastebaskets.

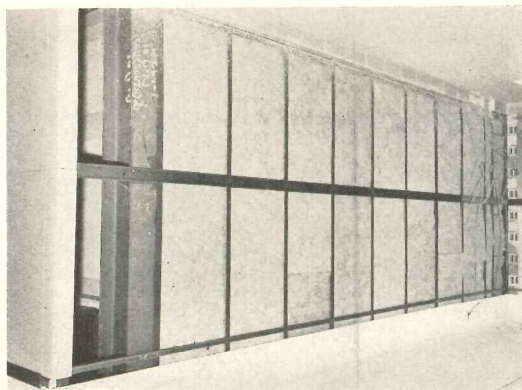

6

7

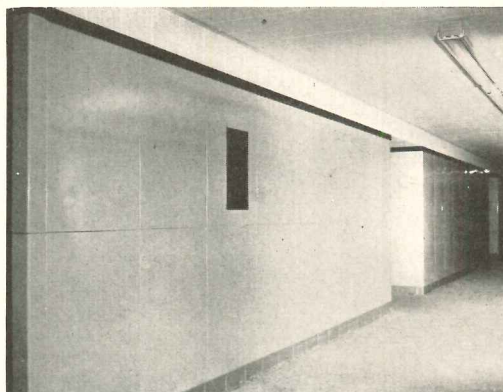



## UNUSUAL VENTING SYSTEM USES CLAY FLUE LINERS



Construction shot shows erection of ventilating columns

An unusual venting system for carrying away acid fumes was incorporated as an integral feature in a \$2.5 million addition to the Milwaukee factory of the Allen-Bradley Co., builders of motor control devices. Architect for the addition was Fitzhugh Scott, Jr.

The venting system employs clay flue liners, contained in the hollow concrete columns which comprise the supporting framework of the building. Each column in the outside walls carries three of these flues as a central core around which reinforced concrete was poured. The liners were erected a story at a time, before any reinforcements were placed or concrete was poured. This was made possible in the following manner: Small metal channels were spotwelded base-to-base to form H-shaped aligning tabs which, when installed, kept the sections of flue liners from slipping sideways. Six of these tabs were used at each joint. Mortar was used at the joints and troweled smooth over the surrounding area. Steel rod reinforcements were then placed and wooden forms were erected. Finally, the concrete was poured to complete the columns.

Five thousand feet of 18 in. sq clay flue liners was used in 25 such ventilating columns, each of which ran from the second story to the roof of the seventh story. Since each bay of the building contains three columns, there are ample flues for present and future needs.

Clay flue lining was reportedly selected for this job because of its resistance to the action of hot and cold fumes with moisture or acid content. It is said

*(Continued on page 240)*

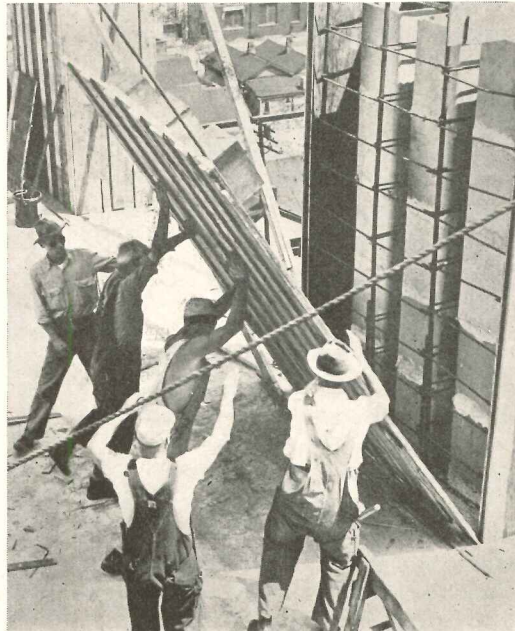
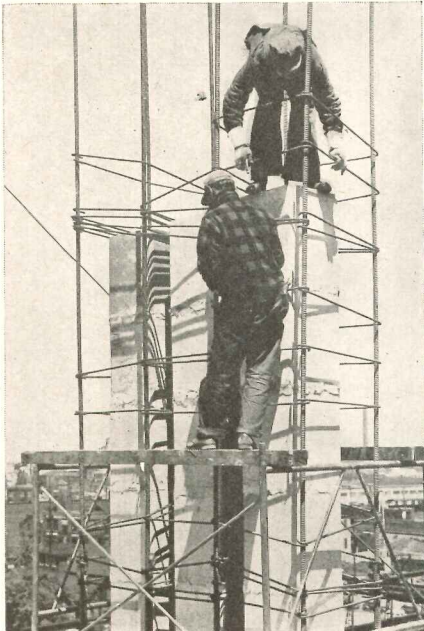

Installation procedure — Above, left; clay flue liners are erected and column reinforcement is placed around them. Above, right; prefabricated plywood forms are placed around reinforcement and concrete is poured. Right; Finished column as it looks from the inside. Flue openings are sealed off here but can be put into operation easily.

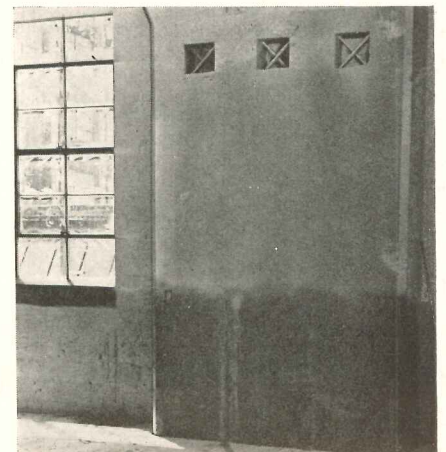



**PLANNING DATA  
FOR  
KITCHENS AND  
LAUNDRIES**

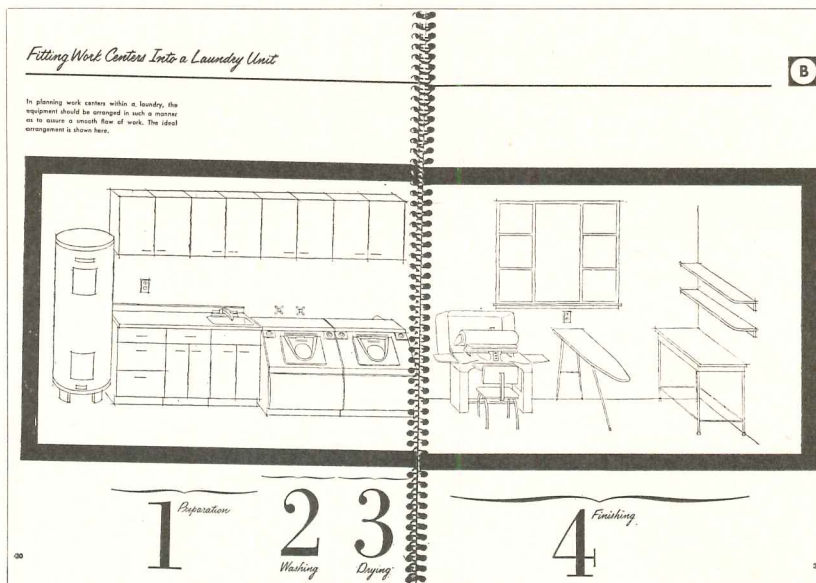

Page of booklet shows recommended laundry layout

• *Kitchen-Laundry Design Ideas.* Manual presents the basic principles for planning a well designed kitchen and laundry for attractive appearance and maximum efficiency. The information included can be readily adapted to kitchens and laundries of any size and shape. Along with planning ideas are shown many convenience ideas, examples of well-designed kitchens and laundries, and suggestions for lighting and wiring. The booklet contains numerous clear diagrams, sketches, dimension-drawings and illustrations. Mentioned as the work centers in the kitchen are 1) Food Storage and Preparation, 2) Cleaning and Dishwashing, and 3) Cooking and Serving. Work areas in the laundry are given as 1) Preparation, 2) Washing, 3) Drying, and 4) Finishing. 48 pp., illus. Fifty cents per copy. *Better Homes Department, Westinghouse Electric Corp., Box 868, Pittsburgh 30, Pa.*

**PHILIPPINE MAHOGANY**

*More Beautiful Homes.* Booklet tells how homes can be decorated either informally or luxuriously with Philippine mahogany. Illustrations of exteriors and interiors point out how effectively the material can be blended with brick, stone, tile and other textural materials, in homes and businesses. 8 pp., illus. *Insular Lumber Co., Philadelphia, Pa.*

*Other product information in Sweet's Architectural File, 1953*

**ELECTRICAL CONTROL COMPONENTS**

*Key Switches and Other Electrical Control Components.* Comprehensive catalog illustrates "telephone-type" components for industrial use. Illustrated with photographs and diagrams, it contains specifications and general data on key switches, impulsing devices, switch-board lamps, jacks and caps, and other control devices. Also included are specification tables designed for easy ordering. 28 pp., illus. *Automatic Electric Co., 1033 W. Van Buren St., Chicago 7, Ill.*

**FOAMED-IN-PLACE PLASTICS**

*Nopco-Lockfoam — New Foamed Plastic.* Illustrated with over forty charts, graphs and photos, booklet outlines foamed plastic's uses as a material for construction, electronic devices, packaging, reinforcement of automotive and aviation equipment parts, thermal insulation, athletic equipment, and vibration dampening. Stress, compression, tension shear, density, and water sorption properties are graphically shown, with testing procedures. 28 pp., illus., *Nopco Chemical Co., Harrison, N. J.*

**DISPLAY CASES**

*Columbus Salesmaster Display Cases.* Catalog presents the complete line of display cases by the manufacturer, with illustrations, descriptions and specifications for the various models. Typical

plans and island arrangements are also given. Bound in heavy cardboard. 79 pp., illus. *The Columbus Show Case Co., 850 W. Fifth Ave., Columbus 8, Ohio.*

**WINDOW SHADES DESIGNED FOR PUBLIC BUILDINGS**

*Draper New Way Shading Unit.* Brochure describes a new shading unit for combination glass block, clear glass windows, especially designed for hospitals, schools, churches and industry. Photographs illustrate how the shades offer easy, complete shade adjustability and thorough daylight control. A photograph of the bracket assembly is included, and measuring instructions are given. 4 pp., illus. *Luther O. Draper Shade Co., Spiceland, Ind.*

**WALL WASHING MACHINE**

*Save Time and Money, No. WW-353.* Brochure gives characteristics of chemical wall washing machine indicating the various working parts. Contains factual report of tests conducted by Michigan State College, giving comparative cost figures on labor and material between machine and hand washing operations. Presents maintenance advantages of modern machine and points out professional results attained by unskilled workers. 4 pp., illus. *Ross & Story Products Corp., 705-7 Dewitt St., Syracuse, N. Y.*

(Continued on page 304)



What?...

# Adlake

windows

in the

Parthenon?

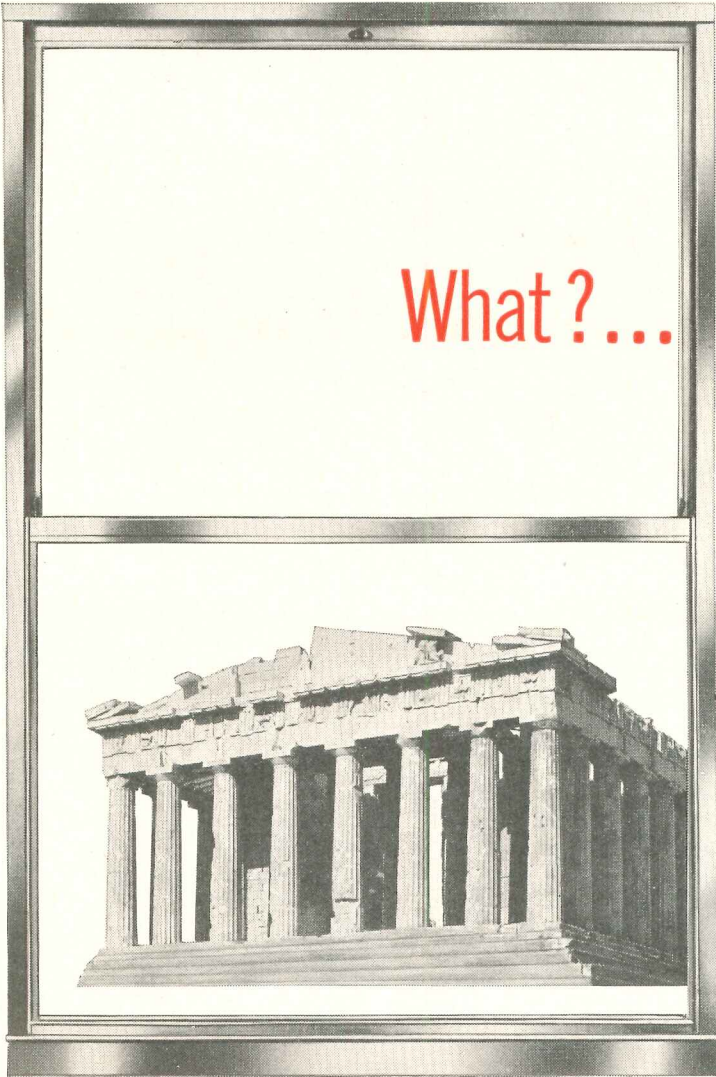

"ADLAKE" was *one* word the Greeks *didn't* have, when the Parthenon was begun in 447 B.C. But we believe that, *had* ADLAKE Windows been installed, they would be in operating condition today!

*With no maintenance whatever,*  
**ADLAKE ALUMINUM WINDOWS WILL LAST THE LIFE OF THE BUILDING!**

Every ADLAKE Window gives these "PLUS" features

- Woven-pile weather stripping and exclusive patented serrated guides
- Minimum air infiltration
  - Finger-tip control
- No painting or maintenance
- No warp, rot, rattle, stick, or swell

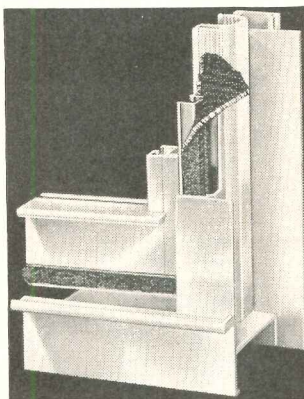

**ADLAKE Windows** pay for themselves by eliminating all maintenance costs except routine washing. Once installed, they'll keep their good looks and easy operation for the life of the building, with no painting or other maintenance whatever! What's more, their woven-pile weather stripping and patented serrated guides give an everlasting weather seal.

**ADLAKE Aluminum Windows** assure lifetime value, beauty, and efficiency. Write for full details... you'll find ADLAKE representatives in most major cities.



THE **Adams & Westlake** COMPANY

Established 1857 • ELKHART, INDIANA • New York • Chicago

Also Manufacturers of ADLAKE Mercury Relays  
and ADLAKE Equipment for the Transportation Industry



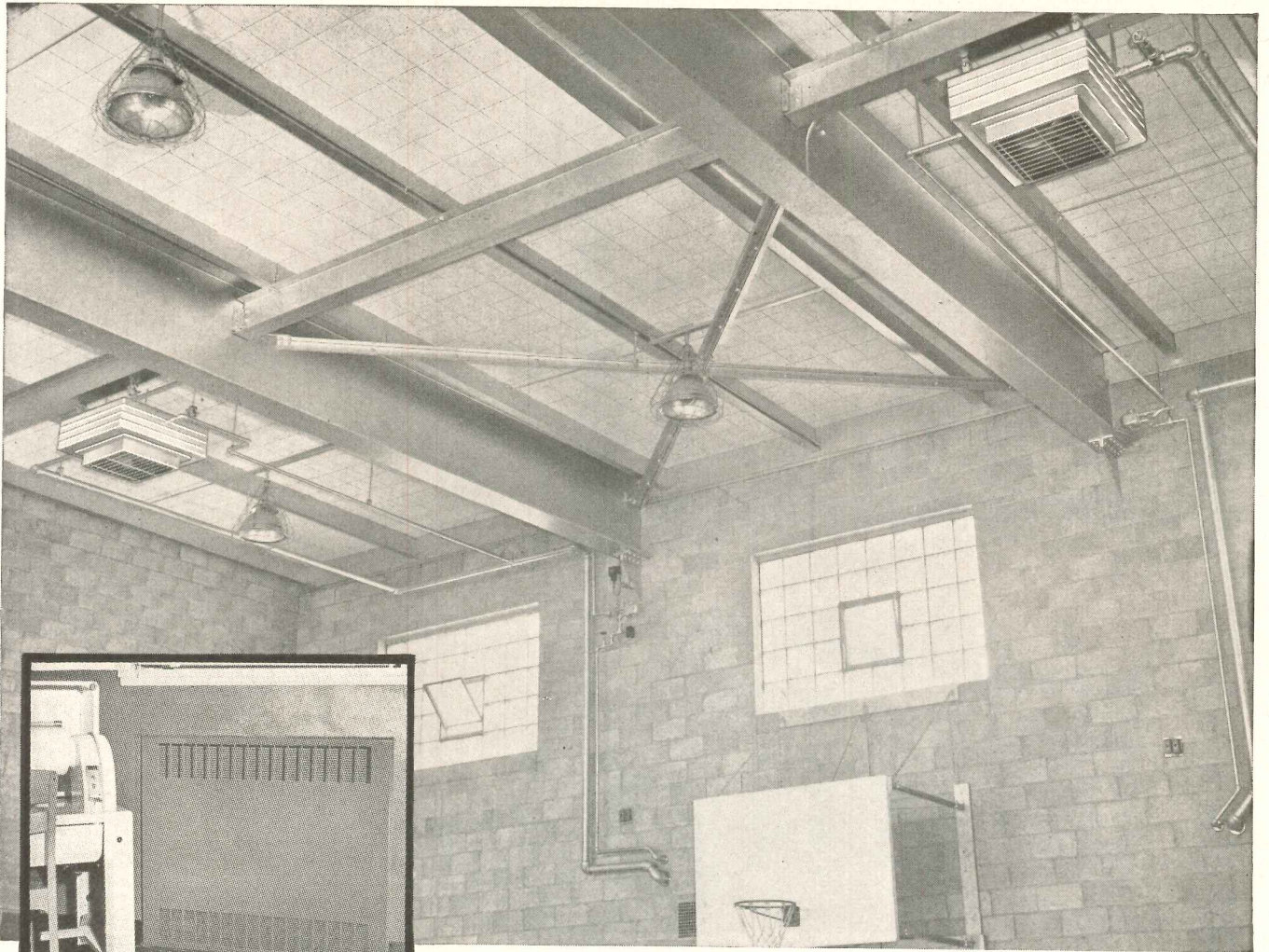

Webster-Nesbitt Down-Blow Unit Heaters up in the air, out of the way, provide heat for the gymnasium. Up in the air and along the wall, also out of the way, are the Webster Series "26" Traps draining the units. Left: Webster Type E Convector alongside ironer in home economics department. The metal front is finished in a bright contrasting color.

## HIGH SCHOOL FOR 1000 STUDENTS

When first put in service in September 1951 the new Ewing High School had 665 pupils from grades 7 to 10 using 24 of the 32 classrooms. Full capacity will be used by fall 1953 according to advance estimates.

Ewing High School is steam heated. Webster Heating Equipment used includes:

Webster-Nesbitt Down-Blow Unit Heaters in gymnasium as illustrated.

Webster-Nesbitt Propeller Fan Unit Heaters in locker rooms, manual training rooms and cafeteria kitchen.

Webster Convectors in home economics room (illustrated), auditorium, corridors, stair landings.

Webster Radiator Valves, Thermostatic Traps and Float and Thermostatic Traps throughout to assure steam circulation.

Modern schools and Webster Heating Equipment are found together all over America. For more information call your Webster Representative or write us.

Address Dept. AR-11

**WARREN WEBSTER & COMPANY**  
Camden 5, N. J. Representatives in Principal U. S. Cities  
*In Canada, Darling Brothers, Limited, Montreal*

**Webster**  
**HEATING**

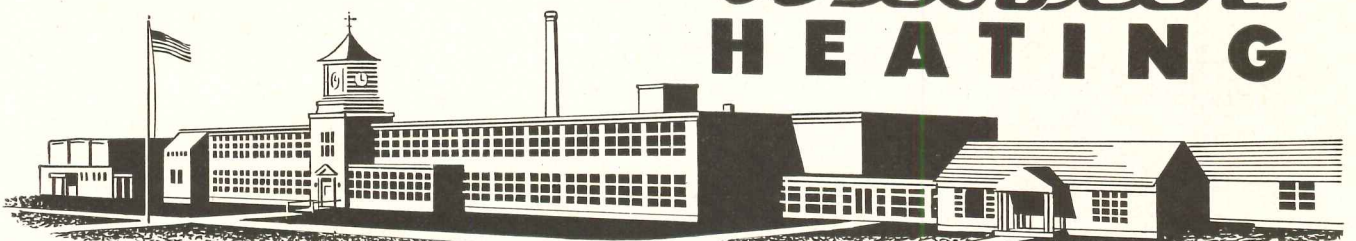

Ewing High School, Mercer County, New Jersey. Built 1951. Architects: Micklewright and Mountford, Trenton, N. J. Consulting Engineers: Runyon and Carey, Newark, N. J. Heating Contractor: Walter E. Bittner, Trenton.



**STRUCTURAL FORMS 28: THIN SHELLS OF REINFORCED CONCRETE**

By Seymour Howard, Architect, Instructor at Pratt Institute

**PRISMATIC SHELLS (Also called flat plate, hipped plate or tilted slab construction)**

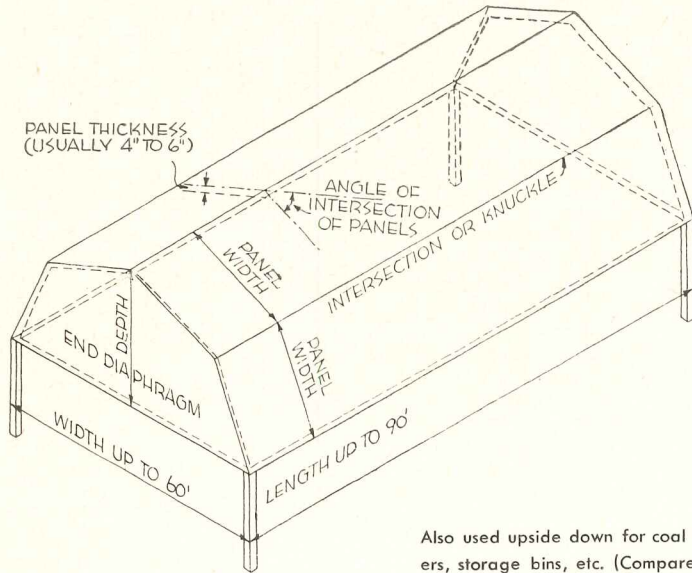

Also used upside down for coal bunkers, storage bins, etc. (Compare A-2, sheet 21)  
(Span of 135 ft. has been proposed)

These are approximations to the curved shells made by flat panels. They bear a relationship to curved shells which is similar to that of a rigid frame to an arch. The transverse bending moments in the panel slabs are much greater than those of a curved shell, and the thickness must be greater. Each panel can be considered as supported at the intersection lines or knuckles and becomes one span in a system of continuous beams.

In the longitudinal direction there is a gradual transition from a pure shell effect for shells with panels which are wide in relation to length to a pure bending effect for shells with panels which are long compared to width. In the latter case the shell may be considered as a beam and stresses figured from the moment of inertia of the whole cross section.

Although prismatic shells are rarely used for very long spans, because the thickness of concrete and the dead load are greater than for curved shells, they may be more economical for shorter spans. The savings on formwork may offset the cost of additional concrete.

**Simply Supported Single Shell (Compare A-1, Sheet 16)**

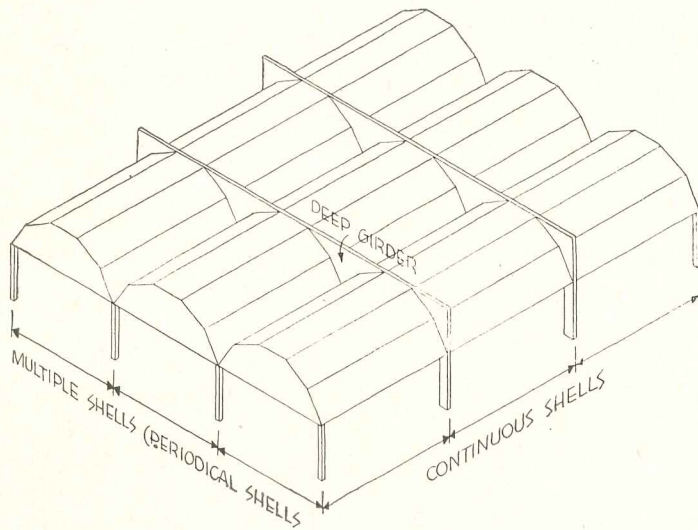

In addition to prismatic shells which approximate the shells of single curvature, prismatic shells can also be used to approximate shells of double curvature (compare B-1, sheet 22, and B-2, sheet 24):

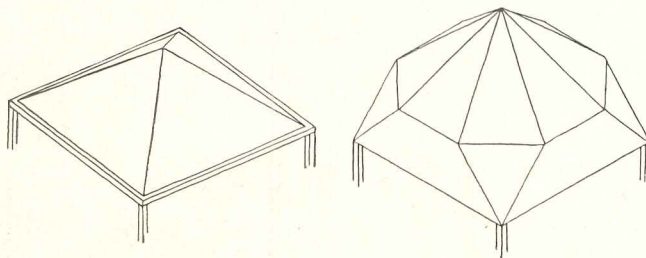

Innumerable crystalline shapes are possible. They may be used as shown or upside down.

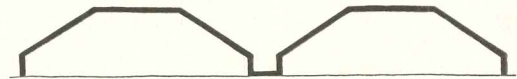
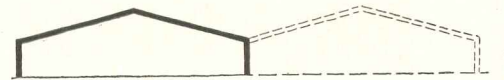

FOR NATURAL LIGHT THIS PANEL CAN BE DESIGNED AS VIERENDEEL TRUSS.

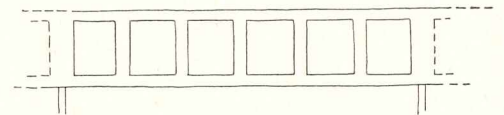

**Typical Cross Sections**

**REFERENCES:**

- American Concrete Institute Journal, Feb., 1953. H. Craemer: "Design of Prismatic Shells."
- Ditto—Jan., 1947. G. Winter and M. Pei "Hipped Plate Construction."
- Also Articles in Publications of Int'l Ass'n For Bridge & Structural Engineering



**fine homes deserve**

**CRA redwood**

Milled with precision, seasoned with care, graded with accuracy, CRA Redwood often means the difference between an outstanding job and a merely satisfactory one. Specify grade-marked, trade-marked CRA Redwood—and be sure.

**CALIFORNIA REDWOOD ASSOCIATION**

576 Sacramento Street, San Francisco 11

Glenview, III., Residence • Architects: Barancik, Conte & Associates, AIA.



**CRA members:** Eureka Redwood Lumber Co • Hammond Lumber Co • Holmes Eureka Lumber Co • Hulbert & Muffly Lumber Mill • Northern Redwood Lumber Co • The Pacific Coast Company • Pacific Lumber Co • Rockport Redwood Co • Simpson Logging Co • Union Lumber Co • Warm Springs Redwood Co • Willits Redwood Products Co • Wolf Creek Timber Co., Inc • Arcata Redwood Co • Coastal Plywood & Timber Co



GYPSUM PLASTER IN RADIANT HEATING SYSTEMS: 1

Presented Through The Courtesy of The Gypsum Association

The editors wish to express appreciation to the Gypsum Association, and to its general manager, Lloyd H. Yeager, for the data presented in these pages. The association has studied the performance of plaster in ceiling panel radiant heating systems for the past several years and has arrived at the following recommendations for installation and operational procedures. A supplementary sheet presenting tables on heat transmission characteristics, densities and thermal expansion coefficients will be in the December TSS.

Types of Systems

The following types of panel heating systems can employ gypsum products:

1. Systems in which small elements for heat conducting mediums, such as pipes up to a maximum of 1/2 in. o.d., electrical wires or screens, are embedded in plaster.
2. Systems in which larger elements, including pipes exceeding 1/2 in. o.d., are embedded in plaster.
3. Systems in which the heating elements are located behind the ceiling panel, either directly in contact with the gypsum product or spaced away from it.
4. Convection or plenum systems, where gypsum products form one or more faces of the ducts or plenums.

Plaster Characteristics

Attention to the characteristics of plaster, with reference to the resistance to heat flow through the material, thermal expansion coefficients and densities, is vitally important. Certain precautions must be taken to minimize, for example, cracking due to thermal shock, 'shadowing' under pipes due to unequal drying rates, or unusual calcination which might be caused by over-heating.

One of the most important considerations is the type and thickness of plaster specified for the radiant heating job. Heat resistance values vary with the type of plaster and aggregate used. The "K" value (thermal conductance) of gypsum sanded plaster is about 4.25. On the other hand, the "K" value of

lightweight aggregate plaster may vary from 1.23 to 1.84, depending on the type of aggregate used and the proportion of plaster to aggregate. The "K" value of some acoustical plasters is as low as .50.

Any proportioning of plaster and aggregate may be specified for the panel heating job, when consideration is taken of the heat losses and the heat flow resistance of the type of plaster specified.

The heat transmission characteristics of plaster mixes depend on the density of the plaster mix. The densities of set and dry plaster mixes are:

1. Gypsum sanded plaster—105 to 115 lbs per cubic foot
2. Gypsum light-weight-aggre-

gate plaster—40 to 50 lbs per cubic foot

In large unbroken ceiling areas, care should be taken to provide relief for expansion of the panel from the induced heat. Careful attention to the thermal expansion coefficients of plaster mixes is required since plaster will expand and contract to a minute degree. If exposed to abrupt thermal shock, cracking may result.

When gypsum lath and gypsum plaster are used in radiant heating panel systems, they should be used in accordance with the applicable provisions of ASA No. A42.1—1950 "Standard Specifications for Interior Lathing and Furring."

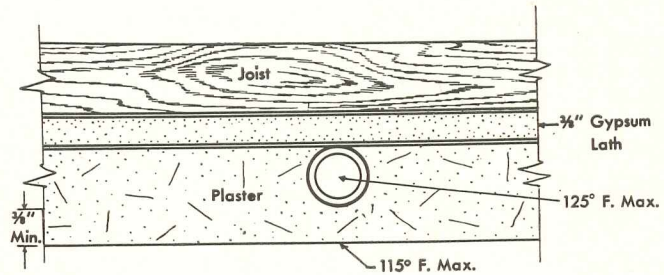

Detail of Recommended Installation Procedure

Where heating elements are embedded in gypsum plaster, a minimum of 3/8 in. plaster thickness must be maintained beneath the heating elements. Ceiling surface temperature should not exceed 115 F, and water temperature in pipes should not exceed 125 F (see footnote on Sheet 2)

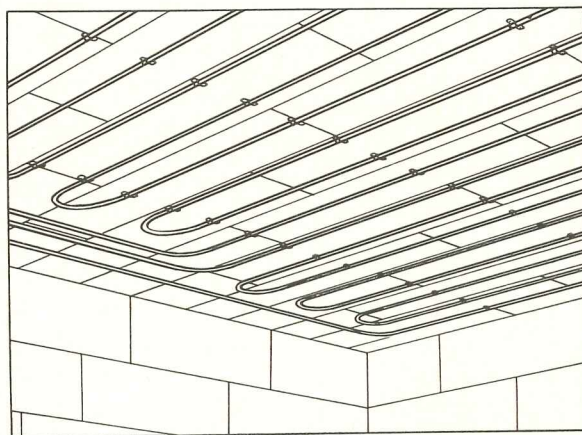

Panel Heating Elements Ready for Plastering

Tubing must be permanently attached to structural framing members, and not to the gypsum lath



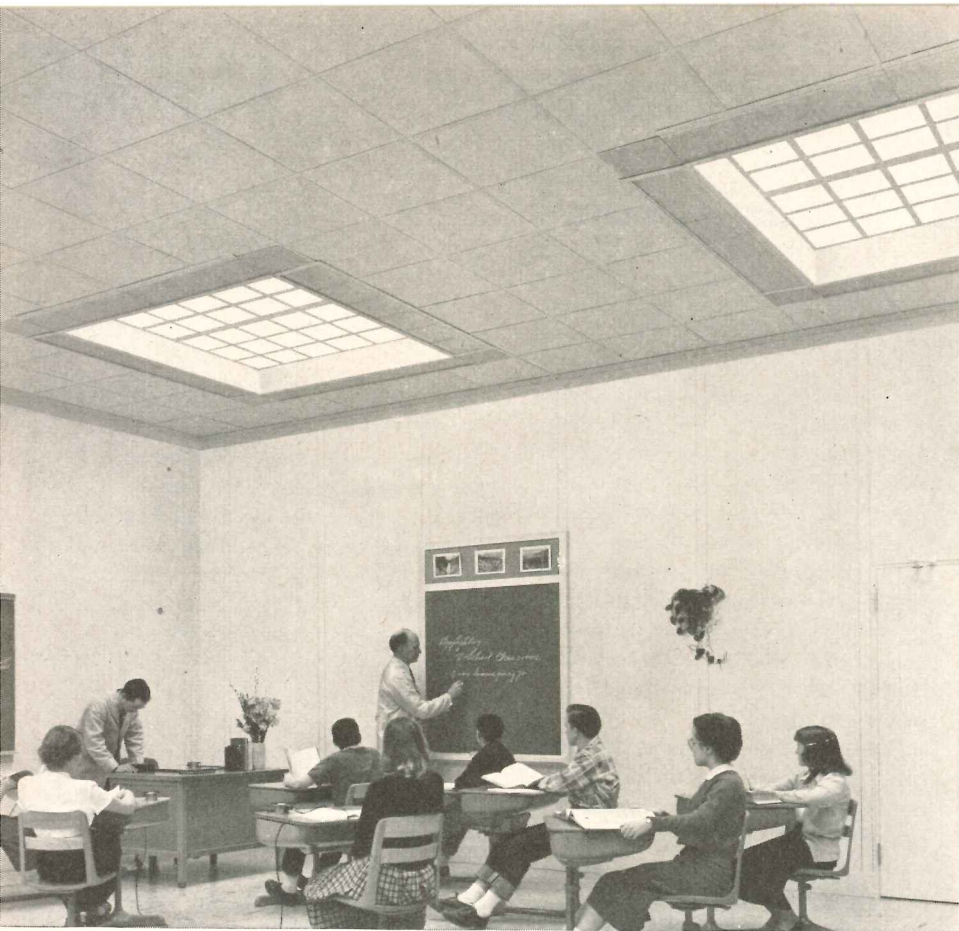

# KIMBLE TOPLITE

*a new system  
for daylighting  
deep rooms*

New Kimble Toplite Panels solve the problem of how to provide daylight for deep interior areas too far removed from conventional, side-wall panels of prismatic Insulux Glass Block®.

This revolutionary new daylighting system lets you bring free daylight in from above through a simple framed, flat roof without monitor, saw tooth, or clerestory arrangements.

**Only the Kimble Toplite offers these features:**

## PREFABRICATION

Kimble Toplite panels are factory-fabricated for uniform quality, and low installation cost. They are made up of an insulated aluminum grid into which special hollow glass units are

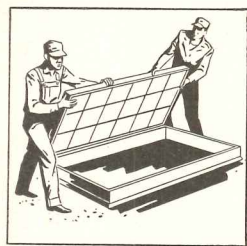

set. The glass units themselves are 10<sup>3</sup>/<sub>8</sub>" square by 3" thick, and are installed in the aluminum grid 12" on centers. Panels are weatherproof with no porous materials exposed to the weather.

## TESTED, TIME-PROVED CONSTRUCTION

Kimble Glass Company, in conjunction with a leading roof light manufacturer, and the Daylighting Laboratory at the University of Michigan have exhaustively tested Toplite in widely scattered locations under widely varied conditions.

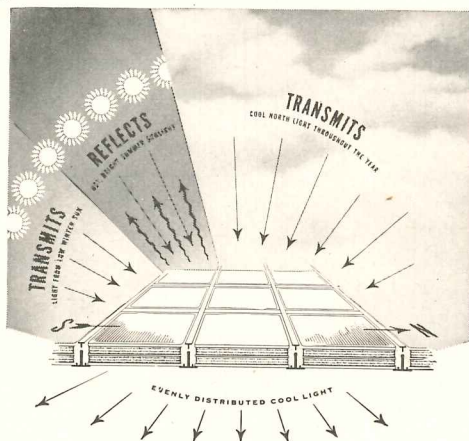
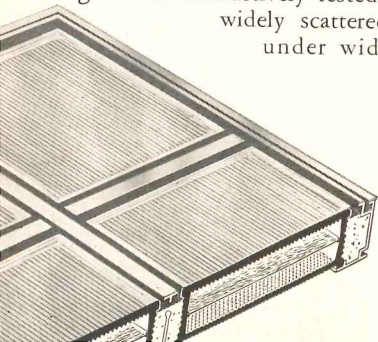

## SELECTIVE CONTROL OF DAYLIGHT

Kimble Toplite Panels are selective in their light transmission. They transmit a high percentage of the light from the low winter sun and from the north sky but reflect much of the direct light from the high summer sun. Light-controlling characteristics eliminate glare and

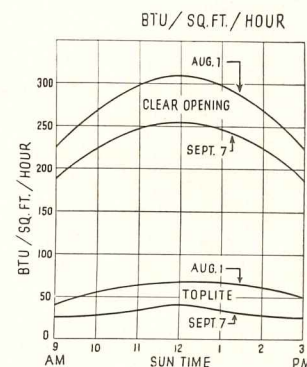

Calculated total heat gain through a Toplite Panel as compared to a clear opening in a horizontal roof for a building located at 37°N. Latitude.

distribute daylight throughout the room so that concentrations of light are eliminated.

## SOLAR HEAT REDUCTION

Panels are designed to reflect hot summer sun and have unusual ability to reduce solar heat transmission. Toplite panels have high insulating value thus reducing troublesome condensation during winter. Loads on heating, air conditioning and artificial illumination systems are reduced.

*More information*

Want more information about this great, advance in daylighting? Send for the new, free bulletin: "Kimble Toplite—a new system in daylighting." Address: Insulux Glass Block Division, Kimble Glass Company, Dept. AR-11, Box 1035, Toledo 1, Ohio.

MANUFACTURERS OF INSULUX GLASS BLOCK



# KIMBLE GLASS COMPANY

Toledo 1, Ohio—Subsidiary of Owens-Illinois Glass Company



GYPHUM PLASTER IN RADIANT HEATING SYSTEMS: 2

Presented Through The Courtesy of The Gypsum Association

The following points are recommended for the use of gypsum lath and plaster in radiant heat installations:

1. In radiant panel heating systems where gypsum products are employed, the surface temperature should not exceed 115 F.
2. In those systems where pipes are embedded in gypsum plaster, water temperature in the pipes in contact with the plaster must not exceed 125 F.\*
3. The temperature of the gypsum plaster should not exceed 90 F or atmospheric temperature (whichever is higher), until the plaster has set and is thoroughly dry. The heating system should not be used to aid in plaster drying.
4. Where heating elements are embedded in gypsum plaster, a minimum of 3/8 in. plaster thickness shall be maintained over the outside of the heating elements.
5. When heating elements are to be embedded in gypsum plaster applied to metal or gypsum lath, the heating elements must be secured to the framing and not to the lath. This does not apply to thin electrical resistance elements embedded in the plaster.
6. When turning the heating system on or off the changes in temperature of the circulating medium should be gradual so that damage from thermal shock will be avoided as much as possible.

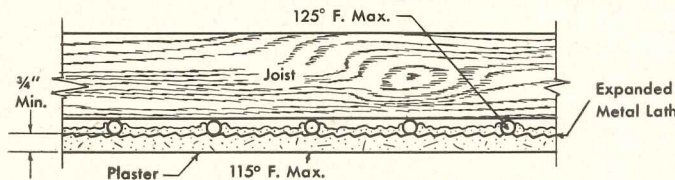

1 | In one typical installation of panel heating systems with gypsum plaster, the metal lath is placed below the heating elements. This type of installation requires only the standard plaster thickness of 3/4 in., but the plaster keys partially surround the heating elements

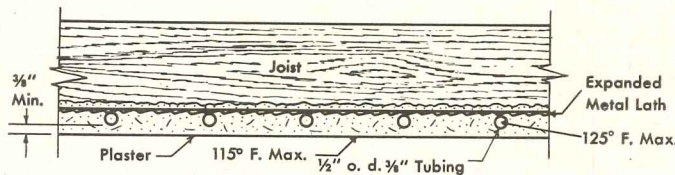

2 | In another type of installation which also utilizes metal lath, heating elements, as shown, are completely embedded in plaster and placed below lath. A minimum plaster thickness of 3/8 in. is required beneath the heating elements in this installation

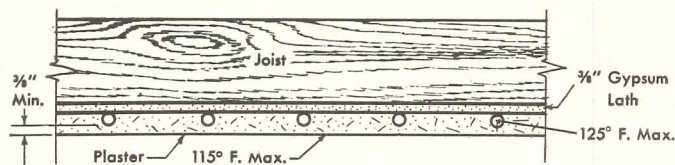

3 | A third installation employs gypsum lath, with heating element located directly below plaster base

\* There is some difference of opinion among heating authorities as to the limitation of water temperature to 125 F. Lloyd H. Yeager defends the Gypsum Association's position with the following points: (1) if higher water temperatures are used to permit a wider spacing of pipes or coils (thereby reducing the cost of the system) this would create a less uniform panel surface temperature and, in their opinion, reduce performance quality. (2) According to their laboratory and field tests, a surface temperature of 115 F which required a water temperature of 125 F did not create a hazardous condition within the plaster, but extremely high temperatures may cause plaster failures. This is not to infer that temperatures slightly higher than 125 F are definitely detrimental, but they feel that temperatures of 140 F may be detrimental to the successful performance of a plastered ceiling.



# All essential ceiling components in a single integrated modular system

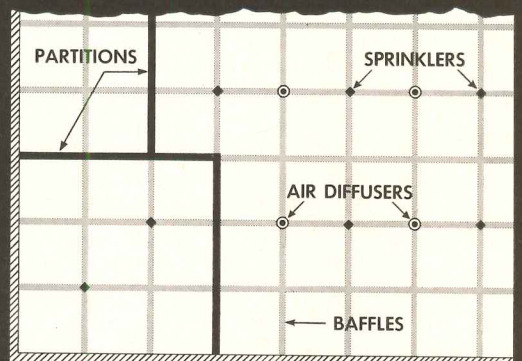
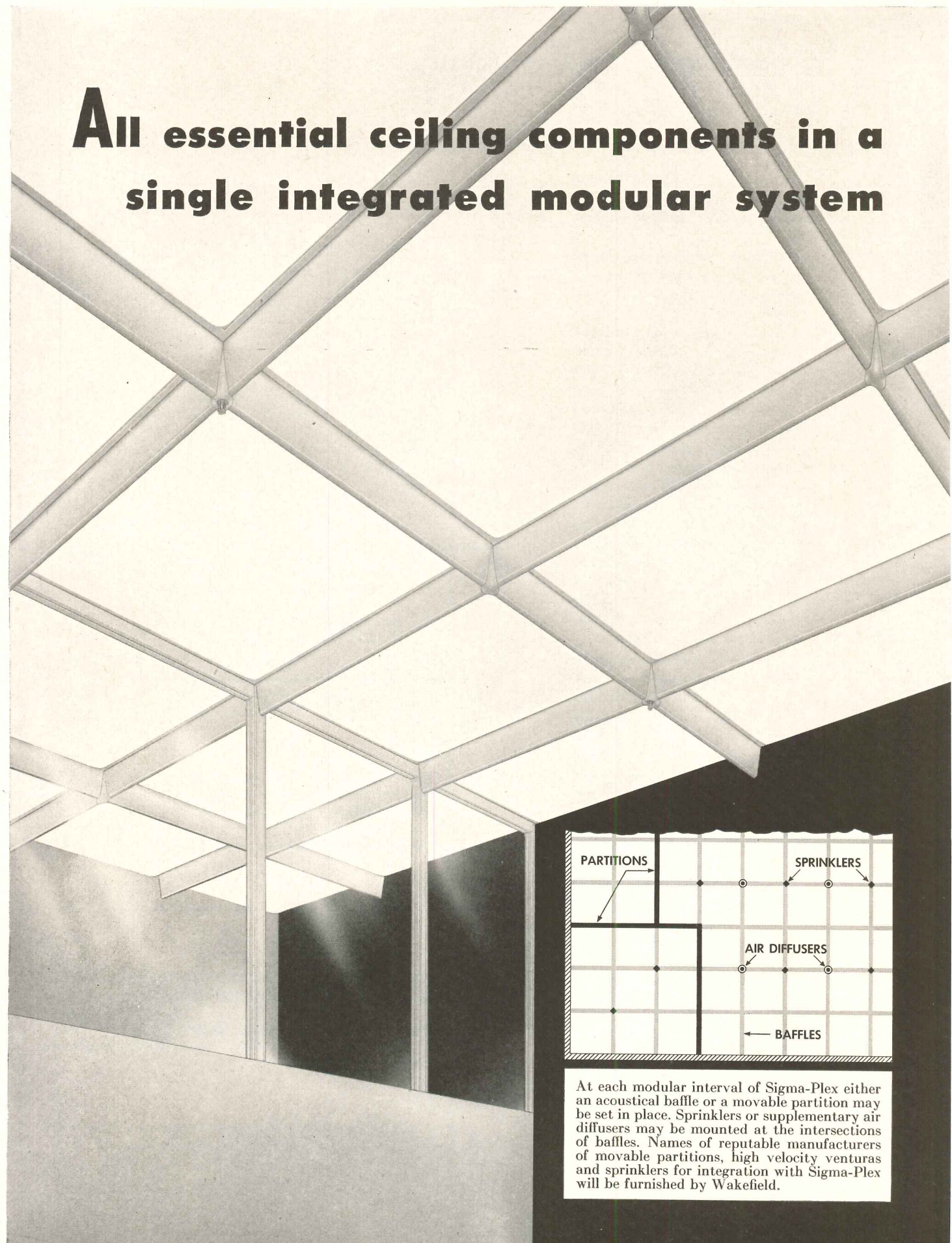

At each modular interval of Sigma-Plex either an acoustical baffle or a movable partition may be set in place. Sprinklers or supplementary air diffusers may be mounted at the intersections of baffles. Names of reputable manufacturers of movable partitions, high velocity venturuses and sprinklers for integration with Sigma-Plex will be furnished by Wakefield.



**in SCHOOLS there is always  
heavy INDOOR HIGHWAY traffic  
..... there you will find**



*Vinylflex*

**PLASTIC FLOOR TILE**

\*Trade Mark

AND

**HAKO ASPHALT TILE**

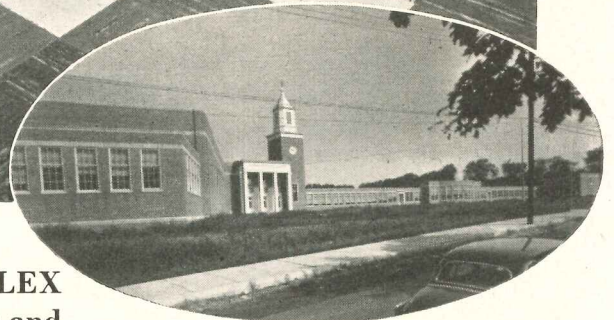

Architects are specifying HAKO VINYL FLEX PLASTIC FLOOR TILE for floors in school rooms and corridors, where ruggedness, modern traffic-lane design and beauty is demanded. This all purpose floor tile with its low initial cost, ease of maintenance, safety and quietness underfoot plus its grease and acid proof features, toughness and longtime wearing qualities, meets the requirements for school floors where traffic areas are exposed daily to the severest kind of treatment.

Of course, Architects still rely on the dependability of HAKO Asphalt Tile Flooring to give complete satisfaction when budget economy is necessary.

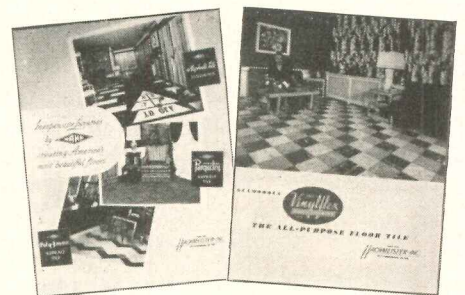

SEND FOR our beautiful new full color descriptive brochures on HAKO Vinylflex Plastic Floor Tile and HAKO Asphalt Tile Flooring.

The Asphalt Tile brochure also contains full color illustrations and complete information about Poly-Krome and Parquetry design.



Since 1903

**HACHMEISTER-INC.**

General Offices

PITTSBURGH 30, PA.

AR-6





## THE RECORD REPORTS

(Continued from page 330)

### 12 PRIZES AWARDED IN NEBRASKA COMPETITION

Prizes totaling \$1750 have been awarded in a competition sponsored by the Nebraska Architects Association, a chapter of the American Institute of Architects, "to apply the value of architecturally-trained talent to the design of homes within the financial reach

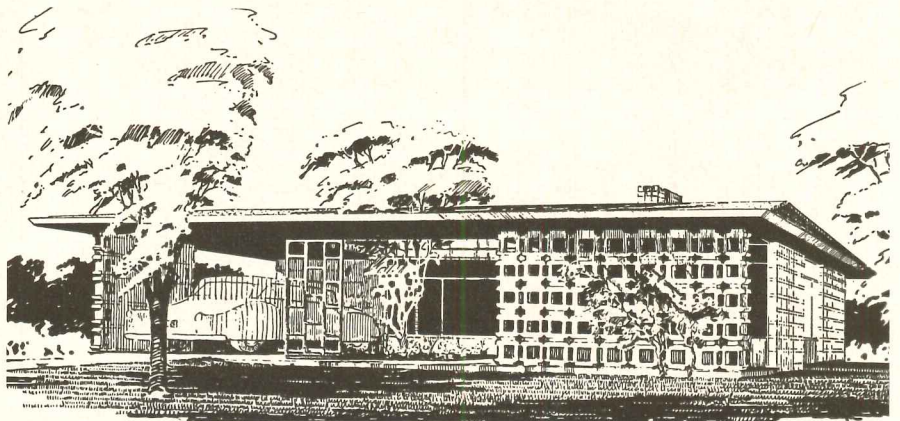

#### FIRST PLACE AWARD

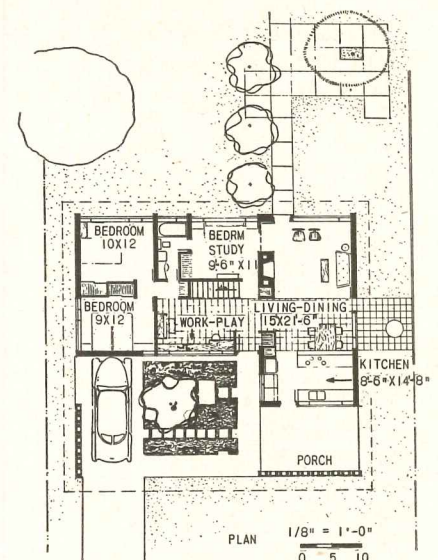

You **Know** what you're getting in

# Airlift...

the completely certified  
Swartwout duct exhaust ventilator

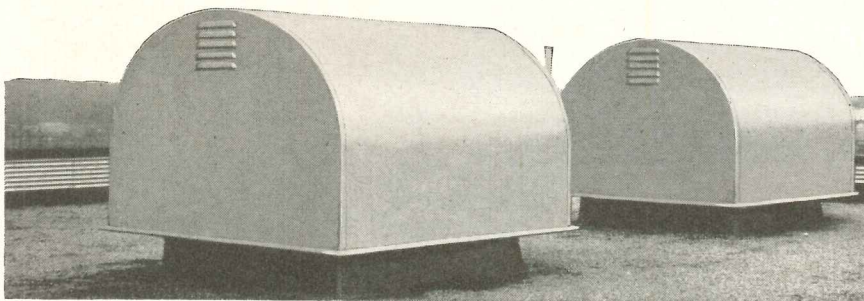

There's no guessing about actual results obtainable from the new Swartwout Airlift. The dynamically balanced heavy-duty centrifugal fan and the complete ventilator unit have been tested by an independent laboratory. The 138 capacity variations (covered by 14 ventilator sizes) have been determined in accordance with the test code adopted by NAFM and ASH & VE. Airlift is guaranteed to deliver catalogued capacities at listed static pressures.

Airlift has an unusually effective fan wheel, permitting lower tip speeds than usually possible — which means lower noise levels.

Other design features reduce turbulence and increase efficiency. Power unit and fan are easily accessible in this new design. Write for Bulletin AL-G.

50 YEARS SERVICE TO INDUSTRY — 1903 • 1953

18511 Euclid Avenue, Cleveland 12, Ohio

## The Swartwout Co.

### Roof Ventilators and Ventilating Louvers

POWER PLANT EQUIPMENT • PROCESS INDUSTRY CONTROLS

of that large segment of the moderate-income, home-seeking public, and to stimulate in the public mind a further desire for architectural services in home design." Association President Edward Sessinghaus of Omaha said as far as he knew it was the first such competition ever held in the state. Prize money was donated by the Nebraska Concrete Masonry Association.

Twelve of the 31 entries received awards at the last quarterly meeting of the architects' group. Kenneth B. Clark and Lawrence E. Enersen, partners in the Lincoln, Neb., architectural firm of Clark and Enersen, received the \$1000 first place award; and the second place award of \$250 went to Sidney W. Campbell and Reginald E. Davies, associated with the firm of Unthank and Unthank, also of Lincoln. Ten awards of merit of \$50 each were given to Alex Weinstein, of Steele, Sandham and Steele, Omaha; Clyde Bourgeois, of the engineering department of Northwestern Bell Tele-

(Continued on page 334)



# Sylvania Announces! A New Industrial-Commercial Fluorescent Fixture Line!

New Sylvania I-C Fixture with 45° x 45° louvered shielding

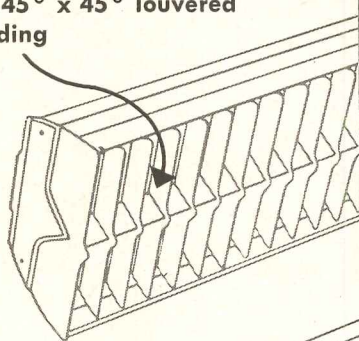

Showing I-C Fixture with "V" type reflector providing 45° crosswise shielding

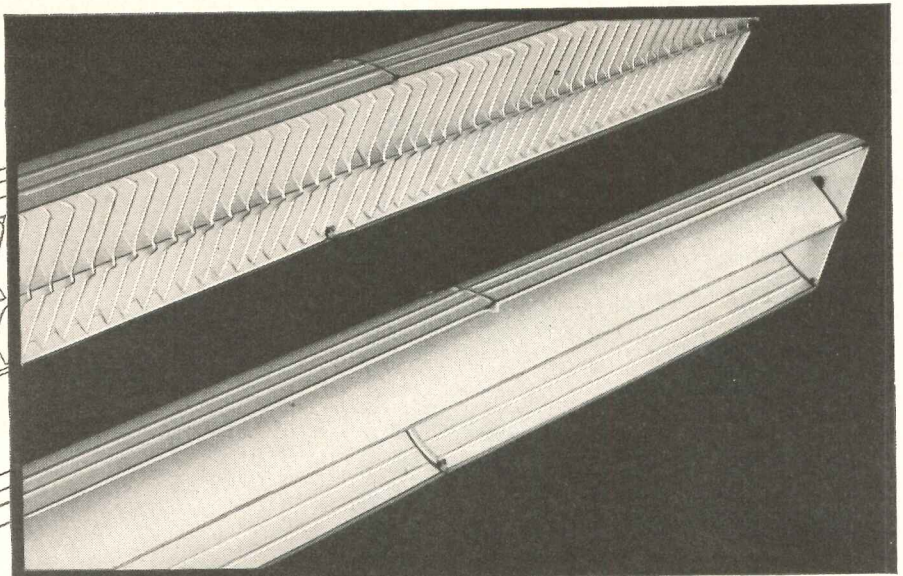
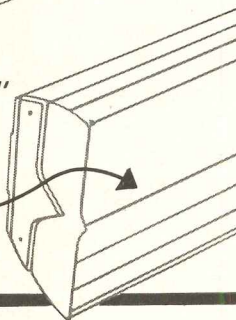

## New from every angle!

### Quality built and packed with these advanced features:

**45° x 45° Louvered Shielding**—Direct Glare is kept to a minimum when 45° x 45° louver shielding is used.

**60%-40% Distribution**—Distribution from I-C fixtures is 60% downward and 40% upward, providing a strong direct component for high levels of illumination.

**Versatile and rugged, too!**—Channels are die-formed of 20-gauge steel. Made with extra knockouts to provide flexibility of installation. Designed for individual or continuous-row installations, pendant or surface mounting. Metal parts Bonderite treated to resist deterioration. Channels, louvers and steel panels finished in Sylvania's high-temperature baked Mira-coat, providing 86% reflectivity.

**T-17 Low Brightness Unit**—The I-C line has been designed to accommodate the 40-watt 60-inch T-17 low-brightness lamp, meeting the need for a unit with minimum shielding. Combines low brightness, comfortable illumination with high efficiency and easy maintenance.

● Now Sylvania comes forward with the new I-C series . . . the most sales-winning lighting fixture line ever offered. It's another high quality Sylvania line, including today's most wanted features. Amazingly versatile, too, with 4, 5, and 8 foot units specifically designed to meet the lighting needs of offices, stores, schools and factories. Ideal for critical seeing tasks such as those encountered at printing plant composing stones or in the machining of specular metals. And, it's a right-priced line to help you win bids . . . for both *industrial and commercial applications*. Remember, this Sylvania I-C line is designed, built and tested and *fully guaranteed* for one year by Sylvania. For detailed information see your Sylvania representative or write directly to: Sylvania Electric Products Inc., Dept. 3X-1911, 1740 Broadway, New York 19, N. Y.

# SYLVANIA



LIGHTING • RADIO • ELECTRONICS • TELEVISION

In Canada: Sylvania Electric (Canada) Ltd.  
University Tower Building, St. Catherine Street, Montreal, P. Q.



## THE RECORD REPORTS

(Continued from page 332)

phone Company, Omaha; Mrs. Blanche Plunkett, a housewife who works on a contract basis for Glen Bouton, Hastings, Neb., architect; Ed C. Gross of the Hoppe Lumber Company, Lincoln; Burkett E. Graf, Lincoln architect; John H. Aylor, of Leo A. Daly, architects and engineers, Omaha; Woodrow Hull, of the Lincoln firm of Davis and Wilson; James W. Nicas, of Steele,

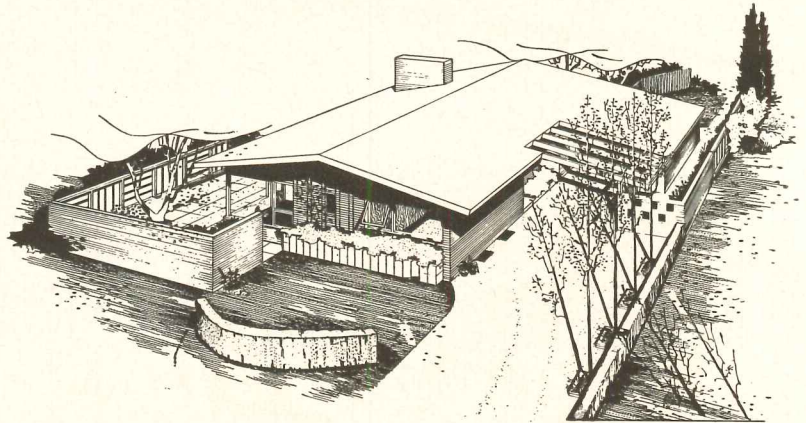

### SECOND PLACE AWARD

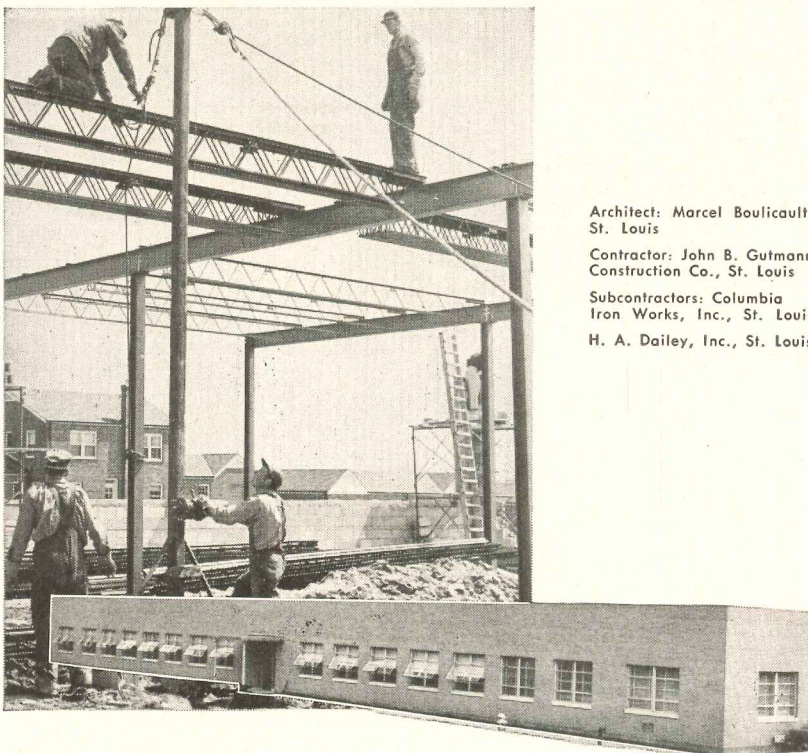

Architect: Marcel Boulicault, St. Louis  
 Contractor: John B. Gutmann Construction Co., St. Louis  
 Subcontractors: Columbia Iron Works, Inc., St. Louis  
 H. A. Dailey, Inc., St. Louis

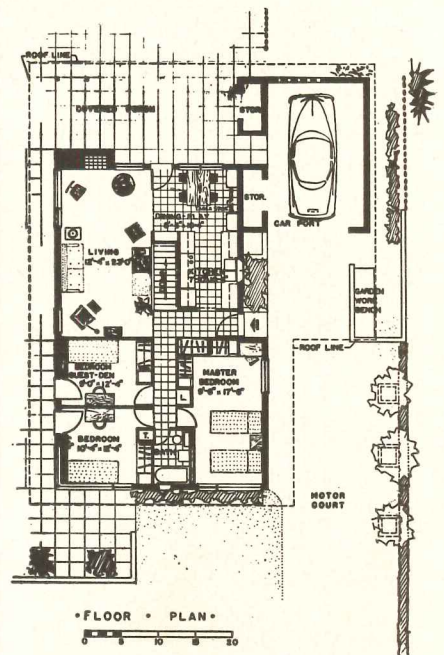

## 65,000 sq. ft. Building Erected in 60 Days with **LACLEDE CONSTRUCTION STEELS**

Laclede Steel service and construction know-how combined to give Ritepoint Company of St. Louis a new permanent-type building in a hurry. The short completion time resulted from using Laclede steel joists, reinforcing bars and welded wire fabric.



**LACLEDE STEEL COMPANY**  
 Producers of Construction Steel  
 St. Louis, Mo.

Sandham and Steele; James A. Lynch, of Noel S. Wallace, Omaha; and Dale L. Gibbs, Roy C. Neumann and Hedy C. Neumann, Lincoln architects.

The winning designs were chosen by a Jury of Award which consisted of Harold Spitznagle, architect, Sioux Falls, S. D.; James T. Lendrum, executive director of the Small Homes Council, University of Illinois, Urbana, Ill.; and R. E. Copeland, director of engineering, National Concrete Masonry Association, Chicago. Martin I. Aitkin of Lincoln was the professional adviser for the competition.

The problem was a three-bedroom house of one story and basement, with living area, all on one level, restricted to 1200 sq ft; lot not to exceed 60-ft frontage, 125-ft depth. Use of modular dimensioned concrete masonry for all exterior walls and interior partitions was mandatory.

(More news on page 336)



for Permanently Leakproof  
Shower Baths

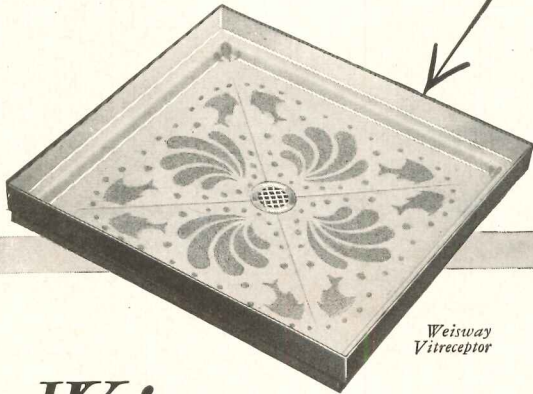

Weisway  
Vit receptor

## Weisway VITRECEPTOR

The perfect receptor with integral flashing for showers having walls other than metal. Formed in one piece of enameling iron with vitreous porcelain inside and out. Textured Foot-Grip, No-Slip floor—safe, sanitary, non-absorbent. No metal underpans required. Write for detailed information on Vitreceptor and catalog of Weisway Cabinet Showers.

**HENRY WEIS MANUFACTURING CO., INC.**  
1103 Weisway Bldg., Elkhart, Indiana

WHERE VENTILATION AND VISION...

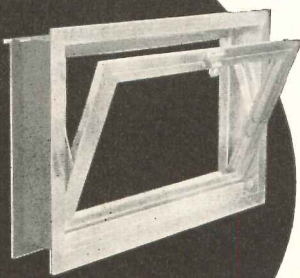

ARE NEEDED IN  
GLASS BLOCK  
CONSTRUCTION...

Install

**MARMET**

### GLASS BLOCK VENTILATORS

Enhance the beauty as well as the utility of glass block panels and walls... install the MARMET Ventilator, the practical window that provides ventilation and vision for glass block construction... can be used in groups, side by side or one above the other... available in stock sizes, but special sizes can be built to your specifications. MARMET Aluminum Louver Block may be used to replace a single 8" by 8" glass block panel... a self-contained unit, glazed and screened with a metal louver on the exterior surface.

**Other MARMET Products...**

MARMET ALUMINUM WINDOWS for glass block construction (ribbon windows, church and chapel windows, casement and projected windows, residential picture windows, custom windows).

MARMET ALUMINUM WALL OF WINDOWS, complete louver blocks... picture windows.

Complete catalogs of information upon request  
WRITE FOR THEM TODAY



Wausau • Wisconsin

FIRST NEW  
WINDOW TREATMENT IDEA  
IN 50 YEARS

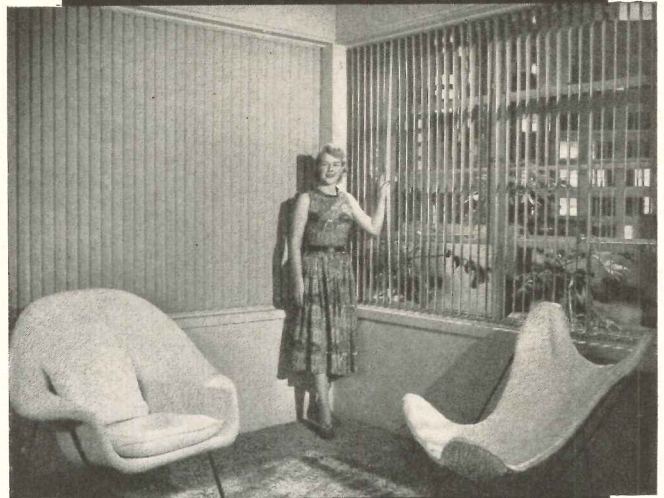

DRAPERIES, BLINDS AND  
CURTAINS...all in one!

SET FROM M-G-M'S "TORCH SONG", FEATURING DOROTHY PATRICK (ABOVE). ART DIRECTORS, CEDRIC GIBBONS, PRESTON AMES. SET DIRECTORS, EDWIN B. WILLIS, JACK B. MOORE

NEW PANELLED  
FABRIC DRAPERIES

BY Sun VERTIKAL

BRING DRAMATIC NEW BEAUTY TO BOTH  
MODERN AND TRADITIONAL INTERIORS!

This entirely new concept in window treatment gives your client the ultimate in window beauty, convenience and light control.

**LITTLE OR NO CARE REQUIRED**—hard-finish fabric panels are vertical, actually repel dust, dirt, grime. Color-fast and shrink-proof.

**SCIENTIFIC LIGHT CONTROL** gives complete privacy, or precise amount of light desired. No tapes or cords. All mechanical parts engineered for a lifetime of trouble-free operation.

**25 DECORATOR COLORS** to choose from, or 1000's of combinations. Panels are quickly installed to individual window requirements. Ideal as partitions, panels, or on French doors.

For complete information and name of your distributor, write Sun Vertikal Blind Co., Dept. R, Box 112, Grand Rapids, Mich.

DISTRIBUTORS: A FEW CHOICE AREAS ARE STILL AVAILABLE

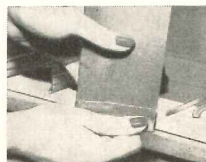

Panels last for years, may be replaced easily and inexpensively for a change in decorative scheme. Photo at right shows concealed control rod which moves panels in unison.

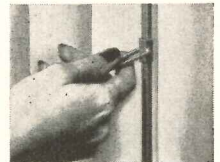

1953 AWARD WINNER

Trophy Presented by The Academy of Color & Design

Panelled Draperies

by Sun VERTIKAL

Made only by the Sun Vertikal Blind Company  
®T.M. Patented, Other Patents Pending.



All About Goff

Bruce Goff, who has been since the late 1920's one of the stormier and not-often out-spoken critics of architectural goings on in the United States, has all that time also been amassing a considerable volume of his own production, work which has often been scarcely less controversial than his criticisms. Now the German magazine *Baukunst und Werkform* has compiled a portfolio of the architect's buildings



Lederle Laboratories Division  
American Cyanamid Company  
Pearl River, N. Y.

Main production building. Minwax waterproofing products specified and used on all buildings in this group.



# Waterproofing Products

**MINWAX CAULKING COMPOUNDS**

Resistant to heat and cold; remain elastic and weatherproof for years. Made in white, grey and buff; soft or heavy consistency. Also Minwax Asphalt Caulking Compound.

**MINWAX WEATHERCAP**

An extruded strip of pure lead to cover masonry joints. Provides permanent protection when embedded as specified in the companion product, Minwax Caulking Compound. (Write for specifications; A.I.A. File No. 7D.)

**MINWAX TRANSPARENTS**

To combat leakage, staining, and frost erosion on exposed masonry. Made in Clear, Colorless, and now with Silicone Base. (Write for new specifications leaflet.)

**OTHER MINWAX PRODUCTS**

Minwax Membrane & Spandrel Waterproofings; Expansion Joint Cement; Asphalt Dampproofings; Terrazzo and Concrete Floor Finishes; Minwax Wood Finishes & Waxes.



A complete  
Waterproofing Service

MINWAX CO., INC.  
11 West 42nd Street, New York 36  
Please send Minwax waterproofing specifications, with name of nearest Regional Representative.  
NAME.....  
ADDRESS.....  
CITY.....STATE.....

Goff Buildings: Above, Naval Base Chapel, California; Below, top, house in Park Ridge, Illinois; Bottom, Methodist Church, Tulsa, Oklahoma, designed in 1926 when Goff was 22 years old

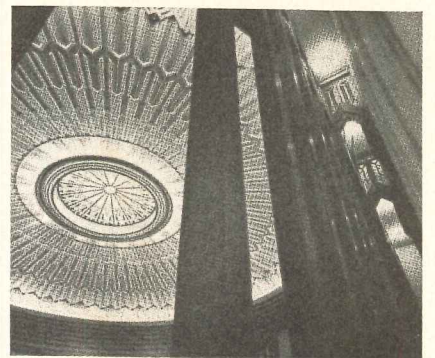
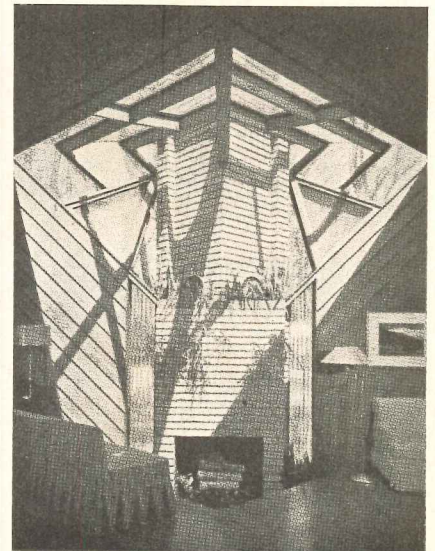

and projects, extending from his earliest structures to the present day. The entire July 1953 issue of the magazine is devoted to the work and thought of Goff, and is copiously illustrated with photographs of his buildings and reproductions of his renderings and paintings. Some of the featured works are shown on this and following pages.

(Continued on page 340)



A PREVIEW OF  
FUTURE CONSTRUCTION  
POTENTIALS WITH  
PARTICULAR REFERENCE  
TO THE YEAR **1954**

# GUNS AND BUTTER **AND** BABIES

By **THOMAS S. HOLDEN**, Vice Chairman; and **CLYDE SHUTE**,  
Assistant Vice President and Manager, Statistical and Research Division;  
**F. W. DODGE CORPORATION**

**ARCHITECTURAL  
RECORD**

**NOVEMBER 1953**







# GUNS AND BUTTER AND BABIES

*A Preview of Future Construction Potentials With Particular Reference to the Year 1954*

*By Thomas S. Holden, Vice Chairman; and Clyde Shute,  
Assistant Vice President and Manager,  
Statistical and Research Division; F. W. Dodge Corporation*

**T**HE way a lot of people have been talking, Ole Man Depression has been breathing right down our necks during the entire year of 1953. Peace might break out at any minute, or the seven-year itch or the 18-year business cycle might catch up with us all of a sudden; and, in general, it seemed a very good idea to be jittery about something.

Actually more people working turned out more goods and services than ever before in the country's history. The American economy acquired 51,000 new customers every single week. Consumers spent more for goods and services and investors spent more dollars for new construction than ever before. To be sure, a great many consumers have gone into debt, running the total of outstanding consumer credit to a record figure, but at the same time either the same people or a lot of others have piled up record totals of savings in the thrift institutions of the country. Just as it was that time back toward the end of the war when a great many people expected eight million unemployed, this country has lately been in a helluva fix.

It now appears that the most enthusiastically press-agented depression of modern times isn't going to happen. At least, it has been postponed. The basic truth is that the American economy is growing so

fast, has such inherent strength, has such flexibility and vitality, that only a major catastrophe is at all likely to retard its continued progress very appreciably at any early date.

To assist the reader in looking at the record, some charts are shown herewith (see next page).

## LET'S LOOK AT THE RECORD

U. S. population increased from 132,000,000 in 1940 to 140,000,000 in 1945 and passed 160,000,000 in mid-August 1953. In the short space of eight years from V-J Day, the net increase was 20,000,000 persons. The U. S. economy in 1953 was 21 per cent bigger than it was in 1940.

If it were merely a matter of more people eating, population growth might not be a measure of prosperity, but the reverse. In a scarcity economy, 8,000,000 or 20,000,000 new consumers in a brief period might mean famine or near-famine for a great many of them. As a matter of literal fact, the American people in 1945, after welcoming 8,000,000 newcomers, and after out-producing the world in war materials and feeding millions of allies, ate better than they ever had before. That is to say, the average American family's diet was more varied and more nutritious in 1945 than at any previous time. For the



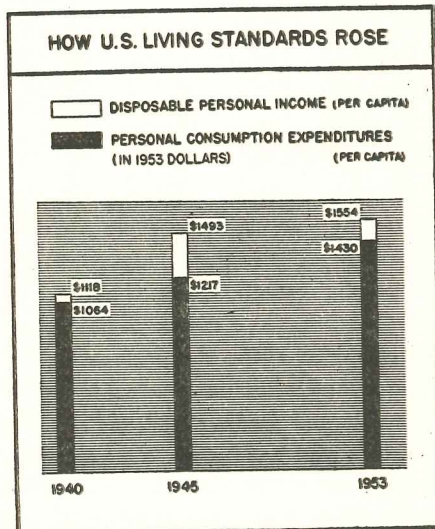
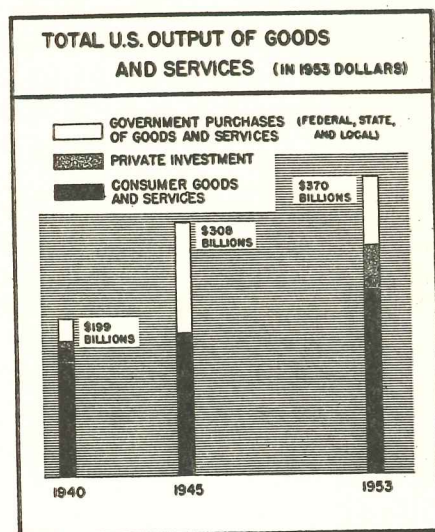
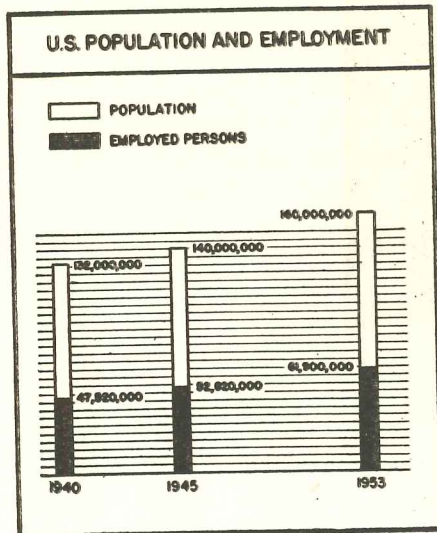

first time in history, a people raised its standard of living while conducting an all-out war. Living standards continued to improve steadily through 1953.

#### MEN AND WOMEN WORKING

This happy result has been in large part due to the important fact that we not only had more people eating, we also had at the same time a lot more people working. As shown in the chart, the number of persons working at gainful occupations and producing goods and services were, in the several years, as follows: in 1940, 47,520,000 persons or 36 per cent of total population (unemployment was still quite considerable that year); in 1945, 53,820,000 persons or 37.7 per cent of the total population; in 1953, 61,900,000 persons or 38.7 per cent of total population.

More people working turned out, not only more products, but more products per worker. As shown in the second chart, total output of goods and services amounted in 1940 to \$199 billion (figured in 1953 prices); in 1945, to \$308 billion (again in 1953 prices); then in 1953, \$370 billion. Apparently output per worker in these years was as follows: \$4188 in 1940; \$5831 in 1945; and \$5977 in 1953 (all calculated at 1953 prices). The high figure of 1945 was in considerable part due to long work weeks and wide prevalence of two- and three-shift operations in industry in that closing year of the war.

#### MORE MONEY TO SPEND

The rise in living standards that has taken place is strikingly shown in the third chart. Here again all values have been calculated in terms of 1953 prices. Per capita disposable income and per capita consumption expenditures are shown for 1940, for 1945 and for 1953. Disposable income, meaning income after direct taxes; roughly speaking, take-home pay. The white spaces at the top of the bars naturally represent per capita savings.

Per capita income increased from \$1118 in 1940 to \$1430 in 1945 and \$1554 in 1953. Per capita consumption expenditures increased from \$1064 in 1940 to \$1217 in 1945 to \$1554 in 1953. People would have spent more in 1945 if they had been able to buy new cars and household appliances and other durable goods which were not being produced for civilians in wartime. However they saved an unusual amount and thus had funds to buy those wanted goods in the



postwar period. They were still saving quite a bit in 1953.

The experience of the war period showed that the U. S. economy could not only produce guns and butter, but could produce guns and more and better butter. In the postwar period the G.I.'s and their brides set about to prove that the nation could support guns and more and better butter and also more and better babies. It has been a noble experiment. The story is by now familiar.

An all-time-high record of marriages in the first postwar year 1946 was followed in 1947 by a record number of births. From a low of 15 per 1000 of population in 1933, the birth rate rose, at first gradually, and then suddenly in 1947, to 25 per 1000 of population, the highest rate since 1915. After 1947 the marriage rate fell off gradually, not because marriage was less popular but because there were each year fewer unmarried people of marriageable age. In spite of this the number of new babies has continued at 3,700,000 to 3,900,000 each year since 1947. The current rate is 75,000 new babies a week, and the net population gain has been about 51,000 a week. The young postwar parents have changed the previous trend toward smaller and smaller families to larger and larger ones.

#### THEY BELIEVE IN THE FUTURE

This somewhat sudden desire for large families is actually a great vote of confidence in America's future by the present generation of newlyweds. One of the strongest traditions in American life has been that each generation fully expects the next generation to have a better standard of living and is willing to work in order to achieve that end. When the outlook for the future seemed rugged, the marriage rate and the birth rate fell.

When Americans learned that their resources and their resourcefulness admitted no ceiling to progress, then numbers of them apparently decided that a houseful of healthy, happy youngsters was about as good an index of a high standard of living as ownership of a car or a washing machine.

The motto of the American people seems to be: "Nothing's too good for our kids." Specialty stores featuring clothes and playthings and toys for infants and small children show up by the dozen in the towns and cities all over the land. Meat packers and food processors have spent millions in research leading to the development of special foods for babies. It has been estimated that the total retail value of merchan-

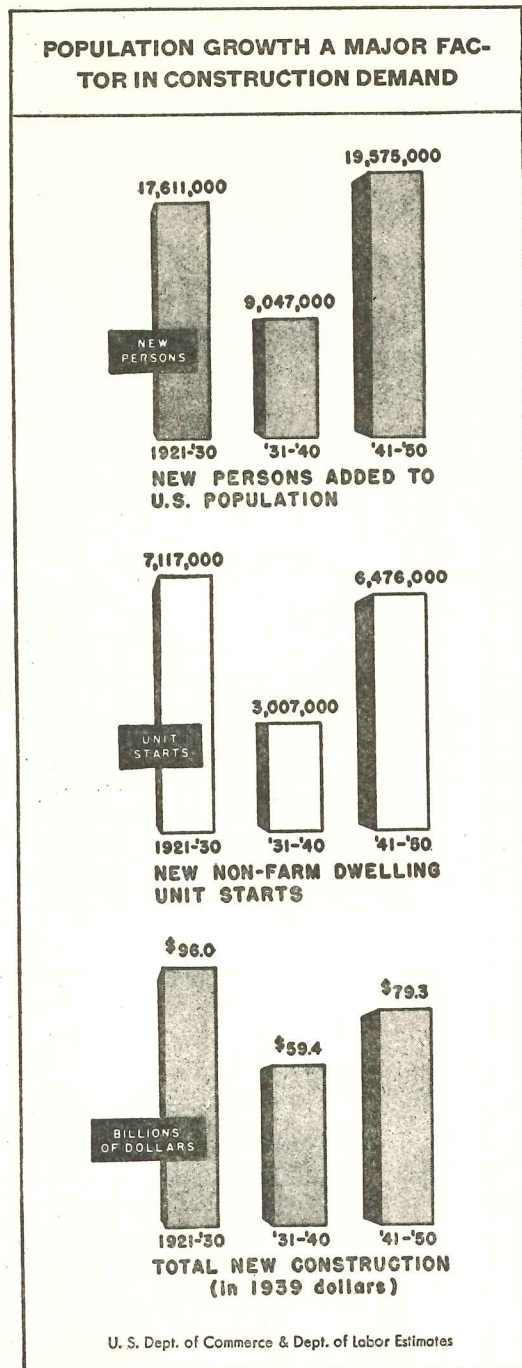



dise produced and sold for the baby and small fry market is running to \$5-6 billions annually.

The building of new schools is booming. There was a backlog of demand at the end of the war, and the school age population has been increasing rapidly. During the past eight years new school buildings have been constructed to a national total of more than 850 million sq ft of floor space. Very important is the fact that the quality of the postwar school buildings is, in terms of functional character, architectural design and structural integrity, up to the highest standards of excellence that have yet been devised. Many of these buildings are very original in construction and very beautiful in appearance. "Nothing's too good for our kids," say the parents and the teachers, and the local taxpayers go along.

### **THEY BUILT QUITE A LOT**

During the eight years since V-J Day, while population increased by 20,000,000, there were built some 8,200,000 new non-farm dwelling units and an unknown number of farm dwellings. Total new construction, in current dollars, has amounted to \$200 billion, according to government estimates. That was quite a lot of construction but actually only eight per cent of the total output of goods and services (Gross National Product) during the period. It has produced no important surpluses.

During the same eight years the total number of registered motor vehicles has increased by nearly 22,000,000. The backlog of demand for improved highways, for replanning of city streets to relieve traffic congestion, and for parking spaces, both indoor and outdoor, is staggering. The aviation industry too, has considerably outgrown its ground facilities.

During depression and war years very few office buildings were built. Since V-J Day numbers of new ones have been built in quite a few cities, but in other important ones the supply of office space is still very short. Huge commercial development projects, similar in general character to Rockefeller Center in New York, are being planned for Boston, New York, Denver and other cities. There are numbers of hotel projects in the offing. Suburban drive-in shopping centers are being constructed in large numbers.

### **A MOMENTUM OF GROWTH**

There is a momentum that is carrying these things along. Population trends have changed in the past

and will change again some day. But if 20,000,000 were added in the past eight years, it is reasonable to expect at least another 15,000,000 in the next seven years; that would give a census total of 175,000,000 in 1960. Barring war or other catastrophe this is likely to require annual construction volumes averaging more than the peak volume of the current year. The close correlation between population growth and construction demand has been brought out in previous studies by Thomas S. Holden. It is worthwhile to repeat here (preceding page) a chart showing such correlation that was published with an article entitled "The Big News is the Birth Rate," in the May 1952 issue of ARCHITECTURAL RECORD. Note that the pattern of construction by decades follows very closely the pattern of population increases by decades.

Housing volume, in terms of new non-farm dwelling units, is currently trending downward somewhat, but the average dwelling unit size and average cost are increasing. Growing families with growing children are demanding houses a little bit bigger and a little bit better than the minimum G.I. houses of the early postwar years.

School age population in 1960 will be 35 to 40 per cent greater than in 1950, and the school building boom will have to continue for at least several years longer to get within hailing distance of demand. Growing towns and cities will be obliged to expand numerous other community facilities besides schools — such as water supply, sewerage systems, paved streets, parks and playgrounds, churches, health centers, hospitals, electric and gas utilities, and telephone services.

### **MORE PRODUCTION NEEDED**

At this moment industrial building construction is trending downward. Largely by reason of the defense program and specific government stimulation, production facilities for basic metals and metal products and other durable goods have been expanded to the point where current needs can be amply met. Soon, however, our growing population will require vastly enlarged quantities of non-durable consumer goods. For the population is not only increasing in numbers, but postwar babies are growing up and requiring more and more. Increased production facilities to take care of increasing numbers of consumers and to provide for each individual consumer more goods and services, will require enormous capital investment — new plants, new modern factory equip-



**TABLE 1: ESTIMATED PHYSICAL VOLUME OF BUILDING**

(in accordance with contract records for 37 eastern states; figures in millions of sq ft)

BUILDING CLASSIFICATION	YEAR 1953 ESTIMATE *	YEAR 1954 ESTIMATE	PERCENTAGE CHANGE
Commercial .....	125	140	+12
Manufacturing .....	98	85	-13
Educational and Science.....	119	125	+ 5
Hospitals and Institutional.....	21	20	- 5
Public .....	11	10	- 9
Religious .....	26	24	- 8
Social and Recreational.....	17	19	+12
Miscellaneous Nonresidential .....	50	47	- 6
<b>Total Nonresidential .....</b>	<b>467</b>	<b>470</b>	<b>+ 1</b>
Residential .....	661	597	-10
<b>Total Building .....</b>	<b>1128</b>	<b>1067</b>	<b>- 5</b>

**TABLE 2: ESTIMATED NUMBER OF NEW DWELLING UNIT STARTS**

(in thousands)

	YEAR 1953 ESTIMATE *	YEAR 1954 ESTIMATE	PERCENTAGE CHANGE
Dodge coverage basis.....	518	466	-10
BLS overall basis.....	1100	990	-10

**TABLE 3: ESTIMATED DOLLAR VOLUMES OF BUILDING AND ENGINEERING PROJECTS**

(in accordance with contract records for 37 eastern states; figures in millions of dollars)

CLASSIFICATION	YEAR 1953 ESTIMATE *	YEAR 1954 ESTIMATE	PERCENTAGE CHANGE
<b>TOTAL</b>			
<i>(PRIVATE AND PUBLIC OWNERSHIP)</i>			
Nonresidential .....	6563	6410	- 2
Residential .....	6201	5575	-10
<b>Total Building .....</b>	<b>12,764</b>	<b>11,985</b>	<b>- 6</b>
Public Works and Utilities.....	3775	4025	+ 7
<b>Total Construction.....</b>	<b>16,539</b>	<b>16,010</b>	<b>- 3</b>
<i>PRIVATE OWNERSHIP</i>			
Nonresidential .....	3929	3730	- 5
Residential .....	5794	5330	- 8
<b>Total Building .....</b>	<b>9723</b>	<b>9060</b>	<b>- 7</b>
Public Works and Utilities.....	815	850	+ 4
<b>Total Construction .....</b>	<b>10,538</b>	<b>9910</b>	<b>- 6</b>
<i>PUBLIC OWNERSHIP</i>			
Nonresidential .....	2634	2680	+ 2
Residential .....	407	245	-40
<b>Total Building .....</b>	<b>3041</b>	<b>2925</b>	<b>- 4</b>
Public Works and Utilities.....	2960	3175	+ 7
<b>Total Construction .....</b>	<b>6001</b>	<b>6100</b>	<b>+ 2</b>

\* Nine months actual, last three months estimated



ment, new sources of power. The electric utilities industry expects to double its present capacity within the next ten years. Since the labor force will probably increase by a smaller percentage than will the total of consumers, it is going to be necessary to increase output per man per hour if all requirements are to be met; this will be a further stimulant to the building of new modern plants. Furthermore, there will have to be a very considerable quantity of warehouse and wholesale and retail sales facilities for the physical distribution of the increased volume and variety of goods that will be produced.

#### **ADJUSTMENTS GOING ON**

The sketch here presented looking forward to further expansion of our dynamic, fast-growing economy and its potential structural requirements is naturally based on the assumption that there will be no major war or other catastrophe of like dimensions. It does not assume that the expected future growth will be at a continuous uniform rate. From time to time temporary slowdowns will be necessary in order to adjust imbalances in the general business picture.

From time to time corrections of farm surpluses and excessive inventories of other goods must be made; credit must be so managed as to avoid both inflation and deflation; undue speculation must be curbed. Considering the potential of increased productivity, competition is likely to rule the market and aggressive and creative selling will be necessary for effective distribution of goods and services and effective development of new demands. Product research and market research must go hand in hand.

Some readjustments were being made last year. Among other things, the government initiated a policy tending to stabilize the dollar and has thus far been successful in this endeavor. Curbing of inflation and restrictions on credit have caused adjustments in those businesses, including housing activity, which had been stimulated by the previous easy money policies. Farm surpluses and the down-

trend of farm prices constitute a problem at the present moment; if this situation should grow very much worse it could ultimately have an adverse effect on the whole economy. Readjustment has continued in 1953 and there will be more of it in 1954.

#### **PROBABLY THE SECOND-BEST YEAR**

The writers of this outlook statement concur, in general, with the majority opinion expressed by the 138 economists who participated in F. W. Dodge Corporation's recent opinion survey. With the majority, we believe the coming readjustment will be a mild one and that for general business activity 1954 is very likely to be the second-best year.

While our construction estimates do not tally exactly with the figures shown in the report of survey results, our opinion as to the trend generally agrees with those of the 138 experts.

Reference to the table of construction outlook estimates will show we expect an approximate three per cent decline from 1953 in total dollar volume of contracts, and a decline of about five per cent in total new building floor space to be contracted for.

Detailed figures in the table indicate that next year we will continue on the downside of the housing boom, and also of the boom in manufacturing buildings; we also expect moderately reduced volumes of hospital and institutional building, public building, religious building and miscellaneous non-residential building. Declines indicated for various classes of nonresidential building will be a little more than offset, we believe, by increased activities in commercial buildings, educational and science buildings, and social and recreational projects. We also expect a moderate increase in expenditures for public works and utilities. The indicated decline in residential building volume is ten per cent.

Each year brings about an increase in the nation's total inventory of building and engineering structures and therefore increases the potential volume of repair and modernization work. The year 1954 promises to be a very good construction year.



## MAJORITY OF LEADING ECONOMISTS EXPECT MILD RECESSION

Composite Opinion of 138 Leading Economists Polled

By F. W. Dodge Corporation in October 1953

**S**TRONG reassurance as to the business outlook is the prevailing tone of reports by 138 of the nation's leading economists recently polled by F. W. Dodge Corporation. The majority opinion expressed by these men indicates that 1954 will likely be the nation's second biggest business year and that the anticipated drop from the boom levels of 1953 will be quite mild.

(Actually 150 economists responded. But only 138 responses were received in time for tabulation. The views of the others if tabulated would not materially change the consensus.)

Among the 138 experts 19 expect next year to be a bigger year than 1953, eight expect activity to continue at approximately this year's levels, 70 expect a quite moderate slowdown, and 41 expect a fairly severe drop. Of this latter group 31 expected the nation's total product in 1954 to be less than the 1952 total but only six of them expect it to drop below the 1951 level; the year 1951 was, overall, the nation's third best.

Of the men who participated in the survey, 49 are economists in business organizations, 41 in colleges and universities, 28 in financial organizations, four in government; the remaining 16 are business consultants.

The summary of replies indicates moderate declines from this year (less than five per cent) in the following economic factors: total output of goods and services (Gross National Product), consumers' price index, wholesale price index, and personal consumption expenditures. Declines greater than five per cent but not more than 10 per cent are indicated for industrial production, new plant and equipment expenditures, total new construction and new non-farm dwelling units. Hourly wage scales, in durable and non-durable goods manufacturing and in building construction, are expected by a fair majority of

economists to trend upward, but nearly all expect average weekly hours to decrease by reason of reduced overtime. A majority expect the total of outstanding consumer credit either to decrease or remain at 1953 levels.

A number of respondents added to their replies to specific questions their individual comments on the business situation. The following quotations are typical of various points of view.

*Reasons for anticipated recession: curbing of upward price movement; less deferred demand for consumer durables; large productive capacity; probable reduction in new plant and equipment expenditures with reverse accelerator effect; large production and stocks of agricultural products; decline in merchandise exports in relation to imports.*

*I feel that the psychology of the business community is bad. Too many people are expecting a depression and the monetary and economic forces are gathering which will make a depression possible. The great difficulty is to keep it from becoming a panic, which of course is always the major problem.*

*Unless our policy regarding Russia and super-bomb developments gives continued artificial stimuli to our economy, we can expect many readjustments. (Total production near 1952 levels.) . . . Otherwise, we must come to the full realization that we are on the downside of a boom.*

*Two of the three major elements in the economy — government and business — are due to decline moderately in 1954. This means that the third major force — the consumer — must expand considerably if the current level of production is to be maintained or increased. At the moment, I cannot see any force at work which would encourage consumers to increase their takings.*

*The effect of tax reductions will be to stimulate personal consumption.*

*If the level of consumers' expenditures can be kept high and government expenditures (Federal, state and local) are not restricted, they will help offset the expected declines in*



*private expenditures for durable goods and construction and keep us from experiencing a serious recession.*

*I expect the demand for goods and services by the government to hold up better than is generally expected at present, and, because of that, believe that the decline in production, overall, will be moderate.*

*The tightening up process can hardly be considered as a recession, as it appears that 1954 may be the second-best year in our business history, not equal to the peak year of 1953 but ahead of 1952.*

*The over-all spending potential in 1954 should be substantially the same as in 1953, particularly as measured in after-tax income. The challenge to business (including construction) must therefore be to offer such values — supplemented by aggressive merchandising—as to induce consumers to continue buying at or near present levels.*

*Basically, I expect a moderate slowdown in most business fields, with reduced Federal spending, less overtime and somewhat higher unemployment. But population growth will moderate the effect. So will new standards and ways of living and harder selling.*

*In 1954 competition among sellers is likely to be more intense, profit margins will be lower, and business failures should be greater. The physical amount of goods to be produced and consumed should be about as great in 1954 as in 1953; however, consumers will be accounting for a greater proportion of Gross National Product while business and government will be consuming less. . . . Cost and availability of credit is likely to become a more important factor.*

*For 1954 — a mild adjustment in selected industries . . . the readjustment period supported by easy credit and a Federal government spending program to offset weaknesses appearing in the economy.*

*I expect changes to be very small for 1954. I am not among the bears . . . personal consumption expenditures slightly up . . . new housing starts down a little.*

*We should recall that goods and services for immediate consumption absorb four fifths of the national income, with the other fifth devoted to durables and to savings. . . . Serious excrescences do not exist in the American economy, hence there seems little likelihood that a far reaching débacle will occur, given moderately sensible government policies and a reasonable psychology on the part of the American public.*

*It appears that the turn has come and some decline is to be expected for the remainder of 1953 and during 1954.*

*It is expected that very moderate readjustments will occur, except in construction where more severe conditions will prevail. A high level economy should prevail during the coming year.*

It is to be noted that not a single commentator mentioned the stock market or the recent drop in security prices.

## **GROSS NATIONAL PRODUCT**

Total output of goods and services (Gross National Product) is expected by a majority of respondents to decline very moderately and gradually through most of next year with the possibility of a modest upturn in the last quarter. Calculations based on median values of 129 answers indicate the following: Gross National Product for the full year 1953, \$369.1 billions; for the full year 1954, \$359.2 billions. The indicated net change is approximately three per cent. Even the indicated low-point for the third quarter of 1954 works out to a figure only four per cent under the third quarter of this year; next year's fourth quarter figure comes out three per cent under this year's fourth quarter figure.

## **PRICES**

The majority of respondents expect moderate price declines. The consumers' price index for all items, as recorded by the U. S. Bureau of Labor Statistics on the 1947-1949 base, stood at 114.7 in July 1953. Median values of 133 survey answers for future dates are as follows: December 1953, 115; June 1954, 113.8; December 1954, 113.

Wholesale prices are also expected to decline in moderate amounts. The August 1953 BLS all-commodity index was 110.6. Median values for future dates of 133 sets of survey answers are: December 1953, 110; July 1954, 108; December 1954, 107.2. It is obvious that the majority of economists expect a nearly stable dollar in 1954.

## **WAGES AND HOURS**

Higher hourly wage scales and reduced average weekly hours for production workers and non-supervisory employes appear to be generally expected. On these two questions respondents were asked to express opinions on the trends without numerical estimates.

In durable goods manufacturing 72 economists expect an uptrend in wage scales, 30 expect a downtrend and 24 expect no change. As to average weekly hours in this field of activity, 130 expect a reduction in average weekly hours and only three expect an increase. In this and other fields of activity the reduction of the work-week is expected to result principally from elimination of overtime.



In non-durable goods manufacturing, 72 expect increased hourly wage scales, against 30 who expect reduced scales and 25 who expect no change. In this economic area, a reduced work week is indicated in 113 answers, an increase in hours by 11, and no change by eight.

In building construction, higher average hourly wages are expected by 62 respondents, lower by 38, and continuation of present scales by 24. Again in this field a reduced work week is widely expected by 125 respondents as against four who expect no change and two who expect an uptrend.

### **INDUSTRIAL PRODUCTION**

In certain earlier months of this year the Federal Reserve Board index of industrial production reached the previous all-time-high records attained during the war years. In March 1953 the index stood at 243; in August at 238.

Median expectations among 134 economists who answered this question were as follows: December 1953, 233.5; June 1954, 225; December 1954, 223. This indicates industrial production volume for the full year 1954 approximately four to six per cent under the 1953 total.

### **NEW PLANT AND EQUIPMENT: TOTAL CONSTRUCTION: HOUSING**

Against an estimated \$27.83 billion investment in new plant and equipment this year, the median 1954 figure among 135 respondents is \$25 billions. This would represent a decline of 10 per cent from 1953.

Moderately declining construction activity is expected by a majority of the economists. Against a monthly average work-in-place total of \$2.95 billions during the first half of 1953, the median expectation for the second half is \$2.8 billions; for the first half of 1954, \$2.7 billions; for the second half of 1954, \$2.6 billions. The figure for the first half of the year is the estimated U. S. total compiled by the U. S. Departments of Commerce and Labor; the advance figures correspond to the recorded government totals. The indication given by the economists is for an approximate eight per cent reduction from 1953 of next year's total dollar volume of construction. Expected annual volumes are: \$34.5 billions in 1953, \$31.8 billions in 1954.

There is a general expectation of declining volume of residential building. Against an average 96,400 non-farm dwelling units per month in the first half

of 1953, 90,000 per month are expected in the second half, 88,000 per month in the first half of 1954 and 85,000 per month in the second half of 1954. From these figures, it is calculated that the economists expect a 1953 total of 1,118,400 units and a 1954 total of 1,038,000 units. The expected reductions in housing volume would be a little over seven per cent.

### **PERSONAL CONSUMPTION AND CONSUMER CREDIT**

Personal consumption expenditures during the first half of 1953 were estimated by the government to be at the annual rate of \$229 billions. Median values of advance estimates by 133 economists were: second half of 1953, annual rate of \$230 billions; full year 1954, \$225 billions. The indicated decrease from 1953 to 1954 is two per cent.

Sixty-seven economists expect a decrease in total outstanding consumer credit in 1954, 59 of them expect an increase and 10 of them expect no change.

### **HOW VALID IS THIS SURVEY?**

This survey, which F. W. Dodge Corporation has conducted each year since the end of World War II, is simply one way of summarizing the opinions respecting future business developments of a certain group of particularly well-informed people. Although replies must be summarized by counting ayes and noes and averaging numerical estimates, there is no pretense that such a procedure yields an exact chart of future trends. No such exact chart exists.

One respondent, a well-known economic consultant, writes: "I consider that your annual survey and forecast has been a distinct service to business and to economic thinking. . . . It is always a pleasure to me to forward to you my best judgment, although subsequent comparison with unfolding events at times evokes humility. However, my forecasts for 1953 have worked out rather well thus far."

Another respondent suggests that this present report include a review of the score established by the 137 economists who participated in the opinion poll a year ago.

Generally speaking the year 1953 has been a somewhat better year than the majority of the economists anticipated. A year ago the survey result was summarized in these words: "High level stability is expected to characterize general business conditions through most of the year with the possibility of a quite mild setback in the second half."

High level stability characterized prices and one



important category of wages. An expected drop of about one per cent in the consumers' price index contrasts with a rise of less than one half per cent. An expected two-point drop in the wholesale price index from July 1952 to July 1953 contrasts with an actual 1.4-point drop. The average hourly earning in non-durable manufacturing, expected by the economists to stand at \$1.58 in July of this year, actually stood at \$1.60.

In durable goods manufacturing the July 1953 expectation was \$1.76 (a minor rise), the actual was \$1.87. In building construction the July 1953 expectation was \$2.28 (holding about even with 1952) and the actual was \$2.44.

Participants in the survey, other than those who asked for anonymity, were:

Wm. J. Abbot Jr., Federal Reserve Bank, St. Louis; A. G. Abramson, SKF Industries; M. A. Adelman, M.I.T.; E. E. Agger, Rutgers; H. P. Alspaugh, H. J. Heinz Co.; Robert S. Aries, R. S. Aries & Assoc.; R. B. Armstrong, American Enka Corp.; Harold E. Aul, Calvin Bullock; P. T. Babson, United Business Service; L. Durward Badgley, Mutual Life; Robert W. Bailey, United Air Lines, Inc.; C. C. Balderston, Wharton School of Finance; Horace R. Barnes, Franklin and Marshall College; Spurgeon Bell; Claude L. Benner, Continental American Life Insurance Co.; E. G. Bennion, Standard Oil, N. J.; Frederick M. Bernfield; George L. Bliss, Century Federal Savings Assn.; Morton Bodfish, First Federal Savings & Loan Assn., Chicago; E. H. Boeckh, E. H. Boeckh & Assoc.; Chelcie C. Bosland, Brown U.; Elmer C. Bratt, Lehigh U.; F. A. Buechel, Houston Chamber of Commerce; Irvin Bussing, Lowell Smith & Evers, Inc.; Francis J. Calkins, Marquette U.; C. B. Camp; Cecil C. Carpenter, U. of Kentucky; John J. Carter, Kingan, Inc.; Francis R. Cella, U. of Oklahoma; Homer V. Cherrington, Northwestern U.; L. F. Church, Emery Industries, Inc.; Ewan Clague, U. S. Bureau of Labor Statistics; P. S. Clements, Loomis, Sayles & Co.; Kenneth B. Colby, Univis Lens Co.; P. E. Coldwell, Federal Reserve Bank, Dallas; Donald R. G. Cowan, U. of Michigan; Dudley J. Cowden, U. of North Carolina; John R. Craf, U. of Louisville; W. W. Cumberland, Ladenburg, Thalmann & Co.; D. H. Davenport, N. Y. State Dept. of Commerce; Frederick A. Dewey; Charles A. Dice, Ohio State U.; Leonard A. Drake, Chamber of Commerce of Greater Philadelphia; Henry P. Dutton; Stahlr Edmunds, National City Bank; R. J. Eggert, Ford Motor Co.; N. H. Engle, U. of Washington; B. E. Estes, U. S. Steel; Robert Ferber, U. of Illinois; Morris D. Forkosch,

Brooklyn Law School; H. G. Fraine, U. of Wisconsin; John D. Gaffey; Roy L. Garis, U. of Southern California; Edwin B. George; Charles A. Glover, American Telephone and Telegraph Co.; Douglas Greenwald, McGraw-Hill Publishing Co.; William L. Gregory, Easton-Taylor Trust Co.; K. F. Griffith, Eli Lilly and Co.; John A. Griswald, Dartmouth College.

Clarence H. Haines, Harvard Trust Co.; L. F. Hampel, United Air Lines, Inc.; Albert Haring, Indiana U.; Eugene Hesz, A. M. Kidder & Co.; Walter E. Hoadley Jr., Armstrong Cork Co.; Walter M. Hollowell, Lowry Air Force Base; James E. Honan, Interstate Milk Producers' Cooperative; Louis Hough, U. of Pittsburgh; Joseph B. Hubbard, Union Service Corp.; Kermit C. Jeffrey; Norris O. Johnson, National City Bank of N. Y.; Homer Jones, Federal Reserve Board; Manley H. Jones, Illinois Institute of Technology; Stephen L. Joseph, Bache & Co.; Vant Kebker, Ohio Wesleyan U.; Donald L. Kemmerer, U. of Illinois; Fred O. Kiel, Federal Reserve Bank, Cleveland; R. T. Killian, Bryant Heater Div.; Hugh B. Killough, Brown U.; E. R. King, Eastman Kodak Co.; Omar Knauth; Byron J. Korb, Koppers Co., Inc.; Richard L. Kozelka, U. of Minnesota; H. E. Kromayer, American Maize-Products Co.; Francis A. Kutish, Iowa State College.

W. Gordon Leith, Consumers Co-op. Assoc.; Robert E. Lewis, Federal Reserve Bank, New York; Oscar F. Litterer, Federal Reserve Bank; Henry D. Locke, Liberty Mutual Insurance Co.; Gordon M. Looney, Libbey-Owens-Ford Glass Co.; B. F. Lynip Jr., California & Hawaiian Sugar Refining Corp.; S. J. Maisel, U. of California; Marion H. Marks, Crown Zellerbach Corp.; Stewart M. Marshall; Alonzo B. May, U. of Denver; Stacy May, International Basic Economy Corp.; Paul W. McCracken, U. of Michigan; Gordon W. McKinley, Prudential Insurance Co. of America; W. L. McMillen,

For the Gross National Product the expected 1953 increase of 1.2 per cent turned out to be in the neighborhood of 7.2 per cent. Actual results with respect to industrial production, new plant and equipment expenditures, total construction and housing activity will all run approximately 10 per cent better than the economists' forecast figures of a year ago.

In short, the economists a year ago anticipated 1953 activity at very high but not record-breaking levels. So long as forecasting remains very largely a matter of considered judgment and informed opinion it would appear that advance estimates which err on the conservative side are far preferable to those which err in the opposite direction.

American Airlines, Inc.; David C. Melnicoff, Penn Fruit Co.; Rodger I. Mendes, Pacific Gas and Electric Co.; Oswald E. D. Merkt, Kidder, Peabody & Co.; K. E. Miller, Armour Co.; Floyd W. Moore, Western Michigan College; Roger F. Murray, Bankers Trust Co.; Robert R. Nathan, Robert R. Nathan Assoc., Inc.; M. R. Neifeld, Beneficial Management Corp.; Robinson Newcomb; Paul H. Nystrom, Limited Price Variety Stores Assoc.

Ralph H. Oakes, Loyola U. of the South; Joseph E. Pogue, Chase National Bank; B. U. Ratchford, Duke U.; Virgil D. Reed, J. Walter Thompson Co.; S. V. Reiss, Graybar Electric Co., Inc.; Lloyd G. Reynolds, Yale U.; Raymond Rodgers, New York U.; John G. Rolph; De Ver Sholes, Chicago Assoc. of Commerce and Industry; C. A. Sienkiewicz, Central-Penn National Bank; Frederic L. Simmons, Guaranty Trust Co. of N. Y.; C. E. Skinner, Gulf Oil Corp.; Arthur A. Smith, First National Bank; George Cline Smith, U. S. Chamber of Commerce; Tillman M. Sogge, St. Olaf College; George Soule, Bennington College; W. R. Spriegel, U. of Texas; W. Mackenzie Stevens, Mackenzie Stevens & Co.; Paul W. Stewart, Stewart, Dougall & Assoc., Inc.; John R. Stockton, U. of Texas; Woodlief Thomas, Board of Governors, Federal Reserve System; Willard L. Thorp, Merrill Center for Economics; Philip C. Torrey, Henry Disston & Sons, Inc.; Clarence W. Tow, Federal Reserve Bank, Kansas City; Rufus S. Tucker, General Motors Corp.; Arthur R. Uppen, Dartmouth College; D. H. Walter, Continental Can Co., Inc.; Q. Forrest Walker, R. H. Macy & Co., Inc.; Paul J. Weber, Hercules Powder Co.; Ray B. Westerfield, Yale U.; Hans A. Widenmann, Carl M. Loeb, Rhoades & Co.; W. H. Winfield, Monsanto Chemical Co.; Donald B. Woodward, Vick Chemical Co.; Charles G. Young, Weyerhaeuser Timber Co.; Eugene C. Zorn Jr., American Bankers Assoc.