

ARCHITECTURAL RECORD



BUILDING TYPES STUDY

RELIGIOUS
BUILDINGS

235

JUNE 1956

Dramatic new
downtown store
depends on . . .



GRINNELL Ceiling-Type SPRINKLERS

When the management of Rich's, Inc., decided to construct its new department store "downtown" in Knoxville, it was a momentous decision—one taken in the face of a strong, continuing move to the suburbs. But experience has proved the wisdom of that action.

Of course, no small factor in the success of Rich's new store were such design innovations as a 450-car attached garage; outside pool and planting area; and a built-in warehouse. The installation of Grinnell Sprinklers was still another move taken to create a relaxed atmosphere and to build customer confidence.

Grinnell Ceiling-Type Sprinklers are unobtrusive. They do nothing to mar the decor of modern interiors. And yet, should fire occur, they operate quickly, automatically to strike fire at its source, anywhere—anytime, night or day. Moreover, they make impressive insurance savings possible.

The time to plan Grinnell Protection is while your buildings are in the blueprint stage. For advice on the best system, for you, invite a Grinnell Fire Protection engineer to call. Grinnell Company, Inc., 269 W. Exchange St., Providence, R. I.

Rich's Department Store in downtown Knoxville. Long, undulating canopy of concrete heightens the dramatic quality of brick and glass construction.

Architects: STEVENS & WILKINSON, ATLANTA, GA.



Modern lighting and automatic ceiling sprinklers give a clean, uncluttered appearance to various departments.

GRINNELL

PROTECTION AGAINST EVERY FIRE HAZARD



Manufacturing, Engineering and Installation of Automatic Sprinklers Since 1878

ARCHITECTURAL RECORD

June 1956 Vol. 119 No. 7

Copyright 1956 by F. W. Dodge Corporation, with all rights reserved. ARCHITECTURAL RECORD (combined with AMERICAN ARCHITECT and ARCHITECTURE) is published monthly, except May 1956 when semi-monthly, by F. W. Dodge Corporation, 10 Ferry Street, Concord, New Hampshire. Editorial and executive offices: 119 West 40th Street, New York 18, New York. Western editorial office, 2877 Shasta Road, Berkeley 8, California.

STAFF OF ARCHITECTURAL RECORD



H. Judd Payne, *Publishing Director*; Robert F. Marshall, *General Manager*; John Knox Shear, A.I.A., *Editor-in-Chief*; Marshall T. Ginn, *Circulation Manager*; Emerson Goble, *Managing Editor*; Frank G. Lopez, A.I.A., *Senior Editor*; James S. Hornbeck, A.I.A., *Senior Associate Editor*; Elisabeth Kendall Thompson, *Senior Associate Editor and Western Section Editor (Berkeley, California, Office)*; Robert E. Fischer, *Associate Editor (Engineering)*; Florence A. van Wyck, *Associate Editor*; Jeanne M. Davern, *Associate Editor (News)*; Daniel M. Kelley, *Associate Editor (Engineering Assistant)*; Herbert L. Smith, Jr., A.I.A., *Associate Editor*; Ernest Mickel, *Dan Street (Washington)*, John Caulfield Smith, M.R.A.I.C. (Canada), *Contributing Editors*; Marjorie Blake, Grace M. Anderson, *Assistant Editors*; Helen E. Cook, *Editorial Assistant (Production)*; Ruth Watson Martin, *Editorial Assistant*; Eugene H. Hawley, *Design Director*; Douglas R. Steinbauer, *Design*; Sigman-Ward, *Drafting Consultant*; Thomas S. Holden, *Industry Relations Consultant*; Clyde Shute, *Statistical Consultant*; George Cline Smith, *Economics Consultant*; Clifford Dunnells, Jr., *Field Research Consultant*; Daniel J. Howe, Jr., *Public Relations Consultant*.

TABLE OF CONTENTS

The Record Reports

Los Angeles and Architecture for the Good Life: The 88th Annual Convention of the American Institute of Architects — opposite page 8	
A Record Special Report. Stained Glass in America	16
Meetings and Miscellany	21
A Washington Report. Women's Housing Congress	32
News from Canada. <i>By John Caulfield Smith</i>	36
Washington Topics. <i>By Ernest Mickel</i>	48
Construction Cost Indexes	54
Required Reading	58
Calendar and Office Notes	296
Current Trends in Construction	366

One Hundred Years of Significant Building

Beginning a series of monthly presentations of the most significant buildings of the past century of American architecture, buildings nominated by a panel of fifty architects and scholars. The series starts here with office buildings; will continue monthly through the year which precedes the 100th Anniversary of the American Institute of Architects.

1. Office Buildings	147
---------------------	-----

The Architect and the Engineers

The author, trained as an architect, has spent most of his business life in the industrial world, surrounded by engineers, practicing as an engineer. He stresses the opportunities for architects and for architectural thinking in this technological era.

An article by <i>Frank L. Whitney</i>	155
---------------------------------------	-----

American Embassy Buildings

A second group of embassy office buildings and housing designed by American architects to symbolize the American way of life in cities throughout the world.

<i>Eleven projects for the Department of State</i>	161
--	-----

The Architect as Universal Man

Fragmentation of the arts into various specialties may seem inevitable in an age of specialization, but it is not conducive to vitality or universality. An article by *Herbert Read*

	166
--	-----



COVER: First Universalist Church, Chicago, Ill.; Schweikher, Elting & Bennett, Assoc. Architects. Hedrich-Blessing photo

Vacation Houses

House in Malibu, Calif.; Henry Robert Harrison, Architect	169
House for Dr. Conto e Silva, Tijuca, Brazil; Affonso Eduardo Reidy, Architect	173
House for Mr. and Mrs. Herbert Perry, Sherman, Conn.; Herbert Beckhard — William W. Landsberg, Architects	176

Administration and Service Building

Mountain States Telephone Company, Phoenix, Ariz.; Edward L. Varney, Architect	179
--	-----

Building Types Study Number 235 — Religious Buildings

Six new religious buildings from a variety of faiths and using a variety of structural means and a proposal for the completion of the Cathedral of St. John the Divine are prefaced by an interview with Engineer Mario Salvadori who points to the real possibility of a revitalized religious architecture which once again may have its point of departure in structural method. A discussion with Mario Salvadori on today's structural potentials

Proposal for the Cathedral of St. John the Divine	186
First Universalist Church, Chicago, Ill.; Schweikher, Elting and Bennett, Associated Architects	190
Jewish Center of West Orange, N. J.; Davis, Brody, Juster & Wisniewski, Architects	194
St. Andrew's Church, Park Ridge, Ill.; Charles Edward Stade & Assoc., Architects	198
St. Francis of Assisi Church, Weston, Conn.; Joseph Salerno, Architect	202
Pilgrim Lutheran Church, Bellevue, Wash.; Grant, Copeland & Chervenak, Architects	206
Interdenominational Chapel, Miramar, Calif.; Richard J. Neutra and Robert E. Alexander, Architects	210

Architectural Engineering

Precast Concrete	215
Moving Sidewalks. An article by G. B. Gusrae	220
Technical Roundup	223
Product Reports	225
Literature	226
Time-Saver Standards: Continuous Beams. By John M. Ruddy	229

Index to Advertising

368

OFFICERS OF THE F. W. DODGE CORPORATION

James McV. Breed, *Chairman of the Board*; Paul Abbott and Thomas S. Holden: *Vice Chairmen of the Board*; Howard Barringer, *President*; Irving W. Hadsell, Chauncey L. Williams: *Executive Vice Presidents*; Howard M. Thompson, *Vice President and Treasurer*; Julius T. Little, Robert F. Marshall, T. Oliver Morgan, O. O. Paulsell, H. Judd Payne, George Cline Smith: *Vice Presidents*; Carl S. Bennett, Clinton C. Bennett, Ralph M. Hairston, Roy J. Hard, Richard H. Ray, John M. Williams: *Regional Vice Presidents*; Edwin H. Freed, *Assistant Vice President and Comptroller*; Walter F. DeSaix, Clifford C. Dunnells, Jr., Clyde Shute, Marc Wayne: *Assistant Vice Presidents*; Sanford D. Stockton, Jr., *Secretary*; William C. Breed, Jr., George W. Morgan, Jr.: *Assistant Secretaries*; Irving B. Satin, *Assistant Treasurer*.

OTHER F. W. DODGE SERVICES

Dodge Reports — Dodge Statistical Research Services — Sweet's Catalog Services — Dodge Books — Dodge Mailing Service — Chicago Construction News — Daily Pacific Builder — Denver Daily Journal — Real Estate Record & Builders' Guide.

Members of Audit Bureau of Circulations and Associated Business Publications. Architectural Record is indexed in Art Index, Industrial Arts Index and Engineering Index.

Every effort will be made to return material submitted for possible publication (if accompanied by stamped, addressed envelope), but the editors and the corporation will not be responsible for loss or damage.

Subscription prices: Published monthly except May 1956 when semi-monthly. U. S., U. S. Possessions and Canada: \$5.50 per year; other Western Hemisphere countries, Philippines and Spain, to those who by title are architects and engineers, \$6.50 per year. Single copy price except Mid-May 1956 issue \$2.00; Mid-May 1956 issue \$2.95. Beyond Western Hemisphere, excluding Philippines and Spain, to those who by title are architects and engineers, \$6.50 per year for 12 monthly issues not including Mid-May 1956 issue. Subscriptions from all others outside U. S., U. S. Possessions and Canada for 12 monthly issues, not including Mid-May issue, \$20 per year. Change of address: subscribers are requested to furnish both old and new addresses, sending if possible stencil impression from magazine wrapper; allow four weeks for change.



FIRST...by design

Cleveland Hopkins Municipal Airport, Cleveland, Ohio

Designed by Outcalt, Guenther & Associates

Built by R. S. Ursprung Company

WESTINGHOUSE WATER COOLERS

Were specified by architects Outcalt, Guenther & Associates for Cleveland's great new airport because, by design, they're . . .

First for Efficiency! Deliver up to 60% more cool water at less cost . . . with Patented Pre-Cooler and Super Sub-Cooler that use cold water to pre-cool incoming water and sub-cool the hot liquid refrigerant.

First for Convenience! Only Westinghouse offers Dual Electric Control—both finger-tip and toe-tip control—at no extra cost. Plus Automatic Stream Height Regulator for no-spurt, no-splash drinking. Compact, space-saving design occupies only 14 square inches of floor space. Stainless steel, splash-proof top is sanitary, unbreakable.

First for Dependability! New Solenoid Water Valve eliminates all possibility of leaks . . . Hermetically sealed Refrigeration System assures more years of trouble-free performance . . . plus E-Z Clean Strainer that prevents water stoppage due to pipe scaling. All models backed by Westinghouse 5-Year Guarantee plan.

Put Westinghouse in your plans . . . just as more and more leading architects are now doing. Specify the *newest* and *finest* of water coolers for your clients. 18 handsome models to choose from. Call your Westinghouse Water Cooler Distributor today. He's listed in the Yellow Pages of your telephone directory. Ask him about the new PAY-WAY PLAN . . . and learn how Westinghouse Water Coolers pay for themselves.

EXACTLY THE RIGHT TYPE AND SIZE FOR EVERY NEED

Westinghouse Electric Corporation
Electric Appliance Division
Springfield 2, Massachusetts

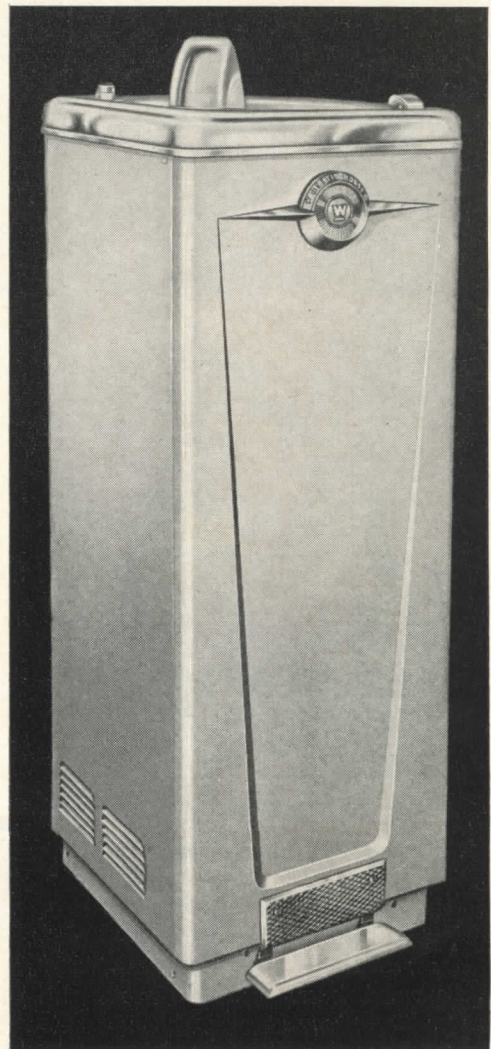

WATCH WESTINGHOUSE WHERE **BIG** THINGS ARE HAPPENING FOR YOU

STAINED GLASS IN AMERICA: A SURVEY OF THE FIELD

Stained glass as an allied art seems to be enjoying a renaissance in the United States, in the view of the respondents to the RECORD's survey of the 87 members of the Stained Glass Association of America. Pittsburgh Studio, for one, was quite sanguine in its outlook: "Stained glass in America today," it commented, "is on the threshold of a great period of design and execution. This has been made possible by the trend in architecture. Now that America

is having her own architecture, I am sure we will have our own stained glass to go with it."

Of the 38 respondents, 28 said that they could see an increase in the use of stained glass — some thought the increase only slight, others thought it "tremendous." There were a few dissenters from the generally happy outlook; at least two studios saw a decrease in the use of stained glass. Fewer churches these days use it, they said.

For, in spite of the reported increase in the use of stained glass, most of the studios saw little increase in its use for anything but church windows. Virtually all of their commissions are for windows: 23 said that 100 per cent of their jobs were in this category. And very few of these windows were installed in buildings other than churches — 27 reported between 80 and 100 per cent. The remainder mainly goes to other

(Continued on page 16B)



1

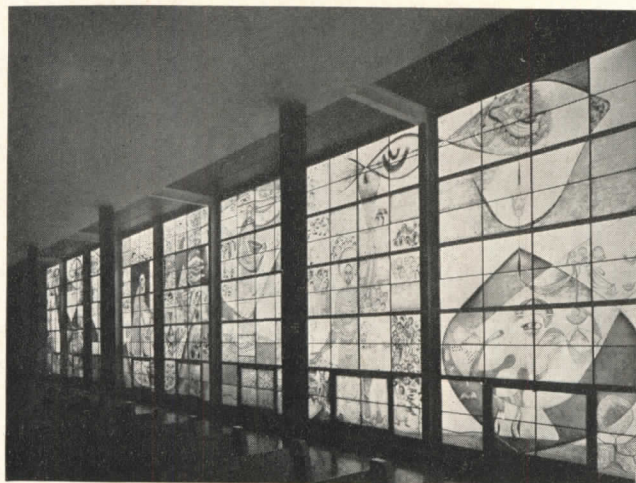

2



3

4



6

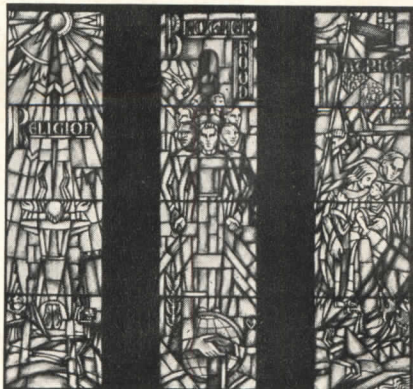

5

1. & 2. Window wall from the studio of Emil Frei, St. Louis, painted on slabs of "seedy glass." 3. St. Patrick and St. Michael, St. Michael's Cathedral, Springfield, Mass.; Charles J. Connick Associates, Boston, designers. 4. Detail from window for St. Anthony's Shrine, Boston; Rambusch Decorating Company, New York, Robert Pinart, designer. 5. Window for Michigan State College, Lansing; Willet Stained Glass Co., Philadelphia. 6. All Saint's Chapel, Morris, N. Y.; J. & R. Lamb Studios, Tenafly, N. J.



Durability in floor tile

If you want extra serviceability under heavy foot or industrial traffic . . . or floors designed especially to resist grease, alcohol, acids, alkalis, oils, chemicals and foodstuffs . . . Kentile, Inc. brings you the features you need, in a wide choice of decorative styles. Each of the tile types

offer the added advantages of uniform thickness, accuracy of cutting, trueness and clarity of color, surface smoothness, built-in durability and dimensional stability . . . another reason why this is the world's most popular line of resilient tile flooring. Tile illustrated is Corktone Kentile.

KENTILE, INC. America's largest manufacturer of resilient floor tiles

KENTILE Asphalt Tile, Carnival Kentile, Corktone Kentile/KENCORK, Cork tile for Floors and Walls/KENRUBBER, Rubber Tile/KENFLEX, Vinyl Asbestos Tile, Carnival Kenflex, Corktone Kenflex/KENFLOR Vinyl Tile, also available by-the-yard/KENROYAL Vinyl Tile/SPECIAL KENTILE, Greaseproof Asphalt Tile/THEMETILE, KENSERTS, Decorative Inserts/KENCOVE, vinyl wall base/KENBASE, wall base.

THE RECORD REPORTS

A SPECIAL REPORT

(Continued from page 16)

religious buildings, less to houses, still less to public buildings and practically none to commercial buildings.

In the design area also there seems to be a quickening of interest in new approaches, both toward design and toward the use of new materials and methods. Asked whether they thought there was increased interest in stained glass of "contemporary design," 31 of the studios replied in the affirmative; only one studio disagreed. (Two studios refused to recognize the distinction.) This is not to indicate, however, that

any of the studios are tossing out traditional design — 36 reported that they work in both "traditional" and "contemporary." Most of the studios said too that they would prefer to continue working in both "styles." Only six of the respondents would care to commit themselves entirely to contemporary design, only one would like to eliminate it from its work altogether.

Regardless of their respective attitudes toward design, many of the studios are participating in experiments either on new methods and materials, or on means of improving traditional techniques. Among the new materials with which the craft has been experimenting is faceted slab glass, mounted

in reinforced concrete (see illustrations, below). The glass, which is an inch or more thick — too heavy for conventional leading — has necessitated a fresh look at handling and design.

In an effort to deal with an ancient bugaboo of stained glass — its comparative lack of interest without light behind it — the Willet studio has been working with sculptured sheet lead, which is flown with gold leaf and put on a background of colored glass. The intention is to provide a textured surface with equal appeal in reflected and refracted light. Other studios have tried similar experiments with gold leaf, and both Cummings and Winterich's have

(Continued on page 314)

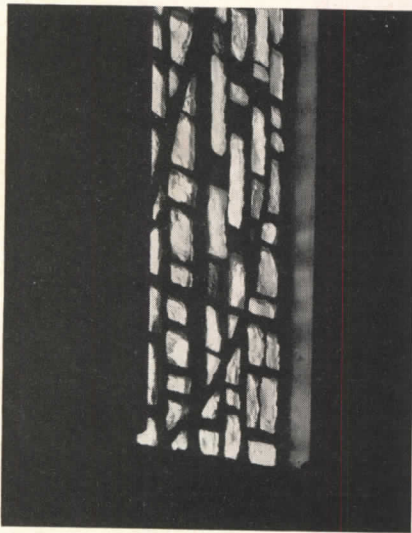

1

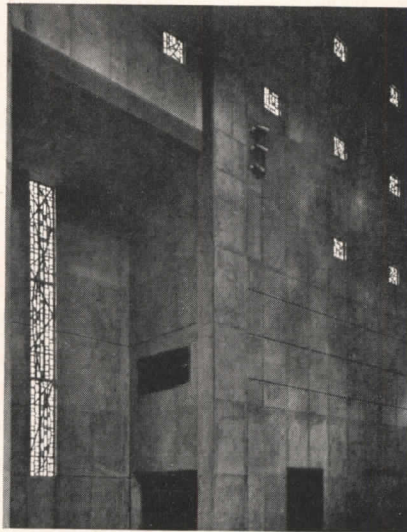

2



3

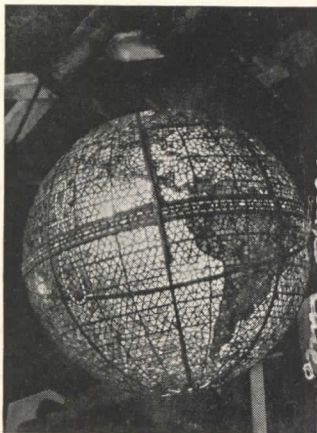

4



5

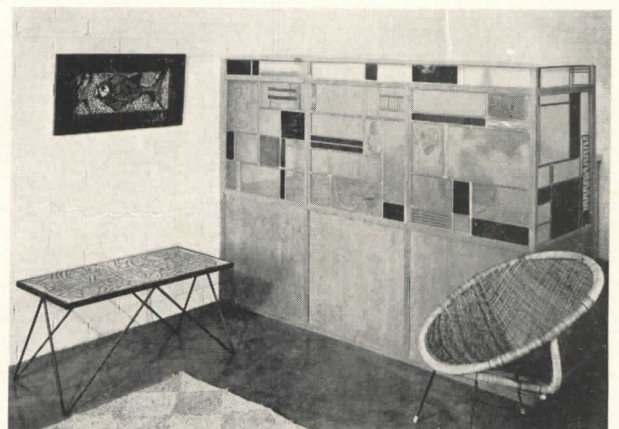

6

1. & 2. Slab glass in concrete installed in St. Stephen's Church, Belvedere, Cal., by Cummings Stained Glass Studio, San Francisco. 3. Another example of the slab glass technique from Conrad Schmitt Studios, Milwaukee; Peter Recker, designer. 4. & 5., Auxiliary applications: globes from, respectively, Cummings studio for Chico State College, Cal. (left),

and from Henry Keck, Inc., Syracuse, N. Y. for Trinity Church, Jackson, Miss. 6. Stained glass screen for office partition, designed by The Flemish Glazier, Scottsdale, Ariz. 7. Window for conference room in office of architects Celli-Flynn, McKeesport, Pa., designed by the architects and executed by Winterich's, Cleveland

7

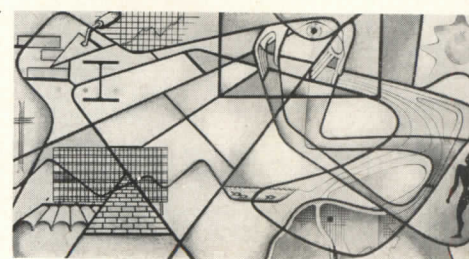

The State of Construction

The upward trend continued in April, with F. W. Dodge reporting a record \$2,421,497,000 total of construction contracts awarded in the 37 eastern states, a four per cent increase over April 1955 and the second highest contract figure for any month in Dodge history. A new first-four-month record was also established. Details are on page 366.

Nervi Visits the U. S. A.

The great Italian engineer Pier Luigi Nervi was paying his first visit to the United States in April and May. In lectures at North Carolina State's School of Design (for the A.I.A. South Atlantic Regional Conference), at Princeton and at Columbia, Nervi discoursed-through interpreter Prof. Mario Salvadori, New York consulting engineer and professor of civil engineering at Columbia — on his "philosophy of building correctly": a combination of empiricism and creative intuition which has produced reinforced concrete structures (see AR, April 1956, pages 257-264) of unparalleled size, daring, poetry — and economy. Nervi explains his approach to concrete construction quite simply by saying that as designer and builder he has tried to achieve maximum economy by doing away with forms as far as

possible through the use of prefabrication techniques and development of his own material — "Ferro-cemento," a very heavily reinforced concrete. But Nervi, whose earnest, unaffected accounts of what he has achieved in the structures shown in his slides frequently had his audiences literally gasping with admiration, says of reinforced concrete that it has "marvelous possibilities" not yet fully realized. And he had no easy answer for the American engineer who asked why structures like his cannot be built in the U. S.: what's lacking, he said, is courage. But he regarded American engineering achievements with the greatest respect. On a whirlwind tour of New York within a few hours of his arrival there, Nervi seemed almost spellbound by what he saw — the highways, the bridges, the piers, the contrasts of discipline and confusion, of beauty and ugliness, above all the tremendous scale of the city: "fantastica," he kept murmuring. *Bellissima* was his comment on Lever House, which seemed to impress him beyond all the buildings he saw: and he added (always, of course, in Italian, and as if to himself), "You could build the most beautiful city. . . ." Of the Brooklyn Bridge, "Poetry. . . ." While the car crawled across Twenty-third Street in rush hour traffic, he wondered, "Why don't they put all these buildings up

(Continued on page 24)

Tommy Weber



At the RECORD's party for Nervi, Frank Lloyd Wright autographs a book to present to the guest of honor as Nervi, Mario Salvadori, Roger Corbetta and RECORD editor-in-chief John Knox Shear look on . . .



. . . poses benignly with Nervi, Shear and (right) engineer Fred Severud. . . .



. . . and expounds his vehement views on the city and on anyone who can (as Nervi just had) call New York "magnificent"

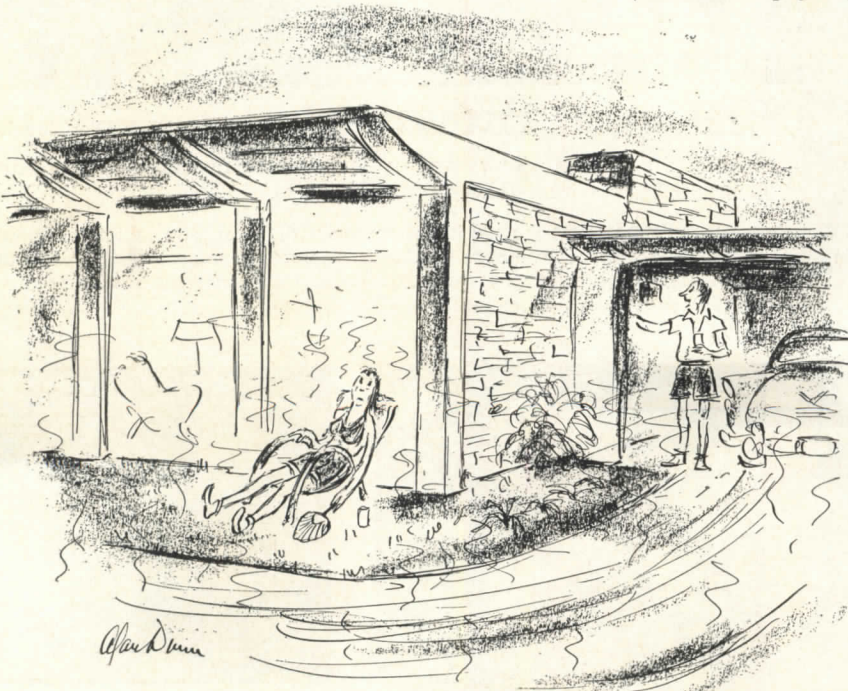

— Drawn for the RECORD by Alan Dunn
 "Good Heavens, we forgot to turn off the heated driveway!"

Thompson Products, Inc

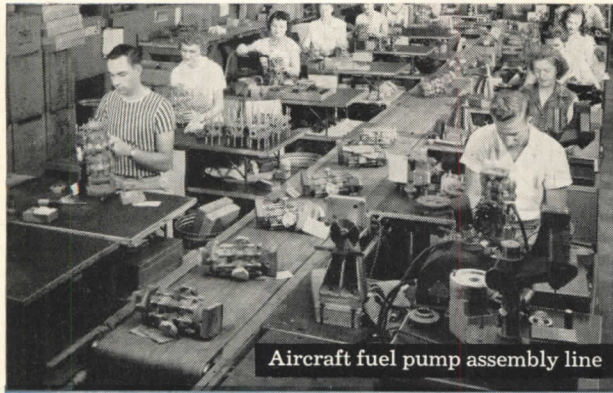

Aircraft fuel pump assembly line

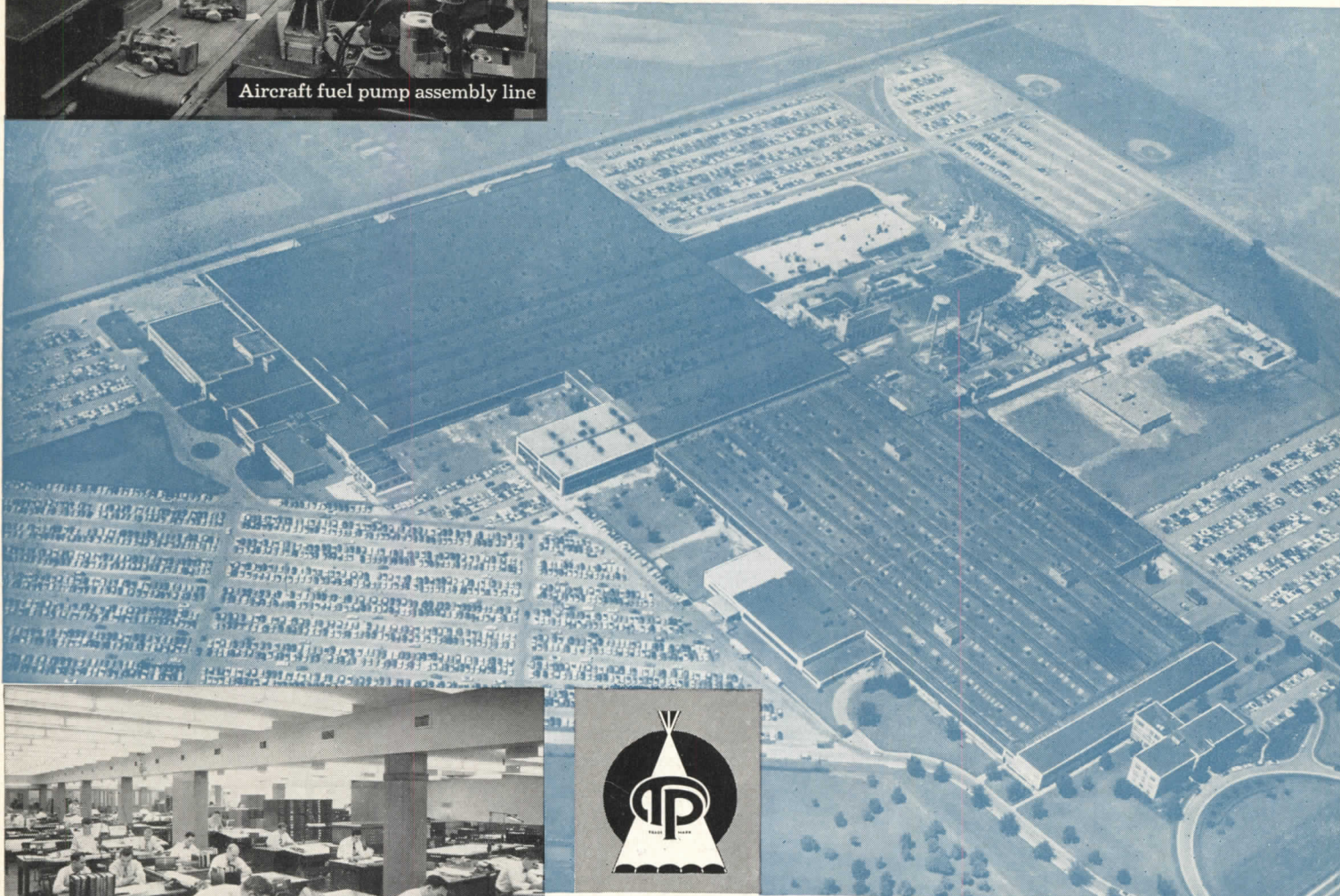

Air conditioned Engineering office

Thompson Products, Inc. TAPCO PLANT, Cleveland, Ohio

One of the 16 Factories owned by this pioneer manufacturer of Automotive, Aircraft, Industrial and Electronic Products.

POWERS CONTROL is used in the majority of Thompson factories. In TAPCO plant, Administration and Engineering offices, production areas, research laboratories and test cells, cafeterias, CRAWFORD HALL auditorium and some processes are equipped with Powers temperature and humidity control.

Below: Installation for testing turbine drives

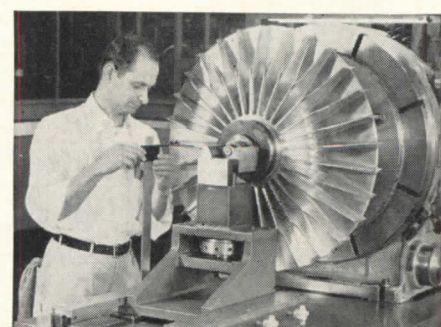
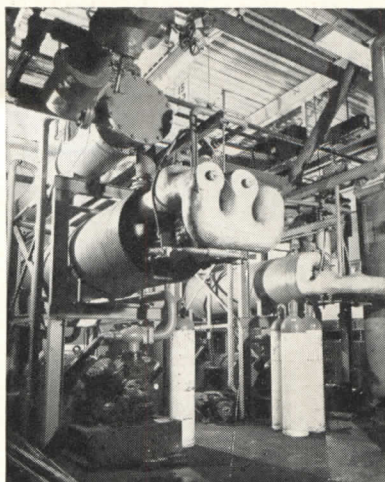
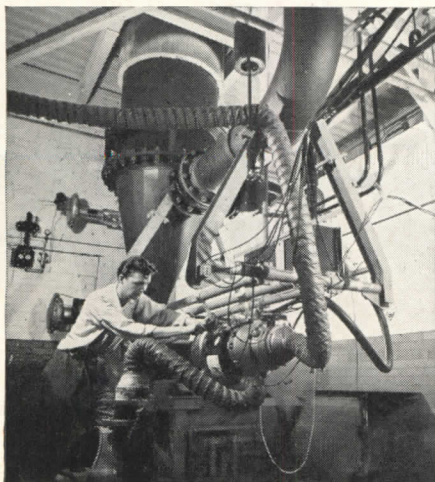

Above: Index head for inspection of vane wheels

Left: Refrigeration system for cooling test fuels

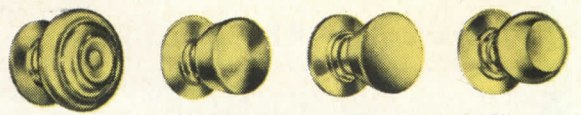

Bedford

Litchfield

Essex

Classic

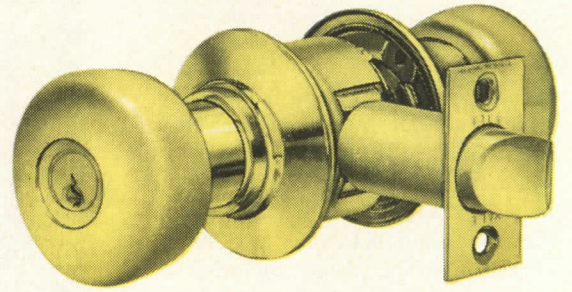

Yale 5400 Series Cylindrical Lock

Pick Locks

for their good looks”

“I’m an architect’s decorator —

I’m style conscious. I get paid for my good taste in picking the right fabric, right tile design, right furniture. Locks, though, have been pretty dull for a long time. So when YALE* introduced the beautiful New 5300 Series Locksets...with their marvelous new trim designs, I quickly made many selections for our clients. I just naturally felt a new glow of inspiration. And now, with the new 5400 Series just announced, why, we decorators love everything—style plus rugged construction for really long service. What’s more, I *know* that in YALE Locksets there is the most advanced engineering, most precise construction and real ruggedness. All of which assure me that YALE beauty will last for years.”

YALE HARDWARE STYLING DEPT.

If you have any special design problem, already existing or still on the drawing board, we will be happy to help you work it out. Write Yale Hardware Styling Dept., White Plains, N. Y.

YALE & TOWNE

The Yale & Towne Mfg. Co.,
Lock and Hardware Div., White Plains, N. Y.

*YALE REG. U. S. PAT. OFF.

5300 TROY
ADISON TRIM

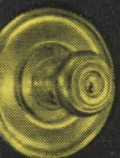

5300 LITCHFIELD
WILLIAMSBURG TRIM



5300 NASSAU
NEWPORT TRIM



5300 LITCHFIELD
SAVOY TRIM



5300 LITCHFIELD
WILLIAMSBURG TRIM



5300 CLASSIC
NEWPORT TRIM

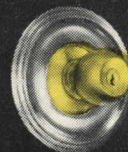

5300 TROY
NORFOLK TRIM

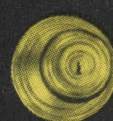

5300 CLASSIC
DALLAS TRIM



MEETINGS AND MISCELLANY

(Continued from page 24)

far more sophisticated context. The session on "Urban Designs of Today," which had Dean Pietro Belluschi of M.I.T.'s School of Architecture and Planning as moderator, provided not only expert testimony as to the complexity of the problem but an indication of what can be achieved even without a new definition of urban design. Mayor David Lawrence of Pittsburgh and Executive Director Edmund Bacon of the Philadelphia City Planning Commission discussed some of the projects which have already brought new beauty to some sections of their cities — Pittsburgh's Golden Triangle and Chatham Village, for example, Philadelphia's Penn Center and neighborhood projects. In an earlier session architect Richard J. Neutra had pleaded — as many times before — for prime consideration for the reactions and sensitivities of human beings in the design of their environment. One of the highlights of the conference was the presentation by architect Victor Gruen of his plan — so far still "under consideration" — for redeveloping Fort Worth: a scheme (AR, May 1956, page 12) which would return to the pedestrian many of his lost amenities. Also pleading for the human touch was Jane Jacobs of *Architectural Forum*, who pointed out that small and sometimes homely details of neighborhood can be important in preserving for people the sense of place and of belonging.

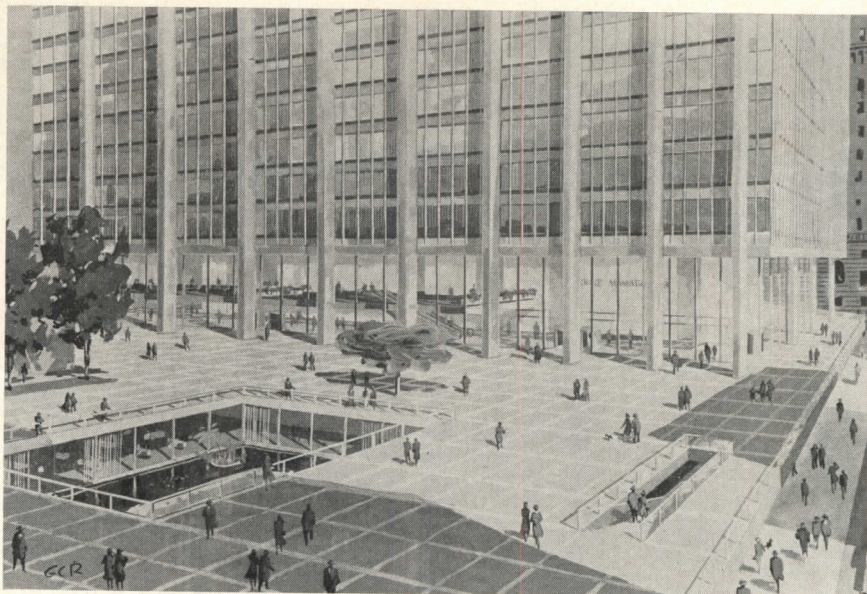

BIRCH BURDETTE LONG MEMORIAL PRIZE for architectural rendering was awarded last month to George Cooper Rudolph of New York for three renderings (one shown above) of the projected Chase Manhattan Bank Building in downtown Manhattan (Skidmore, Owings & Merrill, architects)

When the conference closed, there were tentative plans to hold another next fall.

Technics in the South

"New Materials and New Methods of Construction in Architecture" was the theme of this year's A.I.A. South Atlantic Regional Conference, held April 12-14 at Durham, N. C. with excursions for some sessions to Raleigh and Chapel Hill. A rather star-studded speakers' roster included not only Nervi (see page 21) but also, as keynote speaker, Alonzo J. Harriman of Auburn, Maine; on plastics,

Albert G. H. Dietz, professor of building engineering and construction at M.I.T.; on aluminum, Paul Weidlinger, New York consulting engineer; on laminated wood structures, R. T. A. Johnson of the U. S. Forest Products Laboratory, Madison, Wis. Walter A. Taylor, A.I.A. director of education and research, opened the proceedings with a strong plea for construction industry research as "a basic tool and a top priority investment." Mr. Harriman, discussing the impact on architecture of such current trends as prefabrication and automation, suggested a new A.I.A. "Department of Standards and Research" to provide the research he also said was a major need. In the Honor Awards Exhibit, a jury consisting of John Ekin Dinwiddie, Tulane architecture dean, as chairman, Charles M. Goodman of Washington, D. C., and Frank G. Lopez, senior editor of ARCHITECTURAL RECORD, gave five Awards of Merit and one Citation. An Award of Merit with Special Commendation went to Wilson Junior High School, Mecklenburg County, N. C., A. G. Odell Jr. and Associates, architects. The other Awards of Merit: Fraternal Order of Eagles Building, Atlanta, John Portman, architect; residence for Samuel T. Lemer, John Portman, architect; Gregory-Poole Equipment Company, Raleigh, N. C., G. Milton Small, George Matsumoto, architects (AR, April 1956, pages 253-256). The Citation was given for a parking lot office for Archibald C. Edwards, Joseph N. Boaz, architect.

(More news on page 32)



SLIDING SHUTTERS (above) is the Harwell Harris-designed residence of a New York stockbroker who has announced plans to subdivide part of his estate in Redding, Conn., into ten large sites for houses with the specified purpose of establishing a show-place of contemporary architecture. Gerald M. Loeb, a partner of E. F. Hutton & Co., plans to consult with early purchasers of the sites — they must also be devotees of distinctive architecture — to compile a roster of architects for the houses; but he mentions such names as Frank Lloyd Wright, Harwell Harris, Philip Johnson, Richard Neutra, Marcel Breuer, Paul Rudolph, John Johanson, Edward Barnes, Hy Hebeln, Raphael Soriano, Charles Eames and Bruce Heiser

complete new line of flexible air conditioning units

**Compact units—from 1½ to 106 tons—are easy
to install—have many exclusive features**

Here's a new line of unusually compact air conditioning units for commercial and industrial use in conjunction with central system air conditioning.

Designed by Worthington for easy installation, the standard unit consists of a base section, fan section and coil section. A bypass and damper section can be bolted directly to the coil face at the factory if desired, adding no height to the unit.

Units are extremely flexible. The fan section may be mounted with front, top or rear discharge. You can adjust speed for desired capacity and static pressures. Adjustable motor base offers 3½" variation in center distance for positive adjustment of belt tension. The motor mounts on the front, top, back or either end. Accessories are interchangeable between horizontal and vertical units.

Engineered by Worthington for long, trouble-free life, all sections are constructed of rugged fabricated steel, Bonderized and coated with a corrosion resistant enamel. Dynamically balanced, forward curved fans give maximum efficiency, quiet operation. (Fan shaft rides on lubricated-for-life bearings.)

For more facts on this new line of air conditioning

equipment, write Worthington Corporation, Air Conditioning and Refrigeration Division, Section R-A-6-75, Harrison, N. J.

These features add up to flexibility

- **Exclusive** adjustable motor base assures simple, positive adjustment of belt tension.
- **Motor mounts** on front, back or either end of unit.
- **Fan discharge** can be front, top or rear, as you prefer.
- **Accessories interchangeable** between the horizontal and vertical units.

And look at these extras!

- **Up to 19,000 CFM!** You get more capacity from compact units.
- **Easy installation.** Choose either horizontal or vertical units.
- **Up to 81 different coil combinations.**
- **Lubricated-for-life** fan shaft ball bearings.
- **Accessibility!** Entire fan section can be easily removed. Removable panels and casings simplify inspection, oiling and adjustment.

Section R

WORTHINGTON



CLIMATE ENGINEERS TO INDUSTRY, BUSINESS AND THE HOME

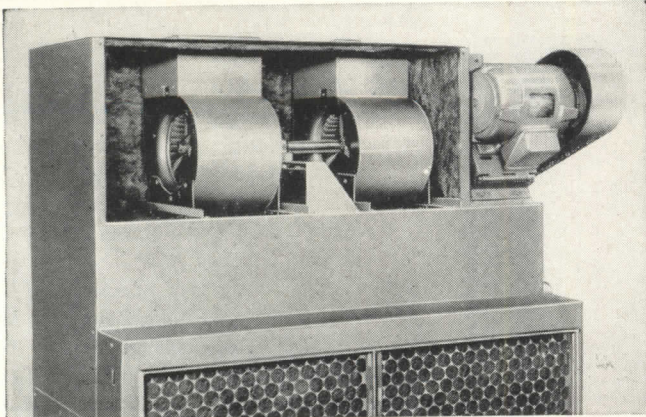

Here's where the new Worthington units get their flexibility

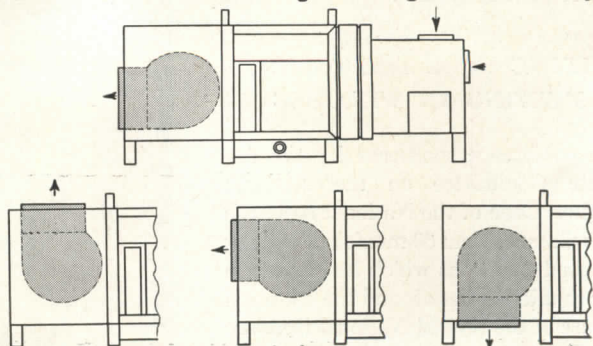

ADJUSTABLE DISCHARGE. Fan section may be mounted with top discharge as shown above. Or discharge may be directed to front or rear of the unit. See diagrams.

**"ROUNDUP IN THE ROCKIES"
THEME OF ANNUAL ASSEMBLY**

The 47th annual assembly of the Royal Architectural Institute of Canada will open on June 6 with pre-assembly council meetings; a "western welcome" is scheduled for that evening. Business sessions, tours and a ranch supper are planned for June 7, and seminars and special events will follow on June 8 and 9. The official activities of the assembly will end on June 9 with the annual dinner.

The day preceding the convention will be taken up with a conference of the Canadian schools of architecture, under the chairmanship of Prof. John A. Russell of Winnipeg.

On June 10, post-assembly activities are planned; these will include a west coast trip which will take many of the delegates and their wives to Vancouver.

**GOVERNMENT FEARS SHORTAGE
OF KEY BUILDING WORKERS**

The labor supply for the construction industry will be tight this summer, according to a report from the Dominion Bureau of Statistics, Department of Labor and National Employment Services. Architects and draftsmen will be hard to get, said the Bureau, but skilled carpenters, bricklayers, tile setters, cement finishers and painters will be even scarcer.

The Bureau did not fear an overall labor shortage as much as the possibility that a scarcity of key skills, particularly in boom areas, might be a serious factor in determining the degree and speed at which employment would be available to others. So far, however, according to employment figures, the seasonal swing has been about normal.

**BUILDING CODE THE TOPIC
AT MEETING IN WINNIPEG**

At a conference sponsored by the Associate Committee on the National Building Code of the National Research Council, more than 80 municipal officials discussed questions which had arisen in their municipalities around the adoption and use of the revised National Building Code. Procedure for adoption differed so from province to province that it was decided such special local problems could

better be reviewed by officials separately in each region. It was thought that the formation of provincial groups would encourage greater participation from smaller municipalities unable to send delegates to a national conference, and a resolution urging such provincial associations was passed unanimously by the delegates.

Earle G. Simpson, inspections engineer for the city of Winnipeg, was chairman of the conference. Director R. F. Legget and other officials from the National Research Council reported progress in the development of the National Building Code. It was announced that copies of the new "Shorter Form" of the code were available, and that work on associated documents was well advanced.

The two-day program included discussion on subjects ranging from town planning to fire research. Many problems of municipal by-law administration, such as procedure for the condemnation of buildings and the acceptance of new materials, were reviewed.

Proceedings of the conference will be available later in the year from the

secretary, Associate Committee on the National Building Code, National Research Council, Ottawa.

**SPECIFICATIONS WRITERS
AT TORONTO FOR MEETING**

Retiring president D. H. Brough reported at the recent meeting of the Specifications Writers Association in Toronto that excellent progress has been made in evolving a framework of basic specifications. Thirty-two subcommittees have been organized to prepare standard specifications for their particular trades, he said. To date 15 drafts of standard specifications have been received and two have been processed by the board of directors over a period of four special executive meetings held for this purpose. One specification submitted to the membership was returned for reconsideration.

Delegates also elected officers for the coming year: O. E. Letherland, president; R. V. Fernandez, secretary; and R. E. Briggs, treasurer. Members of the board of directors are C. S. Jarrett,

(Continued on page 40)

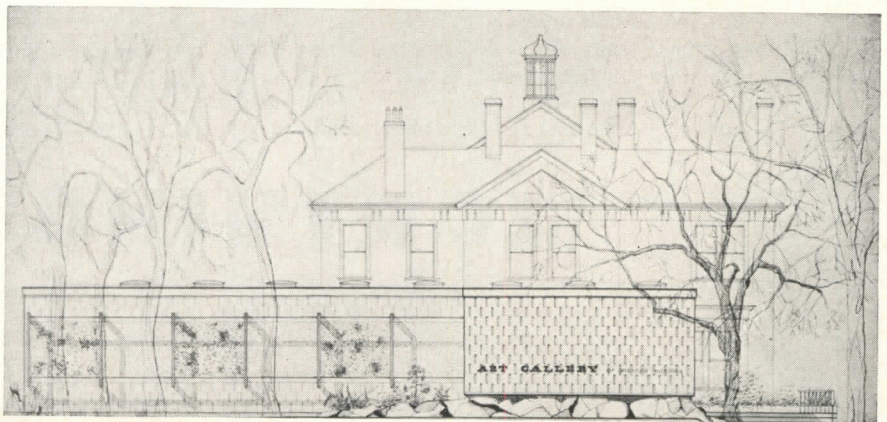

GALLERIES EAST AND WEST:
Above — winner of a competition for a new wing for Victoria's Art Gallery was the design submitted by Clack, Clayton, Pickstone, Architects and Town Planning Consultants of Victoria. No second prize was awarded, but the third prize went to architect W. R. Gibson, also of Victoria. Left — The Department of Public Works, under chief architect E. A. Gardner, designed the temporary quarters for the National Gallery; it will be converted to office space when the permanent gallery (AR, May 1954, p. 26) is completed in about ten years

sheathed with Bildrite

"Quick sale at \$31,500 shows how well architect balanced design and cost factors..."

says Jed K. Giles, Kansas City builder-engineer. This home was sold within 3 days after its first showing. Throngs of visitors looked through it, and nearly all guessed the price to be much higher.

Obviously, the choice of Bildrite gave Architects Linscott, Kiene & Haylett, A.I.A., important advantages. Sheathing cost was reduced about \$100 as compared to wood, and this economy helped pay for "extras" such as Insulite Roof

Deck, topped with wood shingles applied to striping.

Definitely out of the ordinary, this tri-level design appeared in the Kansas City Star series featuring outstanding residential architecture by Kansas City architects; and was featured in House & Home magazine as an award winner among "56 Homes For 1956."

No matter what type of homes you are designing today, Insulite products and services can help you importantly. Want special information about Insulite's Bildrite, or Roof Deck, or Graylite, or Shingle-Backer? Just write Insulite, Minneapolis 2, Minnesota.

build better and save with **INSULITE**



INSULITE, Made of hardy Northern wood

Insulite Division of Minnesota and Ontario Paper Company, Minneapolis 2, Minnesota

INSULITE, BILDRITE AND GRAYLITE ARE REGISTERED T. M.'S U. S. PAT. OFF.



THE RECORD REPORTS NEWS FROM CANADA

(Continued from page 36)

representative of the Ontario Association of Architects; L. M. Bennett, representing the Association of Professional Engineers of the Province of Ontario; G. Bye, general contractors' representative; R. W. Cornell, trade contractors' representative; and E. W. Taylor, manufacturers' and suppliers' representative.

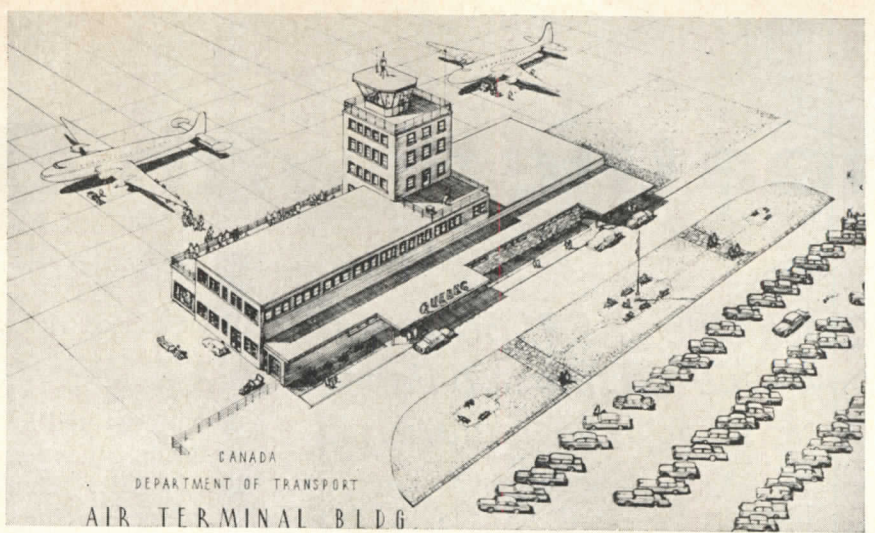

QUEBEC CITY WILL HAVE AIR TERMINAL BUILDING

A \$750,000 air terminal is nearing completion at Quebec Airport in Ancienne Lorette.

The first floor of the new building will be the public area, and will include a space for ticket and reservation counters, baggage handling and waiting room, as well as a snack bar and restaurant. The second floor will house offices for the Radio and Meteorological Services of the Department of Transport, air traffic control and the airport manager, airlines offices and associated services.

Designed with special attention to the possibilities of future expansion, the building has a steel frame which could support additions to the second story; expansion could also be effected by adding to the length of the building.

Architect is the Department of Transport under chief architect W. A. Ramsay.

C.C.A. PRESIDENT CONDEMNS BUILDERS' BELOW-COST BIDS

A. Turner Bone, president of the Canadian Construction Association, has criticized the practice among some contractors of "cut-throat" competition resulting in below-cost contracts. Although believing that intense competition for construction contracts acts as an incentive to increase efficiency and to keep prices at the lowest possible level, Mr. Bone warned that going further and bidding below cost is producing dangerous results.

"In spite of public opinion to the contrary," he said, "many contractors operate at a loss.

"We all recognize that the competitive nature of our business is responsible for the development of efficient procedures; of new methods and materials by which

(Continued on page 44)

The Ideal Sign for Shopping Centers

Shopping centers everywhere are adopting Wagner Changeable Boards because:

- ★ They serve all the tenants.
- ★ They can be integrated into the center without destroying the overall pleasing appearance, as does a hodge podge of displays.
- ★ They do the most effective job of merchandising specials.
- ★ They are self liquidating. Most centers rent space on them, pay for the entire installation within a few years, and then have an added source of regular revenue. Where this policy prevails it has been found that the demand for space by tenants far exceeds that which is available.

Integrated into your plans Wagner Boards lend an air of fresh thinking and sound logic to your proposals. They can be designed without limitation as to size.



One of two 28' x 38' double-faced signs installed at 79th & Cicero Ave., Chicago

Literature which includes design and construction information, will be sent on request.

WAGNER SIGN SERVICE, INC.

629 S. Hoyne Avenue • Chicago 12, Illinois

Please send free literature on Wagner Changeable Boards.

NAME _____

FIRM _____

STREET _____

CITY & STATE _____

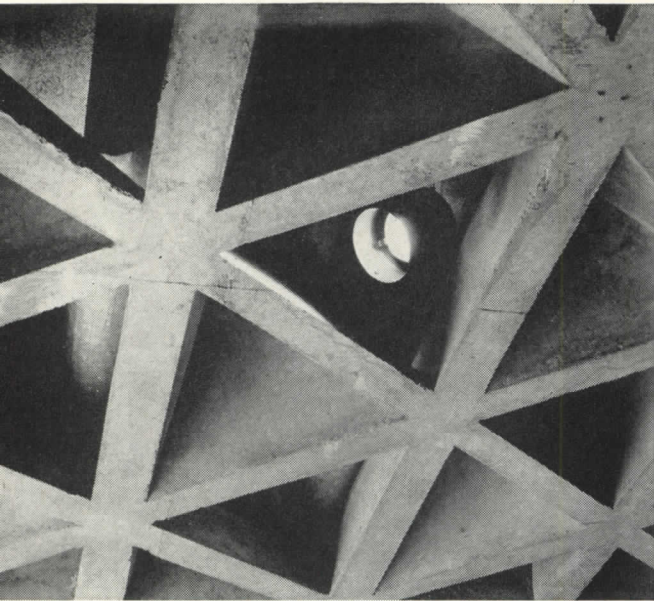

the original texture of Tectum can be seen in the upper left. Tectum, like the framing members, is not painted—nor will it ever need be. If, at a later date, it should be spray painted, its acoustical value will not be impaired.

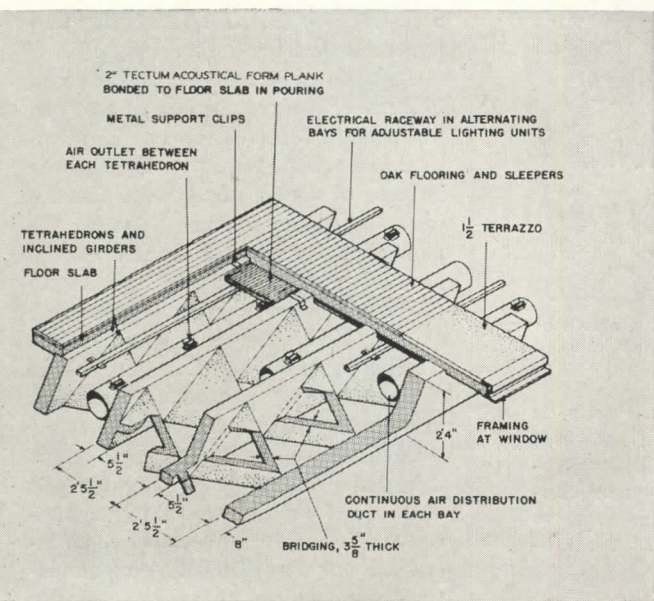
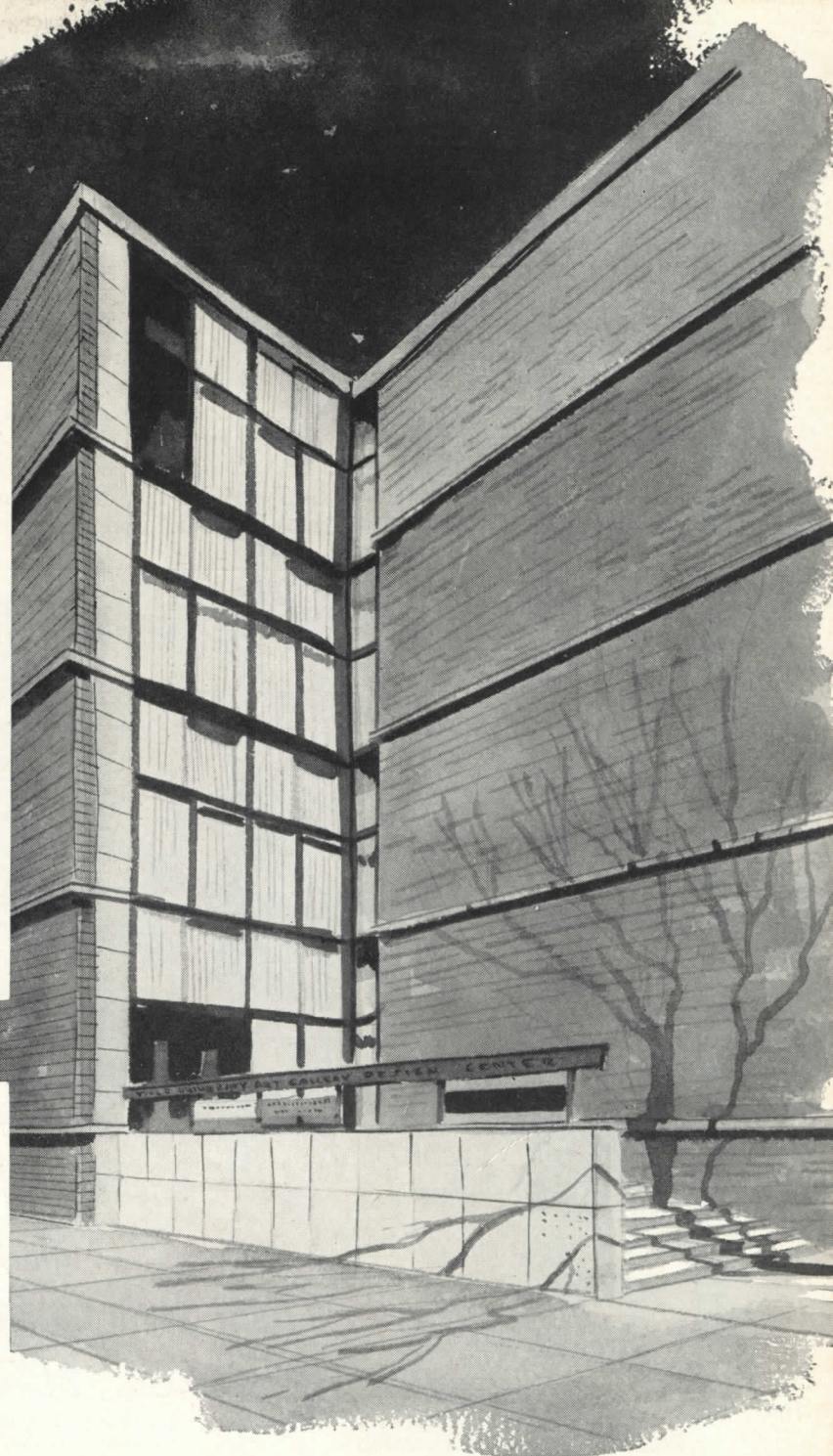

South facade and entrance area. Douglas Orr, New Haven, Louis I. Kahn, Philadelphia, Associated Architects; George B. H. Macomber Company, Boston, General Contractors; Meyer, Strong & Jones, New York, Mechanical and Electrical Engineers; Henry Pfisterer, New Haven, Structural Engineer.

and add acoustical material...

when you get all 3 with the

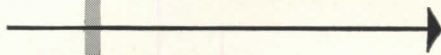

Tectum

METHOD

For Plants • Commercial Buildings • Institutions • Homes

THE RECORD REPORTS NEWS FROM CANADA

(Continued from page 40)

the same results can be accomplished at a lower cost; of greater use of machinery to make up for shortages of skilled and unskilled labor, etc. Savings in cost to an owner from such sources benefit all concerned," he said. "But when owners get cost savings through contracts executed at no profit, or at a loss, the benefits to

them are more than offset by the disturbance to and general weakening of our business economy. It is this situation that we must try to avoid."

MORE ECONOMIC EXPANSION EXPECTED IN NEXT DECADE

The monthly Bank of Montreal *Business Review*, looking back over the last ten years and Canada's postwar economic expansion, named the increase in annual capital expenditure on new plant, equipment and housing "the

Terrace Hall with Kilnoise ceiling, Kent State University, Kent, Ohio



KILNOISE acoustic plaster
specified for handsome
Kent State dormitory by
R. B. Dela Motte A.I.A.

OF FULTON, KRINSKY & DELA MOTTE,
ARCHITECTS, CLEVELAND, OHIO

KILNOISE acoustic plaster is specified for more and more of today's finest buildings for the same reasons that Architect Dela Motte specified it for this new university dormitory. KILNOISE provides a Noise Reduction Coefficient of .60. It is moisture-resistant. It is fire-retardant. And it takes paint smoothly, cleans with ease.

KILNOISE is particularly well adapted

to *Impressed Designs* on walls or ceilings. First used on KILNOISE, Impressed Designs can follow geometric, floral, emblematic or contemporary lines to add interest to commercial, institutional or dwelling interiors.

For perfect applications of acoustic plaster, always specify KILNOISE. *Kelley Island Division of Basic Incorporated, Cleveland 15, Ohio.*



KILNOISE
ACOUSTIC PLASTER

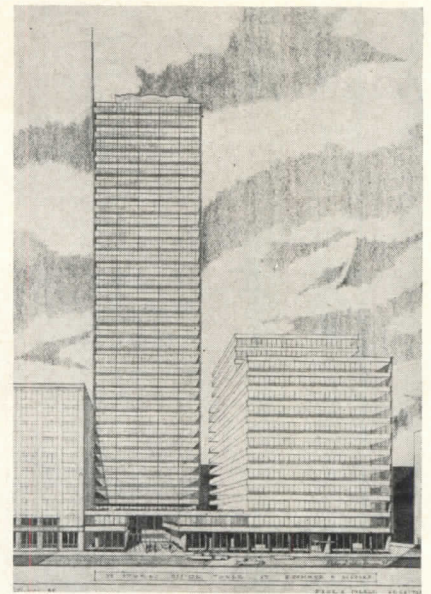

The Canadian Bank of Commerce plans a 38-story office building, reportedly the tallest skyscraper in the British Commonwealth, for Toronto. Architects are Page & Steele

dynamic force behind Canada's postwar growth." Although the *Business Review* doubted that capital expenditures could continue to increase at the same high rate, school, hospital, highway and municipal service needs as well as large projects in mining, manufacturing and power should keep the level high.

Canada's population has increased 29.2 per cent since the end of the war, the bulletin reported. Heavy immigration, averaging 117,000 yearly, and the increase of younger and larger families were the major reasons given for the population growth. Recorded births have risen from 330,000 in 1946 to 440,000 in the 12 months preceding June 1, 1955. The *Review* foresaw the possibility, however, that both births and immigration might fall off somewhat in the next ten years.

Of the employment picture, the report indicated a steady shift since the end of the war from agricultural to non-agricultural jobs. While the labor force increased only by 750,000, non-agricultural employment rose by 1,000,000; about an eighth of this number went into the construction industry. There is a possibility, said the bulletin, of a "relative" labor shortage until the early 1960's.

"There seems good reason to believe," the *Review* concluded, "that growth, with its attendant benefits and problems, will continue to be the hallmark of the Canadian economy."

(Continued on page 46)



equipment heats and snow melting

cooling. And for the many applications where steam-to-water or water-to-water heat transfer is required, B&G Heat Exchangers provide large capacity in compact, efficient units.

Architect and Construction Superintendent: **John Messmer, Milwaukee, Wisconsin** . . . Assistant Construction Superintendent: **Fred Melms** . . . Electrical Engineer: **Gregory Pichel** . . . Heating Engineers: **Joseph H. Volk and William T. Holland, Milwaukee, Wisconsin** . . . Heating Contractors: **E. D. Wesley Co., Bon Heating Co., Wenzel and Henoch, Milwaukee, Wisconsin.**

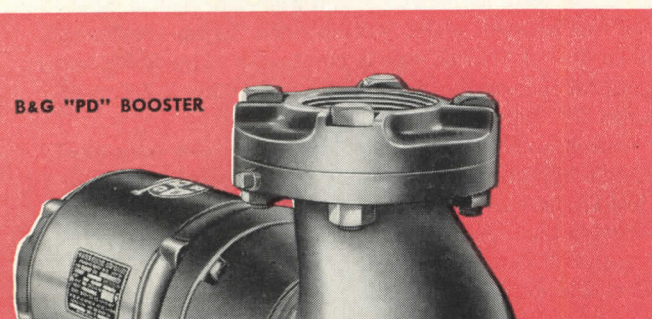

B&G "PD" BOOSTER

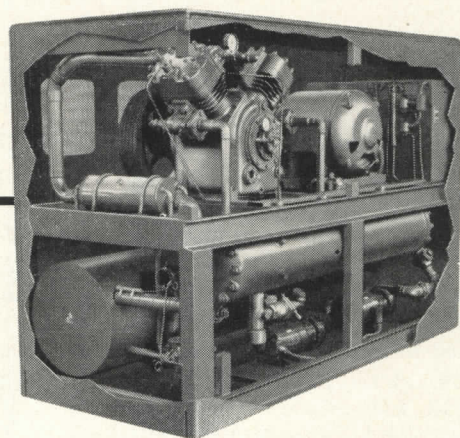

B&G PACKAGE LIQUID COOLERS

Virtually a plug-in unit for a wide variety of applications . . . as a separate space cooler . . . or in combination with a forced hot water heating system . . . or for industrial processes requiring controlled cooling of materials. Available in capacities from 7½ to 100 tons.

Numerous features make the B&G Package Cooler an outstanding unit. Low pressure drop through the evaporator permits a substantial reduction in system pump sizes. The evaporator is located under the compressor for a lower center of gravity—making the unit easier to install and service. An integrated electrical control system provides a high degree of automation without extra cost. Completely wired, including chiller and tower pump.

Write for Bulletin HB-755.



*Reg. U.S. Pat. Off.

BELL & GOSSETT

C O M P A N Y

Dept. EJ-32, Morton Grove, Illinois

Canadian Licensee: *S. A. Armstrong Ltd., 1400 O'Connor Drive, W. Toronto, Canada*

LEWIS MUMFORD:

his contribution to American architecture

By FREDERICK GUTHEIM

From the Ground Up. By Lewis Mumford. Harvest Books (Harcourt, Brace and Co.) New York. 1956. 243 pp. \$1.25

THE DEBT AMERICAN ARCHITECTURE OWES Lewis Mumford is only partially recorded in his essays from the *New Yorker*, here collected in this handy paper-backed volume. But the least architects, and everyone interested in their art, can do is to read these wise, penetrating and often witty observations and see at first hand how well these essays of the moment stand the test of time.

The range is surprisingly small. Fresh Meadows, the UN Headquarters, Skidmore, and a review of Robert Mitchell's book* about sums it up. But in writing about these few topics, Mumford manages to range over the whole of architecture, and much that is better classified as housing, city planning and other fields. Here is a mind that seizes upon relationships — an organismic mind, as Alfred N. Whitehead put it — a mind that sees things as a biologist sees them, with an eye to growth and the influence of environment. But if the architect appreciates Mumford because he explains the conditions surrounding architecture, and concentrates attention on architectural objectives, the lay reader appreciates him because he proceeds from the known to the unknown. Life illuminates architecture. The only substantial objection to Mumford has come from the critics who protest that he seldom comes to grips with what they regard as the ultimate problems of architectural history and esthetics.

The typical method of analysis Mumford employs is description. It can be a devastating weapon, as he shows in his description of the entrance of the new Whitney Museum. It is most convincing when the personal experience in the presence of architectural masterpieces is recreated. But this is essentially a literary and philosophical technique, not the method of art criticism. And however soundly it is buttressed with history, as it is brilliantly strengthened, for example, in the essay on Frank Lloyd Wright's exhibition, it seldom leads to conclusive judgements. Here is a kind of criticism, in fact,

less concerned with judgements than with understanding.

Most of all it is rooted in the healthy tradition of Ruskin and Morris, its moral indignations, its humanism, its suspicion of mechanization, its distrust of the large-scale corporate economy, and often its esthetic blindness and inconsistency. When Mumford finds Lever House good and the United Nations Headquarters bad, it is difficult to know whether the judgement is a moral or an esthetic one. The mechanization of the Manufacturers Trust Building, so extravagantly admired here, is certainly no less than the air-conditioned nightmare of the Whitney which is condemned. In the treatment of Public School No. 33, one is constantly plagued by the thought that the building would fare much worse if it housed a less socially desirable activity.

Of course architecture cannot be judged as sculpture. Mumford's appreciation of housing is enormously strengthened just because he considers a far wider range of human uses and interests that are recognized in design. And if his conclusions are relative, as I believe they are in the case of Fresh Meadows and Peter Cooper Village — which are remarkable only in terms of the peculiar conditions imposed by New York City — they are none the less valid.

These questions are posed because Mumford takes seriously his responsibilities as a critic. He is not writing to amuse people, or primarily to reach judgements. He clearly hopes to educate and to inform, and clearly he has succeeded.

If any architects have difficulty in understanding this, they would do well to read *Herman Melville*, or any of the volumes in the monumental series, *The Renewal of Man*; or even more simply, a recently published quintessence of Mumford's writings in a single volume. They would see there both the importance Mumford attaches to architecture — far greater than most architects dream of — as well as its limits.

The term journalism has become a kind of literary reproach. Yet this is architectural journalism far above the ordinary level. Lewis Mumford writes for the *New Yorker* because he respects its audience, its literary standards, and

(Continued on page 64)

* *Urban Traffic.* By Robert B. Mitchell and Chester Rapkin. Columbia University Press (New York) 1954. 226 pp. \$5.00.

STEEL DECK

and LONG SPAN

M-DECKS

Mahon Long Span M-Deck, shown below, also provides the Acoustical Ceiling in the new Body Engineering Building, Ford Research and Engineering Center. Voorhees, Walker, Foley & Smith, Architects, Bryant & Detwiler Company, General Contractors.

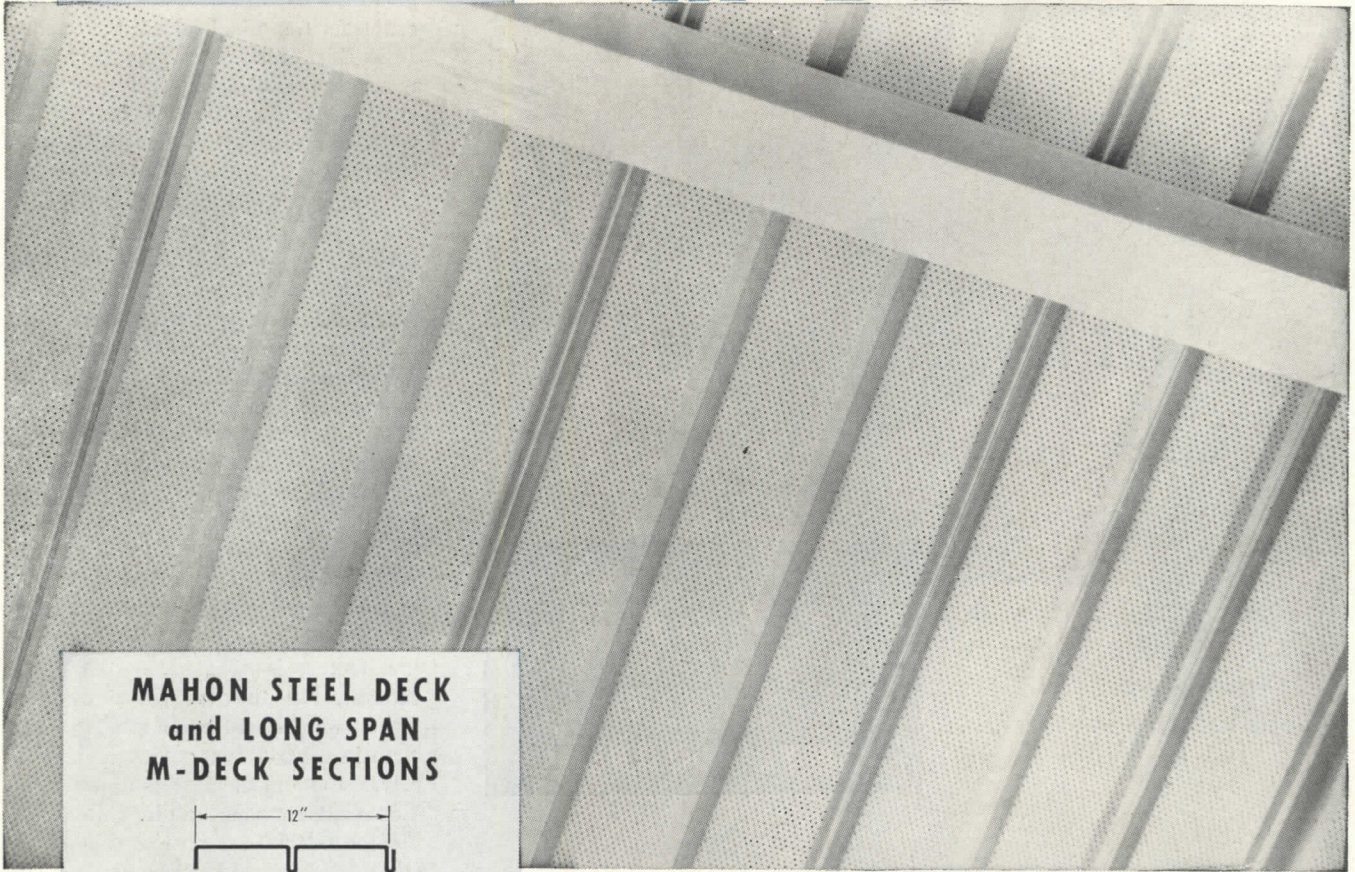

MAHON STEEL DECK and LONG SPAN M-DECK SECTIONS

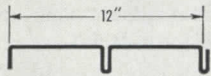

STANDARD DOUBLE RIB

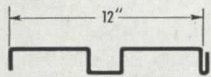

WIDE-FLANGE DOUBLE RIB

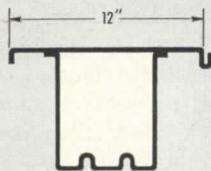

LONG SPAN M-DECK
SECTION M1

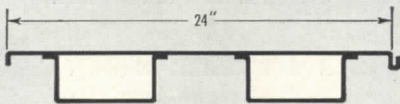

LONG SPAN M-DECK
SECTION M2

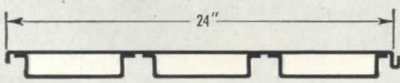

LONG SPAN M-DECK
SECTION M3

Steel Deck is the most practical and most logical material for modern roof construction . . . it is most logical because it is lighter in weight, and because it costs less than any other type of permanent roof building material. And now that Long Span M-Decks are available in a number of structural sections that meet virtually any requirement in roof construction, as well as combined roof/ceiling construction, *STEEL*, employed as the structural unit and interior finish material as well, will roof even a broader range of building types. The illustration above shows a typical combination Long Span M-Deck Roof and Acoustical Ceiling —bottom metal of the Cel-Beams is perforated and sound absorbing material inserted to provide excellent acoustical properties. This same result can be obtained with a beamed ceiling effect, as shown, or with the Cel-Beam Section inverted, which produces a flat metal ceiling surface. Mahon Long Span M-Decks can be furnished in Cel-Beam Sections, Open Beam Sections, or Troffer Sections to span up to 32 feet. See Sweet's Files for information or write for Catalogs D-56 and M-56.

THE R. C. MAHON COMPANY • Detroit 34, Michigan

Sales-Engineering Offices in Detroit, New York and Chicago • Representatives in Principal Cities

Manufacturers of Steel Roof Deck and Long Span M-Decks; M-Floors (Electrified Cel-Beam Floor Systems); Permanent Concrete Floor Forms; Insulated Metal Walls and Wall Panels; Rolling Steel Doors, Grilles and Underwriters' Labeled Automatic Rolling Steel Fire Doors and Fire Shutters.

MAHON

Colorful

beauty

that lasts a lifetime!

All-vinyl . . . with beautiful colors going through-and-through, Amtico Vinyl Flooring is the most complete line and offers unlimited design possibilities . . . takes hardest wear for years.



America's most luxurious flooring, Amtico Rubber Flooring is the quality leader that gives your customers lifetime economy, rich beauty, cushioned comfort and fire-resistance.

Also makers of Amtico Plastex Rubber Flooring

World's Largest Producer of Rubber and Vinyl Floorings

**AMERICAN BILTRITE
RUBBER COMPANY**

TRENTON 2, N. J.

New York Office: 461 Fourth Avenue

In Canada—American Biltrite Rubber Co. (Canada) Ltd., Sherbrooke, Quebec

See SWEET'S FILE, Architectural, for specifications and installation data, or mail coupon below:

AMTICO, Dept. AR-4, Trenton 2, N. J.

Gentlemen:

Please send me Free complete set of Samples and detailed information about Amtico Floorings.

Name.....

Firm.....

Address.....

City..... Zone..... State.....

(Please attach coupon to your business card or letterhead)

REQUIRED READING

(Continued from page 58)

because he is still in love with New York. He writes about technical subjects in the English tradition of, say, Leonard Huxley who did not disdain to give talks to laborers institutes; or as a critic of art, music, books or the theater. It is this which sets him apart from those who write about architecture for architects or for art historians.

This mature and popular kind of writing, then, is the substantial and unique achievement which Lewis Mumford has won in the pages of our most literate periodical. If more people understand who architects are, what they do, and how to tell them apart from each other, it is because of this kind of writing. And it has been published now for a quarter-century, let it be noted, not merely since 1947 when the earliest piece in the present collection was published.

The subjects treated in this volume prompt a final reflection. The laws of libel affect architectural writing somewhat differently than they do criticisms of books or the theater. The courts appear to be more willing to recognize that architecture is affected by the public interest, but they recognize property rights in architecture to a greater extent than in other things which find themselves the object of public criticism. Comment on public buildings offers little difficulty. Buildings presented in a book or an exhibition likewise expose themselves to lawful criticism. Buildings involving public subsidy, or tax exemption, or the employment of public powers also become sufficiently colored by the public interest to be criticized. So are public institutions like museums and libraries, churches or railroad stations. Robert Moses is a fair target, as a public official. But beyond these general lines the criticism of architects and their works must still proceed with caution. One hopes that such a book as *From the Ground Up* will broaden the scope of architectural criticism by its effective demonstration of its value.

STRUCTURAL DESIGN

By William Hoffberg

Applied Structural Design of Buildings. By Thomas H. McKaig. F. W. Dodge (119 West 40th St., New York) 1956. 442 pp, illus. \$12.50

BOOKS ON STRUCTURAL DESIGN are based upon either theory or practice or combined theory and applied problems. In addition, there are the reference

(Continued on page 360)

THE PANEL

MAX ABRAMOVITZ
 JAMES S. ACKERMAN
 WAYNE ANDREWS
 LEOPOLD ARNAUD
 TURPIN C. BANNISTER
 PIETRO BELLUSCHI
 MARCEL BREUER
 GORDON BUNSHAFT
 JOHN E. BURCHARD
 ALAN BURNHAM
 LESLIE CHEEK, JR.
 KENNETH J. CONANT
 GEORGE BAIN CUMMINGS
 JOHN EKIN DINWIDDIE
 DONALD D. EGBERT
 WALTER GROPIUS
 TALBOT F. HAMLIN
 HENRY RUSSELL HITCHCOCK
 ARTHUR C. HOLDEN
 JOSEPH HUDNUT
 PHILIP JOHNSON
 EDGAR KAUFMANN
 GEORGE FRED KECK
 MORRIS KETCHUM, JR.
 A. LAWRENCE KOCHER
 ERNEST J. KUMP
 MAURICE LAVANOUX
 EDWIN BATEMAN MORRIS, SR.
 HUGH MORRISON
 RICHARD NEUTRA
 ELIOT NOYES
 G. HOLMES PERKINS
 BUFORD L. PICKENS
 ANTONIN RAYMOND
 EARL H. REED
 HENRY HOPE REED
 JOHN W. ROOT
 PAUL RUDOLPH
 EERO SAARINEN
 PAUL SCHWEIKHER
 VINCENT J. SCULLY, JR.
 G. E. KIDDER SMITH
 EDWARD STEESE
 HUGH STUBBINS
 WALTER TAYLOR
 WILLIAM W. WURSTER
 MINORU YAMASAKI

The remainder of the panel returned anonymous ballots

1: OFFICE BUILDINGS

DURING THE YEAR PRECEDING the 100th anniversary of The American Institute of Architects, ARCHITECTURAL RECORD will present (grouped generally by building type) those buildings nominated by a panel of fifty architects and scholars as the most significant in the past one hundred years of architecture in America.

Each panel member was invited to name "about twenty buildings in existence today whose over-all significance, in your opinion, has been most important in the stage-by-stage development of our architecture."

Lists of nominations varied from a select six to an inclusive sixty and averaged twenty-five buildings per panel member. Ballot notations and accompanying letters indicated some lists were based largely on the intrinsic value of the buildings, others on the degree of influence the buildings have exerted or promised. Most lists seemed to balance these considerations and the collective balloting appears to reflect this balance.

In some respects the list is smaller than the editors and many of the panel members would have preferred. Any building that received a number of votes will be mentioned in its appropriate chapter of the series, but only those which were named by more than twenty per cent of the panel will be listed and pictured, except in the case of houses where the voting was so much more widely spread that a lower limit was used and a separate list established. The final list shows that, including ties, there are fourteen houses grouped in ten positions and thirty-six other buildings grouped in twenty positions; a total of fifty buildings.

The list must be acknowledged as sharing the shortcomings of all such pollings. However, at the very least its publication will provide a picture record of some important buildings not previously gathered together, while at best it may play a provocative role in focusing the kind of attention on our architectural heritage which will urge practical steps for the protection and preservation of all our meaningful architecture. Since most of the buildings in this list have been generously documented elsewhere, the form of this presentation will be largely that of a pictorial index.

It is not surprising that the work of Frank Lloyd Wright is represented most frequently or that multi-story office buildings are the dominant building type. In addition to the eleven shown here, there were many nominations of Sullivan's Prudential Building, Hood's McGraw-Hill, Polk's Hallidie, and Shreve, Lamb & Harmon's Empire State.

Certainly in our tall office structures America has made for many decades one of its finest contributions to architecture. It is with a group of the best of these that we introduce this series.

John Knox Shear



WAINWRIGHT BUILDING, St. Louis
Louis Sullivan

CARSON PIRIE SCOTT STORE, Chicago
Louis Sullivan

ROCKEFELLER CENTER BUILDINGS, New York
Reinhard & Hofmeister; Corbatt, Harrison
& MacMurray; Hood & Foulhoux

LEVER HOUSE, New York
Skidmore, Owings & Merrill

TRINITY CHURCH, Boston
H. H. Richardson

PHILADELPHIA SAVINGS FUND SOCIETY
BUILDING, Philadelphia
Howe & Lescaze

GENERAL MOTORS TECHNICAL CENTER, Detroit
Saarinen & Saarinen

LAKE SHORE DRIVE APARTMENTS, Chicago
Mies van der Rohe

S. C. JOHNSON & SON, INC., ADMIN. BLDG., Racine
Frank Lloyd Wright

MONADNOCK BLOCK, Chicago
Burnham & Root

DAILY NEWS BUILDING, New York
Hood & Howells

TVA NORRIS DAM & POWER HOUSE, Tennessee
Roland Wank, Architect-in-charge

BOSTON PUBLIC LIBRARY, Boston
McKim, Mead & White

STOCK PAVILION, Raleigh
Nowicki & Deitrick

CHRISTIAN SCIENCE CHURCH, Berkeley
Bernard Maybeck

WOOLWORTH BUILDING, New York
Cass Gilbert

CROW ISLAND SCHOOL, Illinois
Saarinen & Saarinen,
with Perkins, Wheeler & Will

MANUFACTURERS TRUST BUILDING, New York
Skidmore, Owings & Merrill

UNITY CHURCH, Oak Park
Frank Lloyd Wright

NEBRASKA STATE CAPITOL, Lincoln
Bertram G. Goodhue

S. C. JOHNSON & SON, INC., LABORATORY, Racine
Frank Lloyd Wright

UNITED NATIONS SECRETARIAT, New York
Wallace K. Harrison & Consultants

LINCOLN MEMORIAL, Washington
Henry Bacon

M.I.T. AUDITORIUM, Cambridge
Eero Saarinen

EQUITABLE BUILDING, Portland
Pietro Belluschi

ALLEGHENY COUNTY BUILDINGS, Pittsburgh
H. H. Richardson

UNIVERSITY CLUB, New York
McKim, Mead & White

CRANBROOK SCHOOLS, Michigan
Eliel Saarinen

MINERALS & METALS RESEARCH BLDG., I.I.T., Chicago
Mies van der Rohe

ALCOA BUILDING, Pittsburgh
Harrison & Abramovitz

MUSEUM OF MODERN ART, New York
Goodwin & Stone

PENNSYLVANIA STATION, New York
McKim, Mead & White

EXPERIMENTAL SCHOOL, Los Angeles
Richard Neutra

DODGE TRUCK PLANT, Detroit
Albert Kahn

100 MEMORIAL DRIVE APARTMENTS, Cambridge
Kennedy, Koch, DeMars, Rapson & Brown

CENTRAL LUTHERAN CHURCH, Portland
Pietro Belluschi

HOUSES

F. C. ROBIE, Chicago
Frank Lloyd Wright

E. J. KAUFMANN, Pennsylvania
Frank Lloyd Wright

TALIESIN WEST, Arizona
Frank Lloyd Wright

HENRY VILLARD, New York
McKim, Mead & White

WATTS SHERMAN, Newport
H. H. Richardson

AVERY COONLEY, Illinois
Frank Lloyd Wright

W. W. WILLITTS, Illinois
Frank Lloyd Wright

D. R. GAMBLE, Pasadena
Greene and Greene

PHILIP JOHNSON, New Canaan
Philip Johnson

WALKER GUEST HOUSE, Florida
Paul Rudolph

ELLEN SCRIPPS, La Jolla
Irving Gill

WESTON HAVENS, Berkeley
Harwell Hamilton Harris

LOVELL "HEALTH HOUSE", Los Angeles
Richard Neutra

EDITH FARNSWORTH, Chicago
Mies van der Rohe

ONE HUNDRED YEARS OF SIGNIFICANT BUILDING

Wainwright Building, St. Louis, 1890-91, Louis Sullivan. (Tied for first)

"The Wainwright Building turns out more and more to be the prototype of all contemporary office buildings. In the Wainwright Building, Sullivan imposed his artistic will on a pile of identical rooms in such a skillful manner that it can still be studied by the practicing architect today."

Philip Johnson

"In the Wainwright Building, Sullivan gave esthetic form — for the first time in America — to the comparatively new problem of the tall office building. This form, though creative rather than eclectic, was essentially classical. With the age-old qualities of mass, stability, clarity, and finiteness embodied in a new problem, Sullivan created a modern classic. The Wainwright Building stands today as an old masterpiece of American architecture."

Hugh Morrison

"Today we can begin to understand and appreciate the beautiful uncommon sense of the Wainwright Building; here, in 1891 St. Louis — amid eclectic confusion — Sullivan built the first post-Victorian structure using the steel frame, an event as significant to architecture as was Cezanne's work of the same time to painting."

Buford Pickens



Hedrich-Blessing (also opposite page)

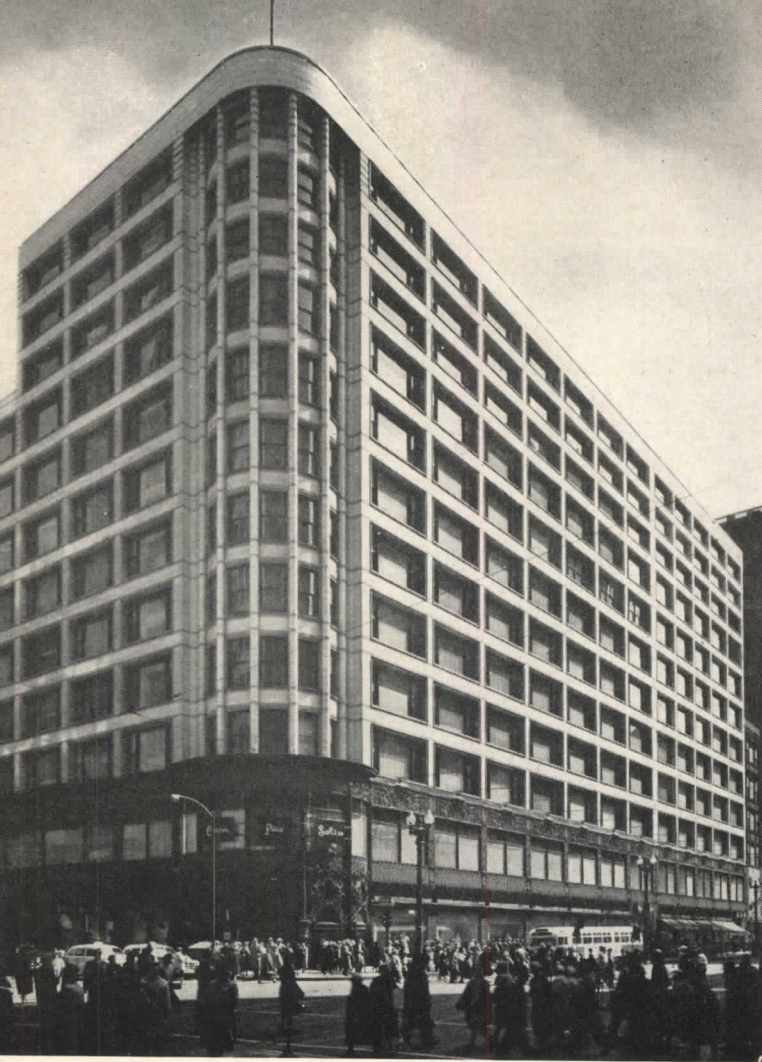

Hedrich-Blessing

*Carson Pirie Scott Store, Chicago, 1899-1904,
Louis Sullivan. (Tied for first)*

"The Carson Pirie Scott Store was Sullivan's greatest building. It was abuilding on New Year's Eve of the 20th century, and every line and surface foretold the esthetic quality of the finest buildings of the next half-century. Never, perhaps, has steel-frame structure been better expressed, but far beyond that, the building had the restless dynamic sweep, the stressed-skin smoothness, the machine-like clarity of today. Esthetically, it is far closer to the fragile, rectilinear precision of the Manufacturers Trust Building in New York than it is to the stable classicism of the Wainwright Building. In this building, Sullivan grasped the mood and tempo of the twentieth century. September 3, this year, will be the centennial of his birth. No other building has so valid a claim as the masterpiece of a century of American architecture."

Hugh Morrison

Wurts Brothers

*Rockefeller Center Buildings, New York, 1932-40,
Reinhard & Hofmeister; Corbett, Harrison &
MacMurray; Hood & Fouilhoux. (Second)*

"The unity of steel and civic order in the Rockefeller Center Buildings is more prescient of great achievement in American architecture than are the most sensitive harmonies of esthetic surface and metallic frame."

Joseph Hudnut

"A new approach to the 'large building' program. In fact, a two or three story block below ground, from which rise several towers of varying heights. The group thus benefits from the services and appurtenances of a single building, and benefits also from the light, air and harmonious massing of a group of buildings."

Leopold Arnaud



Lever House, New York, 1952, Skidmore, Owings & Merrill. (Third)

“After several decades of clouded and misty architecture, I find it refreshing to see the clear glass shaft of Lever House rising in the otherwise drab atmosphere. And I hope the free area at the base of the building is a forerunner of more open spaces which help to reduce the tension of our daily life. In a way, the Lever House reflects the product of the Company and so the great areas of glass are here justified. Even so, all in all, it is a clear and pleasing silhouette in our city of towers.”

Maurice Lavanoux

“I am particularly impressed by the Rockefeller Center Buildings and by Lever House, not so much because of their architecture — fine though that may be — but because their land usage and building relationships are so significant. The space relation of one building to a neighbor and each to the land on which it stands is far too little considered in the United States. These two New York examples shine as beacons in this respect.”

G. E. Kidder Smith



Wurts Brothers

Philadelphia Savings Fund Society Building, Philadelphia, 1932, Howe & Lescaze. (Fifth)

“In 1932 George Howe and the directors of this bank had the courage to create a *purely* modern building, about which even Le Corbusier has said that it was the finest executed and maintained building in the modern style. Here the entire profession was shown the kind of standard to which it is just now, 25 years later, beginning to live up.”

Philip Johnson

“The Philadelphia Savings Fund Society Building is historically significant as the first American skyscraper to reflect — in its direct statement of cantilevered floors and in its “cubistic” shapes — the influence of the so-called international style. It is esthetically outstanding for the beautiful harmony of form and space that transcends and enhances the sheer commercial utility of the building, even while expressing it.”

Donald D. Egbert

“Historically one of the earlier solutions of ‘contemporary’ form used for tall building design. Despite its age, it still holds its place among our more modern skyscrapers.”

Leopold Arnaud





Hedrich-Blessing

Monadnock Block, Chicago, 1891, Burnham and Root. (Tied for ninth)

“John Root’s Monadnock Block is a truly transitional landmark for, at the same time it represents the ultimate and final potentials of masonry construction for tall buildings, it also refines in form the new post-Victorian spirit of the times which Richardson had introduced to Chicago and which Sullivan perfected. Although its plain and geometrical form may have been suggested by economy, this building shows that Root was one of the first Chicago architects to realize the esthetic implications of the form.” **Buford Pickens**

“The original portion of this building is a paradox in that it is, on the one hand, the final, magnificent gesture and achievement of centuries old self-supporting masonry, while on the other hand, its visual and geometric design anticipates the clean direct simplicity of the contemporary in its abandonment of the trivia of eclectic stylism.” **Walter A. Taylor**

Joseph W. Molitor

Daily News Building, New York, 1930, Hood & Howells. (Tied for ninth)

“One of New York’s most impressive tall buildings. Not only beautiful as an abstract composition, but successful also as an expression of multiple-tenant occupancy (floor space rented by the sq ft); as compared, for example, with the McGraw Hill Building for single-tenant occupancy (floors occupied by departments of a single organization).” **Leopold Arnaud**



Woolworth Building, New York, 1910-13, Cass Gilbert. (Tied for twelfth)

"My first job in the United States was with Cass Gilbert where I had the privilege to work on the Woolworth Building from beginning to end. Mr. Gilbert had the genius and ability to exploit the ambition of Woolworth toward the realization of a monumental architectural creation, without precedent. There is credit due to the Chief of Design, Thomas Johnson, and, above all, to the Engineer, Gunwald Aus. When the building was up in steel it was beautiful even from the esthetic point of view of the most exacting of our times."

Antonin Raymond

"This building, which held for a short time the world championship for height of habitable structure, seems to have achieved more acclaim by the public than by the profession. It is the first skyscraper to approach the lightness of scale and expression of the bird-cage essence of the steel frame. The Woolworth with the minimal masonry protection required at that time is therefore a direct progenitor of some of our current solutions."

Walter A. Taylor

Joseph W. Molitor



Joseph W. Molitor

United Nations Secretariat, New York, 1950, W. K. Harrison & Consultants. (Tied for fourteenth)

"It seems to me that the Secretariat of the United Nations group, despite our short time perspective, deserves to join any selection of distinguished American buildings. It is most difficult to be significant on order, yet this structure was required to symbolize architecturally the vigorous magnificence of a new world-wide agreement. Simultaneously it had to house efficiently some 3400 office workers; and its design was to be the result of agreement among a group of architects appointed by various nations. That the Secretariat has met these staggering requirements with such success is surely remarkable and encouraging. For the building is monumental, practical, and beautiful in a purely 20th century manner."

Leslie Cheek, Jr.

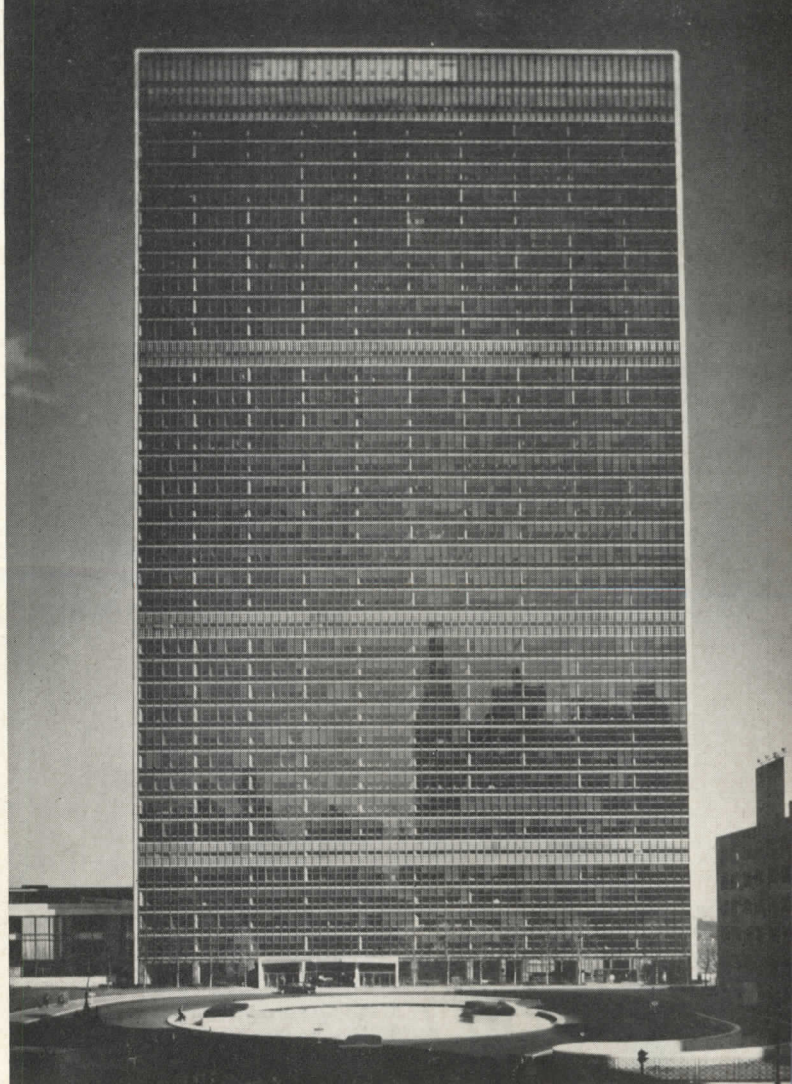



Pictorial Services, by Sturtevan

Equitable Building, Portland, 1948, Pietro Belluschi. (Sixteenth)

"As an early landmark in the development of the now ubiquitous curtain wall, Belluschi's Equitable Building of 1948 gave the first three-dimensional expression to a similar scheme which he had envisioned as early as 1943. Willis Polk's glass-walled Hallidie Building of 1918 in San Francisco preceded it by 30 years and yet little of significance came in between. Today, and in some of the harsher climates, we reduce glass areas to reduce heat loads on air conditioning systems, producing a very different appearing curtain, as in the more recent Alcoa Building, but the beauty of the Equitable is apparent in its large glass areas which merely fill the spaces between the visually defined structural members. The all-glass box may at first glance be more beautiful, but one finally seeks a visual module which can be related to the human figure and to human activity."

Alan Burnham

Photo Associates

Alcoa Building, Pittsburgh, 1952, Harrison and Abramovitz. (Eighteenth)

"Watching the Alcoa Building going up in Pittsburgh, it was difficult to avoid the speculation that here — in this light and lightly clad structure — we had reached another milestone of influence in building development. Now, after five years of vigorous and widespread curtain wall activity, not only the existence of that influence can be affirmed, but constructive and expressive values inherent in the building itself become more and more apparent."

John Knox Shear



The ARCHITECT and the ENGINEERS

By Frank L. Whitney*

IF ONE LISTENS to some current wailing, "the architect" is a lonely spirit in a world that now worships at the feet of "the engineer." As an architect who has long practiced in the industrial world, surrounded usually by engineers, I should like to inject a cheerful note into the current flow of rhetoric. I don't think the architect is "lost"; I am convinced he has a glorious opportunity.

I have thoroughly enjoyed myself in the land of engineers. And, what is perhaps more to the point, I don't seem aware of any lack of architectural stimulus, or lack of appreciation for the viewpoint of an architect.

Dean Hudnut in a recent essay † expressed concern for the survival of art in architecture when placed in the hands of the engineer-architect. He seemed not as greatly concerned with the profession of architecture as with the probability that the art of architecture would shortly become identical with the art of the structural engineer. If such an eventuality should develop, then indeed we should address our attention to the survival of architecture as a profession. For if architecture should become identical with engineering, then the chances are good that the profession would lose its identity. On the other hand if, with advance of the technical society, there remains some desire for artistic expression in building, an area of usefulness will thus be created even for those who would devote themselves solely to artistic contemplation, if that is what some architects want to do.

Yet if architecture as a profession were to confine its interest to esthetics in structures, it would inevitably lose its identity as a profession. If, as Dean Hudnut seems to fear, the architect becomes an artist without an art, then there is little hope that he can survive as an independent professional.

Now I have no quarrel with the esthetic side of architecture, but I should like to see some emphasis on

other assets of the architectural profession. Surely those architects who would defend their position in technical society on the grounds of esthetics alone are picking up their weapons at the wrong end, and pointing them in the wrong direction. If modern architecture is in truth a functional architecture, we shall expect to find our expression coming logically and inevitably from a truly functional approach, and if we start on that basis we shall find our weapons powerful.

One need only observe that while certain architects are sitting on the outside grumbling, others are busily enjoying the world of technology, hiring all the draftsmen and engineers they can steal from one another, adding new junior partners, reveling in everything but the income tax. Speak to them about engineers and they will only ask where they can find more they can hire.

My theme then is that the world of technology needs the architect's kind of thinking, wants it, uses it, demands it. The industrial world asks only that the architect be oriented to the task in hand, that he approach that task with a truly functional attitude, and exert his leadership in the "master builder" fashion. Any architect capable of leadership in industrial matters will find his talents in great demand. And when he then asserts himself on the esthetic side, the industrial world will be glad to follow his leadership there.

There has been a great deal of academic discussion of the architect's position as "master builder," and lamentations that he has lost it. Any architect who develops tendencies toward an inferiority complex might only look in the direction of Detroit, where the automotive industry has leaned heavily on architects to plan and develop its plant facilities. Do not protest that the great firms there which do automobile plants are aggregations of architects and engineers, or even that engineers may outnumber architects in those offices. The leadership in planning is predominantly architectural; the engineering specialties are highly developed and nicely regimented, but the integral thinking of the architect's kind is well in command. It is fitting to remark here that in no other manufacturing field have greater strides been made toward efficient production.

* The author, vice-president of Walter Kidde Constructors, Inc., is licensed to practice architecture in 14 states although he is now practicing as an engineer. Through the war he was doing industrial work for H. K. Ferguson Company, where his most notable project was the Corn Products Refining plant in Corpus Christi (page 156). In charge of the design for Walter Kidde, he is continuing with industrial projects, among them the new manufacturing center for Johnson & Johnson (page 158).

† "The Engineer's Aesthetics" by Joseph Hudnut, ARCHITECTURAL RECORD, Jan. 1956.

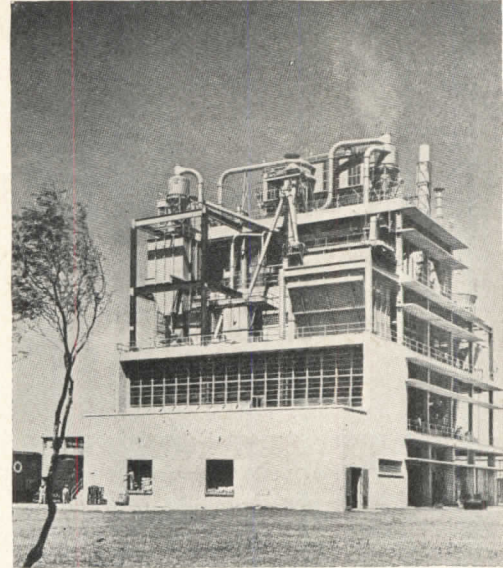

Buildings or machines. The Corn Products Refining Company's plant in Corpus Christi, Texas, is at least an illustration of what can happen when an architect puts together the separate efforts of a great group of process engineers and develops from a complex of technical requirements a unified concept of the whole. The client requested that the plant be visually stimulating; it was already obvious that the housing facility was not to compromise any process necessities, for any reason, least of all for any architectural precedents. This plant was the only industrial group included in "Postwar Architecture: USA" published some years ago by the Museum of Modern Art (see ARCHITECTURAL RECORD, Nov., 1949).

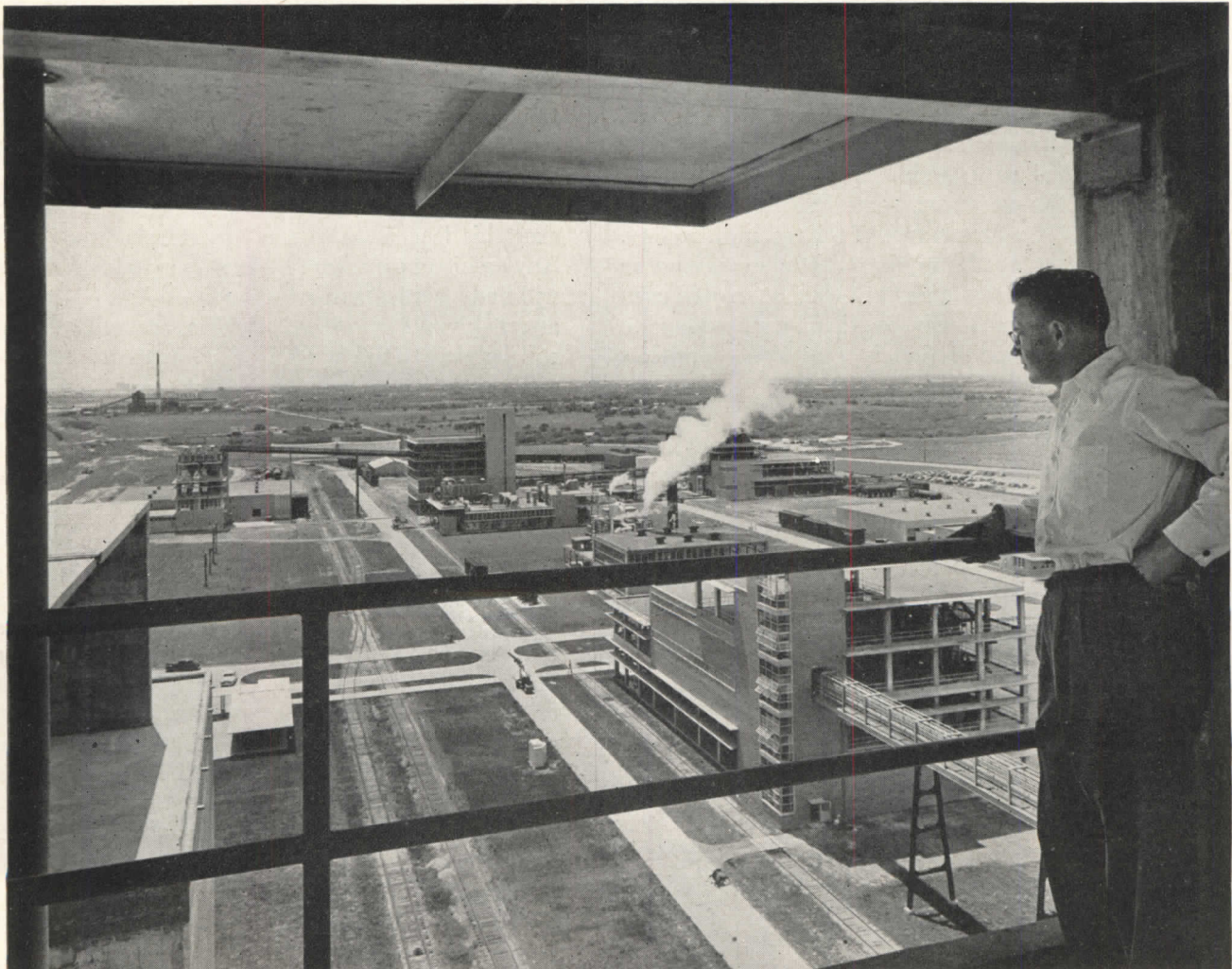

What has been done in Detroit has been done also, if not so spectacularly, in every industrial center in the country. Many architectural firms have been willing and able to fit into the world of technology, and generally speaking they are the biggest and busiest firms in the land. They plan industrial plants, industrial and scientific laboratories, office buildings, warehouses, atomic energy laboratories and installations, power plants, transportation facilities; they also find time and talent for hospitals, schools, housing. If their collective temperament does not always lead them to daring innovations in form or to individual flights of genius, well, that is an esthetic debate, and I shall leave it to Dean Hudnut.

I shall insist, however, that the technological arena holds plenty of excitement and challenge, plenty of scope for design inventiveness and imagination. The opportunity for the architect grows larger, not smaller, as he penetrates closer toward the center of technical activity.

If contact with engineers seems to dilute the architect's ardor, we cannot blame the engineer for that. I might even assert that nobody likes a good architectural result quite as well as an engineer. Engineers will fight lustily for a chance to do their own work well, and they may indulge in some hazing of tyros in their esoteric world. But the fact is they rarely exhibit temperamental tendencies, and are perfectly willing to follow capable leadership. Any architect willing and able to deal with engineers on their own grounds should find the balance of advantage on his side.

Perhaps the key word above is "willing." What I am emphasizing is that there is no question of the architect's ability to get along in technical society, providing only that he is willing to take on its obligations. If the architect (an individual architect) thinks of technology only as a new and stimulating inspiration for esthetic innovation then his talk of "function" is only idle chatter to the industrial client. If that same architect should decide to dive into technology and get wet all over, he would find the water really inviting. And he might find that as a free-style swimmer he has talents or training that most engineers would envy.

A mistake in all such discussions as this is to talk of "the architect" and compare him with "the engineer." In truth there is no such thing as "the engineer." If there is in truth any such entity as "the architect," there has been great difficulty in describing him.

It is interesting to note that the dictionary definition of architect, as well as the definition provided by the American Institute of Architects, is more akin to the ancient concept of the architect's role than to that advanced today by some of the profession's most vocal spokesmen. An architect is "a person skilled in, or a professional student of architecture; one who designs and oversees the construction of buildings." Architecture is: "1. Art or science of building, especially houses, churches, bridges, etc. . ."

The key phrase, for my purposes, is the 'art or science

of building." The first definition for "art" is: "skill in performance, acquired by experience, study or observation; knack."

It is my thesis that the use of the word "art" in the definition is not to mean that the basis for architecture is an esthetic one. Thus the architect in years gone by took his professional status more from the fact that he had made building a profession, through his specialized knowledge, than that his was an art in the same sense that sculpture, painting or music is an art.

Even the more modern A.I.A. definition of the architect fails to recognize esthetics either as a qualification for or an ingredient in (which certainly it should be when in proper focus) the practice of architecture. Here is the A.I.A. definition: "A person with a knowledge of and skilled in the planning and design of construction and its environment, particularly in regard to its suitability to human utilization; one authorized to use the title 'architect' by virtue of having complied with pertinent state or territorial regulations; one having technical training and ability to supervise construction."

The function of the "master builder" is a logical function now as in the past — hundreds or thousands of years ago. There is need for someone to see a construction job in its entirety, rather than in piecemeal segments. In fact, the need is more acute today than ever before, if only for the reason that scope has been enlarged so broadly.

In today's technological race for survival, there has been a tendency, consciously or unconsciously, to make a semi-deity of the engineer. The application of engineering principles is looked to in our society to provide every solution to every problem. According to popular belief, the engineer appears as the well-rounded individual with professional training in all that is complex, the fount from which springs the solution to every technical problem.

But an engineer is a specialist. The nearer he approaches the zenith of his profession, the more specialized he becomes. The graduate mechanical engineer has a general mechanical knowledge when he begins his career. As he advances, his usual pattern is to concentrate his efforts on a more limited field: thus from his broad field in mechanical engineering, he becomes a designer of process piping systems. A next logical advancement is that he becomes a specialist in the design of instrumentation or controls. Always it should be remembered that the engineering profession is so constituted, with its immense attention to minute detail, that the engineer who moves forward does so in a rather well-defined and limited field.

It is incongruous therefore to say that the architect must work with the engineer. Actually, he and his group must work with a group of engineers — conceivably as many as a dozen different individuals. Only in the rarest cases would an engineer possess the qualifications that would enable him to work in more than a single engineering discipline. More likely, the architect will find himself working with a civil engineer,

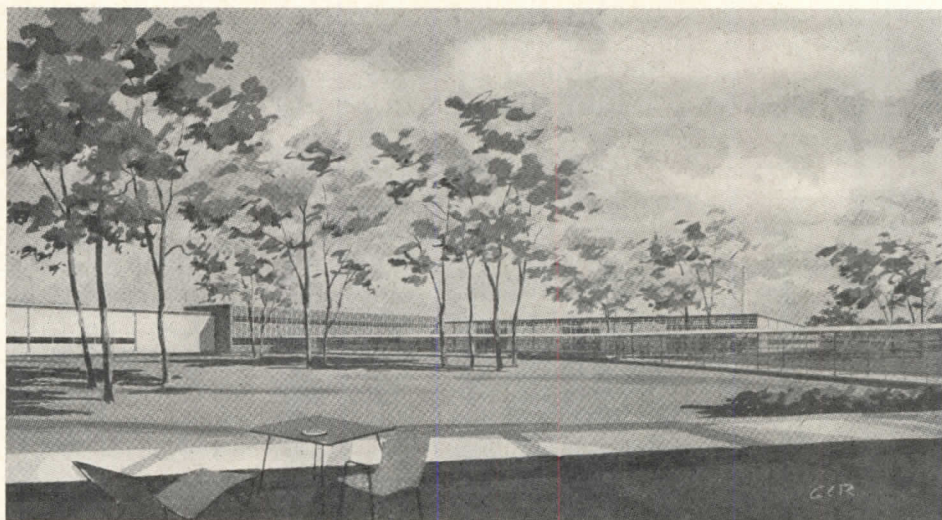
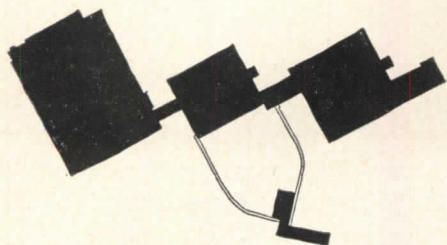

The new manufacturing center for Johnson & Johnson at North Brunswick, N. J. (ARCHITECTURAL RECORD, Feb., 1956), is a current project of Waller Kidde Constructors, Inc. Here study of manufacturing needs and materials handling problems changed what was originally conceived as a huge square pancake into a series of individual buildings, linked together by factory office units, joined also by a drag-line conveyor. The total concept theory here contributed several operating advantages — efficiency, flexibility, expansibility, autonomy of divisions, comprehensible scale — plus a happier esthetic result.

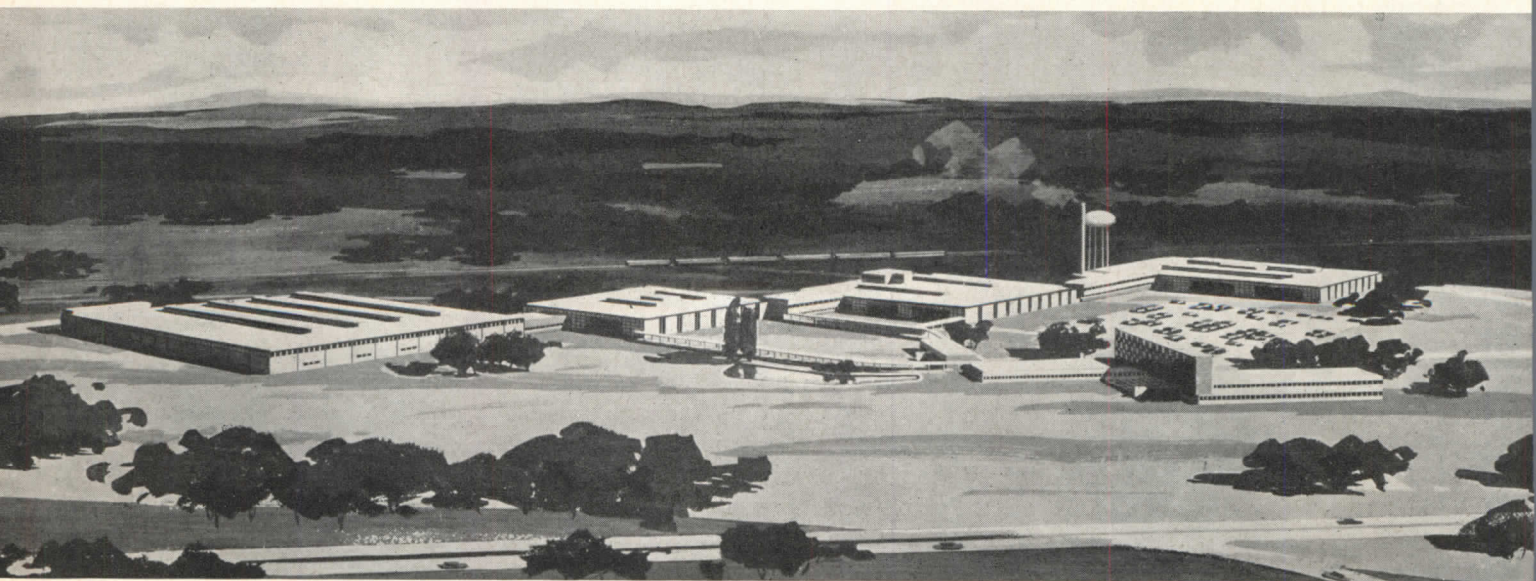

a structural engineer, a mechanical engineer and an electrical engineer on even the simplest building job. On a more complex assignment, he is likely to encounter chemical engineers and such other specialists as engineers whose principal activity is heat exchange, instrumentation, or electronics. He may even encounter engineers with such obviously limited fields as vibration or corrosion.

There are of course engineers, many of them, who have developed their activities along administrative lines, and are doing an outstanding job of coordinating the efforts of the various engineering functions. The point here is that if this administrative or coordinating activity is in connection with the development of a building program, the engineer, regardless of the nature of the diploma or professional license hanging on his wall, is in truth performing the functions of architecture.

If we were to let the engineer assume the technical and, consequently, the dominating aspects of architecture, we would be faced with another dilemma. We should have to find the proper engineer. Mr. Hudnut suggests the structural engineer. The engineering societies would not agree to this. With the increasing complexities of mechanical equipment and mechanical services now going into our present-day structures, we can be certain that the mechanical engineer would insist upon having his say. And with the advance of electronics and its influence on our daily lives, new voices are bound to be heard.

Thus it is obvious that we have been using the word "engineer" loosely, for there is no single engineering science which can within itself pick up all the necessary aspects of a structure and coordinate them into a building entity. Basically, the engineering sciences do not interest themselves in entities or esthetics. The coordination of the esthetic concept of a structure with the application of scientific principles is not, nor ever has been, the interest of any of the engineering societies.

There is no single branch of the engineering professions which is presently devoted to fundamental planning. One need only look at the various curricula of the many engineering schools to substantiate this fact. The industrial engineer, for example, is trained to the end that he may lay out and develop manufacturing and production units. Yet a glance at any of the textbooks used in his education will demonstrate how little consideration is given to a fundamental economic relationship of structure and equipment. Any assumption that the engineering mind has suddenly become well-rounded is entirely false. There is no intent here to disparage the engineering mind. Any competent professional of any engineering science will agree that many of the various aspects of gracious living are somewhat neglected in the acquisition of a technical education. Conversely, it seems this also may be true of architects.

Thus it would appear that within the professional practice of architecture lies the opportunity of the coordination of all the sciences and skills required in

the development of a piece of architecture. Why, then, should the architect relinquish so many of the technical and scientific aspects of his profession when he of all men must know that one cannot successfully separate the architectural design of a structure from its technical and engineering aspects?

"If the architect is to survive," he must again assert his leadership in all those phases which he has with such seeming freedom relinquished to the engineer. He must rekindle an interest and understanding of the sciences.

Actually, there is nothing foreign or incompatible with the desire for scientific interest and the practice of architecture. One can be an artist and still know arithmetic, and many of our outstanding architects are also outstanding engineers.

There have always been in the past, and without question will continue to be, many outstanding designers who, by gifted imagination, may find clients, or patrons if you will, who will not confine them to economic limitations, and with extravagance make limited exploration into the nature of materials. However, the hard core of the profession must design within an economic framework, and because of this must necessarily evolve a thorough technical background.

Structural steel has been utilized as a basic building material in this nation for about 50 years. Yet it has been only in the past several years that the architect apparently through repeated use has been able to utilize it as a medium of design. The architect is only now attacking steel as an element of design, and we have already moved into the new era which may some day be called the "Chemical Age."

At the present, its dominating leader is the chemical engineer. He is designing plastic buttons that look and feel almost like bone buttons. He is designing synthetic fabrics that are serviceable and in many respects better than the existing textiles and imitate them in appearance. He has designed plastic beams that are lighter than steel beams and almost as strong, and they look like steel beams. He is developing panels with the use of chemicals which are an exceptionally good imitation of glass panels, and in many cases lighter and more serviceable.

He is not designing a plastic structure. He can't. To do this he must return to the basic principles of architectural design and these do not lie in the area of his knowledge. If the history of steel design is any criterion, possibly within the next 50 years will evolve the design of the chemical structure. It can come sooner, but only if the professional architect will reactivate his interest in scientific application and become in fact a chemical engineer as well as an architect.

Each day brings new and wider scientific horizons. Each one presents a new problem for the architect and a new area of exploration, and in all this technical welter the architect must reassert himself as a technical leader as well as the guardian of our cultural and esthetic character.

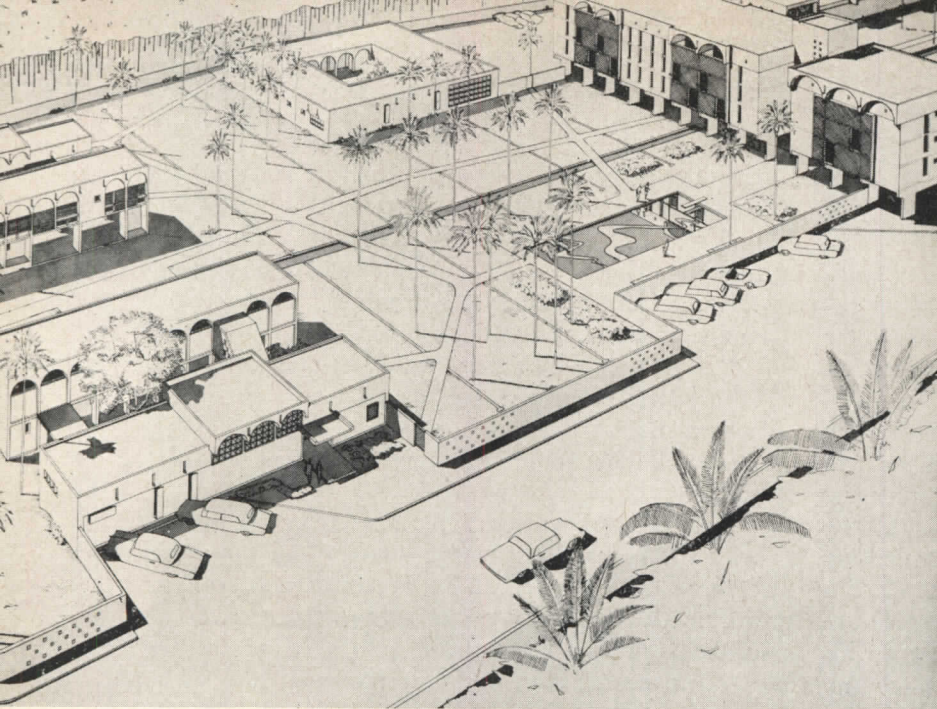

RIGHT:

*Supplemental Office Building
Manila, P. I.*

*Alfred L. Aydelott & Associates,
Architects*

This supplemental office building will be located to the right of the present Embassy office building on Dewey Boulevard. The first floor, built around a garden court, will be of native stone. The central block rising three additional floors will be of reinforced concrete. The exterior walls of floor to ceiling glass windows will be protected from the sun by a patterned screen grid of cast concrete. The building will be completely air conditioned. It will contain some 70,000 square feet of net office space.

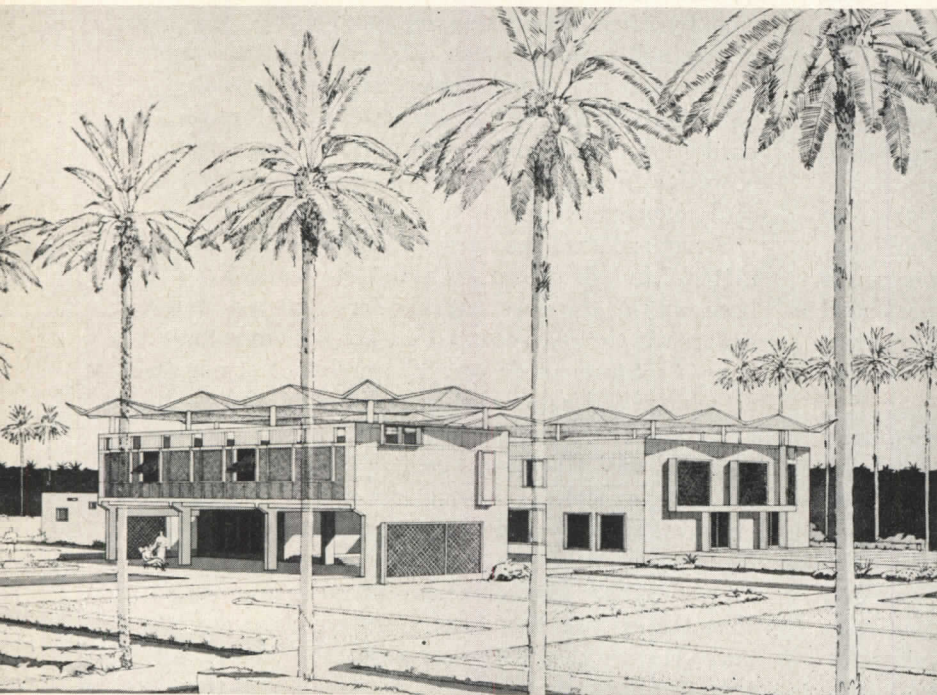

LEFT:

*Staff Housing
Embassy Residence
Office Building
Bagdad, Iraq*

Jose Luis Sert, Architect

The Department's program in Bagdad consists of the gradual development of a new property in the vicinity of the royal palace and bounded on one side by the Tigris River. The buildings currently being planned are a residence for the Ambassador, an embassy office building, and apartments for the staff.

The site is a long trapezoid of land about 1,500 feet in length and 300 in width with the short sides on the river and the principal avenue of approach. The office building is planned for location on the avenue, and the Ambassador's residence on the opposite river end. The staff apartments and other buildings will eventually occupy the middle ground.

The architecture is based largely on sun protection devices which have been skillfully used to create a style of their own. Within a structural scheme of poured and precast concrete, glazed tile and teak wood have been blended to produce a whole ensemble of interesting shapes and colors. Both old forms and new have been exploited fully, and the result is a bold functional architecture that keeps the mark of its locality.

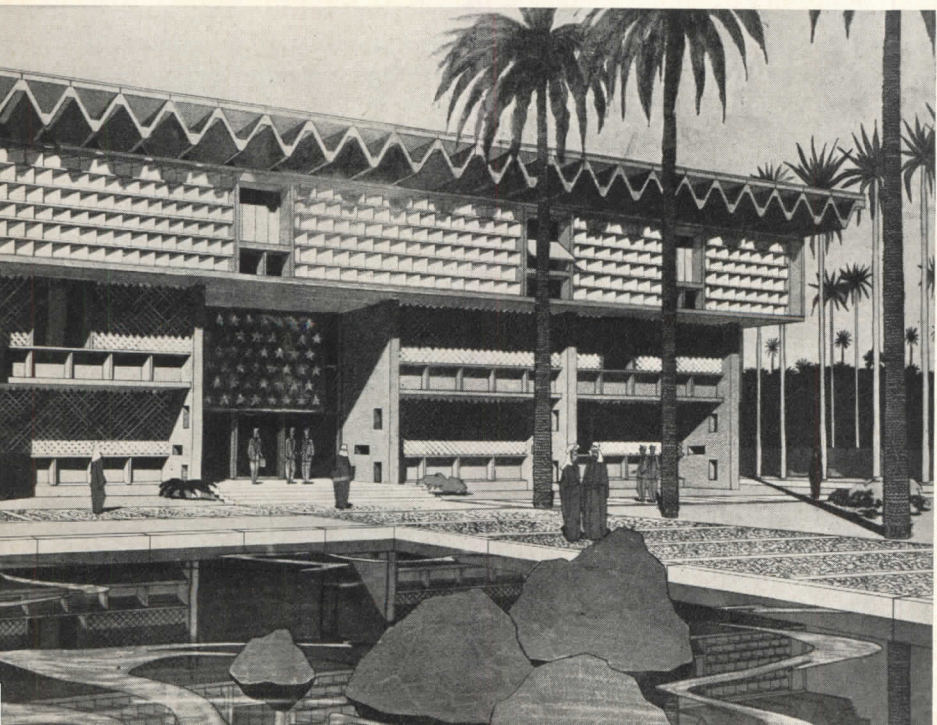



SECOND GROUP OF AMERICAN EMBASSY BUILDINGS

RARELY HAVE AMERICAN ARCHITECTS been challenged as in the program of building embassies abroad by the State Department. Architects commissioned to plan the various buildings are asked for designs which will (1) represent American architecture abroad, and (2) adapt themselves to local conditions and cultures so deftly that they are welcomed, not criticized, by their hosts. Architecture is asked to undertake a highly important diplomatic mission.

The designs here shown are a second group (first group, *ARCHITECTURAL RECORD*, May, 1955) in a program generally characterized as remarkably successful. The device of an architectural advisory panel, assisting the Foreign Buildings Operation of the State Depart-

ment in the selection of architects and in reviewing their designs, has led to good communication between the architectural fraternity and officialdom both in Washington and abroad.

At the beginning of the program the panel consisted of Pietro Belluschi, F.A.I.A., Dean of the School of Architecture and Planning, M.I.T., Henry Shepley, F.A.I.A., Shepley, Bulfinch, Richardson & Abbott, Boston; and Ralph Walker, F.A.I.A., Voorhees, Walker, Smith & Smith, New York; and chairman Col. Harry A. McBride, former Assistant Secretary of State. In a plan of rotation of panel members, Mr. Walker has been replaced by Richard M. Bennett, F.A.I.A., Loeb, Schlossman & Bennett, Chicago.

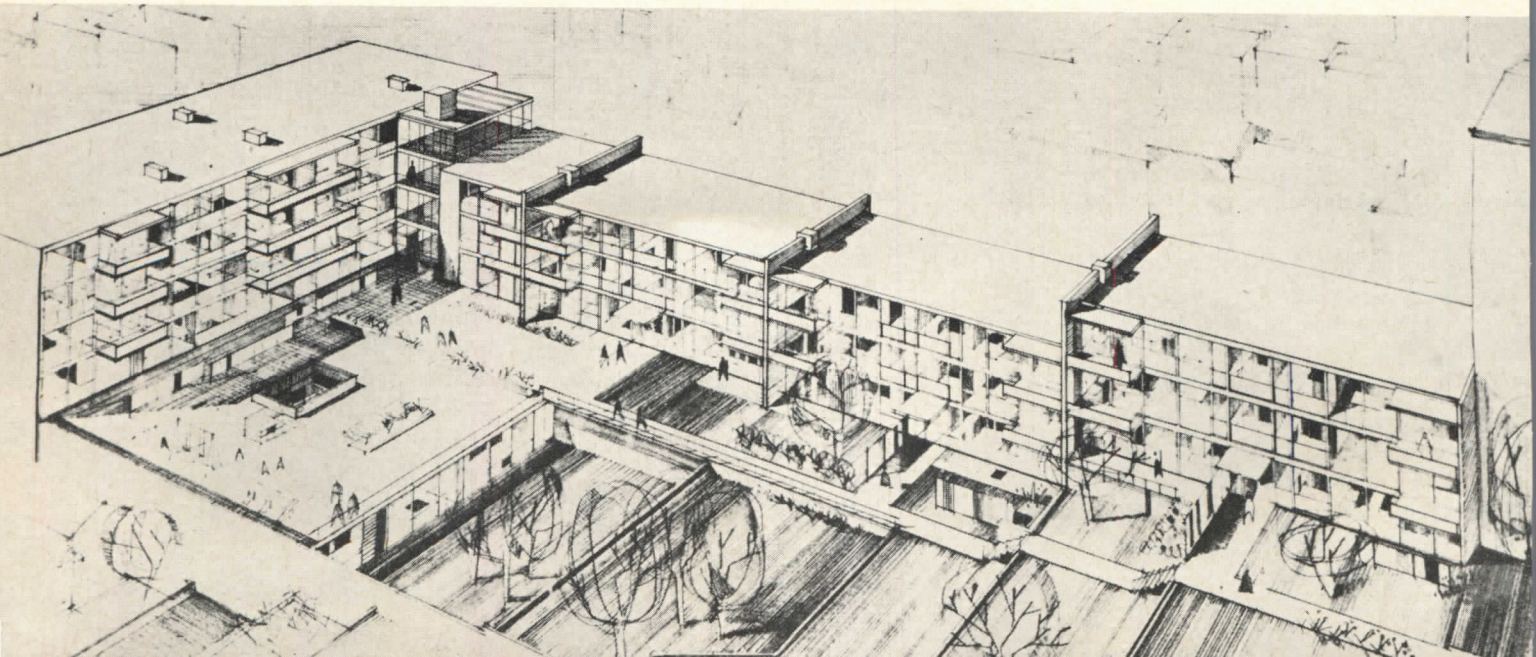
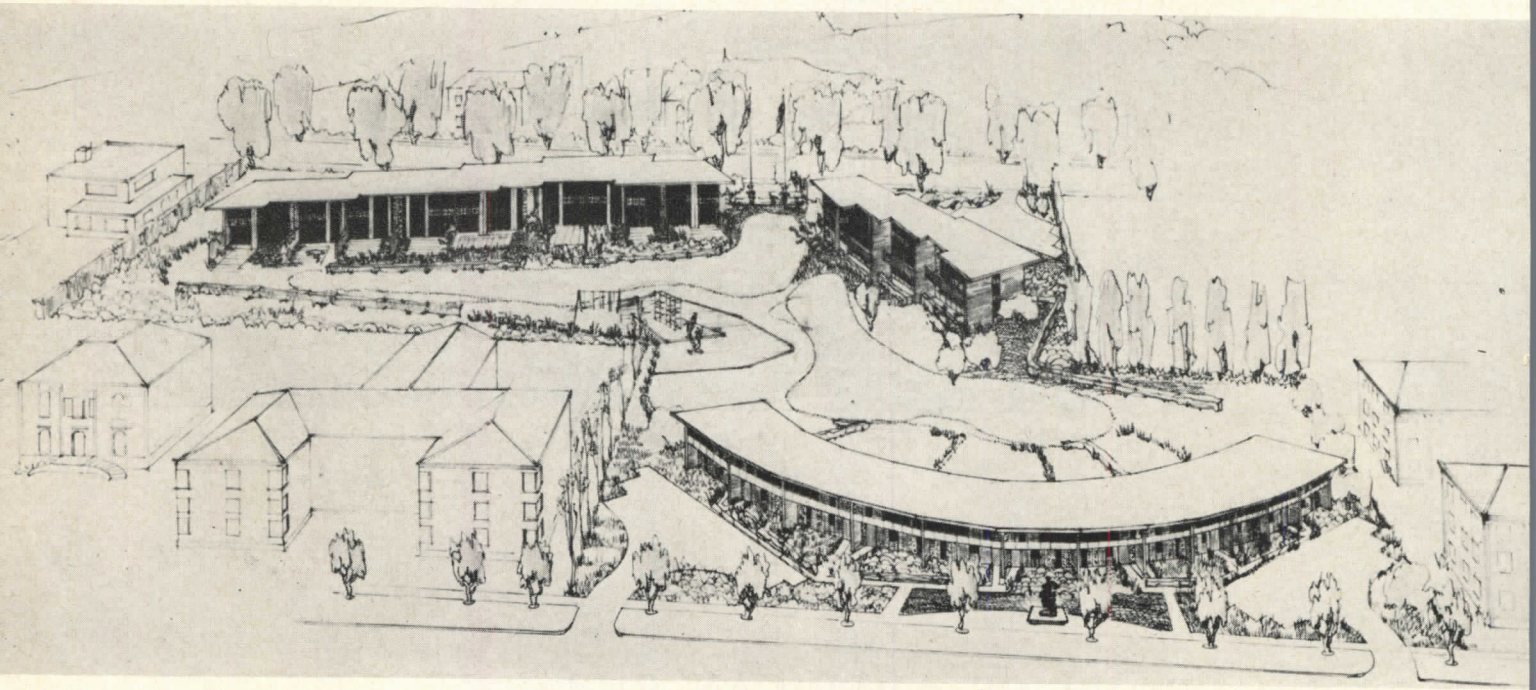

**Embassy Residence and Staff Quarters
Seoul, Korea**

Earnest J. Kump, Architect

The design of the new building recalls Korean precedents, but it is so planned as to permit economical construction in a day when Korea has lost many of its old skills and crafts.

The structure is of reinforced concrete laid out on a modular basis, with walls faced in colored tile and the deeply projecting roof covered with like material. The representational rooms are located in a one story wing connected to the main house which is the family's private residence. A portion of the old residence will remain as a separate part of the architectural composition, and be used for guests.

**Staff Housing
Vienna, Austria**

Henry Hill, Architect

Staff housing in Vienna will consist of two-story, garden type units of one, two and three bedrooms. The units are staggered and arranged in groups around an interior green space.

The structures are concrete with a marked vertical emphasis on mullion supports to give a visual two-story scale to the horizontal masses. Another exterior feature is the decorative use of colored tile inserts in spandrel facings, and in panels in which windows do not occur.

**Staff Housing
Belgrade, Yugoslavia**

Carl Koch, Architect

The buildings will be of reinforced concrete faced with natural or precast stone. This apartment house will be built around an interior garden fronting on two sides with playground facilities for children. Balconies for each apartment will face this garden. A built-in garage and storehouse for the use of Embassy personnel will also be included. As it is built on a sloping street the height of the structure will vary from three to six floors.

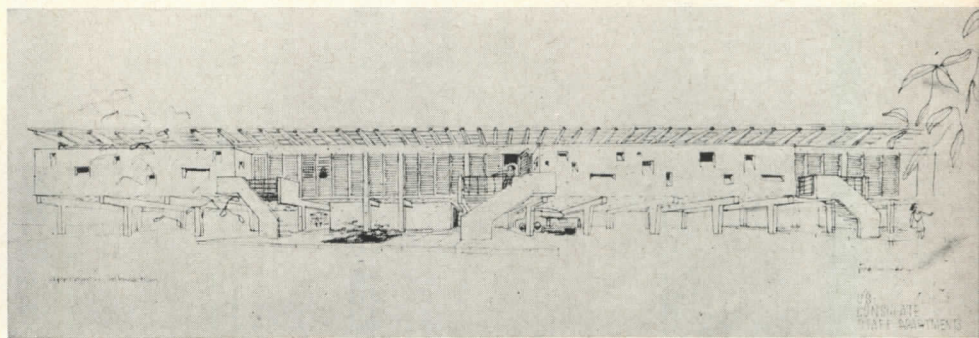
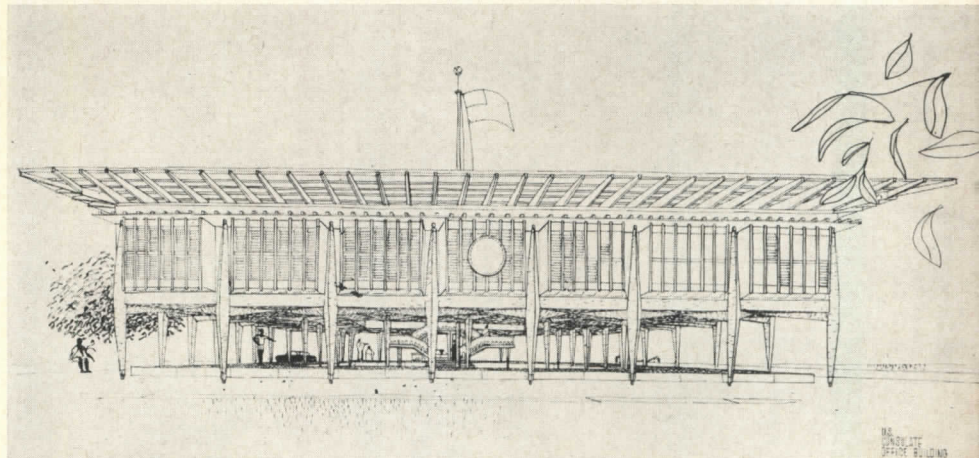

**Office Building and Staff Housing
Accra, Gold Coast**

Harry Weese, Architect

The office building will be set in a one and a half acre plot. It is to be of reinforced concrete raised on stilts around a garden with offices on the second floor. It will not be air conditioned, but the four sides of the building are to be faced with screened wooden jalousies and further protected from the sun by a large roof overhang. The net office space is over 8,000 square feet in area including a gallery and reception room.

The staff housing will be located on 7.39 acres, in two buildings having two one-bedroom, four two-bedroom, and two three-bedroom apartments, making eight units altogether. Later three houses for Consulate officers will be added. Buildings will be of reinforced concrete raised on stilts with open car parking underneath. Exterior walls will be of screened wooden jalousies to catch prevailing breezes. Large overhanging roofs will protect against the sun and rain. The insulated ceilings will be dropped to create a ventilated space under the roof.

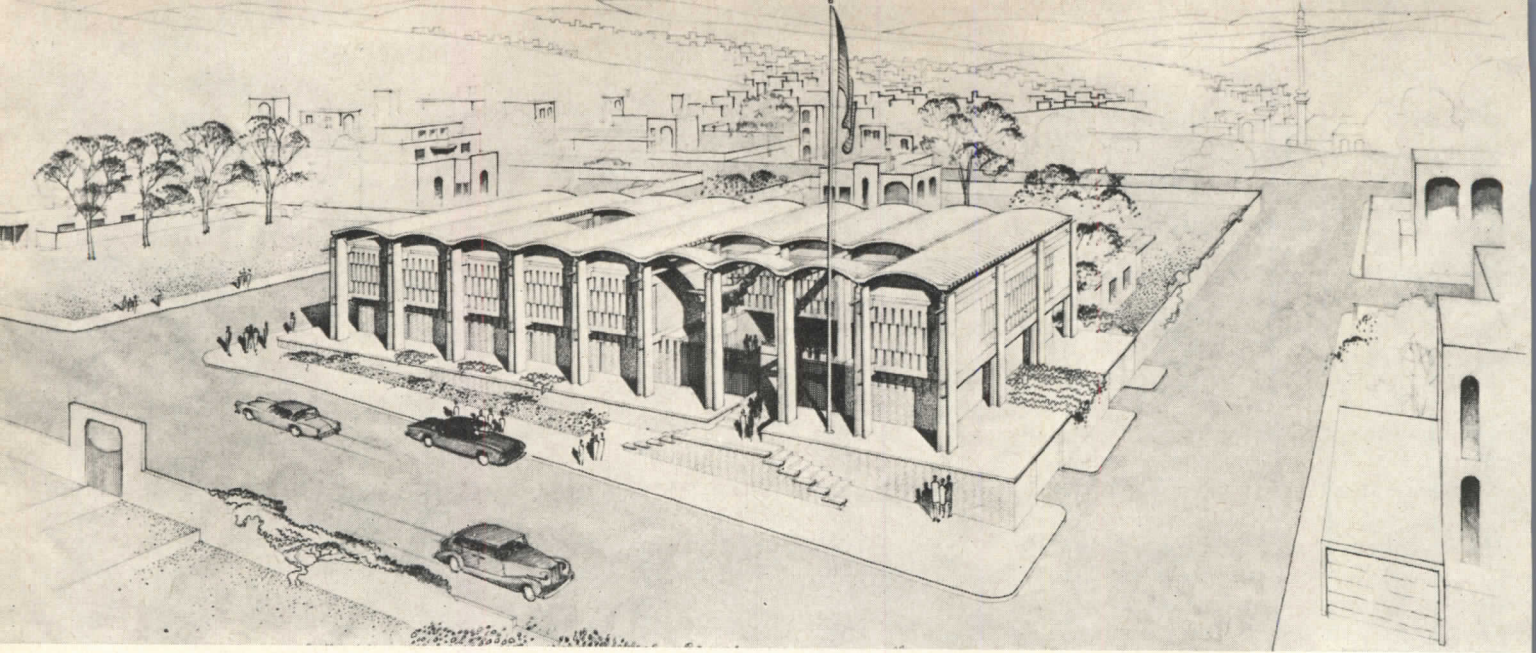

*Office Building
Amman, Jordan*

Paul Rudolph, Architect

The climate does not require air conditioning but the architect has taken pains to provide sun protection for roof and walls. The former consists of a complete roof covering by means of spaced, concrete ribs which are beam-supported on full two-story columns. The latter, wall protection, is accomplished by a cavity wall approximately 20 inches thick.

These two features combine into a unified piece of architectural design; the open roof and its columns providing a disciplined form under which the more irregular mass of the building creates an interesting pattern of masonry.

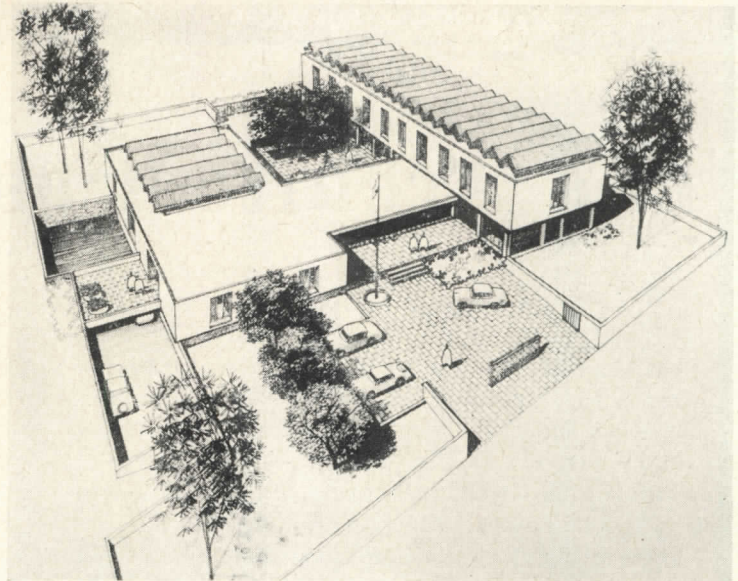

*Office Building
Quito, Ecuador*

Vincent G. Kling, Architect

The proposed U. S. Embassy office building will house the business activities of the Embassy, U.S.I.A., and a portion of the Defense activities. The building will be constructed, in the majority, of native materials and will be a reinforced concrete and anti-earthquake structural system. Although located on the equator, a heating system will be required because of the sudden changes of temperature. The present scheme provides for approximately 30,000 square feet.

*Office Building
Oslo, Norway*

Eero Saarinen, Architect

The building is triangular in plan and virtually occupies the whole of the property. Perimeter offices surround an enclosed interior court. A special feature is the precast exterior wall which is load-bearing at each floor and obviates the use of columns. This permits treatment of the elevations as an over-all pattern of windows, mullions and spandrels.

The exterior facing will be in effect a dark granite chip terrazzo, and the windows double glass casements made of teak wood and painted white.

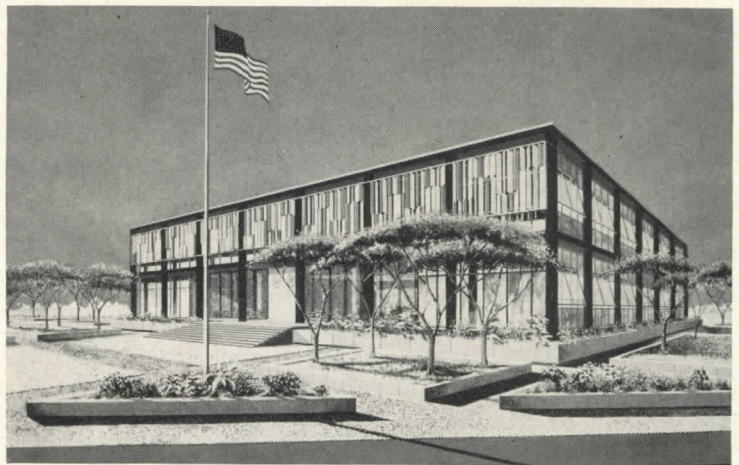

*Office Building
Port-au-Prince, Haiti*

Don Hatch, Architect

The Embassy office building will be located on a triangular site on the present exposition grounds and will overlook the bay. The building will be partially air conditioned with the use of colored aluminum vertical fins and heat resisting glass to reduce the glare of the sun, and will be oriented so as to take full advantage of the ocean breezes. Extensive piling will have to be used as the ground water is approximately two feet below the sidewalk level during the rainy season.

*Office Building
Karachi, Pakistan*

*Richard J. Neutra, Robert E. Alexander,
Architects*

The proposed U. S. Embassy office building will house the business activities of the Embassy, U.S.I.A., I.C.A., and the Defense Attaches, and will be a permanent fireproof building, completely air conditioned.

The office building will contain approximately 69,000 gross square feet, including a garage and equipment wing. A warehouse of 16,000 square feet will also be constructed at the rear to be used in connection with U.S.I.A.

The Architect as Universal Man

IN DUSSELDORF a naked figure of a man realistically modelled by George Kolbe stands incongruously in front of an office building designed by Helmut Henrich and Hans Heuser. The building is not particularly severe — its façade is masked by balconies that are decorative in effect though no doubt functionally justifiable.

There are many other examples in other countries and architecture's last concession to figurative art — the Henry Moore groups outside the Hertfordshire schools is the typical example from my own country. Sometimes a figure will be clamped to a blank wall, like Lipchitz's bronze on the side of the Ministry of Education and Health in Rio de Janeiro, but such an arbitrary juxtaposition of sculpture and architecture serves only to emphasize the totally distinct plastic conceptions that the two arts now represent. Even the Moore screen on the Time-Life building in London, though it represents a solution reached by architect and sculptor in association, and though the sculptures have been "denaturalized" to conform better with a functional building, nevertheless has the air of a concession: the architecture *admits* the sculpture, swallows it up without digesting it. The character of the building would not change if the sculpture were to be replaced by a blank wall.

Architecture was the parent of sculpture — indeed, the earliest architecture *is* sculpture, and even the primitive African hut of our own time is still a work-of-art to live in. Architecture was perhaps the parent of all the plastic arts; certainly the patron. The paleolithic cave was a decorated temple, and even the art of writing may have been first conceived as an inscription on a monument. We must think of the archaic temple as a vast Christmas tree, which is then gradually stripped of the votive works of art that hang on it. But we must also think of the architect as a Father Christmas, capable of distributing these gifts.

The specialization of the arts, like the division of labour, is a process which, as we look back on the history of civilization, seems inevitable. An art like painting would never have become so various and so expressive if it had remained an adjunct of architecture. Nevertheless, it is useful to remind ourselves how comparatively recently that independence was established. There was no "free" painting before the fifteenth century, and no "free sculpture" before Donatello. Indeed, a unitary conception of art was normal until the beginning of the Industrial Age, and as industrial processes have developed in the direction of mass production, so artistic processes have developed in the direction of isolation

and individualism. The *artist* once signified a *man of total plastic sensibility*, just as the artisan was a *man of total practical capability*. Music and poetry were not arts in this sense, but rather accomplishments, modes of communication. Plato distinguished the arts which are based on practical skill (*techne*) from rhetoric, which is a mental exercise.

That this condition of separatism is fatal to the arts is shown in various ways. There is, in the first place, no "monumental" achievement in the contemporary arts; and many of our individualistic painters, perhaps in some measure aware of that failure to function in this total sense have, after a period of restless experimentation, expressed their frustration in forms of art that are essentially private. In this way the plastic arts seem to aspire to the condition of music and poetry — that is, become voices, modes of subjective communication between individual and individual, or between individual and coterie. The monument, on the other hand, is always an autonomous object — a transfusion of personality into a timeless and impersonal construction. An Egyptian pyramid, or the Temple of Somnathpur, or the Parthenon, or a Gothic cathedral, does not "express a personality," or convey a message. We can, it is true, read "serenity" into Greek architecture, or "transcendentalism" into Gothic architecture, but such exercises have nothing to do with the objective reality of the building as such: and in any case, serenity and transcendentalism are universal concepts rather than sensuous reactions.

The quality that concerns me for the moment, however, is the complexity of such monuments — their esemplastic power as Coleridge used to call it — the reduction of a multiplicity of purposes to a unity of effect. This quality may sometimes be due to some kind of collective intuition — the working of several minds to a common conception: the spontaneous overflow of a group consciousness. It is difficult to explain the Gothic cathedrals on any other supposition. But more usually the unity of effect is due to a single controlling mind, that of the master-builder, a man who was capable of conceiving the monument, not as a shell to be adorned (or as a Christmas tree to be "decorated:") but as an organism, every particular cell of which is morphologically and functionally related to the whole.

The last metaphor is misleading if it suggests that every function is utilitarian (in biology or in architecture). Nineteenth century materialism left us with a very narrow conception of utility — the useful was anything that promoted the health, wealth or comfort

by Herbert Read

of mankind — in short, happiness. Those nations that have already secured such blessings (such as the Americans and the Swiss) have discovered that there is something missing — an intangible ethos, wonder, “worship,” glory, or simply beauty. We begin to suspect that this intangible something is just as necessary for life — for life in the strict biological sense — as comfort or wealth: that it is one of the conditions of complete health. Slowly we have become aware of the presence of a psychosomatic equilibrium in life itself, as well as in the human body. Beauty after all is not an elegant addition to the good life: it is the tone or temper of all that actually makes life “good.” It is the style of life when life is positive, expansive, affirmative.

Architecture, which is so intimately concerned with the basic activities of human life (as providing the necessary shelter — the biological shell for a sensitive organism) is thus required to be always affirmative in this sense — stylistically *vital*. But the solution of a practical problem is not stylistically vital in this sense. What moves us, inspires us, incites us is not satisfaction, but curiosity, wonder, endless search for an ideal perfection. Such ideal perfection cannot be limited by necessity or contingency (by functional needs); it must of necessity ignore and transcend the practical.

Fiedler, and probably Semper and Hegel before him, pointed out that Greek architecture (which they assumed to be the highest point of architectonic genius) had never been concerned with practical needs of technical solutions. “The Greeks invented nothing in their architecture, but developed only that which they received, and with such a clear awareness that they necessarily arrived at a result in which everything directly reminiscent of the demands of needs and wants, of the nature of the material need and of the conditions of construction, had disappeared except for faint echoes.”¹ The Greek temple is a pure expression of form, a monument dedicated to ideal beauty and to nothing else. In this sense Fiedler thought it far superior to the Gothic cathedral, which was inspired by practical needs — “the pointed arch was only a technical development; artistically it was an evasion. In a struggle with practical needs man was not attempting to find a higher expression of form and did not hesitate to mutilate the form in order to devise a solution to a practical problem, and thereby renounce any artistic progress from the beginning.” One may protest that nevertheless a

higher expression of form did emerge on the basis of this technical development: that at Amiens and Lincoln the intellect has elaborated a practical device into a free form. But Fiedler has made his point — and it is a good one: architecture is a formal and not a technical development: it is a development of the relatively chaotic and the pragmatic towards ideal form, ideal order: a development which takes part in the aesthetic consciousness of man and not as the solution of a practical problem.

I have already hinted at a distinction between an aesthetic consciousness determined by time-sense (music and poetry) and an aesthetic consciousness determined by space-sense (the plastic arts). There may be intercommunications, but I am more concerned with the unity of plastic aesthetics. I mean that *a priori* the sensibility of the plastic artist should be expressible in any and all the plastic arts: that the segregation of architect, sculptor, painter and craftsman (woodworker, silversmith, weaver, etc.) is merely a *division of consciousness* and has had altogether deplorable effects on the development of the arts, above all, of architecture.

We know that the great monuments of Greece and of the Renaissance were, at their best, conceived in their entirety by a single clear intellect, and we marvel at the capacity of an individual like Pheidias, or Brunelleschi, or Bramante, or Michelangelo or Wren. But what should cause us more surprise is the complexity of an architectural enterprise that leaves the structure to engineers or builders who work by calculation and not by visual intuition; that then expects sculptors and painters to adapt their personal vision (or fragments thereof) to a technical formula; and expects from this conjunction of compromised talents a work of art!

To look at modern architecture from this point of view results in a new valuation. It does not necessarily mean a general condemnation of all functional architecture. On the contrary, we may find among the strictly functional monuments of our time a few that carry technical means to a new clarity of form — that repeat the Greek achievement by intellectualizing all the material elements — the materials are, as it were, dematerialized and what remains is a form as pure as the Pyramids. I would say that certain buildings and projects by Mies van der Rohe approach this condition. It is true that this architect has always been in the past associated with an anti-formal conception of architecture. “We refuse to recognize problems of form, but only problems of building. . . . Form, by itself, does not exist — Form as an aim is formalism, and that we

¹ Conrad Fiedler: *On the Nature and History of Architecture, 1878. Trans. Carolyn Reading. Privately printed by Victor Hammer at the Transylvania University, Lexington, Kentucky.*

reject" (1923). But there are later statements which are not so positive — e.g.: "My attack is not against form, but against form as an *end in itself*. . . . Only what has intensity of life can have intensity of form. . . . We should judge not so much by the results as by the creative process. . . . Life is what is decisive for us. In all its plenitude and in its spiritual and material relations" (Letter to Dr. Riezler, 1927).

"Let us not give undue importance to mechanization and standardization. . . . For what is right and significant for any era — including the new era — is this: to give the spirit the opportunity for existence" (1930). It is true that he continues to oppose "the idealistic principle of order" to "the organic principle of order" (Inaugural Address of 1938), but the distinction is almost verbal, for the organic principle is defined as "a means of achieving the successful relationship of the parts to each other and to the whole," which was the Greek ideal of form. He can repeat "the profound words of St. Augustine: Beauty is the splendor of Truth." His latest work (1950) is:

"Wherever technology reaches its real fulfillment, it transcends into architecture. It is true that architecture depends on facts, but its real field of activity is the realm of significance."

I do not assemble these quotations to give a particular emphasis to statements that might seem to imply a mystical outlook in Mies van der Rohe: his buildings are a sufficient refutation of any suggestion that architecture should be used as a language expressive of states of mind or emotion. Architecture is always regarded as "the crystallization of its inner structure, the slow unfolding of its form." But it is distinct from technology, though dependent on it. "Our real hope is that they (architecture and technology) grow together, that some day the one be the expression of the other. . . ." That is what happened in Greek architecture: the technology was taken over, nothing was invented, but gradually proportions were refined, forms were defined, until the fusion was complete: the ideal form was a purification, an amplification of the organic structure.

I believe such a fusion has taken place in Mies's work in Chicago — the Minerals and Metals Research Building of 1942–43, the Alumni Memorial Hall of 1945–46, the Apartment Houses at 860 Lake Shore Drive (1951), the Chapel for the Illinois Institute of Technology (1952), and the project for the Architecture and Design Building (1952). To these we may now add the project for the National Theatre, Mannheim (1953). But what we must immediately note about such buildings is that they are "undecorated" — no sculptural groups on the façade or in front — no Kolbe declaring its naked humanity on the porch — no "works" by individualistic artists of any kind. The details that may be called decorative on all these buildings are determined by the architect himself, and are usually a decorative use of normal structural materials — "structural elements are revealed with decorative effect," as Philip Johnson neatly expresses it. The Lake Shore Drive buildings have walls of glass which might have

been left with a smooth surface, as they are in the Lever building in New York; but Mies has welded vertical steel I-beams which may serve as wind-braces or mullions, but whose real function is to project as decorative elements. The decorative use of material is more obvious in the Mannheim Theatre project, for the building is shown resting on a plinth of highly dramatic marble.

Mies van der Rohe, so far as I know, practises no art other than architecture, though he is a connoisseur of painting and has a fine collection of the works of his friend Paul Klee. Le Corbusier, to pass to another significant architect of our time, is a painter of considerable achievement, a sculptor in wood and concrete, a designer of tapestry and furniture, and a mosaicist. He is a universal artist of the Renaissance type, like Leonardo or Alberti. He does not hesitate to combine his various talents in a single architectural conception, but in general he has kept his versatility in the background, perhaps realizing that there is a contradiction between the personalist tendency of the painting and sculpture, for example, and the impersonal values of the architecture. A painting or a mosaic in a Corbusier building is by another artist — Charles Edouard Jeanneret-Gris, in fact. Nevertheless, if we look at Le Corbusier's achievement in its wider context — as town-planning, *la Ville radieuse*, a way of life — we see that the marginal decor is of no great significance. It can be swallowed up as a play activity — something taking place *within* the architecture — but it does not fuse with the architecture, and is not a formal purification of the underlying technology. The architecture is a separate conception and a complete unity without the decor. The architecture expresses an intolerance of the detached work of art that extends to the architect's own personalist creations.

These two examples will serve to present the problem. To take further examples — Frank Lloyd Wright, or Gropius, Oscar Niemeyer or Pier Luigi Nervi, Aalto or Breuer — would not resolve the problem, which is basically a revolt against personalist art and an attempt to find in architecture a new universal art: an art represented proto-typically by Greek architecture and later by Byzantine architecture. The Parthenon and Hagia Sophia are the paradigmatic types, the unification of the arts in the monument, and this unification is not achieved by change, or even by conscious coordination: it is the all-inclusive concept of a master mind, a master-builder. We do not know what kind of future lies beyond the threat of nuclear weapons — none at all if the threat becomes a reality and radiation falls like a fatal rain on all mankind. But if there is to be a constructive future, we may be sure that the transition from our present state of culture fragmentation can only be effected through a new conception of the architect: the architect as a comprehensive man of intelligence, a single source of unity and universality. From that new concentration of formal values the arts might once more derive a common style and an organic vitality.

VACATION HOUSES





CALIFORNIA BEACH HOUSE EMPHASIZES VIEW

House in Malibu, Calif.

Henry Robert Harrison, Architect

Eckbo, Royston & Williams, Landscape Architects

A SUPERB OCEAN VIEW was the theme around which this house was planned. The site was difficult: less than 20 ft deep at the western end, it sloped steeply down toward the ocean, dropping over 15 ft in 20 ft. House, garage, patios and deck all had to be placed on a wood piling foundation similar to that used for piers, and at high tide the house is literally over the ocean. Large glass areas and a cantilevered balcony on the ocean side bring the view into all major rooms — kitchen included.

The owners wanted a house which would be comfortable the year around and which could accommodate both

large beach parties and small formal groups in the evening. To meet the first requirement, the house has thermal insulation and floor-radiant heat; on the shore side it is almost totally enclosed so that, as the architect says, "the owners may turn their backs to the elements when desirable." Guest room and bath are adjacent to the entry, connecting with the stairs to the beach through the enclosed patio.

Both exterior and interior walls are redwood, rough-sawn and unstained. Cabinets are birch, highly finished as contrast. Ceilings are untinted tan-white plaster.

VACATION HOUSES



Douglas M. Simmonds

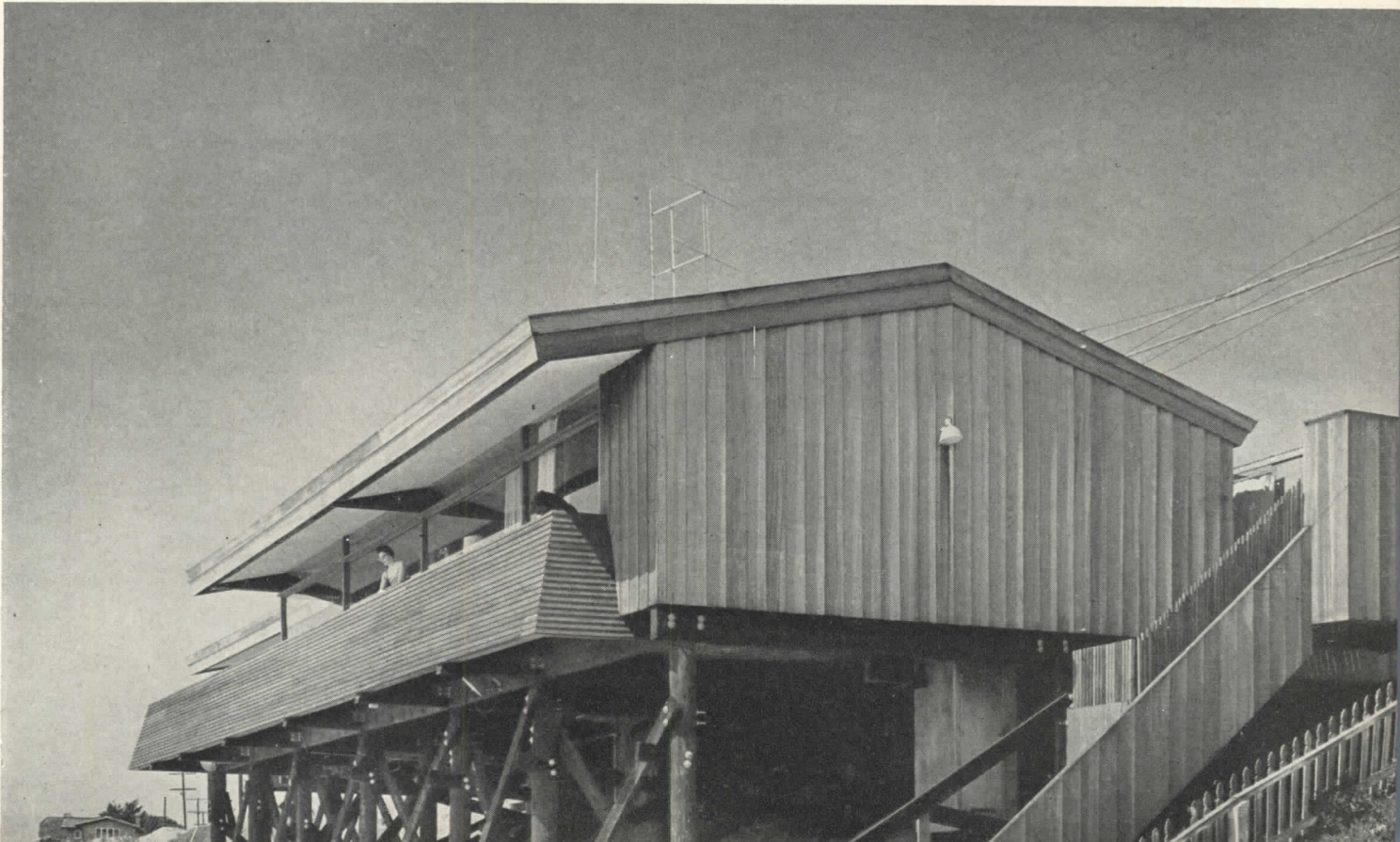
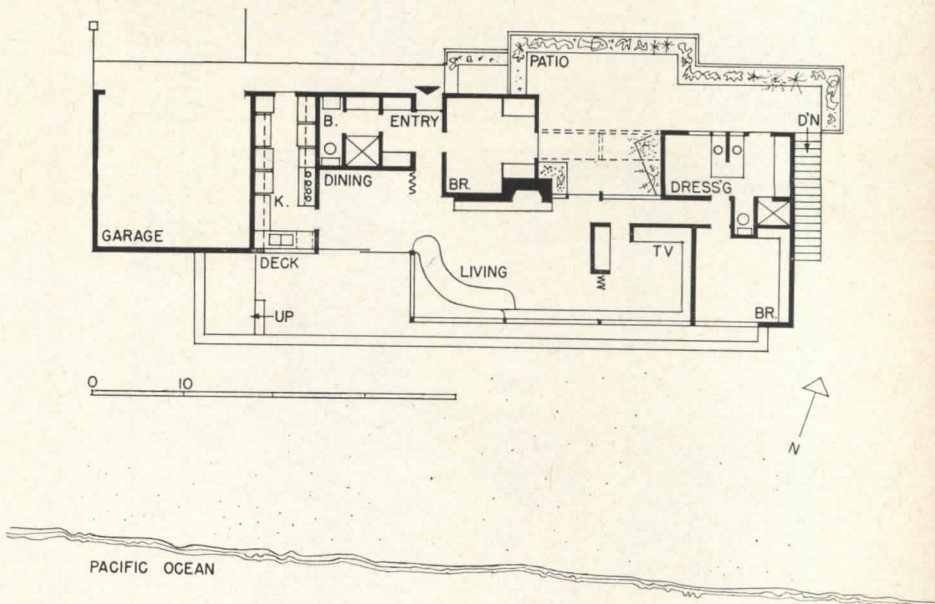

VACATION HOUSES

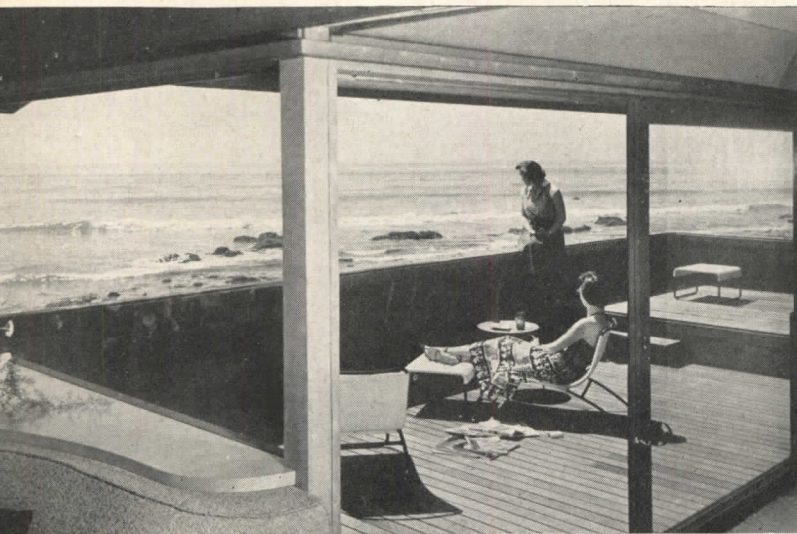
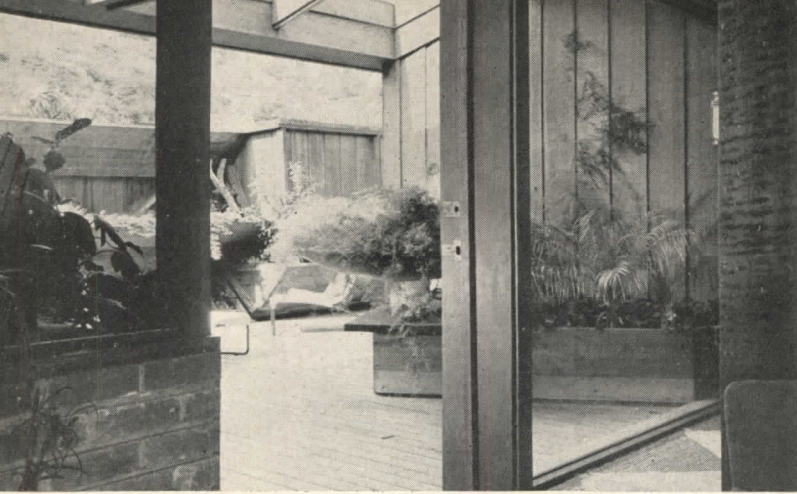

Living room opens to high-walled patio on one side, broad deck on other. Downward slope of ceiling focuses attention on view. Solid brick of fireplace wall is pleasant contrast to openness of opposite side of room. Floor covering is straw

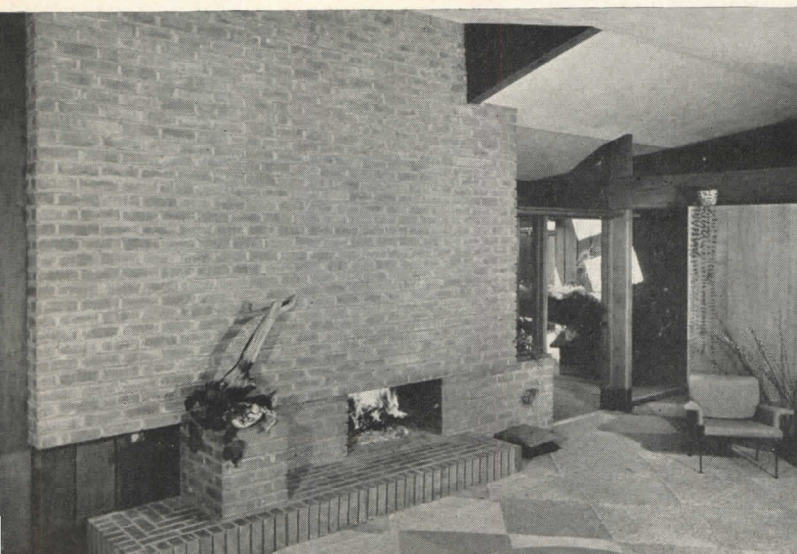



Aertsens Michel

SOUTH AMERICAN HOUSE ON A MOUNTAINSIDE

House for Dr. Conto e Silva

Tijuca, Brazil

Affonso Eduardo Reidy, Architect

THE MOUNTAINSIDE COMMUNITY in which this house is located is only a short distance from the center of Rio de Janeiro. Its excellent climate and proximity to the city have made it a popular weekend and vacation spot — so popular that privacy is not always easy to achieve.

The lot purchased by the owners of this house sloped steeply and irregularly upward from the street, narrowing almost to a point at the upper end. The lower part of the site was the only possible building location (see plan and photos, next two pages), and the house was, accordingly, placed close to the street. The slope on this

side was used to develop a three-level plan with the main living area on the intermediate level, completely enclosed at the front and wide open to the garden at the rear. The bedrooms are over the garage, a few steps up from the entry; although they face the street they are high enough above it to ensure privacy.

The irregularity and steepness of the site produced a natural “zoning” of the garden area: living room terrace and pool are on different levels so that each can be enjoyed simultaneously by different age groups without too much conflict.

VACATION HOUSES

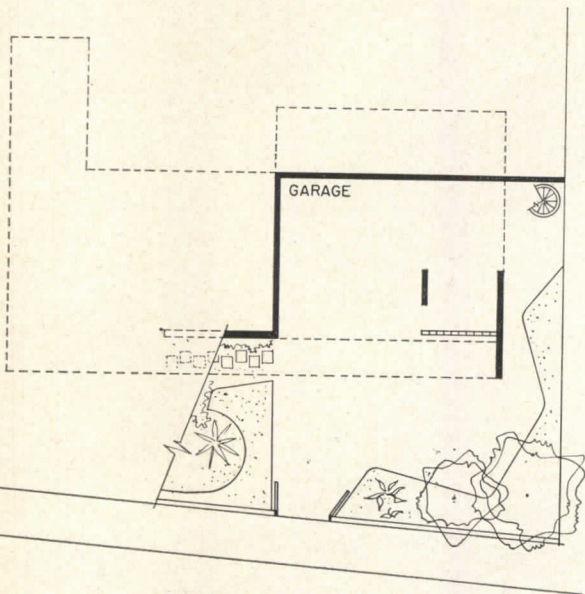

LOWER LEVEL

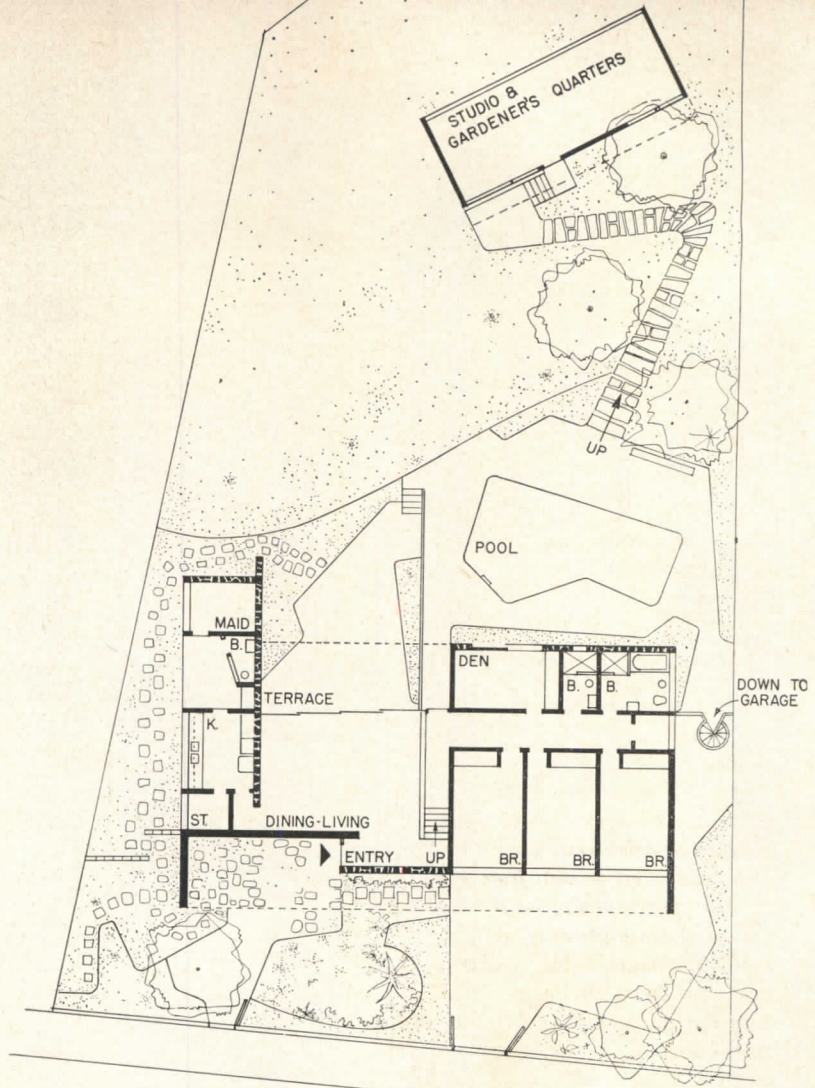

UPPER LEVEL



Site was planned for maximum privacy in crowded neighborhood: garden at rear cannot be seen from street or even from maid's room and kitchen; along sides of lot it is protected by full trees and dense planting. At upper end of site, high above house, is the gardener's cottage which also includes a studio or workshop. Pool, on intermediate garden level, is directly accessible from bedrooms

Aertsens Michel

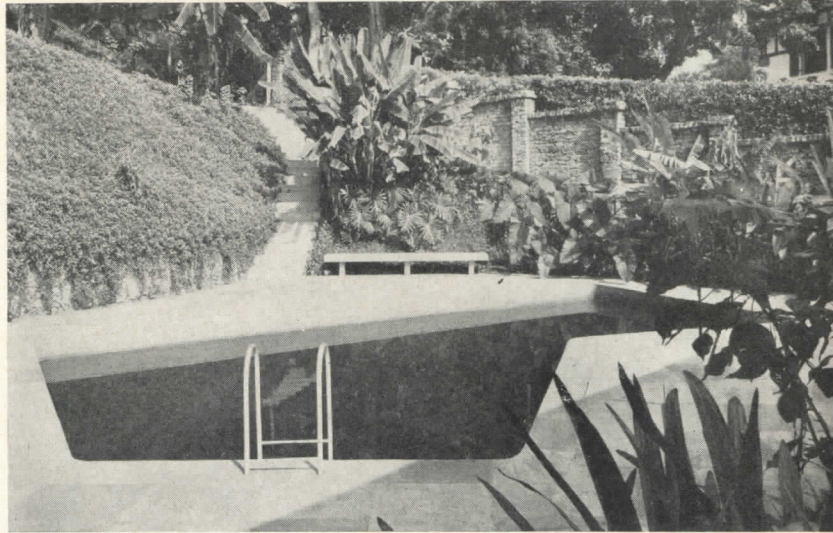
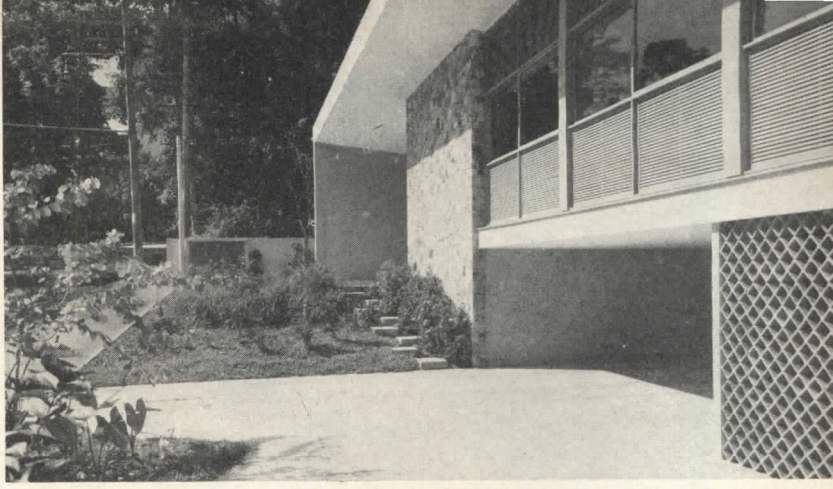
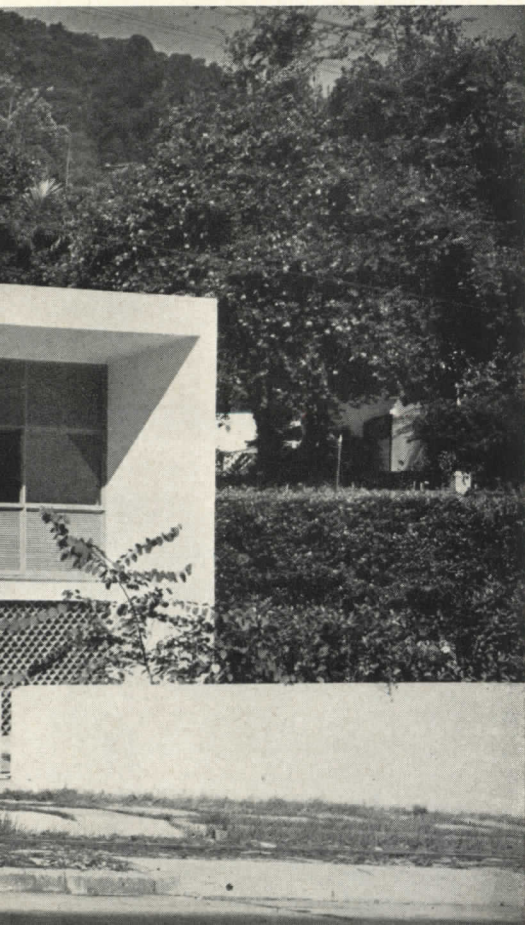



FUTURE PERMANENT RESIDENCE IN CONNECTICUT

House for Mr. and Mrs. Herbert Perry, Sherman, Conn.

*Herbert Beckhard — William W. Landsberg
Architects*

THIS LAKESIDE HOUSE was designed for year-round vacation use and eventual permanent residence. The owners have a number of relatives with whom they maintain close contact and for whom they wished to provide guest accommodations. They also wanted a direct entrance from the beach to a shower to exclude sandy feet and dripping bathing suits from the main living area.

The steeply sloping site had excellent soil conditions, with no rock to interfere with excavation work. It permitted a relatively inexpensive lower level for guest rooms and bathers' shower, plus provision for a future maid's room if desired. This two-level plan made it pos-

sible for every room in the house, kitchen included, to face the fine view out over Candlewood Lake. It also allowed direct access from the living-dining area to the terrace and gave all principal rooms the best possible lake view.

Color was important in the design of both exterior and interior. Exterior is natural cypress with white trim, black accents in moving sash and screens, and horizontal panels in red and yellow. The same colors are carried over into the living room (photo opposite), where yellow walls surround the white brick of the chimney which in turn is accented by a red-painted niche.



Joseph W. Molitor

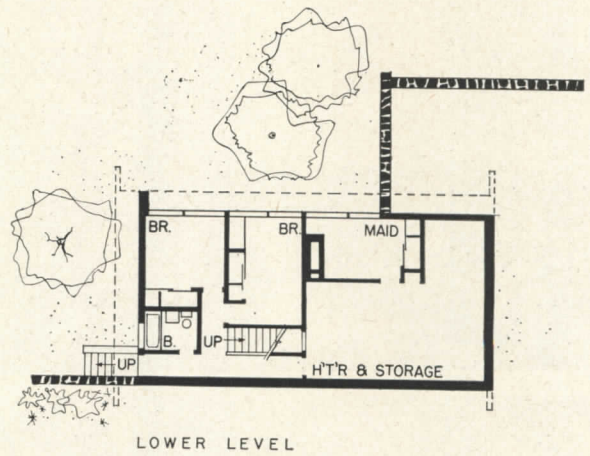
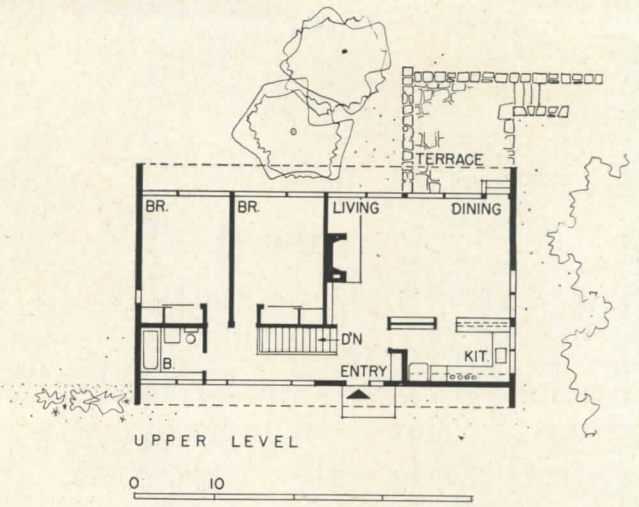

VACATION HOUSES

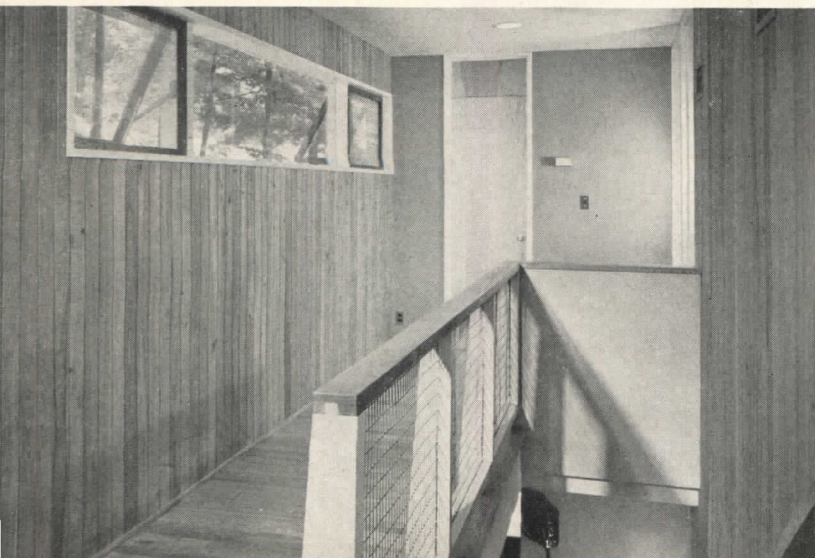
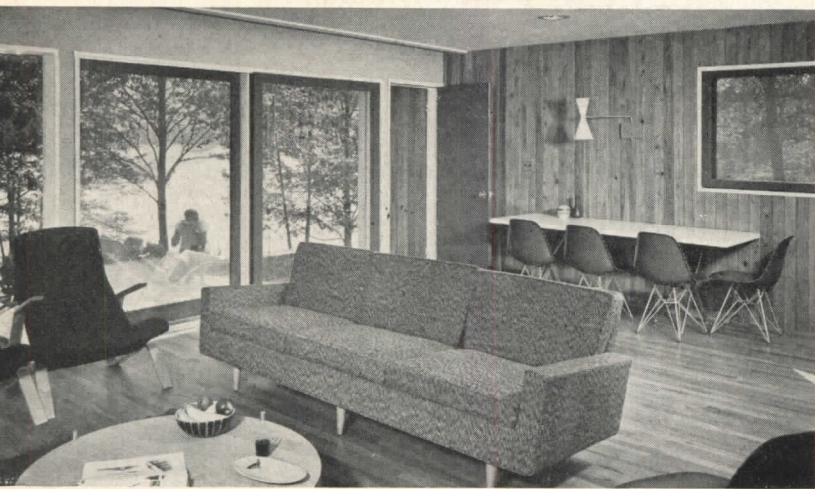
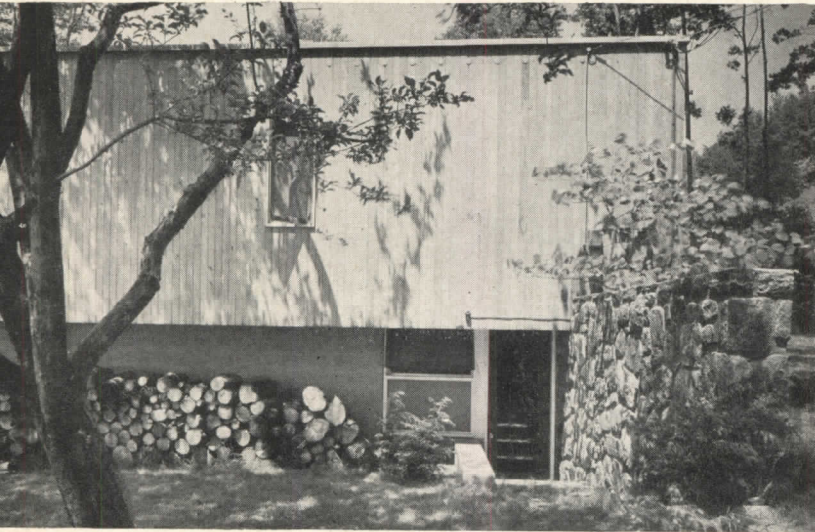
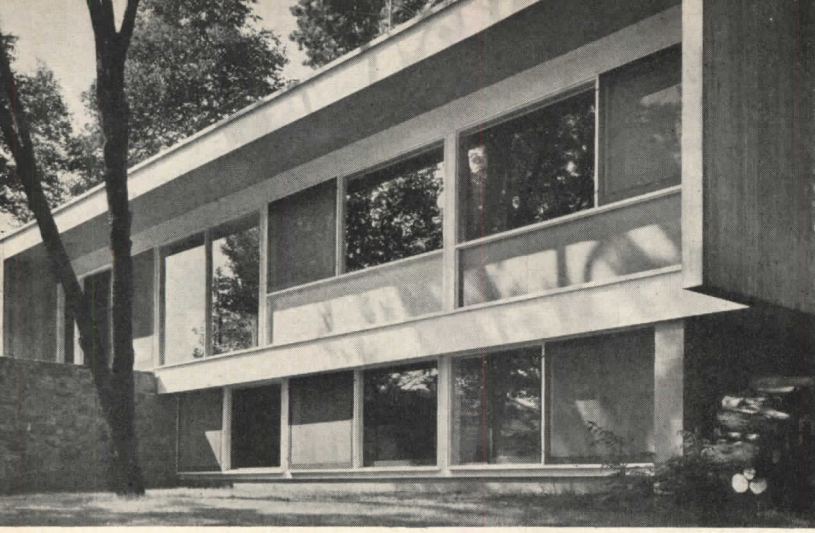

Characteristics of the site have been carefully dovetailed with fenestration and entrances of the house to add much comfort and efficiency. While the south facade, facing the lake, is quite open, relatively blank end walls give privacy from neighbors on the relatively narrow lot. Halls and baths, with high strip windows are placed to the north side. Retaining walls permit development of terraces and entrances to living areas on upper level, shower and guest rooms on the partially sunken lower level

ADMINISTRATION AND SERVICE BUILDING



Stuart Weiner

*Mountain States Telephone Company
Phoenix, Arizona*

*Edward L. Varney, Architect
Ned H. Abrams, Associate Architect
L. W. Wiese, Structural Engineer*

ECONOMY, CLIMATE AND EXPANDIBILITY governed the design of this building for the administration, sales, service and employee training offices of the Mountain States Telephone Company's Arizona operations. Built as a lease-purchase project of the Kitchell-Phillips Contracting Company and the Utah Construction Company, the building represents, says the architect, "a pleasant collaborative association among architect, owner and lessee" which is now being repeated on another project for the same company in northern Arizona.

ADMINISTRATION AND SERVICE BUILDING

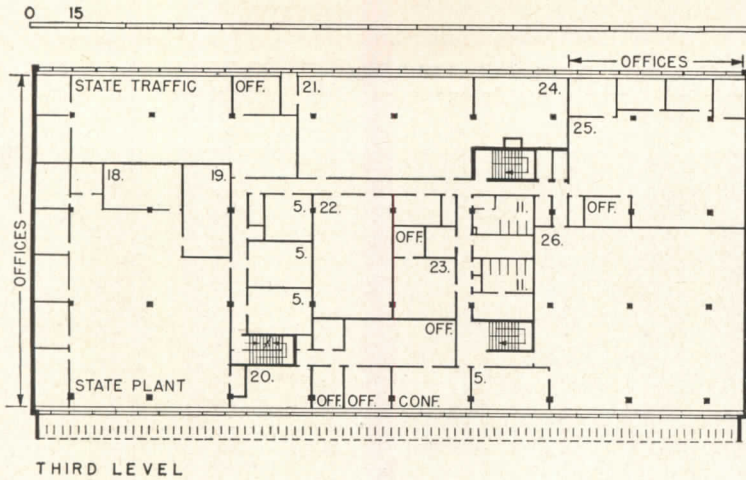

THIRD LEVEL

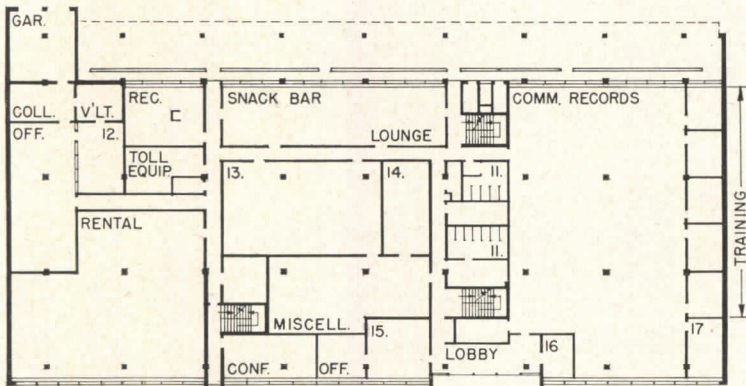

STREET LEVEL

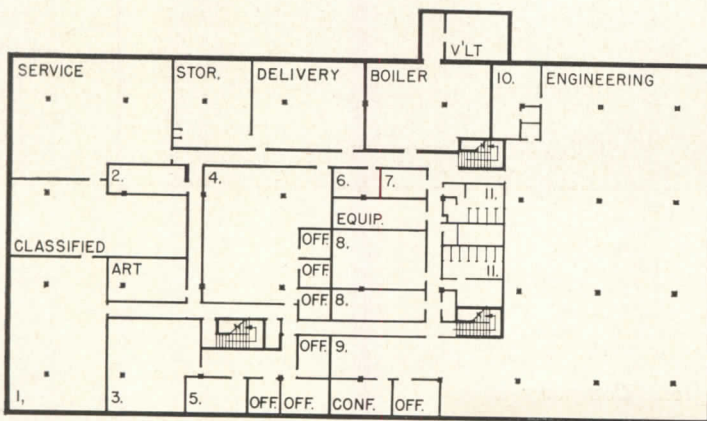

FIRST LEVEL

- | | |
|-------------------------|----------------------------|
| 1. Alphabetical | 14. Mail Tellers |
| 2. Ditto Machines | 15. District Manager |
| 3. Sales Clerical | 16. Service Observation |
| 4. Arizona Sales | 17. Comm. Monitor |
| 5. Training | 18. Personnel |
| 6. Building Maintenance | 19. Stenography |
| 7. Engineering Arch's. | 20. General Manager |
| 8. Archives | 21. North Plant Assignment |
| 9. Toll and Exchange | 22. Assembly and Proj. |
| 10. Blueprint | 23. State Cashier |
| 11. Toilet | 24. Dispatch Group |
| 12. Coin Counting | 25. Arizona Commercial |
| 13. Order Typing | 26. Phoenix Commercial |

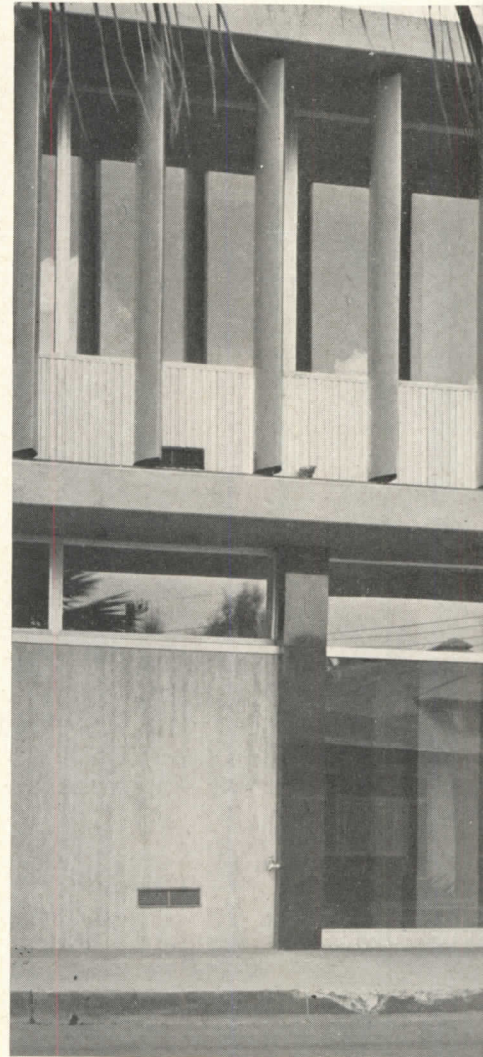

Stuart Weiner

Phoenix's desert climate accounts for the building's most striking feature — the sun-operated louvers along the street front's second floor (actually the building's third floor as the plan is split-level). Left to right, below: lobby at ground floor level; private office protected from sun by louvers; detail of louvers and deck between them and metal-sheathed wall

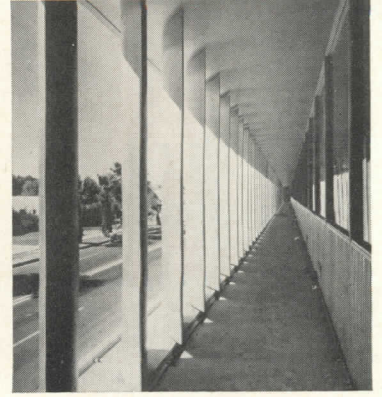
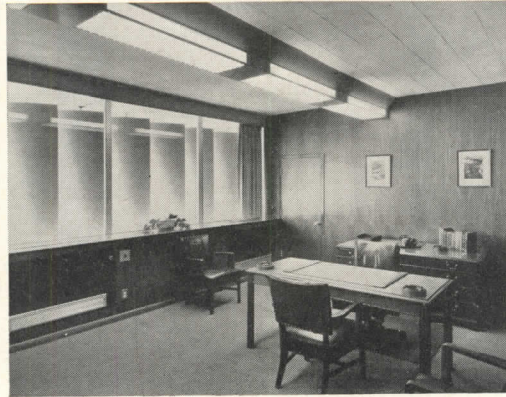

ADMINISTRATION AND SERVICE BUILDING

Economy dictated structure (reinforced concrete); construction method (lift-slab); and simplification of details (such as elimination throughout of furred ceilings). Electrical and air distribution systems are carried in special duct cast in floor slab so furring is unnecessary; architect-designed combination light fixtures and air outlets are fastened to under side of slab. Building cost slightly over \$10 per sq ft. Elevator installation was postponed until building expands vertically (it was designed to take two more floors); with split-level plan, no employee normally climbs more than one flight of stairs and there is little traffic from outside. Below, top to bottom: general office areas, top floor and below grade; parking lot and stalls at rear



RELIGIOUS BUILDINGS

The Horizontal Cathedral

A discussion with Mario Salvadori on today's structural potentials

WE ARE EVERYWHERE TODAY concerned with finding forms suitable to the purposes of our buildings and to the time and place in which we build them. Our churches have been noticeably slower than other building types in finding forms expressive of their ancient purposes, but at the same time suggestive of the dynamic regenerating force of faith.

However, structural method appears still as valid a source of form as it was in earlier days of great church building and great architecture. The dome was developed in Byzantium and vaulting in Gothic Europe. Is the twentieth century developing forms to rank with these?

There is, perhaps, no one who can answer this question since there are so few who are alive to both structural potentials and the significance of our religions and their symbolism. But it is possible to find among America's experienced and forward-looking engineers answers at least to some questions which are being raised regarding physical values in our evolving structural systems. The editors of ARCHITECTURAL RECORD recently sat down with Mario Salvadori, structural designer and teacher, and questioned him on this theme.

QUESTION: If we continue to experience in our lifetime the revival of religious concern which appears now to be happening, do you see particular potentials that structure gives us which could help satisfy, architecturally, the return of mass interest in religion?

SALVADORI: To date we have seen only a revival of church architecture which may be called the revival for the needs of the individual. It seems that most modern architects who have offered essential contributions,

with meaningful structures, have built only small churches, and most of the time, chapels. For example, the chapel in Belo Horizonte, Brazil, by Niemeyer, which I consider very significant — particularly in terms of its location and its motivations. This revival of interest is taking place and there are a lot of difficulties in trying to materialize it in architectural terms. These small buildings are essentially presenting an individual approach to religion, the approach in which between the person and God there is no room for anybody else. But, inasmuch as the psychological approach used by our culture is of the mass kind, we must inevitably respond to the needs of the masses in religion, and I believe that the only way in which this can happen is by producing structures which will actually embrace a large number of people.

In the Middle Ages massive religious interest produced very large structures. It seems to me that in the future we are going to have the same architectural phenomenon — large structures which will permit the mass gathering of people with the kind of resonance between the feelings of the people which will enhance worship. The essential difference I foresee between the large buildings of the past and the large buildings of the future is this: where the great dimension of the Gothic, for example, was vertical, our great dimension will be horizontal. I believe we now have the physical possibility of doing what other people could not do. In the Middle Ages, if you wanted to have a large group of people in a church, you had to have an essentially tall structure, because in stone large spans demanded large vertical dimensions. We are now in the position of being able to cover a very large area without having great heights. So far, none of our modern architects have experimented in this direction in terms of religious structures. Our only large modern structures whose spaces evoke emotions akin to those called up by the cathedrals are those like the hangars of Nervi and Freyssinet, or buildings like the airport terminal in St. Louis. And if you talk to Nervi, and you see the way he writes about his hangars, you will find a feeling of dedication which is typical of the architect who has an almost religious feeling about the building he builds. Here we have the right psychological state of mind of the architect; here is the need of the people for this new

type of religious building; and here are innumerable structural possibilities.

QUESTION: Today what are the several means of this extensive kind of spanning of space?

SALVADORI: We have steel, of course. It is rather strange, but the only cathedrals we have in steel are the old railroad stations like the Pennsylvania train room in New York, which you still see in a few places in Europe, but which are being discarded. The reason is essentially, I think, that they are too costly to maintain.

Then we have concrete. With concrete you can do a variety of things. You can even fake a Gothic cathedral. One of its most interesting uses is in folded plate, or hipped plate, or, as I like to call it, "creased paper" construction. I believe that the potentialities here are very great. One can span distances of 100 to 200 ft with "creased paper" construction and achieve magnificent effect. I have recently seen photographs of a church designed and built by Antonin Raymond in Japan (to appear in an early issue of ARCHITECTURAL RECORD) which is all of this form, and it is very simple and extremely beautiful. If you want to go beyond this, if you want to conceive of the very large cathedrals of the future — really fantastically large and beautiful — in which you would have spans from 200 to 700 ft, the answer is obviously that you have to have curved surfaces. Here we would be going into thin shell design.

Now I believe that in this field Nervi is the one who has really shown us what can be done. His buildings, the large ones, point a direction which is very clear and in which certainly up to 1500 ft, there are almost no practical limitations. Going still further — to a day when we may want to cover areas of say 2000 ft in diameter — I believe you must abandon the idea of a compressive structure, or a shear structure, so you have to abandon both "creased paper" and shells, and you have to go to a tensile structure or a hung roof. Now, if you start using cables and you think of a purely tensile roof, the limits are fantastically high. If you have a cable which can be stressed to only 50,000 lbs per sq in., it can carry itself over a span of about six miles. Of course it wouldn't be able to carry any additional weight, but in the light of this we can easily conceive of spans of a mile. Mr. Viera has shown us that we can now stabilize a roof so that the danger of flutter is completely avoided, and inasmuch as we shall have a little sample of this construction built this summer, I believe we shall be able to find out whether what Viera says is true — and I am sure it is — that no danger of flutter can ever occur. As you know, in tensile structures, it is not the dimension which really stops you. What stops you is that you've got to immobilize the structure.

We are aware that the San Francisco bridge and the George Washington Bridge move sidewise in a strong wind, anywhere between two and six feet. This is perfectly all right, but you wouldn't want a roof over your head that moves six feet.

So the fundamental difficulty in spanning a large distance by means of a tensile structure is the flutter. And it is for this reason that the arena in Raleigh — which in terms of its space is a marvelous building, one of the most successful buildings I've seen — presented serious difficulties. But their problem there has been a problem for the last 30 or 40 years. Paul Weidlinger has a very brilliant solution to this problem. He has a tensile structure which is a sandwich of very thin metal plate which he inflates by a little pressure of air, and in so doing he has a tensile structure which is perfectly steady and will not vibrate.

Camino has recently devised the lovely looking tensile roof of canvas which could well be adapted to a variety of purposes, including the roofing of churches. But I am not certain that it will be flutter-proof in large dimensions.

I think that on top of the Weidlinger and Camino solutions, which have not been actually put into practice, we have the Viera solution, and both Paul Weidlinger and I agree that this is the best answer we have today.

The essence of it is this: you have a tensile structure which you overload. You overload it and it comes down a little. Then you put the roofing material on — leaving gaps between the covering elements which would be either steel or slabs of concrete, or other materials. Then, when the overload is put on, you fill the joints. If this is steel, you may put additional plates that you weld; if it is concrete, you mortar the joints. Then you take the overload off. And the moment you take the overload off, the structure goes up again, freezes the compression into the concrete, and the tension in the cables, and it becomes a prestressed inverted thin shell which cannot move, and there is no need for additional elements to tie down the roof as was done in Raleigh. I think that this is the first fundamentally new idea in construction after the invention of thin shells. It's one of those strokes of genius that people have been reaching toward for 50 years. You know, there have been many bright people thinking about it, and they couldn't get anywhere, and here it is.

Viera's Montevideo sports building is 300 ft across, and it costs \$1.00 per sq ft to roof.

Now in going back to our cathedrals, if we adopt either the direct solution suggested by Viera, or modifications thereof — and it is quite clear that his principle cannot be modified — I am sure that we can make applications in a variety of ways.

Having solved the problem of flutter, I believe that we can actually span tremendous distances, and that we can have what I would like to call horizontal cathedrals.

QUESTION: Does this mean that with this kind of reversed prestressing idea, you will need fairly strong anchorages of some sort on the sides?

SALVADORI: Well, I'm not so sure of that, you see, because one of the beauties of prestressing is that pre-

stressing is self-contained. You don't need external anchorages to have prestressing. You anchor it to itself. Prestressing is lifting yourself by your bootstraps; for example, in the Viera* solution which I have adopted in the building for Camp Columbia (scheduled for presentation in ARCHITECTURAL RECORD), all these guys and stabilizing cables just don't exist. What I have is a ring all around the building, and the cables are anchored to this ring and put in tension by means of weights. Then we are going to freeze the tension in the cables. We don't need any outside guy wires or any stabilizing wires, because this is prestressing, and is therefore self-contained.

QUESTION: What are you supporting the ring on?

SALVADORI: On just a set of columns. The columns can be very, very slender. Because here is another important point. If you adopt this prestressed, tensile roof, it is a self-contained element, which can be put, like a hat, on anything at all. It could be put on a central column; it could be put on a ring; it could be put on four columns; it could be put on anything you like. You have perfect freedom of support.

I have a ring, I put the ring on top of columns, and I don't need to tie it to the columns. I just put it there. The ring takes it. The ring is self-contained. It cannot buckle. Ordinarily if you have a ring, and you push on it from the outside, it may become an oval, and therefore collapse. But this ring cannot collapse, because in order for the ring to become an oval, one of the diameters would have to become longer while the other becomes shorter.

QUESTION: It is tied across the ring in all directions?

SALVADORI: Yes. It cannot buckle. It's just like a bicycle wheel. I'm going to have a wooden ring, 4 in. by 10 in., to take the whole roof which is 50 ft across.

QUESTION: Would a circular shape always be necessary instead of a square or a rectangle?

SALVADORI: It could be done in a square or rectangular form, provided you admitted some bending on the sides, or provided you used cables on the sides, in which case instead of having a ring you would have a catenary, and then at the four corners, you would have to have the guy wires. The variations are infinite; I foresee a great future for this kind of thing in connection with the large buildings of the type we are discussing.

QUESTION: Along with our need for large religious structures, there will continue to be a need for the small church structure. Some of these principles may be applicable and quite appropriate to these, but in addition are there any particular structural methods we have now or can look forward to that will be useful in small buildings?

* Preload Corp. owns world rights to the Viera system.

SALVADORI: It is quite clear that nowadays our structural possibilities are such that we are in danger of running into what Nervi calls "academic structuralism." In other words, the architect knows that he can do anything he likes, and therefore he does wrong things because he can afford to. There are many possibilities that are not even costly. Now in connection with small buildings there is no structural problem. You can use any of the methods we've been discussing here. I believe, for example, that very lovely solutions can be obtained by means of hipped plate, "creased paper" construction in the small scale, or by the continuously curved approach of John Johansen.

QUESTION: You see these as definite improvements over what we actually are using now — bar joists, laminated bents and so on?

SALVADORI: They would be, in my opinion, great advances on two accounts. First of all, it seems to me that when people have been indeed religious, they have expressed their religious feelings by means which had not been used before. When you are deeply in love, and you are a musician, you offer a song which is really new — it must be new because you are deeply in love. And when you deeply love God, and you want to express your feelings for God, you offer something which has never been seen before.

QUESTION: Out of yourself?

SALVADORI: Out of yourself. Now, if you are going to imitate, in a stupid manner, what has been done before, you are not being yourself. Therefore, in one sense, you are not being sincere. And the fact that the modern architect who feels deeply about religion has all these possibilities at his disposal means that the moment we get the right man, we're going to have, even in this small scale, a jewel which represents the integration of his feelings, of form, of structure, of all that makes for a complete expression of religious feeling in the materials of architecture.

Now, for example, I feel that this is what Niemeyer has done in Brazil.

Here is a church which represents the history of the people, represents the countryside, represents through the Portina mural something the people of Brazil feel very deeply. Yet this marvelous chapel has not been consecrated because the officials of the Church do not feel that it is a religious building.

Now, you have asked if I feel that the conservatism of either the client, or the people, or the architect, would prevent some of these possibilities from being realized. My answer is a most emphatic Yes.

It seems to me that if our wonderful potentials are going to be realized, it will not be without difficulties imposed by people, by organized religious groups and their officers. But if the right man gets together with the right denomination, we may have one of these wonderful manifestations soon.

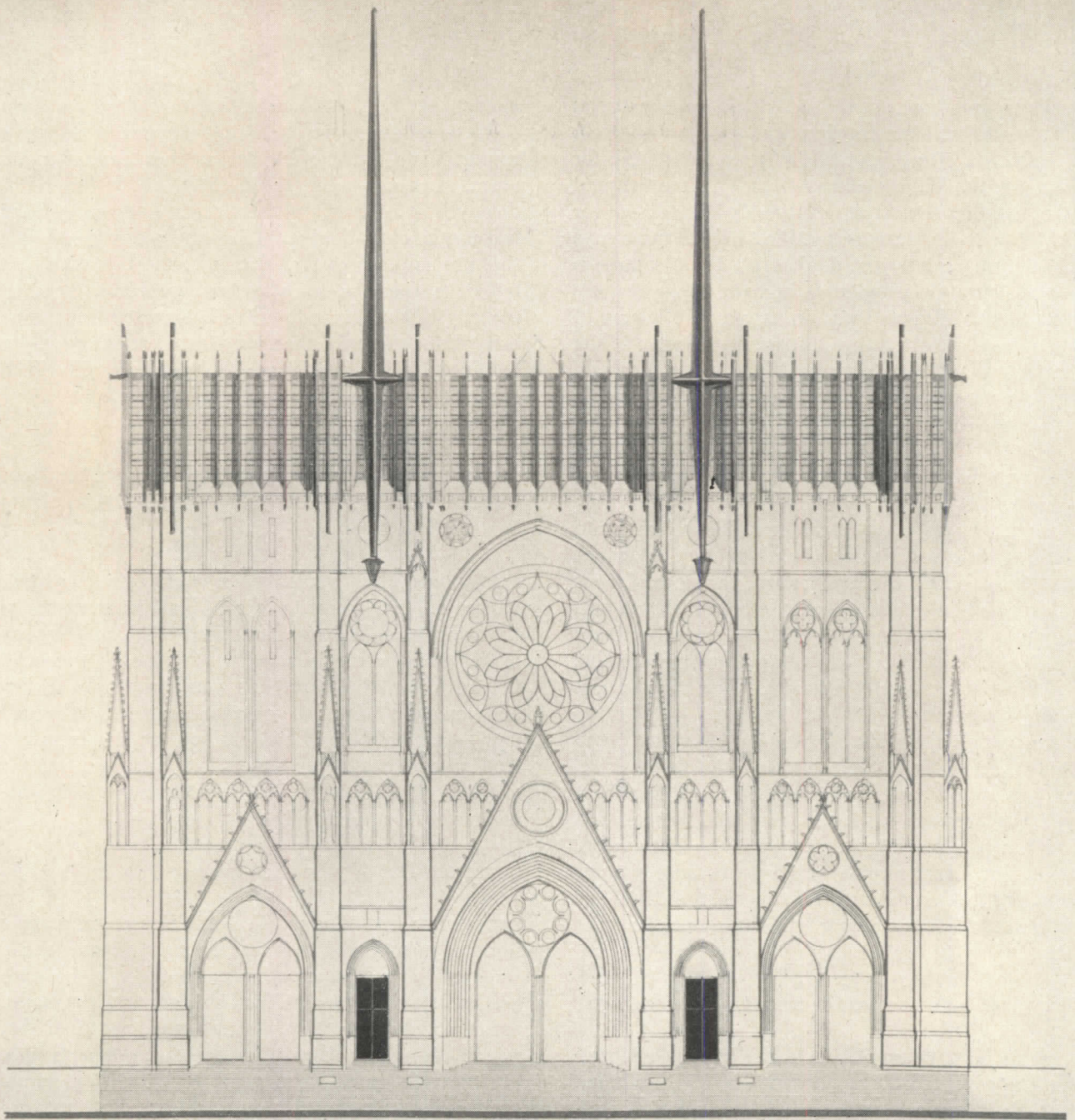

FOR THE CATHEDRAL OF ST. JOHN THE DIVINE



THIS PROPOSAL for the completion of the Cathedral of St. John the Divine was made by John M. Woodbridge in connection with his Master's Thesis in Architecture at Princeton University this year. His general study, of which this was a part, dealt with the problem of relating the new to the old in architectural form. Herewith is the author's description of the way in which he proposes to achieve continuity with the Gothic inheritance through retaining a structural point of departure in which the materials and methods are contrasted.

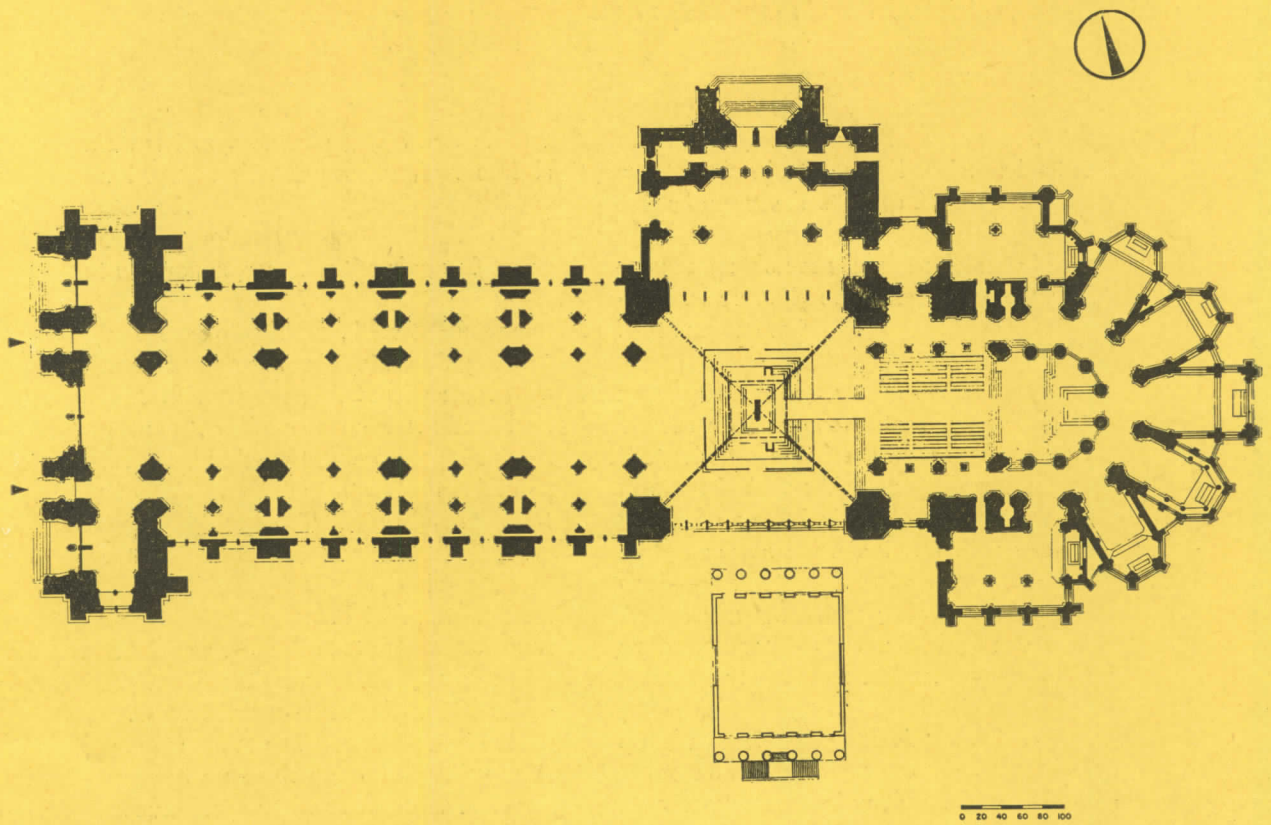

THE INITIAL STEP in the solution was to take account of the existing structural conditions at the crossing, and to place these conditions beside the needs, both esthetic and liturgical, for a powerful setting for the altar in the crossing. The great arches built by Heins and Laffarge to support their tower were the crux of the problem. Cram had virtually discarded them in all of his solutions. But their gigantic scale and the obvious expense of destroying them both argued in favor of keeping the arches if it were possible to integrate them with a contemporary structure. Out of this background came the idea for a tower suspended from diagonal ties within the square of the

great arches, an idea which had three powerful reasons in its favor:

First, it provided a natural means of achieving the major aim of the program, the provision of a focal point at a freestanding altar in the crossing, and the tension system could project into the long vista of the interior without blocking it.

Second, it permitted the use of the arches as an integral part of a radically modern structure, combining old and new in a vivid way.

Third, it utilized a structural system which, by expressing lines of force in a way analogous to that of the adjacent Gothic (tension rods and cables with Gothic ribs), provided the op-

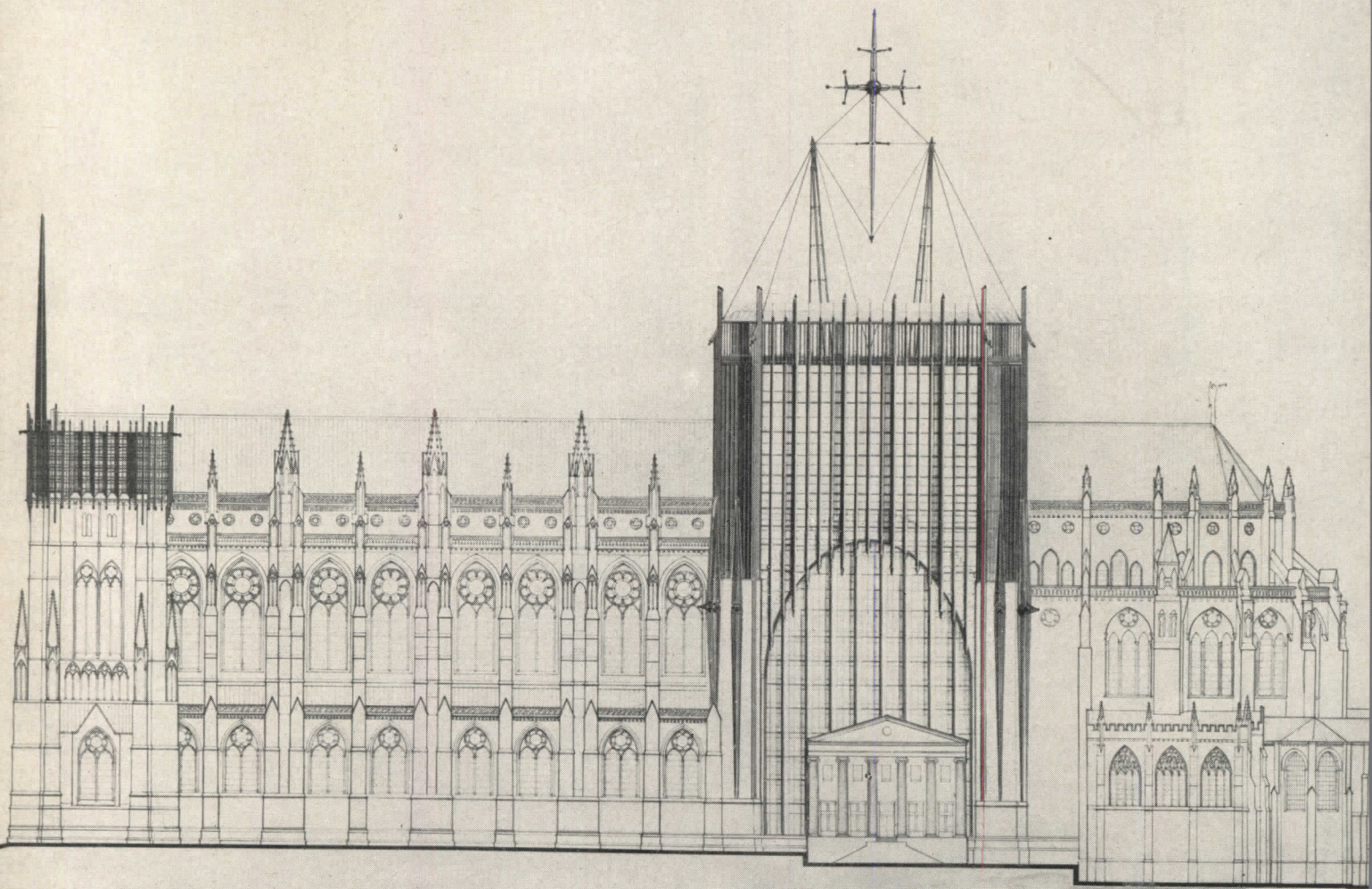

portunity for a structural harmony by contrast.

The scheme involves supplanting the present makeshift buttressing and ties of the arches with diagonal ties across the square supporting four great masts which thrust the ties down into an inverted pyramid centered over the altar. Enclosing the floating tower is a cage structure of concrete slabs and glass built on the arches, providing enclosure against the weather and light control. This cage is designed as an eggcrate with undulating surfaces, deep enough to accommodate the 12 ft thickness of the arches. On either surface of the eggcrate there is a plane of warm-colored diffusing glass bathing the crossing in a high

intensity of warm, diffused light as a contrast with the low intensity of cool light in the other parts of the building. The two surfaces of glass also serve to insulate the great volume of the tower.

Within the side arches is a similar eggcrate of a closer vertical rhythm and smaller depth which would have stained glass on both sides in order to achieve continuity at the ground level with the glass in the existing parts. However, the two surfaces a foot or so apart provide an opportunity for a novel composition in depth, using the two planes to alternate transparent and translucent areas of glass.

The broken surfaces of the cage express the

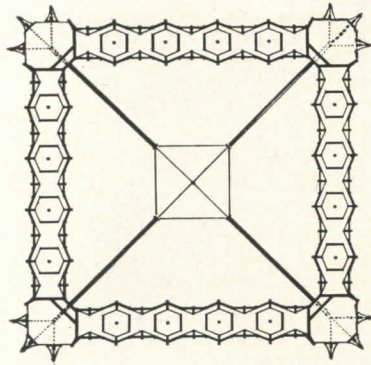

TOWER HORIZONTAL SECTION

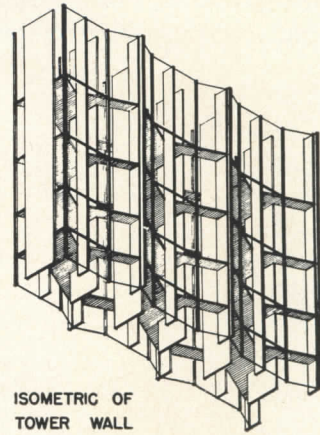

ISOMETRIC OF
TOWER WALL

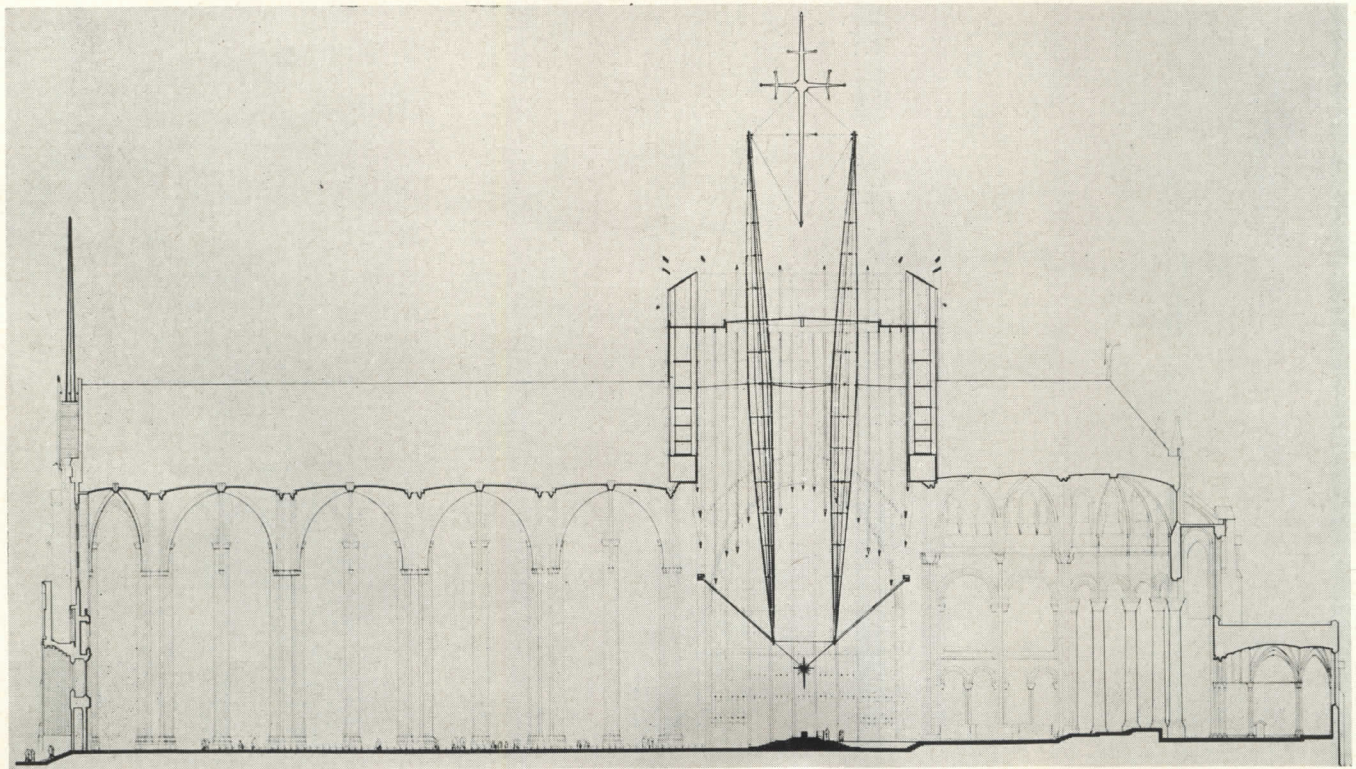

necessity for powerful wind bracing, provide a rhythmic accent in keeping with the rhythm of the buttressing on either side, and break the glass planes so as to achieve an animated surface which insures that the viewer will always be confronted with both a reflecting and a transparent surface.

The roof of the tower is a coffered, polychromed concrete vault with an oculus in the center through which pass the masts. The oculus is intended both to light the interior and to make visible from the interior the separation of the suspended masts from the surrounding cage. As a further expression of the tension system, two crosses are suspended

centrally from the tops and bottoms of the masts. A gigantic omnidirectional one above the roof, and one in scale with the altar inside. Apart from liturgical reasons for crosses in these positions, it seems fitting that these two symbolic elements should appear to tie the whole structure together.

There are those to whom a tension system such as this seems inappropriate to a church, but I felt that such a powerful statement of modern structural possibilities was called for in order to hold its own in these surroundings, and there is after all a powerful precedent in the dome of Hagia Sophia, designed to appear hung on golden chains from heaven.

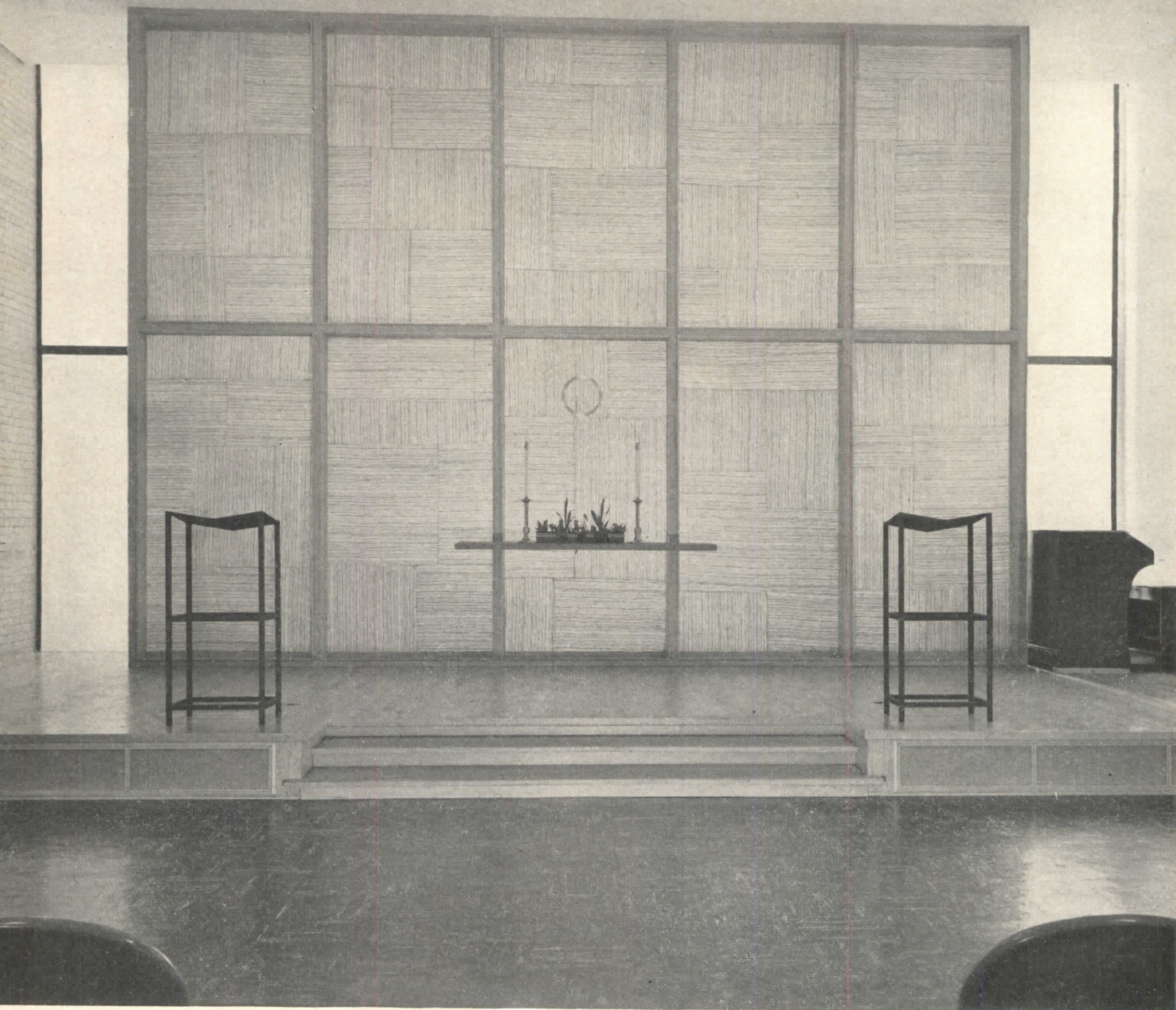

Hedrich-Blessing

FIRST UNIVERSALIST CHURCH, CHICAGO

*Schweikher, Elting and Bennett,
Associated Architects*
Frank Klein, Structural Engineer
*Samuel Lewis Associates, Mechanical
Engineers*
Angelo Testa, Dossal Fabric
*Ashland Construction Co., General
Contractor*

THE FORM OF THIS CHURCH is a response to a non-creedal, liberal congregation's needs on a restricted, urban site.

Seating for 140 in the sanctuary, 20 in the choir and 40 in the balcony accommodates the relatively small membership of the only Universalist Church in Chicago.

Solution to the problem of shutting out the confusion of the city without repelling the public was found in surrounding what is actually a pair of buildings with a brick wall which in part forms the building exterior.

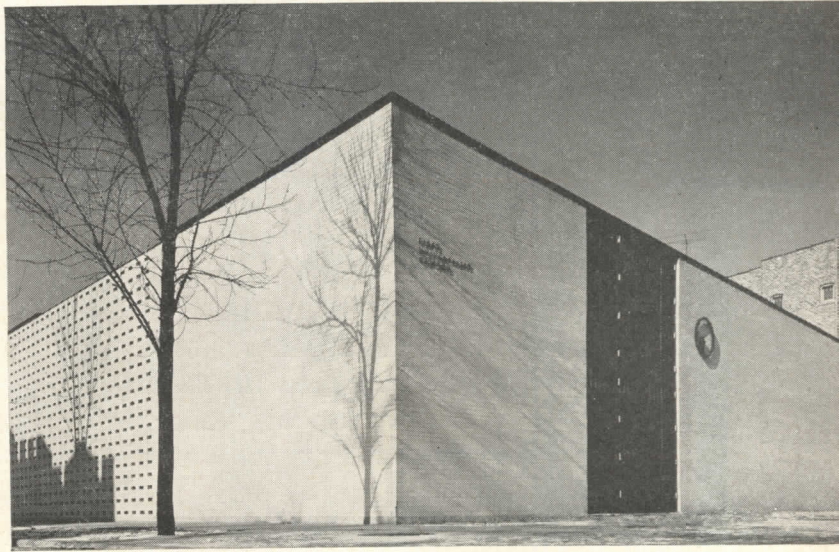
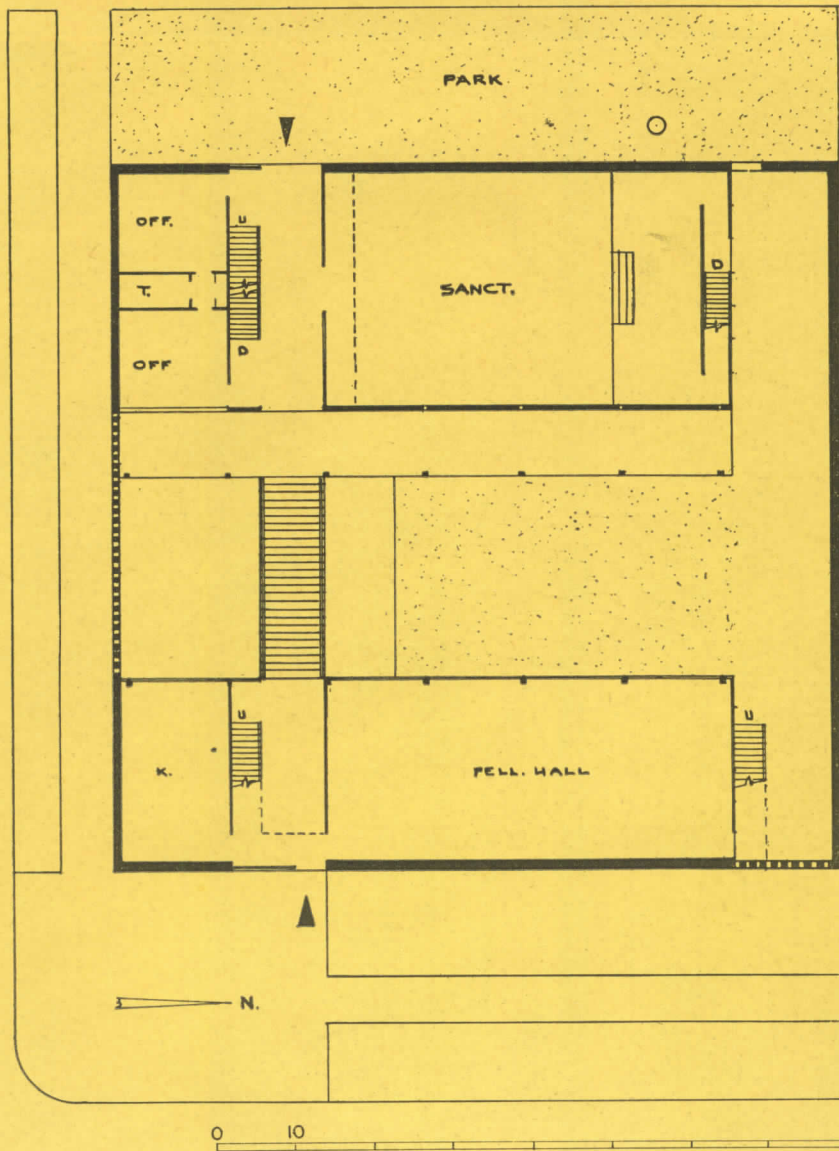

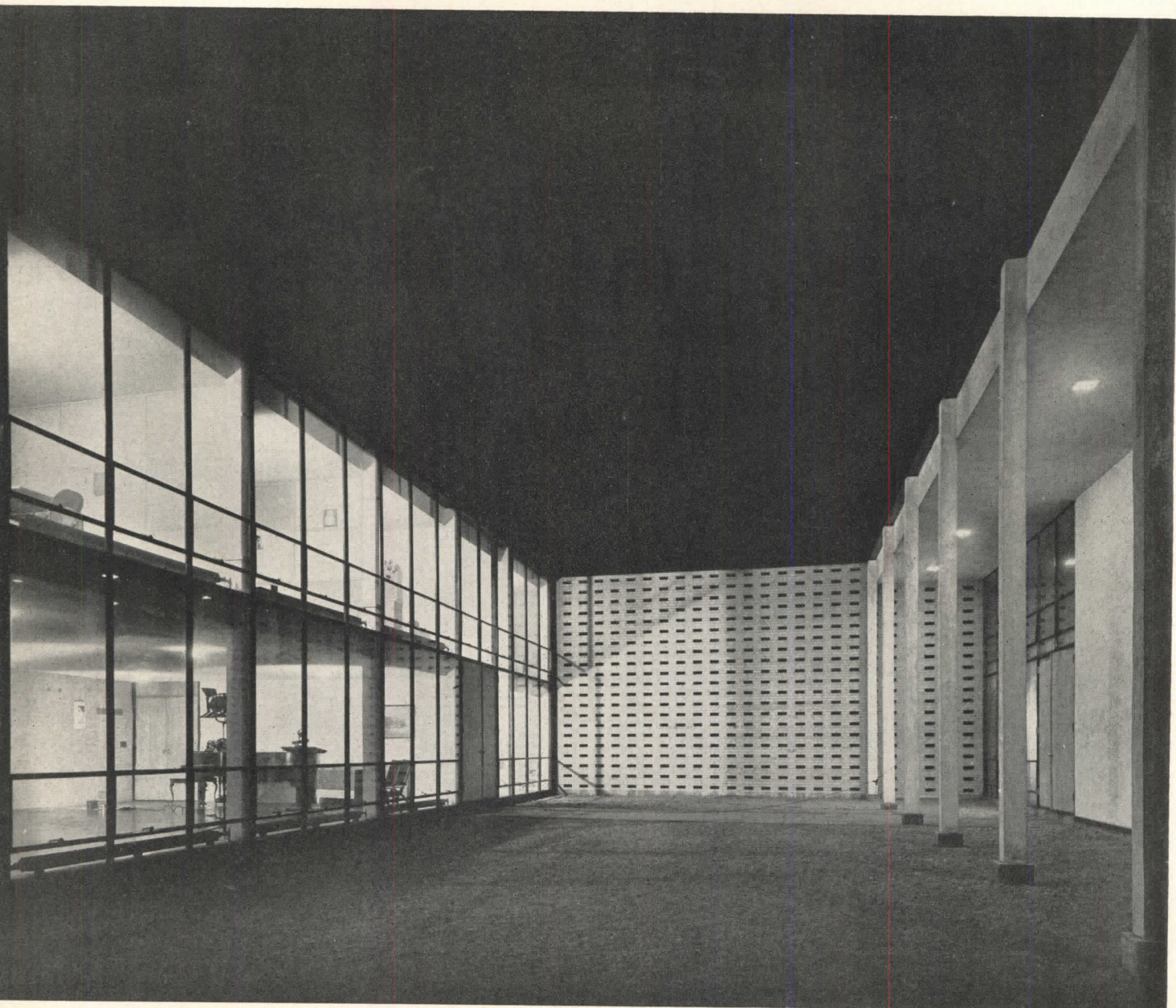

Hedrich-Blessing

An invitation to the passerby is offered through the two large glass areas and the open brickwork.

The building's overall character may be well understood against the background of quotations from a statement on Universalism by the church minister, David H. Cole:

"Truth comes from many sources, chiefly through use of the scientific method rather than solely from Biblical authority.

"Universalists are unitarian in theology, revering Jesus as an inspirational leader, human as other men, and divine in the sense that all men are divine.

"Salvation for Universalists is a matter

of growing toward individual maturity and working together for a democratic society of brotherhood and peace."

Structural system consists of bar joist floors and roofs carried on bearing walls of cavity insulated brick and on steel columns.

Major materials are Belden brick, concrete slabs, gypsum roof decks and plaster or stucco screen walls.

Heating from a single boiler is by forced warm air in sanctuary and offices and finned tube steam radiation elsewhere.

Square foot area of the building is 10,430; cubage: 121,970. Completed in 1955 the cost was \$135,000.

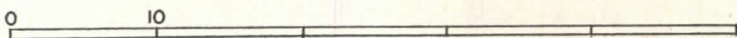
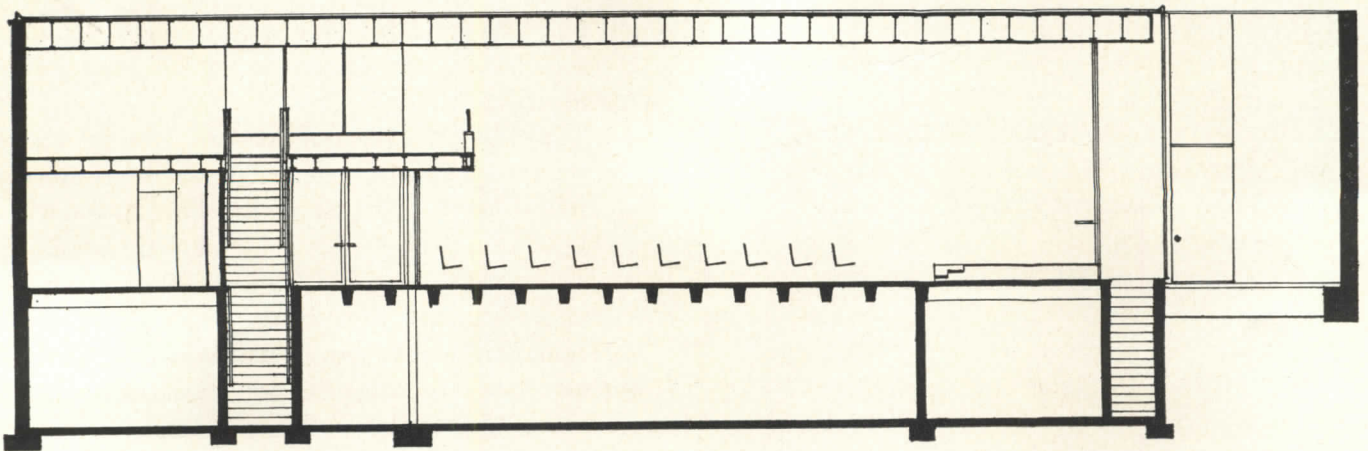
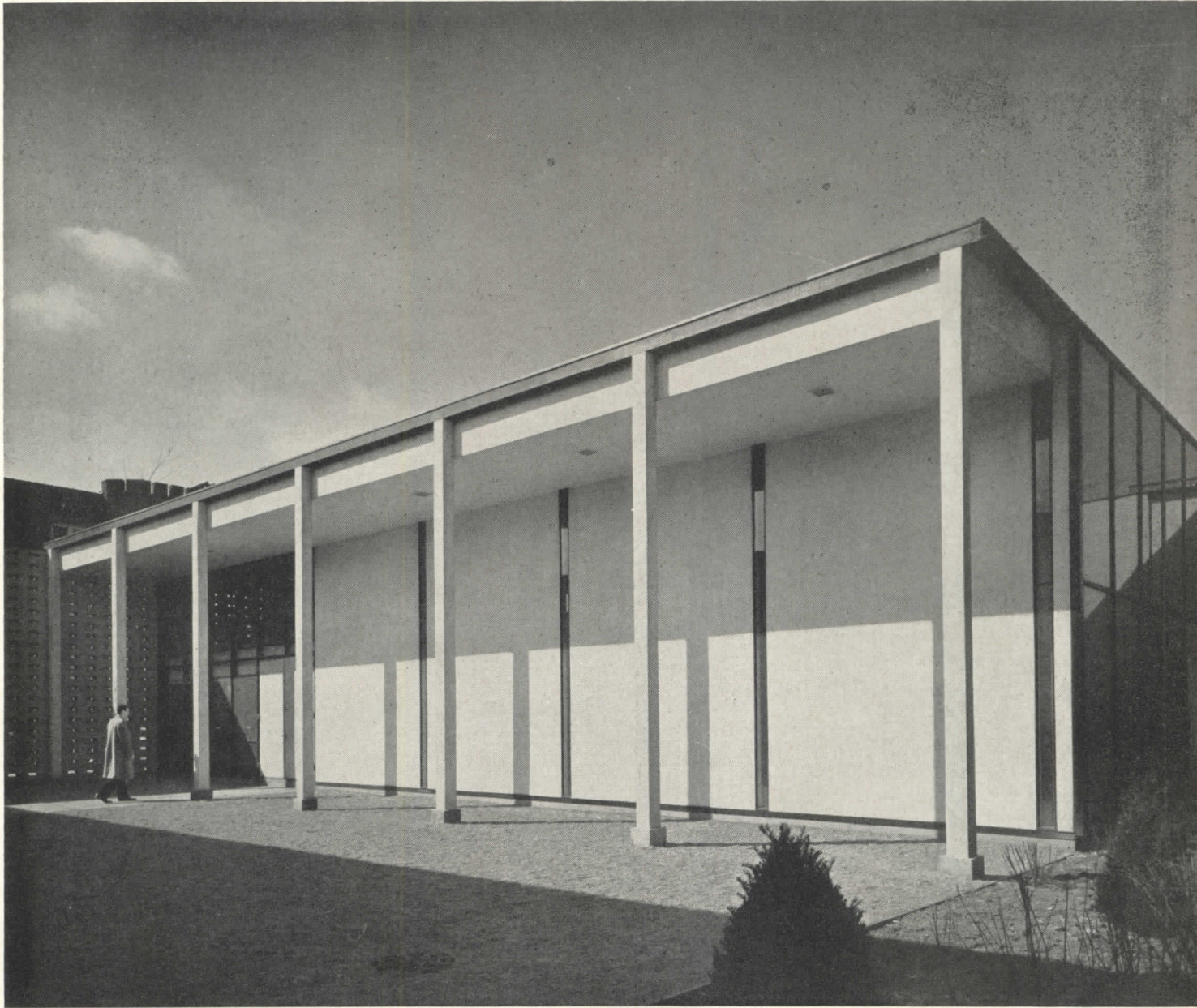



Ben Schnall

JEWISH CENTER OF WEST ORANGE, N. J.

*Davis, Brody, Juster & Wisniewski,
Architects*

*Beck, Simon and Mantel, Structural
Engineers*

G. Robert Goodall, Site Consultant

THIS BUILDING IS actually a community center in which religious, educational, and social facilities have been provided for round-the-week use.

Principal problems were organization of the various functions into an economical and flexible building and the creation of a religious atmosphere for the chapel distinctly apart from the rest of the building's uses.

The chapel seats 250 and is expandable to 350 by using the foyer. The multi-purpose room — normally employed for social and edu-

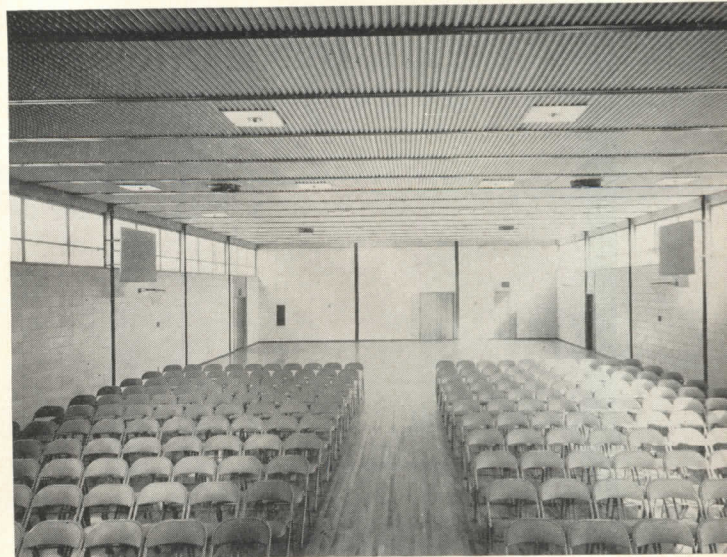
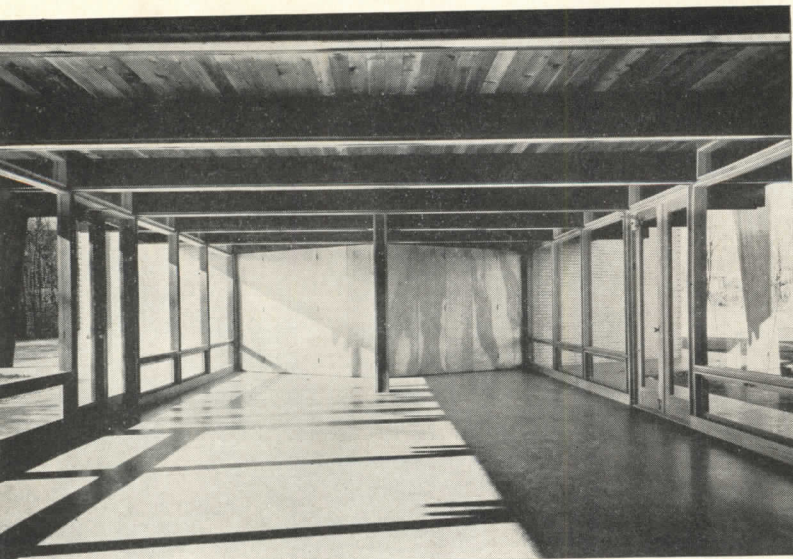
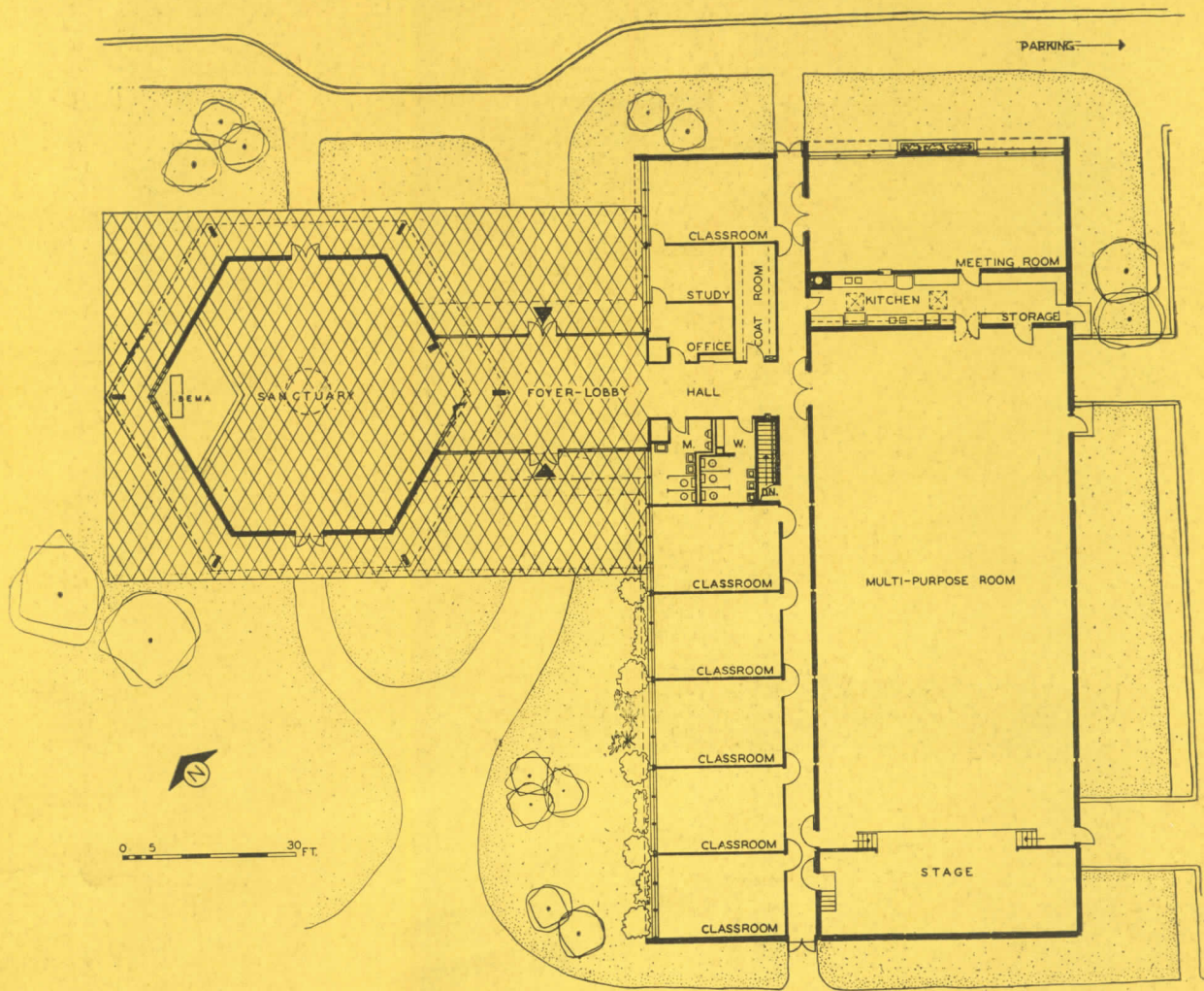



Ben Schnall

cational gatherings — can seat 750 for religious services on the High Holy Days.

The structural system in the chapel makes particularly handsome use of laminated wood arches and brick cavity walls. The roof here employs 4" wood decking as it does also over the classrooms, the meeting room and the foyer where it is carried on wood beams bearing on stud walls and marble faced block cavity walls.

The multi-purpose room is framed in steel using long span joists, composition decking and marble faced block cavity walls. As used here, the white marble faced block is an economical and attractive material.

Other principal materials are the buff manganese spot brick used inside and out in the chapel which has a wood ceiling and terrazzo floor. The same ceiling and floor materials are used in the foyer.

In the classrooms mahogany plywood faces the interior walls, the ceilings are wood and the floors are asphalt tile. The multi-purpose room uses a hung, perforated, white-enamelled, aluminum acoustic ceiling and maple flooring.

Heating in the multi-purpose room is by means of six hot water unit heaters in the hung ceiling, delivering through anemostats and fan-exhausted at the stage end. Elsewhere heating is through wrought iron floor coil.

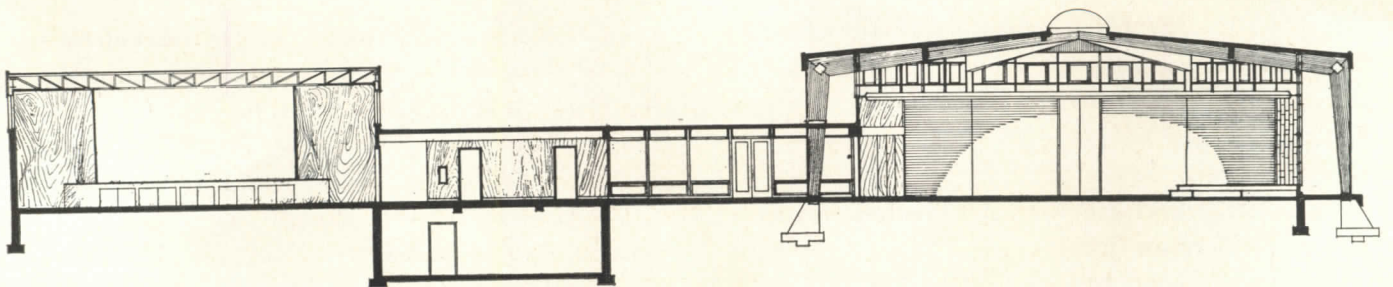
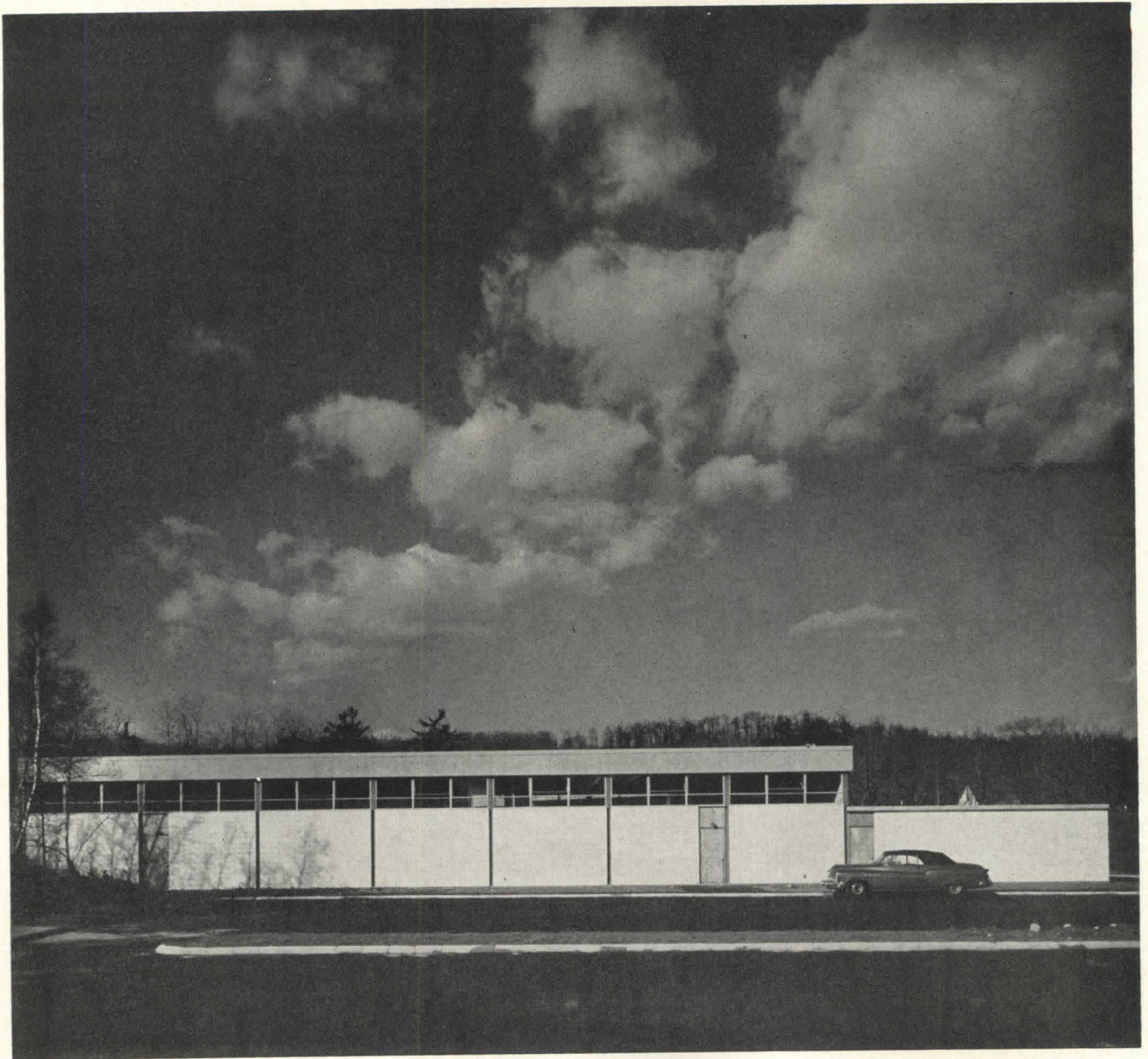



Hedrich-Blessing

ST. ANDREW'S CHURCH, PARK RIDGE, ILL.

*Charles Edward Stade & Associates,
Architects*
*M. Dolan and H. Anderson, Associated
Architects*
*Dr. A. R. Kretzmann, Liturgical
Consultant*
John Torell, Sculptor
*Clark Engineering Co., Mechanical
Engineers*

THIS SUBURBAN LUTHERAN church is a carefully detailed and well executed example of an approach to design which is on the generally conservative side of current efforts. Serving a middle-sized congregation, the combined seating totals 590 using both the meeting area at the rear of the nave and the church parlor as overflow areas.

The site is a level, corner lot, pleasantly shaded by maturing trees and generally free of difficult design determinants except for a busy highway that influenced the retired posi-

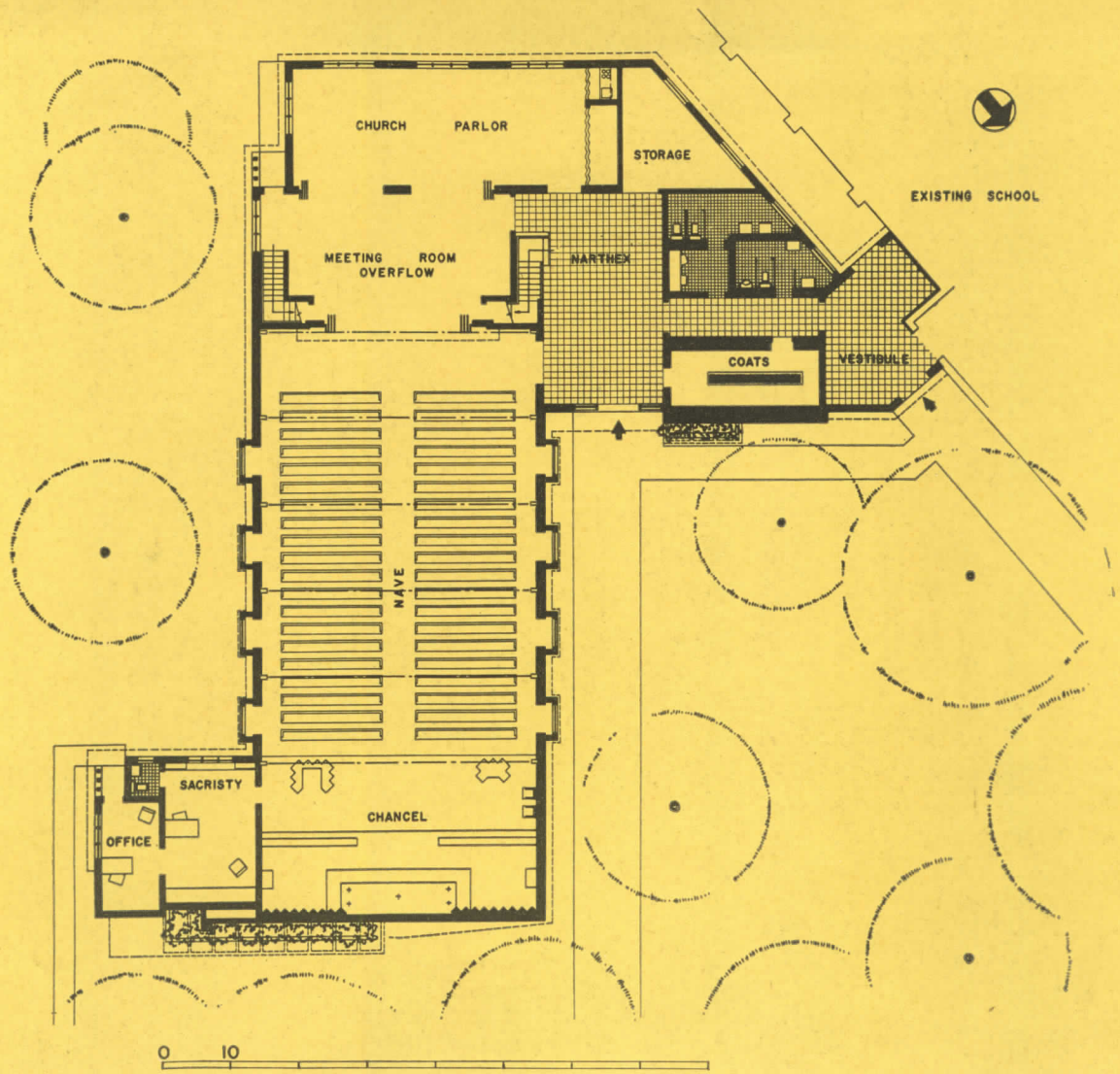



Hedrich-Blessing

tion of the main entrance. The total effect of the natural, and unusually rich, materials is most effective.

The roof structure is of exposed laminated trusses, purlins and beams carrying 2" x 6" T & G "V" joint fir planking. Walls are generally of face brick on both exterior and interior. Roof surface is asbestos shingle.

Cathedral glass is used in the high windows of the nave. Artificial illumination is furnished from concealed cove lighting and the suspended brass fixtures.

The architects have tried to focus principal attention on the large brick and stone altar and on the 21 ft carved oak cross. The three

plaques at the foot of the altar are also of oak as is the panelling in the sacristy.

The reinforced concrete slab floors are finished with asphalt tile. Sash, frames and doors are in wood; gutters, downspouts and flashing are copper. Rigid insulation is used in both exterior walls and on the roof. The exterior siding is redwood and in common with all wood surfaces inside and out is merely stained and protected. Some color accent is used under the eaves and on the doors.

Heating is by means of an oil-fired boiler; radiant hot water coils in a floor slab installation combined with wall convactor radiation.

Total cost of the building was \$151,000.

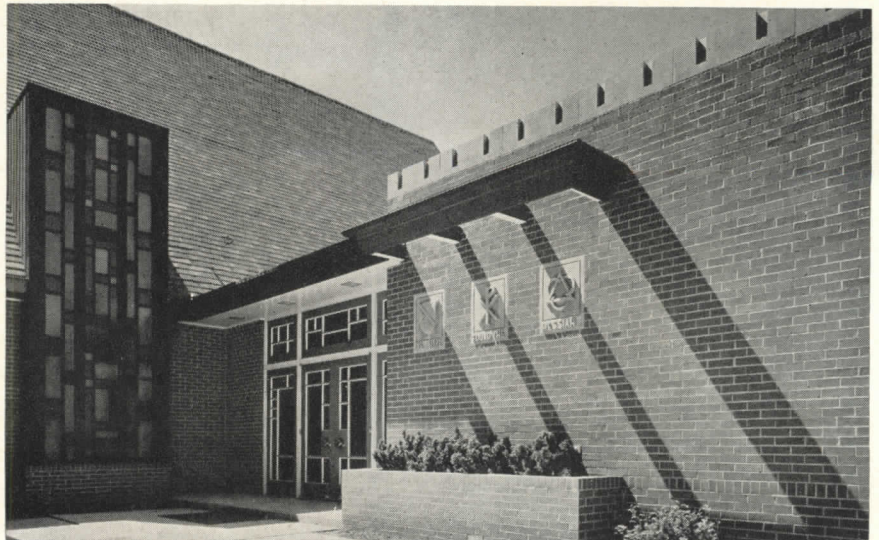
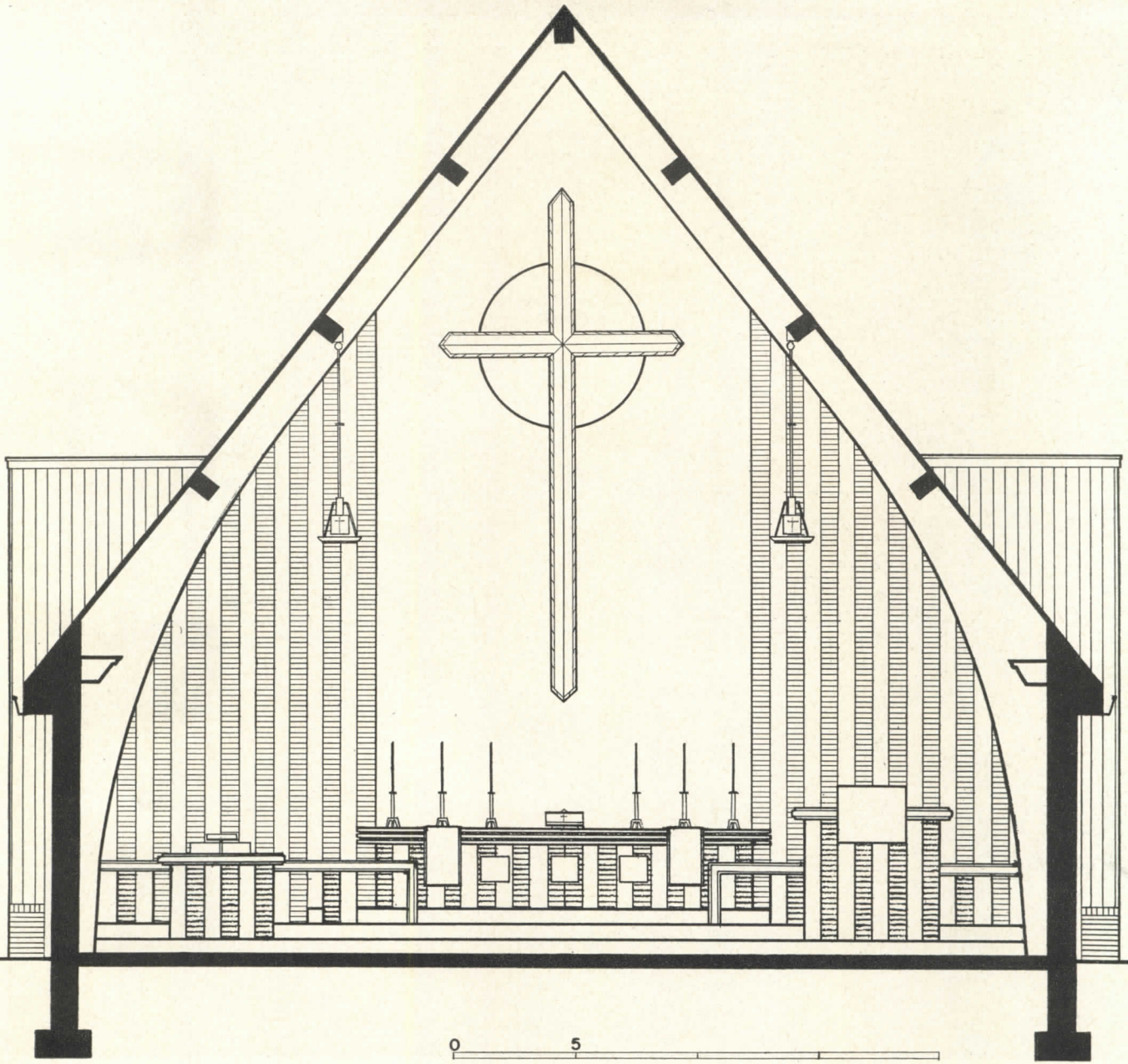



P. E. Guerrero

ST. FRANCIS OF ASSISI CHURCH, WESTON, CONN.

Joseph Salerno, Architect
James Fanning, Landscape Architect

THE CENTRAL FACT of Catholic worship is the altar, the table of sacrifice. In this church, the aim has been to express this idea as clearly and emphatically as possible. Roof and wall all incline toward the center. The variations in natural and artificial light help to accomplish the same thing with the brightest source in the glass steeple over the altar.

Since nowhere does the roof rest directly on the walls the sense of a floating ceiling is provided.

The orientation of the building provides

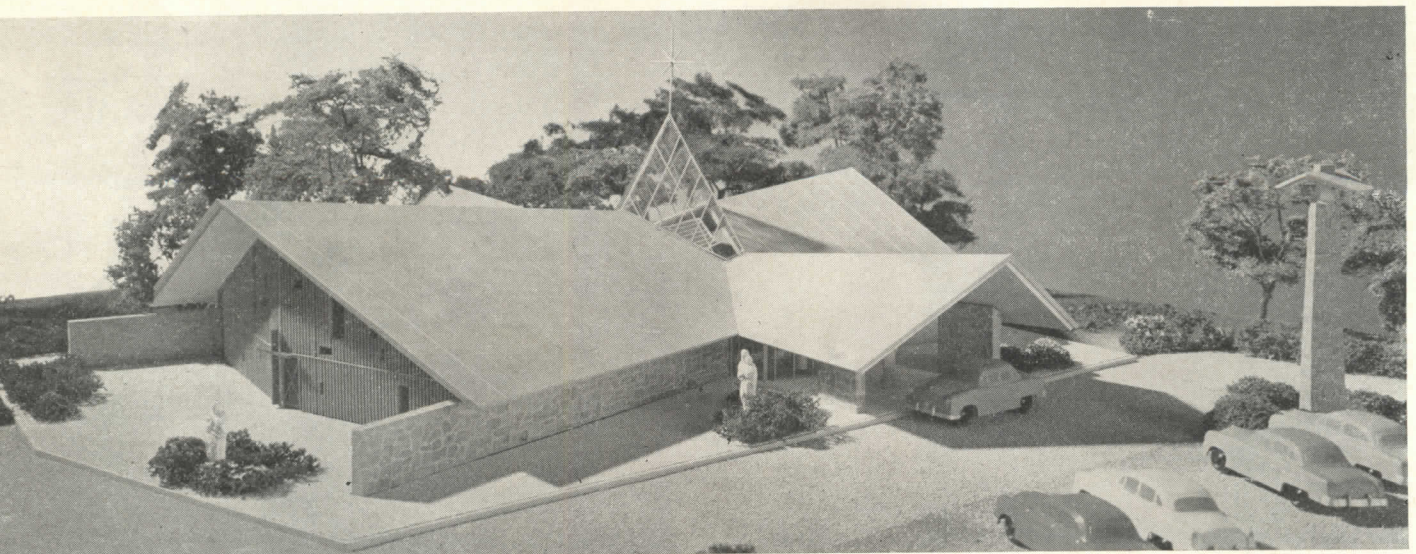
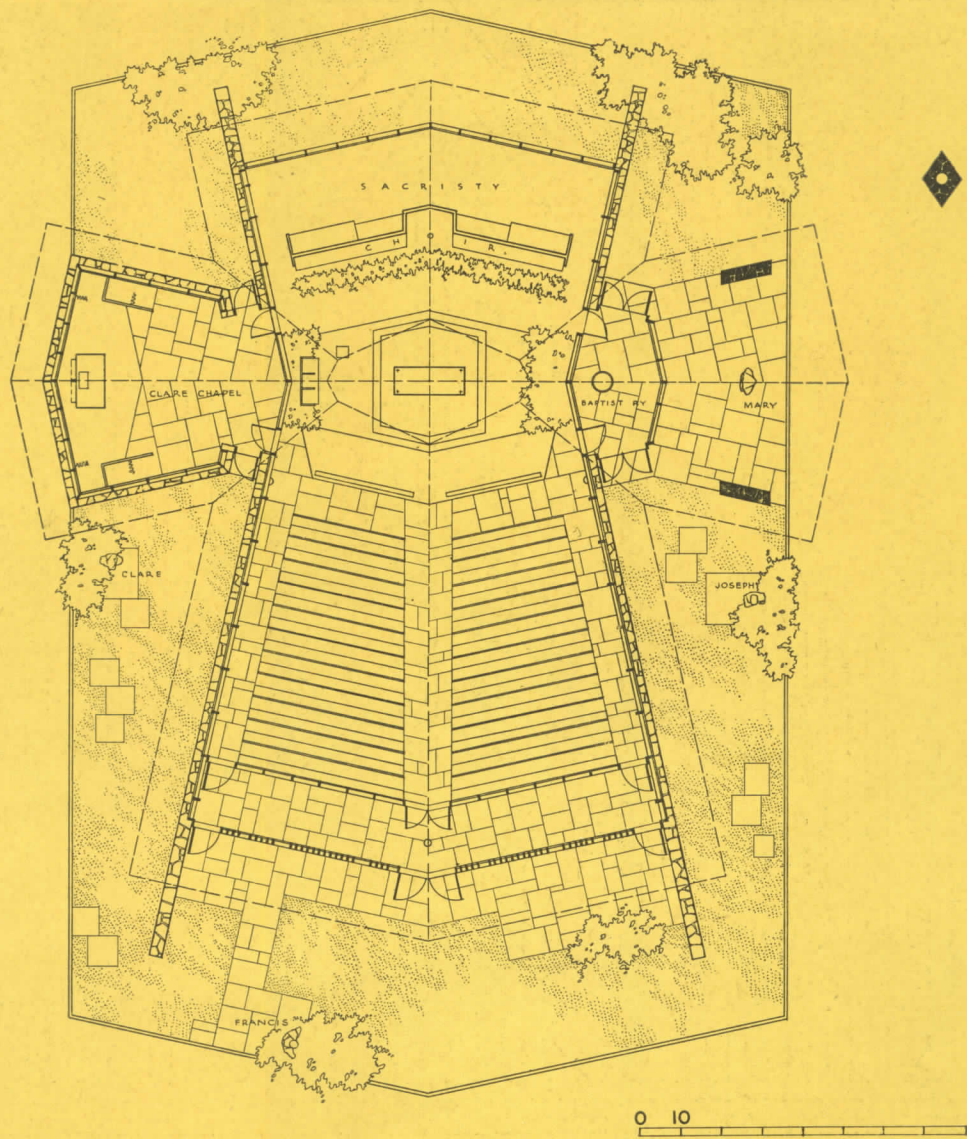



P. E. Guerrero

light from the back of the congregation for morning Mass. The subdued colors of field-stone and wood contrast with the white granite of the altar and sanctuary floor.

The amount of space given to the sanctuary and the liturgical position of the choir is unusual, and interesting. Mass may be celebrated facing the people. Planting in the sanctuary is in honor of the patron, St. Francis of Assisi.

The Clare Chapel serves for reservation, for daily Mass, small weddings, for confession and for small children at Sunday Mass. All sculpture, with the exception of the suspended crucifix over the main altar and the crucifix

in the Clare Chapel, is outside the church. Stations of the Cross will be in stained glass windows contained in the seven bays of the main body of the church. The east wall is designed to be demountable for expansion.

The church is the first building in a group which will include rectory, convent, school and parish hall.

The building was designed under the direction of Msgr. Joseph F. Cleary of Sacred Heart Church in Georgetown, Conn., and his cooperation, along with that of Father Corrigan and Bishop Sheehan of Bridgeport has been notable in the area of architect-clergy relationships.

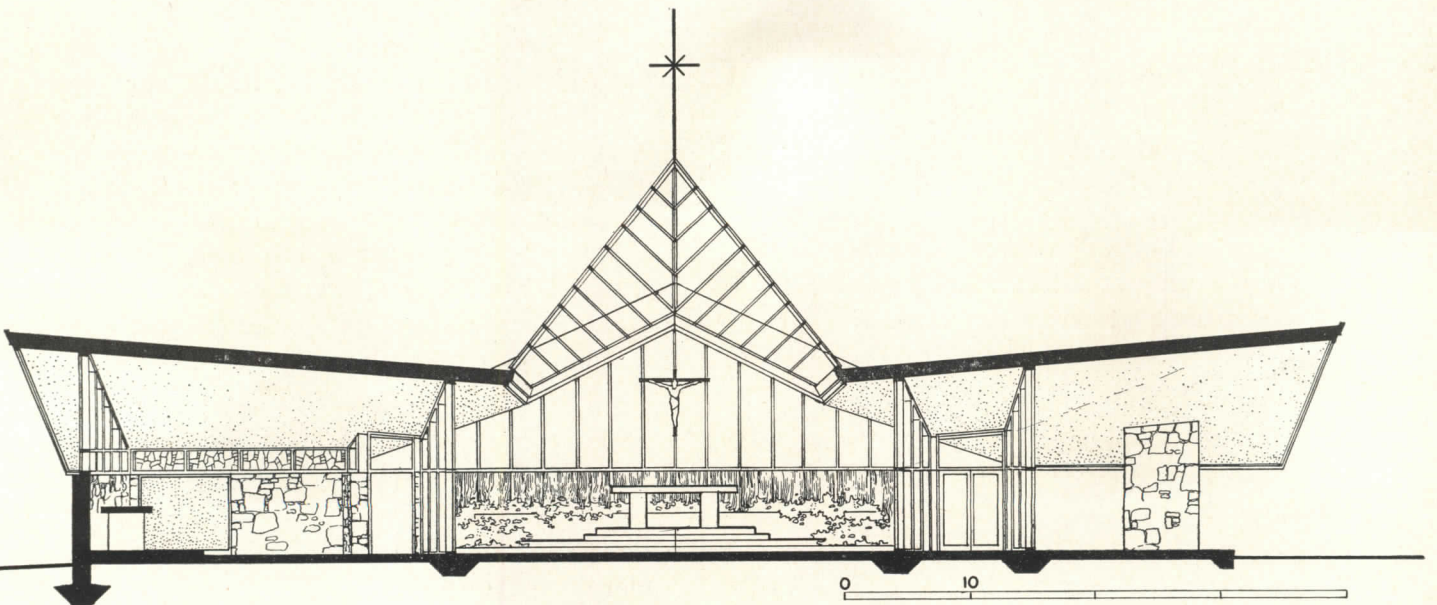
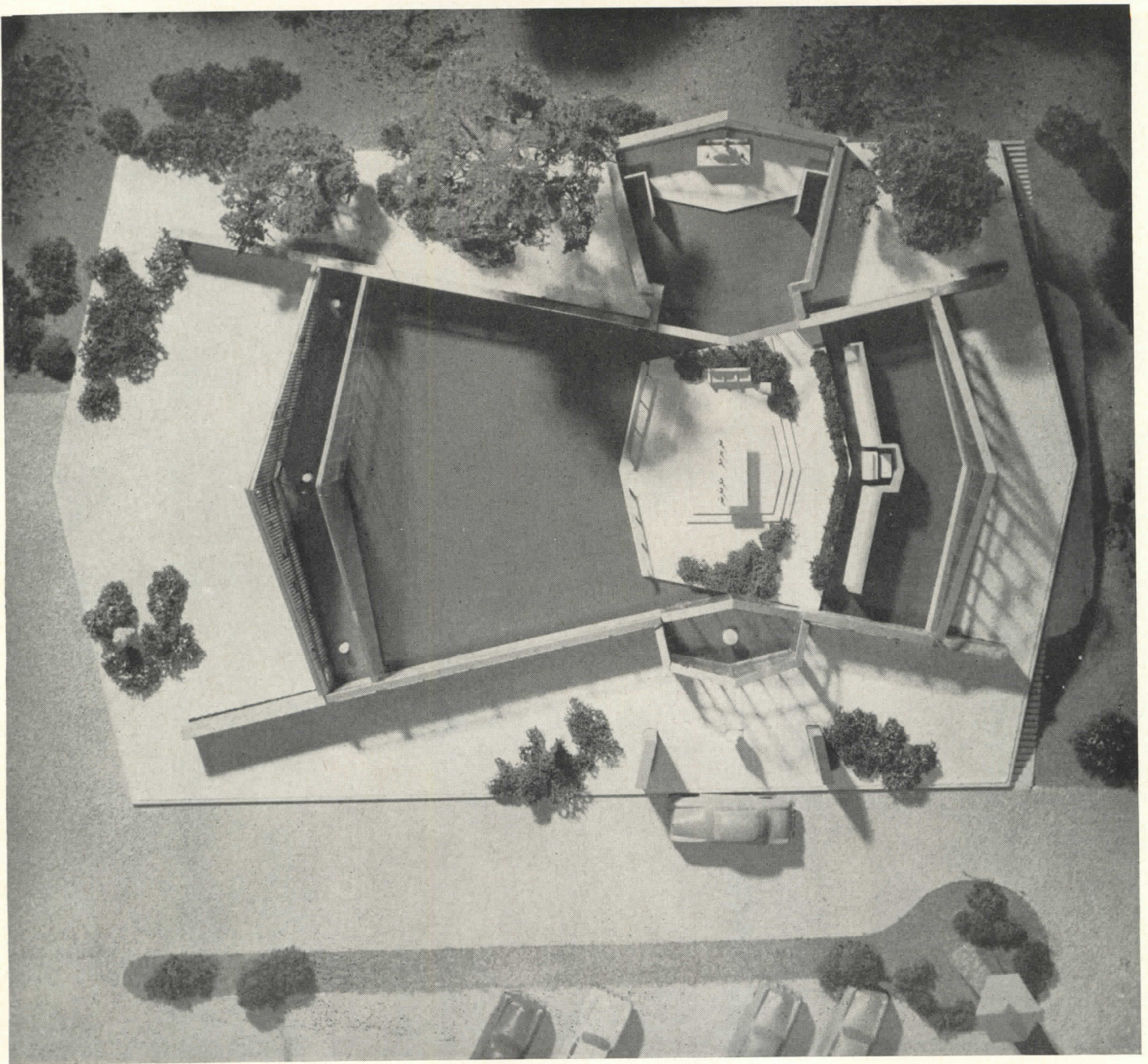



Dearborn-Massar

PILGRIM LUTHERAN CHURCH, BELLEVUE, WASH.

*Grant, Copeland & Chervenak,
Architects*
Stern & Towne, Mechanical Engineers
Howard Johnson, Electrical Engineer
R. C. James, General Contractor

THE PROBLEM HERE involved the design of a building for a new mission congregation in a rapidly growing residential area on the eastern shore of Lake Washington.

The trapezoidal site is about one mile from a small business district and because it is relatively low-lying demanded a membrane slab.

On a budget of \$30,000 the architects were asked to provide seats for about 140 and some method of handling overflow attendance. Here, as in many formative congregations, the archi-

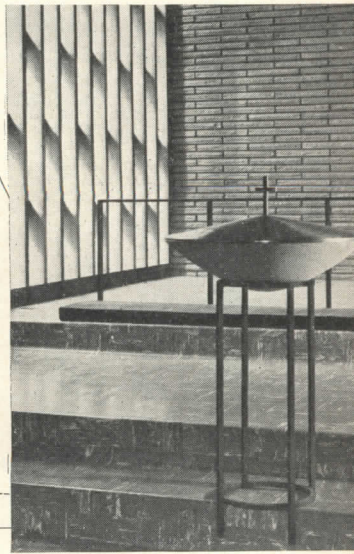
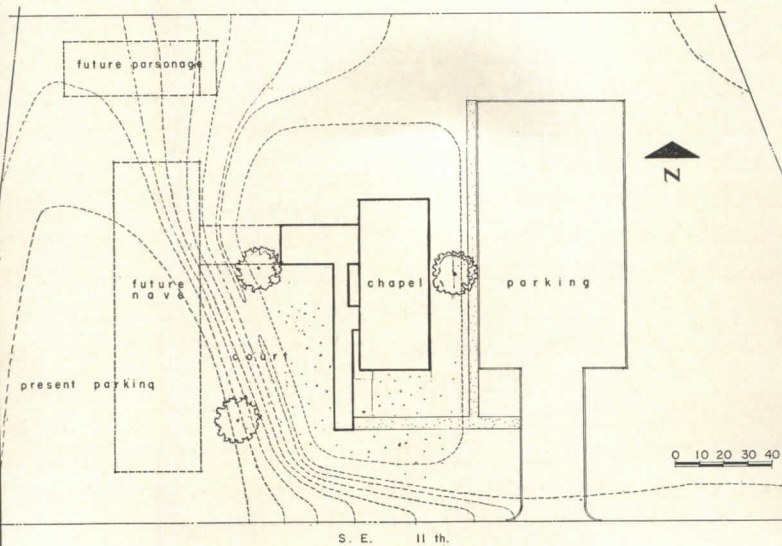
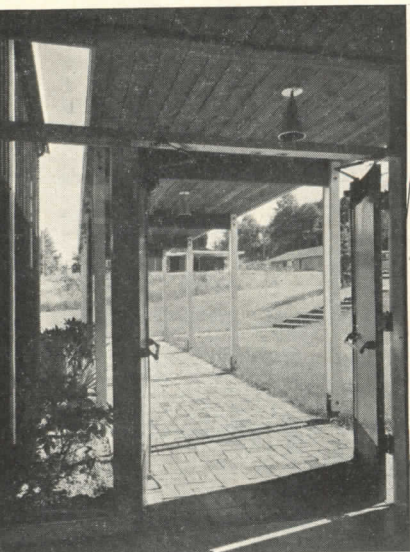
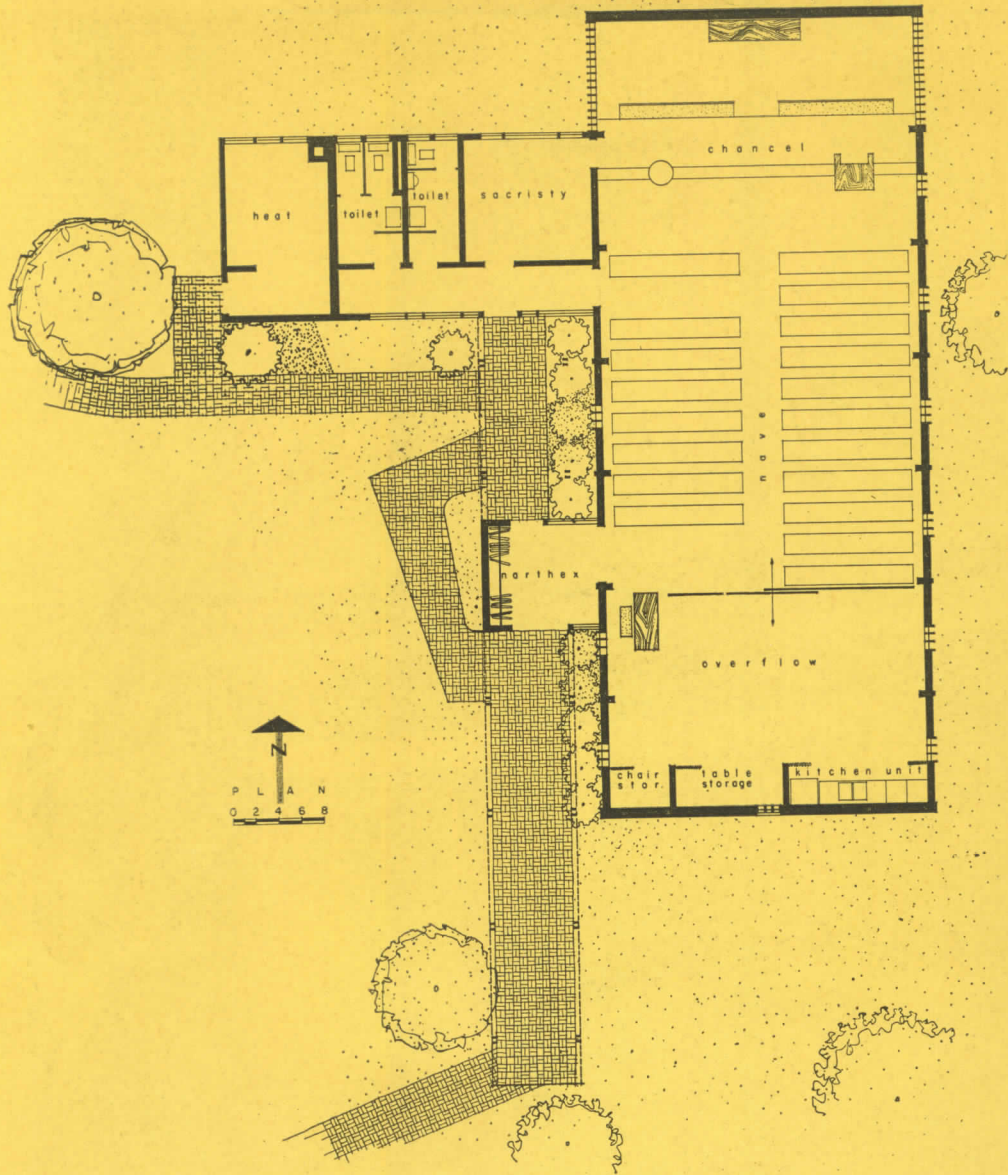



Dearborn-Massar

pects had to design a suitable worship space that would, in time, become an all-purpose parish hall and educational facility. For the time being all activities take place in the temporary nave and are organized by means of a large screen which rolls forward to permit parish activities in the rear and by L-shaped nesting screens which divide classroom spaces there.

The structure consists of glued-laminated arches with 3 x 6 fir "V" joint wood decking for the ceiling and roof construction. Nave walls are 2 x 6 studs with 1 x 8 cedar boards both inside and out where 2 x 3 battens cover the joints.

The full height nave windows are glazed in reds, greens, blue-greens and purples.

Interior colors are stained shades of brown and ivory, accented by the dull black mild steel elements of the communion rail, font and pulpit whose top is white birch. The font is cast stone with a spun copper cover and a copper cross. The altar is faced with travertine.

Exterior siding is stained a warm brown with columns, trim and facias painted white. The roof is covered with white marble chips.

The contracted cost of the chapel was \$28,500 or about \$10.68 per sq ft. Brick sidewalks, interior staining and painting were donated by the members.

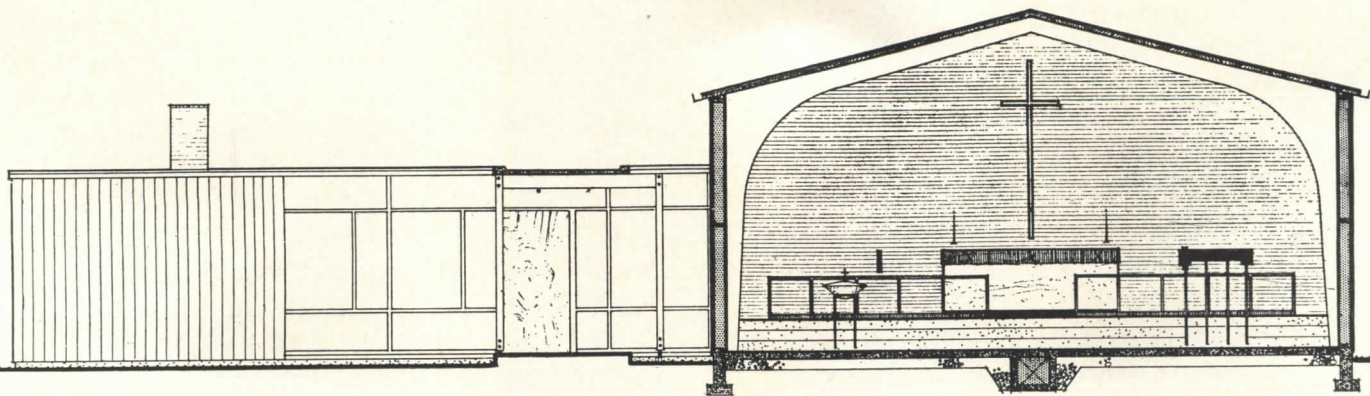

0 2 4 6 8

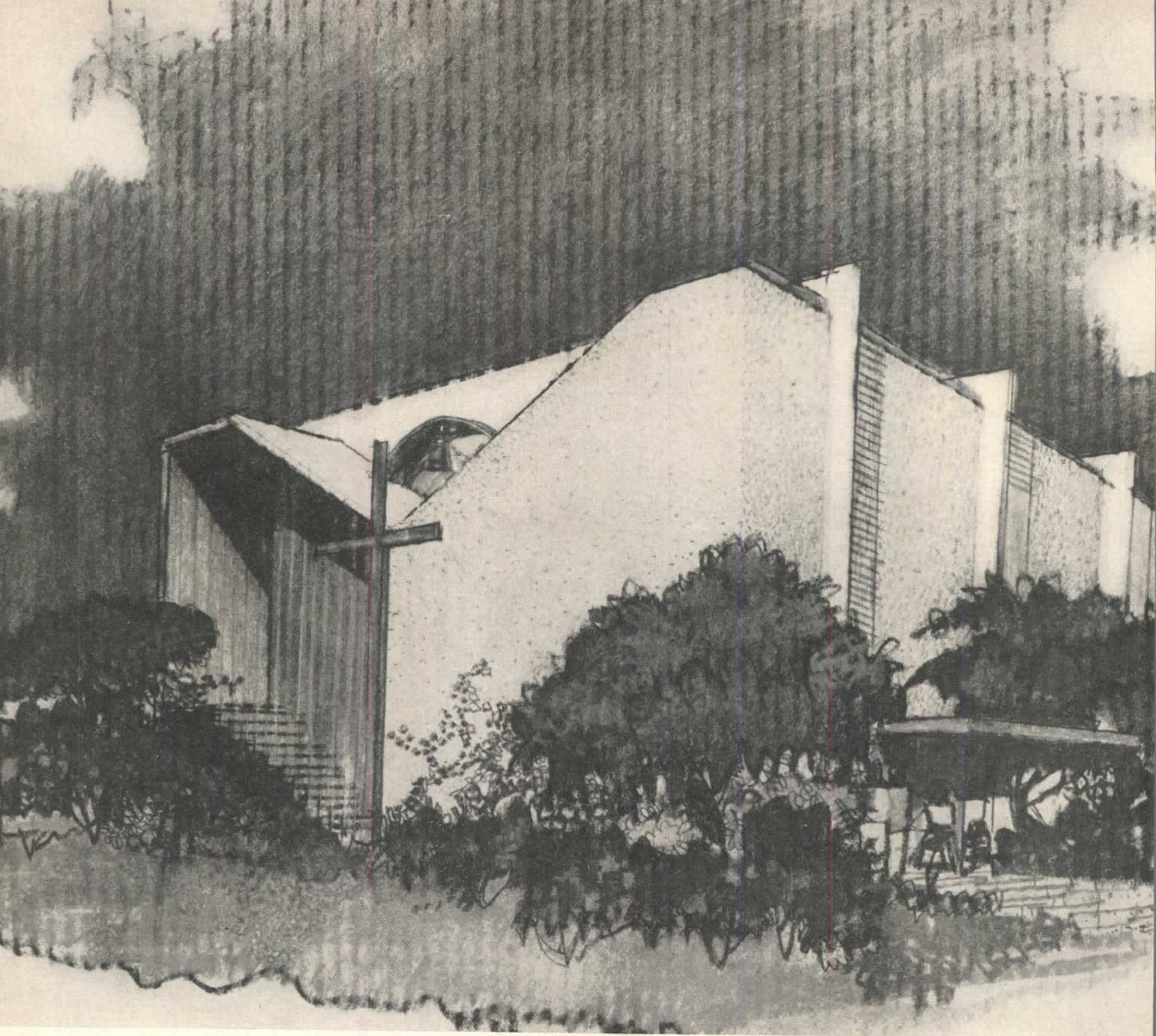

Julius Shulman

INTERDENOMINATIONAL CHAPEL, MIRAMAR, CALIF.

Richard J. Neutra and Robert E. Alexander, Architects

Dion Neutra, Robert Pierce, Howard Miller, Richard Stadelman, Benno Fischer, Sergei Koshin, John Blanton, Toby Schmidbauer. Perry Neuschatz, Gunar Serneblad: Collaborators

*Parker and Zehnder, Structural Engrs.
Boris Lemos, Mechanical Engineer
Earl Holmberg, Electrical Engineer
D. J. Free, Acoustical Conslt.*

THE PROGRAM for this chapel asked for 600 seats plus an additional 120 for religious education and the morning chapel.

The plan was dictated by the site and by such special requirements as the rotating and disappearing altar which has been designed to serve Saturday and Sunday schedules for the interdenominational use of the community.

Structure of main chapel is of precast concrete arches and wall panels, with gypsum roof and hung plaster ceiling. Other structures are of concrete block with wood roofs.

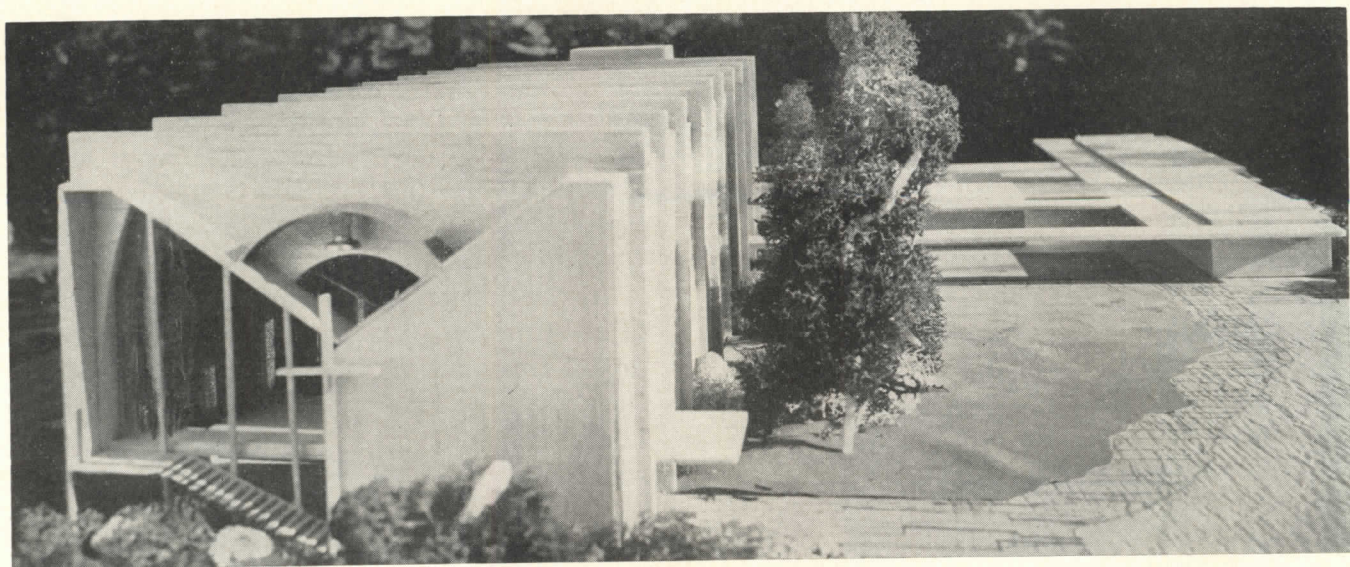
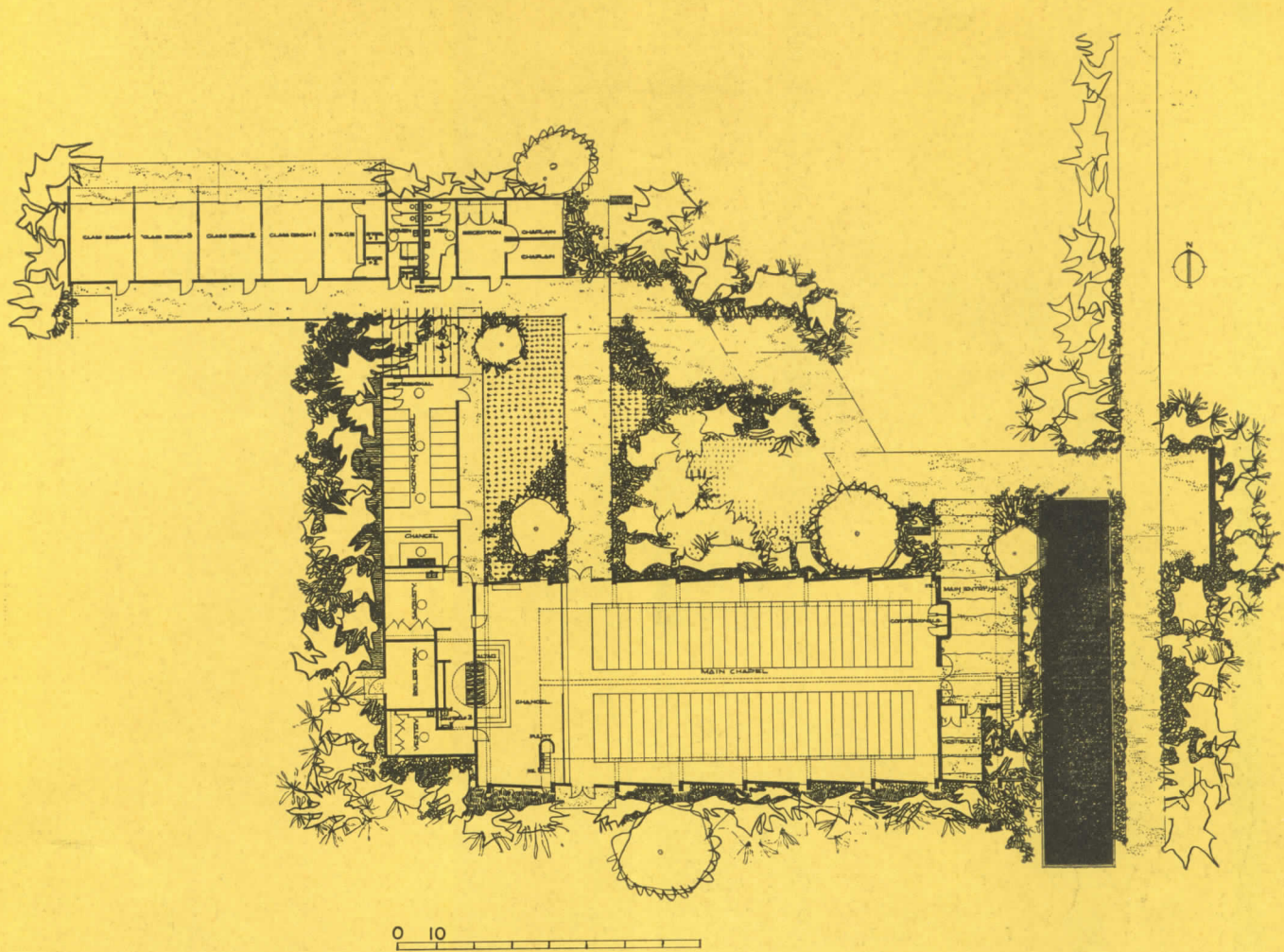

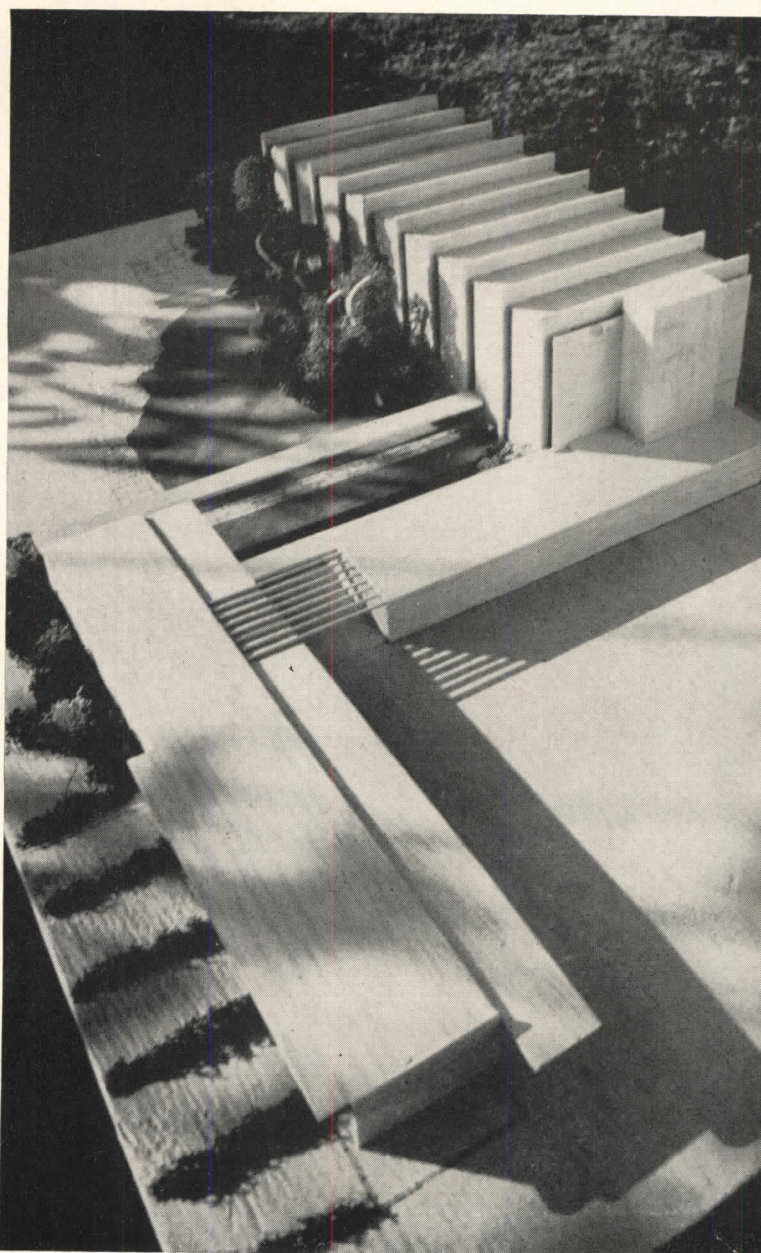
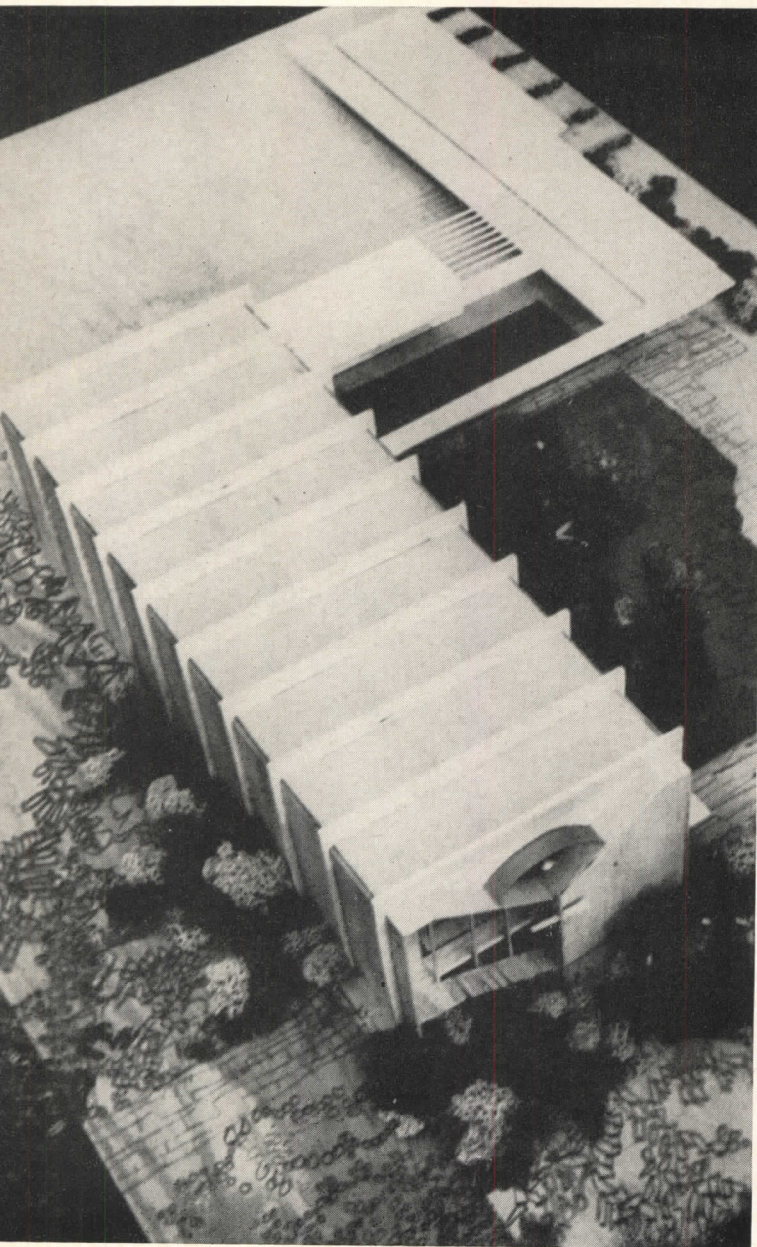

Julius Shulman

FROM THE ARCHITECT'S OFFICE:

The architects feel that the western and in fact most religions have in common the need to express a processional, or dynamic "moving forward," toward the altar or focus of worship. Mr. Neutra, in his book "Survival through Design," has pointed out the physiological basis of ritual patterns as well as of all human behavior. The architect must be interested in this in order to serve man right, whenever and wherever it is.

Space is the great universal experience of

man and it has for man its deep cargo of religious feeling. But this is not geometrical space rationally and abstractly analyzed by Euclid. It is space experienced through all our millions of sense-portals and with all our inner being. Apart from the indifferent Euclidean Space, the vibrant, sensory experience of it is *directional*. It has an up and down, a forward and something overcome and left behind.

Nature has set our eyes in the front of our head, it is no indifferent accident that our arms

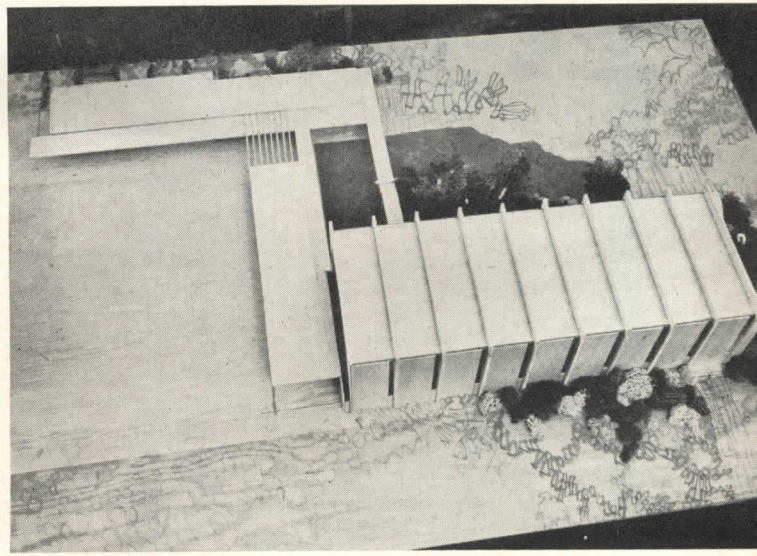
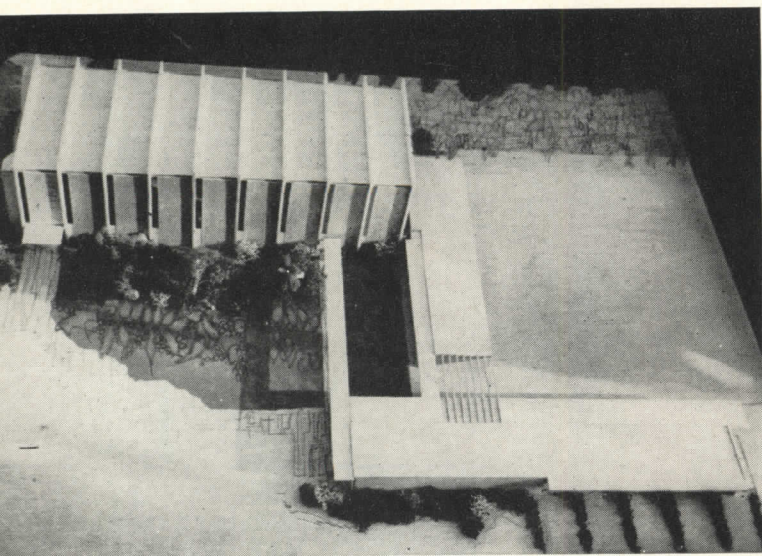
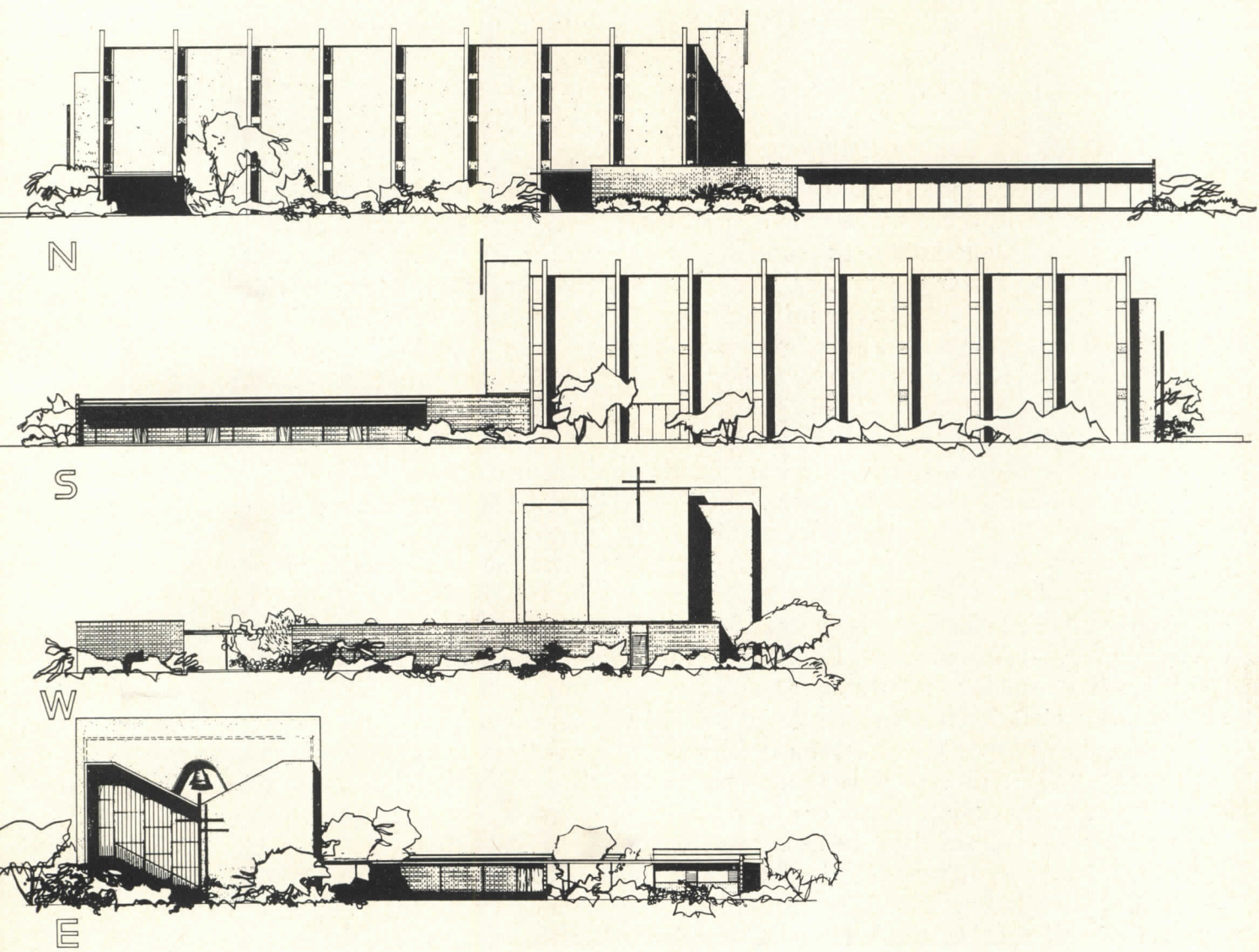

INTERDENOMINATIONAL CHAPEL

are jointed to be raised forward and our legs carry us, where our vision leads. Our entire nervous makeup puts emphasis on direction and direction in space has acquired spiritual accent through one hundred thousand years, and later from Luxor to Chartres.

In addition to the natural forward move horizontally there should also be expressed an upward or heavenward tendency, which must be, by necessity, mostly visual. This feeling should impress itself on the visitor the moment he enters the church, and preferably he should be aware of it even before he enters.

The concept of this church creates this feeling in a way which will be kept in the memory of the onlooker. Starting with the outside, we see a symbolic bell, as has been used for convocation through many centuries. The bell is silhouetted against an interestingly translucent opening which is illuminated at night. This opening is seen over the valley formed by the inverted "V" — an expressive shape — of the ceiling as extended to the exterior of the building. From one side of the ridge is supported a unique hanging stair which, by its upward slant, symbolizes spiritual ascent. A glass screen is all that separates here the interior and exterior, so as to make this entry to a higher plane as inviting as possible.

The main nave entrance is approached through an open archway below the balcony into an interesting covered porch or vestibule. From here one can choose either to ascend the stair to the gallery, or enter the nave.

Immediately on entering, one feels the impression of the upsurge mostly through the shape of the massive concrete frames on both sides which tend to arch over but disappear behind the ceiling, high above, as if over clouds. The only natural light sources occur,

concealed, forward of each frame. Being thus shielded, they will spill light toward the altar but not toward the observer looking forward. The shape of the floating ceiling, being higher at the edges than at the center, will seem to soar upward. But also the ridge of this ceiling, starting low over the balcony, rises and, especially when lighted, guides the eye upward and forward toward the altar.

The altar itself is illuminated by an inconspicuous, rather concealed, continuous skylight across the entire width of the nave, returning down the sides of the chancel or pulpit platform.

An unusual, dynamically graded division of the plastered rear wall of the altar heightens the perspective effect and gently emphasizes the spiritual importance of the altar wall, toward which all the directionalism of the design converges.

Vestment and sacristy rooms are grouped behind the chancel and altar, with convenient access for services to the main chapel and the more intimate morning chapel.

The main court or patio of the chapel is formed by the long wall of the chapel on the south, the cloister of the morning chapel on the west, and the main pedestrian approach walk on the east. Access to the chapel by car is from the west to an ample parking lot, where auditory disturbance is removed from the churchgoer, and then past pleasant Sunday-school class-rooms opening in a friendly way onto nature and onto their own outdoor landscaped patios. The main cloistered courtyard seems to follow an early California pattern.

Faint night illumination of the exterior of the chapel from below, and of its grounds, is planned so that at all times this spiritual focus of a community never disappears.

PRECAST CONCRETE

A survey of current U.S. practice, with emphasis on prestressing

Photo, Lone Star Cement Corp.

WHILE INTEREST in concrete has centered on its dramatic engineering possibilities lately, an aspect of concrete technique which merits close attention is that of factory-made precast units. The list of fabricators who are now producing precast structural members, particularly of the prestressed variety, is growing by leaps and bounds.

To get an idea of what kinds of precast buildings are being constructed, as well as a picture of the average fabricator's practice, ARCHITECTURAL RECORD surveyed some 30 companies. What follows is a background of recent developments along with some specific data regarding fabricators' operations.

The Development of Precasting

Precasting is an old art (strictly speaking, a concrete block is a precast unit). Roof and floor decking as well as precast joists have been available for a long time. But it wasn't until World War II that fabrication of large structural components made much headway. Tilt-up construction became quite popular with wall slabs and framing parts being cast at the site directly on top of the floor slab.

In the last two or three years, precasting has been given a big boost through the use of pretensioning for prestressed members. This is a logical adaptation of the prestressing principle to the construction practice and labor

economy in the United States. It makes possible the casting of hundreds of feet of beams and other structural parts per day on a production-line basis.

What is Pretensioning?

In pretensioning, the strands or wires (sometimes called tendons) are stretched first between heavy anchorages which are part of a casting bed, usually made of concrete (see page 216). Forms are set up and concrete is poured around the wires. After the concrete hardens, the tension on the strands is released gradually, and the force is transferred to the structural member by means of bond between concrete and steel.

In post-tensioning, the structural part is poured around un-stretched tendons, and after the concrete hardens, the steel is stretched to the proper tensile force, after which the steel is fastened to anchorages at each end. The prestressing force, then, is applied initially through the end anchorages, even though the steel may be grouted in later to form a bond.

Why the introduction of pretensioning, and what does it mean to the building industry? When prestressing was introduced in the United States, it was greeted with a mixed reaction of enthusiasm for its structural possibilities, but with doubts as to overall economy because of such factors as these: the complexity of the prestressing operation

itself (post-tensioning was used in all early structures), the cost of anchorages, and the unfamiliarity of contractors. Nevertheless, it was used where long spans and heavy loads justified it — and still is for that matter. Post-tensioning is used also when it would be difficult to transport pretensioned members because of size and when they are not available. Sometimes a combination of post-tensioning and pretensioning is employed. The members are pretensioned sufficiently for handling, and then post-tensioning is applied at the job site for the remainder of the prestress necessary.

Advantages of pretensioning are twofold: lower cost and closer control of quality afforded by central plant production. The prestressing steel and the stressing operation cost only about one-half — and sometimes less — for the same force applied by post-tensioning. In addition, the mechanization achieved with a casting bed reduces the cost per cubic yard of concrete to a minimum.

The maximum economical length for pretensioned girders is in the range of 60 to 70 ft. Even so, above 50 ft serious consideration should be given to a combination of the tensioning methods. Such members are economical up to the maximum lengths that can be transported.

The practice of pretensioning in Europe uses single wires for the tensioning

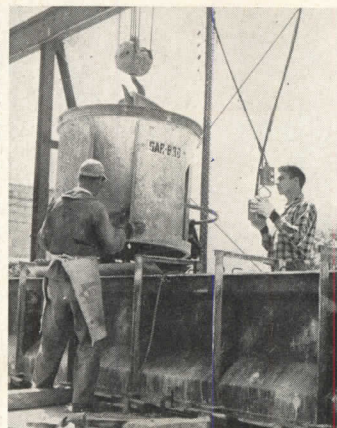
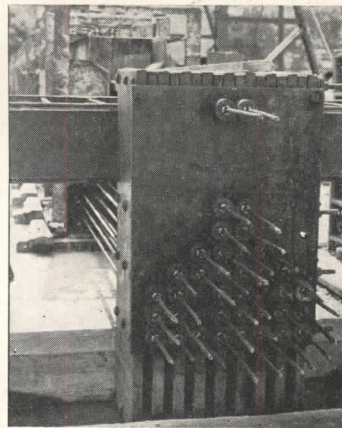
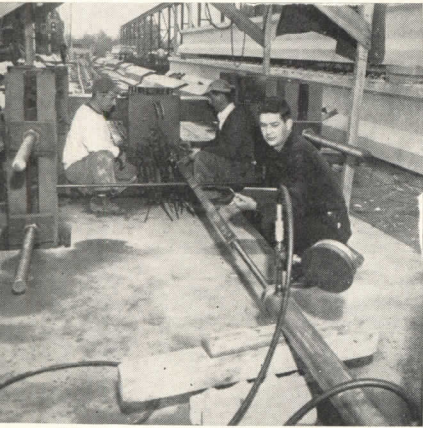

Pretensioning: shown above are bridge girders being fabricated in a casting yard. Stranded wires are pulled one at a time to the required tension (left) and held in place by steel wedges; fixed end of the casting bed is shown in second picture. After the concrete is poured and hardens, tension in wires is gradually released by hydraulic jacks until the total force is transferred by bond to the girder

Post-tensioning: before the girder was poured, flexible conduits containing a group of high tensile wires were hung in a form. After the concrete hardens, a double acting jack tensions the wires simultaneously, after which a ram within the jack drives a cone wedge into the girder for anchoring

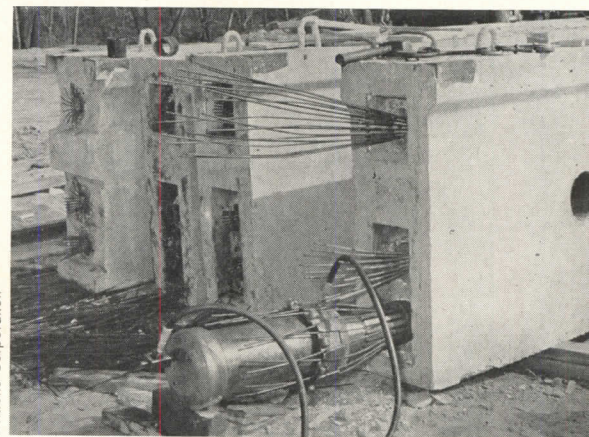

Dextone Corporation

elements. High stress per wire is possible in small sizes, but it takes a large number to get the total pretensioning force.

A recent American development is the manufacture of 7-wire strand, $\frac{3}{8}$ -in. in diameter. The salient feature of stranding is that it concentrates a high prestressing force in a small area, reducing the number of tensioning elements to be handled, perhaps saving up to 8 per cent of the cost of the steel.

The trend is toward larger and larger strands — up to $\frac{1}{16}$ in. — for big girders. For small and thin sections, $\frac{1}{4}$ -in. and $\frac{5}{16}$ -in. strands are used.

This is the way the pretensioning process goes:

(1) Strands or wires are anchored to one end of a casting bed and to a tensioning device at the other end. Tension is applied by a hydraulic jack and then maintained by anchoring each strand, group of strands or wires to the

bed. The tensioning device then can be used elsewhere.

(2) Forms are placed along the bed with additional mild steel as required, and concrete is poured from a mobile bucket.

(3) After sufficient curing to bond concrete to strands or wires, the tensioning device is applied again and the stress is gradually released so that the force acts directly, through bond, to the concrete member. A cutter or welder's torch is used to cut the strands between each member along the length of the casting bed. Casting beds in the U. S. run from around 100 to 450 ft. Some in Europe are over 1000 ft. Concrete, itself, is used for the casting bed to provide a base for the poured member and to provide spaces for anchor posts at various distances along the bed for tensioning the strands or wires.

The tensioning elements are stretched singly when the fabricator desires to make a wide variety of units on the same casting bed. When repetitive operations are called for, such as with channel slabs and other standardized units, then the prestressing steel is tensioned all at once.

The concrete mix is designed to produce high strength and high bonding

Precast roof panels have a pleasing appearance so they were left exposed in this school recreation building. They are supported by precast concrete hinged arches

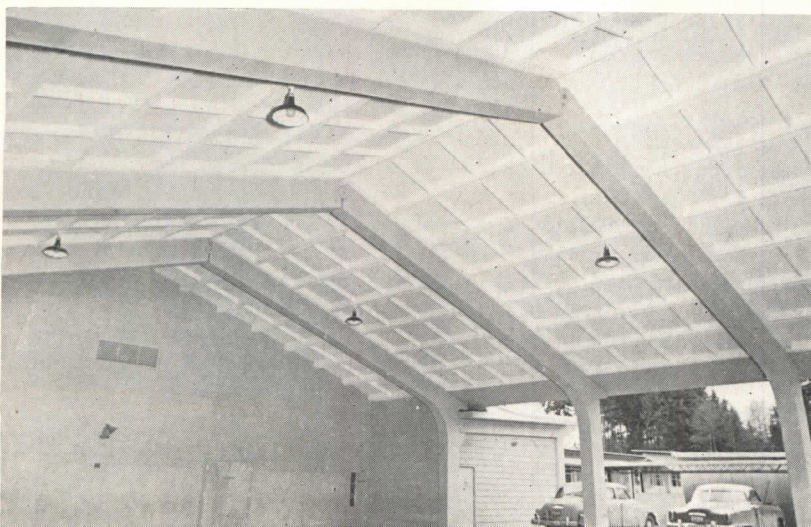

William Arild Johnson, Architect, Associated Sand & Gravel Co.

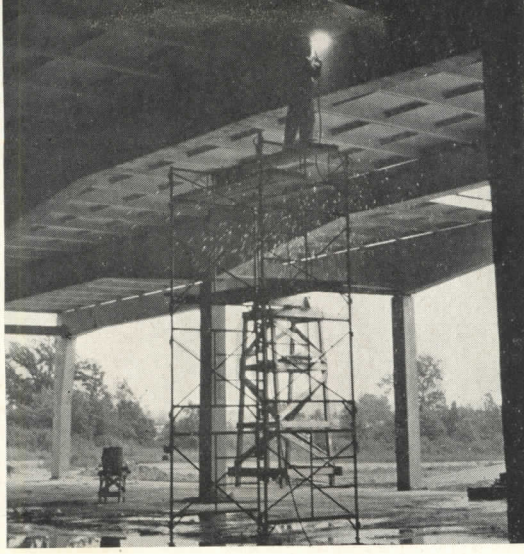
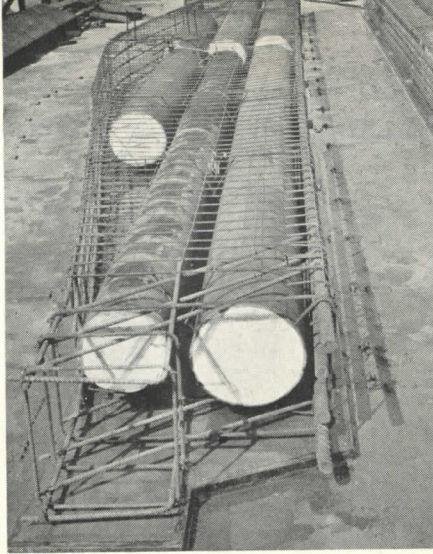

Three similar warehouses, 200 by 600 ft, at Great Lakes Naval Training Center were all-precast concrete consisting of rigid frame members, wall and roof panels and loading dock canopies. Hollow tubes were inserted in the reinforcing cage for the top section of the rigid frame to reduce the dead weight. Roof panels were attached by welding of insert plates

Concrete framing for a school is made up of special prestressed concrete blocks. The 24-ft joists of 8- by 16-in. blocks are supported on ledges of prestressed beams, reducing the total depth from the top of the precast slab to the bottom of the corridor beams to 22 in. Joists were tied together with steel plates attached to anchor bolts. Beams were made continuous over columns by placing reinforcing in grooves provided in the top of the beams

Thomas, Ross and Stanfill, Architects; Ross Bryan, Engineer; Nashville Breco*Block Co.



value in the shortest possible time. To get high-early bond the following practices are employed: (1) very dry mix with air entraining cement; (2) internal and form vibrators, (3) steam or hot water curing; (4) low water-cement ratios. Concrete strengths run from 4000 to 5000 psi, and even higher in some plants (up to 10,000 psi).

The Future for Prestressing

Advocates of prestressing feel that the major problem facing this system today is utilizing it so as to (1) make it fit the standard methods of building familiar to the average contractor, and (2) still provide a building acceptable to architect, engineer and owner.

When precast, prestressed members are fabricated at a plant and hauled to the site and erected, the contractor uses them in much the same manner as he would steel. All he has to do is erect the members, which have been prenumbered as to location, by crane and join them either by welding of steel plates embedded in them, or by pouring concrete joints around projecting reinforcing steel. Only a little concrete needs to be poured in the field; exposed surfaces will have a more satisfactory finish for painting directly.

Advantages of "Factory" Operation

The concrete fabricator can produce structural members in a plant regardless of inclement weather. If the members are ordered far enough in advance, they can be stored in erection sequence, eliminating on-site storage, and they can be ready for use as soon as foundation and floor slab are completed. Steam or hot water curing reduces the setting time to speed up the "production line," and this mass production coupled with trained plant labor greatly reduces cost. High quality, no-slump (very dry) concrete can be made with factory conditions, providing high compressive strengths in the neighborhood of 5000 psi, and sometimes more.

Construction Time

Some fabricators report that often it is possible to complete a structure in less than half the time required for conventional methods in concrete. Since production is unhampered by weather (if the work is done inside), delivery and erection go ahead without delay.

Within metropolitan Houston, one fabricator puts up a complete structure, including walls, at an average speed of 7500 sq ft of area per day. Framing with roof decking averages 10,000 sq

ft per day. The work is handled by a motor crane with a two-man crew, five to six ironworkers, and a superintendent.

Types of Components Fabricated

The types of units produced include the following: *Prestressed* — girders; beams of I, T, WF or rectangular shapes; roof and floor decks of double-T section; channel slabs; joists of I and T section; stadium seating; columns; rigid frames; lintels; light poles; pilings. *Ordinary Precast* — wall panels and spandrels; beams; joists; columns; channel slabs; arches; rigid frames.

Nearly 85 per cent of those answering ARCHITECTURAL RECORD's survey produce prestressed beams and girders; 65 per cent, channel and other roof and floor slabs; 45 per cent, double-T slabs; 50 per cent, joists; and less than 25 per cent, columns.

In ordinary precast concrete, 70 per cent make beams and columns, floor and roof slabs; 50 per cent, joists; and a little over 25 per cent, arches and rigid frames.

Methods of Connection

Connections are made usually by welding of steel plate inserts embedded in the units; poured concrete joints around

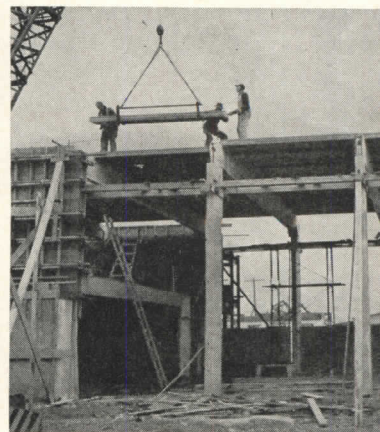
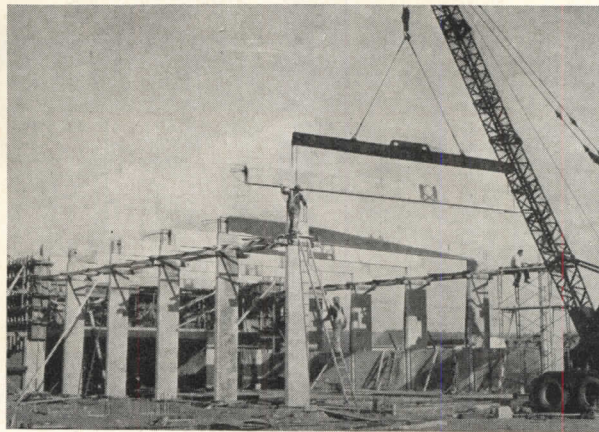
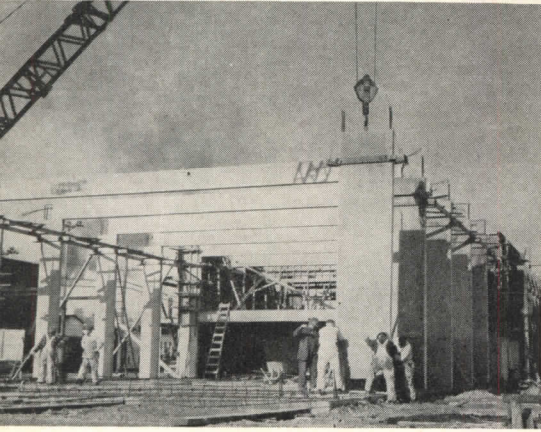

A National Bank of Washington branch building is precast concrete including flat columns, which serve also as fins; prestressed beams and precast roof slabs. Dowels from columns and prestressing steel from beams are welded to form a connection and the corner is poured concrete

The United States Fidelity and Guaranty Co. building in Richmond, Va. also is completely precast. Reinforced columns, 32 ft o-c, have steel plates welded to girder plates, forming a rigid frame. Hollow girders were post-tensioned with 3 cables before erection and 3 cables afterwards. The hollow was grouted following tensioning. The 33-ft, 4-in. double-T floor slabs were pretensioned with 16, 3/8-in. dia. strands

Henley Walker, Jr., Architect; William J. Blanton, Structural Engineer; Concrete Structures, Inc.

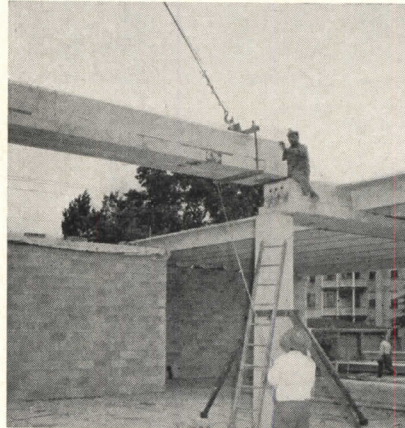

extended reinforcing; grouted joints and keyways; welding of exposed reinforcing bars covered with protective grout; and bolting.

Special Plant Equipment

In the factory-like production of precast concrete, there are many different types of equipment not needed for ordinary poured-in-place concrete. This includes special mixers to get no-slump concrete; casting beds and tensioning equipment; various types of vibrators; steel forms; special forms to remove excess water by vacuum; steam and hot water curing; overhead cranes, bridge cranes, long pole trailers for shipping and lift trucks for erecting precast units.

Advantages of Precast Concrete

Some of the factors that have favored the selection of precast concrete are: (1) economy, (2) low maintenance, (3) fire resistance, (4) finished surfaces, (5) quality-controlled manufacturing, (6) long spans and heavy loads with prestressed units.

Here are some of the reasons given by fabricators for increased use of precast and precast, prestressed concrete."

Cost:

"Low cost for spans and loads not feasible with ordinary concrete."

"When designers learn to adopt standard structural elements that are mass produced in a factory, greater economies will result."

"We can compete on initial cost against steel beams and girders when the loading requires a steel beam that weighs 60 lb or more per ft."

"Actual jobs indicate savings of 30 cents per sq ft over conventional reinforcing and forming on the job."

Fire Resistance:

"Better fire protection is afforded at lower initial costs."

"Big factor is the great difference in fire insurance ratings with large savings in yearly rates for precast-prestressed buildings."

"Our local building code is being enforced with respect to area limitations for anything other than fireproof or semi-fireproof construction. Large warehouses with no obstructing fire walls have to be in concrete."

Speed of Construction:

"Reduction of site time for general contractor and all trades."

"Saving in time."

"Deliveries and speed of erection."

Appearance:

"Ninety per cent of our jobs are exposed ceilings which puts us on a competitive basis with conventional type roof and floor systems."

"Most important factor outside of low initial cost for fireproof construction is the intelligent use of roof and floor slabs providing both exterior support and exposed interior surfaces."

"Color-texture-plasticity."

Characteristics of Precasting Practice

Size of Units Produced. The longest girder reported was 120 ft; others ranged 40, 50, 60, 75 and up to 94 ft. The longest slabs were channel units 64 ft long; others were 20, 30, 40 and 50 ft.

Geographical Area Served. The average distance that precast units were shipped was 150 to 200 miles. The farthest was 800 miles.

Size of Market. Twenty-five firms reported a yearly dollar volume averaging about \$300,000, going up to several at \$1 million, and even one at \$3 million.

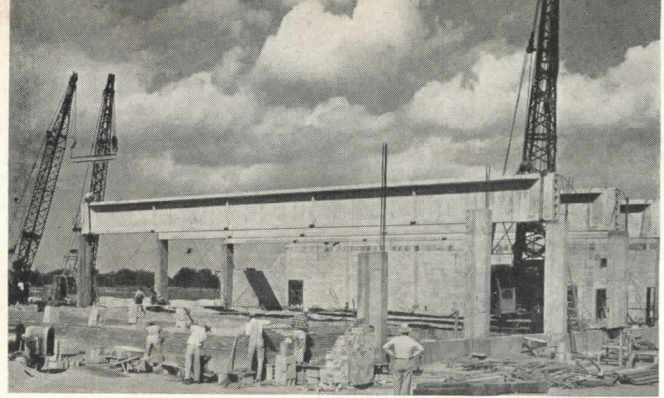

McMinn and Norfleer, Architects

110-ft long, 7-ft high post-tensioned girders being hoisted by crane to give a clear span for a supermarket in Midvale, Utah

Erection of precast thin shell elements for a school playshed in Tacoma. The shells are 1½ in. thick at the crown

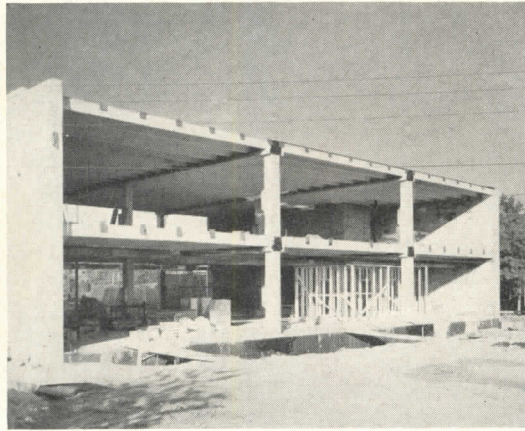

Robert B. Price, Architect; Concrete Engineering Co., Tacoma

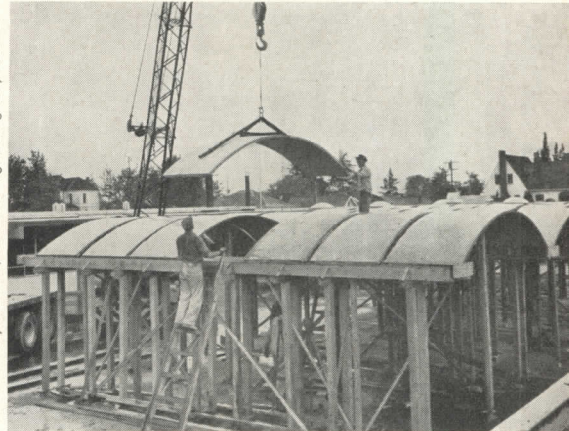

Building Types and Sizes. Most of the buildings using precast units were one or two stories high, with several three or four. Some buildings using precast joists or channel slabs went up as high as seven and eight stories. The building types most frequently employing precast concrete are industrial buildings, warehouses, schools, office buildings and stores (including shopping centers).

120-ft, record-size prestressed girders cover a play area 118 by 118 ft for the Senior High School Gymnasium in Greensboro, N. C. The completed roof consists of 12-in. precast joists spanning 20 ft at 8 ft o-c. and 2 ft wide roof channels

Participants in Survey:

Arnold Stone Co., Greensboro, N. C.; Associated Sand & Gravel Co., Everett, Washington; Basalt Rock Co., Inc., Napa, Calif.; P. F. Blair & Son, Tulsa, Okla.; Otto Buehner & Co., Salt Lake City, Utah; Concrete Engineering Co., Knoxville, Tenn.; Concrete Engineering Co., Washington; Concrete Masonry Corp., Elyria, Ohio; Concrete Materials, Inc., Charlotte, N. C.; Concrete Prestressed Corp., Bristol, Tenn.; Concrete Products, Inc., Skokie, Ill.; Concrete Structures, Inc., Richmond, Va.; Dextone Corp., New Haven, Conn.; Florida Prestressed Concrete Co., Inc.; Formigli Brothers, Inc., Philadelphia, Pa.; Hamilton Concrete Products, Inc., Chattanooga, Tenn.; F. Hurlbut Co., Green Bay, Wis.; Knox-Blox, Knoxville, Tenn.; Lewis Mfg. Co., Inc., Miami, Fla.; Maule Industries, Inc., Miami, Fla.; Nashville Brecko Block Co., Nashville, Tenn.; Parete Mfg. Co., North Arlington, N. J.; Prestressed Concrete, Inc., St. Paul 13, Minn.; The Rackle Co. of Texas, Houston, Texas; Southwest Structural Concrete Corp., San Diego, Calif.; Truscon Laboratories, Detroit, Mich.; United Cement Products Co., Wichita, Kansas; R. H. Wright & Son, Fort Lauderdale, Fla.

Other Sources of Information:

Ross Bryan, Nashville, Tenn.; Freyssinet Co., Inc., New York City; Leap Concrete, Inc., Lakeland, Fla.; John A. Roebing's Sons Corporation, Trenton, N. J.

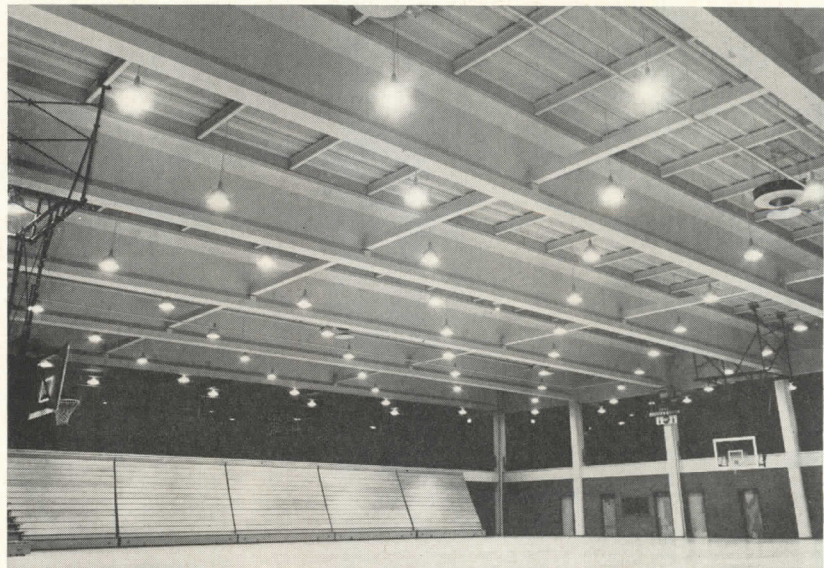

McMinn & Norfleer, Architects; Arnold Stone Co.

MOVING SIDEWALKS

By G. B. Gusrae
Transportation Consultant

The first one was operated as early as 1893. But it wasn't until 1954 that the first commercially successful moving sidewalk was installed. Here is the history of their development along with an analysis of the factors that will affect their future use

A NEW FORM of transportation is beginning to take shape. A form which, judging by the past record of man's ingenuity in avoiding labor, will undoubtedly become indispensable in short order. The new device is the moving sidewalk or the passenger motorway. Already there are a number of experimental and actual installations, and potential applications abound in passenger stations, shopping centers and similar areas. Whether or not they will fit into a particular situation depends on a number of factors such as engineering, economics, and the safety of people riding and stepping onto and off moving platforms.

Early History

It all started almost one hundred years ago when Nathan Ames of Saugus, Massachusetts obtained a patent on August 9, 1859 for a contraption he called the "Revolving Stairs." A number of steps were linked together to form an endless inclined flight of stairs. The endless stair belt presumably was driven by two or three rollers and was intended

to elevate passengers from one level to another.

The next step was taken by Jesse W. Reno of New York when he patented, on March 15, 1892, his "Endless Conveyor." This device, described as a sliding mechanical incline, was provided with a handrail so as to "add to the feeling of security and comfort of the passengers." The inclined steps were equipped with grooves arranged to interlink with prongs of comb-like landing plates so as to guard against passengers stumbling when they would alight from the moving steps.

Reno's conveyor was followed by two other devices: George A. Wheeler's "Elevator" on August 2, 1892, wherein the surface of the moving steps was made horizontal, and the more elaborate "Elevator" of Charles D. Seeberger, who obtained on January 17, 1899 a patent with not less than 66 bulky claims.

Reno, financed by Lyman G. Bloomingdale, the proprietor of Bloomingdale's Department Store, succeeded in

constructing the first practical moving stair which he installed in the 59th Street Station of the Third Avenue "El" in New York City. It was completed on September 5, 1900 and was torn down in October of 1955 during the demolition of the elevated.

The first unit had a rise of 24 ft, was 18 in. wide and measured 65 ft in length, being inclined at about 25 degrees.

Meanwhile Seeberger arranged with the Otis Elevator Company for a unit based on his design. He exhibited his moving stair at the Paris Exhibition in 1900.

Shortly after the first Reno stairway was set up, there was some thought of adopting the device to long distance horizontal travel. The New York Tribune of that time reported that a moving sidewalk to carry pedestrians across Brooklyn Bridge was under serious consideration. A sidewalk of this kind was in operation at the Paris Exposition in 1900, where people were carried from the Champ de Mars to the Esplanade des Invalides at the rate of five miles an

The B. F. Goodrich Co., Link-Belt Co.

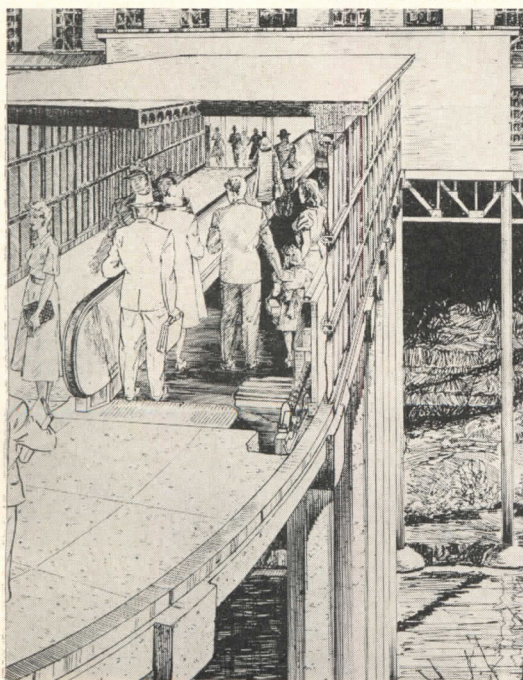

Stephens-Adams Mfg. Co.

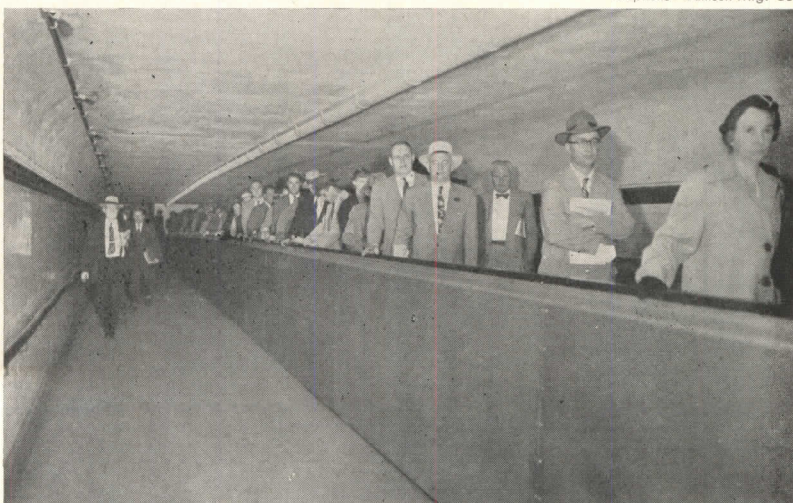

Left: Put into operation in February last year, this 114-ft moving sidewalk takes passengers up a 12 per cent grade into the Sam Houston Coliseum in Dallas. Above: In May 1954, the first commercial unit, 227-ft long with a 10 per cent grade for 137 ft, was dedicated at the Hudson and Manhattan RR terminal

hour. The first operating moving sidewalk, however, was used at the 1893 Columbian Exposition in Chicago.

The Brooklyn Bridge sidewalk, being American in concept, was to travel 10 miles an hour, accommodate 65,000 persons an hour, and have benches every 4 or 5 ft, and to be equipped with awnings. That talk soon died down, but the idea of moving sidewalks has been about ever since.

About 1910, the Otis Elevator Company acquired the moving stair patents of Reno, Wheeler and Seeberger. By combining the best features of each, they succeeded in producing a well designed moving stairway readily acceptable to the public and sufficiently flexible for multi-purpose application.

About 1920, an idea took root to construct a moving sidewalk for the length of 42nd Street in New York City between Grand Central Station and Times Square. An experimental unit, consisting of three parallel sections operating at three different speeds of 3, 6 and 9 miles per hour was constructed in an open lot in Jersey City. The testing demonstration apparently was a fiasco because the company formed to promote it, the Continuous Transit Corporation, soon dropped out of existence.

For a while the management of the 1933 Chicago World's Fair considered the possibility of embroidering the Fair by installing a few moving sidewalks. Eventually, the idea was dropped.

The Rockefeller Center architects spent considerable time in investigating the ambitious project of building a tunnel

and installing moving sidewalks to connect the Center with Grand Central Station. Eventually, this idea too, was dropped as impractical.

An attempt was made to design a moving sidewalk for use between the House of Representatives building and the Capitol building in Washington, D. C. A selected group of engineers investigated this possibility for over a year. Finally the idea was given up in favor of electric bus service similar to the one between the Senate building and the Capitol.

The moving sidewalk idea kept on cropping up. About 1937, when the Board of Transportation of the City of New York was preparing plans for the 6th Avenue Subway, they found it necessary to close down the 33rd Street Station of the Hudson & Manhattan Tubes and use a temporary station about five city blocks further down. The possible use of a moving sidewalk about 1200 feet long to connect the regular station with the temporary station was seriously investigated and finally abandoned on the grounds of it being "impractical due to the insufficient development of the moving sidewalk art."

Finally, at the New York World's Fair, the Westinghouse Electric Corporation installed in the General Motors Building a horizontal moving stairway and a moving sidewalk about 100 ft long. This preceded belt-driven moving chairs arranged to take the viewers through the General Motors Exhibit. The entire combination — the moving stairway, the platform and the chairs —

was designed to travel at the normal moving stairway speed of 90 ft per minute. A number of attendants were provided to assist the people in negotiating their course from moving stairway, to platform, to the chairs and vice-versa. The installation was successful.

Recent Installations

The Stephens-Adamson Manufacturing Company, for some years manufacturers of materials conveying equipment, and the Goodyear Tire and Rubber Company prepared engineering drawings early in 1950 for a moving sidewalk.

In 1952 an exhibit at the Chicago Museum of Science and Industry was equipped with a 65-ft long moving sidewalk designed by Stephens-Adamson. The belt, furnished by B. F. Goodrich, is of four ply rubber construction, $\frac{3}{8}$ -in. thick and 36-in. wide; is equipped with moving handrails; and travels at the rate of 132 ft per minute. The belt rides on a polished maple slider bed and is capable of carrying 5000 persons per hour. At present it transports an average of two million people a year.

In April 1953 Stephens-Adamson and Goodyear erected a full-scale test unit in the Stephens-Adamson plant at Aurora, Illinois. It was made to represent the loading and unloading platform belts for the most ambitious project to date, the proposed passenger conveyor subway system to replace the existing Times Square subway shuttle in New York City.

The unit was variously known as the subway moving platform, the conveyor-

Hewitt-Robins Inc.

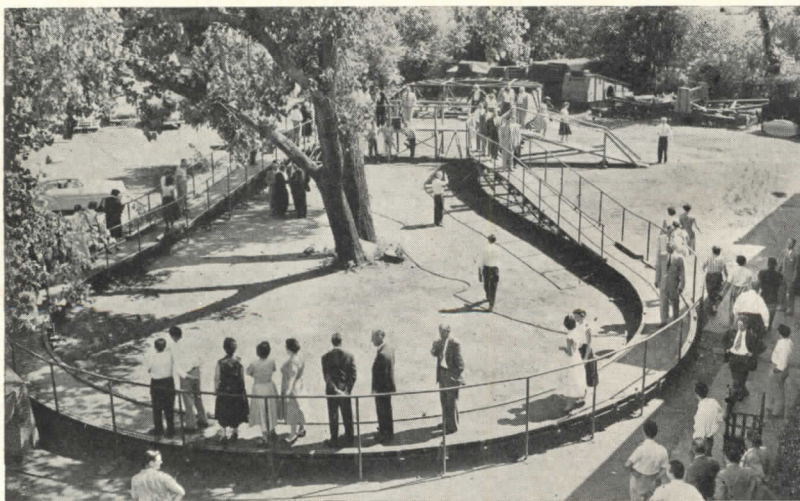

Above: This is a test unit for the only moving sidewalk that can go 'round a curve. A rubber sheet fastened to small flat cars can stretch slightly. Right: Another test model consists of a series of cleated aluminum plates. It rises 6 ft with a slope of 14 degrees on one side and six degrees on the other

Otis Elevator Co.

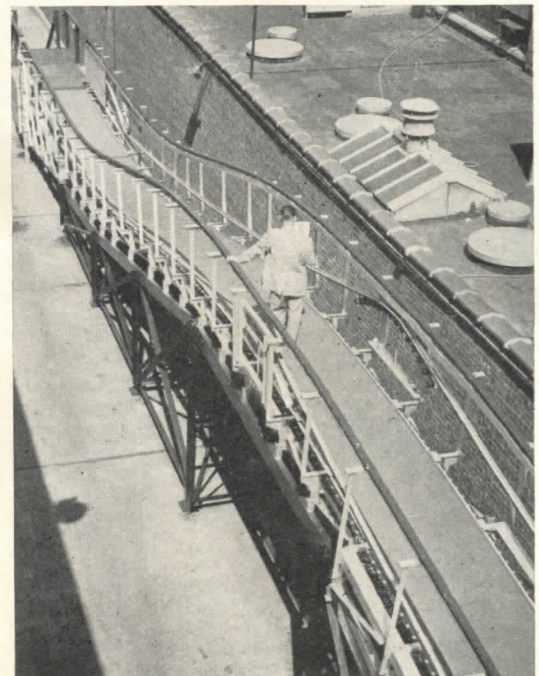

belt subway, the passenger conveyor subway and the Carveyor. The belt is 108-in. wide, has a 60-ft length of travel at the rate of 132 ft per minute and is capable of carrying more than 16,000 passengers an hour.

This experimental moving sidewalk has shown that a $\frac{3}{4}$ -in. thick rubber and fabric combination belt, running on 3-in. diameter rollers set $3\frac{1}{2}$ -in. apart, will give the passengers riding on it a feeling of solidity. It has also been established that the 132 ft-per-minute belt speed will permit any passenger, even on crutches, to enter the belt from a stationary platform and to leave it safely.

The proposed conveyor shuttle was to employ one loading and one unloading platform belt at each end. Adjacent to the platform belts would run a 60-in. wide car belt with a number of 14-passenger capacity cars riding bumper to bumper. At the loading and unloading terminals both belts would travel at the same speed. The passengers would walk onto the moving loading platform and step into one of the cars moving at the same speed as the platform.

At the end of the loading zone, the automatically controlled doors of each car would close; the car would run onto a 33-ft long live roll conveyor where the rolls would turn successively at higher speeds; the car would accelerate to a speed of 15 mph and would be transferred from the rolls to the fast speed belt conveyor for a run of 1800 ft with a spacing of 70 ft between the successive cars.

At the end of the run, the car would move over a 33-ft long decelerating roll conveyor until its speed is reduced to that of the unloading platform belt.

Another working model was installed in April 1954 at the Akron plant of the Goodyear Tire & Rubber Company where it is used to carry large groups of employees up a ramp leading to the factory entrance.

Then in May of 1954, an actual moving sidewalk, known as the Speedwalk, was installed by Stephens-Adamson and Goodyear in Jersey City, New Jersey. It carries commuters at the Hudson & Manhattan Tube Station a distance of 227 ft. For 137 ft of its total travel, the sidewalk moves up a 10 per cent grade eliminating a tedious up-hill climb which the commuters, in grim humor, have dubbed the "Cardiac Ramp."

The rubber belt is $\frac{5}{8}$ -in. thick, 66-in. wide, is equipped with moving handrails, and travels up or down depending on the hour of the day at a speed of 120 ft per minute. The belt rides relatively smoothly over 600 rollers, being driven by a 20 horse-power electric motor through a speed reducer. Emergency stop buttons are provided at strategic points. The motorway is capable of carrying nearly 11,000 persons per hour. In over a year of operation, with 1,250,000 passengers handled, the system has established a perfect safety record.

In February 1955, a moving sidewalk designed by B. F. Goodrich and the Link Belt Company was put into operation at the Sam Houston Coliseum in Houston, Texas. The belt was designed to carry 15,000 people per hour at a height of 50 ft over the Buffalo Bayou to the Coliseum entrance.

The belt is of 7 ply rubber construction, $\frac{7}{8}$ -in. thick and 82 in. wide; is equipped with moving handrails; and travels 132 ft per minute through a dis-

tance of 114 ft at a 12 per cent grade. The belt rides on closely spaced rollers driven by a 25 horse-power electric motor through a speed reducer. The passengers complete the distance in 52 seconds.

The Hewitt-Robins Company of Stamford, Connecticut recently designed a passenger motorway which is the only one that travels along a curving path. An experimental unit was installed in the Hewitt-Robins plant in Passaic, New Jersey. It consists of a rubber sheet without fabric reinforcement which is fastened to a series of small flat cars mounted on wheels and designed to travel along a track. The rubber sheet stretches slightly as cars go around curves. The moving platform is guarded on both sides by stationary railings.

Three of the Hewitt-Robins passenger motorways will be installed in the new air terminal at Dallas, Texas. They will carry passengers and baggage for a total length of 1406 ft.

The Otis Elevator Company has entered the field of passenger motorways with a unit known as Trav-O-Lator which travels at the rate of 135 ft per minute. A working model, with a total travel of 95 ft, has been installed at the Otis Harrison Works. The unit rises 6 ft with a slope of 14 degrees on one side and 6 degrees at the other. In construction, it is a modification of their moving stairway. The moving sidewalk consists of a series of cleated aluminum platforms designed for combing at landings. The platform sections are guided by chains on a wheel and track system similar to that employed on moving stairways. Balustrades and handrails are
(Continued on page 233)

Revolving Stairs

Patented Aug 9, 1859

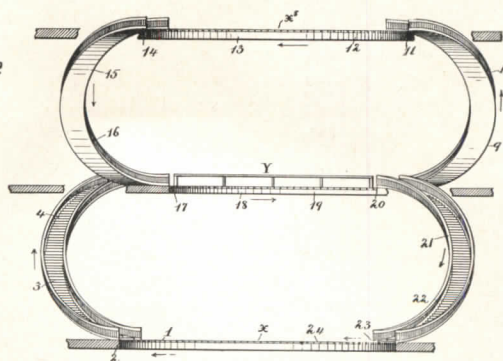
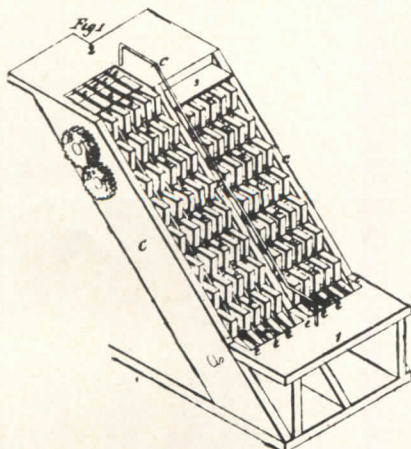

Left: Drawing from the Ames patent which was an endless, inclined flight of stairs. Above: Seeberger's patent showed a series of stairs spiralling from floor to floor. Right: A test model of a three-speed unit in 1923 apparently turned out a failure

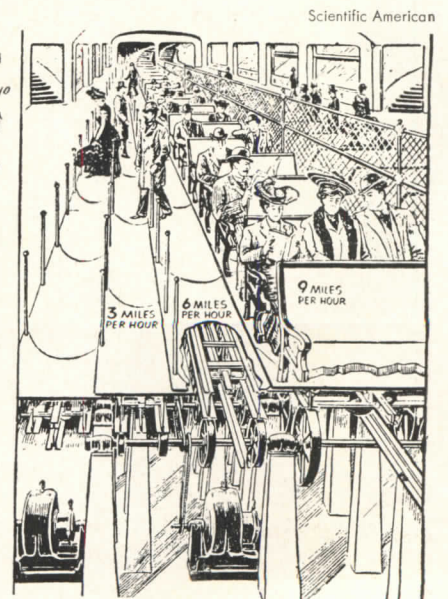

Scientific American

HEAT PUMP EXTRACTS BTU'S FROM BELOW ZERO AIR

A HEAT PUMP SYSTEM which doesn't have to work very hard to produce summer cooling and winter heating even in the coldest weather actually uses below-freezing outside air as a heat source and heats the refrigerant from temperatures as low as -20 F to 110 F in two stages. Installed in the new Philadelphia home office building of The Ballinger Company, architects and engineers, the improved system is heralded by its creator, the York Corp., as a practical year-round air conditioning source which will balance not only the heating-cooling budget of the user but also the load ups and downs of electric utilities.

Basically the system is the same as most other air-source heat pump systems — except that it switches automatically from single-stage to multi-stage compression when the outside air reaches a certain low temperature. Compound, or multi-stage, compression is a familiar refrigeration technique, used for years to achieve economically the extremely low temperatures needed in ice-cream plants and the frozen food industry. It's simply a "helping" device to reduce the total work load necessary in heating the refrigerant gas from low to high actual temperatures by increasing the efficiency of each of the two stages of refrigeration. Heretofore the efficiency factor has been the "bug" which has made the use of heat pumps in northern climates impractical and expensive, because the standard single-stage systems either had to be supplemented by electric strip heaters in cold weather or else had to work very hard at low efficiency (expensive!) to produce enough heat to keep a building warm.

An example is shown in the simplified schematic flow diagram at right of a single-stage system. At temperatures above freezing this system is adequate, because compression ratios are relatively low and so efficiency is relatively high. Compression from a 40 F to a 110 F pressure equivalent gives a compression ratio of only 2.92 to 1. However, as the temperature decreases, the increment through which its pressure equivalent must be raised increases, and so does the compression ratio. For example, when the refrigerant is raised to 110 F from -20 F (at which point it can extract the same Btu's from half the volume of air that would be required at -10 F — and so less fan horsepower is needed to move

the air!), the compression ratio is almost 10 to 1, and that means a lot of work has to be done by the compressors.

In the multi-stage system, shown also in simplified diagrammatical form at right, this compression is accomplished in two stages, so that less total work has to be done. An analogy can be made with a ball which is to be thrown from ground level to a window four stories above. If the ball-thrower tries to accomplish the four-story throw himself, he must put a lot of power behind his toss. However, if he throws the ball to a friend on the second floor, who in turn throws it the rest of the way, neither of them has to do as much work — and, as a matter of fact, the total amount of energy expended by both of them is less than would have been necessary from just one of them attempting the feat without help. In the multi-stage system, the refrigerant, which picks up heat from the warmer outside air (even -10 F is warmer!), is compressed to an intermediate pressure. It is then "de-superheated" in an intercooling chamber and drawn into the second-stage compressor. There it is compressed to a usable level (110 F , for example) and finally passed along to the heating coils. In neither one of these compression stages is the compression ratio very high, and so the heat output per unit of work is much higher than it would be if the refrigeration had to be raised from a low to a high pressure equivalent in one stage. As a point of comparison, the coefficient of performance of a multi-stage system with sub-cooling is almost twice that of a single-stage system without sub-cooling. Sub-cooling is accomplished by inserting coils circulating liquid refrigerant in the fresh air inlet to lower the temperature of the condensed refrigerant while simultaneously heating the inlet fresh air. This sub-cooled high-pressure liquid is expanded into the outdoor-air coils, where the outdoor air boils it into a vapor, thereby starting the cycle over again.

The Ballinger installation is the second one in which the York compound compression heat pump has been used. The first was the Heironimus department store in Roanoke, Va., designed by Hayes, Seay, Mattern and Mattern, architects and engineers. Research is now being done to produce a packaged system for home use.

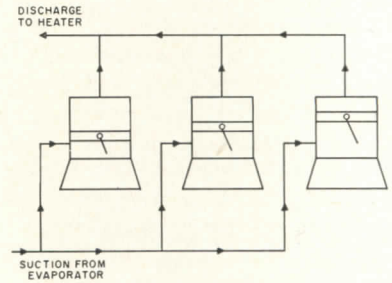

Diagrams show basic difference between single-stage (above) and multi-stage (below) compression. Actually, position of compressors doesn't change when system switches, only line of flow is changed through thermostatically controlled valves

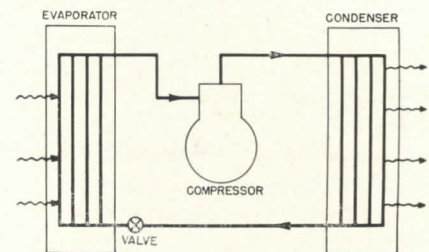
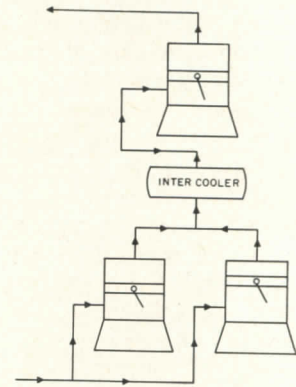

In basic heat pump cooling cycle, liquid refrigerant flows through expansion valve, becoming a low-temperature, low-pressure vapor. Warm room air flows over refrigerant coils (evaporator), becoming cooled as refrigerant absorbs heat. Heated vapor is compressed to a high-temperature, high-pressure vapor and goes on to condenser, where outside air takes heat from coils and condenses refrigerant to a liquid again. Flow is reversed in the heating cycle, with outside air supplying heat to the refrigerant, which gives up its heat to the room air

STRUCTURAL CARDBOARD FOR BUILDING

CORRUGATED CARDBOARD as a structural material to provide the basic element in low-cost housing has been proposed by two young architects, Raymond A. Mettauer of Waldwick, N. J., and John N. Cohen Jr. of New York City. Concerned about the problem of providing acceptable houses for low-income groups, they have conducted some basic research on the economics and structural feasibility of using cardboard in sheet form corrugated to make floor, wall and roof elements in a continuous structural system like that shown in the model above. The cardboard shell on which they are placing so much hope "is fundamentally a system of layers of laminated cardboard integrating strength, insulation and finishes. These laminations are waterproofed, thermally isolated and insulated, and vapor-barriered to meet the requirements of any well-engineered wall, roof, floor." The shell itself might be protected at the surface by a jointless but waterproof skin of glass-fiber-reinforced resin. The cardboard would be chemically treated so that it could not support combustion nor could the flameproof finishes that would be used inside and out.

Messrs. Mettauer and Cohen hope to proceed in two major phases of development. First, they plan to complete an emergency shelter which can be packaged, flown to disaster areas by helicopter, and dropped for fast and easy assembly into temporary housing units. Second, from the laboratory data which can be drawn from these units and from income derived from the licensing of them (patent applied for), they hope to progress to final assembly of a full-size house.

(More Roundup on page 236)

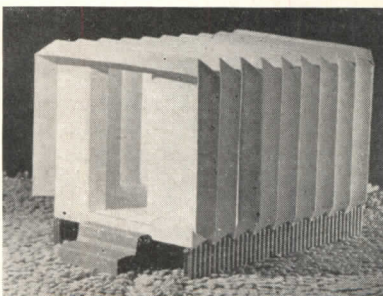
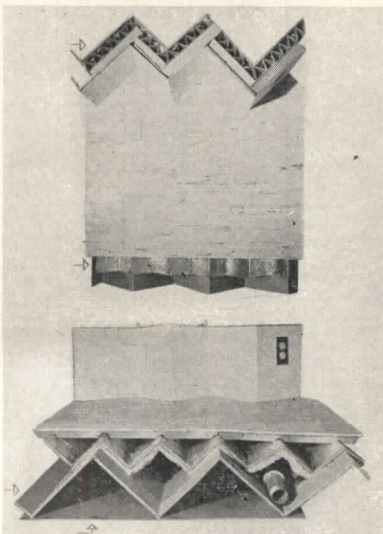
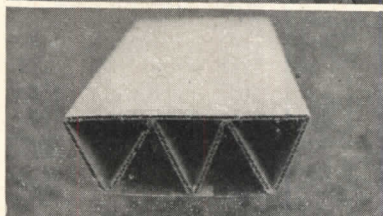
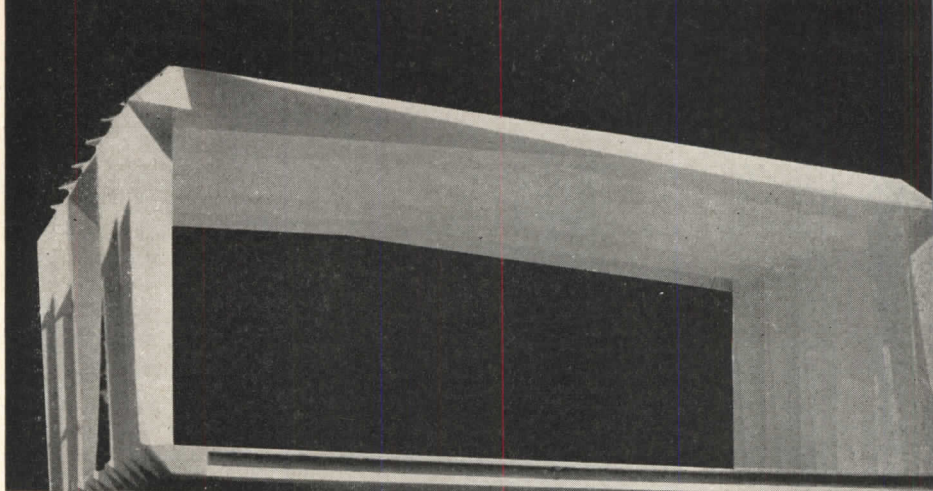

Basic element of floor system includes a top chord for compression, a bottom chord for tension and a web spacer to transfer shear stresses. Aluminum is used for the tension chord because of its high tensile strength and also because it provides reflective insulation. For walls and roofs, which don't have to bear the same loads as the floor, compression and tension members can be replaced with two 0.1-in. aluminum rods glued at the nodes of the corrugations.

In full-scale model of a floor and wall section, floor tubes, which can also act as heat ducts, are laminated with aluminum-coated waterproof membrane. This not only prevents moisture content variation in cardboard and serves as reflective insulation, but also permits emergency draining. Bottom sheet of structural aluminum and Fiberglas insulation prevents transfer of moisture and ground cold from crawl space below, where heating plant is located. Other services can also be run through walls and floor. Finish flooring can be of any type, applied with adhesive.

Simple emergency shelter could be packaged with these elements: corrugated metal base panels, to which would be clipped corrugated "U" for floors and walls; flat floor sheet and end panels which would be slipped into place; corrugated "U" for roof, which would be clipped to lower "U." From research on such a shelter, the designers hope to progress to a full-size house, which could be developed in a number of variations — perhaps like the sketch below.

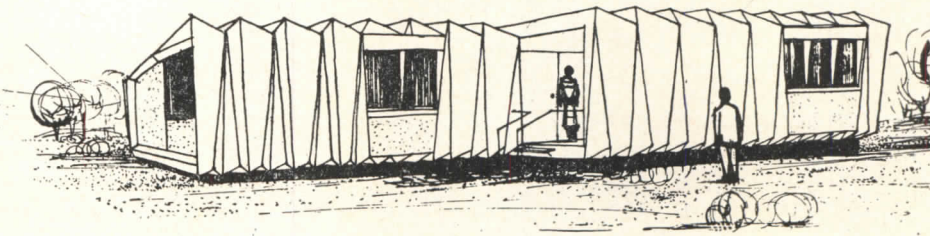

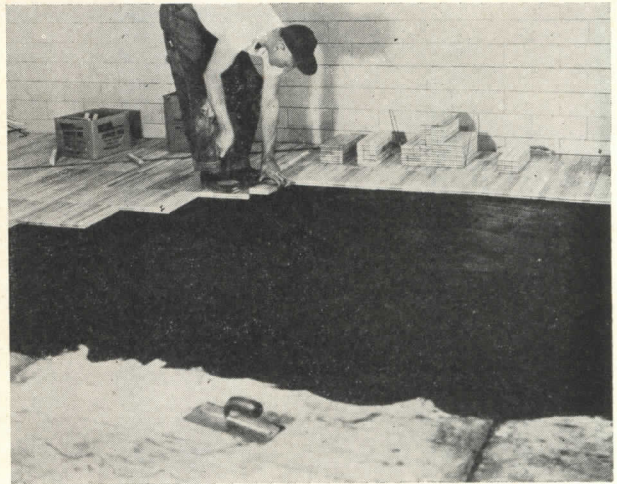

UNDERFLOOR CUSHION PREVENTS BUCKLING OF FINISH FLOOR

AN INSULATING, UNDERFLOOR CUSHION is being produced for installation under wood flooring on grade or sub-grade slabs to eliminate moisture migration into the finish floor. First, the manufacturer recommends, a water- and vapor-proof membrane should be placed on grade to isolate the slab that will be poured over it from moisture and vapor

originating in the soil. Next *Corktile*, impermeable, resilient insulation panels having a constant thermal resistance of about .48 Btu, should be laid in place, with joints staggered, after a coating of asphalt has been spread on the concrete slab. After a generous coating of cut-back asphalt adhesive is spread over the *Corktile*, completely sealing all joints,

the finish flooring is installed as shown in the second photo above. It is claimed that the *Corktile* underfloor cushion prevents a dewpoint within the floor and eliminates the possible buckling and rotting of the finish floor by condensation or ground moisture; also that it produces a floor with low sound transmission. *W. R. Meadows, Inc., Elgin, Ill.*

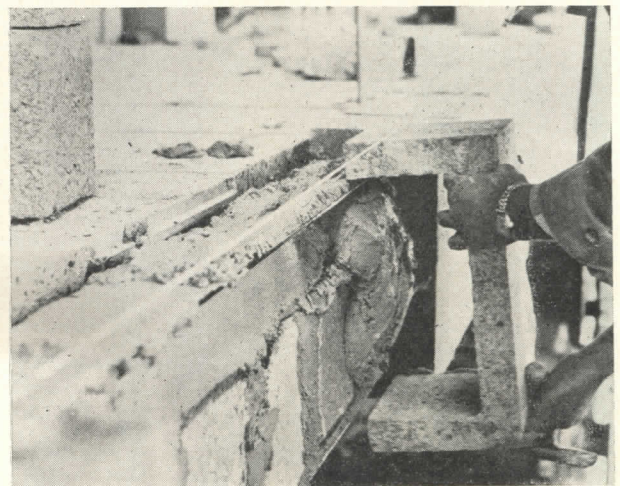
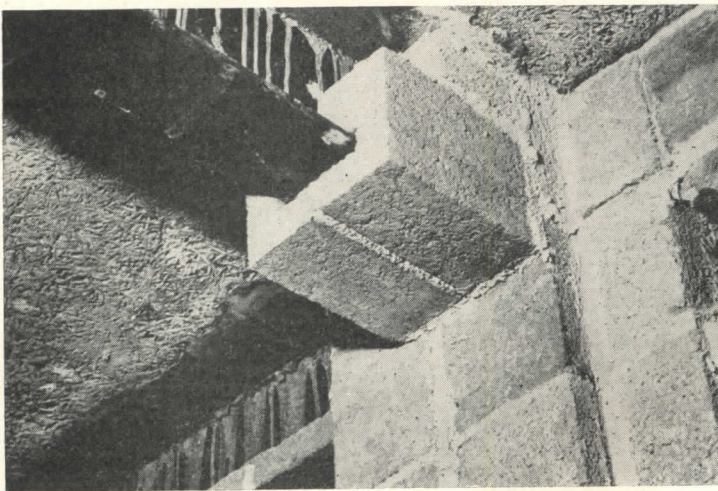

CONCRETE BLOCKS SHAPED TO FIT OTHER STRUCTURAL ELEMENTS

CONCRETE BLOCKS are being fashioned in unusual shapes for use as both structural and decorative elements. They are called "Levitt Shapes," after architect Alfred Levitt, because they were designed for use in his 8-story apartments of block, glass and steel in Queens, New York. Two of the blocks are shown in the illustrations above: The "solid

slotted block" at the left, solid except for a 1-in. slot, encloses overhead I-beams and joins the block wall; it can also enclose vertical I-beams. The "spandrel cover block" at the right is fitted directly onto spandrel beam. Other shapes are a 100 per cent solid coping and an 8-in. radius bull nose. After being fitted to steel members, the

exposed block surfaces can be painted to become finished interior or exterior walls. They will hold nails or other fixtures. The blocks fulfill insulation requirements and can be used wherever steel framework must be fireproofed. *The Cincrete Corp., 29-02 First St., Long Island City, N. Y.*

(More Products on page 250)

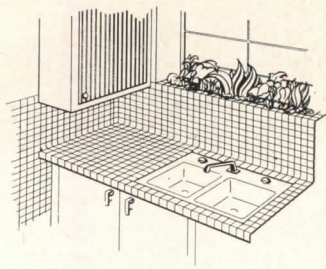

SPARTAN CERAMIC TILE (AIA 23-A-1)

A colorful file folder presents booklets which are indexed in three separate sections: "Spartan Tiles" includes full-color brochures showing color, shapes, patterns and sizes of glazed ceramic tiles. "Details & Patterns" presents typical sketches of tile installations (as shown at left) and a variety of patterns. "Sparamics" discusses ceramic tile mounted on perforated paper backing for direct-adhesive setting. *The Sparta Ceramic Co., East Sparta, Ohio.**

Automatic Private Communication
Data file includes information on a variety of *Private* automatic telephone systems designed for private use. *North Electric Co., Galion, Ohio.*

Industrial Floors
Bulletin 3-3 explains two standard Atlas corrosion-resistant floors and gives complete estimating data. 4 pp. *Atlas Mineral Products Co., Mertztown, Pa.*

Furniture, Glassware, Lamps
Catalogs furnishings designed by Italy's foremost architects. 16 pp. *Allamira, 18 East 50th St., New York 22, N. Y.*

Open Truss Steel Joists (AIA 13-G)
Presents "O-T" steel joists (shortspan series), and includes pages of loading tables. 32 pp. *Truscon Steel Div., Republic Steel Corp., Youngstown 1, Ohio.**

Maulwal Complete Curtain Wall
Presents a curtain wall system which includes a complete range of panel facing materials. 4 pp. *Maul Macolla Corp., 1640 E. Hancock St., Detroit 7.*

Airtemp Product Catalog
Contains information on over 100 cooling and heating products. 24 pp. *Airtemp Div., Chrysler Corp., Dayton 1, Ohio.**

Aluminum Windows (AIA 16-E)
General catalog includes *Vampco* standard and custom windows for industrial and institutional construction. Shows many school installations. 48 pp. *Valley Metal Products Co., Plainwell, Mich.**

CEFCO Sewer Pipe, Perforated Pipe
Explains how bituminized fibre pipe can be used in house-to-sewer, septic tank, foundation drainage, industrial and other installations. 8 pp. *The Central Foundry Co., Newark 5, N. J.*

*Other product information in *Sweet's Architectural File, 1956.*

(Continued on page 282)

BUILDING PRODUCTS LITERATURE AWARDS

The 8th Annual Building Products Literature awards were made on May 14th in Los Angeles at the Producers' Council Spring Meeting. Sponsored jointly by the AIA and Producers' Council to recognize excellence in product literature directed to the architect, the competition was judged by an all-AIA committee which included H. Griffith Edwards of Atlanta, chairman; John W. Hargrave, Cincinnati; John R. Magney, Minneapolis; James B. Newman, New York, and Paul Schell, Pittsburgh. Five Certificates of Exceptional Merit, 29 Certificates of Merit and 33 Honorable Mentions were announced:

CLASS I:

Manuals, Handbooks, Basic Information

CERTIFICATE OF EXCEPTIONAL MERIT
Sound Absorption Coefficients — Acoustical Materials Association, Modern Sheet Copper Practices — American Brass Co.

CERTIFICATE OF MERIT
Alcoa Architectural Stocks — Aluminum Co. of America; Engineering Manual — Bell & Gossett Co.; American Standard Specifications — Marble Institute of America; Technical Notes on Brick & Tile Construction — Structural Clay Products Institute; Curtain Walls of Stainless Steel — Committee of Stainless Steel Producers; Indiana Limestone Specifications — Indiana Limestone Institute

HONORABLE MENTION

Principles of Air Distribution — Tuttle & Bailey, Allied Thermal Corp.; Design Manual Welded Wire Fabric — Wire Reinforcement Institute; Tile for Swimming Pools — American-Olean Tile Company

CLASS II:

Literature on Particular Products

CERTIFICATE OF EXCEPTIONAL MERIT
Technical Data for Architects & Designers — Armstrong Cork Co.

CERTIFICATE OF MERIT

Fenestra Blue Book of Drafting Room Standards — Detroit Steel Products Co.; Paint Specifications & Color Selector — E. I. du Pont de Nemours & Co.; Plumbing Drainage Control — J. A. Zurn Mfg. Co.; P-55 Plumbing Catalog — American-Standard; Pabco Built-up Roofs Specifications — Pabco Products, Inc.; Ceco Windows — Ceco Steel Products Corp.; Truscon Metal Windows & Doors — Truscon Steel Division; Acoustical Materials — Celotex Corp.

HONORABLE MENTION

Fenestra Steel & Aluminum Building Panels — Detroit Steel Products Co.; Thermopane Manual — Libbey-Owens-Ford Glass Co.; Honeywell Customized Controls — Minneapolis-Honeywell Regulator; Ratings, Data & Dimensions — American-Standard; Sanymetal Toilet Compartments — Sanymetal Products Co.; Mills Movable Metal Walls — The Mills Co.; Product Specification Directory — National Gypsum Co.; Reinforced Built-up Roofs — Owens-Corning Fiberglas; Truscon Open Truss Steel Joists — Truscon Steel Division

CLASS III:

General Promotional Literature

CERTIFICATE OF EXCEPTIONAL MERIT
Architectural Achievements — Aluminum Company of America

CERTIFICATE OF MERIT
Sweet's Inserts — Aluminum Co. of America; Architectural Concrete — Portland Cement Association; Armstrong DeLuxe Corkwall — Armstrong Cork Co.; Architects Specification Guide — Kentile, Inc.; Marble for the Home — Marble Institute of America; Brick & Tile Series — Structural Clay Products Institute; Terrazzo with Trinity White Portland Cement — General Portland Cement; Metal Lath

News — Metal Lath Manufacturers Association

HONORABLE MENTION

Cleaning, Maintenance, and Care During Construction — Aluminum Co. of America; Flush Doors — Roddis Plywood Corp.; Ceramic Veneer — Architectural Terra Cotta Institute; Structural Facing Tile — Facing Tile Institute; Suntile — Cambridge Tile Mfg. Co.; Tile for Schools — Hospitals — American-Olean Tile Co.; Tim-Press — Timber Structures, Inc.; Architectural Metal Products — Kawneer Co.; Colors in Floor Tiles — Kentile, Inc.; Mosaic Tile Book of Beautiful Homes — Mosaic Tile Co.

CLASS IV:

Space Advertising Directed to Architects

CERTIFICATE OF EXCEPTIONAL MERIT
Ad Series — Knoll Associates

CERTIFICATE OF MERIT
New Triple Strength Flush Doors — Kawneer Co.; Architectural Space Advertising — Armstrong Cork Co.; Ad Series — Structural Clay Products Institute; Architectural Advertising — A. M. Byers; Ad Series — Overly Manufacturing Co.; Series of Ads — Ceco Steel Products Co.; Ceramic Suntile Means More Color — The Cambridge Tile Company

HONORABLE MENTION

Space Advertising — Davidson Enamel Products; Ad Series — E. L. Bruce Co.; Toplite Roof Panels — Owens-Illinois; Ad Series — 4th Region: S.C.P.I.; Asbestos Siding — Asbestos Cement Products Assn.; Granite — Cold Spring Granite Co.; Ad Series — American-Olean Tile Company; Arts and Architecture — Mosaic Tile Co.; Space Advertising — Sanymetal Products Co.; Frigidaire Imperial Wall Oven — Frigidaire Division, General Motors; Designs for the Future — Flour City Ornamental Iron Co.

PORCELAIN ENAMEL VENEER—1

Courtesy Architectural Division, Porcelain Enamel Institute

Veneer-type porcelain enamel is used frequently for exterior and interior walls, exterior trim and special details. Typical usages in the form of detailed drawings are shown on the following two pages.

Sizes

The average size porcelain enamel on steel panel is 10 to 12 sq ft, with a recommended maximum size of 15 to 16 sq ft. Where large-size panels are required, special provisions may be required to avoid waviness.

Attachment

In general, the attachment device is screwed to furring previously fastened to the wall surface. Furring may be chemically protected wood, painted or galvanized metal set behind vertical or horizontal joints. Sometimes panels are fastened directly to the wall surface, but this is not recommended for remodeling or irregular surfaced structures because of alignment problems.

(Continued on page 231)

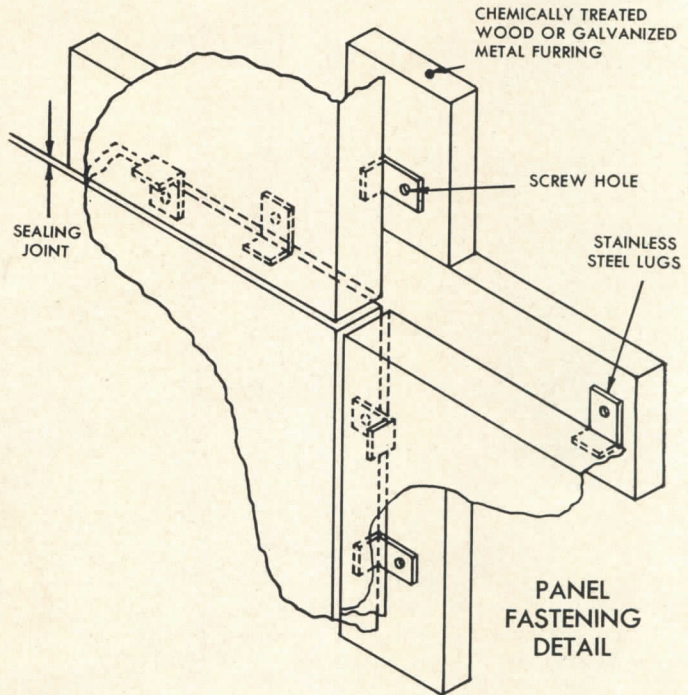

EXTERIOR WALL SECTIONS

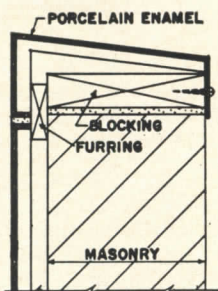

Wall Copings

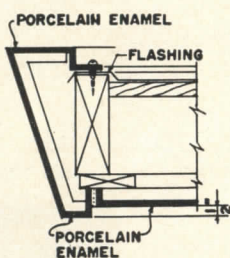
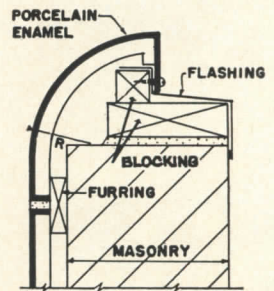
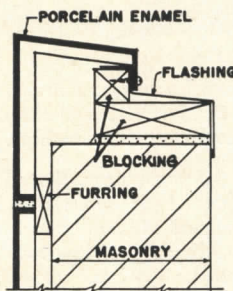

Canopy Fascias

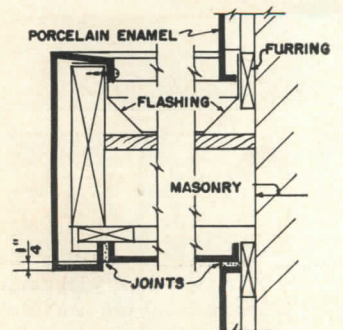
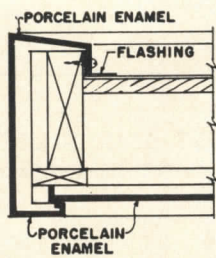



**INTEREST IN EYE COMFORT®
PAYS THIS BANK BIG DIVIDENDS**

Officers of the First Wisconsin National Bank and their Bank's Architect Edwin Kraus know good seeing makes for good banking and good banking pays big dividends. Dividends of employee accuracy and speed. Dividends of satisfied customer relationships. Dividends that continue for years and years.

It is over 50 years now, that Curtis, the greatest name in bank lighting, has been the choice of banks and bankers throughout America. Curtis Lighting is the standard of quality in banks like the First National of Chicago where one of America's first low-brightness bank lighting jobs was installed, and it continues to be the bankers choice in The First Wisconsin National of Milwaukee where Curtis lighting was chosen for this new low-brightness installation illustrated above.

Whether your bank is in Daytona or Dallas, today's dollars invested in Curtis Eye Comfort® lighting will pay big dividends for years to come. Write F3-FM today for illustrated brochure.

NAME _____

ADDRESS _____

CURTIS
LIGHTING, INC.

6135 WEST 65th STREET • CHICAGO 38, ILLINOIS
IN CANADA: Curtis Lighting of Canada, Ltd., 195 Wickstead Ave., Toronto 17, Canada.

PORCELAIN ENAMEL VENEER—2

Courtesy Architectural Division, Porcelain Enamel Institute

Back-up

Veneer installations normally are installed without back-up. However,

unusually large panels, desire for exacting flatness etc., sometimes necessitates use of angle stiffeners, laminated backing or filler materials.

Panels often are sound deadened to some extent by asphaltic compounds. In some cases plywood is bonded to backs of panels.

EXTERIOR WALL CORNERS AND RETURNS

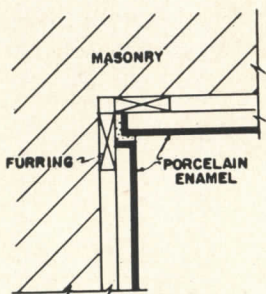

Inside Corner

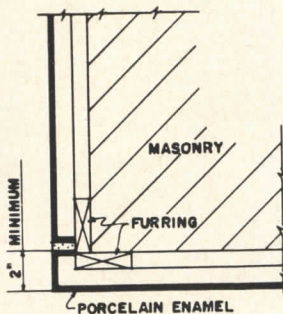

Outside Corner

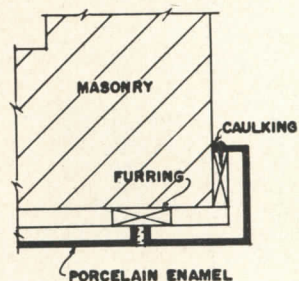

End Return—Square Corner

DOOR JAMB

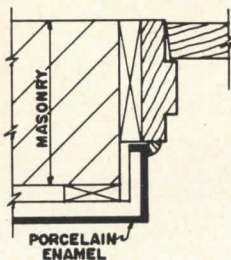

FLUTED PANELS

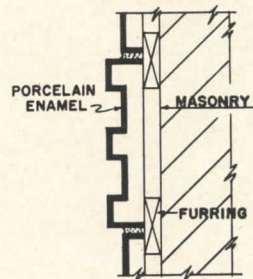

WINDOW TRIM

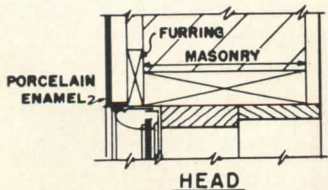

HEAD

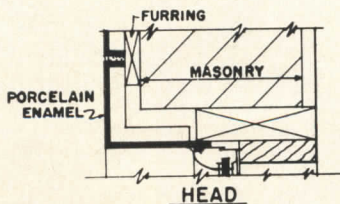

HEAD

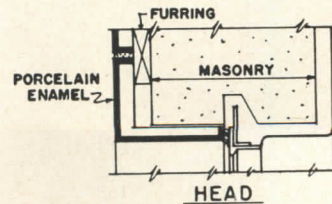

HEAD

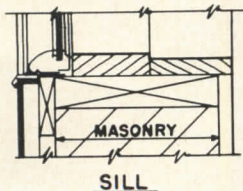

SILL

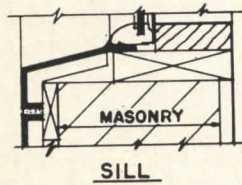

SILL

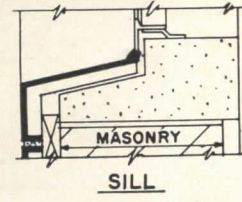

SILL

Show Window

Show Window—Recessed

Metal Sash

appearance IS ONLY half THE STORY!

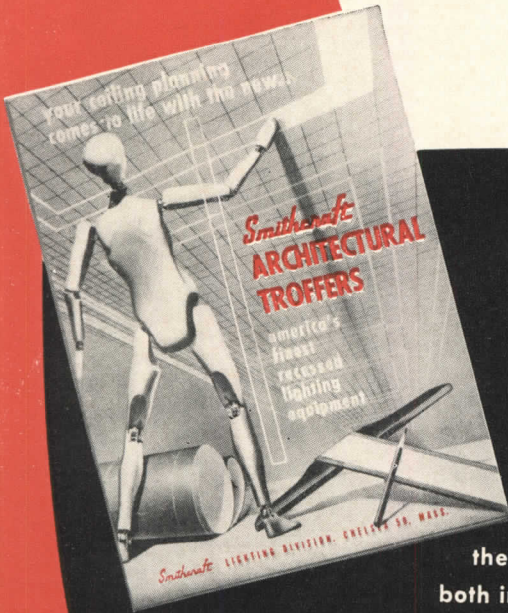
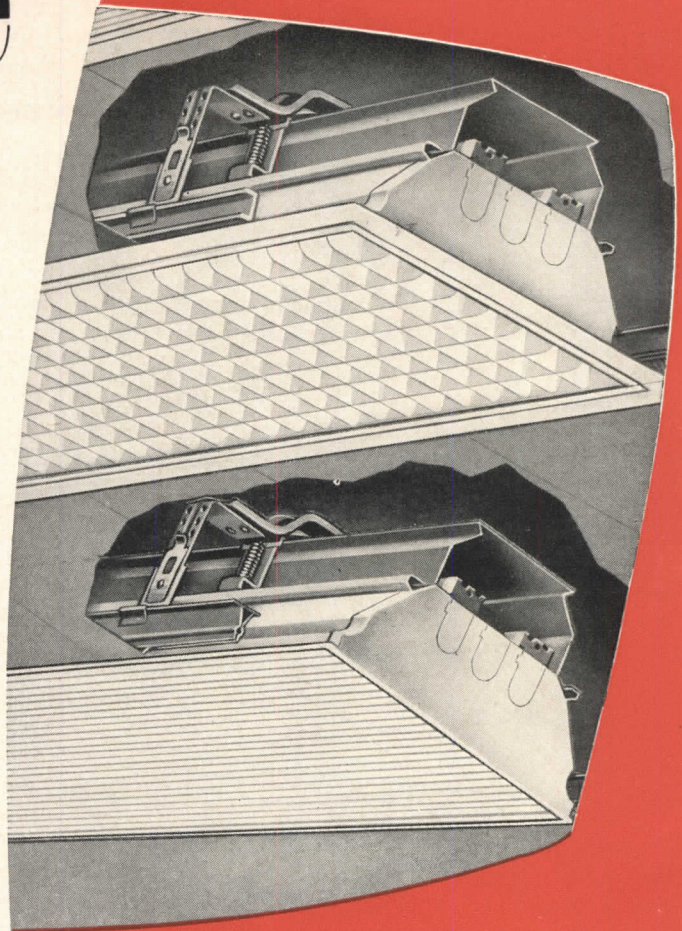

You'll find the whole story in Smithcraft's "Architectural Troffers" Handbook. Write for your copy today!

*Patent #2,597,875
other patents pending

New Smithcraft Architectural Troffers . . . fixtures which assure superlative lighting and clean, trim, uncluttered ceilings. There are no visible catches, latches, hinges, bolts or screws to mar the finished effect . . . and the wide choice of sizes and shielding have made Smithcraft the inevitable choice wherever outstanding appearance is desired.

However, equally important is the other half of the story . . . the exclusive "hidden" features that provide the unlimited versatility, high efficiency and cost-chopping economy in both installation and maintenance. For example, Smithcraft's patented Yoke-Aligner* so effectively simplifies installation that only a screwdriver is needed from start to finish! Developments like these are just as important to the architect and engineer as are Smithcraft's outstanding lighting performance and appearance.

Smithcraft

LIGHTING DIVISION, CHELSEA 50, MASS.

AMERICA'S FINEST FLUORESCENT LIGHTING

MOVING SIDEWALKS

Continued from page 222

provided. A 32-in. wide motorway will carry 7500 passengers per hour. A 48-in. wide motorway will carry 12,000 passengers per hour.

Speed, Safety, Cost

Various enthusiasts have made a number of interesting claims regarding the future of the passenger motorways. Many of these may come true. There are several problems to be faced, however, in any realistic evaluation. These include: potential speed and length of units, safety considerations, and costs.

Firstly, it is doubtful whether the speed of a single lane motorway can be made to exceed 200 ft per minute, the limitation being the safety in stepping on and off the motorway. Such speed would limit the travel to the rate of about 2½ mph or to the speed of a normal walk. It would take about 5 minutes to cover a distance of 1000 ft.

Secondly, the idea of using parallel belts traveling at different speeds — for example, three motorways, the first traveling at 200 ft per minute, the second alongside of it at 400 ft per minute and the third at 800 ft per minute — would make it necessary for passengers to step sideways from one motorway to the other. At present, the majority of people find considerable difficulty in accomplishing this movement with any degree of safety. Consequently, a system of parallel belts running at different speeds appears to be unworkable at least for the life of the present generation.

Thirdly, the length of the motorway. The longest motorway so far constructed has a travel of 227 ft. This could probably be carried to 1500 ft and perhaps even 3000 ft. There is a limit, however, and further increase over this range would present several technical problems not easily solved.

Fourthly, the perennial problem of cost. A running foot of a motorway requires an initial outlay of \$200 to \$600. This compares favorably with the cost of an escalator which is roughly \$1000 per foot. A motorway 100 ft long would cost initially \$20,000 to \$60,000. Based on a 30 year life, the daily cost, including amortization, maintenance and insurance would be in the range of \$6 to \$12, which is not prohibitive. On the other hand, extreme motorways many thousands of feet long, assuming such motorways could be constructed at the rate of \$500,000 per 1000 ft, would be costly.

Potential Applications

It is obvious that passenger motorways can contribute little to the speeding up of normal pedestrian traffic. Their most successful applications pivot about the principle of saving human energy for building good will or for the economic advantage of inducing large groups of people to reach an otherwise undesirable destination. This occurs in at least two instances: (1) where it is necessary to plod painfully up a grade and (2) where heavy or bulky baggage or packages must be carried through unreasonably long distances. There is always, of course, the discouraging combination where heavy baggage must be carried up grade. In such cases the motorways are practically indispensable.

Such instances can be recalled in many of our transportation centers, such as bus terminals, railroad stations, steamship piers and airports.

In all such instances passenger motorways can be of genuine help. One arrangement that suggests itself for long railroad platforms or airport corridors would be a series of standard length motorways installed end to end with a 10-ft spacing between the units. A passenger may then ride with his baggage a distance of 80 or 100 ft and then either get off or walk the 10 ft and continue riding on the next unit, and the following unit until he reaches his destination.

Sport stadiums are other offenders. After the long trip to the stadium, there still remains the long haul up a grade to one's seat.

There are other suggested uses of motorways such as crossovers at congested streets or over highways to reach shopping centers, to span distances between groups of shops, to provide transportation between shopping centers and remotely located parking fields, to span distances in huge parking fields and similar instances.

Code Rules

The establishment of code rules for new devices is often frowned upon as a limit to inventiveness. To some extent this is probably true. But conveying people involves a definite responsibility non-existent when materials are conveyed.

The art of passenger motorways is now sufficiently advanced to permit the preparation of some rules so as to prevent irresponsible designs and to guide future designers who may gain from the

experience of the early manufacturers.

The rules should include at least the following requirements:

(1) The entrance and exit should be at the ends of the motorway. Sidestepping from one motorway to another should be permitted only when both motorways travel at the same speed.

(2) Motorways should be provided with balustrades to guard the sides and with handrails moving at the same speed as the motorways.

(3) The width of the motorway should be limited to permit every passenger to have access to the handrails.

(4) Speed to be limited to about 200 ft per minute for safe access and egress.

(5) Clearance between the moving and stationary components to be limited to ¼ in. for safety.

(6) At the entrance and the exit, the handrails should extend at least 2 ft beyond the moving platform.

(7) Emergency stop buttons should be provided at strategic points.

(8) Protective devices should be provided such as non-reversing device, brakes, overspeed governor, broken handrail device, a stopping device to operate if the motorway platform separates and other similar devices.

The Future

Passenger motorways streaking along at speeds of 30 to 50 mph would be a dreamer's delight. It is possible that some day metropolitan areas would be wrapped with speeding motorway ribbons darting here and there, now in a straight-away, and then in a motospiral encircling buildings all the way up.

It is possible that sidestepping from one speeding ribbon to a still faster one would be so commonplace as to be indulged in by all in the most carefree manner.

Certainly, the continual growth of large population centers will force the adoption of a more efficient means of transportation than by the already overcrowded subway train systems or by individual automobiles on traffic congested streets. Some day, in a not too distant future, the average city traveling time period will become so lengthy as to be ridiculous. The local and express motorways moving continuously may then become the solution to the problem and all men, including the oppositionists, will be only too glad to avail themselves of this means of transportation.

THE
PREFERRED
PLUMBING

CR

What makes Crane America's

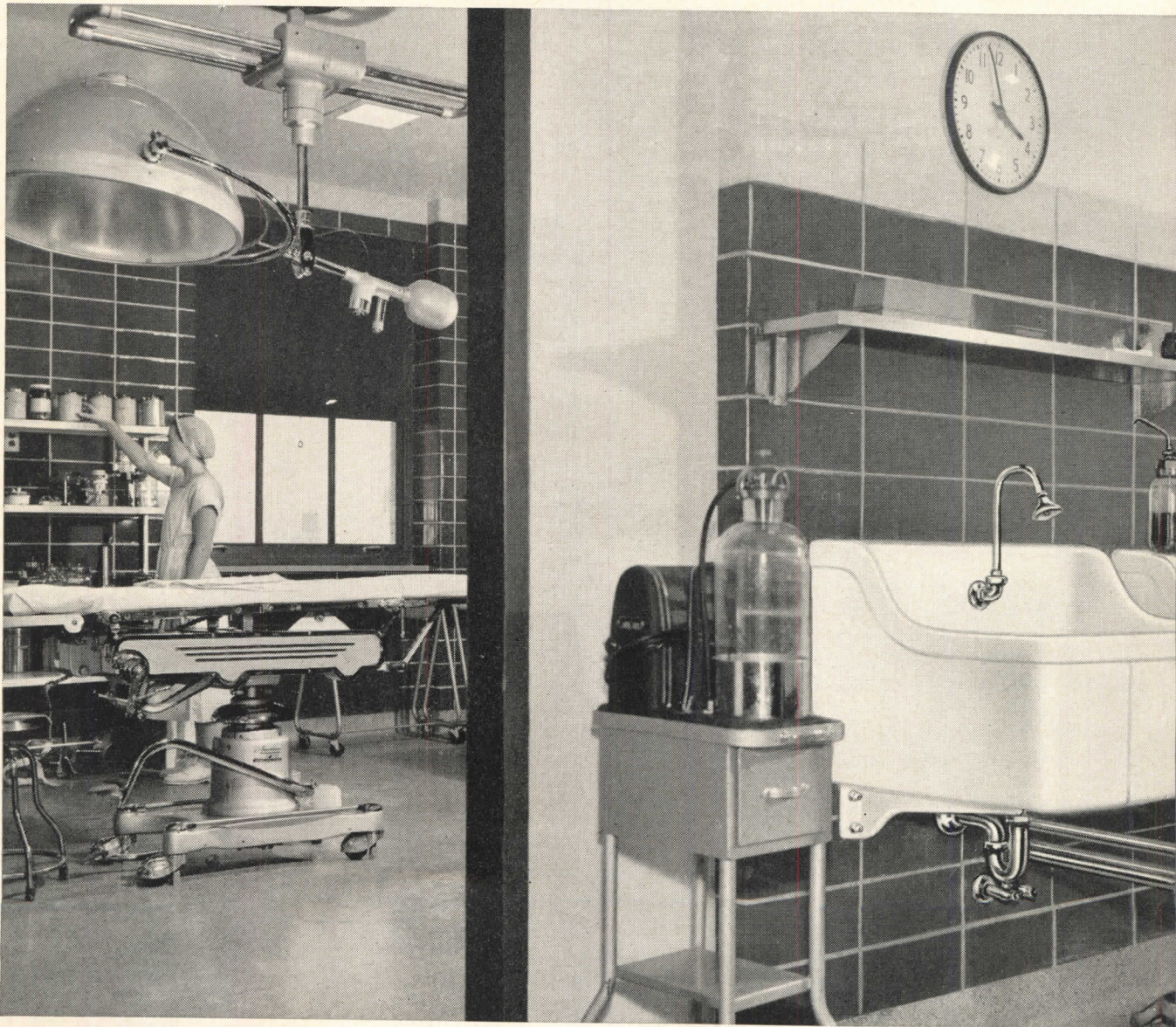

A scrub-up sink that's easy to keep sterile. This special vitreous glazed, all-ceramic product resists thermal shock, abrasion, acid, and stains. Withstands expansion and contraction without crazing. Special shape permits surgeons to scrub to shoulder without touching non-sterile parts.

amcolens in industry

Designers of incandescent lighting for modern offices and executive suites have discovered a new tool, the Art Metal AMCOLENS. The AMCOLENS makes it possible to design incomparable efficiency as well as contemporary beauty into lighting systems. Installed in Art Metal recessed eliptisquares, AMCOLENS builds prestige among customers and employees. For dramatic, advanced lighting for conference rooms, lobbies, alcoves, reception rooms, lounges, offices and laboratories, AMCOLENS are your contemporary keys to better lighting designs.

for OFFICES

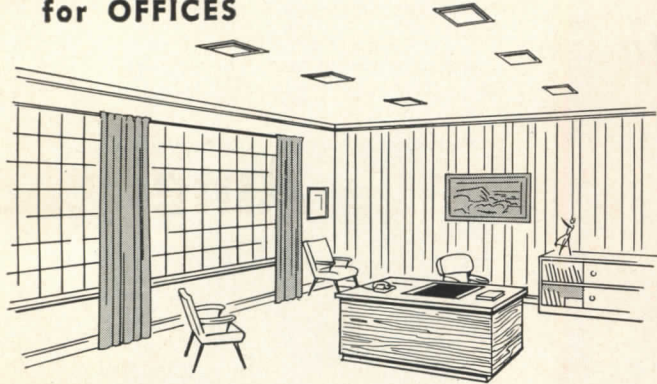

AMCOLENS creates a cheerful office environment where employees enjoy working. Warm, colorful light is multiplied and directed to desks and cabinets by clear glass prisms, the most exact means known to science for controlling the direction of light.

for CONFERENCE ROOMS

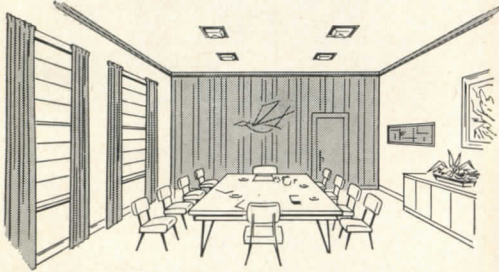

Handsome, deep AMCOLENS provide diffused shadowless illumination and blend with the overall color scheme.

for LOBBIES

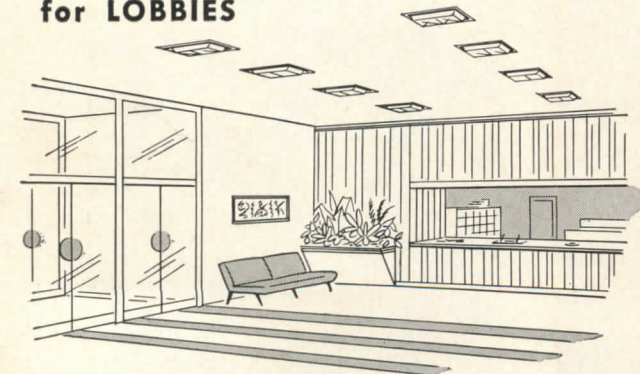

The rich subtle effect of the two-light deep AMCOLENS enhances the decor of any business gathering place. In terms of lighting efficiency and practicality, clear prismatic AMCOLENS has no equal.

TYPES of recessed ELIPTISQUARES

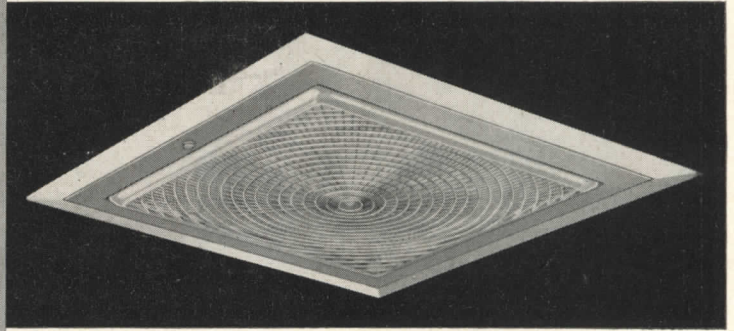

Recessed Flush Eliptisquare—Four eliptisquare sizes accommodate 6½", 8½", 10⅝" and 12" AMCOLENS. The eliptisquare reflector multiplies light output.

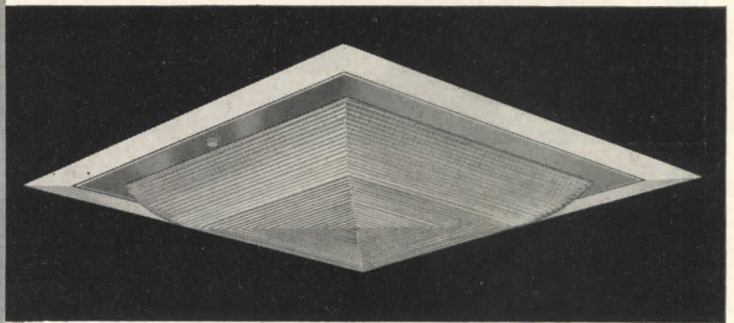

Deep Eliptisquare—Three sizes utilize 8½", 10⅝" and 12" AMCOLENS.

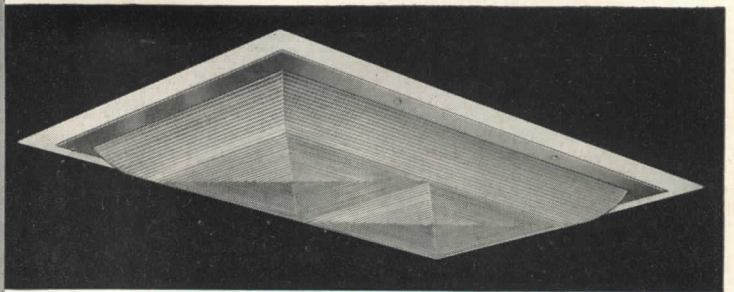

Two Light Eliptisquare—Accommodates one 9½" x 16½" AMCOLENS which incorporates two symmetric lens elements each with its own lamp and eliptisquare reflector. All eliptisquare units have separate hinged doors which rotate open on two spring pin hinges.

AMCOLENS ARE ANOTHER *Lighting Research* DEVELOPMENT OF ART METAL

THE **ART METAL** COMPANY

CLEVELAND 3, OHIO

DEMAND THIS TRADEMARK!

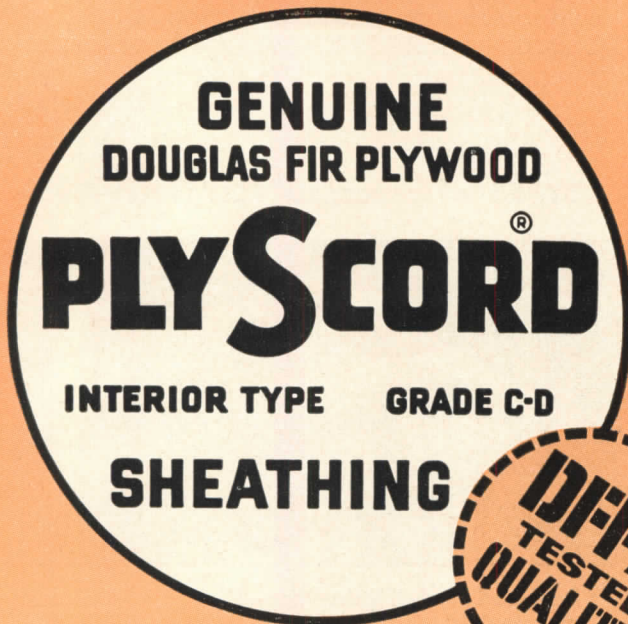

Here's why! **PLYSCORD®**
IS PLYWOOD SHEATHING
QUALITY-TESTED* FOR:

- 1. Correct veneer grades—inside and out**
- 2. Strength, rigidity and stiffness**
- 3. Dependable glue-line performance**

The true quality of plywood sheathing isn't always visible. What's *inside*—glue quality...inner-ply quality—is all-important.

*PLYSCORD® is quality-tested under established industry procedures, according to published Commercial Standards.

Insist on DFPA-PLYSCORD® when you buy, specify, or use plywood sheathing!

Douglas Fir Plywood Association (DFPA), Tacoma, Wash.—a non-profit industry organization devoted to product research, promotion and quality maintenance.

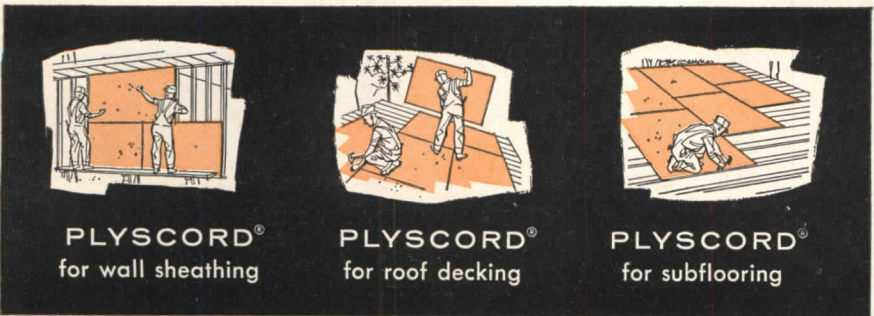

TECHNICAL ROUNDUP

ARCHITECTS WIN COMPETITION FOR ALUMINUM WALL DESIGNS

A \$10,000 first prize was awarded to Alfred Clauss, AIA, of Philadelphia, from 295 entrants in a competition for new design and construction ideas for aluminum curtain wall buildings sponsored by the Aluminum Company of America and the National Association of Architectural Metal Manufacturers.

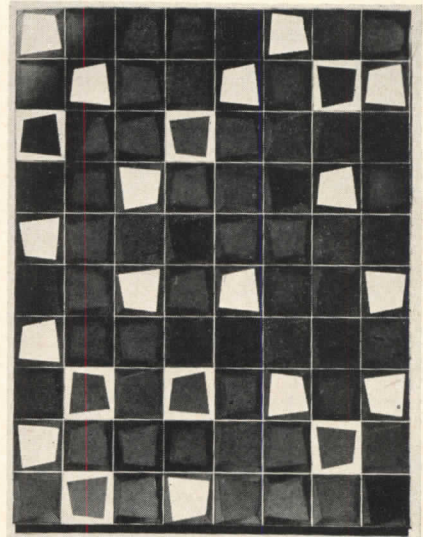

Mr. Clauss' design, a section of which is shown above, features a mosaic pattern effect utilizing an unusual-shaped, pressed aluminum panel and a variation of the Alcoa Architectural colors. The design also offers a new method of fastening metal panels to a building framework.

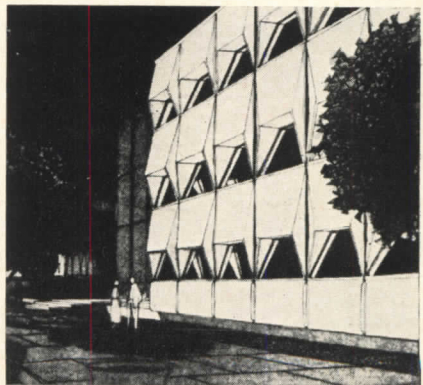

Second prize of \$5000 went to George W. Qualls and William E. Cox, Philadelphia architects, for a unique design using folded aluminum panels, as shown in the perspective above. The design incorporates the mechanical systems of the building into the hollow space in the panels.

THE MARK OF QUALITY



uni-flo

Engineered
Air Distribution

predict and deliver air patterns like this...

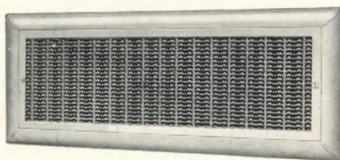
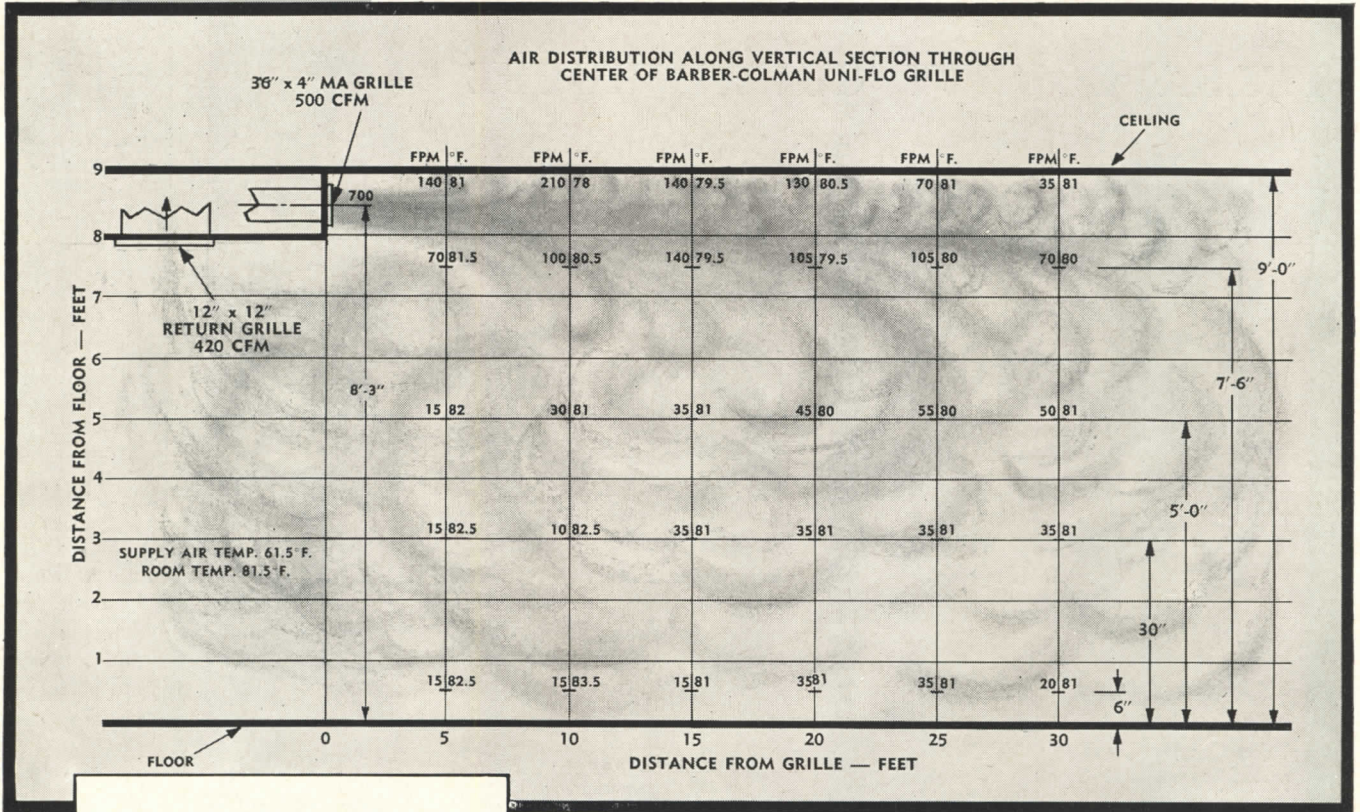

Model MA
Double-Deflection Grille

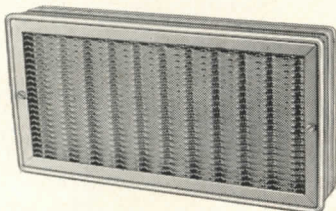

Model FA
Double-Deflection Grille

Precision distribution of conditioned air from sidewall grilles is no problem when you specify Uni-Flo. Uni-Flo Grilles are true sidewall diffusers, designed to give adjustable air pattern and rapid diffusion without air stream drop or excessive air motion. Laboratory-tested, field-proved performance data permit the engineer to create required conditions without guessing. Variety of types available. For complete details, call your nearby Barber-Colman Field Office, or write . . .

Barber-Colman Company

DEPT. F, 1104 ROCK STREET, ROCKFORD, ILLINOIS, U. S. A.

Field Offices in principal cities

THE RECORD REPORTS A SPECIAL REPORT

(Continued from page 16B)

poured a metal alloy casting around glass.

Working with the glass itself, some studios have tried fusing chipped glass on plain glass to achieve a richer texture; others have sandblasted the glass, sometimes have carved and sandblasted it, and accented it with gold and silver leaf. Commercial glass—glass blocks

and fluted glass, for example—has also been used

Experimentation continues also on the older methods. Among the attempts to improve upon the traditional product: Burnham studio says that it is always experimenting with new methods of painting glass, and Blum studio reports new techniques in bracing windows to eliminate bulges after installation. In addition, some studios said that, especially in contemporary design, they have had to exercise particular care in the selection of materials,

and have often had to devise new techniques for handling the job.

In learning about new materials, many studios of course carry out experimentation in their own studios: Winterich reports 110 hours spent each month on experimental work. Learning about the work of others in the field also provides stimulation, of course, although Pike studio complains that there is not nearly enough exchange of

(Continued on page 318)

TULSA COUNTY COURT HOUSE

Tulsa, Oklahoma

ARCHITECTS
Black & West

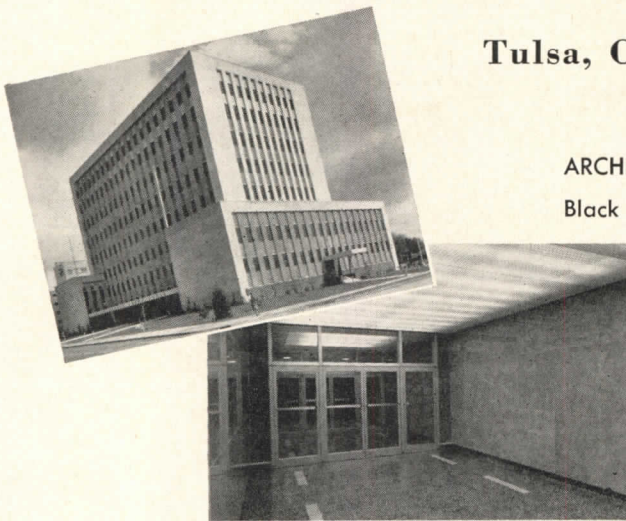

28 Balanced Doors
in the entrances to
Tulsa County Court
House.

more . . .

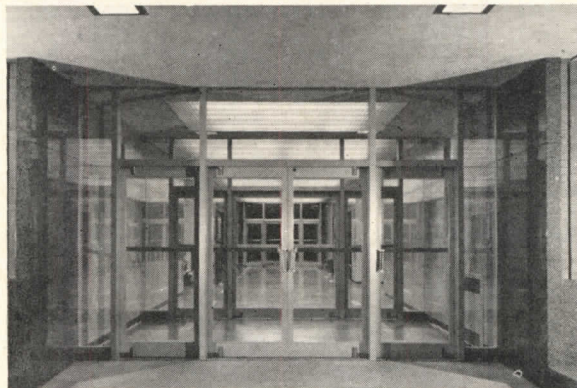

The Door that lets
TRAFFIC through QUICKLY

ELLISON BRONZE CO.
Jamestown, New York

representatives in 77 principal cities in the
United States, Canada and Puerto Rico

Ellison
the **BALANCED DOOR**

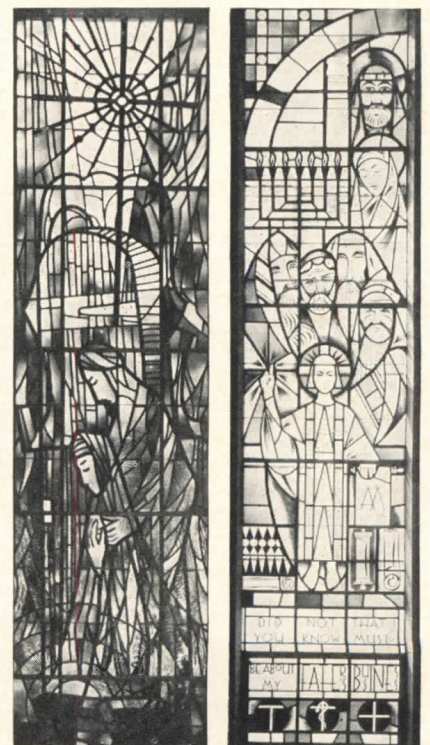
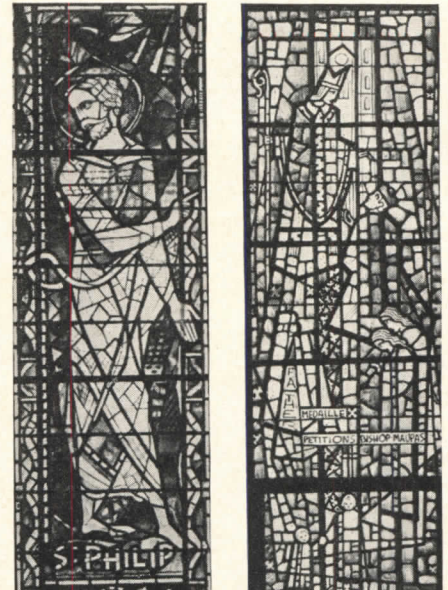

Top: left, from Messrs. Reynolds, Francis & Rohnstock, Boston; right, Pittsburgh Stained Glass Studios. Bottom: left, Orco, Inc., San Antonio; right, Novello Art Glass Studios, Winona, Minn.

**FOR DIRECTIONAL
CONTROL,
LONG THROW,
HIGH OUTPUT
IN
AIR DISTRIBUTION...**

THERMOTANK

drum punkah[®] louvres

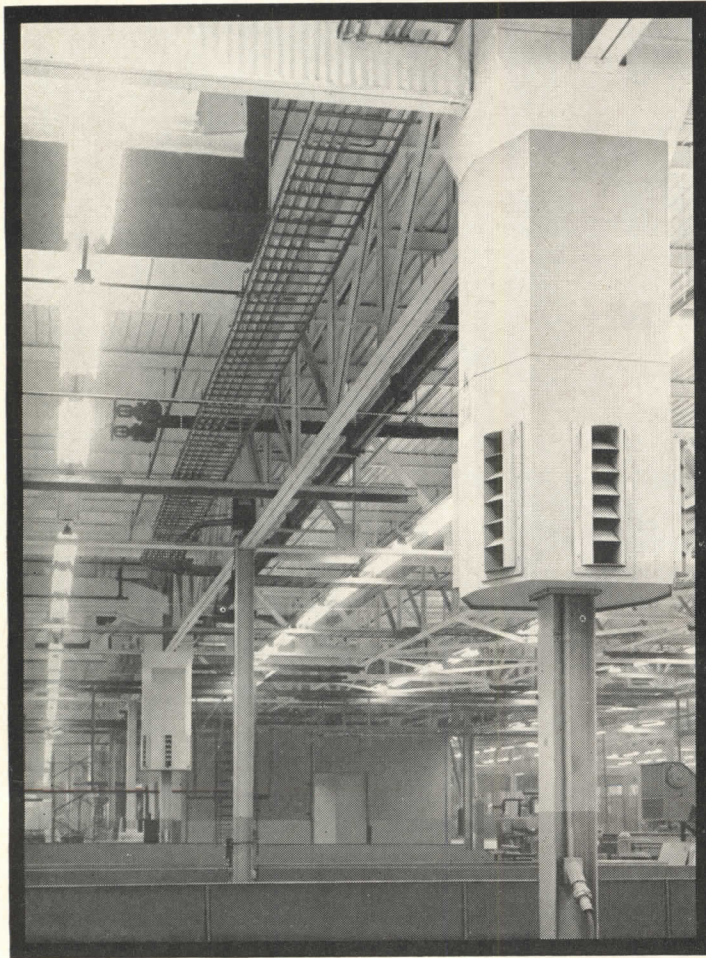
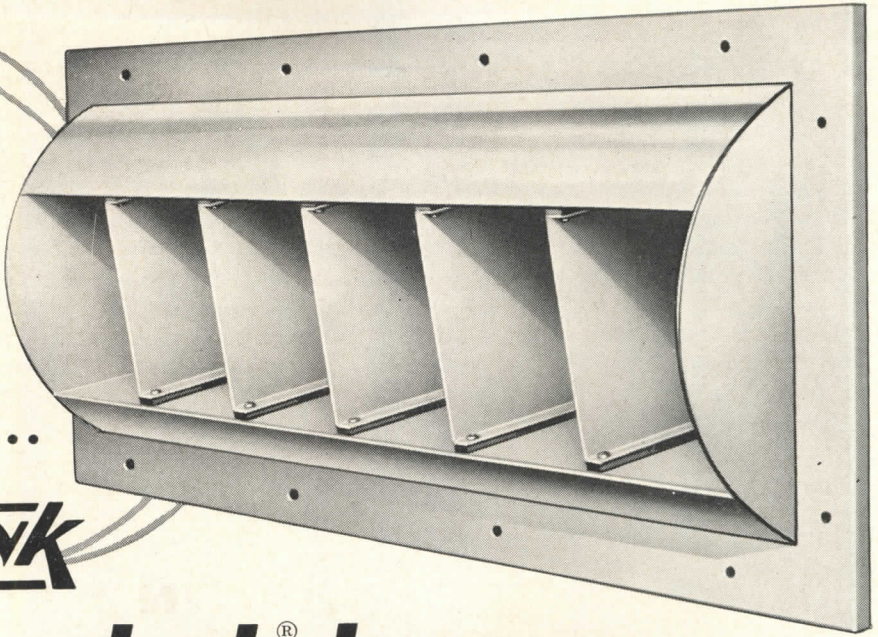

Architect: Albert Kahn Associated Architects and Engineers
General Contractor: Darin & Armstrong, Inc.

FORD MOTOR COMPANY—Sterling Township Machining Plant—Northeast of Detroit
In this new factory, the most advanced of its kind in the world, 500 drum punkah louvres, each handling 3,300 C.F.M., have been installed vertically on hexagonal supply plenums. Thousands of these louvres are being installed in other industrial plants throughout the country.

drum punkah louvres have been used for many years in a wide range of commercial and industrial applications and are finding increasing popularity in modern factories where large areas have to be served with a minimum of ductwork.

ADJUSTABLE DRUM AND VANES

The adjustable drum permits variation of the air stream centerline through an included angle of 60°. This feature, combined with adjustable vanes, gives complete directional control of air distribution. The drum punkah louvre may be mounted horizontally, or vertically as shown at the left.

HIGH CAPACITY

High outlet velocity combined with large free area gives exceptional capacity for its size.

THROW AND ENTRAINMENT

The unusually long throw of this unit reduces the amount of branch ducting normally required. High entrainment of secondary air assures thorough mixing of supply air with room air.

For performance data and range of sizes, write or mail coupon.

THERMOTANK
INCORPORATED
PRODUCTS DIVISION
11191 LAPPIN AVENUE
DETROIT 34, MICHIGAN



THERMOTANK, INC.
11191 Lappin Avenue, Detroit 34, Mich.
Please send me your informative brochure,
DPL-7, on drum punkah louvres.

Name _____
Organization _____
Address _____
City _____ Zone _____ State _____

THE RECORD REPORTS

A SPECIAL REPORT

(Continued from page 314)

such information among members of the Association. Still other studios said that they learned of new materials and techniques from force of necessity in solving new problems — and more than one studio said rather wistfully that they would welcome such problems.

On the subject of cost, most of the respondents agreed that this had in-

creased over the last ten years, although they could not agree on how much prices had gone up. The range of estimates was from no increase to a 150 per cent increase; six studios guessed that prices had gone up 10 to 20 per cent, seven thought about 50 per cent, and six others thought 100 per cent. Practically all of the increase has gone into higher wages; materials costs, said one studio, have been "pretty stable." The one studio reporting no increase in cost explained that "in our instance we

(Continued on page 322)

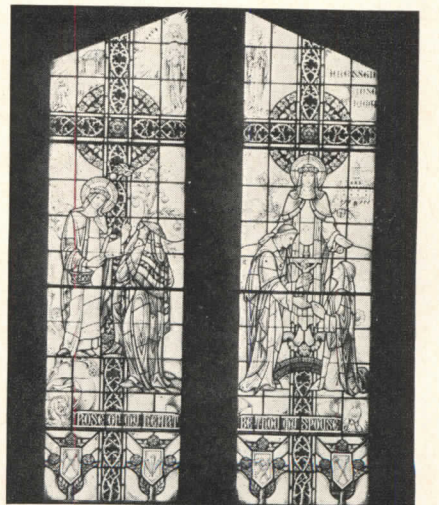
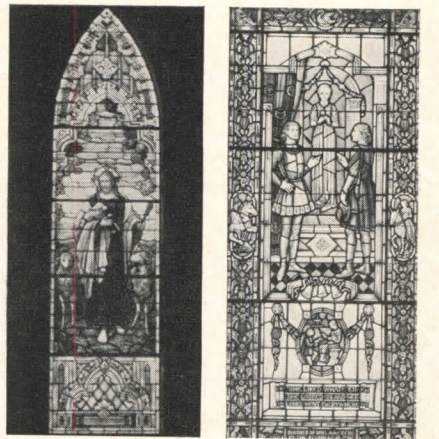

NATURAL SLATE . . . RIGHT **YESTERDAY**
TODAY
TOMORROW

Slate Chalkboards Are Standard Equipment At Brooklyn, New York's Ultra-Modern George W. Wingate High School . . . the "Banjo-Type" School . . . One Of The Many Modern Schools Specifying Slate Chalkboards.

KELLY & GRUZEN Architects - Engineers

Of all chalkboards, slate communicates best. White chalk on slate produces the desired high contrast to permit the student to grasp the written message instantaneously! The writing surface of slate, too, is so superior that it is the standard to which the writing qualities of all other substitutes are compared! Easy to clean . . . virtually indestructible . . . slate is lowest in maintenance costs under normal usage conditions. For timeless beauty and durability, compare before you install . . . inquiries welcomed on specific properties of slate.

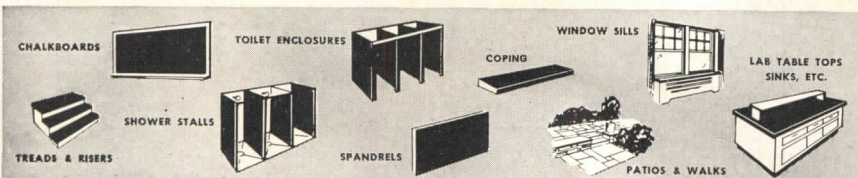

For Your Protection . . . Insist on Slate Quarried in Pennsylvania, U.S.A.

NATURAL SLATE BLACKBOARD CO.
STRUCTURAL SLATE CO.

PEN ARGYL PENNSYLVANIA



natural slate . . . 500 million years in the making

Top: left, from studio of Edward W. Hiemer & Co., Clifton, N. J.; right, from Henry Hunt Studios, Pittsburgh. Center: left, from Blum Ornamental Glass Co., Inc., Louisville, Ky.; right, from Jacoby Art Glass Co., St. Louis. Bottom: Henry Keck Studios, Syracuse, N. Y.

If you are interested in the building market and the reasons why year after year—and increasingly in 1956—more building product manufacturers are placing more advertising pages in Architectural Record than in any other architectural magazine, we will gladly send you by return mail any of the following market and media data. Just circle the key numbers (AR 1, AR 2, etc.) of the items you want *on the coupon below* and mail to Architectural Record.

Market

- AR 1 Analysis, by type of project, of architect-planned work 12 months 1955.
- AR 2 Analysis of architect activity—a study of the work actually done in a 12-month period by 380 representative architectural firms.
- AR 3 Construction potentials for 1956 as estimated by F. W. Dodge Corporation.
- AR 4 Information on architectural specification practice with respect to my product.

Verifiable Market Coverage by Architectural Record of . . .

- AR 5 nonresidential building types,
- AR 6 residential building types.

Readership

- AR 7 A report on 91 *independently sponsored* studies showing the reading preferences of architects and engineers.

Architect and Engineer Circulation

- AR 8 Comparative architect and engineer circulation, three leading architectural magazines.
- AR 9 Publisher's Statement (Audit Bureau of Circulations).

Editorial

- AR 10 Editorial awards
- AR 11 Editorial staff
- AR 12 Editorial approach
- AR 13 Comparative editorial quantity of the three architectural magazines.

Advertising

- AR 14 Pointers on writing architectural copy.
- AR 15 Comparative advertising volume, three leading architectural magazines.
- AR 16 Volume of advertising in product classification of interest to me.

Fill out and mail this coupon

Circle appropriate key numbers to obtain market and media information offered on this page and return to: Advertising Department, Architectural Record, 119 West 40th Street, New York 18, N. Y.

- AR 1 _____
- AR 2 _____
- AR 3 _____
- AR 4 _____
(write in name of product)
- AR 5 _____
↑ (write in types of projects of
↓ greatest importance to you)
- AR 6 _____
- AR 7 _____
- AR 8 Check type of circulation you are particularly interest in:
_____registered architects
_____consulting engineers

_____staff architects and engineers in commerce and industry
_____other (write in)_____

AR 9
AR 10

Name _____
Title _____
Company _____
Address _____

AR 11
AR 12
AR 13
AR 14
AR 15
AR 16

(write in product classification)

After I've had an opportunity to review the above items, please have your representative contact me in case I have any questions.

THE RECORD REPORTS A SPECIAL REPORT

(Continued from page 318)

have tried to refine and better our process to meet the higher wage scale."

A stained glass window could cost anywhere from \$15 to \$200 per sq ft. The average estimate made by the studios, asked to give an approximate minimum sq ft cost for a "high quality" window, was \$45. This, however, is a

(Continued on page 326)

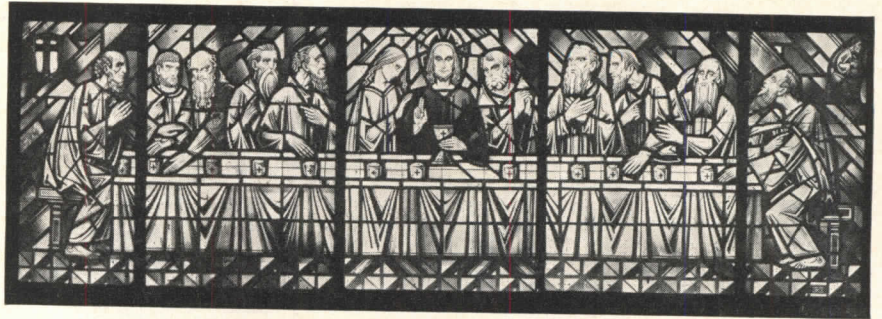

Window for Evangelical Lutheran Church Headquarters from Conrad Pickel Studios, Inc.

When the **PRESSURE'S ON**

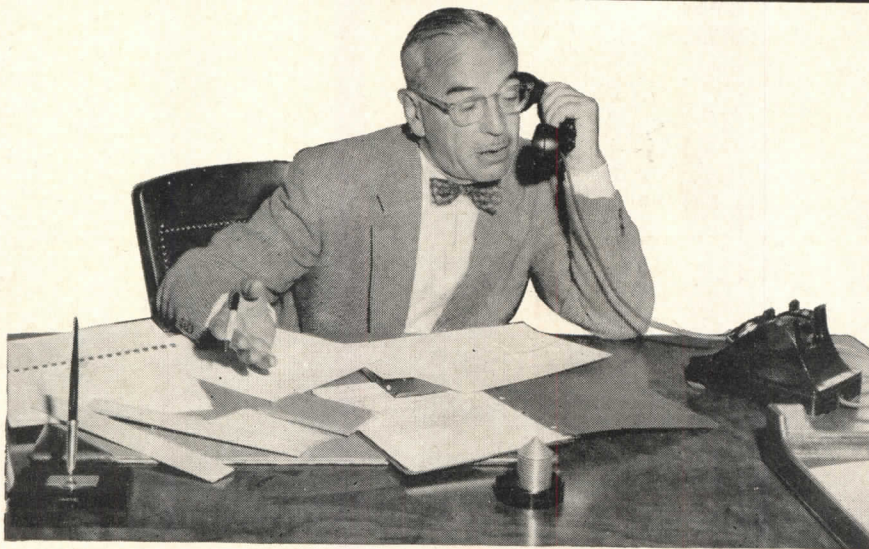

When the pressure's on and you need color plans or painting specifications in a hurry call your Pratt&Lambert representative!

He is an experienced architectural consultant—trained to cooperate personally and promptly in developing complete color plans and painting specifications.

His color plans and specifications will be realistic and practical—in keeping with the results *you want* and *consistent with the project and budget*.

For color planning assistance, information about new products, answers to painting problems—your Pratt & Lambert Representative can give you reliable help. Write your nearest Pratt&Lambert Architectural Service Department: 3301 38th Ave., Long Island City 1, N. Y.; 75 Tonawanda St., Buffalo 7, N. Y.; 326 W. 26th St., Chicago 16, Ill.; 254 Courtwright St., Fort Erie, Ontario.



PRATT & LAMBERT-INC.

A Dependable Name in Paint since 1849

NEW YORK • BUFFALO • CHICAGO • FORT ERIE, ONT.



Top: from the Payne Spiers Studios Inc., Paterson, N. J. Center: from Winterich's, Cleveland. Bottom: from the Judson Studios, Los Angeles.

when
traffic
is
heaviest



OFFICE BUILDINGS



SCHOOLS

W R I G H T

VINYL TILE flooring
gives years more
care-free wear!



HOTELS

WRIGHT Vinyl Tile provides the ultimate in rugged serviceability. Here is truly durable tile flooring, resisting the hardest abuse from scratches, scuff marks, stains. Acids, alkalis, and grease are quickly removed from its water-proof, non-slip surface. Impervious to temperature change, it will not warp, buckle or crack. Maintenance is easier, more economical too, than with any other type of resilient tile flooring.

Completely homogeneous, WRIGHT vinyl meets the most exacting quality control specifications. Its smooth, even surface never loses its brilliance, and the deep, clear colors retain their full richness even after years of wear.

For your next installation, look into the advantages of this beautiful and practical flooring.

WRIGHT MANUFACTURING COMPANY
Div. of Mastic Tile Corporation of America
Dept. W8-6, P. O. Box 986, Newburgh, N. Y.

Please send me full details on WRIGHT Vinyl Tile and WRIGHT Rubber Tile

NAME _____
ADDRESS _____
CITY _____ ZONE _____ STATE _____

W A 14

THE RECORD REPORTS

A SPECIAL REPORT

(Continued from page 322)

very rough estimate, since most of the respondents hastened to say that the complexity of the design is the determining factor. The size of the window also would seem to affect the cost, with the sq ft cost decreasing somewhat on large windows.

Linked with the cost problem is the craft's worst headache at the moment

— competition from foreign studios. There seems to be little disagreement among the studios that the lower wage scale in European studios gives them a competitive advantage; the respondents estimated that American glass costs from 10 to 200 per cent more than imported glass. Several of the American studios thought, however, that it is in the area of cheaper glass that the imports have the advantage, and that the difference tends to disappear in the high cost brackets. One studio, how-

(Continued on page 328)

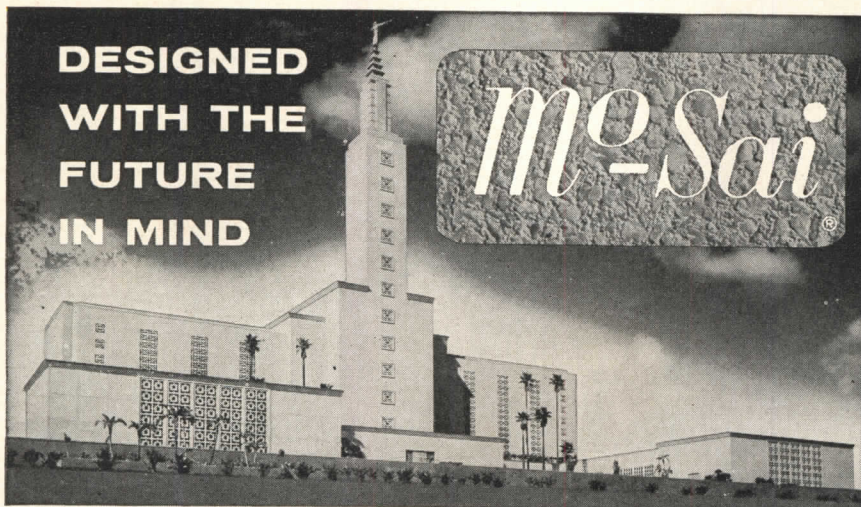

● Church of Jesus Christ of Latter Day Saints, Los Angeles, California. Architect: Edward A. Andersen, Salt Lake City. Mo-Sai by Otto Buehner & Co., Salt Lake City.

135,000 square feet of light golden tan Mo-Sai Precast Facing cover the entire exterior surface and grills of the new Los Angeles Temple.

Mo-Sai suits the mood and sets the tone of this entire structure. Its versatility of color, texture and size provides a freedom of expression unique in architectural design.

When designing with the future in mind—consult the Mo-Sai Associate Manufacturer near you! He will supply details, specifications and samples of this versatile, economical facing material.

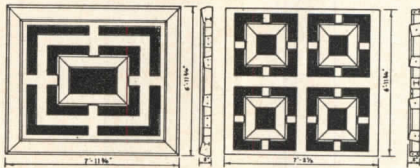
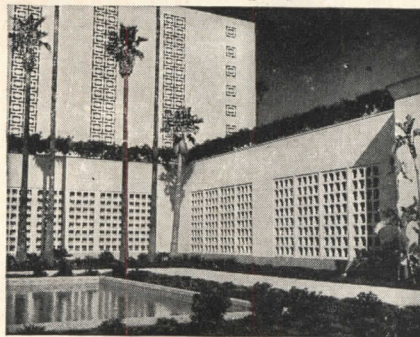

GRILL WORK

MO-SAI ASSOCIATES, INC. Members, The Producers' Council

- | | |
|----------------|---------------------|
| California | Los Angeles |
| Connecticut | South San Francisco |
| Massachusetts | New Haven 3 |
| New York | Allston 34 |
| North Carolina | Rochester 21 |
| Ohio | Greensboro |
| Oklahoma | Cleveland 5 |
| Tennessee | Oklahoma City |
| Texas | Knoxville |
| Utah | Houston 20 |
| Virginia | Salt Lake City 6 |
| Washington | Richmond 7 |
| Wisconsin | Seattle 7 |
| Canada | Oshkosh |
| | Toronto 13 |

- C. D. Wailes Co.
 P. Grassi-American Terrazzo Co.
 The Dextone Co.
 Cambridge Cement Stone Co.
 Goodstone Mfg. Co., Inc.
 The Mabie-Bell Co.
 George Rackle & Sons Co.
 Harler Marblecrete Stone Co.
 Southern Cast Stone Co.
 George Rackle & Sons Co.
 Otto Buehner & Co.
 Economy Cast Stone Co.
 Olympian Stone Co.
 Badger Concrete Co.
 Toronto Cast Stone Co.



Top: window for Christ the King Seminary Chapel, St. Bonaventure, N. Y., from the studio of George Durhan & Son, New York. Bottom: window designed by The Flemish Glazener, Scottsdale, Ariz., for the studio's own showroom



This water closet does not disturb your peace of mind

The famous Case time-tested Non-Overflow One-Piece water closet with the whispering flush...produced in 32 decorator colors and sparkling black and white. Ask your Case wholesaler or write:*

*PATENTED

CASE MANUFACTURING CORPORATION

33 MAIN STREET, BUFFALO 3, NEW YORK

THE RECORD REPORTS

A SPECIAL REPORT

(Continued from page 326)

ever, reversed this, and said that Americans could compete when the cost was near minimum, but were underbid on glass priced at more than \$25 per sq ft.

Still another problem facing the stained glass studios in this country is that of recruiting new artists and craftsmen. Since all of the studios execute their own designs almost exclusively,

the situation could eventually have serious developments. The 38 respondents accounted for a total of 326 craftsmen and 44 apprentices. Of these, 21 reported difficulty in finding suitable trainees, 12 said that there was no problem, and two were uncertain.

In 1942, the Stained Glass Association, working with the union and the Government's apprentice training service, set up an apprenticeship program; now 25 of the 38 studios in the survey have such a program. Most of them

(Continued on page 332)



NEW LAMBERT-ST. LOUIS TERMINAL BUILDING, St. Louis, Mo.
Architects—Hellmuth, Yamasaki & Leinweber

CUSTOM-BILT BY SOUTHERN

Food service equipment designed, engineered, fabricated and installed in any type operation, expertly fitted to available space. You can depend on thorough cooperation by your Southern Dealer, from initial analysis of your food service problems through complete installation and reliable maintenance for the years to come. Get expert help with your next kitchen equipment problem or layout—call your "Custom-Bilt by Southern" dealer, or write Southern Equipment Company, 4550 Gustine Ave., St. Louis 16, Missouri.

SOUTHERN

EQUIPMENT COMPANY



"CUSTOM-BILT BY SOUTHERN" DEALERS: **ALABAMA**, BIRMINGHAM—Vulcan Equip. & Supply Co.; **MOBILE**—Mobile Fixture Co. **ARKANSAS**, LITTLE ROCK—Krebs Bros. Supply Co. **COLORADO**, DENVER—Carson Hotel Supply. **FLORIDA**, DAYTONA BEACH—Ward Morgan Co.; JACKSONVILLE—W. H. Morgan Co.; MIAMI—J. Conkle, Inc.; ORLANDO—Turner-Haack Co.; TAMPA—Food Service Equip. & Engr. Corp. **ILLINOIS**, PEORIA—Hertzels Equip. Co. **INDIANA**, EVANSVILLE—Weber Equip. Co.; INDIANAPOLIS, MARION—National China & Equip. Corp. **IOWA**, DES MOINES—Bolton & Hay. **KANSAS**, WICHITA—Arnholz Coffee & Supply Co. **KENTUCKY**, LEXINGTON—Heilbron-Matthews Co. **LOUISIANA**, NEW ORLEANS—J. S. Waterman Co., Inc.; SHREVEPORT—Buckelew Hdwe. Co. **MICHIGAN**, BAY CITY—Kirchman Bros. Co.; DETROIT—A. J. Marshall Co. **MINNESOTA**, MINNEAPOLIS—Aslesen Co. **MISSOURI**, KANSAS CITY—Greenwood's Inc. **MONTANA**, BILLINGS—Northwest Fixture Co. **NEBRASKA**, OMAHA—Buller Fixture Co. **NORTH CAROLINA**, ASHEVILLE—Asheville Showcase & Fixture Co. **NORTH DAKOTA**, FARGO—Fargo Food & Equip. Co. **OHIO**, CINCINNATI—H. Lauber & Co.; CLEVELAND—S. S. Kemp Co.; COLUMBUS—General Hotel Supply; TOLEDO—Rowland Equip. Co.; YOUNGSTOWN—W. C. Zabel Co. **OKLAHOMA**, TULSA—Goodner Van Co. **PENNSYLVANIA**, ERIE—A. F. Schultz Co. **SOUTH CAROLINA**, GREENVILLE—Food Equipment Co. **TENNESSEE**, CHATTANOOGA—Mountain City Stove Co.; KNOXVILLE—E. Carleton Scruggs; MEMPHIS—House-Bond Co.; NASHVILLE—McKay-Cameron Co. **TEXAS**, AMARILLO—Arnholz Coffee & Supply Co.; CORPUS CHRISTI—Southwestern Hotel Supply, Inc.; EL PASO—El Paso Hotel Supply Co.; SAN ANTONIO—Southwestern Hotel Supply, Inc. **UTAH**, SALT LAKE CITY—Restaurant & Store Equip. Co. **VIRGINIA**, RICHMOND—Ezekiel & Weiman Co. **WEST VIRGINIA**, CLARKSBURG—Parson-Souders Co. **WISCONSIN**, MILWAUKEE—S. J. Casper Co.



Top: from the Ave Maria Stained Glass Studio Inc., Brooklyn. Center: from Whittemore Associates, Inc., Boston. Bottom: from Pike Stained Glass Studios, Rochester, N. Y.

ANOTHER NEW IDEA...

ONE OF A
SERIES OF
IDEAS FOR
YOUR FILES

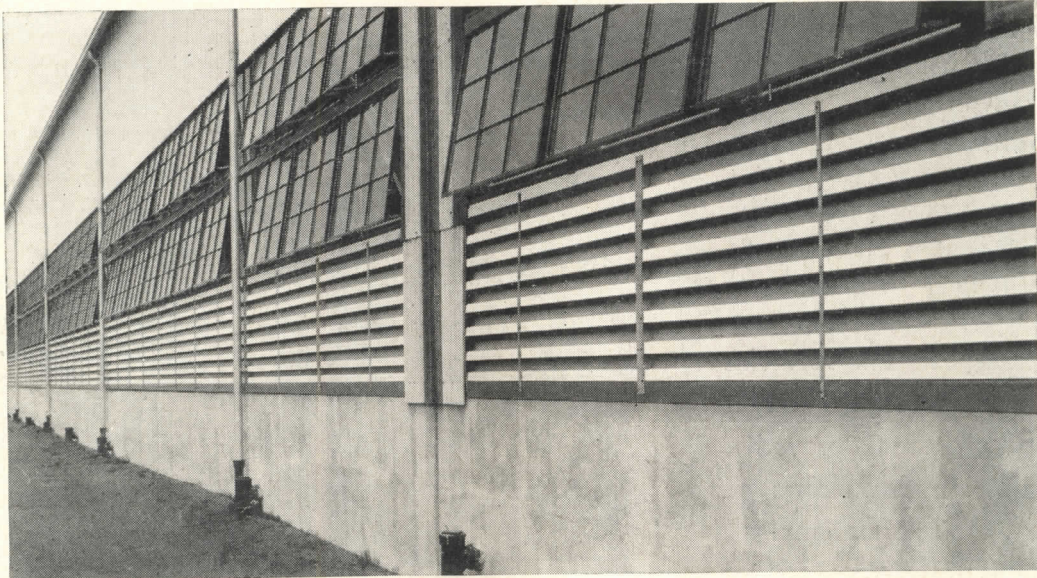

WITH CORRUGATED ASBESTONE

Walls that breathe with louvers of Gold Bond Corrugated Asbestone

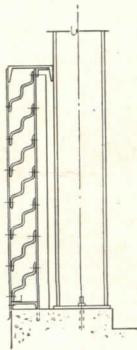

Sidewalls in this Alabama plant ventilate and protect at the same time. Louvers made of fireproof Gold Bond Corrugated ASBESTONE "400" form the lower sections of these unusual sidewalls and add to the general appearance of the plant, too. The diagram at the left illustrates the method used in this system. The upper walls are sided with Corrugated "400" in the traditional straight line method. Rock-like ASBESTONE needs no upkeep... resists weather and corrosion permanently.

How many uses can *you* think of for Gold Bond Corrugated Asbestone? Wherever you use it, you're getting lasting protection and good looks. Write for details on this versatile product. Address Dept. AR-66, National Gypsum Company, P. O. 5257-B, New Orleans 15, La.

Gold Bond Technical Bulletin No. 2032, and Booklet No. 2273 gives full specifications and uses of Gold Bond CORRUGATED ASBESTONE Products.



CORRUGATED ASBESTONE

NATIONAL GYPSUM COMPANY

Gold Bond[®]
BUILDING PRODUCTS

THE RECORD REPORTS A SPECIAL REPORT

(Continued from page 328)

were started about ten years ago, although a couple of them date much farther back.

The RECORD asked the studios also whether they thought architects were sufficiently well acquainted with stained glass to use it effectively. Almost to a man they answered "No." Only one studio gave an unqualified yes. One stu-

dio, though, blamed the craft itself for this situation: "Our craft," it remarked, "has been very backward about telling the public, especially the architects, about our ability to make stained glass an integral part of . . . architecture."

Here follows a list of members of the Stained Glass Association of America, expanded by information received on the questionnaires. Unless noted, all studios are willing to accept commissions anywhere in the country.

THE FLEMISH GLAZENIER, 47 W. Fifth Ave., Scottsdale, Ariz.; est. 1952; staff of four; favor contemporary work.

AMERICAN ART GLASS CO., 7420 S. Broadway, Los Angeles.

CENTURY STAINED GLASS STUDIOS, 157 Fillmore St., San Francisco; est. 1941; staff of two; both traditional and contemporary.

CHURCH ART GLASS STUDIOS, 359 Waller St., San Francisco; est. 1915; staff of two; prefer to work in Western States; favor contemporary work.

CUMMINGS STUDIOS, 475 Francisco St., San Francisco 11; est. 1921; staff of seven; prefer to work in Western U. S.; traditional and contemporary work.

H. DOMBRINK CO., 2416 Market St., Oakland 7, Cal.

JUDSON STUDIOS, 200 South Ave. 66, Los Angeles; est. 1897; staff of 19; traditional and contemporary work.

ANTON REZ, 6046 Bellevue Ave., La Jolla.
WALLIS WILEY STUDIO, 2175 E. Foothill Blvd., Pasadena 8, Cal.

LEN R. HOWARD, Kent, Conn.

SOUTHERN ART GLASS CO., 532 Edgewood Ave., Jacksonville, Fla.

CLINTON GLASS CO., 2100 S. Union Ave., Chicago; est. 1900; staff of six; traditional and contemporary.

DREHOBL BROTHERS ART GLASS CO., 2847 Lincoln Ave., Chicago.

H. EBERHARDT & CO., 2409 W. Roosevelt Rd., Chicago.

GIANINNI & HILGART, 1359 N. Noble, Chicago.

KARL HACKERT, INC., 215 W. Ohio St., Chicago 10.

(Continued on page 334)

IN STEP with advanced school design...

HAWS Deck-Type Drinking Fountains meet the demands of your school building program for improved water facilities inside the class room! Your choice of optional combinations of HAWS Faucets and Fixtures make these fountains adaptable to *all modern classroom needs*. Teachers and students alike, benefit from HAWS!



Series 2400
Model 2444



Series 2000
Model 2050



Series 2300
Model 2350



Series 2200
Model 2255

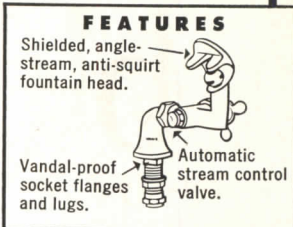

For the **latest** school design . . .

Specify the **latest** . . . HAWS DECK-TYPE DRINKING FOUNTAINS!

Write today . . . for the New HAWS Catalog!

In addition to the complete line of fountains, HAWS also features electric water coolers and emergency eye-wash fountains . . . and, **KRAMER FLUSH VALVES**, for all plumbing fixtures that require an automatic closing valve.



Top: from Church Art Glass Studio, San Francisco. Bottom: from Robert Metcalf Associates, Yellow Springs, Ohio

HAWS DRINKING FAUCET CO.
1443 FOURTH STREET (Since 1909) BERKELEY 10, CALIFORNIA

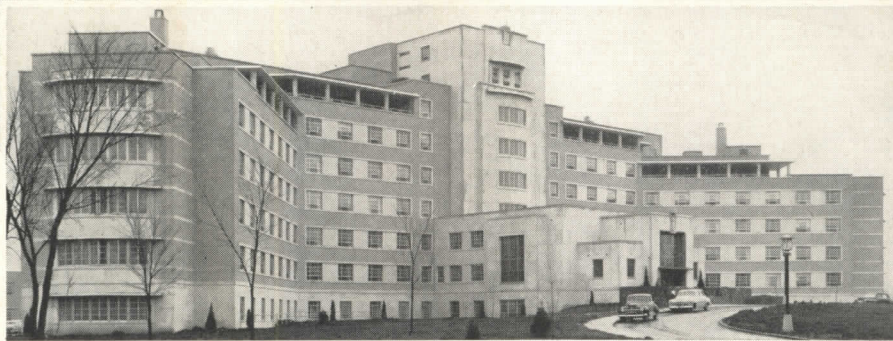
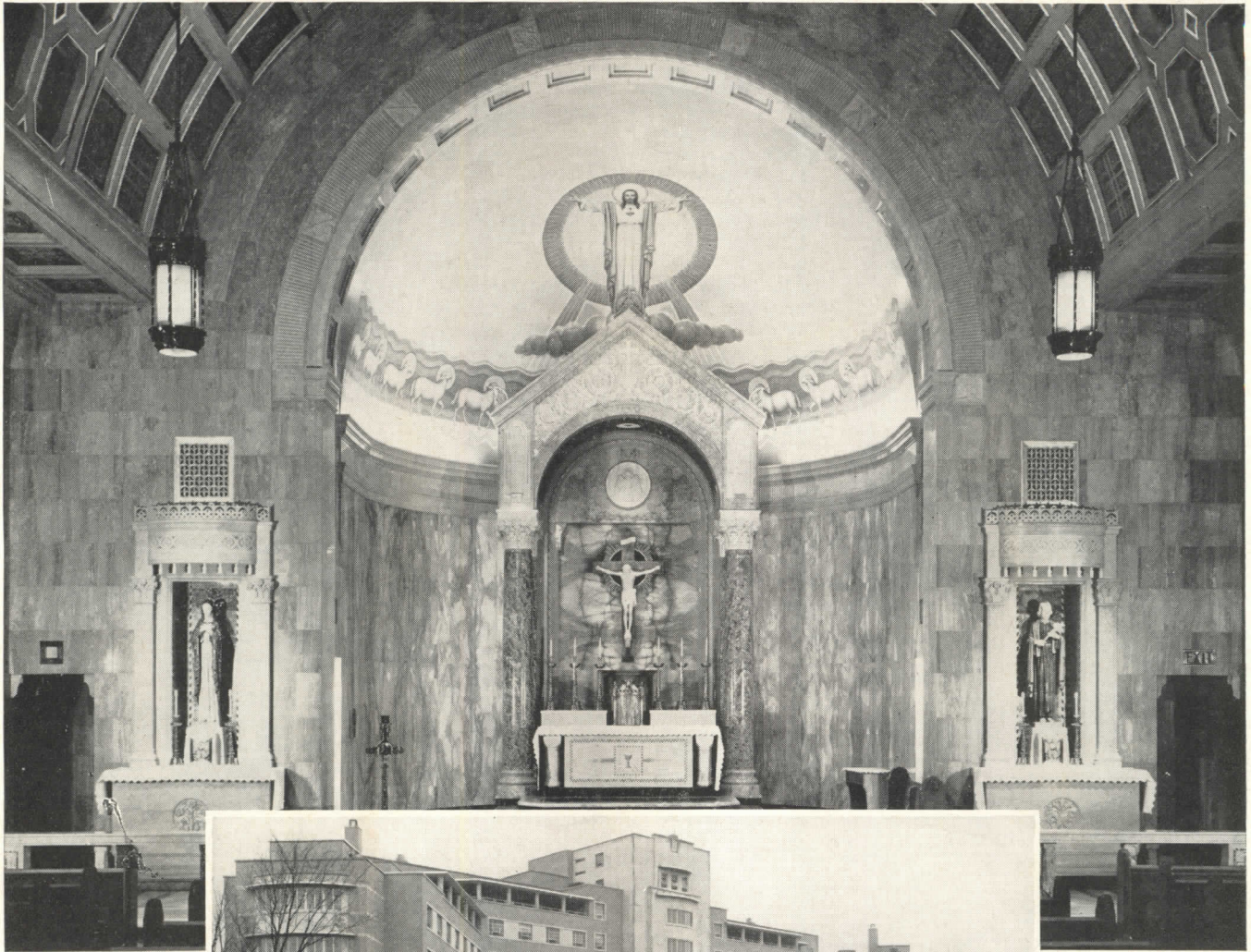

St. John's Hospital,
Springfield, Missouri
Maguolo & Quick,
Architects, St. Louis

marble . . .

used in profusion . . . at little cost

Writes Architect G. J. Maguolo: "It seems quite surprising, in view of the profuse use of marble throughout, that the entire marble installation in St. John's Hospital was but 1.4% of the total construction cost of this building. That, however, is not the entire story, for aside from the beauty and durability of the material there is an all-important factor — marble's minimum annual maintenance — a point which all of our clients have been quick to understand and appreciate."

Literature available **FREE**

"Proof that marble costs less"
"Marble Forecast 1956-57"
"Marble in the Bank"

For more complete data on the basic economy of marble write:

MARBLE  **INSTITUTE OF AMERICA, INC.**
32 SOUTH FIFTH AVENUE, MOUNT VERNON, NEW YORK

THE RECORD REPORTS A SPECIAL REPORT

(Continued from page 332)

MICHAUDEL STAINED GLASS STUDIO, 542 N. Paulina St., Chicago; est. 1896; staff of 11; traditional and contemporary.

CAPITOL GLASS CO., INC., 432 S. Missouri St., Indianapolis.

CITY GLASS SPECIALTY, INC., 2124 S. Calhoun St., Fort Wayne, Ind.; est. 1944; staff of five; prefer to work in 500-600 mile radius; traditional and contemporary.

STEWART-CAREY GLASS CO., INC., 270

Virginia Ave., Indianapolis 4; est. 1840; staff of three; prefer to work in Eastern U. S.; traditional and contemporary.

BLUM ORNAMENTAL GLASS CO., 1018 W. Market St., Louisville; est. 1856; staff of five; prefer working within 400-mile radius; traditional and contemporary.

FREDRICA H. FIELDS, 5214 Oakland Rd., Chevy Chase 15, Md.

MILLER ART GLASS STUDIO, 855 N. Howard St., Baltimore.

WILBUR HERBERT BURNHAM, 1126 Boylston St., Boston; est. 1922; staff of 11; traditional and contemporary.

CHARLES J. CONNICK ASSOCIATES, 9 Harcourt St., Boston; est. 1912; staff of 33.

JOHN TERRENCE O'DUGGAN STUDIO, 116 St. Botolph St., Boston 15; est. 1925; staff of 11; prefer working east of the Mississippi; traditional and contemporary.

REYNOLDS, FRANCIS AND ROHNSTOCK, 1 Washington St., Boston; est. 1921; staff of six; traditional and contemporary.

CARROLL E. WHITTEMORE, 16 Ashburton Place, Boston 8; est. 1944; staff of 7; traditional and contemporary.

DETROIT STAINED GLASS WORKS, 4831-33 Fort St., Detroit.

GRAND RAPIDS ART GLASS CO., Fulton and Front Sts., Grand Rapids, Mich.

GAYTEE STUDIOS, INC., 225 S. Fifth St., Minneapolis.

MINNEAPOLIS ART GLASS CO., 616 S. Third St., Minneapolis.

NOVELLO ART GLASS STUDIOS, 150-152 High Forest St., Winona, Minn.; est. 1950; staff of 12; prefer working in the Midwest; traditional and contemporary

CENTURY ART GLASS CO., 5107 Delmar Blvd., St. Louis.

EMIL FREI, INC., 3934 S. Grand Blvd., St. Louis; est. 1898; staff of 26; favors contemporary work.

JACOBY ART GLASS CO., 822 Wilmington Ave., St. Louis; est. 1896; staff of 25; prefer working in 1000-mile radius; favor traditional work.

KANSAS CITY ART GLASS WORKS, 2002 Indiana, Kansas City; est. 1929; staff of four; favor traditional work.

SAINT JOSEPH ART GLASS WORKS, 806 N. Second St., St. Joseph, Mo.

SEELE ART GLASS CO., 1631 Jonquil Dr., Webster Groves, Mo.

UNIQUE ART GLASS CO., 312 N. 17th St., St. Louis.

B. F. BIEHL, 251 W. Graisbury Ave., Audubon, N. J.

EDWARD W. HIEMER & CO., 140 Wabash Ave., Clifton, N. J.; est. 1931; staff of 23; traditional and contemporary.

J. & R. LAMB STUDIOS, 46 W. Clinton Ave., Tenafly, N. J.; est. 1857; staff of 17; traditional and contemporary.

PAYNE-SPIERS STUDIO, INC., 49-54 E. 13th St., Paterson 4, N. J.; est. 1889; staff of 14; traditional and contemporary.

AVE MARIA STAINED GLASS STUDIO, 541-545 DeKalb Ave., Brooklyn; est. 1901; prefer to work in Atlantic Coast States; staff of 9; traditional and contemporary.

A. L. BRINK; 165 E. 88th St., New York.

DAPRATO STUDIO, INC., 104-112 E. 25th St., New York.

GEORGE DURHAM & SON, 210 E. 35th St., New York; est. 1902; staff of 15; traditional and contemporary.

HENRY KECK; 1010 W. Genesee St., Syracuse, N. Y.; est. 1913; staff of nine; traditional and contemporary.

PIKE STAINED GLASS STUDIOS, 145 St. Paul St., Rochester, N. Y.; est. 1909; staff of eight; accept commissions in northeastern states; traditional and contemporary.

RAMBUSCH DECORATING CO., 40 W. 13th St., New York 11; est. 1928; staff of 18; traditional and contemporary.

HANS ROHLF, 521 Saint Ann's Ave., New York 55.

SOMMERS STAINED GLASS STUDIOS, 280 S. Ocean Ave., Freeport, N. Y.

NICHOLAS WAGNER, 228 W. Broadway, New York 13.

F. G. WIEDEMANN STAINED GLASS STUDIO, 19044 99th Ave., Hollis 7, Long Island.

(Continued on page 338)

Dependability....

... a CIPCO PLUS value

For more than 30 years, Cipco has put into each and every order, each and every job, those unseen things that result in customer satisfaction. Users have come to know and expect Cipco to be more than just good hardware.

Select Cipco for all your architectural hardware needs—in standard or “custom” items. Hardware consultants all over America are aware of Cipco’s cooperation and dependability.



Manufacturers of fine
hardware for over
30 years

2200 COLE STREET
ST. LOUIS 6, MISSOURI