



OPEN PLAN OFFICES FOR THE SCARBOROUGH CIVIC CENTER BY RAYMOND MORIYAMA  
ALAN DUNN: A COLLECTION OF HIS LAST DRAWINGS  
THREE NEW PROJECTS BY GWATHMEY SIEGEL  
BUILDING TYPES STUDY: COMMUNITY COLLEGES—LEARNING FOR EVERYBODY  
FULL CONTENTS ON PAGES 10 AND 11

# ARCHITECTURAL RECORD

JULY 1974 **7** A MCGRAW-HILL PUBLICATION THREE DOLLARS PER COPY





ESKIMO BILDING ENGE



# Cool Slant

In Texas, the sun really unloads on this dramatic structure. Its sloping walls don't just live alongside the sun, they face up to it.

It takes a cool slant on the problem to solve it. And the spectacular Century Building in San Antonio has one: C-E Polarpane "20" Gold Reflective Insulating Units.

C-E Polarpane #2016 Gold was chosen for the entire building. Polarpane performance is the reason. These Gold Insulating Units face up to the sun beautifully, rejecting over 90% of infra-red solar energy. Total indoor heat gain is only 37 BTU/hr per square foot.

Polarpane Gold is easy on the eyes and restful inside thanks to its low 20% visible light transmission. Yet, this light level is sufficient to eliminate a requirement for excessive interior lighting and associated unnecessary interior heat gain.

When the heating season rolls around, Polarpane excels again . . . with a low .31 "U" value that means most room heat is retained by reflection back into the room.

Polarpane Silver works some wonders of its own with similar high performance characteristics.

There's no finer warranty than you get with C-E Polarpane "20" . . . a guarantee of 20 years of performance backed by Combustion Engineering, Inc., one of America's leading industrial firms.

Ask for your free copy of the Polarpane "20" catalog. Or, consult a C-E Glass specialist. C-E Glass, 825 Hylton Road, Pennsauken, N. J. 08110, (609) 662-0400.



Architect: Neuhaus + Taylor, San Antonio, Texas  
Glazing Contractor: Samuels Glass Co., San Antonio, Texas

**CEGLASS**  
COMBUSTION ENGINEERING, INC.

*For more data, circle 2 on inquiry card*





LIBRARY  
LEARNING CENTER



# Busy buildings need hard-working elevators. That's where Dover dependability pays off.

Most buildings are busy and work hard.

That's the kind of building Dover Elevators are made for. At Dover, dependability comes first.

To assure this dependability we manufacture the major components of our elevators ourselves. It's

the best way we know to be positive that the integral parts will work together as they were designed.

Making our own components gives us the highest degree of quality control, too. Dover's standards are stringent, and the hard-nosed quality control people in Dover plants as well as in the field won't settle for anything less than top quality.

The result is elevators that work hard. Elevators that stay on the job. Elevators you can depend on.

And there's a dependable

Dover-built elevator for your building: Dover Oildraulic® Elevators for low-rise buildings, Dover geared traction elevators for medium-rise, and Dover gearless traction for higher-speed, high-rise installation.

The next time you design a busy building, talk to your Dover representative about the elevators. And for a set of Dover catalogs for your files, write Dover Corporation Elevator Division, Dept. A-7 P. O. Box 2177, Memphis, Tennessee 38101. In Canada: Dover/Turnbull.

## DOVER DEPENDABILITY It's better in the long run.

**DOVER**

*For more data, circle 3 on inquiry card*

**Left:** LIBRARY-LEARNING CENTER, UNIVERSITY OF WISCONSIN-GREEN BAY. ARCHITECT: Daverman Associates, Inc., Grand Rapids, Michigan, and Milwaukee, Wis. GENERAL CONTRACTOR: Fluor Brothers Construction Company, Oshkosh, Wis. Four Dover Geared Passenger Elevators installed by Northwestern Elevator Co., Inc., Franchised Distributor, Milwaukee and Green Bay.

**Below:** FIRST NATIONAL BANK BUILDING, DAYTON, OHIO. ARCHITECT: Harry Weese & Associates, Chicago. GENERAL CONTRACTOR: Turner Construction Company. DEVELOPER AND LEASING AND MANAGEMENT AGENT: Arthur Rubloff & Co., Chicago. Six Dover Gearless Passenger Elevators installed by Dover Elevator Co., Dayton.

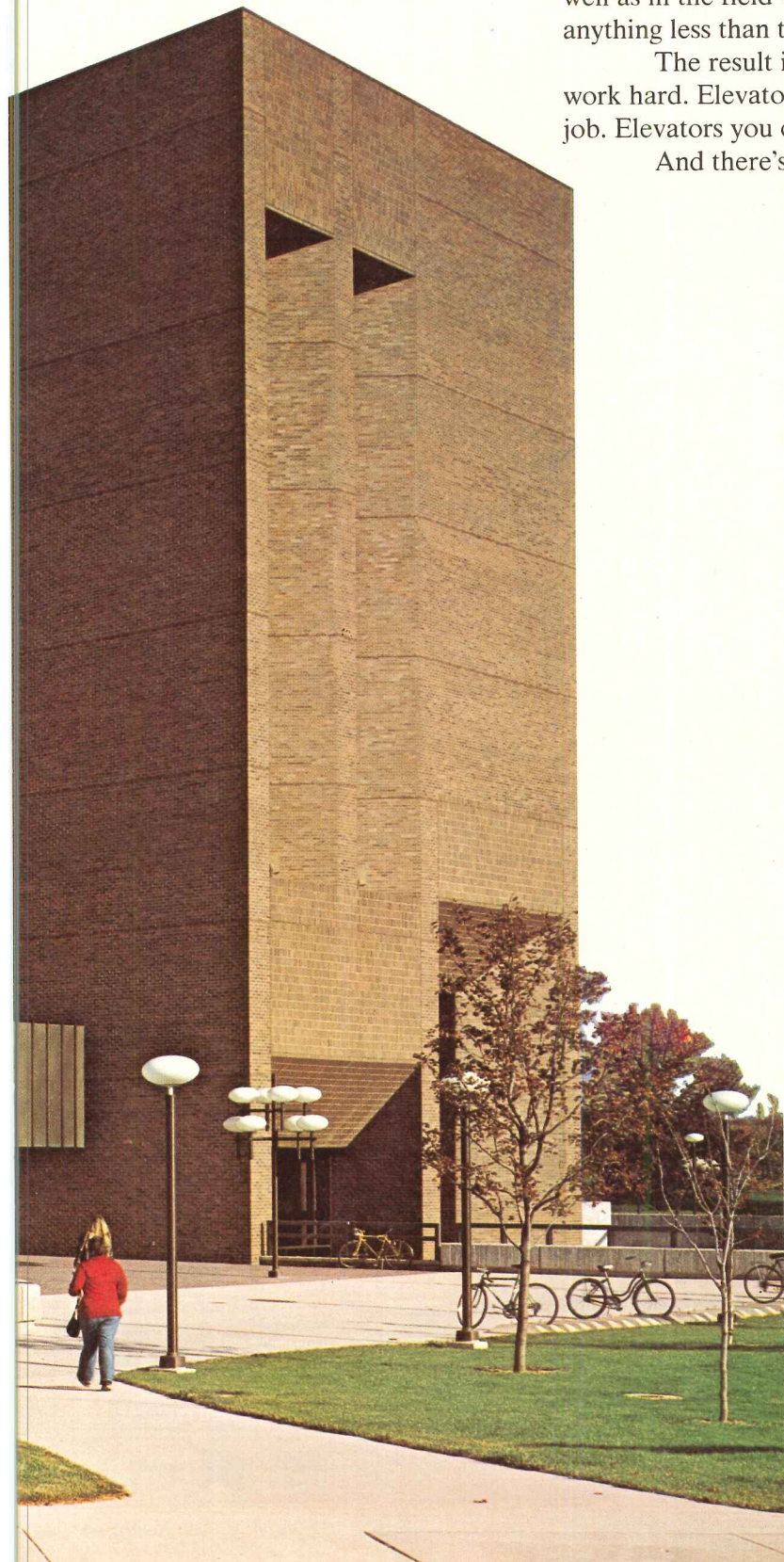



### Letter to the publisher

All the hoopla about the current "Women in Architecture" exhibit at the New York A.I.A. reminds me of the series I did on the same subject for the RECORD way back when. Look it up—you might just find it of publicity value in connection with the exhibit. It was called "A thousand women in architecture" and was published in March and June 1948.

Your publisher's letter is a delightful addition to the Record. Hope you keep it up!

Mrs. Florence A. van Wyck  
New York City

### Letters to the editor

Your editorial on "Energy Conservation standards: too much, too fast?" certainly reflects accurately the mood of those who are involved in products or services for the industry of building. The mood is characterized by ambiguity. "Hurry up and wait?" "Yes there is an energy crisis—maybe." "Reduce the heat loss through walls, but not through windows, etc."

We're seeking ways to help the profession respond. The *GSA Energy Conservation Guidelines* which we helped to prepare are now being revised under our management. We would welcome any comments, suggestions or criticisms from your readers.

John P. Eberhard, president  
AIA Research Corporation

Words cannot adequately express my sincere appreciation for the beautiful coverage of the Whiteside residence in your April issue. Mr. and Mrs. Whiteside share my thanks to you for the article.

Donald Jacobs, AIA  
Sea Ranch, California

The presentation of the Pennsylvania Avenue Corporation Housing in the May 1974 Architectural Record under the heading "Five current projects from the office of Hugh Jacobsen" should have made it clear that the scheme was prepared by the Corporation, which has its own planning and architectural staff under the direction of John M. Woodbridge FAIA, and not the office of Hugh Jacobsen. Mr. Jacobsen served as a design consultant on the housing portion of the over-all plan which has been prepared for submission to Congress by the Pennsylvania Avenue Development Corporation.

Nathaniel A. Owings, FAIA  
Pennsylvania Avenue  
Development Corporation

I have never written a blast against anyone, but enough is enough. The proposal by Hugh Jacobsen for Pennsylvania Avenue in Washington is beyond controversy. It is unjust! It is architecture by form without any economic, social or historical validity. When the trees die in their tubs, the complex will be the ultimate monument to the slum-ghetto life-style (although for rich only) in a city where even the slums are more human and forthright.

Who the (expletive deleted) are you kidding?

John J. Orofino,  
architect  
Silver Spring, Maryland

Bravo to Gerald Allen for a very lucid article on St. Thomas Church. I wonder what Mr. Allen means, however, when he dubs the Canada House plaza "a mistake . . . worth correcting." The truncated photo you publish alongside this observation surely needs comparison with that of page 114, which gives the *whole* point—that the northern accent of the facade and the gradual "bounce" from this to the stronger south tower, only works because of the cavity of the plaza setback (when approached from the north). Jostling at the lot line simply would not do. One may still hold with the architects of Canada House, who, for all their "good manners," are denied a by-line!

James Lamantia,  
architect  
New York City

*I think Mr. Lamantia is right. I didn't mean to say that Canada House was a mistake, but that taking St. Thomas Church as "an elegant curiosity to be treated with delicate respect, rather than a fundamentally urban piece of architecture" was.*

—G.A.

Thank you for publishing Gerald Allen's article on Cram and Goodhue's St. Thomas Church in your April issue. This is the kind of critical analysis our profession has missed for too many years. Please make this a regular feature of Architectural Record.

W. Caldwell Smith, AIA  
Atlanta, Georgia

Today we received our issue of Record Houses. I should like to comment on the excellent graphics. The Record has always had good layouts, but this issue, in particular, is both clean and snappy. (Expletive deleted) good!

Remmert W. Huygens  
Huygens and Tappé Inc.

### Calendar

#### JULY

**28-August 2** Urban Transportation Conference, New England College, Henniker, New Hampshire. Sponsored by The Engineering Foundation Conferences, 345 East 47th Street, New York, New York 10017.

#### AUGUST

**5-7** Fourth Institute on Noise Control Administration, Dearborn, Michigan. Contact: James H. Botsford, P. O. Box 3164, Bethlehem, Pennsylvania. Phone (215) 694-0939.

**5-9** Ninth Institute on Noise Control Engineering, Dearborn, Michigan. For further information, see item above.

**18-22** Exhibition of Architecture for Criminal Justice, sponsored jointly by the American Correctional Association and the AIA, at the 104th Congress of Correction, Houston, Texas. Contact: The American Institute of Architects, 1735 New York Avenue, N. W., Washington, D. C. 20006.

**18-24** International Federation for Housing and Planning, Vienna, Austria. Details from: IFHP Secretariat General, 43 Wassenaarseweg, The Hague, Netherlands.

**28-September 1** Annual Tour—Utica, Rome, New York (Upper Mohawk Region). Contact: The Society of Architectural Historians, 1700 Walnut Street, Philadelphia, Pennsylvania 19103.

#### SEPTEMBER

**8-10** Sixth International Conference on Urban Transportation, Pittsburgh. Contact: Box 2149, Pittsburgh, Pennsylvania 15230.

**30-October 1** Congress and General Assembly, International Union of Building Centers, Prague Hotel Intercontinental, Prague, Czechoslovakia. Details from: UICB Congress Secretariat, Czechoslovak Building Centre, Malestranske namesti 23, Prague 1.

#### OCTOBER

**7-8** Conference on improving efficiency in heating, ventilating and air conditioning equipment and components—residential and small commercial buildings, Purdue University, West Lafayette, Indiana. Contact: Professor V. W. Goldschmidt, Ray W. Herrick Laboratories, Purdue University.

**18-19** Recycling Old Buildings conference, Boston Architectural Center, Boston. Visual presentations, discussions, and site tours are offered. Contact: BAC, 320 Newbury Street, Boston, Mass. 02115.

ARCHITECTURAL RECORD (Combined with AMERICAN ARCHITECT, ARCHITECTURE and WESTERN ARCHITECT AND ENGINEER)

July 1974, Vol. 156, No. 1, Title® reg. in U.S. Patent Office copyright® 1974 by McGraw-Hill, Inc. All rights reserved. Copyright not claimed on front cover and editorial four-color separations. Indexed in Reader's Guide to Periodical Literature, Art Index, Applied Science and Technology Index, Engineering Index, and The Architectural Index. Published monthly except May, August, and October when semi-monthly, by McGraw-Hill, Inc.

Quotations on reprints of articles available. Every possible effort will be made to return material submitted for possible publication (if accompanied by stamped, addressed envelope), but the editors and the corporation will not be responsible for loss or damage.

EXECUTIVE, EDITORIAL, CIRCULATION AND ADVERTISING OFFICES: 1221 Avenue of the Americas, New York, N.Y. 10020. Other Editorial Offices: 425 Battery Street, San Francisco, Cal. 94111; 1249 National Press Building, Washington, D.C. 20004.

PUBLICATION OFFICE: 1221 Avenue of the Americas, New York, New York 10020. Second class postage paid at New York, New York 10001 and at additional mailing offices.

OFFICERS OF MCGRAW-HILL PUBLICATIONS COMPANY: John R. Emery, president; J. Elton Tuohig, executive vice president-administration; David J. McGrath, group publisher-vice president; senior vice presidents: Ralph Blackburn, circulation; John B. Hognlund, controller; David G. Jensen, manufacturing; Gordon L. Jones, marketing; Jerome D. Luntz, planning & development; Walter A. Stanbury, editorial.

CORPORATION OFFICERS: Shelton Fisher, chairman of the board and chief executive officer; Harold W. McGraw, Jr., president and chief operating officer; Wallace F. Traendly, group president, McGraw-Hill Publications Co., and McGraw-Hill Information Systems Co.; Robert N. Landes, senior vice president and secretary; Ralph J. Webb, treasurer.

SUBSCRIPTIONS: Subscriptions solicited only from architects and engineers. Position, firm connection, and type of firm must be indicated on subscription orders.

CHANGE OF ADDRESS or subscription service letters should be forwarded to Fulfillment Manager, ARCHITECTURAL RECORD, P.O. Box 430, Hightstown, N.J. 08520. Provide old and new addresses, zip code or postal zone number. If possible, attach issue address label. Annual subscription prices: U.S., U.S. possessions and Canada: \$10.00 for architects, engineers and other individuals in the fields served, all others \$22.00. Other countries: \$25.00 to architects, engineers; others \$35.00. Single copies \$3.00. GUARANTEE: Publisher agrees to refund that part of subscription price applying to unfulfilled part of subscription if service is unsatisfactory.

ASSOCIATED SERVICES / McGraw-Hill Information Systems Co.: Sweet's Catalog Files (Architectural, Light Construction, Interior Design, Industrial Construction, Plant Engineering, Canadian Construction), Dodge Building Cost Services, Dodge Reports and Bulletins, Dodge/SCAN Microfilm Systems, Dodge Management Control Service, Dodge Construction Statistics, Dodge regional construction newspapers (Chicago, Denver, Los Angeles, San Francisco).

THIS ISSUE is published in national and separate editions. Additional pages of separate edition numbered or allowed for as follows: Western Section 32-1 through 32-2. POSTMASTER: Please send form 3579 to Fulfillment Manager, ARCHITECTURAL RECORD, P.O. Box 430, Hightstown, N.J. 08520.





TEXTURED DOORS FROM KAWNEER

CONTEMPORARY





Needs no venting!...  
completely odorless, thanks to  
Bruning's exclusive PD process.

Large stacking tray.

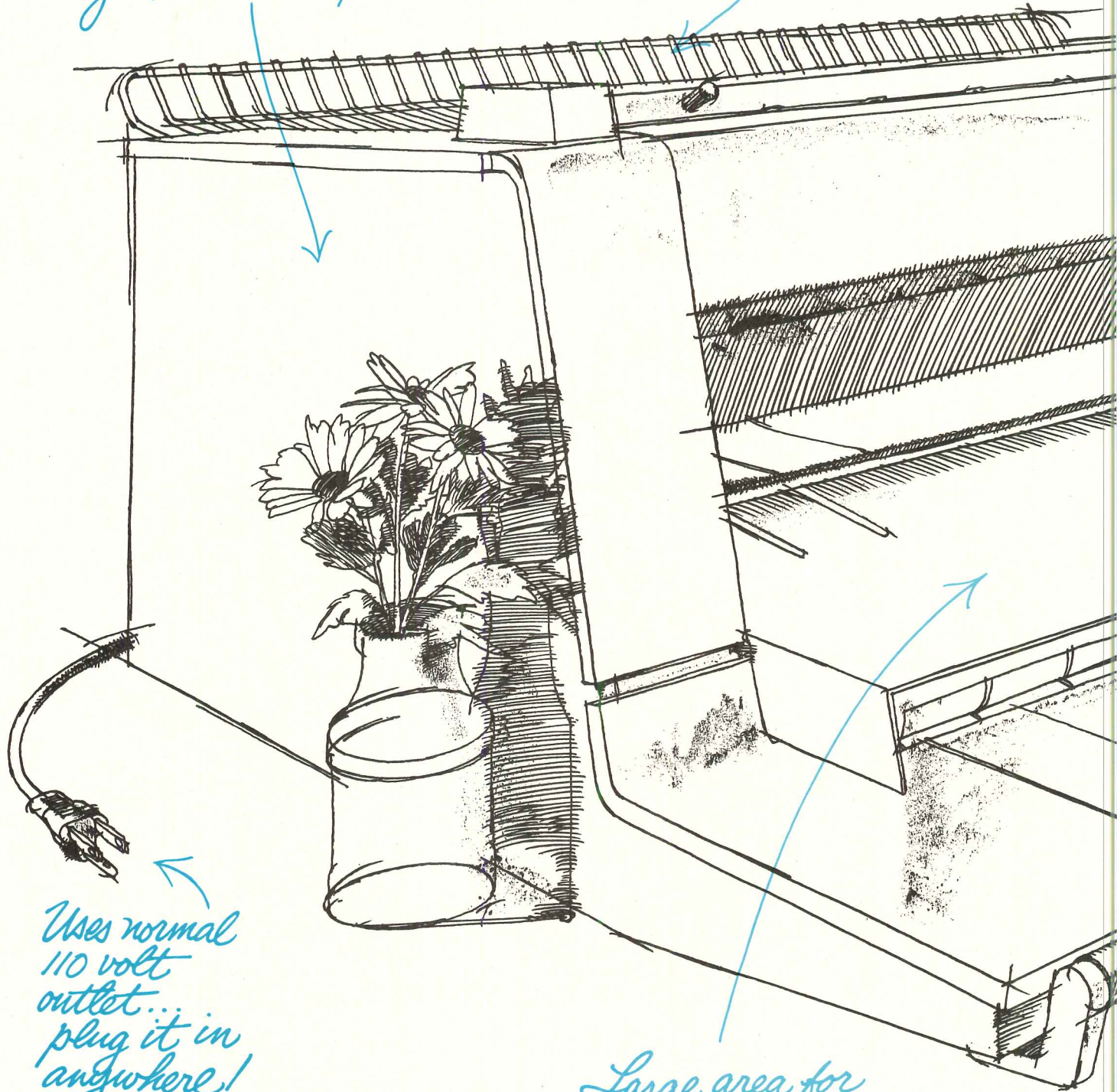

Uses normal  
110 volt  
outlet...  
plug it in  
anywhere!

Large area for  
stacking jumbo size  
tracings.

It's fast --  
40 fpm production-  
level volume.



*Instant On-Off;  
runs only when you make  
prints - saves energy!*

*High quality prints;  
front or rear delivery*

*Saves still more  
electricity; lamps use  
only 600 watts.  
(conventional units  
require 5 times as  
much power.)*

*New "soft"  
feed system  
uncurls and aligns  
drawings. Usually  
found only on more expensive  
copiers.*



Announcing one of the  
world's engineering wonders:

## The new Bruning PD-160 engineering copier.

Only Bruning has the PD® process.

The unique non-polluting process that made our PD-80  
convenience copier famous in less than two years.

Now that same exclusive PD process appears in the PD-160.  
It's an engineering copier that borders on the unbelievable.

Call your Bruning man for a demonstration. Or write  
Bruning, 1834 Walden Office Square, Schaumburg, Ill. 60172.

**Your single best source in engineering graphics.**



# BRUNING

DIVISION OF  
ADDRESSOGRAPH MULTIGRAPH

For more data, circle 6 on inquiry card





## Taming Temperamental Therapists

Therapists have a back, leg and arm breaking job. No wonder they become temperamental at times. One way to make life easier for a therapist is to specify the right plumbingware for the therapy room. To make your job easier, Eljer has designed a full line of institutional plumbing fixtures and fittings — each specially styled to meet specific needs. For example, the 31" waist-high Salem bath with base, the Armstrong instrument sink and tray with a splash back, and the Cascade perineal sitz bath . . . just three of more than 290 fixtures and

fittings, each fully detailed and illustrated in Eljer's "Hospital/Institutional" catalog.

Hospital-styled plumbingware . . . one example of Eljer's ability to meet any commercial building need with a complete line of well-designed, quality commercial plumbing products.

Next job, tame your temperamental commercial client. Send for Eljer's 62-page "Hospital/Institutional" catalog:

**ELJER PLUMBINGWARE**, Wallace-Murray Corp.  
Dept. AR, 3 Gateway Center, Pittsburgh, Pa. 15222

**ELJER**

**WallaceMurray**

For more data, circle 7 on inquiry card





## Ceramic tile, the decoration you build with.

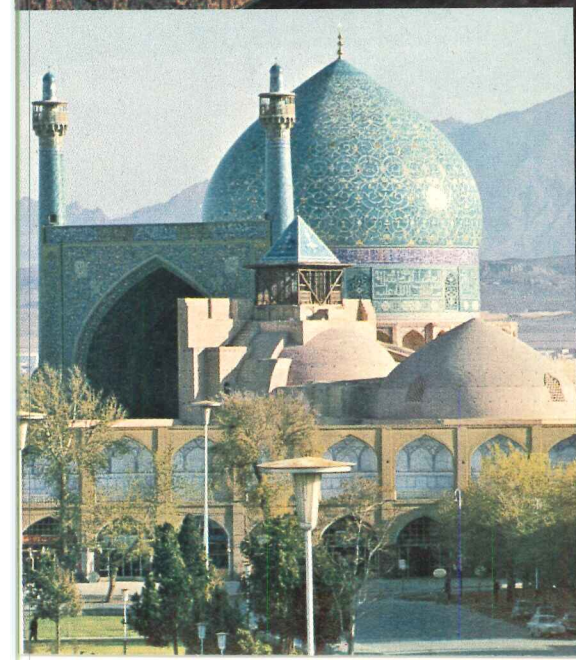

The Mosque of Sheikh Lutfullah, Isfahan, Iran. 1601-1618. By Muhammad Rida ibn Ustad for Shah 'Abbas I.

Inspired architects have been using ceramic tile to unify the decorative and structural aspects of their concepts for more than 5,000 years.

And today's technologies make lavish use of ceramic more feasible, in terms of cost, than ever before.

For a free copy of the Tile Council Handbook, spec sheets, and a full-color brochure of innovative residential tile installations, write to P.O. Box 2222, Room 471, Princeton, New Jersey 08540.

**Tile Council of America, Inc.**

Photographs courtesy of  
H.C. Seherr-Thoss, *Design and Color in Islamic Architecture*.  
For more data, circle 8 on inquiry card

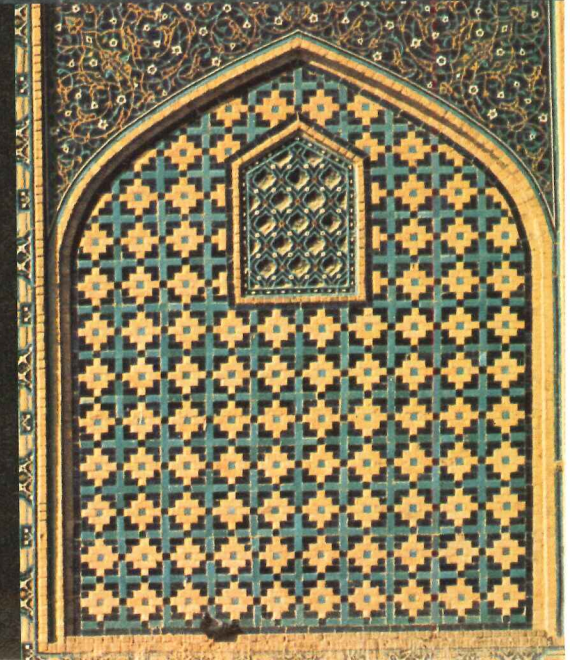



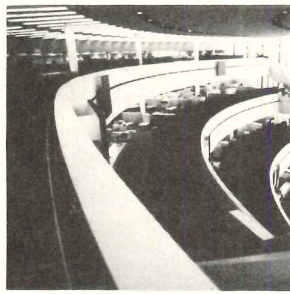

Cover: Scarborough Civic Center, Ontario  
Architects and Planners: Raymond Moriyama  
Photographer: Robert E. Fischer

EDITOR

WALTER F. WAGNER, JR., AIA

MANAGING EDITOR

HERBERT L. SMITH, JR., AIA

SENIOR EDITORS

ROBERT E. FISCHER  
WILLIAM B. FOXHALL  
MILDRED F. SCHMERTZ, AIA  
ELISABETH KENDALL THOMPSON, FAIA

WASHINGTON EDITOR

ERNEST MICKEL, Hon. AIA

ASSOCIATE EDITORS

GERALD ALLEN  
BARCLAY F. GORDON  
CHARLES E. HAMLIN  
CHARLES K. HOYT, AIA

EDITORIAL ASSISTANT

JANET NAIRN

PRODUCTION EDITOR

ANNETTE K. NETBURN

DESIGN

ALEX H. STILLANO, Director  
ALBERTO BUCCHIANERI, Associate  
ANNA-MARIA EGGER, Assistant  
MURIEL CUTTRELL, Illustration  
J. DYCK FLEDDERUS, Illustration  
JAN WHITE, Consultant

EDITORIAL CONSULTANTS

EDWARD LARRABEE BARNES, FAIA  
JONATHAN BARNETT, AIA, Urban design  
GEORGE A. CHRISTIE, JR., Economics  
PAUL RUDOLPH, FAIA  
Foreign architecture:  
*L'Architecture d'Aujourd'hui*, Paris

MCGRAW-HILL WORLD NEWS

RALPH R. SCHULZ, Director  
10 domestic and 8  
international news bureaus:  
Bonn, Brussels, Buenos Aires,  
London, Milan, Moscow, Paris,  
Tokyo.

SALES MANAGER

LOUIS F. KUTSCHER

CIRCULATION MANAGER

HUGH S. DONLAN

PUBLISHER

BLAKE HUGHES

**THE RECORD REPORTS**

**13 Editorial**

Why are architects so intent on being "just plain folks?"

**14 Perspectives**

**4 Letters/Calendar**

**33 News in brief**

Short items of major national interest.

**34 News reports**

Students present energy-use ideas in a new course at the University of Pennsylvania. Tony Smith unveils his latest work, a monumental sculpture, in Pittsburgh. Louisville bank announces loan program for adapting old buildings. New law enacted to save archeological finds at Federal sites. Justice Department pursues crime reduction through environmental design.

**37 Buildings in the news**

Prototype, Division of Corrections, Florida. Corporate Headquarters for Thiokol, Newton Township, Pa. Harold G. Cartwright Hall at Drake University, Des Moines. Boys Club, San Antonio, Texas. Solar Energy Science Building, Greenway, Virginia. Henry Ford Hospital Education & Research Building, Detroit, Michigan. Intersquash Center, Burlington, Massachusetts. P. S. 398, Brooklyn, New York. MLC Centre, Sidney, Australia. The Cove at Surf Lake, Pinehurst, North Carolina. Office park, Denver, Colorado. National Visitor Center (below), Washington, D. C.

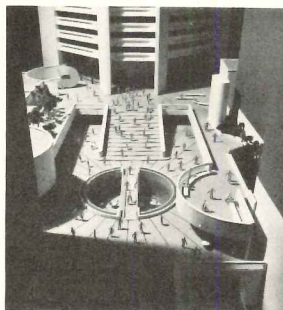

Max Dupain

**43 Human Settlements: World News**

**45 Required reading**

**64A Office notes**

**ARCHITECTURAL BUSINESS**

**65 GSA to alter A-E selection process**

Important changes in the process by which GSA, perhaps the world's largest client, selects architects and engineers for Federal building projects will be initiated at two levels and for two basic reasons. First level (and reason) will be modifications of the present system urged by a special study committee. Second (and later) will be fundamental changes in the detail and scope of the A-E qualification process itself.

**67 Marketing your own personal services: job hunting**

As a former management consultant and present principal in a large professional planning firm, Bradford Perkins offers guidelines for the young (and not so young) applicant for that next important job in building a professional career in architecture, engineering and planning.

**71 Building costs**

Installed costs of outdoor recreational facilities add to the store of this month's general building cost indexes and indicators.

**73 Building activity**

Jim Carlson reviews the housing doldrums and asks: is it really time to shift priorities?





**FEATURES**

**87 Alan Dunn**

A collection of unpublished "roughs," submitted to RECORD for selection, drawn by Alan Dunn shortly before he died on May 20, 1974.

**91 A civic center for Scarborough, Ontario, designed by Raymond Moriyama**

Surrounding a splendid multi-storied central space are open-plan offices for the municipal borough and the board of education. These elements have been organized in a way which dramatizes the function of government and creates a visual and symbolic focus for the town.

**99 Coal Street Pool Wilkes-Barre, Pennsylvania**

This new public facility provides year-round use by means of an inflatable cover of standardized manufacture. Architects Bohlin and Powell have developed ancillary facilities and placed the aquadome in an imaginative way which makes an architectural statement of a "ready-made" product.

**105 Three new projects from the office of Gwathmey Siegel Architects**

A new scheme for low-density housing in Perinton, New York, and two designs for single-family houses for clients with special hobbies illustrate this firm's continuing expertise.

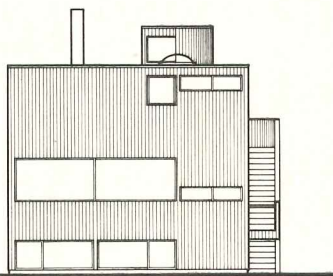

**113 Masterplanning for cars**

Tennessee architects McCarthy Bullock Church & Holsaple have designed two exceptional parking structures in Knoxville: one for a university campus (page 114); the other, an important element in the development of a pedestrian-oriented downtown (page 116).

**BUILDING TYPES STUDY 463**

**119 Community Colleges**

More and more people find that the two-year community college curriculum—available to all persons over 18 years of age at times convenient to their schedules, and in segments suited to their particular needs—are the answer to the universal thirst for knowledge or proficiency in vocations and avocations. Five new community colleges in various parts of the country and in various kinds of locations, are shown here:

**120 Pima Community College Tucson, Arizona**

by Caudill/Rowlett Scott, Friedman and Jobusch, and William Wilde and Associates

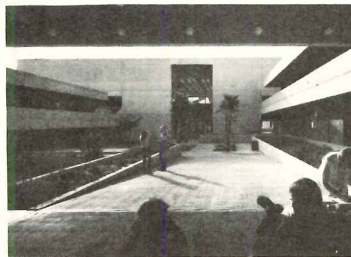

Julius Shulman

**122 Miami Dade Community College Downtown Campus, Miami, Florida**

by Ferendino/Grafton/Spillis/Candela

**126 Crafton Hills Community College near Redlands, California**

by Williams, Clark & Williams and Jones, Poper & Armstrong

**130 Lesley College, Cambridge, Massachusetts**

by Smith Barker Hanssen

**132 Feather River College Peralta Community College District, California**

by Skidmore, Owings & Merrill

**ARCHITECTURAL ENGINEERING**

**135 A multiplicity of air-source heat pumps heat and cool a \$15 million office park**

Winewood Office Park, an eight-building rental complex in Tallahassee, has 151 split-system package heat pumps. Selection was influenced by the local weather, the fuel situation, and the simplicity of the unitary heat pumps.

**139 Product Reports**

**141 Office Literature**

**171 A/e Update**

**200 Advertising Index**

**202 Classified Advertising**

**203 Reader Service Inquiry Card**

**NEXT MONTH IN RECORD**

**A campus library in an urban context**  
The Graduate School of Education Library for Harvard University in Cambridge, Massachusetts by Benjamin Thompson & Associates, Inc. is an unusual open-plan, mixed-use facility which brings the research materials and the users together quickly, conveniently and enjoyably. Of particular interest is its environmental relationship to the Cambridge neighborhood.

**Building Types Study: Medical facilities**  
The building types study for August will provide a variety of exhibits reflecting the scope of today's practice. Health Maintenance Organizations, medical education, new systems and other trends will be demonstrated.



# TOWNSEND®

## ENGLISH CHANNEL OAK

### So Very Proper!

Old England's beauty and tradition are captured in the real wood richness of Townsend English Channel Oak. Townsend wall planks let the creative designer specify the rich look of thick, solid hardwoods. Available in prefinished random widths and lengths, with square cut tongue-and-groove, English Channel Oak offers a distinctive pattern and texture unmatched by any other wall covering. For full wall heights, built-ins and dividers.

- Random lengths and widths
- Prefinished
- Solid hardwood
- Packed in sturdy cartons (nails furnished)

4 more of the 14 Townsend hardwood wall plank finishes:



Cordova Oak

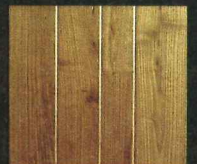

Select Walnut



Colonial Red Oak



Viridian Oak

# Potlatch

Potlatch Corporation, Wood Products, Southern Division, P. O. Box 916, Stuttgart, Arkansas 72160

For more data, circle 9 on inquiry card



## Why are architects so intent on being "just plain folks"?

It's the last night of the Washington convention. A good piece of work has been done. Important themes have been discussed, business sessions have gone smoothly, after intelligent discussion. New products have been seen. Forty seminars have been held and listened to. It's the grand finale—the Annual Ball. New officers and directors are to be introduced. Everybody (almost) is dressed in black tie and formal gowns. . . .

And there's no head table. The officers and executives of the august American Institute of Architects sit, instead, at tables down on the dance floor, in 'umble anonymity.

Who cares? I do, and I'll tell you why. There's a point:

Architecture is something special, not just another business. And architects are something special, not just other businessmen. And so it seems to me that attempts to symbolize being "just plain folks"—like not having a head table at the august annual convention of your organization—is the wrong kind of symbolism.

Years ago, I used to argue with Bob Hastings about what I called his "ecumenical movement"—his earnest feeling that "environmental design" was a better name for what we do than "architecture"; and that architects ought to give up their ancient and honorable title and become—along with a host of other professionals, and quasi-professionals—"environmental designers."

This year—and this seems to be becoming an annual tradition (untradition?)—there was no Gold Medal winner. I know Frank Lloyd Wright and Lou Kahn are gone and I'm certainly not suggesting a lowering of standards—but there are some fine architects doing important work—and what is the world to think of a profession which cannot find one person a year to honor?

And somehow, at the Convention, what had seemed to me a noble and worthy theme—"A Humane Architecture"—didn't catch fire. It seemed to me, at least, that there were lots of negatives and not much positive.

Theme panelist (and architect and planner) Judith Roeder argued: "It is a commonly held truism that architecture reflects society. I do not believe this. Our architecture reflects the establishment version of society and, like the establishment, it responds to change slowly. Our architecture is establishment architecture because architects maintain establishment values. Because architects hold establishment values, they can intuitively design only environments which reflect these values. In

order to create environments for the rest of society, architects must know more about these groups, and about how spatial characteristics affect their activities and life styles."

Ms. Roeder's call for "organized, systematic research about space and behavior to develop this knowledge" is well taken, of course. Everyone is for knowing more about the problems before starting design. But the tendency for architects to scold themselves for the problems of the world continues to bother me. I imagine that there are very few architects who would not favor, indeed welcome, participation in the design process by residents in the case of housing, parents, children, and teachers in the case of a school—in short, the user, along with the client. But the system was not invented by the architect, and—so far at least—the system just doesn't work that way and probably can't.

For example, panelist Theodore Liebman reported that sense of community, child supervision, security, maintenance, liveability, responsiveness to the existing urban context, and flexibility of life style are improved for families, and especially for the low-income families who need housing the most, by low-rise as opposed to high-rise housing. I think most architects would agree with that conclusion, and many architects have designed for many clients (like the New York State Urban Development Corporation, of which Mr. Liebman is the chief architect) excellent low-rise, high-density housing. But there remain, whether we like it or not, real questions about whether such housing can be built in many places—given cost factors, land cost and/or scarcity, and the lack of adequate public transportation. And those problems are not problems which architects should be scolded about.

So a suggestion: How about an AIA convention sometime where we talk about what's *right* with architecture and architects? Let's stop talking about Pruitt-Igoe (which I doubt very much was the architect's fault) and start talking about housing around the country that does work for the residents, and schools that the children and teachers love, and public buildings that the community is proud of, and places of work that people enjoy being in. Let's show what's *good* about the work of good architects—the humane architecture that they design and build all the time, as professionals who feel a professional responsibility to public as well as client interests.

—Walter F. Wagner, Jr.



**A most quotable quote from John Eberhard**

John Eberhard, president of the AIA Research Corporation, and now embarked on a number of very important research efforts indeed, has long interested himself in projects on the front edge of design and construction. So, on the eve of what indeed may be important new behavioral insights into design, this comment by Mr. Eberhard in his presentation to the convention seemed especially important to me:

"I would argue that it is not wise to force open one eye—scientific knowledge—only to close the other—intuition or insight. We need to have both eyes open, to use our minds, our brains, to synthesize the ways of knowing of the scientific world with the ways of understanding of the artistic, or intuitive, world. One way of knowing or understanding by itself leads to narrow vision, much the same way that we lose our ability to perceive things in three dimensions when we close one eye. The combination of scientific knowledge and intuitive understanding are in fact complementary. That is, they are two parts that make up a whole. And I think we could argue, with some conviction, that these complementary aspects are combined in the concept of imagination.

"I would also think we can say with conviction that imagination is the most important qualification for an architect."

Right on, John.

**Los Angeles Mayor Tom Bradley on standing our ground:**

"There is no need for me to catalog for you the things revealed in the flash of insight provided by the energy shortage.

"Cities shaped by automobiles and depending on unlimited energy must now adjust to the uncertainty of these resources.

"A style of growth typified in the scramble to the farthest profitable reaches of the metropolitan areas can no longer be supported. Those who want to live beyond the reef of current development can no longer expect governments to throw out the life-lines of public service.

"Symptoms of social ills, like crime and blight, are increasing in the suburbs. Somewhere we must stand our ground rather than moving on and leaving our refuse."

**The most moving quote came from a Russian architect**

Georgui M. Orlov, of the Soviet Union, honorary AIA and president of the IUA told the convention that "The importance of the architect is constantly growing in this dynamic world. Architects creating contemporary environ-

ments always work in the center of the most vital problems of humanity. . . . Like music, architecture is a universal language of mankind. Architecture lives and speaks not only when songs and legends disappear and keep silence; it speaks in spite of any language barrier. That is why architectural masterpieces of past and present give us one more gratifying occasion to understand, to learn, and to value each other. . . .

"Enthusiasm is the most beautiful word on the earth, and a flight in the name of duty is full of poetry. . . .

"An architect and artist must always be young. That is why I wish the American Institute of Architects to be always young in its creative searches and achievements."

**Tough new action on the political contributions mess**

. . . and hoorays for both the AIA board and the convention delegates for their actions.

First, just before the Convention, the board voted "to establish within the Institute a national committee to investigate allegations of misconduct by architects. If investigation of such allegations warranted, the committee could bring charges of unprofessional conduct before AIA's National Judicial Board, the appropriate state registration board, and/or appropriate legal authorities."

Ad hoc inquiry panels of three to five members will be selected from a pool of as many as 50 architects appointed for this duty by the board.

They will be charged with investigating matters brought to their attention by complaint or otherwise which "appear to involve unprofessional conduct or violations of AIA's Standards of Ethical Practice involving a major public interest, such as recent allegations of illegal political contributions and kickbacks by architects seeking public contracts. Cases involving failure to conform to registration laws, or violations of criminal statutes committed in relation to the practice of architecture, will also be handled by the committee." The committee would act as complainant in instituting proceedings, whether referred to the AIA board, or to the state registration board, or to legal authorities.

And that sounds, given the gravity of the situation and its effect on the dignity and reputation of all architects, to be a good strong step in the right direction.

Another step in the right direction was the passage by the Convention of Resolution 7 submitted by the New York Chapter. Its key thought: "Every architect making a contribution [to political parties, public issues, and candidates for public office] shall do so pub-

licly in his own name, and as an individual citizen (as stated in the Guidelines issued by the board of directors). . . ."

There is, of course, a question of how you make your contribution known publicly—but the intent is clear. Full disclosure, or else. . . .

**Bad news for housing, for people who need housing, and for architects**

"Housing activity stabilized in the opening quarter of the year, following 1973's steep decline, but hopes for recovery in the months ahead have been all but eliminated by the onset of the second credit crunch in less than a year. . . ."

That's the view of George Christie, vice president and chief economist of F. W. Dodge Division of McGraw-Hill Information Systems Company.

Christie figures that the opening quarter's total of 344,575 new housing units was 35 per cent below the same period a year earlier, when the housing market was at its peak, but was only slightly below the low rate reached by 1973's fourth-quarter.

Of the ten metropolitan areas leading the nation in new dwelling units in the first quarter, three were in Florida: Ft. Lauderdale-Hollywood, Miami and Tampa-St. Petersburg. The top ten areas, in ranking order were: Ft. Lauderdale-Hollywood, 13,340 units; New York, 10,018 units; Chicago, 9,010 units; Miami, 8,141 units; Los Angeles-Long Beach, 7,595 units; Dallas, 7,159 units; Phoenix, 6,797 units; Tampa-St. Petersburg, 6,346 units; Anaheim-Santa Ana-Garden Grove, 5,960 units; Atlanta, 5,693 units.

Explaining the housing situation, Christie said, "It was during the second half of 1973—when money markets were tightened to the point where mortgage loans became extremely difficult to obtain—that the steepest part of the recent collapse took place. As credit conditions eased around year end," stated the Dodge economist, "the housing decline leveled off. With adequate financing, housing could have staged a good recovery this year. However, the latest round of monetary tightness by the Federal Reserve, in its effort to slow inflation, means that the expected improvement in residential building this year has little chance of happening."

So while we're worrying about the quality of housing, what in the world are we going to do about quantity? When in the world are we going to realize that housing—especially housing for the poor and in the cities—cannot compete in the free market for money and set up some kind of special fund? As we did for highways, or space? —W.W.





FOR A NATURAL BEAUTY IN ANY CONCRETE CONSTRUCTION,  
use Medusa White Portland Cement. Used naturally  
or color tinted, this extremely versatile true white cement meets the architect's  
creative needs — moldable to any shape, design or texture. And  
Medusa White is dependable and permanent. When  
specifying or using white cement, insist on Medusa quality — developed and  
improved by the originator of white portland cement since 1907.

Medusa would be pleased to work with you. For brochure  
containing specific examples of white cement construction,  
write Medusa Cement Company, P. O. Box 5668, Cleveland, Ohio 44101.



**MEDUSA CEMENT COMPANY** Division of Medusa Corporation

*For more data, circle 10 on inquiry card*





*Children's Health Center and Hospital of Minneapolis, Inc.*

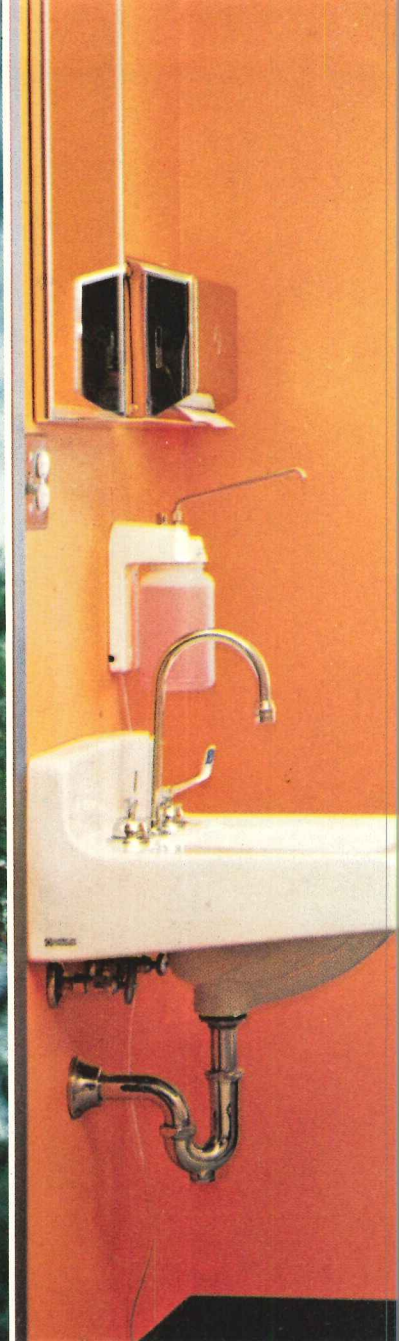

Outside, one of 11 colors to choose from in our low maintenance, acrylic coated aluminum finish.

Pella Clad Wood Windows eliminate two common problems associated with ordinary weather-shielded wood windows. Lack of color choice. And lack of design freedom. In a Pella Clad window, all exterior wood surfaces are covered with an acrylic coated aluminum skin. A well-known and well-respected outside finish. Available in three standard (a) and eight special colors. On our Contemporary and Traditional Double-Hung, Casement, Awning, Fixed and Trapezoidal Windows. And Pella Sliding Glass Doors.



(a)

Inside, the familiar warmth and beauty of a wood window in a child's world.

Wood windows are known for their warmth. Visually. And because of their natural insulating value. And in designing the Pella Clad Wood Window, we left both of those properties unchanged. The exterior aluminum skin does not penetrate the frame or sash (b). Nor is it visible anywhere on the inside of the window. We recognized the need for a weather-resistant, low maintenance window. But seeing no reason to compromise the natural warmth of a wood window, we very carefully avoided doing just that.



(b)

**At the Children's Health Center and Hospital, this Pella Clad window system contributes to the relaxed atmosphere, inside and out.**



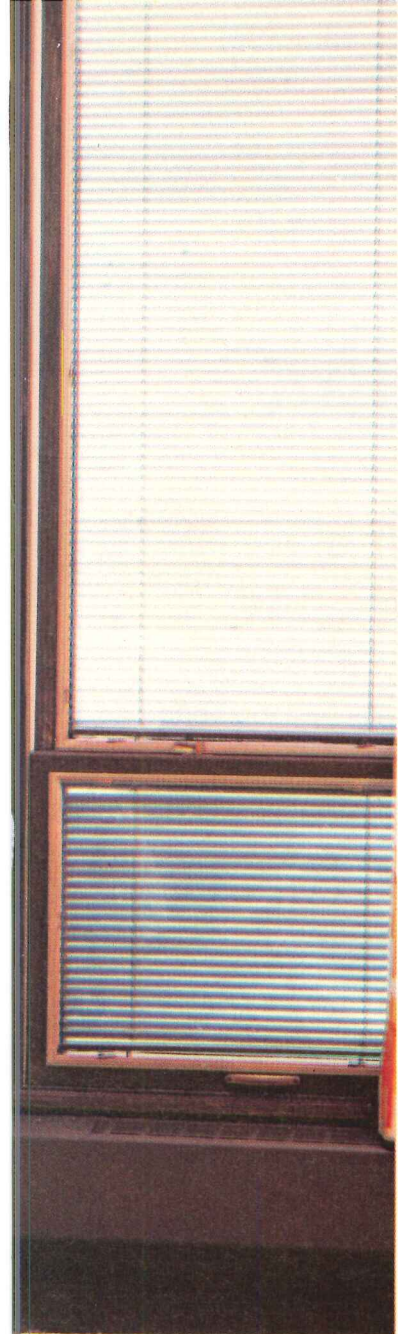

Architect: Ellerbe Architects - Engineers - Planners Builder: Bor-Son Construction Inc. Windows: Pella Clad Fixed Units and Contemporary Double-Hung

**In between, the built-in advantages of Pella's unique Slimshade®.**

The removable inside storm panel in our Double Glazing System gives you any number of interesting options. Like using our Slimshade® (c) to control sunlight, privacy and solar heat gain and loss. Housed between the panes, this fully adjustable blind remains virtually dust-free. The Double Glazing System can also accommodate our snap-in wood muntins or privacy panels. But flexibility is not the system's only built-in advantage. The 13/16" air space between the panes also does a better job of insulating than welded insulating glass.

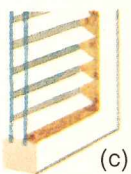

(c)

**Afterward, the ease of washing a counterbalanced, pivoting sash double-hung window.**

Window cleaning is another maintenance factor that must be considered. And here again, Pella design makes an easy job of it. Our Double-Hung Window has a spring-loaded, vinyl jamb liner which allows the sash to pivot. So the outside surfaces can be washed from inside the building. And because each sash pivots at its center point (d), the weight of the sash is counterbalanced. Which makes the whole job just that much easier. Reglazing can also be accomplished from inside, along with sash removal.

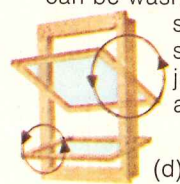

(d)



For more detailed information, send for your free copy of our 24-page, full-color brochure on Pella Clad Windows & Sliding Glass Doors. See us in Sweet's Architectural File. Or look in the Yellow Pages, under "windows", for the phone number of your Pella Distributor.

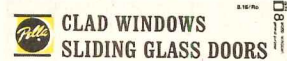

Please send me your 24-page brochure on Pella Clad Windows & Sliding Glass Doors. I am specifically interested in:  Double-Hung Windows,  Casement Windows,  Awning Windows,  Sliding Glass Doors,  Wood Folding Doors.

Name \_\_\_\_\_  
Firm \_\_\_\_\_  
Address \_\_\_\_\_  
City \_\_\_\_\_ State \_\_\_\_\_ ZIP \_\_\_\_\_  
Telephone \_\_\_\_\_

Mail to: Pella Windows & Doors, Dept. T31G 100 Main St., Pella, Iowa 50219.  
Also Available Throughout Canada  
**This coupon answered within 24 hours.**



# Sanspray, the beautiful alternative.

Sure, concrete and masonry are OK. But you know what they cost. Not to mention how much trouble they are.

You have a beautiful alternative. Sanspray®. A plywood siding with decorative stones bonded onto it.

So you can forget about cement trucks or heavy pre-cast panels. Sanspray is light and easy for men to handle and install on the job site. Sanspray panels cut readily with a power saw and they go up easily with a glue gun or a hammer and nails.

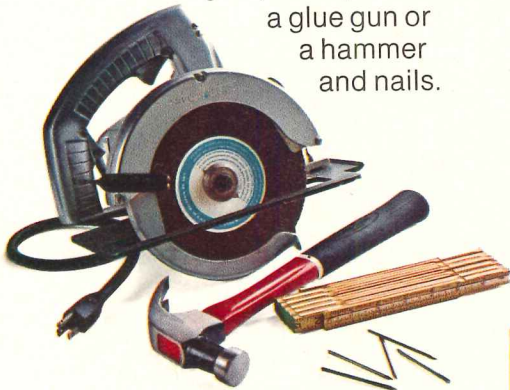

Sanspray is durable. The substrate is 3/8" exterior grade plywood. (Sanspray Shadowline™ is bonded to 5/8" plywood.) In fact, it meets the requirements of FHA/HUD and the major codes for single-wall applications.

Sanspray doesn't need finishing and is virtually maintenance-free. (We're sure. We



industrial complexes. Medical centers and hospitals. Schools and universities. Use it outside. As a siding, skirting or facade. Or use it

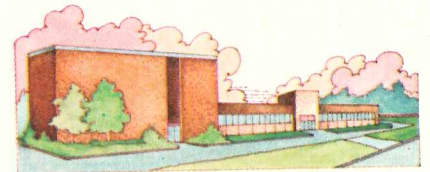
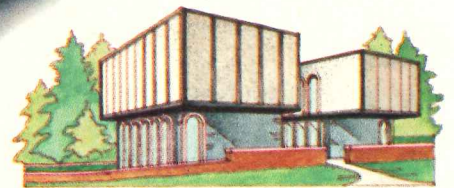

tested it in all kinds of climates for ten years.)

Sanspray comes in Regular, Large and Jumbo size aggregates. And Sanspray Shadowline, which is a regular aggregate panel with vertical grooves spaced eight inches on center.

It comes in eight rich colors. Like Salt and Pepper, Gaelic Green, Monterey Sand and Tangerine.

So it gives you a lot of ways to make a lot of things beautiful.

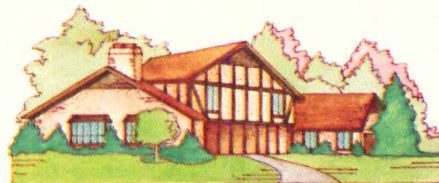
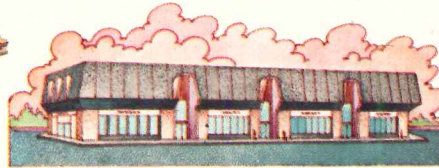

Homes for instance. (It's a natural for a Tudor.) Townhouses and condominiums. Stores and shopping centers. Factories and

inside. In lobbies, waiting rooms and public rooms.

In fact, for just about anything you want to make beautiful, you should use Sanspray, the beautiful alternative.

Find out more about it at your U.S. Plywood Branch Office.



**EXTERIOR**  
CLADDING BY  
**U.S. Plywood**

777 Third Avenue, New York, N.Y. 10017

 **U.S. Plywood**  
Division of Champion International

For more data, circle 12 on inquiry card



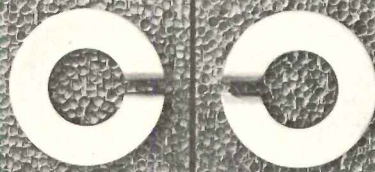

Bonded Bronze doors are now offered detailed in six different ways to accommodate individual design preferences and to make these elegant doors available within limited budgets. Forms & Surfaces Box 5215 Santa Barbara, California 93108 (805) 969-4767

**FORMS + SURFACES**





## New from Armstrong. The first pre-engineered package of products for the open plan office.

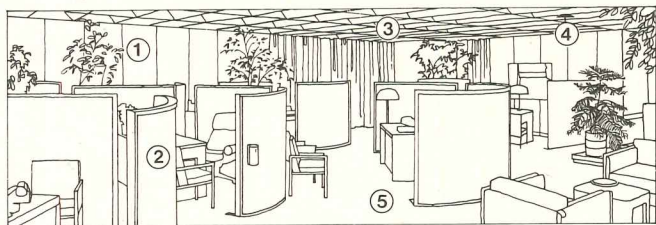

**It combines acoustical and visual privacy, air distribution, and quality lighting, with good looks, too.**

Until now, you've had to deal with as many as five or six different suppliers to put together the various elements required for a successful open office plan.

Now, Armstrong offers a complete product package that functions well, looks as good as it works, and provides, for the first time, a *single-source responsibility*.

### **1. Soundsoak™ Wall Panels\***

These panels are made of an acoustically efficient mineral fiberboard mated to a soft modacrylic fabric. They can be easily installed on interior walls and other flat surfaces and make a substantial contribution to the control of reflected sound.

Available in a wide choice of modern colors, Armstrong Soundsoak Panels are decorative as well as functional. They're 30" wide and available in either nine- or ten-foot heights.

### **2. Soundsoak Divider Screens**

Screens are an indispensable element in efficient open office planning. They provide effective separation of work

\*Patent pending





stations, contribute to acoustical and visual privacy, and add splashes of color to the room. Freestanding and easy to move, they are covered with a tufted-nylon fabric in a wide choice of colors which coordinate with the wall panels. Both curved and straight types are available in five-foot width, and there is a choice of a five- or six-foot height. All models offer a trim selection of either walnut-finished wood or bronze anodized aluminum.

### 3. C-60/30 Luminaire Ceiling System

The most important factor in open planning is acoustical privacy, and the ceiling is the key element in achieving that privacy. The Armstrong C-60/30 Luminaire Integrated Ceiling System provides not only acoustical efficiency but also other important open plan environmental factors such as quality lighting and draft-free air distribution.

In the 100%-vaulted configuration, using a special 1" Classic Open Plan ceiling board, the C-60/30 System

complies with the GSA PBS-C.1 performance specifications for a Speech-Privacy Potential of 60\*\*.

### 4. Sound-Masking System

The Armstrong open plan package includes a completely integrated and matched electronic sound system that introduces into the working area sound of the proper intensity and frequency content to help attain the desired level of speech privacy. The system can be "tuned" to provide evenly distributed, nondisturbing background sound to any open plan space.

### 5. Armstrong Floors

To complete the open plan visual package, Armstrong offers a selection of flooring materials. If carpet is your choice, there is a wide range of colorful Armstrong Commercial Carpets that will add warmth and quiet to any open plan.

Where the practicality of resilient floors is called for, Armstrong Quiet Zone® Vinyl Corlon® is the answer.

\*\*at 10' 6" interzone distance

Thanks to its generous foam-cushion backing, it's both quiet and comfortable.

That's the Armstrong five-in-one open plan package. For more information, mail this coupon to Armstrong, 4207 Rock St., Lancaster Pa. 17604. In Canada, write Armstrong Cork Canada, P.O. Box 919, Montreal 101, Quebec. *For more data, circle 1 on inquiry card*

Please send me your 16-page brochure and complete information on the Armstrong package of open plan products.

Name \_\_\_\_\_

Company \_\_\_\_\_

Address \_\_\_\_\_

City \_\_\_\_\_ State \_\_\_\_\_ Zip \_\_\_\_\_





**THIS IS THE HEADRAIL WE HANG OUR BLIND ON.  
AS YOU CAN SEE, YOU CAN HARDLY SEE IT.**



**THIS IS OUR BLIND.  
AS YOU CAN SEE, IT'S WORTH SEEING.**

Try as they might, until now nobody could make a one-inch blind that was beautiful all over.

The headrail, unfortunately, hurt the overall effect. It looked a little horsey, stuck out, didn't fit in everywhere.

Enter Alcan.

The headrail on our new Mark II Blind is skinnier. Only one inch square instead of the usual one by one and a half.

Not a lot less, but enough to fit almost every window frame ever made no matter how shallow.

There's more, of course. Features you can't find on any other blind.

Like a bottomrail to match. Hardly noticeable. A very light lock-seam tube so strong it keeps the slats perfectly straight, even part way up.

The rest is looks. As pretty as the picture, in any color—or combination—under the sun. But why not see for yourself, in our 16-page book of possibilities called Window Shopping. It's yours for the asking.

The Mark II Blind. As you can see, it's a nice thing to do for a window.

**ALCAN ALUMINUM**  
ALCAN





Three models of fully recessed water coolers in 8 to 12 gallon per hour capacities. In satin finish stainless steel or in bronze-tone finish. Model shown EFR-8A.

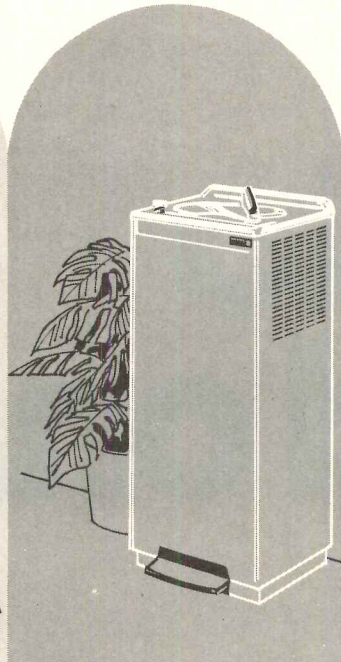

Self contained floor models in 4 to 20 gallon per hour capacities. Panels available in stainless steel, 9 vinyl decorator colors and two in baked enamel. Model shown EF-8.

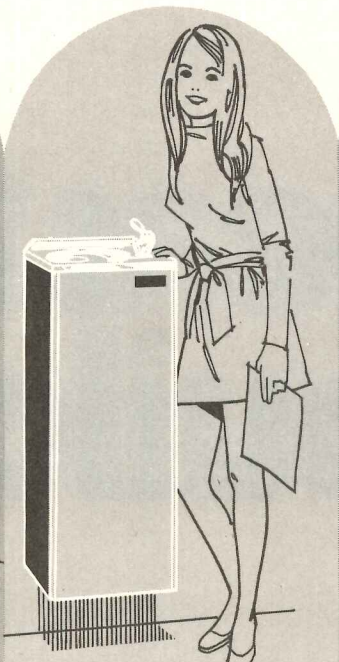

Space-ette series. The ideal water cooler where space is limited. Capacities are 3, 5 or 8 gallons per hour. Also in floor models. Model shown W-701-5.

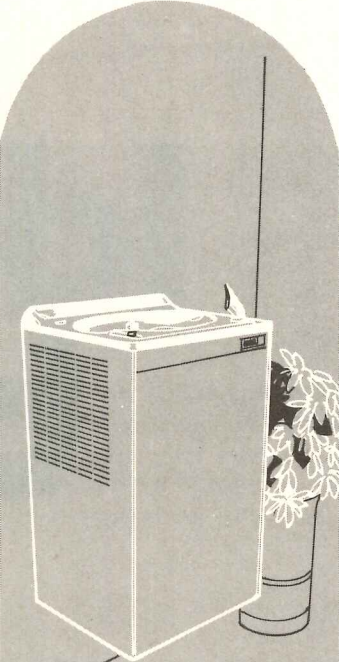

Wall mounted models in regular and compact sizes with Elkay's exclusive Cascade Basin. Full range of colored panels. Regular size 4 to 20 gallons. Compact in 4 to 14. Model shown EW-8.

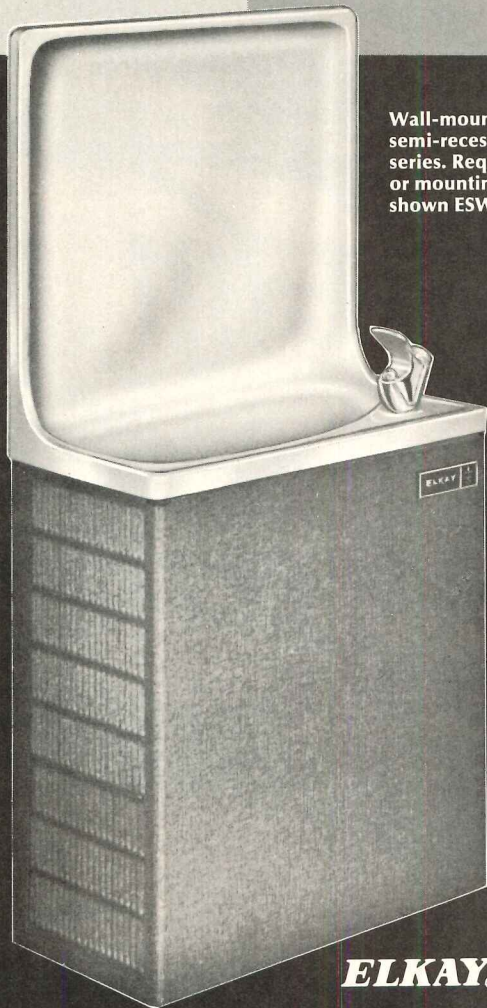

Wall-mounted, simulated semi-recessed coolers, ESW series. Require no wall cut-out or mounting box. Model shown ESW-13.

## Elkay reinvented the water cooler and here's why

Water coolers needed to be redesigned to permit simple, fast and economic installation. Elkay did that with sectional construction to keep mechanical systems away from the plumbing connection area. Water coolers needed a basin that is vandal-proof, minimizes splashing, looks better. And Elkay has created water coolers to fit every need: corner models, free standing, multiple basin models, two-level models. All of them with contemporary styling and finishes and colors to complement any decor.

Write for Catalog DFC-4 for more information.

**ELKAY**® Manufacturing Company, 2700 S. 17th Avenue, Broadview, Illinois 60153



# Ideas to build on.

## A better way to frame.

Design with Inryco/Milcor® Light Gage Steel Framing. Because of their proven economies, steel studs and joists have been used extensively in framing commercial and light industrial structures for many years. Now they are making significant inroads in motel, hotel, condominium and other residential applications. Formed from high strength steel, they're lightweight; will not rot, warp or twist; do not appeal to termites. Their selection is often decided by the substantial insurance savings the owner gains through their "non-combustible" rating.

*For more data, circle 17 on inquiry card*



**Ideas from Inryco help you design**

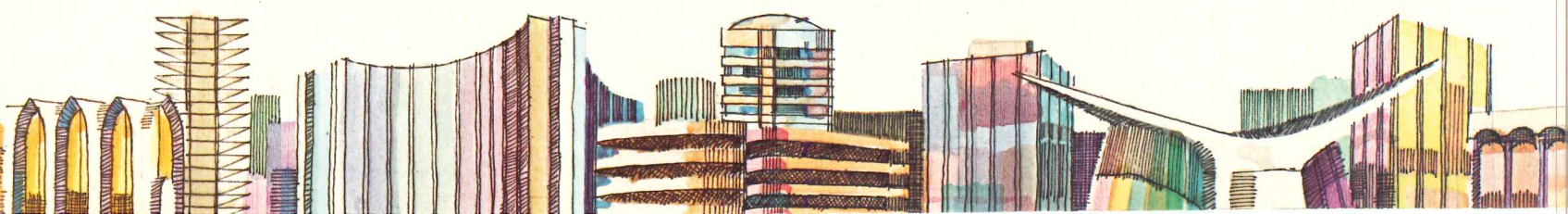



# Efficient firefighters.

When fire strikes, Inryco/Milcor Heat & Smoke Vents open automatically to release heat, smoke and noxious gas. Prompt venting retards the fire's spread, aids the safe evacuation of occupants, helps firemen locate and subdue the blaze. Made in Low Profile or Sloped Cover styles; galvanized steel or aluminum. Sizes from 4' x 4' thru 4' x 8' are Underwriters Laboratories listed and Factory Mutual approved. Special sizes on request. They're part of our broad line of roof hatches, skylights and floor and sidewalk doors.

For more data, circle 19 on inquiry card

## A wall for all reasons.

Inryco® wall panels give you the design freedom you want. With a choice of profiles that offer a variety of shadow patterns. Non-fading, long-life Duofinish™ colors factory-applied over galvanized steel. Or in attractive Cor-Ten® weathering steel, if you wish. Where noise control is a factor, Acoustiwall™ interior surfaces substantially reduce reverberation. In buildings requiring tall interior walls, Inryco long span systems eliminate the clutter of exposed structurals.

For more data, circle 18 on inquiry card

**better buildings**

See our catalogs in Sweet's 

**INLAND**   
**RYERSON**

A member of the  steel family  
Inland-Ryerson Construction Products Co.  
Dept. G, 4033 West Burnham Street  
Milwaukee, WI 53201

Send me more Inryco ideas, as checked:

On Inryco wall panels.  On Inryco/Milcor light gage steel framing.  On Inryco/Milcor heat and smoke vents.

Name \_\_\_\_\_

Title \_\_\_\_\_

Company \_\_\_\_\_

Address \_\_\_\_\_

City \_\_\_\_\_ State \_\_\_\_\_ Zip \_\_\_\_\_



# MAKE SURE YOUR CLIENT'S LOADING DOCK MEETS THE TEST



## CALL IN KELLEY'S DOCK DESIGN SPECIALISTS

Before a modern loading dock can be placed in operation there are hundreds of vital decisions to be made including choosing the correct equipment from thousands of products.

Size, height, traffic flow, lighting, sealing, waiting areas, gates, service roads, aprons, equipment, and now OSHA requirements, all demand correct decisions.

You can save yourself time, by leaving the job to Kelley specialists. They design, lay-out and equip docks every day. We have 350 of these specialists

in the field. They'll work with you and your client . . . and stand behind the results. They'll save you valuable time and headaches plus assure your client that he'll have the safe efficient dock operation he needs. Get the complete story from the responsible dockboard people:



**Kelley Company, Incorporated**  
6768 North Teutonia Avenue  
Milwaukee, Wisconsin 53209  
Telephone: (414) 352-1000  
Telex: 26-661

55-568AR

*For more data, circle 20 on inquiry card*



# MONARCH CARPET DYNAMICS™

PRESENTS CARPETS FOR CLASSIC DESIGNS

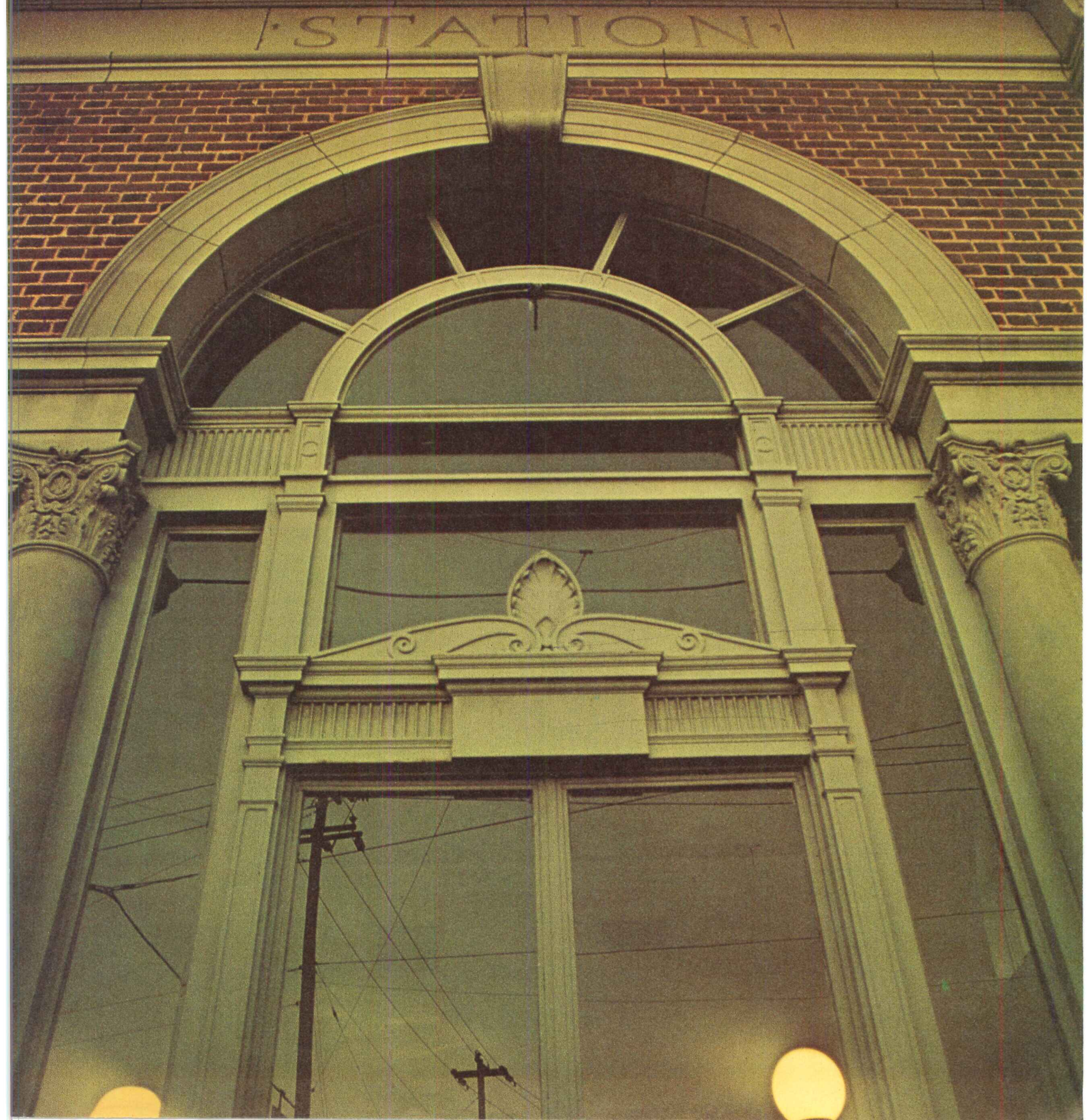





**MONARCH CARPET DYNAMICS  
MAKES CARPETS FOR  
ALMOST ANY JOB, ANY CLIENT.**

Monarch Carpet Dynamics is a whole new entity in the contract carpet field.

And what we offer is the widest selection of contract carpets available from a single source. Nylons, acrylics, polyesters. Prints. Tweeds. Solids.

Plus coordinated tufted wallcoverings to harmonize with and unify your whole design. Almost anything your specs call for, we have.

So, find out about Monarch Carpet Dynamics and our carpets for classic designs.

Call Hugh Bell collect at 404/451-4761 or write Monarch Carpet Dynamics, Chamblee, Georgia 30341.

**MONARCH CARPET DYNAMICS™**  
Contract Division of Monarch Carpet Mills.™

TM A trademark of E. T. Barwick Industries, Inc.

*For more data, circle 21 on inquiry card*









# The design opportunity of the year: it's as big as all indoors.

There are lots of things you do to design lasting quality into your houses, apartments and other projects. Unfortunately, some of these things cannot be seen by your clients. But one kind of quality that *is* visible is wood panel and louver doors—inside and out.

They're a symbol of your careful thought and planning. And an indication of the quality that makes your work a worthwhile investment for the client. That's why so many architects specify wood panel entrance doors. But there's no reason to stop there.

#### **Panel doors add character to every room.**

Good doors are like good furniture—they bring

character to each room. No matter what the decor, carefully sculptured wood panel doors will enhance the beauty of any room. Not only at the front entrance, but all through the house.

For instance, French doors can change a dining room from just a place to eat into an elegant dining experience. With deep sculptured bi-fold doors, a closet becomes a design accent instead of a hole in the wall. Swinging cafe doors give kitchens a light, perky touch. Even the utility room brightens up with an attractive (and practical) louver door.

And, of course, sliding wood patio doors do an excellent job of tying indoors and outdoors together. (Their greater insulation quality means less heat loss than with metal patio doors, too. That's an important consideration with the current need for energy conservation.)

#### **Wood panel doors keep a design theme going.**

Whether you're designing traditional, colonial, Spanish, modern or something else, you'll find the right wood panel doors.

They help you keep the design theme going from the front door to every room. The panel and louver doors pictured here are just a few examples of the dozens of types and styles that you can use to tie every room into the total design.

#### **Consumers prefer wood panel doors.**

In three major surveys conducted in 1968, 1970 and





1972, consumers in 39 states reported what they want most in doors, what kind of door they prefer — wood panel or flush — and why. The results clearly indicate that preference for flush doors has fallen while panel door preference is increasing.

**% who prefer panel or flush doors for exteriors**

	Front, Main Entrance			Rear, Other Entrance		
	1968	1970	1972	1968	1970	1972
Panel Doors	59%	64%	63%	54%	54%	62%
Flush Doors	36	26	28	33	26	24
No Preference	5	10	9	13	20	14

**% who prefer panel or flush doors for interiors**

	1968	1970	1972
Panel Doors	31%	32%	34%
Flush Doors	60	47	49
No Preference	9	21	17

**Wood panel doors meet consumer needs. And yours.** Before you specify the doors in your next project, consider the facts. Our research shows that consumers say appearance and durability are the qualities they want most from their doors. And they rate panel doors better than flush doors in both instances.

From your side, wood panel and louver doors offer great flexibility in design. So you can actually design *with* the doors, instead of around them. It's a happy match of consumer preference and architectural advantage.

**Send for your free copy of our survey report.**

We think you should have a report on the major findings of five years and \$40,000 worth of research — "The consumer of the 70's: a report on his housing plans and preferences." It reveals consumers' preferences for doors and windows as well as their plans for moving and remodeling. It's an important study that can help you know your market a little better and maybe even make you a little more effective in anticipating client needs. Send in the coupon today.



Mail to:

**Ponderosa Pine** Woodwork

Department A-2  
1500 Yeon Building, Portland, Oregon 97204  
A member of the American Wood Council.  
Send me a copy of your research report.

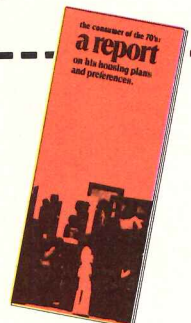

Name \_\_\_\_\_

Position \_\_\_\_\_

Organization \_\_\_\_\_

Address \_\_\_\_\_

City \_\_\_\_\_ State \_\_\_\_\_ Zip \_\_\_\_\_





**Owner:**  
 United Air Lines Incorporated, Chicago, Illinois  
**Architects/Engineers:**  
 Graham, Anderson, Probst & White, Chicago, Illinois  
**General Contractor:**  
 Power Construction Company, Elmhurst, Illinois  
**Steel Fabricators:**  
 Frame: Wendnagel & Company Inc., Chicago, Illinois  
 Exterior: David Architectural Metals Incorporated, Chicago, Illinois  
**Architectural Walls:**  
 H. H. Robertson Company, Pittsburgh, Pennsylvania

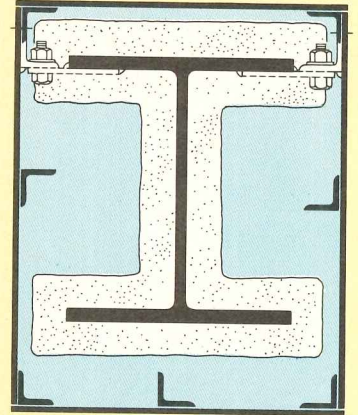

Section through typical free-standing column, illustrating steel plate cladding method.

# PAINTED STEEL IS WORTH A SECOND LOOK.

The clean, crisp lines of this white-painted steel building command instant attention.

It's the Regional Reservation Center in Elk Grove Township, Illinois — the newest addition to a group of United Air Lines buildings not far from O'Hare Airport.

A 1973 AIA Honor Award winner, the building has a modular steel frame and a white-painted carbon steel plate exterior skin — enhanced

by grey insulating glass. The steel — both structural and exterior — is ASTM A-36 from United States Steel.

Spandrel and column cover components were shop-fabricated into sub-assemblies and painted with a primer coat. In the field, these parts were bolted to brackets on the frame, joints were welded and ground smooth and the entire exterior was sealed with two coats of white, acrylic-latex paint.

The striking simplicity of this new structure demonstrates one of the features of a painted steel building: it's well worth a second look!

For further information about this building and for advice on the many ways to use architectural steel, contact a USS Construction Marketing Representative through the nearest USS Sales Office or write: United States Steel, Room C 311, 600 Grant Street, Pittsburgh, Pa. 15230.



TRADE MARK

**United States Steel**



NEWS REPORTS  
BUILDINGS IN THE NEWS  
HUMAN SETTLEMENTS  
REQUIRED READING

**The House of Representatives voted 211 to 204 last month to kill the controversial land use bill** that would have given states Federal aid (\$800 million over eight years) in developing land use planning processes. Technically, the vote was not on the land use bill itself, but on a resolution that set the rules under which it and a substitute measure could be brought to the floor for amendments and debate. Representative Morris K. Udall (D-Ariz.), author of the bill, said that any chance to pass this bill or a similar one seemed very unlikely in this session of Congress.

**Trial began June 5 in Washington, D.C., involving alleged anti-trust violations against the NSPE.** Charges were filed by the Justice Department in 1972 against the National Society of Professional Engineers, and seek to enjoin the professional organization from using its code of ethics to prohibit competitive bidding for engineering services. Details on page 35.

**I. M. Pei's second design for the Kennedy library was presented last month amid continuing opposition.** Environmental issues raised by the Cambridge, Massachusetts community forced a redesign of the project which has yet to be assigned a construction date, pending the conclusion of an impact study. Details are on page 35.

**April posted a large gain in heavy construction, offsetting the currently depressed housing market,** according to the F. W. Dodge Division of McGraw-Hill Information Systems Company. April contracts, showing a two per cent gain over last year in the total value of new construction, totaled \$8,928,908,000. The latest month's seasonally adjusted Dodge Index (1967 = 100) was 179, little changed from the previous month's 181. The average level of this index during 1973 was also 181. See page 10.

**Officers of the AIA have commended the GSA for adopting new architect and engineer selection procedures** for Federal projects. After studying recommendations of a special study committee appointed by GSA in 1973, GSA Administrator Arthur F. Sampson announced immediate implementation of the procedures which include: modification of the make-up of GSA advisory panels for selection of design professionals; and establishment of in-house professional evaluation boards who will rank-order the three top firms recommended by the advisory panels. This ranking was previously done by the administrator who is responsible for the final selection. See page 65.

**Consulting engineers, meeting in May, reaffirmed a self-imposed moratorium on political contributions,** official adoption of a new ACEC Code of Ethics and adoption of disciplinary action to enforce the code. The 1974 convention of the American Consulting Engineers Council in Miami also unveiled a public information program aimed at promoting a total internal and external effort to enlarge the consulting engineer's role as professional manager of design and construction. This method is described by the program as "something better than Turnkey." The aim is to promote the independent consulting engineer, representing the owner-client as project manager, designer, overseer and coordinator of the entire construction process.

**Roger H. Corbetta, chairman of the Corbetta Construction Company, died in New York on May 26,** of an apparent heart attack. He was 77 years old. Mr. Corbetta was past president of the Building Trades Employers Association, the American Society of Concrete Constructors, the American Concrete Institute and the Concrete Industry Board of New York. A member of the Building Research Advisory Board of the National Academy of Sciences, Mr. Corbetta was also a director of the Construction Sciences Research Foundation. His firm, begun in 1922, built the Dulles International Airport terminal building near Washington, D.C., and participated in the building of the Pan American terminal at Kennedy International Airport in New York, the Argonne National Laboratory in Chicago, and the South Mall in Albany, New York.

**Portland, Oregon hosted the Eighteenth Annual Convention of the Construction Specifications Institute,** held June 24-26. Taking as its theme "Construction: Conservation, Sciences and Information" the convention focused on materials, products, methods and energy. A major portion of the program dealt with two CSI proposed standards—the Uniform Documentation System for Schedules and Numbering System—and the Page Format. For details, contact CSI, 1150 Seventeenth Street, N.W., Washington, D.C. 20036.

**Owens-Corning Fiberglas Corporation announces its third annual energy conservation awards.** Entries will be judged on the scope and creativity of the energy-conserving concepts and on the actual energy savings achieved or anticipated. Industrial, commercial, governmental and institutional categories will be judged. Entries must be submitted by August 31, 1974. For more information, contact the Energy Conservation Awards Program, Owens-Corning Fiberglas Corporation, Toledo, Ohio 43659.



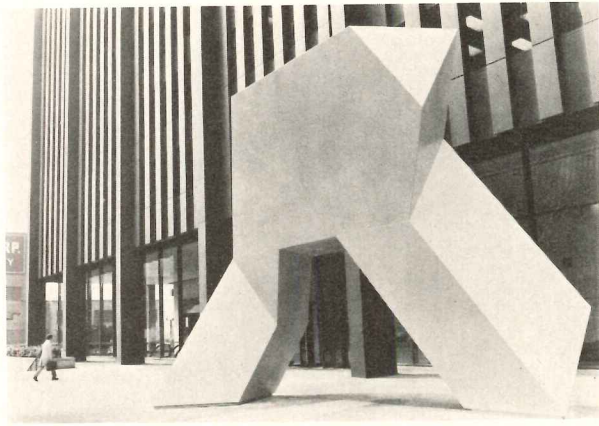

### Tony Smith sculpture dedicated in Pittsburgh

"Light Up," a monumental, welded-steel sculpture (shown) by the American artist Tony Smith was dedicated in May by the artist and Donald C. Burnham, chairman, Westinghouse Electric Corporation. The sculpture stands on the plaza of the Westinghouse Building in Gateway Center, Pittsburgh.

At the dedication, Mr. Burnham praised the artist's work and said that the sculpture represented the "capstone" of the Westinghouse Building's art collection. The collection began about five years ago to create a visually stimulating environment for Westinghouse employees and visitors.

The sculpture stands approximately 21-feet-high and is 29-feet-long and 17-feet-wide. "Light Up" is the only one of the artist's works to be finished in a bright color—in this case, yellow.

The Westinghouse collection now comprises 137 paintings, 23 sculptures, 123 craftings and 985 prints. This is believed to be one of the larger art collections by any company.

The art was purchased

over a five-year period from galleries in the United States as well as in Italy, Germany, France, Spain, England, Switzerland and Japan.

The resulting collection contains diverse styles ranging from the Pop Art school of the early 1960's to the Minimalists to the Neo-Impressionists. In collecting such a variety of art, the company has selected a broad spectrum of works from unsophisticated, primitive works by unknowns to the work of well-known, highly sophisticated artists.

The art was selected under the direction of the company's Corporate Design Center which is responsible for maintaining excellence in all areas where products, facilities and graphics of the company have a visual impact on customers, employees and the public. The design group—headed by J.P. Andrews—became the bridge between the company and the artistic community.

Westinghouse placed the initial challenge of collecting the art on the shoulders of a team headed by Ivan Chermayeff, and Eliot Noyes, the company's design consultant.

### Project seeks to reduce crime through design

The Law Enforcement Assistance Administration (Justice Department) has contracted with Westinghouse Electric Corporation, Baltimore, for a program aimed at crime reduction through environmental design. The contract price is nearly \$2 million.

LEAA officials are counting on good environmental design to promote normal citizen surveillance. The design program will concentrate on crimes of opportunity, (classified as robbery, burglary, rape and assault, among others). By redesigning streets and transportation systems, it is hoped people can be encouraged to use them without fear.

Westinghouse, under the contract recently awarded, will

create a model environmental design project for private residences, schools, transportation systems, and commercial environments. At least two of the projects will be carried through a demonstration phase and evaluated to measure their effect on crime and fear of crime.

Other aspects include:

1) Provision of technical assistance and policy guidance to both private and public planners at the Federal, state, and local levels to help them implement environmental design concepts.

2) Development of curricula for architects, engineers, planners, and criminal justice personnel on the principles and techniques of environmental design for crime prevention.

### Artifacts protected under new law

A new law that may delay Federal construction projects until a search can be conducted for artifacts, has reached the President's desk and was signed into law on May 24.

This measure (Public law 93-291) allows Federal agencies to use up to one per cent of their appropriated funds for salvage of such artifacts and at the same time authorizes \$13 million for salvage operations on Federal project land and another \$6 million for similar operations on private property.

### University shows energy course results

Solar energy systems, innovative building walls and more efficient lighting designs are among the approaches to conserving energy being explored by graduate students enrolled in a new architecture course at the University of Pennsylvania.

The students presented their ideas in reports and displays May 7.

The course from which the exhibit grew is entitled, "Energy Conservation in Buildings." It was developed under a \$27,000 PPG Industries Foundation grant, awarded to the University's Department of Architecture in December, 1972, after a six-month competition among nine leading schools of architecture. Principal developers of the course and its main instructors are architect John-Robertson Cox and consulting engineer Lawrence G. Spielvogel. The two are co-directors of energy programs for the architecture department.

Using the course material and other sources, Cox and Spielvogel are preparing a much-needed comprehensive textbook to introduce energy and conservation as an integral part of architecture studies.

### Golf condominiums manual available

The Urban Land Institute announced publication of a development manual designed to inform land developers, planners, landscape architects, golf course architects and residents of golf course developments of details involved in designing and building golf courses and their residential communities.

The 106-page full-color Technical Bulletin 70, "Golf Course Developments," is available at \$15 per copy from Urban Land Institute, 1200 18th Street N.W., Washington, D.C. 20036.

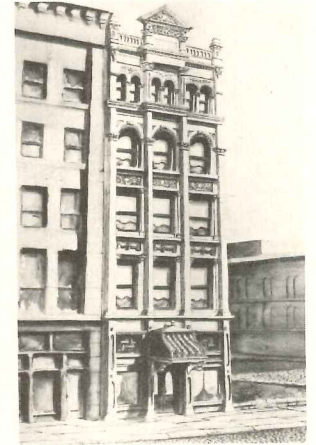

### Low-interest loans for Louisville preservation

The First National Bank of Louisville has announced a commitment of \$1 million to a unique, low-interest loan fund which will enable small business to refurbish, restore and/or recycle old structures in the central city.

First National will itself renovate a 140-year-old five-story commercial building (shown now, and as it will be) on Old Main Street, for a typical \$50,000 small business cost. The building, next door to the now-destroyed original Firstbank, chartered in 1833, will be in high Victorian style, funded by the Bank for five years and donated as a Bicentennial Information Center. It is on the edge of the Sixth-to-Ninth-Street Old Main Street Area which has been given landmark status and chosen for preservation by local architects and businesses as Louisville's salute to Kentucky's 1974 Bicentennial.

While the First National Bicentennial Business Improve-

ment Loans and Bicentennial Savings Certificates are anticipated to have great impact on preserving Main Street, with its unique clutch of cast iron buildings, loans up to \$50,000 may be used in any area of the central city, or, where neighborhood associations exist.

Loans can be had at preferred interest rates, 25 per cent less than typical business improvement loans. First National estimates that the hundreds of 19th century structures available for refurbishings are usually so sound that \$50,000 will be adequate for Class A improvements.

Old Main Street is considered to be one of the last remaining collections of 19th century cast-iron buildings in the nation. Running south from the Ohio River for 16 or 18 blocks, on 2nd, 3rd, 4th, 5th, and 6th Streets the City also has the largest national library of solid, usable 19th century houses stemming from about 1800 through 1899.



### New AIA officers begin one-year term in December

Pictured are newly elected national officers of the AIA who begin one-year terms in December. Front, left to right are: William Marshall Jr., FAIA, of Norfolk, Va. (president), Louis de Moll, FAIA, of Philadelphia, Pa. (first vice president and pres-

ident-elect). Back row: Hilliard T. Smith Jr., FAIA of Lake Worth, Fla. (secretary) and vice presidents Elmer E. Botsai, FAIA, of San Francisco, Cal., John M. McGinty of Houston, Tex., and Carl L. Bradley, FAIA, of Fort Wayne, Ind.



## Justice-NSPE suit enters court

Arguments in the Department of Justice civil antitrust suit against the National Society of Professional Engineers involving a charge of price competition elimination in the offering of engineering services were heard in the U.S. District Court of Judge John Lewis Smith, Jr. in Washington, D.C. last month.

NSPE, a 67,000-member professional society, was charged in 1972 by Justice with specifically violating Section 1 of the Sherman antitrust law through distribution of its code of ethics "prohibiting its members from submitting competitive bids for engineering services," and by agreeing that members must abide by these provisions.

In last month's trial, defense attorneys argued that a "learned profession," such as the NSPE, cannot be subject to the Sherman Act in the sense that manufacturers of hard goods circulating in interstate commerce may be. They contended that the Society's code of ethics was based on sound and traditional policy and that the Brooks Act of 1973, dealing with Federal procurement policies, upheld the principles of the NSPE canon.

The Justice suit was described as a "first impression case," meaning it raised for the first time the question of a learned profession being in possible restraint of trade through one of its code provisions. Basic in the case has been the question of price determination by negotiation or by competitive bidding for engineering services. Section 11 (c) of the NSPE code, central to the trial arguments, states that it is unfair, unethical and unprofessional for a professional engineer to solicit or submit proposals for engineering designs by competitive bidding.

The Justice Department attorney, Richard J. Favretto, told the court that since 1960 NSPE had "engaged in a combination and conspiracy in unreasonable restraint of interstate commerce in violation of Section 1 of the Sherman Act." He held co-conspirators to include NSPE members, other national engineering and architectural societies and NSPE's 54 member state societies. The chief counsel for the defendant, Lee Loevinger, argued, on the contrary, that NSPE as a national organization keeps no fee schedules, that it could not, therefore, be considered a fee schedule case. It was admitted only that affiliated state societies may have variants of fee schedules but that these are not

dictated by the national office.

A flood of evidence has been introduced with hundreds of exhibits identified. Before the case reached Judge Smith's court, the NSPE had turned over to the Justice Department more than 10,000 documents pertinent to the investigation and, it was noted, had cooperated with the Attorney General in every way.

The government has averred that schedules of charges for engineering services, wherever they are posted, require Society members not to accept commissions or fees or salaries below an accepted standard of the profession in specified geographic areas.

Yet, the defendant's pre-trial memorandum said its evidence would show that NSPE has no fee schedules and stressed that none of the state affiliates was a party to the instant case. "Similarly," it stated, "NSPE has never sought to fix fees or prices or been a vehicle for fixing fees or prices in any manner."

The case was heard early in June and it was expected to be several weeks before the Court would rule. An appeal from that decision was expected, probably going directly to the Supreme Court.

## GSA publishes on lighting and construction management

A new publication, entitled "The GSA System for Construction Management," has been released by the U.S. General Services Administration.

The booklet describes the principles of construction management, procedures for selecting construction managers, contract requirements, control systems and performance requirements for CM's.

It defines the role of the construction manager as the over-all coordinator who manages the budget, schedules design and supervises construction.

Copies of "The GSA System on Construction Management" may be obtained by writing: M.S. Blackstone, Room 6329, Public Buildings Service, General Services Administration, 18th and F Streets, N.W., Washington, D.C.

GSA has also released a new document, "Lighting Systems Study," which it said could bring a 35 per cent savings in energy over current techniques.

This is a follow-up to the recently published "Energy Conservation Design Guidelines for Office Buildings."

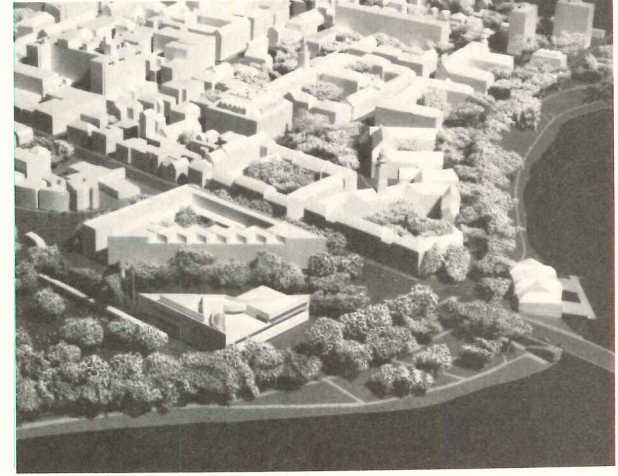
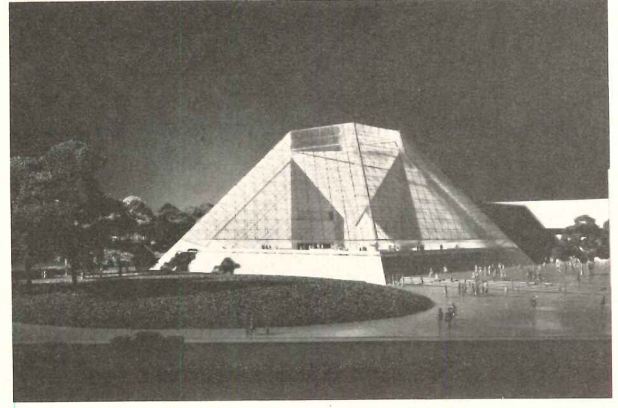
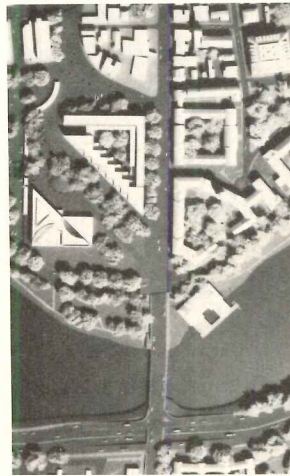
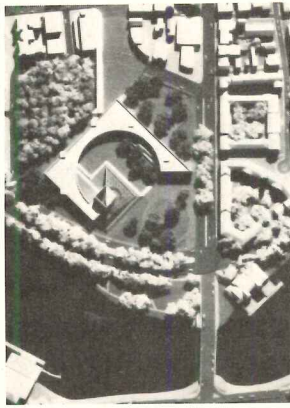

## Controversy continues as second Kennedy library designed is unveiled

In May 1973, I. M. Pei & Partners presented the design shown top for the John Fitzgerald Kennedy Library at Harvard University, and almost immediately the project became the subject of controversy due to the possible tourist impact on the Cambridge, Massachusetts neighborhood adjacent to the Harvard houses.

The General Services Administration, which would own and operate the library—in-

tended as a museum and home for Harvard's renamed Kennedy School of Government and Politics—initiated an environmental impact study which is not yet completed. In the meantime, however, the Pei firm redesigned the project and last month unveiled the design shown immediately above.

It consists of three elements: the library, an academic building for Harvard, and Commonwealth Park. To satisfy the

community's concerns, the architects have reduced the scale of the buildings, eliminated the visitor aspects in favor of purely educational functions, and created a park separating the two buildings and joining the Charles River to Eliot Square.

The 12-acre site, now used for trackless trolley and bus yards, is three blocks from Harvard Square and ranges with beautiful vistas along the Charles River.

## RCA scientist predicts widespread home use of solar energy in five years

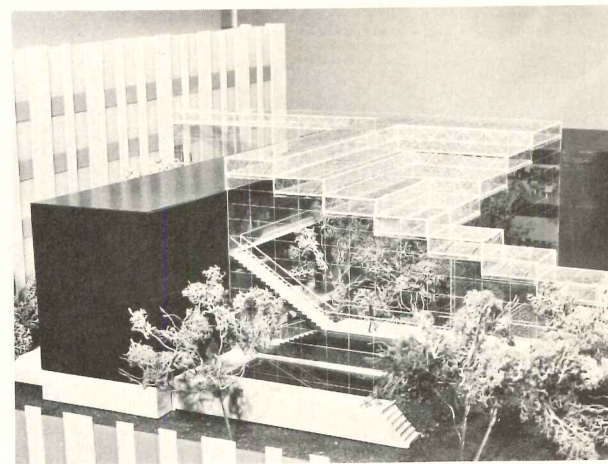

An RCA scientist is saying that based on present trends it is possible to foresee economically competitive solar energy systems in widespread use in homes and other buildings in the United States within five years.

Paul H. Rappaport, of the

RCA Laboratories in Princeton N.J., made that forecast in testimony before a joint session of the U.S. Senate Commerce and Interior Committee, which is considering legislative proposals to provide Federal support for solar energy development.

Mr. Rappaport and Sital

Daryanani, vice president of the engineering consulting firm of Syska & Hennessy, New York, were invited to appear before the joint session and outline RCA's plans to use solar energy to provide part of the heating and cooling requirements for a new addition to the RCA building in New York.

RCA's planned two-story management conference center (shown) will be built on a 12th-floor setback to the 70-story skyscraper. Because it will use large expanses of glass, Mr. Rappaport added, RCA chairman Robert W. Sarnoff directed designers to utilize solar energy as a means of minimizing heat loss in the winter and heat absorption in the summer. Mr. Sarnoff felt that the conference center should be utilized as a pilot plant for developing and demonstrating improved energy savings techniques.



# UNPARALLELED PROTECTION

Solutions for every fire/life safety door control problem. From the pioneer and leader of the field, a comprehensive range of code-orientated smoke detection and door control products... fully tested under actual fire conditions... backed by the industry's best-known staff of fire protection professionals.

Write today for complete information.

## **RIXSON-FIREMARK, INC.**

9100 W. Belmont Ave., Franklin Park, IL 60131  
In Canada: Rixson-Firemark (Can.) Ltd.

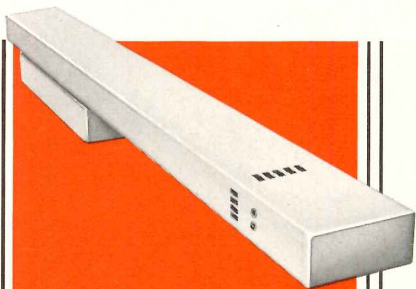

**Smok-Chek IV:**  
Ultimate combination detector and hydraulic door control protection.



**Smok-Chek III:**  
The original combination unit.



**FM-1001M:**  
Advanced photoelectric type smoke detector.



**FM-1601:** Low profile ionization detector.

... and the long Firemark line of electromagnetic door holder-releases.

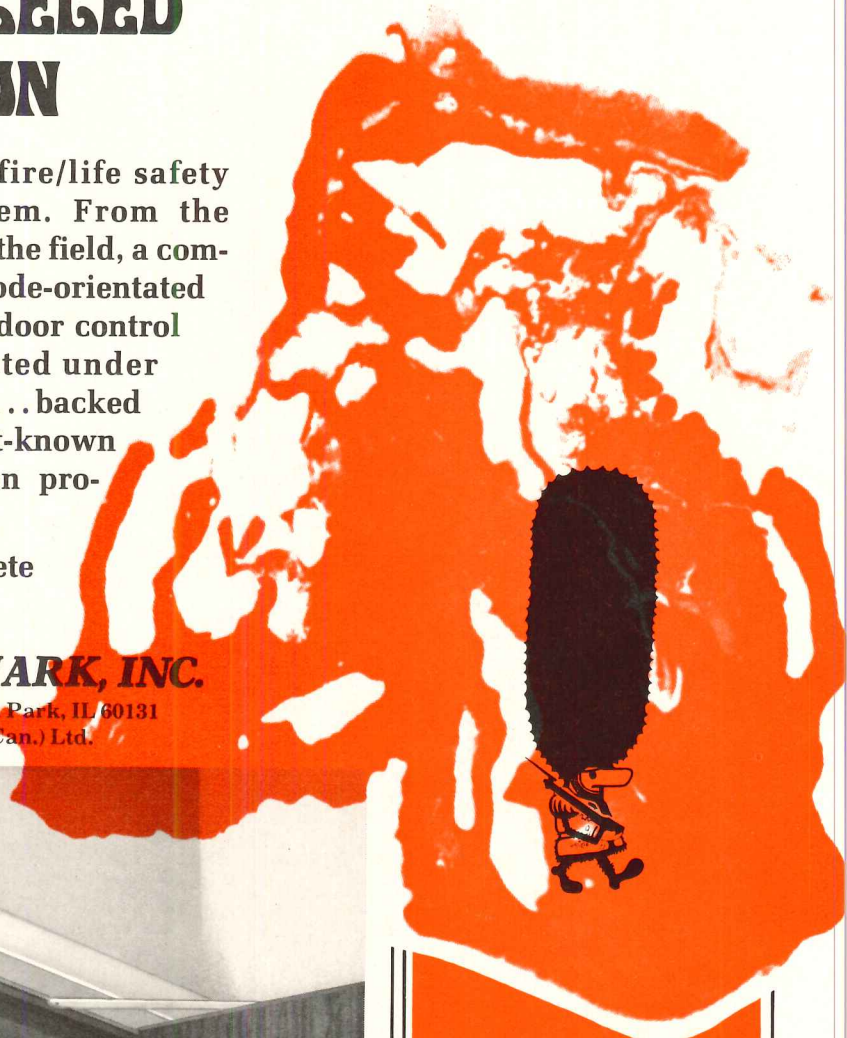

For more data, circle 25 on inquiry card



**Construction begun on Detroit hospital addition**

The first phase in the newly adopted \$300 million master plan for the Henry Ford Hospital in Detroit is this Education and Research building designed by Rossetti/Associates. The \$11 million building, begun in May, will be a concrete structure sheathed in precast concrete. All floors are to be open space organized on a grid providing 10- by 20-foot laboratory modules adjacent to 10- by 10-foot

office and support modules. The connecting corridors will terminate at the all-glass north facade where lounge and common areas overlook an area master-planned for gardens. The site is the original 60-year-old campus of the Henry Ford Hospital. What was a wooded site has become a dense, urban area, so part of the plan is to restore a major landscaped focal point for the buildings.

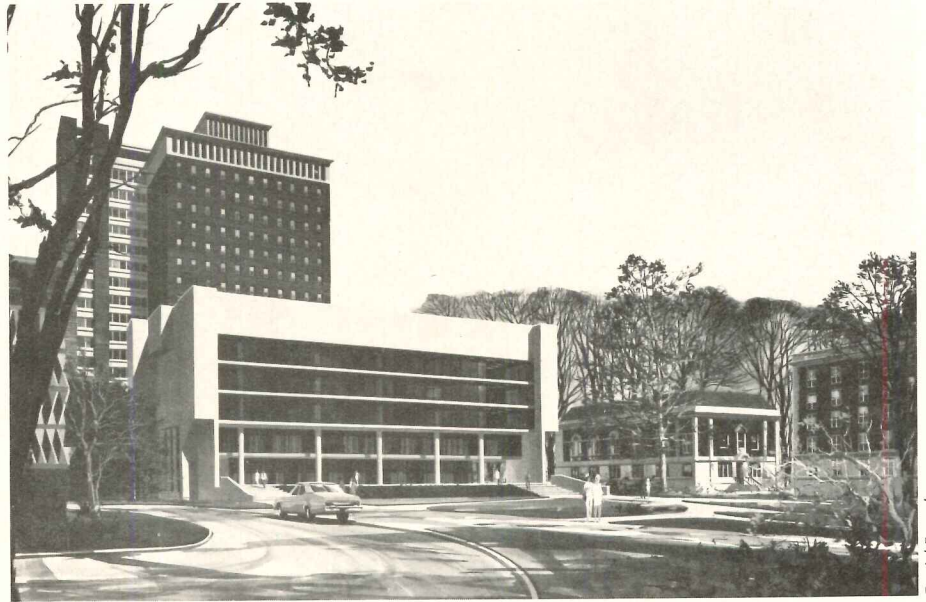

Daniel Bartush

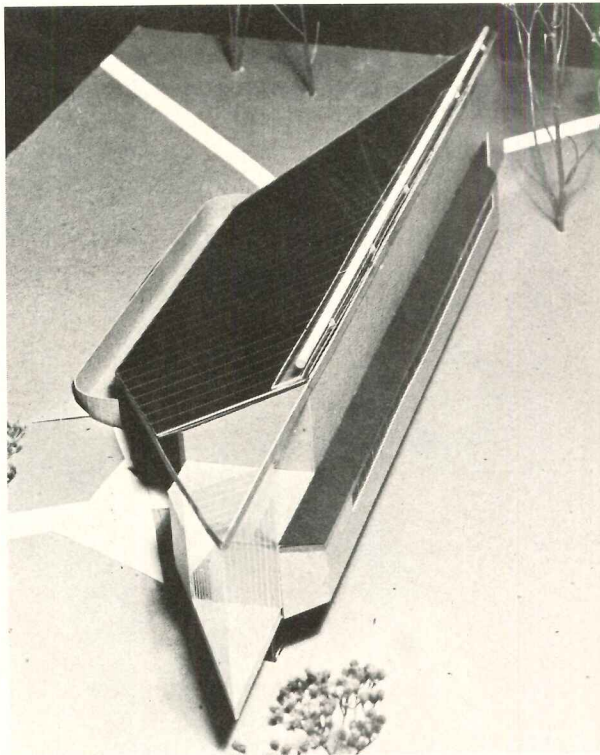

**Solar energy science building will open this year**

A science building powered by solar energy, and containing laboratories for chemistry, biology and physics has been designed by Arthur Cotton Moore Associates for the Madeira School in Greenway, Virginia. The building has been conservatively designed with existing technology and standard fabricated elements to assure performance analyses.

**First public squash center in U.S. planned for Massachusetts**

Intersquash Svenska Ab of Stockholm have announced the opening of the first U.S. public squash center based on international rules and dimensions. Designed by Stahl/Bennett, Incorporated, the building will include a spectators' gallery ac-

commodating 200 people behind the glass back wall of the center court, plus lounge, club-room, kitchen, child care area, locker rooms and sauna. The center will be built in Burlington, and opens in the fall of this year.

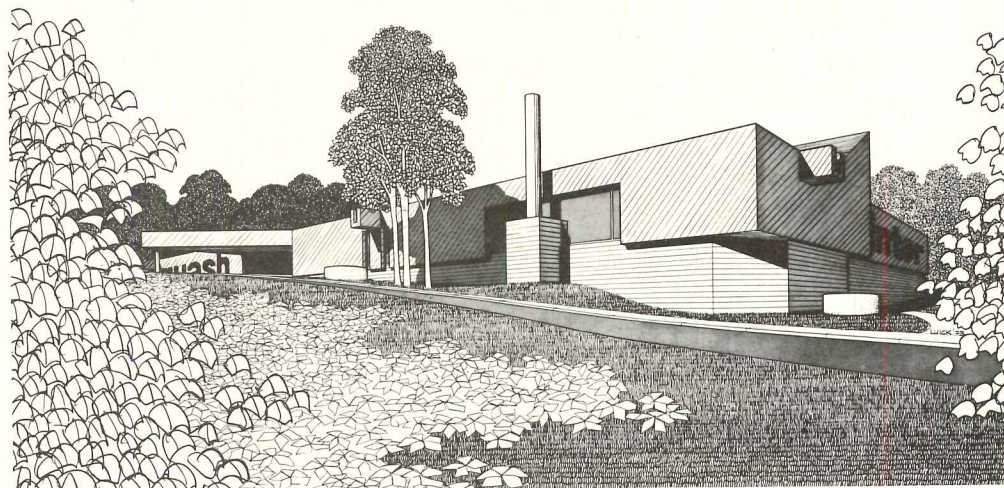





# We designed our best feature to go totally unnoticed.

We call it Hydrachek, Rite-Hite's exclusive new lip holding device. The lip latching function is taken for granted in mechanical dock levelers, yet it is the single most frequent cause of down time, and down time costs you money. Hydrachek eliminates the cause. We've replaced the typical, troublesome mechanical spring and latch with a simple, fully enclosed hydraulic mechanism, which resembles a commercial door closure.

When the leveler is activated, Hydrachek slowly and silently extends the lip and holds it in position until the leveler can be walked into position on the truck bed. How reliable is it? Our test unit has now been cycled more than 20,000 times without a single failure. Which is why you never notice Hydrachek. Because it always works. Write for our Bulletin #HY-1073 for all the particulars on Hydrachek.

**RITE  
HITE**  
CORPORATION

Dept. AR-774  
6001 S. Pennsylvania Ave.  
Cudahy, Wisconsin 53110

Licenses and representatives  
throughout the free world.

For more data, circle 26 on inquiry card



### Corrections facility is a prototype

A college-campus atmosphere is intended for Florida's prototype housing of inmates in a correctional rehabilitation program—which allows participants to hold regular jobs during the day and return to confinement at night on an honor system basis. The architect is Barry Sugarman. Each of the 52 rooms houses two people who share a bath connected to one other room. These living quarters are contained in two identical wings connected to ancillary facilities in a central location. The 19,600 square-feet of space are being constructed at a cost of \$623,000.

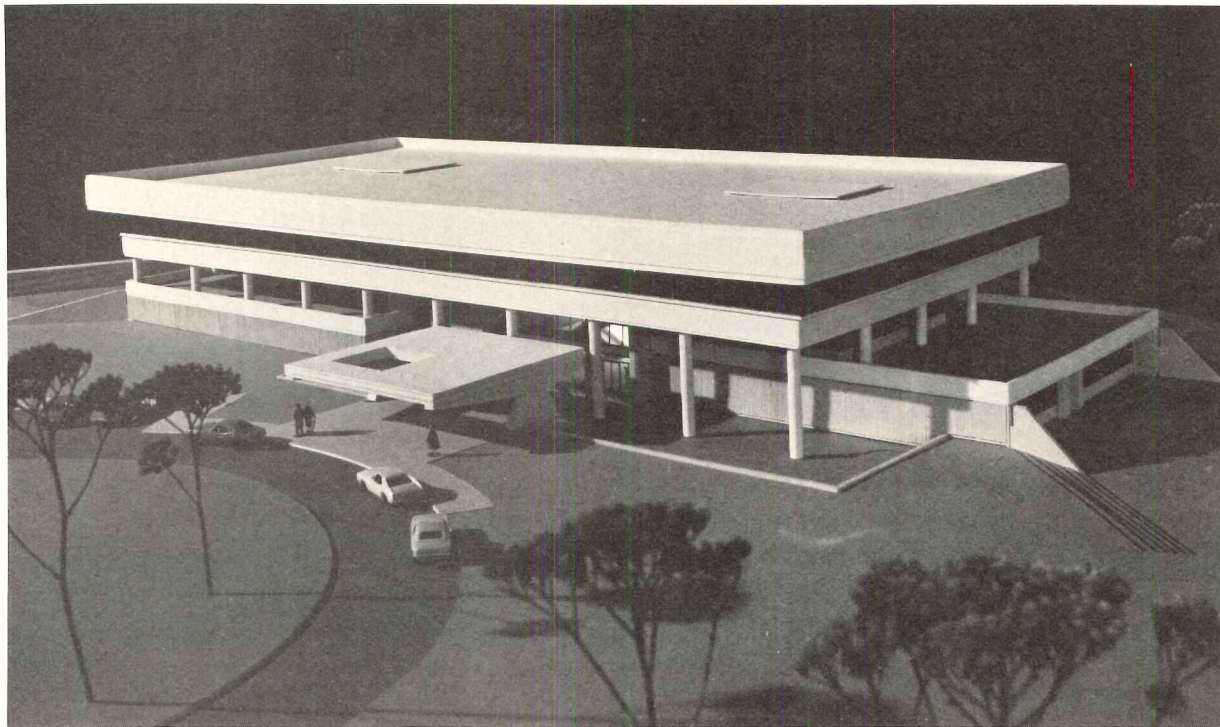
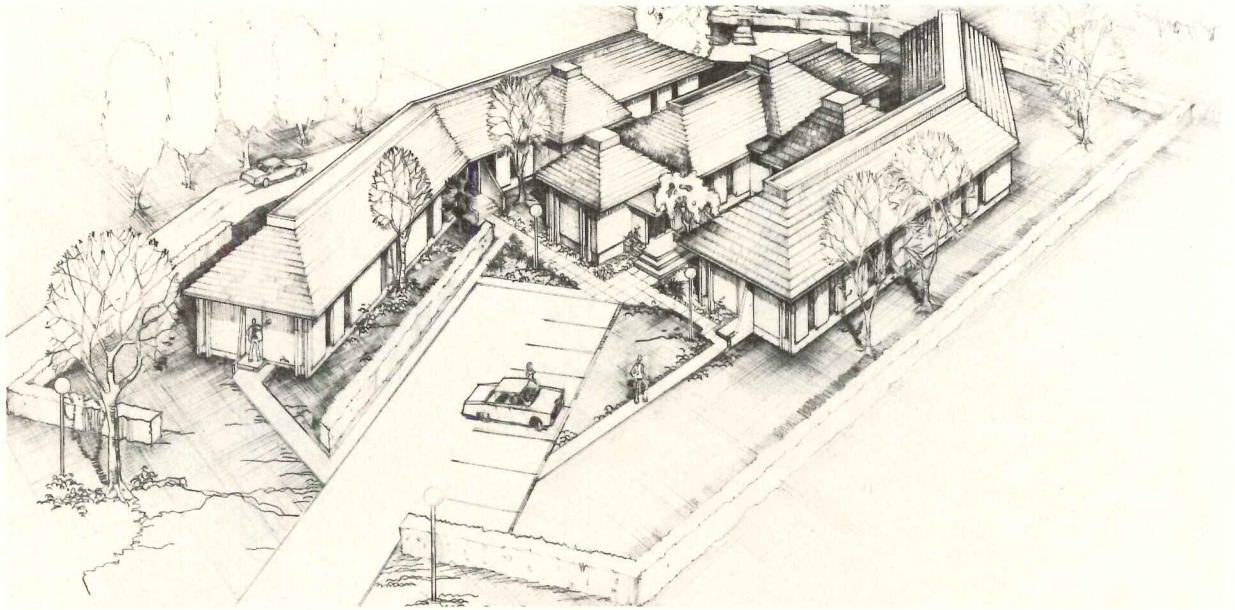

### Thiokol headquarters announced

Construction has begun on 62,000 square feet of office space for Thiokol in Bucks County, Pennsylvania. Up to 180 persons will be accommodated. The site allows for expansion in a campus arrangement, although immediate plans only call for housing the corporation's present needs in the current phase of construction, which is scheduled for completion in 1975. Special program requirements have dictated the relative areas of each floor: executive offices are on the second floor, and general offices are on the top. The architects are Ballinger of Philadelphia. The structure will consist of a steel frame spanned by metal deck and clad in precast concrete.

### Drake University breaks ground for new Law School

An increased enrollment of 450 law students has precipitated the construction of this new facility of 39,400 square feet. The Des Moines building will be called Cartwright Hall in honor of its major donors, and will take the place of the Carnegie Hall across the street, which will be turned into a library. The original facility was designed to accommodate 170 students. The new building will be two stories high and contain a lecture hall with 160 seats, classrooms, a seminar room,

moot courtroom, research areas and offices. High spaces are to be accommodated on the second floor, and a ground-level "mall" will run through the building to a future new library at the rear. The architect is Edward Larrabee Barnes. Construction costs are anticipated to be \$2,250,000. The structure will be precast concrete, and the cladding will be brick. Construction is proceeding on a "fast-tracking" basis and is planned for completion in 1975.

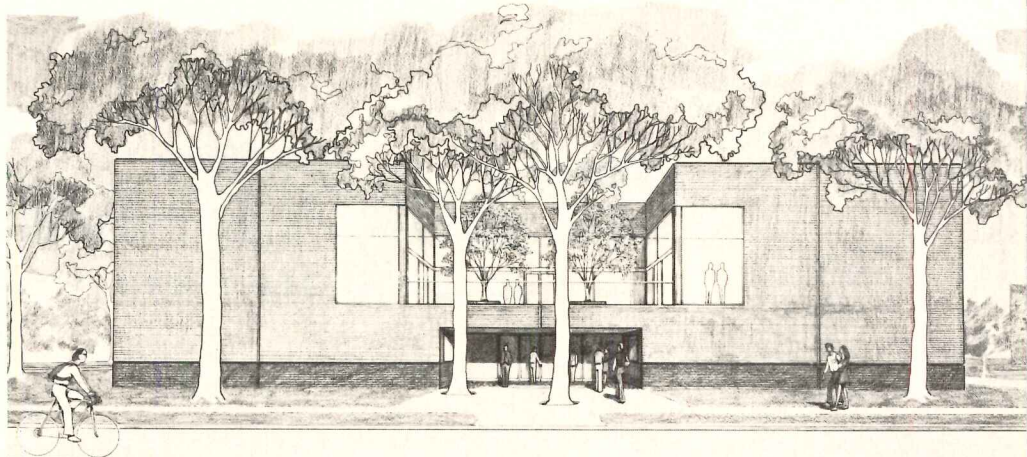



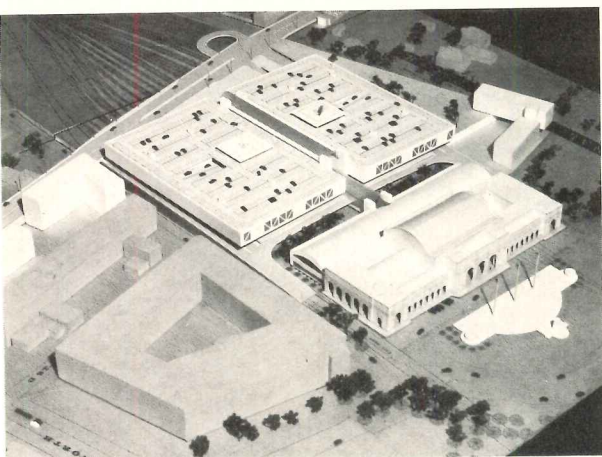

**Washington's Union Terminal in new role**

Union Terminal (right forward) in Washington, D.C. is currently being remodeled to provide a National Visitor Center which will be operated by the National Park Service. To the rear of the terminal—and over the existing railyard—a replacement terminal and parking facility is being constructed to provide parking for 4500 cars and charter buses. Designed by The Office of Seymour Auerbach, the complex will connect to surface transportation and the new subway.

**P.S. 398 in Brooklyn designed by Perkins & Will**

This open-plan elementary school recently begun in the East New York section of Brooklyn will accommodate 1500 students, as well as offer space for many community activities, such shared spaces as playground, sitting areas, a 350-seat theater, gymnasium, community room and open lunchroom for large community meetings.

All common spaces are to be on the first floor. Students will enter the kindergarten and classroom complex on the second floor via wide ramps from the outdoor play areas. The teaching complexes are the equivalent of seven separate kindergartens and nine groups of four classrooms each for the other grades. Each complex is designed with its own study rooms, team-teaching office, toilets and outdoor play deck at the mezzanine level. Construction is mainly of steel and concrete with a barrel roof 25 feet high.

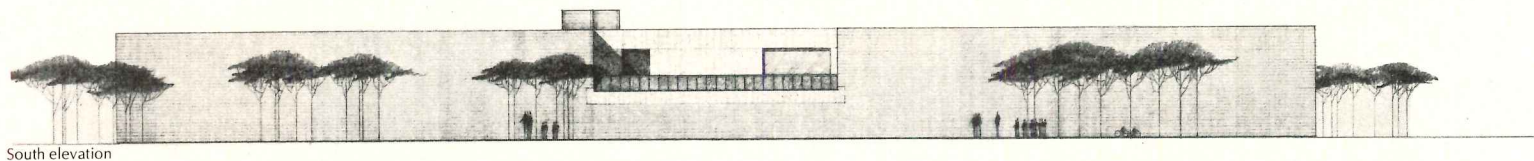
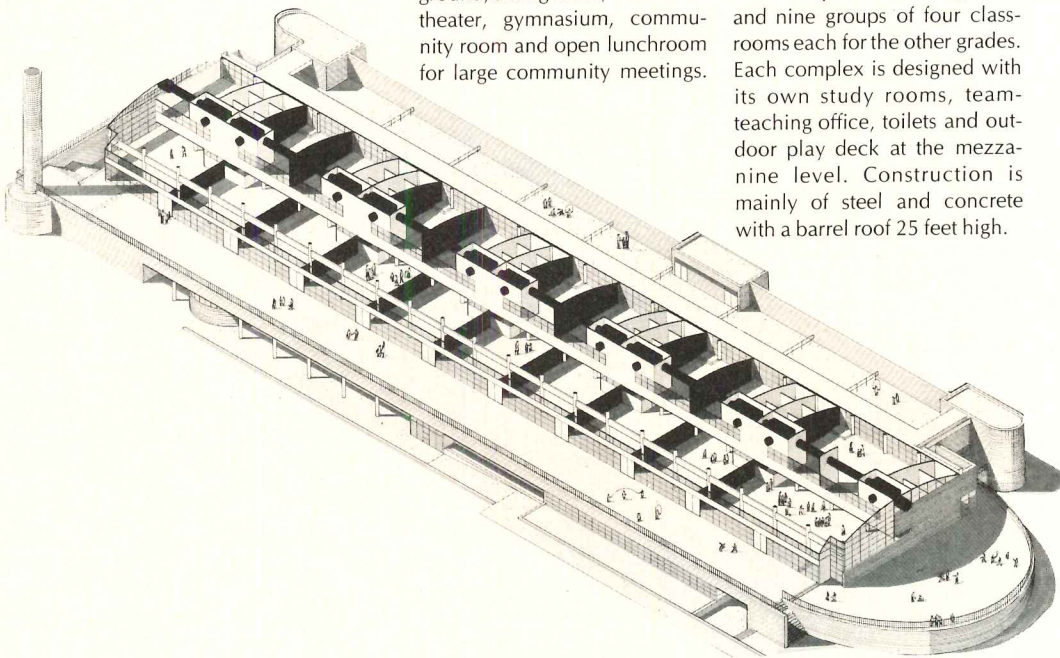

South elevation

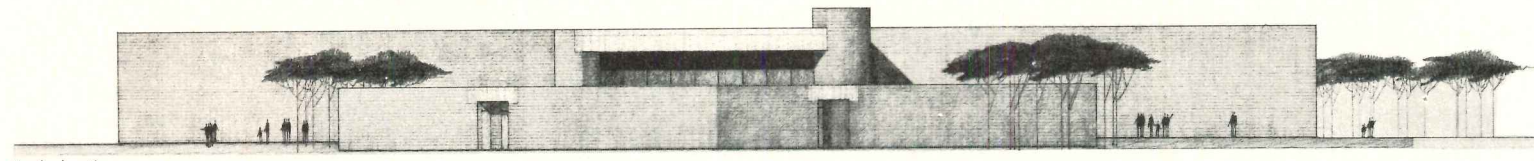

North elevation

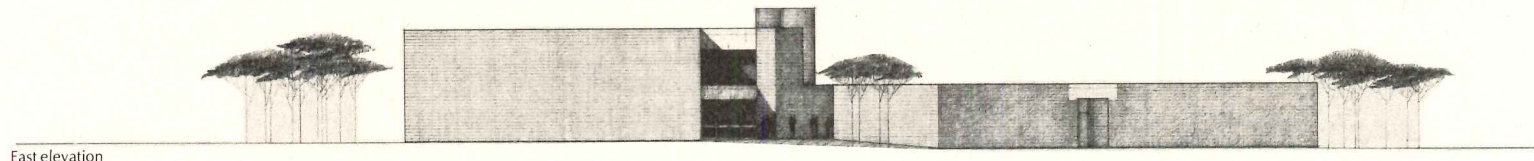

East elevation

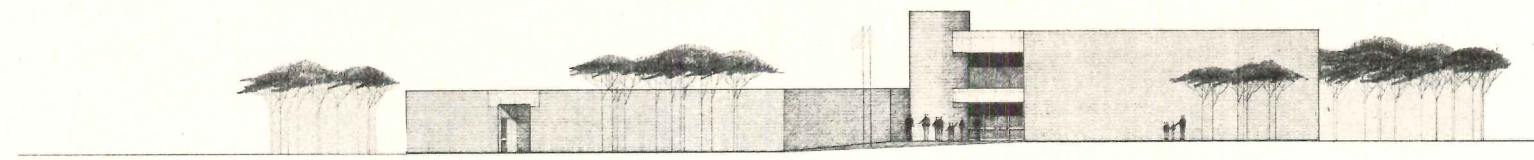

West elevation

**San Antonio Boys Club in Model Cities district**

Martin and Ortega Architects, in association with Haywood Jordan McCowan Incorporated, have designed this boys club now under construction on the west side of San Antonio, in a Model Cities district inhabited primarily by Mexican-American

cans. The buildings will be adjacent to a creek that is being upgraded by the U.S. Corps of Engineers into a linear, pedestrian park. Two entrances to the club are located on the east and west of the central control area (see plan), linking the new creek



## Condominium by the sea—almost

This current project of architects Wheatley/Whisnant Associates for a water-sports-minded developer in North Carolina borders Lake Surf, 1200 acres of inland "sea" equipped with—among other gadgets—a million and a half dollar wave machine capable of generating 6-foot waves with the proper curl for surfing. Then there is the water skiing machine that tows 52 skiers simultaneously ("Think of the pileups," says Murray Whisnant). Finally, the developer has called for a peninsular driving range from which golfers will drive balls out into the water and have them dredged in by a submerged net. Presumably, non-mechanical swimming and sailing can be accommodated.

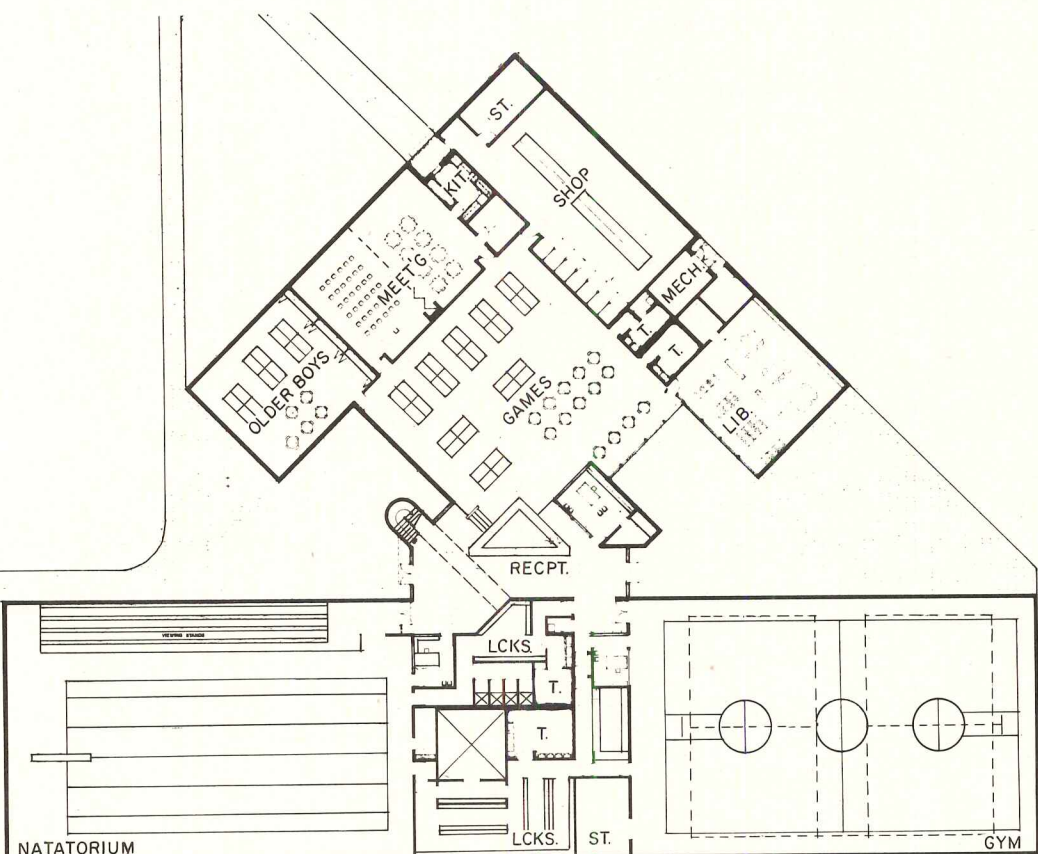
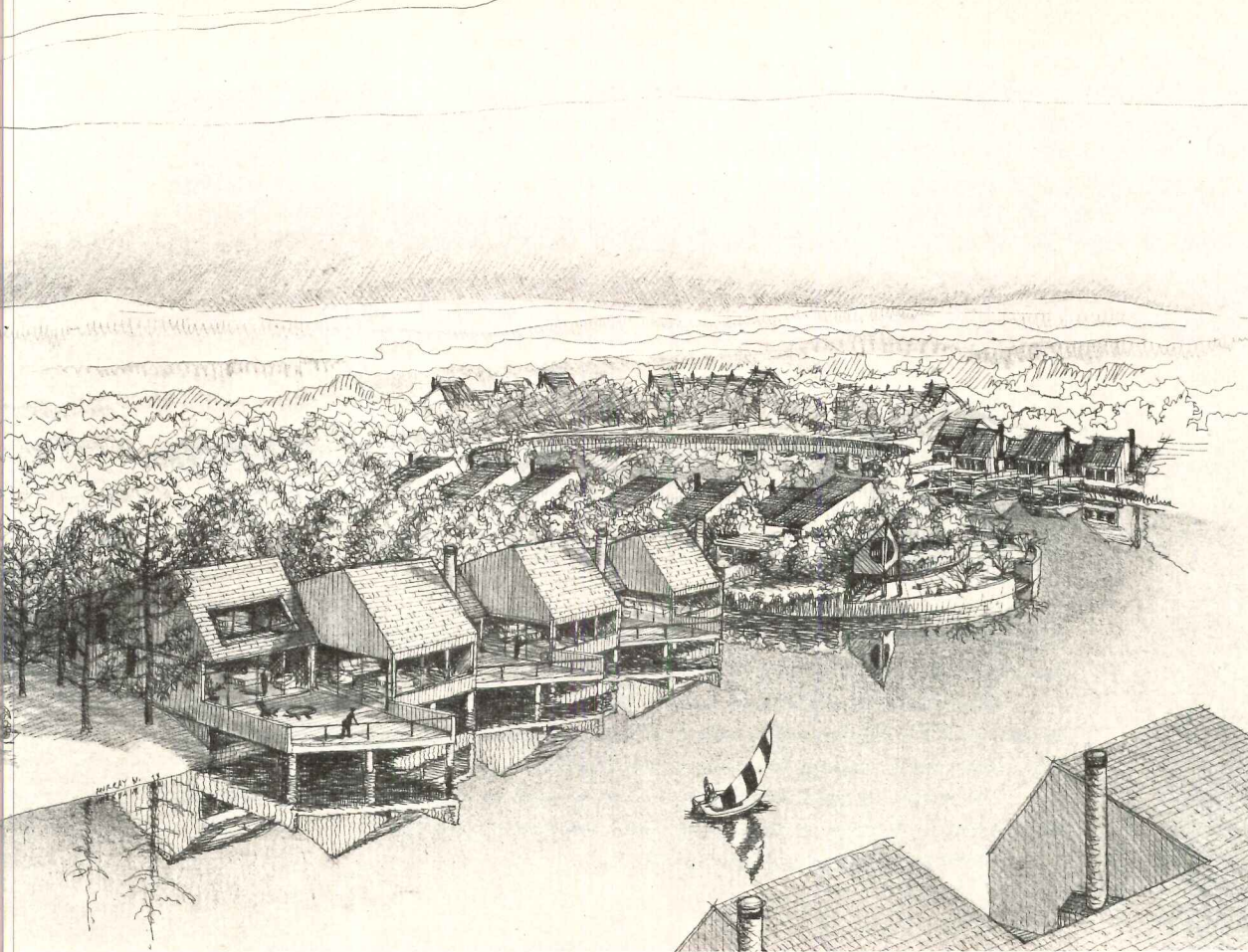

park (right of plan) and the main access road (left of plan). The entries are also located north of the natatorium/gym mass in an effort to minimize the activity and noise impact on the adjacent residences to the south. The open plan allows maximum

control and supervision of entrances, as well as access points to meeting rooms, shop, library, swimming and gym area. Maintenance and security precautions determined the predominantly solid structure with limited glass areas.

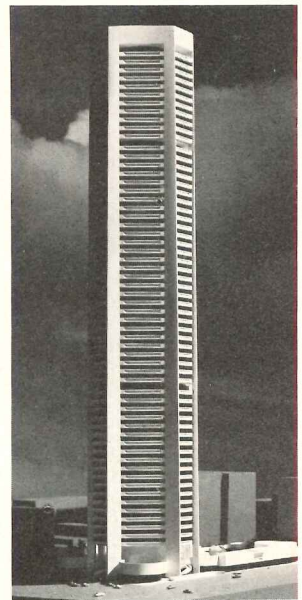

## Australian "super block" to rise in Sydney

Harry Seidler and Associates are the architects for the MLC Centre project to be built in Sydney, and including this 64-story concrete tower for which Pier Luigi Nervi was the consultant. The building will stand on eight massive columns which taper as the loads and stresses diminish. The 800-foot-high reinforced concrete structure will cover a minimum of the site, 20 per cent, leaving the remainder of the land available for pedestrian plazas. Precast concrete—with white quartz chip aggregate—will sheath the tower.



# CHUTE-FED REFUSE PACKER SYSTEM ENDS HIGH RISE INCINERATOR PROBLEMS!

**NEW LOW-INVESTMENT DISPOSAL SYSTEM COMPACTS AND STORES MORE REFUSE IN LESS SPACE WITH LESS COST!**

Now builders and owners can say good-bye to smoky, sooty incinerators and the headaches of meeting strict air pollution standards.

New Dempster high-speed compaction systems meet refuse output of even the largest building. Chutes carry refuse to packers where it's compacted into enclosed containers and picked up by a local private hauler.

For expert counsel in planning a total system for your new building, write today for the name of your nearby Dempster Refuse Consultant.

Free brochure and literature available.

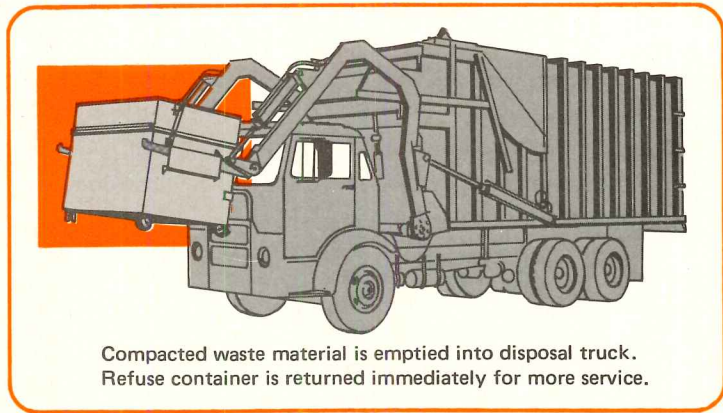
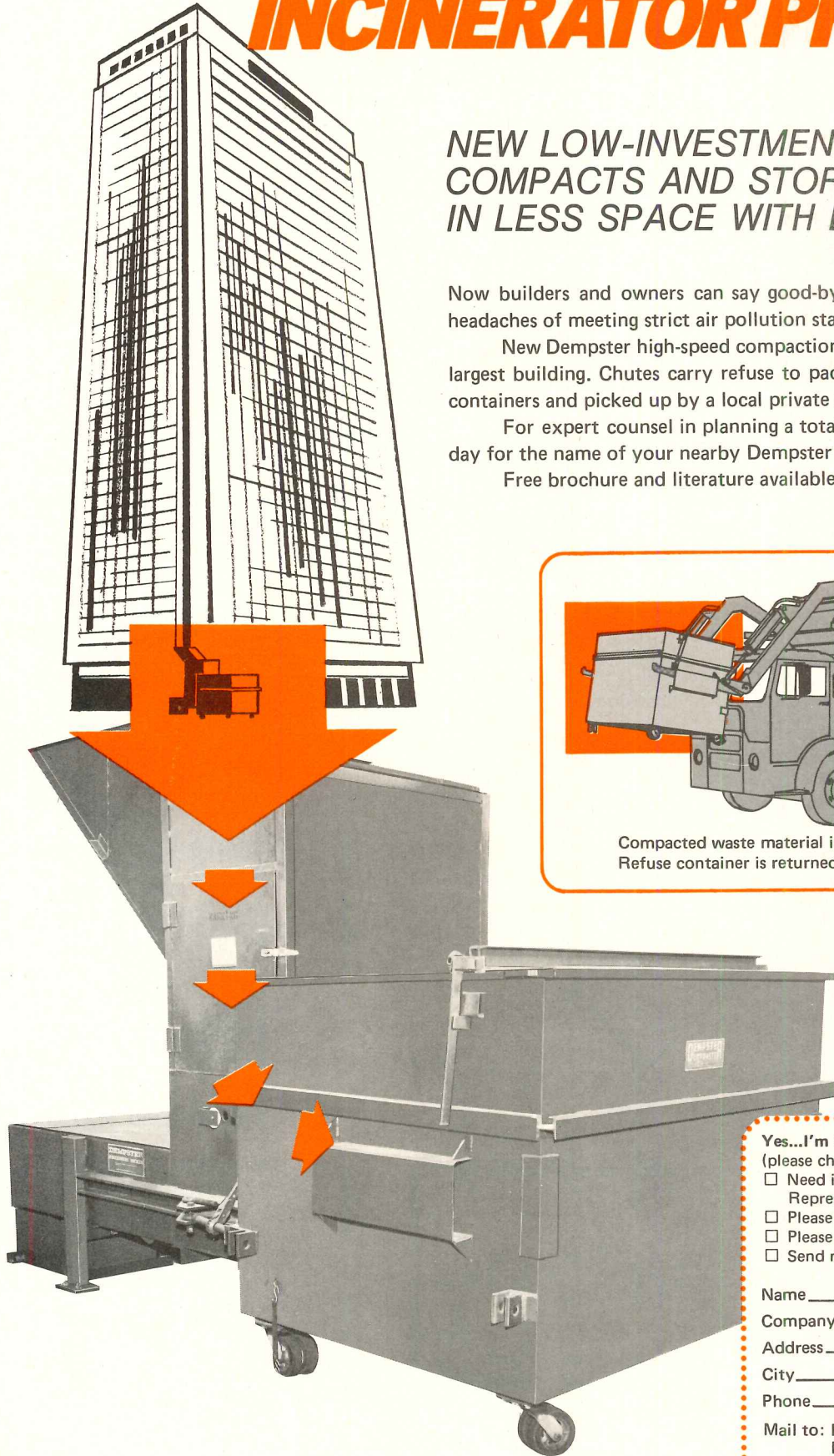

Compacted waste material is emptied into disposal truck. Refuse container is returned immediately for more service.

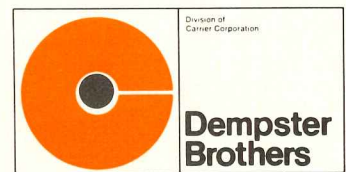

Home Office: P.O. Box 3127, Knoxville, Tennessee 37917  
Western Division: P.O. Box 5703, Compton, California 90221

**Yes...I'm interested in chute-fed packer systems.**  
(please check)

- Need information right away. Have Dempster Representative call.
- Please send literature. AR-7-74
- Please send name of Dempster Consultant.
- Send name of dependable refuse hauler near me.

Name \_\_\_\_\_ Title \_\_\_\_\_

Company \_\_\_\_\_

Address \_\_\_\_\_

City \_\_\_\_\_ State \_\_\_\_\_ Zip \_\_\_\_\_

Phone \_\_\_\_\_

Mail to: Dempster Brothers, P.O. Box 3127  
Knoxville, Tennessee 37917

For more data, circle 27 on inquiry card



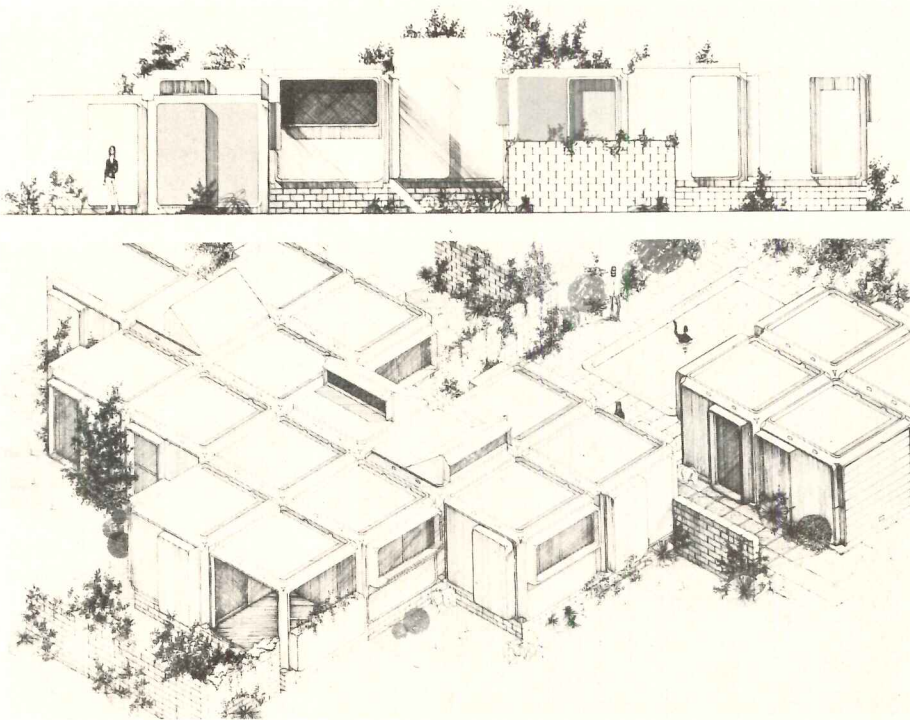

**Australian architect develops low-cost housing modules in fiberglass**

Australia has developed a new low-cost method of home building. The system, designed by a Queensland architect, could reduce the price of average Australian houses, apartments and small office blocks by at least 20 per cent, according to official sources.

The architect, Darryl Bennets, a graduate of the University of Queensland, is seeking markets in Australia, the United Kingdom, New Zealand, France, Indonesia, the Philippines, Japan, Taiwan, Vietnam, Singapore, Hong Kong, Malaysia, Kenya, Nigeria, Sri Lanka, the New Hebrides, Fiji, and the Solomon Islands. Development projects—which may include housing and resort accommodation—already are being con-

sidered by private groups in both Indonesia and Fiji.

An Australian company, Consolidated Mining Industries Limited which has an option to purchase the current patent applications, has declined to reveal details of the Indonesian and Fiji proposals. However, a spokesman said that overseas orders would probably be handled by factories established in "suitable areas" outside Australia.

Simply, the module itself consists of a 10 foot square cube with a floor, roof and open sides. In the actual mold, the module is made in two interlocking pieces for ease of transportation . . . each section like a big four-legged table.

The module walls, with

standard size openings that can be used either as a doorway, ceiling-height window, floor level window or vertical floor-to-ceiling louvers, are also mold-made.

At present, the modules are made of either fiberglass or concrete. A third, more lightweight system of "knock-down" modules using glass-reinforced concrete is also being investigated.

The modules can be combined (like putting together children's building blocks) in a large range of designs at either ground level or for multi-story construction. Many fittings, such as cupboards, electrical and plumbing services could be built in at the factory, according to Mr. Bennets.

**South Africa gains slightly in struggle for building regulations**

South Africa's 25-year-old battle to introduce a set of national building regulations has gotten a slight boost from the National Building Research Institute symposium in Durban. However, uniform national building regulations are still far away.

The South Africa Bureau of Standards (SABS), a co-sponsor

of the symposium, worked on a draft for 23 years before coming up with its standard building regulations in 1970—only to have the majority of local authorities reject them.

A major updating of the original SABS work will be undertaken with the hopes of determining regulations which

will apply on both national and provincial levels. But even if this is accomplished the consensus at the Congress is that it will be many years before uniformity is reached at any level—national or provincial—and that the lack of such regulations will continue to drain construction economies.

**Japan's "Operation Breakthrough" starts in fall**

The Ashiyahama project—about 300 miles west of Tokyo—involves construction of a modern housing complex of condominium buildings on a 244,000-square-yard reclamation site on the waterfront of Ashiya City near Osaka.

Ashiyahama (shown) is not necessarily the largest housing project in Japan, but its significance is that it is a government-sponsored public/private combination housing project being planned as a model of future low-cost urban housing developments.

Japan's construction ministry last summer sponsored the Ashiyahama Contest inviting leading contractor groups to present plans for the Ashiyahama housing complex, based on brand-new low-cost industrialized or pre-fabricated building systems developed especially for Ashiyahama. First place winner of the contest was the ASTM Group including Takenaka Komuten as general contractor and four equipment manufacturers.

ASTM's plan features: 1) A new modular system placing pre-fabricated concrete modular box units into slots of the

steel building frame. 2) Computerized planning of position and heights of individual buildings to assure adequate sunlight into each apartment unit. 3) Sidewalks and building entrances designed with slopes instead of steps for the benefit of aged and physically handicapped persons. 4) Vehicle roads and pedestrian walkways on two different levels for complete separation. 5) Plaza platforms for recreation and emergency evacuation of residents of high rise sections of buildings. 6) Centralized heating and hot-water supply system and centralized garbage disposal system by pipeline.

ASTM hopes to start construction in October. It will construct 46 condominium-type buildings ranging from 14 stories to 29 stories in height, accommodating 3,385 family units. Of the total 3,385 family units, about 600 will be constructed by private money and the rest by public money. ASTM will not necessarily complete the over-all Ashiyahama housing complex by itself; there could be another construction project by another contractor.

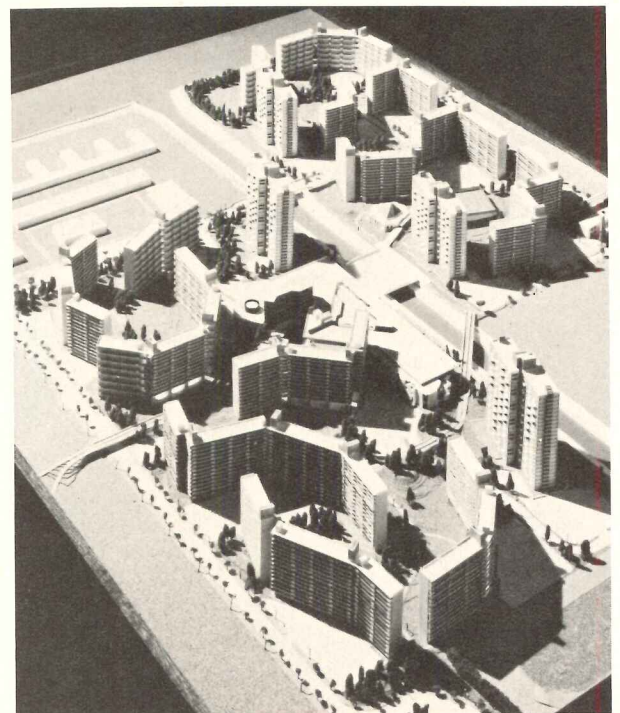



# A roof contract has to be strong to protect you for ten years.

When you specify a Celotex Inspection & Service Contract, what you're getting, in writing, is the assurance that Celotex will back up specific built-up roofing systems and services. With pre-installation planning, periodic inspections during and after installation, and the finest roofing materials.

That's a pretty strong promise. But we know we can keep it. That's why we give it to you in writing.

**Celotex™**  
BUILDING PRODUCTS  
The Celotex Corporation, Tampa, Florida 33622  
a **Jim Walter** company

*For more data, circle 72 on inquiry card*



### The Chicago Plan for all cities

*SPACE ADRIFT: Landmark Preservation and the Marketplace* by John J. Costonis; University of Illinois Press, Urbana, Chicago, London 1974, 207 pages, illus., \$10.00

Chicago could easily become the best test of the concepts of transferring the unused development rights, on sites containing older buildings which do not capitalize on allowable bulk, to sites on which new buildings are going to be built. The incentives are maximal in terms of buildings which are worth preserving for their architectural quality, and historic value in their role of being among the first American buildings with international design influence—not to mention the important visual context which they give to a plethora of recent construction. And they are minimal in terms of practical leverage. Without added development rights loop-zoning already permits the construction of so much floor space on a given lot, that the maximum is often not built. When full advantage has been taken it has resulted in buildings among the tallest in the world, including John Hancock's and Sears'. Ratios of floor area to lot area can reach 40 to 1. (The Empire State Building has a ratio of 25 to 1).

But it is exactly this battleground of conflicting values on which author John Costonis has chosen to illustrate that portable development rights could become a major tool in the salvation of architectural "touch stones", which are presently disappearing at an alarming rate in all urban areas. He cites the statistics: of the 16,000 structures listed in the Historic American Buildings Survey, over a third have been demolished. And that survey did not list the multitude of "background" buildings which have architectural interest but will never achieve a landmark categorization.

The subject of this book, *The Chicago Plan*, may not be able to save the less important buildings, because it ultimately relies on municipalities to make the commitment to individual buildings by enforcing its provisions through muscle. The affected owners can be expected to challenge all but the most obvious designations of historical merit. (The author sees the biggest dangers in the plan as government malfeasance and the challenge to the traditional concept of development rights being tied directly to their particular parcels of land.) Only voluntary transfer of development rights could probably save buildings of lesser than first quality, and that is not going to happen in many cases. While speculative owners of landmarks are not likely to quarrel with the accuracy of the amount calculated to represent their preservation "losses" for which they will



be reimbursed, the "thrill of the chase" is removed and ownership becomes a pre-determined pattern with no expectation of windfall profits at the end. The study deals primarily with buildings which are currently returning a profit to their owners—although not as much as desired. The ultimate reality is that only non-profit or government groups will be able to afford landmarks when increased maintenance costs outweigh feasibility, and the resale value of the building—which is further encumbered with preservation restrictions—will be increasingly lowered as cash-return disappears. The plan addresses itself to keeping buildings in active use for as long as they are tenable. Costonis is a professor of land-development law at the University of Illinois, and he "speaks the language" of the real estate entrepreneur, which makes the thoroughness of his study (backed by H.U.D. through the National Trust) unflinchingly realistic to the real estate-

oriented community and makes the technical portions difficult reading for the layman. He recognizes the inevitability of the profit motive taking precedence over public sensibility, and counters the problems with a system of highly sophisticated incentives to look for new methods of satisfying both sides (including an explanation of the failures of previous plans for development-right transfer such as New York's 1970 plan).

A large part of the book is devoted to the means of calculating what the owner's losses really are, how he will be reimbursed and what the resale value of the development rights will be. In the interests of making the plan palatable to the real-estate interests, losses are not restricted to the reduced value of land encumbered by a landmark. They take into account the amount of money that an owner could expect to make by fully developing his land within allowable zoning. Income at varying rates from differing square footages, floor area efficiency factors, debt service, maintenance, ultimate investment retrieval and many more factors are considered in the formulas producing the amount which is to be reimbursed. A free-market sale of development rights and a municipal bank involving intermediate government purchase are among the methods for carrying out the plan. Tax deductions on the landmark would equal at least the increased value of taxes on the site to which the rights have been sold.

A section on urban planning advocates more detailed zoning consideration in which areas of a city would be considered in the manner of a large scale development rather than on a uniform lot-by-lot basis. Appropriate relationships of buildings of various sizes would be considered, rather than a blanket bulk-allowance for the area. Even preservationists have criticized the plan on the basis of its producing uncontrolled growth and poor scale relationships, but the author has answered such questions in great detail.

—Charles Hoyt

### Also received

*GREENE & GREENE: Architects in the Residential Style*, photographs by William R. Current, text by Karen Current; Amon Carter Museum of Western Art, Fort Worth, 1974, 128 pages, illus., \$15.00.

This is a survey of important works of domestic architecture by Charles and Henry Greene, California architects of the early 20th century. The photographs and drawings are first rate.



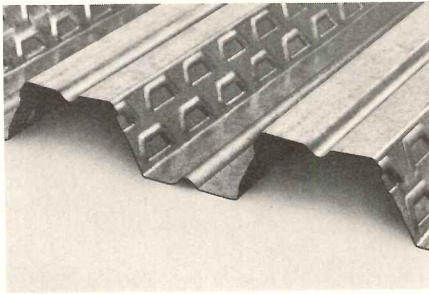

*The unique double embossing technique used on new COMDEK sheets is the key to the strong composite action that makes construction move fast.*

Efficient construction savings is what Granco's new COMDEK is all about. You save time because COMDEK's wide 36" coverage means fewer welds, less labor. You save again because no positive reinforcing steel is added. And you save concrete because the deep, double embossed rib indentations provide super positive composite action. Thus your pouring form becomes an integrated structural unit as concrete sets.

And, for greater economies, COMDEK is available in both 2" and 3" depths. Lengths to 45'.

Like to get down to specifics? Send for the new Granco COMDEK Catalog. Complete specs, fire ratings, and load tables. Write Granco, P. O. Box 40526, Houston, Texas 77040.

*For more data, circle 29 on inquiry card*

**Granco®**  
Building products that perform

 Granco Steel Products Co.  
Subsidiary of  
National Steel Corporation

# New COMDEK<sup>TM</sup> by Granco may simply be the simplest, most efficient composite deck system available today.

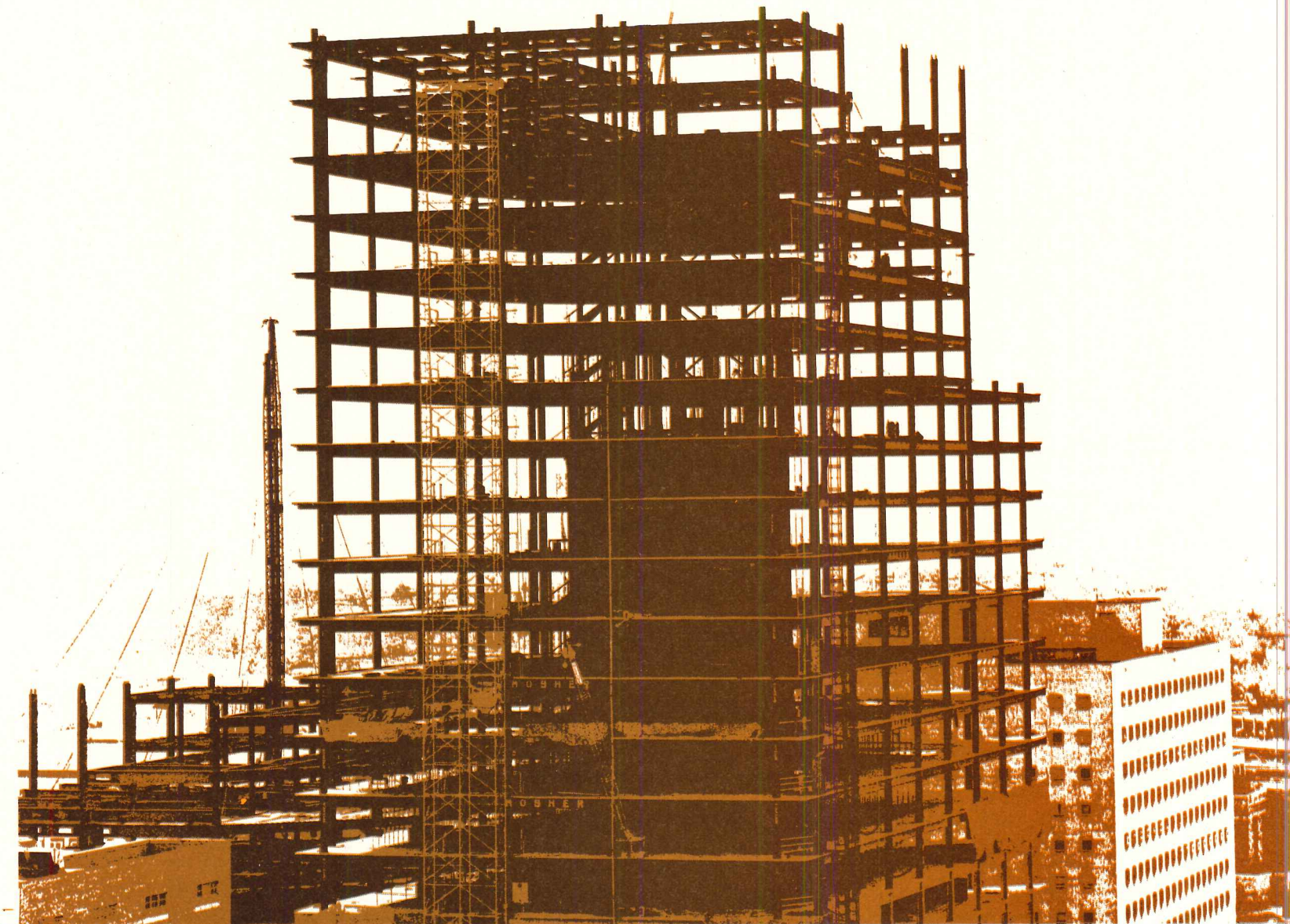



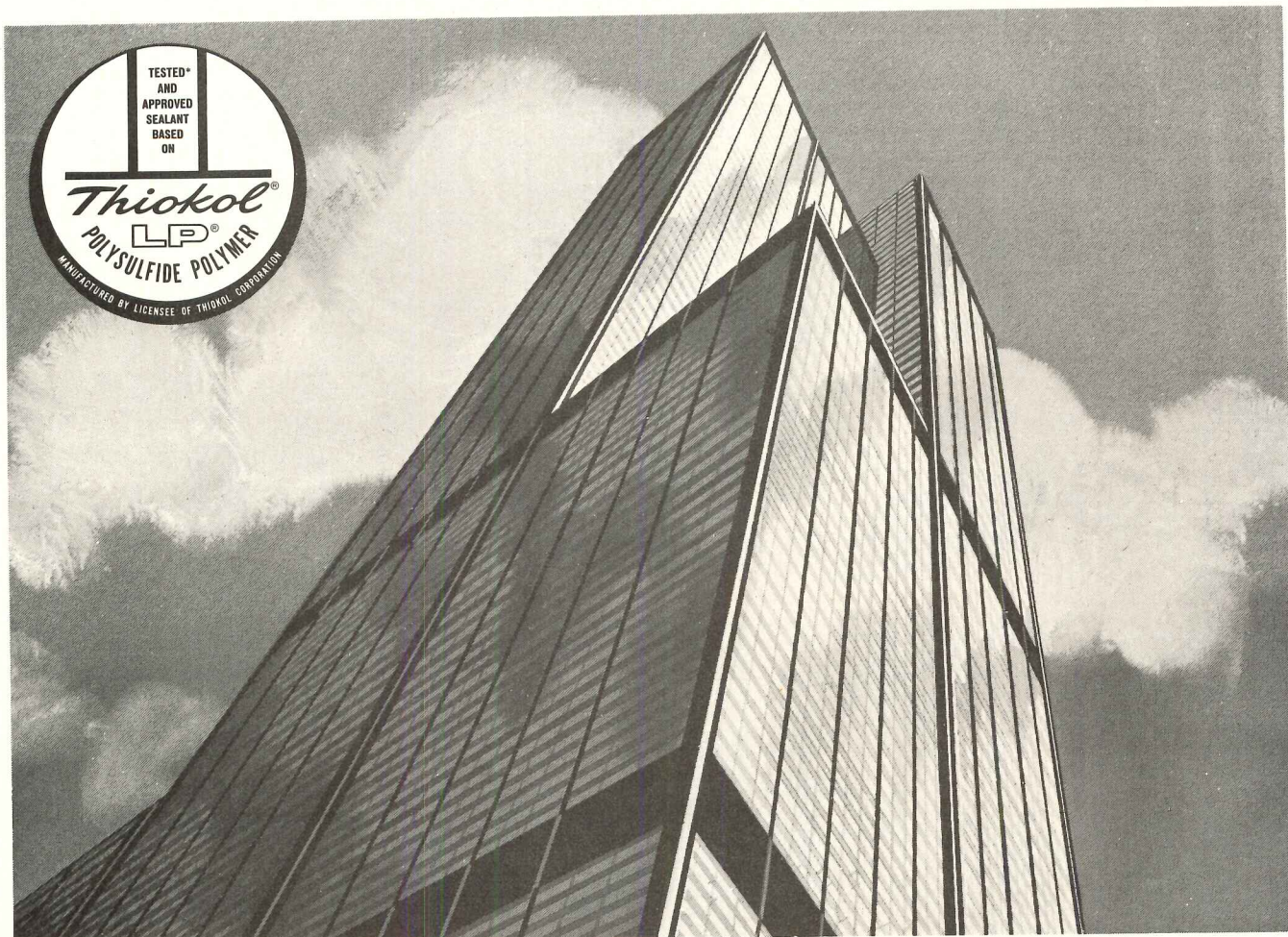

# Polysulfide sealants stick to your job year after year

Years ahead of competing materials, LP® polysulfide polymer base sealants continue to ensure waterproof and airtight construction joints in structures all over the world. For more than 25 years, polysulfide base sealants have been at work in buildings—keeping a tight bond, and preventing moisture and air penetration while expanding and contracting year after year with seasonal temperature changes.

You can't beat this experience record, but you can *buy* it in any of the more than 200 sealants made by 14 manufacturers covered by Thiokol's Seal of Security Program. This program subjects polysulfide base sealants to rigid performance tests conforming to the Thiokol Building Trade Performance Specification. Those that pass are certified as Tested and Approved and carry the Thiokol Seal of Security Emblem.

Specifying and properly applying one of the Tested and Approved one- or two-part polysulfide base sealants will pay dividends for years in providing a trouble-free airtight bond in joints in any kind of construction project, whether it is a high-rise prestige office building, a one-story merchandise warehouse, or a flagstone walkway. The tallest building in the world is built to last with polysulfide base sealants.

Look for the Thiokol Seal of Security—it means years of problem-free performance in construction sealant products properly applied. For highest proven reliability, it's LP polysulfide base sealants every time. Further information—and an answer to your sealant questions—can be obtained from Thiokol/Chemical Division, P.O. Box 1296, Trenton, N.J. 08607, telephone 609-396-4001.

# Thiokol

*Specialty Polymers • Off-Road Tracked Vehicles • Synthetic Fibers & Fabrics • Sprayers • Propulsion • Educational Services  
Disc Brake Pads • Ski Lifts • Pyrotechnic Devices • Closures • Rubber and Rubber Chemicals • Medical Electronics Equipment*

For more data, circle 30 on inquiry card



# Alcoa EZ Wall. A vertically textured facing that adds zest to wall surfaces.

The basic unit is a 12-in. striated aluminum extrusion. But there's no stereotype, no standard effect of these ribbed planks. Do you want a random effect? Alcoa® EZ Wall achieves it for you on fascia, interior wall decor, spandrels, column covers, or as curtainwall facing. If you seek a highly disciplined pattern, EZ Wall can achieve that, too, depending on the modular mix of components and colors chosen by the designer. The point is, it's individual. Re-

strained or free. A modular surface that goes with you. Complements surrounding architecture. Enhances the vertical dimension of the building. Available in Alumilite\* finish, Duranodic\* bronze tones, or the brighter palette of Super Alunalure® colors. And, surprisingly low in installed cost.

For detailed information, send for our EZ Wall brochure. Write to Aluminum Company of America, 1035-G Alcoa Building, Pittsburgh, PA 15219.

\*Trade Name

*For more data, circle 33 on inquiry card*

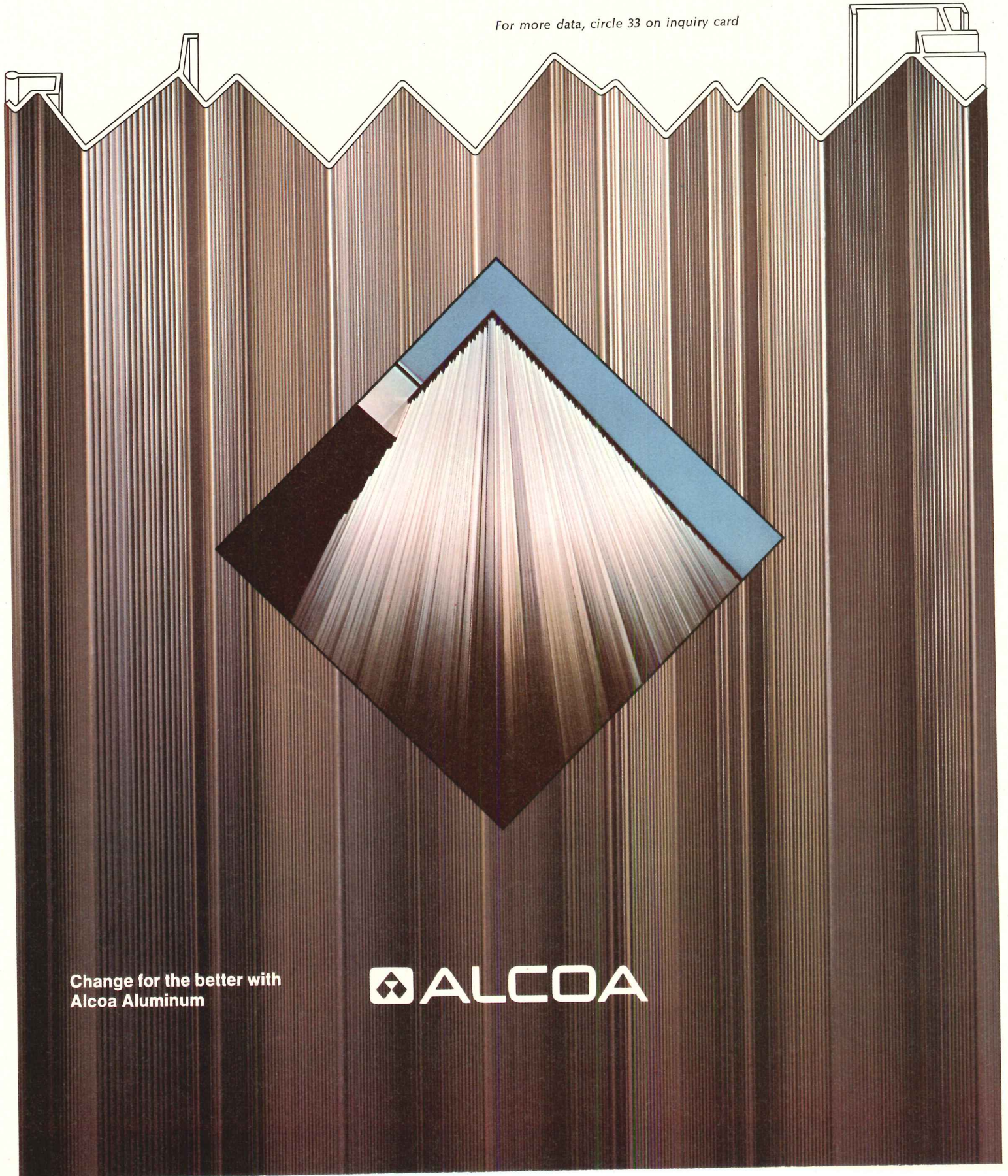

Change for the better with  
Alcoa Aluminum

 **ALCOA**



# The only organic roof that might outlast the Owens-Corning all-Fiberglas roofing system.

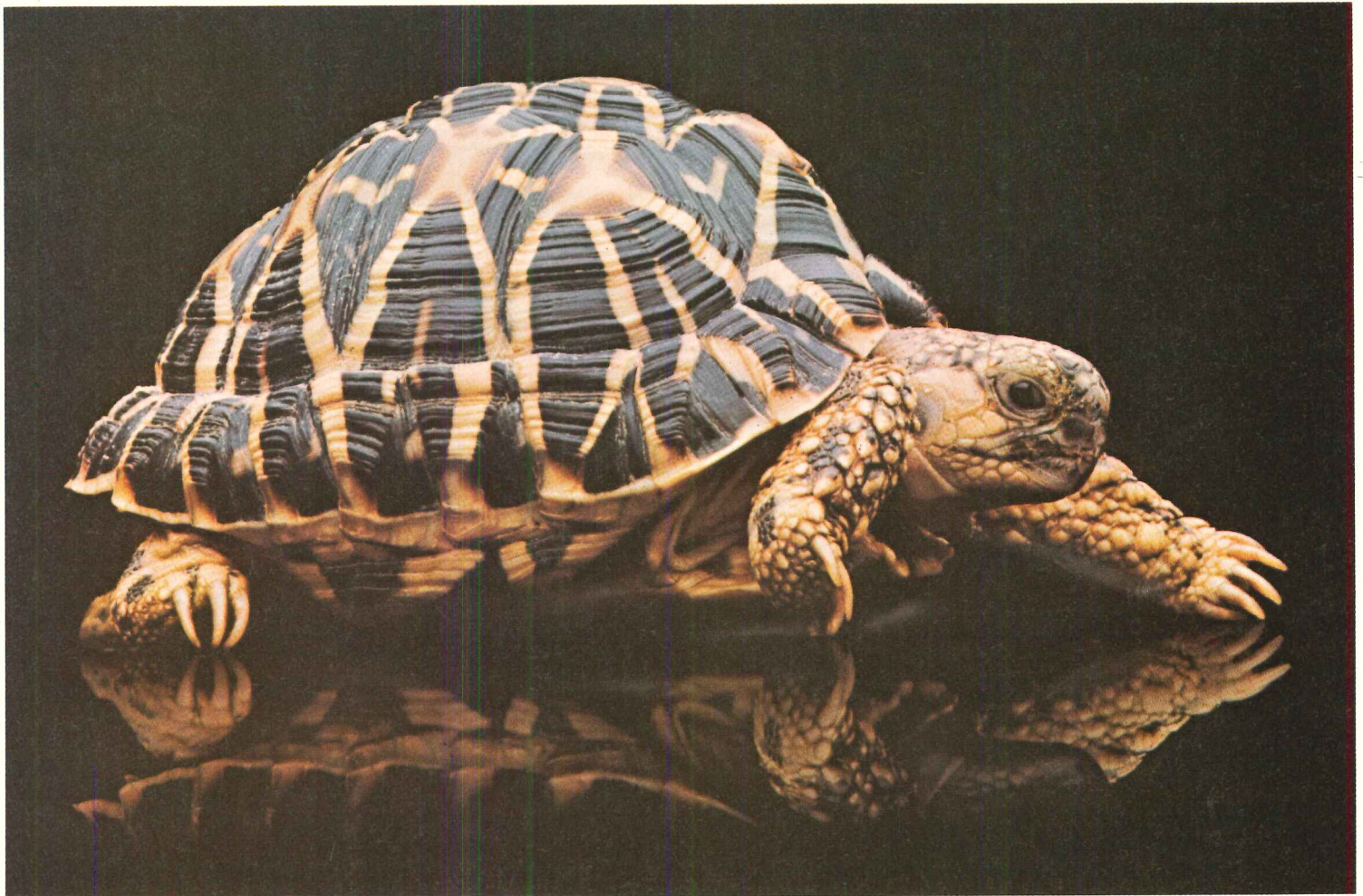

Conventional asphalt roofing systems have organic felts. So moisture and heat can cause them to curl, wrinkle, fishmouth, char and rot. And that can lead to an early failure.

Not so with our all-Fiberglas\* roofing system. Here's why.

**1.** It begins with Fiberglas Roof Insulation. This has a bottom surface that conforms to minor roof irregularities. And a top surface that stays flat. (FM Class 1 construction. UL 1, 2, and 4. Thickness from 15/16ths to 2¼ inches. C-value certification.)

**2.** Fiberglas Roof Tape then provides reinforcement at the roof

insulation joints and helps reduce failures caused by normal deck movement.

**3.** Fiberglas roofing felts come next. Unlike conventional felts, ours

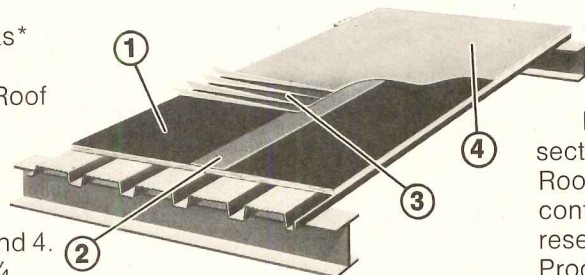

won't absorb or hold moisture. So they won't char or rot. They resist curling, wrinkles and fishmouths.

And they're less subject to contraction and expansion due to changes in moisture.

**4.** Fiberglas PermaCap (where available) tops everything off. It's surfaced with inert, non-combustible ceramic granules that help beautify the roof.

More information? Refer to our section in Sweets Catalog, Built-Up Roofing Systems 7.1/Ow, or contact your Owens-Corning representative. Or write: Architectural Products Division, Attn.: Mr. D. N. Meeks, Owens-Corning Fiberglas Corporation, Fiberglas Tower, Toledo, Ohio 43659.

\*Reg. T.M. O.-C. F.

Owens-Corning is Fiberglas

OWENS/CORNING  
**FIBERGLAS**  
TRADEMARK ®

For more data, circle 34 on inquiry card



# Expect quality carpets And expect their





# to be Antron<sup>®</sup> nylon. look to last.

**The University of South Carolina** wanted their new College of Business Administration to provide an inspirational atmosphere for students. Style and quality weren't the only guidelines, however. Long-term appearance retention and low maintenance costs were also prime concerns. Their final selection was carpet with pile of Antron\* nylon. The wide style variety available made the rest of the job easy. Final choice: this ripple texture loop pile of "Antron" nylon continuous filament across 13,000 sq. yds. of classrooms, offices, conference areas, lounges and stairways.

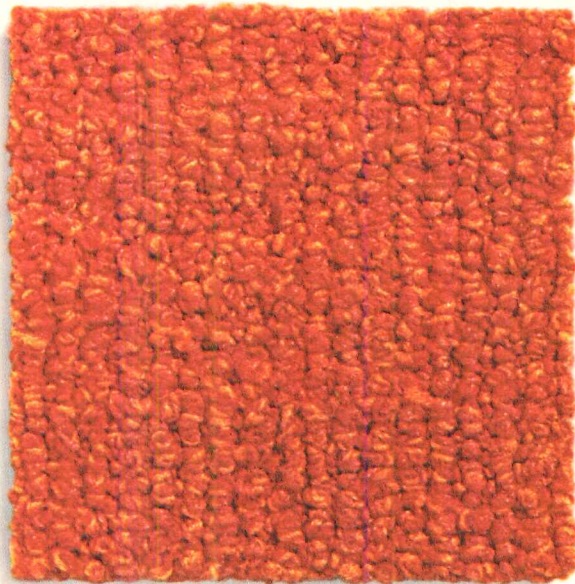

**What you see is what you'll get for a long time.** "Antron" is a soil-hiding carpet fiber. It is the leading commercial carpet fiber brand with more than twice the available styles in "Antron" than those made of the next brand. Its ability to diffuse light helps blend soil concentrations into the overall look of the carpet (normally they would show up as spots). Also, being nylon, "Antron" gives carpet exceptional durability and crush resistance.

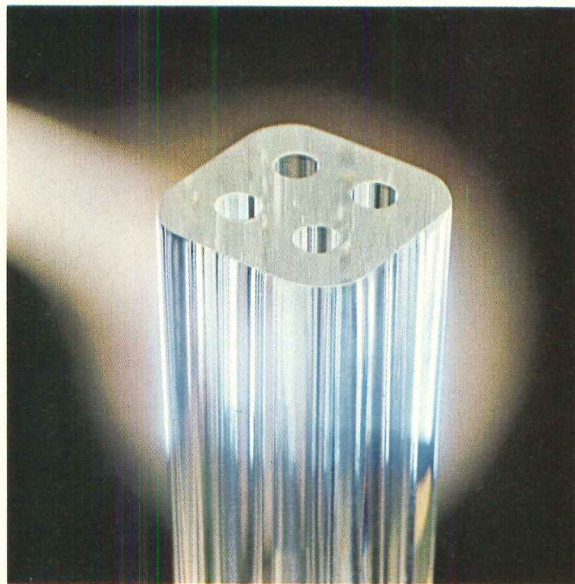

**How "Antron" keeps carpet looking fresh.** Its continuous filament structure is unique, as simulated in this greatly enlarged model. The four microscopic holes scatter light to minimize rather than magnify the dulling effects of soil, while maintaining an attractive, subdued luster. This property of the fiber, together with its remarkable wearability, helps the look of the carpet to last.

**NEW!** "Antron" III nylon for static control is now available in selected styles.



*For more data, circle 35 on inquiry card*

\*Du Pont registered trademark. Du Pont makes fibers, not carpets.



If we tried to solve all your material-handling problems with a single system, it would be like trying to fit square pegs into round holes. So we developed a wide range of systems, to fill the needs of virtually any hospital.

And we back our products with expertise that helps us tailor our material-handling equipment to your building instead of requiring that you plan your building to fit our systems.

We work with you to determine the best system or combination of systems for the job you want done. We gather facts and figures on costs and cost-savings. We design the system down to the last

nut and bolt — and can even employ computer simulation to prove that our plans will work as well in actuality as they promised to on the drawing board.

We supervise installation . . . train hospital personnel in proper and efficient use of the system . . . and remain on hand during start-up and operation to make sure all the bugs are out. To assure that they stay out, AMSCO offers you a nationwide network of service technicians for preventive maintenance or repair.

When it comes to material handling for hospitals, we may not have all the answers. But we're working on them.

# in material handling... we pick the system

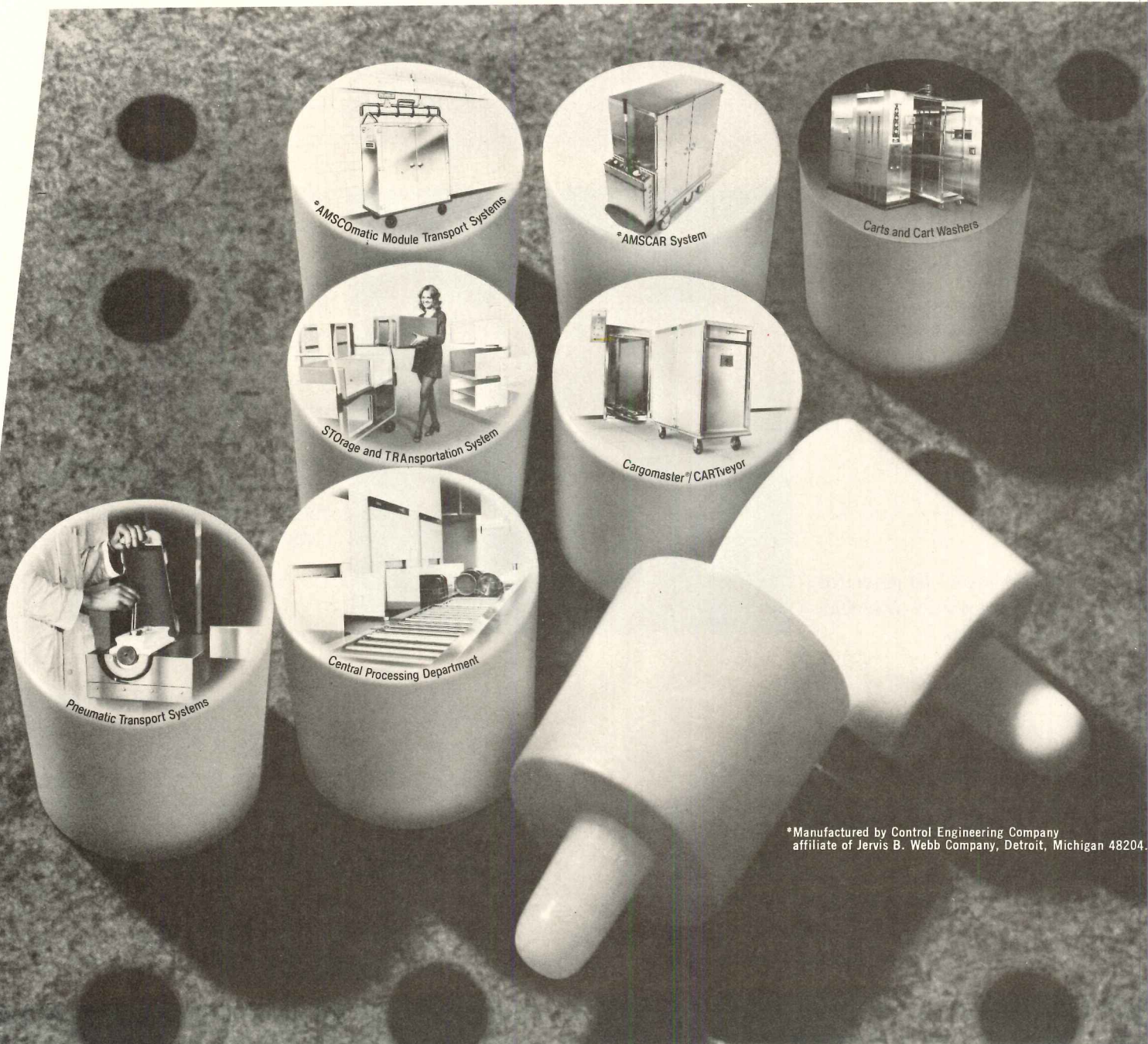

\*Manufactured by Control Engineering Company  
affiliate of Jervis B. Webb Company, Detroit, Michigan 48204.



Presenting AMTS — AMSCOmatic Module Transport System — the first overhead horizontal/vertical distribution system designed exclusively for hospitals. AMTS takes up to 50% less space than conventional overhead systems, which are based upon industrial design. Reduces cross-contamination, with carts that never touch the floor until they reach user-levels. Increases safety, with above-head-height carriers. Frees personnel for jobs more productive than cart-pushing. And with its half-ton capacity and selection of cargo-carrying modules, AMTS handles virtually all your hospital's distribution chores. AMTS. Another first from AMSCO Systems Company, pioneer in automated material handling for the health-care field.

**talk with us. we can help.**



**AMSCO  
SYSTEMS**

Division of American Sterilizer Company

*For more data, circle 36 on inquiry card*

# pegged to your needs

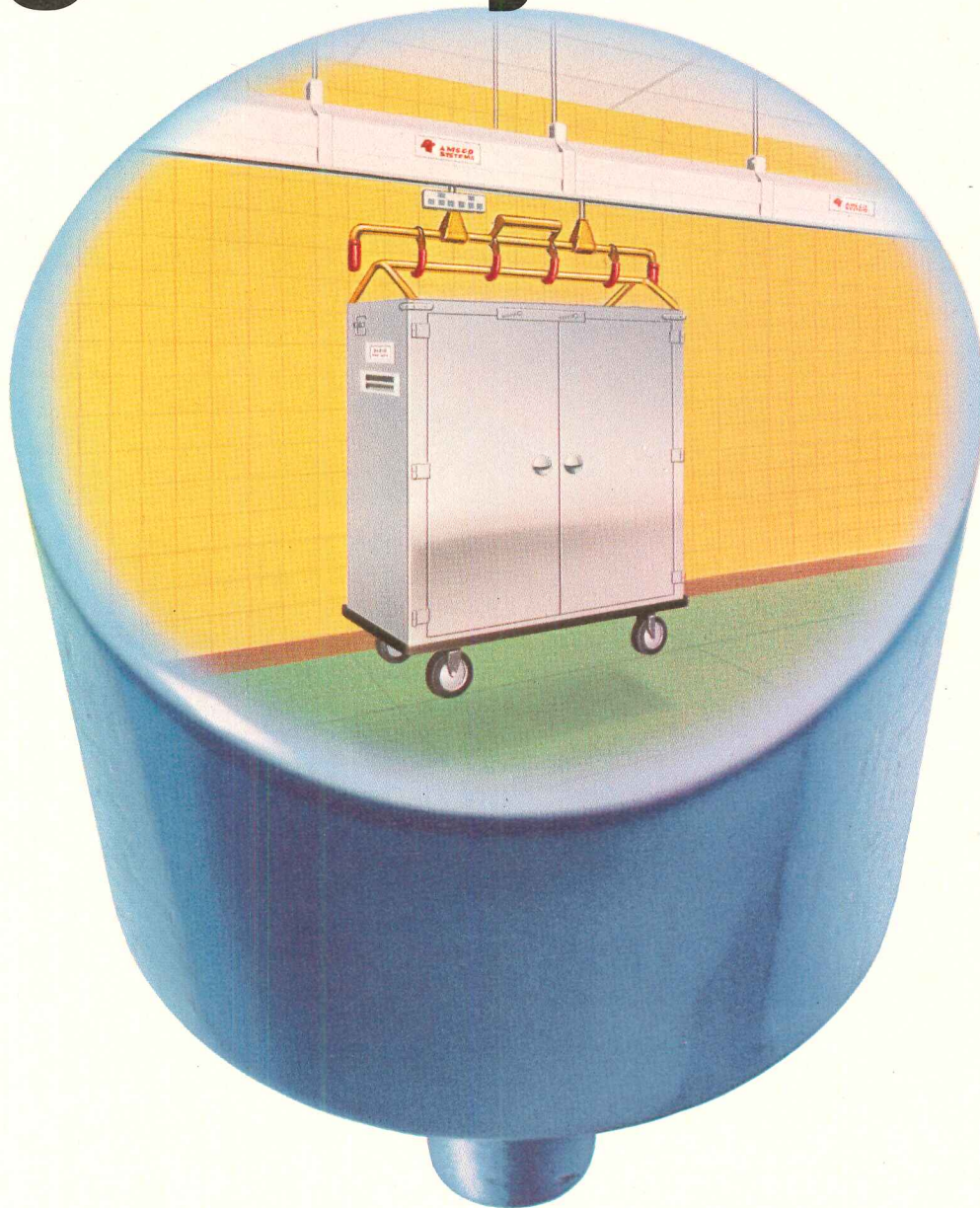



# This beach has the 3 essentials Owens-Corning has the system

1. Acoustically non-reflective "ceiling"



1. An acoustically non-reflective ceiling is a *must*—to keep sound from bouncing to other areas. An independent acoustical testing laboratory examined eight ceilings, including expensive coffered and baffled systems. Their verdict: Owens-Corning's Nubby II Fibreglas\* Ceiling Board (left) in any standard exposed grid suspension system is *best* for achieving speech privacy at economical installed cost.



\*Reg. T.M. O.-C.F.



# for speech privacy in open offices. that puts it all indoors.

2. Masking sound

3. Sound barrier "screen"

2. An unobjectionable background sound helps mask distracting speech. Special electronic speakers, installed in the plenum, make it possible to hear normal conversation clearly within defined areas, without being overheard in other areas.



3. A barrier or the proper acoustical *screen* is necessary to keep unwanted speech from going *directly* between work areas.

All three essential elements should be "tuned" to work together with the help of an acoustical consultant.

For further information and our free 16-page guide, "Achieving Speech Privacy in the Open Office," write: N. K. Meeks, Architectural Products Division, Owens-Corning Fiberglas Corp., Fiberglas Tower, Toledo, Ohio 43659.

Owens-Corning is Fiberglas

OWENS/CORNING  
**FIBERGLAS**  
TRADEMARK ©

For more data, circle 37 on inquiry card



**“With 1,604 tons of Weathertron®  
Winewood is now 100% General**

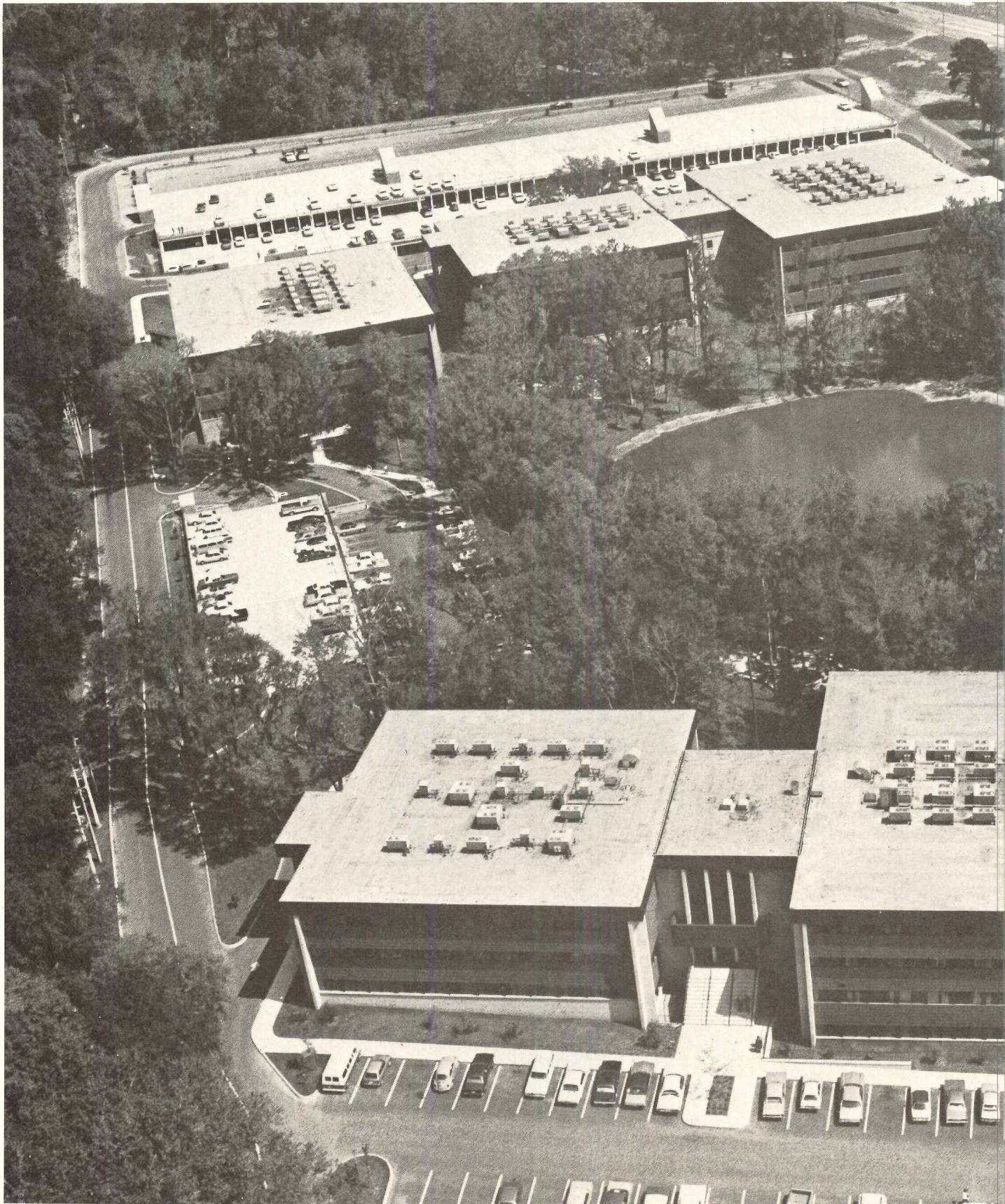



# Heat Pumps in 8 office buildings Electric. I wouldn't have anything else."

Bill Cartee, President & Chairman of the Board, The Winwood Companies

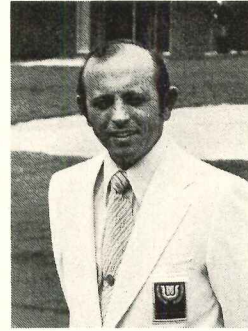

"The apartment complexes at Winwood have General Electric air conditioning throughout. Now I've installed their Weathertron Heat Pumps in all our office buildings.

"Why only GE? Two reasons. First, in my own home and in my developments for the past 12 years I've used General Electric and never had any cause to regret my choice. Second, the service I get from my GE dealer is just about the best anybody has a right to expect.

"Now, with the cost of fuel rising, I'm considering Weathertron Heat Pumps for the villas we're building at Winwood and the private homes we are constructing at Lafayette Oaks, another project here in Tallahassee.

"After all, the price is right, the product excellent, and the service on all installations is superb!"

Winwood Development occupies 287 acres two miles from the center of Tallahassee, Fla. When completed it will contain between 1,500 and 2,000 luxury apartments and villas. The 8 office buildings occupy 25 acres. A golf course, tennis courts and swimming pools complete the environmental arrangement.

Winwood's architect is Joseph N. Clemons, A.I.A. Winwood is served by Central Heating Consultants, Inc., who installed all air conditioning and heat pump units.

Bill Cartee is lavish in his praise of his General Electric dealer and you'll feel the same way about the GE dealer who serves you.

He's in the Yellow Pages under "Heat Pumps" or "Air Conditioning Equipment and Systems!"

**We're going to be in this business for a long time.**

GENERAL  ELECTRIC

For more data, circle 38 on inquiry card



Perma-Shield® Gliding Windows

# THE END OF

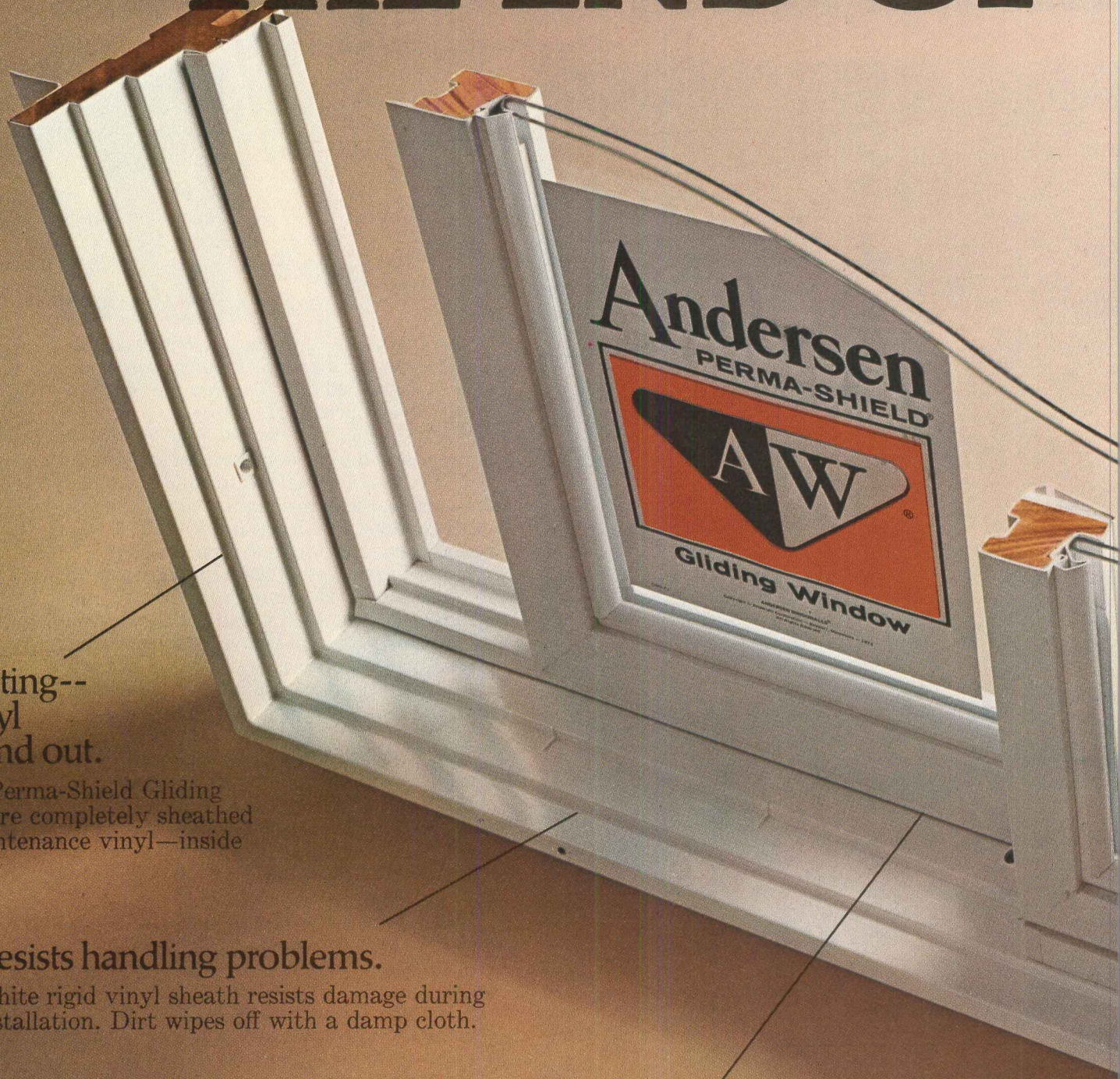

No painting--  
rigid vinyl  
inside and out.

Andersen Perma-Shield Gliding Windows are completely sheathed in low maintenance vinyl—inside and out.

## Resists handling problems.

White rigid vinyl sheath resists damage during installation. Dirt wipes off with a damp cloth.

## Easy operation.

Perma-Shield Gliding Windows slide open easily on chrome-plated steel glides. Andersen quality design insures a snug fitting window that resists sticking or binding.

Condominiums, apartments, motels, schools, office buildings, nursing homes—you name it. Perma-Shield® Gliding Windows complement almost any commercial or institutional building design. And because they have the same neat, trim lines as other Andersen™ Perma-Shield Windows and Gliding Doors, you have total project design flexibility.

For more information about Perma-Shield

Gliding Windows, see Sweets, File 8P. Or call your Andersen Distributor. He's in the Yellow Pages under "Windows, Wood." Or write us direct.

The beautiful, carefree way to save fuel.

**Andersen Windowalls®**   
ANDERSEN CORPORATION BAYPORT, MINNESOTA 55003

For more data, circle 39 on inquiry card



# WINDOW PAINS.

## Fuel savings.

Beneath Perma-Shield Gliding Windows' rigid vinyl sheath lies a wood core, one of nature's best insulators. And with double-pane insulating glass, Andersen Windows can reduce conducted heat loss by up to 35% (compared to single-glazed windows without storms).

## Security.

Spring-loaded rods provide positive locking of window at top *and* bottom. Factory installed, with attractive operating handle.

## Weathertight design.

Perma-Shield Gliding Windows are two times more weathertight than industry standards. Factory applied weatherstripping is rigid vinyl.

## Low maintenance insulating glass.

Only two glass surfaces to clean—no more maintenance than a single light of glass. And sash can be removed so cleaning can be done from the inside.

## Easy installation.

Perma-Shield Gliding Windows come completely assembled for easy installation in all types of wall construction. Continuous installation fin eliminates need for separate flashing. Fin can be removed where wall construction requires. No hardware to apply or lose.



“After 4 years of typical Holiday Inn traffic, carpet would be threadbare.”

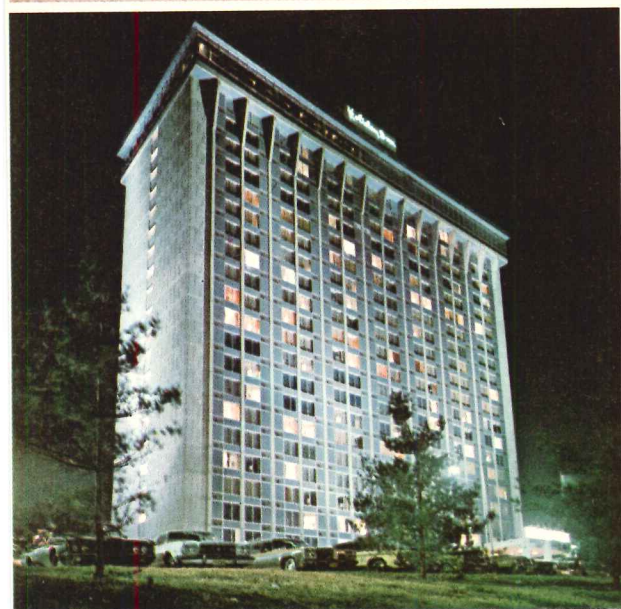

## Tuff-Lite<sup>®</sup> epoxy terrazzo is doing beautifully with a weekly wet mopping.”

Jay King, Chief Engineer, City Line Holiday Inn<sup>®</sup>-Philadelphia

Ease of maintenance and predictable cost of maintenance were important considerations when City Line Holiday Inn-Philadelphia was in the planning stage. They still are.

And its Tuff-Lite epoxy terrazzo flooring by the H. B. Fuller Company is living up to expectations.

Carpeting would have been spot cleaned many times, completely cleaned several times and possibly replaced. Other than mopping, Tuff-Lite requires just a programmed semi-annual seal treatment.

H. B. Fuller also supplies light-weight, epoxy-based wall matrix for beautifully textured interior and exterior walls.



For help with specifying, selection or application information call our toll free number — 800/323-7407.

 **HB FULLER COMPANY**

Architectural Products Division  
315 S. Hicks Rd., Palatine, Ill. 60067, Dept. 526

For more data, circle 23 on inquiry card



# Many new roofs waste a lot of energy. Here's how to cut that loss by 50 percent—without spending an extra dime.



It may sound amazing, but you can do it.

The only thing you have to do is specify thicker 2¼-inch Fiberglas\* roof insulation instead of the thinner 15/16th-inch size.

This dramatically reduces heat loss through your roof. And it actually brings the total cost of your building *down!*

The reason: the improved thermal performance of your roof enables you to get along with less elaborate, *less expensive* heating and cooling equipment.

In general, every dollar you spend on thicker 2¼-inch roof insulation

vs. 15/16th-inch size cuts up to two dollars off original equipment costs. So you come out considerably *ahead.*

On a suburban office building in northern climates, for example, thicker roof insulation could save as much as \$27,000 in equipment costs for every 60,000 square feet of roof.

And, of course, the thicker Fiberglas roof insulation goes on slashing the loss of fuel energy through the roof of your building by 50 percent—and the fuel *bills* by roughly 10 percent—year after year.

The exact savings vary according to climate zone, the size and type of roof deck, "U" improvement, and the added cost of the thicker insulation.

We've worked up all the figures and charts in a handy booklet called "Roof Raiser's Guide to Cost Reduction." For a free copy, write: I. X. Meeks, Architectural Products Division, Owens-Corning Fiberglas Corp., Fiberglas Tower, Toledo, Ohio 43659.

More details: See our section in Sweets Catalog, Roof Insulation Systems 7.15/Ow, or contact your Owens-Corning representative.

\*Reg. T.M. O.-C. F.

Owens-Corning is Fiberglas

OWENS/CORNING  
**FIBERGLAS**  
TRADEMARK ®

For more data, circle 40 on inquiry card





McDonald's.



Midas Muffler.



Days Inn.



National Tea.

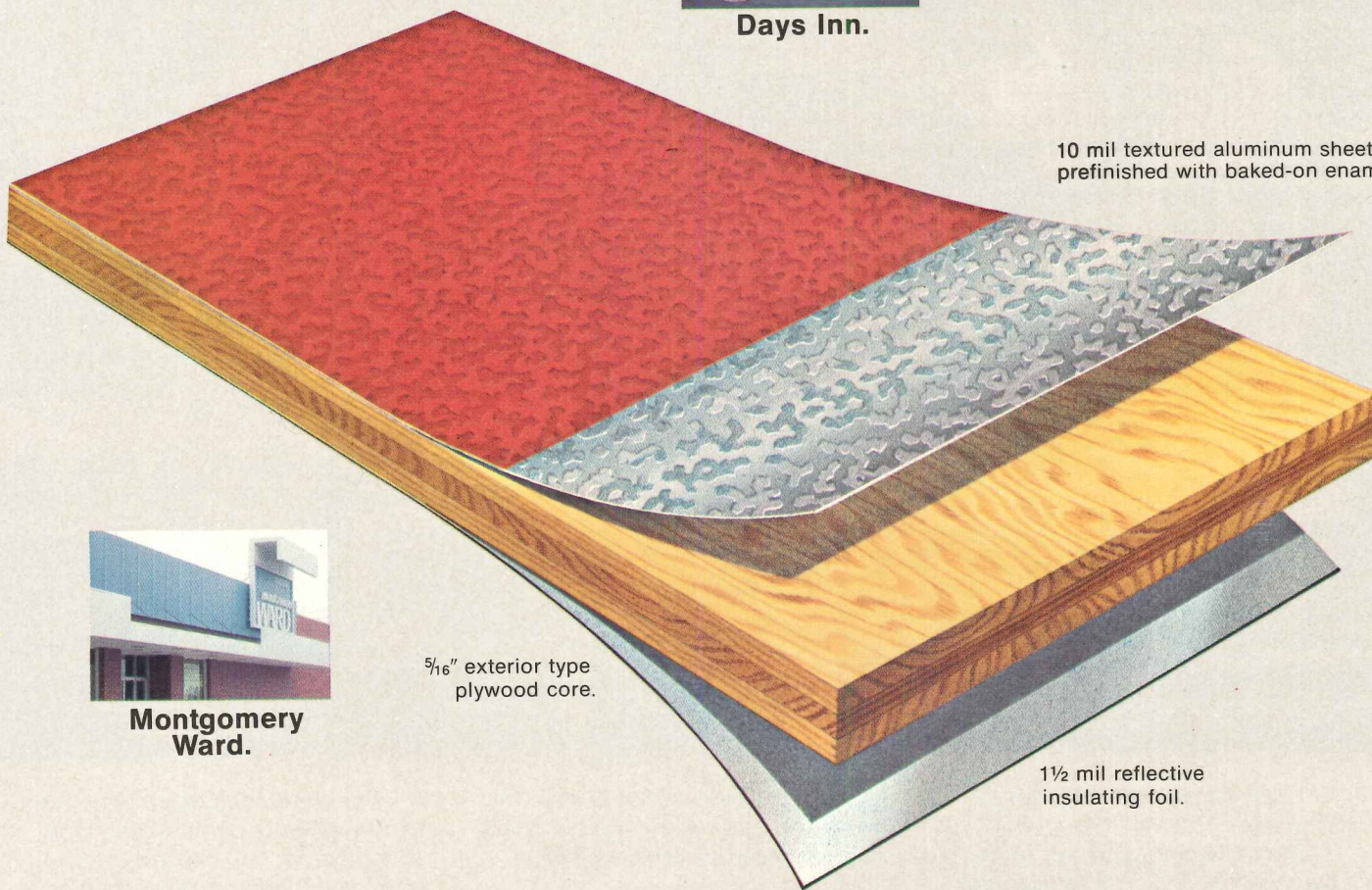

10 mil textured aluminum sheet, prefinished with baked-on enamel.

5/16" exterior type plywood core.

1 1/2 mil reflective insulating foil.



Montgomery Ward.

## Weyerhaeuser Panel 15. For clients who are shrewd, thrifty and famous.

Here are a few reasons why chain operations are sold on Weyerhaeuser Prefinished Siding/Panel 15.

McDonald's. Because Panel 15 costs less than glass, looks terrific with brick and can be cut and fitted on site by ordinary carpenters.

Midas. Because Panel 15 is a complete system, with twenty

accessories (end cap to frieze mold) to finish up beautifully.

Days Inn. Because the double-faced aluminum panel makes a tough, almost maintenance-free spandrel that can take a beating inside and out.

The list goes on.

Panel 15 has a low-maintenance finish guaranteed for 15 years.

Panel 15 has a UL Class II fire hazard rating.

Panel 15 is three materials in one. (Exterior finish, sheathing and insulation.)

Examine the remarkable, fifteen-year guarantee and the selection of great colors in the new Panel 15 booklet.

Send the coupon or check your Sweet's file.



Weyerhaeuser



# OFFICE NOTES

## New firms, firm changes

**Raymond Scott, Architect** has announced the opening of his office located at 83 Madison Avenue, Memphis, Tennessee.

**Perkins & Will**, architects, have moved their New York offices to 488 Madison Avenue, New York City.

Announcement of a new architectural-planning, engineering firm, **Mayer, Garfield, Gawron & Associates** was made recently. Their offices are located at 1740 Westwood Boulevard, West Los Angeles, California.

Gin D. Wong, FAIA, principal of William L. Pereira Associates since 1958, has announced the formation of his own planning and architectural organization, **Gin Wong Associates**, with headquarters at 5900 Wilshire Boulevard, Los Angeles.

**Anselevicius/Rupe/Associates**, Architects, St. Louis, Missouri, announced the opening of an office at 102 Raymond Street, Cambridge, Massachusetts.

**Bottelli Associates**, Architects/Planners, have moved to new offices at 26 Columbia Turnpike, Florham Park, New Jersey. The firm has recently expanded through the merger of Bottelli Associates, New York City and Bottelli & Martins, Maplewood, New Jersey.

**Robinson and Mills**, architecture and planning, have moved to new offices at 10005 Sansome Street, San Francisco, California.

**Richard I. Shope**, formerly of Jacobson & Shope Architects, has announced the opening of his new office for the practice of architecture, land use planning and related disciplines, located at Diamond Block, Helena, Montana.

The firm of Francis X. Gina & Partners, Architects, has been succeeded by **Gina, Levi, Treffeisen**, Architects. The firm will continue in the practice of architecture at 219 East 44th Street, New York City.

Lawrence L. Smith, has announced the establishment of the firm of **Lawrence L. Smith Associates**, 350 Vanderbilt Parkway, Haugepauge, New York.

**Kajima Associates** has announced its relocation to new offices at 299 Park Avenue, New York City.

**Herbert Cuevas**, has announced the moving of his office to 480 North First Street, San Jose, California.

**Walk Jones + Francis Mah Incorporated** have moved to new offices. Mailing address is P.O. Box 171206, Memphis, Tennessee.

Keith Parker and Jeff Krehbiel, architects, have announced the formation of **PKA, Parker Krehbiel Associates**, 1021-1 East Waterman, Wichita, Kansas.

*more office notes on page 202*

### Addendum

In the May 1974 issue, on page 41, the Vacía Talega new community in Puerto Rico was described as masterplanned by William L. Pereira Associates. It should be noted that the master plan was a joint effort with Basora & Rodriguez, Engineers Architects Planners of San Juan.

## Where to get Panel 15.

- NORMENT GLASS COMPANY  
P.O. Box 6129  
Montgomery, AL 36106
- FELIX THOMSON CO.  
4310 South Phoenix  
Ft. Smith, AR 82901
- MICHAEL ZAGORSKY, LTD.  
626 Clyde Avenue  
West Vancouver, BC
- ALUMINUM SERVICE, INC.  
3611 Chestnut Street  
Tampa, FL 33607
- ALUMINUM BUILDING PRODUCTS CO.  
1661 Chattahoochee Ave. N.W.  
Atlanta, GA 30325
- COOPER-WEIR, INC.  
P.O. Box 26023  
New Orleans, LA 70126
- BENOIT, INC.  
635 N. Prior  
St. Paul, MN 55104
- STRUCTURAL WOOD CORPORATION  
1538 White Bear Avenue  
St. Paul, MN 55106
- EASLEY & EASLEY  
P.O. Box 8095  
Jackson, MS 39204
- THRASHER COMPANY  
P.O. Box 4477  
Jackson, MS 39216
- PANELS PLUS  
103 Bennington Avenue  
Kansas City, MO 64123
- THE PORCEL COMPANY  
6506 Pernod Avenue  
St. Louis, MO 63139
- STANDARD PLANNING MILL COMPANY  
1040 N. 11th Street  
Lincoln, NB 68501
- MILLARD LUMBER COMPANY  
P.O. Box 37445  
Millard, NB 68137
- BALLARD APPLIANCE & CABINET  
1238 Hendersonville Road  
Asheville, NC 28803
- H & S LUMBER COMPANY, INC.  
520 West Summit Avenue  
Charlotte, NC 28201
- PRITCHARD PAINT & GLASS  
Box 2897  
Durham, NC 27705
- PRITCHARD PAINT & GLASS  
Box 2886  
Raleigh, NC 27602
- DAKOTA PLATE GLASS  
1203 Main Avenue  
Fargo, ND 58102
- AL DISDERO LUMBER COMPANY  
P. O. Box 42247  
Portland, OR 97242
- WIN-DOR MANUFACTURING CO.  
P.O. Box 1243  
Myrtle Beach, SC 29577
- VIKING GLASS, INC.  
1413 A Avenue  
Sioux Falls, SD 57101
- JONAKIN BUILDING SPECIALTIES CO.  
P.O. Box 726  
Chattanooga, TN 37401
- STEEL & ROOF STRUCTURES CORP.  
P.O. Box 12232  
Memphis, TN 38112
- HADEN COMPANY  
2707 Statsuma  
Dallas, TX 75234
- R. M. RODGERS, INC.  
P.O. Box 35311  
Houston, TX 77035
- COAST SASH & DOOR CO.  
P.O. Box 1777  
Tacoma, WA 98401

**Weyerhaeuser Company,  
Box B-2082  
Tacoma, Washington 98401**

Please send me the Panel 15 booklet and guarantee.

Name \_\_\_\_\_

Firm \_\_\_\_\_

Address \_\_\_\_\_

City \_\_\_\_\_

State \_\_\_\_\_

Zip \_\_\_\_\_



# How to ship small packages in a big hurry.

## DELTA'S DASH

DELTA AIRLINES SPECIAL HANDLING

On DASH shipments Delta guarantees delivery on the flight or routing you specify between most Delta cities.

Packages accepted up to 50 lbs. with length plus width plus height not to exceed 90" total, with only one dimension exceeding 30".

Deliver to Delta's ticket counter or airport air freight terminal at least 30 minutes prior to scheduled departure time. Shipments may be picked up at either location 30 minutes after flight arrival.

Delta's exclusive "Dashboard" control procedure insures constant tracking of your shipment from delivery to pick-up.

DASH charges are nominal. Check Delta reservations for charges between specific points. Pay in cash, by company check, most general-purpose credit cards, special credit arrangements or on government shipments by GBL. **DELTA**  
The airline run by professionals

**Rate examples (Tax included)**

Atlanta-Washington . . . . .	\$21.00
Boston-Miami . . . . .	\$26.25
Cincinnati-Louisville . . . . .	\$21.00
Cleveland-Phoenix . . . . .	\$26.25
Los Angeles-New Orleans . . . . .	\$31.50
Dallas-Los Angeles . . . . .	\$26.25
San Francisco-Atlanta . . . . .	\$31.50
Philadelphia-Houston . . . . .	\$26.25
New York-Tampa . . . . .	\$26.25

For details, call Delta reservations.



# Delta is ready when you are.®

For more data, circle 70 on inquiry card



# Carrier rooftop cooling sits on a curb and hides.

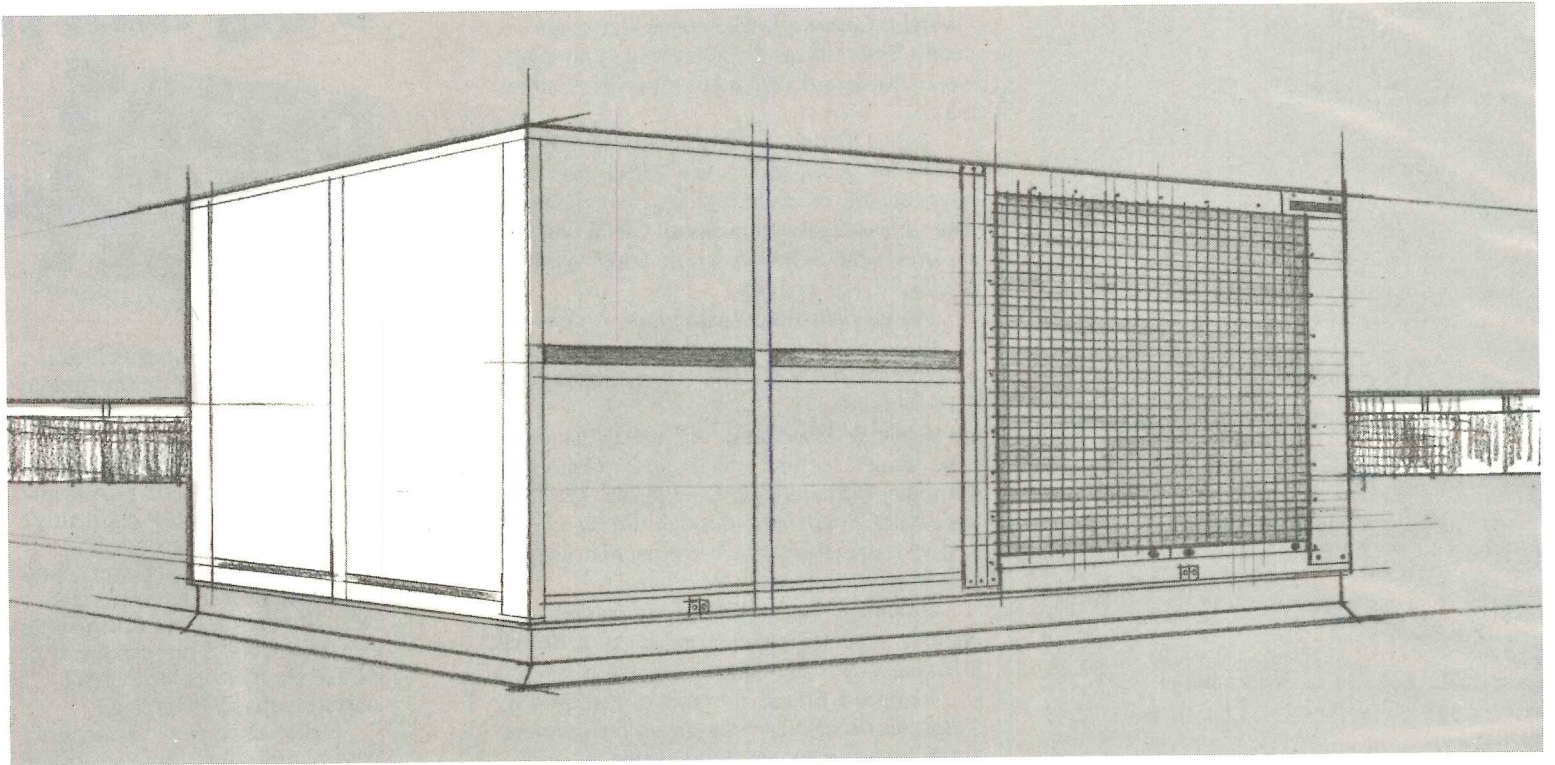

Our rooftop units won't spoil your roof line. Won't take a lot of extra roof support. Won't waste your client's energy. And won't use up indoor space.

To begin with, they sit on a factory-supplied NRCA-approved curb. They're down low, so they can hide on the roof.

In all their 10 through 50 ton cooling sizes, they're easy to handle to cut on-site labor costs.

And you can plan on our factory-installed economizer option to save energy by giving your client free cooling on mild days. Without unsightly sheet metal contraptions.

Gas or electric Carrier rooftop units for cooling (and heating). All UL or AGA approved. Your Carrier representative has the details. Carrier Air Conditioning Division, Syracuse, N.Y. 13201.

Number One  
Air Conditioning  
Maker



Division of Carrier Corporation

**Carrier**<sup>®</sup>



# Don't overdraw. Use these Kodak shortcuts:

---

The snappy restoration shortcut.

---

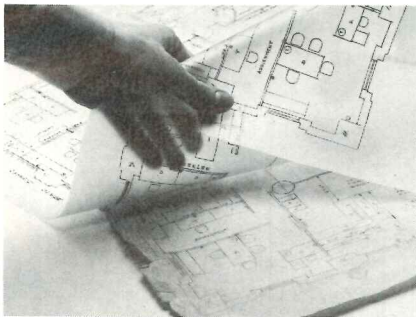

Why waste time retracing your old, battered drawings? Restore them by making sharp, clean photographic reproductions on Kodagraph film. Weak lines come back strong and clear. Stains virtually disappear. And instead of gray lines on yellow, you'll have snappy, contrasty, black-on-white prints.

---

The drop-of-water shortcut.

---

Why retrace the whole design for a few revisions? Just

order a second original on Kodagraph wash-off film. Then use a drop of water and erase unwanted details.

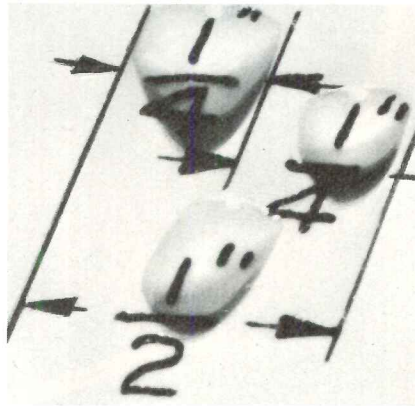

Draw your design revisions on the film and you're done.

---

The multiplication shortcut.

---

Why draw the same detail over and over? Kodagraph film will do the job for you. That way you draw the detail just once. Make as many photoreproductions as you need. Cut them out, paste them down, and make a

Kodagraph film print of the paste-up.

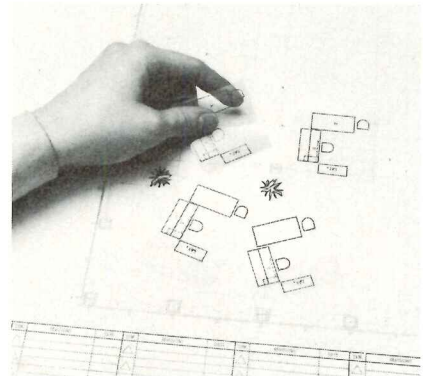

Now you have a superb second original for subsequent printmaking.

---

Get the facts from Kodak.

---

Drop us a line for more facts on how you can reduce drafting time and save money too, with Kodagraph films and papers. Eastman Kodak Company, Business Systems Markets Division, Dept. DP-774, Rochester, N.Y. 14650.

**Kodak products for drawing reproduction.**





# Jute carpet backing... a "microscopic thicket"



(Close-up  
photo  
magnified  
20 times)

## Entangles adhesive and makes carpet glue-down really work

Only Jute among no-pad carpet backings can make that claim. Because only Jute has the interstices and fibrous pores that accept and retain adhesive, bonding carpets securely to any subfloor or old hard-surface flooring.

Specify Jute backing to realize the many benefits of no-pad carpet glue-down. Among them are seam security under heaviest traffic, easy mobility for casters and wheels, lower cost than same carpet plus padding or cushion-backed carpet with equal pile.

- Jute, over twice as thick as other no-pad backings, prevents cracks in old flooring from being felt or outlined.
- When carpet is rolled out, some floor adhesive penetrates Jute to the primary backing, for additional tuft bind and delamination protection.

- Jute's thickness doubles seam sealing area.
- Jute's dimensional stability is essential for floor cut-outs.
- Jute facilitates clean carpet removal, intact for re-installation.
- Jute works with all standard multi-purpose and release adhesives.
- Jute helps qualified carpets meet fire safety codes.

### WRITE FOR ARCHITECTURAL GUIDE SPECIFICATION & CASE HISTORIES

Latter includes 8-year record at Ford Motor Co.

#### JUTE CARPET BACKING COUNCIL, INC.

American Industries, Inc. • Bemis Co., Inc. • BMT Commodity Corp. • C. G. Trading Corp. • Cosmic International, Inc. • D and C Trading Co., Inc. • Delca International Corp. • Dennard & Pritchard Co., Ltd. • A. de Swaan, Inc. • Gillespie & Co. of N. Y., Inc. • Guthrie Industries, Inc. • Hanson & Orth, Inc. • O. G. Innes Corp. • Jute Industries Div., Sidlaw Industries Ltd. • Multiproducts Trading and Manufacturing, Inc. • R. L. Pritchard & Co. • Stein, Hall & Co., Inc. • White Lamb Finlay Inc. • Willcox Enterprises, Inc. • WLF Inc.



# Visit Sao Paulo, Rio, Brasilia—and meet the designers of some of the world's most innovative buildings and places.

The First International Seminar to Brazil...  
October 23 through 31st, sponsored by  
**ARCHITECTURAL RECORD**

## The three cities are varied — but all are showcases of architecture and planning

We chose Brazil because the proliferation of architecture in this booming country is so astonishing as to be of singular significance to the architect or engineer of any nation.

For example, Sao Paulo is the fastest growing city in the world. With a population of over eight-and-a-half million people, it presents a living model of the myriad problems facing the urban developer, architect, or engineer.

Rio de Janeiro, containing four-and-a-half million people between miles of coastline on one side and confining mountains on the other, offers a totally different planning and design challenge.

Then there is the staggering accomplishment of Brasilia — an entire capital city planned and built in the Brazilian jungle — currently housing 700,000 people and showing, after a difficult start, the vitality that was anticipated at the time of its monumental conception.

## You'll meet and exchange ideas with the architects and planners of the best work

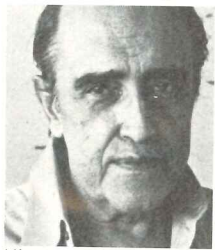

Niemeyer

In Rio de Janeiro, Oscar Niemeyer has graciously agreed to meet with us at his home. The great landscape architect Burle Marx, and Sergio Bernardes — whose work has become famous for its environmental and human concern—will also meet with us.

In Sao Paulo there is Joao Vilanova Artigas, Jorge Wilhelm, Alberto Botti, and John Gian Carlo Gasperini, all of whose efforts are transforming the face of the world's sixth largest city.

Besides meeting with these renowned professionals in formal seminar sessions, you will meet members of the Institute of Architects of both Rio and Sao Paulo—your counterparts in these important South American cities—and establish the informal one-to-one dialogue that makes a trip like this so invaluable.

## ... visit public buildings and parks, houses and housing, office towers and stadiums ...

You will visit sites selected by *Architectural Record* as representing the most important examples of the many architectural genres under discussion.



Brasilia

In Sao Paulo our three-day stay will include visits to Morumbi, the site of the world's largest sports stadium; Casa do Bandeirante, the two sumptuous homes by Paulo Mendes da Rocha; Cidade Universitaria; Ibirapuera Park, an astonishing complex of public buildings; Downtown, where new commercial and residential buildings are marking both the city's remarkable growth and new horizons in design; and other significant sites.

In Rio, where you will spend four days and four nights, you can visit the Ministry of Education, Museum of Art, South American Hospital, Rio Airport, Coastal Boat Station and Seaplane Station, Municipal Church, Flamengo Park, University of Rio, Pedregulho Housing Project, and much more — illustrating in all the broadest possible variety of purpose, problem, and solution.

## ... and see Brasilia, experiment without parallel in the world of architecture

As a living example of what can be done in terms of total city planning when starting literally from *nothing*, Brasilia is of course unique.

An entire day has been set aside for an on-site inspection of this remarkable new capital, planned by Lucio Costa and designed by Oscar Niemeyer.

Particular attention will be given to the Palaces of the Senate and Congress, Palace of Arches, President's Palace, Square of Three Powers, the stunning Cathedral, residential blocks, and new government buildings in progress.

The successful experiment of Brasilia—and the new era it launches—will have a dramatic and lasting influence on any professional who experiences it first-hand.

## The cost\* is exceptionally low — and your wife (or husband) can go for a fraction more

During your four days and four nights in Rio, you will live at the Hotel-Nacional Rio—Brazil's largest and most beautiful hotel, nestled between white sands and green mountains, and designed by Oscar Niemeyer.

In Sao Paulo, your comfort and convenience will be provided for at the lovely San Rafael Hotel.

Total land and air cost of \$895 per person includes:

Roundtrip airfare from JFK (New York) • deluxe hotel accommodations 7 nights • full-course breakfasts and dinners • all transfers

between hotels and airports • baggage handling • all gratuities • all ground transportation to and from seminar events • city sightseeing in each city • everything except personal purchases and lunches.

The all-inclusive travel price is less than the cost of economy airfare alone. Your professional seminar registration fee of \$395, added to the \$895, brings the total cost to you to only \$1290\*. For an additional \$895—your wife can accompany you on this marvelous week in Brazil.

Ample free time is provided for enjoying together all the advantages of a South American trip. And these Brazilian cities offer so much to the visitor that, if your wife does not care to attend the seminar sessions, she will be totally and enjoyably occupied.

## Plan now. Don't delay — registration and attendance are limited.

To establish a group size that makes the professional and cultural dialogue most stimulating and rewarding, it is necessary to limit the size of the group. Registrations will be accepted in the order in which they are received. To assure your attendance at this inaugural *Architectural Record* international seminar, return the coupon below today.

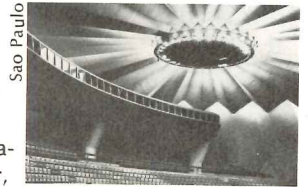

Sao Paulo

### \*Tax Deduction of Expenses:

Income tax deductions are allowed for expenses of education (including registration fees, travel, meals, lodging) undertaken to maintain and improve professional skills (see Treas. Reg. 1.162-5) (Coughlin vs. Commissioner, 203F. 2d 307).

Seminar management by Professional Seminars International; all travel arrangements by their affiliate, American International Travel Service.

Mail to:

**Professional Seminars International**  
516 Fifth Avenue, New York, N.Y. 10036

Please register me for the *Architectural Record* International Seminar, October 23-31, 1974, departing and returning JFK New York. My \$100 deposit per person is enclosed. I understand deposits are totally refundable if I cancel my registration any time up to 45 days prior to departure and that I will be charged \$100 per person for any cancellations after that. I also understand that the balance of the payment(s) are due 35 days prior to departure.

Name \_\_\_\_\_ Spouse \_\_\_\_\_

Address \_\_\_\_\_

City \_\_\_\_\_ State \_\_\_\_\_ Zip \_\_\_\_\_

Phone \_\_\_\_\_

Enclosed is \$ \_\_\_\_\_  as deposit  as full payment for \_\_\_\_\_ people.

(Rates are based on double occupancy. Single supplement is \$60 additional. Please make checks or money orders payable to: Professional Seminars International, Inc.)

Sponsor reserves the right to adjust prices in the event of rate and tariff changes over which it has no control.



Marx



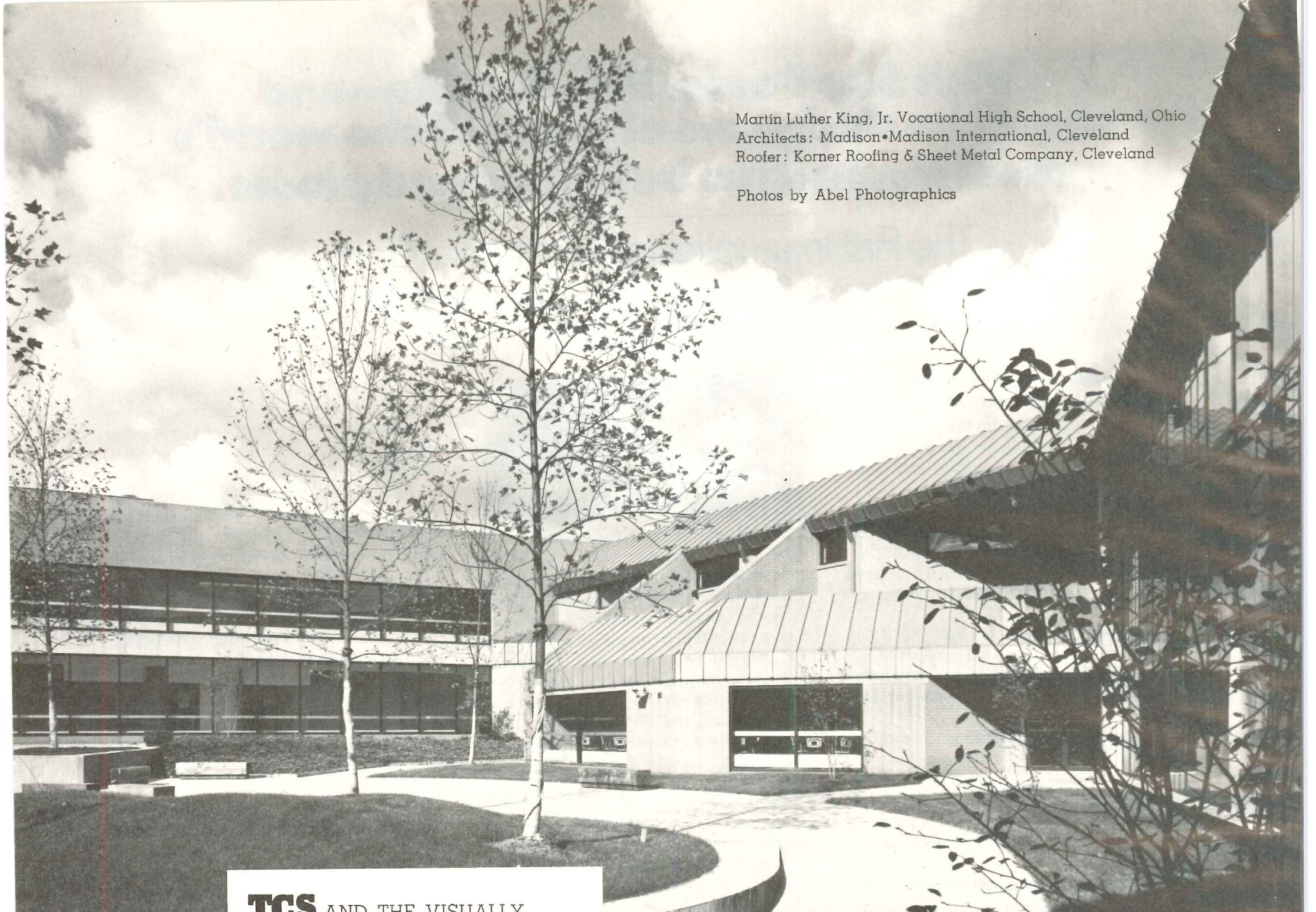

Martin Luther King, Jr. Vocational High School, Cleveland, Ohio  
Architects: Madison•Madison International, Cleveland  
Roofer: Korner Roofing & Sheet Metal Company, Cleveland

Photos by Abel Photographics



**TCS** AND THE VISUALLY  
SIGNIFICANT ROOF

TCS is stainless steel coated on both sides with a terne alloy of 80% lead and 20% tin.

TCS has no equal among standard architectural metals in resistance to atmospheric corrosion.

TCS solders perfectly without the need for expensive pre-tinning, acid fluxes or neutralizing agents.

TCS weathers naturally to a uniform dark gray and does not stain.

TCS provides galvanic built-in safeguards against failure which no competitive product can match.

TCS is reasonably priced and requires no maintenance.

**FOLLANSBEE**

FOLLANSBEE STEEL CORPORATION  
FOLLANSBEE, WEST VIRGINIA

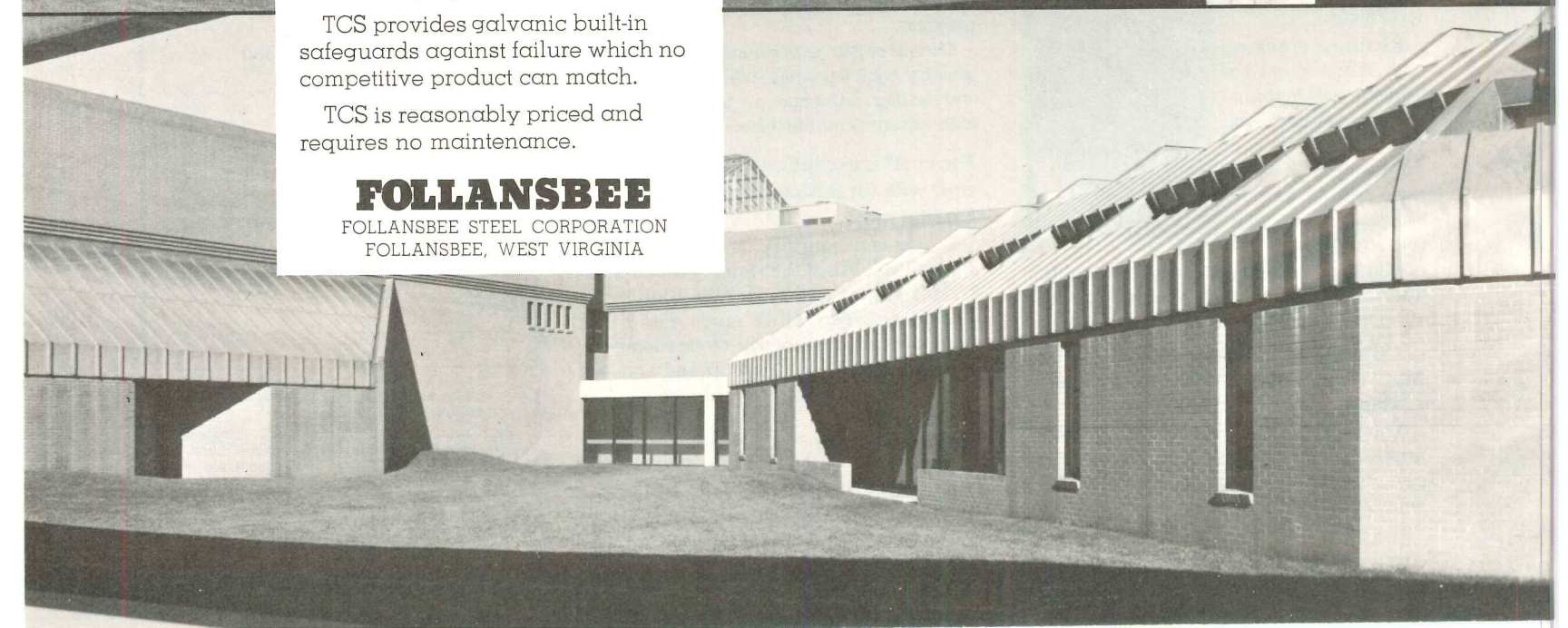



CONSTRUCTION MANAGEMENT  
BUILDING COSTS  
BUILDING ACTIVITY

## GSA to alter selection process for selecting architects and engineers

A special study committee on the selection of architects and engineers has presented recommendations to the U.S. General Services Administration for improving its selection method.

Administrator Arthur F. Sampson, who commissioned the study six months ago, accepted the committee's report and recommendations on June 10 from chairman Gerald D. Hines of Houston, Texas, and said: "It is my intent to immediately implement the majority of the recommendations made by the committee." The key recommendations accepted are:

- Ranking in one-two-three order the three architectural and engineering firms considered most qualified for a particular project will be done by in-house professional evaluation boards. This ranking previously was done by the administrator, who is responsible for the final selection. If he departs from the recommendation of the evaluation board, he must document his reasons.
- Membership on GSA Public Advisory Panels for selection of architectural and engineering firms will be modified, probably by shortening the term of service from two years to one year and insisting that individuals serving will be ineligible for GSA work during their term on the panel. Formerly, they could withdraw from the panel to apply for a commission.
- A national evaluation board will be established to make the recommendations on projects for which the estimated construction cost exceeds \$5 million or on special projects.
- The agency will embark on an intensive public information program, including release of an annual report on A-E selection, to insure that there is a clear understanding of the goals, operations and results of the new process.

### Committee urges further simplification, clarification, communication

Other recommendations of the study committee include:

- simplified procedures for selection and award below certain dollar levels.
- detailed procedures manual outlining every step in the process to guarantee uniformity, equitable consideration and complete documentation.
- a rules manual for selection and operations of the public advisory panels on architecture.
- criteria for joint ventures.
- redesign and streamlining of the qualifications form for architect-engineer firms.
- more opportunities for new, small and minority firms.

Sampson emphasizes that these changes apply only to GSA and do not at present affect the A-E selection procedures of any other Federal agency.

### Chairman outlines scope of the committee study

Chairman Hines said that as part of the committee's task, it compared GSA's procedures and those followed by other Federal agencies, state and local governments, foreign governments, private industries, entrepreneurs and others contracting for A-E services. Additionally, the committee evaluated reports on the subject of A-E procurement prepared by Congressional committees, the Commission on Government Procurement, state and local governments and professional societies. The purpose of the committee's work, he said, was to review the process and not the details of individual contract awards.

"We weighed potential recommendations against many criteria," Hines said, "including whether the recommendation would minimize or eliminate the opportunity for unethical or illegal practices."

The recommendations basically are modifications of existing GSA procedures that the committee deemed necessary in light of the need to maintain public confidence in the Federal A-E procurement process.

Sampson said the agency "will act promptly" to implement the new procedures recommended by the committee. "We will monitor the effect of those changes."

In this regard, he directed the appointment of James B. Stewart, a GSA project manager and professional engineer, as special assistant to the commissioner of the Public Buildings Service. Stewart will work full-time for at least a year to direct the orderly implementation of the changes.

### Sampson sees broad changes beyond scope of present study

"In addition to changes recommended by the committee," Sampson said, "GSA will fundamentally alter the basis for the selection of architect-engineer firms. Instead of depending exclusively on an evaluation of professional competence and reputation, we will begin a process of awarding A-E design contracts on the basis of project proposals. This is something I have been contemplating for some time in response to the realities of a changing construction industry. We want our selection methods to be completely objective and im-

partial and at the same time to result in excellence in architecture."

Sampson has directed his staff to develop by January 1975 plans for implementing the project proposal approach. "Over a three-to-five year period, GSA will require even more—and more detailed—information from architects and engineers seeking our commissions." Further details are in the text of Sampson's remarks which follow.

### Here is the text of Administrator Sampson's remarks

Before I comment on the committee report and our response to it, I want to make two preliminary points. Points which will help you to fully understand the importance of this document, its nature and its content.

First, about the committee itself: this really was an outstanding group. Their names are listed below. Professionals with years of experience in all areas of the construction industry. The committee and staff had only six months to do a difficult job of research and evaluation. And they did it. Their work was orderly and on time all the way along.

The final product of the effort reflects the full independence and the broad experience of the committee membership. That makes it, for us, both a challenge to live up to and a working document we can build on. Which is exactly what it should be.

The second point about this report is this: it responds precisely to the charter which we gave the committee.

In October, 1973, I approved the charter of the committee. It was not to be an investigatory body, a board of inquiry or anything of the sort. This was to be a careful and thorough research effort.

Let me quote from the committee charter:

"The committee will recommend a process to be used by GSA for the selection of architects and engineers to receive Federal contracts. It shall study GSA's present system for selecting architectural and engineering firms, previous systems used by GSA, systems used by state and local governments and systems used in the private sector. It shall take into account the opinions of those experts in the field whose advice it considers of value. It shall have access to all GSA employees and all relevant records. It shall study at least the last four years of GSA experience with the selection of architects and engineers."

In part, the scope of committee research was defined in this way to make it a manage-



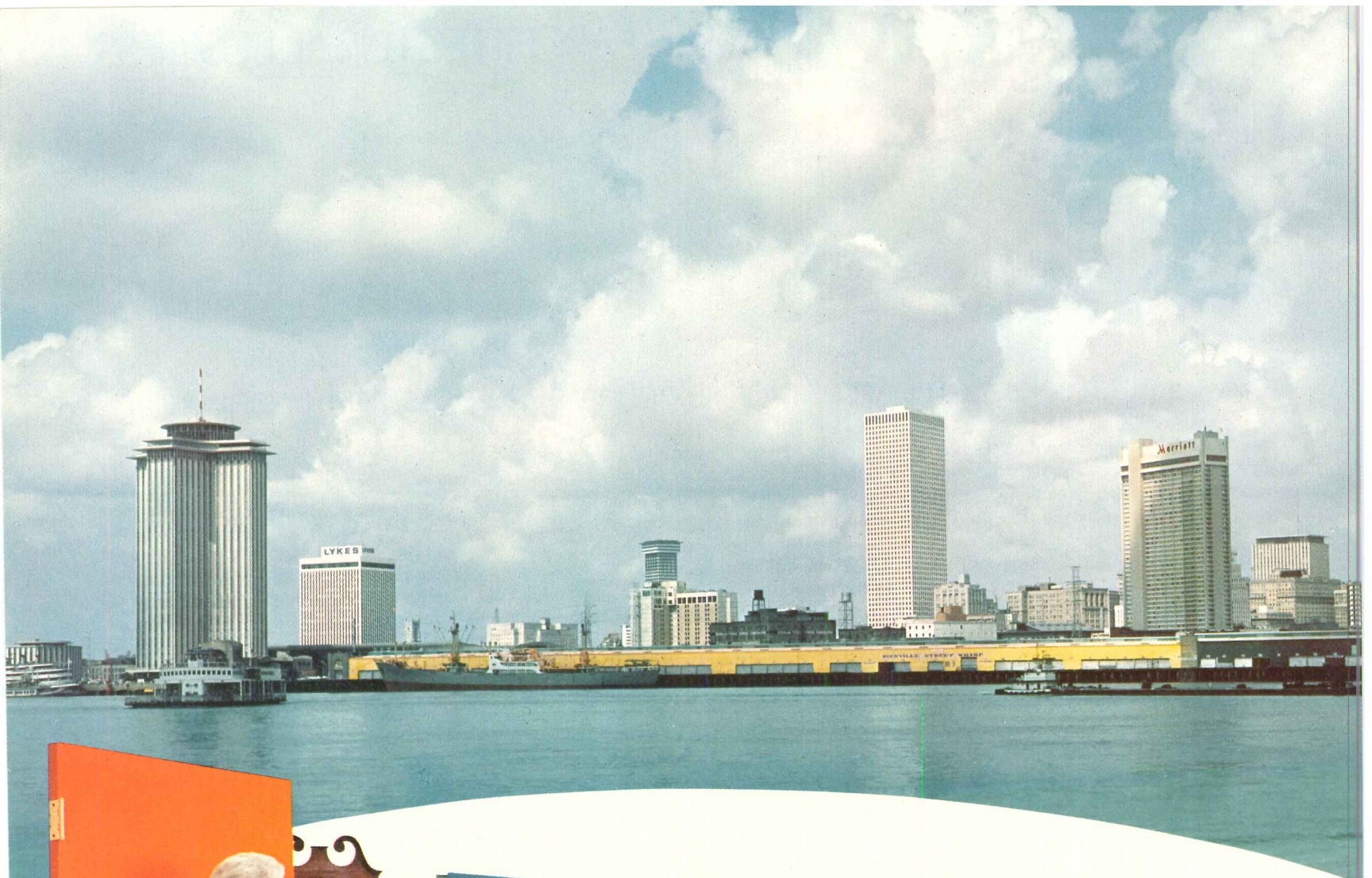

## Ceco doors are in tune with the old charm of new New Orleans

In New Orleans and across the country, architects find Ceco hollow-metal steel doors are perfect accents for interior design. But even more, they like their functional advantages. Ceco doors are secure. They're rugged — won't warp, swell, shrink or rot. And they offer trouble-free performance. The doors and frames arrive at the job site pre-prepared for easy installation and quick attachment of hardware. Ceco Colorstyle doors come with factory-baked finishes kept fresh in poly bags. Let us give you the facts. See Sweet's files or contact your local Ceco district office.



**CECO** steel doors

The Ceco Corporation • 5601 West 26th Street • Chicago, Ill. 60650

*"The door people"*

For more data, circle 42 on inquiry card



able effort. But, more important, the charter of the group was designed to avoid a sensational or emotional approach to the issues. It was designed to produce a set of recommendations that could be acted on because action was so badly needed to restore public confidence.

That's what it did. The final committee report recommends specific action; not high-sounding moral reforms, but detailed steps to improve our selection process and to minimize the opportunity for improper influence in the selection of architects and engineers.

Let me tell you about those recommendations and our response.

I'm glad to be able to announce some decisions on the report the same day we release it. It was for this reason that I have followed the committee's work with close and personal attention.

Chairman Hines has kept me informed of progress along the way. And, on one occasion, the committee as a whole requested a meeting with me to discuss their thinking.

So today, I can announce our response to a number of committee recommendations and some dramatic improvements in our selection process.

The first change I can announce today: the study committee recommended, and I have accepted, the idea of ranking, by GSA evaluation panels, the most qualified firms in order of preference for final selection.

Our new selection process will work as follows: our regional public advisory panels will identify five to eight firms of outstanding professional and technical qualifications.

From that list, an in-house panel will recommend the top three firms. And they will rank them in order of preference. The final selection will continue to be made by the Administrator of GSA.

Now, however, his choice will be clearer and the basis for the choice fully documented. Should the administrator select other than the top ranked firm, he, in turn, will have to document his decision.

This is brand new for GSA. Previously the administrator did the ranking.

What ranking and documentation mean, in effect, is this: the final authority in the selection system—the administrator—will have the minimum opportunity to make a selection based on improper political, personal, or other motives. He will have, still, the freedom to choose among firms that are equal or nearly equal in excellence. But this choice must be fully and carefully recorded.

This is the backbone of our improved selection system. Hand-in-hand with it go several other changes:

- We will make our regional public advisory panel members ineligible for GSA work during their tenure. To maintain the stature of the panels and professional interest in them, we will shorten the individual membership to one year and reduce the number of members.
- We will establish in each region a pool of our best professional talent to evaluate firms recommended by panels. A national evaluation board will be established for major and special projects.

- We will develop a detailed manual of procedures as recommended by the committee to make sure this system operates fairly, consistently and with a minimum of outside influence of whatever nature.

There are other changes to be made in the system, of course, and other recommendations to be studied.

But this is the heart of the new GSA selection process. It will be a system that we believe can operate with even more strength, independence and fairness than our current system.

Another area of change and improvement: the study committee recommended, and we have accepted, a number of ideas to improve the informational aspects of our selection system:

- First, a member of the regional public advisory panel will be invited to sit in as an observer on our in-house evaluation of firms. That will assure the panels that *our* analysis is as impartial and professional as *their own*. And we will, as the committee recommended, fully inform the panel on the final selection made.

- Next, we will maintain and release each year a report on the A-E selections made. Open to the Congress, to other Federal agencies, to the professional community and the general public, this report will be a complete and continuing record of our new selection process.

#### **Project proposals seen as future selection basis**

I want to make another announcement today. It's a change I've been thinking about for some time. One that will fundamentally alter the basis for selecting A-E's.

Instead of depending exclusively on an evaluation of professional competence and reputation, GSA will begin a process of awarding architectural and engineering design contracts on the basis of project proposals.

We are deferring this action until January 1, 1975, so that we can fully explain it, and completely explore its implications with design professionals and their organizations.

Starting in January 1975, firms interested in GSA projects will be asked to submit—in addition to a profile of their firm (standard form 251) which is now required—a new standard form which responds in detail to published project criteria.

This is brand new to GSA.

But it is only the first step.

Over a three- to five-year period, GSA will require even more—and more detailed—information from architects and engineers seeking our commissions.

The exact gait of this process is not yet defined. But the end result *is* defined.

Ultimately, GSA will award A-E contracts on the basis of fully developed project proposals. Proposals that will include evidence of technical and professional distinction; estimated fees; construction and life cycle cost estimates; and planning and design concepts. (In response to questions, Mr. Sampson emphasized that "estimated fees" would not be a factor in the basic selection process but would be related to the scope of work implicit in the proposal. Further, he tentatively suggested that detailed proposals themselves might be commissioned, for a separate fee, by invitation to two

or three prime selectees among panel-selected A-E firms.)

This is a revolutionary step for GSA and, in the long run, may have a significant impact on the construction industry.

This decision responds to no specific study committee recommendation. But it *does* respond to the committee's concern for the production of the finest architecture. And it *does* respond to realities of the construction industry today.

This is an industry which is turning more and more to systems building, to performance specifications and to new ways to manage construction.

We believe that professional competition based on technical proposals is the way of the future, and we're headed that way.

Those, then, are the highlights of the committee report and our reaction to it.

By memorandum dated today (June 10), I have directed the Commissioner of GSA's Public Buildings Service to make those changes which I mentioned—and others.

We will act promptly to put these changes on the books and into effect. And we will monitor the effect of those changes.

To that end, I have directed the appointment of a special assistant to the commissioner of the Public Buildings Service to work full time for at least one full year to make sure the new system goes into operation and works well.

It should be noted and emphasized that these changes apply only to GSA and do not presently affect A-E selection procedures of any other Federal agency.

We will take other steps in the near future.

First, we will actively discuss the report and our changes with other appropriate Federal agencies and departments.

In the end, I believe, this report will prompt cooperation and change in the Federal community which will keep the government a uniform and progressive client for A-E services.

As a second step we will assure the widest distribution of this report to governors and mayors and other officials of building programs. We believe the report is a well-developed document. It urges workable change and improvement. And so we will maximize its exposure. (Copies are available for \$3 at 13 regional GSA Business Service Centers.)

In summary, then, I believe this to be an excellent report. It has proposed and will lead to some dramatic changes in the GSA selection of architects and engineers. And, in the long run, I think it will have national impact in encouraging reform and improving the public image of the professional design community and their work for Federal, state, and local building programs.

#### **Membership of GSA special study committee**

Chairman Gerald D. Hines, owner of Gerald D. Hines Interests, Houston, Texas.

Louis A. Bacon, president and chief executive officer, P&W Engineers Inc., Chicago, Ill.

Ernest W. Brackett, former chairman, Board of Contract Appeals, NASA, Washington, D.C.

Dr. Charles Burchard, dean of the College of Architecture, Virginia Polytechnic Institute of Blacksburg, Va.

William A. Carlisle, senior vice-president and secretary, Lyles, Bissett, Carlisle and Wolff Associates, Columbia, S.C.

*continued on page 69*





**Fast enclosure.  
Design freedom.  
Versatility.  
Economy.**

**They're all built-in  
benefits of J-M's  
new wall system.**

J-M has done it again, with an all-in-one wall system that's attractive, goes together fast, goes up fast, saves money.

This new concept combines punched light gauge structural steel studs with gypsum interior panels, J-M fiber glass insulation and J-M architectural exterior panels.

Prefabrication of large panels can save on-the-job time and speed closure, while lowering construction costs.

And the system is particularly suited to exterior treatments combining the appearance and beauty of natural stone in a man-made panel product with the accent of reveal joints.

For details on the system that might change your ideas about walls, write Johns-Manville, Box 5108, Denver, Colorado 80217.

Exterior walls of the new Huntsville, Alabama, Civic Center are J-M Stonehenge® architectural panels secured directly to the steel studs. Here insulation is sprayed on the back of the panels. A combination of hidden and reveal joints was chosen by the architect.

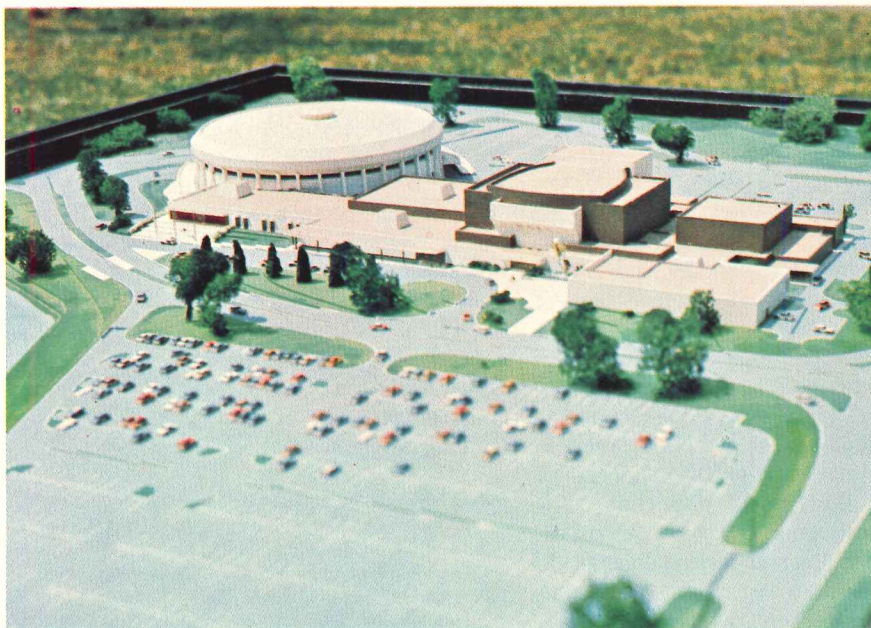

Architects model of the new Von Braun Civic Center, Huntsville, Alabama.  
Architects: Northington, Smith, Kranert & Tomblin & Associates.  
Jones, Mann and Associates. Dickson and Davis.  
Fabricator: Bonitz Insulation Co., Birmingham.



**Johns-Manville**

*For more data, circle 43 on inquiry card*



Rear Adm. John Dillon (ret.) executive engineer, Bechtel Inc., San Francisco, Cal.

Robert L. Durham, president, Durham Anderson Freed Company, Seattle, Wash.

William B. Foxhall, senior editor, *Architectural Record*, New York City.

Harold Gold, attorney with Lewis, Mitchell & Moore, Washington, D.C.

Bill N. Lacy, former dean of architecture, University of Tennessee, Knoxville, now director of architecture plus environmental arts, National Endowment for the Arts.

Walter A. Meisen, GSA assistant commissioner for construction management, Washington, D.C.

Emanuel Pisetznar, partner, Weiskopf and Pickworth, New York City.

Richard H. Stanley, president of Stanley Consultants, Muscatine, Iowa.

J. Neils Thompson, director of Balcones Research Center; professor of civil engineering, University of Texas, Austin, Texas.

Elmer K. Timby, member of the advisory board of Howard Needles Tamman and Bergendoff, New York City.

Bradford I. Towle, vice president, plans and controls, real estate and construction division, IBM Corp., White Plains, N.Y.

R. Randall Vosbeck of Vosbeck, Vosbeck, Kendrick and Redinger, Alexandria, Virginia, a member of GSA's Regional Architectural Advisory Panel.

Ray A. Watt, chairman of R. A. Watt Enterprises, Santa Monica, Calif., a member of the GSA Public Advisory Council.

Richard H. Wheeler, partner, Tweddell, Wheeler, Strickland and Beumer, Architects, Cincinnati, Ohio, a member of GSA's National Public Advisory Panel on Architectural and Engineering Services.

T. L. Peyton, GSA deputy assistant commissioner for construction management, Washington, D.C.

Thomas P. Wolf, previously associate director for administration, Office of Economic Opportunity, was selected by the committee to serve as executive director for the committee and head a staff of both private and GSA professionals made available to assist in completion of the committee's assignment.

## Marketing your own personal services: job hunting

*Here are some do's and don'ts about getting your first job—or your next one—as an employee in an architectural office. Bradford Perkins, managing partner of the New York office of Llewellyn-Davies Associates, speaks from long experience in management consultation.*

Typically, the first challenge any architect faces in his career is getting a job. Currently there is a buyer's market for professional skills (I see five résumés on an average day) so job hunting must be approached in the same carefully thought-out way that an experienced firm follows to get new work.

This article is primarily intended as a guide for new graduates or persons early in their career, but it does make some recommendations that apply to any job search.

The first step is deciding where you want to work. New York, Boston, Aspen or San Francisco may be desirable for personal reasons, but they are also the places where many other architects are seeking employment. One well known architectural dean recommended that his students all consider Houston, or Cincinnati. In any case, the choice of a place should be consistent with both personal and professional goals. Usually more than two or three cities can satisfy both.

Having decided on where, the second decision is to pick a target firm. The big name firms can be, but are not necessarily, the best place to get experience. They may look good on a future résumé, however. It is even worth seriously considering firms outside of your design profession, such as real estate developers, construction managers or public agencies. At times the experience gained in these organizations can be a stepping stone to a better career in your chosen field. It is worth researching the type of work a firm does, how busy they are, ages of the partners, how they are organized, how they use new employees and other key factors.

The ideal sought by most people is a busy firm that has many smaller projects and often delegates considerable project responsibility to younger staff. To business school graduates—who have raised the job search to an art—a key additional criterion is visibility to the senior principals and limited internal strength at their target job level. The theory is that a hard-

working star in a position close to the management will be able to move up in the firm more quickly than the same person in a drafting room full of honor graduates. On a less calculating level, the key thing is to identify as much as possible the firm's primary concerns.

Even if it is not possible to obtain a clear picture of the firm and its needs, it is still essential to think through how a firm will probably evaluate you. This will vary considerably from firm to firm, but the most common considerations are:

1. The interviewer will want to believe that you can do the work he has in mind for you. This is why it is important to know what the job is so that you are able to relate your experience, interests and answers to it.

2. Be reasonable about salary. It is rarely worthwhile to imply that starting salary is the most important issue. It is usually more important to leave the impression that you consider the job first and assume that your salary will be adjusted to your experience and performance. Starting higher than your experience or capabilities warrant can make you far more vulnerable to a future negative performance appraisal. This does not mean that you should accept any salary, no matter how low, since the offer usually reflect the firm's concept of the position you will fill. If it is too low you should be concerned about whether your skills are being adequately appraised.

3. Do not make unusual schedule demands. You should consider, and the employer should believe, that your work—as much as possible—will determine your schedule.

4. If you have specialized skills, make them known in your résumé and your portfolio. In particular, make it known if you have skills in working drawings, rendering, field supervision, equipment selection, building types relevant to the firm's practice, etc. Most firms have great difficulty in staffing the "nuts-and-bolts" end of their projects. Few firms are looking to hire other than well established "designers" or "generalists," although that may be the direction in which your position will evolve.

5. Be personally neat. This does not mean clean-shaven but it does usually mean a jacket and tie and a neatly groomed appearance if

you are looking for a job with responsibility. One of the things an interviewer almost always considers is the impression the candidate will make on the firm's clients.

6. Appearance is also a factor in your portfolio, letter or résumé. Most interviewers will notice if they are sloppy or unusually well done. At worst they should be neutral.

7. Remember that another major criterion to most employers—especially those with small firms—is whether they like you. Try to be interested in the firm, complimentary of their work and relaxed.

8. Make it clear that you can be counted on. Although it is typical for young architects to change jobs several times, frequent job changes are a major drawback. If you have left other firms, explain why.

9. Do not waste the interviewer's time. Be as brief as possible in explaining your experience. As someone tried to explain to Hubert Humphrey, your presentation does not have to be eternal to be immortal!

10. For your interview, get a personal introduction if at all possible. Most professionals are very busy, and most prefer to limit interviews to people they know or ones that acquaintances can recommend, or people with unusually strong résumés.

11. Have a good résumé that clearly states, in no more than two typed pages:

- How to get in touch with you;
- The type of position you are seeking;
- Your educational background, including notes of any special academic experience;
- Your prior work experience, noting your role on the projects you worked on and why you left the firm;
- Any special skills, interests or experience, such as a foreign language, editor of a school newspaper, an article written, etc.
- Personal references—preferably from former employers, clients or professors. Make sure to give their addresses and telephone numbers.

12. Write a brief, personal, neatly typed covering letter. If at all possible say why you are interested in the firm and how your interests, experience or capabilities might relate to the firm's work—do not send a form letter as it will usually get a form response.

This idea is to carefully and realistically match your interests and goals with a job.





Pajaro Dunes, California. George Cody, A.I.A.

## Simpson Ruf-Sawn Redwood Plywood. A natural for going back to nature.

More and more prospective homeowners today are looking for designs and materials that fit in more harmoniously with nature. A natural reason for using Simpson Ruf-Sawn Redwood Plywood siding.

No other commercially available wood surpasses Redwood for beauty in any setting. Left natural, it weathers to a soft driftwood gray. And Redwood is exceptionally resistant to surface checking, making it outstanding for durability and maintenance economy in any climate.

Simpson Ruf-Sawn, with its rustic rough-sawn surface,

enhances Redwood's natural charm. And because it's plywood, you get all the advantages of plywood, too. High strength-to-weight ratio. Easy handling. Excellent workability. Plus economy when compared with solid lumber.

Simpson Ruf-Sawn Redwood Plywood. A beautiful way to get back to nature.

For full information on grades, patterns and sizes, contact Simpson Timber Company, 2000 Washington Building, Seattle, Washington 98101, 206-682-2828.

# Simpson



For more data, circle 44 on inquiry card



**Outdoor recreation facilities costs**

Outdoor recreational facilities that were once restricted to municipalities are now amenities provided by many builders to enhance the salability of their developments. Where once a swimming pool would suffice builders are now going to a wide range of facilities laid out in a park-like setting. The following are some common elements and their costs (including labor):

Chain link fence	5 ft high, 9 gauge
Aluminum	\$4.90/lin. ft
Galvanized	\$4.05/lin. ft
Running track	
Cinders	\$11.20/sq ft
Synthetic	\$29.65/sq ft
Carousels (10 ft dia.)	\$250.00 ea.
See-Saw (2-board)	\$145.00 ea.
(4-board)	\$225.00 ea.
Sliding board (8 ft high)	\$275.00 ea.
Swings (4-seat)	\$200.00 ea.
Swings (8-seat)	\$370.00 ea.
Bicycle racks (8 cycles)	\$165.00 ea.
Picnic tables (portable)	\$96.00 ea.
Basketball backstops	\$310.00 ea.
Asphalt paving	\$4.25/sq yd
Pavement marking	.25/lin. ft
Outdoor barbecue	
Brick	\$290.00 ea.
Cast iron	\$130.00 ea.
Putting greens	\$6.10/sq yd
Outdoor tennis courts	
Grass	\$13,000 ea.
Bituminous	\$20,000 ea.
Clay	\$22,000 ea.

*John H. Farley, senior editor  
Dodge Building Cost Service*

INDEXES: July 1974		1941=100.00 (except as noted)				% change last 12 months
Metropolitan area	Cost differential	Current Indexes			steel	
		non-res.	residential	masonry		
U.S. Average	8.3	458.2	430.3	448.7	438.0	+11.32
Atlanta	7.5	563.9	531.7	551.8	539.8	+ 7.47
Baltimore	8.6	527.1	495.6	514.3	500.7	+16.73
Birmingham	7.1	412.7	383.9	398.2	393.8	+ 9.06
Boston	8.9	463.0	437.5	459.2	446.1	+ 9.87
Buffalo	9.0	507.1	458.2	499.1	484.3	+ 9.97
Chicago	8.3	523.5	497.7	505.2	498.5	+10.45
Cincinnati	8.6	492.8	463.7	478.6	467.9	+12.50
Cleveland	9.0	499.2	469.7	488.9	476.4	+12.28
Columbus, Ohio	8.1	476.6	447.6	465.9	455.5	+10.34
Dallas	7.7	459.7	445.2	448.3	440.1	+11.32
Denver	7.9	483.3	452.7	474.1	460.9	+10.79
Detroit	9.7	526.2	502.3	534.6	573.3	+12.04
Houston	7.1	417.9	392.4	405.2	399.2	+ 9.12
Indianapolis	7.6	412.0	386.9	402.1	394.0	+ 9.53
Kansas City	8.3	443.2	418.8	433.9	422.4	+12.28
Los Angeles	8.4	527.6	482.4	512.2	501.5	+13.39
Louisville	7.6	458.4	430.4	446.5	437.8	+12.25
Memphis	8.1	464.2	436.5	447.5	440.2	+20.91
Miami	7.8	475.2	452.7	461.6	452.3	+11.53
Milwaukee	8.2	510.8	480.2	501.2	487.0	+11.86
Minneapolis	8.5	476.8	448.7	467.5	457.9	+ 9.02
Newark	8.5	437.1	409.6	427.8	419.6	+ 7.59
New Orleans	7.4	445.1	420.2	438.2	428.9	+14.41
New York	10.0	510.3	474.5	497.9	486.5	+ 9.62
Philadelphia	8.9	503.1	479.4	498.0	484.5	+ 7.88
Phoenix (1947 = 100)	7.9	265.2	249.1	256.1	251.8	+11.29
Pittsburgh	8.7	450.5	423.9	444.8	431.6	+ 9.14
St. Louis	8.4	466.6	440.5	459.4	449.8	+ 7.17
San Antonio (1960 = 100)	7.4	175.3	164.7	170.3	166.4	+15.67
San Diego (1960 = 100)	8.4	193.7	182.0	189.6	185.8	+16.54
San Francisco	9.2	663.5	606.5	657.5	636.5	+ 6.68
Seattle	8.5	451.1	403.8	444.7	428.6	+12.64
Washington, D.C.	7.9	437.7	411.1	426.2	415.9	+12.26

Cost differentials compare current local costs, not indexes.

Tables compiled by Dodge Building Cost Services, McGraw-Hill Information Systems Company

HISTORICAL BUILDING COST INDEXES—AVERAGE OF ALL NON-RESIDENTIAL BUILDING TYPES, 21 CITIES											1941 average for each city = 100.00						
Metropolitan area	1964	1965	1966	1967	1968	1969	1970	1971	1972	1973 (Quarterly)				1974 (Quarterly)			
										1st	2nd	3rd	4th	1st	2nd	3rd	4th
Atlanta	313.7	321.5	329.8	335.7	353.1	384.0	422.4	459.7	497.7	516.4	518.0	543.8	544.8	555.2	556.7		
Baltimore	280.6	285.7	280.9	295.8	308.7	322.8	348.8	381.7	420.4	441.8	443.6	474.5	475.5	516.3	517.8		
Birmingham	260.9	265.9	270.7	274.7	284.3	303.4	309.3	331.6	358.3	371.7	373.2	401.1	402.1	405.5	407.0		
Boston	252.1	257.8	262.0	265.7	277.1	295.0	328.6	362.0	394.4	414.0	415.6	436.8	437.8	455.1	456.6		
Chicago	306.6	311.7	320.4	328.4	339.5	356.1	386.1	418.8	444.3	465.3	466.9	507.6	508.6	514.2	515.7		
Cincinnati	269.5	274.0	278.3	288.2	302.6	325.8	348.5	386.1	410.7	430.4	432.0	461.4	462.4	484.5	486.0		
Cleveland	283.0	292.3	300.7	303.7	331.5	358.3	380.1	415.6	429.3	436.7	438.3	461.2	462.2	490.3	491.8		
Dallas	256.4	260.8	266.9	270.4	281.7	308.6	327.1	357.9	386.6	407.3	408.9	435.4	436.4	453.7	455.2		
Denver	287.3	294.0	297.5	305.1	312.5	339.0	368.1	392.9	415.4	429.5	431.1	460.0	461.0	476.1	477.6		
Detroit	277.7	284.7	296.9	301.2	316.4	352.9	377.4	409.7	433.1	463.4	465.0	500.0	501.0	519.5	521.0		
Kansas City	250.5	256.4	261.0	264.3	278.0	295.5	315.3	344.7	367.0	387.7	389.3	404.8	405.8	435.6	437.1		
Los Angeles	288.2	297.1	302.7	310.1	320.1	344.1	361.9	400.9	424.5	453.3	454.9	503.2	504.2	514.3	515.8		
Miami	274.4	277.5	284.0	286.1	305.3	392.3	353.2	384.7	406.4	419.0	420.6	446.2	447.2	467.6	469.1		
Minneapolis	282.4	285.0	289.4	300.2	309.4	331.2	361.1	417.1	412.9	430.6	432.2	455.1	456.1	469.7	471.2		
New Orleans	240.9	256.3	259.8	267.6	274.2	297.5	318.9	341.8	369.7	382.1	383.7	419.5	420.5	437.5	439.0		
New York	289.4	297.1	304.0	313.6	321.4	344.5	366.0	395.6	423.1	453.5	455.1	484.3	485.3	497.4	498.9		
Philadelphia	275.2	280.8	286.6	293.7	301.7	321.0	346.5	374.9	419.5	459.3	460.9	484.1	485.1	495.7	497.2		
Pittsburgh	263.8	267.0	271.1	275.0	293.8	311.0	327.2	362.1	380.3	406.3	407.9	423.4	424.4	443.7	445.2		
St. Louis	272.1	280.9	288.3	293.2	304.4	324.7	344.4	375.5	402.5	427.8	429.4	443.2	444.2	458.7	460.2		
San Francisco	365.4	368.6	386.0	390.8	402.9	441.1	465.1	512.3	561.0	606.4	608.0	631.3	632.3	647.1	648.6		
Seattle	266.6	268.9	275.0	283.5	292.2	317.8	341.8	358.4	371.5	388.4	390.0	423.4	424.4	437.8	439.3		

Costs in a given city for a certain period may be compared with costs in another period by dividing one index into the other; if the index for a city for one period (200.0) divided by the index for a second period (150.0) equals 133%, the costs in the one period are 33% higher than the costs in the other. Also, second period costs are 75% of those in the first period (150.0 ÷ 200.0 = 75%) or they are 25% lower in the second period.



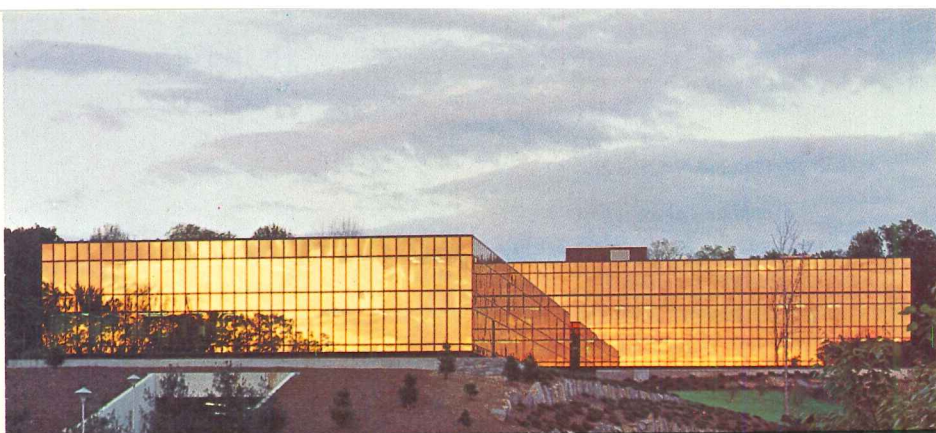

# ASG REFLECTOVUE®

The Glass Company believes anything that wastes energy doesn't deserve to be called beautiful.

So we've made sure that rich-looking gold Reflectovue® does a beautiful energy-saving job. Reflectovue rejects up to 90% of the solar heat when used with ASG's TruTherm® insulating units. It combines this superior heat reflection with an excellent thermal performance, plus a low "U" value and shading coefficient. Reflec-

tovue's ability to control heat loss and gain means less strain on heating and air conditioning equipment. So, while its vacuum deposited thin metallic coating of pure gold is mirroring the environment, Reflectovue is hard at work conserving energy. ASG Reflectovue. It looks—and performs—like a real beauty.



**ASG Industries Inc.**

The Glass Company, P.O. BOX 929, KINGSFORT, TENN. 37662

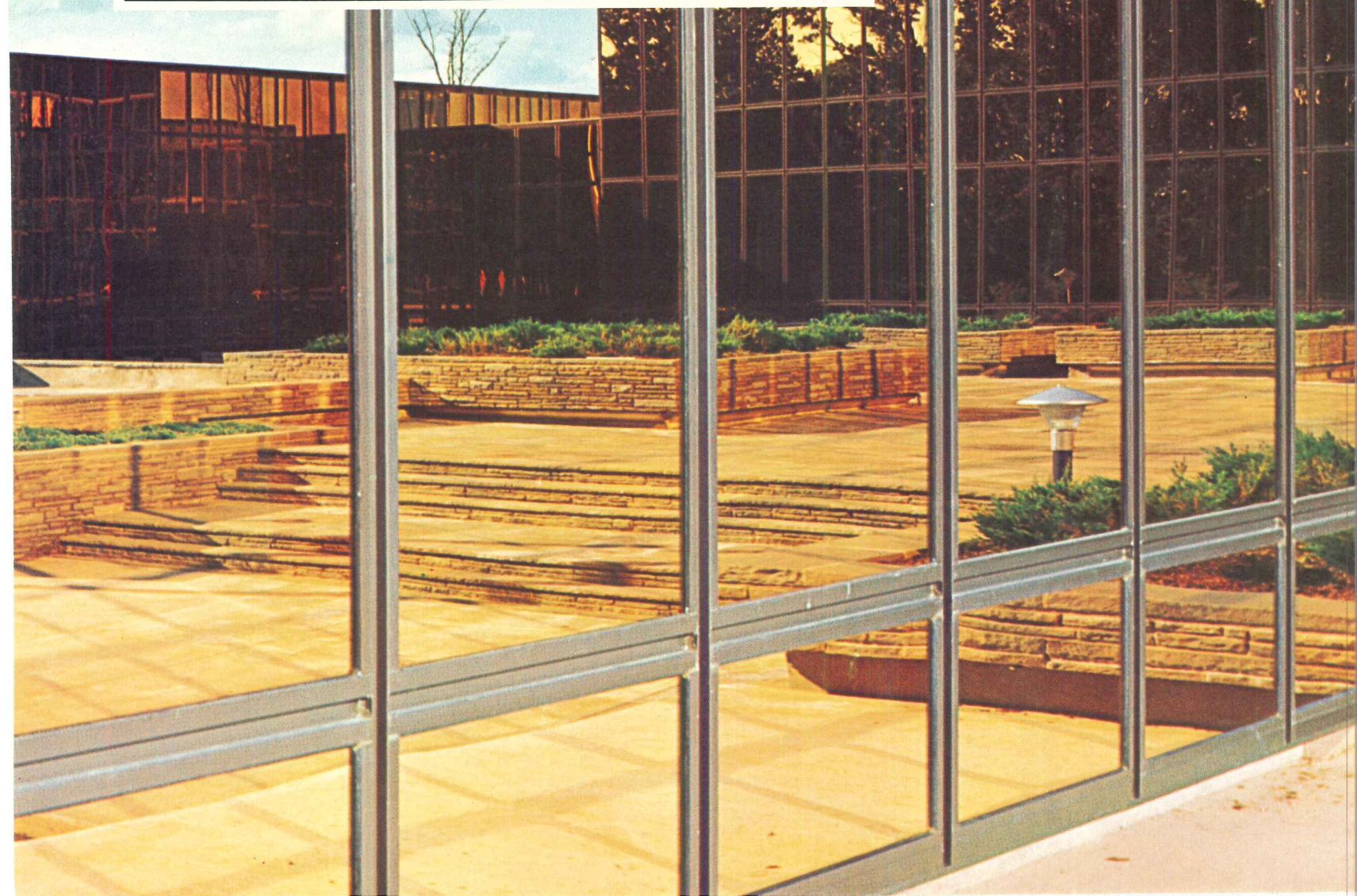
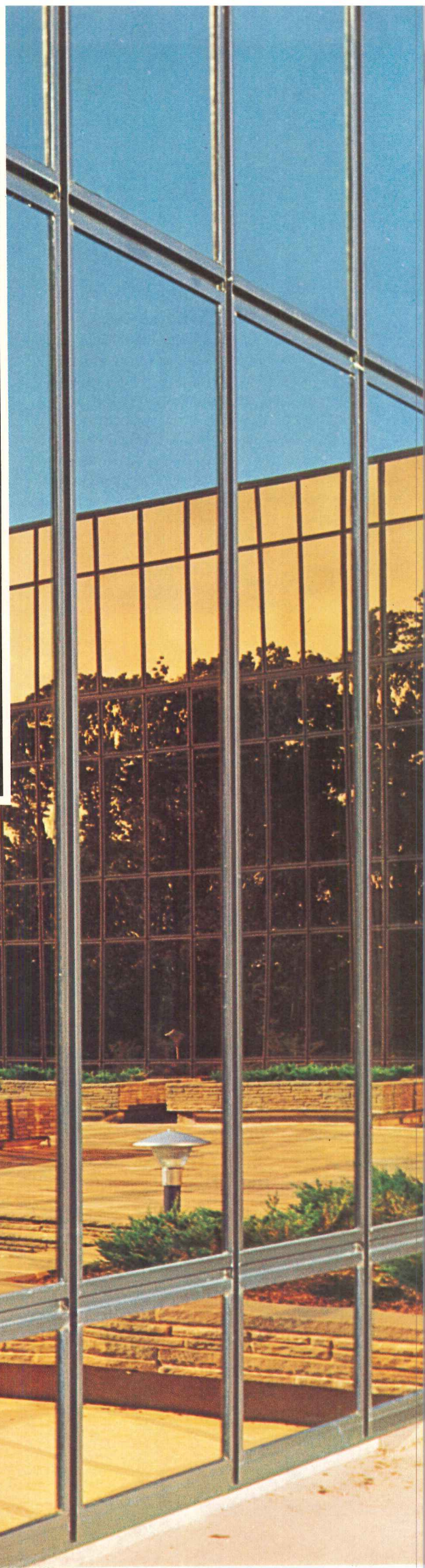



## Housing: Is it really time to shift priorities?

Housing starts are back down around the levels of late 1970.—And the prospect of any immediate relief to the industry from easier credit conditions is dim, now that restrictive monetary policy has become the primary weapon with which inflation is being fought.

Further, government aid to housing is being meted out at levels only high enough to prevent a complete collapse, no more.

The logic of government policy makers is pretty easy to follow here. It reads something like this: Three exceptional years of high-level activity have given the housing industry enough prominence and prosperity to last it for a while. In other words, housing has slipped a few notches in the rank order of priorities. It doesn't "matter" as much as it used to.

Perhaps, it's time to reexamine our housing posture to get a better check on the urgency of our existing needs. Are the policy-makers right in letting housing's priority slip? Just how postponable is new housing here in mid-1974?

Well, it's pretty clear that housing starts are back down around 1970 levels because people are now buying or renting them only at 1970 levels, if that. The demand isn't there—not the *effective* demand, anyway. The nationwide credit squeeze has simply forced large numbers of potential housing customers out onto the sidelines. And, they won't get back in the game until they can get the money to play it.

In effect, large numbers of people who want new housing are going to have to wait a while before they can get it. They'll have to make do with their present surroundings and postpone the purchases to some future date. Within this group of people, though, is a more desperate, hard-pressed sector who really *need* new housing—as opposed to just *wanting* it. Helping these people to obtain better living accommodations, of course, was what that 26-million, ten-year housing goal (remember that?) and the landmark 1968 Housing Act were all about. And, the need is still there even if the priority is not.

The most serious problem with sub-standard housing is that you can't turn your back on it for too long. Much like a still-smoldering camp fire, it flares up again once you walk away from it. Eradication requires a steady, methodical program with the goal clearly fixed, not a program that operates in fits and starts.

A look at some census data should point up this contention. You may have seen a news-

paper headline a month or two ago that went something like this: "The proportion of 'sub-standard' housing in the United States decreased significantly between 1960 and 1970." The data in the article would have been taken from the Census Bureau's follow-up sample of the 1970 Housing Census, called the "Components of Inventory Change," released in March. And, as the headline says, there was a significant decrease. Some 6.4 million year-round housing units, 10 per cent of the 67.7 million counted in the Census were classified as "substandard" in 1970. This compares with a figure of 9.8 million in 1960. The 1960 figure was 17 per cent of the 56.6 million units in existence at that time.

The story may or may not have given more details. But, the fact is that all of this improvement over the last decade was concentrated in one aspect of the housing stock—those units rated by the Census enumerators to be sound structurally, but lacking some or all plumbing facilities. That is, the dwelling may not have hot and cold running water; might share toilet facilities with another dwelling unit; or have some similar deficiency. There were nine million such units in existence in 1960. By 1970, there were only 4.7 million, a decrease of 4.3 million units. As one might expect, most of this decrease was attributable to the upgrading of rural housing. Over half (nearly 60 per cent) of the change was in what the Census Bureau terms rural areas, while rural housing generally accounts for only one-fourth of the total housing stock. And, of the rural proportion close to 90 per cent was in the South and Midwest.

### Statistical games don't mean better housing

What is the importance of this change? I think, considering the improvements that were made in sanitary engineering—sewer and treatment facilities—over the past decade, one would expect, almost as a natural progression of things, that there would be fewer houses that lacked adequate plumbing facilities rather than more. In fact, a decrease in houses of this type would have occurred even if *no* improvements were made, simply by demolitions, and removals from the housing inventory by other means.

The ominous figures in the components of change data are the ones for dwelling units that had all their plumbing facilities, but were considered to be dilapidated by census enumerators. There were 1.8 million of these in existence when the 1970 census was taken, data

shows. Nearly one million *more* than existed in 1960.

Unlike the figures for homes lacking plumbing facilities, the number of dilapidated units corresponded pretty closely with the urban/rural split of the housing stock generally. Over 70 per cent of the increase in the number of units becoming "substandard" was in urban areas.

It's interesting too, that the biggest changes, both in improvement, as with plumbing facilities, and deterioration, as with the dilapidated category, came in renter occupied units. While only one-third of the housing stock is composed of renter-occupied units, over half the *decrease* in the number of units lacking plumbing facilities was in this type of unit. Conversely, over half the *increase* in units becoming dilapidated were also rental units.

Of course, even though the data was released a few months ago, it still has one big drawback. It describes the situation as it existed in 1970. This is 1974. Three years of exceptionally high levels of housing output have occurred in between. Presumably, we've made some improvements over this period. But, the housing market, like the market for any other commodity, responds to the *wants* of the consumer only to the extent that the consumer has the ability to pay for those wants—that's called effective demand. *Needs* are something else again. The market mechanism gets at these only indirectly.

Let's pursue this a little further, in 1971, '72, and '73, the best three years for housing ever, some 900 thousand units were started in the Northeast. Curiously enough that's just about what the Census Bureau says the increase in household formations was in the region over this same period. Assuming that units are becoming dilapidated at the same rate as they were in the sixties, and sound units are being removed from the inventory at the same rate also, 200 thousand of those units would have been needed just to stay even with 1970. What the Northeast appears to be left with at present, then, is 650 thousand dilapidated units.

Far from being the time to downgrade housing priorities, it appears that we should be sharpening them up to focus in on the areas where the need is really critical. Is this a likely prospect? Not as long as the policy makers can still get mileage out of pointing back at the accomplishments of "those three golden years".

James E. Carlson manager, economic research  
McGraw-Hill Information Systems Company





MATTHEWS  
IDENTIFICATION SYSTEMS:

# Successful solutions to signage problems.

Put modern signage to work on your commercial, industrial and retail projects. With identification systems designed to inform, direct, describe and influence. Created specifically to solve communications problems effectively inside and outside.

Depend on Matthews to handle the complete job. We're experts in design, manufacture and installation. Choose from an unlimited number of signage materials, colors and styles. From acrylic parking lot signs to cast bronze corporate logotypes, Matthews can provide the right kind of identification for the most efficient traffic flow.

Matthews is the single source with the system that works. For effective solutions to your signage problems, write or call for the Identification Systems catalog today.



**JAS. H. MATTHEWS & CO.**  
**Identification Systems**

1315 W. Liberty Ave., Pittsburgh, Pennsylvania 15226

Plants in PITTSBURGH, PENNSYLVANIA; SEARCY, ARKANSAS; MILTON, ONTARIO; SUN CITY, CALIFORNIA; SENECA FALLS, NEW YORK; EL MONTE, CALIFORNIA.

For more data, circle 46 on inquiry card



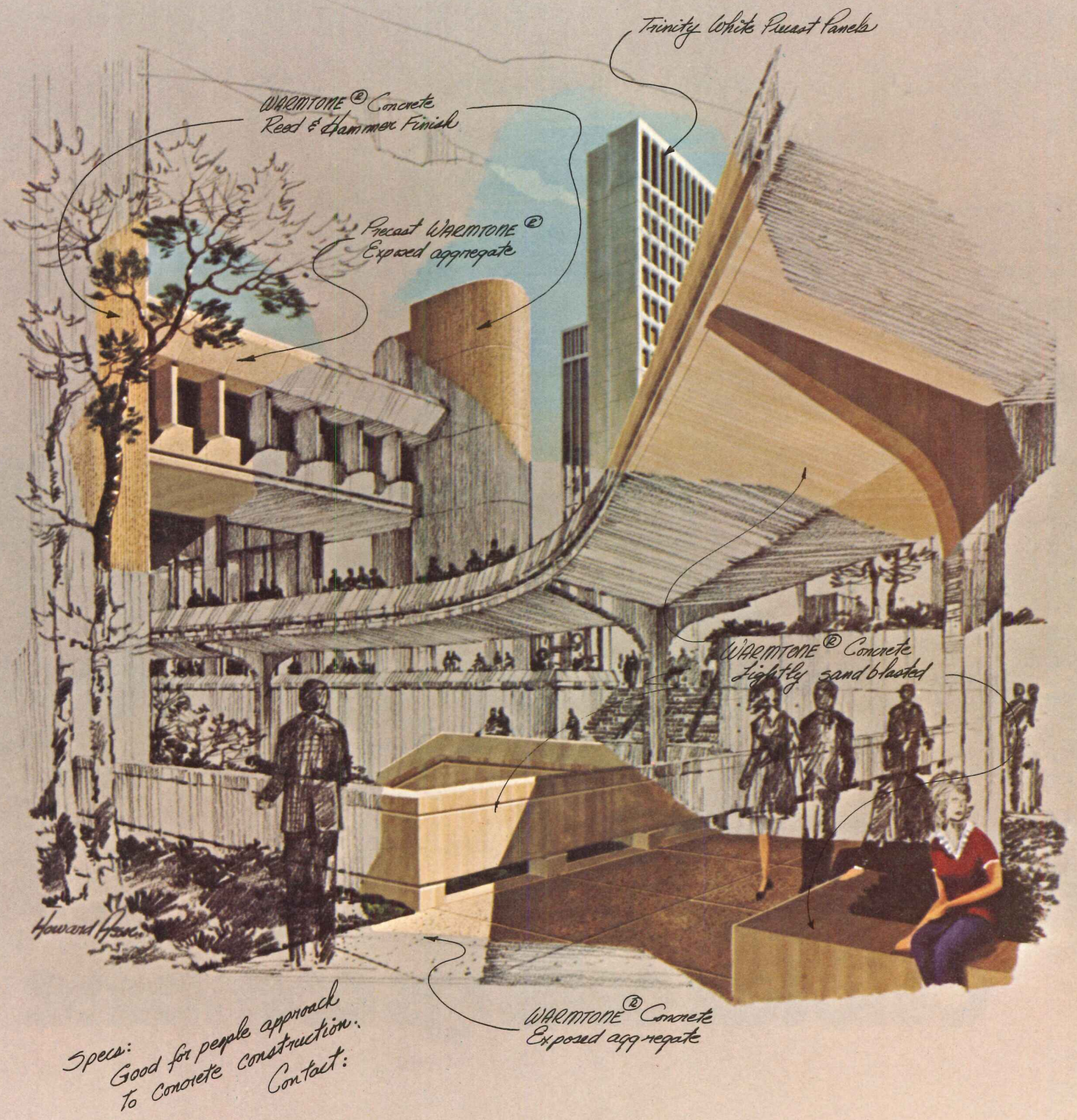

*Trinity White Precast Panels*

*WARMTONE® Concrete  
Reed & Hammer Finish*

*Precast WARMTONE®  
Exposed aggregate*

*WARMTONE® Concrete  
Lightly sand blasted*

*WARMTONE® Concrete  
Exposed aggregate*

*Howard H. Brown*

*Specs:  
Good for people approach  
to concrete construction.  
Contact:*

**Trinity White**

**trinity  
warmtone®**



**General Portland Inc.**

P.O. Box 47524, Dallas, Texas 75247

P.O. Box 22348, Tampa, Florida 33622

OFFICES: Dallas — Houston — Tampa — Miami — Chattanooga

Fort Wayne — Oklahoma City — Los Angeles

For more data, circle 47 on inquiry card





# Celotex ceilings combine

Next time someone says you must sacrifice overhead beauty if you want a functional ceiling—or vice versa—you can answer with one word.

The word is Celotex. And it makes the very notion of an either/or choice between looks and utility seem old-fashioned. Start with that name, and

you can choose a ceiling system with wide design possibilities. Without giving up beauty. Perhaps a non-directional patterned Celotex ceiling tile for a monolithic effect; or a Celotex reveal-edge lay-in panel for a bold contrast; or a design tile for that special interior.

The same reliable name will help you satisfy noise control requirements, because Celotex ceiling products can deliver Noise Reduction Coefficients to .90.

Time rated ceiling assemblies? You can get U.L. time ratings of one, two or three hours with Celotex.





# beauty and performance.

Where the plan calls for complete environmental control, check Celotex Vari-Tec™ systems—sound control, lighting and air handling all provided for in one beautiful, integrated ceiling system.

Which brings you back to where we started: beauty. Your Celotex ceiling can be beautiful as well as functional. Our success

in delivering this valuable combination has made Celotex as popular with architects as with contractors, building owners and managers.

Consult the Celotex Acoustical System catalog. You'll find it in Sweet's Architectural and Industrial Construction Files. Or,

contact your Celotex commercial ceilings representative.

**Celotex™**

**BUILDING PRODUCTS**  
The Celotex Corporation, Tampa, Florida 33622

a **Jim Walter company**

For more data, circle 48 on inquiry card



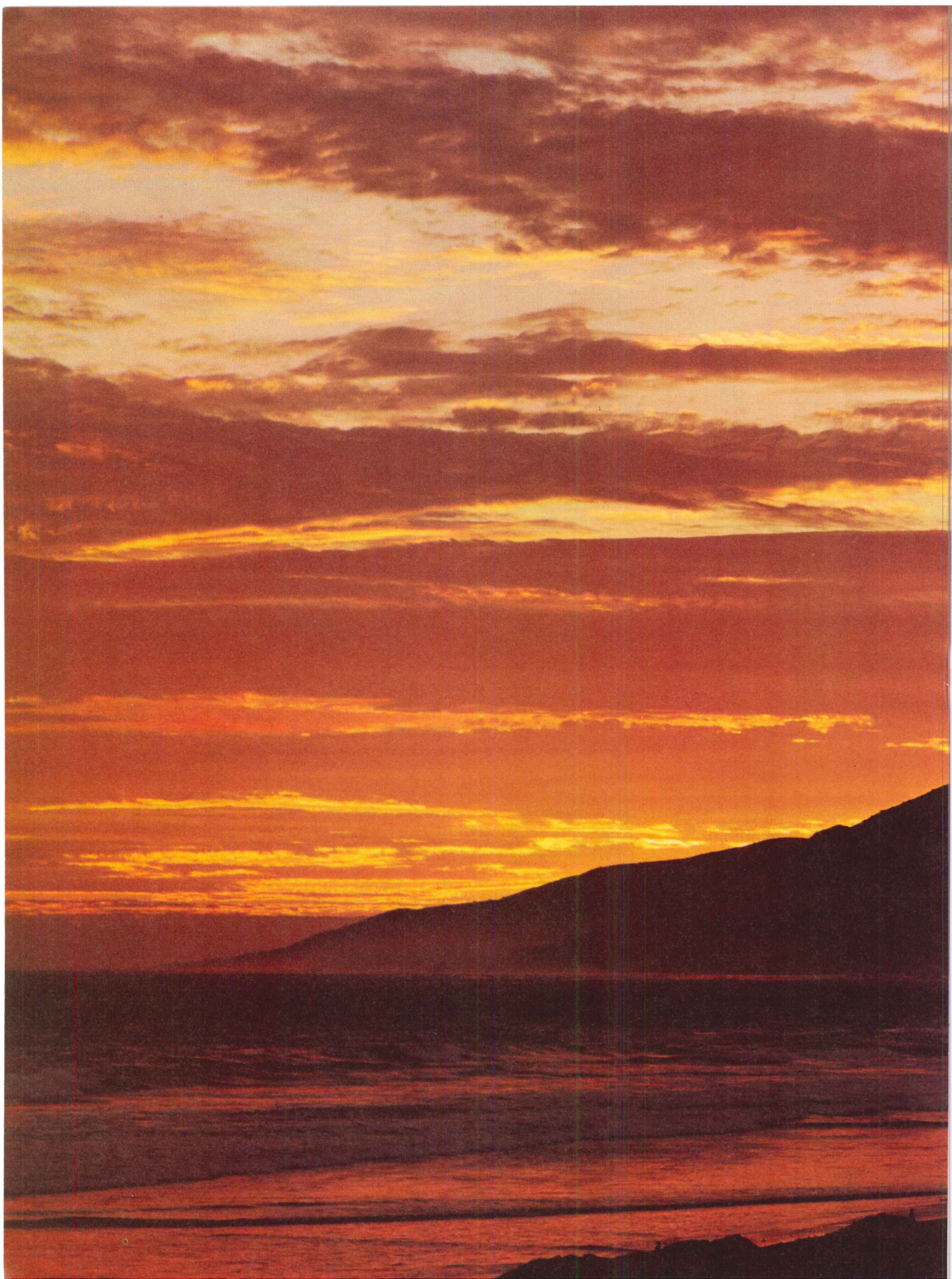



# A good clean story.

California is really a fantastic state. It's got everything. The ocean. Mountains. Climate. Beautiful cities. Movie stars. And now, it's got a "clean" backup power source for its telephone system.

Of course, that last bit of news probably didn't cause you to fall out of your chair. However, if you're interested in good, clean standby power, it's a tale worth retelling.

You see, Pacific Telephone and Telegraph Company, like so many others in the communications industry, discovered they can function reliably only when the power source they use is "clean." That is to say, when it performs with an absolute minimum of frequency or voltage fluctuations.

And this was one of the

big reasons they chose the Allison 501-K15 turbine as the standby power source for their energy system.

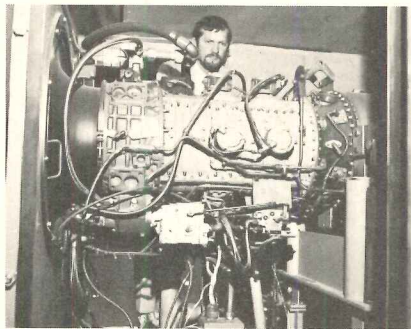

What really sold them was the ability of the gas turbine powered alternator to supply electrical energy with essentially no fluctuation in frequency at all.

There were other reasons, of course. Like minimum vibration. Low noise level. Low levels of pollution. Compact size and light weight. But in some ways, the most impor-

tant reason was that their Detroit Diesel Allison Distributor was able to work out the whole program for them. From start to finish.

So if you're looking for "clean" power. Reliable power. Power that's been proven throughout the world. Just check with your nearest Detroit Diesel Allison Distributor. He's got all the power that you'll need. In turbines. Or diesel engines. And he can handle the entire job. From start to finish.

To find out more, just clip this coupon and we'll send you the latest catalog on Detroit Diesel Allison Powered Electric Sets.



**Detroit Diesel Allison**

Division of General Motors  
P.O. Box 81, Birmingham, Mich. 48012

NAME \_\_\_\_\_

COMPANY \_\_\_\_\_

ADDRESS \_\_\_\_\_

ZIP \_\_\_\_\_

GD01-AR-07-AC

**Detroit Diesel Allison Powered Electric Sets**  
Now you're talking power.

For more data, circle 49 on inquiry card



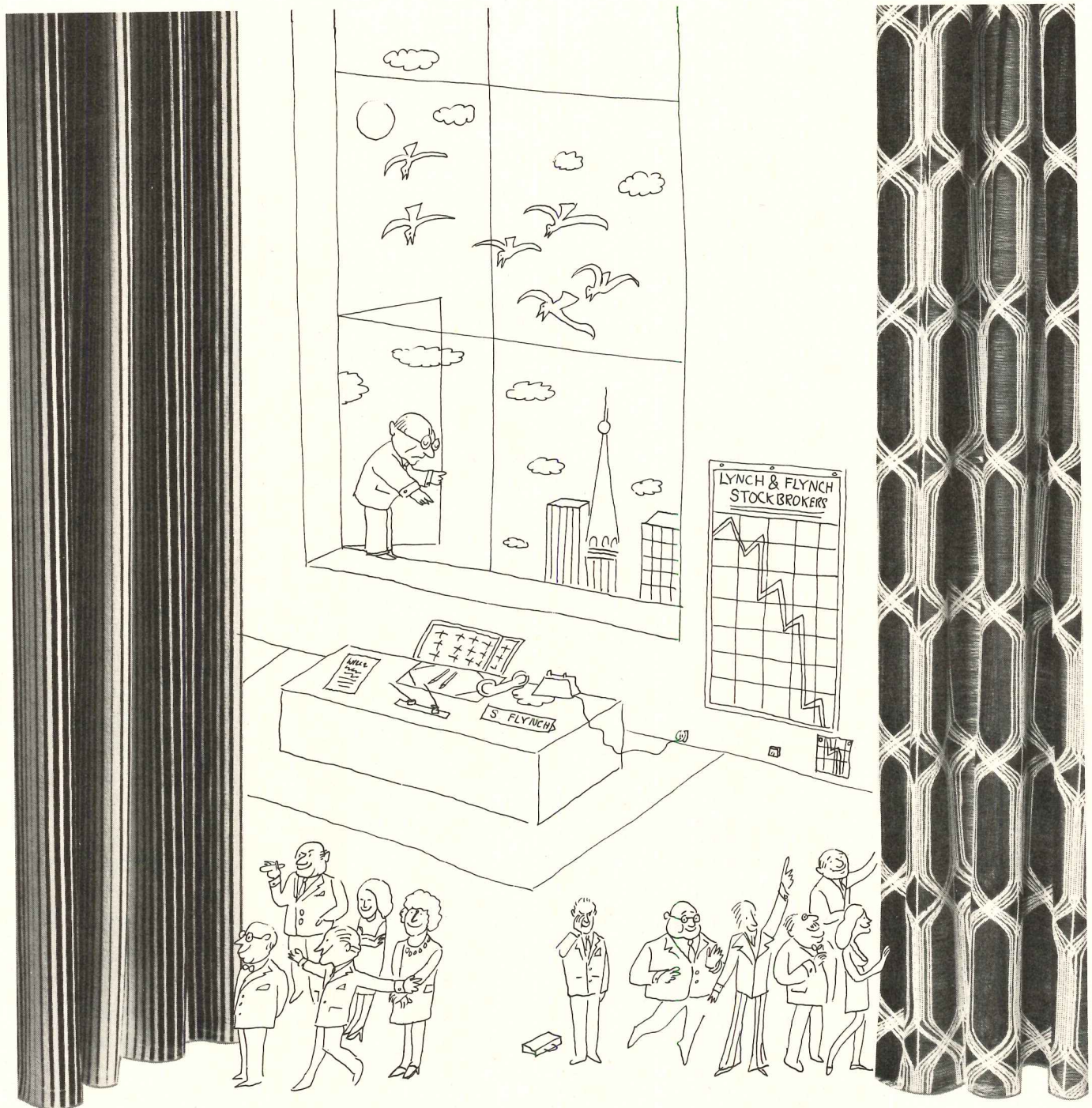

## The New SEF<sup>®</sup> Collection from Maharam: when the market's down, it keeps spirits up.

Contract drapery fabrics are getting a bright new decorating image they never had before. And the reason is SEF, the new modacrylic from Monsanto with superior flame retardant characteristics. If your job is specifying, see this unusual new fiber in action at Maharam. The SEF collection there is an eye-opener.

Because SEF modacrylic can duplicate the fabric aesthetics of an acrylic, Maharam has created visually exciting new pattern effects, architecturally crisp and texturally varied.

Hands are soft, resilient, with a natural drape. SEF is a top contract performer, too, so all these fabrics can pass the California Fire Marshall Test. They have superior flame retardancy, soil release, sun resistance and colorfastness.

Whether your next specifying job is an office, high-rise or motel, see the SEF contract drapery fabrics at Maharam. They'll keep your spirits up too. Maharam Fabric Corp., Rasons Court, Hauppauge L.I., N.Y. 11787 (516) 582-3434.

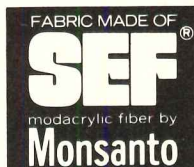

For more data, circle 50 on inquiry card



# Before you pull the padding out from under another rug, read this.

Whenever your carpeting budget is up against the wall, the first thing you're tempted to do is pull out the cushion. Before you do, consider the underlying contributions carpet cushion can make to your next installation.

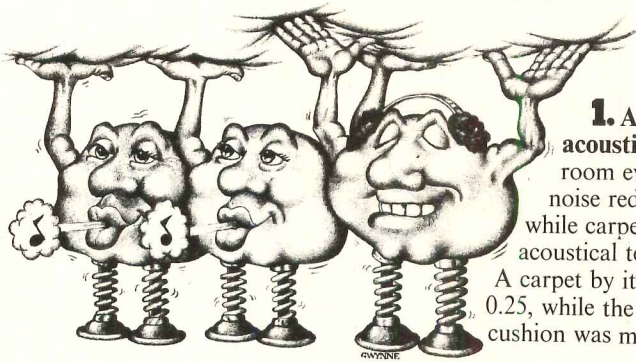

**1. A carpet cushion more than doubles a carpet's acoustical properties.** A carpet with cushion makes a room even more quiet. In tests to measure impact noise reduction, carpet only received a +14 rating, while carpet over cushion had a +25 rating. In a similar acoustical test measurements were taken for noise reduction. A carpet by itself measured a noise reduction coefficient of only 0.25, while the coefficient for a carpet over cushion was more than twice as great, 0.65.

**2. Separate cushion makes a carpet seem thicker and more luxurious.**

It upgrades the carpet's underfoot feel and simply makes it feel better. Cushion also adds to the carpet's ability to lower the peak impact force when an object, such as a foot, hits it abruptly. In a quantitative drop test, cushion reduces the impact exerted on the floor covering by one-half when compared to carpet alone.

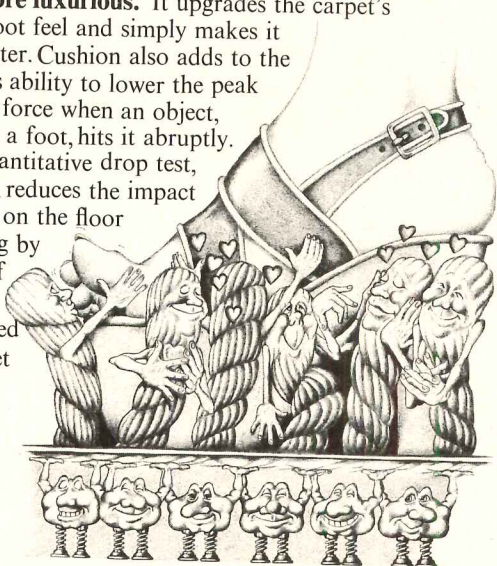

**4. The initial cost of a cushioned carpet need not be more expensive.**

Instead of putting money into a sub-floor, you can put it into a cushion. A cushion plus carpet can mask surface irregularities so that a lower-grade, less costly finish on sub-floors can be specified. In addition, a lighter weight, less expensive carpet can be used since the more expensive face yarns aren't needed to provide cushioning. And there are no expensive labor costs involved in the removal of an old carpet, as there can be with glue-down installations.



**3. Carpet cushion can help retain heat.**

Cushion improves the overall thermal insulation properties of the floor covering. The heat loss factor of a floor covered by a low pile carpet and a cushion is about one-third of what it would be with the same carpet alone.

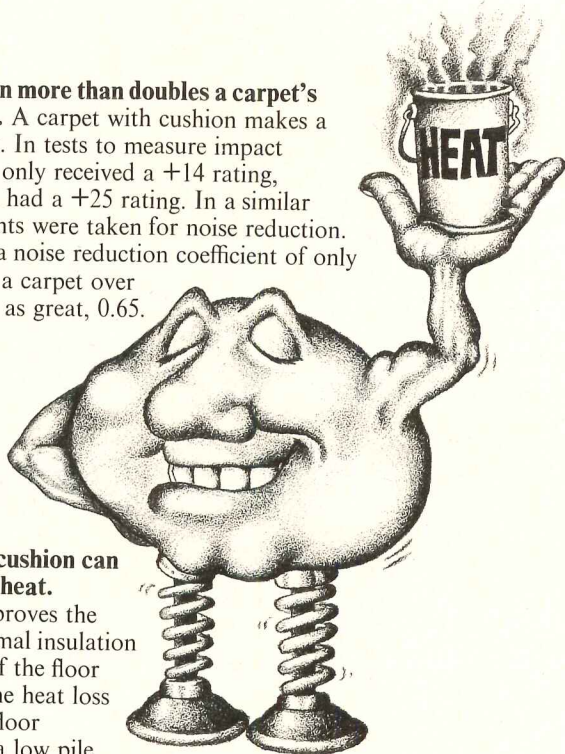

**5. Separate cushion makes a carpet easier to maintain.**

It lowers the maximum forces acting on the fibers, thereby reducing the pile crushing and the grinding action of imbedded dirt that can cut and fray fibers. That means a cushioned carpet—given a fixed maintenance cost—will look better for a longer period of time than a non-cushioned carpet.

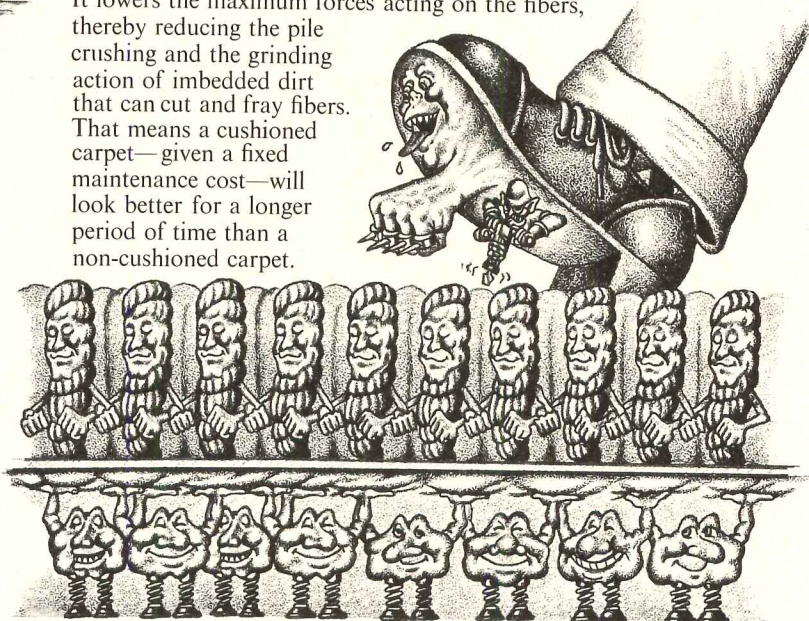

**6.78. and more reasons** why carpet cushion will add life, and cost less to install, can be found in our new brochure. For your free copy of "The Supporting Facts about Carpet Cushion," write: Carpet Cushion Council, P.O. Box 2048, Dalton, Georgia 30720 (404) 278-3176.

 carpet cushion council

For more data, circle 51 on inquiry card



# Al Kaline— the ALL-STAR Tiger— durable, dependable— just like our *Aquapon*<sup>®</sup> and *Pitt-Glaze*<sup>®</sup> Coatings

When Al Kaline of the Detroit Tigers steps to the plate or slides for home, you know this veteran American League All-Star will give you everything he's got. Al's well respected and he earned his reputation as one of baseball's most durable players—one of its toughest competitors.

Just think of the punishment tough professional athletes like Al Kaline give a team locker room. The tromping of cleats, the mud and cinders, steaming hot water from the showers—day in, day out, all season long give any wall or floor coating a good going over.

*Pittsburgh Paints* has a durable duo that can meet this kind of punishment head-on, not only in locker rooms, but in all hard-use industrial and commercial areas—such as corridors, kitchens, machine shops, laboratories, and the like.

For the concrete block walls, there's *Pitt-Glaze* Coating, the Polyester-epoxy that looks and feels like tile.

And for heavy-duty use on concrete floors, there's *Aquapon* Enamel, the Polyamide-epoxy heavy-duty floor coating.

Both can take the kind of treatment the "pros" can throw at them—and more. They're resistant to salt water, alkalis, acids, plus many oils and chemicals. Both can meet the toughest requirements of schools, hospitals, motels, hotels, dairies, breweries, and industrial plants, to name a few.

Put this durable duo to work for you. Give your maintenance costs the one-two punch with *Pitt-Glaze* Polyester-epoxy for your walls and *Aquapon* Polyamide-epoxy for your floors.

Write for complete literature. PPG Industries, Inc., Dept. AR, One Gateway Center, Pittsburgh, Pa. 15222.

**PPG: a Concern for the Future<sup>®</sup>**



For more data, circle 52 on inquiry card



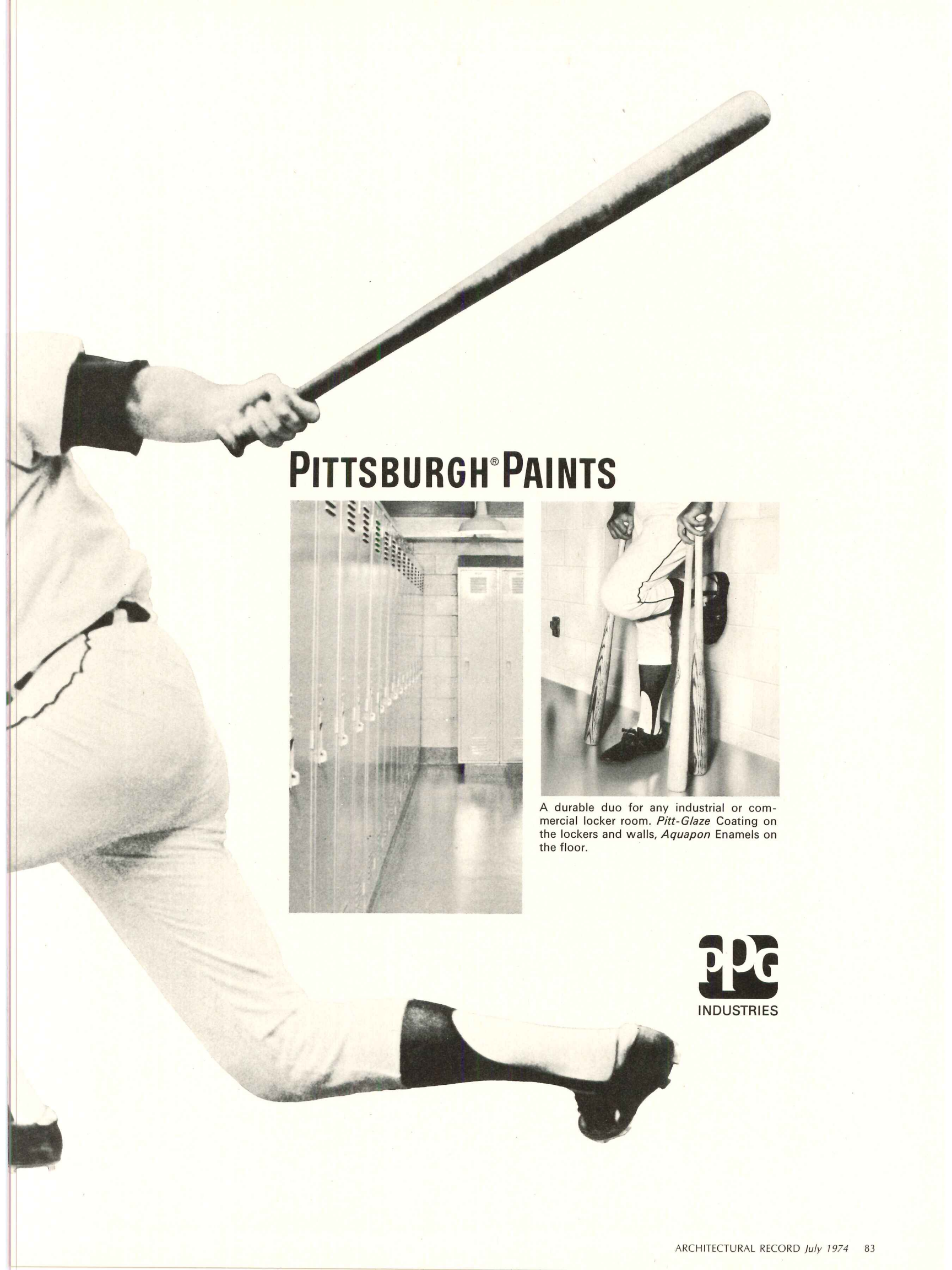

# PITTSBURGH® PAINTS

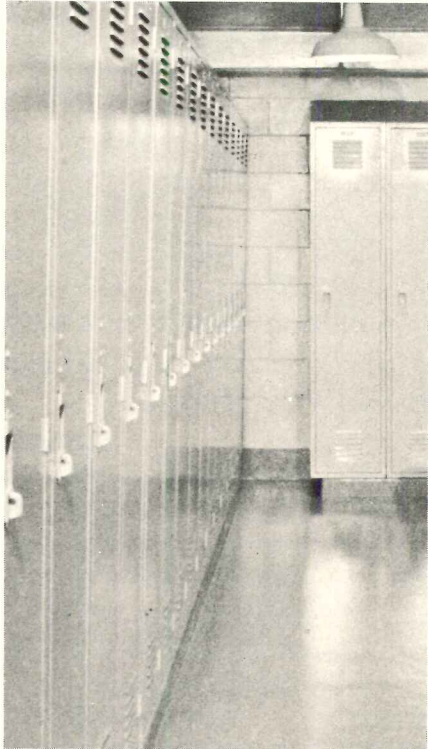

A durable duo for any industrial or commercial locker room. *Pitt-Glaze* Coating on the lockers and walls, *Aquapon* Enamels on the floor.

**PPG**  
INDUSTRIES



# If you're looking into the use of plastic glazing, here are some things to think about.

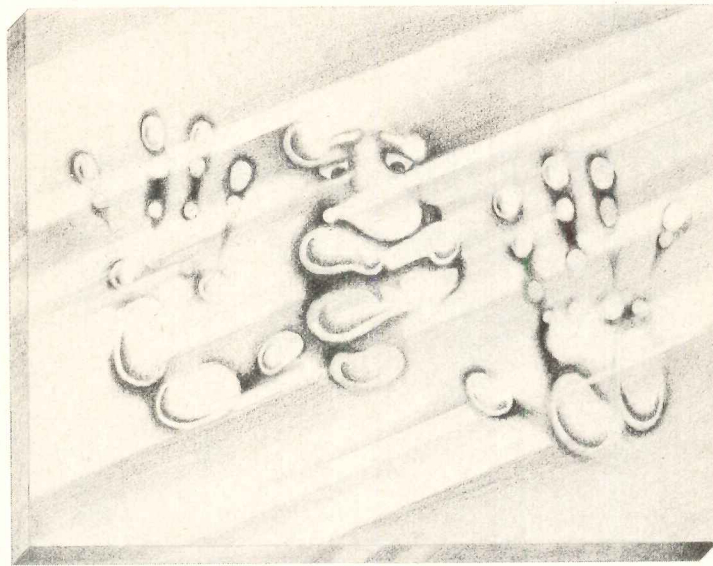

The use of plastics in construction is growing every day, particularly in windows and walls. Plastics are also being used to protect or fabricate frames and exterior wall components. Acrylic and polycarbonate sheet now qualify for use for safety glazing.

Plastics offer many advantages, such as light weight, durability, reasonable cost and handsome appearance. But they also offer special glazing problems that we — Tremco — can help you solve.

## Pre-specification checkpoints.

Before you specify plastic glazing and frame components, you need to know the physical properties and performance characteristics of the plastic.

Many sealants that you can use with glass can't be used with plastic. Sealants must be compatible with each other and the plastic.

Plastic has much greater thermal expansion than glass, wood or metal. So you have to allow for greater movement, especially when you consider that building exteriors are subject to temperature changes ranging over 100°F. in minutes.

Plastics create new tolerance demands

because of their movement factors. A glazing system for plastic must allow for additional movement, and also be highly adhesive, unaffected by ultraviolet and permanently elastic even at low temperatures.

## Designing the sash.

In general, plastic sheets need more "bite" than glass so the sash rabbet must be deeper. The depth and width requirements of the rabbet are determined by the type, thickness and windload requirement of the plastic sheet. Check the manufacturer's recommendation for maximum size limitations.

At this point, it's a good idea to talk to your Tremco man. With his experience, he can recommend the right sealing systems to secure the sheet into the rabbet and to seal the sheet perimeter. He can also check for sealant compatibility and adhesion, especially important on sheets with special coatings.

Glazing methods will vary according to the maximum sash opening, or long dimension.

Shown here are three methods of glazing acrylic or polycarbonate plastic along with the recommended Tremco products. Each method is based on the long dimension. If the long dimension is over 72 inches, you should dis-



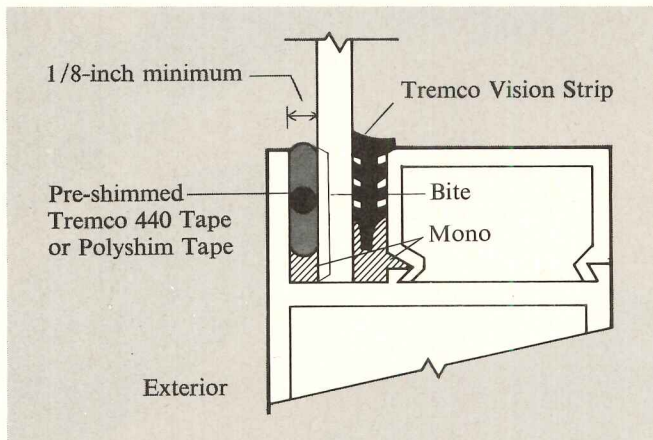

Maximum sash opening up to 36 inches.

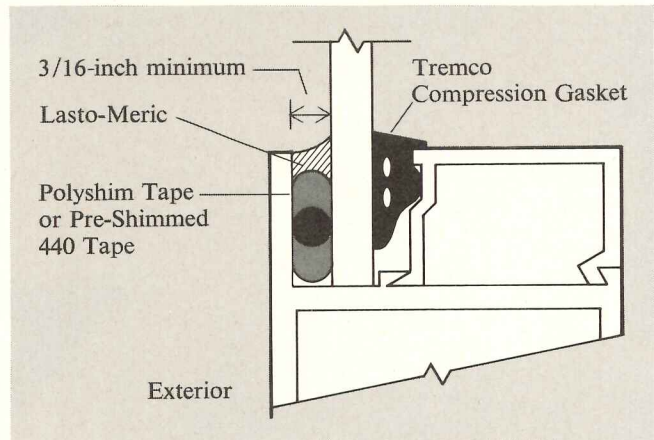

Maximum sash opening 36 to 48 inches.

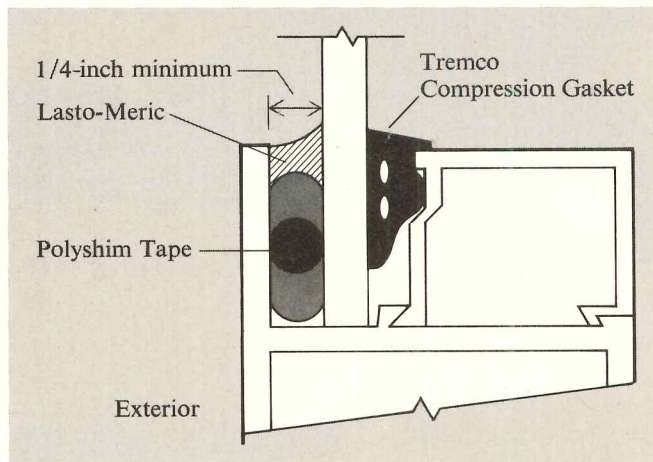

Maximum sash opening 48 to 72 inches.

Discuss the installation with your Tremco man and get his recommendations.

**Extra technical assistance.**

Remember, your Tremco man will be happy to meet with you to discuss the use of plastic

glazing anytime. While you're still in the thinking stage, at the drawing board or when you're making specific recommendations.

Although the use of plastics is relatively new, he can draw on the experience of a company that's been solving all kinds of glazing and sealant problems for more than 45 years.

We have some 15 basic job-proven sealants to choose from, such as MONO®, Polyshim® tape and Lasto-Meric®, as well as compression gaskets. You may also have use for our unique TREMproof® waterproofing systems and Tremline roof edging systems.

So talk to Tremco first. And avoid problems with plastic glazing later. Just contact your Tremco rep. Or write Tremco, Cleveland, Ohio 44104, or Toronto, Ontario M4H 1G7.

**TREMCO®**



The most beautiful roofing material you can use just happens to be the best insulation, too.

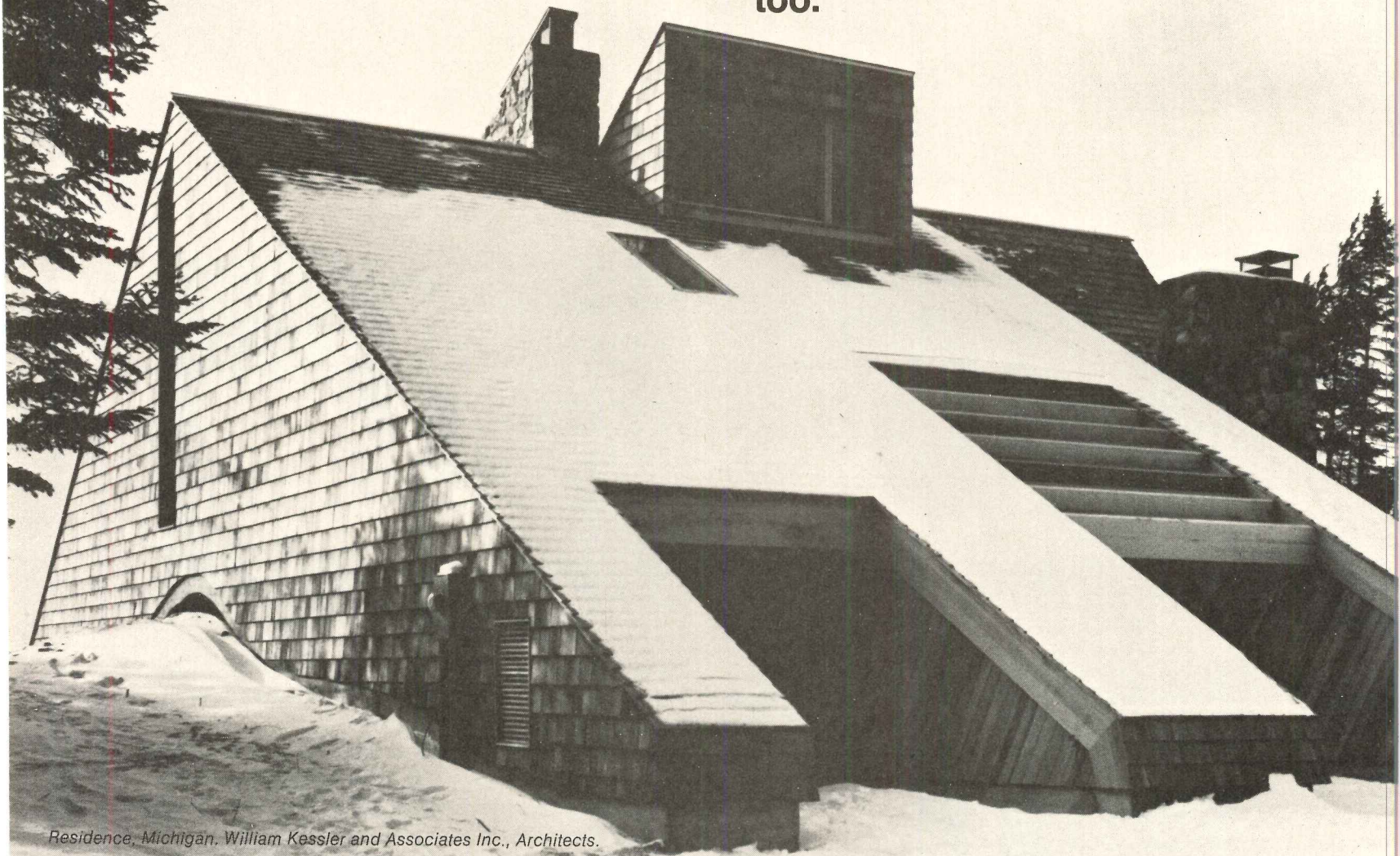

Residence, Michigan. William Kessler and Associates Inc., Architects.

Red Cedar shingles and handsplit shakes are twice as resistant to heat transfer as asphalt shingles. Three times more resistant than built-up roofing. In fact, red cedar out-insulates such roofing or siding materials as asbestos-cement shingles, slate, aluminum and architectural glass.\*

Red cedar deserves close consideration for architects and builders concerned with the energy conservation of their structures. Its unique cellular structure makes it even more insulative than many other woods.

And the traditional overlapping application method effectively multiplies cedar's resistance to heat transfer.

Add to this the design flexibility and durability of red cedar on residences and commercial structures. It's no wonder the most beautiful roof and sidewall covering you can possibly use is also most efficient.

For more details, write Red Cedar Shingle & Handsplit Shake Bureau, 5510 White Bldg. Seattle, Washington 98101. (In Canada 1055 West Hastings St., Vancouver 1, B.C.)



These labels under the bandstick or on cartons of red cedar shingles, handsplit shakes and grooved shakes are your guarantee of Bureau-graded quality. Insist on them.

\*ASHRAE Handbook of Fundamentals, 1972 ed., Chap. 20 "Design Heat Transfer Coefficients" Table 3A, pp. 362-63.

**Red Cedar Shingle & Handsplit Shake Bureau**  
One of a series presented by members of the American Wood Council.

For more data, circle 54 on inquiry card



# Alan Dunn

The Alan Dunn cartoon shown below—the first that he drew for RECORD, and which appeared in the June 1937 issue—began a 37-year monthly contribution of remarkable architectural criticism. It has ended with his cartoon for the June 1974 issue (see page 90), which he sent to us just a few days before his fatal heart attack on May 20th.

Along with that finished drawing, he submitted a collection of idea "roughs" for our selection for the next few issues. We proudly, if very sadly, present them overleaf—just as he sent them, with his own handwritten "gag" lines; they form a testament to his continued fresh and vital concern for architecture at the age of 73.

Dunn was a true artist and professional in every sense. He was never at a loss for new and relevant ideas, and he never missed a deadline. This dedication was accompanied by an extraordinary modesty, in spite of his many, many honors, awards, exhibitions and publications. Recently, he accompanied his



superb-as-usual monthly finished drawing with this note:

"Here 'tis! AR has always been so tolerant of this dilatory artist who puts his foot into the door just as it is closing that I thought the decent thing to do was to get right to work the very minute I finished telephoning you.

"So here I am posting it in the hall box that very evening—at 11 p.m. I hope it's all right."

And after his award of the AIA Architectural Critic's Citation last year, he would frequently append to his little notes: "I find joy in contemplating that beautiful Citation!"

Dunn had an even longer association with *The New Yorker*, which began in 1926 and averaged a drawing in almost every weekly issue through all those years; there, his comments were sometimes on architecture, but more often on the broader, current social scene. His wife and fellow artist, Mary Petty, was also a frequent contributor to that magazine, and drew the sketch of Alan Dunn shown above for the ARCHITECTURAL RECORD

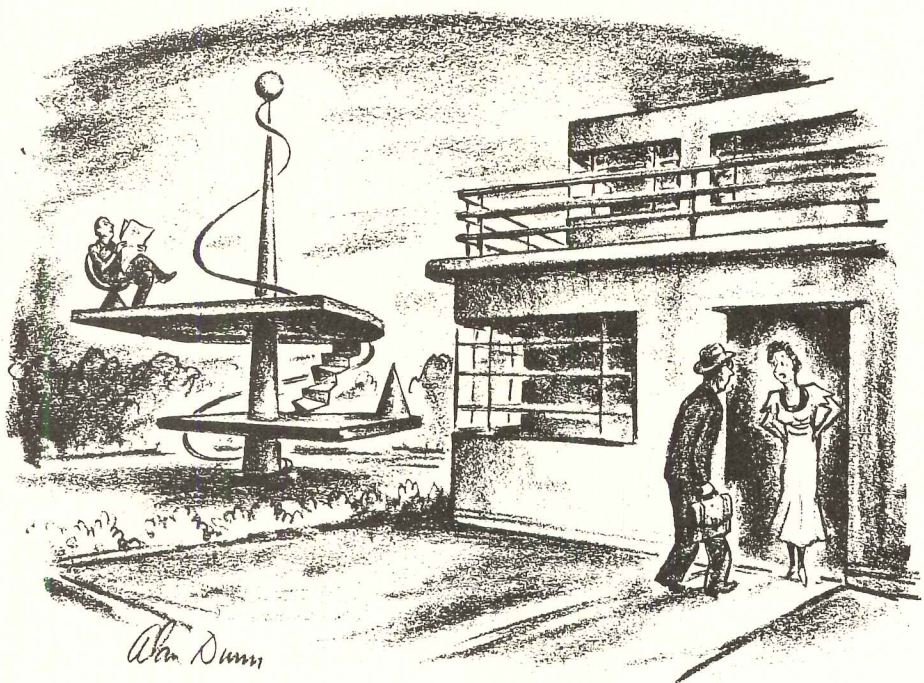

"Well, we're dated!—that abstractionist next door built his house in space-time!"



"The social cartoonist's pen is no sword  
but a titillating feather that reminds us  
constantly that we do not act  
as we speak or think." Alan Dunn

The pencil idea sketches or "roughs" shown below were Alan Dunn's last submission to RECORD editors for selections to be translated into his highly individual,



"Not yet!"



"When you think of the sheer power of  
enclosed nothingness you won't regret the added  
cost"



"Does the AstroTurf go with the house?"



"Why women architects? — Closet space!"



"And now the highest achievement of Roman  
civilization — the Cloaca Maxima — a pollution first!"

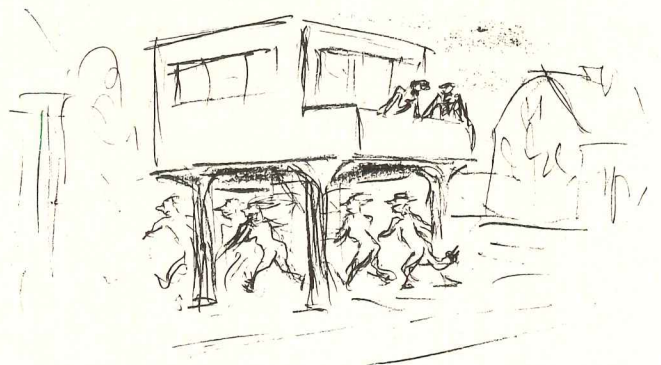



"A gentle approach tends to soften and ameliorate the aggravations of one's times and thereby to enlighten." Alan Dunn

wonderfully witty pen and ink final drawings.

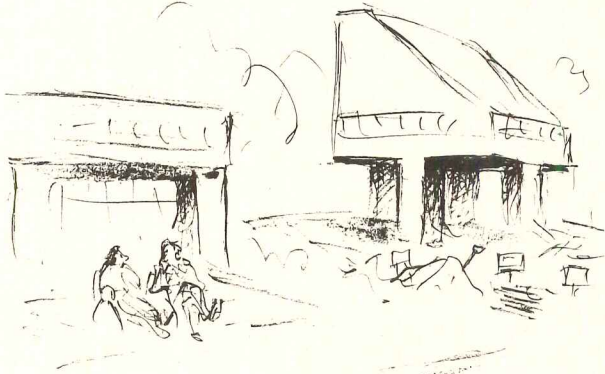

"Damn those Joneses!"

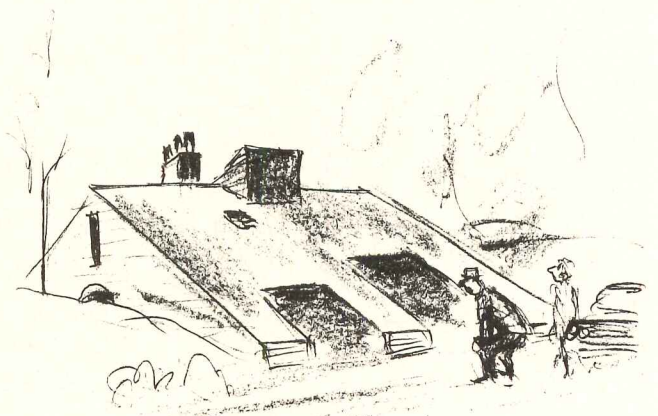

"Anybody home?"



"Furthermore, a full explanation comes with each house -"

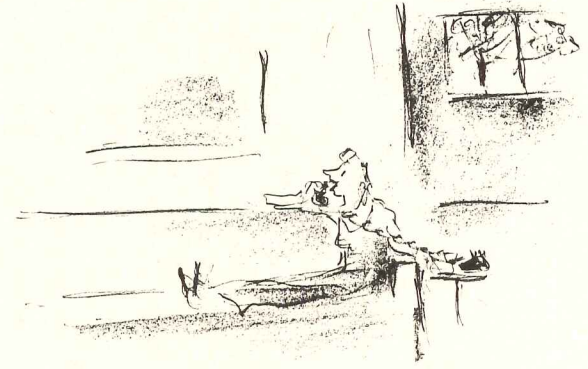

"Talk on! I live in a 'sealed environment' and there's a lot I don't know -"

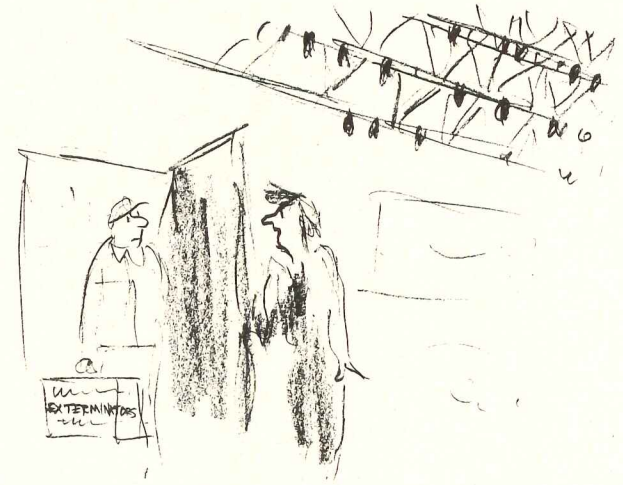

"Yes, bats!"



*“... so why not just curl up in a bean-bag chair,  
bemused and confused, and enjoy man’s predicament  
in coping with an environment that is always changing and  
always will? If you love it it will love you back.  
I love it.” Alan Dunn*

BOOKS’ last collection of his work “Architecture Observed,” published in 1971.

In addition to his wittily incisive mind, Dunn was widely respected for the pure artistry of his work. In its obituary, *The New Yorker* wrote: “In the mysterious fashion of nearly all artists above a certain rank, Dunn’s talent flowered with age; though his drawings remained as vigorous as ever, they grew lyrical and, in terms of their aesthetic intentions, took greater and greater chances.” This kind of recognition led to many exhibitions of his drawings, national and international, and to the inclusion of his work in the permanent collections of the Library of Congress and many museums, as well as the preservation of his manuscripts at Syracuse University.

In the foreword to the catalog of one of his exhibitions—at the Edward W. Root Art Center, Hamilton College, New York in 1968—Dunn described his views on what he called “graphic comment art”:

“There is the political or editorial cartoon with its biting satire and its appeal to factionalism. Then, over in the bleachers, there is comic art with its breadth of reach to the masses and its happy, innocent levity in deal-

ing with everyday problems.

“In the middle lies the work of the social cartoonist, whose pen is no sword but a titillating feather that reminds us constantly that we do not act as we speak or think. Since by its very objectivity it reaches more people and raises fewer hackles, its gentle approach tends to soften and ameliorate the aggravations of one’s times and thereby to enlighten . . .

“Since political cartooning fades with the decline in tyranny, it might be conceivable that if human perfectability were ever to become a reality the social and comic cartoon would also disappear by lack of any further contrast between aim and achievement.

“The ensuing paradise, if one could call it that, would be a world without laughter.”

As I wrote on a happier occasion, “Alan Dunn is one of the most knowledgeable and effective critics of architecture today. And in this role he consistently and wittily reminds us that architecture is for people and language is for communication; if he notes any tendency toward excesses in architectural fads, clichés or obscure jargon, he quickly brings us laughingly back to reality.” We will miss all that laughter.—Herbert L. Smith, Jr.

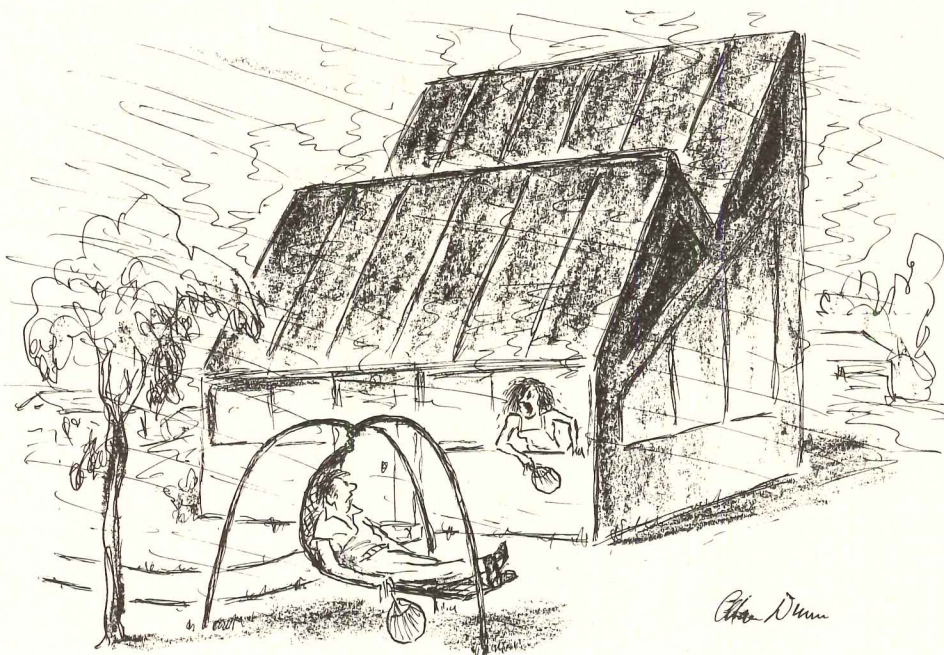

*“How do I turn off the solar energy?”*



# A CIVIC CENTER FOR SCARBOROUGH, ONTARIO— DESIGNED BY RAYMOND MORIYAMA TO CELEBRATE THE DRAMA OF LOCAL GOVERNMENT AT WORK

These days, an architect who creates a monument gets accused of taking an ego trip, and the monument—say his critics—is to himself. Monumental architecture built today is condemned with passion by almost everyone who speaks or writes about architecture. It has been almost forgotten that such architecture, while usually inappropriate, still has its place—especially in buildings where the arts of government are practiced. For democracy to function, people must understand how it works and a good way for them to learn is at the local level from a building which by its form instructs. A building which clarifies, interprets and dramatizes the administration of democratic government while ceremoniously receiving the public, cannot be fitted into one of the standard, anonymous contemporary office building envelopes. If it is successful, it will assume a distinctive form which signals its uniqueness. It will appeal to the mind and emotions as good monuments have always done.

The Scarborough Civic Center by Raymond Moriyama effectively and handsomely celebrates the drama and process of local government and is in itself a memorable image and the hub of the developing town center. As a design, it builds up to a climax reached as one enters its astonishing interior. Any uneasiness which its unorthodox, vaguely Wrightian exterior forms may engender as one approaches, is swept away by the first perception of this powerful space.—Mildred F. Schmertz

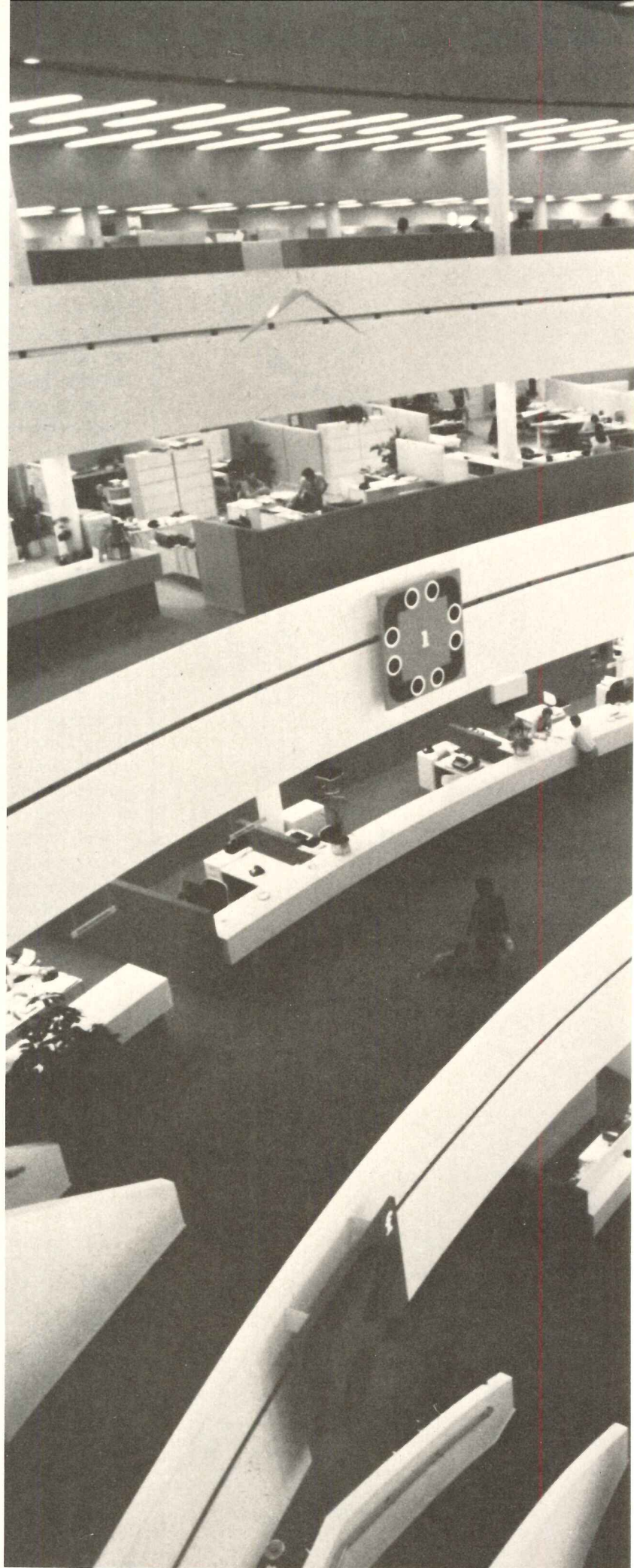

All photographs by Robert E. Fischer except as noted



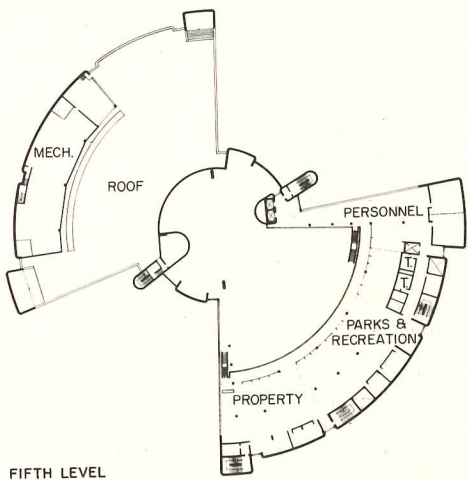

FIFTH LEVEL

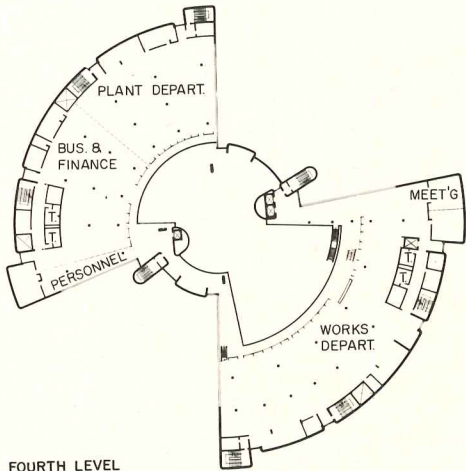

FOURTH LEVEL

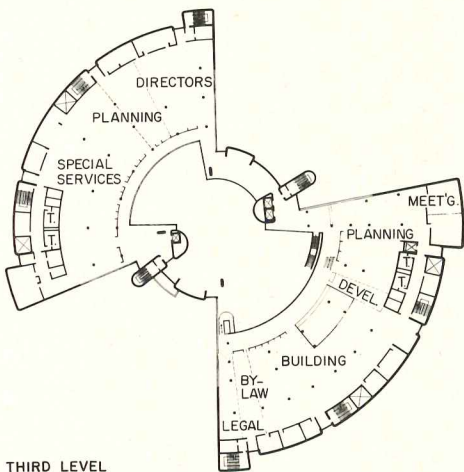

THIRD LEVEL

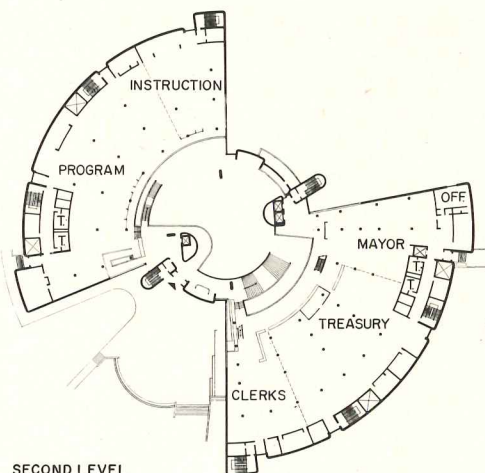

SECOND LEVEL

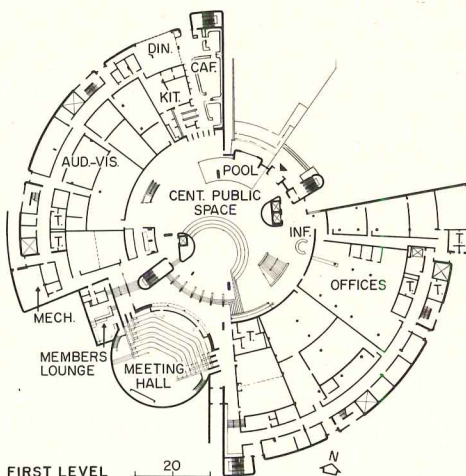

FIRST LEVEL

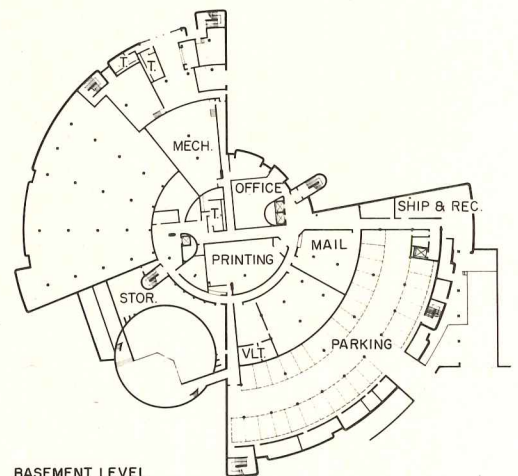

BASEMENT LEVEL

Scarborough, a part of metropolitan Toronto, is a political entity in its own right with its own borough offices, board of education and board of health, all of which the new civic center accommodates. In designing the project, the firm of Raymond Moriyama, Architects and Planners addressed themselves to a problem of which all the concerned parties were aware—namely that Scarborough, a low-density residential community of single-family houses, had no real center. The total project, therefore, has been designed to give Scarborough a central complex which will be the symbolic heart of the town and the focus for its future.

The building features a splendid multi-storied central space through which the public can move freely. The surrounding floors of open plan offices overlook the public area and together form one continuous space which orients the visitor and makes the building comprehensible to him.

The Scarborough Civic Center is part of a 170-acre development known as Scarborough Town Center which is being master planned by the Toronto firm of Bregman & Hamann and developed by Trizec Equities Ltd. The Town Center is primarily commercial and already boasts a 130-store, Y-shaped shopping center, also planned by Bregman & Hamann and in the future will include office buildings, a hotel and high-rise apartments. The area had originally been zoned industrial by the Scarborough council. The developers got their zoning change by coming up with a scheme for a shopping center and town square with a civic building as its focus, donating the land which had been selected for the construction of the borough facilities. This unusual trade-off was largely the work of the late former

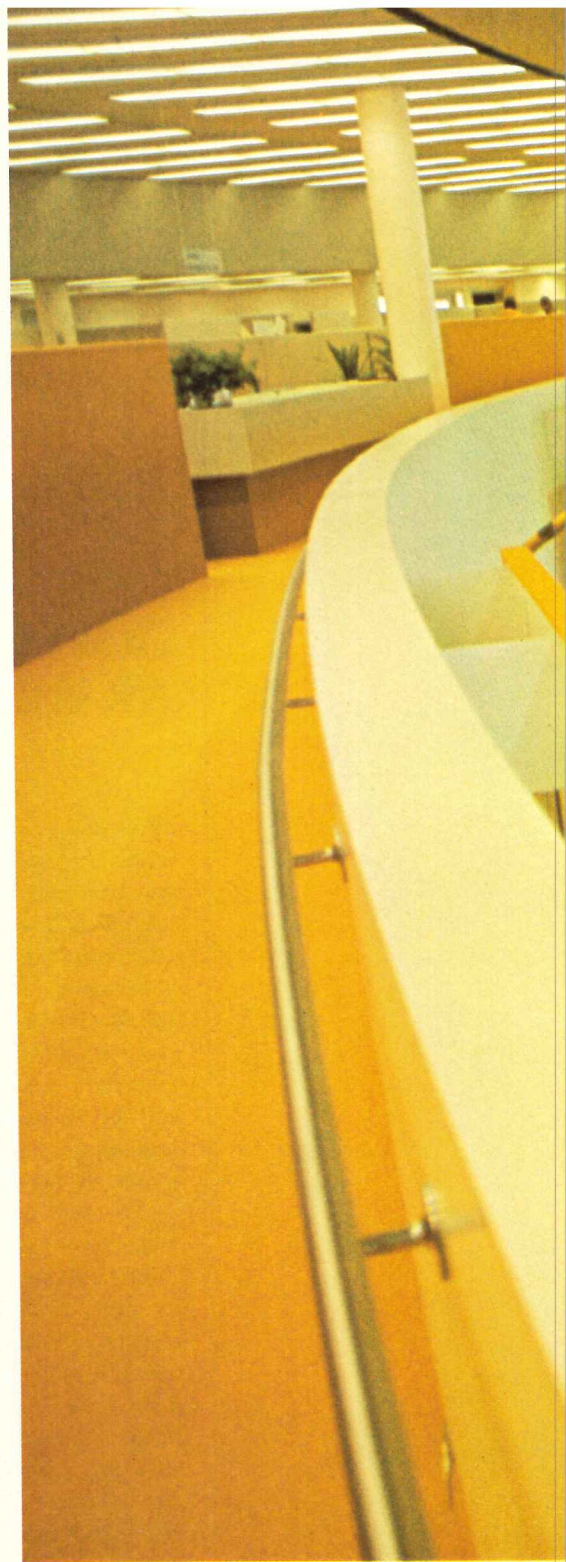





The open plan floors of the borough municipal offices step back. Functions requiring more privacy are located toward the rear of each floor.





Mayor Albert Campbell, after whom the town square has been named.

Moriyama and his firm entered the picture in 1969 with a feasibility study requested by the borough and the board of education to advise them of their land requirements within the Town Center. At this stage, they established the basic design criteria for the civic complex which they were to stick to after receiving the commission to design it. In Moriyama's words, they saw the new center as an opportunity to support and express positive trends such as the demand for openness and accessibility, the desire of the borough residents for a symbol of their collective identity and a need for a focus to draw the attention of outsiders and tourists. From the very first, they affirmed the importance of the proposed town square as a pedestrian domain and as a linchpin for future development in the Town Center.

From the start, Moriyama's firm recommended open planning for the office space in the belief that this approach improves face-to-face communication, relationships between the staff and the public and attracts a high caliber staff. Moriyama's own office has no enclosed private work spaces. Although small, it has a great sense of spaciousness. For Moriyama an open plan building is a democratic building, one in which the public feels it belongs.

The architects' feasibility study advised that the borough and the board of education should cooperate in the planning and financing of certain shared facilities in order to realize savings in capital costs, furnishings, operational and maintenance costs. The municipal offices for the borough and the board of education facilities were to be constructed simultaneously in order to achieve construction and overhead

The entire building is constructed of poured-in-place concrete except for the roof over the central space. It is framed by an 88-foot-diameter ring girder from which radiate 80-foot trusses spanning the office area. The interior walls, ceiling and floor parapets are white and are considerably enlivened by the flags. These were designed by artist James Sutherland to symbolize the functions of the various administrative departments on each level. He also designed the aluminum tetrahedrons (overleaf) and the supergraphics used elsewhere in the building. This central space is joyous and gay, an antidote to bureaucratic fatigue and boredom.

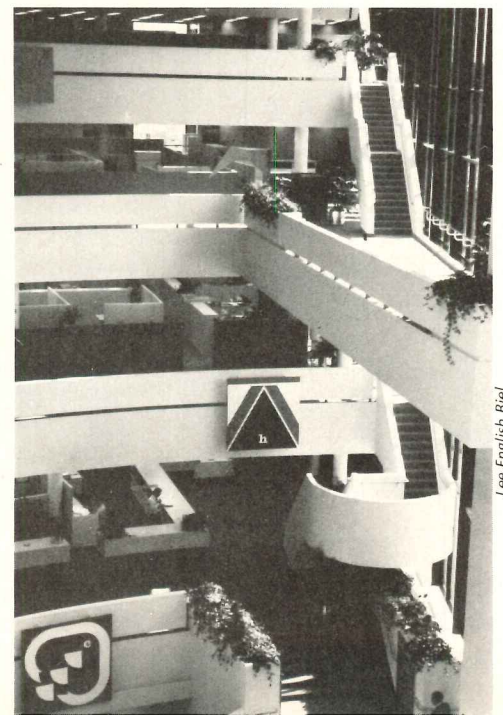

Lee English Biel



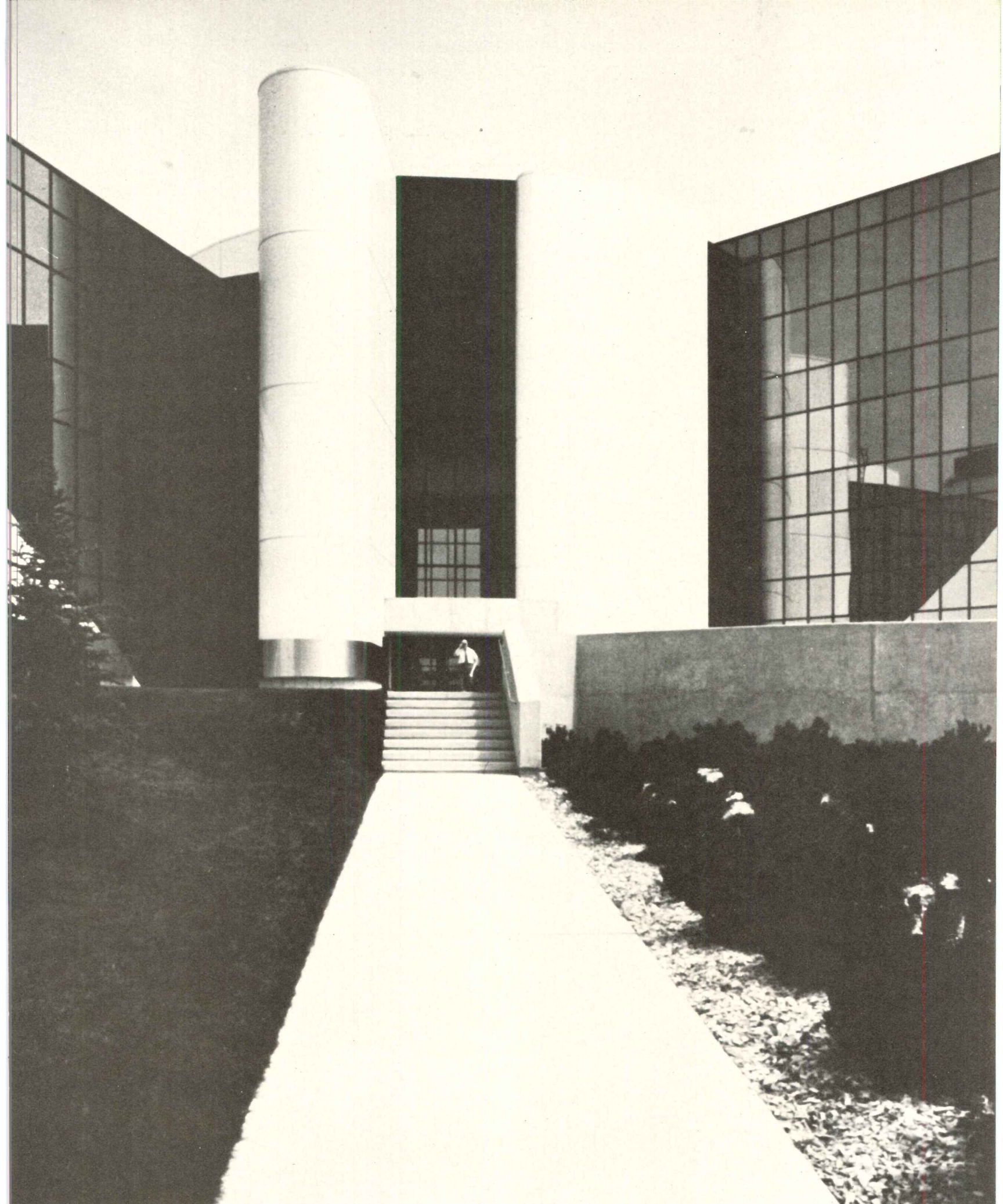

This secondary entrance is on the opposite side of the building to the main entrance which faces the town square. It leads to the second level of the structure above the meeting hall.



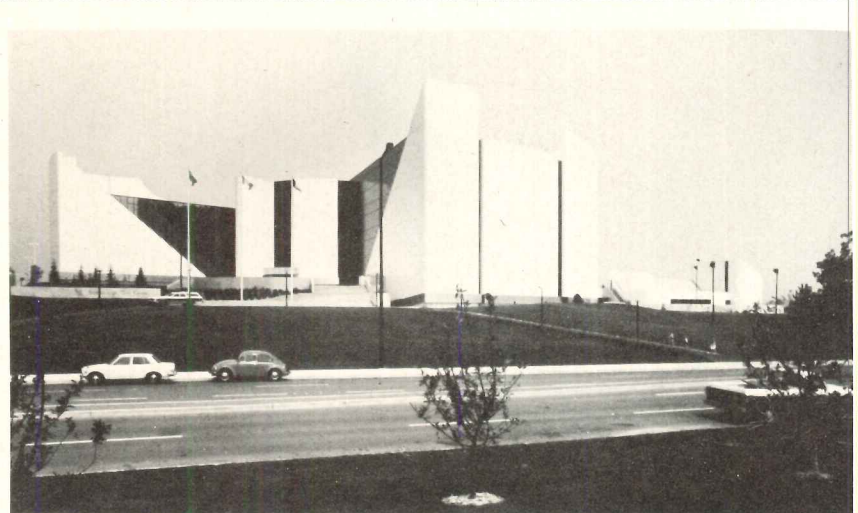
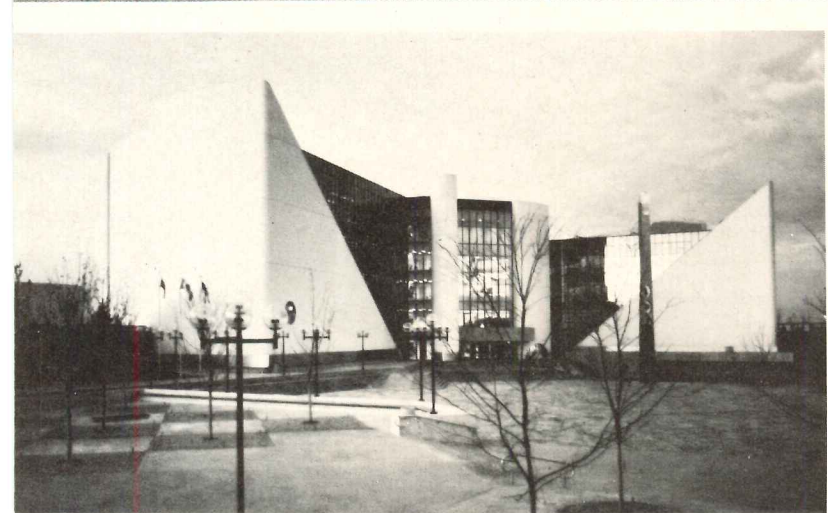

*Lee English Biel*



economies. It recommended that the board of health should be part of a linear expansion system, compatible with the main complex but separate because of special financing arrangements.

After receiving the commission to design the building, the architects studied a number of basic forms. Their obvious first option was to design two buildings—one for the board of education and the other for the borough municipal offices. Said Moriyama: "This would have been the easy way out, but it would have made it impossible to meet our larger objectives. We then explored at some length a single building concept allowing free public access through and under the building to the town square. Our conclusion was that a horizontal building would inevitably look like a lobby to the future taller commercial buildings to rise beyond. The physical volume required by the civic center building was not great enough to make a significant tower. Our new building would have to be distinguished by its form, not its size."

The architects began with a split pyramid concept, but after much study turned the half pyramids around so as to face each other across a single public central space. Still dissatisfied and after studying six different variations, they resolved the problem by adopting a flat roof over the central space and using reflective glass in a triangular form on the four elevations.

Another major problem for analysis was the geometry of the layout. The intent was to ensure that the total departmental area requirement could be accommodated in a stepped arrangement based upon a relatively simple structural system. After much study, the architects agreed upon a scheme which radiates from a single center point with two ele-

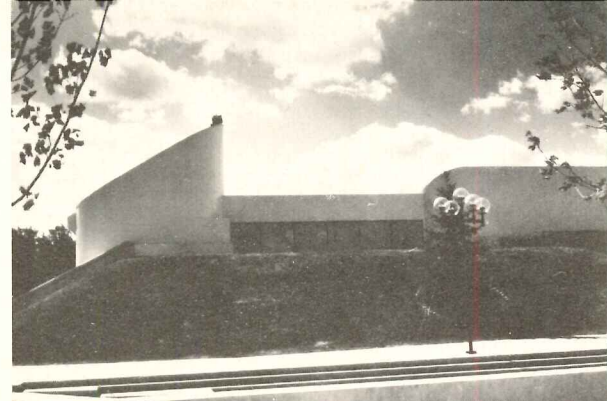

Lee English Biel

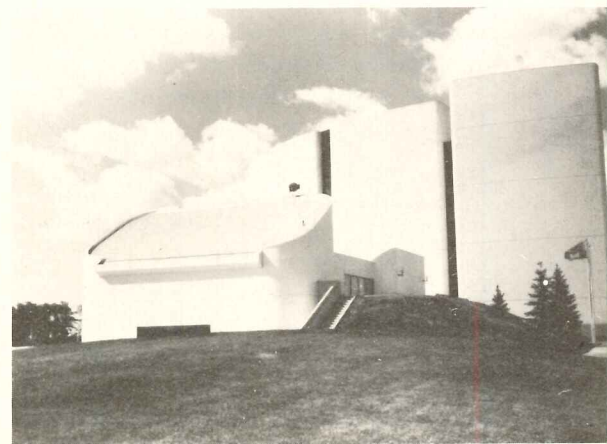

Lee English Biel

The town square (left and below) has been designed as a link between the civic building and the mammoth shopping center (not shown). As such, it represents the collaborative efforts of the Moriyama firm and Bregman and Hamann, master planners for the entire Town Center and designers of the shopping center. It has a reflecting pool (below) which in the winter becomes a skating rink. The health building (above) was designed as a separate appendage to the main building because of special financing arrangements. Both the civic and health buildings are sheathed in aluminum siding with a white silicon modified polyester finish. The stainless steel column has circular apertures for lighting and sound facilities. Films can be projected on the walls of the structure.

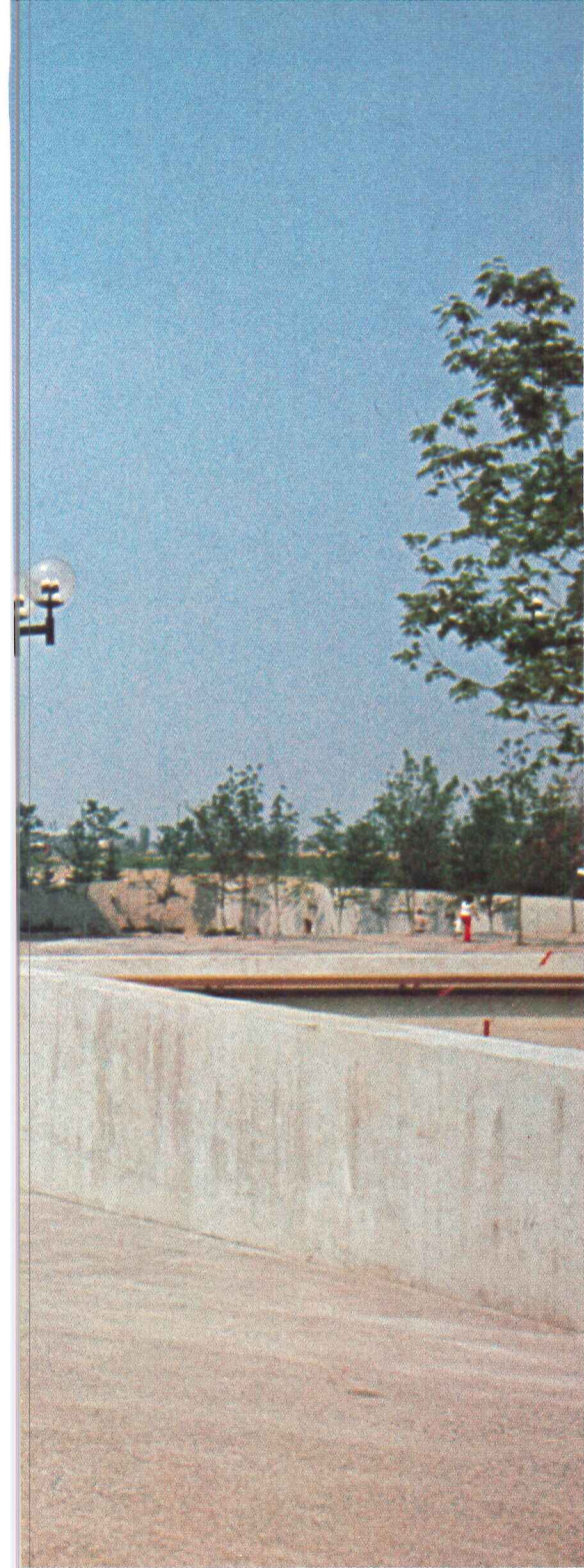

John W. Fischer



Lee English Biel

Lee English Biel



## SCARBOROUGH CIVIC CENTER

vator cores and two columns providing the structural basis for a central space 80 feet in diameter and 67 feet high. The floors on the borough side step back on a regular structural bay of 15 feet, while on the board side the floors cantilever out at variable amounts of 6, 11, and 16 feet from a structural column line.

This combination of form and geometry provided the necessary area and flexibility, reinforced the concept of unity, provided a more generous public space at a lower total building volume and allowed visual continuity from one side of the building to the other at all floor levels. Also this geometry and structural system made it possible to interconnect the board of education and the borough municipal offices by means of mezzanines and bridges.

The joint meeting hall (not shown) has been located under the entrance podium and is directly accessible from the central space.

Of special interest is the exterior skin of the building. The basic structure is of poured-in-place concrete including the columns, walls and floor slabs. Thermal insulation has been placed on the exterior of the concrete walls and this has been covered with aluminum siding with a silicon modified polyester finish. This veneer is lightweight, shiny, white and an effective rain screen.

SCARBOROUGH CIVIC CENTER, Scarborough, Ontario. Owners: Corporation of the Borough of Scarborough, the Board of Education and the Board of Health. Architects: Raymond Moriyama, Architects and Planners—James Wilkinson and Ted Tashima associates-in-charge. Consultants: Robert Halsall and Associates Ltd. (structural); G. Granek and Associates (mechanical); Jack Chisvin and Associates Ltd. (electrical); James Sutherland (architectural graphics/sculpture). Construction management: McDougall Construction Management Ltd.

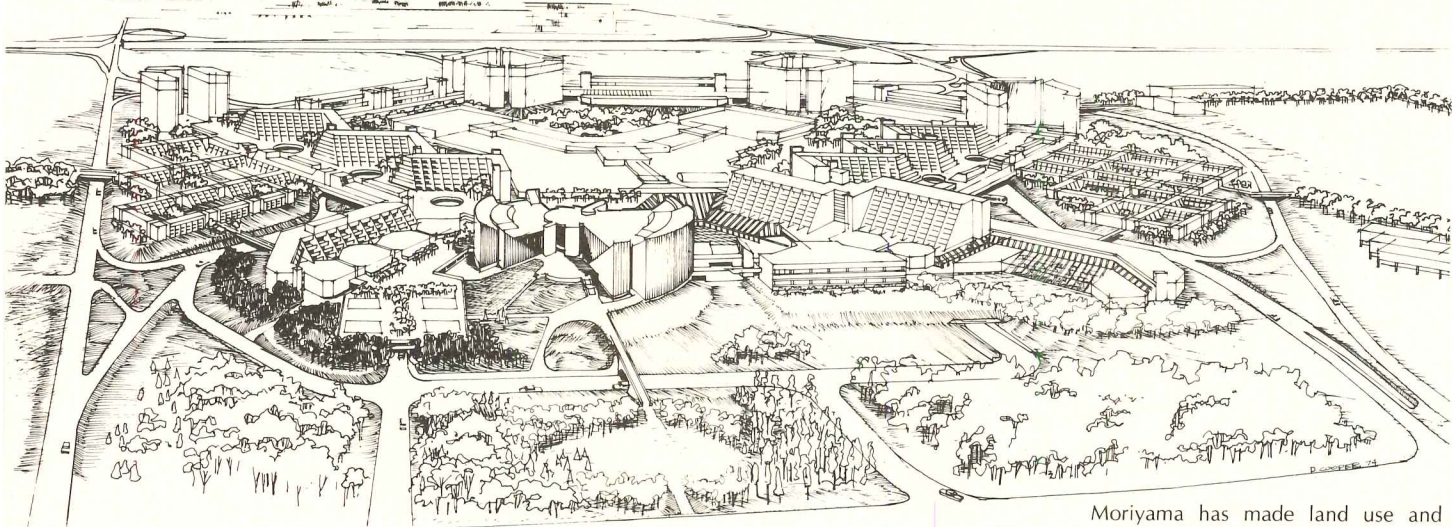
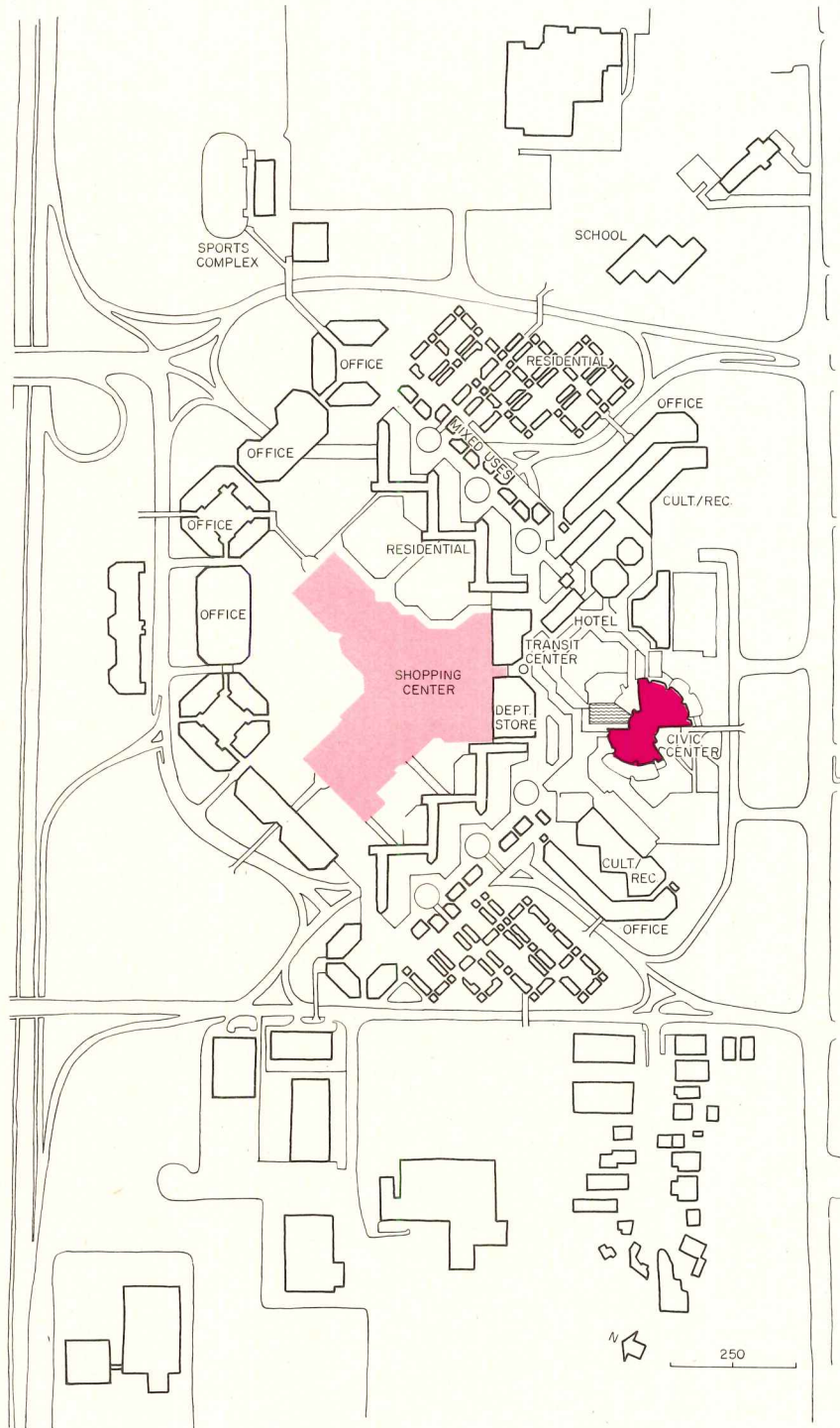

Moriyama has made land use and urban design recommendations for the rest of the 170-acre site. So far only the Y-shaped shopping center and the civic complex have been constructed.



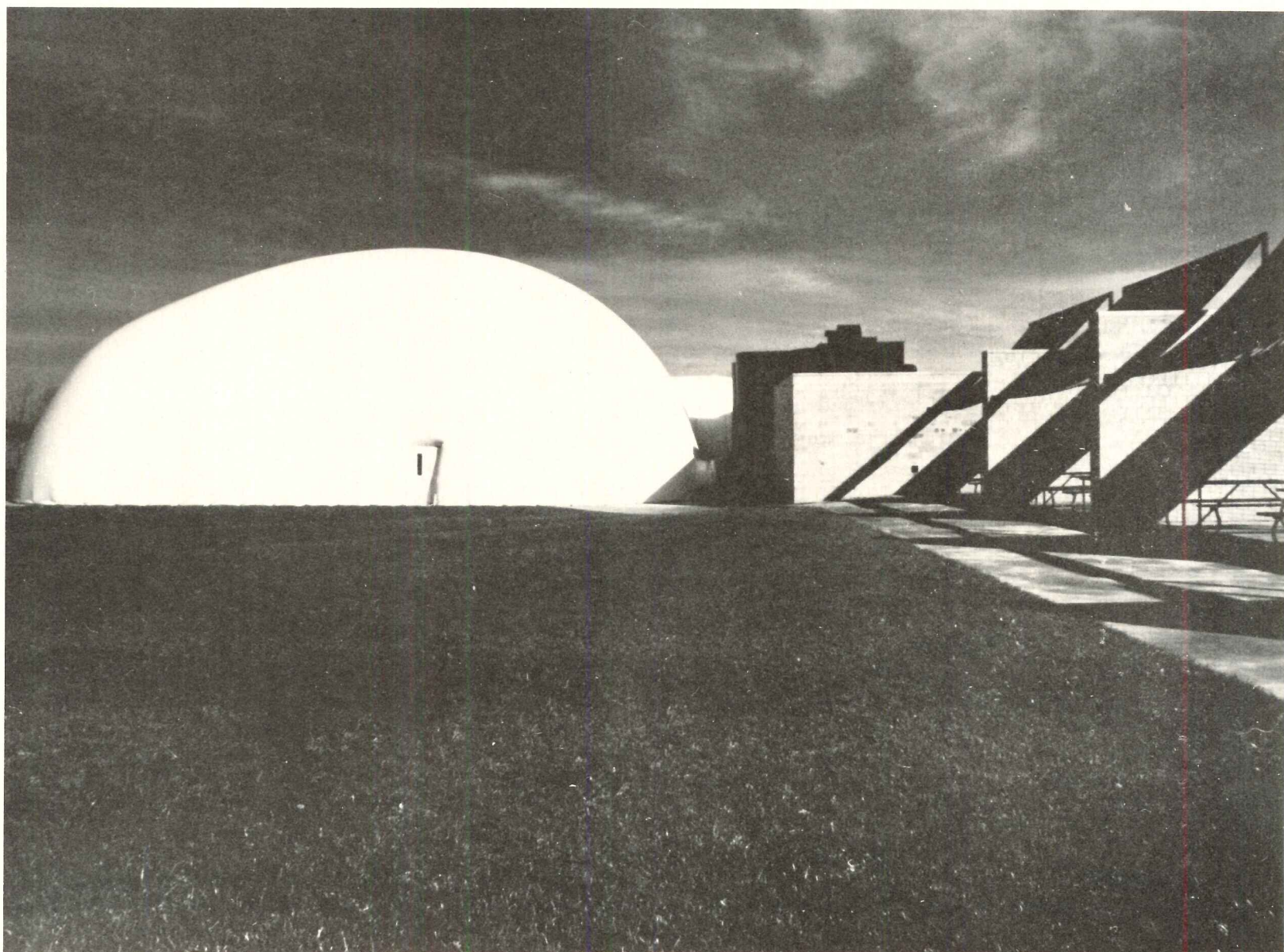

Sandy Nixon

# COAL STREET POOL

Coal Street Park derives its name from a former colliery on the 36-acre site which once separated two economically diverse neighborhoods and is now intended to become a meeting ground of recreational activities. The project was backed by the State Department of Community Affairs, the Federal Model Cities Program, other Federal agencies, and the owners, the City of Wilkes-Barre, Pennsylvania. The latter commissioned The Allen Organization as park and recreational planners, who in turn hired the firm of Bohlin and Powell as architects. When construction of the first facility—the pool—began, the terrain consisted of coal refuse.

The initial problem that confronted the architects was the lack of funding provision for enclosed pools in an area where an exposed facility could be effective for only three months of each year. There was a clear requirement for a solution that would provide more than a sometime use and still be affordable and conform to Federal guidelines. An inflatable structure was the answer here, and the limitations of time, cost and gaining approvals required an uncomplicated product which had been tested by standardized manufacture. The available choices could have posed visual and functional problems, but Bohlin and Powell have been innovative in their imaginative adaptation of a commercial object to fit the context of its use.—*Charles Hoyt*



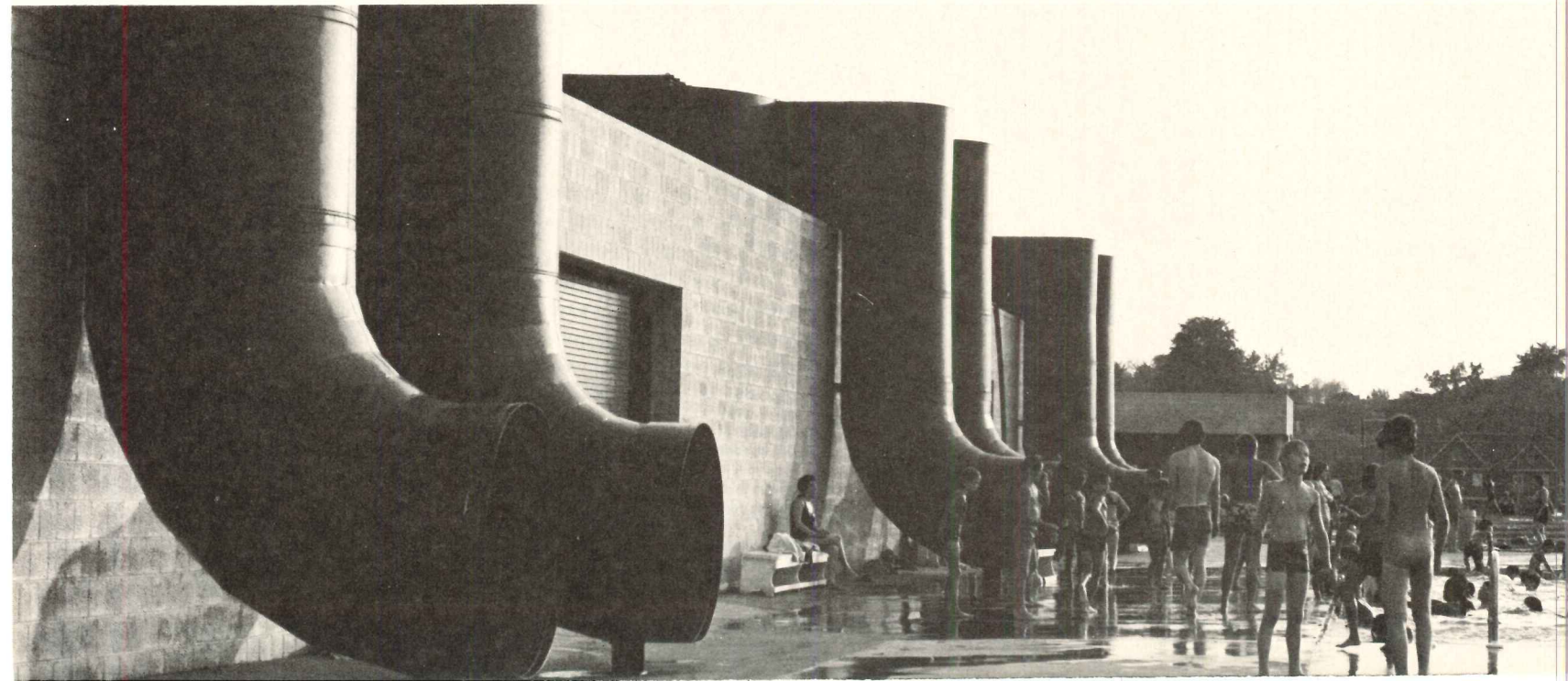
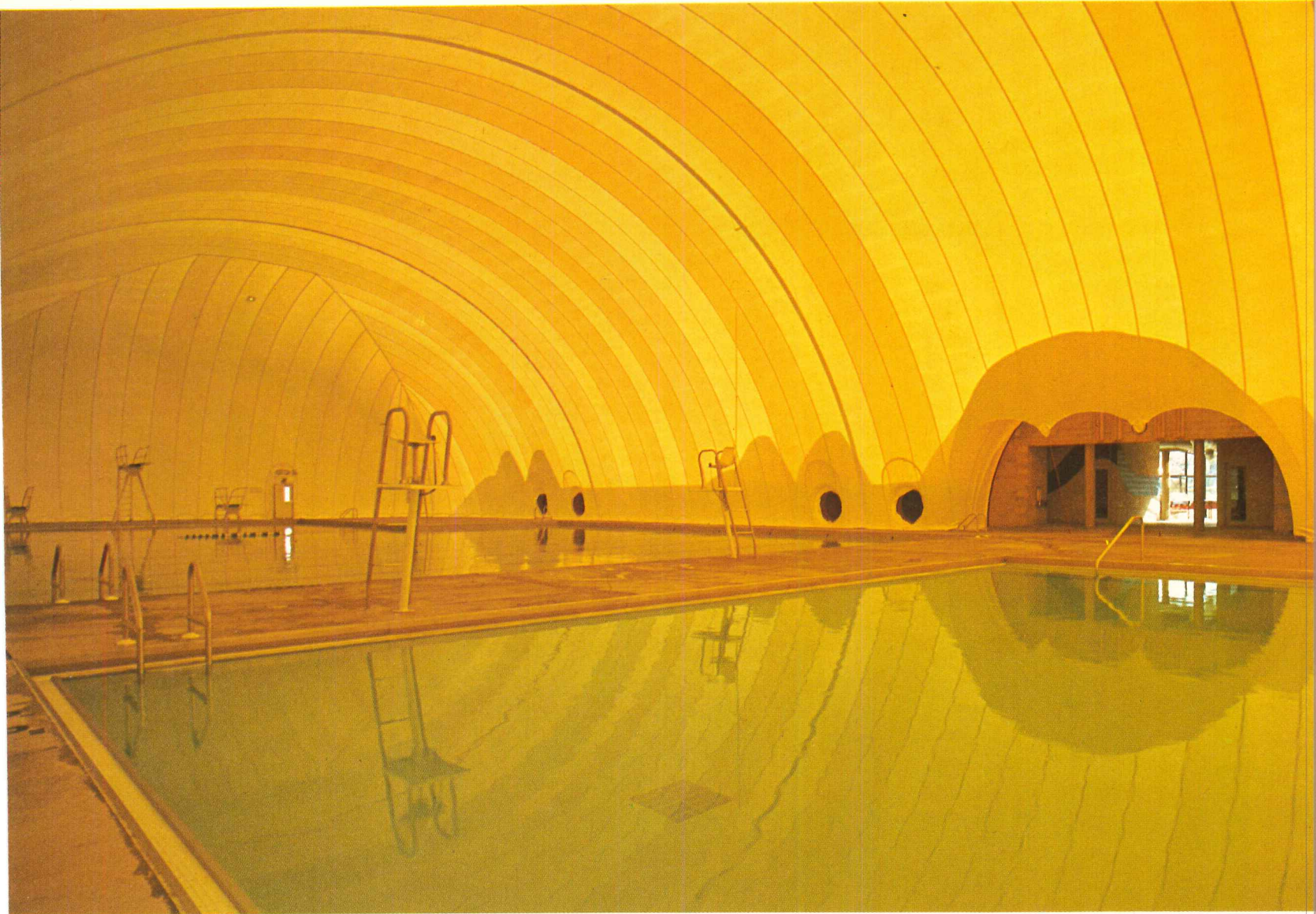



In giving this project a First Honor Award in 1973, the Pennsylvania Society of Architects' jury commented: "Carefully wrought composition in the 'mecho-mod' style. Sensitive land planning and approaches. Designed with a refreshing abandon for simple pleasures." Others, beside Peter Bohlin, were mystified by the exact meaning of "mecho-mod" and whether or not the refreshing abandon might be better applied to the mood of the users rather than to the design process, but the comments do sum up the results fairly accurately.

The linear plan of the permanent structure fulfills two purposes. The first is to direct public traffic in a required progression of access ramp, central lobby, separated dressing rooms and pool, while housing the necessary dressing rooms, offices, pool filtration and air handling equipment, maintenance spaces and air-supported-structure storage. The open spaces beside the ramp contain picnic tables covered with bright yellow canvas awnings, and the "stretching" of the building achieved by the spaces' location have the visual advantage of providing a visually larger and easily identified setting for Coal Street Pool and a hard-edged counterpoint to the rounded shape of the "aquadome" when it is in place. The second reason for the linearity of this concrete frame and exposed-stone-aggregate block building is to relate it to a 800-foot-long walkway which will connect the other facilities of playing fields, children's covered play areas (under construction in the photo right) and an ice skating rink planned for the Park. The eventual plan for the Park can be seen on page 104. The playful configuration of the round air-induction pipes (photo, opposite bottom) which provide the air-support for the canvas structure when it is in place (left), is determined by basic functional requirements. But the architects have not been afraid to take full advantage of the sculptural possibilities by contrasting angular and rounded bends and by painting the sheet metal black on the outside and bright red on the inside. The most economical and tamper-proof location for the air-heaters and blowers was the roof of the permanent building, and the inflatable's manufacturer recommended that the forced air be introduced via the pipes at the bottom of their structure where construction was the strongest and the material least likely to tear. The large size of the ducts was determined by a desire for minimum velocity and thus low draft and noise levels.

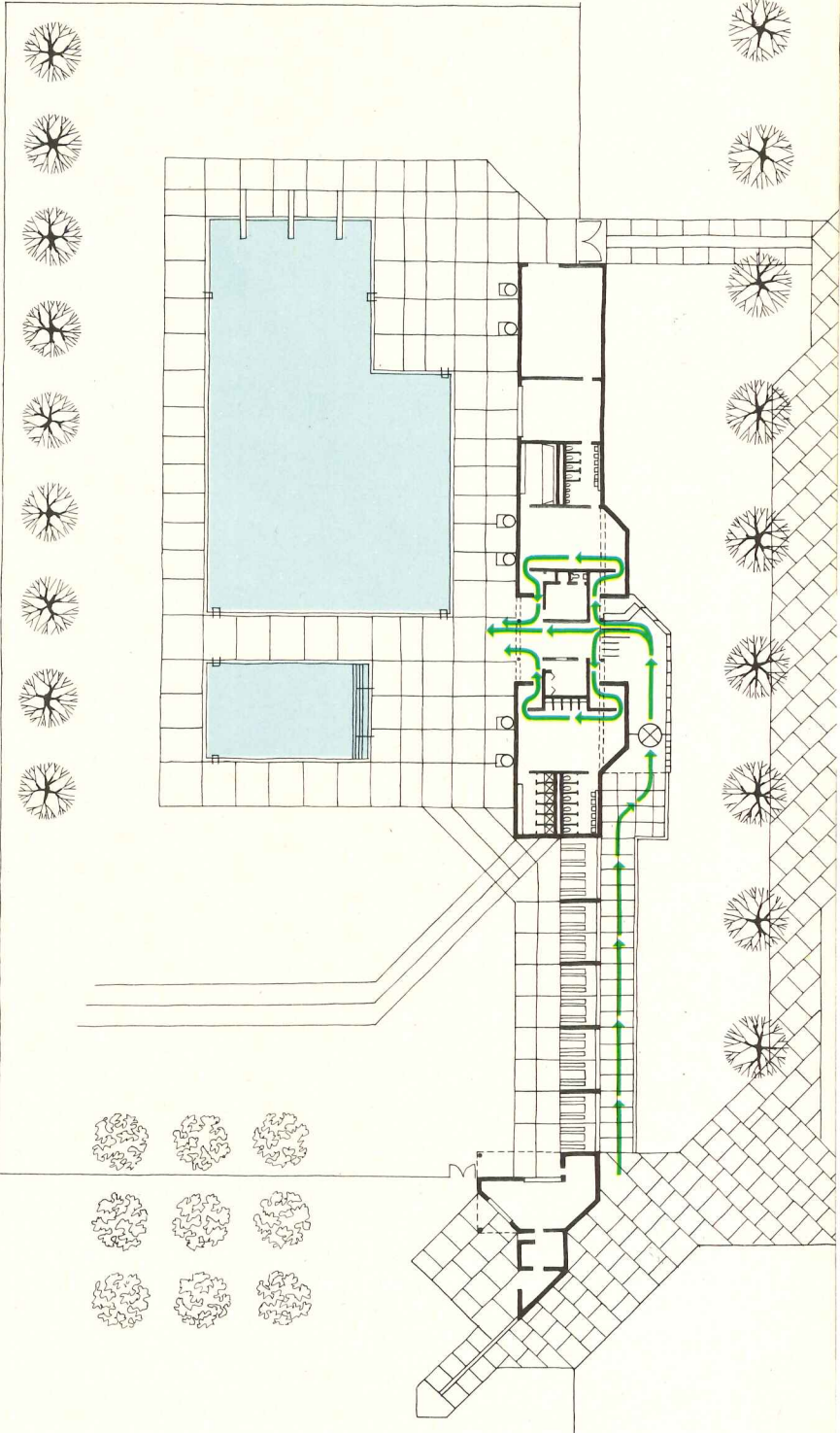
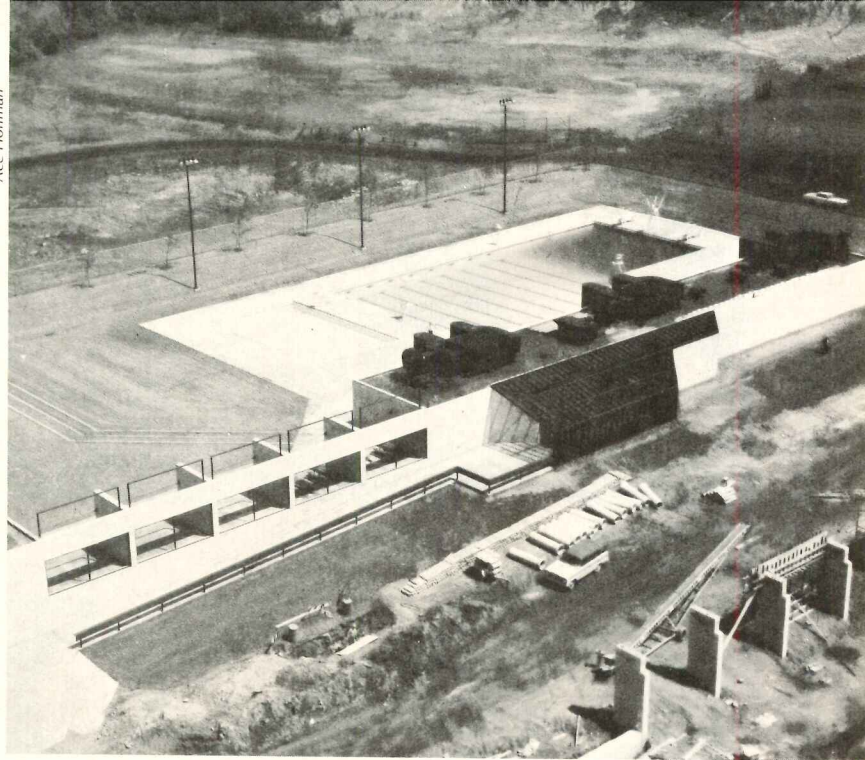

Ace Hoffman

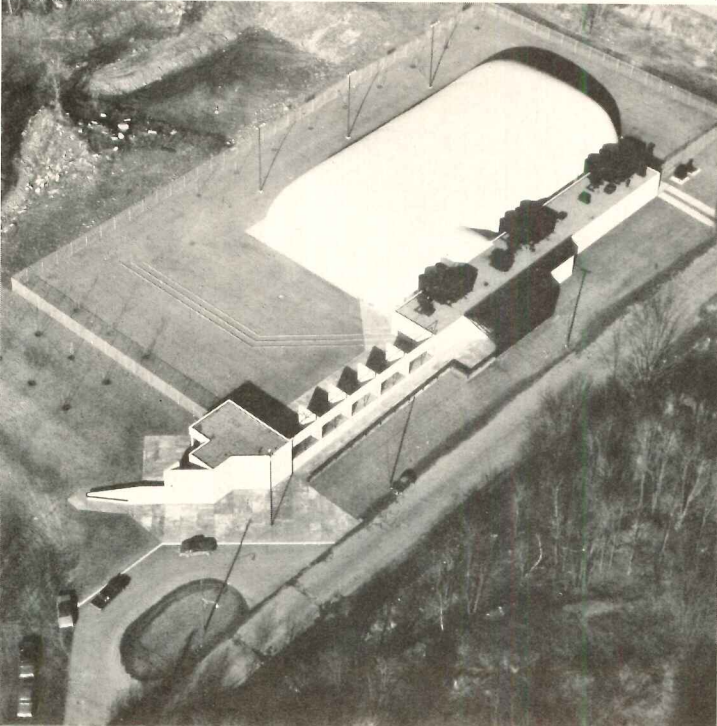



Sandy Nixon

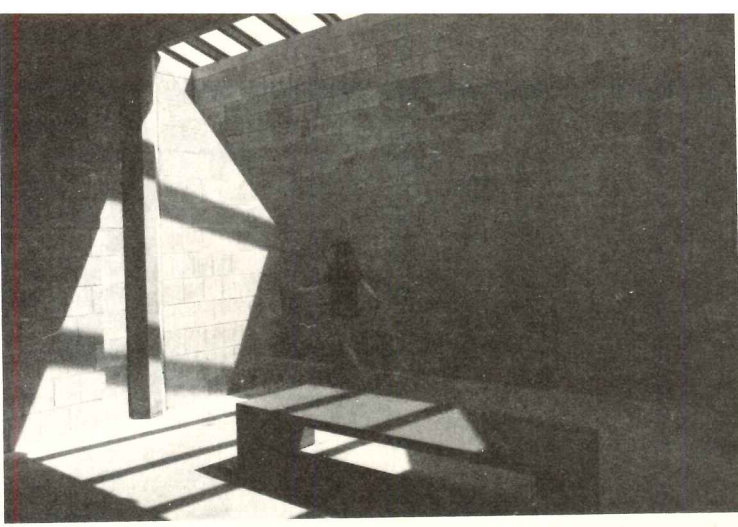

Mark Cohen



There are two "ready-made" structures at the Coal Street Pool. The lobby's glass enclosure (bottom, opposite) is ordered from a manufacturer's catalog and shares the inflatable's theoretical advantages of testing by previous use, predictable costs and speedy erection. But the architects do not see prefabricated buildings as the answer to all problems, and state that the advantages are not always as real as could be supposed. In the case of the inflatable aquadome, the largest disadvantage may be increased long-term costs which have to be weighed against a first construction cost that is far less than that for a permanent structure. The cost of the fabric enclosure was \$38,000 to which \$24,000 was added for footings, extra heating, air blowers and a storage room bringing the total to \$62,000 for the 20,000-square-foot space. The estimated saving over the cost of a permanent enclosure was \$218,000. The premium for operating expenses, including added heat, extra help in putting up and taking down the structure and 10-year replacement costs, was estimated to be \$11,500 annually or \$460,000 over a 40-year-life expectancy for the facility, and it is reasonably certain that these costs will rise. However, an answer to the apparently greater long-term costs here might be found in the interest value of the monies initially saved. For example, \$218,000 multiplied by 8 per cent and 40 years would total \$697,000 leaving a large margin for cost inflation. The above calculations do not take into account the advantages of having the option of an open pool in the summer with only one facility, the appropriately festive atmosphere created by the aquadome or the increased number of possible users when the enclosure is removed. The architects estimate that about 500 people can use the pool at one time in the winter while 2,000 can enjoy the full facilities in the summer. An earth berm has been successful in deflecting the wind during periods of cooler weather when the dome is down. The playful atmosphere is carried into the permanent structure by skylights in the dressing rooms and supergraphics by Mrs. Bohlin.

-----  
 THE WILKES-BARRE AQUADOME, Wilkes-Barre, Pennsylvania. Owner: *The City of Wilkes-Barre*. Park and recreation planners: *The Allen Organization*. Architects: *Bohlin and Powell*—*Ronald W. Huntsinger, project architect, Peter Bohlin, partner-in-charge*. Engineers: *Vincent B. Szykman, Inc.* (structural); *Paul H. Yeomans, Inc.* (mechanical/electrical). Landscape architects: *Kennedy and Brown*. Graphics: *Annie Bohlin*. General contractor: *Charles A. Malpass Sons*.

Mark Cohen

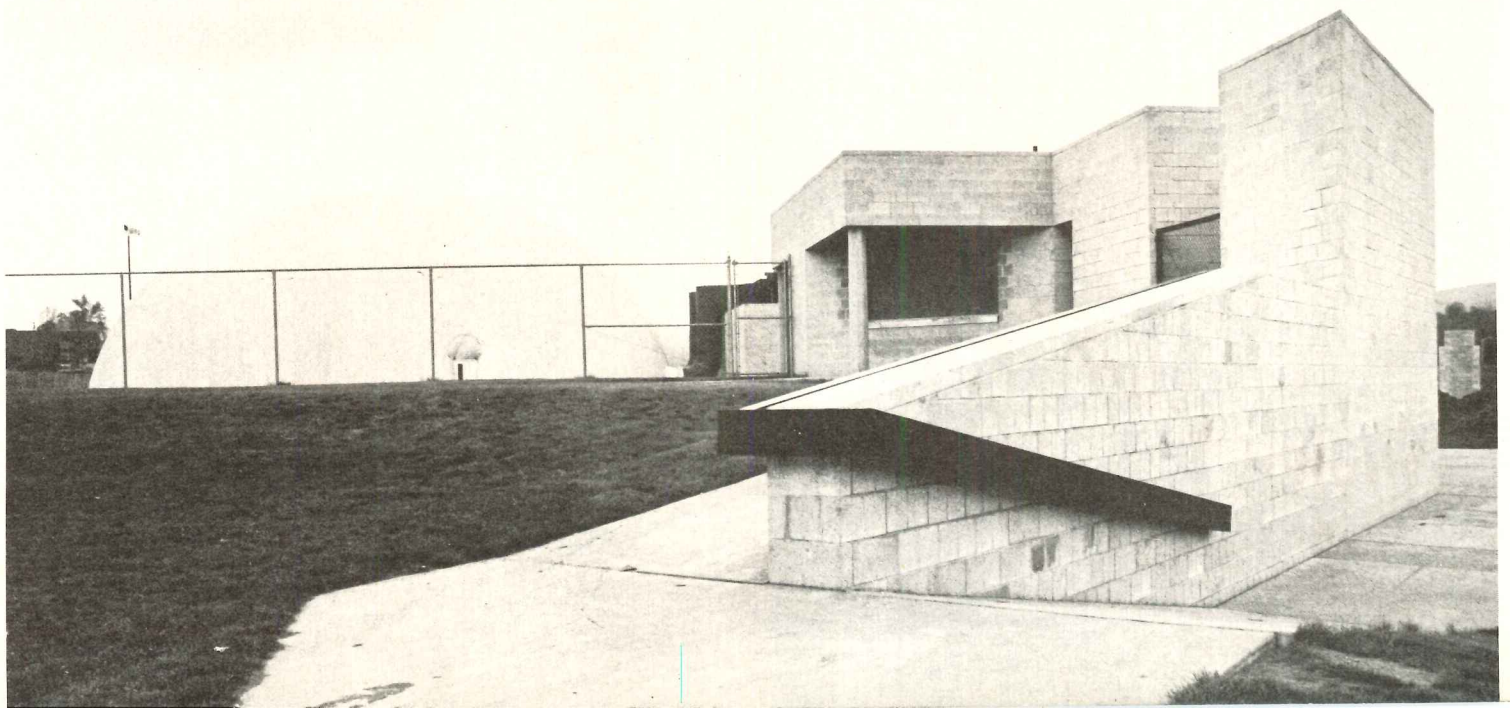





*Sandy Nixon*

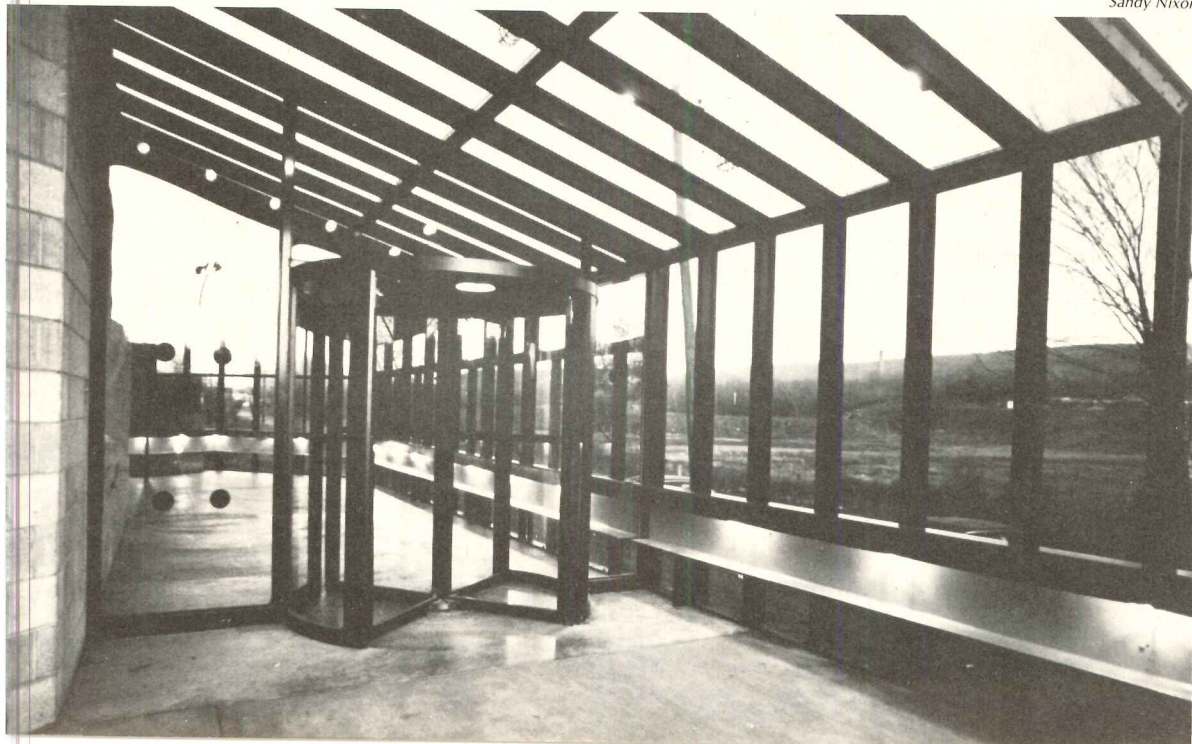

*Sandy Nixon*

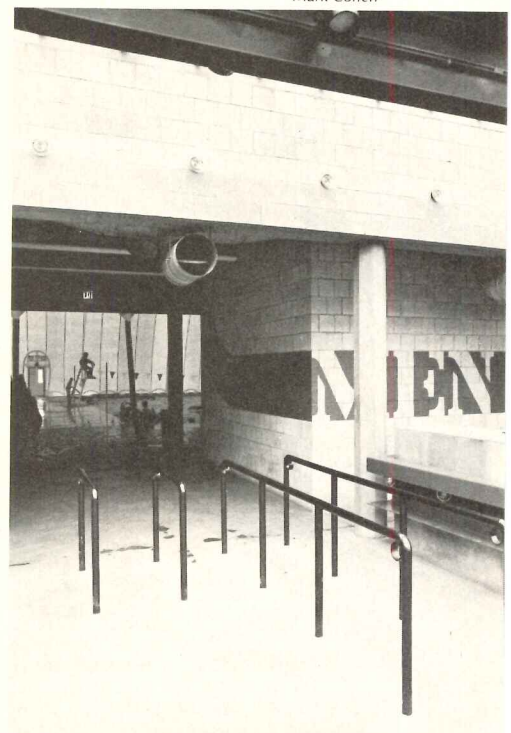

*Mark Cohen*



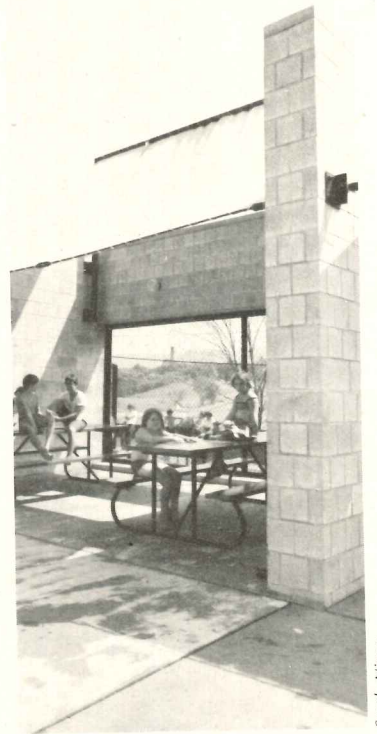
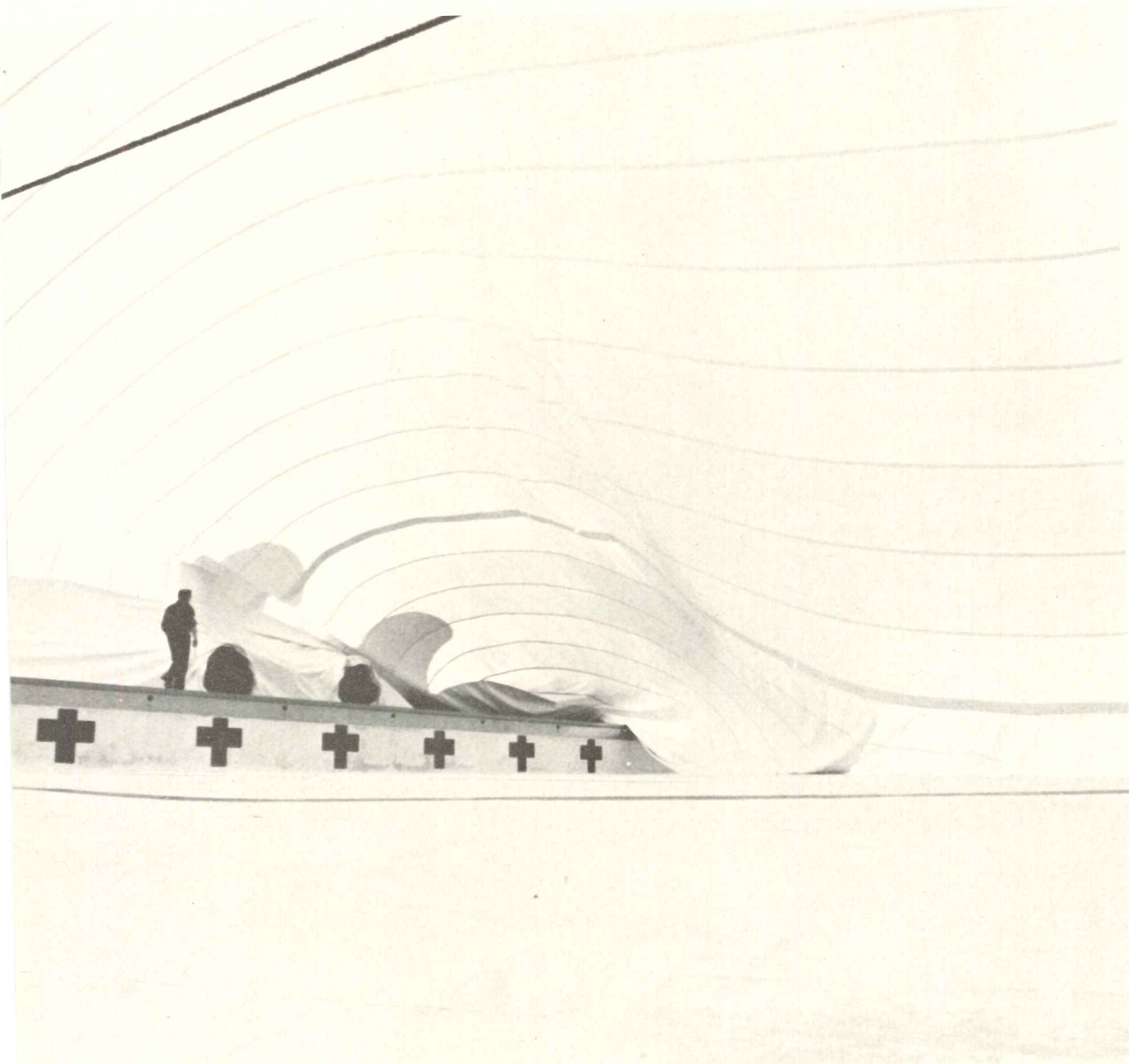

Sandy Nixon



Sandy Nixon

Burnside Photography

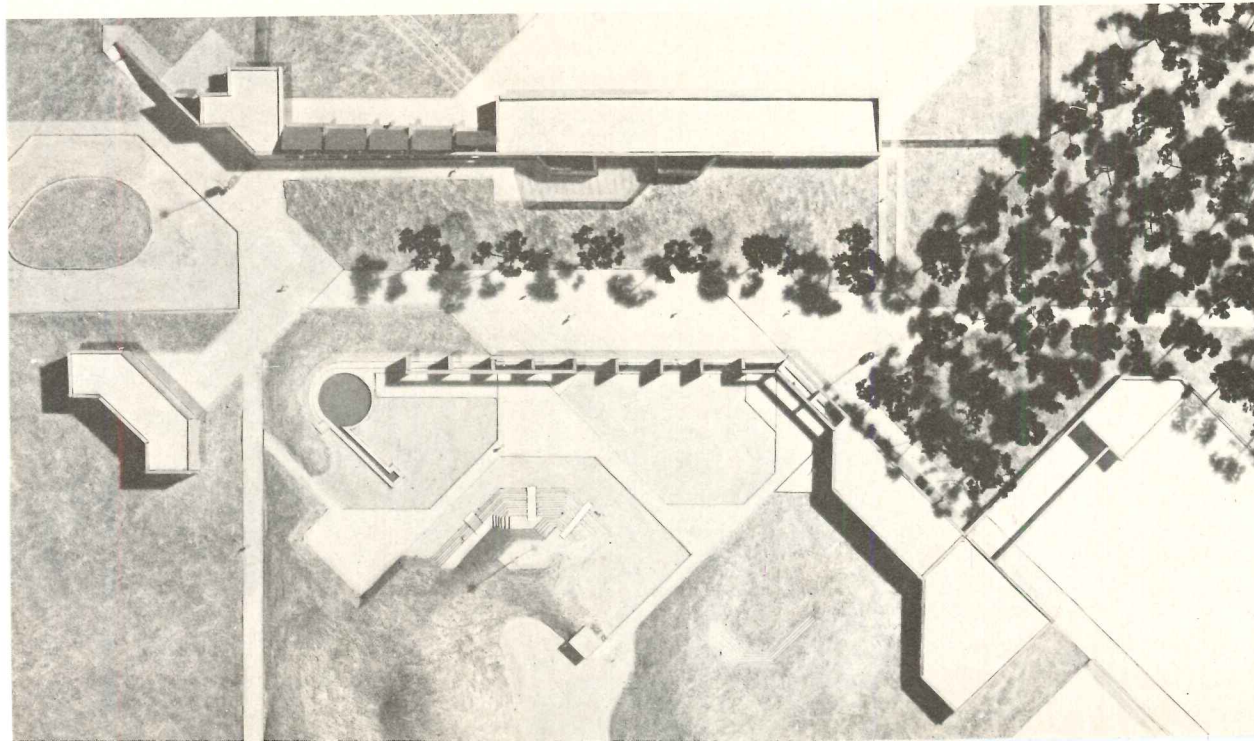

One of the most interesting visual experiences produced by the aquadome occurs twice a year during the inflation and deflation process (left, top). Forced air is introduced through the visible-round ends of the large pipe-ducts seen without the fabric in place (lower photo, above), and adding a playful atmosphere for the many children using the facility. The open picnic spaces (top) are shielded from the summer sun by bright-yellow awnings and overlook the entrance ramp along which they are located. The pool's permanent ancillary-facilities building is located at the top of the Coal Street Park's masterplan (left) and forms an edge to the Park's central walkway between it and the covered-children's-play arcade bordering athletic fields and playgrounds at the bottom of the plan. A future skating rink is planned in the lower right hand corner.



# THREE PROJECTS BY GWATHMEY SIEGEL ARCHITECTS

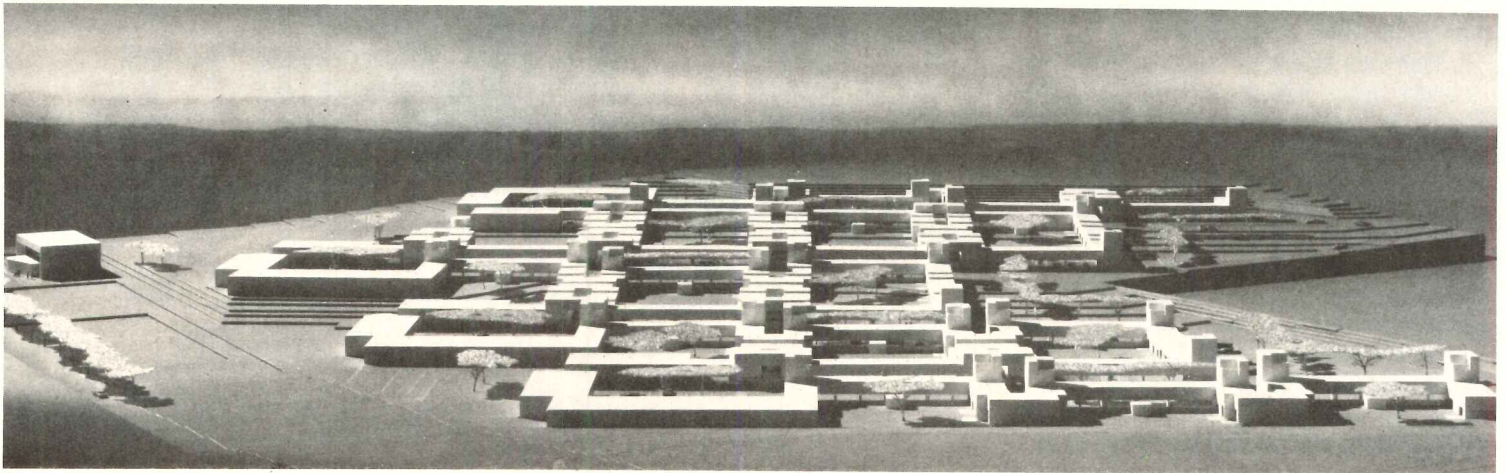

A new 560-unit residential community for the town of Perinton, New York, and two single-family houses for sites in New Jersey are among the current projects in the office of architects Charles Gwathmey and Robert Siegel. The designs for the houses—shown on pages 110-112—provide two more examples of the involvement of these architects, who are already well known for their particular style, with clients who are prepared to invest more than the usual amount of care and energy to make a special house to live in (see also *RECORD*, Mid-May 1973, pages 84-87); in this case the clients themselves seem more than usually special, and so, we predict, will the finished houses be. The Whitney Road Residential Development—a model photograph of which is shown above, and more details on the following four pages—is a different proposition, with somewhat broader goals. Planned by the New York State Urban Development Corporation and its subsidiary, UDC Rochester, Inc., this townhouse and garden apartment complex is intended to help meet general housing needs for the elderly as well as the young and middle-aged, within the reach of their respective incomes, and to provide as well communal facilities and outdoor recreation areas. The goals, that is, are to make a community—and, in accordance with the standard practices of the Urban Development Corporation, there is the additional goal of doing all this with maximum participation by private planners, developers and managers. Construction is already underway on the 43-acre site in upstate New York, and the buildings will finally include a 6000-square-foot community center as well as the housing units. Of the 560 units, 120 will be reserved for elderly occupants, and of these 36 will be efficiency apartments and 84 will be one-bedroom. All of the housing for the elderly will be in a part of the site near the community center, adjacent shopping facilities and buses to downtown Rochester. The rest of the units are designed for occupancy by single people, couples and larger families. Townhouses serving the larger families, in particular, are oriented towards open green areas with semi-private outdoor spaces.



Gwathmey and Siegel claim that in the initial design stages of the Perinton housing they were trying to devise a "prototypical" solution which could then be varied and softened to the particular situation at hand. Their claim may sound a little pompous at first, but it turns out to be pretty levelheaded, just as their search for a new prototype turns out to be justifiable. Low-rise, low-density housing complexes, of course, have been built by the thousands in this country, but, surprisingly, very few of them have seemed—to architects, at least—so successful and so clear in their intentions that they could serve as obvious models to be copied. Many make us uneasy because they seem to gloss over critical questions—like, for instance, "What belongs to who?" What part belongs to the automobile, what part to children at play? What parts, indoors and out, belong to individual families, what parts to the whole community?

In the design for the Perinton housing the architects began with the individual unit, and they made a set of distinctions that architects before them had sometimes made—most notably, perhaps, Louis Kahn in his broad definition of "served" and "servant" spaces. Gwathmey and Siegel's terms are "habitable" and "non-habitable" (top diagram opposite). Parts of the so-called non-habitable spaces are, of course, habitable in a literal sense, so the distinction is really this: the non-habitable spaces are where people perform the *specific* domestic acts (like cooking, bathing, climbing a stair, storing things) that support the more general acts of living, which take place in the habitable spaces.

The individual units are then arranged in two ways. One way clusters them, with all of the non-habitable spaces facing inward around a *cul-de-sac*, which the architects call a "mews" (diagram opposite and drawing above right). The other way lines the units up and raises them one floor above grade to allow for covered parking underneath (diagram opposite and adjacent drawing). The two types of groupings are then connected (bottom diagram opposite) to make a kind of public street on the non-habitable side, and to open onto shared green spaces on the habitable side. The basic concept of the Perinton scheme is thus unabashedly clear—at least as a set of diagrams. More specific details are shown on the following pages.

These details do not necessarily combine to make a successful low-rise, low-density housing development—nor, for that matter, do they necessarily make an unsuccessful one. The complex isn't yet built, and many questions are still unanswered. Will the "street," for instance, feel like a street or a back alley? Will the open green spaces feel like part of the community, or just left over? So far, though, the scheme is remarkable (and well worth studying) because it deals so forthrightly with basic, rather than *ad hoc* problems. —Gerald Allen

WHITNEY ROAD RESIDENTIAL DEVELOPMENT, Perinton, New York. Architects: Gwathmey Siegel—project architect, Marvin Mitchell. Client: New York State Urban Development Corporation. Engineers: Geiger & Berger (structural); Langer Polise (mechanical). Landscape architects: Peter Rolland & Associates. General contractor: Jewel Builders.

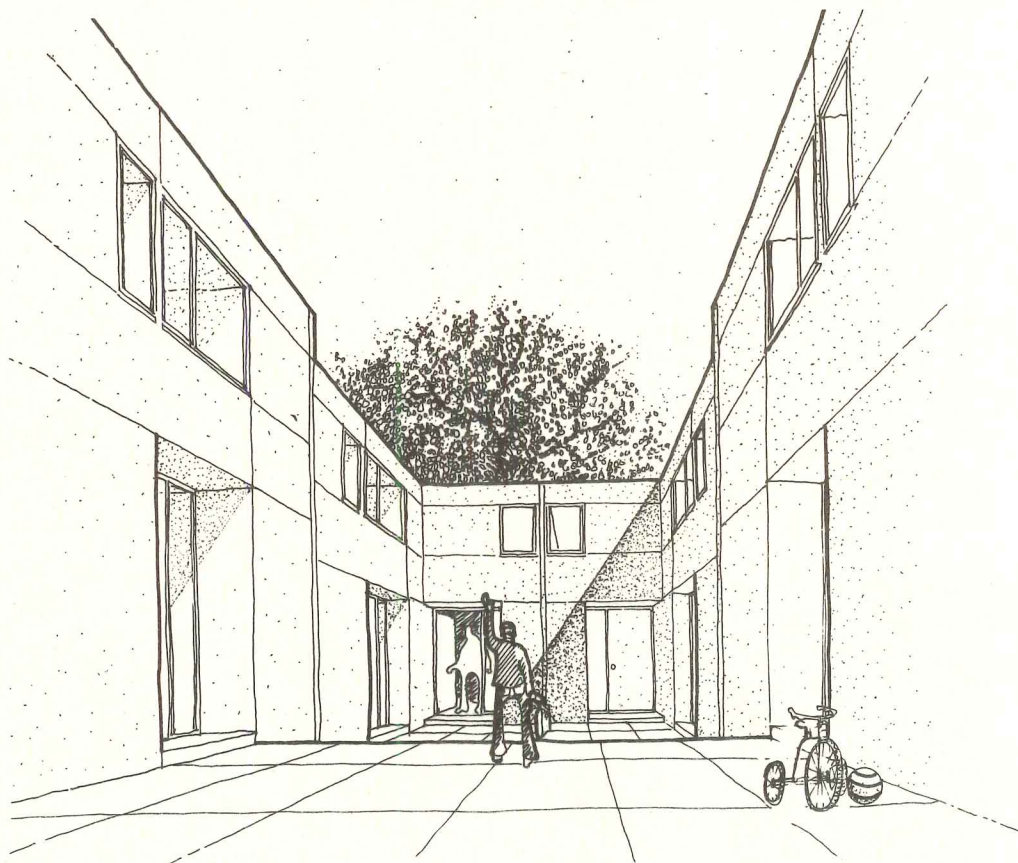

entrance mews

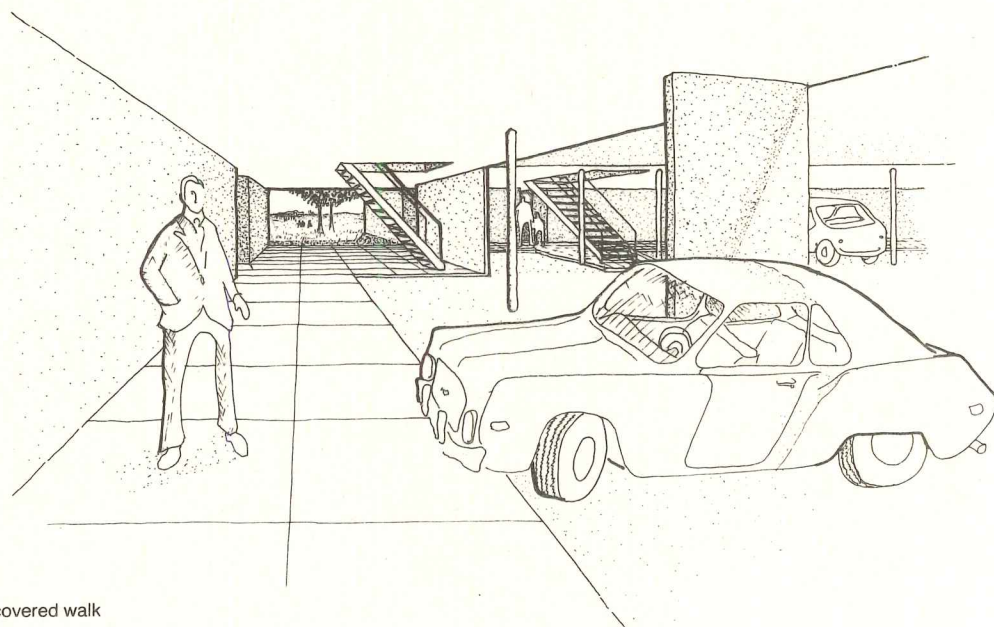

covered walk



GROUPS OF UNITS

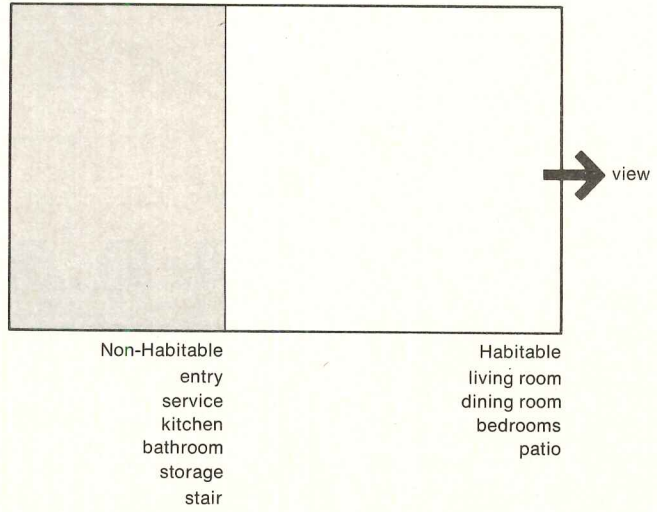

CLUSTER OF UNITS

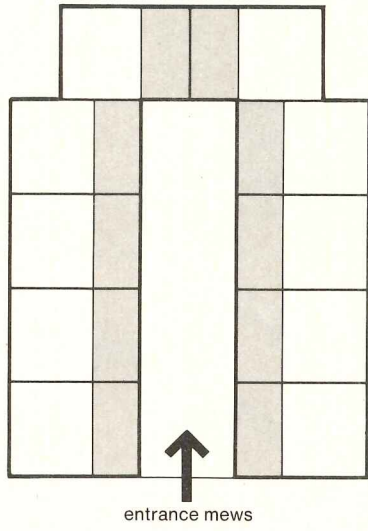

LINE OF UNITS

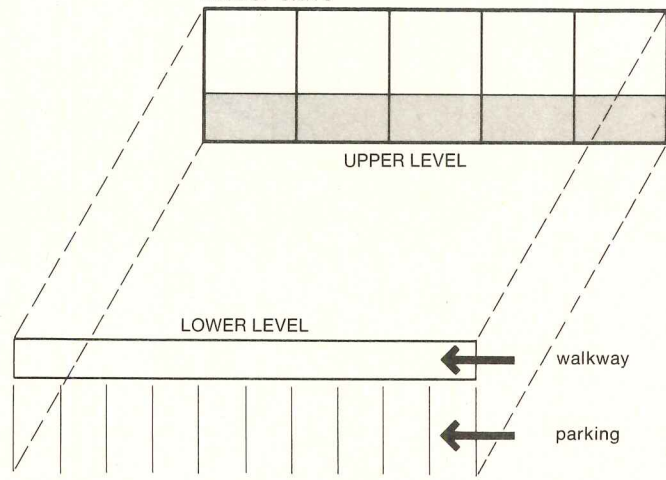

DWELLING UNIT

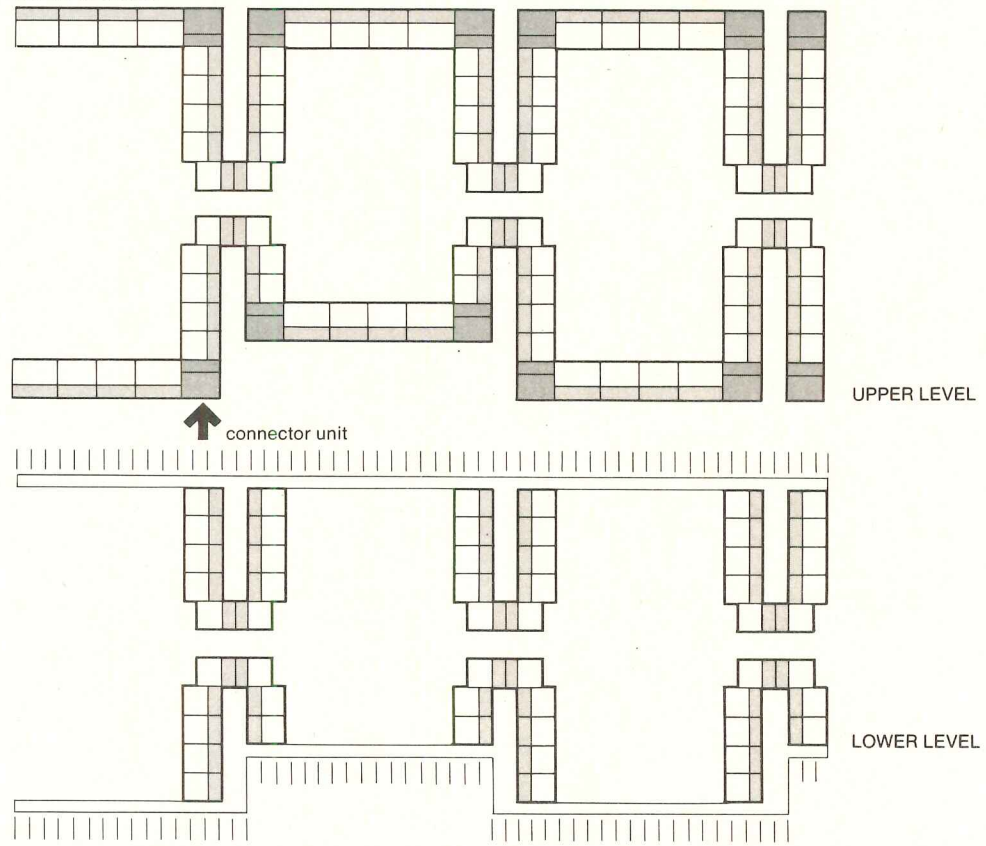



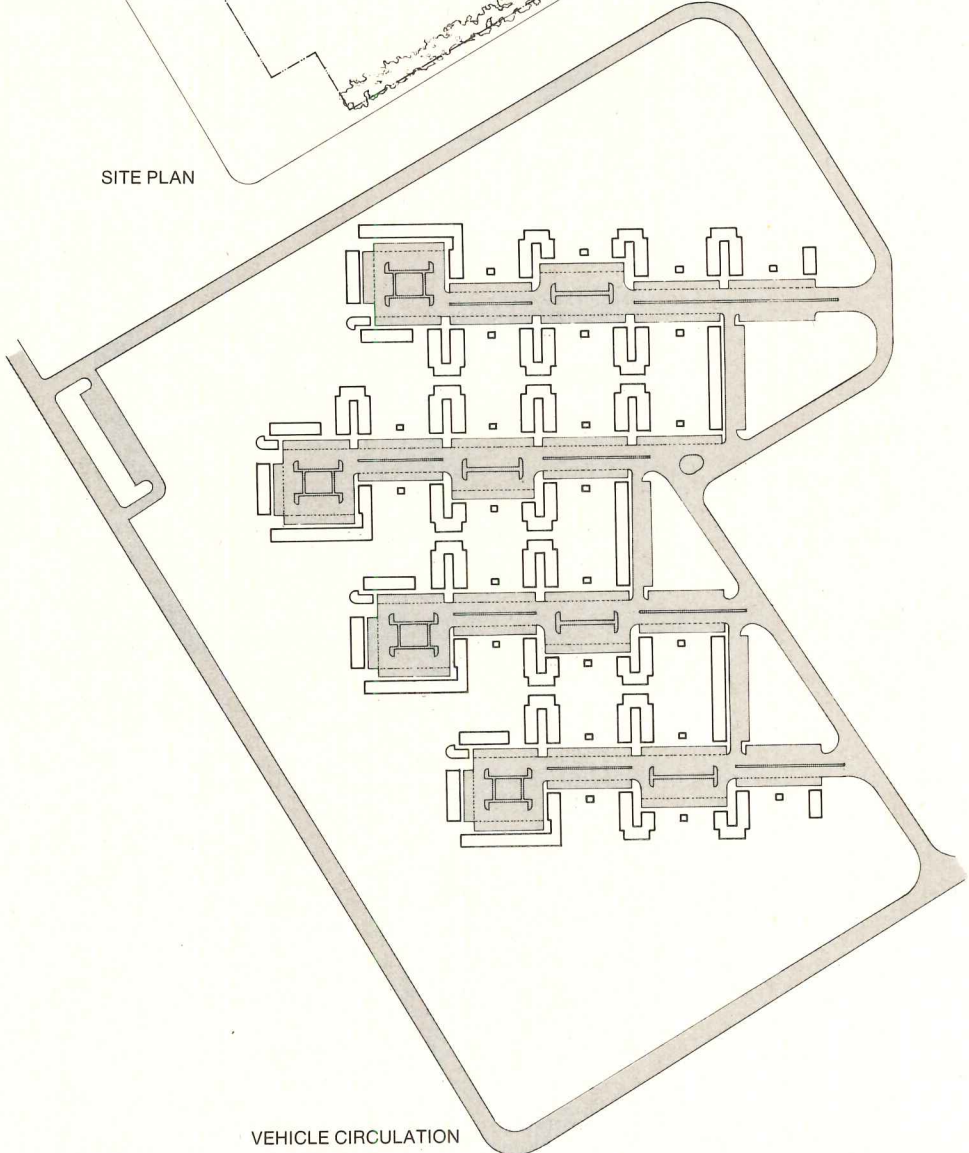
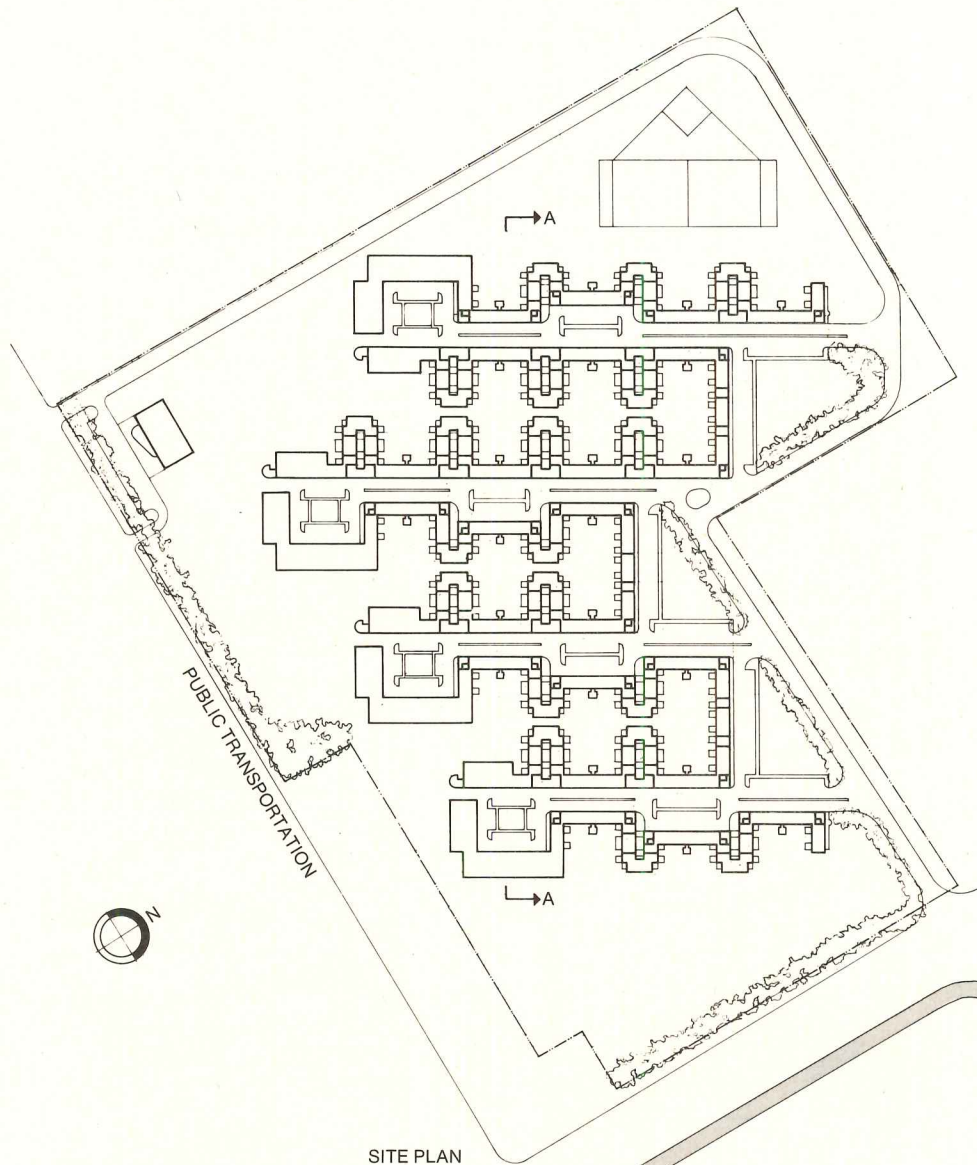
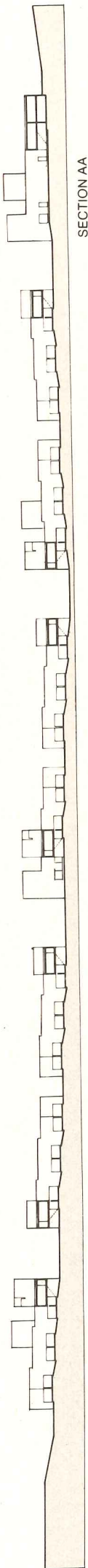



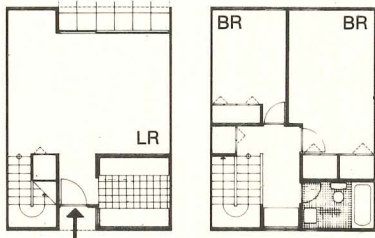

**A** 2 BEDROOM TOWNHOUSE  
150 UNITS

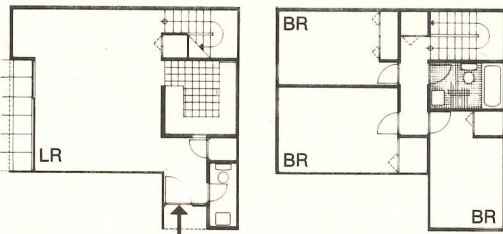

**B** 3 BEDROOM TOWNHOUSE  
40 UNITS

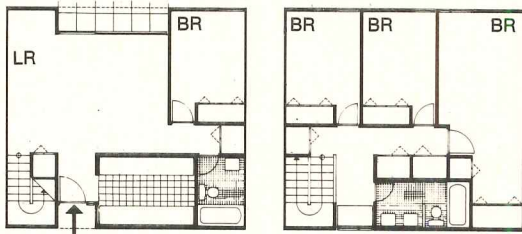

**C** 4 BEDROOM TOWNHOUSE  
30 UNITS

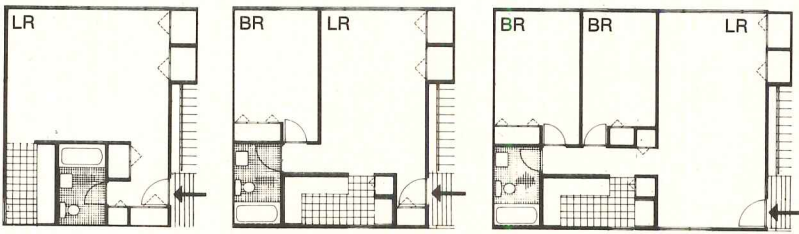

**D** 0 BEDROOM SIMPLEX 36 UNITS

**E** 1 BEDROOM SIMPLEX 204 UNITS

**F** 2 BEDROOM SIMPLEX 52 UNITS

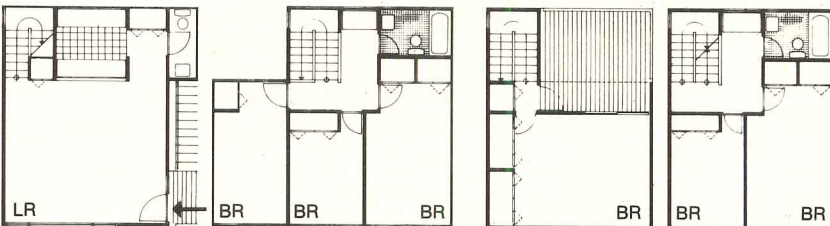

**G** 3 BEDROOM DUPLEX 24 UNITS

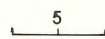

**G** 3 BEDROOM TRIPLEX 28 UNITS

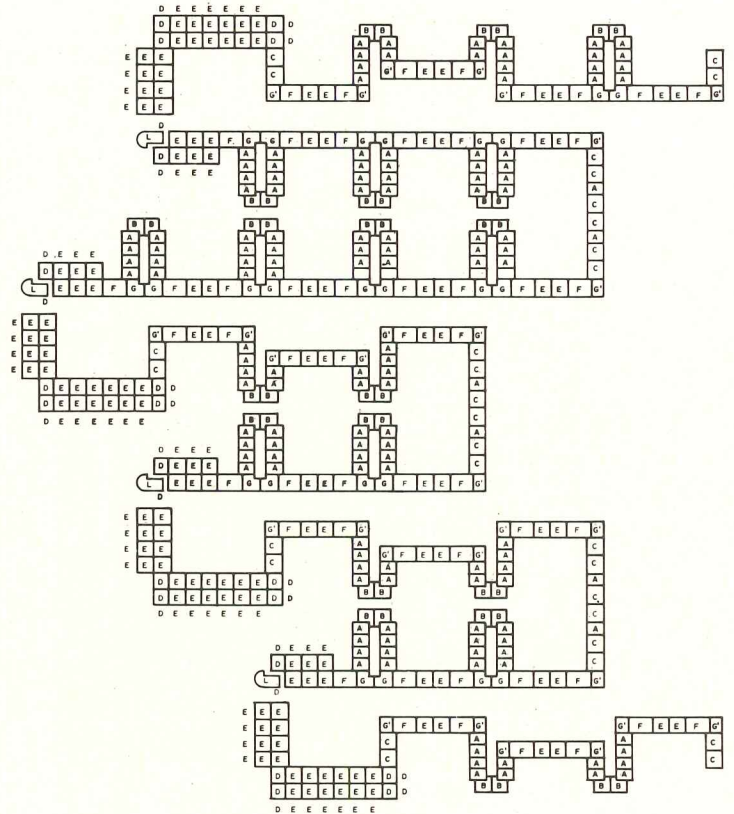

UNIT DISTRIBUTION

Apartment units at the Whitney Road housing site in Perinton are organized along four linear cul-de-sacs, onto which the series of pedestrian mews (shown in the drawing on page 106 and in the adjacent plans). The mews units are connected to each other by rows of apartments raised above the ground to accommodate parking beneath them, and there is additional uncovered parking along each major cul-de-sac. The site plan provides a pedestrian circulation system that allows people to walk on covered walkways or through green spaces throughout the site without necessarily coming into contact with vehicular traffic. Comparison of the vehicular circulation plan and the site plan shows clearly the distinction between mews clusters, which are built on grade, and the rows of apartments, which are raised above. The section (far left) shows in part how the rather formal plan of the whole fits the contours of the site. The keyed plan (above) shows how individual units (left) are mixed throughout the development.



The two projects on the following pages show another side of the housing coin. At the Whitney Road Residential Development in Perinton, Gwathmey and Siegel were faced with the problem of arranging a set of more or less standard units across an undeveloped site and for unknown inhabitants. They had the chance to make a memorable community out of the collection, even as they were denied the chance to shape each dwelling unit to any very special requirements of the people who would eventually live there.

By contrast, the individual houses shown here are each designed for more or less standard sites—but the inhabitants are known (since they are also the clients) and, as it turns out, they have quite special interests they wanted their houses to accommodate. One has a passion for gardening, and the other is a musician whose house must hold a pipe organ.

Accordingly, the first house, which is shown on this and the opposite page, is in part a greenhouse. Its site is midst a row of existing houses overlooking a cliff in New Jersey. On the street side, the greenhouse is the façade (upper photo on the opposite page), and on the other side a ramp leads to a geometrically composed deck which takes advantage of the southern exposure and the view, and from there it leads to the ground. The main living area is also on this side of the house, and the rest of the usual domestic spaces are arranged, with varying degrees of privacy, on three levels. The barrel-vaulted greenhouse laps itself up and over the north of the house, which is covered with mirrors to reflect the greenery.

The second house, which is shown overleaf, is organized in the architects' minds around a single central column, from which an arc is swung to define a slightly more than quarter-cylindrical space. To this, other spaces, rectilinear in plan and specific in domestic function, are appended. In the case of the living room, an intrusion into the semi-cylinder is allowed—by a precise 45 degrees, and the line of intrusion is then extended beyond the wall of the house to demarcate an exterior deck. One result of all this is that a 35-foot-high space is created for the organ (a good 16 of which are needed to take the longest pipe). Another result is that the living room, a two-story space where a piano is, overlooks the organ below, in case a duet seems appropriate.

Mr. Gwathmey and Mr. Siegel, whether they like it or not (and they say they don't), have become identified with a group of architects variously called the "New York School" or the "Exclusivists." What's interesting in the case of these projects is how far removed questions of style seem—even though Gwathmey and Siegel's familiar stylistic trademarks are there in abundance. But will each house be remembered more as an example of the architecture of the "New York School," or as the house for the people who liked gardening, or the house for the man with the organ? Maybe the answer is both. Which is why both houses look like good houses.

—G.A.

SANGNER HOUSE (adjacent), South Orange, New Jersey. Architects: Gwathmey Siegel.

ELIA BASCH HOUSE (overleaf), Califon, New Jersey. Architects: Gwathmey Siegel.

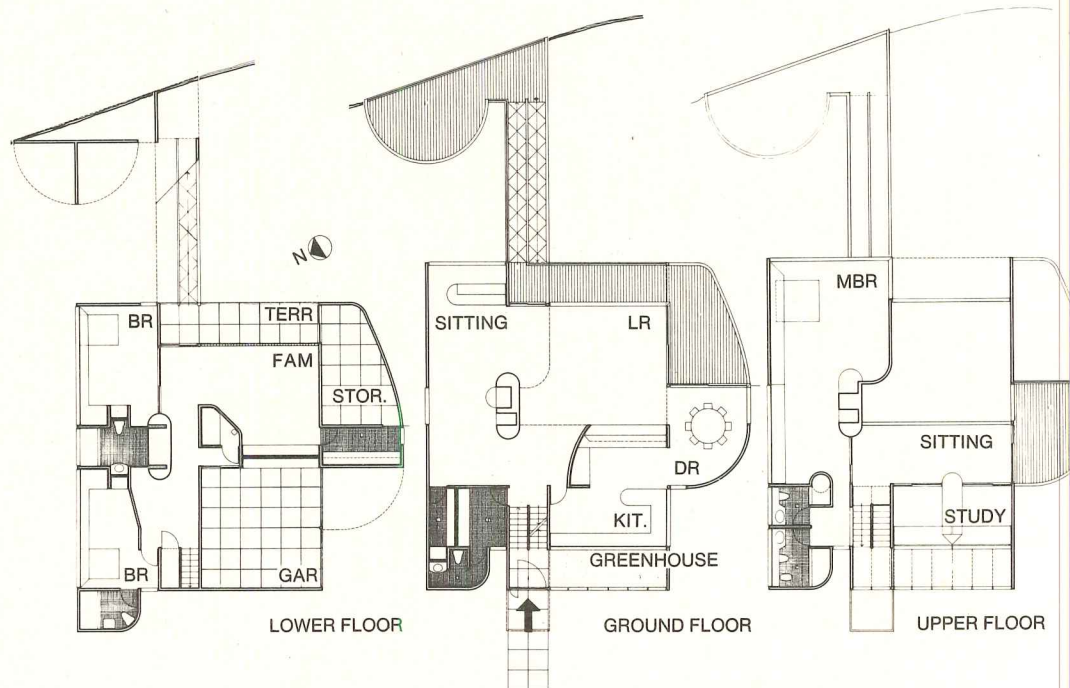
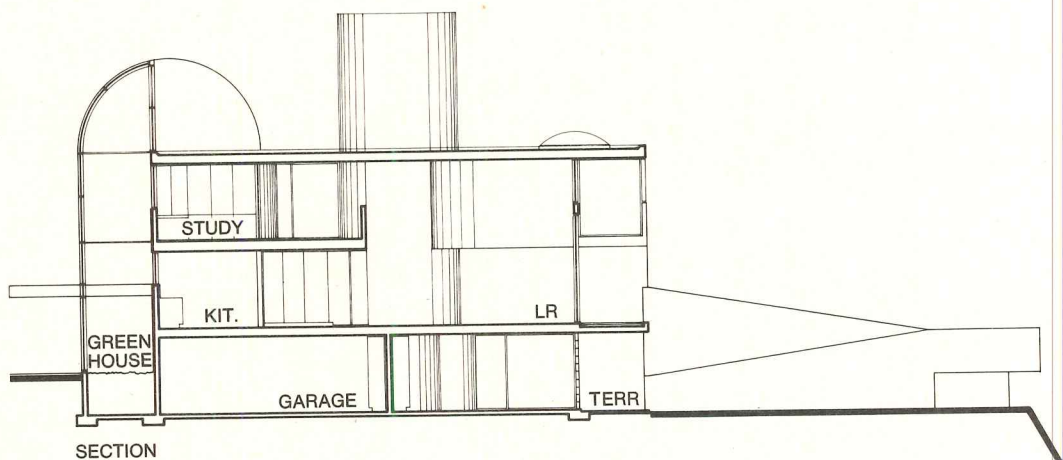
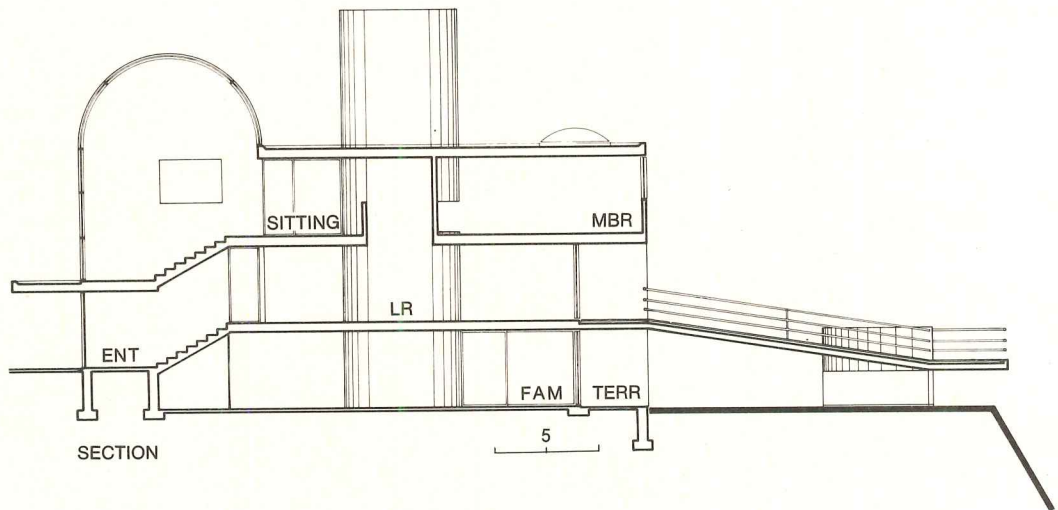



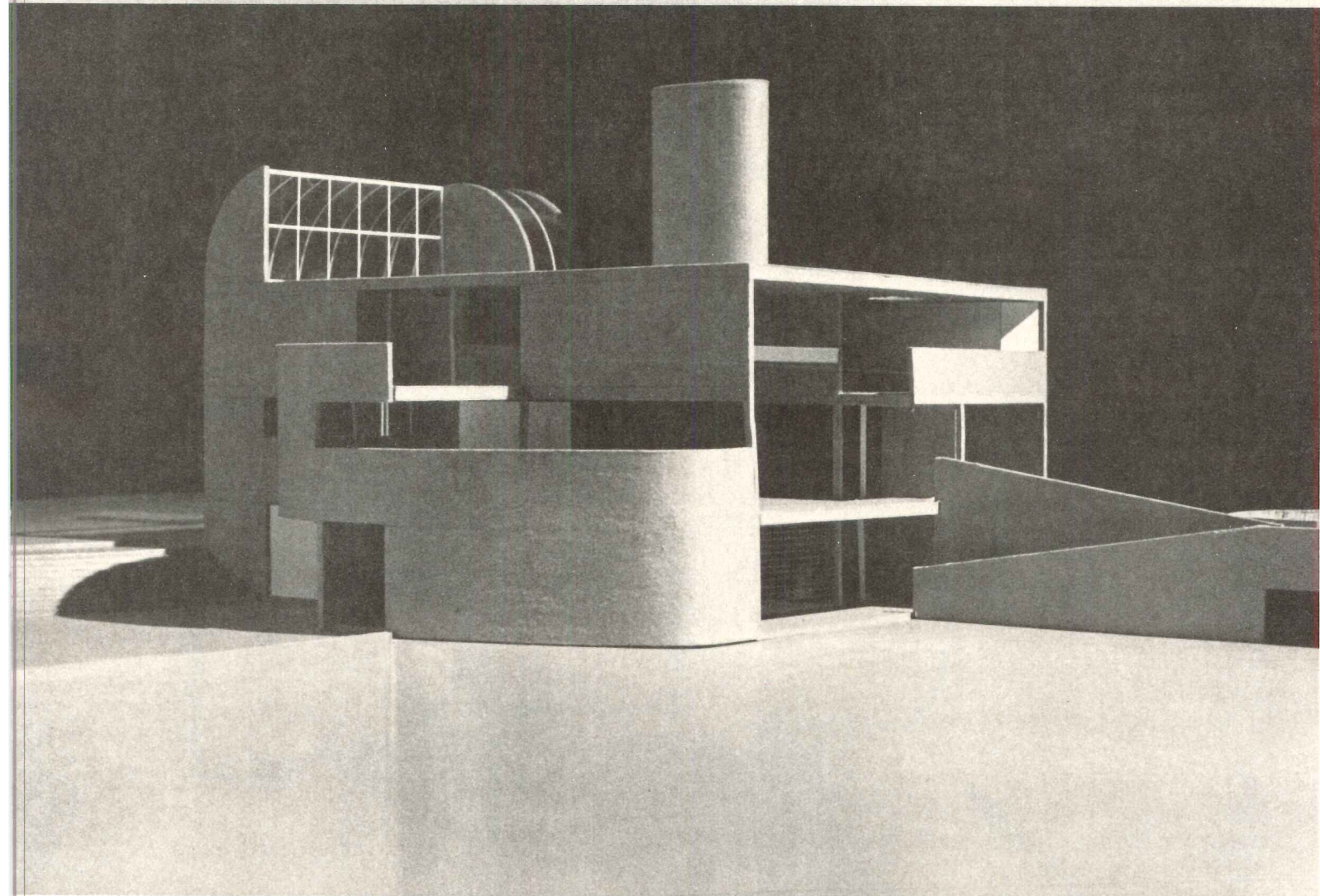
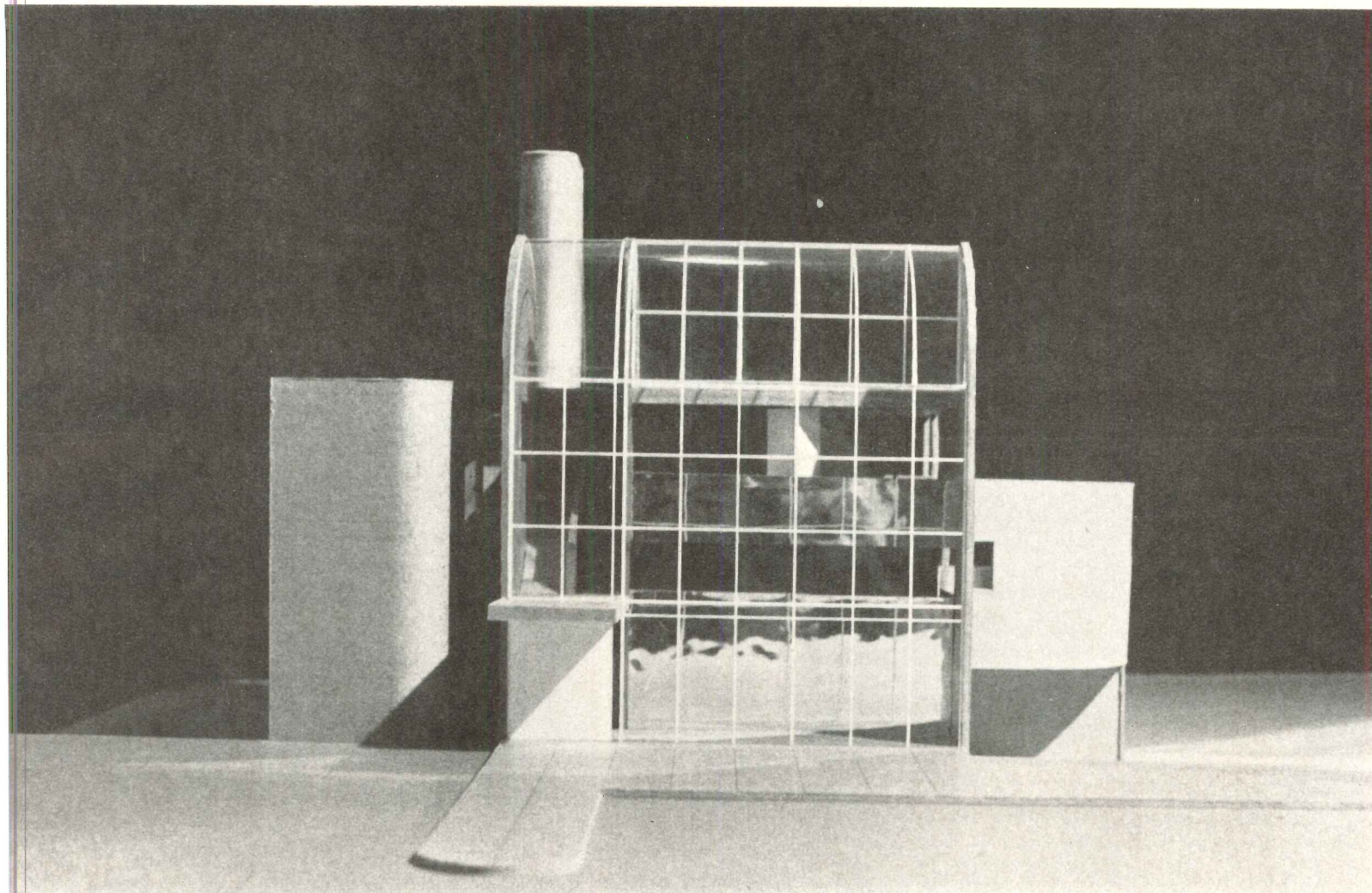



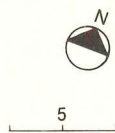
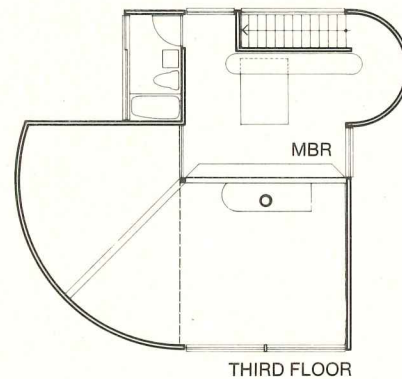
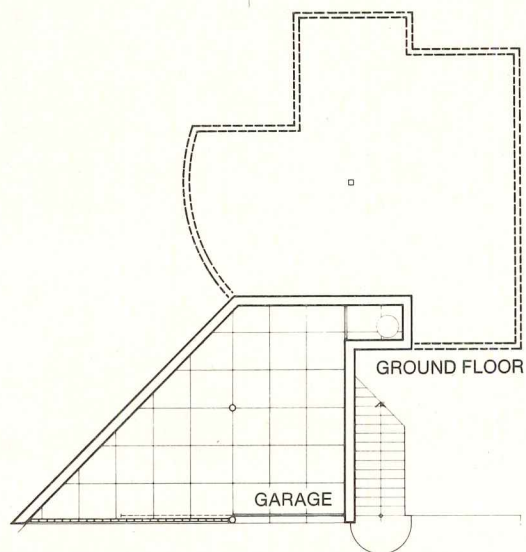
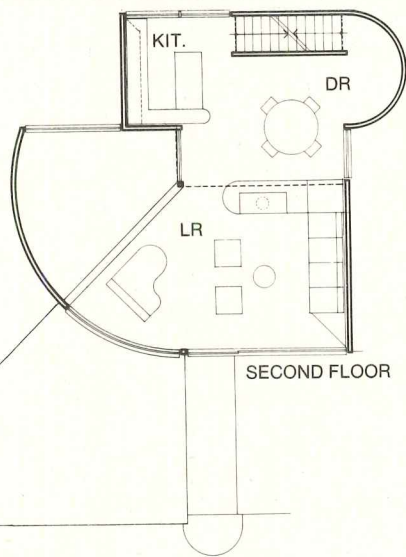
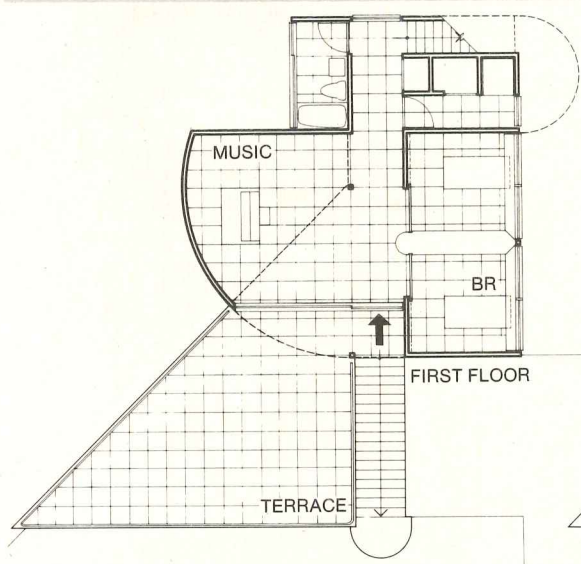
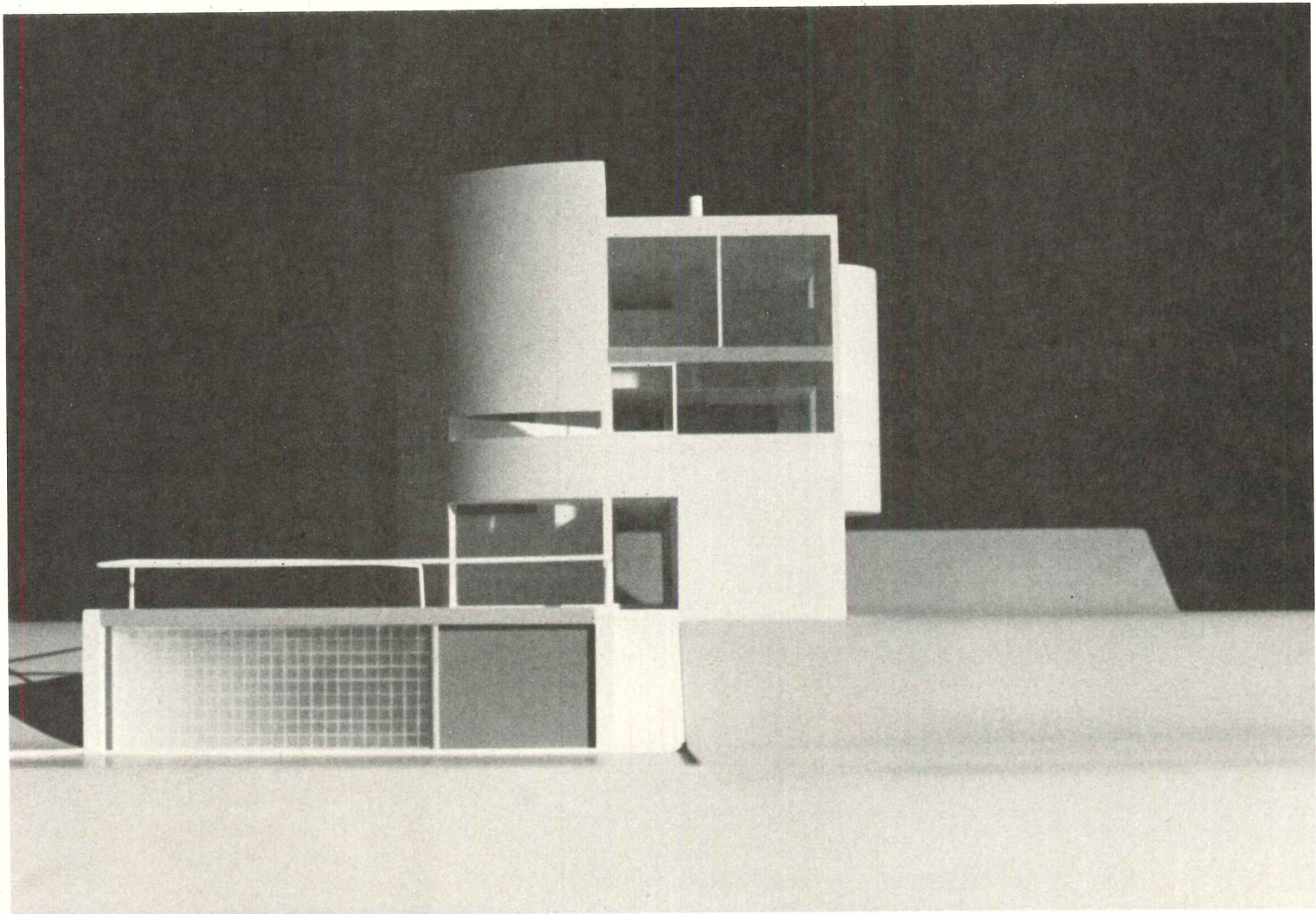



# PARKING STRUCTURES THAT ENRICH A CITY AND INFLUENCE ITS EMERGING URBAN PATTERNS

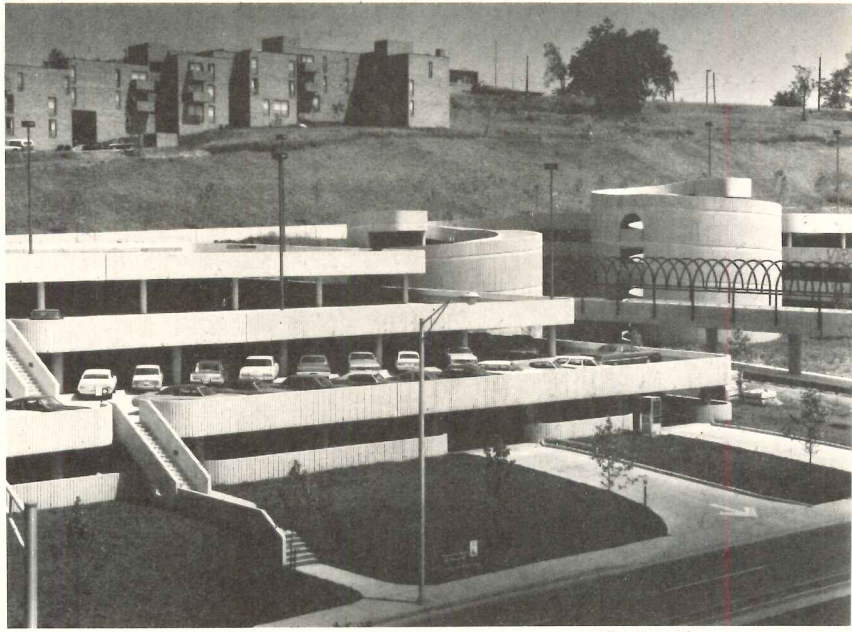

Otto Baitz Photos

Residents fondly describe Knoxville, Tennessee as “a medieval city without an encircling wall,” and like many American cities, Knoxville has been fighting—and losing—the battle against downtown traffic congestion. Architects McCarty Bullock Church & Holsaple, and perhaps the late Bob Church in particular, long envisioned a perimeter parking wall with a pedestrian-oriented downtown in its embrace. Though the idea had some support, the Downtown Loop Study, as the architects called the plan, failed to get the financing it needed, but the skirmish lines were forming. Now, two years after Church’s death, parts of the plan are gradually being implemented.

The Mountain View Parking Garages (photo above) serve a section of the city separated from the main business district by a system of freeways—a section now under development as a civic center. These structures will become a terminal point for cars and an important component in the struggle for a pedestrian downtown. The Student Center Garage (photo below) though technically not part of the Loop Study, serves a similar function for the University of Tennessee. Though utilitarian and plainly designed for the function they serve, both projects incorporate amenities and ideas about urban architecture often discussed, sometimes proposed, but seldom built.

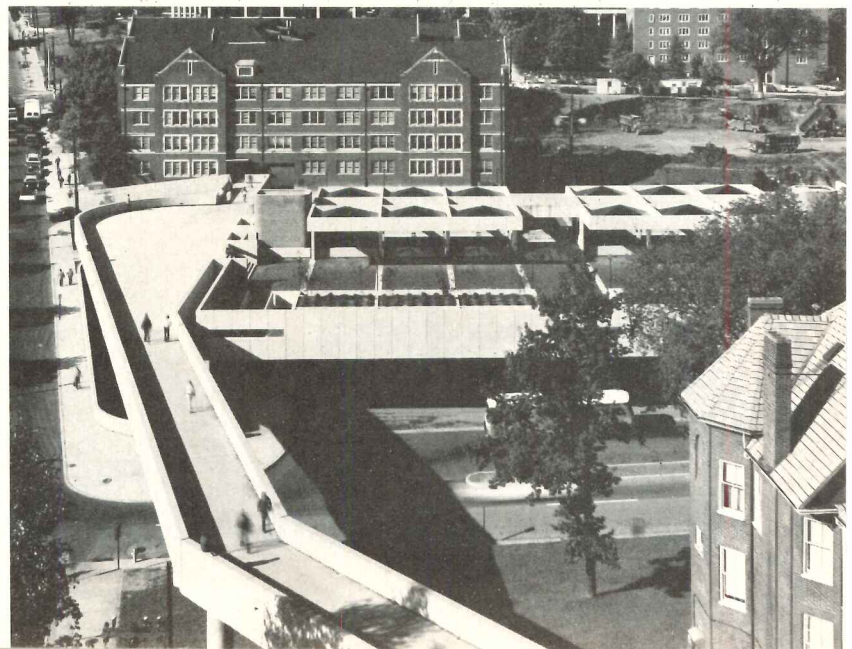



# Parking that forms an integral part of a city's renewal efforts

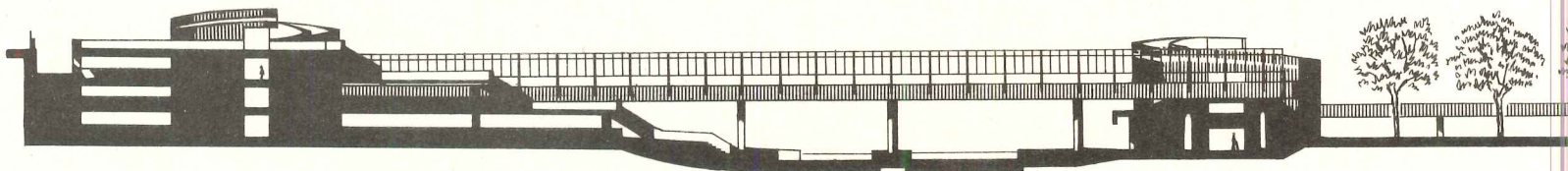

The Mountain View district of Knoxville, a few minutes' walk from the heart of the business district, is an area under heavy renewal. Amid the usual detritus of redevelopment, Knoxville's Civic Auditorium/Coliseum has hosted regular cultural and sporting events that draw large numbers of visitors. As development has continued, parking space—upon which a coliseum depends for its success—has gradually dwindled. In early 1968, therefore, McCarty Bullock Church & Holsaple were commissioned to design for the area a structure or structures that could accommodate 2,500 cars. They were also asked to consider the feasibility of a proposed new convention hall and plan for the orderly development of these facilities in Mountain View's tightening urban fabric.

In the course of these studies, the idea of a single, large-scale parking structure was rejected as both too expensive and too impractical to operate. Instead, the architects planned three separate structures, two built into the hillside north of Church Avenue and expressed architecturally as a series of superimposed trays, each level stepping back to reveal the forward edge of the level below. A third structure, five-stories-high, fronts Hill Avenue and will hold 1,000 automobiles. A system of bridges and covered walks will connect the garages and the

Coliseum to protect against inclement weather. Adjacent properties will be landscaped to create a plaza and strips of park. The Mountain View Parking Garage will also serve the downtown area as city buses shuttle passengers back and forth between the garages and various locations in the business district. Commuters can park for eight dollars a month (including bus fare)—a plan that has already noticeably reduced traffic congestion in the city at the same time that it has provided parking for events in the Coliseum; and a plan that might well be adopted in a host of cities.

The two structures with a combined capacity of 1,500 cars are now complete and were built in reinforced, post-tensioned concrete at approximately \$1,900 per car. The third structure, now under construction in the same materials, is expected to price out at just under \$2,200 per car. All exposed surfaces were sandblasted and sealed.

---

MOUNTAIN VIEW PARKING GARAGES, Knoxville, Tennessee. Owner: *City of Knoxville*. Architects: *McCarty Bullock Church & Holsaple, Weeks Allan Ambrose*, architects, *Francis F. Painter*, architect. Engineers: *J. T. Warren* (structural); *Albert F. G. Bedinger* (mechanical); *Vreeland Associates* (electrical). Landscape architects: *Oliphant & Kersey*. Parking consultant: *Allright Auto Parks*. Contractor: *W. F. Holt*.

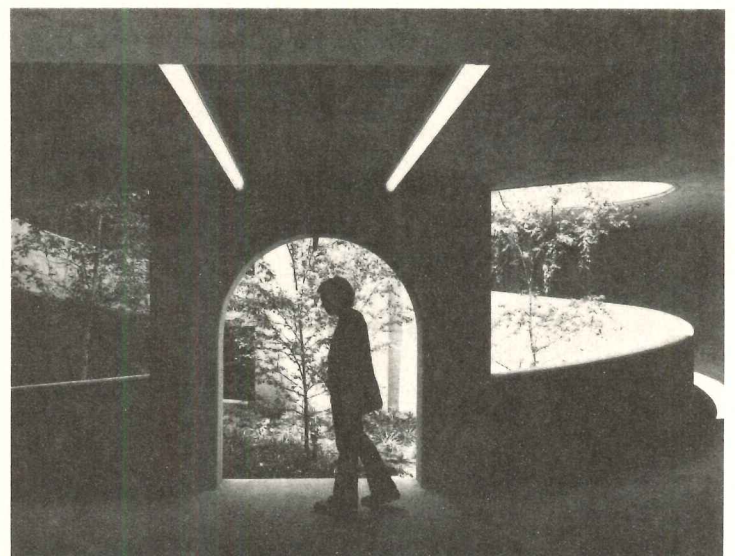
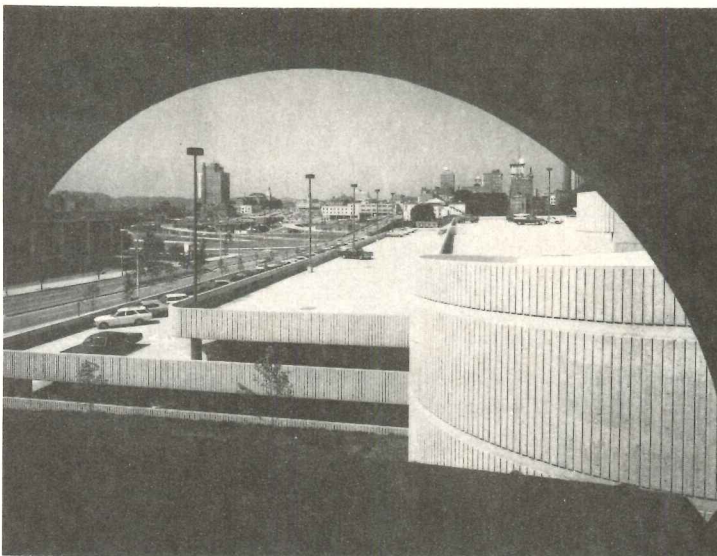



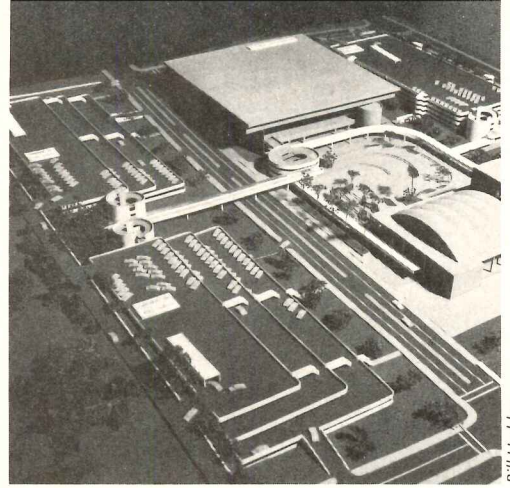

Bill Hardox

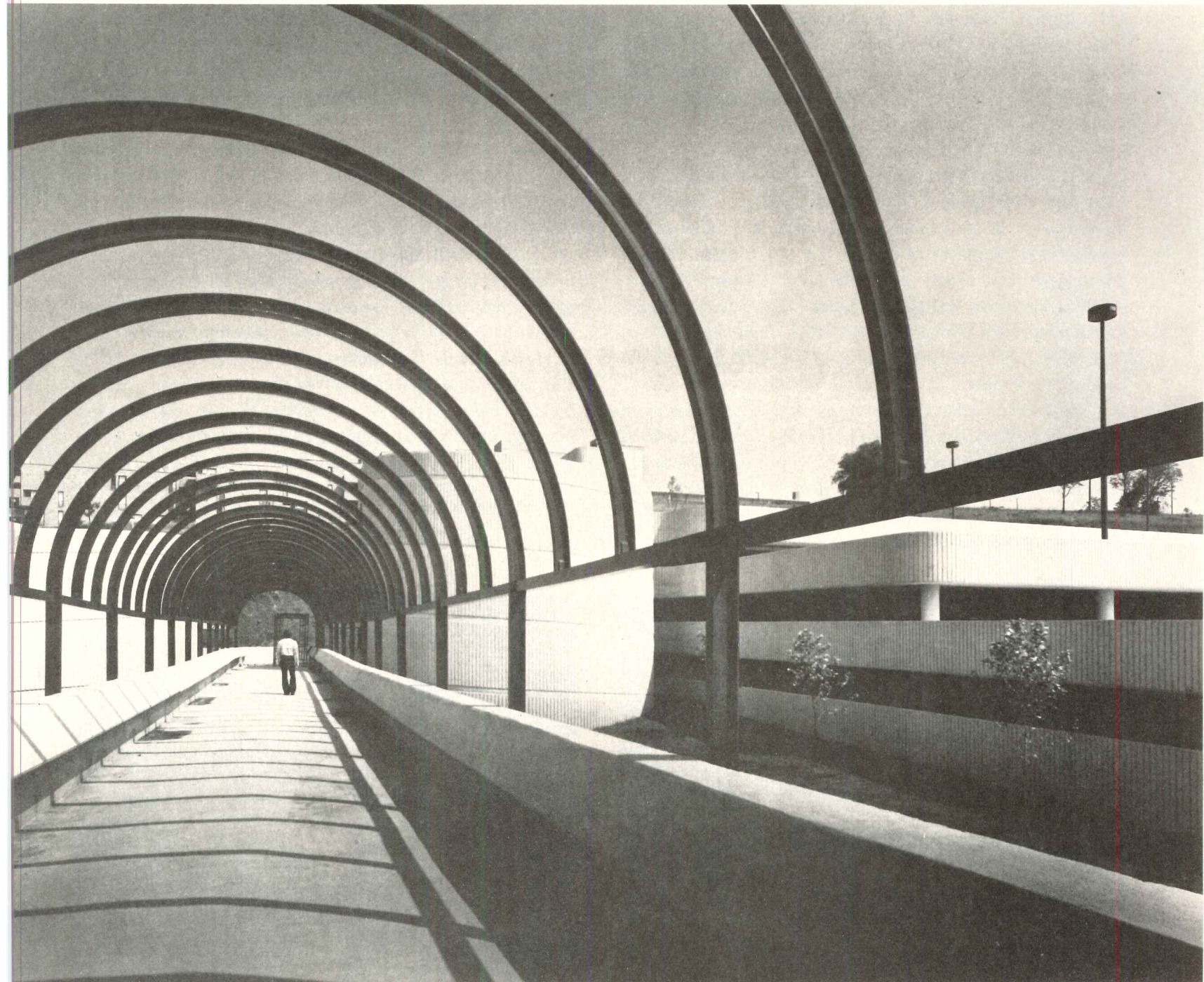
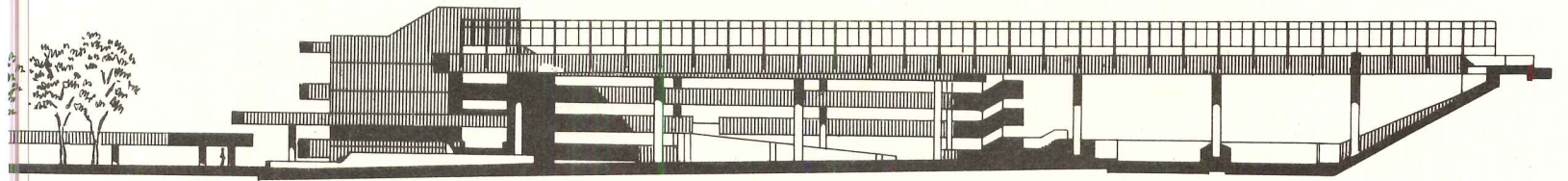



# Parking that serves and enriches an established university campus

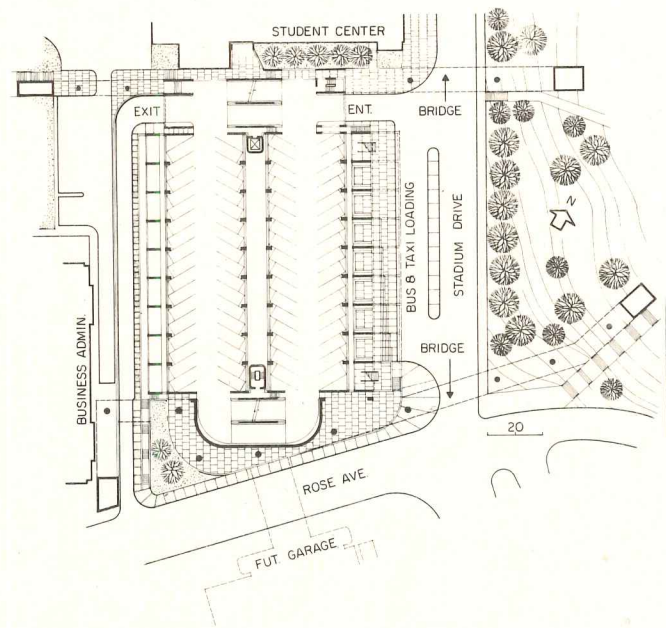

On a tight, 1.7-acre site situated between two campus hills, McCarty Bullock Church & Holsaple were retained by the University to design a 240-car parking structure adjacent to and serving the Student Center at the University of Tennessee. The architects met the program admirably and provided a structure that is much more than just storage for cars. Because the new building is located at an important seam between newer and older parts of the campus along a major avenue of circulation, the roof deck, or portions of it, were paved in black slate and developed as a student plaza. Here students can meet, interact, and engage in a variety of activities either planned or impromptu. Pyramidal skylights, fitted out in tinted acrylic plastic, form a transparent canopy along one edge of the plaza (photo, page 118). Light from these skylights is filtered down to the parking level below.

The building is flat slab construction with brick paving at grade and buff brick on selected walls. Much of the building and ramp system are exposed concrete with a needlepoint finish. Lighting is a combination of fluorescent in parking areas and incandescent along pedestrian ways. Since the building is open on all sides, no ventilation equipment was needed.

Because the project is much smaller and the level of finish higher than Mountain View, costs-per-car rose substantially. The total construction cost was approximately \$1.4 million or about \$5,800 per car. In the parking areas, the price was \$8 per square foot.

The building's virtues—or many of them—are apparent from the photographs. The massing is simple but inventive within the serious constraints imposed by the site. Indeed, and incredibly, the view from the surrounding buildings offers—instead of the usual eyesore—an architectural presence, strong patterns set off by landscaping which will be most handsome when it has matured. The planning for both automobiles and people has clearly been given great attention. In short, in its forms and details, the building is an affirmative statement and it summarizes a great deal of honest design thought about a building type too often given very little design attention—or ignored in the continuing antagonism toward the automobile.

STUDENT CENTER PARKING GARAGE, Knoxville, Tennessee. Owner: *University of Tennessee*. Architects: *McCarty Bullock Church & Holsaple—Robert Church*, designer. Engineers: *Ellers, Reaves, Fanning and Oakley* (structural); *Albert F. G. Bedinger* (mechanical); *Vreeland Associates* (electrical). Landscape architect: *Melvin E. Kersey, Jr.* Contractor: *Wallace E. Goodwin*.

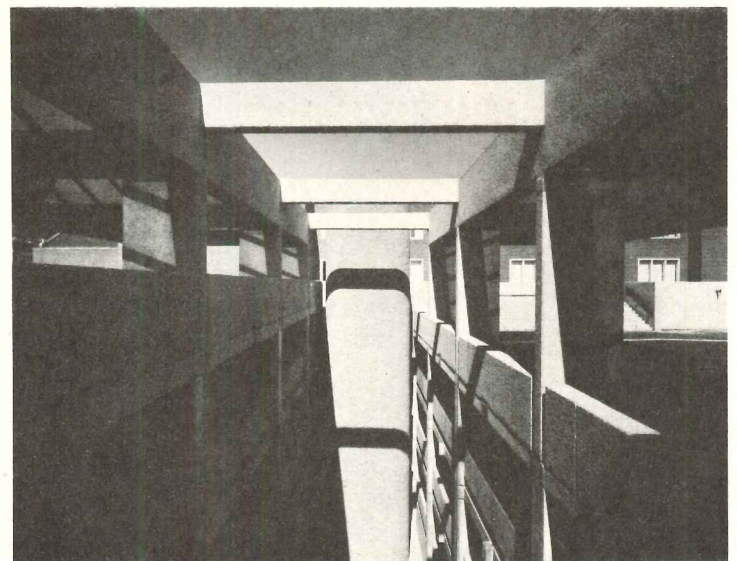
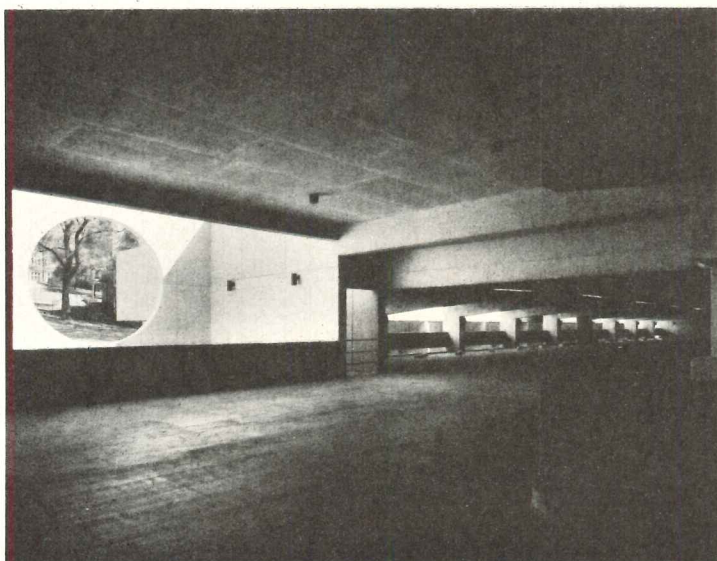



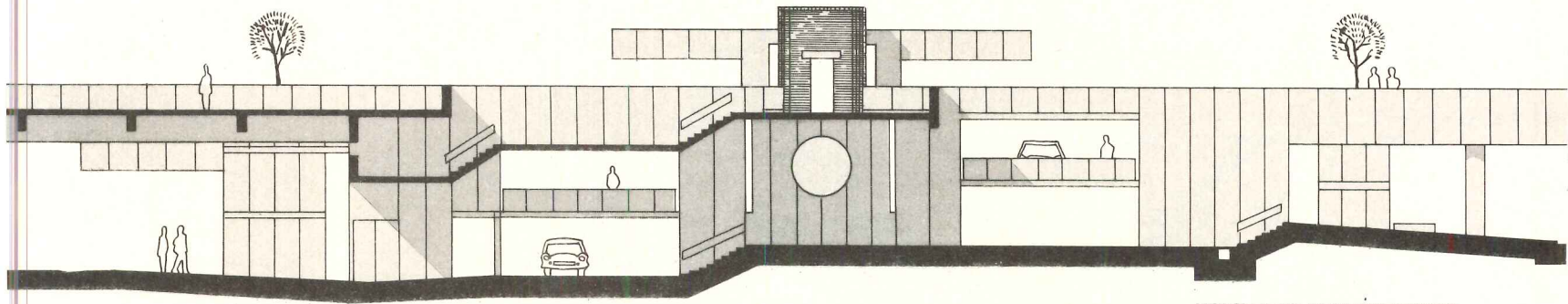

SECTION THROUGH STUDENT BRIDGE

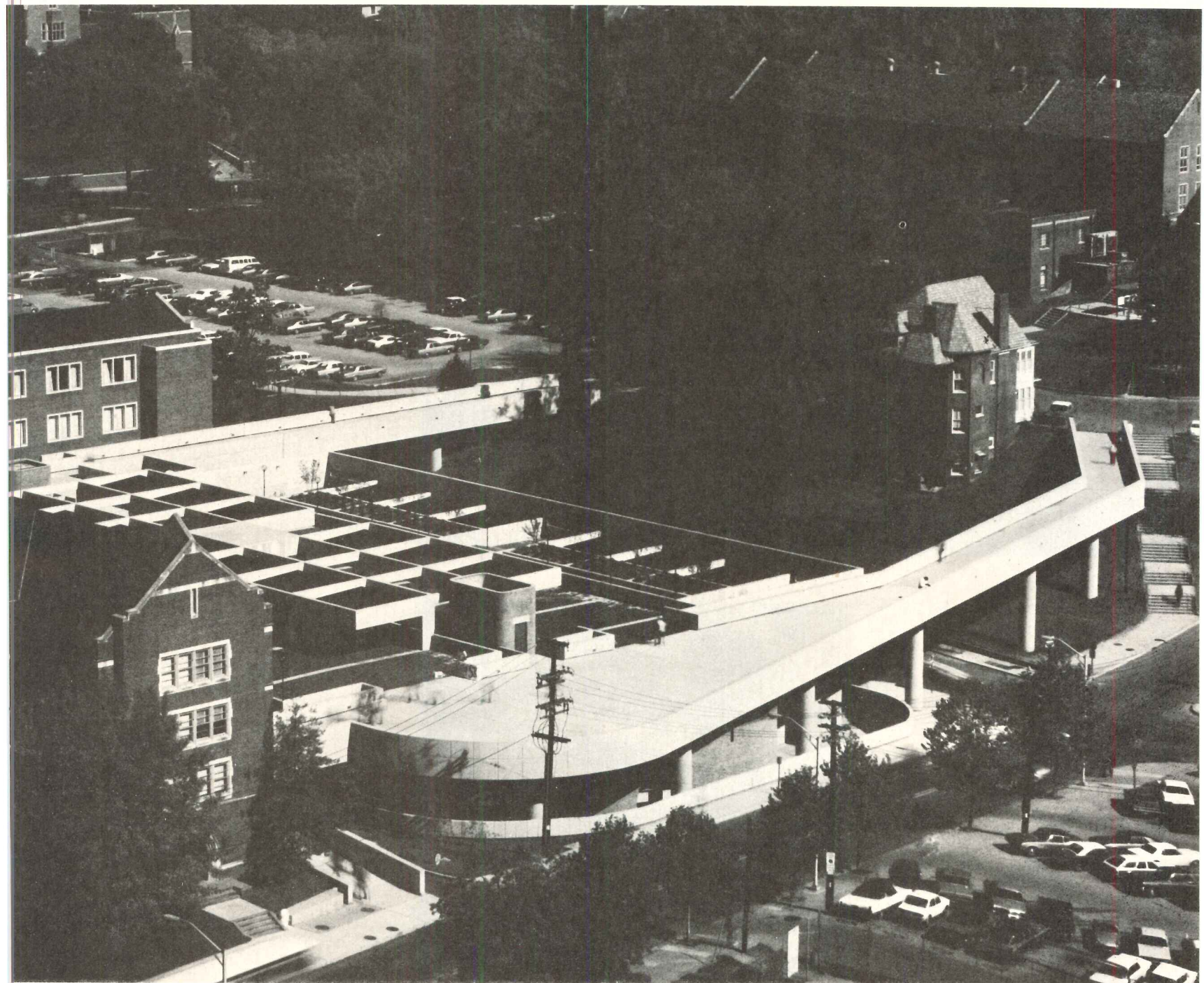



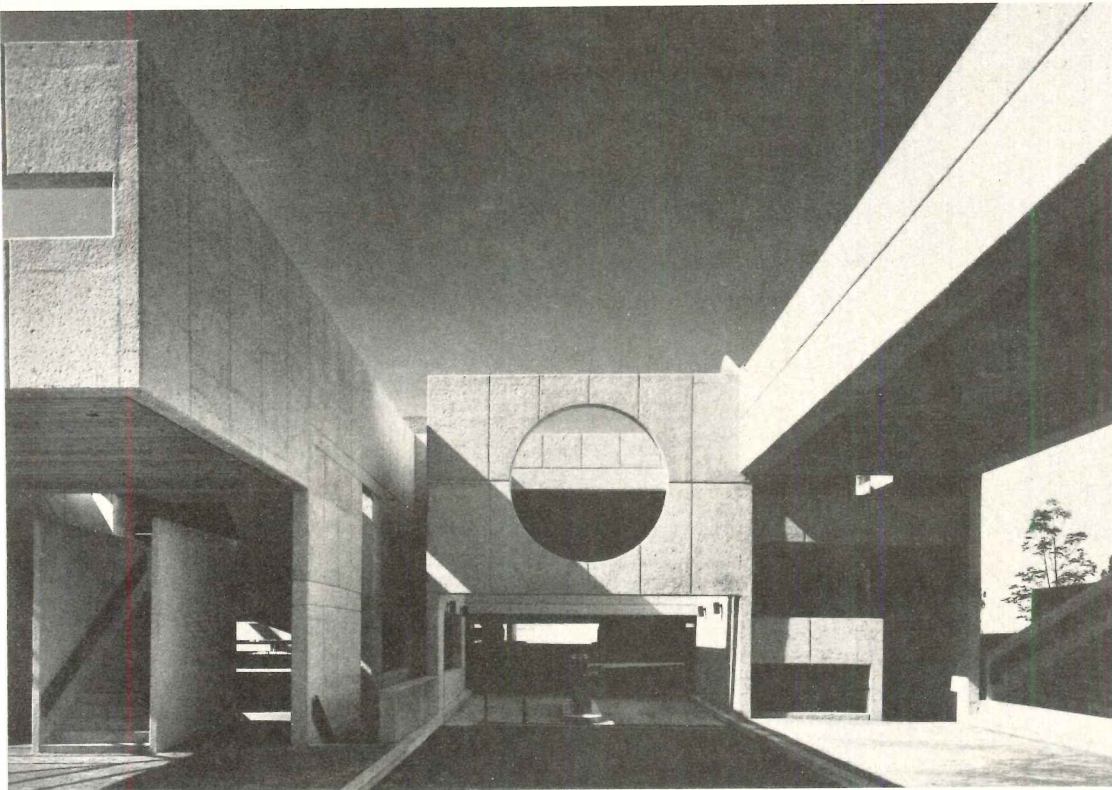
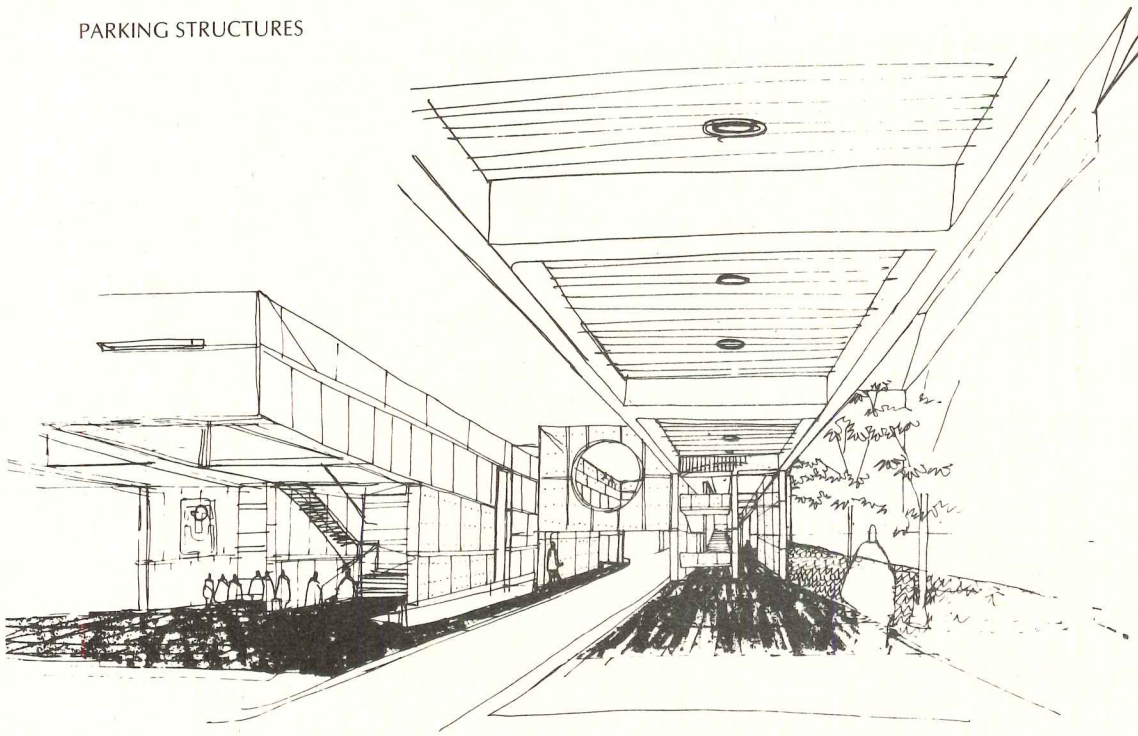

Automobiles enter on grade at an off-street entrance marked by a circular cutout (photo above). Photo right, shows the circulation route at the edge of the upper level plaza—a space designed to draw students from both parts of the campus.

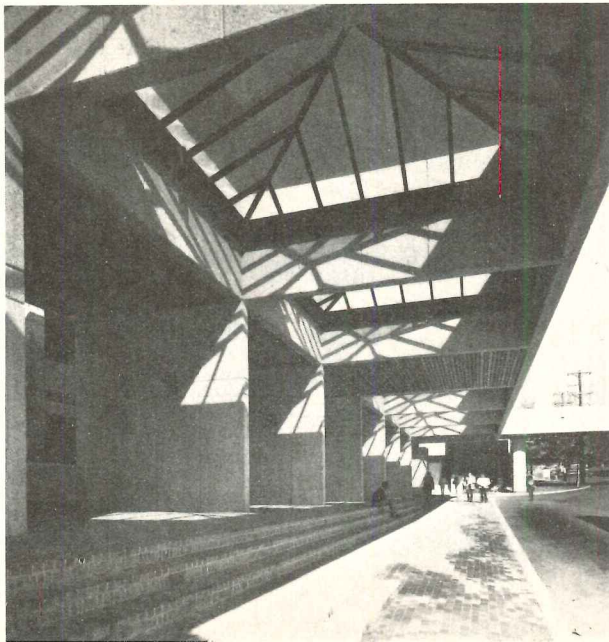



# COMMUNITY COLLEGES



Julius Shulman

No wonder the community college is an increasingly numerous building type: it offers what no other facet of public education can—learning opportunities in a great diversity of fields, responsive to local needs, interests, and aspirations: in places, at times, and in segments convenient to the life of the individual student.

By 1980, community colleges will have almost twice the number of students they had in 1973, and in some cities, state colleges and universities are already being hard pushed by local community colleges, just the reverse of the situation a few years ago. Many new community college campuses are handsome places which generate pride in the students and faculty who use them, and in the community whose votes paid for building and operating them. On the following pages we show a few such examples.—*Elisabeth K. Thompson*



## Educational program and desert site influence design of Pima College

What influenced the design of Pima Community College in Tucson, Arizona, were the requirements of the college's interdisciplinary, interactive educational program and the exigencies of site and climate. The visibility from the city of the 273-acre site in the foothills of the Tucson Mountains, and splendid views out from it, afforded design opportunities for strong forms and pleasant outlooks. Even more important were the hot windy climate and the approach to learning, architecturally reflected in the dispersion of faculty offices to the "houses" and to the student center, facilitating student-faculty mingling, and in the landscaped courts or "oases," sheltered walks or links, and wide overhangs which protect from the sun. Buildings are in two groups: academic—small scale, informal, quiet, at whose heart is the interdisciplinary "house" program, which assigns each student and faculty member to a smaller unit of the college; and public—formal, grand-scaled, a mixing place.

PIMA COMMUNITY COLLEGE, Tucson, Arizona. Associated architects: *Caudill Rowlett Scott, William Wilde and Associates, Inc., Friedman & Jobusch*; James M. Hughes, partner-in-charge; Joseph W. Griffin, project manager; Jack DeBartolo, Jr., project designer; Warren Edminster, production architect. Engineers: John A. Martin and Associates (structural); Warne Associates (foundation); Harry B. Clover, Jr., of Friedman & Jobusch (mechanical); A. E. Magee (electrical); John Paul Jones (plumbing). Landscape architects, interior and graphics design: *Caudill Rowlett Scott*. Consultants: J. C. Beck (cost), James F. Cauley (food service). Contractor: M. M. Sundt Construction Co.

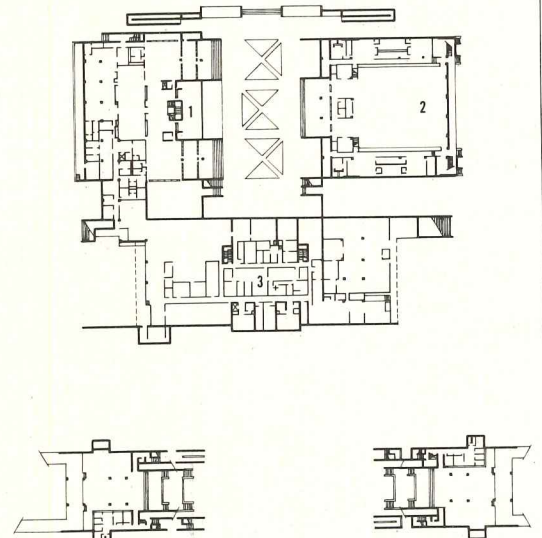
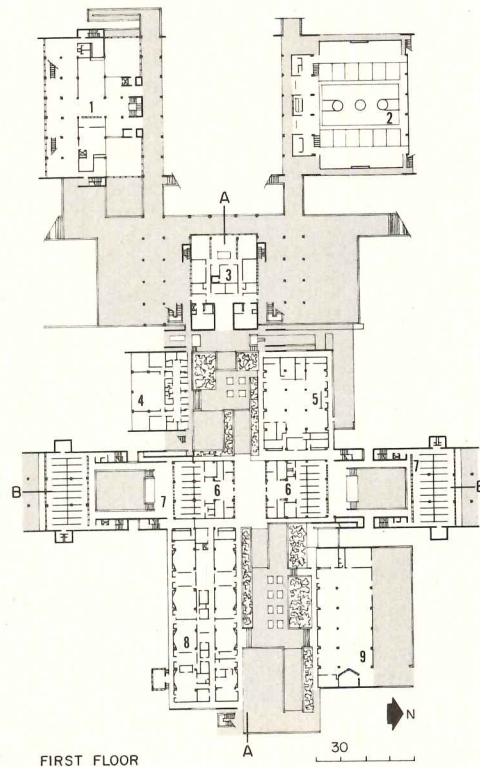
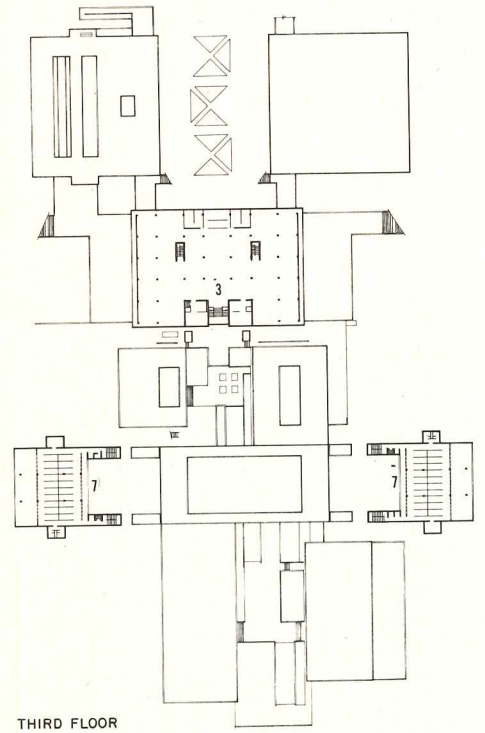
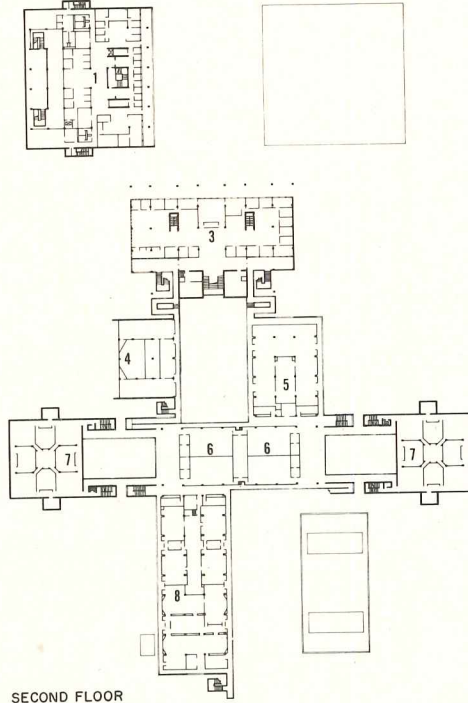

- 1 College Union
- 2 Physical development
- 3 Learning resource center
- 4 Music
- 5 Vocational technology
- 6 Large group instruction
- 7 House
- 8 Science labs
- 9 Propulsions lab

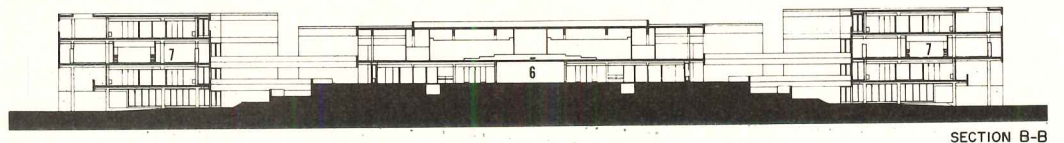
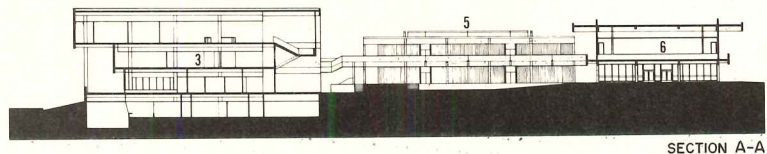
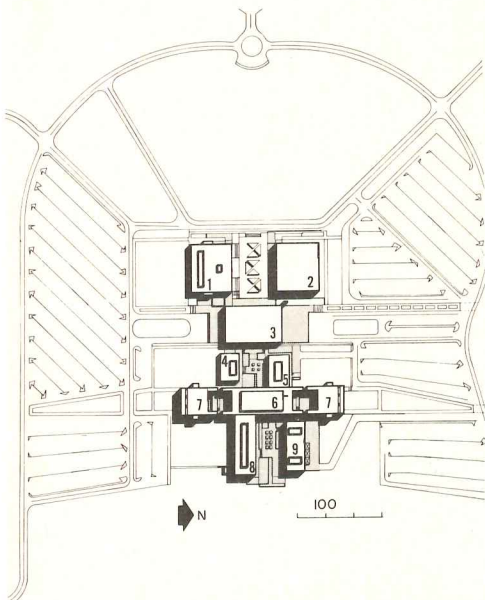



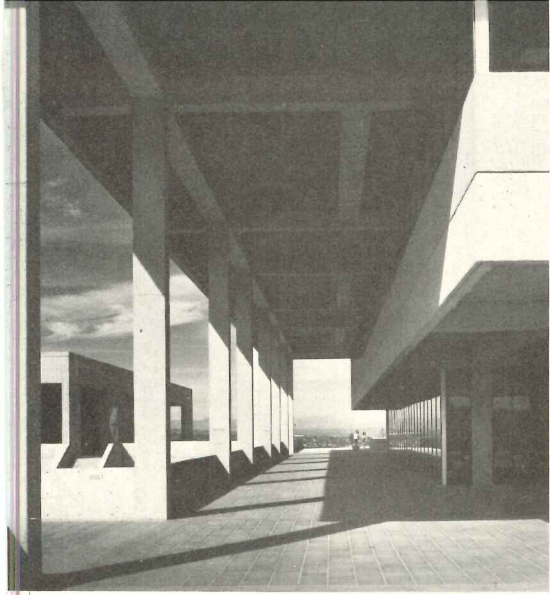

1



4

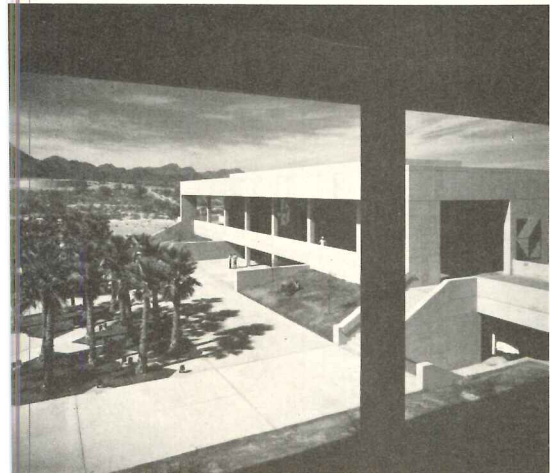

2

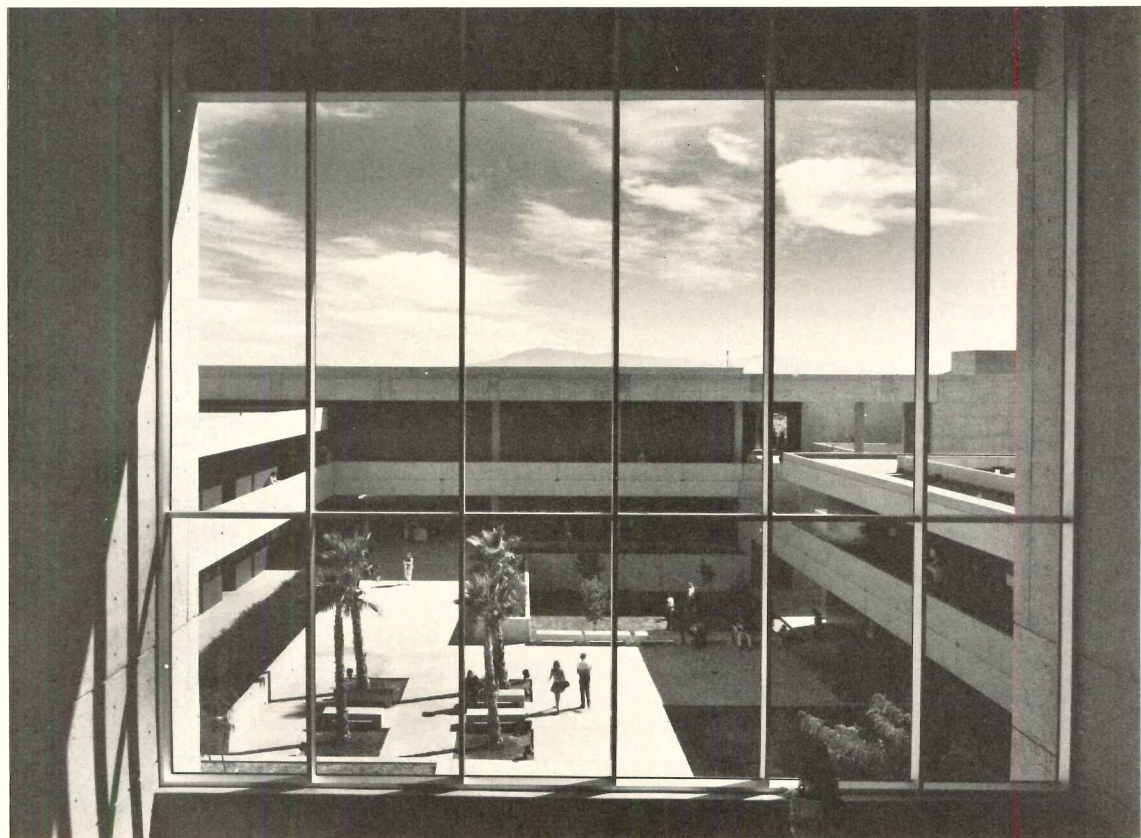

5

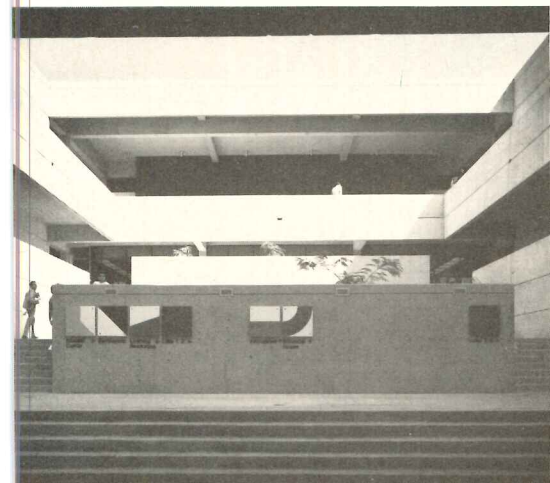

3

Julius Shulman photos

The tight grouping of buildings, with confined malls and courts, respects the desert site and contrasts strongly with its expansiveness. Courts provide protected open space and good mingling places for students. The six divisions of the curriculum are represented in the houses, but these and other buildings are designed for flexibility as education programs change. Ultimate enrollment is 6000; initial was 2800.

1. Concourse at front of Learning Resource Center. 2. Entrance court, Physical Development at right. 3. Steps from house to Large Group Instruction. 4. Court looking to LRC. 5. Same court, toward LGI. 6. Bookstore.



6



## A college designed to serve and revitalize a crowded downtown area

The Downtown Campus of Miami-Dade Community College has a double reason for being where it is: to serve the residents of the surrounding areas, especially the two minority groups in the neighborhood; and to revitalize a deteriorating part of the city. The site is a block across from the 1920 Post Office Building and a Victorian church—both of which benefit from the open landscape in which the building is set. The strong cubistic forms of the buildings are in startling—and intentional—contrast to the old buildings near-by. The plan of the building, like that of the park-like site, integrates campus and city, since the open street level invites pedestrian use of the buildings to cross the block. The most notable aspect of the building's concept is the atrium, a seven-story court, roofed by skylights, which is, in effect, a "vertical plaza" since all circulation is open to it, whether by escalator or stairs, or by corridor. The diagonally placed escalator leads from street level to the first college floor, but the tie to the city is by no means broken at the upper levels, although above street level it is a visual tie.

DOWNTOWN CAMPUS, MIAMI DADE COMMUNITY COLLEGE, Miami, Florida. Architects: *Ferentino/Grafton/Spillis/Candela*—Andrew Ferentino, senior partner; Hilario Candela, senior partner, design; Ralph Portuondo, project architect; Dean Newberry, interiors. Engineers: *Ferentino/Grafton/Spillis/Candela*—Carlos Cardoso (structural), Juan Lagomasino (mechanical), Alberto Otero (electrical). Cost consultant: *Cole Early*. Contractor: *Frank J. Rooney, Inc.*

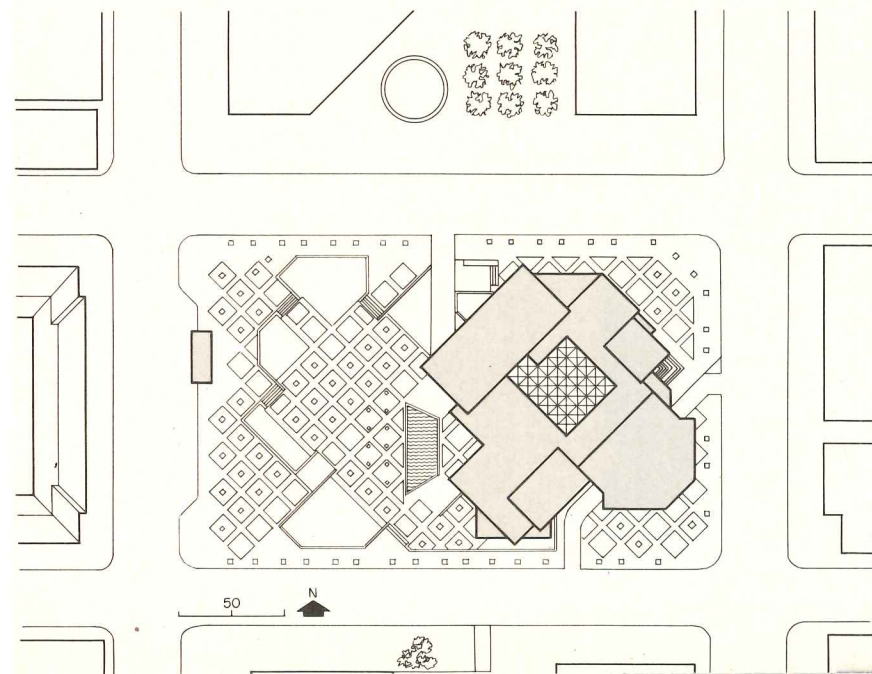
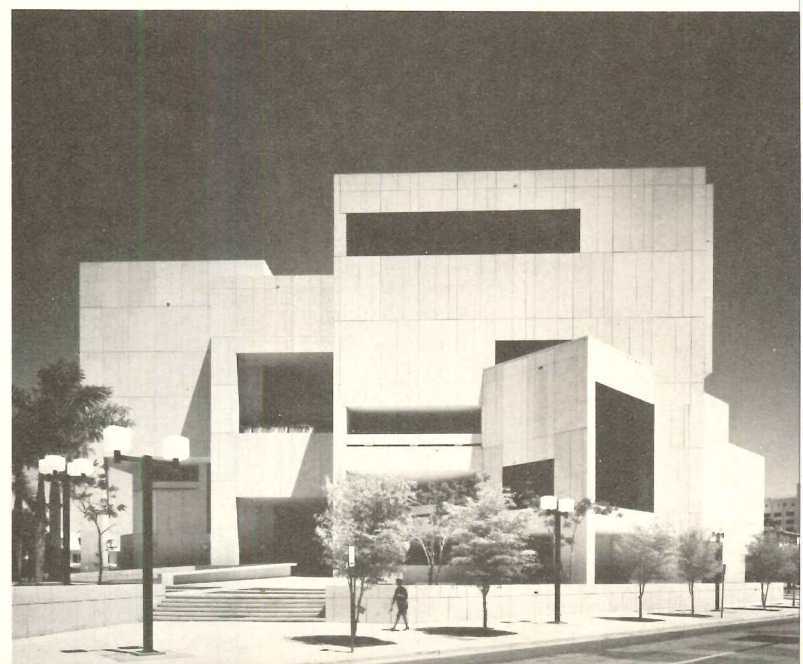
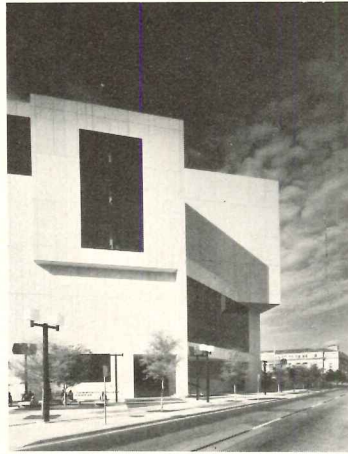





*Joseph W. Molitor photos except as noted*





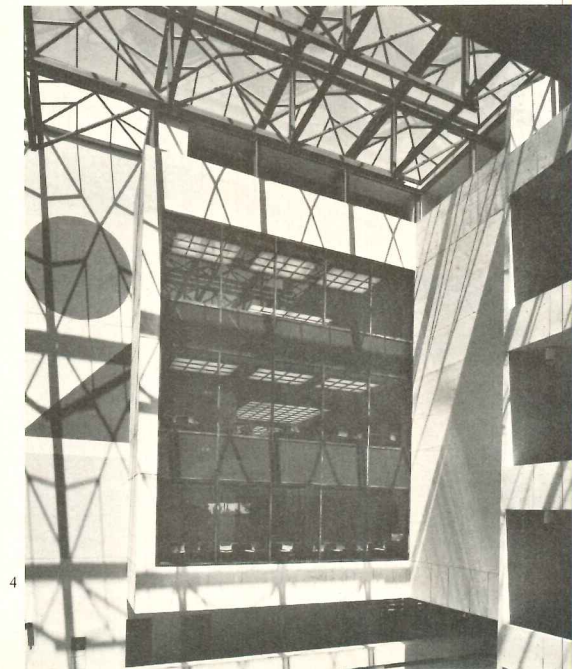
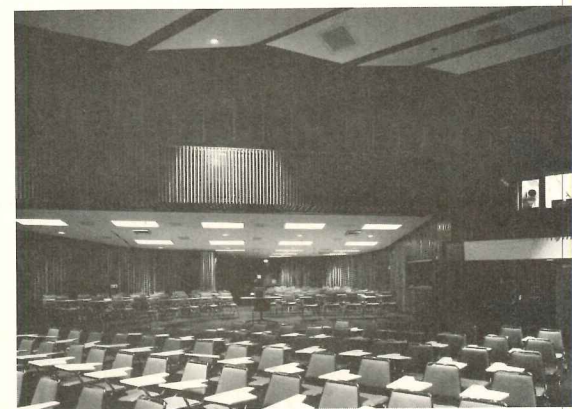
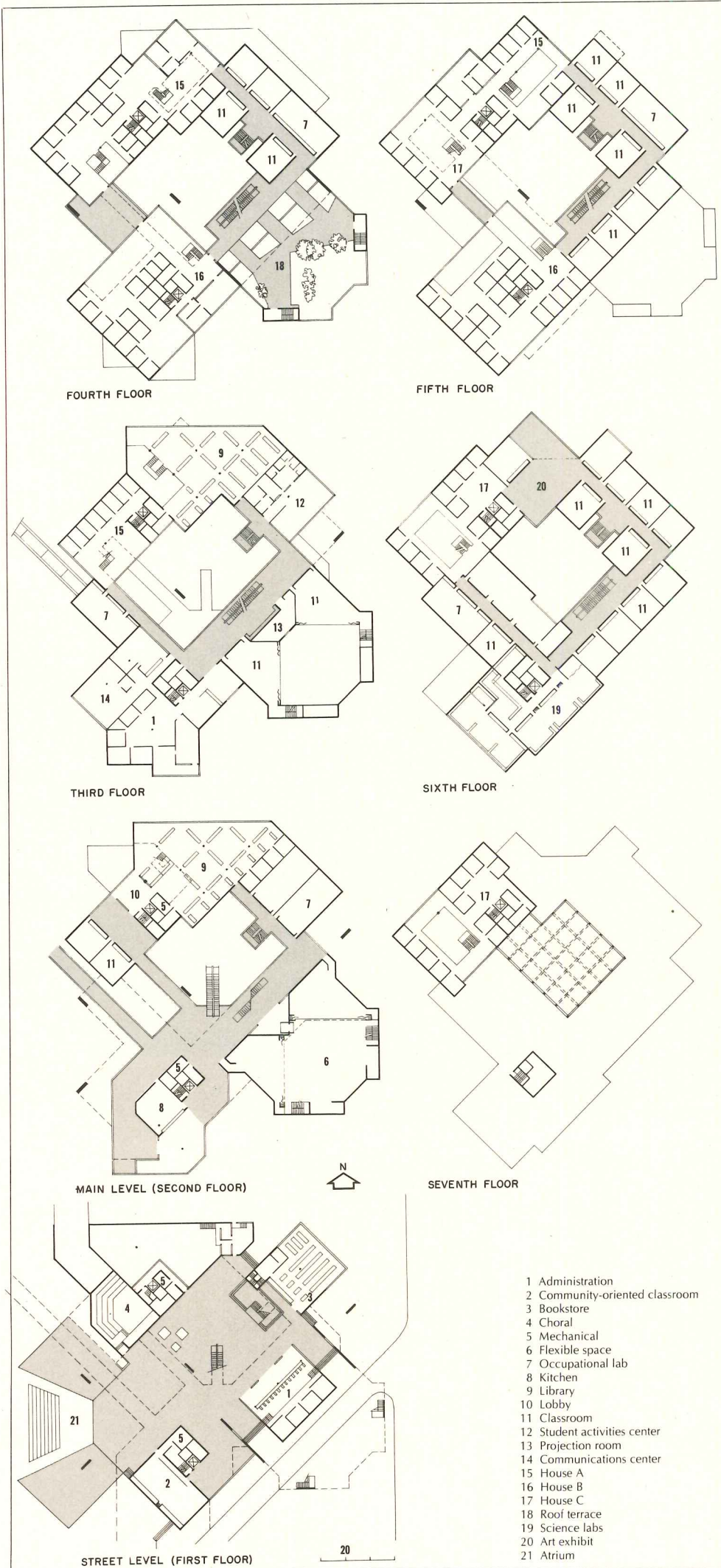





Hedrich-Blessing

The atrium gives the building special distinction. The seven-story openness that it creates is impressive, inviting, involving—just what the college wanted its building to be. The pattern of the escalators enlivens one side of this “vertical plaza”; a projecting stairway and supergraphic numbers do the same on another side. On a third side, a three-story window opens up one of the houses (there are three) to the atrium. Academic and administrative rooms are disposed around the court on the upper six floors. 1. Reading lounge in a house. 2. Flexible space on second floor. 3. Escalators on right, stairs at center. 4. Multifaceted skylight.

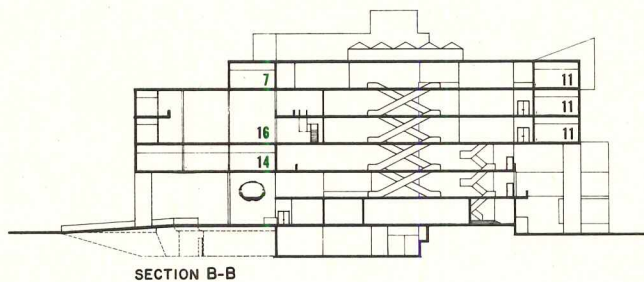
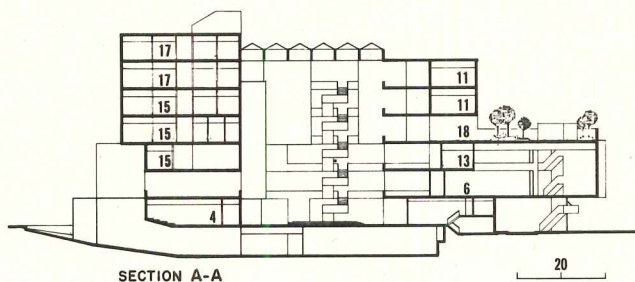



## A stimulating environment on a difficult site in foothill country

Crafton Hills Community College is located between the city of Redlands, California, and the town of Yucaipa, in the foothills of the San Bernardino Mountains. The site is a difficult one, made up of narrow ridges and steep-sided arroyos. Buildings had to be placed on the ridges and then, because there was no room around them for walkways, they had to be raised and opened for foot traffic, a suitable solution in the hot climate with the added bonus of a splendid view out over the valley to the mountains. Eventually the campus—which will be developed in three phases over a 20-year period—is to serve 4000 to 5000 students. The first phase, shown here, included the first classroom center, the library-communications center (designed to take two additional floors) and the laboratory center. The college is administered on a "cluster concept," not unlike the house concept. Each classroom center serves as a place for learning, study and discussion for 1000 students, 40 faculty members and three administrators.

CRAFTON HILLS COLLEGE, near Redlands, California. Associated architects: *Williams, Clark & Williams* and *Jones, Poper & Armstrong*; *Richard Poper*, project architect; *E. Stewart Williams*, design architect. Engineers: *Johnson & Nielsen* (structural); *LeRoy Crandall & Associates* (foundation); *Tharaldson, Matthewson, Argabright & Doby* (mechanical); *H. E. Simmons, Inc.* (electrical); *Hicks & Hartwick* (civil). Landscape architects: *Wimmer & Yamada—Joe Yamada*. Contractor: *Steed Brothers Construction Co.*

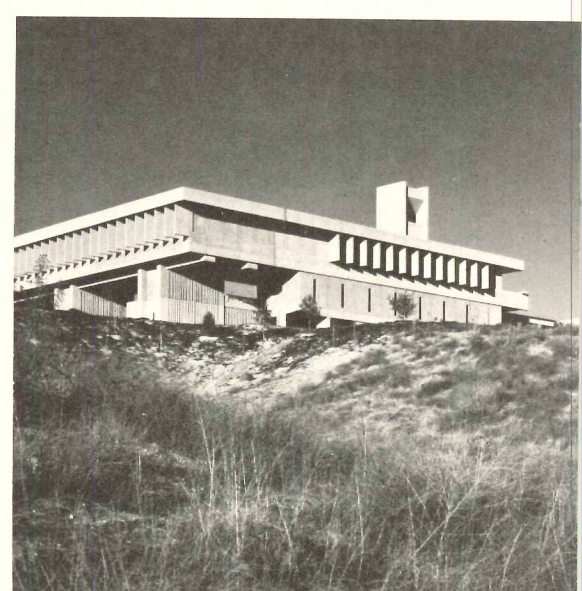
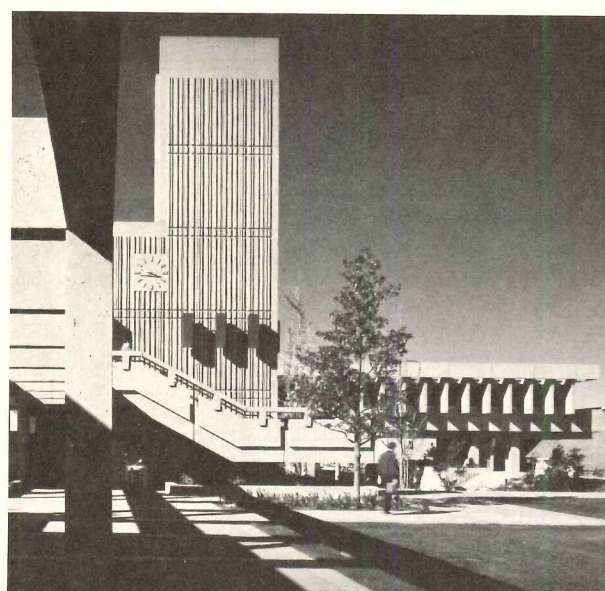
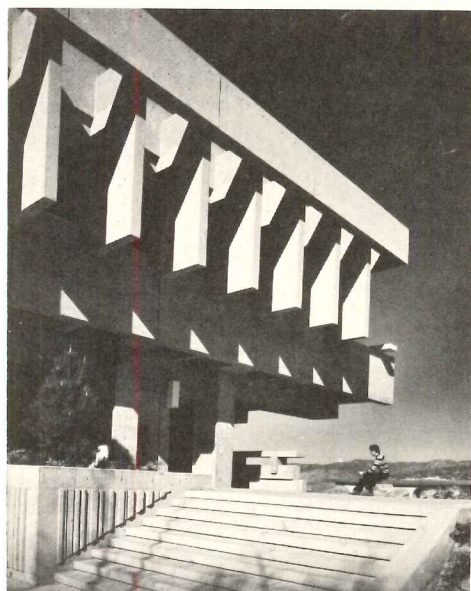
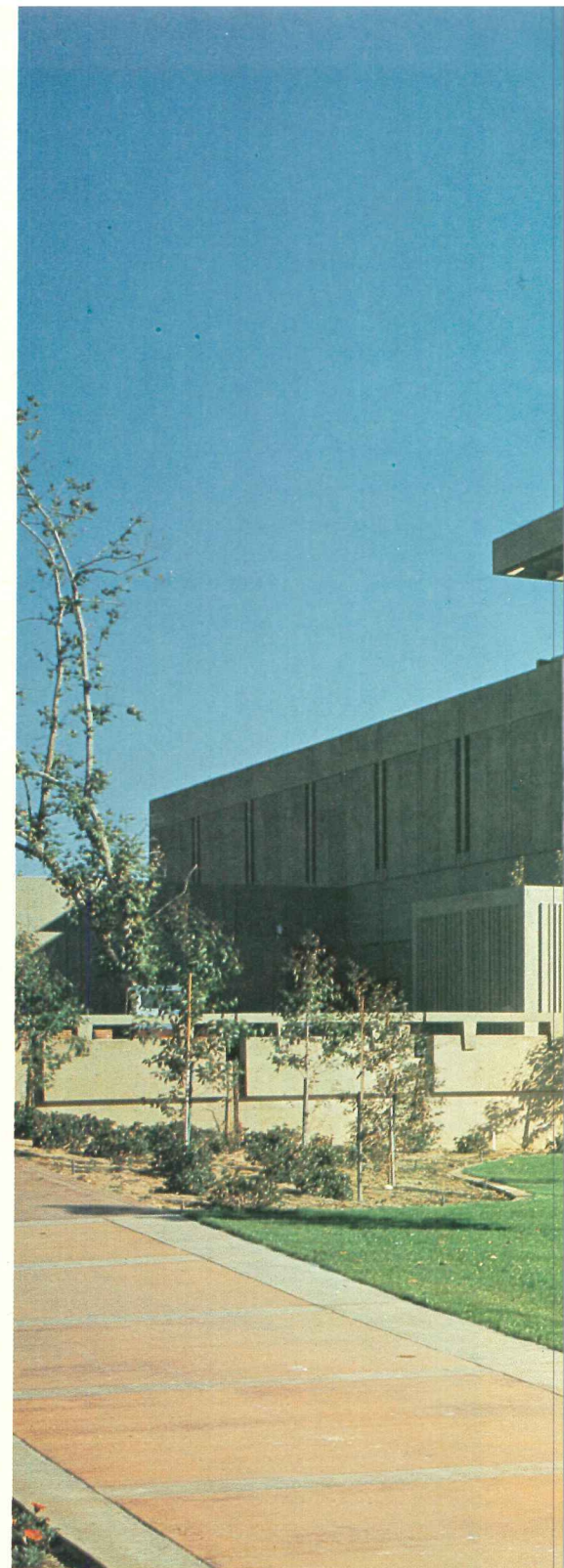
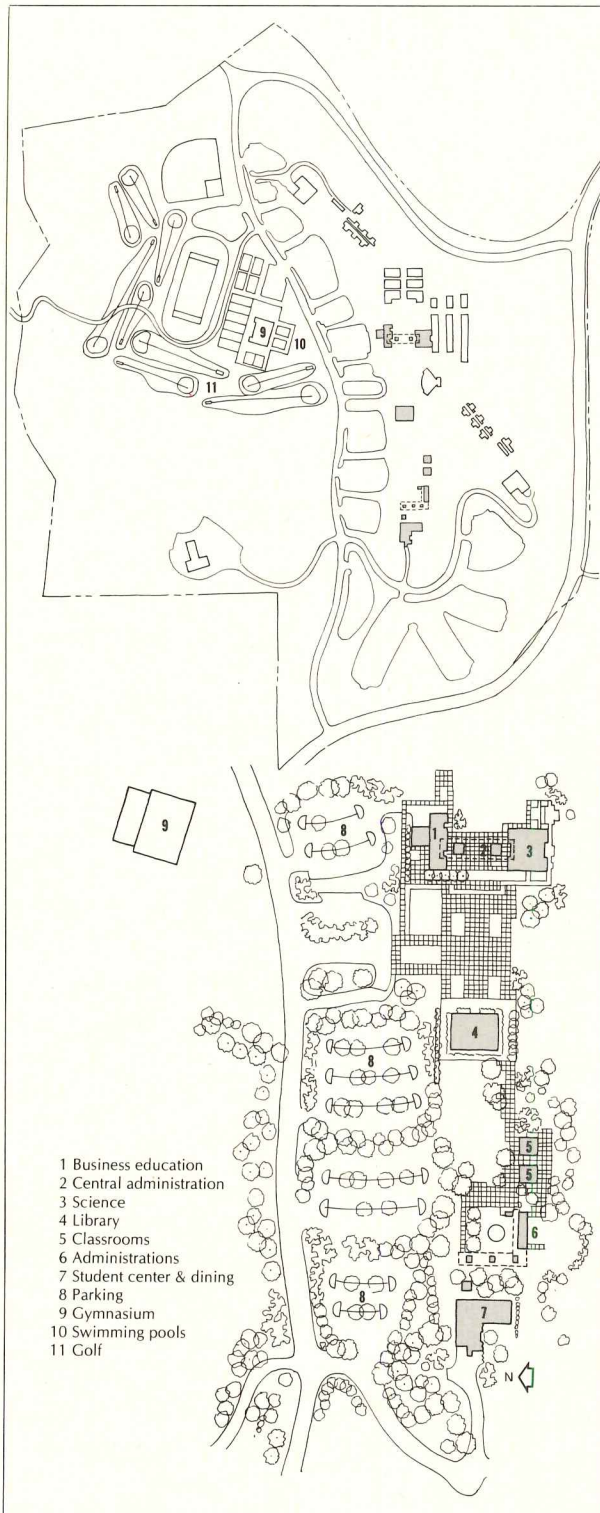



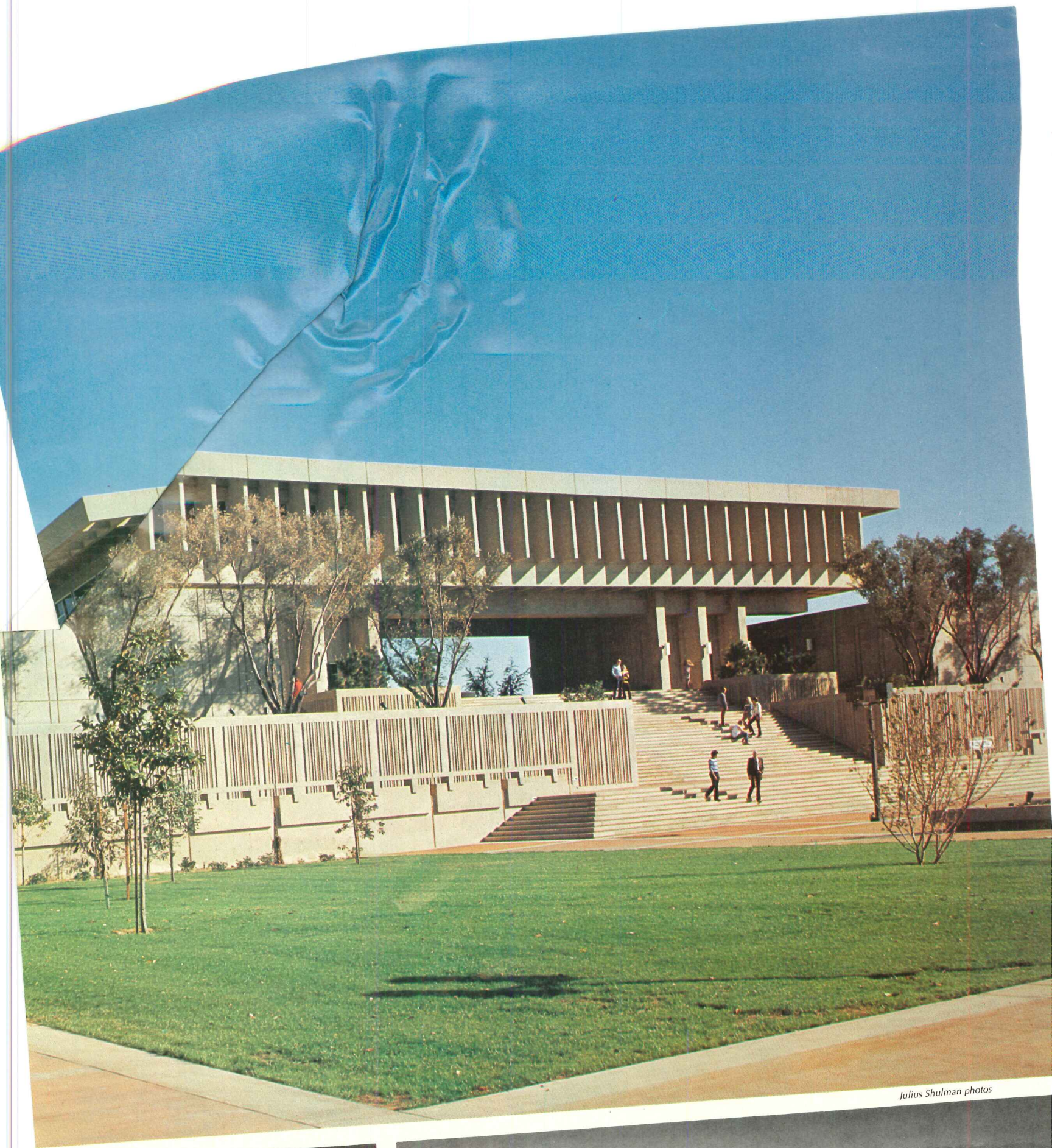

*Julius Shulman photos*





## High density on a small urban site for an "academic village"

Lesley College is a private, four-year college for teacher training and so differs from two-year public colleges. But its program, its urban location and its physical planning are so clearly based on the same concepts of open communication between student and faculty, and of accessibility of learning opportunities that there are similarities between it and the community college. Lesley calls itself a "Laboratory for Learning," and the design for this first phase of a new campus reflects this description. The urban site (across from the Harvard campus) presupposed a dense solution: these first buildings—91,000 square feet—occupy just one and a third acres of land. These two buildings are on either side of an open "Main Street," and are connected by a bridge across the "street" at the second level. Opening onto the "street" are classrooms, laboratories, offices, library, cafeteria, and the bookstore, post office and recreation rooms—a veritable "academic village," contained within the college boundaries but open to the community. Resident students live on upper floors.

LESLEY COLLEGE, PHASE ONE, Cambridge, Massachusetts. Architects: *Barker/Hanssen & Associates, Inc.*—Douglas Barker, designer; Clifford Hanssen, partner-in-charge. Engineers: T. Y. Lin, Kulka, Yang & Associate (structural); Haley & Aldrich and Harding-Lawson & Associates (foundation and soils); Francis Associates (electrical/mechanical). Landscape architects: Mason & Frey. Interiors and graphics: *Barker/Hanssen & Associates, Inc.* Contractor: *Sydney Construction Co., Inc.*

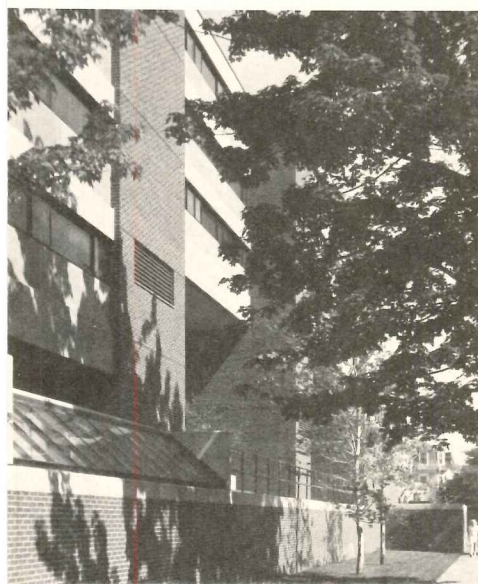
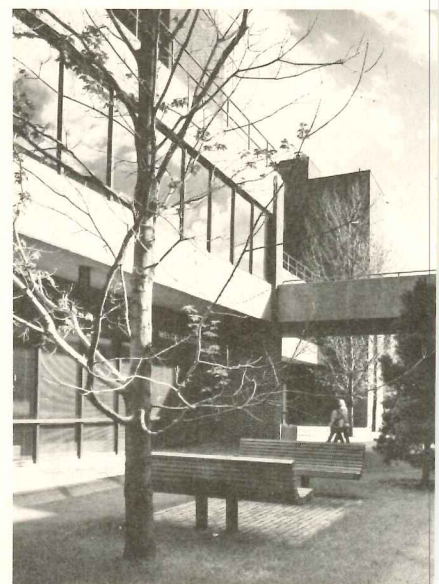
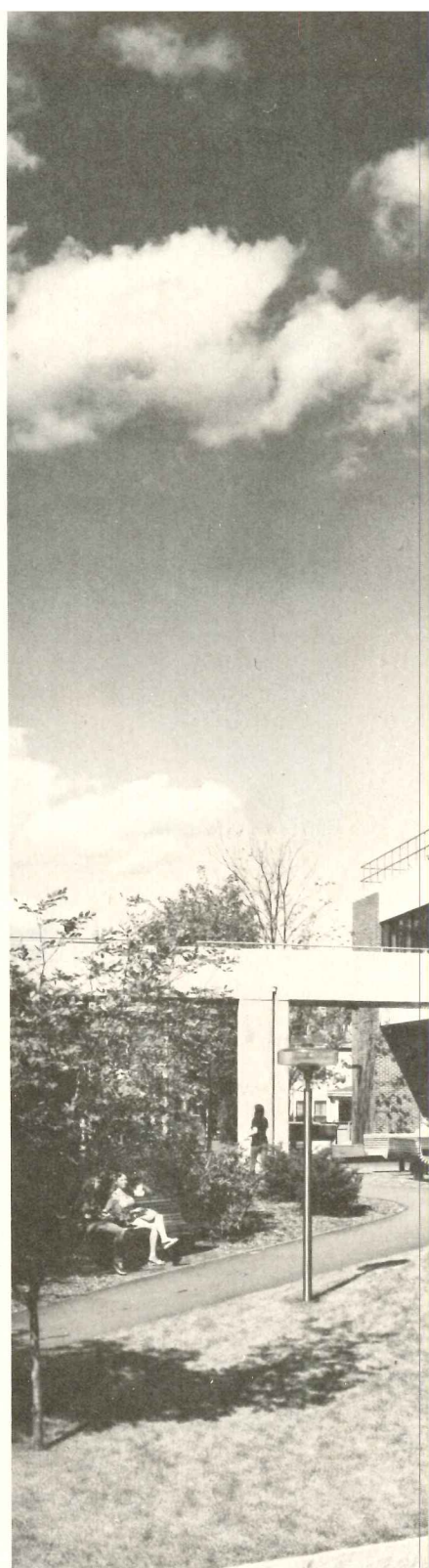
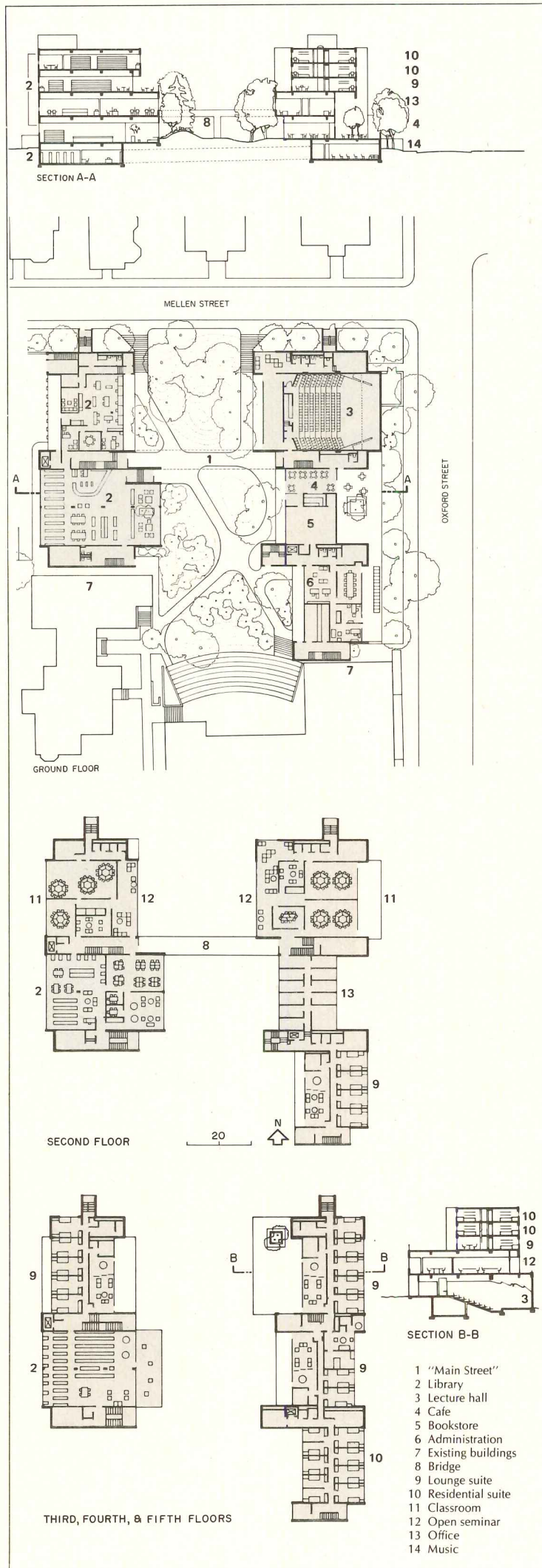





*Phokion Karas photos*





## Sierra location for rural campus of metropolitan district

Feather River College in Plumas County, California, is over 200 miles away from the other three campuses of the Peralta Community College District of which it is a part. Such a geographical spread between campuses is uncommon if not unique, but it has uncommon advantages for both areas. Plumas County had no public college and sought one; Peralta, in the metropolitan Oakland-Alameda area, serves a dense population with a curriculum diversified but oriented toward urban interests and opportunities. Annexation of Plumas' district affords inner-city (and other) young people a chance to attend a small rural college and to study in an appropriate environment such subjects as wildlife management, forestry and geology, as well as courses in science and the humanities. The campus is on a gently sloping wooded site in the foothills of the Sierra Nevada. Its redwood-faced buildings are prefabricated modules, 30 feet square, which use treated poles for their structure. The modules are arranged in checkerboard pattern around courts; steps and ramps into the courts connect modules with each other. The modules ride the site by means of the pole structure, leaving the meadowland undisturbed.

FEATHER RIVER COLLEGE, Quincy, California. Architects: *Skidmore, Owings & Merrill—Walter H. Costa, partner-in-charge*. Engineers: *Skidmore, Owings & Merrill* (structural/mechanical/electrical); *Harding Miller Lawson & Associates* (soils). Landscape architects and interior design: *Skidmore, Owings & Merrill*. Contractor: *Compass Structures*.

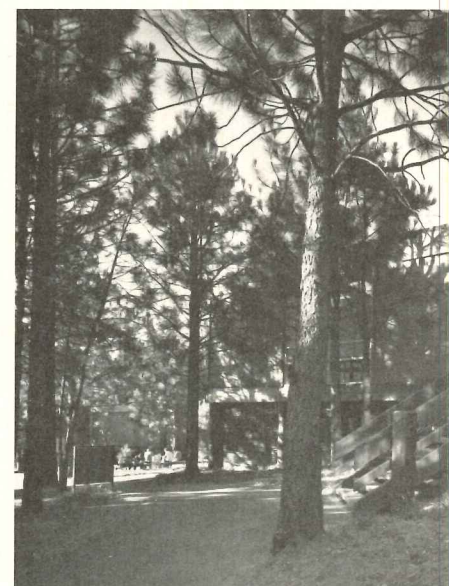
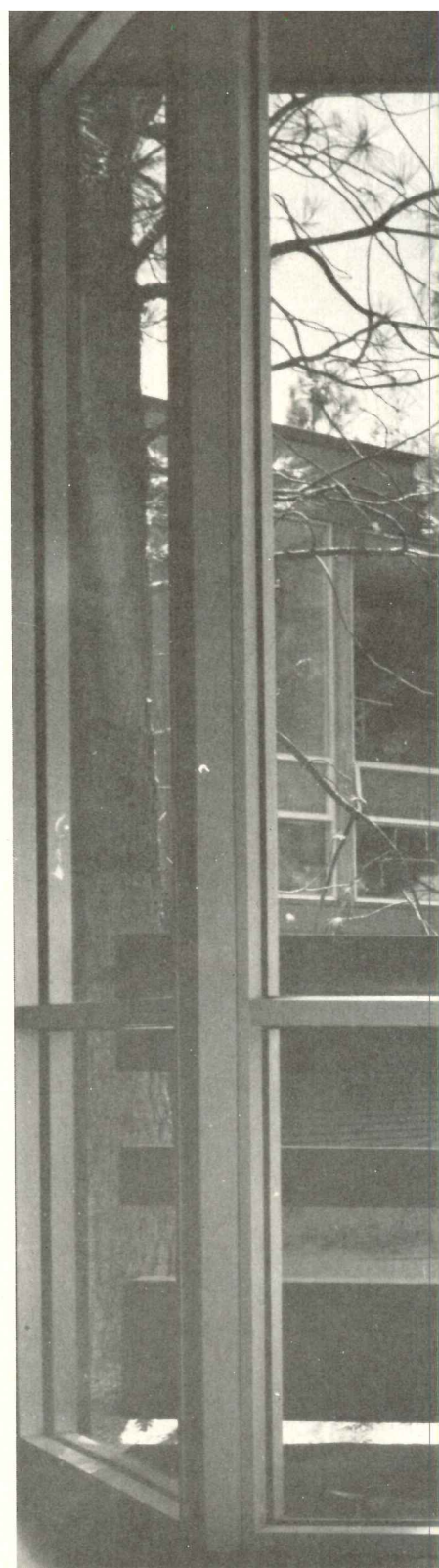
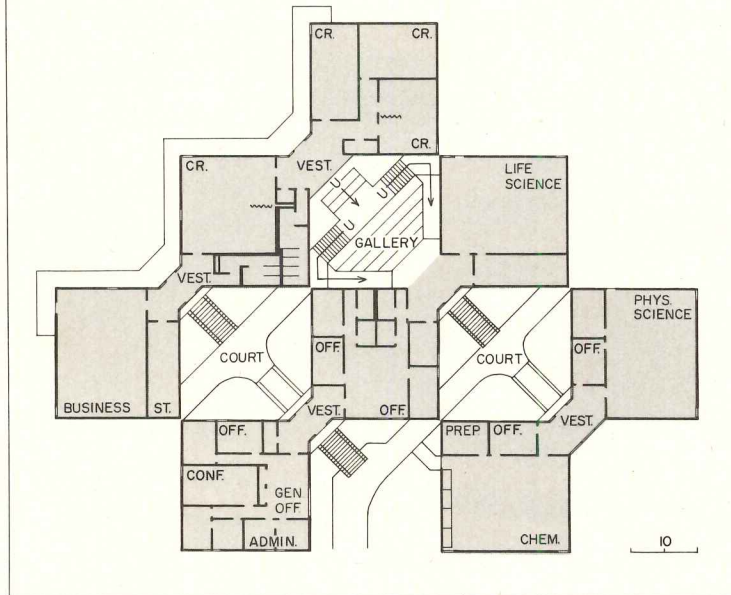
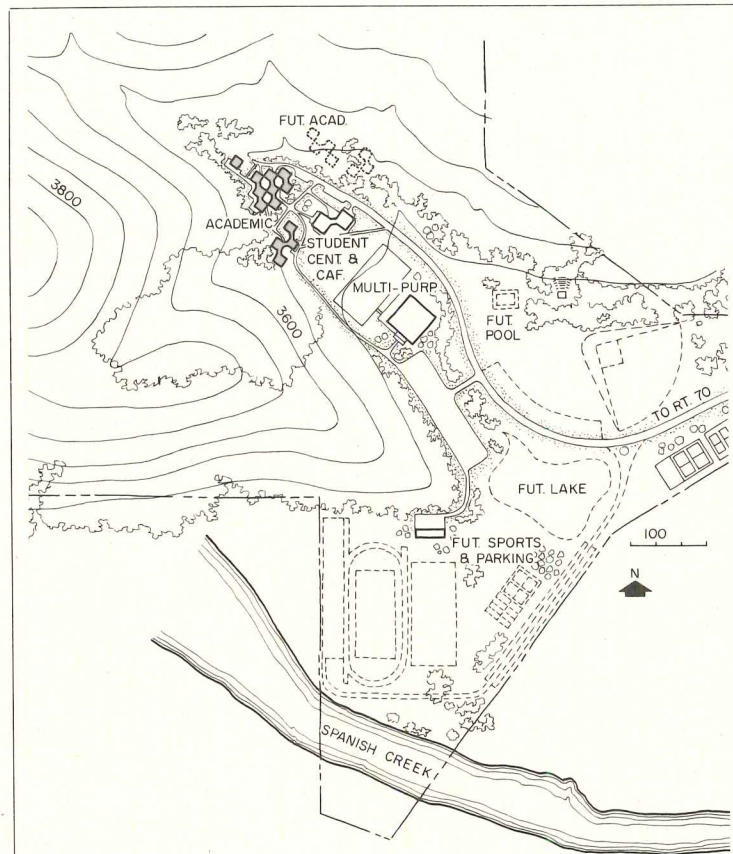





*Philip Molten photos*

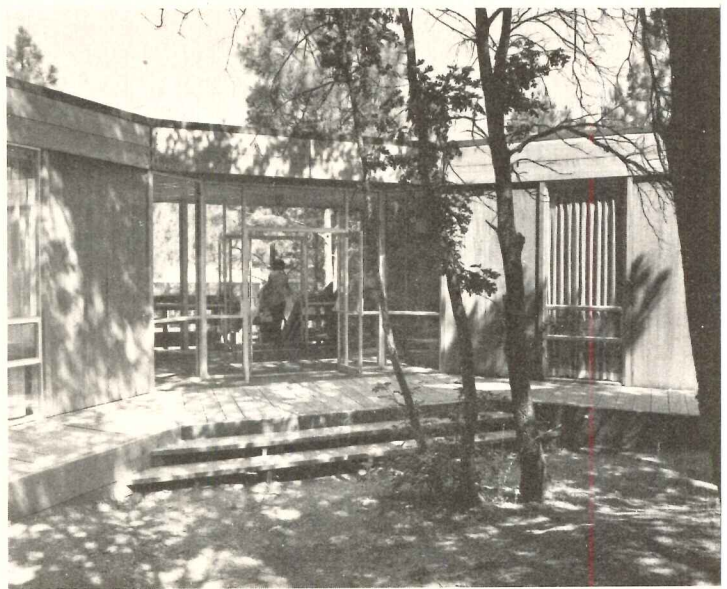
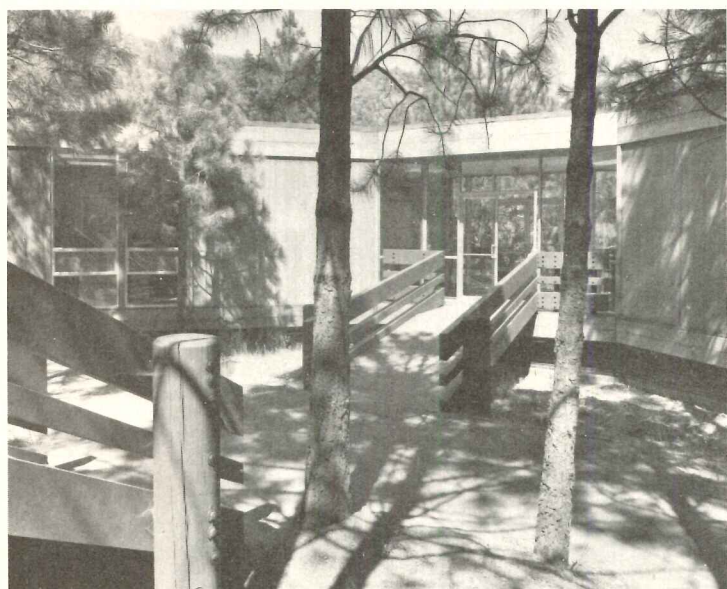





The dramatic roof of this auditorium covers the interstitial space which in other modules is a courtyard between classroom, lab or office facilities. The complexity of the roof structure offsets the simplicity of the other buildings, prefabricated entirely and erected on the site in a three-month period. The college will eventually serve 1000 students, three-fourths of whom are drawn from the Oakland area. Privately-built housing adjacent to the campus provides for out-of-area students. 1. Top of auditorium roof is visible from cluster of modules. 2, 3. Auditorium. 4. Corridor.

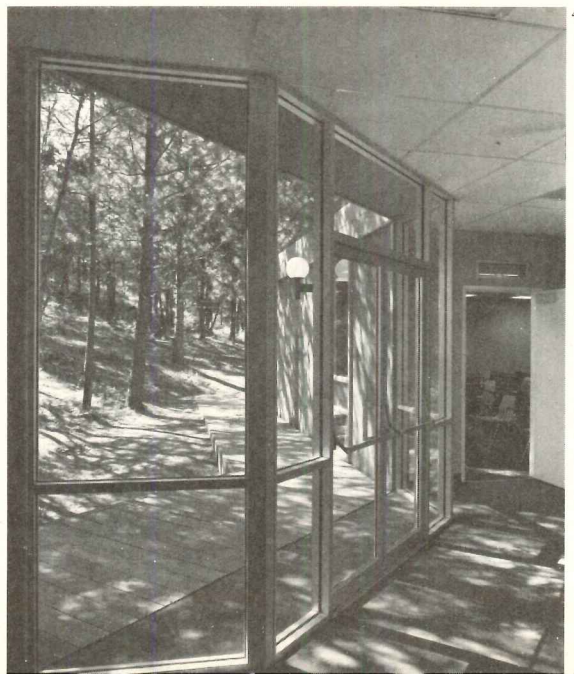
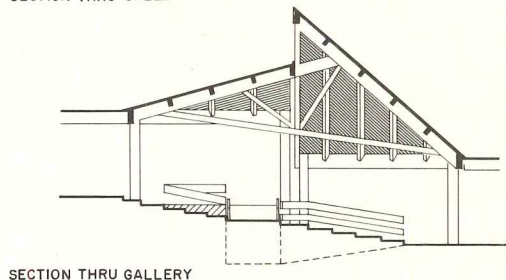
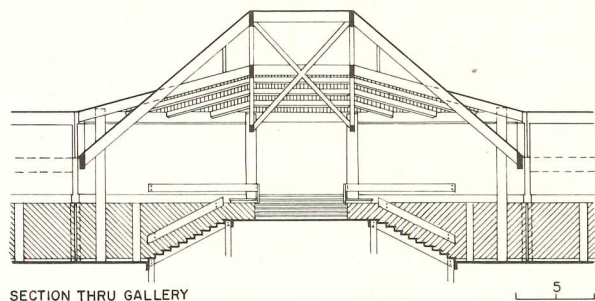



## Roof-top heat pumps for an office park

The first eight buildings of an office-park rental complex in Tallahassee, Florida are being heated and cooled with 151 split-system heat pumps with a total cooling capacity of nearly 1500 tons. The 388,000-square-foot complex includes seven two-, three- and four-story buildings, a separate auditorium and banquet hall for 150 people, and a cafeteria for 150 people. The eighth building, a three-story office structure, is scheduled for completion in December.

The split system heat pumps range in capacity from 5 to 20 tons. Almost half of the units are either 7½, 10, 15 or 20 tons. The advantage of the split-system arrangement is that the fan-coil section can be located close to the zone served, minimizing the amount of ductwork necessary.

The outdoor units on the roofs of the buildings contain the compressor, outdoor coil and fan. The indoor air handlers contain a coil and blower. The sectional drawing on the next page indicates that only a small amount of space is required for running the refrigerant

pipng from the outdoor units to the air handlers. The ductwork consists, then, only of horizontal runs in the suspended ceiling space.

The heat pumps, of course, can either heat or cool, and this is advantageous in climates where there are wide swings in daily temperatures during some seasons of the year. And because the heat pumps operate on electricity, they avoid the problems posed by local fuel shortages and, as in Tallahassee, a recent moratorium on new natural gas customers. Still another advantage of these unitary systems is that they can be operated individually, and a shut-down of one unit does not knock out the entire system. Obviously, too, the initial cost of this unitary equipment is attractive to office-building developers.

According to the owner, the energy consumption for the complex is below the amount that had been programed. Furthermore, with so little space taken up with the mechanical system, more rentable area is available.

WINEWOOD OFFICE PARK, Tallahassee, Florida.  
Architect: *Joseph N. Clemons.*

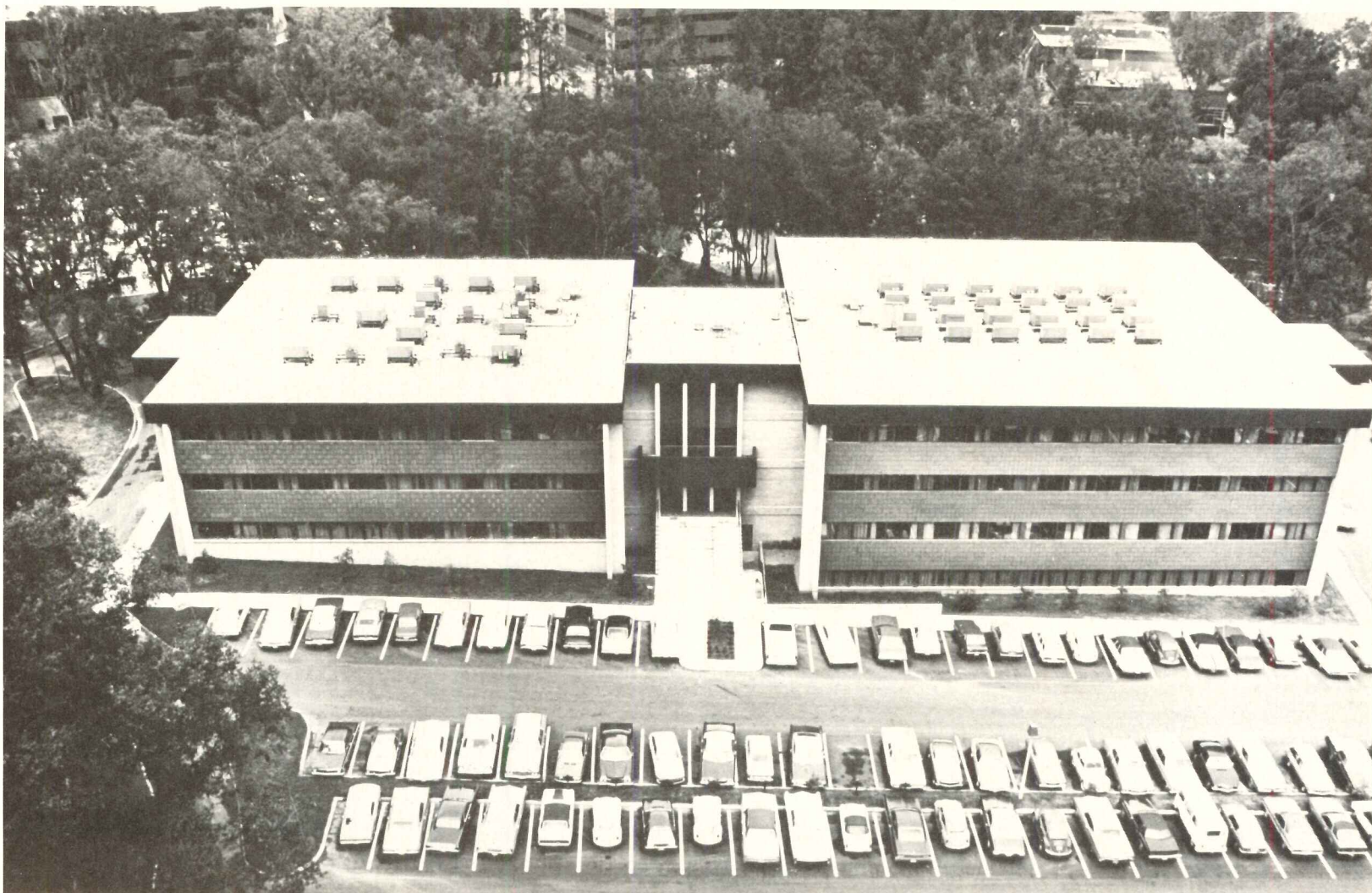
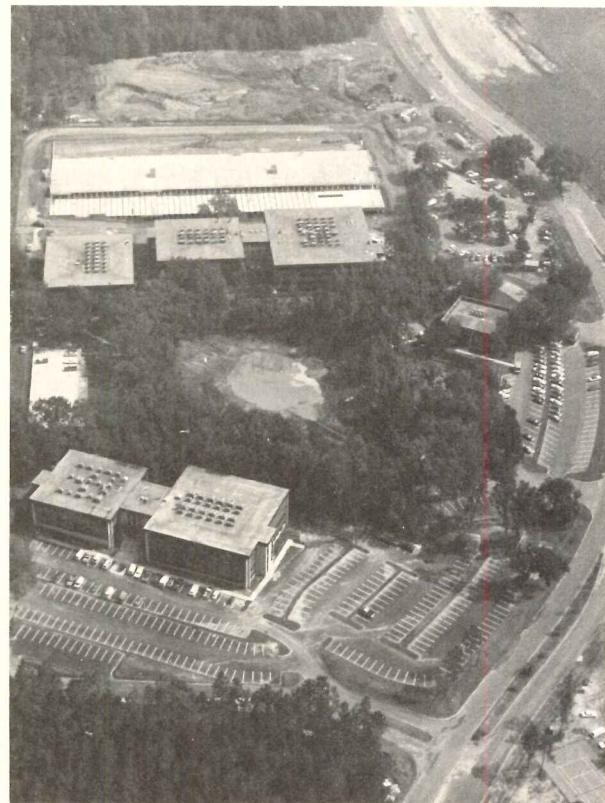



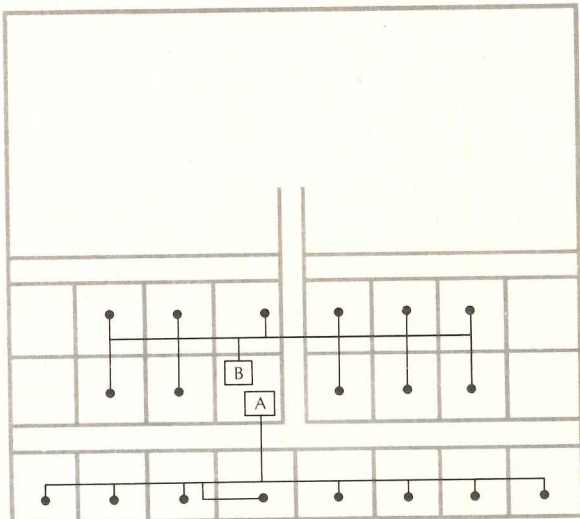

PLAN

The \$15 million office park has 2-, 3- and 4-story buildings. Because it is feasible to run refrigerant piping at least four stories, the use of split system heat pumps meant that there was no need for vertical duct shafts. Condensing sections were located on the roofs of the buildings, and indoor units with blowers and coils on the floors of the zones they serve. Spaces could be zoned along the lines of the diagram above. The heat pumps ranged in capacity from 5 to 20 tons, at least half of them being 7½, 10, 15 and 20 tons. Altogether there are 151 separate heat pump systems totaling 1,494 tons. The drawing, above right, shows diagrammatically how refrigerant piping runs from rooftop units to indoor sections.

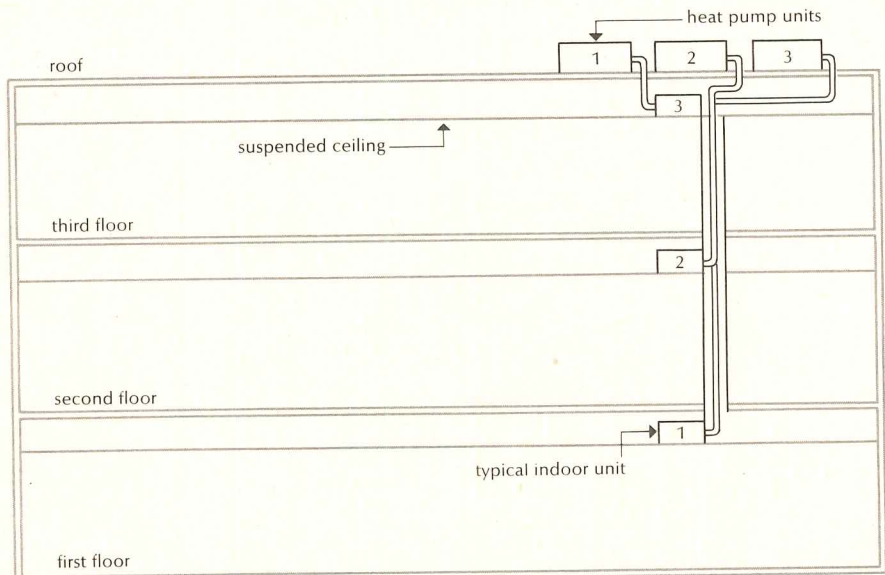

SECTION





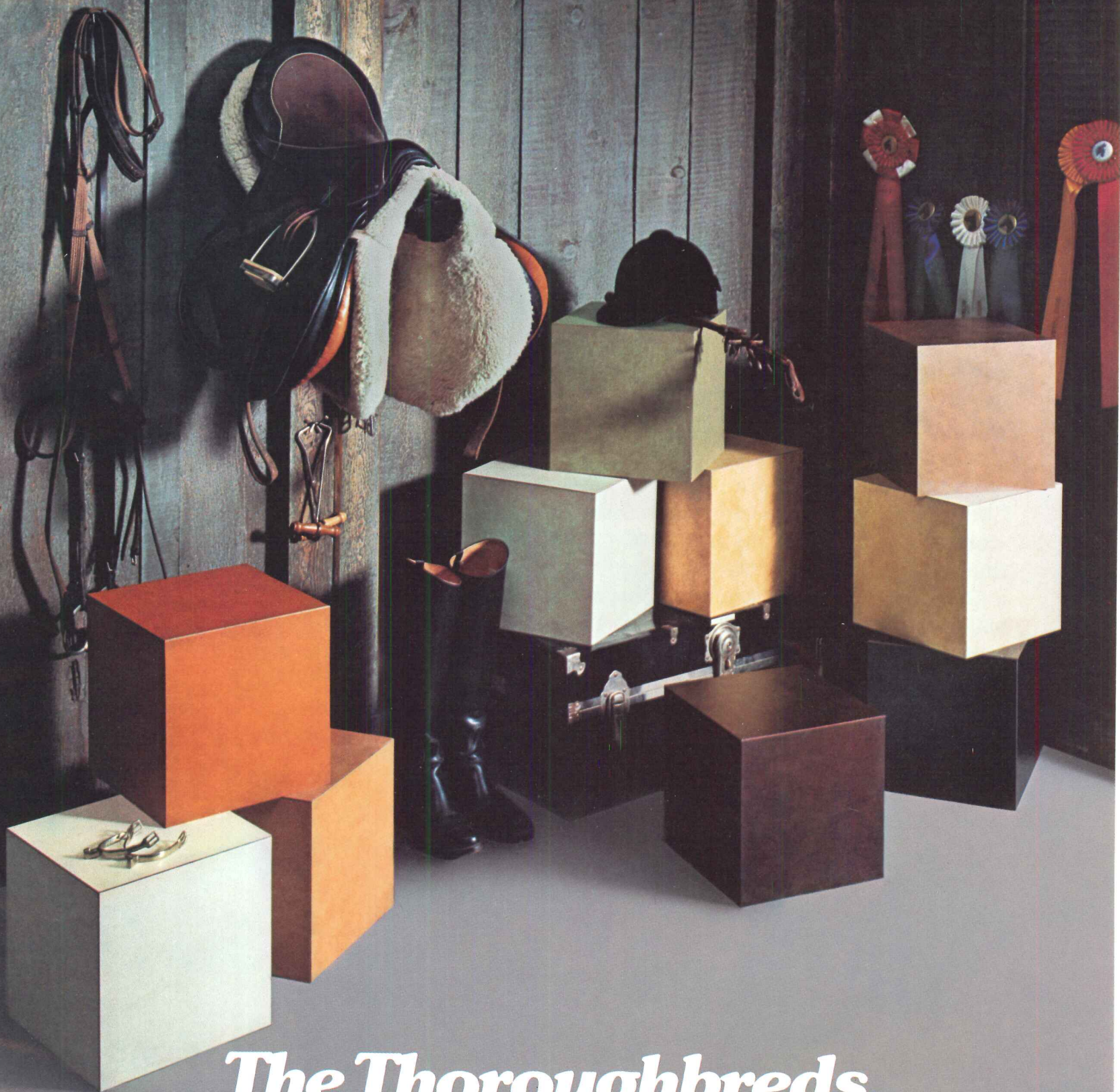

## The Thoroughbreds. Leather grain takes a whole new tack.

Introducing the Textolite pattern that looks so much like Moroccan leather that you'd think it was born that way.

We did it by design. By creating the textured look and feel of real. And we did it with color, too. Actually, ten of them. Including three very new colors that add richness and character to everything they touch.

Palomino Moroccan. We've unbridled beige and given it tones of saddle brown with light-catching highlights.

Burnished Moroccan. An opulent russet reminiscent of a fine leather saddle.

And Blanco Moroccan. An aristocratic white right out of the Spanish Southwest.

We've put all our artistry and ingenuity into all ten Thoroughbreds. And, as always, breeding will tell.

So don't spare the horses. Right now, sample these and the more than 120 other distinctive Textolite solids, abstracts and woodgrains in our full-

line catalog. Write Decorative Products Section, No. One Laminate Avenue, General Electric Company, Coshocton, Ohio 43812.

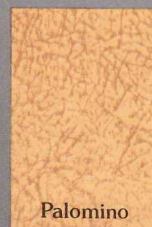

Palomino



Burnished



Blanco

GENERAL  ELECTRIC



# If It's Worth Warehousing, The Building Deserves A Raynor Door

Because Raynor offers so many options and choices, you can virtually customize the door you need for the warehouse you're planning. You can order doors in wood or steel or aluminum or fiberglass, each with custom wound springs and custom hardware that exactly fits the characteristics for a specific warehouse opening. Raynor makes a full range of sizes, from the smallest toolshed to doors for aircraft and locomotives. Each has the same careful attention

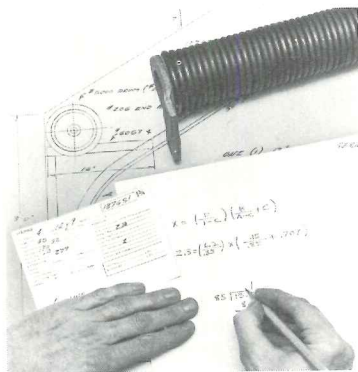

to detail and quality that is characteristic of every Raynor garage door. Why on earth does Raynor go to all the extra trouble in making doors? So you won't have trouble later. If it's worth ware-

housing — or manufacturing or plain protecting — the building deserves a

Raynor door. Send

for our

free catalog.

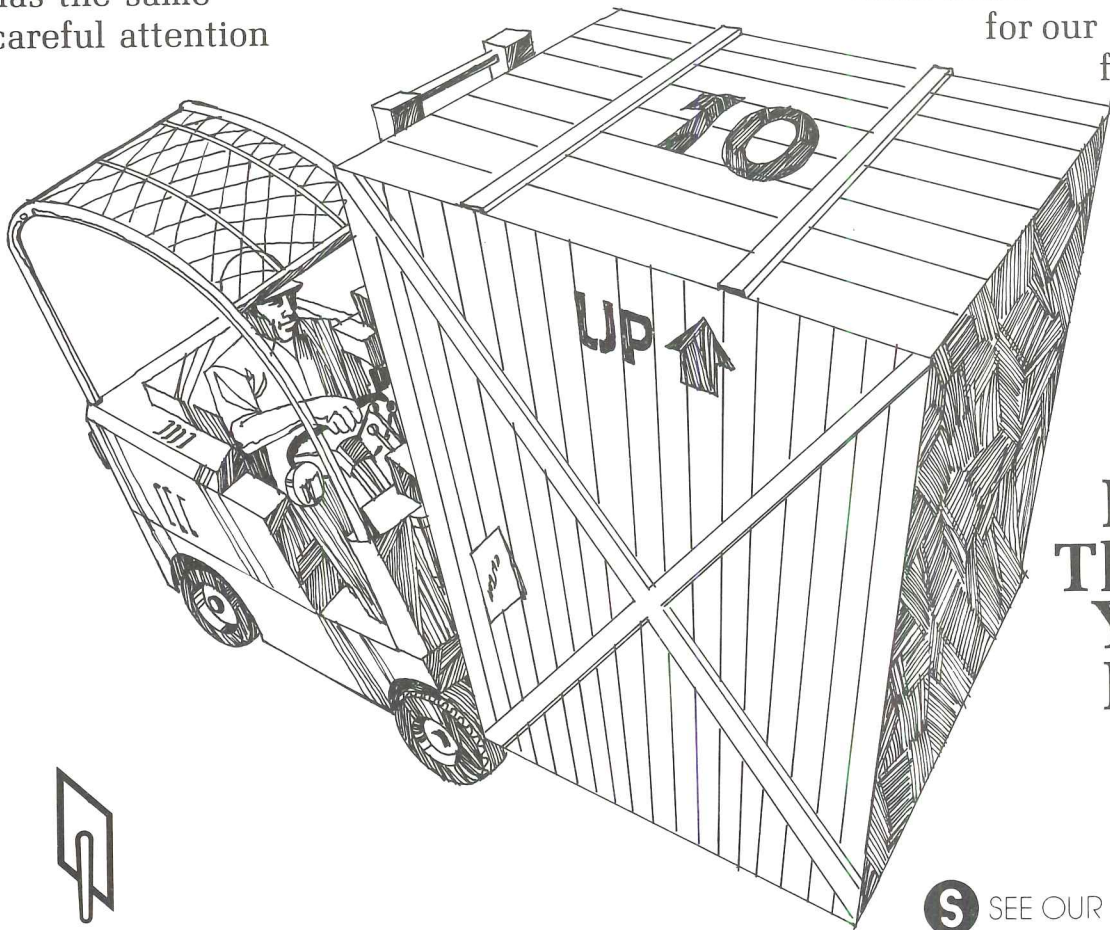
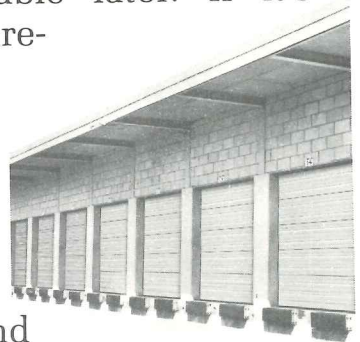

**Raynor  
The Brand  
You Can  
Depend  
On**



**RAYNOR™**  
The Brand You Can Depend On

RAYNOR MANUFACTURING COMPANY, DEPT. AR-8, DIXON, ILLINOIS 61021

**S** SEE OUR CATALOG IN SWEET'S

For more data, circle 121 on inquiry card

◆ For more data, circle 55 on inquiry card



For more information, circle item numbers on Readers Service Inquiry Card, pages 203-204.

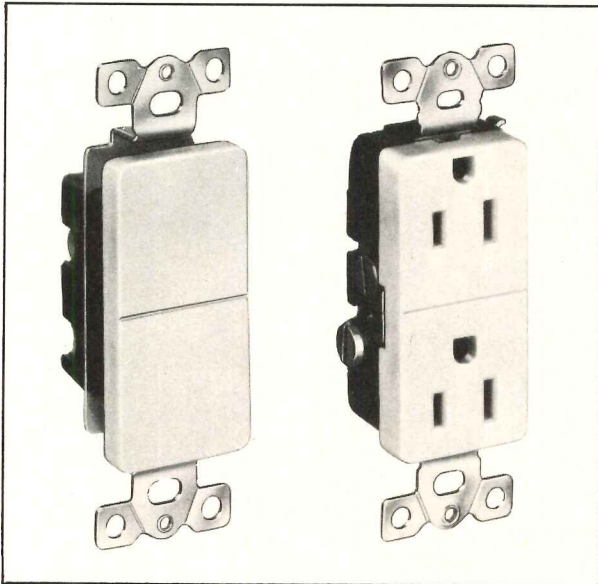

### Contemporary switches, receptacles coordinated

As an integral part of the company's expanded specification grade wiring device line, this matching series of architecturally-designed switches and duplex receptacles is available in gray, ivory, white or brown. Units mount practically flush

with color-mated wall plates. The Doric line includes 15A and 20A rated units in single pole, double pole, 3- and 4-way models. UL-listed, the duplexes are self-grounding. ■ Bell Electric Co., Chicago, Ill.

Circle 300 on inquiry card

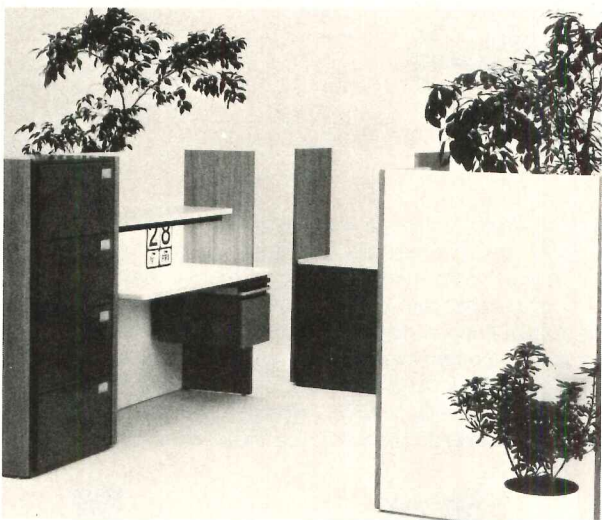

### Wall storage system introduced for open office

This system is an extension of the company's F2 group, which combines wood shells with steel drawer components. The wall system consists of a series of work walls or shells to which work tops, drawers and shelves are attached. Shells in this sys-

tem come in heights of 56 in. and 69 in., and in widths of 33, 39, 48 and 66 in. Finishes are of light, medium and dark oak veneers, or of polyurethane, painted white and doleskin.

■ Sunar Ltd., Waterloo, Ont.

Circle 301 on inquiry card

### Versatile storefront system flush-glazed

Offered in two framing sizes—1¾-in. by 4 in. and 1¾-in. by 4½ in.—System 24 can be anchor set for field and/or shop fabrication; unit set for fast shop installation of glazed lift-in panels; or snap set in a field fabricated system. ■ Northrop, City of Industry, Cal.

Circle 302 on inquiry card

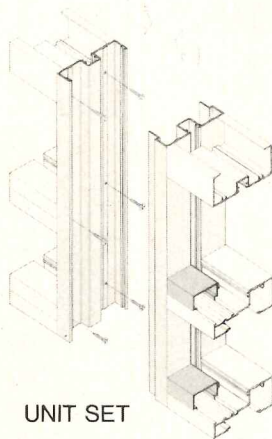

UNIT SET

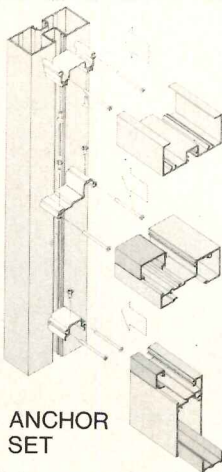

ANCHOR SET

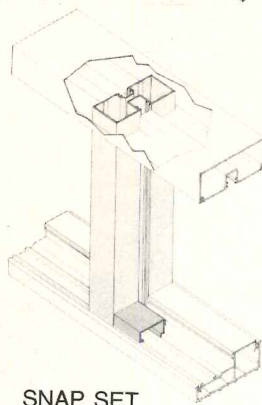

SNAP SET

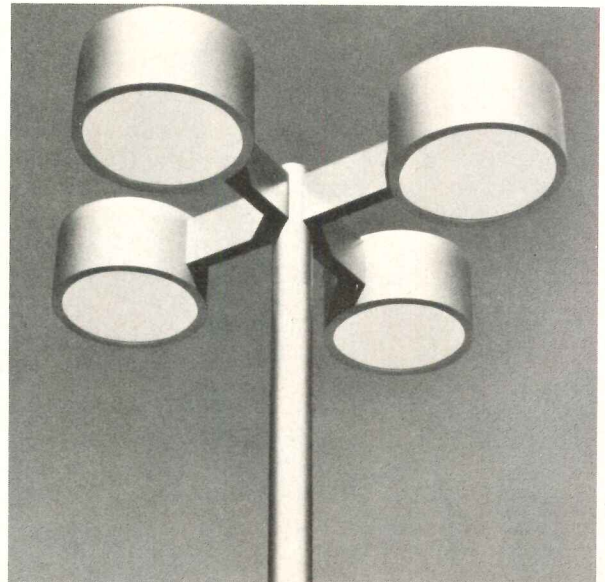

### Drum-shaped luminaires available for area light

Made of extruded aluminum, these units house reflectors that are field-adjusted to provide standard IES distribution patterns and cutoff points, in 50 to 1000 wattages. The luminaire's baked finish is available in various colors, and poles and

mounting heights range from 7 ft. 6 in. to 40 ft. One to four luminaires can be mounted on a pole, or the fixtures may also be wall-mounted. ■ Sterner Lighting Systems, Inc., Winsted, Minn.

Circle 303 on inquiry card

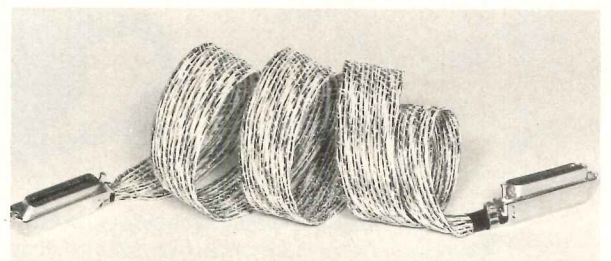

### Flat-woven cable for under-carpet installation

Flat profile and twisted pair construction with each conductor independently insulated and joined without bonding adherents are features of this new telephone key set cable assembly for under-carpet installation. Lengths are available to

any order, and standard plugs and connectors are included. Assemblies are furnished in 25, 50, 75 and 100 pair constructions. ■ Woven Electronics, Mauldin, S.C.

Circle 304 on inquiry card  
more products on page 142



# Bright idea



**Beautiful Washfountains that hold up beautifully.** Bradglas® Washfountains . . . colorful like nature. Brick red. Desert yellow. Surf green. White marble. Driftwood beige. With clean, contemporary lines to fit today's commercial, industrial and school buildings. Durable like steel. Smooth, non-porous. Resistant to abrasion, acid and corrosion. Won't swell, shrink or warp. Won't chip, peel or flake. Vandal-proof and fire-safe, too. Reinforced polyester is tough . . . yet light for easy installation . . . 80% lighter than precast

stone. Bradglas Washfountains cut installation costs because they serve up to 8 people with one set of connections. Save on wall and floor space. Can be installed anyplace . . . washrooms, halls, alcoves. More sanitary than lavatories because they're foot-operated. In 54" and 36" circular and semi-circular models. See your Bradley wash-room systems specialist. And write for latest literature. Or call (414) 251-6000. Telex 2-6751. Bradley Corporation, 9107 Fountain Boulevard, Menomonee Falls, Wis. 53051.

# from Bradley!

Leader in Washroom Fixtures and Accessories



For more data, circle 70 on inquiry card



For more information, circle numbers on  
Readers Service Inquiry Card pages 203-204.

Some day  
you'll be asked  
to design a building  
with a  
heliport.



Get ready for it now  
by writing  
for  
Bell Helicopter's  
Heliport Guide.  
**IT'S FREE**

TO: Bell Helicopter Company  
Fort Worth, Texas 76101

Please send me your  
Heliport Planning Guide.

NAME \_\_\_\_\_

COMPANY \_\_\_\_\_

ADDRESS \_\_\_\_\_

CITY \_\_\_\_\_

STATE \_\_\_\_\_ ZIP \_\_\_\_\_

For more data, circle 57 on inquiry card

**DECORATOR SWITCHES** / A decorator specifier kit will be sent to architects, engineers and specifiers on request. Kit includes sample specification grade heavy-duty *Medalist* decorator switch, *2770 Series*, and matching color-coordinated receptacle. Descriptive literature is also included. ■ Slater Electric, Inc., Glen Cove, N.Y.

Circle 400 on inquiry card

**PUNKAH AND DRUM LOUVERS** / A comprehensive 16-page catalog covers a complete line of punkah and drum louvers. Punkah louvers are for areas requiring spot cooling. Drum louvers are designed to deliver air in areas requiring extremely long throws. The catalog includes quick selection guide, specification drawings, engineering performance and balancing data and installation details for the entire line. ■ Lear Siegler, Inc./Krueger Div., Tucson, Ariz.

Circle 401 on inquiry card

**INSTITUTION SUPPLIES** / A 342-page catalog features a food service section, among others. Also offered are operating forms; supplies; furnishings; communications/TV, room status, wake-up/messages; front office systems; laundry systems; and uniforms. ■ Wilcox International Inc., Chicago, Ill

Circle 402 on inquiry card

**SERVICE DISTRIBUTION** / *Tele-Power* systems for distributing electrical communications and other wiring above a dropped ceiling, and from there via poles to points-of-use, are fully described in a brochure that includes installation drawings; comprehensive descriptions of poles, raceways, other system components; and other information. ■ The Wiremold Co., W. Hartford, Conn.

Circle 403 on inquiry card

**LIGHTWEIGHT CONCRETE** / Ideas and suggestions for *Styropor* lightweight concrete applications are featured in a four-page brochure that includes a selection table listing applications according to the material's density. Technical assistance is also available for formulating and mixing/placing techniques. ■ BASF Wyandotte Corp., Parsippany, N.J.

Circle 404 on inquiry card

**ELEVATOR CALCULATOR** / Architects planning buildings for pre-engineered hydraulic passenger and service elevators can read out the data they need from a pocket calculator offered by the company. Covering the requirements most usually encountered for low-rise elevators, the calculator indicates hoistway and machine-room dimensions. It quickly provides data for one- and two-car installations of elevators with capacities of from 1,500 to 4,000 pounds. ■ Otis Elevator Co., New York City.

Circle 405 on inquiry card

**EXIT SIGNS** / The catalog is designed to give architects, engineers and contractors a comprehensive view of the new *Guidelite* exit sign. Other information includes application, installation and electrical data, and options including special glow-in-dark faceplates that are available in case of power failure. ■ Guth Lighting, St. Louis, Mo.

Circle 406 on inquiry card

**SELF-SUPPORTING HOSE** / A new brochure containing information on non-wire-reinforced self-supporting hose describes current uses, diameters and lengths, available colors, and custom end fittings and explains the parameters of custom-made products. ■ Dayco Corp., Dayton, Ohio.

Circle 407 on inquiry card

**ILLUMINATED CEILING** / Each of four new brochures includes a full-page color cover photograph; a three-page inside spread giving complete architectural and engineering specifications; and a page devoted to: interior planning, lighting design, and budget control. Also included is a chart indicating average footcandles for different lamp spacings in rooms of varying sizes. ■ Neo-Ray Lighting Systems, Inc., Brooklyn, N.Y.

Circle 408 on inquiry card

**OVERLAID PLYWOOD SIDING** / Patterns, end use photos, application and finishing instructions, and the economy of a plywood siding that accepts paint or solid color stains equally well, are cited in this new full-color, eight-page brochure from the company. ■ Simpson Timber Co., Seattle, Wash.

Circle 409 on inquiry card

**KITCHEN/LAUNDRY DESIGN** / A 24-page publication designed to stimulate the imagination and showcase the planning assistance available to builders, remodelers, architects and real estate developers from the company is now available. ■ General Electric Co., Louisville, Ky.

Circle 410 on inquiry card

**CHUTE-FED COMPACTOR** / Literature on the commercial waste and refuse compactors is available with full specifications. ■ The Tony Team, Inc., Minneapolis, Minn.

Circle 411 on inquiry card

**STRUCTURAL BEARING** / The company's high load structural bearing, a product to provide bridges with a mechanism to handle the multiplicity of movements associated with elastic structures, is described in a 16-page brochure. Three types are charted for loads ranging from 50 to 2000 tons—unidirectional, multidirectional and fixed bearings. Complete specifications are included. ■ Watson-Bowman Associates, Inc., Buffalo, N.Y.

Circle 412 on inquiry card

**TOTAL COMFORT SYSTEMS** / The catalog highlights commercial-industrial, as well as residential equipment in a condensed form. The company's product line ranges from window air conditioners to liquid chillers with up to 200 tons of capacity. ■ Mueller Climatrol Corp., Piscataway, N.J.

Circle 413 on inquiry card

**DUCT CLOSURE SYSTEM** / A new booklet illustrates the many applications of *Fiber-Grip*, a new aluminum channel closure system for fiberglass duck board. The 12-page booklet shows how *Fiber-Grip* can be used to fabricate longitudinal and circumferential joints and all types of fittings. It also illustrates several configurations of the extruded aluminum channels and points out that the system simultaneously provides closure and reinforcement and at the same time acts as a hanger. ■ Johns-Manville, Denver, Colo.

Circle 414 on inquiry card

**PARTITIONS AND OPERABLE WALLS** / A 16-page bulletin describing the complete line of portable partitions and operable walls details three series of *Trak-Air-Wall* operable walls which offer easy installation and tight seal characteristics according to the company. The catalog includes a complete listing of features, dimension and installation drawings, specifications and application photos. ■ Richards-Wilcox Mfg. Co., Aurora, Ill.

Circle 415 on inquiry card

More literature on page 155



# SAVE ENERGY

**Fact:** Metal lath/steel stud curtainwalls can offer dramatic reductions in heating-cooling energy consumption and operating costs.

**The U-value** for the lath/stud wall is .079 . . . As compared to .321 for a conventional masonry wall . . . Or .55 for double-plate glass . . . Or .741 for precast concrete.

**On an average summer day** with temperatures in the mid-80s, the heat gain through one square foot of the lath/stud wall will be 1 Btu an hour. Heat gain through a conventional masonry wall would be about 4 Btus an hour. Through a double-plate glass wall—7 Btus. And through a precast concrete wall—10 Btus.

**In other words,** the metal lath/steel stud wall is about 400% more efficient in reducing heat gain than the masonry wall. Roughly 700% more efficient than the glass wall. And over 900% more efficient than precast concrete.

**More facts:** Installed costs for metal lath/steel stud curtainwalls are about 50 percent less than comparable masonry or concrete installations. They are also easy to estimate . . . Go up fast . . . Weigh only about 20 pounds per square foot . . . And allow for shapes impossible with other materials.

**The proof?** These facts are borne out in existing projects—in all parts of the country.

**Write for our complete** Curtainwall Package. It's quite a story.



**Metal Lath/  
Steel Framing Association**  
221 North LaSalle Street  
Chicago, Illinois 60601

For more data, circle 58 on inquiry card

## SWING DOOR OPERATOR

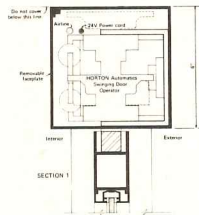

The two principal features of this product are that it is pneumatic and the operator is concealed in a 6-by-6 in. header. The end of the header is capped allowing it to be installed on any size door frame system without being bulky and unsightly.

Other variations include surface applied operator for use on existing doors; operator concealed above the door in the ceiling; operator concealed below the door under the floor and operator concealed in door header with door and frame by others. ■ Horton Automatics, Dallas, Tex.

Circle 305 on inquiry card

## MINIATURE ACCENT LIGHTS

The one-ball model has been designed for use on small paintings, statuary, etc. Two-, three- and four-light models feature 2½ in. balls on universal swivels. The one-ball

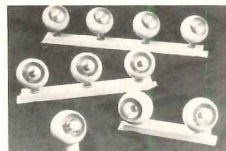

model has a magnetic swivel. Each style has mounting holes and a line-cord switch. Models are available in black or antique white. ■ Roxter Corp., Long Island City, N.Y.

Circle 306 on inquiry card

## ENERGY-MANAGEMENT SYSTEM



Designed to automatically shed peripheral electrical loads whenever building power consumption goes too high, the controller is available as an option with company building-automation systems or as a retrofit package for existing installations. The load-shedding and load-scheduling functions help the user to avoid the heavy-demand penalties imposed by power companies for too heavy start-up demand. Loads usually are shed in order of increasing importance on a programmed basis. ■ Honeywell's Commercial Div., Minneapolis, Minn.

Circle 307 on inquiry card

## ENERGY RECOVERY

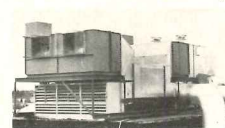

A field-assembled package for very large energy recovery equipment in industrial and large commercial installations ranges from 10,000 to 200,000 CFM. Partitioned, packaged and shipped ready for final assembly in its operating location, erection of the assembly is simplified. ■ Allied Air Products Co., Portland, Ore.

Circle 308 on inquiry card

## PIPE INSULATION

Especially designed to insulate and protect all types of ducts pipes, tubes and other objects, *Thermazip* consists of a PVC jacket with an inner insulating layer of flexible polyurethane foam or fiberglass. The zip closure also allows easy entry for inspection.

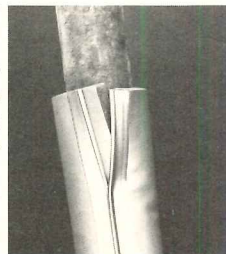

■ APCO, Tempe, Ariz.

Circle 309 on inquiry card

more products on page 145

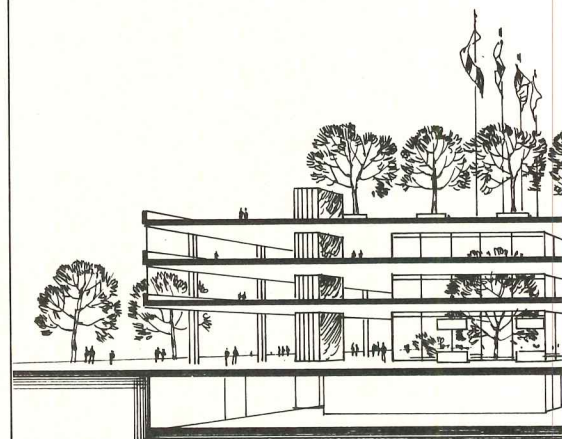

# call the





# For total design

## Bell System when preplanning.

Efficient buildings provide facilities to install today's sophisticated communications systems. Since these facilities should be integrated with your design, we want you to know about our Building Industry Consulting Service.

A Bell System consultant can advise you on local building codes which affect communications, and suggest a system that offers maximum efficiency and makes optimum use of space. And there's no extra charge for this service.

Calling us early can eliminate the need for expensive alteration, or exposed cables and wires.

Our insert in Sweet's Catalogue has basic information. For questions on current or future projects call a Building Industry Consultant at your Bell Company or send in our coupon. At AT&T and your Bell Company, we want to help you produce an efficient end product.

### We hear you.



**Building Industry Consulting Service** K  
**American Telephone and Telegraph Company**  
Room 2238D, 195 Broadway  
New York, New York 10007

I am interested in the Building Industry Consulting Service.

- Please send me additional information.
- Please have a representative contact me.

Name \_\_\_\_\_

Title \_\_\_\_\_ Tel. \_\_\_\_\_

Company \_\_\_\_\_

Street \_\_\_\_\_

City \_\_\_\_\_ State \_\_\_\_\_ Zip \_\_\_\_\_





# Static-tician

**At Dow Badische, he'll guarantee that any carpet carrying our Zefstat™ anti-shock carpet label won't generate a shock for the useful life of the carpet or for 5 years, whichever is sooner.**

When you specify carpet for an installation, chances are you'll ask if the carpet is static-controlled. And chances are, the manufacturer will tell you "yes." We'd like to give you a tip. Ask for how long. It could save you a lot of static later.

Most fiber and yarn producers have static control systems of varying degrees of effectiveness. But at Dow Badische our "Static-ticians" specially engineer our carpet products for permanent and safe shock control. Then we guarantee the certified carpets made of those products against shock — for the useful life of the carpet or for five years, whichever is sooner.

Our unique anti-shock carpet guarantee — Zefstat™ — is the only anti-static guarantee in the market. You'll find it on carpets made of our acrylic, nylons and blends.

Look for the Zefstat label next time you specify contract carpet. It's your only guarantee against static now — and later.



**Dow Badische Company**  
Williamsburg, Va. 23185  
(804) 887-6573

Zefstat™ is a trademark of Dow Badische Company.



**CHINA LAVATORY** / The self-rimming vitreous china lavatory measures 21 by 19 in., and is designed for both residential and commercial installation. Available in seven colors—Pink Champagne, Mexican Sand, Fresh Green, Harvest Gold, Avocado, New Orleans Blue, Cerulean Blue—and white, the unit is shown with white *Flair* handles. ■ Kohler Co., Kohler, Wis.



Circle 310 on inquiry card

**LAVATORY/TOILET** / Providing a vanity/lavatory along with a foldaway, flushable, water-pool toilet, *Modulay* fits next to a patient's bedside and is recommended in coronary-care units. Available in stainless or vinyl-clad steel in a variety of colors, *Modulay* comes in four narrow-depth designs plus a recessed, retractable toilet model and a foldaway, recessed lavatory model. ■ American Sterilizer Co., Erie, Pa.



Circle 311 on inquiry card

**INDUSTRIAL FIRE EXTINGUISHING** / The *Fi-Quench* system has been tested and is listed by Underwriters Laboratories. The system may be discharged automatically by any fire detection system which produces an electric discharge—including a wide variety of sensing devices which bear the UL label. It may be equipped with a back-up battery pack to provide up to 24 hours of automatic security in case of power failure. The system is fully modular and from one to 20 Halon bottles may be discharged by a single control center. The system is designed for total flooding of enclosed areas with Halon 1301. ■ Fike Metal Products Corp., Blue Springs, Mo.

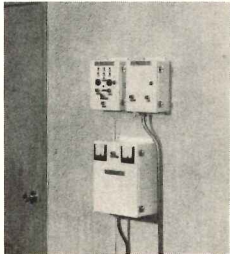

Circle 312 on inquiry card

**RECREATION TRANSPORTATION** / Designed for a variety of transportation uses, these "people movers" provide quiet, pollution-free travel on electrically-powered gliders, which ride on an unexposed underground track. Each glider is controlled by a passenger, manually or by remote control. Gliders can also be programmed to operate automatically. The track is constructed of precision-cast, steel-reinforced concrete and is cast-on-site. ■ TransGlide, Scottsdale, Ariz.



Circle 313 on inquiry card

**DUPLICATING SYSTEM** / The system duplicates at a speed of two copies per second, or 7,200 copies an hour, twice as fast as any previous duplicator made by the company. Its total productivity includes high-speed duplicating directly from an original document. ■ Xerox Corp., Rochester, N.Y.



Circle 314 on inquiry card  
more products on page 147

# 62-63

**JG Furniture Company, Inc.** 121 Park Avenue  
Quakertown, Pa. 18951

Auditorium seat designed by Peter Dickinson  
Installed at the Institute for Advanced Study, Princeton, N.J.  
Architects: Geddes Brecher Qualls Cunningham, P.C.  
Interior Consultants: Semanko-Bobrowicz



◆ For more data, circle 60 on inquiry card

For more data, circle 61 on inquiry card





## Win fire insurance, building code and employee acceptance, specify Osmose Flame Proof<sup>®</sup> fire retardant wood

In addition to allowing the architect to use the economy and flexibility of wood, Flame Proof makes a major contribution to life safety, lower insurance rates and property protection. Flame Proof pressure treated plywood and lumber is UL FR-S classified...a recognized building material. Whether structural or decorative, it is widely specified from floor joists underfoot to trusses and roof decks overhead. Consider it for churches, schools, offices, hospitals, shopping centers, motels, nursing homes, restaurants, anywhere the protection of

fire retardant material is required. For additional information, including personal assistance with fire insurance and building code acceptances, plus name of nearest Osmose treating plant write:



**OSMOSE**

980 ELLICOTT ST., BUFFALO, N. Y. 14209  
SOUTHERN OFFICE, 1016 EVEREE INN RD., GRIFFIN, GA. 30223

*Member Society of American Wood Preservers, Inc.*

*For more data, circle 62 on inquiry card*



**SUN CONTROL FILM** / Reflective sun control films in three colors—gold, smoke and bronze—have been added by the company to complement the firm's original transparent silver-gray films which are applied to the inside of windows to reduce build-up of solar heat, and do not interfere with the transparency and visual properties of glass. The new gold film repels up to 75 per cent of the sun's heat, and the smoke and bronze tints repel up to 64 per cent. All three of the new colored films stop over 95 per cent of the sun's fabric-fading ultra violet rays. ■ 3M Co., St. Paul, Minn.

Circle 315 on inquiry card

**CONTRACT CARPET** / The *Burr-Burr* wool and *Burr-Burr Lan* carpet styles offer eight qualities ranging from tight level-loop constructions to the hand-crafted rope-yarn look, in either 100 per cent *Acrylic Plus* or 100 per cent wool face yarns. All qualities will be stocked in the 12 ft width, in six to eight *Berber*-type colors. ■ Customills, Dalton, Ga.

Circle 316 on inquiry card

**WOODEN BI-FOLD DOORS** / Instead of the usual 1 7/8 in. thickness, the company's bi-fold measures 1 3/8 in. thick, an extra quarter-inch that substantially increases the rigidity of the door and the life of its use, according to the company. Either two-door or four-door, they come assembled with concealed hinges and are machined to receive pivots. The bi-folds come in three basic styles: louvered doors, panel doors and spindle doors. There is a broad range of sizes. ■ E. A. Nord Co., Everett, Wash.

Circle 317 on inquiry card

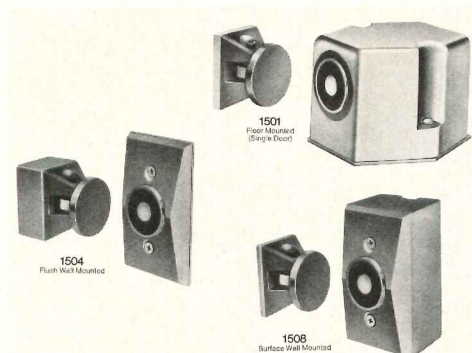

**DOOR HOLDERS** / New low-cost electromagnetic door holders which automatically release self-closing swinging doors can be activated by a fire alarm or smoke detection system, or by pushing a remote button. On walls, they can be flush or surface-mounted. Floor-mounted models are also available for both single-door and double-door (back-to-back) versions. The door holders, which are UL-listed, are completely silent, have 25 lbs minimum holding force, and low power drain. Both AC and DC types are available. ■ Edwards Co., Norwalk, Conn.

Circle 318 on inquiry card  
more products on page 149

# Haws Water Cooler for wheelchair users and foot traffic

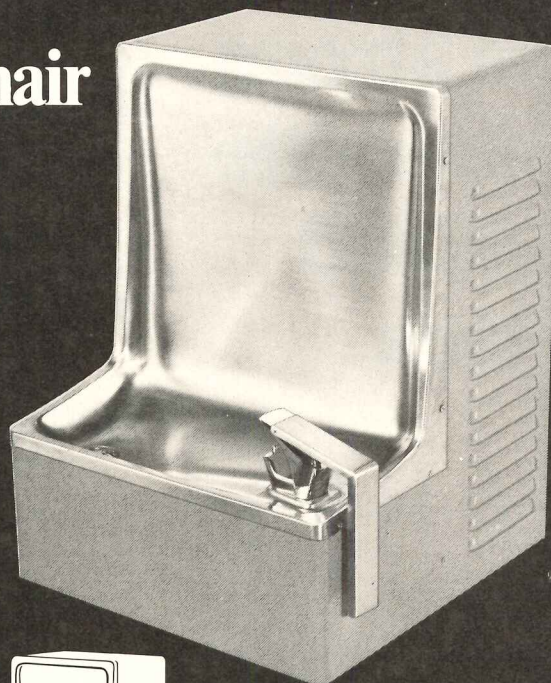

**Haws Dual Use HWC-6 Water Cooler** is designed particularly for persons in wheelchairs, yet it effectively provides service to foot traffic. It extends out from the wall and is mounted at a convenient height from the floor so that a person can easily wheel up to it. A compound-action bubbler valve actuates the cooler from a push on the side or top, making it easy to operate by handicapped persons.

Model HWC-6 (pat. pend.) helps you comply with Public Law 90-480 which states that buildings constructed, leased, or financed by the Federal Government must provide facilities suitable for use by the physically handicapped.

Available in stainless steel at extra cost. Write for detailed information.

**Haws Drinking Faucet Co., 4th & Page Sts., Berkeley, Ca. 94710.**

**Haws**  
**WATER COOLERS**



For more data, circle 63 on inquiry card



**Bally Walk-Ins  
belong where  
the strong  
and svelte  
sun and  
snack**



Bally Walk-In Coolers and Freezers belong everywhere mass feeding takes place. They can be assembled in any size for indoor or outdoor use from standard panels insulated with four inches of foamed-in-place urethane, UL 25 low flame spread rated and Factory Mutual research approved. Choice of stainless steel, aluminum or galvanized. Easy to enlarge . . . easy to relocate. Refrigeration systems from 35°F. cooling to minus 40°F. freezing. Subject to fast depreciation and investment tax credit. (Ask your accountant.) Write for 28-page book and urethane wall sample. **Bally Case & Cooler, Inc., Bally, Pennsylvania 19503.**



© 1973 ALL RIGHTS RESERVED.

ADDRESS ALL CORRESPONDENCE TO DEPT. AR-7

For more data, circle 64 on inquiry card



**WASHER-EXTRACTOR** / A 275-lb laundry washer-extractor with a dividerless cylinder for fast loading and unloading is said to help reduce turn-around time between washing cycles. The 52-in. diameter cylinder provides a big "drop" for washing action. The programmer control permits an almost infinite variety of automated washing formulas, according to the company. ■ Pellerin Milnor Corp., Kenner, La.

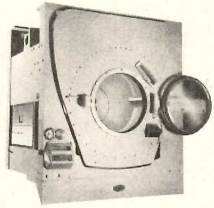

Circle 319 on inquiry card

**SECURITY GRILLE** / A flexible "see-through" security grille of polished aluminum tube will follow the design contour of the area to be controlled, without the need for intermediate guide posts. The lattice grille is said to be particularly suitable for curved bars and window displays. Constructed from 1/2 in. diameter polished aluminum tube, units require only two end guides. Minimum support is needed at the head; a cable and pulley counterbalance arrangement ensures ease of rising and lowering. Installations are individually tailored to customer requirements. The export agent will welcome inquiries from architects. ■ Paramount Concessionaires (London) Ltd., England.

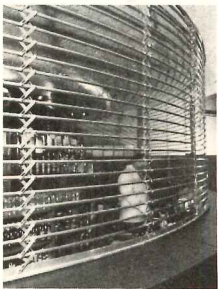

Circle 320 on inquiry card

**RECESSED WASHROOM ACCESSORIES** / The company's "Designer Series" includes the following recessed washroom accessories: combination paper towel dispenser and waste receptacle; waste receptacle; paper towel dispenser; feminine napkin vendor; feminine napkin disposal, and toilet seat cover dispenser. Doors on the units are 5/8 in. thick, with a core of three-ply resin-impregnated wood. The surface is high-pressure laminated plastic in a color or wood grain selected by the architect. Backs are also laminated to provide dimensional stability to the doors and to resist warpage. Doors are fastened to cabinets by concealed full-length stainless steel piano hinges. ■ Bobrick Architectural Service Dept., New York City.

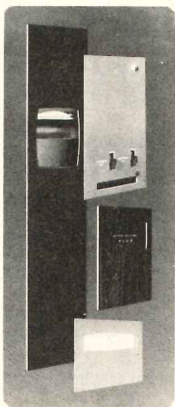

Circle 321 on inquiry card

**ALUMINUM DOOR OPERATOR** / The swing operator is designed for use with swinging, folding and special purpose doors, such as cold storage. Major reasons for the change to aluminum are reduced weight and greater corrosion resistance. New design characteristics make the unit easy to assemble and disassemble, enabling simple maintenance. ■ Air-Lec. Industries, Inc., Madison, Wis.



Circle 322 on inquiry card

**WOOD CASEMENT WINDOWS** / These wood casement and awning units resist dirt, discoloration, ice and dents. The factory-applied exterior combines: (1) water repellent wood preservative; (2) primer; (3) acrylic enamel coat; plus (4) top barrier that actually fuses all four coats into one. Inside, the wood is left unfinished so that the choice of paint, stain or varnish is left to individual taste. A four-edge double weatherstripping system is provided to seal out drafts and rain. Concealed sliding hinges open a full 90 degrees for easy cleaning. Bronze-tone hardware and matching screens are available. ■ Caradco Window & Door Div., Dubuque, Ia.



Circle 323 on inquiry card

**CASELESS CONCRETE PILE** / A cast-in-place caseless concrete pile that is lower in cost and easier to install in comparison with other conventional systems currently in use is said to result in a foundation system which is applicable in a wide range of subsurface soil conditions. In tests, the system has been proven a high-capacity pile for loads up to 160 tons for a 12 in. nominal diameter pile. Advantages of the system include high capacity piles, low vibration level, high uplift resistance, easy driving and economy. ■ Interpile USA, Inc., New Orleans, La.



Circle 324 on inquiry card  
more products on page 151

## Has a moneyman ever given your project the psffft?

You've designed some outstanding projects which now stand as confirmation of your abilities.

Yet how many times in the past has it been necessary to greatly modify or perhaps entirely eliminate the very essence of your plans for the sake of obtaining mortgage monies... each time to the true disappointment of both yourself and your client?

At Conco, we respect the "stay with the proven formula" financing guidelines of the past, but we feel strongly that old limitations and restrictions must be tempered by an understanding of the new values of the present and the future.

Human factors... more creative aesthetics... eco-

logical concerns... precise planning. These will be tomorrow's proven formulas, important to you and to Conco now.

Our business is lending money. We're different. And we're strong. And our strength lies not only in our vast financial resources, but in our ability and our desire to work and plan with professionals... and only professionals. Like you.

Conco means money for better ideas.

If your clients include developers, professional developers, who think in 7 and 8 figure terms, and who understand your better ideas... you should both know Conco.

We understand.

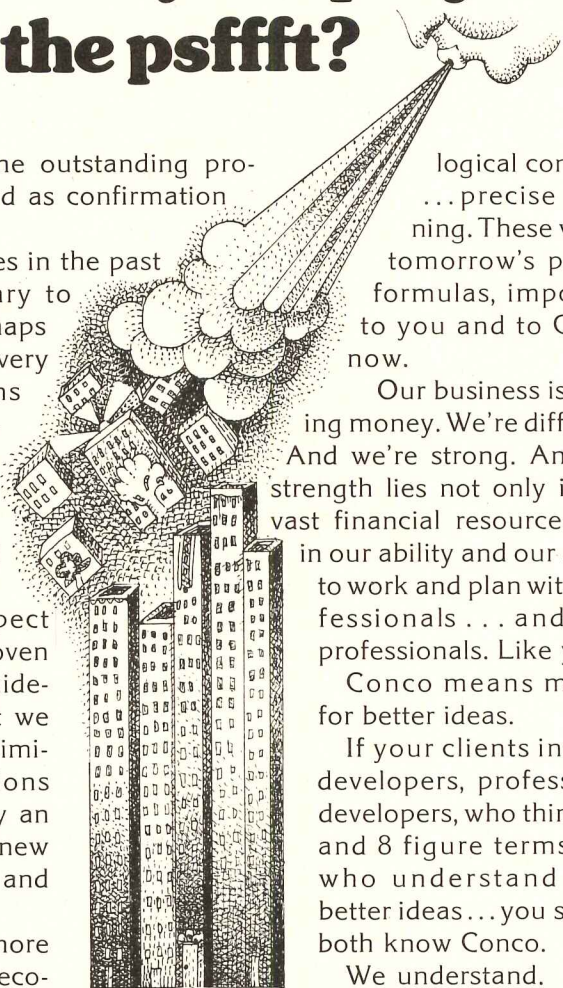

## We should have a conversation.

**CONCO**  
MORTGAGE COMPANY  
Executive Offices:  
50 California Street, Suite 1940  
San Francisco, California 94111  
Tel. (415) 788-1818

Atlanta (404) 256-1562  
Burlingame (415) 692-3304  
Chicago (312) 654-8700  
Dallas (214) 620-2861

(213) 277-2011 Los Angeles  
(305) 666-5831 Miami  
(206) 622-7080 Seattle  
(301) 565-0110 Washington, D. C.

For more data, circle 65 on inquiry card



# ARCHITECTURAL RECORD

PRESENTS

# HOW TO MARKET PROFESSIONAL DESIGN SERVICES

A series of two-day PROFESSIONAL MARKETING WORKSHOPS® produced for ARCHITECTURAL RECORD by the Continuing Education Division of Building Industry Development Services, Washington, D.C.

- Understanding marketing fundamentals
- Organizing for a productive, professional business development program
- Where and how to attract new clients—while retaining the old ones
- Planning for change, expansion and professional growth
- Evaluating existing and potential markets
- Using business development tools—from job histories to preparation of Standard Form 251
- Specialized intelligence gathering and investigation of leads
- Effective selling preparations—what to do before, during and after the interview
- Successful strategies for getting the job
- Political action
- Associations and joint ventures

"Up to now, the design professional traditionally has had to learn selling techniques essentially by experience, through trial and error, and with no real standards against which to measure the degree of his successes and failures."

from HOW TO MARKET PROFESSIONAL DESIGN SERVICES  
a McGraw-Hill book by Gerre L. Jones

These workshops are *not* for the design professional who believes that his client acquisition activities have reached a stage of perfection—or for the firm that, for whatever reasons, is satisfied that it has more clients and contracts than it can comfortably handle over the next 3 to 6 years.

Nor are the workshops geared to firms whose principals are convinced they have achieved the ultimate in

- organization and staff participation in business development
- practice and client mix
- productive, customized, *selling* presentations
- public relations
- all of the tools of job search and acquisition

If you have never attended a professional workshop or seminar on business development, be assured that ARCHITECTURAL RECORD and Building Industry Development Services have assembled the faculty from among the most experienced, knowledgeable people in the field. Discussion leaders will include successful, sales oriented directors of business development from small-to-large firms and client representatives of both public and private sectors. For the first time, participants in ARCHITECTURAL RECORD's Professional Marketing Workshops® will have the opportunity to hear it like it is—from both sides of the marketing fence.

Senior coordinator for the workshops is Gerre L. Jones, executive vice president of Building Industry Development Services, and author of the authoritative McGraw-Hill book, HOW TO MARKET PROFESSIONAL DESIGN SERVICES.

Each participant will receive a set of invaluable course materials for his continuing use. The specially produced course handbook contains ideas, suggestions and sample materials available from no other source.

A unique periodic follow-up program to the workshops assures every participant of continuing interest and advice for up to six months beyond the concentrated two-day workshop session itself.

**b.i.d.s.**

Building Industry Development Services • 202/785-2133

1301 20th St., N.W., Suite 104, Washington, D.C. 20036

Please enter \_\_\_ reservations in my name for the Professional Marketing Workshop® checked at the right of this form and rush complete details about the workshop.

Name \_\_\_\_\_

Title \_\_\_\_\_

Firm Name \_\_\_\_\_

Address \_\_\_\_\_

City \_\_\_\_\_ State \_\_\_\_\_ Zip \_\_\_\_\_

Telephone \_\_\_\_\_

Architect  Engineer  Planner  Designer

Other  \_\_\_\_\_

Check for \$350, payable to Architectural Record-PMW Enclosed.

1974-1975 Professional Marketing Workshops® are planned for the following cities:

		1974
September	17-18	Newark, New Jersey
October	10-11	San Francisco, California
November	7- 8	Houston, Texas
December	5- 6	Phoenix, Arizona
		1975
January	9-10	New Orleans, Louisiana
February	6- 7	Miami, Florida
March	6- 7	New York, New York
April	3- 4	St. Louis, Missouri
May	1- 2	Dallas, Texas
June	5- 6	Seattle, Washington

Dates and locations of workshops in other areas for 1975-1976 will be announced.



# THE PARKER FAMILY...

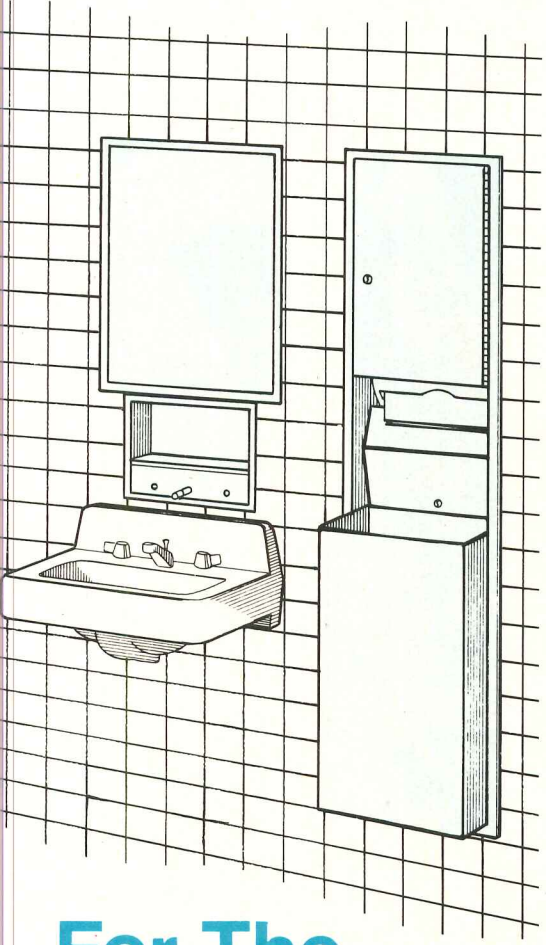

## For The Modern Washroom.

In today's washroom, where space is often a factor, the Parker Family of Washroom Equipment can provide every necessary convenience in a small area. In the washroom shown above, one Parker unit provides a soap dispenser and shelf and one provides facilities for dispensing and disposal of paper towels. These two units, as well as the mirror frame, are constructed of the finest quality stainless steel, making them attractive as well as easy-to-clean.

SEE OUR FAMILY ALBUM IN SWEET'S ARCHITECTURAL FILE 10.16/Pa.

For more data, circle 66 on inquiry card

charles  parker

290 PRATT ST., MERIDEN, CONN.  
06450  
TEL. 203-235-6365

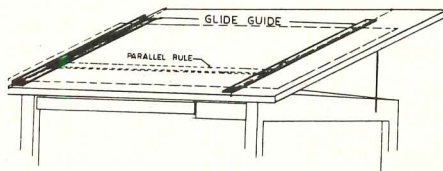

**DRAFTING AID** / The *Glide-Guide* has been designed for use with the parallel ruling straight edge to replace and eliminate the use of makeshift cardboard edge strips. It keeps drawing clean by raising the parallel rule above board-surface and prevents tearing of tracings. Simple installation is featured and the product is easily removed for any size parallel rule. The product is designed by an architect. ■ William J. McNeil, Davenport, Ia.

Circle 325 on inquiry card

**FAN FORCED HEATERS** / For heavy-duty residential and light commercial applications, the series utilizes center flow design that draws (instead of pushes) air over the element, giving even air distribution and eliminating hot spots. The *3250 Series* has a totally enclosed, permanently lubricated motor. A low speed fan is individually balanced for quiet operation and positive air circulation. Capacities range from 2500-4500 watts and 208 and 240 volts. ■ Markel Electric Products, Buffalo, N.Y.

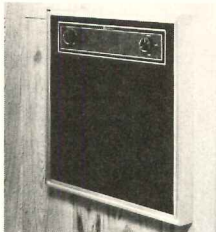

Circle 326 on inquiry card

**PORTABLE DRAFTING** / A compact drafting instrument which performs the same functions as large, expensive drafting machines is said to replace T-squares, triangles, protractors and even the drafting board. This device draws parallel, perpendicular, angular, radial and perspective lines with precision accuracy according to the company. ■ Michael Anthony & Co., Downey, Cal.

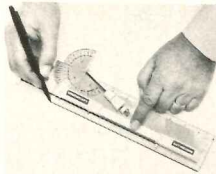

Circle 327 on inquiry card

**INSULATION CALCULATOR** / A slide rule calculator that determines how much thermal resistance is required for specific design conditions can be used in calculating required insulation thicknesses for pipe installations as well as for flat surfaces such as building walls, roofs, perimeters and floors. The calculator also compares physical and structural properties of the most widely used building insulation. ■ Mobay Chemical Co., Pittsburgh, Pa.



Circle 328 on inquiry card

**MODEL PHOTOGRAPHY** / Increased photographic potentiality of *Modelscope* has been set into the instrument according to the manufacturer. In the area of simple viewing a minus-2 diopter lens has been added to the separate eyepiece. The *Modelscope* has a field of view to 65 per cent, with a depth of field from nearly zero to infinity. It still comes in a wooden carrying case and an updated photographic procedure accompanies unit. ■ HCI Sales Corp., New York City.



Circle 329 on inquiry card

# Forming Architectural Concrete Textures

Standard/Custombuilt Form Lining Systems



16 Standard Corrugations

14 Standard Textures

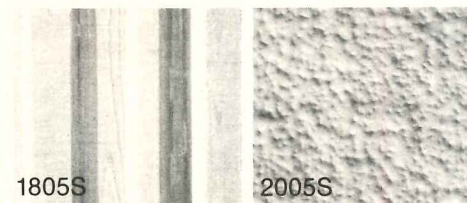
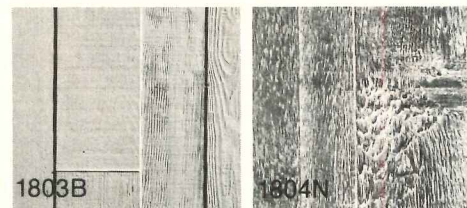
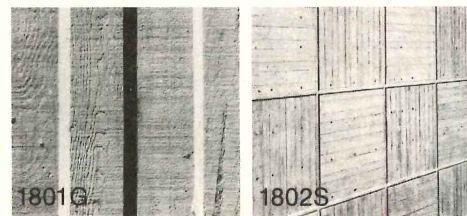

**Total Systems Concept for Concrete Forming**

Standard And Special Domes/Joist Pans/Forms: Beam, Long, Column, Wall, Balcony/Integrated Flying Form Systems/Architectural Formwork/Special Form Hardware

# INTERFORM

**Main Office:** 18744 S. Reyes Avenue Compton, California 90221 Dept. AR 7 L Telephone (213) 537-4063

**Regional Offices:** Los Gatos, California New York, New York Cincinnati, Ohio Denver, Colorado

For more data, circle 67 on inquiry card





## Thinking elevators? Escalators? Look around.

Don't stop at the first or second name you think of. Think of Armor.

We've been in vertical transportation more than 40 years. And right now we're growing faster than ever.

Especially in high-rise construction. With super-fast, super-smooth elevator systems. Sophisticated controls. Plus the sleekest new escalators around. And in low and medium rise buildings calling for tough, dependable geared or hydraulic elevators.

Armor covers them all. And delivers important bonuses too. Like eager, comprehensive design help from pit to penthouse. The finest engineering in the field. Contract maintenance programs tailored precisely to building needs. And more.

When you think of vertical transportation, think beyond the ordinary. Think Armor.

Armor Elevator Company, Inc., Louisville, Ky. 40214.  
Armor Elevator Canada Limited, Pickering, Ontario.

**Armor**

A Subsidiary of **AS** Smith Corporation



# Come Hail or High Water Tapered FOAMGLAS® Insulation Gives Positive Drainage



The best way to get proper slope for positive water drainage is with Tapered FOAMGLAS Insulation. The blocks come pre-tapered  $\frac{1}{8}$  inch per foot to provide proper water drainage and an excellent base for built-up roofing.

Pittsburgh Corning guarantees that Tapered FOAMGLAS Roof Insulation will not absorb moisture, will retain its original insulating efficiency and compressive strength and will remain incombustible for 20 years when applied in accordance with the written guarantee.

Tapered FOAMGLAS Insulation, which is available for prompt delivery, provides one-contractor responsibility for the roofing insulation and built-up roofing. And, the new Tapered II system cuts

installation time and material waste.

Learn more about the Pittsburgh Corning guarantee and the unique inorganic closed-cell construction of FOAMGLAS Insulation.

Send in the coupon below.



**MAIL TO: Pittsburgh Corning Corporation**

Department AR-74  
800 Presque Isle Drive  
Pittsburgh, Pennsylvania 15239

- Yes, I'd like to know more about Tapered FOAMGLAS® Insulation and its guarantee
- I would like to see a Sales Representative

Name \_\_\_\_\_

Title \_\_\_\_\_

Company \_\_\_\_\_

Address \_\_\_\_\_

Telephone \_\_\_\_\_

*For more data, circle 69 on inquiry card*



# When we put it together, we leave out the trouble.

Because we leave out the washer.

Sooner or later any compression washer wears out. The faucet drips. And it's a headache.

That's why we took the washers out of Delta faucets. We replaced them with a patented rotating valve that, tests show, lasts about 7 times longer.

We made Delta faucets easy to install, too.

For instance, Delex Scald-Guard<sup>™</sup> bath units can be put in back-to-back, without worrying about any "wrong side." Both valves connect to the same risers. Just flop the valve 180 degrees and hot stays on the left, cold on the right.

That saves on installation time and crosspiping costs.

Specify Delta single-handle and Delex two-handle faucets in your buildings. Leave out faucet trouble.

They're styled to look good and to work even better. Turned on or turned off.

*For illustrated literature, write  
Delta Faucet Company, A Division of Masco Corporation,  
Greensburg, Indiana 47240, and Rexdale, Ontario.*

## Delta Faucets.

Washerless. To work as good as they look.





**CARPET CUSHION** / A new descriptive folder on the company's cushion, polyester pneumacel, containing actual samples of the material, is currently being distributed to 6000 interior designers who qualify to receive Sweet's Sample File. In addition to the product samples, the new four-page folder offers detailed information on performance characteristics, material standards and specification data for both styles of pneumacel—*Belmeade 3000*, recommended for heavy traffic installations, and *Lansdowne 5000*, recommended for luxury residential use. ■ Du Pont Textile Fibers, Wilmington, Del.

*Circle 416 on inquiry card*

**FLOODLIGHTS** / A line of floodlights for loading and shipping docks described in this brochure includes swinging arm models for wall or column mounting, and a new overhead mounted swing-away model which is UL listed for shock-absorbing use. Both types offer spring-mounted socket and recessed face-plate lamp protection, as well as wire lamp guard and glare/guard accessories. ■ Herculite Loading Lights, Div. Phoenix Products Co., Inc., Milwaukee, Wis.

*Circle 417 on inquiry card*

**EXPOSED STRUCTURAL STEEL PAINTS** / A new brochure featuring painting systems for exposed structural steel includes painting systems for general construction, for heavy industrial, chemical and coastal exposures, and for solvent-restricted areas. Information about surface preparation, application, cost, and life expectancy for each system is given. ■ Tnemec Inc., North Kansas City, Mo.

*Circle 418 on inquiry card*

**SEALANTS** / The company has released two brochures on their new *Sonolastic NP II* sealant. One brochure covers the advantages and benefits of this new two-part, self-priming, elastomeric sealant. The second brochure is a technical format outlining the uses and applications. This brochure is said to be useful for specifying and actual site work because a coverage table and installation procedures are explained in detail. ■ Contech Inc., Minneapolis, Minn.

*Circle 419 on inquiry card*

**SLIDER REPLACEMENT WINDOW** / The aluminum window, which is designed to help reduce heating and cooling costs in commercial buildings by as much as 30 per cent is manufactured as a two light slider with both sashes removable for safe, easy cleaning from inside the building. The literature includes detailed drawings of 10 manufacturing features. ■ Season-all Industries, Inc., Indiana, Pa.

*Circle 420 on inquiry card*

**PLASTIC ARMOR** / A new bulletin for a multi-purpose epoxy protective coating for concrete, masonry, steel interiors and exteriors is available. The improved product is said to be durable, corrosion-resistant, weather and waterproof. ■ Permagile Corp. of America, Plainview, N.Y.

*Circle 421 on inquiry card*

**HOSPITAL LIGHTING** / A six-page illustrated brochure on a wall-mounted hospital patient room lighting system discusses three patient-room lighting functions esthetically combined in one lighting element. The product gives general room illumination, patient's reading light, and staff examination light. ■ Keene Corp., Los Angeles, Cal.

*Circle 422 on inquiry card*

*more literature on page 156*

REINFORCED

# concrete facts

## HIGH-STRENGTH REINFORCED CONCRETE

**9000 psi-plus concrete is here.  
It means bold, new designs and  
big savings in building costs.**

The technology and the materials are here today for practical use of reinforced concrete with compressive strengths of 9000 psi and beyond. So architects and engineers now have a new design tool. And builders and owners have a new way to trim building costs.

A prime example of high-strength concrete in action: A new 23-story office building in Chicago's Loop. On the lower floors, 9000 psi concrete was used for interior columns and 6000 psi concrete for exterior columns. The resulting slender columns permitted more usable floor space. Column interaction with flat plate floors and spandrel beams eliminated the need for shear walls.

The savings were many. Material costs were less. The forms were less congested, thus concrete placement went faster. And no air entrainment was needed to improve durability—another saving in time and money.

By using moderately high-strength concrete of 6000 psi for the facade (exterior columns and spandrels), the designers eliminated cladding costs. The durable exposed surface of the concrete itself served as an attractive exterior finish, eliminating painting costs.

Conventional 4000 psi concrete was used for the flat-plate floor slab except where 9000 psi concrete was puddled in the floor around the high-strength column. Thus, three strengths of concrete were used in lower floor construction.

And when all of the economies of the high-strength concrete frame were added up and compared with structural steel, the result was an impressive \$1.00 per square foot savings.

*Developer:* Fleetwood Realty, Chicago

*Structural Engineer:* The Engineers Collaborative, Ltd., Chicago

*Architect:* Welton Becket and Associates, Chicago

*General Contractor:* Crane Construction Co., Chicago

*Steel Supplier:* United States Steel Supply, Division U.S. Steel Corp., Chicago

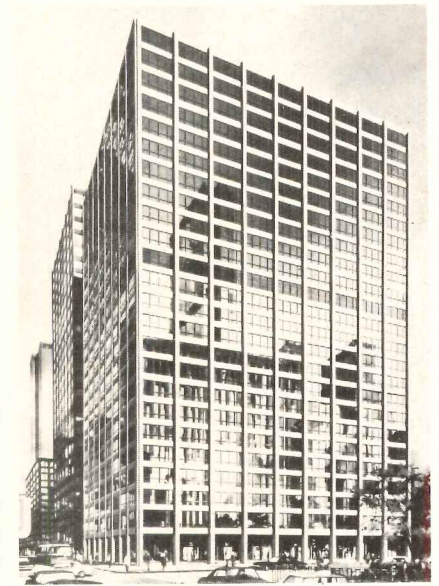

Note slender, exposed high-strength concrete columns.

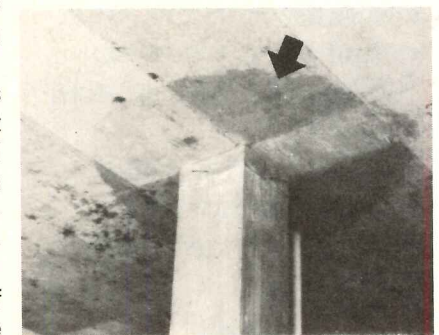

Detail shows contrast between 9000 psi column concrete (in the slab immediately adjacent to the column) and 4000 psi flat-plate floor concrete.



**CRSI**  
**CONCRETE  
REINFORCING STEEL  
INSTITUTE**  
180 North LaSalle Street  
Chicago, Illinois 60601  
Room 1204

*For more data, circle 73 on inquiry card*



# As a businessman, you'd make a terrific human being.

Some of the things you do for a living can make you feel wonderful when you do them for free. To help people living in your community.

Can you set up a budget? Motivate a staff? Program a computer? Type? Read? Tie a shoe?

Yes? Then you can help people.

In fact, there are probably dozens of voluntary organizations right in your town who would love to have you working with them. Join one. Or, if you see the need, start one.

We'll be your contact.

If you can spare even a few hours a week, call the Voluntary Action Center in your town. Or write: "Volunteer," Washington, D.C. 20013.

You'll get to know some terrific human beings. And one of them will be you.



## Volunteer.

The National Center for Voluntary Action



A Public Service of This Magazine & The Advertising Council

**TURF IRRIGATION** / An eight-page brochure, illustrated in color, describes PVC and asbestos-cement piping systems for irrigating turf. Following a discussion of installation and operating costs, the brochure covers joint types, mains, fittings, special couplings etc. Short form specifications for both PVC and asbestos-cement turf irrigation pipe conclude the description. ■ Certain-teed Products Corp., Valley Forge, Pa.

*Circle 423 on inquiry card*

**GRAPHIC UNDERLAYS** / Underlay drawing aids for industrial illustration that include isometric and perspective protractors, isometric gear guides, perspective and axonometric grids and floor plan layout package are listed in a four-page bulletin. ■ Graphicraft, Westport, Conn.

*Circle 424 on inquiry card*

**SEAL COATING** / Seal coating and color sealing products are described in a four-page, full-color bulletin which discusses products for: playgrounds, walkways and other non-vehicular surfaces; tennis courts, shopping malls, lounge areas, etc.; and asphalt pavement surfaces. ■ Borden Chemical, Columbus, Ohio.

*Circle 425 on inquiry card*

**EXPANDED METAL** / There are 1001 uses for expanded metal for home and industry according to a new 32-page, illustrated brochure. Expanded metal can be used anywhere there is a need for a strong, protective enclosure, a safe walking or working platform, partition, decorative screen or barrier, protection against vandalism, and for numerous other applications. Specification charts and a section on cutting and installation are also included. ■ Wheeling-Pittsburgh Steel Corp., Pittsburgh, Pa.

*Circle 426 on inquiry card*

**ARCHITECTURAL PHOTOGRAPHY** / This guide to photographing the exterior and interior of buildings in natural and artificial light was written for both the layman and the professional photographer, and discusses the process of architectural photography in its entirety, from outlining the purpose of taking the picture all the way through developing the film. The bulletin includes a suggested list of equipment for a newly started architectural photographer. ■ Paillard Inc., Linden, N.J.

*Circle 427 on inquiry card*

**GSA FURNITURE GUIDE** / The General Services Administration catalog/price list is available to architects, designers and specifiers. ■ Stendig Inc., New York City.

*Circle 428 on inquiry card*

**CORROSIONPROOF FANS** / Over-all descriptions of fiberglass reinforced plastic blower fans for corrosive air handling are contained in a four-page bulletin that also discusses three optional impeller styles designed to meet varying application requirements, especially where solids are present in the air stream. ■ The Ceilcote Co., Berea, Ohio.

*Circle 429 on inquiry card*

**WINDOW AND WALL TESTING** / A bulletin recently published by ASTM gives basic information on the natural forces that have an influence on the design of curtainwalls, windows, and related structures. It covers test methods that should be specified to assure that the design concept has been met. The publication is well illustrated and each chapter is abstracted and key-word indexed. ■ ASTM, Philadelphia, Pa.

*Circle 430 on inquiry card*

Get the  
tough protection  
this little animal  
can give you.

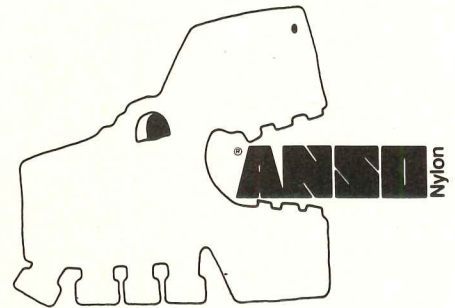

Get Guaranteed.  
The guarantee  
with teeth.

It's yours when you specify  
carpeting of ANSO nylon,  
available from the following  
contract furnishers.

Angelus Carpets  
8380 Melrose Ave.  
Los Angeles, Calif. 90069  
Mr. Ken Snyder  
Tel: (213) OL 1-2730

John Bloeser Carpet Co.  
1325 Channing St.  
Los Angeles, Calif. 90021  
Mr. Terry Welch  
Tel: (213) 627-4738

J.L. Hudson Co.  
Contract Division—13th floor  
1206 Woodward Ave.  
Detroit, Mich. 48226  
Mr. Harry Foster  
Tel: (313) 223-1362, 1379

Kinney/Bernardi  
4611 Malat St.  
Oakland, Calif. 94601  
Mr. William Kinney  
Tel: (415) 261-3211

Orchard & Wilhelm  
Commercial Interiors Inc.  
8815 "F" St.  
Omaha, Neb. 68127  
Mr. John Randall  
Tel: (402) 339-5000

The Slater Co.  
300 W. Hubbard St.  
Chicago, Ill. 60610  
Mr. John Becker  
Tel: (312) 467-7100

Thalhimer Industrial Sales Corp.  
1925 Westmoreland Ave.  
Richmond, Va. 23230  
Mr. H.E. Glave  
Tel: (804) MI 3-4211

All other areas call:  
Allied Chemical Corporation  
Home Furnishings Fibers  
Advertising Manager  
One Times Square  
New York, New York 10036  
Tel: 212-736-7000

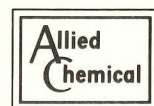





## In the carpet world, Anso<sup>®</sup> Nylon's five year guarantee is on top of the pile.

Two Shell Plaza is Houston's new pride. So in the public areas and hallways, this building has "TXR-10" carpeting from Commercial Carpet Corporation.

It comes with Guaranteeth—the guarantee with teeth. Allied Chemical's assurance that the carpet is guaranteed not to wear more than 10% in five years, or Allied Chemical will replace it, installation included. Promise.

Allied makes this promise because we make ANSO nylon—the second-generation soil-hiding

nylon. And, we test every carpet made of ANSO nylon 10 different ways to be sure it can take it.

So look for the label with the fierce little animal who symbolizes our Guaranteeth. And get the carpet with the five year wear guarantee.

For your free copy of our Contract Carpet Manual, write to: Allied Chemical Corporation, Fibers Division, Contract Department AR, One Times Square, N.Y. <sup>®</sup>

N.Y. 10036. Phone: (212) 736-7000.



### Guaranteeth. The guarantee with teeth.

Two Shell Plaza, Houston, Texas/35,000 yds. "TXR-10"/Commercial Carpet Corp.



For more data, circle 74 on inquiry card



# Our cities can work better today ...and tomorrow.

## Modern ways to transport people.

Cities are having a rebirth, largely because developers are taking a new look at the tremendous investments in urban property. And modern mass transit ideas are helping make this rebirth happen. The automated, computer-controlled vehicles that have helped move people safely and conveniently through airports, are now being applied to the needs of downtown areas, colleges, industrial complexes and recreation centers. Westinghouse is helping make it happen.

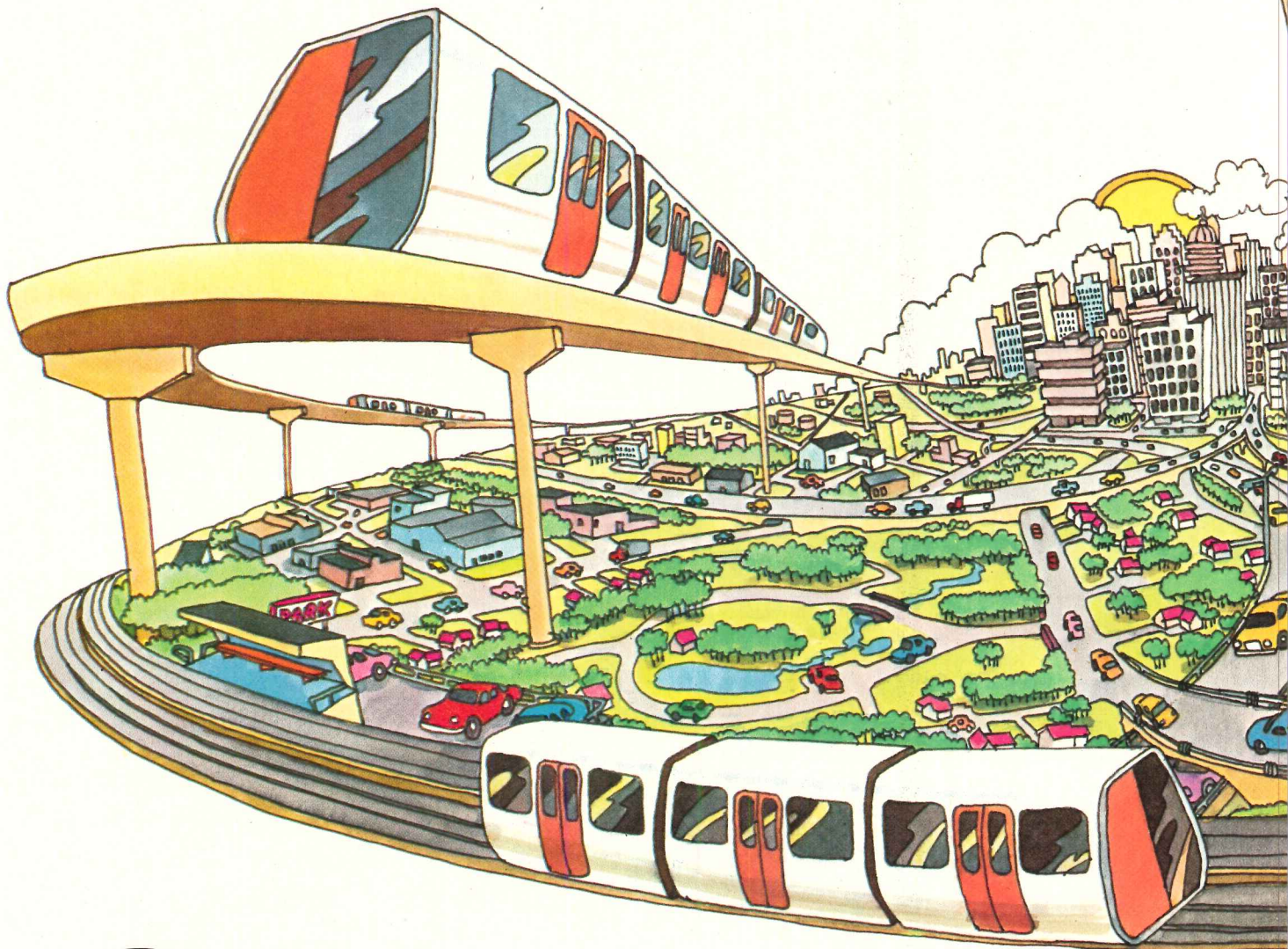

# Westinghouse



**Buildings designed to use less energy.**

New buildings are saving energy these days by using existing heat . . . from the lighting systems . . . to cut heating loads. Circulating water or air picks up the lighting heat and redistributes it throughout the building. In summer, the same system carries the heat out of the building to cut air conditioning needs. Total energy savings can amount to 10% or 15%.

**Better lighting for better safety.**

New Westinghouse Ceramalux™ high-pressure sodium lamps for residential streets deliver twice the light of ordinary mercury vapor lamps for 10% less power, helps discourage street crime. Ceramalux systems are being installed now in New York City, Washington, D.C., and dozens of other cities.

Westinghouse Electric Corporation  
Pittsburgh, Pa. 15222

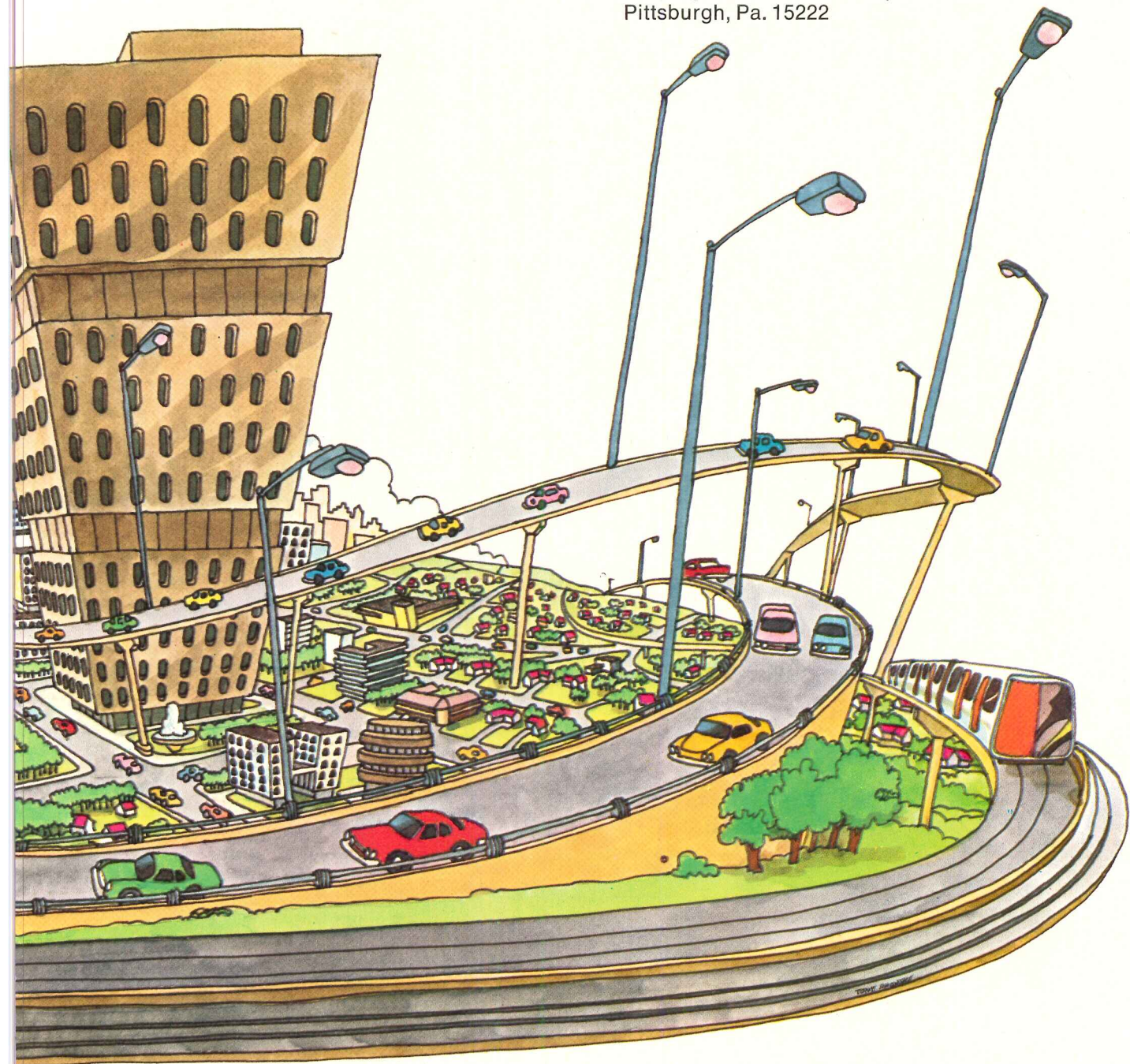

**helps make it happen**

*For more data, circle 75 on inquiry card*



# How to plan your cooling for early move-ins and last-minute changes.

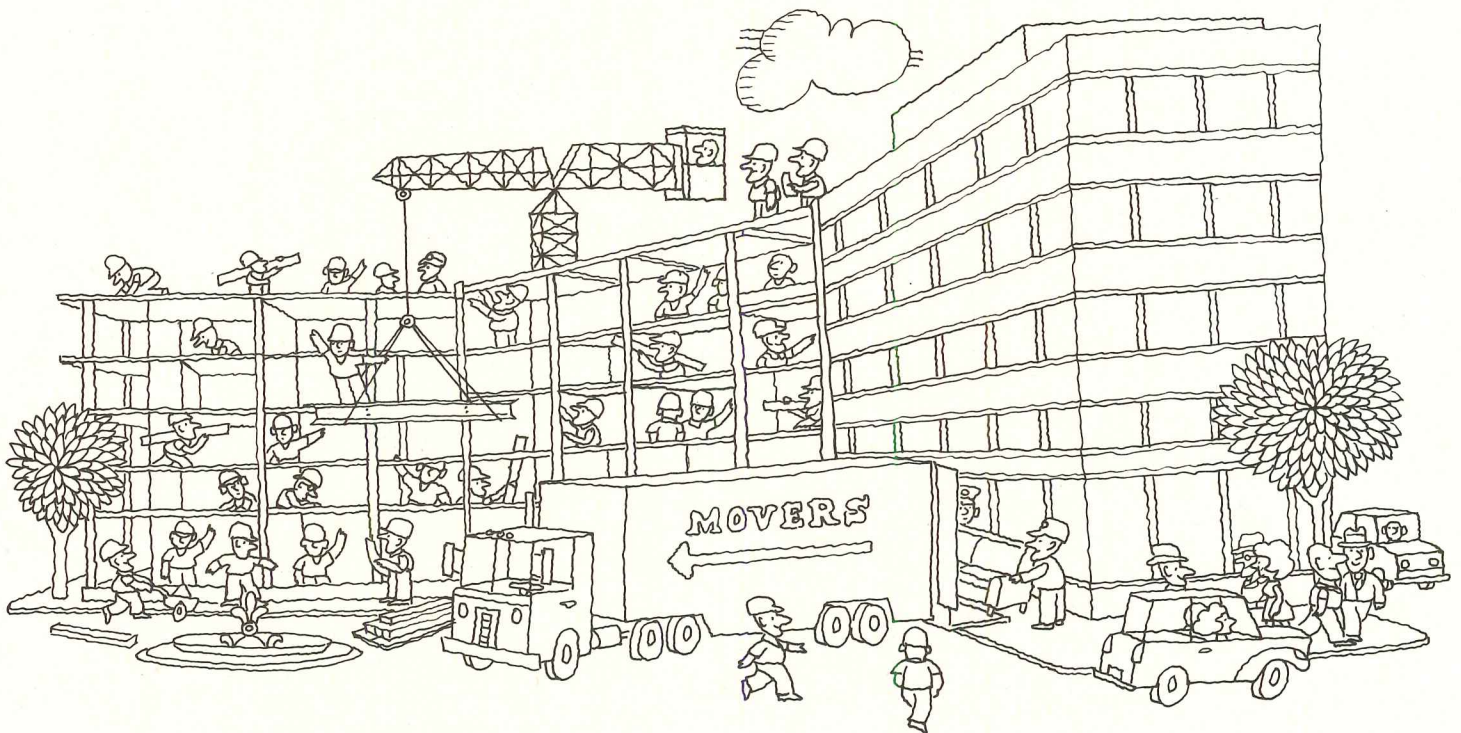

Put your building owner on a fast track design with Carrier's Moduline® cooling system. The all-air, one-duct system with ceiling-hidden diffusers. With unique built-in controls, so the zones can be arranged to fit space usage. At the last minute.

Tenants can be more selective. Move in faster. Pay rent quicker. Stay happier longer.

The Moduline System needs less air, uses smaller ducts, smaller cooling plants, and

takes less space above the ceiling.

It also saves energy by reducing fan horsepower and refrigeration. It even re-balances itself to accommodate load changes. Like a reduction in lighting level.

The Moduline System. Plan on it for your next building with a Carrier representative. Carrier Machinery and Systems Division, Syracuse, N.Y. 13201.

Number One  
Air Conditioning  
Maker



Division of Carrier Corporation

**Carrier**



# WHAT MAKES THIS ALL-GLASS BUILDING SO ENERGY EFFICIENT?





# THE GLASS. PPG SOLARBAN® 480

The First International Building in Dallas is a brilliant example of the efficiency of glass buildings.

Its skin is nearly all glass.

Yet the press has hailed it as "... the most energy-efficient building in Dallas."

This is not in spite of being glass, but because it is PPG Solarban 480 Twindow insulating glass.

## Where the energy goes.

In planning this building the design team saw (as you can see on the chart) that about 50% of the energy would go to light it.

Another 14% to run the fans, elevators and various office machines.

About 7% to heat it.

And because it's Dallas, 29% to cool it.

So they decided to cool it—with the most innovative, energy-conserving air-conditioning system technology could provide.

But they needed high-performance glass to do it.

**It reflects, insulates and saves.**

PPG Solarban 480

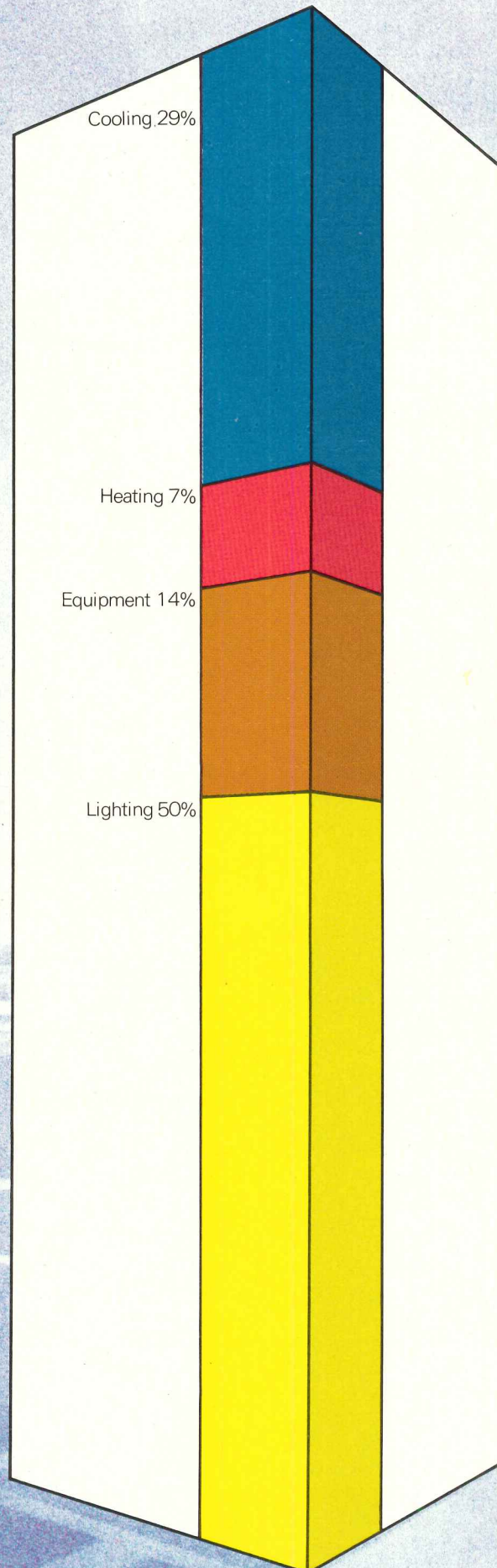

Twindow reflective insulating glass has a shading coefficient of 0.22.

This reduces solar heat gain by 78% compared to single-glazed clear glass.

And the double glazing drastically reduces the conducted heat gain (or loss) through the skin of the building.

## The bottom line is this:

The innovative, all-air mechanical system saves both energy and money. It reclaims heat from the lighting and large interior spaces and redistributes it for perimeter heating when needed.

And the simplicity of its design saves even more money.

As the Herman Blum Consulting Engineers put it: "If you're going to use an all-air system in a high-rise building, you've almost got to have a high-performance glass."

## The right glass is the right answer.

Today, there is a flurry of antiglass invective.



# TWINDOW<sup>®</sup> INSULATING GLASS.

People would have you think that less glass used means more energy saved.

Not necessarily so.

It's really a question of quality, not quantity.

And buildings like the First International Building prove it.

Our graph illustrates one important point to keep in mind with "all-glass" buildings.

A building that's 70% Solarban 480 Twindow insulating glass (and that's 70% vision glass we're talking about) is more energy efficient than the same building using cramped little clear glass windows totaling only 20% vision area (and that's an 80% opaque wall).

## The transparent advantage.

If a glass wall can be used instead of an opaque wall, it's obviously better.

It's transparent.

Experienced owners agree that tenants find a building much more desirable when they can see the outside from the inside. And certainly an important mea-

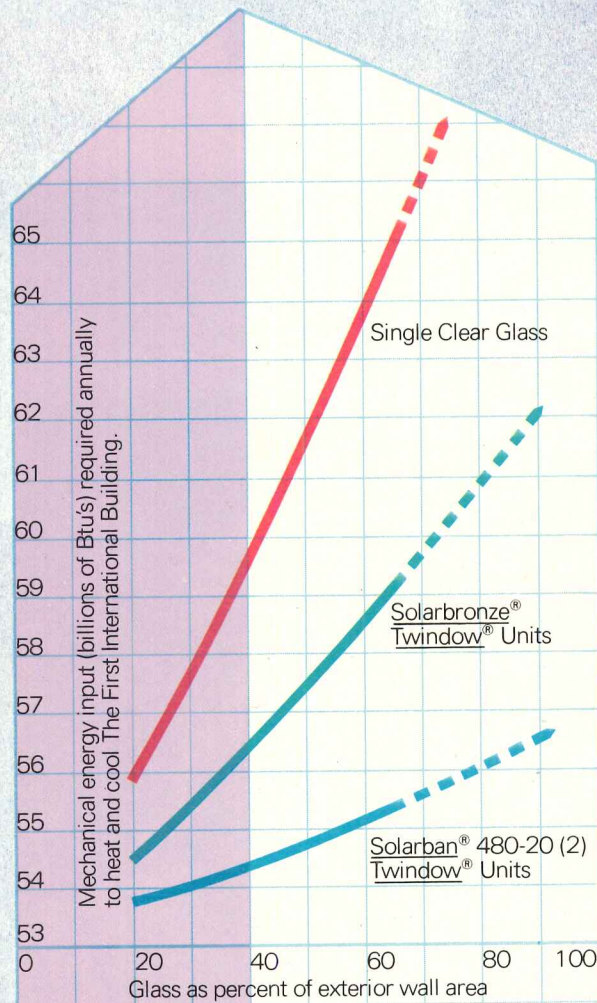

sure of the success of any building is the effect it has on the satisfaction of its tenants.

Economically, esthetically, psychologically—no matter how you look at it—glass is a building material of remarkable potential.

Especially in conserving energy. An important point to remember.

PPG High Performance Glasses come in a wide range of performance values to suit your building's economic and esthetic considerations.

Write PPG Industries, Inc., One Gateway Center, Pittsburgh, Pa. 15222.

The First International Building, Dallas, Texas

Owner: First National Bank in Dallas  
Architects: Harwood K. Smith & Partners, Dallas and Hellmuth, Obata & Kassabaum, Dallas and St. Louis

Mechanical Engineers: Herman Blum Consulting Engineers, Dallas, Texas

PPG: a Concern for the Future



INDUSTRIES

For more data, circle 76 on inquiry card



# J-M puts it



## **A J-M asbestos roof saves energy.**

A built-up roof can take a lot of asphalt. Or it can take a lot less. That's the one big advantage of using J-M asbestos roofing felts. It makes possible a smooth surface roof—one that doesn't need a poured asphalt-gravel protective surface. Use asbestos roofing felts and you save a lot of asphalt. Save asphalt and you're also doing your part to conserve petroleum, a vital energy source.

## **A J-M roof... a systems approach to quality.**

A quality built-up roof is no better than its component parts. And no better than the techniques used to put them together. That's why it's so important when you specify a roof, to consider every aspect of the system, if you expect true value and lasting protection when the job is done. And that's why a J-M built-up roof makes sense. You benefit from the experience of over 100 years in the roofing business—on J-M quality in a complete line of roofing products built to work together—and on the skills of the J-M team of roofing specialists.

## **A J-M roof means single-source materials responsibility.**

Because J-M makes everything that goes into a built-up roof, you can have Johns-Manville quality all the way—from the deck up. From vapor barrier to top dressing, you're assured of components made to go with each other. And when those materials are applied in accordance with J-M specifications, the result is "from-the-deck-up" dependability. Plus, another important benefit: Clear-cut responsibility for the performance of the materials used in the finished assembly. And that can be a real advantage in case follow-up is needed after the roof is completed.



# all together.



## **J-M Asbestogard™ Vapor Barrier System—an unexcelled start for an insulated built-up roof assembly over metal decks.**

If conditions warrant a vapor barrier, make sure the one you use is a good one.

It should permit no water vapor to pass through it. Should be simple to apply. Promise long life. Enhance roof stability. Meet Factory Mutual Requirements for Class I Construction.

Asbestogard vapor barrier applied to the steel deck with cold-application Asbestogard adhesive and followed with a solid mopping of asphalt to secure roof insulation,

provides all these advantages.

Asbestogard Felt is made with long, high-grade asbestos fibers and parallel fiber glass yarns for toughness and tear resistance.

It unrolls easily, stays flat in the wind, doesn't wrinkle. And Asbestogard won't burn through when hot asphalt is applied.

Start your roof installation with the J-M Asbestogard Vapor Barrier System and you'll have J-M quality and dependability from the deck up.

### **SPECIFYING A ROOF IN A PERIOD OF RISING PRICES.**

Because of the energy crisis, prices of all petroleum-derived products—and that includes the bitumen used in a built-up roof—are rising. As a result, a roofing manufacturer cannot guarantee prices for as long a time as normally transpires between the submission of a quote and shipment of materials to the job. For that reason, it is imperative that the specifier and building owner alike allow for that situation and accept the inclusion of escalation clauses in bids. This gives the contractor the flexibility to adjust prices over which he has no control and enables him to make a fair return on a job bid in good faith.

For assistance of any kind with a built-up roofing problem, contact your J-M district sales office. Or write: Johns-Manville, Box 5108, Denver, Colorado 80217.

**The  
single-source  
built-up roofing system.**



**Johns-Manville**

*For more data, circle 77 on inquiry card*



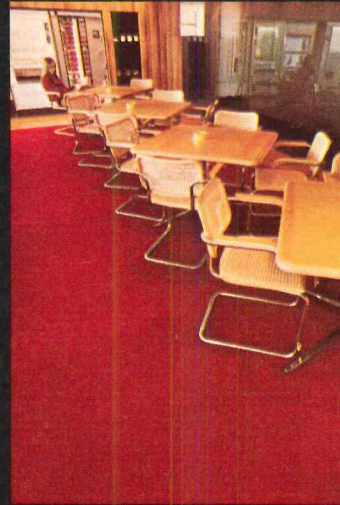
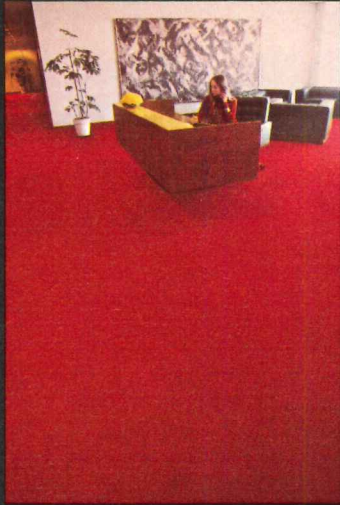

The reason our Acrilan® acrylic fiber is so versatile is that it's made in two distinctly different forms.

Carpets labeled **Acrilan Plus** offer a luxurious look and hand, and the styling versatility to set the tone for the Chairman's suite. In fact, custom designers, who have been traditionally committed to wool, are now using Acrilan® acrylic to make custom carpeting

**Q: THE LOBBY. THE  
THE CAFETERIA. CAN  
BE RIGHT FOR THEM**



that sells for as much as \$50 a yard.

Carpets labeled **Acrilan 2000+** contain the only solution-dyed acrylic fiber available. The color is not applied later, but is an integral part of the fiber, all the way through. Because of this, carpets of solution-dyed Acrilan® acrylic 2000+ are the most color-fast you can specify. In sunny locations with large

glass areas, like most lobbies these days, you can't beat this fiber. 2000+ is a Weatherometer rating, showing no visible fading after 2000 hours of burning noonday sun. (For comparison, the industry rating for normal carpets is 40 hours). And some of our colors actually rate up to 6000 hours!

Acrilan 2000+ carpets are also perfect for the

cafeteria. Or any location where food or chemical spills are a problem. We tested it with more than one hundred hospital stains, and with their solvents, which are even worse. It came through with glowing colors.

What's more, our licensing program is your guarantee of good quality. We insist that constructions meet specific weight/density

standards, because face weight minimums alone can't guarantee quality. We also require that pile density increase as pile height increases.

For all these reasons, consider Acrilan for your next contract installation. Meanwhile, for more information, write Monsanto Textiles Company, 1114 Avenue of the Americas, New York, N.Y. 10036.

# CHAIRMAN'S SUITE. ANY CARPET FIBER ALL?

# A: ACRILAN CAN.



For more data, circle 78 on inquiry card



**When a job calls for beautiful, textured doors with better durability than wood . . .**

Next to the three prefinished embossed hardboard door facings in the Legacy Series from Masonite Corporation, any other door facing is out of its depth.

No flat surface door with a mere grain finish has the deep-textured feeling of Legacy or its deep-rooted durability.

Legacy comes closer to nature than competitively priced doors. The texture is embossed into the substrate before the durable finish is applied. It won't scratch off. The total effect mirrors that of an actual wooden planked surface, each plank with

its own personality.

Mar-resistant Legacy won't split, splinter, crack or check. It can be easily repaired on site in event of damage. Legacy's high dimensional stability and great structural strength make it suitable for use with both solid and hollow core doors.

And the price is right.

Want the names of some quality door manufacturers currently using Legacy? Write Masonite Corporation, 29 North Wacker Drive, Chicago, Illinois 60606.

Legacy and Masonite are trademarks of Masonite Corporation.

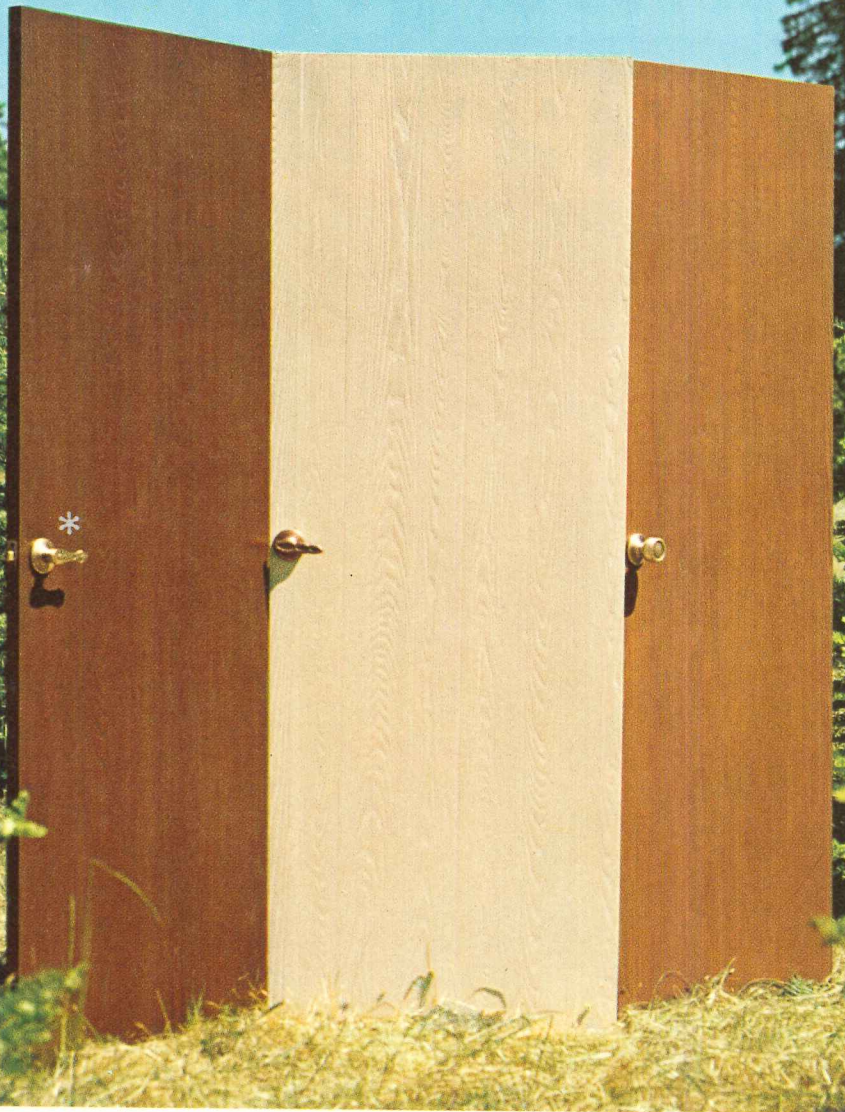

Legacy series of embossed hardboard door facings: Walnut tone, New White and Oak tone.

\*Locksets by Kwikset®.

**...Legacy™  
stands alone.**

For more data, circle 79 on inquiry card



The closer you get  
the better Legacy looks.



# Build a 10 story building with loadbearing masonry and get the 11th story free.

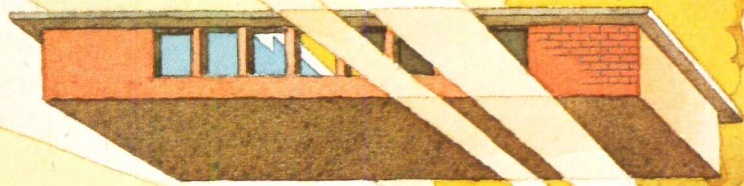

When you build with a modern loadbearing masonry system, you can save as much as 10% on construction costs.

Because masonry lets you save on the two biggest expenses of building. Time and materials.

Instead of building separate structural systems and enclosure walls, you can have them both in one step. Masonry walls work together with roof and floor systems to create one solid structural shell. Complete with enclosure walls and inside partitions.

And you can begin finish work on each floor as soon as the masons begin erecting the floor above it. So your building is finished faster. And you can stop paying interim interest and start charging rent.

You save on maintenance costs too. Because masonry doesn't warp, dent, bend, buckle or rot. It gives superior fireproofing and sound control. And with its inherent beauty, it never needs painting.

When you add all these savings up, you can save enough money to add that eleventh story. If that sounds like an interesting prospect to you, mail this coupon. We'll send you the complete story.



International Masonry Institute  
Suite 1001 823 15th Street, N. W.  
Washington, D. C. 20005 AR

Send me information on the modern loadbearing masonry building system.

Name \_\_\_\_\_

Title \_\_\_\_\_

Company \_\_\_\_\_

Address \_\_\_\_\_

City \_\_\_\_\_ State \_\_\_\_\_ Zip \_\_\_\_\_

Nature of Business \_\_\_\_\_



# Hager gives you the edge on hospital doors with Camtrol®.

Hager's new patented Camtrol® double action pivots insure snug bathroom door fittings without rounding door edges. Camtrol's unique double acting pivot action is specially designed for hospital and nursing home bathroom doors weighing up to 100 lbs. Top and bottom anchor arms are precisely machined from strong, fine quality 3/16" steel for mortising into 1-3/4" doors. Only three moving parts insure a lifetime of dependable use. Plastic cinch anchors make masonry floor installation simple and fast. Base dust covers help provide extra sanitation.

Ask your architectural hardware consultant for an interesting look at Hager's complete line of fine quality institutional door hardware. Or, write Hager Hinge Company, 139 Victor Street, St. Louis, Mo. 63104.

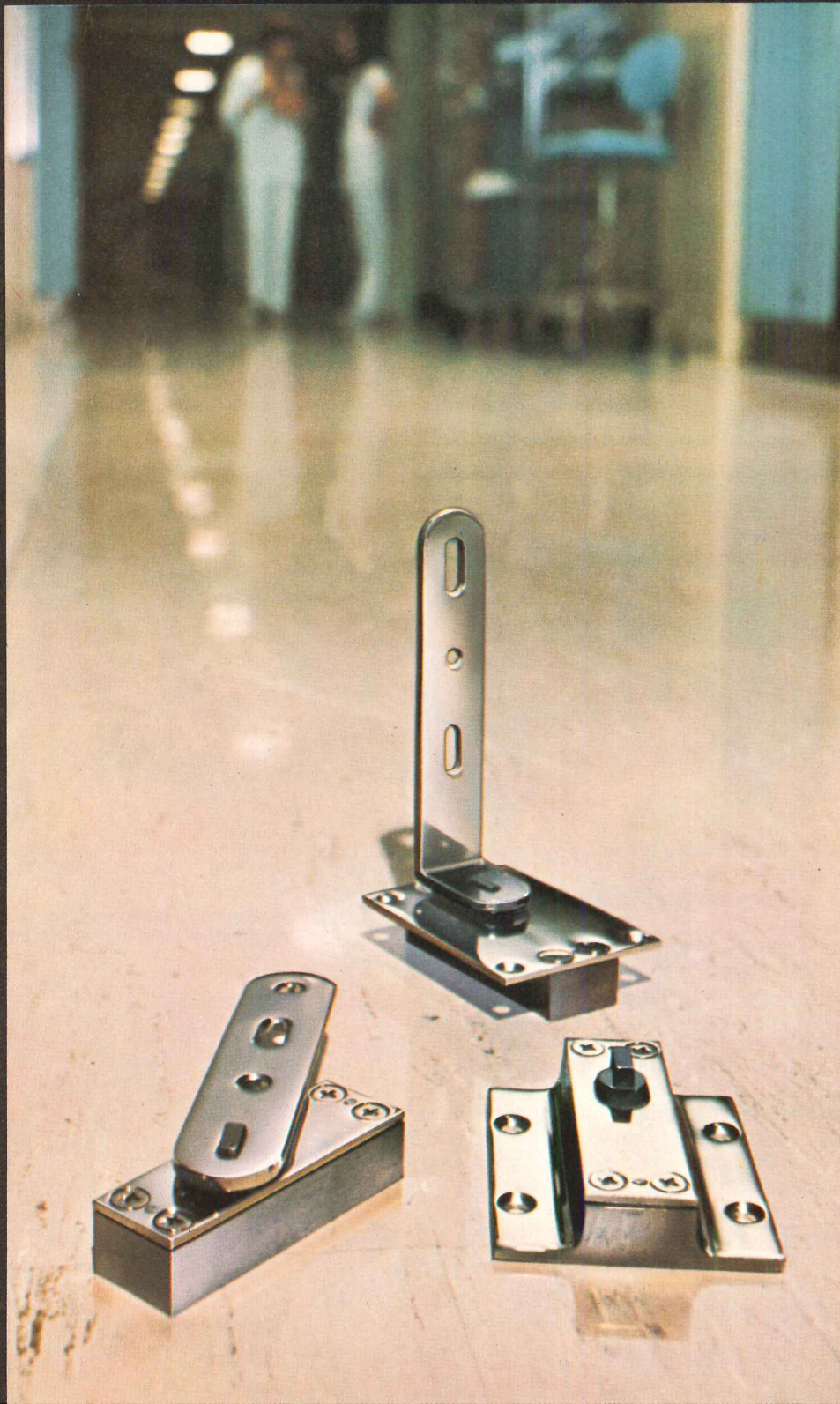

**Hager**  
EVERYTHING HINGES ON Hager!

For more data, circle 81 on inquiry card



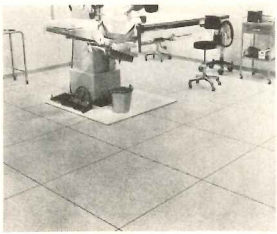

CHOICE OF MICRO-SQUARED™ OR SEAMLESS conductive flooring for hospital operating rooms is now offered by Vinyl Plastics, Inc. Every Conductile® 12" x 12" tile is Micro-Squared to a tolerance of ±.002" to assure uniformity. Seamless floors are seam-welded. Both systems are installed with conductive adhesive and provide positive sterile floor

capabilities. A modern, subtle pattern in four pastel colors and two new dark tones provides design flexibility. For complete information send for your 1974 Conductile Catalog.

For more data, circle 82 on inquiry card

## MORGUE/AUTOPSY PLANNING

BOOKLET helps you in planning a new morgue/autopsy facility or modernize and equipping present facilities. Send for your free 16 page booklet showing equipment specifically designed and manufactured for pathology and anatomy departments in hospitals, universities and animal research labs. Morgue specifications are also included. In addition, on request we offer a morgue/autopsy planning service that can save you time and costly mistakes. Write: Jewett Refrigerator Co., Inc., 2 Letchworth St., Buffalo, N.Y. 14213.



For more data, circle 83 on inquiry card

## VANTAGE-SPACE MULTI-STORY OFFICE BUILDINGS . . .

are now available through Precast Systems, Inc. member/affiliates from coast to coast and in Canada. The system features a fire-resistant precast service core, precast concrete floors and load-bearing walls, column-free space for greater flexibility in planning, an excellent ratio of rentable floor area to total floor area, fast construction, reduced operating costs and attractive appearance. Write Precast Systems, Inc., Dept. AR 74, 10400 West Higgins Road, Rosemont (Chicago), Ill. 60018. Telephone: 312/298-5570.

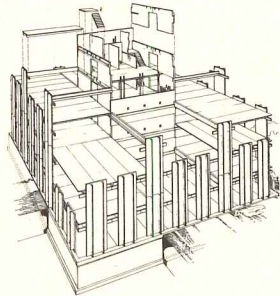

For more data, circle 84 on inquiry card

## PORTABLE SOLID WASTE AND REFUSE COMPACTORS

and systems from The Tony Team, Inc. includes four sizes and great versatility. Pollution Packer™ compactors bale, bag and box all types of wastes and refuse, wet or dry. Machine capacities range from .8 C. Y. to 4½ C. Y. of loose wastes at 10 to 1 compaction ratio . . . operate on low amperage, 110-V60 cycle service. For hospitals, hotels, schools, colleges, restaurants, office and apartment bldgs. Simple adaptation to chute-type disposal systems. Spec sheets and literature available from: The Tony Team, Inc., 7399 Bush Lake Road, Mpls., Minn. 55435.

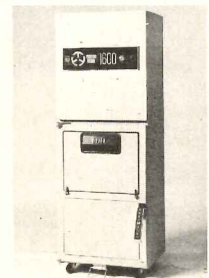

For more data, circle 85 on inquiry card

## Space age insulation for masonry walls available now!

For space age insulation in cavity wall construction, specify Permalite perlite. It's the material used more than any other in cryogenic installations to insulate rocket and other exotic fuels stored at temperatures as low as -400 degrees F.

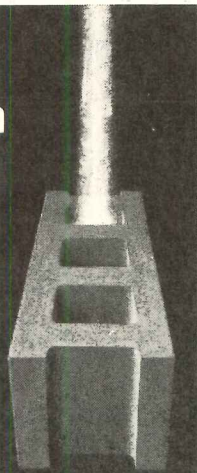

SILICONE TREATED  
**Permalite**®  
PERLITE MASONRY FILL INSULATION

Stays dry because it's silicone treated. Out-performs other types of loose fills, but costs no more. Provides permanence; fire-proofness; freedom from rot, termites, vermin. Write for data and name of nearest processor. He can fill orders promptly! GREFCO, Inc., Building Products Division, 3450 Wilshire Blvd., Los Angeles, CA 90010

 A subsidiary of General Refractories Company

## Save pennies per square foot

### Petrical® Roof-Decks do more.

- Structural Roof-Deck
- Low "U" value
- Noise reduction coefficient up to .85
- Moisture resistant
- U.L. classified
- I.C.B.O. approved
- Non-combustible
- Diaphragm tested
- Wall panel
- Form board
- Prime painted white
- Attractive
- Durable

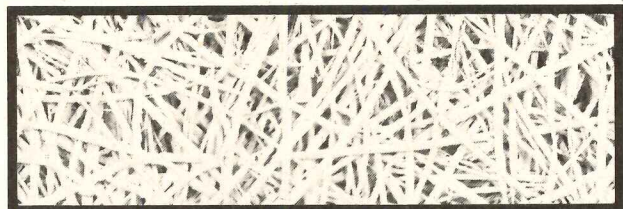

Call or write:

**CORNELL CORPORATION**

808 South Third Street  
Cornell, WI 54732 • Phone: (715) 239-6411  
See Sweet's Architectural File.

For more data, circle 87 on inquiry card



# You can only get Westinghouse water cooler performance from Westinghouse.

You get instant cold . . . the Westinghouse innovation that delivers refreshing cold water the instant the bubbler is pressed. And instant hot, from a factory installed Hot Water Heater.

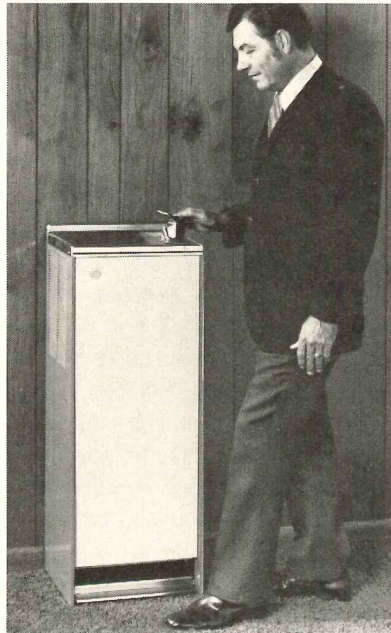

You get a full-width, fully recessed stainless steel foot pedal on all floor mounted models. For safety's sake.

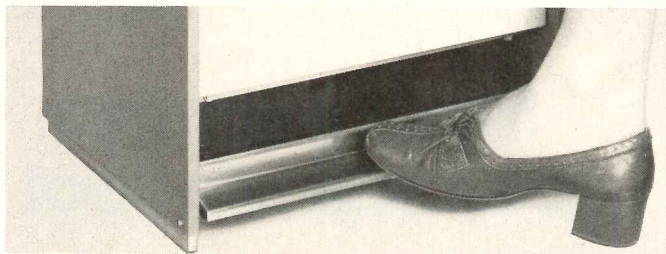

The Sure Service symbol means prompt, complete, professional service by thousands of Westinghouse trained technicians anywhere the water cooler is installed in the U.S.A. **Westinghouse water coolers work for you.**

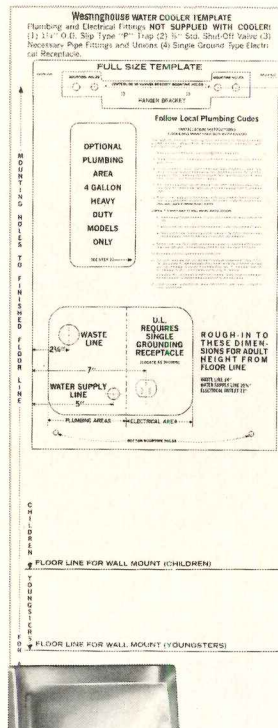

You get a time- and labor-saving full-size installation template with full instructions and dimensions. Just to make everything simpler.

You get a choice of 21 basic water cooler models. Plus a variety of types. A spectrum of colors and finishes. All for design versatility.

But you can only get it from Westinghouse. For people who specify quality. Westinghouse Electric Corporation Water Cooler Department Columbus, Ohio 43228.

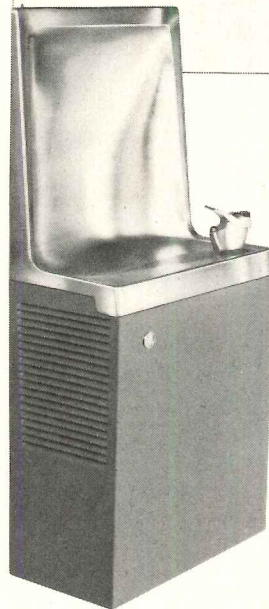

## Westinghouse

Performance certified in accordance with ARI standard 1010-71

For more data, circle 88 on inquiry card



# Only the GAF® 480 Automatic Diazoprinter lets you dial...

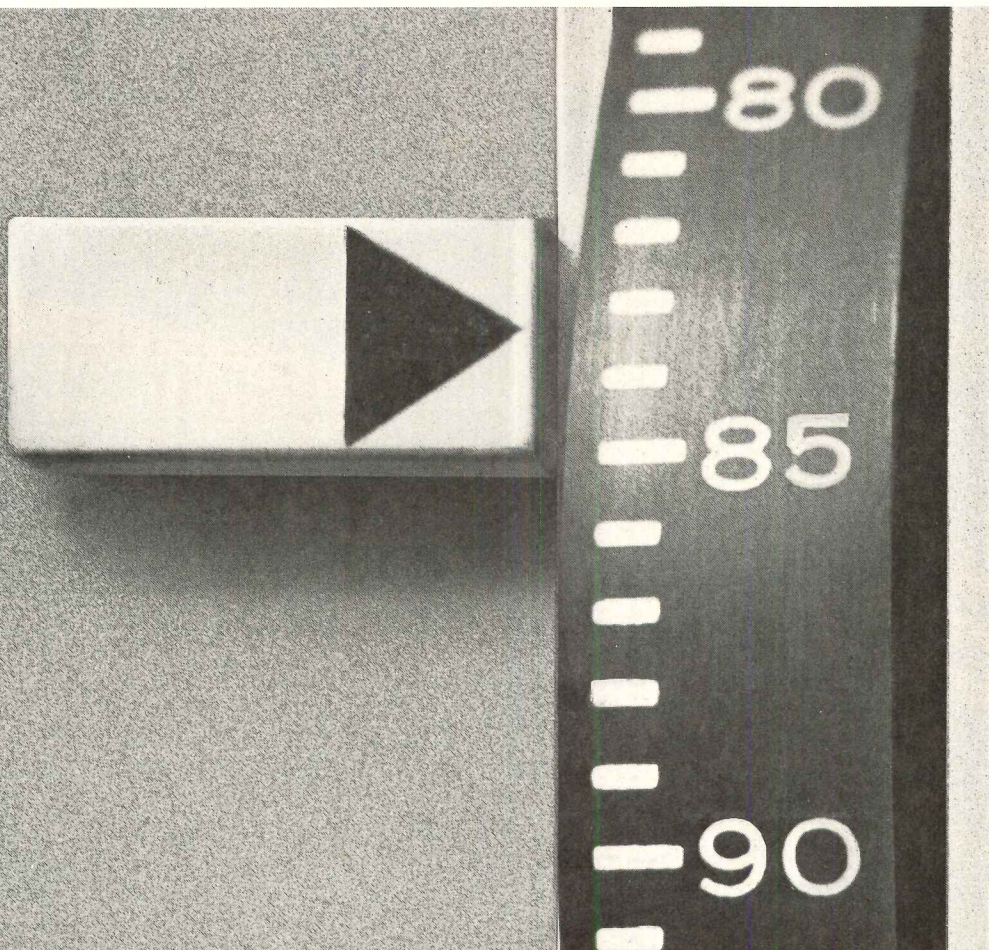

## from 1 to 100 quality copies.

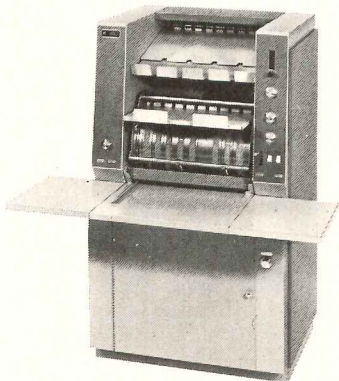

The GAF 480 will copy your masters automatically. It will deliver clean, accurate copies (from 1 to 100) that are sharp, clear images of the original. But that's only the beginning.

The GAF 480 Automatic Diazoprinter is flexible... makes copies from A, B, or C size originals quickly and accurately.

Because it uses rolls instead of cut sheets, the GAF 480 lets you reduce your inventory costs, makes ordering stock a snap, which results in less handling.

And if that's not enough, the GAF 480 is also designed to work with your existing microfilm system. Just take your reader/printer copies of aperture card material and reproduce them on the 480 Diazoprinter...very economically.

With a countdown dial for automatic reproduction of single originals, an electronic drive for smooth, accurate speed settings up to 60 FPM, and an automatic separation of copies from originals...the GAF 480 Automatic Diazoprinter is just what you need for the high quality work you demand.

Rediscover Diazo with the GAF 480 Automatic Diazoprinter. For more details, mail the coupon today.



**Rediscover Diazo...  
the new Diazo.**

© COPYRIGHT GAF CORPORATION

**GAF Corporation** 482-0725  
Office Systems Division, Dept. 666-074  
140 West 51st Street  
New York, New York 10020

Gentlemen: I'm for rediscovering Diazo!

- Please have a representative call me to arrange for a demonstration.
- Please send literature on the new GAF 480 Diazoprinter.

NAME \_\_\_\_\_

TITLE \_\_\_\_\_

COMPANY \_\_\_\_\_

ADDRESS \_\_\_\_\_

CITY \_\_\_\_\_

STATE \_\_\_\_\_ ZIP \_\_\_\_\_

PHONE (AREA CODE) \_\_\_\_\_

*For more data, circle 89 on inquiry card*



# EXPO '74 BY

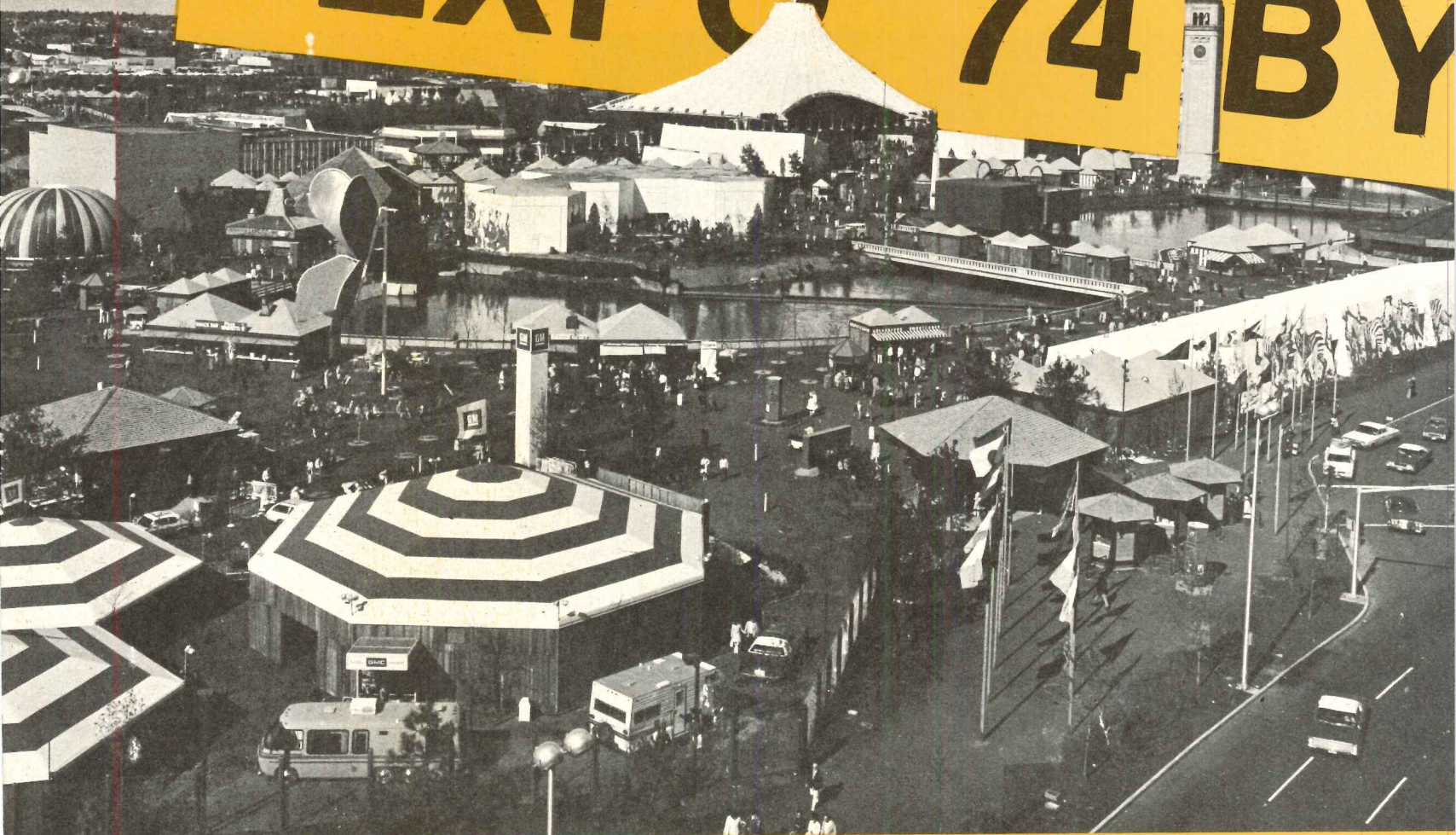

**N**o, we didn't build all of it but we did furnish the roof systems for more than half of the buildings at the World's Fair. This includes the 52,000 square foot USSR pavilion (the fair's largest) and all other foreign exhibits.

The original design called for a steel space frame but the cost proved prohibitive. Then TRUS JOIST came to the rescue, with a space frame made up of wood and steel H-Series and the all wood I-Series joists which spanned 50 feet, and cut costs by more than 50%. We also devised a method of assembling the entire system on the ground and lifting it into place which proved to be another big time and money saver.

The hexagon pods are so constructed that when Expo is over in November they can be disassembled and sold singly or in groups for erection elsewhere, another big economic plus.

Expo '74 is just one more example of TJ's versatility and economy. Whatever your need may be, TRUS JOIST can fill it with a quality roof or floor structural system. There's a TJ man near you who will supply a design manual, design assistance or a free and accurate cost estimate. Just drop us a card and we'll put you in touch.



# TRUS JOIST

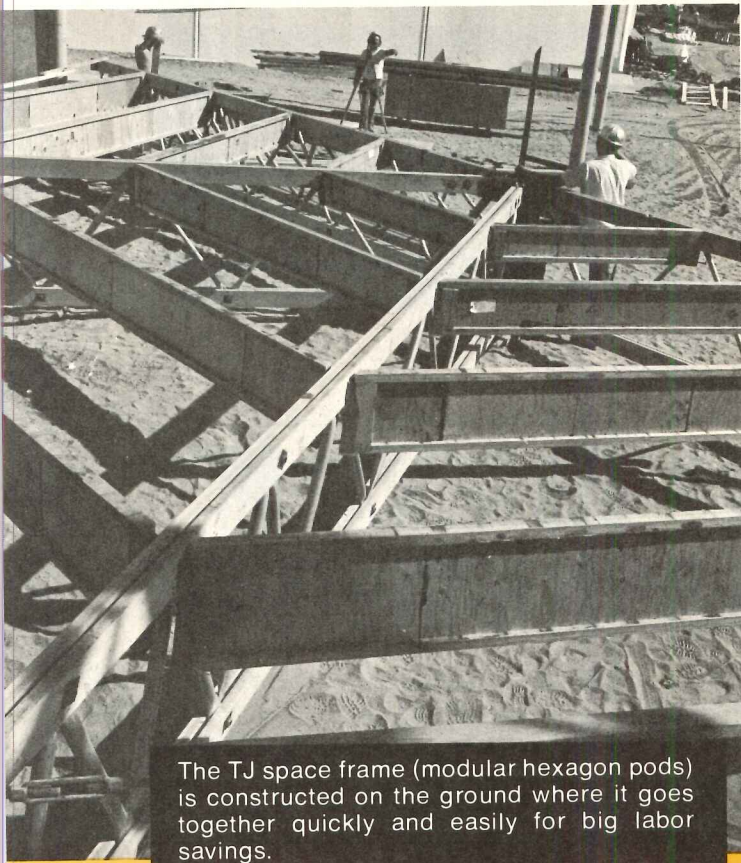

The TJ space frame (modular hexagon pods) is constructed on the ground where it goes together quickly and easily for big labor savings.

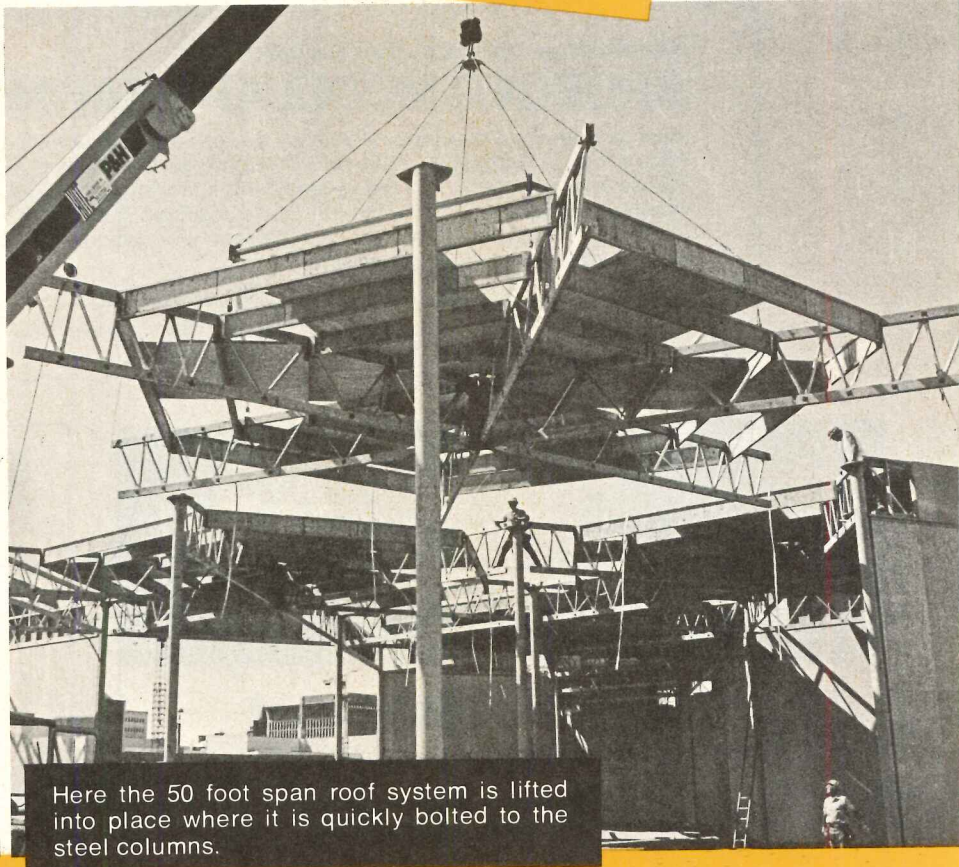

Here the 50 foot span roof system is lifted into place where it is quickly bolted to the steel columns.

**Trus Joist**

**Creative Engineering In Structural Wood.**

9777 Chinden Boulevard, Boise, Idaho 83702

In the foreground is the 52,000 square foot USSR building and behind it the West Germany and Philippines pavilions . . . each with exposed TJ's.

The completed Japanese pavilion which at the end of the fair will be disassembled and sold for erection elsewhere.

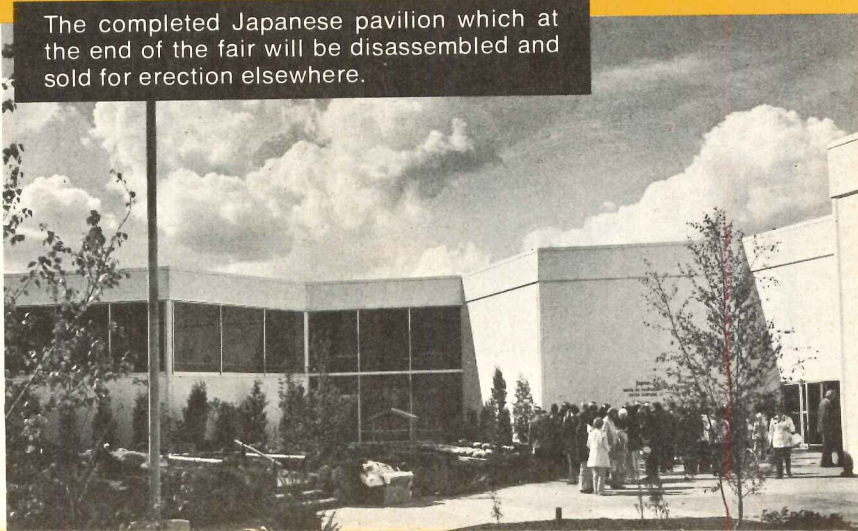
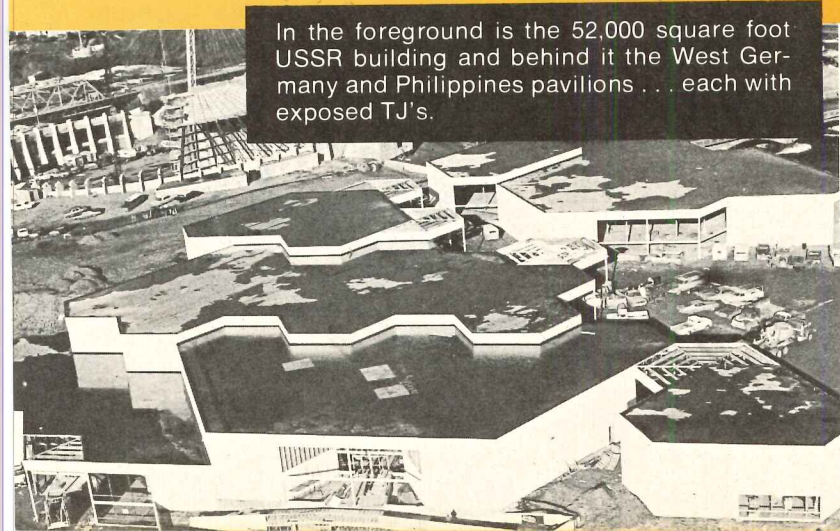



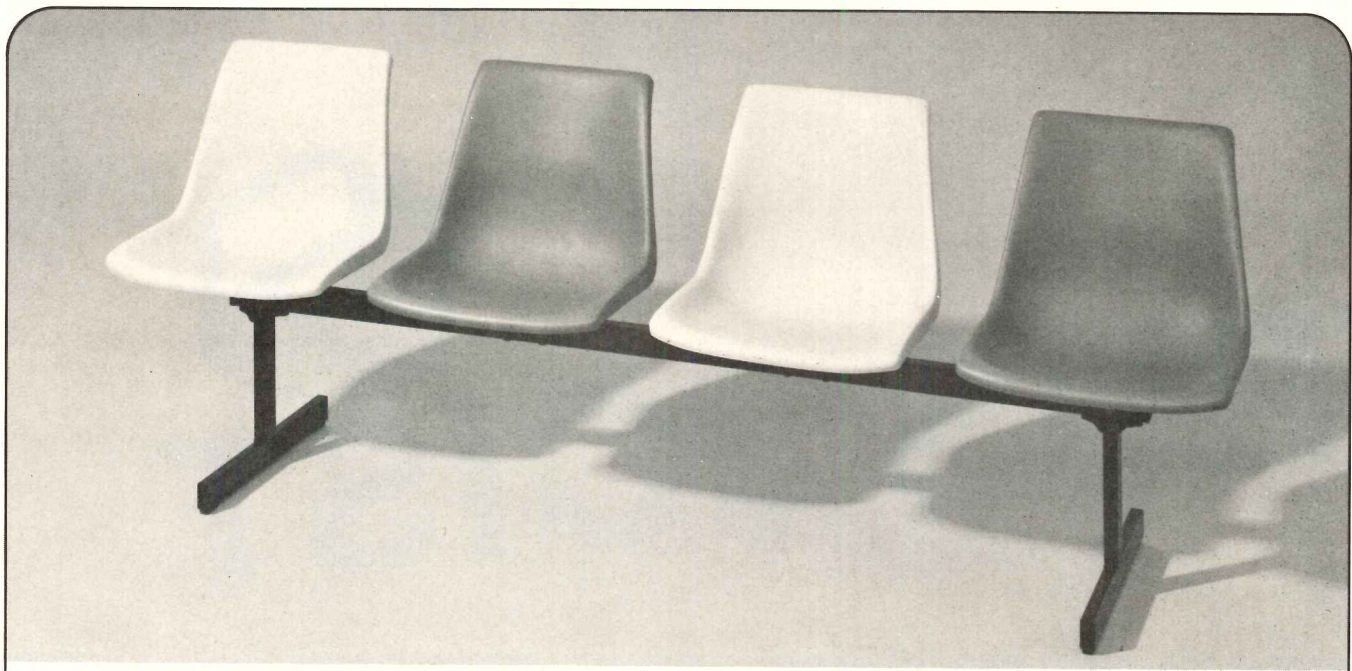

*More design potential than any other line...*

## KRUEGER MODULAR SEATING

Choose from 6 sturdy, comfortable shell designs, ranging from modestly priced polypropylene to luxuriously upholstered fiberglass. Select from 4 base styles. Add the versatility of interchangeable tables, ganging, corner units, infinite lengths, and a spectrum of colors. Now you know why Krueger Modular Seating has more design potential than any other line. Write for brochure.

# krueger

Green Bay, Wisconsin 54306 414/437-3245

New York (212/697-9565) • Boston (617/893-2752)  
 Philadelphia (215/666-9696) • Indianapolis (317/545-5246)  
 Chicago (312/467-5255) • Dallas (214/823-4183)  
 Houston (713/222-1408) • Denver (303/534-6060)  
 Los Angeles (213/272-0301)

For more data, circle 91 on inquiry card

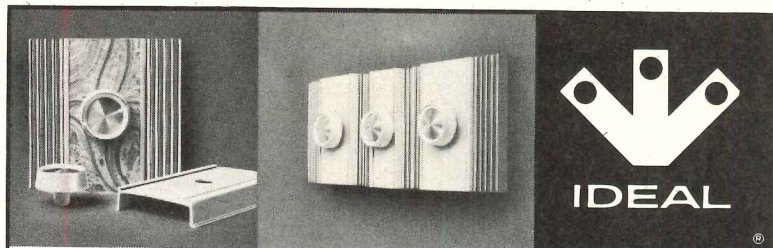

## Incandescent, Fluorescent Dimmer Switches from Ideal.

14 models of incandescent and fluorescent dimmer switches to handle virtually every requirement. Voltage compensated, solid-state circuitry. Complete, self-contained units. From economy units to attractive Decorator Styled designs. Send for your FREE dimmer switch reference file.

IDEAL INDUSTRIES, INC., 1328-G Becker Pl., Sycamore, Ill. 60178  
 In Canada: IDI Electric (Canada) Ltd., Ontario

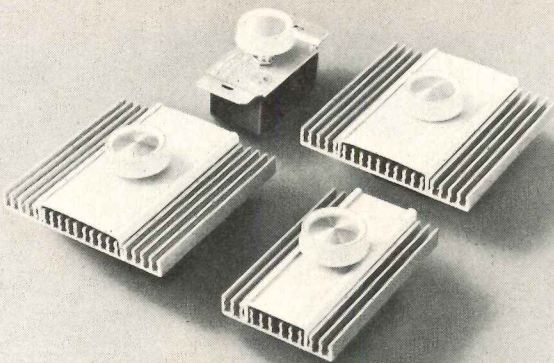

For more data, circle 92 on inquiry card

## New "Rite-On, Wipe-Off"\* Dustless Writing System

System combines AllianceWall porcelain wall panels and dry marker pens to create a COMPLETELY DUSTLESS writing system. Writing dries instantly and can be erased with a dry cloth or eraser. Porcelain panels come with a special finish that enhances both writing and erasing.



Every inch of every wall becomes a productive work surface. Laminated to low-cost gypsum board, the panels are fire-proof, inexpensive to install and maintenance free. No special lighting system is necessary. Boards guaranteed for 50 YEARS and can be used with any partition system.

For complete details write:

Other plants:  
 Okmulgee, Oklahoma;  
 Genk, Belgium and  
 Seden, Denmark.

# AllianceWall®

CORPORATION  
 Box 247, Alliance, Ohio 44601

\*Rite-On, Wipe-Off dry marker pens are now available through local AllianceWall distributors.

For more data, circle 93 on inquiry card



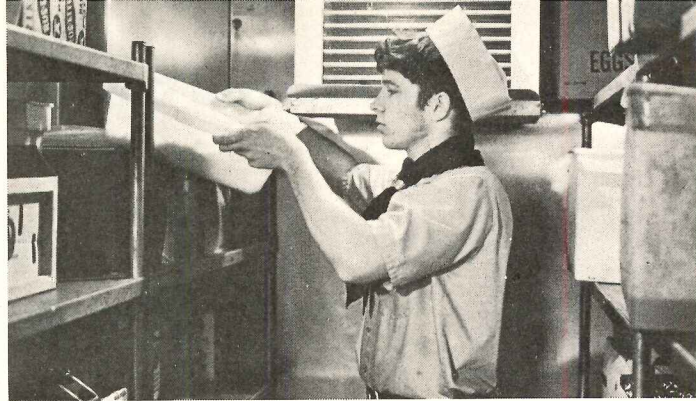

## If you've got 85 people coming for dinner, you can't afford to be waiting on refrigeration equipment.

Providing your customers with an appetizing entree, promptly, is a full-time job. And a complex one. One that requires a variety of food service equipment to help you get the job done and take advantage of the efficiencies that are built into today's food service systems. Equipment selection, however, is an equally complex job. Because there is so much available. And because the equipment you select has to satisfy you, and the people who work for you, and the people that you serve.

Every piece of Nor-Lake refrigerated food service equipment is designed to do a job, consistently and conveniently, day in and day out. Week after week. Month after month. Year after year. With doors that open easily and close tightly. Insulation and compressors that control in-use temperature variation. Designs that maximize storage and minimize cleaning. We make them that way because Nor-Lake equipment is used, day in and day out, by people who can't settle for anything less.

Please send me information on your  Refrigerators,  Freezers,  Walk-In Units,  Beverage Coolers,  full line.

I don't need information, I need answers.  Have someone call me.

Name

Title

Institution/Company Name

Address

City  State  Zip



**NOR-LAKE INC.**

Second and Elm, Dept. #3177  
Hudson, Wisconsin 54016  
Phone: 715-386-2323

For more data, circle 94 on inquiry card



Architectural Record presents...

**fifteen  
issues  
a year  
for  
architects  
& engineers** | **one  
each  
month...  
and three  
spotlight  
issues**

The editors of Architectural Record regularly throughout the year present a wide variety of editorial content specifically geared to the known interests of architects and engineers.

In addition, responding to the need of architects and engineers for in-depth presentations of significant trends and developments in major areas of interest, the editors of Architectural Record each year publish three Spotlight issues. Each is an expansion of a continuing feature in the regular issues of the Record.



**RECORD HOUSES  
AND APARTMENTS**

The annual mid-May issue devoted to the year's best architect-designed houses and apartments. Nearly 44,000 architect and engineer subscribers... plus distribution to 20,000 Sweet's-qualified builders and 4,000 Sweet's-qualified interior design offices.



**ENGINEERING  
FOR ARCHITECTURE**

To be published initially in mid-August 1974 and annually thereafter. A survey and analysis for architects and engineers of the most significant current developments in engineering for buildings. Bonus coverage of newly active building engineers.



**PRODUCT REPORTS**

The annual mid-October round-up of the most interesting new and improved building products. Organized by the Uniform Construction Index, this "product file on the drawing board" provides a quick up date of out-of-date catalogs and literature.

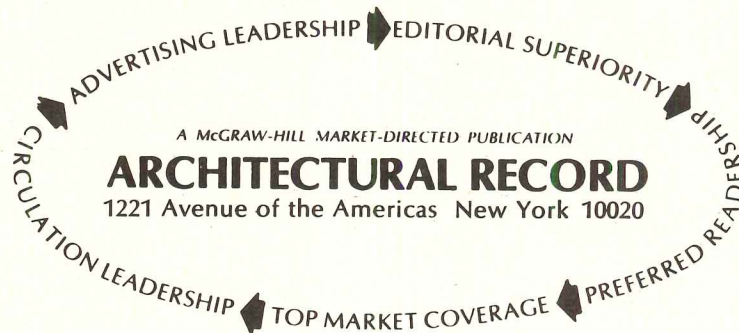



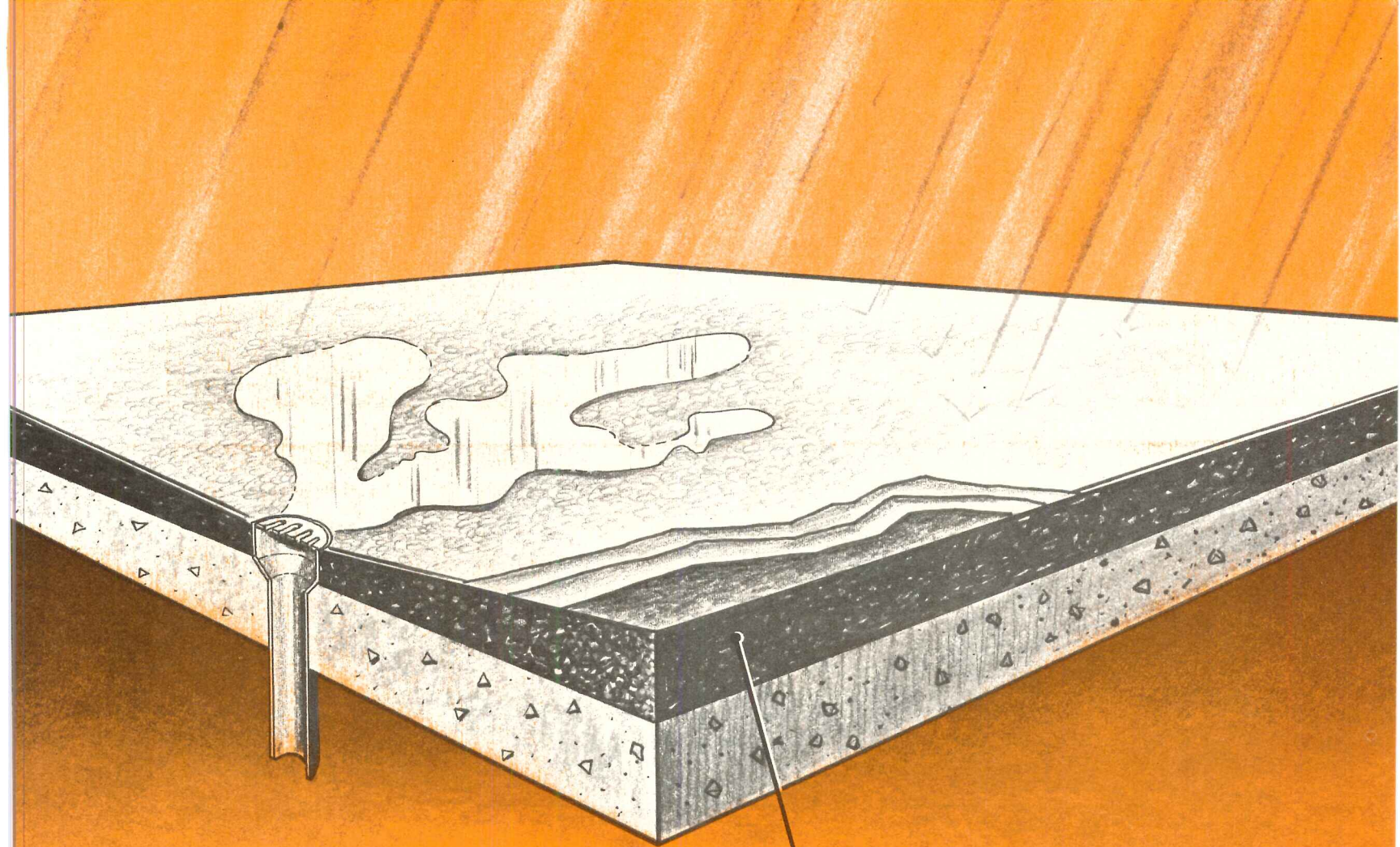

  
 **All-weather Crete**<sup>®</sup>  
**INSULATION**

## How to achieve slope to drains when you insulate the roof deck!

Few things deteriorate a roof and cause leaks faster than ponding water. That's why roofing experts, architects and engineers unanimously agree that roof decks should slope to drains. The efficient, economical way to accomplish this is with All-weather Crete Insulation! This unique material not only provides the finest insulating value ( $K=.40$ ) of any poured fill insulation, but it can be positively sloped to drains, all in the same operation. All-weather Crete is applied hot and dry (even in freezing temperatures) and compacted to form a smooth, seamless, sloped to drain deck which is ready for roofing immediately - no curing is necessary. It speeds construction!

No wonder All-weather Crete is also a top choice for plazas where slope to drains is critical. Compare the life/cycle costs of All-weather Crete with other methods. None can surpass it in the thousands of dollars saved through energy conservation and roof life longevity. Get the facts - contact your local All-weather Crete applicator or Silbrico Corporation, 6300 River Rd., Hodgkins, Ill. 60525, (312) 735-3322.

 **SILBRICO**  
**CORPORATION**

For more data, circle 95 on inquiry card



## More from Jamison!

(means more for you!)

These JAMIGLIDE™ COOLER doors were introduced last year to meet a specific market need

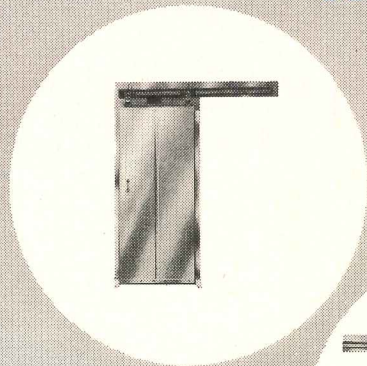

Manually Operated  
Single Leaf  
Cooler Door

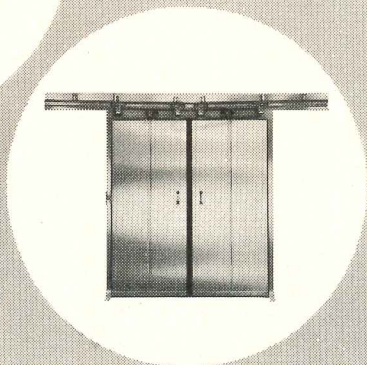

Manually Operated  
Bi-Parting  
Cooler Door

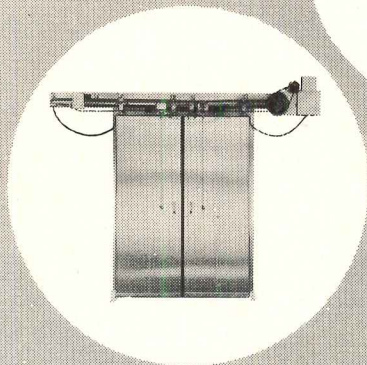

Power Operated  
Bi-Parting  
Cooler Door

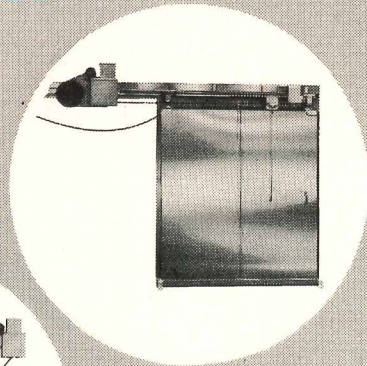

Power Operated  
Single Leaf  
Cooler Door

## Now...announcing new JAMIGLIDE FREEZER doors

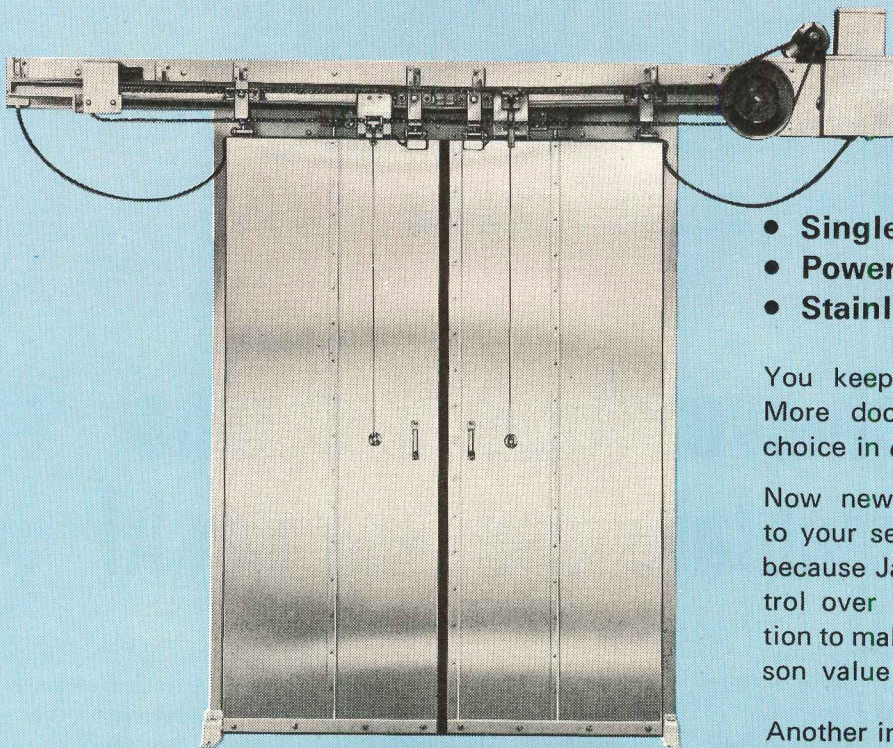

New JAMIGLIDE Power Freezer Doors featuring "Frostop"® heater cables with thermostatic control.

- Single and Bi-Parting
- Power and Manual Operation
- Stainless and Galvanized

You keep getting more from Jamison. More doors. More quality. More of a choice in every price range!

Now new Jamiglide freezer doors add to your selection. And to your economy, because Jamison exercises complete control over design, materials, and fabrication to make sure you get traditional Jamison value and trouble-free performance.

Another important benefit: More technical assistance—from more door specialists—than you get anywhere else.

Write or call for information on the new Jamiglide freezer doors designed and built by Jamison to fill your exacting requirements.

COLD STORAGE DOORS BY  
**JAMISON**

JAMISON DOOR CO • HAGERSTOWN, MD 21740

For more data, circle 96 on inquiry card





# STEEL JOISTS USED IN NEW LAS VEGAS HOTEL

Incomparable is the word for the \$120 million M.G.M. Grand Hotel. Consider the statistics. 2,100 rooms. A 26-story tower. 2½ million square feet of floor area, including 145,000 square feet for convention activities. A grand ballroom with 40,000 square feet of unobstructed area, and a capacity of more than 6,000 persons. A casino almost 1½ times the length of a football field. The M.G.M. Grand Hotel is a standout in a city where lavishness is a way of life.

It was inevitable that open web steel joists, with their economy and speed of erection, would find their way into this glittering hostelry. Over 900 tons of standard joists were used selectively for floor supports and for roof supports in various high-rise and low-rise areas. Architects were Martin Stern, Jr., A.I.A., Architect & Associates, Beverly Hills, Calif., with Joel D. Bergman, A.I.A., as project architect. Structural engineers were Dan Cashdan & Associates Ltd., of Las Vegas. Structural steel contractor was The Herrick Corp., Hayward, Calif. Economy and erection speed are just two of the many advantages of open web steel joists for buildings of virtually every type. Get the complete facts in our latest

*For more data, circle 97 on inquiry card*



edition of Specifications and Load Tables for Open Web Steel Joists, Longspan Joists and Deep Longspan Joists.



## STEEL JOIST INSTITUTE

2001 Jefferson Davis Highway  
Arlington, Virginia 22202

### STEEL JOIST INSTITUTE

74010

7th Floor, 2001 Jefferson Davis Hwy.  
Arlington, Va. 22202

Please send me your new copy of Specifications and Load Tables.

NAME \_\_\_\_\_  
 TITLE \_\_\_\_\_  
 FIRM \_\_\_\_\_  
 ADDRESS \_\_\_\_\_  
 CITY \_\_\_\_\_ STATE \_\_\_\_\_ ZIP \_\_\_\_\_



# INTRODUCING NEW



## STRUCTURAL GLAZED MASONRY UNITS

after 6 years research a major technical breakthrough

## A REVOLUTIONARY SATIN-GLOSS GLAZED FINISH FOR CONCRETE BLOCK

NOW easy to clean and keep clean. Quick-and-easy  
cleandown for the masons. Soap-and-water maintenance  
from then on.

**FOOL-PROOF** color constancy in a finish that resists  
marking.

**TOUGHER** facing. Less job-site breakage.

**HELPS** meet your energy crisis problems with excellent  
insulating advantages . . . And it's **AVAILABLE!**

**EXTRAORDINARY** design flexibility. **LOCAL** suppliers.  
**PLUS** all the economic advantages of traditional block.

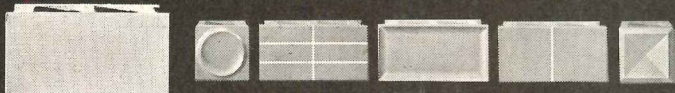

© U.S. Patent Office, Canada and other countries by THE BURNS & RUSSELL CO.  
Box 6063, Baltimore, Md. 21231. 301/837-0720. Cataloged 4.4/Bu. in SWEET'S

For more data, circle 99 on inquiry card

**A seven-year wear guarantee on its heavy-duty Densylon spongebonded carpet has been instituted by CCC. If the carpet is properly installed and maintained and the surface pile in any given area wears more than 10% within seven years, such area will be replaced by CCC with carpet of comparable quality and color. Densylon's built-in sponge rubber cushion is guaranteed without time limit against deterioration and loss of resiliency. Write for more information.**

COMMERCIAL  
CARPET  
CORPORATION  
10 WEST 33rd STREET  
NEW YORK, N.Y. 10001  
(212) 695-2323

For more data, circle 100 on inquiry card

# Seven reasons why your investments deserve Pyrotector photoelectric smoke detectors.

1. They provide earlier detection of incipient (smoldering) fire than ionization detectors. We'll prove this by demonstration.
2. They detect smoke of required density regardless of distance smoke particles have travelled.
3. They have none of the safety problems possible with radioactive devices.
4. They are not "threshold" alarm devices and thus have no threshold-related false alarm or desensitization problems.
5. They are nearly maintenance-free in normal environments.
6. They can be installed in or adjacent to air ducts or entries.
7. They carry all required listings and approvals.

Send the coupon to us at 333 Lincoln St., Hingham, Mass. 02043. We'll send you our brochure with even more reasons why you should protect your investments with Pyrotector photoelectric smoke detectors.

Name, Title \_\_\_\_\_

Firm \_\_\_\_\_

Address \_\_\_\_\_

City, State, Zip \_\_\_\_\_

## PYROTECTOR

The photoelectric way.

For more data, circle 98 on inquiry card



# THE BEST WAY TO PREPARE FOR THE 1974 ARCHITECTURAL REGISTRATION EXAM

**"THE CLOSEST YOU  
CAN COME TO  
ACTUALLY TAKING  
THE EXAM"**

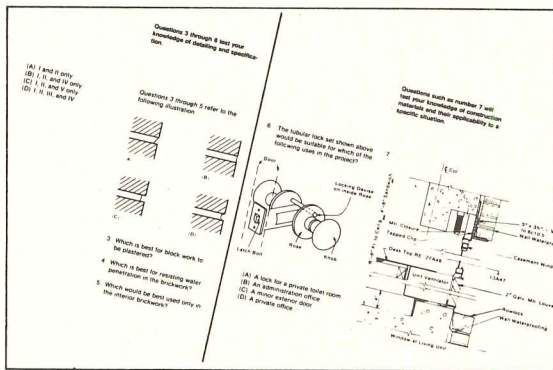
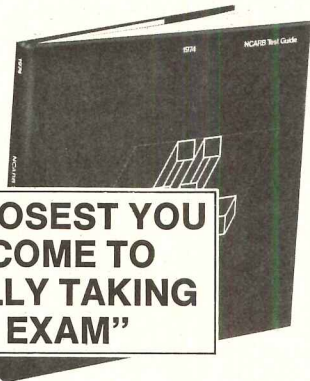

Here—within the pages of a single book—you'll find the information and help you need to prepare for the December, 1974 Architectural Registration Exam. This 186-page Test Guide is the only one sponsored and recognized by the NCARB, the organization that prepares the examination.

New—and expanded—this edition draws its material directly from the December 1973 exam. The questions are the same ones confronted by the candidates who actually took the exam—all the test information for all four parts is reproduced in the Guide.

## EXCLUSIVELY THIS TEST GUIDE FEATURES:

- INSTRUCTIONS AND QUALIFICATIONS for applying for the new professional Examination as well as the equivalency examination.
- The 1973 EXAM—with questions and answers from the actual examination which tested candidates knowledge and judgment in environmental analysis, architectural programming, design and technology, and construction administration.
- RESULTS OF THE 1973 EXAM—how the candidates did nationally, by region and state . . . what the candidates thought of the exam . . . what they thought of their education/training.
- WHAT THE NEW EXAM WILL BE LIKE—with answers to such questions as: How is the new examination structured? . . . graded? . . . scored? . . . Is guessing a good idea? . . . Is there a predetermined pass/fail point? . . . What scores will be reported and to whom? . . . Will credit be given for passing individual parts?
- A GLOSSARY OF TERMS AND IDEAS with which candidates must be familiar with to deal effectively with each problem area.
- A BIBLIOGRAPHY OF RECOMMENDED READING AND REFERENCES encompassing the periodicals and books of special relevance to candidates for the Professional Examination.
- INDISPENSABLE INFORMATION FOR ALL CANDIDATES, describing the philosophy of the new Professional Exam, the new exam and the law, and how the NCARB intends to help the professional after registration.
- REQUIRED READING FOR ALL PRACTITIONERS by shedding light on the whole institution of registration and licensing as a professional prerequisite. Architects already in practice, both here and abroad, can benefit professionally from having their own copy.

## RECOMMENDED BY LAST YEAR'S CANDIDATES

Candidates who bought the first edition in preparation for the 1973 exam readily endorsed the Test Guide as a practical and useful tool in their studies. The expanded 1974 edition is of the *utmost* importance to anyone taking the Professional Exam and will be of professional interest to all educators and practitioners.

The first edition of the Test Guide was completely sold out and paper and printing commitments will also limit the second edition. To ensure that you'll receive your own copy, send your order and payment to:

**ARCHITECTURAL RECORD BOOK • BOX 682 • HIGHTSTOWN, N.J. 08520**

**ORDER  
NOW!  
USE THIS  
HANDY  
COUPON**

**ARCHITECTURAL RECORD BOOK • BOX 682 • HIGHTSTOWN, N.J. 08520**

Please send \_\_\_\_\_ copies of the Architectural Registration Handbook

Name \_\_\_\_\_

Address \_\_\_\_\_ City \_\_\_\_\_

State \_\_\_\_\_ Zip \_\_\_\_\_

Full payment of \$21.00 per copy (plus 50¢ postage) must accompany your order



# SUREWALL<sup>®</sup>, the Surface Bonding Cement Specified for economy and beauty. Build with strength...

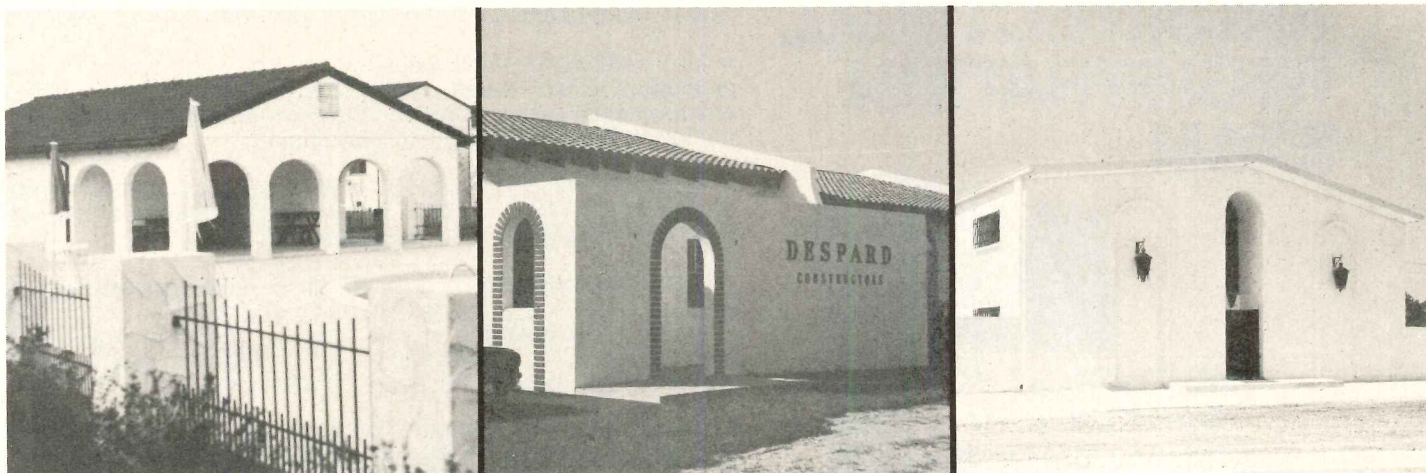

## in Virginia.

**CA** Construction Associates of Tidewater, Ltd. (Newport News), general contractor, and McPhatter & Son, plastering contractor, chose SUREWALL as a water resistant stucco finish coat for the large Cordoba Apartment complex in Hampton.

Results: SUREWALL is superior to regular stucco in resistance to cracking. No further waterproofing agents required. Job time cut by elimination of usual brown coat on block areas. Cost factor, good! They'll use SUREWALL again. Soon.

You can specify SUREWALL with confidence because SUREWALL has major code approvals: Southern Building Code Congress, South Florida Building Code, North Carolina Building Code, BOCA 72-72.

## in Florida.

Despard Constructors (Winter Haven) approved SUREWALL's performance on other jobs. So they chose it for their own new office building — inside and out.

Dave Despard says: SUREWALL is even easier to work with than anticipated. What he likes most is that he has more control over the job. His own people do it all. He also appreciates the many different, attractive SUREWALL finishes. Despard Constructors continue to use SUREWALL. Now, on townhouses. SUREWALL is versatile. And, SUREWALL is pure white. Looks good. Even without paint. (For color, use one coat — not two — of regular masonry paint.)

## in Texas.

Mike Butler Construction Co. (San Antonio), plastering and masonry contractor, used SUREWALL for the Olmos Equipment Co. plant. Only 46 construction days to complete the 5,000 sq. ft. building — despite three ice and two snow storms. SUREWALL was used to bond the concrete blocks. And inside the office areas on dry wall. Butler, and Olmos, like SUREWALL's performance. Homes, apartments, offices, farm and industrial buildings, theatres, bank vaults, sea walls. All built with SUREWALL. Independent tests prove the superiority of SUREWALL concrete block bonding. Complete data is available.

*SUREWALL<sup>®</sup> is a registered trademark of W. R. Bonsal Company, Lilesville, N. C. and Best Concrete Products Company, College Park, Georgia.*

See Sweet's 4.9/BO

## BONSAL COMPANY

P.O. Box 38, Lilesville, N. C. 28091 Phone: 704/848-4141

Other Plants: 4083 Bonsal Rd., Conley, Ga. 30027, 404/361-0900 — 1775 N.E. 205th Terrace, Miami, Fl. 33162, 305/651-4500 — 1200 N.W. 18th St., Pompano Beach, Fl. 33060, 5455 N. 59th St., Tampa, Fl. 33610, 813/621-2427 — Box 395, Flomaton Al. 36441, 205/296-4252. SUREWALL<sup>®</sup> is also available from Barrett Industries, Inc., 6889 Evans Rd., East, San Antonio, Tx. 78218 and INCA Co., Stanton & Empire Sts., Wilkes Barre, Pa. 18702.

For more data, circle 102 on inquiry card



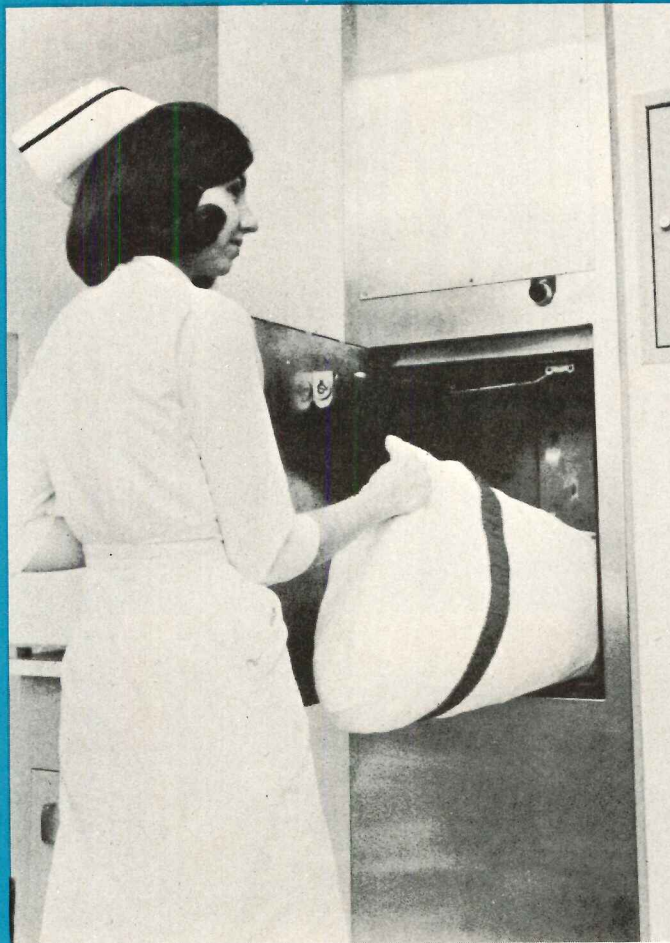

## Trash and linen collection can be a simple operation.

Problems of trash and linen collection plague most hospitals. There's the problem of contamination. Of wasted space. Of wasted time and money spent in collection and disposal.

The ECI Air-Flyte® pneumatic system of trash and linen collection solves those problems, in new or existing facilities. By eliminating manual handling of materials from source to destination, it cuts payroll costs. At the same time it helps safeguard against infection from contaminated materials, while its compactness and efficiency helps conserve floor space.

The heart of the Air-Flyte pneumatic system is a high speed air stream which speeds trash and linen from

source to destination in mile-a-minute time. And in any direction-up, down and sideways and around corners.

Best of all, a single Air-Flyte system can accommodate both waste and linens, discharging them at appropriate terminals in the incinerator room, laundry room, compactor, or loading dock.

For new facilities, the Air-Flyte system offers considerable design

and layout freedom and excellent spatial efficiency. In existing facilities, an Air-Flyte system can be designed to tie in with conventional waste and linen chutes. In either case, your Air-Flyte system will be engineered specifically for the needs of your hospital.

For safety, economy, efficiency and simplicity, there's simply no better way to collect trash and linen than the Air-Flyte way. Ask your ECI representative for the whole story today.

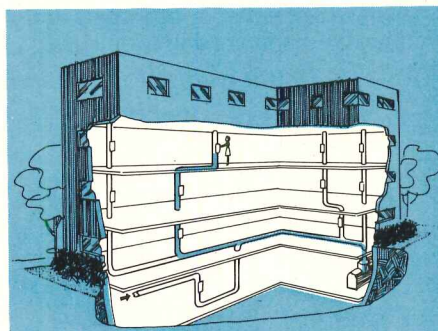

**ECI Air-Flyte Corp.**

Subsidiary of Eastern Cyclone Industries, Inc.  
 15 Daniel Road • Fairfield, N. J. 07006  
 Regional Sales Office:  
 BOSTON • CHICAGO • LOS ANGELES  
 ATLANTA • DALLAS  
 Affiliations in Europe, Africa, Australia  
 and Asia

"AIR-FLYTE" is a registered trademark

For more data, circle 103 on inquiry card



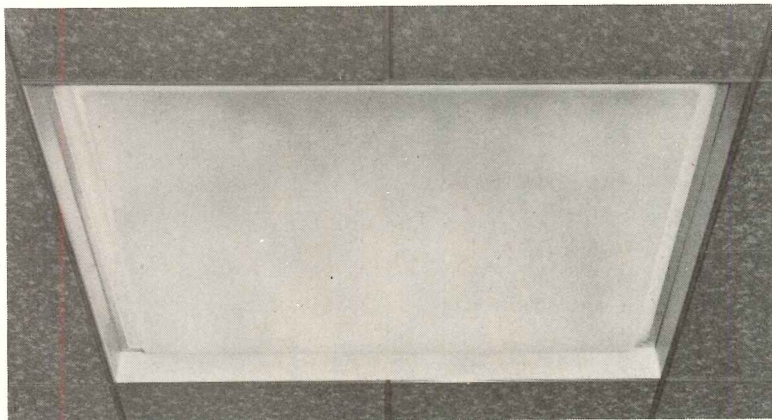

## GUTH LIGHTING'S NEW REGRESSED EXTRUDED ALUMINUM SPLAY FOR THE MODULAR FAMILY LINE

Sharp and clean, with an attractive "skylight" effect, Guth's new extruded aluminum splay fits the recessed fluorescent, incandescent, and H.I.D. members of the "Modular Family" line. Regressed a full two inches and available on static and air-moving types, the new design offers a fresh-looking alternative to dull ceilings.

Get the literature, and read all about it. It's another in a series of new ideas from . . .

(314) 533-3200

**GUTH LIGHTING**



2615 WASHINGTON • ST. LOUIS, MO. 63103

For more data, circle 106 on inquiry card

TOUGH . . . RESILIENT . . . LONG LASTING

## TENNIS COURT COLOR FINISH

**44 Years Weather and Wear  
Proven On All Concrete Surfaces**

Wherever you find recreational, industrial, public utility or commercial concrete construction, you'll likely find Kemiko Col-r-tone.

Col-r-tone's unique chemical composition defies sun, wear, moisture or alkalis for years and years. Won't chip, crack or peel. Non-skid, glare-free in beautiful flat and matte finish. Easily and quickly applied by brush or roller it seeps right in. 8 basic colors that may be intermixed to provide over 50 contemporary colors.

Write today for free illustrated brochure and color chips.

**KEMIKO INC.**

DEPT. AR-74

2443 N. Naomi St.

Burbank, Calif. 91504



For more data, circle 107 on inquiry card

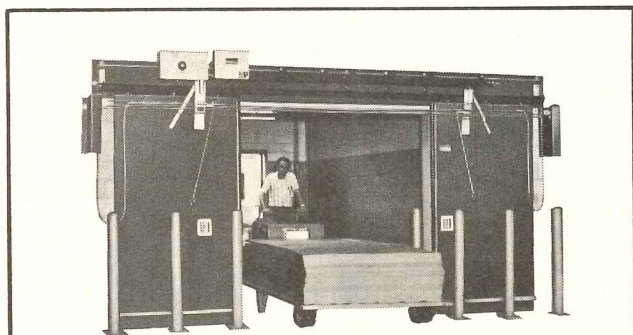

## At last — a fast acting double-slide industrial door that's also a UL-listed, Class A fire door.

Our new Fire Chief™ is the first double horizontal slide Class A, 3-hour endurance rated, UL and FM labeled door that's fast enough for the busiest doorway.

The Fire Chief's complete pre-assembled, pre-wired package installs easily and inexpensively. Provides equal or greater protection than much heavier conventional doors through years of dependable, maintenance-free service.

Before you invest in a fire door and an industrial door, see the one that does both jobs. Available in double or single slide. Write for free literature or find us in the Yellow Pages.

69 Myrtle Street, Cranford, N.J. 07016  
(201) 272-5100 Telex 13-8268



For more data, circle 108 on inquiry card

## The hinge that hides

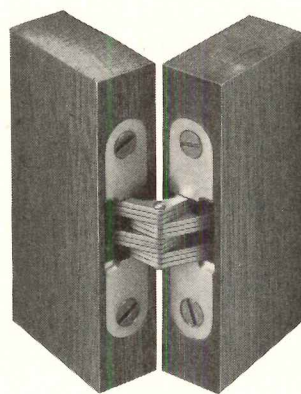

**NOW YOU SEE IT**

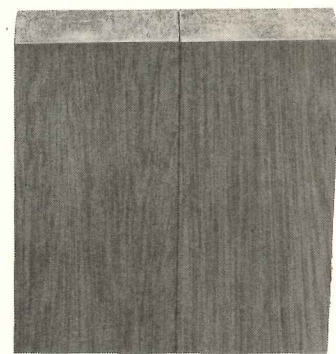

**NOW YOU DON'T**

The Soss Invisibles—for a custom look for any room! These amazing hinges hide when closed, eliminating unsightly gaps, hinges, and door jambs. They're the perfect hidden touch for doors, doorwalls, storage cabinets, built-in bars, stereos, and TV's. Specify the Soss Invisibles wherever looks matter. See listing in Sweet's or write for catalog: Soss Manufacturing Co., Division of SOS Consolidated, Inc., P.O. Box 8200, Detroit, Mich. 48213.



For more data, circle 109 on inquiry card



Georgia-Pacific makes things happen!

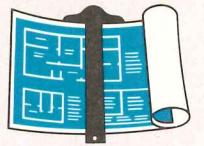

# Georgia-Pacific Eternawall:<sup>TM</sup> \* Resists fire. Looks great. Made to last!

**Eternawall:<sup>TM</sup>**  
The only vinyl-surfaced  
gypsumboard with a  
UL Class A Flame  
Spread Rating of 25.\*\*

And that's just the beginning!

Specify Eternawall<sup>TM</sup> over G-P Sound Deadening Board, and you'll get a UL Class A flame spread rating of 25, plus a one-hour fire rating and, with insulation, an STC of 50!

You'll get a wall that lasts, too. Eternawall<sup>TM</sup> resists most bumps, scratches and stains. And with 30 styles to choose from, you can use it almost anywhere!

Write for our free Eternawall<sup>TM</sup> color swatch brochure. And check your Sweet's catalog. Or give your G-P man a call.

Then, make beautiful things happen. With Eternawall!

\*Vinyl-surfaced gypsumboard.

\*\*This flame spread rating available only with Eternawall's 15 standard colors.

**Georgia-Pacific**



The Growth Company

For more data, circle 110 on inquiry card.



# CONDITION WITH



Plexiglas acrylic plastic is a combustible thermoplastic. Observe fire precautions appropriate for comparable forms of wood. For building uses, check code approvals. Impact resistance a factor of thickness. Avoid exposure to heat or aromatic solvents. Clean with soap and water. Avoid abrasives.



today,  
more than ever...  
it makes such  
beautiful  
sense.

# PLEXIGLAS®

Flat or formed. Clear or color.  
Strong. Light weight. Beautiful.  
Plexiglas brand acrylic plastic.  
Making sense, solving problems  
... any way you look at it.  
In banks where it provides  
transparency, security and  
crystal-clear beauty. In school  
skylights and windows where  
it resists breakage, controls  
glare and conserves energy.  
In homes where its formability  
makes small worlds larger.

Find out more about Plexiglas  
by writing for our brochures and  
engineering data. For on-the-  
spot answers to specific  
questions write or call our  
Architectural Coordinator (215)  
592-6799. See our catalog in  
Sweet's—8.26/Roh

*Building codes limit areas of plastic  
glazing. Approvals for large-area Plexiglas  
enclosures must be applied for on a special  
permit basis. Fire safety design  
considerations must take into account  
the combustibility of Plexiglas.*

Martin Luther King Elementary School  
Pittsburgh, Pa. (above)  
Architects: Liff, Justh and Chetlin  
Pittsburgh

Suffolk Franklin Savings Bank  
Boston, Mass. (left)  
Architects: Bastille-Neiley  
Boston

Beach Cottage, Harvey Cedars, N.J. (right)  
Architects: Murphy Levy Wurman  
Philadelphia, Pa.

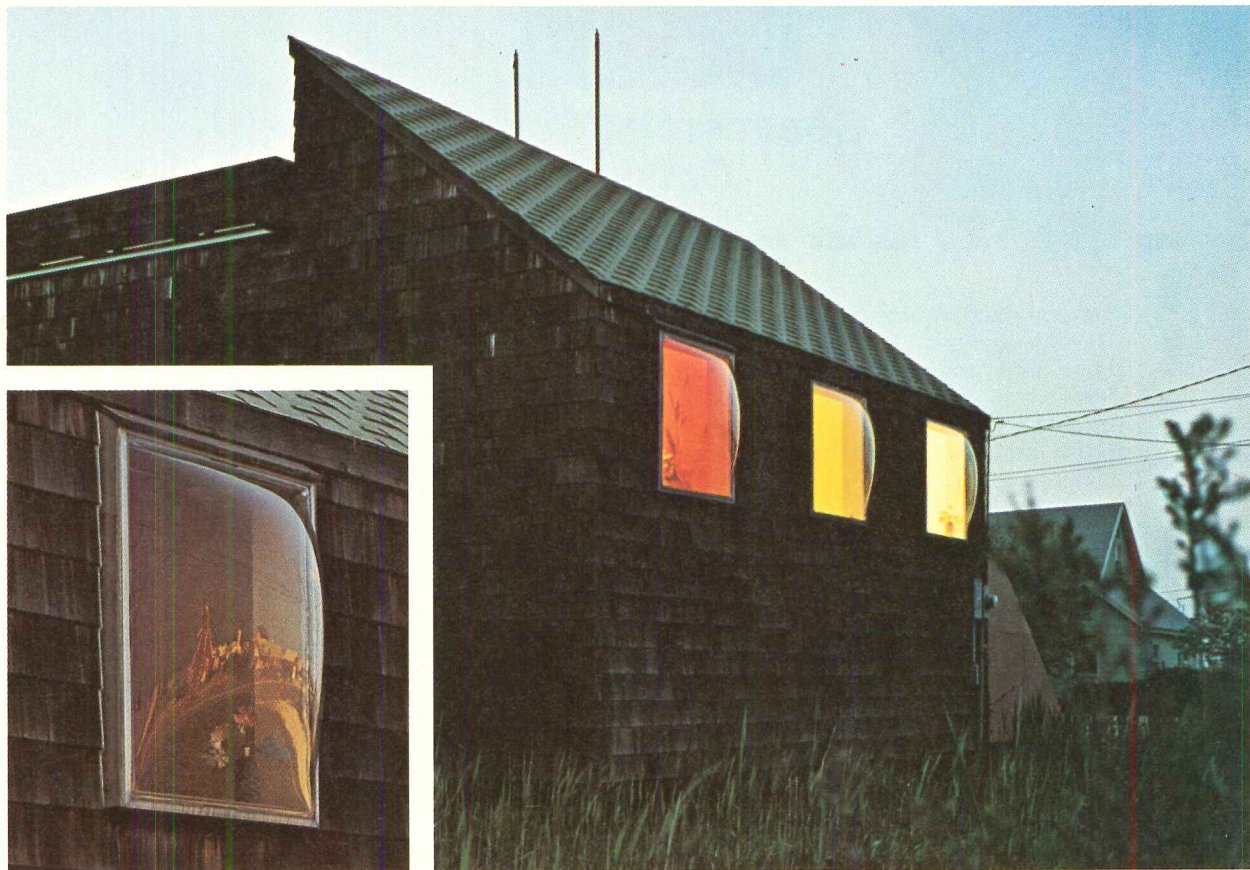

the trademark

PLEXIGLAS

the company

ROHM  
PHILADELPHIA, PA. 19105

For more data, circle 111 on inquiry card



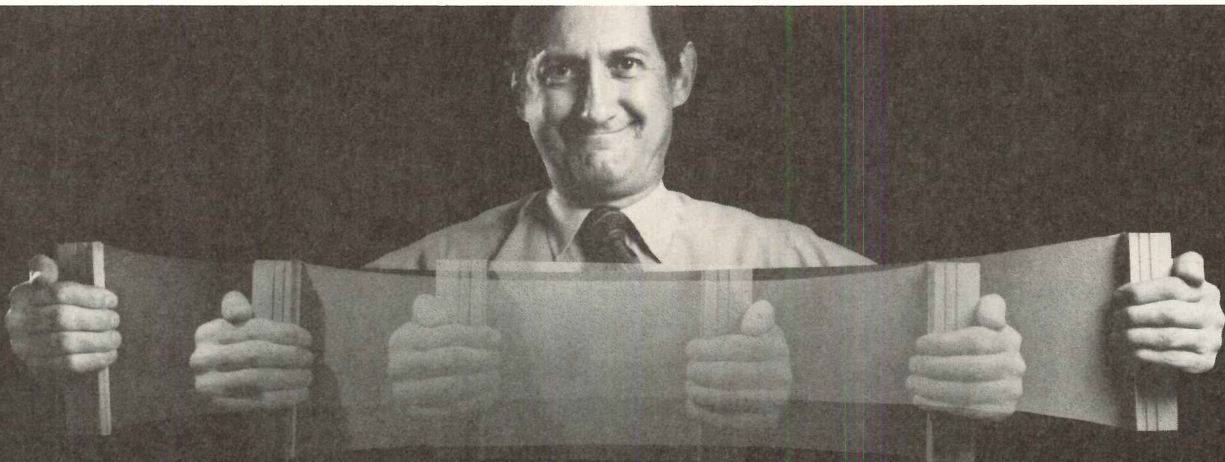

## Your building won't move this much but we're not taking any chances.

That's because Elastalum expansion joint seals can expand to 9 times their original size without loss of seal. Problems usually associated with vertical shear, lateral shear and compression are eliminated because of 360° omni movement.

Elastalum's monolithic seal is waterproof,

dustproof, economical and easy to install. No vinyl gaskets, screws, bolts to assemble. Cuts installation time by 50%. It's shipped to your specified lengths, completely assembled.

Available in three permanent colors. Test for yourself. Write for free sample (and literature).



### CONSTRUCTION SPECIALTIES, INC.

P.O. Box 380, Muncy, Pa. 17756/(717) 546-5941  
725 Twin Oaks Valley Rd., San Marcos, Ca. 92069

40

For more data, circle 113 on inquiry card



Please send me the

# wellco

## Commercial Carpet Catalog

The complete Wellco line of commercial carpets, over 30 running lines. Exceptional quality in every price range from ground floor to executive suite. Options offered include most commercial fibers, custom colors, weights, construction and backings. Plus tech data on traffic ratings, FHA requirements, fiber characteristics, backings and more. Exacting specification guide. Address to: Don Thompson, Advertising Manager, Dept. R7



Because we're committed to commercial quality and nothing else

## wellcocarpetcorporation

WELLCO CARPET CORPORATION □ P. O. BOX 281 □ CALHOUN, GEORGIA 30701 □ TELEPHONE: 404/629-9276  
A WHOLLY OWNED SUBSIDIARY OF MANNINGTON MILLS, INC., SALEM, N. J.

name \_\_\_\_\_

firm \_\_\_\_\_ title \_\_\_\_\_

address \_\_\_\_\_

city \_\_\_\_\_ state \_\_\_\_\_ zip \_\_\_\_\_

For more data, circle 112 on inquiry card

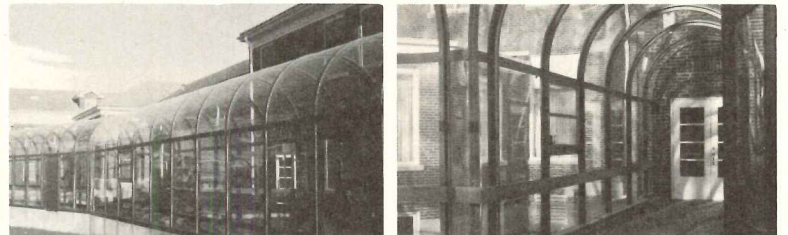

Enclosed passageway—  
Installation: Westminister Village, Indianapolis, Indiana  
Architect: Woolen Associates  
Materials: Aluminum and Acrylic

Write for Complete details and specifications.

o. o. McKINLEY co., inc. Box 55265, Indianapolis, In 46205

SPECIALISTS IN METAL FABRICATION • METAL FINISHING • PLASTICS FORMING

For more data, circle 114 on inquiry card



For more data, circle 115 on inquiry card



# This new circuit breaker offers greater protection for people

Square D introduces an entirely new concept in circuit breakers. It is the first practical and economical device that significantly reduces the hazards of line-to-ground faults to both people and equipment.

The new Qwik-Gard® circuit breaker combines branch circuit overload and short circuit protection with ground fault protection in one compact unit that occupies the same space as a standard QO® circuit breaker. In addition to the QO protection for overloads and short circuits, ground faults are detected and interrupted by sensing an imbalance between line and neutral current in the individual

branch circuit. A current imbalance as low as .005 amperes (5 milliamperes) will cause the Qwik-Gard to trip.

This amazing new unit is available in 15, 20, 25 and 30 ampere ratings for 2 wire, 120V ac circuits with or without an equipment ground. Qwik-Gard circuit breakers fit into existing or new QO load centers, or NQO panelboards. Bolt-on units are available for NQOB panelboards. Since branch circuits are protected individually, a problem on one circuit will not interrupt the power to other circuits.

Qwik-Gard circuit breakers are designed to protect circuits, people and equipment in homes, offices,

factories and swimming pool areas and on construction sites. They are UL listed and meet the requirements of the 1971 National Electrical Code. Qwik-Gard breakers also have the exclusive Visi-Trip® indicator you find on Qwik-Open® breakers. It's a highly reflective red flag that springs into view through a window when the breaker trips. For further information, contact your nearby Square D field office or write Square D Company, Dept. SA, Lexington, Kentucky 40505.

 **SQUARE D COMPANY**  
*Wherever Electricity is Distributed and Controlled*

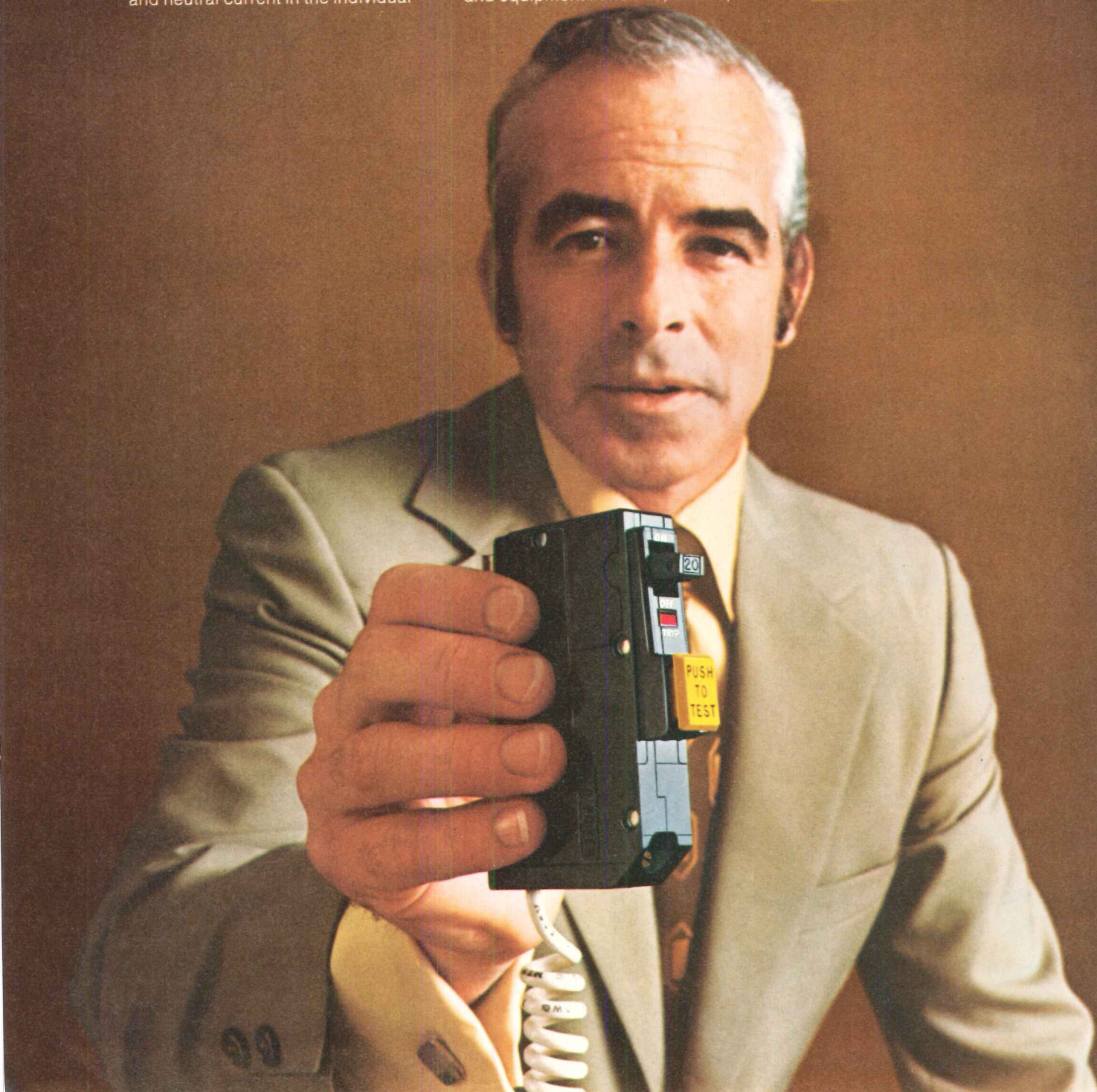





## BUILT-IN TO BLEND IN

All units built to 24" kitchen counter depth to fit flush with cabinets • Front & side panels to match your decor • Use wood, plastic, leather or other materials • 24", 30", 36", 48" wide models • Largest capacity home units manufactured • All refrigerator or all freezer or combination models • Freezer on bottom or side • Built-in ice makers • Individually tested for total performance

SEND 25¢ FOR BUILT-IN REFRIGERATION IDEAS TO  
SUB-ZERO FREEZER CO., BOX 4130, MADISON, WISCONSIN 53711

*Functional disguises in home refrigeration*

**SUB-ZERO**

For more data, circle 116 on inquiry card

## All you need to know about wood.

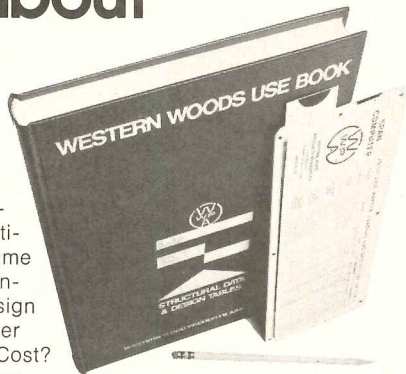

The WESTERN WOODS USE BOOK is the ultimate reference book for designing wood structures. Beautifully-bound 8½" x 11" volume has over 300 pages containing structural data and design tables for softwood lumber species graded by WWP. Cost? Only \$10.00. Send the coupon for your copy of this indispensable book. (Span Computer Included)

### Gentlemen:

Send me the WESTERN WOODS USE BOOK. I am enclosing \$10.00 (check or money order only, please).

Name \_\_\_\_\_

Title \_\_\_\_\_ Firm \_\_\_\_\_

Address \_\_\_\_\_

City \_\_\_\_\_ State \_\_\_\_\_ Zip \_\_\_\_\_



**Western Wood Products Association**

Dept. AR-774, Yeon Building, Portland, Oregon 97204

For more data, circle 117 on inquiry card

## Spotlight on Engineering for Architecture

Architectural Record is planning a timely expansion of its editorial services to engineers, architects and the manufacturers who market to them.



### ENGINEERING FOR ARCHITECTURE

A Spotlight issue devoted to a highly professional presentation and analysis of the most significant developments in engineering for building—featuring:

- the engineer resources: the right way to use the right people to get the right expertise at the right time.
- the technical resources: an overview of the current state of building technology, with a particular look at the most important developments.

Scheduled for publication in mid-August 1974 and annually thereafter.

*A McGraw-Hill Market-Directed Publication*

**ARCHITECTURAL RECORD**

1221 Avenue of the Americas, New York 10020



# LOW ENERGY



## Parabolume! Ahead of it's time in conserving energy while lighting with style & grace

The challenge of a controlled environment—you confront it directly with every building on your drawing board. One question: How do you provide the best lighting levels, increase visual comfort, assure even air distribution and truly conserve energy? The answer? It's PARABOLUME, pioneer energy-saving fluorescent luminaires for over a decade. Light is put on the task where you want it—not in your eyes. Maintains lighting levels at fewer watts per square foot and has VCP values that average 90%. And it keeps on working for life of the building, efficiently, economically; looks great with no maintenance. All standard sizes, static or air. Contact your Columbia Agent for the facts, or write us: then specify PARABOLUME. We have answers to low-energy lighting questions you've yet to ask.



**COLUMBIA**  
lighting, inc.

North 3808 Sullivan Rd. Terminal Annex Box 2787 Spokane, Washington 99220 Phone (509) 924-7000

For more data, circle 5 on inquiry card

A Subsidiary of **GTE SYLVANIA**



# Tectum: decorative, insulating,

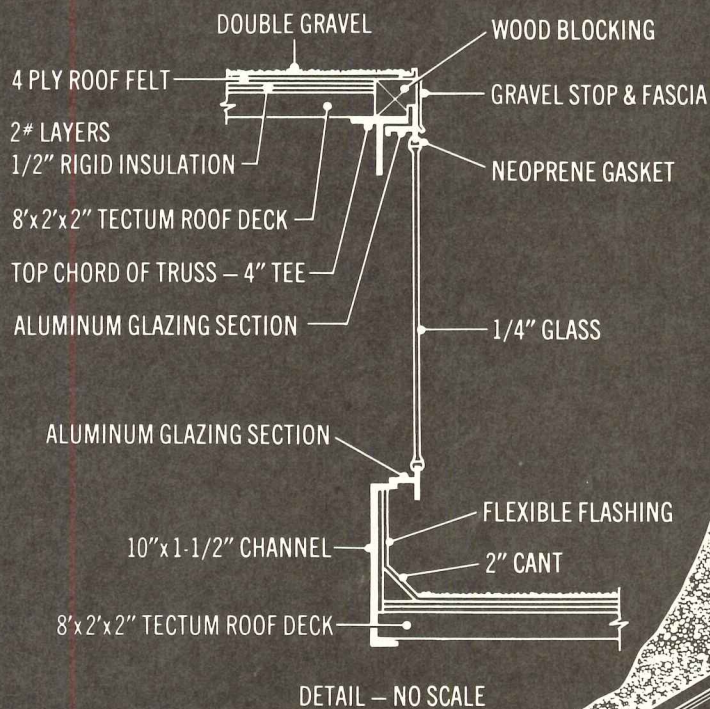

At Gund Hall, Harvard's Graduate School of Design, Tectum was used as a structural roof deck and exposed ceiling in this unique and distinctive canopy of glass and steel. Toronto architect John Andrews specified 2" thick Tectum to span the translucent roof truss enclosures and develop a thin profile for the stepped roof section. The detail shows how this section was constructed. In the open central studio space under the canopy, Tectum's sound absorption is an important factor. Its NRC is in the .50-.60 range.

SEE DETAIL ABOVE

8'x2'x2" TECTUM PLANKS

10"x1-1/2" CHANNEL

#218 BULB TEES 24" O.C.



# structural, acoustical.

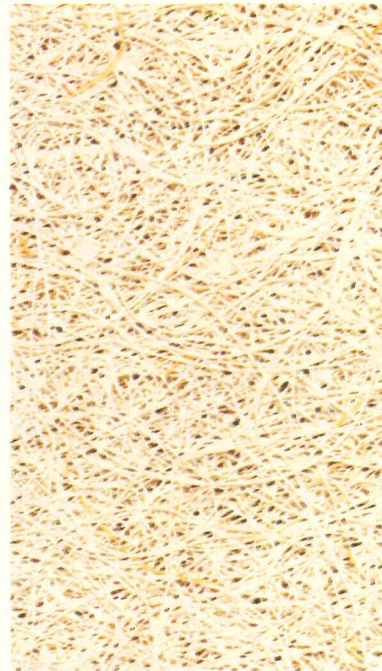

Gund Hall Graduate School of Design, Harvard University, Cambridge, Mass.  
Architects: John Andrews, Edward R. Baldwin and John Simpson, Toronto.  
Structural Engineers: Le Messurier Associates, Boston.  
Tectum Contractor: Bay State Structural Specialties, Boston.

Texture is the thing about Tectum, but not the only thing.

There's no end to the ways you can be constructive with Tectum® Roof Deck. Look at the way it was used in Gund Hall, shown at left. As a structural material, Tectum gives the roof a thin, efficient section, and demonstrates impressive insulating values as well. In the two-inch thickness, resistance to heat transmission is 3.50. With its Noise Reduction Coefficient in the .50-.60 range, it soaks up sound. And with its rugged finish, Tectum looks good exposed.

The reason Tectum is so constructive is because of the way it's put together. An exclusive inorganic binder bonds long wood fibers into a compact sheet under heat and pressure. Like wood, it's easy to cut, shape and install. Tectum has been given an uplift rating of Class 90.

## Long Span Tectum Roof Deck

Tectum is also available in Long Span® Tectum. This adaptation allows even

greater areas of the exposed Tectum surface to remain unbroken by purlins. Tongue and groove edge of Long Span Tectum is designed for galvanized 16-gauge steel channels. These channels permit spans of up to 6' for 3", 5' for 2½", and 4' for 2" thick Long Span Tectum.

Like other Tectum Roof Deck, Long Span Tectum has factory-applied asphalt felt membrane, and is applicable to flat or pitched roofs with steel, wood or concrete framing.

So for a good-looking way to cut roofing costs, why not cut down on the number of materials you use? With Tectum, or Long Span Tectum.

Tectum is one of the reasons that we're gypsum and then some.

For more information, write Gold Bond Building Products, Division of National Gypsum Company, Dept. AR-74 T, Buffalo, New York 14225.

## We're gypsum, and then some.

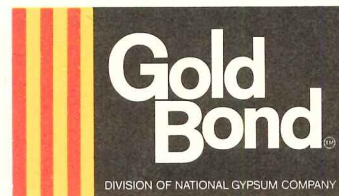

For more data, circle 118 on inquiry card



---

# AN INTELLIGENCE TO RISING EN

---



Owners: Detroit & Northern Savings & Loan Assoc.; Architect: Maurice B. Allen, Jr., A.I.A., Tarapata-MacMahon-Paulsen Corp., Bloomfield Hills, Michigan



# NT RESPONSE ERGY COSTS.

## INSULATION YOU CAN SEE THROUGH, FROM LOF.

Even the most beautifully designed residence can still be economical and practical. For example, this residential guesthouse in Florida, is insulated against solar heat gain by reflective monolithic Vari-Tran® glass. As a result, Vari-Tran also reduces air-conditioning operating expenses.

LOF makes high-performance glass with insulative properties that can mean year-round occupant comfort and an intelligent solution to rising heating and cooling costs.

### COMMERCIAL OR RESIDENTIAL

For Detroit & Northern Savings & Loan in Hancock, Michigan, where temperatures range from 92 above to 30 below zero, another response was indicated.

Thermopane® insulating units were specified to help prevent heat loss in winter. In summer, Vari-Tran/Thermopane insulates against solar heat gain.

Computer studies show that compared to ordinary tinted glass \$47,000 was saved in initial construction costs for heating and cooling alone. Our more expensive glass also saved enough in heating and cooling operating expenses to more than offset the difference in glass cost in the first year of operation.

Intelligent? Definitely—in terms of energy savings and cost-benefit ratios. A total energy concept of design should, of course, take into account all construction materials. But you can see the potential for insulation you can see through.

One of our highly qualified architectural representatives will be happy to help you save energy dollars with the right glass. Call (419) 242-5781. Libbey-Owens-Ford Company, 811 Madison Avenue, Toledo, Ohio 43695.

*For more data, circle 119 on inquiry card*

# LOF

Guesthouse, Dr. Louis Atkins, Northern Florida



# ADVERTISING INDEX

Prefiled catalogs of the manufacturers listed below are available in the 1974 Sweet's Catalog File as follows.

- A Architectural File (green)
- I Industrial Construction File (blue)
- L Light Construction File (yellow)
- D Interior Design File (black)

**A**

A-L Alcan Aluminum Corp.	22
A AllianceWall Corporation	176
D Allied Chemical Corp., Fibers Div.	156-157
A-I-L Aluminum Co. of America	50, 170A to 170D, 187
A American Sterilizer Co.	54-55
A-I American Telephone & Telegraph Co.	142-143
A-L Andersen Corp.	60-61
Architectural Record	178, 194
Architectural Record B.I.D.S. Seminar	150
Architectural Record Books	32-2, 183
Architectural Record Brazilian Seminar	64E
Armor Elevator Co. Inc.	152
A-I-L-D Armstrong Cork Co.	20-21
A-I-L ASG Industries Inc.	72

**B**

A Bally Case & Cooler, Inc.	148
Bell Helicopter Co.	141
A-I Bell Telephone System	142-143
A-I-L W.R. Bonsal Company	184
A-I Bradley Corporation	140
Bruning Division, Addressograph Multigraph Corp.	6-7
A-I Burns & Russell Co.	182

**C**

Carpet Cushion Council	81
A-I-L Carrier Air Conditioning Co.	64B, 160
A-I Ceco Corp.	66
A-I Celotex Corp.	44, 76-77
A-I Clark Door Co., Inc.	188
Columbia Lighting Inc.	195
A Combustion Engineering—C-E Glass Division	2nd cover-1
Commercial Carpet Corporation	182
Conco Mortgage Co.	149
Concrete Reinforcing Steel Institute	155
A-I Construction Specialties	192
Cornell Corporation	171

**D**

Delta Air Lines	64A
A-L Delta Faucet Company	154
A-I Dempster Brothers, Inc.	42
A Detroit Diesel Allison Div.—General Motors	78-79
A Dover Corp., Elevator Div.	2-3
D Dow Badische Co.	144
A DuPont De Nemours & Co., Inc.	52-53

**E**

Eastman Kodak Co.	64C
A-I ECI Air Flyte Corp.—Sub. of Eastern Cyclone	185
Eljer Plumbingware Div., Wallace-Murray Corp.	8
A-I Elkay Mfg. Company	23

**F**

A Follansbee Steel Corp.	64F
Forms & Surfaces	19
A-I H.B. Fuller Co.	62

**G**

GAF Corp.—Diazo Equipment	173
A General Electric Co.—Textolite	137
A-I-L General Electric Co.—Zonline	58-59
General Portland Inc., Trinity White	75
A-I Georgia-Pacific Corporation	189
A Granco Steel Products Co.	46
A-L Grefco Inc., Building Products Division	171
Guth Lighting—Div. Sola Basic Industries	188

**H**

Hager Hinge Company	170
A Haws Drinking Faucet Company	147
A Holophane, A Johns-Manville Division	48

**I**

Ideal Industries Inc.	176
A-I Inland-Ryerson Construction Products Co.	24-25
A Interform	151
International Masonry Institute	169

**J**

A Jamison Door Co.	180
A Jewett Refrigeration Co., Inc.	171
J.G. Furniture Company, Inc.	145
A-I-L-D Johns-Manville Corp.—Architectural Division	68, 164-165
Jute Carpet Backing Council, Inc.	640

**K**

Kawneer Co.	5
A-I Kelley Co., Inc.	26
Kemiko Inc.	188
A Krueger	176

**L**

A-I-L Libbey-Owens-Ford Co.	198-199
-----------------------------	---------

**M**

A-I-L Masonite Corp.	168
A Matthews & Co., J.H.	74
O.O. McKinley Co., Inc.	192
A-I McQuay Group, McQuay—Perflex, Inc.	186
Medusa Corp.	15

Metal Lath/Steel Framing Assoc.	142
Monarch Carpet Dynamics	27 to 29
A Monsanto Company, Textiles Div.	80, 166-167

**N**

A-I-L-D National Gypsum Co.	196-197
A-L-D Nord Co., E.A.	49
A Nor-Lake, Inc.	177

**O**

A Osmose Wood Preserving Co.	146
A-I-L-D Owens-Corning Fiberglas Corp.	51, 56-57, 63

**P**

A Parker Co., Charles	151
A-L Pella Rolscreen Co.	16-17
A-I Pittsburgh Corning Corp.	153
Ponderosa Pine Woodwork	30-31
A-L-D Potlatch Corp.	12
A-I PPG Industries.—Coatings & Resins	82-83
A-L PPG Industries, Inc.—Commercial Glass	161 to 163
Precast Systems Inc.	171
Price Pfister Div.	3rd cover
Pyrotector Inc.	182

**R**

A-I Raynor Mfg. Co.	138
A-L Red Cedar Shingle & Handsplit Shake Bureau	86
Rite-Hite Corporation	38
A Rixon-Firemark, Inc.	36
A-L Rohm & Haas Co.	190-191

**S**

A-I Silbrico Corp.	179
A-I Simpson Timber Co.	70
Sloan Valve Company	4th cover
A Soss Mfg. Co.	188
Southern California Gas Company	32-1
Square D Company	193
Steel Joist Institute	181
L Sub-Zero Freezer Co. Inc.	194

**T**

A-I Thiokol Chemical Corp.	47
A Tile Council of America Inc.	9
Tony Team Inc.	171
A-I Tremco Mfg. Co.	84-85
Trinity White, General Portland, Inc.	75
Trus Joist Corp.	174-175

**U**

A-I-L-D U.S. Plywood Corp.	18
A-I United States Steel Corp.	32

**V**

Vinyl Plastics Inc.	171
---------------------	-----

**W**

Wellco Carpet	192
A-L Western Wood Products Assn.	194
Westinghouse Electric—Corporate	158-159
A-I Westinghouse Electric Corp.—Water Coolers	172
A-I-L Weyerhaeuser Company	64-64A
A Whittlewood Corp., A Div. of Customwood Mfg. Co.	201



## ARCHITECTURAL RECORD

McGraw-Hill, Inc., 1221 Avenue of the Americas, New York  
New York 10020

Advertising Sales Mgr.: Louis F. Kutscher (212) 997-2838

Eastern Sales Mgr.: Robert G. Kliesch (215) 568-6161

Western Sales Mgr.: James A. Anderson (312) 751-3770

Advertising Services Mgr.: Joseph R. Wunk (212) 997-2793

Marketing Services Mgr.: Elizabeth Hayman (212) 997-2858

Research Mgr.: Camille Padula (212) 997-2814

Classified Advertising: (212) 997-2557

### District Offices:

#### Atlanta 30309

Edward G. Graves, 100 Colony Square, 1175 Peachtree St., N.E.  
(404) 892-2868

#### Boston 02116

Robert L. Tagen, 607 Boylston St., (617) 262-1160

#### Chicago 60611

James A. Anderson, Robert T. Franden, Edward R. Novak,  
645 N. Michigan Ave. (312) 751-3770

#### Cleveland 44113

Willis W. Ingersoll, 55 Public Square, (216) 781-7000

#### Denver 80202

Harry B. Doyle, 1700 Broadway (303) 266-3863

#### Detroit 48202

1400 Fisher Bldg., (313) 873-7410

#### Los Angeles 90010

Richard R. Butera, 3200 Wilshire Blvd.-South Tower (213) 487-1160

#### New York 10020

Blair McClenachan (212) 997-3584

#### Philadelphia 19102

Robert G. Kliesch, George T. Broskey, Three Parkway  
(215) 568-6161

#### Pittsburgh 15222

Edward C. Weil, III, 4 Gateway Center, (412) 391-1314

#### St. Louis 63011

Richard Grater, Manchester Rd., (314) 227-1600

#### San Francisco 94111

Richard R. Butera, 425 Battery Street (415) 362-4600

### Overseas Offices:

#### Brussels

Galerie Porte de Namur, 22-26, Chaussée de Wavre  
1050 Brussels, Belgium

#### Frankfurt/Main

Elsa-Brandstroen Str. 2, Frankfurt/Main, Germany

#### London

34 Dover Street, London W.1, England

#### Milan

Via Baracchini No. 1, Milan, Italy

#### Paris

17, rue Georges Bizet, 75 Paris 16e, France

#### Tokyo

2-5, 3-chome, Kasumigaseki, Chiyoda-ku, Tokyo, Japan

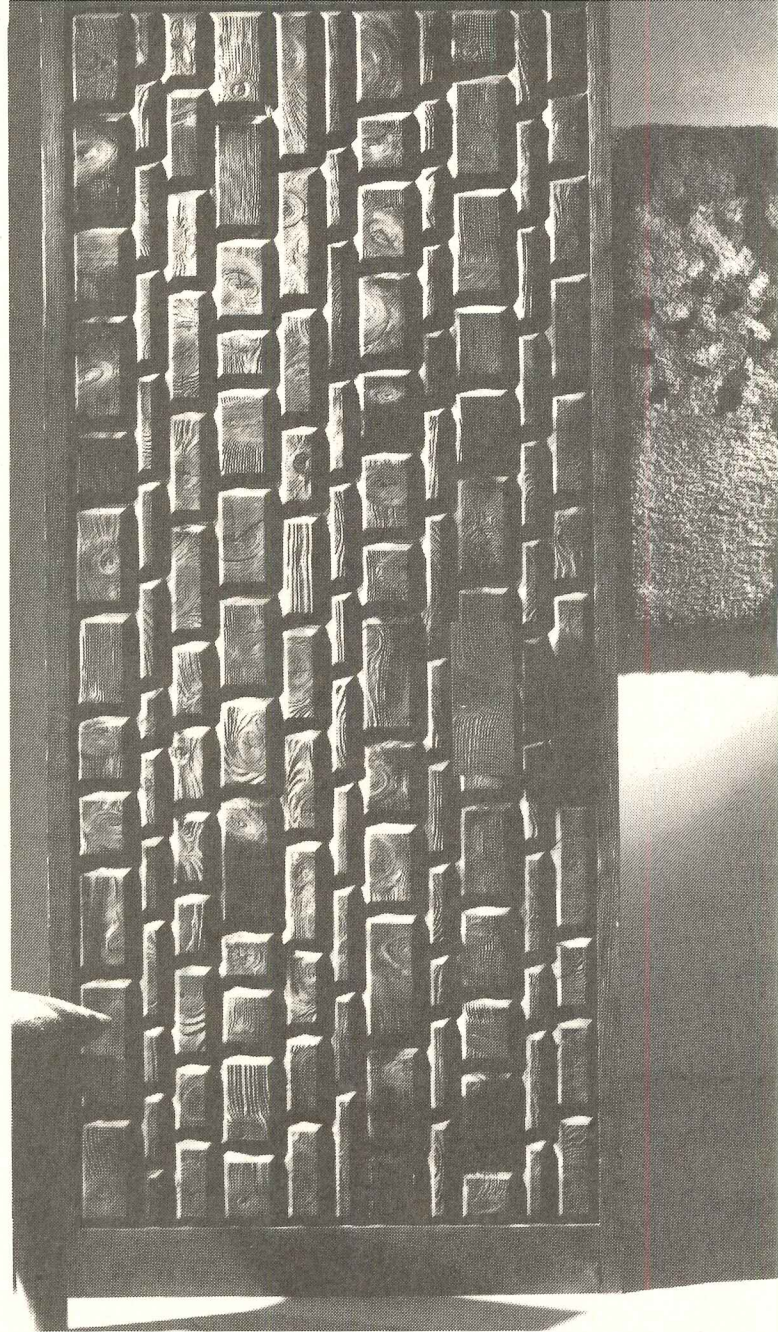

# THE END OF THE DRAB DOOR

**WHITTLEWOOD  
CORPORATION**

A COLORFUL COLLECTION  
OF 29 DOORS TO ADD  
INTEREST TO AND ENRICH  
THE ENTRYWAY.

WRITE TO:

WHITTLEWOOD CORP.  
BOX 26208  
ALBUQUERQUE,  
NEW MEXICO 87125

For more data, circle 120 on inquiry card



# CLASSIFIED SECTION

## POSITIONS VACANT

### SALES AND DESIGN ENGINEER

The nation's largest dealer of food service equipment and supplies has a position for a creative, imaginative, and ambitious Sales and Design Engineer. This individual will work directly with our clients in developing better functional food production layouts, systems, and procedures. Educational experience should include a degree in Architecture, Architectural Engineering, Mechanical Engineering, and/or equivalent job-related experience. Salary is open for negotiation and is directly dependent upon experience and ambition.

Send resume to:

**EDWARD DON & COMPANY**  
2500 So. Harlem Ave. No. Riverside, IL 60546

### ASSISTANT PROFESSOR

Architectural Engineering Technology. Duties: Teach college architectural courses, counsel students, coordinate academic matters with department heads, and update and further develop all courses taught. Qualifications: Master's degree and professional registration in architecture or engineering. Contact:

**Mr. Edmund Turiello**  
**WENTWORTH**  
550 Huntington Avenue  
Boston, Massachusetts 02115  
*An equal opportunity and M/F employer*

**Architects—for positions in working drawings, project management and design.** Many challenging projects in an office with highly qualified personnel in architecture and engineering. Location excellent in community of 300,000. Send resume or call Greg Slaybaugh, Daverman Associates, Architects and Engineers, 200 Monroe N.W., Grand Rapids, Michigan 49502 (616) 451-3525.

**Architecture Faculty—Rapidly developing architectural program seeks qualified professional to teach fundamentals of design and architectural graphics.** Professional degree necessary; teaching experience desired. Full time position in 2-year college starting Sept. 1. Rank and salary depend on qualifications. Send resume to Chairman, Mechanical Tech Dept., S.I. Community College, Staten Island, N.Y. 10301. No phone calls. An Equal Opportunity Employer.

**Landscape Architect/Urban Designer:** Small and expanding landscape architectural firm seeks graduate, minimum 3 years experience with design qualifications to direct broad range of projects. Must be willing to work independently in loose but dynamic situation. Send resume and samples of work to Edwin Sanborn, 620 N. Carroll St., Madison, Wisconsin 53703.

### EMPLOYMENT SERVICE

**Edwards and Shepard Agency:** An architectural and interior placement service for professionals seeking knowledge, guidance, confidentiality and informed representation. Bill Shepard, a Pratt graduate, offers effective results to: Architects, Planners, Production Specialists and Industrial Designers. Interviews by appointment—(212) 725-1280, 1170 Broadway, New York, N.Y. 10001.

**Career Builders, Inc., Agency—Complete range of Architectural and Interior Design placement under the direction of Ruth Hirsch, Apprentices to Senior Designers and Project Architects, Professional screening and personalized service, References checked. 501 Madison Av., New York, NY 10022; PL2-7640.**

### POSITIONS WANTED

**Architect, project directed. Ten years experience.** Project development from programming through construction. Wish to relocate with a progressive firm in an environmentally stimulating area. PW-5534, Architectural Record.

### POSITIONS WANTED

**Director of Design: For medium size A/E firm.** Excellent designer, degreed, licensed, NCARB, 11 years private practice, P&L responsibility. Now design manager, A/E division of large E/C company. Want to leave Northeast. Am successful in selling my design to agencies as well as to clients. 3 design awards. Willing to break in at lower level but should participate in management decisions to warrant my salary. Resume on request. PW-5503, Architectural Record.

**Design Director, AIA, NCARB, B. Arch., M. Arch., 20+ years diverse practice,** management, awards and published work. Design experience includes facilities, furniture, graphics, contract interiors, land planning and automated procedures. Seeks position in South or West Coast to administer facility programming and design, leading to partnership or equity status. PW-5513, Architectural Record.

### BUSINESS OPPORTUNITIES

**Architect: Established east coast architectural-engineering firm with annual construction volume of \$60 million in quality commercial industrial practice seeks design partner.** Unusual opportunity. Reply: BO-5366, Architectural Record.

### SPECIAL SERVICES

**Architectural Renderings—A complete source for the finest in architectural illustrations is described in a color brochure,** available from Kinsey Architectural Arts. Examples of full color and vignette style renderings graduated in cost are included. Additional services include building color selection and photo prints of renderings in a wide variety of sizes. For a cost quotation forward floor plan, elevations and site plan. We will acknowledge by phone the same day received. As a valuable addition to your office file, write for your copy of our color brochure. Kinsey Architectural Arts, 2144 Alexis Dept. 5-A, Toledo, Ohio 43613—Phone: (419) 475-7011.

### OFFICE SPACE

**Space-Architect planning to relocate practice** has entire floor, 3,300 sq. ft. office, Midtown Manhattan, N.Y.—reception, 3 private offices, conference room, drafting room, staff lounge. Available with or without furnishings including air conditioning. For particulars write: OS-5640, Architectural Record.

### OFFICIAL PROPOSAL

#### City of San Diego, CA Artisan Wanted

Experienced Artisan required to restore Churrigueresque ornamentation on historic building. Proposals required by July 20, 1974. Information and proposal forms available from the City of San Diego, Construction Department, 1222 First Avenue, San Diego, California 92101 Phone 714-236-6055.

## New Partners, New Appointments

**Robert L. Bien, AIA, Bernward U. Kurtz, AIA, Thomas H. Price, Jr., AIA, and Robert H. Welz, AIA** have recently been elected as partners in the architectural and planning firm of The Eggers Partnership.

**Kenneth K. Watanabe** has been named project engineer of Adrian Wilson Associates (AWA), with headquarters in Los Angeles. Mr. Watanabe was previously engineer-administrator of Gruen Associates.

John Carl Warnecke and Associates has announced the appointments of **Edward M. Tower, Clifford H. Morse and Charles R. Ince, Jr.** to vice president.

The Hall and Goodhue Community Design Group recently announced the addition of **Timothy Wilkes** of Los Angeles to their staff. Mr. Wilkes was previously with B. A. Berkus Associates.

Dalton-Dalton-Little-Newport have announced the appointment of **Willard C. Pistler, Jr.** as an associate and assistant director of operations.

San Francisco architect **John L. Haag** has been named associate of Esherick Homsey Dodge and Davis, the San Francisco-based architectural and planning firm.

Partners of the architectural firm of Lawrie & Green, Harrisburg, Pennsylvania, have recently announced the appointment of **William L. Umberger, R.A. and James D. Young, Jr., AIA** as associates.

The architectural firm of Deems/Lewis & Partners has announced the appointment of **John C. McKinley, AIA,** as vice president and **Neil Larson, AIA,** as an associate of the San Diego firm.

The Rockford, Illinois architectural firm of Larson & Darby, Inc., has announced the election of **Don L. Gugliuzza, Richard H. Hynes, Norman R. Pedersen and James E. Truitt** as general partners.

**J. Karl Justin, AIA,** has joined the firm of Evans, Delehanty & O'Brien, Architects and Planners, as a general partner.

**Robert Blumin** has been named vice president of business development for the architectural firm of Maxwell Starkman & Associates, Beverly Hills, California.

**Arthur H. Silvers, AIA,** former partner of Kennard & Silvers, has joined the Los Angeles office of Daniel, Mann, Johnson, & Mendenhall. Mr. Silvers has been appointed associate vice president.

**Harold R. Walt,** executive vice president of William L. Pereira Associates, has been named president of the firm. William L. Pereira will continue as chairman of the board.

**William N. Hollman, AIA,** has become a principal in the firm of The Twitchell & Allen Group, Architects-Planners, Sarasota, Florida.

S. I. Morris, general partner of S. I. Morris Associates, announced the promotions of five members of the firm to the position of partner. Those promoted are **Nolen Willis, Jr., AIA; William D. Kendall, AIA; John H. Wiegman, AIA; Thomas B. Daly, AIA; and George W. Spence, AIA.**