

ARCHITECTURAL

RECORD

Business Design Engineering
A McGraw-Hill Publication, Six Dollars a Copy
March 1983



Our finest carpets now



DUPONT
ANTRON NYLON





A futuristic look using Hunter Douglas Luxalon linear ceiling graces the Detroit Science Center. The colors are produced with carefully planned lighting.

Cities tighten belts for new economic realities

American cities have had their ups and downs before, but the current recession and pervasive cuts in Federal grants seem to be qualitatively different from previous cycles, says the National League of Cities. A recent survey shows that for the first time since World War II, cities are cutting spending during a recession, "thereby contributing to the decline rather than working to counteract it."

According to the survey, which covered 79 cities in 36 states plus the District of Columbia, city expenditures are outstripping revenues by an average of 2.3 per cent in fiscal 1981-82. A slight narrowing of that gap to 1.6 per cent is expected for 1982-83.

In terms of geography, the discrepancy is most pronounced in the Northeast and the West. Cities of below 50,000 are hit hardest.

"By and large, most city government officials are throwing up their hands in despair over trying to replace lost Federal grants with local funds other than general revenue-sharing," says the study. It reports that fewer than 10 per cent of the cities queried projected that they will be able to substitute local money for evaporated Federal funds. Three quarters indicated they would not even try.

Cities are turning more often to fees rather than general taxes to raise more money, while high interest rates plus other constraints keep many communities from borrowing for capital improvements.

"The near-term outlook is indeed bleak," says National League executive director Alan Beals. "With the recession likely to continue and the recovery expected to be weak and slow, fiscal conditions—already strained—should worsen."

In an industry comment, the Associated Builders and Contractors president Edward S. Frohling said: "The adoption of merit-shop construction could go a long way to ease the burden of constructing new capital improvements. While the recently enacted Federal gas tax will provide cities with new public-works construction funds, Congress has hamstrung the cities by including Davis-Bacon prevailing wage provisions in the law." Frohling urged city administrators to "present a united front to Congress" and recommend that future infrastructure funding not be subject to Davis-Bacon rules. *Peter Hoffmann, World News Washington, D.C.*

This meant that the building period was often longer than the tenure of the staff members who had initiated the project. So the GSA and other major owners replaced the traditional design-bid-build method with fast track. They still needed a general contractor to coordinate the several different construction packages, however. This meant

Innovative customer guarantees announced by Manville

Countering any questions about the ability to make good warranties and guarantees on roofing materials and fiberglass building insulation, the Manville Corporation has announced two steps to reassure customers that successful claims will be paid on an ongoing basis. These steps are as innovative as the corporation's action that may have aroused doubts—the filing for reorganization under Chapter XI of the U.S. Bankruptcy Code to protect some \$2.2 billion in unencumbered assets from an onslaught of asbestos-related health claims.

The first step, which remains in effect as long as the corporation remains in Chapter XI, gives successful product claims by customers priority over any other kind of claim against the company. Both pre- and post-

petition customer claims will be handled as normal ongoing expenses—separate from bankruptcy proceedings—due to Manville's successful request to the court for this arrangement.

Second, Manville has established a "customer-assurance trust fund" that can pay successful product claims for a period of up to 20 years, in the unlikely event that Manville is dissolved instead of restructured. According to John B. Dorsey, vice president and general manager of the Manville Building Material Corporation's marketing division, the company has a 125-year history of scrupulously honoring its warranties and guarantees with prompt response to product claims. The object of the new steps is to assure customers that this policy will continue. *C.K.H.*

New catalog available on computer disc

The Sweet's division of the McGraw-Hill Information Systems Company has announced that the Carrier Corporation is distributing an "electronic catalog" on a computer disk as part of a new separate volume, devoted exclusively to Carrier hvac products, in the 1983 Sweet's Engineering Catalog File. Citing greater ease, speed and accuracy, Sweet's states that the disk is user-friendly and provides technical data on the types of hvac equipment engineers specify most frequently. While the disk that is issued with the file is compatible with only one proprietary computer, it can be exchanged for one that works on other manufacturers' units.

Computer congress announced

The National Academy of Science's Advisory Board on the Built Environment and The National Computer Graphics Association will hold the second annual *Computers/Graphics in the Building Process*, or *BP '83*, at the Washington, D.C. Convention Center on April 4-8. Among the cooperating organizations are the AIA, NAHB and the NSPE.

Billed as "an international congress and exhibition on the application of computer technology for the building industry," *BP '83* features some 46 seminars on three themes: computers in building design, in the construction process and in the management of built buildings. Subjects range from buying to applying the technology. Exhibits will include demonstrations of computers doing normal office functions.

Many of the attendees will be from Federal facilities departments, although architects, engineers and contractors are urged to attend. For more information, contact the National Computer Graphics Association, Inc., 2033 M Street, N.W., Washington, D.C. 20036, or phone 202/775-9556.

Continued on page 53

the mushrooming fraternity of construction consultants specializing in costs, scheduling, claims, etc.

There were a few in each group who understood the nature of CM's new demands, but most emphasized the familiar portions of their normal services.

Conflicts among these three groups were fought out in sales

Architectural Record March 1983 33

Conflicts among construction managers and architects are common

Architects complain about:
• Construction managers who sell themselves and their services as protection against a naive or spendthrift architect, or who claim that they can reduce the

Architectural Record March 1983 35

Architectural Record March 1988 37

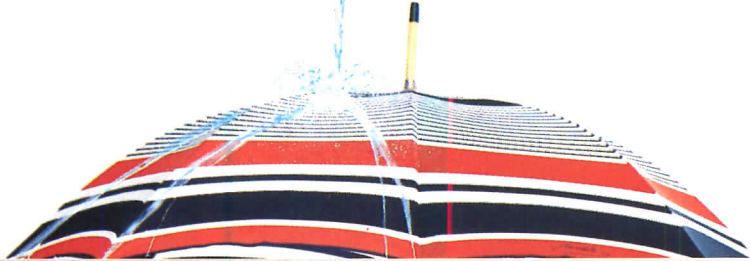

Haworth provides lighting equal to the task.

Office tasks and the lighting to support them should not restrict interior design. TriAmbient™ Lighting by Haworth expands design options. Easily. Economically. Efficiently. Attractively. Fluorescent task and ambient fixtures; and High Intensity Discharge (H.I.D.) freestanding and panel-supported ambient lights allow tasteful, tailored solutions. For accent, vertical display, task or ambient illumination, all fully integrated with Haworth's TriCircuit ERA-1® pre-wired panels. For design options that are equal to any task, consider TriAmbient Lighting by Haworth.



Send for the "TriAmbient Lighting Package". Write:
Haworth, Inc.,
One Haworth Center,
Holland, MI 49423

HAWORTH®



Finance: Fine tuning is needed to spur recovery without more inflation

By Phillip E. Kidd

Everyone agrees that lower interest rates are needed to keep the housing recovery going and to revive the economy's flagging strength. Whether or not rates—especially long-term rates—actually decline throughout all of 1983 may depend greatly on investor expectations about the future direction of inflation.

That may seem a strange statement in light of the sizable reduction in inflation last year and the ample availability of idle capacity (plant, equipment, labor and materials), which should blunt inflationary pressures for a while when the recovery finally begins. Yet the success against inflation was only achieved through repeated episodes of stringent monetary policy, which effectively curbed economic growth over a three-year period.

Moreover, it was not until well after inflation was clearly headed downward that interest rates began tumbling from their historic highs last summer. Significantly, most of that decline simply mirrored the fall in inflation, as real rates remained at extraordinarily high levels (see top graph and RECORD, January 1983, page 39).

Policy-makers are now worried more about double-digit unemployment than inflation And so they are scurrying for policies to stimulate economic growth, not retard it. Outside of the last installment of the tax cut this July, fiscal policy will not provide much new adrenalin this year, despite a flurry of new job and tax proposals. The budget-busting deficits already projected for the next few years preclude that.

That leaves monetary policy as the control valve

Many forecasters are betting that the floundering economy will keep forcing the Federal Reserve to continue liberalizing monetary policy. They reason that this would push short-term interest rates downward, possibly even below the inflation rate. Soon, long-term rates would follow, providing the needed catalyst to edge the economy into recovery. While the economy is struggling, that is appropriate.

But, there is an inherent risk that could stifle growth well before the economy is fully able to maintain an expansionary mode. It is the result of two parallel pressures for liberalizing monetary policy that—uncontrolled—could result in overkill, a new round of high inflation, and thus a loss of investor confidence: The first is

the pressure just to get business moving; the second is the pressure to compensate for massive government borrowing.

Despite the stock-market boom and the reappearance of long-term, fixed-rate loans, financial institutions have not forgotten what a decade and a half of inflation did to the value of their stock, bond and mortgage portfolios. Right now, they believe that inflation is being controlled. Nonetheless, if they sense that monetary policy in league with fiscal policy is adding too much fuel to the economy, their fear of renewed rapid inflation could easily be reawakened.

In turn, investors would abruptly abandon the long-term market. These rates would rise, as they did in the fall of 1980, leading to the same result of dumping the housing recovery and the economy before a solid footing for sustainable growth was established.

Timing is everything—and has to be carefully watched

In the coming months, a major policy decision at the Federal Reserve will concern the timing of a switch from aggressive expansion of the money supply toward a less vigorous, but still accommodative, position. That time will probably come after several more months of good housing starts and after unambiguous evidence that other industries are picking up. From this vantage point, that makes the third quarter particularly vulnerable to a temporary run-up in rates. By then the economy will clearly be on the upswing and the Treasury, after something of a hiatus during the second-quarter tax-collection period, will come elbowing its way back into the market for sizable funding.

Nevertheless, a flexible monetary policy, which supports rather than tries to accelerate the recovery by itself, can alleviate investor concerns about a resumption of inflation. This would limit to a brief period any backup in interest rates due to a transient supply/demand imbalance, permitting the housing recovery to go on gaining momentum.

Mr. Kidd is a prominent economic consultant and former Director of Economics Research for the McGraw-Hill Information Systems Company.

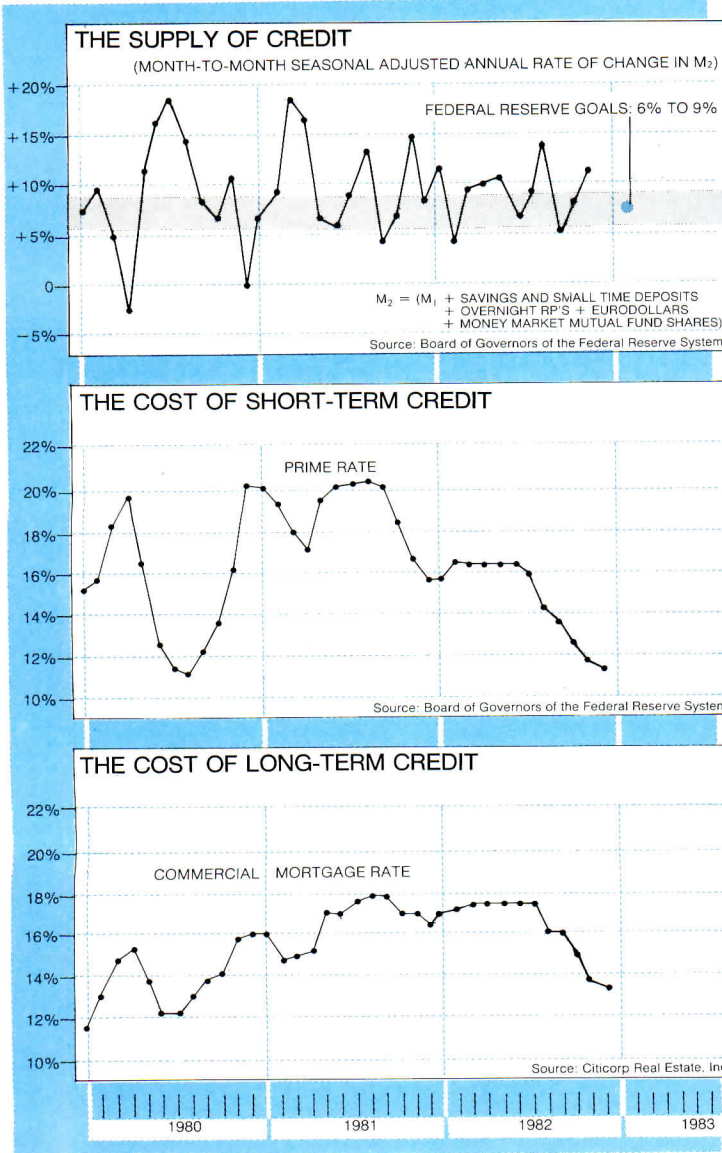



The preferred roof insulation Fes-Core.TM From Manville

Presenting Fes-Core, a composite roof insulation with performance characteristics that make it the smart choice for built-up roofing systems.

It's lightweight. Goes on fast. Needs no joint taping. And it is acceptable for use in most loose-laid single-ply roofing systems.

Top and bottom layers are Manville Fesco[®] Board. The core is polyurethane foam. Fes-Core is available in 3' x 4' panels in R-values from 10 to 20 and C-values from .10 to .05.

Fes-Core is superior in several ways. The top layer of perlite board provides an excellent surface for bonding roofing felts. The bottom layer of perlite board qualifies Fes-Core for use in Factory Mutual Class I construction.

Excellent adhesion, fire resistance, thermal efficiency, superior compressive strength and dimensional stability — all these make Fes-Core the ideal substrate. A product roofers can use with confidence. With the assurance of lasting roof protection and fewer problems.

For details, consult Sweet's. Fes-Core is produced and marketed by Manville Building Materials Corporation, P.O. Box 5108, Denver, CO 80217.

Manville

Circle 22 on inquiry card

Computers: The personal challenge of CAD

The systems manager of Skidmore, Owings & Merrill's New York office discusses the issues design professionals must face in dealing with computer-aided design and graphics

By Barry Milliken

As all must by now agree, the architectural profession is facing a new era of computerized techniques. Many architects have visited our offices in the past year to see our particular computer-aided design systems in use. They generally express excitement by what the new technology promises, but at the same time are bewildered by it.

Their bewilderment is understandable. A person without solid computer experience can't make a thorough evaluation of computer systems: Which system is best? Which is right for my firm? What types of work should the system do first? How do I compare software? Will the system replace people? Will the human element of creativity be lost? What other crucial questions should I be asking?

Mountains of technical information and a good deal of experience must be absorbed before an architect can answer these questions. That's one reason we believe that the profession will not adopt computerized techniques as quickly as some think. Some firms will move faster than others, but the over-all process will be more evolutionary than revolutionary (see *RECORD*, January 1983, page 41).

To use computers effectively, four basic problems must be solved. In order of importance they are:

- 1) Priorities;
- 2) People issues: education, training, management, psychology;
- 3) Software issues: capabilities, flexibility, limitations;
- 4) Hardware issues: capabilities, limitations.

The order of priorities is different from what most people think

It's not "hardware, software, people," it's "people, software, hardware." And getting those priorities mixed is a mistake many firms make.

They tend to launch into an evaluation of hardware and expend great effort justifying the capital expenditure. Then they compare software. And finally, they consider the people issues—maybe.

There are reasons for this: *Hardware* is tangible. You can see it, show it off to clients. *Software* is intangible, and involves "mysterious" concepts foreign to everyday life. These two areas of technological wonders tend to overshadow the abstract people problems.

Hardware requires a large capital cost which can be

calculated and analyzed with some degree of accuracy. Detailed financial plans can be prepared showing cash flow and depreciation. On the other hand, costs of software and training are more difficult to predict and can only be approximated. So the temptation is to turn around and analyze the financial effect of yet another hardware alternative: lease versus purchase.

People problems vary with job function

In recent years, it has become apparent that human problems, not technical problems, are the main obstacles to more effective computer applications in all types of businesses. What is not so widely recognized is that many potential people problems involve senior personnel—those who don't sit at a terminal and use the computer system directly. That's why it's just as important to establish support and understanding with top management and senior architects as with the direct users of the system.

The single most important factor in achieving success with a computer system is in dealing with the knowledge, commitment, fears and expectations of the people involved with the system. Each group has its own problems.

Top management must guard against expecting too much too soon

This is the group that's most likely to be seduced by the hardware itself—after all, it's laying out a lot of money for it. Since the top managers are generally not involved in evaluating the operating details of the system, they are also most likely to overestimate (and be oversold on) its capabilities. For the system to be a success, top management must be committed to it, must understand the priorities, and must not have unrealistic expectations. This takes education and time.

Top management also needs to consider from the start how the firm will be reimbursed for computer usage. On contracts in which the architectural fee is based on a markup on man-hours, careful thought must be given to computer usage rates that will cover overhead and profit.

Senior architects need thorough training—even if they don't operate the system
Without a thorough understanding of the system, senior architects cannot

effectively supervise the architects and draftsmen who work with the system directly. Computer-aided design requires the information describing a building to be organized in new ways. The work flow (from design to working drawings, architect to consultants) must be rethought. Roles must change. Those who have already converted to manual overlay drafting or modular drafting have a small taste of what's involved.

System users must master new ways of thinking

Some of the architects and draftsmen who will actually operate the system to create drawings have years of their lives invested in manual techniques. A change which might seem simple can be very hard for some people. (It's a bit like trying to teach a right-handed person to write with his left hand.) Many long-standing habits must give way to a new approach. It's a frustrating—but potentially rewarding—process.

Full mastery of the more complex systems takes months of experience. User training must be thorough enough to foster ingenuity. Computer systems usually offer a number of ways to get the same result. This can apply to small operations (e.g., replicating a portion of a drawing) or an over-all system concept (e.g., layering the various construction elements, as shown in the top drawing, overleaf).

The user must be able to choose the most effective method in each case. A CAD system can, of course, be used to create a drawing line by line—analogue to manual drafting. But many CAD capabilities, such as translations, scaling, rotations, repetition, patterning, symbols, layering, clipping and three-D viewing, can be used in combination to produce drawings much more quickly.

User training is really only the beginning of a process which must continue as experience with the system increases. This is the process of rethinking all of the basic assumptions on how information about a building is organized and depicted. It is one of the most challenging aspects of CAD systems.

The entire staff should be encouraged to lend help and understanding

At the outset, there won't be enough terminals for everyone who could use one. (No one can afford that many terminals all at once, and besides, it's wise to

Patented Design

Veral roofing and flashing is different. It has a patented design incorporating a fiberglass reinforced modified asphalt base and a factory laminated foil shield that work together against the elements.

Proven Performance

Veral, time-proven for over two decades in the world's climatic extremes, provides a tough, lightweight, weather-tight seal appropriate for a variety of roof designs and substrates.



Dramatic Results

As handsome as it is durable, Veral is available in copper, aluminum or chemical resistant stainless steel foil finishes. All are guaranteed against leaks for 10 full years.

Call Today

For more information on the engineered excellence of Veral or any of SIPLAST's time-proven roofing systems call:

1-800-643-1591

In Arkansas, Call Collect:

501/246-8094

SIPLAST

Hwy 67S, Arkadelphia, AR 71923

grow into a system gradually.) Users should try to generate support for the system even from those who do not use it directly. The latter must learn the various ways they can cooperate with the first users, encourage them and understand their problems of adaptation.

At least one person should be assigned as system coordinator

This person—who should preferably now be with the firm—could handle a variety of tasks relating to the system, such as contacting vendors for maintenance, generating computer billings, training personnel, etc.

Two of these tasks are critical: one is monitoring the progress of the users, working with them to improve their skills; the other is making the best use of the system's user command language (if it has one) to develop special formats for specific projects.

Everyone involved should understand certain basic computer concepts

- The computer is not a brain. It is not analogous to the human mind. It cannot think, reason, create, conceptualize, learn, or design—at least not in the way people do. Computers need people to drive them, just as automobiles do.
- The computer is a tool which frees people from repetitive tasks, so they can spend their time on creative, conceptual ones.
- CAD is in a very early stage of development, so no one should assume that what a system can do today is the limit of what's possible. Everyone should be open to the new ideas. We are involved in an exciting process of development, and everyone should be encouraged to contribute ideas to that process.

Software capabilities vary widely from system to system
Which is why evaluating and choosing software is extremely complex.

One important decision: whether to get a two-dimensional or a three-dimensional system. Three-D systems are much more complex and expensive than two-D systems. But architects must recognize that at least 95 per cent of architectural drawings are two-D. Three-D computer images are not as useful as physical models in many situations. However, computers can produce three-D images very quickly, and permit fast changes to be made in both the building itself and in the observer's perspective (see photos right). If

you choose a two-D system, make sure it can be upgraded to three-D later on.

CAD systems allow the user to manipulate different relationships

Imagine that pencil drawing on paper implies nothing—it's merely a collection of graphite particles on a piece of paper. And that concepts such as those defined by lines, arcs and polygons exist only in the mind of the viewer.

All CAD systems build these and other human concepts into the way graphic information is stored and manipulated (see plan overleaf). The floor plan shown overleaf illustrates two conceptual relationships: the *symbolic* and the *ownership*. These relationships have important uses in architectural drawings, and only some CAD systems have them.

In the symbolic relationship, each item of furniture has been drawn only once in a "catalog" of furniture symbols. The shape of each item is determined by the master copy in the furniture catalog, and if the master is changed, all such items are also changed.

The symbols can be organized according to hierarchies. In this example, furniture items have been grouped into "workstations," each of which has been drawn in a catalog of workstation symbols. For this project, workstations have been grouped on a single floor, and fit together to form clusters enclosed by movable panels. Thus, a three-level symbolic hierarchy is created. Each panel grouping is drawn only once in another catalog. A typical page from this catalog also lists quantities of each panel type used in the cluster.

Ownership relationships in architectural drawings are usually a function of territorial or area boundaries—usually departments or offices in an office building. On the floor plan shown, each workstation or cluster has its own identification number or letter, such as a room number, so that furniture can be listed by location. The boundary of each of these areas is shown on the plan by a dotted line, which the computer uses to determine which workstation belongs in which workstation, and which workstations belong in a given cluster.

As with symbolic relationships, ownership relationships can also exist in hierarchies. Thus, on a larger scale, a building plan may be divided into east wing and

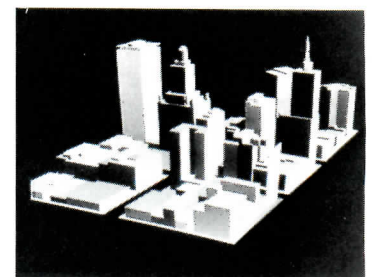
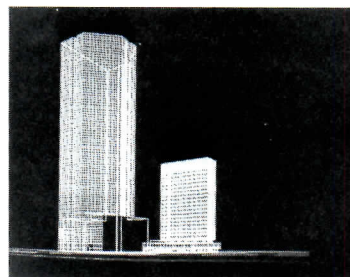
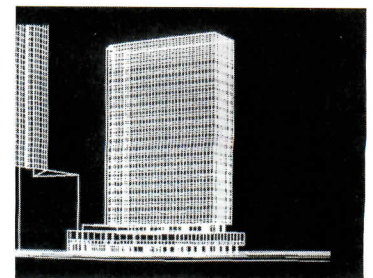
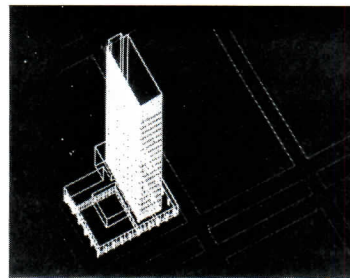
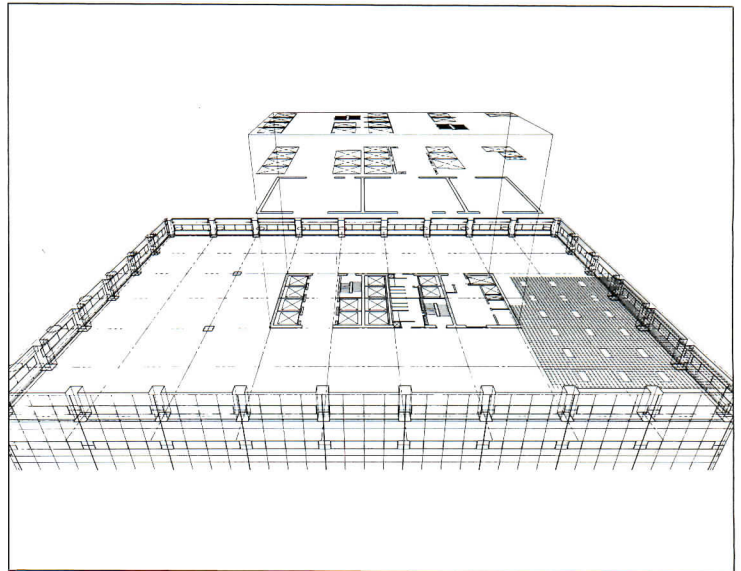

The top drawing results when the computer is used for an over-all system concept in which the various construction elements are shown in layers. The lower illustrations show the ways in which three-D images can be produced and quickly changed to show different perspectives and relationships to the surroundings.

True appreciation of enduring value
grows with the passage
of time.

We want your clients' satisfaction with All-Steel systems furniture and components to be thorough and long lasting. This is one reason our attention is focused on engineering excellence.

Obviously, our components are designed to please the eye and to enable you to make a statement that is uniquely yours. But, they are also designed to perform their intended functions efficiently, productively and for the long term.

The durability of steel, plus the versatility to meet your clients' needs today and tomorrow, makes the All-Steel system an investment your clients will appreciate more and more as time goes on.

See your nearby dealer, write All-Steel Inc., Aurora, IL 60507, or call 312/859-2600.

ALL-STEEL
For all the right reasons.



A COMPLETE LINE OF QUALITY SYSTEMS OFFICE FURNITURE AND ACCESSORIES.

west wing, then each wing may be divided into departments A, B, C, D, etc., and then again into 101, 102, 103, etc. These ownership relationships are important to space planning for producing reports totaling square footages, for working drawings, and for cost estimating, which requires lists of furniture and equipment, doors and hardware, etc. A typical plan shows departmental cost estimating, architectural specifications and material schedules.

Data-base systems help to manage and organize the information within a drawing. But they can also be used to coordinate all of the drawings for a project. All architectural and engineering drawings (plans, elevations, sections and details) can be made up of multiple "layers" of information (the same as in the overlay method of manual drafting), and each individual layer may be reused on other drawings that are otherwise dissimilar. A data-base system can monitor the progress on each "drawing layer" and keep track of which drawings each layer is used for.

Some three-D CAD systems now offer 'solid modeling'

This means that the system is capable of recognizing the concept of solids (volumes such as spheres, rectangular solids, cones etc., and combinations of these) in addition to the linear "wire frame" concepts (lines, arcs and polygons) described.

Solid modeling systems can be used to produce images with shaded and colored surfaces which give a greater illusion of reality, and they can also be used to test for interferences, mass properties etc. However, solid modeling systems are not yet practical for use in most architectural applications. Defining and modifying the model is considerably more difficult than with "wire-frame" systems. And models of large items with thousands of details require a powerful computer. These systems have been designed for use primarily by engineers of machine components, which are much smaller and less complex than buildings.

Some of the imaging capabilities of solid modeling can be achieved by "wire-frame" systems if the software includes some form of "surface modeling," or the ability to recognize flat surfaces. Surface models are easier to manipulate and require less computer time than solid modeling systems (see top photo).

CAD systems need to be designed differently for different uses

Many CAD suppliers recognize this and are tailoring separate modular systems to meet the drawing needs of different industries and disciplines. A system designed for mapping, or for designing electronic circuits, is very different from a system for producing architectural drawings. Even specialties within the architectural profession require specialized tools. The urban planner, architectural designer, space planner, interior designer, landscape architect, renderer, detail draftsman, cost estimator, all need different, but compatible, tools for drawing and analysis. Consider the differences between a site drawing and a zoning-analysis drawing. Satisfying these specialized needs is one of the most challenging aspects of current CAD system development.

The important hardware decisions involve memory, terminals and plotters

A basic CAD system consists of a computer, one or more terminals, and a plotter. The architect works at a display terminal where he creates and modifies drawings. The plotter produces these drawings on paper.

The memory capacity of the computer determines how many terminals can be used

It also determines how complex (and powerful) the software can be. Multiterminal systems using sophisticated software require a capacity of at least 32 bits. Less powerful systems are available, but they offer reduced—often dramatically reduced—capabilities. Costs of computers of all sizes are steadily going down.

In general, the capabilities and sophistication of the system relate to the cost of the system. The complex, sophisticated and expensive systems might provide *graphic design* capabilities, while the lower-priced systems provide various levels of *automated drawing*. More expensive systems can also provide more terminal workstations or greater plotter capability.

Display-terminal technology is advancing rapidly

The earliest practical CAD systems used "storage tubes" which draw by exciting green phosphors on the screen of a cathode ray tube (CRT). The image is "stored" in the phosphors. These systems must redraw the entire image when

any deletion is made.

Now, most systems use "raster" CRTs which work like a TV tube—an electron beam scans many horizontal lines of phosphors many times each second. Deletions can be instant, and multiple colors are possible, but these systems don't display fine detail as well as storage tubes. Thus the architect must use his zoom-in software command more frequently.

Many elementary functions normally performed by software are being gradually built directly into terminals (zooming in or out, translation, scaling, rotations). This can greatly reduce the load on the computer and give the architect faster response.

A third type of terminal, called "vector refresh," can be used to produce moving images on the screen—for example, the illusion of flying over a building. Such systems are much more expensive and not usually justifiable for architects except in very special circumstances.

Two types of plotters are used for architectural drawing

They are the *pen plotter* and the *electrostatic plotter*. And each has its own virtues.

Pen plotters produce drawings of great accuracy and can plot in color. Electrostatic plotters are much faster and more reliable than pen plotters, but cannot (yet) produce color. They are essential for large drawings with a high density of detail (like working drawings).

Electrostatic plotters create drawings by plotting thousands of tiny dots in rows on a roll of paper or vellum. They can shade areas in gray tones. The latest electrostatic plotters can produce line drawings which are very close to the precision of a pen plot.

Continuing development of other types of plotters (ink-jet and laser plotters) will bring additional competition into the architectural plotter market.

This article first appeared in L'Architecture d'Aujourd'hui Volume 223, October 1982.

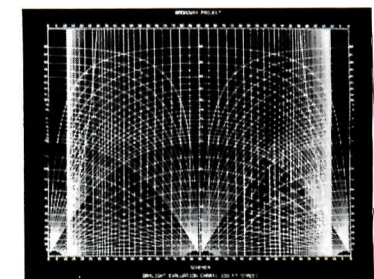
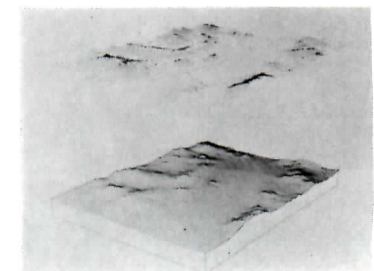
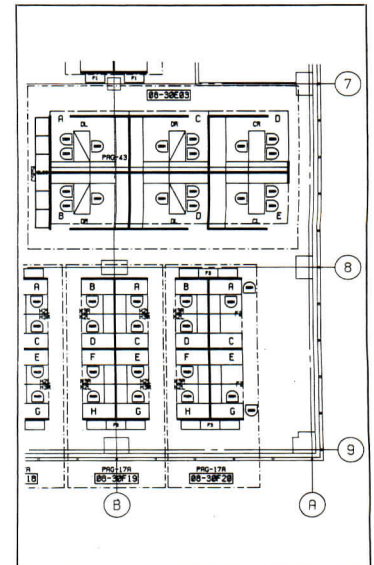

The plan shows an overlay of cost and specification information arranged by floor-area departments for quick graphic comprehension. The two bottom illustrations show how information on the same site must be arranged very differently for the needs of different disciplines such as site design and zoning analysis.

Concept and design by
Sid Diamond Display Corp.
New York

Fabricated by
H.C. Osvold Company,
Minneapolis

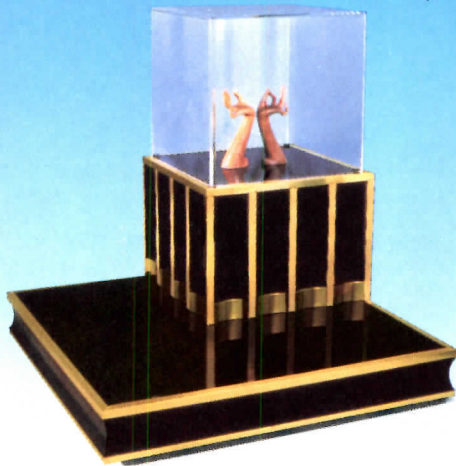

Wilsonart Black (1595-1) Decorative Laminate with brass trim.

Wilsonart expands the ways you design with laminate

Because WILSONART believes you should have a color palette as flexible and advanced as your own designs. So we've assembled Color Quest™: An evolving, expanding solid color collection with a commitment to anticipate your color needs at the leading edge of creativity, and to meet those needs at every point.

Seventy-seven colors for 1983, and still growing.

And because WILSONART believes you should be able to use your color palette to meet even the stiffest of design restrictions, without having to opt for "second-best" material choices. So we made sure Color Quest is formable to very precise tolerances (a face radius as small as 5/16", for example).

Then we added three surface finish choices for every color: from very high gloss, to a soft texture, to a crisply embossed grid. And we've created options that allow you to specify for a Class 1 fire rating. Extraordinary resistance to abrasion and impact.

Even structural enhancement.

WILSONART. Not just another pretty face. For literature, samples, and more information, call:

1-800-433-3222

(in Texas, call 1-800-792-6000)

Copyright© 1983 Ralph Wilson Plastics Company, Temple, Texas



WILSONART
Color Quest™

Marketing: Some useful tips on how to be effective and confident in presentations

By Dorothy A. Lynn



According to Lynn: "The eyes have it" in effective communication. "Contact is absolutely essential. Ignore your audience and the audience will start to ignore you."

You never get a second chance to make a good first impression.

That's particularly true for architects and other design professionals when they talk to clients. Considering the amount of time, money and creative effort that are part of every new business presentation, it's painfully disappointing to see the project you know you've earned go to a competitor.

Conduct a post-mortem on your presentations, and ask yourself: "What did we do right?" Then ask the harder question: "What went wrong?" If you *know* your firm had the required background and experience and you still lost the project, there could be an obvious—but often overlooked—reason: a failure of positive communication skills.

Communicating an idea is not a natural extension of the idea itself

The thinking process and the communicating process are not the same. For example, how many times have you heard a business speaker talk around and around a subject without reaching the main point? That speaker is guilty of assuming that unedited thoughts are transferable.

Even the most mundane conversations are full of potential inaccuracies... "But, I *thought* you said..." or "I *told* you I'd be..." Inaccuracies are minimally acceptable when the stakes are relatively low, but when the stakes are high, as in your important presentations, your ability to communicate effectively should be at its highest level.

The first requirement: show commitment

If the creative forces behind the project participate in the final presentation, this requirement will be met. But often, the most important members of the project team are left out of the presentation. Technical experts are kept in the background because they are perceived as being creative but quiet and nonverbal.

The people who have the greatest stake in any project are those who create or design it. Let the client experience that commitment firsthand. Potential clients are much more likely to accept your ideas, and be more inclined to retain you, when they sense honest commitment.

Focus on people

People hear presentations. And people make decisions. The best

way to get them to act favorably is to understand and address their *human* needs. The idea sounds obvious, but is easily overlooked during the tension and pressure of the presentation.

Most formal presentations are focused on objects, abstractions and numbers rather than on people. This can be a costly mistake, but it's an easy one to avoid. Here are a few basic techniques:

Establish presence

Presence is the quality that evokes attention and respect. All good presenters, from the President of the United States on down, have it. Achieving it is easier than you might think. The secret...

Be prepared

If you are thoroughly in command of the facts you present, if you are confident that you can answer any question the client asks, you will communicate that confidence. Consciously or not, the client will sense this, listen and believe.

Don't worry if you experience stage fright. That's natural. Moreover, it's useful. Use the adrenaline rush to help you express your own excitement about the project at hand. Simply put, it works.

Focus on client benefits

Not only must your presentation be logically organized, but it must be organized to serve a clearly defined objective. In defining this objective, approach it as a strategy. Your earlier conversations with the client should have shown which aspects of the project will be most exciting to that client.

For example, perhaps the client wants a monument or perhaps is most concerned with efficiency. Defining your objective begins with defining the client's real, and perhaps emotional, concern. Address that concern. Emphasize it. Announce it. The client should not have to guess the direction of your presentation or its point.

Moliere said that the playwright must tell the audience what is going to happen on stage, must tell them what is happening, and then must tell them what has happened. The same principle applies in effective communication.

If the client wants a monument, state at the outset that you are going to present a monument. If efficiency is the goal, state at the outset that you are presenting a model of efficiency.

Don't bore the client

Select no more than three or four substantive significant issues. Build your presentation around them. Remember to relate each section to the client's goal. And finally, evaluate each section in terms of the client's interest. Assign a ranking of relative importance. Don't give every section equal emphasis. If everything is equally important, then nothing seems important.

Watch your audience for cues. If you sense discomfort, boredom, or fidgeting, one of two things is happening: the audience is losing interest in your ideas, or they're losing interest in you. So be flexible, and the moment you sense boredom, take action.

- Try varying the cadence and volume of your presentation. Speaking in a monotone or monorhythm loses an audience.
- Check your posture. If you're slouching, keeping your hands in your pockets, or giving other body-language messages of low energy or lack of enthusiasm, the audience will get the message loud and clear and echo it.
- Monitor your movements. If you're playing with your glasses, shuffling papers as you talk, making distracting motions with your hands, stop. If you fidget, the audience will imitate you.
- Move out from behind the lectern. Increase eye contact by physically approaching the audience. This, of course, assumes that you are in complete control of your material.
- Monitor your eye contact. Don't let your eyes become riveted on the charts or slides as you explain them. (You should be as familiar with them as you are with your outline or script.) Continuing eye contact is absolutely essential. Ignore your audience, and the audience will instinctively start to ignore you.

To simply give facts, you could mail your proposal

The reason for presenting instead of mailing is to field your most powerful weapon: YOU. Don't disarm that weapon with boring or distracting behavior.

Mrs. Lynn is executive vice president and chief operating officer of In-Person Communications, Inc. in New York. In-Person specializes in executive development with particular emphasis on effective personal communications. Before joining In-Person, Mrs. Lynn was the director of special programs for the Chief Executive Officers' Division of American Management Associations. She is the author, with Charles E. Reilly, Jr., of The Power of In-Person Communications, published by Hammond Farrell.

40,000 buildings later in the U.S.A... proof-positive Dryvit® is more than a wall.

Dryvit Outsulation® is more than a wall, it's an energy-efficient system that puts massive insulation on the outside while providing a handsome surface finish. Proven in 40,000 buildings across the United States — and in many thousands more in Europe — Dryvit is the exciting versatile answer to a whole range of today's construction challenges.



More than a wall for fast-track efficiency.

It took less than 7 weeks to close-in Control Data's building in Dallas, TX, with Dryvit Outsulation panels. And the work was done during the normally idle months of winter.

The secret? A combination of Dryvit System wall panels fabricated in an off-site factory and fast-track scheduling.

For the owner, it meant a cost-effective, energy-efficient building with a striking up-to-date appearance.

For the contractor: an on-schedule building with no downtime.



More than a wall for design flexibility.

This Arco Oil & Gas building in Plano, TX, gives you an idea of the dramatic inexpensive design opportunities Dryvit offers the architect.

3-Dimensional shapes, aesthetic detail, colorful graphics are easy to achieve with Dryvit's 4-component insulating/exterior finish system.



More than a wall for residential construction.

This Atlanta, GA, home illustrates how Outsulation can create any period, any design. Tudor half-timbering was achieved with wooden beams and Outsulation, built-up to be flush with them. Other Tudor designs have used Dryvit System shapes in a contrasting color finish as a substitute for actual beams.

With Outsulation, the owner gains not only design flexibility and energy savings but more interior floor space and lower structural costs because of the light-weight nature of the System.

More than a wall for energy savings.

With Outsulation adding massive insulation to the exterior of the wall of the Southwest Financial Plaza shown here, many energy-efficient benefits occur. Thermal bridges are sealed. Thermal shock is minimized. Heating and cooling costs plummet — even original HVAC installations can be smaller, for further cost reductions.



More colors! 21 in all.

These architecturally pleasing colors are available in all 4 Dryvit Finishes. Each color is integral with the Finish, whether Quarzputz®, Sandblast, Freestyle, or Earthstone Matrix. All fade and stain resistant. Write for details.



More than a wall:
an energy-efficient system.

dryvit®
OUTSULATION®

DRYVIT SYSTEM, INC.

One Energy Way, P.O. Box 1014
West Warwick, RI 02893
(401) 822-4100

Plant Locations: West Warwick, RI;
Tulsa, OK; Columbus, GA

Dryvit is listed in the General Building File of Sweets Catalog under Section 7.13/DR.

Fourth International Festival of films on architecture and planning announced

Prize-winning films and video tapes submitted in a competition held this spring will be offered for airing to the public on television stations throughout the U.S. and abroad by sponsors FACT/USA. Supported by a grant from the National Endowment for the Arts, this festival was conceived at the last International Conference on Architecture and Urban Issues in

Lausanne in 1979 to broaden the popular perception of the built-environment. Included are documentaries, newsreels and dramatic, animated and experimental films. A schedule announcing dates and locations is available. For information, contact FACT/USA, 491 Broadway, New York, New York, 10012 (212/966-0713 or 877-5572).

It is time to register for the spring meeting of the PSMA

The first semi-annual meeting of the 1,200-member Professional Services Management Association in 1983 will be held on April 13-16 at the Royal Orleans Hotel in New Orleans. The predominantly design-oriented PSMA will focus on "meeting the challenges of rapidly changing times." Meetings in the past have provided lively seminars on a

wide variety of subjects, from computerization to personnel problems to handling government audits (see RECORD, January, 1983, page 33). A similarly stimulating program is planned for this session. Contact James Kinder, 1700 East Dyer Rd., Santa Ana, Calif. 92705 (714/641-1437).

Sweet's to conduct new round of computer seminars

Sweet's will have a new broadened series of seminars on "computers in construction" for architects and engineers beginning at the end of March in a large selection of U.S. cities. The seminars will be conducted by foremost authorities, including William J. Mitchell, head of the Architecture/Urban Design Program at UCLA, and Charles Eastman, Professor of Architecture, Computer Sciences and Urban Planning at Carnegie Mellon University. The seminars last from two to three days. Topics include *Affordable applications for the small design firm*, *Space planning for computers* and *Turnkey systems*. For more information, call 800/257-9406.

Petitions on Davis-Bacon Act hit Congress

The Public Research Council, a lobbying group based in Vienna, Virginia, has delivered some 600,000 petitions to congressional offices demanding an end to the Davis-Bacon Act. The Act, passed in 1931 to set minimum wages for workers on construction projects involving Federal money, has been much criticized by the construction industry for driving up the cost of building to the point where little can now be done (see *Cities tighten belts*, page 33). It has also been called exclusionary for preventing small nonunion construction firms from bidding on such projects. Can some kind of congressional action be too far behind?



Resists high humidity
4'x4' at a time!

AURATONE® Super E Ceiling Panels

Aluminum clad 5/8" thick panels resist high humidity indoors or out. Stand up to damage far better than fragile ceramic-type products. AURATONE Super E mineral fiber panels cut costs, too. Sizes include 2'x4' and new 4'x4' super size to speed installation. Won't sag. Easy to maintain. Perforated or unperforated.

■ Get specifics from your U.S.G. Representative. Or write to Sound Control Products, 101 S. Wacker Dr., Chicago, IL 60606, Dept. AR 383R

© 1982 United States Gypsum

UNITED STATES GYPSUM 
BUILDING AMERICA

Circle 30 on inquiry card

Marlite® Brand Interior Products



We Design
Interior Products That
Relate To People.

Marlite® Brand Products enhance interior spaces and forgive the foibles of those who use them.

People lean. People touch. People spill. People bump. People write. We let them be themselves without ruining the beauty of your designs for the next group coming through.

Discreet protection is added to rich detailing and subtle tones to create walls, doors and even restrooms appealing to the eyes, accommodating to the touch and available from one convenient source... Masonite Corporation, Commercial Division.

Find out more about how Marlite Brand Products can help your interior spaces relate to those who use them, and how the Commercial Division's unique service capabilities can better relate to you. Simply send for more information, today.



Masonite Corporation, Commercial Division, 202 Harger St., Dover, Ohio 44622. (216) 343-6621.

Circle 32 on inquiry card

Office notes

Offices opened

Herbert Beckhard, former partner of Marcel Breuer Associates, and Frank Richlan, former senior associate of MBA, have formed a new firm, Herbert Beckhard, Frank Richlan and Associates, 333 Seventh Avenue, New York, New York.

Thomas Frye, Jr. announces the opening of his professional practice for architecture and planning located at 58 Main Street, Vancouver, Washington.

Steven House and Catherine House announce the opening of their new office, House + House, for the practice of architecture and graphic design, located at 427 Chestnut Street, San Francisco, California.

Bruce F. Meyer and Charles P. Adams, III announce the formation of Meyer/Adams, Architects, 819 9th Street, Greeley, Colorado.

Harley Ellington Pierce Yee Associates, Detroit-based architects, engineers and planners, and Mountain, Kasch and Associates, P.C., Denver architects, have formed a third firm to serve clients in the Rocky Mountain region: Mountain Kasch/HEPY, P.C. located at 1209 19th Street, Denver, Colorado.

Rhodes Design announces the opening of a new office located at 111 North Riverside Avenue, Croton-on-Hudson, New York.

Ross Associates has merged with Wou International to form Ross/Wou International.

Michael Rubin, Architect announces the opening of a new office at 200 Park Avenue South, New York, New York.

Frederick A. Stahl has resumed independent practice as Stahl Associates Architects/Consultants, 73 Tremont Street, Boston, Massachusetts.

Swanke Hayden Connell Architects announces the establishment of a Washington, D.C. office under the direction of Alec W. Gibson. The new offices are located at 1333 New Hampshire Avenue, N.W., Suite 1170, Washington, D.C.

Russell Worley announces the opening of his new office, O. Russell Worley, Inc./Architects, located at 3100 Richmond, Suite 312, Houston, Texas.

Firm changes

Gerald Allen & Associates announces that William Hubbard is now associated with the firm.

Anderson DeBartolo Pan, Inc. announces the appointment of five new associates. They are: John C. Baird, John B. Hand, Robert W. Lisi, David C. Mitchell, Stewart M. Startt. The

firm also announces the election of Dale D. Harman and Stephen J. Sawyer as new partners.

Edward Larrabee Barnes Associates, P.C. announces that Alistair M. Bevington has joined the firm as a principal.

Daniel Sibley and John Hamby have joined the architectural and urban planning firm of Ralph C. Bender and Associates.

Beyer Blinder Belle, Architects & Planners, announces that Elissa F. Winzelberg and Raymond Plumey have been made associates in the firm.

Brownstein Group, Inc. is the new corporate name for Brownstein Associates located at 1627 Locust Street, St. Louis, Missouri.

K. W. John will serve as associate consultant with Dames & Moore.

Daniel, Mann, Johnson & Mendenhall announces that Coriolana Simon is transferring to its Washington, D.C. office to coordinate media relations for the company.

Dominick Associates Architects announces the appointment of Sam E. Leman, Jr. and Gogo Heinrich as new associates.

Griswold, Heckel & Kelly Associates, Inc. announces the appointment of Martin Sperber and Dennis Yaklofsky as senior vice presidents; David Chau, Robert Frank and Richard McNealus as vice presidents. The firm also announces the formation of an executive committee consisting of Dennis Yaklofsky, Martin Sperber, Carl Brosius and Arnold Gentilezza and chaired by Curt Zeiser.

Hansen Lind Meyer, P.C. announces that Loren R. Ellarson and Thomas S. Pearson have been appointed associates.

The board of directors of Hellmuth, Obata & Kassabaum, Inc. (HOK) has named Gyo Obata as chairman of the board and president and King Graf and Jerome Sincoff as vice chairmen. Birch Coffey has been appointed a principal in New York City. Bernard Bortnick has joined the San Francisco office.

Hendrick Associates, Inc. announces the extension of ownership to James A. Ferguson II and Marsha N. Cook. Mr. Ferguson will serve as principal-in-charge of business development/administration/finance and Ms. Cook as principal-in-charge of design. William B. Hendrick will serve as principal-in-charge of corporate planning. Marian Grier has been appointed manager of accounting; Jim Moore has been

Continued on page 57



Low cost panels that look like expensive tiles!

ILLUSION Ceiling Series.

AURATONE® Omni Fissured panels are scored to create four tile design illusions. These large, lay-in units help you make short rooms look longer, long rooms appear shorter and smaller rooms seem more spacious. Elegant pattern selection in 24" x 48" and 20" x 60" sizes. Color choice includes Ivory, Clay Gray, Pumice and Sandstone. ■ See your U.S.G. Representative. Or write to us at 101 S. Wacker Dr., Chicago, IL 60606, Dept. AR 383M



THREE/20



TWO/24

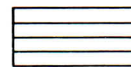

FOUR/48

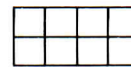

EIGHT/12

UNITED STATES GYPSUM BUILDING AMERICA

Circle 30 on inquiry card

Norasquare™ Flooring Clean Geometric Design

This beautiful new Norasquare floor is wear warranted for ten full years.* It's manufactured in five standard colors, but any color you want is available with a minimum quantity order.

And, just like all Nora floors, Norasquare is self waxing, easy-to-clean, slip-resistant and comfortable. When you see a 100% virgin synthetic rubber floor from Nora, you'll see the best.

Function with Beauty . . . Only from Nora Flooring. #1 in the World.

For more information on Nora Flooring products, write or call: Nora Flooring, 4201 Wilson Avenue, Madison, Indiana 47250, (812) 273-1852

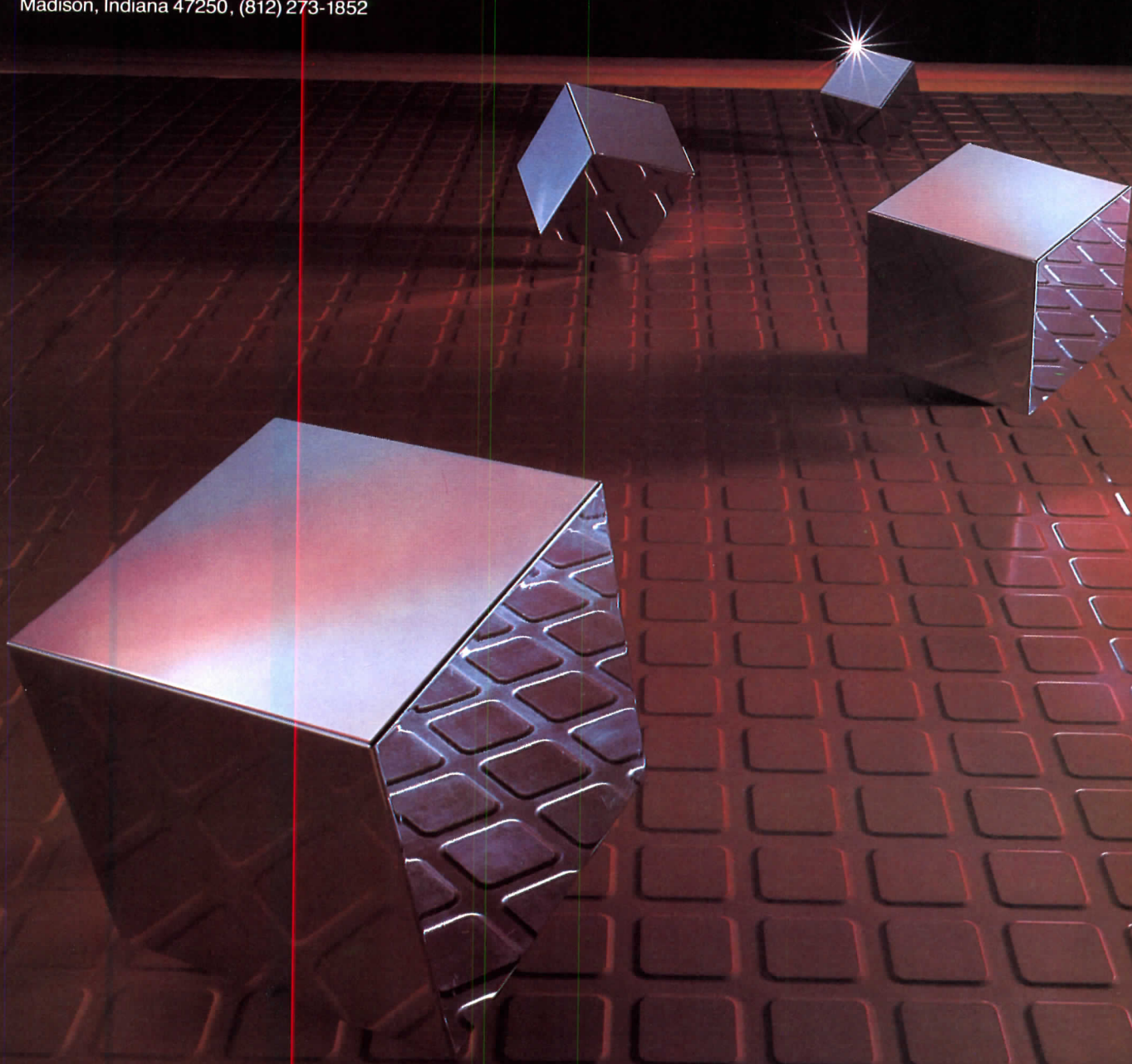

* See your Nora agent or call Nora Flooring for full details about our exclusive limited 10-year wear warranty.

Call Sweet's BUYLINE® 800 toll free.
nora flooring
Division of Robus Products Corp.
A FREUDENBERG COMPANY
© Nora Flooring 1983

Circle 33 on inquiry card

appointed manager of production; Jim Griffo has recently joined the firm.

Kimberly Bodfish has been named senior associate with Hope Consulting Group.

Mel Hamilton has been elected vice president and officer-in-charge of the Chicago office of ISD Incorporated.

Arnold Craig Levin/Design announces a name change to Levin & Associates to reflect the growth of the firm. Carol V. Petretti has joined the firm as marketing director and has been appointed associate.

Marquis Associates announces the appointments of Diane Filippi and Lamberto G. Moris to vice presidents; P. Steven Perls and Gita Dev to senior associates.

Noyes Associates, Architects have expanded their staff with the appointment of Donald R. Pulfer.

Pasanella + Klein Architects announces that F. Thomas Schmitt has joined them in partnership.

Christopher D. Cordry, Thomas E. Daman and Michael J. Green have joined Rees Associates, Inc.

Bruce N. Dani, P.E. has joined RGA Consulting Engineers as a senior structural engineer, and Dan R. Lundwall has been appointed assistant chief structural engineer.

Robinson Mills & Williams announces the addition of James Budzinski, Stephen Guest, Stephen Massey and Robert Teubner as new associates.

Charles E. Kuykendall has joined the architectural firm of Sanders & Sanders Associates, Inc. as a partner and principal-in-charge of construction systems. Alto Z. Parks has also joined the firm as a partner and principal-in-charge of architectural design.

James Sukeforth has been named principal of Sasaki Associates, Inc.

Skidmore, Owings & Merrill/Houston announces that Harold Massop, Alan Resnick, Hal Sharp and John Fogarty have been made associates in the firm.

Swanke Hayden Connell Architects announces that Bruce Harold Schafer has joined the firm as assistant director.

Richard K. Renner has joined George B. Terrien as a partner in the architectural firm of Terrien Architects.

David A. Toner has been named vice president specializing in multi-family/residential operations at the architectural firm of The Architects, Inc.

The Gruzen Partnership, Architects/Planners has named Ralph Steinglass a new partner.

Subodh K. Das, Stephen L. Kennerly and C. Nicholas Reveliotty have been elected partners of The Kling Partnership. Alexander H. Ralston, Jr. was promoted to vice president of Kling/Lindquist, Inc., the engineering division, and manager of construction services. Henry D. Sayer, III has joined The Kling Partnership to

head the firm's re-entry into the architectural and engineering design of hospitals and other health care facilities.

The Luckman Partnership, Inc. announces that John R. O'Donnell, Jr. has joined the architectural firm as director of design.

The Ratcliff Architects announces the following appointments: Syed V. Husain, vice president/professional services officer; Donald Kasamoto, secretary treasurer, business officer; Christopher P. Ratcliff, vice president/personnel officer; Peter G. Scott, vice president/marketing officer. Judd Allyn has joined the firm as marketing manager.

3D/International announces the following: Charles B. Thomsen has joined the firm and has been named president; J. Victor Neuhaus, III has been named senior chairman of the board; Jack M. Rains has been named chairman of the board; William N. Bonham has been named vice chairman of the board. Messrs. Neuhaus, Rains, Bonham and Thomsen comprise the executive committee of the board of directors.

Whisler-Patri announces the appointment of David W. Denton as vice president; Willis A. Gortner, II and Lawrence F. Merrion as senior associates; Joel Hendler, Noah Kennedy, and Richard Carl Reisman as associates.

J. Patrick Lawrence and Donald G. Lee have been named associates at Wimberly Whisenand Allison Tong & Goo Architects, Ltd.

New addresses

Dominick Associates Architects have relocated to 1900 Wazee Street, Suite 350, Denver, Colorado.

Michael A Ernest & Associates announces the relocation of their offices to 100-1152 Mainland Street, Vancouver, B.C., Canada.

Geddes Brecher Qualls Cunningham Architects announces that their Philadelphia offices have moved to 2401 Locust Street, Philadelphia, Pennsylvania.

Halenbeck, Chamorro & Associates announces the relocation and expansion of their San Diego offices to The Brunswick Building, Gaslamp Quarter, 363 Fifth Avenue, Suite 203, San Diego, California.

Ralph Jackson Associates, Inc. has moved to new offices located at 10203 Santa Monica Boulevard, Suite 304, Los Angeles, California.

Kendal/Heaton/Associates Architects Dallas office announces its relocation to 1 Galleria Tower, Dallas, Texas.

Skidmore, Owings & Merrill has moved its New York offices to 220 East 42nd Street, New York, New York.

Charles R. Womack & Associates-Architects, Inc. have moved to Equitable Bank Building, 17218 Preston Road, Suite 3100, Dallas, Texas.



Color clear through for beauty that damage can't mar!

ACOUSTONE® Mineral Acoustical Ceiling Panels

America's prestige ceiling—ACOUSTONE—offers you elegant colors that are not just painted on but moulded right in the mineral fiber base. No more glaring white spots from gouges and scratches. Four earthtones and six natural-texture patterns are standard. Custom-matched colors are available on a special-order basis. ■ For details, see your U.S.G. Representative or write Sound Control Products, 101 S. Wacker Drive, Chicago, Ill. 60606. Dept. AR 383C

UNITED STATES GYPSUM 
BUILDING AMERICA

Circle 30 on inquiry card

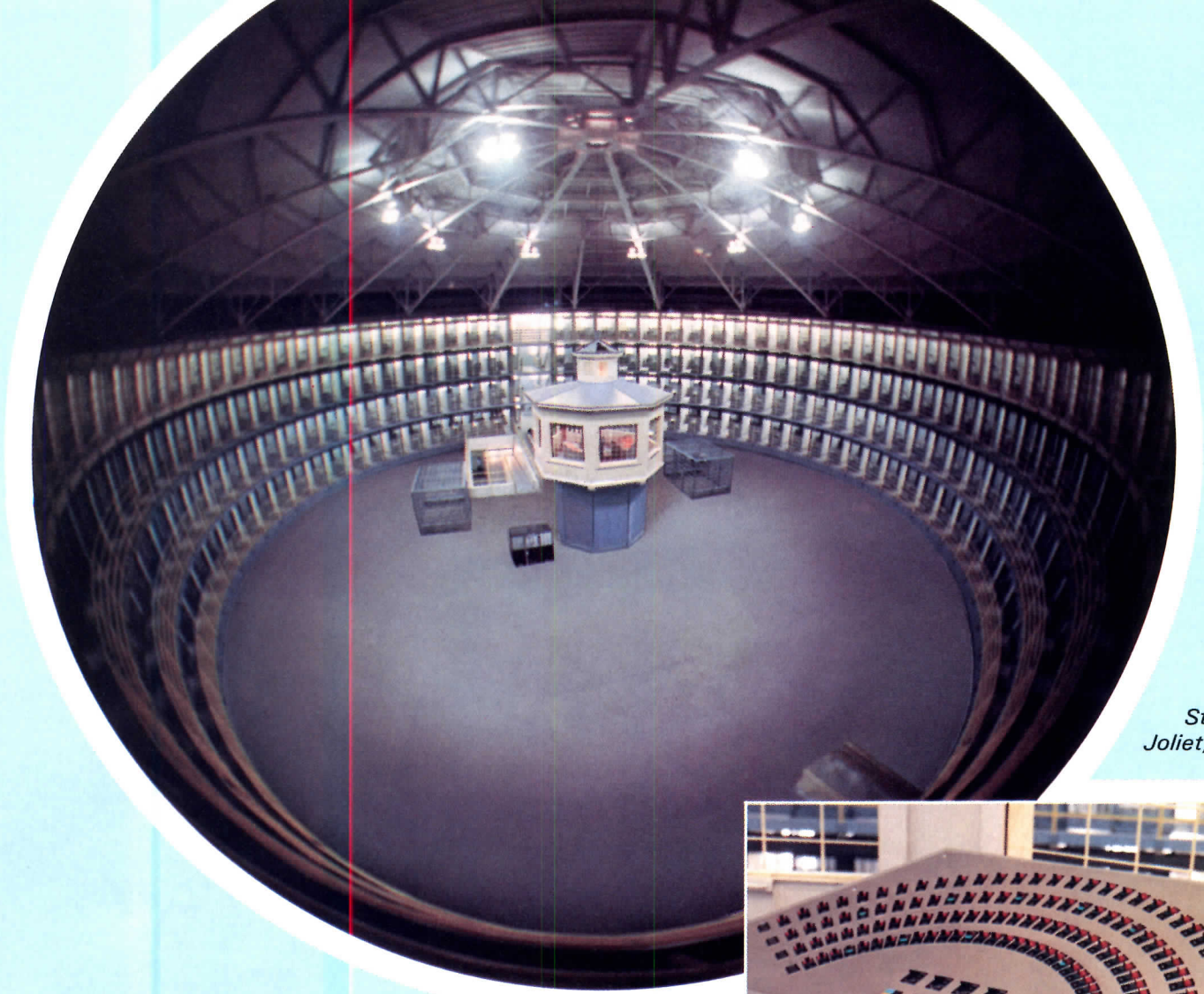

Stateville
Joliet, Illinois

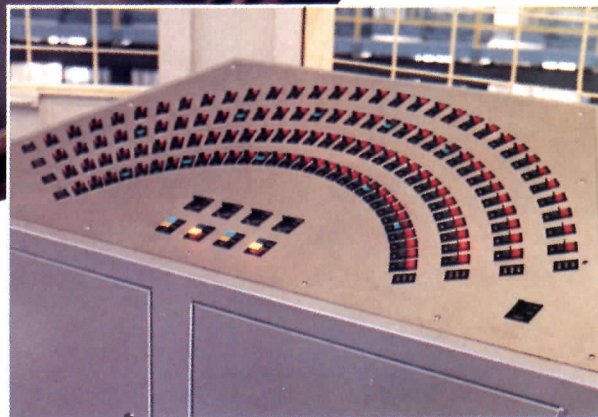

Designed For Security

Some facilities are unusual in concept and present engineering problems which are unique. But FOLGER ADAM engineers have been solving tough security problems for many years.

It may be a multi-tiered, maximum-security cell house with remote-controlled door operators all around, or a small facility with only a few manual locks. Whatever your requirements, you can rely on FOLGER ADAM for the right security equipment.

Locking devices and control systems have long been a specialty with FOLGER ADAM. They

are used in detention facilities around the world. Mechanical and electric locks, door hardware and institutional furniture by FOLGER ADAM are also well known throughout the security field. In fact, they are recognized as the standard of the industry and specified in institutional plans more than those of any other manufacturer.

Architects and planners naturally turn to FOLGER ADAM for institutional security equipment because it has stood the test of time and dependability.

Write or call today, for more information.



FOLGER ADAM COMPANY

P.O. Box 688 / Joliet, IL 60434 / Tel. 815-723-3438 / Telex: 72-3420

Circle 34 on inquiry card

Sullivan's Guaranty Building recaptures former glory

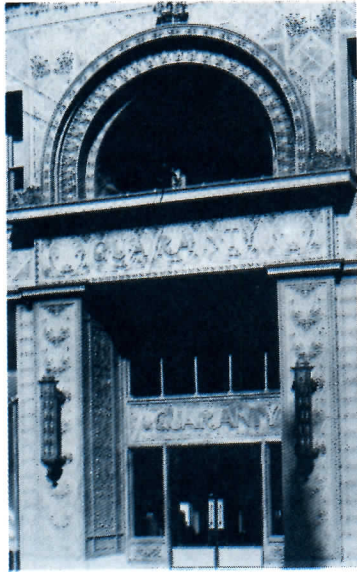

The restoration of its original name at a recent rededication is symbolic of the \$12.4-million restoration and renovation of the Guaranty Building in downtown Buffalo. Designed by Louis Sullivan in 1896, this early skyscraper has been favorably compared with the architect's Wainright Building. Undertaken for Prudential Associates by Cannon Design, Inc. and dePolo/Dunbar, the project included the restoration of the building's exterior terra cotta facades and bronze storefronts and of such interior details as the stairway, elevator grilles, and art glass ceiling. Where appropriate, new materials such as marble mosaic floors, light fixtures, and windows have been matched to the existing.

Isozaki's Museum of Contemporary Art: Back from the drawing board

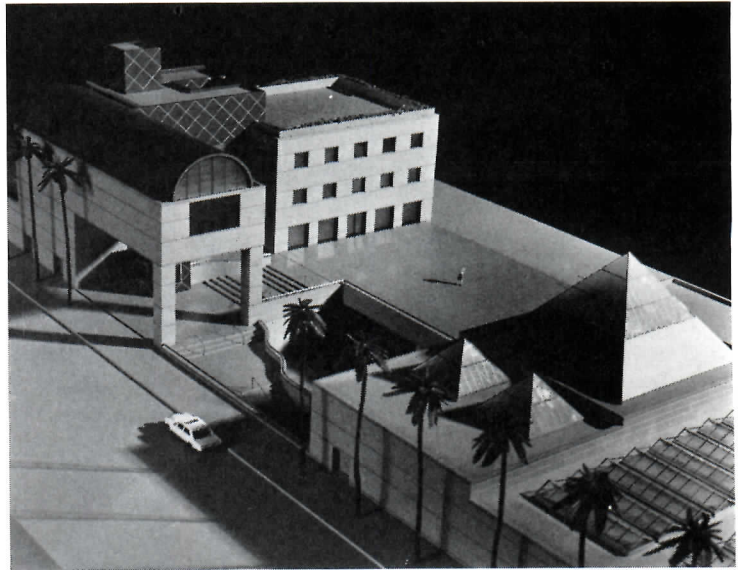

Almost a year after presenting his controversial original design for the Los Angeles Museum of Contemporary Art, architect Arata Isozaki has returned to the trustees with a revised and refined version of the building which MOCA board president William F. Kieschnick characterizes as "promising an extremely fine facility that successfully addresses a number of very challenging design problems."

According to Isozaki, most of the design attention was concentrated on exterior refinements aimed at bringing the new building into closer harmony with its neighbors in the Bunker Hill area and at clarifying the principal entrance and other routes of public access. The main entrance on Grand Avenue now is marked by a

copper-clad barrel-vaulted library overhang through which all museum visitors will pass. The library block, which also contains an auditorium, the bookstore, and offices as well as adjacent gallery space, is located across a central sunken courtyard from a second low gallery structure topped by sawtoothed and pyramidal skylights. Other refinements focus on the exterior surface detailing, which alternates horizontal bands of polished and unpolished red sandstone with accents of diagonally placed painted aluminum panels.

Gruen Associates are associated architects for the museum, and Arthur Erickson is the coordinating architect for the California Plaza development of which the museum is a part.

A facelift for a beauty center

Booth/Hansen & Associates' rejuvenation of a 1912 loft building on the bank of the Chicago River for the new headquarters of Helene Curtis Industries includes the addition of a story-and-a-half penthouse that will be used as a board room and conference center. The street level of the building will feature a working beauty salon used for R & D and a product showroom.

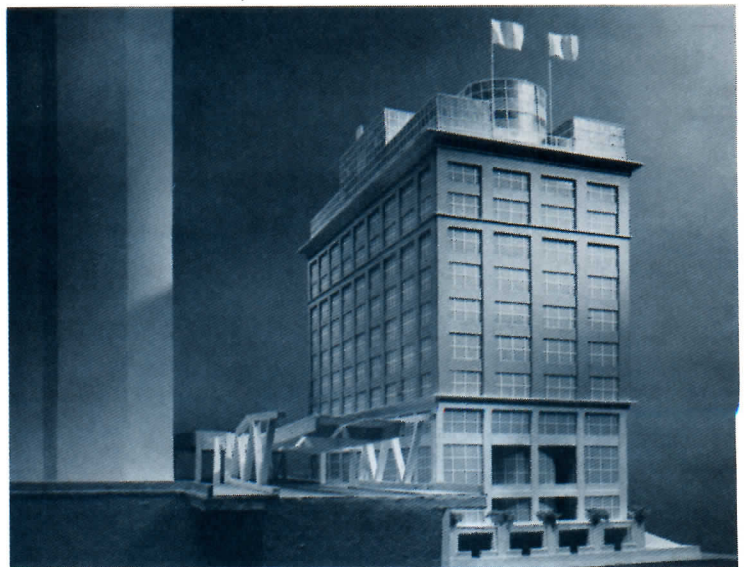

Why was Secur-TemTM security glass used in the Trenton State Prison, a maximum security institution?

On site testing proved to the state of New Jersey's Department of Corrections that Secur-TemTM was the product to install in the control rooms, inmate cells, fire doors and other high risk areas of the recently completed Trenton State Prison.

Discover Secur-TemTM's performance before spec writing your next project. Consider its:

- Superior fire resistance and lower toxicity (when burning) compared to glass-clad-polycarbonate materials.
- Impact resistance equal to glass-clad-polycarbonates.
- Economic control at a 30% to 50% savings compared to glass-clad-polycarbonates.

No other safety glass laminator can equal Globe Amerada's Single Responsibility Program and Modulus of Rupture. Why?

- Modulus of Rupture (MOR): over 30,000 psi average compared to other laminators 18,000 psi published average, insuring Secur-TemTM's outstanding impact endurance.
- Single Responsibility Program: guaranteeing an "in house" operation from chemically strengthening through lamination and insulation—No other laminator can claim this feature.
- 5 year delamination warranty.

Five years and 160 installations later ... Secur-TemTM products are still holding strong! A track record that speaks for itself.

© 1983 Globe Amerada Glass Co.

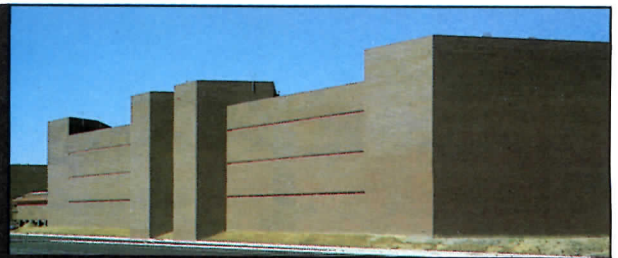

Trenton State Prison; Trenton, New Jersey. Architects (Joint Partnership): The Gruzen Partnership/The Grad Partnership; Newark, New Jersey



Prison Control Room



Prison Guard Towers

Call today toll free 1-800-323-8776 or in Illinois 1-312-364-2900 for additional information, framed test samples and a video tape "live" product demonstration.

GLOBE AMERADA
GLASS CO.

Globe Amerada Glass Company
2001 Greenleaf Avenue
Elk Grove Village, IL 60007

Circle 35 on inquiry card

The contemporary skyscraper: Three contrasting visions

Richard Davies photo

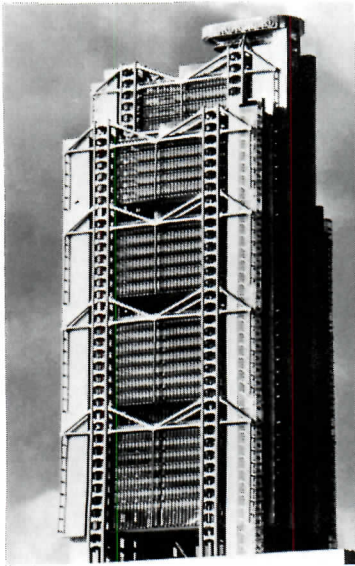

© Ezra Stoller/ESTO photo

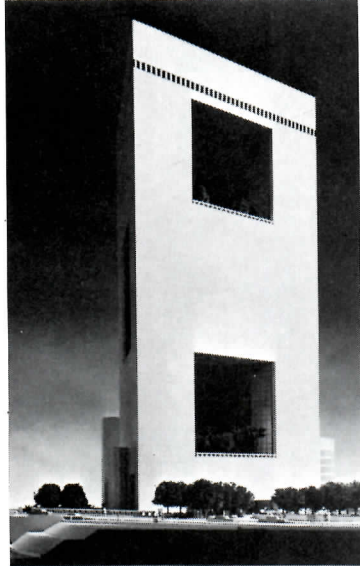

Nathaniel Lieberman photo



The *Three New Skyscrapers* that are the subject of the show at New York's Museum of Modern Art through March 29 were chosen, according to Arthur Drexler, director of the museum's Department of Architecture and Design, to illustrate contrasting approaches to skyscraper design which "involve other issues besides external styling." The three buildings—the Hongkong and Shanghai Banking Corporation in Hong Kong by Foster Associates (above left), the National Commercial Bank in Jeddah, Saudi Arabia by Skidmore, Owings & Merrill, Gordon Bunshaft (above center), and International Place at Fort Hill Square in Boston by Johnson/Burgee (above right)—are notable for their differing responses to structure and the organization of space.

In the Hongkong and Shanghai Banking Corporation, the focus is on the building's structural and technical requirements. Composed of three bays of varying height, the tower has a complex exposed structural system in which suspension rods carry some of the floors, while prefabricated modules clamped onto the building's east and west sides incorporate services, utilities, and stairs so that floor areas remain unobstructed. Inside, atriums of several stories and an elaborate system of elevators and escalators organize the tower into "neighborhoods."

In the National Commercial Bank, by contrast, the focus shifts inward. An equilateral triangle in plan, the tower is pierced by giant loggias—two of seven stories and one of nine stories—in whose recesses glass-

walled offices line mid-air gardens. Elevators and services are clustered in an abutting rectangular structure, leaving the main shaft to rise 28 stories innocent of base or cap—and innocent as well of scale.

Scale, on the other hand, is a dominant concern in Johnson/Burgee's International Place, designed for an irregular site in an existing urban environment. The two towers have been treated to look like six "independent" buildings of differing heights, shapes, and window and wall treatments, all joined by a glass-roofed concourse. The project demonstrates, observes Drexler, "that there is more to eclecticism than the average eclectic dreams of."

Vietnam Veterans Memorial: Once more into the breach

Balked at previous steps in the approval process, would-be "improvers" of Maya Ying Lin's design for the recently dedicated Vietnam Veterans Memorial are attempting a political end run in an effort to overturn the Commission of Fine Arts' recommendation that added elements—a flagpole and a statue of three infantrymen—be separated from the memorial as originally designed. At the close of the 97th Congress, then "lame-duck" Rep. Don Bailey (D.-Pa.) introduced a House resolution aimed at placing the new elements within the memorial's granite "V." This resolution was thwarted in the Senate by Sen. Charles McC. Mathias Jr. (R.-Md.).

In response, the American Institute of Architects has joined with the American Legion, the Veterans of Foreign Wars, and the Vietnam Veterans Memorial Fund in strongly opposing any legislative initiative that would preempt or overrule the already-completed approval process. In a letter to all members of Congress, AIA president Robert Broshar reviewed the existing legislation pertaining to the memorial. "To date," he said, "an orderly and open process has been followed in the design, approval, construction, and dedication of the Vietnam Veterans Memorial. This process should not at this point be compromised by the introduction of political considerations."

"No back door" for Corpus Christi City Hall

"There is no back door to this building," says architect Ben Brewer of the matching north and south facades of the new Corpus Christi, Texas, city hall. In addition to the bow to tradition represented by the stepped porticos, the building features a classic rotunda (read "atrium"). Architects are Lloyd Jones Brewer & Associates with Bennett, Martin & Solka.



Competition calendar

10, may be obtained from the Red Cedar Shingle & Handsplit Shake Bureau, Suite 275, 515 116th N.E., Bellevue, Washington 98004.

- The second annual competition of Women in Design International is open to professionals and students in architecture, graphic design/computer graphics, interior design/space planning, and landscape design as well as related arts and crafts. Selected designers will be awarded publication in the WIDI Compendium, an illustrated source book. Entry forms and slides are due March 31. Women in Design International, P.O. Box 984, Ross, California 94957.

- Entries in six categories—single-family residential, multi-family residential, vacation homes, commercial/institutional, remodeling/restoration, and interiors—are being accepted for the sixth biennial architectural awards program of the Red Cedar Shingle & Handsplit Shake Bureau/AIA. Projects completed after January 1, 1978 are eligible. Entry forms, which are due June



WINDOWS THAT DEMONSTRATE YOUR SENSE OF DESIGN. NOT MERELY WHAT'S AVAILABLE.

If you're tired of trying to fit windows that are rectangular into spaces that aren't, you should know about Marvin Windows.

MARVIN OFFERS SOME NEW ANGLES ON ARCHITECTURAL DESIGN.

Many of them can be seen in The Charter at Beaver Creek, Colorado.

In addition to casements and double hungs, Marvin offers triangles, trapezoids, octagons, arched tops and more. In fact, no other brand of quality wood windows makes so many shapes and sizes.

Marvin Windows are even available with true divided lites. So you can order windows in exactly the style you need to maintain the

integrity of your design.

Yet Marvin Windows cost no more than any of the other major brands of wood windows.

BEAUTIFUL WINDOWS.
BEAUTIFULLY PUT TOGETHER.

The sash, casings and jambs of all Marvin Windows are made of fine-grained Ponderosa pine.



This wood was chosen for its insulating properties and the way in which it accepts a stain and varnish or paint finish.

A Marvin Window not only begins with a high quality wood, there's more of it in a Marvin than in most other wood windows. (For example, our casement has 20 percent more wood in the sash and 22 percent more in the frame than our leading competitor's.) And all exterior wood is deep-treated to protect against rot and decay.

OUR WINDOWS OFFER ATTRACTIVE ENERGY SAVINGS, TOO.

We began offering triple glazing over 20 years ago. And double glazing long before that. Either one offers significant energy savings in summer, as well as winter.

What's more, Marvin Windows are carefully weather-stripped to eliminate drafts and further reduce heating and cooling costs.

MARV-A-GARD ELIMINATES WINDOW PAINS.

Marv-A-Gard is our exclusive maintenance-free exterior available on many styles of Marvin Windows.

It's a precision-fit clad exterior that has a specially cured polyester finish that resists rain, hail and blazing sun.

So you can offer your clients a window that's maintenance-free outside and beautiful wood inside.

MARVIN WINDOWS ARE ALWAYS THERE WHEN YOU NEED THEM.

Even though our windows are made to order, we can deliver most shapes and sizes within 10 days from the time we receive your order.

For more information, consult Sweet's General Bldg. File No. 8.16 MAR. Or for a free catalog, write Marvin Windows, Warroad, MN 56763 or call 1-800-346-5128 toll-free. In Minnesota, call 1-800-552-1167.



Design awards/competitions: Georgia Association, AIA 1982 Awards

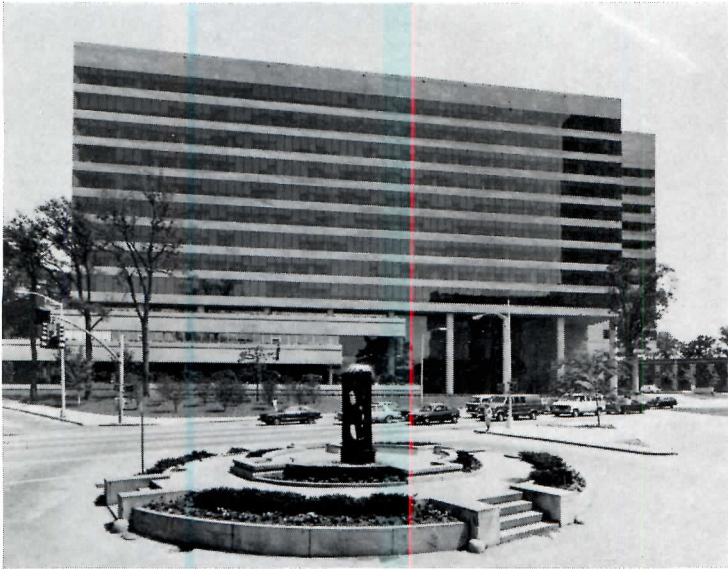

1

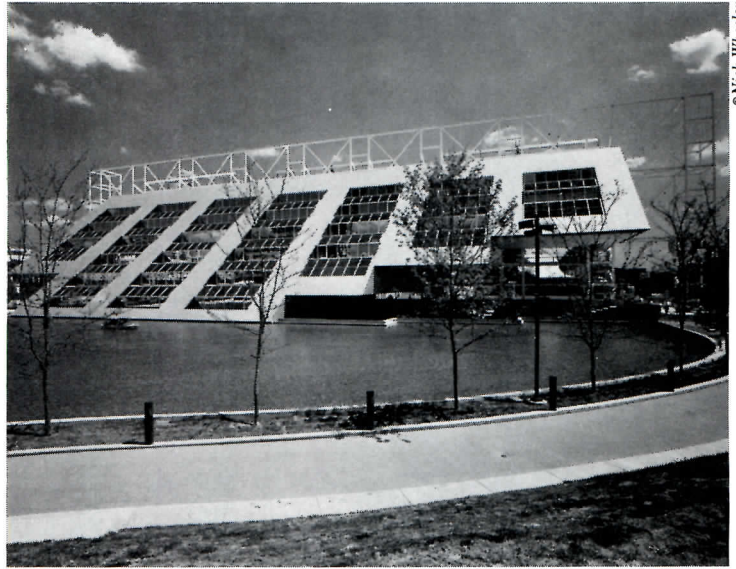

2

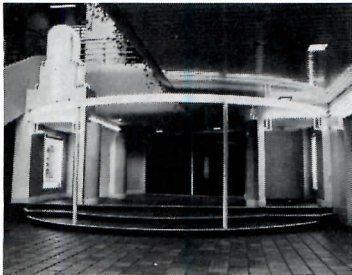

3

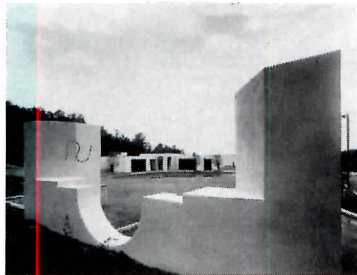

4



5

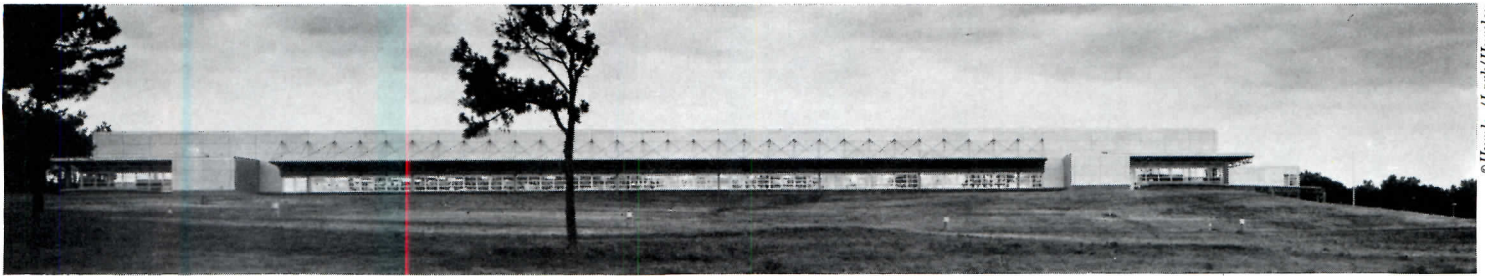

6

1. AT&T Long Lines Southern Region Headquarters, Atlanta, Georgia; Thompson, Ventulett, Stainback & Associates, Inc., Architects. The 14-story, 450,000-square-foot building was designed to fit in with the monumentality of a major cultural center and art museum across the street as well as with the more delicate scale of nearby residential areas. A complex program specified office space for 1,600 employees, audio and television studios, a 500-seat cafeteria, and a conference center. The jury commented: "The shifted forms of the office slab seem well rationalized and the exterior sun screening reinforces the elegant refinement that characterizes every part of *this building.*"

2. United States Pavilion, 1982 World's Fair, Knoxville, Tennessee; FABRAP Architects, Inc. According to the client's program, the 100,000-square-foot exhibit structure was to be convertible into either a 171,000-square-foot Federal office building or a 193,000-square-foot energy research center. To accomplish this goal, FABRAP designed an interior volume that could receive an infill of additional floors. The sloped northern facade allows for extensive daylighting. Despite "reservations about the 'abstract modernist' quality of this building," the jury admired "the appropriateness of the pavilion theme. . . . The problem of the pavilion's conversion to a permanent structure seems well thought through but remains to be seen."

3. Lenox Square Theater Entrance and Lobby, Atlanta, Georgia; Nix, Mann and Associates, Inc., Architects. When expansion of the Lenox Square shopping mall engulfed the formerly freestanding theater building, Nix, Mann were commissioned to create a new entrance to act as a visual magnet. "This '80s update of the Deco movie palace is pure fun. A brave use of neon and jazzy elements that have long since become tired clichés. Here they seem a logical choice given the need to compete with the active visual environment of the shopping mall."
4. PruCare Northeast, Atlanta, Georgia; Heery & Heery, Architects & Engineers, Inc. The 15,000-square-foot project, constructed of a steel frame and metal-stud walls with stucco

facing, comprises two medical modules and shared laboratories. Phased plans call for the addition of two more modules and a dental suite. The jury remarked that the clinic "handles the problem of scale very well through its design of entry and window elements. We also admired the interior detailing, but worried what the back of the building will look like when all of the medical modules are constructed."
5. Clayton General Hospital Child Care Center, Riverdale, Georgia; Nix, Mann and Associates, Inc., Architects. The center is a 24-hour service for hospital employees, capable of accommodating as many as 80 children. According to the architects, the facility offers "no commerce, no pop culture, no domestic haven; it attempts to

Entries in the 1982 Georgia Association, AIA Awards were reviewed in two categories: projects built after January 1, 1977 and projects to be under construction by January 1, 1983. The eight completed buildings appear below, along with the three uncompleted projects given "Awards for Design." The Georgia jury consisted of Chicagoans James L. Nagle, FAIA (jury chairman); Stuart E. Cohen, AIA; Ben Weese, FAIA; and John Zukowsky, an associate curator at the Art Institute of Chicago and visiting professor of architectural history at the University

of Chicago. Awards news continues on pages 66-67, with reports on buildings honored by the Michigan Society of Architects and the Prestressed Concrete Institute.

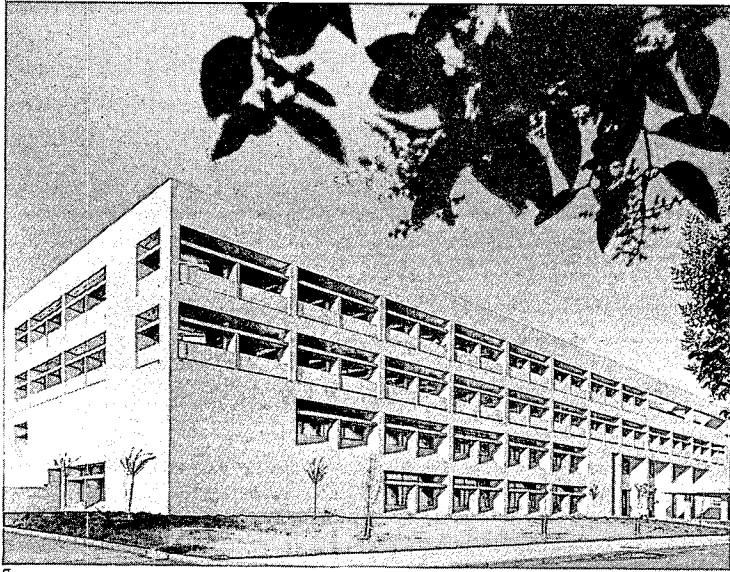

7

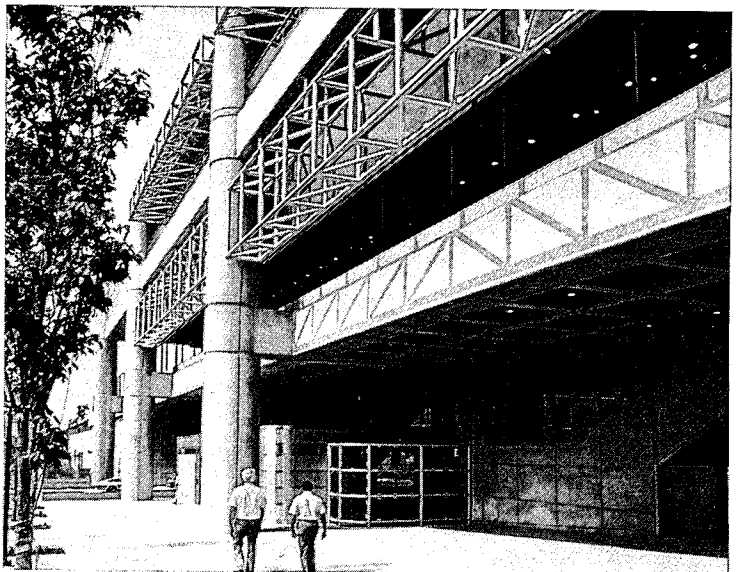

8

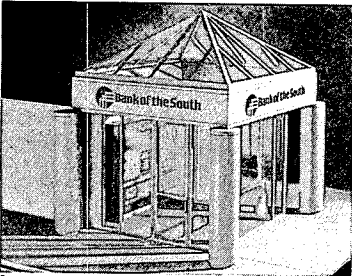

9

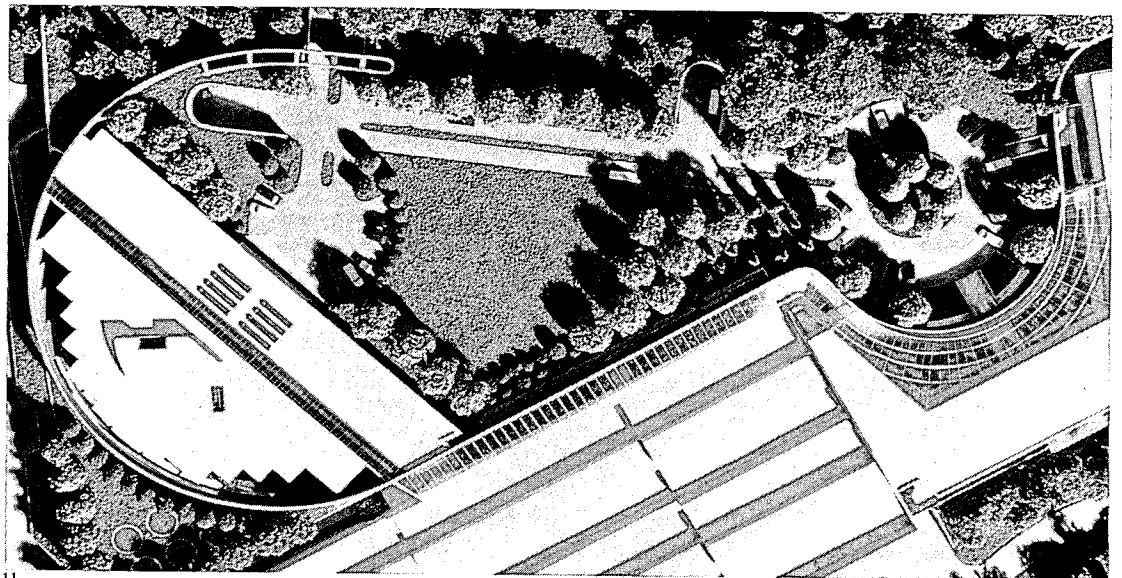

11

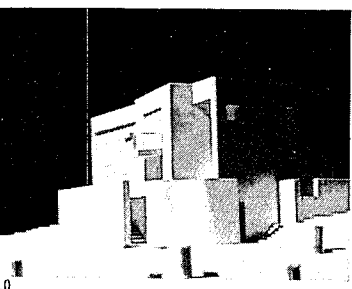

10

provide a clean framework of order as a backdrop for the stimulation of interest as well as play." The jury noted the building's kinship to the work of Aldo Rossi, adding, "We appreciate...the primary geometric shapes and colors, which give the building an appropriate childlike quality...."

6. Herman Miller Roswell Facility, Roswell, Georgia; Heery & Heery, Architects & Engineers, Inc. (see RECORD, January 1983, pages 122-127). "High-tech is alive and well in this superbly designed industrial building. Inventive detailing and elegant proportions set this building apart from what has become a style for this type of structure and place it in the best tradition of the Van Nelle tobacco factory in Holland."

7. Queen Alia Heart Institute, King Hussein Medical Center, Amman, Jordan; Heery & Heery, Architects & Engineers, Inc. This 100-bed cardiac treatment facility is the first component of a health system planned for Jordan's military services. Sun screens are an integral part of limestone-clad facades. "A complex, well-planned building appropriate to its climate," said the jury. "Some of the best hospital work we have seen. The exterior is beautifully proportioned and detailed—the lessons of Le Corbusier well learned."

8. Garnett Street Marta Station, Atlanta, Georgia; Cooper, Carry & Associates, Inc., and Jones & Thompson, Joint-Venture Architects. The station forms a transition between subway and elevated lines. Post-

ensioned waffle-slab construction contrasts with fluted stainless-steel wall panels in public areas. "Almost a non-building, but a straightforward, relaxed, and open expression of a difficult public problem."

9. Prototypical Automated Teller Unit, Atlanta, Georgia; Jova/Daniels/Busby, Inc., Architects. Steel columns, two feet in diameter, are painted to match silver-gray exterior porcelain-panel walls. "This kiosk creates a strong corporate image from the primary elements of architecture. It is...an identifiable reference to the classical bank, and more profoundly, to sources such as Laugier's 'primitive hut'—without being cloying."

10. Pickering Residence, Laurel, Mississippi; Anthony Ames, Architect. "What in lesser

hands would have been yet another 'grid-shift' house, this design shows skill and restraint. [We] were reminded of Meier's Shamberg pavilion—brought into the 1980s by the combination of both continuous and traditionally designed space."

11. Black and Decker Manufacturing Company Corporate Headquarters, Towson, Maryland; FABRAP, Architects, Inc. Scheduled for completion of first-phase construction in 1985, the 80,000-square-foot office complex will adjoin older buildings on a 27-acre site. The jury praised the "imaginative connection of new and existing structures by an element resolving difficult geometries and juxtaposed buildings. The circulation link becomes a sinuous ribbon 'packing' the buildings...."

colorful tile-clad cylindrical bays housing coat and boot alcoves.

19-degree day without mechanical heating.

Architectural Record March 1983 65
once, public restrooms, and a picnic area. A walkway through the center of the cluster, leading from parking to the beach, allows for natural ventilation.

Prestressed Concrete Institute Awards



Galen Court duplex. Builder: Northshore Development
Architect: O'rack Inc.

THE LOOK. NOW TWICE AS FAST.



New Shakertown Colonial II cedar shingle siding will give you the look you want. Twice as fast. Twice as easy.

With two 7" courses per panel Colonial II cuts application time by half over regular 7" lap siding and by three-fourths over individual shingles. Only eleven panels are needed to cover 100 sq. ft.

Colonial II panels are self-aligning which eliminates

measuring and chalk-lining after the first course. Panels are full 8' length with no shorts, no grade fall down and very little waste. Color matched nails are included with only two nails per stud required.

Matching mitered corners complete the system. Get the full story on Colonial II.

Call Joe Hendrickson at
1-800-426-8970.

Shakertown Siding

Box 400, Winlock, Washington 98596 (206) 785-3501

Circle 37 on inquiry card

Jails and prisons

There is more to the widely publicized crisis in America's jails and prisons than the riots, fires, and overcrowded cells that make the headlines. Beyond the danger and grim surroundings that, after all, are everyday facts of life at most such institutions, there is a pervasive uncertainty about the basic goals of our correctional systems. During the 1960s, "Great Society" policy makers were convinced that the overriding goal should be rehabilitation, and architects followed suit with more "normative" facilities. By the end of the '70s, however, this mission had lost its cogency—at least in the eyes of many lawmakers. A steadily rising crime rate, lack of evidence that correctional facilities do in fact rehabilitate criminals, and the ascendancy of the New Right stirred public support for stricter sentencing and more punitive confinement—even as Court rulings established minimum standards for inmate safety, health care and other fundamental rights. The corollary of these sometimes conflicting developments would seem to be that prisons should punish, but do so humanely. Too often, though, literal-minded adherence to these ambiguous guidelines merely produces warehouses for people.

The need for effective design grows ever more acute, since the demand for adequate jails and prisons has created a building boom. Last year alone, state governments spent some \$800 million on 90 prisons to be occupied by the end of 1985. The projected total for state and Federal commissions over the next decade is nearly \$8 billion. Given the great cost and complexity of corrections facilities, clients are increasingly turning to architects for guidance in even the earliest stages of programming (a specialist in criminal justice design examines this process in an article on page 99). The projects shown in the following pages illustrate the enormous range of technical, political, and philosophical questions that architects of jails and prisons are called upon to answer. In view of the different roles of county, state, and Federal facilities, and the special issues of adaptive reuse and legal entitlement, there can be no single prototype with universal applications. Nevertheless, one can trace common principles that typify the best of current correctional design: a larger measure of decency than minimum standards require, and a dedication to reducing the stress of confinement for inmates and guards alike. Above all, one finds flexible planning that can weather future policy changes with its own purpose intact. *Douglas Brenner*

Dispensing a modicum of liberty

Contra Costa County Detention Facility
Martinez, California
Correction Facility Architects

Among the usual group of inmates' families and lawyers registering for visitors' passes to the Contra Costa County Detention Facility, there is often an out-of-state architect or corrections expert, drawn here by the building's national reputation as one of the most innovative, and controversial, projects of its kind. The true novelty of the 383-bed maximum-security jail lies not in the decidedly *un-jail-like* mien of its sun screens, landscaped grounds, and skylit patio. Nor is there anything radically new in the provision of telephones, television, exercise equipment, and lounge furniture in housing module common rooms (photos overleaf). While hardly commonplace, this standard of amenity culminates a trend throughout the 1960s and '70s toward abandonment of the outward symbols and excessive rigors of incarceration. Contra Costa's more significant departures from longstanding practice center on the relative lack of restrictions upon inmates' mobility and the high degree of face-to-face interaction between inmates and custody staff permitted by the physical layout. All standard housing modules adjoin outdoor recreation courts through unlocked doors, to which inmates have free access during the day. Instead of immuring himself within a conventional control booth, entirely shielded by steel and security glass, the guard assigned to each housing module stands at an open desk, similar to a hospital nursing station (electronic signaling devices link staff to a central control post). Correction Facility Architects assert that in creating a less regimented, more "domestic" environment than that of most cell blocks, they help to defuse the tension that triggers disturbances—and enable supervisors to keep closer watch on potential troublemakers.

Basic to the success of this system is a rigorous program for dividing inmates into manageable classification groups, distributed among nine housing modules. Because of the comparatively short terms served in county facilities, and a large proportion of unsentenced inmates under considerable stress, jail populations tend to be less predictable than those of prisons. Consequently, many jails are designed to maximum security standards in every detail. At Contra Costa, the most formidable (and expensive) structural security has been concentrated in the perimeter enclosure and the walls between housing modules. Inside the modules and program spaces, it is presumed that the range of amenities and free movement will act as incentives to self-control, allowing CFA to specify less costly "normal" fixtures and furniture. In any event, there is a firm safety clause in Contra Costa's social contract: inmates who abuse their privileges or pose an active threat to others are removed to a spartan "separation module."

In locating spaces for recreation and dining within each housing module, CFA sought to reinforce the isolation of classified groups and avoid the expense, complicated logistics, and security risk of marshalling large numbers into central facilities. A completely separate network of corridors and stairs permits inmates' families and counselors to walk unescorted to visiting rooms adjacent to housing modules. Of course, the ingenious planning that coordinates these systems is, by itself, no panacea. Staff must have the training, commitment, and assurance of adequate back-up to feel secure on the job without the protection of physical barriers and quasi-military discipline. It is also essential that inmates believe they hold enough of a stake in the future to respond to positive incentives—a reasonable expectation, perhaps, in a county jail, but open to *question in prisons where violent offenders* sentenced for several decades or life may feel they have little or nothing to gain through self-restraint.

Douglas Symes photos



CFA's detention center is the second jail designed for this site. The earlier proposal, a high-rise scheme by another firm, far exceeded the county's budget and drew stiff opposition from Martinez residents, who found it incompatible with the small scale of nearby houses and commercial buildings (site plan overleaf). The \$25-million project actually built won community support in a public

environmental impact review. CFA used landscaped berms and irregular massing to diminish the structure's apparent size. Textured and colored precast surfaces, splayed jambs, and recessed panels counteract the dungeon-like appearance of cell windows. Similar devices created pleasant surroundings in the central courtyard used for group recreation and outdoor visiting (below).



The habitable Tombs

Manhattan House of Detention for Men
New York, New York
The Gruzen Partnership, Architects

No matter how many sociological euphemisms the modern jailor employs, his domain is still charged with primitive emotions. For this reason alone it seems certain that New Yorkers will continue to call the Manhattan Men's House of Detention by its evocative nickname, "The Tombs." This name was first applied to an Egyptian Revival bastille erected in 1838 and demolished in 1902. The present Tombs is an Art Deco jail and courthouse complex designed in the late 1930s by Harvey Wiley Corbett and Charles B. Meyers. The jail, a 21-story tower connected to the courts by Gotham's own Bridge of Sighs, is currently undergoing a \$33-million interior remodeling by the Gruzen Partnership (the jail appears at extreme right in the photo below). Originally intended to house 835 inmates, the jail had reached a capacity of 1,040 by 1974, when substandard living conditions caused the facility to be shut down by court order. In addition to overcrowded, noisy, and poorly ventilated cells, and a dearth of program space, one of the chief complaints of Tombs inmates and staff had been a profoundly debilitating loss of any sense of time and seasonal change. All exterior windows were filled with translucent glass block, and cells occupied the core of the tower, further removing them from the murky daylight. Although the internal layout of the building required nearly total reconstruction, its fine limestone facades are being preserved meticulously. (Corbett had been one of the architects of Rockefeller Center, and he employed similar vertical massing and Moderne decoration at the Tombs.) The cost of renovation is appreciably below that of a comparable new structure, and the site in the downtown justice complex remains as convenient as ever.

Working within the framework of existing floor heights and intermediate mezzanines, Gruzen has subdivided the tower vertically into three six-level management units or "mini-centers," each of which comprises five 32-35 bed housing units, a range of recreational/vocational spaces, and other rooms for counseling and educational programs. All 425 inmates have single cells with security vision-glass windows replacing glass block (the external fenestration pattern is unaltered). Cells are clustered in double tiers around split-level day rooms, with special nooks for television and meals. Diagonal steps, balconies, and chamfered corners form as visually complex an environment as is feasible within the sight lines from the glass-enclosed control post inside each housing module. Stacked in vertical series, these control booths also command an uninterrupted view of open-riser stairways that connect the different levels of each mini-center. Except where security requires strict segregation of housing units—in which case particular stairway entries may be locked—inmates are free to use these stairs to reach program areas located in the two middle levels of each six-story management center. The location of program areas minimizes the distance any inmate has to travel, and yet the options for individual circulation help to convey the impression of a variety of spatial experience in close quarters, without sacrificing thorough supervision—a classic dilemma in high-rise facilities. Because the inhabitants of any given mini-center have been screened upon admittance, it is possible to allow full use of shared program areas without assembling undesirable mixtures of inmates. In order to reinforce this insulation, each mini-center has only one main entrance through a sally port at its elevator stop (service elevators, which convey food and deliveries, are accessible from within the mini-center only during an emergency). Inmates need not be escorted except when traveling to and from new rooftop recreation decks or central facilities such as the intake department, visiting rooms, and infirmary, all of which are located on the ground floor.

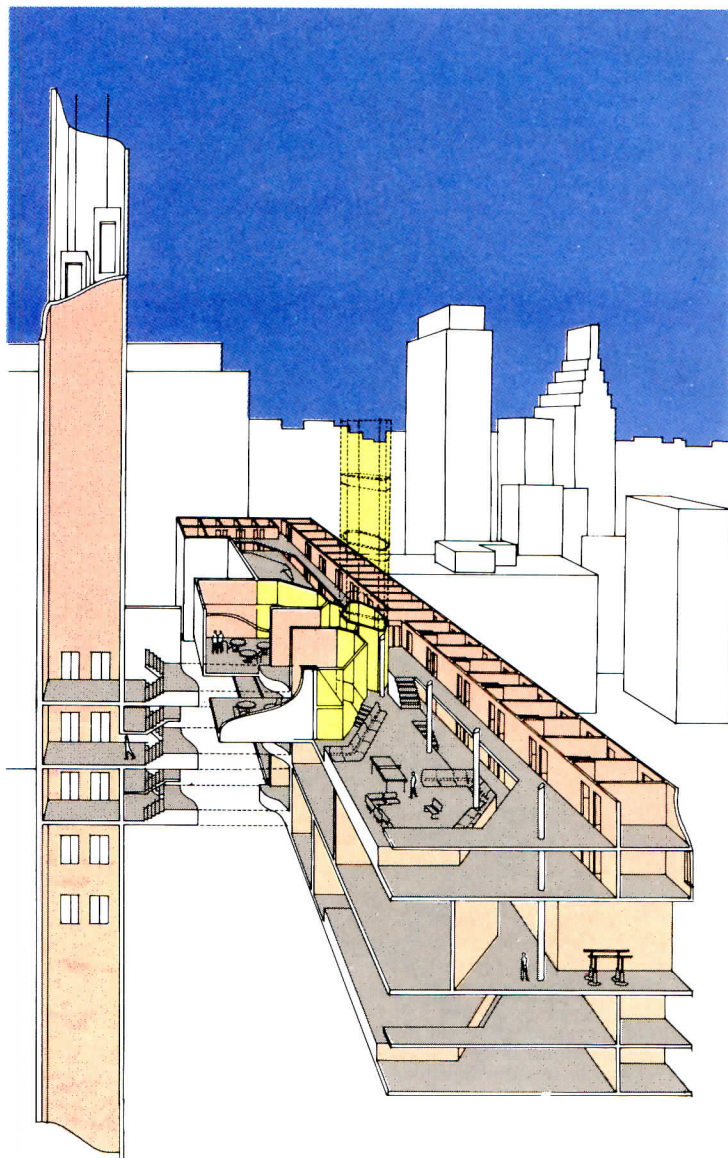

The Bettmann Archive

Manhattan House of
Detention for Men
New York, New York

Owner:
City of New York

Architects:
The Gruzen Partnership—Paul
Silver, FAIA, partner-in-charge;
William D. Wilson, FAIA, project
manager; Frank Repas, project
planner; William P. Bellsey, AIA,
project designer; Adrian Kerod, job

captain; Peter Samton, FAIA,
design director

Engineers:
Severud Perrone Szegezdy Sturm
(structural); Kallen & Lemelson
(mechanical/electrical); Rosser
White Hobbs Davidson McClellan
Kelly, Inc. (security)

Consultants:
Romano/Gatland (food service);
Amis Construction & Consulting
Services, Inc. (estimating);

Gabrielle Roos (color)
Construction manager:
Morse/Diesel, Inc.

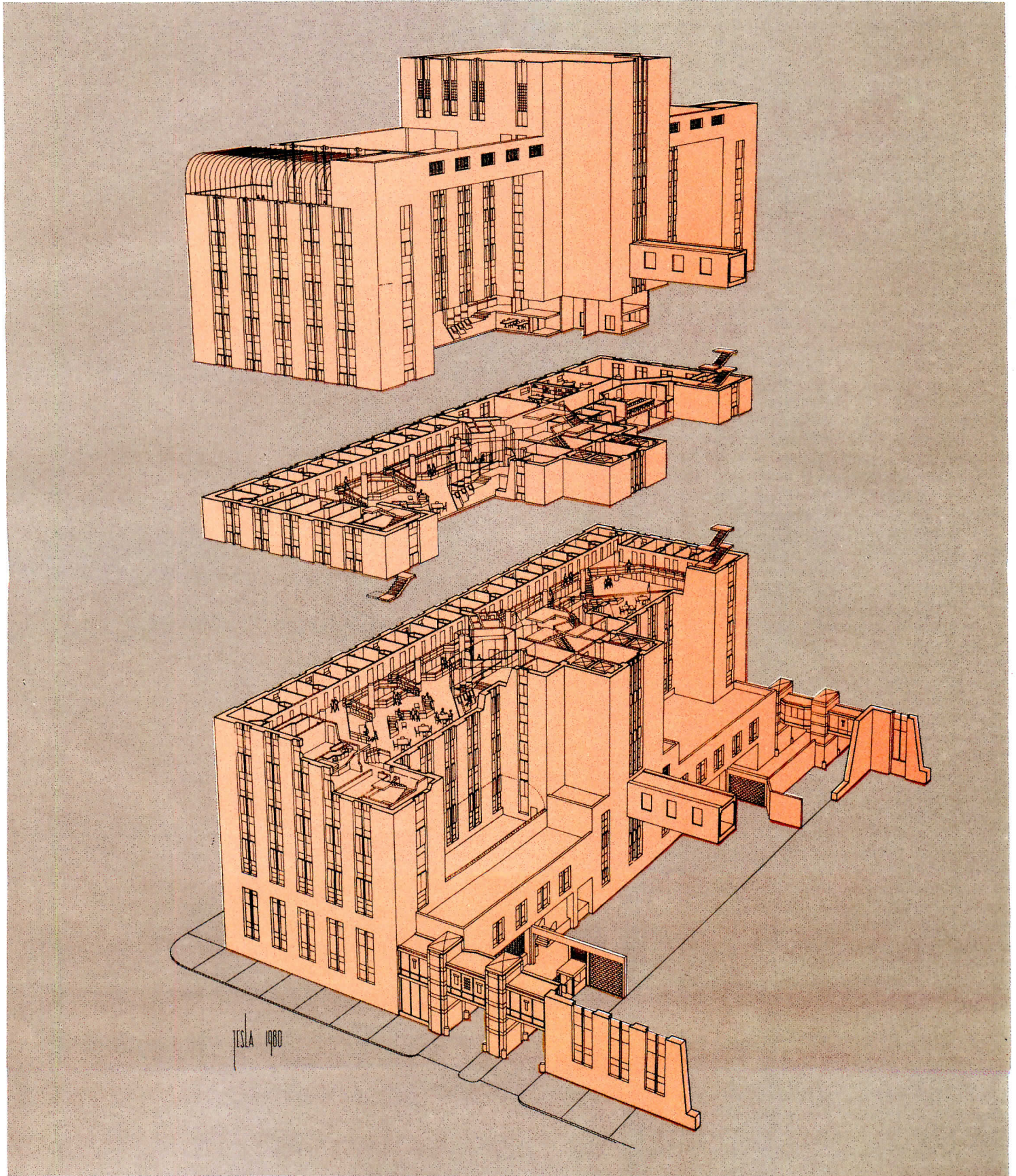

Maximum-maximum security

Rehabilitation of Trenton State Prison
Trenton, New Jersey
The Gruzen Partnership/The Grad Partnership,
Joint-Venture Architects

"Labour, Silence and Penitence. . . That those who are feared for their crimes may learn to fear the laws and be useful." So reads a plaque on the Trenton Penitentiary House built in 1797, now the warden's residence at Trenton State Prison. The ideal of edifying travail expounded in this motto derives from the Quaker reformers who established some of America's earliest correctional institutions. Their work inspired the so-called Pennsylvania prison plan (rows of individual cells with exterior windows, radiating from a central guard house), a scheme which still survives at Trenton State Prison in a 147-year-old Egyptian Revival structure designed by noted penitentiary architect John Haviland (photo above right, plan opposite). Between 1860 and 1907, much of the open ground within the outer walls was filled in with more cell blocks and a congeries of maintenance buildings and sheds. The prison has been notoriously crowded almost since it opened, but the state of New Jersey remains convinced that the accessibility of an inner-city location for visitors and prison employees outweighs the disadvantages of a site with limited room for expansion. A joint-venture team from the Gruzen and Grad partnerships devised a multi-phased plan for partial renovation of existing facilities and the construction of two new housing blocks: a 450-bed maximum-maximum security unit and a 400-bed maximum security unit. The maximum-maximum classification is not hyperbole: over 70 per cent of the people confined here have been convicted of violent offenses.

According to Grad and Gruzen's initial plan, once the "max-max" unit had been finished, two existing cell blocks would be demolished. Clearance of all other old housing would begin with the completion of the maximum-security unit, and the resulting open space would be used for recreation (plan below). Ultimately, however, in view of an ever-expanding inmate population, the state insisted upon a revised scheme that retains all existing cell blocks. Gary J. Hilton, warden of the prison during the planning of the new facility, and now New Jersey's assistant commissioner of corrections, says "Trenton has to be a 'stopper.' We needed a place that could deal with a severe backlog of persons serving stipulated minimums of 20 years and up. It doesn't take long before you get a hostile group. From the standpoints of control and constitutional entitlement, Trenton was intended to deal with anybody the state might send us."

In order to build the project without interrupting prison operations, all new housing has been constructed outside the old eastern walls, with sawtooth bays taking full advantage of the constricted site. The great pharaonic pylon of Haviland's Front House is still visible within a major circulation spine, but it now serves as a security checkpoint and the hub for food distribution and access to playing fields. Instead of confronting this grim portal, visitors now enter a skylighted atrium that resembles the lobby of an ordinary municipal office building (photo page 91). Because the inner life of the prison must be out of sight of the surrounding residential neighborhood, the new structure is an introverted compound, with perimeter walls rather than fences creating a secure enclosure. Visiting areas and cells overlook landscaped courtyards planted with flowering trees (photo opposite). These walled gardens give inmates a rare glimpse of nature, create a reassuring background for visitors, and a less stressful working place for prison staff. Inside the 48-man housing units, furniture is austere and acoustics are harsh, though the architects have tempered this severity with irregular polygonal volumes and bright color (photos overleaf). Nevertheless, when the guard in the glass booth slides shut 48 steel doors by remote control, the clang still echoes the old command, "fear the laws."

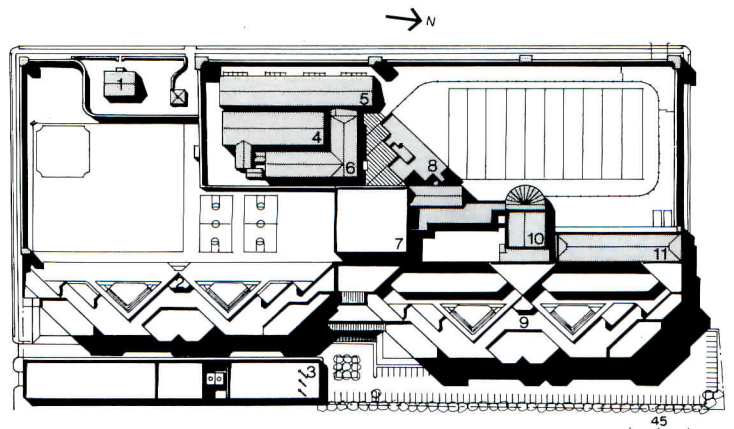
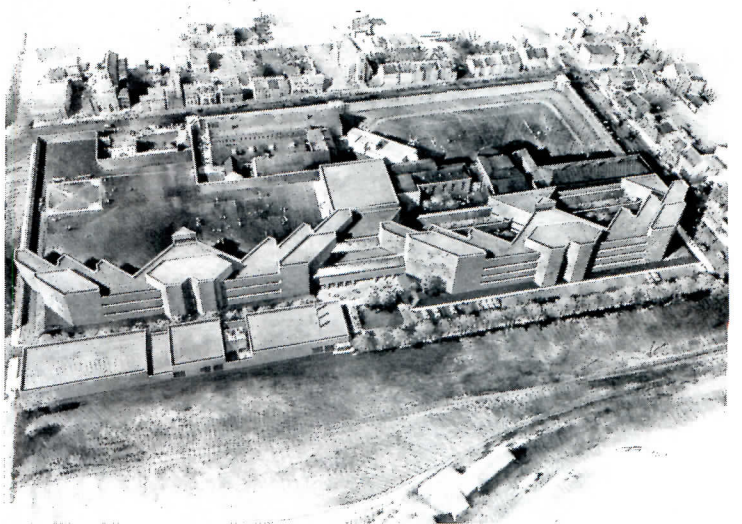
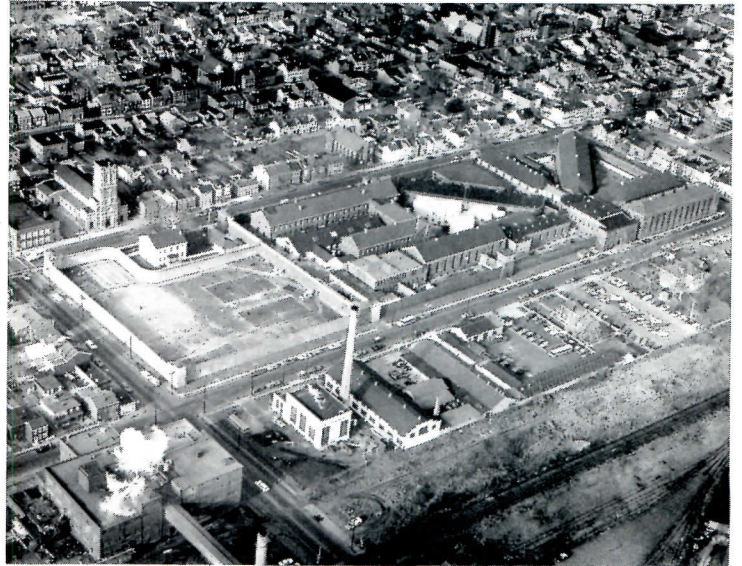

The Egyptian Revival "front house" and spoke-like wings of Haviland's 1836 penitentiary appear in the photo opposite, taken before the present rehabilitation. Also visible is the later in-fill of housing blocks constructed on the Auburn plan (back-to-back windowless cells facing lateral corridors) and a warren of other buildings crammed within the brownstone walls. The plan on this

page records Gruzen and Grad's concept for the first major phase of construction; the bird's-eye view and plan opposite below represent their vision of a fully renovated prison. As it now stands, Trenton represents a fusion of the two plans, since a desperate need for prison beds compelled the state to preserve all existing cell blocks. The project also includes the remodeling of

vocational education facilities, kitchens, and laundry, and construction of a gym, power plant, and staff service areas. The new facilities are poured-in-place concrete structures, with outer walls of brick over metal-doweled concrete blocks with solid grout. Though it still lacks hoped-for open recreation space, the expanded complex offers courtyards and rooftop exercise decks (below).

©Michael Spozarsky photos



1. Warden's residence
2. New 400-inmate maximum-security facility
3. New powerhouse
4. Vocational school
5. Industrial building
6. Print shop
7. New recreation facility
8. Classroom and office
9. New 450-inmate maximum-security facility
10. Front house
11. Cell wing to be renovated
12. Powerhouse
13. Storage and office
14. Visiting
15. Warehouse and garage to be partially demolished
16. Hospital
17. Cell wing
18. Kitchen
19. Dining and assembly
20. Cell wing to be demolished

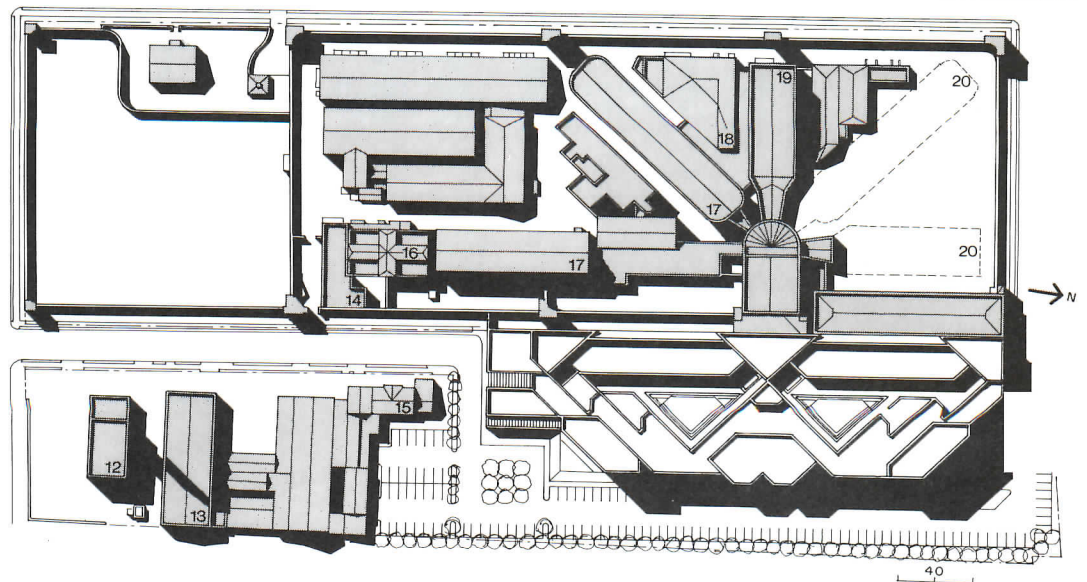

1. Lobby
2. Control station
3. Visitors waiting
4. Contact visiting
5. Outdoor visiting
6. Hearing room
7. Attorney visiting
8. Inmate waiting
9. Non-contact visiting
10. Branch library
11. Classroom
12. Vocational

13. Landscaped recreation
14. Medical
15. Psychological
16. Future link to kitchen
17. Unfinished space
18. Flexible housing (kitchen, phase 2)
19. Holding rooms
20. Intake officer
21. Vehicle sally port
22. Central control

23. Main level activity space below
24. Upper level day space
25. Front house
26. Recreation
27. Main level activity space
28. Lower level day space
29. Pantry

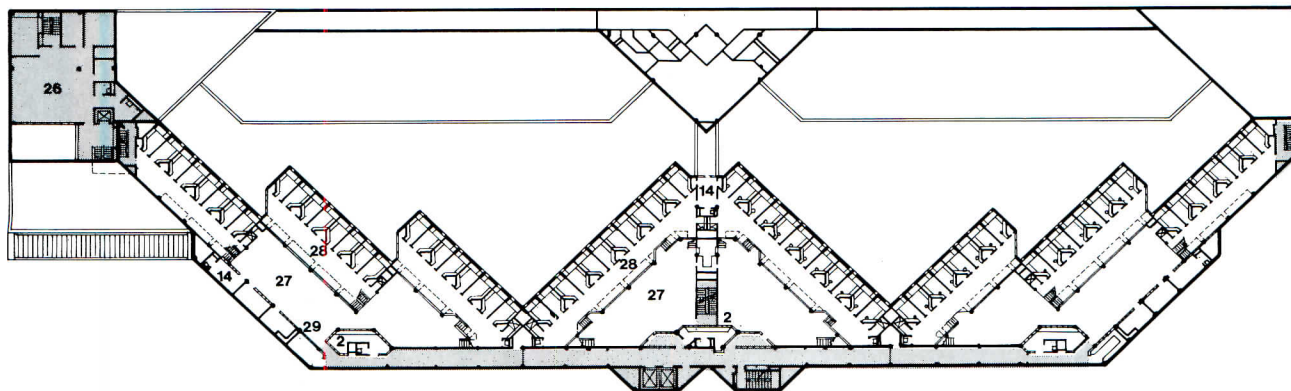

THIRD LEVEL

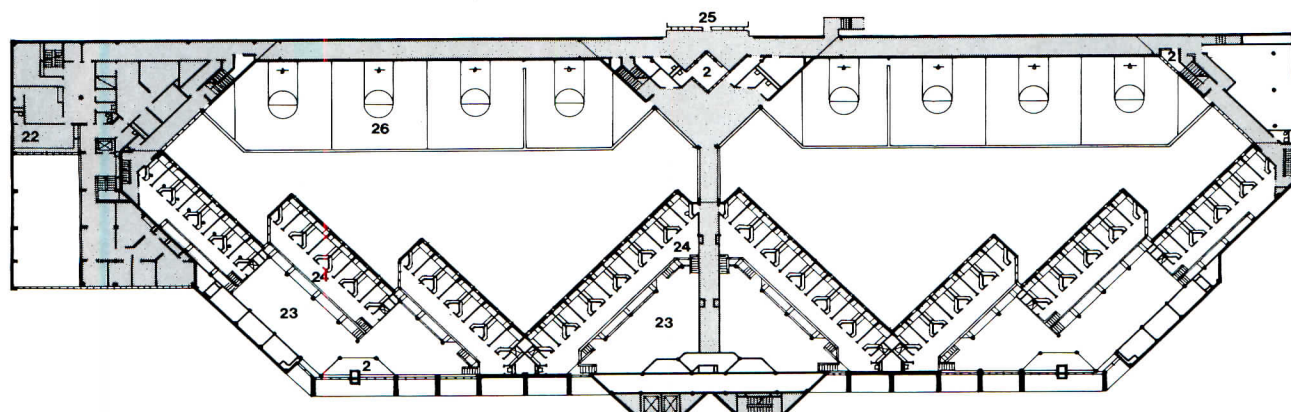

SECOND LEVEL

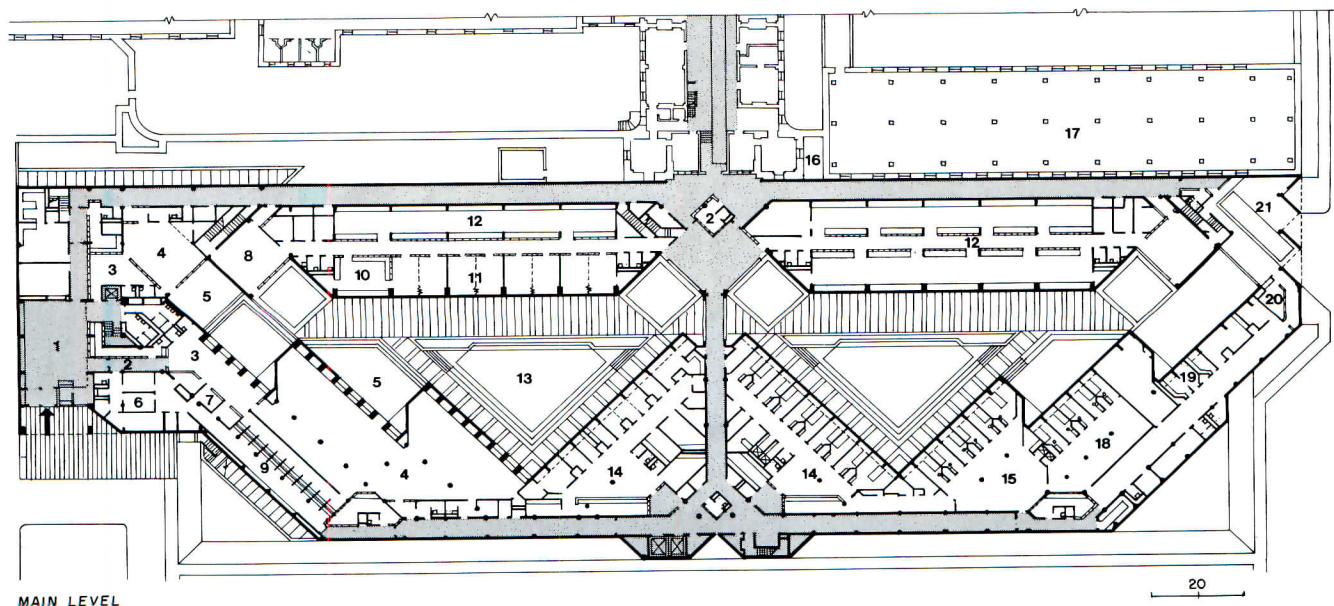

MAIN LEVEL

Rehabilitation of Trenton State Prison
Trenton, New Jersey
Owner:
New Jersey Department of Corrections
Architects:
The Gruzen Partnership/The Grad Partnership, a joint venture—
Michael Savoia, AIA, partner-in-charge; Burton W. Berger, AIA, project director; Paul Silver, FAIA,

justice design partner; Peter Krasnow, AIA, project designer; Martin Frauwrth, AIA, project manager
Engineers:
Paulus, Sokolowski & Sartor/Herbert A. Wiener, a joint venture (structural); Kallen & Lemelson (mechanical/electrical); Andrews & Clark (site and civil)
Consultants:
Romano/Gatland (food service);

Amis Construction & Consulting Services, Inc. (estimating)
General contractor:
Terminal Construction Corp.
Contractors:
Fluidics Inc. (hvac); A. Neri Inc. (electrical); Edwin J. Dobson (plumbing)



The double tier of cells in each 48-man module faces into a common day room (lower left) which subdivides into a multipurpose activity space and eating area. Trenton State's former dining hall, where as many as 1,200 prisoners would gather for meals, was a likely place for riots to start. Food now comes in bulk from a central kitchen to a kitchen in each module, where it is reheated.

Inmates confined in "isolation" receive trays through a food pass built into the wall alongside the cell door. Interior fittings in all living areas are fire- and vandal-resistant. Each cell has its own smoke evacuation system. Push-button plumbing eliminates handles that can be pulled off and used as weapons. Sliding motorized doors are safer than the standard hinged type, which can be swung into the



faces of passers-by in surprise attacks. Individual and gang door controls are part of the battery of electronic devices inside the guard station, which is raised for maximum visibility. Trouble lights for smoke detectors, fire alarms, patrol tour checkpoints, and guards' body alarms all register on a computerized console, part of a prison-wide network that feeds into a control center overlooking the

main lobby. The office-lined lobby (above right) is a crucial node in the circulation pattern, which effectively segregates prisoners, staff, and visitors. Color coding differentiates these linear paths and various functional zones. Multizone air conditioning contributes to over-all energy efficiency, and roof-mounted solar collectors heat nearly a third of the prison's domestic hot water supply.

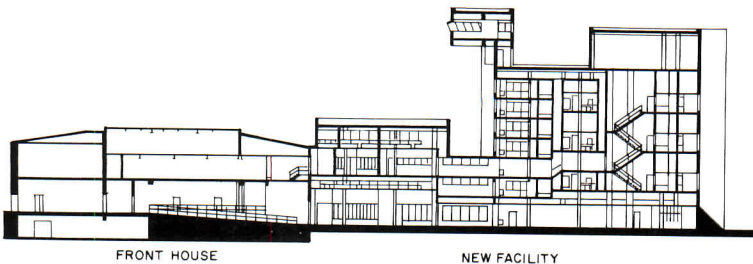

Jails within a jail

Spokane County Correction/Detention Facility
 Spokane, Washington
 Walker McGough Foltz Lyerla, P.S., Architects

A narrow urban site, the need for a direct link to existing justice buildings, and the desire for minimal staffing determined the mid-rise configuration of the Spokane County Correction/Detention Facility. When it is completed in 1985, the tower will mark the northern boundary of the city's government center, which includes the French Renaissance Revival county courthouse, a major Spokane landmark built in 1895, and the Public Safety Building designed in the late 1960s by the architects of the new jail. Even though existing detention facilities in the latter structure represented advanced planning when they were installed, changing criminal justice standards and a growing influx of detainees have rendered them obsolete.

The layout of the projected 391-bed institution conceives the entire plan as a composite of many small jails. Above the ground-floor operations headquarters, there are two bi-level housing modules to a story, jointly served by a circulation core. Inmates sleep either in dormitories or in single rooms opening onto a multipurpose living area, which in turn gives onto an external recreation deck. Outdoor recreation is a rare-enough amenity in any urban jail, and the proximity of these decks eliminates the need for special staff escorts. Visiting, counseling, food, and other services are all brought into the cell areas, and as at Contra Costa, it is proposed that staff will supervise housing modules from open stand-up desks. Of course, the success of this system depends on a thorough appraisal of inmates' potential security risk during intake classification. Most new inmates will move directly to dormitories, single rooms being regarded here as an earned privilege. At present, the client considers dormitories the most practical housing for weekend or other very short-term inmates, although the architects have allowed for possible partitioning of these communal spaces in case the county should later decide to convert them to individual cells. A special housing area has been designated for inmates under protective custody, and there is a high-security module for the dangerous or escape-prone, and other disciplinary cases. An enclosed pedestrian bridge furnishes secure passage from a second-story mezzanine in the new detention center to the third floor of the Public Safety Building, parts of which will become a courtroom and court staging area. In contrast to the jail's multifaceted internal organization, its public aspect—especially the elliptical niche facing the government center and downtown Spokane—is meant to express a unified image of civic dignity.

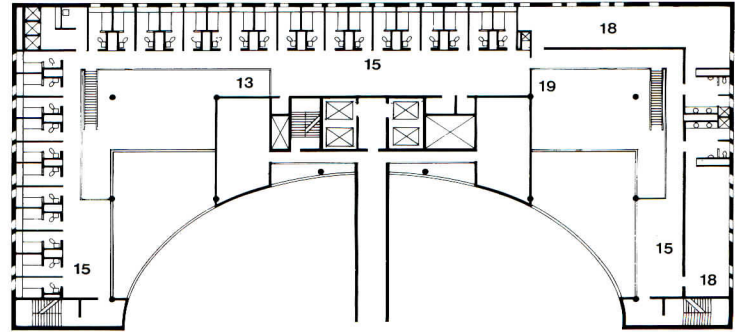

SECOND LEVEL MEZZANINE

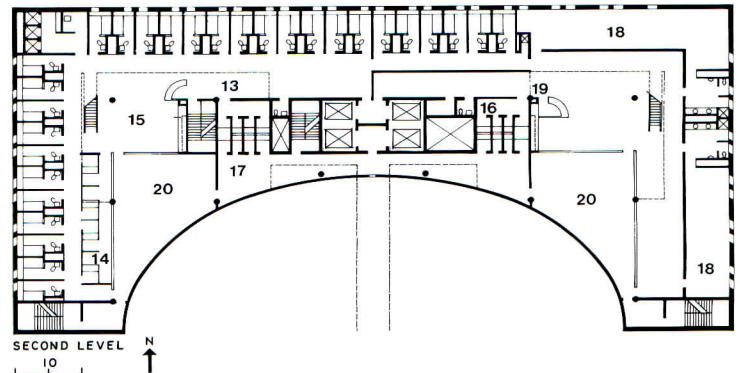

SECOND LEVEL

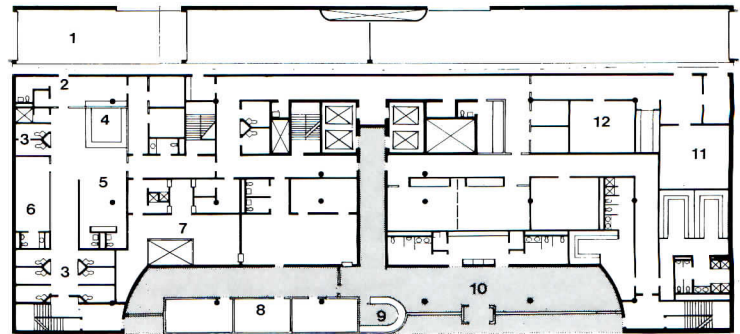

FIRST LEVEL

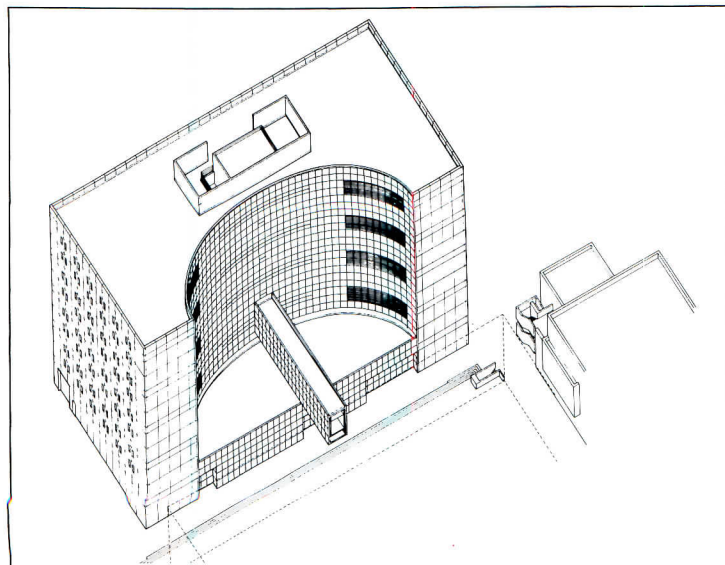

- 1. Auto sally port
- 2. Law enforcement lobby
- 3. Holding
- 4. Booking
- 5. Waiting
- 6. Observation
- 7. Clothes issue
- 8. Office
- 9. Reception
- 10. Public lobby
- 11. Commissary
- 12. Library
- 13. Classification housing
- 14. Interview
- 15. Day room
- 16. Inmate visiting
- 17. Public visit
- 18. Dormitory
- 19. Inmate worker housing
- 20. Outdoor recreation

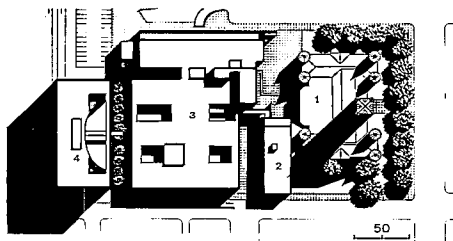

- 1. Courthouse
- 2. Courthouse annex
- 3. Public Safety Building
- 4. Detention/Corrections Facility

Spokane County Correctional
Detention Facility
Spokane, Washington

Owner:
Spokane County

Architects:
Walker McGough Foltz Lyerla,
P.S.—Gerald Adkins, director of
design; Gordon Ruehl, project
manager; Kirk Wise, project
designer; Larry Hurlbert,
project architect

Engineers:
Riley Engineering, Inc.
(mechanical and electrical)
Consultant:
George Bundy (food service)

Photography Unlimited

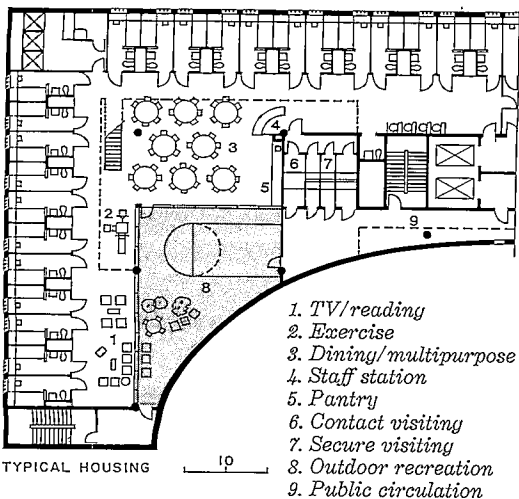
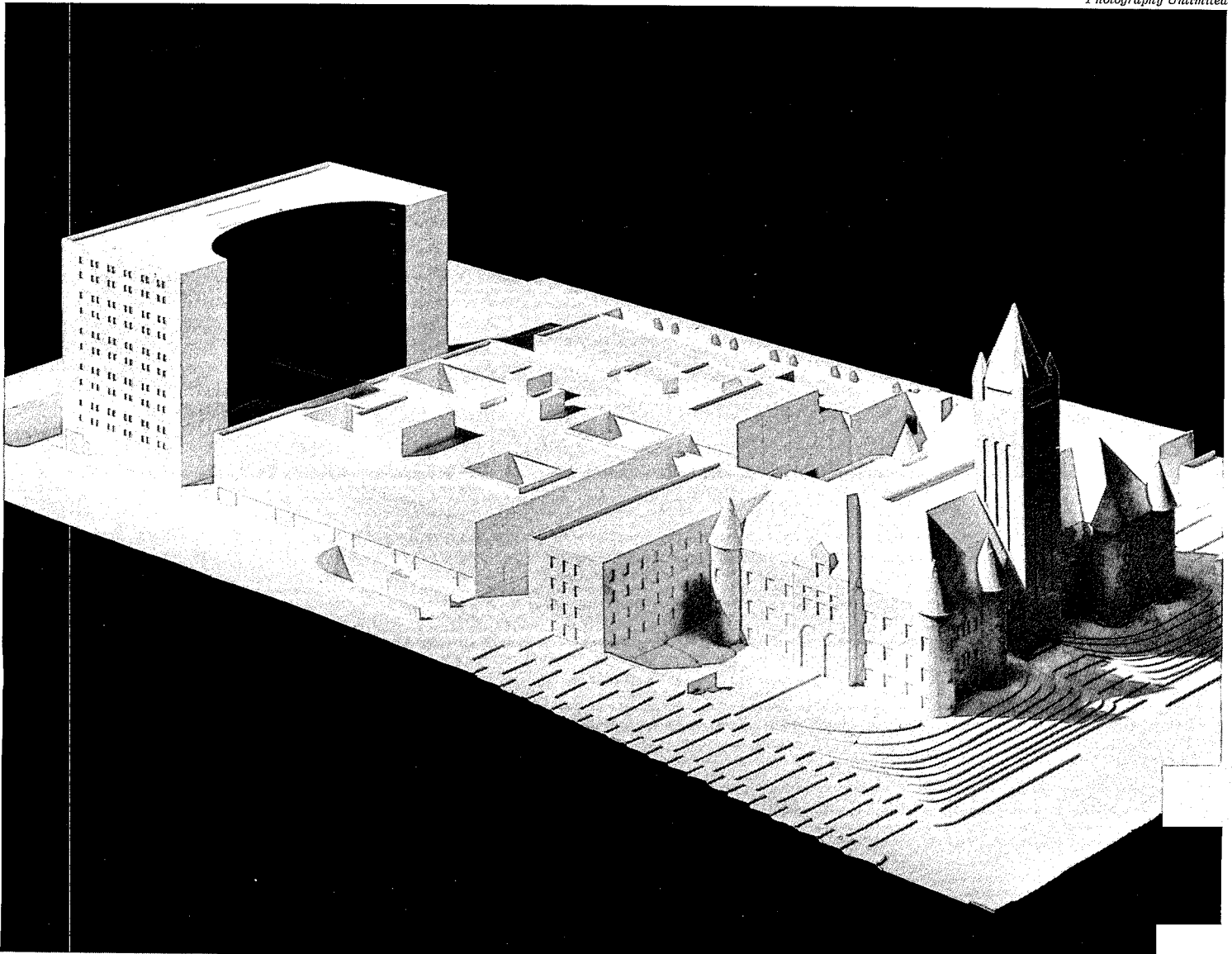

- 1. TV/reading
- 2. Exercise
- 3. Dining/multipurpose
- 4. Staff station
- 5. Pantry
- 6. Contact visiting
- 7. Secure visiting
- 8. Outdoor recreation
- 9. Public circulation

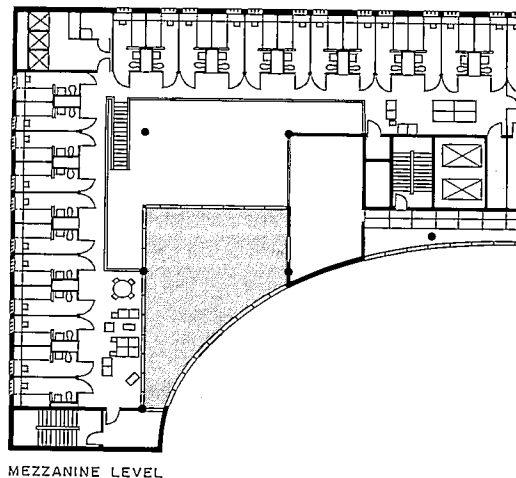

In line with Washington jail standards requiring all jails to be designed for potential expansion of 25 per cent, the model above shows an alternative version of the detention facility, two stories taller than the projected height. The structure is to be reinforced concrete, with panels of exposed aggregate. A curtain wall, with steel-pipe screens enclosing the recreation decks, clads the south-facing niche.

The nurture of rural industry

Washington State Medium Security Prison
 Monroe, Washington
 TRA Associates; Hellmuth, Obata & Kassabaum,
 Associated Architects

Legislatures and government agencies across the country have been backing away from inmate education and "life enrichment" programs, but the state of Washington's Secretary of Corrections Amos E. Reed (who is also past president of the American Correctional Association) affirms the continued importance of what he calls "the helping component" of prison. "I don't know of anybody who can't be helped to some degree," says Reed. "I fully subscribe to the improvement of prisoners' behavior, within the bounds of reason and available resources." The new Washington State Medium Security Prison (scheduled for completion by the end of this year) addresses this task through the resources of technical training and prison industries. It is estimated that nearly three-quarters of the 500 inmates to be housed here will work in the 50,000-square-foot industries section, an open space that lends itself to adaptation for changing uses.

Two correctional facilities already occupy other segments of the prison site, but there was ample room on the 350-acre rural tract to lay out the \$26-million institution as an independent complex, comprising some 25 acres within its own double-perimeter fence. Architects TRA and HOK have located the new buildings in a meadow, where hills and forest block views of the prison from the town of Monroe and a nearby highway interchange. The campus-like cluster of one- and two-story structures—four radial-plan housing blocks and a linear "support structures" framing a landscaped quadrangle—reflects the client's desire for a low-keyed residential atmosphere that would further cooperation between inmates and counselors. Security elements are purposely unobtrusive, yet all-encompassing, and the entire facility is flexible enough to be reclassified maximum security with few alterations. An efficient staffing ratio at *any* security level was paramount in the design of inmate housing. Owing to the alignment of cells along two-story wings radiating from glass-enclosed activity rooms, it is possible for one guard in a pivotal control booth to scan the living areas of 125 men. This 90-degree sweep also takes in the open quad, which is used for general circulation and recreation. Additional staff will rove through the wings, each of which is monitored by a counselor. Vertical steel doors at strategic points throughout the prison can roll down to contain riots or other disturbances. Outside, staff manning guard towers and a hilltop patrol road will constantly supervise the zone between the quad and the perimeter fences, an area that is off-limits to prisoners.

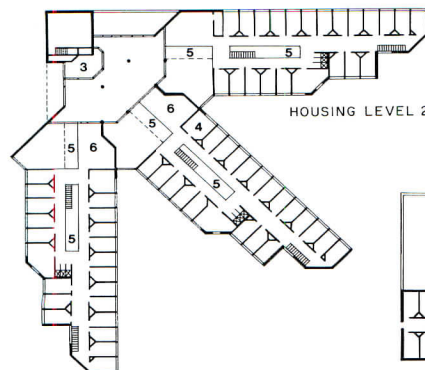
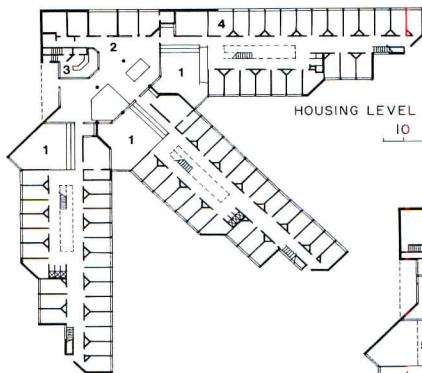
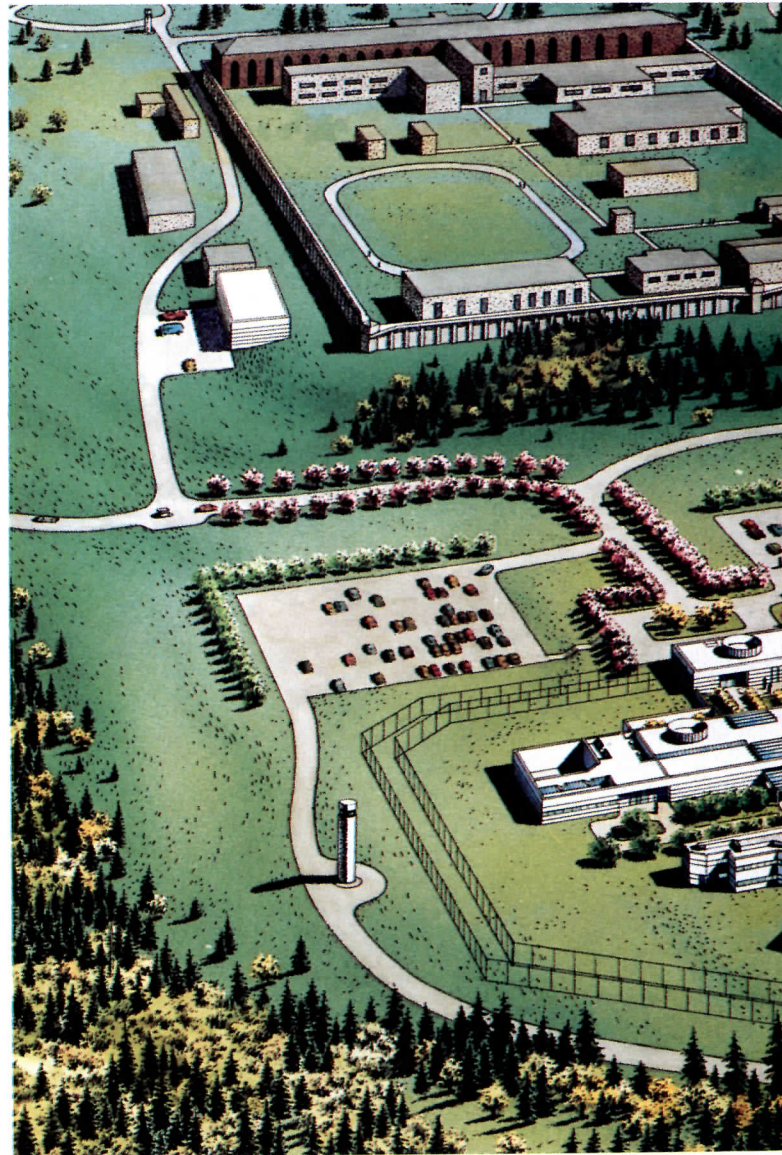

1. Quiet day room
2. Active day room
3. Control
4. Counselor
5. Skylight above
6. Multipurpose

7. Detention/segregation
8. Visiting
9. Reception
10. Central control
11. Outside administration
12. Staff
13. Inside administration

14. Intake/discharge
15. Medical
16. Food service
17. Laundry
18. Warehouse
19. Classroom
20. Library
21. Vocational training
22. Assembly/chapel
23. Activity center
24. Industries
25. Gymnasium

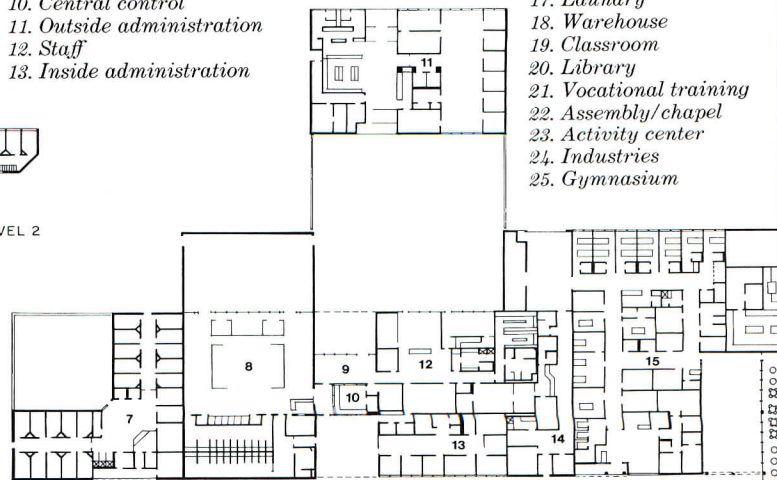

Washington State Medium
Security Prison
Monroe, Washington

Owner:
State of Washington Department of
Social & Health Services,
Adult Corrections Division

Architects:
TRA Associates; Hellmuth, Obata &
Kassabaum (associated
architects)—Phillip Jacobson,
partner-in-charge (TRA); Robert F.

Messmer, director, criminal justice
planning (HOK); Robert Nixon
(TRA), Frank McCurdy (HOK),
Chuck Orafitik (HOK), Jim Kellogg
(HOK), Brent Ekvall (TRA),
project team

Engineers:
TRA Associates (structural,
mechanical, civil, and electrical);
Beverly Travis Associates
(electrical)

Consultants:
Hellmuth, Obata & Kassabaum
(landscaping); Floyd Zimmerman
(designer)

General contractors:
Sollitt Construction Company;
Farmers Construction Limited

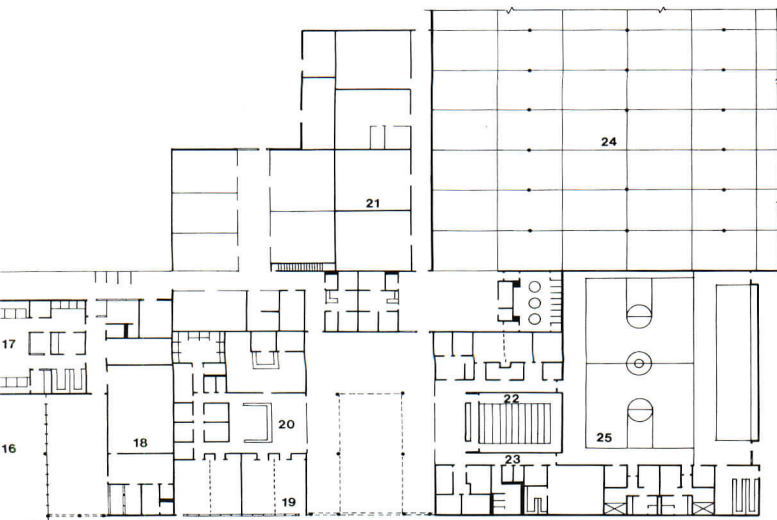
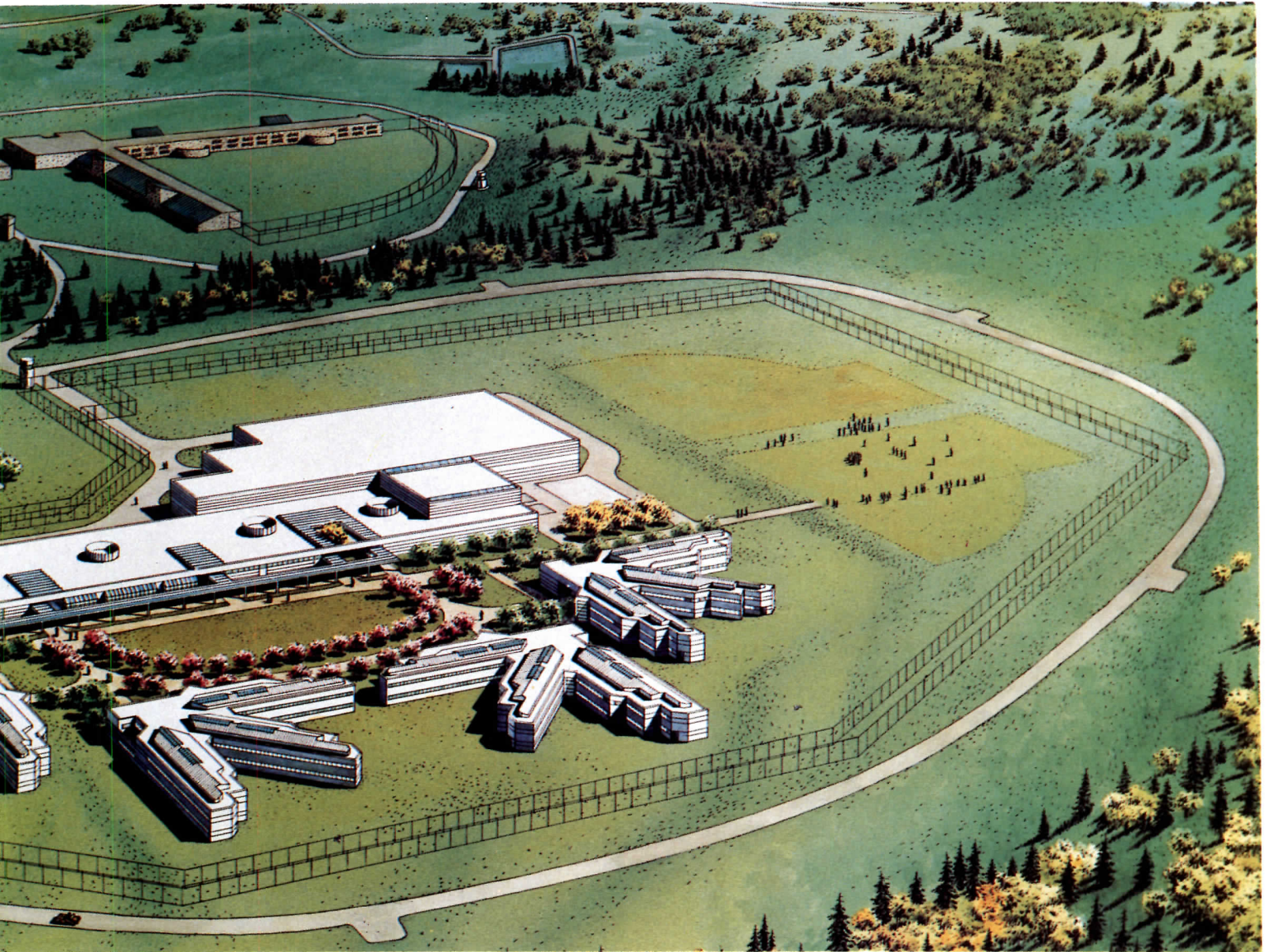

The structure of all inmate housing is site-cast concrete-panel throughout, with a skin of polystyrene insulation and reinforced cement stucco. Lighting and mechanical systems are built into concrete-topped acoustic decks. In the Support Building, bearing and security walls are also concrete panels; non-bearing partitions are metal-stud and reinforced plaster. Exposed

heavy timber roof members lend a measure of warmth and architectural character to major activity spaces. Control posts and central activity rooms in the housing wings have impact-resistant polycarbonate glazing. Cell windows are operable sash with tempered glass and steel bars.

Emblems of discipline and freedom

Gallatin County Detention Center
Bozeman, Montana
RS Architects & BGS Architects

With its original gallows still intact, the 19th-century jail in Bozeman, Montana, is a genuine relic of the Old West, but the sheriff and his deputies have kept up with changing times and moved on to a better home. In the face of rising crime statistics and stricter correctional standards, Gallatin County authorities elected to build an entirely new 43-bed facility next to the County Law and Justice Center, a plain brick box that used to be a Catholic high school. (The old jail is being converted into a museum.) Besides economy of construction, the client's chief concerns were adaptability to future expansion and the separation of pre-sentenced from sentenced inmates, and juveniles from adults. A 12,426-square-foot layout deploys cell blocks along a linear service core with access to an outdoor recreation yard. By extending the wings of housing modules flanking the courtyard to the north, and attaching another module to the south, it would be possible to add as many as 170 beds without altering the building's basic circulation pattern. The serial linkage of one-story housing modules would continue to allow for flexible assignment of discrete classification groups. Because the northern edge of the site abuts a residential subdivision, the architects lowered the jail's apparent height by sinking it four feet into the ground, gaining the practical benefits of economical on-grade slab construction, insulation against perimeter heat loss, and alignment with basement elevators in the Law and Justice Center (section overleaf). The architects also took advantage of the site's downward slope to the north by inserting the exercise yard on grade at that end of the building, where the higher walls of flanking cell blocks provide adequate security and visual barriers. The open roof and part of one side of the courtyard are enclosed with security screens that give inmates a view of the Rockies.

Built at a cost of \$113 per square foot, this low-profile jail achieves a powerful sculptural effect through modest means: concrete roof vaults, round bays, and rhythmic bands of light and dark split-face block. Architects Oswald and Wayne Berg were determined that the jail should project a forthright image of "discipline, order, and rigor." Their sole explicit symbol is an arched trellis of steel reinforcing bars at the main entrance: an "incomplete cell block" that reproduces the dimensions and volume of the standard housing unit. The dual character of this emblematic portal—at once outside and "inside"—is meant to "initiate some thought on the nature of freedom."

Paul Warchol photos

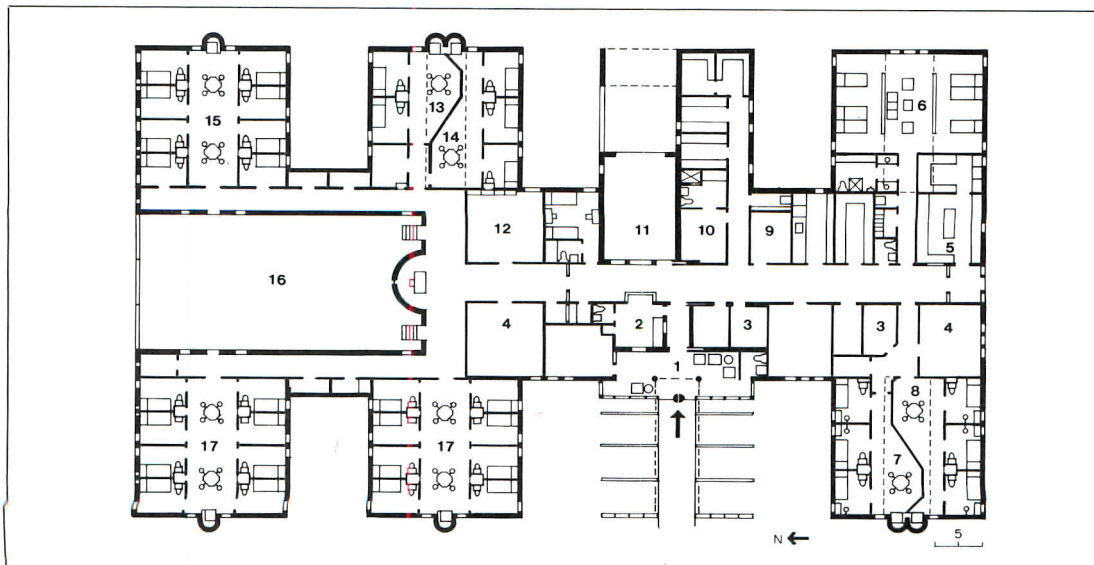

1. Public reception
2. Control
3. Interview
4. Recreation
5. Kitchen
6. Work release
7. Juvenile: boys
8. Juvenile: girls
9. Medical
10. Booking
11. Vehicle sally port
12. Multi-purpose/library
13. Women's sentenced
14. Women's pre-trial
15. Men's sentenced
16. Outdoor recreation
17. Men's detaining

At once castellar and monastic in its over-all form, the jail appears rooted in Bozeman's grassy plain. The seemingly rural site actually lies within the city limits, adjoining a residential subdivision to the north and the Law and Justice Center to the south (visible at far right in photo below left). Arched pavilions break the low roof line to express the contour of precast concrete vaults in corridors and

cell-block day rooms (photo below right). Cell walls are poured concrete; all other walls are grout-filled block. For simple access, utilities occupy a tunnel under the circulation spine. As in much larger facilities, a computerized audio control system governs every door from a central console. Video monitors scan sally ports, corridors, and perimeter walls.

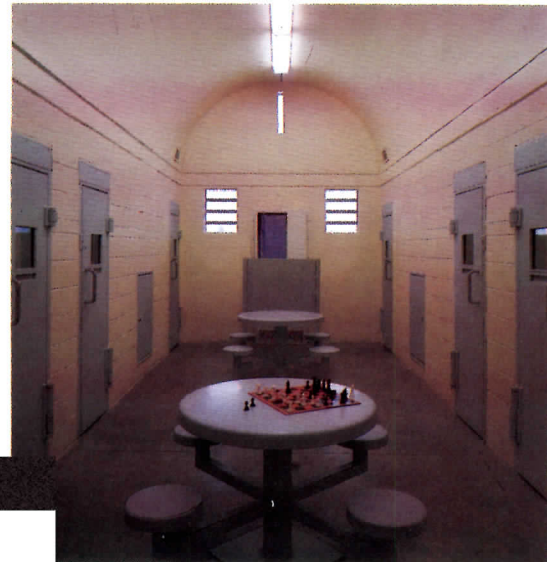

A precast concrete scupper juts out above the bay of a cylindrical shower room (below left). Alternating bands of light and dark split-face concrete block suggest massive rustication—in contrast to the open frame of the symbolic entry “cell block” (below right), which is to be twined with ivy.

Gallatin County Detention Center
Bozeman, Montana

Owner:
Gallatin County

Architects:
RS Architects & BGS Architects—
Wayne Berg, design architect;
Oswald Berg, Jr., project architect

Engineers:
Lyle Beakert (structural); Design 3
Engineers (mechanical/electrical)

Correctional consultants:
Man-Ser, Inc., Ray Meiers
General contractor
Edsal Construction Company

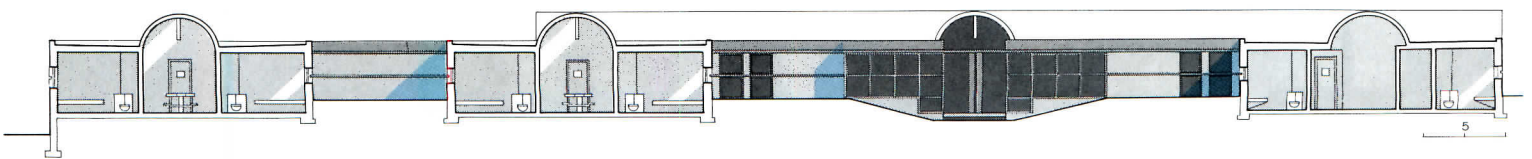

Strategies for corrections programming

by Kenneth Ricci, AIA

Even architects conversant with governmental work have often found that the problems of satisfying the "client" are especially complex in corrections projects because of the involvement of agencies and personalities that cut across jurisdictional (state, county, local), governmental (executive, legislative, judicial), and organizational boundaries. In a jail project, for example, the owner is usually the county, but the user is the sheriff. While the sheriff usually has to go to the county for his budget, he can be a powerful force in his own right. The sheriff runs the jail, but the county commissioners have to take the heat for raising taxes to pay for it. Finally, the decisions made about the jail have to be approved by a state jail regulatory agency. The power and requirements of these agencies vary tremendously from state to state. On jail projects, these complexities are often compounded because the chances are that this is the first and last jail the client will ever build. High construction costs, high operating and staff costs, coupled with economic austerity, fear of litigation over prisoners' rights, and the pressing demand to "do something" about crime create a volatile mixture for decision makers. Prison projects are different, yet similar. They are different from jails in that the owner agency probably has planned and designed at least one or two new prisons or renovations and will have personnel with some experience. They are different also in that there is usually less media scrutiny of the programming and design process. They are similar because the cast of characters in the decision-making process is usually large and diverse, with the same tensions between the owner agency and the user agency (Department of Corrections). Because of the tremendous staffing costs of correctional facilities, we are now seeing an increasing involvement of budget agencies, who often want to see staffing requirements developed along with the space program. This is an excellent idea. However, it requires a lot of additional effort on the part of the programming team and should be accounted for in scope of services and compensation.

The division of responsibility within a state department of corrections is much more compartmentalized than that in the typical small jail. At the state level, there are staff and line functions; staff are responsible for system-wide areas such as administration, security, program, and support. Line personnel are responsible for running the institutions. Some line people will occupy a staff role under one administration and then move back into a line slot. It is important for the architect to understand the organizational make-up of the corrections agency if he is to appreciate the various groups or personalities that have a stake in the outcome of his project. Having a formal system for helping the corrections agency to lay out all of its requirements and schedule, and translating these user needs into a comprehensible program document, serves to minimize misunderstanding and pinpoint responsibility. The usual mandatory regulations governing jail and prison design are state correctional-facility standards, building codes, state fire safety codes, and state health codes. Most states have developed new correctional-facility standards in the last decade, in response to court decisions, life safety code amendments, and increased sophistication on the part of user agencies, funding authorities, and prisoner advocacy groups. Voluntary guidelines have been developed by many organizations such as the Commission on Accreditation for Corrections and the National Sheriffs Association. Mandatory standards are often minimum standards for compliance; by using *voluntary* standards the architect is more likely to develop a

Kenneth Ricci, AIA, is vice president and partner-in-charge of criminal justice facilities with The Ehrenkrantz Group.

successful design and will be better able to ward off litigation by showing that his planning was based on a broad set of contemporary guidelines. Another useful way to defend the client against future litigation is to consult the Federal courts. Federal circuit courts of appeals often overlap several states, so the architect should not just consult cases in his own state. Established case law sets a precedent for the particular region, especially if the issues haven't been decided by the U.S. Supreme Court. One cannot guarantee clients that they won't be sued once they've built a new facility, but the architect can protect the client and his own firm by developing the program from mandatory standards, voluntary standards, and case law.

Determining the appropriate size of a new jail is a matter of public policy and not, as many believe, a technical problem. The purpose of long-range jail planning is not to foretell the future, but to shape the future. The shape of the future should include not only the jail building but also improvements to the criminal justice system that reduce jail populations without reducing public safety. The introduction or expansion of alternatives to incarceration and improved practices by the district attorney, courts and police can substantially reduce the size and cost of a new facility. Going through this process is increasingly important to the success of getting funding for new county jails, because it shows the public that county commissioners are seeking to cut the price tag on the proposed new jail. Another way to control construction and operating costs is to estimate the number of cells required in each security category. The more security, the higher the price. As part of the programming tasks, the architect should include a classification analysis, since it is typical for a client to believe that nearly everyone is maximum security—which is very often untrue. A preliminary functional program should describe the operation of each sub-unit in the facility in detail (for example, medical, visiting, food service). In a collaborative effort between the architect and a staff person designated by the client, each sub-unit is then defined in detail with regard to staffing, security, access, adjacency to other sub-units, hours of operation, equipment, and special characteristics.

The space program is where the efficiency ratio (net divided by gross) for each space and department is established. Our experience has taught us that there will be considerable pressure at this point to keep the total cost down. One way to do this is to diminish the gross building area. Another way is to specify less costly finishes, fewer electronic gadgets, or fewer high-security cells. The danger of reducing the gross area at this stage is that once the budget is established, the user agency will apply pressure during schematic design to increase the net areas. If the gross is already low and the architect succumbs to pressure to increase the net areas later on, the resulting layout will be much more difficult to staff efficiently. An accepted rule of thumb is that the construction cost of a correctional facility is equal to approximately 5 to 10 per cent of the cost of amortizing and operating the facility over a 30-year life span. For this reason, the program tasks must include a staffing analysis, developed parallel to the functional program and constantly updated. Taken together, the functional program, the space program, and the staff analysis are the key activities that aid the project team in articulating the concerns of all who have a stake in the project's outcome—and these documents form a *written record upon which* to base the design process. In the course of decision-making this record then provides benchmarks against which to evaluate design solutions, protects both client and architect, and ultimately promotes a better building.

For Boston: A harborfront hotel

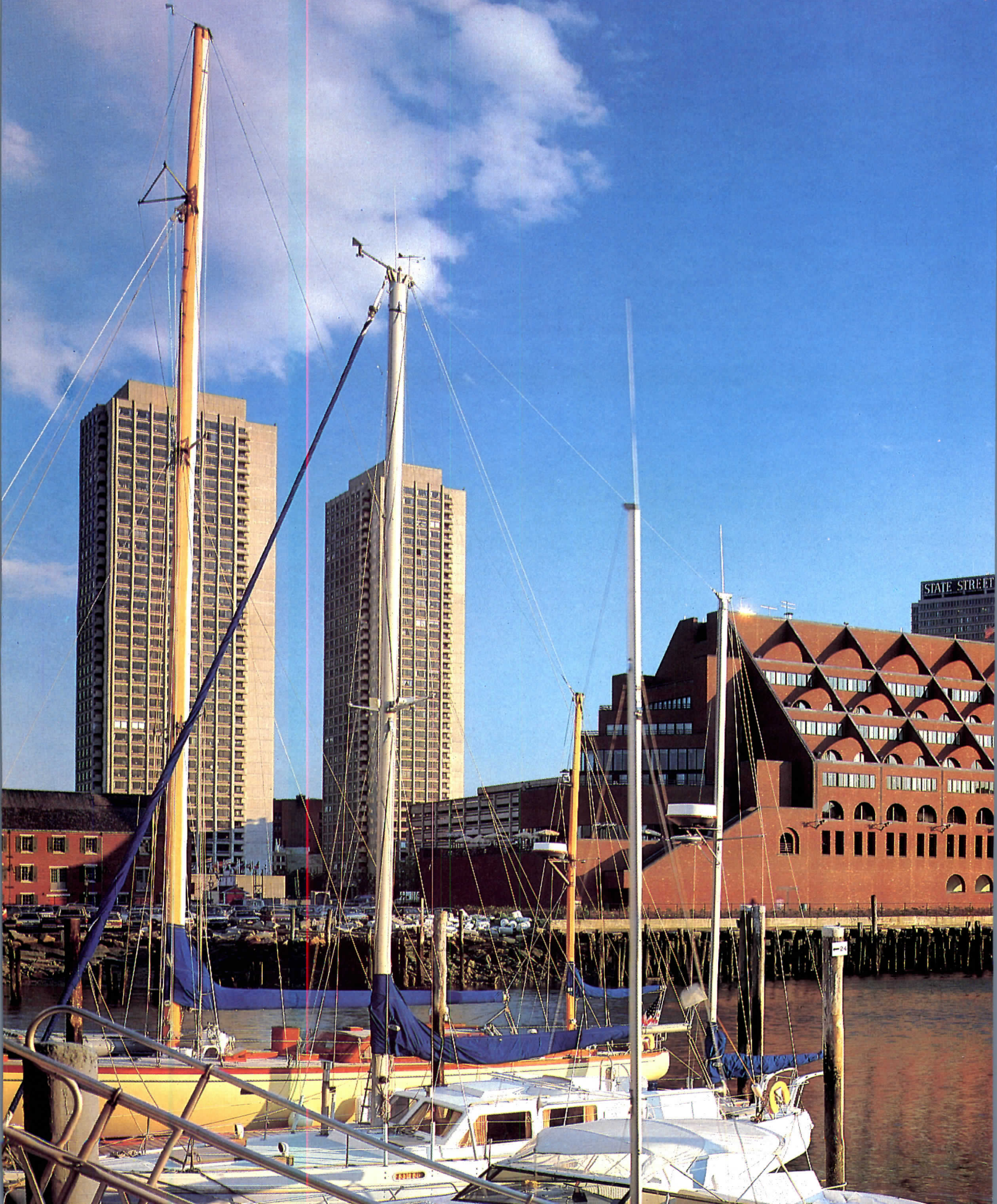

Long Wharf Marriott Hotel
Boston, Massachusetts
Cossuta & Associates, Architects

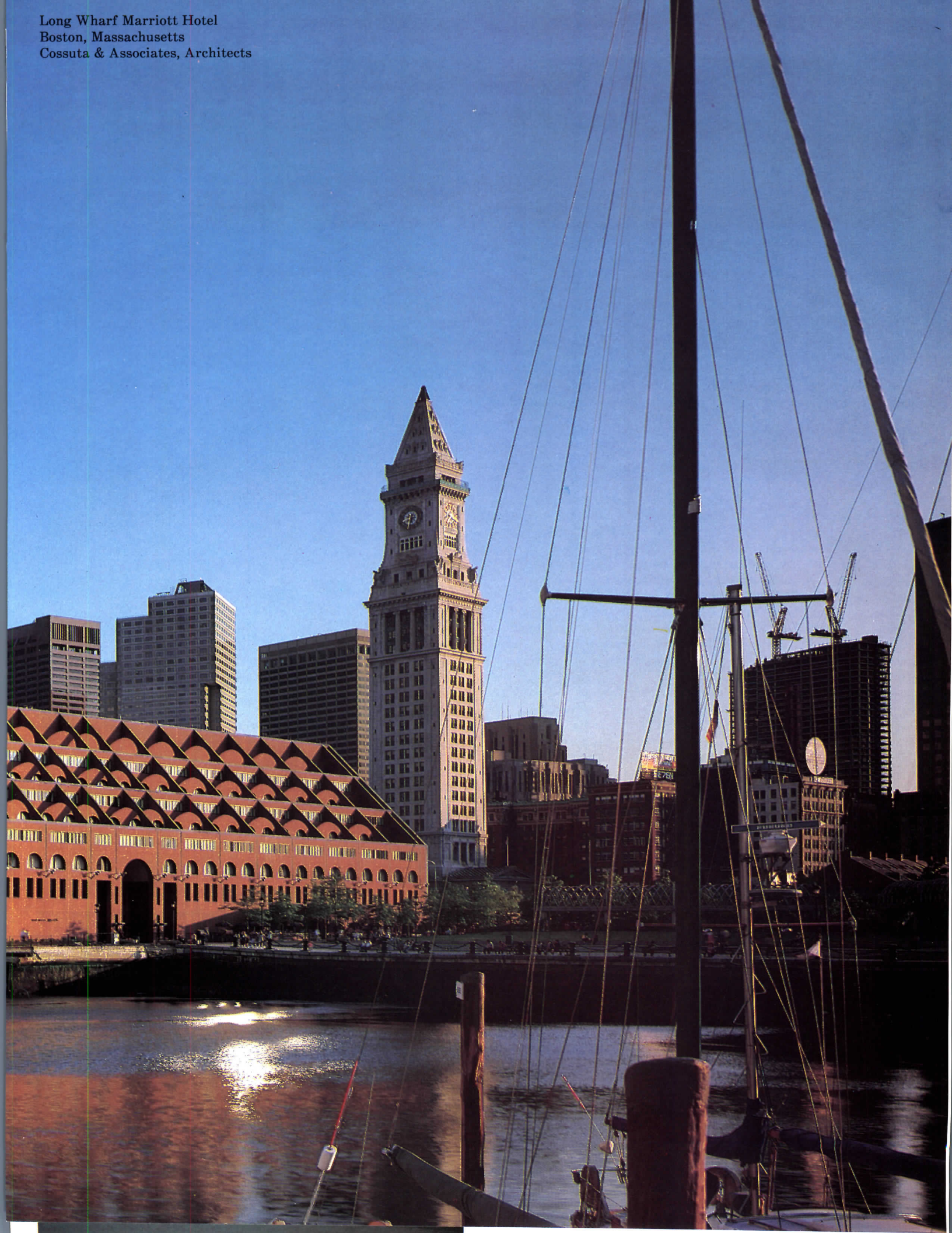



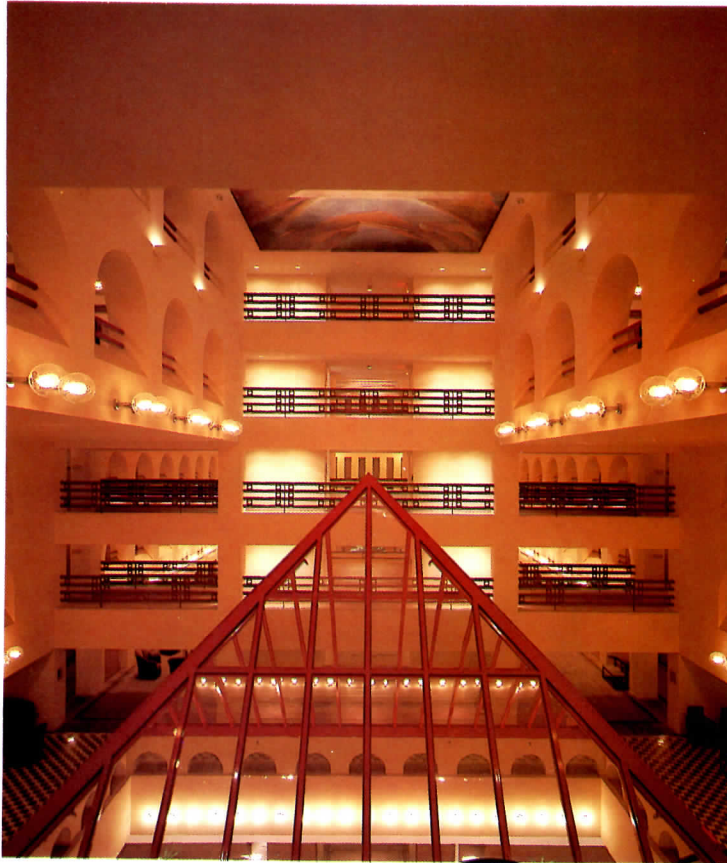

It was a condition for development of the Long Wharf site that public passage be retained along the route of Boston's pedestrian "Walk to the Sea," which crosses the wharf as it wends along the harborfront. As a result the almost-ceremonial arched south entrance to the hotel is duplicated on the northern facade facing the park (opposite), guiding walkers to and through the lower lobby. Escalators to the main hotel floor are "roofed" by an open pyramid of lipstick-red pipe (see section) that marks the transition from the public passage to the semipublic areas of the hotel.

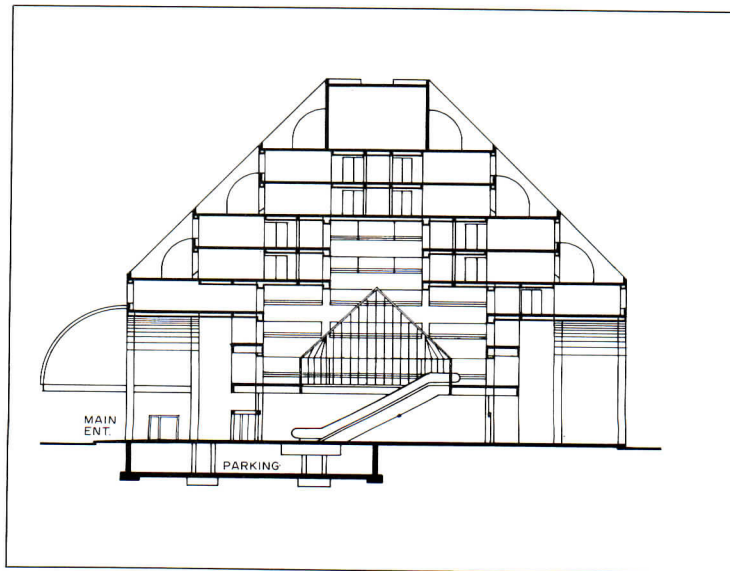

The detailing of those public spaces of the hotel executed by Cossuta & Associates—notably the splendid Palm Garden—are distinguished by a restraint and crispness almost Oriental in quality. But the over-all effect of the soaring space is one of lavishness, from the chessboard marble of the central flooring to the warm-toned ceiling mural by Francoise Schein. Dominating the space are the arcades of the surrounding corridor balconies, which are railed (and brightened) by red pipe that recalls the pyramid at the entrance. Special lighting fixtures help delineate the deep reveals of the arches and lend a welcome note of glitter.

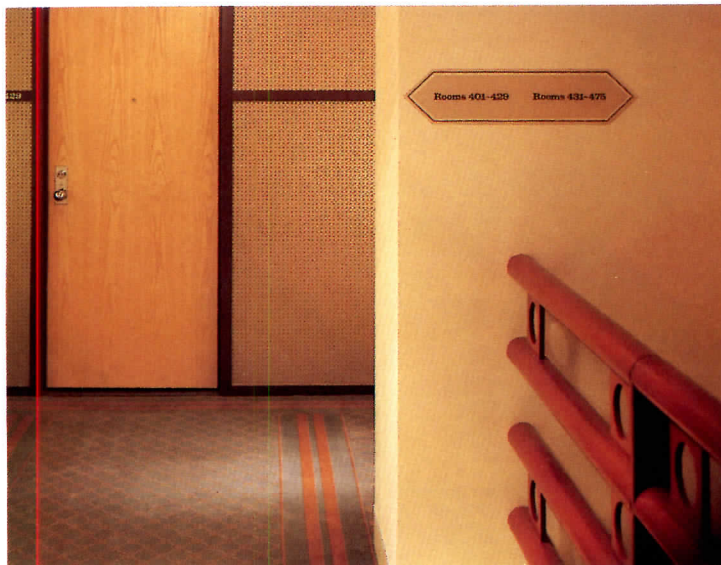

*Long Wharf Marriott Hotel
Boston, Massachusetts*

Owner:
Downtown Boston Properties Trust

Architects:
*Cossuta & Associates—Araldo
Cossuta, design partner; Joseph V.
Morog, architect-in-charge*

Engineers:
*Weiskopf & Pickworth (structural);
Cosentini Associates (mechanical/
electrical); Haley & Aldrich
(foundations)*

Consultants:
*Sasaki Associates (landscaping);
Jules G. Horton Lighting Design,*

*Inc. (lighting); Cerami Associates
(acoustics); Robert Schwartz
(specifications); Robert Flack &
Associates (exterior graphics);
Renee Cossuta (interior graphics)*

Interior design:
*Cossuta & Associates with Suzanne
Sekey, consultant (main entry,
lobbies, Palm Garden, lounges);
Marriott Corporation (restaurant,
ballroom, guest rooms)*

General contractor:
Turner Construction Company



Explorations: Four projects by Gunnar Birkerts

Headquarters Library Competition
Anchorage, Alaska
Gunnar Birkerts and Associates, Architects

It is surely not in fashion these days—especially in an academic environment—to deliver a lecture entitled anything like “Staying with the Modern Movement: Recent Years, 1970 to 1982.” But as first recipient of the Plym Distinguished Professorship in Architecture at the University of Illinois (Urbana-Champaign), Gunnar Birkerts delivered just that lecture two months ago. While “modern” has come to signify to many a certain rather narrow allegiance to the work of Mies and/or Le Corbusier, the Latvia-born, Michigan-based, Saarinen (Eliel and Eero)-trained, Yamasaki-reared architect is quick to remind us that the modern movement was multifaceted; that it included Wagner and the Bauhaus, Scharoun and the International Style, Aalto and Gropius, Asplund and... It is to the former, rather than to the latter, that Birkerts feels a kindred professional spirit.

“I have always tried to be on the cutting edge,” says Birkerts. The claim is not without merit; especially if powerful imagery and advanced technology are the criteria for matriculation—and tenure—in the “cutting edge.” [Consider the Federal Reserve Bank in Minneapolis (ARCHITECTURAL RECORD, November 1973), IBM Southfield Center and Calvary Baptist Church (October 1979), and Duluth Public Library (November 1980): These are buildings one does not soon forget.] Nor without merit is Birkerts’s claim that no single architectural influence or personal/professional mentor can take credit for his work. It looks like no one else’s. It draws from many sources.

Birkerts believes that he designs from the “subconscious”; that data (client, site, budget, program) are fed into his “computer” (brain), where architectural history—from Michelangelo to Michael Graves—is already stored, and out issues a conceptual sketch (right), which, after refinement... is developed into a building design (far right). Birkerts refers to this process as the “intuitive power within the act of creation.” And he sees this process as insurance against being swept too far by shifting temporal currents of architectural trends. However, as the four projects compiled for this portfolio reveal—and as one might have suspected from the Corning Museum of Glass (February 1981)—Birkerts is exploring new forms; and while two of these projects are competition entries which were not premiated, they nonetheless illuminate the exploration. Birkerts’s architecture-as-minimalist-abstract-sculpture/architecture-as-technological-wonder period seems past. Which seems appropriate. It is, however, no less *modern*.

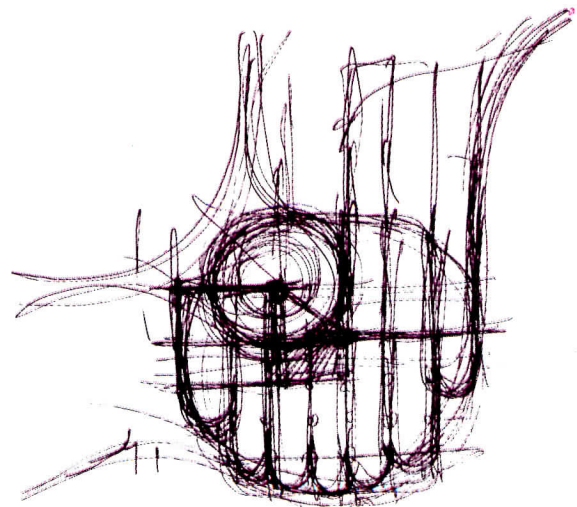
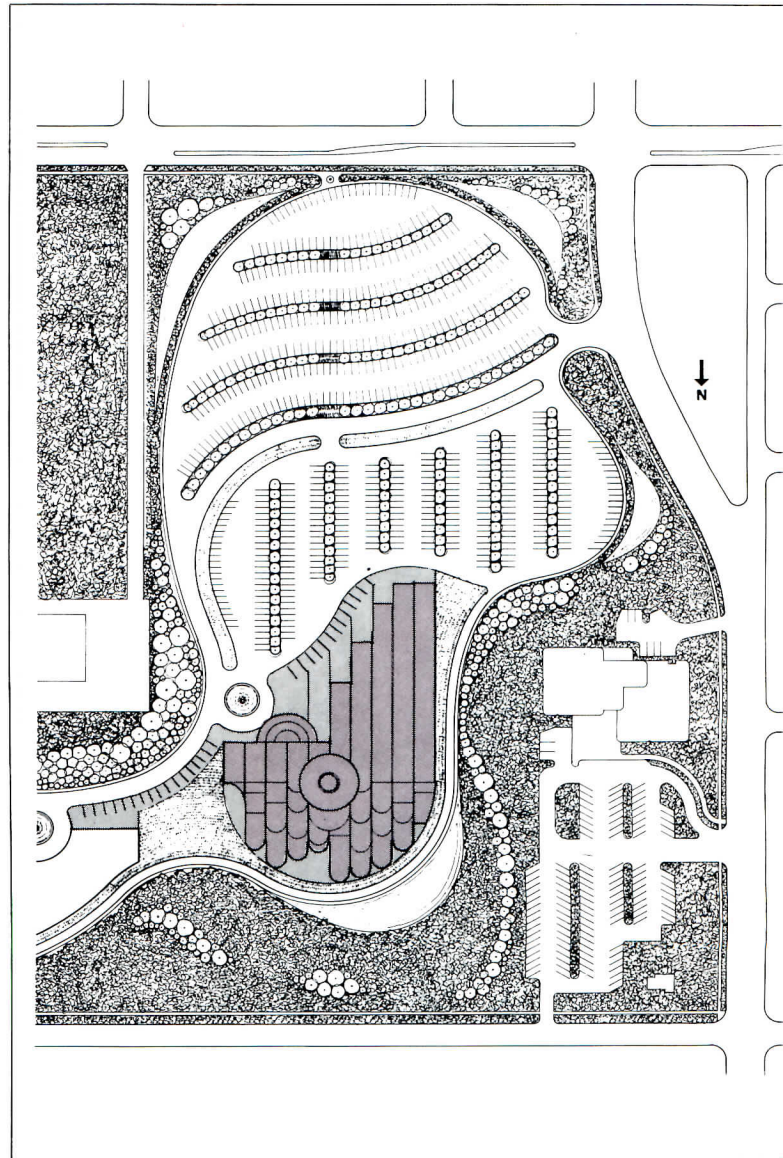

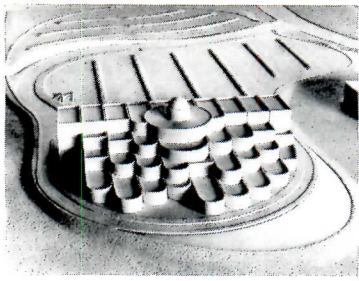

Drawings by Anthony Gholz, Kenneth Rohlfing, Todd Young, Kevin Shultis

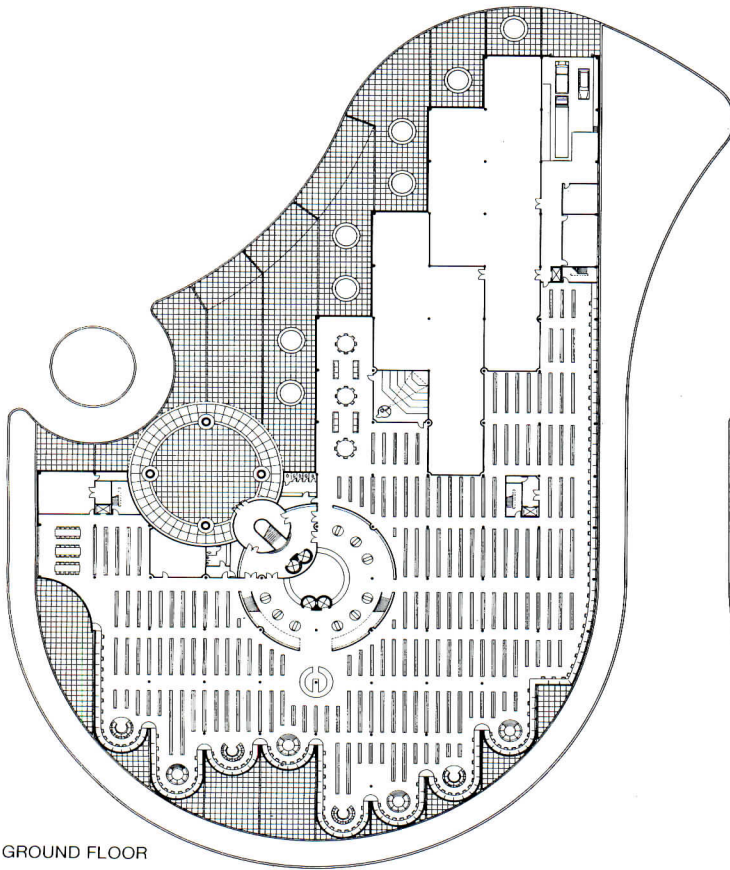

GROUND FLOOR

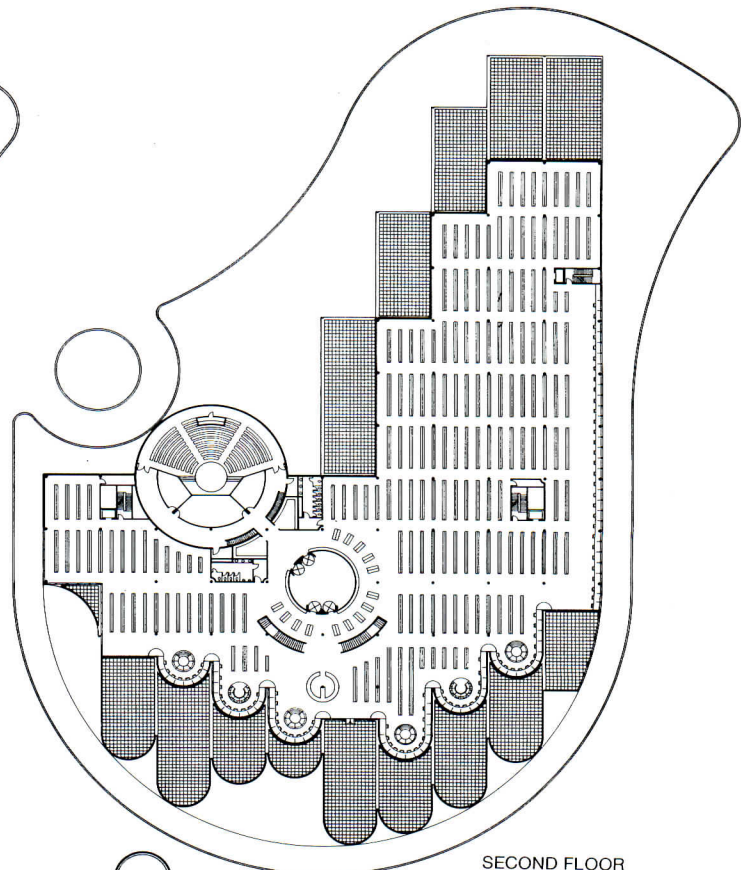

SECOND FLOOR

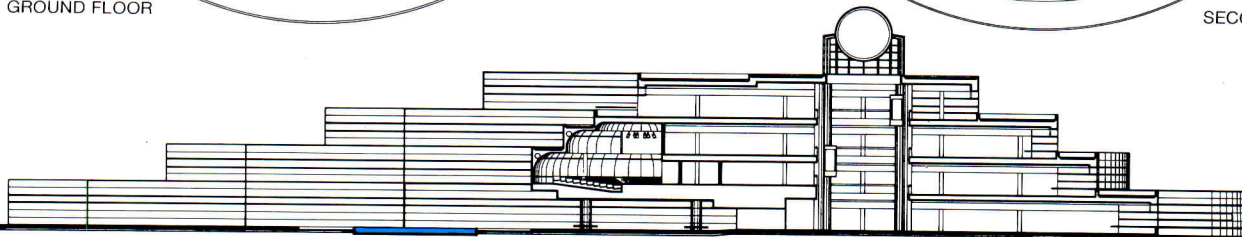

When the Municipality of Anchorage, Alaska, issued a call for entries for a new Headquarters Library, Gunnar Birkerts answered. And while this proposal was not chosen, it is nonetheless worth a look: for it is signature Birkerts. After a visit to the site, he concluded, "There is no vernacular to speak of—nothing to allude to, or relate to—so you look at nature for the outside influence, and then you look at the function inside that you have to perform." And then, if you're Gunnar Birkerts, you respond to the southern sun and southern mountain-range view with a passive solar design that offers extraordinary perimeter area by means of terraced bay projections (reading alcoves), and extraordinary interior daylighting (a Birkerts obsession) by means of a massive central light well capped with a giant glass sphere to

"symbolize the quest for knowledge, the head, the mind, the sun." This is a design intended to be strong enough to be a centerpiece for a growing cultural center—and memorable not just from ground vantage points, but, in a state where "flying in" is commonplace, from the air.

Headquarters Library Competition
Anchorage, Alaska

Architects:

Gunnar Birkerts and Associates—
Kenneth Rohlfing, project director;
Charles Fleckenstein,
principal-in-charge

Associate architects:

Kumin Associates, Inc.

Engineers:

Skilling, Helle, Christiansen,
Robertson (structural)

Chapel & Educational Facility
Camp Wildflecken, Germany
Gunnar Birkerts and Associates
with Giffels Associates, Architects

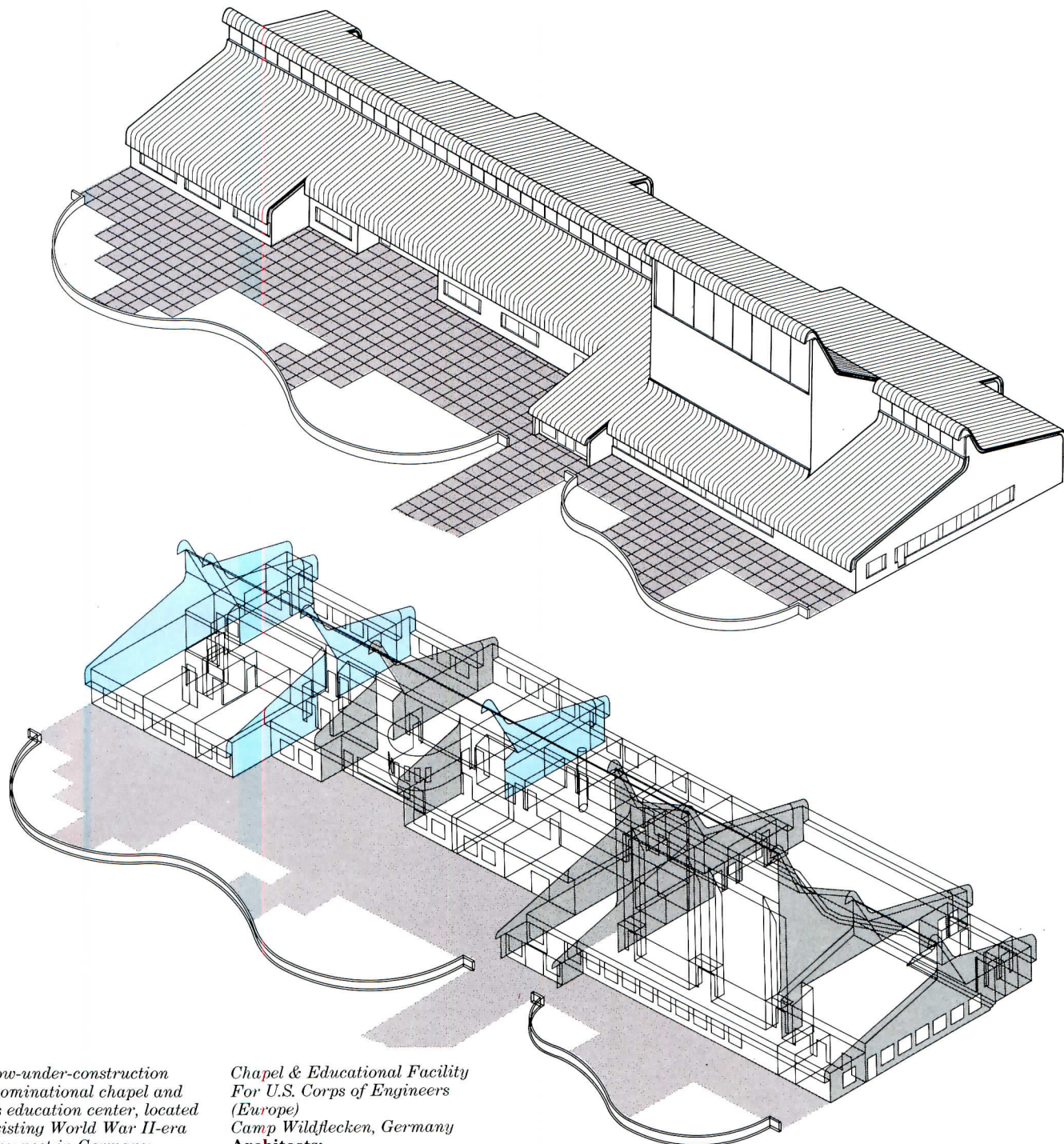

For a now-under-construction interdenominational chapel and religious education center, located on an existing World War II-era U.S. Army post in Germany, Birkerts chose "to express the unique quality and character of this building in the midst of other types by using a metaphor." The metaphor Birkerts chose is of shepherds and their flock. . . "which would apply regardless of the religious order." The symbol is the shepherd's crook, "appearing at different heights and angles marching forward with the flock" and creating a strong roof sheltering interior spaces of varied hierarchy depending on their function. All are lit by the building-long clerestory that strengthens the imagery. The chapel is white stucco masonry on the exterior; the interior is white plaster. The roof is copper.

Chapel & Educational Facility
For U.S. Corps of Engineers
(Europe)
Camp Wildflecken, Germany
Architects:
Gunnar Birkerts and Associates
with Giffels Associates
Associate architects:
Lahmeyer GMBH (Frankfurt)

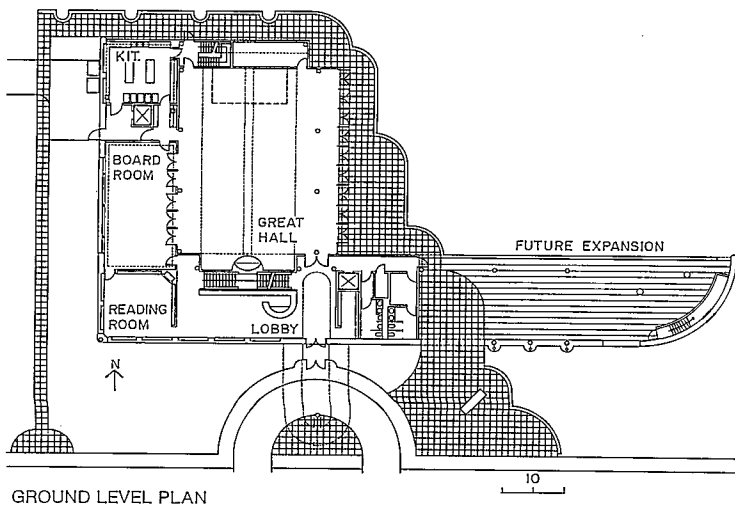
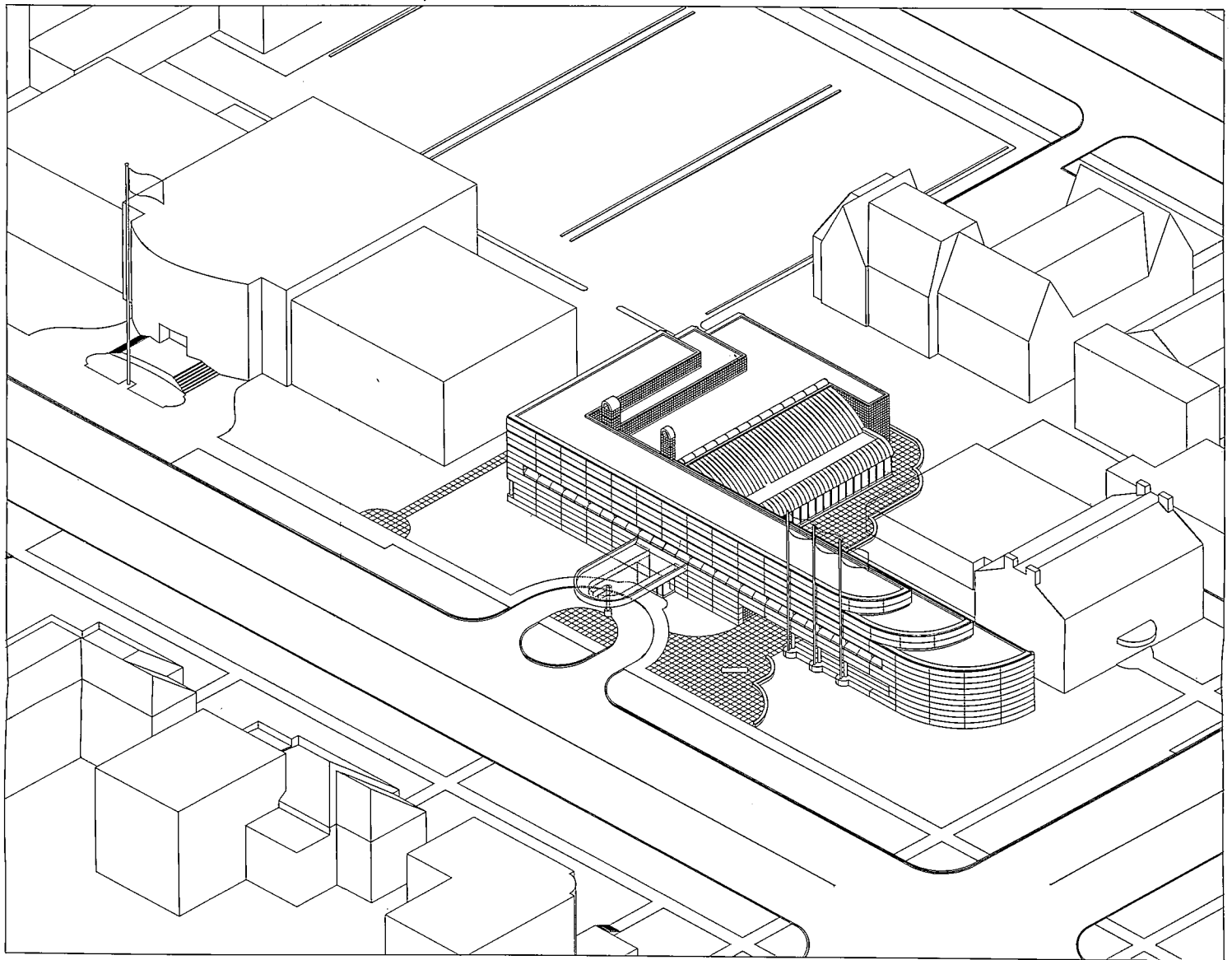

GROUND LEVEL PLAN

The invited University of Nebraska Wick Alumni Center competition was won by Gwathmey Siegel & Associates. But if Gunnar Birkerts had had his way—and won—he would have inserted this L-shaped building on the L-shaped site, between the grand Historical Society Building (to the west) and a not-so-grand sorority house (to the east). In an attempt to relate and respond (to... well, be “contextual”), Birkerts proposed a monumental limestone facade that “peels off, layer after layer, lowering its profile to meet the scale of the vernacular”—read residential. Behind the facade, Birkerts intended “one generous and gracious space not seeking strong definition or separation.” In the main hall, curved roof shapes (echoing the curves in plan) and skylights dramatize the lofty space.

Wick Alumni Center
 University of Nebraska
 Lincoln, Nebraska
Architects:
 Gunnar Birkerts and Associates—
 Kenneth Rohlfing, project director

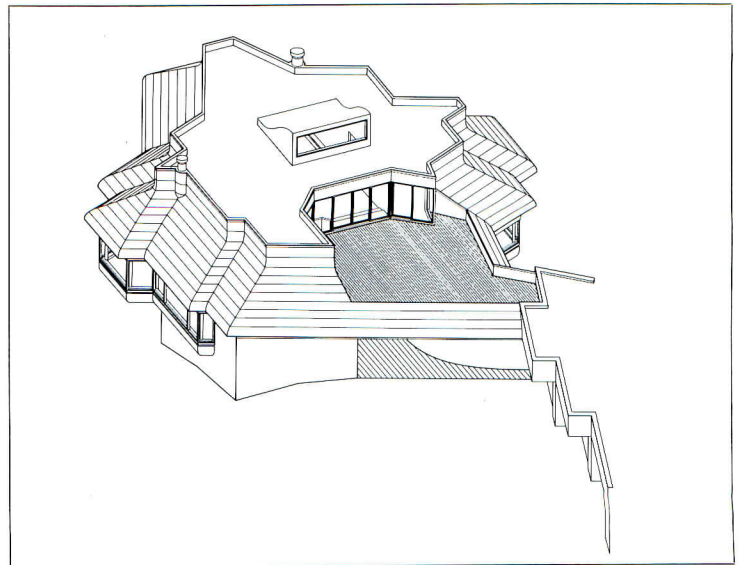
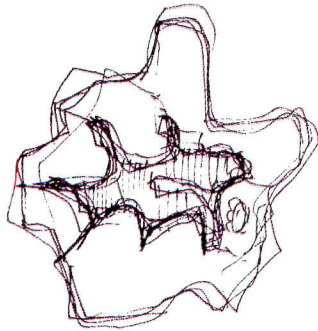
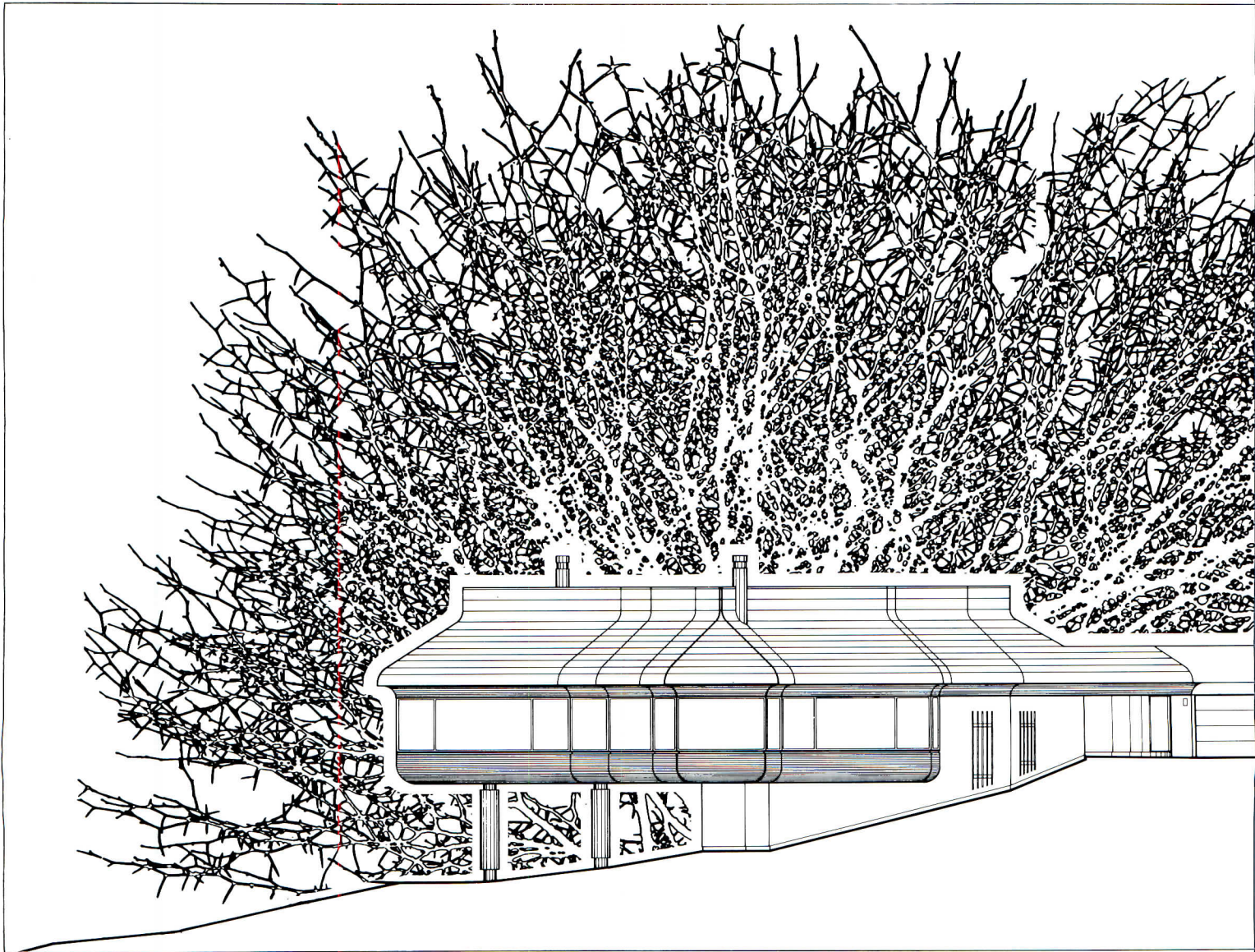

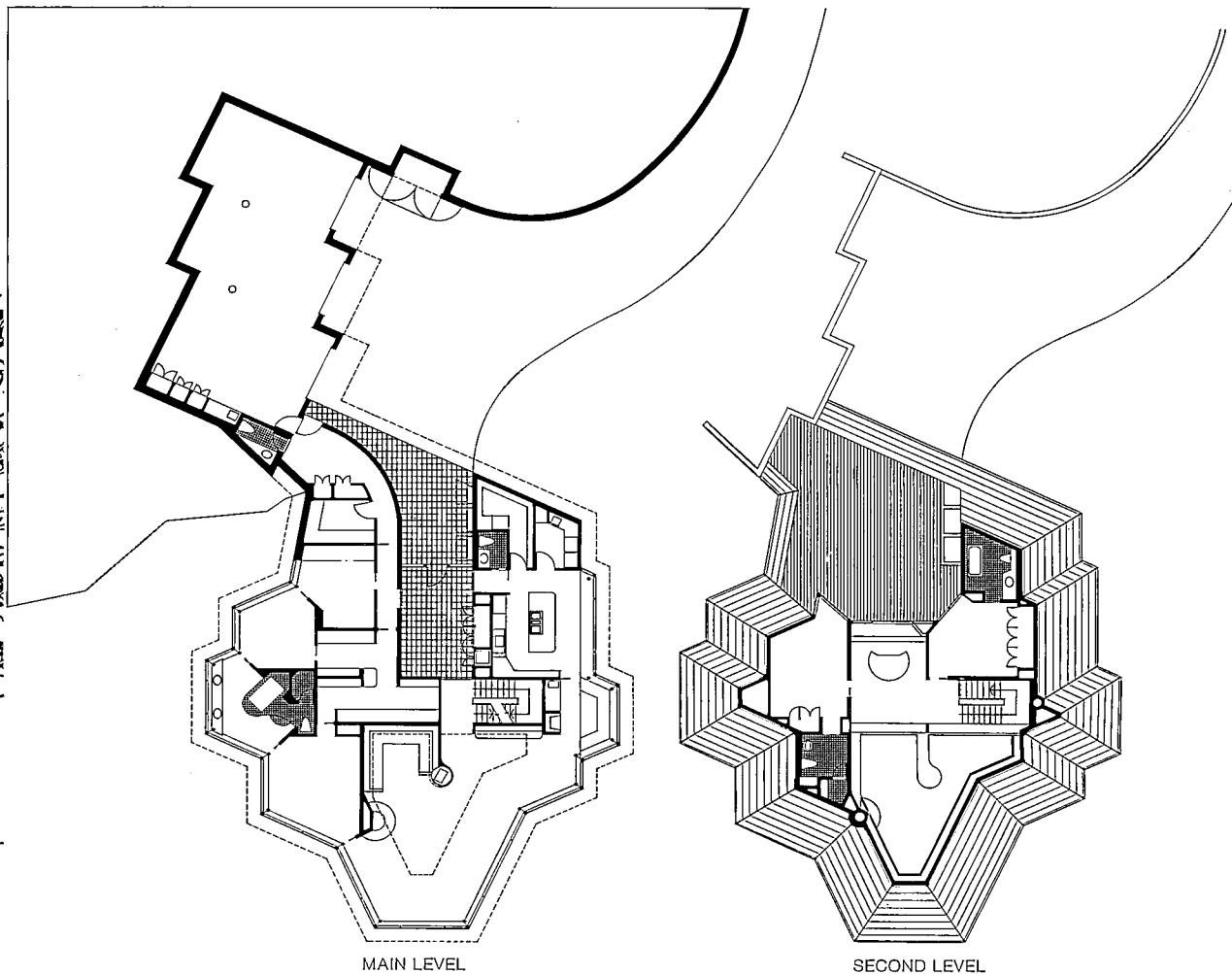

MAIN LEVEL

SECOND LEVEL

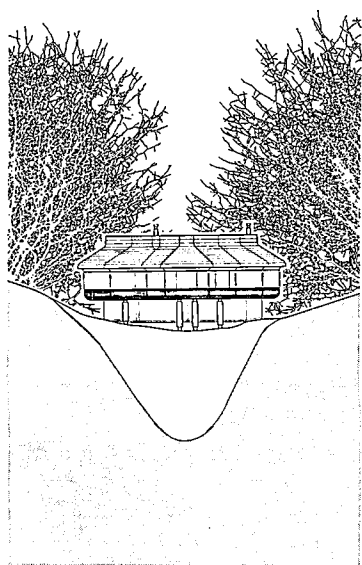

According to Birkerts, the Villa Ginny "is intended to seem organic—as if it grew on the site." He explains: "The dramatic ravine-transversed site contributed to the form-giving influences shaping the concept. . . the development of the concept can be witnessed from the early sketch [far left] through the metamorphosis where it seeks to take on the characteristics imposed by equipment or prevailing building technology." "Organic" on the outside (and finished in stucco, teak, and copper); "high-tech," white, and crisp on the inside, the Villa Ginny signifies to Birkerts "a turning point in my own search for new directions in architecture. . . . The almost organic form created by the exterior enclosure gave me the opportunity to have the freedom I have been searching for; freedom from dogmas I had to live with, belonging to others."

Villa Ginny
Kalamazoo, Michigan
Architects:
Gunnar Birkerts and Associates
Engineers:
Robert Darvas Associates
(structural); Potapa Mancini &
Associates, Inc. (mechanical/
electrical)

Efficiency enriched and enlivened

Philip Morris Operations Center
Richmond, Virginia
Davis, Brody & Associates, Architects

This thousand-foot-long complex has all of the order, the logical planning, the superb detailing, the clearly expressed use of materials that we have come to expect from Davis, Brody's work. Its three-element form (site plan below) grew out of the three functions performed there: administration, research/engineering, pilot-plant production. The plan (next pages) is not just logical—it reflects the (wisely) growing effort to keep managerial offices off the window wall so that everyone can share views and daylight. The character of the building is appropriately high-tech—with a taut skin of bright aluminum, continuous bands of windows with white trim emphasizing the horizontality of the building, spots of bright color (well, of Marlboro red) at the entries. There are even (historical recall?) roof monitors.

But beyond that, Davis, Brody's design achieves for those who work there a remarkable sense of human scale, of welcome, of interaction encouraged, of bright and cheerful workspaces, of almost festive public spaces. The broad public street (pages 120-121) is brightly lit by skylights, framed by elegant pipe railings at each level, and punctuated by semicylindrical stairwells, each a different color and each marked by hanging tapestries of aluminum shapes.

The art in the building, all by Ivan Chermayeff, reinforces its essential shapes—and indeed helps people to “see” those essentials. Most dramatic is his sculpture in the lake at the rear of the building. The cubes echo the rectangular shapes of the three building masses; the tetrahedrons, the 45-degree angle that dominates the plan; and the third sculptural element, made up of cylinders, recalls the railings throughout the building and the half-cylinder stairwells. These same shapes make up the hanging screens (photos next pages) which mark and enliven the main entry and each of the four interior zones at the stairways. Each of these screens is in a different color, matching the color of the stairwell across the “pedestrian street”—and that color is used again as accent in the fabrics and furniture within that working zone. Abstract photos of elements of the building, by Judith Turner, hung throughout the building, similarly reinforce the design concept; as does the neon sculpture in the cafeteria (page 118) and wall paintings in some of the corridors.

This is the newest element in Philip Morris's vast administrative and manufacturing center in Richmond. It is a handsome, appropriate, meticulously detailed, efficient, energy-conservative, and best of all—lively addition. *W. W.*

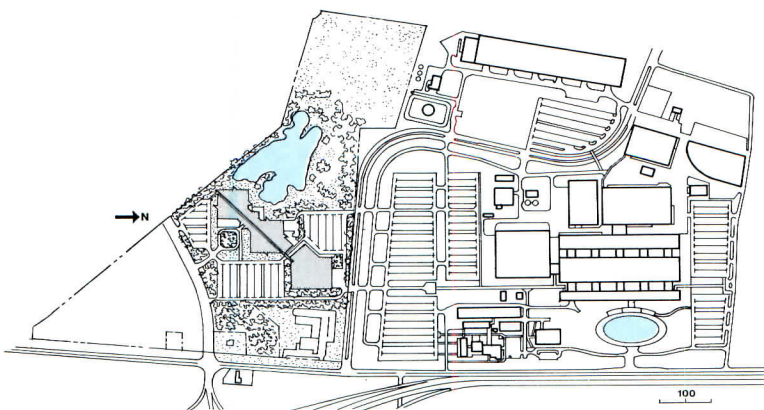

© Wolfgang Hoyt/ESTO photos



The major building elements are two square volumes joined by a skylit atrium running along their diagonal axis, and connected by a covered walkway to a third volume containing the pilot plant (visible in plot plan, but out of photo below to left). The volume at right is primarily administrative offices; the volume at left, closely related to the pilot plant, includes research

and engineering offices as well as laboratory and shop spaces. Between the two main shapes is the cafeteria, with multipurpose room and executive dining on the second level—all overlooking the lake and Chermayeff sculpture. A terrace encourages outdoor lunches. The building skin is beautifully fabricated aluminum panels and 1-inch thick insulating glass. The building is three stories

high on this west side; two stories high in front; with the change in elevation joined by a sloping, skylighted room over the central atrium (see entry-side photo overleaf). The gross floor area is 550,000 square feet, the building footprint is 5.6 acres, the building population is 1300.



At the main entry (below), the taut and beautifully detailed skin of the building is apparent. The sloping roof over the atrium is terne-coated stainless steel. Red gateways signal each of the building's entries (see also opposite) and the covered walk leading to the pilot plant. At night (photo bottom right) the building fairly glows—and the hanging screens and painted wall panels

inside can be seen from the entrance road. The plan is organized in 32-foot bays at right angles to the circulation spine—the drawing below shows the essential planning scheme and typical spaces on both the second and third floors. Note that the glass-walled “enclosed offices” for executives and managers (tinted on drawing) are in clusters held back from the window wall; thus

those in the open-office areas have a broad and uninterrupted view to the windows and the best daylighting. The “edges” of the plan are given over to circulation; the triangular spaces left by the 45-degree rotation of the plan are used for informal lounge areas and conference spaces.

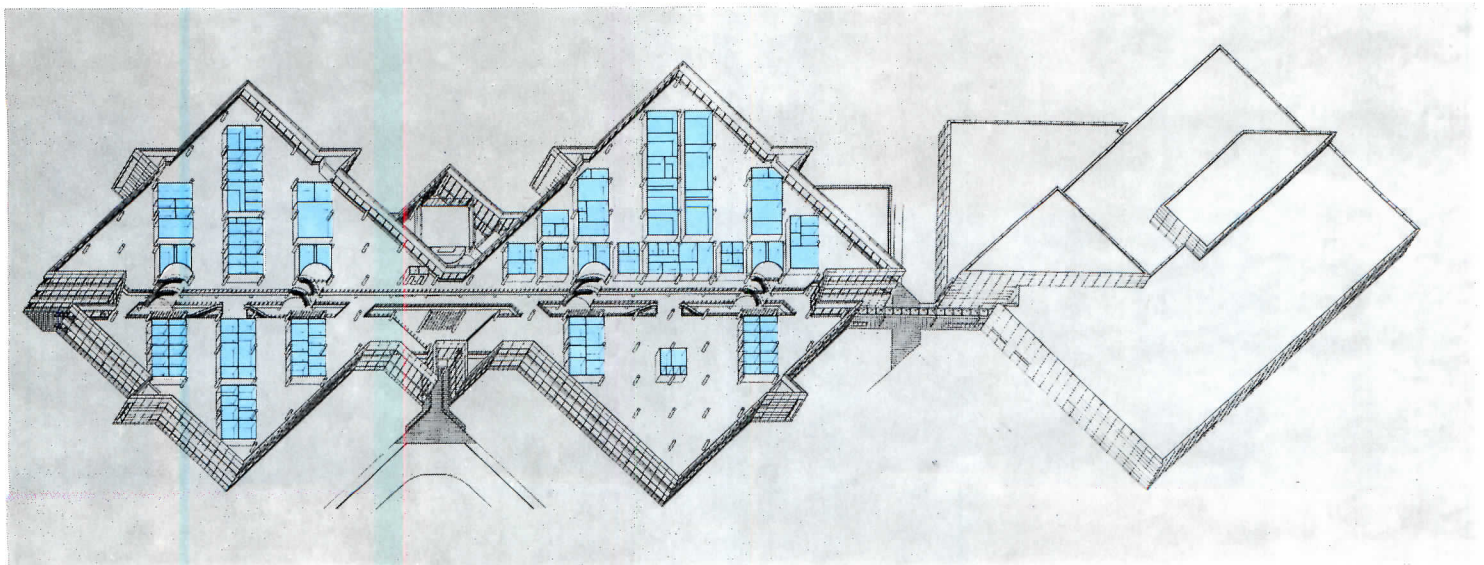
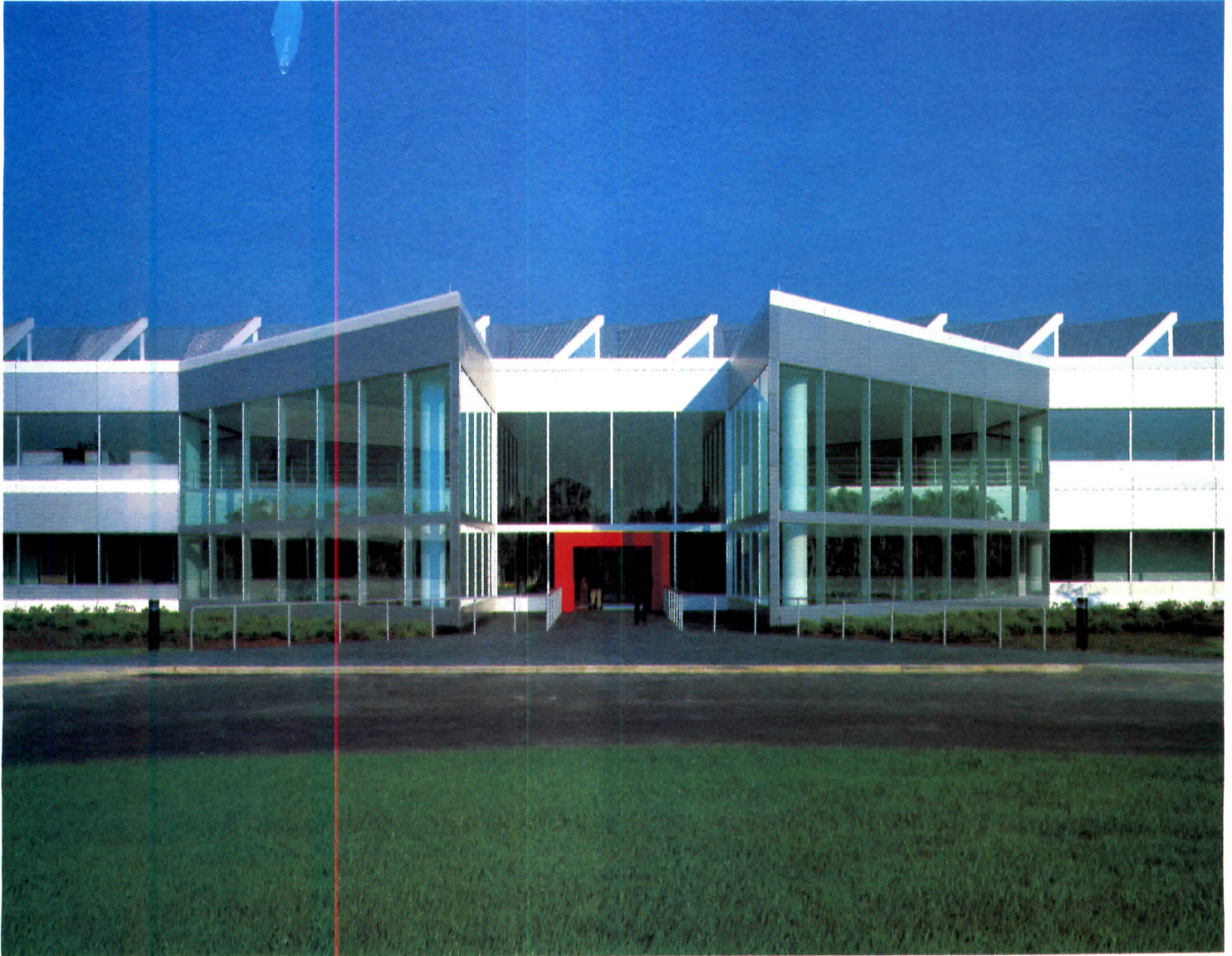

For energy conservation, the building was designed with exterior venetian blinds; supply problems delayed this installation and, as an alternative, computer-controlled translucent fiberglass shades were installed inside the glass. Shades are adjusted every 20 minutes (on each of 24 surfaces) for sun angle, desired sun penetration, and desired solar heat gain. Heating is by

perimeter fin tube; cooling is zoned variable-air-volume distribution with air-side economizer. Operable vents in a continuous strip under all windows can be opened in the event of system failure, and air moved by fans in the skylights. Power and telephone is distributed by underfloor raceways with flat cable under carpet squares in open-office areas.

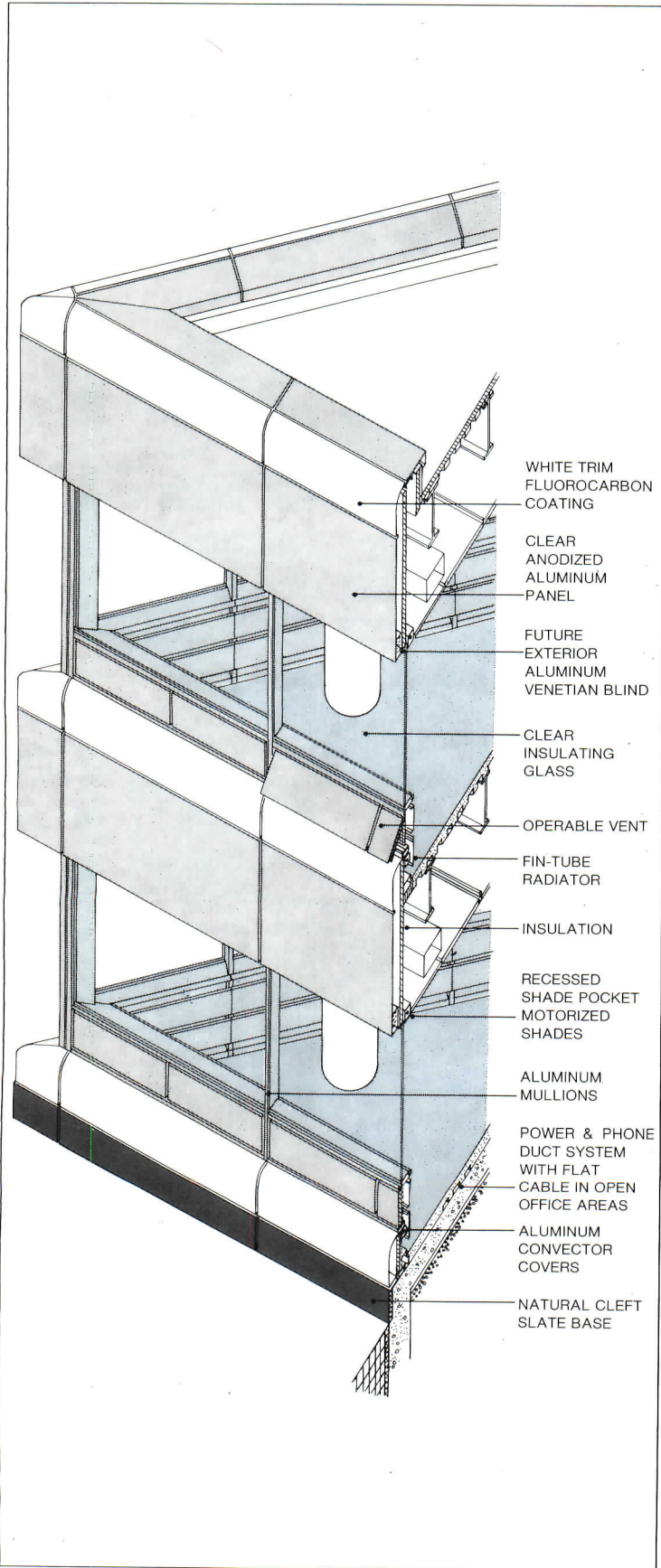

Typical interiors: a second-floor lounge overlooking the entry court, with open-office space in the background; a second-floor executive lounge; the major conference room; an informal conference room at one of the building corners; a typical managerial office; the cafeteria.

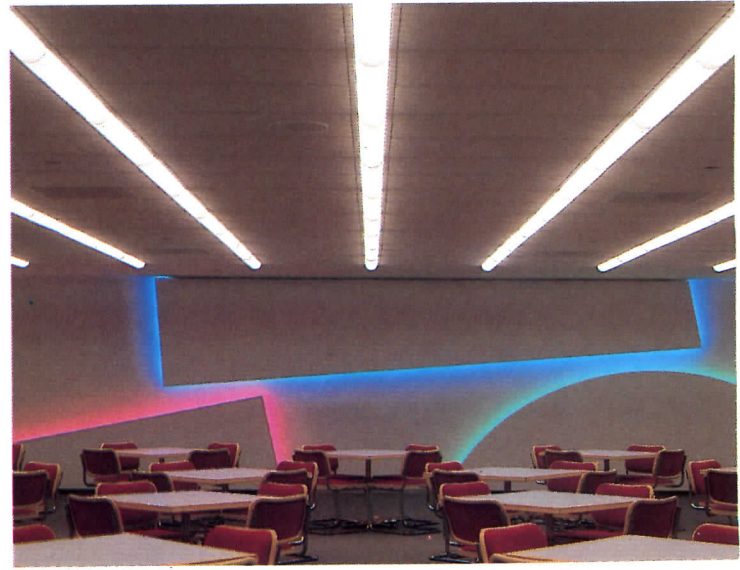

The black-and-white photo at right shows a typical open-office bay marked by a raised ceiling and pendant lighting; note circulation and lounge areas at windows, glass-walled executive offices in background. Below, hallways and circulation space are detailed as carefully as the exterior. Wall painting (on canvas, glued to wall) is one of several in the building.

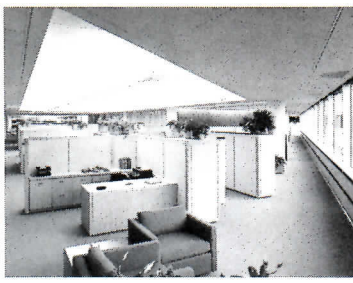

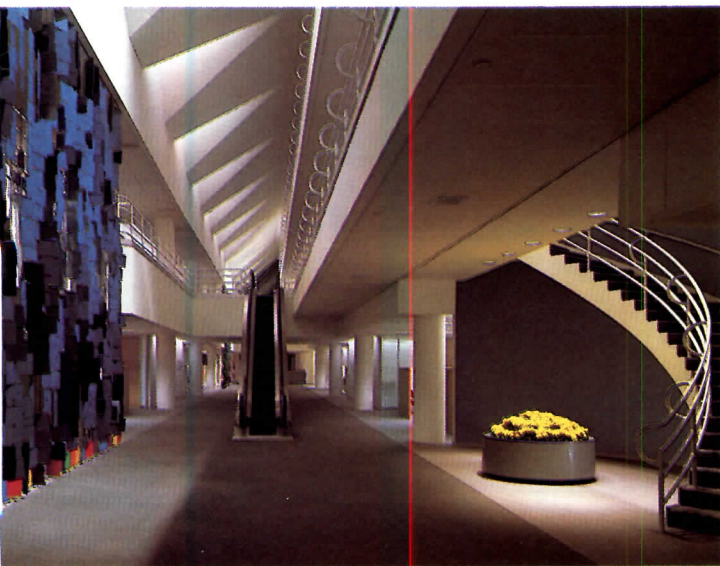
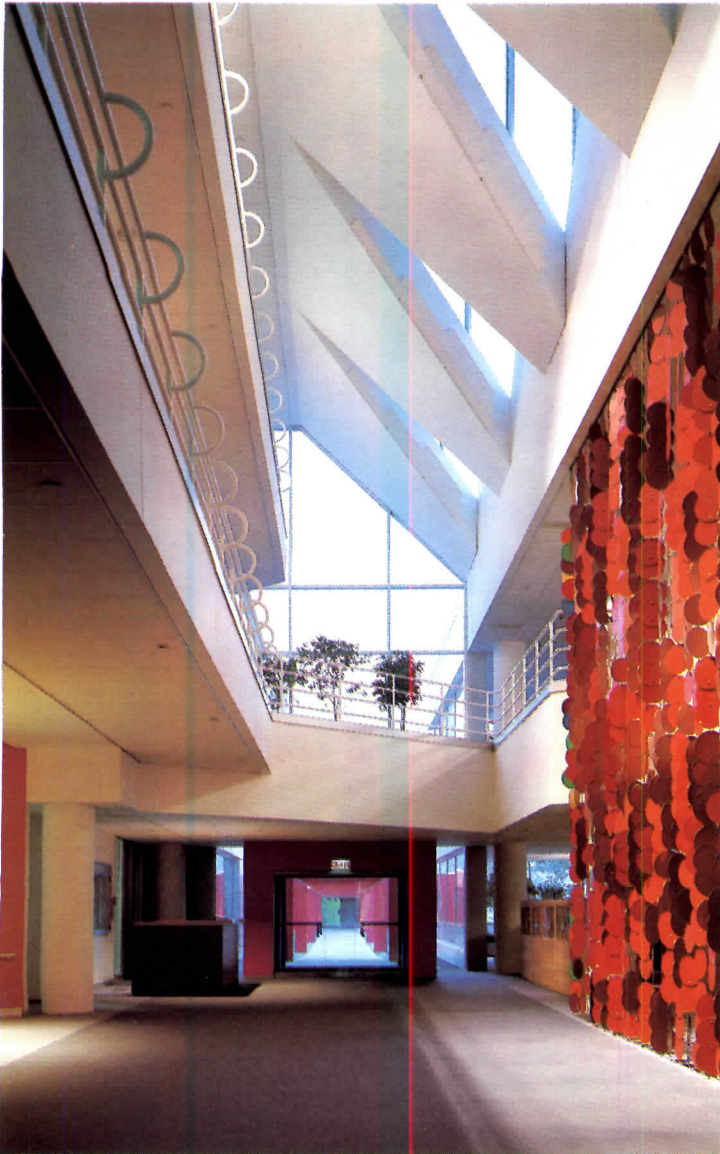

The 700-foot-long central street "is much more important than a simple circulation spine," says Lew Davis. "I wanted it to be a very special place for everyone who works here. The hanging screens, the semicircular stairwells, the detailing of the handrails... are intended to give the street a sense of pace, and importance." Most important are the skylights—tetrahedron shapes let into the sloping roof over this section of the building. Light enters on the north face only—so when you are walking north (photo just below) you see the sky; when walking south (bottom photo), only brightly sunlit planes. Four fluorescents on each of the southern planes come on progressively as the light fails. It is altogether a stunningly successful place—a total surprise to the visitor, functional necessity for those who work there, the most vivid and memorable architectural image for everyone.

*Philip Morris
Operations Center
Richmond, Virginia*

Architects:
Davis, Brody & Associates—
Anthony Louvis, senior project
manager; Ian Ferguson, senior
designer; Norman Dorf, George
Maness, project managers; Max
Pizer, architect-in-field; Fred
Chomowicz, Robert Lubalin,
Lelia Gilchrist, Richard Dickens,
Frank Calcagni, Mark Meyer,
Marie Colasson, Renee Sandoz,
Jonathan Leffell, Andrew Jarvis,
Martin Kupris, Gerald di
Stephano, design team; Geoffrey
Roesch, landscape coordinator;
Birch Coffey, Joanne Newbold,
Elizabeth Pippin, Patricia
Lutkins, interior design team.

Engineers:
Jaros, Baum & Bolles
(mechanical); Wisenfeld & Leon
(structural)

Consultants:
Zion & Breen (landscape); Jules
Fisher & Paul Marantz
(lighting); Ostergaard Associates
(acoustics); Gordon H. Smith
Corporation, (curtain wall);
Robert Singleton (audio-visual).

Construction manager:
Voss International
Consultants to the owner:
Morse/Diesel Inc., (construction);
Chermayeff (art and graphics)



Mix and match: Two small shops in pre-classical free-style

Janovic Plaza Inc.
New York, New York
Voorsanger & Mills
Associates, Architects

Tempietti and *aediculae* abound in this New York City paint store—and these and other ancient architectural fragments create a second world of memory and association for the customers of a SoHo dress shop, Dianne B. (pages 126-127). The architect of both shops, Edward I. Mills of Voorsanger & Mills Associates, is one of the most skillful, zestful and imaginative of the small group of architects who are currently working within the particular post-modernist, historicist, classical vocabulary first articulated by Michael Graves. Mills's way with forms turns out to be just right for these two clients since both the paint store and the dress shop were to be more than merely functional, sensible, tasteful solutions to their practical programs. Each was to say something new to its customers—with style.

For Dianne B., SoHo haute couture was to be hung, draped, tried on and purchased in a setting that would satisfy and divert the fashionable mind, moving purposefully about the Cast-Iron District to visit such art dealers as Mary Boone and O.K. Harris. "Come look at our art too," is the message of the shop's decor. Paul Sinclair, former partner of Dianne Benson of Dianne B., worked closely with Mills on the basic architectural concept and details of the dress shop. "We wanted people to feel glamorous in it, of course, but more than that it is our contribution to the world of SoHo and the world of art. I think the store will date quickly, but then it will become an important period piece because it is so masterfully done."

The Janovic/Plaza store in New York City's Upper East Side also lures the fashionable mind, here intent upon the latest in home decor—paint, wallpaper, fabrics, venetian blinds, bath accessories, etc. Architect Mills tried to nourish that mind by suggesting architecture's mythic origins in countless ways. He has caused the store's merchandise to be displayed upon little structures within structures, primary archetypal forms, columned, architraved, pedimented and pilastered. These aboriginal models of architecture, it is hoped, work upon the customer's unconscious, filling him with desire to remodel.

Additionally Mills created a wonderful palette of colors used on the facade and throughout the store. Originally mixed in Winsor Newton gouache, they are now available in Janovic paints. "We tried to show color the way it would appear in nature," says Mills. "If we had made the store white, there would have been too much juxtaposition between the merchandise colors and the store."

"Our aim," said owner Evan Janovic, "is to show people they needn't be afraid to use color. And because of what we have done—so imaginative and playful—our customers have confidence in us. Painting contractors like to shop here and also the decorators like it. And the environment of color helps couples who disagree with each other to make decisions because it shows that all kind of combinations of colors are possible. Any single area of the store is painted in at least ten different colors and they all work together." After exposure to the rainbow at Janovic's, only the most obdurate householder would continue to paint his walls white. *Mildred F. Schmertz*

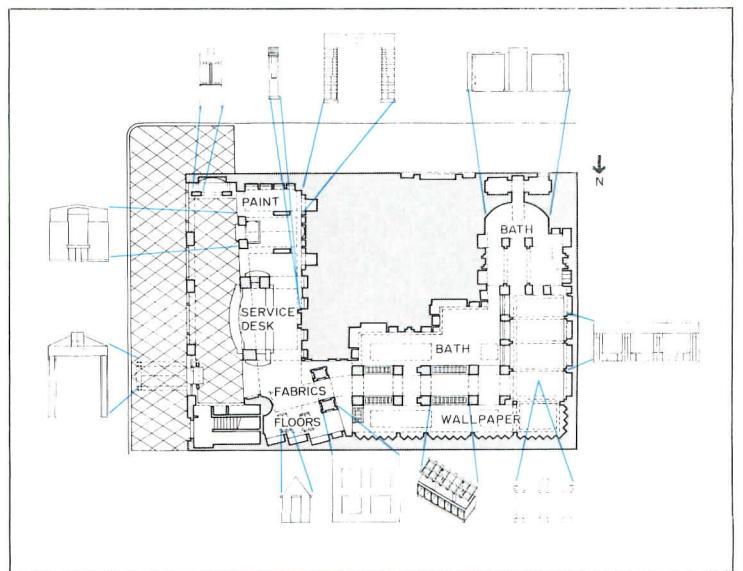
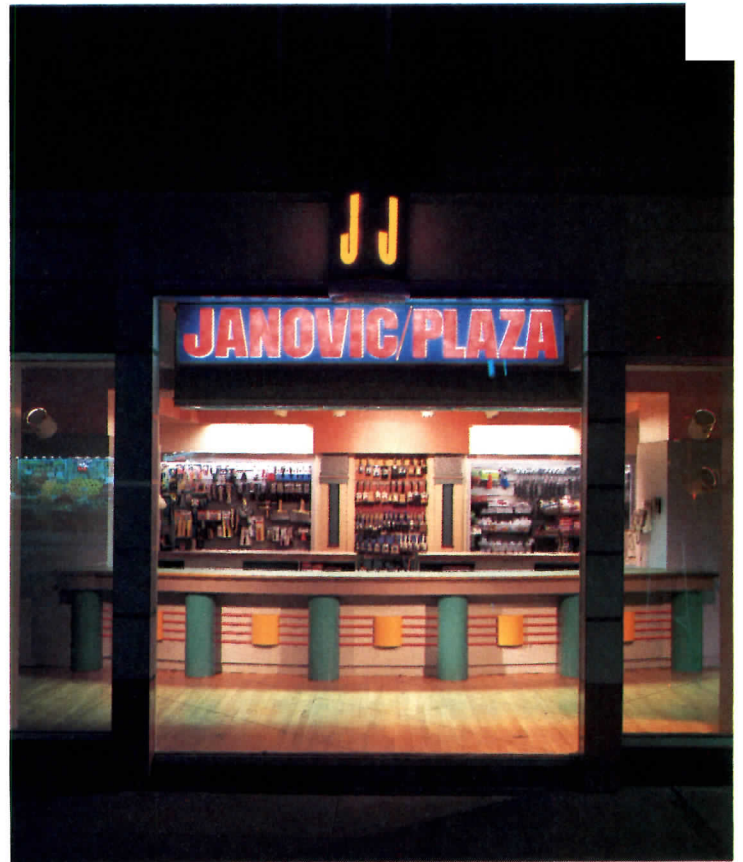

The facade of the store consists of a series of framed portals with glass to the sidewalk, opening the display space to the street. As the plan indicates, the front of the store contains a custom-paint color area and a large service-desk area with painting accessories, as can be seen in the photo above. From the front of the store, the rest of the retail space (photos right and next pages) unfolds down a corridor containing

a large selection of fabrics. To the north and south of the corridor, through framed vistas, are the bath shop and the wallpaper department. Floor tiles are displayed on the roofs of little houses and stored inside (photo right).



© Peter Aaron/ESTO photos

*Janovic Plaza Inc.
New York, New York*

Owners:
Evan and Neil Janovic

Architects:
*Voorsanger & Mills Associates—
Edward I. Mills, partner-in-charge;
Charles B. Crowley, project architect*

Engineers:
Pavane Associates

Consultants:
*Whitehouse & Katz (graphic
design); David Kagan
(merchandising);
Jeff Miller (lighting)*

General contractor:
*F. J. Sciamie Construction Co.
Inc.—Jim Kilkenny*

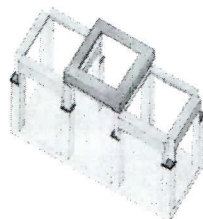



Dianne B.
New York, New York
Voorsanger & Mills
Associates, Architects

The plan consists of a series of boutiques diminishing in size toward the rear of the shop, each proportioned to its respective space. The shapes are cubical, open and unencumbered to walk through, defined on either side by vertical showcases with storage area behind them and by the carpet pattern and the beams spanning overhead. Suspended from the beams is a painted soffit which houses a

mechanical duct and acts as a light bridge. This soffit creates a skewed axis which is juxtaposed against the diminishing orthogonal spaces of the boutiques. This forced perspective is intensified by the receding heights and colors of the shop. The "objects" such as the window stage area, the center stair and the dressing octagon are painted white to further separate and isolate them as objects in space.

Four mirrored doors open from the octagon into the dressing rooms and toilet. This space is the center of activity and the stage upon which the shoppers become actors as well as spectators. An eight-sided cone forms the roof overhead. Painted gold and brightly lit, it reflects a golden light throughout the shop.

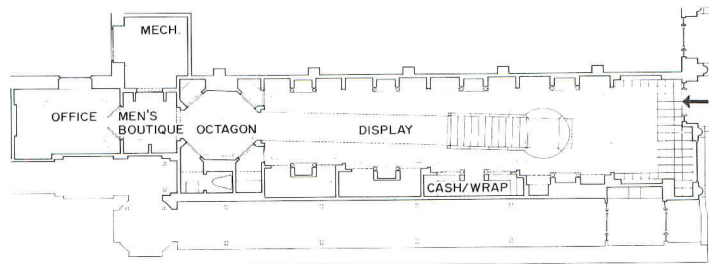

Owners:
Dianne Benson and Paul Sinclair
Architects:
Voorsanger & Mills Associates—
Edward I. Mills, partner-in-charge;
Stuart B. Crawford,
project architect
General contractor:
Parallel Fabricators and
Construction—Howard Reitzes



The Everson Museum, Syracuse, New York (top) has a board-formed spiral stair and balcony. Note the sharp arrises on the stair-rail bottom. Architects: I. M. Pei & Partners; engineers: R. R. Nicolet & Associates. The Landau Chemical Engineering Facilities building at M.I.T. (bottom) obtains contrasting

textures with surfaces formed by boards and by plastic-coated plywood. Architect: I. M. Pei & Partners; engineers: Weiskopf & Pickworth

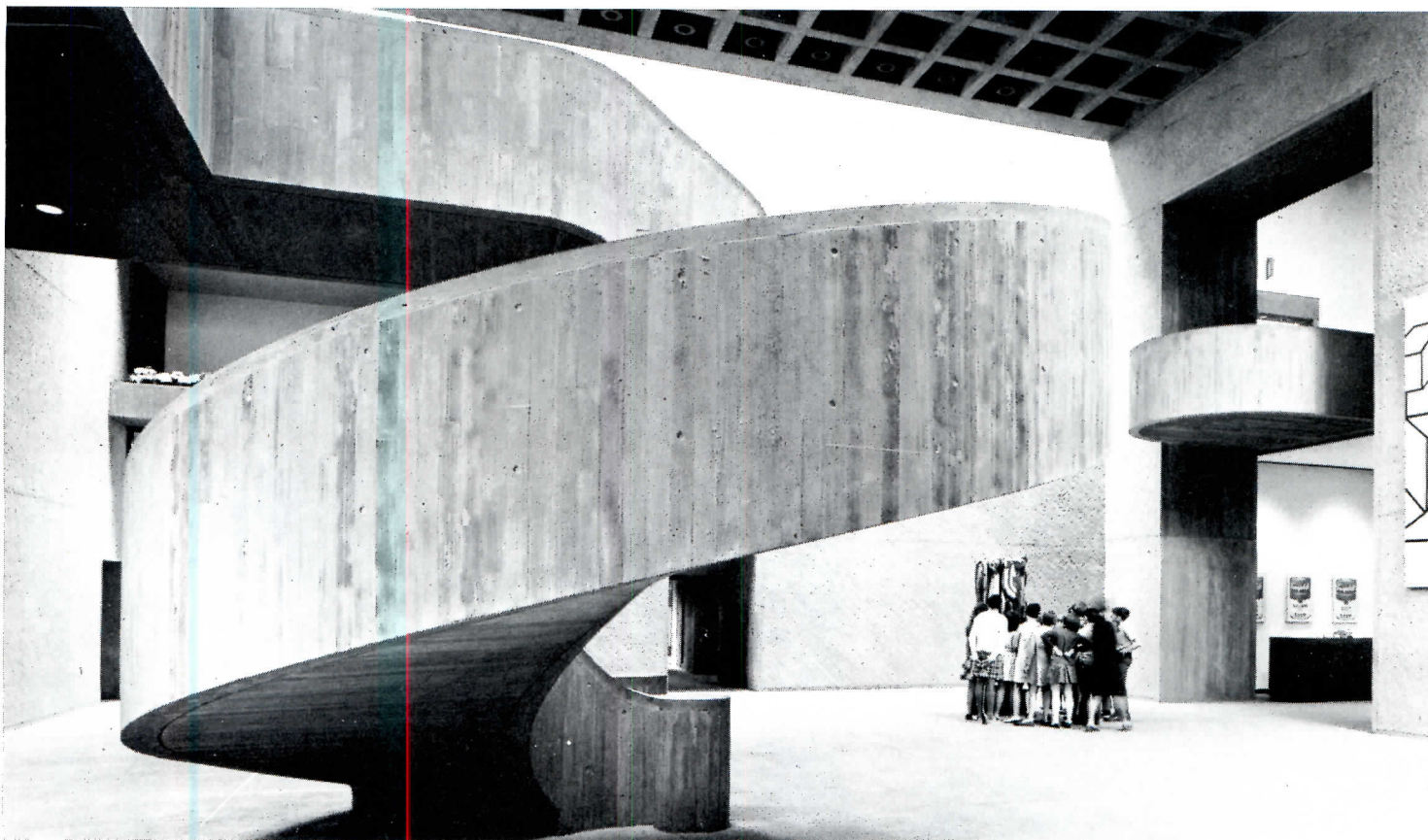

Erna Stoller / © ESTO photo

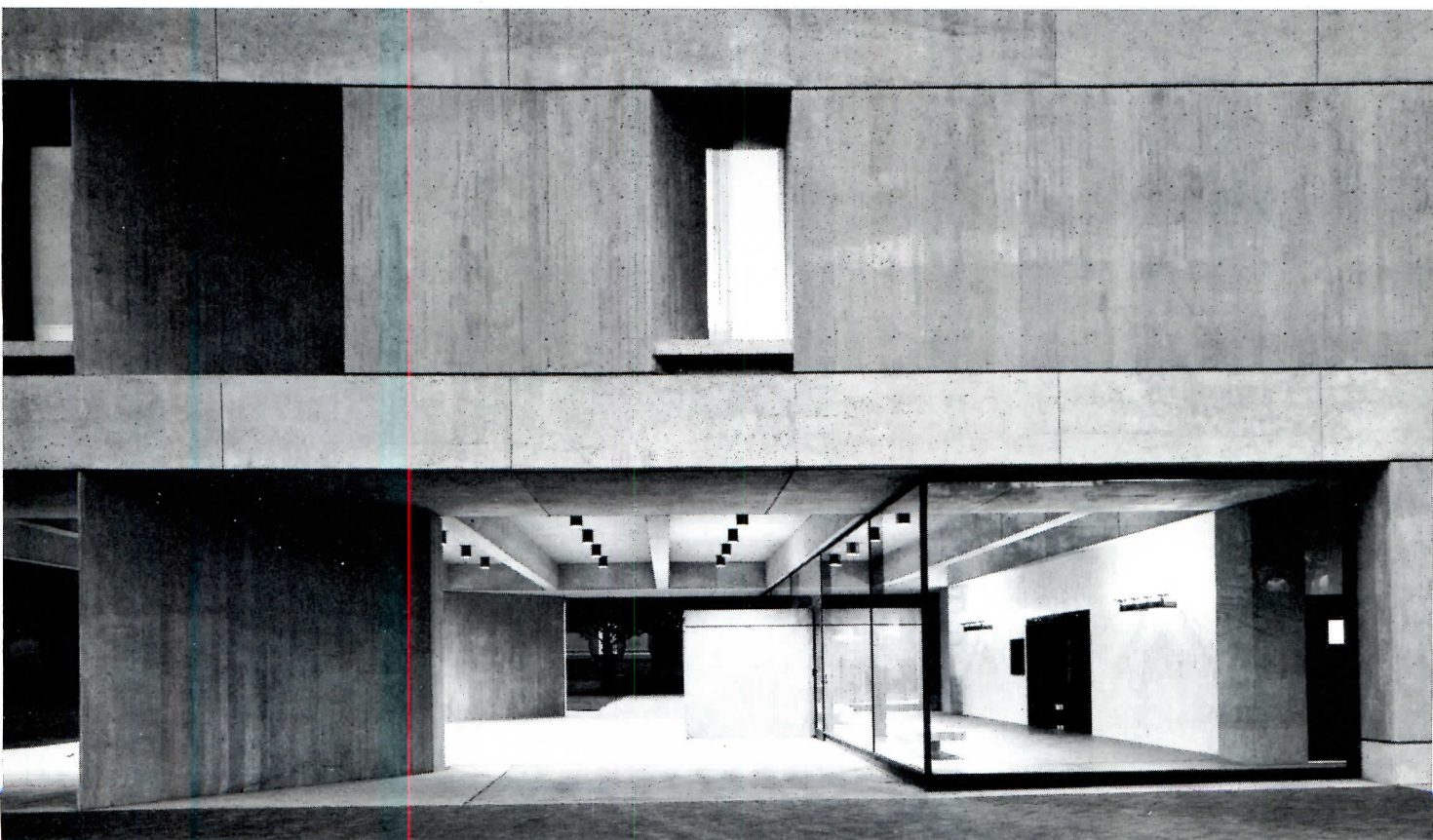

George Csereka photo

The secret to quality in architectural concrete: knowing construction

At RECORD's recent Round Table on Concrete in Architecture (November 1982), Reginald Hough, senior associate in I. M. Pei & Partners, argued that architectural concrete might take on renewed life if architects adopted a more construction-oriented approach to design. Said Hough, "Architects need to know as much about concrete construction when they are designing buildings as contractors do when they are constructing them. The reason that architects have not been confident that they can get a consistent quality with architectural concrete [as they can with factory-made materials] is that the control mechanisms architects and engineers put in their design documents have not been up-to-date and standardized." In this article, which is adapted from a paper Reg Hough presented at an international symposium on formwork in Chicago last November, the author shows how the forming of architectural concrete differs from conventional structural concrete, suggests how the designer can control quality through drawings and specifications, and describes how designer and contractor should interact for a common understanding of the quality the architect expects.*

For quality architectural concrete work to be achieved, the whole operation must be carefully planned, coordinated and executed. The reason is, of course, that cast-in-place concrete is a hand-crafted material, manufactured on site in its final position, frequently under adverse conditions. Every other building component is manufactured off site in a highly controlled, often mechanized, process which in itself provides a high degree of consistency. Architect, engineer and contractor must address this difference in the early stages of their work.

In theory—since forms are not part of the finished structure, the contractor is responsible for their design and manufacture—the quality of the formwork should concern the architect/engineer only as it affects quality of the end product. But in fact, concern for quality control means that architect and engineer share the responsibility for the development of formwork details, particularly those that affect exposed or architectural concrete. Architectural concrete formwork, in contrast with that for unexposed concrete, requires: 1) better quality of form contact surface; 2) greater care in design and fabrication to ensure tight, accurate profiles; and 3) stricter tolerances.

The architect's goals for architectural concrete are 1) to achieve consistency of surface—color and texture, alignment, and layout; and 2) to avoid cracking. These goals are attained first of all by the architect and engineer developing a construction orientation toward the use of architectural concrete—for example, the relative difficulty presented to the contractor in assembling and disassembling forms and in placing concrete. Secondly architect/engineer need to spell out the quality of formwork they want in the specification—one aspect being the tightness necessary to avoid leakage. Finally they must pay particular attention to the submission of samples, to the review of formwork shop drawings, and to the construction of a mock-up.

A construction-oriented design implies that architect and engineer make decisions during design and development with respect to how the building will be constructed so the contractor can achieve not only quality, but also economy and speed.

How a construction-oriented detail can affect quality is clearly illustrated in Figures 1, 2 and 3 of a slab and contiguous

spandrel on page 130. When the slab and spandrel are constructed in a single operation, discoloration of the surface of the spandrel is almost a certainty (see explanation page 130). The problem is avoided if slab and spandrel are constructed separately and joined by a structural construction joint. At first glance, most contractors would regard the detail shown in Figure 3 as uneconomical, since it requires added time for constructing bulkheads and more concrete placements. But if a contractor carefully considers the detail, he will realize that separating slab and spandrel will allow the floor portion to move a lot faster, and it will eliminate delays relating to the simultaneous pouring of a difficult spandrel. Further, the completion of the basic structural frame, which is always the most important item in a construction schedule, is more likely to be on time. The construction of the spandrel, which is not a "critical path" item, can follow in an orderly way. The faster over-all schedule more than offsets the extra time required from carpenters and laborers.

Contractors are responsible for integrity of the formwork and for quality called for in the contract documents

First, contractors are legally responsible for the structural stability and safety of the formwork. Secondly, they are contractually responsible to produce work in compliance with the quality required by the drawings and specifications. Nonetheless, the professional team must be aware of, and take into account, practical construction techniques when preparing documents. The contractor, on the other hand, should intelligently select the materials necessary for quality work, and allow enough time for their procurement. Further, he must plan his approach to the concrete construction early enough so that the work can be done properly. The contractor has four major concerns regarding formwork: 1) speed in handling, erecting and stripping forms; 2) cycling, sequence and separation of placements of concrete; 3) initial and maintenance costs of forms; and 4) whether decisions made on the foregoing, considered together, can produce the quality specified by architect and engineer.

Architect/engineer review of form materials and shop drawings is essential to effective communication

These submissions enable the architect to determine whether design quality is understood by the contractor and provide an opportunity for the architect to clarify the intent of the design documents. Further, this is a means for the contractor to establish his interpretation of the documents and to have it verified by the architect and engineer. Additionally, it allows him to plan his work and coordinate the crews building the project. The architect/engineer should specify shop drawings and submissions of materials in sufficient detail to enable them to determine if the formwork complies with the quality requirements of the project. Some of the items that should be called for include: 1) a description of surface materials; 2) specific layout of all surfaces showing joints, tie locations, clean-out panels, devices and fastening; 3) details (including back-up and hardware) showing how the forms and form joints are aligned and held tight under pressures imposed by wet concrete. The architect should question any detail or procedure that he feels might impair the quality of finish he wants, and should satisfy himself that the contractor has complied with the contract.

Clean-out panels are an especially important item that should
text continued on page 135

*"Forming Economical Concrete Buildings. Proceedings of an International Conference on How to Integrate Forming into the Total Building Design and Construction Process." Sponsored by Portland Cement Association, Concrete Reinforcing Steel Institute, and National Ready Mixed Concrete Association.

Proper sequencing in placing concrete avoids discoloring

Consistency of color is affected not only by the composition of the mix, but also by how the contractor places the concrete. A major cause of discoloration is too long an elapsed time between deposited lifts of concrete. This often occurs when construction requires very large and complicated placements of concrete. A common example is the casting of a floor slab and contiguous spandrel in one operation (Figure 1).

Normally, the contractor first places the concrete for the dropped portion of the spandrel and the slab (Figure 2, section). He would then allow the slab to stiffen slightly before placing the concrete for the upturned portion of the spandrel—otherwise this concrete would flow out of the spandrel form and into the slab area.

Concrete deposited in the dropped portion of the spandrel is allowed to take its own angle of repose (no vibration) so that more can be deposited on top to finish the slab (Figure 2, elevation). During the time lapses between lifts of concrete, the setting process starts. When fresh concrete is placed, a discoloration seam results at the interface of the adjacent lifts of concrete.

Similarly, another area of discoloration develops where the stiffened slab meets the concrete for the upturned portion of spandrel.

The problem is avoided if the structure is designed as shown in Figure 3, with a construction joint in back of the spandrel, so that slab and spandrel placements are separate operations.

Avoiding discoloration could have been even more difficult with the combination of elements shown in Figure 4. But with the details shown in Figure 5, columns, slab and spandrel can be placed separately.

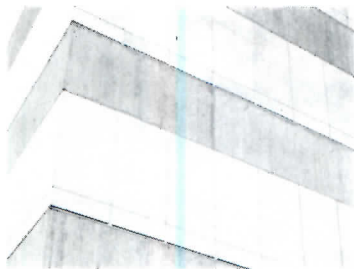

A rich, unblemished spandrel was achieved using the two-step process shown in Figure 3. Akzona Corporate Headquarters, Asheville, North Carolina by I. M. Pei & Partners; engineers: Weidlinger Associates.

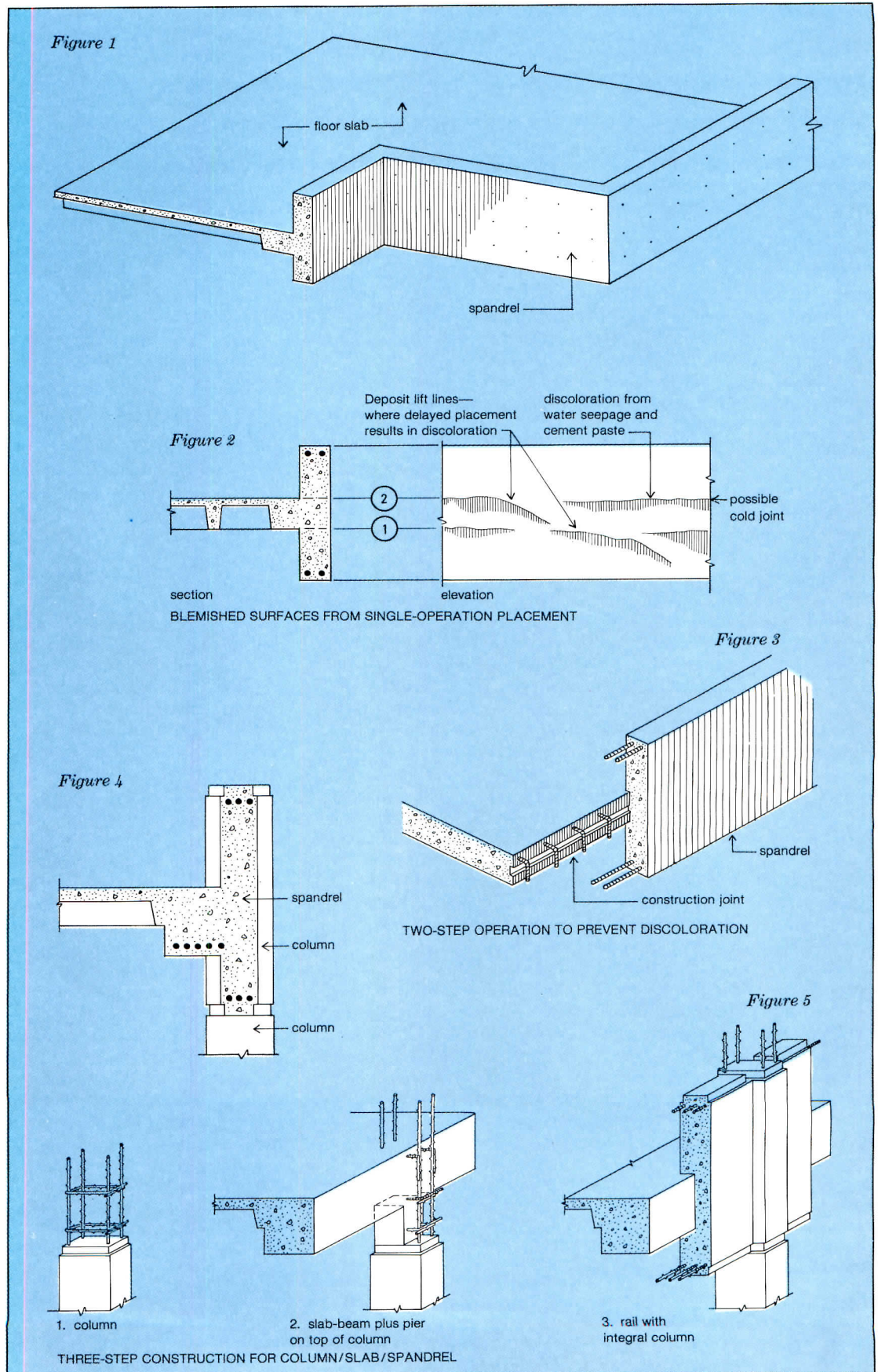

Tightly clamped, sealed forms ensure sharp edges

Improperly designed and assembled forms can cause two types of defects of great concern to architects: 1) out-of-line surfaces in areas that should be flat, and 2) uneven and spalled edges and corners resulting from leakage through cracks.

These problems are avoided through proper alignment of forms, tightness of formwork connections, and fastening of forms to in-place concrete. A specification to ensure that these procedures are followed could be worded as follows:

"Formwork shall be designed so that all field-erected form-corner assemblies and in-plane form-to-concrete assemblies are provided with screw tie rods outside the contact area, and as close to the meeting joint as possible—located in a position that acts to resist the concrete liquid head." The specification further should require a gasket in the joints to prevent leakage.

A typical beam-bottom detail that will produce a consistently high-quality product is shown in Figure 6. The tie and wale (A) are located just below the bottom contact form surface (that part of the form next to the concrete). A closed-cell type elastomeric gasket (B) is applied to the joint to provide the added seal required to prevent water or cement paste from migrating through the joint.

Figure 7 shows the formwork assembly for the spandrel of Figure 4. The reveals or reentrant corner-form pieces (C) should be designed to resist pressures from the weight of the concrete. The detail in Figure 7 shows all the form pieces held together tightly with a screw rod tie-and-wale assembly (A) that clamps the members together.

A typical vertical corner-form assembly using a screw rod to close the joint is shown in Figure 8. The tie seats must be anchored as shown in the detail; otherwise, they will slip and allow the joint to open.

The form for a horizontal construction joint must be held tight to the in-place concrete below; otherwise, an offset (an out-of-plane, jutting-out section) could occur. The method for achieving successive flush surfaces is shown in Figure 9.

Figure 6

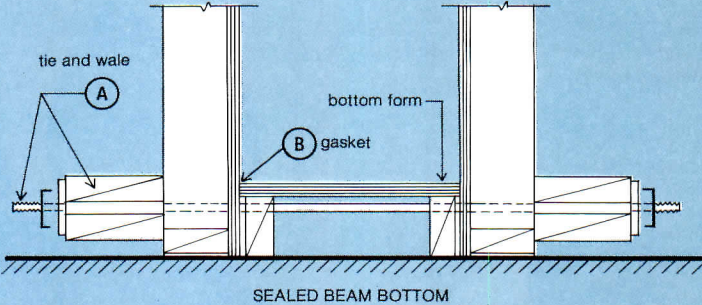

Figure 7

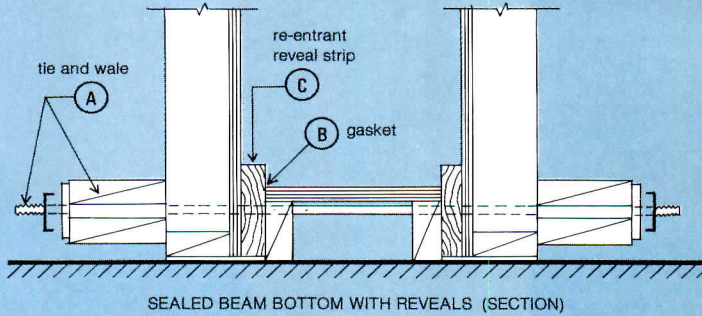

Figure 9

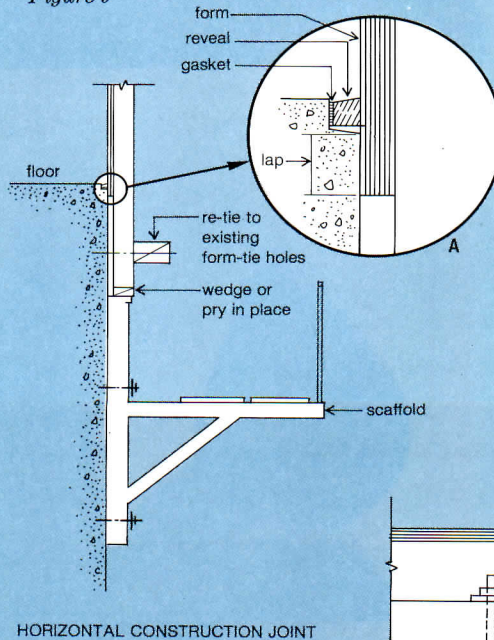
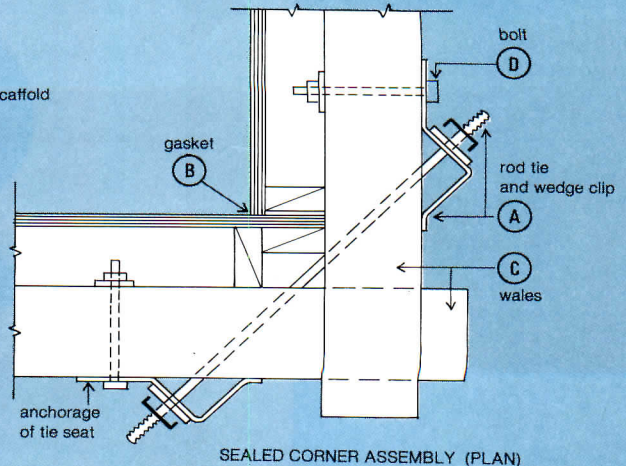

Figure 8



Ordinary forms can lead to spalling and out-of-true planes

The contractor should understand the quality of finish expected by the architect because he will need to detail his formwork accordingly. When finish is not an issue, or the concrete will be covered, beam forms such as shown in Figure 10 are commonly used. The problem with this arrangement is that any unevenness in the form interface, and riding-up of the form sides, or any shifting of the nailed-down kickers during placing of concrete, will cause an overpour and leakage that will destroy the sharp arrises of the edge, distort the profile, and discolor the bottom and side surfaces indicated in the circled inset.

Figure 11 might seem a better approach through use of a separate drop-in beam bottom, but since the side forms are held only by nailed kickers, the same shifting and leaking can occur. The detail is improved by addition of a wedge (circled inset) to force the joint closed. But the risk of poor quality is still high with this detail if heavy drops of concrete are placed, or if the wall is more than one or two feet high.

One of the most common methods of sealing the joints between beam bottom and side forms for conventional concrete is to use a chamfer or skewback in the corner, as shown in Figure 12. The assumption is that the concrete will force the skewback strip into the corner and seal the joint. While the skewback will prevent heavy paste loss, it will not prevent leakage of fine paste, and will not prevent the skewback from distorting during forming and concrete placing. The circled inset shows how overpours around the skewback spall during stripping. Spalling of corners is a possibility any time that leakage seeps through forms because when forms are removed they do not strip cleanly, but spall corners in the process.

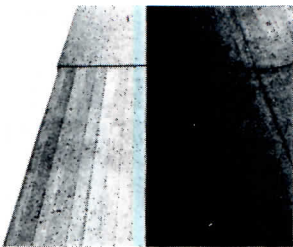

When forms are not tightly clamped, they can loosen and become misaligned, resulting in unsightly jutting surfaces called offsets.

Figure 10

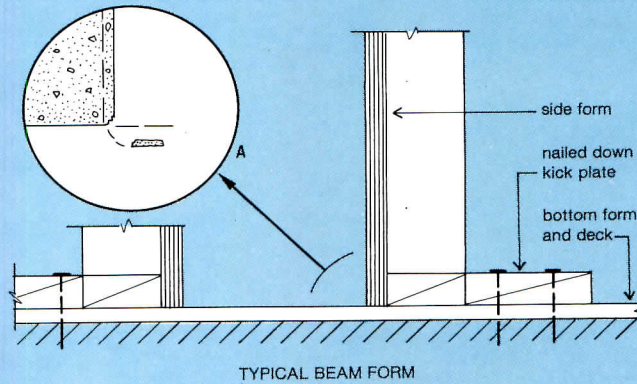

Figure 11

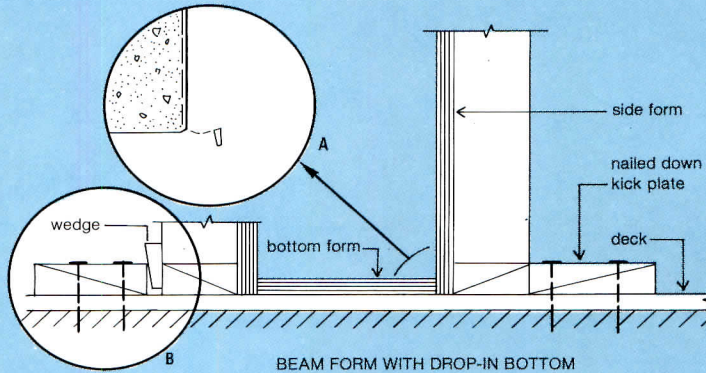
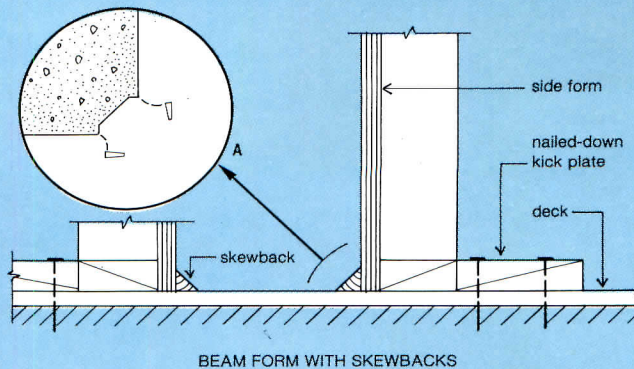

Figure 12



Joins should be planned for function and appearance

Whatever material is in contact with the concrete in the form is, of course, imaged in the finished surface. Boards create very closely spaced lines—the pattern blends and gives the appearance of a large, unjointed surface (photo top, right). Large sheets of plywood create a prominent grid pattern (photo center, right).

Yet, the full implications of the imaging of what is in the form are not always considered by the architect. Examples are the visual effects of form-splice lines and form-tie holes. Material splices, no matter how tight, will show on the surface in various degrees.

Since tie-rod hole size and spacing will be seen, the architect may want to suggest a pattern of form ties appropriate to his design—a symmetrical and consistent relationship between tie holes and form joints. But the responsibility for the structural performance of the ties belongs properly to the contractor.

Two types of joints are inevitable—the construction joint and the form joint. The architect must decide whether he wants them flush (butted) or revealed. If the architect wants revealed joints or feature strips, he should include them as part of the working drawings. Joints should be detailed both in terms of size and of location. A *construction joint* is one that occurs where the concrete work is interrupted during construction, but one that does not affect the structural integrity of the system. A *form joint* occurs where there is any joining or meeting of the contact form material.

The two types of form joints are: 1) a *shop-fabricated joint* which is a material splice made in the shop, intended to remain fixed in the formwork; and 2) a *field-assembly joint*, which is one designed and fabricated for assembly and disassembly in the field.

Another type of joint, the *control joint*, is not inevitable, but highly desirable. Purpose of the control joint is to help ensure that concrete—which inevitably cracks because of shrinkage when sections are longer than 15 ft or so—does so in predetermined locations. Predicting where cracks will occur is more a matter of experience than of formula. Influencing factors are size and shape of member, the steel reinforcement, and protection during curing. A fairly reliable rule of thumb, however, is that an evenly reinforced concrete wall will develop cracks from 10 to 15 ft apart. Random cracks spoil appearance because

of their randomness and because salts can leach out. If the pour is small enough, shrinkage can take place without cracking, though small pours generally are not economical.

Control joints are designed as planes of weakness so cracking will occur at designated locations. Figure 13 shows such a joint in which the weakness is obtained by reducing the concrete thickness, by means of reveals, and by interrupting the reinforcing steel. A revealed control joint is caulked to prevent moisture penetration. With a flush control joint (inset), a neoprene water stop blocks moisture.



The visual effect of form butt-splice joints appears in the spandrel beam of the top photo (shown more completely on the opening page). Plastic-coated plywood and revealed joints give still a different treatment for a wall in the Indiana University Museum of Fine Arts (center, right) Architects: I. M. Pei & Partners; engineers: Weidlinger Associates. The truncated cone over the auditorium of Herbert Lehman High School in New York City (above) has revealed joints. Vertical reveals are approximately 4 ft apart at the base. Control or construction joints were introduced at the reveals every 12 ft; Architects: The Eggers Group P.C.; engineer: Frank Burgess.

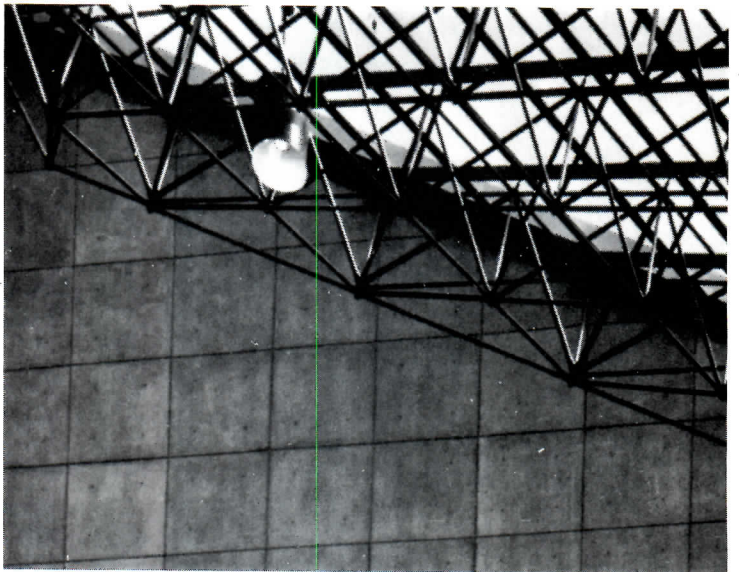
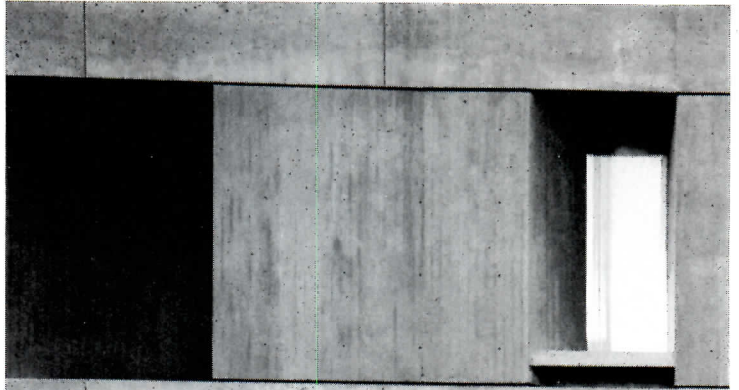
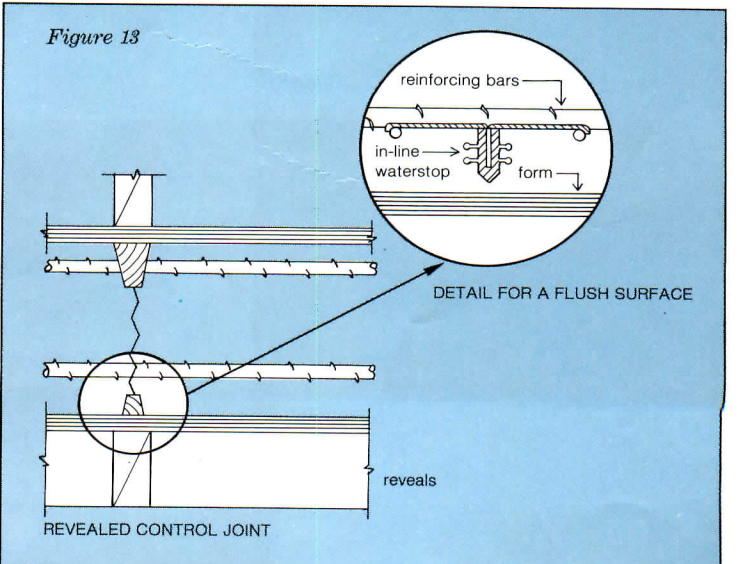

Figure 13



Flush or revealed, joints require tight, true forms

The detailing of construction joints is critical in terms of controlling offsets (i.e., out-of-line surfaces) and leakage. The flush joint is the most susceptible to these problems. The most common way to build this construction joint in a wall or a spandrel is shown in Figure 14, but this method is not desirable for architectural concrete.

The detail shows a face form continuous across the construction joint. For the first placement of concrete, a bulkhead is constructed butting the face form. (To permit structural integrity of the system, the bulkhead is made so that reinforcing can pass through. Thus, while placement of concrete is interrupted to allow separate pours, the reinforcing can be continuous.)

After the first placement of concrete has set, the bulkhead would be stripped so the second placement can be cast. The trouble with this approach is that shrinkage and form movement can result in an overflow of the second placement of concrete onto the first (see circled inset).

This problem can be avoided if a separate form assembly with wales and tie rods is used as shown in Figures 15 and 16. It ensures tight connections on both the first and second placements. Gaskets prevent leakage which could result in rough spalled edges.

Mock-ups—a learning experience for architects and contractors
The architect should require a mock-up of typical portions of the work to demonstrate the contractor's ability to do the work properly. A mock-up also gives the contractor an opportunity to test whether or not his proposed procedures will work.

Since a mock-up is expensive, its size has to be kept within reasonable limits. To be worthwhile, however, it must be large enough to incorporate at least portions of the sections most difficult to build. The mock-up also should be designed to test formwork corners, beam bottoms, edges, connections of soffits to walls, construction and control joints, and other items critical to achieving quality concrete work.

Figure 14

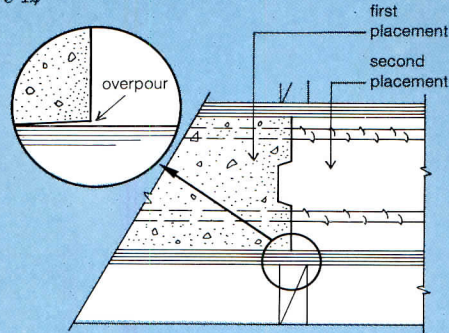

TYPICAL CONSTRUCTION JOINT

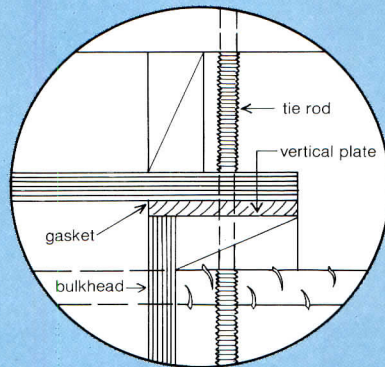

Figure 15

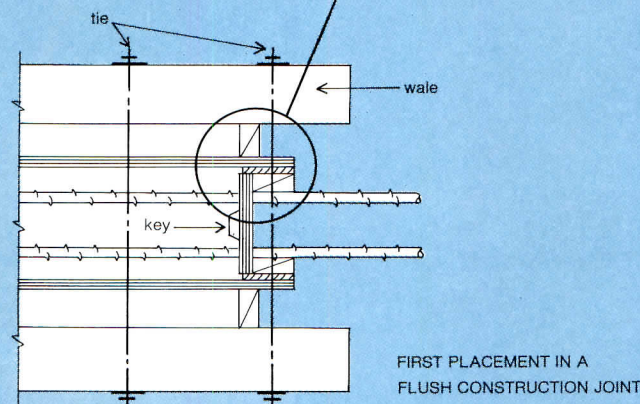
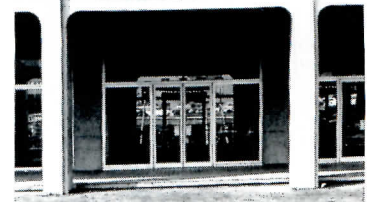
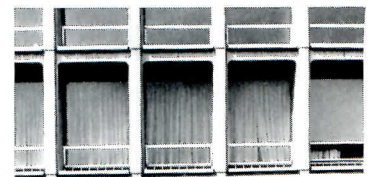
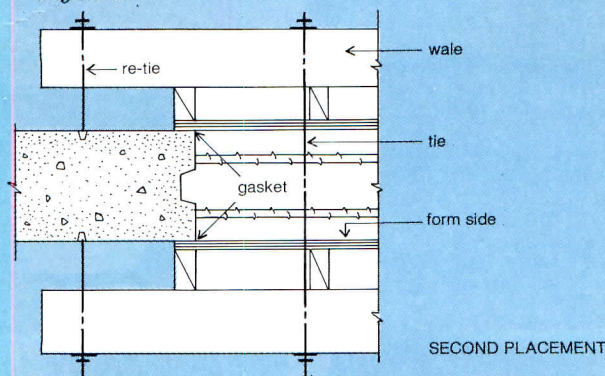

Figure 16



For Kips Bay Plaza in New York City, architect I. M. Pei pioneered in the use of architectural concrete as both structure and skin. The mock-up, larger than usually would be specified today, showed that flush, butted form joints leaked and could discolor the finish, so the joint was changed to a reveal, and the reveal strip in the form effectively blocked leakage. Engineers: S.H. Kessler & Associates.

text continued from page 129

be shown in shop drawings. Their purpose is to allow the debris that finds its way into formwork to be removed easily before the concrete is poured. Debris sometimes is left in beam bottoms and soffits because they are difficult to clean. But such debris is easily removed when clean-out panels are provided in the forms. The architect must ask for these ahead of time and make sure the contractor includes their details in his shop drawings. Since the outline of clean-out panels will show on the surface of the finished concrete, they must be located so these lines are visually acceptable, but at the same time their location must permit a thorough cleaning. If lines are not acceptable, and if the panels cannot be located in unexposed surfaces, then full-height panels, to be removed for cleaning and then replaced, should be incorporated in the formwork.

Approval of drawings and samples should relate to the scope of the work for which the architect is responsible, namely, design integrity of the final product. The following statement, or one similar, should accompany formwork drawing approvals by the architect: "Approval of this architectural concrete formwork drawing constitutes concurrence that the drawing is an acceptable proposal for accomplishing the architectural design as specified. Approval still requires the contractor to perform the work as specified, and to be responsible for the structural capability and safety of the formwork."

Architects can obtain the greatest benefit from the submission phase if the following four-step procedure is followed: 1) require the contractor to submit samples of all materials; 2) require him to submit an abbreviated set of conceptual drawings, showing typical details of formwork, connections, etc.; 3) have him submit shop drawings showing how the mock-up formwork will be built and stripped; 4) have the contractor submit shop drawings for the actual building after shop drawings for the mock-up have been reviewed and approved, and preferably after the mock-up has been constructed.

With this procedure, the formwork is systematically developed and refined with the least amount of time required for reworking. Each step draws on information learned from the previous one, facilitating a speedy, complete shop-drawing phase.

The importance of this shop-drawing and mock-up phase cannot be overemphasized because when the architect, engineer and contractor all understand the fabrication details, erection procedures and formwork use, the likelihood of a smooth-running, fast, high-quality, economical job is enhanced considerably.

The more the architect explains his intent with drawings, the better the bidding climate

With completed contract documents in hand, the contractor can price the work as a bid or as a guaranteed maximum cost, and begin to plan the actual construction. The pricing of architectural concrete must reflect not only the cost of materials and equipment, but also how sequencing of placements of concrete for quality affect the time required for construction.

Because of the highly competitive nature of contracting, the architect must make sure all contractors bidding the work understand the implications of the quality requirements in the construction documents. If they do not consider them fully, bids can be unrealistic, and the risk is high that quality will not be achieved.

Normally, contractors cannot take the time for an in-depth study of specific procedures required for quality architectural concrete; their time is more realistically spent figuring how to

use men and equipment most efficiently to produce a speedy schedule. For this reason the architect/engineer can encourage more accurate pricing by preparing drawings that explain the construction considerations used in developing the design. Such drawings give all the contractors bidding a more informed basis for considering the architectural concrete work. These drawings should have a note stating clearly that they are presented only to aid contractors by illustrating the quality of work required, that they are only suggestions, and that the contractor will be solely responsible for choosing methods to accomplish the work.

Since poor workmanship in architectural concrete is almost impossible to correct, it must be avoided

Typically, if a contractor's quality of materials and workmanship for any building component does not comply with the specification, he is required to remove and replace what is defective. But faulty cast-in-place concrete is difficult to remove. Patching is always a dubious solution. If only the portion of concrete that is defective is removed and replaced, sometimes the cure (patch) is worse than the disease (defective work) in a visual sense.

A contractor sometimes assumes that faulty workmanship will be accepted because of the difficulty of removal and the attendant time delays. This counterproductive attitude causes prospective owners and architects to feel that architectural concrete is a high-risk material. But if the work is properly planned and executed, the chances of getting an unsatisfactory product are minimal. And the cost to the contractor for such planning is negligible.

The drawings in this article illustrating formwork show very simple lumber backup, similar to what would be used in field construction. The purpose of these details, however, is to explain concepts for attaining a quality concrete product. Formwork using other backup, face materials, systemization, etc., can be detailed to produce the same quality product.

Many fine buildings of architectural concrete—such as those on the opening page—testify that a construction-oriented approach can produce superb finishes with a field-manufactured material. But for this to happen, the participants must each understand their role in the process. The architect/engineer must have the foresight to orient the design to construction, and the design documents must allow and encourage good construction practices. The contractor, in turn, must understand the kind of quality the architect seeks, and plan his work with proper documentation prior to actual construction.

A new generation of low-voltage incandescent lamps

With the introduction of *Precise*, General Electric engineers have provided even tighter beam control, greater uniformity of light, a "cooler" light beam, and a much more compact size (fits within a 2-in. cube) than available from other low-voltage incandescent lamps. Further, *Precise* is the first low-voltage lamp to have a reflector with a dichroic coating for cooler operation—only one-third of the heat generated by the lamp is transmitted in the beam, the remaining heat being rejected through the back of the reflector.

These features offer advantages for high-impact display lighting. *Precise* has already been installed in stores throughout the country to display items as diverse as art, jewelry, home furnishings and chocolates. Because spill light is minimized, *Precise* lamps are also useful for conference rooms or classrooms where users might take notes while viewing material projected on a screen, or for offices where CRTs are in use. [They are also suitable for homes—for anyplace, in fact, where standard track or accent



lighting is now used.]

The new lamp, an outgrowth of the company's projector lamp long used for small format movie and 35-mm projectors, consists of a small 2-pin quartzline tungsten halogen lamp which is permanently cemented in a dichroic-coated, one-piece glass reflector. Advanced coil engineering accurately positions the lamp's filament to help resist

handling shock, and the tungsten-halogen cycle insures that light output remains constant throughout the life of the lamp. General Electric Co., Cleveland, Ohio.

Circle 300 on reader service card

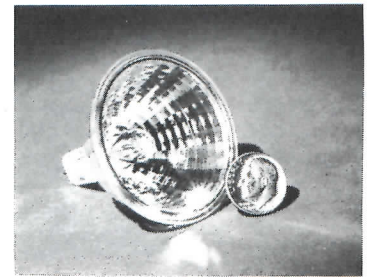

Rethinking public washroom facilities

The *Omni-Lav* addresses a number of common complaints people have about public washrooms: lack of security for personal effects, difficulty in finding a dry place to put down belongings, and lack of privacy. Each interlocking unit, canted to define a user's space, includes a water source, soap dispenser, paper towel dispenser, waste receptacle, shelves and coat hook. A push button with an automatic shut-off controls the flow of hot water, which is preset to 105 to 110 deg and the wash bowl—rarely filled in public facilities—is replaced by a sloped cavity. Towels are directly above and disposal directly below the water source, minimizing the chance for splashes on washroom surfaces. The *Omni-Lav* is molded of fiberglass with a gel coat, and it comes pre-assembled, requiring only a plumbing hook-up and the mounting of a track to the wall. The Charles Parker Co., Meriden, Conn.

Circle 301 on reader service card
More products on page 157



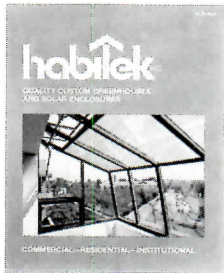

Greenhouses

A 4-page color booklet describes and illustrates applications of custom greenhouses and solar enclosures and introduces the *Extension Bay*, a bay window with a sloped roof of glass. Technical information is included. Habitek, Inc., Norristown, Pa.

Circle 400 on reader service card

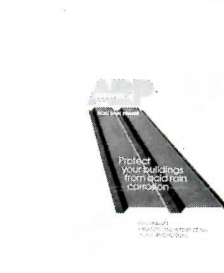

Acid rain primer

A brochure from DeSoto, Inc. describes *Koropon ARP*, an acid-rain-resistant primer developed for use on galvanized steel, which also can be used on any metal substrate. DeSoto, Inc., Des Plaines, Ill.

Circle 406 on reader service card

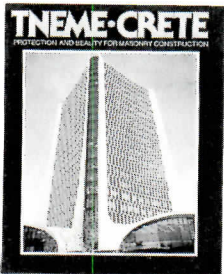

Masonry protection

Theme-Crete is a sand-textured coating claimed to protect most types of masonry construction. An 8-page color brochure describes and illustrates a variety of applications, including residential and office buildings, bridges and towers. Theme Co., Inc., Kansas City, Mo.

Circle 401 on reader service card

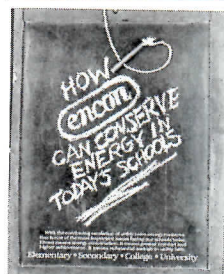

Fans

Conserving energy in schools is the subject of a 6-page color brochure on Encon fans. Photographs show a number of installations, and a diagram illustrates fan components. Charts show air movement at different speeds and wattage.

Encon Industries, Inc., Fort Worth, Texas.

Circle 407 on reader service card

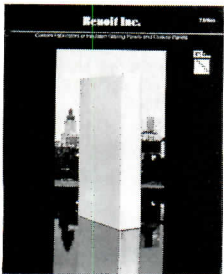

Insulated panels

Custom-made insulated glazing and closure panels appropriate for new construction or retrofit are covered in a 12-page color brochure. Photographs illustrate several possible combinations of facings and cores. Specifications and a color chart are also included. Benoit, Inc., St. Paul, Minn.

Circle 402 on reader service card

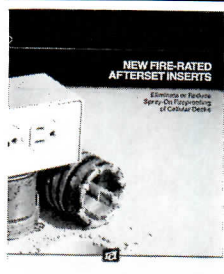

Afterset inserts

Fire-rated afterset electrical inserts, which eliminate or reduce the need for spray-on fireproofing in cellular concrete decks, are described in a 6-page color brochure. Information on installation and removal and typical specifications is included. Raceway Components, Inc., Nutley, N.J.

Circle 408 on reader service card

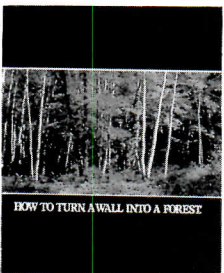

Photographic murals

A portfolio of photographs illustrates the use of pictures to cover entire walls. This company uses color and black-and-white photographs from its own collection or supplied by the client. Murals also may be installed and mounted upon request. Photographic Specialties, Minneapolis, Minn.

Circle 403 on reader service card



Masonry coatings

A catalog of products related to concrete surfacing covers mortars, binders, stucco, and pool plaster. Applications, specifications and performance data are included. W.R. Bonsal Co., Charlotte, N.C.

Circle 409 on reader service card

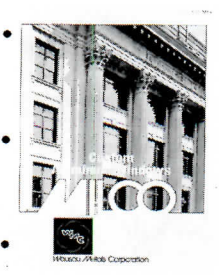

Aluminum windows

An 8-page color brochure shows installations of different types of custom aluminum windows appropriate for new construction and retrofit. Diagrams illustrate the components of each window type. Wausau Metals Corp., Wausau, Wis.

Circle 404 on reader service card



Alarms

A 1983 *Security Catalog* offers technical information on over 2,000 items. Color photographs, diagrams and detailed descriptions of products are also included. Mountain West Alarm Supply, Phoenix, Ariz.

Circle 410 on reader service card

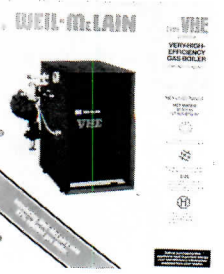

High-efficiency boiler

Cast-iron construction, compact design, and direct venting are the features discussed in a 4-page brochure, which describes the *VHE* residential gas boiler. A diagram illustrates the boiler's operation and specifications are included. Weil-McLain, Michigan City, Ind.

Circle 405 on reader service card



Mats and matting

Rubber and vinyl entrance, inlaid, surface and industrial runner matting are illustrated and described in a 12-page color brochure. Specifications, applications, installation and maintenance are all covered. R.C. Musson Rubber Co., Akron, Ohio.

Circle 411 on reader service card

RESISTS ALL THREATS

Sierracin Glass-Clad Polycarbonate Glazings Resist Ballistic and Physical Attacks, Marring and Fire

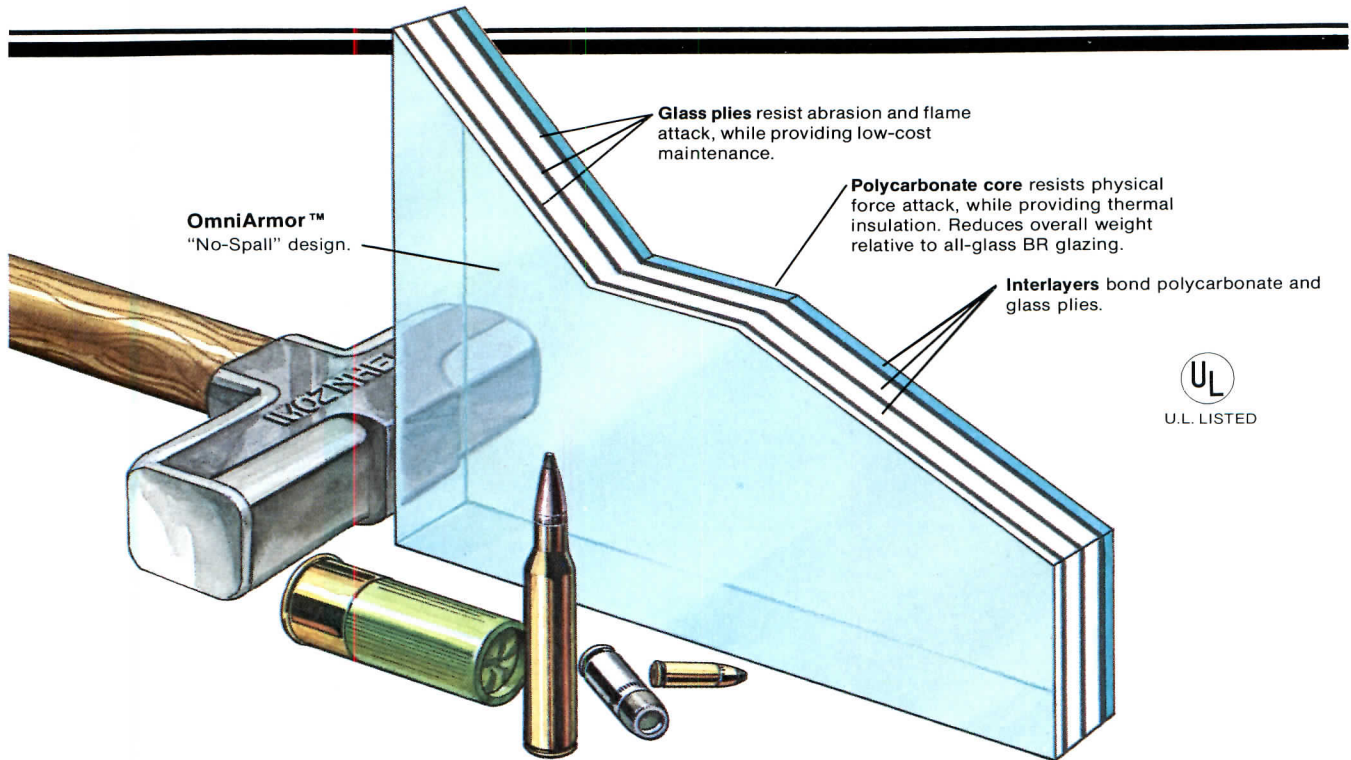

The professional choice...

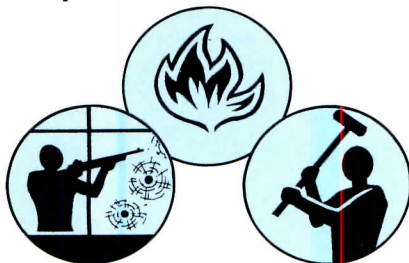

Resistance against high-powered ballistics, even after multiple hits, as well as physical force and flame attack, demands Sierracin OmniArmor.

Resistance against physical force, medium-powered ballistics and flame attack requires Sierracin OmniLite. Used in over 400 prisons and other critical security applications across the country.

Resistance that slows down vandals and burglars, for storefronts, homes and factories, calls for Sierracin OmniGard, an attractive alternative to iron bars.

©1983 Sierracin Corp.

...with certified fire rating.

Sierracin OmniLite, with a 1/4" polycarbonate core and 1/4" outer plies of fully tempered glass or wire glass, offers a 20 minute fire rating conforming to UBC 43.2 and CSFM 43.7 fire code. Test reports available.

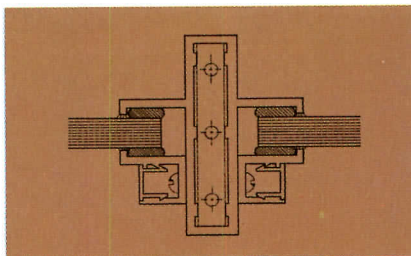

...with the right framing for a uniformly secure system.

Your Sierracin dealer-installer, working closely with Sierracin factory engineers, provides framing and installation designed to match the protection level of the glazing, for a system that's secure throughout.

...with the electronic dimension, for ultimate security.

Sierracin glazings may be ordered with optional alarm capability, to afford maximum reaction time to check penetration attempts.

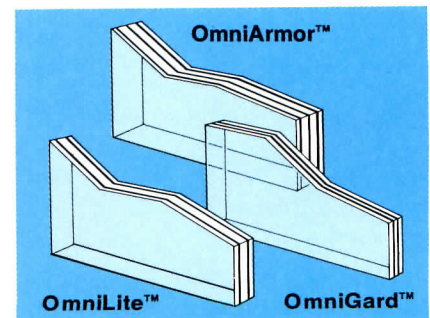

For further information or the name of your nearest dealer, call or write.



Sierracin/TransTech
12780 San Fernando Rd.
Sylmar, California 91342
Phone: (213) 362-6811
Telex: 677122

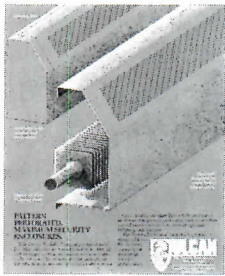

Maximum security radiators
A 4-page brochure features 12- and 14-gauge pattern-perforated radiator enclosures designed for prisons and other heavy abuse areas. Diagrams show dimensions and tables list steam and hot water ratings. Vulcan Ind., South Windsor, Conn.
Circle 412 on reader service card

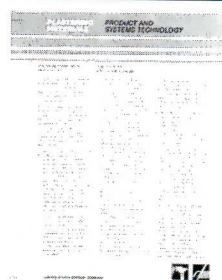

Veneer plaster
The application of veneer plaster, from base preparation to spray finish, is covered in a new bulletin, the sixth in a series on plaster technology. Included are a glossary of terms and information on application and maintenance. United States Gypsum Co., Chicago.
Circle 417 on reader service card

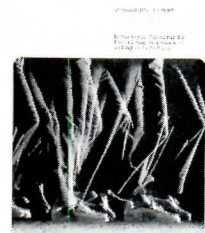

Carpet fiber
A 6-page color foldout brochure introduces DuPont's *Antron XL* contract carpet fiber, which has an enlarged filament claimed to provide superior resistance to soil and crushing. Technical information is included. DuPont Co., New York City.
Circle 413 on reader service card



Bathrooms and furniture
A color catalog in a binder from Paul Associates covers their complete collections of bathroom designs and hardware and contemporary furniture. Price is \$20.00; available from Paul Associates, 42-05 10th St., Long Island City, N.Y. 11101.

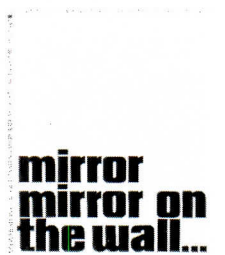

Mirrors
Over 60 innovative residential and commercial mirror applications are shown in a 28-page color booklet. Included are the winners of a recent design competition for ASID members. Price is \$1.00; available from PPG Industries, 5E, Two Gateway Ctr., Pittsburgh, Pa. 15222.



Workstations
A 30-page color catalog, including fold-outs, illustrates and describes how *UniGroup* components can be used to create workstations appropriate for every level of office activity. Descriptions of other open-plan system elements are included as well. Haworth, Inc., Holland, Mich.
Circle 418 on reader service card

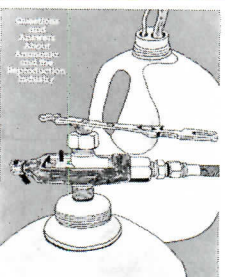

Copiers
Safety in using diazo reproduction equipment is the topic of a 16-page booklet which focuses on the proper handling of ammonia solutions. OSHA regulations are included. Association of Reproduction Materials Manufacturers, Alexandria, Va.
Circle 414 on reader service card

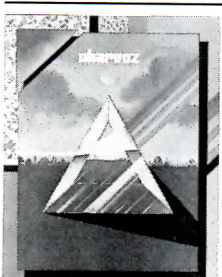

Supplies
Over 1,800 items, available in various colors and sizes, are featured in a catalog from Charvoz. In addition to art supplies, the products shown include ergonomic chairs and stools, drawing tables, drafting kits and planimeters. Charvoz, Fairfield, N.J.
Circle 419 on reader service card

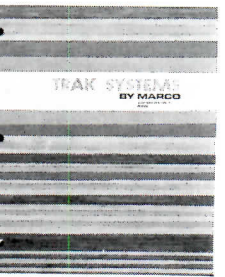

Track lighting
A 30-page color booklet covers a variety of luminaires as well as single- and triple-track systems, accessories and layouts. Mounting procedures are described and diagrams show candlepower curves and wiring loads. Marco, Los Angeles.
Circle 415 on reader service card



Hospital communication
A packet of literature provides information on a variety of hospital communication systems. Included are television, nurse call, central communications, doctors' registry and an information processor for all data. Bunting SteriSystems, Inc., Bridgeport, Conn.
Circle 420 on reader service card

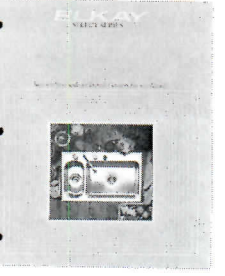

Stainless steel sinks
Sinks, faucets and accessories in different combinations for kitchens, lavatories, laundries and bar areas, are featured in a 24-page brochure on the *Select Series*. Diagrams and charts offer details on dimensions. Elkay Manufacturing Co., Oak Brook, Ill.
Circle 416 on reader service card

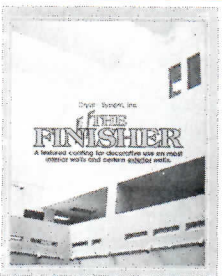

Textured coating
A ready-to-use coating suitable for use on most interior and some exterior walls, the *Finisher* is described in a 4-page color brochure. Representations of 21 colors are shown, plus photos of 4 available textures. Dryvit System, Inc., West Warwick, R.I.
Circle 421 on reader service card

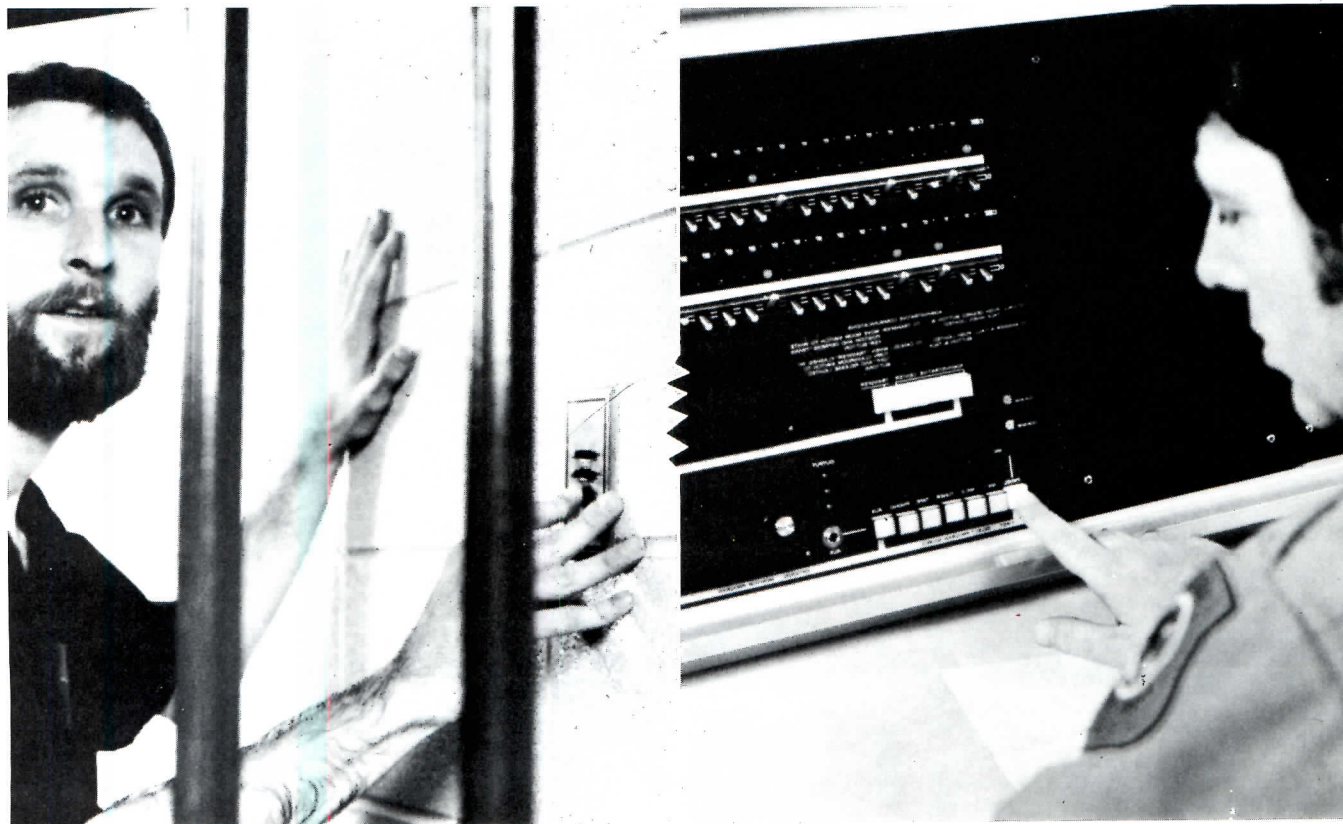

Voice Communication

Critical to the control of your corrections facility

12:01 A.M. Help is needed in Cell Block 3. The message comes in to the communications control center. In a matter of seconds, the alarm is sounded; corrections officers dispatched.

Rapid communication is important, especially in critical situations. Dukane Communications Systems provide immediate two-way communication. The same system can page and locate individuals, monitor any and all areas within the facility and be used as a public address system for general announcements. Dukane has specially designed, tamper-proof, call-in switches and speaker baffles for added security.

Dukane Communications Systems are in prisons, schools and hospitals around the world. You'll find a Dukane System in the new Harris County Jail in Houston, Texas; the Denver Detention Center, Denver, Colorado, and the Dallas Justice Center, Dallas, Texas.

Constructing a new corrections facility or remodeling an old one? We'd like to show you the most cost-effective approach to solving communications problems.

Attach your business card to this ad and send for free information.

DUKANE 

DUKANE CORPORATION/COMMUNICATIONS SYSTEMS DIVISION/ST. CHARLES, ILLINOIS 60174 312/584-2300

Circle 50 on inquiry card



Sealant

Stretch-Guard is a flexible, acrylic-modified, vinyl coating for sealing roofs, walls and vessels. Formulated to expand and contract without cracking, it is said to stretch up to more than twice its coverage area—even at -10F. It also seals cracks up to 1/16 in. wide and adheres to metals, wood, urethane foam, concrete and built-up roofing. Steelite, Inc., Pittsburgh, Pa.

Circle 302 on reader service card

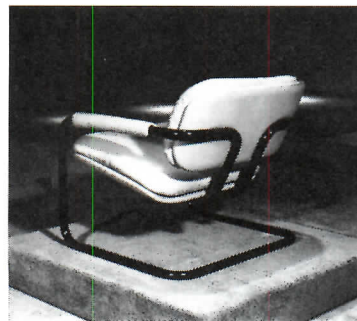

Lounge chair

Designed by Charles Pfister, this chair features a cantilevered upholstered seat and separate back attached to a tubular steel frame. Frames are available in polished chrome or in 19 colors. Metropolitan Furniture Corp., South San Francisco, Calif.

Circle 303 on reader service card



Hardwood grilles

Removable grilles give a multiple-light effect to this manufacturer's *Perma-Shield* line of insulating glass gliding patio doors. The grilles are made of hardwood and finished in white polyurea for easy maintenance. Andersen Corp., Bayport, Minn.

Circle 304 on reader service card

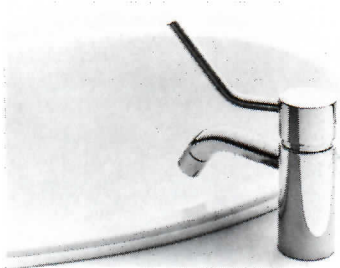

Handicap faucets

A single-control lavatory mixer requires minimal movement to operate. The fixture comes in 10 epoxy colors, polished brass or chrome, and a line of coordinated lavatory accessories suitable for commercial installation is also available. Kroin Architectural Complements, Cambridge, Mass.

Circle 305 on reader service card

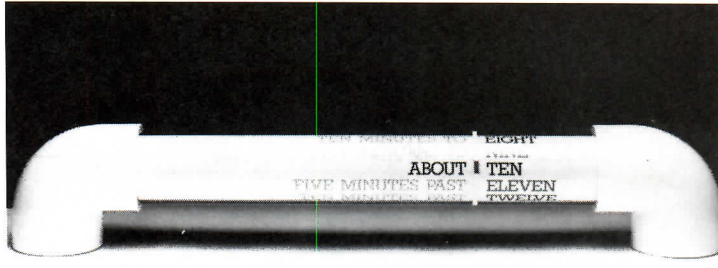

Clock

The *Time Tube* uses words rather than hands to tell time. Measuring 3 ft long by 8 in. high, the battery-powered quartz clock can stand on a table or mount on a wall or ceiling. It has two rotating cylinders, one that moves by the minute while the

other moves by the hour. An adjustable indicator between cylinders marks the time. Muller & Van Dongen Designs, Rosemont, Ill.

Circle 306 on reader service card
Continued on page 159

SCRATCH N' SCUFF

It won't show on Roppe cove base. Made of flexible extruded rubber, the exclusive satin finish resists scuffing, gouging, burns and chemicals. Cleans up with soap and water. Easy to install, Roppe cove base won't shrink, with maximum stability and fit for lasting attractive appearance. In 22 beautiful accent colors with matching molded corners. For your nearest distributor, write Roppe Rubber Corporation, 1602 N. Union Street, Box X, Fostoria, Ohio 44830. Or call toll-free.

ROPPE
1-800-537-9527
In Ohio 419/435-8546

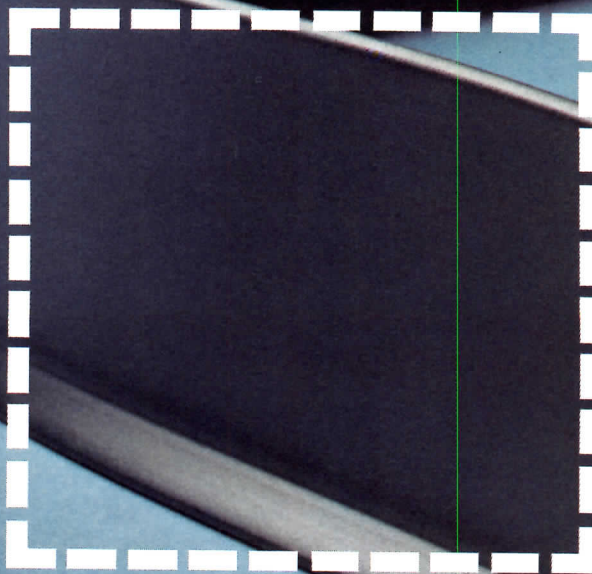

Circle 60 on inquiry card

THE CASE FOR STEEL WINDOWS:



The facts. Steel windows are three times stronger than aluminum windows which means less visual mass and narrower sight lines. Steel windows can be engineered and fabricated to match any window concept in virtually any shape including circular. Steel windows can provide any type of vent operation from casement to projected to pivoted. Steel windows — treated with modern coating technology and materials such as PVC and urethanes — will survive the harshest environments without surface degradation. Steel windows are not prone to bowing or racking problems sometimes associated with large or ventilator windows. Steel windows without thermal breaks deliver thermal performance equivalent to aluminum windows with thermal breaks. These straight forward statements are made by a company that not only produces steel windows but a full line of custom aluminum windows as well. For complete technical information and creative ideas on how your building can benefit from steel windows, call or write Hope's Architectural Products, Inc. / 84 Hopkins Avenue / Jamestown, N.Y. 14701 / 716 665-5124.

HOPE'S
ARCHITECTURAL PRODUCTS INC.

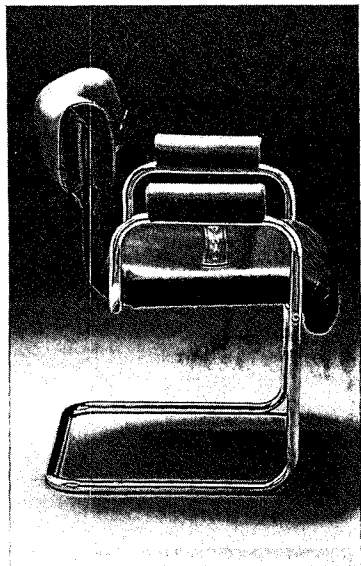

Chair
The #180 *Deka Chair* has a polished chrome frame with a seat height of 18½ in. and an arm height of 26 in. It is available in leathers, suedes or fabrics, with or without upholstered armrests. The Pace Collection, Inc., Long Island City, N.Y.
Circle 307 on reader service card

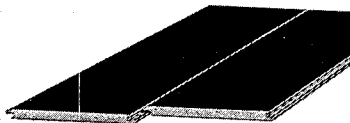

Thermal wall panels
Therm-U-Wall foam panels lock together by means of an innovative channel design said to offer greater panel strength while eliminating the need for clips. Foam thickness of 2½ in. provides an insulating value of U-.05 or R-20. Panels span 30 in. and are available in a variety of gauges, finishes and colors. Moncrief-Lenoir Manufacturing Co., Houston, Tex.
Circle 308 on reader service card

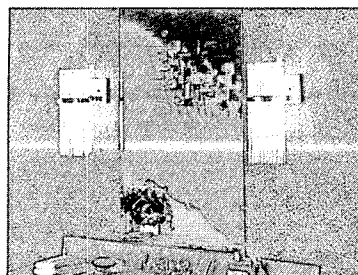

Lights
Glass rods set in triangular brass castings form the *Radiance V* collection of light fixtures which includes the wall-mounted fixtures shown and 7-, 12- and 21-light chandeliers. Custom layouts are also available. Lightolier, Inc., Jersey City, N.J.
Circle 309 on reader service card
Continued on page 161

WE WROTE THE BOOK ON TWO-WAY RADIO. AND IT'S FREE.

Read all about it. How Two-Way Radio can help just about any business lower costs and increase profits via more efficient use of people and vehicles. Plus, how to choose the right radio from Johnson's complete line of mobile communications equipment. All American made by the two-way pioneer not only challenging but pacing the industry. All backed by a full year's 100% warranty on all parts and labor.



Phone toll-free 800-328-5727 Ext. 122.
(In Minnesota, 800-742-5685 Ext. 122.) Or write Johnson Radio Products Division, Waseca, MN 56093, for your free copy.

 **JOHNSON**
Radio Products Division
THE CHALLENGER

Circle 62 on inquiry card

Petro-Lewis

PETRO LEWIS

Oil and Natural Gas Income Program XIII

A series of limited partnerships formed to acquire producing oil and natural gas properties—

including two major specified acquisitions that generate immediate distributions.

No exploratory or development drilling

Minimum subscription—\$2,500
(\$2,000 for Qualified IRA Plans)

This announcement is not an offer to sell or a solicitation of an offer to buy any of these securities. The offering is made only by the Prospectus, copies of which may be obtained in any State only from dealers or brokers who may lawfully offer these securities in such State.

Please see that I receive the latest information on this offering including a current Prospectus.

Mail To:
Kay Grover
Petro-Lewis Securities Corporation
P.O. Box 2250, Dept. H
Denver, CO 80201

Name	Telephone Number
Firm	
Street Address	
City	State Zip

Circle 63 on inquiry card

These doors won't get held up.

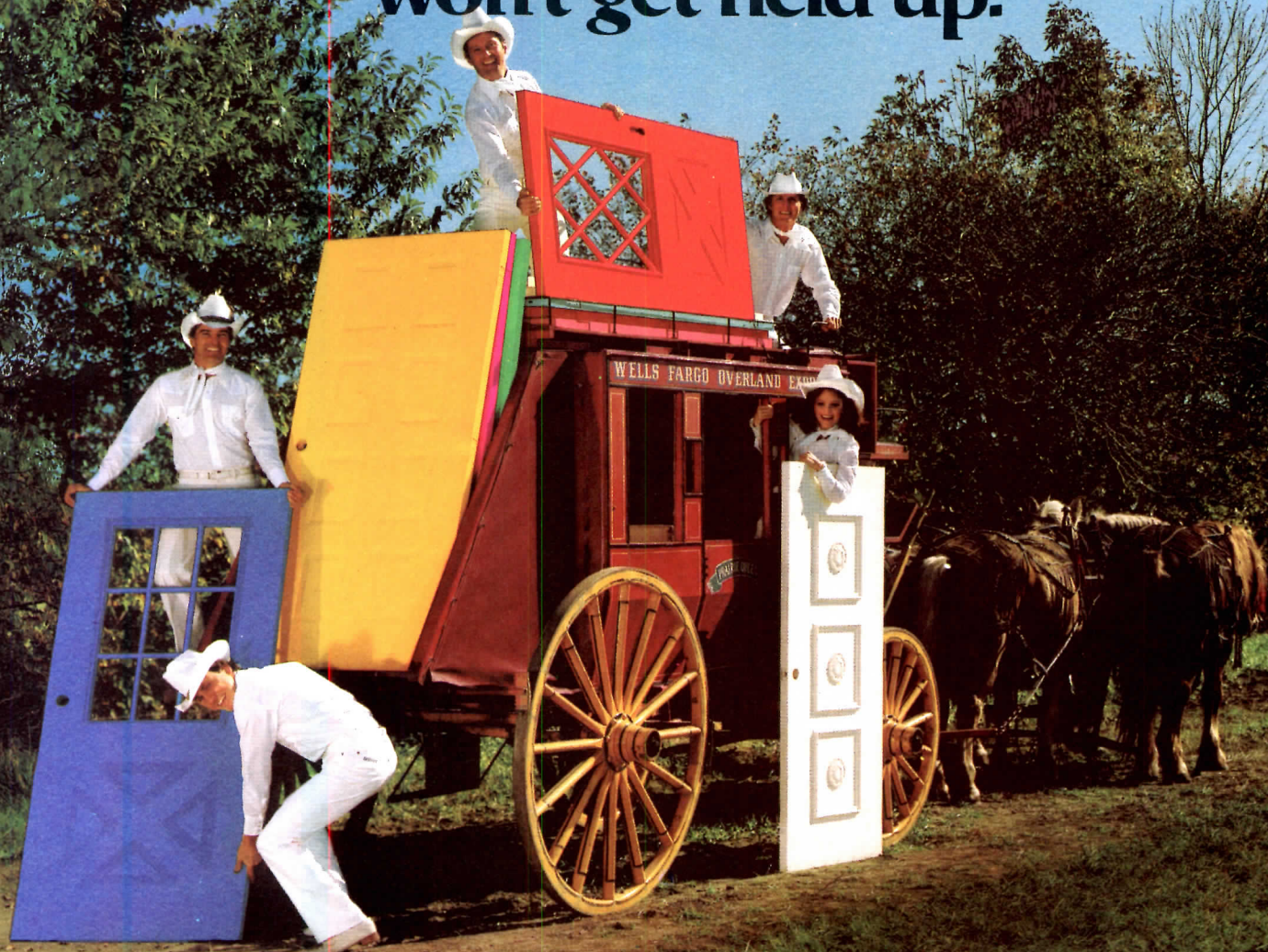

*the high
performance
door
people*

Ceco does everything possible to deliver steel doors on time. We respond to inquiries quickly. We plan down to the smallest detail. We have what you need at over 250 stocking distributors and 21 well-stocked warehouses across the country. And when you need delivery really fast, we go hell-bent-for-leather to make sure your project isn't held up waiting for doors.

But great service is just half the story. Complete selection is the other half. Ceco has thousands of door and frame combinations—plus a full assortment of builder's hardware. Ceco doors meet all national performance standards for hospitals, schools, hotels, and manufacturing and institutional buildings. They're available in a wide range of attractive Colorstyle finishes. We also have doors to meet your labeled fire door requirements. Plus ready-to-install door packages complete with door, frame, lock, hinges and weatherstripping.

Don't be held up waiting for doors, frames or hardware. Depend on Ceco for on-time delivery and complete selection. Call one of our distributors (in the Yellow Pages under "Doors") or contact The Ceco Corporation, 1400 Kensington Road, Oak Brook, IL 60521. Phone: 312/789-1400.



"The door people"™

Do something selfish. Support the arts.

We are speaking here of business support of the arts, and what it can do for your clients, your employees and your company.

In a word, lots.

Because in addition to the rewards that the arts have to offer society, there are rewards that the arts can and will offer business. Very real, very tangible rewards. All very much in your company's self-interest.

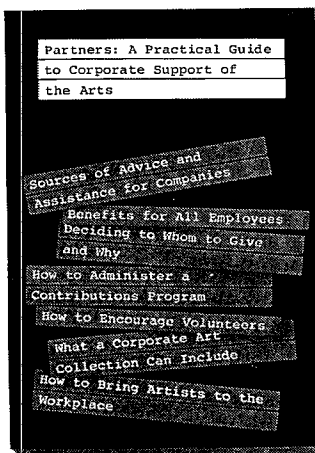

To learn how to go about getting them—or, as the case may be, how to go about it better—there's *Partners*.

Partners is the first practical guide to corporate support of the arts. And for anyone who has anything at all to do with the arts—or would like to—it's indispensable.

In it, you'll find dozens of examples of how business and the arts have helped—and continue to help—one another. Detailed information. No-nonsense advice. Sources to turn to for guidance. Specifics.

Partners: A Practical Guide to Corporate Support of the Arts. For more information and prices, write us today at the address below. And see how much your business can get from supporting the arts.

It's one of the few things in this world that's selfish and selfless at the same time.

Partners.

The first book on supporting the arts that doesn't leave everything to the imagination.

Partners is published by the Cultural Assistance Center, Inc., a nonprofit service organization established to promote and assist cultural institutions.

Write the Cultural Assistance Center, Inc., 330 West 42nd St., New York, N.Y. 10036.

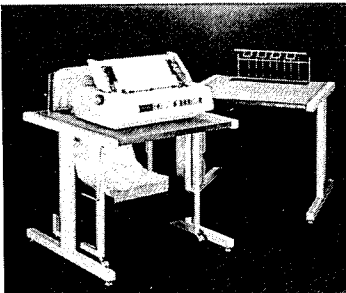

Computer stands

A line of adjustable computer support stands by the HON Company coordinates with its furniture, panels and seating. The HON Co., Muscatine, Iowa.
Circle 310 on reader service card

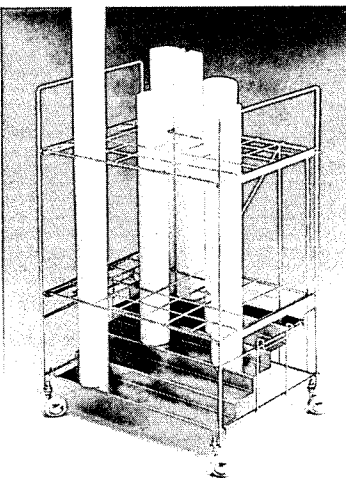

Mobile plan storage

The *Wire Roll File*, with a stair-stepped base, has 35 2½-in. openings to store rolled documents. The file is cadmium plated, measures 20 in. wide by 32 in. high by 14¾ in. deep, and has a built-in gang lock so that files can be joined together. Plan Hold Corp., Irvine, Calif.

Circle 311 on reader service card

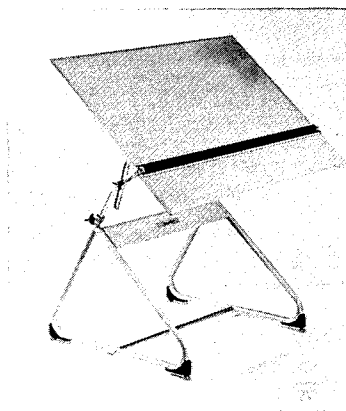

Drafting tables

The *Stylelist* drafting table features a plastic laminate top for durability, comfort and easy maintenance. The table offers easy angle and height adjustments and the tubular steel support frame is available in 3 colors. Mayline Co., Sheboygan, Wis.

Circle 312 on reader service card
Continued on page 189

INDUSTRIAL BUILDING COSTS.



Write For Our 1983 Brochure.

If your company is actively seeking a rail-served site for a new manufacturing or warehousing operation, your best single source for information is the CSX Corporation's railroads.

Our rail units, the Chessie System Railroads and the Seaboard System Railroad, serve 22 states across the East, Midwest and Southeast. So we can help you find the site that suits you best, with impartial and in-depth information.

We offer you construction costs on a representative cross section of industrial buildings, the facts on more than 5,000 different sites, plus the latest data on transportation, labor, water, taxes, you name it.

For your free copy of our 1983 Construction & Cost Data brochure, write: J.R. LeGrand, Vice President Industrial Development, CSX Railroads, Dept. CS-11, 500 Water Street, Jacksonville, Fla. 32202.



CSX Corporation



Chessie System Railroads



Seaboard System Railroad

Chessie System Railroads and Seaboard System Railroad are units of CSX Corporation.
© 1983 CSX Corporation

Circle 65 on inquiry card

SWEET'S SEMINARS ON COMPUTERS IN CONSTRUCTION

FOR ARCHITECTS—BY ARCHITECTS
FOR ENGINEERS—BY ENGINEERS
FOR CONTRACTORS—
BY CONTRACTORS



Benefit From Sweet's Seminars

conducted by leading experts in computer technology. Whether you are considering a computer system, or already have one, you will be able to:

- Decide when, where and how to apply computer technology
- Zero in on specific applications
- Plan for computer evaluation, selection and implementation
- Have your individual needs met because each Seminar is limited in attendance

Choose from the following Seminars:

- Planning for Computer Usage in the Design Office
- Affordable Microcomputer Applications for the Small Design Firm
- Computer Aided Graphic Design for Architects
- CAD Turnkey Systems for Architects and Engineers
- Space Planning and Facilities Computer Management Systems
- Planning for Computer Usage in the Engineering Office
- CADD Systems Between \$30,000 and \$100,000
- Managing CAD Systems
- CAD Systems for Engineers
- Planning for Computer Usage in the Contracting Office
- Business Applications in the Construction Office
- Computerized Cost Estimating in the Contracting Office

Seminars are offered in March, April, May and June in ■ Atlanta ■ Boston ■ Chicago ■ Cincinnati ■ Dallas ■ Denver ■ Houston ■ Los Angeles ■ Miami ■ New York ■ Phoenix ■ San Diego ■ San Francisco ■ St Louis ■ Tampa ■ Washington D.C.

Call Now—Registration is Limited

Call Sweet's Seminar Hotline (800) 257-9406 for more information. In New Jersey, call (609) 764-0100.

Be Sure To Ask About Special Discounts.

Sweet's®

POSITIONS WANTED

Contract Administrator—extensive experience in all phases of design oriented architectural and construction management. Formulation and execution of owner/architect, owner/contractor documents. Present NY area location. 2 month available start. Permanent position desirable, relocation expected. \$60K salary range, resume on request. PW-7245, Architectural Record.

SELLING OPPORTUNITIES AVAILABLE

Leading U.S. Corporation seeking established manufacture representative currently calling on architects/interior designers to carry high commissioned up-scale architecturally specified product line. Reply with brief resume of current business activity, lines carried and geographic territory covered. RW-7271, Architectural Record.

BUSINESS OPPORTUNITIES

Registered Architect with 12 years experience in all phases of general practice including sole proprietorship seeks opportunity leading to partnership and/or assumption of sole proprietorship. Prefer small firm in C. or E. Pa. but will consider anywhere in NE. Reply BO-7231, Architectural Record.

SPECIAL SERVICES

Architectural Renderings; High Quality Color or Ink. Write for free brochure. Architectural Renderings 9010 W. Howard Avenue, Milwaukee, Wisconsin 53228. (414) 327-1601.

Since 1947

RA LICENSE REVIEW

for June '83 Exam

- Dry Runs • Seminars • Workshops
- Do-It-At-Home Problems

For information, call or write:

IDC INSTITUTE of DESIGN and CONSTRUCTION

VITO P. BATTISTA, R.A.; Director
141 Willoughby St., Brooklyn, N.Y. 11201
Tel. (212) 855-3661

EDUCATIONAL

Architect Reg. Exam Study Guide: "The Architect's Responsibilities In The Project Delivery Process." 30 sections on the various aspects of an architectural project & 28 filled out sample AIA Documents & other forms illustrate architect's responsibilities in a representative project. 200 p., soft cover, \$23.95, shipping included. Send order with payment to: H. L. Murvin, AIA, 500 Vernon, Oakland, CA 94610.

FOR SALE

TREE STAMPS

Treeline's crafted rubber stamps combine quality of hand drawn trees and people with speed and convenience of stamps. Write for free catalog.

Treeline
2 Greenwood Rd., Natick, MA 01760
Dept. E

SCAT FI-21
FEET • INCHES • FRACTIONS
CALCULATOR
ADD • SUBTRACT • MULTIPLY • DIVIDE
DIRECTLY
79.95
TECH-AIDES DISTRIBUTORS
3812 MARKET ST. • DENTON, TX • 76201
817-566-2708

OFFICIAL PROPOSALS

Bids: April 1st 1983

NOTICE OF INVITATION FOR CONCEPTUAL ARCHITECTURAL PROPOSALS

The Fairbanks Native Association is soliciting proposals to develop a conceptual design and package for a proposed Community Center. Proposed at approximately 42,500 square feet for approximately \$7 million. The successful applicant will develop a document for soliciting funding for this project. At this time we are seeking the following:

- (1) Interior layout with location of activities with explanation as to why you recommend this layout.
- (2) 35 mm color slide of interior layout.
- (3) Exterior concept with written explanation and 35 mm color slides.
- (4) Must be innovative:
 - a. Well-designed and meeting special weather conditions.
 - b. Imaginative open space concepts.
 - c. Create relaxing atmosphere to attract varieties of people.
 - d. Explain types of materials to be used.
 1. recommend landscaping plan
 2. street furniture

This is to be a multi-purpose facility with small shops, consistent with the proposed activities, to help generate maintenance and operation costs.

For a complete package including history, feasibility study, potential sites call (907) 452-1648 ext. 21 or 24 or write:

Fairbanks Native Association, Inc.
Community Center Project
310 1/2 First Avenue
Fairbanks, Alaska 99701
Proposals are due in to above address by 5:00 p.m. April 1, 1983.

CALL IN
YOUR
CLASSIFIED ADS
212/997-2556



Lavatory

The spacesaving *Minuet* lavatory measures only 14½ in. front to back. It is 21 in. wide, with a 10¼-by-17½-in. basin, and accommodates a 4-in. centerset fixture on either side. The lav has a splash lip and a concealed front overflow. It is made of vitreous china and comes in 9 colors. Crane Co., New York City. Circle 313 on reader service card



Whiteprinter

The *Arrow* is a tabletop model (shown with optional stand) capable of producing prints 48 in. wide by any length. The machine, which features instant operation without warm-up, is available with an optional factory-installed ammonia absorption system so that it can be ready for use minutes after delivery. It is finished in off-white. Dietzgen Corp., Des Plaines, Ill.

Circle 314 on reader service card



Wallpaper

Two Oriental-style patterns were inspired by material in the Cooper-Hewitt Museum. *Sake*, reminiscent of rice grains, was adapted from a 19th-century gouache sketch by a Swiss textile designer, while *Patchwork Border* reproduces an 18th-century French wallpaper design based on Indian prints. Both are available in several colorways. Brunschwig & Fils, Inc., New York City.

Circle 315 on reader service card

REPRINTS OF ARCHITECTURAL RECORD ARTICLES

You can order reprints of any articles that have appeared in Architectural Record, whether in color (if the article was published in color) or black-and-white (if published in black-and-white), in whatever quantities (minimum 100) you need, for use in your own mailings and presentations.

For more information, price quotes and help with layout and format of your reprints, call:

Carol Frances
212/997-6081

ARCHITECTURAL RECORD

S C H I N D L E R
H A U G H T O N



**We're on America's
best-addressed list.**

You'll find Schindler Haughton elevators, escalators and maintenance service wherever you find architects, building owners or managers who value their reputation as highly as we value ours.

Schindler Haughton

ELEVATOR CORPORATION

Toledo, Ohio 43695



©1983, Schindler Haughton Elevator Corp.

Circle 99 on inquiry card

A Sloan life-cycle cost analysis can save you a lot of dollars.

And it won't cost you a cent.

It starts with a movie.

Here's a short subject worth watching. Especially if you haven't yet decided on what's the best flushing system for your new building. And it's all with the compliments of your Sloan Representative.

In less than fifteen minutes, our movie dramatizes the important differences between the Sloan Flushometer and flush tanks. It shows you there are significant savings when you choose Sloan. But you want proof. Just wait.

There's an easy worksheet to fill in.

You and your Sloan representative sit down for a few minutes. You complete a worksheet that summarizes the flushing requirements of your building. Again there's no charge and no obligation.

Finally, your savings—in dollars and cents.

Within a few days, you'll receive a completed life-cycle cost analysis. It gives you the costs

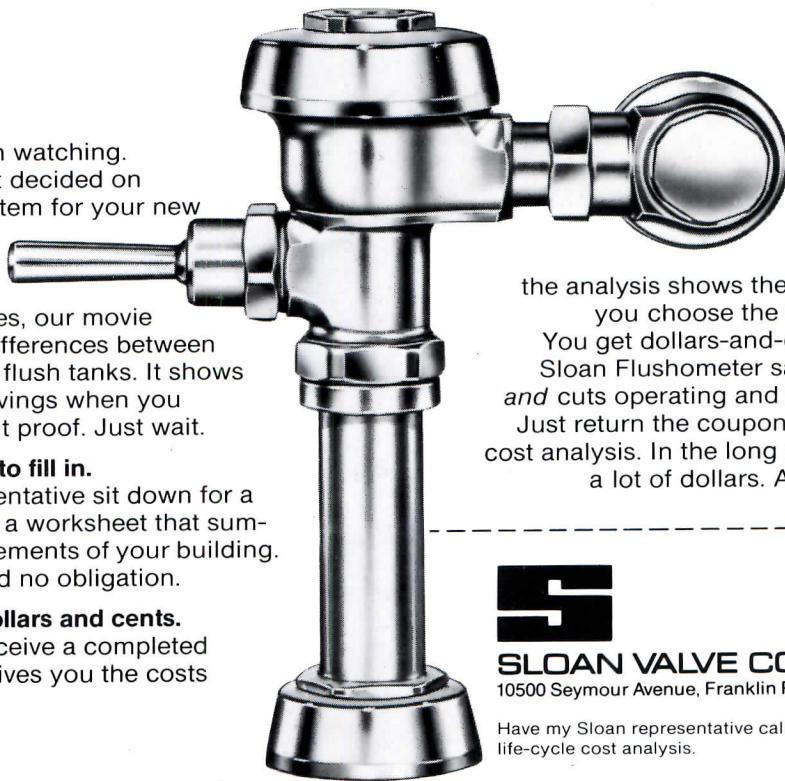

of owning, operating, and maintaining flushometers vs. flush tanks. And, on the bottom line,

the analysis shows the total savings when you choose the Sloan Flushometer. You get dollars-and-cents proof that the Sloan Flushometer saves on water costs and cuts operating and maintenance costs. Just return the coupon for a free life-cycle cost analysis. In the long run, it can save you a lot of dollars. And we can prove it.

***The Sloan Flushometer.
Provable savings.***



SLOAN VALVE COMPANY

10500 Seymour Avenue, Franklin Park, IL 60131

Have my Sloan representative call me to arrange a free life-cycle cost analysis.

NAME _____
TITLE _____
COMPANY _____
ADDRESS _____
CITY _____ STATE _____ ZIP _____
PHONE _____
Area Code _____

AR383