

ARCHITECTURAL  
**RECORD**

Business Design Engineering  
A McGraw-Hill Publication, Seven Dollars  
July 1987

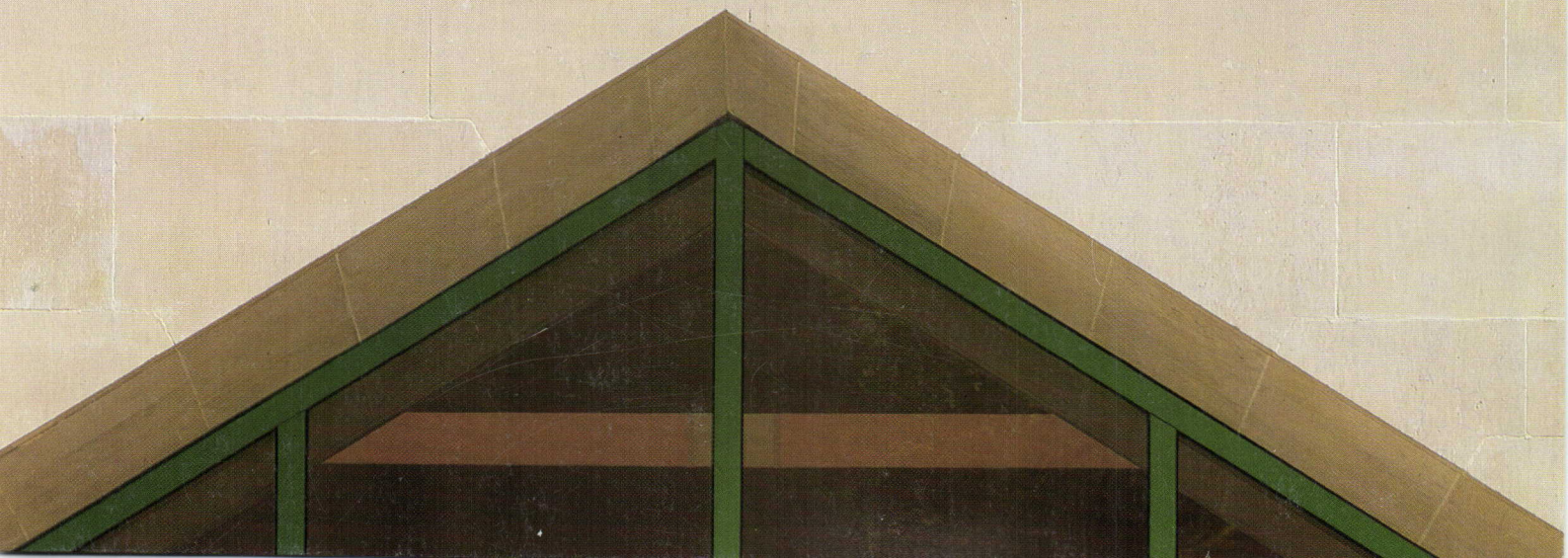

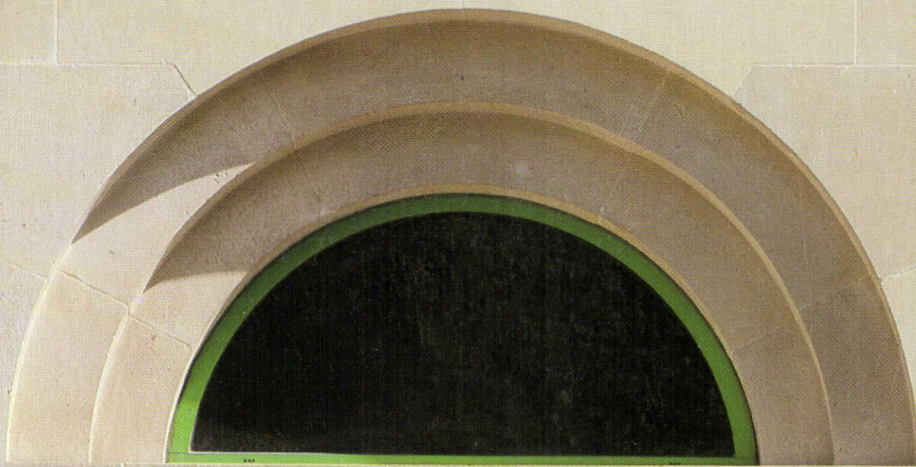



Classic-Step Cirrus (unscored)



Beveled Edge Cirrus



## Cirrus Travertone™. Design alternatives with a delicate touch

The subtle texture of Cirrus Travertone ceilings is available in five distinctive patterns.

This selection increases your design flexibility with softer, more pleasing alternatives to heavily textured or flat-fissured ceilings. All patterns demonstrate the excellent acoustical performance and fire retardance for which Travertone ceilings are known.

For a brochure about our Cirrus selection, call 1 800 233-3823 and ask for Department Cirrus.

**Armstrong**

Circle 1 on inquiry card

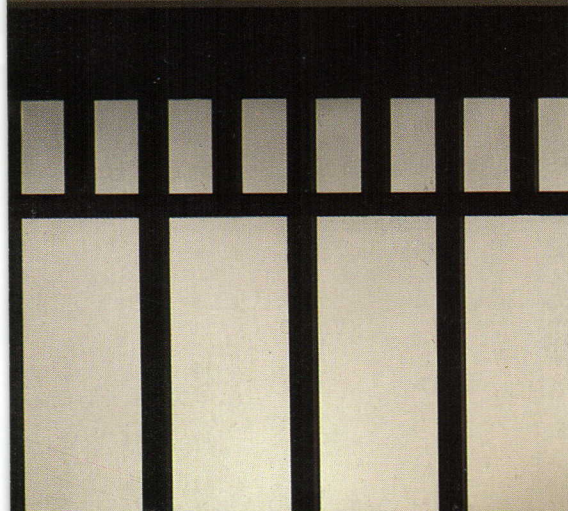



# Quiet is paprika.

Soundsoak™ acoustical wall panels come in 55 colors.

Five fabric finishes. Standard sizes. And most panels are tackable.

So even if your budget is limited, your options aren't. Soundsoak is your economical yet attractive alternative to custom fabric treatments.

Soundsoak products are available locally through Armstrong distributors and contractors. For product literature, call 1 800 233-3823 and ask for Soundsoak.

**Armstrong**

Circle 2 on inquiry card

And  
Light Rose  
Frost Blue  
Flagstone  
Caramel  
Concrete  
Desert Sand  
Brown  
Pearl Grey  
Sea Green  
Mist  
Wheat  
Khaki  
Oatmeal  
Coral  
Persimmon  
Green Neutral  
Pewter  
Wheat Neutral  
Tiger's-Eye  
Opal  
Blue Neutral  
Crystal Blue  
Wedgwood  
Rose  
Rose Quartz  
Garnet  
Seafoam  
Cream Neutral  
Cameo  
Quartz  
Silver Neutral  
Cherry Neutral  
Lavender Neutral

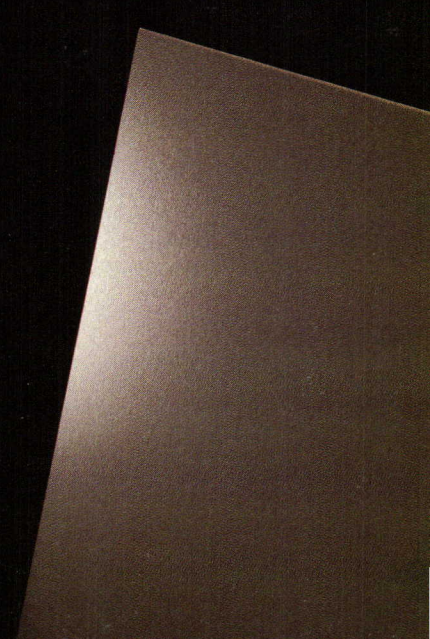



Re the O'Herlihy House [RECORD, mid-April 1987, pages 108-113]:

I am glad Mr. O'Herlihy acknowledged Luis Barragán.

Oh, the difficulty of translations! Frank D. Winder Douglas Orr, Winder and Associates, Architects New Haven, Connecticut

How would one describe the house by Roger Ferri in the RECORD HOUSES issue [ARCHITECTURAL RECORD, mid-April 1987, pages 70-79]? What is this house about? It's far too "refined" to be about experimentation. Obviously, it has nothing to do with proportions, since there aren't any. Could it be about living well, about finally having made it? If it is, it represents an empty affluence at best, and an empty victory at worst.

The author of the accompanying article for this house seems to know what it's about, or so he thinks. Can he really believe that any part of this place "evokes more archaic, European precedents"? Are his standards of appropriateness and plausibility this easily satisfied?

The author also states that this "villa eludes conventional art historical typology." Well, that's true, but this house tries so hard to be unconventional that it simply cannot maintain control. The boldness of those overhangs disintegrates into utter shallowness when one gets around to the courtyard and realizes that they are tack-ons. The bay windows at the front of the house appear to be hanging on by their fingertips, begging for resolution.

How, I wonder, does one come up with Minoan influence? I suppose that has to do with being unconventional. And why should one use an Art Nouveau-like interior and a historical exterior? Art Nouveau sought to do away with specific historical references, among other things. Are we to assume that Mr. Ferri is employing a subtle contradiction? No, I think not, since there is nothing subtle about this embarrassing little house.

If the writer had not spent so much time decorating his article with those trendy foreign phrases, he might have seen the devastating emptiness of this house.

Frank L. Irete, AIA Charlotte, North Carolina

A comment, I feel, may be in order on "The Villa Transformer" [RECORD, mid-April 1987, cover and pages 114-121].

Without any vituperative design remarks, the photography was great!

Craig B. Kelford, Sr., AIA CEL Architects Lomita, California

It is understandable that our entry in the Arizona State University School of Architecture Competition [ARCHITECTURAL RECORD, January 1987, page 47] "appears the least regional of the three finalists" if one looks only at the north elevation presented in your recent news brief. Ironically, our parti is based almost entirely on indigenous planning principles of the arid Southwest, but using today's technology.

To be built of local materials, it is an inward-looking courtyard building of densely planned wings grouped around cool, shaded gardens with water elements. The courtyards provide natural light, protected views, and natural air circulation to all parts of the expanded building. Wooden lattices control the passage of light and the flow of air, reduce the temperature of the air current, increase the humidity of the air current, and provide security and privacy, all in the manner of traditional architecture for hot, arid climates.

Almost all circulation corridors are outdoors, are naturally cooled, and overlook the courts. All glazed openings face north or south. All studio spaces face south and are naturally daylighted. East and west facades have no openings.

The main commons courtyard is based upon the indigenous north-south courtyard that allows entry of the welcome low winter sun but excludes the high summer sun.

Finally, I would like to call to the attention of interested readers Hassan Fathy's excellent new book, *Natural Energy and Vernacular Architecture*. It was enormously helpful to us in providing concise guidelines for designing in the arid Southwest.

Robert Saemisch, AIA George Hoover, FAIA Hoover Berg Desmond Denver

**Corrections**

The photo credit for the offices of Robert A. M. Stern [RECORD, June 1987, pages 102-105] was inadvertently dropped. All photographs were taken by ©Peter Aaron/ESTO.

In the RECORD's story on the Bjornson House/Studio designed by Arata Isozaki [RECORD, mid-April 1987, pages 140-147], Frank Dimster of Los Angeles should have received credit as resident architect.

Designers of the Statue of Liberty Exhibit shown in the report on the Statue of Liberty visitor facilities [RECORD, April 1987, pages 98-103] were Metaform Incorporated, Rathe Productions Incorporated, and Design and Production Incorporated.

**July 15 through August 19**

*Ornamental Architecture Reborn: A New Terra Cotta Vocabulary*, an exhibit sponsored by the National Building Museum; at the Municipal Art Society, 457 Madison Ave., New York City.

**July 22-26**

National Convention, American Society of Interior Designers; in Toronto. For information: ASID, 1430 Broadway, New York, N. Y. 10018 (212/944-9220).

**August 6-8**

"International Perspective on Environmental Graphics," 1987 national conference of the Society of Environmental Graphic Designers; at the Cranbrook Academy of Art, Bloomfield Hills, Mich. For information: Sarah Speare, Executive Director, SEG, 47 Third St., Cambridge, Mass. 02141 (617/577-8225).

**August 16 through September 20**

*Long Island Modern, The First Generation of Modernist Architecture on Long Island, 1925-1960*, showing the works of Wright, Aalto, Breuer, Neutra, and Eero Saarinen, among others; at Guild Hall Museum, East Hampton, N. Y.

**August 20-21**

"Computer Tools for Space Forecasting and Management," a seminar on PC-based facility programming and space management, sponsored by the International Facility Management Association; in Toronto. The program will be repeated August 24-25 in Boston. For information: IFMA, 11 Greenway Plaza, Suite 1410. Houston, Tex. 77146 (713/623-IFMA).

**September 1-2**

Workspace 87, "Conflict, Survival and Opportunity in a Changing Marketplace," exhibition and conference for the office environment, produced by National Fairs, Inc.; at Moscone Center, San Francisco. For information: Workspace, 665 Chestnut St., San Francisco, Calif. 94133 (415/776-2111).

**September 17-18**

Third annual Contract Residential and Design Conference, "Images & Illusions"; at International Market Square, Minneapolis. To be followed on September 19 by a continuing education program, "Construction Technology for the Interior Designer," sponsored by, among others, the Minnesota Chapter, AIA. For information: International Market Square, 275 Market Sq., Minneapolis, Minn. 55405 (612/338-6250).

**September 30 through October 2**

Society for Marketing Professional Services National Convention, "Winning Better Business"; in Chicago. For information: SMPS, 801 S. Fairfax St., Alexandria, Va. 22314 (800/292-SMPS).

ARCHITECTURAL RECORD (Combined with AMERICAN ARCHITECT, and WESTERN ARCHITECT AND ENGINEER) (ISSN0003-858X) July 1987, Vol. 175, No. 8. Title® reg. in U.S. Patent Office, copyright © 1987 by McGraw-Hill, Inc. All rights reserved. Indexed in Reader's Guide to Periodical Literature, Art Index, Applied Science and Technology Index, Engineering Index, The Architectural Index and the Architectural Periodicals Index.

Every possible effort will be made to return material submitted for possible publication (if accompanied by stamped, addressed envelope), but the editors and the corporation will not be responsible for loss or damage.

Executive, Editorial, Circulation and Advertising Offices: 1221 Avenue of the Americas, New York, NY 10020.

Officers of McGraw-Hill Information Systems Company: President: Richard B. Miller. Executive Vice Presidents: Frederick P. Jannott, Construction Information Group; Russell C. White, Computers and Communications Information Group; J. Thomas Ryan, Marketing and International. Senior Vice Presidents:

Publishers: Laurence Altman, Electronics; Harry L. Brown, BYTE; David J. McGrath, Engineering News-Record. Group Vice Presidents: Frank A. Shinal, Dodge; Peter B. McCuen, Communications Information; Ted R. Meredith, Construction Information. Vice Presidents: Robert D. Daleo, Controller; Fred O. Jensen, Planning and Development; Michael J. Koeller, Human Resources; Talat M. Sadiq, Systems Planning and Technology.

Officers of McGraw-Hill, Inc.: Harold W. McGraw, Jr., Chairman; Joseph L. Dionne, President and Chief Executive Officer; Robert N. Landes, Executive Vice President and Secretary; Walter D. Serwatka, Executive Vice President and Chief Financial Officer; Shel F. Asen, Senior Vice President, Manufacturing; Robert J. Bahash, Senior Vice President, Finance and Manufacturing; Ralph R. Schulz, Senior Vice President, Editorial; George R. Elsinger, Vice President, Circulation; Ralph J. Webb, Vice President and Treasurer.

Associated Services/McGraw-Hill Information Systems Co.: Sweet's Catalog Files (General Building, Engineering, Industrial Construction and Renovation, Light Residential Construction, Interiors), Dodge Building Cost Services, Dodge Reports and Bulletins, Dodge/SCAN Microfilm Systems, Dodge Management Control Service, Dodge Construction Statistics, Dodge regional construction newspapers (Chicago, Denver, Los Angeles, San Francisco).

Subscription rates for personnel of Architectural, Engineering, Interior Design, Design and other directly related firms and students thereof, are as follows: U.S. and U.S. Possessions \$35.00; Canada \$37.00; all other countries \$125.00. Single copy price for Domestic and Canadian: \$7.00; for Foreign: \$12.00.

Change of Address: Forward changes of address or service letters to Fulfillment Manager, ARCHITECTURAL RECORD, P.O. Box 2025, Mahopac, NY 10641. Provide both old and new address; include zip code; if possible attach issue address label.

Guarantee: Publisher agrees to refund that part of subscription price applying to unfulfilled part of subscription if service is unsatisfactory. Copyright and Reprinting: Title® reg. in U.S. Patent Office. Copyright © 1987 by McGraw-Hill, Inc. All rights reserved. Where necessary, permission is granted by the copyright owner for libraries and others registered with the Copyright Clearance Center (CCC) to photocopy any article herein for the base fee of \$1.50 per copy of the article plus 10 cents per page.

Payment should be sent directly to the CCC, 21 Congress Street, Salem, MA 01970. Include code with request: ISSN0003-858X (\$1.50 + .10).

Written permission must be secured for any other copying. Write Reprint Manager for such permission at address below, or to obtain quotations on bulk orders.

Subscription List Usage: Advertisers may use our list to mail information to readers. To be excluded from such mailings, subscribers should send a request to: ARCHITECTURAL RECORD, Mailing List Manager, P.O. Box 555, Hightstown, NJ 08520.

Publication Office: 1221 Avenue of the Americas, New York, NY, 10020.

ARCHITECTURAL RECORD (ISSN0003-858X) published monthly with additional issues in April and September by McGraw-Hill, Inc. Second-class postage paid at New York, NY and additional mailing offices. Postage paid at Windsor, Ontario, Canada. Registration Number 9617.

Postmaster: Please send address changes to: Fulfillment Manager, ARCHITECTURAL RECORD, P.O. Box 2025, Mahopac, NY 10641. THIS ISSUE is published in national and separate editions. Additional pages or separate editions numbered or allowed for as follows: Eastern Section 32Ca through 32Eb. Central Section 32Ca through 32Cb. Western Section 32Wa through 32Wb.





Editor  
*Mildred F. Schmertz, FAIA*

Managing editor  
*Carolyn De Witt Koenig*

Senior editors  
*Herbert L. Smith, Jr., FAIA*  
*Charles K. Gandee*  
*Douglas Brenner*  
*Grace M. Anderson*  
*Margaret F. Gaskie*  
*Paul M. Sachner*  
*Charles K. Hoyt, AIA*

Associate editors  
*Darl Rastorfer*  
*Deborah K. Dietsch*  
*Karen D. Stein*

Assistant editor  
*Joan F. Blatterman, new products*

Design director  
*Alberto Bucchianeri*  
*Anna Egger-Schlesinger, senior associate*  
*Muriel Cuttrel, illustration*  
*J. Dyck Fledderus, illustration*

Design consultant  
*Massimo Vignelli*

Editorial production manager  
*Annette K. Netburn*  
*Laura Marchisio, assistant*

Editorial consultants  
*George A. Christie, Jr.*  
*Jonathan Barnett, FAIA, AICP*

McGraw-Hill World News  
*Peter Gall, director*

Director of information systems  
and circulation  
*Richard H. Di Vecchio*

Director of business  
and production  
*Joseph R. Wunk*  
*David E. Sykes, assistant*

Director of marketing  
*Camille H. Padula*

Assistant to publisher  
*Elizabeth Hayman*

Publisher  
*Ted R. Meredith*

*Inquiries and submissions of work for publication may be addressed to any editor, though the editors listed below have a special responsibility for the subject areas named:*

*Charles Gandee, interior design*  
*Herbert Smith, architectural education*  
*Charles Hoyt, business*  
*Paul Sachner, design news, competitions, book reviews*  
*Darl Rastorfer, engineering*  
*Joan F. Blatterman, new products and product literature*

Letters/calendar, 4

Editorial: Oral history—Remembering Robert Moses, 9

## Business

News, 35

Marketing: Base public relations on content, not form, 39

Finance: Business's outlay for plants and equipment holding its own, 41

Architectural education: What kinds do practicing architects want?, 45

## Design

News, 51

Design awards/competitions, 60

Observations/books, 71

Chandigarh revisited, 72

*By Robert Maass*

**Building Types Study 642: Research facilities, 89**

**George M. Low Center for Industrial Innovation, Rensselaer**

**Polytechnic Institute, Troy, New York, 90**

*Mitchell/Giurgola Architects*

**Industrial Technology Institute, Ann Arbor, Michigan, 96**

*William Kessler and Associates, Architects*

**Ortho Research Center, Richmond, California, 100**

*Stone, Marraccini and Patterson Architects*

**The Clore Gallery, The Tate Gallery, London, 104**

*James Stirling Michael Wilford and Associates, Architects*

**In the public interest: Design guidelines, 114**

*By Jonathan Barnett*

**The University Hospital Center at Sart Tilman, Liège, Belgium, 126**

*Charles Vandenhove, Architect*

## Engineering

**Stone: New technology and design, 136**

*By Barry Donaldson*

New products, 146

Product literature, 153

Manufacturer sources, 171

Classified advertising, 168

Advertising index, 182

Reader service card, 185

Cover:

*The Clore Gallery, The Tate Gallery, London*

*James Stirling Michael Wilford and Associates, Architects*

*Photographer: Richard Bryant*

NOTE: THIS ISSUE CONSISTS OF 2 PARTS



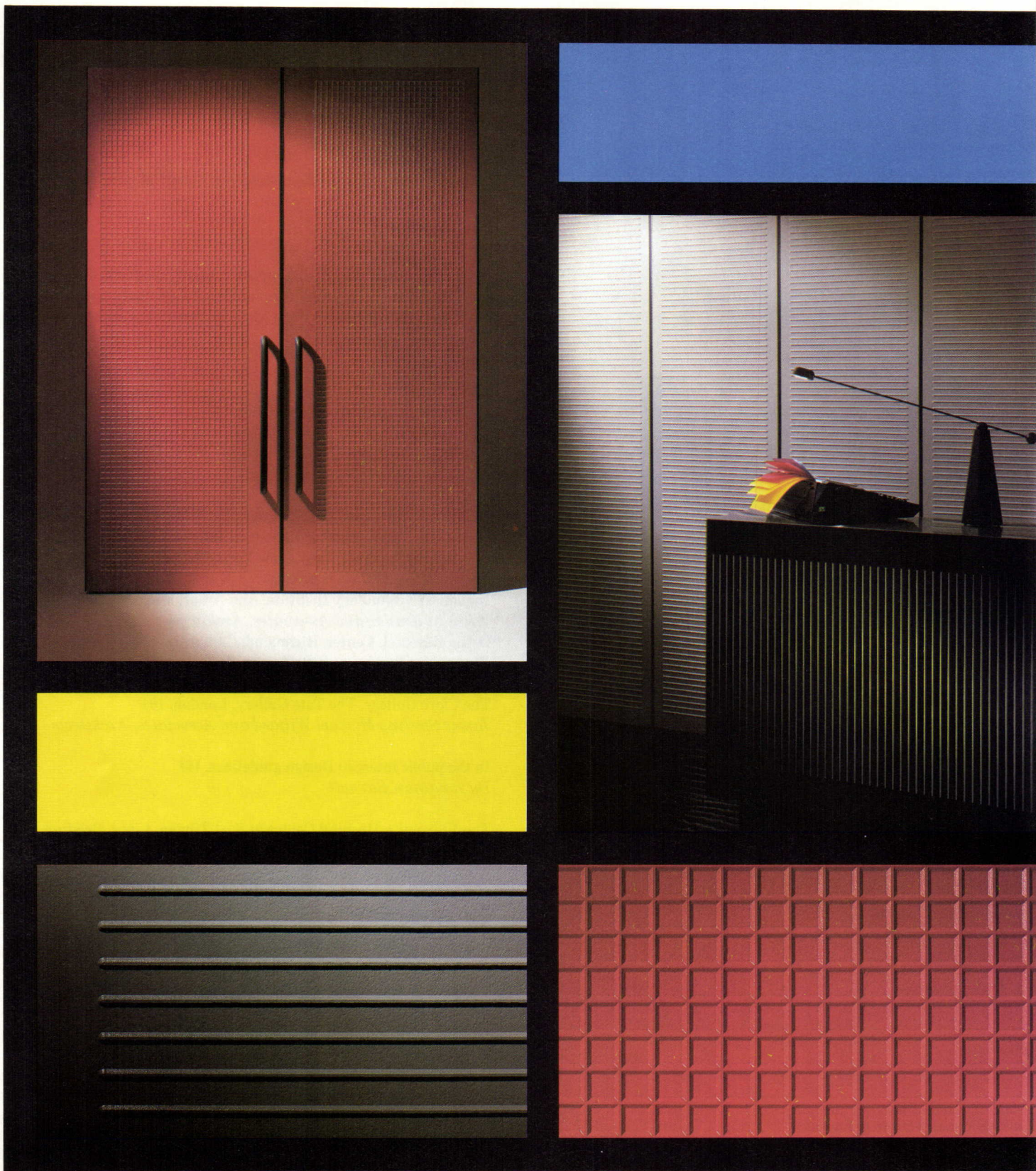

## FS:3 New High-Tech Surfaces

FS:3 panels from Forms + Surfaces. . . a new high-tech series of panels for interior surfaces, that beautifully combines three important features: a non-combustible material. . . deep relief patterns. . . and color limited only by your imagination. Tough, durable, lightweight panels are available in large sizes for easy installation, or assembled as complete doors. Select from 10 classic automobile colors, or field finish in the color of your choice. Create a bold new look on your next project. . . with FS:3 panels.

**Forms + Surfaces** Metal Surfaces Division  
Box 5215 Santa Barbara, CA 93150 (805) 969-7721

**Circle 4 on inquiry card**



## Oral history: Remembering Robert Moses

Six years ago this month, Robert Moses died at the age of 92—hardly the subject for an editorial, one might think. Just last May, however, I joined a day-long bus tour of Moses' nearby works, sponsored by New York City's Municipal Arts Society, a private, non profit, watchdog organization, which has had an even longer life than Moses—95 years to be exact. Today, MAS steadfastly focuses upon architectural, planning, and preservation issues in the five boroughs, helping to deter misdirected development, uphold enlightened design guidelines, and preserve the city's architectural patrimony. Although MAS didn't explain *why* it sponsored this tour, the clear intention was to examine Moses' sweeping, grand-scale accomplishments in the hope that these works and Moses' methods may yet have something to teach us. (Moses, as everyone knows, has been scorned by Lewis Mumford, Jane Jacobs, and Robert Caro as well as by newer generations of architects and planners who advocate smaller-scaled, incremental approaches to city building.) The tour leader attempting the revalorization of the fallen giant was his longtime friend and consultant, landscape architect, and highway engineer Arnold H. Vollmer, who in early and mid-career participated in the design of several of the parks and beltways we were to traverse.

The New Yorkers on the bus consisted of architects and planning professionals, as well as public-spirited laypersons, some of whom in their day may have fought Moses to a standstill more than once. If such vintage community activists were aboard, they refrained from challenging Vollmer's able defense of his mentor. All was harmonious. Moses redux. As the bus tour began, Vollmer announced that the time was right for his re-revisionist theory of history. Why re-revisionist? Because in the 40 years between the mid-1920s and the 1960s, Robert Moses was a popular hero. By the end of the '60s, however, his reputation had been revised downward, and Robert Caro's book, "The Power Broker," first published in 1974, effectively finished it off. Today's emerging re-revisionist attitude, according to Vollmer, "responds at least in part to the fact that we see so little achieved today in what are widely perceived as critically needed public-works undertakings. Private enterprise thrives and monster buildings are erected, but little of the public infrastructure which is needed to support and serve their development is accomplished." As we drove past the U. N. headquarters, Vollmer told us that it was Moses who, at the eleventh hour, persuaded John D. Rockefeller, Jr., to purchase the site from William Zeckendorf and donate it to the U. N. It was Moses himself who, with teams of lawyers, drafted within 96 hours the essential contractual and legislative documentation. Viewing the Triborough Bridge, we learned that just two and one-half years after the plans were completed, the 14-mile long bridge was opened to traffic—complete with suspension span, lift bridge, and viaducts. At Flushing Meadow Park and Shea Stadium (newly painted blue), we were reminded that where we stood was once one of the most hideous and offensive areas in the city, dominated by "Mount Corona," a 100-foot-high depository of the garbage and refuse from Brooklyn. Moses began the transformation of the site by causing the 1939 World's Fair to be located there and completed the task a generation later as President of the World's Fair of 1964-65.

Orchard Beach is a great man-made crescent, the climax of a grandly conceived '30s Beaux Arts scheme that has known better days. Flanked by nobly proportioned but sadly decaying bath houses, the magnificent shorefront view offered an out-of-season surprise. That May afternoon there were no bathers, just a few horsemen galloping wildly back and forth across the sand. Ignoring visions of Arabia, we listened to Vollmer. Moses, he told us, as a young man had spent all of his spare hours walking the city and envisioning it as he thought it should be. Among his schemes was a plan to build a great bathing beach at Pelham Bay for citizens of the Bronx. When he became City Parks Commissioner in 1934, he immediately set to work, completing Orchard Beach in three and one-half years.

Our bus then took us to Riverside Park and Lincoln Center, both sites similar to the others in theme and variations, each beginning as an early dream to be brilliantly and swiftly realized once power was attained. Eventually someone asked whether a 30-or 40-year-old Moses at work today could lick the system. "Whatever the climate," said Vollmer, "he would have coped." In this issue a feature article, "In the public interest: Design guidelines" by urban design consultant Jonathan Barnett (pages 114-125), describes urban power-brokering as it is being done today; how the cities of New York, San Francisco, Boston, Dallas, Pittsburgh, and Chattanooga are currently doing their *own* coping. It's a new day. *Mildred F. Schmertz*



**Sizzling color—  
dazzling design  
These are fountains  
destined to shine!**

**Introducing the Haws Fashion Plates Collection**

Take a walk on the wild side. Indulge in a little fantasy. Dabble in the exotic. Haws' new high-fashion models have great personalities, whether you like boldness or charm, polish or playfulness.

There are alluring shapes that will steal your heart... and hues that will snatch your breath away.





## New construction contracts hold steady and give a few surprises

Despite the adverse influences of rising interest rates, overbuilding in some sectors, and tax reform, new contracts for construction rebounded in March from an uncertain year's start and declined only 1 percent in April, according to the latest survey from the F. W. Dodge division of the McGraw-Hill Information Systems Company. April's annualized rate of new contracts was \$247.6 billion.

## HUD escalates building-renovation efforts as policy

In the contest between rehabilitation and new construction, the U. S. Department of Housing and Urban Development is tilting distinctly toward the former and, in fact, has several well-funded programs for renovation of existing public housing, whole neighborhoods, and small shops. Now, the agency has taken its direction a step further by announcing the Joint Venture for Affordable Rehabilitation.

HUD kicked off the new three-year pilot project May 7 with a meeting in Washington between senior department officials and more than 20 carefully selected mayors, urban economic-development specialists, private developers, and building owners. "In choosing the mayors, we were looking for cities that have really been doing something with rehabilitation," says Henry Felder, HUD's deputy assistant secretary for policy research and development. "We wanted innovative techniques that we can build upon."

The new program—which features rehabilitations and evaluations in two to five cities—will pinpoint the best ways for government agencies and private developers to coordinate retrofitting projects and recommend new renovation technologies. It will also propose ways to avoid time-consuming bottlenecks caused by federal, state, and local housing regulations. "We're trying to find out the extent to which some code requirements in older buildings may not be necessary for safety," says Felder. "Their elimination could lead to a cost savings."

It often takes several years for an improvement effort to begin  
*Continued on page 37*

Even more surprising, commercial construction, which has long been slated for a nosedive, showed no change whatsoever between March and April—the brunt of the 1-percent overall decline being borne by residential and institutional activity. While residential units had been expected to fall off due to apartments' sensitivity to tax reform and single-family houses' sensitivity to interest

rates (the overall category fell by 3 percent in April), institutional building has been and is still expected to be a mainstay of construction volume in 1987.

At the end of the first quarter, the value of all newly started construction was \$75.2 billion, almost even with the year-ago total. But, warned Dodge vice president George Christie, the full effect of interest rates has yet to be felt.

## Fate of would-be landmark hangs in the balance



The 1890 building (above) was designed by John Wellborn Root and is owned by the Society National Bank. Leaders of both the Cleveland Landmarks Commission and the Cleveland Preservation Society have argued forcefully about the importance of saving it in a city that is trying to spruce up its image without losing its character.

The 10-story bank building is red sandstone in the Romanesque-Revival style, with murals painted by the English artist Walter Crane. Placed on the National Register of Historic Places in 1976, it has ornate carved oak in its lobby and board of directors' room.

The peril arises because the building is strategically located near the downtown Cleveland Convention Center on a site that is a prominent candidate for a new-convention hotel. The bank left last year for a new headquarters and, in early May, John Fuller, the bank's vice president for corporate communications, announced that his company favored development proposals for historic preservation. "We feel it's part of our history and it would not be incongruous for it to remain," he said. But he would not make a definite commitment to rehabilitation. And, in early June, the city's landmarks commission announced plans to designate the building as a landmark.

Landmarks commission director John D. Cimperman said bank officials asked that his agency postpone making recommendations to the city council until they had chosen a developer. Their decision is expected in July or August. The commission decided not to wait and is proceeding with the initial stages of the designation process.

"The commission feels strongly that we should go forward with designation," Cimperman said. "Once a building receives a designation, a certificate of appropriateness has to be issued before demolition can proceed. A developer can be forced to postpone plans to raze a structure for up to a year. Cleveland can offer concessions such as Federal Urban Development Action Grants, code variances, or a reduction of required parking."

While noting the need for some 1,500 new hotel rooms for the renovated convention center, he insisted there is no reason not to preserve the historic building. He said new construction is not automatically the only way to achieve the new facilities. He and other prominent Ohio preservationists are convinced that the Society building could be renovated into a stately hotel which, along with new construction on an adjacent site, could provide the required rooms. (The bank also owns a vacant lot just to the east.)

The Landmarks Commission has said an even more innovative plan could be implemented. A new hotel could be built just on the vacant site, allowing developers to renovate the former bank into something else. *Jeff Trehwhitt, World News, Chicago*



# EVEN AFTER 20 YEARS THIS IDEA STILL HOLDS WATER.

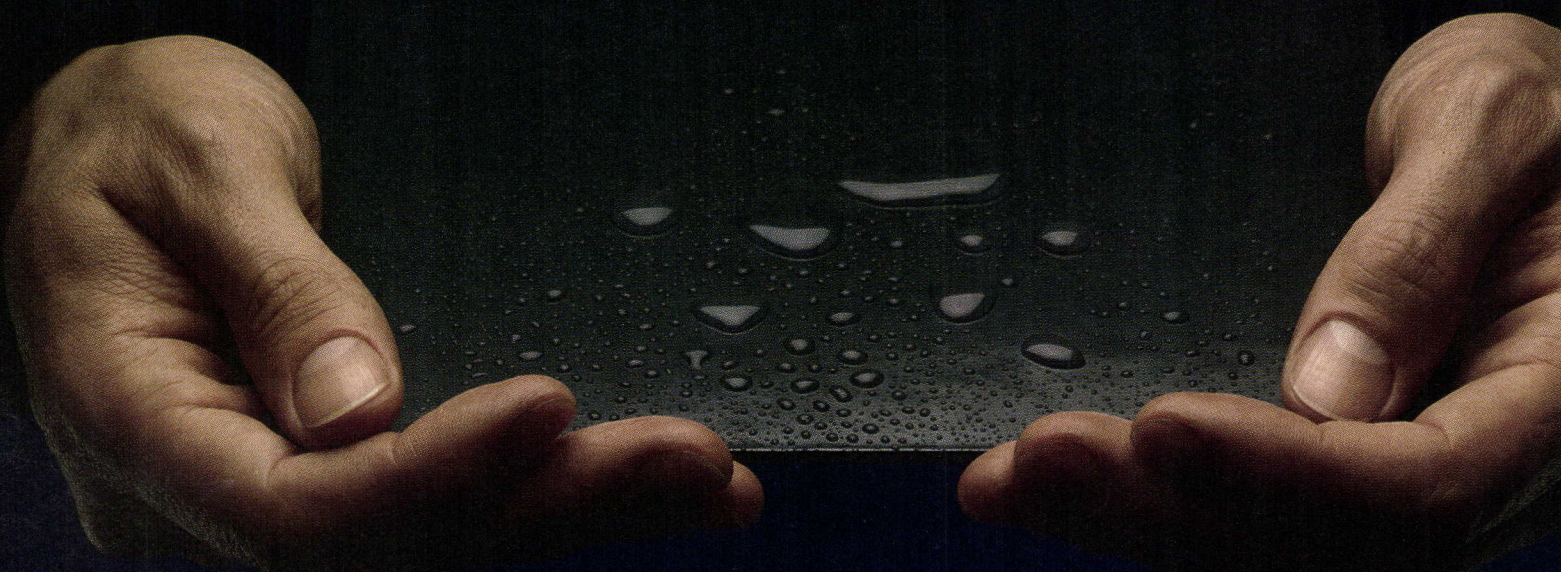

## BITUTHENE.<sup>®</sup>

The waterproofing system engineered  
to keep water out. Once and for all.

Twenty years ago, we introduced a bold way of guarding structures from the ravages of water and time — Bituthene. And it has been preserving the integrity of foundations, plaza and parking decks, subways and tunnels ever since. Now more than 2 billion square feet of Bituthene protection have been installed around the world.

Once it's in place, it's in for good. A rugged, pliable, self-adhering membrane system that was

built to go in once. To go in easily. To stay put. Resist cracking. And never stop working. No matter what the climate.

And it comes to you armed with Grace technical expertise and engineering experience. Protect your structures with a water-tight idea. Bituthene — the waterproofing system with a proven past.

**GRACE**  
Construction Products



## Government backing of research and development in construction urged



American architecture and engineering firms are beginning to take a beating both at home and abroad, with foreign companies gobbling up established American firms and foreign governments subsidizing the operations of their firms in the international arena, a spokesman for the American Institute of Architects has told a Congressional subcommittee.

Nor is the dilemma, which has been building for a couple of decades, limited to architects and engineers. It affects the entire construction community, said two panels of industry spokesmen and academics. We are rapidly falling behind foreign competitors abroad and at home, largely because of insufficient research and development.

### Adams speaks for the AIA as well as the International Engineering and Construction Industries Council

Harold L. Adams (photo), president of RTKL Associates, said billings of top foreign architectural and engineering firms in the United States have "practically doubled" between 1980 and 1985, from \$58.8 million to \$115.4 million.

"In the past five years, British, French, Swiss, West German, Dutch, Canadian, Lebanese, and Saudi interests have bought major shares in leading American firms," Adams said. "Acquisitions or mergers seem to be the easiest, most efficient, and most profitable way to enter the U. S. market. New foreign owners acquire firms that already have the U. S. know-how, have been duly licensed to practice here, are already staffed with registered professionals who are knowledgeable about the intricacies of local codes and laws, and which have all established excellent reputations as leaders in their field. And the foreign owners avoid all the enormous start-up costs of entering a new market."

Canadians have not made large-scale purchases of U. S. firms because of their ease of doing business in the U. S. But, in many instances, "Canada has not allowed equal ease of access to U. S. firms seeking to work in Canada," Adams said. "In fact, Canadian tariffs on architectural and engineering

drawings, at least until recently, could amount to hundreds of thousands of dollars." This has led to harassment of U. S. architects and engineers and even confiscation of their drawings at the border. The U. S. has no tariff on building-design drawings.

According to Adams, foreign governments offer their design firms export credits and grants for feasibility studies and bid proposals, government guarantees on bid bonds, "mixed-credit" export credits blended with foreign aid to provide low-cost loans, and other export-stimulating incentives. "These are massive subsidization programs in countries such as Japan, Korea, West Germany, France, the U. K., Holland, and Spain. And the result is to give them an overwhelming advantage over their U. S. counterparts and competitors."

The bottom line is that American firms have to learn to adapt to foreign ways of doing business, Adams continued. "If America is to be competitive globally, America must accept the fact that the nature of the game changes, that the world does not and will not mirror the American design world, its culture, its habits, its time zones, its languages, and its technology. We need the help of our government, and the sooner the better."

### Other witnesses stress a basic increase in construction R&D

According to Dr. John W. Fisher, director of the National Science Foundation's engineering research center on advanced technology for large structural systems at Lehigh University, "Without strengthening its knowledge base, our fundamental understanding of the behavior of structures, America's construction industry may be courting disaster—while spending millions on repair and litigation. In fact, we are investing in the wrong end of the process. Rather than investing in research, development, and technology-transfer projects to create more reliable structures and prevent problems, we are spending millions of dollars on cures after the fact."

House subcommittee chairman Douglas Walgren noted that recent statistics point to a "two-decade-long downward trend in the productivity of the U. S. construction industry; construction's share of the Gross National Product has fallen, the volume of U. S. construction business has sharply declined, and the number of foreign companies acquiring U. S. construction firms or contracts has increased."

Ranking minority member Sherwood L. Boehlert argued that the recent New York State thruway

bridge collapse in his district "demonstrated tragically that we cannot take construction quality for granted; the cure is more research. While the current inadequate level of research is not the sole reason the construction industry appears to be in the doldrums, research is needed to automate construction, to improve energy efficiency, to develop better structural designs and inspection methods, and to cut construction costs."

Dr. Fredrich Moavenzadeh, director of the Center for Construction Research and Education at the Massachusetts Institute of Technology, said that government policies on trade were indeed pertinent, "but it is wrong to regard them as the fundamental causes of the loss of U. S. leadership in construction. The ability of an industry to exercise worldwide leadership must depend on its internal strengths, not on external props. Unless the U. S. construction industry improves its technological standing significantly, it is in danger of being overtaken by the international competition before the end of this century."

David S. Haviland, dean of the school of architecture at Rensselaer Polytechnic Institute and chairman of a study on construction productivity by a National Research Council committee launched in 1985, testified that "the federal government must take the lead in construction R&D in part because it funds a significant part of all U. S. construction, and also because there is little reason to hope the needed increase will come from the private sector."

Richard N. Wright, director of the National Bureau of Standards' Center for Building Technology, called for more computerization employing an open-systems approach to hardware and software that would allow them to be used interchangeably. This would allow all members of the construction team to exchange information, he said.

At a separate breakfast session with the American Consulting Engineers Council, Wright pointed out that, for an industry of its magnitude contributing close to 9 percent to the nation's GNP, construction is getting much less than its fair share in federal research money. Overall, construction may get about \$200 million annually, much of it from the military, he estimated. Central health care and agriculture—which account for roughly the same GNP share—get about \$6 billion and \$1 billion, respectively, from federal sources. Peter Hoffmann, *World News, Washington, D. C.*

after money has been appropriated, and HUD wants to reduce the time lapse. It also wants to apply innovative new-construction methods to rehabilitation. The data developed during the three-year pilot program will be distributed to cities and their developers.

The cities chosen for the new project could be announced by the end of the summer, and Felder notes that such communities as Detroit, Indianapolis, Trenton, and Chattanooga are in the running.

HUD's support programs for retrofitting that could be helped by the new project include the Comprehensive Improvement Assistance Program, which gives nearly \$1 billion a year to public-housing authorities. The agency also offers communities \$800 million annually in community-development block grants for renovation work. The communities are given more flexibility than the public-housing agencies in how they spend their money.

HUD also allows rehabilitation projects sponsored jointly by private developers and cities to be funded by its Urban Development Action Grants. And it has an urban homesteading program. Residences are turned over to "homesteaders" for nominal fees for renovation. Urban homesteading has been particularly important in bringing new life to downtown Baltimore.

At Retrofit '87, a trade show and seminar program held in early June in Chicago (and co-sponsored by the McGraw-Hill Construction Information Group, among others), one speaker was Dr. Rene A. Henry, Jr., president and chief executive of the National Institute of Building Sciences. Henry used statistics to put into perspective the growing importance of today's retrofitting efforts. "There are estimates that the value of commercial remodeling is between \$70 billion and \$90 billion," he said. "The total rehabilitation market could be somewhere between \$160 billion and \$180 billion."

Henry emphasized that Congress this year, for the first time, is allocating more money for remodeling and rehabilitation than for new construction. And he said a primary motivation of lawmakers is clearly a desire to provide more-affordable housing. "We have heard strong rhetoric for several decades now, but action and results have been missing," he said. "This year looks promising and we should have our first federal housing legislation in six years."

"Retrofit today is a major market that is getting even larger," Henry said. "America has passed the point where the answer to every building need is new construction." Jeff Trewitt, *World News, Chicago*



Innovative Answers to Your Flooring Needs



## New worlds of lasting beauty.

VPI solid vinyl tile possesses a beauty that is undiminished by time. It's attractive the day it's installed, and just as attractive for years to come.

With a new array of eye-pleasing colors and variety of patterns, VPI solid vinyl tile coordinates with today's interior decors as well as VPI wall base.

Colors and patterns extend clear through the tile. Precision gauge control and our exclu-

sive Micro-squaring process result in a smooth continuous floor with tight-fitting seams and no high edges.

VPI tile resists abrasion and most common chemicals. It has good indentation recovery and conforms readily to minor subfloor irregularities without cracking, chipping, or breaking.

VPI solid vinyl tile. Innovative answers from VPI.



Floor Products Division

3123 South 9th Street, P.O. Box 451, Sheboygan, WI 53082 U.S.A.  
Telephone 414-458-4664 • Telex 910-264-3891

Circle 29 on inquiry card



## Marketing:

### Base public relations on content, not form

*Herewith is an argument that a simple presentation of your firm's credentials is not enough when wooing potential clients.*

By Robert L. Miller

While many architectural firms have accepted and even embraced marketing, the realization that marketing communications is, by definition, largely public relations still causes architects some uneasiness. Doesn't PR connote something superficial? Isn't it a sort of tall cereal box with a little cereal—and perhaps other, less healthful things—at the bottom? Is planned communications really the sort of thing with which professional firms, having integrity as their lifeblood, want to get involved?

There is considerable irony here. For true superficiality, architectural firms' own brochures and other communications often take the prize: immaculate in form, but sometimes little more than illustrated credentials when it comes to content.

To architects, photographs of their buildings radiate value and creativity. To clients, they may seem to radiate only a profession's preoccupation with imagery.

#### What content really motivates clients?

A first place to look is general-interest issues that directly concern clients and also clearly involve design. For instance:

- Tax reform's impact on building.
- Planning and zoning changes.
- Opportunities for foreign investors in U. S. building projects.

These kinds of issues may relate directly to the programming and performance of your firm's current projects or simply to ideas about future projects.

Merely raising substantive topics can be persuasive just by being disarming. Braced for a sales pitch or a litany of achievements, clients are instead asked to focus on some question of real self-interest. They can see that someone has taken the trouble to a) research their concerns and b) anticipate how some of their problems might be solved.

But seeing design in the client's terms is more than a device. By extension it implies a whole attitude about marketing communications and about practice too. Martin McElroy (RECORD, July 1985, page 51) accepts the charge that some marketing does no more than cause the same firms to spend more money to chase the same jobs; he calls for exploring and communicating real content as a way of expanding the market for design. "It's not just finding where

the action is, but where it can or ought to be, and developing client awareness of this potential."

#### Show how your firm can fill needs

Your built projects are not taboo. But more credible and involving can be the larger design process. This can include applied research and programming on the front end, and post-occupancy evaluations and operating manuals on the other. Take a survey you've done to show factors both owners and tenants consider important in leasing new office space. The survey data can be expanded to develop 1) an information resource that helps other clients make better market decisions; 2) a list of leads for your own marketing; 3) several speaking engagements at which the survey results can be presented; and 4) publicity that quotes the survey and credits the firm.

A newsletter recently mailed by an architectural firm reviewed the pros and cons of office buildings with built-in telecommunications and automated controls. It targeted small commercial developers in the firm's immediate geographic area. Even though the firm had not completed a true "smart" building, selected photos of other completed office buildings served as reminders of the firm's design skill.

The media for this kind of message need not be unconventional, but the format should not be preceived. "Form follows function" seems an unnecessary reminder for architects but, yes, there are documented cases of firms deciding to produce a brochure or newsletter with little reason for such formats, and an even sketchier idea of what to fill the pages with.

A content-oriented approach to getting published emphasizes the client's turf: not in RECORD but in *Widget World*, appearing not on an AIA roundtable but at a trade-show seminar.

More important, perhaps, is an intimate approach to clients and prospects the firm already knows. Almost any design firm can afford to host an in-office seminar or a tour of a building under construction, or produce a white paper on the effect of a city's new historic preservation ordinance.

And avoid the pitfalls. First, public relations supports marketing and selling, but is not the same as either. The three pursuits have distinct uses. There is a time for making a straightforward new business contact or an assertive pitch; then PR's indirect approach seems dilatory. Conversely, the subtle implication of expertise you produce with an article or talk can be torpedoed by a self-laudatory spiel on your firm or its projects.

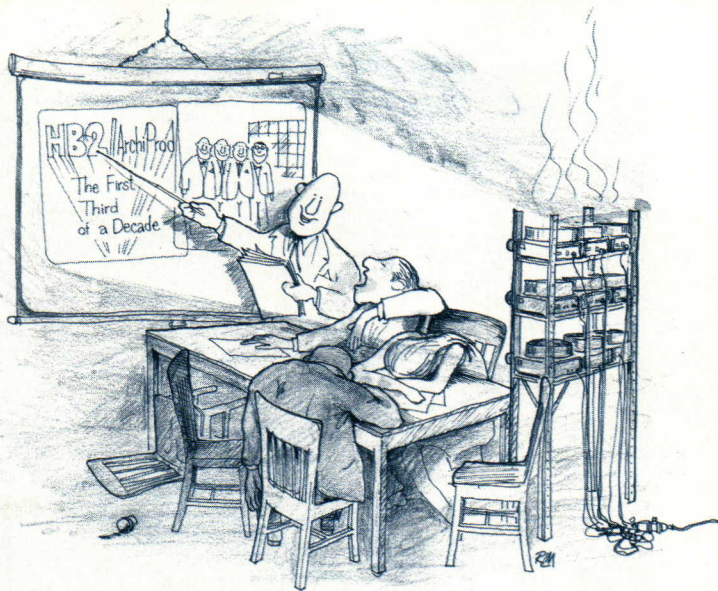

Avoid outdated issues and stay in touch with client concerns. Don't be too general; don't talk about the wonder of CAD, but what a remote terminal can do in the client's office. And there is danger in seeming to promise nonexistent expertise. Better to describe how your design firm is teaming with an expert to study real-estate investment than to describe your firm's own limitless knowledge.

#### Content-based communications can best be seen as a way of improving client relations by:

- Involving clients beyond "who can solve design problems cheapest?"
- Demonstrating your interest in matters beyond design per se—especially in your clients' fields.
- Allowing you to appear as an authority rather than a supplicant.
- Implying compliment such as "We think *you* will be interested."

#### How not to do a brochure

*Mr. Miller here regales us with wording for a brochure that is, as a whole, fictitious. However, it is, he insists, made up of bombastic blatherings he has found in real PR literature.*

##### • Experience

Quality design has long been the hallmark of HB2/ArchiProd for over one third of a decade, due to a longstanding commitment to an innovative, interdisciplinary team approach that maximizes the personal involvement of firm principals. We set clearcut goals, then implement them through an overall action plan sensitive to your specific needs.

##### • People

A wide range of potentially award-winning projects largely completed on time and budget is just part of our story. Beyond the bottom line, our responsiveness to user needs creates people places that are also highly cost effective, energy efficient, and uniquely creative, yet responsive to the overall environment as well as cost and time constraints. Your personnel gain focus and commitment without sacrificing flexibility. The people challenge

• Allowing you to approach potential clients with an established interest in superior services, instead of having to start with a generalized sales pitch.

• Making your client understand you by sharing real interests.

• Creating a natural occasion for getting in touch.

The goal is to stimulate clients' thinking—thinking about new ways they can employ a design firm, additional services they might need, ways in which architectural quality can benefit them. A parallel hope is that, by communicating substantively, architects will think, too, beyond the limits that normally bracket the "design solution." Neither professional credentials nor dedication nor hard work are proof against superficiality. The only sure cure is for architects to listen, and then communicate in terms that honestly invite a response.

is the essential ingredient that turns the blueprint of the project action implementation strategy into vital specific needs.

##### • Process

We're excited! At the same time, meaningful programming concept is ultimately the product of user input, careful assessment of all primary forces, and the proactive establishment of a clearcut overview within time and budget parameters and a well-defined task cycle.

Implementation of a highly integrated organizational network ensures that team involvement at every stage is responsive to your specific needs.

##### • Commitment

Once areas of primary expertise are established, our core team focuses on work facilitation, through our state-of-the-art computer-aided design capability as well as through periodic milestone assessment. Ongoing, interactive liaison with a broad spectrum of project team members (when available) assures a level of synergy unique in itself. Response to your specific needs insures response to your specific needs.

Robert L. Miller is an architect and head of Robert L. Miller Associates, a public-relations and marketing-communications firm in Washington, D. C., and New York City specializing in building design, development, and construction.





On and on and on. For as long as 150 feet without stopping. That's the beauty of Cot-R-Cap® exterior surfacing. Its patented construction offers continuous battens and panels that keep going. Even over ridges and other direction changes.

Think of it as metal sculpture. One you shape at the actual job site, with on-site roll forming by Alumax. A method that eliminates dimensional errors, along with freight damages and costs. That lets you go from roof to fascia to soffit and siding, if you like. With a clean, uninterrupted flow of lines.

Cot-R-Cap is available in steel and aluminum. In time-tested, full strength 70% KYNAR® 500 standard color finishes. Plus an unlimited choice of special colors.

And Cot-R-Cap is as practical as it is beautiful. Its unique construction also means no leaking problems. Because there are no horizontal end laps, folding and bending panels or face penetrations.

## HOW MUCH LONGER CAN THIS GO ON?



The interlocking pans and battens also assure watertightness. And the concealed fastener system allows thermal movement for excellent positive and negative loading, with a UL class 90 rating. And Cot-R-Cap can be installed directly over purlins, or over plywood and other decking.

Cot-R-Cap. The design possibilities are as endless as the product. And it's available from thousands of Alumax dealers, located nationwide. Each prepared at any time to go to any length to please you.

Alumax provides a twenty-year finish warranty on KYNAR 500 coatings. For your copy of this warranty, write to Alumax.

*MADE TO LAST. GUARANTEED TO PROVE IT.*



**ALUMAX**

BUILDING SPECIALTIES DIVISION

P.O. Box 163  
Mesquite, Texas 75149  
(214) 285-8811

KYNAR® 500 is a registered trademark of the PENN WALT Corporation.

For more information on other Alumax roofing systems refer to Sweet's 07410/ALU.



# Finance: Business's outlay for plants and equipment holding its own

*The 40th annual spring survey by Data Resources/McGraw-Hill reveals unexpected vigor and surprising strength in some key construction markets.*

By Robert Ringelstein

McGraw-Hill's latest survey of the nation's capital-spending plans shows U. S. industry ready to raise the investment ante this year to a level not anticipated even six months ago. The results imply that, for most sectors, the worst is over and the time is right to play catch-up. The survey was conducted in April and May and represents responses by 463 companies that account for 22.8 percent of capital investment in the U. S. (The figures have been adjusted to represent spending by all U. S. companies and reflect domestic investment only.)

Specifically, the survey indicates that U. S. investment is expected to rise 3.3 percent to \$391.6 billion. By comparison, respondents to McGraw-Hill's March survey planned a capital-spending increase of just 2.0 percent in 1987; last fall, respondents expected only a 0.4-percent rise.

a 3.0-percent overall increase in plant and equipment outlay this year. Although electric utilities plan a moderate cutback, the huge trade and service component anticipates a significant rise.

### Inflation holds the key to what the real spending levels will be

In addition to the higher nominal spending levels, inflation expectations have edged down slightly: After hanging intractably at 3.6 percent in the previous two surveys, plant and equipment prices are now expected to rise only 3.3 percent in 1987.

If investment outlays and inflation predictions hold true to respondents' expectations, real (inflation-adjusted) capital spending will remain flat for the year. The March survey, by contrast, projected a real investment cutback of 1.5 percent.

that real sales would increase 5.2 percent in 1987 at the same time that they planned real capital-budget cuts.

### The percentage of capital outlays going to buildings will probably follow historical patterns

Perhaps the most noteworthy results to come out of DRI's latest capital-spending survey relate to U. S. manufacturers' priorities for expansion versus replacement and modernization. In the current economic climate of sluggish growth, overcapacity, and nearly cut-throat competitiveness, it is not surprising that 1987 investment plans favor replacement and modernization needs over expansion by nearly a three-to-one margin. As recently as 1978, manufacturers devoted equal amounts to each category. In 1983, the first year of the current recovery, expansion spending still represented a robust 39 percent of all capital investment.

With operation rates of 80.8 percent reported by durable-goods manufacturers at the end of 1986, overcapacity within this sector clearly justifies the small share of 22 percent budgeted for expansion. Nondurable goods manufacturers, on the other hand, finished 1986 with a higher utilization rate and thus with higher sales expectations for this year; consequently, they plan to allot 33 percent of their capital budgets to expansion. The share of spending for expansion ranges from zero for nonferrous metal producers to 79 percent for rubber and plastic companies.

According to the survey, the overall investment breakdown between buildings and motor vehicles and machinery demonstrates its usual historical pattern: 20 percent for buildings, 80 percent for all equipment and machinery. Nonmanufacturers, led by the trade and service industries, plan the largest slice for building construction—some 27 percent in 1987. Consistent with their weak expansion plans, durable-goods manufacturers anticipate the smallest construction budgets, allotting just 13 percent of their total investment outlay; nondurable-goods manufacturers plan a 17 percent share.

### Here, in particular, are the strong segments of each industry

Within the durable-goods manufacturing sector, iron and steel manufacturers anticipate a substantial 20.3-percent increase in capital expenditures this year. Battered by imports for the past several years now, steel producers have reduced capacity significantly. Some breathing room has occurred from the cheaper dollar and the

*Continued on page 43*

Investment in equipment versus buildings by all business (percent of capital spending)

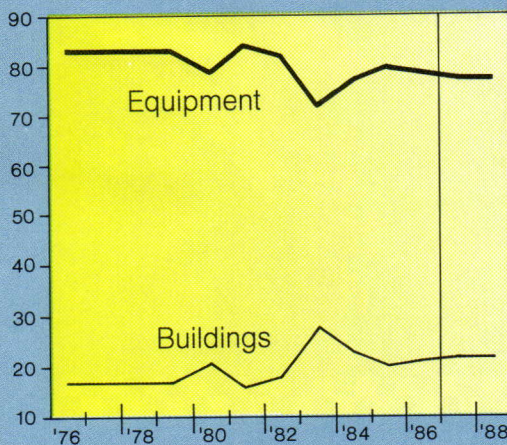

Investment in expansion versus modernization by all manufacturing industries (percent of capital spending)

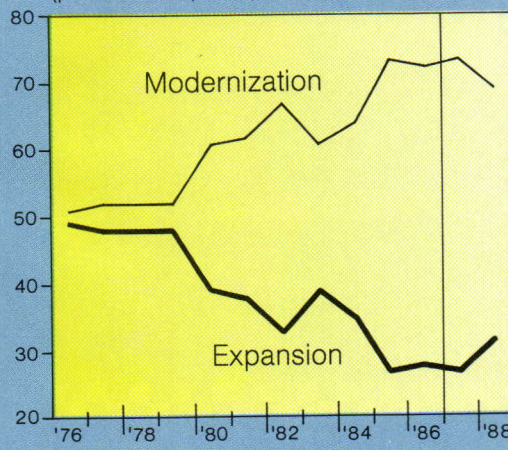

All three major sectors plan to increase spending to some degree. Durable-goods manufacturers have become more optimistic since the last survey and now predict a 2.4-percent investment increase. Iron and steel companies show extremely ambitious spending plans and producers of electrical and nonelectrical machinery look for a modest rise; the motor-vehicle industry, meanwhile, remains in the doldrums. Nondurable-goods manufacturers demonstrated the most bullishness, with plans to increase spending some 4.9 percent in 1987. Chemical companies, food and beverage processors, and other nondurable producers reported the largest spending gains, while petroleum refiners remain cautious. Nonmanufacturing firms anticipate

Over the past several years, the survey has shown that respondents' inflation expectations are consistently too high. Between November 1985 and March 1987, for example, respondents assumed that capital-goods prices would rise between 3.6 percent and 4.7 percent; actual inflation settled below 2 percent. While the latest survey results do record a lower rate of 3.3 percent for 1987, DRI estimates that plant and equipment inflation will again fall below 2 percent.

On the other hand, survey respondents now predict that their product prices will rise an average of 3.8 percent this year. This, coupled with an anticipated rise in sales of 6.6 percent before inflation, produces a real rise in sales of 2.8 percent.

Sales and investment projections now seem more consistent than last fall, when manufacturers predicted

Mr. Ringelstein is with Data Resources/McGraw-Hill.



H I G H  
P E R F O R M A N C E

Vehicle



C O L O R Q U E S T<sup>®</sup>

At this very moment, there are countless designers circling the earth in search of high performance surface solutions. Unfortunately, few companies are willing to go out of their way to supply the answers.

At WILSONART, we have those answers.

Available in three supercharged specialty options, WILSONART Color Quest offers laminate-clad proof you don't have to sacrifice strength for beauty. When you're designing an experimental environment, break new ground with WILSONART CHEMSURF<sup>®</sup>. It's stocked in 15 beautiful Color Quest solids. And it's highly resistant to over 100 solvents, bases and acids.

When fire codes are a concern, steer clear of detours with WILSONART FIRE-RATED. It carries Class I, II, A or B fire ratings, and comes in all 110 Color Quest colors.

If you're in a high traffic area, slip into overdrive with

TUFSURF<sup>®</sup> II. You'll get all the excitement of Color Quest with up to eight times the scuff resistance.

**Now let's talk about that '57 T-Bird.**

We'll be in New York in October for two reasons: first, to talk to you about WILSONART products. And second, to give away the Creative License Thunderbird. Many of you have already filled out the necessary papers and are eligible to win this rare bird. If you haven't, contact your WILSONART sales representative or call us ASAP!

Who knows, you could wind up in the pink.

**HOTLINE**

When you need immediate response to a question, or quick delivery of product samples and literature (within 24 hours), call toll-free (within the continental U.S.A.)

1-800-433-3222 In Texas: 1-800-792-6000 **Circle 31 on inquiry card**

**WILSONART<sup>®</sup>**

BRAND DECORATIVE LAMINATE

Bringing new solutions to the surface<sup>™</sup>

©1987, Ralph Wilson Plastics Co.



*"In polling companies that make over 22 percent of capital investment, the results imply that, for most sectors, the worst is over and the time is right to play catch-up."*

Reagan administration's Voluntary Restraint Agreements, which have limited steel imports. Still, nearly all of their investment budgets will go toward modernization and replacement, especially for new casting technologies in updated existing facilities. Nonferrous metal producers also plan a hearty 12.6-percent investment increase. Like steel, this industry has ample excess capacity and will devote spending to replacement and modernization priorities.

While makers of electrical machinery plan only a modest 2.1-percent increase overall, this estimate masks wide disparities within particular industries. Household-appliance producers, expecting continued strength in consumer spending, expect almost a 90-percent investment increase. Communications-equipment and electrical-industry apparatus makers also plan increases. At the same time, though, electronic-components and microchip makers take a pessimistic view of the fortunes of the computer market they sell to and thus anticipate a 4.6-percent cut.

Auto and truck makers posted huge investment increases during 1984 and 1985. Detroit is now saddled with excess capacity and inventory and is forced to offer periodic dealer-incentive programs in order to empty the dealers' lots. Consequently, investment slipped 4.6 percent last year and survey respondents look for a further retreat of 9.4 percent in 1987.

Following up their generally robust sales performance last year, nondurable-goods manufacturers again responded to the latest survey with strong aggregate spending plans for 1987. U. S. chemicals posted a \$7-billion trade surplus last year; this year's first-quarter surplus already shows a \$460-million advance over the year-earlier level. In addition, the chemical industry underwent extensive restructuring in 1985 that has made it leaner, which, combined with still-low petroleum feedstock costs and rising product prices, has bolstered profit margins.

Even after investment cuts of 32 percent in 1986, the petroleum industry still has excess capacity and anticipates further cuts of 3.6 percent this year. Refiners report an anticipated 1.1-percent decline, while the exploration and drilling companies look toward a 4.8-percent cutback. Nevertheless, the petroleum industry as a whole plans to increase spending 6.6 percent in 1988. Within any industry, however, investment plans a year away must be considered tentative at best.

Paper and pulp mills, in contrast, are operating near their preferred rate. With after-tax profits up 13.8

percent in 1986, this industry plans to increase capital budgets more than 4 percent during 1987. Converted-paper-product makers lead this investment advance.

Textile mills also appear optimistic. As in the paper industry, capacity utilization is near preferred rates and profits rose 67 percent last year. Cotton-weaving, and yarn and thread mills spearhead the industry's planned increase of 4.9 percent. The "other" nondurable goods industries also reported robust investment plans for the year, with spending in printing and publishing up 34.5 percent, apparel up 24.6 percent, and tobacco up 24.1 percent.

Investment increases in the large nonmanufacturing sector are planned almost across the board. Airlines cite the largest boost to spending, but their estimate of 33 percent seems high; they already

increased plant and equipment spending 34.4 percent in 1985 and 30.6 percent in 1986, and another spending surge this year seems unjustified. The extensive and varied trade and service industries, which account for one-third of the nation's total capital investment, look toward 4.9-percent growth in spending. Of the gainers, heavy-construction contractors anticipate an 11.0-percent increase; food stores, a 31.2-percent increase; insurance carriers, a 10.5-percent increase; business services, an 11.7-percent increase; and general-merchandise stores a 1.1-percent increase. Of those businesses scaling back, department stores report a 9.8-percent cutback; hotels and motels, 9.8-percent; health services, 7.3-percent; and computer and data-processing services, 1.3-percent.

Public-utility spending will also

be mixed, with electric utilities expecting an investment cut of 6.9 percent this year and further cutbacks of 8.8 percent in 1988 and 8.7 percent in 1989. Gas utilities, though, are optimistic despite weak sales in 1986. After a 1.6-percent investment cut last year, gas utilities expect to increase capital expenditures 10.4 percent in 1987. Electric companies made large capacity additions during the late 1970s and early 1980s; they now face overcapacity along with weaker-than-expected demand and the question mark hanging over their nuclear power plants.

Overall, U. S. businesses project investment for plant and equipment to nudge up another 0.9 percent in 1988 before slipping 0.25 percent in 1989. As noted above, however, it is too early to consider these projections as anything but tentative.

### Plans for capital spending (billions of dollars)

Industry	Level				Percent change		
	1986	1987	1988	1989	1987	1988	1989
Iron and steel .....	3.35	4.02	4.28	4.24	20.3	6.4	-1.0
Nonferrous metals .....	1.92	2.16	2.85	2.85	12.6	31.5	0.1
Electrical machinery .....	14.09	14.39	14.27	13.16	2.1	-0.9	-7.8
Non-electrical machinery .....	13.62	14.71	15.21	15.34	8.0	3.4	0.9
Autos, trucks, and parts .....	13.96	12.65	12.58	11.75	-9.4	-0.5	-6.7
Aerospace .....	3.80	4.07	3.86	3.75	7.0	-5.1	-2.8
Fabricated metals .....	4.01	3.44	3.55	3.61	-14.2	3.3	1.8
Instruments .....	2.47	2.69	2.64	2.80	8.6	-1.5	5.8
Stone, clay, and glass .....	3.13	3.15	3.20	3.41	0.8	1.6	6.5
Other durables .....	8.73	9.47	10.33	10.03	8.4	9.2	-2.9
<b>Total durables .....</b>	<b>69.08</b>	<b>70.75</b>	<b>72.78</b>	<b>70.95</b>	<b>2.4</b>	<b>2.9</b>	<b>-2.5</b>
Chemicals .....	16.75	18.26	20.45	20.80	9.0	12.0	1.7
Paper and pulp .....	8.77	9.12	9.44	9.13	4.1	3.5	-3.3
Rubber and plastic .....	3.92	2.94	3.37	2.13	-25.1	14.6	-36.6
Petroleum .....	18.13	17.47	18.62	18.65	-3.6	6.6	0.1
Food and beverage .....	10.56	12.01	12.50	12.50	13.8	4.0	0.0
Textiles .....	1.66	1.75	1.87	1.99	4.9	6.8	6.6
Other nondurables .....	13.86	15.67	13.72	14.75	13.0	-12.4	7.5
<b>Total nondurables .....</b>	<b>73.64</b>	<b>77.22</b>	<b>79.96</b>	<b>79.95</b>	<b>4.9</b>	<b>3.5</b>	<b>0.0</b>
<b>All manufacturing .....</b>	<b>142.73</b>	<b>147.97</b>	<b>152.74</b>	<b>150.90</b>	<b>3.7</b>	<b>3.2</b>	<b>-1.2</b>
Mining .....	11.25	11.35	11.82	13.35	0.9	4.2	12.9
Railroads .....	6.64	6.67	7.33	7.36	0.5	9.9	0.3
Airlines .....	6.26	8.32	7.25	6.01	32.8	-12.8	-17.2
Other transportation .....	5.86	5.42	5.14	5.55	-7.5	-5.3	8.0
Electric utilities .....	33.93	31.60	28.82	26.32	-6.9	-8.8	-8.7
Gas and other utilities .....	12.51	13.82	13.03	13.70	10.4	-5.7	5.2
Communications .....	32.94	33.04	34.13	34.15	0.3	3.3	0.1
Trade and services .....	127.17	133.43	135.04	137.33	4.9	1.2	1.7
<b>All nonmanufacturing .....</b>	<b>236.55</b>	<b>243.64</b>	<b>242.57</b>	<b>243.76</b>	<b>3.0</b>	<b>-0.4</b>	<b>0.5</b>
<b>All business .....</b>	<b>379.27</b>	<b>391.61</b>	<b>395.31</b>	<b>394.66</b>	<b>3.3</b>	<b>0.9</b>	<b>-0.2</b>



# NATURALITE

*When your reputation is on the line,  
count on ours.*



**M**any skylight systems look good on paper. But the difference between "meeting specs" and performing in the real world over time, can be dramatic.

*You know what the situation is today in terms of product and design liability. So, it makes more sense than ever to insist upon quality and integrity — in a company and its products. Next time you incorporate skylights into your design, check out Naturalite. Check our client references. Our financial strength. Our guarantee. Our systems. And, most of all — our reputation. You will find that Naturalite builds skylight systems you can stake your reputation on.*

*Your single source for skylights since 1945.*

Monumental • Standard • Residential

For information, please call toll free: Bruce Rayburn, 1-800-527-4018 Circle 32 on inquiry card

Photo: Capitol Marble Company, Marble Falls, TX • Architects: Shepberd & Boyd, Dallas.



## Architectural education: What kinds do practicing architects want?

By William S. Saunders

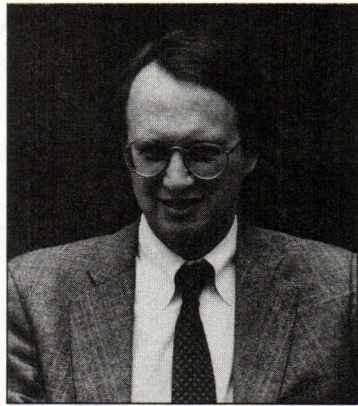

Douglas Cogger photo

In the summer of 1986, the Harvard University Graduate School of Design offered a noncredit course for professionals on Le Corbusier. Three people signed up and the course was cancelled. Meanwhile 46 students walked into the school's largest classroom to attend "Real Estate Development Primer." Harvard is not cut off from trends affecting all the U. S.

What architects think they need to learn is reflected dramatically in the enrollment data from professional-development courses held in 1985 and 1986 at Harvard. The best way to characterize that perceived need is that it seeks practical knowledge and skills. The growth in enrollments in such courses may be assumed to reflect an increased need for them. Let's look at the data in detail.

First, what is the nature of this program? Designed to serve architects, landscape architects, urban planners, and related professionals, the Professional Development Program offers only those courses that have enrollments sufficient to cover expenses. Thus it is directly market-driven. Enrollments have grown 2 1/2 times—from 874 in 1983, to 2,202 in 1986. Although the demand has no doubt been stimulated by extensive and careful marketing, marketing does not work unless the consumer is already inclined to buy.

Responding to market demands, the program offered computer courses, especially CAD, with success in the early '80s, then by and large dropped them in the mid-'80s, when basic acquaintance with computers had spread widely and giant trade shows took care of displaying the latest technology. Since 1984, certainly for Boston-area professionals, real-estate development has been the hot topic.

Along with enrollment increases have come increases in the number of courses offered, so that now in the fall and spring evening sessions (once a week for 3 to 10 weeks) about 35 courses are offered, and in the summer daytime sessions (two to seven days long) about 40 courses are offered. Enrollments are very likely responsive to the overall economy—local evening attendees in New England's booming economy have become more numerous, as national summer attendees have lessened.

Some faculty for these courses are drawn from the school's regular faculty. Most instructors are the best, most knowledgeable professionals in their fields that we can find, locally and (in summer) nationally, who are also strong teachers. "Big name" professionals sometimes teach, but they do not seem to draw students as much as

*One significant way of checking on what is strong or weak in architectural education is to find out what professionals are going back to study.*

*William Saunders presents his research on what is happening in that area at Harvard.*

certain topics. The assumption seems to be that we will find good instructors.

### Who takes these courses?

What students have we attracted in the last two years? In the summer they average 10 years of professional experience, in the fall and spring eight years—so they are by and large in their 30s, aware of their professional needs and, we assume, eager to advance. In 1986, 20 to 30 percent had taken a prior course with us. Most (50 to 73 percent, higher in the summer) call themselves "project designers"; the largest other groups are financial managers (7 to 15 percent), and marketers (7 to 13 percent). They come primarily from private firms (82 to 85 percent) that are primarily small (1 to 10 people, 36 to 42 percent) and large (51 to 300 people, 17 to 24 percent). Those from small firms may feel they need this education most; large firms probably can best afford it.

### What courses are wanted?

What courses have people from architectural firms—mostly architects—been taking in the past two years? Practical courses: (A) those directly relating to increasing general management skills, (B) those relating to acquiring basic knowledge of real-estate development, (C) those relating to specific advanced design communication skills, and (D) those relating to up-and-coming fields.

*Category A*—general management—enrolled the largest number of people from architectural firms: 240. In this category, roughly from largest (35) to smallest (8) architectural enrollments, are the following classes: Project Management, Fee Structuring, Financial Management of Design Firms, Managing Design and Planning Firms, Marketing Promotion, Office and On-Site Construction Administration, Marketing Planning, Starting Your Own Firm, Protecting the Architect's Interest in Document Approvals, and Cost Control. Clearly financial-management issues are perceived to need most study, followed by complex management techniques for projects and for construction.

*Category B*—real-estate development—enrolled 121 in the following courses, again roughly from the largest (20) to smallest (8) groups: Fundamentals of Real Estate Financial Analysis, The Basics of Condominium Development, and Mixed Use Development. Enrollments by those working in architectural firms in more advanced or specialized real-estate-development courses (e.g. Retail and Shopping Center

Development) were low. This suggests that architects are either just getting started in real-estate development (where the big money is to be made) or are just wanting to be familiar with the lingo.

*Category C*—specific or advanced design communication skills—enrolled 73 in: Advanced Architectural Delineation (14), Computer Graphics as a Design Medium, Intermediate Perspective, and Photographic Techniques for Design Firms (9). In contrast, beginning design communications courses had low enrollments from those in architectural firms.

*Category D*—special up-and-coming fields—enrolled 41 in: Hotel Planning and Design (13), Life Care Communities (10,8), and Medical and Dental Facilities Design (10).

Caveats are in order. Some categories are not larger because there were fewer offerings in them. (At the same time, the number of offerings in a category reflects perceived demand.) A course (e.g., Cost Control) that has attracted many people may attract few some of the times it is offered. Certain courses attracting those from architectural firms—Myths and Realities of the Recent Architectural Past (history and criticism), Career Development Paths for Designers, and Building Envelope Failures—fall into no dominant category.

### What is the conclusion?

On the basis of these data, the picture that emerges of professionals in architecture is of a group struggling with management and financial issues, eager to understand or enter real-estate development, interested in improving existing design communication skills, and wanting to find out about new fields. The program name—Professional Development—is reflected in the data. Those in architectural firms by and large do not want to study design or the history of design per se to any great extent. They may believe that they have had enough of those topics in earlier schooling; they may feel that improvement of their professional/financial situation requires most of their attention, and that design and design history will not influence that situation.

There is no reason to believe that architects' interest in practical courses will decrease. One may think that the low level of interest in humanistic courses in design and history is myopic, but in market-driven educational programs one's best strategy may be to make sure that the teachers of practical skills and knowledge are well-grounded in, and sensitive to, the questions of value that inevitably arise.

*William S. Saunders is Associate Director of Special Programs at the Harvard University Graduate School of Design, where he is responsible for noncredit professional-development programs and courses. He has published poems, essays on education, poetry, and fiction, and a book on the American poet James Wright. Before becoming an administrator at Harvard in 1980, he taught English in universities for seven years. In 1982, he taught a course on the functions of studying art at the Harvard Graduate School of Education.*



# SHEATHING IS SHEATHING.. UNTIL IT RAINS.

*Insulation, Gypsum Board, Roof Fiberboard, Roofing Materials, Architectural Shingles, Rebar, Nails, Screws, Insulation, Gypsum Board, Roof Fiberboard*

See wefranly available from Georgia-Pacific, for its terms, conditions and limitations.  
ASTM E119 *Fire Test of Building Construction and Materials*, ASTM E84 *Surface Burning Characteristics of Building Materials*,  
Dens-Glass and "America Builds on our Name" are trademarks of Georgia-Pacific Corporation.  
© 1987 Georgia-Pacific Corporation. All rights reserved.



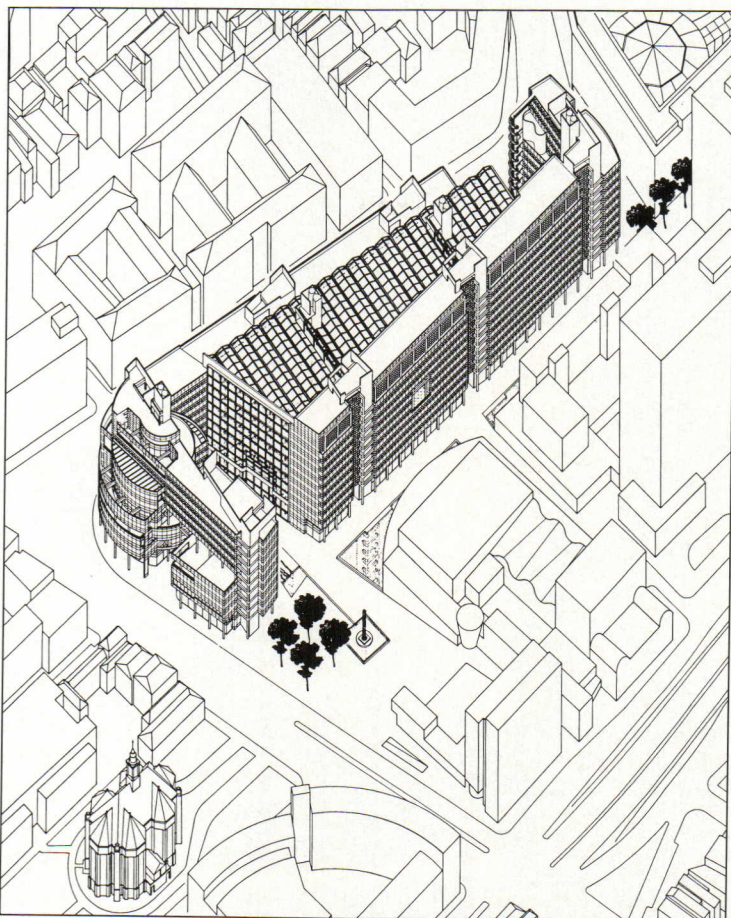

## A house divided. . .

The city council of The Hague has decided to overrule the jury report and to award Richard Meier & Partners the commission for a new city hall in the heart of the city (RECORD, April 1987, pages 54-55). In a debate lasting seven hours, the council voted 36 to 9 against the "Manhattan-motif" entry of Rotterdam architect Rem Koolhaas and in favor of Meier's scheme.

The project is controversial in more ways than one. During the debate, the riot police were called in to break up a group of demonstrators protesting against the building's construction. They see it as a waste of taxpayers' money, no matter who designs it. City officials promise that the new and more spacious city hall will cost no more and, in the long run, will be cheaper, than the maintenance of various locations throughout The Hague. The council has stipulated that the costs may not exceed 320 million guilders (approximately \$160 million, considerably more than the \$100 million originally planned). Although the city failed to obtain written guarantees from the developers against cost overruns, the council can still veto the plan if the costs turn out to be higher when the final contract is drawn up.

Most of the council members do want a new city hall, but were caught in the throes of indecision; many felt the commission should go to a Dutch architect. The only party that didn't split its vote was that of the Christian Democrats; their unanimous support for Meier swung the vote in his favor.

The jury had known from the start that its report was not the deciding factor. The more important consideration was, of course, money. The other three entries—by American Helmut Jahn, the French and Canadian team of Roger Saubot and François Jullien, and the Dutchman Hans Boot—failed to make the final round because they were too expensive. Ultimately, the city felt that Meier's developers offered more solid financial guarantee than Koolhaas's.

If all goes well, Meier's first building in the Netherlands will open in 1992. In a recent interview with a Dutch weekly, the architect offered his assurance: "It's going to be a lively place." *Tracy Metz*

## . . . and a center united

In Los Angeles, Meier recently presented a site model of the J. Paul Getty Center. The Center, to be located on a hilltop, consists of an enclave of buildings clustered along two diagonals formed by intersecting mountain ridges. Formal gardens and a reflecting pool will embellish the courtyards in between.



# Georgia Marble,<sup>®</sup> HCA's Natural Choice



Limestone was originally suggested for HCA's new data center in Nashville, Tennessee, but HCA chairman Thomas F. First, Jr. asked HCA's design committee to consider marble as an alternate.

"The marble was more expensive, but the lower cost of installation and maintenance was an overriding factor, and when we factored in the value of added beauty, we felt very comfortable with our decision," says Joe Hodge, HCA Vice President of Information Systems and a design committee member.

The ability of The Georgia Marble Company to deliver the 1-inch stone veneer within a 14 month fast-track construction schedule was another key factor in HCA's decision.

Give us a call, we think you will agree with others that Georgia Marble fulfills all the requirements for *Beauty, Low Maintenance, and Prompt Delivery.*

1-800-334-0122

In Georgia: 1-800-342-1382

Reference: Sweets Catalog; 09300/GEO



**georgia marble** company  
structural division nelson.georgia 30151 (404) 735-2591  
a jim walter company



Building Owner: Hospital Corporation of America, Nashville, Tenn  
Architects: Gresham, Smith and Partners, Nashville, Tenn  
Material: Pearl Grey Georgia Marble

Circle 37 on inquiry card



News briefs

Shanghai surprise

**Graham Gund Architects** of Cambridge, Mass., has been selected by the Pennsylvania Avenue Development Corporation to design a \$67-million, 572,000-square-foot mixed-used project in Washington, D. C. Construction is scheduled to begin in September 1988 and to be completed in the fall of 1991.

**William Dudley Hunt, Jr.**, an architect who served as a senior editor at RECORD from 1958 to 1963, died recently at the age of 65.

**Daniel Urban Kiley** and Jaquelin Taylor Robertson have been chosen to design a Henry Moore sculpture garden in Kansas City. The garden will include between 9 and 12 pieces, which will be permanently installed amid a 36-acre park adjacent to the Nelson-Atkins Museum of Art.

**Venturi, Rauch and Scott Brown** will design the expansion to the La Jolla Museum of Contemporary Art in La Jolla, Calif., according to a recent announcement made by the museum's director. The project is expected to include increased gallery space and storage capacity for the permanent collection, a renovation of the sculpture garden, an educational area, and expanded library, bookstore, and café space.

The Battery Park City Authority recently dedicated its first outdoor sculpture. The piece, entitled "Upper Room," was created by Ned Smyth and is a colonnaded, open-air courtyard of precast aggregate and bluestone that includes a gazebo-like structure and a table inlaid with chessboards. The sculpture is part of the Authority's extensive public-arts program.

The Williams College Museum of Art in Williamstown, Mass. is currently developing a plan to convert a mill complex in nearby North Adams into a museum of contemporary art and architecture. Dubbed "MASS MoCA," the scheme calls for 350,000 square feet of the 750,000-square-foot complex to be devoted to exhibition space. If realized as planned, MASS MoCA will be the largest museum of contemporary art in the United States.

**KBJ Architects** of Jacksonville, Fla., will add to its original design of the Orlando International Airport. The estimated construction cost of the expansion, which will include new ticketing, baggage claim, and rental-car areas, and preparation for a future hotel and parking garage complex, is \$325 million.

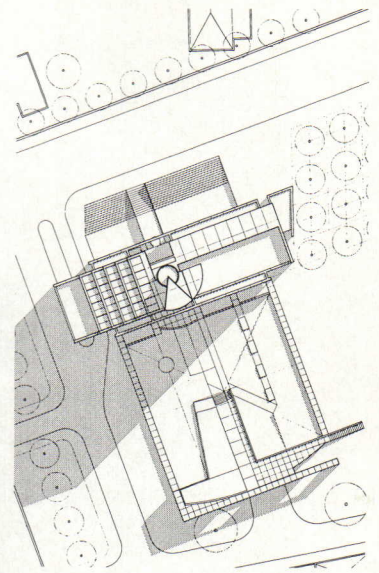
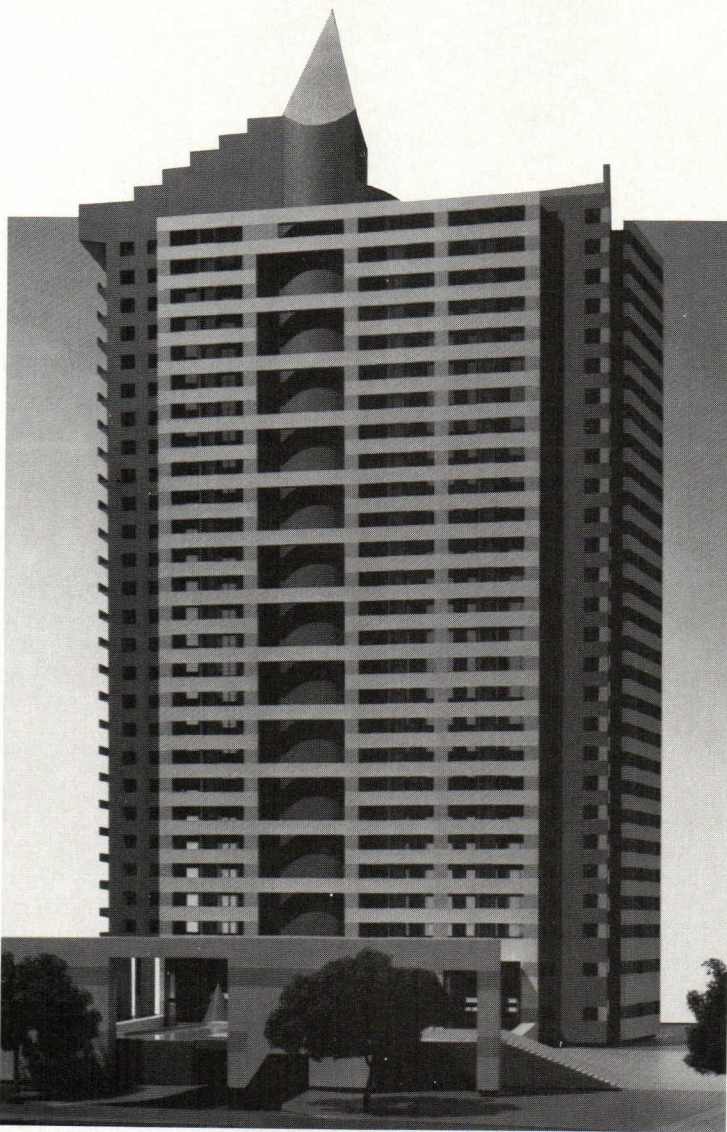

From a townhouse interior in Manhattan's Greenwich Village to a 28-story hotel/apartment house in Shanghai, China, is a substantial leap—in scale and location—but as the model and drawings of the latter project reveal, Calvin Tsao and Zack McKown of Tsao & McKown Architects have made the jump with room to spare. Now in construction under the supervision of the New York-based firm and their Chinese associates, the Shanghai Patriotic Corporation Architecture and Design Office, the building will be a concrete rectangle wrapped with ceramic tile. Although they were asked to accommodate a Western clientele, the architects chose to integrate aspects of Chinese culture. Toward that end, the building is composed of layers of increasing privacy and, when completed, will be a powerful sculptural presence.

© Jack Pottle/ESTO

And the Tate goes on: Stirling's master plan

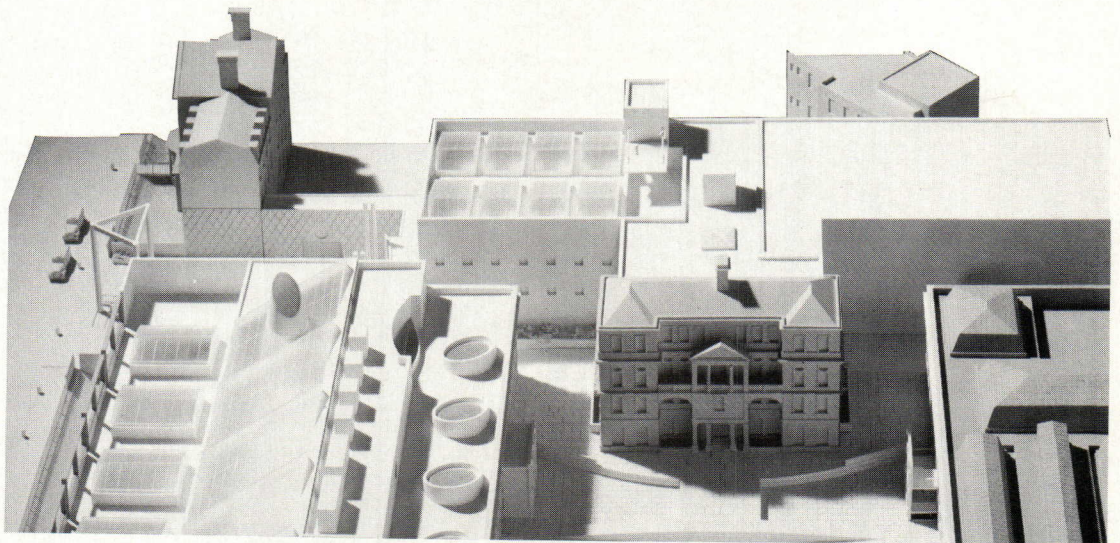

The Clore Gallery (pages 104-113, this issue), designed by James Stirling Michael Wilford and Associates, is the first completed building of the firm's master plan to expand London's Tate Gallery. The new complex will be clustered around a sculpture garden on a site located behind the Clore, now occupied by a parking lot and a military hospital. An L-shaped building attached to the north wing

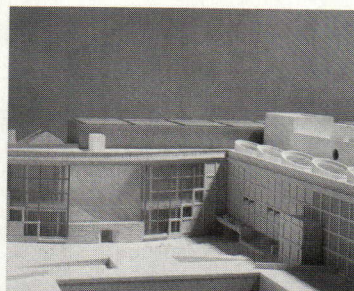

of the Tate will house separate museums for modern sculpture and for New Art that will be joined together to the old gallery by a skylit circulation spine. Across from the bowed bay of this structure, the hospital's administration building will be renovated as a study center and extended by a new museum for 20th-century art. Construction will be phased, depending on the Tate's ability to fund-raise. D. K. D.





The most  
dramatic distance  
between two points  
isn't always  
a straight line.

Introducing new Radius Pipe & Junction. An appealing collection of curves and sweeps to help you define space in new ways. Create softly rounded boundaries. Visual attractions which lead the eye in gentle arcs. Winding forms or flowing sculptural delights. Curved Pipes fit easily into standard Junctions to create dramatic entranceways, suspended ceiling forms, store fixture displays and virtually any other radiused form you can imagine. From Integrated Ceilings, Inc. ... where you can always look for a different route to functional design. Now available from Integrated Ceilings, Inc., 1601 Iowa Avenue, Riverside, California 92507 714-784-5800.

**Integrated Ceilings, Inc.**  
A Subsidiary of USG Interiors



Circle 38 on inquiry card



## Children's hour: A new museum in Las Vegas

The 100,000-square-foot Las Vegas Library and Discovery: The Children's Museum (drawing right, and model below), designed by Albuquerque-based Antoine Predock, will be built near the only natural springs in the city, on a site along Las Vegas Boulevard (known as the "Strip"), which has served in recent years as the playing fields for Las Vegas's softball league. The architect set out to emphasize nature within a glitzy city that is visually at odds with the desert canyon in which it is situated. According to Predock: "The Strip, Glitter Gulch, and the city form a thin, permeable membrane which keeps the desert marginally at bay. Wherever the vigil is not constant, the desert returns, albeit in altered form. Conversely, wherever the desert relents, rectilinear plots of grass and asphalt parking grids prevail." To help maintain plant life, Predock designed a sandstone wall that leads water directly to the entry plaza. The complex will consist of a library with a blue metal, barrel-vaulted roof, wedge-shaped administrative building, science tower, two-level children's museum, desert courtyard, oasis courtyard, and conical birthday room, all serviced by an overhead magnetic-levitation transit system, whose tracks and supporting columns frame the entrance.

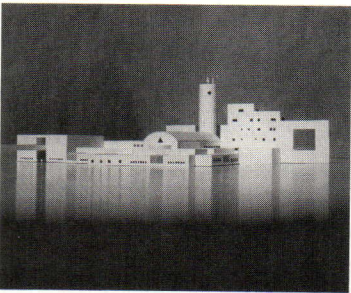
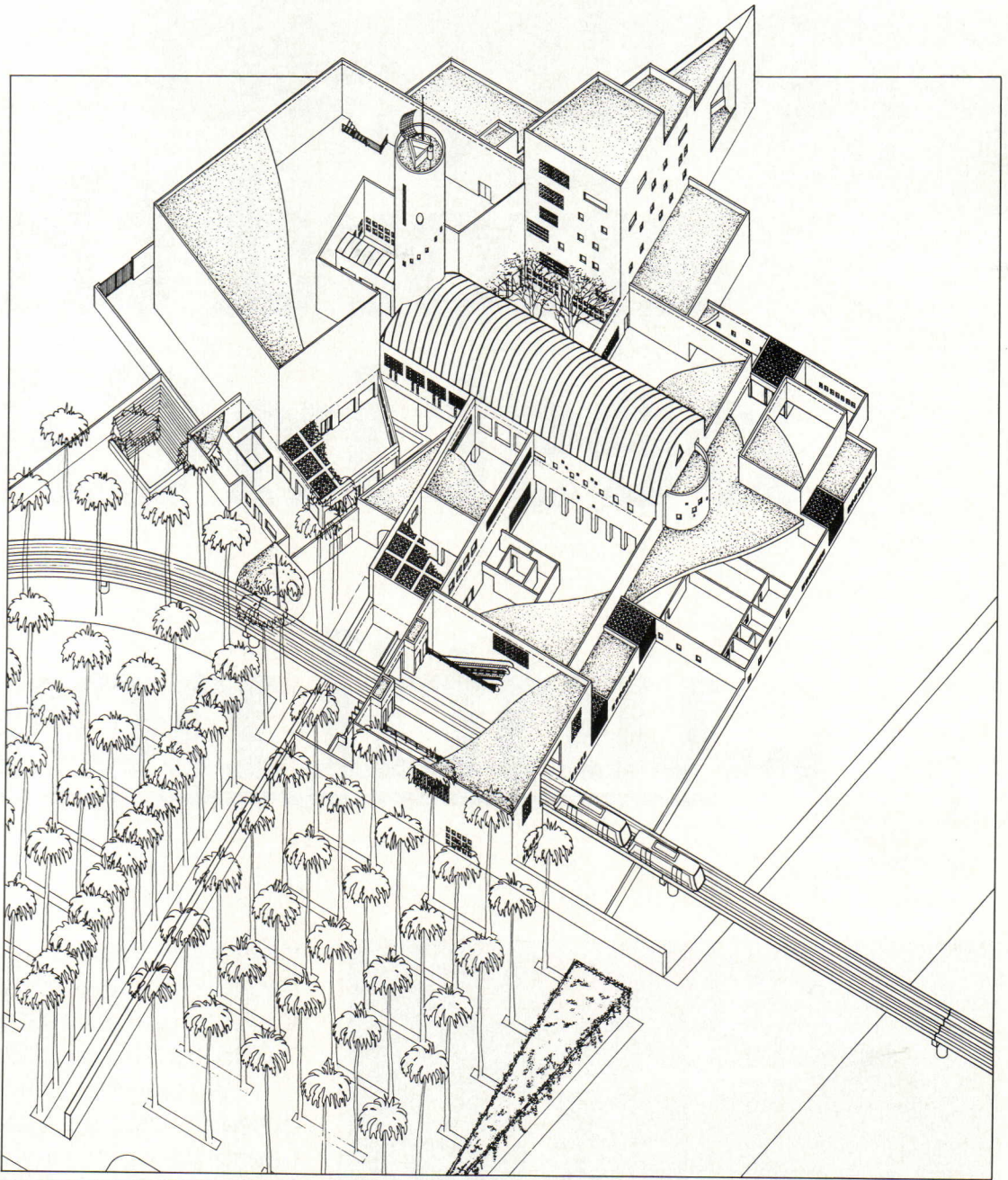

John Fleming

## The Holocaust Memorial Museum in Washington, D. C.

The design of the United States Holocaust Memorial Museum by James Ingo Freed of New York-based I. M. Pei and Partners in association with Notter Finegold and Alexander of Boston was unveiled at a May meeting of the Federal Commission of Fine Arts. The museum, to be located near the south end of the Mall in Washington, D. C., will feature a 6,000-square-foot hexagonal-shaped Hall of Remembrance, which is intended to be a place for contemplation; an atrium-like Hall of Witness; a Hall of Learning, which will supply information about the events of World War II; a Children's Wall composed of 6,000 tiles, each of which will depict an American child's view of the Holocaust; and 11,000 square feet of exhibition space. The museum is expected to be completed in 1990.

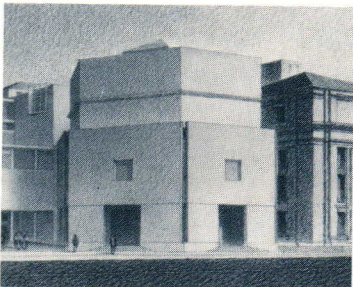
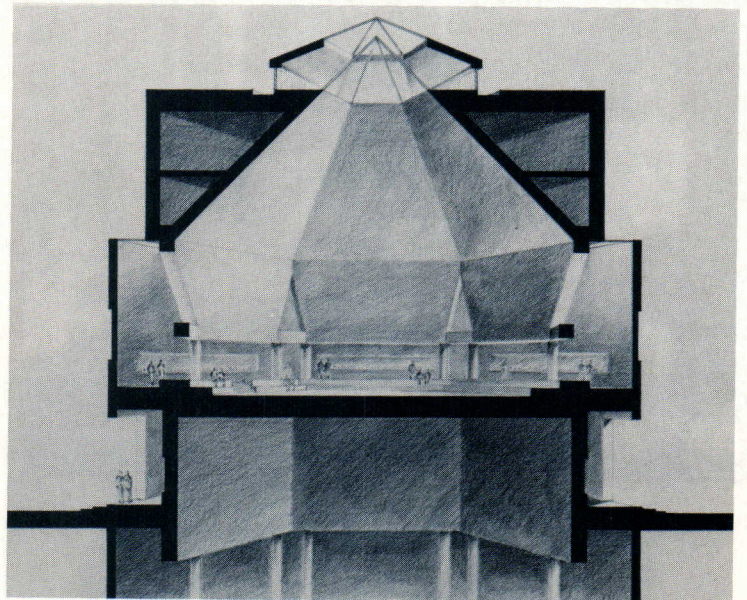



# Only the privileged could afford the best in CAD

## ...until now



Until now only a few "Blue Chip" users have had the privilege of running one of the leading architectural & construction CAD system —GDS, the Graphics Design System.

We can now offer a complete GDS system, based on the new VAXstation II/GPX. Capabilities previously associated with systems many times its price are now available for under \$50,000.

For construction applications, you can't find a more comprehensive system than GDS. It will take you from architectural modelling and engineering design right through to drafting and detailing, from conceptual design to working drawings.

Find out how you can take advantage of the best CAD at the best price. For more information call McDonnell Douglas Manufacturing and Engineering Systems Company 1-800-325-1551.

**MCDONNELL  
DOUGLAS**

Circle 39 on inquiry card



## Competition calendar

• The Prestressed Concrete Institute seeks entries to its 1987 Professional Design Awards Program, open to architects and engineers in the United States and Canada for buildings, bridges, and other structures using prestressed or precast concrete. Entry deadline is July 31. For information, contact Dawn J. Myers, PCI, 175 West Jackson Blvd., Chicago, Ill. 60604, 312/786-0300.

• The New York Foundation for the Arts annually awards six architecture fellowships of \$5,000 each in recognition of excellence of recent work. The deadline for applications for the 1988 fellowships is August 31. For more information, call 212/233-3900.

• The National Park Service and the National Endowment for the Arts are jointly sponsoring a design competition for an addition to the Wesleyan Chapel in Seneca Falls, N. Y., the location of the first women's rights convention, which was held in 1848. Entrants are also required to "celebrate the events of 1848." The deadline for submissions is October 6. To register, send a written request (and a check for \$45 made out to the Elizabeth Cady Stanton Foundation) to: Competition Manager, Women's Rights National Historical Park, National Park Service, Post Office Box 70, Seneca Falls, N. Y. 13148.

## Cultural exchange: Kisho Kurokawa comes to the U. S.

Kisho Kurokawa is currently working on his first two projects in the United States: a mixed-use 44-story tower, called "Gateway Center," in downtown Los Angeles (right) and a sports club in Newport Beach, Calif. (below). Although the Tokyo-based architect will be breaking new ground, he will not turn his back on his own heritage. At Gateway Center, the stone base and the stainless steel, aluminium,

and reflective and transparent glass of the skin will be interwoven "like a Japanese textile," according to the architect. Kurokawa will also bring this sensibility to the sports club, which will feature steel-frame construction, with ceramic tile over concrete and suspended metal roofs; the intention here is to create the "traditional Japanese grid interpreted in high-tech architecture."

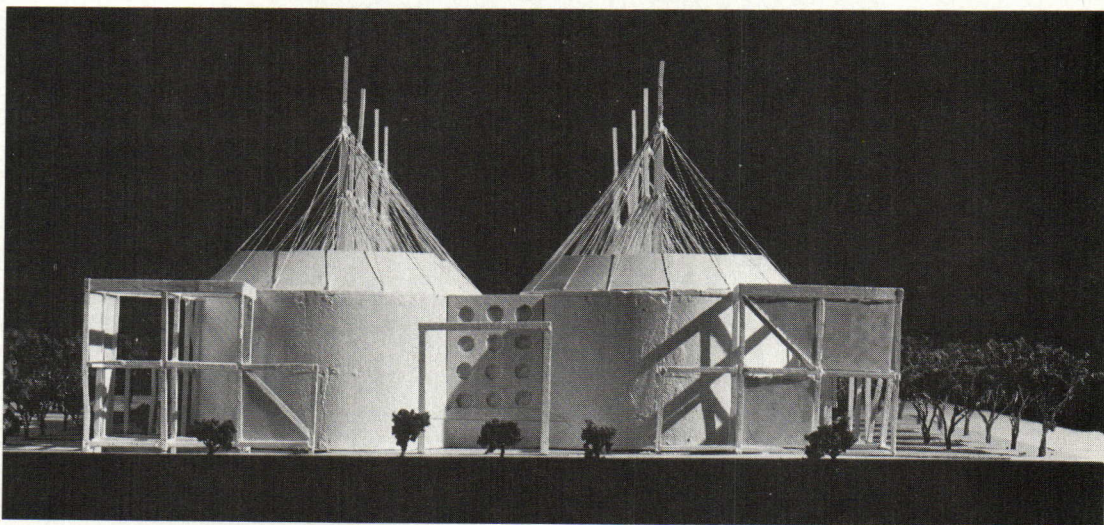
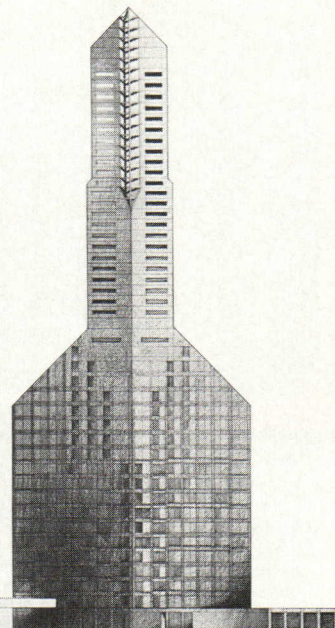

## Standing on sacred ground: A new office building in Milwaukee

Retaining historical perspective in a city that takes pride in maintaining a sense of history is a key goal of the architects of a new 35-story skyscraper in downtown Milwaukee. Though the building, designed by Clark, Tribble, Harris & Li of Charlotte, N. C., will not be the city's tallest, it will stand on land where the first Milwaukee highrise was built. As a result, the architects are trying to recapture the spirit of the original building. "We started out with a modern design, which the city liked, but it was perceived that tenants in Milwaukee want a historical perspective," said project manager Michael Murray. "So we backed up a little bit." *Jeff Treuhitt, World News, Chicago.*

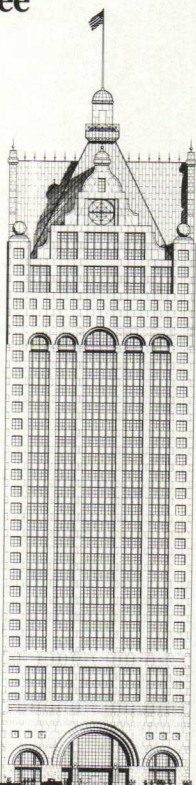

## Campus redesign for Carnegie Mellon University

The Boston firm of Dennis & Clark Associates, working with TAMS/New England, has been named the winner of a campus redesign competition for Carnegie Mellon University in Pittsburgh. The proposal, which includes three new buildings, calls for an esplanade, framed by cloister-like colonnaded walls, to be constructed perpendicular to the original Henry Hornbostel quadrangle.

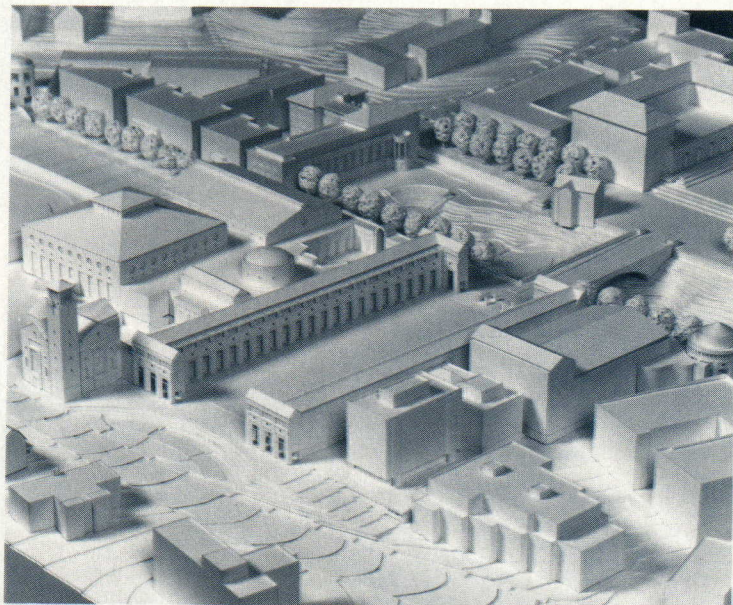



Steelcase Systems Furniture. You can take it to new limits.





Steelcase systems furniture helps you stay on the leading edge of both appearance and function, without sacrificing the reliability of the world's most often specified furniture.

You'll find new opportunities in all Steelcase systems. Fresh faces on some familiar products; new hi-tech options that help you conquer the complexities of the computer-driven office; unexpected

*combinations* of products that let you create unique environments.

Take a fresh look at Steelcase systems. We think they offer exciting new ways to push your abilities *and* your results to new limits.

For more information, contact your Steelcase representative or Steelcase regional office. Or dial toll-free 1-800-447-4700. Steelcase Inc., Grand Rapids, MI 49501.

# Steelcase

The Office Environment Company



Movable Walls. One of many Steelcase systems that offer you new ways to meet *your* objectives.  
Circle 40 on inquiry card



**Design awards/competitions:  
California Council  
1987 Design Awards**



Henry Boules



Jane Litz Photography



**1. Amancio Ergina Village, San Francisco, California;** Daniel Solomon and Associates, Architects (Honor award). These 72 units of subsidized low- and moderate-income housing comprise a perimeter block, with secure gardens and parking areas in the center. Paired bays flank the entrance to each unit, repeating the 25-foot grid that is the basis of San Francisco's scale. Noted the jury: "The project takes the existing forms of the vernacular architecture and reworks them. It tries to use the aggregate parts to make up an urban space and form, and tries to use and exaggerate its own components so that they have a scale larger than the project itself."  
**2. State Compensation Insurance Fund Regional Headquarters, Sacramento, California;** Leason Pomeroy Associates, Architects

**3. The Workstations in Evans Basement (WEB), Evans Hall, University of California, Berkeley, California;** Sam Davis, FAIA Architects (Honor award). This renovation of a computer-filled basement space drew high praise from the members of the jury, who commented that "this remarkable renovation tries to stimulate the senses, as a compensation for being underground, through the use of

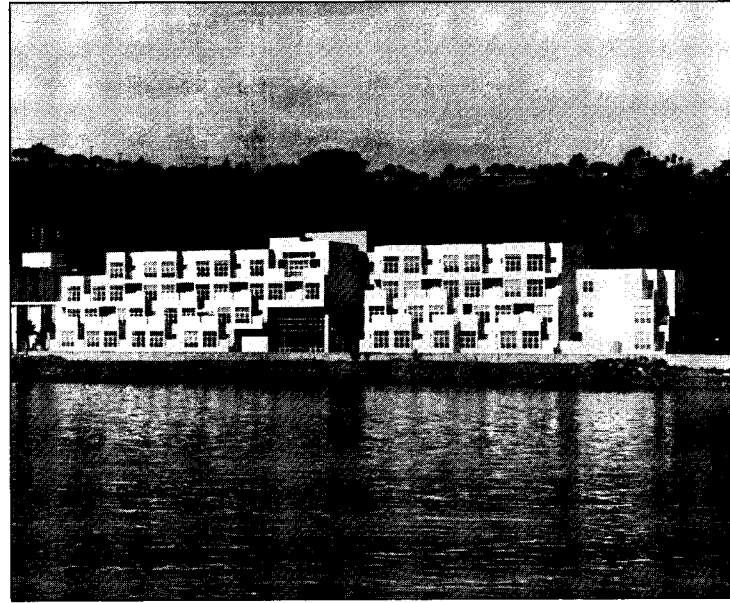
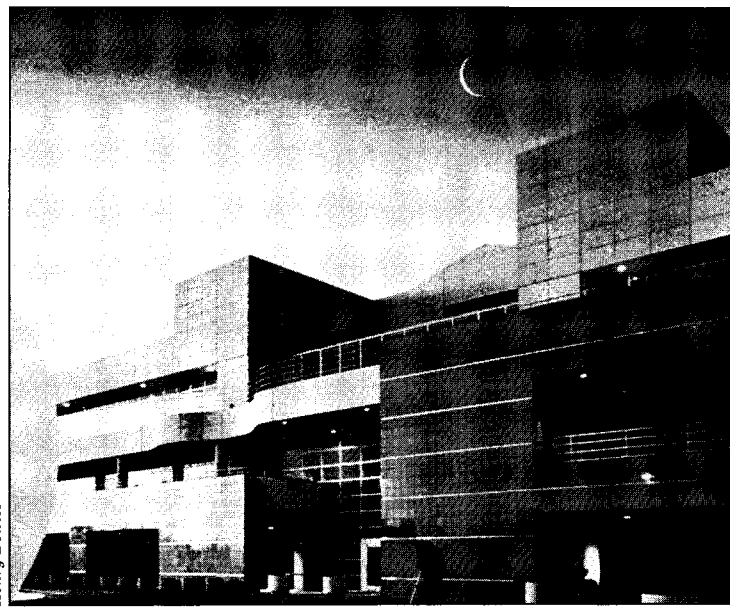

opposing colors, bright lights, and very strong patterning. The scheme is very well organized, with a clear sense of sequence and circulation, along with a nice sense of procession. The strong floor pattern gives evidence of a special organization and provides order in an otherwise incomprehensible space. This architecture is not simply the diagram, but has been developed."  
**4. Clay Street Condominiums, San Francisco, California;** Donald MacDonald Architects (Honor award). The curved bays of this building were designed to maintain the fluidity of the street facade and, in alternation with clerestories, create a visual scale consistent with the surrounding older buildings. Commented the jury: "The design has taken a well-known and traditional element of San Francisco architecture—the bay window—and

reinterpreted it in a significantly new way. The design respects the vernacular . . . but it is adding richness, not slavish imitation, to the whole of the street's vocabulary."  
**5. Bachelor Officer Quarters, Submarine Base, San Diego, California;** Ralph Bradshaw/Richard Bundy & Associates, Architects (Honor award). Housing for 61 officers was accommodated in this four-story single-loaded corridor building. Located on a narrow beach-front site, the building steps back on the sea side to create balconies. The jury remarked that "this project deals very directly and forthrightly with housing, but it doesn't come out in a banal way. Free from urban restrictions, this project needed to make its own form, and it does this beautifully by creating a sense of individual identity within a cohesive



The California Council of The American Institute of Architects recently honored 22 projects—five Honor Awards and 17 Merit Awards—in its 1987 Design Awards program. The jury, which consisted of Galen Cranz, associate professor in the Department of Architecture at the University of California, Berkeley; A. J. Diamond, principal in the Toronto-based firm of A. J. Diamond and Partners; and James Olson of Olson/Sundberg Architects in

Seattle, also selected the Venice, California, firm of Frank O. Gehry & Associates as this year's recipient of the Firm Award, in recognition of having produced "consistently distinguished architecture for a period of ten years or more."

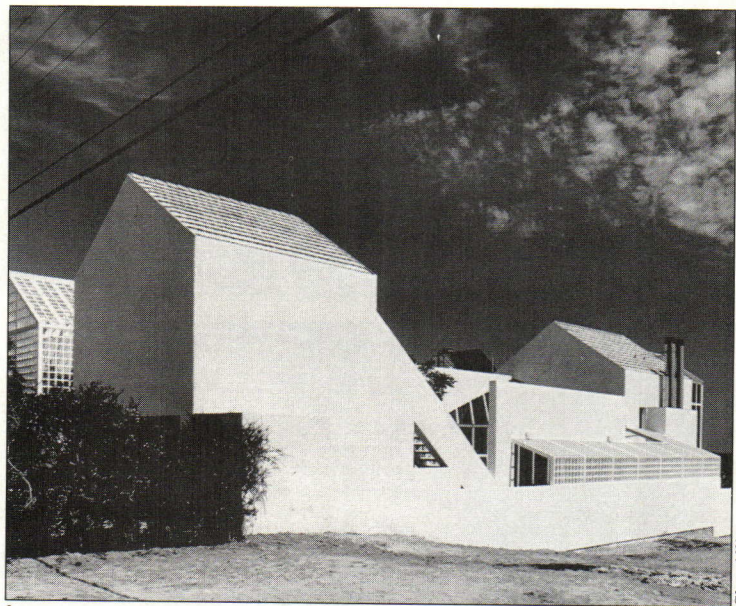

6

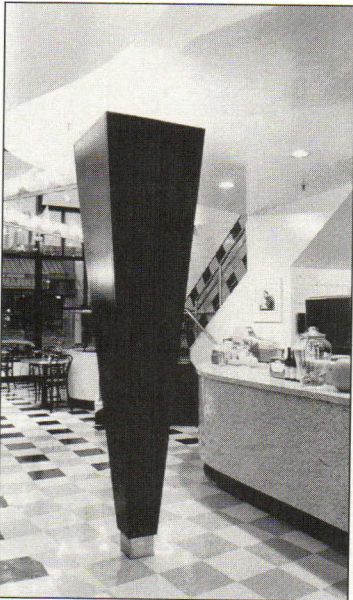

8

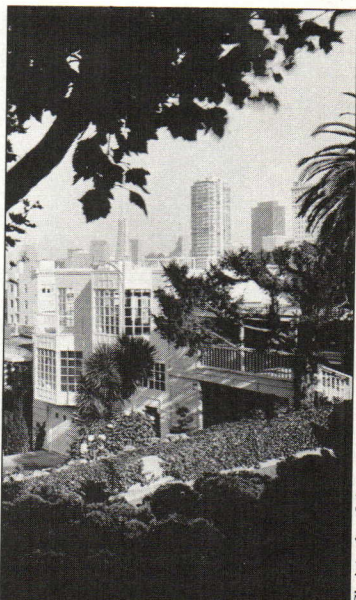

9

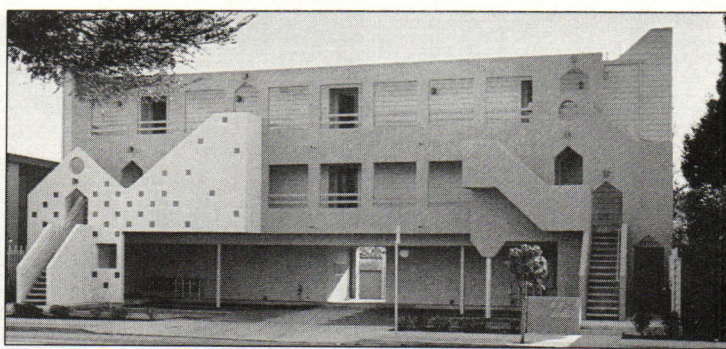

7



10

Galen Allison

Christopher Iron

Robert Mueller

Gil Sanchez

whole . . . There is also a restraint in the use of one material with very subtle shades of the same color. It's sort of clean and white and looks like it should be made by the Navy."

**6. Coleman House, Malibu, California;** Ron Goldman, Architect. This 4,300-square-foot house serves as a weekend and summer retreat for a family of four. The L-shaped plan and detached guest house create three distinct zones (for parents, children, and guests) and form a semi-enclosed courtyard. The jury praised the house for its "sculptural forms reminiscent of traditional beach houses. A wonderful consistency to the design, and a delightful play of textures and solids."

**7. Two Houses, Oakland, California;** Robert Mueller, Architect. The two separate entrances to this eight-unit

apartment building are miniature "houses," which are intended to continue the Victorian character of the neighborhood and to make an event out of the ascent to the second- and third-story apartments. The jury called this project "a transformation of an ordinary building with a celebratory entrance that makes something of the street in a lighthearted manner. This is a very imaginative and relatively inexpensive way to lift that form into another level of artistry, and introduce a sense of procession that can't ordinarily be found in these little boxes."

**8. The Fred Cody Building, Berkeley, California;** David Baker + Associates, Architects. This three-story, 12,600-square-foot retail and office building adjacent to a large bookstore includes an entrance tower and a greenhouse sidewalk cafe. The jury praised the

building for "bringing high style to Berkeley's Telegraph Avenue. This is a very overworked and rich vocabulary, but well done."

**9. 1055 Lombard Street, San Francisco, California;** Hood Miller Associates, Architects. This building fills the last vacant lot on San Francisco's crookedest street and contains three two-story units; the top two boast decks and windows facing the east and Telegraph Hill, and the bottom unit faces a narrow garden. The jury called it "an elegant solution that fits beautifully into the texture of San Francisco. The building is sort of a textured wall on the edge of this wonderful garden, and it becomes a participating, equal part of that wall."

**10. Mission San Jose Reconstruction, Fremont, California;** Gilbert Arnold Sanchez Architects. This church is a

reconstruction of the original mission, which was built by Indian laborers in 1809 and destroyed by earthquake in 1868, that not only incorporates up-to-date heating, lighting, sound, and security systems but also meets current seismic requirements. By means of archaeological digs, the architects located the remains of the original foundations, which helped them to determine the configuration and construction techniques of the original building. The design of the adobe blocks, roof and floor tiles, and even the chandeliers of the new building were based on found fragments. Commented the jury: "It takes a lot for an architect to basically reconstruct what is already there and not try to impose his own will on it. This project has been done with a great deal of integrity and fidelity."



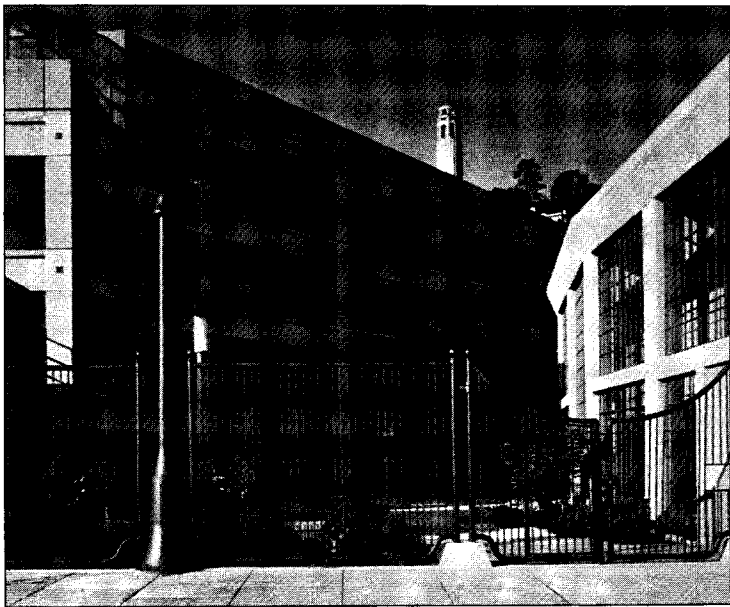

11

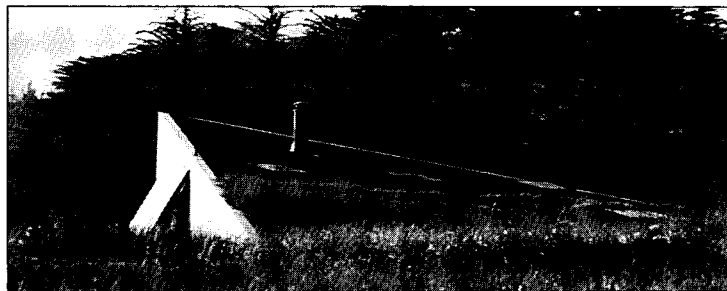

12



13

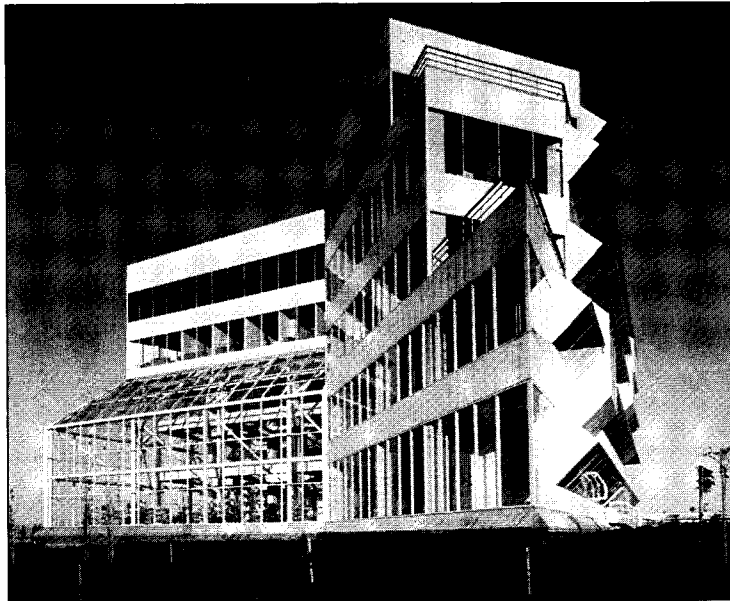

14

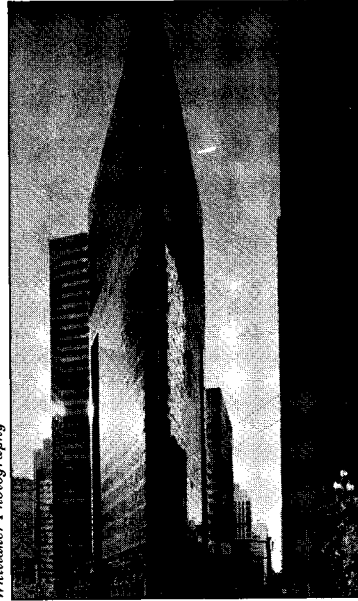

15

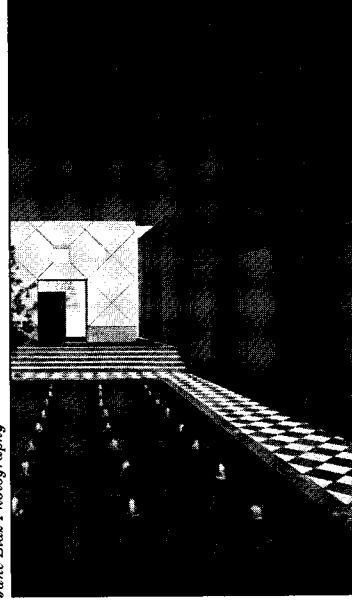

16

**11. Roundhouse Plaza, Telegraph Hill, San Francisco, California;** Daniel, Mann, Johnson & Mendenhall, Architects. This adaptive reuse of two turn-of-the-century landmark buildings—the Roundhouse and the Sandhouse—into a mixed-use facility included the construction of a new building, which was designed as a backdrop for the original structures. The jury called this project a “very refined solution. The building has changed its use without changing its form, doing so with great sensitivity.”

**12. Brugler Residence, The Sea Ranch, California;** Obie G. Bowman, Architect. This 1,730-square-foot vacation/future retirement house is located on a flat meadow lot. The design of the house, including the sod roof, is intended to reaffirm the original Sea Ranch philosophy of building in partnership with the land.

According to the jury: “This house becomes one with the earth in a very sculptural sense. There is a wonderful romance in the way this building grows out of the ground and opens up from below.”

**13. Pacific Gas & Electric Service Center, Geyserville, California;** Roland/Miller/Associates, Architects. This new service center, located on a four-acre site, consists of an enclosed area of 7,450 square feet and a covered work area of 900 square feet. The gabled metal roofs, clapboard siding, and yellow and white paint were intended to both express the facility’s function and help the building blend into the neighborhood. Noted the jury: “At first glance, this appears to be a renovation of buildings that evolved incrementally over time. Instead, it is a new structure, carefully crafted from a series of vernacular prototypes of small agricultural/

industrial buildings and cottages, and put together in such a way as to be part of that environment.”

**14. R. Dakin & Company World Headquarters, Brisbane, California;** Design & Engineering Systems and The Munselle/Brown Partnership, Architects. This building, which houses offices and showrooms for a manufacturer of stuffed animals, includes a three-story steel and glass display “bay window” and an 8,000-square-foot display court visible from a five-story atrium. The building is “a refreshing change from superficial Postmodern forms,” according to the jury.

**15. 388 Market Street, San Francisco, California;** Skidmore, Owings & Merrill, Architects. This mixed-used development contains 91,000 square feet of housing, 9,500 square feet of retail space, 244,500 square feet of office space, and

29,000 square feet of parking, and is situated on an 18,000-square-foot triangular site. According to the jury: “The plan of the building looks as if it has been formed with the site shaped around it, rather than the building being molded to fit the difficult site. The mixed-use highrise in the center of a large city is an important building type, and this one is very clean and elegant, with a wonderful sculptural quality.”

**16. Renaissance Center Phase II, Las Vegas, Nevada;** Leason Pomeroy Associates, Architects. This project (RECORD, November 1986, pages 86-89) is part of a 35-acre planned development of one-story office and retail buildings. Conceived as a pedestrian-oriented environment, the development includes arcades and a series of formal courtyards to provide refuge from the desert climate. “This





17

Tom Bonner



18

Charles Callister Jr.



Jane Lidsz Photography

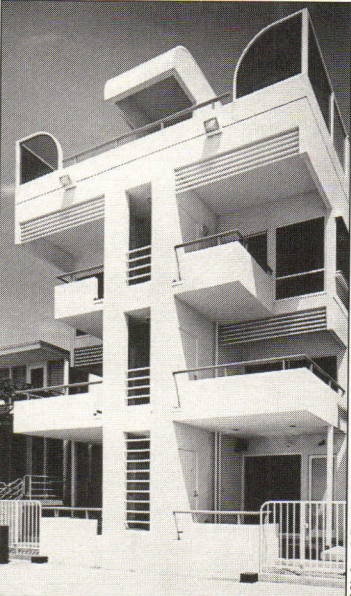

20

Michael D. Arden



21

Robert V. Arrigoni

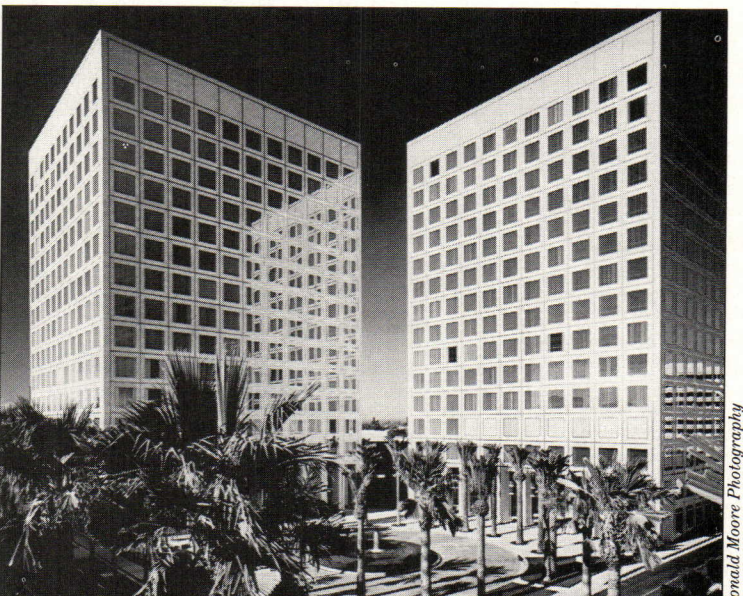

22

Ronald Moore Photography

project does more than simply offer rentable square footage, but also offers something to the community in terms of pleasure and art. A very extraordinary, appropriate architecture in a desert context," remarked the jury.

**17. Arlington II Office Building, Los Angeles, California;** John Aleksich Associates, Architects. This 15,000-square-foot speculative office building is composed of one- and two-story suites grouped around courtyards. The jury noted that the project "takes what would otherwise be a banal rental space and breaks down the scale. The plan introduces transition in the intermediate public areas that appear to be very successful exterior spaces."

**18. The Vintage Club, Indian Wells, California;** Fisher-Friedman Associates, Architects. This country club, sited amidst two golf courses,

was designed to be "an oasis in the desert." The building materials, including Italian travertine surfaces, slate floors, ceramic tile roof, and bronze railings and hardware, were selected to blend with the mountain backdrop. "A palatial mood is created through the use of big-scale, regular, simple structural forms. There is also an appealing use of materials, color, and texture, allowing the building to blend with the surrounding mountains," said the jury.

**19. West Fairacres Village, Omaha, Nebraska;** Daniel Solomon and John Goldman, Architects. This cluster subdivision of 80 houses situated on a 17-acre site has narrow streets lined with porches—a streetscape derived from bungalows constructed in the 1910s and '20s. Six floor-plan types range in size from 1,700 to 2,200 square feet. According to the jury: "This

housing complex addressed the problems of suburban development, while offering all the virtues of suburban housing. The site plan tames the car by bringing it into the interior of the plan around housing clusters, but slowed down, in the tradition of the best European schemes. . . . The plan does address the hierarchy between privacy and the fully public realm."

**20. Mineries Condominium, Venice, California;** Ted Tokio Tanaka, Architect. This three-story building, located on a 40-foot by 90-foot beachfront lot, contains two luxury condominiums. The building includes a roof deck and a subterranean garage. The jury praised this project for its "exuberance and freedom," and called the building "sculpturally seductive, with an expressive voice."

**21. Glennbrook Inn, Glennbrook, Nevada;** Backen Arrigoni & Ross, Architects. The architects were praised not only for their restoration of a historic inn located in a resort community near Lake Tahoe, but also for the development of standards for all new design in the community. Their work, according to the jury, "is not done with cleverness, but with forthrightness and a real sensitivity to what is there."

**22. MacArthur Court, Phase II, Newport Beach, California;** Skidmore, Owings & Merrill, Architects. This project includes 660,000-square-feet of new office space, a large parking garage, and the rehabilitation of three existing low-rise office buildings. "The buildings, the contrasting courtyards, and the plan all come together in an incredibly successful way," remarked the jury.



# FROM THE HOUSE THAT RUTH BUILT TO THE HOUSE THAT JACK BUILT

Incandescent, HID and Fluorescent. Cooper Lighting is the single source that offers a virtually limitless choice of lighting products. The choice for Yankee Stadium, the choice for millions of homes, and the choice for your next project.

Halo, Metalux, Crouse-Hinds, Lumark, McGraw-Edison, Sure-Lites and the SPI lines are now all part of Cooper Lighting. We are an unparalleled resource for manufacturing, engineering, marketing, design and research. Seven regional showrooms provide an opportunity to experience first-hand the effects of lighting.

Brilliance from a single light source. Cooper Lighting, 400 Busse Road, Elk Grove Village, IL 60007.

**COOPER LIGHTING**  

---

**THE SINGLE LIGHT SOURCE**



Circle 41 on inquiry card



**Freestyle: The New Architecture and Interior Design from Los Angeles**, by Tim Street-Porter. New York: Stewart, Tabori & Chang, 1986, \$35.

*Reviewed by Scott Gutterman*

New York has been called the last European city, Los Angeles the first American one. But what does that say about America? That it is obsessed with novelty at the expense of elegance? Or that it encompasses a welcome diversity and openness? The answers to those questions have as much to do with personal preference as anything else. Tim Street-Porter, the noted architectural photographer (as well as English expatriate turned Los Angeleno) demonstrates a clear preference for the architectural ideals of the West Coast. His photo-filled survey of recent design in L. A. makes a strong, occasionally strident case for the city as a monument to American ingenuity. He presents the projects of Frank O. Gehry, Brian Murphy, Frederick Fisher, and others—working in a vein he terms “freestyle”—and concludes that they have helped to “rejuvenate the spirit of freedom and innovation so prevalent earlier in this century as exemplified by the work of Wright, Neutra, Schindler, and Eames.” His argument is well-served by two other persuasive writers: Pilar Viladas, who in her introduction provides welcome background material on L. A.’s history of intense eclecticism, and Paul Goldberger, who in his afterword, boldly claims that the West is currently outstripping the East in terms of design excellence.

The work on display is indeed striking. Gehry’s unique approach to building, though documented elsewhere, is well worth another look. His own house, which is credited with having kicked off the “freestyle” movement, is an unabashed delight; it uses the vocabulary of deconstruction to expand the possibilities of domestic architecture. All of his projects astonish and amuse, and they hold up well under scrutiny as the work of a creative and free-spirited architect. The mixed metaphor approach of Murphy—employing materials as diverse as black astroturf, shattered windshield glass, and corrugated fiberglass—is loaded with shock value, but often seems dangerously close to a kind of planned obsolescence. In Murphy’s Santa Monica house, sublime ideas, such as a sensuous blue-stained oak floor, are freely mixed with ridiculous ones, such as

vegetable-shaped kitchen furniture. The result is lively, but ultimately chaotic. Fisher, a student of Gehry’s, employs a stripped-down, semi-industrial look to good effect in the Jorgensen house. His color palette, mixing pale pinks, greens, and blues with cinderblock grays, is refreshing subtle. Elsewhere, particularly in the work of graphic designer April Greiman and furniture designer Peter Shire, color is used virtually as an assault tactic. Most of the designers here prefer materials and colors that clash and clatter; not all can unite them into a harmonious whole. The firm Morphosis, however, headed by Thom Mayne and Michael Rotondi, manages the trick in its series of Alley Houses, as does Eric Owen Moss, a Venturi-influenced architect, in his carefully proportioned Petal House. Everywhere, a spirit of adventure

abounds. A grand piano against a graffiti-covered wall? Why not. A pink cactus next to a sandbag-encased television set? Worth a try. Permanence takes a back seat to playfulness every time.

All the work on display benefits from Street-Porter’s splendid photography. His images pulse with saturated color and dynamic form, suiting the vibrant and spirited architecture they portray. Subjects come alive before his lens: a cat arches its back in front of a glass-block wall, a rooftop hot tub gurgles under a clean, blue sky. Most impressive is his inventive use of light: shadows are carefully detailed, textures finely wrought, and the California sun bathes everything in its peculiar, serene glow. Street-Porter has a joyful eye, and based on this work he seems capable of becoming California’s unofficial state photographer.

The author’s text runs much closer to the fault line. To say snidely that “references to the Classical past are irrelevant in a city 8,000 miles from the Acropolis” is to ignore the whole Neoclassical strain in American architecture, and the underlying principles that promoted it as a style. In fact, the entire critical perspective is skewed; were it not for the intelligent opening and closing essays (which seem detachable from the rest), the book as a whole would seem slanted toward the very recent past.

But the book’s primary argument is visual, and it succeeds in capturing the bristling energy of L. A.’s new design. The result is a lively introduction to a sensibility that will be, no doubt, increasingly in the public eye. To paraphrase the title of a recent pop hit, with a future this bright, you’d better wear shades.

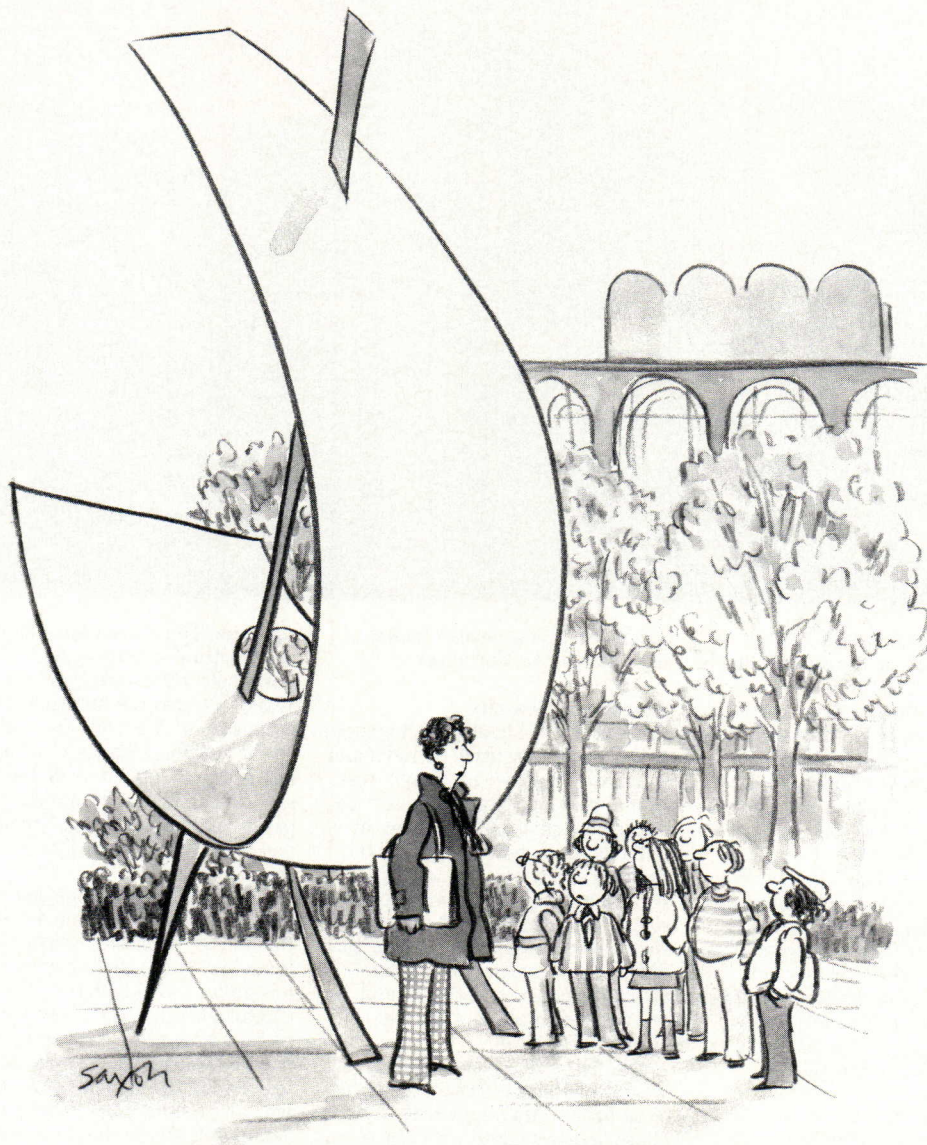

*We are all hoping, Richard, that you can offer a more relevant observation than “big deal!”*

*Scott Gutterman is a New York-based freelance writer specializing in art and architecture.*



## Chandigarh revisited

By Robert Maass



<sup>1</sup>  
In 1987, the year of the 100th anniversary of Le Corbusier's birth, architects and historians are reappraising the buildings, plans, and writings of one of this century's preeminent architects. Although best known for his buildings, Le Corbusier was also a controversial urban planner. With his 1925 book *Urbanisme* (The City of Tomorrow), Le Corbusier was one of the first to herald a geometric city, which the architect called the Contemporary City, composed of a core of huge office towers and separate superblocks for pedestrian and vehicular traffic raised on a park-like setting. This scheme was only one of many carefully

*Robert Maass, a New York-based photojournalist, is a frequent contributor to Newsweek. Maass was permitted to visit and photograph the capitol complex of Chandigarh.*

documented, but never realized, city plans by Le Corbusier.

### Chandigarh: new city

The history of Chandigarh began in 1947 with the partition of India and Pakistan. The state of Punjab was split between the two nations, with the state capital Lahore going over to Pakistan. A new capital for the Indian Punjab was needed. While several existing towns vied for the role, it was decided that a new city would be created at the foot of the Shivalik hills in central Punjab, which for climatic, esthetic, and political reasons was the most favorable location.

The first master plan for the city was drawn up in 1949 by the New York firm of Mayer, Whittlesey and Glass, in association with Matthew Nowicki. Nowicki died in a plane crash in 1950, leaving Albert Mayer, the head planner, reluctant to

continue. The search for a new architectural team led to Le Corbusier, his cousin Pierre Jeanneret, and the husband-and-wife team of Maxwell Fry and Jane Drew. Although hesitant to come on board due to limited available funds and dashed hopes on numerous city plans never realized, Le Corbusier and his group eventually took up the challenge.

From the start Le Corbusier's main involvement was in developing the master plan, the architectural guidelines, and, in particular, designing the buildings of the capitol complex. The designing and planning of the infrastructure—housing, hospitals, schools, etc.—was left to the Indian team, which was an integral part of the project. Jeanneret, who ultimately became Chief Architect and Town Planning Adviser at Punjab, was the nuts-and-bolts leader and on-site man of

Le Corbusier's group, remaining associated with the city until 1965, long after Fry and Drew had left.

### Chandigarh: The capital city

The capitol complex that Le Corbusier designed towers over the immediate landscape (1), but from a short distance south, beyond the adjacent sectors, it is invisible.

Access to the buildings, however, is severely restricted these days because of violent outbreaks in Punjab. Chandigarh is under national jurisdiction known as a Union Territory, and as the capital of Punjab and the state of Haryana, it is the home of the Sikhs and of their holiest shrine, the Golden Temple in Amritsar. Over the past several years Sikh extremists have been involved increasingly in terrorist activities, which make the Punjabi authorities who secure the capitol complex especially vigilant.



In honor of the centennial of Le Corbusier's birth, which occurs on October 6 of this year, RECORD will feature a series of articles on the master, his work, and his architectural legacy. The series begins with this article on the architect's design for the new capital city of Chandigarh in the Punjab state of India—work that spanned the last two decades of Le Corbusier's life.



2 In fact, armed soldiers are encamped within the complex, and public visitation of the capitol buildings has been curtailed. (It is sad that, in the current political climate, the very buildings that make Chandigarh a noteworthy destination for architecture devotees are difficult to view and photograph in detail, particularly from inside.)

The most massive of the buildings is the Secretariat (2,5,6), located on a north-south axis defining the western edge of the complex. This is the main administrative center and is full of activity. The east and west facades of the building have small porches, while at the center, which has a large open portal that can be driven through, the grid pattern is broken up by freer forms. On the roof is a garden, which, though little used, actually does have a few flowers.

The Secretariat, along with the other structures in the government complex, is constructed of exposed or shuttered concrete, not only a Corbusian trademark but also an appropriate building material for the means then at hand. Now 25 years old, the concrete is aged and colored, full of holes from the boards used to mold it. With all its imperfections, the concrete is, nevertheless, a humanizing element in buildings that otherwise dwarf man. (Even Le Corbusier's famous *Modulor*, embedded in the supports of the High Court's portico, is completely out of scale with both an average man's height and that of the building itself.) The porous material is favored by birds, who have built nests in the holes, and large beehives hang from the overhangs.

The Assembly building (3) is the most impressive one in the complex,

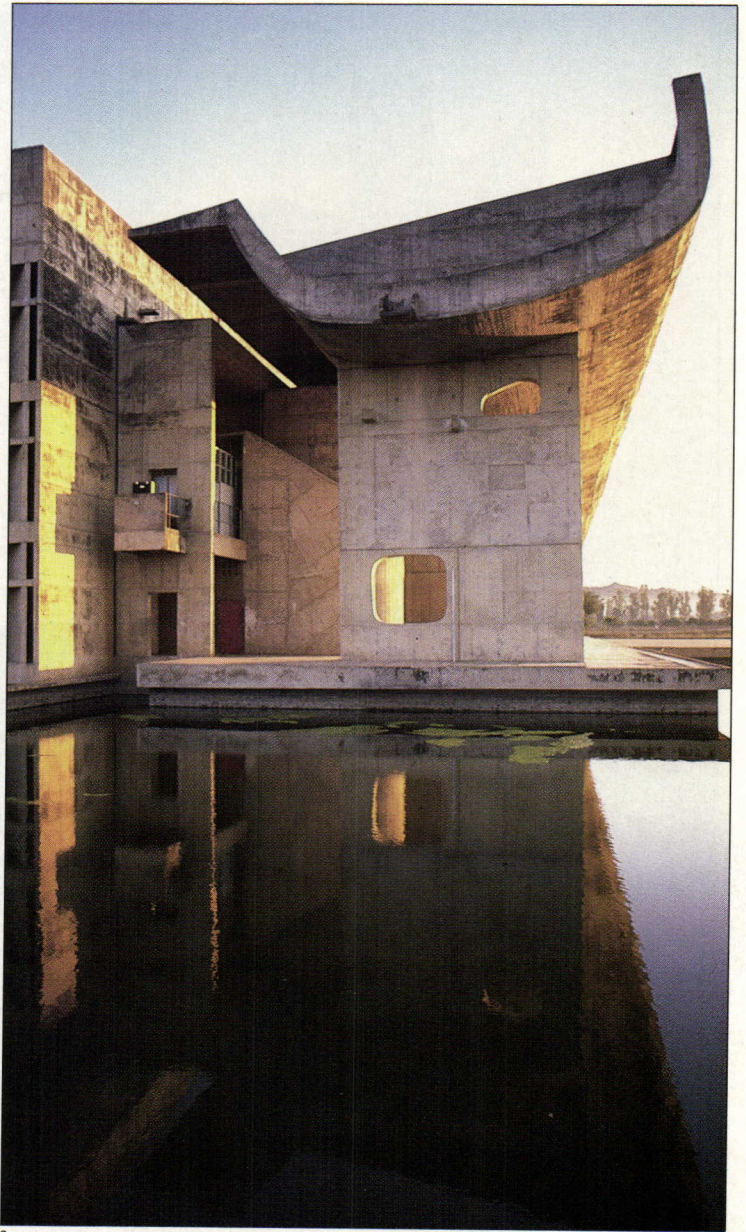

3 with its conical roof that contains the assembly hall—a tremendous space used only a month or two a year. On the east facade, Le Corbusier's murals mark the official entranceway used only by the governor (7). Inside, surrounding the self-contained assembly chamber, are ramps and multi-storied columns holding up vast, dark spaces.

To reach the High Court one crosses a vast plaza past a ramp leading nowhere and the Monument of the Open Hand (4), which is the northernmost structure of the complex. The metal hand conveys a symbolic welcome and an open attitude towards growth and renewal—the principles which Chandigarh was intended to represent. Little mentioned in written descriptions of the complex, or even immediately visible, is that directly beneath this huge metal

hand is a depression of sorts—a concrete box dug out in front of the hand, which has a ramp leading down to a single podium. There are no seats for an audience, nor any clue that the space exists at all until one is upon it. The meaning of this space is unclear: it seems to invite the public to speak openly, yet it is hidden below ground level where it cannot be seen.

By providing porches, each with a brise-soleil, off of the recessed offices, Le Corbusier believed his buildings would deal adequately with the intense summer heat of the region, where temperatures routinely reach 120°F. Although the theory of sun-blocking, ventilation, and passive solar heating appears sound (there is no central heating or air conditioning in any of the buildings), the reality is quite different. The concrete absorbs and



Previous pages:  
 1. View of the capitol complex of Chandigarh  
 2. The Secretariat building  
 3. The Legislative Assembly building

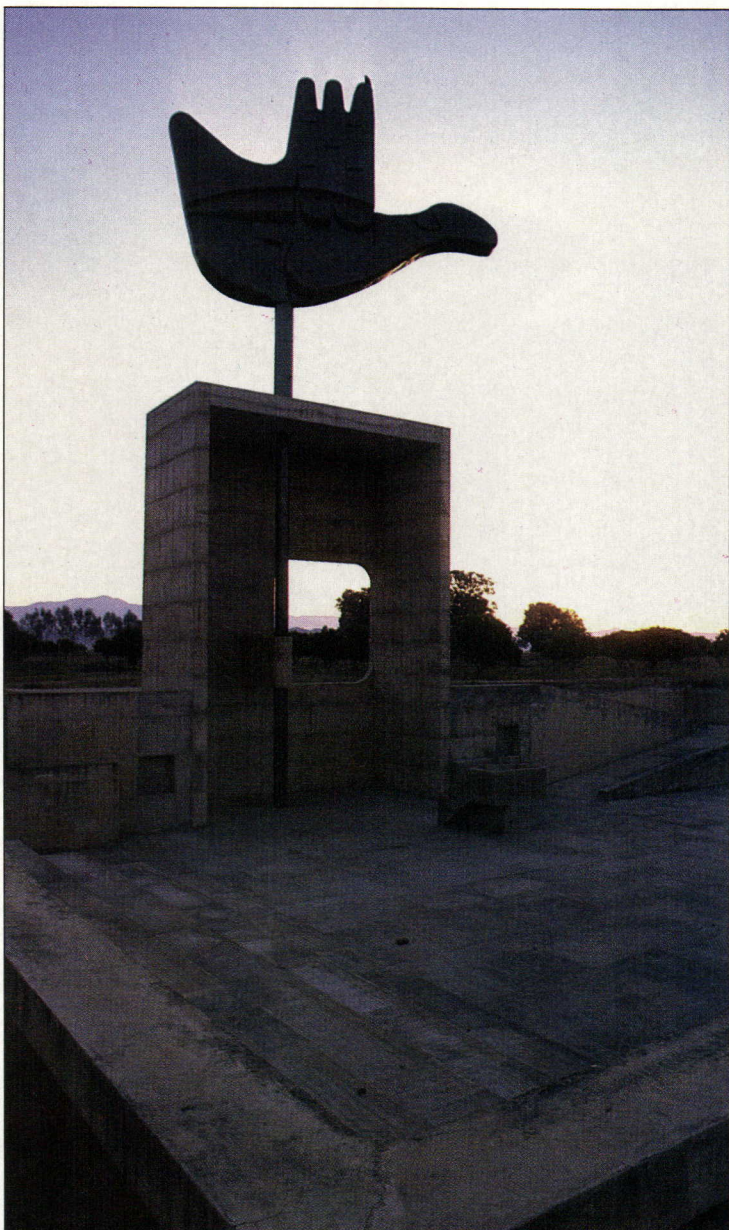

4 retains the heat, leaving offices and courtrooms hot; in the winter the process is reversed. Furthermore, the brise-soleil keep much light out at the time of year it is needed. But the biggest winter problem is the north-south orientation of the High Court and Secretariat. The sun warms the east sides of the buildings for most of the day, also providing light, while the west sides are dark and office workers must use heaters at their feet.

**Chandigarh: The residential city**  
 The rest of Chandigarh is divided into self-sufficient sectors, formed by a grid of roads, although the traffic patterns follow less rigid routes. Within each sector are the basic amenities—housing, shops, schools, health facilities and transportation—all placed amid parks. Sector 17, the central shopping area, contains a variety of

stores. Housing is sturdy, well-maintained, and esthetically uniform—mostly undistinguished, unpainted brick structures. Care has been taken to ensure that all classes of housing (there are 14 classes, from the chief ministers on down to the lowest paid workers), have standard amenities that are uncommon in other comparably sized Indian cities.

That Chandigarh doesn't look and feel like other cities in the country has prompted criticism—the point being that Chandigarh is too Western and untrue to its own culture. Although the grid plan of wide avenues was derived from Western models and differs from the narrow, winding streets of other Indian cities, this plan provides for quick and efficient transportation along tree-lined roads and, happily, spares the city's inhabitants from the intense traffic, rutted roads,

and poor sanitation that are also common elsewhere. Notwithstanding the emptiness along some of these routes, as well as in some sectors which are not fully developed, most residents of Chandigarh will name the preserved green spaces and the well-maintained parks and roads as one of the most pleasing aspects of living in the city.

Chandigarh also has a curious hierarchical social structure that is atypical of Indian cities in that the majority of citizens are civil servants, mostly middle- and low-level bureaucrats. The sectors closest to the government complex (sectors 1-6) are reserved for the wealthiest and most prominent government officials, while the farther from the center one travels, the sectors become middle- to lower-class neighborhoods. (If Chandigarh had been more "democratically"

planned, this order would have been reversed, and the lowest classes, who have the least time and means for travel, would be closest to the government complex, while the higher classes with their scooters and cars would travel farther.) The original plans also provided little housing for the poor. Because of this preordained "sector-defining," one's sector of residence denotes one's income level.

Another phenomenon particular to Chandigarh is the social interaction within neighborhoods. In a typical Indian community there is very little privacy—quarters are so close that neighbors know who comes and goes to every home. As it was put by more than one Indian—if someone unknown in your neighborhood enters your home, your local shoeshine boy will ask you about it the next day. But this is not the case in Chandigarh. The



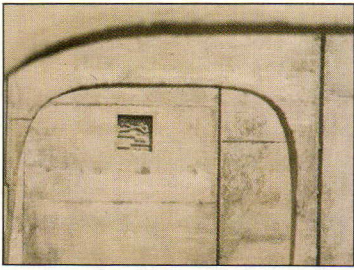

*Opposite and below:*  
 4. Monument of the Open Hand  
 5,6. The Secretariat building  
 7. The governor's entrance to the  
 Legislative Assembly building

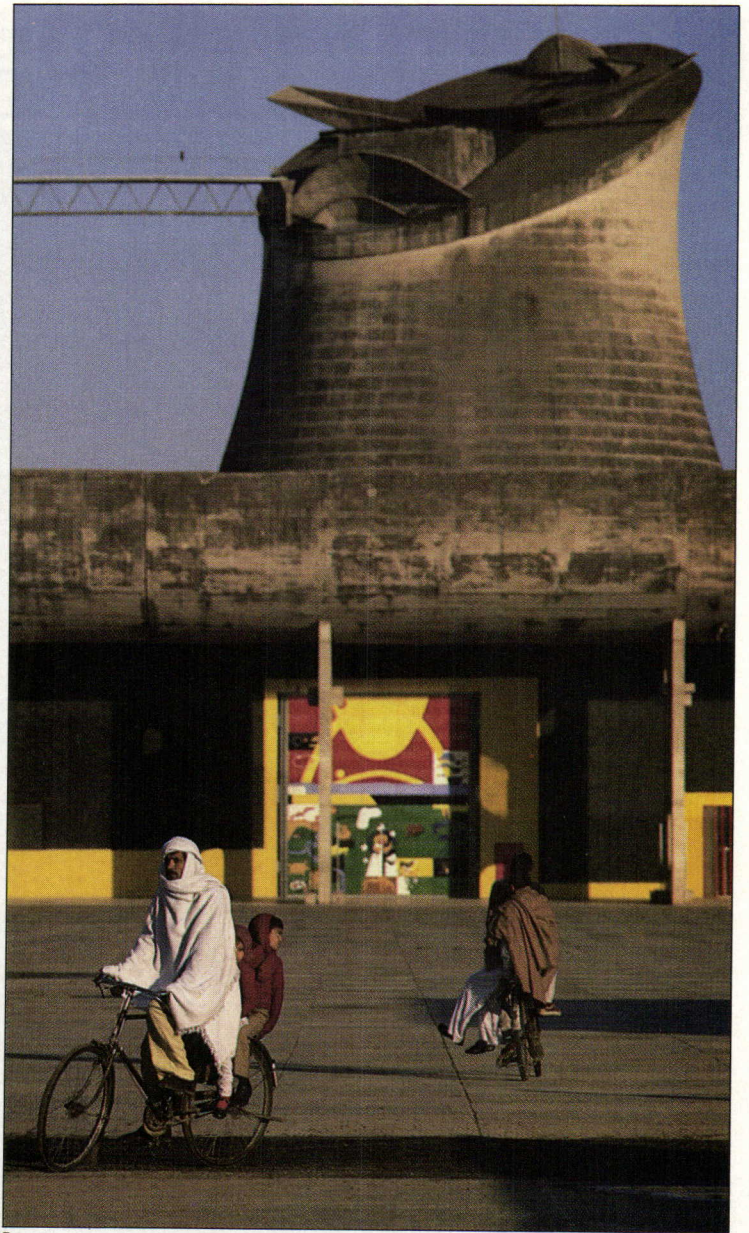
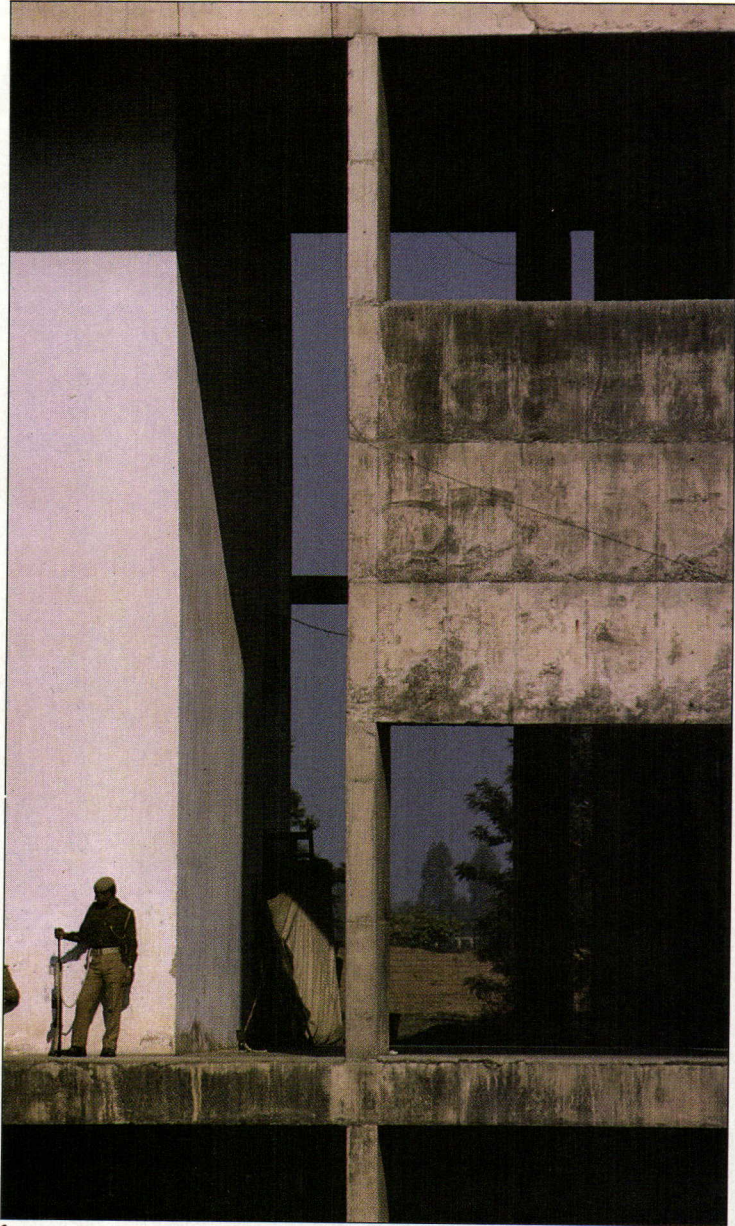

citizens keep more to themselves, and social habits are not the subject of idle gossip. People attribute this to the fact that most residents of the city are educated government employees—in most households both husband and wife work and are too busy to be interested in their neighbors' affairs.

**Chandigarh's impact**

The impact of Chandigarh on Indians—architects and laymen alike—is as a functioning city; the workings of the whole are much more significant to them than the huge Corbusian structures. The capitol complex designed by Le Corbusier is appropriately symbolic of the power and authority of the newly formed centralized government. Certain buildings designed by the architect were never completed as intended—the governor's residence, for one, which

could well have been one of the more interesting of the complex. Nevertheless, beyond Le Corbusier's extant designs one finds a city heavily influenced by his style. This is due not only to the esthetic guidelines laid out in the initial planning, but also to the school of Indian architects that coalesced around the construction and implementation of the city. These architects, who have expanded the city beyond Le Corbusier's original vision, have made significant contributions. To this day, Chandigarh's chief architect and his staff keep a vigilant watch over the design and construction of new structures. Unfortunately in this, the "second" phase of the city, beyond the original 30 sectors, these standards have not been as rigorously held. (There are fewer housing types, for example, the materials used are of

lower quality, exposed brick is being painted colors, and there is generally too little funding available to keep this phase of building as controlled as the first.) Chandigarh was built to be an architectural, urban, and national symbol. Immediately following India's tumultuous independence, the country's first prime minister, Jawaharlal Nehru, proclaimed "Let this be a new town, symbolic of the freedom of India, unfettered by the traditions of the past... an expression of the nation's faith in the future." It was in large measure Nehru's personal patronage and consonance of vision with Le Corbusier's that carried the project through. To the Indian architects and planners who participated in the project, the value of Chandigarh and Le Corbusier's plans was educational as much as architectural; i.e., this city set high

standards to be emulated. Within these design standards Le Corbusier and his colleagues produced buildings that showed how to use exposed brick, setbacks and sight standards to create a harmonious composition, which in turn engendered respect for the idea of a modern city.



# UNFORTUNATELY NOTHING MORE TO OFFER THAN

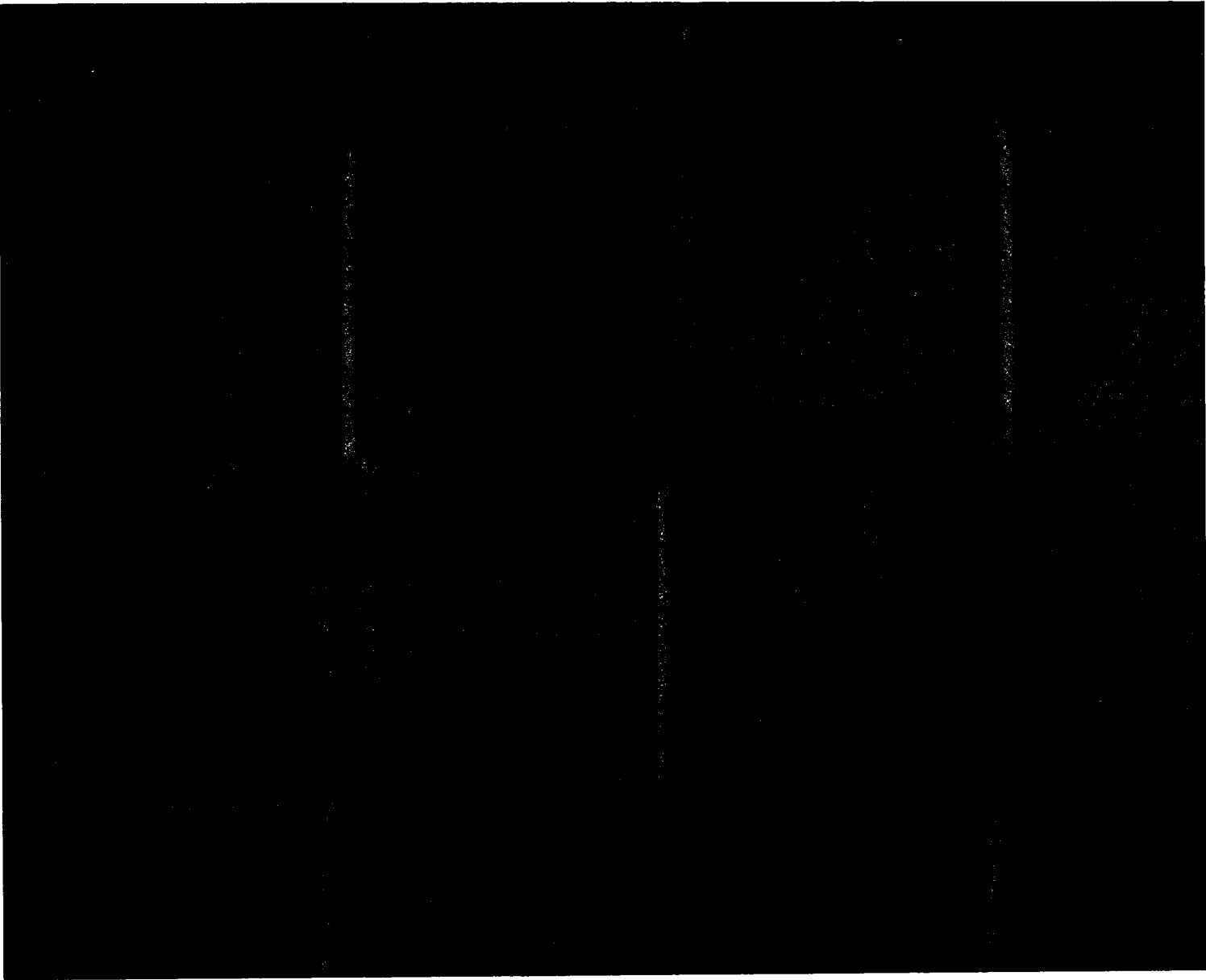

**M**ost paint suppliers and their representatives typically begin with the classic opener, "So you want some paint?"

Then, all too often, this is followed immediately by the now-famous closer, "Well, how much paint do you want?"

Between opening and closing, there's precious little else. Mainly because they don't have much to bring to the party except paint at a price.

What's even worse, picking this type of paint supplier can cause all sorts of related headaches.

Headaches of the costly, aggravating or embarrassing kind.

So how can you make sure you select a paint supplier that brings a lot to the party?

It's easy. There's really only one who has the products, the distribution, the technical know-how and the support programs to help you do the job right.

©1987, The Glidden Company



# Looking forward

In the late 20th century, a standard target for American political orators, corporate spokesmen, and newspaper editorial writers has been the country's loss of international competitive edge through its failure to maintain and advance industrial ingenuity, productivity, and quality. The portrayed victims are usually the automobile and microchip industries, and the portrayed malefactor is usually Japan; the scenario often finishes with finger-pointing at slothful Americans—either labor or management, depending on the speaker.

Even before all the publicity, however, these issues did not go unnoticed by contemplative minds, and a few institutes for industrial research have already come on line. The formation of Rensselaer Polytechnic Institute's Center for Industrial Innovation in Troy, New York, and of the Industrial Technology Institute in Ann Arbor, Michigan, may initially have been responses to regional industrial sinking spells, but both institutes seek more than a quick fix. They not only want to identify the production problems of consulting industries and to devise systems to solve them; they also want to make sure that applications follow upon the solutions—the development part of R&D. Both of these institutes therefore have extensive programs for communications and training; ITI even encompasses a center for commercial and social issues.

All three research facilities shown herein reflect a newly defined respect for technical people. Such respect could be expected perhaps from CII and ITI, not only because of their academic connections but because their mission includes the promotion—even the glorification—of science and engineering. At the Ortho Research Center, on the other hand, the architectural expression of esteem was not entirely altruistic. The research staff there owns that its new quarters were built in part as a response to employment competition. Hot-shots with postgraduate degrees tended too often to laugh dismissively at the center's old utilitarian “temporary” labs and to take their talents elsewhere.

More basically still, all three facilities reflect a changing perception of scientists and engineers. No longer are they seen as solitary thinkers who only want to retire to their laboratories so they can putter and meditate, but rather as sociable human beings who also want to converse with people who understand what they are talking about. What's more, the exchange of information and ideas between members of this technical elite has both intellectual and commercial value. All of these buildings thus provide their research staffs not only with benches but with desks in decent-sized offices, complete with telephones and, of course, computers. And in addition to meeting rooms for formal conferences, each of these buildings provides scattered and accessible lounges to encourage spur-of-the-moment conversation. *Grace Anderson*







The size of the Center for Industrial Innovation, its height and bulk dominating the campus of Rensselaer Polytechnic Institute, conforms with the vision of the late George M. Low, who was the president of RPI. He envisioned a major facility for engineering research into high-tech manufacturing processes and equipment. Such a facility, he thought, would not only establish the small (about 6,200 students) engineering school as an important intellectual center of technological research but would also increase its prestige and its attraction for talented faculty and graduate students.

At this point in history, the issues of process and equipment that industry faces inevitably involve computers, especially in the realm of robotics. Research, as a kind of up-to-date machine design, is needed to determine what sort of robot, or combination of robots, can perform what sort of task, how it can be instructed, how it can be built. Most of the research undertaken by CII—not necessarily confined to robotics—will be into cutting-edge problems raised by industries that intend to apply the solutions. To attack on the various fronts it guessed such industrial problems would present, RPI called for three research “sectors”: micro-electronics, computer-aided design, and manufacturing technology. Architecturally, the Mitchell/Giurgola building gives the center three laboratories to encompass the three sectors. The program also called for auditoriums and seminar space for outsiders asking for reports on the directions and results of the center’s studies; the architects put these functions in a separate wing, connected to the majority of research facilities only by a second-story bridge.

The micro-electronics sector, where one of the main activities will be to design patterns for etching and lithographing microchips, required the most exacting physical environment, free of dust and other contaminations and free of vibration. The large clean room is occupied by a number of small finger labs, which are massed in a three-story wing at the south end of the building. Located on the second floor, it is sandwiched between mechanical floors, with fans above and with filters and scrubbers below. The clean area is rated Class 100—that is, the air has no more than 100 0.5-micron particles per cubic foot. Moreover, the wing’s remoteness from the rest of the building protects it against vibration; a large room near the elevator, used for the delivery and assembly of heavy equipment, is acoustically isolated.

The computer-aided design sector, which occupies most of the seven-story tower, more nearly resembles conventional laboratory space. Here, the notable physical requirements are electrical power and, to the *n*th degree, flexibility. Open cable racks hung from the corridor ceiling allow frequent changes in computer connections without intrusion into lab space, and continuous counter-high horizontal power panels on all walls facilitate connections for experiment set-ups.

To house projects looking into manufacturing technology, which typically involve full-scale mock-ups of machinery, the center provides a high-bay lab. Located at grade beneath the conference wing, this facility lies at the farthest possible remove from the sensitive integrated circuits in the micro-electronic sector, with conference rooms, the bridge, administrative offices, and standard labs interposed.

Quite apart from its significance as research center, the CII has meaning as building within the context of RPI’s campus. The first academic building encountered by the pedestrian approaching from student housing or the Visitors Center across the street, its position as symbolic gateway to the campus greatly occupied the attention of architects and school. Seen from the campus, it covers the face of a 50-foot drop-off and wraps around an existing nondescript building to finish the corner of a depressed lawn surrounded by other academic buildings. In addition to all that, the site bestrides a pedestrian thoroughfare that had become virtually a right of way—the covered walkway under CII’s administrative office wing thus becomes literally the gateway to the campus.

The 200,000-square-foot center cost about \$26 million. *G. A.*

© Paul Warchol

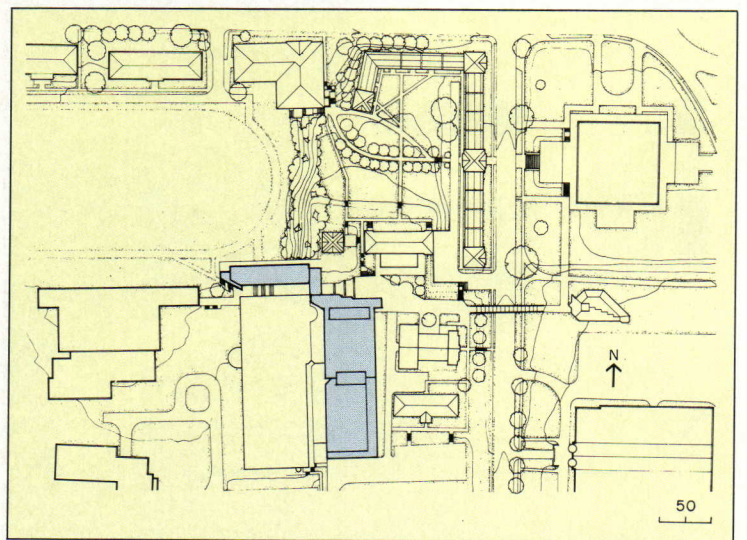

*The size of the laboratory and its siting at the front edge of RPI’s academic precinct evidence the school’s conviction that research is a basic ingredient of scientific scholarship. Its hilltop location, plus its own height make it the dominant element on campus, and from dormitories and private houses uphill it serves as background for the angular Visitors Center and the red clapboard student theater (RECORD, November 1984, pages 110-113). Though RPI’s Georgian facades are typically dark red brick, Mitchell/Giurgola concluded that that material would make the CII seem bulky and overbearing. Instead, the building is faced with off-white brick and trimmed with the familiar dark red brick. A traditional footpath crosses a new plaza between the CII and the faculty dining hall (site plan above and photograph opposite).*



In plan, the CII comprises four more or less independent areas: a micro-electronics lab (clean room) at the south end; a tower with conventional labs bisected by a service corridor; a fingerlike wing for conferences, separated from the building's main body by a walkway; and a high-bay lab at grade below conference facilities (not shown in plans). Because of the enormous amount of hvac demanded by the clean room, it

is sandwiched between mechanical floors (at left in section) and served by a number of vertical and horizontal mechanical/electrical chases. At the base of the site's 50-foot grade change, a brick facade encloses the high-bay lab (opposite bottom), bordering a sunken playing field and repeating the dark red brick traditional at RPI. The triangular protrusions that punctuate upper stories humanize the building's scale



1. Lobby
2. Lab
3. Office
4. Secretary
5. Clean room
6. Classroom
7. Lecture hall
8. Conference
9. Computer room
10. Mechanical

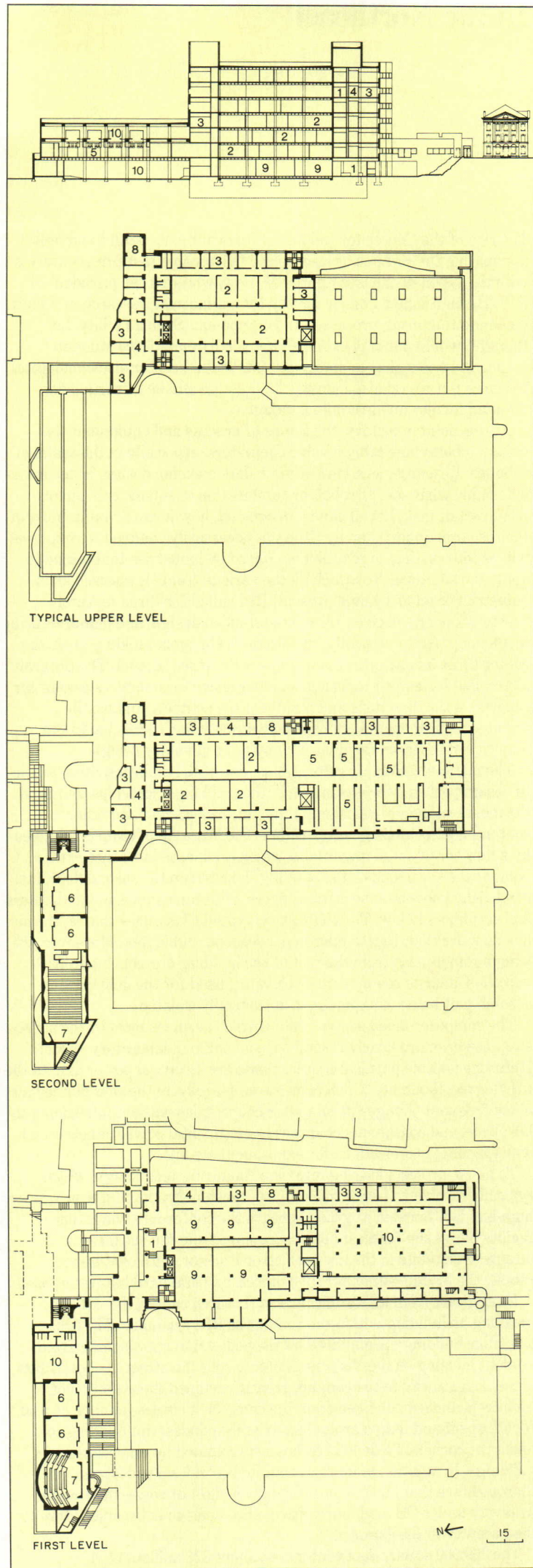



and serve assorted functions: the large red brick element (bottom) encloses a breakout area in the conference center, while a little white brick element (opposite) provides indirect daylighting in an auditorium. The curving white protrusion (bottom) is the rear wall of another auditorium. To accommodate a long-established pedestrian route to the campus, a newly paved and furnished walkway,

protected by an arcade beneath administrative offices, ducks under a bridge joining the main building with the conference wing (seen from the west opposite and the east below). The wall of the office wing zigzags to soften the impact of the building, which, because of its size amid smaller buildings, ran the danger of seeming a bully.

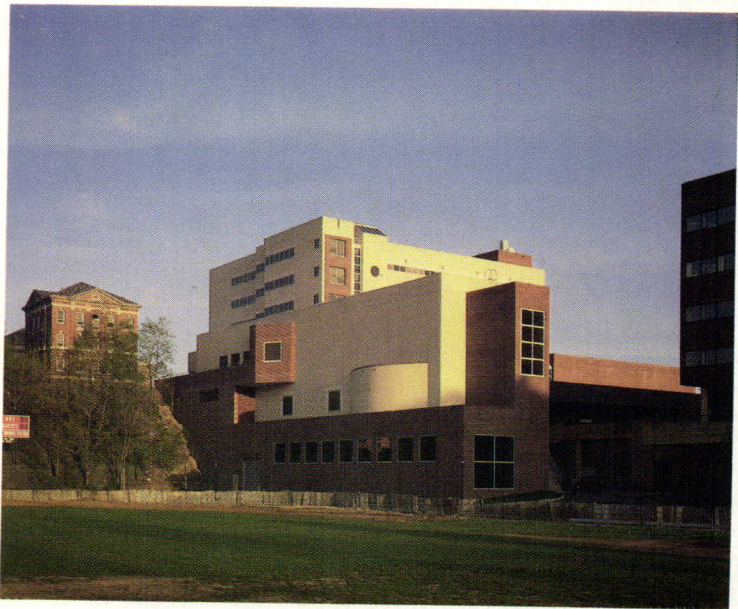



The CII's entrance lobby (below), though its exposed concrete structure and steel-tube handrails reflect the building's no-nonsense purpose, is enlivened by blue tile and gray stucco murals designed by the Scandinavian artist Lin Utzon. Facing the murals from the wall opposite, large windows look out on constant pedestrian traffic along the walkway. The fire stairs, much used for vertical circulation within the

tower, are lit by large circular windows (opposite left), which also provide a major ornamental motif on the exterior. In the high-bay lab (opposite right top), chainlink fencing within the unobstructed space allows quick moves to protect changing experiment set-ups, which generally consist of working mock-ups; a windowed control room, with raised flooring to serve a panoply of computers, commands the area (at





left in photograph). In one of the conventional labs (bottom right), a research engineer designs a computerized model of an industrial sequence, using a supply of miniature parts that suggests to the naive a set of supersophisticated Lego toys.

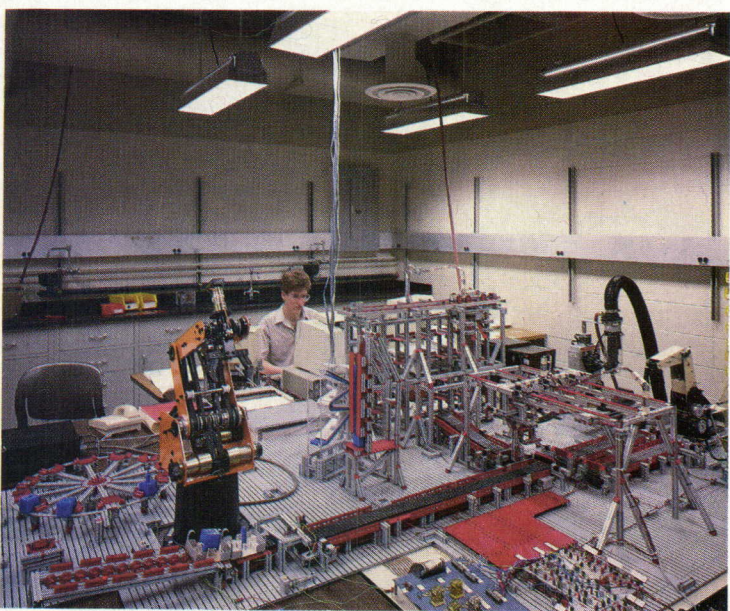

**George M. Low Center for Industrial Innovation**  
Rensselaer Polytechnic Institute  
Troy, New York

**Owner/client:**  
Rensselaer Polytechnic Institute,  
New York State Urban Development  
Corporation

**Architects:**  
Mitchell/Giurgola Architects—Jan  
Keane, James Braddock, project  
architects; Romaldo Giurgola, Clif  
Balch, Dana Beem, Joe Lengeling,  
Carol Loewenson, Steve Gifford,  
Bonnie Marken, Kevin Dickey,  
project team

**Engineers:**  
Leslie E. Robertson Associates, Leroy  
Calender (structural); Kallen &  
Lemelson, Mariano D. Molina  
(mechanical/electrical)

**Consultants:**  
Bond Ryder James Architects  
(architectural); Fisher Marantz  
(lighting); Rasmussen, Ingle and  
Anderson, Marion, Cerbatos, and  
Tomas (clean room)

**General contractor:**  
Couper Construction Company





Though the research purpose of the private nonprofit Industrial Technology Institute is essentially that of RPI's Center for Industrial Innovation described on the preceding pages—that is, the design and application of robotics and other computerized industrial systems—the building took far different form.

Much of the difference, in addition to differences of architectural vision, can be ascribed to differences in site and architectural context. Situated at the bottom of a topographical bowl, ITI's building is virtually invisible until one turns into the axial roadway approaching the front entrance. And though the region abounds in other academic, governmental, and private research facilities, their buildings appear only in the memory. This building, then, had to allude to nothing but its own purpose. Spurred by the owner's specific request for "a modern image," architect William Kessler envisioned "a composition of machine-made products and materials rather than handcrafted natural products." Hence the taut, sleek stainless-steel and glass facade.

At the same time, though, the site, with its meandering creek, wild grasses, and hardwood trees, quite richly presents the charms of nature. As Kessler explains his design, "The building was carefully placed in a rough natural setting that would, by high contrast, amplify the virtues of nature and machine. Thus a low, very horizontal and

precise facade sits amidst the fields and trees." While the front of the building hovers above the creek, its back nestles into the hillside, making site and building "virtually inseparable and fully interdependent." The wilderness was discreetly pruned and furnished with paths and stepping stones to encourage strolling.

Though the institute was designed for 250 permanent personnel, it will also house a variety of transient staff members—consultants, graduate students, and industrial personnel on detached duty. ITI was most anxious that its research staff, both permanent and transient, have a sense of geographical as well as intellectual community. Kessler therefore varied the conventional research center plan, which gangs individual labs at the center of the building and gives each researcher an outside office directly across the hall from his assigned lab space. Rather, ITI puts research offices in the 64-square-foot pods that stretch to the western end of the building. Each floor of the pods accommodates a different department, such as Flexible Manufacturing Systems, Communications and Network Center, Data Systems Center, or Information and Communications Systems. Because all laboratory space occupies the three long pods near the front entrance, its users must traverse the longitudinal corridor from offices to the lobby and laboratory corridors, a journey intended to bond them to the entire



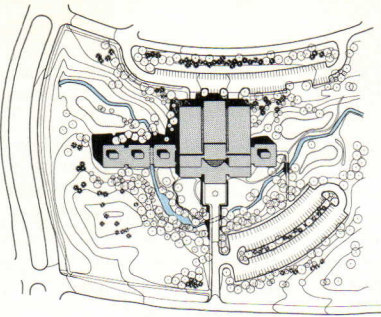

Industrial Technology Institute  
Ann Arbor, Michigan  
William Kessler and Associates,  
Architects



institute as well as their specific departments. In any case, because of the nature of the research, the physical separation of experiment and experimenter is unlikely to prove troublesome: the offices have computer connections to the labs.

Since all three laboratory wings have equally high ceilings, they are all in effect high bays. But the high-bay lab proper, which occupies much of the westernmost long pod, has an uninterrupted 110-foot-long floor of continuously poured plastic-reinforced concrete with rubberized coating; the floor thus smooths the way for robot carts, which are easily distracted by joints and other bumps. The other laboratories, typically 32 feet wide and either 32 or 64 feet deep, are augmented by an electrical shop and a shop for the construction of prototypes. Administrative offices occupy the eastern pods, while conference rooms and common facilities like the library and dining room cluster around the atrium.

The 115,000-square-foot building cost \$17.5 million, \$12.5 million provided by the state to foster development of "the factory of the future" in Michigan, as well as jobs generated therefrom; the remaining \$5 million came from private sources, notably the Kellogg Foundation and, the institute proudly reports, the *voluntary* contributions of its own staff members. *G. A.*

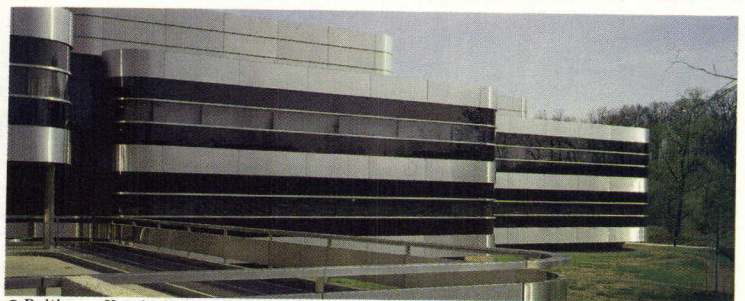

© Balthazar Korab photos



To make clear the emphatic contrast between highly finished manmade object and casual country, the research center floats above the land, cantilevered from concrete columns founded in the creek bed that winds across the site (below left and elevations). The building's skin, unequivocally bespeaking machined finish, consists of stainless-steel panels; Kessler chose the material for its resistance to oil-canning. The

horizontality of the two-story building is emphasized by strips of reflective gray vision glass and black spandrel glass (below right), although in the dining room (opposite right), dark gray vision glass replaces opaque glass above and below customary windows. To define the 64-foot bays externally, their corners are rounded and they are separated from one another by insets of gray glass, which admit

daylight to the lounges and stairways that occupy these "interpodal spaces." The interpodal spaces between the long pods become skylighted corridors serving labs on either side. A butt-glazed window on one wall of the high-bay lab (opposite left) offers research engineers who use the corridor a chance to watch robots at work both for entertainment and as evidence of accomplishment. The dark quarry

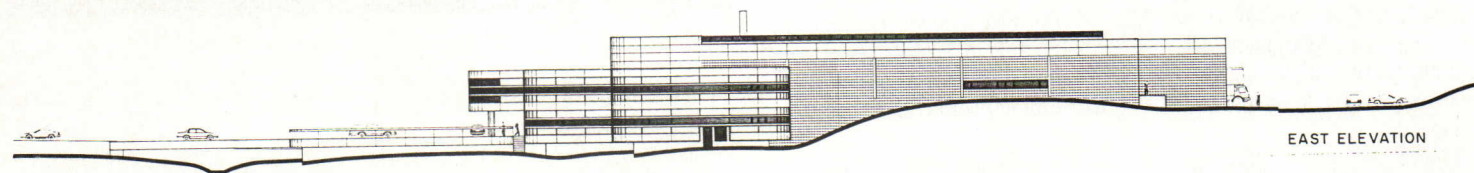
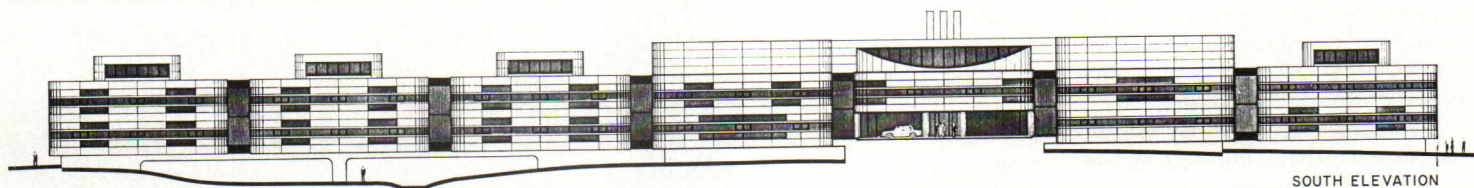
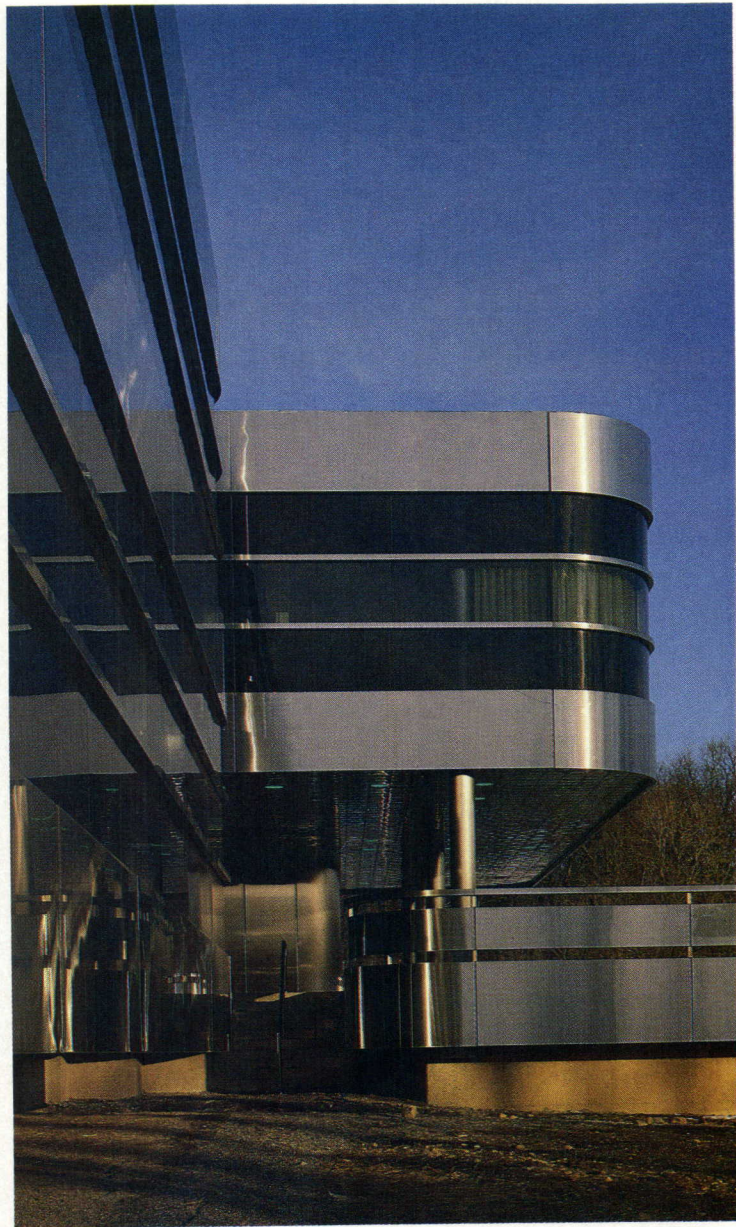



tile that lines the corridors echoes the tiled walls that enclose laboratory pods at the back of the building (east elevation). On the ceiling of the dining room, a highly burnished mechanical/electrical spine, punctuated with similarly burnished disks for sprinkler heads (below right), decorates the room with reflected foliage.

**Industrial Technology Institute**  
Ann Arbor, Michigan  
**Owner:**  
Industrial Technology Institute  
**Architects:**  
William Kessler and Associates—  
William Kessler, principal designer;  
Todd Young, designer; Donald  
Osgood, project architect; John  
Miliacca, Carolyn Cardoza,  
Kimberley Field, interior design

**Engineers:**  
Robert Darvas and Associates  
(structural); Hoyem-Basso  
Associates (mechanical/electrical)  
**Consultants:**  
Johnson, Johnson and Roy  
(landscape architects and civil  
engineers); Edward Colbert Systems  
(cost)  
**Construction manager:**  
O'Neal Construction, Inc.

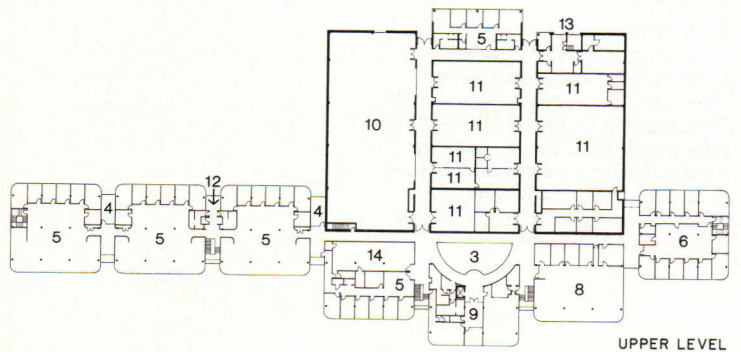
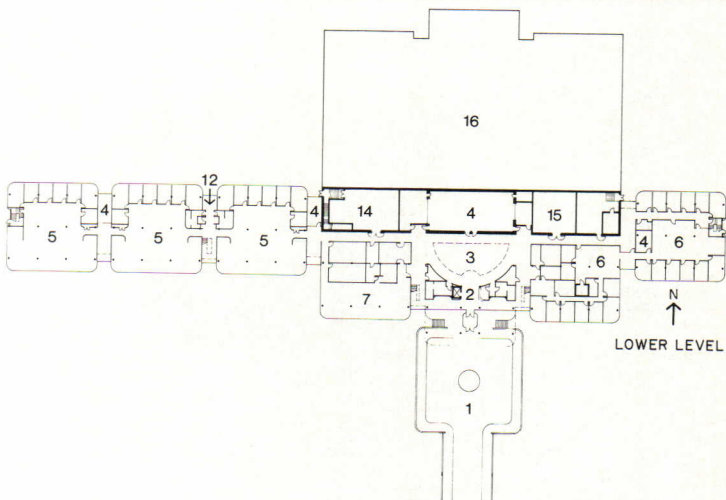

- |                     |                     |
|---------------------|---------------------|
| 1. Courtyard        | 9. Administration   |
| 2. Reception        | 10. High-bay lab    |
| 3. Atrium           | 11. Laboratories    |
| 4. Conference       | 12. Lounge          |
| 5. Research offices | 13. Shipping        |
| 6. Support offices  | 14. Computer center |
| 7. Dining           | 15. Storage         |
| 8. Library          | 16. Unexcavated     |



## On the Pacific Rim



*The research center, which sits on a hill overlooking the Sacramento River and San Pablo Bay, is faced with rusticated precast concrete. The front entrance (above and opposite below) leads to a two-story gallery, from which connections lead in turn to the administrative offices, the "link" building for lunchroom and library, and the laboratories.*

Unlike the other two research facilities discussed in this study, the Ortho Research Center is supported by a specific industrial corporation in its own profit-making behalf. Here, chemists look for ways to eliminate pestiferous weeds, fungi, and other agricultural undesirables (safely, of course), and biologists devise plants with such desirable traits as resistance to disease and controlled growth.

The first problem, almost an enigma, faced by architects Stone, Marraccini and Patterson was technical: the combination in one building of two scientific disciplines, their physical requirements for research at loggerheads. Chemistry labs are inevitably "dirty," requiring a great deal of carefully planned air supply and exhaust. Biology labs, on the other hand, are and must remain "clean"; though they need not be "clean rooms" in strict terms of laboratory design, they certainly cannot tolerate contamination by herbicidal chemicals. SMP avoided conflict by simply providing separate air-handling systems for the two halves of the laboratory building. All air comes into the research center through a very large array of louvers and fans at the back, where it is filtered and chilled; thereafter, however, the air is divided for separate delivery and exhaust. A generously proportioned 22-foot-wide central mechanical shaft accommodates separate plenums (see section on page 102). (The building was designed and built to the rather more stringent requirements of biotechnology, but the company dropped this line of research after construction was completed. The architects report that the laboratories' flexibility allowed retrofit for casework and equipment to be carried out in a matter of days.)

The new center reflects the increased respect granted by industry in the 1980s toward its technical personnel—a recognition that scientists and engineers are people and valued employees rather than only trained thinking machines. Each of Ortho's research scientists has a corner office, just like management. Offices are located around the periphery of the building, as they tend to be in conventional laboratory planning. At Ortho, however, they occupy quadripartite pods flanking complexly shaped niches (opposite). The four offices in each pod share an entrance foyer as well as an informal lounge in the widened corridor, spaces intended to multiply fortuitous meetings and exchanges of thought among the scientists. Moreover, windows in the labs' corridor walls transmit light and views from the glazed niches to the interior spaces. They also allow lab workers to glimpse passing colleagues in the hallway.

The 135,000-square foot complex, which includes administrative offices and a "link" building with library and lunchroom in addition to the laboratories, cost about \$36 million. *G. A.*

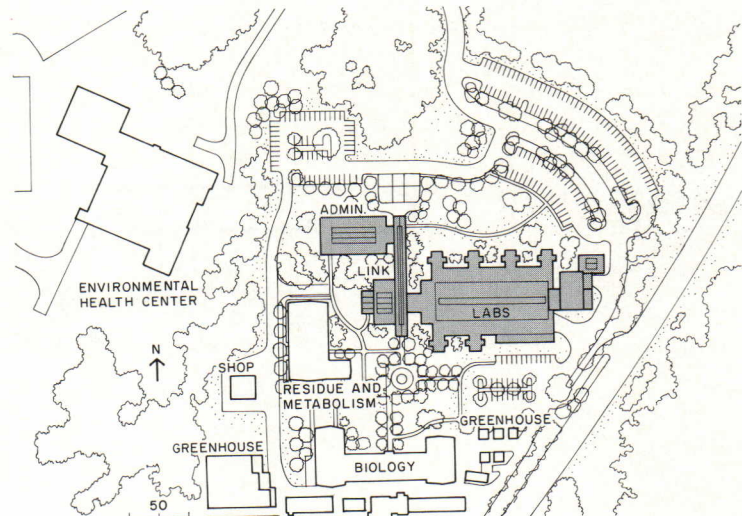



Ortho Research Center  
Richmond, California  
Stone, Marraccini and Patterson,  
Architects

*Gregory Murphey photos*





The two-story gallery (opposite top), under skylights and cross-ties of steel tubing, serves both office and laboratory workers, not only satisfying security needs but also fostering the collegial atmosphere the company sought for its scientists. The structure in the laboratory building differs considerably from the relatively light structure in the gallery and the other two buildings. To begin, a central mechanical shaft

22 feet wide accommodates separate plenums for biology and chemical labs, as well as electricity and plumbing. (In the opinion of project architect John Rollings, "If you don't get the service core right in the first place, you've got nothing.") The little "link" building (sections directly below) is lighted by multiple clerestories. The labs themselves have an unobstructed depth of 51 feet, supported by heavy steel girders

(section at bottom this page). A typical chemistry lab (opposite bottom) might, as here, be a double lab, occupying two 11-foot modules, each module equipped with fume hoods on one side, mechanical/electrical services overhead, and a door to the service corridor at the back. If the central bench and deluge shower were changed, the space could enclose two labs.

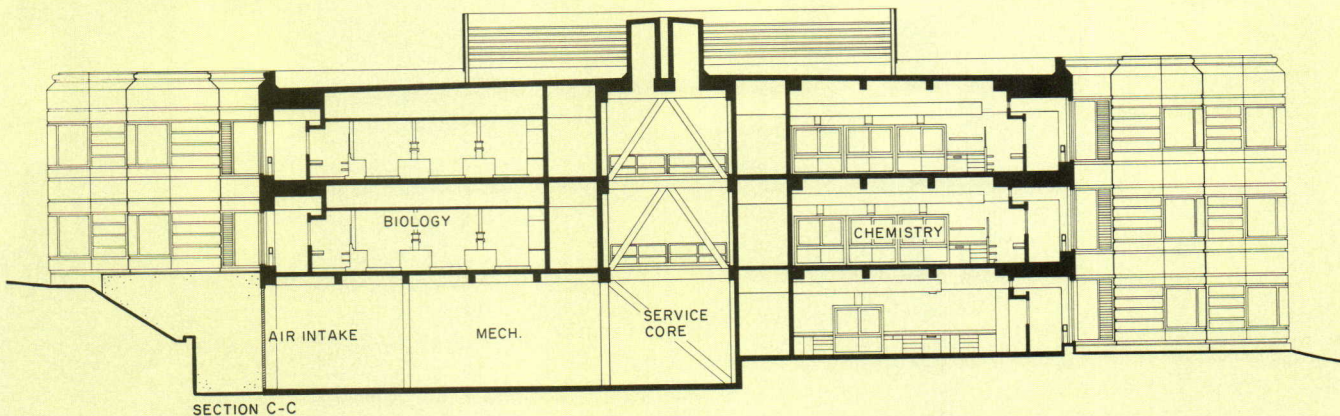
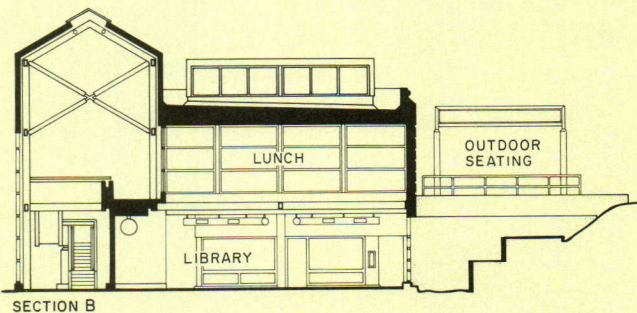
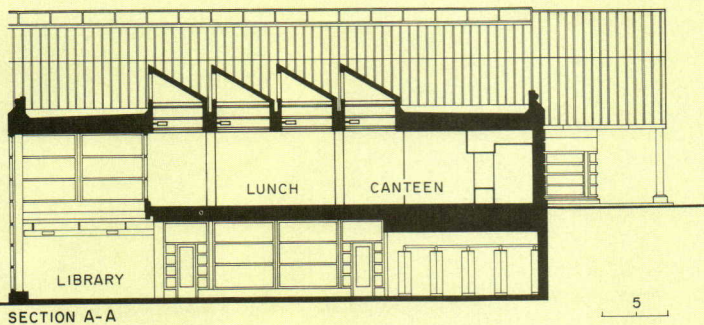



*Ortho Research Center  
Chevron Chemical Company  
Agricultural Research Center  
Richmond, California*

**Owner:**  
*Chevron Chemical Company—John Gorman, project manager*

**Architects:**  
*Stone, Marraccini and Patterson—  
Michael D. Kelly, principal-in-charge; John R. Rollings, project manager; William L. Diefenbach,*

*project designer; H. Gary Pope, project technical director; Russ Akre, Andre Bazire, Larry Bailey, Larry Bongort, Douglas W. Day, Anthony H. Groce, H. David Horn, Ken Jandura, Win Jolley, Harold T. Ono, Rick Thoman, Andrew Tu, project team*

**Engineers:**  
*Forell/Elsesser Engineers Inc. (structural); Gayner Engineers, Inc. (mechanical/electrical); George S.*

*Nolte and Associates (civil)*

**Consultants:**  
*Earl Walls Associates (laboratories); Anthony M. Guzzardo Associates (landscape)*

**Foundations and underground:**  
*Dinwiddie Construction*

**General contractor:**  
*Hensel Phelps Construction Company*

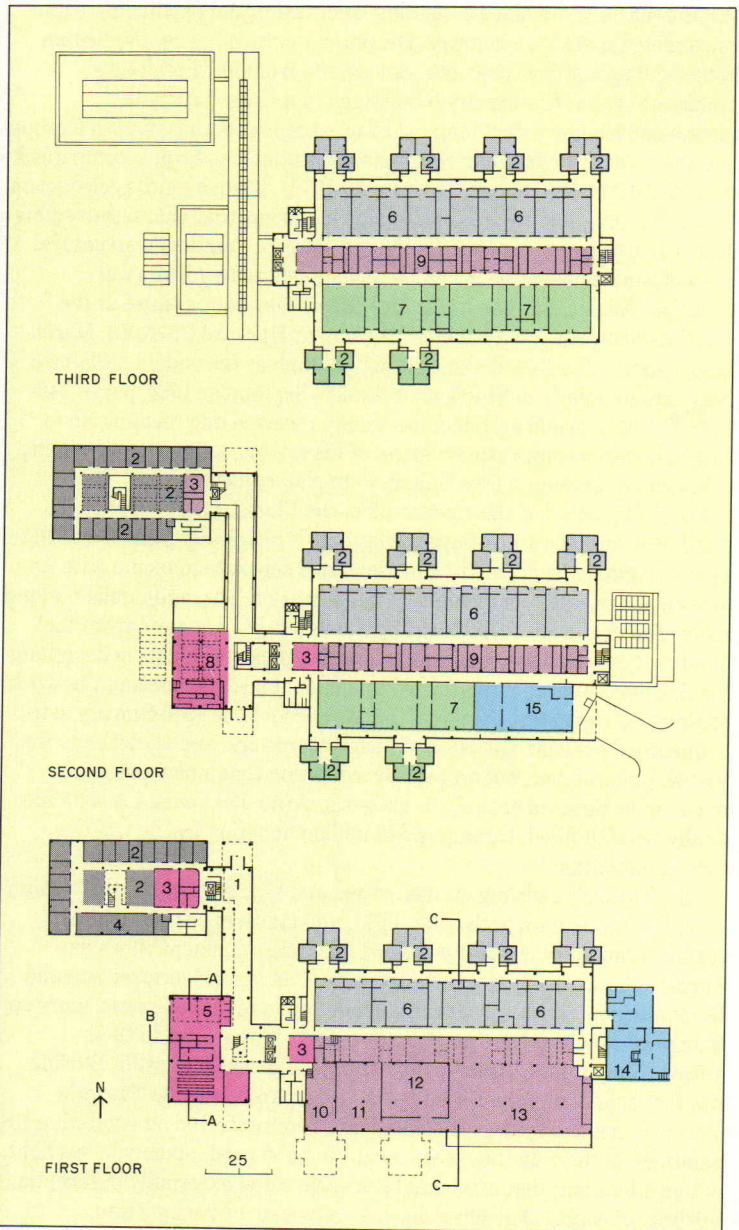

1. Lobby
2. Offices
3. Conference
4. Files
5. Library
6. Chemistry labs
7. Biology labs
8. Dining
9. Service core
10. Electrical
11. Chillers
12. Boiler
13. Fans
14. Chemical storage
15. General stores

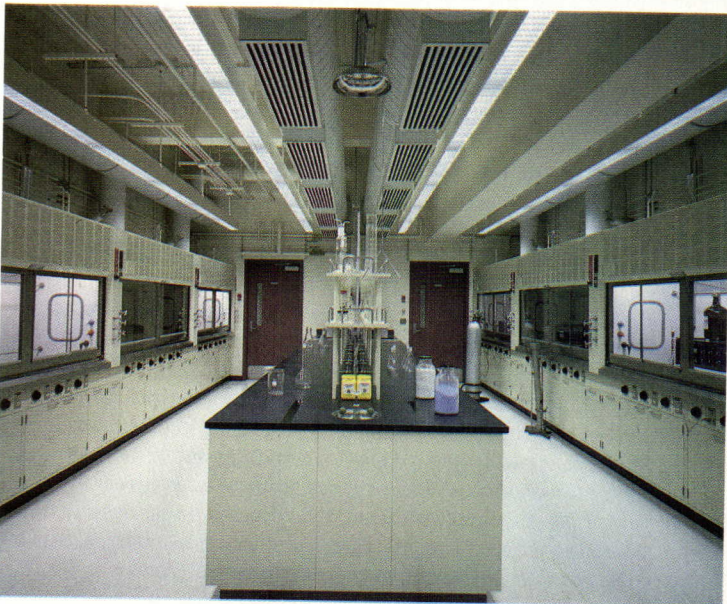



# The homecoming

It has been 10 years since a building designed by James Stirling was constructed in his own country. Despite his cultural exile, the British architect has matured over the past decade from an "architect's architect" with a few executed buildings to an internationally recognized master with a long list of prestigious commissions in Europe and the U. S. The change in Stirling's reputation has been accompanied by a stylistic evolution beginning in the 1970s, when a gentle eclecticism began creeping into the staunchly Modern forms that characterized his earlier housing and academic buildings. But the architect's structural rationalism has never been completely supplanted by historical pastiche. This duality has made for both uneasy compromise at the justifiably controversial Sackler Museum at Harvard (RECORD, March 1986, pages 112-123) and exhilarating triumph at the widely acclaimed Neue Staatsgalerie in Stuttgart (RECORD, September 1984, pages 140-149). The 61-year-old architect has finally received due recognition in England with a commission worthy of his talents, a five-phase building extension to London's Tate Gallery (site plan opposite).

The first portion of this master plan, the Clore Gallery, opened in April. It comprises an L-shaped wing that is physically attached to the Tate's original structure but functions as a separate museum with its own entrance, auditorium, library, conservation labs, and public reading room. The challenge facing Stirling, however, did not stem from the building type or site—he had just tackled similar problems in designing the Sackler—but from the formidable task of accommodating the work of England's greatest painter, J. M. W. Turner. The 19th-century artist bequeathed his vast collection of oils, watercolors, and sketches to the British government, but only on the condition that a new national museum be devoted entirely to his work. After 136 years, his wish has finally been fulfilled, through a \$10 million donation by the Charles Clore Foundation.

Like Turner's swirling studies of sea and sky, Stirling's latest design reveals a fascination with color, light, and landscape. The architect readily admits his sympathy toward the artist: "I like painters like Turner who worked during the transition between Neoclassicism and Romanticism . . . I think transitional periods are rather exotic, more so than periods which have settled down and become fixed in their output." As a representative of a transitional period himself, Stirling has foregone the temptation to settle down and enshrine Turner's oeuvre in neutral spaces. Instead, he has concentrated on exhibiting the paintings in the way they were meant to be viewed, namely in daylight, within a building that is internally assertive and externally deferential. Stirling, of course, has never been an advocate of background buildings, and the Clore is no exception. The public facade of the new addition takes significant cues from the Neoclassical architecture of the Tate and the Georgian "lodge" at the edge of the site—Stirling has extended the cornice line of the original gallery and repeated the materials of both buildings. But unlike the architect's extension to Rice University in Houston, which quietly reflects its campus neighbors, his references to adjacent structures at the Clore serve as a framework through which to express a distinctly separate personality. The huge Portland stone grid, infilled with stucco and brick, and the geometric openings and localized symmetry, which invert the Neoclassicism next door, convey a message of both unabashed modernity and restrained historicism—a stylistic ambiguity that characterizes Stirling at his best. On the east elevation facing the study library, conservation lab, and framing workshop, he abandons the grid for utilitarian yellow brick, strip windows, and a pair of large louvers. This spartan demeanor, which announces that this is the back of the building, is a not-so-subtle reminder that the architect hasn't lost touch with his 1960s roots.

"I think of the Clore as an orangery," declares Stirling, who strengthened the autonomy of his asymmetrical gallery by pushing it back from the frontal monumentality of the Tate into a shady garden setting. Approached along a winding path that leads from a gate at the

street (opposite bottom left) to a sunken forecourt with reflecting pool, the south elevation is enlivened by benches and a heavy timber pergola that will eventually be covered in vines. From this symmetrical facade, the entrance axis shifts diagonally across the forecourt to the side of the building, and the zigzag sequence of arrival continues inside the glazed, arched portal. As at the Sackler, the entrance lobby of the Clore dramatizes the procession to the galleries through a narrow, skylit staircase, and the articulation of the exterior—in this case, the grid—has been repeated on the interior wall. At the Clore, however, the stairs ascend in the opposite direction from the galleries, requiring the visitor to make a left turn at the landing to a low passage that retraces the staircase along a balcony, pass through a small foyer, and finally emerge into the main, high-ceilinged gallery. This Mannerist trick of anticipation transforms the small space of the entrance lobby into a theater of light, darkness, and movement.

The nine new galleries, each devoted to a different phase of Turner's career, are at the same level as the old Tate, affording a gracious, almost imperceptible transition. As at the Staatsgalerie and the Sackler, Stirling has designed the Clore as an interconnected series of discrete rooms with classically expressed doorways. More mannered than his previous interiors, the galleries include some whimsical touches—a tiny cylindrical chamber that encloses an oriel, for example—but, for the most part, they are weighed down by a heavy-handedness that overpowers Turner's art. In the rooms devoted to oil paintings, the framed canvases (and some, true to the artist's intention, unframed) are hung against beige fabric and illuminated by means of a sophisticated system of filtered skylights and computer-controlled louvers. Sunlight, however, is channeled obliquely around the sides of the ceilings, casting a gloom over the center of spaces which, ironically, exhibit the works of one of the greatest painters of light. Stirling has done his best to recall the toplit eccentricities of John Soane's galleries with sculpted vaults and a few cut-outs, but seems to have become unhappily enmeshed in the lighting technology now demanded by conservation-minded curators. The ceilings are elaborated with stepped profiles, similar to those that first appeared in the Sackler; combined with fluorescents, wall sconces, and moldings surrounding the picture plane, they busily distract the viewer's attention away from the pictures.

As usual, Stirling's choice of electric colors has sparked controversy. Acid-green metal windows and shocking-pink handrails are his recognizable signature, and without them, the Clore would lack the characteristic Stirling spice. Surprisingly, more alarm has been voiced over the inconspicuous finishes chosen for the main galleries. Critics argue that the beige fabric is not only unfaithful to the deep red that covered the walls of Turner's own studio, but sucks the life out of the paintings. Given the embellishment of the galleries, however, the decision to unify their diverse elements in neutral tones seems right. Several rooms that the curators insisted on painting "strawberry mousse," as Stirling calls the color, feel oppressive. The low volumes of the reserve galleries, for example, are exaggerated by white ceilings that step back from red walls, crowded with Turner's lesser works, to hover in the middle of the room like rain clouds about to burst.

Stirling's interest in reinterpreting history has deepened over the decade since his German projects of the late 1970s. But he has never played the game straight, preferring to invent his own rules for using the past. The results are never easy, sometimes shocking, usually eccentric, and always original. The Clore reflects this characteristic complexity with mixed results. On the exterior, a contraposition of classicism and abstraction ties a vibrant, contextual knot, achieving what the Sackler conspicuously lacks—an inviting public image and a richly embroidered entrance hall. But the new galleries reveal the darker side of his referential treatment in decoration that overshadows a well-ordered sequence of rooms. In quoting too many sources, Stirling runs the danger of losing his own voice. *Deborah K. Dietsch*



*The Clore Gallery reflects the complexity characteristic of a Stirling-designed building—with mixed results.*

The Clore Gallery  
The Tate Gallery  
London  
James Stirling Michael Wilford  
and Associates, Architects



Richard Bryant photos except as noted

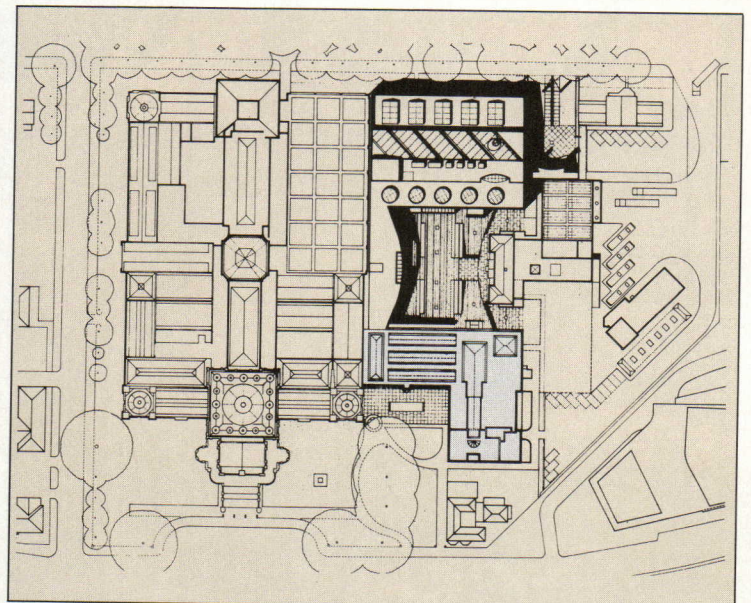





THE CLARE GALLERY  
OF THE  
TURNER COLLECTION  
DONATED BY  
HER MAJESTY THE QUEEN  
LONDON 1982





*Stirling has designed the Clore as an L-shaped transition between architect Sidney Smith's 1897 Tate Gallery and a former military hospital lodge at the southeastern edge of the site, which now belongs to the museum. On the Clore's main elevation (opposite), the Portland stone of the Tate is repeated by a stucco-filled grid and new parapet that extends the cornice line of the older building. An angled oriel punctuates the center of this facade, offering views of the Thames from inside the galleries. Relief for weary visitors is provided by benches placed between the "rustication" of a heavy timber pergola at the base of the south elevation flanking the reflecting pool in the forecourt. Around the corner, the Clore's west elevation (top left) rises to house curators' offices in an attic story and the grid is infilled with panels of brick that step up to match the lodge. "It's as monumental to go down into a building as it is to up," declares Stirling. As proof of his assertion, the Clore is entered by stepping down into a sunken terrace, across a forecourt, and through a huge pediment in the side of the building—a deferential approach that doesn't try to compete with the monumental staircase in front of the Tate. The carved pediment and small lunette surrounding the entrance are Neoclassical elements borrowed from the old museum that appear as sculptural, abstract forms, especially when viewed at an angle (bottom left). The acid green that outlines the metal window frames is, by now, Stirling's signature, but it is not, he firmly insists, his favorite color: "The plastic-coated sections of these German-manufactured windows come in a very limited color range and the green is simply one of the better available."*



*If the Clore's entrance hall looks vaguely familiar, it is because Stirling completed a similar section for Harvard's Sackler Museum before designing the London gallery. In both buildings, the primary means of circulation is a skylit staircase with two different handrails and walls that repeat the pattern of the exteriors. While the narrow staircase at the Sackler shoots straight up the building to the galleries, the open-sided staircase at the Clore leads away from the galleries to continue a winding procession that begins outside the building. To reach the Turner collections, visitors diagonally cross the granite floor of the lobby, climb the stairs, and, drawn by a brilliantly colored arched opening, retrace their steps along a low passage to a foyer behind the arch (right). Balconies on the first and second floors offer views down to the triangular window of the reading room, across to the spiral stair that leads to the reserve galleries (opposite), and through the gridded window surrounding the entrance.*

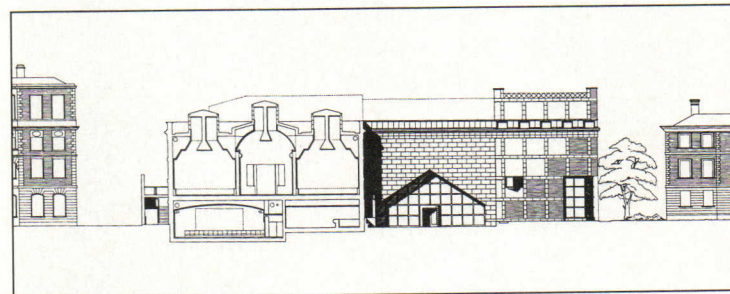
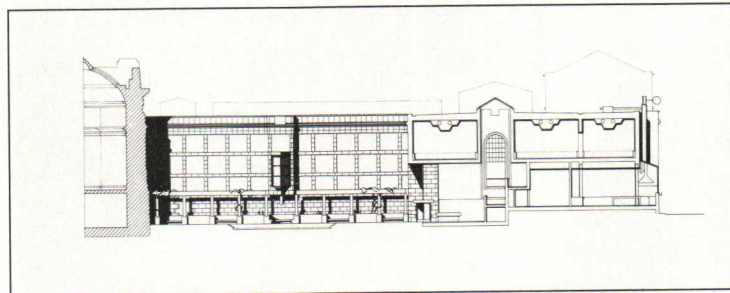











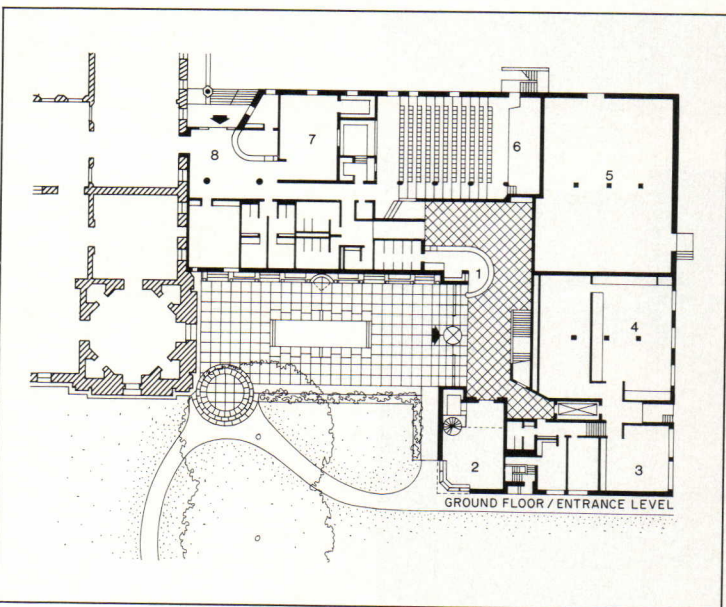
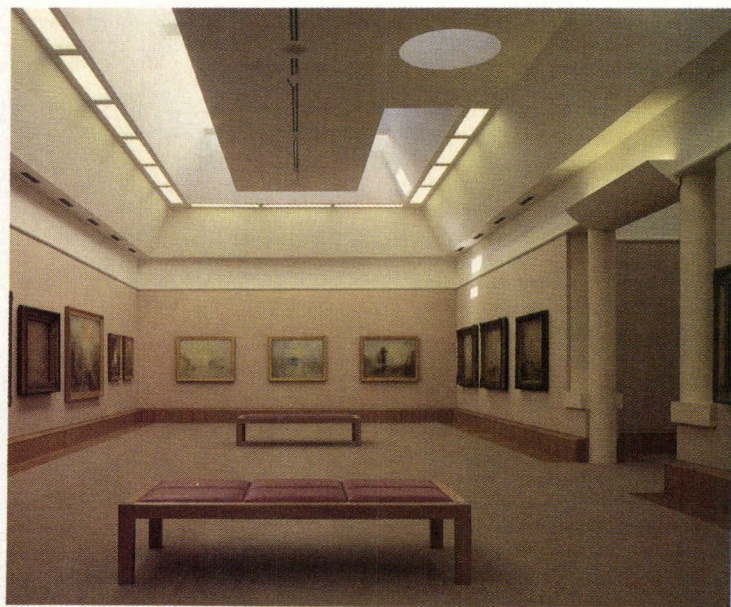
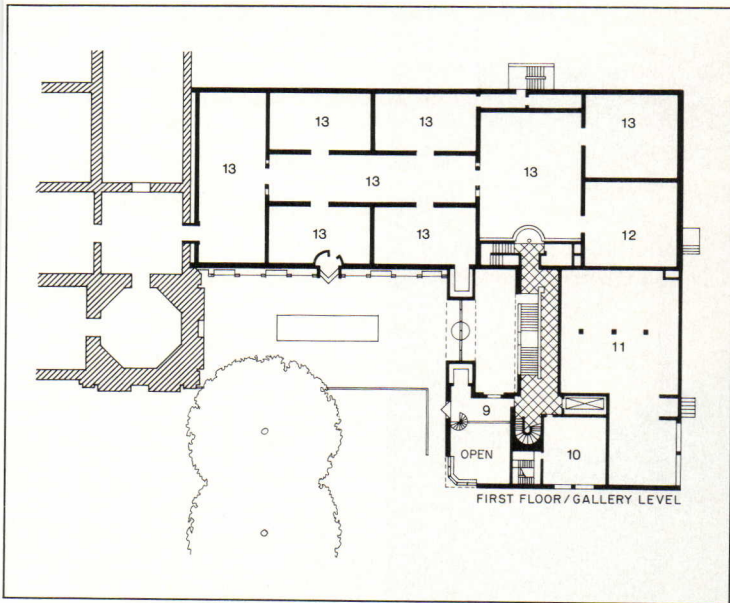

Alastair Hunter

1. Information/sales
2. Reading room
3. Framing and mounting workshop
4. Paper conservation studio
5. Mechanical services plant
6. Auditorium
7. Classroom
8. Schools' entrance
9. Reading room mezzanine
10. Storage
11. Study room
12. Watercolors and drawings
13. Oil paintings

The Clore's nine rooms that display Turner's paintings are located in the wing that adjoins the Tate (top plan), on the floor above the auditorium, classroom, conservation labs, and offices (bottom plan). The rooms are sequentially arranged so that, when entering from the Clore, a visitor proceeds to the largest first, then follows along a "spine" (opposite) to four smaller galleries, before finally arriving in a longer room (top) that is connected to the old Tate on the same level (top plan). In each space, the oil paintings are exhibited on fabric panels and illuminated by sunlight filtered around the sides of sculpted ceilings through louvered roof lights that adjust automatically to compensate for changing weather

conditions. Stirling has spotlighted the uniform natural illumination of these rooms with artificial lighting in uprights over the doors (opposite), wall sconces, and fluorescent fixtures in the ceilings (top). In the reserve galleries, Turner's lesser works are crowded onto red walls in the manner of his own studio, but are overshadowed by a low ceiling that steps down into the room (above).



*Stirling has enlivened the cultural purpose of the Clore with formal idiosyncracies that pop up throughout the building. In an ancillary gallery, he has enclosed the angled oriel window of the south elevation with a half-cylinder to give museum-goers a secluded place for seated reflection and exterior vistas (opposite). In the auditorium, he has pitched the ceiling, provided a strip-illuminated handrail, and custom-designed seating for comfortable views (top right). In the gallery devoted to Turner's watercolors (bottom right), the architect yielded to the curators' request for displaying the artist's sketchbooks in government-supplied cases and his paintings on dark walls—a deviation from the wooden benches, designed by Stirling's wife, Mary Shand, and light-colored finishes in the adjoining galleries.*



Alastair Hunter

*The Clore Gallery  
The Tate Gallery  
London*

**Architects:**  
*James Stirling Michael Wilford and Associates—James Stirling, Michael Wilford, principals; Russell Bevington, project architect; John Cairns, John Cannon, Robert Dye, Lester Haven, Toby Lewis, Walter Naegeli, Sheila O'Donnell, Richard Portchmouth, Stephen Wright, Philip Smithies, Peter Ray, project team*

**Engineers:**  
*Felix J. Samuely and Partners (structural); Steensen, Varming, Mulcahy Partnership (mechanical/electrical); John Taylor & Sons (public health)*

**Landscape architects:**  
*Building Design Partnership  
Landscape*

**Consultants:**  
*Property Services Agency and The Crown Suppliers (project management); Steensen, Varming, Mulcahy Partnership (lighting); The Walker Beak Mason Partnership (acoustics); Theatre Developments Ltd. (audio/visual); Herbert Spencer (graphics/signage); Mary Shand in association with Ronald Carter and Peter Miles (furniture design); Michael Harvey (letter design)*

**General contractor:**  
*Walter Lawrence and Son*

**Quantity surveyors:**  
*Davis, Belfield and Everest*







# In the public interest: Design guidelines

By Jonathan Barnett

The architectural harmony that is one of the attractions of central Paris is not an accident; it is the result of a series of closely related design guidelines imposed over more than two centuries. The facades of the first buildings along the Rue de Rivoli, designed by Charles Percier and Pierre Léonard Fontaine in 1801, were officially adopted in Napoleonic Paris as the design guideline for the entire street. Anyone who wished to build had to follow the facade design exactly. As a means of creating architectural continuity from building to building, this legislation has a wonderful directness and simplicity. It is unquestionably autocratic, however, and belonged to an era of relatively simple building types, when height was limited by the distance that people would willingly walk up stairs.

From 1784 onward, development of buildings in Paris had been controlled by legislation that related building height limits to street width, and imposed a setback angle for attics. Under Napoleon III, Baron Haussmann, who, among his other responsibilities, was what we would today call the urban-renewal administrator for Paris, condemned land on both sides of the new streets he was creating, and sold this property to developers subject not only to the height regulations but to controls that imposed a strict architectural vocabulary. At the end of the 19th century, there was a reaction against so much design orthodoxy and, with the elevator in general use, height limits and attic angles were raised. The buildings along the Rue de Rivoli now have a uniform cornice line but irregular roofs. In the 1960s heights were raised again, and there was a brief period of experimentation with taller buildings set back from the street line; but public sentiment soon led to amendments that reinforced the historic development patterns.

The planning of American cities has been heavily influenced by the example of Paris, at least since the City Beautiful Movement that followed the Chicago Fair of 1893. The renderings for Daniel Burnham and Edward Bennett's 1909 Plan for Chicago show great boulevards lined with buildings of uniform height in the Parisian manner, although the buildings were sometimes drawn as 11 or even 15 stories tall. But how could such uniform development be enforced without the dictatorial powers of a Napoleon III, and in a competitive, free-enterprise economy? The last chapter in the Chicago Plan document is the "Legal Aspects of the Plan of Chicago" by Walter L. Fisher, counsel for the Plan Committee of the Commercial Club, which sponsored the preparation of the Plan. Discussing the control of land adjacent to parks and boulevards, Fisher concluded that "The police power of the state is not available for merely esthetic purposes, and is quite inadequate to the solution of this special problem." The only alternative that Fisher saw was the power to condemn land fronting on new parks and boulevards, and resell it with restrictions, much as Baron Haussmann had done in Paris. Fisher believed that the legislature could give Chicago this power, and the power to borrow the large capital amounts required, but such action to control development of private property was never taken.

Only four years after Fisher's opinion was written, the City of New York established a commission to draw up zoning regulations based on the "police power" of the state to pass legislation required to promote public health, safety, and welfare. The resulting ordinance, adopted in 1916, imposed setback lines on buildings based on the widths of streets—justified not by esthetics, but as the means of preserving access to light and air for health reasons. The effect was to impose a uniform cornice line on streets such as upper Fifth and Park avenues that were largely redeveloped after 1916. Chicago had the plan and New York had the implementation mechanism; it has taken a long time

*Jonathan Barnett, F.A.I.A., A.I.C.P., is an urban-design consultant and director of the Graduate Program in Urban Design at the City College of New York. He is the author of Introduction to Urban Design and the recently published The Elusive City: Five Centuries of Design, Ambition and Miscalculation.*

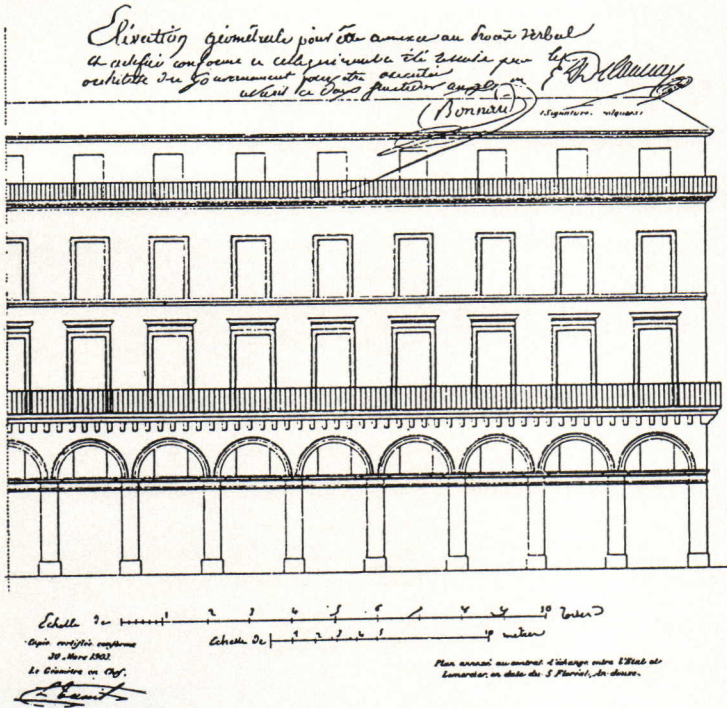

The design dating from 1801 by Charles Percier and Pierre Léonard Fontaine for buildings in the Rue de Rivoli in Paris was adopted by Napoleon as the required elevation for all facades on the street.



*Writing design guidelines means confronting basic architectural issues, such as defining the public's interest in architecture and describing the elements of a building that are essential to its design. Jonathan Barnett presents different approaches, from various regions, to these difficult and important questions.*

to put these elements together. Only in Washington, D. C., where Major L'Enfant's 1793 street plan is an earlier version of the design principles used to lay out Haussmann's boulevards, has a City Beautiful park and boulevard plan had any substantial relation to private investment. The plan was completed in 1901 under the direction of Daniel Burnham, Charles McKim, and Frederick Law Olmsted, Jr. Congress had the authority to enact height limits for the District of Columbia, and had set the maximum height for buildings on the widest streets at 130 feet in 1899. Although these height regulations have subsequently been modified in some locations, an overall ceiling has been maintained. The combination of height limits and demand for development has created uniform building masses in keeping with the concept of the 1901 plan.

Congress did not, however, set any esthetic controls for private development in Washington. Specific architectural controls in the United States have historically been enacted in smaller communities to promote a particular style such as "Colonial" or "Spanish Colonial," with the correctness of proposed buildings evaluated by design review boards. An early example is Santa Barbara, California, where the downtown was rebuilt in Spanish style after an earthquake in 1925, and an Architectural Review Board was set up to monitor the rebuilding process. Other enforcement mechanisms for stylistic uniformity have been deed restrictions in suburban subdivisions, and, more recently, condominium agreements in planned communities. Modern methods of writing design guidelines derive from all three traditional approaches to development control: zoning, deed restrictions, and design review.

Whether "police power" can be extended to include zoning regulations that are primarily "esthetic" in intention is still not a settled issue. Proponents of design regulation look to the precedent established by the Supreme Court in 1954 in the case of *Berman v. Parker*, which upheld an eminent-domain action taken for an "esthetic" purpose. Justice Douglas, writing for the Court majority, argued that "The concept of public welfare is broad and inclusive. The values it represents are spiritual as well as physical, esthetic as well as monetary. It is within the power of the legislature to determine that the community should be beautiful as well as healthy, spacious as well as clean, well balanced as well as carefully patrolled." In any event, whether zoning was intended to be an esthetic control or not, it has acted as one, as bulk and floor-area regulations often added up to an exact prescription of what could be built—leading to the question: if you get what you ask for, why can't you get what you want? Also, not understanding the esthetic implications of zoning when it was enacted does not relieve a legislature of responsibility for the result.

There is no question that a government, or a private owner, can place design restrictions on a property before it is sold; these requirements can then become part of the deed. Design review is a much cloudier area. A large amount of review is part of the more or less unacknowledged process that attends remapping to a different land use or a higher bulk category. Other design review is performed by planning commissions as part of planned development approvals, or site-plan review requirements. Then there are reviews by landmark or historic-district commissions, or by design review boards with a more general charter. The principle seems to be that the more clearly review criteria can be articulated in advance, the more effective a design review process can become. Writing such criteria, or design guidelines for zoning or development parcels, is still very much in an experimental stage. In a period when there is little consensus about what constitutes good design, reducing architectural concerns to any kind of rule system is exceptionally tricky. And, as rules cannot cover every aspect of a building, the guideline writer needs to decide which issues are most important—asking, in effect, what is the public interest in a building, and what are the essential elements of architecture that affect this interest? The following article describes some of the best current practice in drawing up design guidelines.

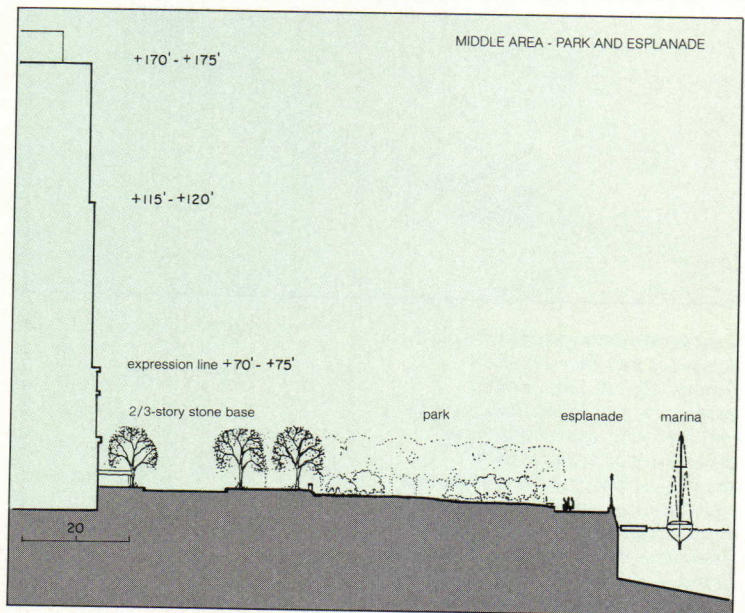
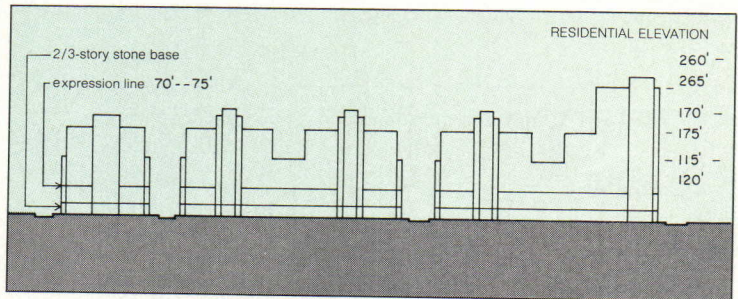
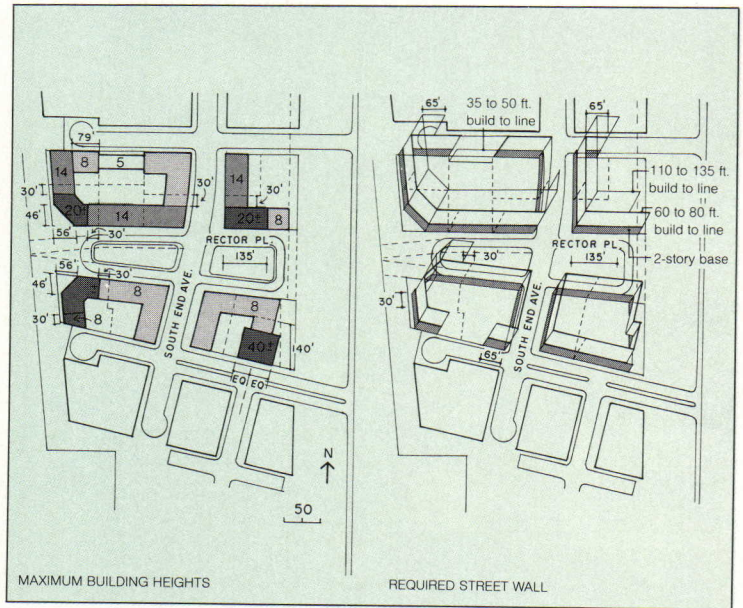

*The top two drawings are part of the design guidelines by Alexander Cooper and Stanton Eckstut for residential buildings at New York's Battery Park City. They define the location of building mass, show build-to lines that define streets, and require special treatment of lower floors. The same firm's guidelines for Hudson Center in Hoboken, New Jersey, go a step further to define building height and mass.*



# Guidelines for a large-scale urban development

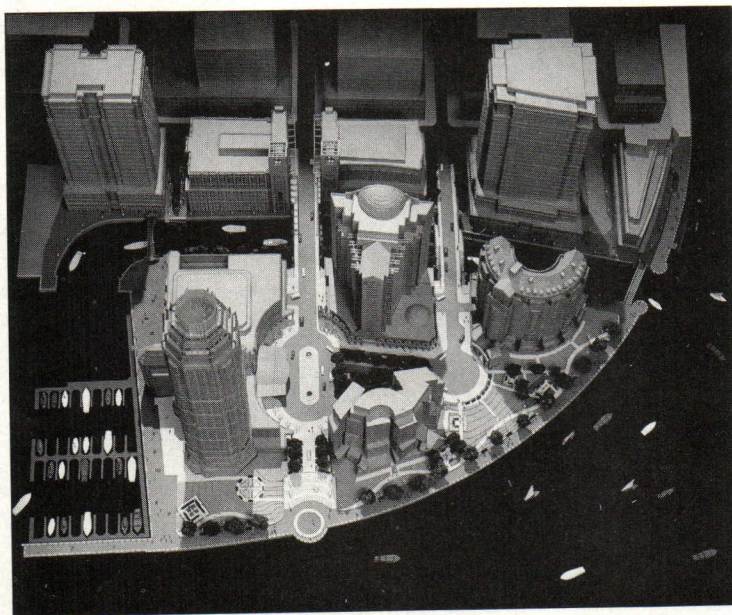

© Steve Rosenthal

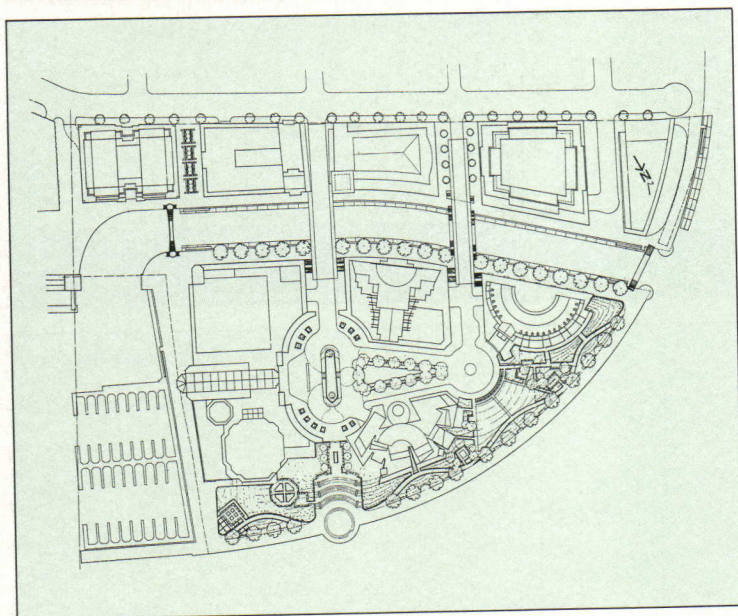

*A model photograph and site plan depict the Fan Pier project in Boston. The site plan, design guidelines, and the buildings in the lower left and upper right-hand corners are by Cesar Pelli & Associates. The architects of the two office buildings that frame the main entrance street are Koetter, Kim & Associates and Hammond Beeby and Babka. Frank O. Gehry & Associates designed the building front and center; the T-shaped apartment house is by Venturi, Rauch and Scott Brown, the curved building by Robert A. M. Stern Architects.*

Downtown development in many cities is taking place on big sites that were formerly railway yards, piers and waterfront loading areas, or warehouse and factory districts. These land parcels, often under one ownership, are larger than many downtown urban-renewal districts put together with federal subsidies a generation ago. Cities also continue to assemble urban-renewal districts, although developers are now usually expected to take over the land without a subsidy. The challenge in these new developments, each likely to be completed by many different developers and architects over a long span of years, is to avoid the severe "parcelitis" to which most earlier urban-renewal projects succumbed. Whatever coherence the original design drawing or model may have possessed would be lost when individual parcels were purchased by separate developers and assigned to different architects.

Many devices now used to set design controls for large developments were codified in New York City special zoning districts during the late 1960s and early '70s. They include the build-to line, which is the opposite of the setback line and is useful in requiring that buildings define spaces or view corridors and maintain continuity along streets; build-to planes, where a percentage of a plane must be filled out by building structure; setback lines and planes; mandated circulation routes, including arcades and pedestrian bridges; special use-groups that, for example, exclude banks and ticket agencies from retail frontages; and requirements for interior and outdoor public open spaces.

What Alexander Cooper and Stanton Eckstut added at Battery Park City to the kind of design provisions found in New York's special zoning district were massing and facade controls for individual buildings. As the land-fill site was essentially like an urban-renewal project, most of the public open space was developed by the Battery Park City Authority, rather than incrementally by individual developers, with costs assigned to the sales price of the parcels (see RECORD, March 1987, pages 112-127.) The design controls shown on this and the facing page have in turn been influenced by Battery Park City. They are the guidelines for the Fan Pier project in Boston, written by the master-planners for the site, Cesar Pelli and Associates. The guidelines have actually been adopted by the developer as part of a complex negotiation with the Boston Redevelopment Authority, but the circumstances in which the guidelines were written are not as interesting as the immediate test they have received from the architects for the individual buildings: Hammond Beeby and Babka; Frank O. Gehry & Associates; Koetter, Kim & Associates; Robert A. M. Stern Architects; Venturi, Rauch and Scott Brown; as well as Cesar Pelli Associates itself.

As at Battery Park City, much of the public environment will be built by the overall development and is not assigned to individual parcels. The design controls thus take the form of simple envelopes with a required base structure that must hold the building line, and then a permitted building envelope projected up to a height limit. Some typecasting is visible in the assignment of architects to different areas of the plan. Gehry has been given a waterfront site where a relatively active, articulated design would have little effect on other buildings. Hammond Beeby and Babka and Koetter, Kim have been given buildings on the inboard side of the canal that is to run through the property, sites where the buildings have to be a background or frame for other development. Stern and Venturi, Rauch and Scott Brown have each been given a difficult transitional site between the canal and the waterfront. Both of these sites have building envelopes too large to be filled out by residential structures, although it would be easy to design an office tower that would use the entire permitted mass. Stern has fulfilled the requirements brilliantly by designing a semicircular form that creates the desired impression of bulk while still being thin enough to provide efficient apartments. Venturi's original T-shaped building, which did not fill out the envelope above the ground floor, has now been recast as an H shape, which does a better job of holding the building lines (and is now shorter, in deference to changes made by the B. R. A.).



The guidelines for residential buildings in the Fan Pier permit office or residential uses interchangeably and thus set up envelopes deeper than those required for apartment towers. It is not unusual for developers to wish to be able to switch from residential to office use, but guidelines that allow both are a challenge to architects. In this case, each architect responded in a different way.

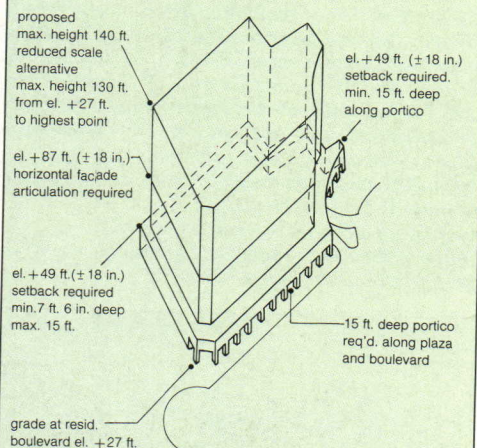
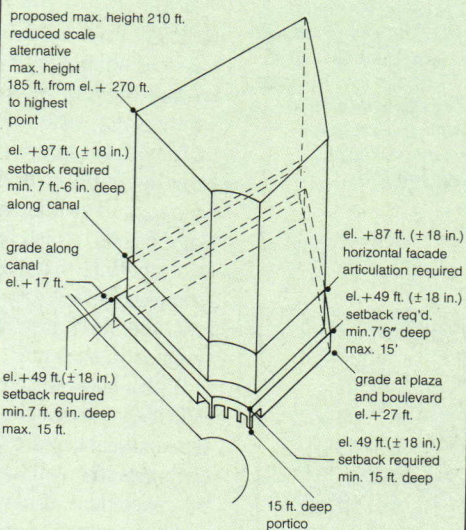
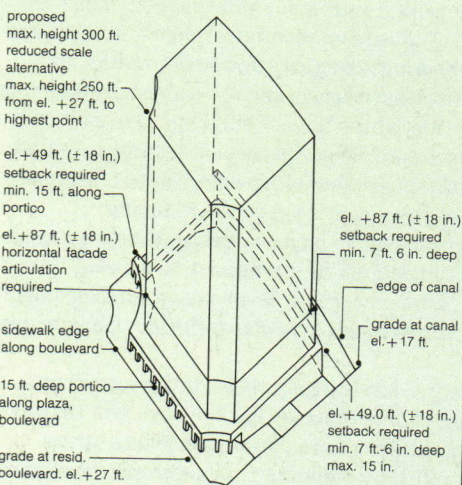
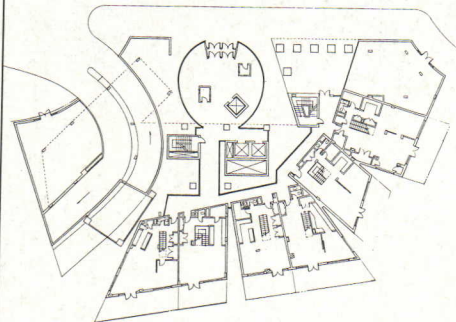
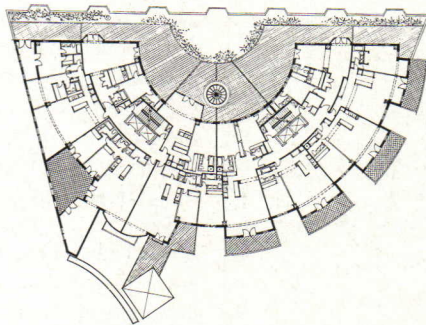
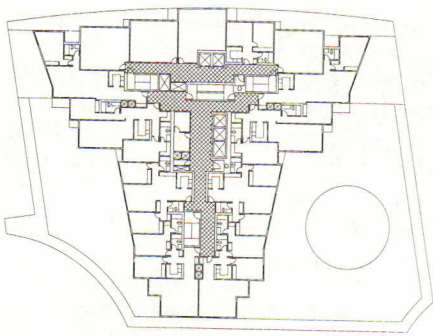
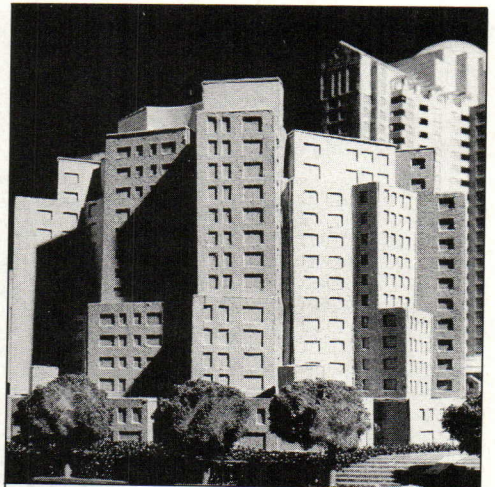

PARCEL F

PARCEL G

PARCEL H

For parcel F, Venturi, Rauch and Scott Brown proposed a T-shaped tower above a health club that held the required street lines on the first floor. This design has now been replaced with a lower, H-shaped building that more completely fills the guideline envelope. The T, while it broke the rules, set up interesting relationships with adjacent buildings and spaces.

On parcel G, Robert A. M. Stern Architects curved the building to give it sufficient bulk to achieve the objective of the guideline envelope.

Frank Gehry's design for parcel H has a similar intention to Stern's design for parcel G. By fragmenting the building and sliding elements forward, the building more completely fills the guideline envelope.



## Interventions in existing cities and suburbs

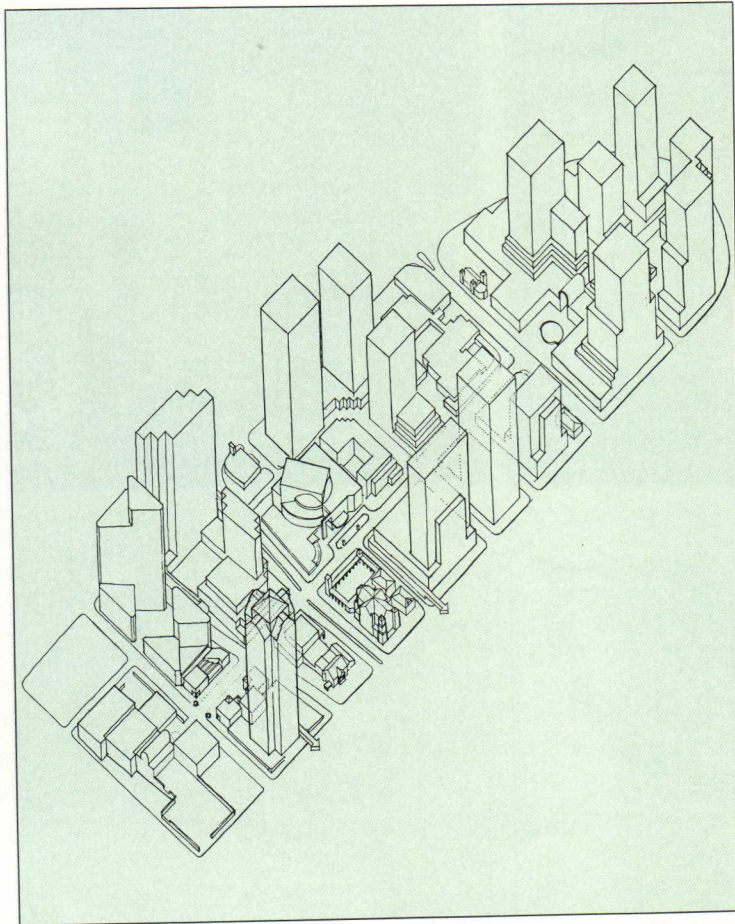

*An axonometric of the Dallas Arts District (above) illustrates how the plan is organized around Flora Street east of the Dallas Museum of Art. The towers shown are either as planned by the developers or for illustration only. Design guidelines by Sasaki Associates (below) do not attempt to control the mass of individual buildings except as they relate to the street. There is a 50-foot height limit at the Flora Street*

*building line and a 100-foot height limit 50 feet behind the property line. Guidelines encourage small retail uses along the Flora Street frontage that will relate to the landscaped street improvements. A retail program for the district was prepared by Halcyon Ltd.*

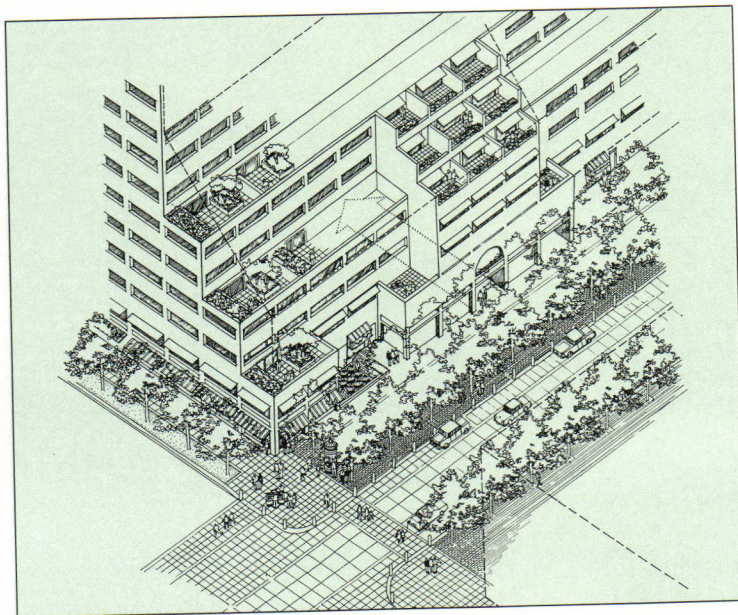

It is far more difficult to set design controls for individual buildings in the midst of downtowns with strong real-estate markets, or for projects in suburbs with little remaining vacant land, than to control the design of parcels in a comprehensive new development such as Battery Park City or the Boston Fan Pier.

San Francisco, Dallas, Pittsburgh, and Irvington (in suburban Westchester County, north of New York City), each in a different way, have tried to write design guidelines that accept uncertainties about what land will be developed next, how much land and existing buildings will be involved, and what developers will wish to construct.

San Francisco has been a leader in controlling growth of its downtown business center, first through urban renewal and zoning bonuses, and then, when development was unexpectedly successful, through a series of ever more restrictive zoning changes—pushed along by elections where height limits and other development restrictions, placed on the ballot by voter initiatives, received powerful public support.

The most recent San Francisco downtown plan was adopted late in 1984. The powerful system of controls in this plan, working within a strong real-estate market, has brought San Francisco closer than any other major American city to designing its future growth. The plan shifts the focus of downtown development to relieve pressure on areas of the financial district considered to be overbuilt. Two hundred fifty-one architecturally significant buildings are designated for preservation, but the unused development rights on these sites may be transferred to designated receiving areas.

The plan also reduces allowable floor areas and height limits in several downtown districts, while creating new high-density development areas to the south and west. The plan also requires developments to pay \$5 a square foot towards housing improvements related to downtown, \$5 a square foot towards transit, \$2 a square foot for downtown parks, and \$1 for child-care provisions.

Within this larger framework, controls for individual buildings are written to reduce the area of towers on their upper floors, to relate the bases of buildings to neighboring structures and street widths, to require the provision of public open space, and to establish sunlight and wind-velocity criteria to be met at the base of buildings. An additional overlay to these urban-design provisions has been a separate absolute growth limitation of 475,000 square feet of new downtown office space each year. The allocation of this space is left to the Planning Commission, which has been using an advisory design-review process that amounts to a design competition for permission to develop. San Francisco has clearly put more power into development guidance than any other U. S. city; whether so much control is politically manageable remains to be seen.

Dallas has—until recently—had a strong real-estate market but a relatively permissive set of zoning controls. For the new Arts District in the northeast quadrant of the downtown, design guidelines stress elements that can be controlled by public and philanthropic investment: the placement of new cultural institutions and the design of the street and public open spaces, with guidelines only for the portions of privately constructed buildings most accessible to the public.

One of the purposes of the Arts District is to direct the expansion of the downtown office center, if it can do so by creating a desirable alternative. The key to the plan is the aptly named Flora Street, which bisects the district, and becomes a landscaped mall with special festive lighting connecting the Museum of Art to the concert hall, and ultimately serving as the main street for the whole area. The major urban-design guideline is a setback section for the lower floors of buildings facing Flora Street, which are meant for retail uses such as cafés that can take advantage of their location on a landscaped street. Because the Dallas ordinance permits buildings far larger than anyone is expected to build, no attempt is made to control the placement of



*These maps are part of the public open-space guidelines for the Village of Irvington, New York, by Jonathan Barnett, Steven Kent Peterson & Associates, with Manuel S. Emanuel Associates. People move to such suburbs for the wooded hills and streams, but as the Village comes close to build-out in accordance with zoning, much of the natural environment would disappear. Guidelines conserve significant*

*remaining environmental elements, and shape them into a framework for future development. Implementation mechanisms combine resource-protection overlays to zoning, public land acquisition, and conservation guidelines for individual sites.*

future buildings except by illustrations in the plan. The public sector establishes a context for private investment but has relatively little control over individual investors.

The City of Pittsburgh has instituted a system of reviewing all new development in accordance with design guidelines issued as a direct response to proposals to develop. General criteria for evaluation of individual projects are spelled out in the zoning, but site-specific requirements are left until it is clear what the scope of proposed development will be. Pittsburgh has long had a site-plan-review provision in its zoning ordinance, but the review powers were being interpreted narrowly to deal only with site-planning issues such as curb cuts and the placement of required open space.

The zoning was amended to provide for Project-Development-Plan Review, a phrase that makes it clear that the full three-dimensional design of the building will be under consideration. Issues to be considered during Project-Development-Plan Review, from the composition of the building on the skyline to the size of truck-docks, are listed in the zoning, but developers are supposed to notify the Planning Commission staff of their intention to bring a proposal for review. If the developer does notify the staff, a written list of criteria relating to the specific site is issued and becomes the basis for the review. There is then a commitment not to bring up new issues at a later date. A developer who skips preliminary discussions with the Planning Commission staff could find the review process dealing with unexpected questions, and risks having to make major changes in a project (see "Designing Downtown Pittsburgh," RECORD, January 1982, pages 90-107).

Irvington's design guidelines seek to preserve sensitive aspects of the natural environment and also the village's traditional scenic character, using a zoning system that permits different intensities of development within the same zoning district, depending on the carrying capacity of the land and the requirements of the master plan. The project-development-plan review criteria are maps adopted as part of the Master Plan for the Village. These maps include a recreation plan, a public open-space plan, a map of protected scenic, environmental, and historical resources, a street plan, and a land-use policy plan.

The Planning Board, under zoning and subdivision regulations, must see that projects reviewed conform to these maps. For example, if a portion of the site has been identified on the map as a recreation area, that area should be deeded to the Village as part of the development. If the recreation area is more than 10 percent of the development's land area, the Village would pay for the additional land.

In addition, the Irvington guidelines include resource-protection factors based on the ordinance developed for Lake County, Illinois, by Lane Kendig and his associates in the county planning department. Environmentally sensitive portions of the site are subtracted for zoning calculation purposes by multiplying the area of sensitive land by a protection ratio. Land in the Irvington reservoir watershed, or wetlands, for example, has a protection ratio of 1, meaning none of this land can be counted for zoning purposes. Land sloping at an angle of more than 15 percent but less than 25 percent has a protection ratio of 0.50, meaning half of such land can be used for zoning calculations. For land at slopes of more than 25 percent, the protection ratio goes to 0.75. The result of this system is that two pieces of land in the same overall zoning district might have different permitted densities, based on the carrying capacity of the land itself.

While there is no such thing as a self-enforcing design guideline, any design guidance written for intervention in an already developed area—even San Francisco—requires skillful administration to be successful. Assessing what constitutes compliance is often a matter of judgment, and knowing when to insist and when to give ground means balancing design requirements of the district against valid design imperatives of the individual building.

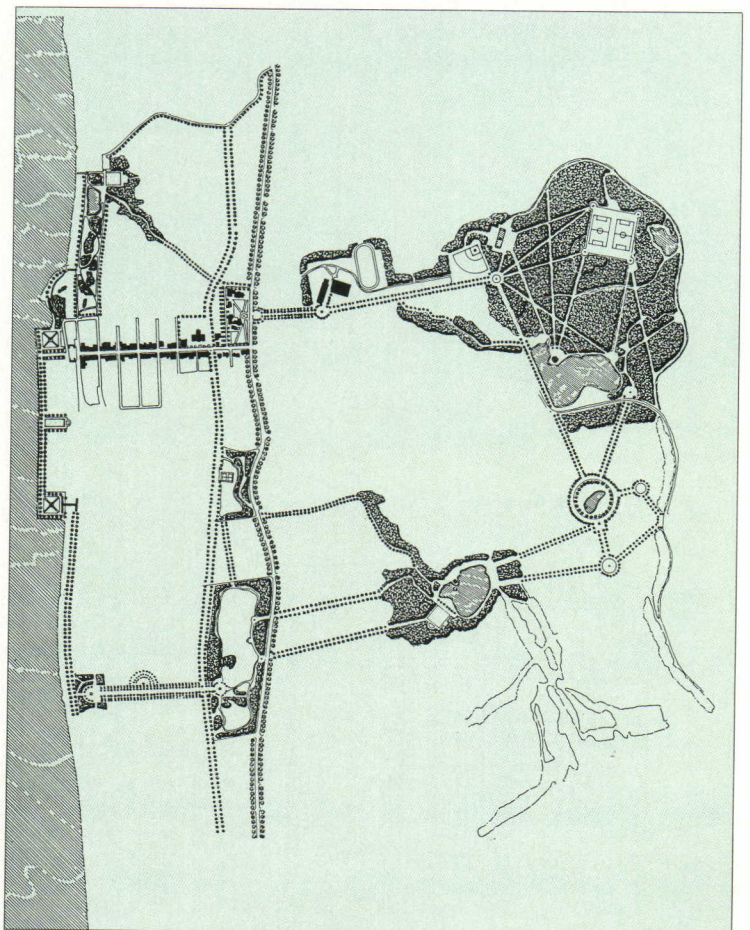
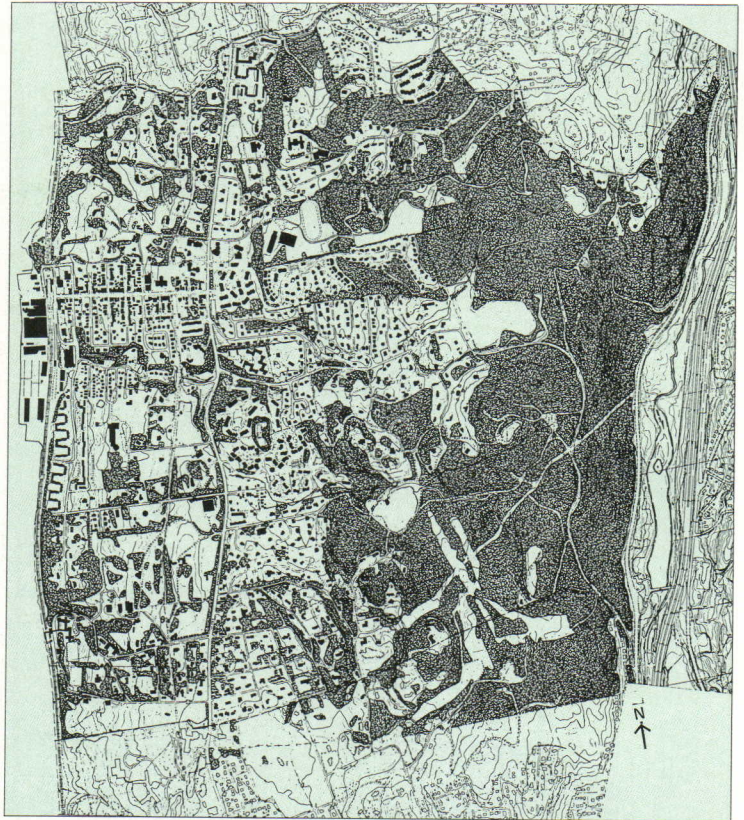

*The map shows existing development, open space, and woodlands (top). The proposed public open-space plan is below.*



# Facade guidelines

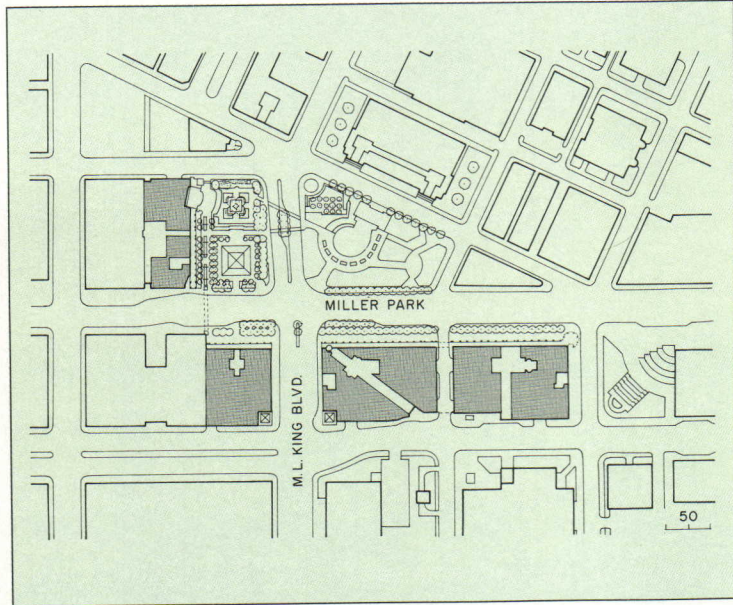

Trying to unify the facades of a group of buildings that has not yet been designed, and for which there may not even be a client, is a difficult task. Neither the Napoleonic solution for the Rue de Rivoli—use this facade or else—nor Baron Haussmann's control system are likely to be available. Even if this kind of power were in the hands of urban designers, there is no modern equivalent to the uniformity of building type and height taken for granted by Napoleon or Baron Haussmann. Nor is there the relative consensus about what constitutes correct architectural expression that was the hidden ingredient in 19th-century Parisian design guidelines.

When Koetter, Kim & Associates prepared facade controls as part of its urban design plan for Miller Park district in downtown Chattanooga, the firm decided to test the guidelines by inviting four architectural firms: Skidmore, Owings & Merrill; Peterson/Littenberg; Tuck, Hinton, Everton; and Robert Seals to participate in a charette in which each firm would design a facade in accordance with the proposed rule system.

The plan requires a uniform 24-foot setback from the property line on Market Street and a uniform open loggia on the Market Street side. There is also a requirement for a tower with a 36-foot diameter at the southern end of the building group, and twin square towers flanking the entrance to Miller Park from the east. While these are plan requirements, the towers are clearly intended to make sure that the facades are inflected at key locations.

Facades along Miller Park are limited to eight floors. The two-story loggia must be 25-feet high, plus or minus two feet. There is a required stringcourse between the third and fourth floors which tends to make the entire third floor read as a band. A setback is required at the sixth floor, and again at the seventh.

At the northern portion of the plan, on both sides of Martin Luther King Boulevard as it enters the square, the permitted height of the buildings, after a setback, goes up to 12 floors. The charette did not deal with this change of height from eight to 12 floors, and thus missed testing one of the most significant aspects of the design guidelines.

Within the horizontal framework created by the loggias, setbacks, and height limits, Koetter, Kim tried to catalog acceptable variations in proportions of column spacing for the loggias, window openings, screening materials, and so on, for all bay spacings from 15 to 20 feet between center lines of columns. A sample is shown at left.

The view of Koetter, Kim's own design, shown at the top of the facing page, is taken from the west along Martin Luther King Boulevard with Miller Park in the background. This is the area where 12 stories would be permitted. The facades facing Miller Park, shown in the studies by Skidmore, Owings & Merrill and Peterson/Littenberg, are limited to eight floors. The guidelines up to the eighth floor define a facade that is analogous to the traditional architecture along Parisian Boulevards: arcade or loggia below, cornice and attic above. The intention behind the guidelines, explored also in Koetter, Kim's guidelines for the University Park development in Cambridge, Massachusetts, is to establish a relationship between building and street that is analogous to the way urban space was defined before the elevator came into use. Taller buildings can then be set into this framework. The six-story pavilions facing New York's Fifth Avenue at Rockefeller Center have a similar intent: they define a context for the RCA and Associated Press buildings, each of which is set back from the street on an axis framed by pairs of pavilions.

The difficulty in Chattanooga is that the facade guidelines assume that buildings will conform exactly to pre-set heights and building mass. But what if the owner of one block wished to build a much taller tower; would the city stop the tower from being built? What if the owner of another block wished to build less than six stories? These guidelines do show, however, that it is possible to have diversity of form and expression within a single regulatory framework.

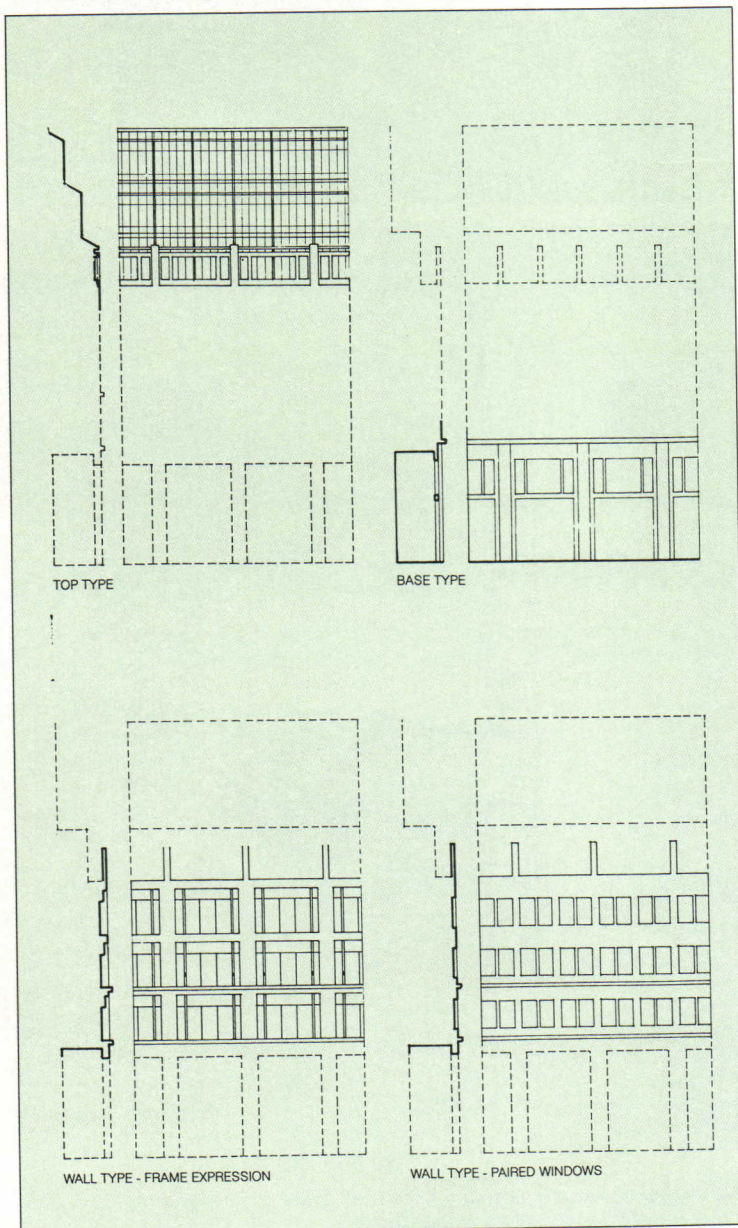



The site plan for the Miller Park District in Chattanooga (opposite) is part of a plan by Koetter, Kim & Associates and The Urban Design Consultancy. Also shown is a sample of the facade guidelines, which catalog acceptable treatments of windows, building tops, and the required loggia at different bay spacings.

Facade studies in accordance with the guidelines appear below. The top drawing, by Koetter, Kim and Associates, shows buildings defining the entrance to the Miller Park district along Martin Luther King Boulevard (Miller Park can be seen in the background). The middle drawing is a study of facades fronting Miller Park done in a charette by a team from Skidmore, Owings & Merrill under the

direction of David Childs. Note that the setback occurs above the loggia rather than at the sixth floor, as shown in the guidelines. Generally in envelope guidelines it is acceptable to build less, unless there is a build-to requirement. The model photo at the bottom of the page is of a

study by Peterson/Littenberg Architects done for the same charette also showing facades facing Miller Park in accordance with the guidelines.

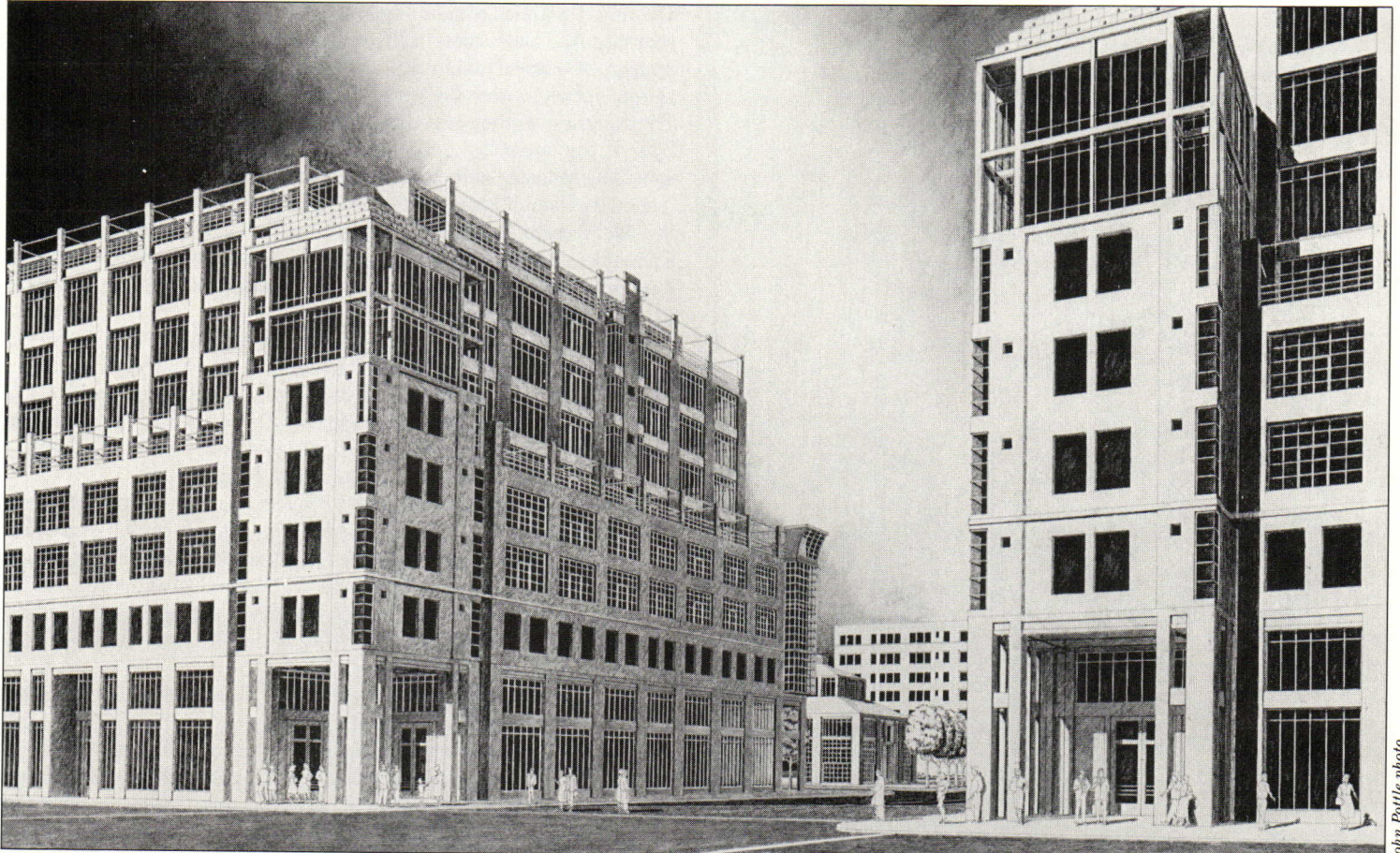

John Pottle photo

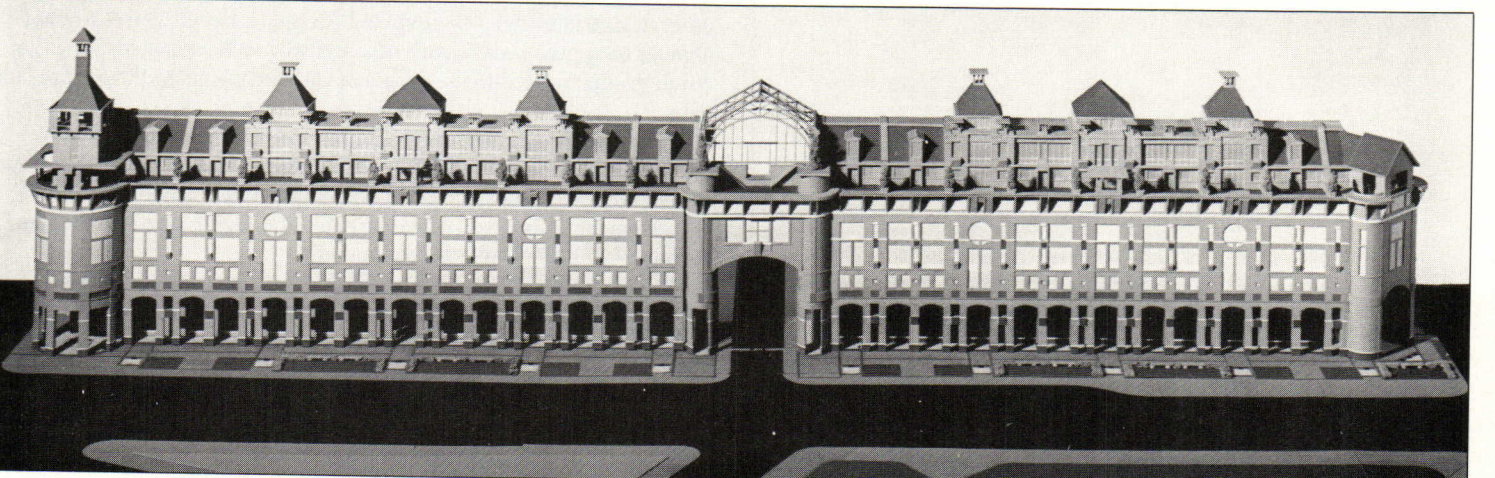
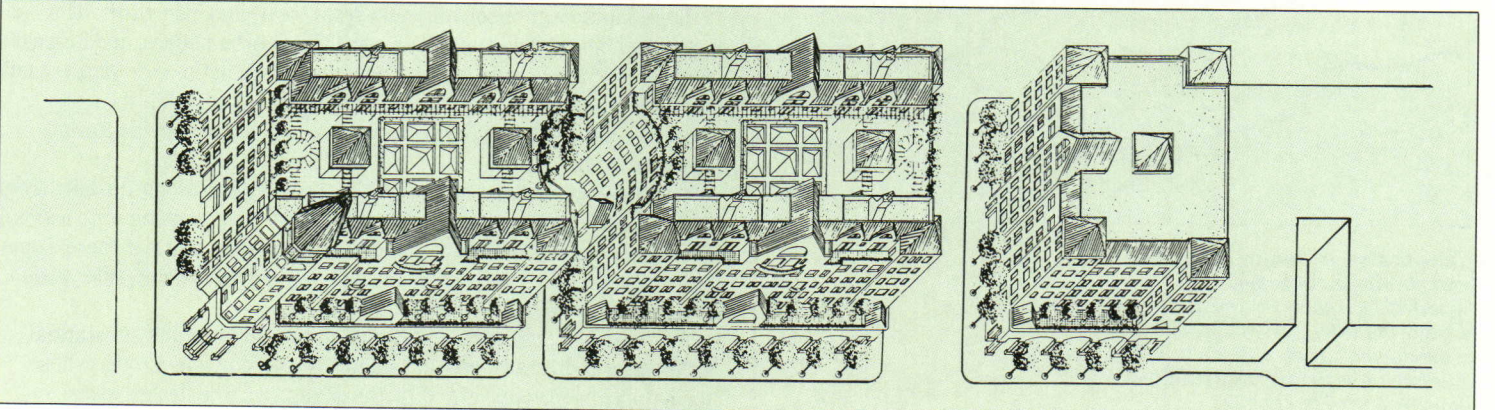



# Guidelines for a large-scale suburban development

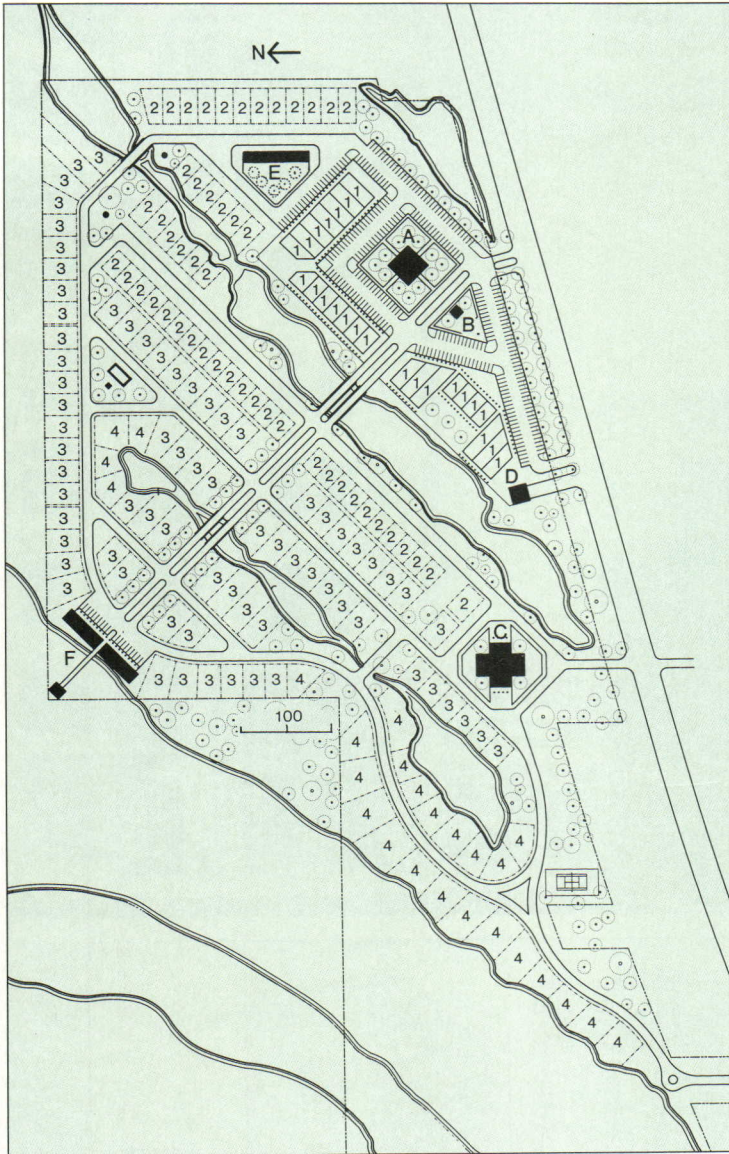

*The site plan of Tannin, a planned community in Alabama, was designed by Andres Duany and Elizabeth Plater-Zyberk. Each lot has a development code, either 1, 2, 3, or 4, which indicates the only building type permitted on that lot.*

Tannin is a planned community in southern Alabama named for the characteristic black lakes of the region, which are created by the seepage of natural tannin into the water table. Black lakes have a special beauty, with reflections of unusual intensity and brightness. The designers of the community, Andres Duany and Elizabeth Plater-Zyberk, convinced the owners that the black lakes were an asset that should be reflected in the community's name.

A refinement of ideas the designers had originally developed for Seaside, Florida, the guidelines derive with elegant simplicity from elements to be found in any subdivision: streets, lots, setback and yard requirements, plus the fact that most developers offer buyers a choice among a range of models.

Many of the key design decisions for Tannin were made in the street plan, which is always true in a subdivision, but at Tannin the street configuration is more clearly part of an overall design concept. The site lies between a lake and a highway lined with commercial developments. Tannin's own strip shopping center is treated as a town square, with storefronts grouped around a green and a meeting hall.

The main boulevard leads from the town center to a hotel and marina at the edge of the lake. The streets on either side of the Boulevard are planned to create distinct precincts, each with either a public building or a body of water as its own focal point. Individual lots are coded 1, 2, 3, or 4, and each lot has its own house type, which can be built on that size lot and no other. Each type of lot comes with obligations for tree-planting and landscaping along the street.

Type-1 lots occur only in the town center. The Type-1 building is likely to be constructed in increments of more than one lot, but conceptually is a two-story row house with an arcade and shop on the ground floor.

Type-2 lots require a two-and-a-half or three-story zero-lot-line house with a side garden and at least a partial side porch, a type characteristic of Charleston, South Carolina. The lots nearest the town center are coded for these Charleston houses.

Type-3 lots require conventional front, rear, and side yards. The permitted height is lower than for the Charleston houses, and at least a partial front porch is required. There is nothing in the code that actually requires a bungalow, but the one illustrated would fulfill the requirements of the lot. Type-3 houses also have to provide for off-street parking.

The high-rent district of Type-4 houses is located along the lake front, and there are more such houses across the street, backing onto a small pond. A two-story verandah is required across the front of these Type-4 houses, which like the Type-3s must have front, back, and side yards, and provide off-street parking.

As at Seaside, the regulatory system actually permits substantial architectural diversity. Requirements are set down in a code, whose format has been copyrighted by the designers. The design ideas illustrated show what can be built in conformity to the code, although other design ideas are permissible. Different types of houses are not allowed to appear next to each other, however. Each house-type is set out in groups related to the design of the streets and to the overall land plan.

The enforcement mechanism at Tannin will be the condominium agreement, a document which is customarily far more detailed than any zoning approval. Approval was given under a Planned Unit Development Ordinance, which accepted the design plan and code as zoning for the whole planned community.

The superiority of Tannin's site plan over a typical subdivision is accomplished with some loss of market flexibility. If more buyers than predicted turn out to want Type-3 houses instead of Type-2s, or the other way around, whole segments of the plan would have to be recast, as streets and lots are tied together. On the other hand, Tannin is far more responsive to change than a planned-unit development, where the building design is part of the site plan.



Portions of the development code for Tannin show requirements for each of the four building types. This format and the coding concept have been copyrighted by Andres Duany and Elizabeth Plater-Zyberk.

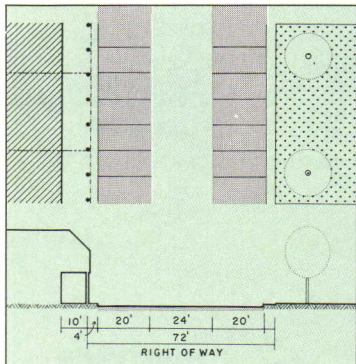

**TYPE 1**  
retail & lodging

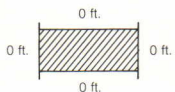

width: 100% min.

**YARDS**

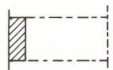

depth: 12 ft. min.  
length: 100% min.

**PORCHES**

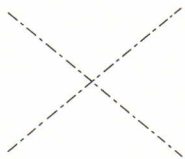

none required

**OUT-BUILDINGS**

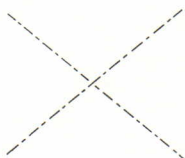

none required

**PARKING**

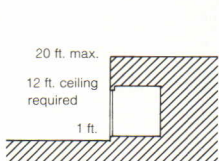

**BUILDING HEIGHTS**

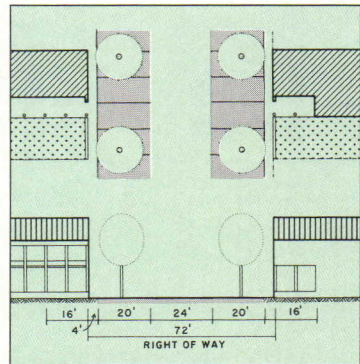
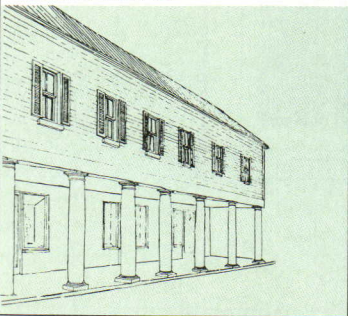

**TYPE 2**  
residential

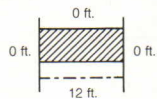

width: 40% min.

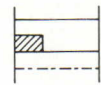

depth: 15 ft. min.  
length: 30% min.

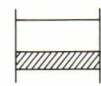

area: 200 sq. ft. max.

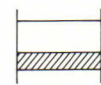

area: 200 sq. ft. max.

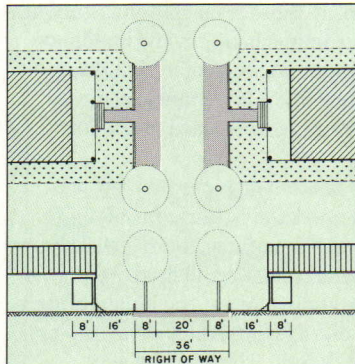
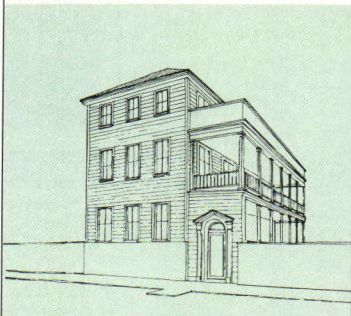
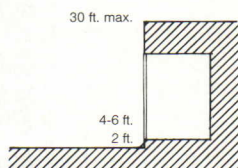

**TYPE 3**  
residential

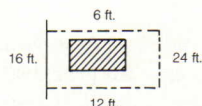

width: 30% min.



depth: 8 ft. min.  
length: 60% min.

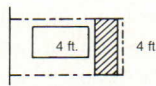

area: 240 sq. ft. max.



1 required

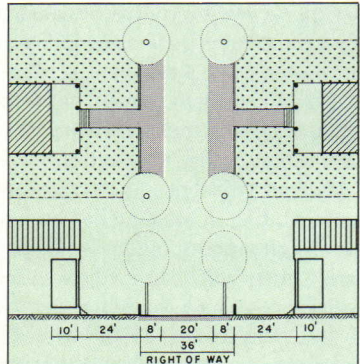
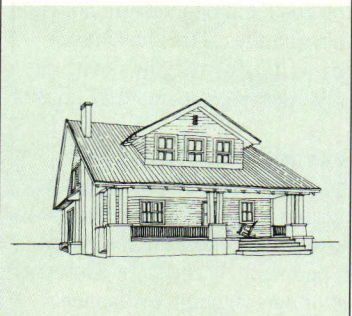
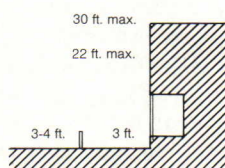

**TYPE 4**  
residential

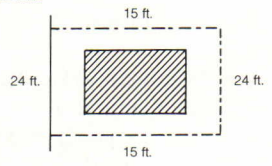

width: 50% min.

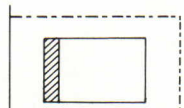

depth: 10 ft. min.  
length: 100% min.

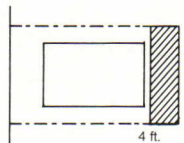

area: 800 sq. ft. max.

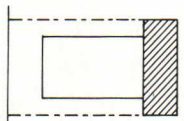

1/2 per br. req'd.

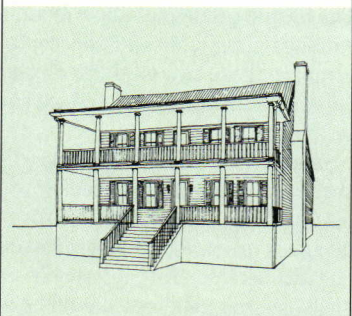
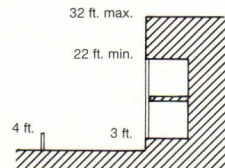



# Guidelines for design review

Design review is a controversial subject. If there is no consensus about what constitutes good design, how can a public body review buildings and decide when a design is right or wrong? Many people would say that they know good design when they see it, but it is much easier to conduct a design review when some articulated standard or guideline has been published in advance.

Without guidelines, the review process often degenerates into a confrontation. A building has been designed and is fairly far along in the design process, otherwise there would be nothing to review. The architecture embodies a whole series of systematic and financial decisions. A simple-sounding suggestion (why not set the building back 10 feet? why can't the roof line be five feet lower?) can have sweeping consequences for an already developed design. All too often a compromise involves both sides giving a little, with a result that is worse than either the original design or the review board's original suggestion.

The guidelines easiest to write are those intended to preserve an existing historic or natural environment. Guidelines for preservation of a scenic area, for example, can deal with visibility from significant vantage points, as well as the general preservation of the ecology. There is one clear, overriding design idea against which any development proposal can be measured: the existing natural landscape should be preserved as much as possible.

Guidelines for restoring old buildings in a historic district are relatively easy to write; the major question is what should be done about new buildings in the district. A younger generation of architects is far less nervous about faking a historic building than its Modernist elders, but a Colonial gas station remains a tough assignment.

Nantucket's design guidelines attempt to abstract design principles from historic Nantucket architecture and present them in a form, such as window-to-wall ratio, where they could be used without overt historical references. It is possible to argue that these principles are simplifications rather than generalizations, or that the historical premises are debatable. The guidelines say that square window openings should be avoided as untraditional, but it would certainly be possible to cite historical precedents for them. Nevertheless, the Nantucket guidelines are clear and go right down to details of building materials. Such guidelines can prevent egregiously incompetent buildings. Unfortunately they also screen out unconventional and inventive designs. There have been several confrontations between Robert Venturi and the Nantucket Historic Districts Commission, to the point where Venturi's firm will no longer accept work on the island.

Where there is no historic district, guidelines for design review must be based on such issues as overall coherence of design, spatial definition, proportions, appropriate scale, and responsiveness to context—as well as on such mundane problems as placement of driveways and service docks. On the facing page are two examples drawn from attempts to go beyond general principles to assemble a handbook of architectural composition. One is a set of design guidelines for development at a ski community called Sugarloaf, in Kingsfield, Maine, by Sasaki Associates, the other is a set of residential design guidelines for San Jose, California, by Daniel Solomon and Associates. The Sasaki guidelines show examples of good and bad design; Solomon catalogs acceptable and unacceptable alternatives. The illustrations compare these two methods of guideline-writing as they deal with the treatment and placement of garage doors and the placement of houses on sloping sites.

In addition to official design review by boards and commissions, there is a great deal of unacknowledged negotiation about design as part of the approvals process for zoning map and text changes. Because design is often not the official issue, there is little discussion of what constitutes the public interest in urban and suburban design. However, such design guidelines should be a part of every zoning ordinance.

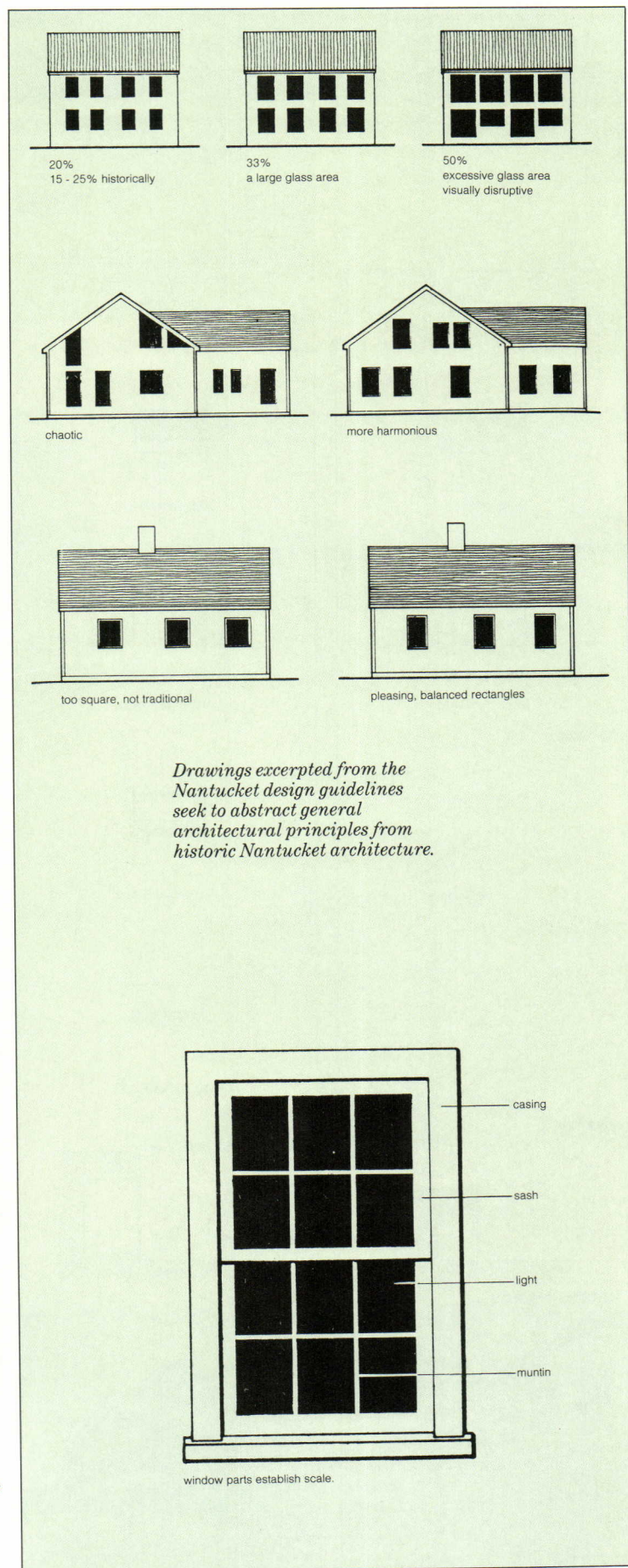



Sasaki Associates' guidelines for design review at Sugarloaf, a ski resort community (top), are compared with San Jose residential design guidelines by Daniel Solomon and Associates (bottom). The Sasaki approach illustrates acceptable and unacceptable designs. The San Jose guidelines catalog and evaluate as many alternatives as possible. In dealing with garage placement, the Sasaki guidelines indicate a garage

treated as porch and pulled back behind the main body of the house as preferable to a more direct treatment of the garage brought forward of the house. San Jose guidelines dealing with paired dwellings require a three-foot setback of the garage or carport behind the front facade of the house, unless there are the mitigating features shown: a trellis structure a minimum of two feet in front of the

garage, usable open space over the garage, or living space over the garage. In any case, garages may not occupy more than half the frontage of the house. The Sugarloaf guidelines show that houses on steep slopes should have a finished treatment on the downhill side. The San Jose guidelines deal with terracing of hillsides, and discourage roof lines in opposition to the slope of the land. Both sets of guidelines

are more extensive than shown, the San Jose guidelines attempt to deal with all design issues that come up in zoning and subdivision approvals.

GARAGES

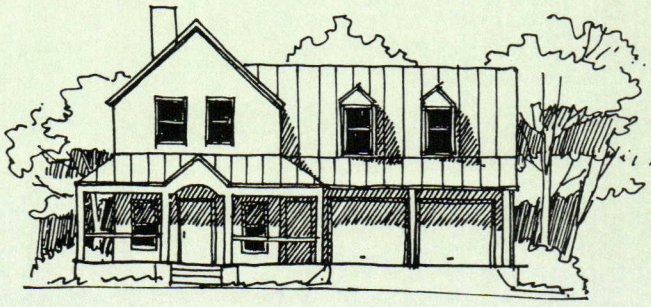

DESIRABLE CONDITION  
garage integrated into house design

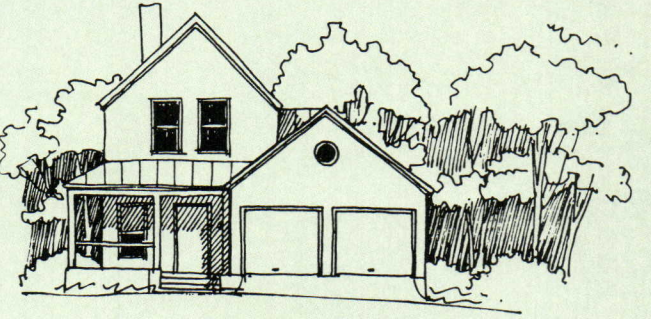

UNDESIRABLE CONDITION  
garage dominates house design

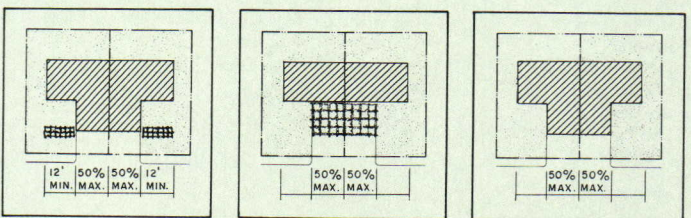

permitted                      permitted                      permitted

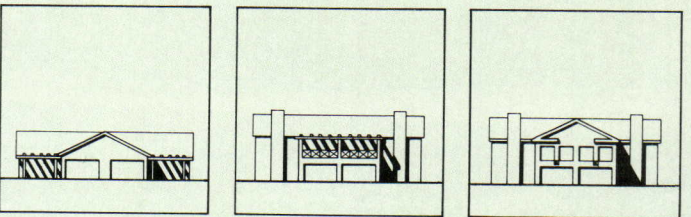

PROJECTING GARAGE WITH MITIGATING DESIGN FEATURE (GUIDELINE 188.2)

FOUNDATIONS

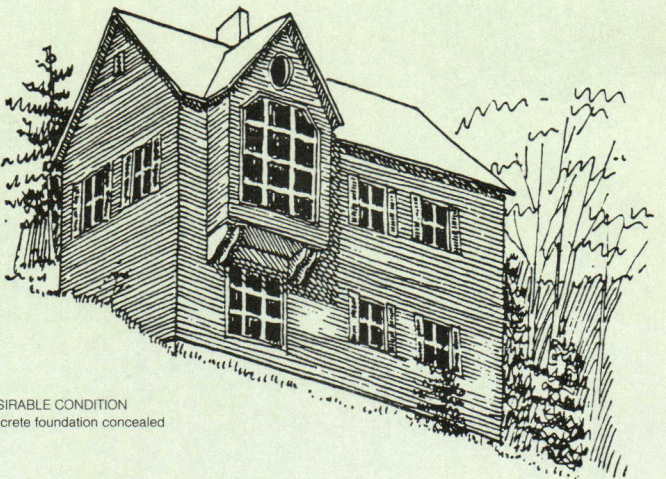

DESIRABLE CONDITION  
concrete foundation concealed

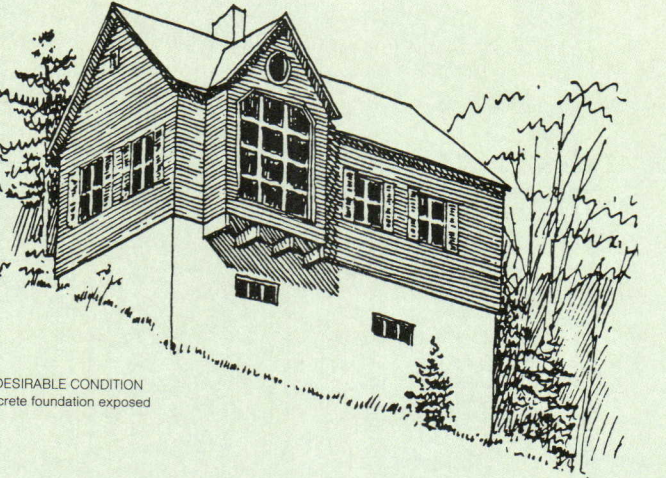

UNDESIRABLE CONDITION  
concrete foundation exposed

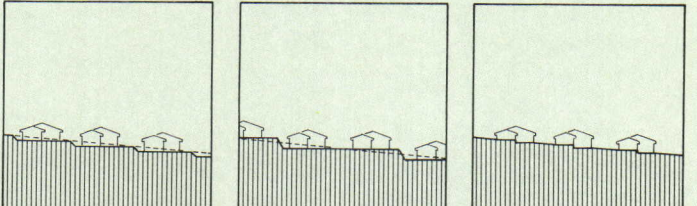

incremental terracing recommended                      wide step terracing discouraged                      split-level buildings recommended

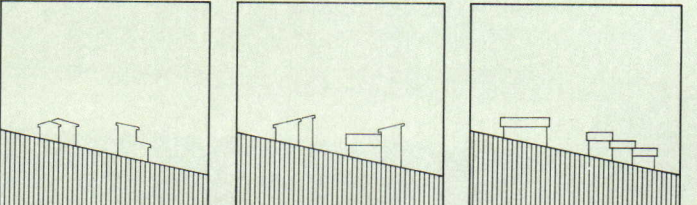

recommended                      not recommended                      recommended



# An unexpected surprise

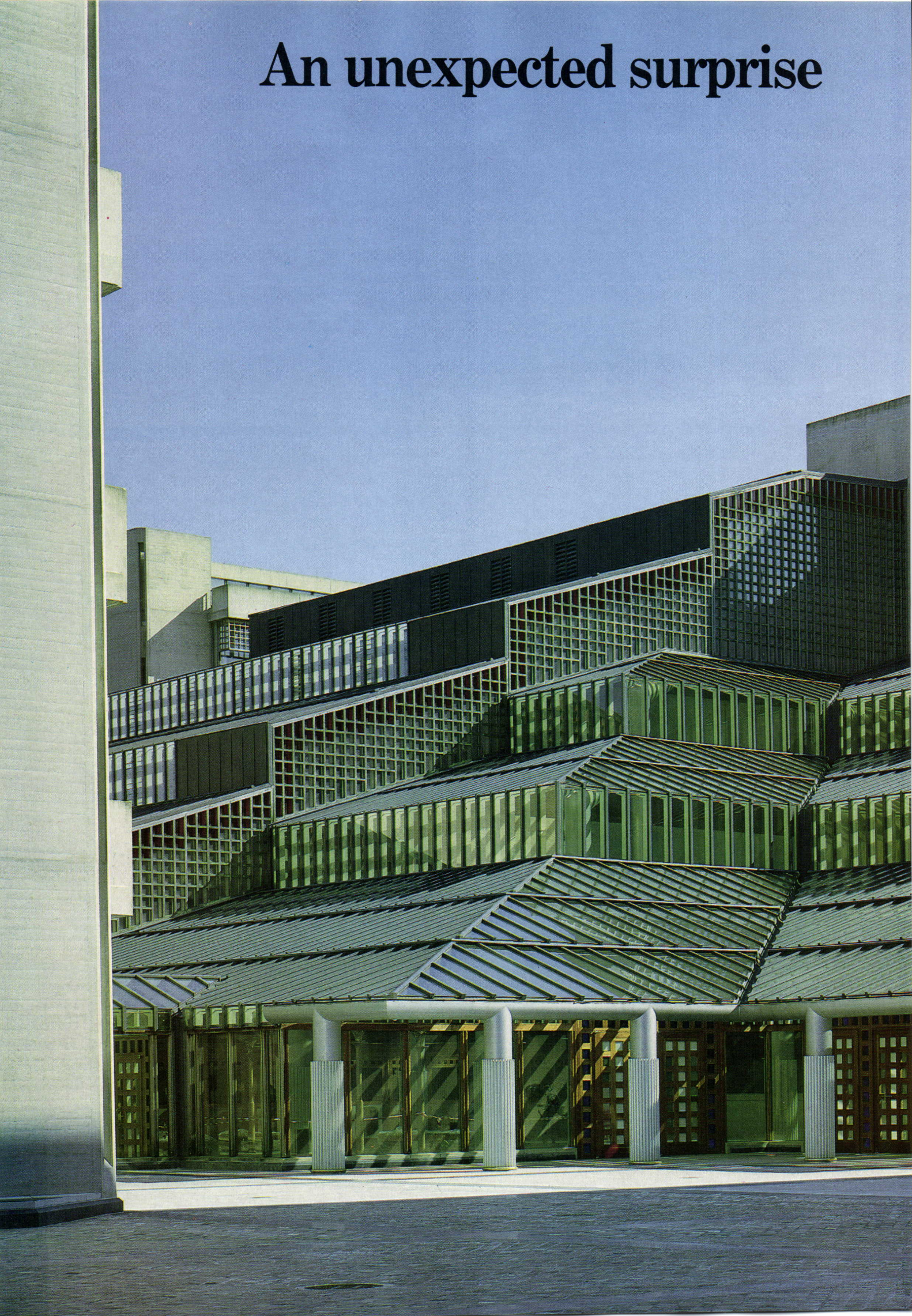



The University Hospital Center  
at Sart Tilman  
Liège, Belgium  
Charles Vandenhove, Architect





“...the building has no ‘facade,’ no ‘front.’ It is never seen in totality; it is discovered by walking around.”

This personal taste is the only connecting link in the list of the artists, who first worked together in the earlier “decoration” of Vandenhove’s Hotel Torrentius, then at this Hospital Center: Daniel Buren, Oliver Buren, Olivier Debré, Léon Wuidar, Sol Lewitt, Claude Viallat, Jo Delahaut, Marthe Wéry, Niele Toroni, Jean-Charles Blais, Jacques Charlier. They don’t adhere to any particular technical methods nor to any school but, even so, they form a distinct enough group. For most all these artists, a work of art is not a testimonial, but more an exploration of ways of creating art, an exploration of their own sense of reality and of reality in general. The relationship to the architecture of Vandenhove is evident. With his architecture, Vandenhove doesn’t want to stylistically proclaim anything, but he wishes to create a building, produce a world, in which everyone can live in his own manner. With some of these artists, the reference to the architecture, or to the environment in general, is direct enough: they don’t create isolated works, but relate their inventive art to the overall space.

The introduction of these works into the building largely surpasses the traditional significance of the term “decoration.” Or, perhaps more correctly, it restores to the term decoration its full sense, like a sort of taking possession or appropriation of the building—an individual, interpretation of its infinite possibilities, an interpretation of its richness, an invitation to dream. These works of art, disciplined and free at the same time, prepare the architecture for a festival, for pleasure: by their forms, their colors, their differences. Each space thus acquires its own personality and, within each space, an imaginary topography develops.

The great diversity of these artistic measures accentuates the experience of the architectural qualities. It is like an invitation to a free and personal way of looking at architecture and the environment. Through architecture, the diversity restores man to himself. It is without doubt there, in the true personalization of this architecture, that one touches on one of the reasons why some have resisted completion of this building. But it is too robust to be treated in an indifferent manner. It is not an object to throw away. Architecture shows its true moral value here, if it has one. In only being itself, not wishing to prove anything, it demonstrates an attitude of integrity—it is a practical building that still appeals to all the senses, to the enjoyment of discovery, and in which one continually participates to create its liveliness.

In this sense, the *Centre Hospitalier* at Sart Tillman is in the great architectural tradition that, according to the critic, Georges Bataille, is directly tied to the foundation of a human order. Bataille, in his *Dictionnaire Critique*, also asks if it is not time to free architecture from any slavery to dogmatism. The intrinsic freedom of the architecture here, which doesn’t want to be anything but what it is, tries to give an answer to this question. The building basically creates an empty space, undefined, a space for the occupants to invent unceasingly. It is an architecture that creates spaces, but doesn’t occupy them.

This paradox is experienced in an impressionable manner in the majestic entrance hall, a great pent-roof which ties together the diverse places of this little town. It is perhaps an overly big space, but one that becomes the very heart of all this community, a place where life can manifest itself, where patients, visitors, and staff can all mingle together. It is here that Vandenhove’s image of a cathedral becomes the most evident, not so much by the resemblance of the forms as by its nature of autonomous social space, uniquely reserved for the exercise of the community conscience. The hall could be a substitution for a town center—which is terribly lacking in this magnificent but deserted place—but it is not used in this manner.

It is sad when one sees that the hospital administration doesn’t employ the space as originally intended, and make it an animated space *par excellence* where patients, visitors, and personnel encounter each

other, stroll around, talk, greet each other, recognize each other, as in a true town.

If all the towers disposed around the center present a strict and autonomous *rectangular* geometry, in the hall it is the *diagonal* that dominates in a very dynamic manner. This diagonal motif is first introduced into the central block via its sloped roofs that descend in cascades, and extends even to overhead light strips in corridors. Even the angled views of the visible solid roofs create diagonals between the communal part, in the center, and the periphery. Across the open court, the placement of the unfinished building housing the auditoriums again accentuates the great diagonals crossing all the complex. This concrete structure, the latest to be started, introduces the outside curb in this orthogonal compound.

The transparent hall is differentiated from the rest of the building complex, not only by the plan and the section, but also by the steel-tube construction, and by its spectacular furnishings. It is true that one finds echoes of this construction in steel tubes that support the glazing in other parts of the building (for example, in the south fenestration of the polyclinics), but they are only echoes of the grandiose shell of the great hall.

Charles Vandenhove had already experimented with this singular mode of construction in his own house. After it had been built for more than 10 years, he constructed a lodge in steel and glass on the roof of the hillside brick house, thus demonstrating that an architecture or a work of art could have elements that were extremely different without denying its coherence, could stay itself yet radically change.

The first impression that one feels in entering this great hall is that of light. It is as if the architecture only existed to dramatize the light, to render the light “luminous.” For, even on dark days, one is surrounded by luminous space. This ambience makes one pause, as if something *must* happen there. This space is there to be enjoyed, a true space for festivals; always restrained, but still exuberant and joyous.

Certainly, all this space superficially surpasses the current needs; but it is a sort of promise for the future. One looks forward to the day that this center will be finished and ready to function as planned, when one will have—and one *will* have sooner or later—the possibility of completing all the elements; then the center will have the liveliness that was intended. The furnishings, although still only partially realized, again reinforce this impression of grandeur—by the color of the windows, the magnificent procession of bronze lamps, the kiosks with their colored panels by Sol Lewitt, the wainscots of Sol Lewitt and Niele Toroni. Nevertheless, this glazed interior also serves a main role of introduction to the rest of the building. At the back, one constantly sees the masonry elevation, with its columns, its galleries, its balustrades. And one is made conscious, by the big descending escalators, of the lower levels that are hidden in the labyrinth of the basements.

At the present, only the basic structure of the auditorium building, which is like a pendant to the great hall, is finished. But the same exacting design concern leads here to an extreme refinement of the overlapping spaces, the stairs which unroll, the lobby which embraces all the space, the columns which launch themselves by dividing into two.

Once again, all these characteristics, as in the rest of the complex, seem to be there only to assert, quite simply but firmly, the dignity of the work: to build a human environment. Or even, as Cioran said in his admiring writings about the work of Saint-John Perse, to create “this space of celebration where the real, never lacking, tends toward an abundance, where everything contributes to a supremacy, because nothing falls under the curse of being replaceable.”



*In contrast to the metal-and-glass structure of the central hall, the other units are all concrete, as can be seen in the view across the entrance court (top left). The emergency entrance is on another side of the complex (center). The surrounding towers are of varying heights, and are edged with balconies and sun screens, as shown in the view across the top of the auditorium building (top right). That building, unlike the*

*strictly rectangular plans of the other units, forms a curvilinear filip to the center, and creates a focal point across the court from the entrance hall (bottom left). Though not yet finished, the interiors of the concrete auditorium structure reveal an almost Baroque delight in flowing forms, especially in the lobby with its dramatic stairs (bottom right).*

*Francois Hers and CH. Bastin-J. Evvard photos*

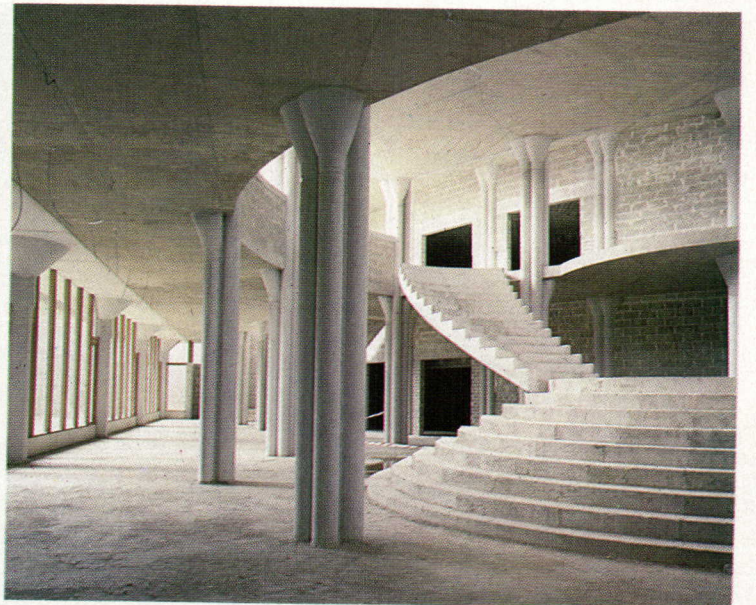
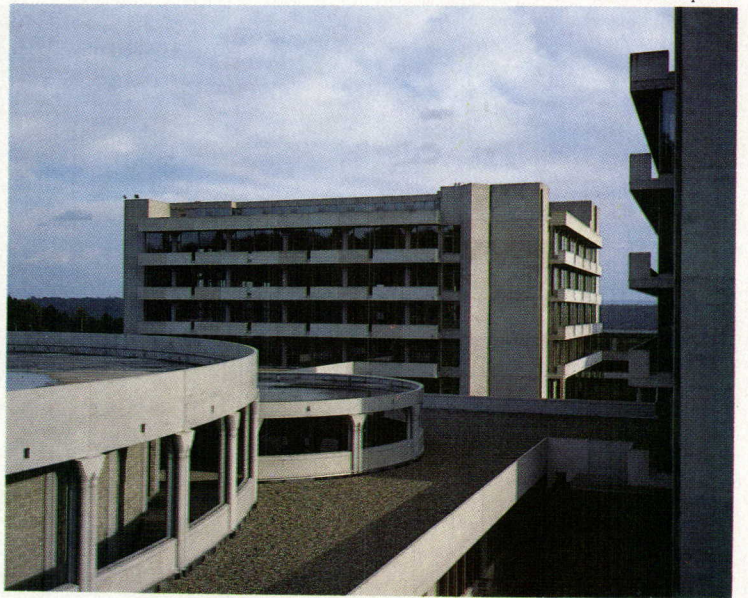











*In the interior of the big entrance hall, the interplay of structural diagonals is as forceful as the cascades of glazed roofs (preceding page and below). Somehow, all that patterning—plus intricate detailing of steel column bases, fenestration with stained-glass inserts, marble floors, and painted panels—does coalesce into a festive community area. The only one of many planned kiosks that has been built houses the*

*center for admissions (opposite top). That has vivid panels by the artist Sol Lewitt, and nestles beneath the concrete balconies of the main part of the building. Such decorative art is a sort of hallmark for the entire complex, and ranges from panels for escalators by Niele Toroni (bottom left), to office corridors by Sol Lewitt (opposite, bottom left), to patient-care areas by Olivier Debré (opposite, bottom right).*





*Le Centre Hospitalier Universitaire  
Au Sart Tilman  
Liège, Belgium*

**Owner:**  
*Université de Liège,  
Henri Schlitz, administrator*

**Architect:**  
*Charles Vandenhove—Charles  
Vandenhove, principal-in-charge;  
Jacques Sequaris,  
Prudent De Wispelaere, Marie-  
Louise Delaïresse,*

*Alain Dirix, Alain Sabbe,  
design team*

**Consulting engineers:**  
*Tractionel, Brussels; René Greisch,  
Liège*

**Interior wall decoration:**  
*Olivier Debré, Daniel Buren, Léon  
Wuidar, Marthe Wéry,  
Sol Lewitt, Claude Villat, Jo  
Delahaut, Niele Toroni, Jean-  
Charles Blais, Jacques Charlier,  
Anshé Romus*

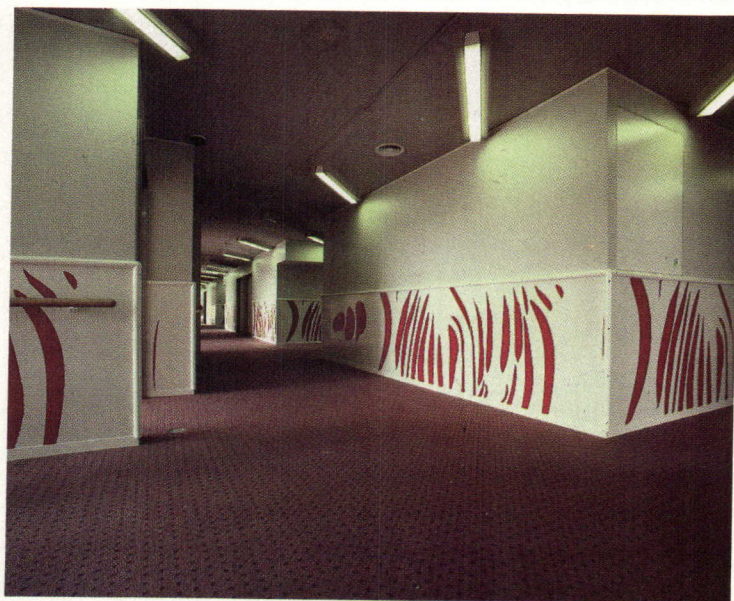



# Stone: New technology and design

By Barry Donaldson

Stone has influenced architecture throughout history and continues to be a source of inspiration for its qualities of color and variation and its image of mass, permanence, and monumental scale. Its recent popularity can be attributed to more permissive and experimental design attitudes and to the availability of innovative construction techniques that enable stone to be cut and fabricated in ways that would not have been possible even 10 years ago. As a result, stone can be expressed in a variety of ways: as a traditional, monolithic, load-bearing material; as a conventionally anchored thick veneer; or as a thin-veneered stick or panel system.

The use of stone as a monolithic load-bearing material has been changing gradually over the last century. Despite the growing use of iron and steel, the work of most late 19th-century architects (for example, H. H. Richardson, Richard Morris Hunt, and McKim, Mead & White) expressed stone as sculptural, load-bearing masonry. There were, however, a few architects who were advancing the use of the steel skeletal frame and experimenting with lighter masonry materials such as brick and terra cotta, expressed as a lightweight veneer. Adler & Sullivan and Daniel Burnham were among those who had embraced the new skyscraper esthetic. Burnham's Reliance Building of 1895 and Louis Sullivan's Wainwright (1891) and Guaranty (1895) buildings exemplified the new design esthetic of the skyscraper, with its emphasis on expressing structural steel as a repetitive frame clad in masonry proportionately much thinner than had been considered possible before.

Throughout the first few decades of the 20th century, European design remained influential in America, and stone applications continued to express its monolithic or sculptural qualities even though technological advancements accelerated the demand for taller and lighter steel-frame buildings. These somewhat conflicting circumstances were often expressed in the design of stone facades: Carrère and Hastings's New York Public Library of 1911, for example, shows a difference in architectural treatment between the three primary street elevations (in a French Beaux-Arts style) and the "back" or Bryant Park elevation, which is a flat, repetitive facade clearly influenced by the new skyscraper architects of Chicago.

During the 1920s and '30s architects such as Bertram Goodhue and Raymond Hood emphasized simplified massing and carved detail in relatively thick limestone facades. Goodhue's Nebraska State Capitol and Raymond Hood's Rockefeller Center both use limestone in a way that juxtaposes the solidity of the smooth stone against the verticality of the windows and overall facade. The uniformity of limestone color and texture, joint treatment, and carved detail all accentuate contrasting perceptions of limestone as a material with mass and weight and, at the same time, a veneer supported on a steel frame.

During the 1940s and '50s, glass curtain walls grew in popularity, reaching their peak in the late 1960s with a profusion of Miesian "boxes" or minimalist glass towers dotting the skyline of every major city in the country. Though the use of dimensional stone declined during these decades, many of the technological advances developed for these glass systems, such as polymer gaskets and structural silicones, are now being applied to the thin stone-veneer systems of the 1980s.

Today, the uniquely American emphasis on architectural eclecticism, combined with technological innovation, is very strong, and its expression is especially clear in the design and technology of stone facades—designs that may range from the rusticated, sculptural treatment of Hardy Holzman Pfeiffer's West Wing at The Virginia Museum of Fine Arts (left), to the massive carved treatment of the AT&T Headquarters Building by Johnson/Burgee Architects (right), to the complex layering of planar surfaces in Kohn Pedersen Fox

*Barry Donaldson is Vice President of Tishman Research Corporation. His book on new stone technology will be published this year by Società Editrice Apuana.*

©Patricia Layman Bazon

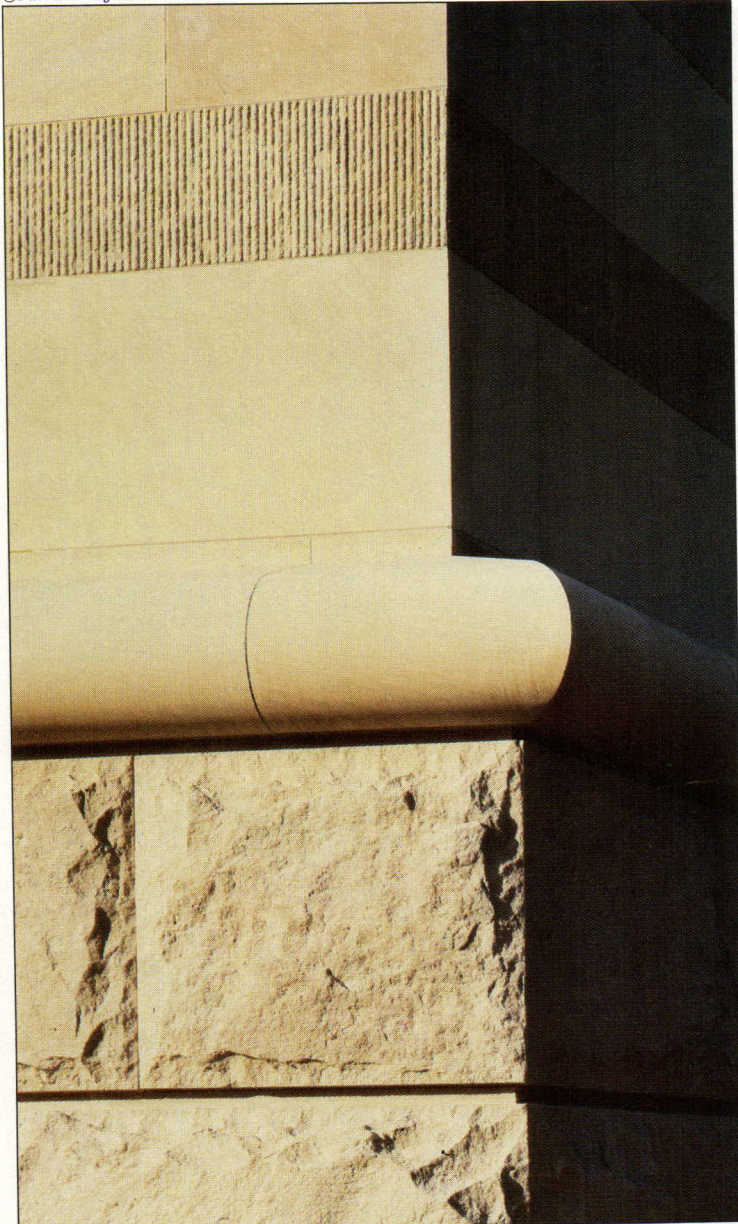

*The Virginia Museum of Fine Arts (West Wing) by Hardy Holzman Pfeiffer Associates*



*New exterior stone-cladding systems are lighter, more economical, and faster to erect than conventionally anchored stone. In the following article, five innovative system types are described in terms of their technological and esthetic implications.*

Associates' One Logan Square (page 138) or the fanciful, coloristic treatment of James Stirling's Stuttgart Museum (page 139). These examples illustrate a variety of expression in the use of stone as a material that reveals its "stoneness"—its inherent qualities of permanence and mass—either as a smooth panel or as a palette of color and texture.

Recent developments in cutting and fabricating techniques allow the use of thin lightweight stone veneers supported by steel truss frames, precast concrete panels, glass-fiber-reinforced cement (GFRC) panels, aluminum "stick frames," or diaphragm panel systems. In addition, the application of latex Portland cements, structural silicones, and polymer gaskets to stone veneers is providing new opportunities for the fabrication of lightweight panel systems. The result is the availability of systems that are lighter, more economical, and faster to erect than conventionally anchored stone. Integration of various building components, reduction of labor-intensive hand-setting, and acceleration of construction schedules have promoted greater use of stone even at a time when skilled stonemasons are fewer and construction costs higher than ever before.

#### Stone selection

Thin stone veneers of a substantial face area are now available as a result of the development of sophisticated fabrication equipment that uses laser-guided and computer-controlled diamond circular saws to cut stone with less vibration and closer tolerances. This technology makes veneers available from 1 1/2 in. to less than 3/8 in. in thickness. (Generally, larger stone slabs are cut in 1 1/4-in. to 1 1/2-in. thicknesses, and stone tiles, sometimes as large as 2 ft square, are cut in 3/8-in. to 3/4-in. thicknesses.) Although thinner veneers mean greater economy, the specific stone specified for a facade system becomes structurally critical when used in veneers 1 1/4 in. or less in thickness. Cutting kerfs for clip or disk anchors and drilling holes for blind-pin anchors or spring clips is much more difficult with thin stone, and especially with stone that has a great deal of veining or physical impurities that will affect its strength, or stone that has a crystalline structure with dimensions large enough to approach the thickness of the slab itself and therefore substantially weaken it.

Not surprisingly, a great deal of controversy has grown around the use of exterior stone veneers 1 1/4 in. and less in thickness. The concern is that there is neither sufficient evidence of the long-term durability of such veneers nor standard test procedures for measuring stone strength, especially in terms of flexure and modulus of rupture. Furthermore, international cooperation to support the sharing of information on stone availability and performance is inadequate. With the growing use of thin stone veneers, strength characteristics, factors of safety, design tolerances, and quality of workmanship have become much more critical to ensuring the durability of the system. Tests for determining compressive strength, flexural strength, and modulus of rupture are defined by ASTM but may require modification to reflect actual stone thicknesses and finishes for a particular job.

#### Selection of panel system

The decision as to whether to build a stone facade with conventionally anchored hand-set stone pieces or with prefabricated stone panels will depend on specific details of the architectural design as well as economic constraints. The primary design considerations are usually stone color and texture, slab and panel size, joint treatment (e.g., stacked bond, running bond), and the ability to translate a repetitive design element into a repetitive building component. Cost is affected by both the level of complexity of the facade and the difficulty of stone delivery and erection.

Highly articulated sculptural detail with a great degree of variation lends itself more readily to hand-set stone installations. On the other

©Richard Payne



AT&T Corporate Headquarters by Johnson/Burgee Architects



*Stone's durability, richness, and color have no equal. With the development of high-performance gaskets and sealants, thin stone veneers, and framing systems that integrate components, stone will continue to influence the look of buildings throughout the next decade.*

Jock Pottle



One Logan Square, by Kohn Pedersen Fox Associates

hand, a relatively flat facade with a large number of repetitive elements may be ideally suited for panelization and prefabrication. In some cases, however, site restrictions or limited accessibility may preclude the use of large prefabricated panels.

Many new stone systems involve fabrication of a number of individual stone slabs into larger panels that are attached to the building structure. Panelization allows for faster building enclosure and acceleration of the start time for interior trades, but requires that repetition of wall elements (e.g., spandrel panels, window panels, column covers, etc.) be distributed over a large enough volume to offset the costs of machining, formwork, or transportation associated with panel fabrication.

The buildings illustrated on the following pages demonstrate a variety of new approaches to the design of stone facades. Although all of these projects are high-rise buildings, the range of their appearance and choice of building systems is quite broad, covering the full spectrum of stone design and technology today.

#### **Steel-truss-framed panels**

The most widely used panel systems for high-rise buildings have been steel truss frames. While some of the earlier steel truss systems utilized heavy structural steel members, such as WF- or S-shaped steel, more recent examples have taken advantage of lighter steel members—channel steel, tubular steel, or light-gauge metal studs. The stone veneer is either prefabricated or site-fabricated to the steel truss, which is then attached to the building structure (see 520 Madison Avenue, page 140; 7 World Trade Center, page 141; and the United Nations Development Center, page 142).

The panel dead load is usually transferred to the building structure with clip angles attached to the bottom edge of the stone slab. In general, the truss is attached to the building structure at the columns so that gravity loads are carried directly to compression members. For especially large column bays that demand long-span truss panels, however, it is often necessary to provide gravity supports at the spandrel beam or slab edge at intervals between the columns as well. Both systems are designed to employ mechanical anchoring and are widely accepted by building codes and standards.

#### **Precast concrete and GFRC panels**

Precast concrete/stone panels have been used widely in high-rise commercial and residential construction. Such panels are especially desirable if the building structure is concrete, or if the facade has numerous three-dimensional articulations such as deeply revealed windows, inside and outside corners, or projections and setbacks. Precast concrete/stone panels are prefabricated from a series of molds and are generally designed so that the precast concrete functions only as a structural substrate for the stone veneer, although the precast can also be partially exposed as an element of the design (see the Delmonico Plaza, page 143).

A variation on precast concrete, which has become more popular over the last few years, is glass-fiber-reinforced cement (GFRC). Like precast concrete, GFRC can be used as a poured or sprayed-on cementitious mix formed in a mold or as a board product to provide the substrate for applied stone veneers. (When used as a board product, GFRC units are usually referred to as glass-mesh mortar units.)

#### **Aluminum "stick-framed" panels**

The translation of aluminum stick-framed curtain-wall technology from glass/metal systems to glass/stone systems is a development of the last five years (see City Spire, page 144). Driven by a declining interest in all-glass buildings and the enormous revival in the use of stone, most of the major curtain-wall manufacturers have broadened their interests to meet those of architects and engineers, and thus maintain or expand



their markets. Stick-framed aluminum/stone panels exemplify a technology that has evolved to meet emerging trends in design.

### Diaphragm panels

Steel diaphragm panels are similar to steel truss systems, but are generally lighter because they use lightweight steel studs with a steel deck, lath, or other substrate that acts as a structural diaphragm to form the backup for the stone veneer. Usually, the stone is attached to the diaphragm panel with a combination of shelf angles or clip anchors to take gravity loads and a structural adhesive to resist lateral loads. Racking is handled entirely by the diaphragm panel itself and does not require consideration of the stone veneer.

The first steel diaphragm panels were designed as systems for the attachment of exterior ceramic tile cladding. Development of one of the most promising systems began approximately six years ago, when McOG Architects, in association with Buchtal Ceramics, engineered the Keraion Panel System (KPS), which consisted of a steel frame, galvanized metal deck, and frostproof ceramic tile attached to the deck with a silicone structural sealant. The original system has since undergone a great deal of refinement and has been modified to incorporate a variety of attachment methods and cladding materials, including thin stone veneer. Extremely lightweight and durable, the Keraion panel can accommodate much greater flexibility than many other types of panels. Its use of lightweight framing and thin granite veneer reduces the overall weight to a range between 7 and 10 lb/sq ft, providing a light, cost-effective solution that allows great architectural variety and interest. Now patented, the system has been used widely on commercial and residential projects throughout the United States (see the Citadel, page 145).

The use of structural silicone for exterior wall systems is somewhat controversial since these relatively new applications are very dependent upon the quality of workmanship, and their long-term resistance to weather deterioration is untested. On the other hand, silicone has served as a structural adhesive for glazing for many years prior to its more recent applications as an adhesive for stone. Cygnus, the manufacturer of the system, has tested the compatibility of granite and silicone, demonstrating excellent bond strength after three-year weatherometer, water, and freeze-thaw tests. To address any remaining skepticism towards entirely adhered systems, the firm has also developed a mechanical attachment to meet particular building-code requirements, solve tolerance problems of leveling and alignment, and handle long-term shear stresses that silicone cannot accommodate economically. The structural silicone handles a portion of the gravity loads and such dynamic tensile loads as positive and negative wind pressures, and provides support for the stone at 6-in. centers; mechanical anchors carry the majority of the gravity loads.

### Influencing the next decade

The growth of new building technologies and the renewed interest in the use of natural stone have led to significant innovations in the ways stone may be applied to the exterior of buildings. Curtain-wall structures continue to become much lighter and faster to install, and stone, as a material unequalled for durability, richness, and color, is replacing the minimal glass curtain-wall designs so popular during the 1960s and '70s.

The development of high-performance gaskets and sealants, the manufacture of thin stone veneers, and the introduction of framing systems that integrate glass and stone will influence the look of buildings throughout the next decade as the use of panelized and framed stone construction systems, as well as thinner stone veneers and laminates, becomes more widespread and technological advances in stone quarrying, cutting, and finishing are consolidated with further refinements in composite stone construction systems.

©Timothy Hursley/The Arkansas Office



Neue Staatsgalerie and Chamber Theater by James Stirling, Michael Wilford and Associates



# 520 Madison Avenue

520 Madison Avenue is faced in a Dakota Mahogany (Sequoia) granite, which is 1 5/8 in. (4cm) thick. The prefabricated panel system is made up of five stone slabs attached to a structural-steel truss by stainless-steel clip angles and threaded stainless-steel studs, which are welded to the truss and fixed to the stone with epoxy. The steel truss consists of structural wide-flange shapes (6WF16) fabricated as a 5-ft-high, 27-ft-long simple frame. At the job site, each panel is attached directly to the steel columns with clip angles at the slab to resist gravity loads, steel channels at the bottom to resist lateral loads, and shims to accommodate construction tolerances. Each panel is then insulated, flashed, and caulked with 2-in. rigid fiberglass insulation, a continuous vinyl (5 mil) moisture barrier, and an elastomeric butyl caulk.

Design of the stone to resist bending is based upon worst-case wind-load conditions and an assumption that the span between supports is the distance between pin anchors. The strength of the stone itself is the limiting condition for defining stone thickness and anchor spacing of anchors.

Thermal and moisture protection are integral to the panel except for fire-safing insulation that is required at the floor slab. Provision for weeping is incorporated at the window head and sill. All of the insulation is mineral-fiber blanket, and waterproofing is a continuous vinyl sheet.

Erection of individual panels and closure of the building were accelerated significantly by the use of large prefabricated elements. Completion of work on the vertical tower was especially fast, although particular attention was required for alignment of the panels at the sloped base of the building where corners intersect at acute angles.

520 Madison Avenue  
New York City

**Owner:**

Continental Illinois

**Architects:**

Swanke, Hayden, Connell & Partners—Der Scutt, principal-in-charge

**Engineers:**

The Office of Irwin G. Cantor (structural)

**Construction manager:**

Tishman Realty & Construction

**Contractor:**

F. E. I. Ltd.

**Stone supplier:**

Georgia Granite

**Fabricator:**

Titan Granite Co.

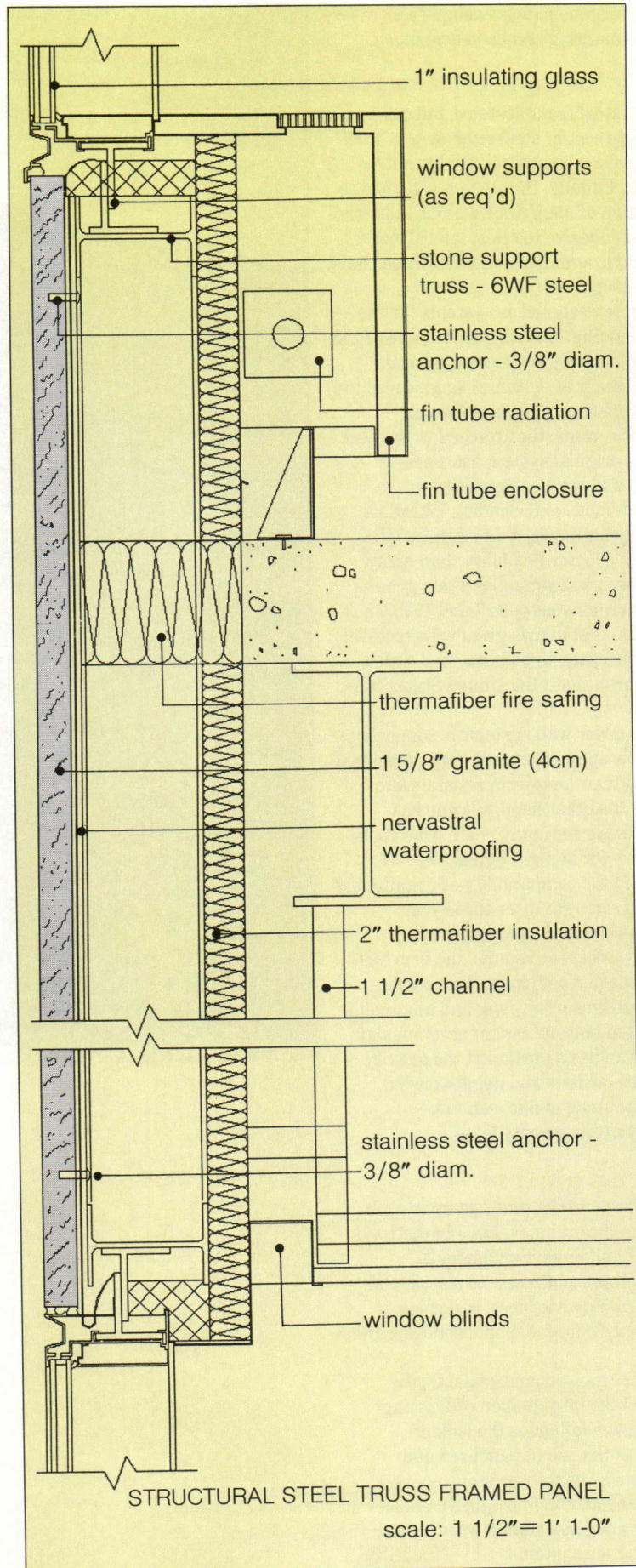



# 7 World Trade Center

7 World Trade Center is faced in 1 3/16-in.-thick (3cm) Carmen Red granite, quarried in Finland and cut and finished in Italy. The stone is attached to a 6-ft by 18-ft by 6-in.-deep (approx.) structural-steel truss fabricated in Ireland. The truss is made up of a combination of structural steel (S-shapes), steel channels, and steel angles welded together in a panel.

Four slabs of the flame-finished Carmen Red granite are anchored to each truss by means of epoxied, threaded stainless-steel pins (10mm in diameter), which are shimmed and bolted to steel angles on the truss at 3-ft 2-in. intervals. After insulation, flashing, and caulking are pre-installed, the stone-clad truss is lifted onto three large structural-steel angles welded to the steel columns of the building and attached to the supporting structure. Five additional ties resist wind load.

*7 World Trade Center  
New York City*

**Owner:**  
*Silverstein Properties*

**Architects:**  
*Emery Roth & Sons*

**Engineers:**  
*The Office of Irwin G. Cantor  
(structural)*

**Construction manager:**  
*Fishman Realty & Construction*

**Stone supplier:**  
*Savema S. P. A.*

**Fabricator:**  
*F. E. I. Ltd.*

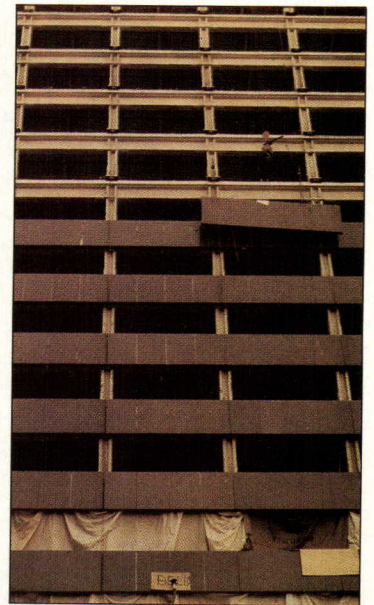
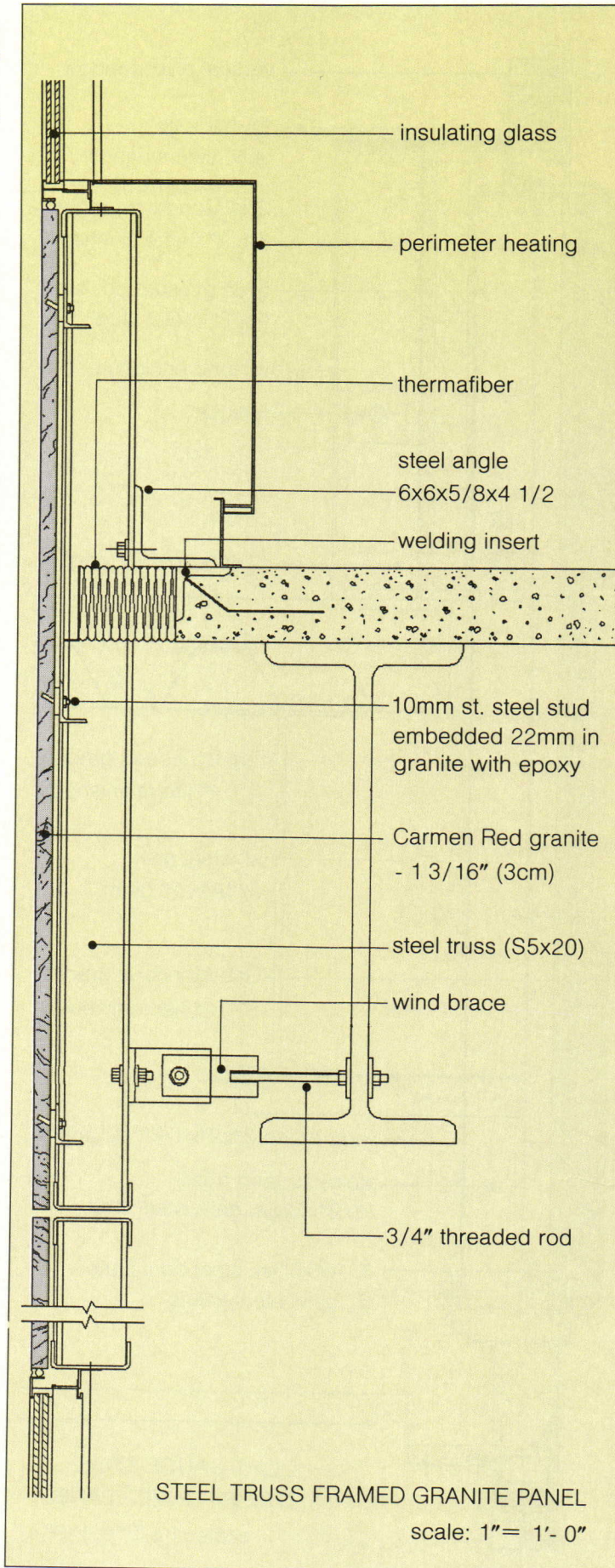

Courtesy F. E. I. Ltd.



# United Nations Development Center

The United Nations Development Center, a 15-story office and residential building in midtown Manhattan, is clad in almost 72,000 sq ft of Gris Mondariz and Verde Laguna granite in alternating horizontal bands.

The stone was site-fabricated onto light-gauge steel support trusses that span approximately 22 ft and are 4-ft 7-in. high. The trusses are attached to the building with steel shelf angles located at the floor slab to resist gravity loads, and steel angles located at the bottom flange of the spandrel beam to resist wind loads. Spandrel trusses and column trusses are used in combination to clad the building.

The Spanish granite veneer is relatively thick for such a panel system: the Laguna Green granite is 1 3/4 in. thick and the Gris Mondariz granite is 2 1/2 in. thick, providing bands of varying depth as well as color.

Generally, the stone is designed for a flexural strength of 1,500 psi. However, since there is an enormous variation in flexural strength, especially for Laguna Green, which can range from as high as 2,000 psi to as low as 600 psi, it was necessary to select and test individual slabs to ensure adequate strength. The relatively thick slabs of Gris Mondariz also contributed to a higher safety factor.

*United Nations Development Center  
New York City*

**Owner:**  
*United Nations Development Center*

**Architects:**  
*Kevin Roche, John Dinkeloo & Associates*

**Engineers:**  
*Robert Rosenwasser Associates (structural)*

**Construction manager:**  
*Tishman Realty & Construction*

**Stone supplier:**  
*Ramilo s. a.; Gramco*

**Truss fabricator:**  
*Hohmann & Barnard, Inc.*

**Installer:**  
*Peter Bratti Associates, Inc.*

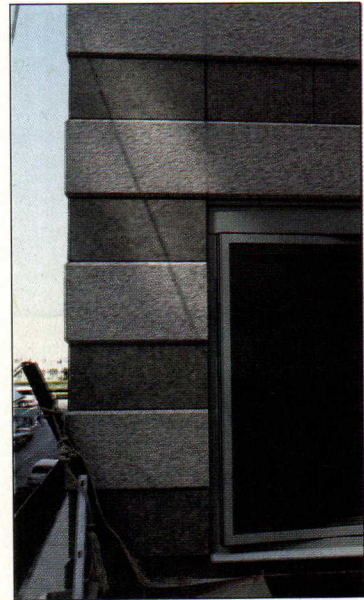
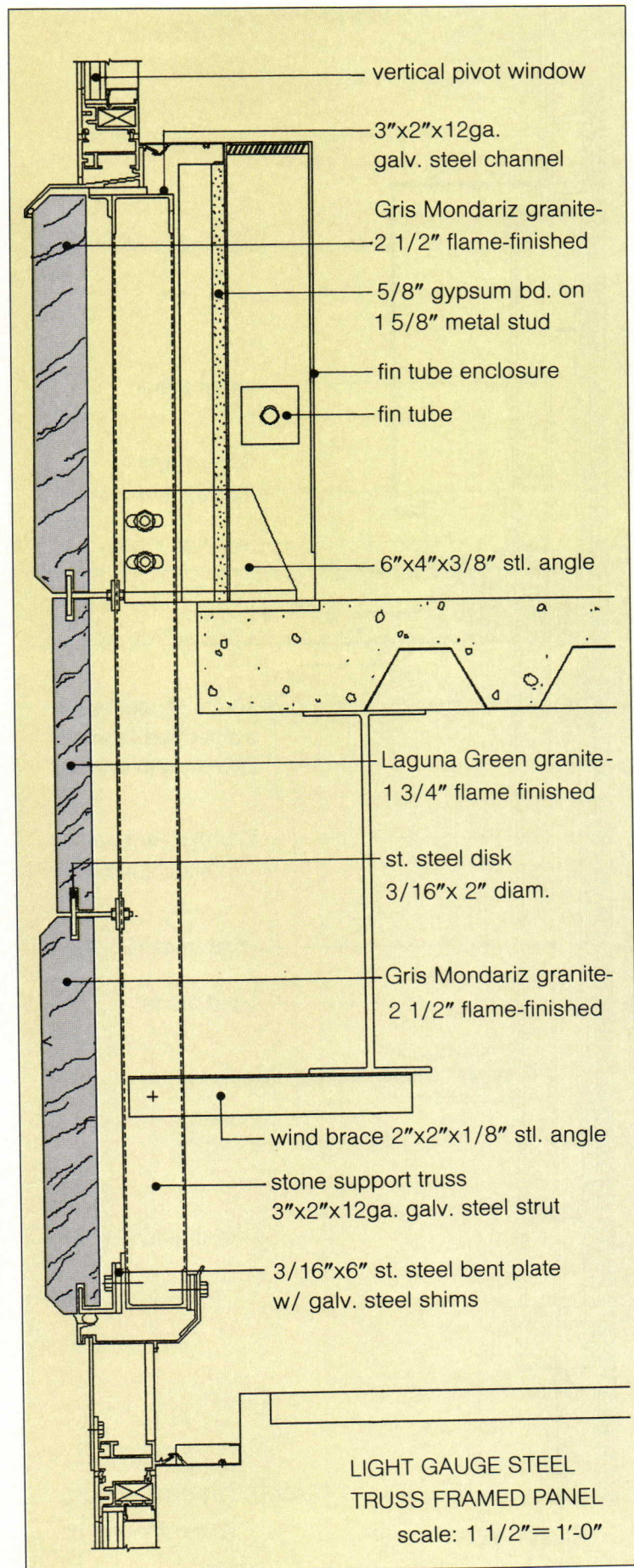



# Delmonico Plaza Office Building

The curved precast concrete pieces at the arcade and in the lobby demonstrate the three-dimensional capabilities of this versatile material. Precast panels allowed for a much less expensive system for securing the exterior walls to the superstructure than would have been provided by a system of individually fastened pieces. The largest panel is fastened to the superstructure at only three points.

Although the architect initially desired a limestone spandrel, the superior quality of the precast made the alternative consideration of a precast-backed limestone veneer unnecessary. Thus, the desired effect was achieved at the least cost to the owner.

As a mediating gesture to the building's two dissimilar neighbors, the facade consists of a variety of materials, including light precast concrete, green English slate, and Solex green glass. The precast panel color and acid-etched finish were chosen by the architect from among many alternative samples formulated to resemble Indiana limestone. Color uniformity of all panels is of very high quality, and factory inspections required no rejections of panels.

Maximum panel size is 5 ft 7 1/2 in. by 30 ft by 4 1/2 in. False joints occur typically at 5-in. intervals and are formed at 3/8-in. thickness to match true joints. All building corners are mitred.

Honed green slate corner and sill elements were placed in the forms and cast together, except at the round columns and in the main lobby, where all pieces were set individually. The color emphasis also reverses in the building lobby, the green slate predominating and the concrete becoming the accent.

*Delmonico Plaza Office Building  
New York City*

**Owner:**  
*Cozwil Associates*

**Architects:**  
*Davis, Brody & Associates*

**Engineers:**  
*Robert Rosenwasser Associates  
(structural)*

**Construction manager:**  
*HRH Construction*

**Precast contractor:**  
*Beer Precast Concrete Ltd.*

**Installer:**  
*Kirkstone Greenslate Quarries*

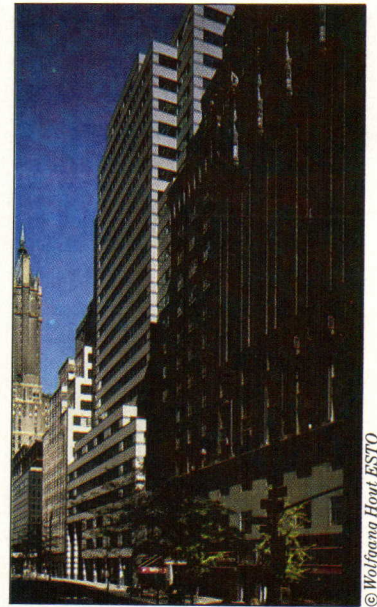
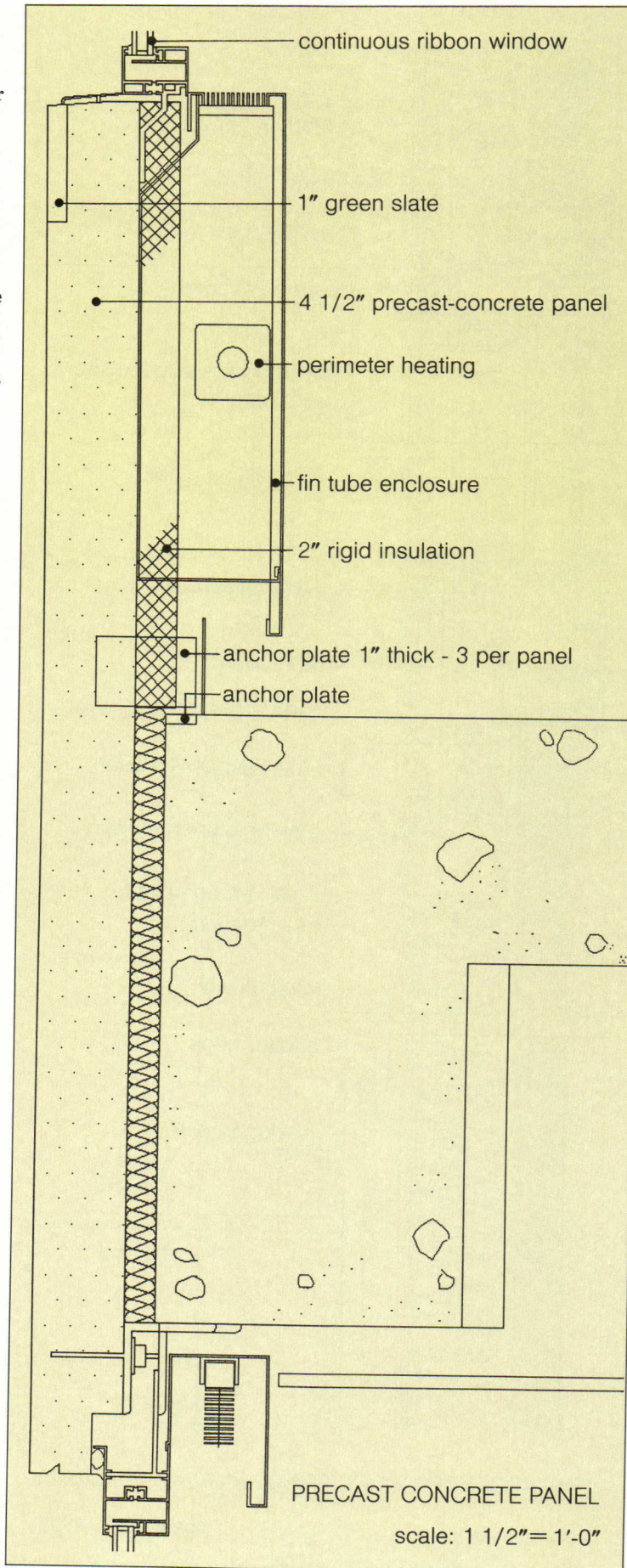

© Wolfgang Hoyt ESTO



# City Spire

This concrete-framed residential tower is currently under construction. City Spire's facade incorporates an aluminum curtain-wall system that frames vision glass and granite spandrel panels in a single system.

The stone used for the spandrel panels is Sardinian "luna pearl," quarried, cut, and finished in Italy. The system is prefabricated at the fabrication plant. Stone thickness is 1 3/16 in. (3cm), and its weight approximately 15 lb/sq ft.

Individual stone slabs are attached on four sides by the curtain-wall framing, without any additional structural backup to resist lateral (wind) loads. The aluminum framing supports the stone by a continuous clip (which is part of the extrusion) that sits in a kerf cut into the four sides of the stone.

Structural capacity is therefore limited by the overall height, or unbraced length, of the stone panels alone. The panel is insulated with 2 5/8-in. rigid fiberglass, sealed with neoprene gaskets, and caulked with silicone. All insulation, sealants, gaskets, and caulking are prefabricated. Glazing is prefabricated within the panel system as well.

*City Spire*  
*New York City*

**Owner:**

*Eichner Properties*

**Architects:**

*Murphy/Jahn Associates*

**Engineers:**

*Robert Rosenwasser Associates*  
*(structural)*

**Construction manager:**

*Tishman Realty & Construction*

**Fabricator:**

*Glassalum Corporation*

**Installer:**

*Diamond Architecturals Inc.*

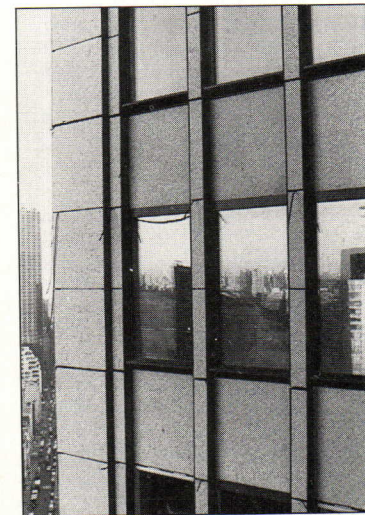
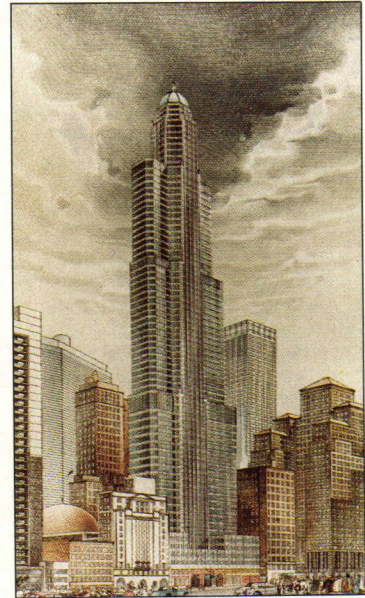
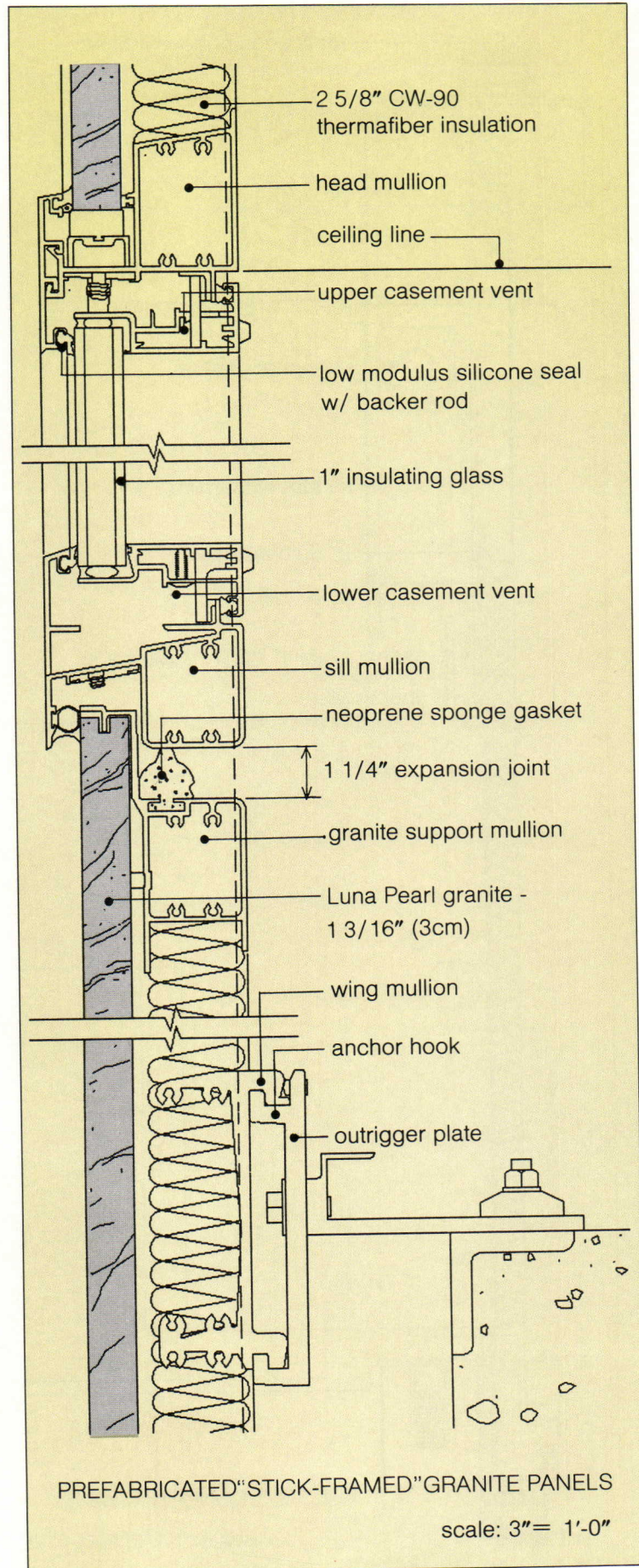



# The Citadel

One of the great advantages of diaphragm panel systems is their inherent flexibility. The panel can accommodate a much greater amount of deflection than would normally be allowed without cracking or otherwise damaging the stone. While normal deflection limits for stone panels may be 1/600 or 1/700, the allowable deflection for a silicone panel system may be 1/360. The stone veneers used in panelized and framed systems cannot themselves take the stresses of wind, thermal, or moisture-related movement, so this movement is taken up by neoprene gaskets and silicone sealants that will accommodate a great deal of movement without deterioration or failure.

The Citadel is a seven-story office building faced in a gray Lombarda Izani granite prefabricated into large panels. The composite diaphragm panel is a lightweight galvanized-steel stud framing with a metal diaphragm attached with screws or rivets. The 3/4-in.-thick granite veneer is fastened with a combination of structural silicone and stainless-steel clip angles.

Polished and flame-finished granite are used in combination (photos, far right). Each panel is lifted into place and attached to the building structure by conventional means, using shelf angles and adjustable bolt connections. Among the innovative aspects of this durable, versatile, and cost-effective system is its use of both adhesive and mechanical attachments.

**The Citadel**  
 Denver, Colorado  
**Owner:**  
 Rosewood Properties  
**Architects:**  
 WZMH Group  
**General contractor:**  
 PCL Construction Ltd.  
**Fabricator:**  
 Elward, Inc.

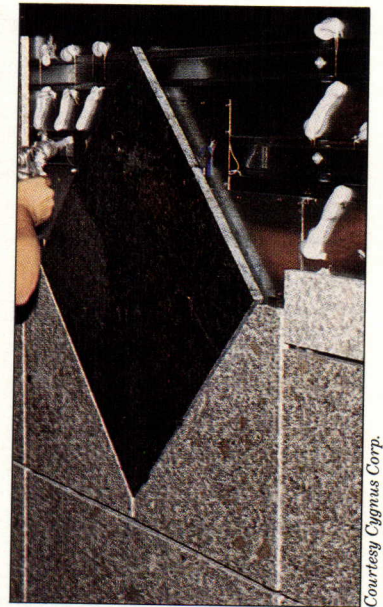
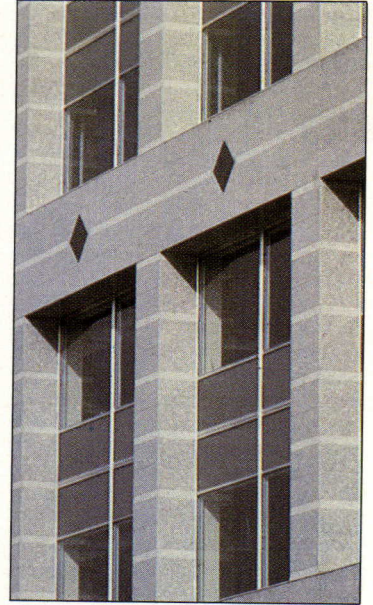
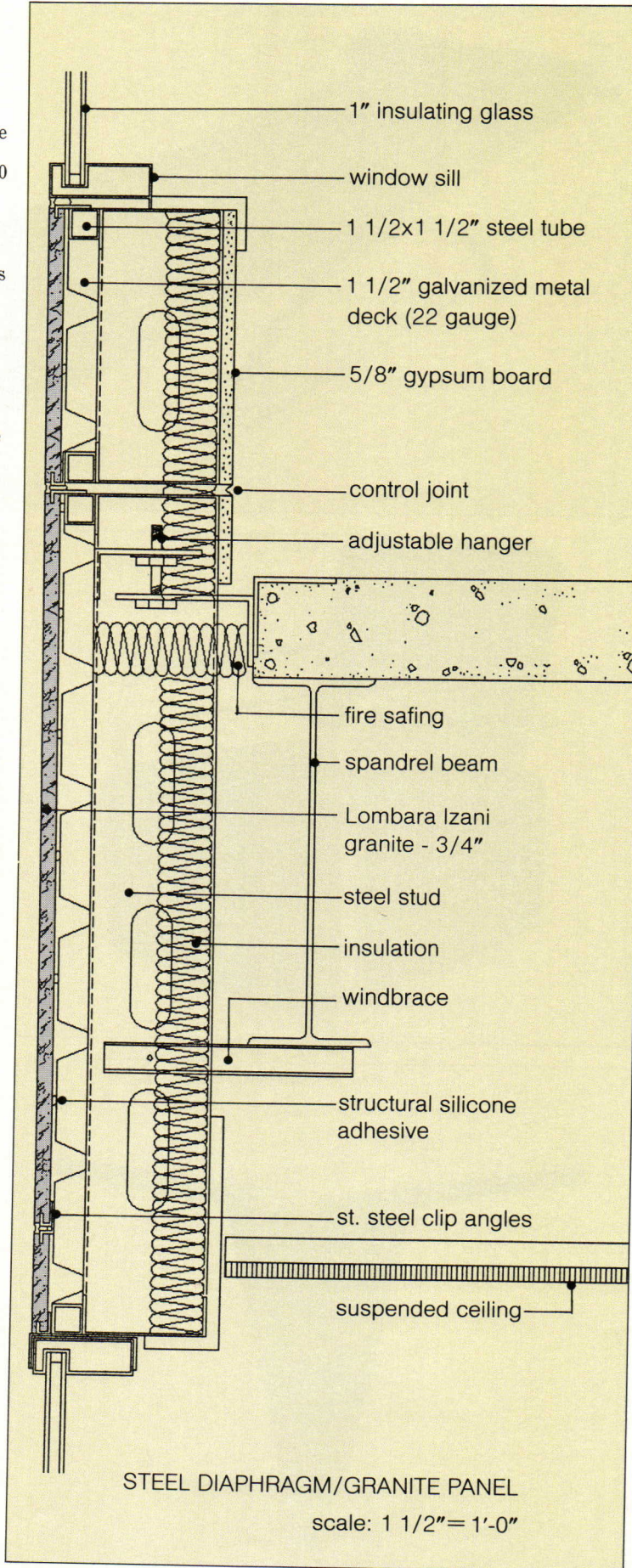

Courtesy Cygnus Corp.



# New products

1. Arc Chaise Longue by Eclair
2. Mona Lisa Chair by Jean-Claude Maugirard
3. Bacchus Chair by Pierre Sala
4. KUB Table by Xavier Pauchard
5. A56 Armchair by Xavier Pauchard

## Vive la VIA

"Seven or eight years ago, contemporary French furniture was essentially a dead issue—Italy had the monopoly," recalls Michael Steinberg, president of Manhattan-based Furniture of the Twentieth Century, and France, apparently, agreed. In 1979, the French Ministry of Industry established the Committee to Promote Innovation in Furniture Design (better known as VIA for *Valorisation de l'Innovation dans l'Ameublement*), a nonprofit agency—funded by a tax paid by French furniture manufacturers—responsible for putting France back on the international furniture map. VIA's various divisions perform a variety of industry-related services: "Support for Creativity in Industry" unites designers and producers of limited editions with furniture manufacturers; the "Educational Assistance Program" trains new designers; and "Reproductions" encourages the rediscovery (i.e., re-editions) of the best furniture designs of this century. Additionally, VIA provides financial assistance for design development, research and tooling, and prototypes. It also helps with distribution, international trade fair promotion, and exhibitions. To raise public consciousness at home, VIA recently opened a Paris showroom, designed by—who else?—France's man of the hour, Philippe Starck. And at the Parc de la Villette, VIA has created "HABITER," the first public exhibition of creative designs for the home. Although American specifiers can find a smattering of VIA-sponsored products at a number of U. S. distributors, at Michael Steinberg's Furniture of the Twentieth Century they can find the greatest concentration—Steinberg holds exclusive stateside distribution rights to some 150 of VIA's 500 furniture pieces. As the 10 examples culled from Furniture of the Twentieth Century's collection at right suggest, VIA is without esthetic prejudice: the gamut runs from the venerable and the classic to the funky and the trendy. The leather club chair (7) and galvanized side chair (5) are, quite obviously, courtesy of VIA's "Reproductions" division; the somewhat threatening-looking daybed (6) and the swirling wire chair (3) are no less obviously more contemporary efforts. Somewhat surprisingly, there is even one piece in the VIA product line that has its roots in this country—Indiana to be precise. The wood-and-web armchair (9) dates from 1910. It was imported by France, and now France—via VIA—is exporting it back. Furniture of the Twentieth Century, New York City. C.K.G. Circle 300 on reader service card

Antoine Bootz photos

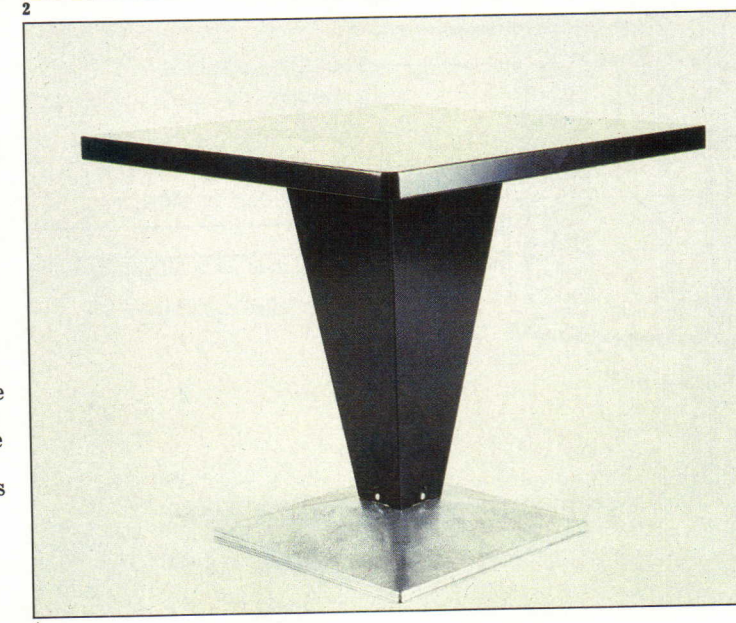
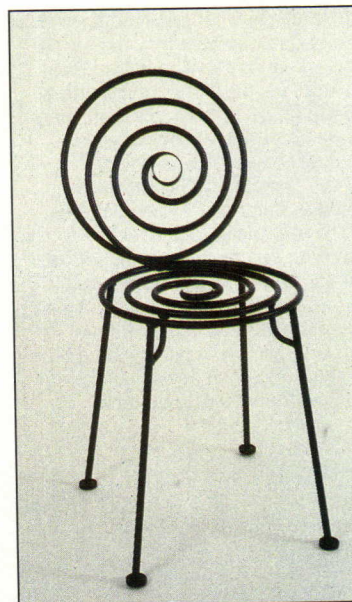



6. *Meduse* Daybed by Jean Louis Godivier  
7. Club Chair, Anonymous  
8. *De Andreis* Desk by Martin Szekeley

9. Captain's Chair, re-edition 1910  
10. *Synthesis* Chair and Stool by Christian Duc

For more information,  
circle item numbers on  
Reader Service Card





Finally, a CAD system created expressly for architects and building design professionals.

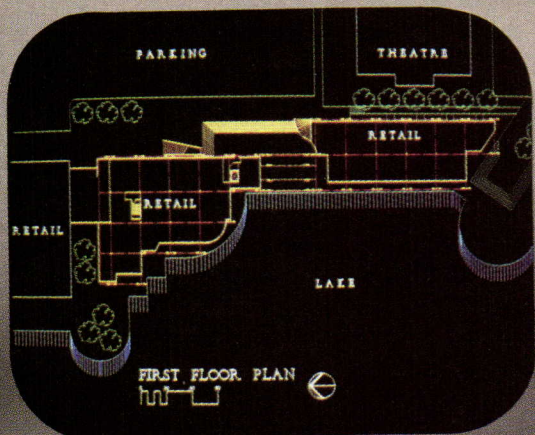

**Production.** Ordinary CAD does drawings one step at a time. ARRIS goes one step further. Simply feed in the basic design parameters, and the system *automatically* does the routine work, and makes any changes. And you can even add ARRIS to your existing CAD system, to complement, extend and enhance its capabilities.

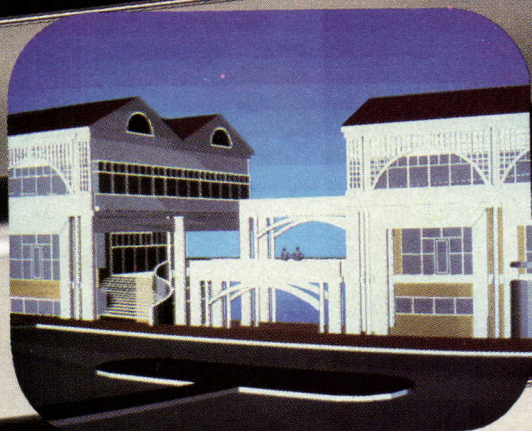

**Presentations.** Ordinary CAD is a generic product. ARRIS has been created specifically for architects and building design professionals. It allows your clients to visualize your projects from any perspective. With sharp, colorful 3-D images that can be transferred easily onto slides.

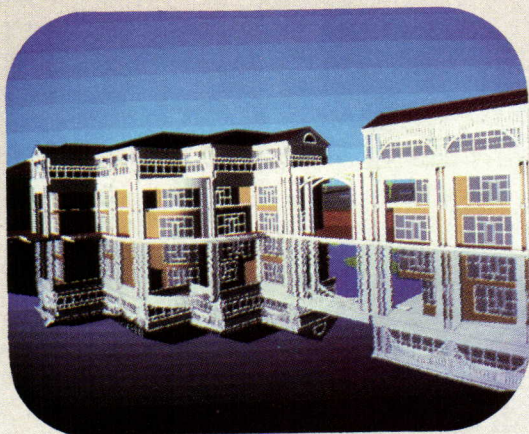

**Plus.** Ordinary CAD was designed and intended for one person, one project. ARRIS is a multi-user, multi-task UNIX-based system. It was designed for the way architects and building designers *really* work, and to allow for future growth. It gives you the competitive edge, and will *keep* you competitive for years to come.

**The leading edge.** Every designer wants it. But as the time change, so do the tools. And today ordinary Computer Aided Design & Drafting is simply not enough.

ARRIS™ has arrived.

Imagine leaving a meeting with a client, making a change in your proposed design — with revised graphics and drawings — and returning to the same meeting *just minutes later*. ARRIS has arrived.

Imagine a CAD system that will not only move a door, window or wall, but will automatically and accurately adjust everything affected. And generate a revised cost estimate based on the changes.

ARRIS has arrived.

Imagine truly *relational* CAD — a single database that incorporates 2D design data and accurate and realistic modeling and rendering. It includes the most advanced techniques available to allow you and your client to view your project from any perspective. Any angle. Any time day or night. And allows you to “walk through” every room and every corridor, as if the building actually existed.





**Panel system**  
A lightweight steel-framed exterior treatment, the *Cygnus* panel can be clad in granite, marble, or ceramic tile, bonded to the steel decking with structural silicone. A color folder provides test data on both natural-stone and ceramic-tile panels. Cygnus, Inc., Denver.  
*Circle 400 on reader service card*



**Curtain-wall framing**  
A brochure describes how the *Universe 2000* curtain wall system interlocks any of four different panels with the attachment members to form a weather-tight seal guaranteed not to leak for five years. The aluminum system can be contoured to create geometric shapes. Dunmon Corp., St. Louis.  
*Circle 406 on reader service card*



**Curtain-wall seal extrusions**  
A Designers Guide profiles typical applications of silicone, dry, and wet/dry glazing seal extrusion products. The complete line of *Vari-Seal* curtain-wall seals includes sponge and wedge gaskets, setting blocks, and spacers for structural glazing. Vari-Seal Corp., Parkman, Ohio.  
*Circle 401 on reader service card*



**Curved aluminum**  
A capabilities folder explains how metal can be stretch-formed into practically any curve in almost any extrusion; individual application sheets illustrate various architectural uses of curved aluminum. Versaform Corp., Santa Ana, Calif.  
*Circle 407 on reader service card*



**Structural glazing**  
An information kit introduces two products engineered to meet structural glazing performance criteria: one-part *Ultraglaze 4000* for on-site work, and *Ultraglaze 4200* for shop assembly of glazed components. Product features for all of this maker's silicone glazing sealants are listed. General Electric Co., Waterford, N. Y.  
*Circle 402 on reader service card*

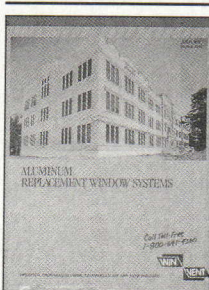

**Dual window systems**  
Projected, casement, and fixed aluminum window systems are shown in a four-page catalog. The dual-glazing technique described allows for vandal-resistant windows with polycarbonate sheet in the exterior light; the interior pane can be glass or other material as required. Win Vent, Inc., Nixa, Mo.  
*Circle 408 on reader service card*



**Architectural panels**  
A 24-page catalog includes structural, dimensional, and test data on wall panels and framing systems; color photos show the manufactured masonry panels used on commercial, multiunit residential, and institutional buildings. Manville, Denver.  
*Circle 403 on reader service card*

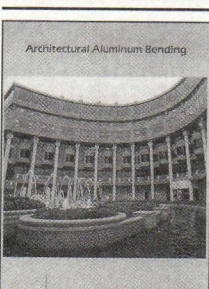

**Architectural aluminum**  
A capabilities brochure highlights the shapes possible in curved architectural aluminum and glazing units. Common bending terms and shapes are illustrated; photographs of the Washington Harbour complex, Washington, D. C., are featured. Dlubak Studios, Inc., Freeport, Pa.  
*Circle 409 on reader service card*



**Veneer wall systems**  
Written by a structural engineering firm as a reference guide for architects, "Designing metal stud/brick veneer curtain wall systems" contains technical information on cavity size, brick-tie spacing, metal-stud design, etc. There is an appendix of manufacturer information. O'Donnell & Naccarato, Inc., Philadelphia.  
*Circle 404 on reader service card*

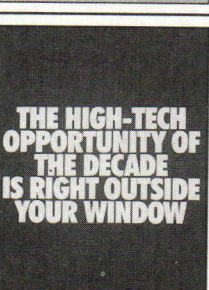

**Highrise window washer**  
A color brochure explains how the *Skywasher*, a mobile robot, cleans up to 50,000 sq ft of windows a day. The 44-lb machine, equipped with wiper blades and washing fluid, crawls along a building's vertical surface on suction-cup feet. Its cost is said to be substantially less than manual washing. I. R. T., Inc., Marina del Rey, Calif.  
*Circle 410 on reader service card*

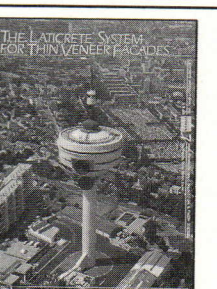

**Installation materials**  
A 12-page booklet uses color application photographs to illustrate the variety of materials suitable for installation with the *Laticrete* system for thin veneer on prefabricated panels. These include ceramic tile, pavers, brick, marble, and natural stone. Laticrete International, Inc., Bethany, Conn.  
*Circle 405 on reader service card*



**Stone panels**  
The *FEI* rigid-steel truss system for constructing exterior walls of granite, marble, and limestone is explained in an illustrated folder. Recent projects using this panelized method are listed. FEI, Tarrytown, N. Y.  
*Circle 411 on reader service card*



# BUILDING REPUTATIONS



## with Laticrete® Panel Systems

Ceramic Tile, Thin Brick,  
Natural Stone

Grout Joint with  
LATICRETE 3701 Admix

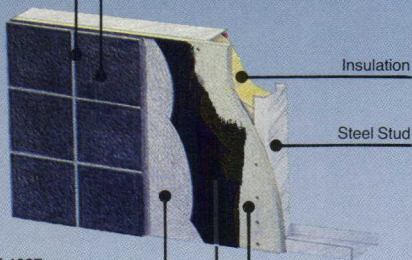

LATICRETE 4237  
Latex Thin Set Mortar

LATICRETE 9235  
Waterproof Membrane

LATICRETE®EP  
Cement Backer Board

Specifying a panel system that is efficient, field proven, and economical can result in a building that is visually exciting as well as functionally efficient. At Laticrete, we've built these key design features into our panel system:

- thin light weight construction
- quick quality controlled fabrication and installation
- variety of form and surfacing materials
- independent laboratory tested — wind load proven
- in shop or on-site fabrication

Build your reputation by building on our reputation . . . specify The Laticrete® Panel Systems.

**See us in Sweets, Section 09390**

Call for technical and architectural service

**(800)243-4788**



**LATICRETE INTERNATIONAL, INC.**  
1 LATICRETE PARK NORTH, BETHANY, CT 06525-3498 U.S.A.  
Tel.: (203) 393-0010, TELEX: 96-3541, TOLL FREE: (800) 243-4788

Circle 55 on inquiry card

© 1985 LATICRETE INTERNATIONAL, INC.



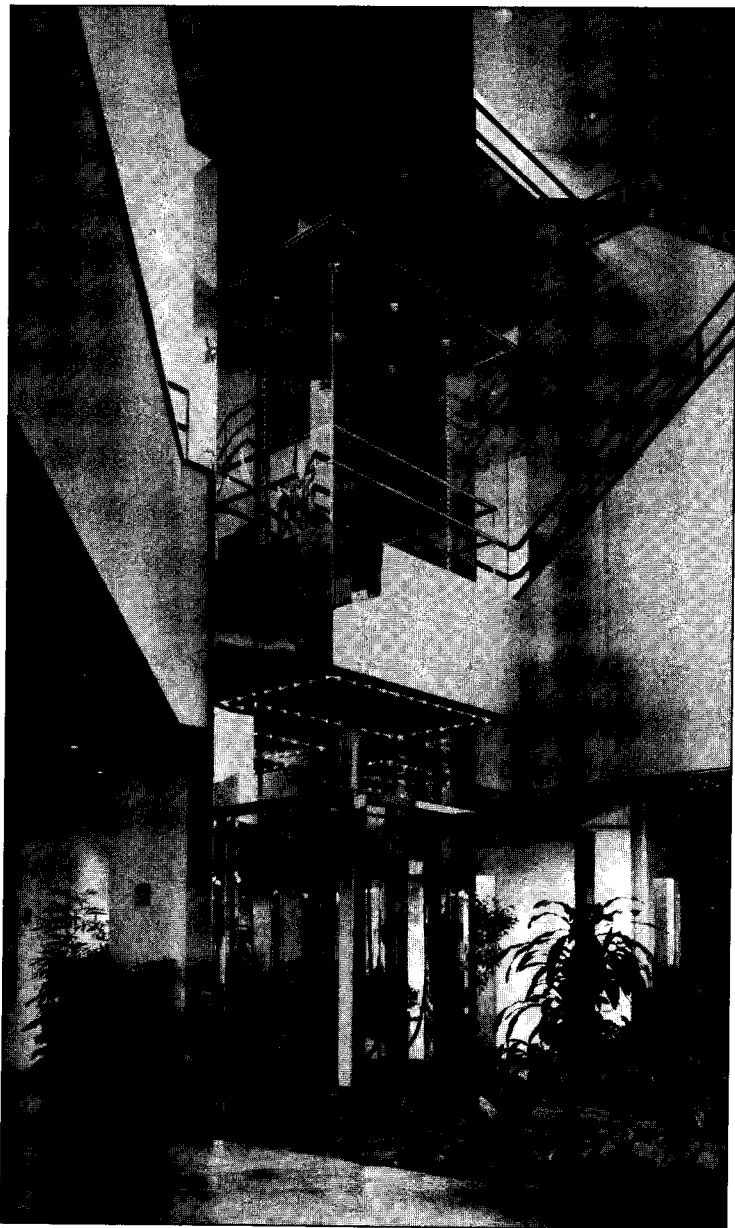

**1**  
**Faster and smarter**  
Hydraulic elevators are widely used in buildings of up to six stories. Usually installed singly or in two-car units, they cannot achieve the speed nor have the programming options of multiple-car, high-rise traction systems. But a new microprocessor control system can make hydraulics excel at what they can do: move people between floors with minimal waiting time (1). The *DMC-1* controller (4) replaces electromechanical controls with a three-element computer network, linking the door operators, car logic (the integral elevator dispatcher), and the position selector.

Cars are dispatched according to position, direction of travel, and the priority of registered calls. Once the system is installed, the *DMC-1* software allows adjustments to more than 40 elevator functions, responding to occupancy or code

changes. It also reduces travel time between floors. For example, when someone holds the doors open, or enters the car as they have started to close (2), the doors reopen just enough, not completely, shaving seconds off travel time. If a user continues to hold the doors open—to finish a conversation or wait for stragglers—a chimed warning will sound, then the doors will gently, but firmly, shut. They start closing as soon as a button is pushed, with no annoying pause before the car moves. Said to be extremely reliable, microprocessors are small enough to be located at point of use: inside the cab behind the control panel, and on the top and sides of the car, precluding damage from heat and vibration of the machine room. Maintenance and changes are effected with a hand-held computer, called a Field Adjusting and Service Tool (*FAST*) (3). Modifications can

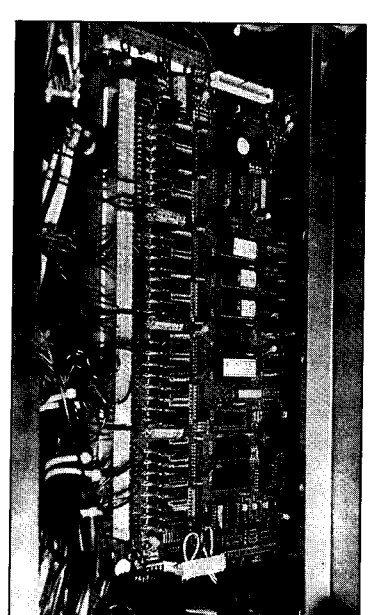

**3**  
be made to door times, rate of travel, slowdown positions, and to program fire emergency or security floor lockout. The *DMC-1* also acts as an on-site observer: any slight in-service malfunctions are stored in its memory and read by the service technician using the *FAST* device during regular maintenance. Dover Elevator Systems, Inc., Memphis, Tenn.  
*Circle 301 on reader service card*



# What made manual AEC drawing obsolete in Japan?

Hitachi HICAD GM-1000™ micro-CADD software.  
Now, for \$1,950, you can use the design tool that's #1 in Japan.

In Japan, efficient space utilization is a well-honed science. It has to be. That's why Hitachi dedicated a division with more than 3,000 software engineers to streamlining AEC design and drafting tasks. The result is the HICAD GM-1000 software package—a dramatic improvement in drawing productivity.

The HICAD GM-1000 software package brings full-function CAD system capability to your desk top, turning your IBM PC®, XT®, AT® or compatible into a CAD workstation.

HICAD GM-1000 gives you the features you need the way you need them—easy to learn and use. HICAD

GM-1000 provides prompts, error messages, and a help button to guide you.

Walls, windows, doors, floors, details, and site plans can be drawn free hand or automatically constructed, then combined, moved, copied, rotated, or scaled to create complex layouts. All entities are stored in a mathematical database that allows high-speed dynamic pan and zoom without interrupting another function.

User definable features include menus, keyboards, mouse, line styles, batches, and advanced macros. Dimensioning, leader lines, balloons, and fail-safe ten-command storage are automatic. Drawings may be separated into as

many as 255 layers and displayed independently or grouped.

HICAD GM-1000 is a package that make manual drawing obsolete for you too. Our demo will show you why. See for details today.

IBM PC, XT, and AT are registered trademarks of International Business Machines Corporation.

## Hitachi America, Ltd.

Computer Division  
950 Elm Avenue, San Bruno, CA 94066  
In U.S.A.: 1-800/538-8157 ext. 867  
In California: 1-800/672-3470 ext. 867



Circle 56 on inquiry card



Image courtesy of Ragan Design Group



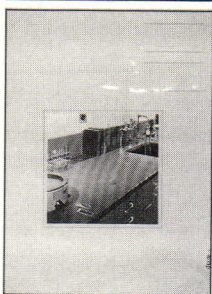

**Laboratory surfaces**

Fiber-cement panels engineered for the stain-, solvent-, and flame-resistant requirements of laboratory work surfaces are covered in a 12-page catalog. *Colorlith II* and *Colorceran II* counters are pictured in place; economical natural gray panel products are also included. Manville, Denver.

Circle 412 on reader service card

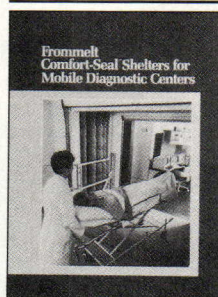

**Patient-transfer shelter**

A color folder explains how custom-designed *Comfort-Seal* fabric shelters extend from the hospital building to protect patients entering mobile diagnostic units. Rolling-frame, inflatable, and sliding-curtain configurations are some of the installations shown. Frommelt Industries, Inc., Dubuque, Iowa.

Circle 418 on reader service card



**Hand-made sheet glass**

A mouthblown glass from Germany, *Restoration Glass* is available in 42- by 42-in. sheets for use in landmark and period restoration projects. A data sheet explains how the slight distortions and occasional pits and imperfections of the glass provide an antique appearance. S. A. Bendheim Co., Inc., New York City.

Circle 413 on reader service card



**Architectural fabrications**

A color catalog illustrates architectural ceiling, soffit, and column installations using prefabricated and custom-molded shapes. Made of high-strength gypsum cement reinforced with glass fiber, *Plastrglas* has a zero flame spread, and is said to be economical and easy to decorate. Plastrglas, Inc., Omaha, Neb.

Circle 419 on reader service card

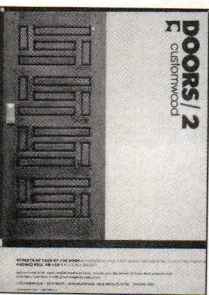

**Wood doors**

Deeply carved passage and entrance doors of red oak, Ponderosa pine, walnut, and Philippine mahogany are illustrated in a product brochure from *Customwood*. Doors are shown in a double-door installation; coordinating bronze pulls are featured with each door.

Customwood, Albuquerque, N. M.  
Circle 414 on reader service card



**Wet-location fixtures**

*Wallmount* light fixtures have a hinged front housing that facilitates relamping. A catalog sheet explains how light from various HID sources is spread out and down from a vertical surface, and suggests *Wallmount* units for garages, ramps, security lighting, and recreational areas. Hazlux, Div. FL Blackburn, St. Louis.

Circle 420 on reader service card

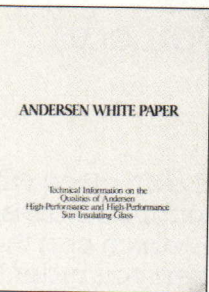

**High-performance glazing**

A five-section technical guide to insulating and low-emissivity glazing describes how heat is transmitted through various glazing configurations. The text compares optical and thermal properties of glass, and explains the differences between "soft" and "hard" glass coatings. Andersen Corp., Bayport, Minn.

Circle 415 on reader service card



**Earthquake design**

A newsletter published by a manufacturer of lead-rubber bearings, *Seismic Isolation Update* deals with the application of advanced seismic technology to buildings and bridges. Case studies demonstrate how seismically isolated structures behave during earthquakes. Dynamic Isolation Systems, Inc., Berkeley, Calif.

Circle 421 on reader service card



**Drafting supplies**

A full-line catalog from a national distributor of drafting and print equipment presents furniture, lights, files, and similar items for the architectural office. New products featured in the 64-page brochure include an expanded line of plotter media, pens, and inks. Dataprint Corp., San Mateo, Calif.

Circle 416 on reader service card

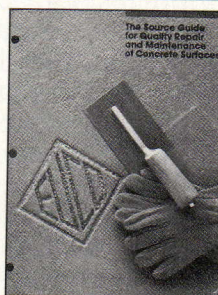

**Concrete maintenance**

A four-page guide charts the proper selection and application of latex, cement-based, and epoxy materials designed for concrete repair and maintenance. Admixtures, patch and joint mortars, and fast-setting products are included. The Euclid Chemical Co., Cleveland.

Circle 422 on reader service card



**Handcrafted ceramic tile**

An information packet from *Epro* describes the various steps in the production of hand-crafted ceramic tiles, and illustrates *Heritage*, *Sandstone*, and *Gallery* product lines. Glazed and unglazed tiles are offered for residential and commercial applications, both interior and exterior. Epro, Inc., Westerville, Ohio.

Circle 417 on reader service card

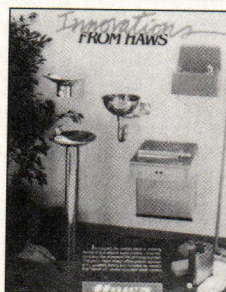

**Fountains/coolers**

Product photos and dimensional drawings illustrate a color catalog on the full line of *Haws* drinking fountains, electric water coolers, and emergency equipment. Sensor-operated coolers are featured. Haws Drinking Faucet Co., Berkeley, Calif.

Circle 423 on reader service card



# The Winning Bid Combination

Dodge Remodel/Retrofit Estimator  
and Dodge Construction Database  
From **Dodge MicroSystems**



...The software estimating package that provides a database you can use **today**...The software that produces bids that are flexible, fast, and right on the money.

Your bids win more jobs because Remodel/Retrofit Estimator puts Dodge's database of labor and material prices right into your PC. Dodge has been tracking construction costs since 1891, and no other source has the same experience or expertise. So your estimates reflect current costs for the area you're working in. Quarterly updates are also available to keep your bids up-to-the-minute.

#### **Versatile Software for Flexible Bids.**

Of course, you can insert your own pricing data for a more customized estimate or to meet special conditions. Remodel/Retrofit Estimator also lets you input descriptions and notes on specific repairs into your estimate. Options for "write-ins" include custom repair, quantity override, overhead and profit, payroll tax, insurance

charges, sales tax, and a "what-if" feature to check the effect price changes would make on your bottom line.

Input residential or commercial project information into the program, then let the software calculate your final estimate. Designed to run on any IBM PC or compatible, the menu-driven program features handy built-in prompts to guide you through each step. There's also a HELP function to turn to for direction. You can print out reports by trade for each estimate, or choose a variety of printing options including one estimate at a time, up to five copies of the same estimate in succession, and a list of all repair descriptions and costs in the Price Table.

#### **Try the Demo Kit First**

You can preview Remodel/Retrofit

Estimator in your own office with our detailed Tutorial/Demo Disk. The kit costs \$25, which can be deducted when you order the full program.

Or order the full program now and receive the current volume of **Dodge Remodeling/Retrofit Cost Data**—free. (\$45 value) Price of Dodge Remodel/Retrofit Estimator \$545. American Express, VISA and MasterCard accepted.

For more information or to order Remodel/Retrofit Estimator or the Demo Kit, simply call our toll-free number today: 800/257-5295 (in New Jersey, call 609/426-7300) or ask for Lee White.



**Dodge Cost Systems**  
McGraw-Hill Information  
Systems Company





**Vandal-proof light**

The *2800 Deco-Cell* is one of a series of fixtures designed for unattended areas in public housing or other sites requiring extremely durable, energy-efficient lighting. It has low-profile, twin-tube 13W lamps set into a 3-in.-deep polycarbonate housing to look recessed without the additional installation cost. Kenall Mfg. Co., Chicago.  
 Circle 302 on reader service card

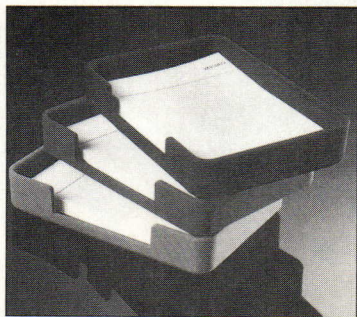

**Desk accessories**

Both of the *Modu Plus* desk-accessory lines from *Smokador* are now available in a suede-like, textured *Nextel* plastic finish called *Sof-Stone*. The accessory collection comes in light and dark gray and black colors. Smokador, Edison, N. J.  
 Circle 305 on reader service card

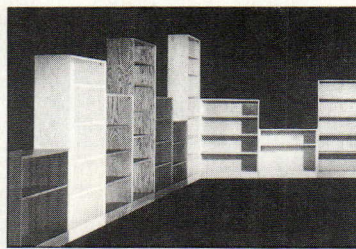

**Library bookcases**

Made of hardwood veneered in birch, oak, or walnut, book and display cases are available in a *European* style, with radius corners, as well as the *Barrister* sectional case shown here. Constructed for library and office use, cases have solid hardwood shelves; finish options include custom-match, natural, and opaque stains. F. E. Hale Mfg. Co., Inc., Herkimer, N. Y.  
 Circle 306 on reader service card

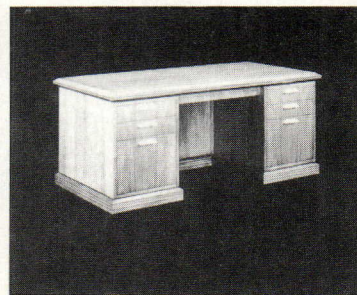

**Executive desk**

Designed by O. J. Holohan for the *Hampton 9500* executive office line, this traditional-style desk may be specified in four tops, including burl walnut and leather. Desk is finished in scratch-resistant catalyzed lacquer. JOFCO, Jasper, Ind.  
 Circle 307 on reader service card  
 Continued on page 165

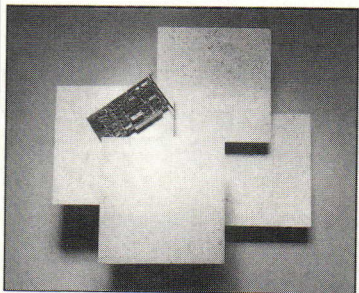

**Static-dissipative flooring**

Designed for the higher electrical-resistance requirements of electronics manufacturing, computer-equipment installations, and clean rooms, *Statmate* solid vinyl tile, adhered with conductive epoxy adhesive, creates a path of moderate electrical conductivity to drain personnel-generated static charges to ground. The *Statmate* floor comes in 12-in. square tiles, and 36- by 36-in. sections for color-matched, seam-welding installations; its marble chip pattern is available in four shades. VPI, Sheboygan, Wis.  
 Circle 303 on reader service card

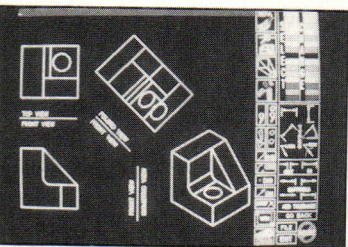

**Desktop CAD software**

Described as a major enhancement of this vendor's 3-D CAD software, *Personal Designer Version 3.0* provides a multiple-view capability, improved geometry-associated dimensioning, and an undo function that allows the user to cancel one or more previously executed commands. In the multiple-view mode (shown), a three-dimensional part is seen from several orientations at once; changes made in one view are automatically updated in the others. Computervision Corp., Bedford, Mass.  
 Circle 304 on reader service card

# Industrial Strength Floor

Nora Flooring has developed a line of synthetic rubber floors specifically for areas subject to extreme conditions. The industrial strength qualities of these floors include:

- ESD control — conductive and static dissipative.
- Heavy duty service — support forklift and cart traffic to high PSI.
- Burn-resistance against cigarettes, solder, welding sparks.
- Oil and grease resistance.
- Softness — to reduce worker fatigue.
- Quietness under foot.
- 10-Year Wear Warranty.

For more information contact Nora Flooring.

#1 in the World

**nora  
flooring**

4201 Wilson Avenue  
 Madison, IN 47250  
 (812) 273-1852

© 1987 Nora Flooring

Circle 59 on inquiry card

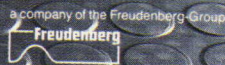



# excellence...

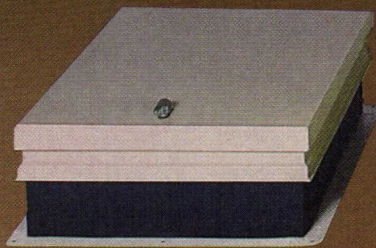
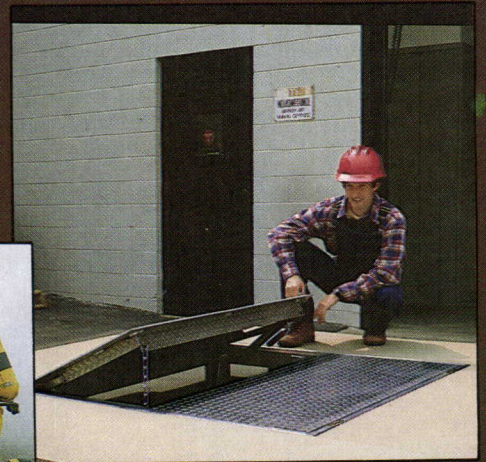
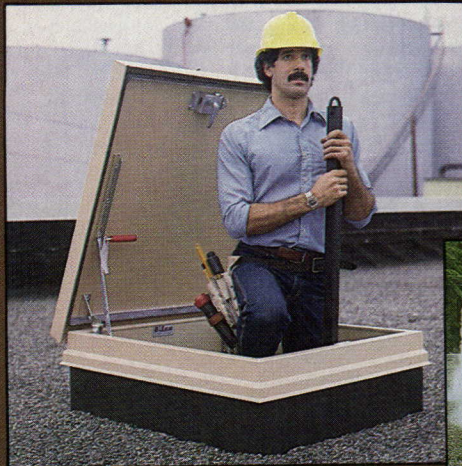

Shown above with the new Bilco LadderUp Safety Post

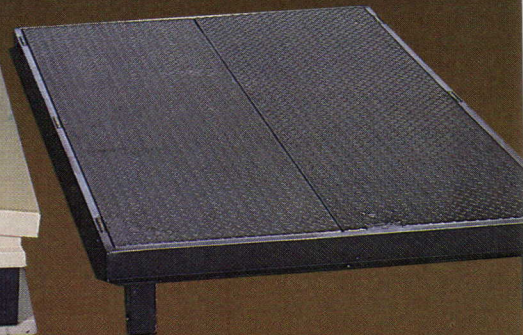
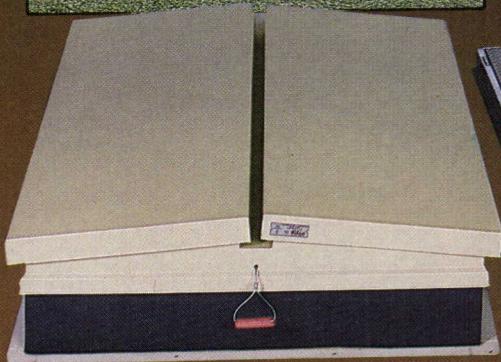

## from the way they're built... to the way they work.

When you specify Bilco horizontal doors or automatic fire vents, you specify products that are built to give long, trouble-free service. Products that are designed to work. Smoothly, easily, reliably.

Shown are three examples of how Bilco excellence in design and workmanship translates to benefits for your client. The Type S ladder access roof scuttle featuring the safety and convenience of one-hand operation. The Type

D-SH automatic fire vent with the exclusive Thermo-latch® positive hold/release mechanism for dependability when fire occurs, and security against inadvertent opening at other times. The Type JD walk-over access door with built-in compression spring mechanisms for easy operation of the heavy plate doors.

Excellence. It comes with every Bilco product.

*Specify Bilco. There is no equal...*

For complete information, details and specifications see Sweet's® General Building, Industrial Construction and Engineering Files, or send for a copy.

**Bilco**®

DOORS FOR  
SPECIAL SERVICES

The Bilco Company,  
P.O. Box 1203, New Haven, CT 06505

Circle 60 on inquiry card



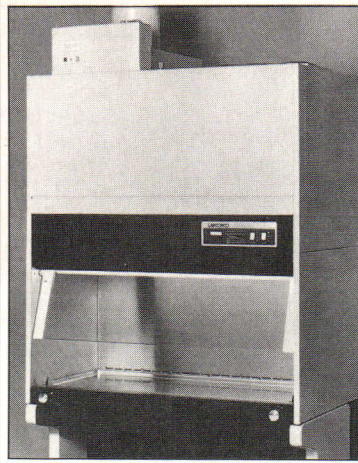

**Exhaust laboratory cabinet**  
Designed for Class II laboratories working with low to moderate risk biologicals, the *Purifier Total Exhaust Safety Cabinet* vents all air through a HEPA filter, with no recirculation into the laboratory. Cabinets come in 4- and 6-ft lengths. The clear glass door swings open and locks in three positions; its slope design is said to provide a closer view than vertical sash. Labconco, Kansas City, Mo.  
Circle 308 on reader service card

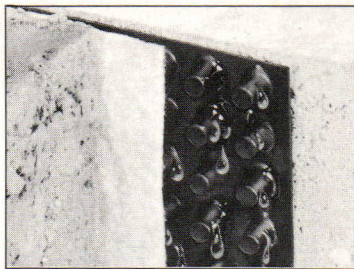

**Foundation drainage**  
Prefabricated of high-impact styrene, 4- by 8-ft *Aquadrain 15X* panels are said to eliminate the uneven placement, compacting, and soil clogging problems of aggregate backfill foundation drain systems. A durable filter fabric is glued to the raised cups that form the drain itself, creating a void network to carry off subsoil water. American Colloid Co., Arlington Heights, Ill.  
Circle 311 on reader service card

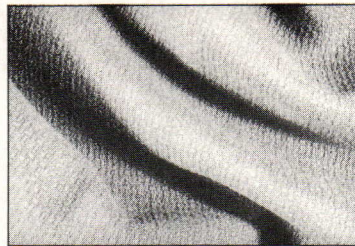

**Fire-resistant fabrics**  
A textured weave, *Granite Cloth* from *Arc-Com* is part of a recently introduced collection of casement, upholstery, panel, and hospitality fabrics made of *Trevira for FR* polyester. Produced to meet the flame-resistant requirements of contract applications, *Trevira for FR* is said to provide superior drapability and a soft hand without any stiffness. Hoechst Fibers Industries, New York City.  
Circle 312 on reader service card



**Side chair**  
This updated version of the *Enrico Elite* chair features a chrome-plated frame with mitered joints. The chair is suggested for reception areas and office use. Loewenstein/Oggo, Pompano Beach, Fla.  
Circle 313 on reader service card  
Continued on page 167

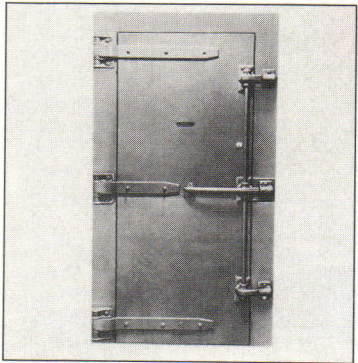

**Sound-reduction door**  
A lighter-weight, competitively-priced line of sound doors includes this 3- by 7-ft personnel door. For theaters, TV studios, industry, and test facilities, doors are said to be easier to install and operate, with gasketing able to provide both RFI and EMI shielding. Door assemblies come in various thicknesses, for certified test values of up to STC 57, and in units up to 30- by 30-ft. Jamison Door Co., Hagerstown, Md.  
Circle 309 on reader service card

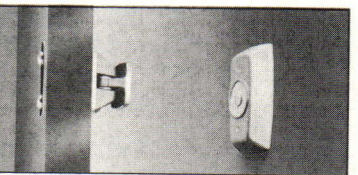

**Fire-door operator**  
Electromagnetic holders for fire and smoke barrier doors have been added to LCN's line of door activator products. The UL-listed *Sentronic* device may be mounted on the floor or wall surface, or recessed into the wall. Heavy-duty magnetic holders are wired into the alarm system, and release the doors with a spring-loaded positive action when triggered by a power cut. Holders may also be used on pocket door installations. LCN Closers, Princeton, Ill.  
Circle 310 on reader service card

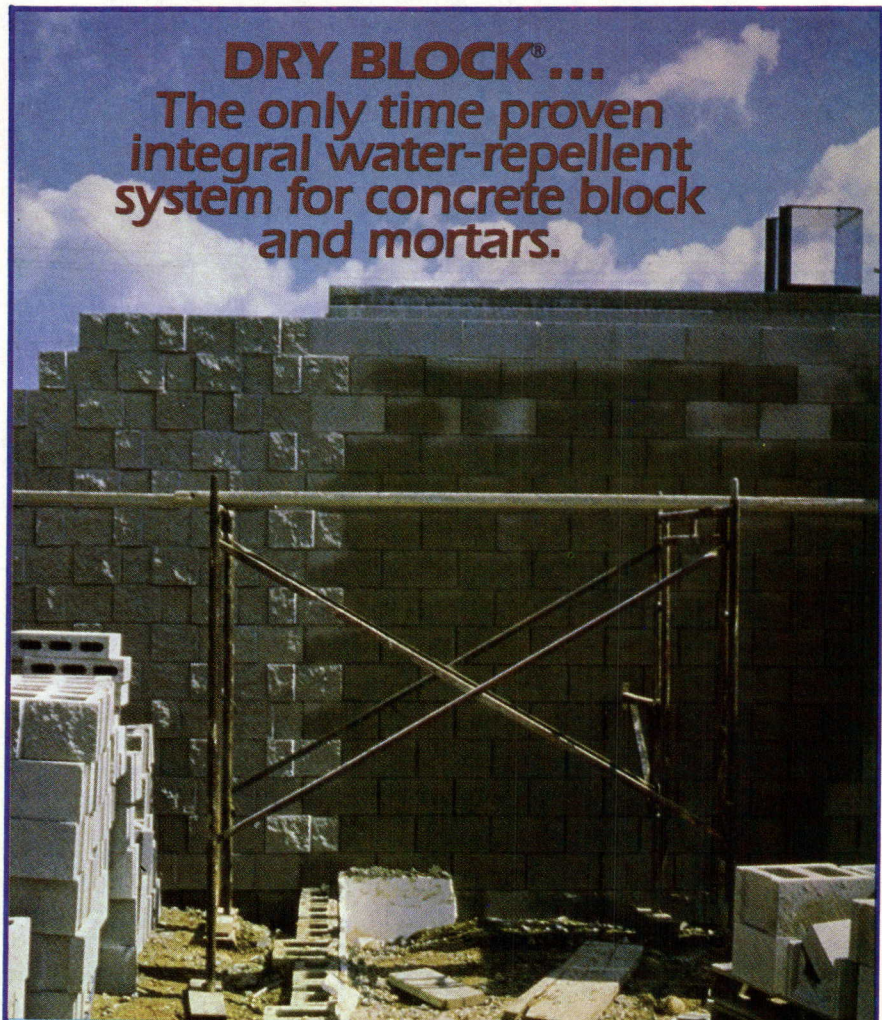

**DRY-BLOCK® ...**  
The only time proven  
integral water-repellent  
system for concrete block  
and mortars.

DRY-BLOCK® wall on left, standard block interior wall on right showing water absorption.

Thousands of applications throughout the United States and Canada prove that the DRY-BLOCK® system really works. Don't be misled by cheap imitations, specify the only proven one... DRY-BLOCK® from Forrer Chemical.

fications, producers and applications in your area available upon request.



Complete test results, speci-

7221 West Parkland Court, Milwaukee, Wisconsin 53223 • 1-800-558-7066

Circle 61 on inquiry card



# HIGH R-VALUE

# PLUS

The Advantages of

# FOAMGLAS<sup>®</sup>

# PC PLUS SYSTEMS<sup>™</sup>

3" UNDERLAYMENT

1½" UNDERLAYMENT

The nucleus of the three PC PLUS SYSTEMS<sup>™</sup> is FOAMGLAS<sup>®</sup> cellular glass insulation — it provides all the Systems with constant insulating value because it is totally resistant to moisture.

PC PLUS SYSTEMS<sup>™</sup> take advantage of the superior insulating properties and physical characteristics of Pittsburgh Corning's cellular glass and foamed plastic insulations. All three systems are compatible with modified bitumen, built-up-roof, and single-ply membranes.

**Each PC PLUS SYSTEM has a Top Layer of Tapered FOAMGLAS<sup>®</sup> Insulation and an Underlayment that Satisfies Specific Insulation Requirements.**

**PC PLUS SYSTEM 1** - Tapered FOAMGLAS<sup>®</sup> Insulation with an underlayment of FOAMGLAS<sup>®</sup>-Board or Block insulation. The All-FOAMGLAS<sup>®</sup> system is recommended where long-term reliability and total resistance to moisture is critical. Ideal for roofs over high moisture, high humidity areas and on refrigerated structures. This system carries Pittsburgh Corning's exclusive 20-year performance warranty.

**PC PLUS SYSTEM 2** - Tapered FOAMGLAS<sup>®</sup> Insulation with an underlayment of Pittsburgh Corning's PF (Phenolic Foam) Insulation boards. PC PLUS SYSTEM 2 offers the stability of FOAMGLAS<sup>®</sup> insulation and the highest R-value of these systems. It's recommended for buildings with normal interior temperatures and humidities and when insulation thickness is limited by physical or cost restrictions. Limited 20-year warranty.

**PC PLUS SYSTEM 3** - Tapered FOAMGLAS<sup>®</sup> Insulation with an underlayment of Pittsburgh Corning PI (Polyisocyanurate Foam) Insulation boards. This system offers the stability of FOAMGLAS<sup>®</sup> Insulation and the high R-value of the PI Underlayment. Recommended for buildings with normal interior temperatures and humidities which require a high R-value roof, or where low cost is important.

For more information, contact Pittsburgh Corning Corporation, Marketing Dept. FB-7, 800 Pres Isle Drive, Pittsburgh, PA 15239 call 800-992-5769 (in Pennsylvania 800-992-5762). In Canada, 106 Lansing Square, Willowdale, Ont. M2J 1T5. Tel: (416) 222-8084.

Circle 62 on inquiry card

**PITTSBURGH**  
**PC**<sup>®</sup>  
**CORNING**

**THE  
INNOVATIVE  
INSULATION  
PEOPLE**





**Breuer seating**  
Working from chairs designed by Marcel Breuer but not produced before his death in 1981, long-time Breuer partner Herbert Beckhard has developed a furniture collection for *Cadsana*. This double-spring chair has an aluminum frame, with a structural leather seat stitched in a manner recalling the wooden slats of the original chaise. A foam-padded fabric construction is also available. *Cadsana*, Greenwich, Conn.  
Circle 314 on reader service card



**Outdoor exercise system**  
The *Fit-Trail* is a self-instructed, self-paced series of exercises using wooden apparatus set at intervals in a landscape, or clustered where space is limited. A 10-station *Fit-Trail* is now offered for smaller sites, as well as a 20-station installation and a less-strenuous series for seniors. Polycarbonate signage is guaranteed unbreakable. SouthWood Corp., Charlotte, N. C.  
Circle 317 on reader service card

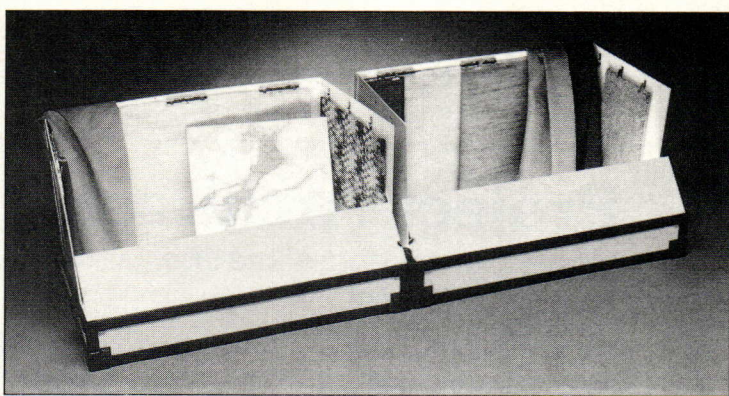

**Portable light lab**  
The *Colite* light viewing display case provides two viewing compartments for testing the effect of eight different sources of artificial light (six fluorescent and two incandescent with dimmer controls) on the appearance of

finishes and fabrics used in interiors. The portable (30-lb) unit comes in an impact-resistant ABS case, and contains trays for storage and protection of the various lamps. *Colite*, San Diego, Calif.  
Circle 318 on reader service card



**Site directory**  
A large-scale directory provides both site identification and changeable panels for tenant names. It may be ordered up to 6-ft-wide. The aluminum sign comes in metallic and polyurethane enamel colors. Charleston Industries, Inc., Elk Grove Village, Ill.  
Circle 315 on reader service card

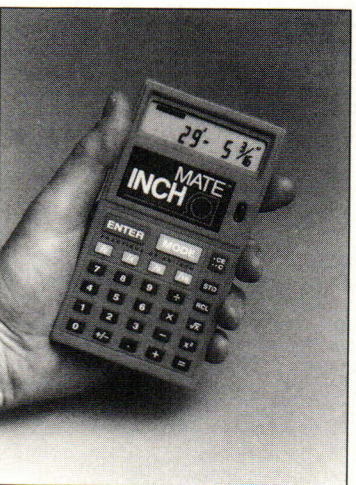

**Dimension calculator**  
The pocket-size *Inch-Mate* directly calculates feet, inch, and fraction dimensions, from measurements entered just as they would be written. It also converts figures to decimal feet or meters. *Inch-Mate* was developed by architects and builders to speed up the lowest common denominator process, with accuracy to 1/16 of an inch. Digitool Corp., Aspen, Colo.  
Circle 316 on reader service card



Union College Mall  
Lincoln, NE  
Clark Enerson Partners, Arch.

**ENERGY EFFICIENT CLEARSPAN SKYROOFS . . .**

**Another of our major advances in the state-of-the-art . . . the Structures Unlimited "Skyroof" System!**

A material that *transmits diffused daylight* to eliminate lighting energy usage in the daytime; that *controls solar heat* transmission to allow maximum heat gain for passive solar applications, or as little as 10% (compared with glass) to save air conditioning costs; that *insulates* up to 86% more efficiently than single glazing!

Combined with our engineered aluminum structural system, Clearspan Skyroofs up to 100 foot span are a reality.

Complete, under only one contract - one responsibility!

**STRUCTURES UNLIMITED, INC.**

P.O. Box 4105, Manchester, NH 03108 Phone 603-627-7887

Circle 63 on inquiry card



# Project Architect

*Come join us and share the beauty of Maine!*

We are seeking a Project Architect with good interpersonal skills, minimum 5 years' experience, skilled in design, design development and project management.

Excellent compensation and benefits package.  
Send resume or call: John A. Missell.

**HARRIMAN ASSOCIATES**  
Architects/Engineers

292 Court Street, Auburn, Maine 04210  
(207) 784-5728

An equal opportunity employer m/f

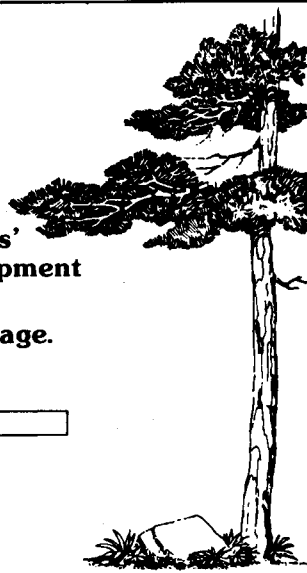

BINKLEY & HOLMES, INC.  
CONSULTING ENGINEERS

1710 SEAMIST DR. HOUSTON, TX 77008  
713/869-3433

101 SIMONTON, CONROE, TX 77301  
409/760-3371

7800 STEMMONS FWY. #360, DALLAS, TX 7524  
214/637-3414

- WATER RESOURCES
- WASTE MANAGEMENT
- TRANSPORTATION
- CIVIL/SITE DEVELOPMENT
- COMMERCIAL/INDUSTRIAL MEP
- POWER & INSTRUMENTATION
- CONSTRUCTION MANAGEMENT
- COMPUTER DESIGN & DRAFTING

POSITIONS VACANT

**Coordinator of Chinese Historical Art and Architectural Research and Design.** Full time position available in experimental design studios. Duties include: research of contemporary and historical Chinese art and architecture; design of commercial and residential interiors and exteriors, blending Far East and Western design concepts; serve as liaison with Chinese consultants; prepare scaled drawings and models; conduct on-site inspections of works in progress. Requirements: BA degree in Architecture or related field; fluency in Chinese and English; basic knowledge of Chinese Western art and architectural history. 40+ hrs. per wk. \$8.28 per hr. Time available for overtime. Apply to: Job Service, 5 Trade St., Charlotte, NC 28202. Job #NC6602056. DOT code 001.061-010.

**Architectural Designer — Formulate layout and design proposals for commercial, industrial and public buildings in compliance with site and code restrictions.** Consult with clients to determine that design meets requirements of budget, program, function and space. Conduct market research. Prepare information design specifications, materials and estimates. Prepare graphic and large format graphic layout and computer graphics for project. Integrate architectural elements into unified design. Prepare scale model, drawings and contract documents for bid and to build. Provide contract administration services. Photograph architecture for publications. \$27,200.00/hrs./wk., 8a.m.-5p.m. Requires Master's in Architecture and 2 years experience as Graphic Designer. Send resume to Job Service of Florida, 105 E. B Blvd., Ft. Lauderdale, FL 33301, Attn: Job #FL5748241.

**New York City Architectural firm seeking Principal Level Person or Persons to lead a new Design Affiliate Firm.** Current volume of interior design commissions will support 8-12. Proven design in mixed use office and specialized care settings. Client relationships, business development and management are important. Base compensation of \$2124, Architectural Record.

**Architects — \$25,000-85,000 Growth Search Executive Architectural Recruitment positions nationwide at all levels with Fortune 500 & National firms.** Experience in research and development, health care, commercial, criminal justice, educational, institutional, industrial and multi-family projects. Confidential. No salary requirements. 4917 Ehrlich Suite 103, Tampa, FL 33624, (813) 969-0500

# PROJECT MANAGER

Interstate Hotels Corporation—the largest owner and operator of Marriott Hotels—is currently seeking a Project Manager. Based in Pittsburgh, this executive would have on-site responsibility for management overview of general contractor, separate owner—provided contractors and consultants. While also conscientious of design, the Project Manager must meet critical deadlines and manage under demanding budgets for up to two new hotel projects at any one time. The Project Manager would additionally coordinate the installation and turnover aspects of Hotel pre-opening with operations staff.

The position requires at least three years of prime responsibility in the construction of first-class, full-service hotels with a degree in Architecture Engineering or Construction. The ideal candidate would also be a Registered Professional. Compensation includes competitive base and insurance with bonus, car allowance, and relocation.

Send resume or letter, or call: Michael Lawrence or Leslie Braun—Interstate Hotels Corporation, 218 Frick Building, Pittsburgh, PA 15219, 412-227-6700.

An Equal Opportunity Employer



## PROJECT DIRECTORS PROJECT ARCHITECTS

N.Y., Chicago

### HEALTH CARE MARKETER

Orlando

### SR. PROJECT DESIGNER SR. MECHANICAL ENGINEER SR. ELECTRICAL ENGINEER

Iowa City

Due to staff expansion and new, large long-term projects, Hansen Lind Meyer Inc., is offering you the opportunity to join one of the largest A/E design firms in the country. Share in a variety of challenging opportunities with a growth-oriented firm. Enjoy a diversified client base and be part of our team approach to projects. Please submit letter of application, resume and salary requirements to Director of Personnel.

#### HANSEN LIND MEYER INC.

Plaza Centre One  
Drawer 310  
Iowa City, Iowa 52244

EOE/M/F

POSITIONS VACANT

**Architect / Chief Designer. We offer top career opportunity, leading to Director of Architecture position and full partnership in our well-established A-E firm.** We have provided quality service over four decades to institutions, major corporations and various state and federal agencies. Location in Midwest regional center with quality university and other cultural enterprises. Please submit personal letter and resume with compensation requirements, in confidence to: P-2153, Architectural Record.

POSITIONS VACANT

**Michael Latas & Associates, Executive Search and Professional Recruiting Consultants, Specialists in the architectural and engineering fields.** Operating nationally. Inquiries held in the strictest of confidence. 1311 Lindbergh Plaza Center, St. Louis, Missouri 63132; (314) 993-6500.



# Sometimes what you thought would last, lasted. But not the way you thought.

If you've been swayed to believe that glazed tile is a good choice for high traffic floors, you've been presented with a lopsided view.

Real quarry tile is the only smart choice for long-lasting results in heavy traffic areas. Summitville quarry tile is made from the



finest clay and shale, extruded to provide uniform density, strength and color — a full 1/2" of solid color that lasts and lasts.

Compare that to the .0025" surface treatment of a glazed paver tile that has been advertised as suitable for high traffic areas.

Why risk performance with a product that claims to be "the smart choice over quarry" when you can have the real thing...Summitville quarry tile, a proven performer that passes the tests of time and heavy traffic.

Check the standards before you specify. Glazed tile that wears out before its time could set your best laid plans askew. But Summitville quarry tile will last just like you thought it would.

 **Summitville<sup>®</sup>**

Summitville Tiles Inc. • Summitville, Ohio 43962

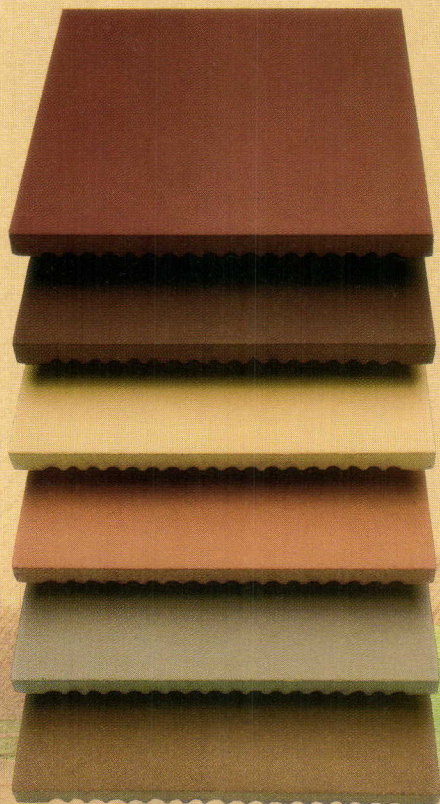





1



2



3

# Six major reasons to specify Sloan...

# the first time.

At first glance, it's difficult to imagine how these six different buildings are related. But if you take a closer look at their histories, you'll find they all share a common theme: the washrooms in all six buildings have been refitted with Sloan flushometers.

True, these buildings don't look old enough to need major plumbing repairs. But the fact is, the original flushometers that were installed just didn't hold up. Even after repeated servicing, they continued to malfunction. They didn't shut off properly. They leaked at the stops. In some cases, they even flooded the washrooms. In short, they weren't Sloan flushometers.

Unlike substitutes, Sloan flushometers offer proven, reliable service. With built-in quality at an affordable price. That's why today more buildings are equipped with Sloan flushometers than with any other brand.

Only Sloan's rugged, tamper-proof design can assure the quiet, dependable operation so critical in buildings like these. Plus, Sloan flushometers are built to last for years with only minimal, routine maintenance—an important consideration for specifiers who value time and money.

The next time you consider specifying a substitute, think about these six buildings. Then specify Sloan. The first time.



4



5

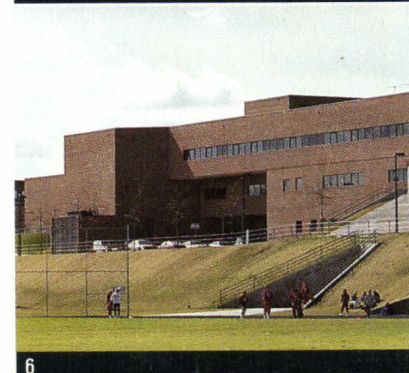

6

1. Psychiatric Center of Michigan Hospital, New Baltimore, MI   2. YMCA of Raleigh, NC  
 3. Barnett Bank, Tampa, FL   4. S.E. Louisiana University School of Nursing, Baton Rouge, LA  
 5. Southwest Financial Plaza, Phoenix, AZ   6. North Central High School, Spokane, WA



**SLOAN VALVE COMPANY**

10500 Seymour Avenue, Franklin Park, IL 60131

*A Tradition of Quality and Pride*

