

# ARCHITECTURAL RECORD

Business Design Engineering  
A McGraw-Hill Publication, Seven Dollars  
November 1988



**the  
public  
interest:  
new  
wards program**





# CUSTOM CEILINGS

New 2' x 2' Syllables<sup>®</sup> ceiling system. Seven systems available. Each offers unlimited custom opportunities. For our brochure, call 1 800 233-3823 and ask for Custom Ceilings.



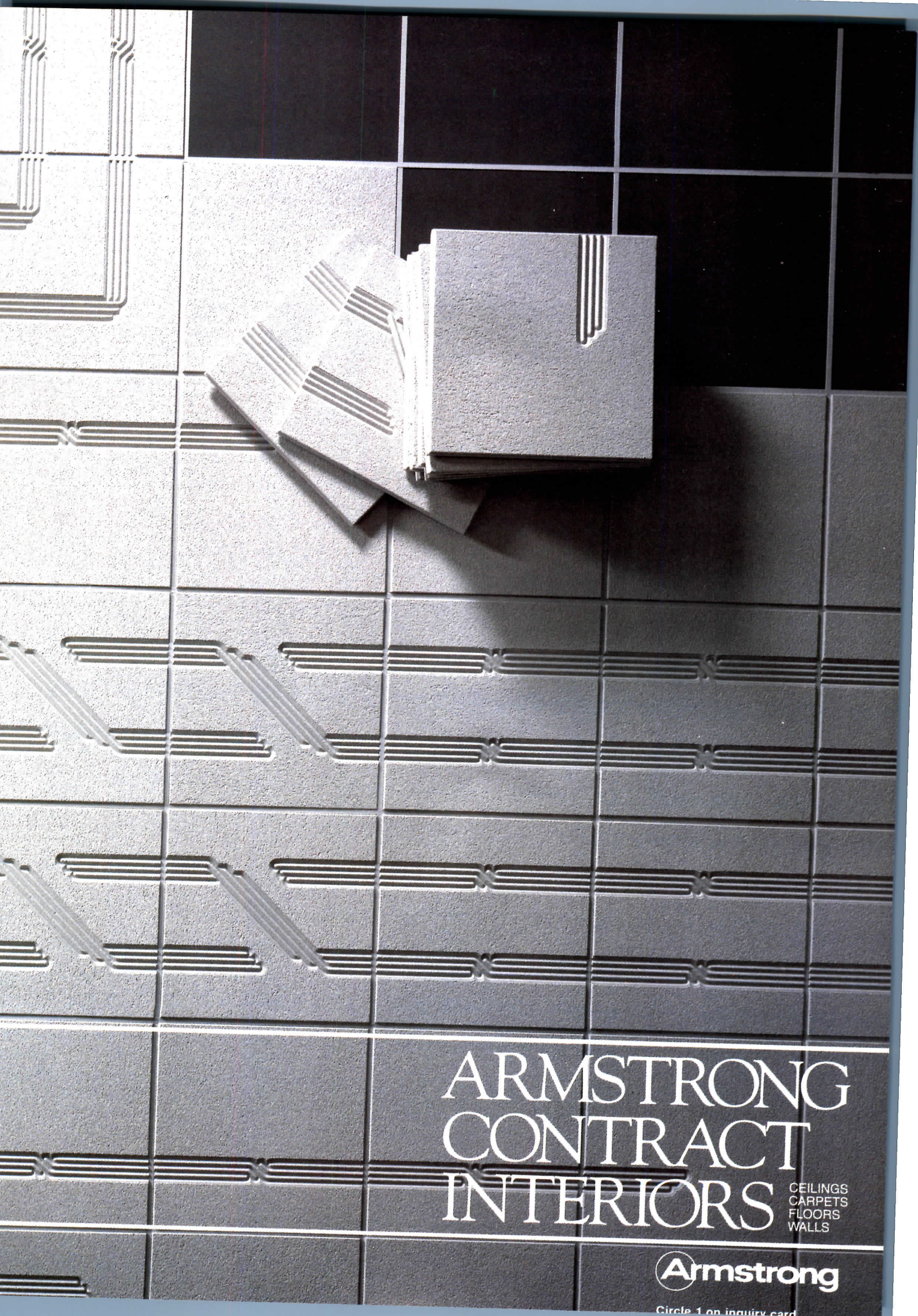

# ARMSTRONG CONTRACT INTERIORS

CEILINGS  
CARPETS  
FLOORS  
WALLS

**Armstrong**

Circle 1 on inquiry card





# NEW VINYL FLOORS

Random chips of color contrast with a classic background.  
Ten colorways. Rolls 6' wide. For our brochure,  
call 1 800 233-3823 and ask for Suffield™.





# ARMSTRONG CONTRACT INTERIORS

FLOORS  
CEILINGS  
CARPETS  
WALLS

**Armstrong**

Circle 2 on inquiry card



On behalf of the Chicago Chapter AIA, thank you for your excellent article on design/build competitions for public buildings [ARCHITECTURAL RECORD, August 1988, pages 46-49].

As you know, we have been concerned about the design/build competition process as it applied to the Chicago Public Library ever since we were informed by the city that it intended to pursue this method of procuring design services. We tried to improve the process in a minor way, but did not succeed in swaying the City of Chicago to make the fundamental changes we felt were important to assure a high-quality project.

Your article raises extremely important and timely issues, which demand further discussion by the profession. We hope your message will get through to the government agencies that now seem to favor such design/build competitions.

Frank E. Heitzman, AIA  
President  
Chicago Chapter, American  
Institute of Architects  
Chicago

Congratulations on your editorial in the August 1988 issue of ARCHITECTURAL RECORD [page 9]. The basis of the reciprocity dispute between California and the National Council of Architectural Registration Boards has always been mystifying to me. It was not necessary to have a Ph. D. in political science to predict that California's decision to go it alone would ultimately cause boycotts and split the NCARB or cause the California Board of Architectural Examiners to return to the national fold.

All of us who like to think that we are involved in the rational practice of our profession applaud these peace talks. Again, congratulations on a fine and well-tuned editorial.  
Earl R. Flansburgh, FAIA  
Boston

Thanks for your intelligent and unbiased editorial on "Saving the national reciprocity system." Bad communication caused the problem and, one hopes, good communication has solved it.

Walter T. Carry, AIA  
Cooper Carry & Associates,  
Inc., Architects  
Atlanta

Regarding the use of "Freelance employees—" [RECORD, May 1988, page 35] within an architectural firm, several questions must be answered favorably by organization principals before temporary professionals/technicians are recruited.

(1) Can we effectively communicate our corporate and project philosophies and objectives to someone unfamiliar with our internal operations?

(2) Can we make the commitment needed to ensure that the free-lancer receives the direction, support, and resources to complete his/her tasks according to specification and corporate policy, and within budget constraints?

(3) Can we provide the proper environment to (a) enable the free-lancer to function effectively and (b) enhance the experience mutually for both him and our regular staff?

(4) Can we give up our privacy to someone who may or may not follow and respect the same rules of confidentiality and principles of business ethics that all internal personnel adhere to?

The decision to bring a free-lancer into the organization can create exciting opportunities for everyone in the firm. And with a deep commitment from the leaders, the experience of employing a skilled, energetic, and flexible temporary worker can add renewed interest in the company's endeavors both great and small, paid and voluntary.

Sandra K. Stepler  
Consultant  
Valparaiso, Indiana

**Through January 8**

"Six Mementos for the Next Millennium," in which the works of Franklin D. Israel Design Associates inaugurate the museum's *Architecture Tomorrow* series; at the Walker Art Center, Minneapolis.

**Through January 8**

"Erich Mendelsohn: Architectural Drawings," from the Berlin Kunstbibliothek SMPK; at the Cooper-Hewitt Museum, New York City.

**November 14-16**

"Light and Color for Human Performance," a seminar sponsored by the American Society of Interior Designers and others, and conducted by Georgia Institute of Technology; in Atlanta. For information: Education Extension, Georgia Institute of Technology, Atlanta, Ga. 30332-0385 (404/894-2547).

**November 30 to December 3**

Vermont Granite Symposium, sessions for design professionals sponsored by the University of Vermont, the state Economic Development Department, and Barre Granite Association; in Stowe and Barre, Vt. For information: Vermont Travel and Information Service, Brookfield, Vt. 05036 (802/276-3120).

**December 6-8**

1988 AEC Expo, The Show and Conference for Architects and Engineers, focused on computing and management; at the Javits Convention Center, New York City. For information: Expoconsul International, Inc., 3 Independence Way, Princeton, N. J. 08540 (609/987-9400).

**December 7-9**

Interiors Conference and Exposition for Historic Buildings, sponsored by the National Park Service, the American Society of Interior Designers, the General Services Administration, and others; in Philadelphia. For information: Interiors Conference, P. O. Box 27080, Washington, D. C. 10003 (202/343-9578).

ARCHITECTURAL RECORD (Combined with AMERICAN ARCHITECT, and WESTERN ARCHITECT AND ENGINEER) (ISSN0003-858X) November 1988, Vol. 176, No. 13. Title© reg. in U.S. Patent Office, copyright © 1988 by McGraw-Hill, Inc. All rights reserved. Indexed in Reader's Guide to Periodical Literature, Art Index, Applied Science and Technology Index, Engineering Index, The Architectural Index and the Architectural Periodicals Index.

Every possible effort will be made to return material submitted for possible publication (if accompanied by stamped, addressed envelope), but the editors and the corporation will not be responsible for loss or damage.

Executive, Editorial, Circulation and Advertising Offices: 1221 Avenue of the Americas, New York, NY 10020.

Officers of McGraw-Hill Information Services Company: President: Walter D. Serwatka. Senior Vice President: Robert D. Daleo, Finance; Vice President: George R. Elsing. Executive Vice Presidents: Russell C. White, Construction Market Focus Group; Kenneth E. Gazzola, Aerospace and Defense Market Focus Group; Brian H. Hall, Legal and Accounting Market Focus Group; Ira Herenstein, Computers and Communications Market Focus Group; Robert P. McGraw, Healthcare Market Focus Group; Vice President-Group Publisher, Construction Magazines: Ted R. Meredith.

Officers of McGraw-Hill, Inc.: Chairman, President and Chief Executive Officer: Joseph L. Dionne. Executive Vice President, Office of the Chairman: Richard B. Miller. Executive Vice President, General Counsel and Secretary: Robert Landes. Senior Vice President, Treasury Operations: Frank D. Penglase. Senior Vice President, Editorial: Ralph R. Schulz.

Associated Services/McGraw-Hill Information Services Co.: Sweet's Catalog Files (General Building, Engineering, Industrial Construction and Renovation, Light Residential Construction, Interiors), Dodge Building Cost Services, Dodge Reports and Bulletins, Dodge/SCAN Microfilm Systems, Dodge Management Control Service, Dodge Construction Statistics, Dodge regional construction newspapers (Chicago, Denver, Los Angeles, San Francisco).

Subscription rates for personnel of Architectural, Engineering, Interior Design, Design and other directly related firms and students thereof, are as follows: U.S. and U.S. Possessions \$39.00; Canada \$39.00; all other countries \$125.00. Single copy price for Domestic and Canadian: \$7.00; for Foreign: \$12.00.

Change of Address: Forward changes of address or service letters to Fulfillment Manager, ARCHITECTURAL RECORD, P.O. Box 2025, Mahopac, NY 10541. Provide both old and new address; include zip code; if possible attach issue address label.

Guarantee: Publisher agrees to refund that part of subscription price applying to unfiled part of subscription if service is unsatisfactory.

Copyright and Reprinting: Title© reg. in U.S. Patent Office. Copyright © 1988 by McGraw-Hill, Inc. All rights reserved. Where necessary, permission is granted by the copyright owner for libraries and others registered with the Copyright Clearance Center (CCC) to photocopy any article herein for the base fee of \$1.50 per copy of the article plus 10 cents per page. Payment should be sent directly to the CCC, 21 Congress Street, Salem, MA 01970. Include code with request: ISSN0003-858X (\$1.50 + .10). Written permission must be secured for any other copying. Write Reprint Manager for such permission at address below, or to obtain quotations on bulk orders.

Subscription List Usage: Advertisers may use list to mail information to readers. To be excluded from such mailings, subscribers should send a request to ARCHITECTURAL RECORD, Mail List Mgr., P.O. Box 555, Hightstown, NJ 08520.

Publication Office: 1221 Avenue of the Americas, New York, NY, 10020. ARCHITECTURAL RECORD (ISSN0003-858X) published monthly, additional issues in April and September by McGraw-Hill, Inc. Second-class postage paid at New York, NY and additional mailing offices. Postage paid at Windsor, Ontario, Canada. Registration Number 9617.

Postmaster: Please send address changes to: Fulfillment Manager, ARCHITECTURAL RECORD, P.O. Box 2025, Mahopac, NY 10541. THIS ISSUE is published in national and separate editions. Additional pages or separate editions numbered or allowed for as follows: Eastern Section 32Ea through 32Eb. Western Section 32Wa through 32Wb.



Telephone 617 492-4000  
Telefax 617 492-4001

Kroin Sanitary Fittings offer a comprehensive system of all-brass faucets, fixtures and accessories for the kitchen, lavatory and bath. All models are available in twelve epoxy colors, polished brass and chrome.

Design: Prof. Arne Jacobsen  
Selected for the Design Collection, MoMA.





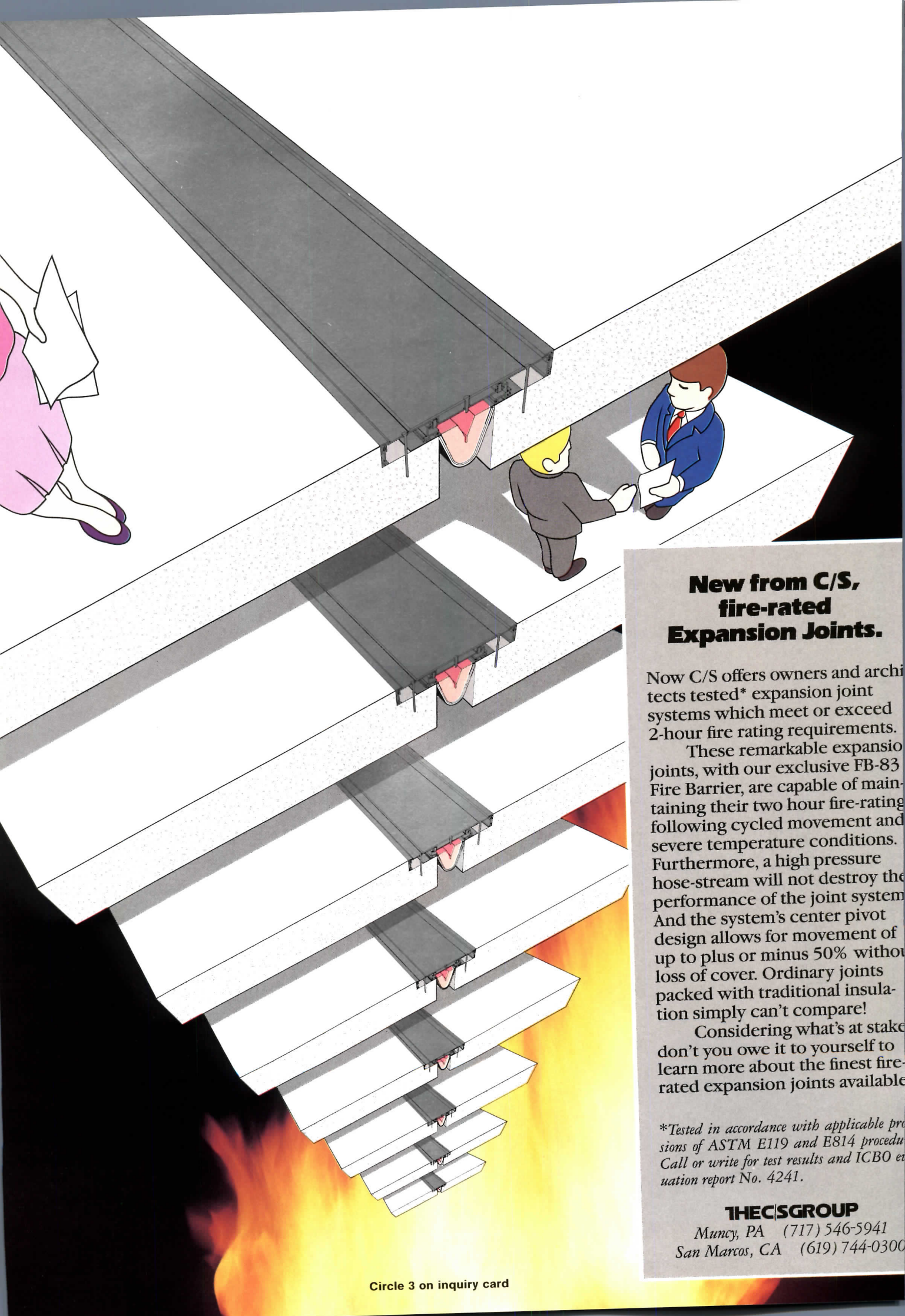

## New from C/S, fire-rated Expansion Joints.

Now C/S offers owners and architects tested\* expansion joint systems which meet or exceed 2-hour fire rating requirements.

These remarkable expansion joints, with our exclusive FB-83 Fire Barrier, are capable of maintaining their two hour fire-rating following cycled movement and severe temperature conditions. Furthermore, a high pressure hose-stream will not destroy the performance of the joint system. And the system's center pivot design allows for movement of up to plus or minus 50% without loss of cover. Ordinary joints packed with traditional insulation simply can't compare!

Considering what's at stake don't you owe it to yourself to learn more about the finest fire-rated expansion joints available

*\*Tested in accordance with applicable provisions of ASTM E119 and E814 procedures. Call or write for test results and ICBO evaluation report No. 4241.*

### THE C/S GROUP

Muncy, PA (717) 546-5941  
San Marcos, CA (619) 744-0300

Circle 3 on inquiry card



Editor  
Mildred F. Schmertz, FAIA

Managing editor  
Carolyn De Witt Koenig

Executive editor  
Douglas Brenner

Editor-at-large  
Herbert L. Smith, Jr., FAIA

Senior editors  
Grace M. Anderson  
Margaret F. Gaskie  
Paul M. Sachner  
Charles K. Hoyt, AIA  
Darl Rastorfer  
Deborah K. Dietsch

Associate editors  
Karen D. Stein  
James S. Russell, AIA

Assistant editor  
Joan F. Blatterman, new products

Design director  
Alberto Bucchianeri  
Inma Egger-Schlesinger, senior associate  
Muriel Cuttrell, illustration  
Dyck Fledderus, illustration

Design consultant  
Massimo Vignelli

Editorial production manager  
Annette K. Netburn

Editorial consultants  
George A. Christie, Jr.  
Nathan Barnett, FAIA, AICP

McGraw-Hill World News  
Peter Gall, director

Group circulation director  
Richard H. Di Vecchio

Circulation manager  
Thyllis Josselson

Director of business  
development and production  
Joseph R. Wunk

Director of marketing  
William H. Padula

Assistant to publisher  
Elizabeth Hayman

Associate publisher  
Dorothy C. Smith III

Publisher  
Robert R. Meredith

Correspondence and submissions of work for publication may be addressed to any of the editors listed below, although the editors listed below assume a special responsibility for the subject areas named:

Deborah K. Dietsch, houses  
Karen D. Stein, interior design  
James S. Russell, design news and competitions  
Charles K. Hoyt, business  
Darl Rastorfer, engineering  
Joan F. Blatterman, new products and product literature

Letters/calendar, 4  
Editorial: Serving the larger public, 9

## Business

News, 35  
Construction economy outlook: A soft foot on the brakes now may mean a quicker return to full speed, 37

## Design

News, 51  
Design awards/competitions, 60  
Observations/books: "Life on the edge: Toward a new suburbia," by Daniel Solomon, 63

**Building Types Study 660: In the Public Interest, 81**

**Heroes in our own backyard, 82**

*An essay on housing, by Paul M. Sachner*

**Low-income housing: Cabrillo Village, Saticoy, California, 86**  
*John V. Mutlow Architects*

**Mixed-income housing: Tent City, Boston, 90**  
*Goody, Clancy & Associates, Inc., Architects*

**Shelter for the homeless: St. Vincent de Paul/Joan Kroc Center, San Diego, 94**

*F.A.D. Architecture & Planning, Architects*

**Shelter for the homeless: Wood huts, Atlanta, 98**

*The Mad Housers, Architects/Builders*

**Public housing rehabilitation: Washington Elms Public Housing, Cambridge, Massachusetts, 100**

*Bruner/Cott & Associates, Inc. Architects*

**Residential hospice: Coming Home Hospice, San Francisco, 104**

*Asian Neighborhood Design, Architects*

**Residential alcohol-treatment facility: Women's Alcoholism Center, San Francisco, 108**

*Asian Neighborhood Design, Architects*

**Housing for the disabled: Creative Living II, Columbus, Ohio, 110**

*Schooley Caldwell Associates, Architects*

**Housing for the elderly: Lincoln Towers, Secaucus, New Jersey, 114**

*Arthur Lubetz Associates, Architects*

**Housing for the disabled: Diamond Park, Philadelphia, 116**

*Cecil Baker & Associates, Architects*

**Housing for the elderly: Robert Shaw ECHO Village, Austin, 120**

*Tom Hatch Architects*

## Engineering

Computers: Software reviews for architects, by Steven S. Ross, 135

New products: New York Design Shows, 142

New products, 145

Product literature, 148

Manufacturer sources, 153

Classified advertising, 168

Advertising index, 182

Reader service card, 185

Cover:

*Cabrillo Village, Saticoy, California*

*John V. Mutlow Architects*

*Photographer: © Wayne Cable/Cable Studio*



**The non-stop fire/smoke stop.**



**The savings never end.** Because the THERMAFIBER™ Fire/SmokeStop System saves on initial material cost as well as installed cost. You combine economy and life-saving dual protection against both fire and smoke.

With THERMAFIBER Safing and the big 5-gal. bucket of SMOKE-SEAL Compound, it's easy to breeze through sealing of poke-through penetrations. There's no stopping to re-load. And no framing or bracing to things down. (Also available in 30-oz. and 3.5 gal. pail.)



Note this system has been tested per ASTM E814 and is UL-Classified as a poke-through penetration fire stop. In addition, USG Research has tested the system to conclusively demonstrate its effectiveness as a smoke stop.

Start saving with the THERMAFIBER Fire/SmokeStop System. Write: Thermafiber Division, USG Interior Inc., 101 S. Wacker Drive, Chicago, IL 60606-4385 Dept. AR1188

Interiors from every angle.

**USG Interiors, Inc.**  
Thermafiber Division



FILL, VOID OR CAVITY MATERIALS  
CLASSIFIED BY UNDERWRITERS LABORATORIES INC.  
FOR USE IN THROUGH-PENETRATION FIRE STOP  
SYSTEMS NUMBER 165





---

# Serving the larger public

In the last eight years the construction of subsidized housing, the acquisition and development of recreational open space, and the extension and rehabilitation of all forms of government-owned infrastructure such as roads, bridges, harbors, airports, and the buildings that go with them, have come to a virtual halt, federal funds having been cut to almost zero. This has meant—and continues to mean—that commissions typically sought by and available to architects consist almost exclusively of custom-designed houses, market-rate and luxury housing, and commercial, industrial, cultural, or institutional buildings. Such projects are shaped to some degree by legislated public concerns, conforming, for example, to zoning and land-use regulations, local preservation laws, and building codes.

There is more to the idea of “publicness” in architecture, however, than conforming to regulations. The public nature of architecture is an intangible quality rarely experienced in the recently built sectors of our cities, but its presence or absence remains the most important criterion by which civic buildings, plazas, parks, and open space should be judged. Just as importantly, it is the force that drives successful design for our neglected public: the poor, the homeless, the handicapped, the addicted, and the terminally ill. Unfortunately, both grand and humane conceptions of the role of architecture continue to lose ground in our increasingly privatized world.

To help put public sensibility back into the foreground of architectural thought, discussion, and accomplishment, RECORD has launched an annual awards program, IN THE PUBLIC INTEREST. Each year we will select a category of construction that serves the public sector and extend an open invitation for entries. For our start, we chose affordable, appropriate housing, premiated eleven projects, and made them the subject of this issue. As Paul Sachner, editor-in-charge of this year’s program, points out in his introductory essay (pages 82-85), we were pleased and excited by the high quality of the submissions. In spite of all the constraints that combine to defeat such efforts—low budgets, low fees, bureaucratic red tape, internecine warfare within multi-leveled client-user groups, etc. —good and skillful architects, motivated in large part by idealism (Sachner calls them heroes), are continuing to do imaginative, inventive, yet practical work in behalf of our poorest and most disadvantaged citizens. *Mildred F. Schmertz*



“I don’t want to put something on the market that can be easily copied. I want people to scratch their heads and wonder how on earth it’s made. Edgewood’s miter detail—the chamfered edge—is as old as wood joinery itself. But here it is reinterpreted on new equipment, so technology is achieving a precision not possible when furniture had to

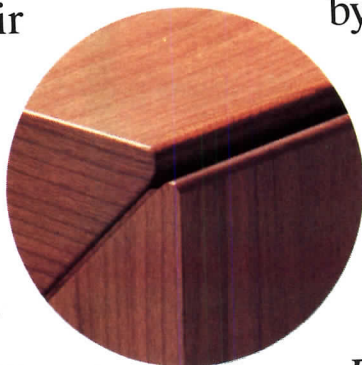

be hand-made. And you get absolutely no clue as to how it’s held together by looking at it.

“There’s no better way to do it than with heavy tooling, big machinery, and years of trying to get it right.”

—*Edgewood™ designer Robert Taylor Whalen.*

Edgewood—pedestal and table desks, credenzas, vertical cabinets,



**Award winner.**



and service modules. A freestanding furniture collection that can fit even a modest budget.

So popular that selected executive settings are available for immediate shipment.

Winner of the IBD and ROSCOE awards for design excellence, and the Canada Award for Business Excellence.

# Stow & Davis

*A Division of Steelcase Inc.  
The Office Environment Company*

*For more information, call 1-800-333-9939*

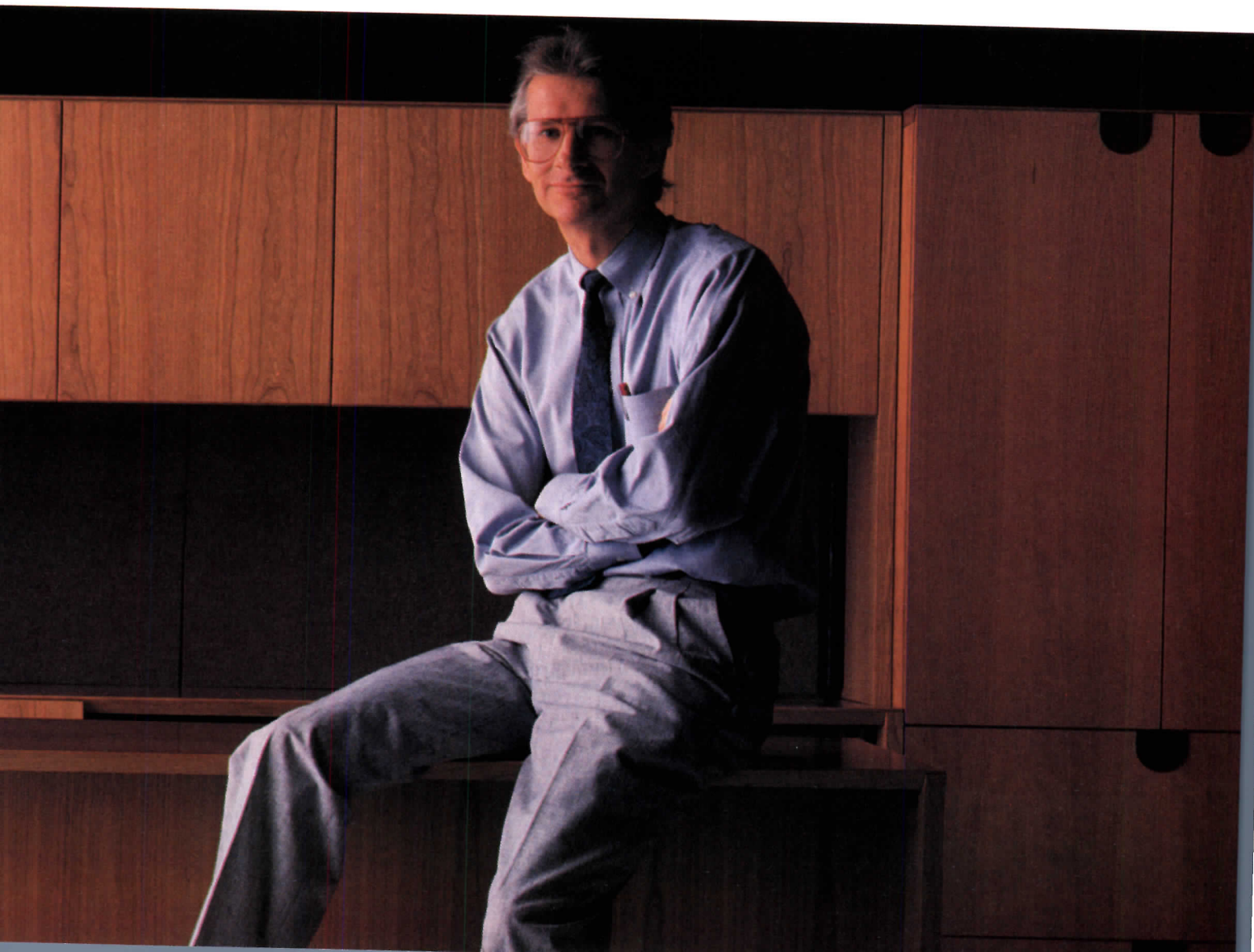



# BEFORE YOUR ROOF DOES THIS, CALL 1-800 342-3745

Sooner or later, every roof leaks.

But Owens-Corning can help you avoid the problems a leaky roof can cause.

We start by advising you about the best roofing system for your building.

We make the highest quality materials.

And as the largest roofing manufacturer, we have a system to fit every budget.

We have a network of certified roofing contractors, and independent auditors to make

sure the roof is installed correctly.

And to back all this up, Owens-Corning offers the best guarantees and warranties in the industry — up to 20 years on materials and installation. If repairs are needed, we'll pay all authorized costs — including labor.

So don't wait for your roof to leak, call us today at the number above. Or write C. E. Z. Meeks, Owens-Corning Fiberglas, Fiberglass Tower, Toledo, Ohio 43659.

OWENS/CORNING  
**FIBERGLAS**

© O.-C.F. Corp. 1988



**Is  
this  
any  
way to  
treat  
your  
work?**

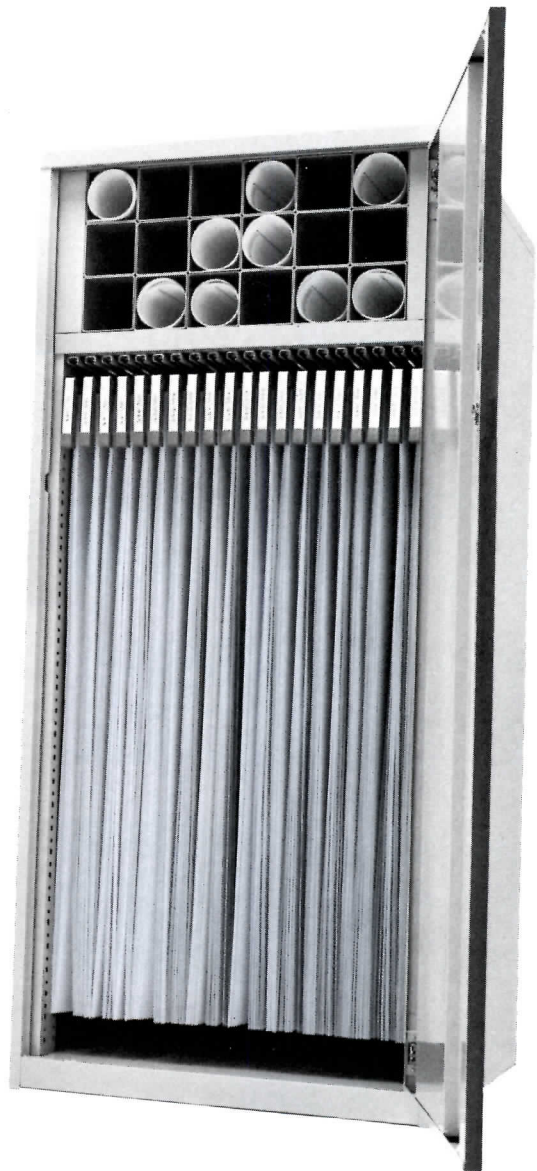

VariFile  
801VF-30

**Not any more.**

If your work ends up in piles instead of files,  
it deserves better treatment.

It deserves the VariFile.

Say goodbye to battered blueprints. Dis-  
tressed drawings. Ruined renderings. Or  
misplaced materials. The VariFile's unique  
design will see to that.

What's more, the VariFile is available in a

number of pre-assembled interior configura-  
tions, including drawers, binders, tube  
storage areas and a lockable door. You can  
store vertically, flat or rolled—in a  
convenient, all-in-one, secure system.

Learn more about how the VariFile can  
give you a storage system custom-fit to  
your needs.

Call 1-800-443-0100, Ext. 347 today.

**VariFile™**

**PLAN HOLD**  
A CPG International Company

Circle 8 on inquiry card



# Only Dover Elevators with the

JONES & CO. 8

Jones

4 5 6 7

4 5

LOBBY ★ L 2 3

LOBBY ★ L



In a changing world, count on Dover to keep you current. With an innovative and flexible approach to elevator signal fixtures—Impulse.

Impulse® is the first system that lets you integrate signage directly into the cab operating panel. So tenants' names (or any other kind of ID) can be right there by the button. Even better, it's completely modular. You can add to, delete, re-arrange elements as needed.



# ator keeps up Joneses.



Signage and buttons are recessed at a 20° angle facing up, so they're easy to read, easy to use.

Since it's pre-engineered, Impulse can be assembled and delivered quickly. Which can be important when you're keeping up with the Joneses.

For more information on Impulse signal fixtures, call your local Dover office or write Dover Elevator Systems, Inc., P.O. Box 2177, Memphis, TN 38101.

**DOVER**<sup>®</sup>  
**ELEVATORS**

*Making more  
elevators makes  
Dover No.1*



# QUALITY ROOFS BY DESIGN CARLISLE

## Unique design considerations make Carlisle's Fully-Adhered Roofing System Max Klein's choice.

"Design A" follows the irregular contours of the roofline — and fits them like a glove.

Call it unique, exciting or striking. When Max Klein, a major plastics housewares products manufacturer decided to build a new corporate headquarters, he resolved it would be unconventional, beautiful and memorable.

Designed by Detroit architect, Harvey Ferrero, the Southfield, Michigan structure is all of these.

The inventive architectural concept is difficult to describe. Its spirals, curves, slopes and angles flow with an irregular but fluid geometry.

And the first-class-plus building required a top-of-the-line roofing system. One flexible enough to follow the intricate geometry of the roofline. A system strong and reliable enough to perform outstandingly under Michigan's rigorous weather conditions. A system that is fully adhered to hold fast for thousands of tomorrow's.

**They chose Carlisle's "Design A" Fully-Adhered Roofing System.**

Owner, Phil Brodak, Brodak Roofing of Wixom, Michigan observed "The roof has more angles than I've ever seen. It is flat, circular, barrel-shaped and juts in every imaginable direction.



Architect: Harvey Ferrero  
Roofing Contractor: Brodak Roofing & Sheet Metal  
Carlisle Manufacturer's Representative: Holmes Associates

And because the roof is visible, it had to have a smooth, perfect, solid black surface."

Concluded Brodak, "The Carlisle 'Design A' system is the only roof I know that could perform well under such design considerations. It was the perfect solution. Its fully-adhered roofing system allowed us to go wherever the roof went." Carlisle's roofing membranes include the standard EPDM and a new polyester reinforced EPDM. Both are available in designer colors—basic black Sure-Seal® or the innovative white-on-black Brite-Ply™.

Next time you need a roofing system try a Quality Roof by Design . . . try Carlisle.

### Need more information?

Call a Carlisle representative/distributor. Or call Carlisle SynTec Systems toll free at 1-800-233-0551. In Pennsylvania, 1-800-932-4626. In Canada, 1-416-673-5557. Or write Carlisle SynTec Systems, P. O. Box 7000, Carlisle, PA 17013.





## REVOLUTION OF THE SPECIES



Can you imagine the possibilities for a revolutionary composite material which unites the best characteristics of real wood and decorative laminate?

Envision wood surfacing products which are handled, fabricated and postformed as easily as postforming grade decorative laminates. And are available to you in 16 "hybrid" species, ranging from familiar domestics to rare exotics (like Brazilian Rosewood, shown above).

The products are WILSONART® Craftwood™ Laminates. And by creating them, we've also created a whole new way of thinking about wood surfacing.

The strength of this material is a tough phenolic backer sheet, faced with unfinished, A grade veneers. Together, they make Craftwood Laminates the natural selection for any interior application demanding the warmth and beauty of bookmatched wood . . . without the problems associated with fragile standard veneers.

Another revolutionary idea: rethink the notion that the tree is planted only when you specify the wood surfacing product. Craftwood Laminates are quickly and easily obtainable . . . as you expect every WILSONART product to be.

### HOTLINE

When you need immediate response to a question, or quick delivery (within 24 hours) of product samples and literature, call toll-free (within the continental U.S.A.):

1-800-433-3222

In Texas: 1-800-792-6000

**CRAFTWOOD™**  
L A M I N A T E S

The Natural Selection™

**WILSONART®**  
BRAND DECORATIVE LAMINATE

*Bringing new solutions to the surface™*

©1988, Ralph Wilson Plastics Co.

Circle 10 on inquiry card





# There's a New Global It's Also The World's Leading

With the recent acquisition of Borg-Warner Chemicals, GE Plastics can now supply worldwide markets with the broadest line of ABS resins in the industry. Combined with our total resources in high-performance engineering polymers, this expansion forms a global product offering that is unmatched in its scope and versatility—a product range totally supported by the technologies which made these ABS resins and engineering polymers the world leaders in sales.

## GE Plastics

Now designers and manufacturers all over the world have one source for a wider choice of products and properties to fit specific application needs—products that provide a new dimension of design possibilities and manufacturing efficiencies. LEXAN<sup>®</sup> resin, NORYL<sup>®</sup> resin, VALOX<sup>®</sup> resin, XENOY<sup>®</sup> thermoplastic alloys, LOMOD<sup>®</sup> engineering elastomers, CYCOLAC<sup>®</sup> ABS, PREVEX<sup>®</sup> polymer,

\* LEXAN, NORYL, VALOX, XENOY, LOMOD, CYCOLAC, PREVEX, ULTEM and GELOY are registered trademarks of General Electric Company or affiliates.

™ SUPEC is a trademark of General Electric Company.



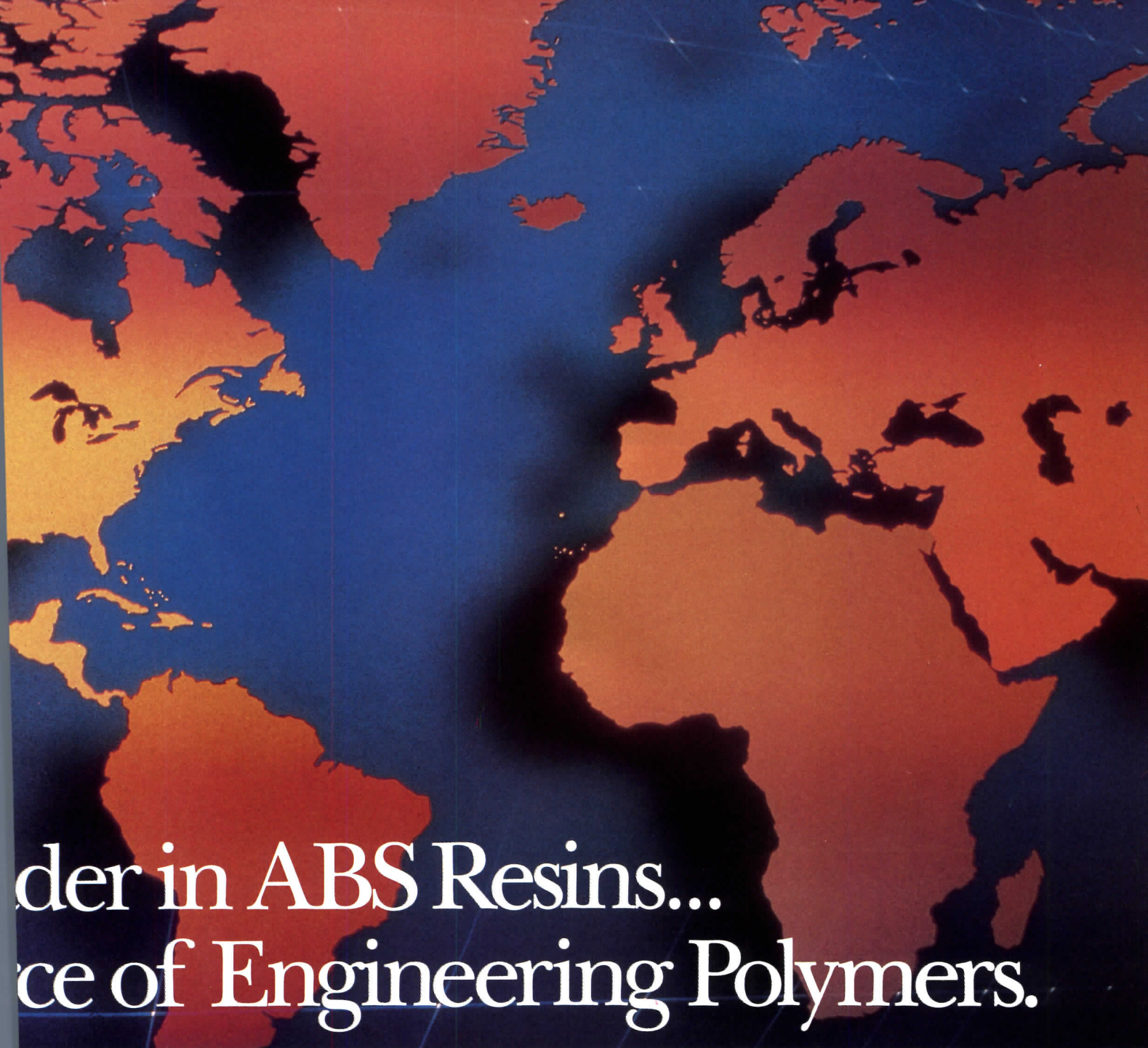

# Leader in ABS Resins... Choice of Engineering Polymers.

ULTEM<sup>®</sup>, SUPEC<sup>™</sup> and GELOY<sup>®</sup> resins, and many more.

With a network of technical, R&D and manufacturing facilities and sales offices spanning the globe, GE Plastics customers get fast response, dependable supply and delivery, and hands-on support from the industry's largest technical staff and market development team.

GE Plastics: creating more options, more opportunities—all over the world.

For information on LEXAN, NORYL, VALOX, ULTEM, SUPEC and GELOY resins; XENOY thermoplastic alloys; and LOMOD engineering elastomers, call (800) 845-0600.

For information on CYCOLAC ABS and alloys and PREVEX polymer, call (800) 624-2611 (In Canada, call 416/372-6801).



***GE Plastics***









# There's not much that's typical about this office building.

## Except, maybe, the relentlessly red Pella Windows.

The owner wanted an alternative to the typical office building around Tucson.

The architect said that playfulness had been left out of today's architecture.

And from the beginning, Pella's custom color was the logical choice for carrying out the design.

Needless to say, this 70,000 square foot office building stands out in a neighborhood of predictably severe granite and glass offices. Williams Center features rounded corners, the playful juxtaposition of unusual shapes, and a dashing color scheme of red and white. You can't miss it.

In fact, the main entrance is easily recognized. It's under what appears to be a giant red metal water slide. Inside, however, the mood changes. Visitors and tenants reach their offices after passing through a charming courtyard with waterfall, meandering pool, lush vegetation, waterside seating, and contemporary sculpture.

The building's shape is the logical outgrowth of a desire to give all tenants a sense of place, regardless of how much or how little space they have. Small tenants aren't stuck with just a carved out portion of a rectangle. Here, tenants can even choose spaces with higher ceilings, or two-story spaces.

### About those red windows.

It actually started with the red metal roof. Pella's custom color department scientifically matched the roof manufacturer's color, and applied it to the windows and trim. And, to be sure that the doors matched perfectly, even supplied the paint for the metal door manufacturer.

Pella's custom color capabilities are unlimited. You may choose the most unusual color in the known world, and putting it on a Pella Window will just be typically Pella. Plus, it's a super tough enamel finish that resists

cracking, fading, chipping, and all sorts of plagues due to exposure. Yet, for all this protection on the outside, all you see on the inside is solid wood, ready to stain or paint.

### The Pella Type E Slimshade.<sup>®</sup> For the sake of appearances and energy savings.

All windows feature the insulating efficiency of the Pella Double Glazing System with adjustable Type E Slimshade<sup>®</sup> blinds between the panes of glass. This gives an attractive, consistent appearance to windows from the outside, and the convenience of built-in blinds from the inside.

For the owner, it also means low maintenance because the blinds are protected from dust and damage by the removable inner glass panel.

Energy saving, too. The low E coating on the blinds is highly effective at reflecting radiant heat back outside, which saves on air conditioning inside. And Pella's low air infiltration means energy dollars won't be lost.

For more information on Pella products for commercial projects, contact your local Pella distributor. Look for Pella in the Yellow Pages under "Windows," call Sweet's BUYLINE, or see Sweet's General Building File. Or simply return this coupon.

Please send me more information on Pella Clad products for commercial projects.

Name \_\_\_\_\_

Firm \_\_\_\_\_

Address \_\_\_\_\_

City \_\_\_\_\_

State \_\_\_\_\_ Zip \_\_\_\_\_

Phone \_\_\_\_\_

**Mail to:** Pella Windows and Doors Commercial Division, Dept. T31K8, 100 Main Street, Pella, IA 50219. Also available throughout Canada.

© 1988 Rolscreen Company.

### Bring your designs to Pella.

Williams Center  
Tucson, AZ

Architect  
John Campisano & Associates  
Tucson, AZ

Owner  
Shull/Jones Builders, Inc.  
Tucson, AZ





# Sunbrella Firesist Designers' Bigge





# Takes Care Of t Hang-Ups.

Finding fabrics for awnings and other fabricated items hasn't been easy. Because any materials that have met commercial fire codes have been stiff, shiny and even plastic looking.

But with Sunbrella Firesist, you can have the look and feel of canvas you've wanted. Because our fabric hasn't been coated with chemicals or laminated with glossy resins. And it isn't made out of vinyl, either. Instead, it's actually woven from self-extinguishing fibers. What's more, these fibers are made of color-pigmented modacrylic. Which means they provide rich, saturated hues. Hues that are locked in so they can't be faded or washed out.

Even better, Sunbrella Firesist won't crack, peel, harden, mildew or rot. And it's highly soil resistant, too. In fact, we're so sure it'll live up to these promises, it comes with a 5-year limited warranty. And it has yet another advantage: It's highly breathable, making it very energy efficient.

Of course, Sunbrella Firesist also meets the toughest codes like the requirements of the National Fire Protection Association and the California Fire Marshal's test. Which means you can put it up just about anywhere.

So find out about our wide selection of solids and patterns. Contact your local fabricator or Glen **Sunbrella Firesist**<sup>®</sup>  
Raven Mills, Inc., Glen Raven, NC 27215, 919/227-6211.



\*Sunbrella Firesist is a registered trademark of Glen Raven Mills, Inc. \*SEF-PLUS is a registered trademark of Monsanto Chemical Company.







# Neopariés.

## The building material for modern buildings.

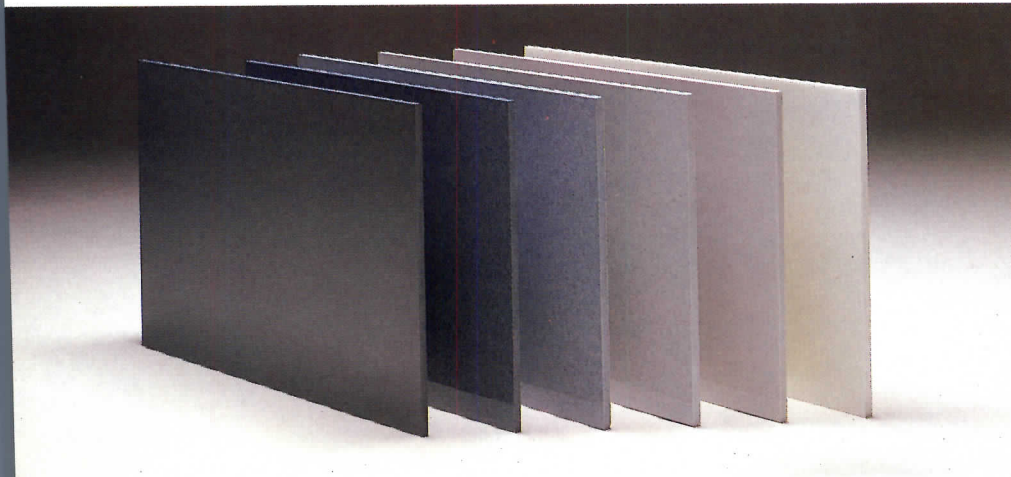

When the marble outer walls of the BMA Tower were replaced with Neopariés, the benefits were immediately obvious – superior strength, greater resistance to weathering and a warm, lustrous appearance. Neopariés is a unique building material produced by a special glass crystallization technique which gives the glass a soft, marble-like texture and appearance. Neopariés is light in weight, installs easily and requires little maintenance to keep its beautiful luster. Find out why both exterior and interior architects are praising this new material. Call or write today for more information about Neopariés, the building material for modern buildings.

- **Superior weatherability and durability**  
Neopariés is superior to marble and granite in resistance to acid and alkali. It will not deform or discolor, and it maintains its strength and original sheen under all environmental conditions.
- **Zero water absorption rate**  
Neopariés has a zero water absorption rate, so it can never be damaged by moisture or freezing. Rust, mortar lye and other stains won't seep in and can be easily wiped away.
- **Warm, natural luster**  
Neopariés is produced by a special crystallizing method which forms fine needle-shaped crystals in the glass. These crystals delicately reflect incident light, giving Neopariés a soft, warm, marble-like appearance.
- **Greater strength-to-weight ratio**  
Neopariés has three times the bending strength of natural stone and no joints, so building plates can be 30% thinner or lighter than natural stone materials.
- **Easily formed into curved or corner panels**  
Neopariés glass-like properties means that it can be easily formed into curves or corners by simple heating and softening.
- **Available in a variety of colors**  
Neopariés is available in 19 colors to match any design or color scheme.

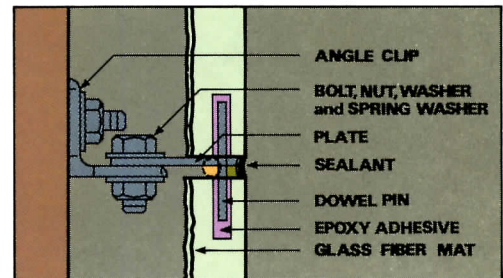

Neopariés installs easily using stainless steel fasteners — today's most advanced mortarless method — making it ideal for exterior walls and interior walls over 4 meters in height.

## NEOPARIÉS

Comprehensive engineering data and installation information are available on request. Please call or write:

Distributor

**FORMS + SURFACES**

Box 5215 Santa Barbara, CA93108

Phone (805) 969-7721

Manufacturer's Chicago Representative Office



**Nippon Electric Glass Co., Ltd.**

3158 Des Plaines Avenue, Suite 227 Des Plaines Illinois 60018

Phone (312) 297-7020

Circle 14 on inquiry card

**BMA Tower**  
The BMA Tower in Kansas City, Missouri. Acclaimed by architects for its style and beauty.



# A M E R I C A

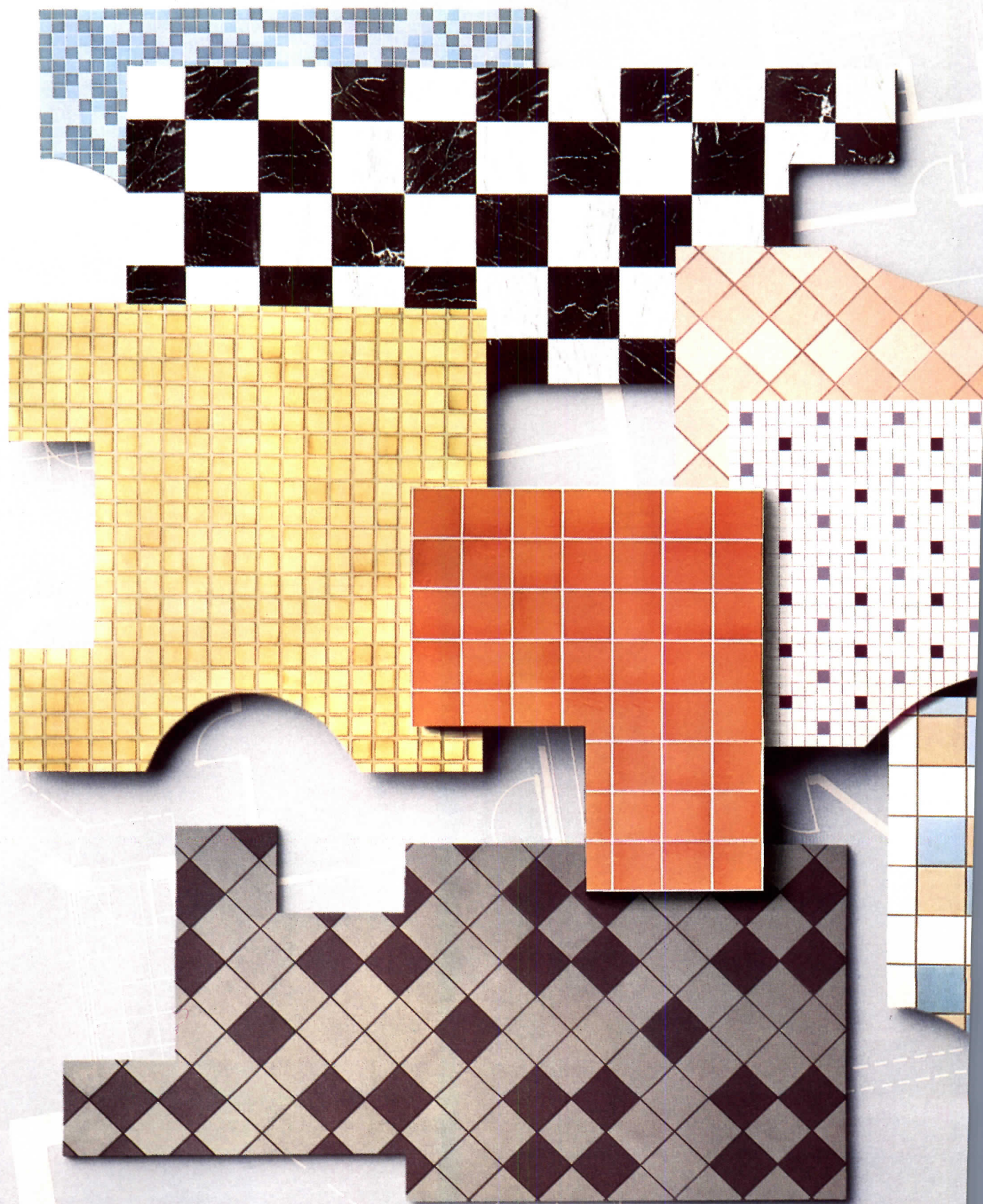

American Olean offers floors in every way, shape and form you can imagine. 20 styles. 22 textures. 25 sizes. And colors, colors, colors—296 in all. That adds up

to a stunning variety of floors for every design need. All from American Olean. Your ceramic floor tile company of choice.







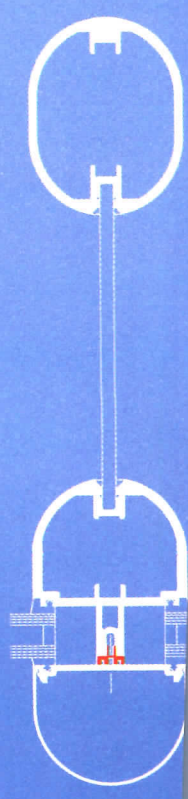
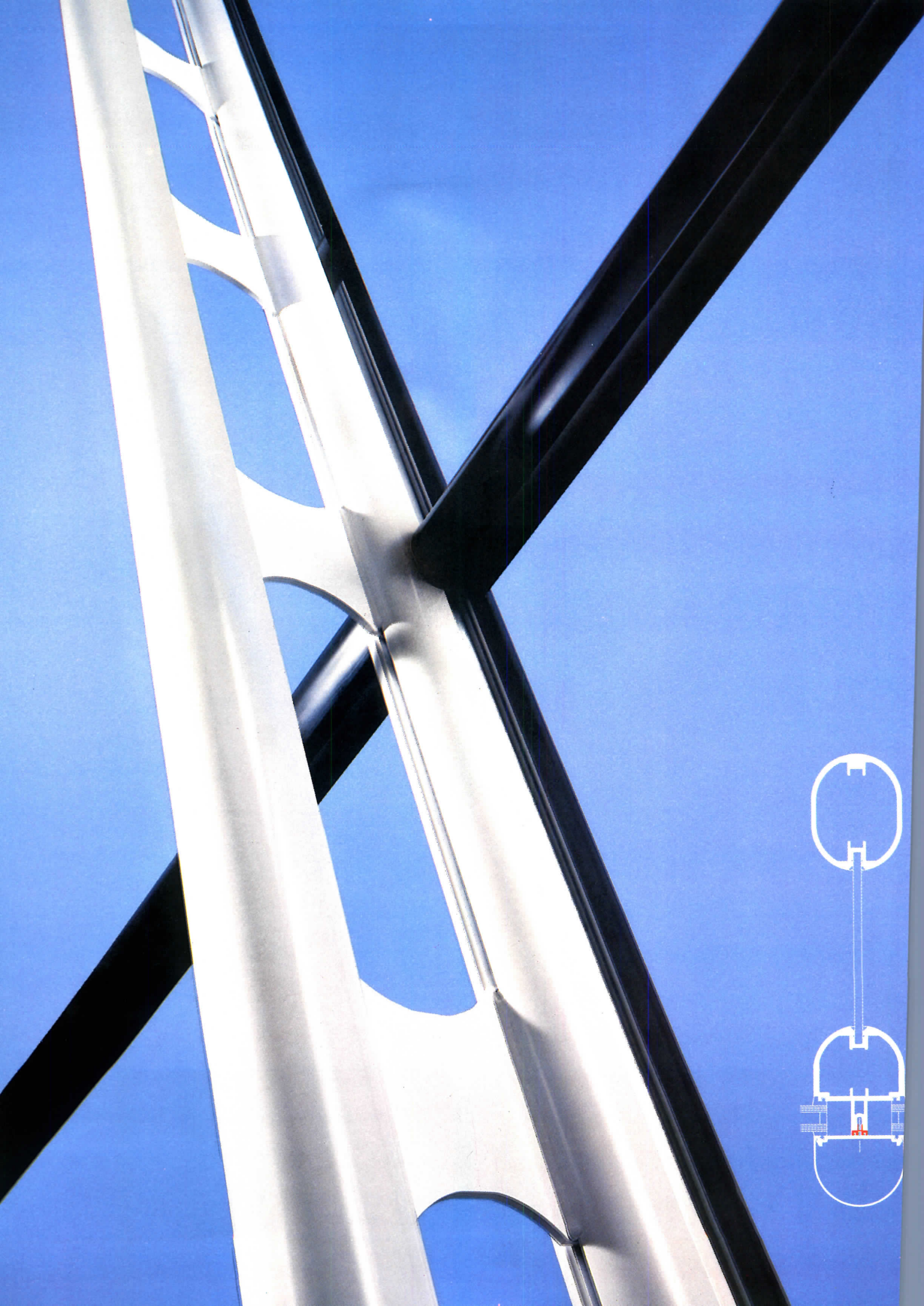



# TRUSSWALL

## T H E · S H A P E S · O F T H I N G S · T O · C O M E

Trusswall from Kawneer introduces the rounded look to the high span entrance. Trusswall spans the clear story entrance area with the structural strength and the desirable aesthetic appeal of the rounded mullion. Formed by circular extruded aluminum chords connected by a separating web that adds stability, strength, and variety, Trusswall becomes a real design alternative.

### **There are two sides to every story.**

On the outside, Trusswall presents a number of faces. One is the innovative circular cover for the sculpted look. Another is the more austere approach, silicone glazing, for an uninterrupted line. And the rectangular cover presents a third more traditional light.

On the inside, Trusswall offers a customization limited only to the imagination. The two-piece construction allows the exterior finish to mix or mate with the building exterior while the interior chords can complement the interior attitudes. The color palette of Fluropon® finishes suggests even more design alternatives.

With four web options to choose from, design flexibility increases. The choices are offered. The choices are yours.

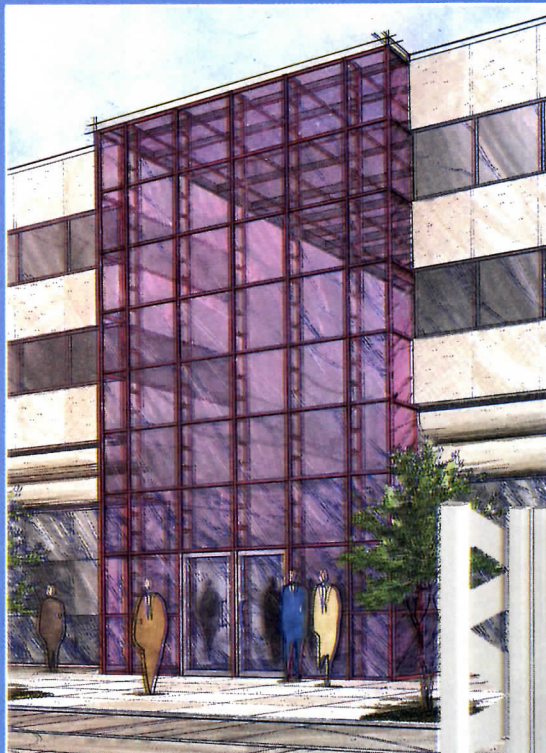

But while the design options offer flexibility, the integrity of the structure remains inflexible. A thermal break, and the flexibility of either 1/4" or 1" glass attest to Trusswall being ready and willing to take on nature's harshest elements.

Trusswall. Further evidence of Kawneer's commitment to space.

**Kawneer**  
THE DESIGNER'S ELEMENT.

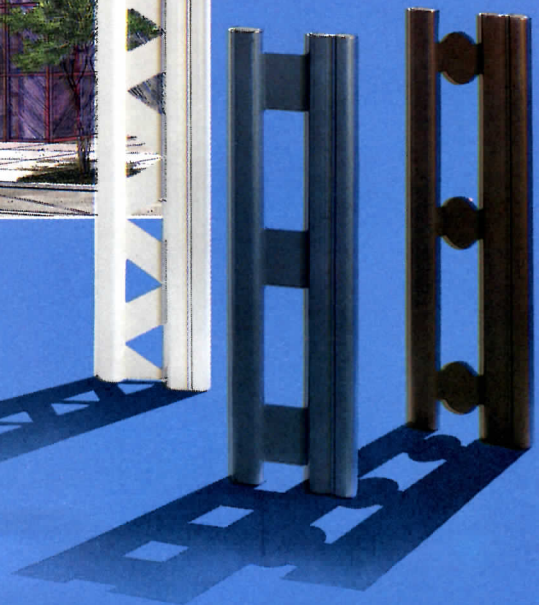

For product information on Trusswall contact:  
Kawneer Company, Inc. Department C  
Technology Park—Atlanta 555 Guthridge Court Norcross, GA 30092

Circle 16 on inquiry card



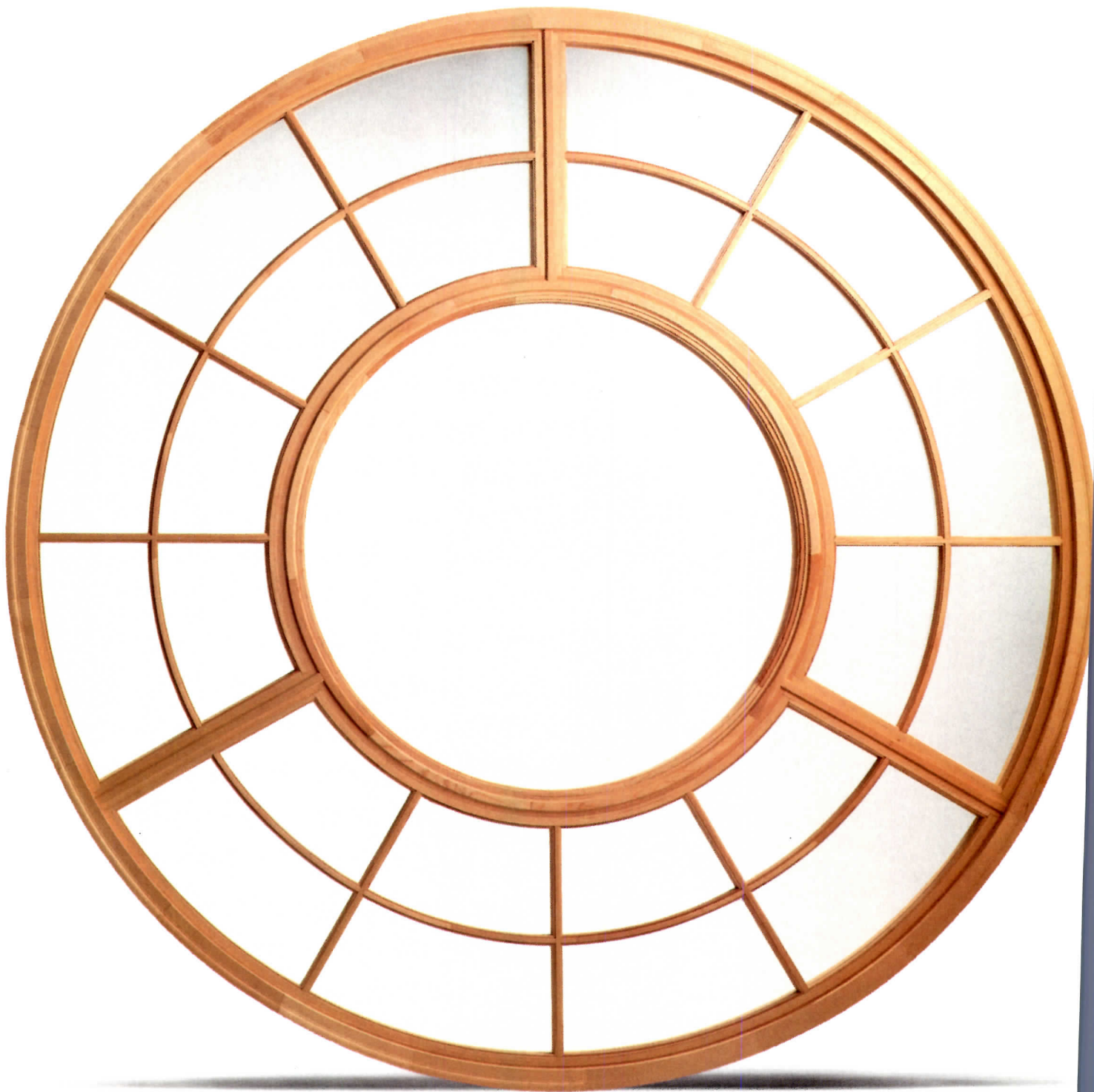

## **WE MAKE WINDOWS FOR IMAGINATIONS THAT HAVE NO LIMITS**

Some people are under the mistaken impression that Marvin only makes custom windows. Those incredible units seen in some of the world's finest and most-often-photographed new homes.

But while we've always prided ourselves on our ability to build a window in virtually any size and shape, we have been equally proud of our ability to provide that same quality of craftsmanship in our more economical standard sizes and shapes, now numbering over 8000.

With made-to-order Marvin windows, you'll find your projects go smoother as installation costs are reduced. (*Jamb* extensions and exterior finish options can be applied right at the factory.) You'll find yourself using the windows as a premiere feature of the home. And with our innovative maintenance-free



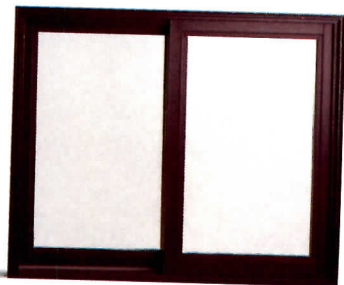

**AND BUDGETS THAT DO.**

energy-efficient options, you'll have provided that homeowner with an investment that will stand him in good stead for years to come.

So whether you're involved in projects that will be splashed across the pages of *House Beautiful*, excitedly shared between friends over coffee, specify Marvin windows. Just because you have to think with your wallet sometimes, it doesn't mean your imagination has to take a back seat.

To learn more, call us toll-free at 1-800-346-5128 (in Minnesota, 1-800-552-1167, Canada 1-800-263-6161), or write: Marvin Windows, Warroad, MN 56763.

**MARVIN WINDOWS ARE MADE TO ORDER.**



Circle 17 on inquiry card



# "The Color And Clarity Are Amazing, It Really Gives Impact To Our Ideas"

Kevin Shotsberger,  
DeLeuw, Cather.



## To Our Ideas"

When your business concerns reach from Lake Michigan to the South China Sea, you need a copier with far reaching capabilities.

So when Kevin Shotsberger was asked to find a new color copier for the engineering firm of DeLeuw, Cather & Company, the Canon Color Laser Copier was the obvious choice.

"We've used other color copiers in the past," says Kevin. "But the quality just was never there. Now we can make single color prints of artist's renderings or use the slide projector and multi-page enlargement to make room-length presentation boards."

Turn-around time is equally important with the complexity of the presentations DeLeuw, Cather prepares. Work that once required outside sources can now be done entirely in-house. And at a fraction of the cost.

"To do this kind of work on the outside would be positively prohibitive," Kevin explains.

"We can merge documentation photos with text, or use color conversion to highlight or even change the color for greater emphasis—with the Color Laser Copier we can do overnight what used to take days. Add that to the cost savings we can pass along and everyone comes out a winner."

For a company with interests as widespread as DeLeuw, Cather, the Color Laser Copier makes a world of difference.

**Canon**   
**COLOR LASER COPIER**



Digital Full-Color Copies



Color Copies From Slides

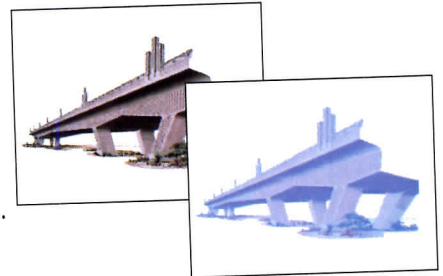

Color Conversion

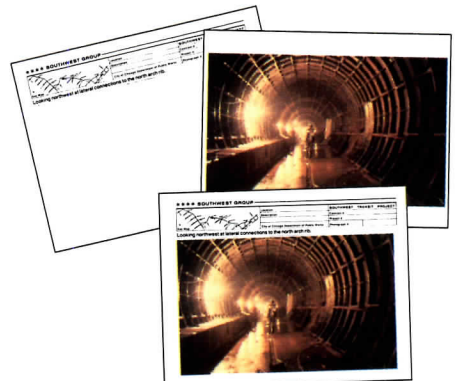

Image Composition



Area Designation

Multi-Page Enlargement

**Canon** Enjoy easy extended payments with the Canon Credit Card. Ask for details at participating Canon dealers and retailers. Available only in U.S.

For more information, call toll free 1-800-OK CANON. Or write Canon U.S.A., Inc., P.O. Box 5023, Clifton, N.J. 07015. © 1988 Canon U.S.A., Inc.



nally, vinyl siding for people  
who hate vinyl siding.

## RESTORATION COLLECTION®

Some readers will see the words "vinyl siding" and turn the page. Their loss. In our view, the news that Restoration® premium vinyl siding is now available in five distinctive styles and profiles is pretty heady stuff.

Still, it would all be academic if the siding choices in the new Restoration Collection® didn't complement your project in the first place. They do. Because each new selection features the satin-smooth, low-gloss finish perfected by Wolverine back in 1983. In fact, it's the same "no fake wood grain" finish, in heritage-inspired profiles, that's made Restoration the non-wood siding of choice—even with Historical Commissions.

If that fact alone doesn't make you want to run out and side something, at least keep us in mind. Because now when you want the best-looking vinyl siding there is, you get to choose among 3" clapboard, rolled edge, 3" or 4½" Dutch Lap, or even 6" beaded styles. They're all in the Restoration Collection. All premium vinyl. All from Wolverine.

So if you'd like more information and rather not use a stamp to get it, call toll-free: **1-800-521-9020.**



**Wolverine Technologies**  
A CertainTeed Company



Cambridge  
3" Clapboard

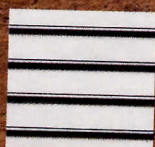

Chapel Hill  
6" Beaded



Cumberland Mill  
3" Dutch Lap



Stockbridge  
4½" Dutch Lap

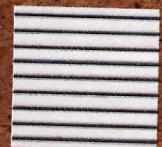

Monterey  
3" Rolled Edge



# IF YOU WANT TO CUT SPEC TIME BY 75%, GET THE LEAD OUT.

SuperSpec<sup>sm</sup> is a computerized spec writing system that alleviates the tedium and difficulty of the task. It's quick, easy and cost effective.

Developed by professional architects and spec writers, SuperSpec uses a simple, specially-designed checklist which you fill out.

Most importantly, this expert system can help eliminate your liability concerns. Its accuracy is unquestioned. Its language is continually updated. And virtually all options and selections are included to help you prepare broad or narrow scope sections.

Let us show you how SuperSpec can turn your spec writing into a pleasant experience that takes minutes, not hours or days. Call us at (800) 252-SPEC for more information.

## **SUPER**SPEC

Our reputation is building

SuperSpec, Inc., Box 16627, Jacksonville, Florida 32245, (904) 636-8880  
SuperSpec is a service mark of SuperSpec, Inc.  
© 1988 SuperSpec, Inc. A Corbel Company

Circle 20 on inquiry card

09660  
RESILIENT TILE FLOORING

*Commentary*

### 6. Wall Substrate

- a.  concrete
- b.  concrete masonry
- c.  brick masonry
- d.  gypsum board
- e.  vinyl
- f.  other

### 7. Base Material

- a.  non-slip
- b.  vinyl
- c.  rubber
- d.  other

### 8. Type

- a.  rubber
- b.  stone
- c.  other



CHICAGO METALLIC CORPORATION

Introduces

# NOVARA 3900 SYSTEM



Remember  
when ceiling  
grid used to  
be flat?

For as long as there has been acoustical ceilings, the suspension grid has been flat and lifeless. Now, Chicago Metallic Corporation introduces a major innovation in exposed ceiling grid design... Novara 3900. It is a revolutionary and refreshing new look in ceilings. Novara 3900 features a narrow  $\frac{3}{4}$ " wide face which extends  $\frac{3}{16}$ " below the ceiling plane and has a distinctive bevel on each side, creating a unique three dimensional appearance. Mitred intersections and a custom wall molding help create a geometric picture frame effect that incorporates shadow lines, contrast and texture into the overall ceiling design. Novara is available in over 100 designer colors and reflective finishes, including laminated wood veneers. Novara 3900... it will make flat grid nothing more than a memory.



$\frac{3}{4}$ " wide face with beveled edges.

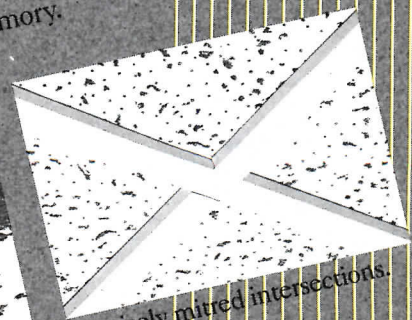

Precisely mitred intersections.



Chicago Metallic Corporation

Chicago (312) 563-4600 Baltimore (301) 796-8220 Los Angeles (213) 582-1100



# Rise Above It All With An Esco Custom Elevator.



Where innovative design is the rule, the elevator must be as unique as the interior. That's why, for more than 50 years, architects and building owners throughout the world have specified ESCO elevators. ESCO's individualized manufacturing processes ensure that custom designs are cost-effective while meeting your exact specifications.

Call or write ESCO today for a free brochure. We'll show you how to rise to any occasion with a custom elevator from ESCO.

 **ESCO**  
ELEVATORS, INC.

P.O. BOX 445 ■ FORT WORTH, TEXAS 76101 ■ 817-478-4251



## More controversy over new AIA General Conditions

Last March, RECORD published an article by attorney Carl Sapers (pages 36-38) which pointed to possible problems created for architects in the 1987 AIA General Conditions. Now a legal-profession newsletter, *The Professional Liability Perspective*, has published an article outlining many of the same problems, specifically as they affect architects' liability: the redefinition of "work" to possibly include on-site safety (Section 1.1.3), the possibility that architects and engineers may assume responsibility for means and methods of construction (3.3.1 and 4.2.7), the obligation of architects to give information to subcontractors and material suppliers on payments made to the contractor for their portion of the work (9.6.3 and 5), and the duty of architects to make judgments on disputes between the owner and contractor over PCBs or asbestos (10.1.2).

## Know better what a structural engineer does

The Coalition of American Structural Engineers is completing a set of guidelines that defines the role of the structural engineer in the construction process. Though the text will clearly state that the guidelines cannot be used to establish legal responsibilities or standard of care, the engineers hope to clarify just what services can be expected from them by clients and architects, although contracts will continue to prevail. The most obvious by-product: to prevent some misconceptions of standard practice and to point out services that might be added or deleted from the basic ones.

## AIAS announces new officers



The student arm of the AIA, AIAS, which meets this month in Chicago during Thanksgiving week, is now headed by president Matthew Gilbertson (photo), a graduate student at the University of Minnesota. Other officers are vice president Irene Tyson, Mississippi State

University, and directors Doug Bailey, Montana State University; Peter Franks, University of Cincinnati; and Thom Burns, Rhode Island School of Design. As president, Gilbertson proposes to "represent students in dialogue with the profession and the public." He serves on the AIA board and is the publisher of *CRIT*, the AIA student journal. The Thanksgiving meeting, Forum '88, will be chaired by Ken Colliander, University of Illinois. For information, write Gilbertson at the AIAS, 1735 New York Ave., N. W., Washington, D. C. 20006.

## Can't agree on an arbitrator? Pay a judge

According to Duke University's Private Adjudication Center, one way to get disputing parties to solve the major problem in binding arbitration—agreeing on an arbitrator—is to hire a person who would seem eminently qualified, a judge (usually retired). In recognition of the increasing popularity of the practice, enabling legislation has been enacted in California, New York, Oregon, Washington, Nebraska, and Rhode Island. References to appropriate individuals can be sought from organizations that administer dispute resolutions or, if the case is filed in court, from that judge.

## Counter to the prevailing tide, a big firm decentralizes

While most large architectural firms are developing management structures that resemble the giant commercial corporations, one firm offers managers facing this prospect another idea. 3D/International currently provides architecture, engineering, and project-management services on some \$2-billion worth of construction worldwide. And that, its managers think, is more than one firm should do. Accordingly, they have formed four new subsidiaries in the last 18 months alone, bringing the total to seven. Some of these, such as the most recent, the architectural firm of Hoover & Furr, have been split off the existing company. Others, including architects and interior designers Baker-3D/I, McClelland Management Services, and architects and engineers 3D/I Hong Kong, have been formed by a combination of splitting, partnerships, and acquisitions.

"We believe the future of the design and construction industry lies in specialized groups which are capable of quickly integrating into large, multi-disciplinary teams when the project demands," says chairman J. Victor Neuhaus III.

Decentralization is a pet subject of president Charles Thomsen (photo). "There's nothing wrong with the pyramid concept of management," he asserts. It has a very specific purpose in industry, the military, and government. But it is inappropriate for organizations that deliver creativity, so it must be balanced with collaboration—while management often shifts into the role of support.

Where did Thomsen get these ideas? Many of the large brainpower organizations in Houston, like 3D/I, did well during the oil boom, he says. Centralization seemed to work well. But when the bust came, many companies were forced to



develop new strategies to survive. They might have recognized that diversification into new geographic areas and services was the answer, but few took it as far as 3D/I.

Each semiautonomous division is responsible for, as Thomsen puts it, "their top and bottom lines." Each maintains its own clients, operations, and—perhaps most important when offices literally extend around the world—culture appropriate to its market. The hierarchical pyramid is still there, admits Thomsen—but to surface only when the network becomes tangled. *Charles K. Hoyt*



**“For this building, selection of the roofing manufacturer was as important as the roofing.”**

**Adi Mistri, AIA**  
J. N. Pease Associates  
Project Architect for the award  
winning Charlotte Macklenburg  
Government Center,  
Charlotte, NC



“Bond Cote® roofing met all our demanding project requirements. On past projects, WestPoint Pepperell impressed us with outstanding installation management and quality control. We selected Bond Cote roofing on that basis. And the installation went like clockwork.”

Whether you're an architect or a roofing contractor, Bond Cote Roofing Systems will make you look good. Call us toll-free: 1-800-368-2160. Or write Bond Cote Roofing Systems, P.O. Box 71, West Point, GA 31833-0071.

**BOND COTE®**  
ROOFING SYSTEMS



**WestPoint Pepperell**  
THE BEST ROOF FOR YOU.

Circle 24 on inquiry card

**TREVIRA®**



# Construction economy outlook: A soft foot on the brakes now may mean a quicker return to full speed

By George A. Christie

*Key indicators of the construction market are sending conflicting signals—a sign that the industry is in the midst of reversing direction. The value of building-materials shipments, with an assist from strengthening export demand, holds a comfortable 7-percent lead over 1987. Expenditures for construction put in place, the measure of domestic construction projects being brought to completion, has lost the momentum of five years of expansion, but still remains even with last year's spending. Contracting for new construction, on the other hand, declined 3 percent during the first eight months of 1988. This leading indicator of future construction activity and building-products demand reached its peak in the final quarter of 1987, fell sharply in this year's opening months, and then stabilized through the summer, as if wondering which way to go next.*

*The state of the construction market at the end of 1988 can be described as: one quarter in decline, another quarter in limbo, and the remaining half in jeopardy.*

*The portion in recession is, of course, the overdeveloped commercial-building sector (offices, apartments, etc.), which soared to unsupportable heights during the mid-1980s. Square footage of newly started construction has since declined by 40 percent, but high vacancy rates persist.*

*The portion in limbo is public-works construction. As one of the "hostages" of the deficit-reduction mandate, federally funded construction projects are barely managing to hold even with last year's level of contracting.*

*The portion in jeopardy is the interest-rate-sensitive part of the building market—principally, but not*

*exclusively, single-family housing and institutional buildings. Rising mortgage and bond rates pose a threat in the near future to at least half of all construction activity.*

## **Some things old and some things new will make the difference between a slowdown and recession**

In 1989, several aspects of the economic, social, and political conditions that are shaping this year's construction markets will not change greatly. Year-to-year movements in the demographics of the marketplace are barely perceptible. What you see in the way of demographic support in 1988 is what you get in 1989. The constraints of deficit reduction are already built into the federal budget for fiscal year 1989. For practical purposes, federal construction programs for development of the infrastructure will remain "capped" as they were in 1988. Finally, the glut of vacant offices and apartments will still be there, and will require further reduction of new-construction starts to speed their absorption.

Some things about 1989 will be different. The certainty of a new president offers the possibility of different political priorities. Interest rates will move up, down, or both. The safe bet is that they will not stay the same. There is also a strong case for a different economic environment in 1989. With the Federal Reserve applying monetary restraint to keep inflation under control, the choices concerning the strength of economic activity next year are narrowed to two: slowdown or recession. A few assumptions about these changes are the stuff that forecasts are made of.

Concerning the presidential contest, it is assumed that, if the electorate has voted its pocketbook (not issues; not personalities), George Bush will have been elected. This outcome

*By acting in the summer of 1988 rather than waiting until after the election, the Fed has improved the odds on guiding the economy through a period of inflation/recession stress with little worse than a needed cooling down.*

implies an extension of current priorities, especially in the choices between military vs. domestic programs. The constraints of a pledge not to raise taxes and the mandate for deficit reduction leave little room for new initiatives, however. Bush's role: caretaker of the Reagan Revolution.

Economic slowdown, but not recession, rests on the assumption that the Fed will be successful in its attempt to contain inflationary pressures without resorting to monetary overkill. Even though past experience with "fine-tuning" leaves a lot to be desired, it is expected that, in 1989, real GNP growth will be reduced to about 2 percent (roughly half its 1988 rate), and inflation will be held at its current 5 percent. The trade-off, of course, is higher interest rates. The risk is having to endure both high interest rates and recession.

Although the consequences of credit restraint are unpleasant for housing and other interest-rate-sensitive types of construction, it would be hard to fault the Fed for doing what it must do. Demand-pull inflation typically occurs at the peak of the business cycle as the economy's capacity to produce fails to keep pace with demand, and prices are bid up. In 1988, a surge of export demand has accelerated the process. Conventional strategy for dealing with demand-pull inflation is straightforward enough: restrain demand by raising the cost of credit, giving productive capacity a chance to catch up.

By acting in the summer of 1988 rather than waiting until after the election, the Fed has improved the odds on guiding the economy through a period of inflation/recession stress with little worse than a needed cooling down. Delay might have required a harder application of the monetary brakes early in

1989, with greater likelihood of recession.

It is expected that the strategy that is already in effect will lift the conventional mortgage rate to 12 percent by mid-1989. It is further assumed that the Fed will relax its restraint during the second half of next year as inflationary pressures subside, and that mortgages will settle back to 10 percent in 1990.

It is hard to escape the conclusion that in 1989, a temporary (but necessary) dose of monetary restraint will be compounding other problems which have already turned construction contracting down. One object of this forecast of 1989 construction activity is to assess the severity of the cyclical decline that is already almost a year in progress.

## **A short-term forecast of single-family housing starts usually began, and often ended, with a forecast of mortgage rates**

For the past few years, however, this technique would have led to unfulfilled expectations.

As academics are fond of saying, "Other things being equal," a 1-percent change in the mortgage rate should lead to a change—in the opposite direction—of approximately 100,000 single-family housing starts. This relationship, with minor refinements, would have kept the housing forecaster out of trouble from the late 1970s to the mid 1980s—a period that spanned a wide range of interest rates and building activity. Somewhere around the middle of this decade, however, other things ceased being equal.

Beginning with 1986, a forecast of single-family-house building that was based on the pre-existing relationship with mortgage rates would have overestimated demand by an average of 150,000 to 200,000 units per year during the second  
*Continued on page 39*



**ANNOUNCING  
SYSTEM 2002...**  
Tech Wall's New Dry Joint System.  
Ask us about it!

# T E C H W A L L

*Top Left:  
Margie's  
Bridal Boutique  
Chicago, IL  
Balsamo/Olson Group*

*Below Center:  
R.A.B. Motors  
San Rafael, CA  
Esherick Homsey Dodge  
and Davis Architects*

*Top Right:  
1522 K Street  
Washington, D.C.  
Don A. Hawkins  
Associates*

*Bottom:  
Central Park Square  
Phoenix, AZ  
Clark — Van Voorhis  
Architects, Inc.*

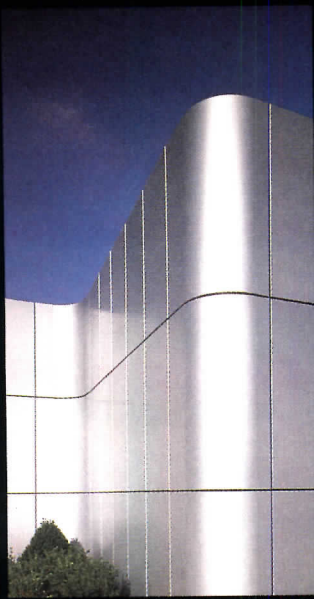
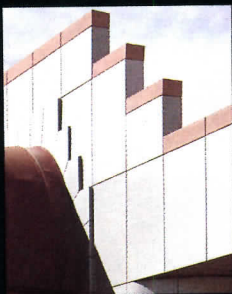

Tech Wall offers architects and builders a stunning range of design possibilities — without the compromises common to other systems.

From radiused corners to intricate compound curves; from continuous coping to projected curved panels; *almost anything you can design can be realized with Tech Wall.*

And since Tech Wall is solid aluminum, *there are*



*no standard sizes. Every panel is made to meet the architectural requirements of your job.*

Tech Wall also offers a virtually unlimited range of tested and proven finish options.

For further information, call today.

1-800-631-7379  
in New Jersey 201-272-5200

**THECSGROUP**

Circle 25 on inquiry card

**U N C O M P R O M I S E D   D E S I G N   F L E X I B I L I T Y**



## 1989 National Estimates Dodge Construction Potentials

	1988 Pre- liminary	1989 Forecast	Percent Change 1989/88
<b>Nonresidential Building</b>			
<b>Floor Area</b> (millions of square feet)			
Office Buildings	235	190	-19
Stores and Other Commercial	545	420	-23
Manufacturing Buildings	155	175	+13
<b>Total Commercial and Mfg.</b>	<b>935</b>	<b>785</b>	<b>-16</b>
<b>Total Institutional and Other</b>			
Educational	123	117	-5
Hospital and Health	70	68	-3
Other Nonresidential Buildings	152	140	-8
<b>Total Institutional and Other</b>	<b>345</b>	<b>325</b>	<b>-6</b>
<b>Total Nonresidential Building</b>	<b>1,280</b>	<b>1,110</b>	<b>-13</b>
<b>Contract Value</b> (millions of \$)			
Office Buildings	\$21,050	\$17,750	-16
Stores and Other Commercial	23,025	18,900	-18
Manufacturing Buildings	8,225	9,600	+17
<b>Total Commercial and Mfg.</b>	<b>\$52,300</b>	<b>\$46,250</b>	<b>-12</b>
Educational	\$12,300	\$12,425	+1
Hospital and Health	7,775	7,750	—
Other Nonresidential Buildings	14,450	14,175	-2
<b>Total Institutional and Other</b>	<b>\$34,525</b>	<b>\$34,350</b>	<b>-1</b>
<b>Total Nonresidential Building</b>	<b>\$86,825</b>	<b>\$80,600</b>	<b>-7</b>
<b>Residential Building</b>			
<b>Dwelling Units</b> (thousands of units*)			
One Family Houses	975	900	-8
Multifamily Housing (*F.W. Dodge basis)	440	425	-3
<b>Total Housekeeping Residential</b>	<b>1,415</b>	<b>1,325</b>	<b>-6</b>
<b>Floor Area</b> (millions of square feet)			
One Family Houses	1,629	1,488	-9
Multifamily Housing	453	430	-5
Nonhousekeeping Residential	78	72	-8
<b>Total Residential Building</b>	<b>2,160</b>	<b>1,990</b>	<b>-8</b>
<b>Contract Value</b> (millions of \$)			
One Family Houses	\$ 88,350	\$ 85,025	-4
Multifamily Housing	21,900	21,775	-1
Nonhousekeeping Residential	6,725	6,650	-1
<b>Total Residential Building</b>	<b>\$116,975</b>	<b>\$113,450</b>	<b>-3</b>
<b>Nonbuilding Construction</b>			
<b>Contract Value</b> (millions of \$)			
Transportation Construction	\$ 24,200	\$ 24,675	+2
Environmental Construction	18,200	18,200	—
<b>Total Public Works</b>	<b>\$ 42,400</b>	<b>\$ 42,875</b>	<b>+1</b>
Utilities	\$ 3,500	\$ 3,700	+6
<b>Total Nonbuilding Construction</b>	<b>\$ 45,900</b>	<b>\$ 46,575</b>	<b>+1</b>
<b>All Construction</b>			
<b>Contract Value</b> (millions of \$)			
<b>Total Construction</b>	<b>\$249,700</b>	<b>\$240,625</b>	<b>-4</b>
<b>Dodge Index</b> (1982 = 100)	159	153	

*If, as expected mortgage rates recede in 1990, single-family building can be expected to rebound to better than one-million units.*

half of the 1980s. This is not to say that the cost of credit isn't still a major factor. It is, and no housing model is complete without it. But quite obviously, something else has been influencing the housing market lately. Why has the volume of single-family-house building been consistently and significantly below expectations under the relatively favorable credit conditions of the past several years? Let us round up the usual suspects.

*Affordability* doesn't seem to be the culprit. Affordability, which concerns the combined costs of owning a home (amortization of the mortgage, real-estate taxes, maintenance and repair, etc.) in relation to family income has become *less* of a burden—26 percent of income in 1987 vs. 37 percent in 1982. Neither have changes in *lending terms* been a constraint on demand. If anything, recognition of the combined resources of two-income families and the widespread use of adjustable-rate mortgages have made it easier to buy a home. The steadily diminishing rate of *household formation* is having a negative impact on total housing demand, but a closer look at the age composition of the population (fastest growth in the 30-to-50 cohort; shrinkage of the 15-to-30 group) reveals that its threat is mainly to the apartment market. In the meantime, demographic support for owner-occupied housing is expanding. Nor is the shortfall explained by a recent change in *public policy* toward housing. HUD has not been an active participant in the new-housing market since very early in the decade. Still another explanation is the *displacement* of single-family housing demand by condominiums (a variation on the affordability theme). This might explain the altered relationship between traditional single-family housing starts

and mortgage rates in the past few years, except for the fact that, instead of expanding to displace single-family houses, starts of multifamily units (condos and apartments) declined by more than 40 percent since 1985. And that just about exhausts the list of recent structural changes in the national housing market.

Regional data reveal some developments that are buried within the national aggregates. Until the mid 1980s, *all* regions exhibited a similar and consistent relationship between housing demand and mortgage rates. And in several regions—the Northeast, the Southeast, and the West—that relationship still holds. But in two other regions—the North Central and the South Central—the relationship began to go awry at mid decade. As mortgage rates declined, housing activity failed to respond the way it did in the other areas.

One does not have to look far to find the cause. The oil depression and the trade deficit, both with their roots in the mid 1980s, bore selectively on the South Central and the North Central regions. Above-average unemployment and weak housing demand (at any level of mortgage rates) are but two of the symptoms of these regional recessions.

Lacking the full participation of these areas, this year's total of single-family housing starts is heading for a disappointing 975,000 units (F. W. Dodge basis). In 1989, when mortgage rates rise temporarily, single-family building will sag further to a total of 900,000 units as adverse credit conditions inhibit construction in this year's still viable markets.

If, as expected, mortgage rates recede in 1990, one-family building can be expected to rebound to better than one-million units. Just how far above *Continued on page 41*



# You asked for a high gloss laminate with our tough ARP SURFACE®.

## Here it is.

Now Nevamar's exclusive ARP SURFACE® is standard on our Glossie laminates in 26 colors...with more to come! While we still don't recommend using even ARP Glossies for heavy-use/high wear horizontal applications, never before has a gloss laminate offered this much toughness...to keep your interiors looking new longer. And with many times the wear resistance of ordinary laminates, there's less damage during fabrication and installation, too. (Resistance to dulling by sliding abrasion tests on ARP SURFACE gloss is improved by at least 20 to 1 over conventional gloss laminate.



Conventional  
Laminate



ARP  
SURFACE®

Contact Nevamar for details.) Want proof? Ask your distributor for our free Glossies ARP SURFACE Prove-It-Yourself kit, and see how we stand up even to steel wool! Check out the rest of the Nevamar line, too, because now you'll find the ARP SURFACE on almost all Textured Finish items.

So why use anything else? If you really want to shine for your clients, specify Nevamar ARP SURFACE laminates. For more information, call 1-800-638-4380. In Maryland, call 1-800-233-9485. Nevamar Corporation, 8339 Telegraph Road, Odenton, Maryland 21113.

**NEVAMAR®**  
DECORATIVE LAMINATES





## 1989 Regional Estimates

### Dodge Construction Potentials

Construction Contract Value (millions of dollars)

South Atlantic DE, DC, FL, GA, MD, NC, SC, VA, WV	1988 Pre-	1989	Percent Change 1989/88
	liminary	Forecast	
<b>Nonresidential Building</b>			
Commercial and Manufacturing	\$12,375	\$10,225	-17
Institutional and Other	7,100	7,125	—
<b>Total</b>	<b>\$19,475</b>	<b>\$17,350</b>	<b>-11</b>
<b>Nonbuilding Construction</b>			
	\$ 7,875	\$ 7,825	- 1
<b>Residential Building</b>			
One Family Houses	\$22,075	\$21,150	- 4
Multifamily and Nhskpg.	7,550	7,500	- 1
<b>Total</b>	<b>\$29,625</b>	<b>\$28,650</b>	<b>- 3</b>
<b>Total Construction</b>	<b>\$56,975</b>	<b>\$53,825</b>	<b>- 6</b>

South Central AL, AR, KY, LA, MS, OK, TN, TX	1988 Pre-	1989	Percent Change 1989/88
	liminary	Forecast	
<b>Nonresidential Building</b>			
Commercial and Manufacturing	\$ 5,400	\$ 5,200	- 4
Institutional and Other	5,475	5,325	- 3
<b>Total</b>	<b>\$10,875</b>	<b>\$10,525</b>	<b>- 3</b>
<b>Nonbuilding Construction</b>			
	\$ 8,700	\$ 8,750	+ 1
<b>Residential Building</b>			
One Family Houses	\$ 9,725	\$ 9,700	—
Multifamily and Nhskpg.	1,400	1,375	- 2
<b>Total</b>	<b>\$11,125</b>	<b>\$11,075</b>	<b>—</b>
<b>Total Construction</b>	<b>\$30,700</b>	<b>\$30,350</b>	<b>- 1</b>

West AK, AZ, CA, CO, HI, ID, MT, NV, NM, OR, UT, WA, WY	1988 Pre-	1989	Percent Change 1989/88
	liminary	Forecast	
<b>Nonresidential Building</b>			
Commercial and Manufacturing	\$11,700	\$10,175	-13
Institutional and Other	7,375	7,725	+ 5
<b>Total</b>	<b>\$19,075</b>	<b>\$17,900</b>	<b>- 6</b>
<b>Nonbuilding Construction</b>			
	\$10,100	\$ 9,875	- 2
<b>Residential Building</b>			
One Family Houses	\$24,700	\$24,175	- 2
Multifamily and Nhskpg.	8,100	8,450	+ 4
<b>Total</b>	<b>\$32,800</b>	<b>\$32,625</b>	<b>- 1</b>
<b>Total Construction</b>	<b>\$61,975</b>	<b>\$60,400</b>	<b>- 3</b>

*As retail-construction contracting tracks homebuilding through the next year or two, the normal lag between these two markets will cause them to go separate ways at some point.*

one million depends on the revival of the economies of the Central regions.

#### As goes housing, so goes retail building

Progression from house building to the demand for retail facilities is a natural one, since the need for shopping centers and related warehousing capacity is derived largely from residential development. The simple logic of this proposition is borne out by the statistics of contracting for stores and commercial warehouses.

The linkage between single-family housing and retail building involves allowance for a brief lag. Since the early 1980s, each 1,000 single-family housing starts has been accompanied—over a period of several quarters—by 230,000 square feet of new retail space. In turn, each 1,000 square feet of newly built stores required approximately 900 square feet of warehousing backup. These relationships represent the average experience of the 1980s, with year-to-year variance as the leads and lags expanded and contracted.

During the mid 1980s, contracting for retail building was stimulated beyond its normal relationship with housing by the special incentives made available through then-prevailing tax laws. Building soared to a peak of just over 500-million square feet in 1985, perhaps 10 percent more than the level of house building might normally have justified. The subsequent decline to this year's 440-million square feet has, consequently, been greater than the relatively gentle slide of house building would have prompted.

As retail-construction contracting tracks houses through the next year or two, the normal lag between these two markets will cause them to go separate ways at some point. In 1989, as rising mortgage rates

restrict the demand for new single-family houses to 900,000 units, retail building—still mildly overbuilt relative to housing—will shrink by 20 percent. In 1990, as lower mortgage rates enable a recovery of house construction, the lagging retail-building market will continue to decline—by another 5 to 10 percent. It won't be until 1991 that the 1990 recovery of housing starts will turn retail building around.

#### Institutional building will feel downward pressures less

After a long dry spell, the unique demographics of the institutional-building market have finally coincided with a period of workable interest rates. The result: reversal of the declining trend of building that began in the early 1970s and extended all the way into the early 1980s, and several years (1985 to the present) of strong recovery.

Demand for institutional buildings is generated by needs created at the extremes of the population's age spectrum—the "under 15s" and the "over 65s." With both these age groups now growing faster than the population as a whole (though not as fast as the 30s to 50s), most of the current action is concentrated among elementary schools and nursing homes. Another category, prisons, has been expanding rapidly, proving that sociology as well as demographics is a factor in the institutional building market.

Institutional buildings are provided mostly by state and local governments, which means that tax-exempt bonds are a favored source of funding. It is a fairly safe generalization to say that since demographic/sociological trends change only very slowly, the needs they create for schools, health-care facilities, and other institutional buildings will be met when the





# Kwikset's new keyed leverset. A new concept in opening doors.

For the first time, the manufacturer of America's largest-selling residential locksets unveils a dramatic new innovation in entryway locking – our key-in-leverset for finer residential and business entries.

The most advanced leverset in our history, it uses the same heavy-duty mechanisms embodied by Kwikset's Premium Entry Lockset.

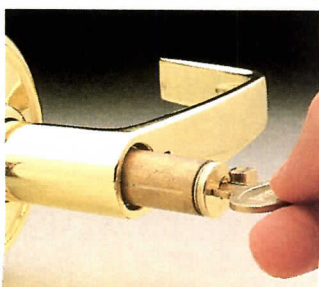

Featuring components of solid brass, steel and space-age materials, it's engineered to meet most building and handicapped code requirements and is specifically built to withstand the heavy demands of high-traffic areas.

©1988 Kwikset Corporation



Winston Design No. 500WL

The 6-pin solid brass entryway cylinder provides many more keying combinations and can be quickly and easily removed for keying convenience while the leverset is on the door. And, a separate key for removing the cylinder is provided with every keyed leverset. It is ideal for rekeying apartments and businesses.

Our new UL Listed keyed-leverset has the quality, strength and durability to merit a 10-year limited warranty, yet it carries an attractively low price. It all adds up to the best value in a leverset today.

For a complete illustrated catalog, write Kwikset, P.O. Box 4250, Anaheim, CA 92803-4250.

EMHART

**kwikset**



*Although the demographic base of the institutional building market will remain firmly in place in the years immediately ahead, the volume of new construction is not likely to maintain its recent strong pace.*

## 1989 Regional Estimates Dodge Construction Potentials

Construction Contract Value (millions of dollars)

North-east	CT, ME, MA, NH, NJ, NY, PA, RI, VT		Percent Change 1989/88
	1988 Pre- liminary	1989 Forecast	
<b>Nonresidential Building</b>			
Commercial and Manufacturing	\$10,625	\$ 9,250	-13
Institutional and Other	6,925	6,400	- 8
<b>Total</b>	<b>\$17,550</b>	<b>\$15,650</b>	<b>-11</b>
<b>Nonbuilding Construction</b>	<b>\$ 9,250</b>	<b>\$ 9,800</b>	<b>+ 6</b>
<b>Residential Building</b>			
One Family Houses	\$15,450	\$14,200	- 8
Multifamily and Nhskpg.	6,400	6,150	- 4
<b>Total</b>	<b>\$21,850</b>	<b>\$20,350</b>	<b>- 7</b>
<b>Total Construction</b>	<b>\$48,650</b>	<b>\$45,800</b>	<b>- 6</b>

North Central	IL, IN, IA, KS, MI, MN, MO, NE, ND, OH, SD, WI		Percent Change 1989/88
	1988 Pre- liminary	1989 Forecast	
<b>Nonresidential Building</b>			
Commercial and Manufacturing	\$12,200	\$11,400	- 7
Institutional and Other	7,650	7,775	+ 2
<b>Total</b>	<b>\$19,850</b>	<b>\$19,175</b>	<b>- 3</b>
<b>Nonbuilding Construction</b>	<b>\$ 9,975</b>	<b>\$10,325</b>	<b>+ 4</b>
<b>Residential Building</b>			
One Family Houses	\$16,400	\$15,800	- 4
Multifamily and Nhskpg.	5,175	4,950	- 4
<b>Total</b>	<b>\$21,575</b>	<b>\$20,750</b>	<b>- 4</b>
<b>Total Construction</b>	<b>\$51,400</b>	<b>\$50,250</b>	<b>- 2</b>

Prepared October, 1988 by  
the Economics Department  
of McGraw-Hill Information  
Services Company  
George A. Christie,  
Vice President and Chief  
Economist  
© 1988 by McGraw-Hill, Inc.,  
All rights reserved.

bond market is cooperative—and postponed when it isn't.

The 1980s offer examples of both situations. During the early part of the decade, double-digit interest rates got in the way of market potential. Despite strengthening demographic support, contracting declined. Once rates came down, institutional building came forth. In the middle years of the decade, with similar demographics, contracting for institutional buildings was 25 percent stronger than during the early period.

Although the demographic base of the institutional building market will remain firmly in place in the years immediately ahead, the volume of new construction is not likely to maintain its recent strong pace. After three years of making up for the below-normal rate of building during the high-interest-rate era, the backlog of deferred demand appears to be satisfied. (This change could explain 1988's setback of 5 percent in institutional square footage.) In 1989, when bond rates will be higher, contracting will be further inhibited by perhaps another 5 percent as institutional building needs are postponed.

The changing composition of institutional building—more elementary schools and nursing homes; fewer colleges and hospitals—has been having a profound effect on average building cost in the 1980s. For the past five years (1982-87), institutional-building cost per square foot has risen at a rate of only 2 percent per year. This compares with an average of 12 percent per year during the previous five-year period.

### A tight lid on growth for public-works construction

A five-year splurge of contracting for public-works construction lifted annual contract value from \$26 billion in 1982 to \$42 billion in 1987. This

extraordinary 10-percent annual rate of expansion ended abruptly in 1988 when priorities changed. Under the constraints of deficit reduction and the New Federalism, it won't get much better in 1989.

Without a general tax increase, the mandate for deficit reduction translates into a freeze on funding for most federal programs. The New Federalism (which encourages local self-determination) put the public-works ball in the court of state and local governments. This change from "top down" to "bottom up" responsibility for the development of the nation's infrastructure will be keeping a tight lid on growth for the next several years.

**• Transportation construction**  
The biggest single factor behind the strong growth of public-works construction during the mid 1980s was the Surface Transportation Assistance Act of 1982 with its 5¢-per-gallon fuel tax. The subsequent 1987 STAA sustained federal funding for highway, bridge, and mass-transit construction at its current high level, but added no new resources.

Under the terms of the latest highway program, federal allocations to the states are subject to a ceiling of \$12.4 billion per fiscal year. Along with an additional billion dollars of "exempt" programs, DOT spending authority is approximately \$13.4 billion annually. In both fiscal 1988 and 1989, however, actual disbursements ("obligations") by the federal government are being held slightly below that level in the interest of meeting the deficit targets. These constraints leave room for an increase of no more than 2 percent in fiscal 1989 over the reduced 1988 federal disbursements for surface transportation, holding next year's funding about  
*Continued on page 45*



# 1891 Sullivan

Entablature detail of Wainwright Building by Louis Sullivan. Restoration by State of Missouri.



Truly great architectural masters understand the magic of detail in their buildings. And now, you can create a little magic of your own with Graphiclad panels by Cupples.

The finish on a Graphiclad panel adds revolutionary detail to aluminum cladding for your building, without adding greatly to its cost.

Through a proprietary process, graphic images are phototransferred in Duragraphic™, a fluoropolymer coating by PPG, to aluminum sheets. Images on Graphiclad panels can be solid, geometric, or even appear to be three dimensional, using any combination of two colors. The limits are in your imagination. The possibilities are endless.



What's more, each design is a one-of-a-kind creation. Yours. You'll never see your pattern repeated for anyone else, so each Graphiclad panel reflects your singular appreciation for final detail.

This unique cladding is very affordable, putting ornamentation within reach of just about everyone — and every budget.

For more information about this revolutionary new product, write to **Cupples Products**, 2650 S. Hanley Rd., St. Louis, MO 63144, or call Phil Moran at (314) 781-6729 today.

**CUPPLES PRODUCTS**  
DIVISION OF H. H. ROBERTSON COMPANY

# 1988 Graphiclad™



*Surveys of business capital-spending intentions confirm that industry has upgraded expansion plans from single-digit to double-digit magnitude.*

where it was in 1987.

Rail and other mass transit, which also depend upon the Surface Transportation Assistance Act for major funding, are bound by the same budgetary limitations as highway construction. Airport development, however, draws on a separate federal trust fund, and appears to be enjoying a higher priority than surface transportation. Federal obligations for airport-construction subsidies have been raised by nearly 10 percent to \$1.4 billion for fiscal 1989.

**•Environmental construction** Federal funds will be at least as scarce for environmental construction (water resources, waste-treatment plants, etc.) as they will be for transportation construction in 1989, with one variation. The time has come to begin making the transition from direct EPA construction grants for financing sewage-treatment facilities to state revolving-loan funds.

In 1989, EPA construction grants will not only be reduced, but states will be required to use half their shrinking federal allocations to set up revolving-loan funds for future sewage-treatment-plant construction.

Moreover, states will be expected to supplement the federal government's capitalization with a 20-percent contribution to the loan funds.

With federal grants reduced by half and with less-appealing loans as an alternative, it is estimated that 1989's sewer/waste-treatment construction contracting will decline temporarily.

Water-resource development (Corps of Engineers; BUREC) will also fail to achieve potential in 1989. The constraints of deficit reduction mean that, despite a large backlog of newly authorized projects, no new ones will be started next year. The squeeze on new projects will hold 1989 contracting for various

stages of ongoing dam, reservoir, and river/harbor construction close to its 1988 level.

Contracting for water supply and transmission, a derivative of general building activity, reached its peak in 1988 and can be expected to decline by 1 percent in 1989 as the building cycle ebbs.

Another exception to the generally repressive circumstances for publicly financed construction in 1989 is work related to hazardous-waste disposal. With the backing of EPA's Superfund, this category of work, currently at an annual level of \$500 million, will be showing sustained growth.

**•Total public-works construction**

For the indefinite future, the rapid growth of public works during the middle years of the 1980s must yield to other priorities. In 1989, as in 1988, the value of construction contracting for infrastructure projects will hold its current \$43-billion level, but there is no support for more than a nominal increase.

**Industrial construction is one of the few types of building that has a "plus sign" in front of it for 1989, and there's good cause** The export-driven manufacturing sector of the economy is rapidly approaching the limits of its capacity.

A rising rate of capacity utilization is the sure-fire indicator of a need for additional manufacturing space, and the range between 80 and 85 percent of capacity in use is particularly critical. When capacity utilization falls below 80 percent, capital-spending decisions focus on productivity. That means machinery, not buildings. Above 80 percent the emphasis shifts to construction.

Throughout the mid 1980s, when office building was booming, industrial activity remained depressed as long as

the hard dollar invited the substitution of imported goods for domestically made products.

With capacity utilization below 80 percent, annual contracting for manufacturing buildings averaged a sluggish \$8 billion. In 1987, the softening dollar reversed the tide of international trade, and as U. S. industrial production rose to the occasion, capacity utilization crossed the 80 percent threshold. By 1988, the utilization rate approached 84 percent, and bottlenecks led to rising costs.

Industry is notoriously slow to respond to its need for expansion. If this were not the case, industrial construction would be booming in 1988, but it isn't. Typically, business capital spending lags economic activity, and industrial construction is no exception. This suggests that most of the expected response to the 1988 capacity squeeze is yet to come—in 1989.

Not surprisingly, McGraw-Hill's surveys of business capital-spending intentions confirm that industry has upgraded expansion plans from single-digit to double-digit magnitude. Significantly, manufacturers are putting 30 percent of their investment outlays into plant expansion, up 5 percentage points from a year earlier. Heading the list of big spenders: paper and pulp, iron and steel, chemicals, instruments, and food processing.

As contracting for manufacturing buildings continues to strengthen through the remainder of 1988, the value of next year's newly started factories and warehouses is forecast to top \$9.5 billion, a gain of better than 15 percent. As is sometimes the case, however, next year's additions to plant capacity may turn out to be poorly timed. If productive capability is growing rapidly when the Fed's anti-inflationary restraint is putting the brakes on

economic activity, capacity utilization will fall. The collision of these events could lead to a stretchout of the manufacturing sector's ambitious expansion plans.

**The "tax shelter" group, mainly offices, apartments, and hotels, has gone from boom to bust since the mid 1980s**

The near future offers more problems than potentials for this trio of building types. The reason: not interest rates, but vacancy rates.

The boom period for tax-shelter building began with the Economic Recovery Tax Act (ERTA), which offered accelerated depreciation on commercial buildings as an incentive to help speed the economy's recovery from its early-1980s recession. It ended with the 1986 Tax Reform Act, which not only rescinded the fast write-off, but disallowed "passive losses" as an offset to other income. Suddenly, real-estate investment was brought back to reality.

During the four-year boom period (1983 to 1986), enough offices, apartments, and hotels were built to satisfy the normal requirements of five years and a bit more. At the 1985 peak, the combined square footage of building reached the extraordinary total of 1.25 billion—roughly half again the 800- to 850-million square feet the market is capable of absorbing, even in a good year.

Vacancies soared, of course, and, upon losing the artificial support of tax write-offs, construction plunged to its current (1988) rate of 750-million square feet.

Even though contracting for new construction of offices, apartments, and hotels has shrunk to only 60 percent of its 1985 peak rate, vacancies have just recently begun to recede. A match-up of current

*Continued on page 46*



*Construction economy outlook continued from page 45*

average vacancy rates against levels that are associated with a market in reasonable equilibrium gives an indication of the lack of near-term potential for recovery.

#### National vacancy rates

	Peak	Now	Workable
Offices	21%	19%	10%
Apartments	8	7+	5
Hotels	35	35	25

In order to restore balance to these distorted construction markets, contracting for new buildings at volumes below their absorption rates is inevitable. The adjustment to the tax-shelter boom appears closest at hand for apartments, and farthest for offices. Having already plummeted from more than 800-million square feet in 1985 to its current 450-million square feet (a drop of nearly 50 percent over three years), the further downside risk for apartments is relatively small. The bottom to the decline of multifamily building should be reached in 1989 in the range of

400 to 450 million square feet, although little or no improvement can be expected in 1990.

The office-building adjustment has a longer way to go. In defiance of persistently high vacancy rates, contracting for offices still remains close to its (theoretical) 250-million square feet of current demand—an inconsistency that can only be rationalized on a regional basis. However, those regions that were latecomers to the 1980s office boom (e.g., the Northeast and the North Central) have recently begun to weaken. With office building now declining throughout the nation, an accelerated reduction of close to 20 percent (to 190-million square feet) is likely during next year's economic slowdown. Bottom will be reached at about 175-million square feet in 1990. As in the case of apartments, subsequent recovery will be inhibited by lingering oversupply and weak demographic support.

The remaining category in this group offers a contrast between commercial and resort hotels. The larger (by far) commercial

hotel market is tracking the decline of office building. Developers of resort hotels, on the other hand, are planning for expansion. On balance, a net decline of between 5 and 10 percent is indicated for total square footage of new hotel/motel building in 1989.

Collectively, the overbuilt "tax shelter" group is perhaps another two years from stabilizing. In 1989, a further decline of between 5 and 10 percent is in order for this \$50-billion-per-year building market.

#### 1989: like 1988 with higher interest rates

High vacancy rates and rising interest rates in private-sector building markets, along with a tight lid on public-construction programs, leave little opportunity to reverse the current decline of construction contracting in 1989. Instead, the value of newly started construction is on its way to a secondary setback of approximately the same magnitude as 1988's decline. An overall reduction of 4 percent

(-7 percent for nonresidential building, -3 percent for housing, and +1 percent for nonbuilding construction) will leave next year's total construction-contracting value at \$240.6 billion, less than the 1988 total by about \$10 billion.

The letdown will be gentle. Comparison of the current decline of construction contracting with previous cyclical reversals turns up some differences worth noting. After adjustment for inflation (which is necessary to make comparisons with other cycles), it becomes apparent that the recent peak of construction contracting was reached in 1986, not in 1987. With the decline already in its second year, one further setback (in 1989) adds up to a cumulative peak-to-trough shrinkage, in constant dollars, of an estimated 16 percent. By recent standards, this would be an unusually soft landing from a four-year ascent. By contrast, the early-1970s building cycle concluded with a 26-percent letdown (1974-75), and the one that followed (1979-82) ended with a decline of 33 percent.

**The panel architects recommend**

IPS® insulated panel systems are recommended by architects and engineers alike. You can't beat the excellent BTU insulating value or top test ratings from independent labs. System flexibility and visually pleasing panels

have made this commercial grade panel system a favorite among architects, too.

**Cuts Energy Costs.**  
26-gauge galvanized steel panels, insulated with rigid polyurethane foam, satisfy temperature

differentials from arctic cold to desert heat—providing maximum resistance to heat flow and cut energy costs.

**Thoroughly Tested.**  
All IPS panel systems are approved by Factory Mutual. Extensive



Why should the conclusion to the mid-1980s building cycle be only half as exciting as the two that preceded it? Nonresidential building is *not* the answer. The average decline from the last two cyclical peaks for the total of commercial, industrial, and institutional building was 20 percent. This one—owing to the overstimulation of commercial building in the mid 1980s—is heading for a 25 percent peak-to-trough comedown.

In the more volatile housing sector, where the norm for cyclical decline is more like 50 percent, the constant-dollar value of residential building will be falling by only half that much this time around. Measured in dwelling units, housing starts will be bottoming out in 1989 at 1.3 million, compared with 1.1 million in 1982 and in 1975.

Although the demographics of the housing market are no longer as supportive as they once were, today's credit conditions—even in a period of tightening—are not as confining. In the mid 1970s, disintermediation was the issue (no loans at any rate of interest);

in the early 1980s it was extreme monetary restraint (18-percent mortgage money, if you wanted it). In the current downturn, the housing sector, for all its shortcomings (affordability, overbuilding, etc.) is helping to minimize the construction market's inherent tendency toward cyclical.

#### The next recovery

With publicly financed construction under constraint for the foreseeable future, getting the construction industry's recent slide turned around will depend upon lower interest rates to support a better volume of house building, and the continued absorption of surplus offices to revive commercial building. One of those two conditions—falling interest rates—should be available by the end of 1989, but the vacancy problem is apt to persist for a year or more beyond that. This suggests that a recovery of construction activity could take hold in 1990 with a rebound of the housing market, and then pick up reinforcement in 1991 as equilibrium is restored to nonresidential building.

## Less construction contracting doesn't always mean less building

Construction contracting is the leading indicator of two other important measures of the status of the construction sector: work in progress, and manufacturers' shipments of materials.

To derive estimates of expenditures for work in progress from construction-contract value, it is necessary to supplement the contracting data with values for types of construction that are not covered by contracting data (e.g., additions and alterations to single-family houses; any other projects valued at less than \$50,000), and apply the appropriate lead time for various categories of construction (short for houses, longer for nonresidential projects, longest for public-works construction).

The value of shipments of construction materials must take into account variations in the mix of construction as well as changes in inventories and exports.

As might be expected, construction contracting is a good deal more volatile than work in progress. This year's 3-percent decline of contracting is causing a barely perceptible (less than 1 percent) reduction of work in progress. In 1989, a further 4-percent decline of newly started construction will lead to a shrinkage of between 2 and 3 percent in the value of construction put in place.

The worst that usually happens to the value of building-materials shipments during periods of declining construction activity is to hold approximately even with the previous year's level. This is what took place in 1970, 1975, and 1980. The only departure from that pattern in 1982 was a very special case. In 1989, it is most likely that the value of manufacturers' shipments of building products will remain steady at the current (record) \$202-billion level, and then resume its average 3- to 4-percent rate of expansion in 1990.



**the panel engineers recommend.**

illustrate the panels' resistance to the spread of fire. Thermal stability, strength, wind uplift, water penetration and air filtration results provide conclusive evidence that IPS panels are engineered for performance.

**Products for All Applications.** From standing seam roof panels to linear styled wall panels and Rockwall® aggregate stone coatings, IPS offers the most complete insulated product line for architects and engineers.



Insulated Panel Systems, Inc.  
P.O. Box 650189, Houston, Texas 77065-0189  
713/896-8700

IPS is a subsidiary of ECI Building Components, Inc.  
Sweets Catalog #07401 / INS Buyline 3911



# To be truthful, the Sanyo Split System does come with a few negatives.

- NO DUCTWORK.
- NO WINDOWS REQUIRED.
- NO LOST FLOOR SPACE.
- NO NOISE.

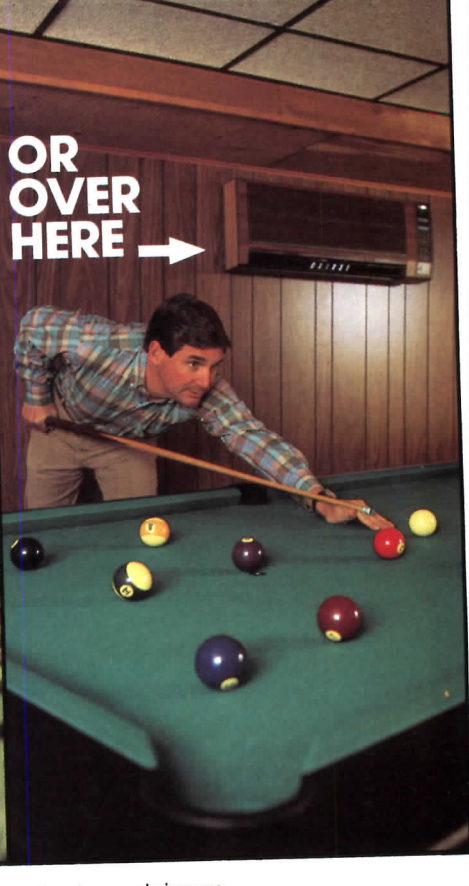
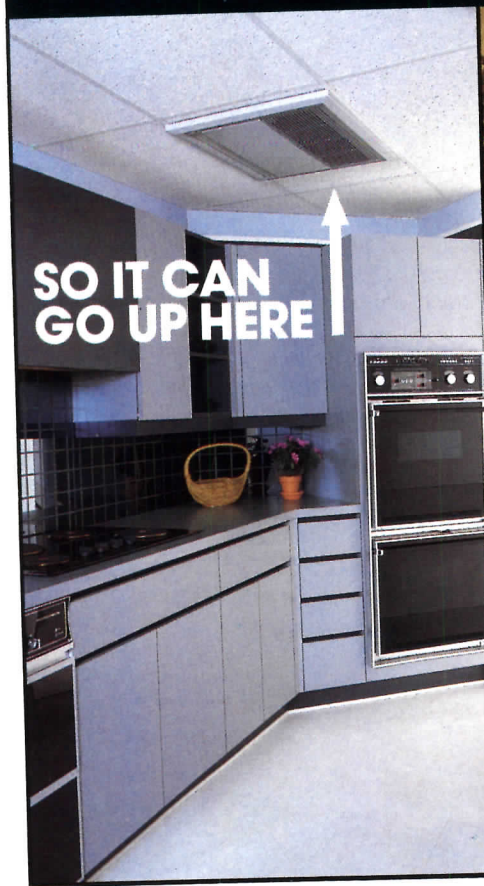

## No Problems.

The Sanyo Split System goes where heating and cooling systems have never gone before. The slim inside units can be wall or floor mounted, ceiling suspended or ceiling recessed. The quiet, vibration-free, condensing units go outside. No ductwork or windows are required. Only a three-inch opening in the wall is needed to connect the two sections, which can be up to 65-feet apart. With the Sanyo Split System, you can keep windows unobstructed and

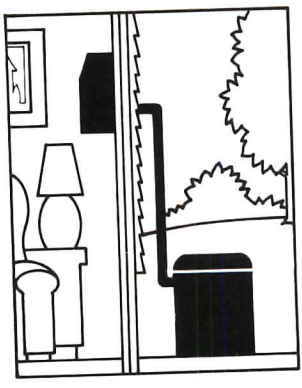

noise to a minimum. Remote control is another unique feature that helps provide greater comfort and energy savings. And, homeowners have the option of choosing a cooling unit, or one that cools *and* heats utilizing an energy-conserving heat pump. Today, no other heating and cooling system gives you the flexibility and convenience offered by the Sanyo Split System.

**Sanyo Ductless Split System Air Conditioners and Heat Pumps. The best solution to your HVAC problems. Positively.**

**SANYO**  
SPLIT-HEATING  
AND COOLING SYSTEMS

For further information, please call or write:  
Mr. Jay Spiegel, National Sales Manager  
SANYO FISHER (USA) CORP.  
Air Conditioning Products  
200 Riser Road  
Little Ferry, NJ 07643  
(201)641-2333





## WHAT'S BEHIND THE DOOR?

visitors and customers, a Stanley Magic-Door system is a welcome convenience. After all, busy people appreciate the hands-free operation of automated entrances. And they see your presence as a sign of a successful thriving business.

For you, an architect, owner, or manager, that same system is your assurance of the quietest, most dependable, trouble-free entrance you can buy.

What makes our door systems so reliable? While other manufacturers promise dependable operation, we can match Stanley for design, manufacturing and service innovations *proven*, both in the

lab and in the field, to increase the ownership convenience of automated entrances.

Stanley Magic-Door employs new computer-aided design and manufacturing techniques. New, state-of-the-art computerized testing and quality control. We've made exciting, cost- and time-saving advances in micro-processor circuitry as well as field-programming. And we have a new, centralized training center. All these innovations give Stanley Magic-Door systems reliability you can count on. Day after day, year in and year out.

Choose Stanley Magic-Door for automated swinging or sliding entrance systems, operators, controls

and accessories. For custom colors, bronze or aluminum finishes. For standard entrances or interior applications, or systems custom-designed to fit your style. Whatever your requirements in automated door systems, step up to Stanley Magic-Door. And get behind the leader.

See our *Sweet's* catalog 08720/STA or for more information, call 1-800-232-3663 (in Connecticut, (203) 677-2861).

# STANLEY

The People Who Help You Do Things Right

Stanley Magic-Door® Division of  
The Stanley Works, Farmington, CT 06032



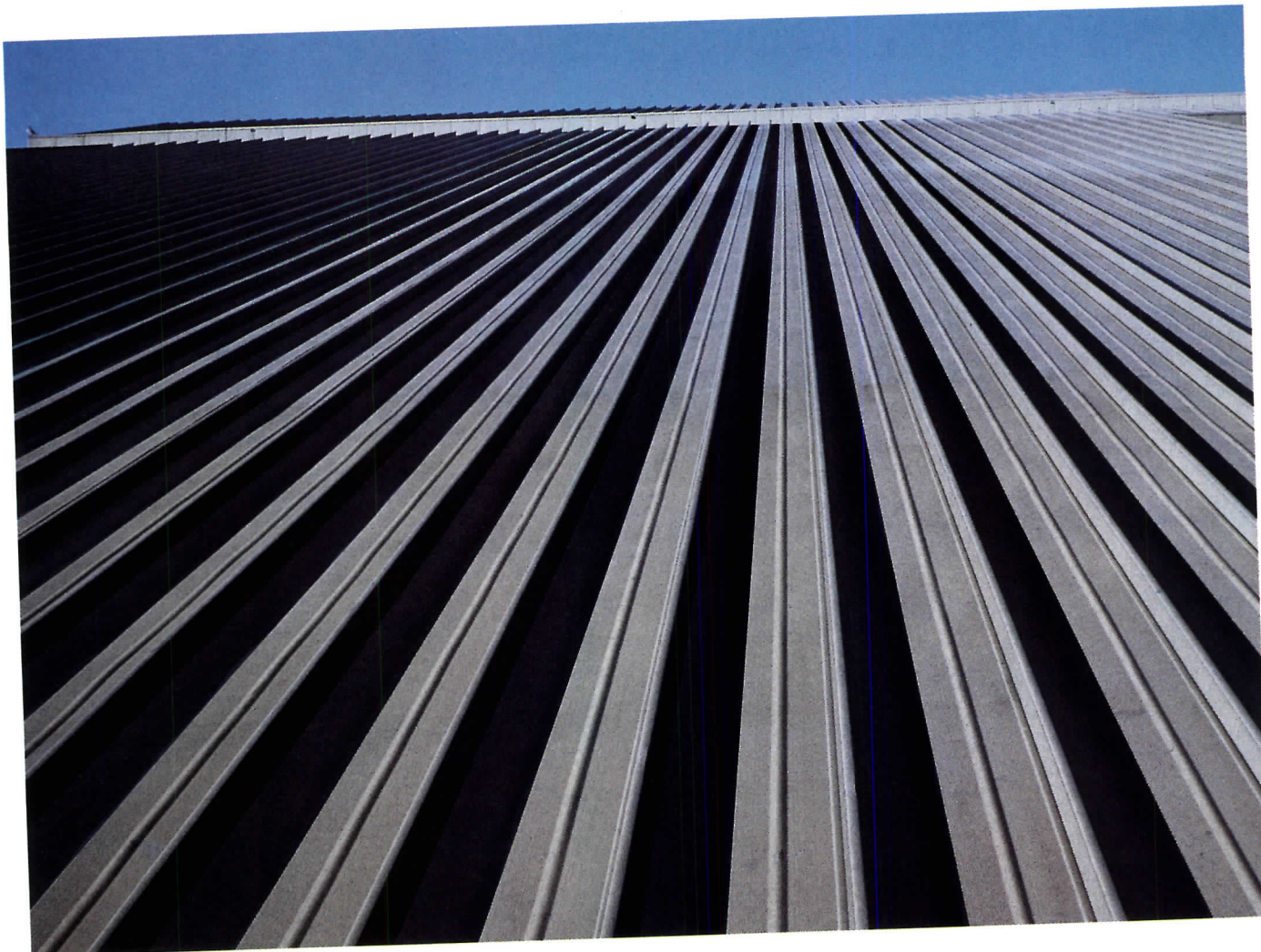

On and on and on. For as long as 150 feet without stopping. That's the beauty of Cot-R-Cap® exterior surfacing. Its patented construction offers continuous battens and panels that keep going. Even over ridges and other direction changes.

Think of it as metal sculpture. One you shape at the actual job site, with on-site roll forming by Alumax. A method that eliminates dimensional errors, along with freight damages and costs. That lets you go from roof to fascia to soffit and siding, if you like. With a clean, uninterrupted flow of lines.

Cot-R-Cap is available in steel and aluminum. In time-tested, full strength 70% KYNAR® 500 standard color finishes. Plus an unlimited choice of special colors.

And Cot-R-Cap is as practical as it is beautiful. Its unique construction also means no leaking problems. Because there are no horizontal end laps, folding and bending panels or face penetrations.

## HOW MUCH LONGER CAN THIS GO ON?



The interlocking pans and battens also assure watertightness. And the concealed fastener system allows thermal movement for excellent positive and negative loading, with a UL class 90 rating. And Cot-R-Cap can be installed directly over purlins, or over plywood and other decking.

Cot-R-Cap. The design possibilities are as endless as the product. And it's available from thousands of Alumax dealers, located nationwide. Each prepared at any time to go to any length to please you.

Alumax provides a twenty-year finish warranty on KYNAR 500 coatings. For your copy of this warranty, write to Alumax.

MADE TO LAST. GUARANTEED TO PROVE IT.  
 **ALUMAX**  
 BUILDING SPECIALTIES DIVISION

P.O. Box 163  
 Mesquite, Texas 75149  
 (214) 285-8811

KYNAR® 500 is a registered trademark of the PENNWALT Corporation.

For more information on other Alumax roofing systems refer to Sweet's 07410/ALU.



## The edifice's new clothes: Temporary transformations in Chicago and Paris



©George Lambros

Though wrapping buildings has long been a trademark of Christo's, two other artists have lately found their own way to reinterpret architecture (at least temporarily) using fabric. In honor of "Convergence '88," a meeting of textile artists last summer, the headquarters of the *Chicago Sun-Times*, a low-slung 1957 design of Naess and Murphy, was bedecked in cotton strips tie-dyed in the Japanese Shibori method by artist Maya Romanoff (above). Restrained at top and bottom, the 120-ft-long panels were strung together with elastic cords so that the whole series would react

kinetically to passing breezes. Sunlight played on the building through and between the fabric panels, which were held away from the facade by a retaining wall along the Chicago River. Romanoff saw the piece as a metamorphosis of the Miesian aluminum-and-glass elevation, a "yielding" architecture that "moved with nature's grace." The subtle color gradation in *Bess's Sunrise* (named after the artist's mother) was the result of dyeing individual panels as many as 28 times.

In Paris, the workshop of Catherine Feff specializes in monumental paintings on walls,

on banners celebrating exhibitions, and on tarpaulins covering scaffolding at construction sites. Renovations at the Arc de Triomphe provided the artist with her latest opportunity: the painting of a scrim covering falsework at the 16-story-high monument. Normally a figurative painter, Feff turned here to abstractly patriotic shadings (achieved with four tons of paint on 27,000 sq ft of polyethylene netting). Underneath her *Tricolor*, cleaning and restoration are readying the arch for the bicentennial of the French Revolution, in 1989.



©A. F. P.



# FRY MOLDINGS: A COMPLEMENT TO THE BEST DESIGNS.



When The Nadel Partnership chose to use Fry Reglet curve aluminum moldings as a major feature of their own interior, we were flattered. It showed that architects have the utmost confidence in our product. After all, a company's own office makes a strong statement about them, so we had to be right. Fry moldings, which for over 20 years have added function and design to interiors, are now enhancing interiors as well.

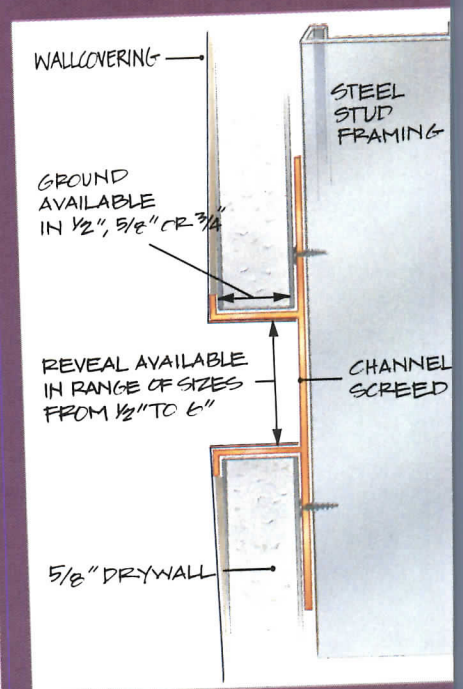

When you are searching for something special to complement your design, specify Fry and bring your rich imagination to life.

**FRY REGLET**  
Aluminum Architectural Molding

Headquarters of The Nadel Partnership - Architecture, Planning, Interiors. Los Angeles, California.

Look for us in Sweets Catalog 09200/FRY.  
625 South Palm Avenue ■ Alhambra, CA 91803 ■ (818) 289-4744 ■ Fax (818) 289-0537  
2777 Peterson Place ■ Norcross, GA 30071 ■ (404) 441-2337 ■ Fax (404) 441-3194

Circle 34 on inquiry card



# Back to neighborhood basics

# U. S.-designed newspaper headquarters in Norway

A missionary fervor was evident in remarks by participants in the symposium "City and Suburb," held September 16 and 17 at the University of Michigan. The city component went essentially unmentioned in Ann Arbor as panelists Leon Krier, Andres Duany, Ian McHarg, and Robert Davis focused instead on the Traditional Neighborhood Development (TND) as the land-development planning device of the future. Krier, as self-proclaimed polemicist, led off with a familiar but nonetheless compelling plea for the restoration of an urbanism of streets and squares. Since drawing up the master plan of Seaside, Fla. (the model for subsequent TNDs, and the site of a Krier-designed house now being constructed), Andres Duany and Elizabeth Plater-Zyberk have planned over a dozen communities. As prophet of the movement, Duany foresees the inevitable triumph of TNDs over land-wasting planned unit developments, shopping centers, and office parks. Ian McHarg applauded the borrowing of ecologically local building traditions (along the lines of his fill-in-print *Design with Nature* 1969), which have now been coded in TND covenants. Robert Davis, the developer of Seaside, spoke of his travels through the South in search of just such a "cracker vernacular." According to the panelists, successful elements of these plans are becoming clear: a walkable district (or series of districts) of one-quarter-mile radius; a mix of residential, neighborhood-commercial, and office or light-industrial uses; narrow streets to slow the speed of vehicles and improve the pedestrian environment; segregation of green spaces and structures to create a specific community identity; and—unlike hermetic pod developments—divers linkages to adjacent communities. *J. S. R.*

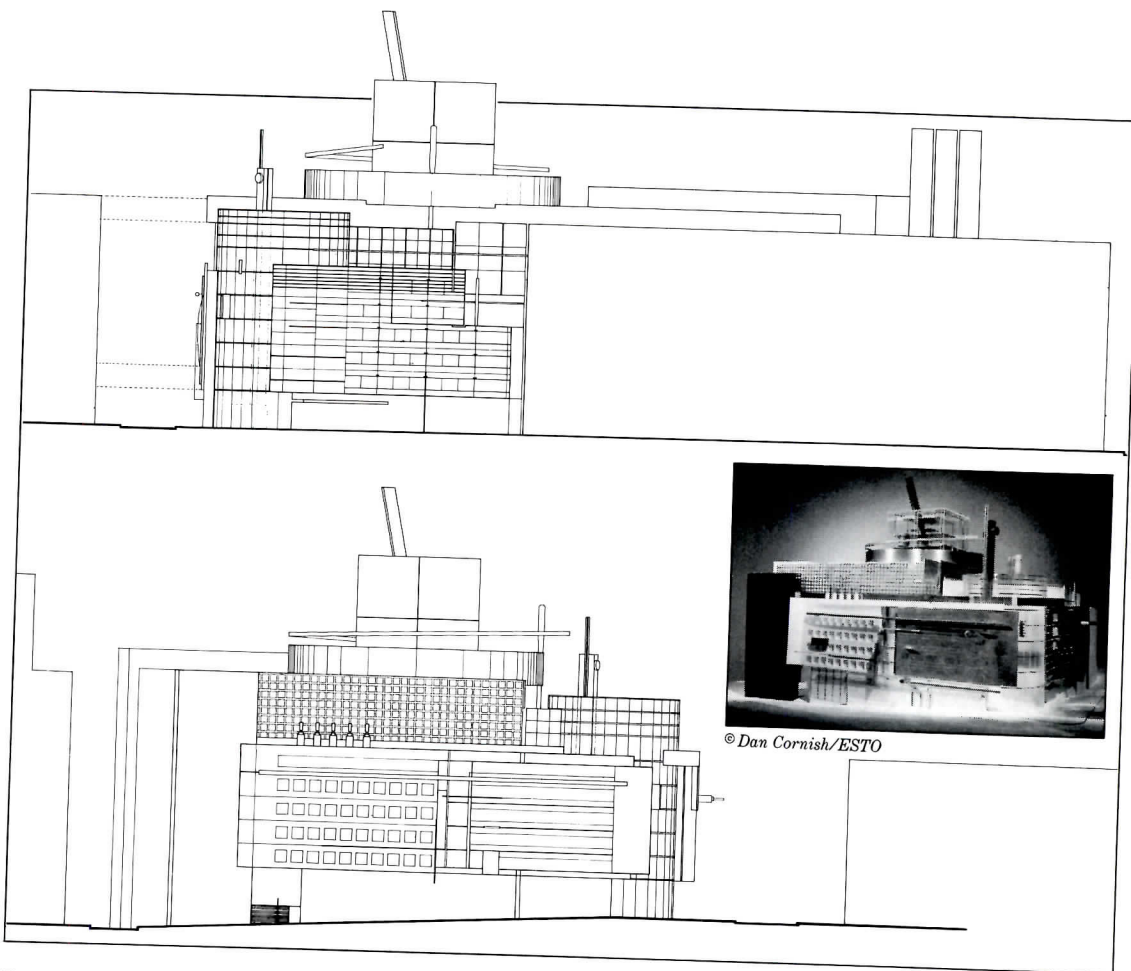

© Dan Cornish/ESTO

Peter Pran, design principal at Ellerbe Becket, describes his competition-winning design for the Schibsted Gruppen in Oslo as "expressive of movement and complexity"—appropriate imagery for Norway's two largest newspapers, *Aftenposten* and *Verdens Gang*, which will be

housed in the new structure. The copper, glass, concrete, and stone elements of the Apotekergata Street side (model and bottom drawing) express varied functions within. The adjacent glass-and-steel facade (elevation top) extends the Modernist proportions of the

existing newspaper building. These varied treatments meet at a curved corner entrance, which leads diagonally to a cylindrical light court at the center of the block. A cubical space, suspended within the drum above the ninth floor, houses an employee cafeteria.

Restoration of the 1878 capitol in Lansing, Mich., by architect Richard C. Frank (original architect Elijah Myers) necessitated removal of floors installed in 20-ft-high historic rooms. To receive the displaced functions and return offices scattered in various nearby buildings to the capitol, Gunnar Birkerts has proposed a 400,000-sq-ft skylit underground addition

## Michigan master plan saves views and landscape



as part of a preservation master plan. The elliptical new construction will surround the existing legislative structure with office space and furnish parking for up to 600 vehicles. The \$163-million project will be constructed in phases as funds allow.



# CARADCO



We give you  
imagination  
room to work

Think of Caradco windows as frame works for adding architectural emphasis to your design. For enhancing the shape of a room. For turning your houses into showcases.

With our product and our support program and our capability, there is no limit to what you can do.

Custom or in-stock Caradco wood windows and doors give your imagination room to work, and your business room to grow.

Compare the quality.

Compare  
**Caradco**

A Kusan, Inc. Company, Rantoul, Illinois 61866

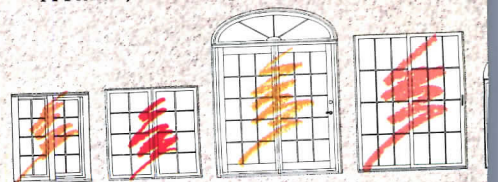

A complete line of quality wood windows and patio doors: casements, sliders, awnings, double hungs, round tops and custom. In both primed and clad.



News briefs

The street is his canvas

**The University of California at San Diego** has approved the establishment of a new school of architecture. The curriculum will include undergraduate study leading to a liberal arts degree, a master's degree and doctoral program, and continuing education for practicing professionals. A research component will emphasize architectural technology, computer-aided design, investigation of facilities for the homeless, and analysis of problematic patterns in urban communities similar to those faced by the San Diego-Tijuana, Mexico, urban complex. The school will begin accepting students in 1991.

**Hans Hollein**, of Vienna, has received the Haas International Award, which honors foreign alumni of the University of California.

**Hassan Fathy**, the Egyptian architect, artist, and poet, has donated his entire collection of drawings and writings to the Aga Khan Trust for Culture, which will use them as the nucleus of a new Hassan Fathy Centre for Ornamental Architecture.

**Enrico Botta** has been approved to design the new home of San Francisco's Museum of Modern Art [RECORD, October 1988, page 18]. Now housed in cramped quarters in the city's historic financial center, the new structure, to be opened in 1993, will enclose between 150,000-170,000 sq ft.

**The Crystal Dome and Tower**, the centerpiece of a new 200,000-sq-ft reflective-glass-clad shopping mall in Ankara, Turkey, is a geodesic dome containing a revolving restaurant and discothèque that will rise 360 ft above the city. Designed by Turkish architect A. Sinan Sip Buluc with Wendel R. Starnet of Starnet Structures in the U. S., it is symbolic, according to promoters, of Turkey as a new international center, emulating such centers as Korea.

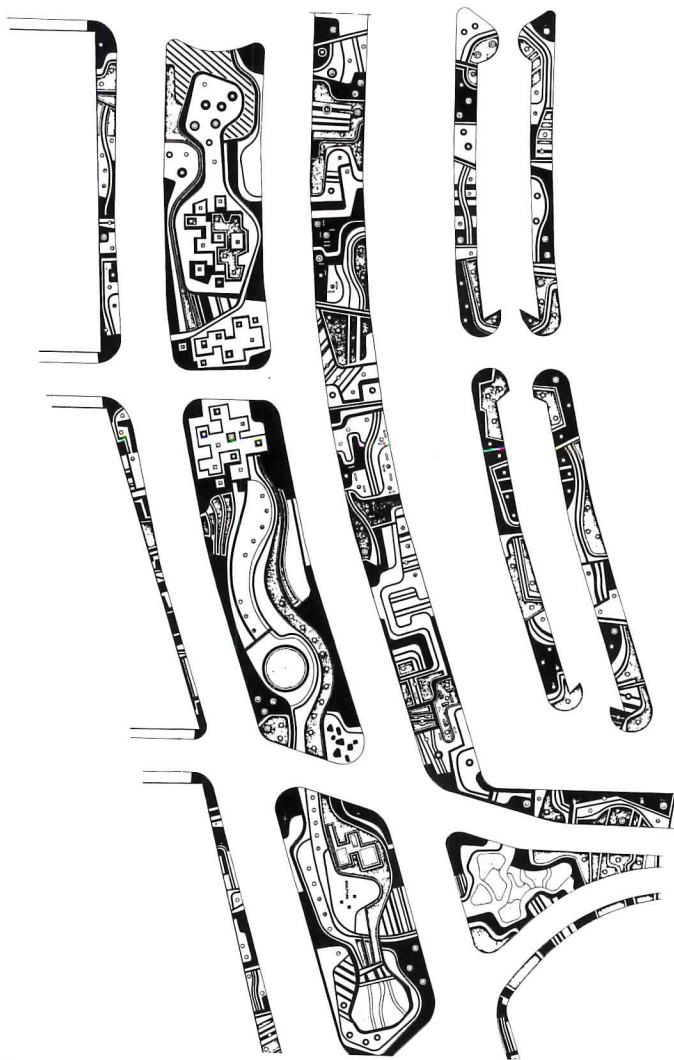

A 1.6-mile stretch of downtown Miami's Biscayne Boulevard will be transformed into a sinuous tapestry of trees, paving bricks, and flowers in a recently approved proposal by Brazilian artist and self-trained landscape architect and botanist Roberto Burle Marx. As part of rebuilding the street, sidewalks will be widened and replaced, and palm-lined median strips, benches, and light standards will be added. The patterns of brown (black areas on plan left), red (mottled areas), and beige paving tiles are said to be influenced by such wide-ranging sources as pre-Columbian art and early Portuguese pottery, and carry on themes developed previously by Marx at esplanades in Ipanema and Copacabana, Brazil. Pending completion of public and private funding, the scheme will be linked to two parks that stretch from the street to the bay, one of which is being redesigned by sculptor Isamu Noguchi.

Headquarters structures by Kohn Pedersen Fox in Cleveland and St. Paul

Two recent projects by Kohn Pedersen Fox respond to unique settings. The Ameritrust Center, in Cleveland, houses a 484-room hotel in its buff-granite base, which matches the massing of buildings on landmark Public Square. A reflective-glass tower encloses more than one million sq ft of office space. In the St. Paul Companies headquarters addition, a domed employee cafeteria looks out on a landscaped forecourt at the apex of a wedge-shaped site. A 17-story tower and nine-story slab, which act as a backdrop, are connected by a bridge to the company's existing center.

Ameritrust Center, Cleveland (1); St. Paul Companies Headquarters Addition (2, 3)

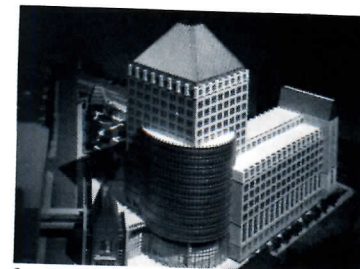
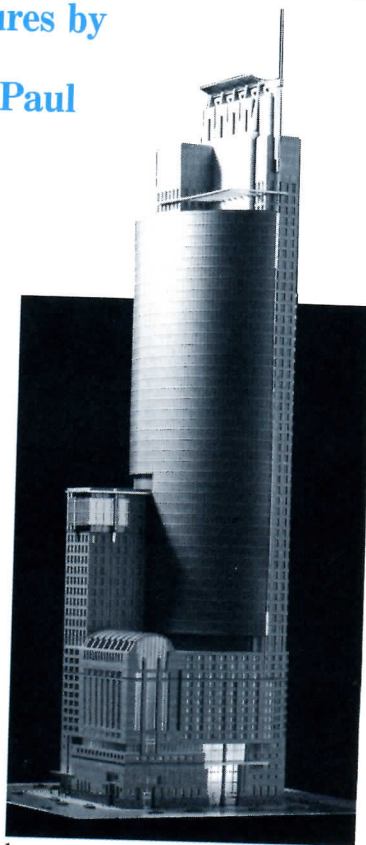

1 Mort Tucker

3





# Astro-Glass®

(O-SX-SX-O)

Dor-O-Matic's full glass automatic sliding door entrance

The Astro-Glass® automatic sliding door package is unique in what it includes. And what it doesn't. First, the package comes **complete** with 1/2" clear tempered glass in doors and sidelights. Yet the ensemble of glass doors and sidelights has **no vertical stiles** to intrude on the panoramic view! All Astro-Glass packages come complete with safety reversing and two horizontal safety beams.

To meet exit code requirements, the two sliding glass doors can be opened to 90° in an emergency from any position in their cycle thus complying with N.F.P.A. #101.

A manual lock in the bottom door rails is available for night security.

For information, call toll free 1-800-543-4635 or write for our new Astro-Glass Package Brochure.



**DOR-O-MATIC**  
AUTOMATIC DOOR EQUIPMENT  
Circle 36 on inquiry card

7350 West Wilson Avenue  
Chicago, Illinois 60656-4786  
Attn: Sales Mgr.-Auto Division  
(312) 867-7400 • Telex 317607  
Fax (312) 867-0291



News briefs

6 rms, riv vu, gdn w/artwk

**Four multifamily housing projects:**

**New London Mills (1)**, in Connecticut, offers clusters of town houses that range from two to seven stories and surround courtyards along the waterfront of Long Island Sound. Included in the development, designed by Beyer Blinder Belle, are a yacht club, a marina, and a retail town center. The most prominent spot on the site will be occupied by a 14-story residential tower.

Occupancy will begin in 1992. **Brown & Howard Wharf (2)**, a reconstructed pier on Narragansett Bay in Newport, R. I., evokes the area's Shingle Style roots in its massing, patterned siding, and brick base. Architect Bergmeyer Associates will convert existing structures for commercial space and a sailing school. When completed in the spring of 1989, yacht moorage will be available to all residents.

**931 Massachusetts Avenue (3)** is a 13-story condominium under construction near Harvard Square in Cambridge, Mass. Bruner/Cott & Associates (see also pages 100-103) responded to a vibrant context in the slim massing of the tower (four units per floor) and in the traditional detailing of gray brick, six-over-six metal windows, and precast concrete trim. The 54-unit building includes covered parking; it will be finished by year's end.

**Clippership Wharf (4)**, a cluster of 350 luxury condominiums, will offer panoramic views from East Boston across the harbor to the city skyline. Childs Bertman Tseckares & Casendino is the architect of the seven brick-clad structures (one of which will house residents of low-to-moderate income). Consistent with regional guidelines, public access to the waterfront is provided; a ferry terminal is also planned.

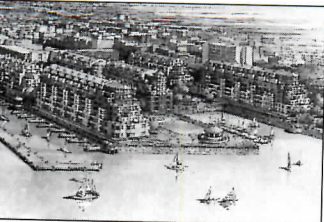

Lynn Moser photos

Works in the 911 Contemporary Arts gallery's "Homes for Art" exhibition in Seattle expressed ambivalence about America's detached-single-family-residence culture in various ways. Reactions ranged from the statically indeterminate (*A Sculpture Restrains Expanding*

*Walls*, top left, by Beliz Brother) to the structurally expressive (*An Entrapping Bamboo Billboard*—in an Asian neighborhood—top right, by Alan Lande), to the overtly symbolic (*Landscape of Buried TV Sets*, by Susan Galligan and David Loseno).

**Competition calendar**

•The Korean War Veterans Memorial Advisory Board has announced a single-stage national design competition for a memorial to honor Korean War veterans. Written expressions of interest should be submitted by December 16 to the Korean War Veterans Memorial Design

Competition, P. O. Box 17045, Baltimore, Md. 21203-7045.

•Designs are being sought for 100 units of affordable elderly housing in the city of Colton, Calif. The first-stage deadline is December 20. Contact Brian S. Oulman (714/370-5052).

•Two student competitions: "A Riverboat Center on the Mississippi River" (registration closes February 15, 1989) and "A Cultural Exchange Center for Beijing, China" (registration closes April 30, 1989). Information for both is available from AIAS, 1735 New York Avenue, N. W., Suite 710, Washington, D. C. 20006.



# GUESS WHO WON THE RACE IN INDIANAPOLIS THIS YEAR?



The 29-story First Indiana Plaza in downtown Indianapolis used 439,440 square feet of Vulcraft 3<sup>rd</sup> comf



...e conditions put the 29-story First Indiana Plaza project five weeks behind schedule. So the contractors and engineers found themselves in a race against time. But it was a race they won, thanks in large part to Vulcraft composite deck. That's because composite deck is a lot easier to put down than poured-in-place concrete, which requires the installation and later removal of cumbersome forms.

It's more economical too, because it's less labor-intensive. And the decking's 3" depth adds strength which allows for fewer steel beams. That saves money too.



*Installing Vulcraft composite deck is faster and more economical than poured-in-place concrete.*

But the nature and the quality of the deck weren't the only factors that put the project on time and on budget. The attitude Vulcraft people had a lot to do with it too. We were required to meet a very exacting, very coordinated delivery schedule, arriving at specified times with specified materials to be off-loaded by crane. We met that schedule, and in doing so avoided costly downtime on labor and crane rental.

So before you start your next project, consider Vulcraft composite deck. It's strong, it's economical. And it beats poured-in-place concrete to the finish every time.

For more information, contact any of the Vulcraft plants listed below. Or see Sweet's 05300/VUL.

**VULCRAFT**

*A Division of Nucor Corporation*

7, Brigham City, UT 84302 801/734-9433, \*PO Box F-2, Florence, SC 29502 803/662-0381, PO Box 169, Fort Payne, AL 35967 205/845-2460, 86, Grapeland, TX 75844 409/687-4665, \*PO Box 59, Norfolk, NE 68701 402/644-8500, \*PO Box 1000, St. Joe, IN 46785 219/337-5411. Manufacturing locations. Developer: Duke Associates; Architect: CSO Architects, Inc.; Design Architect: 3DI International; Construction Manager: Duke Construction Management, Inc.; Structural Engineer: Walter P. Moore & Associates; Steel Fabricator: Ferguson Steel Company.



## Design awards/competitions: California Council/ AIA 1988 Design Awards

A record 307 entries were winnowed by three judges in this year's California Council awards program. Four projects received Honor Awards, nine Merit Awards, and one, The Bear Valley Visitors Center at Point Reyes, Calif. (not shown), by the firm of Volkman Stockwell, received the council's first People in Architecture Award. Although work located in such diverse places as Hong Kong, West Berlin, and Holland was premiated, only one residence in this house-proud state was

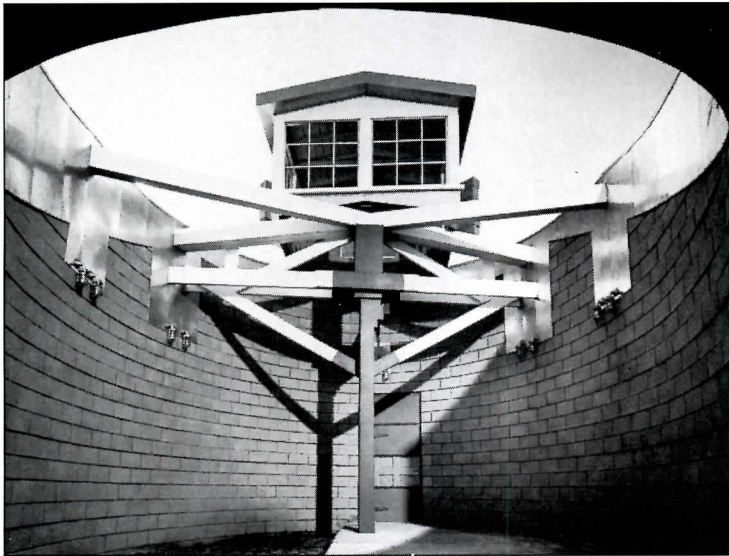

1 ©Tom Bonner

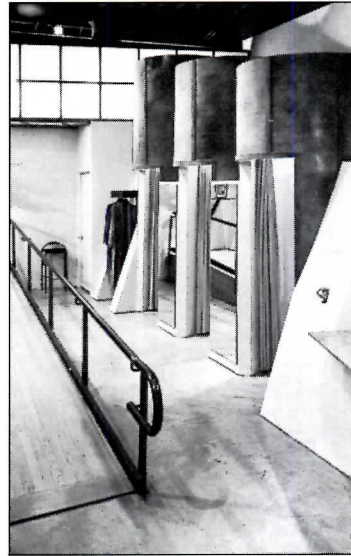

4 ©Tom Bonner



5 ©Tom Bonner

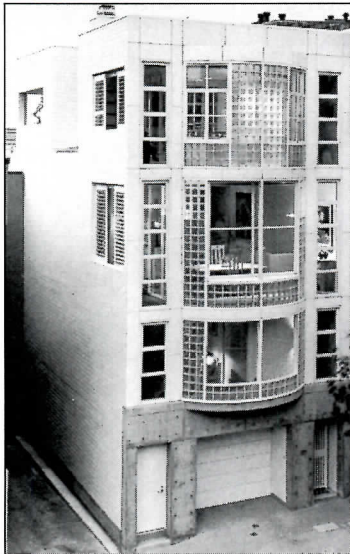

2 Dennis Anderson

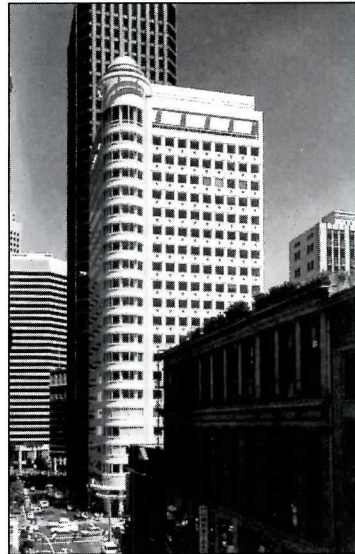

3 Greg Murphy

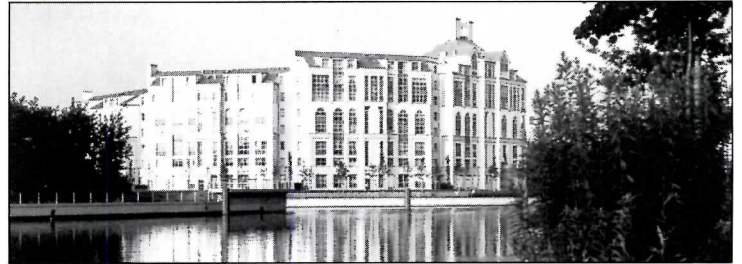

6 Richard Bryant



7 John Durant

**1. 8522 National Boulevard, Culver City, Calif.;** Eric Owen Moss, Architect [RECORD, April 1988, pages 90-97]; Merit Award. Five separate structures totaling 60,000 sq ft ("the most mundane circumstances," according to the awards panel) were unified by the use of simple industrial-building devices—a metal canopy, heavy-timber trusswork—to become "almost pure art . . . a lively, exhilarating space."

**2. Glickman Residence, San Francisco;** Backen Arrigoni & Ross, Architect; Merit Award. Architectural screening devices permit ample light to penetrate

this four-story, 2,575-sq-ft city home while maintaining the owner's privacy. The jury called the bay-windowed front "a witty gesture for the city street."

**3. 88 Kearny Street, San Francisco;** Skidmore, Owings & Merrill, Architect; Merit Award. A new office building which incorporates a landmark 1907 terra-cotta-clad structure, the project was commended for its "restraint in overall form."

**4. Archilla Clothing Store, Santa Monica, Calif.;** William Adams, Architect; Merit Award. Both "high style," in its use of angular ramps and "old-world" in the patina of its material

palette, this showcase for men's clothing was designed with a "sure artistic hand."

**5. Kate Mantilini Restaurant, Beverly Hills;** Morphosis, Architect; Merit Award. Among other manipulations of a former bank, a sculpture, dangling from the ceiling in this "personal vision," suggests the workings of a clock. The jury commented: "This is a late-20th-century version of the 1930s Los Angeles supper club."

**6. Tegel Harbor Housing, Berlin, West Germany;** Moore Ruble Yudell Architects; Honor Award. Part of Berlin's famous IBA program, this 170-unit

apartment complex encloses courtyards and focuses views outward to the harbor. The panel praised the tiny layouts (required by codes) as "simple yet sculptural . . . The architect was able to give individual character to the units and not compromise the overall strength of the design."

**7. The Scripps Clinic at Carmel Mountain Ranch, San Diego;** Austin Hansen Fehlman Group, Architect; Merit Award. The interplay of forms in this 87,000-sq-ft medical complex was accomplished with tilt-up concrete panel technology. The entrance colonnade leads to a



selected by the jury, which comprised Elizabeth Ericson, of Shepley Bulfinch Richardson and Abbott, in Boston; Robert Frasca, of Zimmer Gunsul Frasca Partnership, in Portland, Ore.; and E. Fay Jones, of Fay Jones and Maurice Jennings Architects, in Fayetteville, Ark.

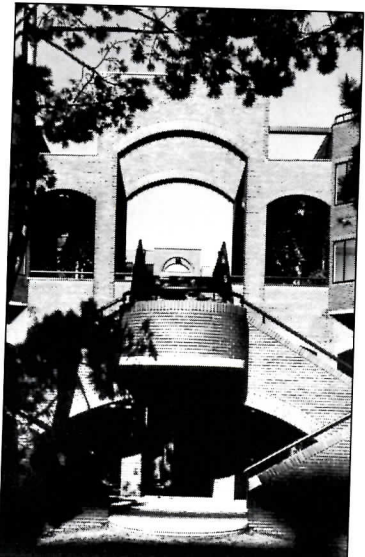

kylit atrium, the focus of clinic wings. Jury accolades: "human in scale . . . a unique sense of space extremely hard to achieve in medical facilities."  
**Environment for a Papal Mass;** Bissell Architects; Merit Award. A temporary but "very dramatic setting" was created in the Los Angeles Coliseum for 5,000 communicants by the suspension of a 6,000-sq-ft space above from cranes, and the extension of a multitiered platform (to hold an altar) into the field-level seating area.  
**The American Club, Hong Kong;** William Turnbull Associates, Architect; Honor

Award. Focused on a formal dining room, the massing of octagonal and rectangular forms composes a distinctive silhouette on a hillside site overlooking Tai Tam Bay. The concrete structure makes use of "native wood and an indigenous palette of colors to create a handsome atmosphere."  
**10. Shell Central Headquarters, The Hague, Holland;** Skidmore, Owings & Merrill, Architect; Honor Award. An addition to an existing structure, the 300,000-sq-ft brick office block steps up from four to eight stories in a continuation of the residential scale of its historic neighborhood. The jury noted

that "the building connects to the place that it is in," and appreciated its "extraordinary craftsmanship."  
**11. Sunset multiuse complex, West Hollywood;** Architectural Collective; Merit Award. Above underground parking are two stories of office space with terraces; the upper floors are occupied by loftlike residences. Finding the project "playful," the jury also praised the concrete-framed structure as "an intriguing solution to housing."  
**12. Golden Gateway Commons, San Francisco;** Fisher-Friedman Associates, Architect; Merit Award. An urban redevelopment,

155 condominium units rise above a podium containing office space and parking. With its landscaped courtyards and terraces, the project won recognition for its "volumes, vistas, and a small scale that is hard to achieve in a large city."  
**13. Carousel Park at the Santa Monica Pier;** Moore Ruble Yudell/Campbell & Campbell, Architects; Honor Award. Improvements surrounding the historic carousel included a playground, boardwalk-style retail space, and a new wheelchair-accessible entrance plaza. The project was applauded as "a delightful urban stage."



# EXPAND YOUR HORIZONS.

Forget about the restrictions imposed by conventional timber. Now there's Parallam, the new engineered wood product that expands your creative horizons.

Parallam PSL is made of long strands of veneer that are bonded, pressed and cured in a patented new microwave process... resulting in splice-free timbers up to 66 feet in length. Parallam is stronger and stiffer than conventional lumber, glulam or LVL. And its good looks enhance exposed applications.

Parallam renews the design possibilities of post and beam construction. It has the workability of wood and the



predictability of steel.

You can design for shallower beams with less sag. And eliminate builder-rigged headers or oversize walls.

Produced at a constant 11% moisture content, Parallam won't shrink, warp, cup or bow. Its high reliability means less liability for you because it has none of

the flaws of conventional wood like knots or splits. In fact, Parallam expands your horizons while reducing your risk.

**Parallam**<sup>®</sup>  
PARALLEL STRAND LUMBER

For more information and to learn when Parallam will be available in your area write:

 **MacMillan Bloedel Building Materials**  
P.O. Box 1563  
Atlanta, Georgia 30301

Circle 38 on inquiry card



## Life on the edge: Toward a new suburbia

By Daniel Solomon

As one drives through the great Central Valley of California, or east from Phoenix, or south from Los Angeles through the vast settlements in the non-town counties of Orange, Riverside, and San Bernardino, there is no question that, despite the efforts of planners, architects, developers, traffic engineers, and building officials, no one *likes* living in the places they are building. And as community after community elects anti-growth officials and enacts no-growth legislation—with California again in the vanguard—the utter lack of design leadership in the making of these places becomes more obvious and more acute.

Notwithstanding greenbelts and buffer zones, atriumed shopping malls and picturesque jogging paths, the suburban landscape, though now our predominant urban form, increasingly confounds us with its problems. Sprawling development voraciously consumes land (in many parts of California there is simply no longer countryside nor are there distinct towns), consumes gasoline, water, air, and the ozone layer, and requires a huge infrastructure (the imported golf-course landscape of suburbia is energy-intensive and non-self-sustaining—turn off the switch and it goes away). More than ever, hours of vacuous motorized torture are required to get from one place to the next, and suburbia is built in such large homogenized chunks that it discriminates against everyone who is not part of a “target market.” Worst of all, this new, sanitized, antiurban world is a place of diminished experience and diminished insight. It is significant that the word for the maturation of public space in traditional cities is

frequently coupled with a word to describe intelligence, as in the adjectival “street-smart.” There is no comparable form of suburban wisdom—mall-smart? cul-de-sac smart?

If one asks any of the city-making experts why they chose to make the place the way they did, their response echoes the familiar cry of bureaucrats caught red-handed: “I didn’t do it. All I did was my little job, but I don’t control the system.”

Architects are the most vigorous defenders of their own nonculpability. Architects did not build this town, they say, it was the developers, the bankers, the traffic engineers; it was the distribution of goods, lending policy, the electronics industry, the accumulation of capital . . .

Whoever would have thought that the tiny wars fought at faculty meetings would leave the American landscape in such smoldering environmental ruin? A generation ago, a new age of specialization befell academia, and the long-term effects of this process of atomization are now visible everywhere. City planners scurried into the heady realm of public policy, and left physical planning to the thick-fingered working lads. Smart landscape architects headed into forestry and habitat management, with the slow ones left mindlessly applying the Zipatone of a vacant post-Olmstedian pastoralism to any and every design task. Architects joined in an ever more hermetic stylistic fratricide, of interest to no one but themselves, and the new American townscape emerged as fractured and disjointed as the disciplines involved in its construction.

It was during this time that the legacy of Clarence Stein and Henry Wright—in the form of traffic on arterials, and houses on curving cul-de-sacs—found its way into the FHA Minimum Property Standards that controlled the GI Bill-financed

*Nobody really likes the contemporary suburb, asserts Daniel Solomon, but architects can do more than share the blame for this much-maligned type of development—they can help lead the way to reshaping it. Solomon’s own projects on individual sites have been documented earlier in RECORD [August 1988, pages 100-107]; here he describes plans for entire California communities—in San Jose, Pasadena, and San Francisco—to make places that are truly “civilized, urbane, and communal.”*

explosion of suburbia after World War II. In a dramatic and essentially unexamined departure from centuries of urban form-making, these standards imposed a pattern of enclaves as opposed to continuous urban fabric. Houses in these privacy-obsessed subdivisions were shaped directly or indirectly by Frank Lloyd Wright’s Usonian house, which took its definitive form in the Jacobs house of 1937. Wright’s ideal residence opens every room to a private garden, and welcomes the automobile into the heart of the plan, using it as a buffer between house and street. Richard Neutra

reinterpreted the Usonian house in California, which, in turn, was knocked off by developers like Joseph Eichler in the form of huge subdivisions. The antiurban values of these houses were then disseminated by powerful shelter magazines such as *Sunset* and *House & Garden*.

The sensual embrace of the Usonian house did not survive as a part of the American scene, but the essential elements of its plan—each space open to a private “wilderness,” the garage a blank visage to the public street—are still standard builder offerings. By 1960, the conventionality of the banal house in the amorphous



*“Now, before I show you this condominium, I would like you to give us a brief statement explaining your philosophy of Modernism, Postmodernism, and contextualism as you see it.”*

*Daniel Solomon heads his own architectural firm in San Francisco.*



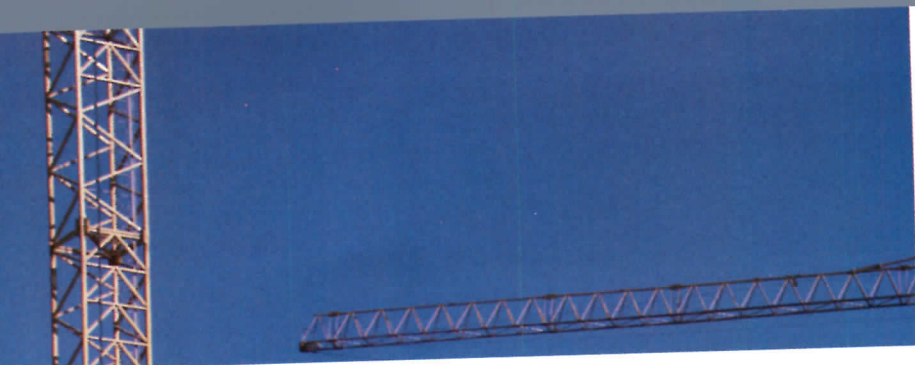

Use in your car,  
or go portable and  
carry it with you.

# Transportable Cellular Phone

Radio Shack's CT-201  
puts the whole world  
in your hand!

A Full-Featured Mobile Phone for Only \$999. Now you can make and take calls from your car, truck or van. You can stay in touch while going to and from work, or make a service call or making a delivery. You'll be able to confirm meetings and appointments in advance to avoid wasted trips, as well as receive important messages from home, office and customers.

The CT-201 Can Go Where You Go! Just snap on the Portable Adapter Pack and you can easily use

the CT-201 away from your vehicle. Carry it with you to make calls at a job site, in a rental car, aboard a pleasure boat—wherever there's cellular service. The 3-watt output is five times the power of many other portables for maximum range and clear sound. The CT-201 also features the 832-channel capacity now being used in some cellular cities.



Turn the CT-201 into a Portable for Only \$159. You'll get the Portable Adapter Pack (17-203), which includes a portable antenna, DC power adapter/charger with auto lighter plug and shoulder strap; two rechargeable batteries (23-181); and an AC Charger (17-204).

You Can Be Sure of Quality Service and Support. Radio Shack handles the start-up paperwork, obtains your personal cellular telephone number and programs your phone right in the store. The CT-201 is backed by a One-Year Limited Warranty, which covers both parts and labor. Service is available at 7,000 participating Radio Shack stores and dealers nationwide.

Come In Today for a No-Cost, No-Obligation Demonstration. Whether for business, family or personal use, the CT-201 (17-1005) is an excellent investment at \$999\*, or \$50 per month\*\*.

**Radio Shack**  
**The Technology Store**

A DIVISION OF TANDY CORPORATION



Handset Mounts in Your Car

Transceiver Mounts in Trunk



\*Mobile antenna and portable adapter extra. \*\*Radio Shack revolving credit. Payment may vary depending upon account balance. Prices apply at participating Radio Shack stores and dealers.

Circle 39 on inquiry card



In Pasadena, the garden—enclosed by buildings or by low walls and trellises—is seen as an architectural element that unifies disparate building types. Green spaces of designated proportions (lightly shaded areas, top) are required

under a proposed ordinance. The informal yet perceptible street enclosure visible in a row of Pasadena bungalows (bottom) is the model for new guidelines in that city and in San Jose.

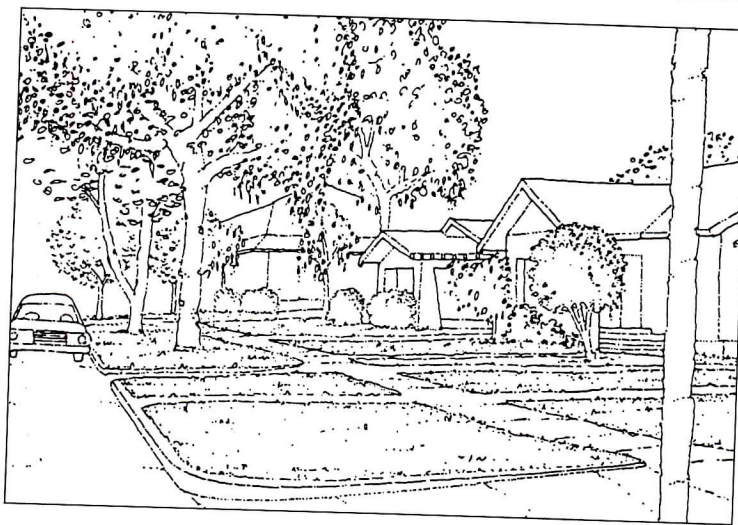
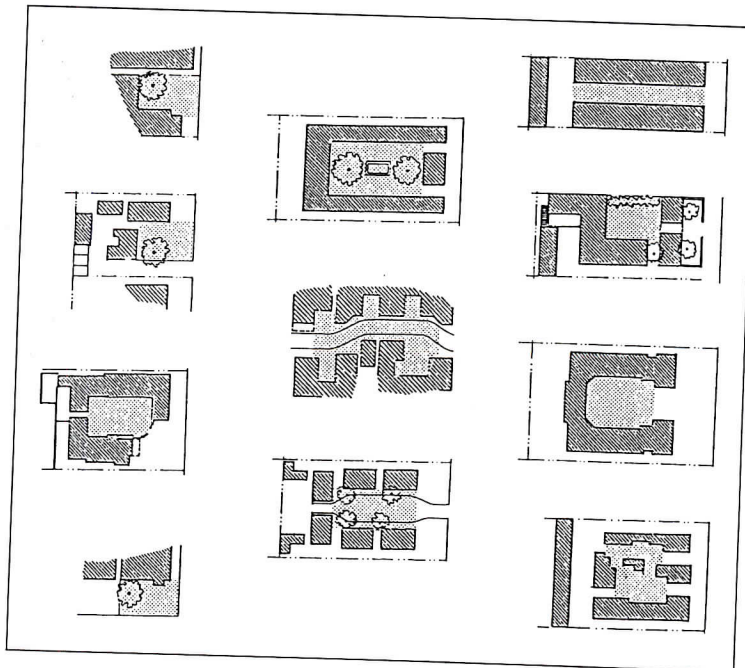

The predictable and edited world of the shopping mall, the office park canteen, and the condo rec room relates to traditional urban life as a kind of sad Club Med—an antidote to civilization.

But if one becomes a scholar of planning ordinances, which, in their turgid language summarize successive generations of academic debate, schism, and polemic, one can see the process—perhaps twisted—by which architectural and planning rhetoric is translated into the built world. It is evident that architects and planners, collectively, are not passive

victims of circumstance, but can instead be the *creators* of circumstance.

Architects can bring a planning language to urbanizing suburbs that describes some of the ordinary things about towns that people like, and then use that language to bridge the gulf between the vagaries of land-use planning and the minutiae of design review. In four recent projects in California, our firm has taken planning beyond arid terms like Dwelling Units Per Acre, Floor-Area Ratio, Permitted Use, and Required Open Space, to develop the

properties of towns that make them civilized, urbane, and communal.

San Jose adopted a planned-development ordinance in 1965 and more than doubled its population in the ensuing 20 years. In 1985, the City Council concluded that the outcome of this experiment was profoundly flawed and initiated the writing of new residential-design standards. The ordinance written by our firm was passed in November 1986. While *Toward Community: Residential Design Guidelines for the City of San Jose, California* retains the PD as the basic unit of urban structure, it does significantly change site-planning principles and building typologies so that they are more like those of the older gridiron town. In the process, every phrase and comma of the 65-page document was reviewed and debated by San Jose's development community. Builders would not allow guidelines that caused significant loss of density, increased the cost of construction, or affected housing marketability. The ordinance met their concerns, but changed the way PDs work in significant ways: walls around projects are discouraged, except along freeways or primary highways and, where allowed, must be integrated with buildings and must provide transparent breaks for views to common areas and gardens. Street widths are narrowed and setbacks are reduced (though less than we originally proposed) to slow traffic to a small-town pace. Units are encouraged to have a frontal orientation to the street and to enter directly from it. Site plans with continuous perimeter parking drives are not permitted. Pedestrian walkways are required in parking lots to break them into bays and must relate to building entrances and articulations. A new type of entry drive is created which has

subdivision was being heavily criticized. Architects argued that setback requirements wasted land and created mindless rows of identical houses. Thus, the Planned Unit Development was introduced, in which architects were free to push dwellings into little clusters, to consolidate gardens and parking areas, and to place tastefully landscaped walls around the assemblage, severing them utterly from any notion of urban continuity. The lost identification with the city was replaced by the '60s landscape of metaphor, in which places of genuine character were evoked (rather than built) by marketing and by architectural shorthand: Mariner's Cove, Tonga Gardens, Briar Heath.

With the advent of environmentalism, the making of cities was placed in the hands of "experts": environmental planners, civil engineers, zoning lawyers. Unfortunately, the ways in which the activities of people are laced together and the subtlety with which buildings shape public spaces in real towns was not part of the language of those wielding the multicolored felt-tipped markers. In spite of all this scientific expertise, increasing control over development continues to be sought by citizens, even in today's antitax, antiregulatory environment. Design review is taken by many communities as the next step. Since this typically deals with the profile of window trim or with shades of driftwood grain, there is nothing to mediate between the scale of land-use jobs and the relative correctness of a wooden roof angle. The whole legacy of urban life has fallen into a silent chasm.

The full and unedited range of human experience encountered by street-smart urbanites, while it includes failure, tragedy, and evil, also opens a liberating range of living, working, and social possibilities.



# DID YOUR LAST OFFICE BUILDING USE THE ADVANTAGES OF METAL?



Metal offers you more design options than any other roofing material. You can bring the roof out into the open and make it part of your design.

When you specify an MBCI roof system, we want you to be satisfied. We will work with your design team to insure the proper product selection for your design.

For a copy of the MBCI design manual, call or write the nearest MBCI plant. Metal is our only business and we want you satisfied.



**METAL BUILDING COMPONENTS, INC.**

Houston 713/445-8555  
Lubbock 806/747-4291  
Oklahoma City 405/672-7676  
San Antonio 512/661-2409  
Dallas 214/988-3300  
Atlanta 404/948-7568  
Tampa 813/752-3474  
Richmond 804/526-3375  
Indianapolis 317/398-4400

Circle 40 on inquiry card



*Prototype housing in the Mission Bay Plan adapts traditional elements of San Francisco building to modern requirements. Housing surmounts retail in the Neighborhood Commercial Corner (1) and the*

*Neighborhood Commercial/Housing Half-block (4); units in the Two-level Podium Mid-rise Block (2) are reached by generously scaled stairs; the Combined 3- and 4-story Block (3) surrounds a small park.*

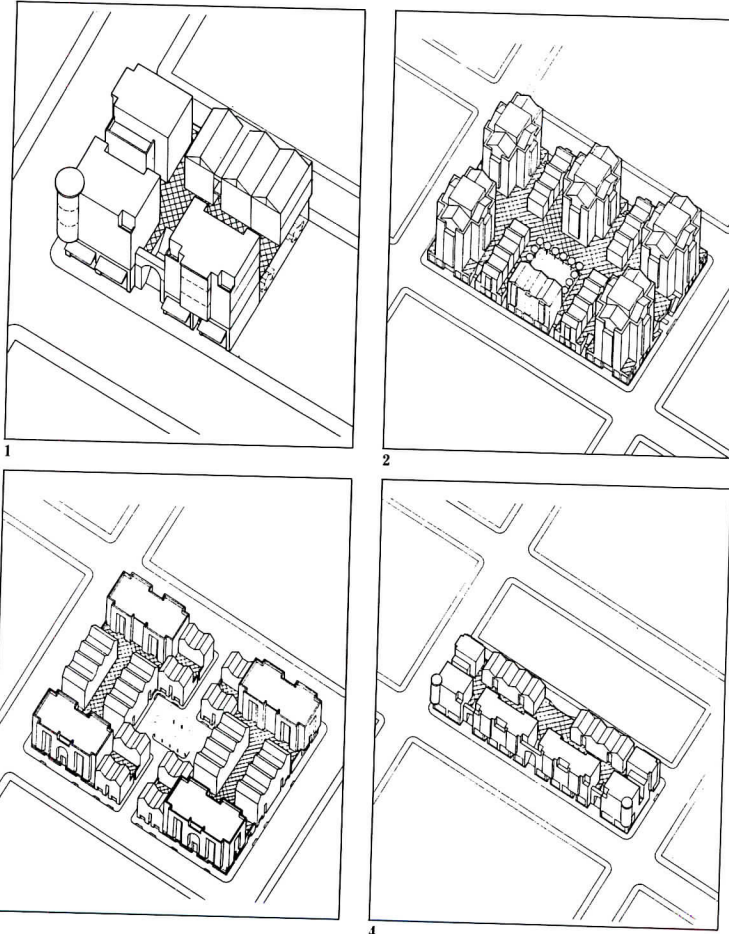

the characteristics of gridiron streets so that the parking lots are not the main public areas of projects. Standards for building articulations and embellishments are established. Grading standards prohibit terracing hillsides into flat pads. Building typologies are revised so that curb cuts and garages no longer dominate the street.

Pasadena has a beautiful and consistent block-and-lot gridiron structure with many examples of distinguished high-density housing. In recent years this fabric has been damaged by the widespread production of a building type known locally as a "six-pack," which consists of a single or double row of party-wall townhouses turned perpendicular to the street, its blank side facing the public way. Typically the full width of the drive opens off the street and parking is semidepressed, offsetting the structure from a traditional relationship to the neighborhood. The units are entered from a tiny, usually trim, sliver of side yard. Our guidelines, *A City of Gardens: Pasadena Design Ordinance for Multi-Family Housing* (a collaboration with Christopher Alexander and Phoebe Wall), do away with the six-pack pattern, and elevate the residential garden—the most important element of Pasadena's heritage—to a morphological status equal to that of parking layout and unit design. It was necessary for us to design hundreds of case-study site plans that show that changes proposed could be achieved without unacceptable density or cost consequences. Compromises were struck on relatively less important issues such as side-back requirements in the rear portion of lots and the proximity of parked cars to units, but the document shows that historic front and garden typologies can be reconstituted with modern densities and parking ratios.

Obsolete railroad land will be transformed into a 200-acre mixed-use development in a new plan for Mission Bay in San Francisco, the product of a large multidisciplinary team—led by the firms EDAW and ELS—that is working for the City of San Francisco and with the Santa Fe Pacific railroad's own consultants. The Solomon office participated in creation of the overall plan, but specifically developed block patterns, building typologies, and design guidelines for approximately 7,700 units of new housing on 90 acres. The Housing Design Plan will prevent an onslaught of suburban PD-type development, and guide construction of new residential fabric based upon an adaptation of San Francisco's originally platted grid of 25-foot lots, yet include the high parking ratios, unit security requirements, and construction

efficiency demanded by large housing developers. Entrances and architectural articulations are required to punctuate the 25-foot grid, and a three-foot band between the building line and the public sidewalk—called an encroachment zone—permits, or even requires, a variety of architectural or landscape features. High densities are accomplished through a rethinking of the same device that gives 19th-century San Francisco much of its flavor: the small midblock alley. In the plan it allows the perimeter of blocks to increase and ensures that streetscapes will not be faced by blank walls of garage doors.

Work, commerce, and dwelling in suburbia are typically separate and linked only by automobile. Zoning, financing, and development conventions have evolved to perpetuate that

separation. It is the architect Peter Calthorpe, a teaching colleague, whose eloquence about the plight of suburbia has inspired more comprehensive thinking than could be promulgated in the tightly constrained planning projects discussed above; he has forged a collaboration of faculty and students at three universities. Graduate students at the University of California in Berkeley have been assigned a scheme, called Pedestrian Pocket, that combines suburban office buildings, a convenience shopping center, and a residential development as they were in a traditional town on a site of about 90 acres. The automobile is accommodated as easily—and in the same numbers—as conventional suburban prototypes, but the design is intended to liberate people from total dependence upon it for all of their activities. The pedestrian-pocket type would be erected by typical suburban developers and financed by the usual suburban lenders. It would be built along a light-rail system, and as the system is extended, parking adjacent to office buildings would be reduced. The Pedestrian Pocket would grow to a finite size, limited to the one-quarter-mile radius that can reasonably be walked from the transit stop. Its edges would be fixed in perpetuity by a combination of agricultural zoning and the transfer of development rights.

The ideas embodied in these projects represent a collective view held by enough people (realized in a different form in Seaside, Florida, for example) that changes are likely to be brought about. It is the hope of these planners that projects with a new, simple, and subtle language can emerge that adapt the heritage of the American town to the colossal growth of suburbia.



No matter how colorful your design and no matter what your design considerations, you'll find Andersen Perma-Shield® windows beautifully compatible. They're available as Andersen High-Performance and High-

# IF WE HAVEN'T ALREADY DONE SO, PERMIT US NOW TO COLOR YOUR OPINION.

Performance Sun glazings. Both are designed to detect heat and keep it where you want it, permitting the use of large glass areas for bigger views and maximum light.

There are other glazing options available, too. Your choice of tinted, reflective, safety, spandrel, decorative or double-pane.

In short, no matter how you color it, there's an Andersen glazing to complement any commercial design.

So if your opinion of Andersen windows until now has been otherwise, perhaps we have kept you in the dark too long.

Call 1-800-635-7500 for the name of your local Andersen commercial representative. Or write Andersen Commercial Group,™ P.O. Box 12, Bayport, MN 55003.

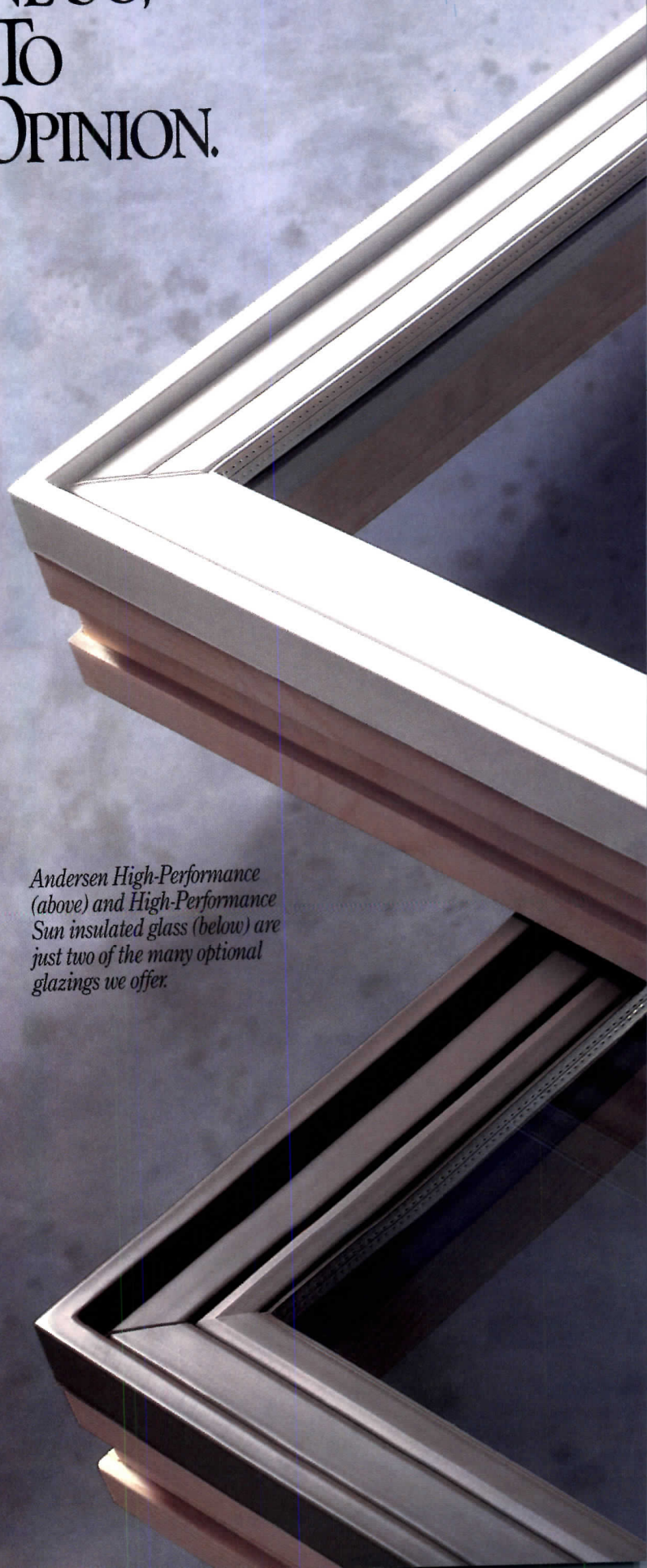

*Andersen High-Performance (above) and High-Performance Sun insulated glass (below) are just two of the many optional glazings we offer.*

**ANDERSEN  
COMMERCIAL  
GROUP**



Circle 41 on inquiry card







# GE IS THE LIGHT THAT WILL RESHAPE THE WAY

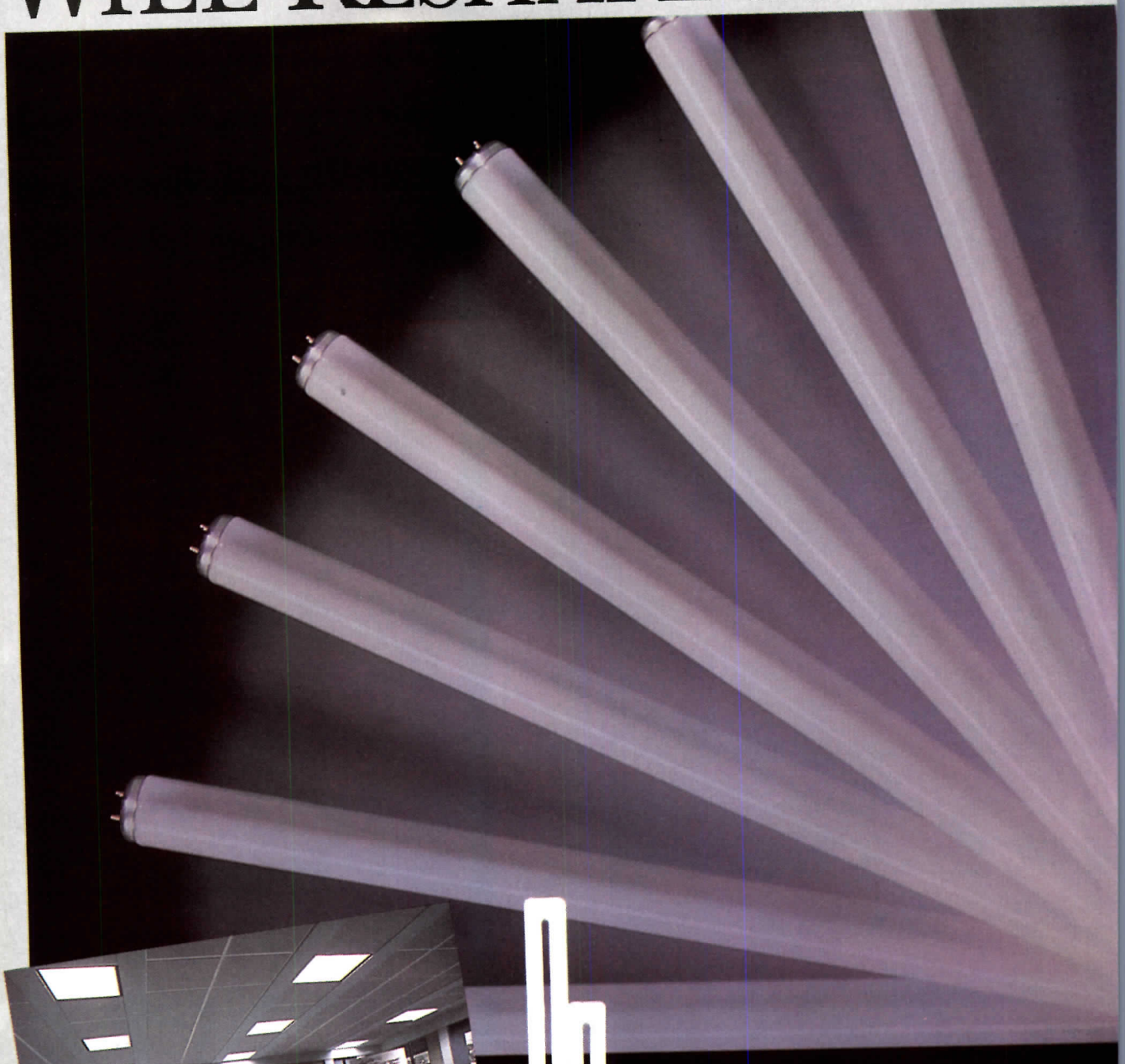

**GE BIAX lamps  
make everybody and everything,  
including operating costs, look better.**



It won't take you long to discover that with GE BIAX™ 40-watt lamps, the design possibilities are endless.

Because they're only 22.5 inches long, yet deliver all the light of standard four-foot fluorescent, you can design with smaller fixtures. And that means more attractive ceilings.

And because BIAX lamps make colors look richer and more vibrant than standard fluorescent,



# YOU DESIGN LIGHTING.

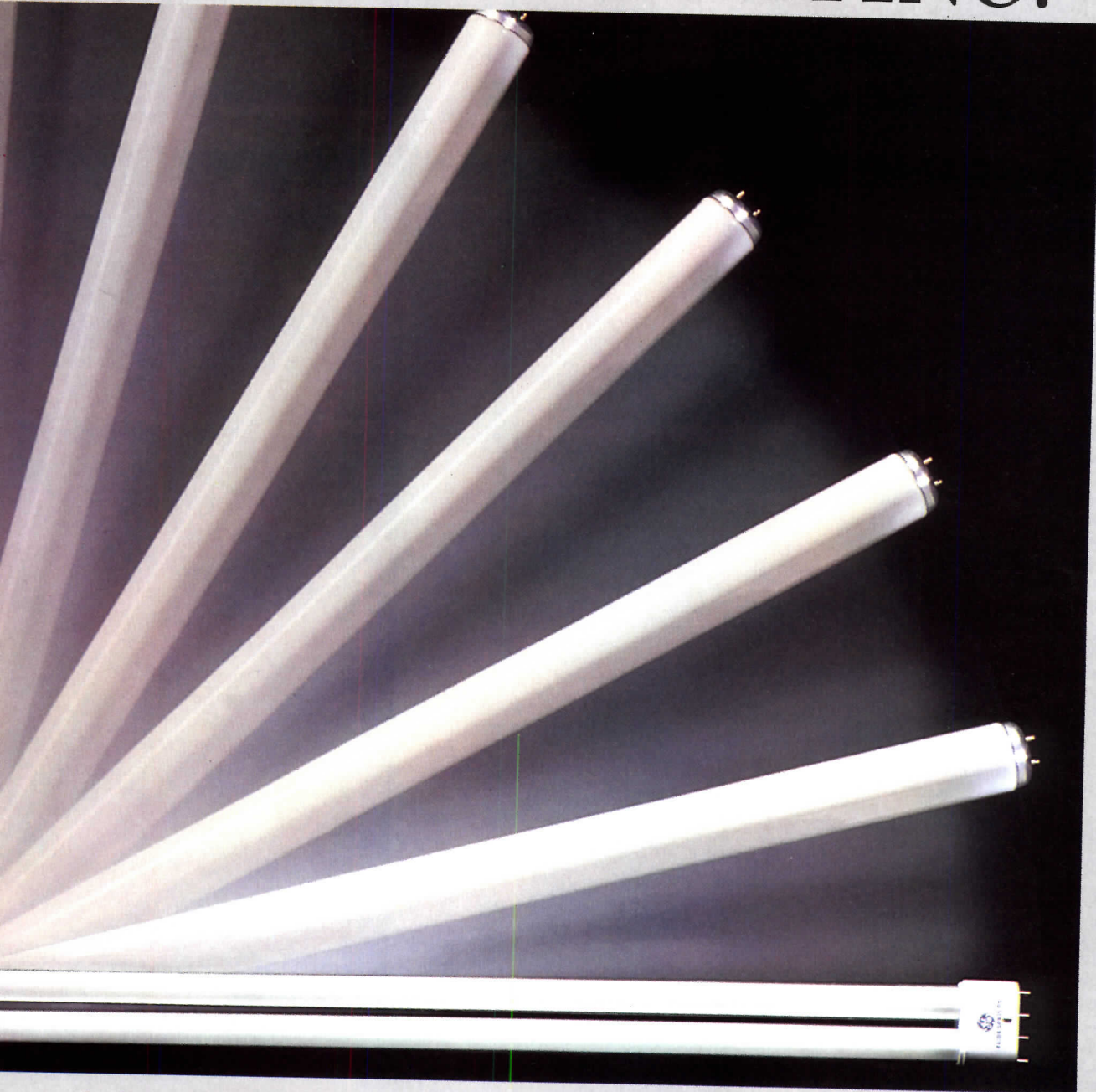

ts can, the lighting you design will make the environment and the people who work in it re attractive. Equally attractive is the amount your clients save on operating costs. GE BIAX 40-watt ps, you see, last up to 8,000 hours longer a conventional U-shaped tubes. And 13 es longer than incandescents. east your imagination on the endless pos-

sibilities of the GE BIAX family of lamps.

For more product or application information, call your local GE Specification Area Manager. Or call the GE Lighting Information Center at 1-800-523-5520.

**GE is Light.**



**GE Lighting**

Circle 42 on inquiry card



# United States Aluminum's Series 3100 Silicone Curtain Wall creates beautiful undisturbed architectural reflections.

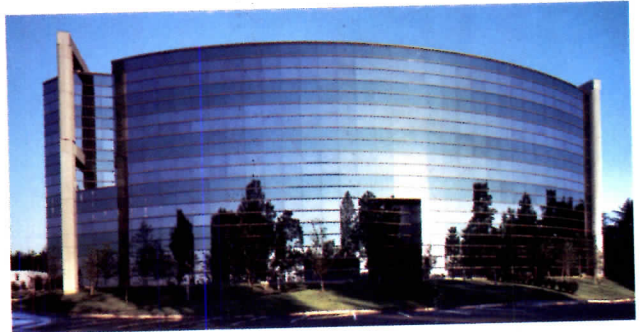
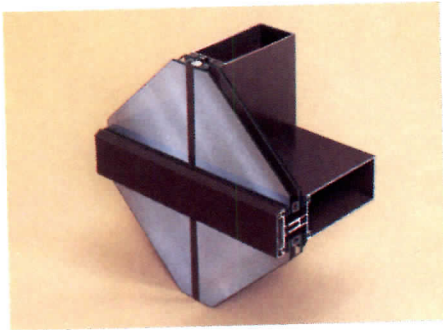

Series 3100 Curtain Wall system offers the architect an option which blends a glass wall with two-side conventional support horizontally and two-side silicone support vertically to form a superior structural design.

#### **Design Features**

**Thermally Broken** — Interior aluminum framing is thermally isolated from the exterior by continuous thermal spacers, interlocked with the horizontal pressure plates.

**Labor Savings** — Pressure plates are factory fabricated with thermal spacers installed, pressure bolt and weep slots prepunched. Reusable injection molded nylon twist-in and twist-out temporary glass retainers. System accommodates 1/4" and 1" glazing infills.

**Horizontals** — Face covers have a beveled water shed edge. Injection molded nylon water deflectors are furnished at joint intersections for positive water control.

**Super Mullions** — In addition to 3 1/2" and 5" deep mullions, 8" deep "Super Mullions" are stock items for high span conditions.

**Performance** — Certified test reports that meet or exceed AAMA 501 standard test procedure for E-283 air infiltration, E-330 structural performance and E-331 water penetration, are available.

United States Aluminum gives you over 25 years of proven quality.

Available in clear, bronze, or black anodized finish or custom painted to architect's specifications. See us in Sweets 08400/UMV

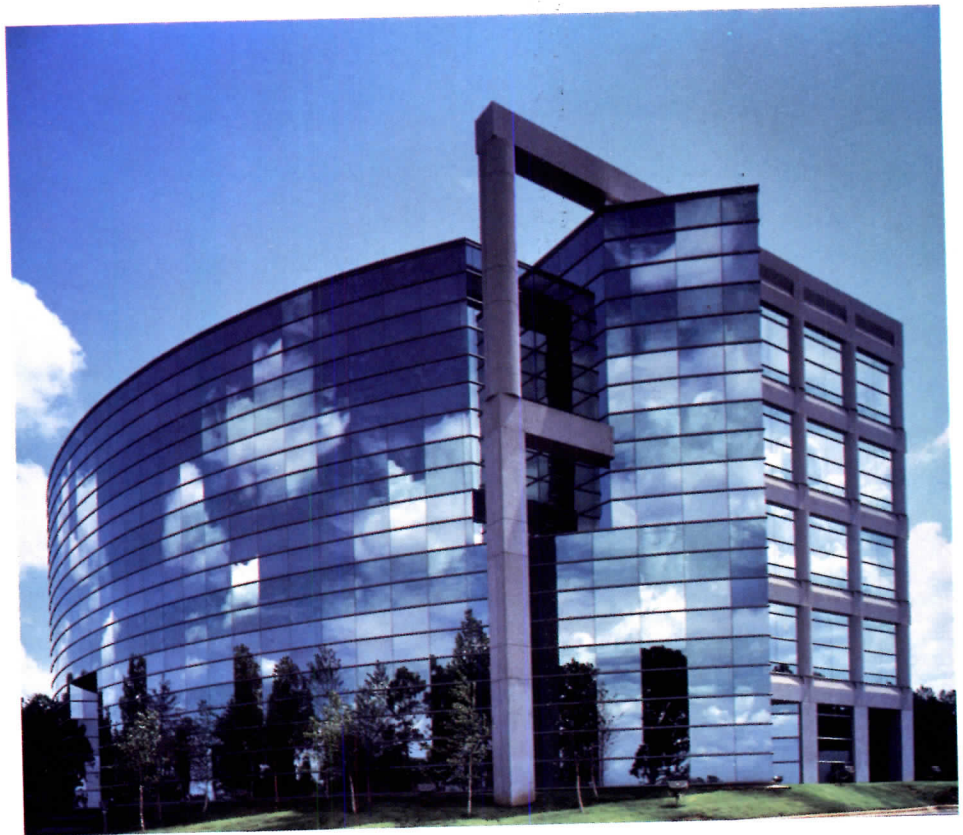

For complete information call 1 (800) 527-6440, in Texas call 1 (800) 442-3247, or write:

## United States Aluminum Corporation

### Manufacturing Facilities

3663 Bandini Blvd.  
Vernon, California 90023  
Telephone (213) 268-4230

200 Singleton Drive  
Waxahachie, Texas 75165  
Telephone (214) 937-9651  
or (214) 299-5397 metro

6969 West 73rd Street  
Chicago, Illinois 60638  
Telephone (312) 458-9070

720 Cel-River Road  
Rock Hill, South Carolina 29730  
Telephone (803) 366-8326

Subsidiaries of International Aluminum Corporation

Customer: Pritchard Paint & Glass • Architect: Jenkins-Peer Architects, PA • Photos By: Dennis Nodine Photography  
Charlotte, NC Charlotte, NC Charlotte, NC

© 1988 International Aluminum Corporation

Circle 43 on inquiry card





# 2000X<sup>®</sup>

## THE SOLID THAT SHAPES THE FUTURE.

FORMICA<sup>®</sup> brand 2000X<sup>®</sup> building products invite you to let your imagination soar. These advanced solid products with color running through their entire thickness offer you unlimited design possibilities. Now you can create the look, as well as the feel, of stone and marble like never before.

FORMICA brand 2000X products also provide the kind of versatility that will greatly expand your design horizons. It represents a range of solid surfacing products unequalled by any manufacturer. The list includes vanities with integral backsplashes, bath and shower surrounds, bathtubs and shower basins, and sheets.

The look is stone, but the subtle palette is warm and welcoming. 2000X products from Formica Corporation are available in six colors, including Frost pictured here. All colors coordinate naturally with our entire line which offers our on-going tradition of quality and reliability.

2000X products will help your most creative designs take shape, because they're the solids that are the shape of the future.

For additional information, call 1-800-524-0159; in NJ call 1-800-624-1914.



Circle 44 on inquiry card





# A FEW SIGNS OF OUR SUCCESS WITH DENS-GLASS® PAPERLESS GYPSUM SHEATHING.

**A Lot Of Big Names Have Discovered The Big Benefits Of Dens-Glass.**

The problems of wind, weather and dampness have become virtually obsolete with Dens-Glass® paperless gypsum sheathing from Georgia-Pacific. This revolutionary paperless gypsum sheathing stands up to job-site weather hassles and hazards like no other product on the market.

When exposed to weather, ordinary paper-faced gypsum sheathing can delaminate, sag and warp, resulting in expensive replacement costs. Dens-Glass, however, is manufactured with unique fiberglass mats on the front and back of a water-resistant core. This design makes it the only gypsum

#### Dens-Glass Paperless Gypsum Sheathing

**DESCRIPTION:**  
Water-resistant gypsum core, fiberglass mats on front and back.

**SIZES:**  
1/2" and 5/8" thick; 4' x 8', 4' x 9', 4' x 10'.

**APPLICATIONS:**  
Sheathing; soffits; exterior ceilings. Ideal substrate for exterior insulation finish system and other exterior finishes.

**INSTALLATION:**  
Can be applied horizontally or vertically.

**FIRE RESISTANCE:**  
Independent tests produced zero flame spread; zero smoke developed.

**WARRANTY:**  
6 month limited commercial warranty\*\*



EMBASSY  
SUITES  
HOTEL

LECHMERE

sheathing panel durable enough to offer a six-month limited warranty\*\* against the weather's damaging effects. And since Dens-Glass contains no paper, it provides unmatched fire resistance as well.

Because of its unique properties, Dens-Glass has become the sheathing of choice for a large number of commercial architects and contractors. On building projects for big names such as Macy's, IBM, Lechmere, Holiday Inn, and Embassy Suites, the dimensional stability and resiliency of Dens-Glass has been perfect for a variety of exterior applications.

Discover what a lot of astute architects and builders already know: Dens-Glass is the absolute best at making the problems associated with exterior sheathing obsolete. It's a

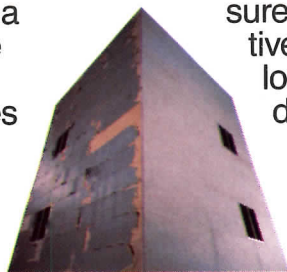

The long-term effects of weather on conventional gypsum sheathing, left; and on Dens-Glass, right.

sure sign of your concern for superior, innovative building design—and that makes you look good, as a superior, innovative building designer.

For complete Dens-Glass exposure test results, product information, warranty, samples and a brochure outlining Dens-Glass application details on a variety of recent projects, call 1-800-225-6119. In Georgia, call 1-404-521-5716. Or write: Georgia-Pacific, Dept. AR-DGS, P.O. Box 2808, Norcross, Georgia 30091.

\*ASTM E119 Fire Test of Building Construction and Materials; ASTM E48 Surface Burning Characteristics of Building Materials.

\*\* See limited commercial warranty, available from Georgia-Pacific, for its terms, conditions and limitations. MORE POWER TO YOU! is a trademark, and Dens-Glass is a registered trademark, of Georgia-Pacific Corporation. © 1988 Georgia-Pacific Corporation. All rights reserved.

Georgia-Pacific  
**MORE POWER**  
*To you!*™

Circle 45 on inquiry card for Literature

Circle 46 on inquiry card to speak with a Sales Representative



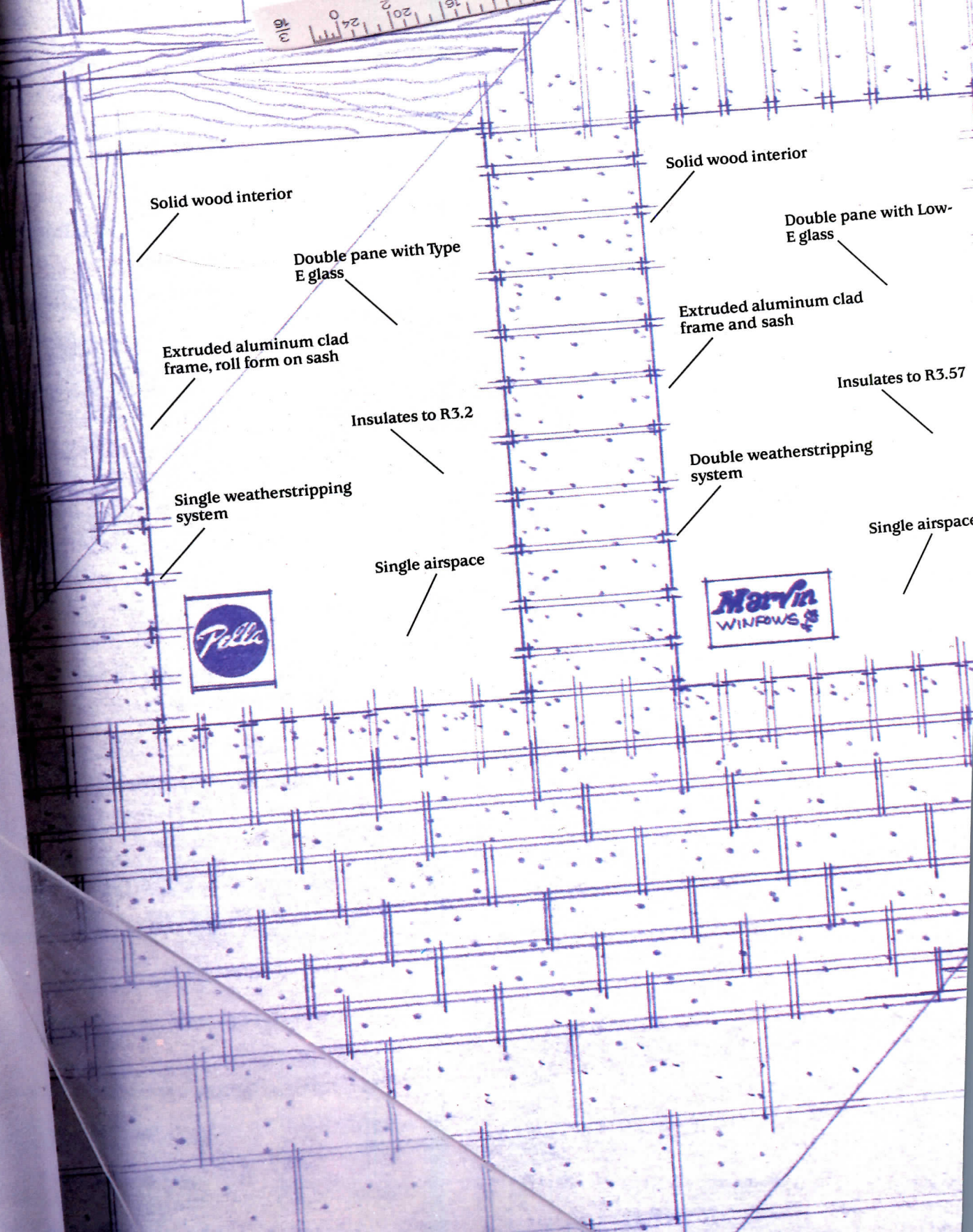
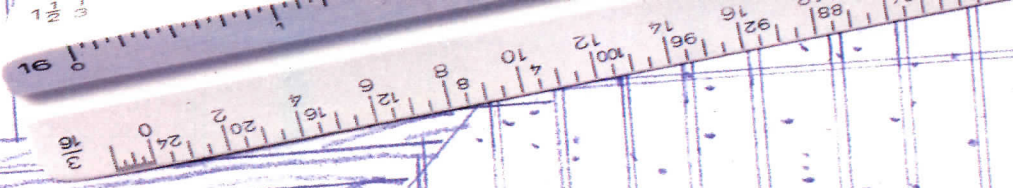

Solid wood interior

Double pane with Type E glass

Extruded aluminum clad frame, roll form on sash

Insulates to R3.2

Single weatherstripping system

Single airspace



Solid wood interior

Double pane with Low-E glass

Extruded aluminum clad frame and sash

Insulates to R3.57

Double weatherstripping system

Single airspace



RESIDENCE  
SITE PLAN  
ELEVAT  
REVIS



Solid wood frame, vinyl sash interior

Double pane with High-Performance glass

Vinyl clad frame and sash

Insulates to R3.3

Double weatherstripping system

Single airspace



Solid wood interior

Double pane with Heat Mirror™ film

Extruded aluminum clad frame and sash

Insulates to R4.0

Triple weatherstripping system

Dual airspace

# Draw your own conclusions.

Hurd windows with Heat Mirror™ may be the best windows you'll ever spec.

Beautiful select Ponderosa Pine interior, thick extruded aluminum clad exterior, Heat Mirror insulating glass, triple weatherstripping —and those are just the obvious differences.

Feature for feature, no other leading window gives you more comfort, performance or value —in more standard sizes.

From casements, double-hung, bows, bays, picture windows, trapezoids and circle tops to the largest range of patio doors available, Hurd lets you spec more performance for the money.

See for yourself. Ask your Hurd distributor for a demonstration. Or call 1-800-2-BE-HURD for more information.



## The ultimate wood window™

Comparison based on 1988 Sweet's mfrs. specs. Andersen Windowall, Marvin, and Pella are registered trademarks of Andersen Corp., Marvin Windows, and the Rolscreeen Co., respectively. Heat Mirror is a registered trademark of Southwall Technologies Inc.



D U P O N T





A N T R O N<sup>®</sup>



## CARPET OF ANTRON PRECEDENT<sup>®</sup> BRINGS MAINTENANCE COSTS DOWN TO EARTH.

The wrong carpet can turn out to be your worst enemy. Its looks quickly begin to fade, your cleaning bills soar. But not with Antron Precedent<sup>®</sup>. That's because Antron Precedent<sup>®</sup> resists soiling and stains better than any other commercial carpet.

So you can enjoy lower maintenance costs. And, because it keeps its texture longer, the beauty lasts

up to twice as long as many other carpets. Beauty, durability and lower maintenance costs. No wonder people are falling for Antron Precedent<sup>®</sup>.

For more information, call 1-800-448-9835.

**THE ANSWERS COME EASY WITH ANTRON<sup>®</sup>**



Circle 48 on inquiry card





# HEAT MIRROR™ made it fly

Create a naturally-lighted glass enclosure for thirty-nine full-size aircraft, and still comply with one of the country's toughest energy codes. That's the challenge Ibsen Nelsen and Associates faced in designing the Museum of Flight at Boeing Field, Seattle, Washington.

The solution? Use over 55,000 square feet of Heat Mirror insulating glass. Heat Mirror provides the same level of solar control as dark tinted glass, yet lets in *over four times more natural light!* There's less need for artificial lighting and a net reduction of 35 percent

in the Museum's projected annual energy budget.

Compared to other low-e glazings, only Heat Mirror offers *Total Performance*: controlling winter heat loss, summer heat gain, ultraviolet radiation, sound transmission and condensation better than any other insulating glass available today.

To find out how Heat Mirror can open up your design options, contact Southwall Technologies, 1029 Corporation Way, Palo Alto, CA 94303. (415) 962-9111. Or see us in Sweet's: 08810/SOU.

For immediate help on a current project, call our Architectural Services Department, toll-free:

(800) 365-8794



Southwall  
Technologies



Heat Mirror is a trademark of Southwall Technologies.  
© Southwall Technologies 1988.



# In the Public Interest



Jean M. Smith

Washington Elms Housing, Cambridge, Massachusetts

**T**he editors of RECORD announce the results of *IN THE PUBLIC INTEREST*, an annual awards program aimed at recognizing excellence in the design of architecture that serves a public outside the usual circle of commercial and institutional clients. Each year we intend to select a different building type and solicit entries in that category from architects, private developers, government agencies, public/private development consortiums, and community design centers for projects completed over the past three years. The building type for 1988 is housing, and we are pleased to present on pages 86-123 the 11 premiated projects, selected by an editorial jury comprising Mildred Schmertz, Carolyn De Witt Koenig, Douglas Brenner, Deborah Dietsch, Margaret Gaskie, and Paul Sachner.



# Heroes in our own backyard

For the editors involved in planning RECORD's first-year awards program honoring the architects and clients of specialized housing, the issue of affordable, appropriate shelter is a part of everyday life. Over the past two decades, those of us living in New York have observed seemingly stable middle-class neighborhoods in many parts of the city disappear, as the opposing forces of gentrification and building abandonment have conspired to create an incongruous metropolitan juxtaposition of dazzling wealth and utter devastation. We have watched well-intentioned but hopelessly grim public housing projects built during the years following World War II deteriorate into drug-infected urban landscapes far meaner than the tenement-lined streets they replaced. We've been puzzled by a convoluted system of municipal controls and market forces that entitle a landlord to an unrealistically low rent for one apartment while permitting him to charge exorbitant rates on a similar "decontrolled" unit down the hall. In the suburbs we have seen once-affordable "starter" homes soar beyond the means of even prosperous two-income families, and found examples of elderly people driven from familiar neighborhoods by the unavailability of inexpensive housing. And throughout the country we've been unhappy witnesses to the problem of homelessness, a growing crisis that a group of scientists meeting this past September in Washington, D. C., called "an outrage, a national scandal . . . an inexcusable disgrace [that] must be eliminated."

A few telling statistics underscore the state of housing in the United States today:

- Each year some 2.5 million Americans are displaced by redevelopment, rent hikes, housing abandonment, and condominium conversion.
- Various sources estimate that on any given day, there are between 250,000 and 400,000 homeless people in the country. The National Coalition for the Homeless, an advocacy group, claims an annual figure approaching three million.
- In California, where the median price of a single-family house has risen to \$167,000, only 25 percent of the population can afford to purchase a home. As a result businesses in the Golden State are having difficulty recruiting entry-level workers.
- During the Reagan administration, federal spending on housing declined from \$30 billion in 1981 to \$7 billion last year. In 1987 only 23,000 units of new government-sponsored housing were built, compared with around 100,000 annually during the late 1970s. The cornerstone of Washington's current policy is a voucher program of rent subsidy—"The issue of housing in the U. S. is affordability, not availability," claims HUD's assistant secretary for public housing, James Baugh—and yet, according to a *Business Week* study, insufficient federal funding means that only four million out of 10 million eligible households receive voucher assistance.

Amid these dreary figures, however, there have also been clear indications that local government, private nonprofit organizations, and public/private development consortiums are attempting to fill the gap created by Washington's gradual withdrawal from bricks-and-mortar funding of the subsidized housing business. New York City, to name a highly visible example, has embarked on the most ambitious municipal housing program in the country, a \$4.2-billion, 10-year megaplan that will raise the annual output of new or renovated units from a current level of 4,000 units to over 15,000 units per annum. Many new projects undertaken by various municipalities involve creative financing—low-interest government-

*A pictorial sample of runners-up in the awards program, opposite and on page 84, exemplifies the caliber and variety of entries received.*

supported loans, for instance, or profits from market-rate units helping to underwrite lower-income dwellings—and a surprising number work under the assumption that new housing is most socially responsible when it includes a mix of people from several income brackets. Although the notion of scatter-site subsidized housing has met with resistance in some communities—the protracted battle in Yonkers, New York, is the most notorious, but by no means only, example—other localities have been more successful integrating low-income residents into upper-bracket neighborhoods. In wealthy Montgomery County, Maryland, for example, one of the largest scatter-site housing programs in the country requires builders to set aside 12 percent of units in residential developments for families with low and moderate incomes, at rents or mortgages they can afford. San Francisco and Richmond, Virginia, have similar programs. In Newark, New Jersey, a local community group called La Casa de Don Pedro has built Prospect Gardens, a seven-unit condominium whose low per-unit prices of \$37,500 to \$53,400 were made possible by the use of Mount Laurel regional contribution agreement funds, which are allocated by prosperous suburban towns for low-income housing not necessarily sited in the better-off communities.

In a surprising number of instances, architects have become direct partners with government agencies and nonprofit groups to encourage the construction of low- and moderate-income housing. The Indianapolis chapter of the AIA, for example, recently cosponsored an affordable-housing design competition with the city's Housing Strategy Task Force. The city will use the results to produce infill housing on 22 vacant midtown blocks. More significantly, perhaps, the national AIA in September celebrated the completion of a pilot project—the renovation of the McAdoo Hotel in Shreveport into housing for 45 homeless people—in its Search for Shelter program, a national homeless-housing initiative that seeks to coordinate efforts in over 30 cities among local architects, bankers, developers, builders, and housing agencies.

Projects like these gave us cause to suspect that 1960s-style social consciousness among architects was not dead—or even dormant—but instead was laboring quietly in the fashion-conscious, intensely privatized milieu of the 1980s. The time seemed right to publicize the efforts of those humane and enlightened people, both architects and clients, involved in the construction of nonprofit, limited-profit, or otherwise special-focus housing; the best way to accomplish this aim, we felt, was not to solicit unbuilt proposals—those brainstorming often amount to little more than intellectual heat lightning—but to single out completed buildings of proven substance in a broad variety of residential types, ranging from new and renovated low-income public housing subsidized mixed-income complexes, and housing for the elderly, shelters for the homeless, housing for the physically and mentally disabled, and residential alcohol- and drug-treatment centers.

Despite having enthusiastically endorsed the *concept* of a design-awards program that would focus its first installment on housing, some of our editorial jurors were a bit apprehensive. We really weren't sure what existed "out there," and even though plenty of architects telephoned to inquire about the new program the May 1 entry deadline approached without a flood of submission folders pouring into our offices. (We forgot, of course, that architects procrastinate as much as anyone else, and what began as a trickle of submissions during March and April ended up as a torrent of Federal Express packages on May 2.) But more than t



*Runners-up:*

*1. Housing for the elderly: St. Luke's Village, Gladstone-Peapack, N. J.; Michael Burns, Architect*

*2. Emergency shelter for the homeless: Federal City Shelter, Washington, D. C.; Conrad Levenson, Architect*

*3. Housing for the elderly: Villa Vasona, Los Gatos, Calif.; Fisher-Friedman Associates, Architects*

*4. Single-room occupancy residence: Moravian House, New York City; Pratt Institute Center for Community and Environmental Development*

*and Peter Woll Architects*  
*5. Low-income public housing: Commonwealth Development, Brighton, Mass.; Tise Architects*  
*6. Subsidized artists' housing: Clafin School, Newton, Mass.; Moore Heder, Architects*  
*7. Mixed-income housing: Pickleweed Apartments,*

*Mill Valley, Calif.; Hooper Oltsted & Hrovat, Architects*  
*8. Housing for the elderly: Evanston Elderly Housing, Cincinnati, Ohio; Glaser Associates, Architects*  
*9. Shelter for the mentally ill homeless: The El Rey, Seattle, Wash.; ARC Architects*



*Vince Babak*



*Roger Torda*

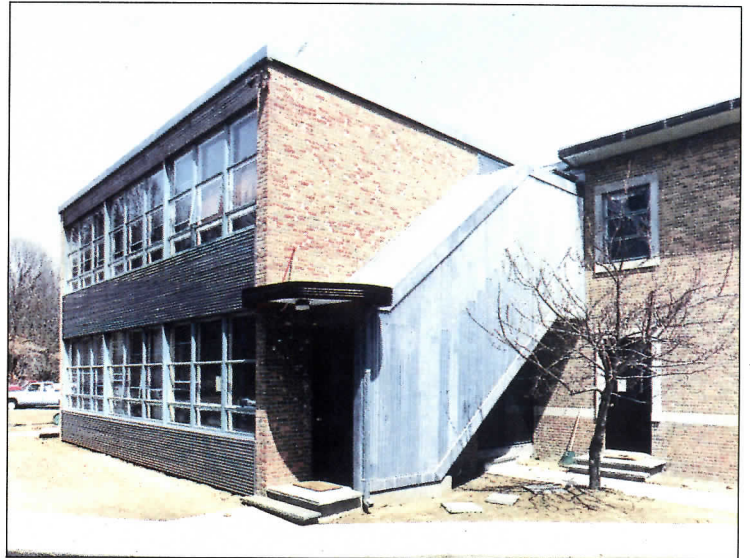

*Clements/Howcroft*



*Photo/Stephenson*



*Gerald Ratto*



*Ron Forth*



*Brian Rose*



*©Nick Wheeler*



*©Chris Eden*



10. Low-income public housing: Pence Place, Columbus, Ind.; Gwathmey Siegel & Associates, Architects

11. Low-income public/private housing: Gateway Commons, Menlo Park, Calif.; Y. H. Lee, Michael Pyatok, and William Olin, Architects



10 ©Sadin-Schnair



11 Michael Pyatok



12 Wayne Thom



13 Mel Adelglass

12. Housing for the physically disabled: Arrowhead Vista, San Bernardino, Calif.; Ruhnau McGavin Ruhnau/Associates, Architects

13. Mixed-income housing: Underhill Gardens, Brooklyn, N. Y.; Geoffrey Freeman Associates, Architects

14. Children's shelter: New England Home for Little Wanderers-Macomber Children's Residence, Boston, Mass.; Sunset Street Associates, Architects

15. Housing for the elderly: Castillo Homes, Santa Barbara, Calif.; L. Dennis Thompson, Architect

16. Union-sponsored housing: Andrew Square Rowhouses, Boston, Mass.; William Rawn Associates, Architects

17. Housing for the homeless: H. E. L. P. I, Brooklyn, N. Y.; Alexander Cooper + Partners, Architects



14 ©D. K. Smith



15 ©Paul Sha



16 ©Steve Rosent



17 John Pe



number of submissions (103 entries eventually arrived from all parts of the country), we wondered about architectural quality. In the past RECORD has written about projects grand and humble, and the magazine has consistently adhered to the notion that a tight budget by no means precludes good design. All the same, we were keenly aware of the bland and at times downright oppressive design of postwar housing projects in our own backyard. We also knew, of course, that architecture and city planning have changed dramatically since these towers-in-a-park were erected during the 1950s and '60s; the question was, have architects practicing today been able to respond creatively to those changes within the restrictions imposed by inevitably limited fiscal resources?

In the end, there was little cause for worry. As the group of non-primed entries shown on pages 83 and 84 illustrates, while there may be less new subsidized housing being erected today than 30 years ago, what *is* being built seems much more responsive to context and program. (The word that kept cropping up during the jury's deliberations was *appropriate*.) Especially in the area of low-income public housing, it is gratifying to report that architecture of the street is back, and that the emphasis has shifted from big blockbusting projects to smaller-scaled, almost self-effacing, work that fits comfortably into its surroundings (see photos 5, 10, and 11 for three examples). Affordable housing for the elderly has undergone a similar transformation: the generic motel-like towers of the 1960s and '70s are now joined by pleasingly domestic low-rise complexes—frequently organized around communal open space—whose architecture more often than not reflects the distinctive character of a region's residential vernacular (photos 1, 3, and 15). The same might be said of the diverse new breed of mixed- or subsidized middle-income housing, which can take the form of a California garden-apartment complex (7), renovated New York City tenements (13), or a block of tawny-rick Boston row houses (16).

Sensitivity to context, scale, and human needs characterized many of the submissions, but nowhere were these tendencies more evident, or more welcome, than in the group of entries that might be called "specialized housing"—shelters for the homeless, single-room-occupancy hotels, residential drug- and alcohol-treatment centers, and housing for the physically and mentally disabled. Here, architects seemed intent on integrating *institutional* requirements like counseling services, medical facilities, employment offices, and continuing-education programs into a *residential* environment acceptable not only to inhabitants but also to members of the surrounding community. Some of these projects—a new 202-unit shelter for homeless families in Brooklyn (7), for example, or a similar facility for single homeless men and women carved out of a former office building in Washington, D. C.—are heartening prototypical efforts by a society struggling to shelter people who, each night, simply have nowhere to go. Others accommodate people with more specific needs—abused or neglected children in Massachusetts (14), physically handicapped adults in California (12), and mentally ill homeless men and women in Seattle (9), to name three examples.

Picking out individual buildings in such a well-intentioned body of work proved challenging; it was also enormously gratifying. In addition to supplying the required architectural plans and photographs, many of the submission folders arrived brimming with clippings from local newspapers and testimonial letters written by everyone from proud U. S. congressmen to grateful

tenants. Reflecting on his 21-month stay at Creative Living, a housing complex for severely handicapped adults in Columbus, Ohio (pages 110-113), R. Dennis Smurr wrote that the facility was "a special caring environment designed to help someone like myself learn how to live more independently than I ever thought possible. And, thank God, it continues to serve the needs of others who have had their lives drastically altered by catastrophic physical injury or illness." Another letter, from Richard Cherry, executive vice president of the New York Urban Coalition, describes Underhill Gardens (photo 13 opposite), a mixed-income project created by the gut rehab of five Brooklyn tenements. "With 40 apartments now fully rehabilitated and occupied," Cherry writes, "our vision is fulfilled. The drug dealers, broken glass, and abandoned cars are gone. [The architect's] design reinforced our social goals . . . and an efficient use of space helped bring the project in at budget, [which is] critical to keeping rents and maintenance charges affordable." In a thank-you note to architect Cecil Baker following the dedication of Diamond Park, a low-income housing development for the handicapped in Philadelphia (pages 116-119), Christine Washington of the Advocate Community Development Corporation calls the architect's work "a gem," adding that "neighbors and merchants are thankful and proud."

They should be. Diamond Park, like the 10 other projects featured on the following pages, exemplifies the broad range of social goals and design skills we had hoped to uncover when we initiated *IN THE PUBLIC INTEREST*. The group is deliberately a mixed bag, ranging in geography, typology, and architectural mode from Cabrillo Village, an adobe-style housing development for farmworkers near Ventura, California (cover and pages 86-89), to the recent renovation of Washington Elms, a 1940s-vintage public housing project in Cambridge, Massachusetts (pages 100-103). In the area of housing for the homeless, we primed an ambitious 450-person shelter in downtown San Diego (pages 94-97) and a group of wooden huts erected in Atlanta on an ad-hoc basis by a group of architects called the Mad Housers (pages 98-99). Two complexes for the elderly—Lincoln Towers, in Secaucus, New Jersey (pages 114-115), and Robert Shaw Village, in Austin, Texas (pages 120-123)—are physically quite different, but in each case, the architect successfully dealt with the dilemma of privacy versus community that all designers of this particular housing type face. In the area of mixed-income housing, Tent City, in Boston, is a new national model for cities attempting to deal with the double-edged issue of gentrification (pages 90-93). And finally, the hard work of Asian Neighborhood Design in San Francisco earned this community design center two awards—one for Coming Home Hospice (pages 104-107), the first building of its type in the nation designed primarily for people with AIDS, and a second for the Women's Alcoholism Center (pages 108-109), a residential treatment facility that addresses the impact of addiction on both mother and child.

Above all else, perhaps, the architects of these buildings share an ability to close the gap between common sense and ingenuity, to keep their eyes on the exigencies of a client's fiscal bottom line without losing sight of their own idealistic vision. These architects inhabit the realm of the possible, yet their accomplishment, in terms of solving problems and encouraging human values, verges on the heroic. If that sounds improbable in today's society, we invite you to turn the page and judge for yourself.

Paul M. Sachner



Low-income housing:  
Cabrillo Village  
Saticoy, California  
John V. Mutlow Architects

## Migrants no more

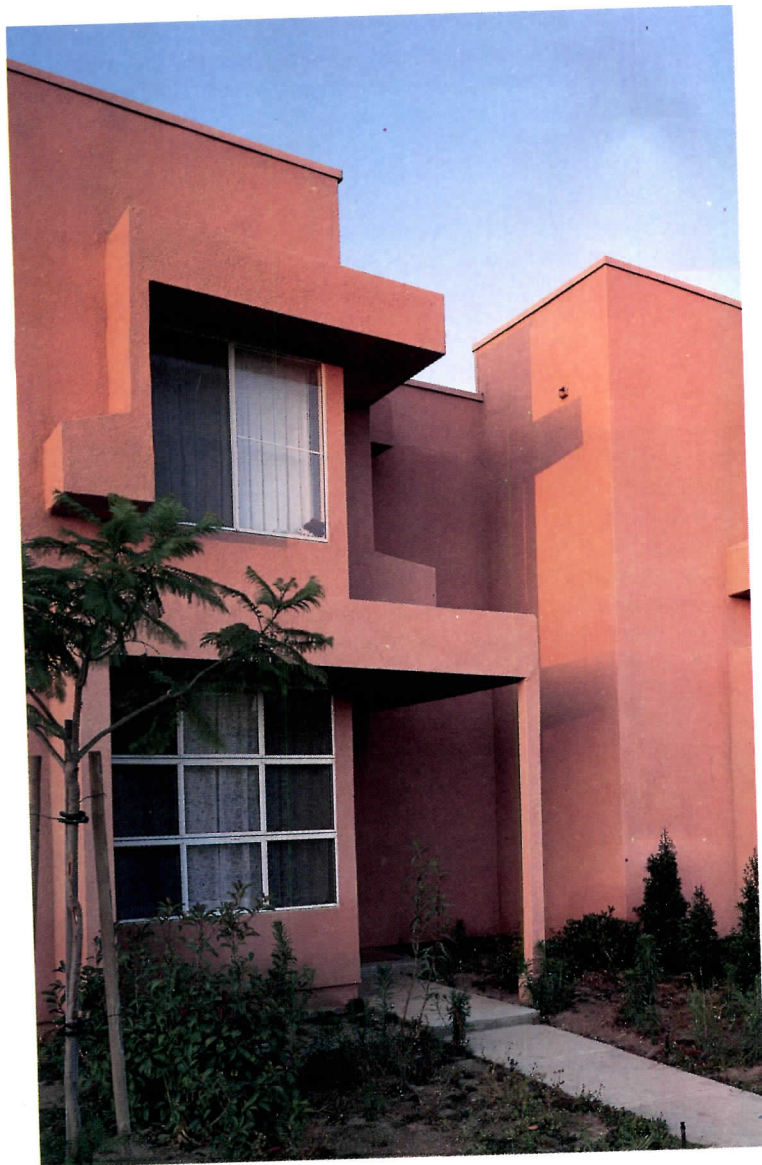

*Sunshades and overhangs articulate the boxlike massing of Cabrillo Village's most recently completed housing (above and opposite). The stepped configuration of the row houses terminates at the southeastern edge in an angled block of four-bedroom units that connects the central green to a soccer field (opposite and site plan).*

Cabrillo Village represents a significant victory in the continuing struggle of native Mexican farm workers to establish a permanent place in southern California. The original settlement, built in 1937 as a camp for migrant laborers, consisted of 100 cabins located on an 18-acre floodplain of the Santa Clara River near Ventura. In 1975, after being notified by the state that the 480-square-foot houses violated health and safety regulations, the lemon growers decided to demolish, rather than upgrade, the uninsulated barracks. However, their attempts to evict the farm workers, including offers of \$500 to cover each family's relocation costs, met with organized resistance. A year earlier, the workers had waged a successful strike with the assistance of the United Farm Workers Union, whose leader, Cesar Chavez, urged them to buy their own property. And by May 1976, after the growers began bulldozing the vacated houses (some tenants had decided to take the \$500 and move), the newly formed Cabrillo Cooperative Housing Corporation had raised enough funds to purchase the remaining 82 units. The farm workers then set about establishing their self-sufficiency by building a church, school, grocery store, butcher shop, ceramic tile factory, and administrative offices (site plan, top right). In 1977, the cooperative commissioned the Los Angeles-based team of Barrio Planners and John Mutlow to renovate the existing board-and-batten cabins and create 35 new single-family units on the southwestern portion of the site (plan, bottom right). Mutlow, whose experience in designing low-cost housing includes nine projects for the Pico Union Neighborhood Council, an advocacy group for a Hispanic district of downtown Los Angeles, drew upon indigenous prototypes by clustering L-shaped structures around courtyards and incorporating references to vernacular Southwestern architecture.

His latest design for Cabrillo Village, a complex of 39 residential units that has been occupied since 1986, reflects this sensitivity to regional traditions overlaid with further refinements. "We wanted to extend the first phase of housing," Mutlow explains, "but the Farmers Home Administration thought it looked too expensive, like middle-income housing, even though it was built well within the budget." Instead of repeating the form of the earlier quadriplexes, he reinterpreted their balance of public and private spaces by grouping two-, three-, and four-bedroom row houses around a common green and flanking them with private front and back gardens. The enclave steps back to create a forced perspective—reinforced by subtle color variations to distinguish each unit type—that fans out toward the mountains to the northwest. (The housing was to have extended in this direction, but the adjacent parcel will be converted into a baseball diamond.) At the northern edge, the architect connected the new complex to the rest of the village by providing a community center for meetings and family celebrations. Despite numerous design restrictions imposed by the FmHA, Mutlow managed to vary the two-story stuccoed terraces with flat roofs, overhangs, and sunshades—elements that evoke Dutch social housing of the 1920s as much as the more regionally relevant precedent of adobe construction. Now engaged in a similar project for the farm workers of nearby Rancho Sespe, the architect remains adamant that low-cost housing need not be synonymous with low-style design. Given what Mutlow has accomplished for \$33 per square foot at Cabrillo Village, even the most budget-conscious bureaucrat would have to agree. *Deborah K. Dietsch*



*In 1975, the farm workers of Cabrillo Village banded together to form their own housing cooperative. The group's latest development is an enclave of row houses designed by a Los Angeles architect who surmounted the limitations of low-cost housing with respect for local heritage.*



© Wayne Cable/Cable Studio photos





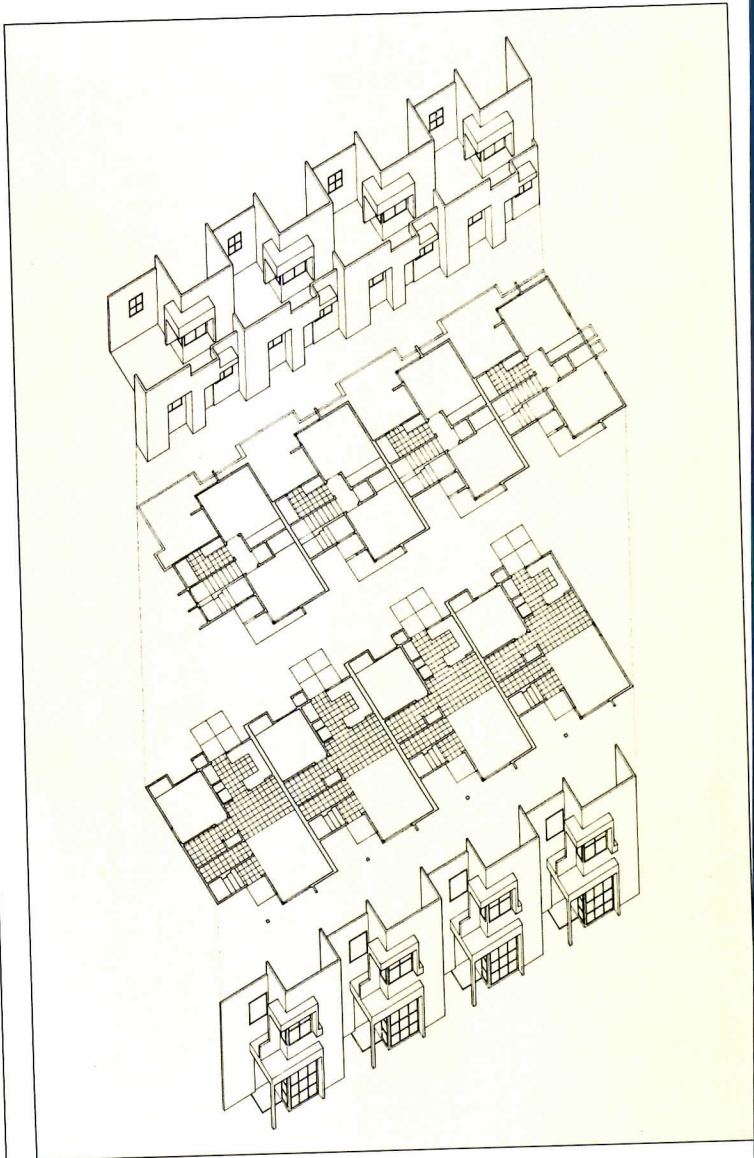
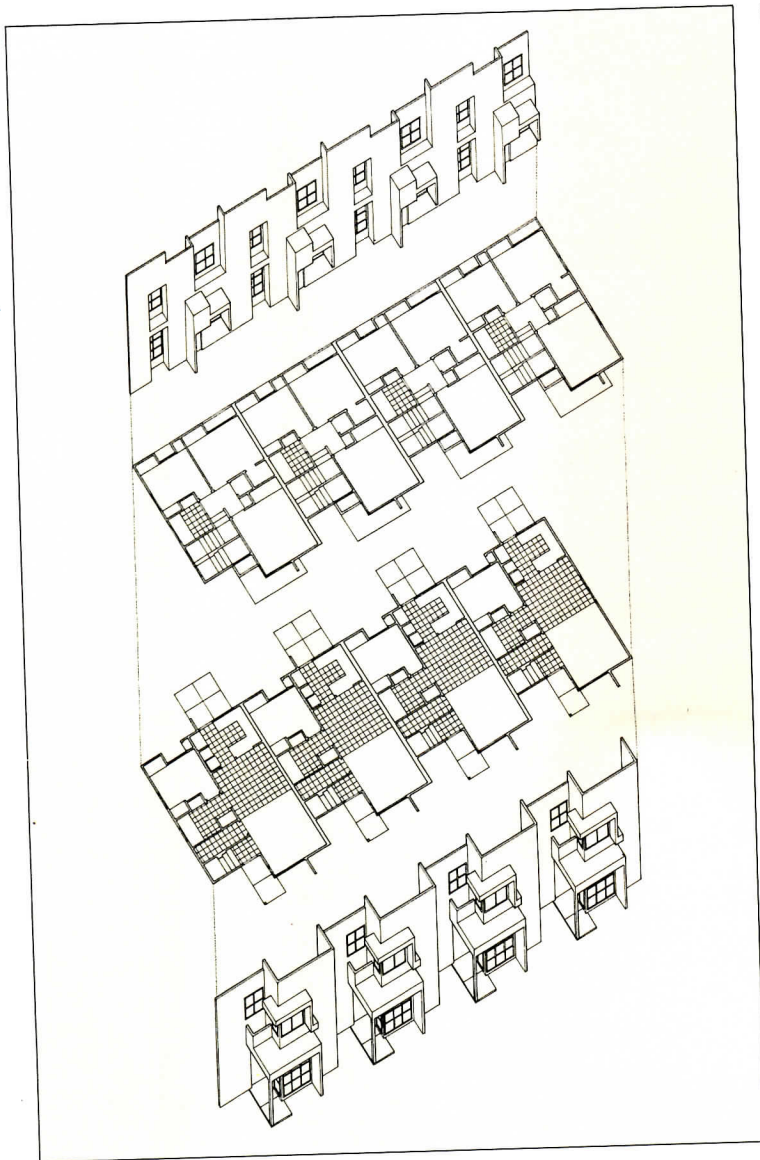

*In response to a design preference survey conducted by the architect, the row houses of Cabrillo Village are arranged simply on two levels. The ground floors of the three- and four-bedroom units are almost identical (axonometric drawings), with a living/dining area, kitchen, and a bedroom at the rear. The upper floors are designed so that a roof deck is transformed into another bedroom for the largest unit type. The two-bedroom units (not shown) are narrower, with a second floor similar to the three-bedroom model. Several one-story units are also*

*provided for the handicapped. Although the front elevations of all the units are uniformly designed with changes in paint color the only indicator of different plan types, the rear elevations shift to reflect organizational variety. In contrast to the flat-roofed housing, the community center at the northern corner of the site (opposite) is crowned by a truss-supported gabled roof and portico. This building's 3,200-square-foot central space (opposite, bottom left) is used by the cooperative for meeting and rented out to residents for private celebrations.*





*Cabrillo Village*  
*Saticoy, California*  
**Owner:**  
*Cabrillo Cooperative Housing*  
*Corporation*  
**Development management:**  
*Cabrillo Economic*  
*Development Corporation*  
**Architect:**  
*John V. Mutlow Architects—*  
*John V. Mutlow, project*  
*designer; John V. Mutlow, John*  
*Teel, project team*

**Engineers:**  
*Ronald L. Rogahn (structural);*  
*Roy Dehbibi (mechanical);*  
*Zachary Vorgias (electrical);*  
*Robert Forrey (landscape)*  
**General contractor:**  
*McGall Contractors*



# From tents to town houses

*On a central Boston site where housing activists once pitched tents, a new neighborhood houses tenants of assorted ages, races, and conditions.*

Although the residents of the original Tent City had to fold their tents 20 years ago, they did not silently steal away. They organized themselves as the nonprofit Tent City Corporation and persisted in their quest for affordable housing until they got the 269-unit complex seen here.

In 1968, we were just beginning to hear some terms that quickly became fighting words—words like *urban renewal*, *gentrification*, and *displacement*. Boston's South End is a rich and complex neighborhood that embraces a multi-ethnic, multi-racial, multi-income population. Architecturally, a standard building type characterizes the neighborhood: four- or five-story Victorian brick buildings with bay windows, some of them private houses, most of them containing flats. But about 20 years ago the city perceived some of them as decrepit and past salvation, and it started to condemn and demolish them as the first step in urban renewal. At the same time, the affluent middle class elsewhere in the city perceived the buildings as spacious, charming, and much nicer than most modern urban housing, and they began to gentrify. Both activities displaced earlier residents, who got sore.

In a parking lot on this very site, a community of about 100 protesters set up temporary shelters, and though the settlement only existed over one weekend in April 1968, it earned the nickname "tent city" from the local newspapers. Tent City supporters made sure that the name became a permanent honor, not an ephemeral put-down.

However determined that affordable housing in the South End must be more than a dream, the Tent City activists were otherwise ordinary men and women who had never had to deal with even the rudiments of real-estate development. They therefore retained the services of Greater Boston Community Development, Inc. This firm started life some 25 years ago as a nonprofit developer of housing in the South End, but rather soon it saw that it had accumulated a useful body of financial, legal, tax, and political information. Now serving as a consultant to nonprofit housing developers, it helped the Tent City people assemble the necessary land and locate sources of money. The latter included various governmental funds—city, state, and federal—that were established for just this purpose but whose existence is known only vaguely, if at all, to most of us; the

consultant not only knew of the funds but knew how to take advantage of them and understood the art of writing applications.

Another essential actor was the Urban Investment Development Corporation, owner of Copley Place and once of this site. UIDC seriously wanted parking space for Copley Place, but the city rejected plans for a large garage. Instead, the city and UIDC struck a compromise by which the developer kept these underground rights, which it used for a two-level garage, but swapped surface and air rights for another site given by the city, upon which the developer will build a luxury condominium.

In order to ensure a constant source of income, Tent City Corporation's rental policy for its apartments and town-house duplexes is designed for tenants of mixed income—25 percent of the units are reserved for the poor, the rents subsidized by state and federal governments; 50 percent of the units are assigned to people of moderate income, who are required to pay 30 percent of their income for rent, the remainder of the cost to be met with recycled UDAG funds from the development of Copley Place; and 25 percent of the units are rented at market rates. Should market-rate tenants tend to feel resentful of this arrangement, they have only to reflect on the reasonableness of the rents at this choice location—across the street from the Back Bay Station, across the Southeast Corridor pedestrian parkway from Copley Place with its prestigious shops and offices, and within easy walking distance of various mass-transit stations.

So far in this narrative, architects and architecture have played little apparent part. But one can see that architects Goody, Clancy & Associates not only succeeded in clothing their client's desires in convincing South End style, but also in giving them a well-defined, self-contained neighborhood. Bay windows, tile ornament, mansard roofs, and one hexagonal tower enliven the brick exteriors. Moreover, to add contextual verisimilitude, the architects varied color, composition, and ornament slightly from section to section. Most important, perhaps, is the site plan, which makes of Tent City a coherent enclave at one corner of the South End and which gives it its own semiprivate street, Yarmouth Place, wrapping three sides of a cluster of town houses.

One is not surprised to learn that all units were rented as soon as they became available. *Grace Anderson*

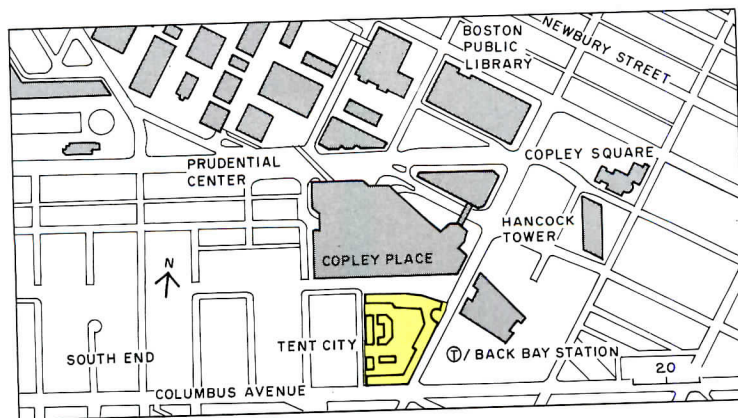



Though Tent City is clearly of the 1980s, its town houses (directly below and bottom right) effectively evoke the Victorian residences of Boston's South End. The mixed-income residences combine four-story town houses with a midrise apartment tower, the

latter mediating the residential scale of the South End and the high-rise scale of Copley Place (directly below) and the Hancock Building (bottom right). The curving facade, following the railroad tracks below, borders the Southeast Corridor pedestrian parkway.

**Mixed-income housing:**  
Tent City  
Boston  
Goody, Clancy & Associates, Inc., Architects

©Steve Rosenthal photos





*Tent City's landscaped courtyards afford benches for languid adults and play space for energetic children. The tower has a markedly important entrance on Dartmouth Street, a major thoroughfare, and the forecourt offers access to the parking*

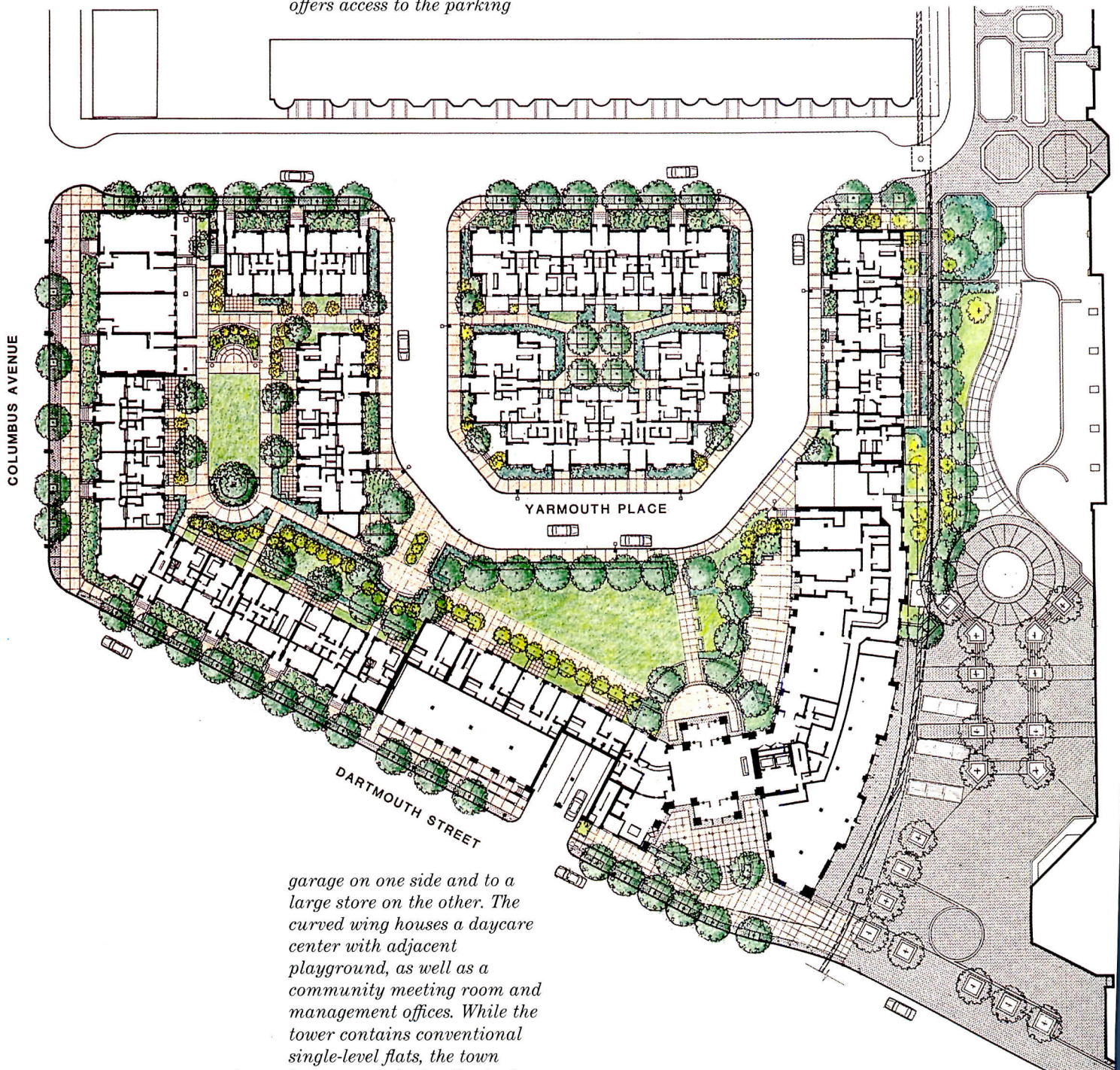

*garage on one side and to a large store on the other. The curved wing houses a daycare center with adjacent playground, as well as a community meeting room and management offices. While the tower contains conventional single-level flats, the town houses contain family-sized duplexes. The houses face either city streets or semiprivate Yarmouth Place; each has both a front and a back door (plans opposite), the doors serving four units in each house. Along one side of Tent City, the Southeast Corridor threads its way between the South End and the Back Bay to Fenway three-quarters of a mile away.*



The lobby of the apartment tower (directly below) fills more uses than the typical apartment lobby. In addition to tenants, it receives children and parents going to the daycare center, office visitors, and resident pedestrians taking a shortcut to Yarmouth Place.

Moreover, the balconies overhanging the space serve as routes to the laundry and as social spaces with tables and chairs. The lower floors of the houses on Columbus Avenue get dropped living rooms because of changes in ground level (two photos at bottom).

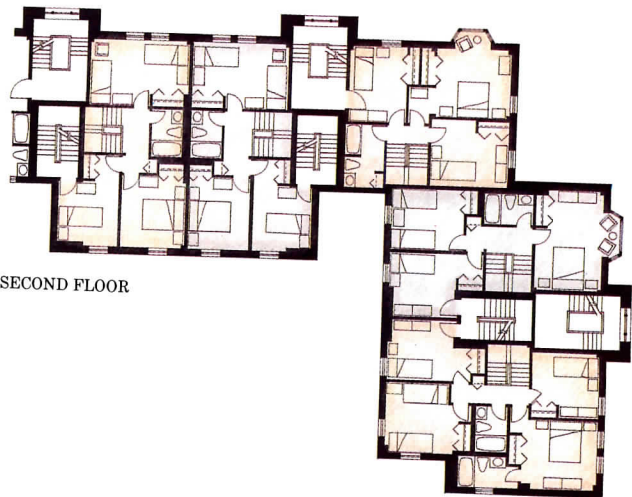

SECOND FLOOR

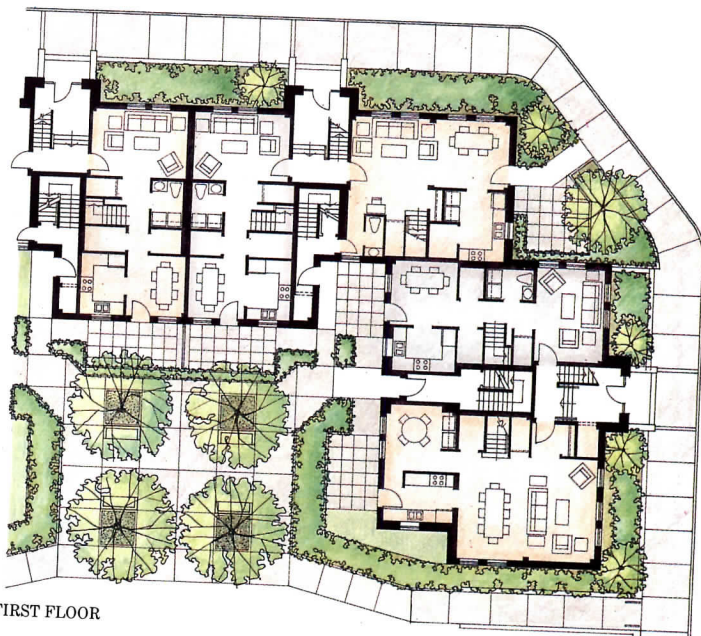

FIRST FLOOR

*Tent City  
Boston*

**Owners:**  
*Tent City Corporation  
(housing); Urban Investment  
Development Corporation  
(garage)*

**Architect:**  
*Goody, Clancy & Associates,  
Inc. — John M. Clancy,  
principal-in-charge; Paul H.  
Dudek, senior associate;  
Geoffrey Wooding, William H.  
Masterson, Donna L. Harris,  
project team*

**Engineers:**  
*Zaldastani Associates, Inc.*

*(structural); C. A. Crowley  
Engineering, Inc. (mechanical);  
Verne G. Orman Associates,  
Inc. (electrical); Haley &  
Aldrich (geotechnical)*

**Consultants:**  
*The Halvorson Co., Inc.  
(landscape); Falk Associates  
(specifications and cost);  
Cavanaugh-Tocci Associates  
(acoustical); Greater Boston  
Community Development, Inc.  
(development consultant to the  
owner)*

**General contractor:**  
*Turner Construction Company*



# Mission accomplished

*Cited by numerous organizations as a model for housing the homeless, a San Diego shelter combines a hotel-like atmosphere with practical social services to promote dignity and respect.*

You enter the Mission Style building under a picturesque bell tower through an arched doorway, which leads into a softly lit lobby. After registering, you follow a skylit corridor to your room, whose door is unlocked by a key card. Once inside, you are greeted by cool ocean breezes wafting through open casements, which provide either tranquil courtyard views or dramatic skyline panoramas . . . . Though it sounds like a blurb from a luxury hotel brochure, this prose in fact describes the country's most comprehensive shelter for the homeless.

Even before opening its doors a year ago, the St. Vincent De Paul/Joan Kroc Center in San Diego began attracting national media coverage. From TV shows like *60 Minutes* to articles in *Reader's Digest* and *RECORD* [June 1986, page 139], reports on the project cited its ambitious goal of permanently breaking the cycle of homelessness within an attractive building that challenged the depressing, dormitory arrangements of the typical shelter. In addition to offering temporary residential accommodations, the center promised to incorporate on-site facilities for a broad range of social and health services—from job-placement offices to a medical clinic—and both the construction and operation of the freestanding, block-long structure were to be financed entirely through private donations, without a single government “hand-out.” Not surprisingly, when San Diego's Catholic Diocese first proposed the shelter in 1982, many were skeptical that such an ambitious feat could be—or should be—accomplished in behalf of the urban poor. But Father Joseph Carroll, whom Bishop Leo T. Maher appointed to lead the project, is no ordinary fund-raiser. Feisty, quick-witted, and energetic, he quickly began to search for a striking architectural image that would draw public attention. Hearing of his plan, a young architecture student, Marc Bucon, suggested to Carroll that he construct an authentic mission based on historical precedents, and enlisted the services of a San Diego architectural firm, Krommenhoek, McKeown & Associates, to help realize his concept. A specific design was developed by architect Fred A. De Santo, who subsequently took charge of its realization and started his own firm in the process. Father Carroll, armed with a perspective sketch of the Mission Style building, began soliciting community and national support, which slowly grew over the next several years but lagged behind the increasing scope of the building and escalating costs of construction. Finally, this campaign caught the attention of McDonald's hamburger heiress and philanthropist Joan Kroc, who generously donated \$3.5 million in 1985, enabling the shelter and its underground parking garage to be completed (at a total cost of \$11.7 million).

Opened August 31, 1987, the St. Vincent De Paul/Joan Kroc Center lives up to all the publicity that has surrounded it since its inception. The three-story mission occupies a full city block between 15th Street and Imperial Avenue, in a rundown area of downtown San Diego, and its stuccoed volumes are well-proportioned, carefully detailed, and spotlessly maintained. “If you give somebody a home worth taking caring of, they'll respect it,” asserts assistant director Harvey Mandel, who, in conducting a tour of the facility, points out a conspicuous lack of graffiti. The center's residents are *not* down-and-out drifters, drug addicts, or chronic alcoholics, he explains, but the “motivated homeless,” whose average stay at the center is a month rather than overnight. “They are predominantly families who have run into a crisis, lost their jobs, or suffered an illness and are referred

to us by social service and community agencies,” Mandel adds. The center accommodates up to 350 residents in two types of housing: emergency shelter on the second floor for short-term stays of up to one month, and transitional housing on the third floor for families who are allowed to reside there for as long as 18 months (a six- to nine-month sojourn is more typical, according to Mandel). Both levels consist of private rooms arranged on either side of 12-foot-high corridors. On the ground floor, a spacious dining hall serves the residents plus 1,500 more of the city's estimated 3,000 homeless, and a drop-in medical clinic provides health care ranging from pediatrics to ophthalmology. Down the hall from the reception lobby, an interdenominational chapel, sculpted to resemble Le Corbusier's church at Ronchamp, ministers to spiritual needs, while a children's playroom, meeting and TV rooms, a library, and laundromat meet ordinary daily requirements. These rooms face a courtyard at the center of the building, a cloistered retreat for residents that offers recreational space away from the street. On the second floor, an employment counseling office is equipped with telephones (and soon, computers) for job searches. For staff and volunteers, amenities such as private conference rooms, offices, and a parking garage help prevent “burn-out” from the stress of social work.

The unusual multifunctional character of the shelter is complemented by spacious interiors that have been furnished with donated furniture, carpet tiles, and acoustical ceilings to create a noninstitutional setting. De Santo extended the Southwestern vernacular of the exterior inside with carefully rendered details, such as precast concrete columns, moldings, and quatrefoil window surrounds, and exposed timber beams. The architect's most unusual achievement, however, is utilizing the Mission Style elements to reduce utility and maintenance costs. The “bell tower” above the entrance, for example, captures prevailing winds from the west and channels fresh air through second- and third-floor corridors, which act as ducts. Hot air is then drawn out through a venturi and exhausted from the east-facing tower. De Santo augmented this natural ventilation system with a cogeneration and waste-heat recovery cycle, thermal storage, passive solar features, extensive daylighting, and a computerized management system to coordinate the energy-saving devices.

As an innovative prototype, St. Vincent's is continually visited by shelter sponsors, government officials, and community groups who are attempting to build similar structures in cities as different as Orlando, Salt Lake City, Charlotte, and Bakersfield. The project has also won international awards from organizations such as the Building and Social Housing Foundation, based in Leicestershire, England, as well as the California Energy Commission. Meanwhile, plans are under way to expand the shelter's services into an adjacent warehouse, which will be renovated into a 25,000-square-foot overnight facility by De Santo, who is also designing housing for Los Angeles's skid row. A more immediate challenge confronting St. Vincent's, however, is finding enough funds to support its \$2-million operating costs and a growing roster of activities. “It's easier to raise money to build a building than to run it,” says Mandel, who considers St. Vincent's only one of many possible solutions to the epidemic of homelessness which continues to cripple a diverse population of men, women, and children—people often not unlike ourselves. After all, he reports, the first person to register at St. Vincent's was an unemployed architect. *Deborah K. Dietsch*





© Larry Plaster

Shelter for the homeless:  
St. Vincent De Paul/  
Joan Kroc Center  
San Diego, California  
F.A.D. Architecture &  
Planning, Architects

© Barbara White photos except as noted





*San Diego's St. Vincent De Paul/Joan Kroc Center is literally designed as a mission for the homeless. On the ground floor, a series of public spaces surround a cloister (below), enclosing a contemplative environment away from the street. They*

*include a chapel with stained-glass windows designed by a local artisan (opposite top left) and an arcaded hall (opposite right) that doubles as a gymnasium and cafeteria/dining room, capable of serving meals to 350 residents and 1,500 of the city's street population.*

*The upper two floors of the shelter are divided into private rooms for temporary one-month stays and transitional housing for periods of up to 18 months. Furnishings include bunk beds for families (opposite bottom left).*



1. Lobby
2. Waiting/interview
3. Staff offices
4. Multiuse
5. Chapel
6. Clinic
7. Schoolroom
8. Residents' laundry
9. Commercial laundry
10. Kitchen
11. Dining
12. Day use
13. Barbershop

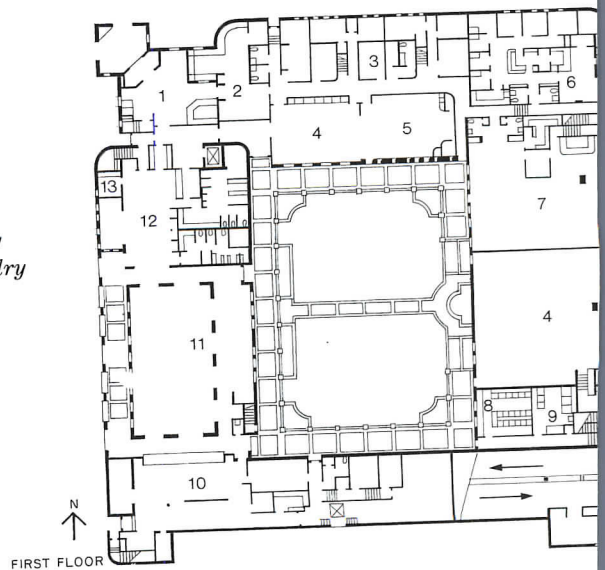



*St. Vincent De Paul/  
Joan Kroc Center  
San Diego, California*

**Owner:**  
*Catholic Diocese of San Diego*  
**Architect:**  
*F.A.D. Architecture &  
Planning—Fred A. De Santo,  
principal-in-charge; James J.*

*Holmberg, III, project architect;  
Susan L. Crook, job captain;  
Jana Jenkins, Ann C.  
Holmberg, interior designers*  
**Associated architect:**  
*Krommenhoek, McKeown &  
Associates*  
**Engineers:**  
*Burkett & Wong (structural);*

*D. G. Gardner Company  
(mechanical); M. L. Electrical  
Systems (electrical)*  
**Consultants:**  
*F.A.D. Architecture &  
Planning, Verle Williams &  
Associates (energy); Con-Tech  
Inc. (security); Gillespie  
DeLorenzo & Associates*

*(landscape)*  
**General contractor:**  
*KVAAS Construction Co.*

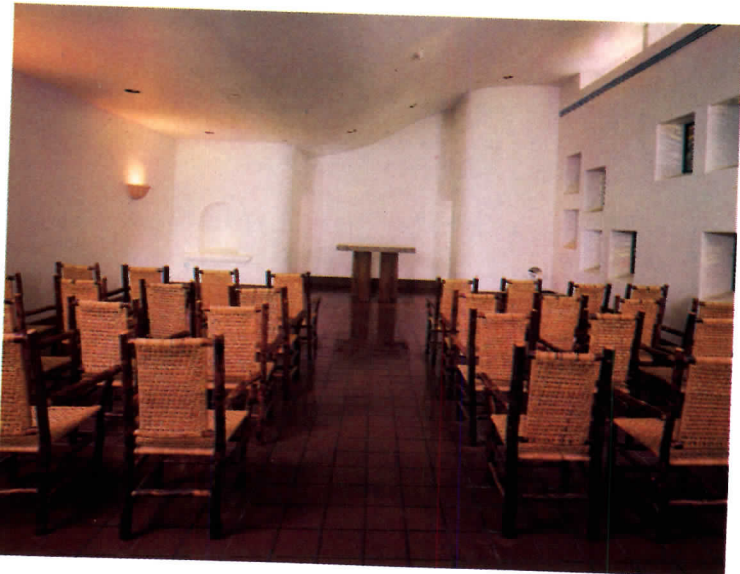

© Larry Plaster

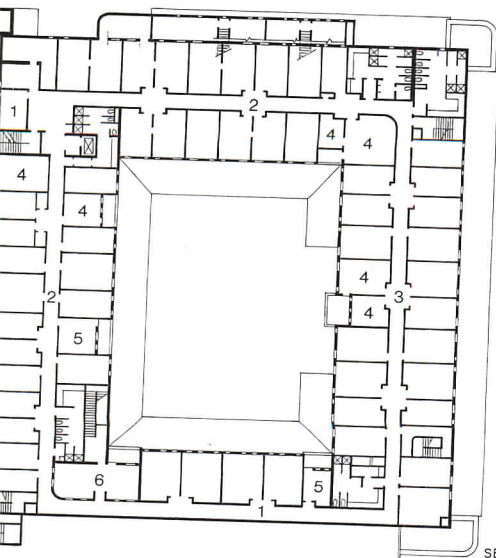

SECOND FLOOR

1. Staff offices
2. Families
3. Single men
4. TV room/lounge
5. Library
6. Resource center



# Guerilla welfare

*A group of young professionals in Atlanta choose to spend their weekends with unlikely companions, the homeless. Building huts for their less fortunate neighbors, these "Mad Housers" have made part-time philanthropy a full-time preoccupation.*

During the week, they are scattered around Atlanta in design studios, law offices, accounting firms, or even in business school; but come the weekend, they band together as the Mad Housers to build huts for the city's homeless. Every other Saturday morning these up-and-coming professionals assemble with the down-and-out at the Majestic Food Shop, purveyor of "the best cheap breakfast in town." From there, they car-pool to donated warehouse space in Billy Bob's Bargain Basement, where they refashion salvaged lumber into walls, floors, and roofs. The only catch to this model of philanthropy is that the culmination of the unlikely group's efforts is on the wrong side of the law. The various components of the huts are erected on vacant parcels of government-owned or private property—acts of trespassing that, for the most part, city officials have chosen to ignore. In fact, even before national media attention surrounded the Mad Housers (and their house-raising ritual reminiscent of Colonial American settlers protectively shielded by public support), local law-enforcers gave unofficial endorsement to the group's unorthodox actions by looking the other way as members converged on pre-selected sites, attempting to top-off huts in less than their record time of 17 minutes. Their "guerilla welfare" has even received the measured praise of Atlanta's mayor, Andrew Young, who recently referred to the group's semicovert operations as "the kind of civil disobedience of which I approve."

The building materials that the Mad Housers use in their fight to shelter some of the city's estimated 10,000 homeless are principally financed out of the builders' own pockets. Their united front belies the members' political heterogeneity; the group includes Democrats, Republicans, Socialists, and self-styled Libertarians, all of whom hold equally diverse opinions on exactly how government should respond to the plight of the homeless. "The only thing we can all agree on is that we should build the huts," confesses Mad Houser/architecture student Bailey Pope. Although the 6- by 8-foot huts provide the barest essentials of shelter and privacy, they are also, according to the Mad Housers, the first step on the road to social integration. Once residency is established, group members point out, the occupants are more likely to get jobs, and, in some cases, be eligible for Social Security benefits. To be sure, the Mad Housers have lofty aspirations—"The dignity of a man who owns a house, albeit minimal and illegal, over a man who sleeps on the ground . . . or the legitimizing effect of sleeping in a structure rather than stealing a nap on a park bench all contribute to the individual, helping him to improve his own circumstances," wrote Cabell Heyward in the Starter Kit distributed to out-of-towners interested in forming a Mad Houser chapter of their own. And yet they are refreshingly down-to-earth when questioned about their own motives for participating: "It's fun," says member Amy Phillips. Such secular sincerity often surprises the street-wise beneficiaries of their good will. After observing the group construct a hut for a friend, a homeless man named Walter arranged for the Mad Housers to build one for him. "What church are you with?" he asked member Susan Nicholson, anticipating his own required attendance at future group prayer meetings. "We're not with a church," Nicholson explained. "Wow!" was Walter's only reply.

Although the Mad Housers may lack the backing of a formally recognized political or religious organization, the group has developed a definite method to its madness. Formulated in 1987

by Mike Connor as a result of research for his master's thesis at the Georgia Institute of Technology College of Architecture, standard operating procedures guide the group's dozen architecturally trained "principals" and assorted amateur volunteers. Typically, they initiate contact with potential "clients" by visiting soup kitchens and social work agencies; increasingly, past clients make referrals. In consultation with their client, the Mad Housers then select a site, which must satisfy several criteria—it must be secluded, near a food supply and labor pool, and convenient to public transportation. Once client and site are determined, the members assemble materials according to availability. (In a pinch, the Mad Housers have hired themselves out to do demolition work in order to get whatever lumber they disassemble in lieu of payment.) The standard building kit includes 1/2-inch-thick plywood boards and 2-by-4 framing for the walls, floors, and ceilings; mesh screen and polyethylene film for windows; and cinder blocks to raise the structure off damp ground (drawings opposite). Although the majority of the approximately 40 huts built to date have shed-type roofs, the group's architects have also created a gable version, which they find a more potent symbol of home. But unlike typical architectural commissions, the work of the Mad Housers doesn't stop once construction is complete: a subgroup of Mad Housers, the Aftercare Committee, periodically visits with past clients to see how they, and their huts, are faring.

The Mad Housers' generosity with time and resources is all the more impressive since they initiated their project with no expectations of public recognition. Satisfying individual longings for a place of one's own was motivation enough. Initially secretive about their activities and identities, the Mad Housers decided to go public on television programs such as ABC's *20/20* when they realized that national exposure might benefit their homeless clients. This coverage not only rallied previously complacent politicians and private citizens to their cause, but also resulted in financial and material donations. Publicity reached a fever pitch last summer during the 1988 Democratic Convention, when the host city of Atlanta was in the spotlight. To honor the occasion, the group built a red-white-and-blue hut, stenciled with patriotic phrases, in the Omni Center's parking lot (opposite, top left). In defending their methods to conventioners during their own less heavily attended gathering, members repeated what has become something of a Mad Houser motto: "It's a question of morality rather than legality."

Catch phrases aside, the group is undeniably hindered by its breach of the law. Immediately prior to the convention, Atlanta's Department of Transportation saw fit to dismantle several huts, supposedly at the request of the Secret Service, in order to "secure" certain areas adjacent to the Omni. Such technically legitimate interference of city agencies only highlights the temporary nature of the Mad Housers' solution. Mike Connor is realistic about the long-term accomplishments of his group: "It's only a stop-gap measure," he admits. But, as he and his colleagues see it, the proliferation ("to the point of saturation") of such structures in Atlanta and (with the founding of similar organizations in San Francisco and Portland, Oregon, each equipped with its own Mad Houser Starter Kit) around the country, will finally force the federal government and the private sector to devise more permanent housing alternatives for the nation's almost 3 million homeless. *Karen D. Stein*





**Shelter for the homeless:**  
 Wood huts  
 Atlanta, Georgia  
 The Mad Housers, Architects/Builders

**Project team:**  
 Mad Housers—Mike Connor,  
 founder; Brian Finkel and  
 Frank Stevens, co-founders;  
 David Brown, Lyle Green,  
 Leslie Hare, Cabell Hayward,  
 Brian Nicholson, Bailey Pope,  
 Clark Tefft, architects/builders;  
 numerous volunteers

©Dennis O'Kain photos

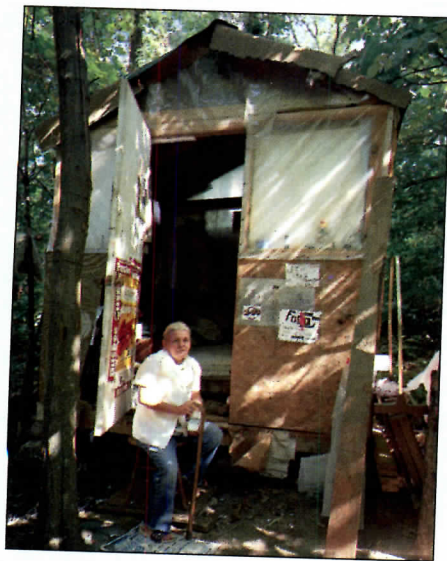
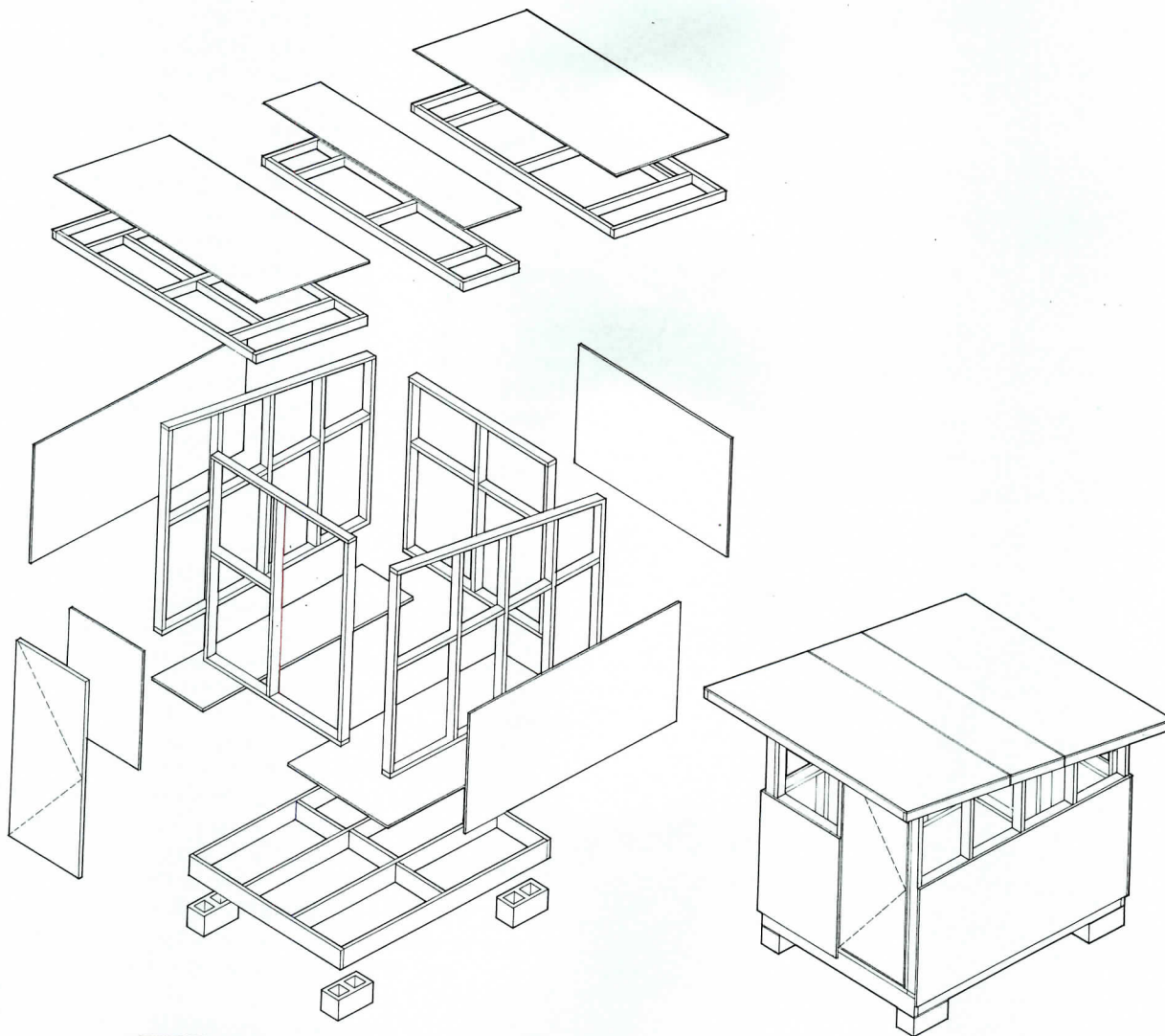



**Public housing rehabilitation:**  
 Washington Elms Housing  
 Cambridge, Massachusetts  
 Bruner/Cott & Associates, Inc.,  
 Architects

# Making it work

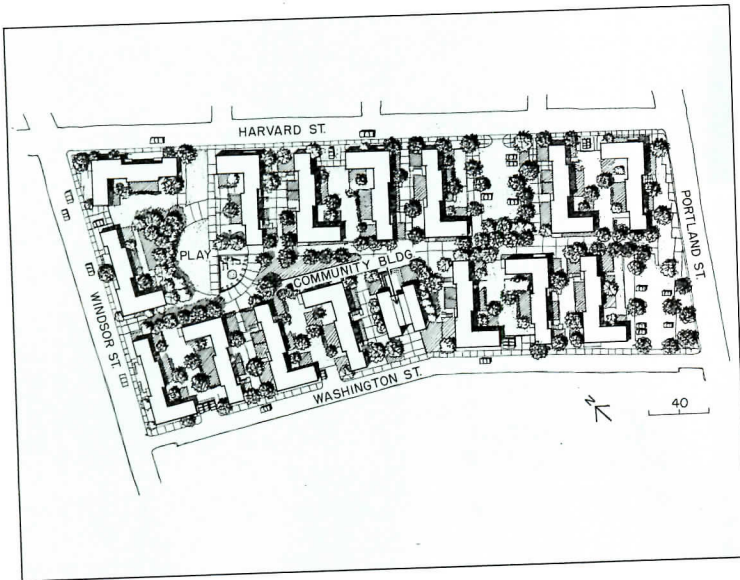

**B**uilt in 1943 by the Cambridge Housing Authority, Washington Elms is one of the oldest public housing projects in the United States. By the late 1970s, it was crime-ridden and in serious disrepair, a social and visual blight upon its upscale neighbors. Occupying a 7.4-acre site two blocks from MIT, eight from Harvard, and too close for comfort to Polaroid, Boston Properties, and Technology Square, it could not be allowed to decay any further. When rehab design began in 1980, 80 percent of the apartments had already been boarded up, tenants having been evicted for nonpayment of rent, lease violations, and crime. Eligible low-income applicants were refusing placement there.

Washington Elms was in bad physical shape partly through vandalism, but also because of inadequate public maintenance. Until the 1960s, rents in public housing were set by operating costs, while debt service was handled by the federal government. During the '60s and '70s, however, tenants became poorer and poorer at the same time that maintenance costs were rising. Because rents no longer covered operating costs, Congress amended the housing legislation to require that tenants pay 25 percent of their net income for rent (an amount subsequently adjusted to 30 percent of gross income). Of course, such measures merely created a shortfall, because base incomes were too low. A subsidy became necessary, but the funds made available were insufficient, and so much maintenance had to be deferred that buildings began to fall apart. A rehab of Washington Elms became feasible only in the late '70s, when Congress launched the Comprehensive Improvement Assistance Program for a nationwide modernization program of public housing. Under the aegis of that program, the Cambridge Housing Authority awarded a \$10.5-million contract to Bruner/Cott, a 40-person firm that receives 25 percent of its fees from public-sector housing. (Leland Cott's Peace Corps experience in Colombia, where he served between earning architectural degrees from Pratt and Harvard, and his command of Spanish impressed the CHA as key assets, since many Washington Elms tenants are Hispanic.)

Two fundamental imperatives shaped the remodeling. The first was the need to transform interior public areas such as entryways, corridors, and stairs—all of which had become a dangerous no-man's land—into private space within the apartments, along with reassigning a generous portion of common outdoor space (pre-rehab photo top left) into common yards accessible only to the apartments that border them (site plan and photos opposite bottom). The second imperative was to reduce densities. Older public housing is too compact by today's standards, with room sizes so mean that the apartments require redesign from scratch. Three buildings that had deteriorated beyond repair were demolished to provide open space and additional on-site parking. As a result of these changes, there are now 23 units per acre at Washington Elms instead of the original 44, or a reduction from 324 units of housing to 175.

RECORD's award to Washington Elms comes late in the series of honors it has received. We are not the first to recognize that this rehabilitation solves many of the problems that gave public housing a bad name, and has much to teach anyone who tries to address them. CHA's executive director Daniel Wuenschel kindly assures us, however, that we should not feel remiss: "I cherish your late award more than all the others, because if Washington Elms still looks good four years after opening day, it makes all our efforts count." *Mildred F. Schmertz*



*Public housing, in spite of the unfair rap it receives, is a good investment for the country. What is wrong with it can be fixed, as the successfully rehabbed Washington Elms, once the most troubled project in Cambridge, effectively demonstrates.*

*Jean M. Smith photos*





Apartment layouts before the upgrade (bottom) were cramped and poorly planned. Bruner/Cott's rehab reduced the density of the development by creating larger apartments, either as floor-through units or as duplexes. Public stair halls became private staircases

offering a more secure environment, and interior public circulation areas were converted to private dwelling-unit space (plans and sections below). A new community building (opposite) provides meeting facilities, office space for the Cambridge Housing

Authority and tenants' representatives, a community kitchen, and facilities to house a Head Start program.

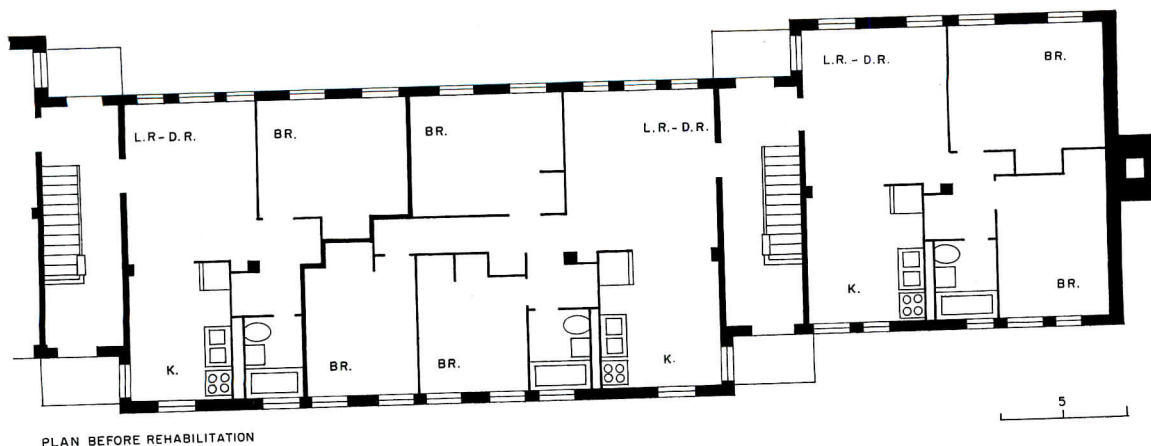
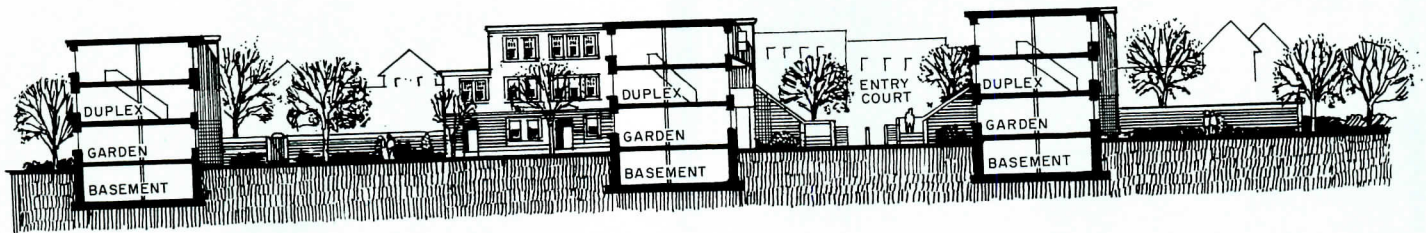
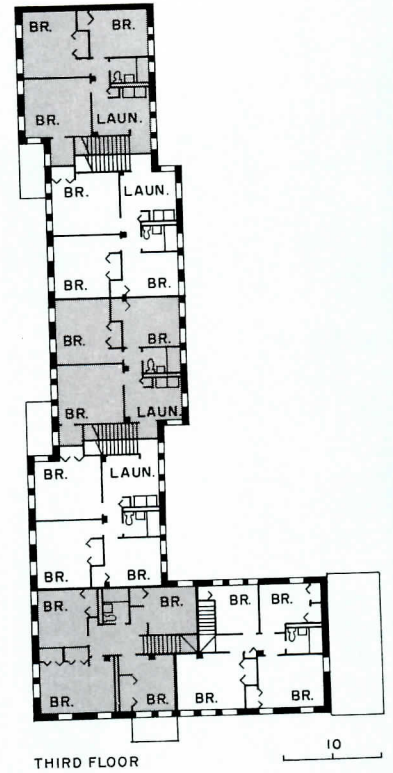
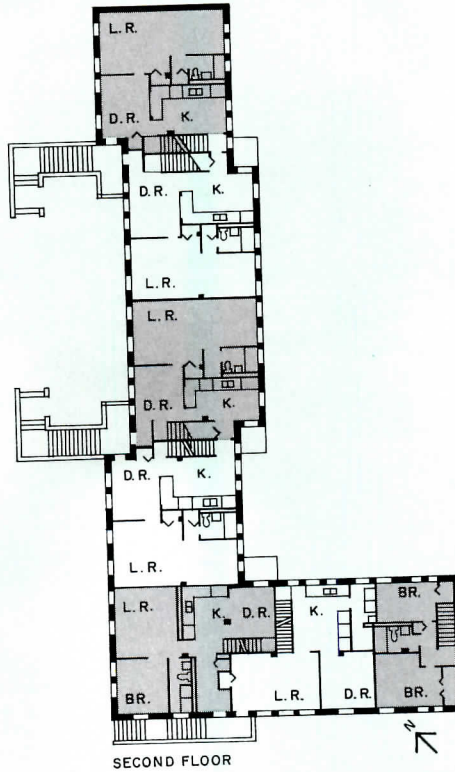
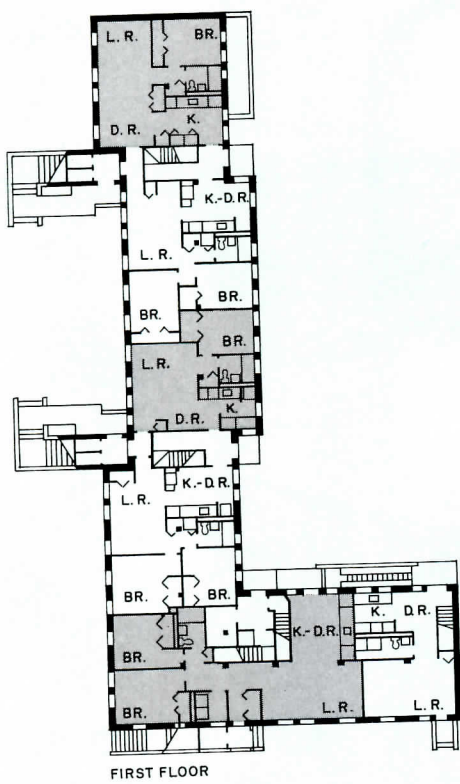

5



*Washington Elms Housing  
Cambridge, Massachusetts*

**Owner:**  
*Cambridge Housing Authority*

**Architects:**  
*Bruner/Cott & Associates,  
Inc.—Leland D. Cott,  
principal-in-charge, Eric  
Pfeuffer, associate, Bruce*

*Flenniken; Arnold J. Jacobsen  
& Associates, Inc., architectural  
consultant to Washington Elms  
Tenant Council*  
**Engineers:**  
*Rene Mugnier, Inc. (structural);  
Panitsas/Zade Associates  
(mechanical);  
Bay Design Group (electrical)*

**Landscape architect:**  
*Michael Weinmayer*  
**General contractor:**  
*Peabody Construction Co.*

©Lucy Chen





Residential hospice:  
Coming Home Hospice  
San Francisco  
Asian Neighborhood Design,  
Architects

## A place of passage

©Mark Citret photos

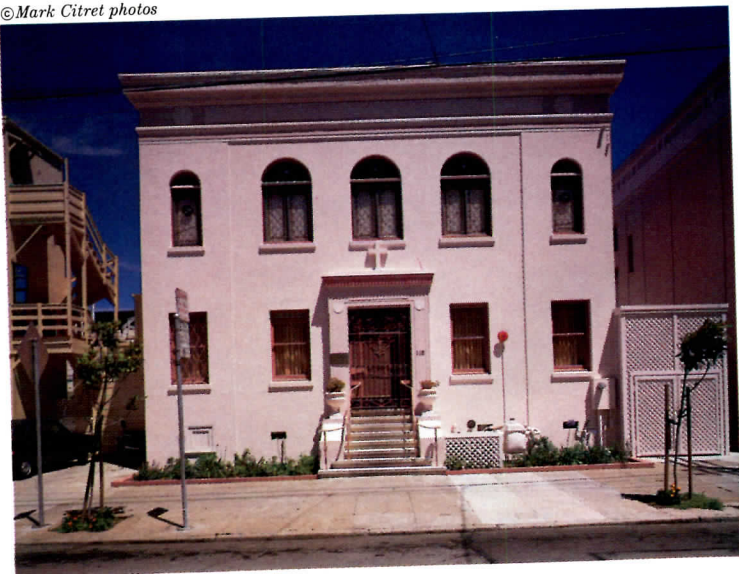

*Coming Home Hospice is part of an ecclesiastical complex along Diamond Street, erected between 1906 and 1926, that includes the parish church, rectory, school, and convent of Most Holy Redeemer Church (top photo opposite). In recent years the area surrounding the church has evolved into San Francisco's largest gay neighborhood, and Most Holy Redeemer today welcomes a lively mix of younger gay and older, mainly Irish-American, parishioners. The round-arched*

*second-story windows of the erstwhile convent chapel now frame delicate leaded casements designed by local artists Dan Scanell and Gary Van Velsor to harmonize with the stylized dove motif of the windows' original stained-glass tympanums (above).*

The modern concept of hospice care dates back to the late 19th century, when an associate of Florence Nightingale opened a home for the terminally ill in Dublin. Based on the belief that it is possible to ease the difficult journey from life into death by exchanging pain and isolation for peace and acceptance, hospice programs have evolved over the past century into a worldwide movement (there are 1,679 programs in the United States alone) that allows people to face death outside the clinical atmosphere of a hospital, most frequently in the patient's home through visiting-nurse programs but sometimes in inpatient facilities. Hospices usually comprise interdisciplinary teams of licensed vocational nurses, social workers, home health aides, and volunteers, working under the supervision of a physician. Each team member's overriding goal is not to prolong life but to enhance it by tending to the material and spiritual needs of patients, their families, and friends. Although hospices, like hospitals, rely on pain-killing drugs to ease physical suffering, their therapeutic regimen also includes countless hours of "hand-holding" to help assuage a patient's emotional anguish. In a recent *Time* magazine interview, Dame Cicely Saunders, the much-honored English physician who founded St. Christopher's hospice in London 21 years ago, noted that hospice environments "allow patients to speak for themselves, to suggest what we ought to do to give them safe conduct."

Nowhere is the need for hospice care more acute today than in San Francisco, a city whose beauty belies the grim fact that it is one of two epicenters, along with New York, of the current AIDS epidemic. The impact of AIDS has been especially severe among San Francisco's sizeable gay population, but if there is a bright side to the dark statistics that continue to document the rising toll of deaths and new cases of people infected with the AIDS virus, it is the increasingly unified efforts among leaders of the gay community, heads of the city's municipal government, and concerned members of the general public to overcome the plague of fear, indifference, and misunderstanding that so many victims of the disease have endured in less enlightened places.

Coming Home Hospice is perhaps the most tangible—and poignant—symbol to date of this cooperation. Located just off Castro Street in the heart of San Francisco's most visible gay neighborhood, Coming Home is the nation's first hospice designed primarily to serve AIDS patients. The 15-bed facility, open since March of last year, offers 24-hour-a-day care by licensed vocational nurses who work in three eight-hour shifts. The hospice has no live-in staff, though a registered nurse and a social worker are present during the day. At least 10 of the hospice's beds are reserved for AIDS patients; the remainder are occupied by mostly older cancer patients. The average length of stay at Coming Home is 28 days and, to be admitted, one must have a physician's prognosis of six months or less before the disease runs its course, reside in San Francisco or San Mateo county, and be in need of home care. The cost of a stay—\$40 a day and downward—is determined by a patient's financial means, and most pay between \$7 and \$25. Like all hospices, Coming Home has no medical facilities, but its staff will do everything in its power to ensure that the patients' final days are as painless as possible. "If a patient is having trouble breathing," explains the hospice's facilities manager, Linda Edelstein, "we will supply oxygen to make him more comfortable, but we don't have respirators or any other life-extending equipment."



*The domestic environment of San Francisco's Coming Home Hospice helps people with AIDS and their families confront the physical and psychological ordeal of impending death.*

Coming Home is the result of a remarkable collaboration among three Bay Area organizations: the Visiting Nurses and Hospice of San Francisco, which in 1985 recognized that AIDS patients often had no place to go as the disease consumed their physical and financial resources; the Catholic Archdiocese of San Francisco, which agreed to give the hospice a 15-year lease on the unoccupied former convent of Most Holy Redeemer Church; and Asian Neighborhood Design (A.N.D.), a nonprofit group of architects, planners, and community organizers that applied its past experience in housing rehab and renovation to oversee conversion of the convent into a 7,000-square-foot residential hospice facility.

In selecting A.N.D. as its architect, the hospice based its decision partly on the recommendation of Libby Denebeim, a well-known member of San Francisco's school board and co-chair of a capital campaign that raised over \$860,000 for Coming Home's renovation. As a board member of the Women's Alcoholism Center, whose new home was designed by A.N.D. in 1986 (see pages 108-109), Denebeim had witnessed the community design center's ability to carry out controversial projects and function within a group decision-making process. A.N.D.'s experience in coordinating ideas and facilitating consensus proved especially critical for the hospice project. "There was a massive response from the gay and design communities in terms of money, materials, and opinions," recalls R. Thomas Jones, A.N.D.'s director of architecture. "Everyone wanted a say in the design, and everyone wanted it to be perfect. As architects, we had to temper some people's images of the facility as a grand hotel with the realities of everyday life in a hospice."

Jones and project designer Lindsey Jang also had to bridge the gap between a hospice's official status as an institution and its practical need for interiors that are as comfortably domestic as possible. For its part, the convent was in reasonably sound repair, and the nine-by-twelve cubicles that had once accommodated two nuns apiece proved ideally adaptable as single-patient rooms. To meet code requirements for a hospice, the architects installed new heating and sprinkler systems, an elevator, and accessible bathrooms, and completely remodeled the convent's outmoded kitchen. They left the austere classical exterior intact, save for the construction of a landscaped redwood sundeck off the basement (bottom right) and the addition of an unobtrusive entrance ramp along the building's south flank, separating the hospice from a private school next door (right in top photo opposite). The school's close proximity raised a particularly difficult issue. "We always spoke of the building in life-affirming terms," says Jones, "but we were also aware that the sight of bodies being taken down the ramp might be traumatic for the schoolchildren." A high latticework screen erected between the two buildings solved this dilemma.

Time and again during the course of construction, the architects were reminded of the urgency of their mission, as several people active in the project themselves succumbed to AIDS, while others bravely volunteered their services, knowing that their lives, too, would be cut short. In the end, however, the notional stress was clearly worth it. "Working on the hospice was one of the most rewarding professional experiences I've ever had," says Lindsey Jang. "So often today architecture is about corporate image and the bottom line; Coming Home reminded me that it can also be about caring." *Paul M. Sachner*





*Coming Home's deliberately eclectic interiors include (below, clockwise from upper left) a vaulted lounge that occupies the former convent chapel, a second-floor corridor, a typical patient room, the main dining room, the kitchen and pantry, and a basement*

*library and lounge. Staff can monitor patient needs through call-button annunciator panels, one of which is located in the entrance foyer (opposite). Over 100 volunteers assisted in the building's renovation, and members of the Design Showroom Association of San*

*Francisco donated most of the hospice furnishings (the Association designated Coming Home as its annual charity for 1986). Other businesses contributed track lighting, ceramic tile, vinyl flooring, kitchen equipment, television sets, and VCRs, while Bay Area*

*artists, working through a local foundation called Art for Healing, donated paintings and photographs for public rooms, hallways, and stairwells. Bedrooms, which retain sinks, closets, and radiators from the original convent, are sparsely embellished to allow occupants*





to create their own décor. (Most have responded by covering the walls with cards and letters from loved ones.) The architects specified warm shades of beige and pink throughout the facility, and illumination is kept dim in response to many patients' sensitivity to light.

*Coming Home Hospice  
San Francisco*

**Owner:**  
Hospice of San Francisco—a joint venture of the Visiting Nurses Association of San Francisco and the Pacific Presbyterian Medical Center

**Architect:**

*Asian Neighborhood Design—  
R. Thomas Jones, project architect; Lindsey Jang, project designer; Steven M. Suzuki, job captain*

**Engineer:**  
Uno Veideman (structural)

**Consultants:**  
Berens Kaminsky (volunteer

coordinator); Andrew Belschner and Gary Hutton (interior design); Edward A. Nicolaus III and Mike Immel (landscape architecture)

**General contractors:**  
Samson Construction Company (phase I); Van der Sterre Construction (phase II)





**Residential alcohol-treatment facility:**  
 Women's Alcoholism Center  
 San Francisco  
 Asian Neighborhood Design,  
 Architects

# A home for healing

©Mark Citret photos

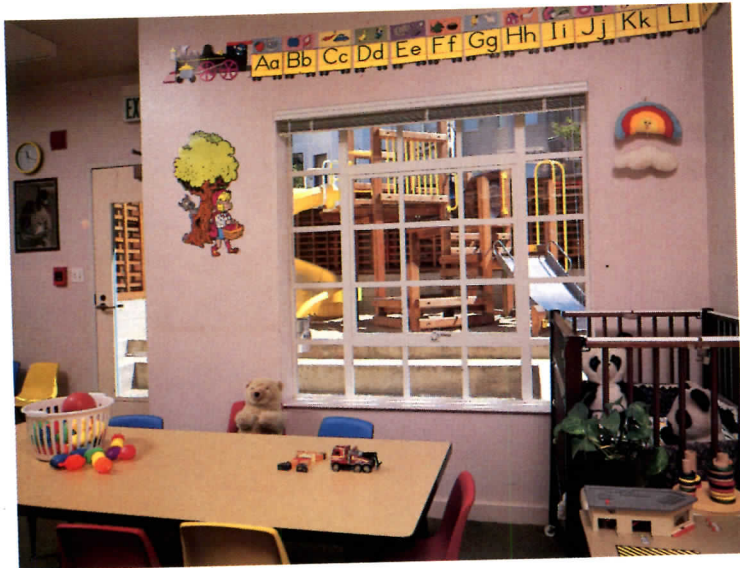
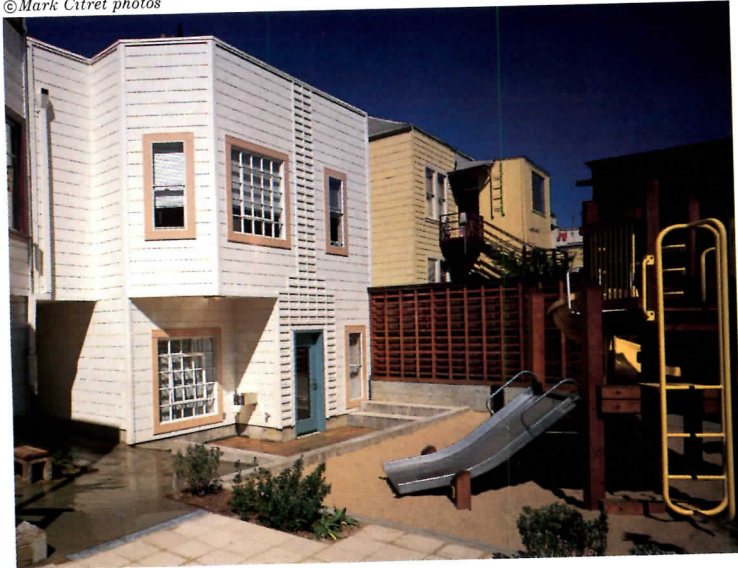

*Women's Alcoholism Center  
 San Francisco*

**Architect:**  
*Asian Neighborhood Design—  
 R. Thomas Jones, director of  
 architecture; Harry Wong  
 Leong, project architect; Lily  
 Pai Soo Hoo, project manager*

**Engineers:**  
*Kwan & Associates (structural);  
 S & J Engineers (mechanical);  
 Pete O. Lapid & Associates  
 (electrical)*

**Consultant:**  
*Jeffrey Miller (landscape)*

**General contractors:**  
*Gonzalez Construction; PFW  
 Associates; Landmark Building  
 & Engineering*



Alcohol abuse affects more people in the United States than any other form of drug addiction. Although alcoholism cuts across all economic, ethnic, and geographic barriers, no population is more vulnerable to the feelings of low self-esteem and isolation that so often feed this disease than single mothers struggling to raise children in poor inner-city neighborhoods. Recognizing that reality 10 years ago, a group of recovered alcoholics in San Francisco founded the Women's Alcoholism Center, an outpatient clinic located in the city's Mission District. W.A.C.'s underlying goals then, as now, were not only to address the specific problems of addicted women but also to break the intergenerational cycle of alcoholism by including children in treatment. In 1983, the Center's staff decided to take its successful day program a step further by developing the then-radical concept of a residential facility where women and their children could live together in a sober, structured setting. Far too often, the organization's founders had witnessed, women determined to recover from alcoholism were forced to release their children to institutional or foster care and hope to be reunited later. W.A.C., by contrast, offers a more humane alternative—a comprehensive treatment program whose intention, according to director Rhonda Ceccato, is "to encourage abstinence as a way of life while maintaining family unity."

In 1984, W.A.C. turned to Asian Neighborhood Design (see page 104) for assistance in planning a new facility that would consolidate its day and residential programs into a single complex comprising separate but related buildings. Besides its role as project architect, A.N.D. helped W.A.C. obtain a conditional-use permit from the city and investigate public and private funding sources. Together, A.N.D. and the Center combed San Francisco for potential sites until they came up with a three-story bow-fronted row house on a double-width lot on Bryant Street (right in photo opposite). The architects converted the existing structure into a comfortable residence for 21 women and children, and designed a stylistically compatible 3,400-square-foot building next door—the Lee Woodward Counseling Center (left in photo opposite)—that houses W.A.C.'s offices, child-care facilities, and individual and group-therapy rooms. The two buildings are joined by an interior courtyard (top left) that maximizes natural light in both structures and provides a sheltered entry (bottom left) to ground-floor community rooms (Alcoholics Anonymous holds public meetings at the Center four times a week).

W.A.C.'s clients reside at the Center for periods ranging from six months to one year and, depending on income, pay between \$400 and \$600 a month for rent, food, and treatment (nearly all residents receive public assistance). During the first six months, residents spend at least four hours a day in individual counseling and group therapy; the rest of the time is occupied by household chores, including food shopping and preparing two meals a day. After six months, therapy continues, but on a reduced schedule that allows the women one or two days off a week for outside job training. Beyond all else, perhaps, the Center simplifies its clients' lives by giving them the physical resources and emotional support they need to carry out even the most prosaic everyday task. "A lot of real life-changing work gets done at the house just in the course of the women being with their children, cooking meals, and talking late at night with the house manager," observes W.A.C.'s president, Mary Pat Power. "For the families living here," she adds, "the house itself helps them heal." *P. M. S.*



*Living together in a dignified atmosphere of mutual support and respect, low-income alcoholic mothers and their children wage the battle against liquor dependency 24 hours a day, one day at a time.*

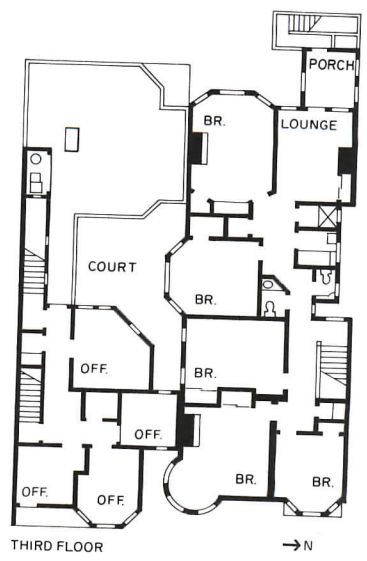
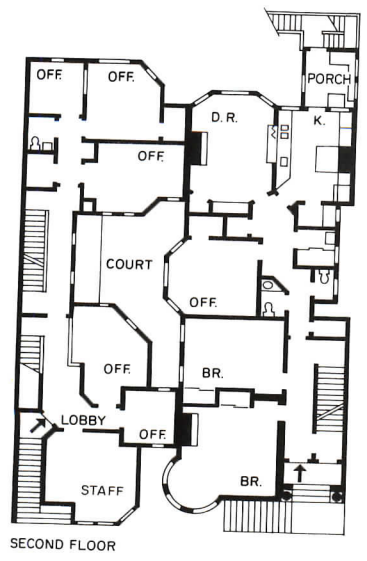
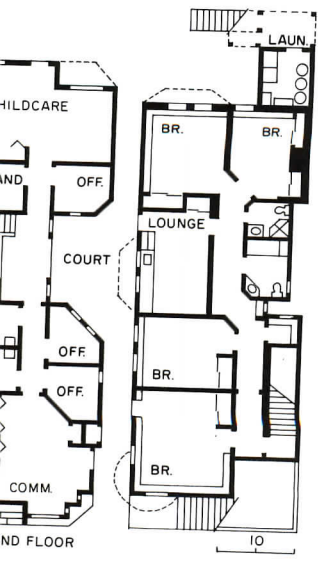



A "graduate" of *Creative Living*, Charles H. Snow, III, summed up its mission in a letter to *RECORD*: "[This] is housing for the handicapped designed not to look like housing for the handicapped. More importantly, it allows people with handicaps not to live handicapped lives."

© Wayne Cable/Cable Studios photos

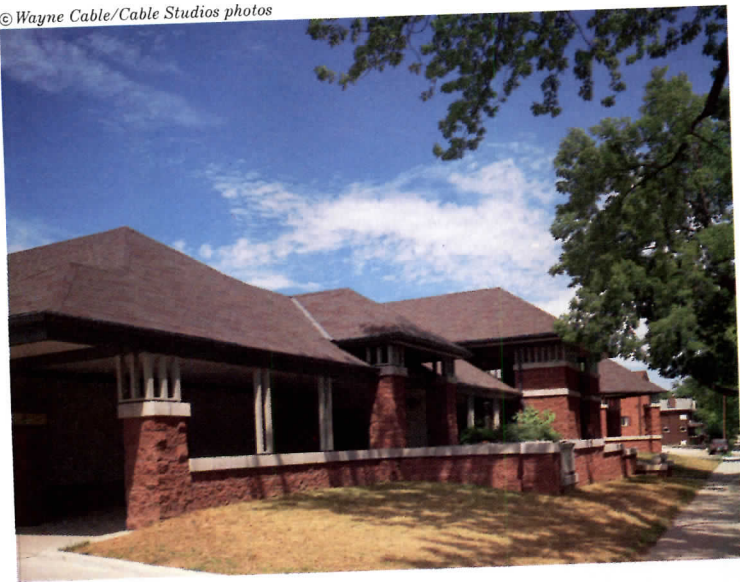

**Housing for the disabled:**  
Creative Living II  
Columbus, Ohio  
Schooley Caldwell Associates,  
Architects

## On their own—together

Over the past two decades, America has come a long way toward lowering legal and practical barriers for the disabled, though not nearly far enough to warrant complacent self-congratulation. The many obstacles that remain loom especially large for young quadriplegics, whose loss of most or all use of their limbs too often traps them in a homebound dependency or institutionalized isolation that wastes the unimpaired intelligence, talent, and drive they would eagerly put to use as autonomous adults. Back in the late 1960s, recognition of the need for an environment where severe physical handicaps would not preclude an independent, productive life inspired community leaders in Columbus, Ohio, to establish an apartment complex for quadriplegics, Creative Living I (completed in 1974). Innovative for its time—and still a rarity—this venture abolished ranks of hospital-style wards along double-loaded corridors in favor of self-contained, one-bedroom flats, each with its own entrance off a common courtyard. The success of such housing relied on several key factors: proximity to the educational, medical, and recreational facilities—and transportation network—of Ohio State University and other places of learning; varied employment opportunities in greater Columbus; the presence of a centrally stationed staff assistant on 24-hour intercom call; a ready supply of neighbors, mostly students, whom Creative Living residents could hire individually for part-time help with morning and evening routines, hygiene, and meals; and, of course, a layout accessible throughout to people in electric wheelchairs.

Extraordinary demand for the 18 original apartments spurred development of the 16-unit Creative Living II, now in its third year of operation, only a few blocks away. The availability of a forerunner to analyze, as well as general advances in the study of barrier-free design—to which the architects of the later facility, Schooley Caldwell Associates, and Ohio State University personnel had already made significant contributions—allowed for genuine improvements. At the same time, however, specific conditions posed new constraints. The site, generously leased by Ohio State at a fee of \$1 per year, was a tight fit for the assigned 10,400-square-foot program area, and its location in an official historic district posed the added challenge of composing an exterior congenial to high-style Victorian surroundings on a low budget (\$64.37 per square foot, all inclusive). Funding consisted of a \$633,600 construction loan generated through HUD's Program 202, which is primarily geared to housing the elderly; \$200,000 in grants from the Columbus and Yassenoff foundations; and hundreds of private donations. Schooley Caldwell convinced federal authorities that exceptional—by normal HUD standards—amenities such as microwave ovens, side-by-side refrigerators-freezers, and oversize bathrooms and storage spaces were in fact necessities, given the logistics of life for a busy single person in a wheelchair (for details see page 112). The architects were also ingenious in their use of basic building volumes and inexpensive materials (contrasting concrete blocks articulate the street facade) to evoke the presence of one all-embracing family house: a welcome symbol for residents, connecting as it does the private domains of their own apartments with the shared public areas of sheltered outdoor passages, a laundromat, a front porch, and a multiuse lounge just inside the main entrance. By the same token, simple but imposing parapets, pillars, and hipped roofs combine to suggest a dignified Prairie Style structure, comfortably at home in a neighborhood of solid citizens. *Douglas Brenner*







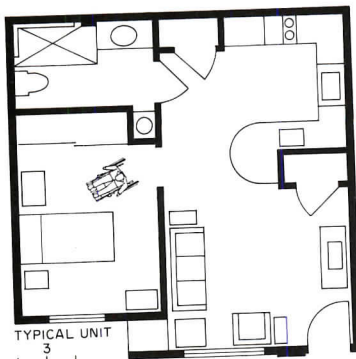

Three variants on a basic 520-square-foot apartment layout (above) enabled maximum site use without sacrificing individual outdoor entrances, a multi-use lounge (top left photo), or a front porch (opposite). Openings, sill heights, cabinetry, and appliances take into account the full range of electric wheelchair sizes and turning radii, accessibility from a seated position, and jutting knees and toes. Surprisingly high cupboards above kitchen counters (bottom left) were installed at residents' request: they need the space for household provisions, which personal attendants can bring down as needed. Special requirements include room to park a spare wheelchair close to an outlet for battery recharging, outside bathroom chests for medical supplies, lever faucets, and flexible shower heads next to sinks for attendant-aided shampoos. Bathroom doors are a courtesy to guests, but residents unanimously rejected bedroom doors as hindrances. Otherwise, décor reflects individual taste, since flats are let unfurnished.

*Creative Living II*  
Columbus, Ohio

**Owner:**  
Creative Living Housing Corporation

**Architect:**  
Schooley Caldwell Associates—John P. Schooley, Robert D. Loversidge, Jr., principals; Thomas R. Matheny, project manager; Robert L. Bates, Jr., designer; Thomas F. Schifer, project architect

**Engineers:**  
SCA—Mark A. Taylor (mechanical); William R. Laughery (electrical); Kabil Associates—Shashi P. Savla (structural)

**Landscape architect:**  
SCA—Brian P. Kinzelman, Gregory P. Leffel

**Interiors:**  
SCA—Barbara J. Schooley  
**General contractor:**  
Lincoln Construction, Inc.

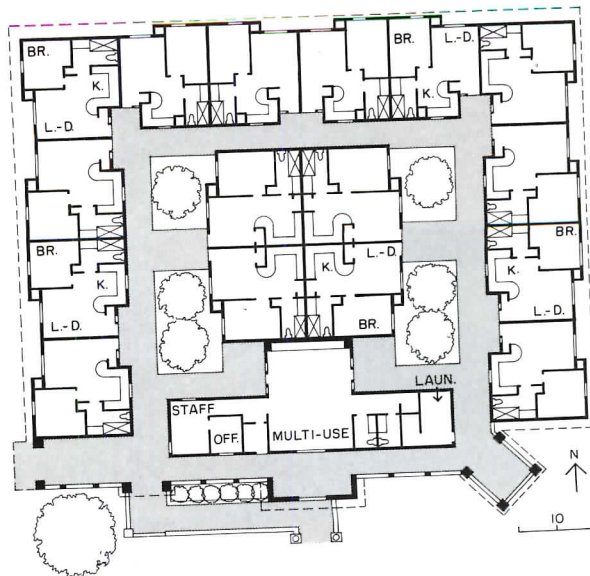







Housing for the elderly:  
Lincoln Towers  
Secaucus, New Jersey  
Arthur Lubetz Associates,  
Architects

# High spirits

© Malcolm Varon photos



*Lincoln Towers*  
Secaucus, New Jersey  
**Owner:**  
Secaucus Housing Authority  
**Architect:**  
Arthur Lubetz Associates—  
Arthur Lubetz, principal-in-  
charge; Richard Miller, project  
manager  
**Consultant:**  
Gensert, Bretnell, Bobel  
(structure)  
**General contractor:**  
Massarro Corporation



**M**otorists whizzing past it on Route 3 or the New Jersey Turnpike can hardly miss Lincoln Towers' just-shy-of-primary colors and bold vertical massing, but few would readily identify the building as housing for the elderly—and public housing at that. Rejecting the condescending stereotype equating “old” with “foggy,” architect Arthur Lubetz also spurned traditionalism in favor of an energetically sculptural form that would celebrate the project's prominent site in the bustling urban corridor west of New York City and convey a contagious vitality.

The games with geometry, scale, and color, however, are not played merely for their own sake. To encourage interaction among residents, for example, the 100 one-bedroom units (including 10 lower-floor units for the handicapped) are divided between the two offset square towers, each floor pairing four-apartment social groupings around clustered entries. The vivid red wedge thrust through the yellow-beige stuccoed high-rise blocks expands these compact twin “neighborhoods” to such shared spaces as a central sitting room with adjacent laundry facilities, and a small lookout lounge off the elevator lobby. (Blue-sheathed elevator and stair shafts define vertical circulation routes, and a deep-gray “wainscot” wraps the towers' bases in an illusory screen that becomes real at the building's offset.) Similarly, spaces reserved for individual and small-group activities are concentrated in well-trafficked ground-floor areas. The most prominent common spaces, however—a community dining room with adjoining library/lounge (photos top and bottom left) and rooftop deck—occupy a penthouse social center that exploits the tower's spectacular views of the Manhattan skyline. Throughout, the straightforward linear plan combines with an interior reprise of the exterior's color code and shifts in material to provide consistent cues for orientation within the building.

Lubetz's emphasis on a symbolic linkage with the distant city—urbanity at a remove—prompted a building profile somewhat higher than that dictated by a limited site, but the towers are also heightened visually by such devices as the double-tiered punched windows in individual apartments (photo middle left). In contrast to the panoramas revealed by the public spaces' wide apertures, these smaller openings frame scenic vignettes that shift as the occupant sits or stands or changes vantage. *Margaret Gaskie*

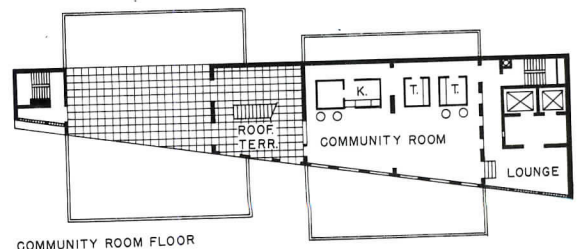



*A suburban apartment tower for the low-income elderly draws on lively color and bold geometry to evoke a sprightly urban image that challenges the timid traditionalist clichés of aging.*





Housing for the disabled:  
Diamond Park  
Philadelphia  
Cecil Baker & Associates,  
Architect

## Declaration of independence

©Tom Bernard photos



*Though its North Philadelphia environs have experienced considerable abandonment, the vicinity of Diamond Park has seen relatively little demolition (most of the vacant lots that do exist have been turned into gardens). The project comprises two separate buildings that nonetheless extend the finely grained scale of the street in their respective sites. For budgetary reasons the structures are three-story slabs, but the row-house rhythm of*

*adjacent buildings is evoked in corbelled-brick cornices, a glazed-face-block water table, and brick-shrouded downspouts (above and opposite top). Glazed-face-block stripes and precast-concrete lintels and projected sills echo the street's historic verticality.*

From her soft-spoken demeanor, it is not easy to discern whether Christine Washington found the process of husbanding 48 units of rent-subsidized housing through the federal and city bureaucracy too exhausting to relive ("I don't know how I should expound upon that"), or whether she simply hesitates to bore her interviewer. It is, however, community-based groups like Christine Washington's Advocate Community Development Corporation that are widely seen as the crucial ingredient in government-assisted housing these days, and Mrs. Washington, her neighborhood, the city of Philadelphia, and the U. S. Department of Housing and Urban Development are all justly proud of the two new brick structures, called Diamond Park. Nonetheless, the actuality of the completed project is nearly subsumed in the memory of the participants by the struggle to bring it to fruition.

Though many buildings on Diamond Street and nearby Susquehanna and Broad are now abandoned, sober brownstones and exuberant wrought-copper-trimmed brick row houses remain as emblems of the industry-based wealth that came to North Philadelphia in the last two decades of the 19th century. With the city's later painful transition away from a manufacturing economy, the neighborhood's fortunes slid slowly yet inexorably downward, until the Reverend and Mrs. Paul Washington, shepherds of an increasingly poor flock in the area, saw the quality of its extant housing as a basis for renewal. The parish formed the Advocate Community Development Corporation in 1970, beginning with the construction of 15 new government-assisted houses, and has since built or gut-renovated dozens of residences on surrounding streets. In all, ACDC has returned over 200 units to the neighborhood housing stock.

In 1978, at the request of officials at Inglis House, a residence for the disabled, ACDC agreed to develop a project for the handicapped. To that end, with backing from the Episcopal diocese and a board drawn from the community, ACDC spearheaded an effort that formed the Partnership for Urban Development. Armed with the partnership's expertise (and the seed money it raised), as well as a committee of 22 advisors, two housing consultants, and a lawyer knowledgeable in the ways of bureaucracy, a proposal was submitted. It took five attempts over the same number of years, however, before HUD funded the project. How did ACDC finally do it? "The architect documented *everything*," responds Washington. "It was so well grounded that HUD had to accept it. And we stayed on our knees a lot." HUD holds the 40-year mortgage under its 202 program. As is typical for such developments, Section 8 subsidies bridge the gap between a fixed percentage of each resident's income paid as rent and the fair-market rent established by HUD for the region. To stretch its funds, the agency required the city to make both on- and off-site improvements using block-grant funds.

Architect Cecil Baker found the government inflexible on many issues. "The client wanted a project that was 100-percent accessible to the handicapped, and this was the first of a series of items that flew in the face of HUD regulations." Among other elements of the design requiring negotiation were the mix of studio, one-bedroom, and two-bedroom units; the issue of whether handicapped persons would choose to live in the Diamond Park neighborhood; and compliance with historic-district regulations. Leonard J. McCuen, one of the HUD architects who worked on Diamond Park, explains: "This is a very competitive program, and



*The first entirely wheelchair-accessible housing built under HUD's 202 program, Diamond Park has been called a "minor miracle" for incorporating low-cost assisted housing into a beleaguered but historically significant neighborhood.*



*Located on small city blocks typical of Philadelphia, the structures face streets at front and rear. The front facade, along a relatively wide thoroughfare, looks out on a playing field (above and opposite). The rear, adjoined by row houses facing a narrow street, forms a courtyard in which the main entrance is flanked on the left by a garden (tree-shaded but still awaiting some minor construction*

*before being developed by the residents) and on the right by a small parking area. Security concerns and plan economies required a single wheelchair-accessible entrance on the rear facade, although front-facing fire exit stairs (opposite) recall 19th-century stoops.*





Though less tidy than a conventional design, the open plan of the units offers flexibility as well as accessibility. One resident, for example, has opted for a dining table in a traditional arrangement (top), while another has placed a smaller table in the kitchen (bottom), enlarging the sitting area to accommodate visits from an extended family. A partition supporting mailboxes in the lobby (opposite) encourages neighborliness by diverting residents through the adjacent, as yet underfurnished, common rooms.



our review process is comprehensive. Each project is analyzed for conceptual design, real-estate valuation, and compliance with fair-housing requirements. We look at whether the sponsor can demonstrate the ability to develop and then run the project." Christine Washington is a little more sanguine than Baker—she has been through it more often: "The process is the process. It's very costly, and that is the most frustrating thing, because while you wait for answers the [project] cost escalates."

In Baker's approach to the design, the \$50-per-square-foot budget was uppermost in his mind. The massing of the structures is identical, the smaller of the two sites governing the dimensions. Each is a simple rectangle ("no fancy shapes," says Baker) which, with neighboring buildings, forms a tree-shaded open space in the rear, the location of the entrance. The rhythm and scale of nearby row houses is evoked by simple gestures in ochre-brick detailing. Within, a small lobby opens onto generous common rooms (see plan opposite); the apartments are located along straight, double-loaded corridors.

The 202 program was originally set up to support independent, fixed-income elderly persons. ACDC's scheme broke ground in proposing independent living for the *nonelderly* handicapped. The advisors to ACDC further suggested pairing individuals with complementary disabilities: a blind person without a hearing impairment, for example, could help out a deaf but sighted person, and vice versa. "HUD cost-containment policies are such that property standards established as minimums are now considered maximums," Baker observes. "The Minimum Property Standard said that the master bedroom had to be a given size but would not allow additional bedrooms to be as large. This meant that we have had to ask unrelated people [sharing one unit] to choose." (HUD relented slightly on the mix of apartments, allowing more two-bedroom units, but would not change its room size standards.) Accommodating the turning radius of wheelchairs without exceeding HUD regulations became the single greatest obstacle for the architect, however, and caused a rethinking of apartment-layout conventions. In such small spaces, Baker might have tucked the kitchen into a galley, its outside walls forming a corridor separating the more public living room from the bedrooms and bath. But by drawing together kitchens and living areas, he has instead fashioned easily navigated kitchens-cum-corridors (plan, and photos left). The openness of the design is a boon to residents, who have reinterpreted the functional plans to suit their own needs, giving the apartments a personal stamp in ways that a richer or more definitively architectural approach might have precluded. The tenants are the first to declare that this sense of independence and control over their own lives—a freedom the unimpaired population takes for granted—is profoundly important.

Fully occupied, with a lengthy waiting list, Diamond Park is unquestionably a success, and not just in bricks and mortar. HUD has reviewed its procedures and, all parties agree, is now more flexible. "We're going after all-handicapped-accessible projects," asserts McCuen. Like many housing advocates, he foresees even greater dependence on community groups as sponsors. But the length of the process and the difficulty of staying motivated and organized throughout is still a major stumbling block. Baker would work again with ACDC but has turned down commissions from other groups. "We were afraid they didn't have what it takes." *James S. Russell*



*Diamond Park  
Philadelphia, Pennsylvania*

**Architect:**  
*Cecil Baker & Associates—  
Cecil Baker, partner-in-charge;  
James Wolters, project  
architect; Kate Cleveland,  
William Cheeseman, staff*

**Engineers:**  
*Snyder Hoffman Associates,  
(mechanical/electrical);  
O'Donnell & Naccarato,  
(structural)*

**Consultants:**  
*Donald J. Reape, Urban  
Partners, (housing consultants)*  
**General contractor:**  
*Fletcher & Sons*

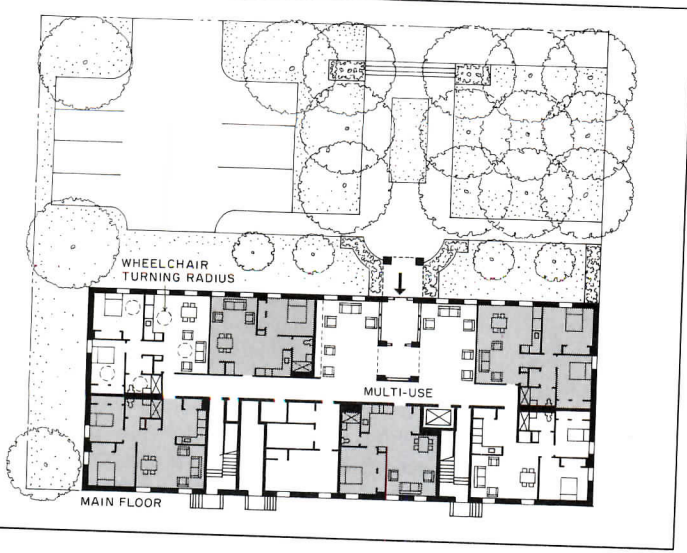



Housing for the elderly:  
Robert Shaw ECHO Village  
Austin, Texas  
Tom Hatch Architects

## A gentle echo



*In addition to the five cottages arrayed along a central commons, Robert Shaw Village for the elderly includes a larger (550-square-foot) two-bedroom house (center left in photo opposite) for a live-in manager who maintains the property and assists the householders. To give it identity, the manager's residence is oriented to the street and one of the site's peripheral off-street parking areas, but links back to the village green with a rear porch and laundry room shared by all residents. A "gateway," gazebo, and common garden complete the complex.*



In Austin, as in many other expanding communities (as recently as 1984, Austin was the fastest-growing city in the country), successive spurts of suburban growth have leapfrogged over the long-settled residential areas around the central business district. Predictably, the ensuing drain of people and money has opened these areas to decline; less predictably, their present, mostly low-income, mostly minority, residents now have mixed feelings about reversing the spiral. As architect Tom Hatch, whose client roster includes several such neighborhoods, observes, "They want to fix things up—but not too much."

The issue is no less than the inner-city neighborhoods' survival as havens of affordable housing, which is increasingly threatened by the same proximity to downtown that once contributed to their neglect. In addition to pressure from commercial interests eyeing close-in sites for development, the communities are resisting the blandishments of gentrification, which could boost housing costs—particularly for rental units—well beyond the reach of current occupants. And the Blackland area, home of the vest-pocket village for the elderly shown here, also faces inroads from the bordering University of Texas, whose pursuit of space for expansion is swallowing up houses and land by the block.

With funds coming to hand in trickles rather than a reliable flow, Blackland and other inner-city neighborhoods have found the most promising route to controlled revitalization to be infill development of new or renovated single-family detached housing, owned and managed by the community itself through a nonprofit corporation. In pursuing it, they have been abetted not only by Tom Hatch's firm, which has worked with them for the past five years, but also by Henneberger, Paup + Associates, who, having helped organize the neighborhood development corporations, continue to serve as consultants and developers.

Perhaps the most telling sign of the residents' hands-on participation is the glove-fit between housing and setting. Not only do the client/users insist on compatibility with existing dwellings, they hold firm ideas about which precedents should be honored: no "slave-quarters" board-and-batten siding or metal roofs, thank you. In Tom Hatch's sympathetic hands, client conservatism and minimal budgets have translated for the most part to a decorous '30s-bungalow style—"friendly and easy," he says, "with just a bit of edge to it"—so unassuming it takes a second glance to sort the new houses from the old.

Robert Shaw Village, which Hatch describes as the littlest PUD in Texas, exemplifies both the decorum and the timelessness. The enclave is based on the ECHO (Elder Cottage Housing Opportunity) model of compact, energy-efficient residences for old people, usually placed behind or beside an existing single-family house. Here, five one-bedroom, 440-square-foot cottages, plus a two-bedroom house for a resident manager, are instead grouped together on a single corner parcel, but they offer residents a comparable balance between the privacy and independence of living in one's own separate house and the companionship and sense of security of having watchful neighbors nearby.

In true village fashion, the tidy cottages face one another across a common green, their ample front porches providing householders an easy half step between solitude and sociability. Introduced by a freestanding gate that doubles as a mailbox shelter, the central courtyard also boasts a gazebo with adjacent barbecue pit, which has become the village social center, and a shared vegetable garden. *M. F. G.*



*A vest-pocket village of tiny cottages in a subtle update of the neighborhood's favored bungalow style houses an "extended family" of old people with fitting dignity and decorum.*

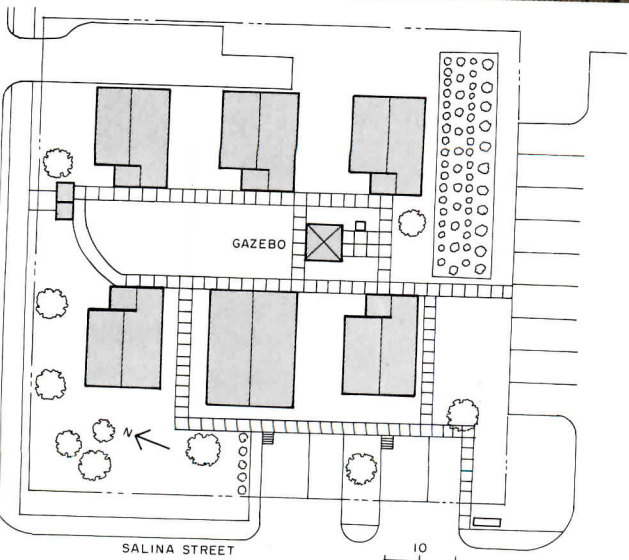



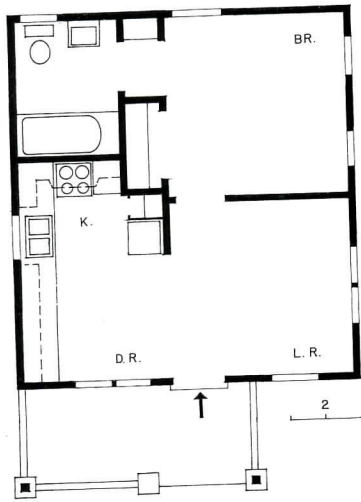

*Familiar forms and materials—trim white teardrop siding, green gabled roofs, pier-cornered front porches—root the new cottages in the old neighborhood, despite a tautness of detail that betrays their present-day provenance. Constructed on-grade for easier handicapped access, the compact but efficient houses offer their elderly residents such amenities as air cooling, wheelchair-accessible baths, and generous storage, in addition to the shared common spaces, at a cost low enough to allow rents of only \$100 a month.*

*Robert Shaw ECHO Village  
Austin, Texas*

**Owner:**  
*Blackland Neighborhood  
Development Corporation*

**Architect:**  
*Tom Hatch Architects—Tom  
Hatch, partner-in-charge; Pat  
Cornelison, project architect*

**Consultant:**  
*Henneberger, Paup +  
Associates*

**General contractor:**  
*Ash Creek Homes*







# Long-Range Forecast: Clear, Warm And Beautiful.



\* Registered Trademarks of General Electric Company.  
\* Details of limited warranty available upon request.



**LEXAN® XL Sheet:** versatile overhead glazing with unique surface protection against punishing sun and weather. Virtually unbreakable. Easily cold-formed on site. Tough, UV-resistant XL sheet—the brilliant solution for long-term weatherability in advanced architectural design. Or for added thermal insulation, specify double-laminated LEXAN THERMOCLEAR® sheet. For enduring beauty backed in writing\*—the family of high-performance LEXAN polycarbonate glazing products from GE. See Sweets Catalog 08840 GVD or GEN, or call (800) 845-0600.



Translucent LEXAN THERMOCLEAR sheet provides up to 40% better insulation than single-pane glass.



With a proprietary UV-resistant surface, LEXAN XL sheet is ideal for barrel vaults, covered walkways and skylights.

*UV surface treatment*—ensures long-term durability and weatherability without special maintenance.

*Transparent*—offers high light transmission and excellent appearance.

*Impact resistant*—250 times stronger than glass and 30 times tougher than acrylic.

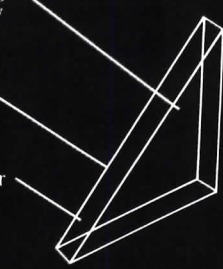

General Electric Company  
One Plastics Avenue  
Pittsfield, MA 01201

XL • MR5 • LEXGARD® LAMINATES  
LEXAN THERMOCLEAR® SHEET

Circle 50 on inquiry card



**GE Plastics**



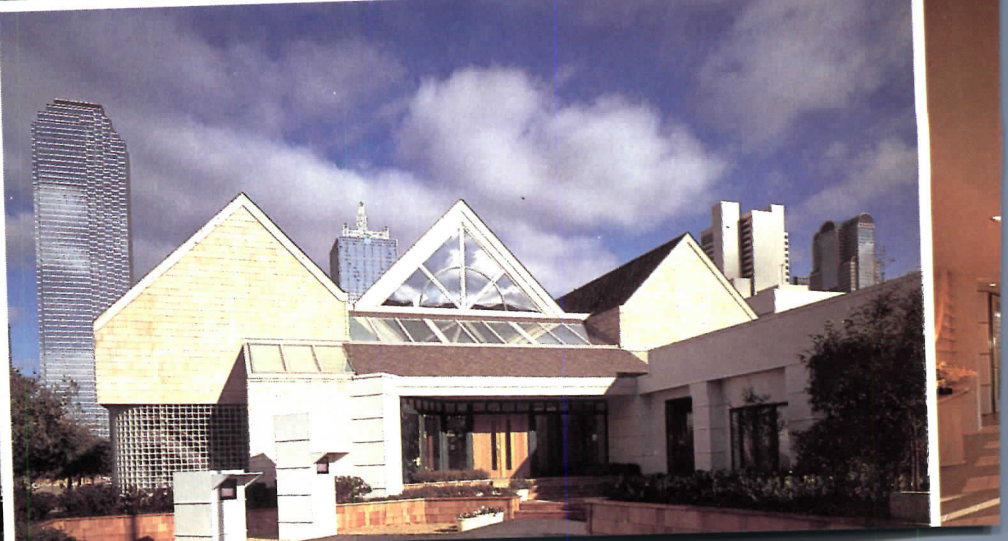
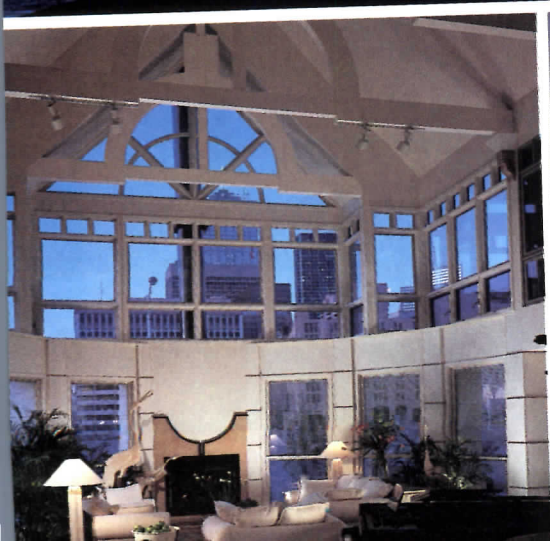



# To display all of our design ideas at NAHB, we had to redesign our booth.

For one week it was the talk of Dallas. The first ever Window Idea House from Pella—two striking stories, 4600 square-feet, and room after room of windows and doors that would enhance any residential or commercial project.

Punctuated by contemporary and post-modern themes, the architectural design included a dramatic two-story great room, a master bedroom suite with bath, two additional bedrooms with a full second bath between them, two baths on the main level, kitchen, dining room, family room, garden room and two stairwells.

But to the 38,000 builders and architects who toured the house, the highlights were Pella's innovative applications. From our new wood entry doors to 290 windows and skylights of every shape, size and style, Pella offered a stunning display of functional, decorative design ideas that maximized the use of natural light.

Architects, in particular, quickly recognized how Pella windows excel as a primary design focal point for creative and dynamic living environments. And just as important, how Pella's broad product line, unique features, and custom

capabilities signify a commitment to design freedom and customer value, today and beyond.

For more information on design opportunities with Pella products, return the coupon or call your Pella distributor today. He's listed in the Yellow Pages under "Windows." And be sure to ask for a private tour of the Pella Window Idea House via video cassette. You'll see more outstanding ideas than you've ever seen in one booth.



Please send me more information on Pella Products for commercial and residential construction.

Name \_\_\_\_\_

Company \_\_\_\_\_

Address \_\_\_\_\_

City \_\_\_\_\_

State \_\_\_\_\_ Zip \_\_\_\_\_

Telephone \_\_\_\_\_

**Mail to:** Pella Windows & Doors Commercial Division,  
Dept. T31K8A, 100 Main Street, Pella, IA 50219  
Also available throughout Canada.  
© 1988 Rolscreen Company



## Bring your designs to Pella

Pella Idea House, Dallas, TX

**Architect:** The Bloodgood Group,  
Des Moines, IA

**Interior Design:** Stephen Mead  
Associates, Des Moines, IA

**Contractor:** Heritage Display Group,  
Dallas, TX

**Project Manager:** Paul Rohrig,  
Dallas, TX

Circle 51 on inquiry card



# THE BALANCE OF POWER

## Ellison Doors Put Force In The Hands Of The People

**B**efore Ellison there was no balanced door. So the act of opening a door was a one-sided contest which invariably left people on the losing end. But rethinking the weighty principles of how a door swings changed the balance of power and put physical forces where they belong — in the hands of the user.

The solution to the problem was so widely accepted it's now taken for granted. And yet we all know the difference when opening a heavy swing door and a heavy balanced door. All things being equal, it takes half the energy to open a balanced door in a 20 mph wind. The principle at work becomes evident when the door begins to open and the hinge stile swings inward. The effect of exterior wind or interior suction is greatly diminished by this movement, rendering the door amazingly easy to open.

The balanced door is a convenience for most of us. It can represent



something much more valuable to the physically challenged.

There are other benefits of course. Ellison balanced doors save space. They move in an elliptical arc. Because travel is confined lobby space can be saved and sidewalk obstruction is reduced.

There's more. Ellison balanced doors are particularly well suited where building design requires a large or heavy door. Consider the advantage of reduced wear and tear on hardware in addition to the obvious operational benefits.

Ellison Balanced Door Long respected for their custom craftsmanship in bronze and stainless steel are now available in economical aluminum designs. Call or write us for more information on the doors that put power in the hands of the people.

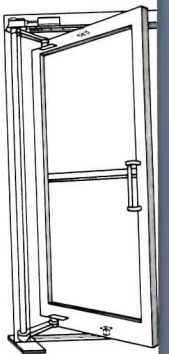

### ellison

Ellison Bronze Co., Inc.

125 West Main Street • Falconer, New York 14733  
716-665-6522

Circle 52 on inquiry card



Just a few  
months ago,  
computers this powerful  
were tracking  
planetary movements,  
pondering  
quantum physics  
and building  
rockets.





Now they're taking





# care of business, too.

**Introducing the COMPAQ DESKPRO 386/20e. 20-MHz 386 performance designed to fit the increasingly sophisticated needs of 286 users.**

People who work with 386 personal computers used to be called rocket scientists. Now they're also called accountants, engineers, managers and CEO's. Thanks to the new COMPAQ DESKPRO 386/20e.

It delivers 386 power to people whose demanding needs have outgrown the capabilities of their 286 PC's. Better yet, it packs all this power

into a design that fits neatly on your credenza.

Start with speed. Everything in the new COMPAQ

DESKPRO 386/20e is optimized to go faster.

Its 20-MHz Intel 386™ microprocessor with cache memory is surrounded by the exclusive COMPAQ Flexible Advanced Systems (Flex) Architecture. This high-speed combination runs the world's largest library of software 25% faster than non-cache 20-MHz 386-based PC's. And 50% faster than non-cache 16-MHz 386-based PC's.

Its optimized 32-bit design also enables you to take full advantage of powerful 386 software and

multitasking operating systems such as Microsoft® Windows/386, MS® OS/2, XENIX® and UNIX.

You'll find that a long list of high-performance features is built in. One megabyte of memory. Sharp, high-speed VGA graphics. Support for 5¼" and 3½" diskette drives. And standard interfaces to connect a printer, mouse and communications devices.

Of course you have growth potential. Five expansion slots are available: four for a network card, mainframe communications board, modem or other devices, and one high-speed 32-bit slot that allows you to expand memory up to 16 megabytes.

You have options, too. There's room to add two high-speed fixed disk drives, with 110 or 40 megabytes of storage. You can choose a 135- or 40-megabyte tape backup. Or match the number-crunching power of a dedicated engineering workstation by adding a powerful Intel 387™ or Weitek 3167 coprocessor.

With its integrated design and performance, the COMPAQ DESKPRO 386/20e represents the ultimate space vehicle.

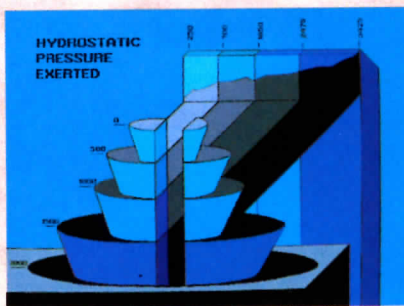

*High-speed VGA graphics are built in.*

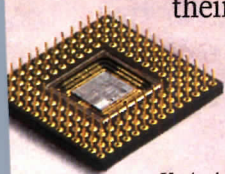

*You're in business with a 20-MHz 386 microprocessor.*

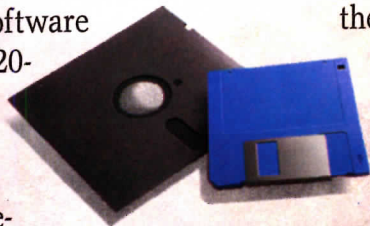

*Choose 5¼" and 3½" diskette drives.*

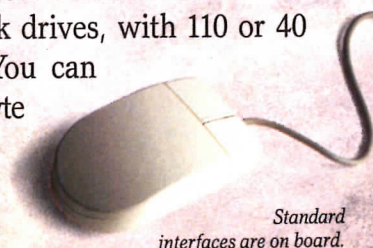

*Standard interfaces are on board.*

## COMPAQ

It simply works better.



# Compaq makes high performance everybody's business.



COMPAQ DESKPRO 386 s

COMPAQ DESKPRO 386/20e

COMPAQ DESKPRO 386/25

Whether you use a personal computer for launching rockets or corporate acquisitions, Compaq delivers the highest-performing solution.

For those who want everything, now, the COMPAQ DESKPRO 386/25 is the most powerful PC available. For growing performance requirements, the new COMPAQ DESKPRO 386/20e is a move into the power structure. And for users considering 286 PC's, the COMPAQ DESKPRO 386s is an affordable route to the fast track.

These PC's are simply the highest-performing in the world. That's one reason PC experts rate COMPAQ highest overall. And why for the past four years COMPAQ has been added by more FORTUNE 1000 corporations than any other brand.

To make this performance part of your business, call 1-800-231-0900, Operator 70. In Canada, call 1-800-263-5868, Operator 70. We'll give you the location of your nearest Authorized COMPAQ Computer Dealer and a free brochure.

COMPAQ® is a trademark of Compaq Computer Corporation. Intel® Intel 386 and Intel 387 are trademarks of Intel Corporation. Microsoft®, MS® and XENIX® are trademarks of Microsoft Corporation. MS® Windows/386 and MS® OS/2 are products of Microsoft Corporation. Product names mentioned herein may be trademarks and/or registered trademarks of their respective companies.  
\*Registered U.S. Patent and Trademark Office. COMPAQ DESKPRO 386/25 graphics ©1988 Accent Software, Inc. ©1988 Compaq Computer Corporation. All rights reserved.

## COMPAQ

It simply works better.



DESIGN YOUR FLOOR WITH  
FLEXCO'S SPEC 1™ SYSTEM AND ALL  
THE PIECES FALL INTO PLACE.

Flexco just made your job easier. Because now, with the Spec 1 system, you can actually see the floor you're designing before you install it. In fact, you can see several flooring variations—all in a matter of minutes.

The Spec 1 flooring system from Flexco contains a supply of one-inch tiles in more than 25 exciting colors, and several styles and textures, plus a large grid on which to build your floors. You choose the colors you want—in the styles you want—to create endless floor design possibilities. As a result, Spec 1 system not only helps you design better, more applicable flooring solutions but it makes it a lot easier to sell those designs to your clients.

Order Spec 1 through your participating Flexco distributor. Or, for more information, call 1-800-633-3151 or write Flexco, P.O. Box 81368, Atlanta, GA 30366.



FLEXCO

WORKING FLOORS FOR THE WORKING ENVIRONMENT.

Circle 53 on inquiry card



# Why VersaCAD?

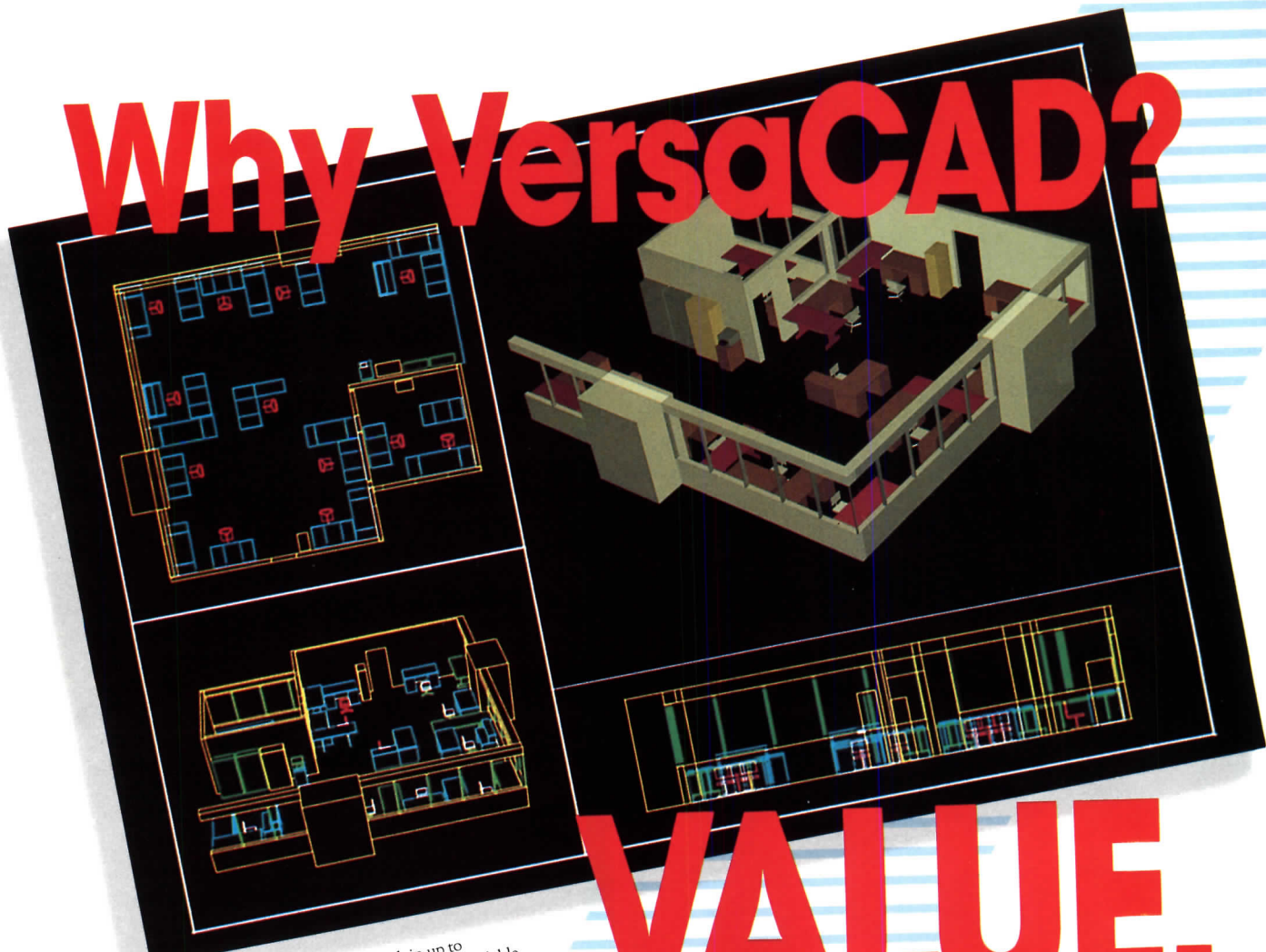

Multiple 3D viewports let you work in up to 16 views at once. Programmable template available for automated architectural design.

# VALUE.

- 1. Everything you need.** VersaCAD® DESIGN integrates 2D drafting, true 3D with color shading on any screen, bill of materials and universal translators. No need to buy extra-cost add-ons.
- 2. Aggressive pricing.** VersaCAD value includes affordable site licenses that grow with your company. Quantity discounts. Low-cost upgrades. They stretch your design power, not your budget.
- 3. Total support.** The industry's most respected technical support staff is just a phone call away. You can always get direct help from the experts, no matter what your question.
- 4. Fast productivity.** VersaCAD is consistently ranked the easiest to learn of the full-scale CAD systems. And our CAD programming language works just like BASIC. So you can do it yourself.
- 5. Use all your computers.** VersaCAD runs on MS-DOS, Macintosh and UNIX platforms, with complete drawing transfer. Plus proven 2D/3D IGES and DXF translators, all built into the system.

And every VersaCAD system is backed by the strength of Prime Computer, Inc., one of the two largest CAD companies in the world.

Find out why 60,000 users have committed to VersaCAD value. See your authorized dealer today, or call Customer Service at (714) 960-7720.

**VERSACAD®**  
*Design*  
The Total Design Solution

**"Top Value Rating"**  
— Infoworld

Versacad Corporation, 2124 Main Street, Huntington Beach, CA 92648  
A Company of Prime Computer, Inc.

Circle 54 on inquiry card



# Software reviews for architects

By Steven S. Ross

## Drawbase 105

Versatile 2-D/3-D layer-based CADD software with excellent database facilities, a good command language that allows easy customizing by users, and a wealth of on-screen drawing tools. Drawbase runs successfully on computers as small as the old IBM XT and compatibles, but requires a digitizing tablet to routinely access its multitude of commands. A versatile shading program is built-in (although 3-D shading and shading with hidden-line removal is a \$495 extra). Views in 3-D are 1-, 2-, and 3-point perspective,

orthographic, and axonometric. Drawbase is capable of true 3-D. That is, changing something in the 2-D view will automatically change the 3-D. It will also update the underlying database. And users can walk around (or through) a 3-D view.

**Equipment required:** IBM XT, AT, PS/2 or compatible; also runs on the HP VECTRA (a near-compatible), 640K, PC-DOS or MS-DOS 3.1 or higher, hard disk, coprocessor chip (8087, 80287, 80387), 12- by 18-inch digitizing tablet (strongly recommended; a 12 by 12 will not work) or Logitech C7 mouse, parallel port (for security device). The program files take up about 5 megabytes on disk, and drawing files (with their associated databases) can run 100 kilobytes or more, each. That means a 20 megabyte disk is about the minimum.

Accepts input directly from Calcomp, Numonics, or GTCO E-size digitizers as well, even with tablet also installed. Handles CGA, PGC, VGA, IBM VGA 514A, Image Manager 1024, Verticom H16 or M16, Artist 10, Pepper, Imagraph, or Hercules

Mr. Ross is a prominent computer consultant and a regular contributor to RECORD.

monochrome graphics boards.

Graphics output can be to plotters similar to the Calcomp 1043 (960 or PCI format), Houston Instruments DMP-42, or any Hewlett-Packard (HPGL) system. Data can be picked up directly by most word-processing software, or printed through an HP laser printer or any printer using Epson/IBM control codes. **Vendor:** SKOK Systems, Inc., 222 Third St., Cambridge, Mass. 02142. 617/868-6003, 800/CAL-SKOK. Prices (including 30 days service): 2-D, \$1,995; 2-D and 3-D, \$2,995; 2-D and database, \$3,995; 2-D, 3-D, and database, \$4,995. Service contract, \$50 per month. Drawbase SHADE, \$495.

### Summary

**Manual:** Good command reference manual, fair tutorial (an improved version was due as this issue went to press), inadequate installation instructions (see below). Some useful information on the command language and on equipment configurations is included only in text files that must be printed out by the user. Little guidance on using 3-D commands.

**Ease of use:** Good for so versatile a package. A large digitizing tablet (and the supplied overlay) is all but mandatory, however. There is an on-screen menu system (invoked with the ALT-F9 key combination), but it is cumbersome and not at all intuitive. The PAN command is within Zoom controls, for instance, and the Librarian commands refer to storing and saving the main drawings, not the libraries of standard symbols. Frequently used command sequences can be programmed into the function keys to get around the menu. Hitting the F1 key brings up the help system's directory. The system is not context-sensitive (that is, it does not sense what one might need help about), but is fairly easy to move around in.

Top: The command line at the bottom of the screen is best for entering coordinates. Use the menu or the digitizer for commands. Bottom: On-line help is voluminous. Sub-menu will bring forth several hundred words of text.

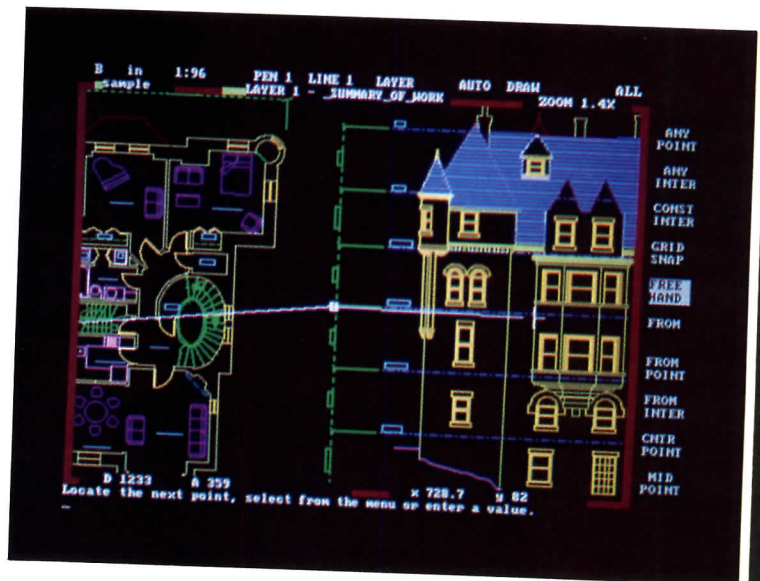

Most commands that take a long time to execute can take place in the background while executing common commands such as pans, zooms, and area calculations. There are lots of nice touches, like automatic cleanup of wall intersections—including nonperpendicular walls. Even the hatching updates properly when objects are stretched.

**Error-trapping:** Good. It is difficult to lose a drawing. In fact, Drawbase automatically backs up the files of a drawing into a temporary file *before* one can start working on it. This essentially guarantees there will

be room for the day's work when it is saved back to disk. It is fairly easy to move backward, "undoing" unwanted changes to drawings. (The command is EraseLastElement; repeating it removes the elements in the reverse order in which they were placed.) Error messages are cryptic, but intelligible if the reference manual has been read. The five files that make up each drawing can be collapsed into one for merging into other drawings.

The underlying database updates automatically as the drawing evolves. As with most

*Continued on page 137*



# New... SuperProject Software What The Experts Have To Say:

**"Just Released for OS/2—  
SuperProject Expert/2"**

**Aerospace:** "SuperProject is the best. Earned Value Reporting and Work Breakdown Summarization give me complete project control and the graphics make impressive presentations." Barry Feeley, Technical Manager, Ford Aerospace.

**Construction:** "The familiar SuperCalc® and 1-2-3 menu system makes it really easy to learn and use. It handles multiple projects, networking and flexible

report writing. The multiple resource calendars and histograms manage resources very efficiently." Ted Ritter, CEO, O'Connor Construction Co.

**Data Processing:** "The Outliner allows me to quickly sketch critical schedules from the top down. Expert is way ahead of the pack." D.W. Nesper, Regional Consulting Manager, Wang Labs.

The SuperProject® Family—Plus, Expert and Expert/2—is the most advanced PC project management software available. The smallest to the largest and most complex projects imaginable are easily handled thanks to its virtual memory management skills.

Newly released SuperProject Expert/2 running under OS/2, gives you true multitasking. For example, this enables you to enter data in the foreground while outputting a report in the background.

And only Computer Associates gives you PC and mainframe project management. Develop your project planning on a PC and then upload to a mainframe with CA-PLANLINKS™. You can then consolidate that project with others via CA-TELLAPLAN™ and take advantage of its resource pooling and presentation graphics.



## The SuperProject Series

FEATURES	SUPERPROJECT		
	PLUS	EXPERT	EXPERT/2
PERT, Gantt Diagram w/CPM	Yes	Yes	Yes
Outline/Work Breakdown Chart	Yes	Yes	Yes
Resource Histogram	Yes	Yes	Yes
Resource Leveling	Yes	Yes	Yes
Tasks Per Project (Max)	1,560	1,560	Unlimited
Mainframe Link	Yes	Yes	Yes
Calendars	Yes	Yes	Yes
Export/Import (Partial or All)	Yes <sup>1</sup>	Yes	Yes
Multi-Project Resource Pooling		Yes	Yes
Built-In Graphics Output		Yes	Yes
Networking		Yes	Yes <sup>2</sup>
Plotter Support		Yes	Yes
Multitasking			Yes

<sup>1</sup>Exporting only    <sup>2</sup>When LAN Mgr. is available

For your free demo diskette or more information, call 800-533-2070 (Ad 57310) In Canada: 1-800-663-6904

Computer Associates  
1240 McKay Drive, San Jose, CA 95131

© 1988 Computer Associates International, Inc.

**COMPUTER ASSOCIATES™**  
Software superior by design.

- World's leading independent software company.
- Broad range of integrated business and data processing software for mainframe, mid-range and micro computers.
- Worldwide service and support network of more than 70 offices.

Accounting • Spreadsheets • RDBMS • Graphics • Project Management • Resource & Operations Management

Circle 55 on inquiry card



Top: Cursor traces create an annoying clutter on Paradise EGA display, staying on the screen until the user specifies a redraw, usually with the DISPLAY ALL command.

function. Here, the editor option is being used to change the AUTOEXEC.BAT file created by Drawbase during installation.

Bottom: "Editor" option opens the door to a powerful database

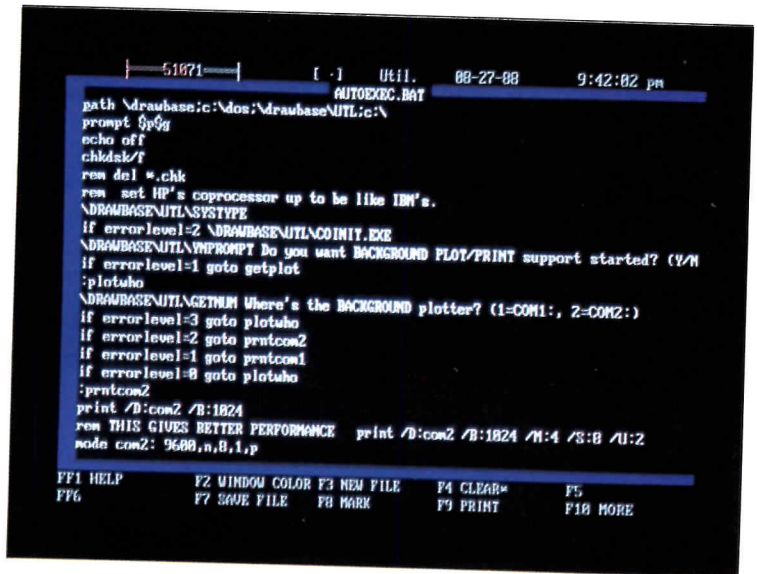
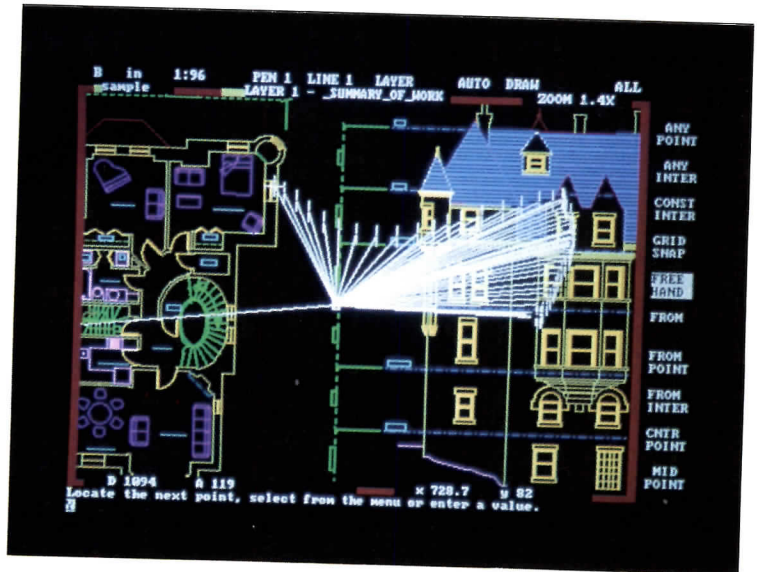

makes a mouse or tablet work. It placed that software in a subdirectory of drive D, but assumed it was on C as well. The mouse, therefore, did not work until we manually rewrote the CONFIG file.

The installation program also wrote a new AUTOEXEC.BAT file, which it was supposed to use in place of the existing one. But instead of placing the file in the root directory of drive C, Drawbase put the new AUTOEXEC file in its own subdirectory on drive D. Users could start Drawbase by going to drive D, changing directories to the Drawbase subdirectory,

typing AUTOEXEC, then typing DRAWBASE. But that could have all been included in a file called DB.BAT that the installation program creates, but that bypasses the AUTOEXEC file on drive D. Get it? Easy for one thoroughly familiar with DOS. Impenetrable, if not, although the extra twist of handling both the CONFIG and the AUTOEXEC file wrong—but wrong in different ways—may be unique.

Drawbase puts drawings up on the screen—even a simple Hercules or EGA screen—quickly. There is also provision

develop its own programming expertise, or have such expertise on call. Part of the reason is that the community of third-party developers for Drawbase, among architects, is small. Also, Drawbase lends itself to special situations. It can accept or produce raw data in mainframe formats such as comma-separated values, for instance (that is, with data points separated by commas instead of spaces or tabs). The number of people who use such capabilities is not large, but for those in an office that needs such data because they're working with an engineering group or because scheduling information is voluminous, Drawbase may be particularly attractive.

Another example: the six supplied fonts are adequate for most purposes. But for those who want different ones, edit them with the font editor that's included.

The expertise a user needs starts with the installation. Earlier versions of Drawbase had to be installed on drive C. This version is advertised as being installable on any drive. It is, but it can't be installed by following the manual. When we tried to install Drawbase on a 40-megabyte drive partitioned as a small C drive (holding DOS) and a large D drive (holding everything else), Drawbase correctly located its program files on drive D.

Drawbase placed its own CONFIG.SYS file on drive C, replacing (and renaming) the original CONFIG.SYS file that contained the special instructions allowing DOS to recognize the D drive in the first place. If the computer had been rebooted at that point, the user would have had some difficulty putting everything back together. The installation program should have merely added its instructions to the existing CONFIG.SYS file. The Drawbase CONFIG.SYS file activates the software that

CADD software for personal computers, however, changing data types or lengths of allowable descriptions in the database can cause problems. Estimate a price (for a window type, for instance) as a whole number integer value, and then change the data type to reflect a dollars-and-cents amount. The software may be unable to calculate the total cost by multiplying the number of windows by the price.

An object or group of objects can be moved from one layer to another with a single command. The software checks to make sure that objects only exist on one layer at a time, preserving the integrity of the underlying database. Reports can be derived from any databases on the disk—even those associated with separate drawings that may not be active (or updated to reflect changes). But users savvy enough to do that are probably savvy enough to do it right.

Drawbase Version 105 is a competent package for producing drawings, and an excellent one for associating data with those drawings. Need to work on something at home or at a client's office? Want to use a low, cheap machine for training, or in an emergency? Take your drawing files and the Drawbase security lock with you, and you can run the software on an IBM AT clone with hard disk, mouse, and Hercules monochrome graphics—a mere \$1,300 to \$1,500 worth of equipment.

Worried about compatibility with more widely used software, such as AutoCAD and PersaCAD? Drawbase has an excellent module for converting files to and from the DXF standard. The conversion deserves much of the underlying database—the list of items in the drawing—in a useful, structured format. To take advantage of all of the versatility, however, an architect's office will have to



Canon

Boardcopier A-1

*It's a whiteboard.  
And a copier.  
It's the perfect combination  
to improve your next meeting!!*

Canon's Boardcopier lets you create presentation materials on the spot. Whatever you write, draw or place on the board is transformed into clean, professional-looking letter-size copies instantly, at the touch of a button. And because the Boardcopier is actually two convenient products in one—an electronic whiteboard and a personal copier—you can also operate each component separately. Alone or together, it all adds up to the perfect combination for a successful meeting.



# Canon

## Boardcopier A-1

*Limited offer*

© 1988 Canon U.S.A., Inc.



Snappy S

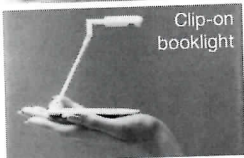

Clip-on booklight

Just complete and mail coupon. You'll be contacted for a demonstration plus FREE clip-on booklight without obligation. Purchase a Boardcopier, and you'll receive a Canon Snappy S camera, FREE!\* But hurry—offer expires 12/31/88.

Offer void where prohibited. Available at participating dealers only. Request must be postmarked before January 31, 1989. \*For requirements contact your local participating dealer.

Name \_\_\_\_\_ Company \_\_\_\_\_

Address \_\_\_\_\_

City \_\_\_\_\_ State \_\_\_\_\_

Zip \_\_\_\_\_ Phone \_\_\_\_\_

Mail coupon to: Canon USA, Inc., c/o Canon Response Center, 1825 Chicago Avenue, Minneapolis, MN 55404



*Drawbase is a competent package for producing drawings, and an excellent one for associating data with these drawings.*

for many dual-screen arrangements, with the drawing on one screen and the underlying data on another. That turned out to be particularly important when we used the software with a Paradise AutoSwitch EGA card; screens quickly got cluttered with cursor movements and other extraneous material. The Paradise card is not one of those certified as working with Drawbase. Either it or Drawbase is nonstandard enough to cause the problem.

The DISPLAY ALL command redraws the whole screen. Various other Display options can be used to reduce redraw time even more, by forcing a redraw only of a section or specific layer. Redraw commands are used often enough that a function-key combination such as CTRL-F10 should be assigned to one or two of them.

Drawbase has a particularly easy system for creating forms (data sheets) for attaching attributes to drawings. Simply select the Form Window command, then select the Add New Form option. At this point, Drawbase's architectural pedigree shows, a form can be attached to an entire space, a floor, a room, or a building. Type PACES to describe the form, and accept the message to "append attribute" to the drawing by hitting the INS (insert) key. Next, select the kinds of attributes wanted from a long list—area, perimeter, lighting, doors, windows, project name, and so forth—or add to the list.

Up to 50 attributes can be usually connected to any object in the drawing. The list can be any length; 200 didn't slow Drawbase down. Technical support says it begins to get sluggish at 500. There can be up to 100 lists in a drawing, and up to 32,767 database records.

Attributes can be transferred to other software, such as Lotus 3. SKOK, for instance, has

experimented with moving data from Drawbase into Paradox, a standard database package. Paradox could, in turn, be used to write a facilities management program, or other applications. The database can also be edited globally (to change a labor cost, for instance) from inside the drawing (Drawbase has its own word processor built in) or outside.

Handling of units and tolerances is intuitive. Users set a tolerance for any measure. Dual units can be attached to a drawing—metric and English, for instance, with drawings up to about 17,000 units wide. A drawing can be dimensioned in inches, then redimensioned in millimeters with all displayed dimensions and tolerances recalculated automatically.

Nine types of lines can appear on screen, offering different widths and dash patterns. Thus, drawings can be set up for plotting fairly close to the way they appear on the computer. Users can assign an on-screen color to a given pen in a plotter carousel, too. Color (not only hue, but also saturation) can be changed in a 3-D model even after it has been shaded—a great time-saver. Any view (shaded or wireframe) can be saved as a "slide." Slides can be played back in groups for presentations, with automatic intervals or outright pauses between views.

There are four standard hatch patterns, including one that simulates brick. Users can create their own patterns by writing command macros. The macros, in turn, can be attached to a single command key or to a single "button" (area on the digitizing tablet). Macros can also be combined into entire programs.

## Stepping Out II

A screen-extender program for the Macintosh, ideal for presentations. It allows users to zoom a section of an original drawing to 16 times the original on-screen size, or reduce a drawing to one-fourth original size. The effect is one of seeing the original screen greatly enlarged, through a "window" or magnifying glass consisting of the physical Mac screen. This "window" can be moved over any part of the original screen. *Equipment required:* Macintosh Plus, SE, or II, System 4.1 or higher, Finder 5.5 or higher. Works with Multifinder. Because the software stores the screen image in memory, zooming to really huge screens requires huge amounts of RAM.

Doubling the virtual screen size requires roughly an extra 200K for a monochrome image. Does not work with large 24-bit color monitors for the Mac II. Does not work with common screen-saver programs such as AutoBlack (which dims the screen after a short period of non-use, to keep the phosphors from burning out).

*Vendor:* Berkeley System Design, Inc., 1700 Shattuck Ave., Berkeley, Calif. 94709. 415/540-5536. \$95.

### Summary

*Manual:* Concise and to the point.

*Ease-of-use:* Flawless. It is easy to install (transfer the Stepping Out II icon to your system folder), easy to invoke (at any point in your presentation, go to the apple on the menu bar, choose the Control Panel, and move to the Stepping Out II icon). It is easy to change screen sizes (bring up the menu and choose one of seven preset sizes, or create a new size of your own).

*Error-trapping:* The only warning that memory is running short is that screen-scrolling

slows down. Because Stepping Out II works only in RAM, it cannot change or damage disk files containing drawings. Sometimes, the original software (such as VersaCAD) can't be used to change screen size while Stepping Out II is engaged. Setting the control panel to automatically engage Stepping Out II before starting VersaCAD did not work—it froze the system with no warning. Start VersaCAD, then invoke Stepping Out II.

Say you're making a presentation to a client who has a Macintosh, and your designs were done on a Macintosh. But to play your designs back, the client needs a hard disk to hold your CADD software. And the drawings, with their underlying data, are huge and sluggish on the screen. What to do?

Convert the drawing files to a PICT format, and play them back to the client with a simple program such as MacDraft. Use Stepping Out II to zoom in on specific details.

You can even make changes on the screen and save the new art. Sections along the screen edge can remain normal size and fixed, leaving menu tools available for use. The menu bar at the top of the screen always stays normal size.

Or perhaps you are designing a poster or other large-page text output with a word processing program. Use Stepping Out II to reduce the image so all of it fits onto the screen at once, to check the layout. The reduction allowable is to 25 percent of original size on a monochrome monitor, 50 percent on a color monitor.

Apple never standardized add-on big screens for the Plus and SE, so not all of them work with Stepping Out II.



“ The DPIC education program has caused us to do continuing education, at the most basic contract level, that we probably wouldn't have gotten around to doing as a whole group. There may have been a person here or there that would have been enthusiastic about it, but their premium credit program requires all partners and technical staff to participate and take the exams. So, without the program, I think it would have been unlikely we would have gotten 100% participation. But because it is required, we do get it. In fact, we are considering making the DPIC tests, including reading the book, a requirement for all staff.

I can't imagine anybody not participating in the educational program, because of the cost savings aspect of it. I mean, let alone the fact that it can help your practice.

I think we've saved on the order of \$30,000 over two or three years. We've found DPIC's premiums, with and without the education program, to be generally competitive, so we do regard it as a savings.

You might find another carrier that could provide the same insurance for that net amount. But I think DPIC has been conscientious, in not saying, 'OK, we'll lower our price and forget about the educational program', and I think that speaks well for them. ”

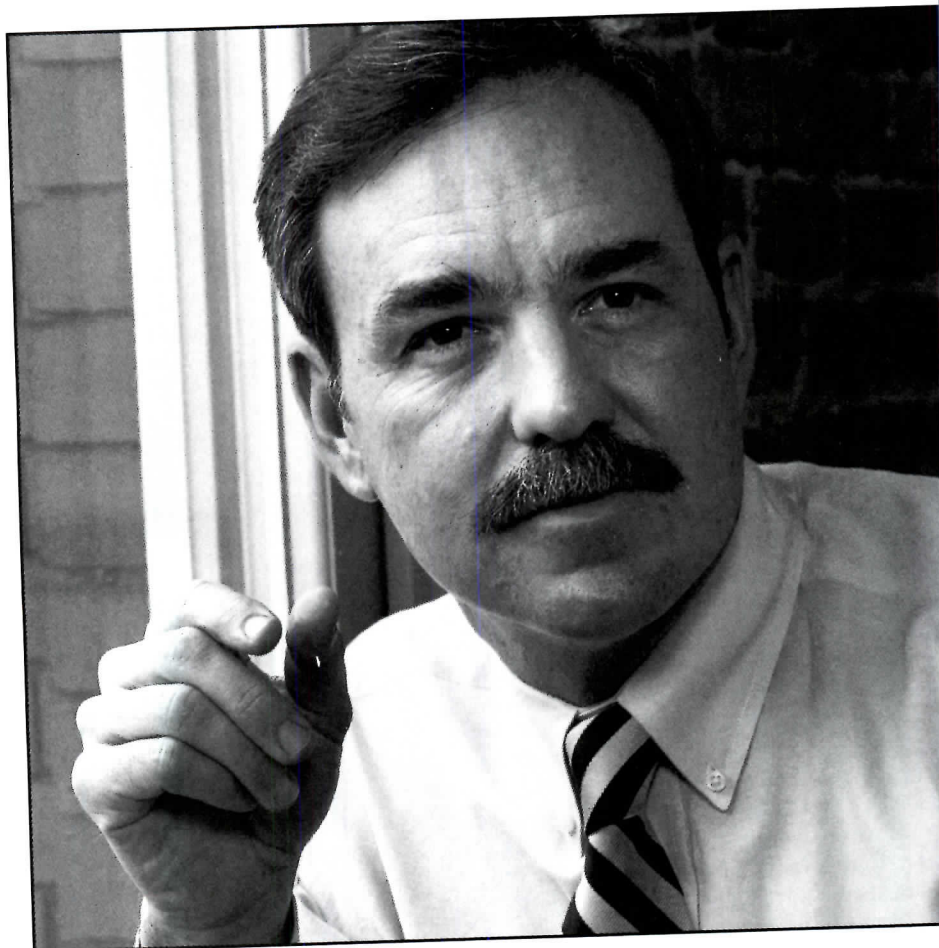

*Jack Corgan is a principal of Corgan Associates Architects, a 65-person firm based in Dallas, Texas. He is also a former Assistant Professor of Architecture at Oklahoma State University. We value our relationship with his firm, and thank him for his willingness to talk to you about us.*

Professional Liability Insurance  
For Design Professionals

**DPIC COMPANIES**



Design Professionals Insurance Company • Security Insurance Company of Hartford  
The Connecticut Indemnity Company  
Available through an exclusive network of independent agents. Please call  
1-800-682-3400 (in California) or 1-800-227-4284 for the agent serving your area.

2959 Monterey-Salinas Highway, Monterey, California 93942

Circle 57 on inquiry card



# Sherwin-Williams introduces assorted chocolates.

Would a sprinkling of Coco sweeten your next design? Or maybe a gallon of Belgian Chocolate top it off better?

Ask Sherwin-Williams. About our new ColorAnswers system. And get tomorrow's color answers to today's design questions.

From Carob Brown to Fudge Bar, ColorAnswers is over 800 of today's freshest colors. Tinted neutrals. Clear pastels. Refined deep-tones. The colors today's architects and designers are specifying.

ColorAnswers is more than just the newest colors from the leader in the paint industry. It's a compact, convenient, and easy-to-use system.

Just select your color from the fan deck. Note the color's name and number. Find that color on the tab dividers in the color case. Then just pull out the swatch—a large, easy-to-work-with, 3<sup>5</sup>/<sub>8</sub>" x 4<sup>1</sup>/<sub>4</sub>" sample

that works for everything from pencil concepts to final elevations and paint color specifications.

Call now for more information on Sherwin-Williams ColorAnswers. 1-800-321-8194. (In Ohio, 1-800-362-0903.)



## With our new ColorAnswers™ system.



Ask Sherwin-Williams for ColorAnswers.



# New products: New York Design Shows

*Design New York/Designer's Saturday/Fall Market—by any name, it happened October 5 through 8. We illustrate some of the more notable products introduced at these events.*

## 1. Separate tables

In 1985, Howe Furniture commissioned engineer/designer Niels Diffrient to examine both the form and function of its folding tables, widely used in corporate, institutional, and hospitality interiors. The result: a reinvention of this type of table, according to Howe, with improvements that added neither cost nor complexity. The new push-button folding mechanism locks the legs either upright or folded against the table top. Plastic base end caps reflect the detail of the table corners; top options pictured include oak veneer with a solid wood edge and laminate with a polyurethane cushion edge. Howe Furniture Corp., Trumbull, Conn.

*Circle 300 on reader service card*

## 2. Supporting cast

Herman Miller expanded the Ethospace system with work and coat cabinets designed by Geoff Hollington and Jean Beirise. Ranging from 38 to 70 in. high, the slab-sided units may be freestanding or structurally attached to partial-height system panels. When framed, they work as return walls, lowering the cost of a workstation. Herman Miller, Inc., Zeeland, Mich.

*Circle 301 on reader service card*

## 3. Perfect posture

Part of Unifor's inaugural collection at the IDCNY was Aldo Rossi's Milano Chair for Molteni. The light-scaled chair, available in walnut and red or black lacquer, has curved back splines that pass through the seat slats. Unifor Inc., Long Island City, N. Y.

*Circle 302 on reader service card*

## 4. Dual purpose

This suspended version of the Mikado low-voltage light acts as both sculpture and lighting fixture. Rods with MR16 bulbs may be placed like Pick-Up-Sticks at any position between powered aluminum extrusions connected to a remote transformer. Design: F. A. Porsche. Artemide Litech, Farmingdale, N. Y.

*Circle 303 on reader service card*

## 5. Power to the desk

The Quest office system is based on the desk, not the panel: gable-end supports and structural metal raceways fit together to form a freestanding unit, which in turn carries acoustical privacy screens and snap-on finished modular components. Quest was designed by James Hayward. Kinetics, Rexdale, Ont.

*Circle 304 on reader service card*

## 6. Scaled down

Less monumental than the manufacturer's Onda seating, the Ondina Series by De Pas, D'Urbino, and Lomazzi uses a continuously curved tubular stainless-steel frame to hold seat and back cushions. International Contract Furnishings, Inc., New York City.

*Circle 305 on reader service card*

## 7. Contemporary wood

Calvin Morgan based the design of the Acanthus chair and tables on the geometric configuration of a circle meeting a square. The simple shapes, in either cherry or walnut, can be stained to match all Stow & Davis finish colors. Stow & Davis, Kentwood, Mich.

*Circle 306 on reader service card*

## 8. Objet d'art

Part of a numbered, limited-edition accessory collection from Gunlocke, Terrance Hunt's Spring Table has black, splatter-painted springs that appear to pass through a bird's-eye-maple top. A black leather-wrapped pyramid seems to balance the table like a seesaw. The Gunlocke Co., Wayland, N. Y.

*Circle 307 on reader service card*

*More products on page 145*





*For more information,  
circle item numbers on  
Reader Service Card*

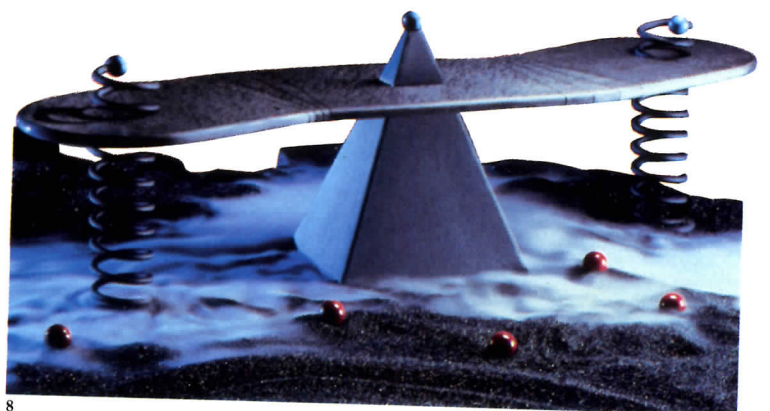
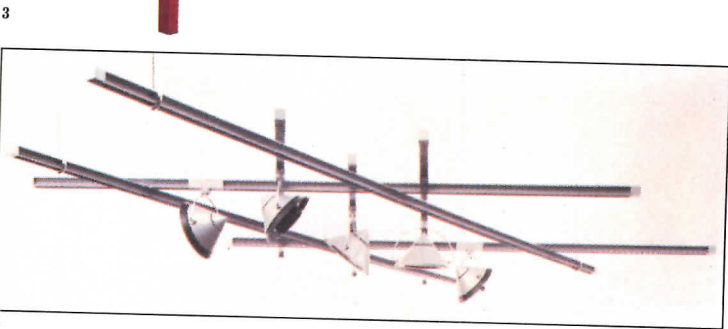



© TEFLON is a registered trademark of DuPont. Only DuPont makes TEFLON.



**Teflon® protects  
dots from dashes.**

**Protect fabric aesthetics—and  
reduce costly maintenance—with  
Teflon® soil and stain repellent.**

It's the fabric finish that helps keep upholstery, wall coverings and draperies looking better, longer.

Teflon® protects against wet or oily spills, dust and dry soil. It may be used on virtually any fabric—even silks and velvets—without affecting the hand. Making a wider range of fabrics and colors more practical.

Specify Teflon® at the design stage. At any point during manufacturing. Or, after interiors are completed. You're assured of quality, because

fabrics treated with Teflon® are tested to make sure they meet DuPont standards.

So help keep replacement and maintenance costs to a minimum, while maximizing design possibilities. Treat it with Teflon®. And keep your dots looking dashing. For more information, call (302) 774-0027.

Fabric by DesignTex.

**TEFLON®**  
DU PONT SOIL & STAIN REPELLENT

DESIGNED FOR THE  
CONTRACT ENVIRONMENT

**DU PONT**  
REG. U.S. PAT. & TM. OFF.



For more information,  
circle item numbers on  
Reader Service Card

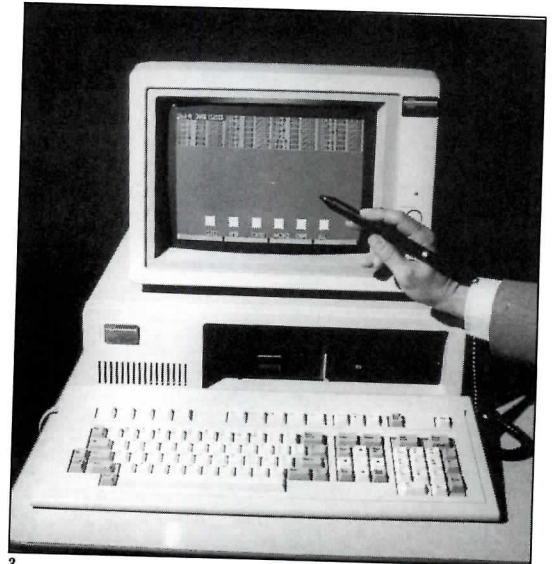
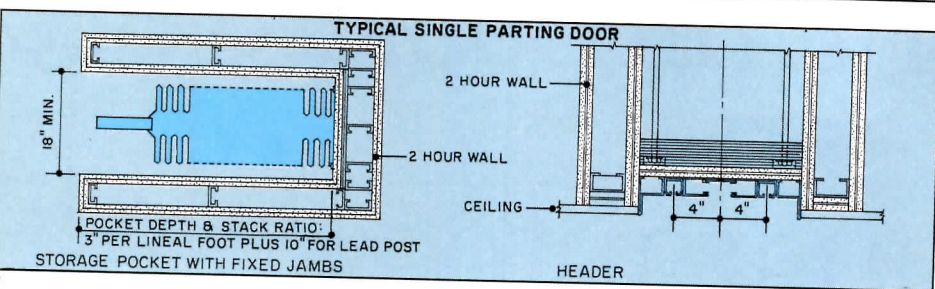

3



4

**Accordion-type fire doors**  
New central-station computer-control equipment and recent NFPA, BOCA, and other code revisions have extended the application of double-panel steel folding doors as area- and occupancy-separation fire doors. The FireGuard horizontal sliding fire door has been approved by the Council of American Building Officials for use in place of side-hinged swinging doors as elevator-lobby separation in high-rise buildings (1). Installation of folding fire doors can reduce the amount of loop corridor space needed to provide protected access to the two fire exits

required by code on each tenant floor. They can also convert some atrium spaces into vertical openings, meeting the required fire separation between adjacent spaces without sprinklers. FireGuard doors provide wide-span separation of mixed-use occupancies, with no practical limitation as to the length of the folding partition, according to UL evaluation of the door.

Doors fold compactly in wall pockets (2), with a stack ratio of 3 in. per linear ft for the 1 1/2-hour door. Made with hinged, insulated steel panels suspended on ball-bearing rollers, the FireGuard hangs

from parallel tracks. Doors can adapt to curves with a minimum radius of 10 ft.

A central-control computer shows the position and operating status of each door in the system, as well as the condition of all back-up DC batteries (3). Office building personnel can electromagnetically lock these doors at night to prevent the loss of heated air from tenant spaces through elevator shafts, and to upgrade the security of the elevator lobbies. Off-hours workers need a key to enter, signaling the central unit that the door is open. But any hazard that activates the fire/smoke

alarm instantly releases the electronic lock, permitting manual use of the panic hardware.

Vertical hardware requires only a slight bump—3 lb of pressure—to open the power-operated door (4). The Life Safety standards of NFPA 101, as well as the major building codes, now permit use of the FireGuard as a smoke barrier and horizontal exit in health-care facilities, as well as an exit from space when the rated occupancy is under 50. Won-Door Corp., Salt Lake City.

Circle 308 on reader service card  
More products on page 146



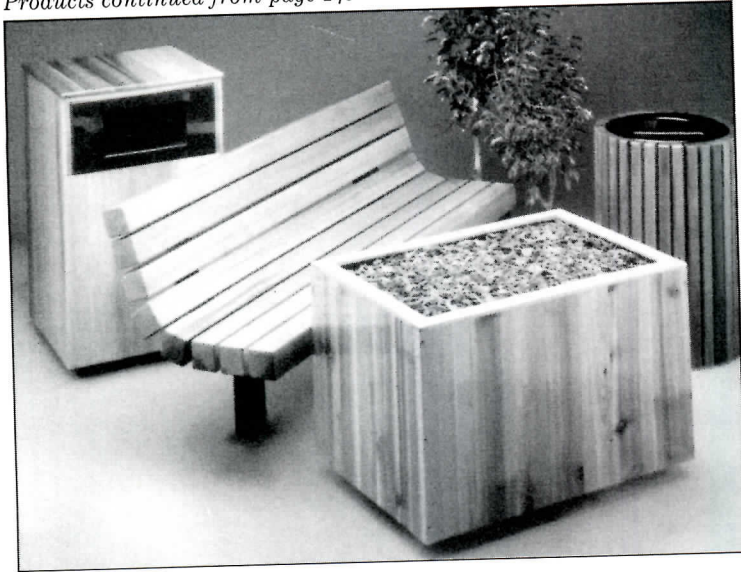

**Site furnishings**

Fibremart Designs, a line of wood and fiberglass benches, trash receptacles, tables, chairs, and planters suitable for most heavy-use public areas, offers a new surface finish for all

fiberglass components. The orange-peel texture, similar to that used on refrigerator doors, is said to help hide the dirt and smudges of constant use. Kadee Industries, Inc., Solon, Ohio.  
*Circle 309 on reader service card*



**Playground equipment**

A new item from Landscape Structures/Mexico Forge, this child-powered backhoe is made of vandal-resistant cast aluminum and galvanized steel. The SuperScoop, which rotates 360 degrees on maintenance-free bearings, is part of a full line of park and recreation equipment. Landscape Structures/Mexico Forge, Delano, Minn.  
*Circle 310 on reader service card*

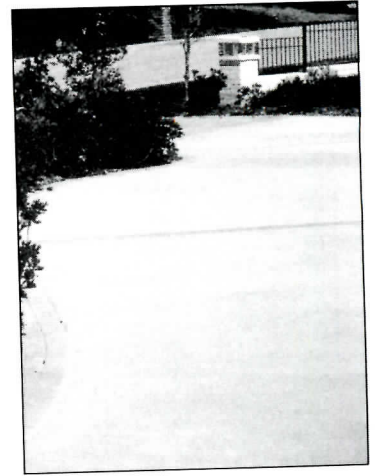

**Concrete resurfacer**

A spall-resistant, water-mix cement topping, Ardex A-300 is said to resurface any damaged or uneven exterior concrete driveway, patio, etc., in one pour. Applied with a spreader in a layer of from 1/8- to 1/2-in. thick, the concrete is ready for foot traffic in four hours, and may be driven on after 36 hours. Ardex, Inc., Coraopolis, Pa.  
*Circle 311 on reader service card*

# If you think all copiers are Look at guarantees.

You can look at copiers for days but, in many cases, there's no real way to tell them apart.

Here's our suggestion. Look at copier guarantees. That's where you find out if a company stands behind its copiers. If they're as committed as you are to keeping your business running smoothly.

Once you look at guarantees, your job will be easy. Because Harris/3M copiers come with

the best guarantee in the business. Take a look at our Promise. Compare it to the guarantee of your present copier. Then send in the coupon. Or give us a call at 1-800-TLC-COPY. We'll send you a free copy of our 8-page *Consumer Guide to Copiers*.

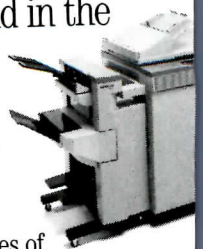

Harris/3M copiers have features for all sizes of offices. That includes the 6070. Seventy copies a minute, guaranteed.



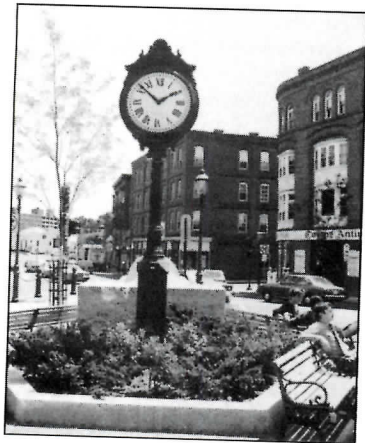

**Post clock**

A replica of the E. Howard post clock, the Good Old Days clock is cast of aluminum from the original molds. The translucent two-face clock dial is back-lit by fluorescent lamps. Crystals may be shatterproof glass or unbreakable polycarbonate; standard case and post finish is blue-black enamel. Electric Time Co., Inc., Medfield, Mass.

Circle 312 on reader service card



**Access floor**

New construction methods are said to have improved the lifetime service performance of SolidFeel II access floor panels for general offices and computer rooms. Features include four-way support structures, internal

beams, continuous steel draw corners, and a cementitious fill. Panels may be ordered bare for carpet tile, or with integral trim. USG Interiors, Inc., Linthicum Heights, Md.

Circle 314 on reader service card  
More products on page 151

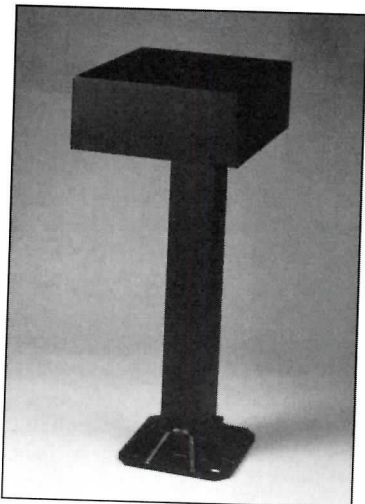

**Landscape lighting**

The Castellan downlight, a new linear style, is set on a 4-in.-sq post at heights of from 36 to 42 in. The luminaire has an easy-access hinged aluminum housing, and a precisely controlled, low-level beam spread from mercury vapor, metal halide, or high-pressure sodium lamps. Guth Lighting, St. Louis, Mo.

Circle 313 on reader service card

same, don't look at copiers.

**The Harris/3M Copier Promise**

1. 98% guaranteed up-time or your money back for the time it's down.
2. A free loaner if your copier is out of service for more than 8 hours.
3. An after-hours, toll-free helpline to assist you with minor emergencies.

*C. Lance Herrin*  
C. Lance Herrin  
Vice President - Copying Systems Division

Yes, I'd like to know more about Harris/3M copiers and the Harris/3M copier Promise. Please send my free guide.

NAME \_\_\_\_\_

COMPANY NAME \_\_\_\_\_

ADDRESS \_\_\_\_\_

CITY \_\_\_\_\_ STATE \_\_\_\_\_ ZIP \_\_\_\_\_

PHONE # ( ) \_\_\_\_\_

\_\_\_\_ I'd also like information on your full line of fax machines.

Harris/3M P.O. Box 785, Dayton, OH 45401

**HARRIS/3M**

Offer is valid for a limited time and other restrictions and limitations apply; see your Harris/3M sales representative for details. ©1988 Harris/3M Document Products, Inc. Harris is a trademark of the Harris Corporation. 3M is a trademark of the 3M Company.



For more information,  
circle item numbers on  
Reader Service Card

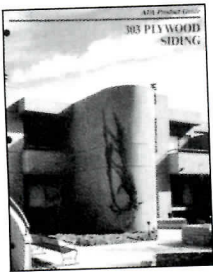

### Plywood siding

A 22-page color brochure illustrates all patterns and textures offered in 303 Plywood Siding, and includes finishing, refinishing, and maintenance tips. American Plywood Assn., Tacoma, Wash.

Circle 400 on reader service card



### Ornamental fencing

Picket fences and gates, made of polyester-coated aluminum and galvanized steel for commercial, industrial, and residential sites, are shown in a 4-page specification catalog. Anchor Fence, Inc., Baltimore.

Circle 401 on reader service card

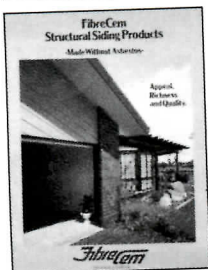

### Cementitious siding

An 8-page brochure describes a new line of fiber-reinforced, nonasbestos cement siding, said to be particularly suitable for structural and decorative use in coastal environments. FibreCem Corp., Charlotte, N. C.

Circle 402 on reader service card



### Brick sculpture

Waterwalls, intaglio murals, and three-dimensional sculptures made of brick are illustrated in an 8-page color booklet. Brick Institute of America, Reston, Va.

Circle 403 on reader service card

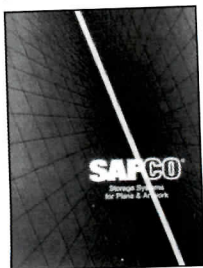

### Graphics art storage

An expanded series of office storage systems for plans and artwork is described in a full-line catalog. Safco Products Co., New Hope, Minn.

Circle 404 on reader service card

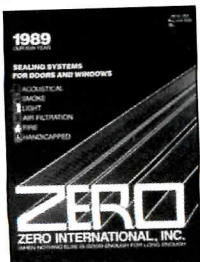

### Door and window seals

A 28-page architectural catalog covers rated systems for stopping the filtration of light, smoke, fire, air, and sound, including Z door seals that meet new NFPA 12-A standards. Zero International, Bronx, N. Y.

Circle 405 on reader service card

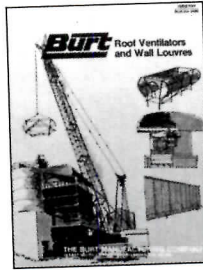

### Ventilators and louvers

A 12-page technical bulletin explains design and construction features of ridge ventilators, wall louvers, and automatic heat and smoke ventilators. The Burt Mfg. Co., Akron, Ohio.

Circle 406 on reader service card



### Light-diffusing skylights

Six different lightweight, aluminum-grid Luminous Skylights are shown in a 12-page color brochure, including the snap-together Trim-Beam System. Integrated Ceilings, Riverside, Calif.

Circle 407 on reader service card

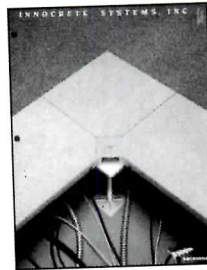

### Structural-slab access flooring

An 8-page brochure explains how structurally reinforced S-Floor modules provide stability, comfort, and noise control in raised-flooring applications. Innocrete Systems, Inc., Cranford, N. J.

Circle 408 on reader service card



### Ergonomic seating

A booklet shows the Cyborg chair in use by air-traffic controllers, funds traders, and general office workers, stressing the chair's contribution to productivity. Rudd International Corp., Washington, D. C.

Circle 409 on reader service card



### Wood casegoods

One of a series of selection guides to office furniture, a color folder highlights dimensional and design details of conference tables, credenzas, desks, and storage units. CorryHiebert Corp., Irving, Tex.

Circle 410 on reader service card



### Safety railing

Saftron balcony, stair, and safety railing, made of laminated vinyl in a number of colors and styles such as bamboo and wood grain are illustrated on-site in an 8-page brochure. Saftron Inc., Miami.

Circle 411 on reader service card





**Elements of style.  
Hardware classics by Sargent.**

Choose a design that's always right. Demand door closers engineered to perform and endure. Specify Sargent and get elements of style that include a century-long record of craftsmanship, service and on-time delivery.

For enduring qualities in door closers, locks and exit devices, choose the complete Sargent line. And get classic architectural hardware.

**SARGENT  
ESSEX**

INDUSTRIES INC.

Sargent, New Haven, Connecticut 06511  
Sargent of Canada Ltd.

**Circle 61 on inquiry card**



# TOP LEVEL INTELLIGENCE.

**Build R/26 structural roof systems in one step with TUPS™: the smarter, faster way to build.**

Smart architects have discovered an intelligent way to stay on top of current demands for higher energy ratings *and* lower costs.

They go to the very *top* and choose a structural, insulating roof system panel that can save energy, reduce cost, eliminate labor-intensive steps and cut time.

They choose TUPS.

Only TUPS features a load bearing, stress skin panel integrating structural Homasote 440 Boards with an insulating core of rigid polyisocyanurate foam.

In just one step, you can install an interior ceiling ready for paint or other finish. And an energy efficient layer of insulation. Plus a structural nailbase ready for shingles, slate, tile, BUR or single-ply membrane roofing system.

ready for shingles, slate, tile, BUR or single-ply membrane roofing system.

All with one-step TUPS roofing panels. That's intelligence at the top level.

For full details, call (609) 883-3300. Or write The Homasote Company directly.

Choose TUPS™ and install —in one step— a structural deck, insulation and nailbase. That's intelligence at the top level!

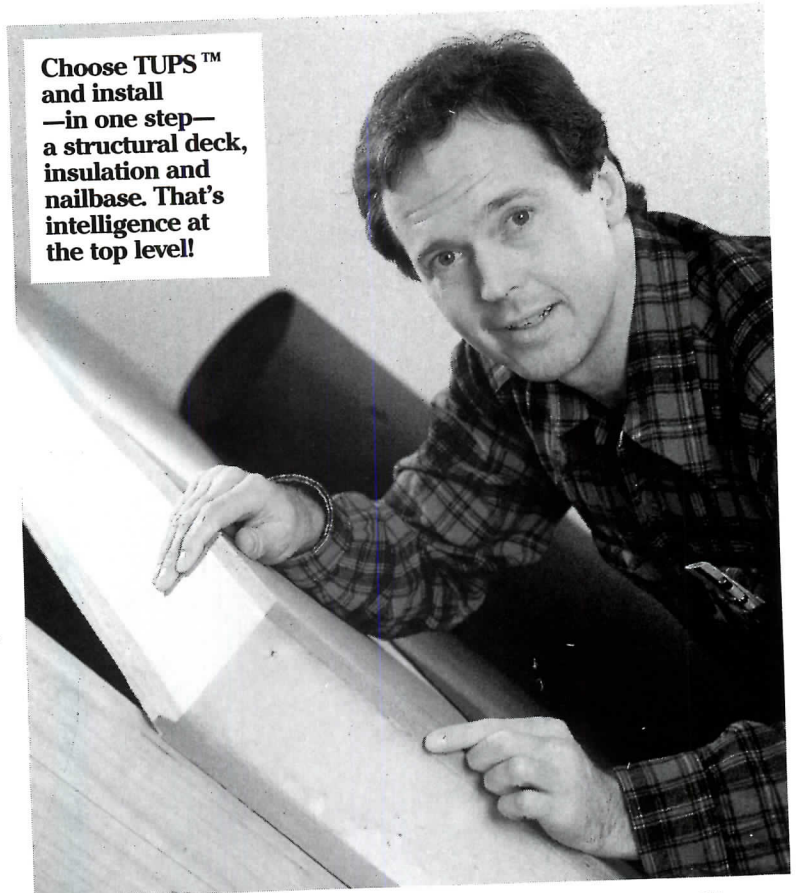

Panels sizes, nominal 4' x 8', 10' and 12' with T & G Long Edges	Nominal Thickness	
	4"	5"
R-FACTOR AGED	19.2	25.48
R-FACTOR SYSTEM*	20.43	26.71
Lbs. per sq. ft.	4.2	4.4
Foam Thickness (nominal)	2½"	3½"

\*Includes air film and asphalt shingles.

## homasote

C O M P A N Y

P.O. Box 7240, West Trenton, New Jersey 08628-0240

# **SMART ARCHITECTS CHOOSE HOMASOTE.**

5666

Circle 62 on inquiry card



Products continued from page 147

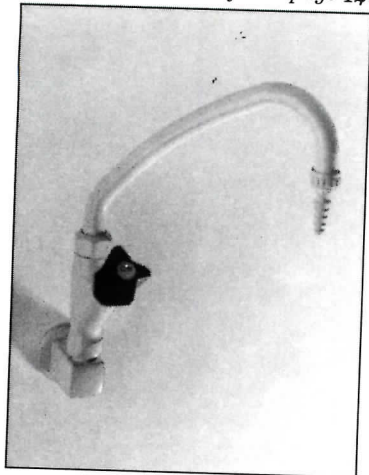

**Laboratory fixtures**

A new product line for this manufacturer, fixtures by Broen of Denmark come in a chemical-resistant white finish accented by handles color-coded for 10 different laboratory services: cold, hot, and distilled water; oxygen; nitrogen; etc. The faucet's nonrising spindle prevents the formation of calcium deposits. Fisher Scientific, Pittsburgh. Circle 315 on reader service card

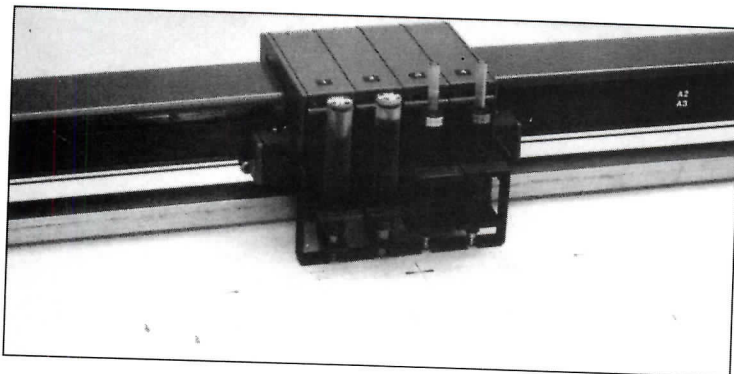

**Pencil plotter**

A pencil adapter for the RY-5214 D-size plotter is said to offer an inexpensive and quick means of producing check plots of CAD drawings. The unit holds

two each of 0.3mm and 0.5mm pencils; pressure is controlled either manually or by program. RDK Inc., Austin, Tex.

Circle 317 on reader service card

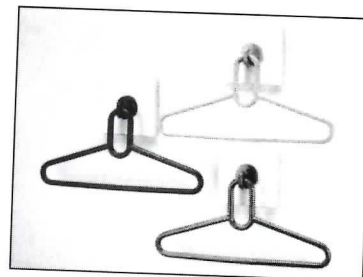

**Garment hangers**

Colormatch series hooks and hangers may be ordered in any combination of black, blue, gray, brown, beige, and red laminates and molded plastic fittings.

Vogel Peterson, Elmhurst, Ill. Circle 318 on reader service card  
More products on page 171



**Air-tight clean-room door**

Part of a new line of doors for pharmaceutical plants, hospitals, and research laboratories, the Ultra Clean 221 is made of noncorrosive, scratch-resistant stainless steel, fiberglass, or ABS plastic. A continuous air filtration seal, set on all four sides of the electrical-pneumatic sliding door with no exposed fasteners, resists out-gassing to form an airtight closure. Horton Automatics, Corpus Christi, Tex.

Circle 316 on reader service card

**Specify the Door...  
That Matches the Floor**

When you need floor access that blends beautifully with the surrounding floor covering, specify a Type "T" Bilco floor door. The Type "T" comes equipped with molding strips to receive composition flooring or direct glue-down carpet. Manufactured of maintenance-free aluminum, it has specially designed, concealed hinges for consistently close tolerance between the cover plate and frame on all sides.

Bilco. Time tested, performance proven products for your clients. Floor, pit and sidewalk doors, basement doors, ceiling doors, automatic fire and explosion vents, ladder safety posts, and roof scuttles, see our catalog in Sweet's or send for a copy.

**Bilco**® DOORS FOR SPECIAL SERVICES  
The Bilco Company, P.O. Box 1203, New Haven, CT 06505

Circle 63 on inquiry card





# ALPOLIC

**The Lightweight, Rigid, Bendable Composite Material.**

ALPOLIC combines beauty with superior flatness and easy workability. Used for exterior sheathing, display panels, sign boards, and other applications, it resists weather and corrosion. Used for interior applications such as displays, it will enhance the beauty of your designs.

ALPOLIC is available in silver, light bronze, dark bronze, gold and black anodized and painted in a range of colors.

# A-LOOK EX

**The Lightweight, Flexible, Unbreakable Mirror For Exterior Use And Where Humidity Is High.**

Indoors and Outdoors, A-LOOK EX supplies the reflective beauty of a mirror. You can bend it, cut it and hang it. It's ideal for store fronts, eaves, entrance areas and signs as well as for any variety of indoor applications including spas, bathrooms and other areas subject to humidity. The fluoride resin surface of A-LOOK EX provides outstanding weatherability and resistance to humidity.



**MITSUBISHI KASEI AMERICA INC. (MKA)**

800A Corporate Court, South Plainfield, NJ 07080  
Phone: 201-757-6900/800-422-7270/FAX: 201-757-6690



# Manufacturer sources

*For your convenience in locating building materials and other products shown in this month's feature articles, RECORD has asked the architects to identify the products specified*

**Pages 90-93**  
Tent City, Boston  
Goody, Clancy & Associates, Inc., Architects  
Brick: Boren; U. S. Brick; Endicott; Elgin Butler. Shingles: Supradur. EDPM roofing: Firestone. Gutters: Benchmark. Entrance: Built-Rite. Windows: Graham Architectural. Glazing: Solar Seal. Door hardware: Sargent. Partitions: Modernfold. Vinyl flooring: Armstrong. Exterior lighting: Bega. Interior lighting: Lightolier.

**Pages 94-97**  
St. Vincent dePaul/  
Joan Kroc Center  
F.A.D. Architecture & Planning  
Built-up roofing: Manville.  
Doors, windows, security screens: Torrance Steel Window.  
Exit devices: Rixson. Controls and locksets: Schlage. Paints: Sherwin Williams. Ceiling tile: Armstrong. Ceramic and quarry tile: American Olean.  
Cementitious flooring: Gyp-Crete. Carpeting: Interface.  
Basketball hoop: Medart.

**Pages 100-103**  
Washington Elms Housing  
Bruner/Cott & Associates, Inc., Architects  
Brick: South Eastern. Wood siding: Weyerhaeuser. Membrane roofing: Carlisle. Shingles: GAF. Skylights: Kalwall. Rolling doors: Overhead Door.  
Partitions: Modernfold. Paints: Benjamin Moore. Sprinklers: Rinnell.

**Pages 104-107**  
Home Hospice  
Asian Neighborhood Design, Architects  
Wood doors: Alwood. Locksets: Schlage. Closers: Norton Door Controls. Cabinet hardware: Julius Blum. Paints and stains: Mann-Edwards; Fuller O'Brien. Laminates: Nevamar. Tile: American Olean; I.A.C.; Gail. Vinyl flooring: Armstrong.

Carpet: Bentley Mills. Bathtubs: Kohler. Kitchen sinks: Elkay. Indoor lighting: Halo; Lightolier; Juno. Intercom: Auth Electric.

**Pages 108-109**  
Women's Alcoholism Center  
Asian Neighborhood Design, Architects  
Metal doors: Amweld Building Products. Wood doors: Artesia. Windows: Bonelli Window Systems. Glazing: Libbey-Owens-Ford. Locksets: Schlage. Hinges: Hager. Closers: Norton Door Controls. Paints and stains: Fuller O'Brien; Martin Senour. Laminates: Formica. Floor and wall tile: Gail International.

Vinyl flooring: Armstrong.  
Carpet: Bentley Mills.  
**Pages 110-114**  
Creative Living II  
Schooley Caldwell Associates, Architects  
Vinyl siding: Wolverine Technologies. Truss roof: Automated Building Components. Shingles: Georgia-Pacific. Metal doors: Currier. Windows: Pennco. Through-wall AC: Magic Chef.

**Pages 116-119**  
Diamond Park  
Cecil Baker & Associates, Architects

Brick: Glen-Gery. Entrances: Kawneer. Wood doors: Weyerhaeuser. Windows: Capitol Industries. Locksets: Kwikset. Closers: Stanley. Textured ceilings: Gold Bond. Paints: Finnaren & Haley. Epoxy floor surface: Dec-O-Tex. Vinyl flooring: Azrock Industries.

**Pages 120-123**  
Robert Shaw Echo Village  
Tom Hatch Architects  
Shingles: General Products. Entrances: Challenge Door. Windows: Alenco. Paints: Kelly-Moore.

## HOW TO LIGHT AMERICA

SPRING CITY DOES IT WITH GRACEFUL, ORNAMENTAL CAST IRON LIGHTING POSTS



Look around America and you will see Spring City Cast Iron Lighting Posts as part of the charm of landscapes in thousands of cities, towns and villages. There are reasons for the wide popularity of these posts: grace and beauty to enhance any location; the enduring quality of cast iron; historical accuracy and the superb American craftsmanship which has been a tradition at Spring City for over 60 years.

The light sources we offer include: incandescent; mercury vapor; metal halide and high pressure sodium.

Call or write today for a video presentation or for our full color literature.

See Us in Sweets and LA File

SPRING CITY ELECTRICAL MFG. CO.

P.O. Drawer A, Spring City, PA 19475-0030  
Phone: 215-948-4000  
FAX: 215-948-5577

**MADISON POST**  
Shown in New York City's Public Park System. Heights vary from 6'3" to 12'6" (excluding luminaire + adapter), 1 1/2" O.D. base. Available with twin arms for 2 luminaires and as a bollard.

**WASHINGTON POST**  
Shown at the Peabody Hotel in Memphis, Tenn. 12' to 16'10" heights (excluding luminaire) 2 1/2" and 2 3/4" O.D. bases. Available as 4 or 5 luminaire unit.





# Trial by fire.

When the Edmonton Law Courts wanted a fire-retardant panel for their expansion project, the decision was in favor of Duraflake® FR. The Class I fire-rated particleboard that's gone through trial after trial.

It has a UL flame spread rating of 20. And a smoke developed rating of 25. Plus it's stable and won't bleed chemicals. Important requirements when laminating fine veneers such as the teak used in Edmonton's courtrooms.

You can order Duraflake FR cut-to-size, or in four- or five-foot wide panels of standard length. Four-foot wide panels are also available up to 18 feet in length. It's even available as a high-pressure laminate panel called DuraDesign® FR, for use in casegoods and furniture.

If you have to meet strict fire codes, call (503) 926-5866 for Duraflake FR. And give it a trial.

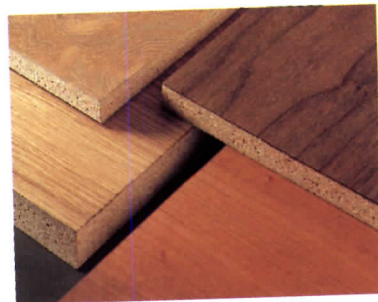

**Duraflake® FR**

Duraflake Division  
Willamette Industries, Inc.  
Albany, Oregon 97321  
(503) 928-3341



# FROM THE HOUSE THAT RUTH BUILT TO THE HOUSE THAT JACK BUILT

Incandescent, HID and Fluorescent. Cooper Lighting is the single source that offers a virtually limitless choice of lighting products. The choice for Yankee Stadium, the choice for millions of homes, and the choice for your next project.

Halo, Metalux, Crouse-Hinds, Lumark, McGraw-Edison and Sure-Lites are all part of Cooper Lighting. We are an unparalleled resource for manufacturing, engineering, marketing, design and research. Seven regional showrooms provide an opportunity to experience first-hand the effects of lighting.

Brilliance from a single light source. Cooper Lighting, 400 Busse Road, Elk Grove Village, IL 60007.

**COOPER LIGHTING**  
**THE SINGLE LIGHT SOURCE**





# The new surface anodized can't match.



**commcoat**  
FLURODIZE COIL

What you see here is a brand new building material. Commcoat™ Flurodize® Coil.

The remarkable finish is made by bonding a Flurodize coating to our finest aluminum substrate, right in our rolling mill.

Commcoat looks a lot like anodized aluminum. Only better. And it comes in seven exciting colors. (Extrusions, too.)

For a price no higher than anodized.

But the difference is, Commcoat Flurodize Coil keeps on looking good

year after year. With far less weathering, fading or staining than anodized.

Nor does its color vary from panel to panel. Or crack when sharply bent.

To get your hands on some, call any of these distributors: Petersen Aluminum Corporation, Wrisco Industries or Idéal Métal Inc. Laminated panels are produced by Alucobond Technologies. Or call us at 1 (800) 556-1234, Ext. 174. In California, 1 (800) 441-2345, Ext. 174.



**COMMONWEALTH  
ALUMINUM**

Commcoat is a trademark of Commonwealth Aluminum Corp. Flurodize is a registered trademark of DeSoto, Inc.

Circle 68 on inquiry card



**THINK NYLON**  
**THINK COLOR**  
**THINK . . .**

The concept is simple. Elegantly disciplined. One perfect material, nylon (tough yet warm to the touch), molded into sleek design systems including custom railings, door hardware, cabinet and bath hardware, plus a complete complement of

wall-mounted accessories. All in a palette of twelve clear-through colors. European design, American manufacturing — respected internationally. Think Normbau for limitless variations and design continuity. Residential, commercial. Indoor, outdoor.

**normbau**  
 design-systems

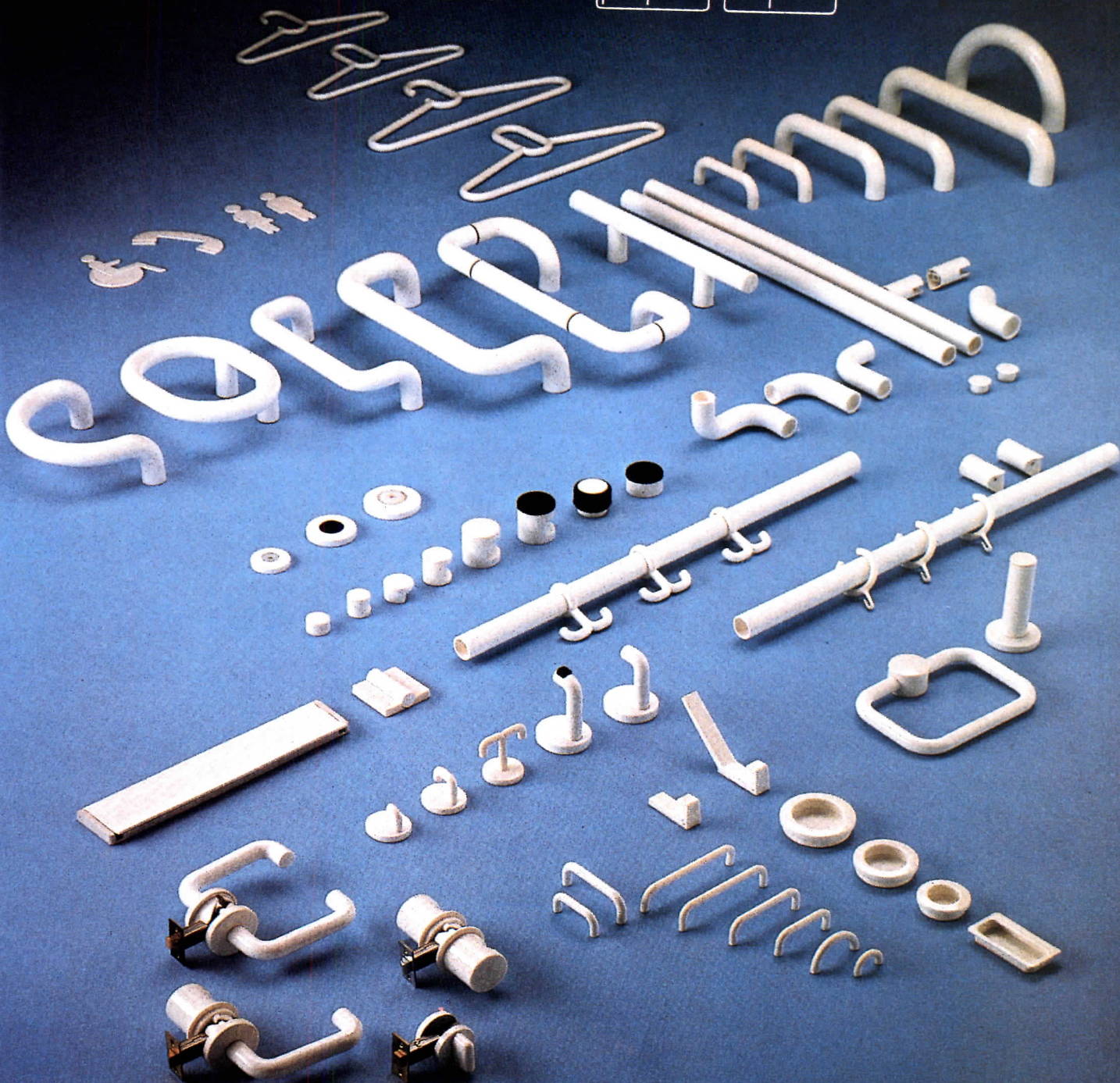

Colors are subject to slight variation.



For literature, and information on our "Style with Substance" design seminars, call or write.  
 NORMBAU, Inc., 1040 Westgate Drive, P.O. Box 979, Addison, Illinois 60101

Phone (312) 628-8373  
 Fax Phone (312) 628-8534





The Royal	L'Institut	Office of	Bureau du
Architectural	Royal	the President	Président
Institute	d'Architecture		
of Canada	du Canada		

September 22, 1988

Dear Mr. Manufacturer:

In all sectors of the economy the processes of handling information are undergoing significant developments. The Royal Architectural Institute of Canada and Sweet's Catalogue Services are committed to being at the forefront to any such changes in the construction industry. With this in mind, we are currently developing a joint research project to identify such changes so that we might be a part of them and help direct their development.

Sweet's Canadian Construction Catalogue File continues to serve as one of the foundation stones of the information base of any architectural practice. It is an important source for the selection and specification of details in our ongoing work.

Together we hope to shape the future development of this important resource to meet the needs of our changing industry. We will be pleased to share with you the results of our joint research once complete.

Yours sincerely,

THE ROYAL ARCHITECTURAL INSTITUTE OF CANADA

Alfred C. Roberts, FRAIC  
President

ACR/js

0294D/

Chamberlain House · 328 Somerset West · Ottawa, Ontario · K2P 0J9 · 613/232-7165

Circle 70 on inquiry card





# Why roofers should hate EC acrylic coatings.

## But don't.

Considering all the ways coatings made with Rhoplex® EC acrylics protect and prolong the life of existing roofs, you would think that roofers would want nothing to do with them.

After all, EC acrylics help building owners eliminate the need for costly, continuous patching by providing years of easy maintenance. They withstand UV degradation that deteriorates asphalt roofs. Plus, they resist dirt pickup, so the white coating retains its reflectivity for increased energy savings.

EC acrylics are only a raw material in roof coatings. Successful performance of final roof coating products depends upon proper formulation, manufacture and application.



Yet, for all the years they help postpone roof repairs, roofers actually like EC acrylic-based coatings. Why? For one, they're easy to apply — they just spray or roll on. For another, they help keep customers happy. And a satisfied customer is going to remember a roofer who helped him cut his maintenance costs.

So the next time you're faced with roof repairs, do yourself and your roofer a favor. Finish the job with coatings made with EC acrylics from Rohm and Haas. To learn more, contact your contractor. Or call ROOFMASTICS at 800-858-3814.



**FINISH THE JOB WITH AN EC ACRYLIC.**

Check local building codes or proper authorities before applying any roofing system. Rhoplex is a registered trademark of Rohm and Haas Company.

Circle 71 on inquiry card





*Authentic divided lites for that distinctive Early American look.*

*Maintenance-free exterior cladding resists anything the weather throws at it.*

*Glazing options like Low-E glass helps keep heat in during winter, heat out during summer.*

# NEVER LET ANYONE SAY YOU CHOSE A MARVIN DOOR JUST FOR ITS LOOKS.

Of course, we could understand if you did.

After all, it hasn't escaped our attention that our long line of patio, terrace and French door styles is opening a lot of eyes around the country. And with the additional design opportunities presented by sidelites, transoms, authentic divided lites, leaded glass inserts

and more, we're opening a lot of minds as well.

But this ad isn't about how great our doors look, it's about how great our doors perform.

---

DOORS BUILT EVERY BIT AS GOOD AS MARVIN WINDOWS.

---

You're no doubt familiar with Marvin

Windows, some of the most finely crafted products in America today. Our doors are quickly building that same reputation. That's because we believe, first and foremost, a door should perform. And perform for years to come.

So we start with the highest grade of materials, employ the most advanced techniques in design and



*Fine-grained Ponderosa pine accepts a beautiful stain or paint finish.*

*Tough maintenance-free sills wear longer than wood or metal.*

*Our hardware is specially designed for beauty, durability and security*

engineering, and then add the best finishing touches we know of. For example, we fashion all frames, stiles, rails and muntin bars from fine-grained Ponderosa pine. The wood is deep-treated with a PILT solution for longlasting protection against rot and decay. Then each piece is designed and cut by hand to interlock perfectly with the piece next to it.

Our sills are made from an indestructible, scuff-resistant, space-age material that has 1400

times the insulating value of aluminum.

Maintenance-free Marv-A-Gard aluminum cladding provides a tough exterior, and, when combined with our solid wood doors, virtually eliminates denting and other damage.

Locksets and hardware, in many cases, are custom made to our specifications for smooth operation, long life and added security. Extensive weatherstripping reduces air infiltration, and, in combination with a variety of glazing options like

new energy-saving Low-E glass, gives Marvin Doors energy efficiency ratings that in most cases far exceed industry standards.

#### WHAT'S BEHIND OUR DOORS HELPS KEEP US IN FRONT.

Behind every Marvin Door is a list of services that helps it practically sell itself. We provide the fastest delivery in the industry, no matter what style of door you order, or what options you choose. And the highest level of technical and design support is available right from your local distributor, as well as back-up service that assures your customer that everything will work perfectly.

So perhaps recommending Marvin Doors purely on the basis of their looks is not a bad idea. After all, we all know beauty is more than skin deep.

To learn more about Marvin Doors, call toll-free **1-800-346-5128** (in MN, 1-800-552-1167, in Canada, 1-800-263-6161), or write Marvin Doors, Warroad, MN 56763.

**MARVIN DOORS** 





ELEGANCE...



Architect: F. S. Platou

Sheraton Hotel, Oslo

OVERALL  
QUALITY...



Architect: SOM

Clark Building, Bethesda, MD

DURABILITY...

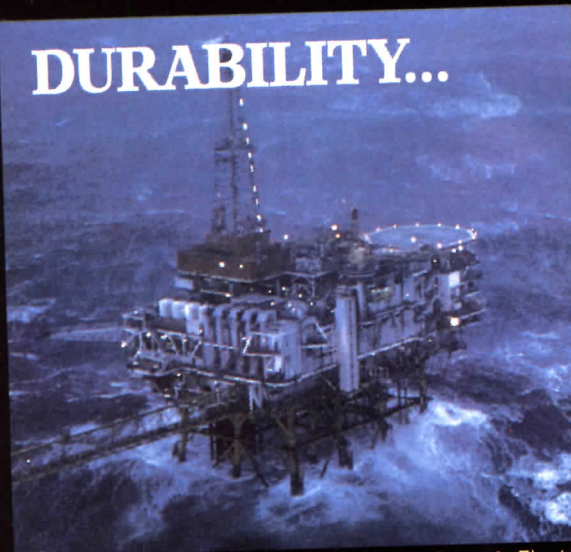

Architect: Götaverken

Consafe Floatels

DORMA door closers have been field-proven around the world in applications varying from sharp architectural styling to severe environments requiring excellent durability. But this is not the only reason why DORMA has been the fastest growing door control manufacturer in North America in the 1980s. Our reputation is based upon our superior...

- Consistent product quality—a less than 1% return rate
- On-time delivery—delivery promises are kept
- Customer service—beyond order taking to problem solving
- Product innovation—meeting tomorrow's demands today

At DORMA customer satisfaction is the ultimate measure of our success. ***Our commitment shows.***

**DORMA Door Closers...**  
a perfect fit for any  
application



DORMA Door Controls, Inc.  
Dorma Drive, Reamstown, PA 17567  
Telephone (215) 267-3881 • FAX (215) 267

DORMA Door Controls, Ltd.  
1680 Courtney Park Drive, Unit 13  
Mississauga, Ontario L5T 1R4  
Telephone (416) 673-1281 • FAX (416) 673

Circle 73 on inquiry card



# THE BEST WAY TO SEE THE FUTURE IS TO LOOK AT THE PAST.

One look at Notre Dame's magnificent rosette window is all it takes to see that the design was far ahead of its time. Constructed in 1163, it's still a brilliant example of innovative glass architecture.

Dow Corning can help you build tomorrow's monuments, today. Because our glazing technology is far ahead of the competition. And far ahead of its time. State-of-the-art products and technical knowhow that let you work with the most advanced materials, to build the most futuristic designs.

DOW CORNING® 795 for example, is a unique one-part structural silicone adhesive/sealant for both in-shop and field glazing, as well as curtain wall assembly and weatherseals. It provides exceptional primerless strength and adhesion to more substrates than any other silicone sealant.

DOW CORNING® 983 is a two-part adjustable-cure silicone curtain wall glazing sealant/adhesive. It helps to speed production and delivery of structural curtain-wall units that are glazed in-shop.

DOW CORNING® 790 offers unmatched movement capability and adhesion for a variety of weather-sealing applications in stone, concrete and metal curtain-wall construction.

You get something else with Dow Corning glazing sealants that only the world's largest silicone producer can offer: The Dow Corning commitment to research and development, technical service and quality products.

For specification information and technical literature call toll-free 1-800-346-9882 ext 8207. Or write Dow Corning, Dept 4009, Midland MI 48640. We'll help you build for the future, today.

DOW CORNING

Circle 74 on inquiry card

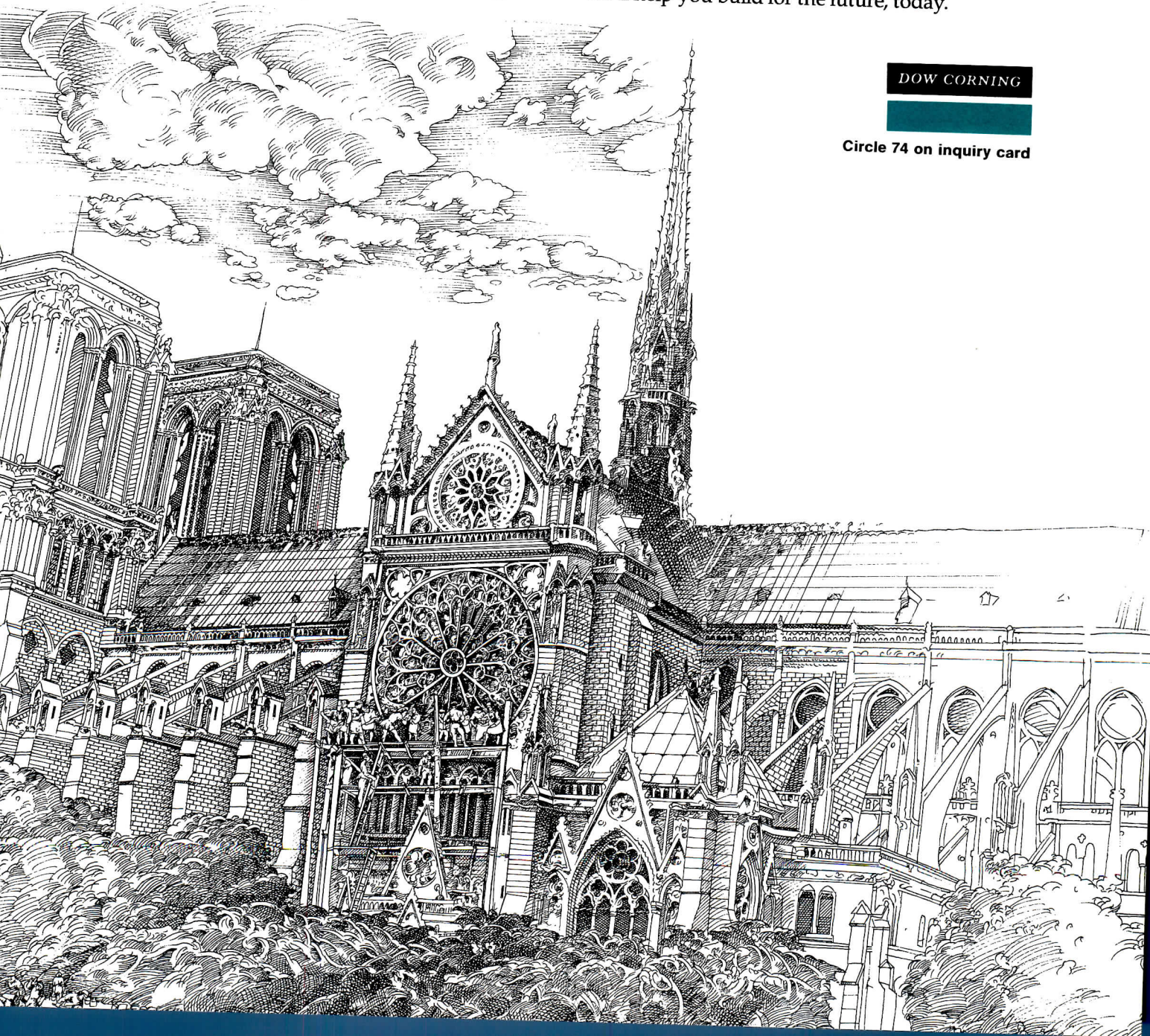



# TCS and the Corporate Ediface

In designing the new United Airlines Terminal at O'Hare, Helmut Jahn has made an architectural statement that is memorable for its appearance and exciting in its distinction as one of the most outstanding airport terminals in the world.

So as not to repeat the typical spiritless and dismal environment so common to such facilities, Jahn uses conceptual clarity in the choice and combination of materials.

Happily, TCS (terne-coated stainless) is used to cover the folded roof sections of the Ticketing Pavilion. Already having

weathered to an attractive, warm gray, TCS quietly contributes to the overall beauty of the terminal's total visual eloquence.

TCS is a unique roofing material. Its finest testimonial is the roster of distinguished architects such as Helmut Jahn who continue to specify it for major projects.

Requiring no maintenance, TCS promises a life span which can be measured in generations rather than years.

We feel that it deserves your consideration whenever metal roofing or weathersealing is specified.

Architects:  
Murphy/Jahn,  
Chicago, Illinois  
Project: United Airlines  
Terminal 1 Complex  
O'Hare International  
Airport  
Chicago, Illinois  
Roofer: Esko-Young,  
Chicago, IL



UNITED AIRLINES

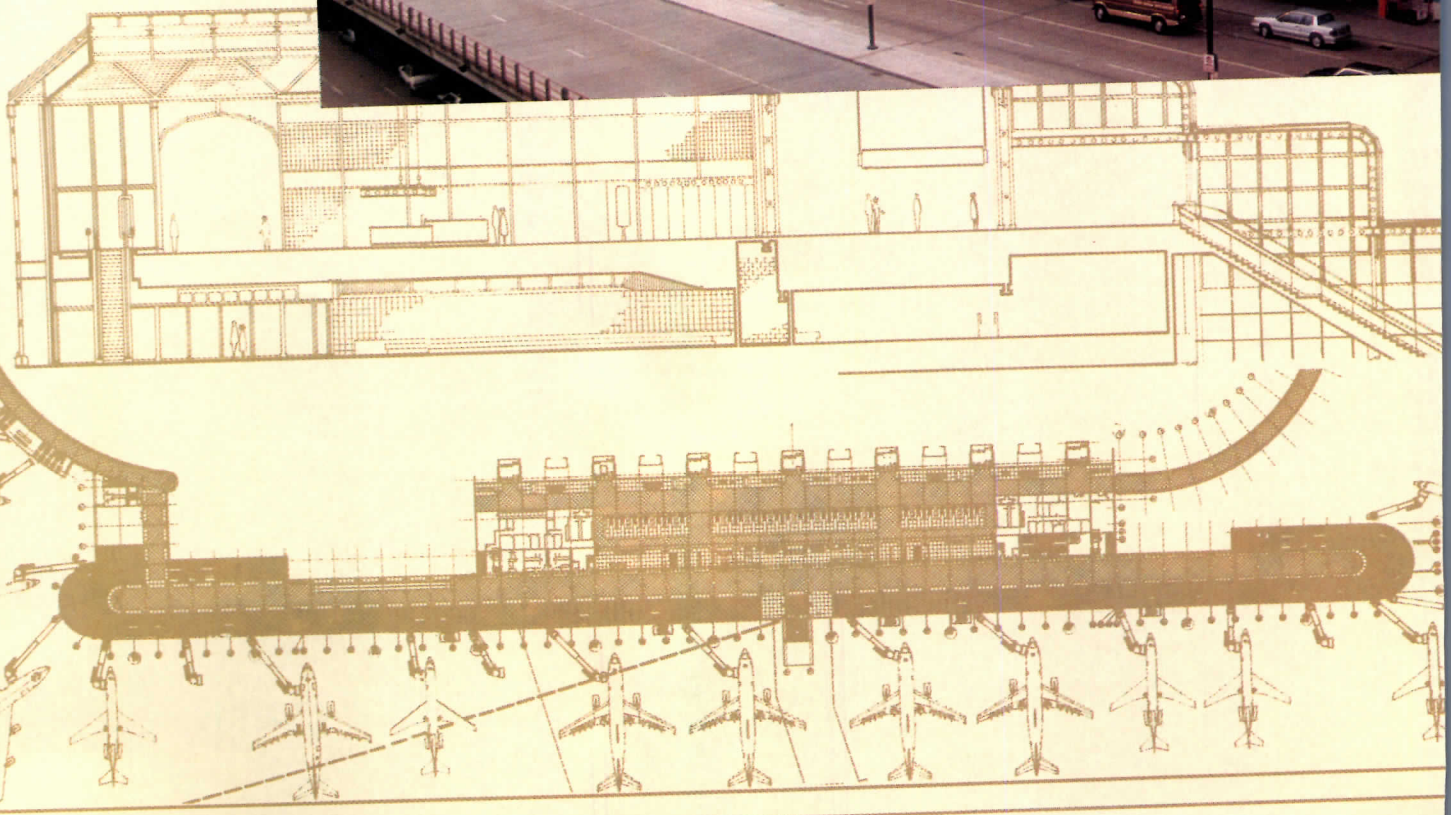

**TCS**  
TERNE COATED STAINLESS

**FOLLANSBEE**  
FOLLANSBEE STEEL • FOLLANSBEE, WV 26037  
Call toll free 800-624-6996



**ELECTRONIC SWEET'S...It's About Time.**



# Sweet's R•Evolution in better product specification writing comes full circle

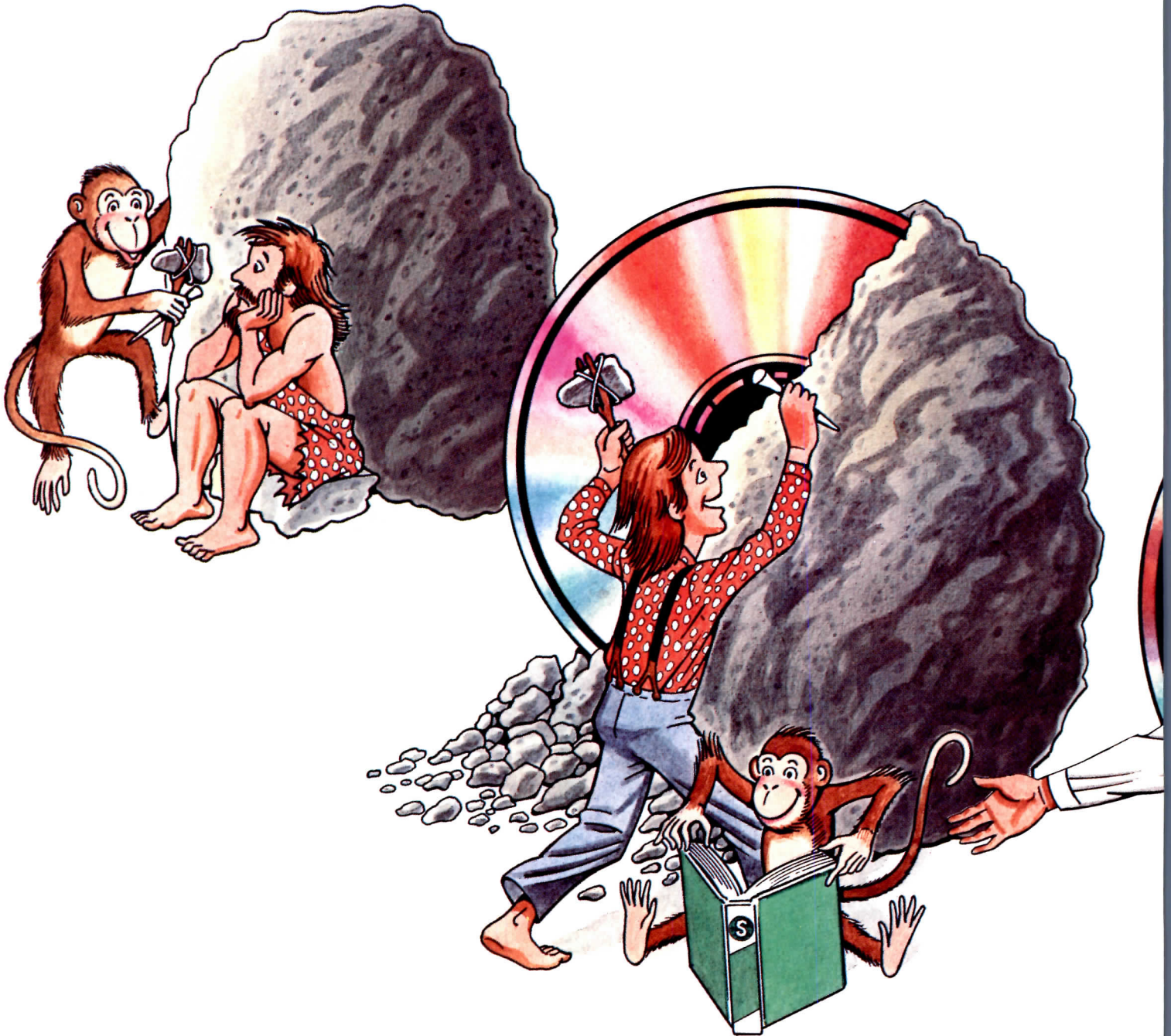

## Don't let the R•Evolution pass me by!

Please send me complete details about Electronic Sweet's and the special NEC CD-ROM Reader offer.  
My company currently  receives  does not receive Sweet's Catalog Files.

Name \_\_\_\_\_

Title \_\_\_\_\_

Company \_\_\_\_\_

Address \_\_\_\_\_

City \_\_\_\_\_ State \_\_\_\_\_ Zip \_\_\_\_\_

Telephone (\_\_\_\_\_) \_\_\_\_\_

Attach the coupon to your company letterhead and mail to:

Sweet's Group  
McGraw Hill Information Services Company  
1221 Avenue of the Americas  
New York, N.Y. 10020  
Attn: Electronic Sweet's Special Offer

For faster service, call

**1-800-848-9002**



# tion and January...

## Are You Ready?

In the beginning of time, man made the wheel, and it revolutionized the world.

In 1906, Sweet's introduced the first Sweet's Catalog File, and it revolutionized the way design and construction industry professionals obtained manufacturers' building products information.

In the beginning of next year, you can get Electronic Sweet's on Compact Disc which will help "R•Evolutionize" the way you select products and write specifications.

Delivered automatically to qualified recipients of Sweet's General Building & Renovation or Engineering & Retrofit Catalog Files, Electronic Sweet's is the next step in the evolutionary process, enabling you to move from time-consuming manual methods of finding and specifying the building product information you need... to computerized methods that do the work for you—in minutes.



After all, the less time you spend on searching for products which meet your design requirements, the more time you'll have to design. The less time you spend on producing specification documents, the more time you'll have to produce. And time is money.

Electronic Sweet's is about time. **Your** time. And how to make the most of it, with:

*SweetSearch* which...

- Finds products by criteria of your choice;
- Assures that **every** product in Sweet's Catalog Files relevant to your project needs is found;
- Uses product search characteristics developed by and for design professionals;
- Displays uniform product profiles for easy product comparisons; and,
- Does it all with electronic ease...in seconds!

And with *SweetSpec* which provides you with...

- Fully customized specifications for your individual projects;
- The most current specification data available;
- "Tutorials" for decision-making assistance;
- Comprehensive, accurate, high quality specifications; and,
- Printed specification documents on your desk for your professional review in a matter of minutes!

But Electronic Sweet's won't be able to do a thing for you without a CD-ROM Reader for your IBM-compatible PC to "play" it on. And, for a limited time, Sweet's can help you save more than 50% on a state-of-the-art NEC CD-ROM Reader. For complete details, call 1-800-742-2255 or return the coupon in this ad.

Save money on this special offer now, and **you** will be ready to save both time and money when Electronic Sweet's arrives next year.

Join the Electronic Sweet's R•Evolution. We're changing with the times. Shouldn't you?

## R•EVOLUTION

### ELECTRONIC SWEET'S It's About Time.



## SWEET'S MCGRAW-HILL

Information To Build On

Sweet's Group • McGraw-Hill Information Services Company • 1221 Avenue of the Americas, New York, N.Y. 10020



**Architect/Marketing Director \$18,000** per year 8 a.m. to 5 p.m. 40 hours per week. Will provide professional services in research, development, design, construction, alteration, or repair of real property, such as private residence office buildings, theaters, public buildings, or factories. Will consult with client to determine functional and spatial requirements and will prepare information regarding design, specifications, materials, equipment, estimated costs, and building time. Will plan layout of project and integrate engineering elements into unified design. Will prepare scale and full size drawings, using personal computer and CAD/CAM system, and contract documents for building contractors. Will furnish sample recommendations and show drawings review to client. Will assist client in obtaining bids and awarding construction contracts. Will supervise administration of construction contracts and conduct periodic onsite observation of work in progress. Will prepare operating and maintenance manuals, studies, and reports, where necessary. Will assist management of firm in marketing in general and CAD/CAM architectural drawing system in particular; will advise management regarding financial planning and business proposals. Requirements: B. Arch. and B.A., Bus. Adm. or Marketing; or M.B.A. or substantial completion of M.B.A. and B. Arch.; at least three credit hours in Computer Science or Information Systems. Contact LA Office of Employment Security. Job Order 174111, 617 St. Charles Avenue, New Orleans, LA 70130.

**Associate Architect. Provide professional** services in development, design & construction of mixed use health care facilities with an emphasis on both the technical aspects of building construction & structural planning, & the architectural style that will meet clients' functional & spatial requirements. Plan & prepare conceptual design, construction documents, & prepare schematic structural planning to provide optimal structural systems. Review architectural & structural design documents. Coordinate & interact closely with both the architectural & structural departments. Requires Master's in Architecture with a major in Design. Experience not required, but undergraduate degree must be in Civil Engineering. Portfolio required. Salary offered, \$2,392/Mo., 40 hrs. P.W., 8-5 M-F. Send resume to: Illinois Department of Employment Security, 401 S. State Street-3 South, Chicago, Illinois 60605. Attn: Marie Ninneman, Ref.: #8480-N. An Employer Paid Ad.

**Graduate Architect — Provide Professional** services in research, development and design of large scale, mixed use residential and commercial projects. Prepare and plan conceptual designs and site planning through application of computer cartography. Design and develop software (using BASIC and PASCAL languages) to suit company's specific requirements. Work also involves model making and presentation of client presentation drawings. Requires Master's Degree in Architecture plus 1 yr. experience or 1 yr. related experience as a Graduate Architect performing general architectural duties. Education must have included one course in Computer Cartography and one course using BASIC and one course using PASCAL. Salary \$2,000 per month, 40 hours per week, 9 AM to 5 PM M-F. Send resume to: Illinois Department of Employment Security, 401 S. State St., 3 South, Chicago, IL. 60605. Attn: Marie Ninneman, ref. 7846-N. An Employer Paid Ad.

**Architects — \$25,00-85,000 Group One** Search Executive Architectural Recruiters. Key positions nationwide at all levels with Regional & National firms. Experience in research/development, health care, commercial, criminal justice, educational, institutional, industrial and multi-family projects. Confidential. No Fee. Include salary requirements. 4917 Ehrlich Road, Suite 103, Tampa, FL 33624, (813) 969-0544.

# ARCHITECTS/ URBAN DESIGNERS

The New York City Department of Transportation's Bureau of Traffic Operations, needs several bright, enthusiastic, innovative architects to work in its Office of Urban Design. Help make our City streets, squares, and other public spaces into civic places with their own distinct character reflecting the forces and desires of each neighborhood.

**ASSOCIATE URBAN DESIGNER:** Prepares construction documents and diagrams/drawings related to urban design and development; develops concepts and prepares preliminary and final designs; conducts field inspections and surveys; and prepares reports. Two years architectural or urban experience required.

**ASSISTANT URBAN DESIGNER:** Prepares construction documents and diagrams related to urban design projects; assists in the preparation and presentation of design concepts; prepares material for approval by community boards; and undertakes field investigation. One year architectural or urban design experience required.

Baccalaureate degree in architecture required for both positions. Master's degree in architecture, urban design, or city planning may substitute for one year of experience.

Salary \$30K-\$50K, commensurate with experience; excellent benefits package. Send two copies of both your resume and cover letter (stating salary history and position for which you are applying) to: Recruitment Office (JK), NYC Dept of Transportation, 40 Worth Street, Room 801, New York, NY 10013.

NYC residency required within 90 days of appointment.

Equal Opportunity Employer

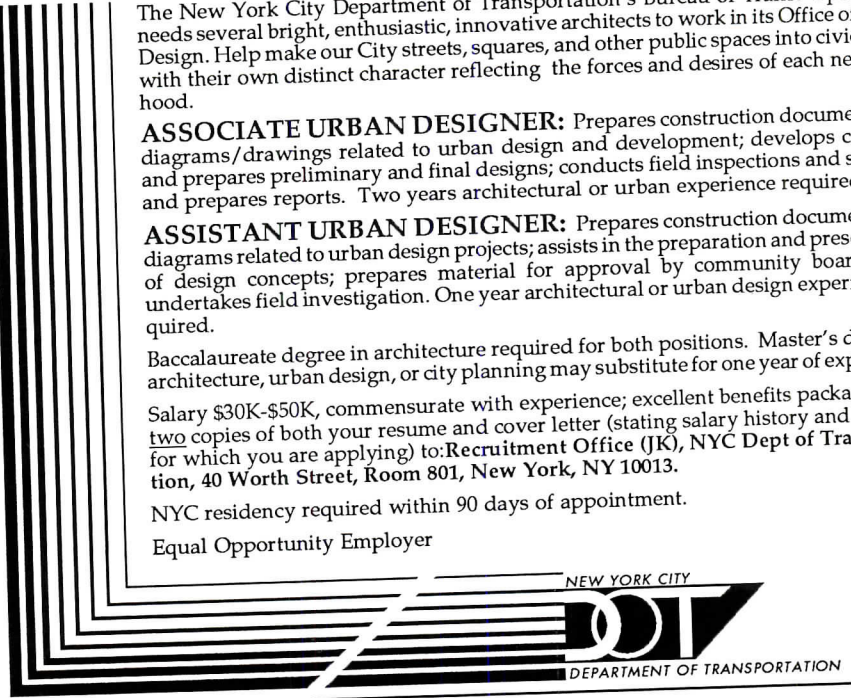

## ARCHITECT

Rewarding responsibility, professional growth, outstanding financial compensation and company ownership are all available at our real estate development and design/build management company. If your ambitions are greater than your opportunities, call David Souers, RA.

**THE EDGEWATER COMPANIES**  
RD6 Box 434, Kingston, NY 12401  
914-336-4002

**Marketing Representatives. Hansen Lind** Meyer Architects and Engineers, Inc., a nationally recognized leader in the design of health care, high-tech, criminal justice and commercial facilities, is currently building our marketing staff to ensure continued growth. Successful candidates will have a strong academic background in architecture or marketing, prior experience in marketing professional design services and excellent communication skills. Marketing representatives are responsible for developing client leads, follow-up and coordination of project marketing strategies. Positions are currently open in our Iowa City, IA, and Chicago offices for highly-motivated, growth-oriented professionals. These are highly visible positions and offer significant opportunities for both personal and professional advancement. Travel required. We offer competitive salaries, outstanding benefits and a professional work environment. Please forward a cover letter, resume and office preference to: Duane R. Roggow, Hansen Lind Meyer Inc., Plaza Centre One, Drawer 310, Iowa City, IA 52244 EOE M/F.

## SPECIFICATION WRITER

THE SEAR-BROWN GROUP, a multi-disciplined design A/E consulting firm, has an excellent opportunity for a Senior Specification Writer. This is a newly created position and will require experience in OGS, Master Specifications and CSI format. The individual will need to have current knowledge of materials and production processes for all disciplines and the ability to develop and manage a supportive staff. A degree in architecture and registration is a definite plus.

We are an employee-owned firm and provide an excellent benefits and compensation package. Please send resume in confidence to:

**SEAR-BROWN GROUP**  
85 Metro Park  
Rochester, NY 14623

An Equal Opportunity Employer



## POSITIONS VACANT

**Senior Architect/Manager of Technical Services.** Design-oriented, diverse, coastal Maine architectural firm seeks experienced registered architect to direct production, day-to-day scheduling, and quality control. Successful candidate will be a key player in a growing 18-person practice committed to quality design, social responsibility and client service. This position reports directly to the principals with potential for associate-level involvement. We seek a technically-oriented professional with minimum 10 years post-registration experience in preparation & review of contract documents, & excellent managerial & supervisory skills. The Design Alliance offers a pleasant work environment, a competitive salary and benefits package and advancement opportunities to qualified individuals. Please send resume and salary requirements to Barry Stallman, President, The Design Alliance, 75 Market Street, Portland, Maine 04101 (707) 773-1765 (An Equal Opportunity Employer).

**Engineer II — Bachelor's degree in civil engineering or related field and 2 years experience performing related duties.** Range \$28,916-\$48,343. Please send resume to: Collier County Government, Human Resources Department, 11 E. Tamiami Trail, Naples, FL 33962. Equal Opportunity Employer. Veterans and their spouses may receive preference in employment and are encouraged to apply.

**Assistant Director of Research: School of Architecture.** Supervise graduate students; coordinate professional research; liaison with state and local government; teach one course. Qualifications: professional degree in architecture; environmental design or building industry research preferred; administrative exp. preferred. Send resume: Personnel Box ADR, New Jersey Institute of Technology, Newark, NJ 07102. Employer does not discriminate on the basis of sex, color, handicap, national or ethnic origin, or religion in employment.

**Michael Latas & Associates, Executive Search and Professional Recruiting Consultants,** Specialists in the architectural and engineering fields. Operating nationally. Inquiries held in the strictest of confidence. 1311 Lindbergh Plaza, St. Louis, Missouri 63132; (314) 433-1500.

## FACULTY POSITIONS VACANT

**Barry Stallman, School of Architecture, The University of Notre Dame,** effective beginning in the fall semester of 1989. Qualifications to include: Master of Architecture or higher, distinguished record of scholarship and design, excellent teaching, demonstrated leadership ability and experience in administration. The School currently includes faculty at the home campus and at the School's Rome Center, offering a balanced first professional degree program and a second-degree masters program with an emphasis on design. The School consists of approximately 225 undergraduates in the five year program and 10 graduate students. Persons interested should submit a Curriculum Vitae and letter of interest and qualifications, three references and any other material which may be relevant including brochures of designs. Nominations and applications should be sent to the Search Committee of the School of Architecture, c/o Norman Crowe, Committee Chairman, School of Architecture, University of Notre Dame, Notre Dame, Indiana, 46556. The University of Notre Dame is an Equal Opportunity/Affirmative Action Employer.

## FACULTY POSITIONS VACANT

**University of Cincinnati, College of Design, Architecture, Art and Planning:** Searching for outstanding leader in architecture and/or interior design to be administrative head and educational leader of the School. Reports to the Dean of the College. Tenured appointment at full professor level. A master's or doctorate degree, teaching and administrative experience, and professional accomplishment in an architecture or interior design discipline are required. Deadline for completed applications is December 1, 1988. Search will continue until a suitable candidate is found. Position is available September 1, 1989. Send letter of application, curriculum vitae, samples of work and names of three references to: Prof. Kristi Nelson, Search Committee for SAID Director, College of Design, Architecture, Art and Planning, University of Cincinnati, Cincinnati, Ohio 45221-0016. Affirmative Action, Equal Opportunity Employer.

**The Department of Architecture, Tuskegee University** is seeking applicants for faculty positions within the department to be filled by January 1989. Appointment conditions: Full time contract, tenure track positions. Academic rank and salary will be commensurate with the applicants' qualifications and experience. Qualifications: a.) Candidates should have a graduate degree in Architecture, Construction Science, Civil Engineering, or related discipline. b.) Candidates should be qualified to teach Architectural Design, Architecture History and Theory, or Construction Methods and management courses. Application procedures: Applicants should submit letter of application resume, undergraduate and graduate transcripts and names, phone numbers and addresses of three references to: Charles W. Raine, Associate Dean and Department Head, Department of Architecture, Tuskegee University, Tuskegee AL 36088.

## FACULTY POSITIONS VACANT

**Arizona State University. The School of Architecture** seeks qualified applicants for faculty positions beginning Fall, 1989. Appointments are anticipated in the following subject areas: architecture research/science; advanced architectural administration; practice and design. A record of research, significant practice, or other recognized scholarly achievement is expected for appointments at an advanced academic rank. The School of Architecture plays a prominent service role at ASU and within the dynamic Phoenix metropolitan area. All faculty participate in its research, instructional and public missions. Minorities and women are encouraged to apply. Applications will be received commencing Nov. 21, 1988 and will continue until positions are filled. For requirements and additional information contact: Search Committee; School of Architecture; ASU: Tempe, AZ 85287. (Tel. 602-965-3536). ASU is an Equal Opportunity/Affirmative Action Employer.

**University of Cincinnati, School of Architecture and Interior Design,** Invites applicants for two-tenure track positions in the Department of Architecture for 1988-90 to develop and direct a Center for the Study of the Practice of Architecture, along with related teaching and research responsibilities. Applicants for an Associate Professor position must have a master's degree (preferably a doctorate), a thorough knowledge of architectural practice, and a substantial record of research and scholarship. Assistant professor applicants must have a master's degree, substantial knowledge of architectural practice and qualifications for research. Send resumes, examples of work, and names of three references by January 4, 1989, to: Gordon Simmons, Acting Director, School of Architectural and Interior Design, University of Cincinnati, Cincinnati, OH 45221-0016 513-556-6426. The University of Cincinnati is an affirmative action employer.

## HIRE 1990 & 1991 GRADUATING ENGINEERS — NEXT SUMMER! —

First, it's in our industry's best interest to hold and encourage its life-blood by providing career-conscious undergraduate engineering students with meaningful summer job experience in their future profession.

Second, since there'll always be more anxious applicants than openings, you'll be able to select the cream of the crop, then evaluate them under "game-conditions" with an eye towards hiring them after they graduate.

By filling out and returning the coupon below, your organization will be included in summer job listings to be featured in the January 1989 issue of McGraw-Hill's GRADUATING ENGINEER.

This edition will be distributed to 83,000 engineering students on over 300 campuses by Deans and engineering department heads.

Please supply the name of the person students should contact, and a phone number for our checking purposes only.

PLEASE PRINT OR TYPE

### Free summer job listing

MAIL TO: ARCHITECTURAL RECORD/POST OFFICE BOX 900/NEW YORK/NY 10108

NAME/TITLE of individual to be contacted

Your Signature

NAME OF ORGANIZATION

Telephone (our use only)

ADDRESS: Mailing address of your personnel office

TYPE AND NUMBER OF STUDENTS SOUGHT: Architect    Illustrator

Mechanical or Civil Engineer/Computer Science/Draftsperson/Model Builder



Note: Last date coupons can be accepted for this year's summer job listings is November 20, 1988



# FINALLY!

## A FLUSH POKE-THRU

### The Headless Poke-Thru is here.

If you're an architect or interior designer we just "made your day". We finally got rid of the electrical outlet "doghouse".

If you're a specifying engineer, you'll be happy to hear that Raceway has developed the first **Flush Poke-Thru** with full capacity... two services

in a single 3" hole; 15 or 20 amp, 125V duplex receptacle power. Plus two individual openings for low tension wiring for telephone, signal or data communications. **U.L. Classified and Listed.**

If you're a contractor, put this into your calculator. The Raceway **Flush Poke-Thru** comes factory pre-wired, terminating in a junction box which is **integral to the fitting.** (Perfect for renovation since it installs over

existing wires.) Just drill the hole... step on it... you're finished.

There are so many more exciting features. Color-coordinated choice of retainer ring... a sliding polycarbonate receptacle cover... but that's why we printed a brochure. It's all in there.

**Send for it. Join the rush to get flush.** Write or call Raceway Components, Inc., 263 Hillside Avenue, Nutley, N.J. 07110. 201-661-1116.



RACEWAY COMPONENTS, INC.



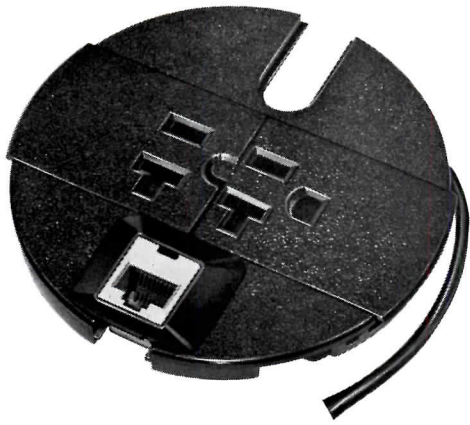

## NOW AVAILABLE WITH LOW TENSION DISCONNECT

The Raceway Flush Poke-Thru is becoming a family. Here's a new "baby" with a special low tension disconnect. Now you can instantly disconnect the data and communications links as easily as power. Abandoned fittings remain energized for future activation. No "doghouses" present unsightly impediments to the movement of furniture and people. If desired, the device's 8 pin, plug-ended cord is also easily disconnected and reconnected from service.

A special AT&T® adapter accepts a coax plug and connects into the modular disconnect jack, permitting full use of data as well as data/voice integration at the workstations.

The Raceway Low Tension Disconnect comes integrated into the Flush Poke-Thru for new installation. Or, it can be supplied for retrofit into installed Raceway Flush Poke-Thru's. Learn more about them by writing Raceway Components, Inc., 263 Hillside Avenue, Nutley, N.J. 07110. 01-661-1116.

AT&T is a registered trademark of AT&T Inc.



**RACEWAY  
COMPONENTS, INC.**

Circle 90 on inquiry card

Continued from page 151



### Upholstered seating

Conrad Marini used flat welting to outline the main components of the Milan Series leather- or COM-covered armchairs and sofas. Krug Inc., Kitchener, Ont. Circle 319 on reader service card



### Cabinet hardware

Offset, square, and rounded pulls are included in Baldwin's new 43-piece hardware series. Finishes range from polished brass to black nickel. Baldwin Hardware Corp., Reading, Pa. Circle 320 on reader service card



### Synchronized seating

Created by the Ahrend Design Team, the Sessio chair has a contoured seat and back that respond automatically to changes in the weight and posture of the user. Sessio can be stacked, and is available in arm (pictured), armless, bookrack, and tablet-arm styles. Thonet/Madison Industries, Statesville, N. C.

Circle 321 on reader service card

## PROFESSIONAL SERVICES

### NYC DEPT. OF BUILDINGS EXPEDITING SERVICES

Thorough building code & zoning consultation. Reliable & complete service for all types of commercial and residential filings including Certificates of Occupancy.

**HANNIBAL GALIN & ASSOCIATES**  
(718) 783-6052

## FOR SALE

### Church Pews

For more information, call: 1-800-537-1530 In Ohio, 1-800-472-2722

**SAUDER®**

## BOOKS FOR SALE

### FEEES FOR ARCHITECTS!

MELTON ARCHITECT'S SERVICES is a book of more than 200 pages that shows you the way to determine the minimum cost of Architect's Basic Service for more than 75 different types of buildings. It is 5½" x 8½" in size and has a beautiful leatherette back with wire roll binding and heavy weight pages for long life.

PREPAID \$29.95

Send to T. L. MELTON CO., P.O. BOX 2644 ATLANTA, GA 30301

## SPECIAL SERVICES

### AS COMPLETE PREPARATION FOR THE REGISTRATION EXAMS

Architectural License Seminars (213) 208-7112  
Box 64188 Los Angeles California 90064

**Cost Estimating, Quantity Surveys, Computer Applications, Corp., DOD, GSA, VA, Construction Cost Systems, Chicago (312) 858-5441; Tampa — (813) 887-5600.**

## BUSINESS OPPORTUNITIES

**Architectural firm for sale. Lucrative practice Southwest US. 15-18 employees. Owner burnout. Call Paul A. Ramsower, Rober Cox & Associates, 505-842-6400.**

## TO ANSWER BOX NUMBER ADS

Address separate envelopes  
(smaller than 11" x 5")  
for each reply to:

Box Number (As indicated)  
Classified Advertising Center  
Architectural Record  
Post Office Box 900  
NY 10108



# The Architectural Spectrum

Spectrum's wide array of high performance glass products could be instrumental to resolving your fenestration problems.

Select Thermopane® insulating glass with neutral Janusite® coating to enhance thermal performance, but retain the aesthetics of uncoated glass. Or choose from 34 varieties of Vari-Tran® solar control glass, ranging from bright and shiny to dark and subdued. Coatings include Antique Silver, Sterling Silver, Sapphire Blue and Burnished Bronze.

Design spandrels with glasses which closely match the appearance of vision areas. Or band the building subtly or in a bold expression of color.

For further details on the complete array, call or write Spectrum Glass Products, P.O. Box 408, Clinton, NC 28328. (919) 592-7101. Telex: 910 380 9098.



Circle 76 on inquiry card

## New Cheney Victory® Wheel n' Chair Lift offers sleek, hi-tech accessibility to public buildings.



- Many unique features never before available.
- Carries wheelchair or a seated passenger up to 3 flights of most stairway configurations.
- Accelerates to 25 ft. per minute and automatically slows to 12 ft. per minute on turns and before stations.
- Coded Key Card access and call and send controls.
- Factory pre-programmed to suit installation.
- Check Sweets Catalog for more details.

FOR FREE BROCHURE, WRITE OR CALL:

**1-800-782-1222.**

In WI 1-800-552-7711.

*The Freedom of Movement®*

**CHENEY** 

*A Mediquip Healthcare Company*

Dept. AR, P.O. Box 188, 2445 South Calhoun Road, New Berlin, WI 53151.

Circle 77 on inquiry card

# Why you should specify Accuride slides

### For residential furniture

A full line of specialty hardware for buffets, armoires, bedroom suites, home entertainment centers and office furniture.

### For kitchens and baths

Ultra-smooth slides for butcher blocks, two-way drawers, kitchen drawers, pull-out pantries, oversized pan drawers and adjustable shelves. 32mm systems available.

### For fine office furniture

Slides are available for desk pedestals and lateral files in wood, metal and systems office furniture. Flipper Door™ slides for overheads. Heavy duty lateral file slides for drawers up to 60" wide.

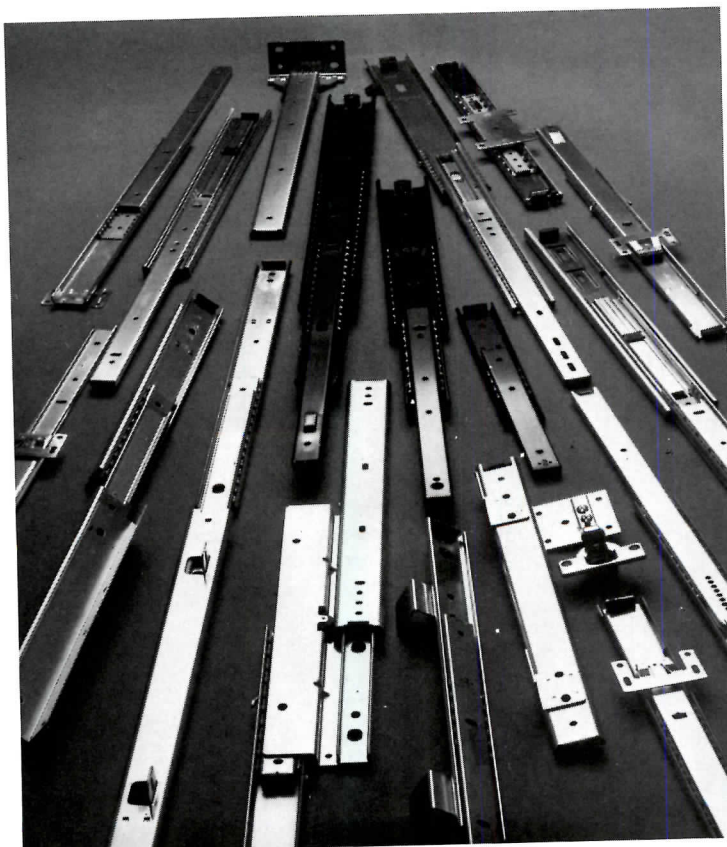

Circle 91 on inquiry card

### For national distribution

Accuride has a network of distributors in all major U.S. and Canadian markets. Well stocked and ready to serve your needs.

### For Quality Assurance

Custom Features can be designed in to meet special requirements. Free design services by Application Engineers are also available.

See our catalog pages in Sweets.

Call our Customer Assistance Hotline now for all the facts.

Accuride  
12311 Shoemaker Ave.  
Santa Fe Springs, CA 90670  
(213) 944-0921

**Accuride**



Sound Walls • Retaining Walls • Exposed Foundations • Spandrels

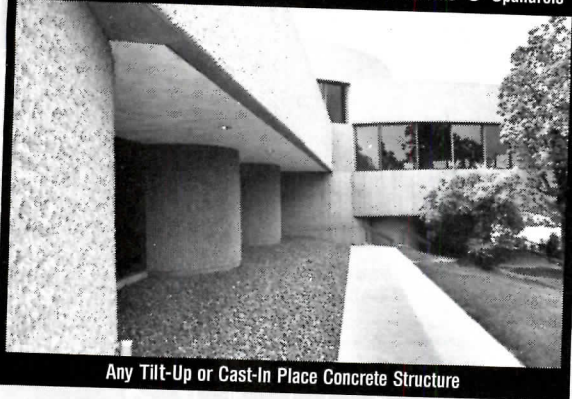

Any Tilt-Up or Cast-In Place Concrete Structure

**ARCHITECTURAL CONCRETE  
with GREENSTREAK FORM LINERS**  
*The First Choice For Beauty & Economy*

ALL patterns available in  
three different use ranges. . .

UNI-CAST®: Single use Form Liner

MULTI-CAST®: For up to 10 uses

DURA-CAST®: For up to 25 uses

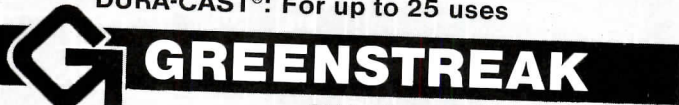

See Sweets  
03100/GRD  
SPEC-DATA®

CALL 800-325-9504  
Missouri Residents 314-225-9400  
Box 7139 • St. Louis, MO 63177

Circle 78 on inquiry card

# Risk And Liability

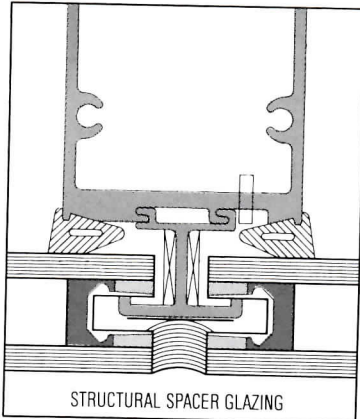

Now you can reduce your exposure to risk and liability and still achieve the streamlined exterior aesthetics of structural silicone glazing.

Introducing the Duratec Structural Spacer Glazing System from Spectrum Glass Products. A simple but innovative solution to the specific problems of glazing without outside stops.

The Duratec system features specially designed insulating glass which is mechanically fastened without exposed stops, fasteners or field-applied structural sealants. Standard window wall and curtain wall packages for low- to mid-rise construction are available right now.

For complete details, call or write Spectrum Glass Products, P.O. Box 408, Clinton, North Carolina 28328. (919) 592-7101. Telex: 910 380 9098.

**Duratec™**  
Structural Spacer Glazing

Circle 79 on inquiry card

**BUSINESS TAKES OFF  
WITH DODGE/SCAN.**

Because Dodge/SCAN makes takeoffs so easy—right in your office. That's why so many firms depend on Dodge/SCAN for all the plans, specs, and addenda they need. Fast. Cost-efficient. Complete.

Call your Dodge Representative for more information.

FW. Dodge McGraw-Hill Information Services Company

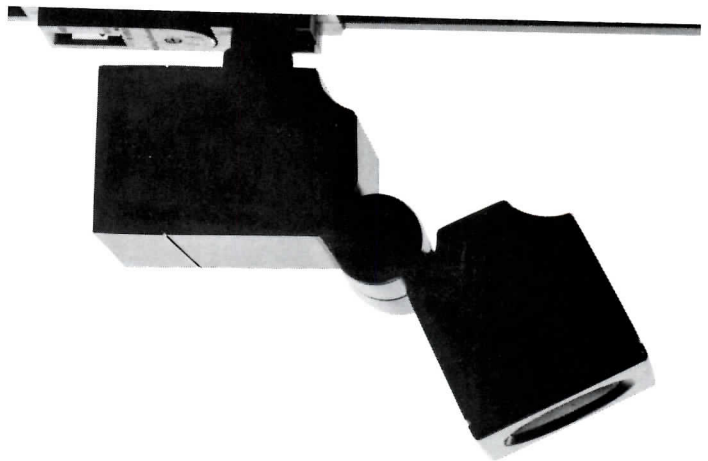

**MICKEY**

We knew we had something very special in our hands (actually, hand. It's that small) when we developed the MR-16. But your response has been literally overwhelming. Keep those cards and letters coming in, we may start a fan club.

For an information kit, write on your letterhead to:  
Lighting Services Inc., Industrial Park Rt. 9W,  
Stony Point, NY 10980-1996 (914) 942-2800



Circle 80 on inquiry card



# THE SOLUTION WAS NEVER SO SIMPLE.

Business Management  
General Ledger  
Accounts Payable  
Payroll  
Fixed Assets  
Resource Scheduling  
Custom Reporting Query

# Wind-2

Fully Integrated Financial Management and Accounting Software Designed Specifically for Architects and Engineers.

For product or price information call or write:



1901 Sharp Point Drive, Suite A  
Fort Collins, CO 80525 • 303 482-7145

Circle 81 on inquiry card

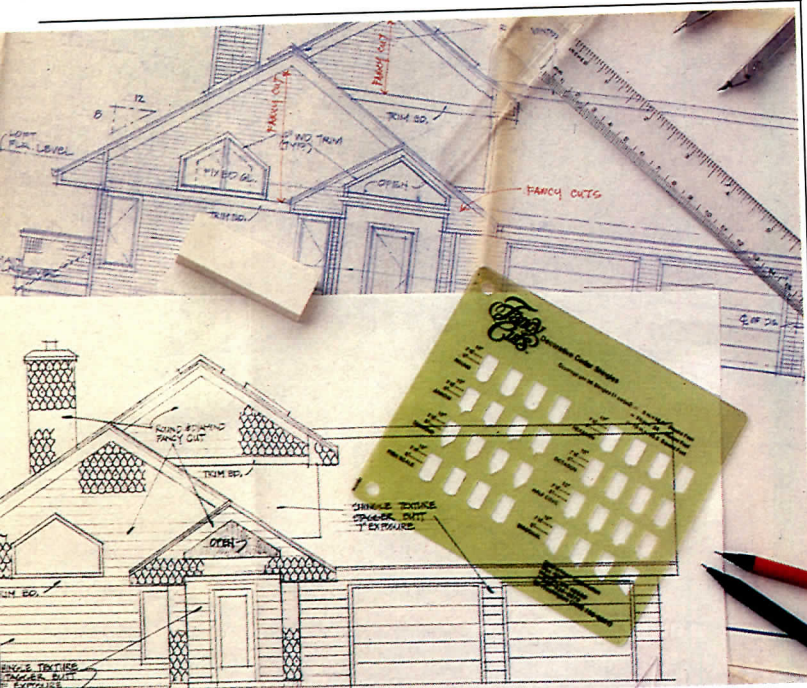

## MAKE YOUR PROJECTS MORE PROFITABLE — EFFORTLESSLY!

Love those decorative cedar shingles but hate to draw them? Save valuable time with our Fancy Cuts Template. Each template shows exposures for both interior and exterior applications along with square footage achieved per 6-piece carton based on exposure.

Call now: 1-800-426-8970 for your free template and design kit to make your next project more profitable.

### SHAKERTOWN FANCY CUTS®

Send for a free design kit: Shakertown, Box 400 AR-FC-12-87, Winlock, WA 98596 or call 1-800-426-8970.

Circle 82 on inquiry card

## U. S. POSTAL SERVICE STATEMENT OF OWNERSHIP, MANAGEMENT AND CIRCULATION (ACT OF AUGUST 12, 1970: SECTION 3685, TITLE 39, UNITED STATES CODE)

1. Title of publication—Architectural Record (combined with American Architect, Western Architect and Engineer).  
Publication number: 0003858X.
2. Date of filing—September 14, 1988.
3. Frequency of Issue—Monthly with additional issues in April and September. Number of issues published annually: 14.  
Annual subscription price: \$39.00.
4. Complete Mailing Address of Known Office of Publication—1221 Avenue of the Americas, New York, NY 10020.
5. Complete Mailing Address of Headquarters of General Business Offices of the Publisher—same as above.
6. Full Names and Complete Mailing Addresses of Publisher, Editor and Managing Editor—Publisher: Ted R. Meredith, 1221 Avenue of the Americas, New York, NY 10020; Editor: Mildred F. Schmertz, 1221 Avenue of the Americas, New York, NY 10020; Managing Editor: Carolyn De Witt Koenig, 1221 Avenue of the Americas, New York, NY 10020.
7. The owner is McGraw-Hill, Inc., 1221 Avenue of the Americas, New York, NY 10020. Stockholders holding 1 percent or more of stock are: Donald C. McGraw, Jr.; Harold W. McGraw, Jr.; John L. McGraw; William H. McGraw; June M. McBroom; Elizabeth McGraw Webster; all c/o McGraw-Hill, Inc., 1221 Avenue of the Americas, New York, NY 10020. Twentieth Century Investors c/o US Trust, 770 Broadway, New York, NY 10003; Pioneer II Fund c/o FNBB Shareholders, 1 Financial Center, Boston, MA 02111.
8. Known bondholders, mortgagees, and other security holders owning or holding 1 percent or more of total amount of bonds, mortgages or other securities—None.
9. Not applicable.
10. Extent and nature of circulation:
  - A. Total number of copies printed—average number of copies of each issue during preceding 12 months, 81,145; actual number of copies of single issue published nearest to filing date, 78,147.
  - B. Paid and/or requested circulation—1. Sales through dealers and carriers, street vendors and counter sales—average number of copies of each issue during preceding 12 months, none; actual number of copies of single issue published nearest to filing date, none. 2. Mail subscriptions—average number of copies of each issue during preceding 12 months, 73,977; actual number of copies of single issue published nearest to filing date, 74,487.
  - C. Total paid circulation—average number of copies of each issue during preceding 12 months, 73,977; actual number of copies of single issue published nearest to filing date, 74,487.
  - D. Free distribution by mail, carrier or other means—samples, complimentary, and other free copies—average number of copies of each issue during preceding 12 months, 5,326; actual number of copies of single issue published nearest to filing date, 2,970.
  - E. Total distribution—average number of copies of each issue during preceding 12 months, 79,303; actual number of copies of single issue published nearest to filing date, 77,457.
  - F. Copies not distributed—1. Office use, left-over, unaccounted, spoiled after printing—average number of copies of each issue during preceding 12 months, 1,842; actual number of copies of single issue published nearest to filing date, 690. 2. Returns from news agents—average number of copies of each issue during preceding 12 months, none; actual number of copies of single issue published nearest to filing date, none.
  - G. Total—average number of copies of each issue during preceding 12 months, 81,145; actual number of copies of single issue published nearest to filing date, 78,147.
11. I certify that the statements made by me are correct and complete.

McGRAW-HILL, INC., Ted R. Meredith, Publisher



# MUSSON

## Marbleized rubber stair treads and tile

NO. 800  
Lo-Disc

NO. 1000  
Horizontal  
bar

NO. 500  
Rectangle design

NO. 622  
Diamond design

All Musson marbleized stair tread and tile systems are made of resilient homogeneous rubber and have the advantage of architectural styling, easy cleaning, durability and a safer surface for heavy traffic.

LO-DISC TILE



Write For Free Brochure & Samples:

**MUSSON RUBBER CO.**

P.O. Box 7038 • Akron, Ohio 44306 • 216/773-7651

Circle 83 on inquiry card

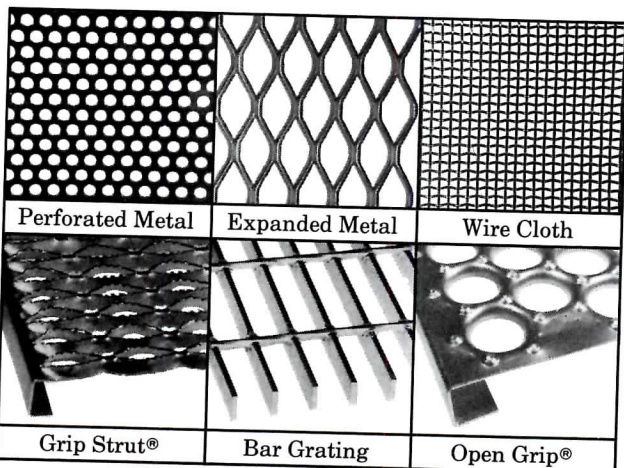

### SHOPPING FOR METAL WITH "HOLES"?

Then Call the 'Hole Store'!

NATIONAL SERVICE CENTERS  
Complete Stocks - Fast Shipment



National  
Toll Free: **800-237-3820**

**McNICHOLS CO.**

P.O. Box 30300 / Tampa, FL. 33630-3300  
FAX: 813-879-4979 Telex: 52706



Cleveland • Chicago • Dallas • Atlanta • Newark • Boston • Tampa

Circle 84 on inquiry card



### MERLIN

Not much to look at is it? Ah, but it has hidden powers. Just screw in a PAR38 lamp of 90 watts and it will put out a high intensity beam of 150 watts. Magic! For an information kit, write on your letterhead to: Lighting Services Inc., Industrial Park Rt. 9W, Stony Point, NY 10980-1996 (914) 942-2800



Circle 85 on inquiry card



# WHEN YOUR ROOF JUST HAS TO LAST.



A dependable roof is a way of life. It has to protect its owner from anything the elements can dish out; sun, chemicals, severe temperature swings, even acid rain. And look good doing it.

That's where Robertson comes in. With our Total Performance Roof. Protected by Versacor® PF. A coating system that combines our Versacor® epoxy base coat with a PPG Duranar® finish. And creates what is simply the most durable metal roof available.

What's more, the Versacor PF Coating System costs only about 15 cents more per square foot than most ordinary thin-film paints. So you can include it in your specs without running for cover.

Skeptical? We'll prove it. Just write H.H. Robertson Company, Department AR11, 400 Holiday Drive, Pittsburgh, PA 15220. Or call (412) 928-7500. We'll send you a free copy of our Independent Test Results brochure. And show you how to get roofing problems off your back. Once and for all.

## The No Compromise Roof



Robertson

Circle 86 on inquiry card



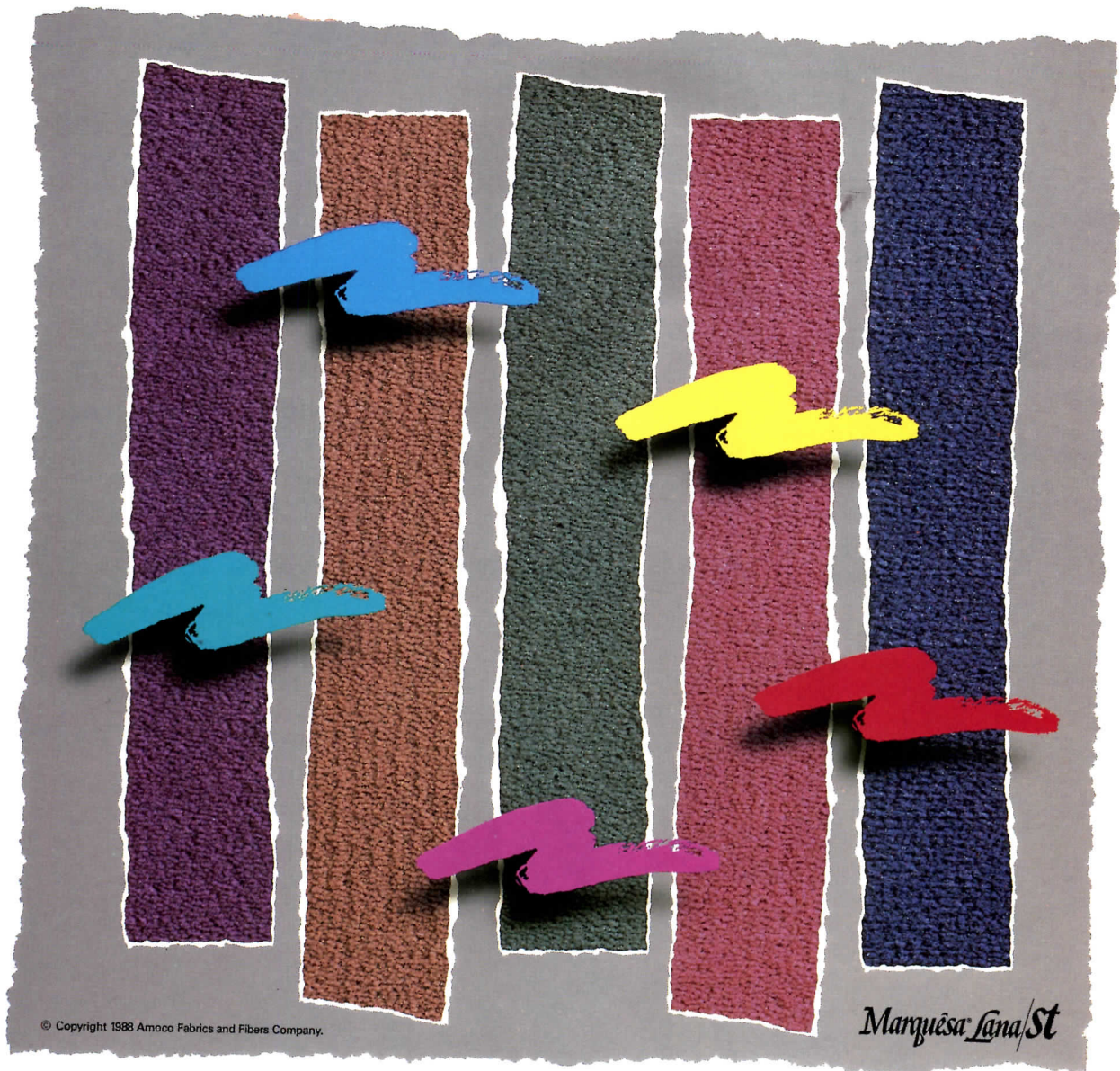

## Colors that get down to business.

For health care and hospitality, office buildings and small businesses, PermaColor™ warranted commercial carpets come in over 150 beautiful colors that don't quit. Specify colors that you never dared to before. Even lighter shades work overtime to resist stains and fading. Amoco guarantees it for five full years.



For warranty details and more information, call: **1-800-BY-AMOCO** or write: *Advertising and Merchandising Department, Amoco Fabrics and Fibers Company, 900 Circle 75 Parkway, Suite 550, Atlanta, Georgia 30339.*

**Scotchgard®**  
Carpet Protector

Scotchgard® is a registered trademark of the 3M Company.

Amoco Fabrics and Fibers Company makes fibers and yarn, not finished carpet.



Amoco Fabrics and Fibers Company



MORE GREAT RATES FROM  
THE EMPLOYEE-OWNERS\* OF AVIS, INC.

# For Rent By Owners.

The employee-owners of Avis, Inc. meet the competition head-on. Check our rates and compare for yourself.

Since we bought the company one year ago, we've been trying harder than ever to give you more

for less. More late-model GM and other fine cars.

More fast, efficient service. In other words, more value for your money.

To get these low rates, here are some things you should know. These rates include a free mileage allowance, but there's an additional charge per mile thereafter. There is no refueling charge if you return your tank full. These rates are available at participating U.S. locations and are higher in the metro N.Y. area. They are nondiscountable and may change without notice.

These cars are subject to availability, and blackout periods and additional seasonal charges may apply. For

renters under 25 and additional drivers, there are extra charges. Cars must be returned to renting location.

Taxes and optional Collision Damage Waiver

(\$9.95/day, higher in certain areas), Personal Accident Insurance, Personal Effects Protection and Additional Liability Insurance are extra.

To find out what an owner can do for you, call 1-800-331-1212, or call your travel consultant.



We're trying harder than ever



Pontiac Grand Prix

**\$39**

per day



Pontiac Bonneville

**\$41**

per day

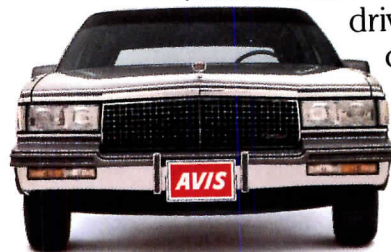

Cadillac Sedan de Ville

**\$45**

per day

Avis features GM cars.

\*Employees at all corporate locations. © 1988 Wizard Co., Inc.



# FANTASTIC

*The flame-like shapes pictured here form the roof structure for a multi-story electric power pavilion at the Tsukuba Expo. After dark, floodlights with rotating color create a vibrant effect of flickering flames. By day, the roof structure remains a striking eye-catching design, though quite different from its nighttime appearance.*

*The white translucent fabric reduces daylight lighting requirements and conserves energy.*

... curvilinear shapes of the simplest, purely functional membrane structure are dramatic and exciting. The design magic you can achieve with tensioned membrane structures is limitless. But this is only one of the reasons architects are utilizing them. Economy, minimum disturbance to the site, and speed of construction are some of the others.

Could a tensioned membrane make sense on a project of yours? As the world leader in architectural fabric structures, Helios has the technology and experience to translate your preliminary design into workable structures. We offer a complete design, engineering, and fabrication service.



For more information, or assistance with a specific project, call or write:



**HELIOS INDUSTRIES, INC.**

20303 Mack Street  
Hayward, California 94545, U.S.A.  
Facsimile 4158870134, Telex 176226  
Telephone (415) 887-4800

Circle 94 on inquiry card



# The Marketplace

To Advertise Call  
(212) 512-2815  
(212) 512-2236



**Heavy-Duty Aluminum Railing Is Maintenance Free.** Superior Series 900 Railings give strong, durable, rust and corrosion-free protection. Available in heights from 30" to 60". Fabricated to your specs in lengths to 24' in five finishes. Flat columns plus inserts and scrolls, too. Check the appropriate number for free folder. *Superior Aluminum Products, Box 430, Russia, OH 45363. Phone 513-526-4065.*

Circle 95 on inquiry card



**Planning a Laundry? Free File Tells How.** Milnor's laundry planning file explains why efficient laundries can save your clients money. It also includes case histories, space requirements, equipment specs, plus laundry planning questionnaires. It's free from *Pellerin Milnor Corporation, P.O. Box 400, Kenner, LA 70063. Phone 504-467-9591, Ext. 227.*

Circle 96 on inquiry card

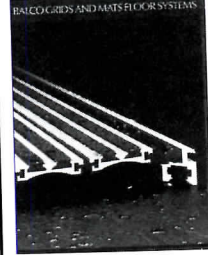

**Balco 1989 Floor Grids and Mats Catalog.** Balco's new 1989 catalog features the company's complete line of roll-up mats and floor grids including the new AirTron floor mat with exclusive air cushion design. Floor systems are available in carpet, vinyl and abrasive finishes for recessed or surfaced applications. *Balco Inc., 2626 South Sheridan, P.O. Box 13249, Wichita, KS 67217. Phone 316-945-9328.*

Circle 97 on inquiry card

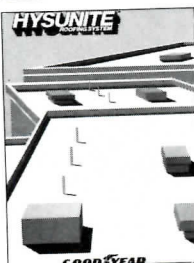

**Goodyear's Hysunitetm (Hypalon®) Roofing System** resists UV, wind, weather, air pollution, fire and structural movement. Heat-sealed, leak-proof seams; energy-efficient white surface. Brochure includes specs/installation info. *The Goodyear Tire & Rubber Company, Roofing Systems, 1144 E. Market St., Akron, OH 44316; Jim Bidlack-216-796-9373.*

Circle 98 on inquiry card

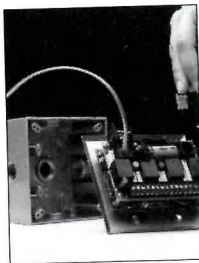

**Easy To Install Security Access Control.** The new, updated Schlage Electronics 9025 Proximity access control system is here! Ideal for new and remodeled small office buildings or parks. Regulates 1 or 2 doors and operates over twisted pair wiring. Controls up to 2600 Cardholders. Modular architecture means system is easier to install. *Schlage Electronics 5452 Betsy Ross Dr., Santa Clara, CA 95054. Phone 408-727-5170.*

Circle 99 on inquiry card



**Solve Roof Drain Problems with RetroDrain.** RetroDrain allows you to replace a broken existing drain entirely from the roof top. No access is required to the building's interior and installation is completed in minutes. Interior ceilings are not damaged and work inside the building is not disruptive. An easy cost effective method of replacing roof drains. *Uflow Inc., Box 1470, Buffalo, NY 14240. Phone 716-854-1521.*

Circle 100 on inquiry card



**Frank Lloyd Wright's Timeless Essays IN THE CAUSE OF ARCHITECTURE.** A collection of essays (until 1927) written by Wright, has retained the agelessness of his ideas. Edited by F. Guthrie and reprinted as a 246 page, high-quality paperback. \$12.95 (includes postage & handling.) Send to: *ARCHITECTURAL RECORD BOOKS - 41ST FLOOR - 1221 Avenue of the Americas - New York, NY 10020.*

Circle 101 on inquiry card

**BIRD BARRIER**  
NIXALITE BIRD CONTROL

- Humane and ecological
- Virtually maintenance free steel spikes
- Commercial, institutional or residential
- Proven reliable for 39 years

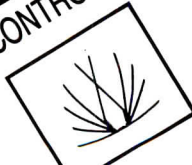

**NIXALITE of AMERICA**  
1025 - 16th AVE. • BOX 727  
EAST MOLINE, IL 61244 • 309-755-8771  
800-824-1189 • FAX 309-755-0077  
SPECIALISTS IN BIRD CONTROL

For more info., see Sweet's section 10290/NIX

Circle 102 on inquiry card

**COLUMNS**



**Architectural columns crafted in Ponderosa pine.** Shipped direct from our factory to your job site. Sizes from 6" to 30" diameter and a full range of capital styles. Competitively priced. Worthington, the premier name in columns. *Worthington Group, Ltd., P.O. Box 53101, Atlanta, GA 30355. Phone 404-872-1608.*

Circle 103 on inquiry card





**N.T.B. Fastening Systems Inc.** N.T.B. Fastening Systems is a manufacturer of non-penetrating, non-corrosive fasteners for structural cement fiber and lightweight concrete roof decks. Also available is our new line of fasteners for metal, reinforced plastic fiberglass and wood roof decks. *N.T.B. Fastening Systems Inc., 788 Western Ave., Mosinee, WI 54455. Phone 715-693-4545.*

Circle 104 on inquiry card

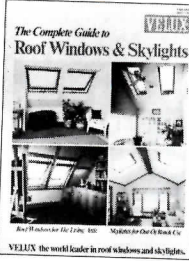

**Attention To Details.** Special attention to details mean exceptional value, quality and satisfaction. *VELUX* offers you pages of information and ideas in our color brochure that can be used in building and remodeling plans. The more you know about *VELUX* roof windows and skylights, the better you can compare. *VELUX-AMERICA INC., 450 Old Brickyard Rd. P.O. Box 3208, Greenwood, SC 29648. Phone 803-223-3149. FREE.*

Circle 105 on inquiry card



**Sternberg Lighted Bollard.** One of a complete line of bollards/ coordinating posts, authentic post base design, deep fluted 5" dia. shaft, heavy wall castings with .750 floor, inside anchor bolts, one piece construction and Alzac reflector. The 4201-LB scales 17"x42" variable hgt. White acrylic recessed lens, mercury vapor, high pressure sodium, metal halide and PL. Specializing in historic, ornamental posts/fixtures. *Sternberg Lanterns Inc. 5801 N. Tripp, Chicago, IL 60646. 312-252-8200.*

Circle 106 on inquiry card



**Plaster in a Roll.**™ A gypsum-impregnated, flexible wall covering, is manufactured specifically for concealing cracks, patches, holes, and other wall problems.

It is suitable as a replacement for conventional plaster and is widely used in schools and hospitals. Flexi-Wall<sup>®</sup> Plaster in a Roll adheres to tile, cement block, glass, wood and plaster. GSA contract #GS-07F-17572, also under HUD contract. Flexi-Wall Systems, Inc., Box 88, Liberty, SC 29657. 803-855-0500.

Circle 107 on inquiry card

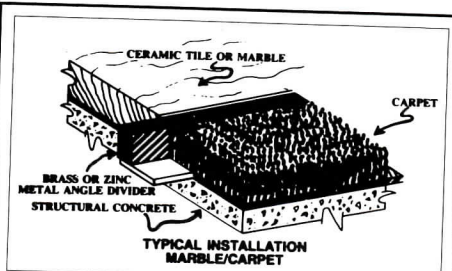

**PTE Brass Dividers for Protection of Marble/Tile Edges—UPS to West Coast.** Can be used with ceramic tile, marble and pavers to protect edges and provide attractive linear design when used with carpet, parquet and other types of flooring. For a sample or literature call 1-800-241-0681. *KLEIN CO., P.O. Box 80415, Atlanta, GA 30366.*

Circle 108 on inquiry card

**If You Need em OUTWATER'S Got em**

Make OUTWATER your one stop warehouse for everything you need. All in-stock, ready to ship, in any quantity—backed by Outwater's dedication to super service. Great prices, too! Samples always available.

**FREE!**

Your Warehouse In A Book

Write or call for Outwater's NEW catalog, now available. Thousands of items you need and use everyday.

**TOLL-FREE 1-800-631-8375**  
In NJ: (201) 340-1040 Fax: (201) 916-1640

**OUTWATER PLASTIC/INDUSTRIES Inc.**  
4 Passaic Street/Wood-Ridge, New Jersey 07075  
Telex: 133-526

Circle 109 on inquiry card



**Decorative Grilles in Color.** Add a new dimension to your designs with these decorative grilles which can be used to make striking unusual effects. Choose from an array of

custom colors to match or contrast existing grilles. Designers can also create numerous metal forms for interior or exterior applications. Write for catalog: *Register & Grille Mfg. Co. 202 Norman Avenue, Brooklyn, NY 11222. 718-383-9090.*

Circle 110 on inquiry card

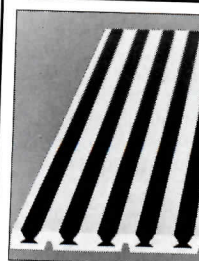

**Zero's New Traction Tread™ Saddles and Nosings.** Revolutionary design in which profiled aluminum saddle grooves are fitted with

long-wearing, flush, rubber inserts. Superior traction, an even smooth surface and easy installation. For information, and a copy of Zero's 1989 catalog, contact: *Zero International, Inc., 415 Concord Ave., Bronx, NY 10455; Phone: 1-800-635-5335. FAX: 212-292-2243.*

Circle 111 on inquiry card



**A Practical Solution to Roof Paver Stone Applications.** New bulletin shows a better way to transform a roof into a patio, terrace, balcony, walk-way,

plaza, podium, promenade, or just plain roof deck, using the Pave-El Pedestal system. Designed to elevate, level, and space paver stones for drainage in any weather. Pave-El reliably protects roof, paver stone, membrane and insulation. *Envirospec Inc., Ellicott Station, Box 119, Buffalo, NY 14205. 416-252-2090.*

Circle 112 on inquiry card



# Advertising index

For detailed data, prefiled catalogs of the manufacturers listed below are available in your 1988 Sweet's Catalog File as follows:

- (G) General Building & Renovation
- (E) Engineering & Retrofit
- (I) Industrial Construction & Renovation
- (L) Homebuilding & Remodeling
- (D) Contract Interiors

## A

- Accuride, 172; 91 [D]  
(213) 944-0921  
Alumax Building Specialties, 50; 33 [G-D]  
(214) 285-8811  
American Olean Tile Co., 26-27; 15 [G-D]  
(800) 541-TILE  
Amoco Fabric & Fibers Co., 177; 93 [E]  
Andersen Corp., 68-69; 41 [G-L]  
(800) 635-7500  
Armstrong World Industries, Inc., Cov.II-1; 1, 2-3; 2 [G-E-D]  
(800) 233-3823  
Avis, 178  
(800) 331-1212

## B

- Bilco Co., 151; 63 [G-E-L]  
(203) 934-6363  
Bond Cote Systems Co. Div., WestPoint Pepperell, 36; 24 [G]  
(800) 368-2160

## C

- Canon U.S.A., Inc., 32; 18, 138; 56  
(800) OK CANON  
CARADCO, a Kusan, Inc. Co., 54; 35 [G]  
(217) 893-4444  
Carlisle Syntec Systems, Div. of Carlisle Corp., 16; 9 [G-E-I]  
(800) 233-0551  
Chemstar, Inc., 32Wa; 21  
(800) 523-8977  
Cheney Co., 172; 77 [G]  
(800) 782-1222  
Chicago Metallic Corp., 33; 22 [G-I-D]  
(312) 563-4600  
Commonwealth Aluminum, 156; 68  
(800) 556-1234  
Compaq Computer Corp., 129 to 132  
(800) 231-0900  
Computer Associates, Inc., 136; 55  
(800) 533-2070  
Cooper Lighting, 155; 75  
C/S Group, 6; 3, 38; 25 [G-E]  
(800) 631-7379  
Cupples Products, Div. of H.H. Robertson, 44; 28 [G]  
(314) 781-6729

## D

- Dor-O-Matic, Div. of Republic Industries, Inc., 56; 36 [G]  
(800) 543-4635  
Dorma Door Controls, Inc., 162; 73 [G]  
(215) 267-3881  
Dover Elevator Systems, Inc., 14-15 [G-I]  
(601) 393-2110

- Dow Corning Corp., 163; 74 [G-E-I-D]  
(800) 346-9882  
DPIC Companies, 140; 57  
DuPont Co.- Teflon, 144; 59  
(302) 774-0027  
DuPont Co.- Textile Fibers, 78-79; 48 [G-D]  
(800) 448-9835

## E

- Ellison Bronze Co., Inc., 128; 52 [G]  
(716) 665-6522  
Esco Elevators, Inc., 34; 23  
(817) 478-4251

## F

- Flexco International, 133; 53 [G]  
(800) 633-3151  
Follansbee Steel Corp., 164; 67 [G]  
(800) 624-6906  
Formica Corp., 73; 44  
(800) 524-0159  
Fry Reglet Corp., 52; 34 [G]  
(818) 289-4744

## G

- General Electric - C&I Lamps, 70-71; 42 [G-E-I-D]  
(800) 523-5520  
General Electric - Plastics, 18-19; 11 [G-I]  
General Electric Plastics - Lexan Sheet, 124-125; 50 [G-I]  
(800) 845-0600  
Georgia-Pacific Corp., 74-75; 45, 46 [G-I-L-D]  
(800) 225-6119  
Glen Raven Mills, Inc., 22-23; 13 [G]  
(919) 227-6211  
Greenstreak Plastic Products, 173; 78 [G-E]

## H

- Harris/3M Document Products, Inc., 146-147; 60  
Helios Industries, Inc., 179; 94 [G]  
(415) 887-4800  
Homasote Co., 150; 62 [G]  
(609) 883-3300  
Hurd Millwork, 76-77; 47 [G-L]  
(800) 2BE-HURD

## I

- Inclinor Co. of America, 184; 116 [G]  
Iolite Corp., 184; 115  
(206) 821-2140  
IPS Insulated Panel Systems, Inc., 46-47; 29 [G]  
(713) 896-8700

## K

- Kawneer Co., Inc., 28-29; 16 [G]  
Kroin, Inc., 5; 6 [G]  
(617) 492-4000  
Kwikset Locksets, 42; 27

## L

- Lighting Services, Inc., 173; 80, 175; 85  
Lutron Electronics Co., Inc., Cov.III; 117 [G-E-D]  
(800) 524-9466

## M

- MacMillan Bloedel Building Materials, 62; 38  
Marvin Windows, 30-31; 17, 160-161; 72 [G]  
(800) 328-0268  
MBCI, 66; 40  
McNichols Co., 175; 84 [E-I]  
(800) 237-3820  
Mitsubishi Chemical Industries America, Inc., 152; 64 [G-D]  
(800) 422-7270  
Musson Rubber Co., 175; 83 [G-I]

## N

- Nevarmar Corp., 40; 26  
(800) 638-4380  
Nippon Electric Glass Co., Ltd., 24-25; 14 [G]  
(312) 297-7020  
Normbau, Inc., 157; 69 [G-L]  
(312) 628-8373  
Nucor Corp., 58-59; 37 [G]

## O

- Owens-Corning Fiberglas, 12; 7 [G-E-I-L]  
(800) 537-3476

## P

- Pella Rolscreen Co., 20-21; 12, 126-127; 51 [G-L-D]  
(512) 628-1000  
Philips Lighting, 48A; 31  
Plan Hold Corp., 13; 8  
(800) 854-6868

## R

- Raceway Components, Inc., 170-171; 90 [G-E]  
(201) 661-1116  
Radio Shack, 64; 39  
Red Cedar Shingle & Handsplit Shake Bureau, 183; 114  
Register & Grille Mfg. Co., Inc., 183; 113 [G-E-D]  
(800) 521-4895  
Robertson Bldg. Products Group, H.H. Robertson Co., 176; 86 [G-E-I]  
(412) 928-7500  
Rohm & Haas, 159; 71 [G]

- Russwin Div., Emhart Hardware Group,  
2 page advertising supplement included with Eastern copies only.  
(203) 225-7411

## S

- Sanyo Fisher (USA) Corp., 48; 30  
(201) 641-2333  
Sargent & Co., 149; 61 [G]  
(203) 562-2151  
Shakertown Corp., 174; 82 [G-L]  
(800) 426-8970  
Sherwin-Williams Wholesale, 141; 58 [G-E-I]  
(800) 321-8194  
Sloan Valve Co.- Plumbing Div., Cov.IV; 118 [G-E-I]  
Southwall Technologies, Inc., 80; 49 [G]  
(800) 365-8794  
Spectrum Glass Products, 172; 76, 173; 79 [G]  
(919) 592-7101  
Spring City Electrical Mfg. Co., 153; 65 [G-E]  
(215) 948-4000  
Stanley Magic-Door, Div. of The Stanley Works, 49; 32 [G]  
(800) 232-3663  
Stow & Davis, 10-11; 5  
(800) 447-4700  
Super Spec, 32Eb; 20  
Sweet's Canadian Construction Catalogue File, 158; 70  
Sweet's Div.- McGraw-Hill Information Systems, 165 to 167

## U

- USG Interiors, Inc., 8; 4 [G-E-L-D]  
United States Aluminum Corp., 72; 43 [G]  
(800) 527-6440

## V

- VersaCAD Corp., 134; 54  
(714) 960-7720

## W

- Willamette Building Products, 154; (503) 928-3341  
Wilsonart, 17; 10  
(800) 433-3222  
Wind-2 Research, Inc., 174; 81  
(303) 482-7145  
Wolverine Technologies, Inc., 32E; 19 [G-L]  
(800) 521-9020



## Sales offices

### Main Office

McGraw-Hill, Inc.  
1221 Avenue of the Americas  
New York, New York 10020

Publisher  
Ted Meredith (212) 512-4685

Associate Publisher  
Roscoe C. Smith III (212) 512-2841

Director of Business and  
Production  
Joseph R. Wunk (212) 512-2793

Director of Marketing  
Camille Padula (212) 512-2858

Classified Advertising  
(212) 512-2556

### District Offices

**Atlanta**  
170 Ashford-Dunwoody Road  
Atlanta, Georgia 30319  
Gregory Bowerman (404) 252-0626

**Boston**  
77 Boylston St.  
Boston, Massachusetts 02116  
Louis F. Kutscher (203) 968-7113

**Chicago**  
5 N. Michigan Ave.  
Chicago, Illinois 60611  
Anthony Arnone, (312) 751-3765  
Thomas P. Kavooras, Jr.,  
(2) 751-3705

**Cleveland**  
Public Square  
Cleveland, Ohio 44113  
George Gortz (216) 781-7000

**Denver**  
10 S. Alton Ct. Suite 111  
Englewood, Colorado 80112  
John J. Hernan (303) 740-4630

**Houston**  
10 W. Tidwell, Suite 500  
Houston, Texas 77040  
Clyde Seegar (713) 462-0757

**Washington**  
President Market  
Development  
Federal Government  
R. D'Armiento  
K Street NW  
1170  
Washington, D.C. 20006  
463-1725

### Overseas Offices

**Munich/Main**  
Poststr. 19  
Munich/Main, Germany

**London**  
100 West St.  
London S14ES, England

**Rome**  
Via Sacchetti No. 1  
Italy

**Paris**  
Rue de la Harpe St-Honoré  
Paris, France

**Los Angeles**  
Media Sales Associates  
23232 Peralta Drive  
Laguna Hills, Calif. 92653  
William W. Hague (714) 859-4448  
Richard Ayer

**New York**  
1221 Avenue of the Americas  
New York, New York 10020  
Laura Viscusi (212) 512-3603

**Philadelphia**  
1234 Market St.  
Philadelphia, Pennsylvania 19107  
Frank Rose (215) 496-4966 PA  
(203) 968-7112 CT

**Pittsburgh**  
6 Gateway Center, Suite 215  
Pittsburgh, Pennsylvania 15222  
George Gortz (412) 227-3640

**San Francisco**  
Media Sales Associates  
William W. Hague (415) 345-0522  
Richard Ayer

**Stamford**  
777 Long Ridge Road  
Stamford, Connecticut 06902  
Louis F. Kutscher, (203) 968-7113  
Frank Rose, (203) 968-7112

**Tokyo**  
2-5, 3-chrome  
Kasumigaseki, Chiyoda-ku  
Tokyo, Japan

**South America**  
Empresa Internacional de  
Comunicacoes Ltda.  
Rua da Consolacao, 222  
Conjunto 103  
01302 Sao Paulo, S.P. Brasil

## Decorative Grilles in Color

Adds a new dimension to your designs. Unusual visual effects emerge when our grilles are used for area effects. Choose from an array of custom colors that will match or contrast your grilles. As an innovative industry leader we see beyond black and white.

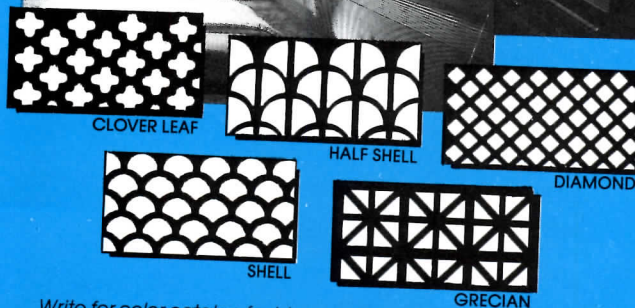

Write for color catalog for ideas on the use of decorative grilles  
**REGISTER & GRILLE MANUFACTURING CO., INC.**  
202 NORMAN AVENUE, BROOKLYN, NY 11222 (718) 383-9090  
CALL TOLL FREE 1-800-521-4895

Circle 113 on inquiry card

## OUR FREE GUIDE PUTS YOU ON TOP OF CEDAR ROOF CONSTRUCTION.

This manual is designed to aid architects and builders in the proper application of cedar shakes and shingles.

Every page is filled with details and guidelines. Covering topics such as mansard roofs. Low slope and cold weather roofs. Vapor barriers. Fasteners. And much more.

It's everything you need to stay on top of cedar roofs. And it's free!

**NEW ROOF  
CONSTRUCTION**

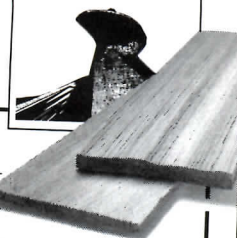

Please send me the free brochure "New Roof Construction."

Name \_\_\_\_\_

Address \_\_\_\_\_

City \_\_\_\_\_

State \_\_\_\_\_ Zip \_\_\_\_\_

**RED CEDAR SHINGLE & HANDSPLIT SHAKE BUREAU**

515 116th Avenue NE, Suite 275, Bellevue, WA 98004-5294

Circle 114 on inquiry card



INTRODUCING

Ioline LP3500  
D-size pen plotter



## The New Standard in Ease of Use

- Value priced at \$3,195
- One-year, no-cost warranty
- Professional plot quality
- Revolutionary plot utility eliminates learning curve
- Supports HP-GL and DM/PL
- Unlimited plot-size flexibility: 23"x81" to 1.5"x1.5"
- Optional oak stand available

**IOLINE**<sup>TM</sup>  
CORPORATION

Call (206) 821-2140 or write for more information  
12020 - 113th AVE. N.E., KIRKLAND, WA 98034

Circle 115 on inquiry card

## INCLINATOR PRESENTS A COUPLE OF STAIR-RELIEVERS.

"Elevette" is an elevator for the home. It's custom-built and serves two or more floors.



◀ **Inclinette** is a single seat deluxe passenger lift that'll carry one up 'n' down the stairs easily at the push of a button.

These stair-relievers are tax-deductible if recommended by a doctor.

Send for free literature. Write:



**INCLINATOR COMPANY OF AMERICA**

Dept. 66 P.O. Box 1557, Harrisburg, PA 17105-1557

Circle 116 on inquiry card

# Use your STAC number!

XXXXXXXXXX5-DIGIT 69699  
6400 009876543-2 FEB90 S07  
TERRY DOE, TD & ASSOCIATES  
128 MAIN STREET  
ANYTOWN IL 69699

**N**eed product information fast? Your Architectural Record Subscription Telephone Access Card number can help speed information to you about any product or service (advertised or new products/manufacturers literature items) described in this issue.

Architectural Record's exclusive STAC number system enables you to send and key your "more information" requests directly into our computer touch-tone telephone. Your personal STAC number is conveniently located above your name on the mailing address label for each issue. **IMPORTANT:** Your STAC number starts after the first four numbers and is separated from them by a space. If your STAC number starts with one or more zeros, ignore them by a space. If your STAC number starts with one or more zeros, ignore them by a space. If your STAC number starts with one or more zeros, ignore them by a space, as well as the hyphen. (For example, the STAC number on the label is 98765432.)

Soon after your call, advertisers can access your requests by phone from a computer, and start speeding information to you. So when you need information fast, free help is as close as your STAC number. And STAC service is available to you 24 hours a day, seven days a week.

### BEFORE YOU DIAL:

- Write your STAC number in the boxes in Step 4 below. Do not add leading zeros.
- Write the Reader Service numbers for those items about which you want more information in the boxes in Step 6. Do not add leading zeros.

### CALL STAC:

- Using a standard touch-tone telephone, call 413/ 442-2668, and follow the computer-generated instructions.

### ENTER YOUR STAC NUMBER AND ISSUE NUMBER:

- When the recording says, "Enter your subscriber number..." enter your STAC number by pushing the numbers and symbols (# or \*) on your telephone keypad. Ignore blank boxes. Enter:

#  #

- When the recording says, "Enter magazine code and issue code..." enter these numbers and symbols:

#   #

### ENTER YOUR INQUIRIES:

- When the recording says, "Enter (next) inquiry number..." enter the first Inquiry Selection

Number, including symbols from your list below. Leave blank boxes. Wait for the prompt before entering each subsequent number (maximum numbers).

1.	<input type="checkbox"/>	<input type="checkbox"/>	<input type="checkbox"/>	<input type="checkbox"/>	#	<input type="checkbox"/>
2.	<input type="checkbox"/>	<input type="checkbox"/>	<input type="checkbox"/>	<input type="checkbox"/>	#	<input type="checkbox"/>
3.	<input type="checkbox"/>	<input type="checkbox"/>	<input type="checkbox"/>	<input type="checkbox"/>	#	<input type="checkbox"/>
4.	<input type="checkbox"/>	<input type="checkbox"/>	<input type="checkbox"/>	<input type="checkbox"/>	#	<input type="checkbox"/>
5.	<input type="checkbox"/>	<input type="checkbox"/>	<input type="checkbox"/>	<input type="checkbox"/>	#	<input type="checkbox"/>
6.	<input type="checkbox"/>	<input type="checkbox"/>	<input type="checkbox"/>	<input type="checkbox"/>	#	<input type="checkbox"/>
7.	<input type="checkbox"/>	<input type="checkbox"/>	<input type="checkbox"/>	<input type="checkbox"/>	#	<input type="checkbox"/>
8.	<input type="checkbox"/>	<input type="checkbox"/>	<input type="checkbox"/>	<input type="checkbox"/>	#	<input type="checkbox"/>
9.	<input type="checkbox"/>	<input type="checkbox"/>	<input type="checkbox"/>	<input type="checkbox"/>	#	<input type="checkbox"/>
10.	<input type="checkbox"/>	<input type="checkbox"/>	<input type="checkbox"/>	<input type="checkbox"/>	#	<input type="checkbox"/>
11.	<input type="checkbox"/>	<input type="checkbox"/>	<input type="checkbox"/>	<input type="checkbox"/>	#	<input type="checkbox"/>
12.	<input type="checkbox"/>	<input type="checkbox"/>	<input type="checkbox"/>	<input type="checkbox"/>	#	<input type="checkbox"/>
13.	<input type="checkbox"/>	<input type="checkbox"/>	<input type="checkbox"/>	<input type="checkbox"/>	#	<input type="checkbox"/>
14.	<input type="checkbox"/>	<input type="checkbox"/>	<input type="checkbox"/>	<input type="checkbox"/>	#	<input type="checkbox"/>
15.	<input type="checkbox"/>	<input type="checkbox"/>	<input type="checkbox"/>	<input type="checkbox"/>	#	<input type="checkbox"/>
16.	<input type="checkbox"/>	<input type="checkbox"/>	<input type="checkbox"/>	<input type="checkbox"/>	#	<input type="checkbox"/>
17.	<input type="checkbox"/>	<input type="checkbox"/>	<input type="checkbox"/>	<input type="checkbox"/>	#	<input type="checkbox"/>

### END STAC SESSION:

- When you have entered Inquiry Selection Number, the recording prompts the next inquiry number, call by entering:

#  #

If you are a subscriber and need assistance, call 212/512-3442. If you are not a subscriber, fill out the subscription card in this issue, or call Architectural Record Subscription Services at 914/628-0821.



**NEW!**

# Lutron dims **ELECTRONIC** Low Voltage lighting

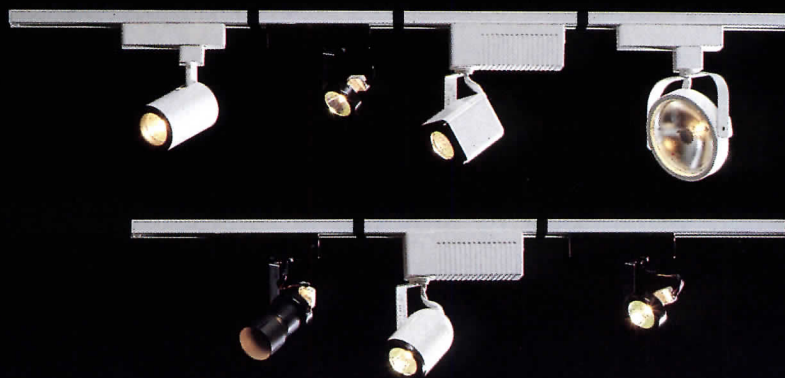
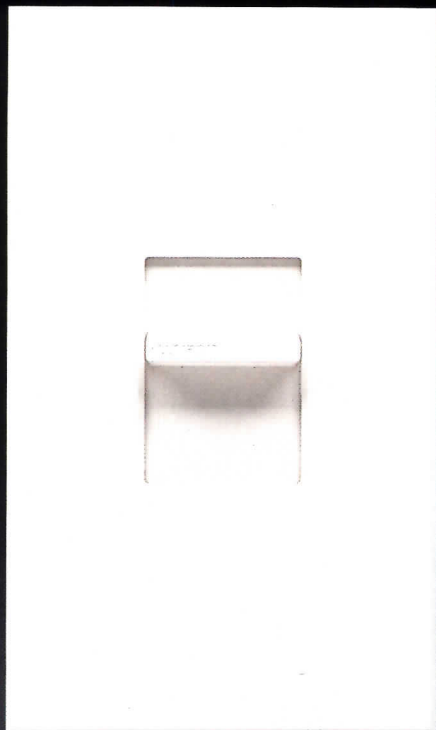

## NEW Sol-Lo™ Technology... (Solid-State Low Voltage)

Lutron introduces **Sol-Lo** dimming technology, the only dimmer technology expressly developed for electronic (solid-state) transformer low voltage lighting.

In response to the need to control electronic low voltage lighting, Lutron developed special **Sol-Lo** dimming circuitry after an extensive engineering research and development program.

**Sol-Lo** technology is now available in these Lutron products:

### Specification Grade



*Nova T*☆,  
*NTELV-300*  
300W  
capacity 



*Nova*,  
*NELV-450*  
450W  
capacity 

### Designer Style



*Skylark*, *SELV-300P* & *SELV-303P*  
300W capacity 

## Quiet Dimming of Electronic Low Voltage Fixtures

All Lutron **Sol-Lo** technology dimmers feature:

- Advanced circuitry for quiet dimming—without annoying transformer or lamp buzz.\*
- Overload protection, voltage compensation and short circuit protection.
- Soft-start—helps extend lamp life.

Call the Lutron toll-free **Hotline** for a free *Guide to Dimming Low Voltage Lighting* (describes dimming **ELECTRONIC** and **MAGNETIC** low voltage lighting).

For help with applications, systems layout or installation call the **Lutron Hotline** toll-free:

(800) 523-9466 (800) 222-4509 (Pennsylvania)  
(215) 282-3800 (Outside U.S.A.)

\*Typical fixture is inaudible in a quiet room of 27dBA at a distance of 3 feet.

This product is covered by one or more of the following U.S. patents: 3,735,020; 3,746,923; and corresponding foreign patents. Foreign and U.S. patents pending. Lutron, Nova T☆, Nova, and Skylark are registered trademarks. Sol-Lo is a trademark of Lutron Electronics Co., Inc. ©1988 by Lutron Electronics Co., Inc.

# LUTRON®

Lutron Electronics Co., Inc.  
205 Suter Rd.  
Coopersburg, PA 18036 U.S.A.

CALL TOLL-FREE  
FOR LUTRON DISTRIBUTORS  
IN YOUR AREA  
STOCKING THIS PRODUCT.





4



5



6



3



2



1

At first glance, it's difficult to imagine how these six different buildings are related. But if you take a closer look at their histories, you'll find they all share a common theme: the washrooms in all six buildings have been refitted with Sloan flushometers.

True, these buildings don't look old enough to need major plumbing repairs. But the fact is, the original flushometers that were installed just didn't hold up. Even after repeated servicing, they continued to malfunction. They didn't shut off properly. They leaked at the stops. In some cases, they even flooded the washrooms. In short, they weren't Sloan flushometers.

Unlike substitutes, Sloan flushometers offer proven, reliable service. With built-in quality at an affordable price. That's why today more buildings are equipped with Sloan flushometers than with any other brand.

Only Sloan's rugged, tamper-proof design can assure the quiet, dependable operation so critical in buildings like these. Plus, Sloan flushometers are built to last for years with only minimal, routine maintenance—an important consideration for specifiers who value time and money.

The next time you consider specifying a substitute, think about these six buildings. Then specify Sloan. The first time.

***Another***  
**six reasons**  
**to specify**  
**Sloan...**

**the first**  
**time.**



- 1. Valley Forge Park Place, King of Prussia, PA
- 2. Virginia Mason Hospital, Seattle, WA
- 3. Swedish Hospital, Seattle, WA
- 4. Heartthrob Cafe, Orland Park, IL
- 5. Spruance Hall, Embry Riddle University, Daytona Beach, FL
- 6. Foster Plaza Building No. 6, Pittsburgh, PA



**SLOAN VALVE COMPANY**

10500 Seymour Avenue, Franklin Park, IL 60131

*A Tradition of Quality and Pride*