

# BUILDING NEWS

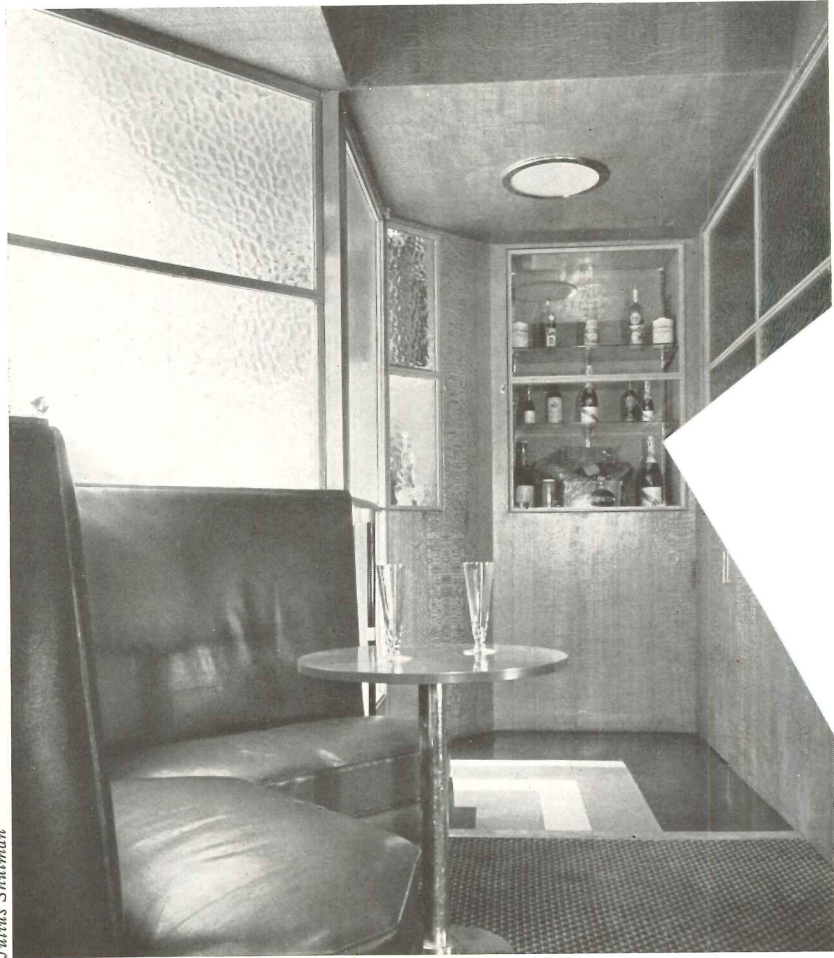

*Julius Shulman*

**Sardi's—a Seat for Every Purpose . . .**

**ARCHITECTURAL**

*Record*

# U. S. PAVILION CARRIES "SKYSCRAPER" MOTIF TO PARIS

PAUL LESTER WEINER, Designer

JULIAN CLARENCE LEVI

CHARLES H. HIGGINS

Associate Architects

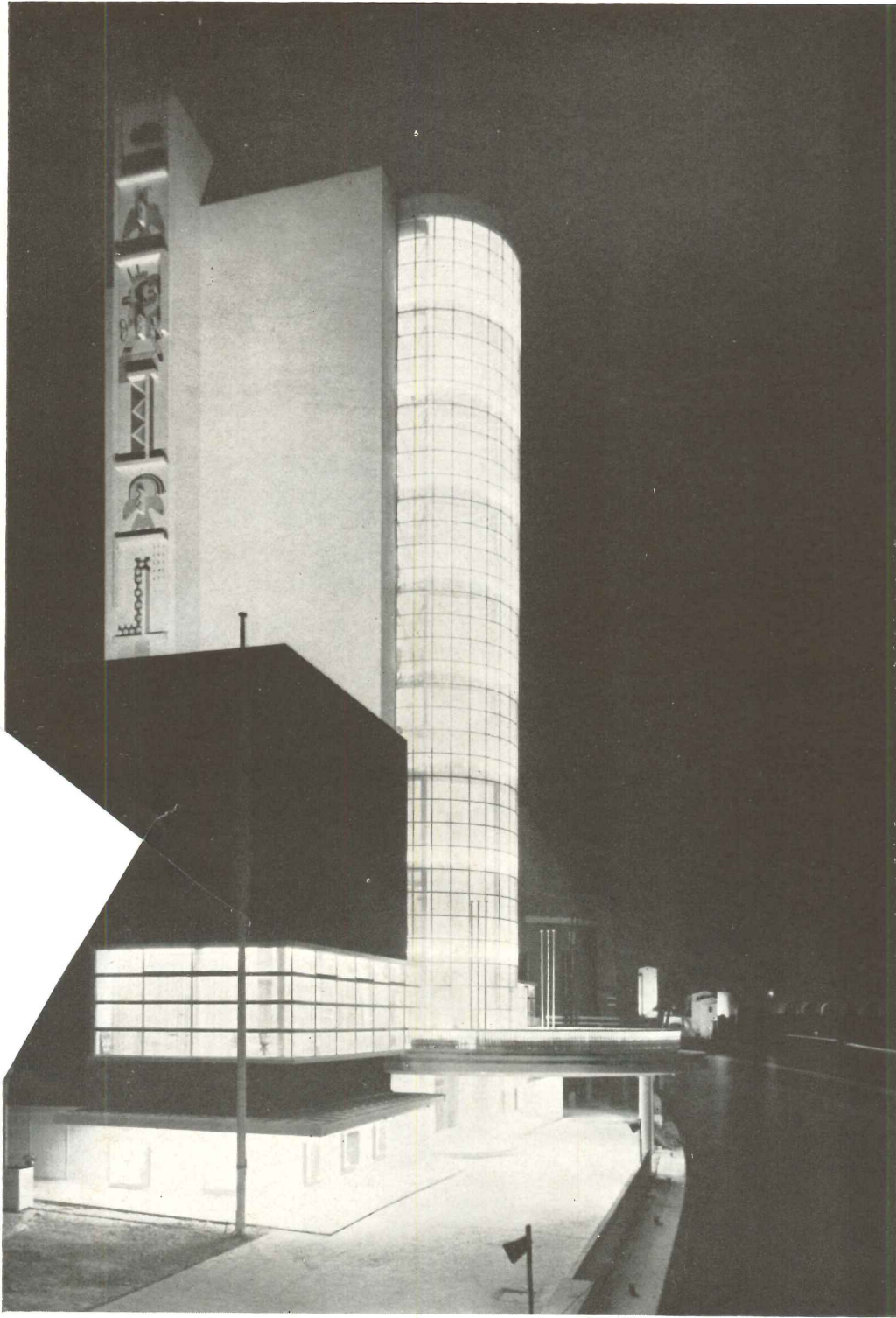

*Photos by Landshoff*

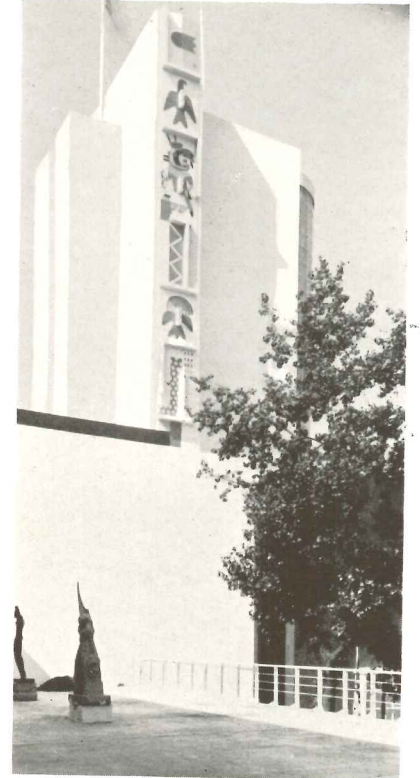

AN ELEMENT OF EMERGENCY has threaded the entire history of the United States Pavilion at the Paris Exposition. From that day last January when plans for the building were radioed across the Atlantic (see RECORD, February, 1937, page 4) to beat the spring floods on the Seine, until July 4, when the Stars and Stripes were finally raised before a group of such notables as Ambassador Bullitt and General Pershing, Designer Paul Weiner and his associates were never more than one jump ahead of the devil. Working in three shifts, with French, Flemish and British labor, they completed this steel frame and stucco structure in 69 working days at a cost of \$230,000.

More time was apparently available for the design process itself, since it was studied in detail. "In designing the United States Pavilion," says Mr. Weiner,



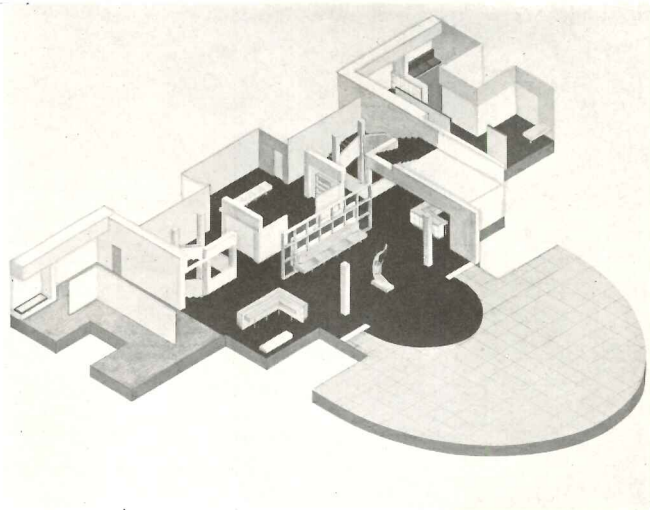

Isometric of Pavilion at balcony level.

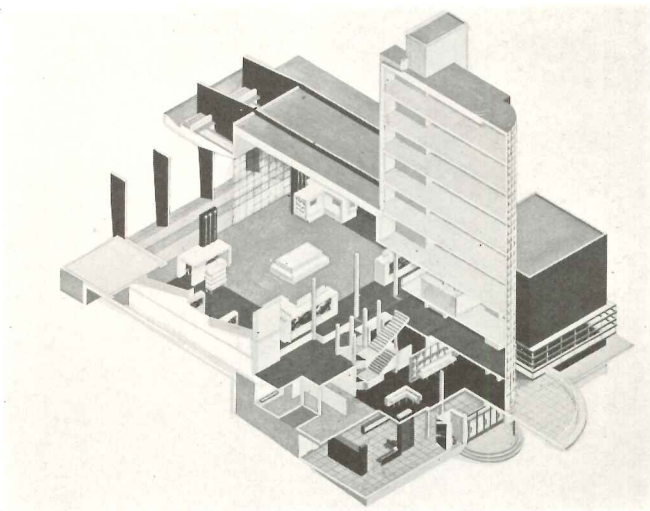

Isometric of entire Pavilion. Four rigid-frame trusses carry the structure across the railroad tracks over which part of the Pavilion is built. Because the semi-circular glass bay is independent of the structure proper, floor levels do not appear at night.

“our intention was to create a symbol of the chief American contribution to modern architecture. It goes without saying that our one outstanding achievement in this field is the skyscraper. To build a real skyscraper on the banks of the Seine was, of course, impossible, since the pavilions were to be temporary and since we could not exceed a certain height and mass allotted to us in the general plan of the Exposition. An imitation skyscraper would certainly not do. Our plan, then, was to concentrate on the distinguishing characteristics from which the skyscraper takes its name—its vertical lines rising from the ground toward the sky.

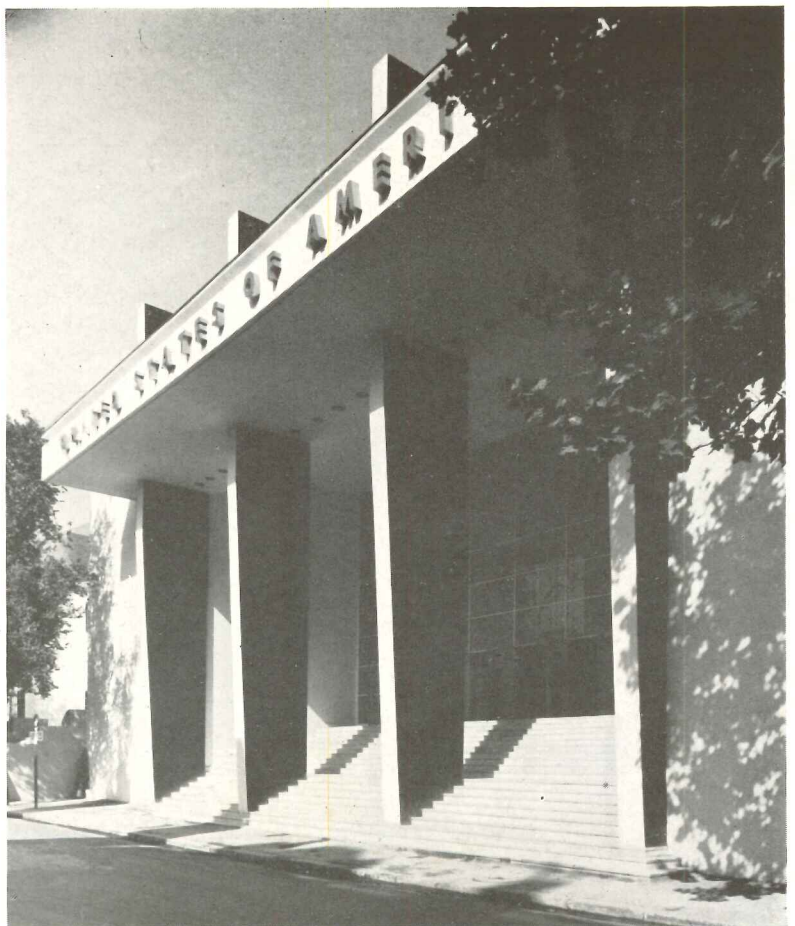

Two views of the Quai D'Orsay entrance showing (above) decorative use to which the trusses—sheathed in plaster and painted blue—were put and (below) the glass screen with its map of the U. S. A.



“The materialization of this conception was conditioned by the building site which had been given us—a plot at the intersection of the Avenue de Suffren and the Quai d'Orsay, at the extreme right of the group of foreign pavilions on the left bank of the Seine. Naturally this called for a mass which would balance the Italian Pavilion, diametrically opposed to ours. Another condition was the variation in the different levels of the plot (a difference of 21 feet between the street level and the river's edge) and the necessity of spanning a four-track railroad system.”

The height of the building, 145 feet from the river's



# UNITED STATES PAVILION; PARIS EXPOSITION

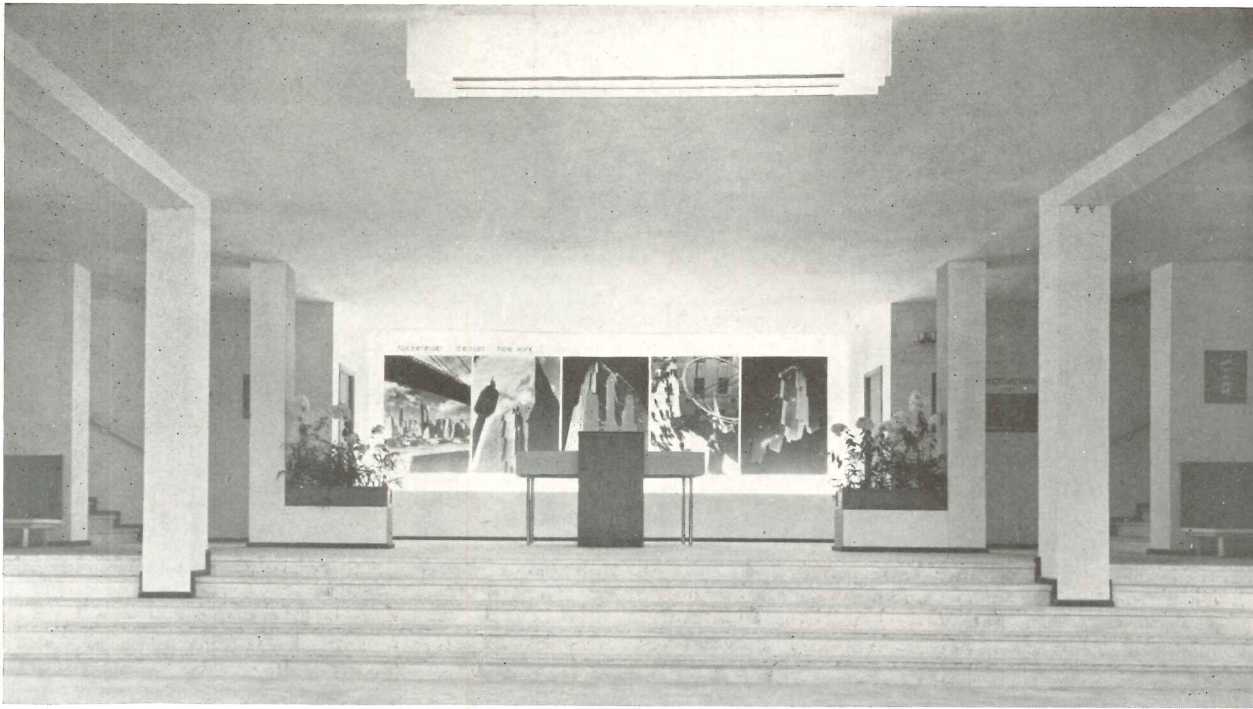

Landshoff



The lobby on the river level (top) and that of the Quai D'Orsay level (bottom).

edge to the top of the tower, is the greatest in the foreign group—not excepting the German Pavilion. The vertical line of the tower is emphasized by the curtain hanging in continuous folds behind the glass, unbroken by any horizontal elements. Especially at night is the full effect realized when the interior lighting makes the tower a single luminous unit. The base of the building is formed by two flanking wings painted blue. Beneath each of these wings on the river front are continuous glass areas forming a strong horizontal motif, which acts in counterpoint to the tower.

Decorative effects were obtained by utilizing the integral and structural elements of the building, that is, the contrast of building materials, glass, and stucco; the contrast of color—vermilion, blue, and white. The only non-organic ornaments are the two American Indian motifs flanking the tower. “Just as other foreign pavilions used the folk art of their countries as decoration,” says Mr. Weiner, “we chose Indian art, heritage of the first real Americans, to identify our pavilion.” Designed by Mr. Buk Ulrich, recognized authority on Indian art, these motifs are used in such a way as to emphasize



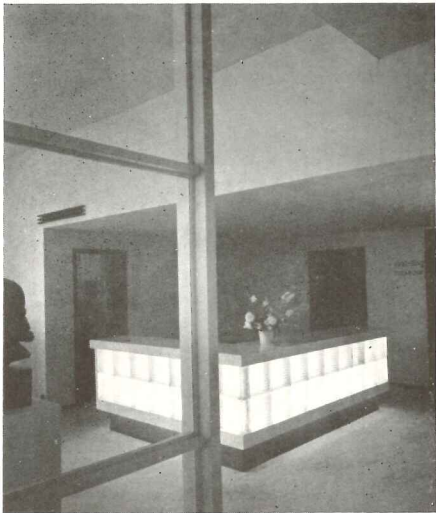

Glass in many forms played an important role in the design of Pavilion interiors.

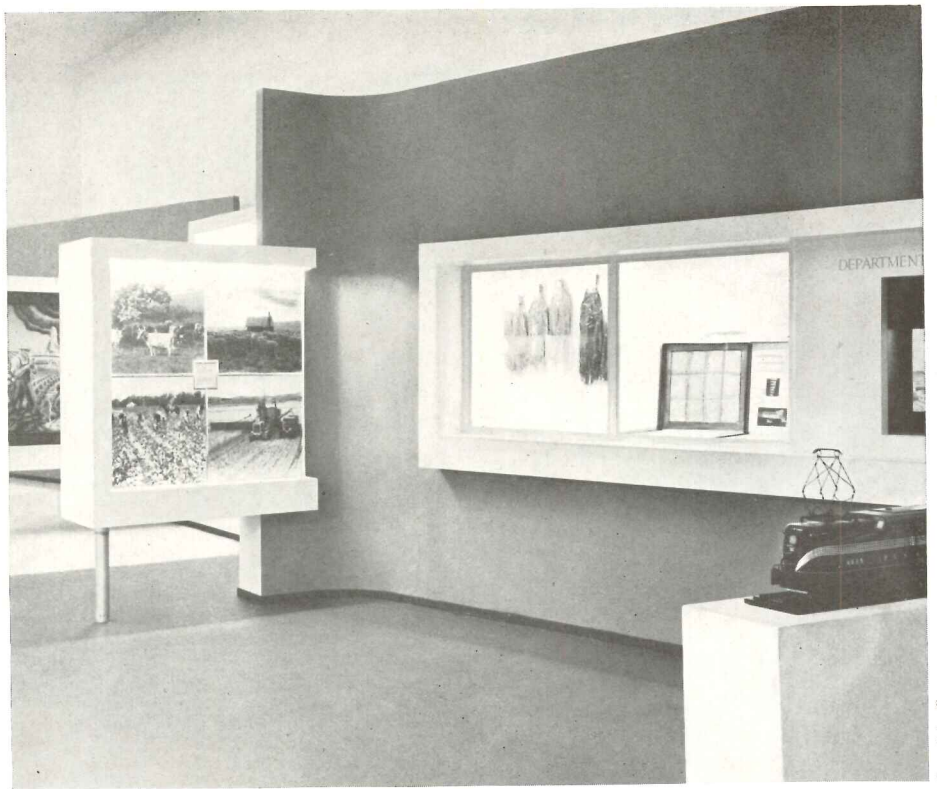

Landshoff

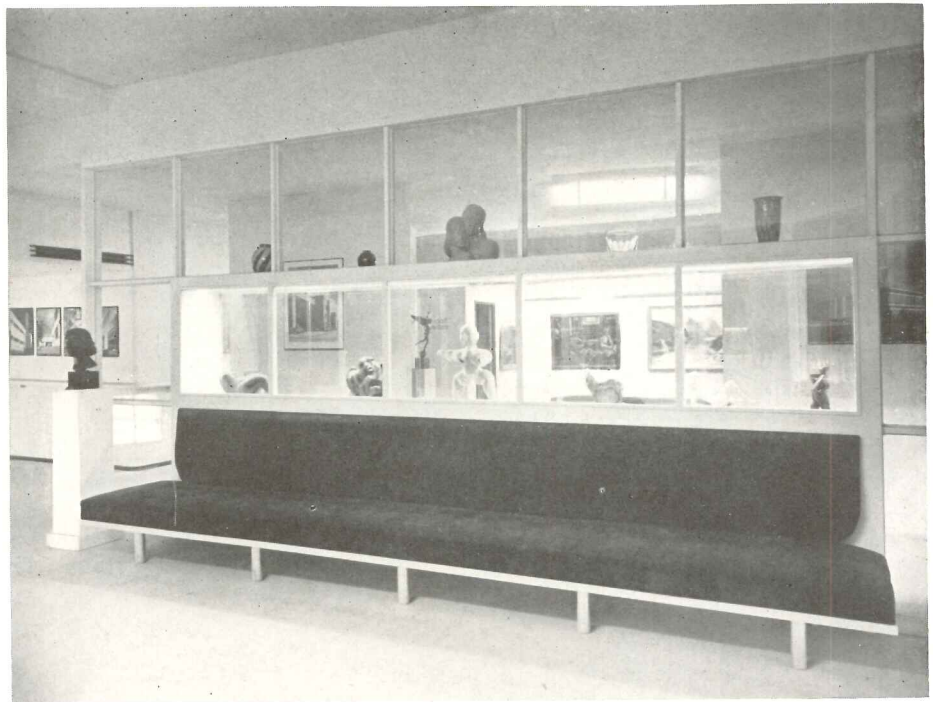

Bonney

Typical display unit (top); upholstered bench (below).



Bonney

further the verticality of the tower, and to set off the flat masses of the building from each other.

The symmetrical plan of the U. S. Pavilion and the wide disparity of scale between the structure proper and its contents both serve to emphasize the "architecture" at the expense of the exhibits. Thus—perhaps because of the inadequacy of the exhibition material—the interiors of the Pavilion appear more institutional than ex-

positional. Faced with a preponderance of two-dimensional, static material (photographs, charts, plaster models, etc.), the designers were forced to a wide use of special display cases. Designed to be "as integral a part of the Pavilion halls as a fire place", these cases are asymmetric in shape, size, and location; they are somewhat unified by typical construction details, and use of a typical color scheme.



# DICKEYVILLE: AN OLD MILL TOWN GETS ITS FACE LIFTED



Typical of the transformation of Dickeyville are these two views of the same street; (below) the tenements as the developers found them in 1935 and (above) as they are today.

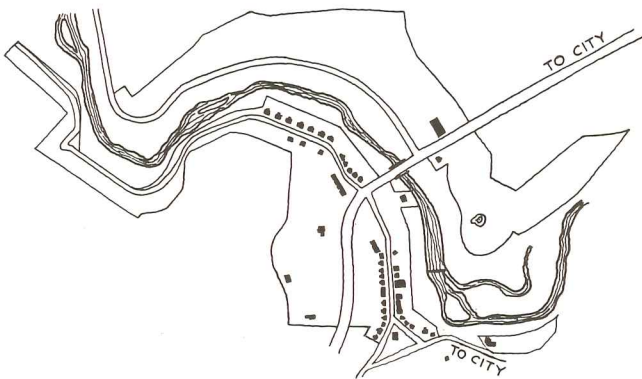

Plan of Dickeyville showing town limits and park strip along both sides of the mill stream. All construction to date has been remodeling, but eventually the area north of the stream will be developed.

UNTIL A FEW SHORT years ago, century-old Dickeyville, five miles west of Baltimore, was a somnolent mill town of the pre-industrial era. Then in stepped the Roland Park Company, flushed with the success of its famous Baltimore development of the same name. The town was ideal for restoration. Completely untouched by the industrial expansion which has begrimed Baltimore, Dickeyville presents an astonishing array of building styles—Maryland Colonial, Classic Revival, Victorian—in a setting of great beauty.

A program for the town's development was evolved. A permanent park was created along the mill stream and property for future expansion secured to the north. All old structures were to be reconstructed before there was new construction; and these old structures were to be merchandised like antiques—either "in the rough" or reconditioned. (Except for the first houses, most sales have in fact been made prior to reconstruction, buyer and architect working out plans together.) All designs were to be subject to approval by sponsors. Prices were to be moderate—from \$6,500 to \$14,000—and financing available.

How correct this program was is attested both by the rapid progress of reconstruction and the character of the individual jobs. Particularly interesting to the building designer is the latter. This was no task of simple restoration; the houses shown are typical *modernization* projects while the Drummond house (page 26) is a typical *restoration*. The policy of leaving restoration to the buyer and his architect, aside from being good merchandising, has contributed a sparkle to the architectural character of Dickeyville which a full-time staff of designers might well have missed.



**THE ROLAND PARK COMPANY,**  
Developers

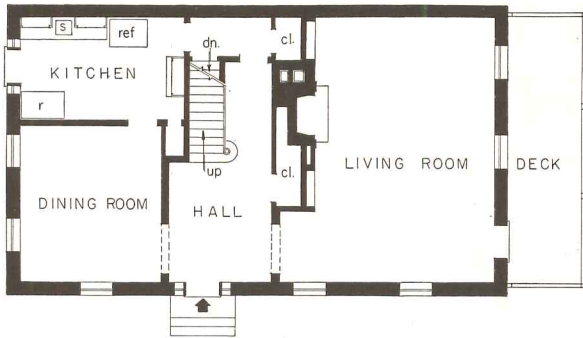

First floor after remodeling.

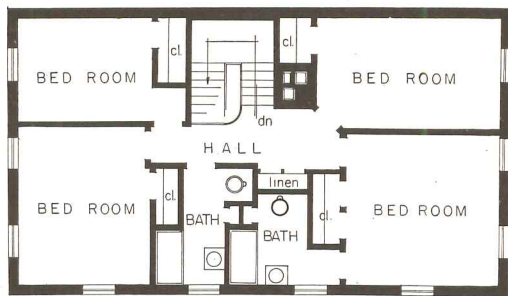

Second floor after remodeling.

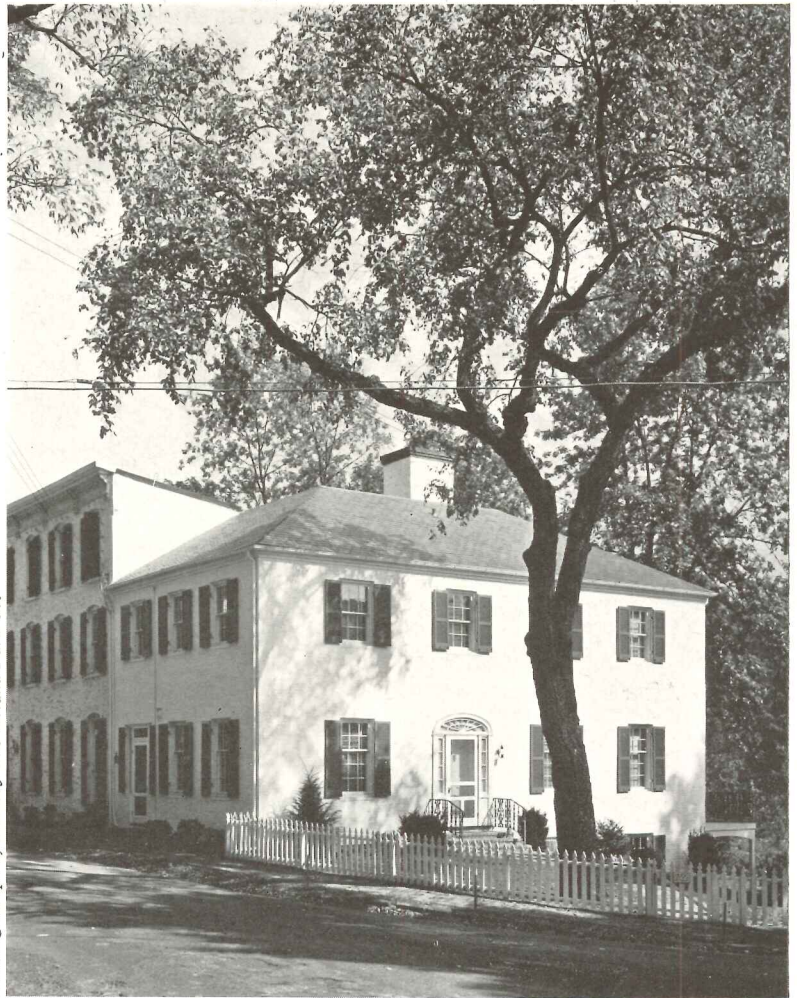

Photos © Leopold, courtesy The Roland Park Co.

The new residence for Dr. and Mrs. John T. Howard (above) was formerly the combination store and warehouse seen (second from right) below.



Another "before and after" view of Dickeyville. The structures in the lower picture are essentially the same as those above.



Architect Harold Stilwell's work on the Howard residence is characteristic of the "Dickeyville Renaissance." Taking the brick shell of an old country store and wrecking the frame ice house in the foreground, Mr. Stilwell produced the simple and effective residence shown above. The walls were cut off at the former cornice line and a new hipped roof constructed. Since the original structure was innocent of partitions and had only a few columns, reconstruction of the interior was a relatively simple matter. Existing openings in the end walls got new frames and sash, while openings were cut in the new front wall and an entrance doorway installed.

*(Continued on next page)*



# DICKEYVILLE: 2 HOUSES SHOW EXTENT OF RENAISSANCE

Photos courtesy The Roland Park Co.



After

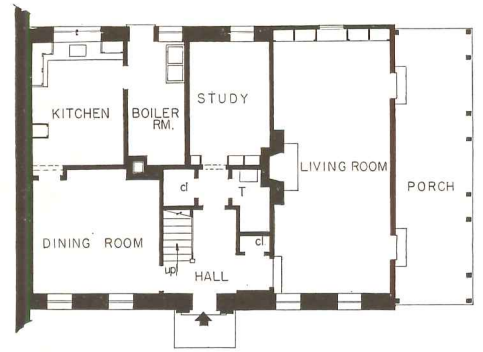

First floor after remodeling.

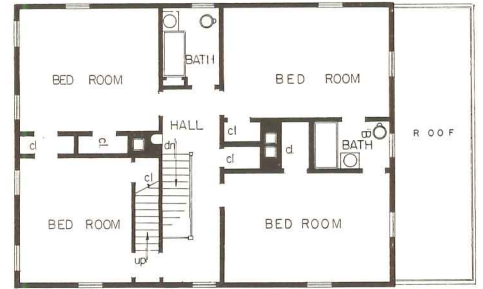

Second floor after remodeling



Before

In this reconstructed residence for Mr. and Mrs. John Duering, the firm of Palmer and Landin achieved little short of the miraculous. Using the original foundations, framing, and exterior walls of the gaunt old tenement at the left, they removed the top floor, built a new roof and new chimneys, replanned the interior—and turned over to the owners the house shown above. The simple and chary use of detail is characteristic not only of Dickeyville but also of much contemporary Baltimore work.



A provincial example of the Classic Revival, this old house was bought by Mr. and Mrs. Theodore Drummond and restored by Architect Harold Stilwell. The original design with its four blunt pediments—one for each point of the compass—was left relatively unchanged ;



the interiors were replanned for modern necessities but original features, such as fireplaces and stairs, were retained as far as possible. Here again, the essential structure of the century-old building was found quite sound.



# REMODELED BASEMENT YIELDS ROMANTIC SALESROOM

ATLEE B. & ROBERT M. AYRES  
Architects

Four views of the "Spanish Patio", de luxe salesroom of the San Antonio Public Service Company's Home Economics Department: Office (right) and (below) Auditorium, Kitchen "B", and Fountain Patio.



Photos by Harry Patterson

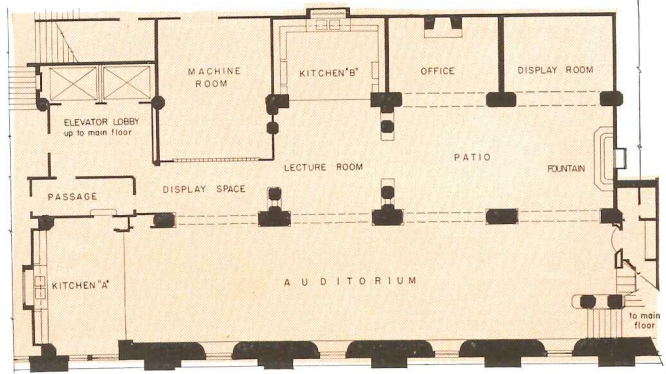

OF STEADILY growing importance to all electric power companies has been their sale and servicing of household appliances; and this trend has led to their ubiquitous "Home Economics Departments" as an adjunct to their merchandising layout. Housing "Home Economics" has raised special problems of design, since the main object is not so much one of direct sales as creation of good will. For this, an informal and "clubby" atmosphere is important, as San Antonio's Public Service Company was well aware when it commissioned the Brothers Ayres to design its new Spanish Patio. Using part of a former basement, the architects have evolved an elaborate and spectacular layout. Aside from the highly flavored style of its interiors—all aspects of which the architects supervised, "even to the gold fish in the fountain"—the project is notable for its lighting system. Little natural light was available, but the feeling of the light's being natural was important; thus illumination was made both ample and concealed in its sources. Color was confined to white for all walls, columns, etc., with gray-white timber work; floors are slate and soft red tile; fountain is in blue and white Mexican tile.



# NEW SARDI'S CAFE MAKES INGENUOUS USE OF GLASS



The Dining Room (above) seen from the Terrace. Here compact and efficient planning of a relatively small area is visually enlarged by the scale of the furnishings, the unadorned walls, most of all, by the zigzag glass screen which separates Dining Room and Bar. Another view of the Dining Room (right) looking toward entrance.

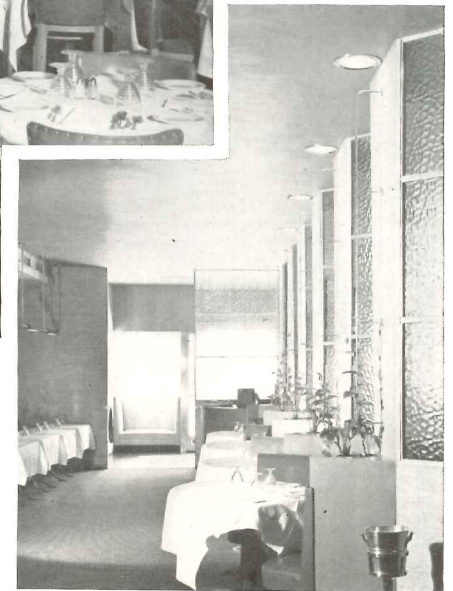

Photos by Julius Shulman

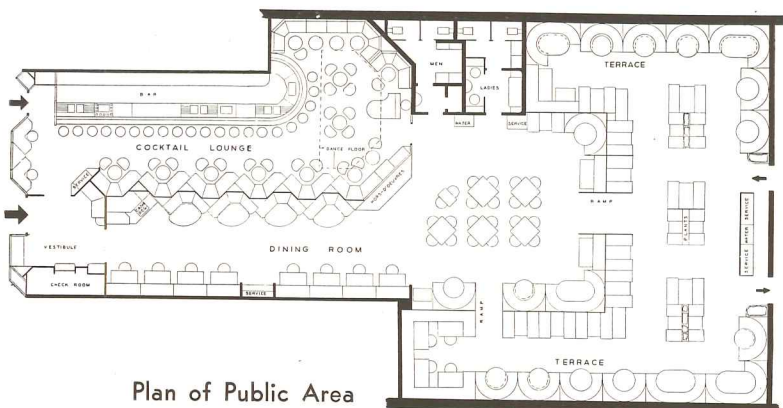

Plan of Public Area

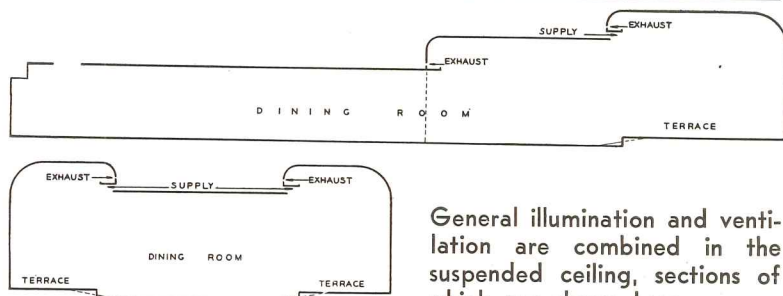

General illumination and ventilation are combined in the suspended ceiling, sections of which are shown here.

IN REMODELING the interiors of Sardi's Cafe in Los Angeles, the designer had to take into account several important considerations. In the first place, the management, with a well-established and discriminating clientele, required a bar and a restaurant with separate entrances—not a simple task on an irregular interior lot with a frontage of only 33 feet. Added to this was the necessity for accommodating a large number of patrons with maximum ease and privacy; and this in turn implied a highly diversified seating plan with provisions for groups of from 1 or 2 to 10 or 12 diners. Designer Davidson has met both these requirements with skill and economy, particularly in his use of the zigzag glass screen between Cocktail Room and Restaurant.

Employing a preponderance of his own specially-built fixtures, the designer was able to control the scale of the new interiors. And using a subtle and complex color scheme, he was able further to extend their quality of spaciousness. Beginning with the vestibule—with its



# J. R. DAVIDSON

Designer

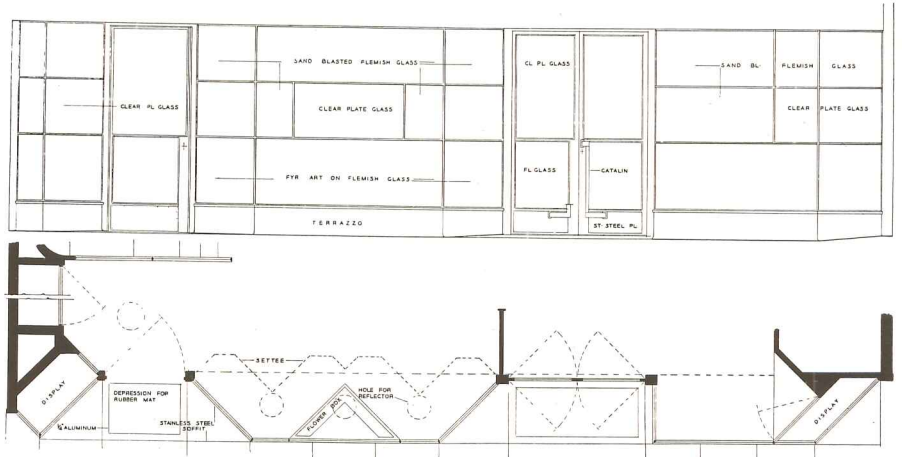
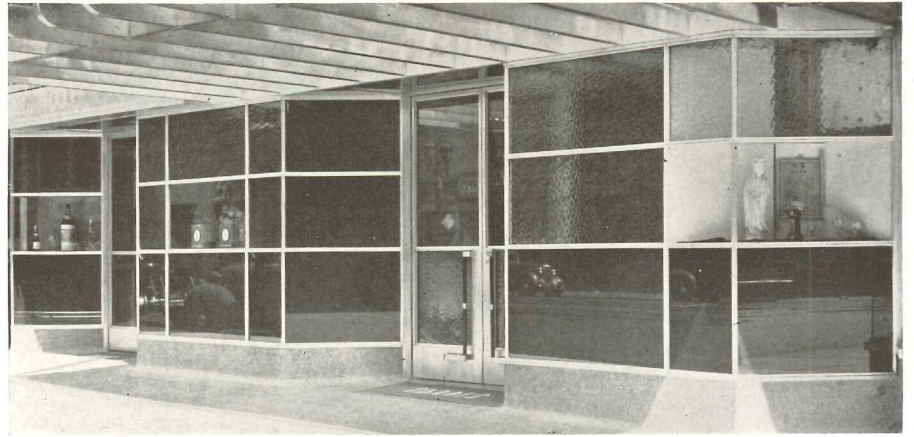

Quite innocent of ornament, the street front depends upon color and texture for effect. With all metalwork in extruded aluminum, the two upper sections are a water-blue translucent glass, while the bottom row is a wine-red Carrara. The base and sidewalk are a purplish terrazzo.

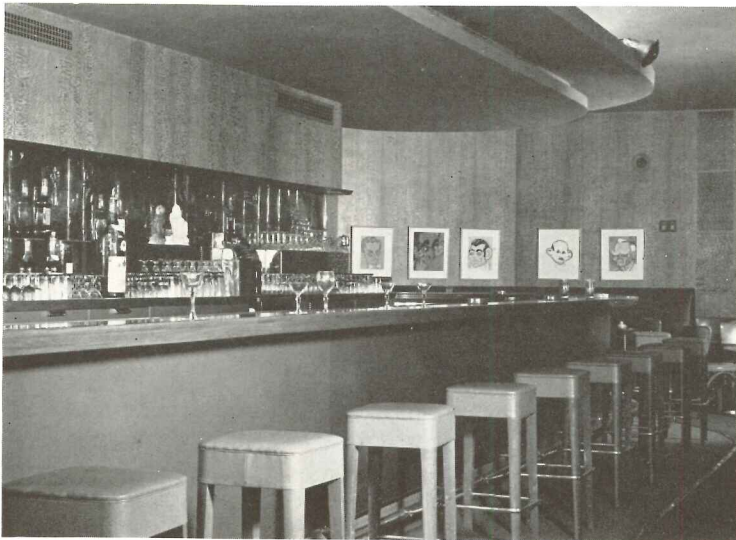

Bar in Cocktail Lounge

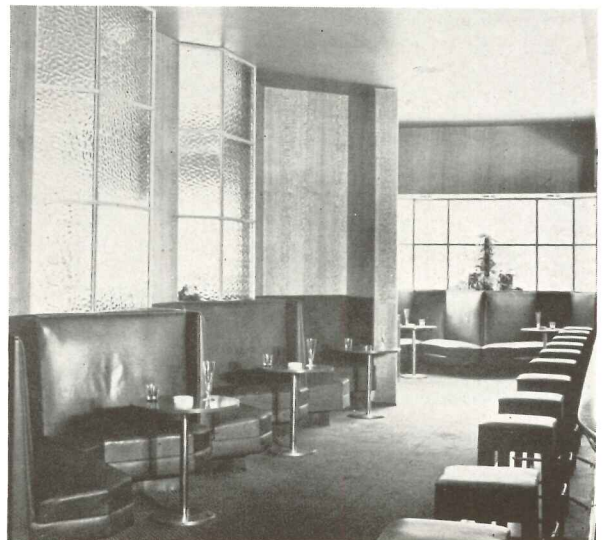

Interior wall of Cocktail Lounge

white upholstery, white-and-grey asphalt tile floor and blue ceiling — he carried blue into the Cocktail Room with a medium blue ceiling, blue Fabrikoid upholstery, blue Formica table and bar taps, gray Harewood veneer. In the Front Restaurant, separated from the Bar by the water-blue glass screen, the designer used tan grass-

cloth and rust-red Fabrikoid. In the main Restaurant at the rear he used a dusty orchid for the walls with the coved ceiling in gold leaf. Upholstery is in coral and rust-red. A small patterned blue-and-coral carpet is used throughout.

*(Continued on next page)*



# MULTIFORM SEATING FEATURE OF SARDI'S CAFE



Typical ramp to Terrace level

The seating in Sardi's is worthy of note, for the designer not only evolved a general seating plan but paid especial attention to the design of various types of seats. He evolved three general types—for waiting (right, center), for drinking (bottom, right), and for dining (above and below) — each of different dimensions and construction. The dining units in each case have special tables with controlled illumination.

*Photos by Julius Shulman*

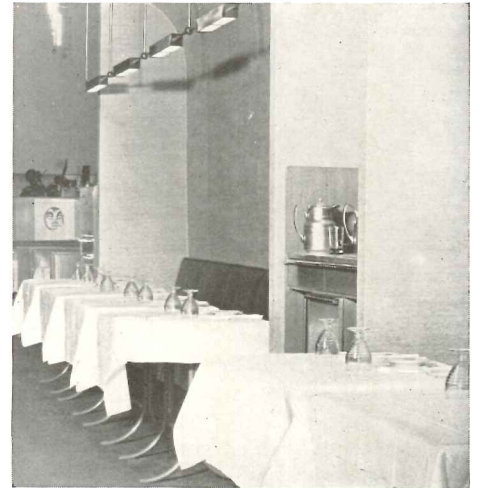

Typical Restaurant Seating

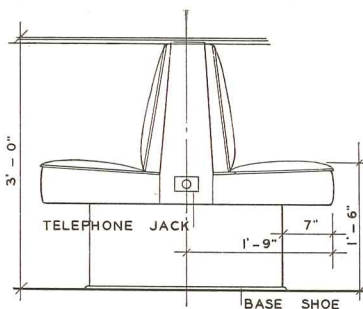

Detail, Restaurant Seating

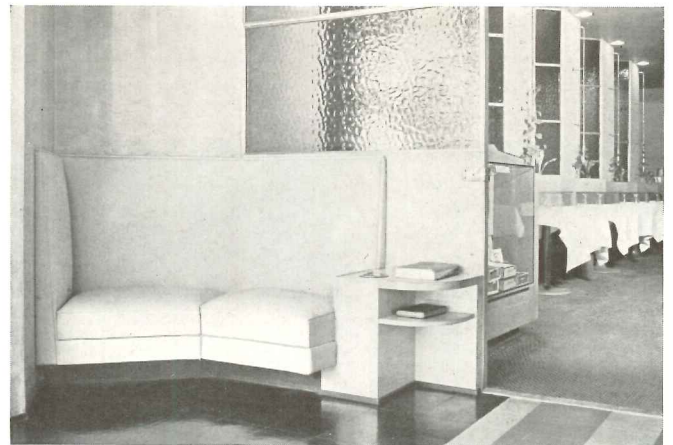
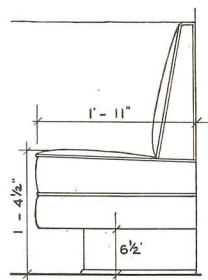

Seating in Vestibule



Seating in Cocktail Lounge; detail at left



# CLEVELAND BUILDING EMPLOYS FIRST WOOD RIGID FRAMES

## Hayes and Simpson Borrow Technique from Steel

THE PRINCIPLE of the rigid frame, widely used in concrete and steel construction, was utilized in wood for the first time in the Hall of Progress at Cleveland's Great Lakes Exposition. No hasty decision on the part of Architects J. Byers Hays and Russell Simpson led to this innovation in wood construction. Not only were complete analyses, including cost, made of various types of building materials for side-wall and roof construction, but—when wood was selected as least expensive and best suited to the short life of an exposition building—tests to determine load limits and best methods of assembly were carried on.

Relying upon established practice in steel and concrete rigid frames, the architects evolved a tentative design for one of lumber and plywood. Under the direction of Prof. Fred L. Plummer of the Case School of Applied Science a model of this rigid frame, at 4/10 full size and using ordinary 1/4" commercial plywood, was set up in the Case Testing Laboratory. Vertical loads were applied at the one-eighth points and a load equivalent to 4 1/2 times the design load was applied without visible distress.

A complete celluloid model of the highest rigid frame was then built at 1/12 full size, and was subjected to both vertical and horizontal loads. Undue horizontal deflections were found to prevent any reduction in depth of exterior legs. In addition to these tests, stress diagrams of all possible loading conditions were plotted, and points of maximum moment ascertained. Plywood jointing was so laid out that the full cross section of the member was available at points of maximum moment. At points of low moment chord members were spliced. From these tests it was also decided to develop all joints by nailing, thus eliminating the necessity of gluing or special bolting details.

A light framework of stock 2" x 6" and 2" x 10" members incased in a 5/8" plywood covering was used throughout. Frames were composed of two 30' spans, spaced 20' o.c. throughout the length of the building. Carpenters assembled the rigid frames during cold and rainy weather, but no evidence of deterioration was discovered. A small motor crane lifted the frames into place after assembly. Simple span girders and columns between frames were assembled as large T-members for easy erection. Fabrication and erection of the 52 wood rigid frames, 34 built-up girders, and 22 simple columns was accomplished in ten working days.

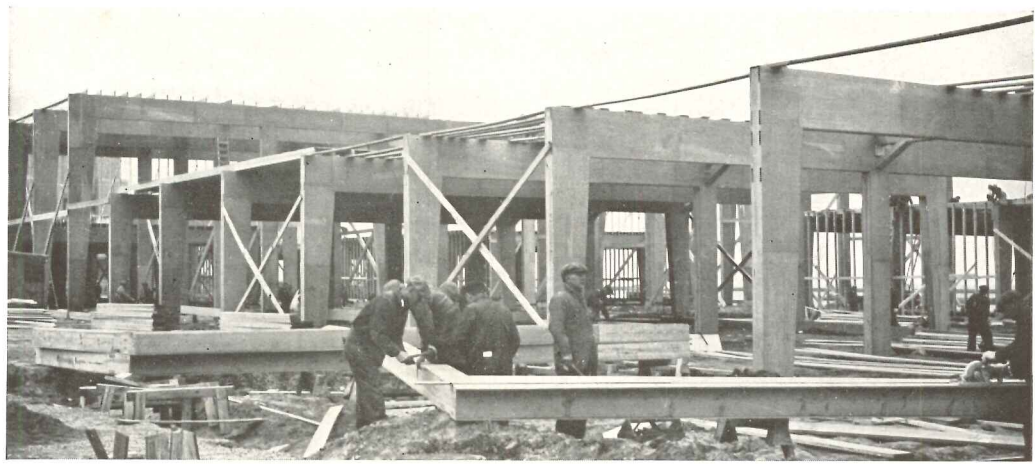

FABRICATED ON THE SITE, THE RIGID FRAMES WERE SWUNG into place (above) and secondary framing proceeded (below).

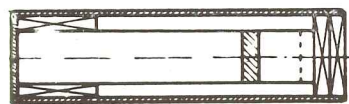
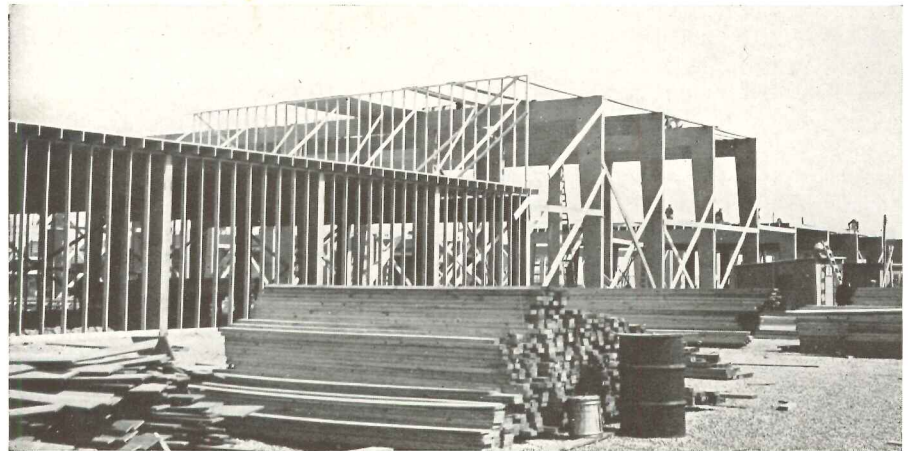

SECTION A-A

ELEVATION OF THE RIGID FRAME (right), showing internal trussing and jointing of plywood at points of maximum moment.

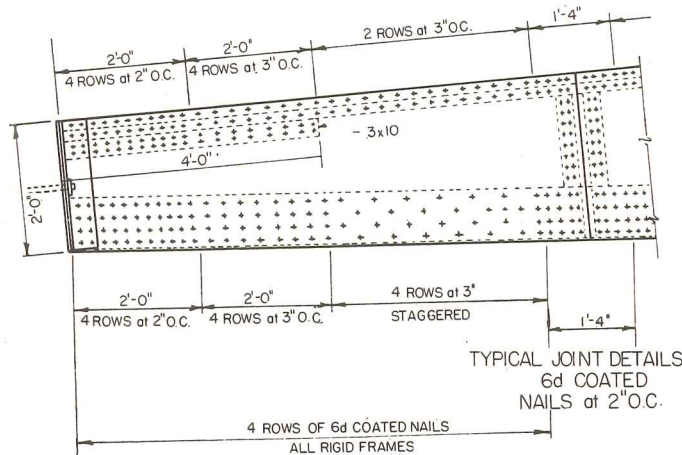

SCIENTIFIC NAILING APPEARS FOR THE FIRST TIME in these lumber and plywood rigid frames. Since fabrication on the site eliminated controlled gluing, the nailing had to be as carefully analyzed as riveting in steel.



# NEW DEVELOPMENTS IN STEEL FRAMING INDICATE WIDER USE

## English Demonstration Flats Include New Floor Unit

A NEW BLOCK of flats in London, built by England's Sheet Steel Market Development Committee to demonstrate the use of various kinds of materials, employs a number of construction systems already familiar to architects in this country. Notable, however, is the floor and roof system used in the experimental building. Basic to both is a  $4\frac{1}{2}$ " x 2'-0" x 12'-0" spot-welded cellular unit made of corrugated sheet steel.

Although the King's Cross Demonstration Flats for obvious reasons use a steel frame construction, both floor and roof systems are applicable to other types of framing.

In the floor construction these units bear directly on the beams of the steel frame without (in this case) any anchoring. It is usable immediately as a working floor; lightly reinforced concrete later fills interstices between the units, and a top surface of cement screed is floated on, forming a monolithic element. When finished, the floor weighs 21 lb. per sq. ft., and has an over-all thickness of 6", including plaster ceiling finish. Although such a floor is adequate for most purposes, a floating over-floor has been added in the London building, as an experiment in reduction of floor-to-floor sound transmission. This floating floor consists of a further screed-covered layer of the corrugated steel sheathing; the latter rests on timber battens cushioned with asbestos strips on the screed surface of the structural floor.

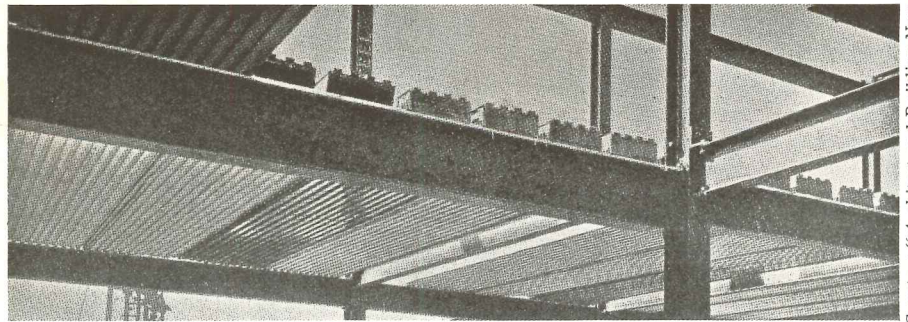

Courtesy "Architect and Building News"

Floor units, laid directly on steelwork, require no anchorage . . .

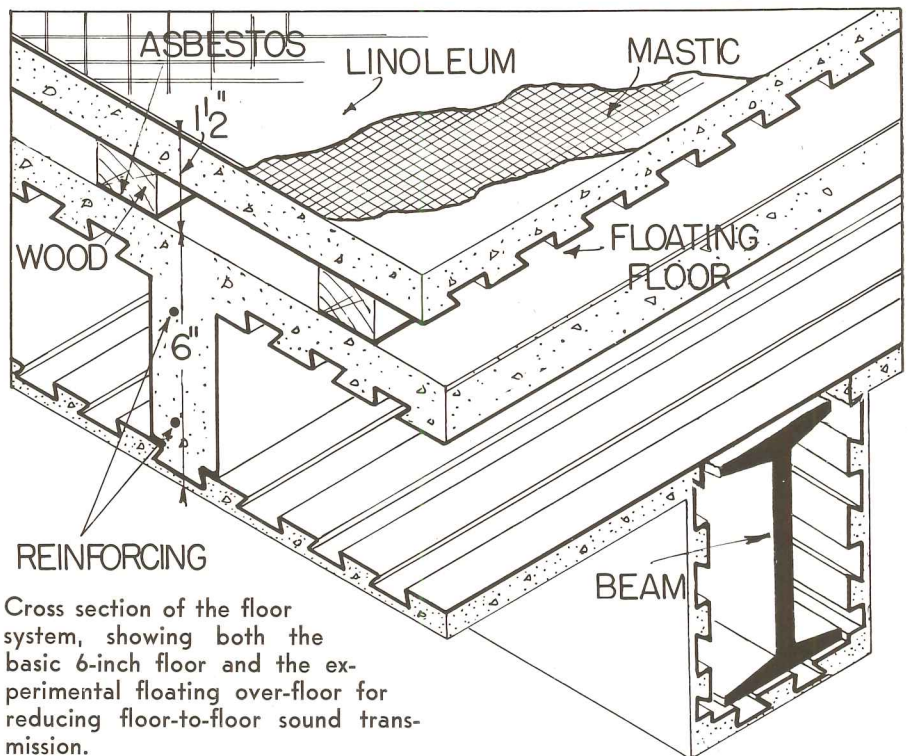

Cross section of the floor system, showing both the basic 6-inch floor and the experimental floating over-floor for reducing floor-to-floor sound transmission.

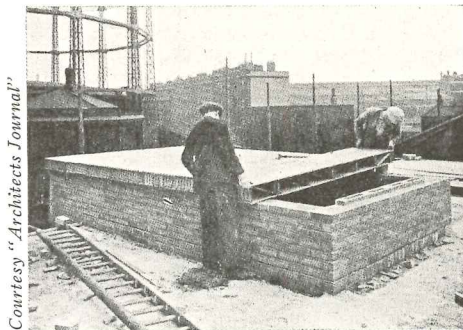

Courtesy "Architects Journal"

### Laying the braced roof unit

Similar to the floor units, but internally stiffened with vertical and diagonal ribs are the roof units, which are mechanically joined into each other at the sides. A continuous  $4\frac{1}{2}$ " air space is provided to insulate the top floor rooms from heat and cold. The units are cantilevered over the outside walls to form ample eaves, which are plastered. The top surface is covered with screed to a slight pitch. Final finish is a waterproof membrane of bituminous roofing.

### Engineer Finds Steel Construction Still Too Costly

SUMMING UP the various criteria for the use of flat-rolled, light-gauge steel in the residential building field, F. T. Llewellyn, Research Engineer for U. S. Steel, told delegates to the recent AISC Convention, that steel as a material for residential framing and covering has yet to overcome the largest single factor of public acceptance—cost. So far, according to Mr. Llewellyn, none of the prevailing systems of steel construction for low-cost housing have been able to overcome this. Even the argument that maintenance cost is low has been unavailing. Two solutions to this problem were offered by Mr. Llewellyn: "a campaign of education to explain and impress the advantages of steel; or a concession in the price of steel construction."

Although advantages of steel construction are many, difficulties in its use are likewise manifold. Adequate

steel framing avoids or reduces the shrinkage which subsequently causes cracking of tile or plaster, misfit of doors and windows, and infiltration of air and moisture through the opening of joints in walls. But, Mr. Llewellyn pointed out, a wall is no better than its joints, and some otherwise satisfactory systems have been abandoned because exterior joint details provided no resistance to infiltration of moisture.

Important in framing are problems of structural strength, connectivity, and durability. Sections of steel less than  $\frac{3}{8}$ " thick may be readily shaped to form by bending, with or without welding; but large unbraced areas of light-gauge material, which buckle under flexural and compressive stresses, require stiffening by crimping at intervals, and by flanging at the edges. Connectivity involves two features: steel members must be attached to each other, and also



# NEW MATERIALS BROADEN BUILDING FIELD

(Continued from preceding page)

to other materials, by lath, nails, or anchors. Several methods of accomplishing this have been used, but there is so far no indication of standardized practice.

Resistance to corrosion is the primary consideration in durability of light-gauge steel. (See RECORD, June 1933, pp. 439-442, for article on steel in residence construction). This resistance can be further enhanced by giving a small copper content (0.20%) to the metal. Paint, baked priming coat, or enamel also assure longer life. The avoidance of metal-to-metal contact through the wall is of critical importance, as this will prevent condensation by the adsorption of warm moist air on cold surfaces.

Light-gauge steel has been less generally used for covering. From the standpoint of practicability, certain requirements are mandatory. Panels must not only appear substantial, but must be strong enough to withstand accidental blows without denting. Because steel is a poor insulator against noise and heat, special insulation of loose, board, or foil type is necessary. Ingenious solutions in a number of construction systems have more or less solved the problem of moisture infiltration. Surface finish is of special importance, particularly if no other material is to conceal the steel panels. Paint, vitreous enamel, plastic paints, and lacquer finishes can all be applied to steel, and have an average life under ordinary atmospheric conditions of from 5 to 10 years (except vitreous enamel, which, provided the edges are adequately protected, is expected to last considerably longer). Mr. Llewellyn documented his paper with a detailed examination of 17 current systems employing steel in one or another form.

## Translucent Glass

### Lets in Sun, but No Heat

COMBINING the features of glass block and double glazing, Thermolux, a translucent glass developed in Italy, transmits sunlight minus sunheat. Its structure consists of a central lamina of spun silk threads regularly arranged, held between two sheets of clear glass. Edges of this porous layer are hermetically sealed so that the air it contains is not disturbed. The construction is such that the visible wave lengths of the spectrum are not distorted. Thermolux, according to *Glass Digest*, is soon to be manufactured in this country, and will be sold and installed through regular glass outlets.

## Inorganic Glass Textiles Will Aid Building Designer

EXPERIMENTS in the weaving and coloring of glass textiles are now being carried on at the recently opened Research Laboratory of Owens-Illinois Company, Newark, Ohio. Employing Fiberglas yarn, already well established in the insulation field as "glass wool",

Fiberglas yarn is composed of 102 filaments and contains 100,000 yards per pound. Sixteen ounces of a single filament have a length of 10,000,000 yards, and each filament is 1/20 the diameter of a human hair, with a fiber tensile strength that is greater than steel, claims the manufacturer.

these experiments are expected to lead to the manufacture of textiles in a wide variety of weaves and colors. Because of their characteristics—they are said to be wholly inorganic, unaffected by acids, resistant to extreme temperatures, and flexible—glass textiles are adaptable to fields closed to organic textiles. They will thus offer new possibilities to the designer in theaters, airplanes, ships, etc. Moreover, experiments indicate that they may eventually compete with ordinary textiles for use in interior design as curtains, draperies, and upholstery.

## Dutch Scientists Produce Glass from Potato Starch

FROM POTATO starch comes a new product known as "Anras Glass." Announced recently in the Dutch publication, *Chemisch Weekblad*, this substitute for glass is the result of a four year program to broaden the industrial outlets for potato starch. "Anras Glass" has all the quality of transmitting the short wave lengths of light, and can be colored or clear. From tests already made the "ersatz" glass is stable to all wave lengths of light, but, because of its newness, its reaction to long exposure has yet to be determined.

## Tests Show Bronze Windows Have Low Air Infiltration

INFILTRATION tests on windows, conducted recently at the Daniel Guggenheim School of Aeronautics of New York University, showed that bronze windows permitted 0.14 cfm of air infiltration per foot of sash perimeter at a wind velocity of 24 mph in comparison to the 1.25 cfm allowed by U. S. Government specifications for such windows. At a 40-mph wind velocity, which caused the glass to bulge, the air infiltration was 0.4 cfm, or less than a third the volume allowed for wind velocity of 24 mph.

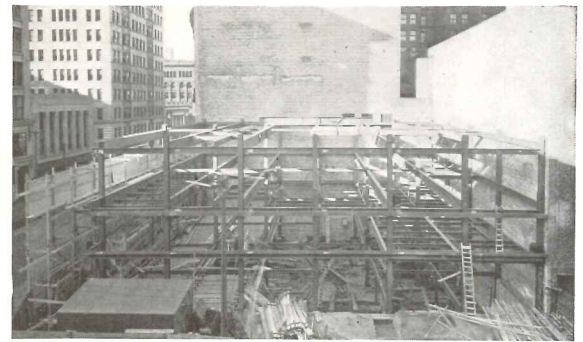

Sheathing the framework for winter



Work goes on behind the plywood coat

WINTRY BLASTS FROM LAKE MICHIGAN delayed not one bit the completion of this glass tile building for the Plankinton Trust, Milwaukee, Wis. Unit heaters and adequate lighting provided comfortable working conditions inside the wooden enclosure topped by a canvas roof.

## Wood Bonded to Steel Makes Wall Panels

WOOD VENEERS, permanently cemented to steel sheeting, constitute a new product called Robertson Bonded Metal, announced recently by H. H. Robertson Company of Pittsburgh, Pa. Developed through the company's fellowship at the Mellon Institute of Industrial Research, the new product is for use on interior walls, elevator cabs, air conditioning cabinets, bars, furniture, etc. RBM is available in sheets up to 3' x 8', which may be cut, stamped, spot-welded, drilled, and bent, without damage or separation, and when used for paneled walls and partitions, may be installed without noticeable seams or joints. The steel reinforcement, in gauges from 30 to 18, permits either great stiffness or sufficient flexibility to form the sheets into the small radii and curves used in modern furniture and interior design. Thirty different American and foreign woods are supplied as surface veneers, and fire-resistant insulating cores are cemented to the steel backing to make one-piece partitions. Phenolic resin adhesive is used for bonding. Shrinkage, warping, and cracking is eliminated, according to the manufacturer, despite extreme humidity or dryness.



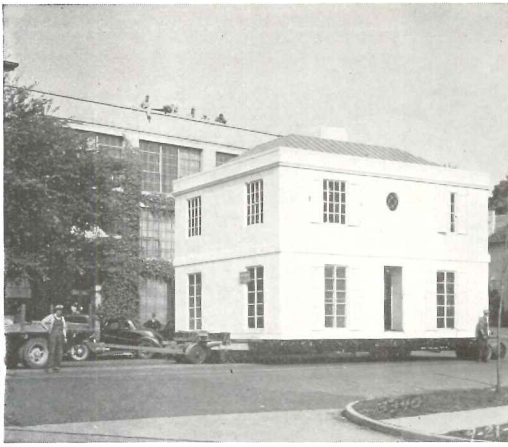

NEW OR OLD, THE HOUSE IS IN LIVELY DEMAND: A NEW SEVEN-ROOM all-welded house (left) caught during its "delivery"—with three painters finishing up the interiors; and an old Detroit number ready to set sail for its new foundations, 25 miles across the waters.

## CONTROL OF ATMOSPHERE DESIGNER'S NEXT JOB

THE LETHAL character of our urban atmosphere is increasingly apparent from investigations being carried on in a number of fields. And the attempts to correct it inevitably affect building design, whether in the field of prevention (municipal control of atmospheric pollution) or cure (protection against polluted atmospheres in individual building types). Largely because of the uneven and inadequate development of municipal control over such matters, most current activity is of an individual nature; and since equipment remains quite expensive, most activity is confined to public and semi-public building types.

### School air found infested

For designers of school buildings, the recent WPA Air Pollution Survey in New York City is something to mull over. Working with the Delmar Institute of Public Health, the Survey found that the highest concentrations of air-borne *alpha hemolytic streptococci*—source of the dangerous throat affection—existed in public schools. Close second in contaminated air was that of the subways, and in diminishing order followed streets, non-air conditioned theaters, and Central Park. The Survey established a distinct relation between the degree of air pollution and the number of humans present in the locality. The latter is probably influenced by the quality of ventilation, for in schools of the Lower East Side where the buildings are poorly constructed, with small rooms difficult to keep clean, air samples showed a higher average of streptococci per cubic foot than schools of other parts of the city. Adequate control of such conditions would demand not only circulation of the air but also bactericidal equipment such as that being developed at Duke

University (see RECORD, April 1937, page 96).

### Coal smoke encourages pneumonia

Implied in two surveys from Pittsburgh is the necessity for a dust- and smoke-free atmosphere for hospitalization of pneumonia patients. Dr. Samuel B. Haythorn of the William H. Singer Memorial Research Laboratory, and H. B. Meller, head of Mellon Institute's Air Pollution Investigation, made a survey of pneumonia deaths in Pittsburgh, which has a high mortality rate from that disease. Although they could find "nothing tangible to connect the pigment deposits with the high pneumonia incidence and mortality rates", the researchers determined that recovery from pneumonia was decidedly slower than normal when enough soot to show signs of anthracosis was present in the lungs.

Working along much the same lines, Dr. Lucy Schnurer, also of the William H. Singer Memorial Laboratory, recently concluded a series of experiments with rats and rabbits on the effect of inhalation of smoke from common fuels. Her experiments indicated that among animals exposed to the products of combustion of bituminous coal there was the greatest incidence of bronchitis, the greatest number of uncomplicated pneumonias and the most pronounced blood change.

### Hospital to try "conditioned" operations

Although control of temperature and humidity is gradually becoming indispensable in hospital operating rooms in reducing risk of explosion of anesthetic gases and increasing the comfort of both patient and surgical staff, increased knowledge of the requirements of patients under various operations is needed. To this end, Pittsburgh's

Magee Hospital is installing an experimental air conditioned operating room where the "best atmospheric conditions for all types of operations" will be studied. Also included in the project is an air conditioned "recovery" room.

### Special hospital requirements outlined

Atmosphere control has much to do with the treatment of disease, especially in those parts of the country subject to heat waves, according to C. P. Yaglou in *Heating, Piping and Air Conditioning*. And because complete conditioning of large hospitals involves considerable expense, conditioning of certain sections of the building should be considered, portable conditioners being used when a built-in system is out of the question.

In hospital operating rooms this is of prime importance because the patient's organism often loses the ability to regulate its own body temperature and is extremely sensitive to air changes and post-operative complications. An air flow of 8 to 15 air changes per hour is desirable: (1) to reduce the concentration of the anesthetic; (2) to remove excessive heat and moisture from sterilizing equipment, surgical lights, solar heat, and from the bodies of the surgical staff; (3) to provide extra capacity for quickly preparing the room for emergency operations. Recommended also is the air conditioning of a ward adjoining the operating room for the treatment of post-operative fever.

Air conditioned nurseries for premature infants, where the relative humidity is about 65%, temperature 77° F. with an air change of less than 20 fpm, have been found to produce the best chances for life because of the high humidity and uniform environmental temperature. In such wards recirculation should not be used because of odors and dangers of infection.

Recommended for use in the treatment of diseases by fever therapy is an air conditioned chamber, at the rear of which is a small compartment containing electric air heaters, a water pan for humidification, a centrifugal fan, and controls. Warmed air at 130° to 150° F. and 30% to 50% relative humidity is forced over the patient. The heat is then turned low and adjusted so as to maintain the desired individual body temperature. For treatment of conditions which require oxygen therapy, air conditioning is a necessity, as the rich oxygen atmosphere in these chambers can be reconditioned in a closed circuit by removing excess heat moisture and carbon.

Wide World



# CHICAGO CLEANS AIR WITH ELECTRIC PRECIPITATOR

## Electric Precipitator Achieves World's Cleanest Air

ELECTROSTATIC cleaning of air, recognized as the outstanding method of dust removal, recently had its first commercial application in Chicago's Field Building. Developed by the Westinghouse Research Laboratory (see RECORD, September 1937, page 25), the method consists essentially of cleansing the air of dust and smoke by precipitation—that is, by imposing an electrical charge on all dust particles, even the most minute, and then pulling them through an electrostatic field which catches them in much the same manner as magnets attract iron filings. It is neither an air conditioner nor a dehumidifier, but can be used in conjunction with such equipment.

Courtesy Westinghouse

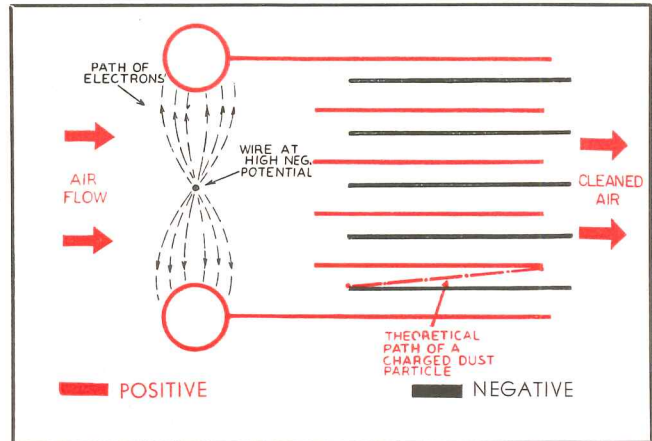
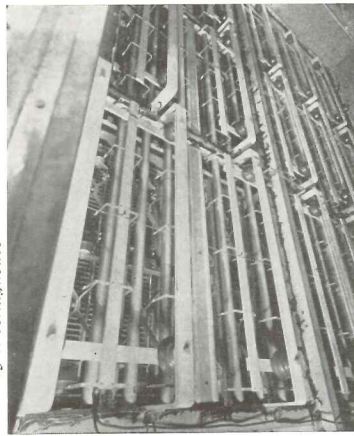

**HOW IT LOOKS (LEFT) AND HOW IT WORKS (RIGHT): INCOMING AIR, forced through the electrical "screen", leaves its charged dust burden on the grid and emerges up to 99% cleaner than when it entered.**

tioning apparatus proper, where its temperature, humidity, and circulation are determined.

Installed in the Field Building are 18 units with a total capacity of 272,000 cu. ft. per minute. Removing up to 99%, by weight, of all particles in the atmosphere, the estimated result of this installation will be a collection at the end of a year of 600 bushels of impurities, 90% of which will consist of particles 1/100 the diameter of a human hair. The collection will consist, by weight, of one-third ash, one-third fixed

carbon, soot, lampblack, and other derivatives, and the remaining third volatile matter (oils and greases). All this, and sulphur, bacteria, and seasonal pollens as well, will be deposited on the plates, which can be cleaned (with the current off) by hosing with water every month or six weeks.

Operating costs in terms of current are low, says the manufacturer: a unit capable of cleaning the necessary amount of air in an average home requires as much current as a 60-watt bulb.

## NEW PRINCIPLES USED IN HEATING

### New Heating System Circulates Air and Water

FIELD TESTED in 12 homes for over three years, but only recently announced for distribution in the New York City area, is American Radiator's new domestic heating system, Thermo. The system consists of four essential elements: the usual boiler to which is attached a compressor, the distribution system consisting of three 5/8" copper tubes (two for circulating hot water, one for air), the Thermo Heating Unit with an air-driven fan, and the automatic controls, or Relay. Actually a domestic adaptation of the automobile heater, this system is equally compact and operates in much the same manner. Air is filtered in the heater room unit, compressed and delivered through one of the copper tubes at the rear of the radiator. The force with which the air hits the fan sets it in motion, creating a small silent turbine. Although the radiator holds only one pint of water, each Thermo unit is capable of warming 50 cu. ft. of air. Because of its compactness (10" wide x 14 1/2" high x 4 3/4" deep), the unit can be installed flush with the wall.

### Heated Floors have Novel Electrical Unit

AN ELECTRICAL heating system of novel design, installed in the concrete floor of Douglas Aircraft Company's 8,000,000-cubic foot hangar at Santa Monica, California, solved the problem of heating this huge area without taking up usable space. A single resistance-wire heating element 53,000 feet in total length and spaced by 1-inch porcelain insulation tubes, was placed in a 3/4-inch galvanized conduit filled with transil oil. The conduit was run

Transil oil, a refined mineral oil, was developed jointly by General Electric and various oil companies to meet the special requirements of electrical transformers. Because of its high transmission qualities, transil oil serves as a vehicle for conveying heat from the electric cable to the conduit and thence to the floor of the hangar.

across the floor in loops 300 feet long, spaced two feet apart, and arranged in twelve sections, each controlled by a thermostat. Peak-limiting equipment controls the heating load (supply voltage is 460, with 230 volts applied to each element), so that use does not increase the maximum demand of the plant.

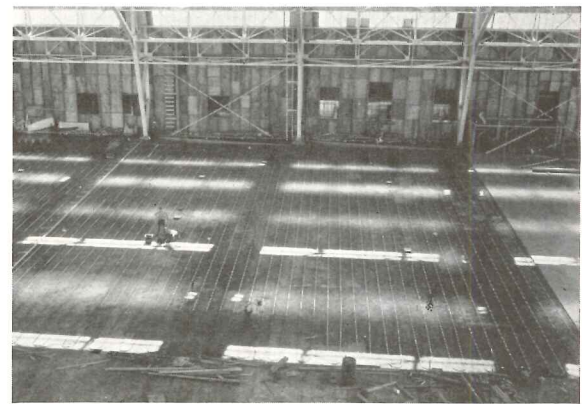

Courtesy "Electrical World"

### LAYING THE HEATING SYSTEM preparatory to pouring concrete

The system is designed to eliminate fire hazards, fumes, and tampering by employees, and to provide a comfortable working temperature at the floor level. Although the heating system produces a floor temperature of 80° F. under average conditions, a noticeably lower temperature results in severe cold periods, and when the 275' x 35' hangar doors are open. "Sweating" of the concrete floor, which occurred over earth fills when the heat was first turned on, stopped as soon as the earth dried out.



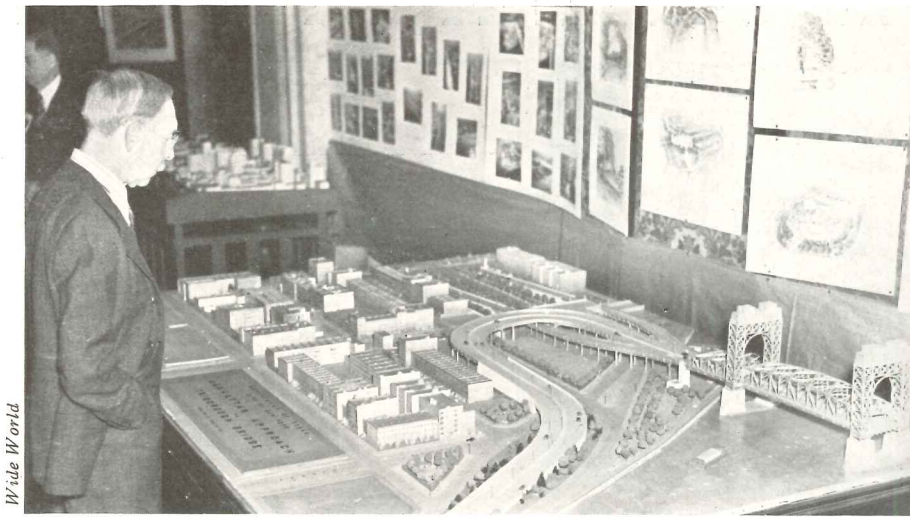

Wide World

THIRD ANNUAL CONVENTION OF S. P. E. SAW, AMONG OTHER things, this model of Manhattan's approach to the Triborough Bridge.

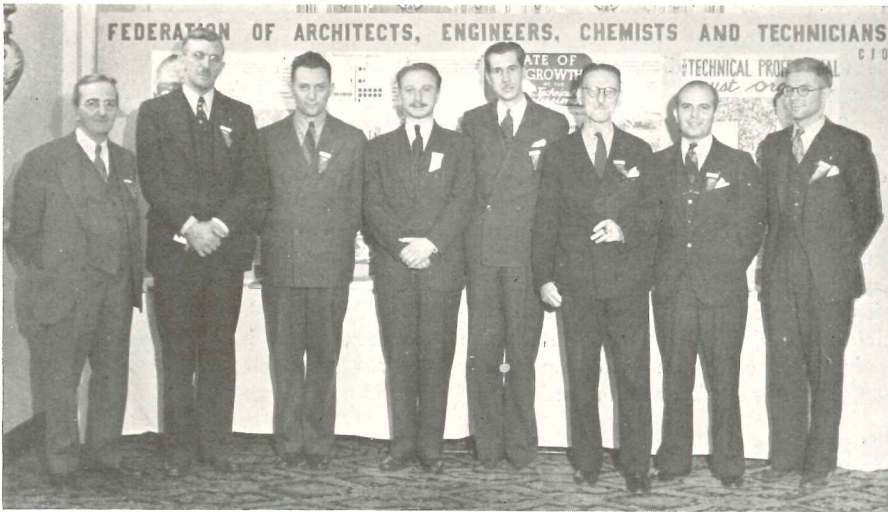

Arthur S. Siegel

THIRD ANNUAL CONVENTION OF FAECT, CELEBRATING ITS FIRST CIO year, elected these men to organize the technicians: (left to right) W. E. Johnson, G. K. Young, Marcel Scherer, L. A. Berne, R. M. Sentman, J. A. Gaynor, John Vasta, and B. Z. Boris.

### Nathan Straus takes charge of the United States Housing Authority



Wide World

#### Mr. Straus, ready to begin

LAST MONTH presidentially-appointed Nathan Straus of New York took over his duties as Administrator of the Federal Housing Authority and its \$526,000,000 slum clearance program. No mean job is this, aptly char-

acterized by Straus as one which "calls for action and very little talk"; for trends in urbanization indicate the necessity for construction of enough suitable dwellings to house the increasing population, and the demand for proper housing in the low-cost field is becoming more and more insistent.

Under the U. S. Housing Act (known variously through several stormy Congressional sessions as the Wagner Bill and the Wagner-Steagall Bill) the Federal Government is essentially a financing agency through which funds are made available to the qualified borrowers and grantees. But this is no centralized program. All responsibility for initiating, constructing, financing and operating housing and slum clearance developments lies with the local authorities. For this reason one of Administrator Straus' major problems is the fact that 18 delinquent states

### Two Organizations Debate Future of Technical Man

MEETING simultaneously—the Society of Professional Engineers in New York City, the FAECT in Detroit—the national conventions of the two organizations recently locked horns in a sharp verbal tilt. While FAECT discussed extension of its organization of technical men, SPE's national President Arthur V. Sheridan attacked unionization of engineers. Proposing that the Wagner Labor Relations Act be amended to exclude technical employees, Mr. Sheridan at once drew the fire of FAECT, which charged that such an amendment would actually rob the technical employees of their legal right to organize and bargain collectively. This friction was further complicated by SPE's charges that the CIO in general, and the FAECT particularly, were guilty of "coercion" in organizing. Again the telegraph wires hummed: of Mr. Sheridan the FAECT demanded proof—"a single example of such coercion." None was forthcoming and the discussion lapsed.

Aside from this, both conventions proceeded according to schedule. SPE's delegates heard and discussed a number of technical papers, as did the open sessions of the FAECT convention. But main emphasis in Detroit lay on a series of knotty organizational problems. Reviewing a year under CIO—during which an estimated \$3,500,000 in wage increases, back pay, restoration in cuts had been won for its members—FAECT remodeled its constitution, welcomed three A. F. of L. groups into the fold, discussed independent political action, and adopted a number of resolutions.

have no housing legislation authorizing participation of local subdivisions in the new program, and the remaining 30 either have inadequate legislation or have failed to take full advantage of existing laws. Only 50 cities have municipal housing bodies, and many of these have only a nominal existence. Without these subsidiary state, county and city organizations the Housing Act cannot function.

Projects built under the provisions of the Act will be state or municipal, not Federal. Any existing Federal projects which newly-created authority acquires by transfer, it is to divest itself of as soon as practicable. New projects must meet cost requirements of the Act: in cities of 500,000 or over, construction costs will be limited to an average of \$1,000 per room, or \$4,000 per unit; in larger cities the limit will be \$1,250 per room, or \$5,000 per unit.



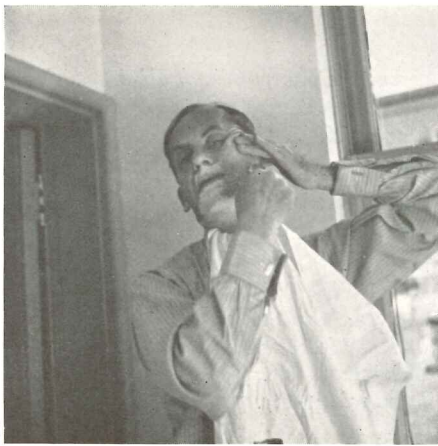

1

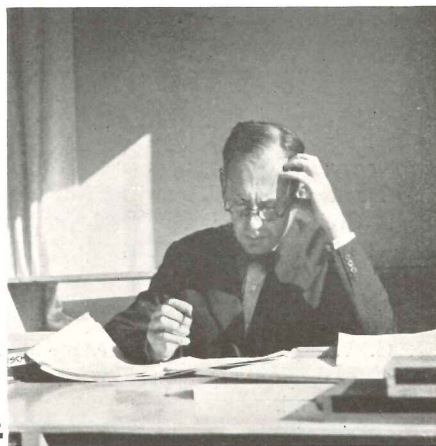

2



3



4

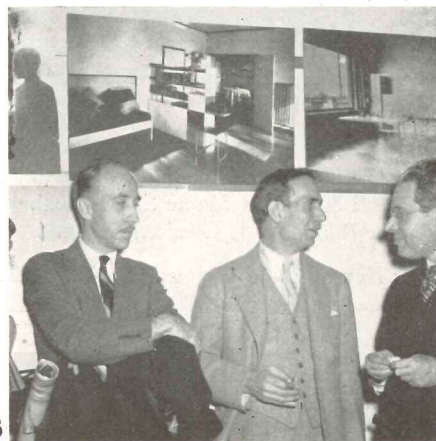

5

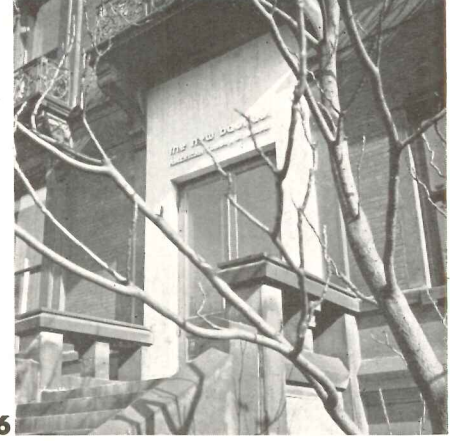

6

MOST WESTERLY INCARNATION OF A FAMOUS NAME, CHICAGO'S "New Bauhaus" was formally opened last month in a blaze of publicity. Present at the opening of the latest project of the Association of Arts and Industries were many of those who at one time or another were connected with the German original, including the new director, L. Moholy-Nagy and Dr. Walter Gropius (to whose Harvard Bauhaus was recently added the English modernist, Marcel Breuer). In greeting the new institution in his dedication speech, Moholy-Nagy departed from the festive note long enough to hope for "an atmosphere of artistic and intellectual freedom" which would be the opposite of Europe, "where the condition of the cultural workers . . . is rather desperate today", where the artist is the servant of totalitarian regimes whose "special aim is the preparation for war." Seen above at the opening are (1, 2, and 3) Dr. Gropius preparing for and delivering his speech, Moholy-Nagy with (4) the sculptor member of the staff, Archipenko, and (5) RECORD's editor, A. Lawrence Kocher. External evidence of new life in the old Field mansion—the new entrance (6) and the fire escape (7).

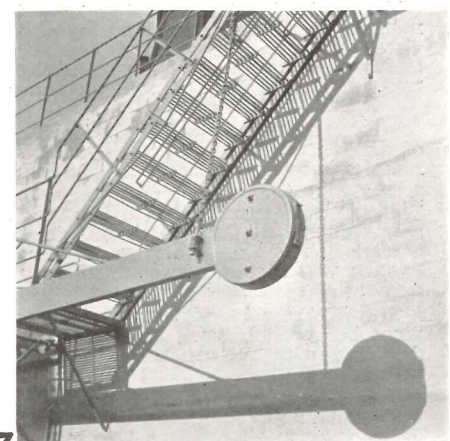

7

Herbert Matter

## ANNOUNCEMENTS

FELLOWSHIPS at the American Academy in Rome have been announced for 1938 by Roscoe Guernsey. Entries for competitions must be sent to Mr. Guernsey at 101 Park Avenue, New York City, before February 1, 1938. Available to unmarried men under 30 years of age, citizens of the United States, are fellowships in architecture, landscape architecture, painting, sculpture, musical composition, and classical studies. Each fellowship is valued at \$1,250 per year (term of tenure is two years), with \$300 allowance for transportation to and from Rome. Residence and studio at the Academy are provided without charge, and fine arts fellows receive \$200 to \$300 for materials.

## CALENDAR OF EVENTS

- December 6-10—Annual Meeting, American Society of Mechanical Engineers, N. Y. C.
- December 13-14—Conference on Urban and Rural Zoning, National Resources Committee, Chicago, Ill.
- December 28-29—American City Planning Institute, Princeton, N. J.
- January 12-15—Annual Conference, American Institute of Decorators, Chicago, Ill.
- January 17-19—Annual Meeting, American Society of Landscape Architects, Williamsburg, Va.

## CHANGE OF ADDRESS

The RECORD publishes changes of address only on request, making no attempt to keep a day-to-day account. Only organization in the country with facilities for this is Sweet's Catalog Service, whose painstakingly maintained list undergoes an average of 23 changes per day for every working day in the year.

Hal A. Miller, architect, announces the removal of his office to Suite 302, 421 St. Paul Place, Baltimore, Md.

E. J. Russell, W. D. Crowell and W. O. Mullgardt announce a change in firm name to Mauran, Russell, Crowell and Mullgardt, architects, Chemical Building, St. Louis, Mo.

M. T. Livingston has moved to 629 Chaffee Avenue, Augusta, Ga.



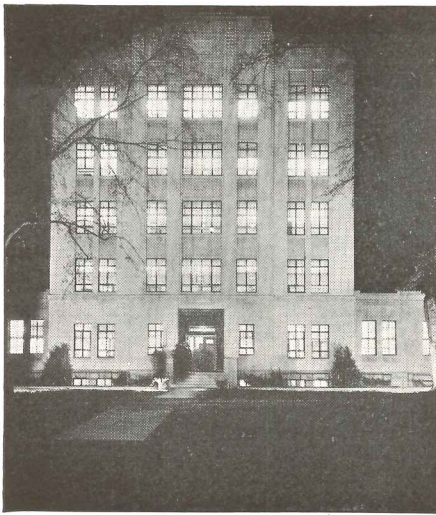

Cooperative GLF Office Building Ithaca, N. Y.

## NEW GLF BUILDING GETS MODERN HEATING

Low Cost Heating and Long-Time Effectiveness Provided in the Webster Moderator System

### Concealed Webster Radiation

Ithaca, N. Y.—Built during 1936, the modern, five-story office building of the Cooperative Grange League Federation stands as a tribute to the careful planning and sound business management of the Cooperative officials.

Working on a limited budget, officers of the GLF sought long life and low maintenance cost in selecting equipment.

Study of the performance records of Webster Systems of Steam Heating in scores of installations convinced Grange officials that the Webster Moderator System was a sound investment for the heating of their new building.

The Webster Moderator System provides balanced heating service. Heat is delivered continuously to all radiators, without overheating in mild weather. Heating costs are held at a minimum.

The installation includes 70 concealed Webster System Radiators. The grilles of these "out-of-the-way" concealed radiators harmonize with the modern interior and increase available floor space. All cast-iron radiators used in the building are equipped with Webster Three-Point Valves to insure maximum flexibility.

Two Webster Boiler Protectors guard against accidental low water in the low-pressure heating boilers. If water is lost from a boiler accidentally, the Webster Boiler Protector automatically maintains emergency level and provides the operator with definite indication that water has been lost.

The Webster System was installed in the GLF Building by the American Warming & Ventilating Co., well-known heating contractors of Elmira, N. Y. The building was designed by Arthur N. Gibb, a leading Ithaca architect.

If you are interested in heating new buildings, or in improved heating service and lower heating cost in your present building, address WARREN WEBSTER & CO., Camden, N. J. Pioneers of the Vacuum System of Steam Heating. Representatives in 60 principal U. S. Cities—Est. 1888

SEE WEBSTER EXHIBIT  
HEATING AND VENTILATING EXPOSITION  
New York, January 24 to 28, 1938

## NEW PUBLICATIONS

### General

*American Planning & Civic Annual.* By Harlean James. American Planning and Civic Association, 901 Union Trust Bldg., Washington, D. C. Price, \$3.00.

*Architectonische Details.* By Prof. J. G. Wattjes. N. V. Uitgeners-Mij. "Kosmos", Keizersgracht 133, Amsterdam, Holland.

*Hedendaagsche Architectuur in Nederland.* By the Bond van Nederlandsche Architecten. N. V. Uitgeners-Mij. "Kosmos", Keizersgracht 133, Amsterdam, Holland.

*Household Furniture and Interior Decoration.* By Thomas Hope. John Tiranti & Co., 13 Maple St., Tottenham Court Road, W. 1, London, England.

*It's Fun to Build Things.* By W. T. R. Price. Hillman-Curl, Inc., 66 Fifth Ave., N. Y. C. Price, \$1.50.

*Parkways and Land Values.* By John Nolen and Henry V. Hubbard. Harvard University Press, Cambridge, Mass. Price, \$1.50.

*Regional Planning, Part V—Red River of the North.* National Resources Committee, Washington, D. C. August 1937. Price, \$0.25.

*Rigid Frames for Bridges and Buildings.* By Harold D. Hussey. American Institute of Steel Construction, Inc.

*Spanish Colonial Architecture in the United States.* By Rexford Newcomb. J. J. Augustine, 30 Irving Place, N. Y. C. Price, \$12.00.

*The Cabinet and Chairmaker's Real Friend and Companion.* By Robert Manwaring. John Tiranti & Co., 13 Maple St., Tottenham Court Road, W. 1, London, England.

### Structural Materials and Parts

*Art Metal Sectional Sound Insulated Partitions.* Art Metal Construction Co., Jamestown, N. Y.

*Cold Weather Conditioning.* Inco Division, Lone Star Cement Corp., 342 Madison Ave., N. Y. C.

*Precision-Built Homes.* The Homesote Co., Trenton, N. J.

*Pre-fab in Pictures.* Harnischfeger Corp., Houses Division, 6785 W. Greenfield Ave., Milwaukee, Wis.

*Tempryte Insulating Windows.* Truscon Steel Co., Youngstown, Ohio.

*Vacuum Concrete Floor Finishes.* Vacuum Concrete Corp., 30 Rockefeller Center, N. Y. C.

### Equipment

*Speakman Diamond and Wilder Catalog No. K-3 of Showers and Fixtures.* Speakman Co., Wilmington, Del.



*Art Metal Work Center Kitchens.* Art Metal Household Institute, Division of Art Metal Construction Co., Jamestown, N. Y.

*Benjamin Catalog No. 26 of Lighting Information.* Benjamin Electric Manufacturing Co., Des Plaines, Ill.

*Bradley Group Washing Fixtures.* Bradley Washfountain Co., N. 22nd and W. Michigan Sts., Milwaukee, Wis.

*Cabinet Sinks for the Well-Planned Home.* Crane Co., 836 S. Michigan Ave., Chicago, Ill.

*Chicago Faucets Catalog F.* The Chicago Faucet Co., 2700-2722 N. Crawford Ave., Chicago.

*Worthington Horizontal Dry Vacuum Pumps, Single-Stage and Two-Stage.* Worthington Pump and Machinery Corp., Harrison, N. J.

### Air Conditioning, Heating and Insulation

*Basement Plans for Modern Bituminous Coal Heating—A New Service for Architects and Builders.* National Coal Association, 804 Southern Building, Washington, D. C., and 307 N. Michigan Ave., Chicago, Ill.

*Controlled Automatic Heating, Ventilating and Air Conditioning.* Condensed Catalog and Price List. Minneapolis-Honeywell Regulator Co., 2753 Fourth Ave., South Minneapolis, Minn.

*Double Duty Model L Air Filters.* Independent Air Filter Co., Inc., 228 N. LaSalle St., Chicago, Ill.

*Red Jacket Automatic Water Systems.* Catalog No. 101. Red Jacket Manufacturing Co., Davenport, Iowa.

*Year Round Insulation Costs You Nothing.* Kimberly-Clark Corp., Neenah, Wis.



# New Glass and new Metal



The "Modern Shopping Center" erected by Chevrolet at the New York and Chicago Automobile Shows. L·O·F products were used exclusively.

## FOR NEW TRENDS IN storefront architecture

● Today, one of the most noticeable trends in modern commercial construction is the increased use of glass in storefronts and building exteriors. Modern merchandising demands the transformation of drab, uninteresting, uninviting fronts into areas that appeal with color and light—that compel attention and invite entrance.

Glass has long contributed its remarkable utility and beauty to every type of construction. And NOW new kinds of glass appealing to the eye, advanced in smartness are practical for use as a part of the structure itself. Vitrolite, the Colorful Structural Glass is one. Another, Vitrolux Color Fused Tempered Plate Glass, is the ONLY glass that combines ALL of the characteristics essential for practical and effective luminous storefronts. For Vitrolux—with colors fire-fused to become an integral part of the glass—offers unusual resistance

to thermal shock and is not affected by rain or snow coming in contact with the warmed surface of the lighted glass area.

And for the first time Libbey·Owens·Ford Glass Company now offers EVERY material required in the construction of the modern storefront—permanent materials that outlive the structure itself and are unexcelled in ease of maintenance. Write TODAY for information on L·O·F Storefronts. Complete technical, installation and lighting data are available. LIBBEY·OWENS·FORD GLASS COMPANY, TOLEDO, OHIO

# LIBBEY·OWENS·FORD

## Complete Storefronts

**L·O·F**  
**STOREFRONT MATERIALS**



Vitrolux—Color Fused Tempered Plate Glass; Vitrolite—Colorful Opaque Structural Glass; Polished Plate Glass; Aklo Heat-Absorbing Plate Glass; Blue Ridge Figured and Wire Glass; Extrudalite—Revolutionary Line of Metal For Storefront Construction.



# NEW!! A DRAWING PENCIL

CREATED FOR MODERN  
DRAFTING ROOM USE

With the introduction of the Mars Lumograph Pencil, reproductions from pencil originals became universally practical. A new, patented light resisting element, *found only in Mars Lumograph*, produces sharp, clear blueprints. It is no longer necessary to make tracings, or "ink in" your finished work. The majority of your drawings can be blueprinted successfully from your Mars Lumograph originals.

Give your pencil drawings a new blueprinting strength with the Mars Lumograph pencil. There are seventeen true degrees, from ExExB to 7H.

THERE IS NO SUBSTITUTE FOR  
**MARS LUMOGRAPH**

**J. S. STAEDTLER, Inc.**  
53-55 WORTH ST., NEW YORK

DISTRIBUTORS

KEUFFEL & ESSER CO. CHARLES BRUNING CO., Inc.  
Hoboken and New York New York, Chicago and  
and Branches and Branches



15¢

EACH

\$1.50 PER  
DOZEN

Ask your  
dealer, or  
write for a  
trial order.

When ordering, please  
specify degrees wanted.

## Here's Real News!

*Fenestra* STEEL WINDOWS,  
BONDERIZED and finished by a  
New Process Never Before Applied  
to Steel Windows, . . . . . are now  
**RUST-RESISTING**

A new and important saving  
in maintenance costs for Build-  
ers and Building Owners.  
This new process makes  
*Fenestra* Steel Windows abso-  
lutely rust-inhibitive.



**THIS FREE BOOKLET—**

shows you how Bonderizing makes Fenestra Steel Windows absolutely rust-inhibitive . . . makes possible new and important savings in window maintenance costs. Write for a copy today.

**DETROIT STEEL PRODUCTS COMPANY**  
2260 East Grand Blvd. Detroit, Mich.

THE COMPLETE WINDOW  
*Fenestra*

## Many Advanced Features

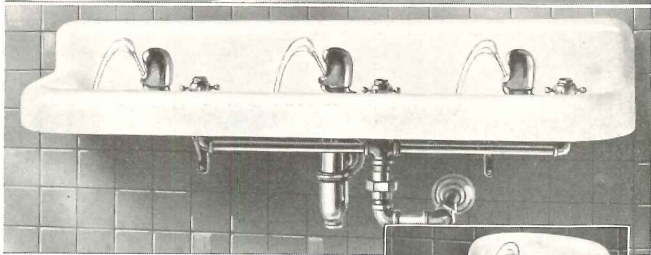

The Halsey-Taylor Drinking Fountains embody features of merit so far advanced in mechanical excellence and in hygienic advantages that you can't afford to select any other make. Especially since Halsey-Taylor's cost much less per year of service!

THE HALSEY W. TAYLOR CO., WARREN, OHIO

# HALSEY TAYLOR



## DRINKING FOUNTAINS

### PLAN TO USE COPPER TUBE

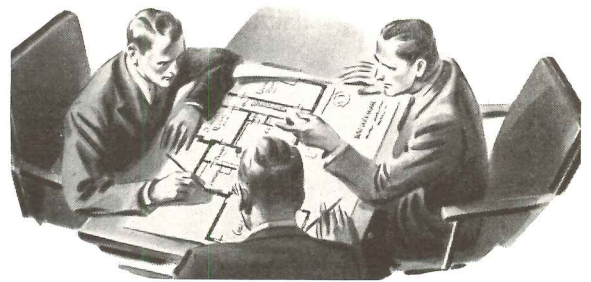

### For Water, Steam, Oil, Refrigerant, Air

Final costs considered, the use of Revere Copper Tube in place of rustable material adds little to total building costs and provides a permanently efficient piping system that will add materially to the investment and functional value of the completed structure. Attractive and modern appearance is a further asset, of appreciable importance where piping is exposed. Write for special booklet—"Revere Copper Water Tube."

## Revere Copper and Brass



INCORPORATED

EXECUTIVE OFFICES: 230 PARK AVE., NEW YORK CITY



Just off  
the press

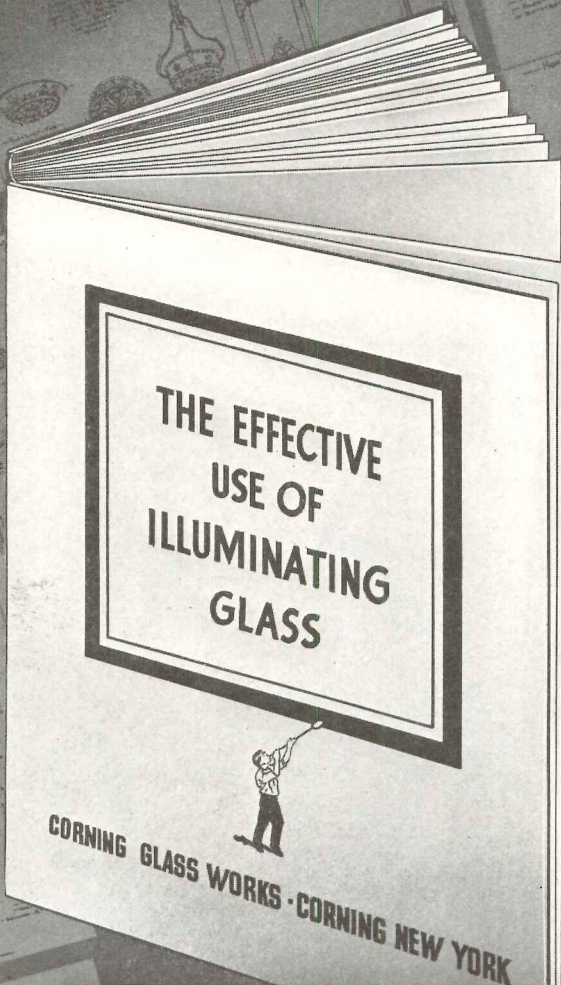

IT'S FREE  
GET  
YOUR COPY

PACKED WITH PRACTICAL IDEAS  
*88 Page Book*

OF LATEST INFORMATION ON ILLUMINATING FACTS

A book that will be valued by any architect or designer of lighting fixtures . . . 88 pages of new, authoritative and workable ideas on lighting . . . Tables that tell how to specify illumination for various types and sizes of interiors . . . complete scientific data on the several kinds of glass from which light-

ing globes are made . . . plus page after page of practical, beautiful and efficient suggestions for original installations . . . In order that this book does not get into the hands of persons not entitled to have it, we ask that you send in your request on your own letterhead.



ILLUMINATING AND OPTICAL DIVISION, CORNING GLASS WORKS  
CORNING, NEW YORK



IMPROVEMENTS ADD

# EXTRA Convenience and Service

to the famous Jenkins Standard Bronze Valves

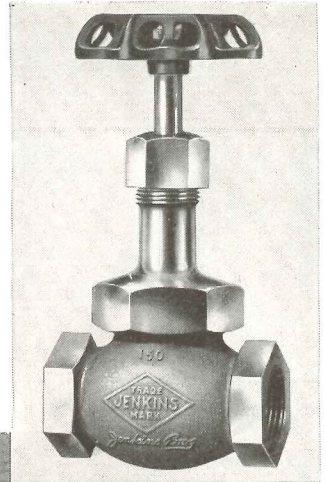

A POPULARITY vote by men who are concerned with valve installation and operation would undoubtedly rank Jenkins Standard Bronze Valves as the outstanding favorite. There's a good reason. For more than seventy years Jenkins Bros. has constantly striven for perfection. Many improvements have resulted but the effort to make the best valve possible never ceases.

The latest results of that effort are seen here . . . three features that mean even greater convenience, even better and longer service:

### 1—Perfection in a Handwheel!

It doesn't seem possible to beat the scientifically correct design of the new handwheel you see here. Any man's hand finds a perfect grip in the deep scallops, no matter what size the wheel may be. It's a cool wheel, too, and the depressed center prevents the hand from touching a hot wheel nut. Neat and trim, yet it has the strength of superior malleable iron.

### 2—Trouble Saving Valve Index Plate!

Held by the wheel nut is a superior Index Plate, of aluminum with permanently bright markings that tell both valve figure number and disc number and service. An important time and trouble saver when replacements are needed.

### 3—New, Long-Life Composition Disc!

Two years' service tests show that our new No. 119—A Renewable Composition Disc, when used in the service for which it is recommended, will outlast any other composition disc we know about, including hard rubber and Bakelite. This new disc replaces No. 119 and is recommended primarily for steam service, although we believe it to be the nearest thing to a "universal" disc that has ever been developed.

These three advantages will be found in the Jenkins Standard Bronze Valves you purchase in the future. A folder, telling more about them and the many other features of these valves, will be sent on request.

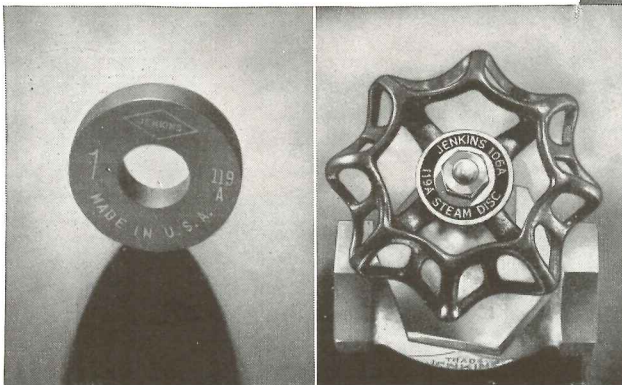

JENKINS BROS., 80 White Street, New York; Bridgeport, Conn.; Boston; Philadelphia; Chicago; Atlanta. JENKINS BROS., Ltd., Montreal; London, Eng.

## JENKINS VALVES

BRONZE—IRON—STEEL





# Some London Hairdressing Shops Done with **FORMICA!**

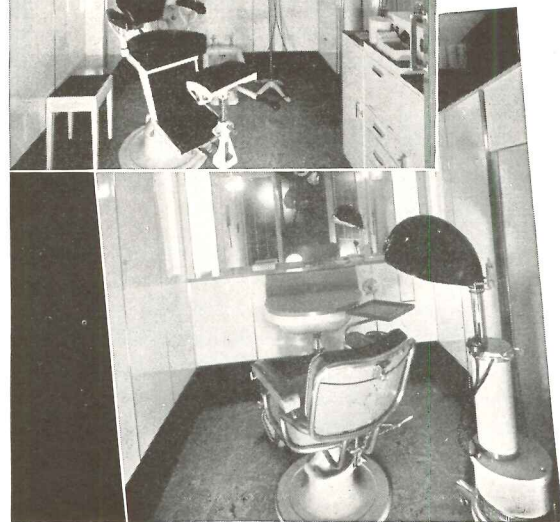
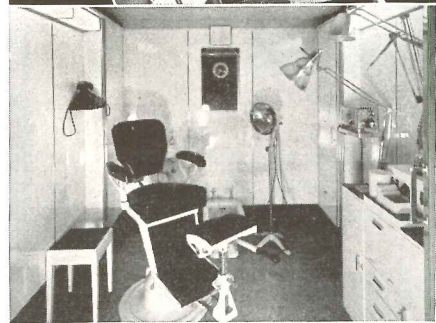
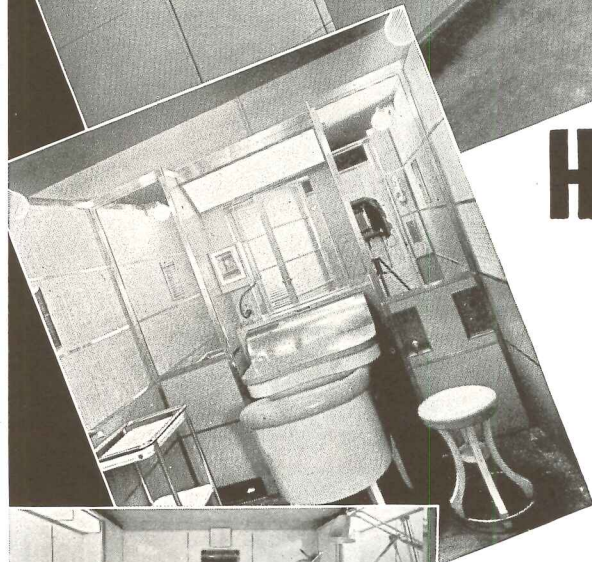

Formica, as a good-looking, durable and modern wall covering, is appreciated in Great Britain as these cubicles and reception desk at Herrods and at P. H. Evans & Co. hairdressing shops indicate. The Formica wall sheet is installed with bright metal trim in the modern manner, and some of the tops are Formica veneered on plywood.

There are more than 70 colors, and decorations of one color may be inlaid on another. Metal inlays also are possible. The material is crack proof, and resists stains and has a smooth, hard and long lasting surface.

Let us send you our literature including many plates in full color suggesting possible designs.

**THE FORMICA INSULATION COMPANY**  
4620 Spring Grove Ave., Cincinnati, O.

# FORMICA

**F O R B U I L D I N G P U R P O S E S**



# STADIUM FINISHED 6 WEEKS SOONER; 'INCOR' SAVED \$9400 ON FORMS ALONE

## 24-HOUR CEMENT USED IN L.S.U. STADIUM; 5-STORY DORMITORY UNDER GRANDSTAND



Photo by Edward Agnelly. © 1936, by The Times-Picayune Publ. Co.

Louisiana State University's new Baton Rouge stadium is a profitable structure. The concrete grandstand, seating 46,000, roofs a 5-story dormitory housing 1,000 students in 499 rooms; yearly rental, \$108,000. Designed by Weiss, Dreyfous & Seiferth, architects, New Orleans, the stadium was erected with W.P.A. labor, under supervision of George A. Caldwell, of L.S.U. Preliminary plans indicated completion by last New Year's Day. By using 'Incor' 24-Hour Cement, the stadium was ready for big game Thanksgiving Day—6 weeks saved. Reason:

'Incor' is self-supporting 5 times as fast. You fill forms with concrete one day, strip them the next. That speeds completion, reduces form costs—forms are used over and over again, fewer forms needed.

On L. S. U. stadium, for example, 'Incor' saved

\$9400 on form material alone. Not to mention 6 weeks saved on contractor's fixed costs or overhead. Figuring time at a nominal \$50 a day, 6 weeks saved means \$2100.

And, in winter, 'Incor' cuts heating costs, because it is safe from freezing days sooner. On 5 jobs recently surveyed, 'Incor' saved 45¢ to \$1.22 a cu. yd. of concrete.

Savings like these, on large jobs and small, suggest that architects encourage contractors to figure every job two ways—with both Lone Star and 'Incor'. Use 'Incor'\* if it saves money; if not, use Lone Star. You gain either way, because better cement makes better concrete. Write for book, "Cutting Building Costs." Lone Star Cement Corporation, Room 2235, 342 Madison Ave., New York. \*Reg. U. S. Pat. Off.

### LONE STAR CEMENT CORPORATION

MAKERS OF LONE STAR CEMENT... 'INCOR' 24-HOUR CEMENT



# Christmas Book List

HERE IS AN OPPORTUNITY to add one or more important architectural books to your working library, or to give as a gift to someone else.

Each one of these books is a standard on its particular subject and is well worth the price.

## ✓ THE MODERN HOUSE

By F. R. S. Yorke, A.R.I.B.A.

This book contains about 500 photographs, plans and constructional details of modern dwellings by architects in Europe and America. Price \$6.00 postpaid, in United States.

## ✓ ANTONIN RAYMOND . . .

HIS ARCHITECTURAL WORK

A pictorial presentation of the work of an American architect who has practiced chiefly in Japan. 172 pages—294 illustrations, including exterior and interior views, details, plans and models. \$6.00 postpaid, in United States.

## ✓ THE AMERICAN HOSPITAL

of the Twentieth Century. Third Edition.

By Edward F. Stevens.

Mr. Stevens, himself, has planned more than 150 hospitals and institutions. The book describes the development of medical institutions in Europe and America; it is the recognized authority on hospital planning and equipment; 550 pages, 660 illustrations and floor plans. Price now \$7.50 instead of \$15.00 as formerly.

**NEW DETROIT ADJUSTABLE FEED**

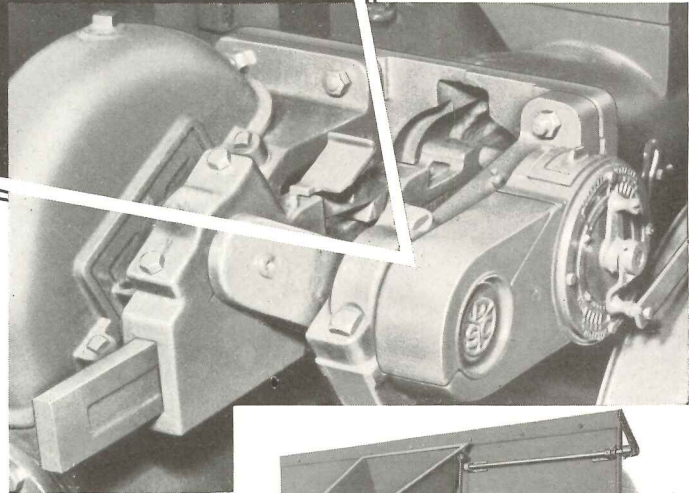

## For BETTER COAL FEED CONTROL

The Detroit Adjustable Feed provides a large number of positive rates of feeding coal to the Stoker Retort. Widely varying demands for steam can be taken care of automatically and the fuel bed maintained in prime condition at all times.

## For DETROIT SINGLE RETORT STOKERS

Detroit Adjustable Feed may be operated either manually or by an automatic regulator. Its design is simple and sturdy. The mechanism is fully enclosed. May be applied to existing installations of Detroit Single Retort Stokers.

Write for Bulletin 664

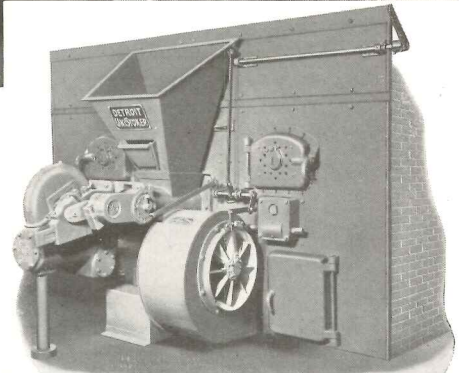

**DETROIT STOKER COMPANY**  
 Fifth Floor, General Motors Building, Detroit, Michigan • Works at Monroe, Michigan  
 District Offices in Principal Cities • Built in Canada at London, Ontario

## ✓ THE RESTORATION OF COLONIAL WILLIAMSBURG

A reprint of the December 1935 issue of Architectural Record. 104 pages, bound in cloth. \$1.50 per copy.

## ✓ THE NEW ARCHITECTURE IN MEXICO

Modern architecture, painting and sculpture in Mexico, collected and arranged with photographs, by Esther Born. \$3.50.

12-37

## ARCHITECTURAL RECORD

119 WEST 40TH STREET - - - - NEW YORK

In accordance with your Christmas book list, send me at once the books checked, for which I enclose \$.....

NAME .....

ADDRESS .....

CITY AND STATE.....

- The Modern House - - - - - \$6.00
- Antonin Raymond - - - - - 6.00
- The American Hospital - - - - - 7.50
- Colonial Williamsburg - - - - - 1.50
- New Architecture in Mexico - - - - - 3.50



## Disused market building becomes an ideal community center



Transformation scene! Middletown, in Dauphin County, Pa., buys in neglected stone market house and with the able aid of Architect Wm. Lynch Murray, turns it into a fine Borough Hall and Community Building, housing a spacious auditorium and gymnasium, recreation rooms, and certain borough offices.

Congratulations to Middletown for the vision and judgment of its borough officers in carrying through this project. Particularly as it provides for

**HEAT AND  
HOT WATER SUPPLY  
BY THE**

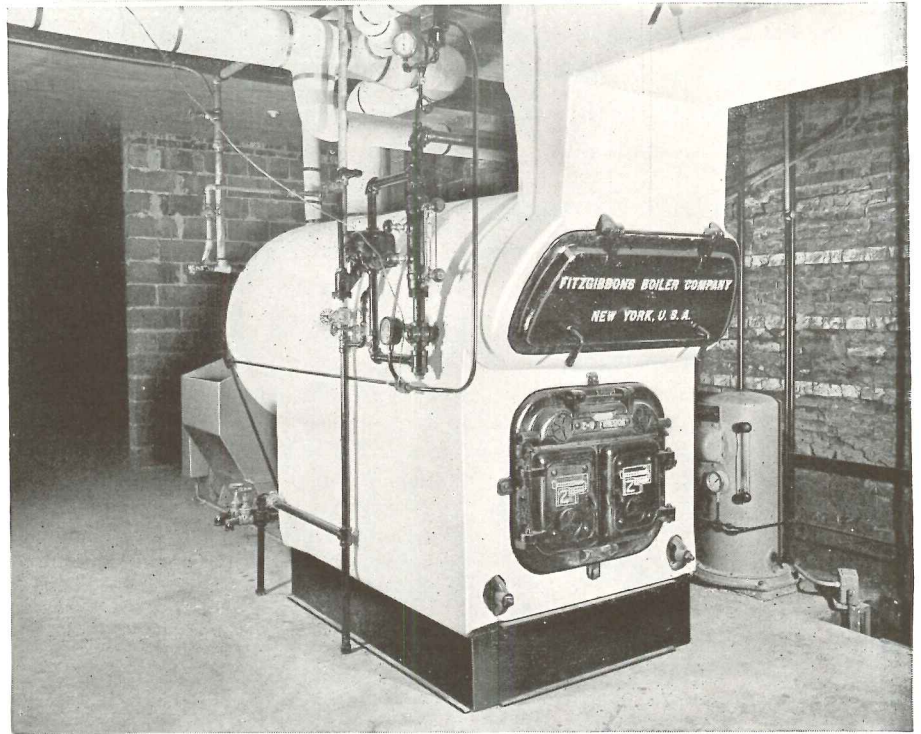

# FITZGIBBONS Z-U STEEL BOILER (Stoker-fired)

Notice the photo of the heating installation. A beautifully clean job throughout, installed by Fuel Savers, Inc., Harrisburg, Pa. A difficult job, too, as the chimney location required a boiler with front smoke outlet, while the coal bin location arbitrarily placed the anthracite stoker at the rear of the boiler. The Fitzgibbons Z-U, however, met these conditions perfectly, while permitting easy removal of ash and unobstructed access to flues for cleaning. Hot water supply for all purposes is provided *without a storage tank*, by the Fitzgibbons Tanksaver, a submerged copper coil, built integrally into the boiler.

As shown in this installation, the adaptability of the Fitzgibbons Z-U Steel Boiler is equalled only by its fuel-saving efficiency.

*Write—Today—for the "Z-U" Catalog.*

**Fitzgibbons Boiler Company, Inc.**

General Offices: ARCHITECTS BLDG., 101 PARK AVE., NEW YORK, N. Y.

Works: OSWEGO, N. Y. • Branches and Representatives in Principal Cities

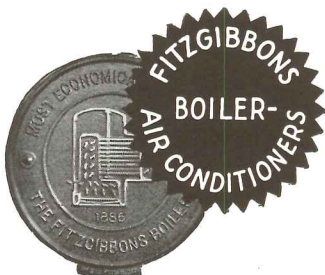



# DESIGN TRENDS

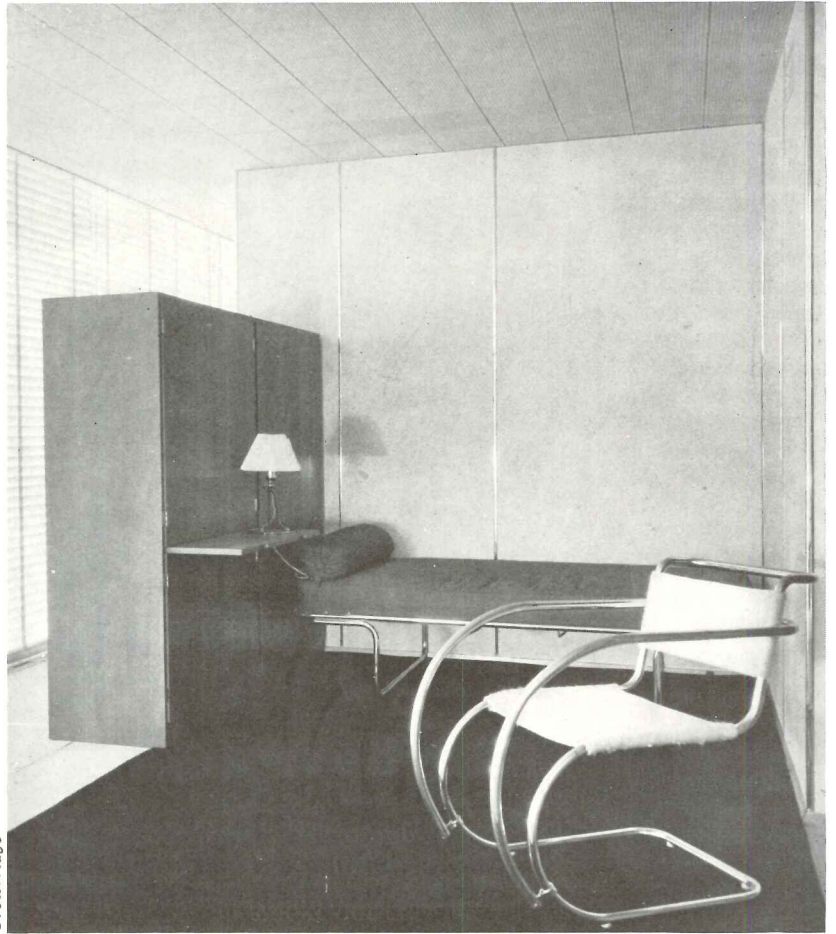

Troubridge

House Interior. George Fred Keck, Architect

ARCHITECTURAL

Record



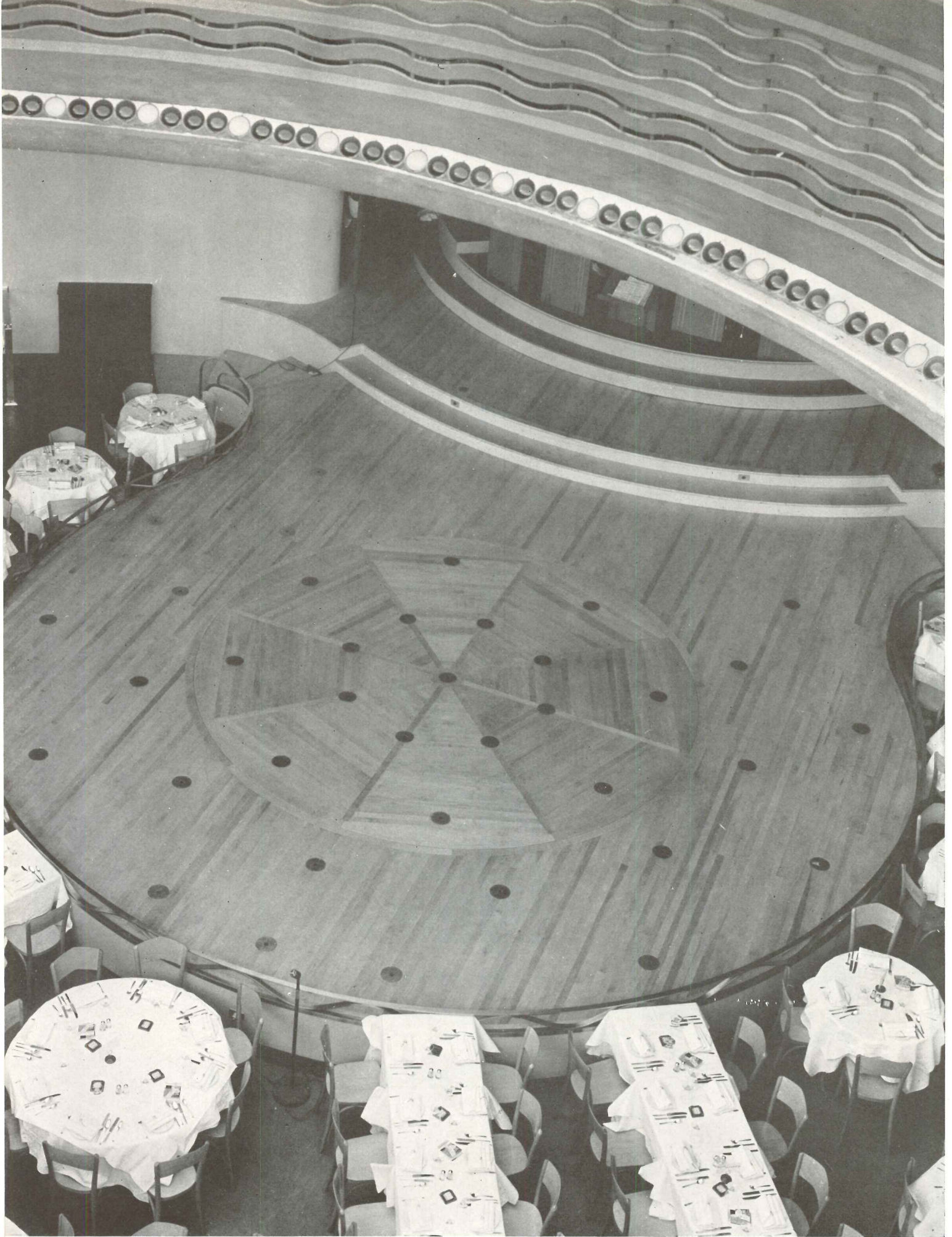

*Photo by Eckman Studio*

**DANCE FLOOR, Ben Marden's Riviera. Louis Allen Abramson, Architect. This view, taken from the open roof, shows the 14-foot turntable used for dancing and floor shows.**



# Push Buttons and Photoelectric Cells Simplify Life and Conserve Space

By JULES KORCHIEN, R.A.

THE INCREASING NUMBER of mechanical aids to living is having its effect on numerous building types. This trend, manifesting itself on every hand, sometimes fires the imagination of today's building designer and sometimes leaves him wondering how to keep abreast of it all. In the following article the RECORD, as an initial effort to supplement the mechanical developments constantly reported in the *Building News* section, analyzes and describes a group of installations by one concern of specialists. It is hoped that readers will gain therefrom not only an idea of some of the stimulating things which are now available for use, but of some of the things which they and other designers will include in buildings of tomorrow. From time to time other studies in the RECORD will consider the subject of the mechanization of building from different angles.

THE DICTUM of the exponents of modern architecture that there must be a "marriage" of indoor and outdoor space for purposes of "better living" is found nearer realization in the increasing use of mechanized architectural elements. The constant pressure on building designers for economies in construction and in space arrangements is taxing their ingenuity more and more. More frequently than ever single areas are being planned to serve a multiplicity of purposes. The consequence is that a "flexible", "fluid", or "dynamic" quality is being introduced into architecture, upsetting many of the old concepts of rigid structure.

Mechanical aids to living were in existence even before Archimedes enunciated the first principles of mechanics, yet a thorough, practical use of mechanical formulas awaited economic necessity. Even during the period of the Roman Empire, no such necessity existed. Incentive for conserving space or human effort, there was none. The Romans had a world of resources at their feet and an endless supply of slaves from conquered territory. Mechanization was largely limited to the machines of warfare. It took the Middle Ages and the Early Renaissance, the Feudal period of society, to invoke the predecessors of our automatic doors, elevators, bascule bridges. How could a castle defend its gates without a drawbridge and portcullis? Who ever read of a dungeon without a villainous trapdoor that dropped the enemy out of sight forever?

The history of the development of movable bridges gives us some background to our present-day mechanized designs. Viollet-le-Duc describes these early bridges. The so-called *pont-*

*levis* was used early in the fourteenth century in France for fortified gates; it was simply a wooden platform raised with iron chains. When gunfire was first used in warfare, toward the end of the fifteenth century, these bridges became useless. It was a simple matter to shoot away the exposed chains. This difficulty was overcome by the development of the bascule bridge, where the mechanism was hidden. These bascule bridges were of two types, one with a leaf raised to close half of the gateway above, another with a leaf which hinged down into the moat. The latter was used in the east of France and along the Rhine. Another common type of medieval drawbridge was the retractile bridge. This was put into service by sliding it forward on rollers until the end projected across the moat or opening. It was used in Italy and southern France much earlier than the fourteenth century. Warfare dictated architectural developments, even as it is doing to an increasing extent today (witness bombproof shelters, flameproof roofs, etc.).

Seldom does the progress of an idea or invention follow along a methodical, direct path. It is possible to establish the ultimate outlines of an invention, however imperfect. The intermediate steps may not have been traced, but they eventually become apparent. Consider the auto trailer, for example. Here, perhaps, is the ultimate in architectural mechanization; rooms expand, roofs open, "gadgetry" is a necessity, while the structure itself attains mobility. Our architects have come to learn much from the formerly humble trailer. Here, efficient utilization of space is a necessity—and this is the touchstone of contemporary architecture.



Photos by Charles L. Frank



**MUNICIPAL AUDITORIUM, New Orleans. Favrot & Livaudais, Architects. This large arena can be used as single auditorium or converted into two halls for concerts, sports, etc. A part of the floor can be raised and lowered to become stage and orchestra pit.**

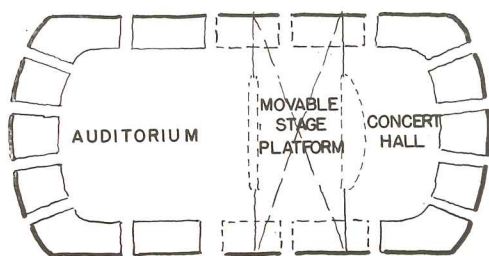
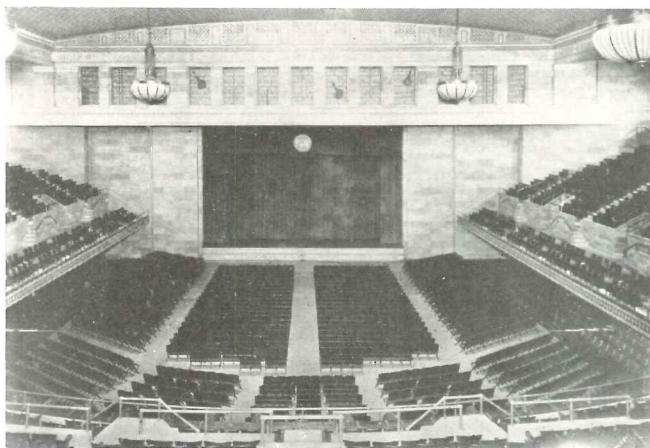
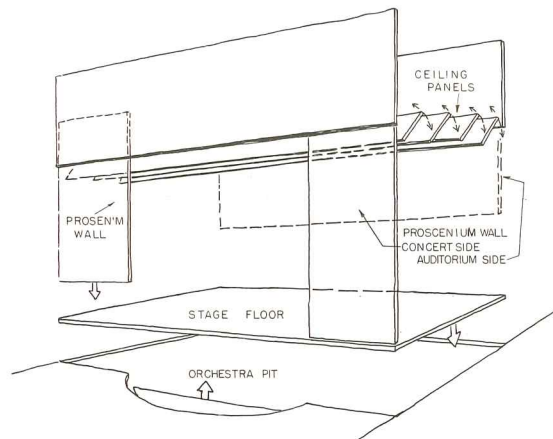

Saving of costs in construction and maintenance, saving of human effort in operation, and minimum space idleness are architectural imperatives. One-purpose space enjoying only a seasonal or intermittent use—such as we find among our leisure-time public buildings and auditoriums—is an unreasonable economic burden.

Practically any part of a structure can be made today to eliminate manpower. Motor operation is achieved by the mere pressing of a button. But because this potentiality has been achieved by degrees—a revolving stage here, a motor-driven door there—we are perhaps not as conscious of the implications of mechanization as we might be. What has been done in the field of mechanization? What can be done? What does it mean to building design? In the extensive work of one firm, Allen Automatic, Inc., of New York, lies at least a partial answer and a first-hand opportunity for a case study.

### Auditoriums Which Can Be Subdivided

For the purposes of this discussion the architectural elements mechanized may be classified as follows:

Walls: Interior.

Exterior (including store fronts; windows; garage, factory and hangar doors; jail gates).

Floors (revolving, elevated and rotating).

Ceilings.

An outstanding demonstration of all three classifications in one project (motor-operated walls, ceiling, floor) is the Municipal Auditorium at New Orleans. The problem was to convert a large arena into two halls for concerts, theater, etc. To accomplish this, proscenium walls are made to lower into place; the ceiling over the stage portion rotates in sections about a horizontal axis so that the sections are in a vertical position forming a fly gallery, while the floor beneath may be raised and lowered to become stage and orchestra pit. The stage area is 6,500 square feet and weighs approximately 240,000 pounds. The wall sections located on both sides of the stage cover a total area of 11,000 square feet, are 40 feet in height, and split into ten sections with special telescopic guides between the sections. Their weight is approximately 250,000 pounds and they are operated by comparatively small hp.-motors. The total weight of all movable sections, exclusive of their counterweights, is 300 tons.

The seats and platforms between the two proscenium walls were originally removable. But they were later mechanized. With the



aid of a motor the seats now fold up flat against the wall. This device permits the "addition" of floor space when it is needed for a gymnasium or auditorium. When folded, the seats give the appearance of a smooth unbroken wall, with no openings or mechanical parts visible. A further suggestion for increasing the adaptability of this arena into two halls is to equip the main floors so they tilt to a proper slope for stage productions.

Another demonstration of the practical nature of a sliding interior wall is that in the Intramural Sports Building at the University of Michigan. The dividing wall separates swimming pool from gymnasium. When more seating area is required during swimming meets, the wall is raised and bleachers installed on the gymnasium floor. Walls of this kind can be finished in any manner. Although they are made soundproof, the main requirements so far as the mechanics are concerned, are that they have a rigid frame. The steel members which carry the chains or cables must run continuously the full height of the partition to transmit the load evenly. Cast dowel pins are placed at the bottom of the walls, while the floor carries automatic opening and closing pockets to receive them. This makes for rigidity in the event of heavy thrusts near the floor line. The face of the floor pocket is of bronze and is set flush with the floor. The bottom of the wall is faced with felt or rubber ceiling strips to close any opening which may occur because of unevenness of the floor. The wall mentioned here is made to resemble heavy stone masonry construction with rusticated piers. We do not consider this necessary. Designers are finding it less desirable to disassemble and will undoubtedly treat these walls in the future frankly for what they are—rigid frame, soundproof sliding walls and not, as in this instance, heavy permanent masonry walls.

### Restaurants With Disappearing Fronts

The Longchamps Restaurants in New York City have installed motor-driven disappearing fronts in all their new locations. The motors used vary with the load, but are only from one-tenth to one-half horsepower. This company has found the open front in its restaurants meeting with wide favor from patrons. The dining room achieves a lively character, giving an appealing, inviting appearance to prospective customers. It helps recreate the congeniality of a continental cafe and has indeed altered sidewalk elevations in the vicinities where the restaurants are located.

There is some doubt here as to whether this

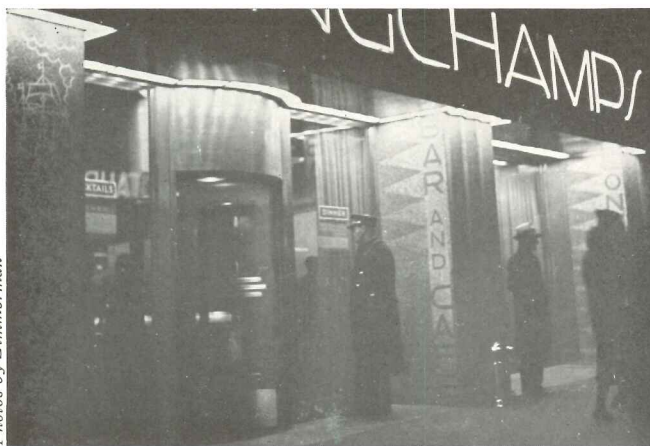

Photos by Zimmerman

**LONGCHAMPS RESTAURANTS, New York City. Louis Allen Abramson, Winold Reiss Studios, Architects and Designers. Motor-driven disappearing fronts permit dining in open air.**

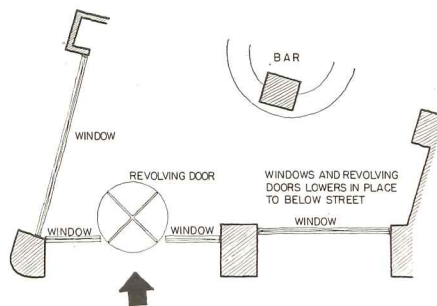

open design is preferable to air conditioning in warm weather. The air conditioned dining room, with its closed front and closed doors, automatically creates a somewhat forbidding exterior, beyond which only the initiated venture. However, a compromise has been evolved by Longchamps; both devices are frequently used. In entering one of their open dining rooms one is greeted by a blast of cold air from the air conditioning system within. The psychology employed is similar to that of the air conditioned movie palaces, and some of the "five-and-tens" on Fifth Avenue. The cold air on a hot summer's day is an invitation not easy to resist.

Walls, of course, can be made to slide up in a pocket, down, or sideways. Exterior walls, we



Photo by Zimmerman

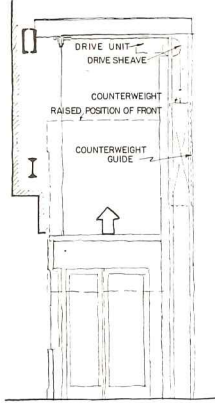

TOPPS RESTAURANT, New York City. Louis Allen Abramson, Architect. Front slides up behind large signs. Closed and open positions are shown.



find, usually slide down to the basement where they do not interfere with the rest of the structure. Early work of this type was comparatively simple because it concerned showroom windows of glass and rigid metal frames. Today the principle of operation (motor-driven unit and counterweight) remains the same, but is complicated by the introduction of additional materials of varying strength in store fronts. A unique recent installation is the disappearing store front of Topps Restaurant in New York City. It comprises plate glass, glass brick walls, and curved swinging doors. It weighs 3,500 pounds and is finished in aluminum. It is kept in perfect alignment at all times, closed, open, or moving, by the use of guide construction and accurate workmanship. The swinging doors are interlocked so that it is impossible to move the front unless the doors are locked. This front differs from most in that it moves up in vertical position back of a huge sign. The entire mechanism and counterweighting device are in the overhead area, hidden by the sign.

The disappearing front should prove a boon to fruit and vegetable markets. These markets invariably have immense sidewalk displays and are compelled to move them twice a day. The sliding front would eliminate all that.

Heretofore the greatest demand for movable floor installation has come from the theater. Today most stages not only revolve, but may be elevated in sections for any desired series of levels. This idea has been taken over by night clubs and dance halls, which have introduced revolving dance floors. A playful use of the revolving floor is in the Merry-Go-Round Bar. The moving unit takes a bar 40 feet in diameter, seating 120 people. At the center, there is provision for feeding water, disposal of waste, and electric lines. The entire unit, fully loaded,

makes one revolution in 15 minutes. The capacity load of 65,000 pounds is powered by three one-quarter hp.-motors. The entire structure is supported and moved on non-metallic rollers and all moving parts are equipped with grease-sealed ball bearings. While this type of moving floor may be used for recreation, it is virtually a necessity for stages. With it, all acts of a play may be set up simultaneously, thus cutting scene-shifting time and pauses between acts.

A practical use has been made of the revolving floor or turntable by many bus stations; located as these are in congested areas, where space is at a premium, the use of turntables makes great savings possible. Ordinarily, our modern busses



Photo by Zimmerman

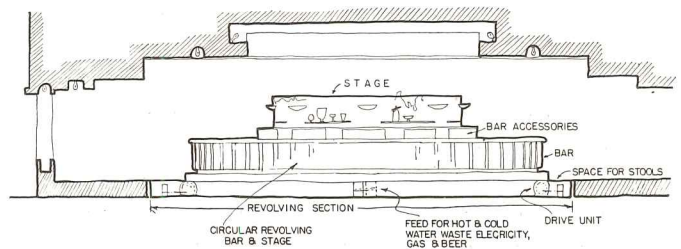

MERRY-GO-ROUND BAR, Elizabeth, N. J. Forty feet in diameter, seating 120 people. The entire unit makes one revolution in 15 minutes.



would require ten times the space now available for entering and leaving a depot.

A comparatively recent development permits the complete shifting of ceiling and roof to open a room to the sky. A startling example is that of Ben Marden's Riviera in New Jersey near the George Washington Bridge. The ceiling above the main dining room here is a curved dome just above a cove of light. The dome is of wire lath and acoustical plaster on a fabricated steel frame. This frame is hung from 32 steel cables reeving to geared drums and provided with 32 safety chains with a safety factor of 16. The dome is raised six feet in one minute without vibration or strain by a 2 hp.-motor. The housing within which this dome is raised is a 43-foot square structure resting on the roof. This housing, containing the dome, is then propelled at a speed of 30 feet per minute, noiselessly and without vibration, to one side, leaving a clear opening to the sky.

This superstructure, complete with the dome, weighs 60,000 pounds and is supported on ten double-flanged grease-sealed ball-bearing steel wheels, rolling on rails, bolted to the structural steel of the building. It is built of steel frame with wood beams and studs, and the exterior is covered with stucco. The drive machinery consists of one-and-a-half hp.-motor, speed reducer, and necessary sheaves and cables to assure a smooth and quiet operation. In the event of power failure, the cables may be disconnected from the moving roof, and the roof easily closed by two men.

Special arrangement of the flexible power and control cables was necessary because of the moving features of this structure. Exposed buss bars or third-rail control, which would be so hazardous on such a building, are eliminated. Electric interlocks and pilot lights infallibly determine the proper sequence of operations in the raising of the dome and opening of the roof and remove any possibility of accidents. Mechanical stops are provided at both open and closed positions as well as automatic limit switches. We thus have safety, durability, and ease of operation.

It is well to describe the rest of this night club which is one of the most flexible or "dynamic" of recent structures. All of its 14' x 15' long, 3/8-inch plate glass windows can be lowered completely or partially out of sight by remote control. The dance floor, which is also used for special floor shows, has a 14-foot turntable. This is equipped with surface-mounted colored lights fed from a collector ring arrangement in the center bearing assembly, thus allow-

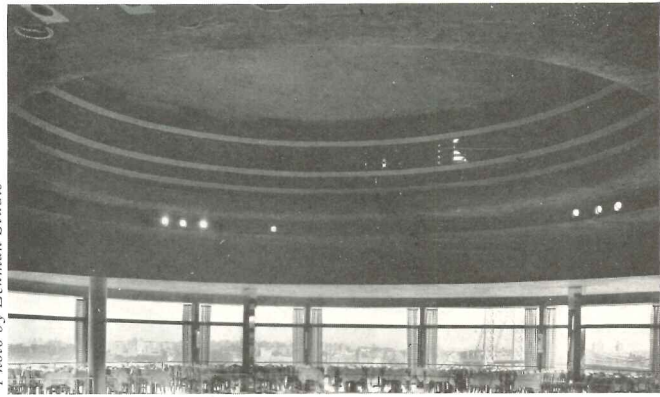

Photo by Eckman Studio

**BEN MARDEN'S RIVIERA** night club. Louis Allen Abramson, Architect. The dome illustrated is propelled 30 feet per minute to one side, leaving a clear opening to the sky.

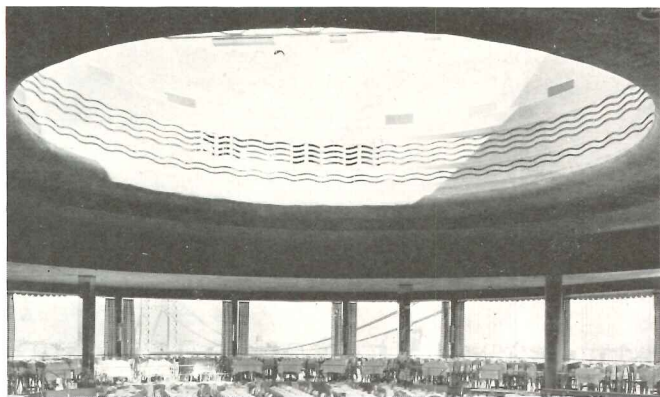
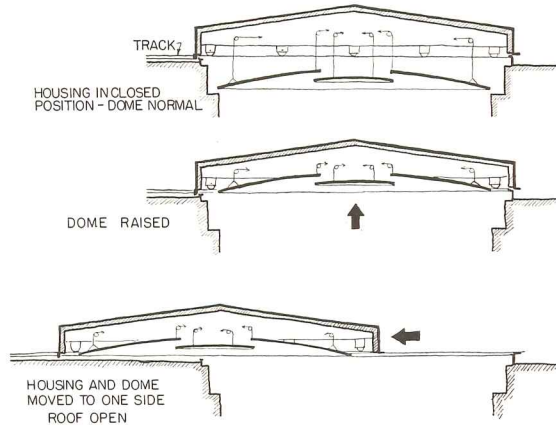

Photo by Stadler

ing the lights to be on while the turntable is revolving. It also has a moving stage in two sections, for two orchestras of different size, either of which can be turned to the diners and moved forward or backward. The stage has a curved, rigid steel frame curtain on a track, and is remotely controlled from the stage manager's station.

#### Other Mechanical Devices

Motor-driven remote control operation has been installed for some eight doors and gates. There are some variations to these types. The



range includes doors for all kinds of buildings. We shall mention but two of the most ingenious developments for jail gates and airplane hangar doors. One of the latter, designed in 1925 for the hangars in Detroit, is of 16 sections, half of which slide to each jamb of the opening. The doors are on eight separate tracks and operate at eight different speeds. At the press of a button the center doors meet the end doors at the jamb simultaneously. Jail gates have been installed in numerous prisons, among which are Sing Sing, Elmira, Albany, Naponach and New York City jails. Construction ranges from bars and armor plate to bulletproof glass, and operation is by remote control. A system for inspection of ingoing and outgoing traffic has been devised by the use of double gates. The first gate is opened for traffic and then lowered. The traffic is thus halted before the second gate, then inspected, following which the second gate is opened on signal. It is impossible to open the second gate unless the first one is closed.

A new development in jail work will permit the operation of gates and doors to the individual cells and tiers from a master control board in the warden's office. Such a system will completely eliminate the use of keys for a coordinated, checked, and electrically-controlled system, removing the possibility of jail breaks.

Arrangements are being made for a standardized, mass-produced, remote-control unit governing the opening of windows. This unit is already operating on demonstration projects. It is designed for both casement windows and double-hung sash. The device is compact and may be set either at the window sill or lintel and requires no more than four inches of depth. The control can be placed anywhere in the room. It should prove a boon to the open window fans on wintry days. There is no necessity now for having to shiver on cold mornings in closing the bedroom window. The press of a button does the trick.

The possibilities for the use of motor-driven movable building parts are limitless. Some probable future developments are:

1. A combination gymnasium and swimming pool with an automatic electrically-operated floor section to cover the pool when not in use.
2. A combination gymnasium and grandstand in connection with a stadium. By the use of movable wall sections on the exterior of the building and movable bleachers on the interior of the building, the gymnasium could be used as a grandstand at any time with automatic operation.
3. The electrical operation of the exterior

walls of any building, permitting its conversion into practically an open air shelter.

4. A roof garden or loggia with a movable roof.
5. Swimming pools may become skating rinks in winter, while the bathhouses could become gymnasiums.

A project demonstrated at the housing exhibit in January at Madison Square Garden will soon become a reality: a living room with a semi-circular end of all-glass sections. The glass sections were lowered out of sight when the occupant intercepted the light of a photoelectric cell. One could thus walk unchecked out onto the garden lawn. One objection raised against this device was that the house owner's dog might intercept the light and thus lower the window at a time when the owner wanted it shut. The prospective owner contended, however, that the dog might indeed need the window lowered more urgently than he did. A compromise was finally achieved, whereby the dog would have a small window section to fit his height with the photoelectric eye placed near the floor. The dog could then be trained to use this window, while his master would use a photoelectric eye higher placed. This house is also to be air conditioned. These easily operated exterior openings will save the cost of operating the air conditioning equipment in comfortable weather. In fact, an automatically-controlled push button or entirely thermostatic equipment can be made to work the openings in connection with the air conditioning.

For the commercial field there is now being developed a fully automatic parking garage which will house hundreds of cars and be entirely automatic in its operation, from receipt to delivery of the vehicle. This type of building is an absolute necessity at the present time and has been for several years in our larger cities. Traffic congestion, caused by parked automobiles, is costing a tremendous amount of money and lost time. Until an economical and efficient way of handling parked automobiles is provided, it is practically impossible to prevent cars from being parked in the streets, regardless of laws and ordinances. The proposed garage will be so equipped that the interruption of equipment service in one section will not interfere with the handling of automobiles in another.

And so, on and on, into an ever-increasing number of building types, mechanization is penetrating. Throughout the United States there are new developments daily. At first they are "news"; in time some show up as "trends"; and eventually some enter that classification most aptly termed "standard equipment."





LETTERING at entrance to Pavilion, Union of Decorative Artists, Paris Exposition

## Sign Lettering

SIGNS are used as a means of imparting information. They serve to identify buildings, objects, locations, directions, etc. Their purpose is strictly a functional one. Signs and their component letters should therefore be easily read, their meaning should be readily understood. The size of lettering is determined by height of location, required distance of appeal, and by the nature of building or other designation. Letters, to be seen in all weathers by motorists and intended to make them stop, must be bold (to give emphasis) and extreme in clarity (to make instant comprehension possible).

Flexlume Corporation developed the following information on average letter sizes:

4" letter legible at a distance of	200 feet
8" letter legible at a distance of	400 feet
12" letter legible at a distance of	675 feet
24" letter legible at a distance of	1,300 feet*

Sign letters should, where possible, be uniform as to size, form, and color.

In spacing letters, the object should be to attain evenness of tone. This is a matter, not of exact measurement of letter space, but of observation and judgment. Wide spacing reduces unevenness of tone because variation of spaces surrounding letters will then be less noticeable.

Where more than a single word is used, the

\*The Gasoline Filling and Service Station. By K. Lönberg-Holm. THE ARCHITECTURAL RECORD, June 1930, page 577.

spacing of words should be close so as to be easily readable. Close spacing is required since we read by seeing and comprehending several words at a time. Excessively wide spacing destroys continuity.

Signs intended to be seen at night as well as by day should be illuminated by reflector, by floodlight, or by incorporating light units within the letters. In continuous day and night lighting, the illumination can be controlled by photoelectric cell, which will light the sign whenever daylight fails, regardless of the time of day.

Color should be considered as an adjunct of signs in relation to its attention-arresting value. Occasionally the sign color will be determined by reflecting surface of wall or by the color tone of building or surroundings.

Because signs are often intended more for motorists than for pedestrians, the location of signs above eye level is important. The low level of visibility from a car will influence sign placement.

The examples of lettering shown on the following pages are selected for variety of form and use. Luminous tube letters, because they are made with necessarily uniform and thin tube, usually appear as skeleton forms. Occasionally, double and sometimes triple tubes occur. A single Neon tube combined with parallel tubes of chromium-plated metal is shown on page 56.



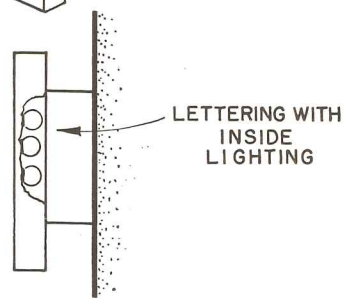
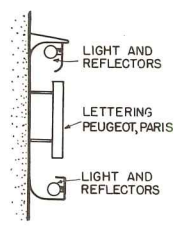
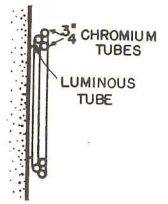
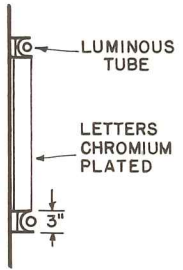
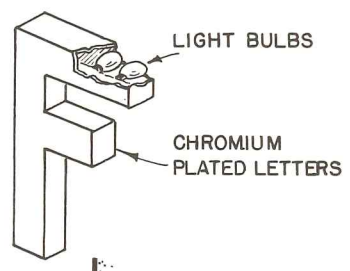
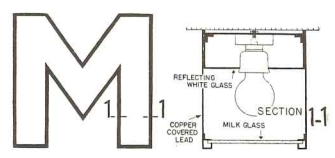
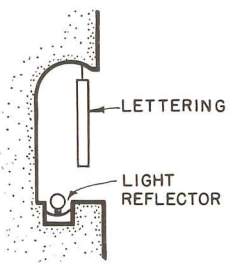
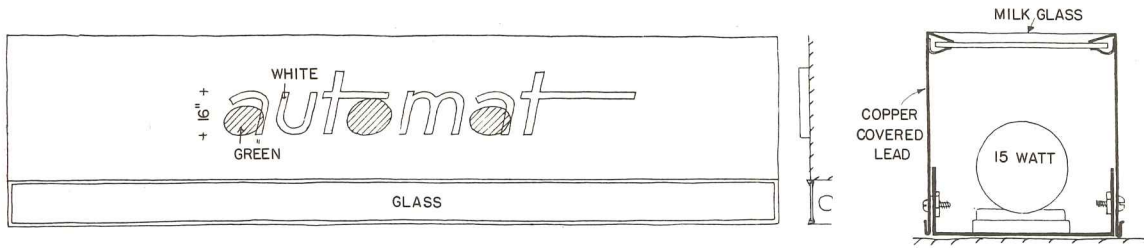

**CHROMIUM PLATED TUBES** used with a central neon tube.

**SECTIONS** showing lighting methods and attachment of letters to building



**LETTERS** for signs are drawn to full size combined on a small size sheet



## Commercial Signs in the U.S.

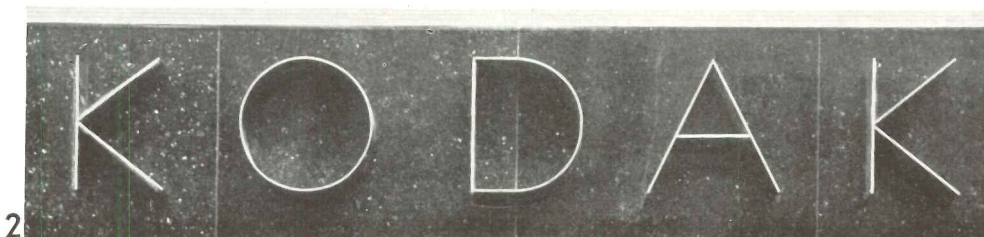

2 *John Wallace Gillies, Inc.*



3 *Hedrich-Blessing Studio*

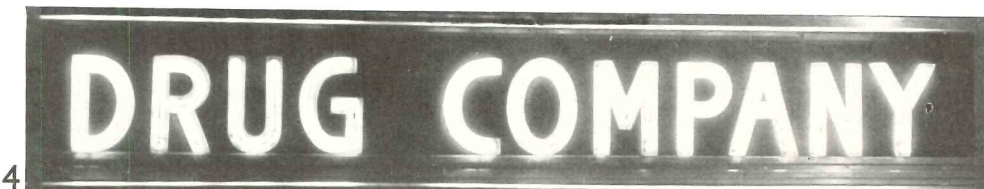

4 *Richard Garrison*



5 *Luchhaus Studio*

On the opposite page: Construction details for sign letters and their illumination.

On this page: 1. Lettering of double luminous tubes. Trufood Restaurant, New York. H. V. St. George, Architect. 2. Bronze letters against a granite background. Eastman Kodak Shop, New York. Designed by W. D. Teague and R. B. Sherburne. 3. Bronze script lettering. Palmer House Products Shop, Chicago. Holabird and Root, Architects. 4. Luminous letters with reflecting metal background. Pennsylvania Drug Store, New York. Allmon Fordyce, Architect. 5. Luminous tube letters as a single line. Lora Lee Shop, Hollywood. Designed by J. R. Davidson.



# Signs at the Paris Fair

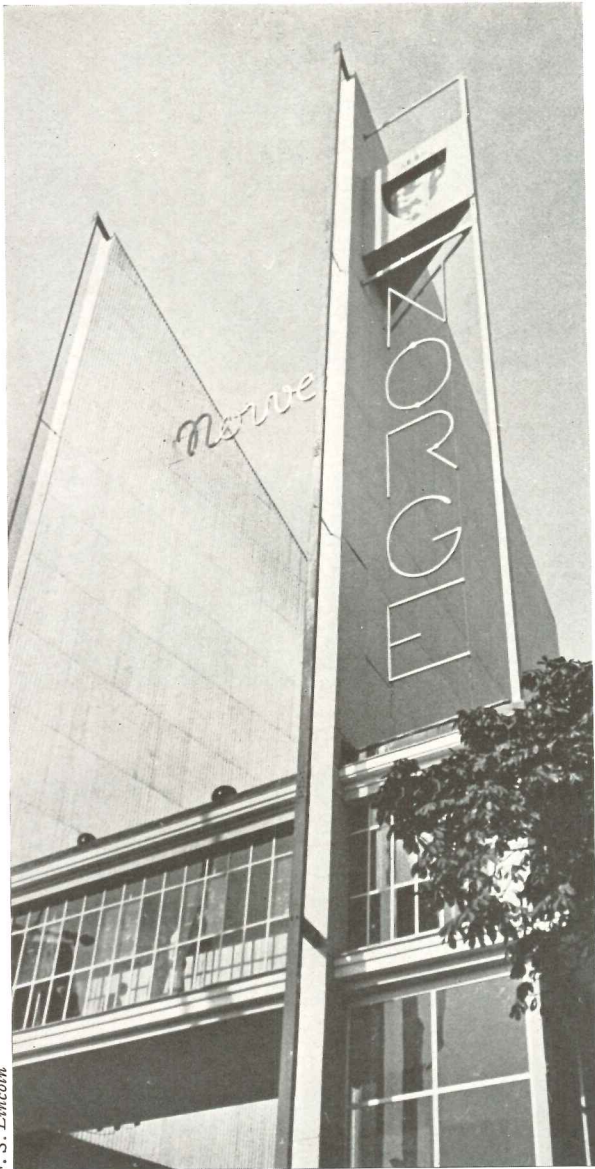

F. S. Lincoln

Luminous letters, Norwegian Pavilion.

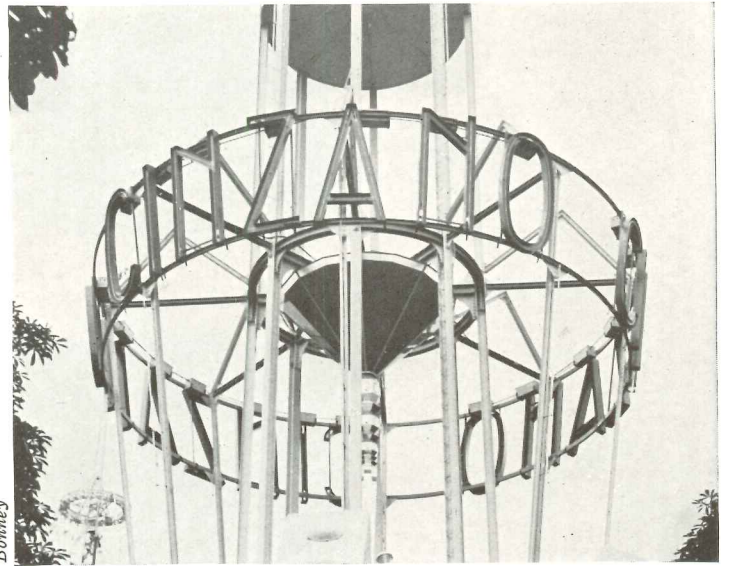

Bonney

Blue and red tube lettering, Cinzano Pavilion.



F. S. Lincoln

Lettering above main entrance, Danish Pavilion.

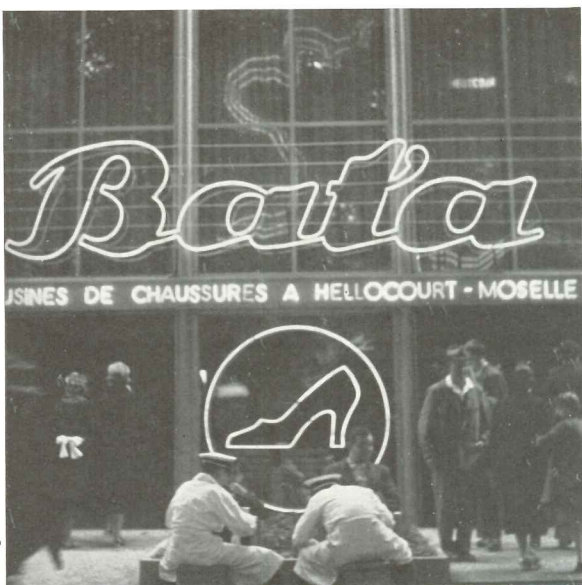

Bonney

Letters and shoe motif in blue Neon.

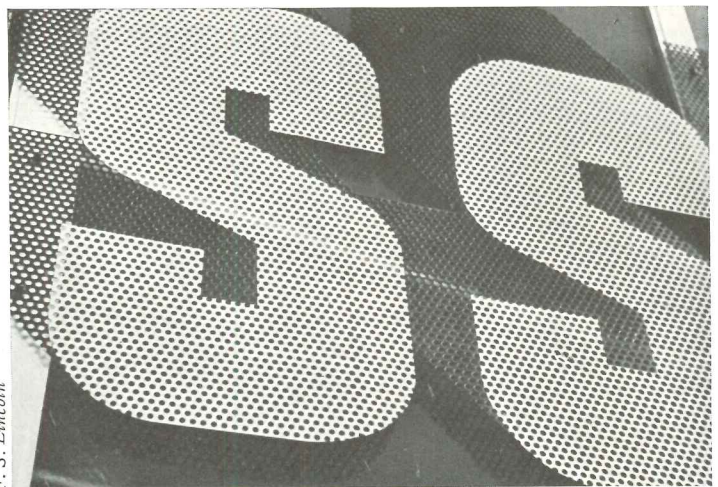

F. S. Lincoln

Lettering of perforated stamped steel, Swiss Pavilion.



F. S. Lincoln

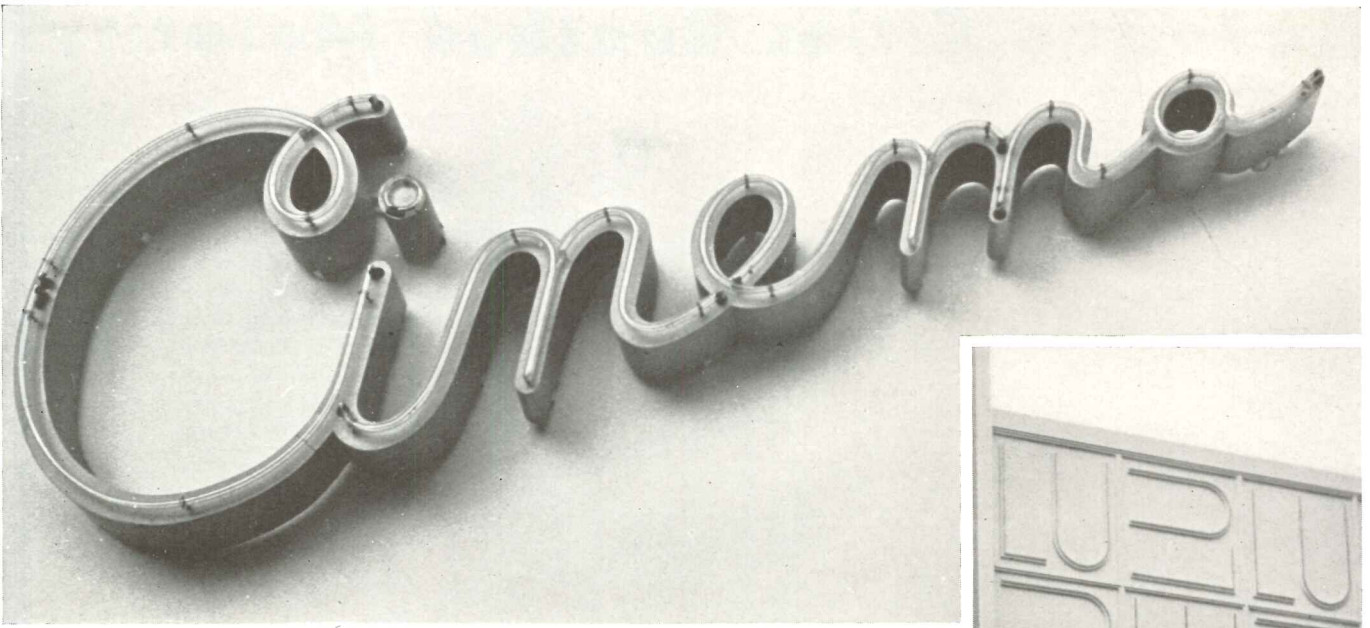

Lettering for Cinema theater,  
a part of Danish Pavilion.

Bonney



Lettering in white plaster on pale  
green wall, Portuguese Pavilion.

Facade adver-  
tising a French  
cracker. . . LU.  
Beige cement  
with letters in  
gold.

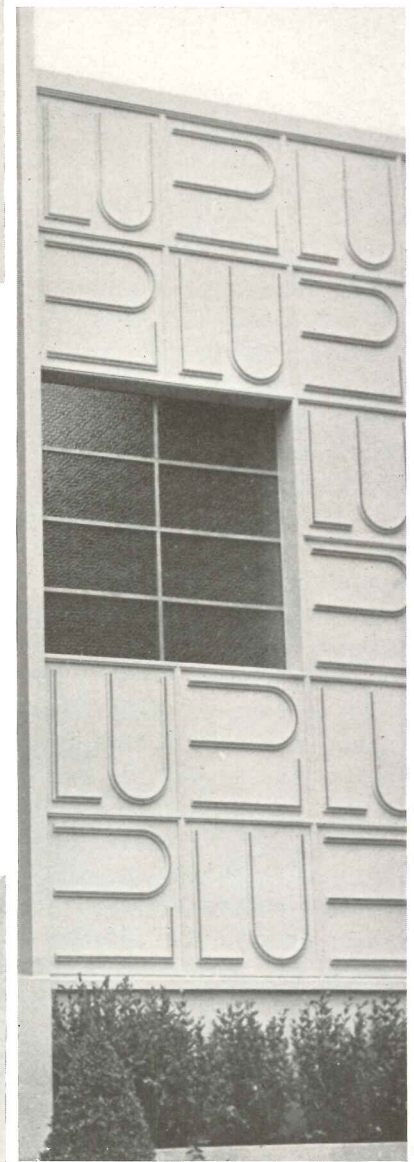

Bonney

F. S. Lincoln



Raised lettering on Austrian Pavilion as seen from approaching stairway.



# Have the Cities Reached Maturity?

By M. A. MIKKELSEN

**THIS REPORT** advances recommendations for meeting or alleviating some of the problems of the American city which are the immediate concern of architects, town planners, and engineers. The facts presented relate to the influence of the city on the population as a whole, together with the more significant problems arising from the extremely rapid and intensive growth of cities in the United States.

THE REPORT on *Our Cities, Their Role in the National Economy* to the National Resources Committee\* is "the first national study of cities in the United States where over half of our people live and where a large proportion of the nation's wealth and the nation's problems are concentrated." It comes a generation after the first national study of rural conditions in 1909 by President Theodore Roosevelt's Country Life Commission and proposes a federal agency to perform for urban communities functions comparable to those now performed for rural communities by the Department of Agriculture.

More than one-half (56.2 percent) of the total population in 1930 was urban and lived in 3,165 urban places, each with 2,500 or more inhabitants. From 1900 to 1930 the urban population "grew from 30 million to nearly 69 million, or by about 130 percent. During the most recent of these census decades (1920-30) urban population growth had slowed down to 26 percent, and in the period from 1930 to 1935 was still further reduced to an estimated 3 percent. While this indicates a considerable retardation in the pace of urban growth, it is still significant because it exceeds the rate of growth of the population as a whole and contrasts with the relative stabilization of rural America."

## Urban Growth by Rural Migration

The 1,400,000 annual increase of urban population recorded in the 1920-1930 census period was reduced to an estimated 400,000 a year increase in the first half of the current decade. The United States is approaching a roughly stable rural-urban equilibrium, which has

\**Our Cities, Their Role in the National Economy*. Report of the Urbanism Committee to the National Resources Committee. June, 1937. For sale by the Superintendent of Documents, Washington, D. C. Price 50 cents (paper cover).

already been reached by the major European industrial countries.

Urban population is growing mainly through migration from the rural areas, where the birth rate is relatively high. More than one-half of the urban population lives in 93 cities having each 100,000 or more inhabitants in 1930. Of these cities only three had a surplus of births over deaths. "Making certain assumptions about the improvement in the expectation of life until it is about five years higher than at present, and allowing for a slowing down in the decline of the birth rate, our urban population would—if it were deprived of migration—reach a maximum of about 71 million (less than two million more than at present) in 1945 and then decline until in 1960 it reached a point 600,000 lower than it was in 1930."

Meanwhile the technological trend in agriculture insures a continuance of the migration to the extent that the cities develop need for additional workers. For some time the large cities have as a rule grown more rapidly than the small, indicating that the national urban pattern is becoming fixed. Nearly one-half of the population of the United States lives within a radius of from 20 to 50 miles of cities of over 100,000 inhabitants. These metropolitan areas absorbed 74 percent of the total national population increment in the decade ended 1930. Those of the 96 metropolitan districts that have grown most rapidly since 1900 are in the Great Lakes region, in the South and on the West Coast, stimulated by the rise of new industries, such as the automobile and the motion picture, new oil fields and other special factors. Otherwise there has been no evident tendency for industry to decentralize. Of the 3,074 counties in the United States, 155 are industrial. In 1929 the 155 counties had 74



percent of all industrial wage earners, 81 percent of all salaried employees, 79 percent of all wages paid, 83 percent of all salaries paid, 65 percent of all industrial establishments, 80 percent of the value added to manufactured products, and about three-fourths of the wholesale trade.

### Urbanism and Technology

Urbanism is a characteristic result of technology. Consequently, when one recalls that 18 of the major industries of today did not exist in 1870, it is perhaps not surprising to learn that the majority of urban places are less than 60 years old. However, it is disconcerting to find that one-sixth (532) of all urban places declined in population during the 1920-30 decade. The declining places lay outside metropolitan areas, were mostly in the group having fewer than 5,000 inhabitants and were all in the group having fewer than 250,000. The larger of the declining cities are located for the most part in New England.

It is evident that there are problem areas in the urban pattern of the country as well as in the pattern of agriculture and extractive industries. Can the surplus population of depressed urban places and of such impoverished areas as the Southern Appalachian Coal Plateaus, the Old Southern Cotton Belt, the Great Plains, and the Cutover Region of the Great Lakes be moved to the growing metropolitan districts? The report recognizes the need for a national economic policy worked out by federal and local planning boards in conjunction with industry, and suggests means of implementing the policy. A unified tax system and a unified labor program would check such socially disadvantageous migrations of industry as are induced exclusively or mainly by free sites, tax exemptions, and unorganized labor. The transportation system may be coordinated to reduce costs and relieve terminal congestion. Similarly, coordination of public and private generating, transmission and distribution facilities can be used to promote the national economic interest.

### Stabilization of Urban Population

So far as can now be seen the national urban pattern is more or less fixed. Expansion is likely to be from the existing 155 industrial counties into adjoining counties. However, it is impossible to say at what point, in time or number, the urban population will be stabilized. The factors determining population growth are primarily economic, not biologic. Given a sufficient

upturn in urban industry, accelerated population increase would follow. In fact the trend toward stabilization of urban population experienced in Europe and America since the World War is the result of a corresponding trend in industrial production.

The school of thought optimistic with regard to urban growth starts from the fact that, while the capacity of a people to consume agricultural products is physically limited, its capacity to consume industrial products increases indefinitely so long as its purchasing power rises. Among the evidences confirming this fact is the 50 percent expansion of employment in the service industries, predominantly urban, during the post-war decade, as against a 3 percent expansion of employment in the basic industries. Increased purchasing power with respect to consumption of industrial products means (1) a more even distribution of the national income in the form of wages, salaries, and profits and (2) elimination of innumerable forms of waste. The recommendations of the report are in accord with this school of thought.

The trends of change in the pattern of individual metropolitan districts have become well known to architects, many of whom have had a share in developing the modern principles of city planning adopted in the report. For example, William Stanley Parker, a leader in the affairs of the American Institute of Architects and a frequent contributor to ARCHITECTURAL RECORD, served on two committees which made specific studies for the report. The rise of news and critical opinion on such topics as the trend of population, retail trade, and industry away from the metropolitan center to the suburbs and satellite cities, the effects of the aging of the

### PROPORTION OF RURAL AND URBAN POPULATION

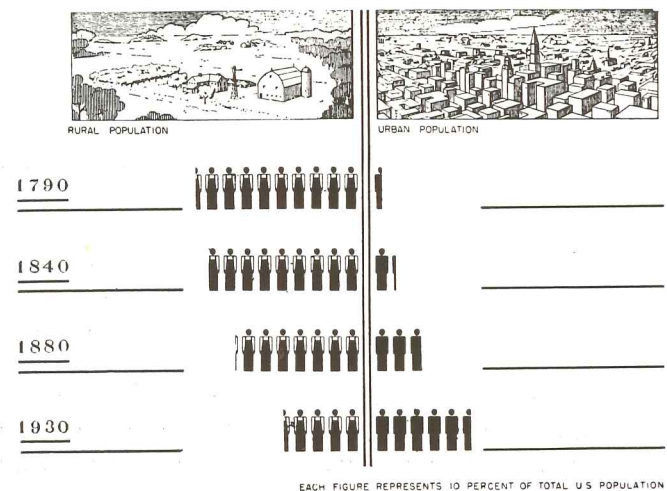

EACH FIGURE REPRESENTS 10 PERCENT OF TOTAL U.S. POPULATION



NUMBER OF CITIES BY SIZE GROUPS

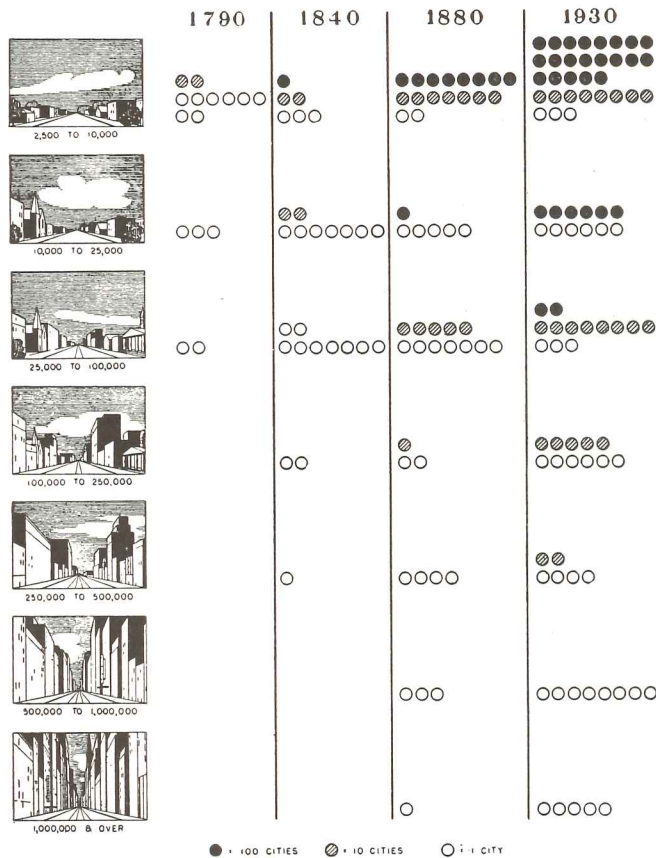

population on particular types of building, slum clearance, housing, and the like has been contemporaneously recorded in this magazine, and it would be too largely a matter of repetition to follow the report into local urban defects and remedies. The report avoids speculation and perforce makes no attempt to clarify what is now obscure as to the future of the building industry, namely, the prospect of revival of private construction at the center of the individual metropolitan district.

**The Defects of Urbanism**

The defects of urbanism are practically identical in all metropolitan districts. They have their origin in dislocations caused by industrial inventions. Urban industry and commercial farming are equally the product of technology, which reacts on all the functional social institutions. The major social problems of today, urban and rural, are problems of eliminating maladjustments occasioned by technological advance. This was made clear in the National Resources Committee's report on Technological Trends and Social Policy, which should be read

as an introduction to its present study of urbanism. "The endless types of readjustment required under modern conditions present more points of likeness than of difference between urban and rural communities."

A significant point of likeness is the uniformity of thought promoted by the modern system of communication. Mass distribution of mental goods is as characteristic of the machine age as is mass distribution of material goods. The radio in one of its aspects is a national forum of debate before an immense cross section of the population. The debate offers heresy as well as sound doctrine, but the audience, grounded by the public school in the aims and methods of the Constitution, tends to reject subversive ideas. Diffusion of knowledge as to the reciprocity of their economic interests must accelerate the political cooperation between town and country which has become marked in recent years. With the population approximately half urban and half rural, such cooperation is necessary if a reversal is to be brought about in the present trend of urban industries to become stagnant from excessive costs of doing business and from narrowing of markets by chronic unemployment.

**Overlaying Taxing Jurisdiction**

Two conspicuous examples of waste in business costs may be mentioned by way of illustration.

In 1930 "there were 272 separate incorporated places in the New York-Northeastern New Jersey metropolitan district, 135 in the Pittsburgh district, 115 in the Chicago area, 92 in the Philadelphia district, and 56 in the Los Angeles district. Together with their overlayers of counties, townships, school districts, sanitary districts, sewer districts, library districts, health districts, park districts, forest preserve districts, street lighting districts, utility districts, water districts, and even mosquito-abatement districts—each of them a separate body politic and corporate—these communities present an odd picture of independent bailiwicks performing related or even identical governmental functions." To this picture must be added special metropolitan authorities, inter-municipal and extra-territorial contractual and functional relations, and interstate and federal arrangements. One out of every 30 gainfully employed persons in the United States is a municipal employee. In addition to the Federal Government and the state government, there are 182,000 taxing jurisdictions in the United States.



The second example is the multiplicity of railway stations and terminals. Thirty-seven percent of the total of railroad freight operating expenses in 1932 consisted of terminal costs. The Philadelphia district has 700 freight stations.

As this review has limited itself to national aspects of urbanism, the recommendations of the report with regard to federal action are reproduced here. It is to be understood that a large part of the report is devoted to local municipal defects and that recommendations concerning them are addressed to the various states and local authorities. The recommendations in this category deal with urban land policies, housing, planning and zoning, modernization of city government, reorganization of metropolitan areas, reshaping of local taxation and special assessments, and the like.

**One:**

Because many of the most acute and persistent problems of the city cannot be solved until the fundamental issue of adequate and secure income is met, the Committee urges that the efforts already made by Government, industry, and labor toward raising the level of family income and increasing economic security be continued and intensified. Further, that the United States both study and act upon the problems of chronically depressed urban areas.

**Two:**

The Federal Government should continue its policy of cooperation with and assistance to the social welfare programs of urban communities, including public assistance, crime prevention and control, use of urban leisure time and cultural activities. Since unemployment problems carry national significance, federal assistance for prevention and relief of unemployment should be continued in cooperation with state and local agencies. Better to equip the future urban citizen reared in the country and to satisfy the just claims of rural areas, the Committee recommends the equalization between country and city of as many material and cultural opportunities as possible.

**Three:**

A section for urban research should be set up in some suitable federal agency which should perform for urban communities functions comparable to those now performed for rural communities by the Department of Agriculture.

A clearing house of urban information should be created in the Bureau of the Census which would serve as a central depository and clearing

house of all information about urban communities collected by all governmental agencies on all levels and by authoritative private organizations.

The central statistical board should give special consideration to the inadequacies in the existing urban data and the shortcomings in the methods of collecting them, and the possibilities of a program for collecting such important census data as place of work or place of daily activity, as well as place of residence, and such important current information as employment and unemployment.

Immediate consideration should be given to the urgent necessity of coordination both at Washington and in the field of the related service and activities performed by the various federal agencies operating in urban areas. A prompt and thorough study should, therefore, be undertaken by a division of administrative research in the Bureau of the Budget of the best methods and administrative techniques for bringing about the closer coordination of federal activities in urban communities and for improving and facilitating collaboration between the cities and the Federal Government.

**Four:**

The Committee recommends the consideration of legislation primarily for periods of economic distress creating a federal credit agency authorized to make loans and grants under adequate legislative safeguards to local governments for the purposes of public works construction (including housing), acquisition or construction of

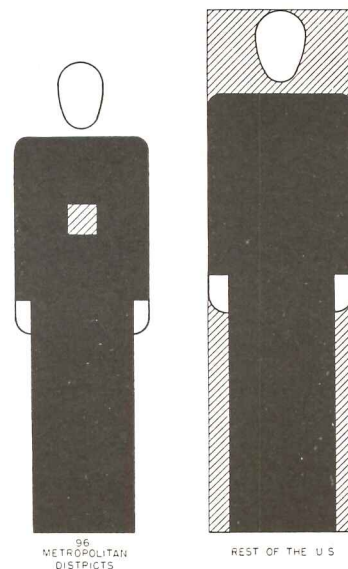

96 METROPOLITAN DISTRICTS . . . . . REST OF THE U S  
 [Hatched Box] LAND AREA  
 COMPARISON BETWEEN THE LAND AREA AND THE POPULATION OF THE 96 METROPOLITAN DISTRICTS AND THE REST OF THE UNITED STATES. - 1930



public utilities, land purchases, and similar outlays. On the other hand, in times of prosperity the Committee believes that federal expenditures in cities should be reduced to a minimum.

**Five:**

The Committee recommends that the Congress establish a permanent federal public works authority which should be directly responsible for the formulation and execution of a specific and detailed nationwide program of public works, and for the encouragement and cooperation in public works planning, between national, state, and local agencies.

**Six:**

The Committee urges that a national policy be adopted for rehousing the low-income groups at acceptable minimum standards, as a cooperative undertaking among Federal, State, and local Governments, and private enterprise. The Federal and State Governments should extend, in accordance with local needs, financial assistance to local authorities conditioned on the existence of a comprehensive city plan and a housing program meeting satisfactory standards. This policy should be designed to stimulate local initiative, recognize differences in local circumstances, and vest the control, save in exceptional cases, in the local authorities—to the end that the urban slum may be outlawed.

**Seven:**

Engage, among other things, in the following activities of benefit to urban communities:

(a) To continue and extend encouragement, cooperation, and support to state, regional, and local planning agencies.

(b) To continue, systematize, and improve the long-range programming of public works in cooperation with state, regional, and local planning agencies.

(c) To lend encouragement and cooperation to industrial communities and regions in their efforts to review systematically and plan constructively to improve the soundness and stability of their industrial structures.

(d) To prepare, in collaboration with state planning boards and appropriate federal agencies, the broad general plan of a coordinated transportation system directed toward an economically more effective and socially more desirable urban pattern and distribution of economic activities.

(e) To make further inquiry into the probable effect on urbanization of the wider distribution of electric power.

**Eight:**

To clear up the confusion and inconvenience in the allocation of governmental revenue, a comprehensive and thorough-going inquiry should be made by the present tax revision council or other suitable agency of the entire subject of conflicting fiscal policies and taxation in local, State and Federal governments.

**Nine:**

The Congress should pass legislation giving advance consent and laying down the conditions under which there may be adopted interstate compacts enabling the several communities within the same metropolitan region, but in separate states, to deal jointly with the regional aspects of health, sanitation, industrial-waste regulation, the control of public utilities, planning, public safety and welfare, education, recreation, and other governmental functions of regional scope.

**Ten:**

The Federal Government should continue to cooperate in the enactment and administration of uniform criminal laws and interstate crime compacts and regional cooperation among police systems, federal, state and local, and other law-enforcing agencies, including the judicial branch, should be encouraged and fostered. The Federal Government should cooperate in programs directed toward crime prevention.

**Eleven:**

The serious need of raising the competence and prestige of the urban public service in various communities leads the Committee to recommend that:

(a) States and urban communities availing themselves of federal grants-in-aid should be expected by the Federal Government to conform to minimum personnel standards under the merit system in the area in which the grant is made.

(b) The Federal Government should extend its present efforts in vocational training for public-service occupations. Pending the submission of the report of the President's Committee on Vocational Education, no definite recommendations are made here.

(c) The United States Civil Service Commission should furnish eligible lists to local authorities at their request and prepare model personnel standards applicable to the same classes of positions on all levels of government with a view to encouraging the interchange of public personnel among the various levels of government.



# Interiors and Furniture

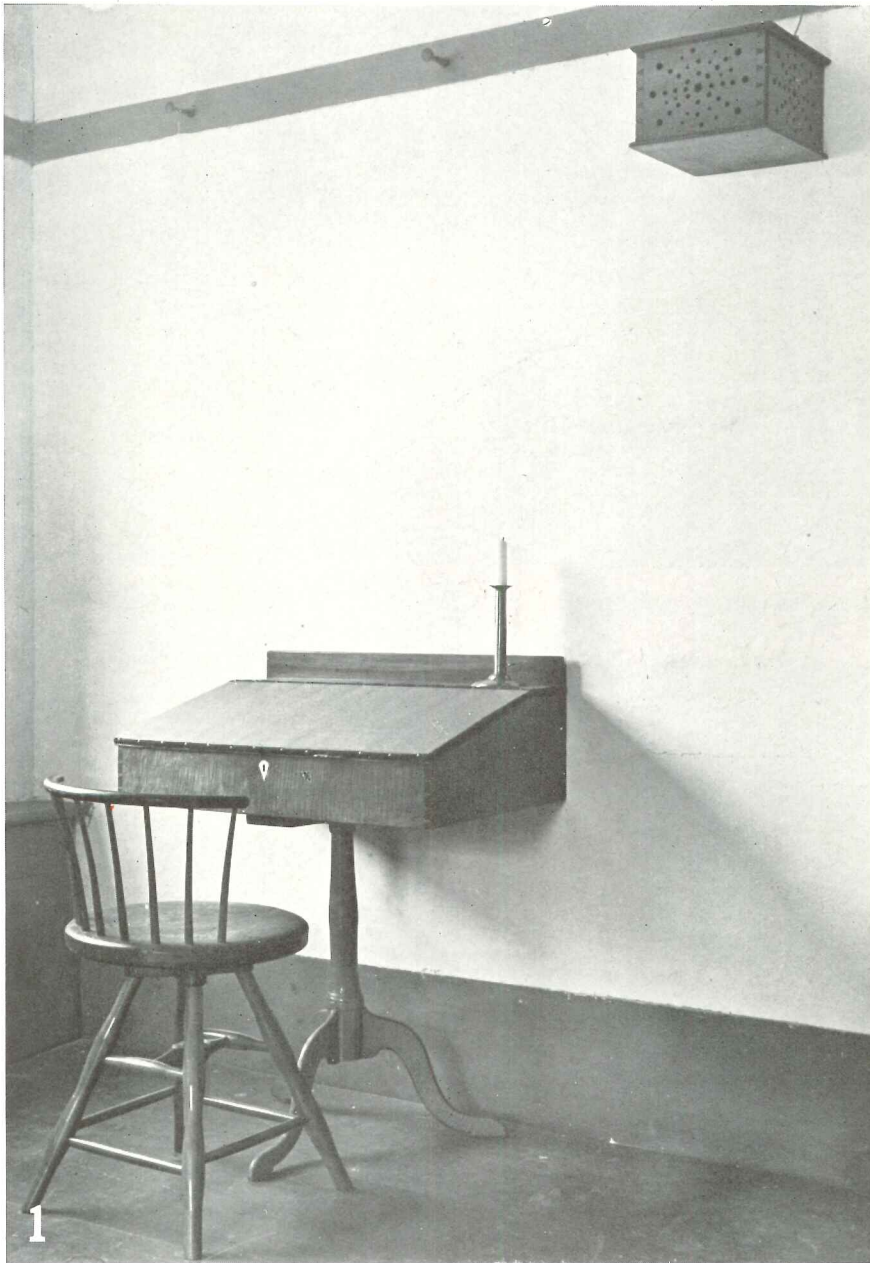

Photo by Vicentini-Herlick, Courtesy Museum of Modern Art

1. Early American writing desk, chair and heater, Shaker Colony at Hancock, Mass. 2. Desk in 1937 manner designed by Wells Coates, Architect. It can be moved to any desired position in the room and is not everyman's piece of furniture. It is designed for a person who prefers to type at a table which is delicately balanced, with a footrest bringing the knees tightly under it. The metal extension can support a small drawing board as shown in the detail. For parties, the desk is moved against the wall bookcase and telescopes into it, to form a buffet table top with twice the width of the wall fitting.

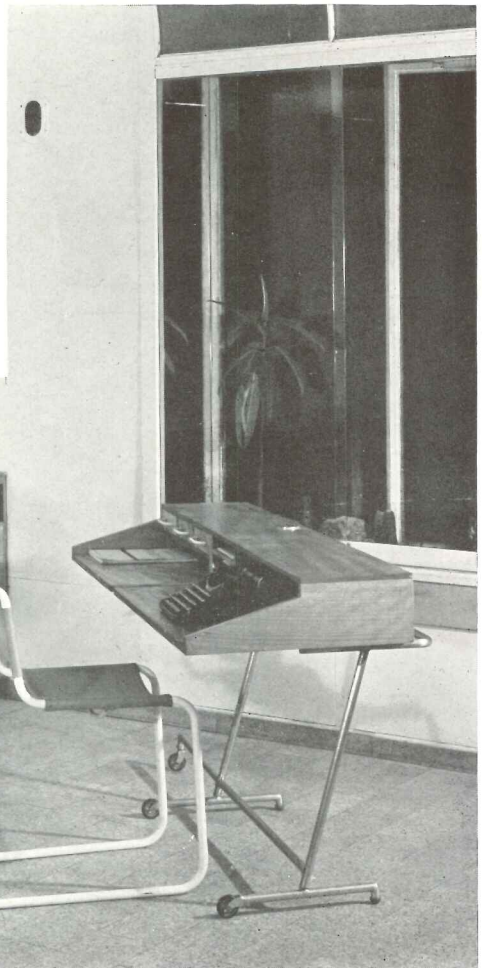
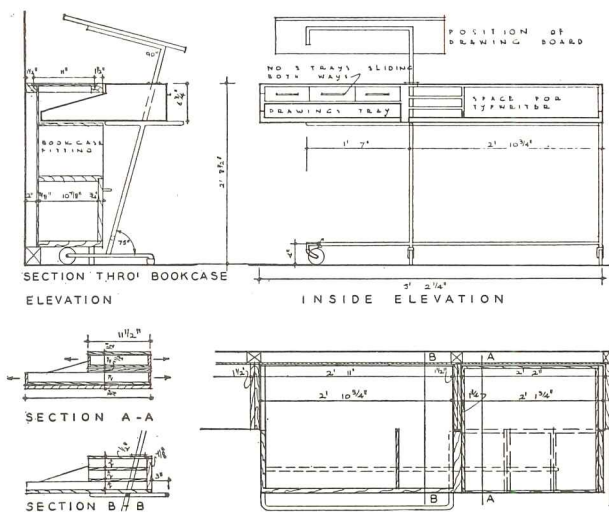

Photo by Millar & Harris



Courtesy "The Architectural Review"





1

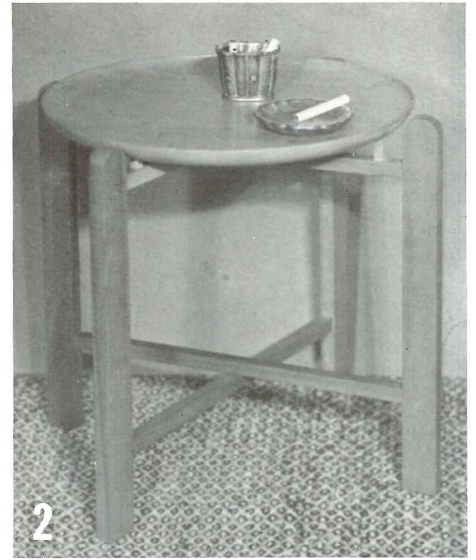

2

FURNITURE AND ACCESSORIES designed by JAMES L. PRESTINI



5



3

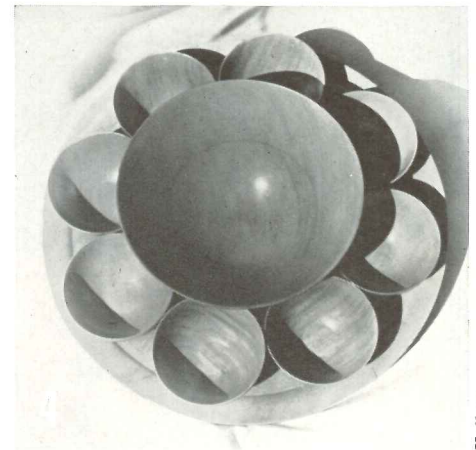

Kollme

1. Chair and coffee table in natural birch, light green upholstery. 2. Folding table in poplar. Top can be used as a tray. 3. Salad bowl in Cuban mahogany; tray, Mexican mahogany. 4. Continental salad service in Cuban mahogany. 5. Dressing table and stool in natural-finished cherry. Stool upholstered in rust-colored canvas. The hung-type dressing table conserves space and can be placed at any desired height from floor. Most of these pieces are on display at Chicago Workshops, Chicago.



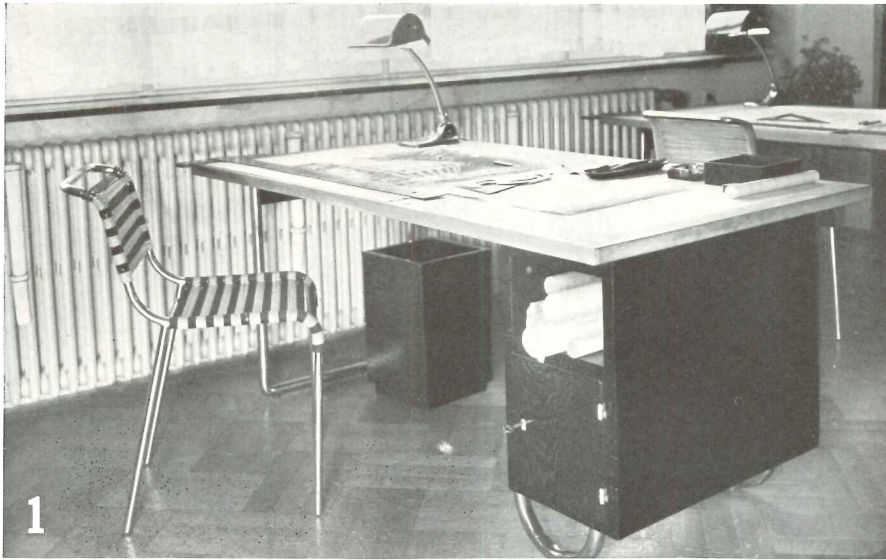

Sellman

OFFICE INTERIORS FOR PROFESSIONAL USE



Bonney

1. Drafting table with open and closed storage compartments at base. The top may also be tilted. Steel tube chair with cord seat and back. Studio in home of Rudolf Frankel, Architect. 2. Office with table (or desk) that moves on wall track. Furniture of light ash; walls and curtains in white; carpet in beige. Bookshelf compartments with glass partitions. Designed by Wolfgang Ewert for Photographer Moral, Paris. 3. Interior, Private Office of Oscar G. Stonorov, Architect, Philadelphia. Glass-top table; rug, rust-brown; walls of brown and black Bakelite.



Philip B. Wallace



Luckhaus Studio



1

1. Porch lounge, house for Albert Ruben, Santa Monica Canyon, California. Richard J. Neutra, Architect. This lounge faces, on the northwest, the wooded Santa Monica Canyon with its polo field; on the southwest, a view of the Pacific Ocean. These fronts are plate-glazed and have sliding metal-framed doors. A buffet cupboard, 4'-6" in height, articulates the room in its length. The easterly bay has a white-lacquered round breakfast table with plain chairs of similar finish. Built-in upholstered seats are backed against this buffet and face the Hollywood mountains. Upholstery and drapes are natural color; floors are linoleum of eggplant color.

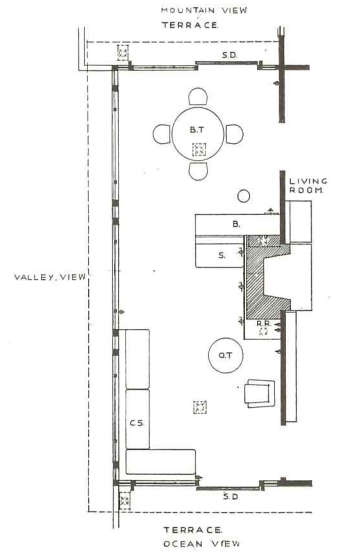

- C.S. Corner seat
- S. Upholstered bench
- R.R. Radio; record storage
- B. Buffet
- B.T. Breakfast table
- O.T. Occasional table
- S.D. Sliding metal and plate glass doors

2. Bedroom interior, House of Edwin A. Halberg, Palm Springs, California. Van Pelt and Lind, Architects. As far as possible, equipment is built-in and recessed into structure. Bedroom closets and linen cases form, in some instances, a projection on the outside rather than in the interior. There is an absence of trim.

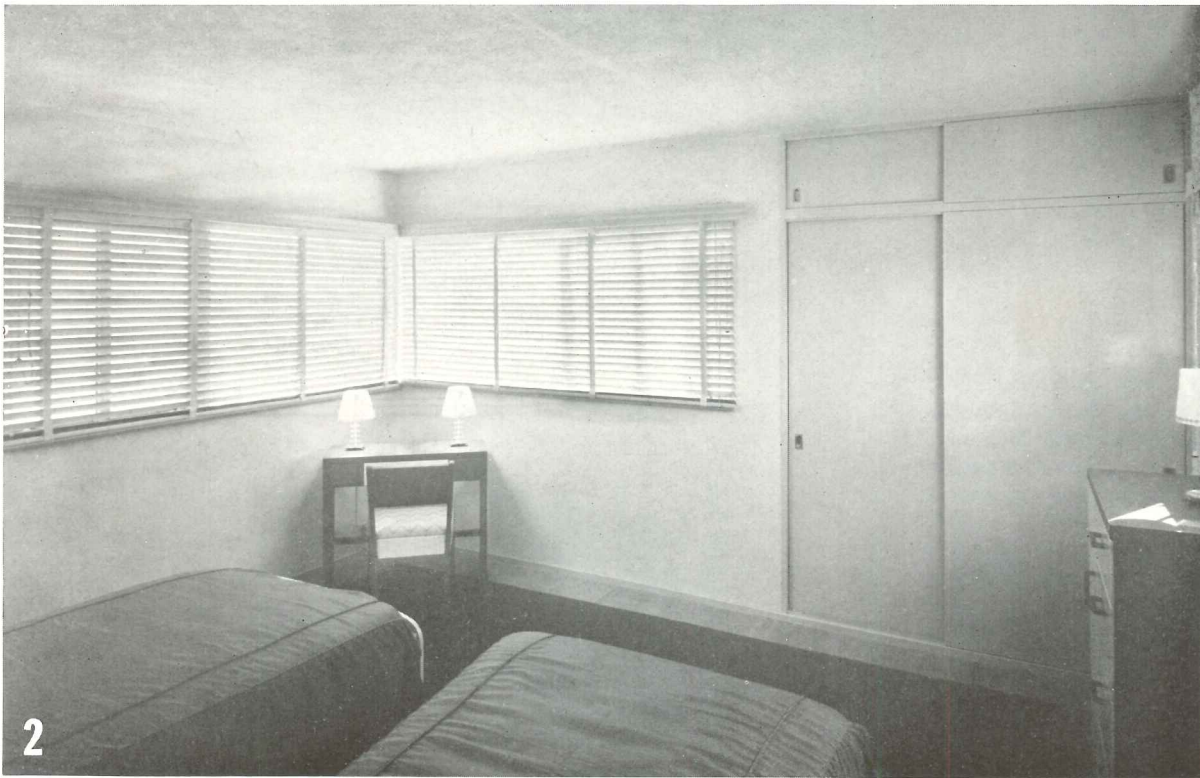

2

Stephen H. Willard



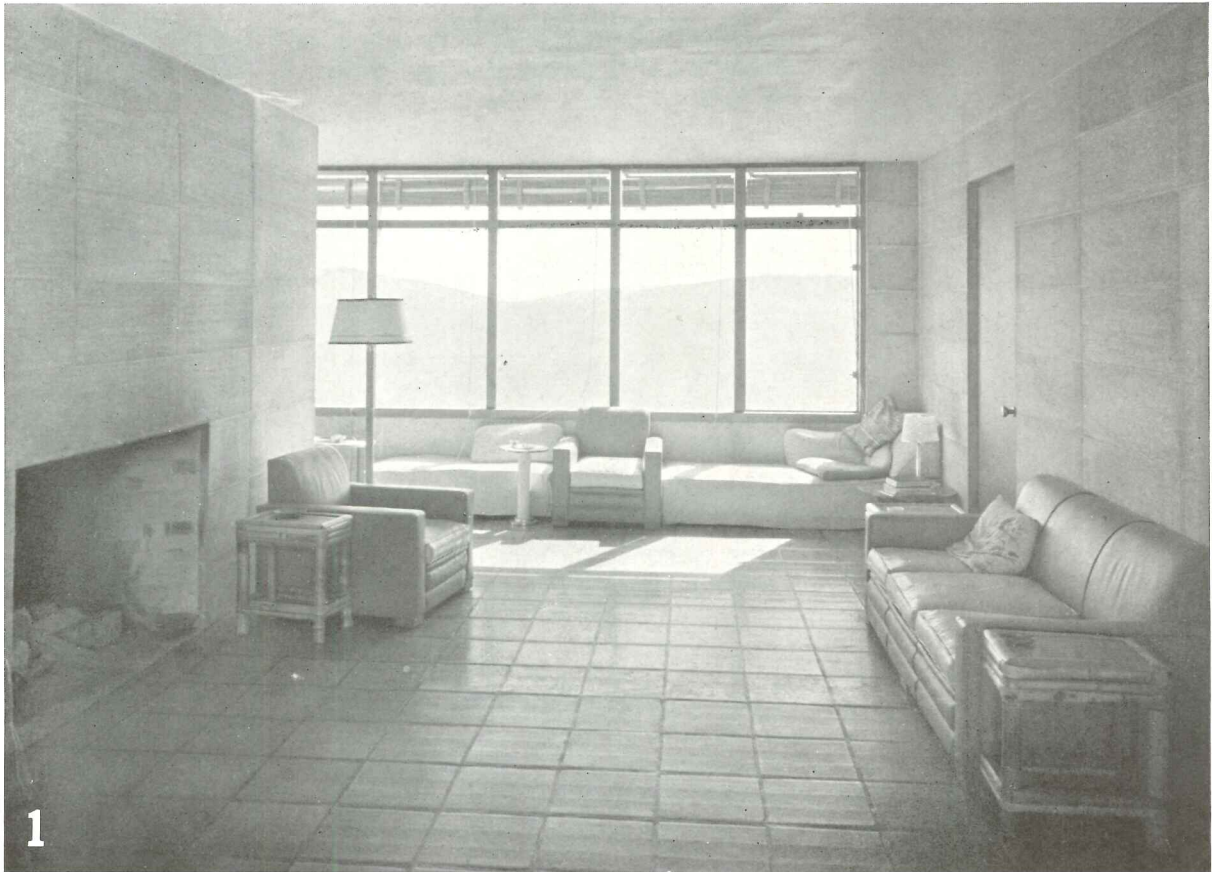

HOUSE OF PROFESSOR AND MRS. MATHURIN DONDO  
RICHMOND, CALIFORNIA

WILLIAM WILSON WURSTER, Architect



1. Living room with windows that overlook the ocean. Floor is of large red tiles. 2. Living room with its continuation as an outdoor court. Walls of large rectangular blocks of concrete are alike for court and living room. The dining table is shown facing this court.





"CARLTON ANNEX" STUDIO APARTMENT  
MEXICO, D. F.

KUNHARDT AND CAPILLA, Architects; CAROL NOVARRO, Designer of Interior

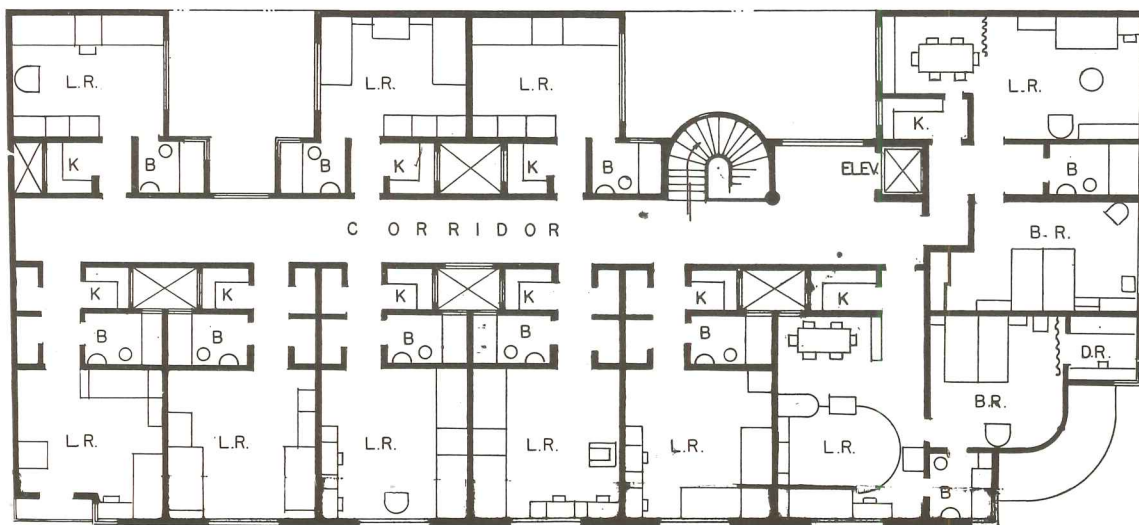

TYPICAL UPPER  
FLOOR PLAN





1. Lobby and dining space are entirely open, except for a low parapet wall at sides. Plan at left is a typical floor with single room apartments having a variety of furniture arrangements. Each apartment has its small kitchen and a bath. 2. Dining alcove off living room. Walls: white, chartreuse, and olive green. Chairs have leather-strip upholstery. 3. A living room with walls in olive green and white; couch covers, gold corduroy; rug, mixture of henna tan and brown; couch frame of cedar. 4. Bed couches with covering of yellow corduroy; walls, white and light brown, color changing at edge of window. 5. Bedroom with cedar furniture; corduroy bedspreads; walls of rust-rose, pale blue, and white.





Dell and Wainwright

ARCHITECT'S OWN FLAT AT YEOMAN'S ROW  
LONDON, ENGLAND

WELLS COATES, Architect

Plan and Sections courtesy "The Architectural Review"

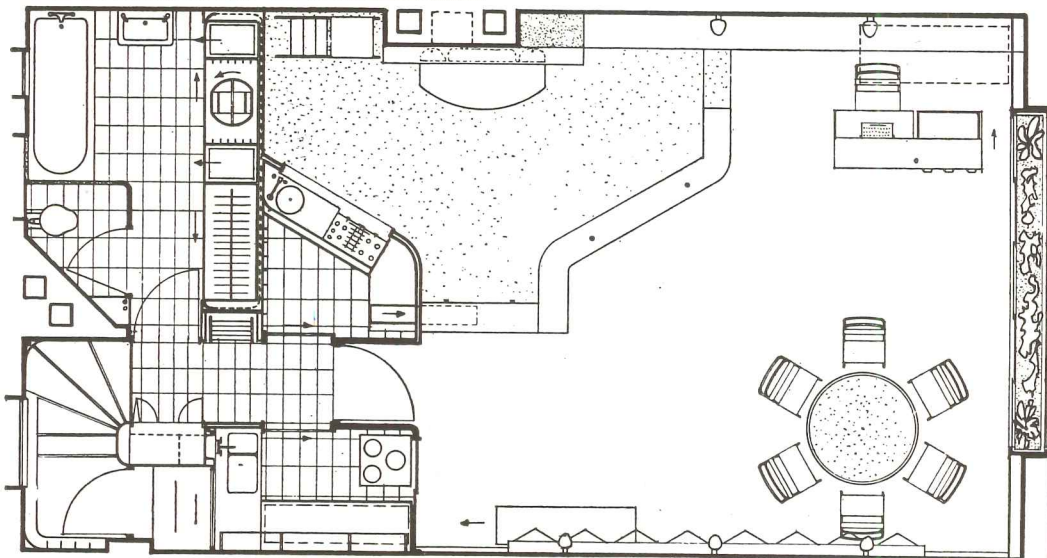

PLAN OF  
MAIN FLOOR LEVEL



The architect built this apartment as an experiment in arrangement for one or two people who desire the apartment "way of life." Several years were spent in securing a desirable location and gradually completing details. "A few items," remarks the architect, "have still to be added, but I have not altered anything since the original drawings were made. I find it a very pleasant place to live in."

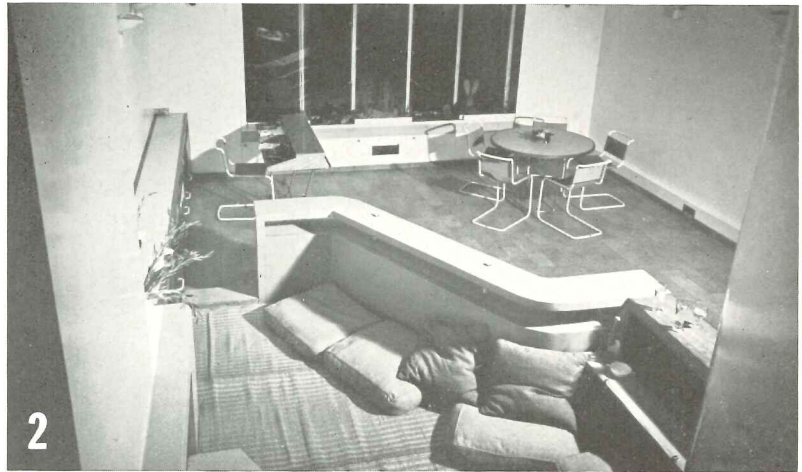

Dell and Wainwright



Müller & Harris



Müller & Harris

1. The huge studio window creates its own special values; it is double-glazed for warmth and for keeping out noises from the streets below. There is a window garden between the occupant and the outside world. Under the window there is a fan unit, which filters dustless air into the room. The heating is by direct radiation from the ceiling, 12 feet from the floor. The architect dislikes big sofas and easy chairs, so a hearth scene, *à la japonaise*, was created, penned off by a shaped parapet which is a bookcase on one side and a backrest for the cushions on the other side. Your book, your glass, your cigarette are at hand at the proper level and cannot be carelessly knocked over. 2. Enclosure facing fireplace. 3. The walls, the ceiling, and the various internal constructions are painted in four or five tones of white; the floor is covered with light compressed cork in oblong slabs, laid with a broken joint. The wall bookcase and desk are in Honduras mahogany, dull-polished. 4. Door to passage is painted Eton blue as are the plywood shelves of the shaped fittings in the foreground. Tubular steel forms for chairs, desk, dining table and for the ladders are ivory, copper, and Eton blue respectively.

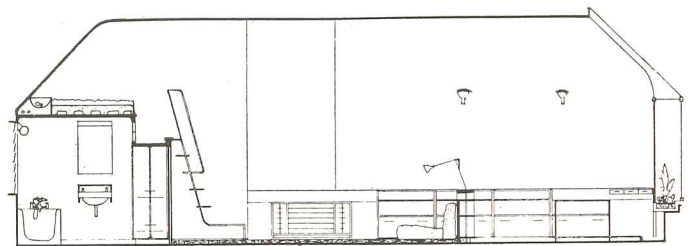
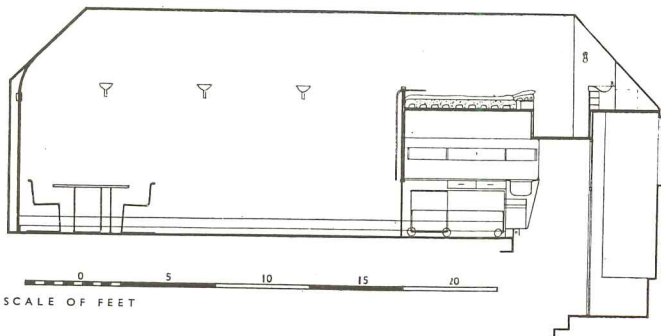

SECTIONS showing living room area with 12' ceiling height and sleeping accommodations over bathroom. Sleeping bunk is reached by ladder and has a runway.







# Building Volume and Cost Trends

By CLYDE SHUTE, Manager, Statistical & Research Division, F. W. Dodge Corporation

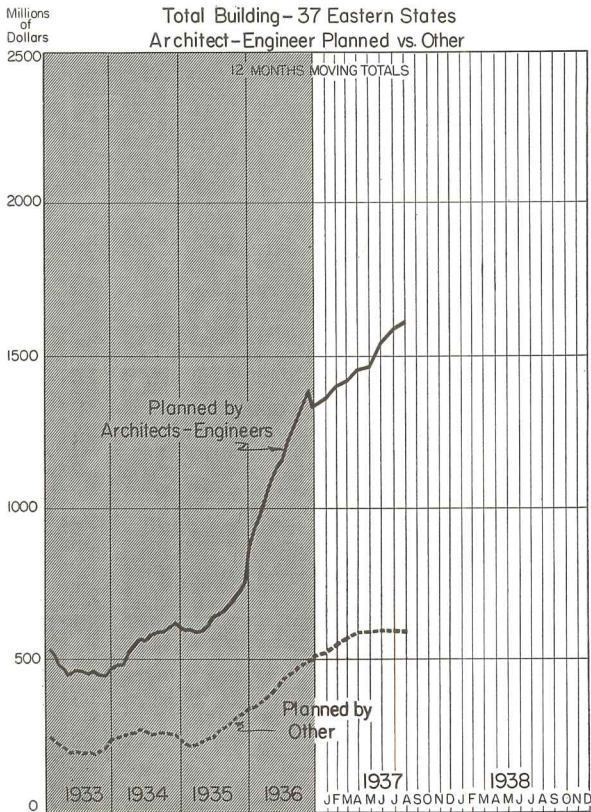

**TOTAL BUILDING — 37 EASTERN STATES  
ARCHITECT-PLANNED VS. OTHER—BY CLASSIFICATION**  
FIRST NINE MONTHS 1937

CLASSIFICATION	ARCHITECT PLANNED		OTHER		TOTAL Thous. Dollars (000 Omitted)
	Thous. Dollars	%	Thous. Dollars	%	
Commercial Buildings	146,451	62	89,987	38	236,438
Industrial Buildings	152,617	57	113,988	43	266,605
Educational Buildings	151,411	93	11,562	7	162,973
Hospitals & Institutions	53,207	87	7,784	13	60,991
Public Buildings	65,926	85	11,693	15	77,619
Religious & Memorial	23,420	82	5,192	18	28,612
Social & Recreational	47,451	77	14,206	23	61,657
<b>Total Non-Residential</b>	<b>640,483</b>	<b>72</b>	<b>254,412</b>	<b>18</b>	<b>894,895</b>
Apartments & Hotels	162,643	89	20,291	11	182,934
1 & 2 Family Houses	251,809	45	301,647	55	553,456
<b>Total Residential</b>	<b>414,452</b>	<b>56</b>	<b>321,938</b>	<b>44</b>	<b>736,390</b>
<b>TOTAL BUILDING</b>	<b>1,054,935</b>	<b>65</b>	<b>576,350</b>	<b>35</b>	<b>1,631,285</b>

## Construction Cost Index

THE BASE DATA for the charts displayed on the following two pages are secured from E. H. Boeckh & Associates, Incorporated.

The United States average for 1926-1929 is used as the base period, or 100, because prices of both labor and materials showed greatest stability during these years.

We shall present six general construction types because the quantities of the different building materials and the amounts of the different classes of labor vary in each type of building. The six types to be shown will be (1) Brick, (2) Steel, (3) Frame, (4) Brick and Wood, (5) Brick and Concrete, and (6) Brick and Steel.

Similarly, sixteen representative but widely scattered cities are shown, because material prices and labor rates are different in the various localities and do not change at the same time in all cities, nor to the same degree.

For example, in a frame building the price of lumber and the labor rate for carpenters have great influence, while the price of steel and the labor rate for steel erectors have absolutely none. In a steel-framed building, the price of steel and the labor rate for steel erectors are larger cost factors than the price of lumber and the labor rate for carpenters.

The charts provide a ready means of comparison of current reproduction costs of identical buildings in various cities or at different times within the same city.

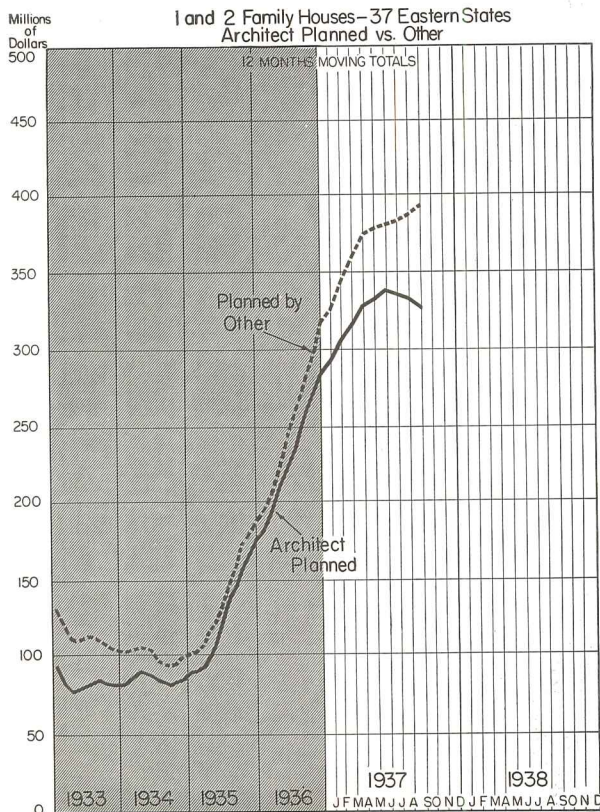

Data and charts for this page are provided by the Statistical & Research Division of F. W. Dodge Corporation and are based upon Dodge Reports for 37 Eastern States.



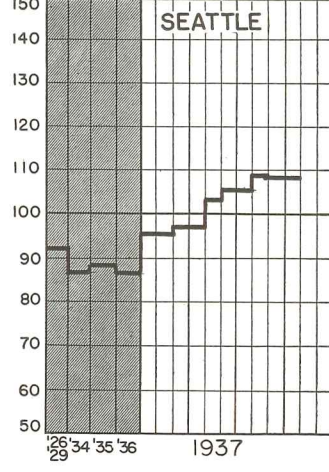
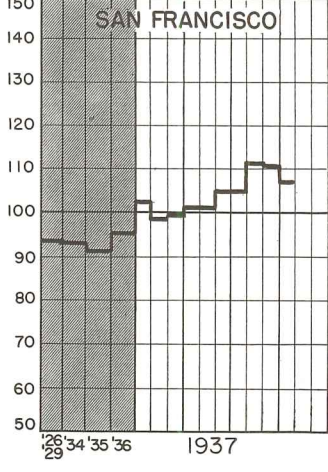
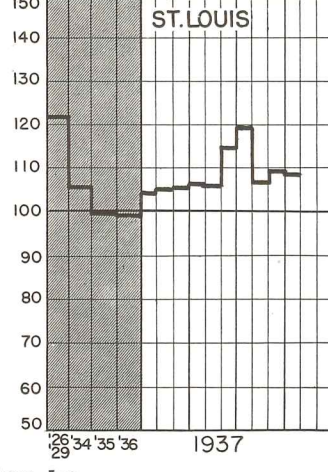
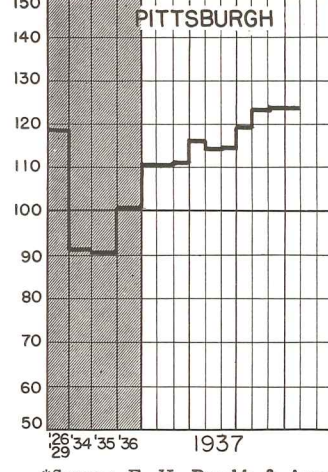
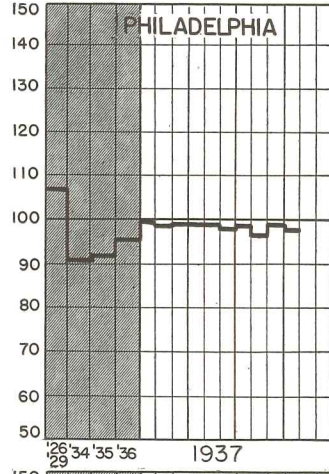
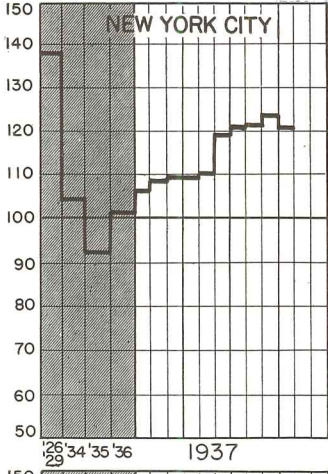
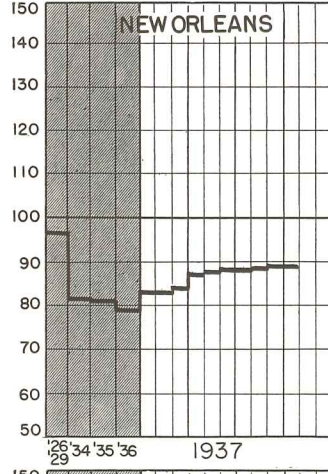
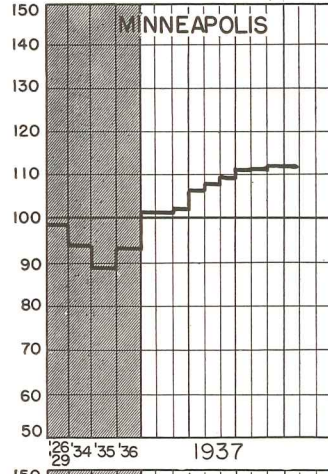
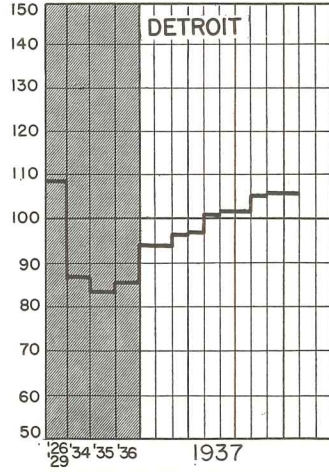
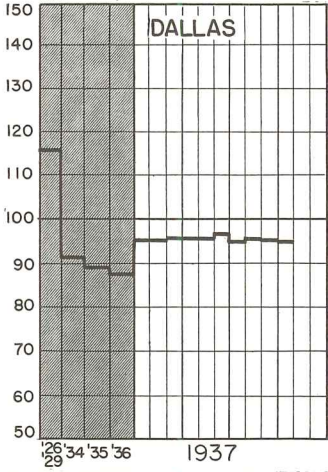
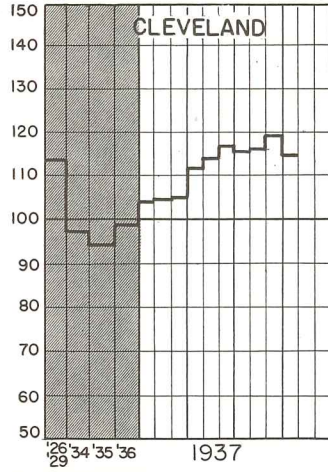
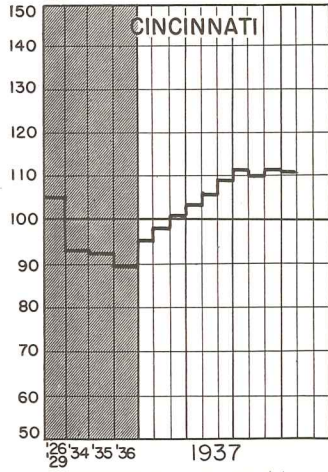
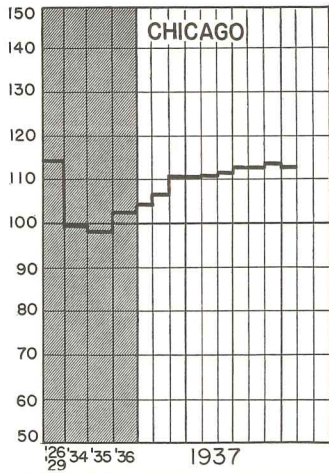
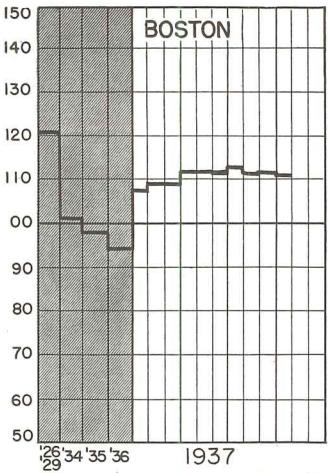
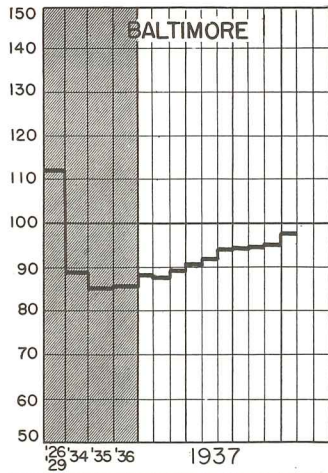
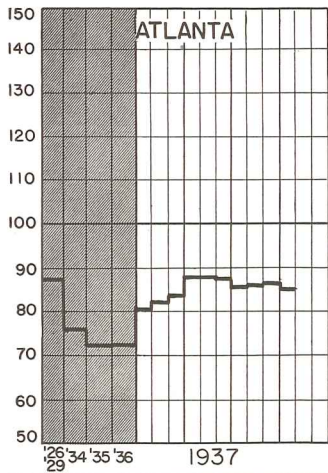

\*Source: E. H. Boeckh & Associates, Inc.



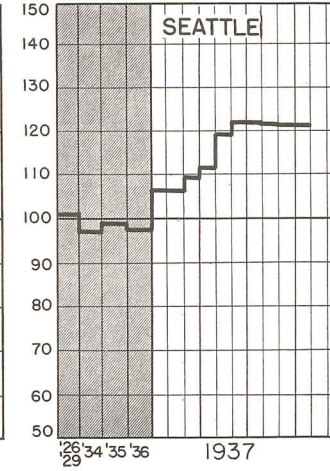
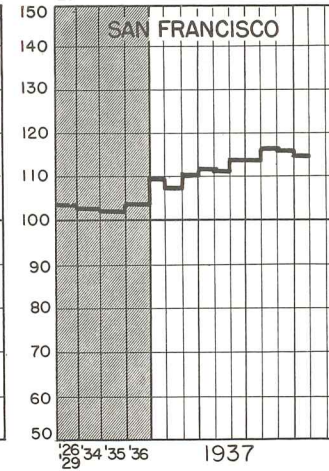
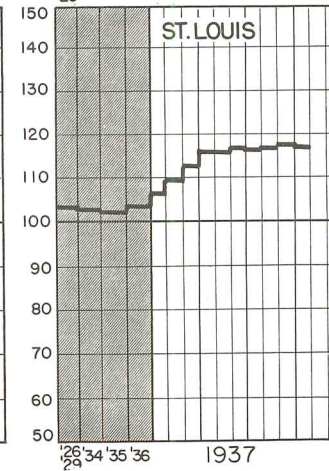
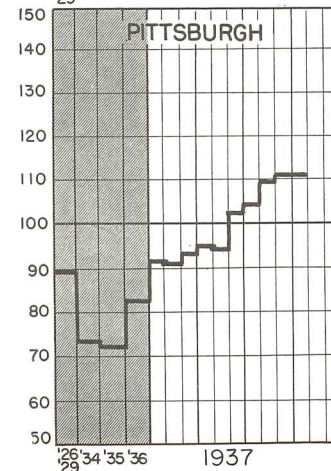
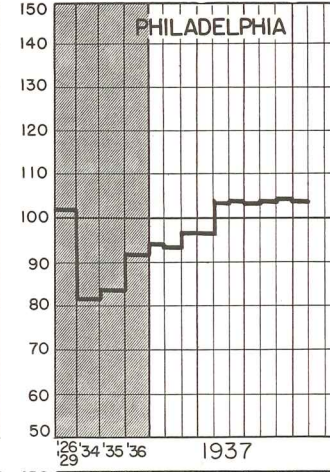
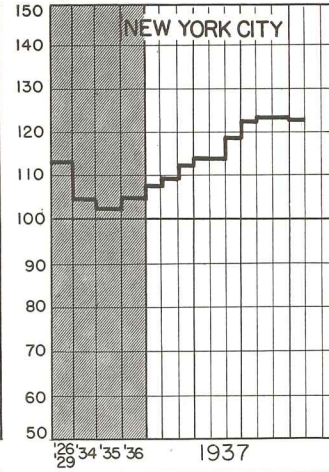
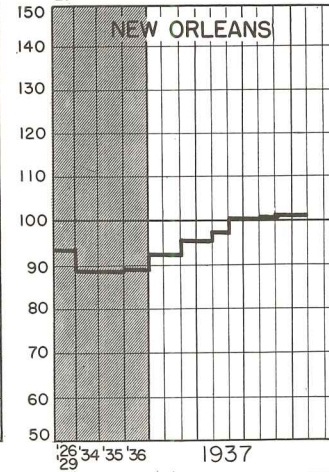
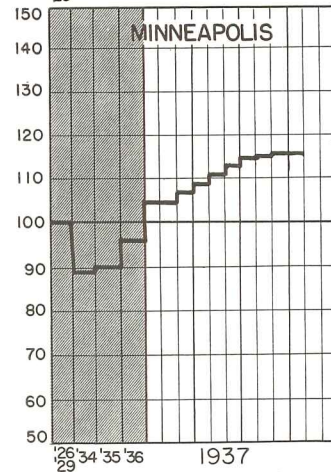
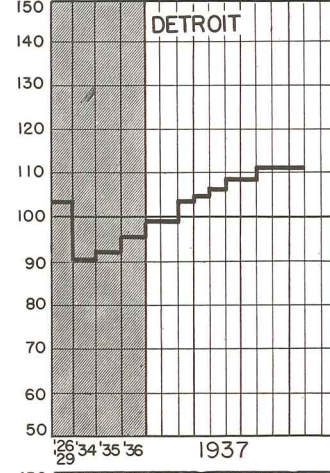
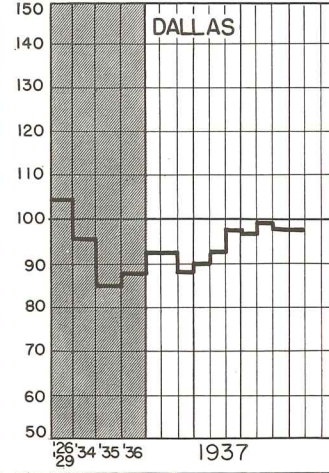
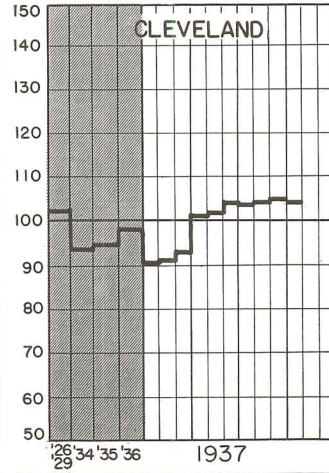
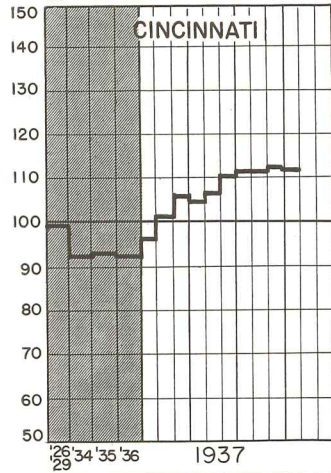
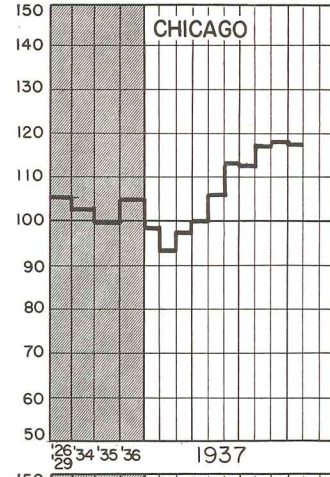
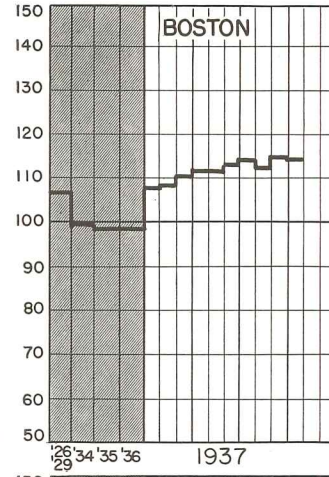
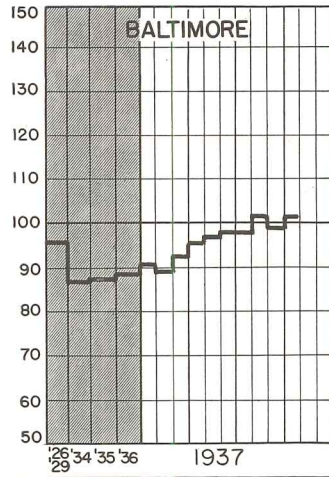
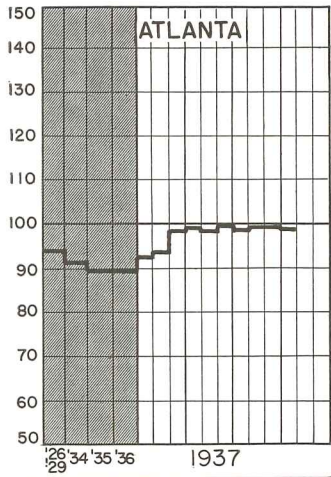

\*Source: E. H. Boeckh & Associates, Inc.



# Reviews of New Books



Photo by George French

**VISUALIZING THE CURRICULUM.** By Samuel B. Zisman and Messrs. Charles F. Hoban, Sr. and Jr. Cordon Company, New York City. 1937. Price, \$3.50.

It will probably be well worth the while of the designer and builder of tomorrow's school to think in terms of visual education. This idea within the last two or three years appears to have gained unusual attention among forward-thinking educators and, what is more, bids fair to become an integral as well as supplementary part of the standard school program.

Visual education incorporates a number of aids designed to complement and improve on textbook teaching. There is the school journal, there is the museum material, there are graphic materials and still picture materials, and there are the moving pictures. This last form deserves particular notice. It takes no great amount of imagination to appreciate the remarkable potentialities which the movies can have, and the part they probably will play, in the educational scheme. Already a score of responsible organizations have interested themselves in the promotion of this phase. Film libraries and exchanges have been established. And the support of the Motion Picture Producers and Distributors of America (Will Hays' office) has been enlisted. But there appear to be several factors which tend to retard early adoption of school films on any wide scale. One is that projection equipment is relatively costly. Another might be the prejudices often held by local school authorities against any deviation from time-honored teaching methods. Unsuitable room facilities would be a third factor. Proper exhibition of movies in the classroom would require its ready conversion into darkroom, with special screen arrangements and booth and storage for projector-sound equipment and films.

Here is a question which concerns the architect. In

planning new school buildings, and in reconditioning old, he will probably have to consider the physical requirements of moving pictures and other forms of visual education. Messrs. Zisman, Hoban and Hoban have produced a book which should prove helpful in this connection. Its 300 pages contain a fairly exhaustive treatise on the whole field of visual education. One complete chapter, 54 pages long, is devoted to the motion picture, and another chapter contains "Architectural Considerations." While the book is profusely illustrated and is made up in a novel way, some readers may find it a bit too academic and schoolish. NILS HANSILL

**THE WORKING-CLASS HOME, ITS FURNISHING AND EQUIPMENT.** British Library of Information, 270 Madison Avenue, New York City. 1937. Price, 35 cents.

A report by the Council for Art and Industry covering the design and chiefly the furnishing of houses of low cost. Consideration is given to the nature and extent of the requirements of the family and the prices of goods available for satisfying them. There are illustrations of selected examples of low-cost furniture.

**EVERYDAY SCIENCE.** By A. W. Haslett. Alfred A. Knopf, Inc., New York City. 1937. Price, \$2.75.

This book reviews the part that latest discoveries of science play in our daily life, how modern science affects the home, food, health, clothes, amusements, etc. There is a chapter on "The Builder's Problem"—speed and economy, the modern need, improvements in old and new materials, walls, weather, and noise.

**AMERICAN PLANNING AND CIVIC ANNUAL, 1937.** Edited by Harlean James. American Planning and Civic Association, Washington, D. C. Price, \$3.00.

A record of recent civic advance, including the papers read at the National Planning Conference. The Annual is not a balanced treatise but rather includes the best of current thought by specialists on housing, regional planning, national parks, and zoning.

**FINANCIAL SURVEY OF URBAN HOUSING.** Superintendent of Documents, Washington, D. C. Price, \$3.25.

Data collected in 1934 on property values, rentals, family income, mortgages, interest rates in 22 cities; basic material for economic studies in the housing field.

**SHOPPING DISTRICTS.** By S. R. De Boer. American Planning and Civic Association, Washington, D. C. 1937. Price, \$3.25.

This book, written by a distinguished town planner, deals with the recommended location of shopping districts, a major consideration in the determination of zoning districts. It includes the traditional downtown shopping centers as well as the decentralized shopping areas which are now being located to serve suburban residence neighborhoods.



# "THE WHOLE AUTOMATIC HEATING AND AIR-CONDITIONING PICTURE IS *changed*

## WITH ANTHRACITE EQUIPMENT"

"I thought I was posted on all modern equipment, but my eyes opened wide at the amazing advances in automatic Anthracite heating and air conditioning."

More and more architects and builders show decided preference for modern Anthracite equipment. Check the reasons. (1) The range of modern Anthracite equipment permits automatic heat within the budget of the most modest dwelling. You can supply automatic heat with an adequate furnace, or boiler, and an inexpensive thermostat, thus stretching fueling periods to 12 hours or more. You can install a magazine feed boiler, that needs no attention from 24 to 48 hours, or you can provide all-season fueling and ash handling with an

automatic Anthracite burner. (2) Anthracite equipment is sturdier and far more permanent. (3) Anthracite offers advantages no other fuel can match. It is safest, cleanest and most dependable. Anthracite prices have steadily dropped, while costs of other fuels have risen. The savings with Anthracite often pay for the equipment.

Send for a copy of the book "Modern Anthracite Equipment." It contains pictures and descriptions of modern Anthracite equipment in the newest designs. You will find it very interesting.

Anthracite Industries, Inc., also stands ready to help you with any problem affecting Anthracite. Write ANTHRACITE INDUSTRIES, Inc., Chrysler Building, New York.

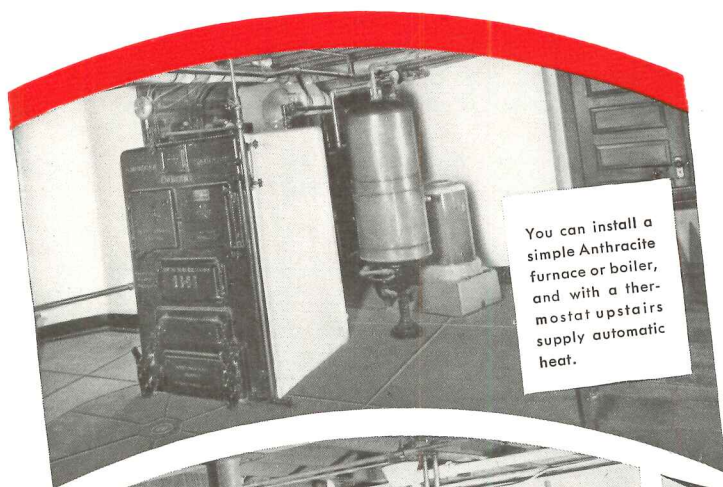

You can install a simple Anthracite furnace or boiler, and with a thermostat upstairs supply automatic heat.

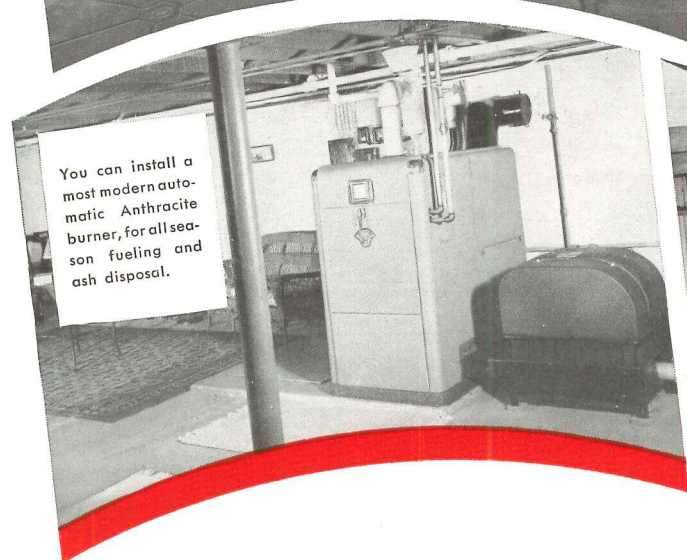

You can install a most modern automatic Anthracite burner, for all season fueling and ash disposal.

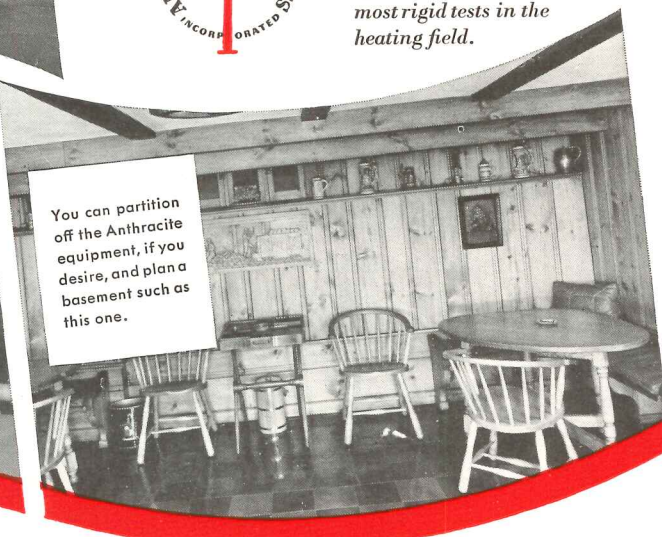

You can partition off the Anthracite equipment, if you desire, and plan a basement such as this one.

## Pennsylvania ANTHRACITE COAL



This seal of approval appears on Anthracite equipment only after it has passed the most rigid tests in the heating field.

THE SOLID FUEL FOR SOLID COMFORT





A perfect example of how Transite Walls, here shown with quilted-maple veneer, add to the attractiveness of an office. This modern material takes lacquer, paint, wood veneer, fabric or any other finish. Or it can be left in its natural, neutral color. (Installation for Schenley Distillers, New York. Designed by Hegeman Studios, Inc.)

## REMARKABLE FLEXIBILITY ACHIEVED IN MODERN MOVABLE WALLS . . .

**T**ODAY, any architect can plan office-partitioning needs with every assurance that future changes can be easily and economically accomplished.

This is made possible by Transite Walls—the most adaptable of all modern movable wall materials. Because Transite Walls have a unique construction method, they can be rearranged or completely relocated with no loss of material. And erection . . . in every instance . . . is a dry, almost noiseless process.

Here, too, is a partition that—though movable—provides the solidity and privacy of fixed walls. For Transite is asbestos-cement in composition, hence inherently durable, permanently

fire- and sound-resistant, immune to rot or decay. In addition, Transite Walls offer a flush, projection-free surface with unlimited decorative possibilities.

An illustrated Transite Walls brochure, containing complete details, is available on request. It can be secured by writing Johns-Manville, 22 E. 40th St., New York, N. Y.

The secret of Transite Walls' great flexibility is the special construction method used. Concealed steel studs and holding devices permit fast, easy relocation of Transite Walls with 100% salvage. And yet, they provide the solidity and privacy of fixed walls.

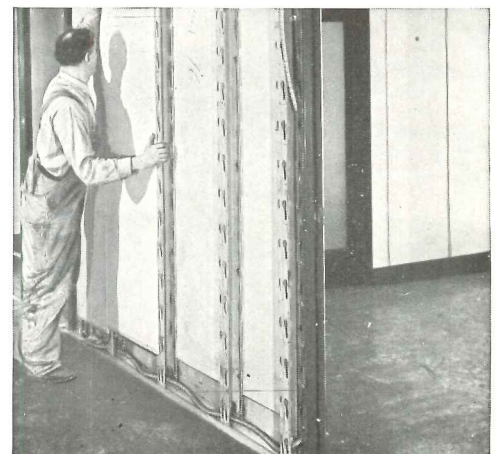



# The Vital Element.

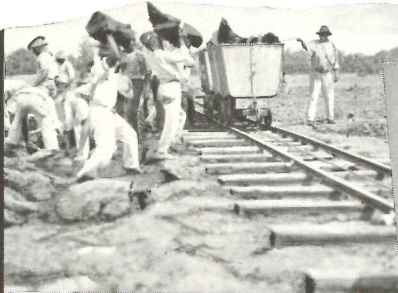

THE VITAL ELEMENT, dug from the lake

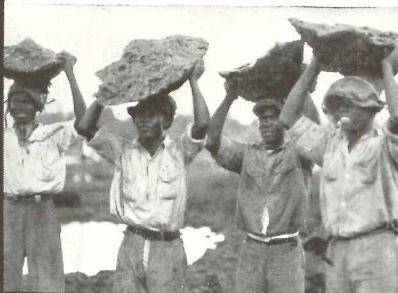

transported on natives' heads



and across a half-mile cableway

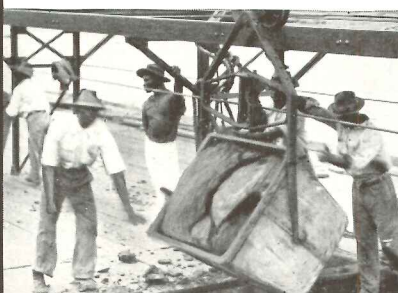

to ships for the United States



Stevens Hotel, Chicago, Ill.

to make Barber Genasco Bonded Roofings

THE MOST FASCINATING STORY  
IN THE *Roofing* INDUSTRY

**B**ARBER brings the architect a story of quality seldom equaled in roofing history. It is the story of a great natural asphalt—*The Vital Element*—made by Nature on the southern Caribbean Island of Trinidad. It is a story that is exclusively Barber's, applying only to Barber Genasco Roofings—and no others!

Trinidad Lake Asphalt—*The Vital Element*—was discovered by Christopher Columbus. Sir Walter Raleigh used it to caulk his leaky ships. And Barber has spent many years using it in the highest quality roofings.

What is the secret of *The Vital Element*? First, it is a native asphalt, made through countless generations at only tropical temperatures. Second, it possesses an inherent vitality that has never been deadened—even after millions of years of exposure to a year-round summer sun. Third, it contains a colloidal suspension of fine volcanic ash, never yet duplicated in any asphalt. This inherent mineral filler definitely contributes to longer wear and protection against the weather.

With a thorough knowledge of roofing combined with a thorough knowledge of asphalts and *The Vital Element*, Barber has perfected Barber Genasco Bonded Built-up Roofings—bonded for 10, 15 or 20 years—as well as other types of built-up roofings, which you can specify with confidence. Barber will be glad to forward specifications and a free copy of the descriptive folder, "The Maximum Roof Protection." Specify Barber Genasco Roofings and remember—*The Vital Element* has no equal.

**THE BARBER COMPANY, INC.**  
ASPHALT HEADQUARTERS SINCE 1883  
PHILADELPHIA • PENNSYLVANIA

SHINGLES • SIDINGS • ROLL ROOFINGS • BUILT-UP ROOFINGS  
ASPHALT WATERPROOFINGS OF EVERY DESCRIPTION



# WINDOW GLASS

## The Revealer

Just as glass reveals thousands of twinkling lights shining through the windows of buildings at night, so does it reveal scenes of beauty to delight the eyes. The quality of glass with which windows are glazed fulfills or defeats one of their most important functions, that of clear vision. To assure clear vision and the maximum of light transmission, consider one pane windows, and . . .

**SPECIFY**



**Clearlite**  
SHEET GLASS  
A QUALITY

EASY ON THE EYES

**FOURCO GLASS COMPANY**  
General Offices—CLARKSBURG, W. VA.  
Branch Sales Offices—NEW YORK • CHICAGO • FT. SMITH, ARK.

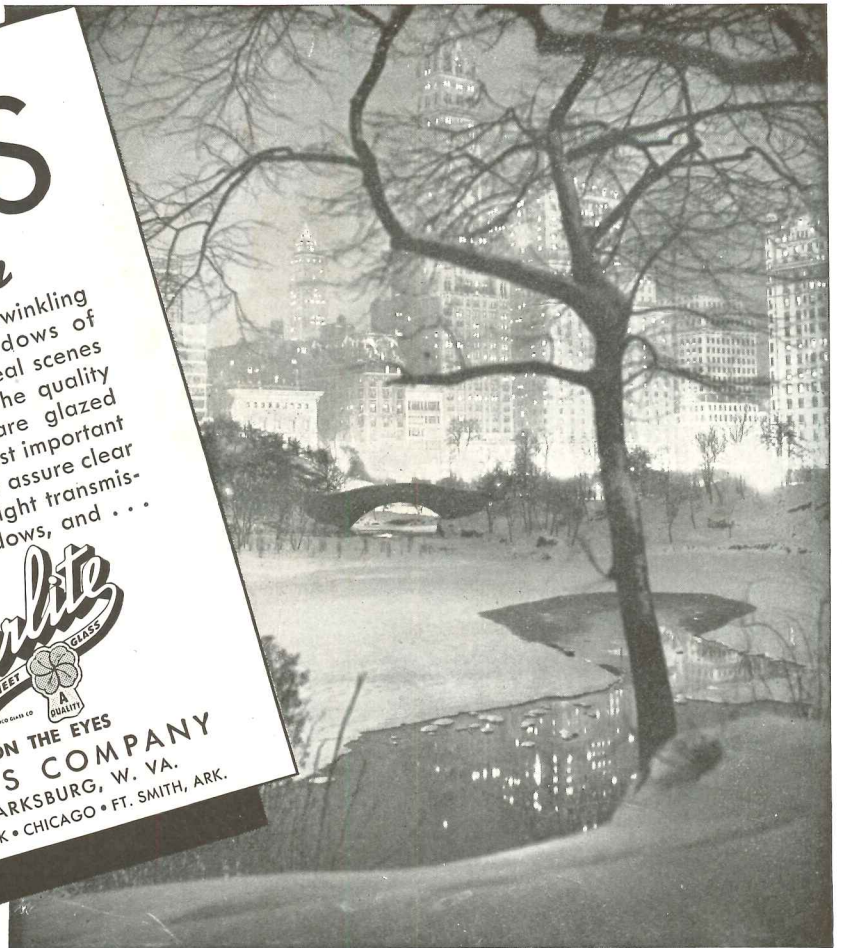

## THERE IS A NEARBY SOURCE FOR CLINTON PERFORATED METAL GRILLES



Local distribution is important. Samples of Clinton stock designs and finishes can be inspected, special requirements discussed, and instructions given . . . personally. If the local representative has not made himself known to you, write us and we will see that he calls. Clinton Grilles are available in a wide variety of designs and metals up to 60" x 156".

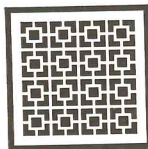

**WICKWIRE SPENCER STEEL COMPANY**  
41 East 42nd Street, New York

Buffalo - Worcester - Chicago - San Francisco

Send for this new GRILLE FOLDER



**WICKWIRE SPENCER**  
perforated metals

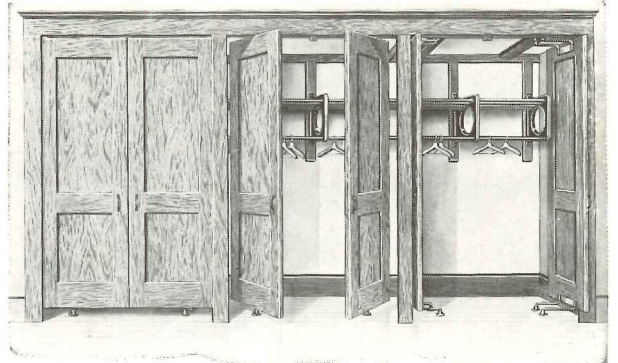

**EVANS**  
"Vanishing Door"  
WARDROBE

Style X

equipped with either "Floor" type (as illustrated) or "Jamb" type hinges. This is Style P wardrobe if made with flush doors.

### CLASSROOM WARDROBES

*High in Quality—Low in Cost*

Made to set in a recess flush with the wall. Plaster back, ends and ceiling. No partitions, but with mullions between pairs of doors. Blackboards if required. Five-shelf bookcase instead of clothing equipment at no extra charge when desired.

The "Vanishing Door" hinges on which the doors are hung are made with double pivoted arms and swing the doors back into the wardrobe entirely out of the way. Simple—trouble-proof—and last as long as the building.

Wardrobes are furnished complete in the knockdown, with all woodwork cut to size, and only need to be nailed in place. The hinges are easier to put on than common butt hinges. The entire cost of installation is small.

We make many other styles of school wardrobes, fully illustrated and described in Catalog "O." Send for your copy.

**W. L. EVANS CO.**  
WASHINGTON, INDIANA, U. S. A.



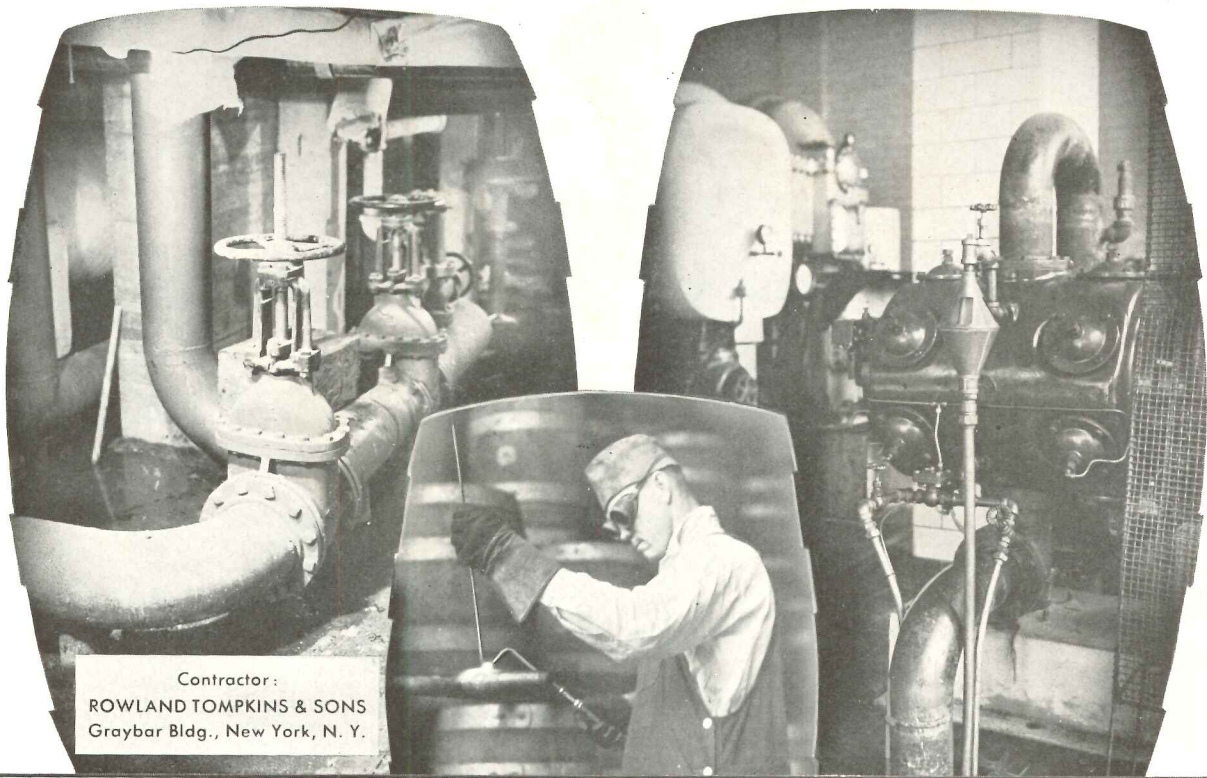

Contractor:  
 ROWLAND TOMPKINS & SONS  
 Graybar Bldg., New York, N. Y.

# Multi-Layer AIRCOWELDED Piping in *Schaefer* Brewery's New Power Plant

Multi-layer AIRCOWELDING is the process, recently perfected by AIRCO, that simplifies and cuts the cost of welding extra heavy and double extra heavy pipe, and at the same time assures welds of superior physical properties.

It proved its worth in the welding of the high pressure system designed by Fred Ophuls & Associates, Consulting Engineers, and installed in the new power plant of the Schaefer Brewery, in Brooklyn, N. Y., which operates at 450 lb. per square inch.

AIRCO No. 1 High Ductility Alloy Steel Rod, another recent AIRCO contribution to welding progress, as well as AIRCO Oxygen, Acetylene, Welding Apparatus and the practical cooperation of AIRCO's field engineers, all combined to produce piping that readily passed the insurance inspections and tests.

The AIRCO Way is the profitable way to install piping for power, heating, plumbing and refrigeration.

## SEND FOR THESE TWO BULLETINS

They explain the decided advantages and economies of the AIRCO pipe welding processes—AIRCOWELDING for standard weight pipe and Multi-Layer AIRCOWELDING for heavy weight pipe. They are fully illustrated and one of them contains model pipe welding specifications.

WRITE FOR YOUR  
 COPIES—TODAY



# AIR REDUCTION SALES COMPANY

General Offices: 60 East 42nd St., New York, N. Y.  
 DISTRICT OFFICES IN PRINCIPAL CITIES

A NATION-WIDE WELDING and CUTTING SUPPLY SERVICE





**STURTEVANT FANS**  
**SERVE NEW YORK WORLD'S FAIR**  
*Air Conditioned Administration Building*



**I**N keeping with its thoroughly modern design, the Administration Building of the New York World's Fair has been scientifically air conditioned.

It is significant that Sturtevant Fans were chosen to circulate the conditioned air in this model project which houses 700 executive officers and staff.

Designed and engineered by the World's Fair architectural and engineering staff. Baker, Smith and Company of New York, Contractors.

B. F. STURTEVANT COMPANY, HYDE PARK, BOSTON, MASS.  
*Branch Offices in 40 Cities* B. F. Sturtevant Co. of Canada, Ltd.—Galt, Toronto, Montreal

**Sturtevant**  
REG. U. S. PAT. OFF.  
*Puts Air to Work*

**Fans, Blowers, Air Washers, Air Conditioning, Heating, Vacuum Cleaning, Drying, Mechanical Draft Equipment**



*When* DEFLECTION *is the*

**GOVERNING FACTOR**

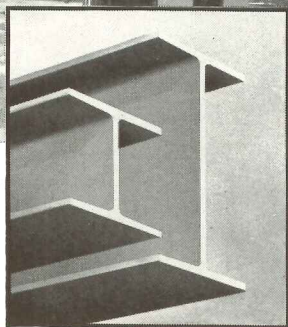
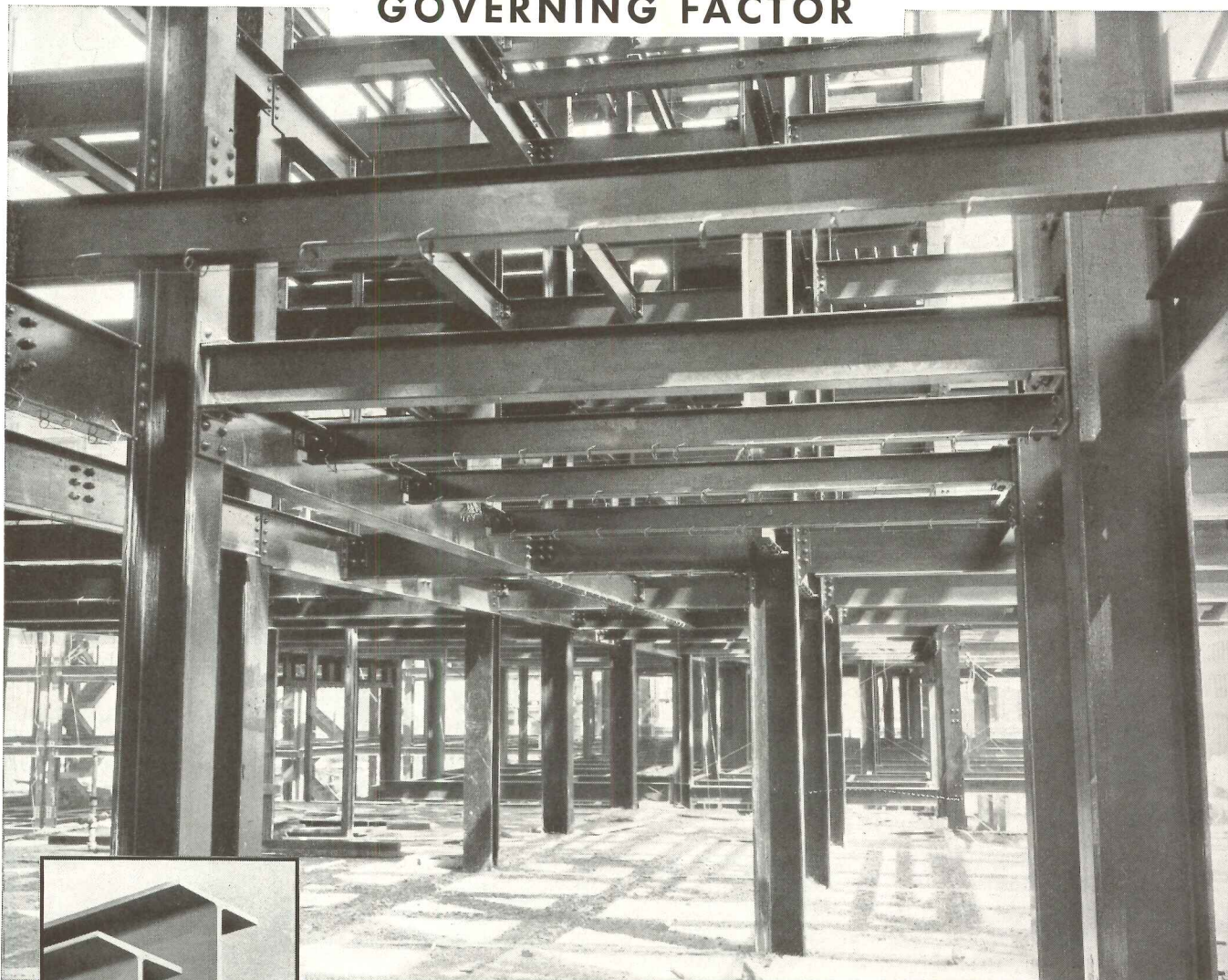

**BETHLEHEM**  
*Light* **SECTIONS**

**BRING SAVINGS**

**B**ETHLEHEM Light Sections may be used effectively in any part of a structure where loads are less than the capacity of heavy sections of depth dictated by the span. They find frequent application in floor construction and in all types of upper tier work.

Although Bethlehem Light Sections are light in weight for their depths, the thickness of metal in both flange and web makes them eligible for use in all first-class construction, conforming with all building code requirements. Rolled to essentially the same shapes and dimensions as the regular heavier sections, Light

Sections are fabricated and handled in the same way and create

no special engineering or designing problems.

In apartment buildings, hotels, office buildings, hospitals and similar structures, Bethlehem Light Sections keep floor slab thickness within economical limits without using more steel than called for by the load. In addition to their utility in floor construction, Bethlehem Light Sections are widely used as spandrel beams, columns in upper stories, struts between columns and as purlins in roof construction, particularly of industrial buildings.

**BETHLEHEM STEEL COMPANY**





*Foresee  
unseen damage*

*Protect timbers from  
decay and insects with*

**GRASSELLI**  
*Chromated*  
**ZINC CHLORIDE**

**T**HE modern wood preservative, Chromated Zinc Chloride, is an improved form of the long established zinc chloride treatment. It possesses properties repellent to termites and resistant to rot-producing fungi. It is also fire-retardant.

**FOR PERMANENT CONSTRUCTION**

Wood, a most versatile building material, becomes a better investment when properly treated with GRASSELLI Chromated Zinc Chloride. For both commercial and residential construction, treated wood offers structural strength and low maintenance expense, which more than justifies the slight extra cost. Take a "tip" from railroads and mines who have used treated wood for many years, realizing the importance of safety and maintenance.

Treatment with GRASSELLI Chromated Zinc Chloride is not superficial, but is applied by commercial treating plants which thoroughly impregnate the lumber under pressure. Those who buy, and those who specify, will be interested in the obvious advantages of C.Z.C. preserved lumber. If you are not able to conveniently obtain treated wood, write us.

**E. I. DU PONT DE NEMOURS & CO., INC.**  
**GRASSELLI CHEMICALS DEPARTMENT**



Wilmington, Delaware



*Treated Lumber is Clean, Odorless,  
Paintable and Fire-Retardant*

**AEROFIN**  
Heat-Exchange Surface

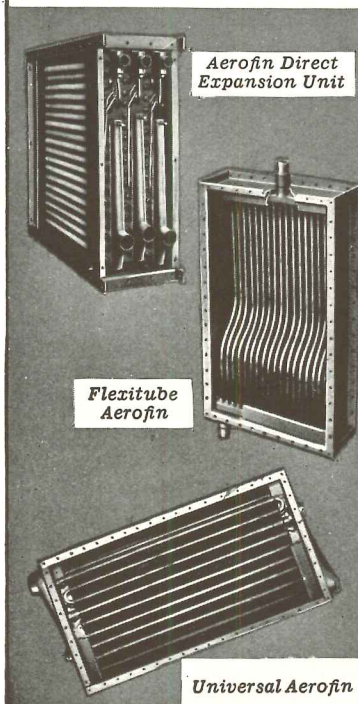

**A**EROFIN standardized fan system heat exchange surface has been engineered to meet the most rigid specifications and the most exacting demands of those who expect unequalled service.

The experience that has gone into Aero-fin's design and manufacture and the completeness of its line for every cooling and heating requirement, has made it the preferred equipment with consulting engineers, architects and contractors.

The confidence which they have reposed in Aero-fin has always been justified. Why?

Because Aero-fin's record of satisfactory performance in thousands of installations, both large and small, in such famous public buildings as the United States Capitol and many others, is definite evidence of its superiority.

Investigate the merits of Aero-fin. Let us tell you about the special features that have been incorporated in Aero-fin which makes it outstanding.

Write today for complete engineering information or ask any of our district offices for technical assistance. No obligation.

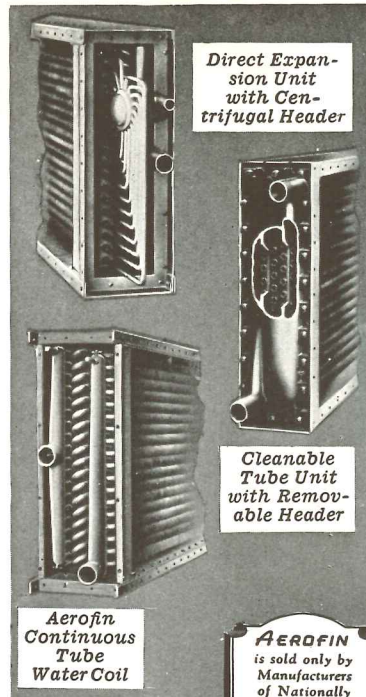

*Direct Expansion Unit with Centrifugal Header*

*Cleanable Tube Unit with Removable Header*

*Aero-fin Continuous Tube Water Coil*

**AEROFIN**  
is sold only by  
Manufacturers  
of Nationally  
Advertised  
Fan System  
Apparatus.  
List upon Request

**AEROFIN CORPORATION**

410 SOUTH GEDDES STREET  
SYRACUSE, N. Y.

Chicago • Detroit • New York • Philadelphia • Dallas • Atlanta





A mural decoration embellishes this Q.C.F. Fairhurst folding wall in the Miriam Osborn Memorial Home, Harrison, N. Y. James Gamble Rogers, Architect.

## FAIRHURST *folding* WALLS

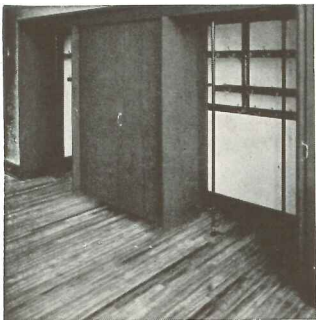

Also Q.C.F. Fairhurst school wardrobes. Dual operating hardware permits the operation of each pair of doors by the movement of a single door...right, or left, whichever is most convenient. Strong, sturdy, space saving. Widely used by leading schools.

Where flexibility in the use of space is desired, the solution will often be found in the Unitfold folding wall, as manufactured by the American Car and Foundry Company under the well and favorably known Fairhurst patents, issued November 7, 1933, and August 25, 1936.

Fairhurst folding walls when in place have the rigidity of a solid wall. They provide ample allowance for any building settlement, floor or ceiling sag. No bolts or hinges are used, there is no visible hardware. Shuttle or communicating doors can be placed anywhere in the Unitfold folding wall. The wall can be so finished as to harmonize with any surroundings. When folded, the partitions are concealed without the use of pocket doors, since the last door to be folded acts as closure for the recess.

They are also furnished with pocket doors, thus completely closing recess.

MAKERS OF FINE ARCHITECTURAL WOODWORK

**AMERICAN CAR AND FOUNDRY COMPANY • 30 CHURCH STREET, NEW YORK, N. Y.**



# Supreme IN BETTER CLASS BUILDINGS

STREAMLINE is the original capillary attraction solder type fitting. It is the only fitting that incorporates the true visual inspection feature by which the operator can tell at a glance, without resorting to an actual pressure test, that the joint he has just made is permanently leak-proof.

STREAMLINE

## FULL FLOWING *Service* "PEAK LOAD" AT ALL TIMES

● In the better class public buildings and, in fact, in every form of construction from the modest home to the largest commercial building, STREAMLINE Copper Pipe and Fittings have been installed for their many outstanding advantages.

One of the most important is that STREAMLINE furnishes absolute safety in concealed work where pipe lines are installed behind walls, floors, partitions or ceilings. The hidden leaks, which gradually develop with threaded fittings and rustable piping materials, causing extensive damage to furnishings, inconvenience—and costly repair to the line itself, cannot happen with STREAMLINE.

Whether the installation is for new construction or remodeling, it is a permanently lasting one, as long as the building stands.

STREAMLINE Fittings and Copper Pipe are being successfully used today in hundreds of industrial applications. They are in widespread use for all lines in hot water heating for low pressure mains, risers, branches and returns in steam heating systems—and for drainage work. They are extensively used in marine work, dairies, oil refineries, laundries, glass industries, sewage disposal plants, sugar refineries, powder and explosives, etc. STREAMLINE Copper Pipe and Fittings are now installed on 36 major railroads for air conditioning purposes.

Specify STREAMLINE Fittings with STREAMLINE Copper Pipe for your next construction job.

A catalog of STREAMLINE products is already on file in your office. You will find it in Sweet's or write for our A.I.A. File 29 B4.

**STREAMLINE**  
PIPE AND FITTINGS DIVISION  
**MUELLER BRASS CO.**  
PORT HURON, MICHIGAN



# BUILDING TYPES

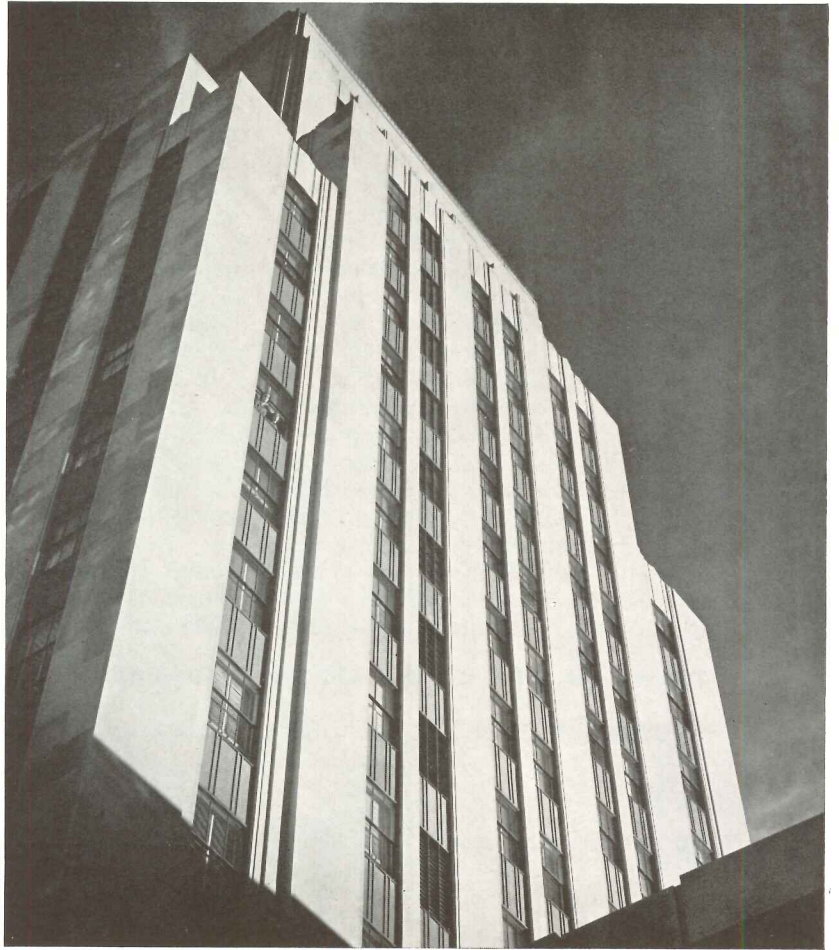

*F. S. Lincoln*

O F F I C E B U I L D I N G S

**ARCHITECTURAL**

*Record*



# Office Buildings

By R. STANLEY SWEeley

ACCORDING to C. B. Loudon, of the Division of Research and Statistics, F. W. Dodge Corporation, the estimated volume of new office building construction in the 37 eastern states for the year 1937 is but slightly larger than last year's total and is not likely to reach 10,000,000 sq. ft. of floor space. This is considerably below the figures for both 1931 and 1921. Vacancies in office buildings, however, have been steadily declining in the past four years and stand now at less than 20 percent. An appreciable occupation of vacant floor space must be effected before the volume of new work can be foretold. Despite this there is a general improvement in new office space demand, some of which is being supplied, naturally, by the improvement, alteration, or modernization of existing structures.

This better occupancy condition is also reflected in a somewhat improved rental situation. In a recently conducted survey (see Real Estate Record, October 2, 1937) of fifteen cities, rates on first-quality space ranged, generally, from \$2 to \$3 per sq. ft. This represents a gain of from 5 to 10 percent in the past year. It does

not, of course, compare with the one-time \$6.00 or more per sq. ft.; the days of such rates are gone, perhaps forever. Certainly the designer of office buildings, where structures are to be erected for investment, should predicate his planning on reasonable anticipated rental rates, indicated as being currently obtainable.

## Rentable Area?

Unfortunately, no clear and generally accepted definition of what constitutes a square foot of rentable floor space exists. Effort has been made constantly (and is still being made) to achieve a standard of comparison in this matter. Some have gone so far as to lay responsibility for the confusion on the doorstep of the architect, claiming that many errors of floor space area are traceable to his inexact dimensioning of plans from which rental contracts are to be made. Undoubtedly some errors do exist on even the most carefully executed drawings. More often than not, these are the result of last minute changes determined by the owner, building manager, or others.

The necessary reform, now being

sought by various national and local real estate groups for the development of a standard yardstick for office space measurement, should enlist the support of every architect. Various codes or agreements defining office space have been proposed. Some of these have been exceedingly complex; one of the simpler proposals stated that usable area should be considered as that floor area which can be overlaid with a covering, carpet, etc., and which can be used by the tenant for office purposes—for desks, file cabinets, and the like. At present it is generally agreed that observance of the definitions set up has been slight and limited.

## Type Analysis

Comparative returns from rentable areas is not a primary concern in all classifications of office buildings. For instance, a project may be financed by government funds appropriated for the housing of municipal, state, or federal agencies. Even private ownership may erect a building for special as well as for general purposes, or for owner occupancy; in some rare instances, advertising value may be the dominant consideration.

In construction, an office building may be fireproof or nonfireproof, multi-story or simply a walk-up. It may be only a portion of another type of structure, such as the office section of an industrial plant, or again it may be a taxpayer property—a structure of essentially temporary character peculiar to sectors of relatively high land value, erected as an expedient for the payment or partial payment of taxes.

As a result of the increase in the number of government employees (throughout the nation as well as in Washington, D. C.) in the past few years, government office building construction cuts a sizable swath in the total activity in work of this type. Because there is at all times a certain amount of rented space occupied by government bureaus, and because there is also a pronounced trend on the part of the government to dispense with renting, it is fairly certain that the planning and construction of government-owned office

TREND IN OFFICE BUILDING CONSTRUCTION SINCE 1920

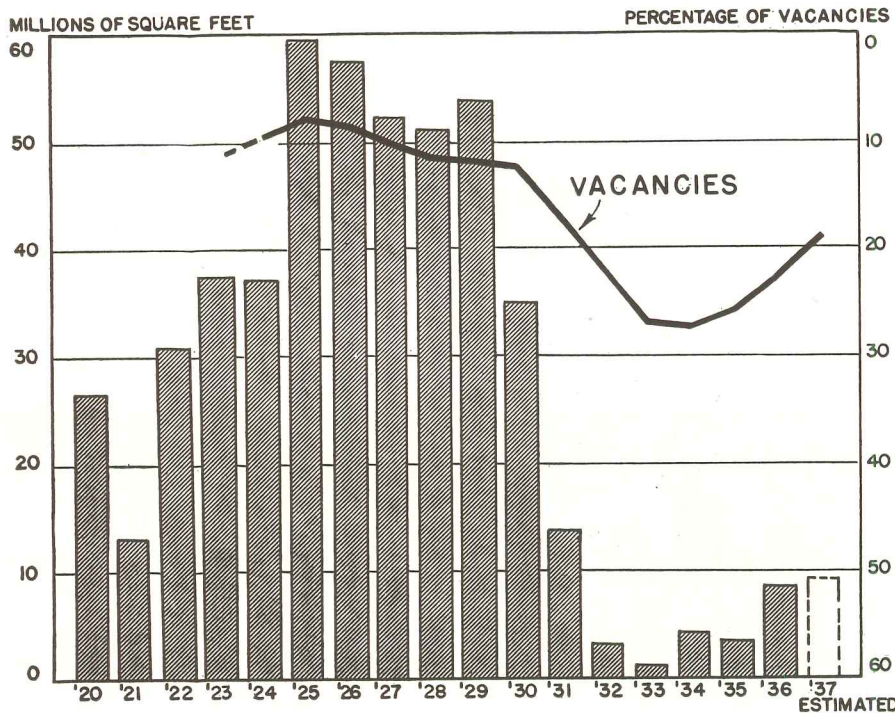



buildings will continue to be important in volume of expenditure and creation of floor space.

More and more attention is being given today to the planning of office space for industrial plants. This is especially evident in smaller structures where a portion of the building, usually the front, is separated from the fabricating area and provides office space for the executives, the planning group, clerical workers, and often the reception of buyers, visitors, and salesmen as well. In this field, current example suggests that special effort is being made to establish a facade character which is more readily identified with the office element than the industrial, and one which in many cases is in itself a medium of advertising value. Larger industrial developments include separate buildings for offices; these are comparable to commercial properties in their space and mechanical provisions, although they are usually restricted vertically to one or two stories. In every case, orientation and integration in respect to the most advantageous control and management of the plant areas and subdivisions is of paramount importance. The management function is, of course, an integral part of the factory flow line and must be considered simultaneously with the development of the production analysis. (For further discussion see "Flow Analysis", RECORD, August, 1937; page 107.)

The privately owned urban office building, offering floor space for special or general occupancy promises to be the most important type in this field, as it has been in the past, both from the standpoint of volume, investment, and potential future use. Certain factors have, however, served to restrain the number as well as the size of operations. Foremost is the understandable determination of realtors, investors, and building managers to protect existing investments as far as possible. This protection naturally takes the form of discouraging the erection of newer buildings. There are in every large city buildings, financed on the basis of 90 percent occupancy within five years from the date of their completion. Many of these structures were completed in 1929 or 1930 and few have, as yet, achieved the anticipated tenancy, despite considerable adjustment in expected rentals. Further, financing the office building of '29-'30 involved a complex pyramid of first and second mortgages, frequently debentures and stock issues. The equity

of the latter disappeared often before the depression was well under way.

### Present Trends

Although the erection of office buildings affording upwards of a quarter of a million square feet of floor space has been arrested, another smaller type goes steadily ahead. This newer structure is generally a fire-proof building of fewer than fifteen stories offering approximately fifteen thousand (or fewer) square feet per floor. This type, designed for a tenancy of professional or business groups, incorporates the highest standards of performance and the most comprehensive of operational systems. In view of the foregoing, this study is focused on buildings of this type; the material, however, is readily adaptable to other office building classifications where elements are similar.

At present, structures designed for special and owner occupancy are more in evidence than those intended for general rental. In some locations, especially the west coast, small one- or two-story office buildings are being developed for dentists, doctors, and other professional groups. Frequently these buildings are located in areas where mid-city traffic is not a problem. Larger elevator-equipped office buildings for insurance companies, utility companies, and other associations are also represented in the special purpose classification. In all office building planning of this character, there are implications of advantage accruing from the precision with which space and equipment factors are determined.

The special significance of precision in planning office layouts need not be restricted to buildings erected for single tenancy, nor for those occupied by groups of tenants engaged in the same enterprise or profession. Recently several moderately large office buildings have been designed expressly for predetermined occupants with widely dissimilar needs. Floors or zones were arranged to permit the most efficient use of space and at the same time to facilitate the flow of work for each particular occupant. Structural members, mechanical equipment, and interior finishes were selected and located to conform with the layout. Mechanization and straight-line production are factors as well established in office routine as in a factory; yet full acknowledgement of this is seldom reflected in the planning of the structure. Admittedly, such planning is difficult, if not

impossible, where the occupancy is an unknown factor; but it appears reasonable to expect that greater control of this situation will develop through the projection of office buildings for previously arranged tenancy. Detailed discussion of several special tenant requirements are presented in this study as an indication of variable needs in planning.

### Maintenance

Economy is a most important consideration in the maintenance of an office building; therefore, an acquaintance with operating costs as well as rates of obsolescence for the materials and equipment specified is clearly indicated. An examination and comparison of tables and data should influence the designer's effort toward a better selection, or toward elimination of those elements which incur high cost in upkeep. This information is available in the latest Experience Report of The National Association of Building Owners and Managers as well as the depreciation statistics in The Preliminary Report of The Bureau of Internal Revenue, U. S. Treasury Department, 1931. Since, in operating costs there are but few places where savings can be reasonably expected or hoped for, cleaning, maintainance, and repair should be even more thoroughly explored in an effort to continue the lowering of these costs, which are a considerable portion of the total. Much has already been done in this direction, more remains to be done. Little change can be effected in the cost of upkeep of mechanical equipment, according to recorded comparisons; further, it seems improbable that any change can be expected in regard to the even more rigidly fixed charges of taxation, interest, insurance, etc.

Modernization work accounted for a total expenditure of more than \$18,500,000 in 1936 and should, from present indications, account for a larger total in 1937. Although no survey is available for a breakdown of this work into the various items, it seems probable that elevators and public areas such as lobbies and corridors are foremost as subjects of modernization. Added to these are a number of alterations which resulted in a more economical division of floor area.

Since a completely detailed analysis of all the component elements relating to office buildings is impossible within the limitations of this study, a supplementary reference list has been included.



# 1 A 16-STORY GENERAL PURPOSE OFFICE BUILDING



**GEORGE WATTS CARR**

**ARCHITECT, A.I.A.**

**SHREVE, LAMB & HARMON, CONSULTANTS  
SYSKA & HENNESSY, MECHANICAL ENGINEERS  
W. W. CHAPIN, STRUCTURAL ENGINEER**

ONE ELEVEN CORCORAN STREET  
DURHAM, NORTH CAROLINA

ONE OF THE LARGEST of recently completed office buildings, this structure is notable in being designed for rental by tenants with diverse needs. The first floor has been planned so that the frontage on the principal shopping street could be leased to a department store, which occupies a large portion of basement, first and second floors. The building, completed at a cost of \$750,000, contains 216 offices in addition to bank and store areas. It was 85 percent rented two months after completion.

*Photos by F. S. Lincoln*

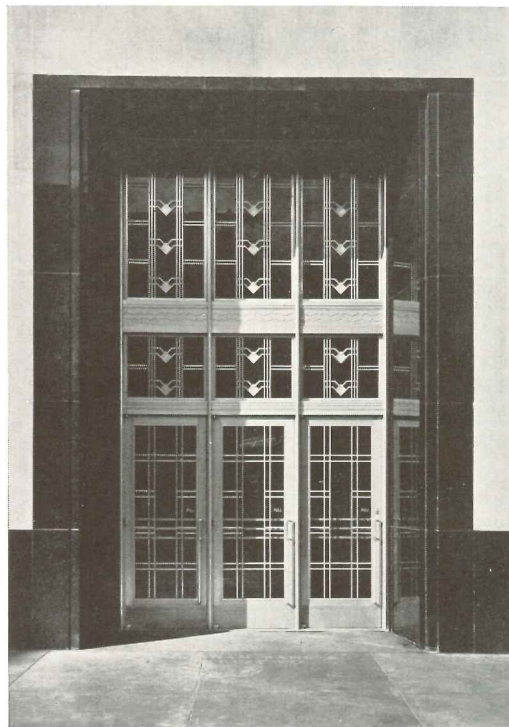

**ENTRANCE**



**LOBBY**



# RENTABLE AREA, 90,250 SQ. FT.

**1**

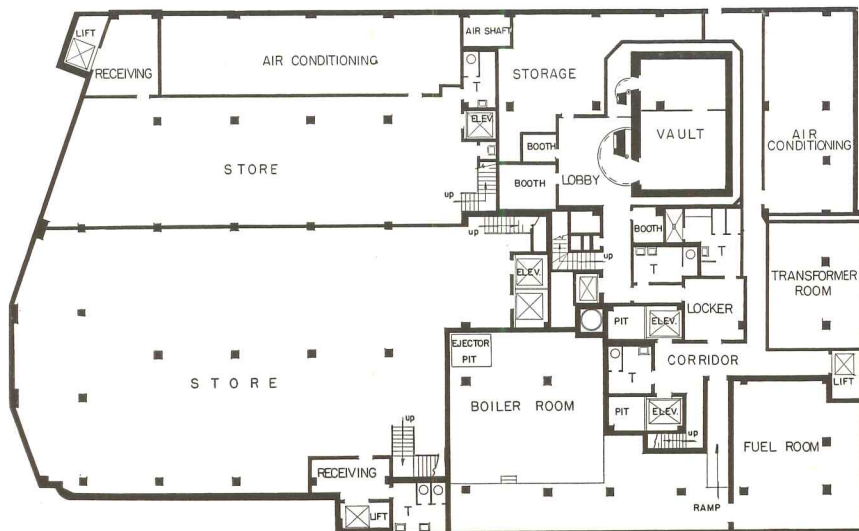

**BASEMENT FLOOR PLAN**

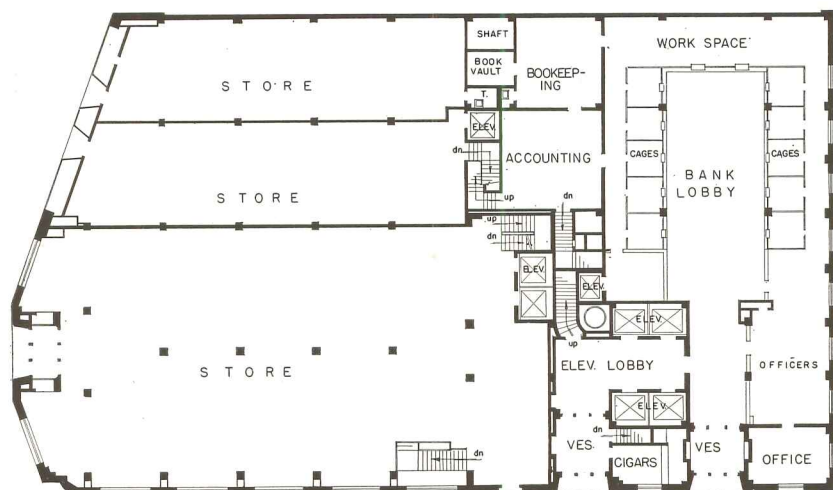

**FIRST FLOOR PLAN**

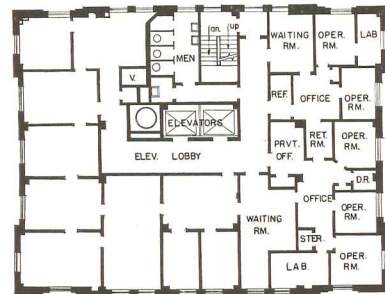

**TENTH FLOOR PLAN**

**SHOWING SPACE arrangement for dentists' and doctors' offices.**

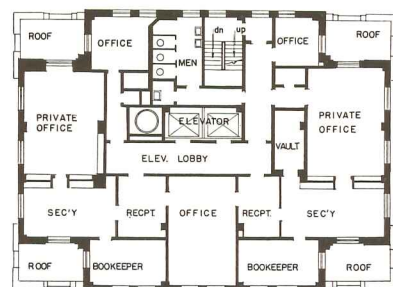

**THIRTEENTH FLOOR PLAN**

**THE UPPER STORIES provide special facilities required by prearrangement with prospective tenants. Requirements for dental, medical, and law offices are provided for in the tower section. Larger open areas for general office development, as required by insurance companies, etc., are on the fifth and sixth floors.**

## SCHEDULE OF EQUIPMENT AND MATERIALS

<b>FOUNDATIONS</b>	Reinforced concrete
<b>STRUCTURE</b>	Structural steel; reinforced joists and slabs
<b>EXTERIOR</b>	
Walls	Indiana limestone, backed up with brick; black granite base
Roof	Built-up gravel surface, The Barrett Company; promenade tile on setbacks
Sash	Double-hung steel sash, S. H. Pomeroy Co., Inc.; fixed aluminum, The General Bronze Co.
Metalwork	Aluminum spandrels, The General Bronze Co.
Doors	Aluminum doors and frames, The General Bronze Co.
<b>INTERIOR</b>	
Floors	Terrazzo
Walls	Verde antique marble in lobby; figured teak in main banking room; walnut in public space around vault; Clay tile partitions
Ceilings	Acoustical treatment in banking area
<b>WATERPROOFING</b>	Ironite, interior basement walls and floors

<b>INSULATION</b>	2" cork under roof decks
<b>HARDWARE</b>	Bronze, Sargent & Co.
<b>PAINTING</b>	Benjamin Moore's
<b>GLASS</b>	Standard and plate glass, Pittsburgh Plate Glass Co.
<b>CONDITIONING</b>	Steam, Detroit stoker-fired Kewanee boilers; Sturtevant non-ferrous convactor-type concealed radiation; complete air conditioning in basement, first and second floors and some offices, with provision for future installation in remaining areas—Carrier Corp., B. F. Sturtevant Co., American Blower Corp.
<b>PLUMBING</b>	Copper pipe; Standard Sanitary Mfg. Co. fixtures
<b>LIGHTING</b>	Indirect, Westinghouse; tower equipped with floodlighting
<b>ELEVATORS</b>	500-fpm, automatic, self-leveling, Westinghouse Electric Elevator Co.
<b>VAULT EQUIPMENT</b>	York Safe and Lock Co.



**1** A 16-STORY GENERAL PURPOSE OFFICE BUILDING

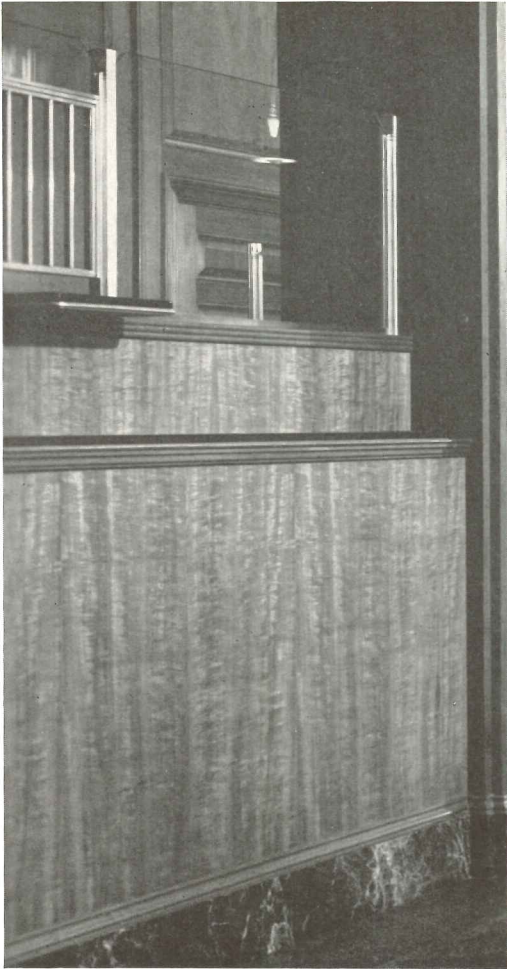

*Photos by F. S. Lincoln*

**BANKING AREA**



**INSURANCE COMPANY'S  
GENERAL OFFICE**





**ALONZO H. GENTRY,  
VOSKAMP & NEVILLE, INC.  
ARCHITECTS**

WOLCOTT BUILDING  
HUTCHINSON, KANSAS

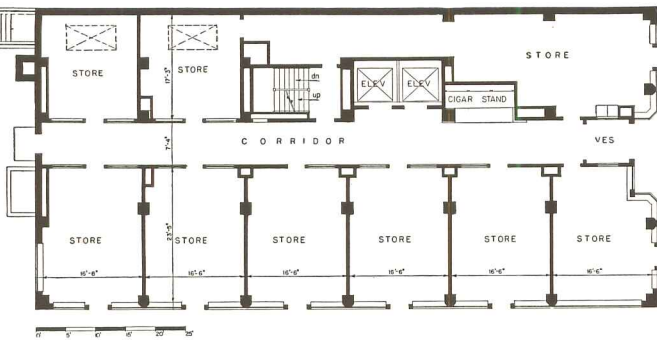

**FIRST FLOOR PLAN**

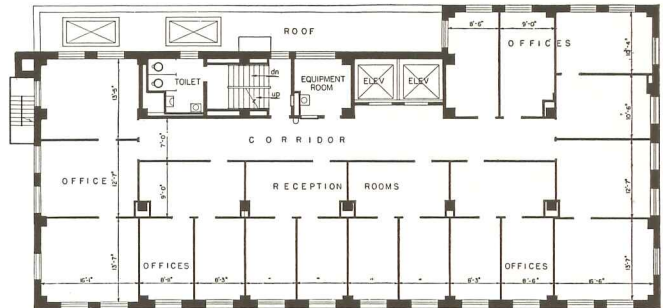

**TYPICAL FLOOR PLAN**

**SCHEDULE OF EQUIPMENT AND MATERIALS**

<b>FOUNDATIONS</b>	Reinforced concrete
<b>STRUCTURE</b>	Reinforced concrete
<b>EXTERIOR</b>	
Walls	Brick; verde antique marble base; Indiana limestone trim
<b>INTERIOR</b>	
Floors	Terrazzo in corridors, stairways, halls, and toilet rooms
Walls	Sand-finished plaster; Tennessee marble in lobby
<b>GLASS</b>	Pittsburgh Plate Glass Co.

<b>PARTITIONS</b>	Pyrobar
<b>HEATING</b>	Steam, Kewanee Boiler Corp.
<b>AIR CONDITIONING</b>	All-year air conditioning, Carrier System; Powers thermostatic control of heating and cooling in private offices
<b>ELEVATORS</b>	Micro-leveling, high speed, Otis Elevator Co.
<b>LIGHTING</b>	Semi-direct in all offices
<b>HARDWARE</b>	Sargent
<b>PLUMBING</b>	Sloan valves in all toilets Temprite drinking fountains on all floors



# 3 A 12-STORY GENERAL PURPOSE OFFICE

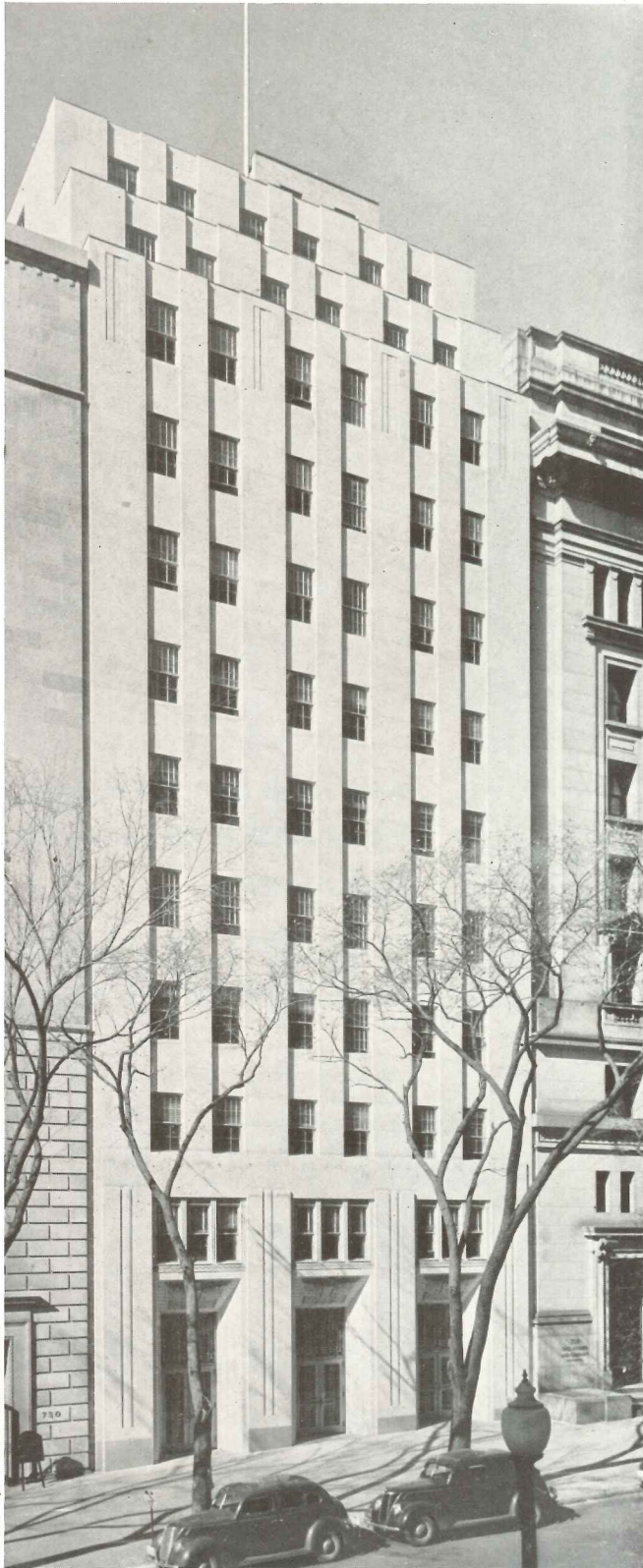

Photos by W. F. Roberts Co.

**PORTER AND LOCKIE,  
ARCHITECTS, A.I.A.**

**WALKER BUILDING  
WASHINGTON, D. C.**

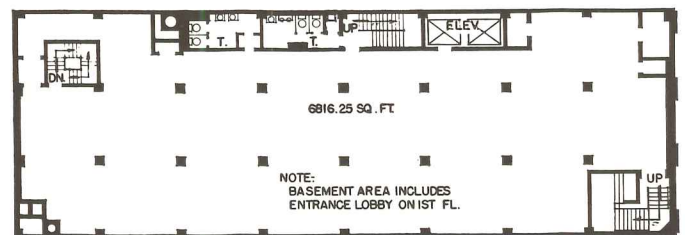

**BASEMENT FLOOR PLAN**

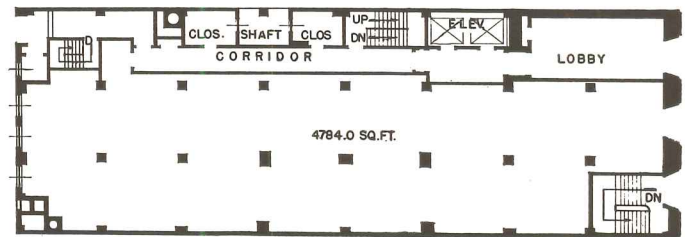

**FIRST FLOOR PLAN**

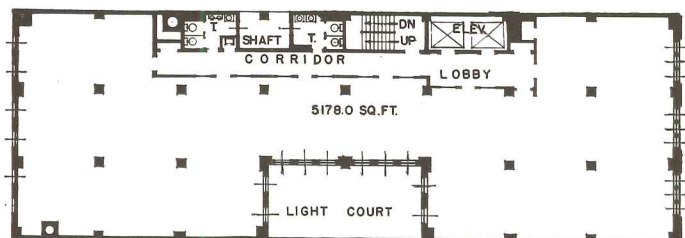

**THIRD FLOOR PLAN**

**OCCUPYING** a narrow interior lot, this structure rises to the maximum height permitted by Washington's building code. Above the third story, the floors are similar except for the 5-foot setbacks, which occur front and rear on the eleventh and twelfth floors. The entire building is leased to a single tenant for general office purposes.





**SCHEDULE OF EQUIPMENT AND MATERIALS**

<b>FOUNDATIONS</b>	Concrete
<b>STRUCTURE</b>	Structural steel, combination tile and concrete floor slabs, Carnegie-Illinois and Bethlehem Steel Corps.
<b>EXTERIOR</b>	
Walls	Indiana limestone front; sides and rear of light brick, Hanley Co.
Roof	Built up with slag surface
Sash	Double-hung aluminum sash and frames in front; steel elsewhere, Crittall Manufacturing Co.
Metalwork	Copper
<b>INTERIOR</b>	
Floors	Combination tile and concrete First floor lobby: black terrazzo divided in squares with brass strips; upper floors, asphalt tile with rubber base, by Johns-Manville Corp.
<b>WATERPROOFING</b>	Sub-basement, basement, trenches, and pits entirely waterproofed, Ironite Walls above grade are waterproofed with Ply-Rite

**INSULATION**

Suspended ceiling of top floor entirely insulated with 4" rock wool, Johns-Manville Corp.

**HEATING**

Warren Webster vapor orifice system; Kewanee Co. boilers; Link Belt Co. stokers

**PLUMBING**

Plumbing fixtures, Standard Sanitary Co. fixtures; water-cooling system, Westinghouse

**LIGHTING FIXTURES**

Indirect lighting fixtures trimmed with aluminum, Lightolier Co.

**HARDWARE**

Aluminum finish, Corbin Co.

**GLASS**

Plate glass in doors and windows, Libbey-Owens-Ford Glass Co.

**ELEVATORS**

Otis Elevator Co.

**ELEVATOR DOORS**

White-bronze etched on main floor, dull-blue aluminum binders on other floors—Dahlstrom Metallic Co.

**AIR CONDITIONING**

Individual Units: Carrier Co. and York Co.

**OFFICE PARTITIONS**

Movable partitions throughout building, E. F. Hauserman Co.

**VENETIAN BLINDS**

Columbia Mills, Inc.



Photos courtesy of York Ice Machinery Corp.

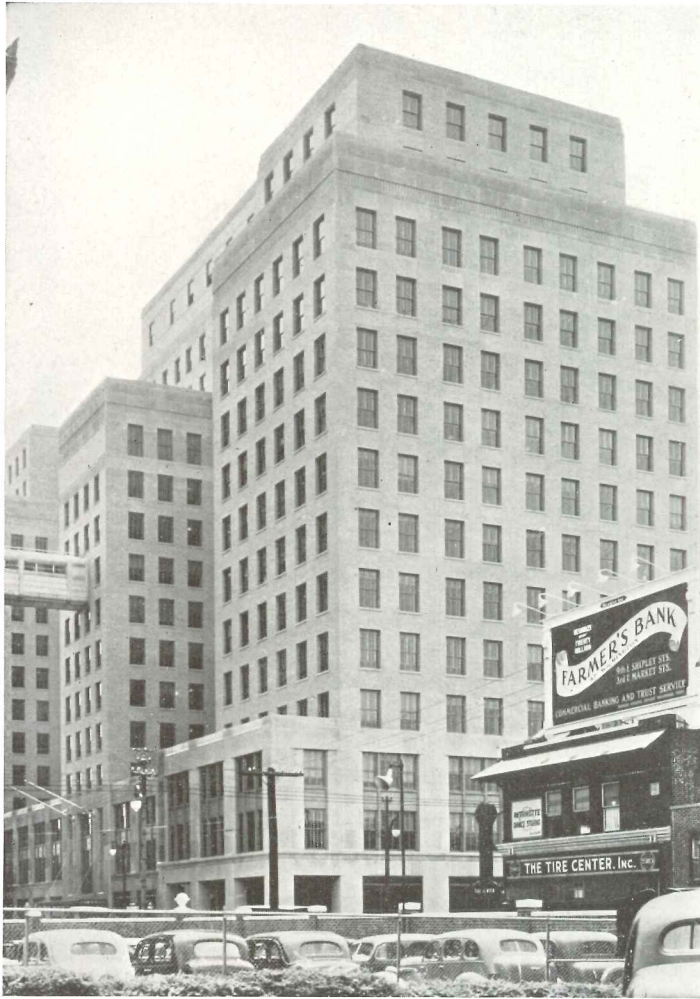

NEMOURS BUILDING  
WILMINGTON, DELAWARE

THIS BUILDING with 433 rooms above the ground floor provides a total of 176,180 sq. ft. of floor space. Fifty percent of the ground floor area is rented by outside tenants with the remainder of the building reserved for company occupancy.

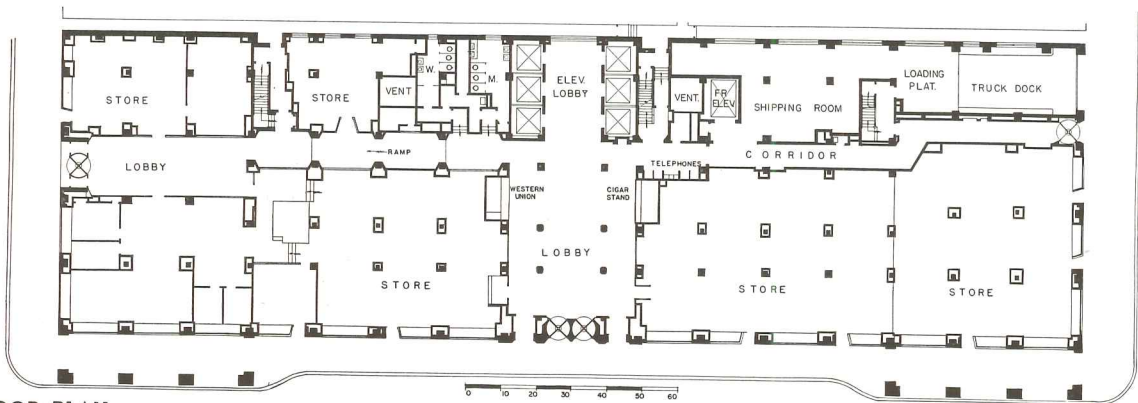

FIRST FLOOR PLAN

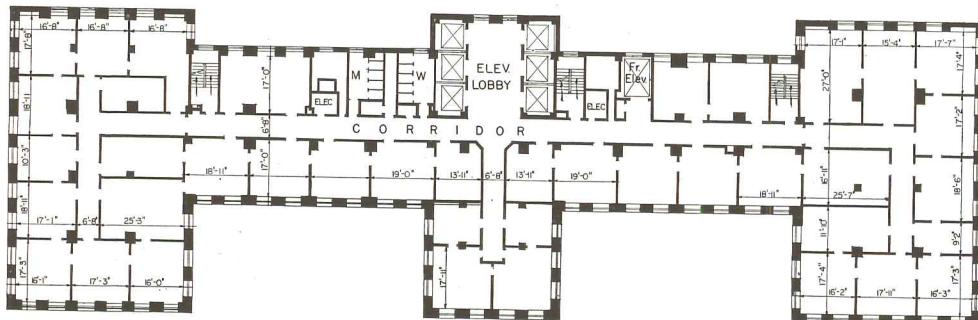

TYPICAL FLOOR PLAN





INTERIOR OF GROUND FLOOR BROKERAGE OFFICE



MEETING ROOM

**INNOVATIONS** include the use of photoelectric cells in the passenger elevators. Safety beams control the doors; they are projected horizontally across the door opening, one 9 inches and one 3 feet from the floor; the doors will not close if the beams are interrupted by the body of a passenger.

Connection with the existing building is made by a basement tunnel and a bridge which crosses the street at the ninth floor level. Doors to the bridge are also controlled by photoelectric cells at both ends, which keep traffic to the right.

Recently developed elevator signal apparatus indicates, by light and gong, the location of the next car traveling in the direction desired by the person signaling. Time and temper are saved by this forewarning of the location of the next available car.

Air conditioning is subject to tenant control by the throttling of air supply and by regulating the radiators. Windows, however, are locked to prevent interference by their being opened; janitors and window cleaners are furnished with keys. In the bottom section of each office door is a grille to permit air to escape into the corridor, from which it is then exhausted mechanically. The system is divided into five zones: one each for the three lower floors; the other two are north and south vertical zones, serving the third to thirteenth floors. The fourteenth and fifteenth floors house the air conditioning equipment and elevator machine rooms.

**SCHEDULE OF EQUIPMENT AND MATERIALS**

<b>FOUNDATIONS</b>	Reinforced concrete
<b>STRUCTURE</b>	Structural steel, electrically welded Reinforced concrete slabs
<b>EXTERIOR</b>	
Walls	Belgium brick and Indiana limestone
Roof	Quarry tile on built-up roofing, Certain-teed Products Corp.
Sash	Steel casement and double-hung
<b>INTERIOR</b>	
Floors	Tennessee marble in lobby and main corridors; linoleum or carpets in offices, 3/16" Armstrong

<b>Walls</b>	Vermont marble in lobby and main corridor wainscoting; Corning glass brick in panels
<b>HEATING</b>	Complete air conditioning; York Ice Machine refrigeration; American Radiator Co. "Arco" air mixers; Voight oil-burning boilers
<b>LIGHTING</b>	Direct illumination in offices, average 3 watts per sq. ft.
<b>ELEVATORS</b>	Automatic push-button control, Westinghouse
<b>SOUND-PROOFING</b>	Johns-Manville Sanicoustic and U. S. Gypsum Acoustone



# 5 AN ADDITION OF RENTABLE AREA



Photos by Rocky Mountain Photo Co.

**WILLIAM E. FISHER AND ARTHUR A. FISHER, ARCHITECTS**

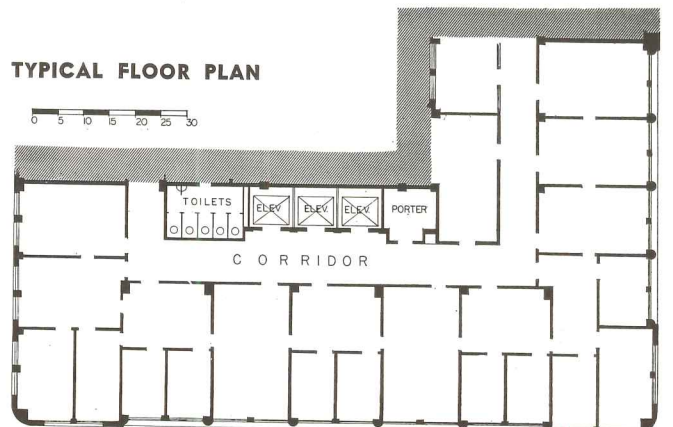
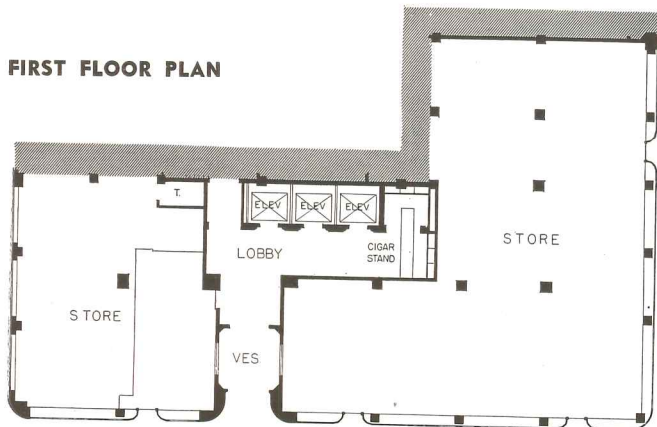





ELEVATOR LOBBY

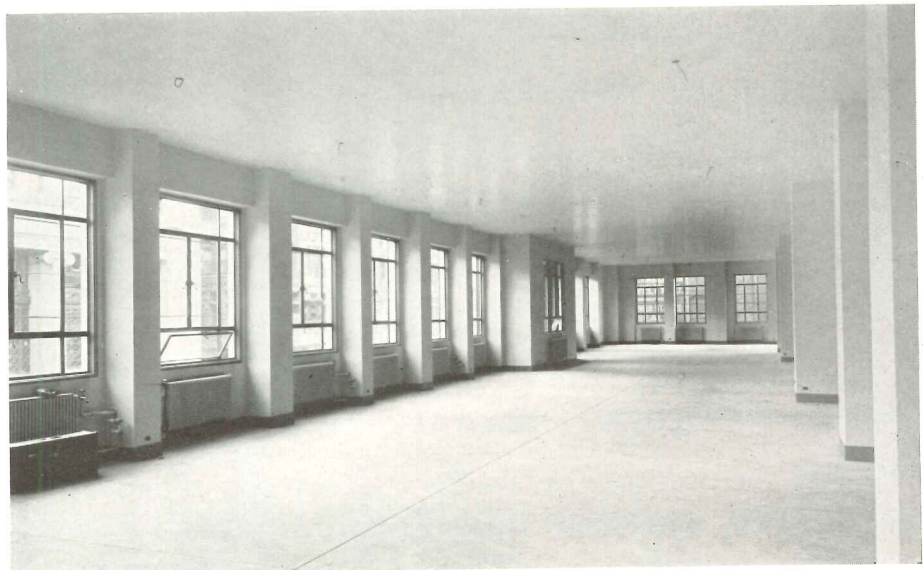

TYPICAL FLOOR

RAILWAY EXCHANGE BUILDING, DENVER, COLORADO

**SCHEDULE OF EQUIPMENT AND MATERIALS**

<b>FOUNDATIONS</b>	Concrete; spread footings for columns and walls
<b>STRUCTURE</b>	Reinforced concrete skeleton frame, "Smooth Ceilings" System flat slab, with clay tile fillers
<b>EXTERIOR</b>	Indiana limestone backed with brick; black granite base and entrance
Walls	Flat slab roof "Smooth Ceilings" built up with asphalt and felt
Roof	Steel, Fenestra Tiltin
Sash	
<b>METALWORK</b>	Extruded aluminum store fronts and entrance doors
<b>INTERIOR</b>	Master Builders' red mix cement finish; terrazzo in corridors and toilets
Floors	

**Ceilings**

Plaster applied directly to the slab without special bond coat; suspended metal lath and plaster ceiling for top story

**GLASS**

Muralex and Polished, Blue Ridge Glass Corp.; Libby-Owens-Ford Glass Co.

**INSULATION**

Cork on roof

**HEATING**

Steam

**ELEVATORS**

Signal-controlled geared type, Otis Elevator Co.

**LIGHTING**

Corning Glass Works; Holophane fixtures

**HARDWARE**

Corbin

**PAINTING**

Interior: light buff

Cost: Approximately 38c per cu. ft.





**RICHARD J. NEUTRA, ARCHITECT**  
**PETER PFISTERER, COLLABORATOR**

SCHOLTS ADVERTISING BUILDING  
 LOS ANGELES, CALIFORNIA

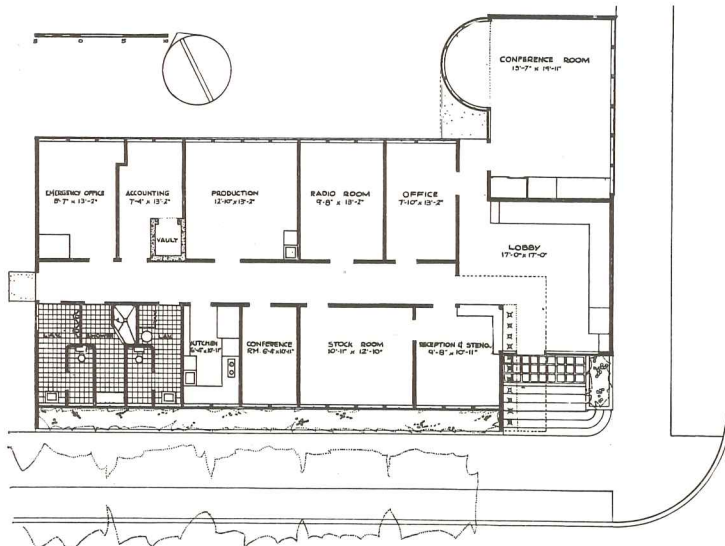

**FLOOR PLAN**

**SCHEDULE OF EQUIPMENT AND MATERIALS**

<b>FOUNDATION</b>	Reinforced concrete, Portland Cement Co.; Anti-Hydro waterproofed cement slab placed over gravel bed	<b>INSULATION</b>	"Celotex Lath" at ceilings, Celotex Corp.
<b>STRUCTURE</b>	4" x 4" milled posts 4"-diameter steel pipe columns, Jones & Laughlin Steel Corp.	<b>WATER-PROOFING</b>	Anti-Hydro on cement slabs, Anti-Hydro Waterproofing Co. Exterior wall surfaces painted with oyster-shell waterproof brush coat, U. S. Gypsum Co.
<b>EXTERIOR</b>		<b>HEATING</b>	Ventilated gas wall heaters
Walls	Cement plaster	<b>PLUMBING</b>	Fixtures, Kohler Plumbing Fixture Co. Wrought-iron hot water pipes, Byers Co.
Roof	4 Layers of composition roof, Pioneer Flintkote Co., with asphalt-embedded gravel surface	<b>LIGHTING FIXTURES</b>	Recessed ceiling lights with metal trim, especially built; hemispherical globes with chromium trim, custom-built
Sash	Steel casement	<b>WIRING</b>	General Electric Co.
<b>INTERIOR</b>		<b>PAINTING</b>	Woodwork, National Lead Co. products; stains, Pratt & Lambert; aluminum paint, Aluminum Co. of America
Floors	Wood joists; reinforced concrete slabs, Portland Cement Co.; 6 x 6 No. 10 reinforcing mesh, Johns-Manville Co. Lobby and conference room finished with wood, covered with linoleum by Armstrong Cork Products Co. Elsewhere, cement finished with integral color topping	<b>HARDWARE</b>	Plymouth design, chromium-plated, Schlage Lock Co.
Walls	Aluminum coated "Presdwood" panels, Masonite Corp. and Aluminum Co. of America	<b>GLASS</b>	Double-standard, "A", Libbey - Owens - Ford Glass Co.; 1/4" plate glass, Pittsburgh Plate Glass Co.; obscure ribbed glass, Mississippi Glass Co.

**FOLLOWING** the trend of business decentralization, the Scholts Advertising Company located its office building on the outskirts of the business district proper to allow ample parking facilities for its clients. The design endeavors to take advantage of existing tree groups; the effect of these is enhanced by additional landscaping and a lawn patio for the use of employees. The total cost, including furnishings and landscaping, is \$11,750.



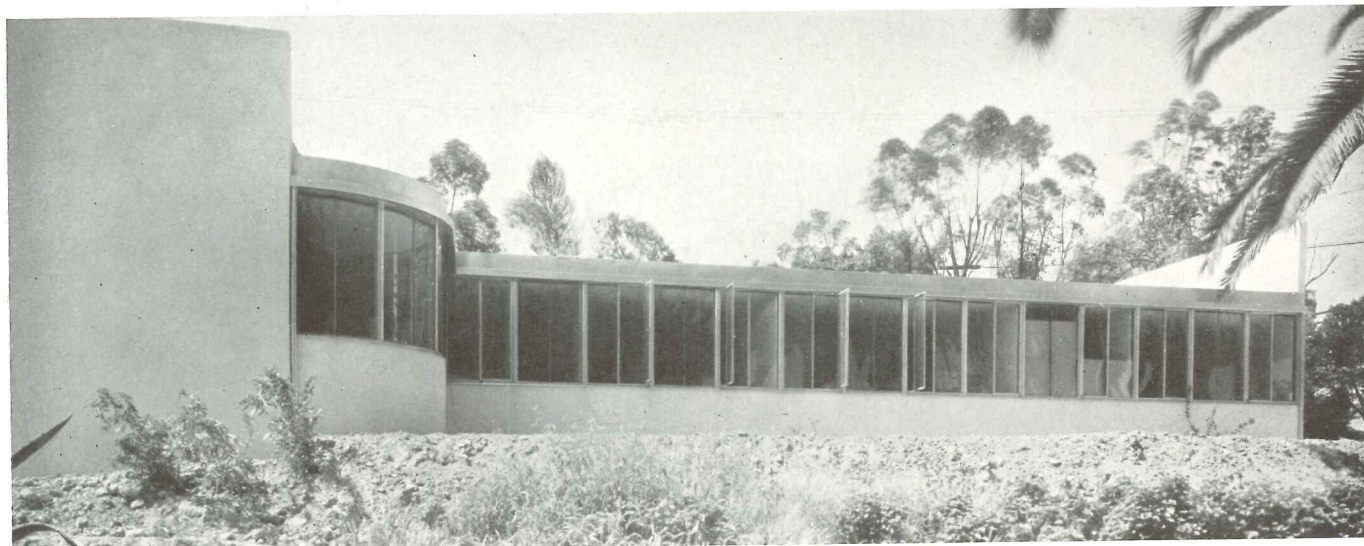

REAR ELEVATION



THE ENTRANCE LOBBY for clients is placed at the corner and raised several steps between concrete plant containers. An aluminum-faced lighting soffit over the information counter continues through the glass front entrance. Low built-in upholstered couches on two walls face the information bay. Flush wall paneling and furniture are of natural-finish light mahogany; the movable chairs, and an occasional table are chromed metal and plate glass. A large conference room facing the palm-shaded lawn patio with a semi-circular glass bay is finished on all its solid walls with mahogany flexwood and matched by conference table and furniture.

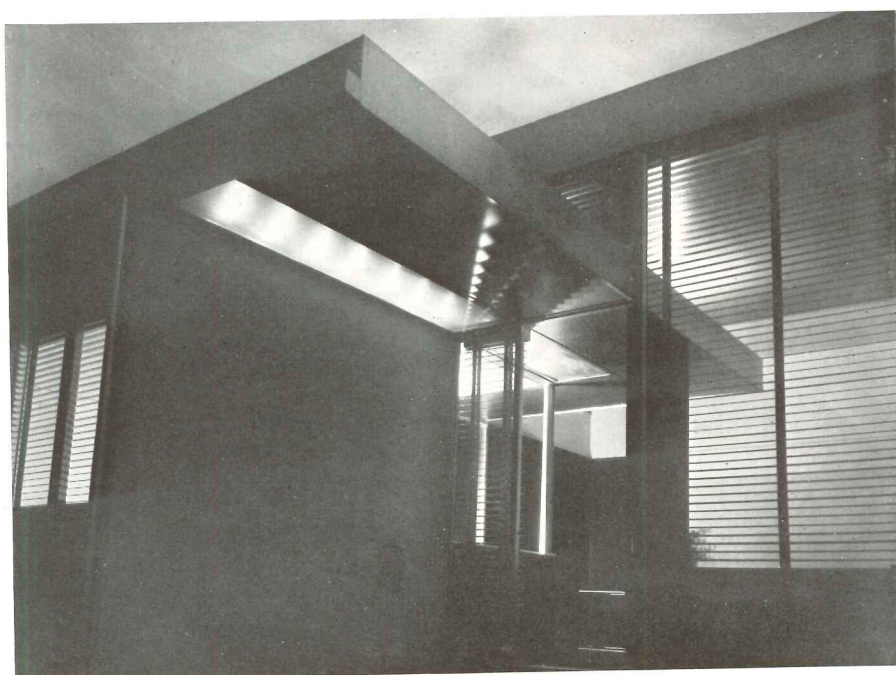

ENTRANCE, night view





**ARTHUR N. GIBB**  
ARCHITECT, F.A.I.A.

CO-OPERATIVE G. L. F. BUILDING  
ITHACA, NEW YORK

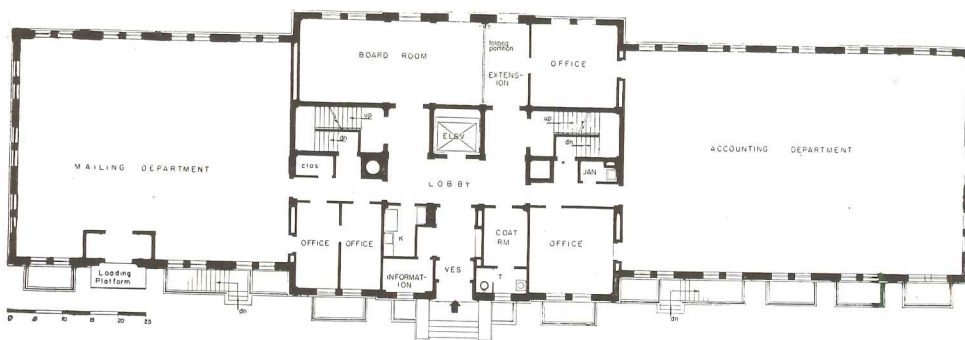

FIRST FLOOR PLAN

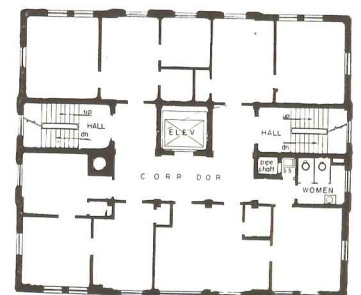

TYPICAL FLOOR PLAN

**ERECTED** at a cost of \$200,000, this structure houses a farmers' marketing organization, the Grange League Federation. The 3-acre site includes a parking lot adjacent to the building. The executive offices occupy the center section. The basement, partly above grade, contains rest rooms, classroom, service and storage areas.





**ACCOUNTING ROOM**



**MAILING ROOM**

## SCHEDULE OF EQUIPMENT AND MATERIALS

<b>FOUNDATIONS</b>	Concrete
<b>STRUCTURE</b>	Steel frame, McClintic-Marshall
<b>EXTERIOR</b>	
Walls	Solid brick, Ingalls Stone Co. Limestone backed by hollow tile
Roof	Five-ply built-up gravel surface, The Barrett Co.
Sash	Heavy steel casement, Truscon Steel Co.; bronze screens
<b>INTERIOR</b>	
Floors	Junior steel beams and reinforced concrete slab; finished with terrazzo and linoleum
Partitions	Steel, Art Metal Construction Co.
Doors	Soundproof, Robert Mitchell
<b>LIGHTING</b>	Direct and semi-direct, Edwin F. Guth Co.
<b>ELEVATORS</b>	Automatic, Otis Elevator Co.; G. E. wiring

### ELECTRICAL INSTALLATION

Rigid conduit concealed throughout; Westinghouse circuit breakers; National Electric Products underfloor duct for future telephone and electrical connections

### HARDWARE INSULATION

Bronze, Sargent & Co.  
Acousti-Celotex ceiling plus 3" mineral wool insulation above plus 1" cork on the roof slab

### WATERPROOFING

Asphaltic on exterior walls; membrane under basement floors

### AIR CONDITIONING HEATING

All-year complete air conditioning in wings only, Carrier Engineering Corp.

Steam, concealed direct radiation in tower section

### GLASS

Standard, plate glass, and "Syenite", Mississippi Glass Co.



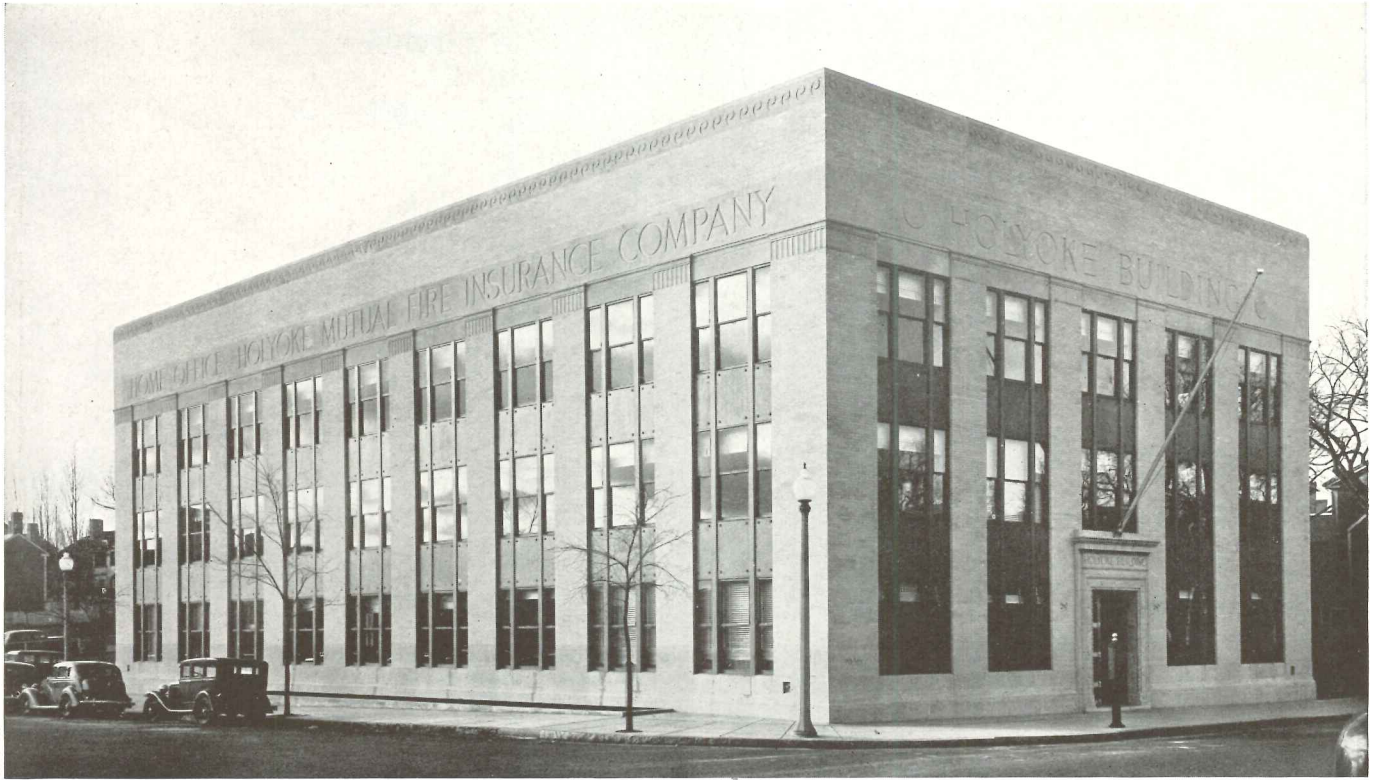

Boecker

**SMITH AND WALKER,  
ARCHITECTS**

**HOLYOKE MUTUAL FIRE INSURANCE  
COMPANY IN SALEM, MASSACHUSETTS**

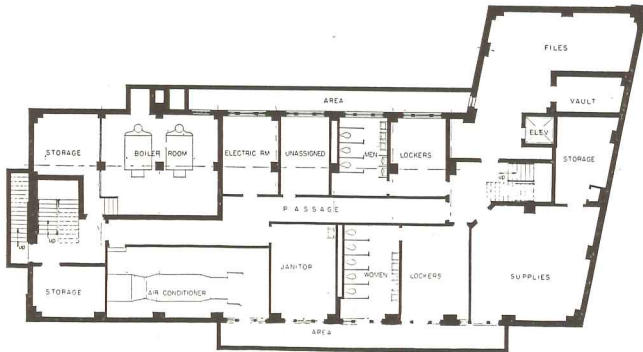

**BASEMENT PLAN**

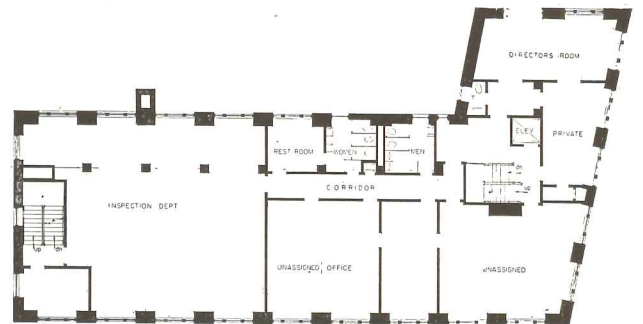

**SECOND FLOOR PLAN**

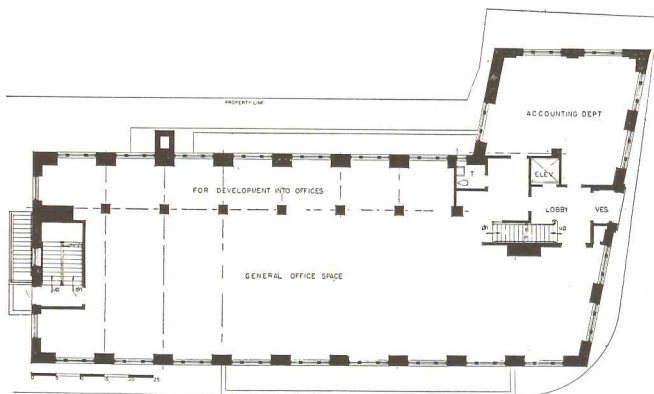

**FIRST FLOOR PLAN**

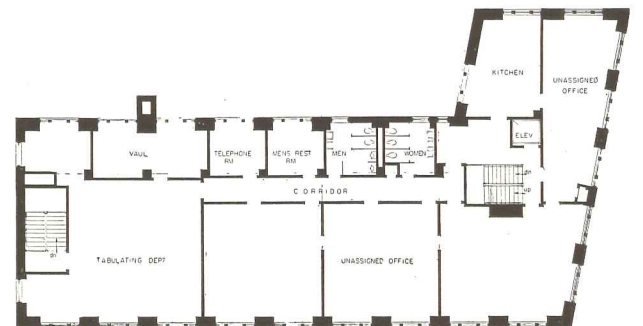

**THIRD FLOOR PLAN**





GENERAL OFFICE

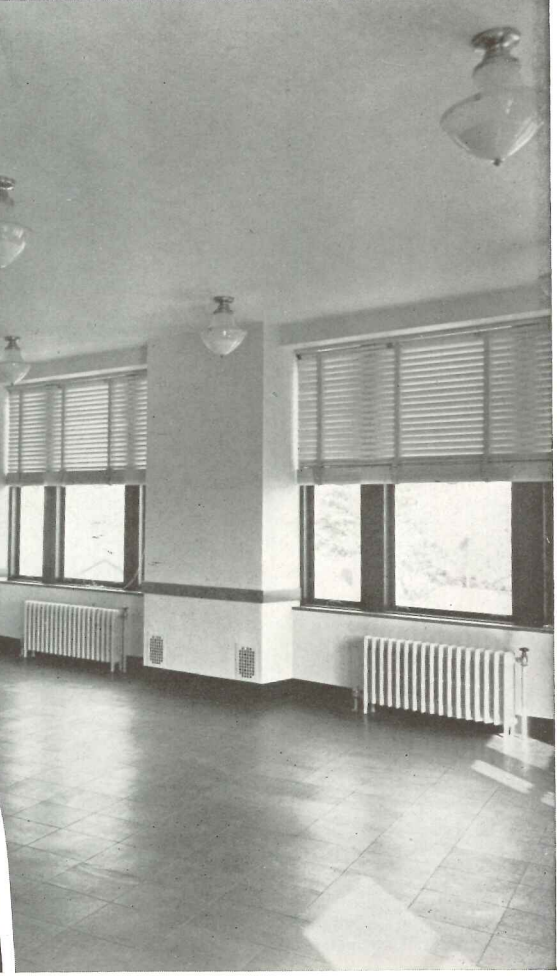

TYPICAL FLOOR AREA

**CONSTRUCTION NOTES:** In the longitudinal section, the framing of this structure is reasonably uniform; but in cross section, the floor space allotments made necessary one extremely wide bay and one comparatively narrow bay. This condition resulted in relatively light moments in the exterior columns and considerably higher moments in the interior ones. The requirements of air conditioning dictated wide but shallow ducts, where these crossed from the outside wall to run along deep long-span beams.

**SCHEDULE OF EQUIPMENT AND MATERIALS**

<b>FOUNDATIONS</b>	Reinforced concrete
<b>STRUCTURE</b>	Reinforced concrete, pan system slabs
<b>EXTERIOR</b>	
Walls	Light buff brick
Trim	Precast stone, Emerson-Norris Co.; slate spandrels, Vermont unfading green slate
Roof	Built-up asphaltic gravel surface
Sash	Double-hung steel sash, Campbell Metal Window Corp.
<b>INTERIOR</b>	
Floors	Cement finish, mastic tile, and terrazzo.

<b>GLASS</b>	Pittsburgh Plate Glass Co.
<b>WATERPROOFING</b>	Asphaltic on outside of basement walls and inside of all exterior walls; Ironite on entire basement floor and walls
<b>HEATING</b>	Steam; air conditioning without cooling, H. B. Smith and American Blower Co.
<b>PLUMBING</b>	Kohler Co. fixtures
<b>HARDWARE</b>	Corbin Co.
<b>LIGHTING</b>	Holophane, Crouse-Hinds, and Wheeler Fixtures
<b>PAINTING</b>	Interior: Dutch Boy lead and oil in buff and ivory tones





Photos by Elmer L. Astleford

LOBBY

**GIFFELS & VALLET, INC.**  
ARCHITECTS AND ENGINEERS

SQUARE D COMPANY  
DETROIT, MICHIGAN

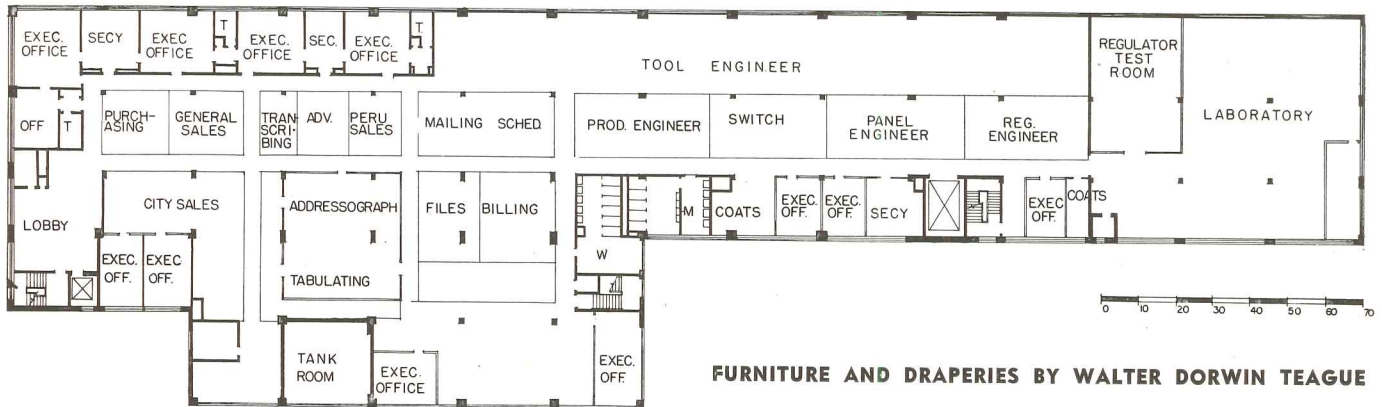

FURNITURE AND DRAPERIES BY WALTER DORWIN TEAGUE

**PLAN**

**OFFICE LOBBY** Dark-green linoleum; plastered walls with glass block (Owens-Illinois) and photo-murals; information desk of oak; elevator doors, frame, and all trim and hardware are of polished brass

**GENERAL OFFICE** Dark-green linoleum; plastered walls and glass block; acoustically treated ceiling; skylight trim of stainless steel

**PRESIDENT'S OFFICE** Carpeted floor; furniture, flush-panel doors, and built-in bookcases of walnut; acoustically treated ceiling

The offices are completely air conditioned (Worthington Pump Co.). Painting was done in a flat-finish buff and tan.





**GENERAL OFFICE**



**PRESIDENT'S OFFICE**



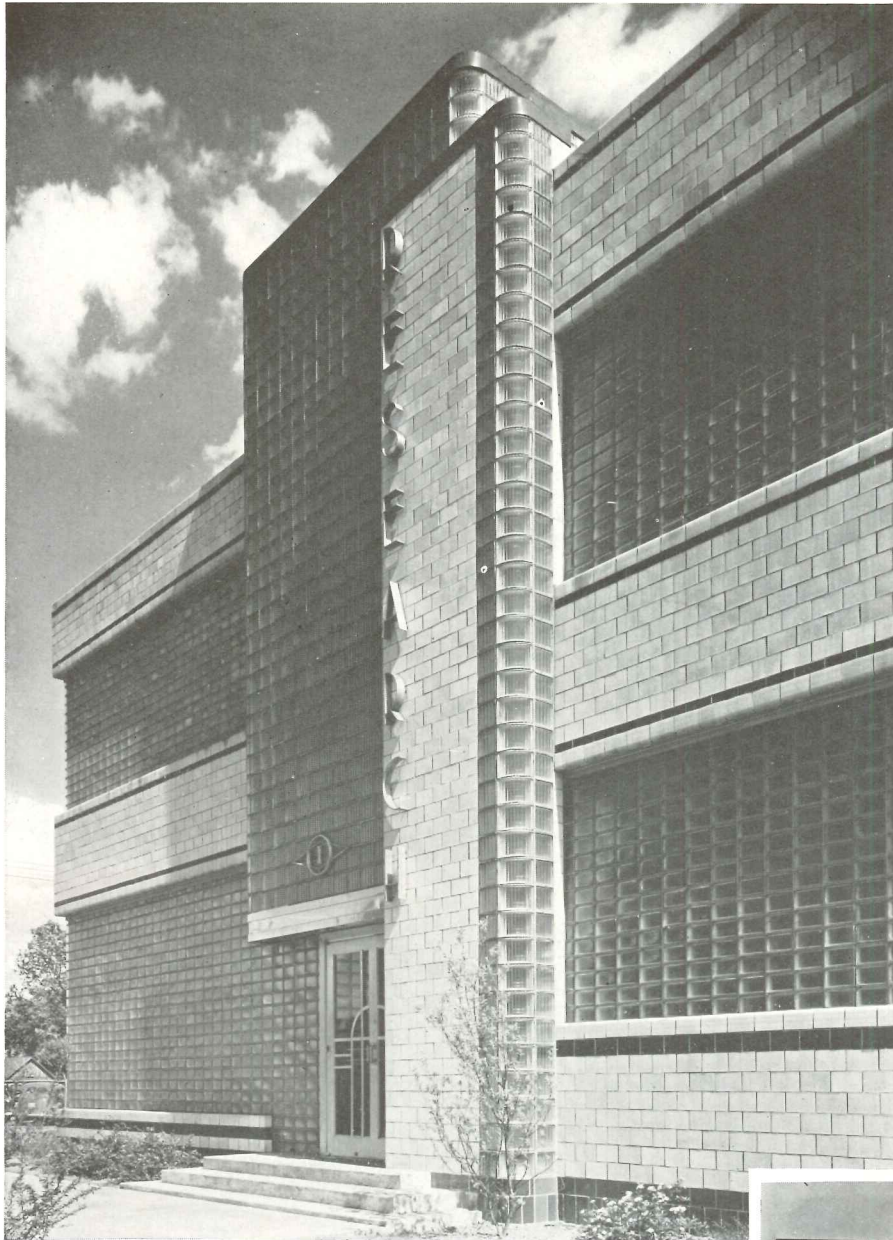

**BUILT** to house the technicians engaged in the development of glass products, this office building is essentially an air-tight, well insulated enclosure. Various patterns of glass block were determined by the orientation of the building: a higher percentage of light transmission was allowed on the east and north where solar radiation is low; but on the west and south, blocks were specified to reduce solar radiation. Interior corridors are well lighted by means of full-height glass partitions.

The air conditioning unit supplies the means of temperature control: a two-sectional chamber—one section designed to heat the air, the other to cool it. Rooms are zoned according to similar conditioning needs and each zone is supplied with a separate air supply duct. Automatically operated by room hygrometers, atomizing water sprays maintain desired humidity. Zone thermostats control warm and cold air dampers. The air is changed once every five minutes in summer and once every ten minutes in winter.

**FOSTER ENGINEERING CO.,  
ARCHITECTS AND ENGINEERS**

OWENS-ILLINOIS GLASS COMPANY  
NEWARK, OHIO

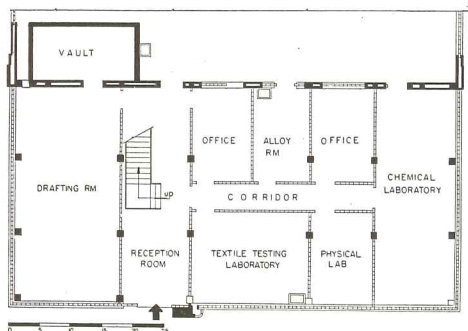
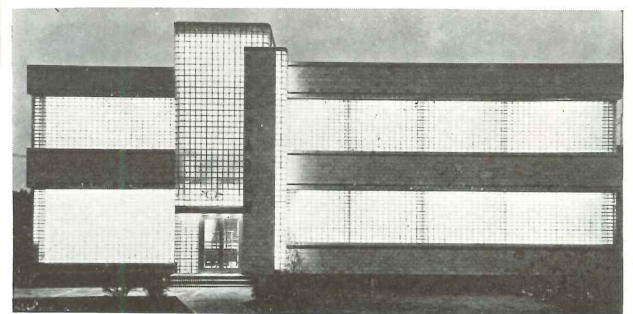

**FIRST FLOOR PLAN**

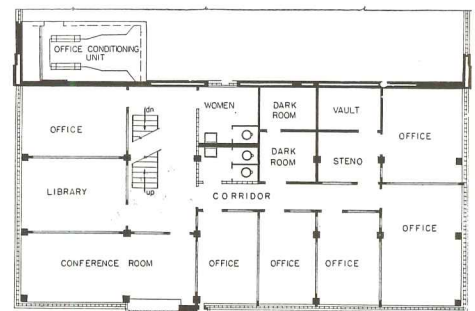

**SECOND FLOOR PLAN**



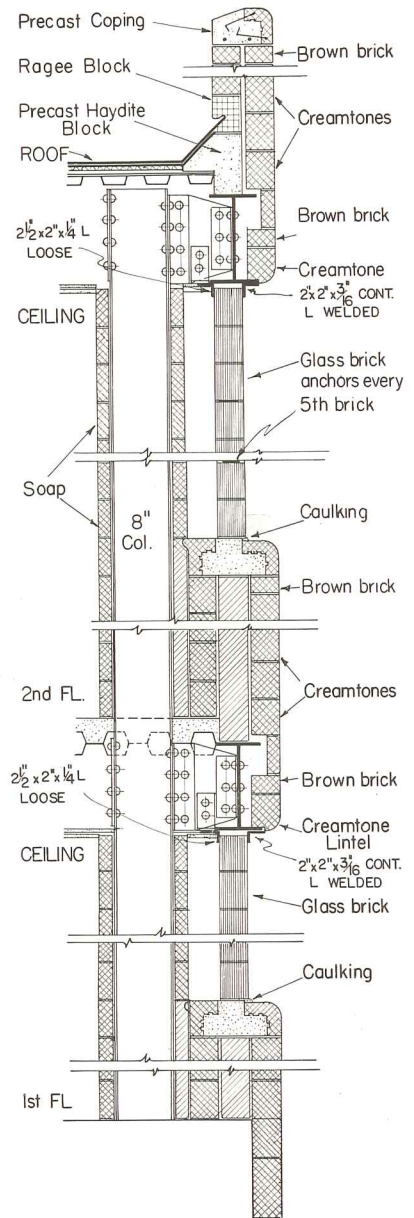
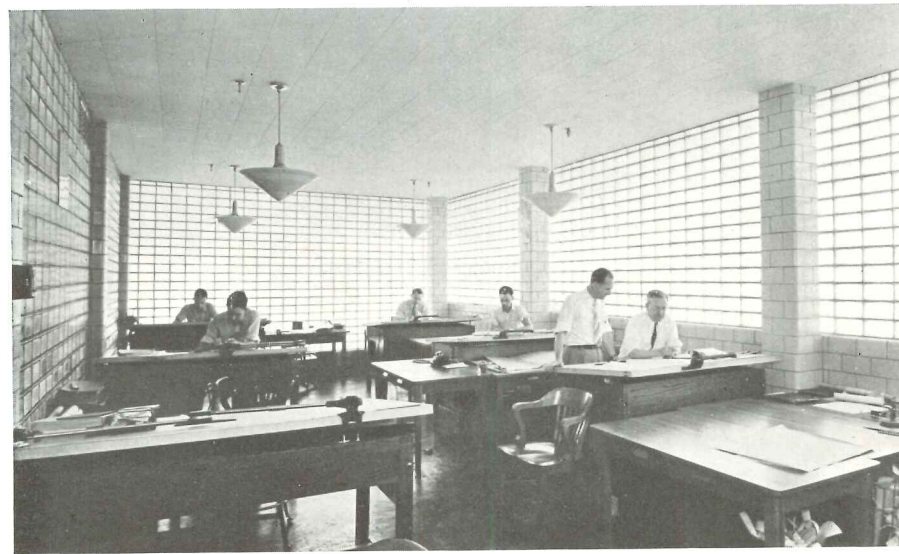
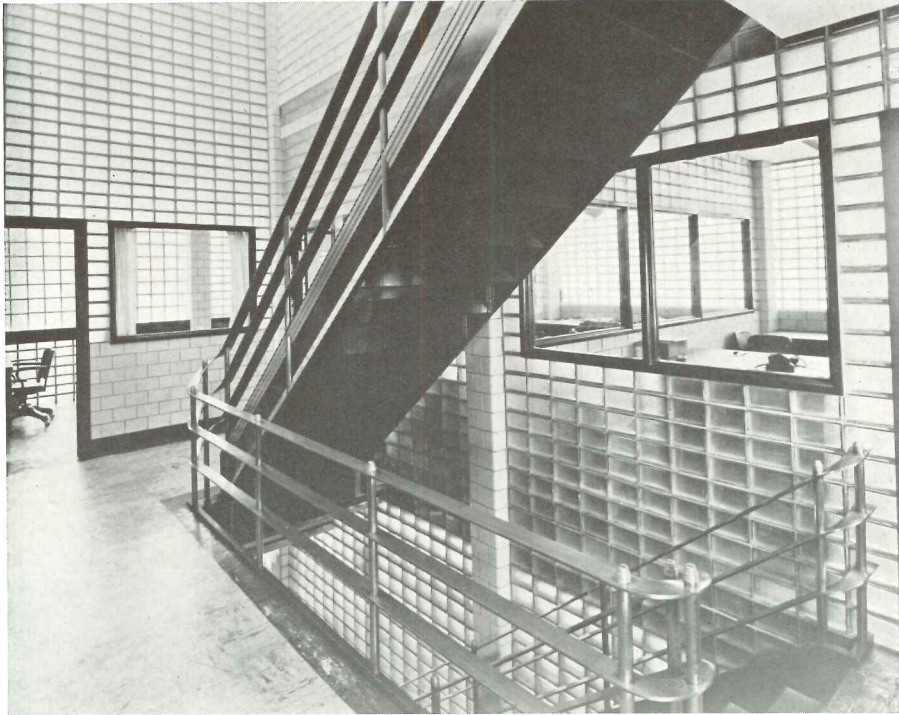

**DETAIL OF WALL SECTION**

**SCHEDULE OF EQUIPMENT AND MATERIALS**

<b>FOUNDATIONS</b>	Reinforced concrete floating mat and concrete block
<b>STRUCTURE</b>	Structural steel frame with Robertson cellular steel floor, concrete slab over
<b>EXTERIOR</b>	
<b>Walls</b>	Brictile, Stark Brick Co.; glass block, Owens-Illinois Co.
<b>Roof</b>	Twenty-year, tar and gravel surface, Barrett Co.
<b>Sash</b>	None
<b>Metalwork</b>	18-24 gauge galvanized iron
<b>INSULATION</b>	Red Top glass wool in all ceilings

**INTERIOR**  
**Floors**

Walls  
Ceilings  
Doors

**PLUMBING**  
**HEATING**

**LIGHTING**  
**COLOR**

Terrazzo in toilets, asphalt tile in vault and darkrooms, rubber tile elsewhere  
Glass block, brictile  
1/2" sheet rock, U. S. Gypsum Co.  
Dahlstrom hollow metal doors, rolled steel frames and bricks  
Crane Co. fixtures  
Complete air conditioning system, E. K. Campbell Heating Co.  
Semi-indirect fixtures, Westinghouse  
Exterior: brown and cream. Interior: ivory and brown





**DOUGLAS ANDREWS  
DESIGNER**

DAVIDSON ENAMEL PRODUCTS  
LIMA, OHIO

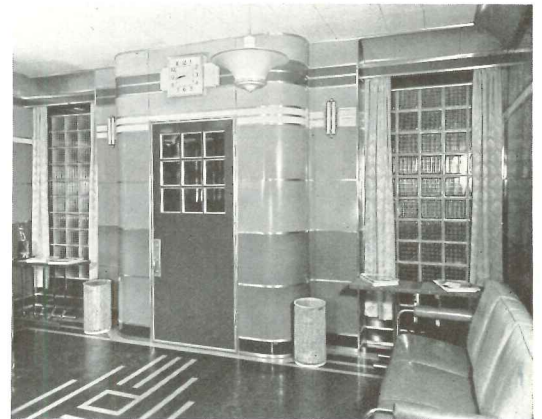

RECEPTION ROOM

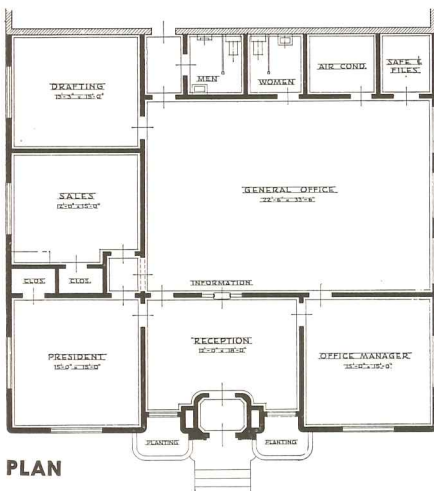

PLAN

**OCCUPIED** by the company's executives, this structure also serves as an exhibit of the company's product. A special effort was made to include a variety of shapes and finishes suitable for wall elements. Above and below the glass block, the sections are in a light buff, semi-mat ripple finish. Between these areas, they are light tan with bronze snap-on moldings. The coping is of tan and chocolate, the area above the doorway is ivory. Further demonstrating the color range available are the plaques in nine tones from ivory to chocolate. For experimental purposes, one side wall was built of masonry, with the porcelain enamel pans fixed to wood nailing strips.

**SCHEDULE OF EQUIPMENT AND MATERIALS**

<b>FOUNDATION</b>	Concrete
<b>STRUCTURE</b>	Masonry and frame
<b>EXTERIOR</b>	
<b>Walls</b>	Enameled 14- and 16-gauge pans and semi-pans; glassblock, Owens-Illinois Glass Co.
<b>Roof</b>	Built-up asphaltic gravel surface
<b>Sash</b>	None
<b>INSULATION</b>	Rock wool in walls and roof; rigid insulation board in walls

<b>INTERIOR</b>	Armstrong cork board in some offices; porcelain enamel sheets with insulation board backing and snap-on molding elsewhere
<b>Walls</b>	
<b>Floors</b>	Rubber tile in reception room; carpet in main offices; mastic tile elsewhere; all masonite-cushioned
<b>Ceilings</b>	All acoustical cork
<b>HEATING</b>	Complete air conditioning, Carrier Engineering Corp.
<b>PLUMBING</b>	Crane fixtures
<b>LIGHTING</b>	Indirect



# Apply Factory Technique to Office Planning

By WILLIAM S. MILLER, *The General Fireproofing Co.*

PLANNING a modern office requires not only a knowledge of equipment available, but also a conception of its adaptation to specific needs. Equipment must be selected for a definite job to be done, arranged in a manner most convenient and efficient for all concerned—and the building designed around it. A study of office layout must take into consideration all factors affecting the ultimate efficiency of the office as a whole. These include: type of work, filing systems, relationship of departments, and flow of work. Structural and comfort-securing factors like temperature control, lighting, are not treated here, although they are, of course, equally an element of the complete equation.

In considering the type of work to be done, thought may be given first to the executive office. While it was common practice a few years ago for the executive to have a massive desk with a multitude of pigeon holes and drawers, for the safekeeping of confidential data, the tendency today is toward streamlining, with nothing in the desks except current work, reports, and the like.

Today a commonly used arrangement is the combination of a flat-top desk and a table, matched in size and appearance, with a chair between. The chief advantage of this arrangement is that confidential papers may be kept on the flat-top desk in the rear, with the table cleared for current work. Matched desks and tables for this purpose are manufactured in

a number of sizes, the one most often used being 60" x 34". There seems small need for anything larger than 66" x 36".

In addition to desks, an office should have a telephone stand and a wastebasket. If there is a secretarial office adjacent, an executive chair, guest chairs, and a bookcase will complete the necessary equipment. Otherwise additional filing space should be provided: files may be had in two-, three-, four-, or five-drawer heights, or in sectional units which may be built to any height. A safe should also be provided for valuable papers. A very comfortable private office with a 60" x 34" desk and table combination, telephone stand, bookcase, and necessary chairs may be provided in a space 12' x 15'; of course, it may be much larger where necessity or preference dictates.

A separate secretarial office adjoining the private office is usually desirable. The size of this office is dependent on the volume of work handled and on whether or not private office files, safe, etc., are kept in the private or the secretarial office. Unless the volume of work is unusually heavy, a room 10'x12' is large enough. Where the secretarial work is heavy, the best arrangement of equipment is a double pedestal, drophead typewriter desk, 60"x34", with table to match, arranged in the same manner as the desk and table in the private office. A secretarial chair, perhaps one other chair, a typewriter and a waste basket are all the

equipment necessary. If a dictating machine is used in the private office, provision must be made, of course, for the transcriber. If the volume of work is not heavy, a typewriter desk with the typewriter in the pedestal is sufficient. This provides convenient use of the typewriter and leaves the entire surface of the desk top free for other work. This desk is built by various manufacturers with typewriter in either right or left pedestal, approximately 60"x34".

In all departments, desks and tables should be arranged in rows, taking into consideration flow of work, light, and relationship of departments. They should be spaced 36" apart where 8-leg desks are used. Because of the greater freedom, 30" is ample where 4-leg desks are used. The length of aisles and the amount of traffic must be given consideration in determining their width. In most cases, 5' is sufficient for main aisles and 3' for secondary aisles.

Numerous surveys have been made to determine the number of square feet of office space required per person, but there has been such a wide variation in different lines of business as well as in different concerns in businesses of the same kind, that definite standards have not been established. It may reasonably be said that 80 to 100 square feet per person, space for executives included, is sufficient for any business. This will vary somewhat with the number of employees; the area required per person is less where there are 300

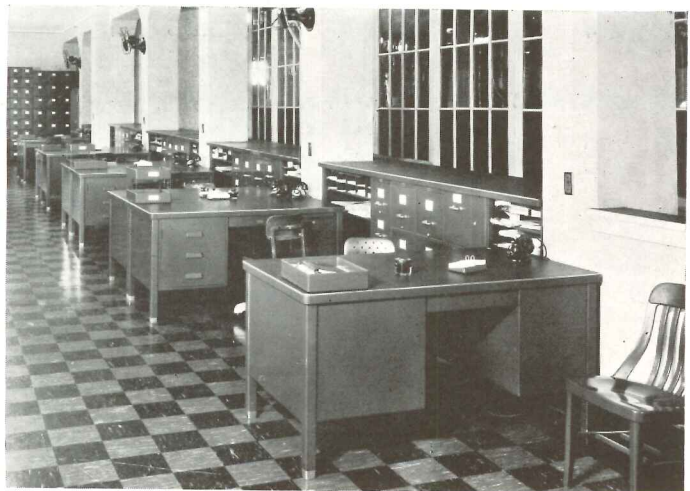

Photos courtesy The General Fireproofing Co.



employees than where there are only 50.

A study of flow of work must include the flow of work within departments, and from department to department as well. In almost every office, there is some major activity which is all-important, to which everything else is subordinate. For instance, in a sales organization it is the order; in a bank the receiving and paying of money; in an insurance company the application and the policy. All departments should be so laid out that this major activity will flow through the various steps in their logical sequence, as on the production line in a manufacturing plant. The lesser operations should be placed so that they will feed into the production line properly.

The filing department is primarily a service department for the whole organization, the final co-ordinator between the firm and the people with whom it has business dealings. Here, space requirements depend on the nature of the business, the details connected with each transaction, the frequency of the transfer period, and the length of time that records are kept. A reasonable space allowance in any type of business would be 15% of the entire office area. In many organizations, it should not be more than 10%, in some possibly as little as 5%.

### Wall and Floor Treatment

In the matter of wall treatment, in addition to color considerations, thought must be given to sound ab-

sorption. The extended use of office machinery and the increasing volume of exterior noises make this problem of greater importance daily. Noise is fatiguing to the nervous system and must be reduced to a minimum.

Isolation of noisy machinery and the placing of drapes or other sound absorbing materials near the sources of noise, will help reduce noise, but thought should also be given to acoustical treatment with felt, tile, or similar materials. In the selection of floor covering, consideration should be given to original cost, maintenance, cost, appearance, durability, and sound absorption. Thought should be given to the type of floor covering in selecting chair casters and foot castings.

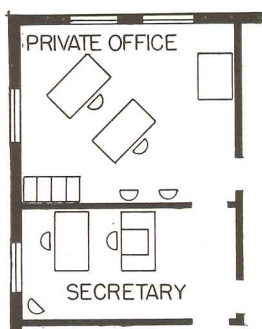

FIGURE 1

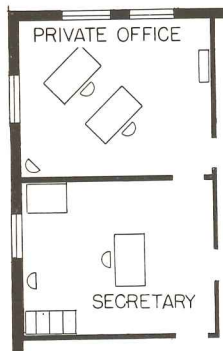

FIGURE 2

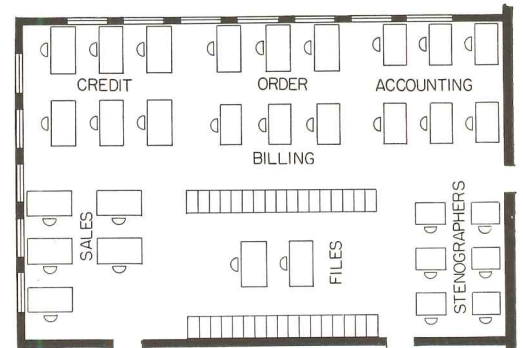

FIGURE 3

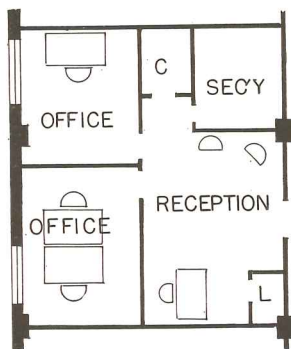

FIGURE 4

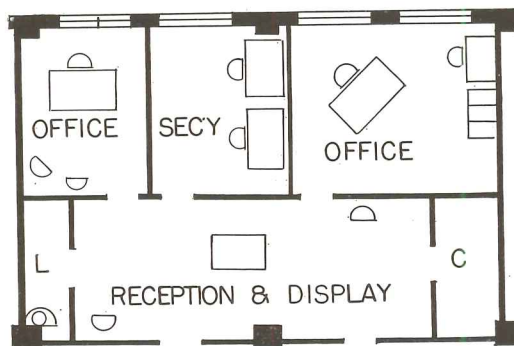

FIGURE 5

FIGURES 1, 2. Private and secretarial office layout. FIGURE 3. Typical general office layout. FIGURE 4. Typical 1 1/2-bay small office unit. FIGURE 5. Display office unit occupying 2 bays

### OFFICE DEPTHS

In general, an office should not be more than 20' deep except, perhaps, in very favorably exposed rooms where a maximum of 25' might be used. On court exposures, office depths should be reduced, with about 16' as a maximum. Depths are defined by the effective natural lighting of the rear or farthest removed portion of the room, which condition is reflected in the higher rentals obtained by well-lighted rooms; very deep rooms are often difficult to rent. Economically, the question of depth is closely associated with building costs: exterior wall cost, operating cost, land value, and similar factors. Office ceiling heights are approximately 10', although in some cases a height of 9'-6" is adequate.

Reports indicate that more than 70% of all office building space is rented in small units, of five rooms or fewer. The integration of these small units with public areas such as corridors, toilets, stairways, elevators, etc., is always an important consideration.

Corridors, when long, should be at least 7' wide. When offices are located on both sides of a corridor, the entrance doors should be staggered. Main doors are recommended to be at least 3'-6" wide in order to admit furniture.



# Lay Out the Planning Office for Production

## CHECK LIST FOR A DESIGNER'S OFFICE

### Private Offices and Suites

Equipment: desks, chairs, tables, etc.

### Secretarial Department

Equipment: desk, chairs, files

### Sample Room

Equipment: tables, shelves, cabinets

### Contractors' and Conference Room

Equipment: chairs, table, shelves

### Drafting Room

Equipment: drawing boards and seats, files, tables, etc.

Supply Room, Cloakroom, Toilets

Standard drawing tables are 36" x 60"; larger sizes include 42" x 84"; minimum clearance is approximately 2'-0".

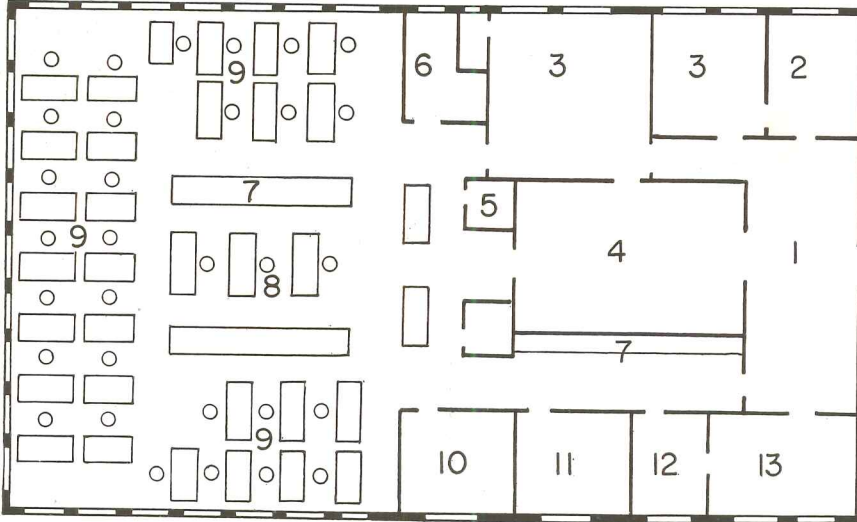

### LARGE OFFICE

- |                                |                         |                          |                                |
|--------------------------------|-------------------------|--------------------------|--------------------------------|
| 1. Reception                   | 5. Supplies or storage  | 8. Designing             | 11. Specifications             |
| 2. Secretarial and information | 6. Toilet               | 9. Drafting              | 12. Samples                    |
| 3. Executive                   | 7. Files and catalogues | 10. Drafting supervision | 13. Contractors and Conference |
| 4. Library                     |                         |                          |                                |

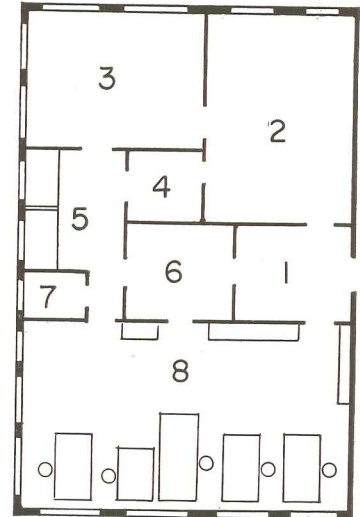

### SMALL OFFICE

- |                |                   |
|----------------|-------------------|
| 1. Reception   | 5. Specifications |
| 2. Conference  | 6. Library        |
| 3. Executive   | 7. Toilet         |
| 4. Secretarial | 8. Drafting       |





# Standards for Dental Offices

By H. MORTONSON, The S. S. White Dental Mfg. Co.

DENTISTRY as a profession has made enormous strides in the past fifty years, developing from a mechanical art to one which is basically a health service. In former days a dental office consisted principally of a waiting room for patients, an operating room and a laboratory. Often the waiting room was separated from the operating room only by a screen or low wood partition. Little thought was given to such problems as arrangement, decorative schemes, privacy, or comfort.

Along with the advancement of dentistry into a prominent position in the medical sciences came the need for carefully planned offices making possible routine efficiency, cleanliness, and dignity in the decorative scheme. Since nearly all dental practices are conducted on an appointment basis, they must be regulated according to definite schedules, which in turn demands office arrangements that will hold to a minimum lost motion and wasted time.

The modern dental office arrangement has thus developed and now conforms to a definite pattern. This can be illustrated by a chart (Fig. 1) showing the administration office as the control room and center of activity around which all other rooms are conveniently placed. This is important as it is desirable that all service rooms be directly accessible, without the need of passing through one to gain entrance to another. The chart illustrates the proper functional arrangement.

The chart illustrates the theory of arrangement, but room sizes that will permit proper functioning are of prime importance. Normal sizes will

be referred to as those dimensions which have proven most satisfactory for each room purpose.

Some variations from the theory expressed in the chart are unavoidable, inasmuch as each office building suite presents its individual problem through depth of space and window and door position. The dental office floor plans illustrated show the application of the theory of arrangement as applied in actual problems.

## Reception Room

The vast majority of dental offices do not have more than three operating rooms. Obviously the one-chair office is tenanted by but one dentist, while the two- and three-chair offices may be tenanted by either one or two dentists—the three-chair office occasionally by as many as three dentists. The reception room accordingly should be of a size ample to accommodate the number of patients expected. A room 8'-0" x 12'-6" may be considered as typical, although a room of slightly smaller dimensions should prove fairly satisfactory. If a physician is to share the reception room a larger area is necessary, since physicians do not usually control their practices by patient appointment. Wall space is important because it determines the seating capacity of a room; if more than two doors are necessary, the dimensions should be increased proportionately.

The reception room is the least productive space in a dental office, and consequently may be located away from a window. The "inside" reception room has become quite acceptable to dentists, because if a win-

dow is required, yearly rental costs will be increased considerably.

## Administration or Business Office

This room is used to control the office routine and must accommodate a desk and necessary files. Wall space must be made available to care for those fixtures and yet allow sufficient floor space to permit patients and office personnel to pass conveniently through it to the other rooms. The size should be approximately 6'-0" x 8'-0", although the office arrangement may permit or require a larger room.

## Operating Room

The equipment required in an operating room must be placed in certain relative positions, have minimum clearances, and provide definite convenience for the dentist. Wall space and window and door positions are important. Natural daylight is necessary and the window should be in a position with its center about one foot to the left of the center line of the operating room of normal size, and in line with the center of the dental chair. All doors should be to the rear of the room. This will require a room about 7'-6" x 9'-0". The room must accommodate a dental chair, a dental unit, a dental cabinet, a sterilizer, a washbasin, and often an X-ray machine. The minimum space allowable between the front of the cabinet and the side of the chair is 24 inches. (See operating room detail.)

The source of daylight for an operating room is important to a dentist and ranks in preference as follows: north, east, south, and west.

Fig. 1

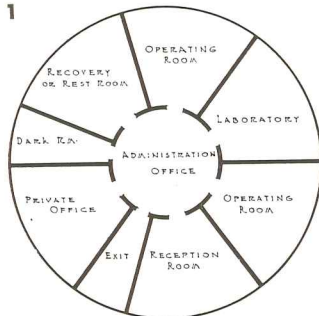

Organization Chart

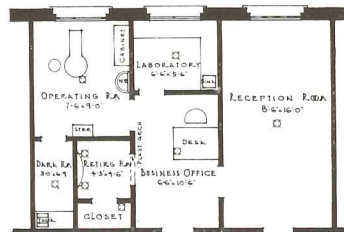

Floor plan no. 1 is a one-chair dental office offering the features essential for modern practice.

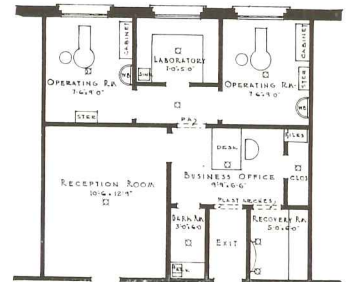

Floor plan no. 2 is a two-chair office requiring but little greater area than that of floor plan no. 1, yet it offers a possible 100% greater earning capacity.



Light from in front of the chair only is advisable. A window in the wall to the left of the chair should definitely be avoided as it produces what is termed a "cross-light", which is detrimental to the dentist's eyes.

Some dentists limit their services to a certain branch of their profession such as general dentistry, exodontia and oral surgery, orthodontia, periodontia, prosthodontia, and children's dentistry. The room size and requirements as given are proper for each of the special branches. The principal differences in requirements are in the type and design of equipment installed. Equipment requirements for each follows:

*General Dentistry, Periodontia, and Prosthodontia:*

1. Dental Unit, complete with electrically heated and compressed air instruments, dental engine, spittoon, bracket table, sprays, and warm water syringe.
2. Dental Chair.
3. Dental Cabinet.
4. X-ray Apparatus.
5. Waste Receiver.
6. Operating Light.
7. Sterilizer.
8. Drinking Glass Cabinet.
9. Washbasin.

*Exodontia and Oral Surgery:*

1. Dental Chair.
2. Pedestal or Bracket-type Spittoon.
3. Surgical-type Cabinet.
4. Sterilizer.
5. Operating Light.
6. Waste Receiver.
7. X-ray Apparatus.
8. Instrument Table.
9. Drinking Glass Cabinet.
10. Washbasin.

*Orthodontia:*

1. Dental Chair—Child's.
2. Orthodontia Cabinet.
3. Dental Unit, without electrically heated instruments or a Pedestal-type spittoon.
4. Operating Light.

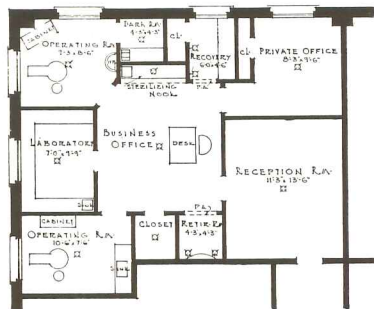

Floor plan no. 3 is another two-chair office with the added feature of a private office which may also be used as a consultation room.

5. Waste Receiver.
6. Drinking Glass Cabinet.
7. Sterilizer.
8. X-ray Apparatus.
9. Washbasin.

*Children's Dentistry:*

1. Dental Chair—Child's.
2. Dental Cabinet—Child's type.
3. Dental Unit, without electrically heated instruments.
4. Operating Light.
5. Sterilizer.
6. X-ray Apparatus.
7. Waste Receiver.
8. Drinking Glass Cabinet.
9. Washbasin.

**Laboratory**

The dentist's laboratory should be supplied with workbenches containing drawers for various tools and supplies, and cupboard space for storage of appliances and supplies. The sink, of small size, 12" x 12" or 12" x 16", should be supported in the bench flush with the working surface. The bench should be supplied with gas, compressed air, and electricity. The air compressor unit should be placed under the bench, where it should be attached to an electrical outlet and the air pipe. In buildings equipped with compressed air, the compressor unit should be omitted from the laboratory. The other equipment used would consist of a dental lathe, casting machine, electric porcelain furnace, and incidental equipment. The laboratory should have a window for providing light, but may be located in space without daylight. The room should be approximately 6'-0" x 7'-0"; how-

ever, individual requirements may alter the size.

**Darkroom**

The darkroom is necessary for the development of X-ray films. It should be equipped with a workbench containing a developing tank of three compartments, one each for the developing solution, the fixing or hypo-solution, and for cold running water. The tank should be piped for hot and cold water and waste. The room should be painted throughout in flat black paint or a special darkroom paint such as Rubylite. It should have a ceiling light and a double-receptacle wall electric outlet to accommodate a ruby or safelight and a small fan. The room must of course be lightproof. Lightproof ventilators should be installed in the wall, one near the floor and the other near the ceiling. A darkroom for dental X-ray developing work should be approximately 3'-0" x 3'-6" in size.

**Recovery or Retiring Room**

An office in which exodontia is practiced, either in general dentistry or in specialized practice, should be equipped with a recovery room for the convenience of those patients who may become ill following the extraction of teeth. This is especially true in offices where general anesthetics, such as nitrous oxide and oxygen are given. In the office limited to exodontia, two or more recovery rooms are needed, according to the extensiveness of the practice; and at least one should have an outside window. The room should be equipped with

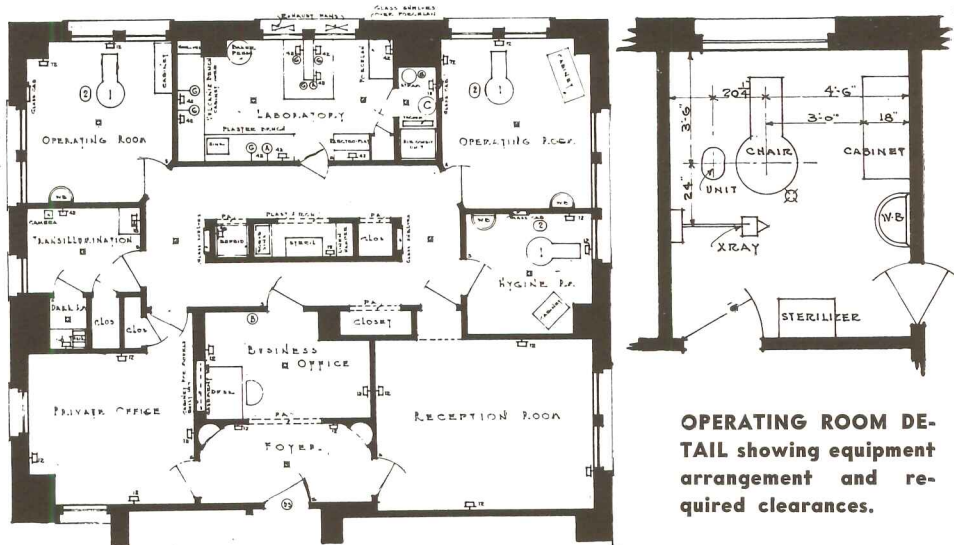

**OPERATING ROOM DETAIL** showing equipment arrangement and required clearances.

Floor plan no. 4 illustrates an office designed to accommodate a highly developed practice for one dentist who employs a dental hygienist, a secretary, a dental nurse, and a laboratory technician. The plan illustrates the possibility of obtaining a good functional arrangement even in the most complex projects.



a box couch at least 6' long and 22" wide, a shallow console table with a small chair and mirror, to be used as a dressing table. The exodontia office, should have a small washbasin too. A recovery room of average size measures about 6'-0" x 4'-6".

The other types of dental practice do not need recovery rooms, but should have retiring rooms for the convenience of lady patients. Retiring rooms should be equipped with a shallow console table, a small chair or bench, a mirror and a pair of wall lights, one each side of the mirror. The retiring room should be approximately 4'-0" x 4'-0", although where space is very limited an inset arch about 3'-6" wide and 15" deep in a wall of the administration office will serve as a substitute.

### Mechanical Requirements

Practically all dental equipment is available for use on either alternating or direct current and does not require a power line.

Essential pieces of equipment necessary for a dental practice are:

**Dental Unit:** A Unit is a combination of several accessories: motor, spray bottle heater, water heater, transformer for low-voltage instruments, accommodations for attaching an operating light and a branch circuit for operating the air compressor. With all of these operating simultaneously, a maximum rating of 10 amperes is established.

**X-ray Apparatus:** 14 Amperes No. 10 Wires. In an office of more than one operating room, one X-ray outlet is usually sufficient.

**Sterilizer:** Single boiler type, 8 amperes.

**Lathe:** 4.2 amperes.

**Compressor:** 3.1 amperes.

**Engine:** When used independent of the Unit—1 ampere.

**Electric Porcelain Furnace:** 7 amperes.

**Operating Light:** When not a part of the Unit—300 watts.

**Water and Waste Requirements:** Hot and cold water is necessary for all washbasins and sinks. The dental unit and spittoons require only cold water. X-ray developing tank requires both hot and cold water for controlling solution temperature.

**Compressed Air Requirements:** Dental units require compressed air. A maximum of 40 pounds is sufficient. Dental laboratories require compressed air for operating casting machines.

**Gas:** Gas is required in a dental office for laboratory use and in dental units for a Bunsen burner.

**Temperature Control:** In a dental office this is not absolutely essential but is desirable. In office buildings which are not air conditioned, the unit type of air conditioner has generally given satisfaction.

**Ventilation:** If a building is not equipped with a system of forced ventilation, the dental office is usually ventilated through the adjustment of

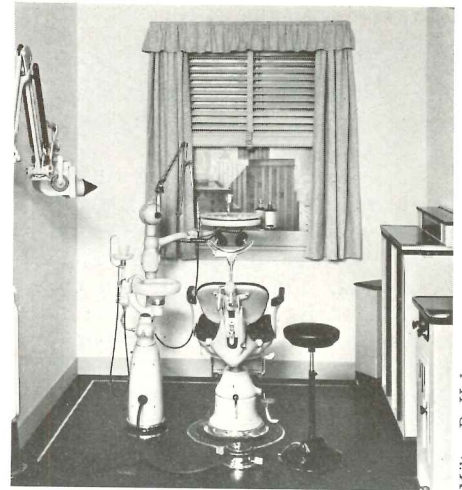

Milton R. Holmes

DENTAL OPERATING ROOM

windows and doors. It is, however, desirable to have some simple method of forcing fresh air to such inside rooms as the reception room and private office. This may be accomplished by the installation of ducts in the walls, with the air driven by small fans.

Equipment for dentists is available in seven standard colors as: cream white, snow white, ivory tan, pearl gray, Neptune green, mahogany, and black and are all trimmed with gold striping. These colors are standard, and have been adopted by the various manufacturers of dental equipment.

### Private Office

A private office is desirable for the more highly developed practices, and a room 8'-0" x 10'-0" is ample for this purpose. The room need not have a window for outside light. Closets to serve as wardrobes should be supplied in a dental office plan. A private exit from the administration office is desirable.

A TYPICAL ARRANGEMENT of a one-story structure providing office space for group practice of dentistry and medicine.

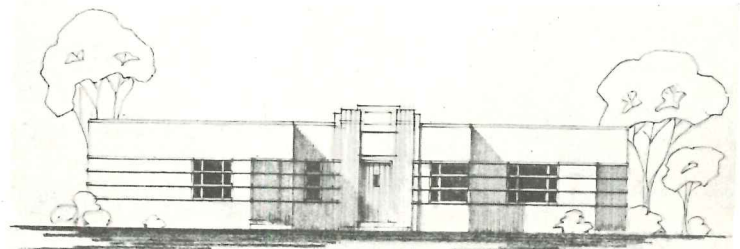
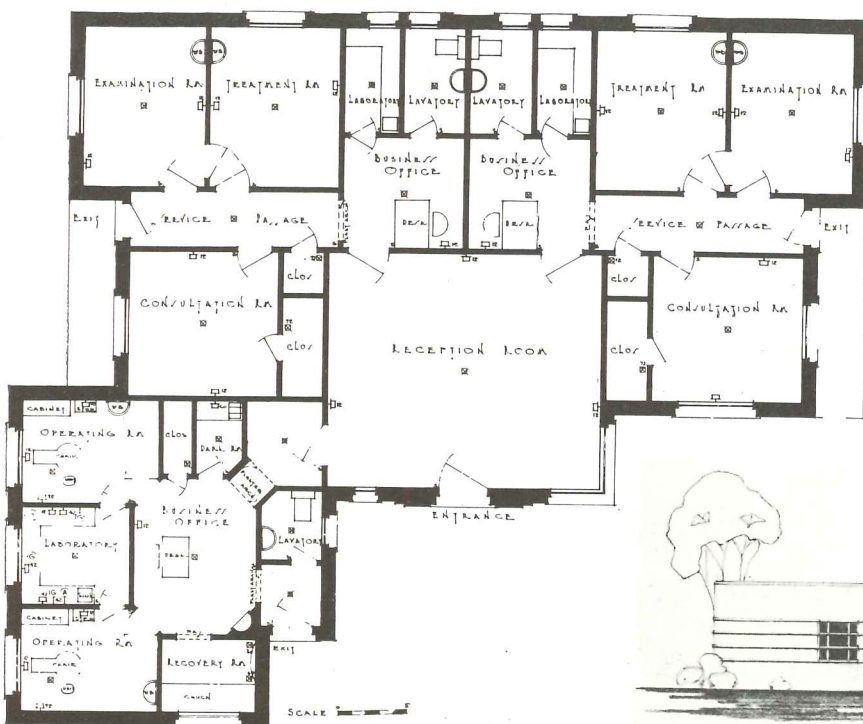



# Office Lighting Specifications

By DEAN M. WARREN AND FRANK B. LEE, General Electric Company

TODAY'S LIGHTING recommendations for offices are based on seeing requirements. Eyes are the important working tools for which lighting is designed, and because of the variety of tasks they are called upon to perform in the office work-world of today, a different lighting prescription is necessary for various tasks.

Dr. M. Luckiesh, well-known scientist, expresses the new thinking on light and seeing in the following words: "Footcandle recommendations of the past must now be recognized as being based largely upon what lighting specialists thought could be sold. Even when made on the basis of knowledge available in the past, the shortcomings of that knowledge must now be recognized. No one can justly criticize anyone for doing the best he can with the knowledge available. However, in recent years a science of seeing has greatly increased our knowledge of what light and lighting can do for human beings. Also it has refined and greatly extended the concepts of vision into seeing. Therefore, dogmatic recommendations by anyone who assumes the scientist's role must be criticized in the light of current knowledge. It is necessary to distinguish between what is ideal and what is practical. Oddly enough, the former is now easier to agree upon than the latter, for the latter involves past practices and old habits. It also involves the balancing of various costs and values, not only in tangible money, but in intangible human resources and happiness."

## Recommended Footcandle Values

There is no danger of obtaining too much light under modern sources of artificial lighting, properly applied. The best lighting systems supply meager light compared to nature's lighting. This is apparent when we compare 5 to 10 footcandles, average indoor values, with 500 to 8,000 footcandles of outdoor daylight.

The eye will function and distinguish objects under lighting of less than 1 footcandle. However, in order to avoid premature aging of the eyes

and needless expenditure of nervous energy, it is necessary to provide more light than just enough for seeing. This can be done economically today because of the progress the electrical industry has made. The cost of energy, equipments, and lamps has been decreasing constantly and lamp efficiency has been increasing steadily to such an extent that the lighting dollar now purchases ten times as much light as it did twenty-five years ago and twice as much light as it did only ten years ago.

It cannot be too strongly emphasized that lighting levels sufficient for mere perception or identification have nothing to do with good seeing. Far higher values than these are needed if the eyes are to be relieved of the strain of constantly working at their utmost capacity.

The footcandle values given in the accompanying table represent standards for various seeing requirements in the office. While these recommendations are extremely conservative when compared with levels of illumination that are to be found outdoors, they do represent practical steps toward the much higher footcandle levels that appear to be ideal.

## Quality Considerations

Any lighting installation which merely achieves specified standards of footcandles, at the sacrifice of comfort, is neither economical nor acceptable. In this respect the presence of glare or reflected glare is the principal offender.

Glare has been proved to cause nervous muscular tension just as low levels of illumination do. For example, a glare source of 20 degrees from the line of vision, providing five footcandles at the eyes and five footcandles upon the visual task, will produce the same degree of nervous muscular tension as will the same visual task illuminated by one footcandle without glare.

Direct glare is the most frequent and serious cause of bad lighting. It occurs in the form of unshaded or inadequately shaded light sources within the field of view, or as a contrast between the bright light source and a dark background.

Reflected glare comes from polished objects, such as glass-top or varnished desks or from glossy paper and paint. It is generally impossible to change the character of the work or nature of the seeing task in order to avoid these potential reflections, but the architect, alert to all such conditions, can reduce these reflections by (1) properly shielding the light source, (2) specifying a source of such dimensions that it is of low brightness, (3) locating the source in such a manner that most of the reflection is away from the eyes.

## Lighting Equipments

Three classifications of lighting equipment—semi-direct, semi-indirect and totally indirect—are suitable, depending on conditions existing in various office areas.

SEEING TASK	Recommended Watts	
	Footcandles	per Sq. Ft.
Bookkeeping and Accounting . . . . .	30	7
Conference Room . . . . .	10	3
Corridors and Stairways . . . . .	5	1-2
Desk Work—Intermittent Reading & Writing . . . . .	20	5
Desk Work—Reading Blueprints and Plans . . . . .	30	7
Rough Drawing and Sketching . . . . .	30	7
Filing and Index References . . . . .	20	5
Mail Sorting . . . . .	20	5
Reception Rooms . . . . .	10	3
Vault . . . . .	10	3
Business Machines—Calculators, Key-Punch, Bookkeeping . . . . .	50-100	7*
Art and Layout Work—Computing, Studying, Designing, etc. . . . .	30-50	7
Drafting . . . . .	30-50	7
Stenographic . . . . .	30-50	7

\*The watts-per-square-foot value specified is an approximation intended to provide only for the general illumination needed. Supplementary lighting must be provided to obtain desired footcandles.



**TABLE I—SPACING OF LIGHTING OUTLETS**

Ceiling Hgt. (Or Hgt. in the Clear) (Feet)	Spacing Between Outlets		Spacing Between Outside Outlets and Wall		Approximate Area per Outlet (At Usual Spac- ings) (Sq. Ft.)
	Usual (Ft.)	Maximum (For Units at Ceiling) Not More Than*	Aisles or Storage Next to Wall	Desks, Workbenches, etc. Against Wall Not more than*	
8	7	7½	Usually one-half actual spacing between units	3	50-60
9	8	8		3	60-70
10	9	9		3½	70-85
11	10	10½		3½	85-100
12	10-12	12		3½-4	100-150
13	10-12	13		3½-4½	100-150
14	10-13	15	4-5	100-170	
15	10-13	17	4-5	100-170	
16	10-13	19	4-6	100-170	

\*Where it is definitely known that some form of indirect lighting will be used, the maximum spacing between outlets may be increased about two feet and the distance from the outside outlets to the wall may be increased by one foot.

**TABLE II—FOOTCANDLE VALUES**

Area per Outlet (Sq. Ft.)	Room Width Divided by Height	SEMI-DIRECT			SEMI-INDIRECT			TOTALLY INDIRECT				Combination System One 250-Watt Mercury and Two 200-Watt One 500-Watt	
		Units such as enclosing globes			Lamp Size—Watts			Lamp Size—Watts				Two 200-Watt	One 500-Watt
		150	200	300	300	500	750	300	500	750	1000		
55-64	4	16-19	21-25	.....	26-31	46-50	.....	24-20	36-43	.....	.....	.....	.....
	2	14-17	19-23	.....	22-26	39-46	.....	20-17	30-36	45-50	.....	44-50	.....
	1	12-14	16-19	.....	17-20	31-36	.....	16-14	25-29	37-43	.....	36-42	.....
65-74	4	14-16	18-21	.....	22-26	40-46	.....	18-20	32-36	47-54	.....	46-50	.....
	2	12-14	16-19	.....	19-22	34-39	.....	15-17	26-30	39-45	.....	39-44	46-50
	1	10-12	14-16	.....	15-17	27-31	.....	12-14	21-25	32-37	.....	31-36	38-43
75-84	4	12-14	16-18	.....	20-22	35-40	.....	15-18	28-32	41-47	.....	40-46	46-50
	2	11-12	14-16	.....	17-19	30-34	.....	13-15	23-26	35-39	.....	34-39	40-47
	1	9-10	12-14	.....	13-15	23-27	35-40	11-12	19-21	28-32	.....	27-31	33-38
85-94	4	11-12	14-16	.....	18-20	32-35	47-53	14-15	25-28	37-41	.....	36-40	43-48
	2	10-11	13-14	.....	15-17	27-30	40-44	12-13	21-23	31-35	44-49	30-34	37-40
	1	8-9	11-12	18-20	12-13	21-23	31-35	10-11	17-19	25-28	36-40	24-27	29-33
95-109	4	9-11	12-14	23-26	15-18	27-32	40-47	12-14	21-25	32-37	45-50	31-36	38-43
	2	8-10	11-13	18-21	13-15	23-27	34-40	10-12	18-21	27-31	38-44	26-30	32-37
	1	7-8	9-11	15-18	10-12	18-21	27-31	8-10	14-17	22-25	31-36	21-24	25-29
110-124	4	8-9	11-12	18-20	13-15	24-27	36-40	11-12	19-21	28-32	40-45	27-31	33-38
	2	7-8	10-11	16-18	11-13	20-23	30-34	9-10	16-18	24-27	33-38	23-26	28-32
	1	6-7	8-9	14-15	9-10	16-18	24-27	7-8	13-14	19-22	27-31	19-21	23-25
125-144	4	7-8	10-11	15-18	12-13	21-24	31-36	9-11	16-19	24-28	34-40	23-27	28-33
	2	6-7	9-10	14-16	10-11	17-20	26-30	.....	14-16	20-24	29-33	20-23	24-28
	1	5-6	7-8	12-14	8-9	14-16	20-24	.....	11-13	16-19	24-27	.....	19-23
144-170	4	6-7	8-10	13-15	10-12	18-21	26-31	.....	14-16	20-24	29-34	.....	24-28
	2	5-6	7-9	12-14	8-10	15-17	22-26	.....	11-14	17-20	25-29	.....	20-24
	1	4-5	6-7	10-12	.....	12-14	17-20	.....	9-11	14-16	20-24	.....	.....

cases, this distance must be exceeded, the loads should be reduced or the wire size increased to provide for a voltage drop not exceeding 2% at the last outlet.

*Branch Circuits for Convenience Outlets:*

No wire smaller than No. 12 should be used for any circuit supplying convenience outlets.

Runs exceeding 100 ft. in length from the panelboard to the first outlet should be avoided where-

ever practicable. If unavoidable, such runs should be no smaller than No. 10 wire and the wire between outlets should be no smaller than No. 12.

In office spaces there should be at least one branch circuit to supply convenience outlets for every 800 sq. ft. of floor space or major portion thereof.

**A Simplified Design Procedure**

A detailed engineering procedure for lighting calculations is given in

the bulletin "Illumination Design Data", published by the Engineering Department of the General Electric Company at Nela Park, Cleveland. The design procedure given here is a simplified method of determining outlet spacing, lamp size, and mounting height.

Table I gives the usual spacing as well as the maximum allowable spacing for various ceiling heights, assuming the units are mounted as high as possible. Determine area per outlet and apply in Table II.



When the lighting layout has been made, the type of equipment selected, and the conditions established, refer to Table II to obtain the footcandles produced by various sizes of lamps under the conditions of use. Choose the lamp size necessary to produce the footcandles recommended for the office in question. These values are calculated assuming a ceiling with a reflection factor of 75% and side walls with a reflection factor of 50%.

### Paint

The use of indirect lighting in offices is growing rapidly. Obviously office ceilings should always be of light color with as high a reflection factor as possible. Pure white, ivory or cream, is usually to be preferred. Not only is the color of the ceiling important; the finish must also be considered. A glossy surface is not recommended since it results in high brightnesses at some points; these are disturbing and may cause eyestrain. A flat or mat finish, as provided either by oil or some of the newer casein-base paints, is the ideal finish.

For the side walls, colors such as greens, blues, and grays, are recommended. These are termed cool colors. They have the psychological advantage of producing a receding effect. For instance, a room painted in a light tone of green will appear

larger than one painted in tan. Buffs and tans are warmth-suggesting and should be avoided in large areas in working locations. However, since it is desirable to avoid monotony, small amounts of warm complementary colors are desirable.

It is often desirable to stipple the walls in order to diminish the effect of smears, small blemishes, and fingerprints. This may be done with cloth, paper, or brush, depending on the pattern desired. A very satisfactory pattern is a fine mottled one which gives the wall a soft quiet tone. Where large patterns are used, a prominence is given the wall surface which is not generally liked.

A process called "buttermilking" will flatten and lighten glossy or shiny paint surfaces. It is also an aid toward preserving the paint from dust and dirt. The buttermilked surface may be washed off at the end of a year or two leaving the paint fresh and clean. A new coat of buttermilk can then be applied and the process repeated several times.

In painting office walls it will usually be found satisfactory to paint the walls up to the ceiling, in one color. Exposed pipes and radiators should be painted to harmonize with the walls.

The following table gives an approximation of the amount of light reflected by different colors:

White .....	85%
Ivory .....	77%
Cream .....	66%
Buff .....	56%
Silvery Gray.....	50%
Light Blue.....	50%
Cream over Blue—Stippled....	45%
Ivory over Sage Green—	
Stippled .....	40%
Gray over White—Stippled....	40%
Sage Green .....	40%
Olive Green .....	20%
Cardinal Red .....	20%
Antique Brown .....	9%

### Controlling Light Automatically

With the development of low-cost photoelectric tube equipment, considerations should be given to its application for controlling lighting circuits in large office areas. Past experience has indicated that the eye is not a reliable judge of levels of illumination, hence lights are often on when not needed, and more frequently off when daylight is insufficient.

Daylight decreases so rapidly away from windows that at a distance of 15 or 20 feet there is not adequate illumination for office tasks. This makes it necessary to operate inside rows of lighting units practically all the time. The outer row or two, depending on daylight conditions, may or may not be needed, and can be conveniently operated by means of photocell control equipment.

## Supplementary References on Office Buildings

### Circulation

Vertically circulation is most frequently dependent on electric elevators. It is accelerated or retarded by the adequacy of equipment, by the relationship of speed, control, and size of the cab to its use. Changed or changing tenancy often indicates the necessity for analysis of existing equipment. Improvement of elevator installations by addition of more modern signal control, greater speeds,\* and proper ratio of available space to traffic demands often results in obtaining and keeping a building tenanted. Lack of such planning and provision results in eventual blight, loss of revenue, and hastened obsolescence. Escalators for traffic between lower floors are proving the advantages of this type of mechanical circulation by the resultant higher values created for the basements, second,

and, possibly, third floors of a structure. Implied also is re-study of corridors and lobbies, the means of horizontal circulation. These areas must be adequate, adjusted to the volume of traffic which they serve.

1. **Motors, Electrical and Elevator Equipment Power.** Vol. 80, pp. 741-5 Mid-December, 1936. Electric Elevators, by Fred Ansley. Second Edition. McGraw-Hill Company, New York. 1935.
2. **Better practice; elevators.** W. F. Bartels, Architecture. Vol. 73, pp. 87-90, February, 1936.
3. **Electrical Engineers' Handbook.** Vol. 1, Electric Power. Edited by W. H. Pender and W. A. Del Mar. Third Edition. John Wiley & Sons, New York City. 1936.
4. **Electric Wiring.** By A. A. Schuhler, Third Edition. McGraw-Hill Company, New York. 1936.

### Construction

Welding of structural members in-

creasingly replaces riveting, as standards of workmanship, inspection, and technique are brought under more rigid control and as building codes are revised to permit such construction.

New materials to replace masonry in the walls are constantly being developed. The use of stainless steels and vitreous enameled irons on building exteriors is one of the most significant of contemporary trends. Among the advantages offered by these materials are: 1. The rate of building is much faster; there is no need to wait for cement to set. 2. Stainless steels are easily welded or riveted directly to the steel skeleton. Vitreous enameled iron parts are fastened by clips or bolts. In either case, there is greater ease and rapidity in erection. 3. Much thinner walls are possible, allowing more floor space and lightening the dead load. 4. Walls of metal construction,—plus one of

\*Because of physical reactions of passengers, 1500 fpm is, at present, the maximum rate of travel.



the many forms of insulation now available, such as corkboard, fiberboard, rock wool, and asbestos cements—make an effective shield against changes in temperature and humidity as well as noise.

Glass, too, is a material of great possibilities for office building design.

In office buildings, as in all structures, construction should be such as to permit the most economical, flexible, and most readily altered or modernized finishing at some future time.

#### Foundations

##### References:

1. **Skyscrapers and the Men Who Build Them.** By Col. W. A. Starrett. Charles Scribner's Sons, New York. 1928.  
Includes: Description of various types of foundations; construction routine.
2. **Foundations of Bridges and Building.** By Henry S. Jacoby and Roland P. Davis. McGraw-Hill Book Co., Inc., New York. 1925. Second Edition. Includes: Timber piles and drivers; concrete piles; metal and sheet piles; box and open caissons; pneumatic caissons; pier foundations in open wells; spread foundations; underpinning of buildings; bibliography.

#### Structure

##### References:

1. **The Working, Heat Treating, and Welding of Steel.** By Harry L. Campbell. John Wiley & Sons, Inc., New York. 1935.
2. **Welding Technology and Design.** By G. F. P. Fox and F. Bloor. Charles Griffin & Co., London. 1935.
3. **Stainless Steel:** A digest with abstracts and bibliography. By Albert E. While and Claude L. Clark. Engineering Research Bulletin, No. 4, November, 1936. Department of Engineering Research, University of Michigan, Ann Arbor.
4. **Theory of Modern Steel Structures.** By L. E. Grinter. The Macmillan Company, New York. 1936.
5. **Stainless Steels and Vitreous Enamelled Irons in Architecture.** By J. R. Morris and K. Kautz. Industrial and Engineering Chemistry, October, 1935. Vol. 27, pp. 135-7.

#### Wind Bracing

##### References:

1. **Wind Bracing.** By Harry V. Spurr. McGraw-Hill Book Company, Inc., New York. 1930.
2. **Wind Stresses in Buildings.** By Robins Fleming. John Wiley & Sons, Inc., New York. 1930.  
Includes: Winds; wind pressure and velocity; wind stresses in many-storied buildings; design of details in tall buildings; earthquake resistance; references to engineering literature.
3. **Practical Wind Bracing.** By Harry E. Schneider. Buffalo, New York. 1930.

Includes: Easy and rapid methods of figuring wind stresses in high buildings.

4. **Practical Design of Wind Bracing.** By Clyde T. Morris. American Institute of Steel Construction, Inc., New York. 1927. Methods of calculating wind stresses.

#### Earthquake Resistance

##### References:

1. See Reference 2 under wind bracing.
2. **How Structures Withstood the Japanese Earthquake and Fire.** By H. M. Hadley. American Concrete Institute Proceedings, Vol. 20, pp. 188-209, 1924.

#### Fire Protection

##### References:

1. **Bibliography of Fire Resistive Qualities of Concrete.** Proceedings of the American Concrete Institute. 1925. Vol. 21.
2. **Recommended Minimum Requirements for Fire Resistance in Buildings.** U. S. Department of Commerce. Gov't. Printing Office, Washington, D. C. Building and Housing, No. 14. 1931.  
Includes: list of sources.
3. **Fire Resistant Construction.** By R. E. Stradling and F. L. Brady. Great Britain. Scientific and Industrial Research Department, Building Research Board. Special Report No. 8, London. 1927.
4. **Fire Prevention and Fire Protection as Applied to Building Construction.** Second Edition, Revised. John Wiley & Sons, New York. 1921.
5. **The Skyscraper.** By W. L. Clark and J. L. Kingston. American Institute of Steel Construction, New York. 1930.

#### Air Conditioning, Heating, and Ventilating

There are many plausible arguments for air conditioning office buildings, but the experience record offered by the Tribune Tower, Chicago, provides some tangible figures. During the twelve-month period preceding the installation of air conditioning equipment, 22 percent of the total number of employees became ill enough to remain away from their jobs one or more days. In the subsequent twelve-month period, after air conditioning had been installed, the figure dropped to 13 percent. Add such health dividends to the dividends resulting from increased efficiency of the workers, and the reasons why air conditioned office buildings have a low vacancy record are obvious.

As instruments for measuring quantitatively the extent of the control gained over temperature, humidity, dust, odors, etc., become more and more precise—witness dust-counting apparatus, for example—higher and higher standards of air

conditioning performance are being set. But since these standards are constantly changing, it's impossible to review them in limited space.

1. **The Value of Air Conditioning in Renting Skyscraper Space.** By H. Chapman. Refrigerating Engineering, January, 1937; page 9.  
This is a case study of Philadelphia Savings Fund Society Building. Though non-technical, it presents interesting data on tenant experience, costs, electrical load, personnel requirements, etc.
2. **Air Conditioning Methods for Income Properties.** By C. M. Burnam, Jr. Buildings and Building Management, January 1937; page 31.  
Angled to the building owner and manager. Discusses different systems and refers to eight office building installations.
3. **Influence of Stack Effect on Heat Requirements.** By J. C. Hardigg. Real Estate Record, August 21, 1937; pages 18-20.  
A study of the little known factor of heat loss caused by upward exterior drafts of high structure, indicating possible adjustment of required radiation for various height locations.
6. **Duct Construction.** By O. W. Kothe.
7. **How Much Cooling?.** Domestic Engineering, April 1937; page 73.  
Case study of an office cooling installation in existing building. Office size: 25' x 35'. Occupancy: 40 persons. Recirculation diagram, calculations of heat gain, details of installation, etc.

#### Plumbing

Air conditioning often imposes new loading conditions on waste and sewage systems; possible future installations may seriously overload piping not designed for this contingency.

1. **Industrial Piping.** Chicago: The Keeney Publishing Company. 1937. Methods and formulas for design, layout, construction, operation, and maintenance of steam, water, gas, air, oil, and hydraulic and refrigerating piping. Illustrative charts, diagrams, and tables.
2. **Industrial Piping.** Chicago: Engineering Publications, Inc. 1933.  
A case book of proven practices and methods, being articles from Heating, Piping, and Air Conditioning.
3. **Modern Plumbing Practices.** R. W. Sherman, American Architect and Architecture, Vol. 148, Nos. 2646 and 2647.  
June 1936; pp. 99-110, 120, 122, 124, 126, 128, 130. Sizes of drainage pipes, horizontal plumbing, fixture ratings and stack sizes, drainage system sections, etc.  
July 1936; pp. 81-9, and 98. Characteristics of water, water conditions, corrosion of pipe materials; cold and hot water distribution systems.