

But... Frigidaire Refrigerators!

9 NEW MODELS — A TYPE AND SIZE FOR EVERY REFRIGERATION REQUIREMENT

Never before has there been a line of refrigerators like this new Frigidaire line. They offer architects, builders, building owners and managers a complete choice of types, as well as sizes, in refrigerators . . . the opportunity to select exactly what is needed, no matter what the individual installation problem.

Compared to anything you have ever seen, these are completely new refrigerators, new inside and out . . . in appearance . . . performance features . . . in design that gives up to 50% more storage space in the same kitchen area.

Your nearby Frigidaire Dealer will gladly furnish you full information about the many features of the new Frigidaire Refrigerators. Also, with information on the new Frigidaire Electric Ranges, Water Heaters, Home Freezers, Kitchen Cabinets and Sinks, Automatic Washer, Automatic Dryer, Electric Ironer.

Today, more Frigidaire Refrigerators serve in more American homes than any other make. And this year—more than ever—you'll be wise to specify Frigidaire.

SEE YOUR FRIGIDAIRE APPLIANCE DEALER for complete information. Find name in Classified Phone Directory. Or write: Frigidaire Division, General Motors Corporation, Dayton 1, Ohio. (In Canada, Leaside 12, Ontario.)



3. DE LUXE MODELS—features of both Imperial and Master models; (1) full-width Super-Freezer Chest gives more space, lower temperatures for longer storage of frozen foods; (2) large food compartment, cooled partly by Super-Freezer—partly by cooling coils concealed in back and bottom of cabinet. Less air circulation to dry out foods. Sizes: 7, 9, 11 cu. ft.

YOU'RE TWICE AS SURE WITH TWO GREAT NAMES



MADE ONLY BY

FRIGIDAIRE GENERAL MOTORS

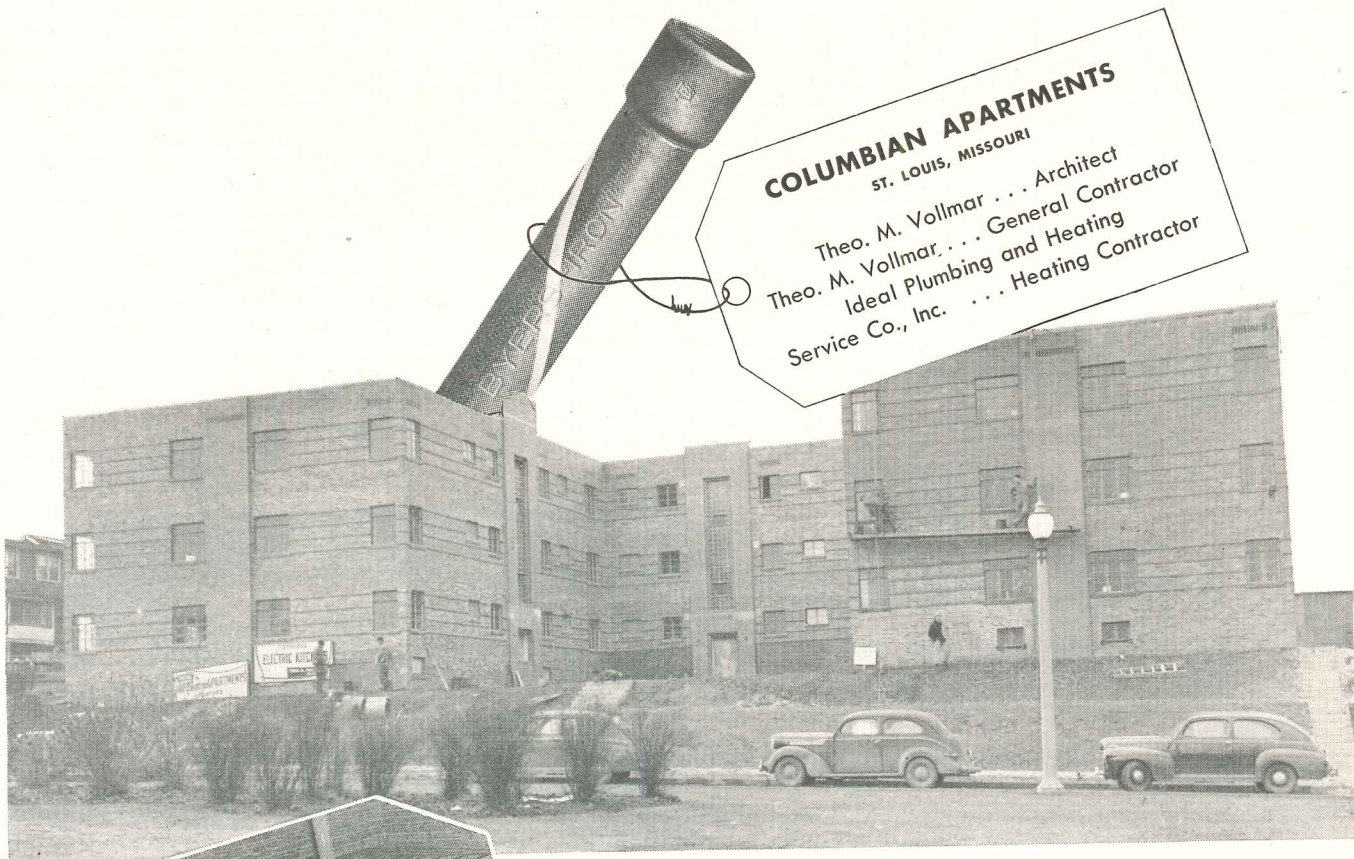

COLUMBIAN APARTMENTS
ST. LOUIS, MISSOURI

Theo. M. Vollmar . . . Architect
Theo. M. Vollmar . . . General Contractor
Ideal Plumbing and Heating
Service Co., Inc. . . . Heating Contractor

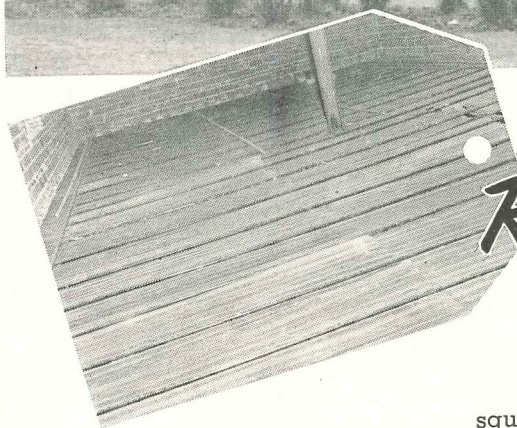

Moving into this new apartment—
RADIANT HEATING with
Byers Wrought Iron Pipe

Latest multi-family project reported as using radiant heating is the Columbian Apartments, a 36-unit building, FHA approved and financed under "608". The heating installation is doing an important preliminary job, by speeding the drying-out of the construction materials. Tenants are moving in as rapidly as decoration is completed. Byers Wrought Iron pipe, in $\frac{3}{4}$ -inch and 1-inch sizes, was used exclusively for the coils.

WIDE APPLICATION

Radiant heating with Byers Wrought Iron pipe has been installed in a dozen or more multi-family, multi-story structures. With today's high costs, every square foot of floor space is precious, and radiant heating permits every

square foot to be utilized, with no restrictions on furniture placement, and no curtailment of living area.

SPECIAL ADVANTAGES

Designers have been quick to acknowledge the unusual combination of desirable qualities offered by wrought iron. The material is easily formed and welded, which speeds installation. It has a high rate of heat emission. It expands and contracts at almost identical rates with concrete. And its corrosion-resistance has been demonstrated over periods of many

years in installations where service conditions were identical.

LITERATURE AVAILABLE

Our bulletin, "Byers Wrought Iron for Radiant Heating", is a complete treatise on the subject, discussing principles; calculation methods; layout; installation; and results. We will be glad to send you a copy.

A. M. Byers Co., Pittsburgh, Pa. Established 1864. Boston, New York, Philadelphia, Washington, Atlanta, Chicago, St. Louis, Houston, Salt Lake City, Seattle, San Francisco. Export Division: New York, N.Y.

CORROSION COSTS YOU MORE THAN WROUGHT IRON

BYERS
GENUINE WROUGHT IRON
TUBULAR AND HOT ROLLED PRODUCTS
ELECTRIC FURNACE QUALITY ALLOY AND STAINLESS STEEL PRODUCTS

A PAUSE THAT REFRESHES 87
 An Editorial . . . by Kenneth K. Stowell

"BEAUTY" FOR US 88
 Demands Architecture of Larger Scope at Vastly Broader Scale. By Douglas Haskell

25 BEDS GENERAL HOSPITAL OF MINIMUM SIZE 92
 An Additional Type Plan for the Coordinated Hospital System. U. S. Public Health Service

LARGE HOSPITAL FOR A RURAL AREA 94
 Crittenden County General Hospital, West Memphis, Arkansas. Dent & Aydelott, Architects; George Sheats, Hospital Consultant

THE ARCHITECT'S STAKE IN PRIVATE ENTERPRISE 97
 By Miles Colean, F.A.I.A.

SPACIOUS PRIVACY ON A SMALL LOT 100
 Ritchie Lowry House, Burlingame, California. Francis Ellsworth Lloyd, Architect

ECONOMY STILL FAVORED THE TWO-STORY TYPE 103
 House in Winchester, Mass. Eleanor Raymond, Architect

PROTECTED OPENNESS IN SUBURBAN LOCATION 106
 House for Hinsdale, Ill. Harry J. Harman, Architect

LARGE ACTIVITY RANGE IN SMALL COMPASS 107
 House for River Forest, Ill. Joseph Salerno, Architect

A THOUSAND WOMEN IN ARCHITECTURE: PART II 108

BUILDING TYPES STUDY NO. 138 . . . RELIGIOUS BUILDINGS . . 116

THE "SEVEN ARCHETYPES" OF RUDOLF SCHWARZ 117

THE FUTURE OF STAINED GLASS 120
 The Workshop and Designs of Emil Frei, Inc.

PLANNING THE CHURCH COMMUNITY CENTER 127
 Data from a Study by Elbert M. Conover

PROJECTS

Church of St. Clement (Episcopal), Alexandria, Va. Joseph H. Saunders, Jr., Architect. 129

Projects for the First Baptist Church, Flint, Mich. By Saarinen, Swanson and Saarinen, and by Robert Swanson Associates, Architects 134

Congregation Hillel, Northwestern University. Harrison & Abramovitz, Architects 138

ARCHITECTURAL ENGINEERING . . . Technical News and Research . . . 141

A METHOD FOR CALCULATING INSULATION ECONOMIES . . . 141
 Developed by the Technical Staff, Housing and Home Finance Agency

PRODUCTS . . . for Better Building 145

TIME-SAVER STANDARDS . . . School Classroom Details 146

Built-in Cabinets Serving as Room Partitions. Perkins and Will, Architects. . . 146

Egg-crate Lighting over Entire Ceiling. Perkins and Will, Architects. 149

Standardized Storage Furniture. Curtis, Kistner and Wright, Architects. 153

MANUFACTURERS' LITERATURE 150

THE RECORD REPORTS . . . News from the Field 7

CONSTRUCTION COST INDEXES 26

REQUIRED READING 28

EMPLOYMENT OPPORTUNITIES 224

SEMI-ANNUAL INDEX 244

INDEX TO ADVERTISEMENTS 248

**ARCHITECTURAL
RECORD**



Copyright 1948 with all rights reserved F. W. DODGE CORPORATION • Publishing Director, Magazine Division, H. Judd Payne • EDITORS: Editor-in-Chief, Kenneth Kingsley Stowell, A.I.A.; Managing Editor, Emerson Goble; Senior Associate Editor, Douglas Haskell; Associate Editors, John W. Ragsdale, Florence A. van Wyck; Assistant Editor, Robert E. Fischer; Western Editor, Elisabeth Kendall Thompson; Associate in South America, Edmund J. Whiting, A.I.A. • ART DEPARTMENT: Myron S. Hall, 3rd, Director; Frances Torbert, Assistant; Peter Piening, Consultant; Sigman-Ward, Drafting • CONSULTANTS: Industry Relations Consultant, Thomas S. Holden; Statistical Consultant, Clyde Shute; Building Economics Consultant, Norbert Brown; Field Research Consultant, Clifford Dunnels, Jr.

Architectural Record (combined with American Architect and Architecture) is published monthly by F. W. Dodge Corporation, 10 Ferry St., Concord, N. H., with Editorial and Executive Offices at 119 West 40th Street, New York, N. Y. Western Editorial Office, 2813 Channing Way, Berkeley, Calif. Thomas S. Holden, Pres.; Howard J. Barringer, Vice-Pres. and Treas.; Irving W. Hadsell, Vice-Pres.; Chauncey L. Williams, Vice-Pres.; Sanford D. Stockton, Jr., Secy.; Walter F. De Saix, Asst. Treas.; Edwin H. Freed, Asst. Treas. Member Audit Bureau of Circulation and Associated Business Papers, Inc. Architectural Record is indexed in Reader's Guide, Art Index and Industrial Arts Index. Subscription rates: United States and Possessions, Canada, Cuba, Mexico, Central and South America, and Spain, \$4.50 the year, \$7.50 for two years, \$9 for three years; elsewhere, \$6.50 the year, \$11.50 for two years, \$15 for three years. Single copy, \$1. Circulation Manager: Marshall T. Ginn. Every effort will be made to return material submitted for possible publication (if accompanied by stamped, addressed envelope), but the editors and the corporation will not be responsible for loss or damage. Other Dodge Services: Real Estate Record & Builders' Guide, Sweet's Files, Home Owners' Catalogs, Dodge Reports & Dodge Statistical Research Service.

Adjustable Flush Valves Overwhelmingly Preferred

by 7 out of 8

ARCHITECTS

Based upon 288 replies from an unbiased survey made among 500 architects selected at random from the distribution list of Sweet's Architectural Catalog File.

by 20 out of 21

PLUMBING CONTRACTORS

Based upon 508 replies from an unbiased survey made among 1,154 of the country's leading plumbing contractors, including those registered at the 1947 N.A.M.P. Convention.

by 8 out of 9

FLUSH VALVE USERS

Based upon 247 replies received in an unbiased survey conducted among 458 hospitals, schools, hotels, office buildings, and similar public and commercial buildings; lists supplied by publishers of leading trade magazines.

Seldom has a single feature of any product received such overwhelming endorsement. These surveys show that all those who have anything to do with flush valve selection, installation, or maintenance vote almost unanimously in favor of making flush valves adjustable.

If you have a job that needs flush valves, be sure you get the kind that *can* be adjusted to provide maximum water savings accord-

ing to the needs of each individual fixture . . . the kind that is fully capable of maintaining peak operating efficiency despite years of service or changing operating conditions.

All Watrous Flush Valves are that kind. It was Watrous who first pioneered and developed the adjustable idea, and it is one of many contributions that make Watrous Flush Valves today outstanding for dependability and lasting economy.

THE IMPERIAL BRASS MANUFACTURING COMPANY
1240 W. Harrison Street, Chicago 7, Illinois

For complete information on Watrous Flush Valves see Sweet's Catalog, or write for Catalog No. 448A. Also ask for Bulletin 477 giving a summary of "Architects' Views on Flush Valve Applications."

A few additional words in your specifications, such as: "All flush valves shall have an external adjustment for length of flush," will bring all the above advantages.

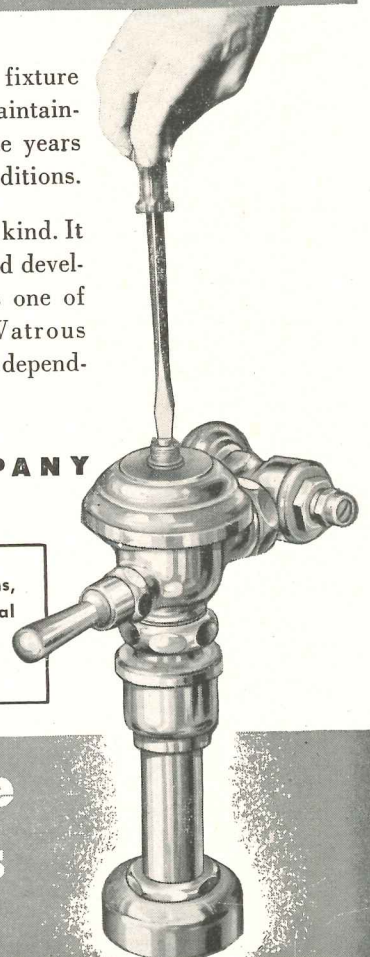

Watrous Adjustable Flush Valves

BOTH DIAPHRAGM AND PISTON TYPES

THE RECORD REPORTS

Allocations Ahead; Shelf of Controls Asked; Housing Bill Compromises Drawn; Steel Outlook Uncertain; Building Spurts when Spring Comes

As the first half of 1948 draws to a close, three major governmental influences appear in the housing picture.

First, the voluntary allocation of scarce commodities, which got the green light from Congress last fall, is taking definite form.

Second, the new defense program with its additional call on materials brings talk of a partial war economy with resultant controls.

Third, the revised general housing legislation (Taft-Ellender-Wagner Bill) promises to affect the long-term prospects in housing.

Voluntary Plans Drawn

Of the four major items in the voluntary allocation program, as worked out under the aegis of the Department of Commerce, freight cars and housing have moved along best, petroleum equipment and farm equipment not so well. Steel allocations have been promised to keep freight car construction up to 10,000 a month.

In housing, most active work has been done in the cast iron industries — soil pipe, pressure pipe, radiation and lower pressure boilers, warm air furnaces, enamel ware fixtures, plumbing drainage fixtures. Advisory committees from all groups have conferred with the Department and, in all but one instance, have favored a voluntary program.

After the preliminary conferences, an overall figure on pig iron requirements had to be studied by a Commerce Department committee to work out a schedule of the number of tons for each category. On completion of the schedule, the individual industries proceed with their procurement. Some of the cast iron industries — furnaces, for instance — also use steel, and sessions were to follow subsequently on steel needs.

All of the programming, it should be pointed out, is geared to a total of one million homes for the year.

Advisory committees were formed for the gypsum board and lath and the plywood industries, but meetings disclosed that their problem was one of distribution, a field into which the voluntary allocation program does not reach.

Controls May Return

Practically everybody in Washington except the Congressional leaders who

would have to pass the requisite bills expects some economic controls to come back. There is a kind of fatalistic waiting, as for the depression. It isn't a matter of politics, so it is argued, or of bureaucratic aggrandizement. "It's in the cards," people say, and go on to explain why.

The military budget will steadily expand. During the immediate 1948-49 fiscal year not much will be spent; it will be a year for letting contracts. More will be spent in the 1950 year, and as for 1951, that will be a year to be reckoned with. The contracts let now will mature. Slowly rising capital plant of the Armed Services will be taking bigger outlays for maintenance.

Shelf of Controls Asked

The military high command, Forrestal especially, press the point at every opportunity that you can't rebuild the Services simply by spending money. You must order steel, wood and other products — and you must be sure that you get them. To make sure, you might need to slip a legally enforceable priorities ticket into your purchase order, or you might need to allocate the major materials in the first place.

Congressional leaders, naturally

enough, campaign against the idea of economic controls. But the campaign speeches, if carefully read, usually contain, so to speak, some out-clauses, accepting the curbs that the exigencies of defense might force. Indeed, the old Defense Committee of the Senate recently went much further: it called in simple language for a shelf of control legislation that might be put into effect fast in case of war. The controls asked for went a little further than those of 1942-45.

This does not mean, of course, that the old wartime L-41 Order is about to be restored. But over the longer pull the very materials used in construction might also be needed by the military. If they are, the military will come first. This includes steel, pig iron, possibly lumber, and certainly labor. The experts of the departments see some possibility, though not much, that all this can be avoided.

Housing Bill Passed

The Taft-Ellender-Wagner housing bill got through the Senate. Major clash arose over the public housing feature, but the Cain amendment to eliminate this was rejected by a vote of 49 to 35, although it was known that there was strong opposition to this feature in the House. The House-approved extension of NHA Title VI loans was made part of the bill.

An anticipated clash between Senator McCarthy, Vice Chairman of the Joint Housing Committee, and Senator Taft over the McCarthy proposals failed to materialize as the two Senators worked out a series of compromises.

(Continued on page 10)

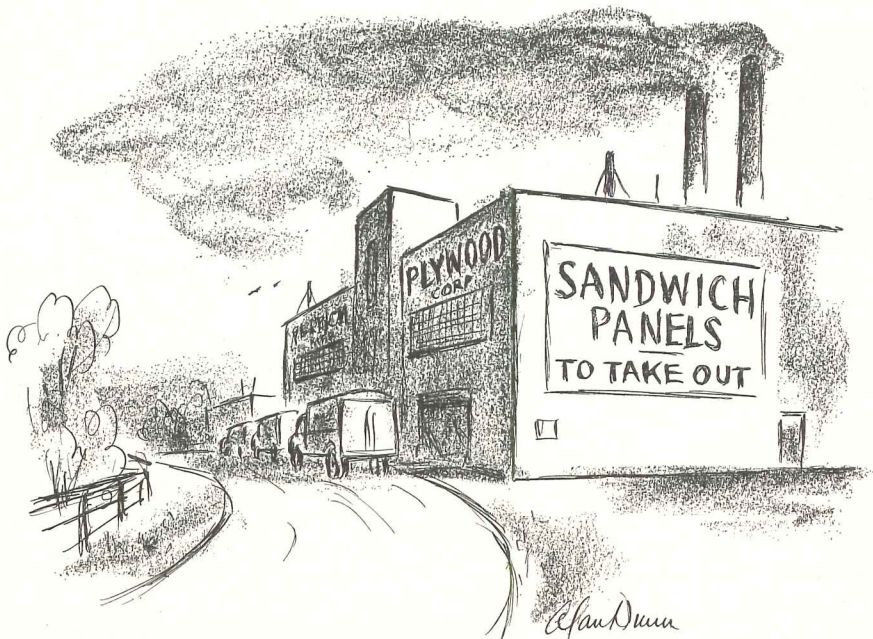

Drawn for the RECORD by Alan Dunn

New uses of Glass

Knowing how vitally important it is to select the proper glazing material for the windows of schools and other public buildings, many architects have standardized on Pittsburgh Glass to glaze such areas. For flawless transparency and maximum surface beauty—Pittsburgh Polished Plate Glass. To meet all sheet glass requirements—Pennvernon Window Glass. And for greater insulating efficiency—Twindow, "Pittsburgh's" new window with built-in insulation. Architects: Overstreet and Town. (Jackson, Miss.)

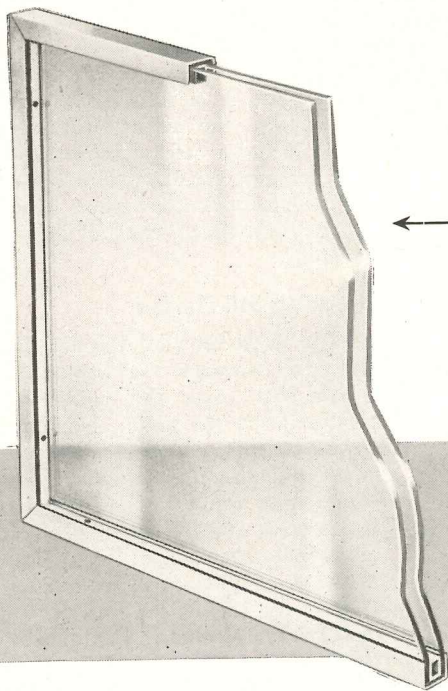

← Twindow—"Pittsburgh's" new window with built-in insulation, consists of two or more panes of Pittsburgh Glass separated by hermetically sealed air spaces, and enclosed in a protecting frame of stainless steel. Its insulating effectiveness becomes greater as additional panes of glass with corresponding air spaces are added. Twindow minimizes downdrafts, cuts heating costs, helps to prevent steamed windows.

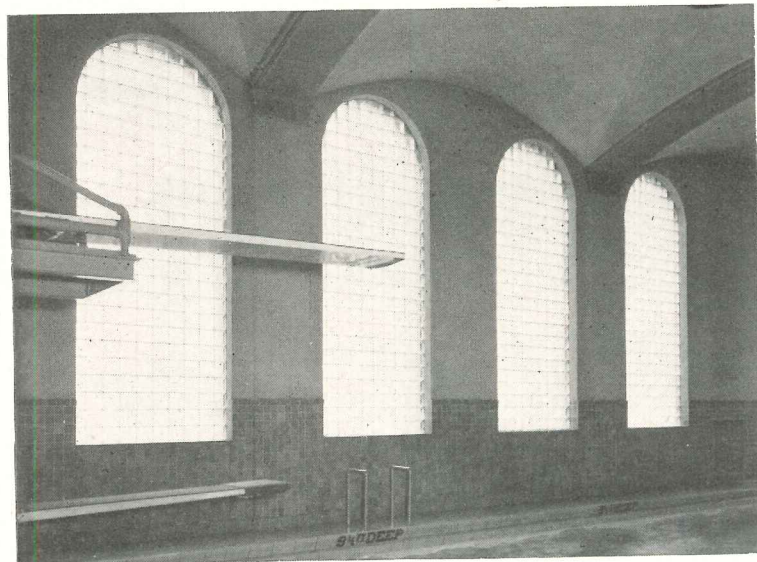

Little wonder that Pittsburgh Corning Glass Blocks are so popular for swimming pool enclosures. These blocks transmit daylight generously. They preserve privacy. And besides being exceptionally attractive in appearance, they have excellent insulating properties that contribute to uniform, economical heating. Architects: Bebb & Jones. (Seattle)

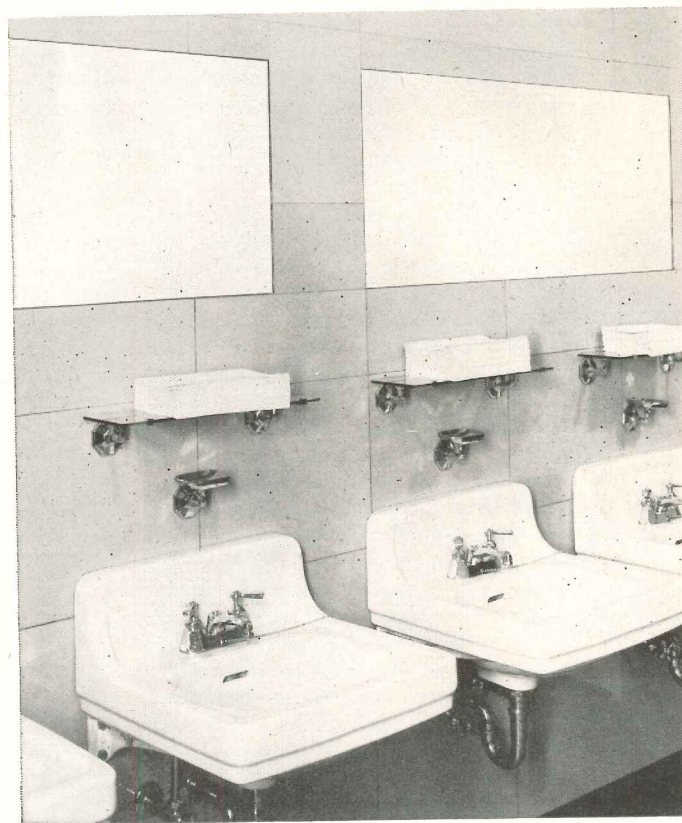

Easy-to-clean—exceptionally good looking, Carrara Structural Glass is ideally suited for public washroom walls, stiles and partitions. Carrara is impervious to moisture, chemicals, pencil marks. It won't fade or stain or absorb odors. It won't check or craze. It is easy to keep spotlessly clean. Available in 10 pleasing colors. Architect: R. A. Spahn. (Cleveland, Ohio)

PITTSBURGH PLATE GLASS COMPANY

in public buildings



Because it has the beauty and transparency of regular Plate Glass yet is four times as strong, Herculite Tempered Plate Glass is regarded by many architects as the ideal material for entrance doors as illustrated; for partitions; and for stair rails, and other applications where transparency combined with strength is desired. Architects: Maritz, Young & Dusard, Inc. (St. Louis)

We believe you will find much to interest you in our illustrated booklet of ideas concerning the use of Pittsburgh Glass in building design. Send the coupon for your free copy.

★ Design it better with

Pittsburgh Glass



PAINTS • GLASS • CHEMICALS • BRUSHES • PLASTICS

Pittsburgh Plate Glass Company
2156-8 Grant Building, Pittsburgh 19, Pa.
Please send me, without obligation, your free booklet entitled "Ideas for the Use of Pittsburgh Glass in Building Design."
Name.....
Address.....
City..... State.....

ITTSBURGH PLATE GLASS COMPANY

THE RECORD REPORTS

(Continued from page 7)

Among Senate amendments of note are provisions for farm housing (\$25 million for the first year's operation), a \$4500 limit on Title I loans, and an increase from 4 per cent to 4½ per cent in the maximum interest rate on G.I. loans. The bill generally provides a corporation to buy, as a secondary mortgage market, FHA and VA loans; it provides for housing research, rental housing, yield insurance, slum clearance and urban redevelopment, as well as public housing.

Steel Outlook Mixed

The European Cooperation Administration, in carrying out the Marshall Plan, will have far-reaching effects on domestic business. Since the inception of the Plan, questions have arisen as to how it will ramify into various industries. A recent study by the House Select Committee on Foreign Aid goes into the role of steel in the program for European recovery.

This study points up the following
(Continued on page 12)

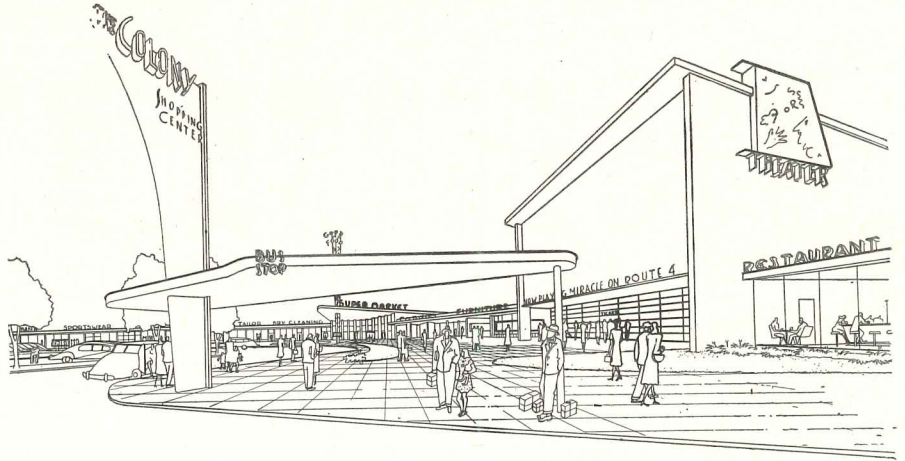

Shopping center planned for Bergen County, N. J.; Kelly and Gruzen, Architects

BUILDING NOTES

Business Center

A \$6,000,000 business center containing a major department store, a market, specialty stores and a 2000-seat cinema, is planned for Bergen County, N. J., on Route 4, at North Hackensack. It will have a frontage of over 3000 ft. on State

Highway 4, the most heavily traveled route in northern New Jersey, and the principal artery linking New Jersey and New York via the George Washington Bridge. An average traffic flow of 23,000 motor vehicles per day past the site, according to a recent official count, makes it an ideal spot for such a center.

(Continued on page 174)

NEWS FROM CANADA

By John Caulfield Smith

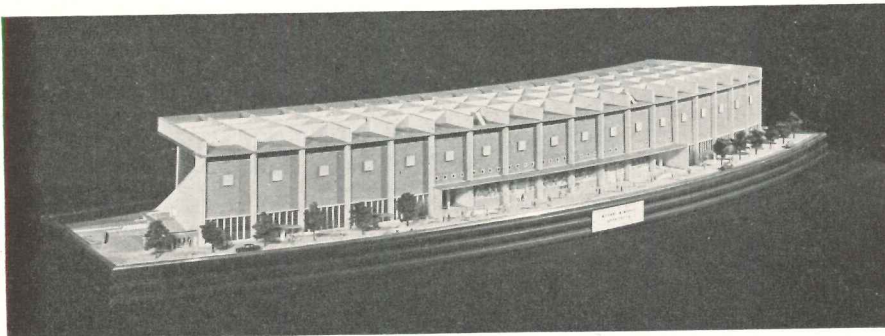
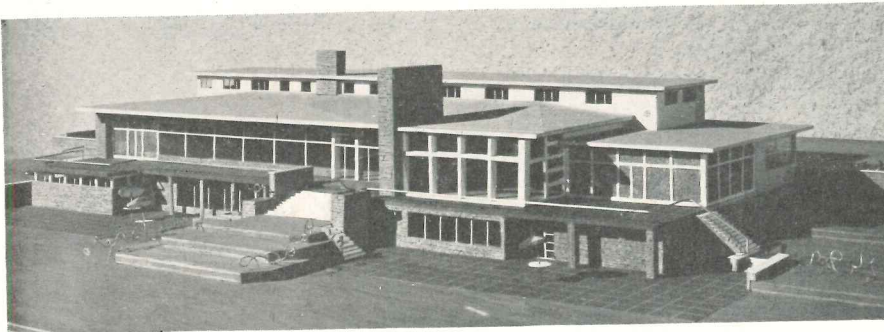

Two new projects among many others that are adding up to a sizable building program for Canada, despite controls and materials difficulties. Upper photo, model of a golf and country club building, Kaplan & Sprachman, architects. Lower, model of a new grandstand for the C.N.E., Toronto, Marani & Morris, Architects

Provinces Aid Housing

A bill to accelerate production of new housing has been enacted by the government of Ontario. Designed for flexible administration, it provides for financial commitments totaling upwards of \$30 million.

The money may be spent in the following ways: (1) up to \$10 million to reduce down payments required on new houses; (2) up to \$2 million to encourage improved construction methods; (3) up to \$15 million to assist in redevelopment of blighted urban areas; and (4) up to \$3 million to enable municipalities to provide sites for rental housing.

The first provision will benefit about 10,000 families by reducing their down payments an average of \$1000 apiece. The second will stimulate interest in arresting and ultimately reducing building costs. The third will help clear slums and replace them with new rental housing. The fourth will ease the burden of municipalities which must provide serviced land for Dominion Government housing projects. It allows a contribution of \$300 per site for a maximum of 10,000 dwelling units.

Ontario's legislation is somewhat more extensive than that passed by the
(Continued on page 156)

DOUBLE DUTY DOUBLE DUTY INSULITE

SEALED LOK-JOINT LATH (INSIDE) . . . BILDRITE SHEATHING (OUTSIDE)

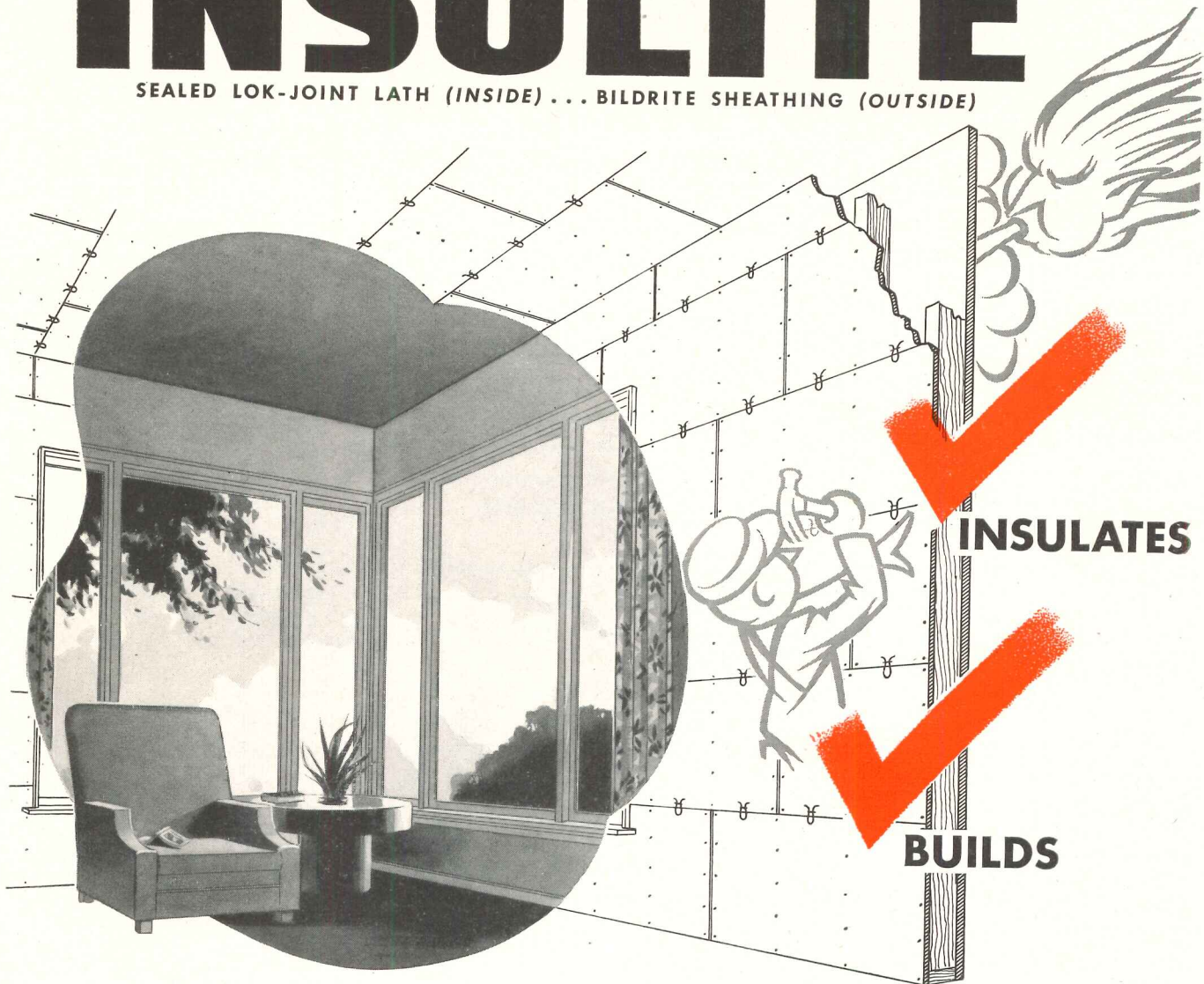

You give your client *double value* when you build this wall—*inside* and *outside*—with Double-duty Insulite. It *insulates* as it *builds* . . . TWO duties for the price of one. On the outside; Bildrite Sheathing not only provides superior bracing strength, but extra insulating value. On the inside; Sealed Lok-Joint Lath does more than provide a firm strong plaster base—it makes an *insulated* plaster base—warmer in winter, cooler in summer. The two together guard against inner wall condensation.

Refer to Sweet's File,
Architectural Section 10a/9

INSULATES AS IT . . .
BUILDS AS IT

INSULITE DIVISION
PAPER
MINNEAPOLIS 2, MINNESOTA



MINNESOTA & ONTARIO
COMPANY

double-duty
INSULITE
The GENUINE

BUILDS
INSULATES

"Insulite" is a registered
trade mark, U.S. Pat. Off.

**FOR SPANS UP TO 180 FEET
A STANDARD CATALOGED
ITEM WITH MACOMBER**

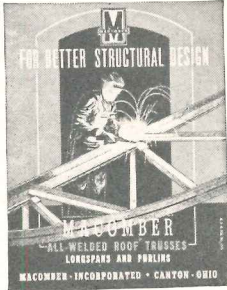

MACOMBER BOWSTRING ROOF TRUSS

DESIGN STANDARDS have been established for all sizes of Macomber Trusses. You can order by catalog number for the required load and span. We have absorbed this colossal engineering task through years of concentration in this field.

RESULT — an accurately engineered, bow-string truss in the quantity you need, laid down at the building site at very nominal cost.

YOUR COMPLETE ROOF SYSTEM — Macomber Trusses, Purlins or Longspans and Steel Decking delivered on schedule from one source warrants investigation. Write us.

ALSO
ROOF PURLINS
LONGSPANS &
STEEL DECKING

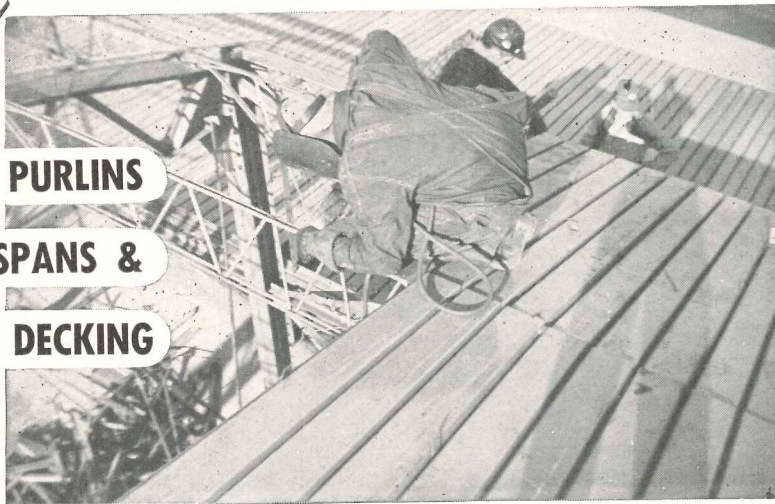

V-BAR JOISTS AND PURLINS • V-STUDS • TRUSSES • LONGSPANS • DECKING

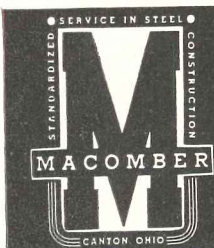

MACOMBER
INCORPORATED
CANTON, OHIO

STANDARDIZED STEEL BUILDING PRODUCTS

THE RECORD REPORTS

(Continued from page 10)

conclusions, among others:

"Steel as a whole is now in tight position domestically and (barring a sharp and protracted recession) will remain so during fiscal 1949 and fiscal 1950, even if exports are held to the annual rate prevailing in the first nine months of 1947.

"During fiscal 1951 and fiscal 1952, on the other hand, domestic supply should improve sufficiently to permit total exports at the 1947 rate and still enable our industry to serve virtually all home needs even if conditions of full employment obtain. Since the pressure for exports to extra-European markets are likely to slacken in three years, the United States ought easily to be able to meet higher-than-1947 demands from Europe should these materialize. . . .

"So far as can be seen at this writing, sheet steel will present serious problems in fiscal 1949 and the forepart of fiscal 1950. . . . Home supply promises to remain inadequate to meet domestic and extra-European export demands during this period even with additional continuous mill capacity in operation. . . ."

Building Spurt Resumes

As spring arrived, home building spurted. Federal statisticians noted the marked seasonal upswing, pointing out that housing starts in the first quarter surpassed the first three months last year by 16 per cent, despite the fact that builders in many areas of the country marked time in January and February because of weather conditions. The high level of housing activity, they found, prevailed in all areas of the country, with particularly noticeable gains in the Middle Atlantic States, the East North Central States and the East South Central States.

Construction expenditures generally in March were up 32 per cent over the corresponding month last year. Private residential construction was reported by the Commerce Department's Construction Division at 58 per cent above March, 1947.

The high production rate of building materials, which continued into the first part of 1948, later slumped somewhat. The inventory picture improved.

Non-farm mortgages were estimated by the Home Loan Bank Board at 7 per cent higher in February than the year before and a third above the aggregate for the same month in 1946. All classes of lenders, except commercial banks, extended their activity — insurance companies by 47 per cent.

(Continued on page 14)



CORKOUSTIC IS BACK

NOW ARMSTRONG'S CORKOUSTIC is available again. This versatile sound absorbing material is ready to help you specify proper sound control, even for areas where there is a serious moisture problem.

This tough, fissured acoustical tile is made entirely of cork particles. Since cork is naturally highly resistant to moisture, Corkoustic is ideal in natatoriums or other areas where humidity is high. Corkoustic is particularly efficient in quieting high pitched noise, absorbing 89% of the sound waves at 4096 cycles.

Each 12" square tile of Armstrong's Corkoustic weighs only 0.84 of a pound—yet it's a full 1½" thick. And a ceiling of Corkoustic has the extra advantage of eliminating condensation and minimizing heat loss.

Armstrong's Corkoustic comes with two coats of resin-emulsion white paint on face and bevels. The finish reflects a high percentage of the light that strikes it, and it is easy to clean and repaint without loss of acoustical efficiency. It is quickly cemented to any rigid, level ceiling. Flexible enough to fit moderately curved ceilings and arches, Armstrong's Corkoustic can help to solve many of your most difficult design problems.

For help with any of your acoustical problems, call your nearest Armstrong office, or write direct to Armstrong Cork Company, 2406 Stevens Street, Lancaster, Pa. 

CORKOUSTIC: Sound Absorption Coefficients at Various Frequencies

Thickness	Size	Coefficients at Cycles Tested						Noise Reduction Coefficient
		128	256	512	1024	2048	4096	
1½"	12"x12"	.06	.16	.73	.69	.56	.89	.55

FOR DETAILS

see the Armstrong pages in section 11-a of Sweet's Catalogue. Or write today for your special copy of the Armstrong insert.

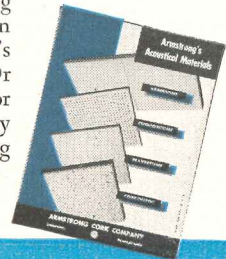

TRAVERTONE IS A TRADE-MARK FOR WHICH REGISTRATION IS PENDING

ARMSTRONG'S ACOUSTICAL MATERIALS
CUSHIONTONE® — TRAVERTONE — ARRESTONE® — CORKOUSTIC®

HOW TO - Eliminate Slipping Accidents In YOUR Plant . . . On YOUR Products

Slipping accidents cost industry thousands of dollars and hundreds and hundreds of man-hours each year. Today it is important to reduce costs and to get maximum production. AW Super-Diamond Floor Plate helps you to do this in three ways: 1. It prevents men from slipping. Wet or dry it grips without a slip. 2. Heavy traffic, oil, heat and fire do not damage it. Therefore maintenance costs are eliminated completely. 3. It is easy to clean (water drains and dries quickly from the exclusive AW Super-Diamond Pattern), and it's easy to match. AW Super-Diamond Floor Plate has over 1001 uses in plants, and on products such as saddle tanks, lift-trucks, machine bases, etc. Do as leading Architects and Designers do and specify AW Super-Diamond Floor Plate . . . for your plant and products.

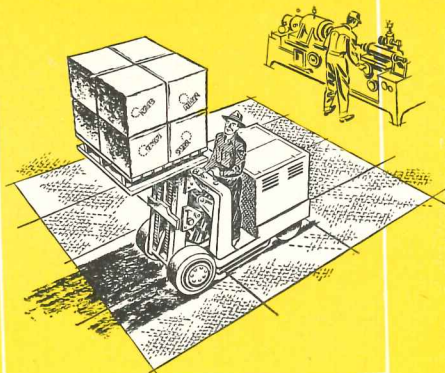

FREE—a 16-page catalog. Mail Coupon for your copy.

AW SUPER-DIAMOND FLOOR PLATE GIVES YOU THE EXTRAS, AT NO EXTRA COST



GRIP WITHOUT A SLIP!

EASY TO CLEAN!

EASY TO MATCH!

AW SUPER-DIAMOND FLOOR PLATES THAT GRIP

Alan Wood Steel Company, Conshohocken, Pa.

Please send me a copy of your informative catalog L-33

Name _____

Company _____

Address _____ City _____ State _____



A Product of **ALAN WOOD STEEL COMPANY**
Other Products: Billets • Plates • Sheets • Carbon & Alloy



THE RECORD REPORTS

(Continued from page 12)

Court Rules on Prices

Late in April the Supreme Court upheld a Federal Trade Commission order outlawing the concerted use of a multiple basing-point delivered-price system in the cement industry. It held that such a system is a collusive price-fixing device which violates both the Federal Trade Commission Act and the Clayton Anti-Trust Act.

In the words of the FTC, the decision "has a definite and substantial impact upon the status of similar systems of identical delivered prices used by a number of heavy goods industries. In the aggregate the commodities priced under such systems are important factors in the cost of housing and other construction and of semi-fabricated products used as raw materials in a host of other industries." Meanwhile, the Commission awaited decisions in three similar cases pending in the United States Circuit Courts of Appeals, two involving steel products and the third, book paper.

Odds and Ends

Other items of note among federal agencies:

1. HHFA has completed its top organization. Besides Raymond M. Foley as HHFA Administrator, other top officials include Franklin D. Richards as FHA Commissioner, John T. Egan as Public Housing Commissioner, and William K. Divers, Chairman, and J. Alston Adams and O. K. LaRoque members, of the Home Loan Bank Board. Tighe Woods is Housing Expediter.

2. A 330-page handbook, *Manual on Wood Construction for Prefabricated Houses*, has been published by HHFA, giving basic scientific and engineering information about wood and wood-base materials used in housing. It is believed to be the first complete technical treatise on efficient utilization of lumber, plywood, fiberboard, and related materials, and embodies results of more than 12 years of research in prefabricated house design and construction by the U. S. Forest Products Laboratory at Madison, Wisc. It is available from the Government Printing Office, Washington, D. C., at \$1.50 a copy.

3. HHFA's Division of Law has prepared a 10-page chart, giving a comparative outline of the principal provisions of state statutes authorizing direct or equity investment in housing by various types of financial institutions.

(Continued on page 16)

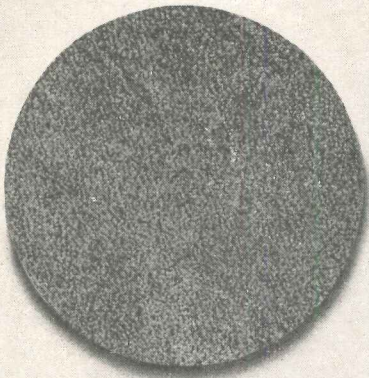

NAUGAHYDE KEEPS YOUNG

AND BEAUTIFUL!

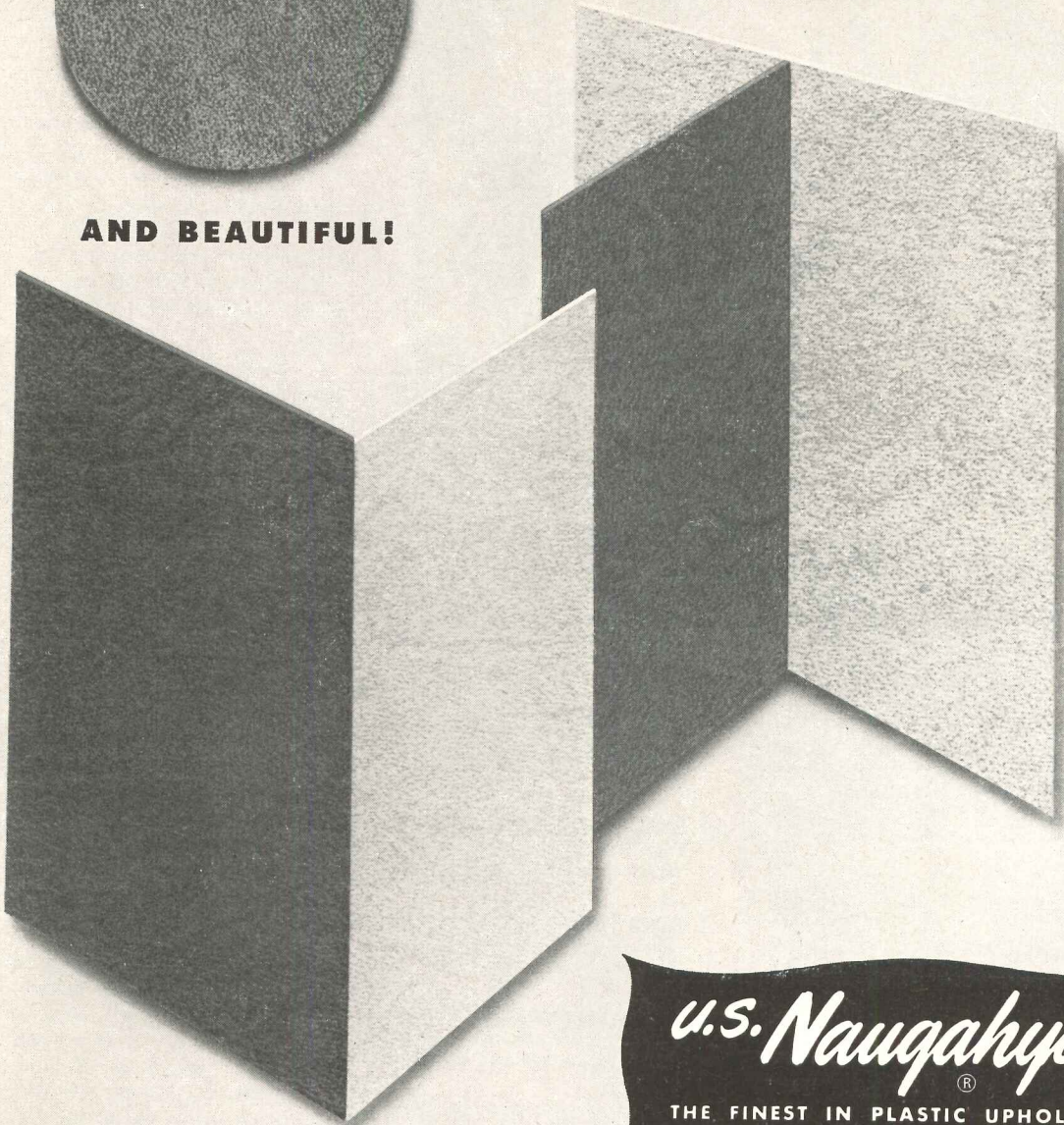

u.s. Naugahyde
THE FINEST IN PLASTIC UPHOLSTERY



Decorators' Colors
Won't fade or grow dull



Sunproof
Won't crack, flake or chip



Scuff-Proof
Tough—wear resistant



Stain-Proof
Grime can't dig its way in



Washable
Spills wipe off easily



Non-Inflammable
Won't support a flame



Flexible
Easy to tailor

MADE ONLY BY

U.S. RUBBER
SERVING THROUGH SCIENCE



COATED FABRICS DIVISION • MISHAWAKA, INDIANA

UNITED STATES
RUBBER COMPANY

(Continued from page 14)

Underground War Plants?

Army engineers say they have not abandoned totally their plans for underground installation of war plants. In fact, investigations are going forward now on two fronts: (1) underground explosion tests are being started in central Utah and western Colorado; and (2) the Guy B. Panero engineering firm of New York City is continuing to investigate the feasibility, the cost of construction and operation of underground plants and storage sites.

By no means have all types of underground facilities been ruled out by the Army.

A recent report did state that the idea of placing huge steel mills, aircraft plants and heavy manufacturing industries beneath the earth's surface is considered a stupid one. The report cited a danger to worker morale and the ease with which poison and radioactive gases could be carried through the large ventilating systems which would be required to serve installations of this kind.

Army technicians point out, however, that studies for underground or "protective" construction are continuing.

The explosive tests now beginning will take at least five months to complete. T.N.T. charges up to 32,000 pounds will be used to demonstrate to engineers the effects on underground structures.

Quite frankly, the Army says results will establish design criteria for future subterranean structures and tunnels able to resist enemy bombings. The tests will be made in four types of soil — dry sand, wet sand, dry clay and wet clay; and in four kinds of rock — granite, sandstone, limestone and shale. The explosions will provide the Army engineers with basic data on tunnel depth and underground structure design, not only for their own strategic purposes but for industrial plant location as well.

The Panero firm surveys are being pushed to provide information for potential protection of war plants. "The overall program," said the War Department, "entails investigations in this country and in Europe. It includes cost and technical data on existing foreign underground installations, insofar as is practicable." Involved also are aboveground and underground comparisons of cost, construction and operation.

In making his findings, Panero and his staff of engineers have access to design, construction costs and operat-

(Continued on page 18)

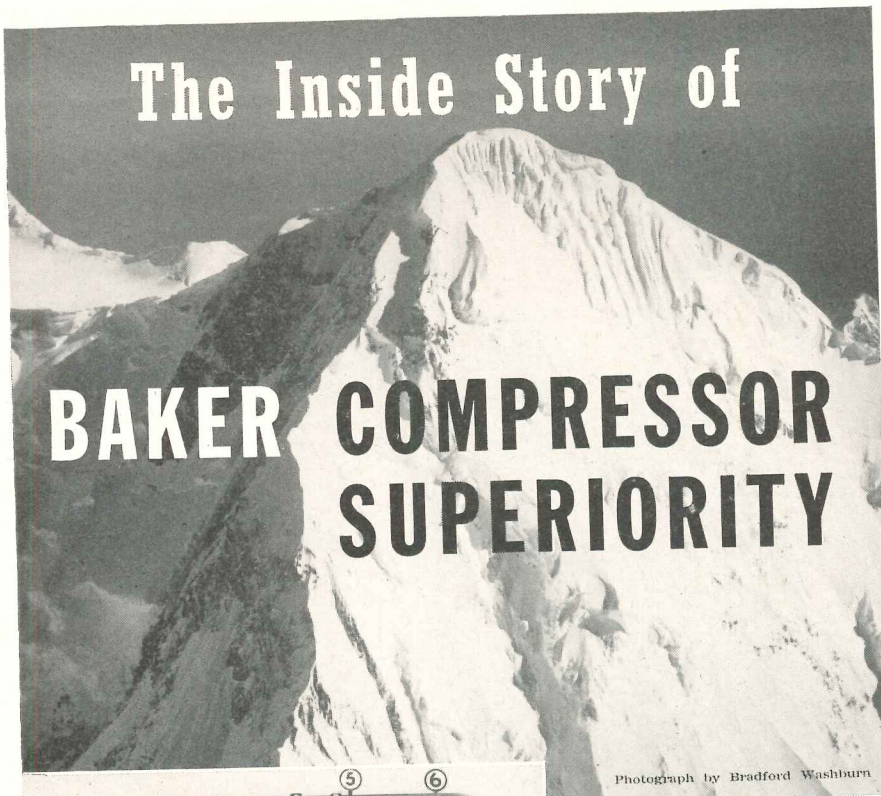

The Inside Story of

BAKER COMPRESSOR SUPERIORITY

Photograph by Bradford Washburn

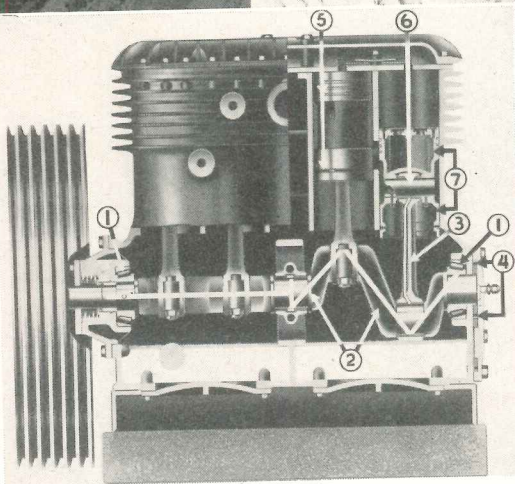

- 1 TIMKEN TAPERED ROLLER BEARINGS** — Eliminate friction and lateral play . . . assure perfect alignment.
- 2 THREE-BEARING CRANK-SHAFT** — Drop-forged, extra heavy . . . rifle-drilled for full pressure lubrication . . . large bearing surfaces.
- 3 I-BEAM SECTION CONNECTING RODS** — Drop-forged . . . crank bearing of Nickelite for long wear.
- 4 GEAR-TYPE OIL PUMP** — Provides positive, high-pressure lubrication throughout the compressor.
- 5 SPECIAL FORMULA PISTON RINGS** — Precision-machined to correct tension in honed cylinders.
- 6 FULL LENGTH PISTON PINS** — Hollow construction . . . hardened steel . . . accurately ground to fit honed bushings.
- 7 DOUBLE TRUNK PISTONS** — Precision ground and with piston pins centrally located to distribute side thrust evenly. c-1

For over 40 years Baker has built its reputation on quality and sound engineering. Today it offers a full line of Freon and Ammonia equipment — compressors, condensers, coils, valves, fittings, etc. — all engineered to highest standards. No matter what your requirements in air conditioning or refrigeration, it will pay to consult Baker. Write today for address of nearest office: Baker Ice Machine Co., Inc., South Windham, Maine.

BAKER

Zone balanced • Engineered

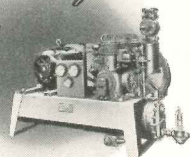

AIR CONDITIONING AND REFRIGERATION

FACTORIES AT OMAHA, NEB. AND SOUTH WINDHAM, ME. • • HEADQUARTERS: SOUTH WINDHAM, ME.

To specify **FULL VALUE** in fixtures

CHECK 'EM FOR TURRET* LAMPHOLDERS

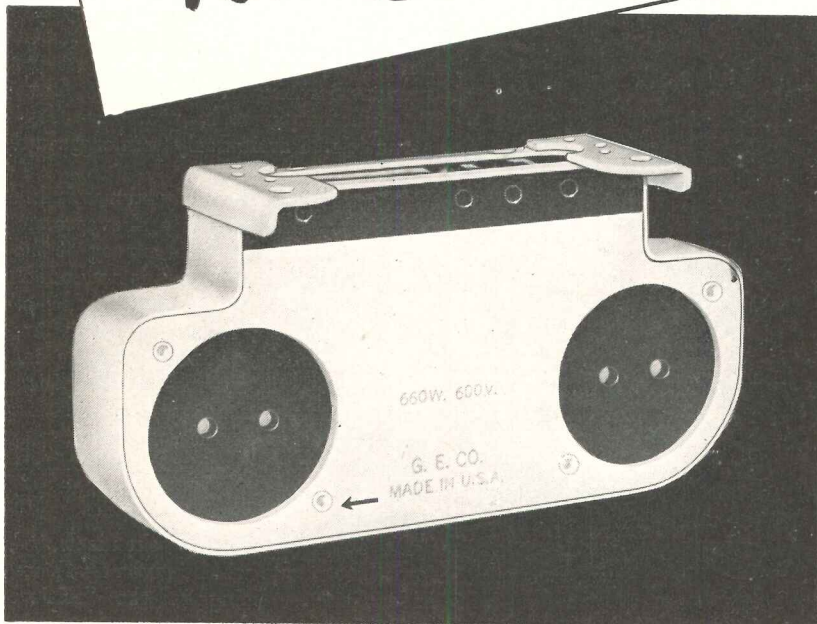
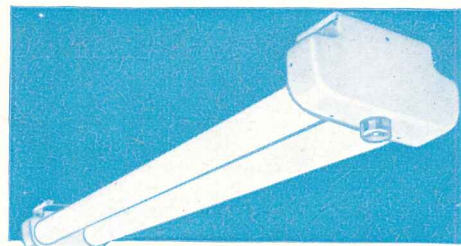

SAFETY FEATURE—The hazard of falling lamps is virtually eliminated when fixtures are equipped with General Electric Turret lampholders. Each spring-backed plate contains two holes into which the fluorescent lamp pins are inserted. Snug fit and uniform spring tension hold the lamps in place.

CONVENIENCE—Lamps can be installed from either end of the Turret lampholder. Either face of the lampholder is depressed by one end of the lamp, and the other end is then slipped into place. The lamps are automatically held in firm contact. Removal of dead lamps is equally easy. The starter socket is built-in, and is readily accessible.

ECONOMY—Turret lampholders have the ability to withstand rough handling without being damaged, which means that there is no costly replacement problem. Elimination of safety gadgets means another saving. In addition, the availability of three sizes of Turrets simplifies fixture design, and permits a wide selection of lamp arrangements.

SERVICE—The sturdy metal construction of General Electric Turret lampholders is designed to stand hard usage. All working parts are made to give long service—as long as the fixture itself lasts. This durability helps to provide top-notch fixture performance . . . maximum lighting efficiency.

When you specify fixtures for fluorescent lighting in industrial and commercial buildings, look into the “user advantages” first. Check the four big features that make General Electric Turret lampholders appeal to your clients. It’s an “inside story” of top-notch fixture performance.

Remember, only General Electric makes Turret lampholders. Many fixture manufacturers use them, but the best way to be sure that they are in the lighting fixtures you call for is to specify *General Electric Turret lampholders* every time.



A new General Electric Turret lampholder will accommodate three lamps. Two-lamp lampholders are also available, with receptacles spaced on 3½-inch or 5-inch centers. For additional installation and design data, write to Section Q12-65, General Electric Company, Bridgeport 2, Connecticut.

*Trade-mark Reg. U. S. Pat. Office.

GENERAL  ELECTRIC

Planning a
Chemical Plant
Oil Refinery
Paper Mill?
 ... or an addition ●

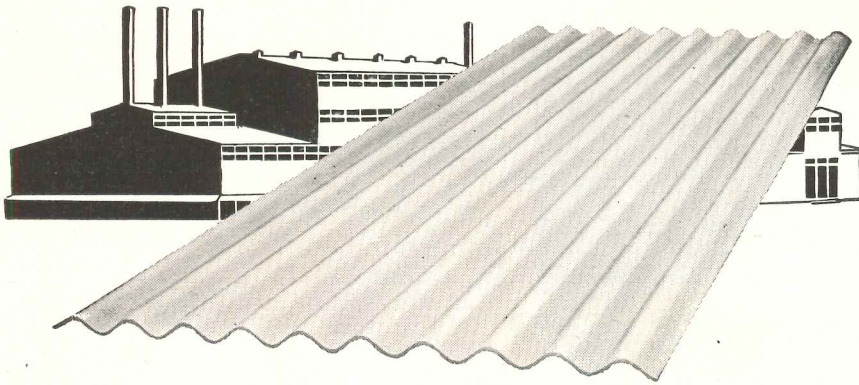

You can now get
ASBESTONE

Asbestos-Cement Corrugated Roofing & Siding

—the lifetime roofing and siding that's fireproof and corrosion-proof. Asbestone can't be damaged by weather, rats, or termites. No painting. No upkeep.

Here are a few of the many prominent users:

- LONE STAR CEMENT CORP.
- CALIFORNIA OIL CO.
- CHAMPION PAPER and FIBRE CO.
- ETHYL CORPORATION
- FREEMPORT SULPHUR CO.
- NEW ORLEANS PUBLIC SERVICE
- MOBILE PAPER MILL CO.
- CROSBY CHEMICALS, INC.
- STANDARD OIL OF N. J.
- UNIVERSAL ATLAS CEMENT CO.

Why we can assure you early delivery

We are concentrating on production of this single industrial product. Stocks are now ample to make some immediate shipments. Free Engineering Service, available on request, shows how Asbestone can be adapted to your needs.

ASBESTONE CORPORATION

5300 TCHOUPITOULAS STREET NEW ORLEANS 15, LA.

Specialists in Asbestos-Cement Building

Products for over 25 Years

THE RECORD REPORTS

(Continued from page 16)

ing experience records of several major firms engaged in plant design, construction and operation during World War II. This part of the investigations is under the policy direction of the Army and Navy Munitions Board.

The entire subject was pointed up recently in a statement by Lt. Gen. R. A. Wheeler, Chief of Engineers: "There are problems, however, in planning for future construction requirements which I think you will find interesting. Underground construction is one field. The results of the bombing in the last war, the advent of the atom bomb, and the realization that ocean barriers are no longer adequate to prevent bombing of this country, have intensified interest in protective construction. Particularly underground protection.

"Because it is obviously impracticable to provide protection by aboveground construction, a thorough survey of the country's mines and caves is now under way. Moreover, a few pilot models of underground industrial activities are being installed to obtain further information. It is agreed that dispersion is the more practical means of securing protection; our studies, however, will give us valuable data on the few critical activities that will require special protection."

It is expected that chemical and ordnance plants will be given first consideration as being in the "critical activities" class as this program develops.

Management-Labor Agreement

It is going to be easier, from now on, for the construction industry to handle its own jurisdictional disputes.

Since May 1, building labor has been under a new management-labor agreement with work stoppages ruled out pending issuance of binding decisions. It may not be an overall panacea for labor ills in the construction trades, but it is a major step toward harmony and has drawn the plaudits of government.

The National Labor Relations Board welcomes the new plan as an influence to lower its case load. The Department of Labor observed: "Costly and time-consuming jurisdictional strikes in the building and construction industry appear to be coming to an end."

The agreement placed in effect May 1 provides that pending a decision by the joint board formed specifically to review jurisdictional disputes, or arrangements within the A.F. of L., there can be no work stoppages arising from this cause.

(News continued on page 20)

ONLY *Olsonite* SEATS Have All These Selling Features!

Whether White, Black, Color or Pearlescent, It Is the Same Solid Olsonite Throughout . . .

Long Life, Stain-proof Bumpers Used On All Olsonite Seats . . .

Complete line of Models and Colors

Scientifically Designed In Both Proportion and Contour with Smooth Curves and Edges . . .

When Installed, No Metal Fastenings Show — Brass Metal-Hinge Posts are Smartly Olsonite Covered . . .

Exclusive New, Patented Olsonite Hinge Design.

Absolutely Flat Under-Surface — Avoids Dirt and Germ Deposits!

Beautiful, Lustrous, Olsonite **ALL THE WAY THROUGH!**

NOT CONCAVE —
NOT CORE-COVERED —
NOT HOLLOW —
BUT LUSTROUS OLSONITE
ALL THE WAY
THROUGH!

Lowest-Priced Seat of This Quality on the Market — and Guaranteed a Lifetime!

Olsonite Seats are far superior to ordinary wood, rubber, sheet-covered, or plastic-coated seats . . . and are far greater values! They won't crack, chip, peel, stain, or lose luster! Non-inflammable! No exposed metal. (Sold only through authorized plumbing and heating jobbers to Master Plumbers.) Contact your local jobber today. For full information write Olsonite Plastics Division.

Olsonite PLASTICS DIVISION

DIVISION OF SWEDISH CRUCIBLE STEEL COMPANY, DETROIT 11, MICH. (856) BUTLER AVE.



THE RECORD REPORTS

(Continued from page 18)

ON THE CALENDAR

June 11: 25th Annual Golf Tournament for Architects in the Southeast, East Lake Country Club, Atlanta, Ga.

Through June 12: Exhibition of about 80 original drawings and renderings and several models of prize-winning and other designs entered in the Jefferson National Expansion Memorial Competition for a waterfront memorial at St. Louis, Architectural League of New York, 115 E. 40th St., New York City.

June 12-22: Construction Industries Home and Building Exposition of Southern California, Pan-Pacific Auditorium, Los Angeles, Calif.

June 15-17: 2nd Short Course in Hot Water and Steam Heating, sponsored jointly by The Institute of Boiler and Radiator Manufacturers and the University of Illinois, University of Illinois, Champaign-Urbana, Ill.

June 21-25: 51st Annual Meeting, American Society for Testing Materials, Detroit, Mich.

June 22-25: Annual Convention, American Institute of Architects, Hotel Utah, Salt Lake City, Utah.

June 28-July 1: First Congress of the International Union of Architects, Lausanne, Switzerland.

June 30-July 3: National Catholic Building Convention and Exposition, Stevens Hotel, Chicago, Ill.

July 6-10: 2nd International Store Modernization Show, Grand Central Palace, New York City.

July 21-23: Summer Convention, American Society of Civil Engineers, Olympic Hotel, Seattle, Wash.

Aug. 2-27: 2nd Annual Silversmithing Workshop Conference for teachers, Rhode Island School of Design, Providence, R. I.

Aug. 4-8: 2nd Annual Pacific Northwest Arts and Crafts Fair, Bellevue, Wash.

CONSTRUCTION REPORTS

New High Mark Set

A new first-quarter high mark in dollar volume of construction contracts has been set in the 37 states east of the Rocky Mountains with a total of \$1,986,936,000, F. W. Dodge Corp. statistics show. This volume surpasses by 23 per cent the previous first-quarter record established last year.

While the dollar volume of residential contracts was maintained at a level equal to the first quarter of last year, non-residential contracts were up 42

(Continued on page 22)

STYLING CAN CHANGE WITH THE SEASONS WHEN BASED ON *Oak Floors*

In your houses, owners can change from winter to summer furnishings and still have harmonious rooms—provided the flooring is oak.

The mellow luster of this rich wood blends subtly with the soft, cool pastels of summer, and glows warmly amid the bolder tones of winter decor. Seasonal styling becomes far more flexible and economical when such an adaptable flooring is used.

The same adaptability to new ideas and styles lasts for the life of the home. New wallpaper or paints meet no discords from beautiful oak. The natural grain and texture form a harmonious base for whatever colors and styling may be chosen in replacing the original decor.

The most versatile floors you can suggest—and at the same time, those with the most enduring beauty—are oak.

ASK FOR ARCHITECTS' DATA BOOK—which gives quick and usable information for specifying, laying, finishing and maintaining oak floors. Available from your local oak flooring dealers or from the National Oak Flooring Manufacturers' Association, 814 Sterick Building, Memphis, Tenn.

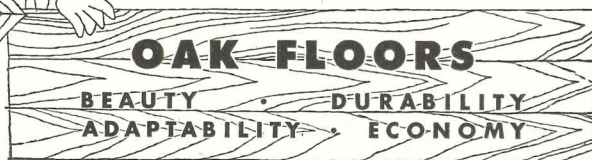
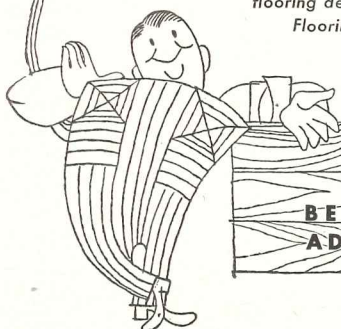

When your plans include an ORGAN INSTALLATION...



You'll find this Reference Manual most helpful and informative. A copy is yours for the asking!

A 16-page brochure covering features you must look for in any organ you specify: organ nomenclature; American Guild of Organists' playing specifications; relationship of tone, space and cost, acoustics, pipe organ vs. electronic organ; essential and auxiliary equipment; installation requirements and techniques.

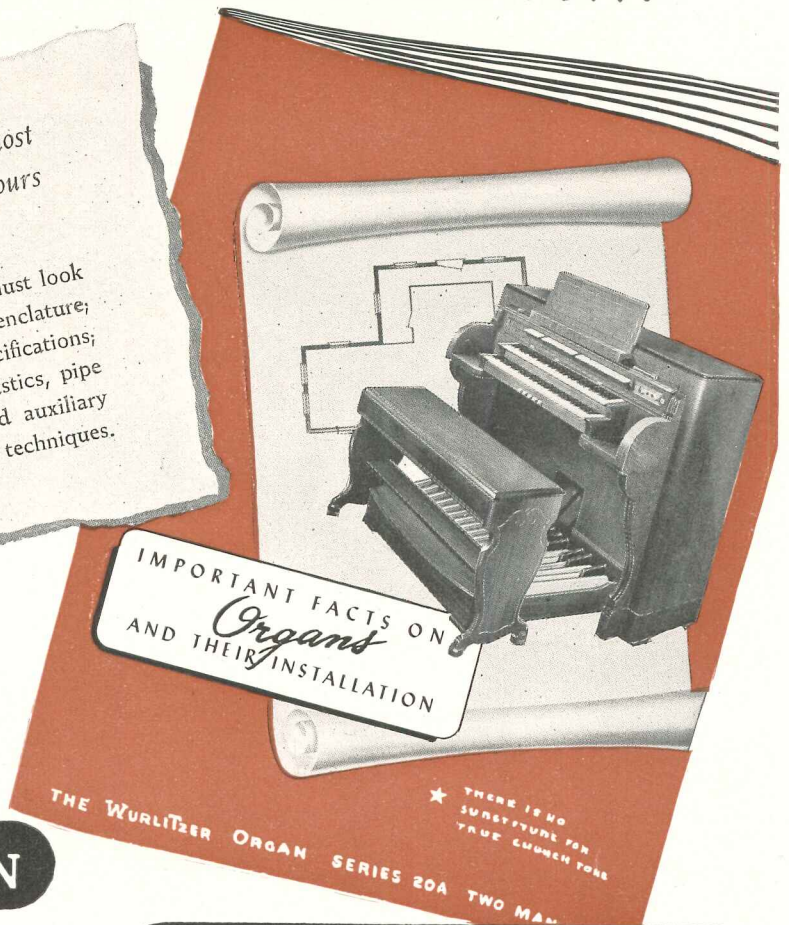

**SPACE SAVED
by the**

WURLITZER ORGAN

Series 20 Two-Manual

**can be used for a larger, better
equipped church**

● If you compare the 600 to 11,500 cubic feet that are generally necessary to house a large organ, to the 98 cubic feet required for a Wurlitzer Electronic Organ, it immediately becomes apparent that here is a saving of space that can be utilized for many additional facilities. In churches, for instance, this space-saving factor can be interpreted in terms of increased seating capacity, a Pastor's study, a Sunday school room, recreation center or kitchen . . . all desirable features . . . made possible through the space and money saved by a Wurlitzer Organ installation.

When you specify a compact Wurlitzer Organ you eliminate space-consuming blowers, organ chambers, huge pipes and relay rooms without sacrificing traditional organ music.

To achieve this valuable saving of space, the classically beautiful Wurlitzer Organ has added electronic selection, modification and amplification of tone to principles that have always governed fine organ tone production.

Architects, everywhere, are finding that by recommending a Wurlitzer Organ, they can include many extra facilities at little or no increase in the original building cost and, hence, get faster acceptance of their plans.

consider these Extra Facilities then specify with confidence the Wurlitzer Organ



additional pews



pastors study



kitchen



nursery

THE RUDOLPH WURLITZER CO.
N. Tonawanda N. Y., Dept. AR 6.

Gentlemen:

Please send me, without obligation, your 16-page Reference Manual... "Important Facts On Organs And Their Installation."

Name.....

Company.....

Address.....

City..... Zone..... State.....

Another

★ michaels installation

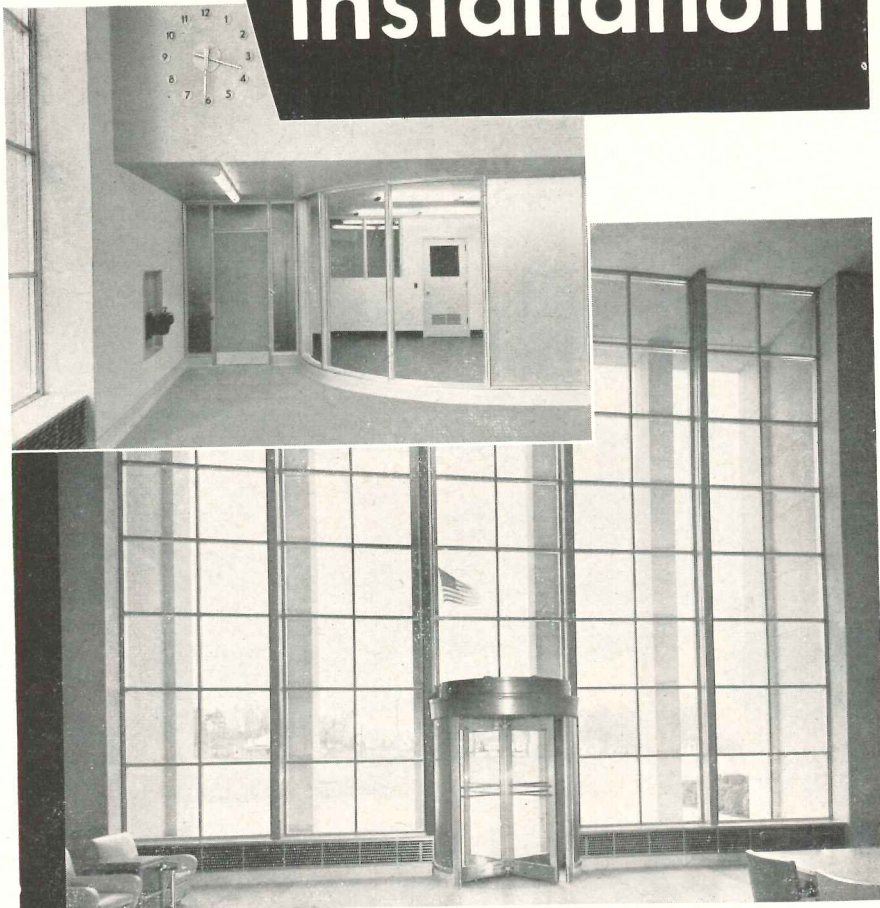

Ford Motor Company, Hapeville, Ga.

Albert Kahn, *Architect*

The general acceptance of Michaels building products by architects and builders everywhere is the result of our ability to follow implicitly minute details, and faithfully reproduce in metal the most exacting specifications. Then, too, Michaels is well-known for the high quality of its products and dependable service. ¶ The partial list at the right will give you an idea of the wide range of Michaels products. It's a distinguished line, made by a concern rated high among the producers of ferrous and nonferrous metal products. Michaels, with seventy-eight years' experience, has much to offer the architect and builder. Whatever building product you need, if it's made of metal, chances are we have it or can make it. Talk over your requirements with our engineers. Upon request we'll be glad to send you complete information on specific products.

MICHAELS PRODUCTS

- Bank Screens and Partitions
- Welded Bronze Doors
- Elevator Doors
- Store Fronts
- Lettering
- Check Desks (standing and wall)
- Lamp Standards
- Marquises
- Tablets and Signs
- Name Plates
- Astragals (adjustable)
- Stair Railings (cast and wrought)
- Wrought and Cast Radiator Grilles
- Grilles and Wickets
- Kick and Push Plates
- Push Bars
- Cast Thresholds
- Extruded Thresholds
- MI-CO Parking Meters
- Museum Trophy Cases

The MICHAELS ART BRONZE COMPANY, 234 Scott St., Covington, Ky.
Member of the National Association of Ornamental Nonferrous Metals Manufacturers

THE RECORD REPORTS

(Continued from page 20)

per cent and heavy engineering awards increased 46 per cent over the comparable period of 1947.

Gains in dollar volume of construction contracts were shown for 11 of the Corporation's 15 reporting regions. Those areas whose gains were equal to or greater than the average for the 37 states are: upstate New York; the Middle Atlantic states; the Southeastern states; southern Michigan; northern Illinois, Indiana, Iowa and Wisconsin; eastern Missouri, southern Illinois, western Tennessee and Arkansas; Louisiana and Mississippi; Minnesota, North Dakota, South Dakota; western Missouri, Kansas, Nebraska and Oklahoma. Other regions showed a gain over the first quarter of last year except New England, down 7 per cent; metropolitan New York and northern New Jersey, off 2 per cent; southwestern Ohio and Kentucky, down 19 per cent; and Texas, off 4 per cent.

Industrial Capacity Expanded

American industry has invested approximately \$3 billion in manufacturing plant expansion and new industrial buildings in the 37 states east of the Rocky Mountains since the close of World War II, an analysis made by F. W. Dodge Corp. shows.

The actual dollar volume of contracts awarded for manufacturing building for the two and a half years covering the last quarter of 1945, the full calendar years 1946 and 1947, and the first quarter of 1948 was \$2,725,856,000. The figures are for structures only and exclude processing machinery and equipment contained in buildings.

Processing industries, such as chemicals, rubber and textiles, accounted for \$1,595,363,000 in building contract awards during the 30-month period, while the manufacturing industries, such as automobile and machinery manufacturing, accounted for the remainder.

The largest volume was for buildings to be used in food processing, with a total of \$412,284,000, followed by: chemicals with a total of \$299,080,000; refineries, \$193,345,000; textiles, \$151,066,000; and paper and pulp processing, \$131,778,000.

Among the mechanical group, iron and steel manufacturing led with a total in building contracts of \$212,074,000, followed by automobile and aircraft manufacturing buildings valued at \$107,989,000.

The volume of manufacturing building contracts declined in 1947 to \$941,427,000 from the exceptionally high total

(Continued on page 160)

brings not only **MORE LIGHT** *without annoying glare* *
 ... but a **NEW** experience in **SEEING!**

**...the ceiling that actually
 GLOWS WITH LIGHT!**

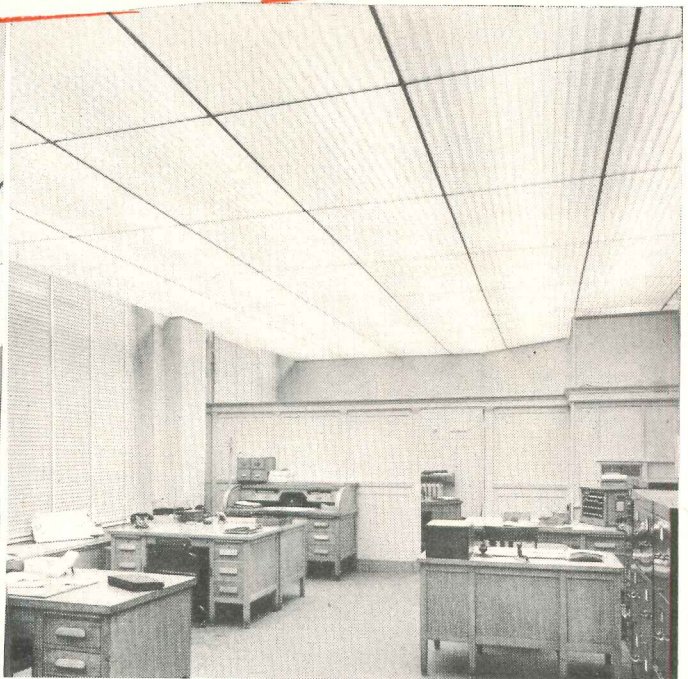
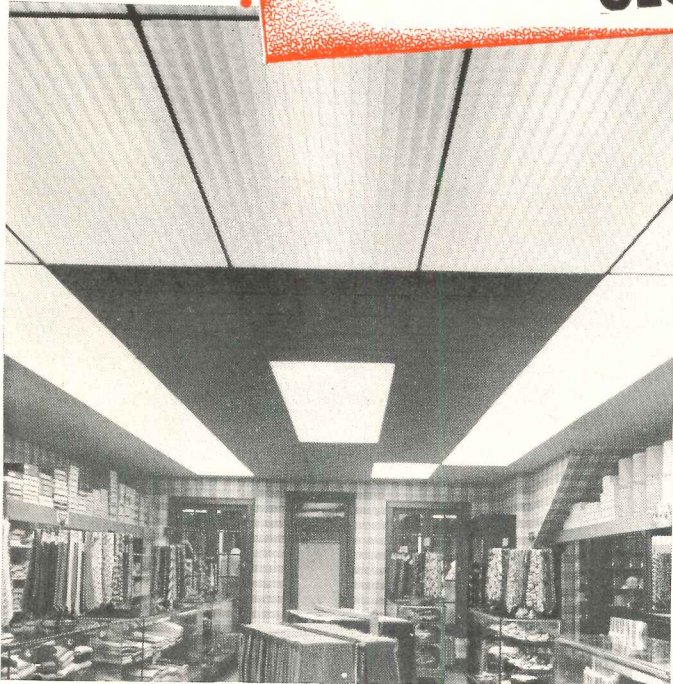

SEE OUR EXHIBIT
**STORE
 MODERNIZATION
 SHOW**
 JULY 6th to 10th
 Grand Central Palace
 NEW YORK CITY

for schools — stores — offices

High levels of illumination... 100—120—130—or more foot-candles... but only a light meter would know it! That is the miracle of Sky-Glo... high levels of illumination without awareness of the fact! Ease of seeing... without awareness of the reason —so restful... unobtrusive... and stimulating is Sky-Glo lighting!

SKY-GLO IS A SYSTEM OF VINYLITE LOUVERS, CHANNELS AND FITTINGS... that make possible ceilings which glow with light. For rooms old and new. Expensive ceiling alterations are unnecessary as Sky-Glo can be installed below the ceiling, at any point from 8'6" above floor. Vinylite is a product of Bakelite Corp.; has a light transmission factor of 71%.



Sky-Glo cannot be described. You must actually be present in a Sky-Glo illuminated room. Then, only, can you appreciate the statement that Sky-Glo makes possible a new experience in seeing! Then, only, can you see what a *difference* there is between a glowing ceiling of light and individually hung light sources.

READY, NOW, is the Sky-Glo "Bulletin SC"... the book that tells why Sky-Glo is one of the most significant developments in fluorescent lighting... in terms of lighting performance... in terms of installation... application... modernization... maintenance! Mail the coupon for your free copy.

*At 130 footcandles, ceiling brightness is less than 1 candle per sq. in. (452 foot lamberts).

BENJAMIN
TRADE MARK

Sky-Glo

LUMINOUS
 LOUVERED
 LIGHTING
 SYSTEM

Distributed Exclusively Through Electrical Wholesalers

BENJAMIN ELECTRIC MFG. CO.
 Dept. Q1, Des Plaines, Illinois

Send, without cost or obligation, copy of Sky-Glo "Bulletin SC", just off the press.

Name

Company

Address

City State

B-2661

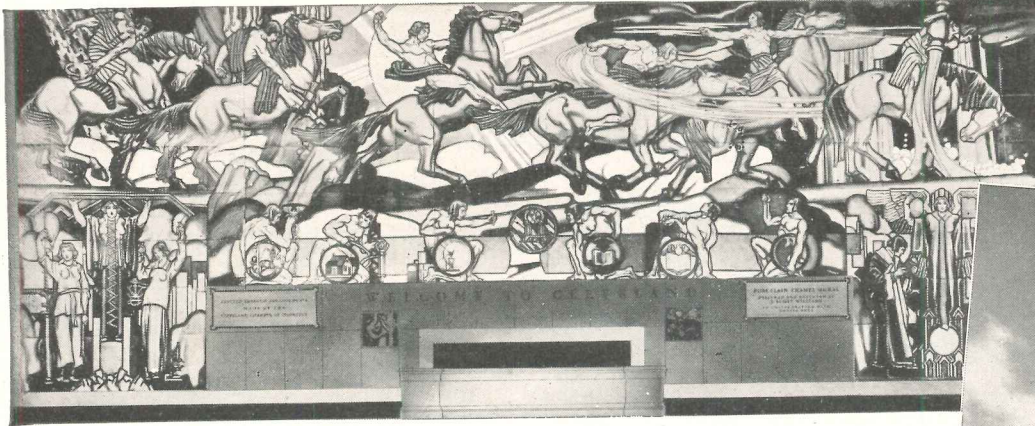

Multi-colored porcelain enamel mural, size 72 feet by 28 feet, given to the Union Terminal, Cleveland, Ohio, by the Ferro Enamel Corp., Cleveland. Designed and executed by J. Scott Williams in Seaporcel's plant.

SATTLER'S DEPT. STORE
Buffalo, N. Y.



Sign by FLEXLUME SIGN CO.
Buffalo, N. Y.

An old FACADE gets a FACE LIFTING JOB

↓ [A New Store Gets an
Eye-catching Sign] →



MILES SHOE STORE—34th Street, New York City
Michael Polom, N. Y., Designer

SEAPORCEL PORCELAIN enamel manufacturing techniques and metal fabricating skill produce store and building fronts which are a distinct departure from the commonplace flat surface designs. Today Seaporcel turns out your project in almost any *odd* shape you want . . . be it fluted, reeded, pyramided or serrated like the Miles Shoe Store Building. Here's a building that certainly was given a master face lifting.

THE OLD FACADE—(if we dare say so)—was a wreck. The transformation is a thing of beauty . . . sparkling, colorful . . . 55 ft. high by 25 ft. wide with separate raised letters. Here the designer's ideas were given full sway. Permanence and beauty fully complement other elements of design. Seaporcel can be hung as a curtain to hide outmoded building exteriors.

MR. ARCHITECT, MR. DESIGNER . . . here are new avenues of approach for versatile and flexible design. Seaporcel Porcelain Enamel is available in almost limitless colors—and quite a few textures—that remain lustrous in a material that is practically ageless. Light in weight, Seaporcel is easily handled. Installation is by concealed fastenings.

Write today for catalog showing applications and current jobs.

SEAPORCEL PORCELAIN METALS, INC.

Formerly Porcelain Metals, Inc.

28-02 Borden Avenue, Long Island City 1, N. Y.

Complete American Federation of Labor — Metal Fabricating and Enameling Shop

Also manufactured on the West Coast by

SEAPORCEL CORPORATION OF CALIFORNIA

represented by: Douglas McFarland & Co., 1491 Canal St., Long Beach, California

SEE OUR
BOOTH NO. 12

Store Modernization Show

July 6th to 10th

GRAND CENTRAL PALACE

Seaporcel

Member: Porcelain Enamel Institute, Inc.

SEE OUR
CATALOG IN
SWEET'S

It's good electrical practice ...

to make sure that continuous duty, constant load fusible devices have a rating at least 50% in excess of the amp load.



USE SWITCH FOR ...

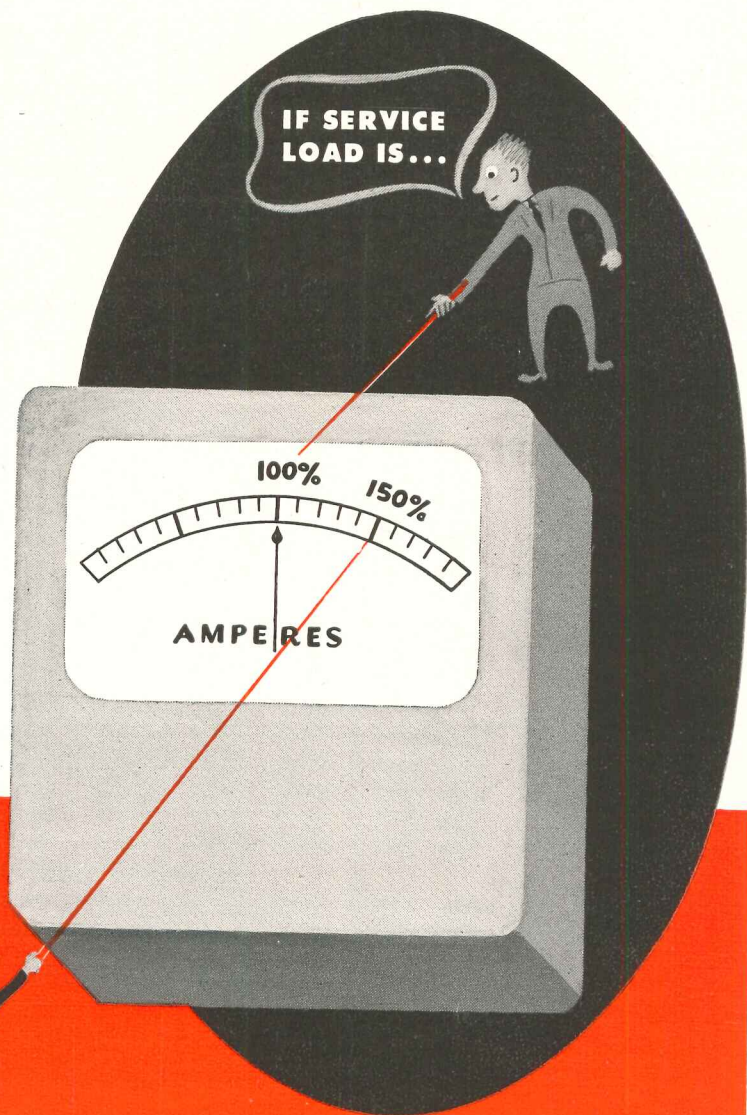

It's good Electrical Practice

... to use a Trumbull Type D Enclosed Safety Switch for entrance service and general purposes. Its 30 amp capacity is more than adequate for such duties as controlling small motors.

Front operated, the Trumbull Type D switch has a sturdy, "KING-SIZE" HANDLE ... more than AMPLE WIRING SPACE ... double break, SILVER TO SILVER CONTACTS under heavy pressure ... contacts fully enclosed for protection of op-

erators, and holes provided for sealing by power company. With its modern streamlined design, the Type D is the switch of tomorrow - today.

Safety switches or switchboards, motor controls or control centers, branch circuit distribution systems or main feeders ... it's always good electrical practice to specify Trumbull, the name that safeguards your safe practice. THE TRUMBULL ELECTRIC MANUFACTURING CO., Plainville, Conn. Other factories and offices throughout the United States. Foreign representation.

MEN WHO OBSERVE THE
BEST PRACTICES MAKE
IT A PRACTICE TO USE
TRUMBULL

TRUMBULL  ELECTRIC

CONSTRUCTION COST INDEXES — Labor and Materials

United States average 1926—1929 = 100

Presented by Clyde Shute, manager, Statistical and Research Division, F. W. Dodge Corporation, from data compiled by E. H. Boeckh & Associates, Inc.

NEW YORK

ATLANTA

Period	Residential		Apts., Hotels, Office Bldgs. Brick and Concr.	Commercial and Factory Buildings		Residential		Apts., Hotels, Office Bldgs. Brick and Concr.	Commercial and Factory Buildings	
	Brick	Frame		Brick and Concr.	Brick and Steel	Brick	Frame		Brick and Concr.	Brick and Steel
1920	136.1	136.9	123.3	123.6	122.6	122.8	122.9	108.6	109.8	105.7
1925	121.5	122.8	111.4	113.3	110.3	86.4	85.0	88.6	92.5	83.4
1930	127.0	126.7	124.1	128.0	123.6	82.1	80.9	84.5	86.1	83.6
1935	93.8	91.3	104.7	108.5	105.5	72.3	67.9	84.0	87.1	85.1
1939	123.5	122.4	130.7	133.4	130.1	86.3	83.1	95.1	97.4	94.7
1940	126.3	125.1	132.2	135.1	131.4	91.0	89.0	96.9	98.5	97.5
1941	134.5	135.1	135.1	137.2	134.5	97.5	96.1	99.9	101.4	100.8
1942	139.1	140.7	137.9	139.3	137.1	102.8	102.5	104.4	104.9	105.1
1943	142.5	144.5	140.2	141.7	139.0	109.2	109.8	108.5	108.1	108.7
1944	153.1	154.3	149.6	152.6	149.6	123.2	124.5	117.3	117.2	118.2
1945	160.5	161.7	156.3	158.0	155.4	132.1	133.9	123.2	122.8	123.3
1946	181.8	182.4	177.2	179.0	174.8	148.1	149.2	136.8	136.4	135.1
Dec. 1947	231.3	234.1	219.8	218.4	215.1	189.3	194.0	166.7	164.5	169.4
Jan. 1948	238.8	242.7	225.1	224.6	220.0	191.9	196.7	168.6	166.7	171.4
Feb. 1948	239.2	243.2	225.2	224.8	220.1	194.4	198.5	172.1	172.7	173.8
Mar. 1948	244.8	246.4	233.9	237.0	229.9	194.6	198.7	172.4	172.9	174.0
	% increase over 1939					% increase over 1939				
Mar. 1948	98.3	101.2	79.1	77.6	76.6	125.6	139.1	81.2	77.5	83.7

ST. LOUIS					SAN FRANCISCO					
1920	118.1	121.1	112.1	110.7	113.1	108.8	107.5	115.2	115.1	122.1
1925	118.6	118.4	116.3	118.1	114.4	91.0	86.5	99.5	102.1	98.0
1930	108.9	108.3	112.4	115.3	111.3	90.8	86.8	100.4	104.9	100.4
1935	95.1	90.1	104.1	108.3	105.4	89.5	84.5	96.4	103.7	99.7
1939	110.2	107.0	118.7	119.8	119.0	105.6	99.3	117.4	121.9	116.5
1940	112.6	110.1	119.3	120.3	119.4	106.4	101.2	116.3	120.1	115.5
1941	118.8	118.0	121.2	121.7	122.2	116.3	112.9	120.5	123.4	124.3
1942	124.5	123.3	126.9	128.6	126.9	123.6	120.1	127.5	129.3	130.8
1943	128.2	126.4	131.2	133.3	130.3	131.3	127.7	133.2	136.6	136.3
1944	138.4	138.4	135.7	136.7	136.6	139.4	137.1	139.4	142.0	142.4
1945	152.8	152.3	146.2	148.5	145.6	146.2	144.3	144.5	146.8	147.9
1946	167.1	167.4	159.1	161.1	158.1	159.7	157.5	157.9	159.3	160.0
Dec. 1947	217.5	220.9	194.9	193.4	196.3	209.7	209.3	196.8	200.6	200.2
Jan. 1948	220.6	224.0	198.1	200.9	199.6	212.7	210.5	199.8	206.8	202.9
Feb. 1948	221.4	224.8	199.4	202.3	200.4	213.8	211.5	201.6	208.9	203.9
Mar. 1948	223.6	227.5	200.2	202.9	201.3	214.0	211.7	201.9	209.1	204.1
	% increase over 1939					% increase over 1939				
Mar. 1948	102.9	112.6	68.6	69.4	69.1	102.7	113.2	71.9	71.6	75.2

The index numbers shown are for combined material and labor costs. The indexes for each separate type of construction relate to the United States average for 1926-29 for that particular type — considered 100.

Cost comparisons, as percentage differences for any particular type of construction, are possible between localities, or periods of time within the same city, by dividing the difference between the two index numbers by one of them; i.e.:

$$\begin{aligned} \text{index for city A} &= 110 \\ \text{index for city B} &= 95 \end{aligned}$$

(both indexes must be for the same type of construction).

Then: costs in A are approximately 16 per cent higher than in B.

$$\frac{110-95}{95} = 0.158$$

Conversely: costs in B are approximately 14 per cent lower than in A.

$$\frac{110-95}{110} = 0.136$$

Cost comparisons cannot be made between different types of construction because the index numbers for each type relate to a different U. S. average for 1926-29.

Material prices and wage rates used in the current indexes make no allowance for payments in excess of published list prices, thus indexes reflect minimum costs and not necessarily actual costs.

These index numbers will appear whenever changes are significant.

Anaconda

THROUGH-WALL FLASHING

drains itself *dry*
on a level bed

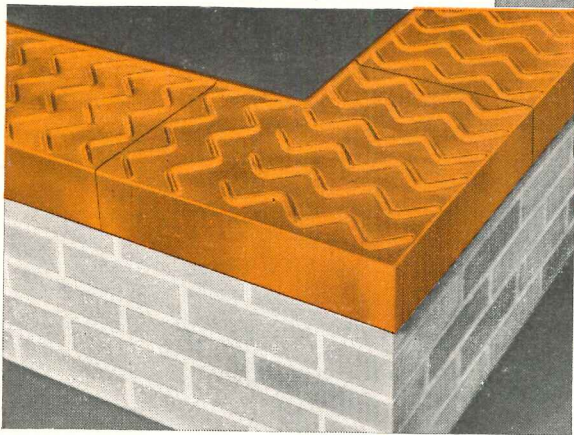

Wherever through-wall flashing is specified, as at parapets and in masonry walls, this patented Anaconda flashing offers both efficiency and durability. The design of Anaconda Through-Wall Flashing provides a complete mortar bond and prevents lateral movement in *any* direction.

Sheet metal men like the die-stamped dam and corrugations that make this flashing easier and faster to lay. End joints are made simply by overlapping and nesting one corrugation. The flat selvage permits neat, sharp bends for counter flashing, without danger of distortion

that might inhibit drainage. Die-stamped corner pieces (for both inside and outside corners) are nested in place as easily as the straight lengths.

Since it "drains itself dry on a level bed," Anaconda Through-Wall Flashing provides positive, controlled drainage. For detailed information, see our file in Sweet's.

4856A

ANACONDA
from mine to customer

Anaconda

COPPER

THE AMERICAN BRASS COMPANY
General Offices: Waterbury 88, Connecticut
Subsidiary of Anaconda Copper Mining Company
In Canada: ANACONDA AMERICAN BRASS LTD.
New Toronto, Ont.

REQUIRED READING

AMERICA'S DESIGN HERITAGE

American Interior Design. The tradition and development of domestic design from Colonial times to the present. By Meyric R. Rogers, Curator, Decorative Arts and Industrial Arts, the Art Institute of Chicago. W. W. Norton & Co., Inc., New York. 8½ by 11 in. 309 pp. illus. \$20.00.

Probably the highest praise that can be bestowed on any author is the statement that he successfully accomplished what he set out to do and that his purposes were worthy. A casual perusal of Meyric Rogers' book will show the reader the embracing scope of his treatment of our American domestic design heritage. Careful reading will prove his successful completion of this self-appointed task of providing in one volume not only the *what* and *when* of our domestic design development, but the *how* and *why*. In this he has provided a lucid, much-needed and sure-to-be-appreciated guide to the understanding and appreciation of American interior design. In one readable and beautifully illustrated volume he has accomplished what he set out to do, which, in brief, and in excerpts from his own words, was: "This book is intended to survey the field of our artistic expression which is concerned directly with our homes. These settings which we have created or adapted to our more immediate daily needs have been, and are, not only a more or less involuntary expression of our ideals, but are a constant if silent force in the formation of our esthetic standards. . . . This story of our design for living cannot, however, be satisfactorily told in its major implications without also considering first the main outline of the historical complex of which it is both an active part and a symbol. . . . An effort has been made to characterize the historical and social background . . . and to sketch briefly the architectural developments which accompanied it. . . . Though four out of its five sections are concerned with the past, the book has been considered very largely as providing a background against which the present will appear more intelligible. . . . It is hoped that as a whole this book will emphasize the continuity of our cultural development."

His subject matter is arranged historically in five chapters: "The Age of Settlement, 1630-1730; The Age of Colonial Achievement, 1730-1790; The Age of Federal Adolescence, 1790-1850; The Age of Continental Expansion and Industrial Empire, 1850-1920; The Age of Social Readjustment, 1920-Present." Following this is a section of some 80 pages devoted to the history of

American interiors as presented in those remarkable American rooms in miniature created by Mrs. Thorne, whose models are now the property of the Art Institute of Chicago. This series of "plates" is most attractively and intelligently presented, for the most part by reproduction in full color accompanied by a similar photograph in black and white, and opposite each plate is explanatory text and a small illustration of the house, or type of house, in which the interior might be found originally. In addition, a clear and carefully selected glossary explains technical terms necessarily used throughout the book. Biographical notes concerning the designers, craftsmen, and architects mentioned are a most helpful addition, and a selected bibliography points the way to additional reading for those who would care to go further into particular aspects of the general subject. A comprehensive index completes the work.

While handsome and readable in its typography, and splendid in clarity of printing as well as in the selection of illustrations, the text is too frequently interrupted by an interposed two or three pages of solid illustrations and caption. In giving credit where credit is due, Morris Sanders might have been listed as the designer of the modular furniture shown on page 192. But such criticism may be carping rather than constructive.

To anyone, including architects, desiring to understand as well as to review the American design heritage, this one book comes nearest to being the *sine qua non*. Mr. Rogers has accomplished his purpose.

SWISS WOODEN HOUSES

Schweizer Holzhäuser. By Paul Artaria. Wepf & Co. Verlag Basel. 6¼ by 9 in. 127 pp. illus. Fr. 10. — Suisse

The Swiss have always been adept in the use of wood, using it both logically and imaginatively. After a brief historical introduction, well illustrated with photographs beginning with hewn-log houses with their low pitched roofs and their broad, spreading eaves. It includes discussion of characteristics of houses from other lands including a seventeenth century American farmhouse (called a "blockhaus"). The rest of the book is devoted to interesting photographs, plans, sketches, and details showing a wide variation of Swiss houses from the typical chalet to contemporary houses that might well find their counterpart in the American scene. There is inspiration

for American architects throughout this little volume. Roof treatments, interesting balconies, wall textures, simple interior details, are sure to have suggestions for adaptation to the smaller American house.

LOCAL ORIGINS

Local Styles in English Architecture. An Inquiry Into Its Origin and Development. By Thomas Dinham Atkinson, F.R. I.B.A. London, W. 1 (15 N. Audley St.), B. T. Batsford, Ltd. Winter 1947. 5½ by 8½ in. VIII + 183 pp. Drawings, prints and photographs.

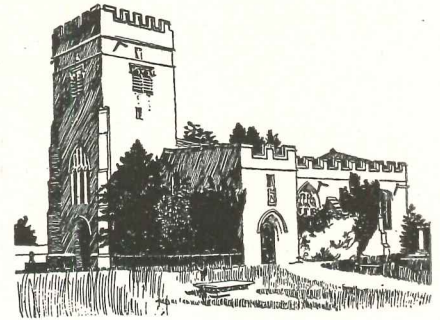

Having established in a previous work, "English Architecture" (now in its 12th edition), the distinctly national character of British building in overall comparison with types and styles elsewhere in Europe, the author in this volume turns his discernment to variations *within* the Island, analyzing local differences, refinements, and the reasons therefor down to shire and even borough influences. Churches predominate as subject and illustration, principally because of most abundant survival from early times, though secular buildings are treated to the extent that they exist and exemplify regional varieties and causations.

The author demonstrates that the great periods of local style were the fourteenth and fifteenth centuries for church architecture and the sixteenth and first half of the seventeenth for domestic, due to the acceleration of culture and activity of mind concurrent with these times, and the consequent elaboration in architectural forms and materials which made variety possible. Economic and social changes, the relative cessation of religious building, and the introduction of classic forms brought with them the practical disappearance of distinctly local architecture in the early 1700's.

Mr. Atkinson develops the primary sources of regional variation as seven — *Geology and Geography, Race, Religion, Foreign Influence, Wealth, Transport and Fashion* — in accounting for such unquities as the pinnacles and parapets of church towers in Somerset, the plain mass and substance of the northern types (see cut), decorative half-timber-

(Continued on page 30)

save your building

WITH A WATERFOIL RAINCOAT

now you can protect your
weatherbeaten plant and
decorate it to look like new...

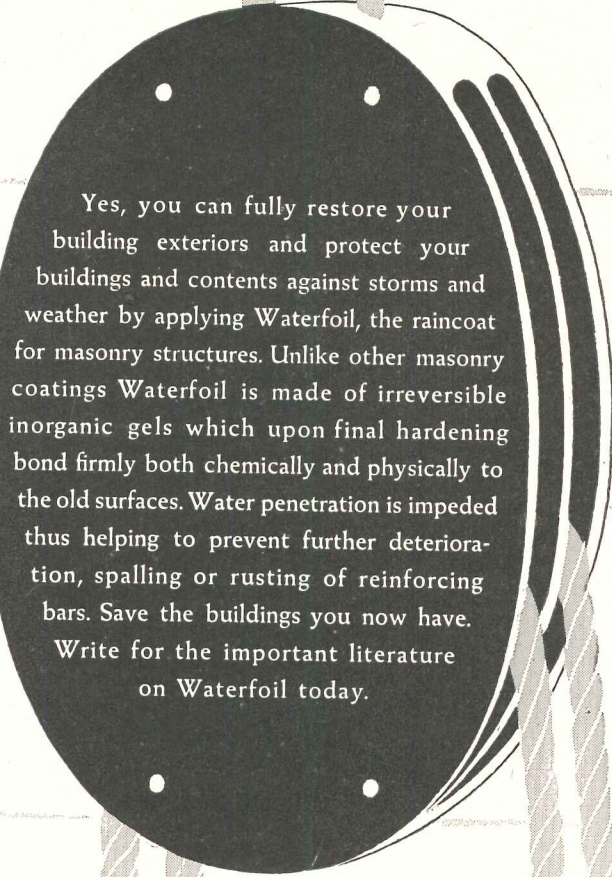

Yes, you can fully restore your building exteriors and protect your buildings and contents against storms and weather by applying Waterfoil, the raincoat for masonry structures. Unlike other masonry coatings Waterfoil is made of irreversible inorganic gels which upon final hardening bond firmly both chemically and physically to the old surfaces. Water penetration is impeded thus helping to prevent further deterioration, spalling or rusting of reinforcing bars. Save the buildings you now have. Write for the important literature on Waterfoil today.

WATERFOIL
THE UNIQUE TREATMENT FOR EXTERIOR MASONRY SURFACES



A.C. HORN CO., INC.

manufacturers of materials for building maintenance and construction
10th STREET & 44th AVENUE, LONG ISLAND CITY 1, NEW YORK
HOUSTON • CHICAGO • SAN FRANCISCO • TORONTO

DAYLITER *by* Smithcraft

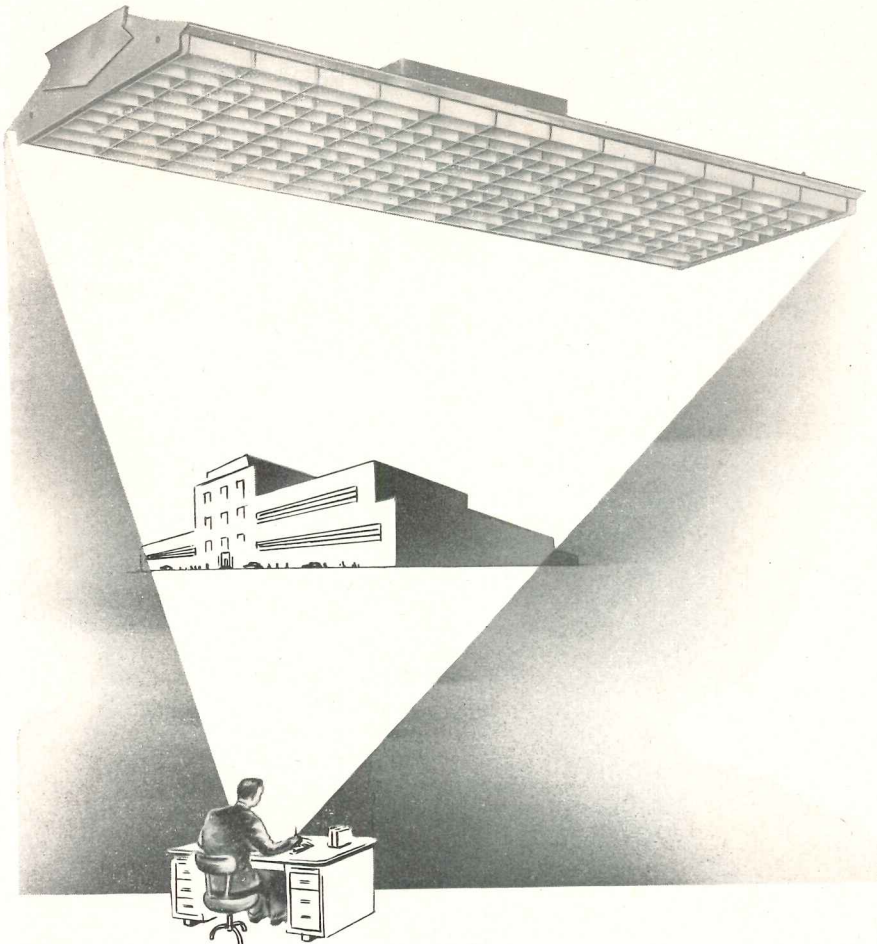

For DAYLIGHT INSIDE

• A fluorescent fixture — original in design — slim and smart in appearance, with exclusive louver pattern for high efficiency, better light output and lower brightness. Now being used with complete satisfaction in schools, offices and stores. Dayliters are easily installed and maintained. For complete information address Dept. 500.

Smithcraft
LIGHTING DIVISION
CHELSEA 50, MASSACHUSETTS

REQUIRED READING

(Continued from page 28)

ings along the Welsh Border, and the remarkable structural timber-work of East Anglian hammer-beam roofs. In the course of historical and critical development under each heading, the author turns up and down such a number of related and contributing byways that the book provides immense cultural, social, and political information and entertainment, in addition to important and original material concerned purely with the development of local styles in English architecture.

BASIC FACTORY PLANNING

Planning Industrial Structures. By Clarence W. Dunham. New York 18 (330 W. 42nd St.), McGraw-Hill Book Co., Inc., 1948. 6 by 9 in. 480 pp. illus. \$6.00.

Without presuming to tell architects anything about esthetics, the author has written an immensely practical book dealing with that area of planning industrial structures in which the architect and the engineer work together. The book deals with the principles and planning of structures that precede the engineering calculations: the choice of materials and general type of construction; discussion and illustration of good practice in building with steel, wood, and concrete; and considerable discussion of the basic action of structures, especially those used in industrial construction. The book nevertheless is exceptionally well illustrated with structural details.

Although structure and allied matters occupy the bulk of the book, there are chapters also on daylighting, electric lighting and power, ventilation. Here again the book is concerned more with basic planning than with the details and calculations of the final engineering. The author is Associate Professor of Civil Engineering, Yale University and a Consulting Structural Engineer.

ADDENDA

The attractive and logical Redevelopment Plan for Grand Haven (ARCHITECTURAL RECORD, Feb., 1948) was completely developed as a collaborative thesis by the authors when students in the Department of Architecture, University of Cincinnati, under the direction and criticism of Dean Ernest Pickering and Mr. Marshall Rainey.

Credit should have been given to the firm of Edward E. Ashley, consulting engineers, for their work in connection with mechanical, electrical, and lighting of the Lord and Taylor Westchester Store, ARCHITECTURAL RECORD, Apr., 1948.



Now Ready!

...an interesting new booklet on



Hydro-Flo^{*} Heating

You've never seen a more attractive, convincing presentation of *forced hot water heating* . . . prepared especially to answer the pressing demand for information on B & G *Hydro-Flo* Heating Systems. You'll

find this booklet an excellent help in visualizing to your prospects the benefits of today's preferred heating method . . . a valuable contribution in the interest of better heating for modern homes.



Send for Your Copy

Beautifully printed in four colors—every page alive with interesting, vital information on forced hot water heating . . . fascinating reading for home planners. Shows how the comforts of radiant heating can be obtained with radiators, panels, baseboards or convectors—plus the convenience of year 'round, low-cost hot water for kitchen, laundry and bath.

Please write on your business stationery.

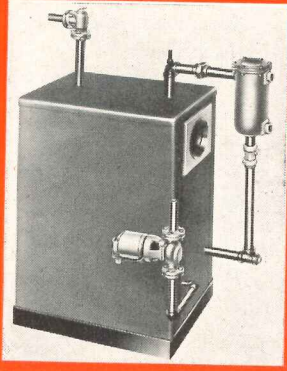

BELL & GOSSETT

Company

Dept. AO-32, Morton Grove, Illinois

*REG. U. S. PAT. OFF

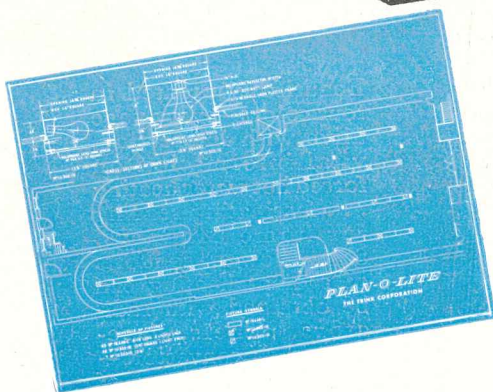

Roberts Bros., Springfield, Ill. This modern men's store is illuminated by an impressive combination of fluorescent and incandescent in continuous rows. Incandescent boxes (No. 1U505-12) are semi-recessed; moldings match L-I-N-O-L-I-T-E Series 12.

FOR TRUE LIGHTING SATISFACTION . . .

A FRINK *PLAN-O-LITE*

Whatever your lighting requirements may be, there's one way to be *sure* of achieving complete satisfaction and maximum efficiency. Take advantage of the unique *PLAN-O-LITE* service offered by Frink, makers of famous high-quality *L-I-N-O-L-I-T-E* fluorescent fixtures.

This convenient service supplies you with a *PLAN-O-LITE*, an individual layout of your proposed fluorescent installation, *custom-designed*

by Frink's engineers to meet your lighting needs. There is no extra charge for a *PLAN-O-LITE*. It's your guarantee of *planned* lighting efficiency at *standard-fixture* costs.

Send for the sample packet of *PLAN-O-LITE* layouts and photos of resulting installations. See for yourself how *PLAN-O-LITE* has benefited many of America's leading corporations. Mail the coupon today.

CLIP THIS TO YOUR LETTERHEAD



THE FRINK CORPORATION
27-01 Bridge Plaza North, L. I. C., N. Y.
Without cost or obligation, send your sample packet of *PLAN-O-LITE* fluorescent layouts and photos to the

Attention of . . .
() also please send catalogue of new Frink fluorescent fixtures.

6-AR

There's a Frink *L-I-N-O-L-I-T-E* fixture correctly engineered for every commercial fluorescent lighting need. Seventeen standard designs of highest quality workmanship and materials, each available with matching incandescent down-lights if desired. Check coupon at left for your copy of the Frink catalogue today.



THE FRINK CORPORATION

27-01 BRIDGE PLAZA NORTH, LONG ISLAND CITY, N. Y.

ENTERPRISE BURNERS . . . 3-time Choice!

IN CHURCH - AND SCHOOL

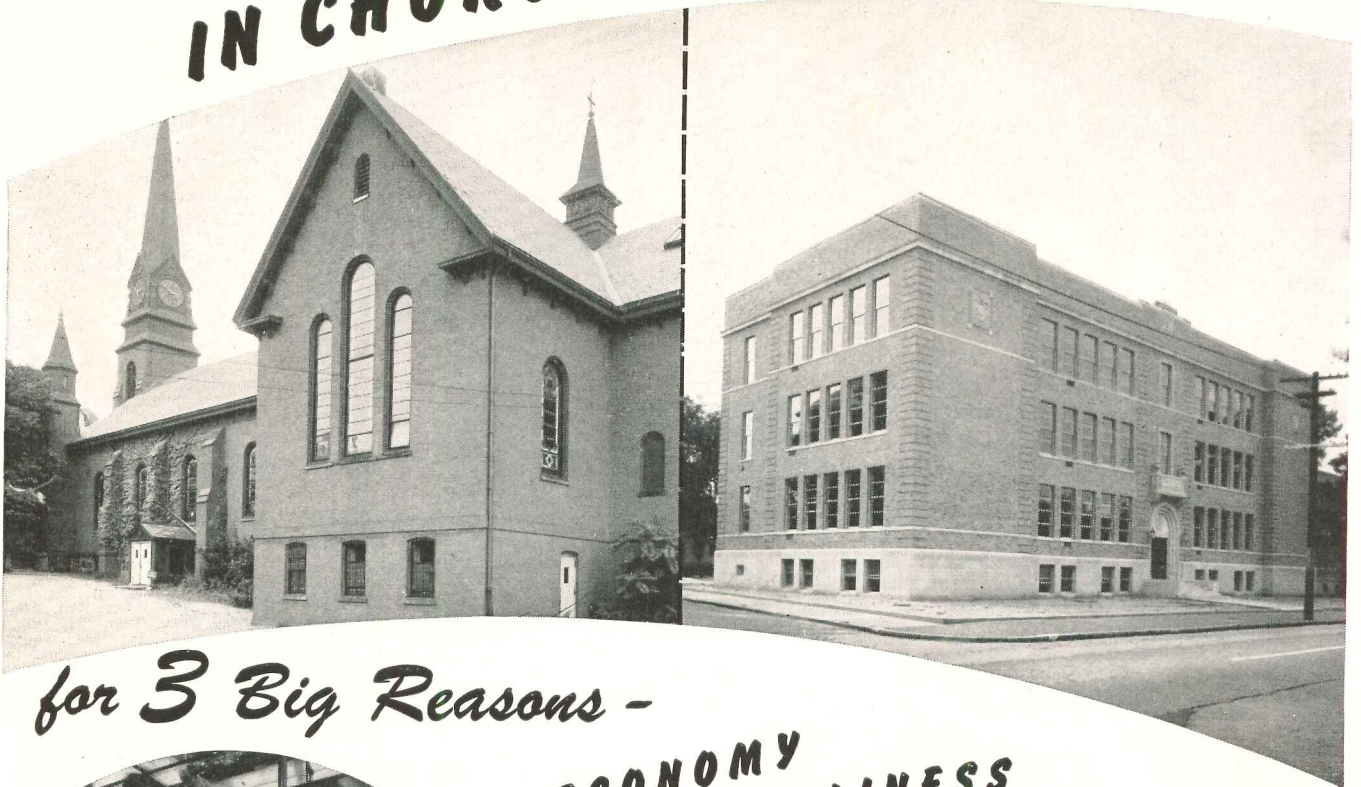

for 3 Big Reasons -

- ★ ECONOMY
- ★ CLEANLINESS
- ★ HEATING EFFICIENCY

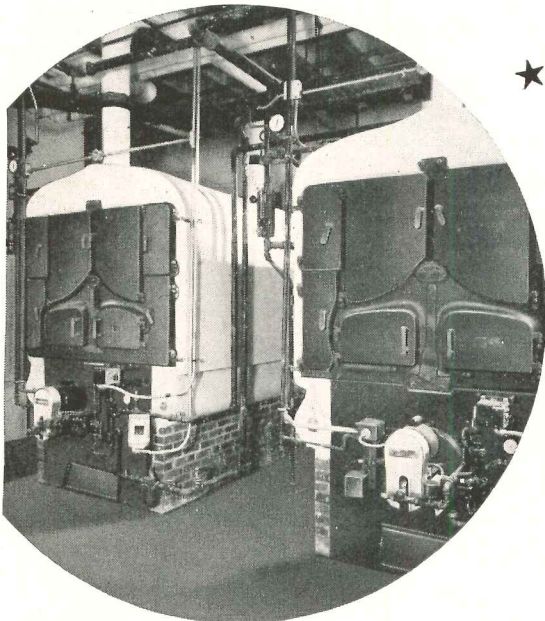

Pictured above are the two Enterprise model EP Oil Burners serving the Immaculate Conception School building. Developing 115 Boiler HP, these units are responsible for furnishing constant, uniform heat to 96,000 square feet of floor space. Installed by Enterprise Oil Burner Sales Co; Distributor, Enterprise Oil Burner Distributors, Boston, Mass.

One . . . two . . . three buildings at Immaculate Conception, Malden, Mass., have been equipped with modern Enterprise heavy-duty burners in the past two years! Highest satisfaction enjoyed in the first installation has made the choice Enterprise every time.

In churches and schools, colleges and universities throughout the land, Enterprise Burners have for years played an important role in providing clean, efficient heating at low cost. In Massachusetts alone, Enterprise counts among its many satisfied customers these outstanding institutions: Holy Cross College, Worcester; Notre Dame Academy, Tyngsboro; St. Anthony's, New Bedford; Boston College, Boston; St. Leo's, Leominster; Sacred Heart in Quincy.

For *your* next heating installation choose Enterprise Burners—choice of combustion experts everywhere. A wide range of sizes, in oil or combination gas-oil burning models.

ENTERPRISE BURNERS

BURNER DIVISION OF ENTERPRISE ENGINE & FOUNDRY CO.

18th and Florida Streets
San Francisco 10, California



Distributors in Principal Cities

...Want to Keep Theatre Carpet

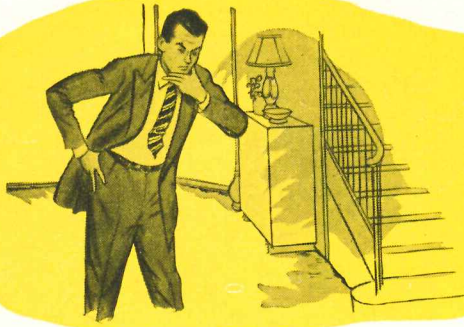

When you are wondering what kind of carpet to put in the lobby...

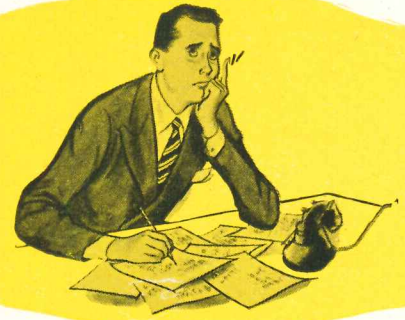

...and how you can save on yardage...and how much it all will cost...

Consult a Contract Carpet Specialist!

Are you planning a theatre job? Take a tip from us and consult a carpet specialist - an Alexander Smith carpet contractor or sales representative. He is a theatre decorating specialist...a color and texture expert...a traffic technician all rolled into one. He will save you headaches and your client money.

Give him a chance to:

1. Cut your costs by estimating accurately - keeping yardage down.
2. Save on upkeep by advising the most

economical grade and weave for each specific location.

3. Increase your satisfaction by suggesting the design and color which will harmonize best with your interior.

He is ready to show samples and estimate. He will see that you get an expert laying job.

The Alexander Smith and Masland lines handled by Alexander Smith contractors and sales representatives include types, grades, and colors of carpet suitable for every theatre installation.

ALEXANDER SMITH ★ MASLAND

Contract Carpets

Costs Down, Mr. Architect?

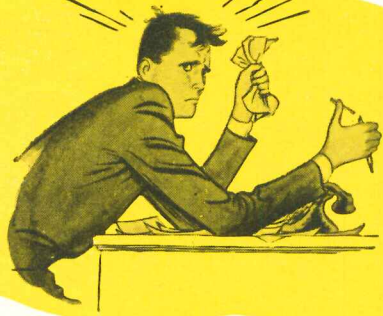

...and what is the most economical grade for that particular spot...

...and what color and pattern to get...relax!

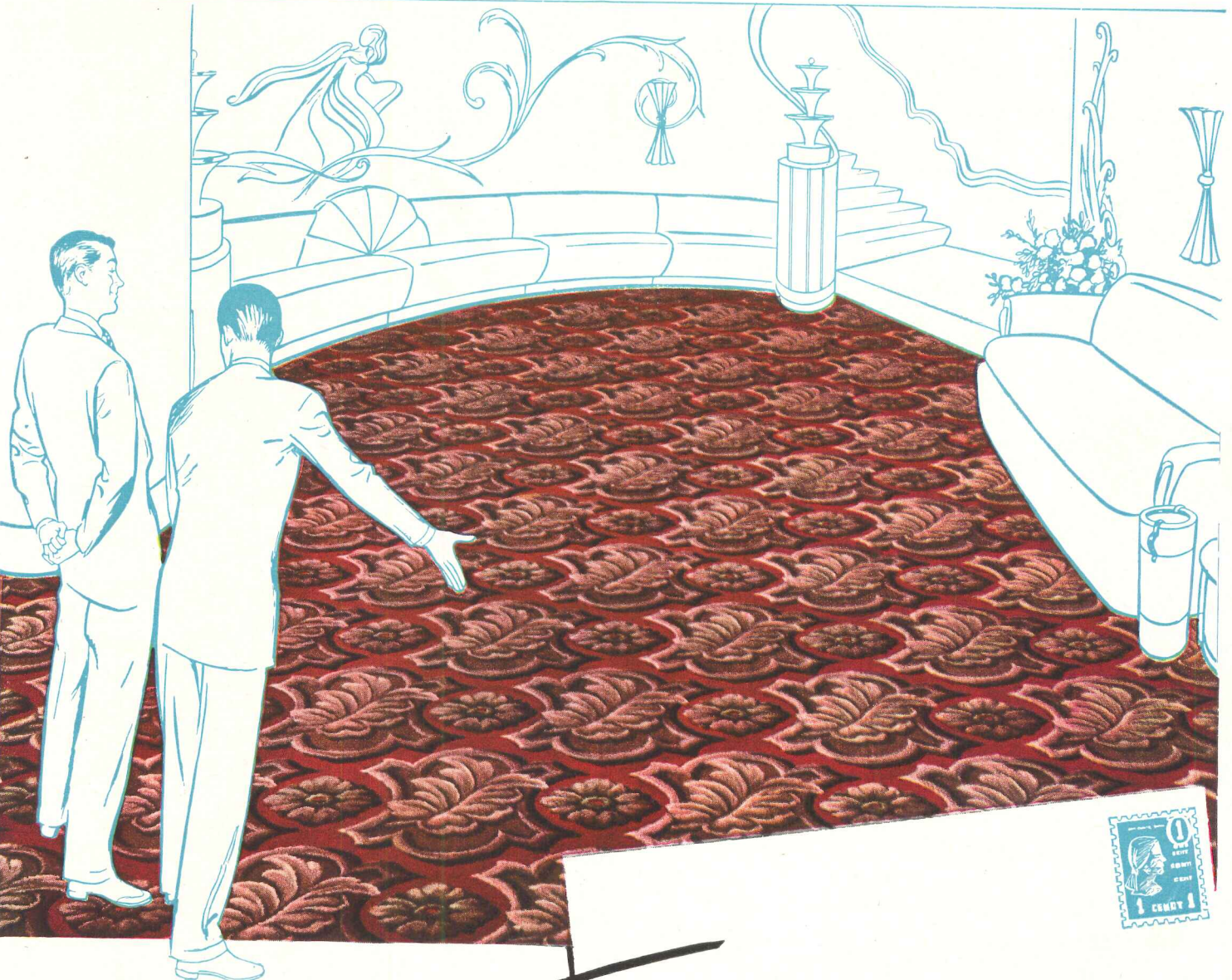

Write

Alexander Smith-Masland
Contract Service Department
295 Fifth Avenue, New York 16, N. Y.



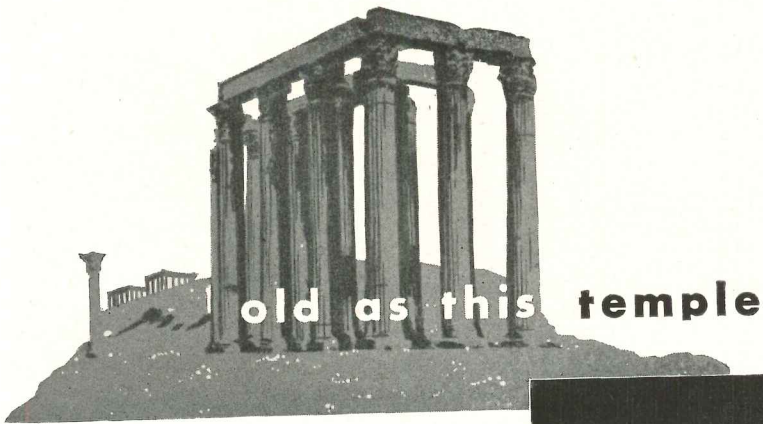

old as this temple

new as this church

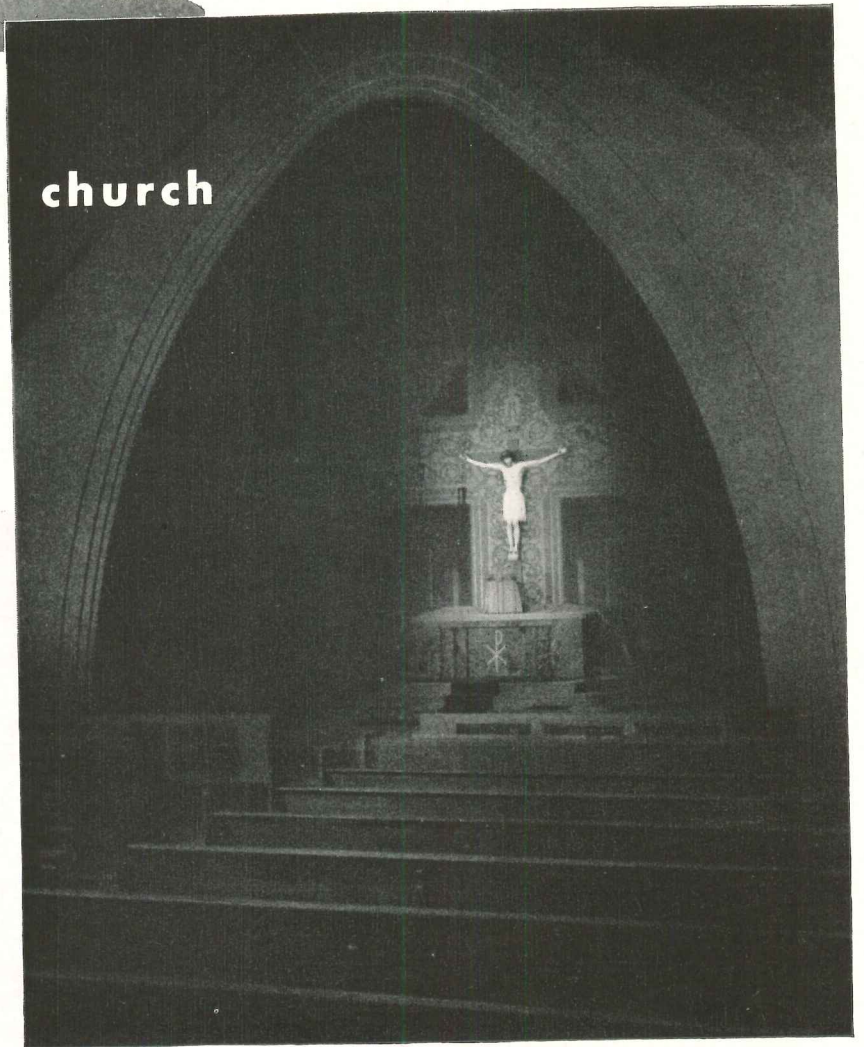

Marble is ageless . . .
its pristine beauty has served
to express man's reverence
for his Creator since time began.

Today, as in ages past, no other material is endowed with such natural glory;
none is so durable, so inherently clean, so easy to maintain.

*Information about Marble
and Marble Service
will be given promptly by the
Marble Institute's Managing Director
Romer Shawhan, R. A.*

*New "Standard Specifications and
Scale Details for Interior Marble"
in preparation. Write for your copy.*



**Marble Institute
of America, inc.**

108 FORSTER AVENUE, MOUNT VERNON, N. Y.

WHEN IT'S YOUR

Responsibility

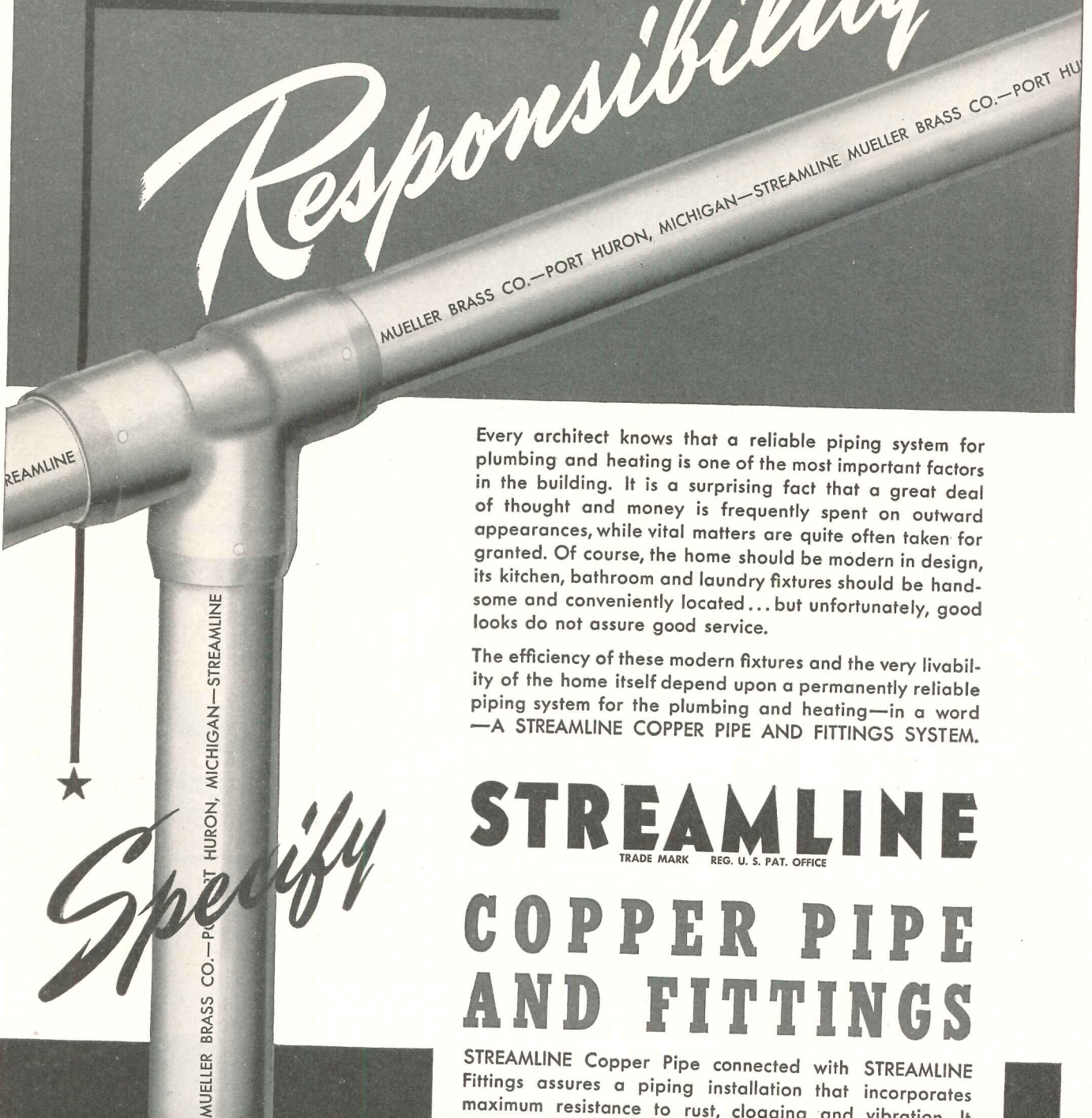

Specify

Every architect knows that a reliable piping system for plumbing and heating is one of the most important factors in the building. It is a surprising fact that a great deal of thought and money is frequently spent on outward appearances, while vital matters are quite often taken for granted. Of course, the home should be modern in design, its kitchen, bathroom and laundry fixtures should be handsome and conveniently located... but unfortunately, good looks do not assure good service.

The efficiency of these modern fixtures and the very livability of the home itself depend upon a permanently reliable piping system for the plumbing and heating—in a word —A STREAMLINE COPPER PIPE AND FITTINGS SYSTEM.

STREAMLINE

TRADE MARK REG. U. S. PAT. OFFICE

COPPER PIPE AND FITTINGS

STREAMLINE Copper Pipe connected with STREAMLINE Fittings assures a piping installation that incorporates maximum resistance to rust, clogging and vibration. It affords a permanently reliable conducting system that insures efficient service from fixtures and radiating units year in and year out. With the possible exception of abnormal water conditions, STREAMLINE will outlast the building in which it is installed.

When you include STREAMLINE Copper Pipe and Fittings in your specifications, you are actually providing future insurance of comfort and convenience for the building.

STREAMLINE
PIPE AND FITTINGS DIVISION
MUELLER BRASS CO.
PORT HURON, MICHIGAN

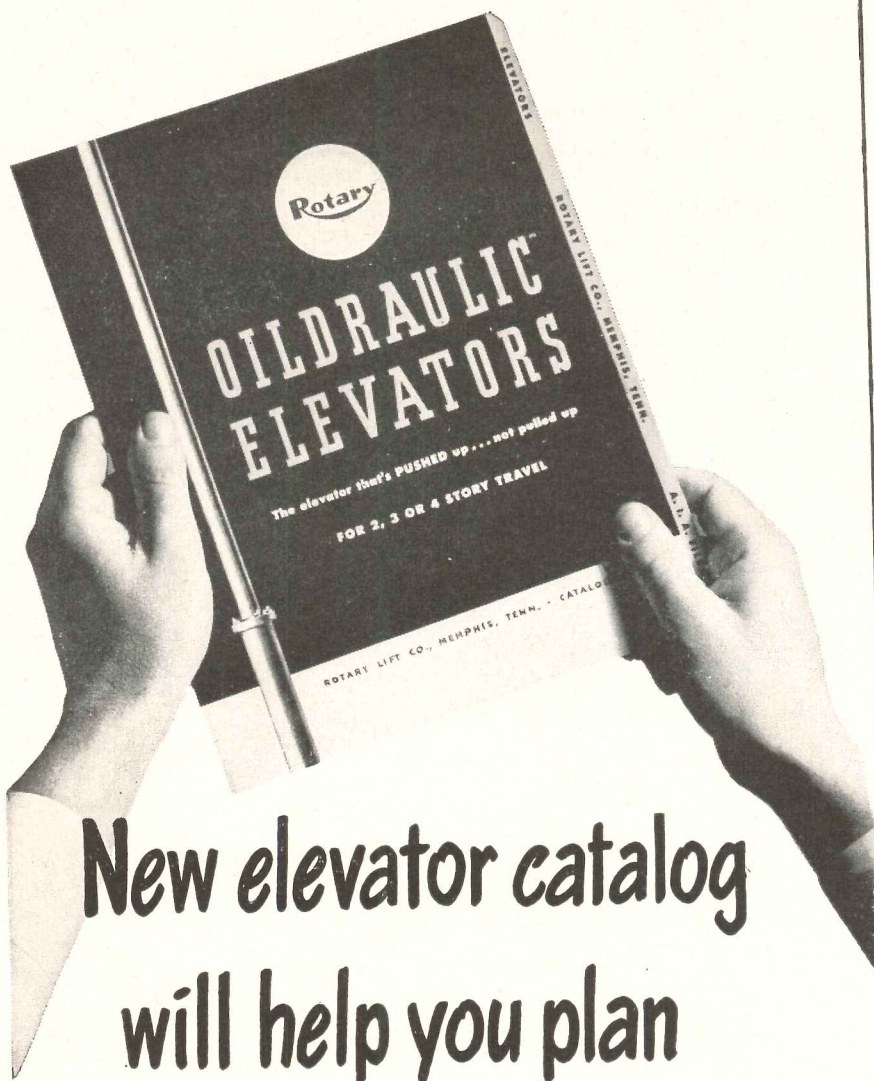

New elevator catalog will help you plan 2, 3 & 4-story buildings

ROTARY LIFT CO., 1104 Kentucky, Memphis 2, Tenn.
Send your new Catalog RE-302 (AIA File 33) to:

Name.....

Address.....

City and State.....



OILDRAULIC* ELEVATORS

*Reg. U. S. Pat. Off.

Oildraulic Elevators
have these very important
advantages for modern
2, 3 and 4-story structures

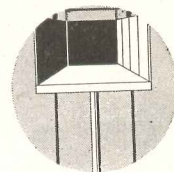

Lighter Shaftway Structure

No need for heavy, load-bearing supporting columns to carry the elevator and its load. The Rotary Oildraulic Elevator is PUSHED up from below by a powerful hydraulic jack . . . not pulled from above.



Accurate Landing Stops

Guided by the highly efficient "Oildraulic Controller," this modern elevator operates smoothly and stops at floor landings with accuracy. Very important where loading and unloading is by power vehicles.

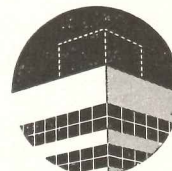

No Costly, Unsightly Penthouse

The Oildraulic Elevator does away with the old-fashioned penthouse that interferes with modern, streamlined designs. No special machine room is required . . . the compact power unit can be placed in any convenient space.

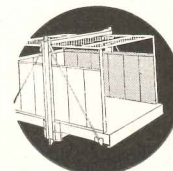

Rugged, Heavy-Duty Construction

Every Oildraulic Elevator is built to take roughest jolts and jars. Construction is all-steel with deep-formed members electrically welded. Sling and platform heavily reinforced. Each car is engineered to do the job for which it is ordered.

Suntile

RESEARCH

points the way to:

Continuous research is one good reason your Suntile job wins approval.

Continuous research is behind the making of Suntile. Together with rigid manufacturing control, it is responsible for Suntile's extra quality in form and finish—for Suntile's color-balance which makes harmonious blends so easy to achieve.

Continuous research is behind every Suntile installation. It leads to better methods of application and to the selection and the training of the man who does the job for you. His work is skilled, safeguarding the excellence of the product he represents.

For better tile—better installation, let us send you the name of an Authorized Suntile Dealer. He can show you real clay Suntile in 16 wall colors. In addition, he can show you impervious unglazed ceramic mosaic Suntile in 15 colors—and Suntile Camargos in 10 colors—both in modular sizes.

See Sweet's Catalog for more complete information. The Cambridge Tile Manufacturing Company, Cincinnati 15, Ohio.

 **BETTER TILE**

 **BETTER INSTALLATION**

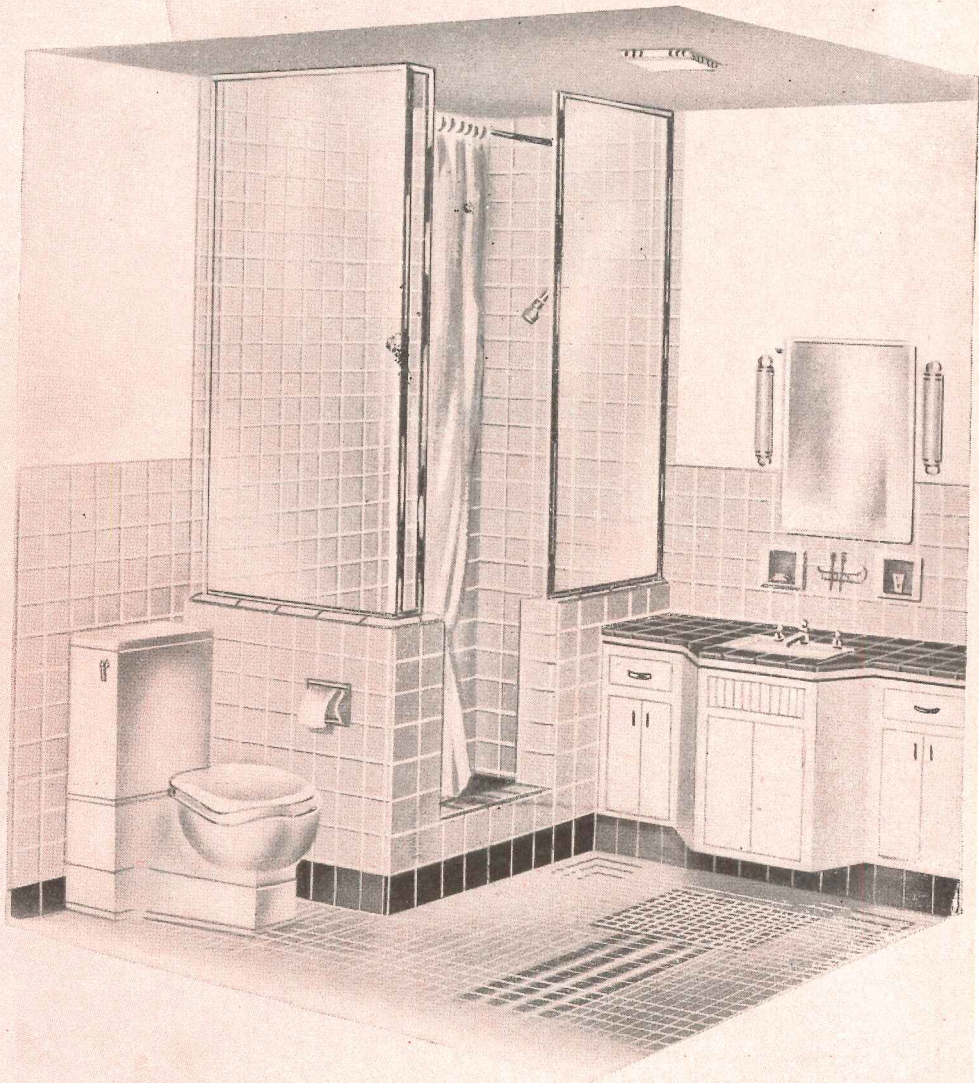

COLOR BALANCED

Suntile

... Bright with color

..... Right for life



Suntile OFFERS YOU BOTH - *Better Tile.... Better Installation*



KOHLER QUALITY has all the advantages home-planners want

THE lustrous beauty of durable, glass-hard Kohler enamel, the harmony of matched sets with good proportions—these form the surface appeal of Kohler quality. Even more important is the Kohler reputation for long serviceability, created by the satisfaction home owners find in the reliability of every working part.

The illustration shows how easy it is to make efficient use of moderate-size space with Kohler fixtures arranged along one wall, allowing for ample storage facilities and a large mirror.

The Cosmopolitan Bench Bath is of non-flexing iron, cast for rugged

strength and permanent rigidity, and coated with the famous Kohler enamel. The Triton Shower Mixer is convenient and simple to operate. The Jamestown vitreous china lavatory is the roomy ledge type, equipped with the Centra mixer type fitting. The quiet, smooth-acting Wellworth closet completes the set, which comes in pure white or soft pastel shades. All the fittings are chromium plated, durably made. Kohler quality is now a 75-year-old tradition. Kohler Co., Dept. 20-B, Kohler, Wisconsin. Established 1873.

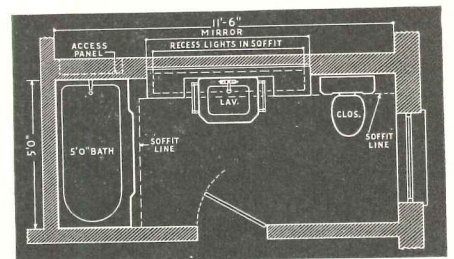

This practical, well-balanced arrangement of Kohler fixtures with all outlets leading the same way simplifies piping and allows easy access to both fixtures and storage facilities.

KOHLER OF KOHLER

PLUMBING FIXTURES • HEATING EQUIPMENT • ELECTRIC PLANTS

ANEMOSTAT

DRAFTLESS AIR DIFFUSERS

in the Hartford Hospital

For comfort, for health, for safety, conditioned air in the new Hartford Hospital is distributed through Anemostat air diffusers. These devices permit a high number of air changes per hour with complete freedom from drafts. They assure uniform temperature and humidity throughout the enclosure and prevent stratification or stale air pockets.

The problems encountered in air conditioning hospitals are unusually complex. Unless forced-air movement is draftlessly diffused and directed, discomfort, bacterial pollution by infected dust and explosion hazards exist. The use of Anemostat air diffusers has solved these problems in over 200 leading hospitals.

Write for full information on the use of Anemostats for heating, ventilating or cooling or ask for a consultation with an Anemostat engineer.

Coolidge, Shepley, Bulfinch and Abbott—Architects
 Hollis French — Mechanical Engineer

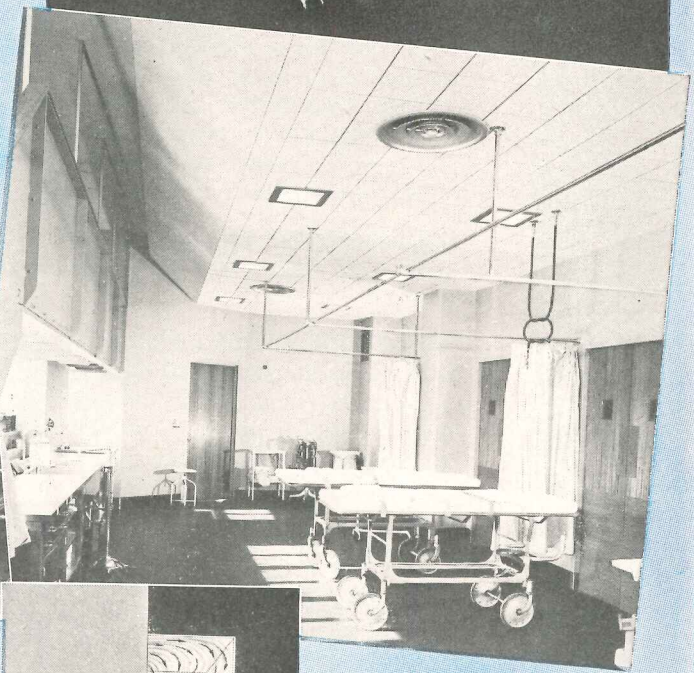
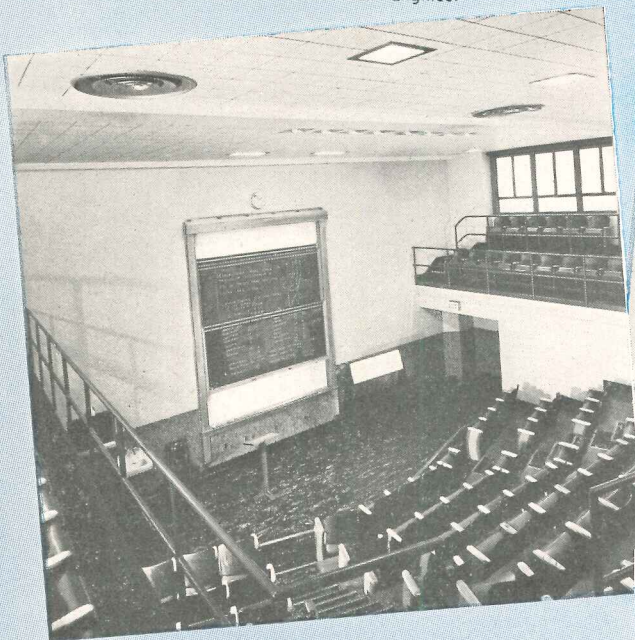
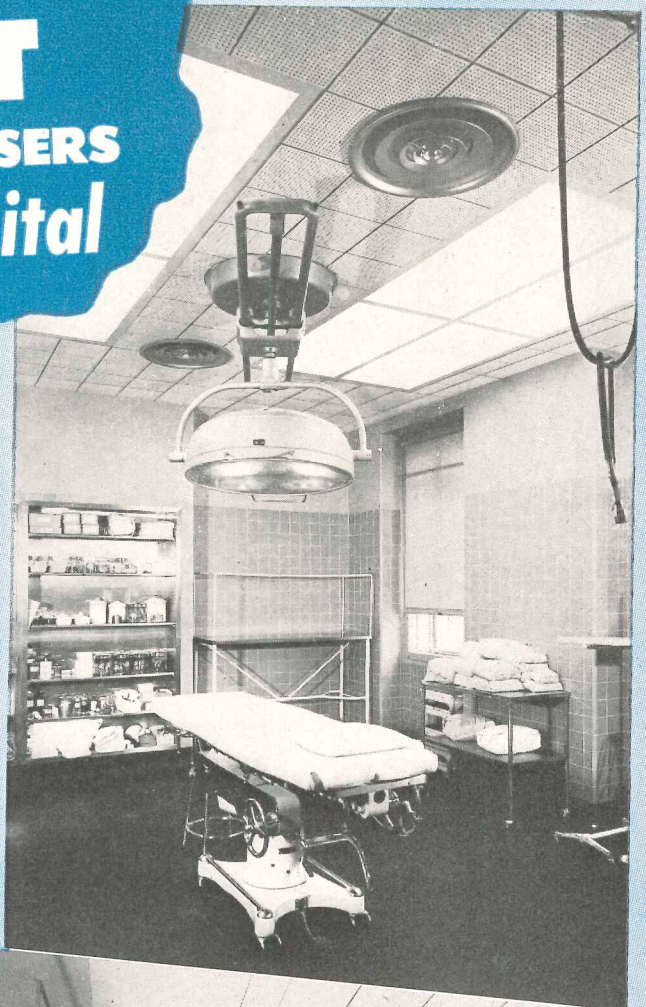

ANEMOSTAT

REG. U. S. PAT. OFF.

DRAFTLESS AIR-DIFFUSERS

ANEMOSTAT CORPORATION OF AMERICA

10 EAST 39th STREET, NEW YORK 16, N. Y.

REPRESENTATIVES IN PRINCIPAL CITIES

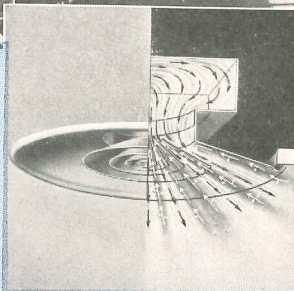

The Anemostat Air Diffuser is distinguished by the exclusive feature of aspiration . . . the drawing of room air into the device where it is mixed, within the unit, with the supply air before it is discharged in a multiplicity of planes.

**"NO AIR CONDITIONING SYSTEM
 IS BETTER THAN ITS AIR DISTRIBUTION"**

AC-1182

GOOD-LOOKING METAL DOORS

Immediately Available at Low Cost!

Fenestra Fireshield Swing Doors combine attractiveness with durability. Here are quality metal doors that you can recommend with confidence for many uses—for entrances, exits, stairwells, communicating doors, etc.—for apartments, stores and other commercial buildings, and factories, to mention a few.

IMMEDIATE SHIPMENT—standardization of types and sizes enables your building supply dealer to carry ample stocks to meet your needs for many door uses.

WHY LOW-PRICED—these doors are standardized in six sizes most commonly used for single swing doors. That streamlines production, means lower cost. You get a sturdy metal door for far less than many doors now on the market. Installation costs are reduced, too—swing doors come to the job complete with frames and hardware machined, fitted, ready to assemble.

UNDERWRITERS' LABEL—doors of same design are available with Underwriters' B Label.

For full information on these doors, as well as counterweighted doors, call the nearest Fenestra office. Or write to Detroit Steel Products Company, AR-6, 2252 East Grand Blvd., Detroit 11, Mich.

Fenestra

**FIRESHIELD SWING AND SLIDE
METAL DOORS**

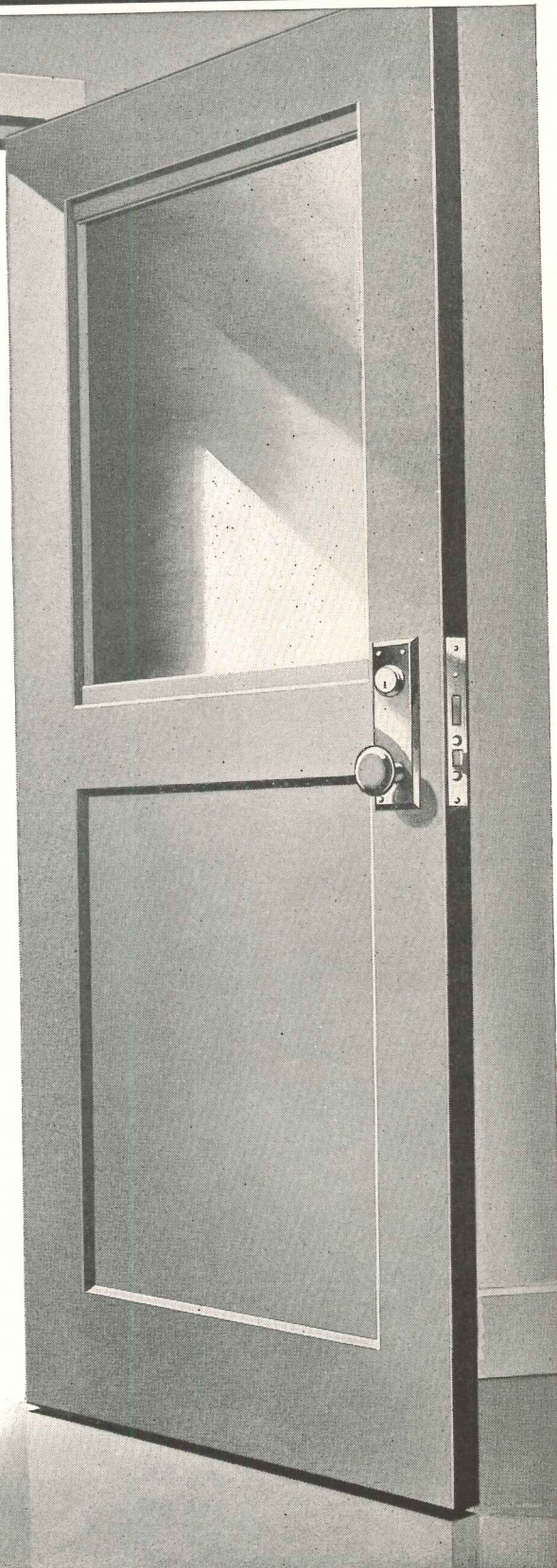

"'Tontine' Shades have been in service 8 to 10 years"

"We welcome the opportunity to express our satisfaction for the long years of service we have received from our 'Tontine' shades.

"We have four hundred windows here at the Hotel Lincoln, and they are all equipped with 'Tontine' shades. The length of time these

shades have been in service ranges from eight to ten years, and they are washed once yearly. Replacements in a year's time are very few.

"It has been a pleasure to deal with your company during these years. Your product is right; your service all that we could ask."

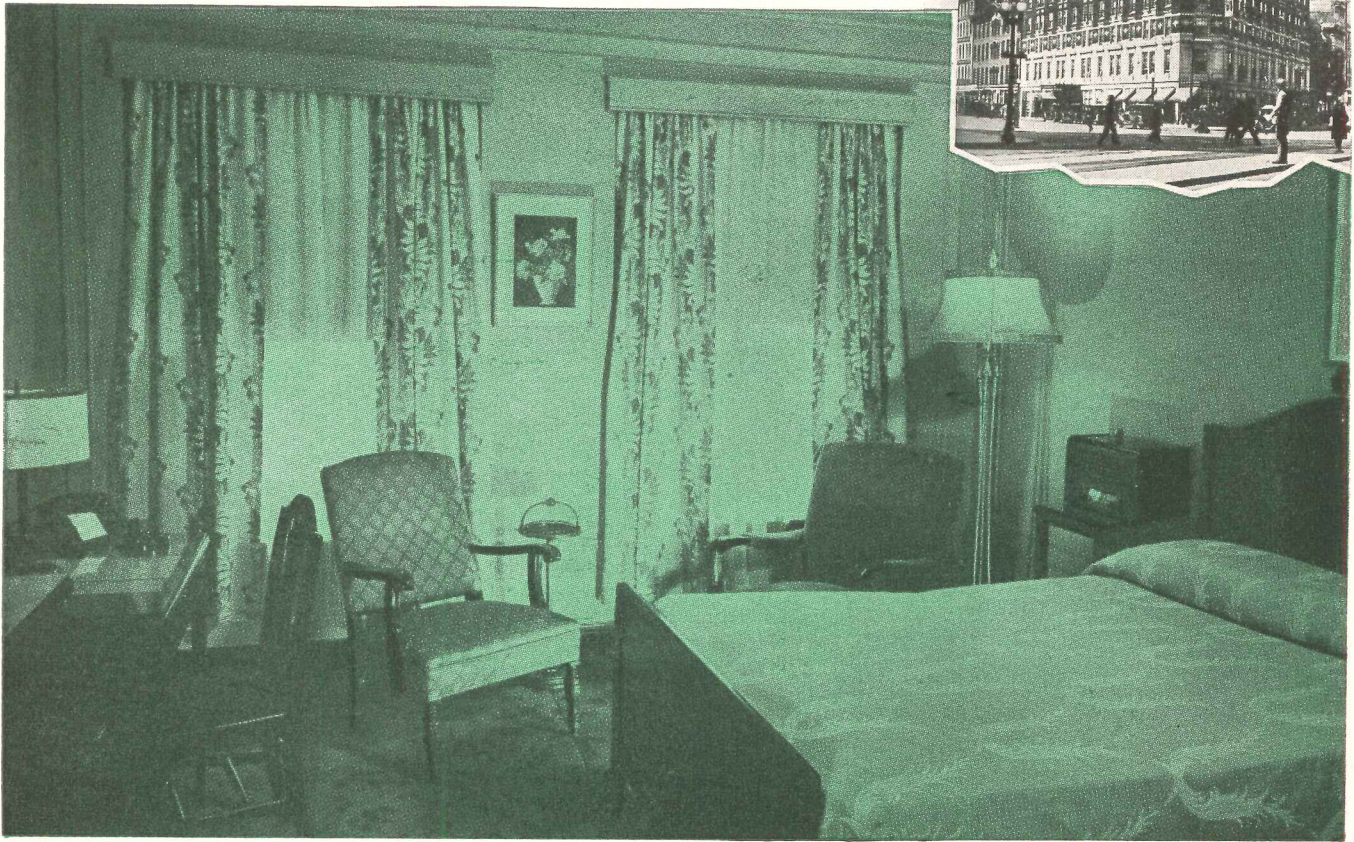

Guest Room—Hotel Lincoln, Indianapolis, Ind.

Your clients, like Mr. P. E. Rupprecht of the Hotel Lincoln, Indianapolis, will find that "'Tontine'* is the economical window shade cloth. It's washable . . . resists cracking, fraying, pinholing, and fading. It comes in a variety of attractive colors. Recommend "'Tontine.'" Your clients will discover how low the upkeep on window shades can be.

E. I. du Pont de Nemours & Co. (Inc.), "'Tontine'" Sales, Newburgh, New York.

**"TONTINE" is Du Pont's registered trademark for its washable window shade cloth.

DuPont Tontine

REG. U. S. PAT. OFF.

washable window shade cloth

looks better longer



REG. U. S. PAT. OFF.

BETTER THINGS FOR BETTER LIVING
... THROUGH CHEMISTRY

A COMPLETE substation and distribution system



ORDERED • INSTALLED • OPERATED AS ONE COMPACT UNIT

Here is a new heart for your building's power distribution system—the *Westinghouse Close-Coupled Air-Cooled Power Center*. It saves time in ordering, installation and operation. It eliminates piecemeal assembly on the job! It can be installed *anywhere* indoors without a vault—because it is completely air-cooled. It's lighter, too. Install it anywhere in the building with complete safety.

This complete station assembly results in substantial savings in materials and labor, and cuts service interruptions. It permits location of the Power Center at or near the centers of load.

The Westinghouse Air-Cooled Power Center is only one item of the complete equipment Westinghouse can supply. Others are: motors, control, circuit

breakers, panelboards, lighting, elevators, Precipitron and air conditioning—in fact, all the apparatus needed for any building's electrical system. By ordering from *one* supplier, you place responsibility in one place . . . save time in ordering, installation and co-ordination for operation.

Complete specifications on all equipment are available to help you PLAN NOW for postwar construction. Phone your Westinghouse Office, or write Westinghouse Electric Corporation, P. O. Box 868, Pittsburgh 30, Pennsylvania.

J-94681

Westinghouse
PLANTS IN 25 CITIES . . . OFFICES EVERYWHERE

500 Kva Dry Type Air-Cooled Power Center with a 13,200-volt incoming line, oil circuit breaker, a 500 Kva Air-Cooled Transformer and 120/208 volt draw-out load feeder and main air circuit breakers.

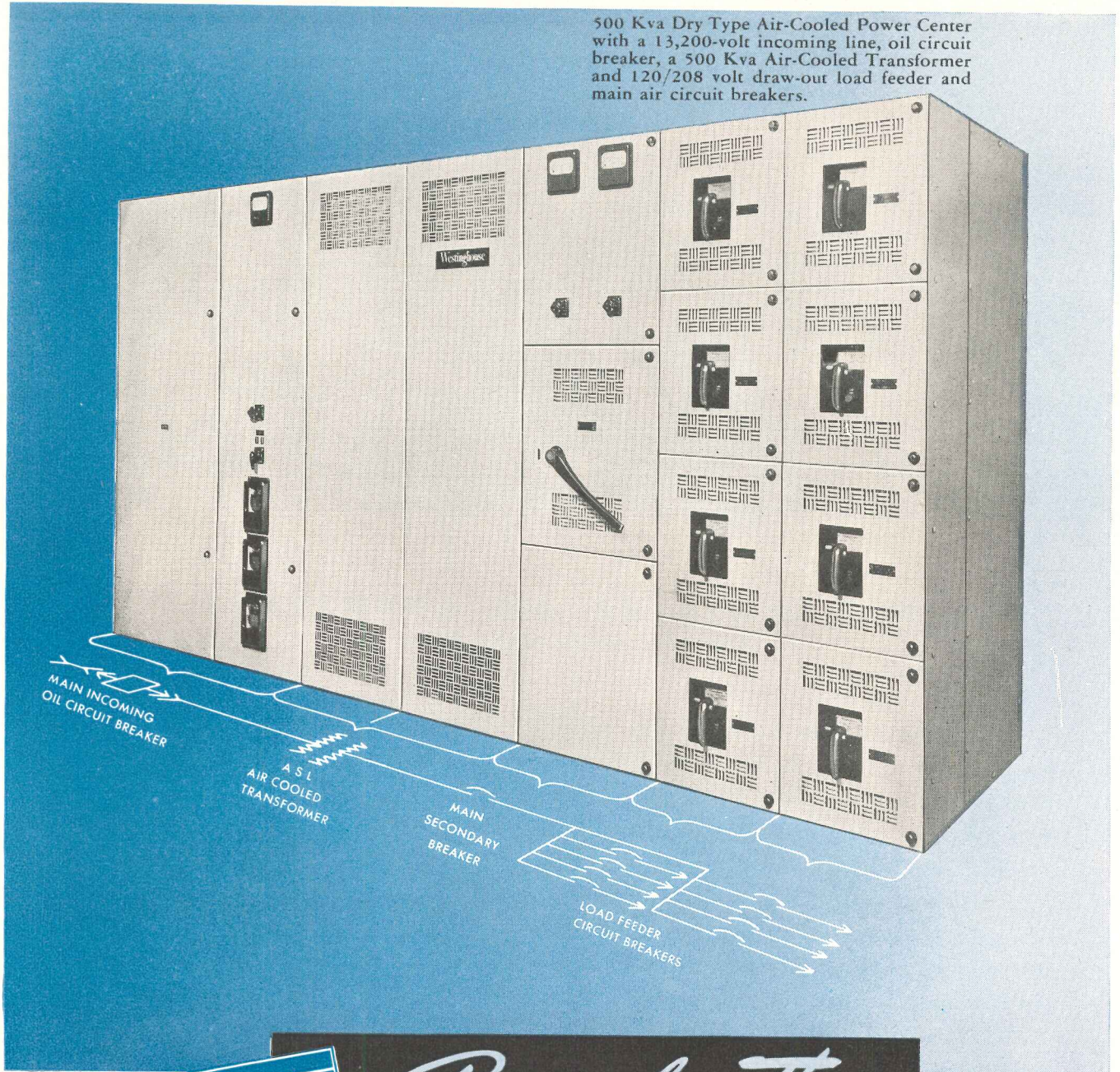

Remember This:

Westinghouse Air-Cooled Power Centers pay for themselves by

- Eliminating fireproof vaults
- Reducing installation costs
- Saving floor space
- Permitting location at center of load
- Providing better voltage regulation
- Safer operation and lower maintenance



Call your Westinghouse representative today for advice and practical help in laying out your postwar power and lighting distribution systems. It pays to *blueprint now for tomorrow's needs.*

AIR-COOLED POWER CENTERS FOR BUILDINGS



PORTRAIT OF AN ARCHITECT

(who knows a good thing when he sees it!)

Here's an architect who knows how to please his clients and simplify his job of writing specifications at the same time! He's the fellow who checks over his plans, notes the rooms in which colorful, practical interiors are needed, then simply specifies Marlite plastic-finished wall and ceiling panels. To make the job complete, he specifies Marsh Mouldings and Marsh Adhesives and, in bathrooms and washrooms, Marsh Bathroom Accessories.

Genuine Marsh products offer every architect an opportunity to simplify specifications on new construction or modernization, in every type of building where beautiful, durable interiors are required. Complete information is available in SWEET'S FILE, ARCHITECTURAL, or direct from the factory.

MARSH WALL PRODUCTS, INC.
605 Main Street ★ Dover, Ohio



for Creating Beautiful Interiors

plan on
Marlite
walls

MARLITE PLASTIC-FINISHED WALL AND CEILING PANELS



MARSH MOULDINGS

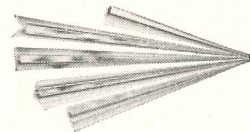

MARSH BATHROOM ACCESSORIES

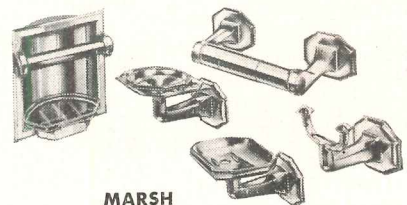

MARSH ADHESIVES



MARLITE POLISH



MARSH CAULKING

GET BETTER BRICKWORK WITH **BRIXMENT!**

Good workmanship requires that all head joints in both face brick and back-up work be *completely* filled with mortar, by any of the three methods pictured below.

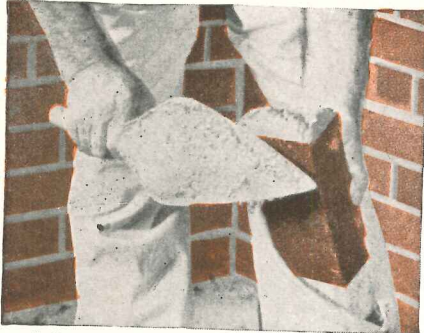

Method 1. Plenty of mortar should be thrown on the end of the brick to be placed.

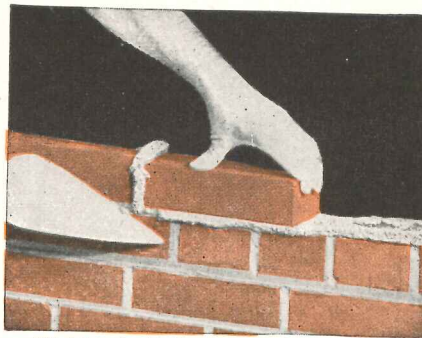

The brick should then be pushed into place.



So that the mortar oozes out at the top of the head joint.

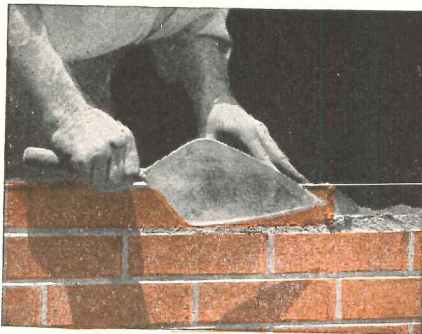

Method 2. A dab of mortar should be spotted on the corner of the brick already in place.



Then plenty of mortar should be thrown on the end of the brick already in place.

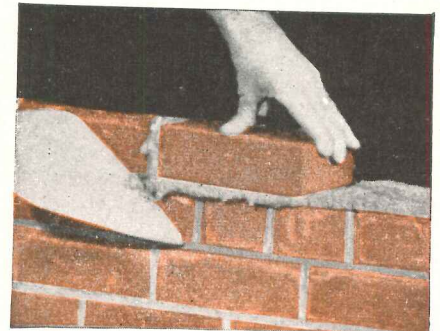

So there will be more than enough mortar to fill the joint completely when the next brick is pushed into place.



Method 3. A full trowel of mortar should be thrown on the wall.



Then the brick should be shoved into this deep bed of mortar.



So that the mortar oozes out at the top of the joint.

BRIXMENT permits the bricklayer to do the kind of work pictured above. It does not stiffen up too fast, when it hits the brick. It remains rich and plastic long enough to allow the bricklayer to place the brick, easily and accurately.

In addition to its greater plasticity, Brixment mortar has higher water-retaining capacity and bonding quality, and greater resistance to freezing and thawing. Because of this *combination* of advantages, Brixment is the leading masonry cement on the market.

LOUISVILLE CEMENT COMPANY, Incorporated, LOUISVILLE, KENTUCKY



Moreland, Griffith, Smith—Architects

SMALL HOME COMPLETE—WITH TELEPHONE RACEWAYS

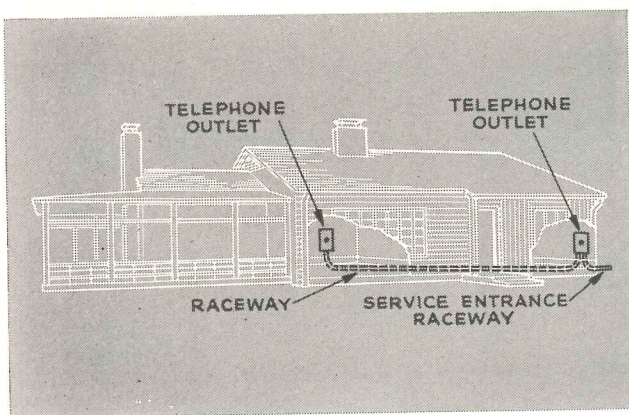

An eye to detail is important when you build livability, comfort and convenience into the small home. Telephone raceways, installed during construction, avoid exposed wires on walls and woodwork and assure greater telephone convenience to the owner.

In the one-story house without basement, a few pieces of pipe or electrical tubing under the floor provide a concealed raceway for telephone wires to outlet locations.

Whether you build small homes or large, your Bell Telephone Company will be glad to help you plan modern telephone arrangements. Just call your Telephone Business Office and ask for "Architects and Builders Service."

BELL TELEPHONE SYSTEM



STEEL DECK

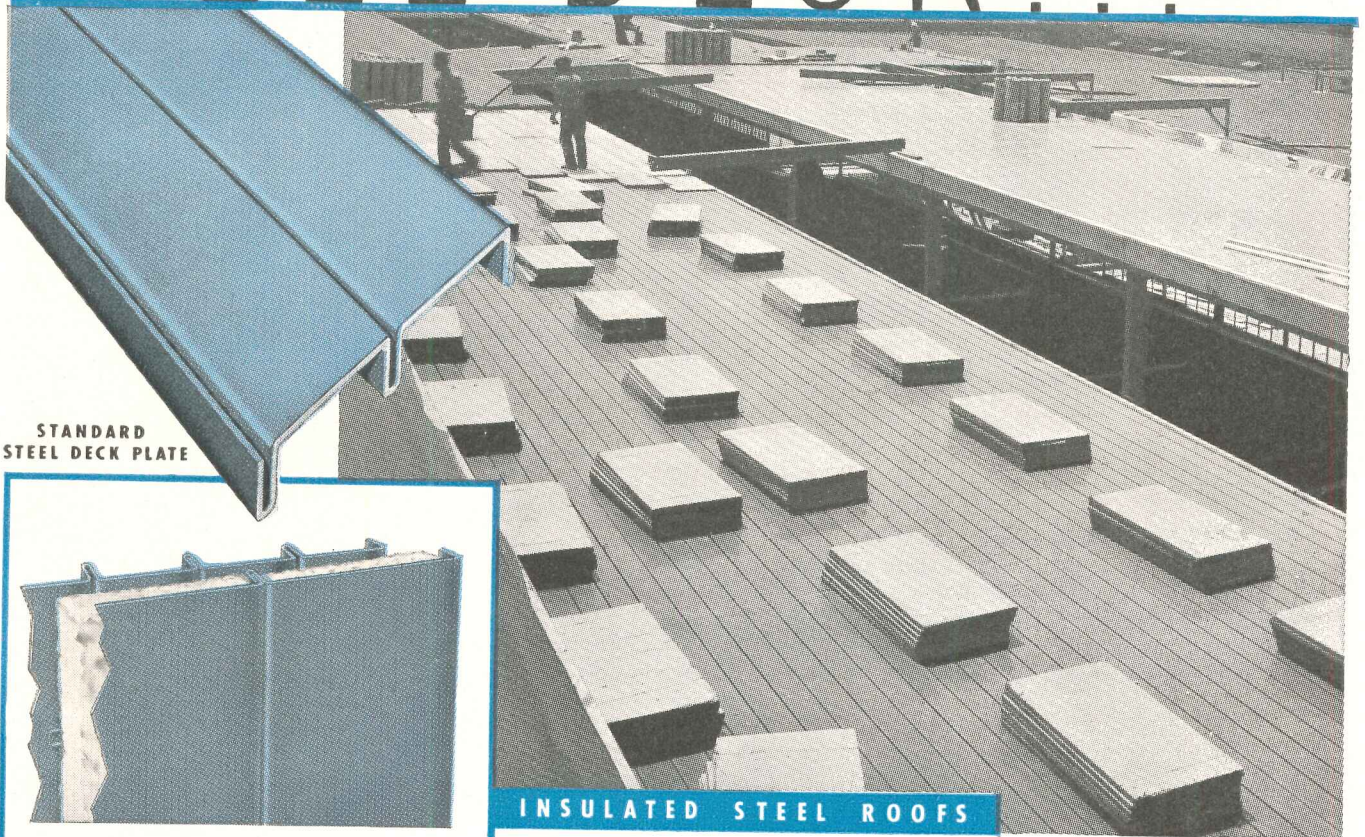

STANDARD
STEEL DECK PLATE



INSULATED STEEL ROOFS

INSULATED STEEL WALL
(FIELD CONSTRUCTED)

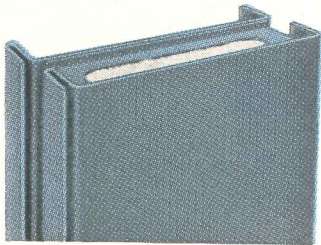

INSULATED STEEL WALL PANELS
(PREFABRICATED)

for ROOFS and WALLS!

Insulated Steel Deck Roofs and Insulated Exterior Steel Walls are rapidly becoming general practice with architects in the design of many types of industrial and commercial building. In the past seven years many complete industrial plants, power houses, warehouses, loading and transfer docks, and other special purpose structures, including sidewalls, roof and floor of conveyor bridges, have been constructed with Mahon Insulated Steel Walls and Mahon Insulated Steel Deck Roofs. See Mahon Inserts in Sweet's File for complete information, details and specifications . . . you will find that Mahon Steel Deck, due to its basic design, lends itself to a broader range of uses in modern construction.

THE R. C. MAHON COMPANY

HOME OFFICE and PLANT, Detroit 11, Michigan • WESTERN SALES DIVISION, Chicago 4, Illinois

Representatives in all Principal Cities

Manufacturers of Steel Deck for Roofs, Sidewalls, Ceilings, Floors, Partitions and Doors. Also Roof Sumps and Recesses, Rolling Steel Doors, Grilles, and Underwriters' Labeled Rolling Steel Doors and Fire Shutters.

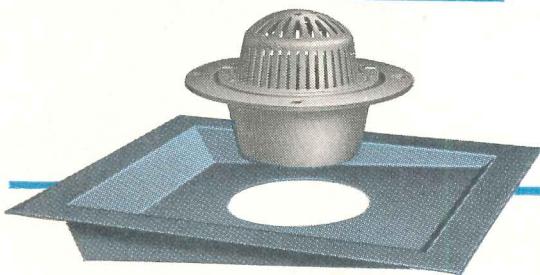

Mahon Cast Iron Roof Sumps and Steel Sump Recesses, Designed and Produced for Use with Mahon Steel Deck, to Meet Any Drain Requirement.

MAHON

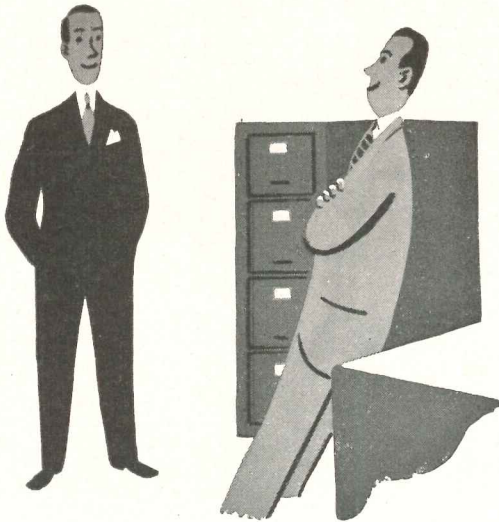

"SPEAKING OF VENETIAN BLINDS, I FIGURE it pays to know a lot about who makes them and how. That's why I'm sold on Columbia . . . Columbia-Controlled-Construction covers every step from specifying steel gauges to styling tape colors. Better check these Columbia features..."

Why does CCC[®] insure longer wear?

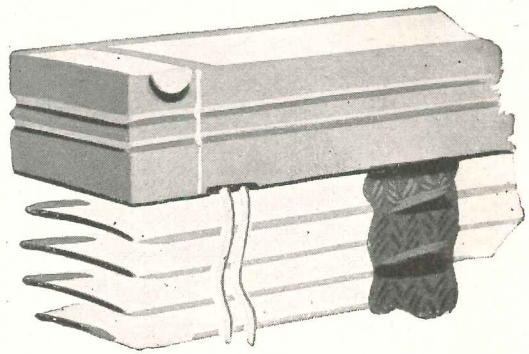

SAVES TIME AND MONEY . . . The smart-looking new headbox completely encloses all working parts. Keeps them dust-free, trouble-free. Effects time and money saving in easy maintenance. With steel or aluminum slats.

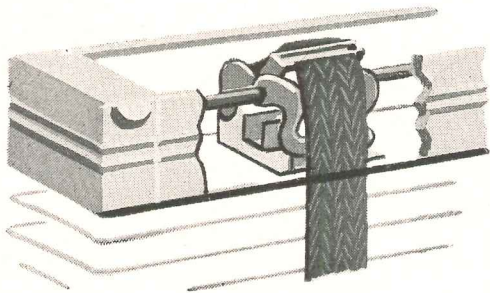

LONG LIFE FROM HEAVY-GAUGE STEEL. Headbox, installation brackets, tilter, clip-grip for tapes, automatic stop . . . they're all made of long-wearing, heavy-gauge steel in the new Columbia blind!

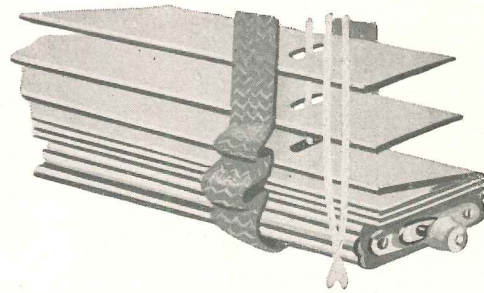

BLIND WON'T BANG OR RATTLE when the window is open, with Columbia's new Snap-Stop. Holds blind fast at any height. Another feature for smooth operation. (Optional).

Columbia
VENETIAN BLINDS
AND WINDOW SHADES

Chalk up additional improvements and new features to "CCC"! Ask a Columbia authorized dealer to point them out . . . to help you select the right style and color for your particular needs. Just say "Columbia" . . . that's the first step!

*"CCC" means Columbia-Controlled-Construction

THE COLUMBIA MILLS, INC. • 225 FIFTH AVENUE, NEW YORK 10, N. Y.



Perfect Control

...with  N1P - L

Raintite

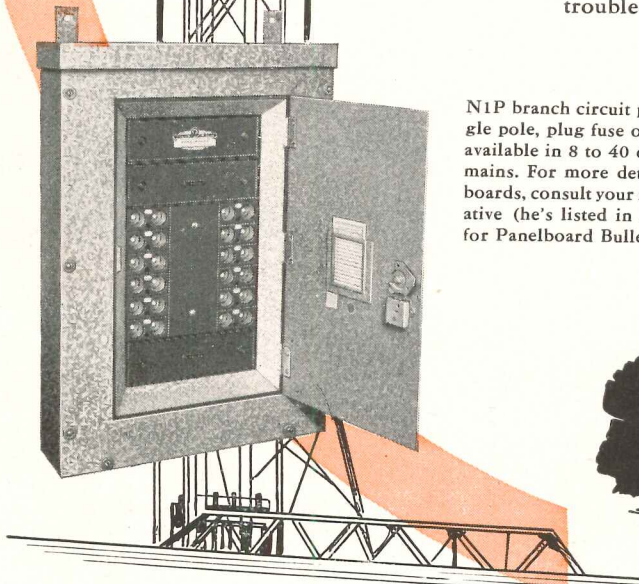
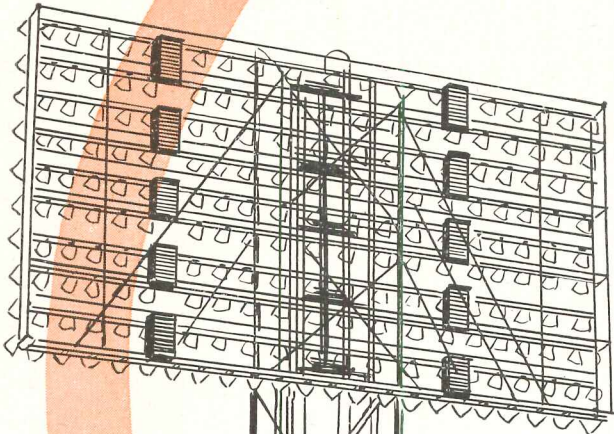

PANELBOARDS

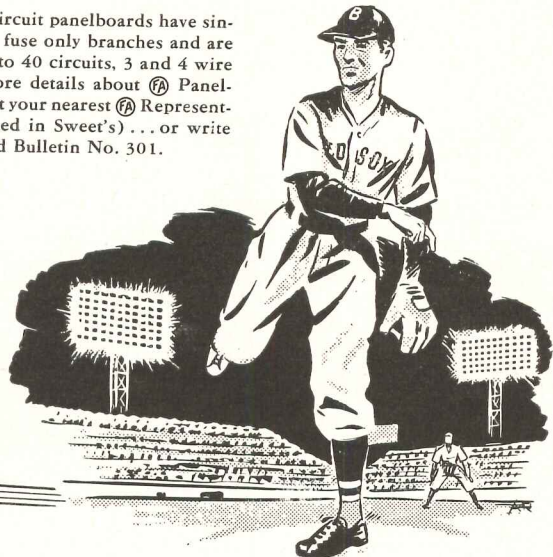

N1P branch circuit panelboards have single pole, plug fuse only branches and are available in 8 to 40 circuits, 3 and 4 wire mains. For more details about  Panelboards, consult your nearest  Representative (he's listed in Sweet's) ... or write for Panelboard Bulletin No. 301.



LIGHTING EQUIPMENT AND PITCHERS are judged in much the same way...their control has to be perfect. And at Fenway Park, home of the Boston Red Sox, the lighting controls for night baseball games are providing the same kind of dependable performance that fans expect of a 20-game winner.

These lighting controls are  N1P-3L Raintite Panelboards. Approximately 1300 circuits and floodlights are controlled by 46 of these efficient  Panelboards. In addition, each panel is weather-protected with "raintite" enclosures to assure night after night and season after season of dependable performance.

This same type of perfect control is available in a variety of  Panelboards for industrial plants, stores, offices or wherever light and power control has to be dependable, trouble-free... perfect, that is.



Frank Adam Electric Co.

ST. LOUIS 13, MISSOURI

Makers of BUSDUCT • PANELBOARDS • SWITCHBOARDS • SERVICE EQUIPMENT • SAFETY SWITCHES • LOAD CENTERS • QUIKHETER

New Decorative Alumigrid The Modern Ceiling for Modern Interiors

Kawneer's aluminum louvred ceiling—

- Handsome, contemporary styling
- Efficient, non-glaring illumination
- Easy to install—Economical to use
- For new construction or remodeling

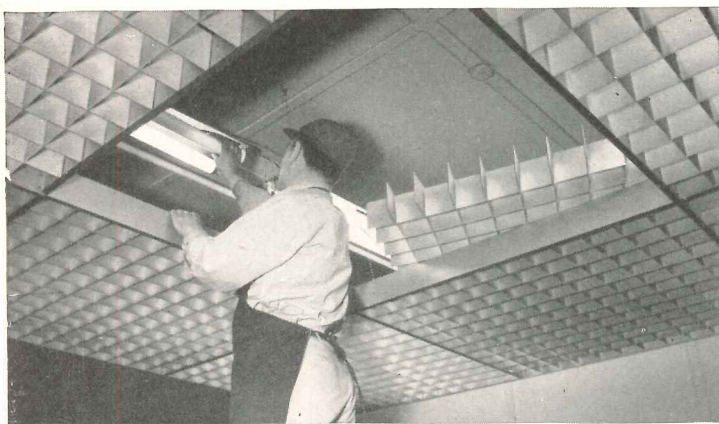
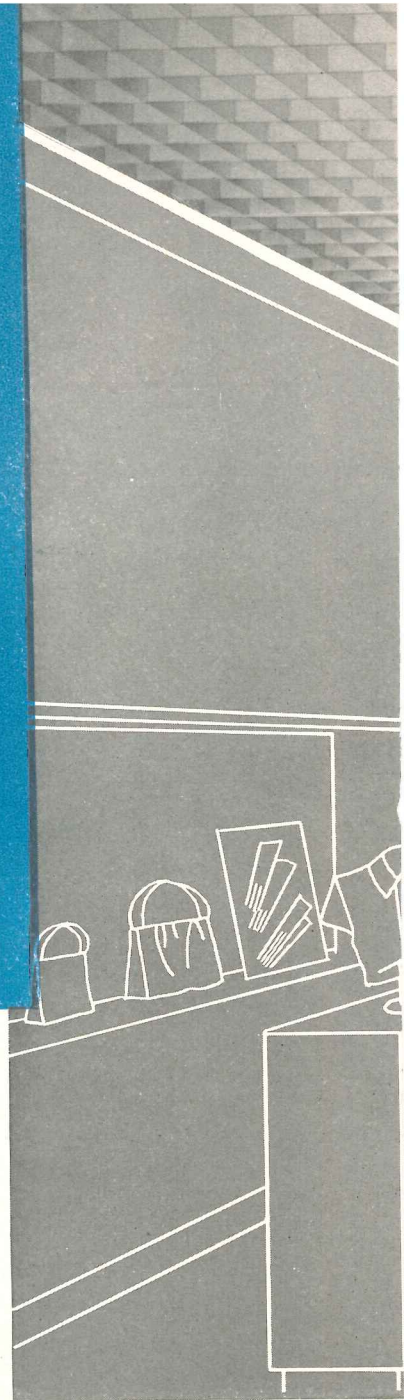

Easy-to-install Alumigrid units are 4-foot square and weigh only 10 pounds. Supported by a framework of aluminum rails, these units are easily lifted aside for re-lamping or maintenance work on ceiling elements above.

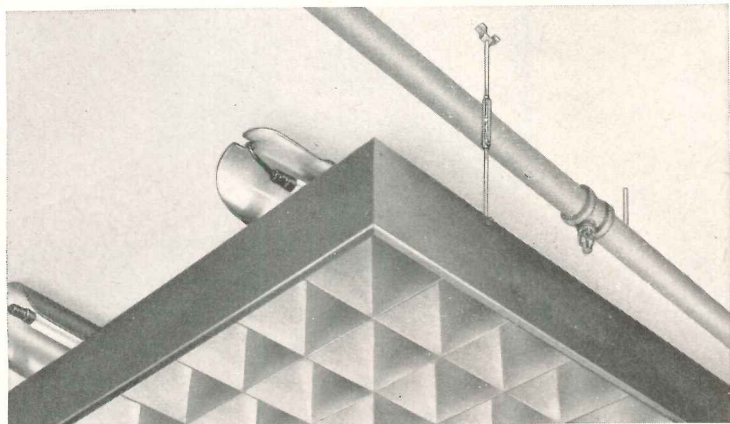

A perfect ceiling treatment for remodeling work or new construction, Alumigrid is suspended and anchored from the ceiling overhead. It conceals beams, pipes, ducts, sprinklers, and electrical systems.

See our exhibit at the STORE MODERNIZATION SHOW July 6th to July 10th
Grand Central Palace, New York City

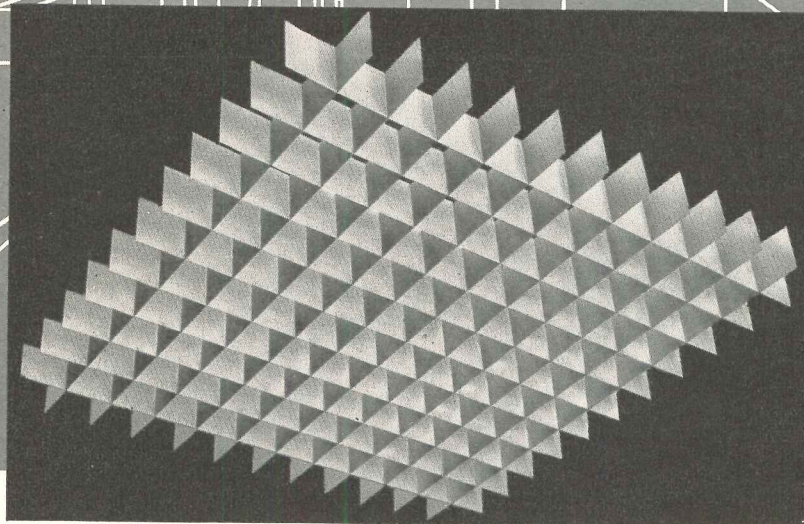
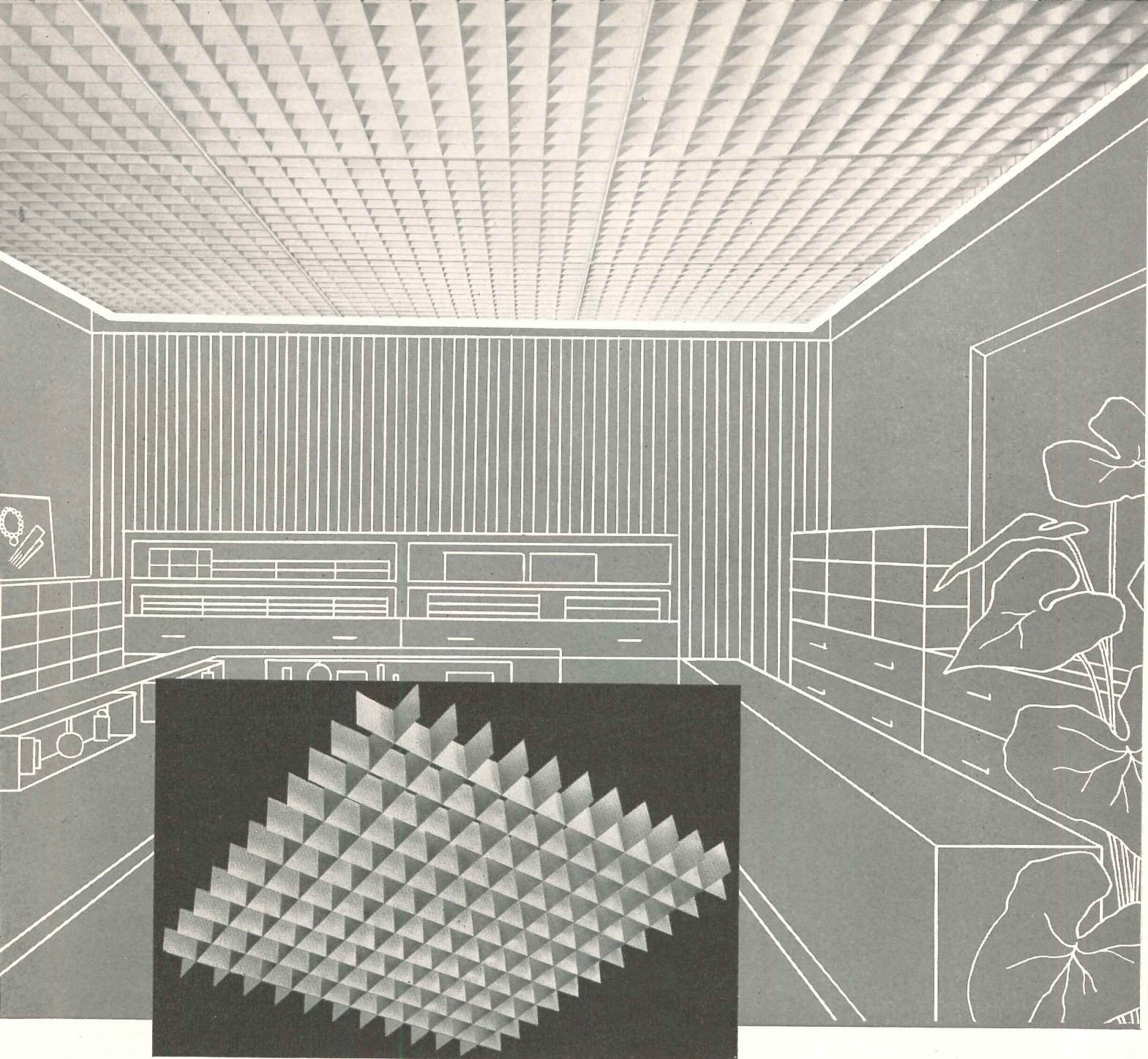

**FOR STORES • SHOPS • RESTAURANTS • HOTELS • CLUBS
SCHOOLS • HOSPITALS • OFFICES • AUDITORIUMS**

No matter what type of building you are designing, consider the unprecedented advantages offered by Alumigrid.

Its clean-lined, simple styling harmonizes gracefully with modern interior design—while concealing such unsightly overhead elements as beams, pipes, ducts, sprinkling systems. A soft satin finish enhances its appearance and increases its light diffusion factor.

Illumination through Alumigrid is exceptionally uniform and efficient. Its many squares diffuse and reflect light downward to provide pleasant, eye-level illumination throughout the room.

Alumigrid is easy and economical to install because it is suspended below the ceiling without interfering with its structural elements. The lightweight 4-foot square units are

supported by a framework of aluminum rails which are securely anchored to the ceiling.

Each Alumigrid unit weighs only ten pounds and is quickly slid to one side for re-lamping or maintenance work on ducts, sprinklers and wiring.

This outstanding new ceiling is available now—for the job on your drafting board—so write today for specifications and installation instructions. The Kawneer Company, 106 North Front Street, Niles, Mich., or 2511 8th Street, Berkeley, California.

THE
Kawneer
COMPANY

GORDON B. ROTH BUILDER

September 22, 1947

Kimberly-Clark Corporation
Neenah, Wisconsin

Gentlemen:

It gives me great pleasure to advise you that in my twenty-five years of building private homes, apartment houses and commercial buildings, I have tried many types of insulation and have never really been satisfied until five years ago when I started using Kimsul.

In the Tompkins house, I used 3200 square feet of Double Thick Kimsul in the walls and ceilings. As a result of this, I feel fuel bills should prove to be very nominal. I have also built ten modern homes in Long Beach, New York, ranging in price from \$18,500 to \$40,000. And some twenty-five one-family houses selling from \$14,000 to \$15,000. All of these homes are insulated with Kimsul.

My post-war program is very extensive and I will continue to use Kimsul.

Very truly yours,



Gordon B. Roth

GBR:rr

Tried many insulations, satisfied only with KIMSUL*

—says leading New York builder

The fully KIMSUL-insulated home of Gilbert C. Tompkins in Hewlett Bay Harbor, New York. Marcel Breuer was the architect. Photograph by Ezra Stoller, Pictorial Services.



It's true. Many-layer KIMSUL* insulation is fast becoming the favorite of builders and architects from coast to coast. For KIMSUL automatically provides uniform insulating efficiency over every inch of covered area. Its "k" factor is 0.27. It's the only insulation with the PYROGARD† fire-resistant cover. And one of the easiest to install quickly and

profitably—no need for expensive machinery.

KIMSUL comes in handy, compact rolls, compressed to 1/5 installed length. To give maximum protection at lowest cost, specify it by thickness: Commercial Thick (about 1/2 in.) for walls and floors. Standard Thick (about 1 in.) for walls, attics and floors. Double Thick (about 2 in.) for attics.

Free insulation booklet. Here's a new, illustrated manual covering the latest techniques in the field. Write us for your free copy of the KIMSUL Insulation Book. Mail your request on your business letterhead.

KIMBERLY-CLARK CORPORATION
KIMSUL Division • Neenah, Wisconsin

Insulate when you build.

Over-all insulation
means ready salability.

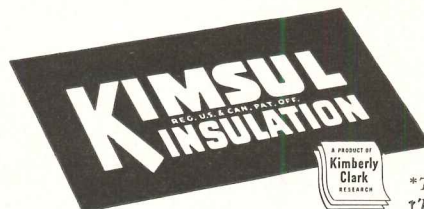

*T. M. Reg. U. S. and Can. Pat. Off.
†Trademark

make **SURE**...make it **CRANE!**

● Reason number one—and a *big* one, too—is **PROVED POPULARITY!** Crane is the name your clients prefer . . . as proved time and again in nation-wide surveys.

Reason number two is **QUALITY** . . . as reflected in the lasting brilliance, the smart styling and the extreme dependability of every Crane fixture. And don't overlook such Crane extras as finger-tip *Dial-ese* controls—in all Crane bathrooms, kitchens and laundries.

Reason number three? **COMPLETENESS!** Crane offers a style for every taste—a price for every budget. In heating, too, the Crane line is complete, providing equipment for any system, any fuel.

When making selections, refer to your copy of "Crane Service for Architects," or ask your Crane branch to supply one. Of course, not all fixtures are immediately available everywhere . . . check your requirements with your Crane branch or wholesaler.

Featured in the Crane Bathroom below are the 1-110 Drexel Lavatory, the 2-83 Criterion Bath, and the 3-120 Drexel Toilet.

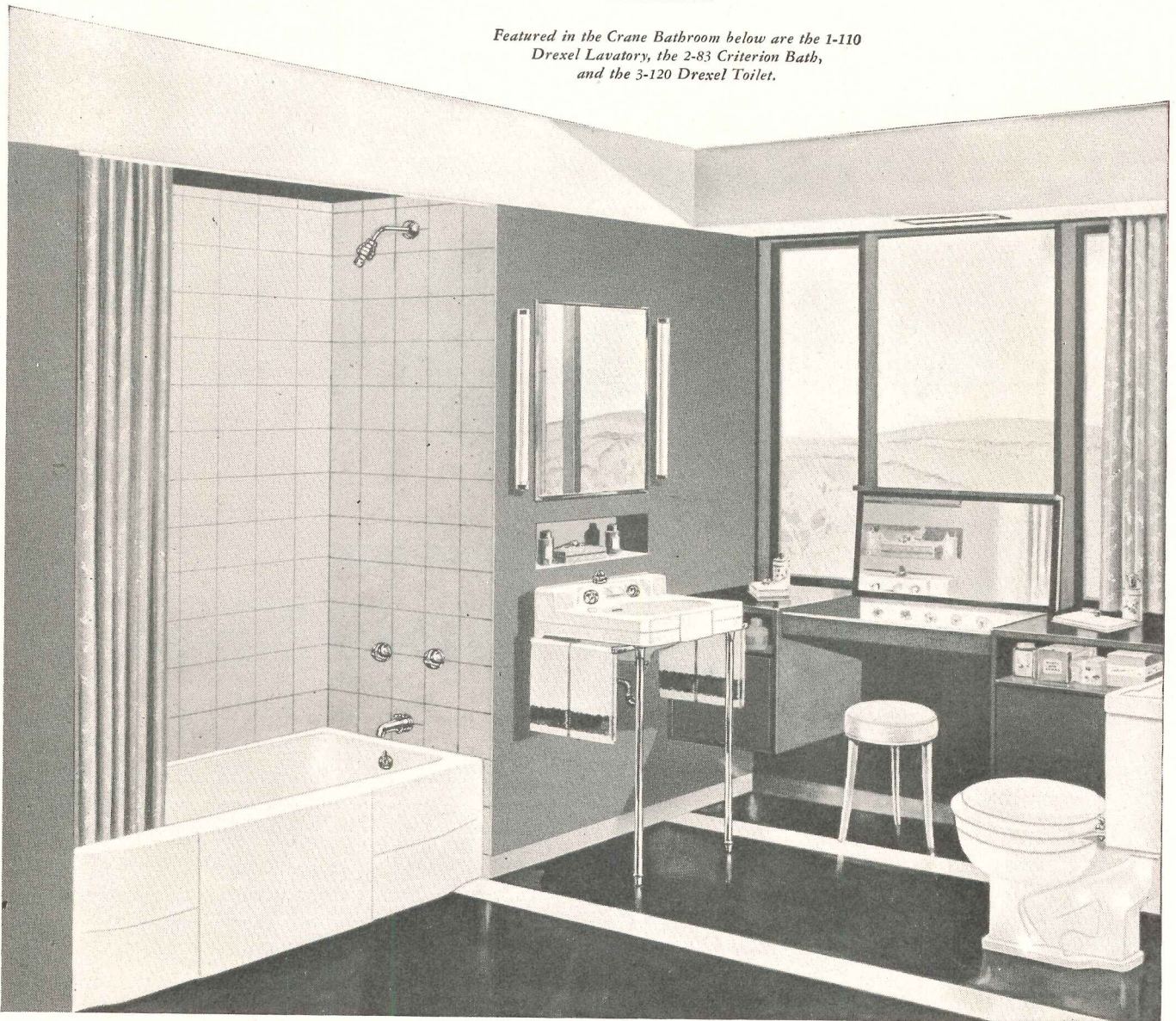

CRANE

NATION-WIDE SERVICE THROUGH BRANCHES, WHOLESALERS, PLUMBING AND HEATING CONTRACTORS

CRANE CO., GENERAL OFFICES:
836 S. MICHIGAN AVE., CHICAGO 5
PLUMBING AND HEATING
VALVES • FITTINGS • PIPE

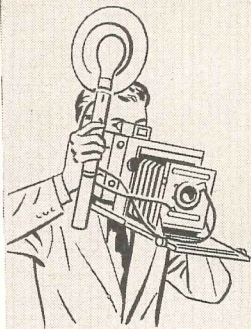

➤ Smart appearance—smart merchandising. This wide-open photo shop extends an invitation to come in and buy. The *Tuf-flex** tempered plate glass door completes the visual effect of the entire front. Architect: Wallace A. Stephen, Burlingame, Calif.



◀ The manager of this store reports 85% more sales since his new shop opened—sure evidence of client satisfaction. Cadet blue and peach *Vitrolite** flanks the large plate glass window. A low bulkhead virtually eliminates any visual barrier between pedestrian and sales floor. The diagonal front leads directly to the attractive *Tuf-flex* door. This powerful 24-hour salesman is only 20 feet in width. Architect: Horace Wachter, Toledo.

DESIGNED FOR

Full exposure to passing traffic

Architects for these photo shops opened the fronts with glass—focusing attention *inside* to the displays.

That's design for merchandising—Visual Front design that pays off in client satisfaction. This architectural treatment makes the entire store a showcase and is suited to every type of front—narrow or wide.

Glass offers wide design latitude—use it clear, translucent or opaque. Glass keeps its look of newness, washes sparkling clean, never needs refinishing. For information on types of glass available—and for interesting storefront design ideas—write for our Visual Fronts Book. Libbey-Owens-Ford Glass Company, 4568 Nicholas Building, Toledo 3, Ohio.

*®



LIBBEY · OWENS · FORD

a Great Name in **GLASS**

THE FINEST BUILDINGS OF THE POSTWAR

HAVE Q-FLOORS

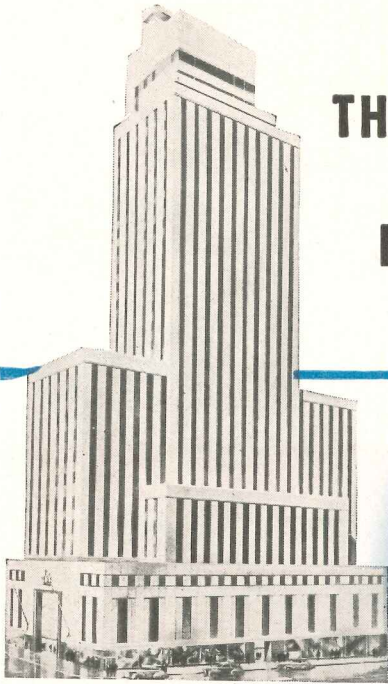

Mercantile National Bank, Dallas, Texas. Tallest office building in the South. Architect—Walter Ahlslager, Dallas. Contractor—Henger Construction, Dallas.

John Hancock Mutual Life Insurance Co., Boston, Mass. Largest office building in New England. Architect—Cram and Ferguson, Boston. Contractor—Turner Construction Co., N. Y. C.

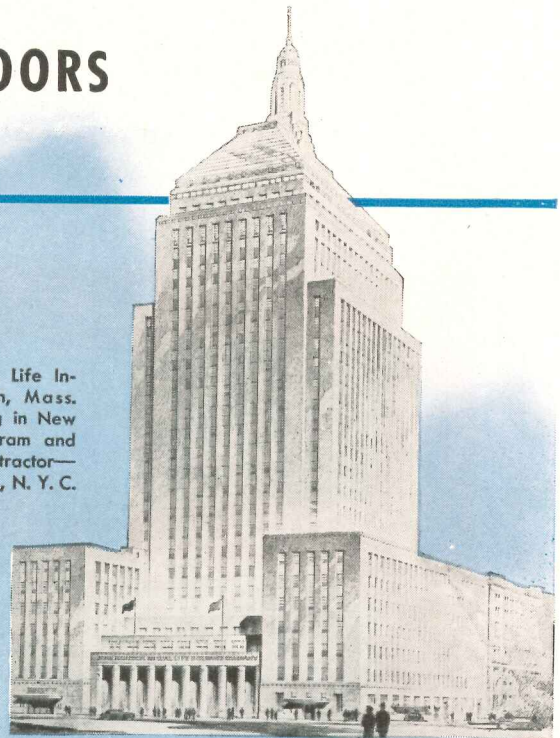

Burdine's Store, Miami, Florida. Largest department store in Dixie. Architects—E. L. Robertson, Miami; J. R. Weber, N. Y. C. Contractor—Rodney Miller, Miami.



Waterman Steamship Building, Mobile, Ala. Most striking office building of the postwar. Architect—J. Platt Roberts, Mobile. Contractor—J. P. Ewin and Co., Mobile, Ala.

Federal Telecommunications Laboratories, Nutley, N. J. Largest all-metal commercial group in the world. Architects—Louis S. Weeks, N. Y. C. (groups 1 & 2); Giffels & Vallet, L. Rossetti, Detroit (groups 3 & 4).



Contractor — George A. Fuller Co. New York City

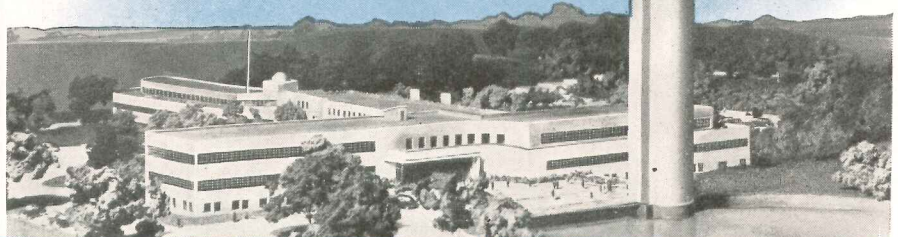
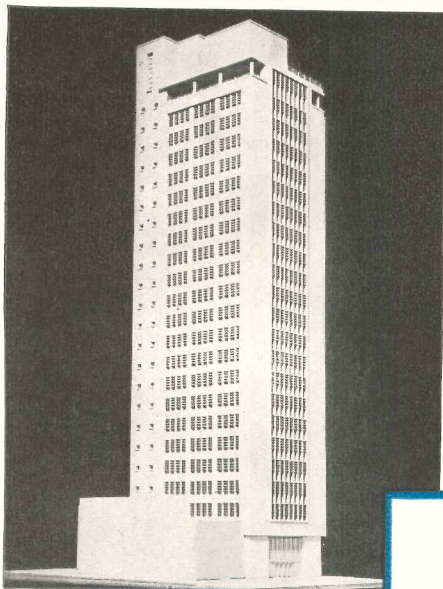

If you want to know why these architects specified Robertson Q-Floors, please write for literature.

H. H. ROBERTSON COMPANY

2404 Farmers Bank Building
Pittsburgh 22, Pennsylvania



Offices in 50 Principal Cities
World-Wide Building Service



THIS IS 7 SQ. FT. OF Q FLOOR

still **1ST** choice among designers, *...MULTI-FAMILY and*

since **1937!**

... WHEN BRYANT PIONEERED INDIVIDUAL SUITE HEATING IN A GREAT BOSTON APARTMENT BUILDING

● Bryant *Personalized Heating* has been proved with spectacular success the country over, in hundreds of large and small apartment buildings, garden-type apartments, row houses, duplexes . . . and in individual home projects that were planned for heating by a central system.

Leaders in the housing field have found that with this improved system, original equipment and operation-maintenance costs are *lower* . . . complaints and equipment failures are *fewer* . . . buyer and tenant comfort and satisfaction is *greater!* *Personalized Heating*, with Bryant *project-proved* automatic heating equipment, means a new high in *comfort and convenience* . . . a new high in *operating efficiency* . . . a revolutionary simplification in *design, construction and management*. It's the new *success factor* in mass and multi-family housing!

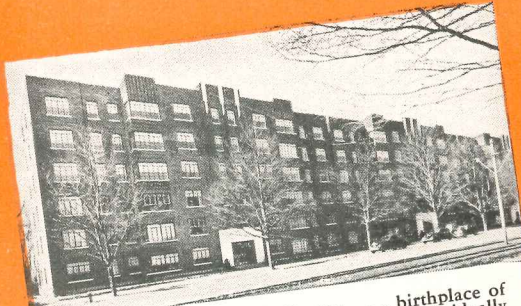

PARKLAKE APARTMENTS, Boston . . . birthplace of *Personalized Heating*. 152 luxurious suites, individually winter air-conditioned by Bryant Model VBs, world's most successful vertical units.

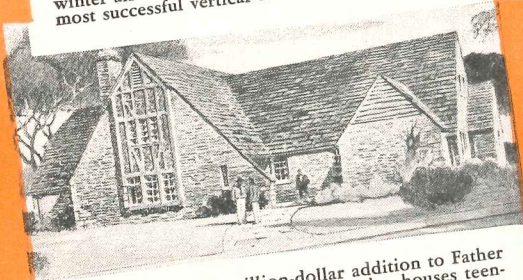

BOYSTOWN. New 3-million-dollar addition to Father Flanagan's famous *Boystown*, Nebraska, houses teenage boys in cottages like these. Heated by Bryant Model BA-88 winter air conditioners.



PEACHTREE HILLS APARTMENTS, Atlanta, Georgia, are among the newest and most modern in the South. Owners chose *Personalized Heating* with Bryant Model VB winter air conditioners.



GREENWOOD GARDENS is a Philadelphia row house development, one of several similar projects in the West Oak Lane section of the city that uses a total of over 2,000 Bryant Model GF-56 Gravity Warm Air Furnaces.

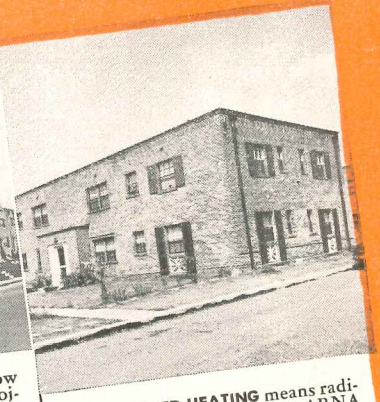

PERSONALIZED HEATING means radiation heating, too! Above is ARNA Valley, Arlington, Va., where more than 600 suites in 8-family buildings are individually heated by Bryant Model 26 boilers.

builders and operators of the Nation's Top *MASS HOUSING DEVELOPMENTS*

in 1948!

**... THOUSANDS OF RESIDENTS OF
NEW MULTI-FAMILY CONSTRUCTION
WILL ENJOY THE ADVANTAGES OF
BRYANT PERSONALIZED HEATING!**

● *North, east, south, west...* you'll find Bryant *Personalized Heating* installations in new multi-family projects all over the country, among them the Tremont Apartments, Allentown, Pa.; Pine Tree Village, Winnetka, Ill.; Allenhurst Gardens, Amherst, N. Y.; and more than a dozen projects in and around Houston, Texas. In many of these new developments you'll find Bryant *Modernaires*, newest vertical winter air conditioners, paired with gleaming white Bryant water heaters, installed in the *same* small utility closet. With this system, residents will have complete control of all space and water heating equipment serving their homes.

These installations will save owners and operators many thousands of dollars in space, building, installation and maintenance costs. How do we know? Because we've *proved* it hundreds of times in housing all over the country. And we can prove it in *your* project! Ask the Bryant representative nearest you to show you the proof in facts and figures with the illustrated presentation, *Bryant Personalized Heating*.



Photograph of an actual Bryant *Personalized Heating* installation, showing winter air conditioner and water heater installed in a small closet.



Let the pup be furnace man

bryant
AUTOMATIC HEATING

BRYANT HEATER COMPANY • CLEVELAND, OHIO

One of the Dresser Industries

because of Steel Pipe

They'll "live better ever after"

Lucky couple! The honeymoon need never be over for them. A bright horizon, aglow with opportunities for better, happier living, lies invitingly ahead.

She will not come back home to a lifetime of household drudgery like her grandmother did. He will never know the petty irritations caused by lack of modern conveniences.

They'll just press a button, turn a tap, depress a lever . . . and presto! . . . they'll have health-guarding pure water when needed, heat that radiates like sun-warmth from walls or floors, fuel that is clean and safe, comforts and conveniences almost without limitation.

All this, steel pipe makes possible!

Durable, reliable, adaptable . . . and within pocketbook's reach of everyone . . . steel pipe goes on serving and extending its usefulness for the health, convenience, comfort and happiness of us all.

The interesting story of "Pipe in American Life" will be sent upon request.

COMMITTEE ON STEEL PIPE RESEARCH of American Iron and Steel Institute, 350 Fifth Avenue, New York 1, N.Y.



STEEL PIPE MAKES IT POSSIBLE!



. . . better living through pipes of steel for plumbing and heating purposes.

Its *Simplicity*

is your assurance
of efficiency

The Delany Flush Valve has only 6 moving parts, the simplest assembly of any flush valve and the quickest and easiest to repair.



DELANY FLUSH VALVES are highly recommended for private homes, and particularly for "rental construction" as now planned by the Government.



**INSTANT
OUTSIDE
CONTROL
OF FLOW**

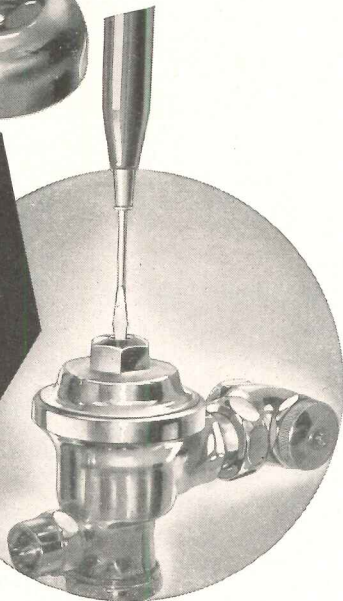

The simplicity of DELANY VALVES and DELANY VACUUM BREAKERS guarantees long lasting efficiency of operation. *The proof of which is:*

1. The obviously, simple outside control provides a pin point adjustment of water consumption, compensating for all of the variable factors of volume, pressure and flush fixtures (left illustration).
2. The simplified operating assembly, only six parts, insures low replacement costs (see illustration above).
3. The accessibility, when repairs are necessary, reduces maintenance man hours to the absolute minimum.

Available thru all leading supply houses.

SINCE 1879
Coune & Delany Co.
BROOKLYN N.Y.

FLUSH VALVES · VACUUM BREAKERS · PLUMBING SPECIALTIES

IN CANADA: THE JAMES ROBERTSON COMPANY, LIMITED • MONTREAL • TORONTO • ST. JOHN, N. B.

Weigh all the advantages

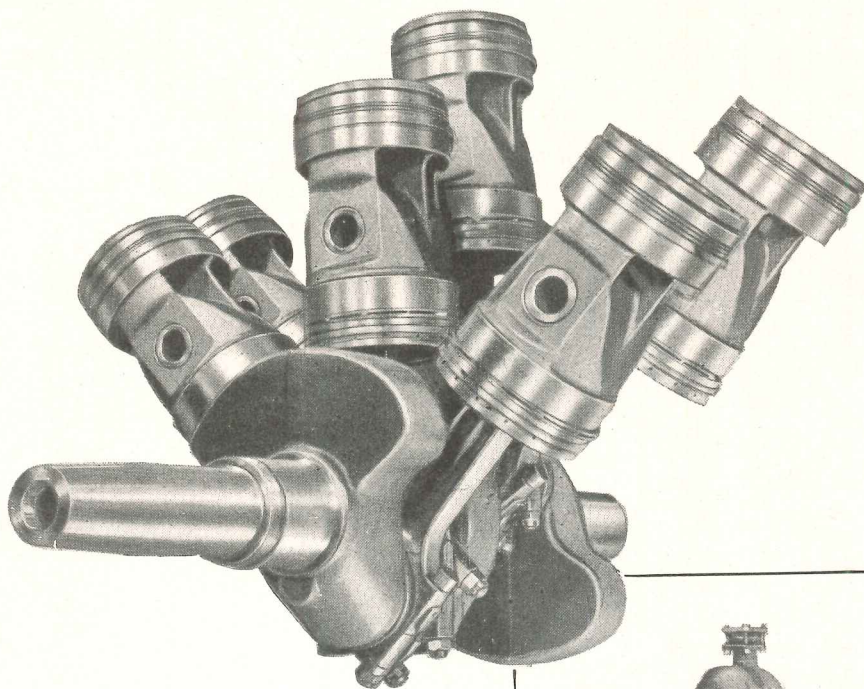

V/W "AIRCRAFT BALANCE"

means freedom from vibration

This unique V/W crankshaft and piston assembly is a study in static and dynamic balance and suggests a radial aircraft engine with its lower half placed in line with the upper. In addition to accurate control of the weight of individual parts, the arrangement of rotating and reciprocating parts in this ingenious V/W design results in vibrationless operation. As a result of these innovations, York engineers were able to produce the first re-

frigeration compressor that could be mounted on upper floors, in roof trusses, that required no special foundation.

Exclusive design is but one of the many features of V/W "the compressor that never wears out," and is representative of the character of York engineering throughout its complete line of refrigeration and air conditioning equipment.

York Corporation, York, Penna.

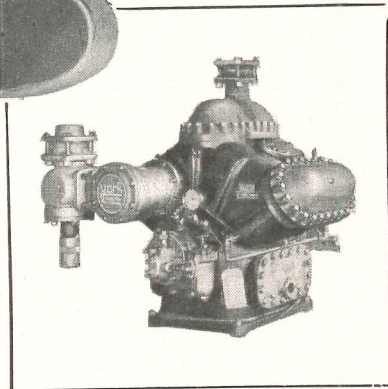

York's Engineering Assistance backs up York's Outstanding Equipment

Experience and practical technical assistance unequalled elsewhere are available to you as a York customer . . . wherever you may be.

In the Pacific District, for example, Manager Lauer located in Los Angeles, assisted by fourteen York-trained sales engineers, is at the service of York customers in this district. The highly practical, up-to-the-minute assistance and advice of these gentlemen are available to you at all times, whether you are planning, purchasing, installing or operating refrigeration or air conditioning systems or equipment.



R. F. LAUER
District Manager

Assisted by

J. N. Berger
E. J. Berlet
W. R. Eby
Maron Kennedy
W. B. Ludwig
T. A. Marshall
H. T. Orebaugh
M. R. Overbye
G. F. Sainsbury
W. W. Sandholt
C. A. Shapiro
F. H. Stephens
D. D. Stone
G. H. Walker

YORK *Refrigeration and
Air Conditioning*



HEADQUARTERS FOR MECHANICAL COOLING SINCE 1885

WHERE BEAUTY IS A MUST...



General Electric Textolite paneling adds warm color to the rich atmosphere of the famous Coty Beauty Salon in New York City.

● In smart salons and gay cafes—it's G-E Textolite plastics surfacing for fresh and sparkling beauty. See how handsomely it serves as decorative paneling! And durable General Electric Textolite is ideal for *table and counter tops*.

Lustrous and hard, G-E Textolite plastics surfacing withstands shock and resists scratching better than low-carbon steel. Easy to wipe clean, it is unstained by food acids, household chemicals, alcohol, or boiling liquids. Even scalding grease won't blister this plastics sheet material.

Use General Electric Textolite surfacing in restaurants . . . hotels . . . cocktail bars . . . soda fountains . . . home kitchens and dinettes . . . wherever good looks must survive severe wear. You have a variety of standard colors and designs to choose from. Send for your copy of the booklet showing Textolite patterns in *full color*. It's free! Just drop us a line, or use the coupon. Plastics Division, Chemical Department, General Electric Company, 1 Plastics Avenue, Pittsfield, Mass.

*Reg. U.S. Pat. Off.

GENERAL  ELECTRIC
CD48-1,2
EVERYTHING IN PLASTICS

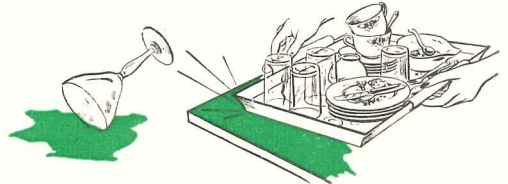

G-E TEXTOLITE can't be harmed by alcohol, food acids, disinfectants, boiling water . . . resists scratches better than low-carbon steel . . .

General Electric Co.
 Section A W-6
 1 Plastics Avenue
 Pittsfield, Mass.



Send me my copy of "Textolite Decorative Surfacing Materials for Table and Counter Tops."

Name.....
 Business.....
 Address.....
 City.....State.....

FLAGG  FLOW



the first threadless malleable fitting

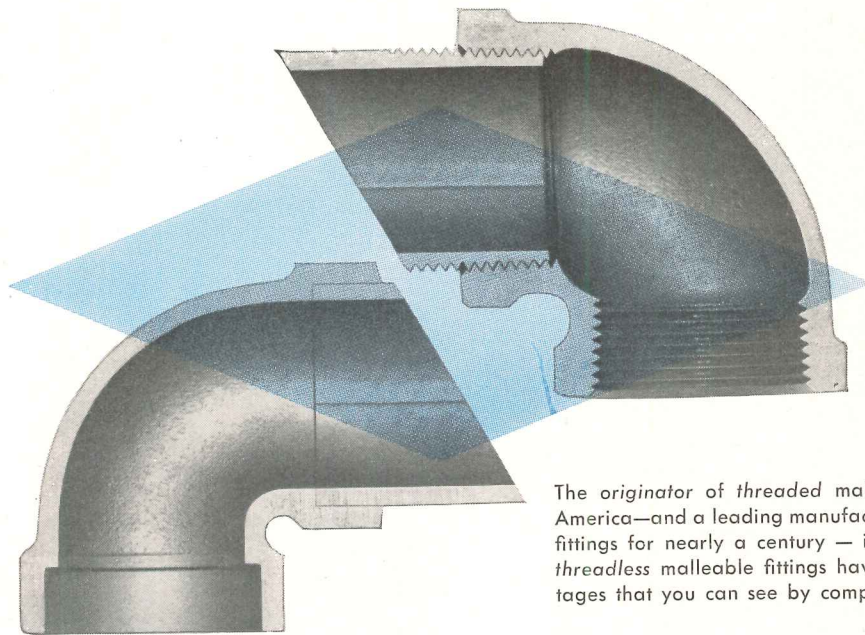

The originator of threaded malleable fittings in America—and a leading manufacturer of threaded fittings for nearly a century — is again first with threadless malleable fittings having basic advantages that you can see by comparison.

FLAGG-FLOW uses full thickness of pipe — no threads to cut away half of the wall in sizes under 3". FLAGG-FLOW permanently bonds pipe and fitting into "one-piece" security that is stronger than the pipe itself, eliminating the weakness of threads in withstanding shock, vibration, expansion or contraction.

There are no pockets or enlarged chambers in FLAGG-FLOW to increase turbulence, no distortion

strains from strong-arm wrenching, no special skill required for installation — and no increased cost over screwed pipe installations. Having the same wall thickness as a threaded fitting, FLAGG-FLOW is substantially lighter and takes less space — with *no decrease* in strength. FLAGG-FLOW is the first 150-pound malleable fitting sold from stock to be *air-tested under water* for your protection, eliminating the fear of "leakers."

MALLEABLE IRON FITTINGS, STD. EX. HVY. AND AAR • CAST IRON FITTINGS • DRAINAGE FITTINGS • FLANGE UNIONS • FLANGES
GROUND JOINT UNIONS • BRONZE THREADED FITTINGS • BRONZE SOLDER FITTINGS • UNDERGROUND TANK FITTINGS

threadless

EVERY advantage that has made FLAGG-FLOW the talk of the piping industry is now available in *bronze* as well as malleable iron.

Now you may select the piping material that best meets your needs — wrought iron, steel, brass and copper pipe or tubing — and still enjoy FLAGG-FLOW “one-piece” security and simplicity of installation.

Moreover, FLAGG-FLOW in bronze gives you freedom of choice in brazing alloys. With a precision-machined cup that permits close tolerances, you may stick-feed any capillary brazing alloy that you desire to any FLAGG-FLOW Bronze Fitting taken from stock, with the assurance that Capillary Action will draw the brazing alloy into the joint to make a perfect, permanent bond. Any competent pipefitter can make joints stronger than the pipe itself by observing the simple three-step rule: CLEAN-FLUX-HEAT.

But beyond this simplicity of installation are other important advantages. FLAGG-FLOW means *free-flow* through smooth, unbroken, pocketless channels that are,

now available in bronze

in effect, continuations of the pipe itself. Thus FLAGG-FLOW gives you stream-lined interior, low friction-loss advantages — at a cost no higher than for ordinary threaded jobs.

FLAGG-FLOW ends many piping bug-a-boos. You can now have *complete* freedom in piping layout, for FLAGG-FLOW can be installed wherever pipe will go and a torch will reach — in tight spots around machinery, or in awkward corners that defy a wrench. No longer need you worry about inaccessible spaces — thin partitions — lines subjected to shock, vibration or temperature changes — in short, *for piping that has to last*, FLAGG-FLOW may be installed and *safely* forgotten.

For new or replacement work you owe it to yourself to be fully informed on this modern technique of joining pipe. Fully descriptive booklets on either malleable or bronze FLAGG-FLOW are yours for the asking.

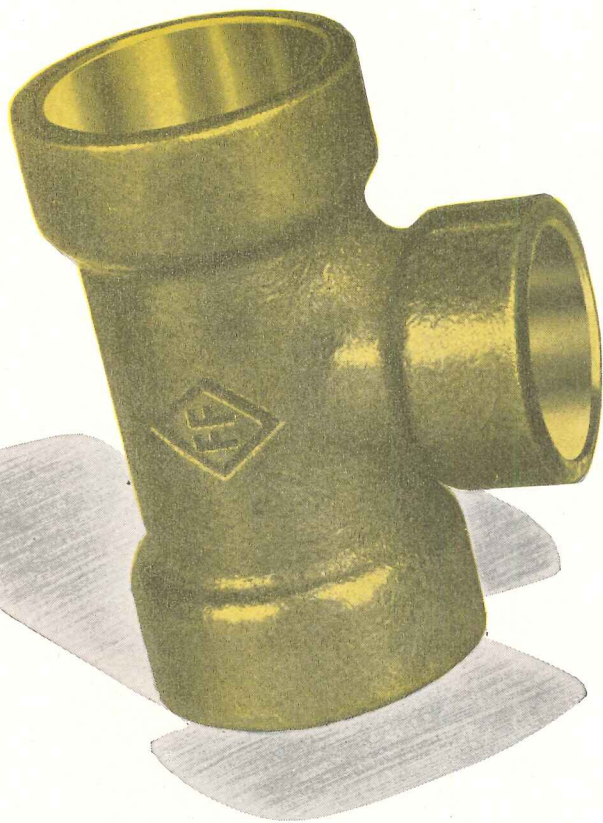

FLAGG-FLOW Bronze Fittings may be had in the same sizes and patterns as FLAGG-FLOW Malleable Fittings. Their method of installation is also identical. Choose, with freedom, the material best suited for your job.



STANLEY G. FLAGG & CO., INC.
1421 Chestnut Street, Philadelphia 2, Pa.

In Equitable Life's "Clinton Hill" Apartments ...It's Bruce Block Floors!

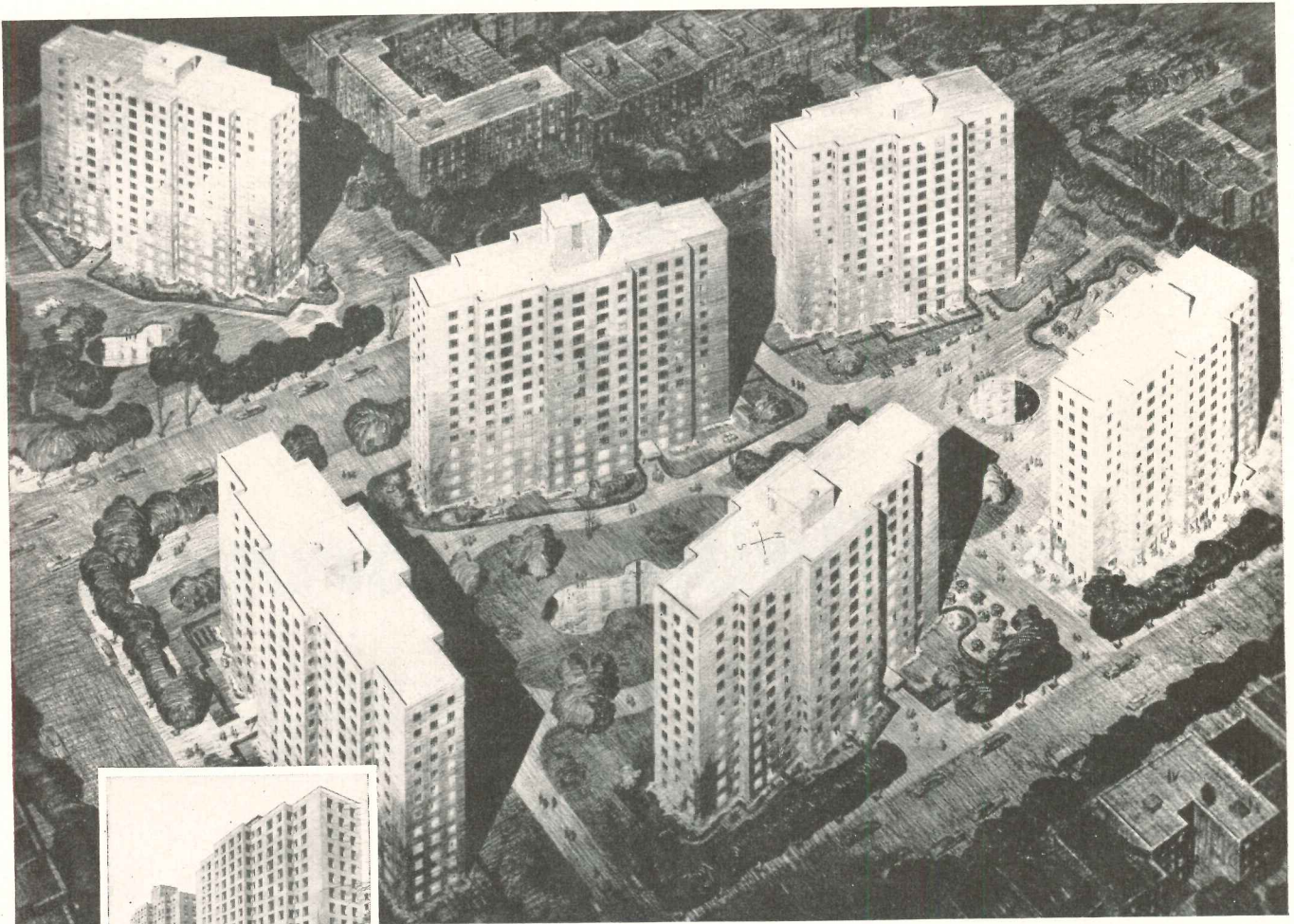

There are 11 buildings with 1160 apartments in the newly completed Clinton Hill project—Brooklyn, New York. This outstanding housing development is owned and managed by Equitable Life Assurance Society of the United States. Architects: Harrison, Foilhoux & Abramowitz. General Contractors: Starrett Bros. & Eken, Inc. Flooring Contractors: John T. Swanson Co.

This modern hardwood flooring has advantages for architects, owners, and tenants

For modern apartment projects, no other type of flooring is so satisfactory as Bruce Blocks. Advantages include these very important ones:

- (1) Easily and economically installed over concrete.
- (2) A permanent part of a building—not a floor that must be replaced every few years.
- (3) Distinctive, modern and beautiful.
- (4) Comfortable — warm, resilient and quiet underfoot.
- (5) Easily maintained in perfect condition.

Production on Bruce Blocks has been increased, but still does not equal demand. Specify this flooring on projects being planned now for future construction. See our catalog in Sweet's, or write:

E. L. BRUCE CO., MEMPHIS, TENN.
World's Largest Maker of Hardwood Floors

Bruce Block **HARDWOOD FLOORS**

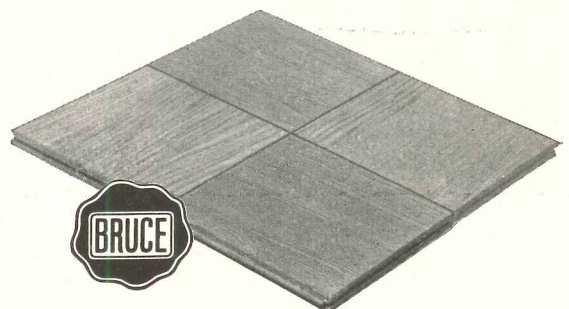

FIRST

in heating and plumbing
because they're the best
for both important jobs!

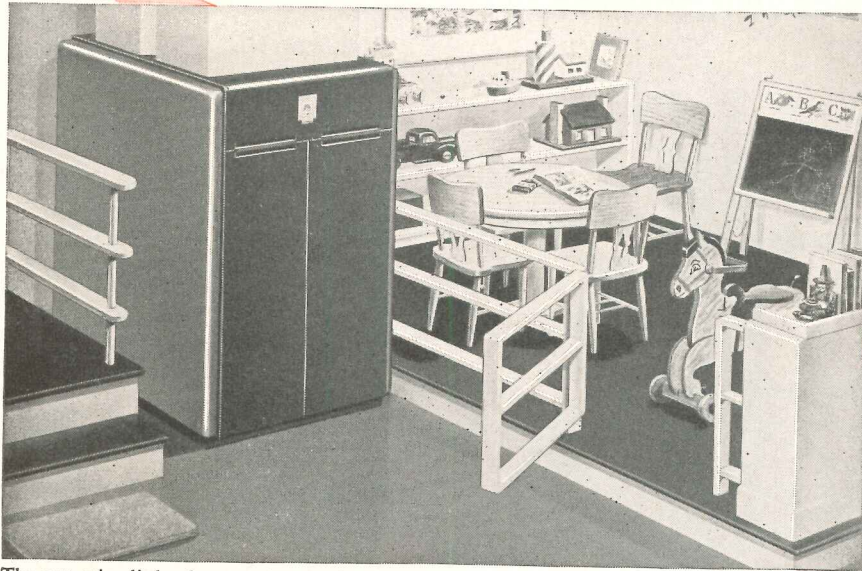

The attractive little playroom is a good example of the practical use you can make of a small basement when your heating unit is both good looking and compact. The **MOHAWK** Winter Air Conditioner shown here lends a distinctive, pleasing decorative note to this basement setting, while providing clean, dependable heat to the entire house. Famous for its beauty, sound engineering features and sturdy construction, the Mohawk burns natural, manufactured, mixed or liquefied petroleum gas with maximum efficiency and economy.



You achieve the ultimate in bathroom luxury when you choose the **NEO-ANGLE** bath and harmonizing fixtures from the American-Standard line. The bath, occupying space only about four feet square, is the recessed model of the Neo-Angle with its two integral seats and wider, flatter bottom; the lavatory is the graceful **ROXBURY** with large square bowl, tapered legs, and convenient towel bars. Fittings and other exposed metal finished in gleaming, non-tarnishing Chromard. The water closet is the **MASTER ONE-PIECE**, with quiet, thorough syphon vortex water action.

LOOK FOR THE MARK OF MERIT—It identifies the world's largest line of Heating and Plumbing Products for every use . . . including Boilers, Warm Air Furnaces, Winter Air Conditioners, for all fuels—Water Heaters—Radiators, Convectors, Enclosures—Gas and Oil Burners—Heating Accessories—Bathtubs, Water Closets, Lavatories, Kitchen Sinks, Laundry Trays, Brass Trim—and specialized products for Hospitals, Hotels, Schools, Ships and Railroads.

■ As the world's largest manufacturer of heating equipment and plumbing fixtures, American-Standard is your most dependable source for both. Not only does American-Standard give you the widest choice of styles, types, models and sizes, but it also is your assurance of the finest quality in *both* heating equipment and plumbing fixtures. That's why more American homes have heating and plumbing by American-Standard than by any other single company. Yes, you'll find that it pays to "make it American-Standard all the way"! For detailed information about the complete range of products, contact your Heating and Plumbing Contractor. **American Radiator & Standard Sanitary Corporation**, P. O. Box 1226, Pittsburgh 30, Pa.



AMERICAN-Standard
First in Heating and Plumbing

IN EVERY TYPE OF HOUSE
LET REVERE COPPER GUARD
THESE VITAL POINTS

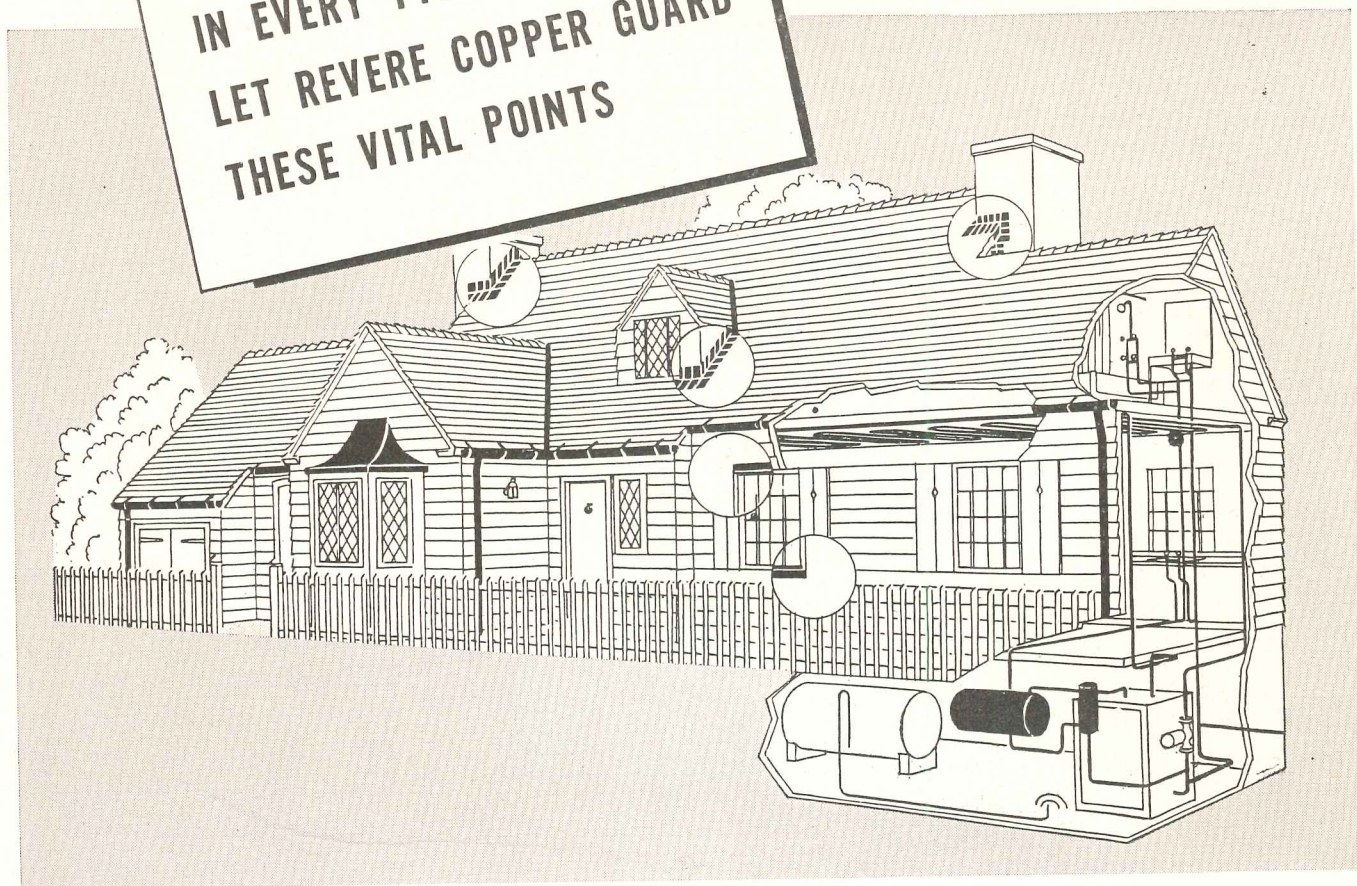

TROUBLE always costs more than Revere Copper. That's why it pays to let Revere Copper guard those vital points where water will cause other materials to rust, rot or corrode.

HEATING. In radiant panel, steam or hot water heating systems, Revere Copper Water Tube insures a lifetime of trouble-free service. Its permanently smooth interior reduces frictional resistance to a minimum. And because it bends readily, and joints are made quickly with solder fittings, it is easier to install, too.

WATER SUPPLY. You insure a free flow of sparkling-clear water when you specify Revere Copper Water Tube for hot and cold water lines. Since interiors do not become clogged by corrosion, the lines can usually be a size smaller than would be required with rustable pipe.

WASTE LINES. Large sizes of Revere Copper Water Tube are now available for soil, waste and vent lines. Experience has proven that copper provides lifetime-resistance to the corrosion action of ordinary waste materials.

FLASHING. Every home, large or small, can now have the protection of copper flashing at all joints where leaks might occur. Consult Revere engineered specifications for every type of construction.

Other Revere products include: Red-Brass Pipe; Sheet Copper and Herculoy for tanks, ducts, pans and trays; Copper oil burner, heat control and capillary tubes... and, of course, Sheet Copper for roofing, flashing and other sheet metal construction. They are handled by leading distributors in all parts of the country.

REVERE
COPPER AND BRASS INCORPORATED

Founded by Paul Revere in 1801

230 Park Avenue, New York 17, New York

*Mills: Baltimore, Md.; Chicago, Ill.; Detroit, Mich.;
New Bedford, Mass.; Rome, N. Y.*

Sales Offices in Principal Cities, Distributors Everywhere.



KENCORK
® floors and walls

Let's get Personal!

Breaking in upon the privacy of a lady's boudoir, we find floor and walls of Kencork. There are many practical reasons for Kencork's being there. Natural cork, it is one of nature's insulators—warm enough in winter for barefoot walking, yet comfortably cool on sultry summer days. It is exceptionally quiet underfoot and the natural cork texture provides a non-slip floor surface.

But perhaps more important to your client is Kencork's rich, quiet beauty. Its neutral coloring of tans and browns makes an ever-changing, never-tiresome pattern that harmonizes with modern furniture and fabrics—fits into any color scheme. A room with Kencork walls and floor is a perfect starting point for an exquisite interior.

Knowing Kencork's many practical advantages, its lifetime durability and reputation for great luxury—many architects are agreeably surprised at its low initial cost. Ask your flooring dealer about Kencork or write us for the colorful Kencork catalog.

David E. Kennedy, Inc., 71 Second Ave., Brooklyn 15, N. Y. —
 350 Fifth Ave., New York 1, N. Y. — Ring Building, 1200 18th St.
 N. W., Washington 6, D. C. — 1211 N.B.C. Building, Cleveland
 14, Ohio — Bona Allen Building, Atlanta 3, Ga. — Merchandise
 Mart, 222 West North Bank Drive, Chicago 54, Ill. — Kansas City
 Merchandise Mart Inc., 2201-5 Grand Ave., Kansas City 2, Mo.
 — Western Merch. Mart, 1355 Market St., San Francisco 3, Calif.



TILT-UP, the fast, modern and economical method of concrete construction was used in building the Luthe Hardware Company warehouse in Des Moines, Iowa—a structure with more than two acres of floor space.

Tilt-up construction is adaptable to individually designed or standard buildings and is practical for one-story or multi-story structures. It is quick and easy and reduces form building and form handling to a minimum.

Wall panels are cast flat in simple edge forms—usually right on the concrete floor—and then tilted up into position with power cranes or hoists. Panels can be sized to meet a wide variety of requirements. Cast-in-place piers and beams tie the panels together into one integrated unit.

Structures built by the tilt-up method have all the desirable properties of any concrete building.

They are firesafe, decay-proof, trim and neat in appearance. Their first cost is moderate, they last a lifetime and cost little to maintain. They are truly **low-annual-cost** construction.

Learn more about this time-saving, economical method. Write today for free technical bulletins, containing design and construction details. Distributed only in the United States and Canada.

The new Luthe Hardware Company concrete warehouse in Des Moines is a 240 x 420 ft. structure with a two-story, 45 x 75 ft. office wing. Tilt-up construction was used throughout, except for the office wing projection, which is cast stone.

Tilt-up panels are 11 ft. high, 13 ft. 8 in. long and 6 in. thick. Only seven sets of edge forms were used to build 73 wall panels.

Engineering and construction work by The Weitz Company, Inc.; Brooks-Borg, architects of Des Moines, consultants on architectural design.

Upper photo shows 5½-ton wall section being tilted into position. Lower photo is a view of the completed building.

PORTLAND CEMENT ASSOCIATION

Dept. 6-8, 33 W. Grand Avenue, Chicago 10, Ill.

A national organization to improve and extend the uses of portland cement and concrete . . . through scientific research and engineering field work

Now Available . . .

SOUND FILM ON TILT-UP CONSTRUCTION

Our new 16 mm. sound film on tilt-up construction is available for showing at group meetings of architects, engineers or contractors. Requests should be made at least three weeks before date of meeting.

Wiring Change-Over Problems *SOLVED* with National Electric

SURFACE *RACEWAYS!*

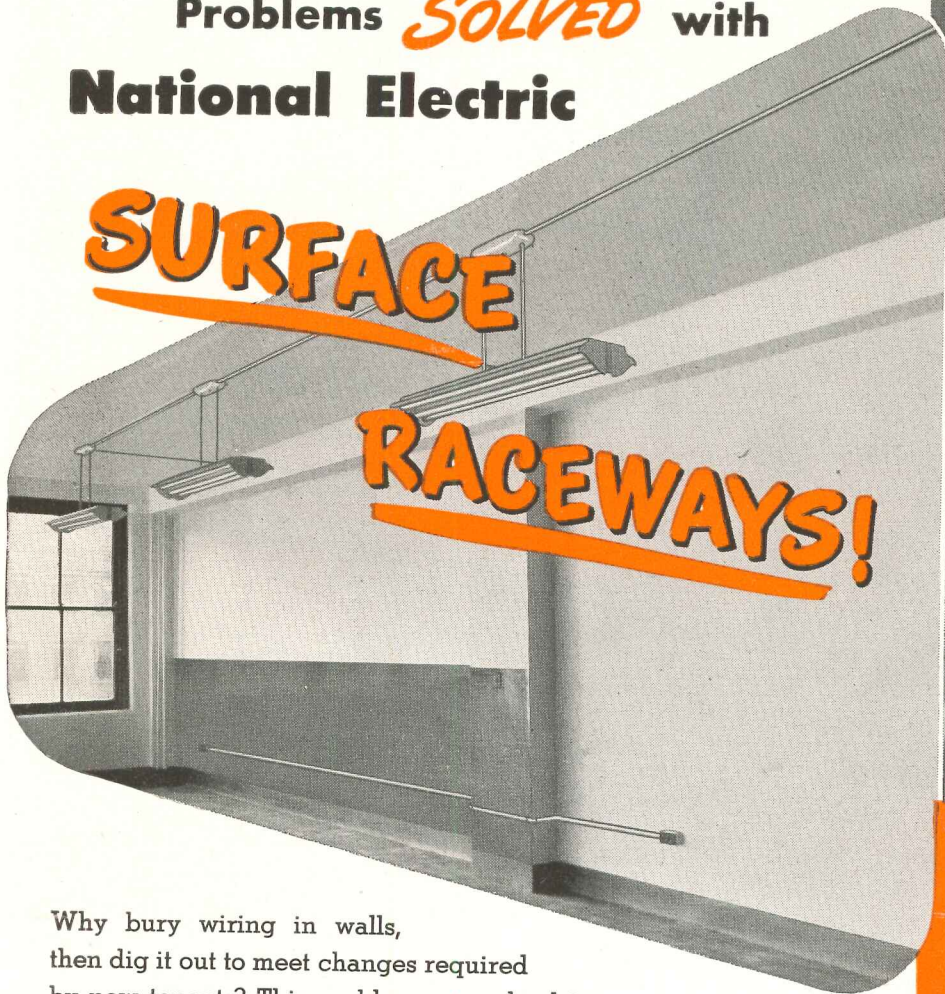

Why bury wiring in walls, then dig it out to meet changes required by new tenants? This problem was solved in the Edwards Building, Cincinnati, through the use of NE *Surface-duct* and *Metal Molding* to place electrical fixtures and outlets exactly as required by incoming tenants. In addition to eliminating the inconvenience of rerouting in-the-wall wiring, NE Surface Raceways reduced wiring costs by 30%!*.

For remodeling, as well as for economical, new construction, you can make similar substantial savings with NE Surface Raceways—

**Xtensionduct . . . Metal Molding . . . Florduct . . .
Plug-In Strip . . . Surfaceduct**

All NE Surface Raceways have the famous lay-in feature—no fishing of wires required. Attach the base, lay-in the wires, snap on the capping, and the job is done! Easy to re-wire . . . Easy to reroute.

Let us send you a copy of "National Electric Surface Wiring Systems"—an illustrated catalog of all NE Raceways and Fittings.

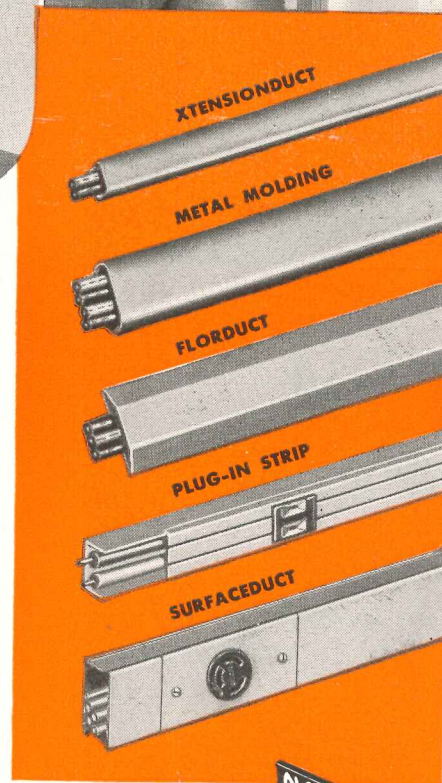
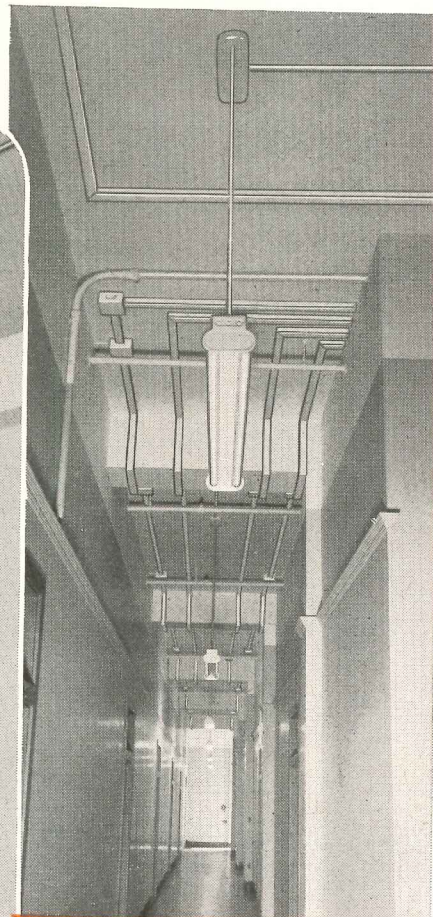

Everything in wiring points to NE

National Electric

PITTSBURGH, PA.

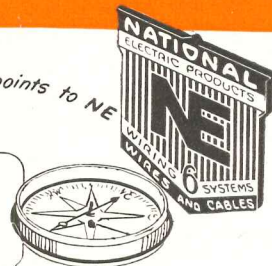

*As reported by Mr. Joseph Gangloff, electrical contractor and chief electrician for the Edwards Building.



Architects: Coolidge, Shepley, Bulfinch and Abbott, Boston. General Contractor: George A. Fuller Co., Boston. Steel Fabricator: Utica Structural Steel Co., Utica, N. Y.

Addition to Hartford Hospital

Eye-appealing in its facing of white, semi-glazed brick, this new hospital at Hartford, Conn., is to be known as Hartford Hospital High Building. It is 15 stories in height and will provide 750 beds. Like many other attractive buildings now under construction throughout the country, it embodies a framework of Bethlehem Structural Shapes.

BETHLEHEM STEEL COMPANY, BETHLEHEM, PA.

On the Pacific Coast Bethlehem products are sold by Bethlehem Pacific Coast Steel Corporation

Export Distributor: Bethlehem Steel Export Corporation

Bethlehem
**STRUCTURAL
SHAPES**



LOOK... ONE REASON FOR *ELKAY* *Lustertone*!



AND THERE are many more good reasons for installing *Lustertone* Stainless Steel Sinks:

- Won't chip, peel, flake or wear off — never will discolor — always retains original new look.
- One-piece bonded construction eliminates all seams — no crevices to hide dirt and germs.
- Hot utensils can't mar the lustrous surface. Never a crack or craze from waste food disposer or automatic dish-washer action.
- Millions now know Stainless Steel means utmost permanence, sanitation and lasting beauty.
- Available in seven popular sizes ranging from 54 to 96 inches. Supplied with quality cabinets, or sold to fit other cabinet lines.



Guaranteed to outlast any home in which it is installed



CUSTOM BUILT

ELKAY Stainless Steel is the one best answer when continuous surfaces are desired—without seams or crevices.

WRITE TODAY

for catalog and prices or consult 23 a/6 Sweet's Architectural File.

Lustertone

ELKAY MANUFACTURING COMPANY

1870-F South 54th Avenue

Chicago 50

STAINLESS STEEL SINKS

Made only by ELKAY —oldest manufacturer of Stainless Steel Sinks — Established 1920

Modern drama:

Barker Bros.' new 5th floor

Leading rolls:

Bigelow Carpets



When Los Angeles' Barker Bros. remodeled their famous store, they followed what is practically a tradition among America's leading stores, and ordered Bigelow Carpet throughout.

For general beauty and long wear: Bigelow's classic Gropoint, the top commercial-choice carpet with its uncut surface that resists shading... never tattles about traffic lanes.

For special drama in decorator room-settings: such Bigelow beauties as Contempora... Sonata... Ceredo.

Most stores, hotels, and other business establishments find it easy to fill their needs from the regular Bigelow line.

When you have occasion to plan a carpet installation, you may well find your problem as simple as fingering a Bigelow swatch-book.

Bigelow's own Carpet Counsel is always available to help you with any problems, from the smallest to the largest. Our experts will help you make your carpeting dollars go farthest... with advice on most suitable types of carpets, designs, and colors.

Bigelow will custom-plan special orders—from original design to final installation. One of our 26 Carpet Counsel offices is near you—waiting for your call.

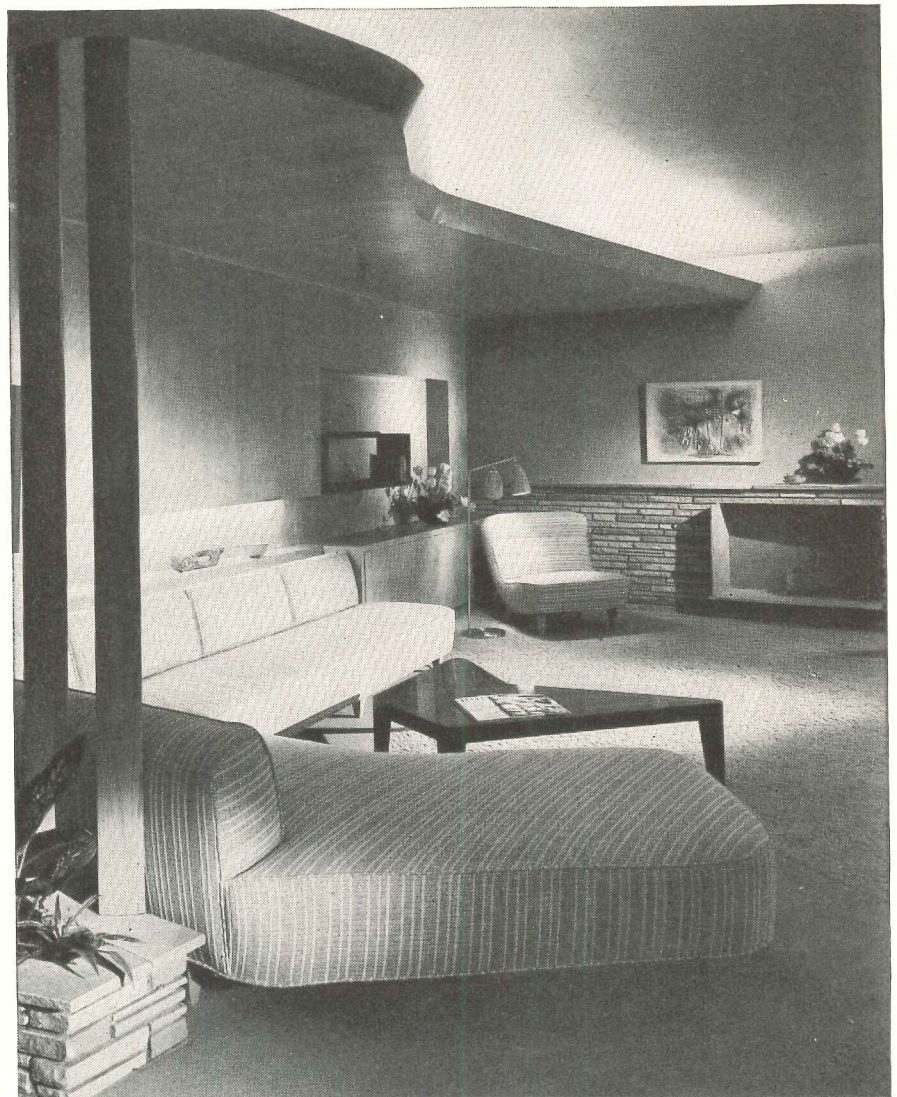

A corner of Barker Bros.' remodeled 5th floor. Setting by Greta Grossman. Luxurious textured Contempora carpet by Bigelow.



Bigelow Rugs and Carpets

Beauty You Can See... Quality You Can Trust... Since 1825

6 common conditions

where ***WOLMANIZED** PRESSURE TREATED **LUMBER**

protects against DECAY and TERMITES



1. Wherever moisture is condensed because of concrete or masonry.

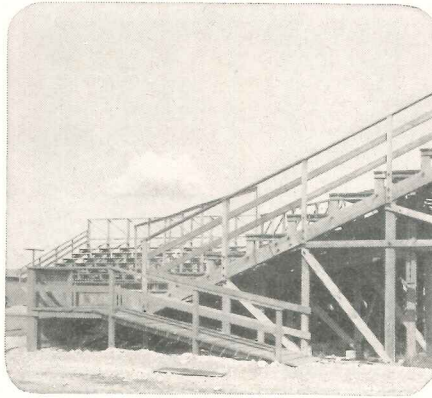

2. Ground moisture and rain held in joints, etc., of outdoor structures.



3. Wood used in or near the ground open to attack by termites.

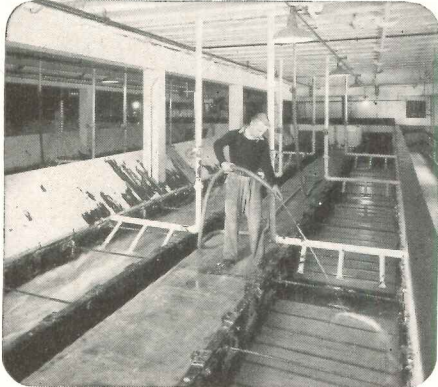

4. Where steam and vapor from industrial processes are prevalent.

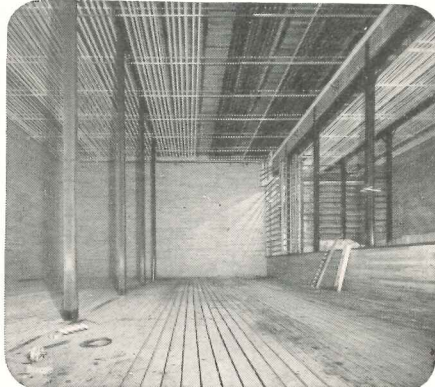

5. Walls, floors, ceilings subject to condensation from refrigeration.

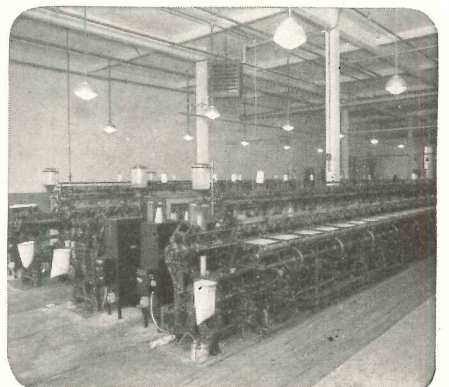

6. Wood exposed to moisture in artificially humidified buildings.

This Treatment COSTS LESS Than "Replacement-Labor"

You offer your clients genuine economy when you write "Wolmanized" pressure-treated lumber into the specifications.

When you consider its lasting protection against wood-decay and termites, this lumber's extra cost is always less than the cost of labor alone in replacing prematurely failing, untreated wood.

What's more, actual service records prove that Wolmanized pressure-treated lumber lasts 3 to 5 times as long as ordinary wood.

Wolmanized lumber is treated

with salts which are toxic to decay fungi and termites. The treated wood is clean, odorless, paintable and non-corrosive to metals. You can specify it with complete confidence that you are improving the building and offering a long-time saving, which will reflect to your advantage with a permanently satisfied client.

For full information and suggested specifications, write today to American Lumber & Treating Company.

The latest information on this proved good will builder

Complete information on Wolmanized lumber, including suggested specifications, is available in this new booklet. Write for your copy today.



*Registered Trade Mark

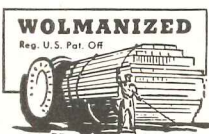

Boston 9
141 Milk Street

New York 17
420 Lexington Ave.

Washington 5
831 Southern Bldg.

Jacksonville 2, Fla.
719 Graham Bldg.

Los Angeles 15
112 West 9th St.

San Francisco 5
604 Mission Street

AMERICAN LUMBER & TREATING COMPANY

General Offices: 332 South Michigan Ave., Chicago 4, Illinois

Beauty **IN THE BATHROOM THAT** *Endures*

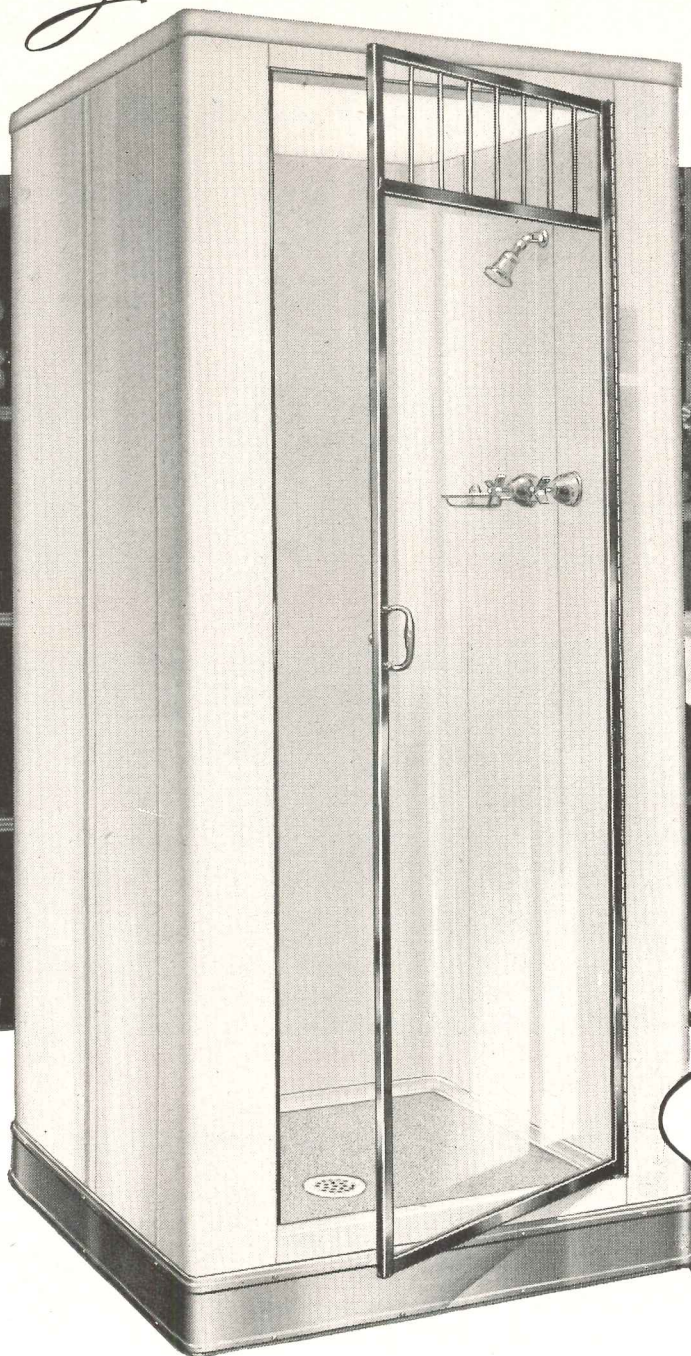
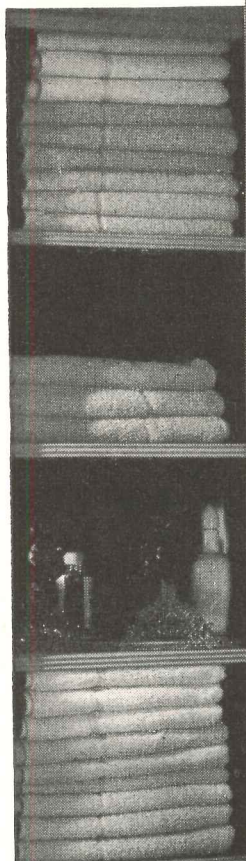

Sizes: 36" x 36" x 80",
40" x 40" x 80".
Corner cabinet.
Terrazzo receptor. White Bonder ized enameled aluminum alloy cabinet. Underwriters approved lights. Chromium plated brass door. Non-clogging shower head. 6" center valves. Soap dish.

TODAY, in their bathrooms, new home owners want the luxury of modern design in shower cabinets combined with utility and real durability. Now Tiletone, and only Tiletone, offers a shower cabinet that really graces any bathroom no matter how luxurious. It is Model 75. Here is a shower cabinet that is con-

structed to hold up better—is durable. Made of aluminum alloy, it is non-rusting and is protected by a Bonderized baked enamel finish. Model 75 has a new improved terrazzo receptor—shoulder height shower head, is lighter, yet rigid . . . solid! So it's easier to handle, easier to install.

MODEL **75** **TILETONE**
Shower Cabinet

TILETONE COMPANY • 2323 WAYNE AVENUE • CHICAGO 14, ILLINOIS

Only 44 inches high!

That's the low-down on the new Richmond Gas Winter Air Conditioner. Horizontal design takes the headache out of duct work installations on low head-room jobs. Cast-iron for long life.

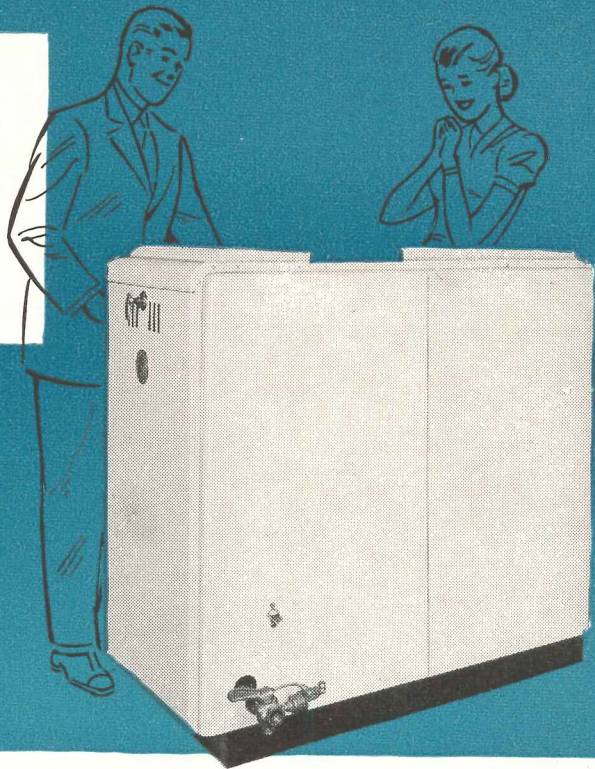
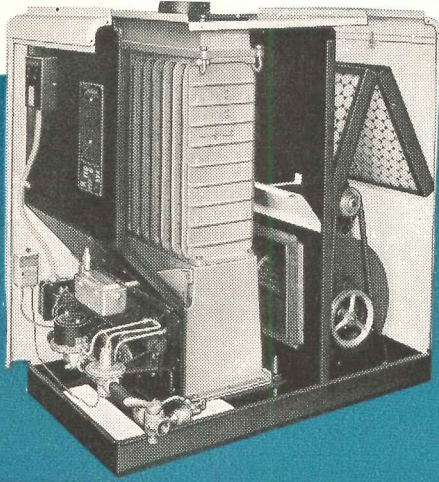

New installations in 4 man-hours .. with RICHMOND GAS WINTER AIR CONDITIONER

The keen interest shown by architects, builders and heating contractors in this new Richmond unit is no accident. This new Richmond conditioner allows installation the way you want it—FAST!

In new construction, Richmond Gas Winter Air Conditioners can usually be installed in four man-hours (somewhat longer on replacement jobs). Unit comes completely wired and assembled, with exception of Control Manifold, which is shipped assembled in separate carton, ready for easy installation. Estimated saving \$20 to \$35 on installation costs.

Brilliant white jacket packs sales appeal, because it stays white.

Protective shipping bag guards jacket before, during and after installation. Compact, horizontal design permits small-space installation. Low basements are no problem. Available now in four capacities: 66,000, 90,000, 115,000 and 140,000 Btu. input.

See these and other new Richmond products at our exhibit in the NAMP Show at Philadelphia. Or, for complete details, clip and mail the coupon today! And—any other questions you may have will be quickly answered. Helping with heating information has been an important part of our business since the day we first opened shop back in 1867...



RICHMOND RADIATOR COMPANY
AFFILIATE OF REYNOLDS METALS COMPANY

Enameled Cast Iron Ware • Vitreous China • Perma-Gloss • Gas Boilers
Oil and Gas Winter Air Conditioners • Gas Gravity Furnaces • Radiators



"We've come a long way since then!"

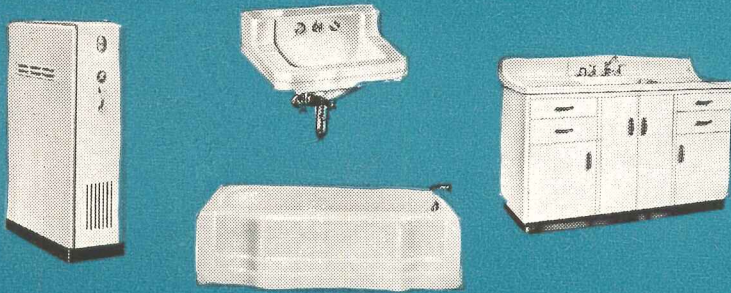

Richmond Radiator Company
19 East 47th Street, New York 17, N. Y.

6AR

Gentlemen:

I am interested in the New Richmond Gas Winter Air Conditioner. Please send me full details. No obligation, of course.

Name

Company

Address

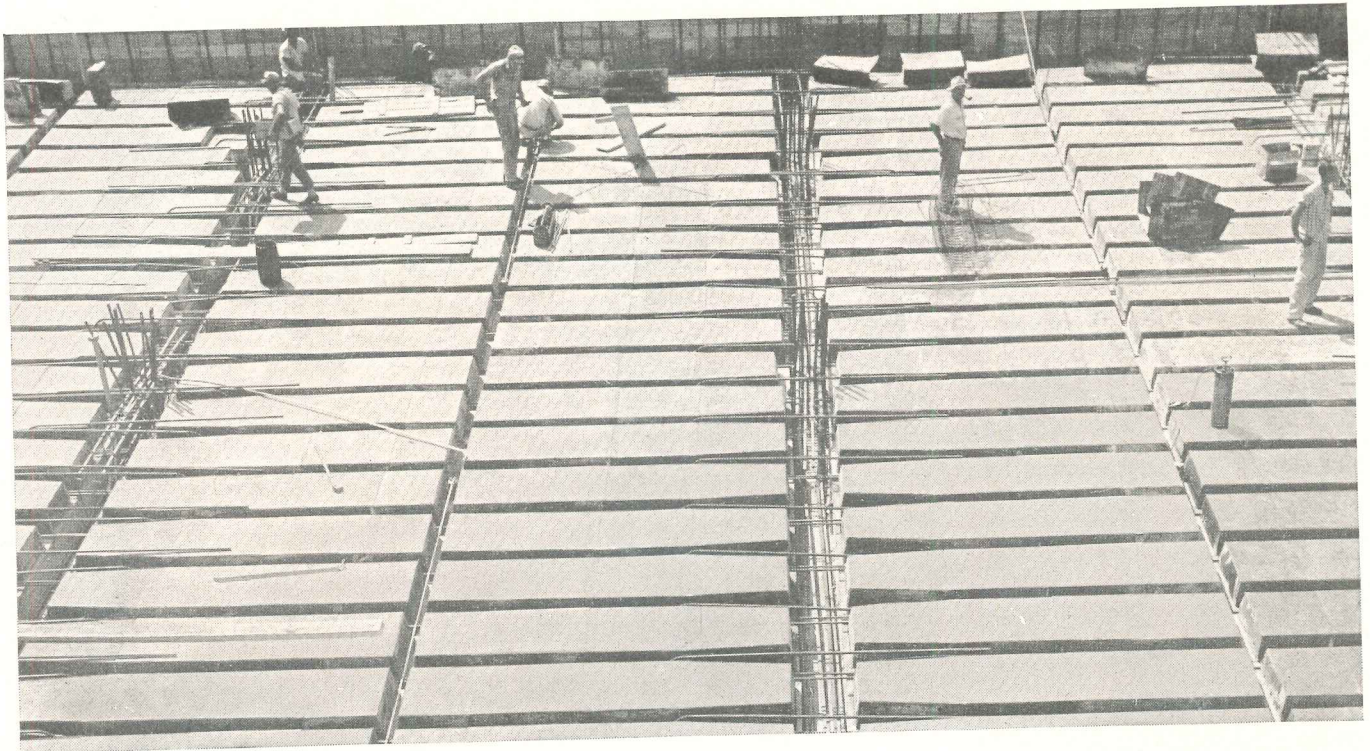

Strength and durability considered,
CONCRETE JOIST CONSTRUCTION

Costs Less!

In these days of high costs, economy in building is important, provided strength and durability are not sacrificed. Here is where concrete joist construction comes in—since it provides rigid, strong, sound-proof buildings which are fire resistive, yet construction cost is lower. That is because the amount of concrete and, consequently, the dead load, are kept to a minimum for any span or live load. The concrete joist and monolithic top slab are formed with cores of removable Meyer steelforms, supported on skeleton centering. Once the concrete has set, the forms are removed and re-used from floor to floor and from job to job. Therefore, a nominal rental charge can be made for each use. Construction is speeded up.

WHY SPECIFY CECO?

Ceco originated the removable steelform method of concrete joist construction. The company is first in the field—actually providing more services than all competitors combined. So, when concrete joist construction fits your need, call on Ceco, the leader over all. Thirty-five years of experience in the field, on the job, have given Ceco a sure grasp of all concrete joist construction problems. This fund of knowledge is yours to command, in 23 strategically located offices from coast to coast.

CECO STEEL PRODUCTS CORPORATION

General Offices: 5701 W. 26th St., Chicago 50, Illinois

Offices, warehouses and fabricating plants in principal cities

Other Ceco Products Include—Reinforcing Steel, Welded Wire Fabric, Steel Joists and Roof Deck, Metal Windows and Doors, Metal Frame Screens, Aluminum Storm Windows, Metal Lath and Accessories



In construction products **CECO ENGINEERING** *makes the big difference*

FOR BETTER HOMES IN BETTER TASTE

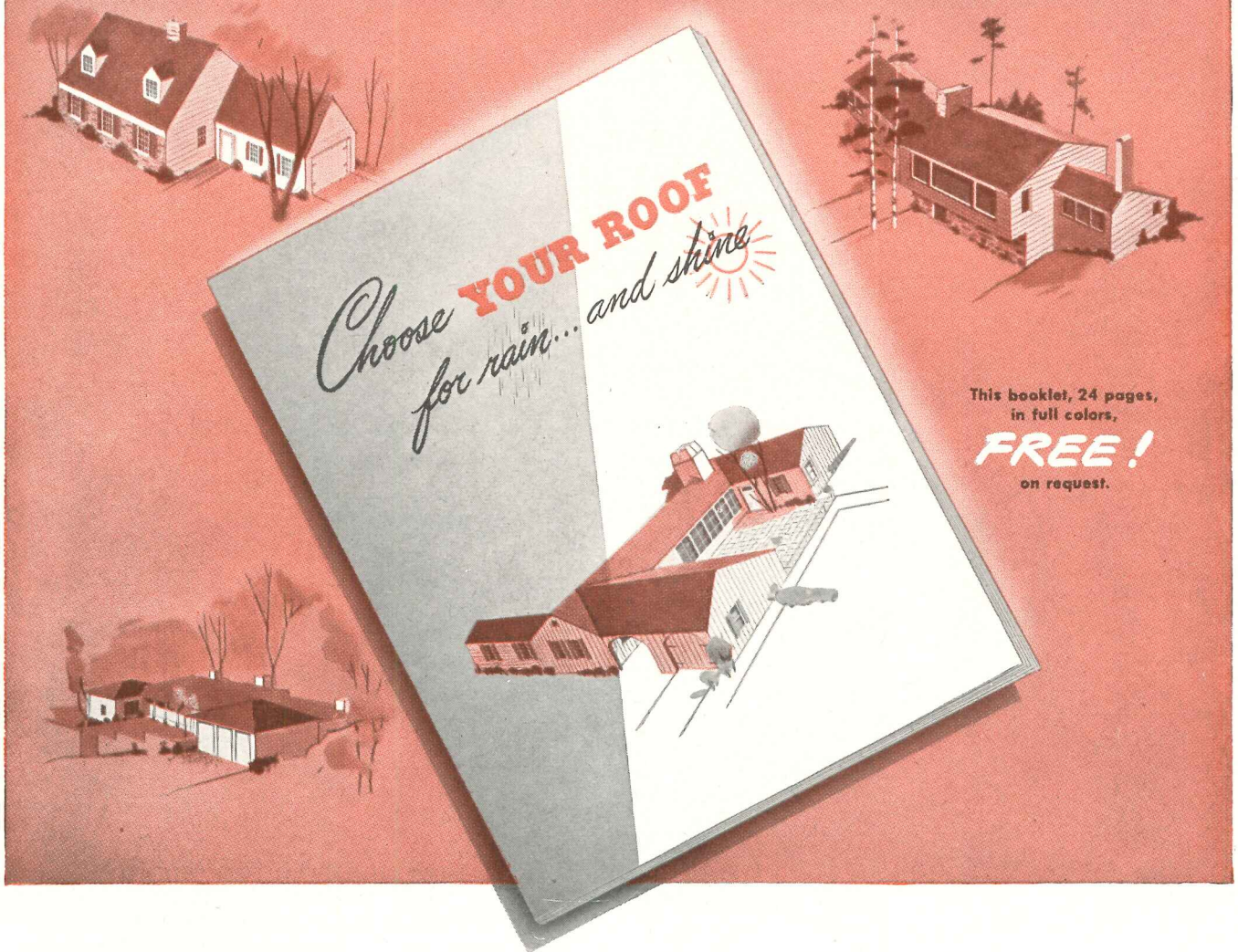

You see two sides of a roof at once in this book!

Above all, a roof must be practical. But it doesn't have to be dull about it. Along with taking the weather, a roof has time to be gay.

The above book, prepared with the help of architects for the home owner, talks both good sense and good taste in roofs. On the practical side, it talks values in weather protection, fire safety, economy. Then, it urges attention to the "fair weather" side where the roof keynotes the mood or color scheme of the entire exterior. The use of color in mass, in accent . . . in harmony, in contrast . . . is discussed by color experts.

With the unmatched values offered today by colorful, fire-resistant Asphalt Strip Shingles, it will pay to examine fully their possibilities in terms of current plans.

**CONSTRUCTION'S BIGGEST
DOLLARS WORTH**

ASPHALT SHINGLES

ASPHALT ROOFING INDUSTRY BUREAU
Room 1752 • 2 W. 45th St. • New York 19, N. Y.
Sponsored by 28 Leading Manufacturers of
Asphalt Shingles • Roll Roofings • Sidings
and Built-Up Roofings

COLORFULLY BRIGHT FUNCTIONALLY RIGHT

heating and cooling
for year-round comfort—
both from a
single system

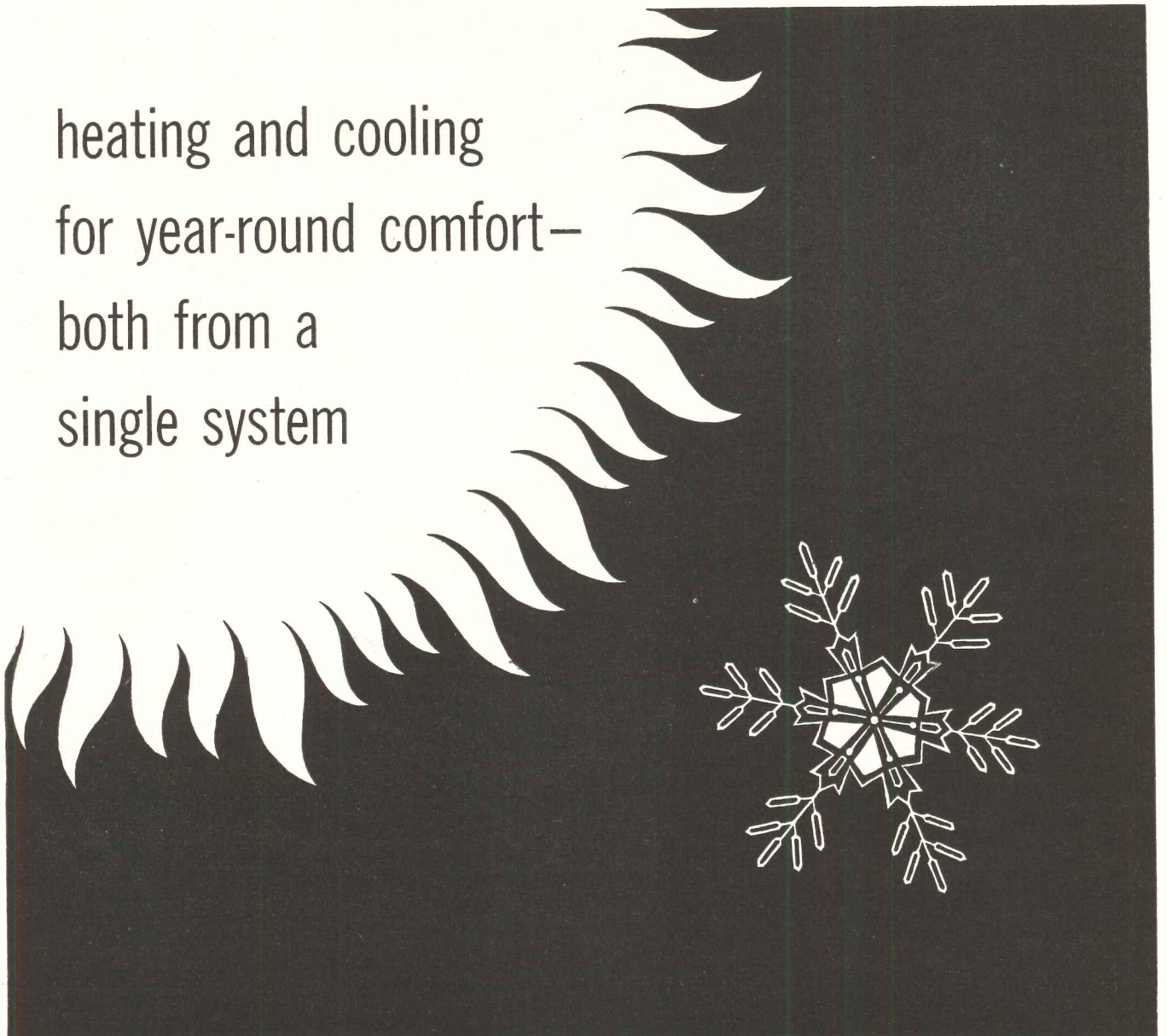

There's no winter lay-off for Carrier Conduit Weathermaster air conditioning . . . no planning a separate, costly heating system for the cold months. With this modern, flexible air conditioning, any multi-room building can have economical comfort in every room any season *with a single system*.

Both cooling and heating are furnished by the same compact individual room unit located under the window. That's space and money saved. The room units have no moving parts to need service and replace-

ment. That means quiet operation, low maintenance costs.

Individual room control lets tenant or guest choose the temperature he wants at the twist of a simple valve. Since there is no interroom recirculation, there's no transfer of noise or odors. Space saved by small-diameter conduit gives the owner more rentable area. For buildings up to five stories, there's the Carrier Duct-type Weathermaster system. This, too, provides room-by-room temperature control and year-round heating and cooling.

Carrier systems are designed and built with the same unrivaled skill that created the air conditioning industry. They're bringing dependable air conditioning to the world's best-known hotels, office buildings, hospitals, apartments, stores, factories and steamships. Carrier's experienced engineers for years have worked closely with architects and consulting engineers to bring the utmost in air conditioning comfort to each individual installation. Carrier Corporation, Syracuse, New York.



AIR CONDITIONING • REFRIGERATION • INDUSTRIAL HEATING

Skylines



LOUVERALL CEILINGS

BRING NORTH SKY LIGHTING INDOORS...

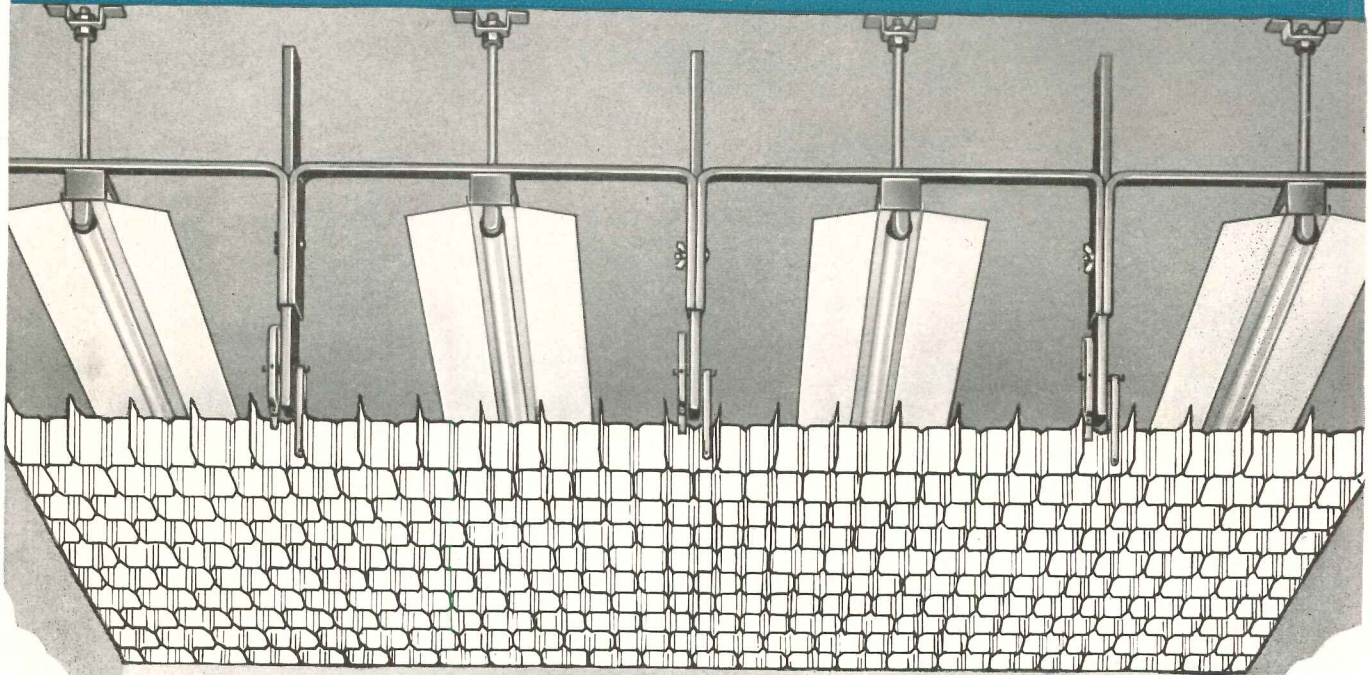

- Aluminum louver sections, 2 x 4 ft., are individually hinged or removable.
- Rigidly welded construction—light-weight, yet sturdy and durable.
- Completely adjustable as to height, mounting levels and spacing of lighting strips.
- Unique engineering results in unusually rapid, low cost installation.
- Honeycomb pattern optically obscures minor imperfections due to installation conditions.
- Effective ceiling patterns may be formed with solid metal panels in place of louver sections wherever desired.
- Spotlights available centered in louver sections or metal panels.

GARCY ALSO MAKES COMPLETE LINES OF:



Recessed Troffers Strip Lighting Luminaires Incandescent Units
Write for Lighting Catalog No. 48

Garcy

GARDEN CITY PLATING & MFG. CO.
1750 NORTH ASHLAND AVENUE
Chicago 22, Illinois

Offices or Representatives in Principal Cities

Patent Applied For

SKYLINE, Garcy's unique approach to louverall design, combines louvered aluminum ceiling, supports, and lighting into one integral assembly. It provides effective leveling and aligning features to insure a perfect installation. It eliminates unsightly strips and runners that interrupt the louver pattern. The cost is low, comparing favorably with installations of conventional drop ceilings and lighting. With "Skylines", you can step up indoor lighting to new high levels... with uniform distribution, lower surface brightness and complete absence of objectionable contrast... lighting to rival

Mother Nature's finest, the north sky.

MAIL COUPON FOR Literature

GARDEN CITY PLATING & MFG. CO.
1750 N. Ashland Ave., Chicago 22, Illinois

- Send folder on "Skylines" louverall ceilings.
- Send lighting catalog No. 48.
- Have your representative call.

• Check the appropriate squares, attach to your card or letter-head, and mail.
•

Signed _____

THIS CHARMING COLONIAL HAS A PROFITABLE SECRET!

The idea of a permanent monthly income from a 2-family house appeals to a lot of folks. But they often chill when they think of the usual monotonous design that immediately identifies it as a 2-family flat.

That's why we think the Colonial home featured in the Gold Bond series will interest a lot of people. You'd never suspect it but it's a 2-family house with the entrance to the second floor through the breezeway.

NATIONAL GYPSUM COMPANY, BUFFALO 2, N. Y.

(Appears in full color in the Saturday Evening Post May 22nd.)

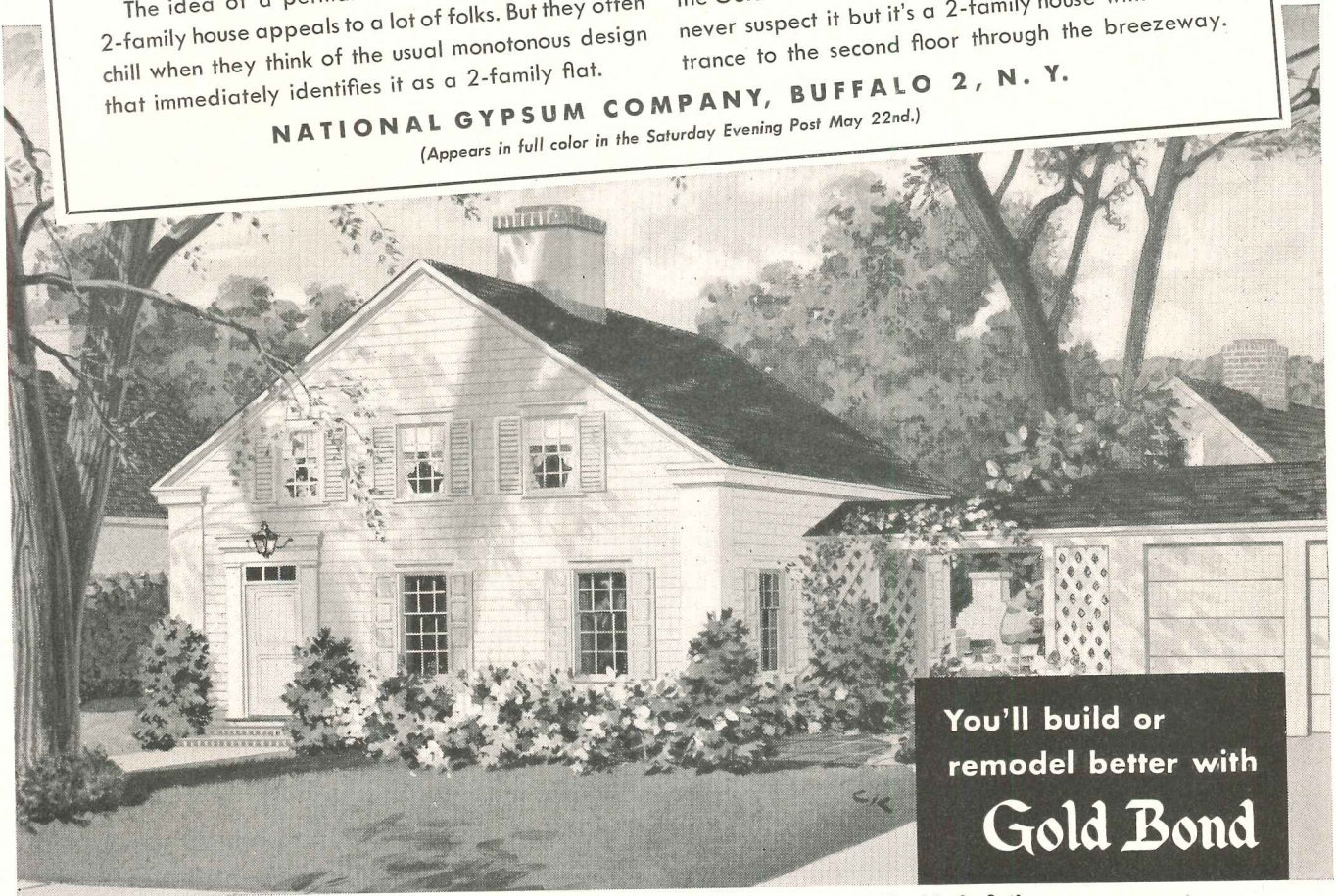

You'll build or remodel better with
Gold Bond

For the newest in building and remodeling products, see your local Gold Bond Dealer first!

"The nicest young couple is paying our taxes!"

"I never believed a house could actually help pay for itself. But ours is doing it, and here's how: We had our architect plan a separate income apartment upstairs! Now the rent more than pays our taxes. And we didn't have to sacrifice quality at one single point!"

Yes, you can build the kind of house you've dreamed about, out of the finest materials research has developed. Materials that add extra permanence, beauty, and fire protection—at no extra cost!

In place of old style inflammable sheathing under clapboards or other outside finish you can have fire-safe walls; stronger, more weatherproof at less cost.

Just ask your architect or builder to specify National Gypsum's fireproof Gold Bond Gypsum Sheathing

Then there's new Gold Bond Rock Wool Insulation that keeps summer heat out, furnace heat in. Saves up to 40% on fuel costs. Don't skimp by using insulation only 1 or 2 inches thick. Full thick Gold Bond Rock Wool batts completely fill space between framing members, provide an effective fire-stop, and insure full insulation comfort. Can be "blown" into outer walls and top floor ceilings of existing homes. Call your local Gold Bond applicator, listed under "Insulation" in the phone directory.

You'll have firesafe interior walls of lasting

beauty if you use Gold Bond Gypsum Lath and Plaster. For the newest in decoration, there's Gold Bond Sunflex Wallpaint that dries in an hour with no painty smell!

Your local Gold Bond lumber and building material dealer is headquarters for over 150 Gold Bond building products, each guaranteed to do a specific job better. Whenever you're ready to build or remodel, your Gold Bond dealer can give you good, practical advice. See him first!

NATIONAL GYPSUM COMPANY
BUFFALO 2, NEW YORK

Gold Bond Building Products add greater fire protection, permanency, and beauty at no extra cost. These include fireproof wallboard, lath, plaster, lime, sheathing, wall paint, insulation, metal and sound control products.

DEMAND THESE SIX GOLD BOND FEATURES IN YOUR NEW HOUSE

GOLD BOND FIREPROOF GYPSUM SHEATHING



Big, weatherproofed panels of Gold Bond Storm Sealed Gypsum Sheathing add structural strength and built-in fire protection. Costs less than old-style sheathing.

GOLD BOND FIREPROOF GYPSUM LATH



Gold Bond Gypsum Lath is the perfect plaster base. Can't warp, expand or contract. Adds fire protection and structural strength for better wall and ceiling construction.

GOLD BOND FIREPROOF GYPSUM PLASTER



Gold Bond Gypsum Plaster is especially processed to bond perfectly with gypsum lath. Builds fire-safe, rock-like walls and ceilings with greater durability and beauty.

GOLD BOND FIREPROOF FINISH LIME



Over the plaster, goes a coat of Gold Bond Finish Lime. This is the smooth white finish that you see in a new house before the wallpaper or paint is applied.

GOLD BOND FIREPROOF ROCK WOOL INSULATION



Builds a fireproof blanket of insulation around the house for greater year 'round comfort, family health, and fuel savings up to 40%. Available for new or old homes.

GOLD BOND SUNFLEX 1-HOUR WALL PAINTS



Dries in one hour with no objectional painty, after-odor. Easier to apply. This modern decoration is now available at your dealer's in a full range of colorful tones.

How to plan HIGH PRESSURE STEAM CONNECTIONS TO LAUNDRY EQUIPMENT

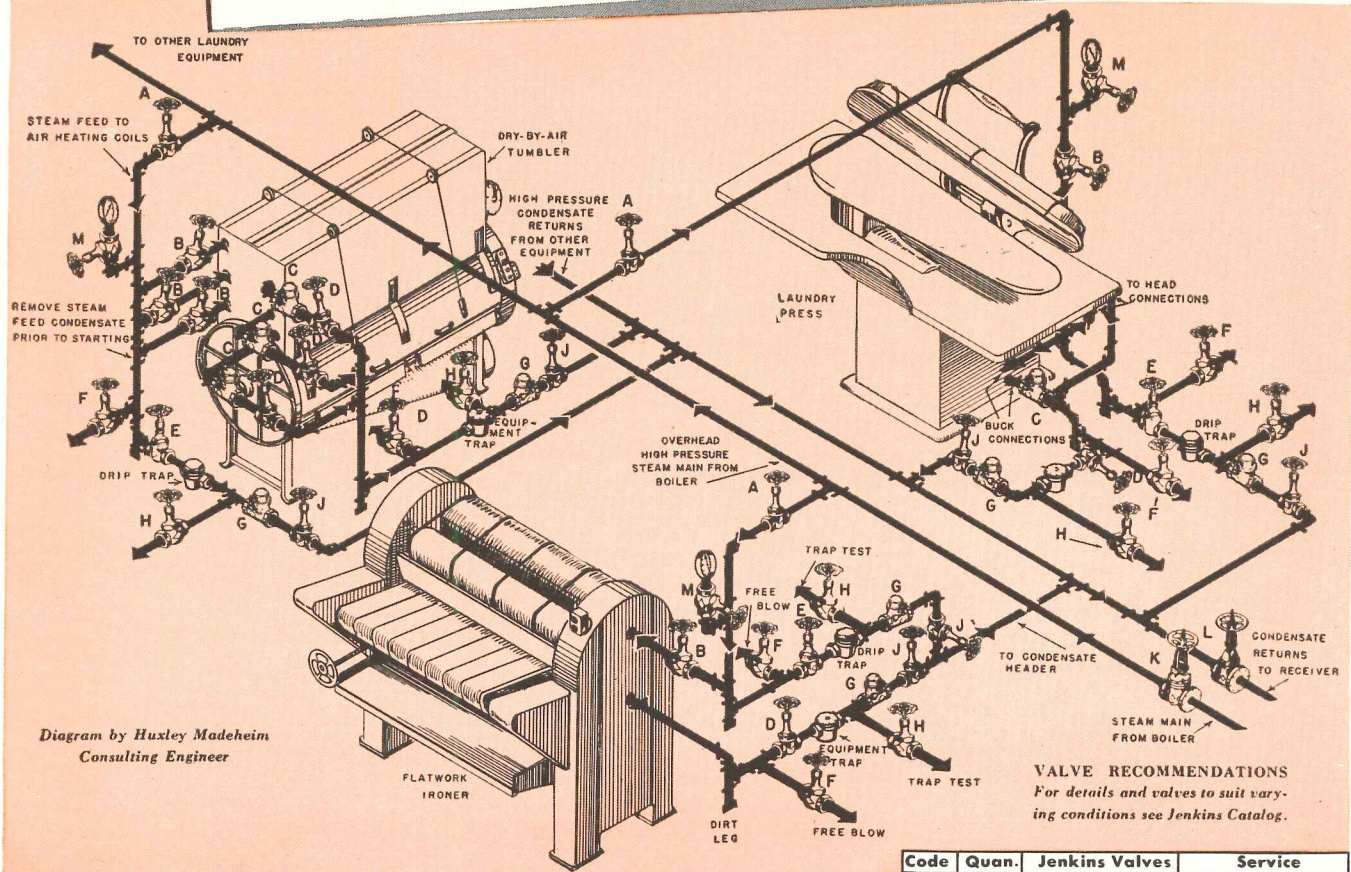

Diagram by Huxley Madeheim Consulting Engineer

VALVE RECOMMENDATIONS
For details and valves to suit varying conditions see Jenkins Catalog.

Typical steam connections to air drying tumblers, flatwork ironers, and power steam presses, commonly used in commercial or institution laundries, are illustrated in this layout.

The tumbler illustrated here is equipped with three independent heating coils over which air is passed and heated before entering the tumbler proper. Check valves on the coil outlets prevent any backflow if an outlet valve is left open when the coil is shut down.

All steam feeds to equipment are individually trapped so that accumulated moisture can be removed before steam goes into the equipment. Each trap is provided with a free blow by-pass and a bronze globe trap test valve marked "H". The free blow line assures uninterrupted operation during trap maintenance or the

starting up period after a long shutdown.

Consultation with accredited piping engineers and contractors is recommended when planning any major piping installation. Copies of Layout No. 32, enlarged, with additional information, will be sent on request. Just mail coupon.

A CHOICE OF OVER 500 VALVES

To save time, to simplify planning, to get all the advantages of Jenkins specialized valve engineering experience, select all the valves you need from the Jenkins Catalog. It's your best assurance of lowest cost in the long run.

Jenkins Bros., 80 White St., New York 13; Bridgeport, Conn.; Atlanta; Boston; Philadelphia; Chicago; San Francisco. Jenkins Bros., Ltd., Montreal.

LOOK FOR THIS  DIAMOND MARK

Since *Jenkins Bros.* 1864

Code	Quan.	Jenkins Valves	Service
A	3	Fig. 370 Bronze Gate	High Press. Steam Distribution to Equipment
B	5	Fig. 106-A Bronze Globe	Steam Admission to Equipment
C	4	Fig. 92 Bronze Swing Check	Prevent Backflow into Heating Coils
D	6	Fig. 370 Bronze Gate	Equipment Outlet Shutoffs (Trap Shutoff)
E	3	Fig. 370 Bronze Gate	Steam Line Condensate Removal (Trap Shutoff)
F	6	Fig. 106-A Bronze Globe	Free Blow for Equipment
G	6	Fig. 92 Bronze Swing Check	Prevent Condensate Backflow
H	6	Fig. 106-A Bronze Globe	Trap Test
J	6	Fig. 370 Bronze Gate	Condensate Returns to Header (Trap Shutoff)
K	1	Fig. 142 IBBM Globe	Steam Header Shutoff
L	1	Fig. 651 IBBM Gate	Condensate Return Header Shutoff
M	3	Fig. 106-A Bronze Globe	Pressure Gage Shutoff

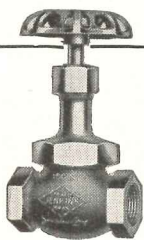

JENKINS VALVES

For every Industrial, Engineering, Marine, Plumbing-Heating Service . . . in Bronze, Iron, Cast Steel, and Corrosion-resisting Alloys . . . 125 to 600 lbs. pressure.

Sold Through Reliable Industrial Distributors Everywhere

JENKINS BROS., 80 White Street, New York 13, N. Y.

Please send me a reprint of Piping Layout No. 32

Name.....

Company.....

Address.....

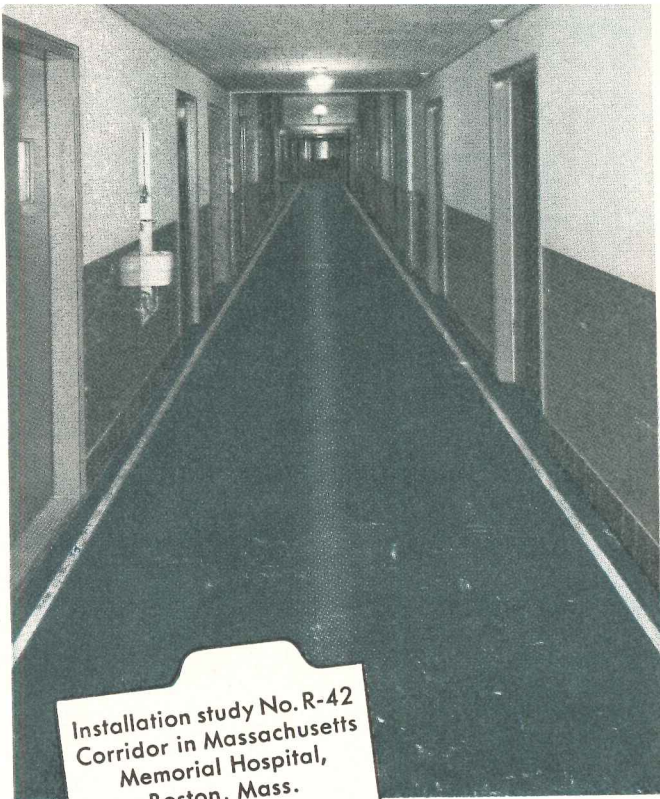

**Why Specifications Say:
"Hood or Equal"
For Rubber Tile Flooring**

It takes proven performance year-in and year-out to reach the "Hood or Equal" stage . . . and it's just *that* performance that makes Hood Rubber Tile the choice of the country's leading architects. Here's proof that

HOOD RUBBER TILE FLOORS LAST A LIFETIME

Hood Rubber Tile, installed in the Massachusetts Memorial Hospital in Boston, Mass., has withstood the daily wear of busy hospital traffic for 13 years! And yet, these floors show no appreciable wear today!

Yes, for 23 years, the combination of Hood mastery of manufacture with B. F. Goodrich's world-renowned research has been a guarantee of the *best* in resilient flooring. For full information, see Sweet's or write for full-color catalog today.

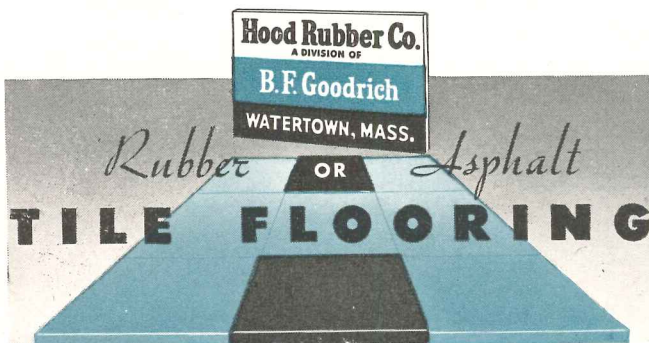

Blair Aluminum Furniture Co.

Duran

**all plastic upholstery
graces fine interiors**



COLORFUL, PLIANT, VERSATILE

. . . adds radiant beauty, new comfort on chairs, booths, stools . . . superb decorative effects on walls, doors, ceilings and panelling.

LONG-WEARING, WASHABLE

. . . resists wear, scuffing, fading and damage by grease, alcohol and perspiration . . . a damp cloth removes sticky food stains, soil and smears.



DISTINCTIVE AND DEFINITELY DIFFERENT

. . . all plastic . . . will not peel . . . For new installation, re-upholstering or redecorating, specify Duran — an exclusive Masland creation. Available in pale pastels or rich, mellow tones.



**THE MASLAND DURALEATHER COMPANY
3236-90 Amber Street, Philadelphia 34, Pa.**

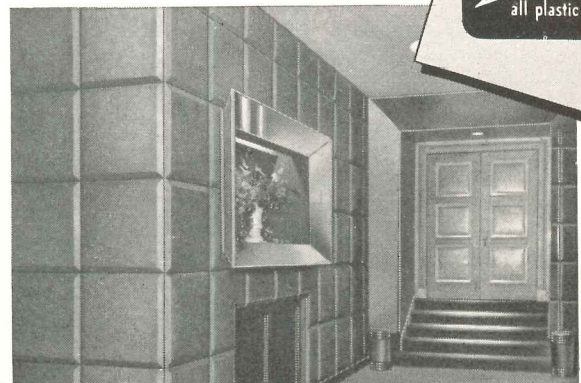

Broadwood Hotel, Phila.

American Decorating Co., Phila.



Archts., Sidney H. Morris & Associates, Chicago, Ill.

SELLEVISION



-on the
Sales Front

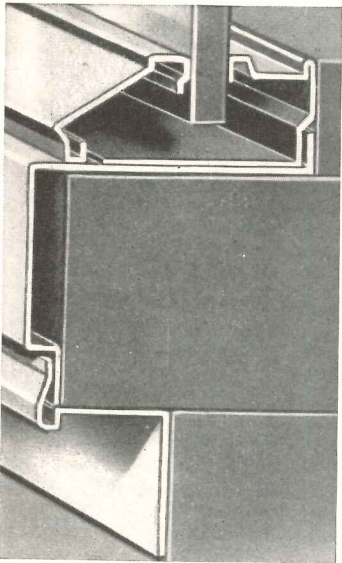

One of the five new Brasco Safety-Set Sash, 3/4 size.

SELLEVISION transforms show windows into sales windows by eliminating visual barriers between shop and shopper. It does a pre-selling job by putting the entire store on display . . . invites immediate entrance with "something in view".

With Safety-Set Store Front Construction the maximum benefits of Sellevision are easily obtained. Visibility is definitely increased with Safety-Set's lowered sash height. Heavier bars of special design provide positive support for enlarged glass areas. Our exclusive FINGERTIP SETTING establishes new standards of safety . . . it holds glass firmly and uniformly in Brasco's deeper grip.

Safety-Set is new, handsome, durable construction, expertly fabricated in heavy gauge stainless steel and anodized aluminum. Wide choice of attractive sash and sill combinations permits authentic interpretation of individualistic design with versatile standard members and stock millwork. See our catalog and details for pertinent information. They are yours for the asking.

BRASCO MANUFACTURING CO.
HARVEY (Chicago Suburb) ILLINOIS

Specialists in Metal Store Front Construction for more than 35 Years



Copr. 1948 by Brasco Manufacturing Co.

BRASCO MANUFACTURING CO., Harvey, Ill. (R6)

Please send Catalog — Half size Details.

Name and Title

Company

Address

City..... Zone..... State.....

LAVISH WITH COMFORT!
 A MISER WITH FUEL!

EVERY NIGHT
 THIS MIRACLE
 THERMOSTAT
 SAVES FUEL

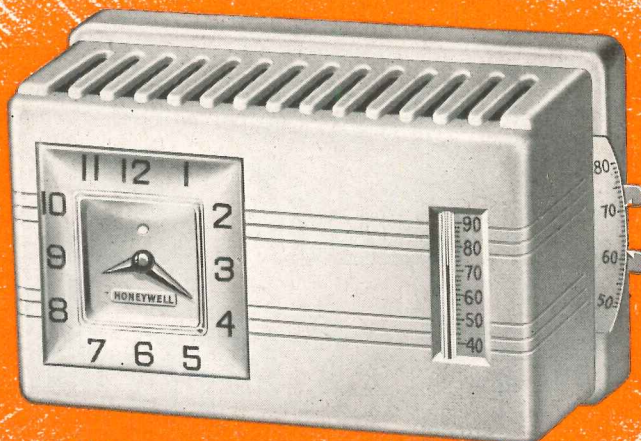

THE **NEW**

Chronotherm

WITH Chronotherm, Honeywell's handsome new electric clock thermostat, owners of your homes can enjoy the most carefree heating comfort they have ever known—and at the same time save fuel! Chronotherm keeps homes at just the right comfort temperature from morning to night. Then, when the family retires, it automatically switches to lower fuel-saving temperature, or in mild climates, shuts off the heat. In the morning, the desired daytime temperature is

restored gradually, without overshooting. The result, according to government authorities, is savings of 10 per cent or more of the heating bill—with complete comfort and convenience. Make certain you specify Honeywell's new, nationally advertised Chronotherm in the houses you design. It is another way to provide your clients with the latest in modern improvements. Minneapolis-Honeywell, Minneapolis 8, Minnesota. In Canada: Toronto 12, Ontario.

MINNEAPOLIS
Honeywell
 CONTROL SYSTEMS

73 BRANCHES FROM COAST TO COAST WITH SUBSIDIARY COMPANIES IN: TORONTO • LONDON • STOCKHOLM • AMSTERDAM • BRUSSELS • ZURICH • MEXICO CITY

A PAUSE THAT REFRESHES

IN the spring each year there comes a pause in the everyday work of the architect and he journeys to some pleasant spot (at least by proxy) to convene with his fellows. This year at Salt Lake City he will discuss with them a most important and interesting theme, "Fundamentals of Design." The fact that the basic principles of design have been chosen for consideration and discussion indicates the profession's recognition of a need for the clarification of its philosophy of design. "Real fundamentals" is a rather all-inclusive term which embraces practical and technical considerations as well as esthetic — firmness and commodity as well as delight. But if we read aright between the lines, the emphasis this year would seem to be less on the mechanics and more on the mores of the art and their possible present-day mutations.

This may seem to imply a certain uncertainty regarding design criteria and a healthy desire to appraise current trends and to establish (or re-establish) standards of design evaluation. It is significant in that it indicates a change of emphasis, a trend toward the integration rather than the segregation of the practical, technical, materialistic factors with the esthetic, humanistic, or spiritual values of design.

The Institute's seminars thus seem designed to be enlightening not only in determining and defining fundamentals, but in ascertaining what effect such sciences as sociology and physiology may have on them and on their application to specific design problems. At some time the profession might consider the impact of economics and politics* as well. It would be worth while also to review the latest findings of the psychologists as they relate to the effects of size, shape, color, texture, light, air and temperature, etc., on average humans as well as on the trained and sensitive. Such broader knowledge of psychological needs, desires and reactions of the "common man" might help enormously in formulating valid and vital fundamentals of design. It might indeed be a mighty stimulus to the imagination and to creative effort. But no one convention could attempt to cover all the aspects of the "fundamentals of design" for that exhaustive discussion would leave no time for their application, and it is in their application to the planning and building needs of the country that they are put to the final test.

In this period of confusion, tension and conflict, there are like soul-searching efforts in many fields to reappraise values, to seek fundamentals, to reorient our thinking, to determine desirable ends and devise means for reaching them, in fact to grasp the sorry scheme of things entire if we could. It is well then, and perhaps inevitable, that architects should pause in their preoccupation with costs and cubage, clients' whims and contractors' extras, and all the necessary mundane minutiae of daily practice, and give thought to design fundamentals for a few days that they may continue to be "of ever increasing service to society." This pause that refreshes should provide a firm and broader base for renewed efforts to provide architectural design attuned to our expanding needs and our changing times.

*See "The Architect's Stake in Private Enterprise," by Miles Colean, F.A.I.A., page 97.

Kenneth K. Stowell

EDITOR

‘‘BEAUTY’’ FOR US

demands architecture of larger scope at vastly broader scale

By Douglas Haskell

Remarks made at the Ann Arbor Conference on Esthetic Evaluation,
University of Michigan, April 3, and edited for the RECORD

ALARGE and serene sanity will underlie any architecture, I believe, that we shall call beautiful; and the work will have to be done at far wider scope and vastly broader scale.

It is impossible for me to testify as other than a journalist, who has the habit of viewing events as of today, with one eye on the deadline. For the historian it seems possible to hover disembodied over time, like a cosmic humming bird or Barnaby's godfather in a helicopter. We, on the other hand, are intensely aware that any building has a life, a death, and only rarely a resurrection. Cynical realists are always reminding us that the building is erected as part of an operation. The designer tries for a certain kind of living beauty for living people in a living building. If he has been inspired, blessed, or just supremely lucky, all those aftermeanings of history which Dean Hudnut has so eloquently described are "added unto him," even after he and his building have both died. The original use has shrunk out of the living project, and into the graceful shell there has been poured a myth. Or, like the Parthenon, the building has died and is resurrected as a spirit.

I am trying to say that in his actual design the responsible architect seeks for everlasting qualities only through the present moment. We journalists live for the day and seek for beauty in the enhancement of immediate life.

WHAT can an architect do to make our life more "beautiful" through architecture?

That is something which a journalist can assuredly not answer, but he can report as much as he can see. We are concerned over a trend in certain quarters, which rips apart our publications and finds widely separated files for the technical news and for the glamour photograph. It is a trend which has scorn for

engineering and technology as something cold, dry, and thin, and pretends that "art" finds totally different, and independent, sources of human feeling. Whereas it would seem as if the failure had occurred not in science itself but further along the way, through limited insight in *converting* the truth obtained by discovery, and verified by test, into human satisfaction.

Science and engineering have been not thin or weak but quite boundlessly and terrifyingly creative — half the world lies in ruin through the sheer creativeness of their mismanaged power.

One example must serve to show how basically scientific thought is transforming not merely architectural details but basic design theory:

It is interesting to note how completely our discussion of architecture as an art has been couched in terms exclusively visual, spatial, plastic. Meanwhile a generation of industrial engineers, crass, noisy, and commercial, has actually put under our noses a powerful aspect of architecture, just as the structural engineers, a century ago, began giving us new eyes and a new kinesthetics — a new visual rhythm and the possibility of structure as a new *dance*, floating, hovering. The tools of these present-day engineers are such crafts as "air conditioning," "thermal control," "sound conditioning," and all the rest. But what these add up to is a new totality of sense impact. When a warm radiance vibrates in your nerves, and fresh air fills your lungs and pores, and the light is right and the sounds are right, and the air is charged with fragrance like that of blossoming clover, you are lifted far above a mean low level of life. There may be nothing new to *see*, and yet you are suffused with that "exalted sense of vigorous well being" to which health authorities have given the name of "euphoria."

This systematic new activity, which lets architecture deal integrally with all the sense organs, not alone

the eye, is charged with esthetic meaning. It leads to the profound difference between the concept of a "spatial" art and an art that harmonizes physical environment. This still retains all the resources of our accustomed "spatial" art; and yet the satisfaction of each new sense in turn raises the whole experience to a new power, a new vitalization.

THE idea of architecture as an environmental art impinges not only on this question of sensuous richness but on social purpose, as expressed in "plan and elevation." Esthetically, we are told, architecture is an art of formal relationships, and this is true as far as it goes, and a great contribution has been made by the new researches into visual joy and into vision as a language. Yet my friend Harwell Harris, expressing himself in broader environmental terms, has said that he thinks of architecture less as a visual art than as a kind of music, setting up relationships which direct, pace, and condition the way in which people can live. He would be willing, he declares, to repeat whole series of visual combinations and motifs, a, b, and a', from building to building, and he wouldn't even fret if other people cribbed them from him wholesale, because the real essence of the matter lies not in the visual passages but in the manner in which the total combination serves and declares a specific living circumstance.

There are, we have said, whole groups of architects who complain of the meagerness and sparseness of modern architecture, who seek for "enrichment" or "expressiveness" or the "human heart" in all its sentiment. Considering the desperate needs of the world today, these architects might actually display more "heart" if they did not scorn simple research, even though it spoke of families with 3.8 children, and though it established nothing more than the needs of the woman in Alan Dunn's cartoon who wanted "not mutative continuity but a closet." Our mutative continuity we shall have to pull out of that closet. A more significant beauty will arise where this has been done with grace, and gratitude will supply the full sentimental halo. Sentiment comes; it cannot be designed.

Is it not, incidentally, a false reading of "sentiment" which associates it only with what is old and familiar, or else intentionally "sweet"? Gratitude is more intense where the architect has fully met his client's needs and beyond that has *awakened* the client—to his own role as creator. He becomes aware of the fresh elements in his own mode of life; his awakening is the architect's greatest pleasure. If architecture may be likened to music, then this response has the character of a dance.

This is especially true where the architect has opened the possibility that people may really play with their homes. People are always trying to play games, but compared to the artist they are repressed, and the chief game they seem to have arrived at in the domestic field is antique furniture. But when Alden Dow shows them how to let children climb chimneys and run safely over roofs, this is an assimilation of architecture that is charming.

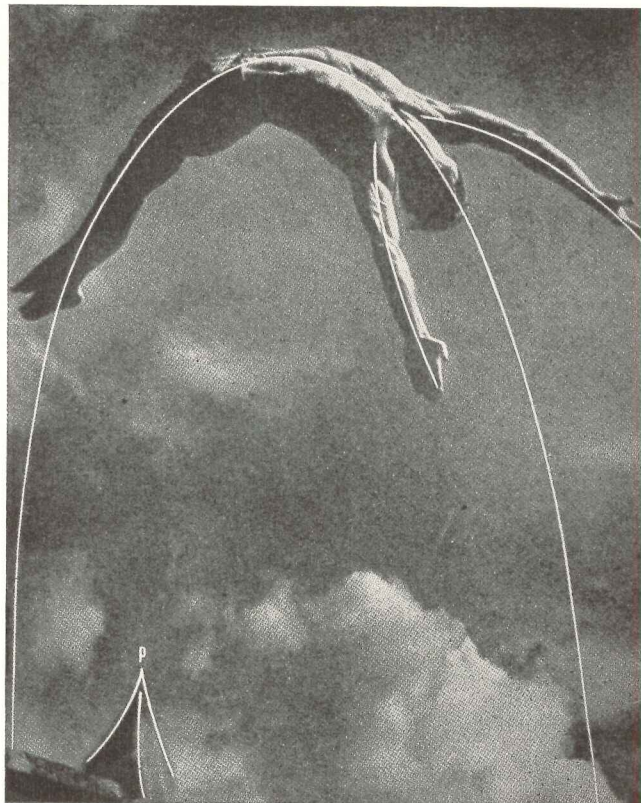

Karl Oeser Photo

"... the structural engineers, a hundred years ago, began giving us new eyes and a new kinesthetic sense . . . the possibility of structure as a new dance, floating, hovering"

The satisfaction of senses other than the eye cannot be conveyed by the glamour photograph. This is the portrait of an aroma, but it does not look like a smell. "In an art that harmonizes physical environment, the satisfaction of each new sense in turn raises the whole experience to a new power." (Volatile emanation of a coffee bean in monomolecular layer, approx. 1/10,000,000 in. Copyright, Joseph Breitenbach)

Joseph Breitenbach A.R.P.S. Photo



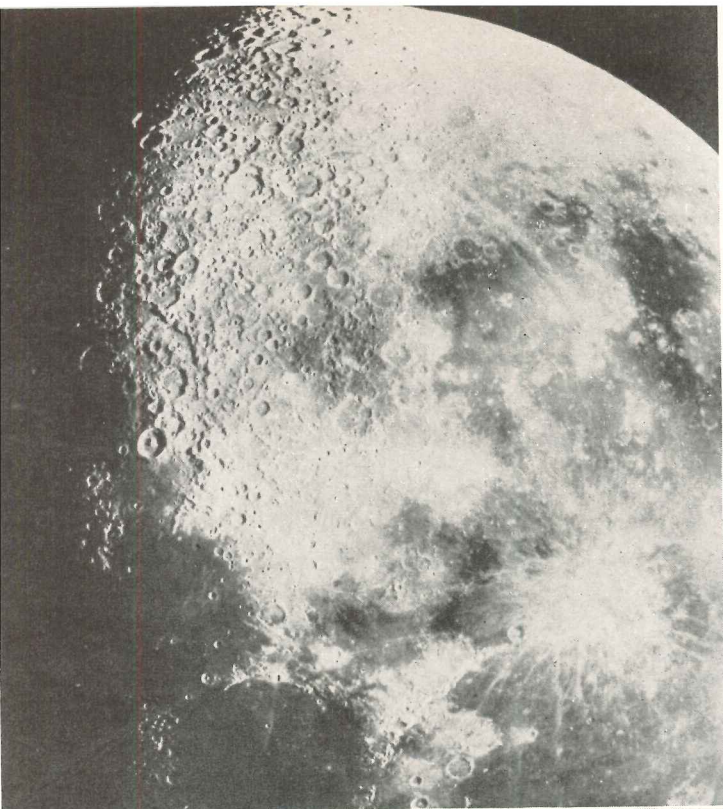

"Man has become a major force of Nature"

THE concept of architectural beauty as something that grows out of harmonizing physical environment, and the thought that it should concentrate now on scope and scale rather than on richness and refinement, is the more urgent because of the situation of all mankind today. *Within recent decades — and not until recent decades — man has become a major force of nature.* Incomparably the most creative power in modern life has been not religion or art but science. Yet despite a certain great beauty in its processes and implements, the result has not been uniformly beautiful. Despite the terrible sublimity of the atomic cloud, we find no beauty in the total architecture of Hiroshima and Bikini.

According to Fairfield Osborn, in his new book, with its masterly urbanity and understatement, man as a force of nature spells despoliation and erosion, on a planetary scale, to a degree that is alarming. Projecting present trends into not too distant a future, he foresees an earth as dead and uninhabitable as the moon, and warns that man must cease defiance and "learn to cooperate with nature."

**"an earth
as dead
and
uninhabitable
as
the moon"**



I LIKE to think that our new architecture, in its visible beginnings, intuitively symbolizes the healing power of cosmic cooperation among men, and between man and nature. Its most symbolic act is doing away with walls and stiff enclosure.

A thinner or non-existent wall demands that you must reconcile yourself with your enemy.

Then the way we bring flowers, trees, rocks, sky, pools, even waterfalls into our houses implies affectionate cooperation with nature which the *unconverted* power of industrial engineering and war has so violated. Again, we like to reach out from our buildings with all kinds of arms to embrace natural surroundings, and we like to mingle materials which our industrial science has transmuted with those other materials which have been formed "naturally" by Nature.

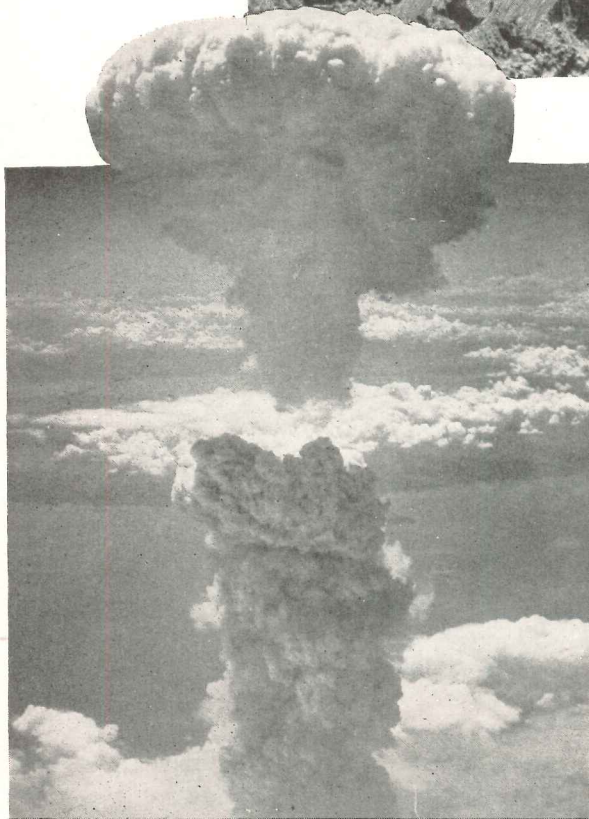

"THESE ARE THE WILD HORSES THAT

Left: Press Assoc. Photos. Below: L'Ossature Metallique Photo

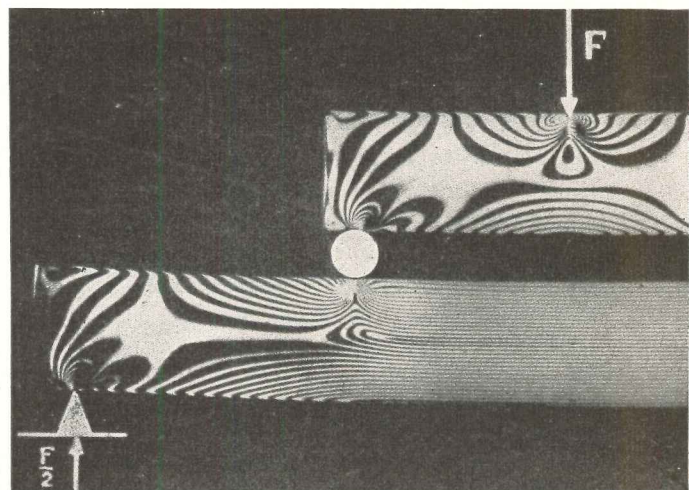

If we are sometimes overcome by the puniness in scope, extent, or breadth, of what we can add by our humble effort beginning on next Monday, then on a Saturday afternoon, at least, we are entitled to view the grandest prototype yet produced, and dig into its message of human feeling. Some may recall flying over the Tennessee Valley and glimpsing there the *possibility* of an architecture at vast scale, in which walls and roofs are relatively insignificant, and man as a natural force has evoked a more *humane setting* (the object of architecture) *directly out of Nature*. Yesterday Charlie Eames suggested to a sculptor the shaping of the earth — and that is what was begun in the Valley, again through the medium of potent engineering, and at supreme scale, for harmoniously creative purposes having at their core the concept of neighborly cooperation.

Whoever thinks that the architecture there consists of the dams and structures has never really seen the Valley — with the striking feature of its new water courses, flowing among fields reshaped by contour plowing, and threaded by freeways; with its planned balance between land formed and “cultivated” by man and that still reserved to Nature, and that occupied by communities; with the new growth of reforestation pushing up through the ruins of the soil. Surely all this appeals not only to the mind but to the heart, and all is architecture, the conversion of the earth into a beautiful place of human habitation.

Moreover it is in the Valley that we are developing previously unheard-of resources through the atom. Indeed, while architects sit and gossip about relationships between “building” and the “machine” the men in the Valley have reduced them both to the status of hammers and wrenches, both mere accessories, since the real secret of work is horsepower and energy conversion.

These are the wild horses that the dilettante seeks now to escape and that the architect of the future will have to ride.

Already we hear of experiments controlling climate out of doors, using no building at all, over large areas.

THE ARCHITECT MUST RIDE”

Press Association Photo

Some twenty years ago there was made the fanciful suggestion of architecture that could convert environment without resort to building. Technology makes this now a possibility in fact.

Thousands of years ago there was promulgated a myth of architecture that required no walls but supplied all that was needed for an unparalleled euphoria of life. It was the myth of the earthly Paradise. When we think of the incredible gap between the potential and the present condition, especially in Europe, we must revert to the conviction that whoever now seeks beauty must train his thought to be very large and very sane.

Philip D. Gendreau Photo



“... at vast scale, in which walls and roofs are relatively insignificant, and man as a natural force has evoked a more humane setting directly out of Nature. All this is architecture, the conversion of the earth into a habitation”

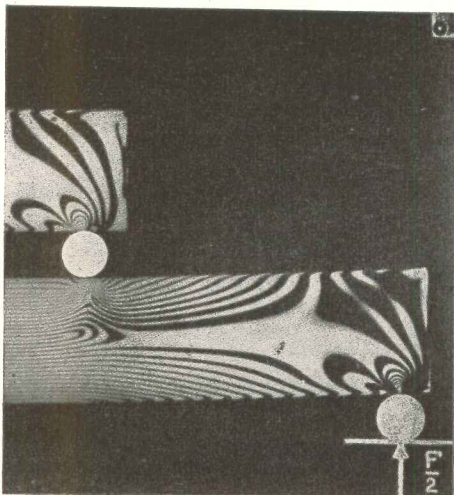
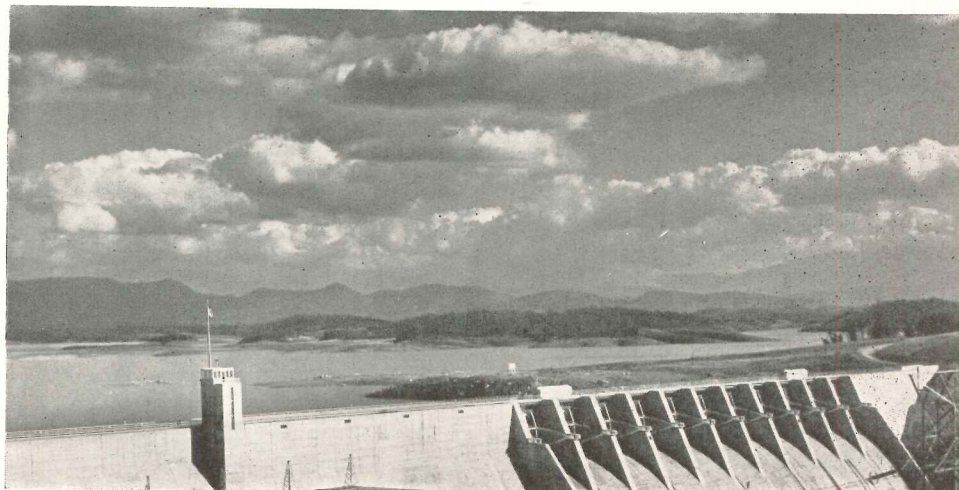

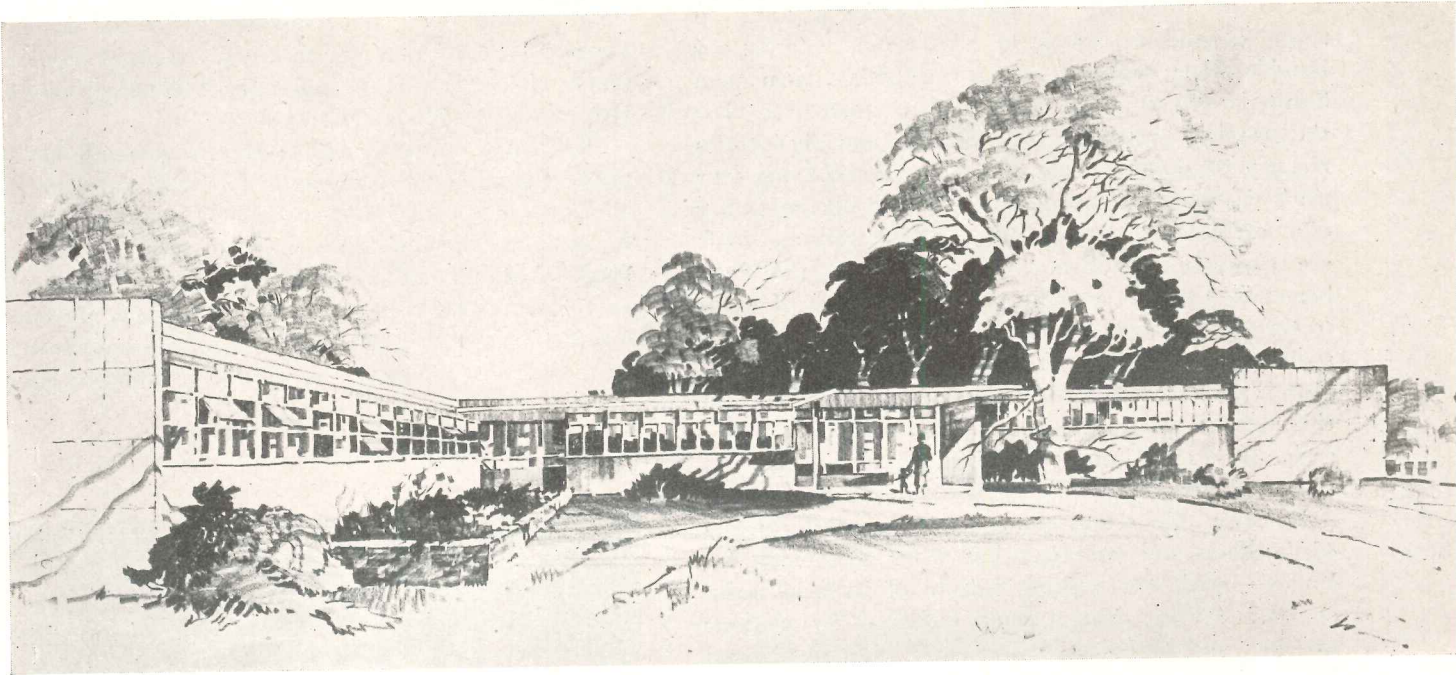

Richard Collins Del.

25 BEDS

GENERAL HOSPITAL OF MINIMUM SIZE

An Additional Type Plan for the Coordinated Hospital System

THIS plan is a variation of the small general hospital. It has been stated that if fully adequate hospital services are to be furnished a community, it would be inadvisable to consider a hospital of less than fifty beds. However, the fact is that there are areas in the country where smaller institutions will be required. In most of these cases limited finances will demand the utmost in building economy, and will make a low per-bed area mandatory.

To this end, some departments have been condensed to the practical minimum, and in some cases different functions have been combined in one area. The emergency room, for example, can be used both as the treatment room and the out-patient room. Dental services also can be provided here although a separate dental room is preferable, if at all possible. No separate medical record room has been provided, but the space allowed in the business office is generous enough for this important function.

The more important principles of hospital planning have been observed in this plan despite its size and condensation of certain areas. The concentration of the administrative, clerical and service units will permit a limited staff to operate efficiently and economically.

With these facilities general medical, obstetrical, and minor and emergency surgical cases can be cared for adequately. Since specialized surgical and diagnostic

services could not be offered here, patients requiring such services would be referred to larger hospitals.

Inasmuch as most activities of the small hospital revolve immediately about it, the nurses' station has been located at the juncture of the two nursing wings to provide control of both corridors. Its relation to the business office and information counter allows the nurse on night duty to observe the lobby and to maintain control of the business office (when the clerical staff is off duty) without being isolated from her station.

The nursing units are well insulated from the street and service court. The maternity nursing unit has been given the south orientation and is separated from the other services — a highly desirable feature which is seldom found in the small hospital. The close relationship of the nursery to the maternity beds will save nurses' steps in transporting the babies to their mothers. A small formula preparation room has been provided, the formulas to be sterilized in the central sterilizing room. The utility room location makes it convenient to both nursing wings.

The surgical and delivery suites are located at a dead-end area, and are separated from each other and from the emergency room. Both these suites may be considered minimum.

The relation of the emergency room to the lobby, although certainly not good practice in the larger hos-



TOTAL GROSS AREA OF HOSPITAL 12 500 SQ. FT.
GROSS AREA PER BED 500 SQ. FT.

GRAPHIC SCALE
0 4 8 12 16 FT.

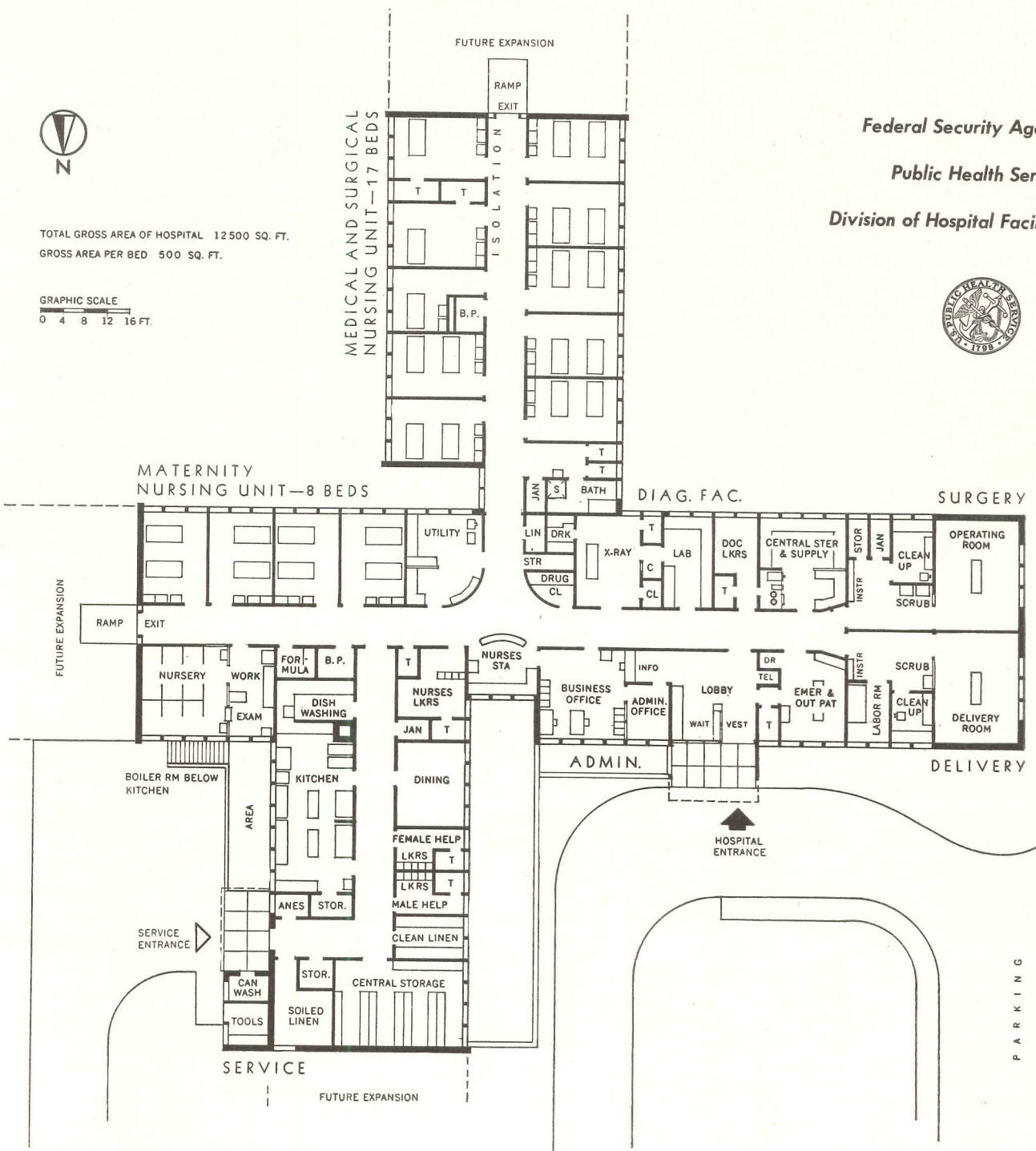

Federal Security Agency

Public Health Service

Division of Hospital Facilities



pital, is acceptable in the smaller institution where the volume of accident work is limited.

The service wing provides a minimum of storage space with a separate closet for the storage of equipment in general use. Clean linen storage is separated from the main storage room. The soiled linen room allows space for a domestic washer for laundering diapers; the rest of the linen would be done commercially, since no laundry is provided in this plan.

The kitchen is conveniently related to the nursing wings for easy service of trays. It is sufficiently isolated to prevent kitchen noises from disturbing patients. A can washing room and tool room are placed on the loading platform accessible from outside the building.

The boiler room has been placed below the kitchen, although it may be at grade if conditions demand.

The central services will allow a limited future expansion.

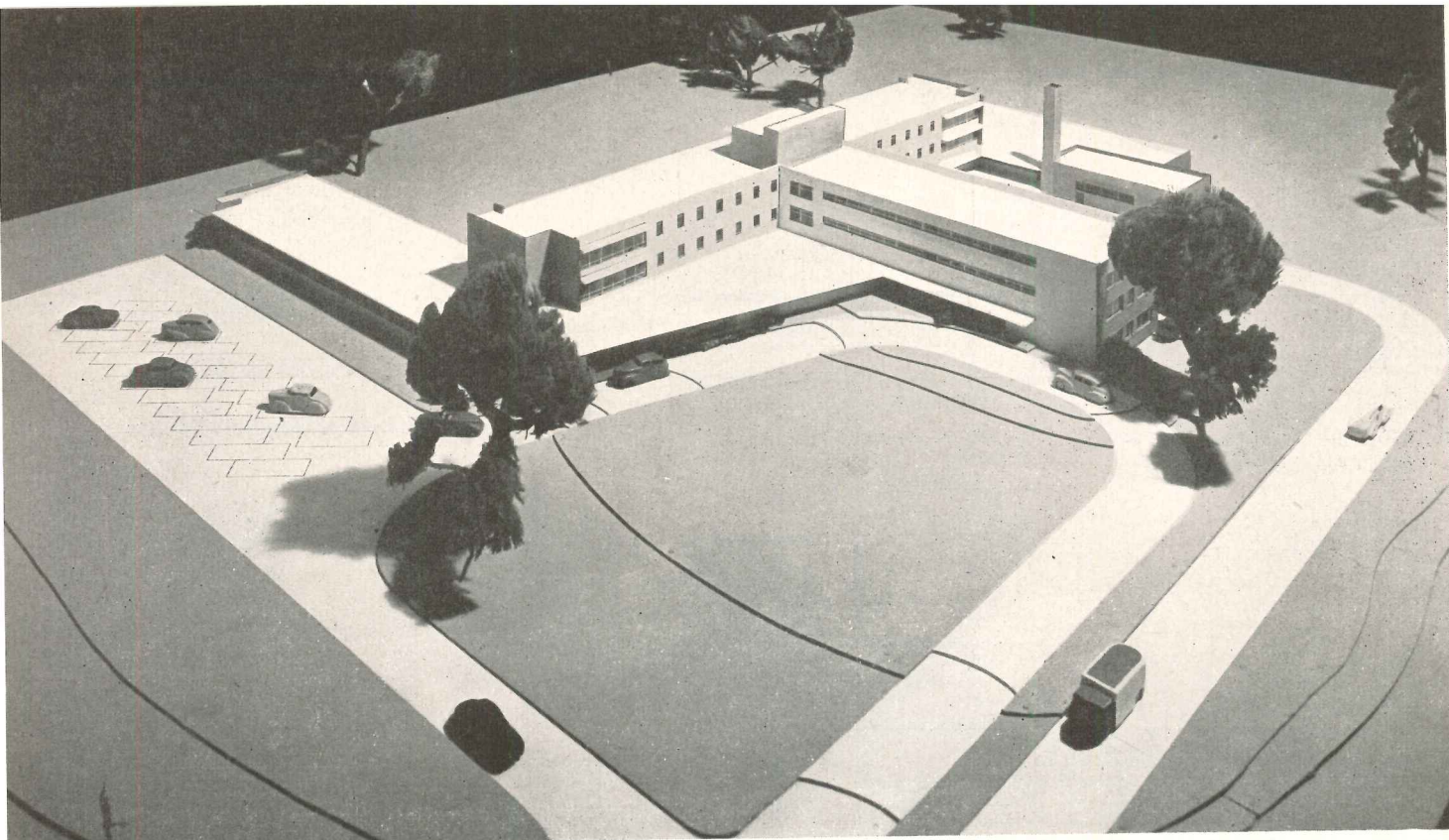

Hitchings Photos

Since this model was made, and plan drawn, roadways have been replanned to reduce paving. The parking area remains as shown in the model photo, but access roads have been shortened; entrances remain as shown here

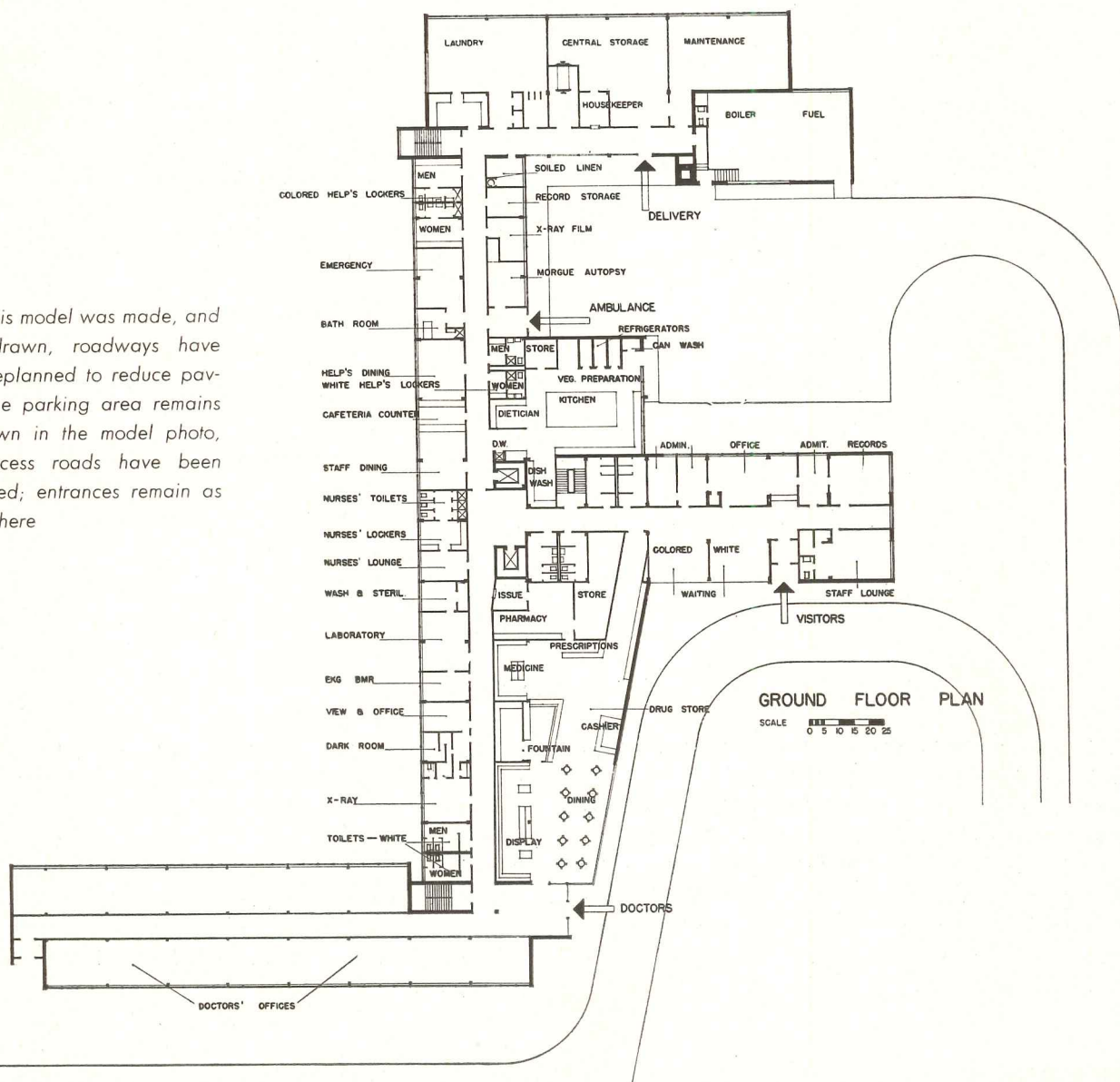

LARGE HOSPITAL FOR A RURAL AREA

Crittenden County General Hospital, West Memphis, Arkansas

Dent & Aydelott, Architects: George Sheats, Hospital Consultant

ONE of the earlier hospitals to be planned under the program of "Public Law 725," this one is an excellent illustration of the principal objective — providing modern functional hospital facilities for districts not adequately served heretofore. Though with its 108 beds it is larger than most that will be built in outlying areas, it does illustrate nicely the special needs of those locations.

It is an institution for the tenant-farmers or "sharecroppers" of Eastern Arkansas, formerly inconveniently

cared for across the Mississippi in Memphis. The project was organized by a group of land-owners following one of the state surveys so long advocated by the U. S. Public Health Service. A tax levy, supported by popular ballot, anticipated a budget of \$1,200,000; application for federal aid has already been approved.

Crittenden County, a focal point of all Arkansas traffic through the south-central river area, formerly depended upon Memphis hospitals, but crowded conditions there, coupled with special needs of indigents,

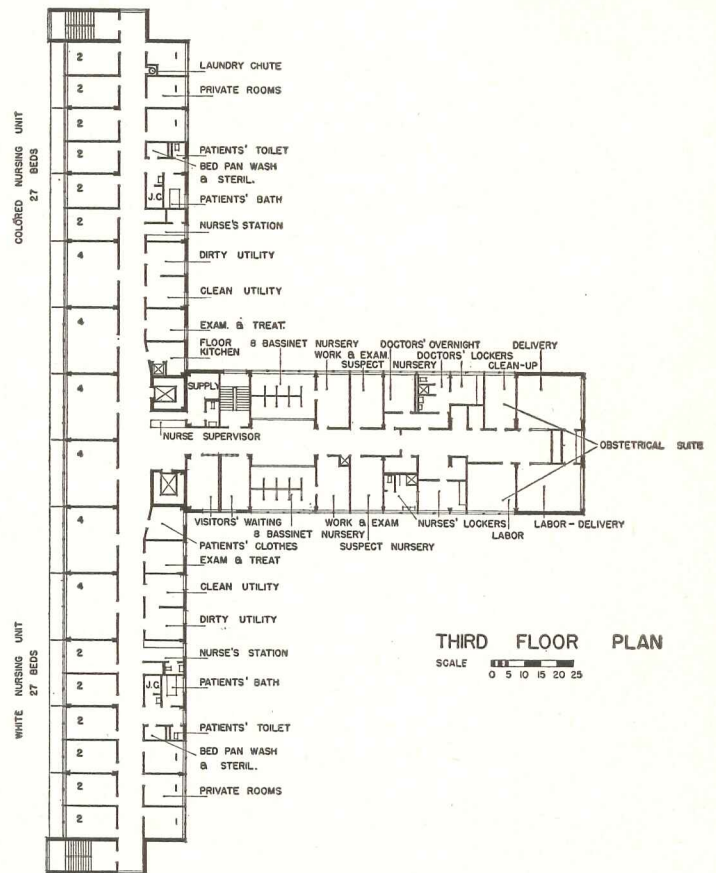
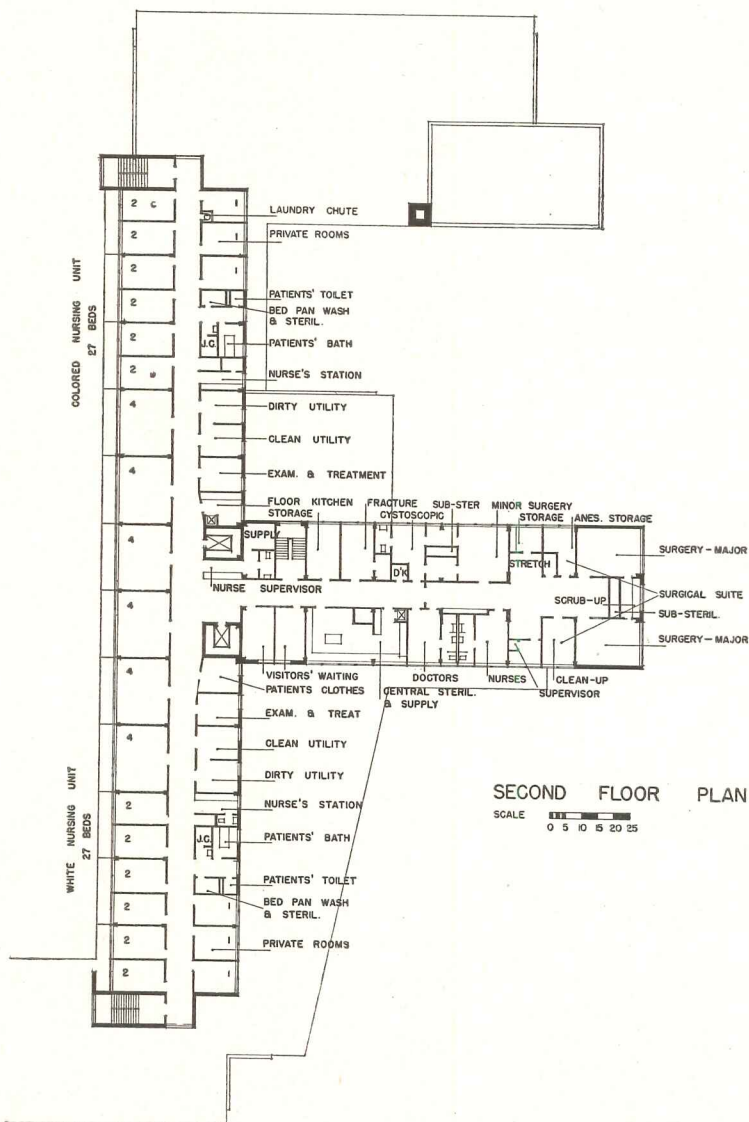

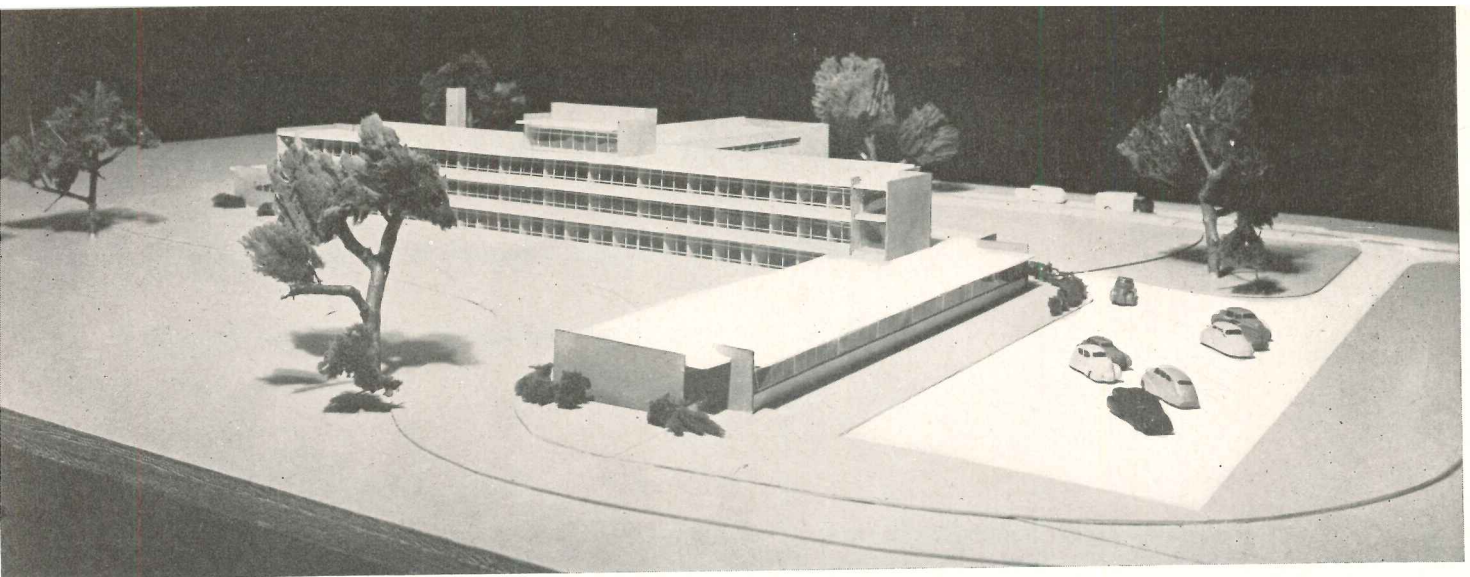

Hitchings Photos

made it logical to build on the Arkansas side. There is to be a new bridge connecting Memphis with West Memphis, another factor that points to development of the west bank area and makes logical this placing of a rather large hospital.

The consultant's analysis of needed facilities indicated a "district" type of hospital in the Public Health Service scheme, which would be aligned medically with Memphis physicians and surgeons, who would have courtesy staff privileges, and would thus broaden the range of services.

The hospital is therefore planned to handle: (1) surgical cases in orthopedics, eye, ear, nose and throat, gynecology, G. U., and brain surgery; and pathological and radiological services would be available on a consultative basis; (2) general medical cases, except psychiatric, tubercular and contagious; (3) obstetric cases, with all complications.

As for the planning, the basic point from which the scheme stemmed was the age-old segregation problem of the South, a problem handled here with good finesse. The bedrooms are arranged in a long row along the south exposure, in an off-set corridor scheme — utilities ranged at the north side of the corridor. Segregation can be maintained in the bedrooms and wards, but the color

line can be shifted one way or another as demanded by varying patient loads. And the line is never a fixed physical barrier. Each half of the nursing wing has its own facilities and utilities, but the half-way mark can be as flexible as required.

Since the terrain is low and flat, and subject to high water in flood periods, there are no basement areas. Construction will be a concrete column and flat slab system, with the windows carried up to the soffit of the slab, which is also the ceiling line. Plumbing and heating runs are kept vertical, and cubage is about one fifth less than would be required were the ceilings furred down for pipes run horizontally.

The scheme contains excellent possibilities for expansion in the future. Elevator runs are carried up to the roof of the building, so that they could serve an additional 50 beds in another story over the nursing block. The doctors' office section could be extended either vertically or horizontally, still preserving its excellent relationship to adjunct facilities, drug store, and so on. The doctors' office section, by the way, is an interesting addition to the hospital concept, being a means of better integrating health facilities particularly in a largely rural district.

The service corridor is arranged so that a nurses' home, to be added at a later date on the west end of the property, may be connected by a covered passage.

Circulation is pivoted around the elevator lobby. The architects expect that separate use of the two elevators, one for passengers, one for service, will enable the important traffic to function more smoothly than if both elevators were assigned to double use. Keeping the height down to three stories, they feel, should eliminate need for more than two elevators.

As for exterior detail, principal walls will be architectural concrete, with aluminum casement windows. End walls of solid brick masonry will provide contrast as well as texture. The architects make it plain that they are attempting no design exhibition, but rather are designing for minimum cost, in the general effort to bring greatly increased health facilities to doctors and patients who have not up to now been accustomed to even an obsolete minimum.

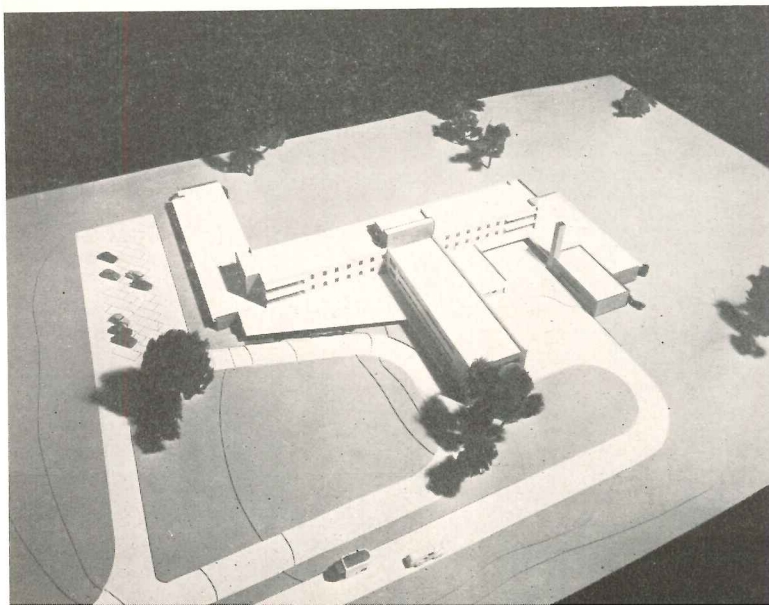

THE ARCHITECT'S STAKE IN PRIVATE ENTERPRISE

By Miles Colean, F.A.I.A.

Consulting Economist

*Former Assistant Federal Housing Administrator; author
American Housing, 1944, 20th Century Fund Housing Survey;
former vice-president Starrett Brothers and Eken, Inc.*

ARCHITECTS have always taken pride in their professional integrity and have striven to maintain their esthetic independence irrespective of the threats and blandishments of clients. They have also shown concern as a group with social betterment and have sought through the exercise of their talents to help create better houses and better cities. Far from seeing any conflict in these two purposes, they not only have considered them compatible but have felt that one properly served the other. The danger that this article will point out lies in the tendency of a quite proper enthusiasm for social betterment to destroy the very integrity and independence that has made the architectural profession an important force for civic welfare.

The danger arises from this circumstance: enthusiasm for social betterment begets impatience — impatience with the slow and often indirect methods that a private enterprise system must use to bring about improvements within its structure. Impatience begets an urge for a panacea, a quiet cure that will promptly remove all ills. The cure-all is invariably government action.

In the field of the architect's interest the argument runs in this now familiar vein. Private building enterprise has allowed slums to develop. Private building enterprise has selfishly concerned itself only with the demands of the well-to-do. It has neglected the broad purpose of a better city and a better society. It has failed to end slums. It has failed to build new houses for all income groups. It has failed, period. And since it has failed, we must turn to government to do the job.

Among the architectural profession, this conviction — amounting almost to a sense of guilt — has existed for a long time; and, as a group, the profession has supported every move to push the federal government toward greater influence, control and direction of building enterprise. Back in 1932, architects were prominent in urging direct government loans (through the newly formed RFC) for limited dividend housing corporations and in securing modifications in state laws to make this proposal effective. They were ardent backers of the first PWA Housing Division. Representatives of the A.I.A. testified in favor of the National Housing Act of 1934 and of the United States Housing Act of 1937. Through its official spokesmen, the profession has since supported the continuance and expansion of these and similar measures up through the present Congress.

The cynical might claim that this consistency of support represents merely desire to create more jobs for architects. But either architects have been deceiving themselves or the cynics are wrong. The architects hardly could have been deceiving themselves, for they already have had sufficient experience to know that the only jobs that government control of building is certain to bring about are jobs as employees of the governmental bureaus established to carry out the various programs. When work is given to architects in private practice it is always at the option of the bureau and never as a matter of right, and then usually only because of the vigilance and pressure of the profession's representative.

Throughout the depression period, for instance, when professional offices were in the direst need of work, the federal public building program was almost exclusively a bureau program. Today the veterans' hospital program, after various vicissitudes, threatens again to be a bureau program. The architect has had a look-in mainly when the amount of work was great and the need for speed did not permit concentration under the bureau roof, and then frequently under such close direction as to make professional independence and integrity a fiction. The long, wavering, and unending battle with the bureaus to permit the participation of independent private architects is a well known chapter in professional history.

Certainly from any long range view, therefore, the architects, in their advocacy of governmental intervention in housing hardly could be accused of seeking to advance their own selfish interests; and the history of the housing agencies provides ample evidence that architects did not achieve through them any improvement of their independent professional status.

The Architect and Public Housing

Let us first take a look at the record of the public housing program. As first embodied in the limited dividend housing program in 1933 and 1934, private architects in considerable numbers participated in housing schemes for submission to the federal authorities. The applications piled up in the office of the PWA Housing Division. In most cases the proposals did not meet the tests of financial soundness that the Division had set up. But, as the policy of the Division shifted from one of private loans to direct grants, another reason for rejection quickly appeared — the architectural designs were in most cases not satisfactory to the official examiners.

To be sure, these examiners were architects, but they were architects now clothed in the mantle of authority. Confident of their own planning principles, they imposed them with increasing rigidity on their brethren who were employed, often at the behest of the Division, by the local official or quasi-official groups which sponsored the projects. As the program grew in scope (particularly after the creation of the United States Housing Authority in 1938), the jurisdiction of the federal agency over design was expanded.

Architects for the separate projects were still private practitioners. But they were now selected by local official bodies subject to the approval of Washington officialdom. The relatively small number of firms receiving commissions was often explained by the fact that housing project design was a new art and that the number of architects who understood its principles was small. At the same time, the agency architects proceeded to perfect these principles according to their own special inspiration and to dictate in greater and greater detail the character of the planning, both by the publication of model plans and by the close checking of all individual designs. The considerable variety of design that had characterized the earlier work of the

PWA Housing Division was lessened until a monotonous similarity was the outstanding characteristic of public housing.

The process reached its ultimate during World War II. In that period, the agency developed standard plans in complete detail accompanied by completely detailed standard specifications. These were given to private architects, who, under close official scrutiny, were assigned the task of adapting the standard plans to special site conditions. Rarely were any changes permitted in the official plans and specifications; and supervision of the work was wholly removed from the architect's jurisdiction (except when some trouble arose in which his advice was sought). The excuse was the urgency of the war: there was not time for experimentation and individual planning; moreover, there weren't enough architects sufficiently competent to handle the work in relative independence.

What of the future? There is no evidence that the trend will be changed. The inactive years since the war have given the Public Housing Authority opportunity to review, study and develop its own architectural theories. We may confidently expect that the architects on future projects will be no less fully instructed than in the past. Moreover, as a program of this sort settles into its groove, it invariably becomes more and more political. Selection of architects will be primarily in the hands of local official agencies which in themselves are bound to become increasingly subject to political forces. The tendency to reward friends and to parcel the work among a coterie of the faithful seems inescapable.

Just where this leaves the independence and integrity of the private architect, it is not difficult to say. The extent to which his work is pre-cut for him or eliminated from his jurisdiction by the agency makes a high degree of professional competence unnecessary. Docility rather than ingenuity, resourcefulness, and independence, becomes the most desirable quality he can offer.

The Architect and the FHA

The history of the architect's relationship to the Federal Housing Administration, while it follows somewhat different lines, ends up in approximately the same place. The FHA operation falls into that category of governmental activities known as "aids to private enterprise." On the face of it, it is simply a financial institution engaged in the prosaic task of insuring mortgages on residential property made by private lending institutions. This task would seem to keep it remote from any immediate impact on the freedom of the architectural profession. But not so.

In the first place, if you are going to insure a mortgage, you will want to be as certain as possible that the mortgage is sound. In order to do this, you must see that the structure that is the security for the mortgage is a good one. You will have your own ideas about what is good and what isn't and, since, as an official, you are responsible for the outcome, you will, to the extent

TABLE 3 — Heating System Efficiency

Type of Fuel and Firing	Type of Heating Apparatus			
	Boilers	Warm Air Furnaces	Overflow Heaters	
	Steam or Hot Water	Forced Gravity	Space Heaters	
Gas — Apparatus designed for gas	80%	70 to 80%	70%	70%
Conversion burners	70	60 to 70	60	—
Oil — Apparatus designed for oil	75	65 to 75	65	60
Conversion burners	70	60 to 70	60	—
Anthracite or Coke				
Hand fired — No controls	60	50 to 60	50	40
Hand fired — With "	70	60 to 70	60	—
Stoker fired	75	65 to 75	65	—
Bituminous Coal				
Hand fired — No controls	50	40 to 50	40	40
Hand fired — With "	60	50 to 60	50	—
Stoker fired	65	55 to 65	55	—

ing system is to be automatic forced warm air, burning oil at 12.5¢ per gallon. Would it be advantageous to substitute ½ in. insulation board lath for the plaster base at an additional first cost of 2.0¢ per square foot of wall?"

"Solution: Degree days for Washington (Table 2) 4598
Heating plant efficiency (Table 3) 70%

"From chart (page 143) read across from 4600 degree days to 70 per cent curve and down to fuel scale. Reading on scale is 1.32 gal. per sq. ft. per year where 'U' = 1.00.

"The 'U' factor for the wall as designed is 0.25 while the 'U' factor for the wall with insulation board lath is 0.19. The difference in favor of the latter is therefore 0.06.

"Multiplying 0.06 by 1.32 gal. by 12.5¢ per gal. gives 1.0¢ per sq. ft. saved each year by the wall using the insulation board lath.

"Since the added cost of the second design is 2¢, the fuel saving would pay for the investment in about two years, after which the saving of 1¢ per sq. ft. would continue for the life of the wall."

"CASE 2. In the same circumstances as Case 1, would it be economically wise to install 2 in. of flexible insulation at 11¢ per sq. ft. retaining the plaster on plaster lath finish?"

"Solution: The 'U' factor for this wall

with 2 in. flexible insulation would be .09 whereas the 'U' factor for the uninsulated wall is 0.25. The reduction by the insulation is therefore 0.16.

"The fuel factor from the chart remains 1.32 gal., which, when multiplied by 0.16 and by 12.5¢ per gal. gives 2.64¢ per sq. ft. of wall surface per season as the saving by using the 2 in. flexible insulation.

"If we assume the structure to be an average small house, 26 by 32 ft., with normal window arrangements, the net wall surface would be approximately 800 sq. ft. The installed cost of the insulation would be 800 × 11¢ or \$88.00.

"The economy of the insulation could be expressed in terms of dollar savings per year, as if the cost of the insulation were included in the original capital cost of the house and amortized over a 25-year mortgage period.

"The cost of the \$88.00 investment under these conditions would be about \$5.58 per year to repay capital and interest at 4 per cent. Fuel savings would be 800 times 2.64¢ or \$21.12 per year. The net saving would be \$21.12 minus \$5.58 or \$15.54 per year each year during the life of the mortgage, provided that fuel costs remain practically constant. Any increase in fuel cost would increase the net saving."

How do the insulation methods in Cases 1 and 2 compare? "In Case 1, it was shown that a saving of 1¢ per sq.

ft. of wall per season was available. For an average of 800 sq. ft. of wall, this would amount to \$8.00 per year due to the use of insulation board plaster base. In Case 2, the saving was 2.64¢ per sq. ft. of wall or \$21.12 per season, due to the use of 2 in. flexible insulation.

"These figures show that Case 2 will save \$21.12 less \$8.00 or \$12.12 per year more than Case 1, while the added cost of the 2 in. flexible insulation is about \$72. The added expense therefore is made up in about six years, after which the insulation treatment of Case 2 will show an annual saving of \$21.12 over the uninsulated wall or \$12.12 over the insulation treatment of Case 1.

"The uninsulated wall at 'U' equals 0.25 meets the minimum requirement for comfort in the Washington, D. C., area, but this economic analysis gives a base for determining the relative value of the two proposed methods for providing a greater degree of comfort and for conservation of fuel."

In setting up the economic analysis, savings on such cost items as maintenance and repair, power for operating equipment or ash handling expenses have not been considered; the possible economies have not been included resulting from reduced sizes of heating equipment made possible by exceptional heat loss savings from insulating materials. At the same time costs have not been considered for louvers, ventilators, fans and associated equipment if needed to prevent condensation when insulation is applied. The method is intended as a guide only and the added refinement of such determinations is probably very small.

By using this suggested analysis, the architect, builder, owner or tenant can obtain a quick check on the comparative value of various insulating treatments which might produce minimum or optimum comfort conditions. The cost analysis will indicate where and how much insulation should be used for any particular case.

TABLE 4 — Conversion Factors
To convert gallons of fuel oil to other fuels multiply by the following factors:

	Factors	Heat Content*
For cu. ft. of gas	127	1100 Btu per cu. ft.
	140	1000
	155	900
	175	800
	200	700
	233	600
For lbs. of coal	280	500
	10.0	14,000 Btu per lb.
	10.8	13,000
	11.7	12,000
For therms	12.7	11,000
	14.0	10,000
	1.4	(one therm equals 100,000 Btu)

*These values may be obtained from the local gas company or coal dealer.

FUEL REQUIREMENTS CHART

HEATING SYSTEM EFFICIENCY—PERCENT

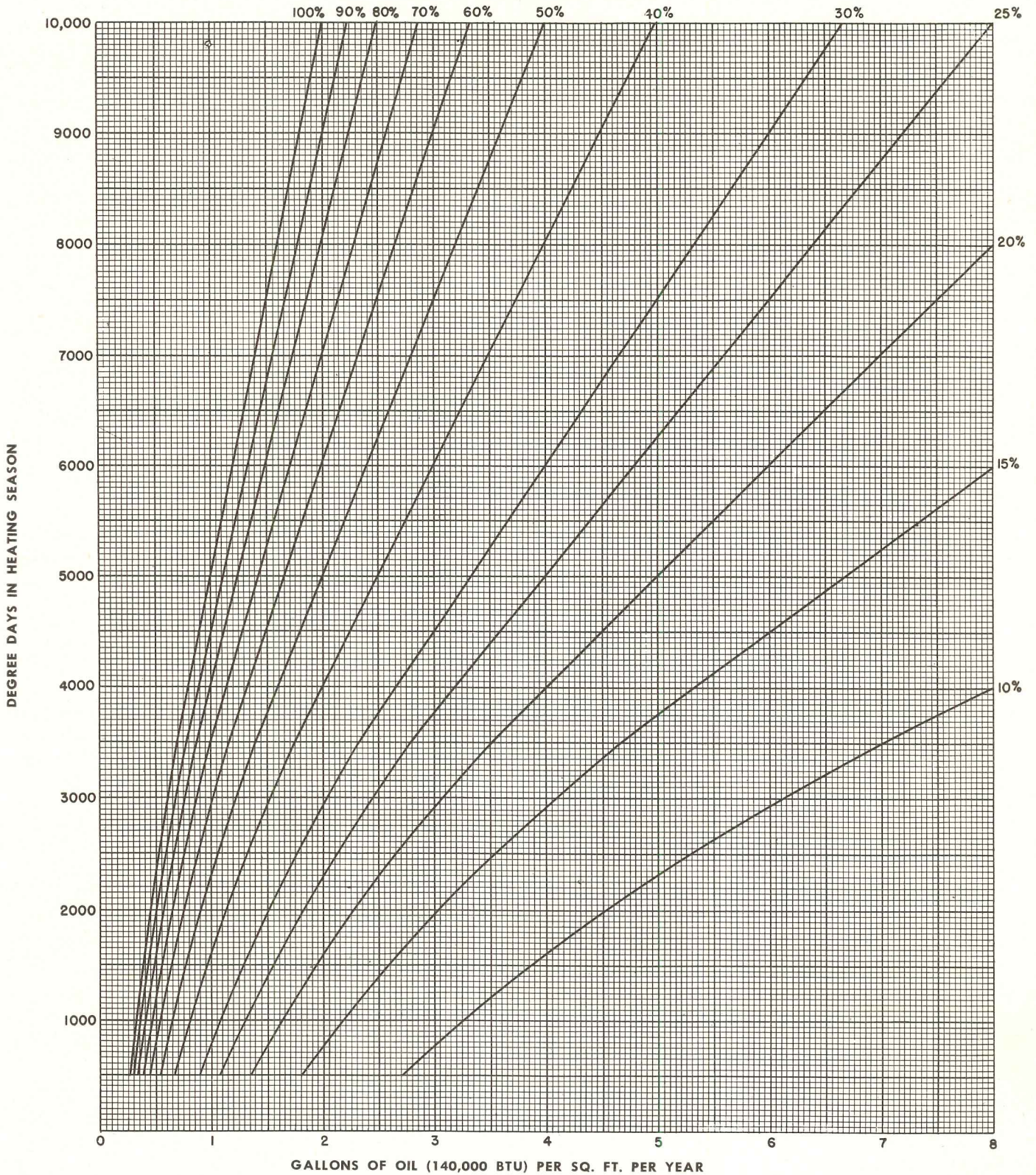

Cost Analysis

Having determined the difference in fuel consumption of any two constructions, the cost of one construction can be compared with the other. If desirable, the installation cost of each can be set up as a yearly charge covering interest

on the first cost and repayment of the principal. Adding the annual excess fuel cost to the yearly charge of the construction having the greater heat loss will give a close approximation of the difference in annual cost.

The following examples have been

taken from the HHFA paper, "Insulation — Where and How Much."

"CASE 1. A house is to be constructed in Washington, D. C. The walls are to be 4 in. common brick veneer, wood sheathing on 2 in. by 4 in. studs with plaster on plaster lath finish. The heat-

Economic Analysis

Once comfort conditions are met, an intelligent selection can be made from the many methods for adding thermal protection to any building where the costs are known. The initial cost of any structure is not the only one that concerns owners or tenants. Operation economies may be sufficient to offset an additional initial expenditure and any interest charges. The selection of insulation beyond that necessary to provide minimum comfort conditions should be based on economic analysis and such additional insulation methods should be capable of repaying their costs.

Since fuel prices and construction costs vary considerably over the country, a method has been developed for expressing fuel savings in terms of fuel units and areas of the building elements involved. When several construction assemblies are possible, it is relatively simple to calculate the annual cost of each. With these costs indicating the annual saving of one construction over another, the designer can determine if an additional first cost of one will be adequately repaid in fuel savings.

It is also possible to evaluate the savings resulting from thermal protection added to existing structures. Here, however, it is necessary to add a note of caution: where a building element or section has been in use, the addition of thermal protection will change the temperature conditions which existed in the element. This addition lowers temperatures in those parts of the element toward the outer side and raises temperatures in the parts on the inner side. Water vapor passing through the element from inside the house may condense on the cold surfaces unless means have been provided to effectively reduce excess vapor flow by installation of a vapor barrier or by proper ventilation of the element.

Fuel Requirements

When the "U" value of any building element or section is known, the fuel units lost through it per year can be obtained from the curves on the chart, page 143. These curves indicate the approximate number of fuel units required annually by each square foot of surface for various efficiencies of heating systems and for the number of degree days in the heating season, when the "U" factor is 1.00. Multiplying this figure by the actual "U" factor will give the approximate number of fuel units required annually per square foot for the particular case.

The curves shown on the chart have been derived from formulas published in the *Guide of the American Society of*

Heating and Ventilating Engineers, 1947, with some modification to indicate the additional fuel requirements in those sections of the country where the heating load is light because of reduced efficiencies at low loads.

Amounts of fuel obtained from the chart are correct within about 5 per cent for the average heating season. The chart takes into account a night cutback in inside temperature to 55° F for eight hours. If no night time reduction in house temperatures is contemplated, an additional 7 per cent should be added to the fuel consumption.

Use of Chart

To use the chart on page 143, first determine the number of degree days per year for the locality where the house is or will be built. The annual degree day figure is a measure of the seasonal heating load and can be obtained from the U. S. Weather Bureau or from local fuel dealers. Table 2 gives a representative list for major cities as given in the 1947 A.S.H.V.E. Guide.

Next, select the appropriate heating efficiency curve. The efficiency selected should represent that part of the heat in the fuel as purchased which is useful

in heating the entire dwelling. This efficiency is affected by variations in construction detail and quality, heating plant design and quality, accuracy of installation, operating control methods and apparatus, and by living habits. Table 3 lists some efficiencies suggested for use with the chart.

Having selected the efficiency and the degree days, locate the degree day figure on the vertical scale of the chart. Proceed horizontally to the selected efficiency curve and from this point drop vertically to the horizontal fuel scale. The reading on this scale gives the annual number of gallons of fuel oil (at 140,000 Btu per gallon) required for each square foot of building element or section where "U" equals 1.00. (Conversion factors for other fuels are given in Table 4.)

The fuel required per square foot can be multiplied by the area and "U" factor for any element or section to obtain annual fuel consumption requirements for each such element or section. Or, it could be multiplied by the difference between the "U" factors of any two possible constructions to determine the annual difference in fuel requirements for the two possibilities.

TABLE 2. Normal Degree-Days for Cities in the United States, Canada and Newfoundland

State	City	Total	State	City	Total
Ala.	Birmingham	2618	N. D.	Bismarck	8969
	Mobile	1567	Ohio	Cincinnati	5013
Ariz.	Phoenix	1446		Cleveland	6171
Ark.	Fort Smith	3230		Columbus	5536
	Little Rock	3005	Okla.	Oklahoma City	3698
Calif.	Los Angeles	1390	Ore.	Baker	7219
	San Francisco	3143		Portland	4379
Colo.	Denver	5863	Pa.	Philadelphia	4749
	Grand Junction	5647		Pittsburgh	5466
Conn.	New Haven	5879	S. C.	Charleston	1870
D. C.	Washington	4598		Columbia	2504
Fla.	Jacksonville	1161	S. D.	Huron	7997
Ga.	Atlanta	3002		Rapid City	7225
	Savannah	1647	Tenn.	Knoxville	3665
Idaho	Boise	5659		Memphis	3078
Ill.	Chicago	6287		Nashville	3620
	Springfield	5463	Tex.	El Paso	2538
Ind.	Evansville	4387		Fort Worth	2356
	Indianapolis	5487		Houston	1360
Iowa	Des Moines	6391		San Antonio	1424
	Sioux City	6909	Utah	Modena	6605
Kan.	Dodge City	5077		Salt Lake City	5637
	Topeka	5101	Vt.	Burlington	7930
Ky.	Lexington	4791	Va.	Lynchburg	4082
	Louisville	4428		Norfolk	3385
La.	New Orleans	1208		Richmond	3944
	Shreveport	2127	Wash.	Seattle	4864
Me.	Portland	8451		Spokane	6305
	Portland	7338	W. Va.	Elkins	5814
Md.	Baltimore	4522		Parkersburg	5091
Mass.	Boston	5943	Wis.	Green Bay	7956
Mich.	Detroit	6580		LaCrosse	7442
	Marquette	8786		Milwaukee	7086
Minn.	Duluth	9766	Wyo.	Cheyenne	7549
	Minneapolis	7989		Lander	8237
Miss.	Vicksburg	2073	Alta.	Calgary	9,927
Mo.	Kansas City	4984		Edmonton	10,289
	St. Louis	4610	B. C.	Vancouver	5,755
	Springfield	4567	Man.	Winnipeg	11,130
Mont.	Havre	8474	N. B.	Moncton	8,886
Neb.	Lincoln	6010	N. S.	Halifax	7,682
	Omaha	6102	Ont.	Ottawa	8,674
Nev.	Winnemucca	6371		Port Arthur	10,488
N. H.	Concord	7391		Toronto	7,715
N. J.	Atlantic City	5049	P. E. I.	Charlottetown	8,384
N. M.	Santa Fe	6124	Que.	Montreal	8,341
N. Y.	Albany	6658		Quebec	9,467
	Buffalo	6935	Sask.	Saskatoon	11,493
	New York	5306	Newf.	St. John's	8,919
N. C.	Raleigh	3281			
	Wilmington	2432			

METHOD FOR CALCULATING INSULATION ECONOMIES

Developed by HHFA Technical Staff

To make possible fairly precise calculation of fuel savings resulting from insulation, engineers of the Housing and Home Finance Agency have developed a method of analyzing insulation costs in relation to fuel economies.* Based on the thought that, once minimum comfort conditions are satisfied, additional insulation should pay for itself, the method is intended to permit comparison of various insulation proposals in monetary terms.

The analysis starts with consideration of wall and floor surface temperatures from the standpoint of comfort, fixing minimum and optimum temperatures that ought to be maintained. If any insulation is required to maintain those temperatures, it is considered necessary without regard for costs. Beyond that, further insulation is weighed in terms of fuel savings.

Surface Temperatures

Usually when inside surface temperatures are low during winter heating, an excess of bodily heat is lost by the occupants (through radiation or conduction) to the cold surfaces.

The body area of an occupant exposed to the ceiling is smaller than that to the walls and floor; therefore, the ceiling temperature need not be considered for comfort requirements. Moreover, the ceiling is further eliminated as a source of discomfort because of its distance from the occupant and also because the ceiling surface is usually warm from the heated air at the top of the room, regardless of insulation.

Without ceiling or roof insulation, however, transmission losses in winter and solar gain in summer might be excessive. The decision whether or not to insulate here has to be based on the degree of summer comfort demanded and on an analysis of fuel economy.

Wall Temperatures

Ordinary frame walls with wood sid-

ing, wood sheathing, 2 in. by 4 in. studs and plaster finish have been commonly used in areas where the outdoor air temperature drops to 0° F. The rate of heat transfer through these walls with 70° F inside air temperature and 0° F outside air temperature results in an inside surface temperature of 59° F. Although this is not a minimum wall temperature based on physiological data, common practice and consumer acceptance indicate that this figure can be assumed for minimum comfort. Federal housing authorities recommend 65° F as optimum.

Single-glazed windows, with an inside surface temperature about midway between indoor and outdoor air temperatures, not only cause a chilling effect when occupants are near the surface but also induce undesirable drafts. Most doors have high transmission losses and, like single pane glass, lower the overall average inside surface temperature.

When large window and door areas exist, either wall surface temperatures must be elevated by adding insulation there or else thermal protection must be provided by using double-glazed glass or storm windows and storm doors to compensate for the increased exposed area.

Floor Temperatures

Where floors are over basements or heated spaces, the surface temperature is usually satisfactory, but when they are over unheated spaces or in direct contact with the ground, thermal protection might be needed.

Floors over crawl spaces lose heat through the entire area and should be insulated accordingly. Concrete slabs on the ground are best insulated according to suggestions of the Housing and Home Finance Agency (see ARCHITECTURAL RECORD, Jan., 1948).

The minimum standard temperature for floors is based on the accepted use of wood floor on wood subflooring over well-ventilated crawl spaces. Again using 0° F outside air and 70° F inside air design temperatures, the minimum temperature for this type floor is 60° F.

"U" Value

Since the inside surface temperature and heat transfer of a section depend on the type, thickness and arrangement of materials used as well as inside and outside air temperatures, the minimum and optimum temperatures can be translated into a heat transmission factor "U." This represents the heat transfer in Btu per hour per square foot of assembled structural section, per degree Fahrenheit temperature difference between inside and outside air.

Table 1 lists "U" values for walls from the minimum temperature (59°), through the optimum (65° to 68°), and for the minimum floor temperature (60°) with the range of outdoor design temperatures from minus 40° to plus 30°.

The "U" for any combination can be calculated; however, the values for many composite arrangements can be found in published guides (see ARCHITECTURAL RECORD, Nov., 1936 and the Guide of the American Society of Heating and Ventilating Engineers, 1947).

TABLE 1 — "U" Factors Which Will Produce Minimum and Optimum Surface Temperatures (all temperatures, °F)

Outdoor Design Temp.	Walls				Floors Minimum*
	Minimum 59	63	Optimum 65	68	
+30	0.45	0.30	0.20	0.10	0.60
20	0.36	0.24	0.16	0.08	0.48
10	0.30	0.20	0.13	0.07	0.40
0	0.26	0.17	0.11	0.06	0.34
-10	0.23	0.15	0.10	0.05	0.30
20	0.20	0.13	0.09	0.044	0.27
30	0.18	0.12	0.08	0.040	0.24
40	0.16	0.11	0.07	0.036	0.22

*For floors over unheated, well-ventilated spaces.

*"Insulation—Where and How Much," Laurence Shuman, Mechanical Engineering Adviser Technical Staff, HHFA Technical Bulletin No. 3, March 1948.

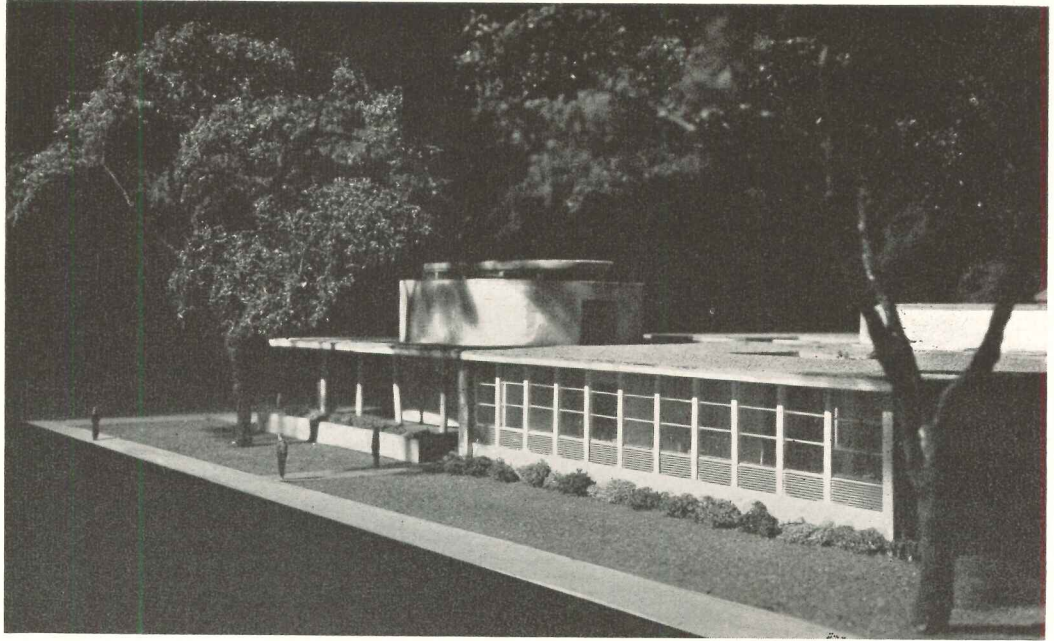

Hedrich-Blessing Photos

“It was desired that the passing public receive an impression of the use and character,” say the architects. “To the individual coming to visit the Chapel, the openness of the plan and the visual sense of the various rooms placed about the court would accent the joint activities of the social and educational; to those interested in the social aspects, a realization of the religious program would be physically manifest; and to the student attending seminars or auditorium, no matter what faith, a sense of the other aspects of the building would

be conveyed in a frank and open manner devoid of mystification or seclusion.

“The plan developed with the elements disposed around the courts, producing various qualities of light; and the Chapel placed to the east and rising through and above the roof gives an added significance to the building from the main approaches.”

In the view of the architects' model, above, is seen the emphasis on the chapel; below, top-lighted passage and courts



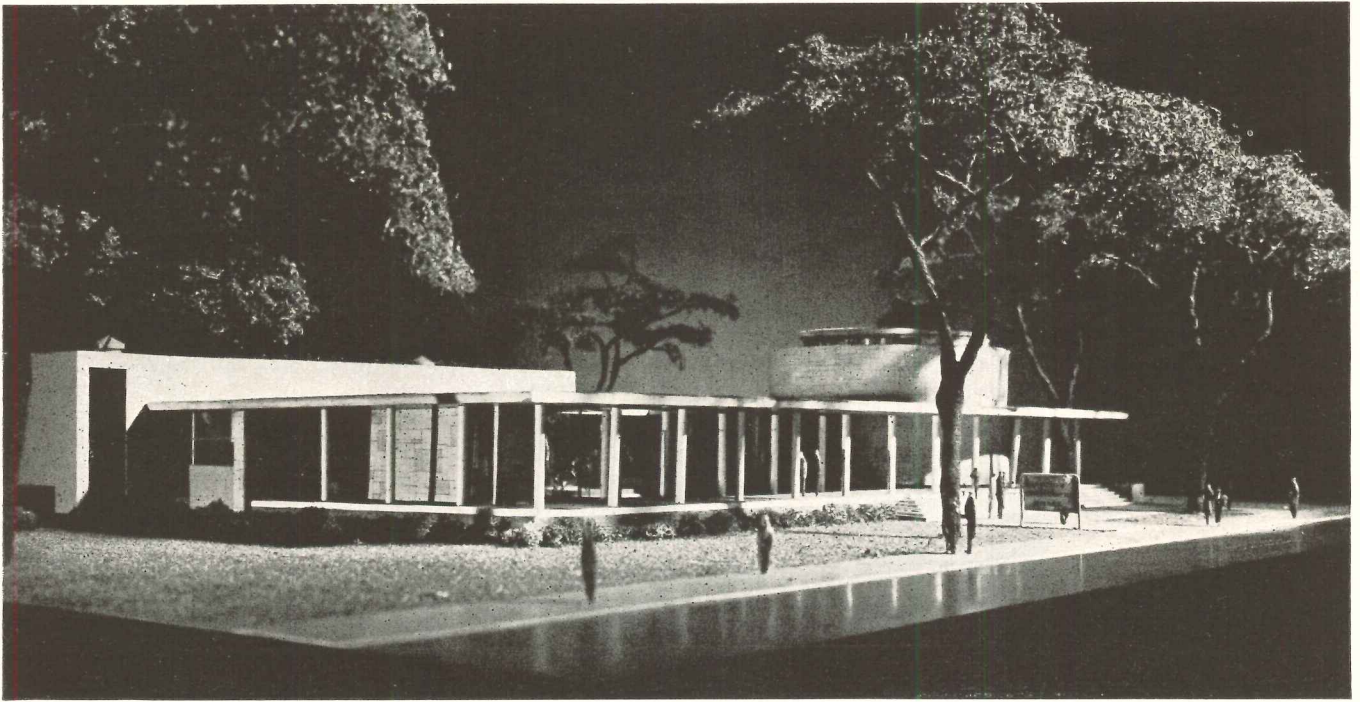

STUDENT RELIGIOUS CENTER BASED ON SYNAGOGUE

Evanston Congregation Hillel, Northwestern University

Harrison & Abramovitz, Architects

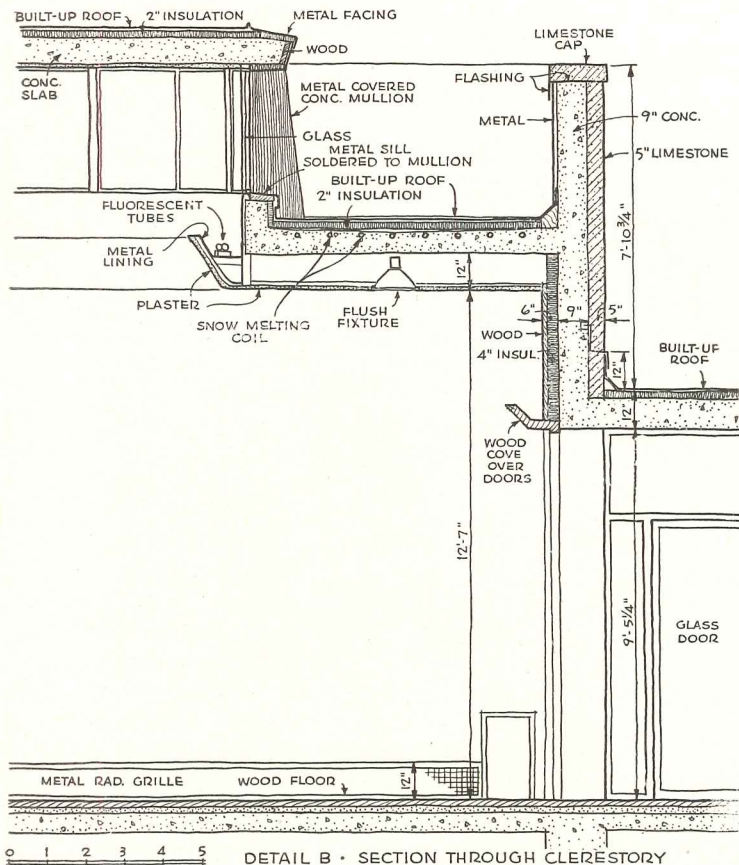

THIS building is to be erected to provide a center for the religious, cultural, and interfaith activities of the Jewish Community of Evanston, and for the students of Jewish faith at Northwestern University. The problem was to express, in planning and in use, the inter-relationship of these three-fold activities.

The site has many tall trees which will contrast with the horizontal structure; and to the east there is a view to Lake Michigan (the main floor is raised three feet to take advantage of it).

The requirements included, 1. a chapel for 100 for normal religious services; 2. an auditorium for 300, for lectures, dramatics, social gatherings and recreation, and for use as a religious hall on high holidays; 3. a kitchen to be used for suppers and teas; 4. seminar rooms for the use of students and community; 5. library; 6. social rooms for quiet social uses; 7. an administrative suite; 8. caretaker's suite; 9. a courtyard or enclosed area to recall the biblical "Courtyards of the Lord," and to provide areas to be used in relation to religious festivals.

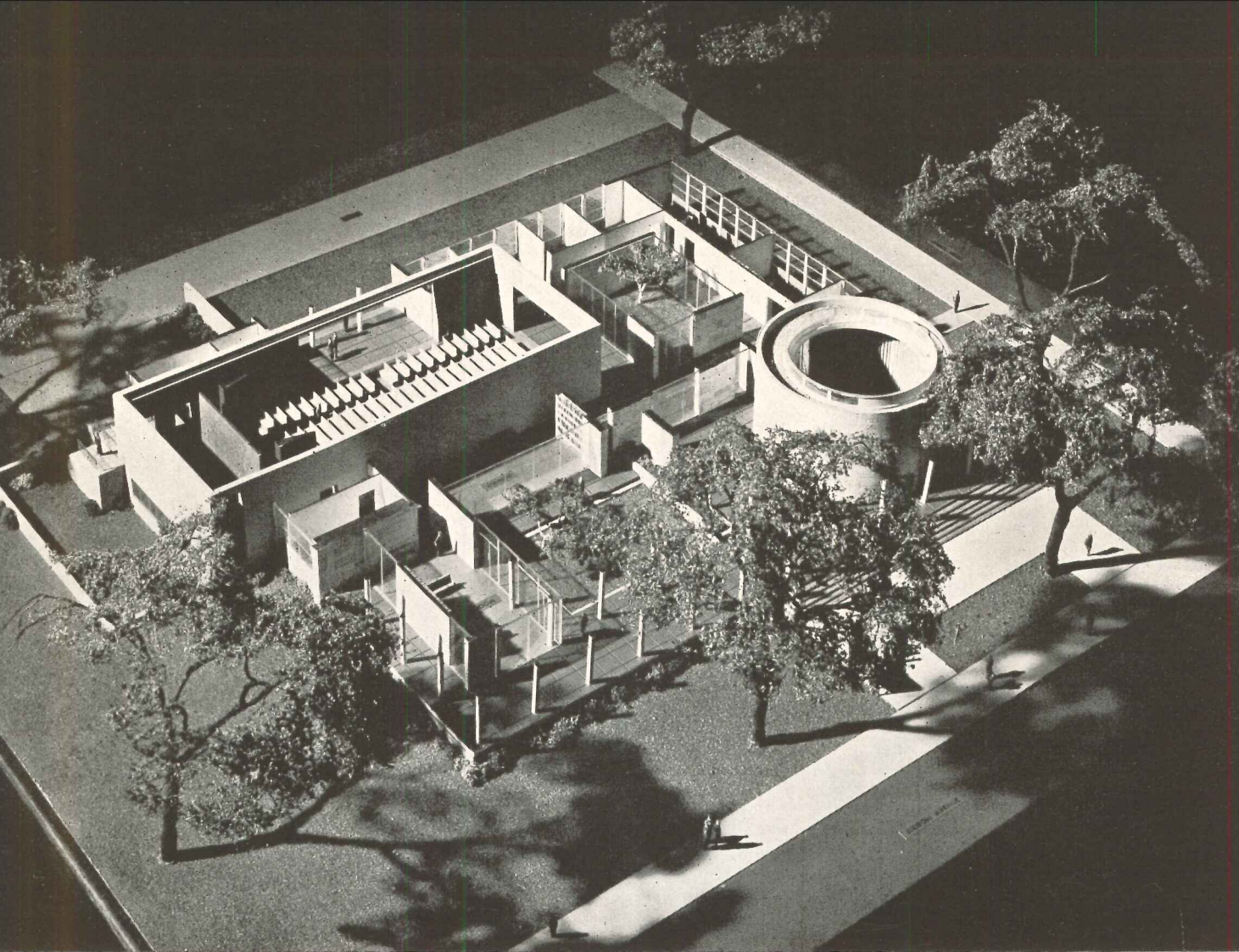

Hedrich-Blessing Photos

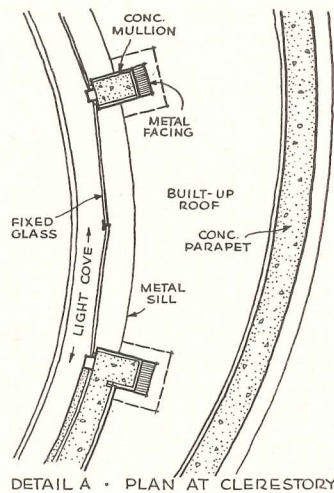
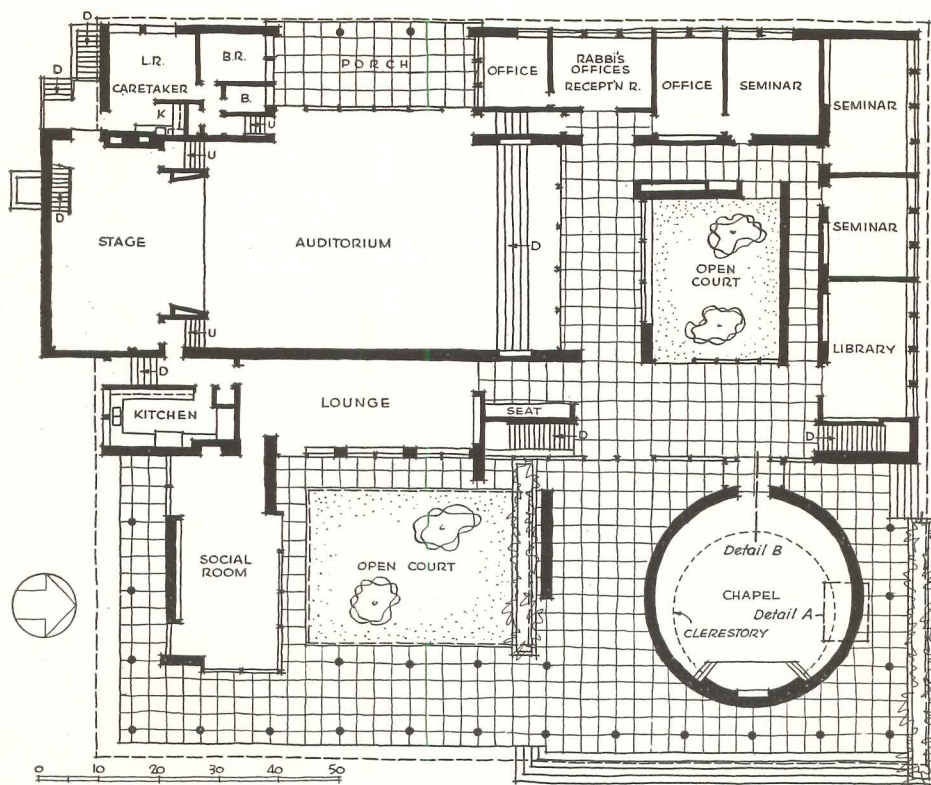

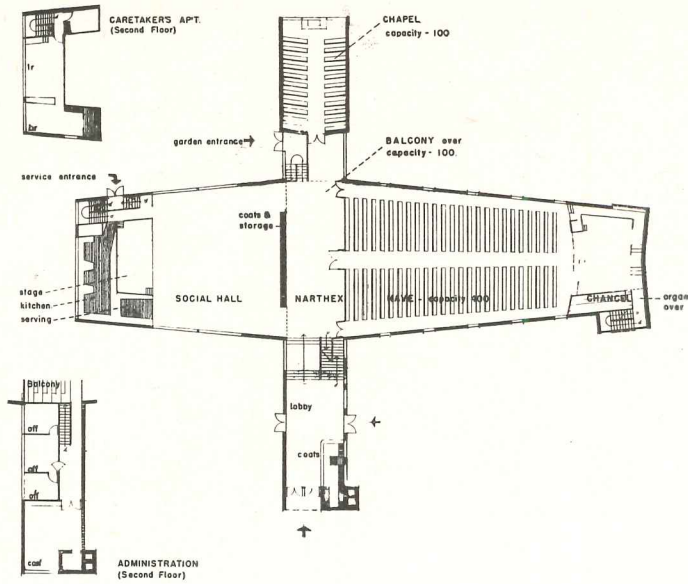

UPPER FLOOR

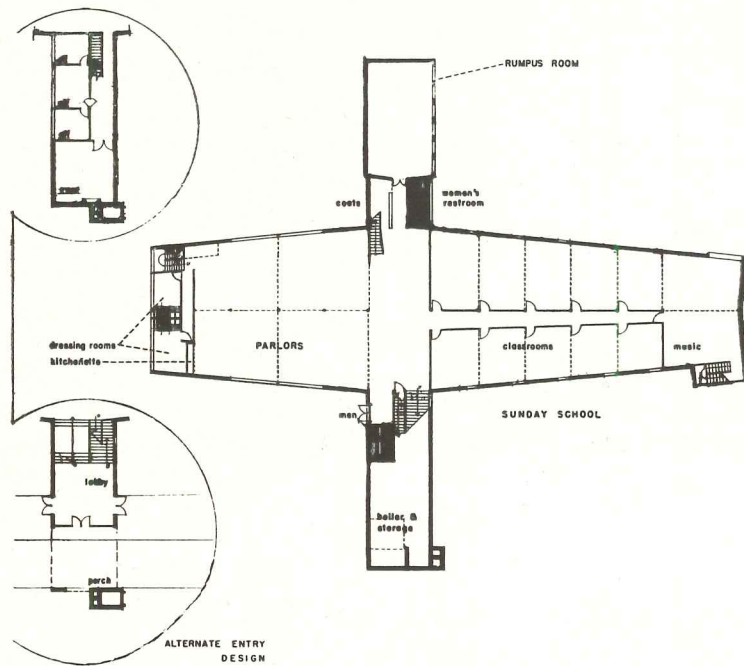

LOWER FLOOR

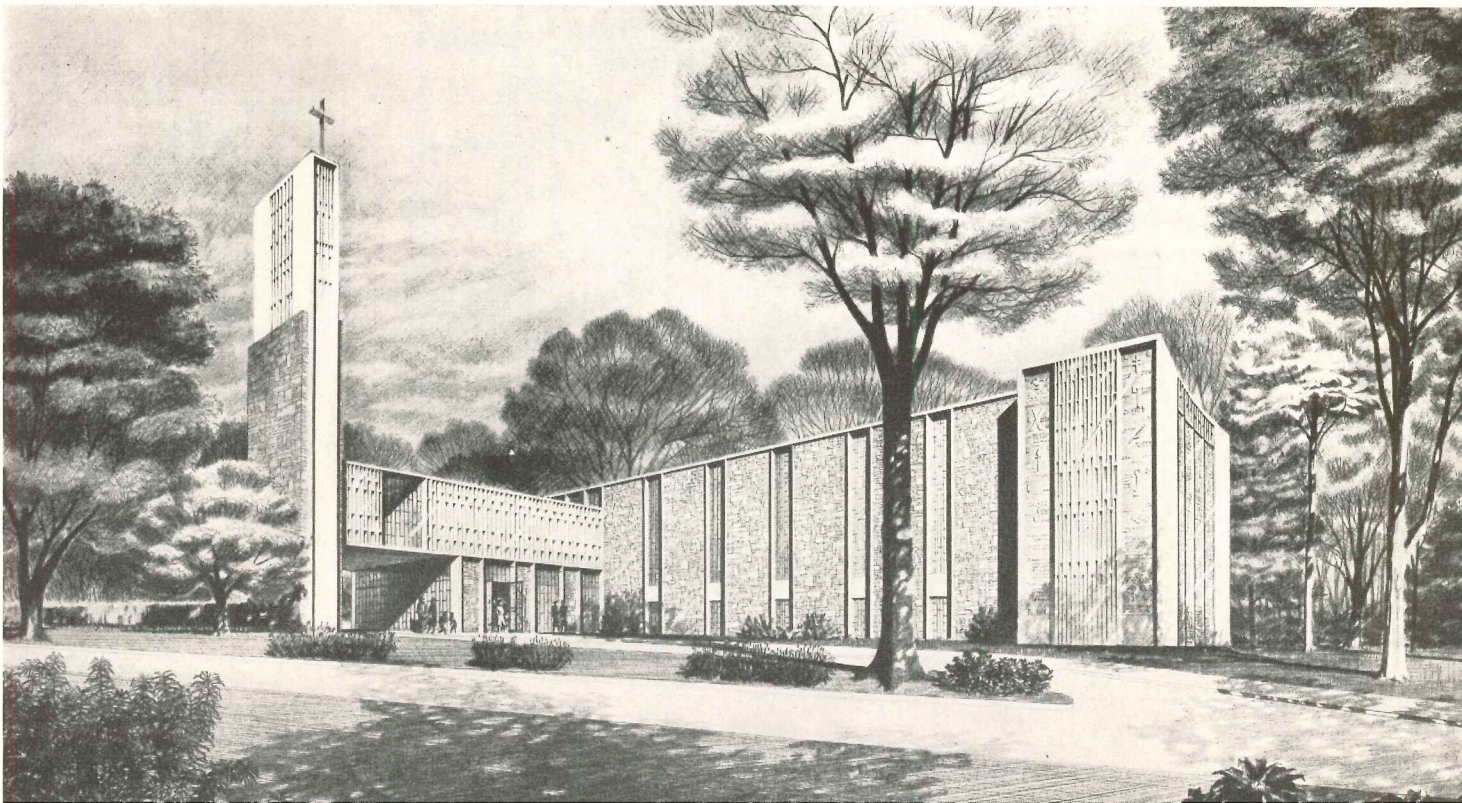

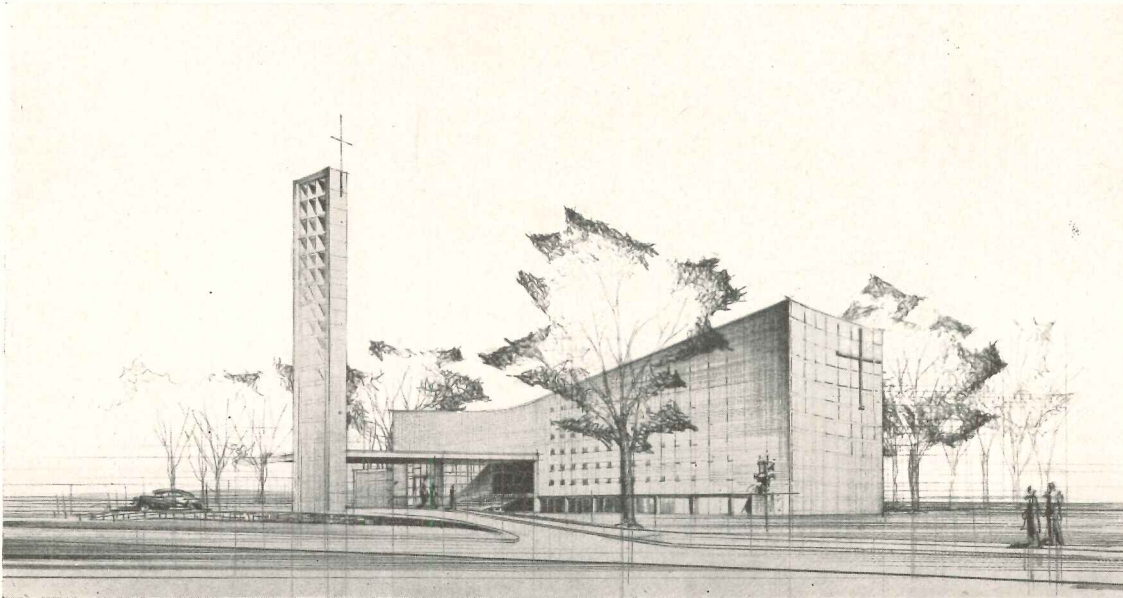

The rendering seen above presents the second study in an alternate version, still by Saarinen, Swanson and Saarinen. The main entrance is from the west.

The latest project, by Robert Swanson Associates, keeps the west entrance and provides, to the north, for parking, usually badly neglected in church plans. The west wing, greatly reduced, occupies the bridge to the campanile, and is administrative, including the

pastor's study. The social hall, directly opposite the nave, benefits from a joint storage partition, and its service entrance is logically located.

A mild criticism might be made of the classroom lighting which has been subordinated to continuity of effect in the tall lancet windows. Yet the project as a whole handsomely expresses the Protestant concept of a complete church institution.

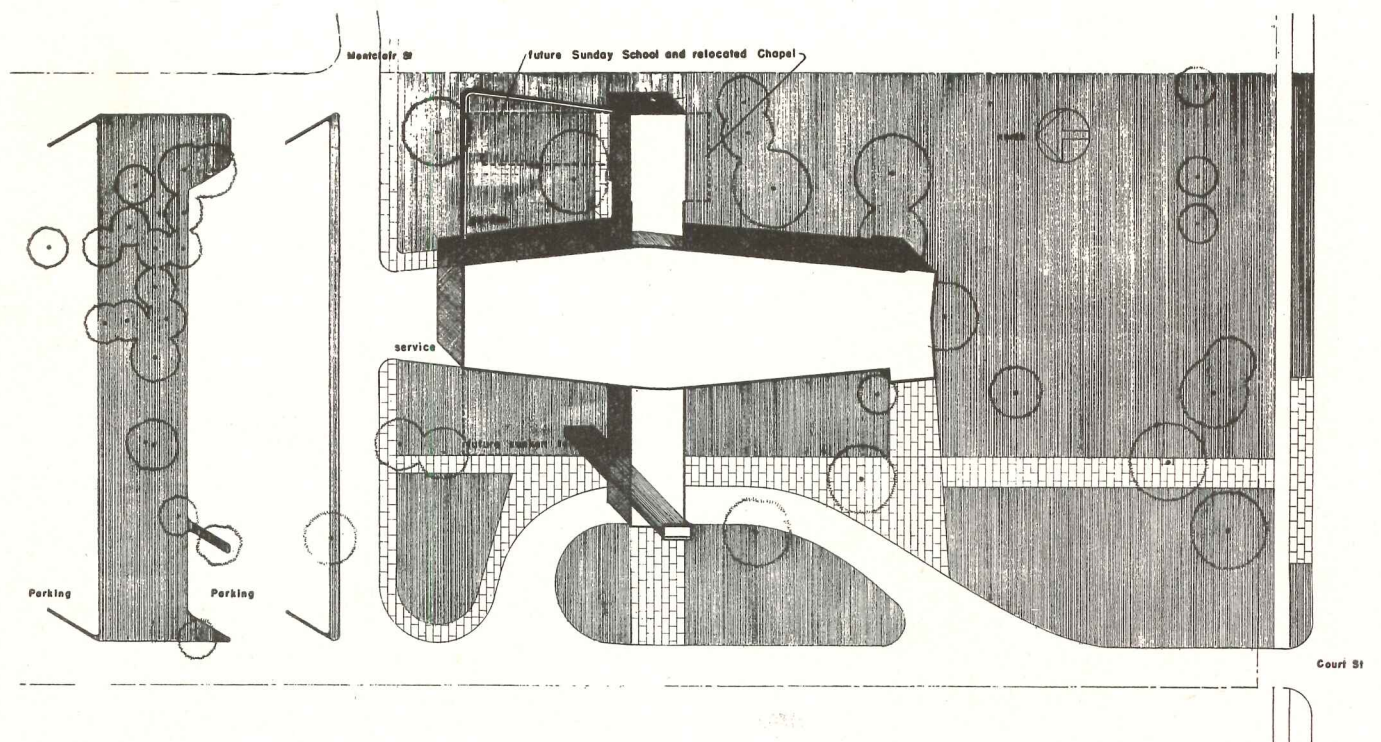

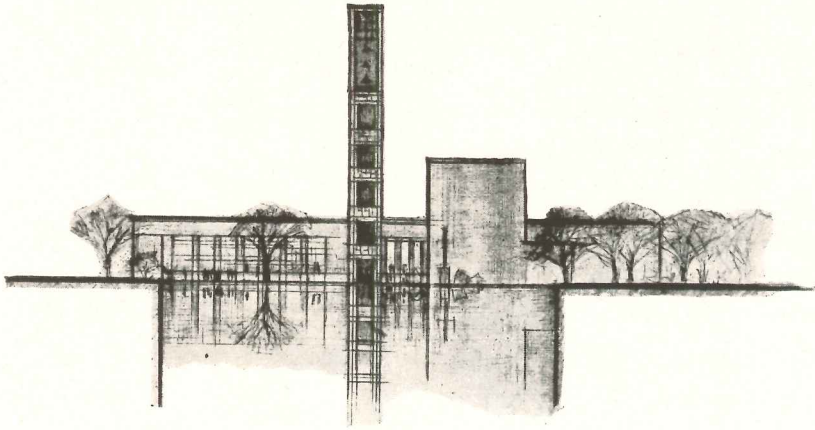

The reflecting pool has been exceptionally well handled. The monumental flight of steps above the terrace makes possible a view, from within the social rooms, at a higher angle

THE three projects presented herewith for a single church are not to be considered as successive improvements but as modifications to meet circumstances.

The first scheme, opposite page and above, was developed before the separation of the original architectural firm into two separate establishments. It shows the skilled Saarinen hand at large-scale architectural organization. Access is from the east (north is to the left in the plan as seen here) with separate entrances to

large narthex and the two-story church school. The latter is logically lighted from the west (being used in the morning). The church itself gets the full morning light filtered through enormous windows. The transverse arrangement of the large social halls makes the large entrance space available to them also, and gives them a beautiful view across the reflecting pool.

In the second study by Saarinen, Swanson and Saarinen, seen below, economy brought many eliminations.

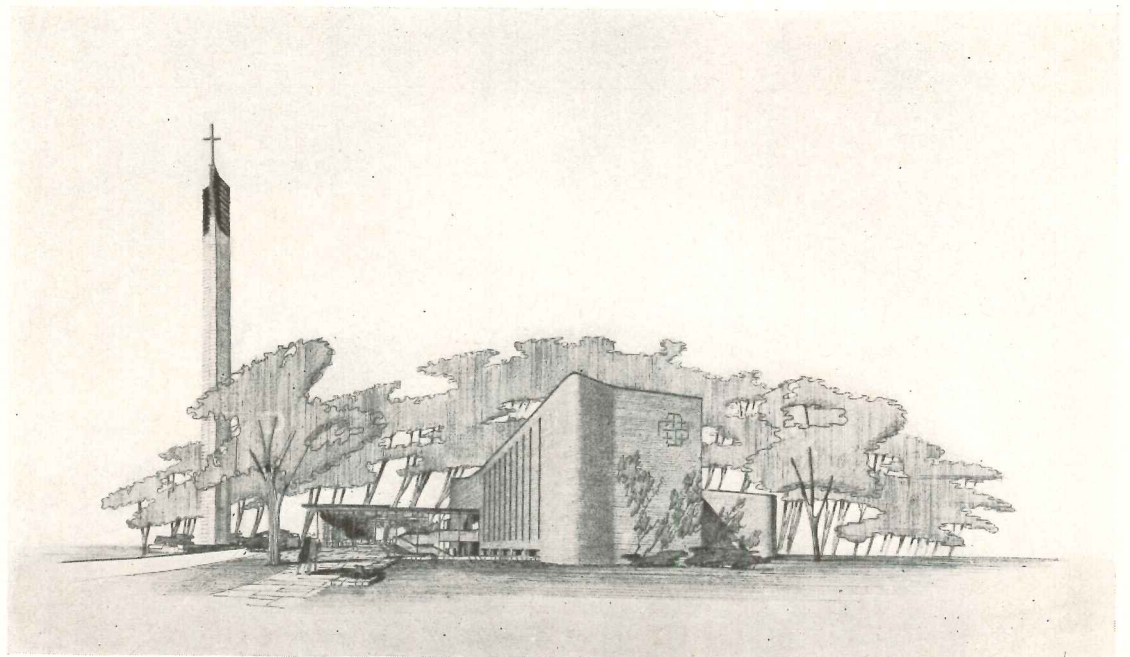

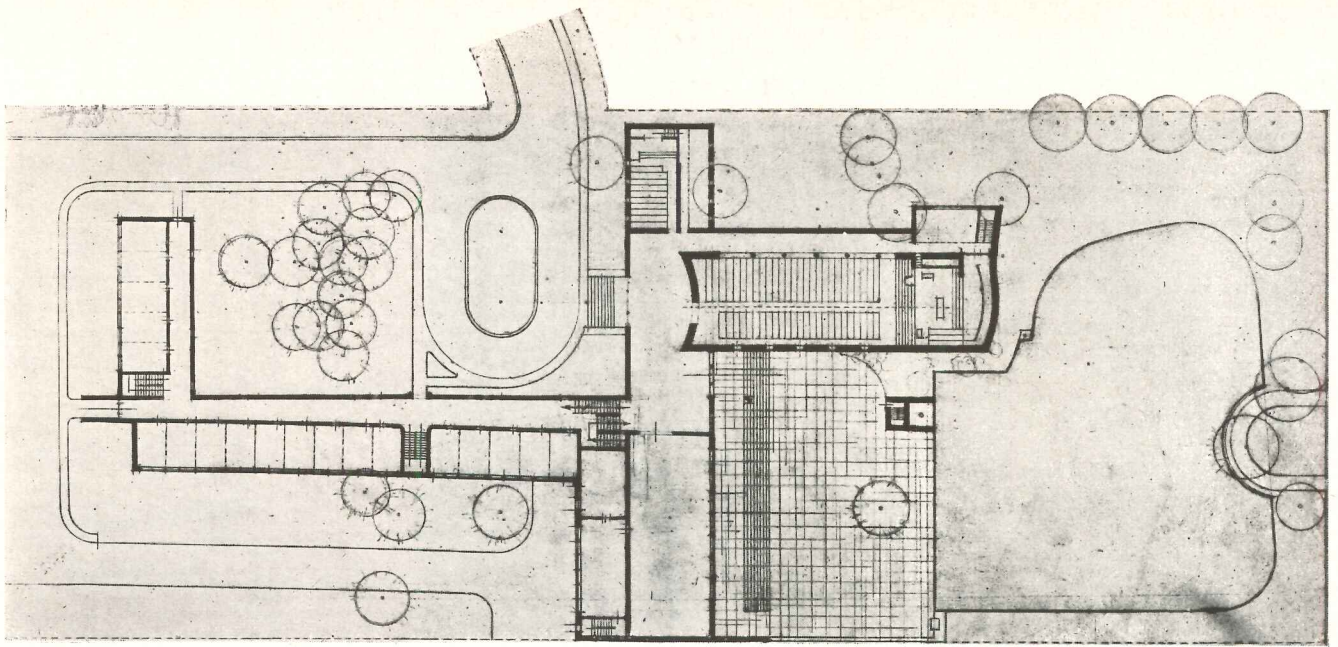

A COMPLETE CHURCH PLANT IN THREE VERSIONS

Projects for the First Baptist Church, Flint, Michigan

By Saarinen, Swanson and Saarinen and by

Robert Swanson Associates, Architects

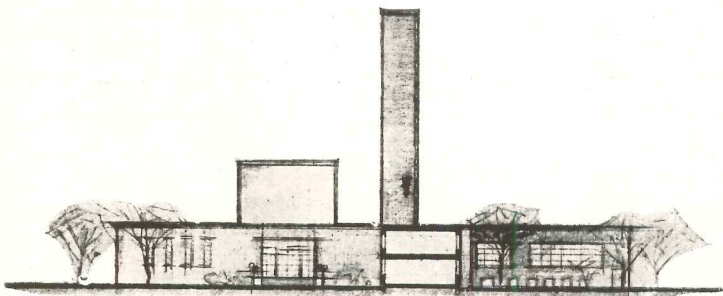

The first scheme is based upon subtle and complete organization: the separation, both exterior and interior, of movement and quiet

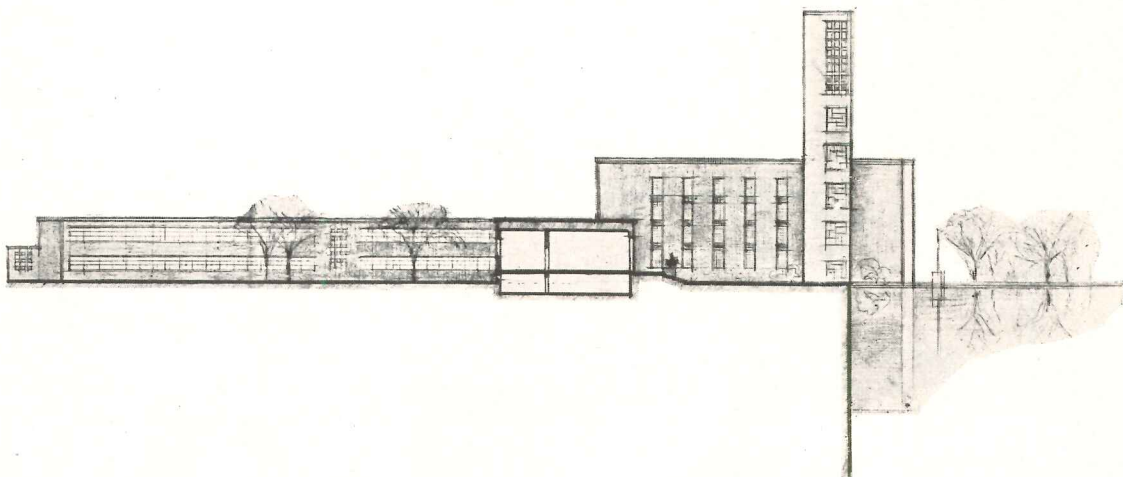

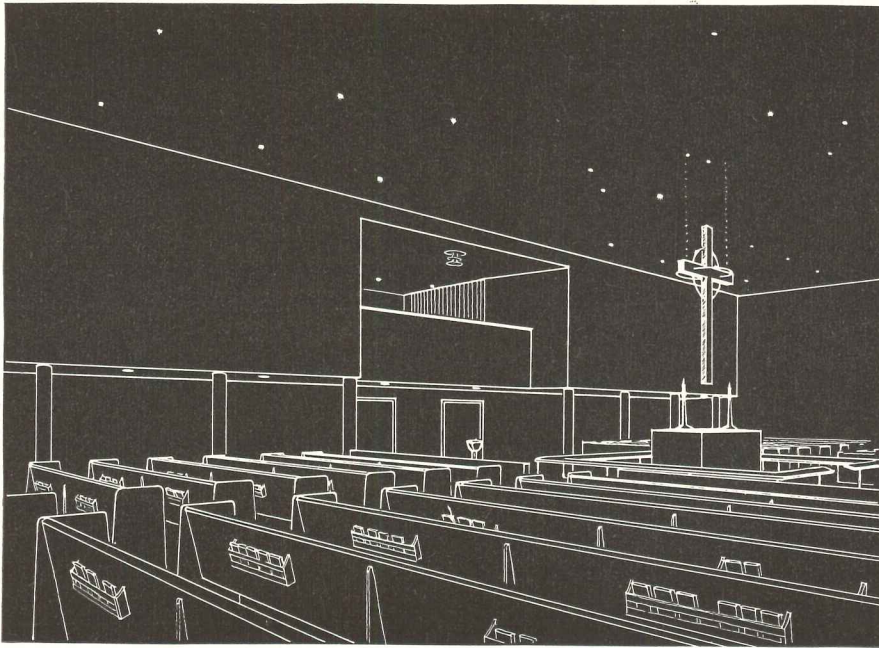

Seating and accessories were designed by the architect

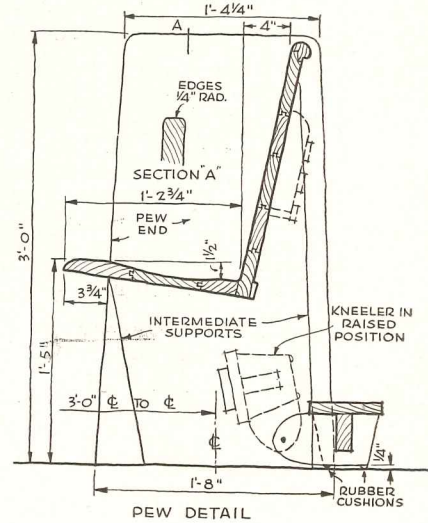

The program for this church was summarized in a statement of the rector, the Reverend Darby Wood Betts, from which excerpts are quoted:

"The Church to speak clearly must speak in current or contemporary language in buildings as well as in sermons. This has certainly been her history. . .

"For some reason or other, today finds the Church pursuing an uninspired course of slavishly following

the past with imitation Colonial or what is worse imitation Gothic . . .

"The Church is first and foremost a family called into being by its Father which is God. Therefore we sit facing one another rather than looking at the backs of each other's heads as does an audience; we are a congregation, those called together. Secondly, we have in the midst the symbols of the Originator and Head of the family. The altar has always stood for God's throne and presence; around the altar is the communion rail at which the family is nourished by the divine food provided by the Father. Over the altar hangs the empty cross, symbol of the sacrifice through which we are saved . . .

"The pulpit-lectern, the place of the Word, or Bible read and preached, is on one face of the altar and the Font, the place of birth into the Christian family, on the other face of the altar by the main entrance. The building in its entirety represents the first installment of life in heaven which is the realization of God's fully achieved presence. Therefore we have strained every device known to our day to shut out the world, which is only a temporary dwelling place, in order that we might anticipate our final home and thus return to the world inspired and refreshed to fight against its powers that would destroy us . . .

"We look up into the darkness that reminds us of the vastness of the mystery of the over-brooding presence of God as does the night sky, and all variations of light and darkness, heat and cold, wind, rain, snow, and sound are shut out as much as is humanly possible. . . ."

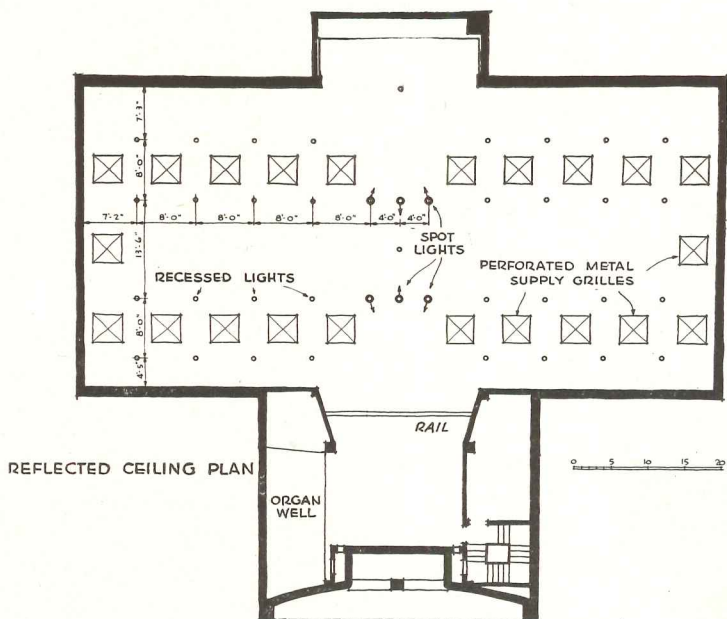



Gottscho-Schleisner Photos

Every effort has been made to destroy the sense of boundaries in the interior. Pinpoint lighting is just adequate for vision; spotlights pick out the simple oak chancel, the sandstone altar, and the baptismal font. The main walls are of the same plain red brick as the exterior; the wall on the choir side is acoustical plaster painted a deep blue, the ceiling black. Conditioned air is supplied through grilles in the ceiling, exhausted through side walls just above the floor. Chancel, altar, font, choir, form the central axis

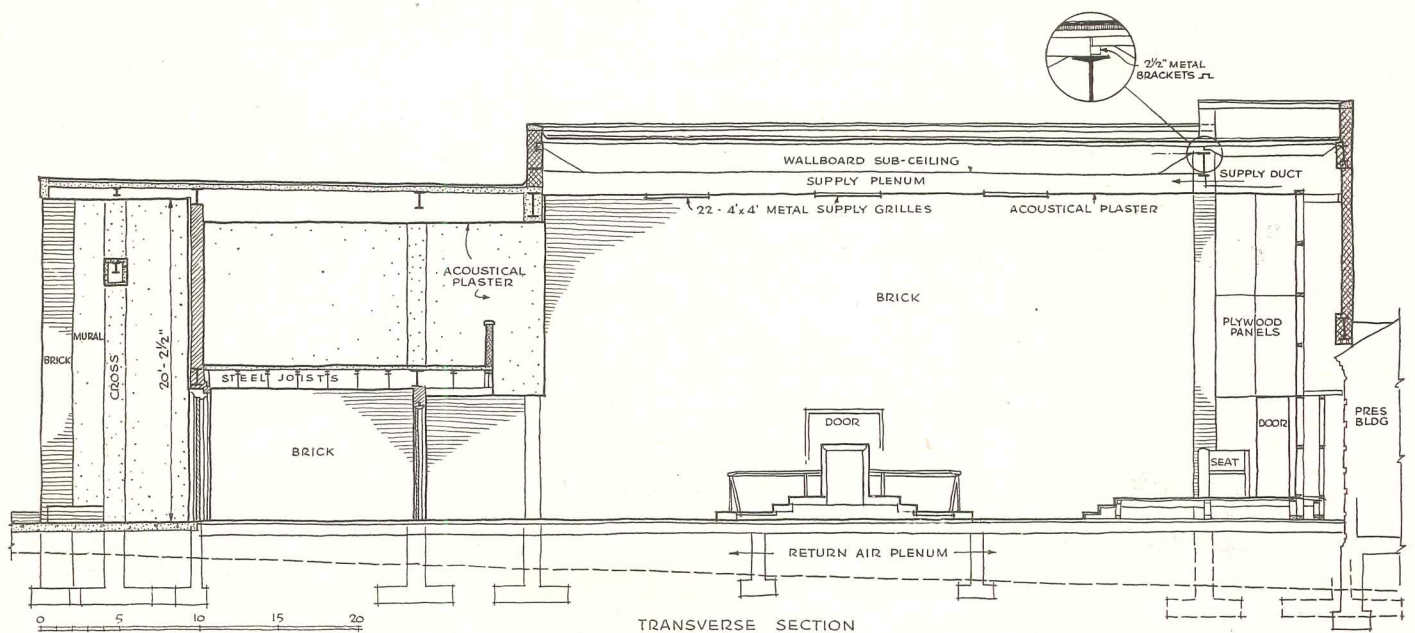

FUTURE EXPANSION

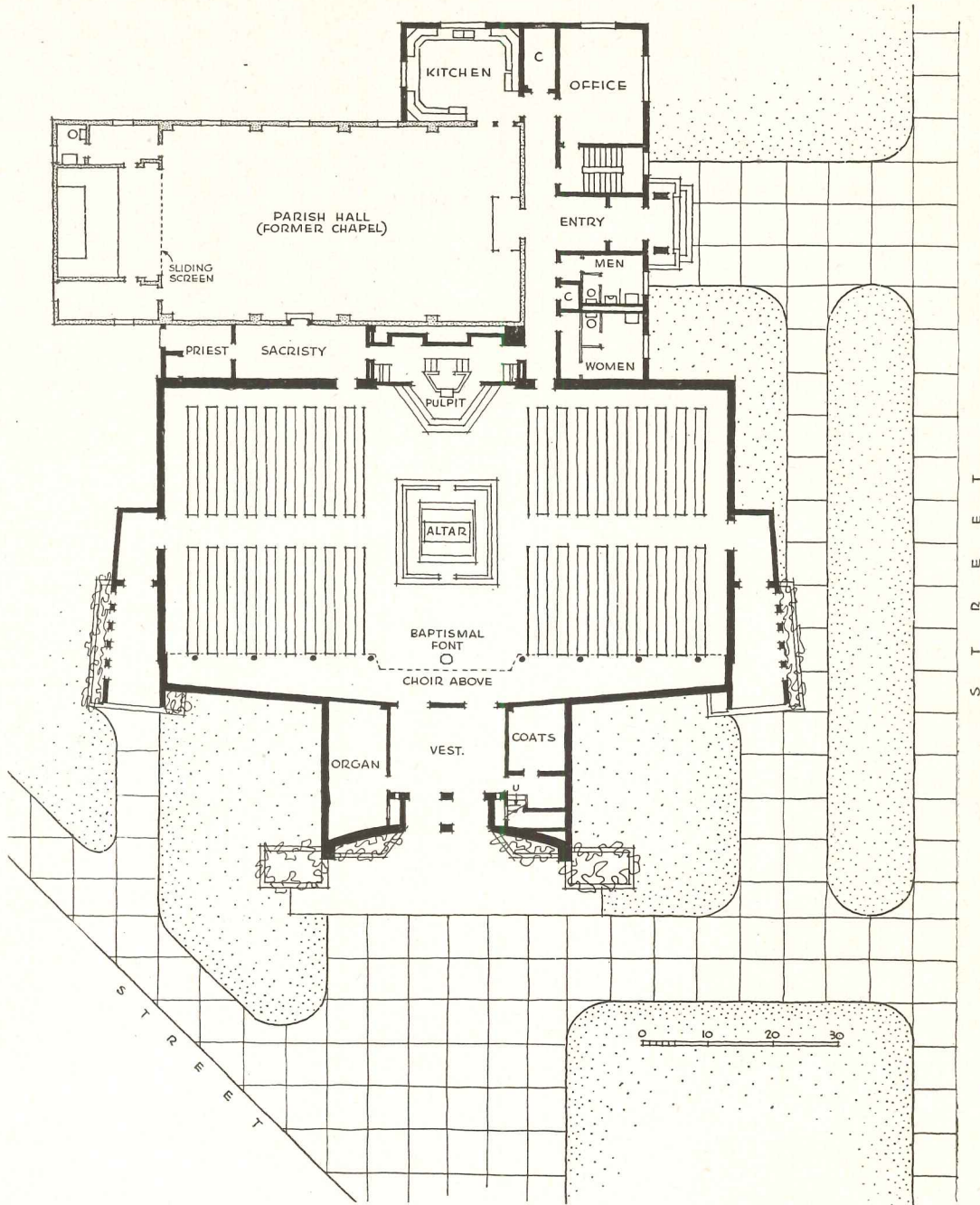

Gottscho-Schleisner Photos

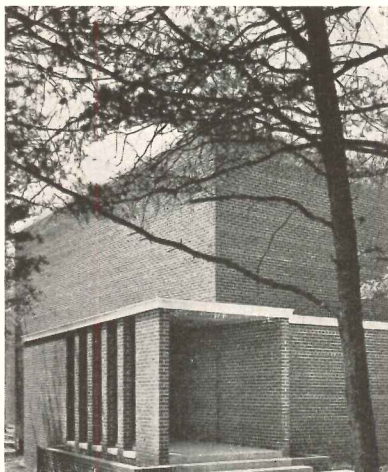

Situated among trees within the V formed by two major highways, and lying between two large housing developments, the modest little red brick building is planned to make effective visual use of its strong white cross and murals. The distinctive character of the building was made possible largely by the energetic rector, who built the original chapel in 1944 before there was a congregation, and has accordingly had strong influence

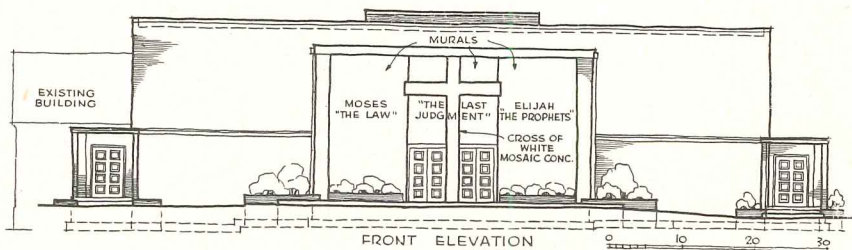



A WINDOWLESS CHURCH WITH CENTERED ALTAR

Church of St. Clement (Episcopal), Alexandria, Virginia

Joseph H. Saunders, Jr., Architect



Gottscho-Schleisner Photos

THIS remarkable little church, seating a congregation of 400, departs radically from the "stained glass tradition" in its entirety, and converts the new sciences of artificial illumination and air conditioning into instrumentalities for worship. Strongly liturgical in concept, it places all emphasis upon the central altar and a plain oak cross, which gives the illusion of hovering (it is suspended by chains from the ceiling); the dim "inward" light of the room rules out distraction.

The focal element in the whole concept is that the congregation shall not merely look upon one another's backs but shall see one another, as a "family," joined at "the Lord's table." Though the actual form is truncated it would be represented diagrammatically by a ring, a striking example of the first "archetype" described by Rudolf Schwarz as quoted on page 117.

The exterior of the entrance, not yet completed, is to be dominated by a white cross flanked by murals.

10. *Six classrooms for children 6–11 years of age*, varying in size, allowing about 12 sq. ft. per person for from 15 to 18 pupils and one teacher in each room.

11. *Coatroom space* for above group of six rooms: boys and girls *lavatories* within easy reach of this group of rooms.

12. *Equipment* for rooms of 6–11 year old children: built-in blackboards, about 3 by 4 ft. in size; shutters to be used as tack boards for each blackboard; a closet for teacher's wraps and supplies; clear glass windows with small, colored inserts.

13. *A children's chapel*, seating 60 children and choir of 12; tinted glass windows; a worship center; leader's desk at one side; portable blackboard to be available.

14. Equipment for showing *sound pictures* in this chapel room. (This room will be used twice each Sunday by two or three grades grouped together and occasionally by single grades according to schedule.)

Youth Division

1. Provide a Junior High *assembly room*, 480 sq. ft. A worship center will be at one end and a fireplace at the opposite end. Closet, 18 in. deep, top half of one side with shelves, other side full length for leaders' wraps. Have two classrooms, 200 sq. ft. each. (One class and small commissions will use assembly room.) Coat hanging space adjacent.

2. *A youth room*, 500 sq. ft., with fireplace at one end and worship center at the other. Built-in book cases, closet, kitchenette adjacent. This room to be scheduled at Sunday School period for Senior High assembly and also at another period for young people's assembly when required.

3. Provide *five classrooms* varying in size from 100 to 120 sq. ft. each, to be available for Junior High, Senior High and older youth groups.* (Tablet arm chairs to be used.) May be on second floor.

Adult Division

1. *Fellowship hall* to be used by largest adult group; church parlor and boys' and girls' club rooms and the room for floor and table games to be assigned to adult groups.

2. *The choir* is to be organized as a class in the religious arts, the choir room to be used for this group.

3. *Three adult classrooms*, about 210 sq. ft. each, to hold about 30 persons.* One of these on main floor.

Fellowship and Recreation

1. *Fellowship hall* with 18 ft. ceiling and an unobstructed floor area, 40 by 70 ft.; stage, 20 ft. deep, with widest possible proscenium opening; no partitions at the ends of the stage; straight front; no foot lights; trap door, 24 by 72 in., in floor of stage.

2. *Kitchen* at end of the hall opposite the stage, with 9 ft. ceiling; serving room space and counter between hall and the kitchen working space.

Room above kitchen may be the youth parlor with

removable panels, to be used for overflow for fellowship hall audiences and, also, for placing moving picture equipment.

3. *The church parlor*; 800 sq. ft. of floor space; fireplace constructed of rocks gathered by boys and girls of the church; kitchenette available unless the parlor can conveniently be located adjacent to the main church kitchen; built-in book shelves so that this room can do double duty as a church library.

4. *Three bowling alleys*.

5. *Recreation room* with 9–10 ft. ceiling, large enough for two ping pong tables and two shuffleboard courts. (This room doing double duty as an adult classroom and small dining room.)

6. *Boys' club room* with floor space of 500 ft.; 4 built-in storage closets occupying 20 sq. ft.; equipped with drawers and shelves. Have fireplace built of rocks to be gathered by the boys.

7. Note: Youth room to do double duty for girls' club work. Built-in closets for these groups as requested by the recreational committee.

8. Note: Recreational unit of the plant may be a two story unit with the ground floor excavated 4 ft. below grade and on this lower floor, bowling alleys, game rooms, club room and very liberal provision for lavatories and storage; the fellowship hall on the main floor. 9 ft. ceiling for the lower floor. See suggestive sketches provided from other churches by the church building consultant.

9. *Refreshment booth*, easily accessible to game rooms and fellowship hall.

For the Music Program

The following items in the program presented by the Committee on Worship and the Religious Arts is fully approved and their inclusion in the building program is urged by the Board of Education.

1. *Choir assembly room* to be used also as studio for the minister of music.

2. Choir room to have minimum clear floor space of 480 sq. ft. for assembly of 40 persons; ceiling to be treated acoustically so that the choir may sing at full volume; room located so the choir can enter nave at the end of the center aisle.

3. *Men's and women's robing rooms*, opening off the choir room.

4. Also have *boys' robing room* and *girls' robing room* for children's choir, or space for additional cabinets; space for hanging robes for a total of 40 men and boys and 40 women and girls.

Recommendations as to floorings, mechanical equipment, wiring, lighting, heating and ventilation, color treatment, decorations are approved as in the general building program.

We understand that a future unit to contain additional rooms to be built when the growth of the school warrants it is considered a part of the total building program.

* Impossibly tight. Minimum space per person in small rooms like this would be 10 to 12 sq. ft. — Ed.

PLANNING THE CHURCH COMMUNITY CENTER

Data from a Study by Elbert M. Conover

What follows is a program for a church school and church community center, comprehensive enough and typical enough to serve as a suggestive checking guide. It is taken, by kind permission, from the manuscript of a handbook on *The Church School and Parish House Building* by Elbert M. Conover, of the Interdenominational Bureau of Architecture. The full volume is to be published late this year.

The outline is fairly complete, and from it may easily be read requirements, in terms of square feet per person, for various kinds of rooms. The editors have added footnotes where the recommended stand-

ard has seemed too tight, in the pursuit of economy.

In common with most of the architectural literature that comes from church sources, this outline neglects those important factors of planning that deal with the arrival (by differing means of transportation) of church groups, the use of vestibules and the like for gathering areas, the efficient arrangement of interior circulation (and also the parking of vehicles). There has been some discussion of these factors, however, in earlier studies in the RECORD (October, 1946; September, 1947), and also of room arrangement for multiple use, such as extra church seating in a parlor.

Administration

1. *General church office* for church secretary; desk space for financial secretary, church school superintendent, and secretary; and counter separating desk space from reception room.
2. *A work room* adjacent for filing cabinets, shelves, supplies, addressograph and mimeograph equipment.
3. *Fireproof vault* in the basement story.
4. On the second floor, *pastor's conference room* with fireplace, lavatory, clothes closet, built-in book shelves, and minimum clear floor area of 240 sq. ft.
5. *Study for minister of education*, with closet, book shelves, and minimum floor area of 120-160 sq. ft.
6. Similar room for possible addition to staff.

Children's Division

1. *A nursery for children under 1½ years*, 250 sq. ft., for 10 children and attendant.
2. *A nursery room for "toddlers," 1½-2½ years of age*, about 300 sq. ft., for 15 children and two helpers.
3. *A nursery classroom for 2½-3 years of age*, 400-450 sq. ft., for 20 children and two helpers.

4. *A lavatory* with juvenile size fixtures to be adjacent to the above rooms.
5. *A classroom for 4-year-old children*, 320-340 sq. ft., for 16 children and one teacher.
6. *A classroom for 5-year-old children*, 360 or more sq. ft., for 16 to 18 children and two teachers.
7. *A lavatory* with juvenile size fixtures to be easily accessible to the above rooms.
8. *Hot and cold water* to be available and bathinette for the use of those in the first two rooms. Coat hanging space to be immediately adjacent to the rooms where attendants can help the children with wraps.
9. *Ceilings* to be 8 ft. in height, liberal amount of clear glass in windows with small colorful "incidentals" inserted. Decorations to be planned in conference with shelves for each of the above rooms. Tack board and picture rails with groove in the rooms for 4- and 5-year-old children. Tack boards to extend 2 ft. above the picture rail which is to form the base of the tack board, center of tack board to be at average eye level of the child.* Closet space with low shelves for light rugs to be spread on floor when needed. . . .

* 38 in. (See Time Saver Standards, ARCHITECTURAL RECORD, Feb. 1948, page 147)

Stained and painted glass is a badly neglected medium, which, once released from the trammels of purely conventional thinking, can be used in secular contexts as well as religious ones. In the larger view is seen the suggestion of great stained-glass shields or screens, placed in the open as shelters against breezes. This screen was designed by the shop of Mr. Frei for Joseph Murphy, St. Louis architect, as part of his project for the Jefferson Memorial. If colored glass, carrying its own painted design, were to be used in conjunction with colored light, the architect would command an embarrassment of riches

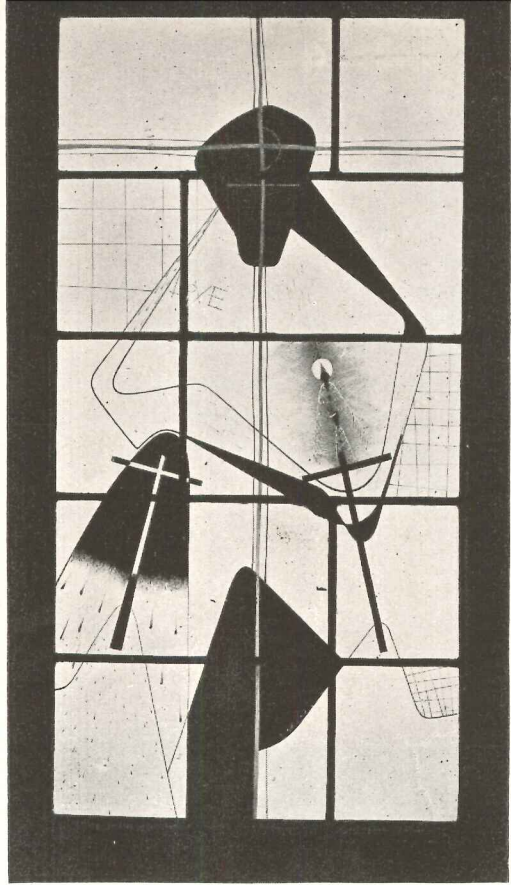

Robert Frei Photos

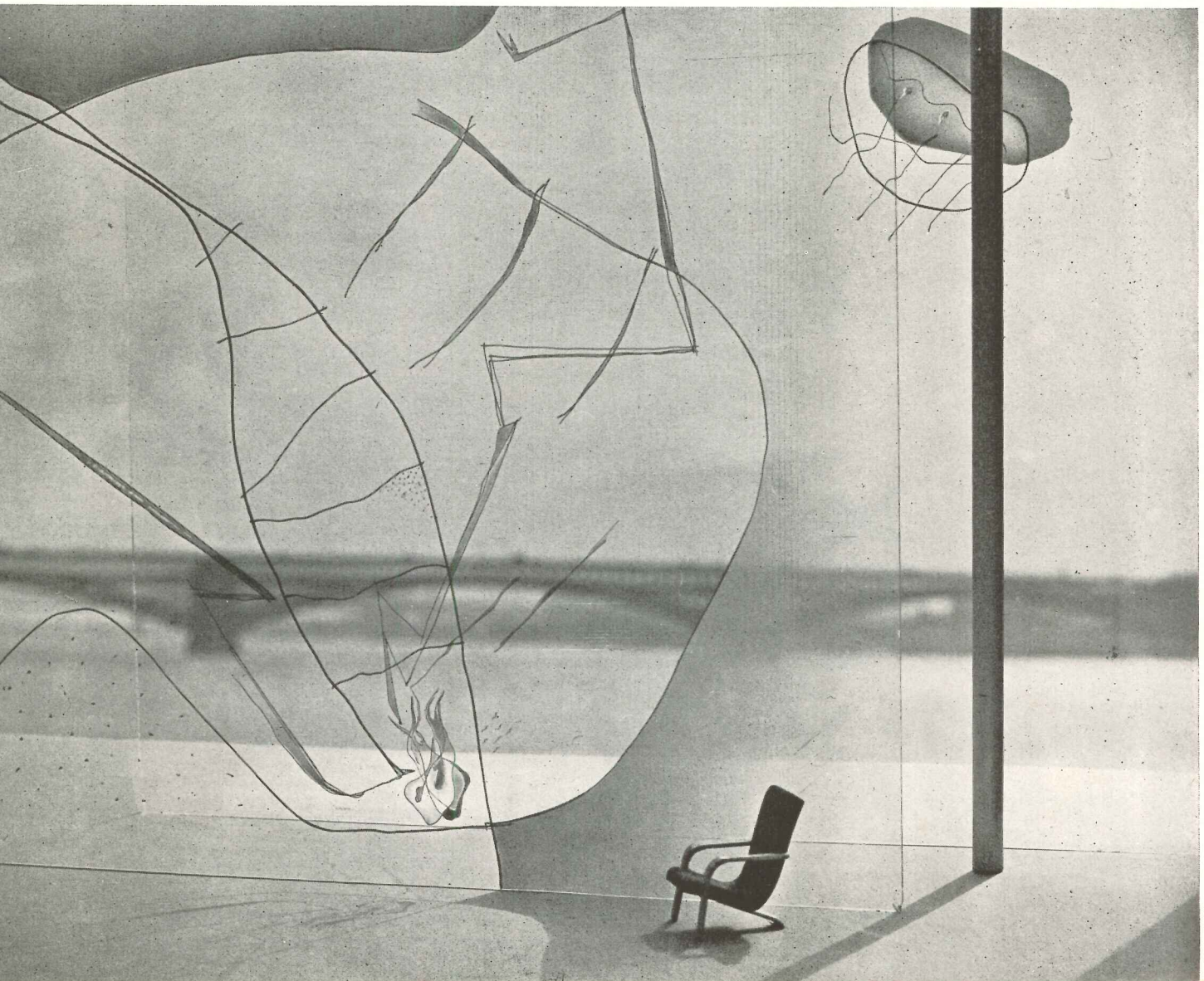

Top views are of medallions in the Baton Rouge Church of which Bendernagel and Cazele were architects. The larger picture represents a window in the Union Avenue Christian Church, St. Louis, of which Grey and Pauley were architects. It shows the richness of pattern, combined with permanence, possible to modern painting in no other medium than stained glass with its translucence

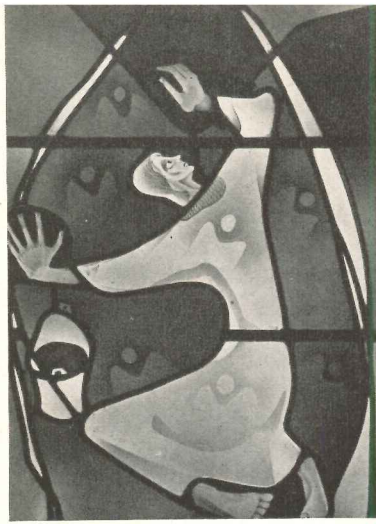

Robert Frei Photos



DRY BRUSH

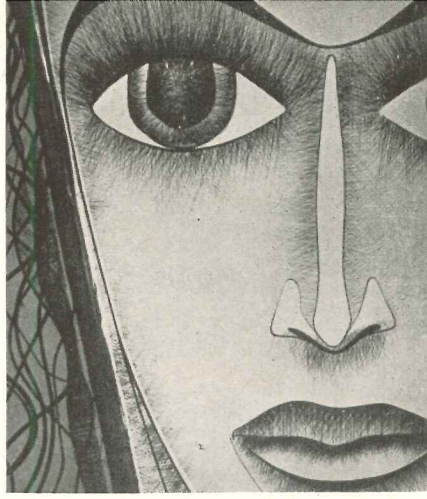

Painting techniques include any current method available. Dry brush technique, left, is used in "Christ the Worker" window, made for Mr. Otto Spaeth for exhibition in Dayton museum of fine arts, Barry Byrne, Architect. Air brush technique is seen in medallions for Sacred Heart Church, Baton Rouge. Cross-hatching was employed in St. Mary's Church, Taylorville, Ill., by Aschauer

AIR BRUSH



CROSS HATCH

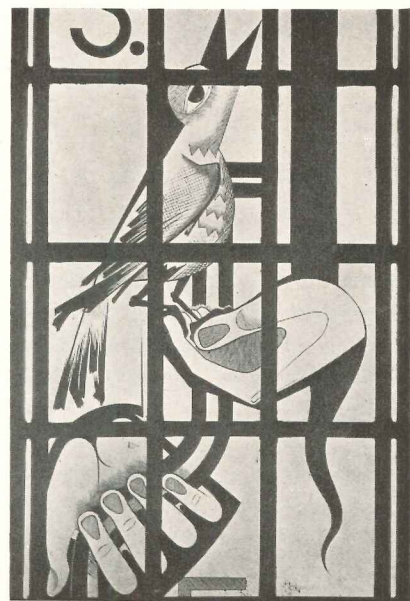

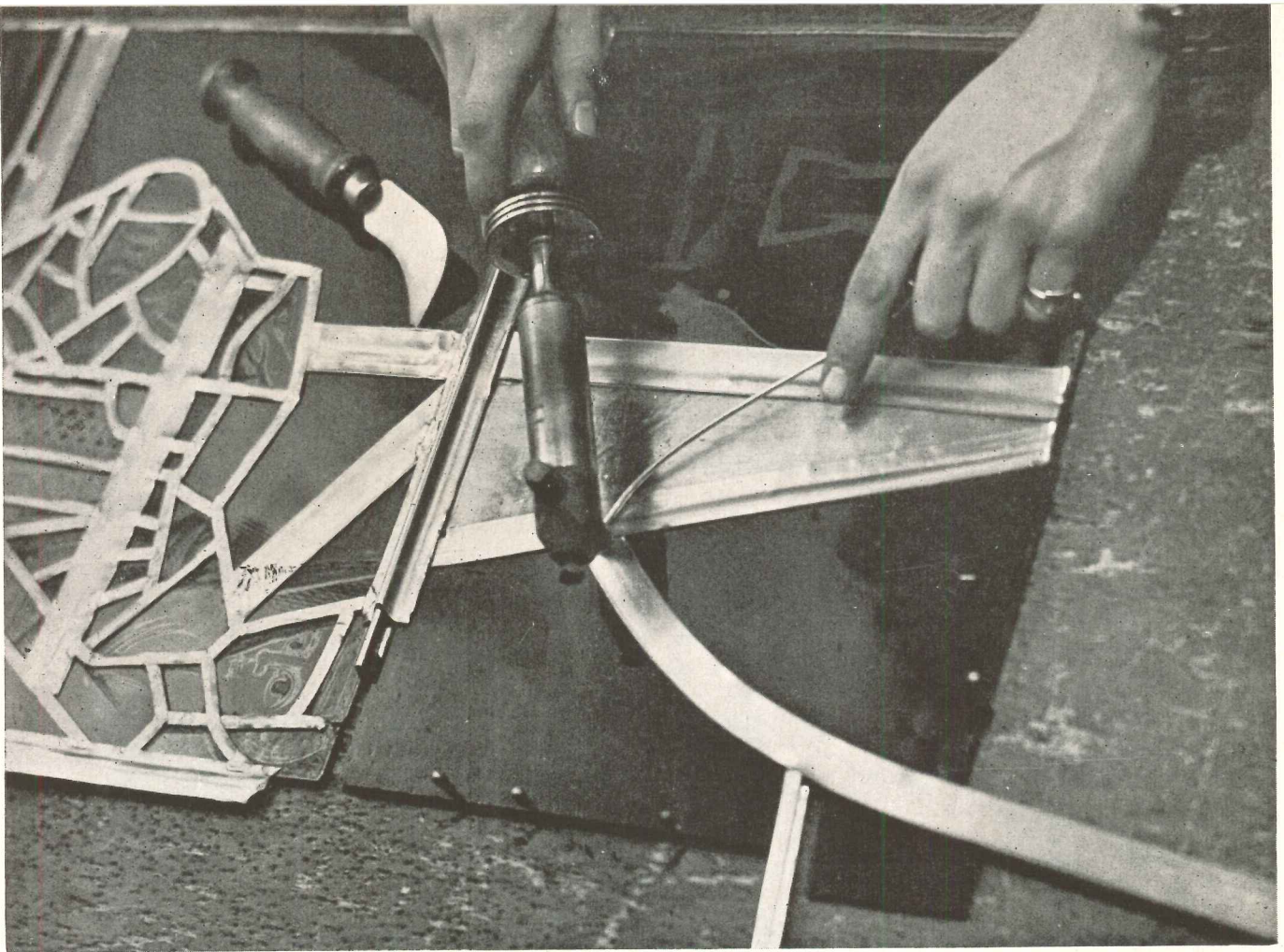

9

Pliable lead comes are bent, cut, placed, flattened, soldered, and a waterproof cement brushed in to hold glass securely

Robert Frei Photos

The bane of the stained-glass designer (he is really a glass painter) is the religious patron who wants to reproduce a banal picture postcard in his window. Stained glass designs must first of all have a character sufficiently formalized to consort with architecture (right).

A good many designers, seeking an "antique" effect, cover whole areas with a ground which is then etched away but leaves a film and particles caught in cracks and bubbles of the glass. This appreciably dims the brightness of the final effect. Mr. Frei prefers clean techniques which leave the full "glass" sparkle

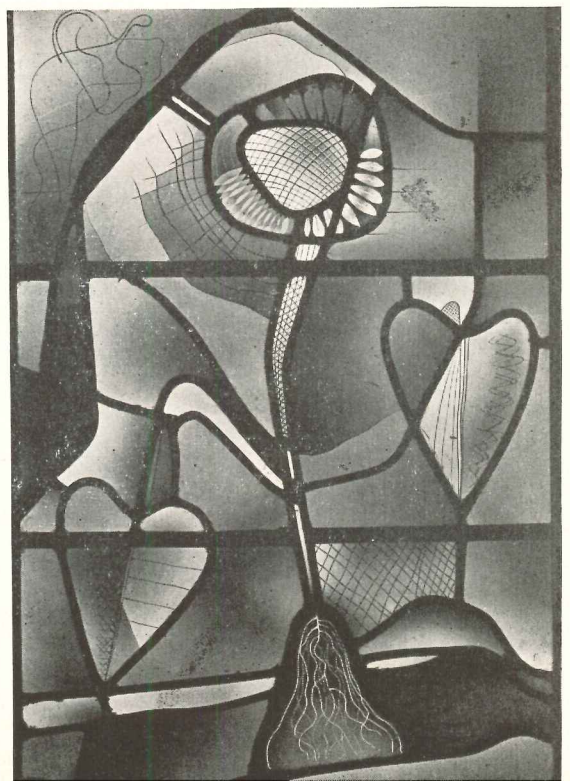

Flash firing of the glass in a gas oven at approximately 1200° makes the painted design an integral part of the glass and the window. Cooled glass is assembled (8) for final leading



8

7

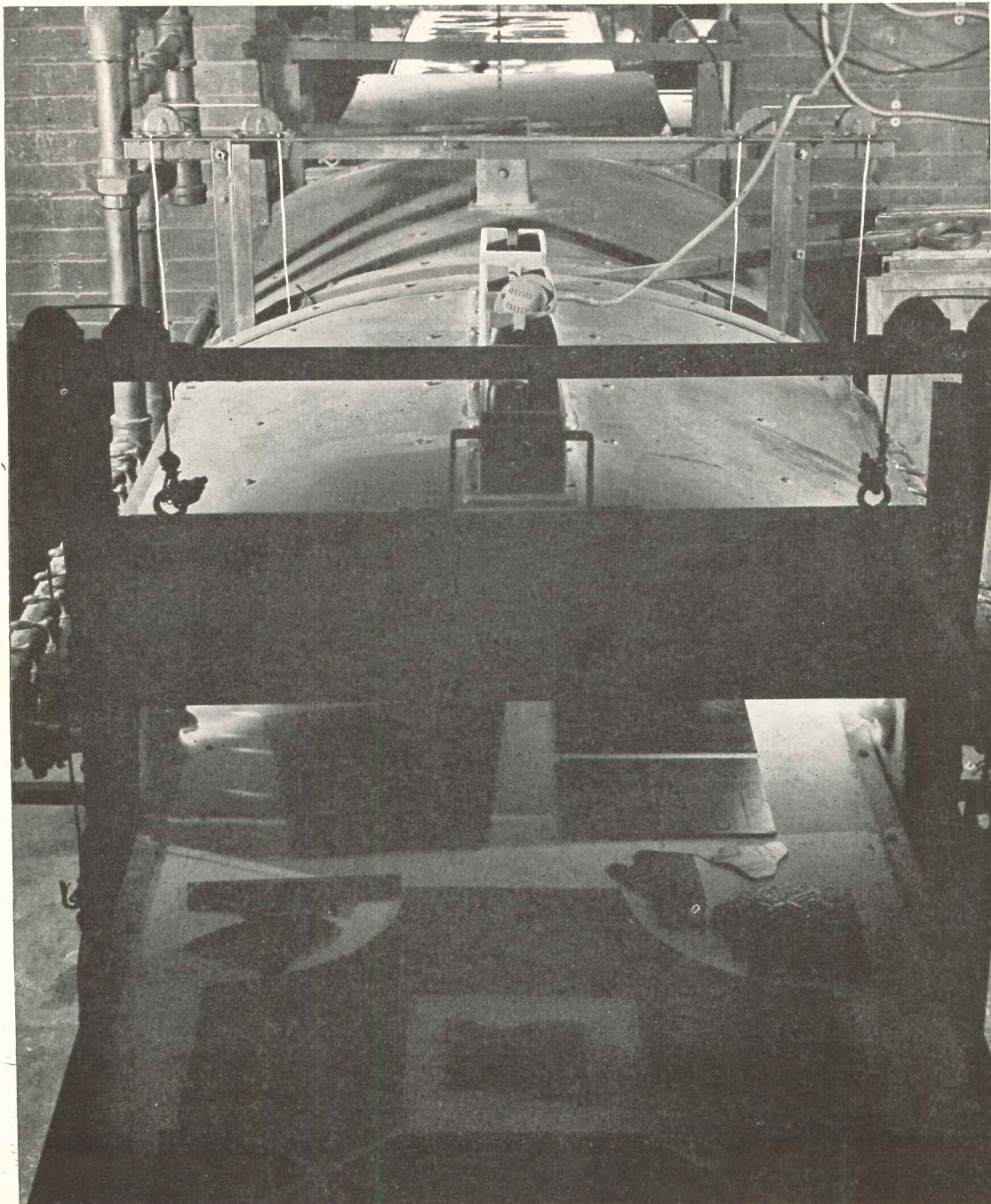

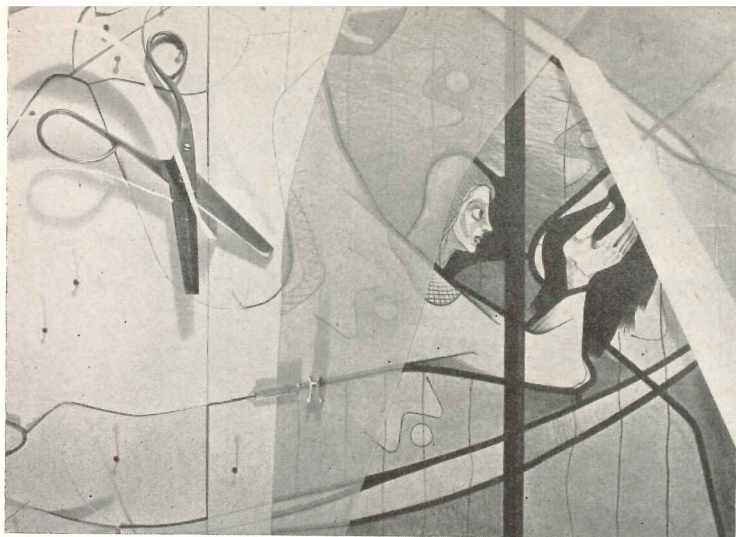

2



3

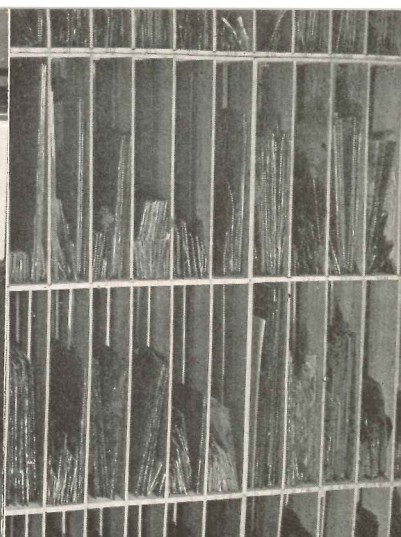

4

Using the cartoon as guide, patterns are cut out of paper with double-edged shears (2) which automatically allow space for the lead strips or "comes" between pieces of glass. Colors are matched against some 1600 numbered samples (3) keyed to compartments (4)

THE FUTURE OF STAINED GLASS

The workshop and designs of Emil Frei, Inc.

A COMMONPLACE of church architecture is that "the stained glass of the twelfth and thirteenth century cannot be equalled." The contemporary work of Emil Frei does not make this futile attempt. In the faith that divine inspiration did not exhaust itself in the thirteenth century it seeks to produce the best that can be laid upon the altar in the light of the present

day. Those who look ever backward have missed those new opportunities that present themselves. There follows a pictorial presentation of workshop methods, designs and projects, for the sake of clearer understanding by church architects of the present and future of glass. The Frei family, incidentally, has been making stained glass as far back as anybody can remember.

5

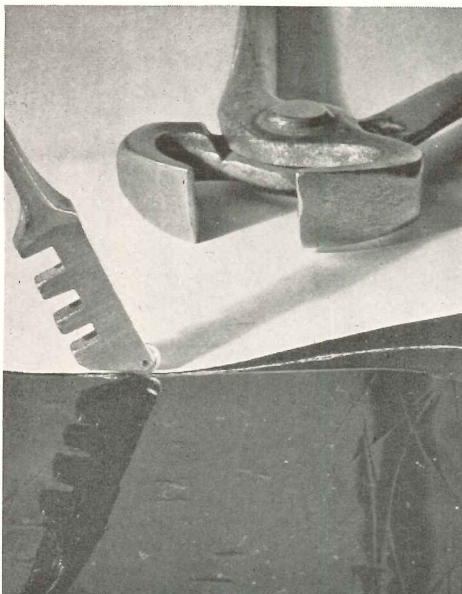

6

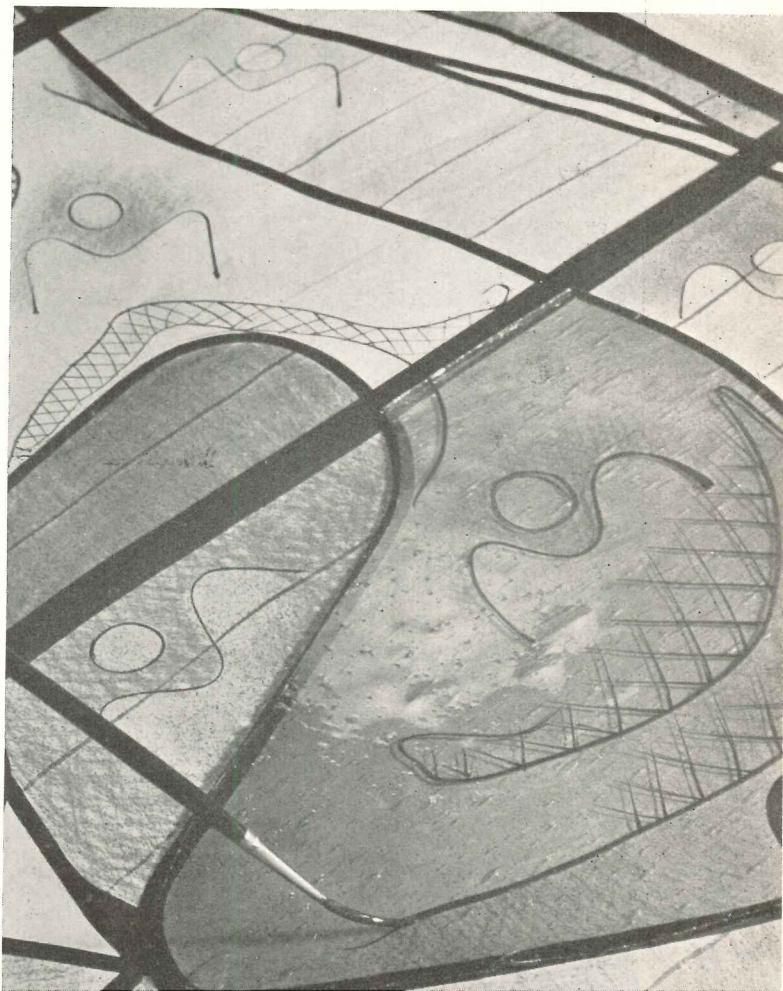

Glass is cut to the pattern with ordinary glass cutters (5) and assembled on a large piece of plate glass for viewing, after which the painted design is added (6). Colors are metallic oxides containing a flux which permits vitrification by firing



Robert Frei Photos

1

The first step in the creation of a stained glass window, after the preliminary sketch, is the production of the full-sized "cartoon." In working on this opaque medium, the designer must be aware what will be the ultimate effect when light is transmitted through the glass, under differing conditions of direction and intensity. The designer seen at work is Robert Harmon

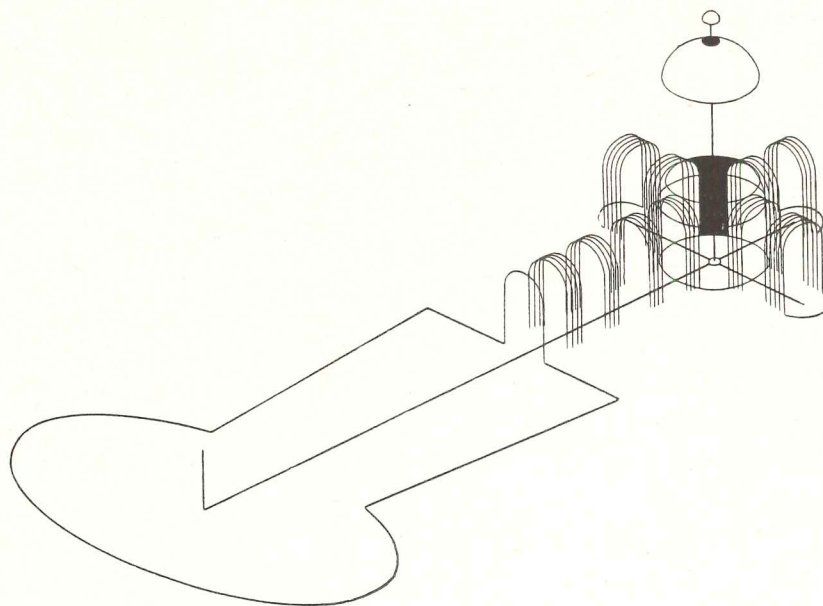

9

continuous from horizon to horizon (Illustration 6).

Yet with all its wealth of insight and association, declares the author, Gothic church architecture is nevertheless bound to an epoch, and its basic form no longer answers to us. Its arches do not declare, however beautifully they attempt, "reaching to heaven"; and its linear perspectives merely return upon themselves when infinitely projected.

Beyond this "fourth type" of "the sacred way," there is a fifth series of essays based on the journey completed in an "arrival." This fifth group is conceived in terms of "the dark chalice." The diagrams representing it are among Schwarz's most beautiful, as for example, 8. Here the vault as well as the plan is parabolic, rising to its full height above a large red rose over the large portal. ("The parabola is intrinsically open.") Above the altar, on the curving back wall, is proposed a painted image of Christ with open arms. And yet the ultimate significance of "the dark chalice" is a configuration of death.

So, at another cast, a sixth group is added to the allegory — this time, beyond death, the "dome of light." This is a transformation of the very first plan, the rounded central dome, but bright not dark — a dome to be built of light, suffused with light, soaked in light, so that every point, including communicants, becomes "a star" (10). This was prefigured, says Schwarz, in the Baroque, which began just where Gothic ended, arriving at a burst of light at the end of the Gothic pilgrimage (9). Historically this "bright star" succeeded where least expected, in the Church of the Fourteen Saints at Neresheim, in which "the heaven within answers to the heaven round about, and what remains of the earth in the surrounding walls is clad in white the color of the bride."

So the allegory culminates in a seventh archetype, the "dome of all times," uniting in itself the main components evolved out of all the rest (4, 6, 10) — the "dark star" of the germinating seed, the successive arches of

"the way" through the day and history, and the "bright star" of the final culmination. (Frontispiece, page 116.)

So brief a review does grave injustice to a deep and poetic book, escaping as it does from small controversies of the day, with the rare gift for humility and for viewing time "sub specie aeternitatis."

Many who do not share the religion of Schwarz have admired the book for the manner in which history is not assembled and "modified" but distilled, and present-day architecture is searched for the large symbol.

Third basic element: "bright star" of the "dome of light"

10

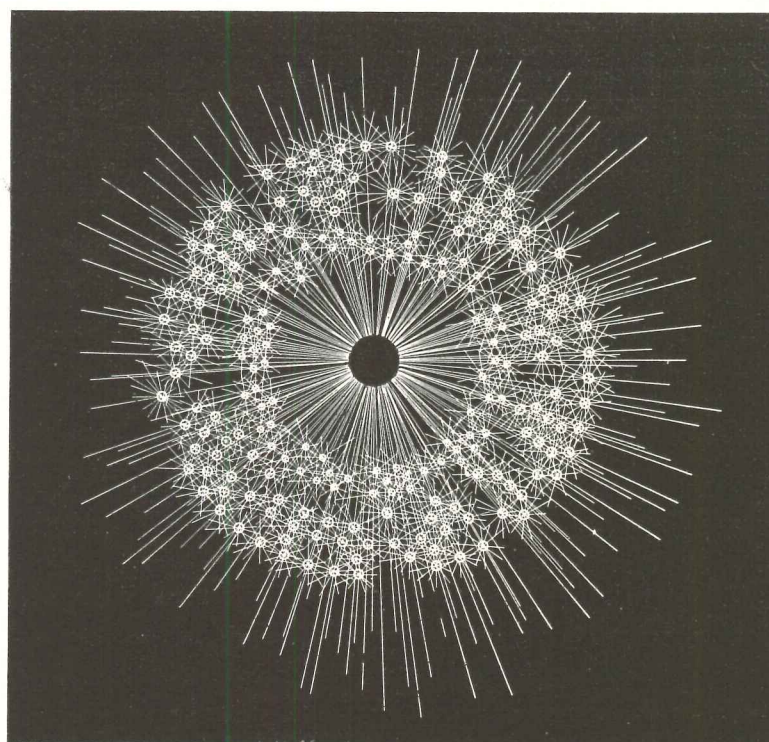

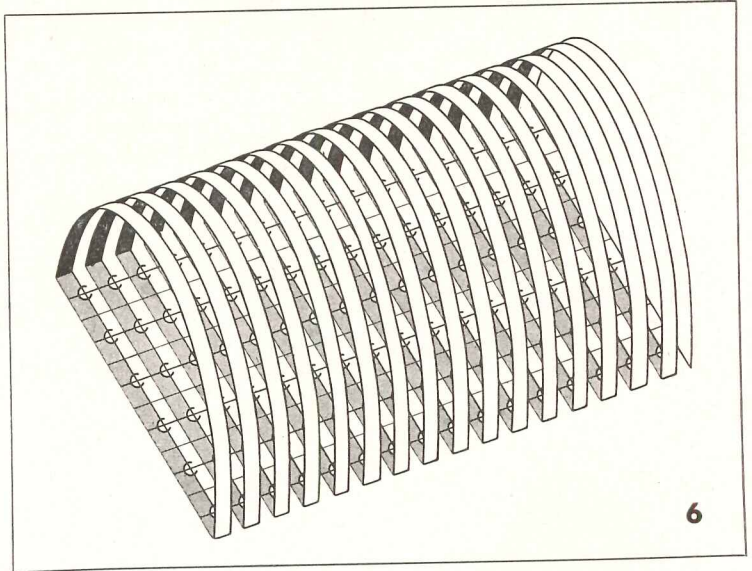
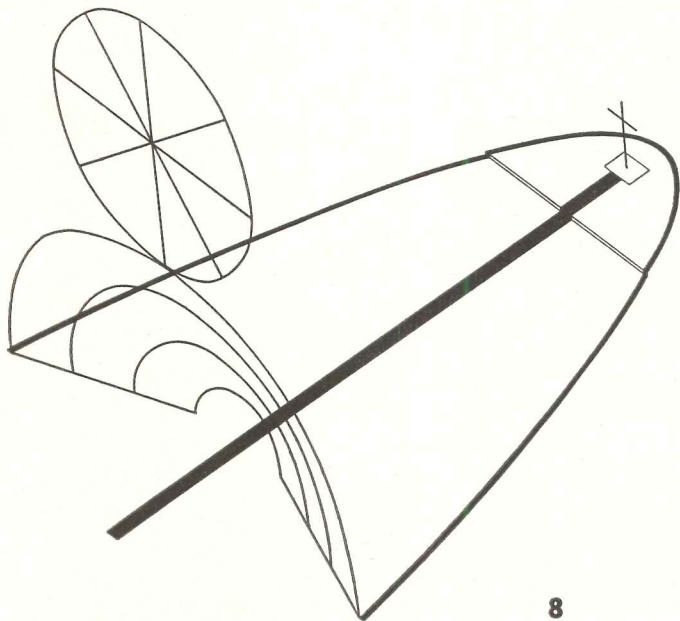
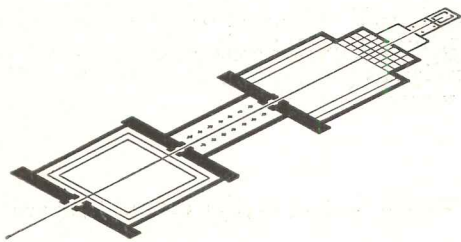
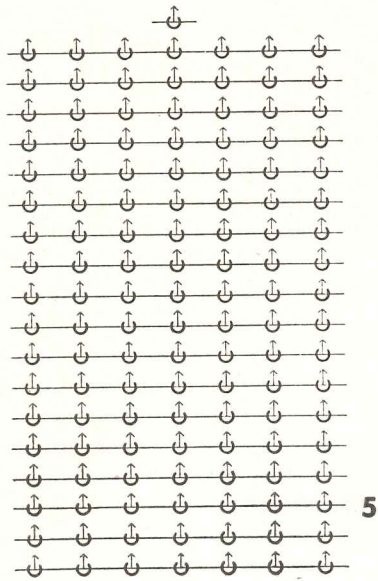

Second basic element: light and darkness along "the Way"

sacred fullness"); the congregation in circles ("strongest form of the community"); walls and roof are the outermost container, a "firmament." The people, directing their glances toward Christ at the center, become a "dark star of beseechment and prayer" (4), answered by a "radiant star of light." Or, transforming the image, the plan becomes "the image of the Lord and His mystical body as a wheel or rose."

Figure 2 (previous page) transforms the dome into a fountain, strengthened by light concentrated upon the altar but capable of being reversed for greatest strength at the circumference so that the space may be "re-created" by light.

Into this closed germinal scheme, however, there intrudes a "sacred cleft" (fig. 3, previous page) — awareness that the world is insufficient, struck to its core by "heaven, the coming kingdom."

How to represent this coming realm, which no "man has seen," without fatal error and distortion, is a problem beyond solution, but one, says Schwarz, that must be met as best possible. His discussion explores devices such as vanishing perspectives, or an intruding white wall ("white, the color that negates all individual colors, yet unites them all"), or clear glass opening on emptiness, or pictures of saints, or light from above ("the open chalice"). The broken ring and the open chalice are his second and third plan types.

Once the ring is broken, there follows the "sacred pilgrimage" — for awakened men who stand in Time and are sent out into history, and know that they have a home and yet must follow a "path" (5) — and a church must be found to declare this transition "between the day of the germinating seed and the coming kingdom."

This idea of the "sacred way," prefigured in Egyptian pagan temples (7) with their sense of progression, was beautifully suggested, says Schwarz, in the Gothic nave. His own image for it is a vault in which the idea of "light along the way" is declared in successive bands

THE "SEVEN ARCHETYPES" OF RUDOLF SCHWARZ

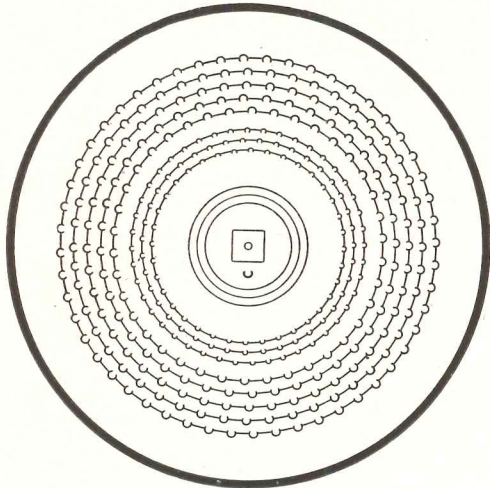
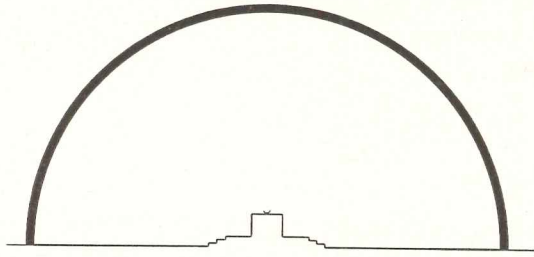

1

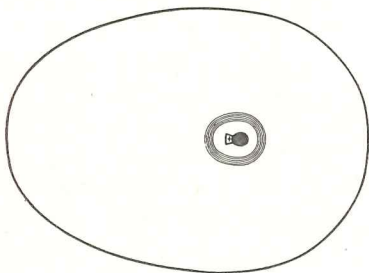
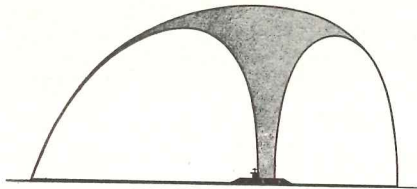

2

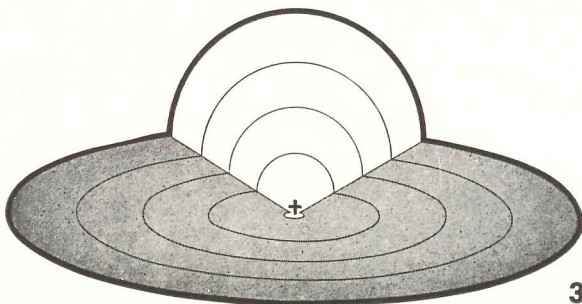

3

THE drawings on this and succeeding pages are not to be construed as "projects" but as images of ideas; and a little study will reveal the depth of their content. Cutting across current shallow clichés, they are taken from a little known volume by Rudolf Schwarz, published in German and entitled *Vom Bau der Kirche* ("On the Building of the Church"). The volume itself has a German cast, metaphysical and allegorical, but the language of the drawings is clear and universal.

Little known outside his native country, Schwarz has built very few churches, none since Hitler's accession in 1934; yet there are those who do not hesitate to assign him the very highest rank among living architects of churches. A devout Catholic, Schwarz thinks of the church as being simultaneously an *instrument* of worship, a symbolic *representation* of the deepest relationships, and a sacred *participation* in "creating the mystical body of the Lord."

The seven archetypes, or groups, into which he divides church plans, represent not only a historical development but a religious progression.

The first, "childhood" plan (1), puts the altar at the center ("the rising earth"); on it the chalice and platter (the chalice the "innermost container"); the candle ("living light radiating from the center"); space ("a

First basic element: "dark star," wheel, or rose

4

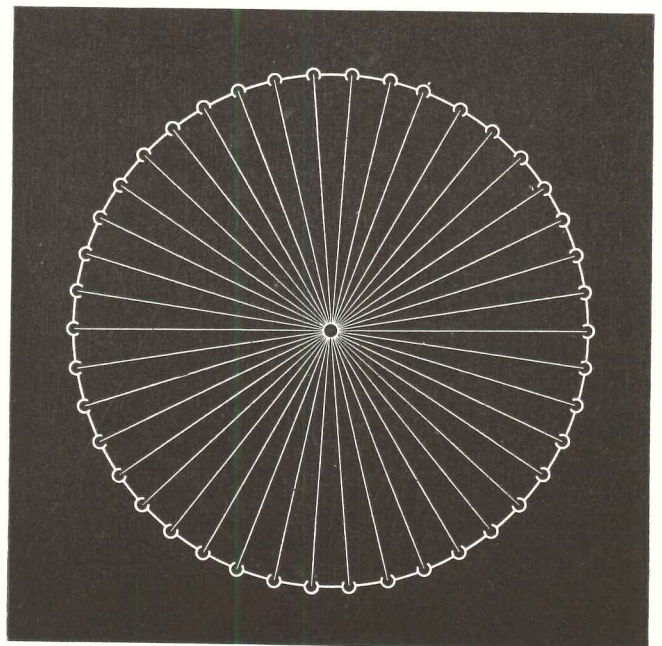

RELIGIOUS BUILDINGS

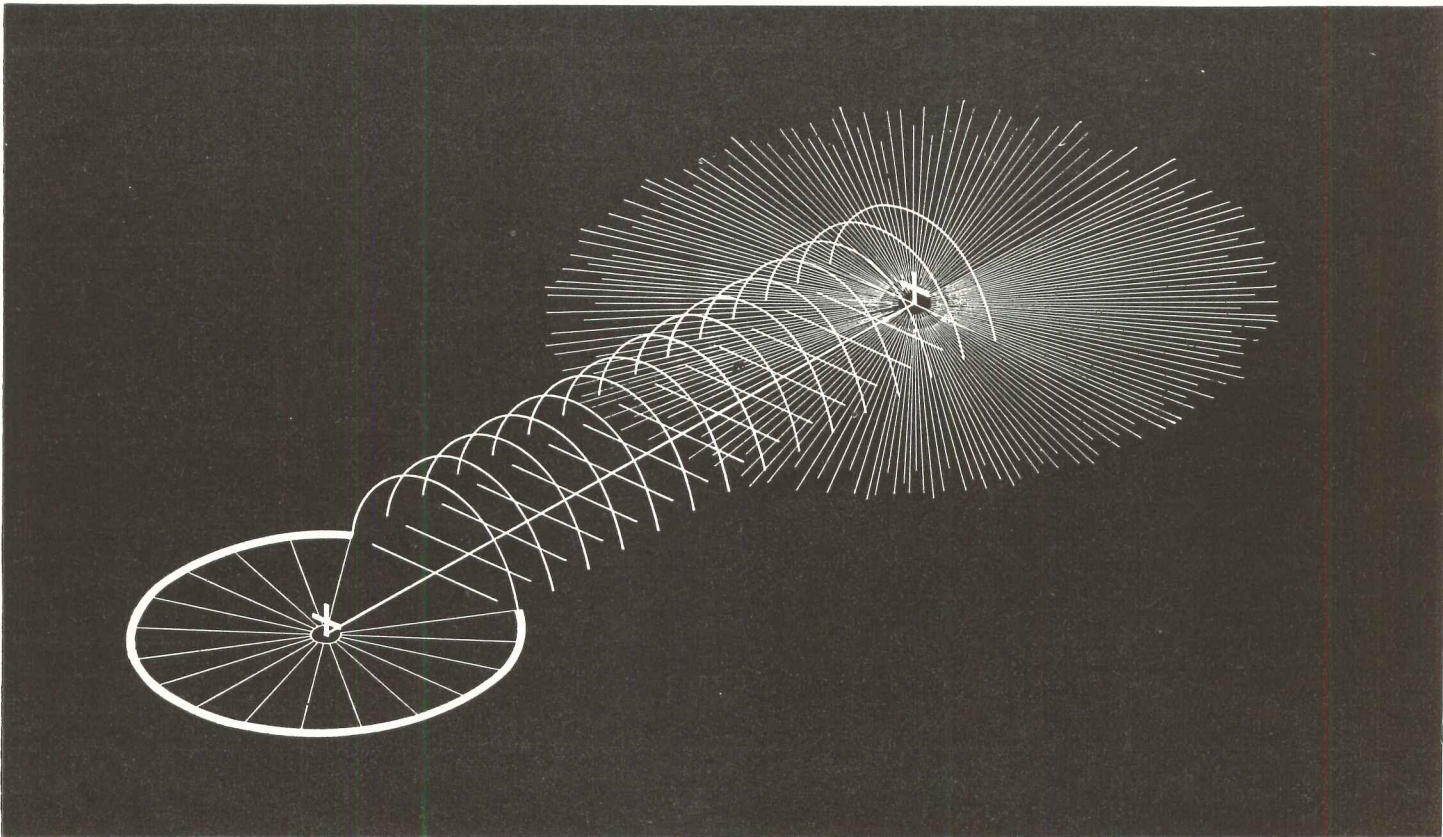

"Church of All Ages"—culminating plan of Rudolf Schwarz (See Article on opposite page)

In the present study we find a collection of opposites. The review of the seven archetypes of Rudolf Schwarz is concerned entirely with church forms in their most basic significance. The notes on the church community center, on the other hand, pick up those practical necessities which are often slurred in religious literature.

A richly illustrated article by Emil Frei, showing current processes and design in stained glass, lays stress on a continuation of historical development from past to future. By contrast, a new church with no windows at all, by Joseph

H. Saunders, Jr., displays new means for an enriched liturgy and worship supplied by the present-day arts of illumination and air conditioning.

The sunny courts of the Jewish religious center project for Northwestern University, by Harrison and Abramovitz, is religious, again, in a different mode and temper; and the Baptist project for Flint, Mich., involving studies first by the Saarinen and then by Robert Swanson, exhibits the problem of the complete church plant under conflicting demands of economy and of taste.

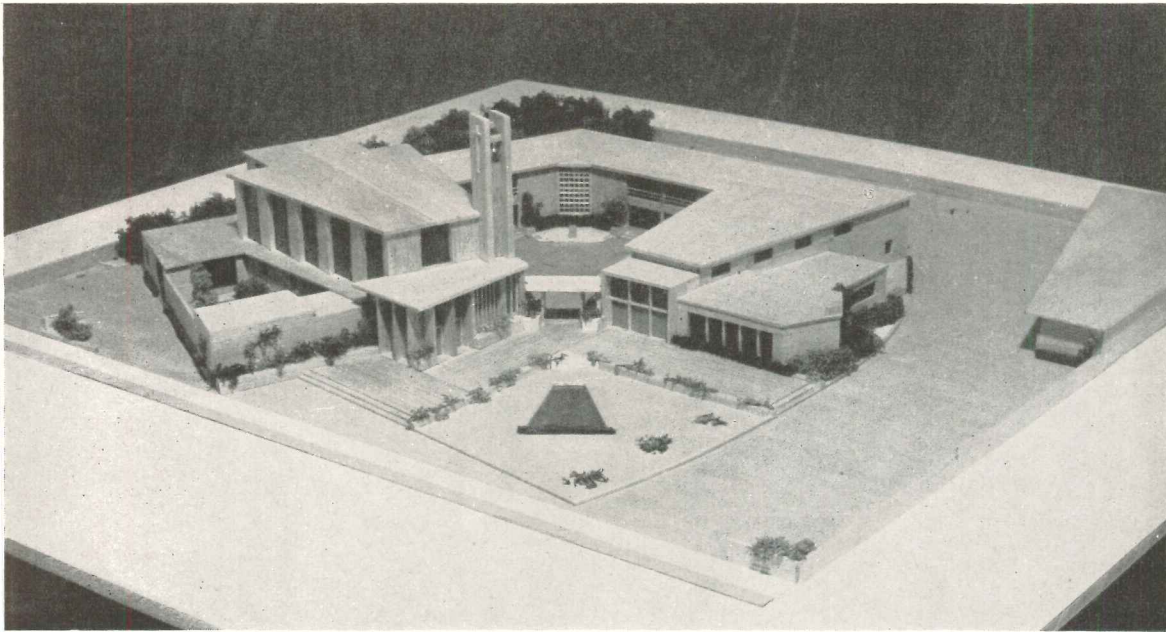

Model of a church for a small town. Office of Walter R. Hagedohm, A.I.A., Architect (Irene McFaul, designer)

IRENE McFAUL, A.I.A.

LOS ANGELES, CALIFORNIA

Emerging from the University of California at Berkeley with her M.A. and membership in Delta Epsilon, Miss McFaul started in an electrical contractor's office "reading blueprints." After serving as draftsman in San Francisco and conducting her own residential practice in California, she is now a chief draftsman with Walter R. Hagedohm in Los Angeles, doing mostly churches, residences, and public buildings.

EMILY H. BUTTERFIELD, A.I.A.

ALGONAC, MICHIGAN

Miss Butterfield received her architectural training at Syracuse University when there were but few women in the profession. For a number of years she was partner in the firm of Butterfield and Butterfield, practicing in Detroit and Pontiac, Michigan, designing schools, churches, and residences. She has written much, including "Young People's History of Architecture," and she still finds time for her hobby, water-colors.

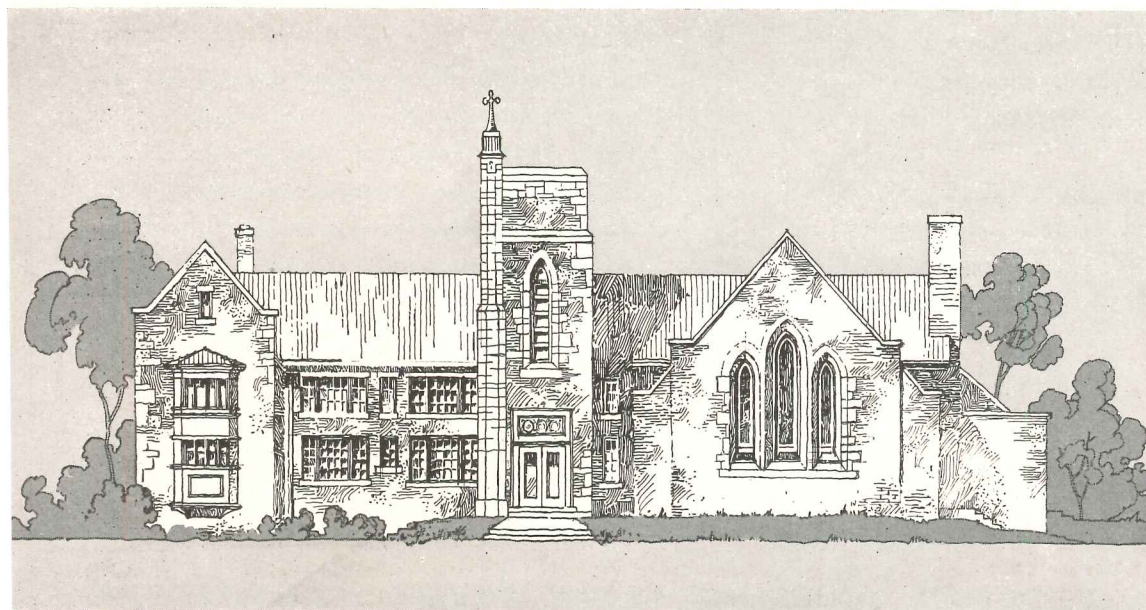

A preliminary sketch for Christ Community Church, Methodist, Inkster, Mich. (suburban Detroit); Emily H. Butterfield, Architect

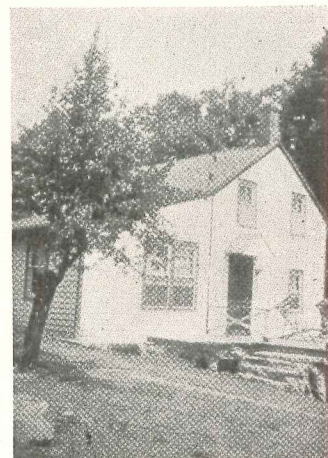

Gottscho Photos

"After and before" photographs show the transformation wrought by Miss Coit in an old, nondescript farmhouse

ELIZABETH COIT

A.I.A.

NEW YORK, N. Y.

Housing has long been the subject of Miss Coit's critical analysis and constructive research. In 1938-1940, she held the Langley Fellowship of the A.I.A., and her findings were reported in "Housing from the Tenant's Viewpoint." She has worked with the Technical Division of the Federal Public Housing Authority, and is now assisting the New York City Housing Authority in research and editorial work as well as being associated with the firm of Mayer and Whittlesey, New York. She is a graduate of M.I.T. holding the degree of B.S., Arch., and is registered in New York, Virginia, and New Jersey, also holding a National Council certificate. She was book reviewer for the ARCHITECTURAL RECORD for several years.

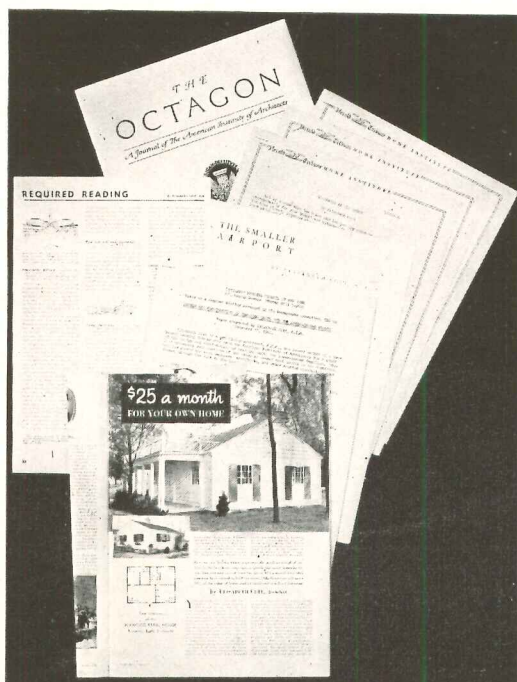

Left, random pages from the pen of Miss Coit, architectural author. Below, the sturdy stone work and Virginia craftsmanship of the Winslow Sommaripa house, Boyce, Va., accent an unusual plan arrangement

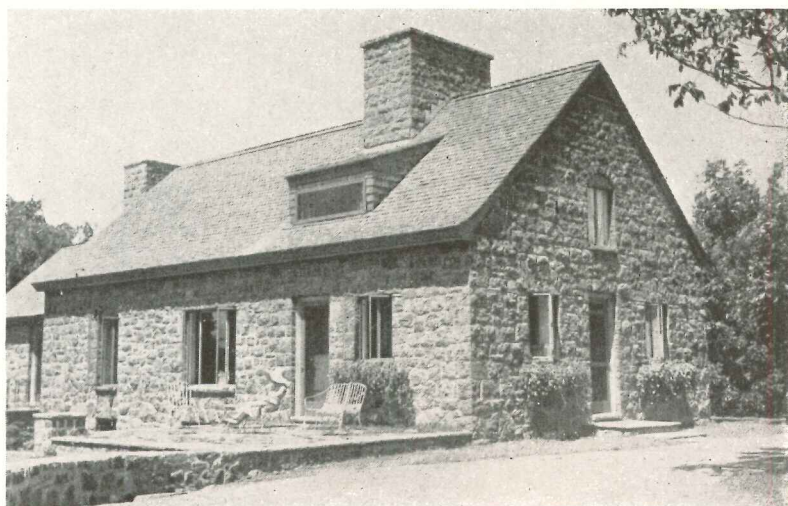

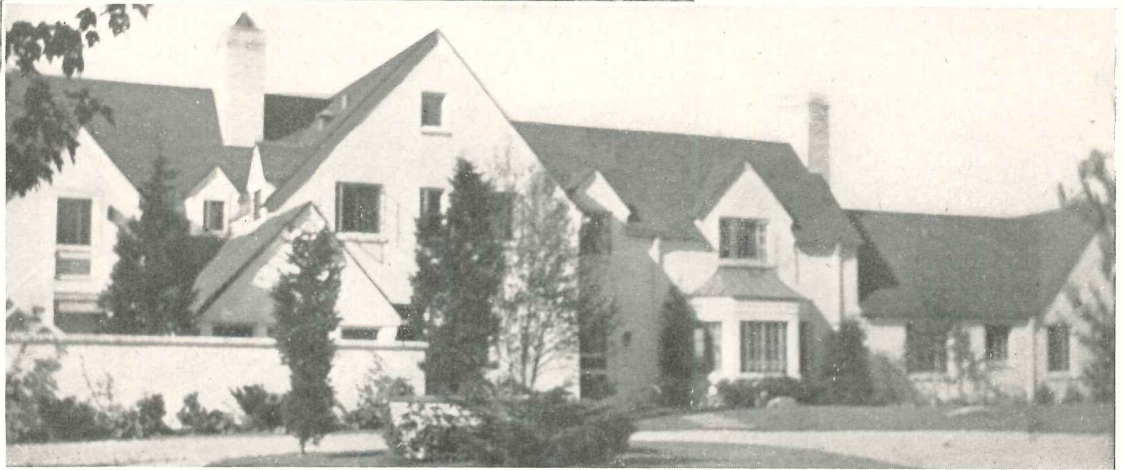

The Maryland estate at top of page was just a square house (right) before remodeling. Immediately above: a walled garden, upstairs game room, service court and stables are features of this Bedford Village, N. Y., estate, now owned and occupied by Tallulah Bankhead

**CARINA EAGLESFIELD MILLIGAN
A.I.A.**

Unlike most young architects, Carina Eaglesfield Milligan went into private practice immediately after her graduation from the Cambridge School of Architecture (later taken over by Harvard). Her career had actually started, however, while she was still a student: she was paid \$35 for a drawing of a house which not only was built but, she says, is "still good." She has since won a dozen competition prizes for her house designs. A member of the A.I.A., she holds a National Council Certificate and is registered in New York, New Jersey, Connecticut and Virginia. In addition to maintaining her own office in New Canaan, Conn., she is an associate of Louis E. Jallade and L. E. Jallade, Jr., New York.



NEW CANAAN, CONNECTICUT

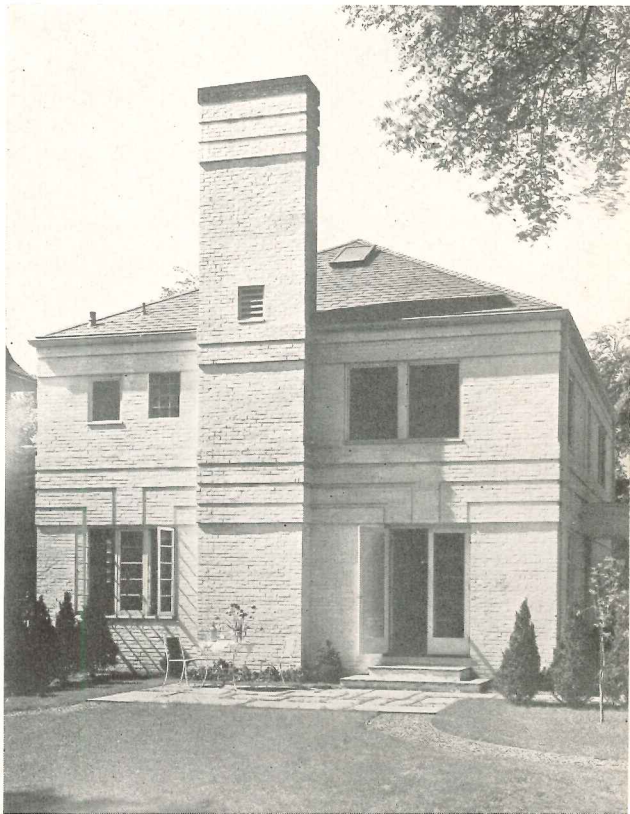
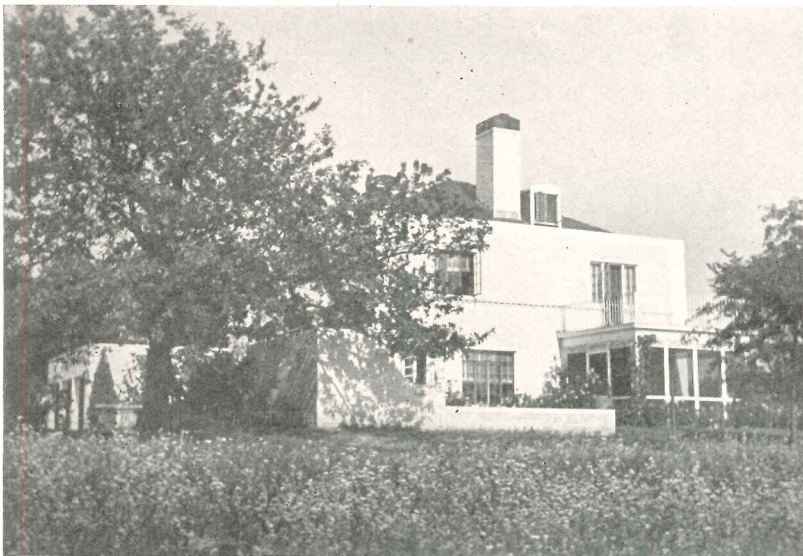

The home of Prof. and Mrs. R. F. Flint in New Haven (right) brought Mrs. Milligan another commission—from Van Wyck Brooks, for whom she did the formal Regency above, with a walled garden where he could write in quiet

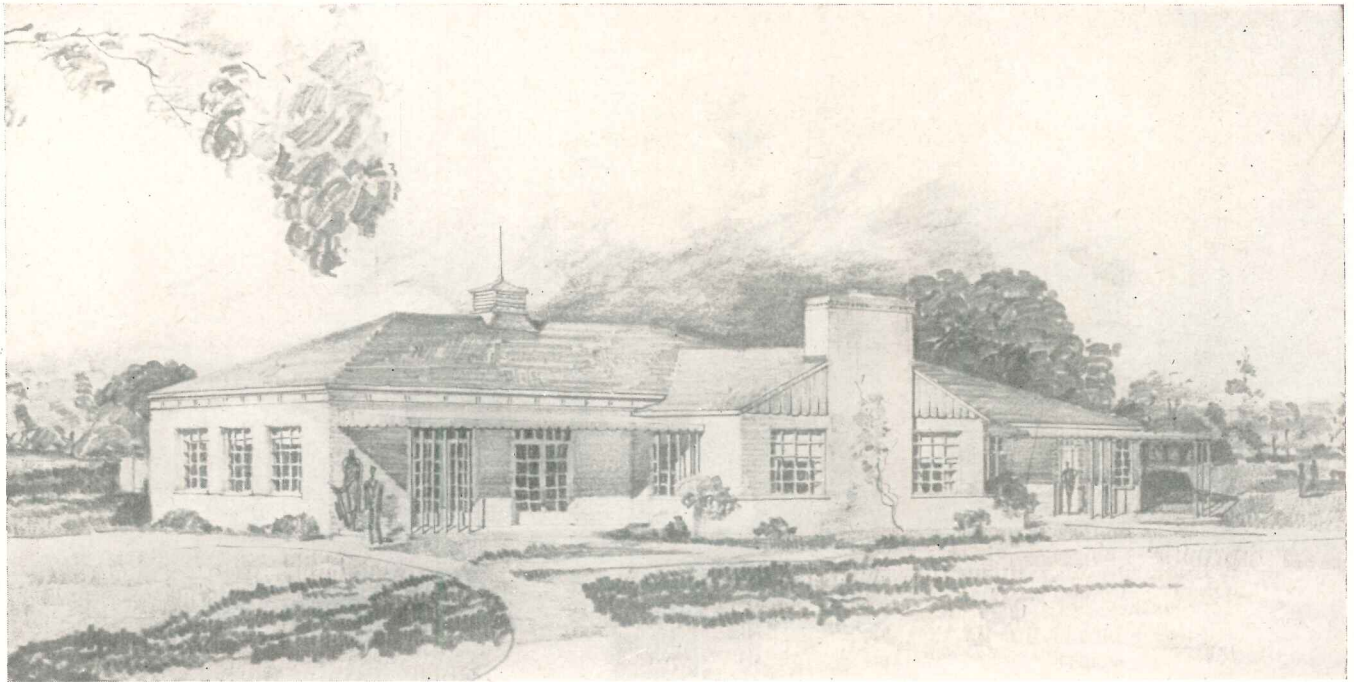

Mrs. Wiatt and her husband, J. Streeter Wiatt, collaborated on the plan of Woodley Country Club, Montgomery, Ala., but Mrs. Wiatt did the exterior design. The lounge and dining room overlook the golf course from a hilltop; locker rooms and pro shop are at the rear

**TENNIE OWEN WIATT
R.A.**

MONTGOMERY, ALABAMA

Tennie Owen Wiatt is a graduate of Alabama Polytechnic Institute, where she won the A.I.A. award for excellence in scholarship. Starting out as a draftsman in the office of G. Howard Ryan, McComb, Miss., she had much varied architectural experience in Mississippi, Louisiana and Alabama before settling down permanently in Montgomery with her architect husband, J. Streeter Wiatt. She is now affiliated with the firm of Sizemore & Campbell in Montgomery, doing residential design and all phases of drafting, but expects shortly to join her husband when he opens his own office. Registered in Alabama, she believes a woman's greatest opportunity in architecture lies in the residential field.



The Wiatts collaborated in the design of the small office building at right, where their own office will be located. Below, "The Ranch," a highway restaurant designed by Mrs. Wiatt around a plan developed by the owner. Chimney window permits public to watch a pig being barbequed on a revolving spit

Collier, Pierce & Kraus Photo;
Joseph C. Maschi Rendering

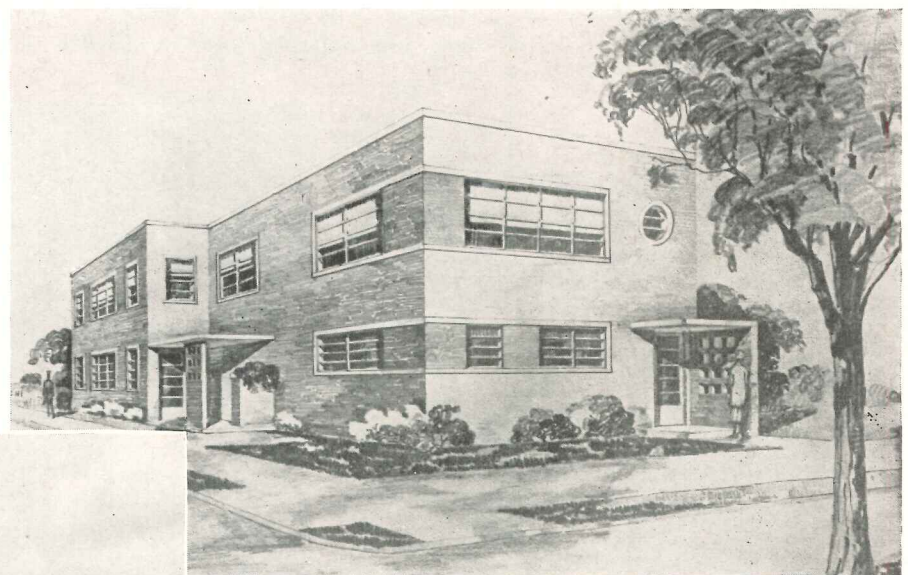



Maynard Parker Photo



Living room (left) and entrance side (right) of residence for Miss Gladys Caldwell, Hollywood, Calif. Lot is irregular, slopes steeply

**ROSE CONNOR
A.I.A.**

Rose Connor received her architectural education at the Pasadena Atelier, Beaux Arts Institute of Design, studied art at Colarossi's in Paris, and interior decoration at the New York School of Fine and Applied Arts. She first put her training to use as a draftsman in the office of Soule and Murphy, Architects, Santa Barbara, Calif. During the war she spent three and a half years designing camouflage and doing other work for the U. S. Engineers. A member of the A.I.A., Miss Connor is registered in California, has her own office, specializing in residential work. She says: "Most owners and contractors like to work with women architects, once the ice has been broken, for they find we are very practical. . . ."



PASADENA, CALIFORNIA

Below: left, beach house for Mrs. F. L. Ransome, Three Arch Bay, Calif., has oyster white stucco and brick exterior, soft corn yellow wood shutters and entrance, eucalyptus green sash; right, main entrance of residence for Miss Margaret Hickman, Eagle Rock, Calif.

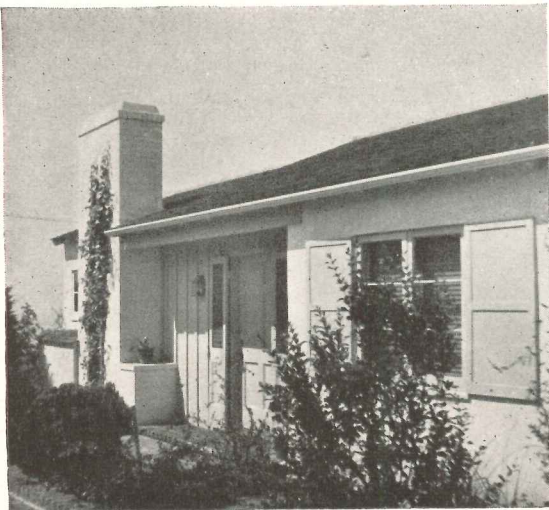

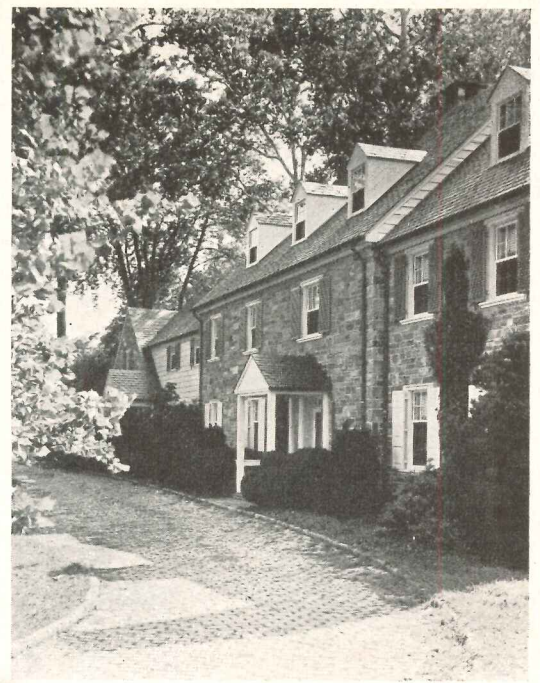

Walter Wilcox Photos

The residence of Judge and Mrs. J. Edgar Murdock has a beautiful setting among native sycamores, elms, and boxwood

GERTRUDE SAWYER
A.I.A.

WASHINGTON, D. C.

Most architects are content with registration in one state, but Miss Sawyer is registered in the District of Columbia, Maryland, Pennsylvania, Ohio, and Florida. She has her own office in Washington, D. C. It is natural that she should specialize in residential architecture and country estates for she is a graduate in landscape architecture from the University of Illinois, and holds a Master's degree in architecture from the Cambridge School of Architecture and Landscape Architecture. During the war her talents were engaged in the engineering department of Fairchild Aircraft Corporation, and she was a lieutenant in the U. S. Navy Civil Engineer Corps Reserve. She is a member of the American Institute of Architects.



Left below, the residence of Mr. and Mrs. Jefferson Patterson at Peterson's Point, Maryland, above the Patuxent River, is of handmade rose-colored brick. The owners' French furniture determined the style of the residence for Mr. and Mrs. Nathan Scott II (below, right).



Horydczak Photos



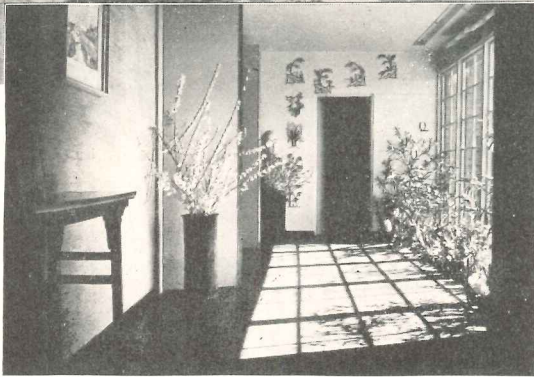
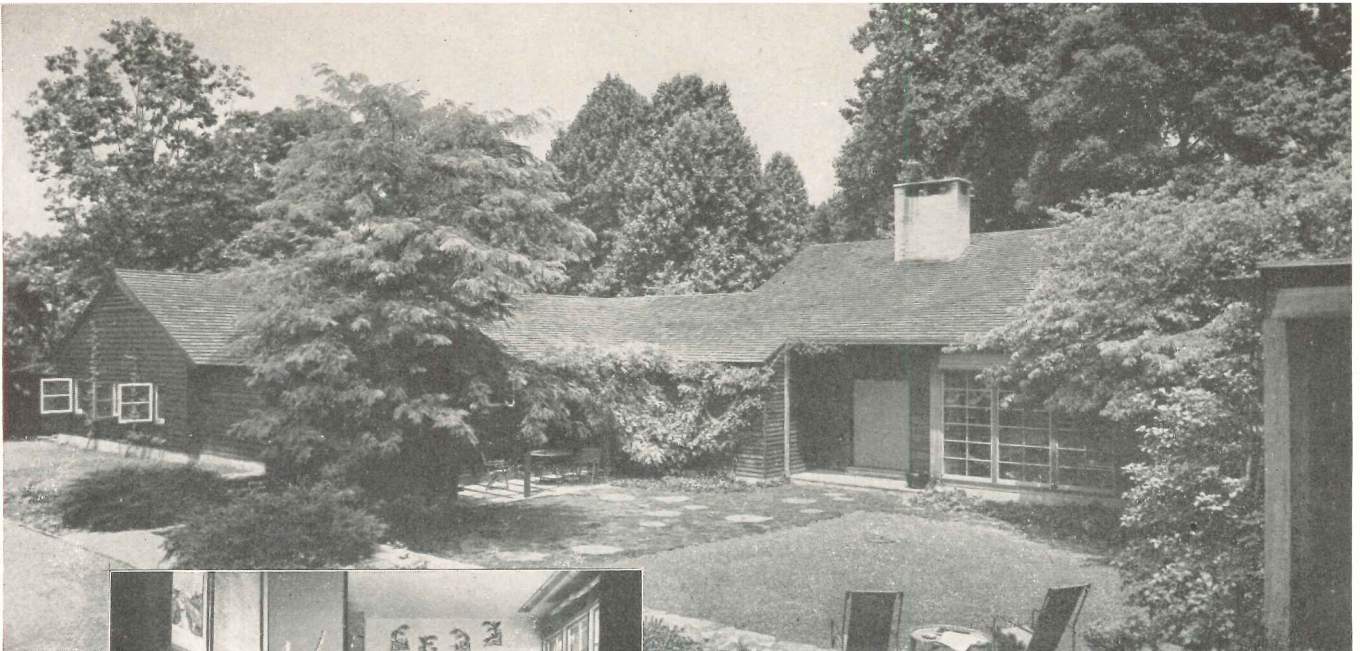

Left: Stowell Photo. Right: R. M. Damora Photo

The house which the Homseys designed for themselves at Hockessin, Del., has separate children's wing (left, above) and service wing forming a pleasant entrance court. Left, the sunny entrance hall, looking toward the service wing

**VICTORINE HOMSEY
A.I.A.**

WILMINGTON, DELAWARE

"When I stop having fun," says Victorine Homsey, "I'll stop practicing architecture." A graduate of Smith College Graduate School of Architecture, Mrs. Homsey started her career as a draftsman in the office of Allen & Collens, Boston, Mass. She and her husband, Samuel Homsey, now are one of the best-known husband-and-wife architectural teams in the country. Practicing as Victorine & Samuel Homsey, they specialize in domestic architecture, schools and theaters. During the war Mrs. Homsey did temporary war housing for the FPHA, and schools at Greenbelt, Md. She is registered in Delaware and the District of Columbia, and is a member of the American Society of Planners and Architects.



Seaford Golf Club, Martin Farms, Seaford, Del., features a lounge the full depth of the building. Victorine & Samuel Homsey, Architects

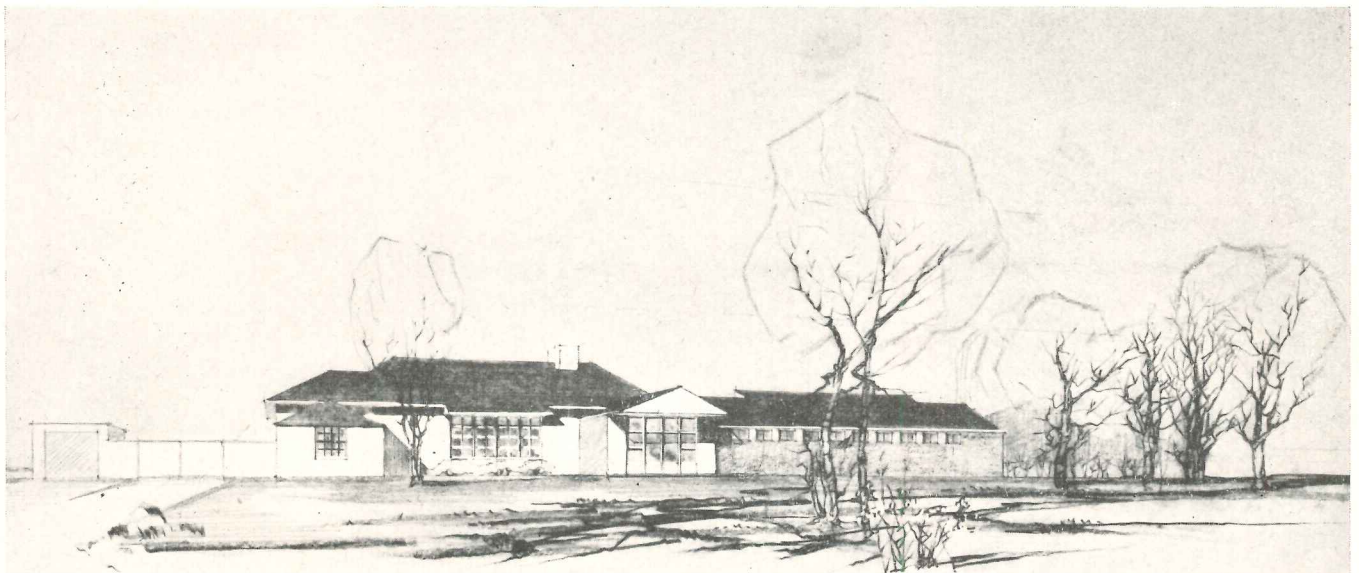



A THOUSAND WOMEN IN ARCHITECTURE

Presenting a few more pages of the survey of women architects and their work, as proof, if any were needed, that architecture is a field where women's talents are being accepted and appreciated

PART II

EVERY male architect at some time in his career (and probably many times) has had his dinner partner exclaim, "So you are an architect; oh, if I'd been a man, I'm sure I'd have been an architect too. I just love houses and plans and things." Of course, if she'd really had the urge she could have been. An architect, we mean. For architectural schools have been open to women students for years. Even Harvard has seen the error of its strictly masculine ways and now competes with its Cambridge compeer, M.I.T., in the number of distaff designers on its roster.

But all has not been easy for the rising young woman in architecture. Time was, and place too, when "the chief" looked askance at the hopeful draftsman in skirts, and hesitated to inject a feminine note in the earthy esprit-de-corps of the drafting-room. By sheer ability, coupled with innate tact and diplomacy, however, women have found places in, and up through, many offices throughout the country. And after apprenticeships, both arduous and amusing at times, many have branched out on their own and have established successful offices under their own names or in partnerships. Some husband-and-wife partnerships have been particularly successful, and have done outstanding work.

While the survey and the photographs received from women architects show a preponderance of domestic architecture, their creative ability and technical knowledge have been employed on almost every type of structure imaginable. It is natural that residential architecture should be their particular forte as traditionally and through long experience they are familiar with the problems of creating a better environment for the family. They understand the meaning of step-saving in planning and flexibility for multi-use of space. They are conscious of maintenance and operating problems from the standpoints of both time and economy. Their interest lies thus both in logical planning and in careful detailing and selective specification writing. For some reason or other they also seem particularly sensitive to the aspects of color, texture, and form in creating homes that have distinctive character.

The same thoughtful analysis and intuitive sense of the appropriate runs through their contributions to the designing of schools, churches, hospitals and every other type of building. As time goes on and they increase both in numbers and experience, their influence will be more strongly felt in the creation of an architecture that is not only utilitarian but soul-satisfying as well.

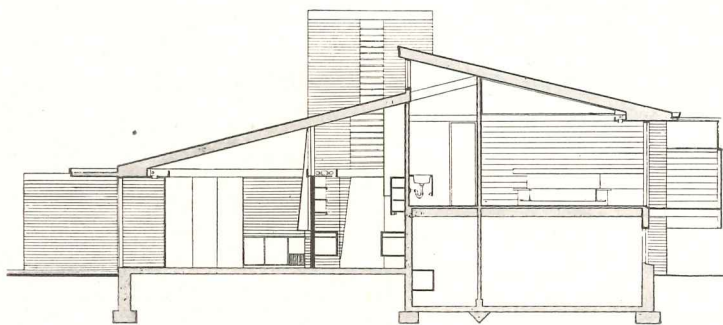
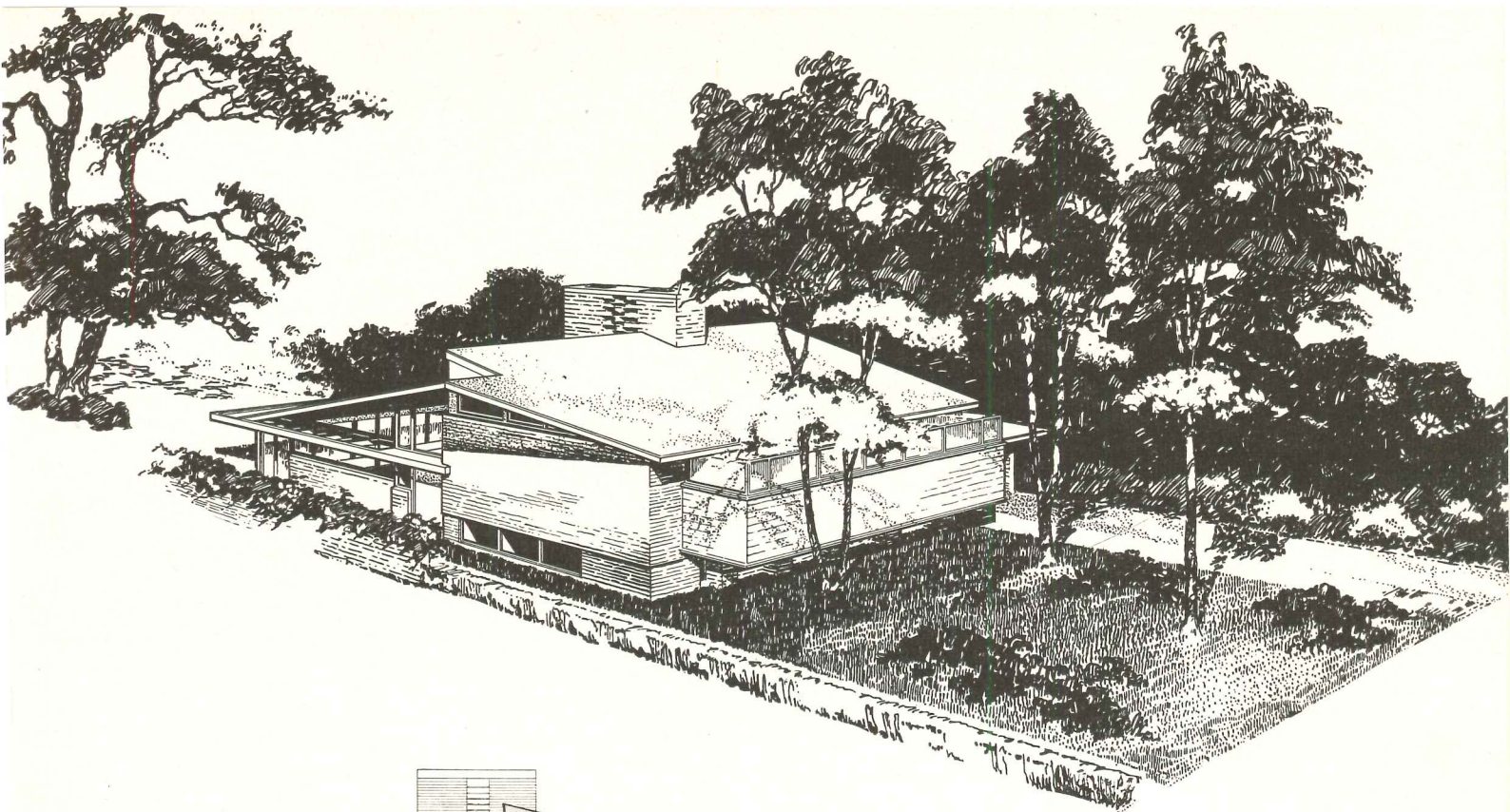

House for River Forest, Illinois

Joseph Salerno, Architect

LARGE ACTIVITY RANGE IN SMALL COMPASS

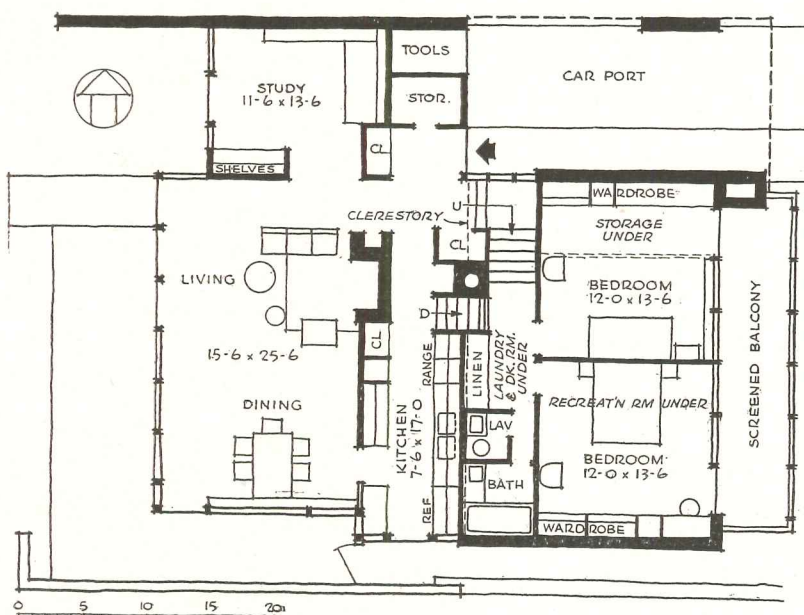

PRECISE calculation provides here for a relative multitude of living, working and hobby pursuits within extremely compact limits. The owner-to-be is an engineer, thus the study for occupational purposes; it may also serve for guest usage. Photographic and carpenter avocations, as well as ping-pong, laundering and storage, are accommodated on the sub level, to which light and air are plentifully admitted by raising the bedroom floor and cantilevering the glass-roofed and windowed balcony. This elevation also permits interior light flooding and cross ventilation through the clerestory.

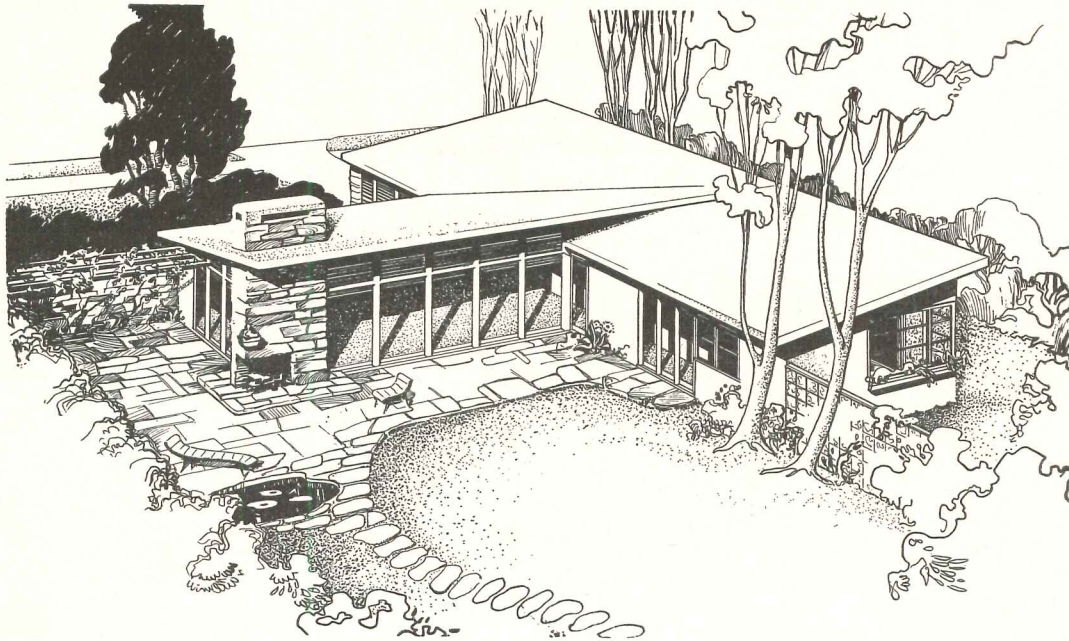

PROTECTED OPENNESS IN SUBURBAN LOCATION

House for Hinsdale, Illinois

Harry J. Harman, Architect

RESPONDING to the unanimous petition of the Thorne family (Mr., Mrs., son, and daughter) for the utmost in secluded openness on a fairly confining suburban plot, the architect provides a main terrace for general activity, double flanked by the house for protection and readiness of access through sliding glass doors. A feature particularly favored by the clients is the barbecue fireplace built into the main chimney. In addition, a second terrace, convenient to all bedrooms, provides for more seclusive individual purposes. Features inside include two accordion doors, one to partition the dining area, another for converting the large living room alcove into study or guest room. The plan was based on a 4-ft. module, insuring full economy in the use of plywood and plastic sheets.

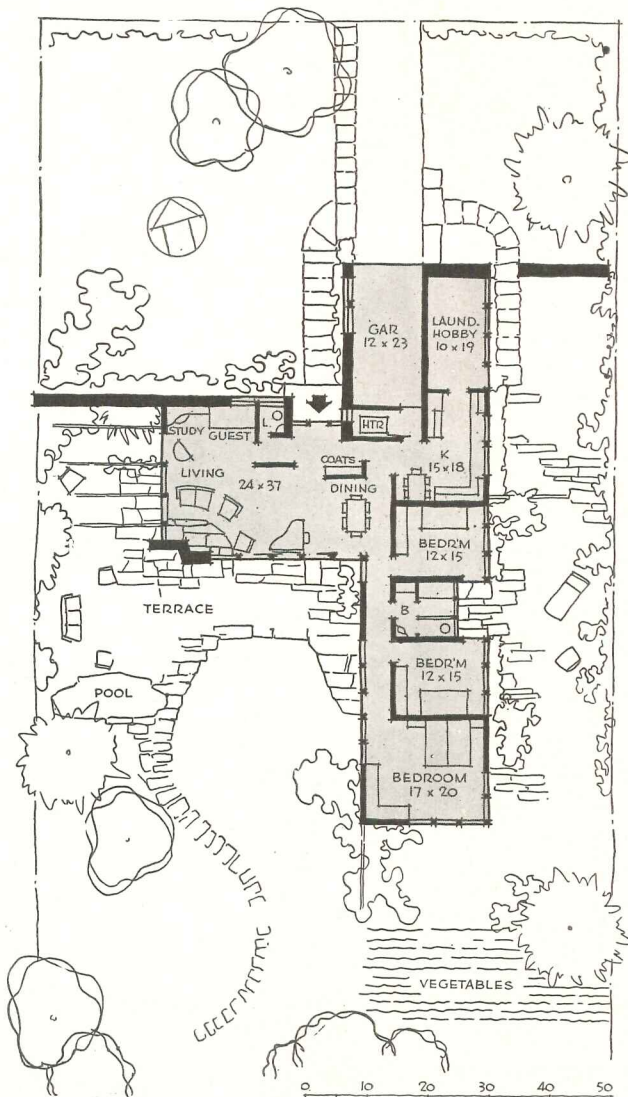

Variations between original and final plans include: sheltered main entry, with convenient bench for overshoe removal; expanded kitchen and laundry facilities; interior access to the garage, where extensive storage and freezer space have been added

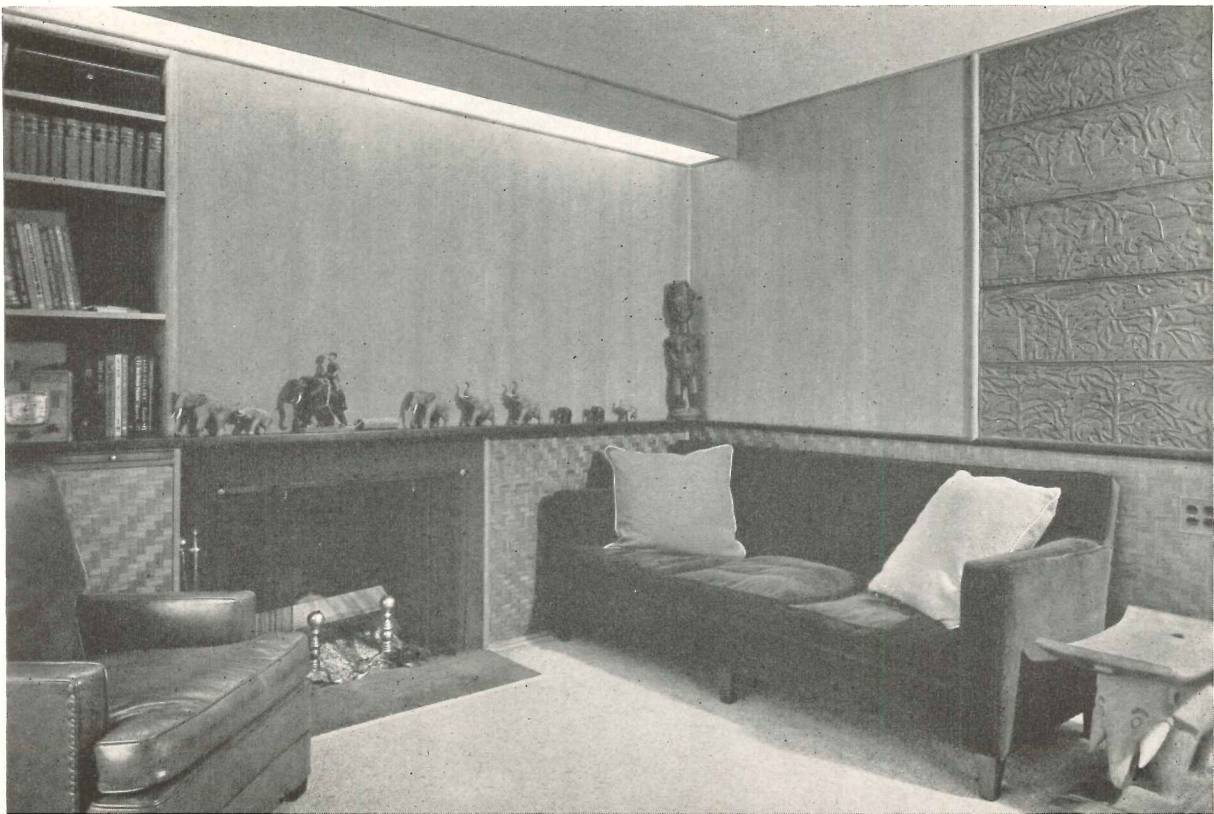
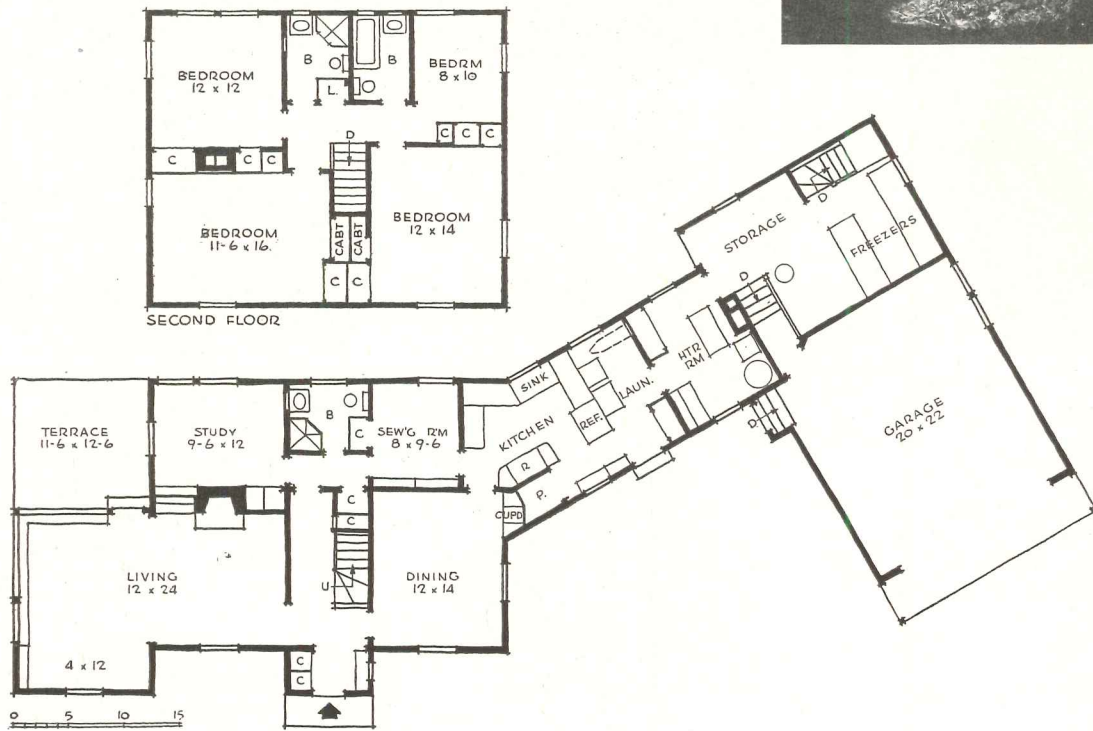
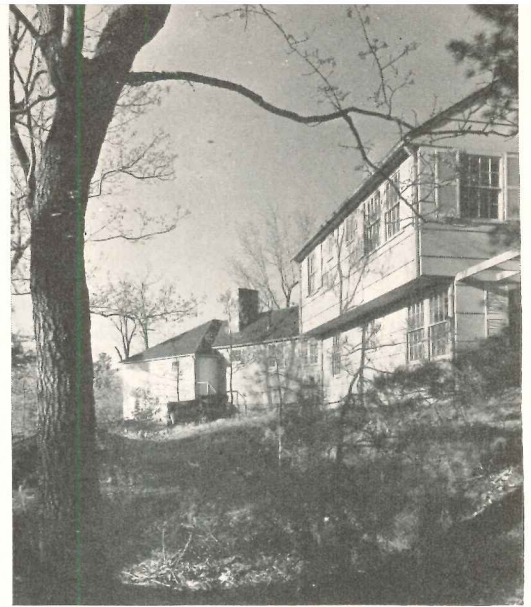



Essential characteristics of New England are maintained with full use of modern materials and equipment. Both outside and interior finish walls are entirely of plywood, as are roof, wall and floor boarding. Living room (two bottom photos), dining room and main hall are finished in mahogany; study, prima vera; walls elsewhere are finished in fir. Heating is radiant with copper ceiling pipes. Garage has floor pipes under car engines, and directly outside the doors for melting snow

Haskell Photos



ECONOMY STILL FAVORED THE TWO-STORY TYPE

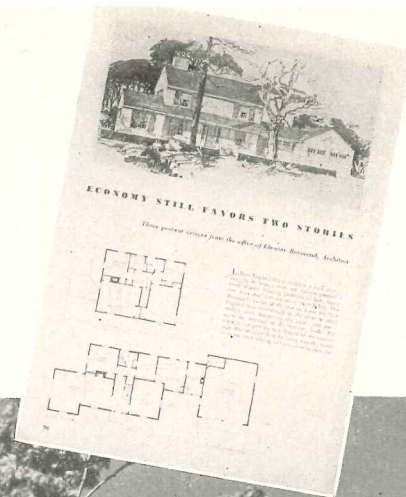

Haskell Photos

House in Winchester, Mass.

Eleanor Raymond

Architect

THE flash-back inset above (p. 96 of ARCHITECTURAL RECORD for May, 1945) recalls the Parker house as nascently published three years ago in a study looking forward to The Post War Small House. More than just a project, it represented Miss Raymond's clincher in an argument favoring two-story design, of a relatively conservative character, in keeping with New England climate, conscience and requisites of thrift. The process of realization required adaptation of the project to an entirely different plot. In final form, then, the garage wing has been swung at an angle to give direct approach from the street, and permit proper sun and view orientation for the rest of the house. Changes otherwise were fairly incidental.

Right: kitchen placement (see plan) provides equal ease in service to living room and garden. Center: inside finishes are plaster board and combed plywood; exterior walls are rough board and batten

Stone and Steccati Photos

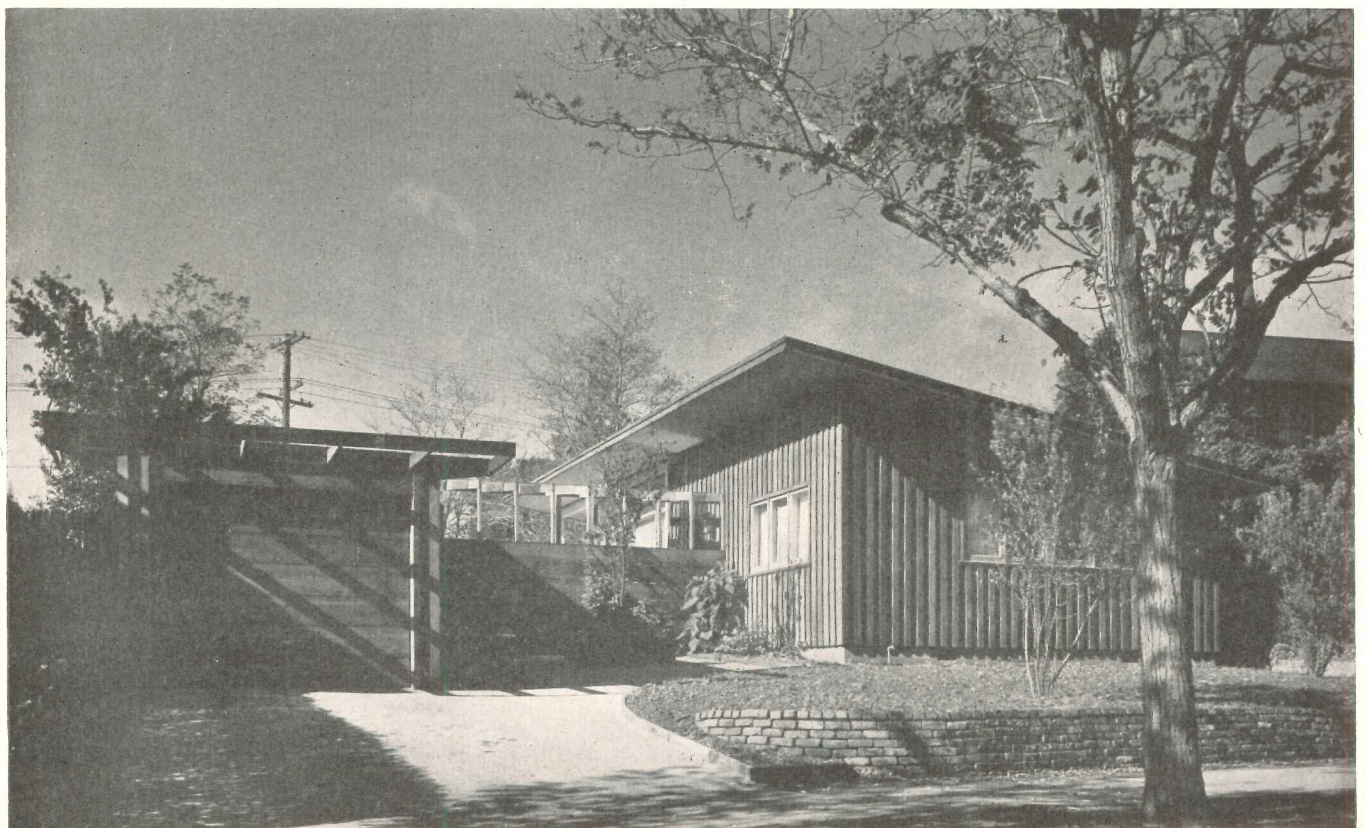
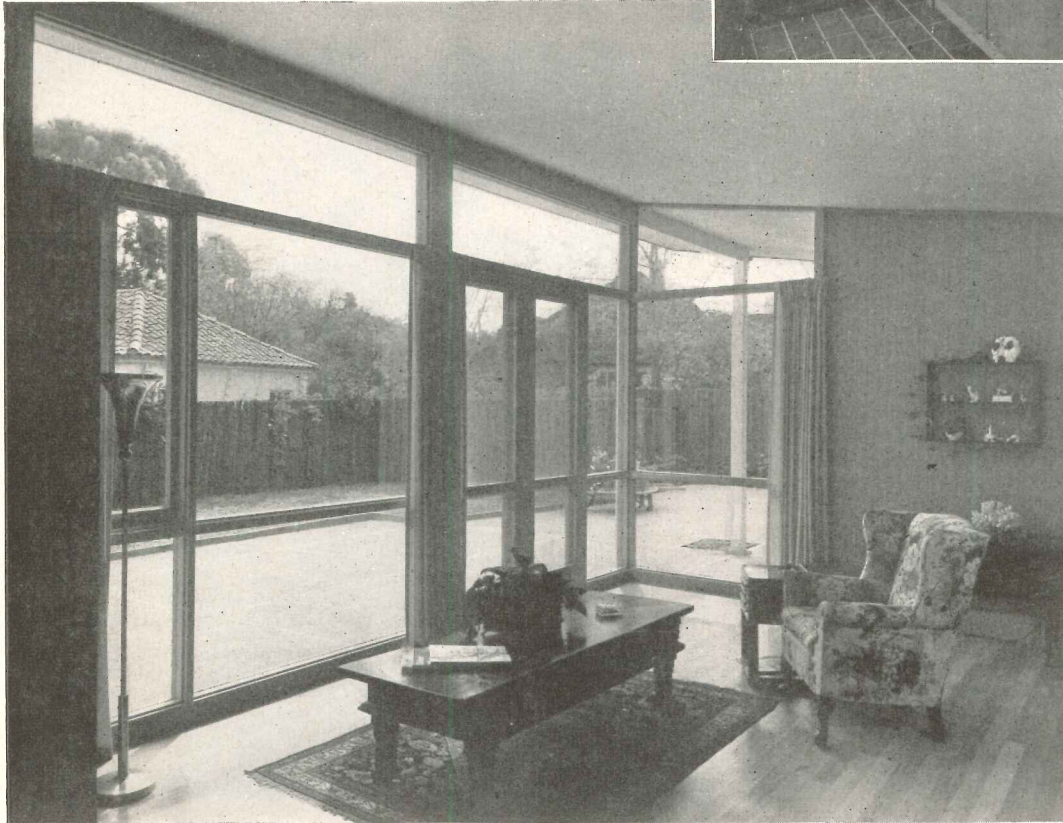
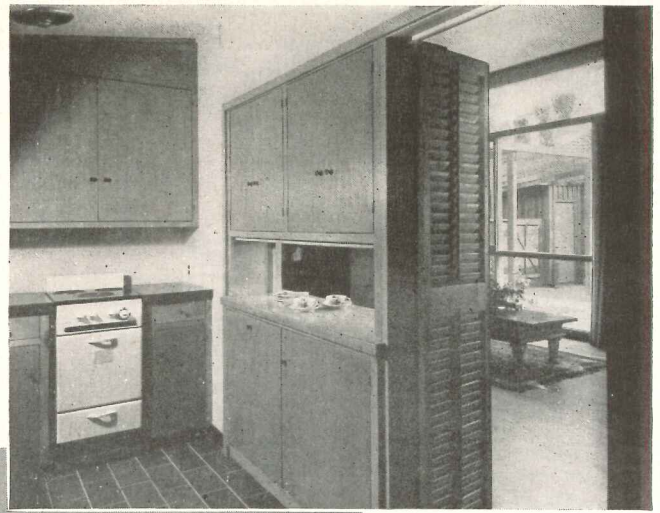

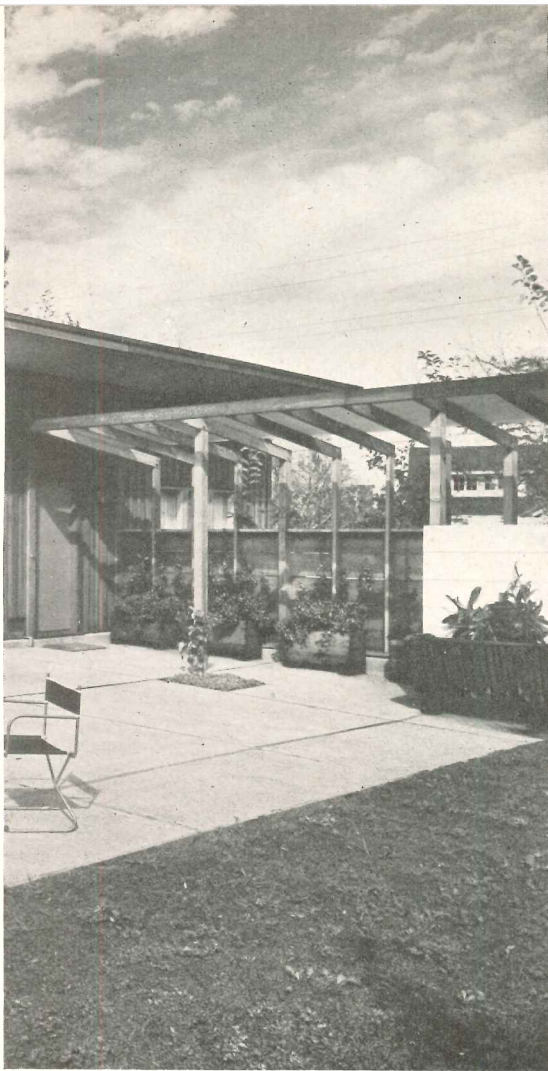

Left: roof is tar and gravel laid on 1-in. sheathing; screened vent to insulation space (discernible along edge of carrying beam) is matched by similar provision at rear of house. Below: glass-roofed arbor shields traffic from garage to house without precluding sun. Garden and landscaping designed by Douglas Bayliss

Stone and Stecatti Photos

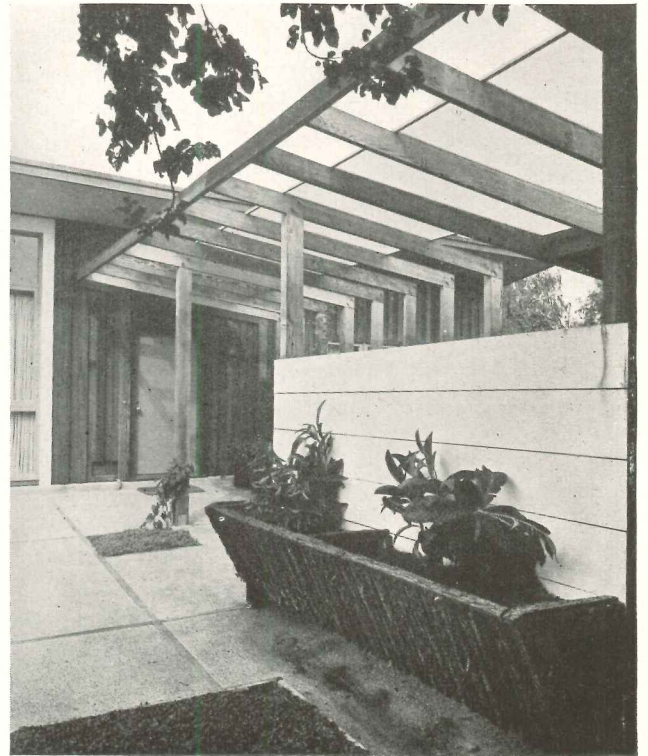

Francis Ellsworth Lloyd, Architect

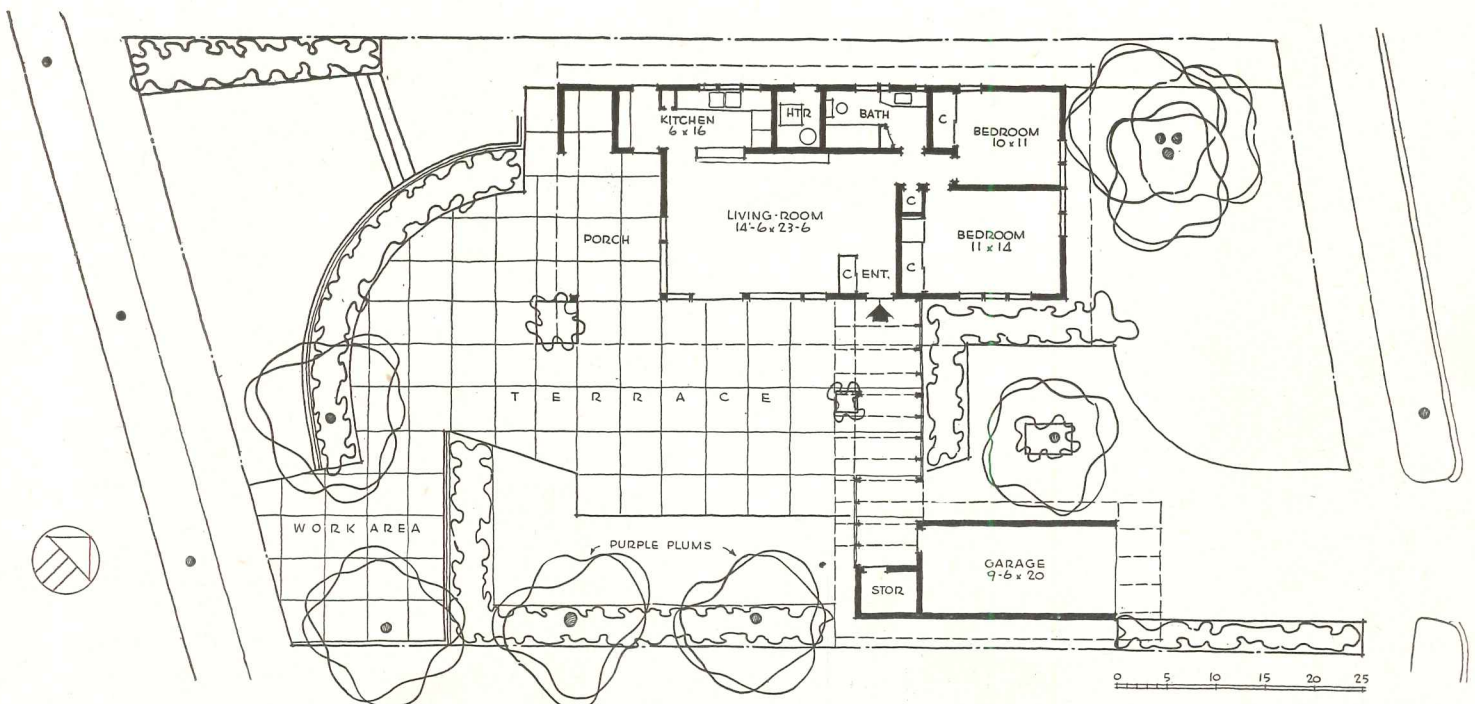

Ritchie Lowry House,

Burlingame, Calif.



SPACIOUS PRIVACY ON A SMALL LOT

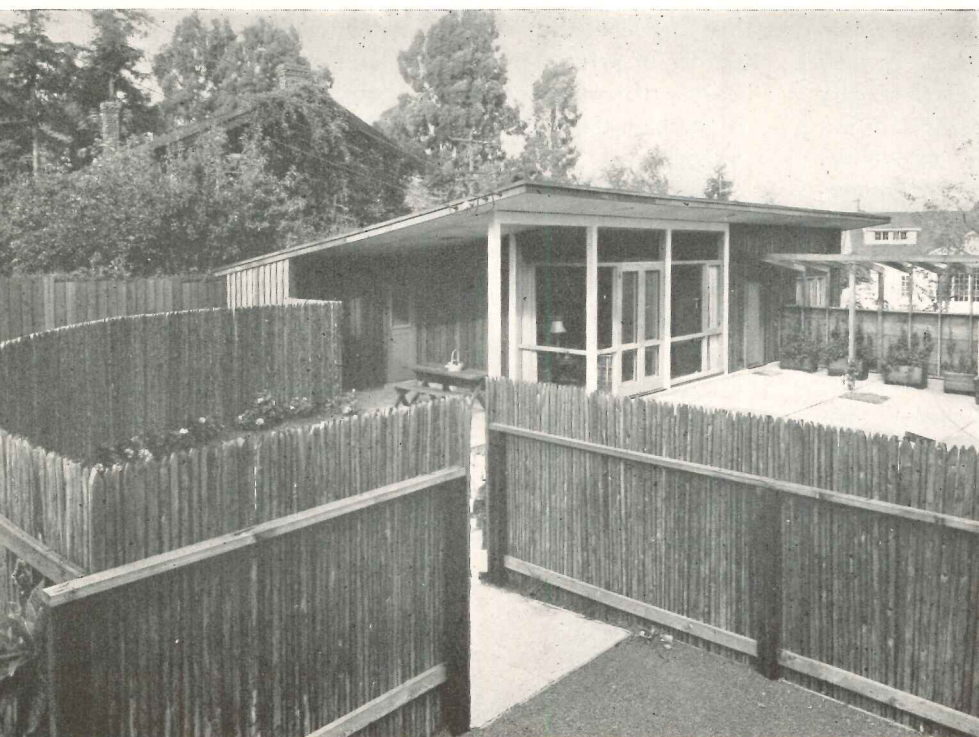

EXPERT disposition and interrelation of elements achieve qualities here of mountain remoteness amid suburban surroundings, and of almost manorial spread within dimensions strictly appropriate to the needs and means of a young couple. Northern placement of the house protects out-of-door spaces from witness and weather, prevailing from this direction. The pitch of roof and wide overhang give shade to the terrace side in suitable season, and during the cold months admit maximum sun to the living room. Detachment of garage, with interconnecting arbor, contributes to the general effect of seclusion and expanse.

ARCHITECTURAL RECORD

that your power lets you, impose your standards of goodness on those who seek your aid.

So you begin by setting up standards of sound construction with which all mortgaged properties must comply. These become in effect little building codes for housebuilding. They are written in specification form like most other building codes, and, as time goes on, they become more detailed and more rigid. But the structure is only part of the problem. Neighborhood layout has obviously an important bearing on mortgage security. So you establish neighborhood planning standards as well as construction requirements; and, since this is difficult to do abstractly, you undertake in each case of a new subdivision to tell the applicant what he should do. Seeing that this meets a fairly docile reception you begin, by publishing model designs, to tell the applicant the kinds of houses you would like him to submit. He submits, in more ways than one.

But these relatively simple matters do not mark the end of official influence. An important test of mortgage soundness is whether, in case of foreclosure, the property would find a ready market in the community. This test of marketability permits you to range widely over the whole area of design and to make determinations not only as to room sizes and arrangements and basements or no basements, but as to architectural style as well. So your judgment as to what will sell promptly leads you to dictate in these matters.

It is of course possible that your ideas are right and that the program is the more successful because you are able to enforce them. But you have inevitably limited the range of private decision. The applicant, who is a busy man with money at stake, finds it more profitable to follow your instructions than to argue with you. So the word is passed on to his designer, "Find out what they want and give it to them."

In the realm of rental housing, these tendencies are more pronounced. The FHA has always followed the practice of examining individual rental housing plans as closely as the Public Housing Authority has the plans for public projects. The examining process is unavoidably time-consuming, but, if it involves consideration of some unconventional concept, it may become indefinitely protracted — and even then may end in rejection. The simplest procedure is, in the first instance, to offer what is known to be acceptable. Originality, experimentation, and other argument-provokers and time-consumers are to be avoided.

The result is plain in the standardized colonialesque style of most FHA rental projects, and in the very conventional character of most individual houses financed with insured mortgages. Again, where does this leave the architect? Certainly not as a free, creative force. Even in a supposedly "private enterprise" program he finds the hand of government guiding his pencil. It will be contended that not all FHA houses are conventional; and this, of course, is true. But where it is true, it is due to the liberality of the examiner. It is his, rather than the designer's, decision that is final.

And, the greater the dependence of builders and owners upon the government aid, the greater will be the finality of the decision.

Government Intervention Means Extinction for the Architect

Thus whether the government influence is exerted through the means of direct contracts, loans, or subsidies, or through mortgage insurance and similar aids to private operators, the result in limiting the creative freedom of the architect is substantially the same. The result is necessary and inescapable in the interventionary process: wherever government carries the responsibility, government will set the rules and make the decisions.

In the process of bureaucratic evolution the range even of official decisions tends to be lessened. The setting of standards tends to a freezing of standards. A constant fluidity is disruptive to administrative procedure; and it is both easier and more economical to follow a fixed pattern than a constantly changing one. In the same process, it often appears easier to do the architectural and site-planning work within the agency than to spend what may be an equivalent time in examination, discussion and revision of the work of others.

Against such forces, the private architect can offer little resistance once they are well set in motion. We need only to look to England to see how he fares when governmental intervention in the construction field is complete. Work becomes narrowly concentrated, wholly under the domination of government where it is not done directly by government; and the architect as an independent factor in society is gone.

There may be some architects who believe this outcome of an interventionary program can be avoided, but the facts argue against them. There may be some who accept the proposition that, if their future status is to be that of bureau functionaries, their service to society need not be lessened thereby. But this proposition is certainly questionable. Without diminishing the contributions of many sincere and able architects now serving in government agencies, it can be suggested that their contributions are possible because the opportunities of private practice are still open to them and because there are courageous and independent practitioners on the outside to lead the way and lend them support.

There is something in the ideas of artistic integrity and creative freedom that the architectural profession has sought to maintain, and that something is important to a free society. But, by the same token, it is possible only in a free society. If architects, in their impatience at the slowness of achievement in a private enterprise economy, seek the supposed short cuts of an interventionary economy, they will solve neither their own problems nor those of the society they mean to serve. Instead, they are likely to eliminate themselves as a vital influence; and that loss in the end is bound to retard the progress they are intent upon. There are no short cuts to the millennium.



VA Hospital

Construction of a new 1089-bed VA hospital in Houston is scheduled to start this summer. The \$18 million project, consisting of 23 buildings covering all branches of medicine, will provide facilities for general hospitalization and rehabilitation. Architect is Kenneth Franzheim.

Building to House X-Ray

Recently completed at the Barberton, Ohio, plant of the Babcock & Wilcox Co. is a building especially designed to house a 2,000,000-volt x-ray machine used to examine the welds in high-pressure, high-temperature boiler drums.

The 70 by 30-ft. building was designed to give complete protection against x-rays and at the same time to give full freedom of movement in examining the largest pressure vessels built by the company. It will accommodate drums up to 13 ft. in diameter and 70 ft. in length.

Walls are of concrete, with a maximum thickness of 40 in., decreasing to 9-in. thickness toward the top of the 32-ft. room. Access to the control room, which is an extension on one side of the building, is through a concrete maze with walls 40 in. thick. The 120-ton x-ray room door moves horizontally on an overhead track and the floor along the doorway is raised to fit into an upward curve in the bottom of the door so that no x-rays can pass under the door when it is closed. A safety switch within the control room makes it possible to halt operations in case a workman finds himself in the room at the time testing is to begin.

Housing Development

To help ease the housing situation in Cambridge, Mass., Harvard University has announced plans for the building of a garden housing development on the present site of the University's Botanical Garden.

The development will provide housing for 123 families in one- and two-family houses and garden apartments. It will be financed from University endowment funds as an investment enterprise.

Des Granges and Steffian of Boston, architects for the project, have planned the development to preserve a maximum number of the Garden's unusual collection of trees and shrubs. The famous Gray Herbarium, center of the Garden, will be preserved as a research center.

Plans call for three one-family houses and a group of two-family houses as well as a series of four apartment house courtyards. Family entrances of all buildings will open on the courtyards, and delivery entrances will open on the surrounding streets and the driveways of the development. Garage facilities will be provided.

**SEA VIEW
HOTEL**
Miami, Florida
Architect: Roy France
Builder:
Feldman Const. Co.

Where luxury
is demanded
and space
must be saved

MURPHY-CABRANETTE KITCHENS
PORCELAIN ON STEEL

Only in these remarkable kitchens will you find the permanent beauty of genuine vitreous porcelain so easy to *keep clean* . . . the complete convenience of a modern kitchen in such compact space.

Available in 4 sizes, these new models feature electric refrigeration with push-button doors and frozen food compartments of stainless steel . . . gas or electric ranges of advanced design . . . one-piece sink-and-range tops.

Tenants are quick to tell you how well they like Murphy-Cabranette Kitchens. Building owners and operators will tell you of their trouble-free operation and their negligible cost of maintenance.

Write for new catalog now in process.

DWYER PRODUCTS CORPORATION
Dept. F5 — MICHIGAN CITY, INDIANA





At about half
the price of other
rustproof gutters



...nationally
advertised...



ample supply
available now!

The Mighty Metal of the Air
takes a Sensational New Turn...



ALUMINUM GUTTERS

Rustproof, at about half the price of other
rustproof materials... Immediate Delivery!

No painting, no soldering... no stain from rust or corrosion.
Ample strength, to take a full drainage load. Yet these
Reynolds Lifetime Aluminum Gutters are much lighter on your eaves
... a 10-foot length weighs only about 3½ pounds! Complete with
downspouts and accessories. Choice of Colonial box type or
half-round design. See your local supplier now! Or write for literature.
Reynolds Metals Company, Building Products Division, Louisville 1, Kentucky

15,000,000 FEET ALREADY SOLD AND DELIVERED!

MADE BY THE WORLD'S LARGEST PRODUCER OF ALUMINUM BUILDING PRODUCTS:
Clapboard Siding, Shingles, Sheet Roofing and Siding, Windows, Wall Tile, Reflec-
tive Insulation, "Alumi-Drome" (prefabricated utility building)

REYNOLDS PIONEERING MADE ALUMINUM COMPETITIVE... TAKE ADVANTAGE OF IT!



One of a series
of 4-color na-
tional advertise-
ments on the new
gutters preferred
by Architects for
choice of design
... by Builders for
ease of handling
and application...
by Owners for ap-
pearance, perform-
ance and price!

NEW!
O. G. STYLE

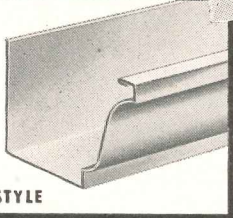

More than 15,000,000 feet already sold!

Write for illustrated A. I. A. File brochure!

REYNOLDS METALS COMPANY, BUILDING PRODUCTS DIVISION

Louisville 1, Ky.—Offices in 32 principal cities

water system will find heat outlet in Capitol thin-tube radiation (U. S. Radiator Corp.), and the hot water will be conducted through an underground Ric-Wil conduit system, with radiators piped-in off the main. Automatic in operation, the system will be figured on a basis of 200° F. water when the outside temperature is 0° F.

Gross-Morton Co. are builders of the development; architect is Benjamin Braunstein.

Research Laboratory

Construction is expected to begin soon on a large research laboratory for the Portland Cement Association in Skokie, Ill., just north of Chicago.

Designed by Carr & Wright, Chicago architects, the laboratory will comprise two architectural concrete buildings connected by a covered walkway. Total floor area will be approximately 98,000 sq. ft.



Proposed concrete research laboratory

The group will contain more than 25 specialized laboratories, moist curing rooms, fog rooms, low temperature rooms, freezing and thawing rooms, all equipped with the most modern scientific apparatus obtainable, including a million-pound compression testing machine. The steaming heat of African jungles, desert dryness or Arctic cold will be simulated in the laboratories to facilitate research into the durability of concrete structures under all climatic conditions.

Interior partitions will be of concrete masonry; concrete subfloors will be finished with terrazzo, composition tile and mastic. Special room treatments include precast granites and marble, cement plaster and acoustical ceilings. Lighting will be both incandescent and fluorescent. Heating will be by tempered air.

Plans also call for an auditorium, technical library, reading room and a cafeteria.

Florida High School

Under construction at Hollywood, Fla., is the \$1,500,000 South Broward High School, designed to accommodate 1500 students. Architects are Clinton Gamble Associates of Fort Lauderdale and Bayard C. Lukens of Hollywood.

The school will consist of 11 buildings connected by loggie, nine of them devoted to classrooms. The two-story administration building will have a four-story tower; the three academic classroom buildings and the industrial arts building will be single-storied, the science and home economics buildings two-storied. All will be hurricane proof, with steel bar joist roof support, 15-year bonded built up roofs, awning type windows. Separate buildings will house the auditorium and gymnasium, seating 1500 and 800 respectively.

Spinning Mill for Burma

The Union of Burma, through its ambassador, I. So Nyun, has employed Lockwood Greene Engineers, Inc., of New York, as consulting and supervisory engineers for erection and layout of Burma's first cotton spinning and weaving mill, which will cost about \$3 million when completed. It will be equipped with 20,000 spindles.

(Continued on page 178)

THE *Outstanding* PACKAGE
SELLS *Today!*

L. B. SHITTY
MOTOR CORPORATION

ARCHITECTURAL PORCELAIN ENAMEL *Attracts TRADE... Boosts SALES*

Clean, colorful architectural porcelain enamel buildings attract trade for hard-to-package bulk goods. The first impression of the passer-by is, "that looks like a good place to stop". Architect's drawings are the basis for our quotations and the subsequent entire fabrication and erection of "Modern Packaged" buildings in Architectural Porcelain Enamel that offer these advantages.

1. All colors and textures.
2. Multitone colors.
3. Any shape or form.
4. Light weight.
5. Permanent resistance to weather.
6. Application to masonry or steel.
7. Easy thorough cleaning.
8. Everlasting beauty and utility.

Erie Architectural Porcelain Enamel is ideal for Service Stations, Store Fronts, Restaurants, Food Stores, Offices, Factory Buildings.

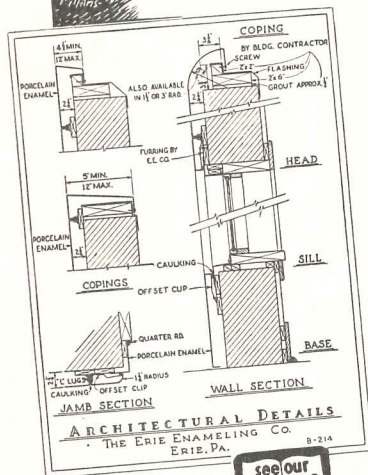

WRITE *Today* FOR THIS BULLETIN

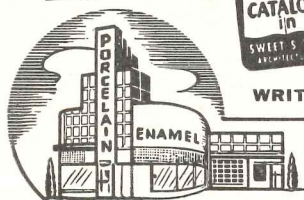
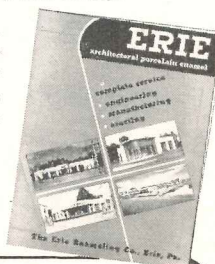

THE ERIE ENAMELING COMPANY
ERIE, PENNSYLVANIA

Member of Architectural Division Porcelain Enamel Institute.

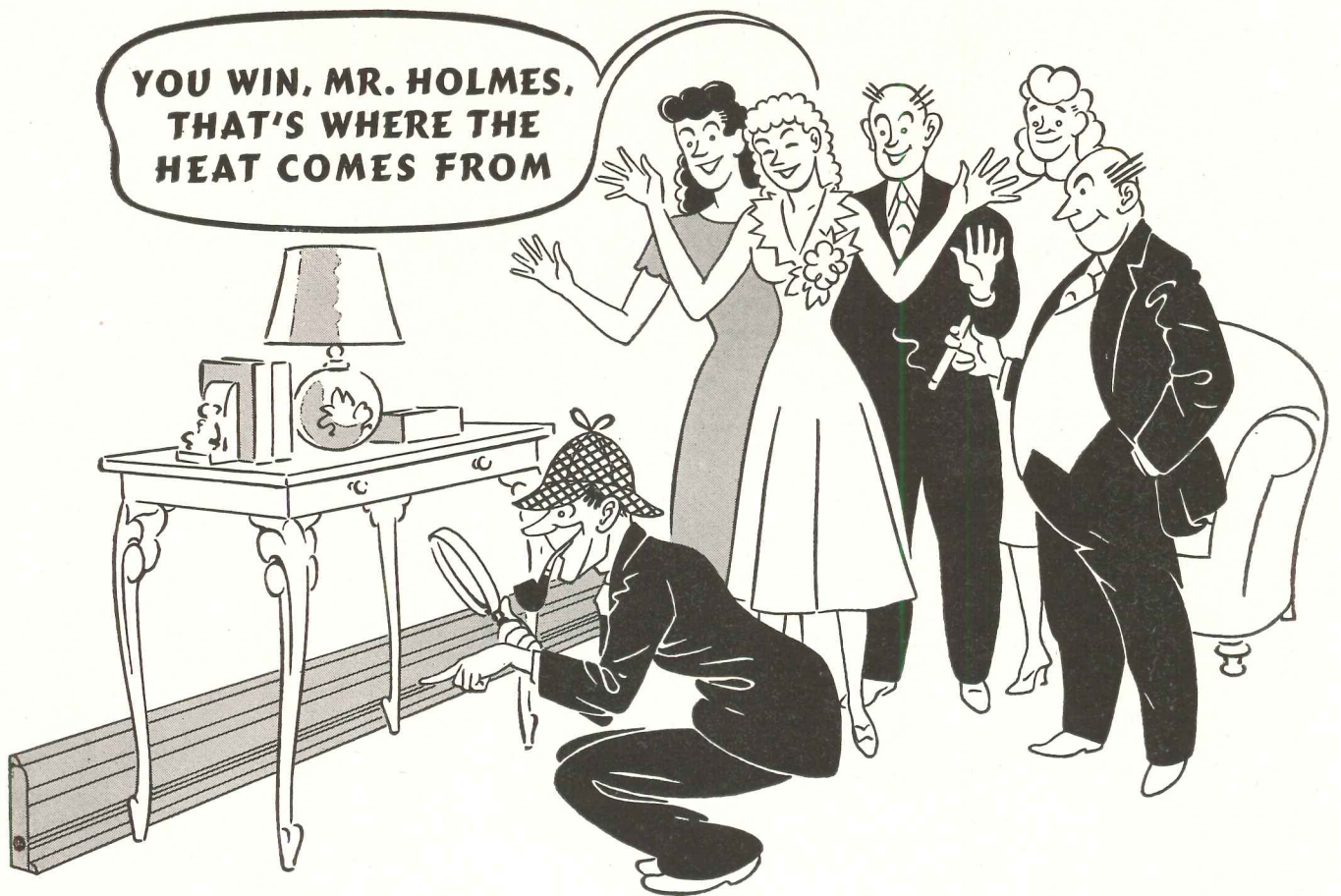

Solving the Problem of *INCONSPICUOUS Radiant Heating* with **BASE-RAY RADIANT BASEBOARDS**

Homes heated with BASE-RAY* offer the obvious advantages of *radiant panel heating* in its simplest form. When painted to match trim or walls, Burnham's Radiant Baseboards are practically invisible—and so completely out of the way they don't interfere in the least with the placement of furniture and furnishings. They provide a room-long source of clean, even, draft-free Radiant Heat, and can be used with any Hot Water, Two-Pipe Steam or Vacuum System.

BASE-RAY requires no special and costly structural changes. Instead of being embedded in floors or ceilings, they are installed at the bottom of outside walls where they are completely acces-

sible should repairs to the heating system be necessary at any time.

Burnham BASE-RAY Radiant Baseboards are a proven product. They have demonstrated their utilitarian and decorative appeal in thousands of homes during the past 3 years. Our advertising in national magazines such as *Better Homes & Gardens*, *American Home*, *House Beautiful*, *House & Garden* and *Small Homes Guide* will continue to point out to Mr. & Mrs. Home Owner the reasons why BASE-RAY offers the best in Radiant Heating.

*Reg. U. S. Pat. Off.

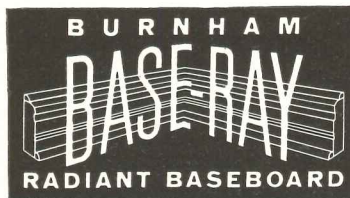

NOW! Increased Base-Ray production reduces delivery time.

Burnham Corporation

"PIONEERS OF RADIANT BASEBOARD HEATING"

IRVINGTON, N. Y., Dept. AR-68



Mail coupon below for Booklet which gives ratings and installation data on BASE-RAY Radiant Baseboards.

Burnham Corp., Boiler Division Dept. AR-68
Irvington, New York

Please send me copy of "Ratings and Installation Guide" on BASE-RAY Radiant Baseboards.

Name
Address
City..... State.....

Designed by Kelly and Gruzen, architects of New York and Jersey City, the center will provide parking for 2500 cars, and has in reserve parking space to meet any future requirements. In addition to the department store—which will be the largest in Bergen County—and the market, there will be five large chain store super-units, drug and furniture stores, and a personal service unit combining dry-cleaning, tailoring, laundering and shoe repair.

There will be 30 smaller specialty shops with an overall uniformity of architecture, but each will be individually designed for the particular tenant. Other features will be a restaurant, a cocktail lounge, a nursery-florist, a bank, and professional offices.

The owner-builder of the project is the N. T. Hegeman Co. of New York. Michael M. Burris and Associates, consulting engineers, of Englewood, are in charge of the site development.

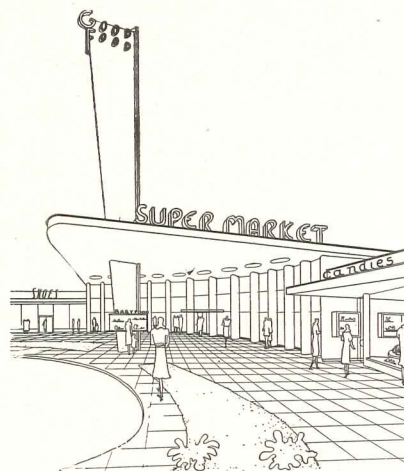

Shops in Bergen County project



Same bedroom with single hinged closet door and with parallel sliding doors. Direct access to either half of closet is possible as each sliding door opens to opposite side of door frame. Note added floor space available with sliding doors.



For more "living" room
USE VANISHING DOORS



Whether the job calls for tiny kitchenette apartments or a palatial mansion, there's no getting around one fact—hinged doors waste space! That is why more and more residential building plans specify vanishing doors for closets, wardrobes, connecting rooms, etc.

With vanishing doors, sliding from side to side, there's no interference with the location of furniture, lighting fixtures, pictures, rugs—nothing in the room gets "behind the door." Used for closets and wardrobes, they permit direct access to entire contents without fuss or bother.

SPECIFY R-W VANISHING DOOR HANGERS AND WOOD-LINED TRACK

For smooth, silent, trouble-free operation, specify vanishing doors installed with Richards-Wilcox No. 719 Vanishing Door Hanger and Wood-Lined Steel Track. No oiling required... hanger wheel has Olite self-lubricating bearing, rolls on self-centering woodtrack lining without metal-to-metal contact.

FOR USE IN 2" x 4" STUDDED WALLS

Richards-Wilcox No. 719 Vanishing Door Hangers and Wood-Lined Steel Track are designed for use in 2" x 4" studded walls. This outstanding feature is made possible by the R-W engineered "Ordinary Wall" pocket.

For complete details—or free consultation without obligation—call or write the nearest Richards-Wilcox office.

Apartment Village

A self-contained village of garden apartments, with modern department stores, a theater, library and public school, is now under construction on Long Island just within New York City limits. Known as Glen Oaks Village, the project ultimately will house a population of 15,000 in 3800 apartments.

The first two sections of the development, comprising 576 and 2342 units respectively, are largely completed and occupied, and the third section is now undergoing preliminary surveys.

All buildings are two stories in height, red brick veneer with white trim, and Colonial in style. Four-fifths of the 175-acre site are devoted to playgrounds and recreation areas. An unusual feature is the inclusion of recreation rooms, with completely outfitted kitchens, for use by tenants entertaining friends. Day nursery facilities, workshops, and photographic dark rooms are also provided.

To heat the project there will be 40 boiler rooms, each serving from 32 to 76 apartments units. Each will be equipped with two Pacific boilers (Pacific Steel Boiler Division, United States Radiator Corp.). A one-pipe forced hot

(Continued on page 176)

1880  1948
OVER 68 YEARS

Richards-Wilcox Mfg. Co.
"A HANGER FOR ANY DOOR THAT SLIDES"
AURORA, ILLINOIS, U.S.A.

Branches: New York, Chicago, Boston, Philadelphia, Cleveland, Cincinnati, Washington, D.C., Indianapolis, St. Louis, New Orleans, Des Moines, Minneapolis, Kansas City, Los Angeles, San Francisco, Omaha, Seattle, Detroit, Atlanta, Pittsburgh.

IN THE HAND

An Overhead Concealed
Door Closer and a
Floor Concealed Closer
Cost About the Same

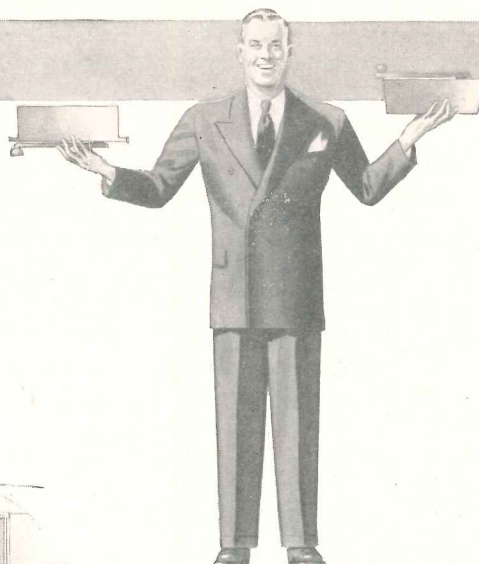

INSTALLED

An Overhead
Concealed
Door Closer
Costs Less



BECAUSE OF:

1. No cutting of floors
2. No trouble with beams or conduits
3. No special thresholds
4. No expensive moves
5. No extra door holders
6. No extra shock absorbers

IN THE LONG RUN

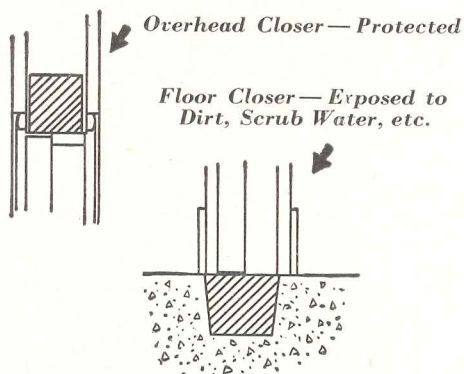

An Overhead Concealed Closer Costs Much Less!

The simple cross-section diagrams at left show clearly the big reason why overhead concealed door closers cost so much less than floor concealed closers *for maintenance*. No closer in the floor can escape the destructive effects of fouling with floor dirt, scrub water, etc. (We know, for we make floor type closers, too — some of the finest.) The closer concealed over the door, within the head frame, is protected from such harm. It lasts longer, calls for much less servicing, does a better job mechanically, costs far less in the long run. The LCN catalog 11-a gives a wealth of detailed information on good door control. We'll gladly send you one on request. LCN Closers, Inc., 466 W. Superior St., Chicago 10, Ill.

LCN

Overhead and Floor Type
Concealed *and* Surface Type Door Closers

tember 5, the National Association of Home Builders has announced.

On-site demonstrations of modern home building methods used by the industry, completed houses, tours of large-scale housing projects, exhibitions of homes and apartments in all phases of planning and construction through completed jobs will be featured in local observance of the week.

"Home builders are meeting the housing shortage on all fronts with an

amazing production of homes," Milton Brock, Los Angeles builder and president of the N.A.H.B. said in announcing the plans. "We have been turning out houses at the rate of 6½ completed homes every working minute of every day—401 houses per hour. . . . We think the people of the nation ought to understand the tremendous change that has taken place in the housing outlook, and should see for themselves how the job is being done."

GERALD A. HOLMES, A.I.A.

1887-1948

Gerald Anderson Holmes, architect, well-known, respected and beloved by his contemporaries, died April 19th in his home at 126 East 19th Street. For the past six years he had been assistant superintendent of school building for New York City in charge of architectural design.

Born in Philadelphia, he was a son of the late Gerald Holmes and the former Margaret Wellwood Anderson. Mr. Holmes received a Bachelor of Science degree in architecture from the University of Pennsylvania in 1908, and then spent two years in the office of Day & Klauer, Philadelphia architects.

In 1910 Mr. Holmes came to New York and entered the office of McKim, Mead & White, where he remained for thirteen years. He became a member of Thompson, Holmes & Converse of this city and Rochester, N. Y., in 1923 and continued this partnership until 1938. During the next four years he was active in school design associated with the New York Board of Education.

Mr. Holmes designed the Bellevue Psychopathic Hospital and buildings for City College and Hunter College. He was associated with the designing of the Civic Center and Municipal Building in Rochester; the Hotel Carling in Jacksonville, Fla.; the Hotel Andrew Jackson in Nashville, and others.

Among the private residences designed by him are those of Rogers Caldwell in Nashville, Tenn.; Frederick G. Crane, Jr. in Dalton, Mass.; and Edgar V. O'Daniel in Bronxville, N. Y.

A former chairman of the Education and Civic Design Committees of the New York Chapter of the American Institute of Architects, Mr. Holmes was vice-president of the chapter in 1935-36, and was a member of the executive committee for six years. In 1939 he was elected a fellow of the American Institute of Architects in recognition of his "public service, untiring and constructive interest in his profession, and the excellence of his work." He gave unstintingly of his time and effort to the cause of better architecture and his sound and friendly counsel was often sought by his fellow practitioners.

In 1934 he was a member of the Architects' Emergency Committee, which raised funds for unemployed architects and draftsmen. He had given lectures at the University of Pennsylvania and was visiting architect to Princeton University. Mr. Holmes belonged to the Century Association and the Architectural League of New York.

THE CHOICE WAS

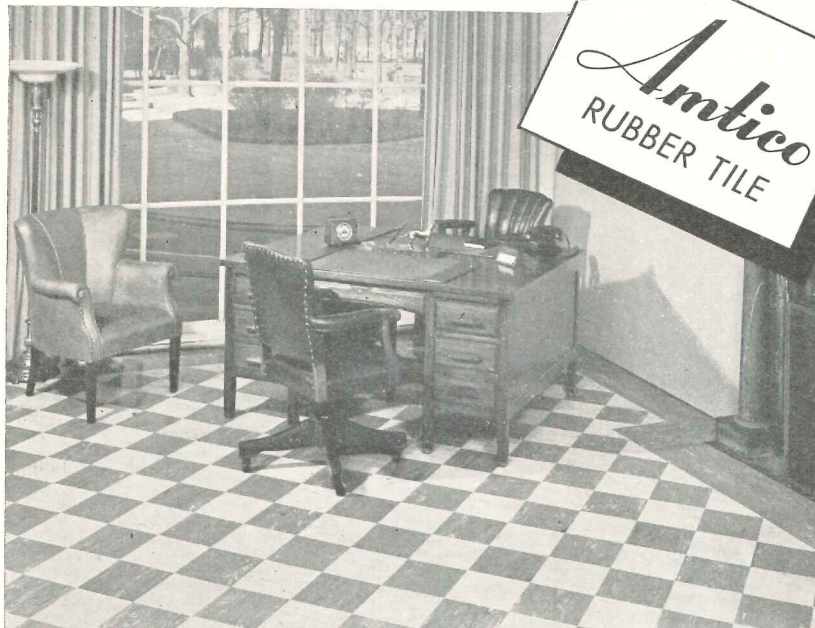

FOR BEAUTY

Made of Antico Rubber, it has all the beauty of marble, plus carpet-like quiet and comfort underfoot. The smart design combinations are almost unlimited.

FOR QUALITY

There is no substitute for quality. When planning this new office, the architects naturally chose Antico Rubber Tile, knowing they were specifying a floor of lasting satisfaction.

FOR SERVICE

Bright, new looking floors are essential to good business. Antico Rubber Floors keep their new appearance through the years, for there is no better flooring material. Whether for an "acre," or a powder room, here is the floor for long life—the floor to give constant satisfaction to your clients.

Pioneers in the manufacture of rubber flooring for over 30 years

AMERICAN TILE & RUBBER CO. TRENTON, N. J.

SEND FOR YOURS

AMERICAN TILE and RUBBER COMPANY
Perrine Avenue, Trenton 2, New Jersey

Please send me samples and literature showing Antico Rubber Flooring in full color.

NAME.....

ADDRESS.....

*On windy spring days . . . nothing stops
entrance drafts like a revolving door . . .*

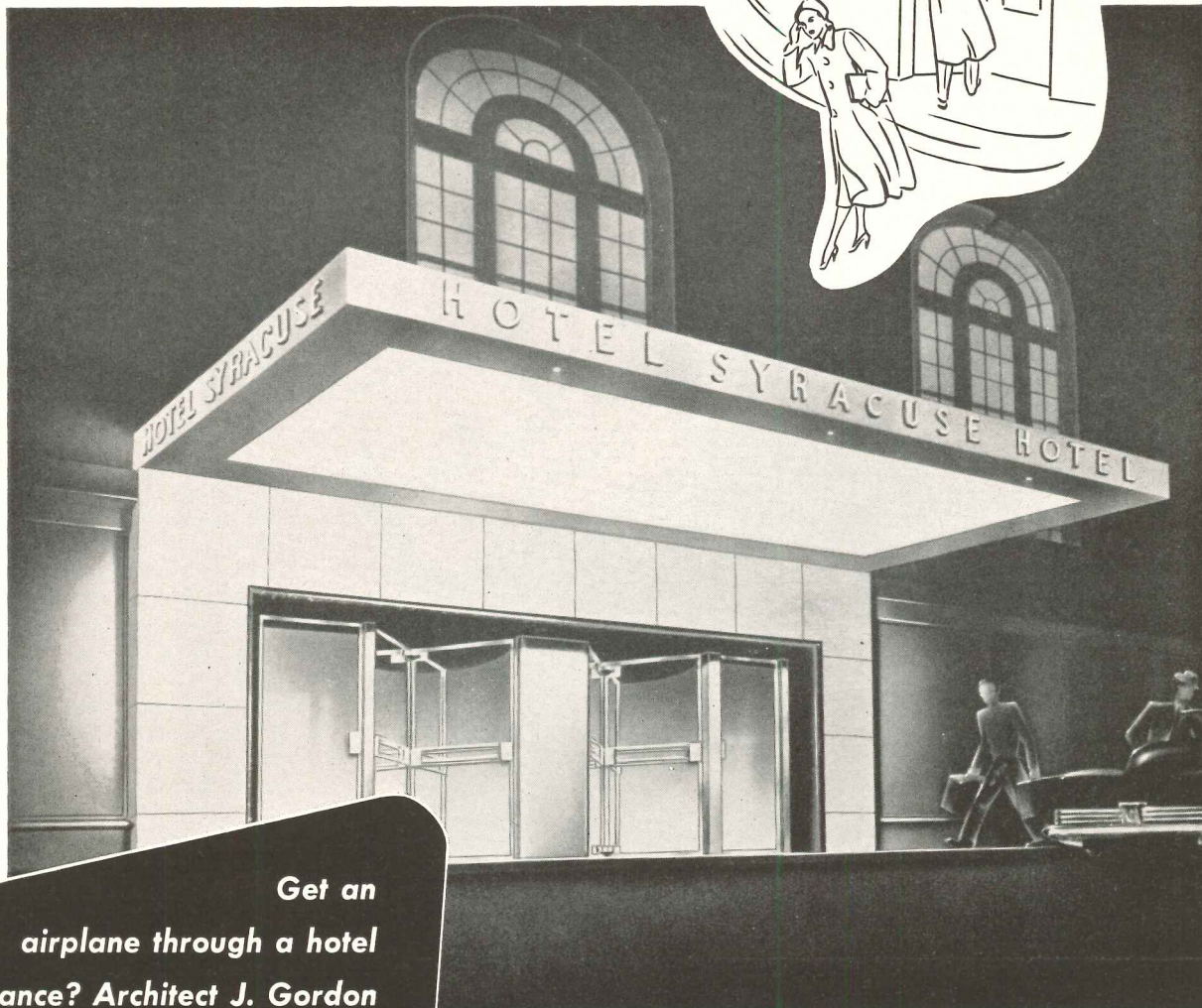

**Get an
airplane through a hotel
entrance? Architect J. Gordon
Lippincott & Co. did it . . . by
using Revolving Doors!**

To the enterprising Syracuse Hotel in upstate New York, revolving doors are nothing new. They've been providing smooth traffic flow and insuring lobby comfort here since 1923. The old doors were recently replaced with three modern, specially designed all-glass models, constructed of hollow stainless steel. As specified by Architect J. Gordon Lippincott & Co., the two-door entrance (above) has movable enclosure walls to permit passage of large objects—even automobiles and airplanes—for display in the lobby. Its extraordinary features open bright new possibilities in entrance design and usage. You, too, may have difficulties that can't be overcome by ordinary entrance doors. International's designers know entrance problems and have the capacity and imagination to tackle tough jobs . . . and lick 'em. Let them help you and your architect. A request on your letterhead will do the trick.

**REVOLVING
INTERNATIONAL VAN KANNEL
DOORS** EVANSVILLE, IND.

DIVISION OF INTERNATIONAL STEEL CO., 1606 EDGAR ST., EVANSVILLE, IND.

TOURS ANNOUNCED

To Europe

Following its successful 1947 European Reconstruction Seminar, World Studytours has announced a similar project for this summer. Intended primarily for specialists and advanced students in the fields of regional and community planning, housing and architecture, the tour will enable intensive on-the-spot study of specific reconstruc-

tion, planning and building programs in two West and two East European countries.

The 5½-week itinerary will cover England, Czechoslovakia, Poland and Sweden. The group will meet with officials, planning and building specialists and professional and consumer organizations. Conferences will be combined with field trips to devastated areas, reconstruction and new town sites, specific housing and building projects, and build-

ing industry enterprises. Leader of the travel seminar will again be Hermann H. Field, A.I.A.

The group will leave on July 16, returning on September 9. For further information, address World Studytours, Columbia University Travel Service, New York 27, N. Y.

Through the U.S.A.

Another travel seminar announced by World Studytours and the Planning and Housing Division of the School of Architecture, Columbia University, is a tour to selected urban areas in the United States. This is a Columbia University Summer Session course in planning, and may be taken for credit toward a degree.

The itinerary for the six-week tour covers New York City, Philadelphia, Baltimore, Greenbelt, Washington, Williamsburg, Richmond, TVA, Knoxville, Louisville, Cincinnati, Chicago, Milwaukee, Detroit, Toledo, Buffalo and Albany. Travel will be by private automobile, and enrollment will be limited to about 20 persons. The tour starts on July 6.

ELECTIONS, APPOINTMENTS

Prentice Bradley, of Pittsfield, Mass., has been named technical consultant to the Producers' Council. Mr. Bradley, a practicing architect, will assist the Council in the further development of modular coordination and in the engineering of typical buildings, and will advise on research and technical matters. He also will serve as technical secretary of the American Standards Association's Committee A-62 for the coordination of dimensions of building material and equipment. He is a member of the firm of Bradley & Gass, Architects, of Pittsfield, Mass.

E. A. Pratt, consulting engineer of New York City, has been appointed the representative of the International Organization for Standardization in its relations with the Economic and Social Council of the United Nations.

At the annual meeting of the Wood Fiber Blanket Institute in March, R. B. Sawtell, sales manager of the Kimsul Division of Kimberly-Clark Corp., was re-elected president, and J. D. Fischer, manager of specialty products sales of the Wood Conversion Co., was elected secretary-treasurer.

The Institute is composed of Kimberly-Clark Corp., Masonite Corp., and Wood Conversion Co.

"HOME WEEK" PLANNED

A "National Home Week," emphasizing the progress being made in meeting the housing need, will be conducted throughout the country the week of Sep-

(Continued on page 172)

A Schlage Installation because...



Schlage is convenient

When they planned their home, the Montgomerys didn't know one kind of lock was more convenient than another. But their Architect did. The Schlage locks he specified have provided them with finger tip locking convenience, and automatic unlocking when leaving a room.

See Schlage in Sweets Architectural File



SCHLAGE
LOCK COMPANY
SAN FRANCISCO NEW YORK

ORIGINATORS OF THE CYLINDRICAL LOCK

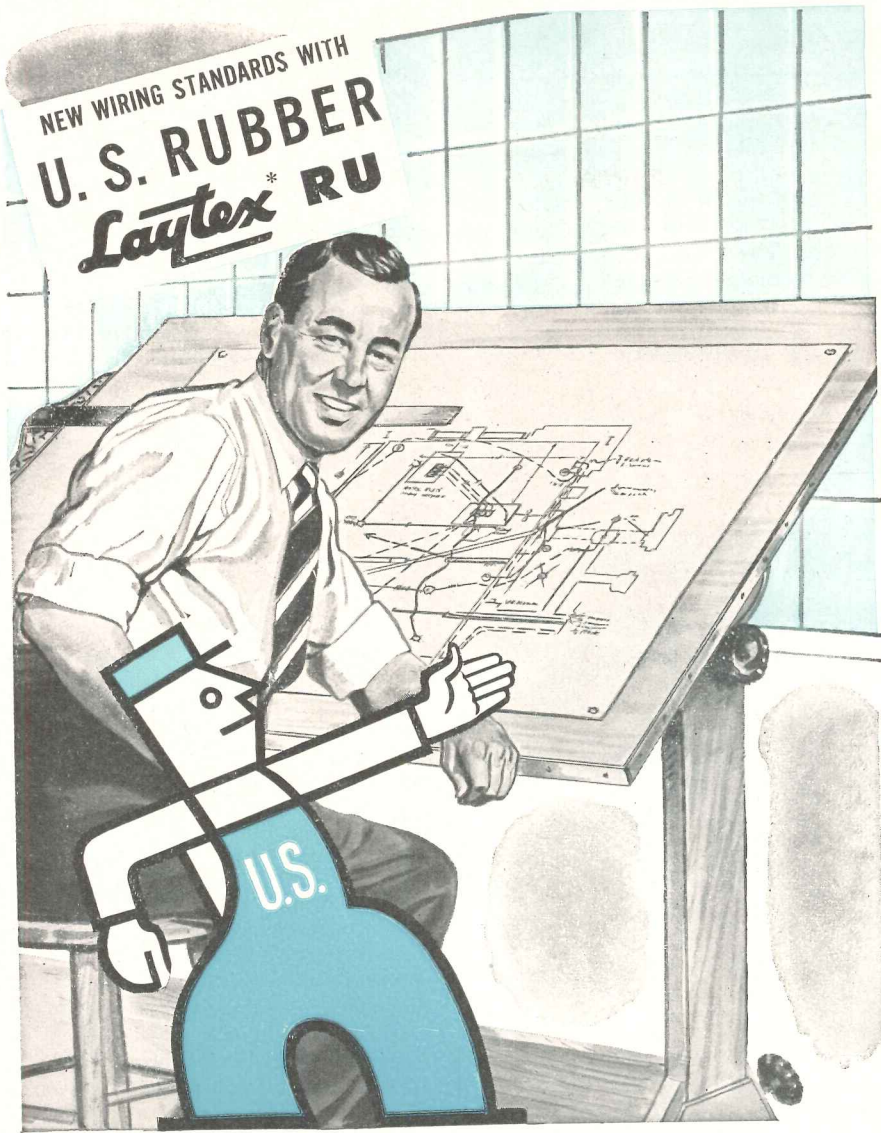

United States Rubber Company's unique dip or pass method applies the insulation in *perfectly uniform* layers. Moreover, this insulation is 90% pure rubber, unmilled in order to preserve its high physical qualities. The extra strength of natural rubber, plus a strong fibrous cover and special finish gives extra protection against mishandling, sharp bends, moisture and flame.

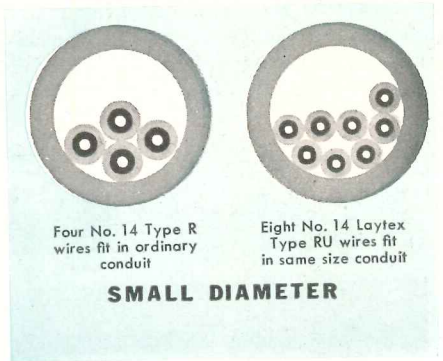

Four No. 14 Type R wires fit in ordinary conduit

Eight No. 14 Laytex Type RU wires fit in same size conduit

SMALL DIAMETER

Yet, despite the unusual safety features of Laytex RU, this wire is smaller in diameter and lighter in weight than any other natural rubber covered wire on the market. Not only is Laytex unsurpassed in physical and electrical qualities, but it will also permit *more wires per conduit*.

The tensile strength of Laytex RU is over 7 times that of Type R, and twice that of Type T. Its insulation resistance constant is over 3 times that of Type T, and over 8 times that of Type R. Add all these advantages up, and no wonder Laytex RU is the finest building wire on the market today.

U. S. Laytex RU is labeled by the Underwriters' Laboratories and listed in the National Electrical Code as an all-purpose wire. Send for a sample and free booklet. Write Wire and Cable Department, United States Rubber Company, 1230 Avenue of the Americas, New York 20, N. Y.

*Reg. U. S. Pat. Off.

"This Wire's got Safety and long Life...It's **Laytex RU.**"



PERFECT CENTERING

So says Mr. USRUBBY, the Wire Engineer. And you, Mr. Architect, will agree with him. For when you specify U. S. Laytex RU, you are

getting a wire that will not suffer from the dangerous thin spots formed on ordinary wires. Why? Because

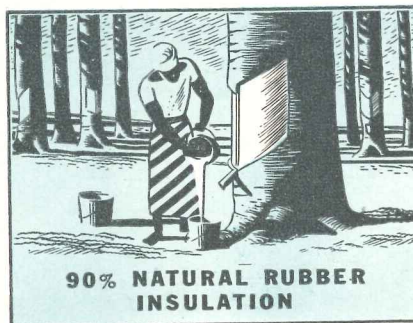

90% NATURAL RUBBER INSULATION

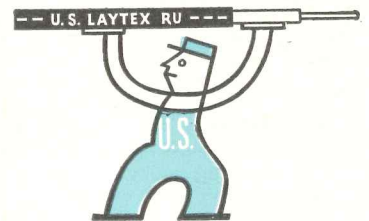

A PRODUCT OF

U.S. RUBBER
SERVING THROUGH SCIENCE

UNITED STATES RUBBER COMPANY

All wiring with **RU?**

from 1912 to the present, and included scale models of the new 100-acre campus of Illinois Tech, for which he has designed 19 academic, laboratory and scientific research buildings, five of which already are in use. The exhibit was shown at the Museum of Modern Art, New York, for five months prior to the Chicago showing.

Awards Announced

Two veterans, architectural students

at Carnegie Institute of Technology, have been awarded the Rust Engineering Company prizes for their designs of a plant to produce low-cost housing in large volume.

First prize of \$100 was awarded to Lewis D. Klein, of Wadsworth, Ohio, and second prize of \$50 to Thomas J. Madden, Jr., of Pittsburgh, Pa. Both designed plants for the Pittsburgh district, embodying recent trends in industrial building capable of being

adopted in the foreseeable future, including modern provisions for employee comfort. Each plant is designed to produce 1500 homes per month, constructed of cellular steel panels. Students competing in the project did all original research and made the drawings within a four-week period.

Fellowship Awarded

Ronald A. Dick, of Beckenham, Kent, England, has been awarded a \$1500 special fellowship offered to a foreign student by the College of Architecture at Cornell University. The award is for the year 1948-49.

Alternates for the fellowship are: Florian Vischer, Basle, Switzerland; Marcelo Urrets Zavalía, Córdoba, Argentina; and Lloyd E. A. Orton, Melbourne, Australia. Architectural students in 14 countries applied for the grant, which was made from an anonymous fund for the encouragement of study in fine arts.

A graduate of the Ecole Speciale d'Architecture in Paris, the winning candidate is now completing his studies at the Bartlett School of Architecture, London. During the war he was a lieutenant colonel, Royal Engineers, and served in Burma. He has made a special study of airport buildings. The alternate candidates are all graduates of foreign architectural schools.

Traveling Fellows Named

Three recent graduates of the College of Architecture, Cornell University, have been awarded Robert James Eidlitz fellowships of \$1000 each for study and travel abroad in 1948-49. They are: Eric Quell, of Forest Hills, N. Y.; Vincent Moscarella, of Brooklyn, N. Y.; and John J. Wallace, of Middletown, N. Y.

Established in 1938 by Mrs. Sadie B. Eidlitz of New York City in memory of her husband, a Cornell graduate of 1885, the Eidlitz graduate fellowships in architecture are awarded each year to exceptionally promising graduates to supplement their professional training through advanced study and travel.

All three winners have their plans well in hand. Eric Quell, whose special interest is in civic and cultural buildings such as museums, auditoriums and libraries, will study design at the Eidgenössische Technische Hochschule in Zurich, Switzerland. Vincent Moscarella plans to register as a student in the Faculty of Architecture, University of Rome, and will study recent planning and housing techniques used in the reconstruction of devastated areas in Italy. John Wallace will go to Sweden for graduate work in architectural design at the Royal Academy of Art, Stockholm.

(Continued on page 170)

VERMONT MARBLE . . .

Masterpiece of enduring dignity and beauty



United States Post Office, Court House and Custom House, Albany, N. Y.—Eureka Danby marble exterior. Gander, Gander & Gander, Architects, Albany, N. Y.



McGregor Mausoleum, Wichita Falls, Texas—Imperial Danby marble. William Henry Deacy, Architect.

From the scenes of his earlier years of accomplishment a man may go to his final resting place always sheltered and dignified by marble of enduring beauty.

COLOR CHARACTER
PERMANENCE • LOW MAINTENANCE

crystalline VERMONT MARBLE

VERMONT MARBLE COMPANY • PROCTOR, VERMONT

Branch Offices:

Boston • Chicago • Cleveland • Dallas • Houston • Los Angeles • New York • Philadelphia • San Francisco
Ontario Marble Co., Peterboro, Ont.



Now!

STANDARD EQUIPMENT WHICH GIVES

Custom Designed
LIGHTING



PITTSBURGH REFLECTOR COMPANY PRESENTS FOR THE FIRST TIME a line of recessed units in architectural modules—whose application is limited only by the requirements of the designer. These units may be mounted individually, in continuous rows, patterns and squares.

FOUR INTERCHANGEABLE SHIELDING ASSEMBLIES provide every type of shielding. Each Assembly is self-contained within a metal-frame and quickly attaches to the Troffer. Frames are piano-hinged and latched to simplify maintenance.

COMPANION INCANDESCENT EQUIPMENT, designed especially for use with Universal Troffers, complements the line and gives the "accent" lighting needed for planned lighting installations.

For details on the Universal Troffer and companion equipment, send for Advance Notice Sheet 40.

PITTSBURGH REFLECTOR COMPANY

OLIVER BUILDING • PITTSBURGH 22, PENNSYLVANIA

MANUFACTURERS OF FLUORESCENT AND INCANDESCENT LIGHTING EQUIPMENT
DISTRIBUTED BY BETTER ELECTRICAL WHOLESALERS EVERYWHERE

Permalector Lighting Engineers in All Principal Cities

A.I.A., have announced their association as Ertz, Hartford & Kuettnner, Architects, with offices at 1205 S. W. 18th Ave., Portland 5, Ore.

Holabird & Root, Architects, have announced that the name of their firm has been changed to Holabird & Root & Burgee. Offices remain at 180 N. Wabash Ave., Chicago 1, Ill.

Hudson and Gilmore, Architects and Engineers, have announced their affiliation with William E. Campbell, Jr.,

for the continued practice of architecture and engineering as Hudson-Gilmore-Campbell, with offices at 203 Bartlett Bldg., Montgomery, Ala.

Albert Kahn Associated Architects and Engineers, Inc., announces the election of a representative group of technical employees of the organization as members of the firm.

Lucille Bryant Raport (Raport & Hicks), Architect, has announced the change of the firm's name to Lucille B.

Raport and James M. Hicks, Architects. Address: 4508 Forman Ave., N. Hollywood, Calif.

Walter Raymond, A.I.A., of Pearisburg, Va., and Charles A. Pearson, Jr., A.I.A., of Radford, Va., have announced the formation of a partnership to be known as Raymond and Pearson, Architects, with offices at Pearisburg and Radford, Va.

Kenn Trumble, John J. Carlos and Gaylord A. Van DeBogart have announced the formation of a new design office and practice, Kenn Trumble and Associates, 335 Buffalo Ave., Niagara Falls, N. Y.

Turner Construction Co. has opened a Chicago office in the Bankers' Bldg., 105 W. Adams St., under the direction of Clarke I. Knudson, contractor-engineer.

AT THE COLLEGES

Competition Announced

A competition among architectural students for the design of a model "shopping center of the future," conducted by the Store Modernization Show in cooperation with the American Institute of Architects, has been announced by John W. H. Evans, managing director of the Show. Judges will be a committee of the A.I.A. and retailing executives.

Twenty-two architectural colleges already have agreed to submit entries. There will be three prizes with cash awards of \$500, \$250 and \$125 respectively, and two honorable mention awards of \$75 each. Models and drawings of winning entries will be exhibited first at the Store Modernization Show at Grand Central Palace, New York, July 6-10, and later may be sent on tour of chambers of commerce in key cities of the United States and Canada.

The problem is the unification, both in interior and in exterior appearance, of a square block of retail stores into an ideal shopping center. The stores must be in a presently established commercial center of a city of approximately 75,000 inhabitants near each college campus. The model shopping center must include 10-12 medium-sized shops, a general food store or supermarket, a department store, a newsreel theater, a restaurant and snack bar, a nursery, a relaxation area for children and adults, and a street-level parking area.

Mies van der Rohe Exhibit

A comprehensive exhibition of the architecture of Ludwig Mies van der Rohe was shown on the campus of Illinois Institute of Technology last month. Designed and installed by the architect himself, the exhibit consisted of plans, renderings, and 12-ft. photographic reproductions of his chief works

(Continued on page 168)

WEISART

Compartments for Fine Buildings

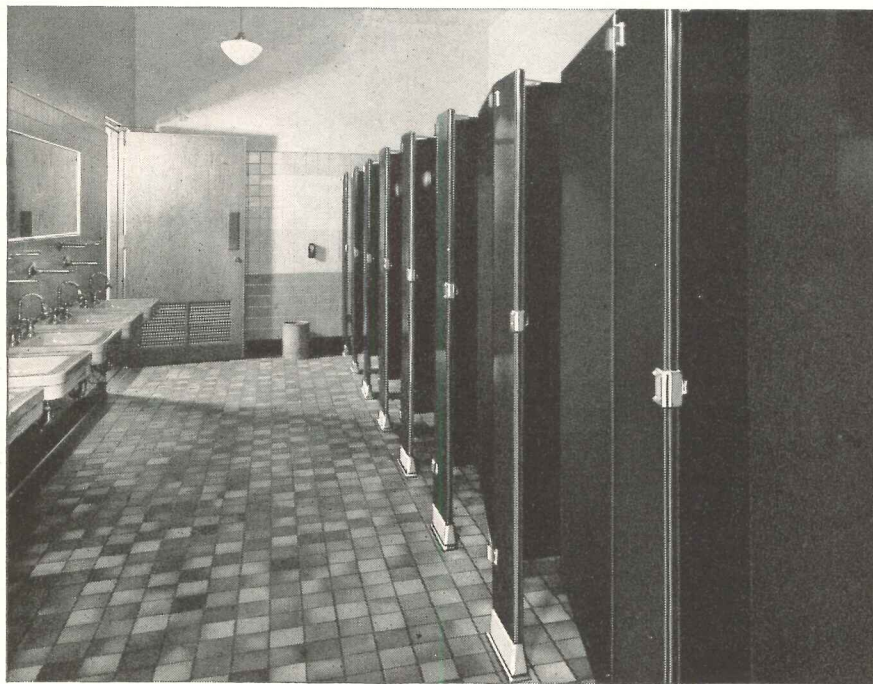

Typical WEISART installation in offices of the Liberty Mutual Insurance Co., Boston, Mass. Architect—Chester Lindsay Churchill, Boston

Designed and engineered to harmonize with new trends in finest buildings, WEISART Flush Compartments are thoroughly field tested, and have won wide acceptance. The rigid, flush stile construction eliminates posts and head rails. Weis cut-out type top gravity hinge permits doors and stiles to line up at top.

Doors, stiles and partitions are of highest class flush construction

of bonderized, zinc-coated steel, with edges locked and sealed. Synthetic baked enamel finish is easily cleaned, available in any solid colors selected for desired color treatment. Partitions and stiles are supported clear of walls, eliminating dirt-catching corners.

Write today for your copy of Catalog No. 19 containing detailed information on WEISART and WEISTEEL compartments.

Henry Weis Mfg. Co., Inc., 603 Weisway Bldg., Elkhart, Ind.

**Pennsylvania
builder uses
CHASE COPPER TUBE
RADIANT HEATING
in
185 homes!**

At Chester, Pa., F. A. Collins has erected 185 one-story, 6-room cellarless homes with Chase Copper Tube Radiant Heating. Wilson Bros., Collingdale, Pa., Heating Contractors.

HERE'S WHY

you, too, will want Chase copper tube in your Radiant Heating Installations!

- EASY TO BEND
- LIGHT IN WEIGHT
- SOLDERED FITTINGS
- SMALL DIAMETERS
- LONG LENGTHS
- LOW COST
- LONG LIFE



ONE advantage of Chase Copper Tube for radiant heating is the fact that no special bending tools are needed for installation. Flexible and small in diameter, it's easily bent by hand. It comes in long lengths of 60' and 100' requiring fewer joints. For ceiling installations, the light weight and smaller outside diameter of Chase Copper Tube is ideal. It can be installed in the standard 3/4" ceiling plaster coat.

These facts, and the many other advantages listed in the panel on the right, are the reasons why builders of low-cost housing as well as builders of expensive homes turn to Chase Copper Tube for radiant heating installations.

SEND FOR **FREE** BOOKLET!

For Radiant Heating information, cut and mail coupon today. Illustrated literature will be forwarded to you promptly.



MAIL THIS COUPON TODAY

Chase Brass & Copper Co., Dept. AR68
Waterbury 91, Conn.

Gentlemen: Please forward your new booklet "Suggestions For Designing Radiant Panel Heating with Copper Tube."

Name _____

Address _____

City _____ State _____

Chase



the Nation's Headquarters for
BRASS & COPPER

WATERBURY 91, CONNECTICUT

SUBSIDIARY OF KENNECOTT COPPER CORPORATION

THIS IS THE CHASE NETWORK . . . handiest way to buy brass

ALBANY† ATLANTA BALTIMORE BOSTON CHICAGO CINCINNATI CLEVELAND DETROIT HOUSTON† INDIANAPOLIS KANSAS CITY, MO. LOS ANGELES MILWAUKEE MINNEAPOLIS
NEWARK NEW ORLEANS NEW YORK PHILADELPHIA PITTSBURGH PROVIDENCE ROCHESTER† SAN FRANCISCO SEATTLE ST. LOUIS WATERBURY (†Indicates Sales Office Only)

Expansion Association, beginning in August.

For information regarding space requirements, weight and rental fees, address The American Federation of Arts, 1262 New Hampshire Ave., N. W., Washington 6, D. C.

MOBILE MUSEUMS

Scientific and industrial museums soon will operate on a "one-night-stand" basis. Sponsored by American Science

and Industry, Inc., four mobile museum units are being constructed which will travel to smaller communities throughout the country to acquaint the public with specific developments which are likely to affect living conditions in the future.

Howard T. Fisher & Associates, Inc., of Chicago have been retained as consultants on the construction of the units, planned for erection within six hours and dismantling in less than three. The

displays will consist of show-window cases, measuring 4 by 8 ft. Each industry in the group — including construction, electronics, plastics, aeronautics and transportation — has been allotted 20 such "windows" to be hung in sequence to present a fluid story of industrial and scientific progress.

OFFICE NOTES

Offices Opened, Reopened

Arnold Lawrence, Architect, has announced the opening of an office for the general practice of architecture in the Orford Bldg., 869 Main St., Manchester, Conn.

Sheldon M. Rutter, Industrial Designer, has announced resumption of his services specializing in traditional and contemporary furniture. Address: 212 E. 49th St., New York 17, N. Y., or (studio) Leatherhill Under, Wingdale-Webatuck, N. Y.

Milton Sherman, A.I.A., has reestablished his office for the practice of architecture and industrial design at 141 N. E. Third Ave., Miami 32, Fla.

New Addresses

The following new addresses have been announced:

John Hancock Callender, Architect, 299 Madison Ave., New York 17, N. Y.

Nairne W. Fisher, Architect, 111 W. Washington, Chicago 2, Ill.

A. Mertin, Architect, 467 Pearl St., New York 7, N. Y.

S. Z. Moskowitz, A.I.A., Deposit and Savings Bank Bldg., Wilkes-Barre, Pa.

Archie Protopapas, A.I.A., 121 E. 23rd St., New York 10, N. Y.

Schreier, Patterson & Worland, Architects, 1420 K St., N. W., Washington 5, D. C.

Abraham Waronoff, Architect, 1110 13th St., N. W., Washington, D. C.

Firm Changes

E. W. Bolton, Jr., A.I.A., Briton Martin, A.I.A., and Theo B. White, A.I.A., have announced the formation of a partnership under the firm name of Bolton, Martin & White, Architects, and the moving of their offices to 266 S. 17th St., Philadelphia 3, Pa.

William E. Brackett, Jr., and Marion McD. Brackett have announced the opening of the office of William E. Brackett, Jr., Architect, in the Technical Bldg., Asheville, N. C.

Rosario Candela has announced the formation of a partnership with Paul Resnick under the firm name of Rosario Candela, Architect — Paul Resnick, Associate Architect. Address: 654 Madison Ave., New York 21, N. Y.

Chas. W. Ertz, A.I.A., Morgan H. Hartford, A.I.A., and Otto J. Kuettner,

(Continued on page 166)

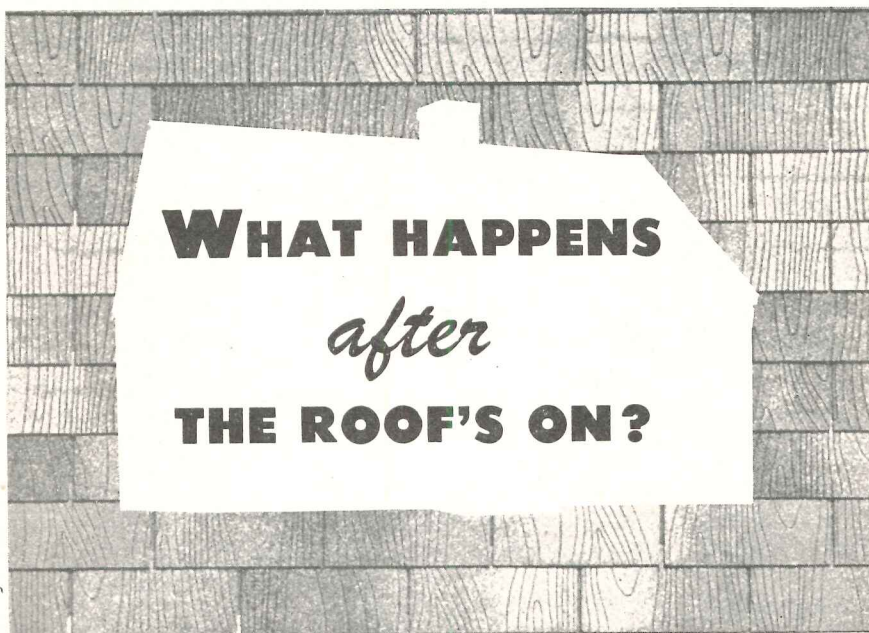

A roof is no better than its shingle . . . and unless it's a *good* shingle, the effort and skill you put into your building is wasted.

Bird Masterbilt Thick Butt Shingles stand the test of time . . . a Bird roof is a better roof. *Extra* layers of asphalt and deeply embedded mineral granules give tough lasting protection *where it counts* . . . on exposed tabs. The rugged surface defies weather . . . and fire resistance is greatly increased for the long life of the shingle. Narrower cut-outs and heavier shadow-lines give added massive beauty . . . and a wide range of handsome lasting colors and blends is available.

Test Bird Masterbilt Shingles yourself . . . compare them. They are your assurance of years of extra wear, of lasting beauty.

★ ★ ★

Bird helps you build better homes in many ways. Neponset Black Vapor Barrier guards against costly damaging in-wall condensation, yet costs approximately \$20 for a \$10,000 house. Investigate it today.

East Walpole,
Mass.

BIRD & SON, inc.

Established
1795

New York

Shreveport, La.

Chicago

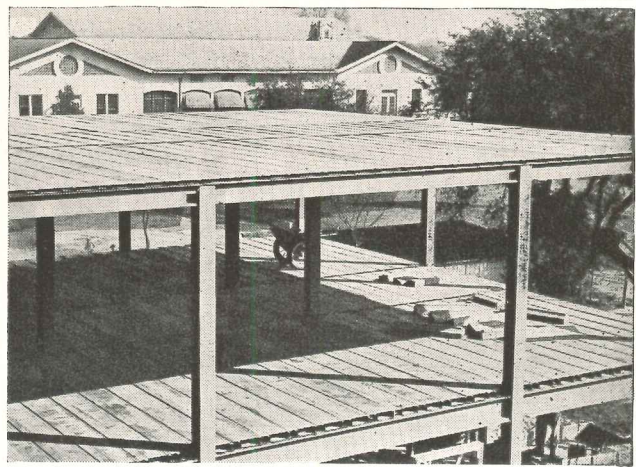
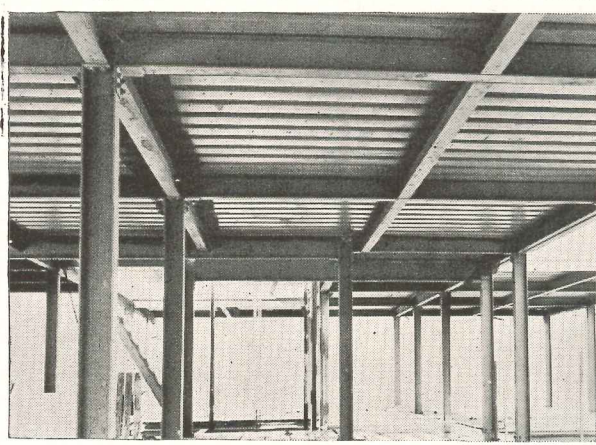

Duval County Psychiatric Hospital, Jacksonville, Florida—Architect: Reynolds, Smith & Hills; Contractor: George D. Auchter Company

Fireproof Construction

...in a hurry!

Speed may not be the first requirement—but it's an important factor in many construction jobs these days.

It follows right on the heels of those prime requirements—good fireproof construction and low cost.

To get all three benefits, Fenestra* Metal Building Panels were specified for this building. 7,200 square feet of 1½"-deep Type D Panels were used as base for its built-up roof. 14,200 square feet of 3"-deep Type D Panels were used for the second and third floors, a concrete slab being poured over the panels and a suspended

ceiling installed underneath for fireproof construction.

Fenestra Panels are quickly laid and interlocked without special skills or special tools. Other work can proceed without delay . . . the panels provide a flat surface that is ideal for wheeling in other materials.

Fenestra Building Panels are suitable for all types of buildings. They save construction time and money, not only in floors and ceilings, but also in walls, partitions and roofs. See Sweet's Architectural File for 1948 (Section 3c-1) or mail the coupon for full information. *Trademark

THESE NONCOMBUSTIBLE FENESTRA PANELS SPEED ALL TYPES OF CONSTRUCTION



TYPE C FOR WALLS. Two metal members pressed together, with felt at each side to prevent metal-to-metal contact. Filled with insulation and closed at the ends, at the factory. Standardized in 3" depth and 16" width, in 18 gage painted steel or 16 B & S gage aluminum.

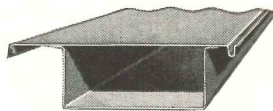

TYPE D FOR FLOORS. Box beam formed by welding together two steel sections. Side laps interlock to form continuous flat surface. Standardized in 16" width. Depth 1½" to 9". Gages 18 to 12. Type AD available with two flat surfaces.



HOLORIB ROOF DECK. Steel sheets reinforced by three integral triangular ribs on 6" centers. Flat surface for mopped application of insulation and roofing. 18" wide. Lengths to 24' to fit. Gages 18 and 20 are standard.

Fenestra

BUILDING PANELS FOR

ROOFS

WALLS

FLOORS

DETROIT STEEL PRODUCTS COMPANY
Building Panels Division
Dept. AR-6, 2252 E. Grand Boulevard
Detroit 11, Michigan

Please send me, without obligation, information on Fenestra Building Panels.

Name _____

Company _____

Address _____

(Continued from page 160)

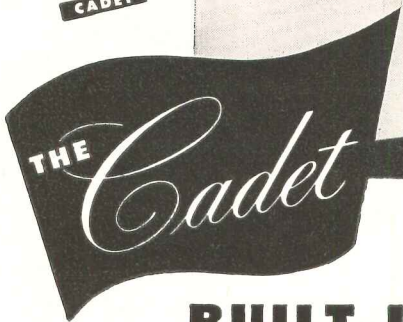

BUILT-IN SHOWER CABINET

DESIGN NO. 19-B

The built-in Cadet promises to be one of the most popular shower cabinet models in the Fiat line. Redesigned with new construction features such as the elimination of all interior screws and with smooth curved corner joining the Cadet can be classed as the modern shower of the future.

The demand for the ultimate in clean cut appearance, and the trend toward a built-in or enclosed shower has inspired the new built-in Cadet. Equipped with a Zephyr or Dolphin glass door as illustrated the Cadet model 19-B is a natural for installation in the average, as well as the better class of homes.

The exclusive Fiat escutcheon type door frame conceals the joint between wall material and cabinet stiles. This unit is of particular interest to operative builders because of its beauty of design and savings over built-on-the-job shower construction.

Size 36" x 36" x 80", receptor precast terrazzo with cast-in drain. Walls, bonderized, galvanized, steel finished in white baked-on synthetic enamel. Can be supplied with Dolphin or Zephyr glass door, or shower curtain.

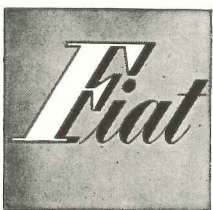

Metal Manufacturing Company

CHICAGO 13, ILL.

LONG ISLAND CITY 1, N. Y.

LOS ANGELES 33, CALIF.

In Canada Fiat showers are manufactured by The Porcelain and Metal Products, Ltd., Orillia, Ont.

mentation will have to be on an individual basis. It is possible that some chapters of the Institute may be in a position to sponsor and organize units, even of company size. However, for the most part, it is anticipated that interested architects who are equipped to do so will make application individually."

Architects who affiliate with the Corps of Engineers are given definite assignments on the organization tables of various reserve military battalions, companies and detachments. There are more than 1000 Engineer units ranging in size from Engineer Construction Groups to highly specialized Engineer Model Making Detachments. Opportunities for affiliation of architects with other branches of the Armed Services will be made possible in the future, Mr. Purves reported.

He pointed out that the present announcement pertains only to the Corps of Engineers of the Army, but that opportunities for affiliation of architects with other branches of the armed services will be made possible in the future, as the effort progresses toward organization of the civilian potential.

STORE-PLANNING CLINICS

A five-day conference on problems of store modernization to coincide with the International Store Modernization Show at Grand Central Palace, New York, July 6-10, has been announced.

Clinics will be conducted twice daily at 1:30 and 4:00 p.m. for the five days. Subjects to be covered are "Store Layout and Traffic," "Store Lighting and Color," "Displays and Fixtures," "Store Fronts," and "Planning and Budgeting for Modernization." Each panel will be conducted by retailing executives, store architects and designers, and manufacturers of modernization equipment. Slides and other visual aids will be used.

Invitations to the Show and advance registration cards for the conference may be obtained from John W. H. Evans, managing director of the Store Modernization Show, 40 E. 49th St., New York 17, N. Y.

EXHIBIT AVAILABLE

The American Federation of Arts, Washington, D. C., has announced a new traveling exhibition, "St. Louis' Jefferson Memorial Competition." The exhibit consists of 35 drawings commemorating St. Louis' position as "The Gateway of the West," and includes the prize-winning designs. The national tour of 10 museums and galleries is sponsored by the Jefferson National

(Continued on page 164)

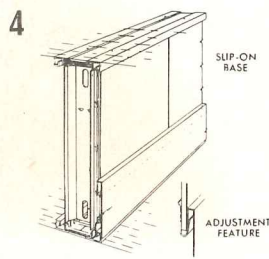
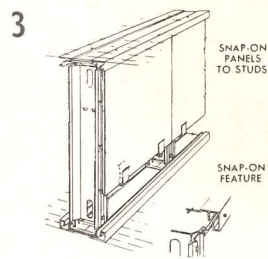
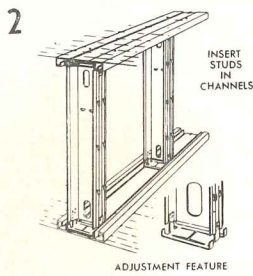
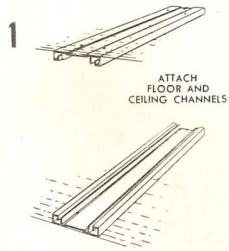
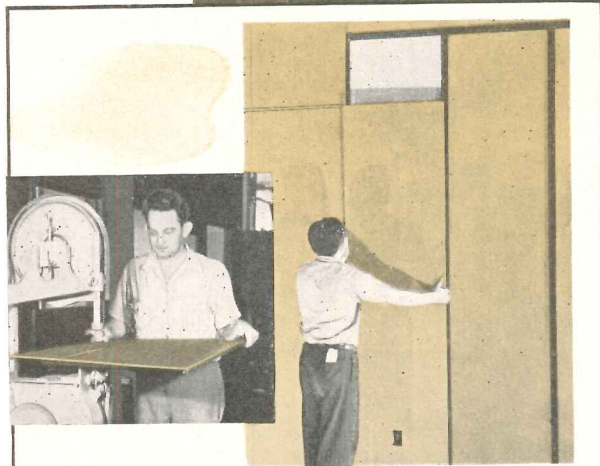
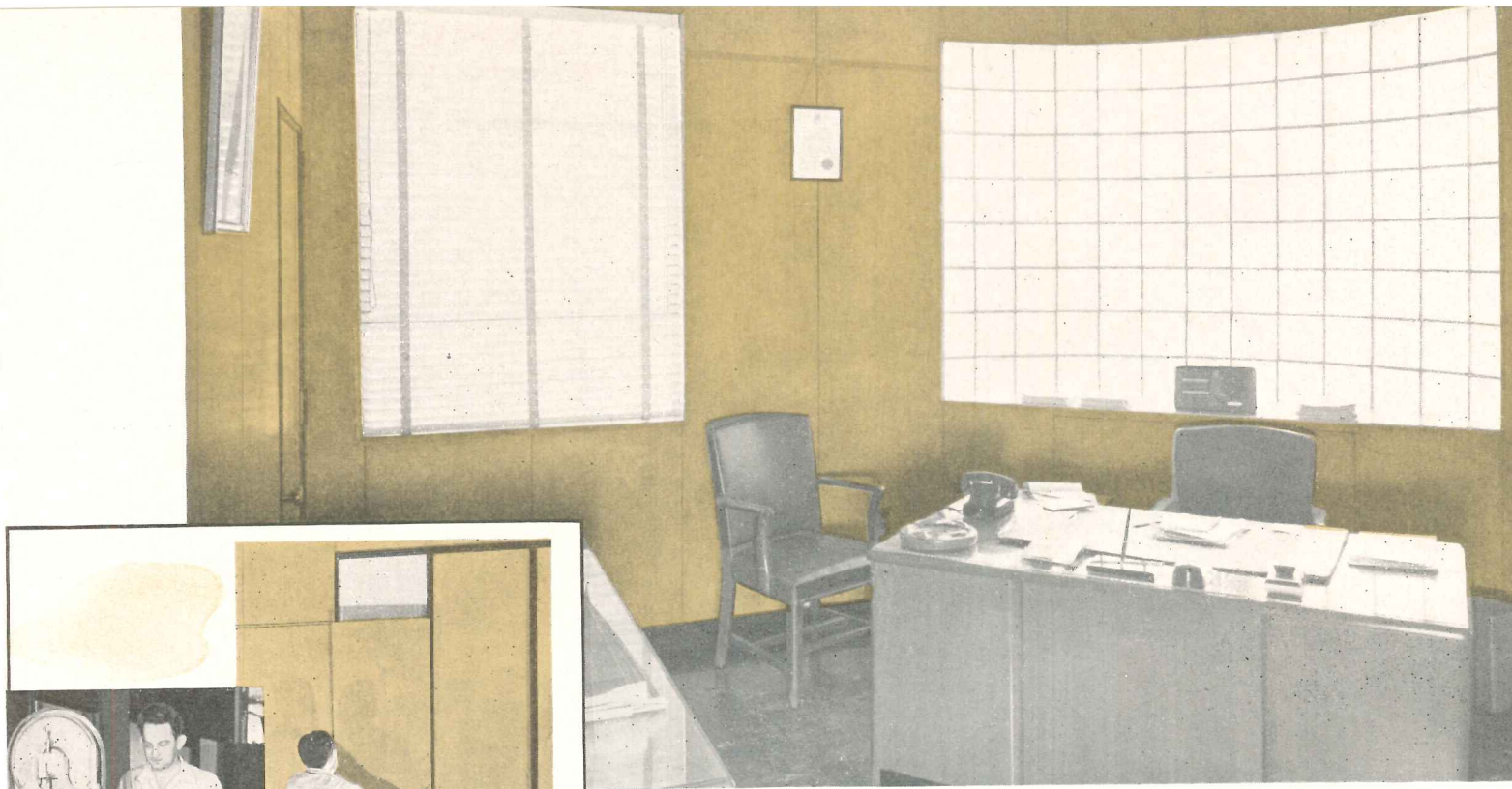

EASY ON THE EYES! Martin-Parry Metlwal Movable Partitions and Panelings are factory finished in rich, natural wood grain reproductions or baked enamel finishes in a wide variety of colors. These beautiful surfaces will not chip, crack or craze . . . *do not reflect harsh, metallic light* . . . are Bonderized against rust and corrosion.

EASY TO ERECT! Four simple steps are taken to install Metlwal. Workability is complete since all panels and parts may be cut on the job, as shown at the left. *And the Metlwal panel can be handled in full-size by one man.*

MODERN PRODUCTION FACILITIES! Martin-Parry's modern, fully automatic production equipment . . . in our new Toledo plant (below) . . . insures uniformity necessary to preserve the interchangeability of Metlwal panels. Martin-Parry's painstaking quality-control pays dividends in long-wearing installations that hold maintenance costs to a new low.

WRITE TODAY for your copy of our latest catalog A-6. See how Metlwal can help you plan beautiful interiors—quickly cover interior walls and divide space—with *only a few standardized parts, from local distributors' warehouse stock.* Learn why

Metlwal is easily movable without waste—easy to maintain—eliminates the need for plaster in new construction and for filler boards of other materials at ends or above cornice level. Just drop a line to: Martin-Parry Corp., Toledo 1, Ohio.



MARTIN PARRY
MP
 PRODUCTS

METLWALS

**ALL-FLUSH PANELING
 MOVABLE PARTITIONS**

68 Years of Service

ENGINEERING AND ERECTING SERVICE AND
 WAREHOUSE STOCKS FROM COAST-TO-COAST

Bertha... "THE SEWING MACHINE GIRL" is really cozy now!



How to keep 25,000 square feet of unbroken floor area warm enough that women's fingers could keep pace with high speed sewing machines, even on coldest days? Mr. M. M. Barry, manager of the Connellsville Sportswear Company, a garment manufacturing plant in Connellsville, Pennsylvania, had this seemingly expensive heating problem to solve.

Mr. Barry found a simple, low-cost solution by providing heat directly at working level with Dravo *Counterflo* Heaters. Four heaters, one on each wall, blanket the factory working area with a draft-free "cross-fire" of warm air above the heads of the workers. Heat distribution is uniform at 72 to 75 degrees throughout.

Completely automatic, the Dravo *Counterflo* Heaters require only a fuel line, power line and short vent stack—no boiler room. The thermostat is lowered or shut off completely at night for additional, important economies.

Dravo heaters produce warm air quickly. Sturdy, carefully engineered construction, plus a stainless steel combustion chamber, minimize maintenance cost. Equally efficient with oil or gas, sizes ranging from 400,000 to 2,000,000 BTU per hour output are available. A touch of the selector switch converts them immediately to high-capacity air-circulating units for summer use.

If you would like more information to help solve your own heating problems, write for Bulletin JE-516, Heating Section, Dravo Corporation, Dravo Building, Pittsburgh 22, Pennsylvania.



Living room comfort speeds production and cuts absenteeism in this modern garment manufacturing plant. As the manager, Mr. Barry says, "Women employees cannot be expected to operate sewing machines properly if their hands and feet are cold or if they are otherwise uncomfortable."

Dravo also manufactures the **DRAVO CRANE CAB COOLER** for air conditioning hot-metal crane cabs

DRAVO CORPORATION

Sales Representatives in Principal Cities

PITTSBURGH • CLEVELAND • PHILADELPHIA • DETROIT
NEW YORK • CHICAGO • ATLANTA • BOSTON



THE RECORD REPORTS

(Continued from page 22)

of \$1,317,256,000 reported by the Corporation for 1946. During the first quarter of this year manufacturing building contracts in the 37 eastern states totaled \$181,240,000 against \$242,495,000 during the corresponding quarter of last year.

WITH THE A.I.A.

Walker and Levi Will Represent A.I.A. at Lausanne

Ralph Walker and Julian Clarence Levi, both F.A.I.A., of New York, have been chosen to represent The American Institute of Architects at the First Congress of the International Union of Architects from June 28 through July 1 in Lausanne, Switzerland. The Congress is expected to attract architects from throughout the world to discuss such subjects as: "The Architect and Planning," "The Architect and the Industrialization of Building," and "The Architect, State and Society."

Mr. Walker, a member of the New York firm of Voorhees, Walker, Foley and Smith, is a past president of the New York Chapter, A.I.A., and the Architectural League of New York. He served on the Board of Trustees of the Beaux Arts Institute of Design for eight years, and is a member of the New York Citizens Housing Council.

Mr. Levi, a member of the New York firm of Taylor and Levi, and chairman of the Institute's Committee on International Relations, served as chairman of the U. S. Delegation to the VI Pan American Congress of Architects held in Lima, Peru, last year. He has held the offices of treasurer, secretary and vice president of the New York Chapter, A.I.A., and is a former president of the Architectural League.

Army Program Endorsed

The Executive Committee of the Board of Directors of the A.I.A. has endorsed a War Department affiliation program which will enable architects to serve in a reserve capacity with the Army Corps of Engineers.

In announcing the endorsement, Edmund R. Purves, Director of Public and Professional Relations of the Institute, said: "The Affiliation Programs initiated by the War Department are conceived in the belief that it is advisable for the country to so organize its potential as to insure that in the event of an emergency there will be available a trained reserve.

"In the case of the A.I.A. the endorsement is general, but the imple-

(Continued on page 162)



This metal label is fastened to the top edge of every Weldwood Fireproof Door.



Picture shows absolute protection afforded by Weldwood Fireproof Door. After withstanding an intense fire for sixty minutes, the Weldwood Fireproof Door still prevented passage of fire, smoke, heat, gases and remained cool to the touch on the unexposed side.

Announcing THE NEW WELDWOOD FIREPROOF DOOR

Weldwood Fireproof Doors bear the official label of the Underwriters' Laboratories (official testing agency for fire insurance Underwriters).

They attained the one-hour fire rating by withstanding a free-burning fire for one hour, the ultimate temperature being 1700°. And after that, the impact of a 30-pound pressure hose stream, applied 20 feet from the fire side, for one minute.

Weldwood Fireproof Doors are a *must* for hospitals, schools, institutions, offices, and apartment buildings.

And these amazing doors are as beau-

tiful as they are safe! They're dimensionally stable . . . stay straighter and are lighter in weight than other fireproof doors. The original cost is moderate, maintenance cost is practically non-existent, and Weldwood Fireproof Doors last for the life of the building.

For additional information write to: United States Plywood Corporation, New York 18, N. Y.

A Wood-Faced Fireproof Door which offers all these advantages

1. Increased Safety

The *only* wood-faced fireproof door which bears the Underwriters' label. All Weldwood Fireproof Doors are approved for class B openings.

2. Beauty

Because of their beautiful wood faces Weldwood Fireproof Doors harmonize perfectly with any decorative scheme.

3. Durability

The Underwriters' Laboratories tested a Weldwood Fireproof Door for durability by mechanically opening and closing it 200,000 times. At the end of the test, the door was unaffected and still opened and closed perfectly.

4. Dimensional Stability

Weldwood Fireproof Doors are so dimensionally stable that we guarantee them against sticking in summer or rattling in winter due to any dimensional changes in the door.

5. Light Weight

At last . . . a really fireproof door that is *not* heavy or unwieldy. A standard 3 x 7 door weighs approximately 80 lbs.

6. Vermin and Decay Proof

The mineral composition Kaylo core used in Weldwood Fireproof Doors is permanently resistant to fungus, decay, and termites.

7. High Insulating Qualities

Another noteworthy characteristic of Kaylo insulation is its high insulating value over a wide range of temperatures. It is efficient against temperatures from freezing up to that of superheated steam.

8. Moderate Cost

Investigate these doors for use on your next job. You will be pleasantly surprised at the low initial cost, and the minimum of maintenance required.

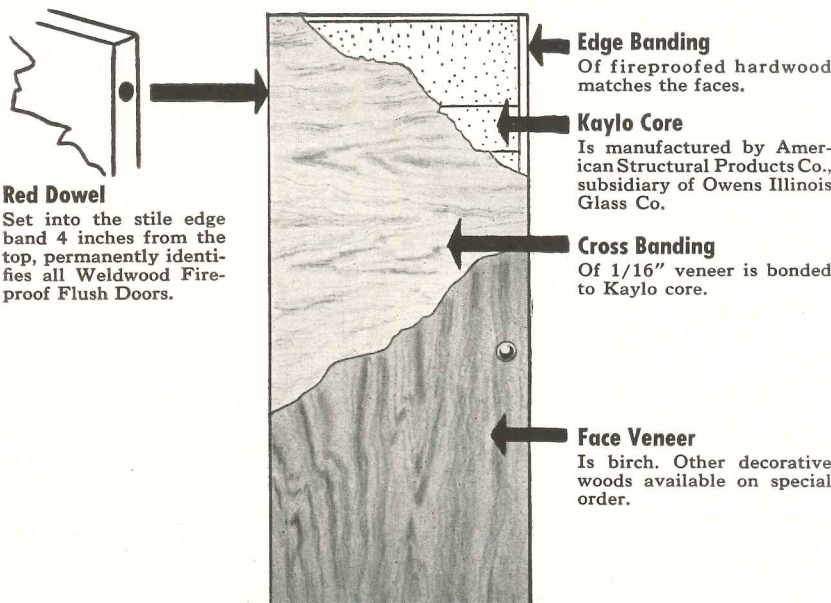

UNITED STATES PLYWOOD CORPORATION

55 West 44th Street, New York 18, N. Y.

Distributing units in Baltimore, Boston, Brooklyn, Chicago, Cincinnati, Cleveland, Detroit, Fresno, High Point, Los Angeles, Milwaukee, Newark, New York, Oakland, Philadelphia, Pittsburgh, Portland, Ore.; Rochester, San Francisco, Seattle. Also U. S.-Mengel Plywoods, Inc. distributing units in Atlanta, Dallas, Houston, Jacksonville, Louisville, New Orleans, St. Louis, Tampa. In Canada: United States Plywood of Canada, Limited, Toronto.



Boston University's Administration Building lobby. Architect, Cram & Ferguson; Terrazzo Contractor, De Paoli Mosaic Co.; both of Boston

For lasting beauty in Terrazzo

ATLAS WHITE CEMENT

Here's a floor that withstands constant pounding and scuffing of feet, yet retains its colorful beauty. It's Terrazzo... made with a matrix of Atlas White Cement.

Atlas White Cement sets off the color values of aggregates or pigments used in Terrazzo, Stucco, Cement Paint and Architectural Concrete Slabs. Such a white matrix has the uniform clarity to complement the desired colors, whether in contrast or blend.

Atlas White complies with Federal and ASTM specifications for portland cement. It has the same advantages for concrete and is used in the same way. Atlas White concrete looks clean, fresh and colorful... and it cleans easily. Maintenance costs are low.

For further information on the uses of Atlas White Cement, see SWEET'S Catalog, Sections 4B/2 and 13B/8, or write to Atlas White Bureau, Universal Atlas Cement Company (United States Steel Corporation Subsidiary), Chrysler Building, New York 17, N. Y.

AR-T-13

FOR BEAUTY AND UTILITY

ATLAS WHITE CEMENT

FOR TERRAZZO, PAINT, SLABS, STUCCO



"THEATRE GUILD ON THE AIR"—Sponsored by U. S. Steel Subsidiaries
Sunday Evenings—September to June—ABC Network

THE RECORD REPORTS

(Continued from page 156)

construction supply picture. According to a second government report, dealing with the 1948 production of building materials in Canada, it is brighter than ever before. Of 30 key items surveyed, increases of from 10 to 50 per cent are expected in 10, existing or slightly higher levels will be maintained for 18, and decreases will be shown by only two — i.e., cast iron water pipe and fittings, and cast iron radiators.

With supply bottlenecks all but eliminated there appears to be little in the way of Canadian public and private investment totaling \$4 billion in 1948.

Summer School Held

A summer school for architects, town planners, surveyors and others interested in land subdivision for community purposes is now in session (May 31 to June 9) at Macdonald College, Ste. Anne de Bellevue, Quebec. Sponsor is the School of Architecture, McGill University.

The course, which is concerned with the technical and administrative aspects of planning as they apply to central and eastern Canada, is being conducted with few lectures and much discussion. The first section of the program is devoted to investigation of needs and practices, and formulation of tentative standards. The second section is reserved for analysis and solution of actual planning problems.

List Restricted Imports

At its members' request, the Royal Architectural Institute of Canada has prepared a memorandum concerning construction materials whose importation is restricted by the Dominion Government.

Now on the banned list, according to the R.A.I.C. memorandum, are tarred paper, prepared roofings and shingles, insulation (including mineral wool, but not including fiber glass), building boards, wall papers, fillers, paints and varnishes, plumbing fixtures, semi-manufactured lumber, hardwood flooring, door and window frames and sash, plywoods and veneers, millwork and wire screens. Importation is also prohibited of building stone, marble, granite, structural iron and structural steel. Equipment items denied entry include refrigerators, domestic washing machines, apparatus designed for heating (including boilers), air conditioning and cooking, electric light fixtures and appliances, and domestic water heaters and garbage disposal units.

While the list has been approved by the government as of April 1, it is subject to change without notice.

LESS LOST LIGHT...LESS DEAD WEIGHT

**Alcoa Aluminum
Head**

**Alcoa Aluminum
Egg-crate Diffusers**

**Alzak* Aluminum
Reflector Surface
on Aluminum
Reflector Shell**

**ALZAK* REFLECTORS
IN ALUMINUM FIXTURES**

**Alcoa Aluminum
Tubular Hangers**

More light where you want it when you install high-efficiency Alzak Aluminum Reflectors. Made by leading manufacturers of all types of lighting, Alzak-treated aluminum may have a reflectivity as high as 83%. And they maintain high efficiency even in severe industrial exposures. Normal grime is readily removed with soap and water to keep them at top efficiency.

Alzak Reflectors are aluminum throughout . . . cannot spall nor rust if dented. They are light in weight to reduce loads on supports and structures.

Get maximum savings in weight and avoid periodic painting . . . order fixtures with Alcoa Aluminum Tubing for hangers, and Alcoa Aluminum Castings for head housings, end fittings, and other parts.

Your electrical supplier carries complete lines of Alzak Aluminum Reflectors made by leading manufacturers. Tell him you want to go aluminum all the way.

ALUMINUM COMPANY OF AMERICA, 1474 Gulf Building, Pittsburgh 19, Pennsylvania. Sales offices in 54 leading cities.

*Patented process

ALCOA FIRST IN
ALUMINUM



1888

1948

60 YEARS OF SERVICE

Better CONTROL of Door Costs



Quick, easy, push-button control featured by Kinnear Motor Operated Rolling Doors gives you a tighter grip on *all* door costs. It helps cut heating and air-conditioning costs through prompt, rapid closing of doors. It saves time and steps (you can have any needed number of additional controls at remote points). It avoids traffic bottlenecks at doorways. And along with these operating advantages, you get the extra durability, protection and space-saving efficiency of these rugged, all-steel doors with their

MOTOR OPERATED
with **KINNEAR** STEEL ROLLING DOORS

world-famous *coiling upward* action. Built any size, for installation in old or new buildings. Write today for complete information.

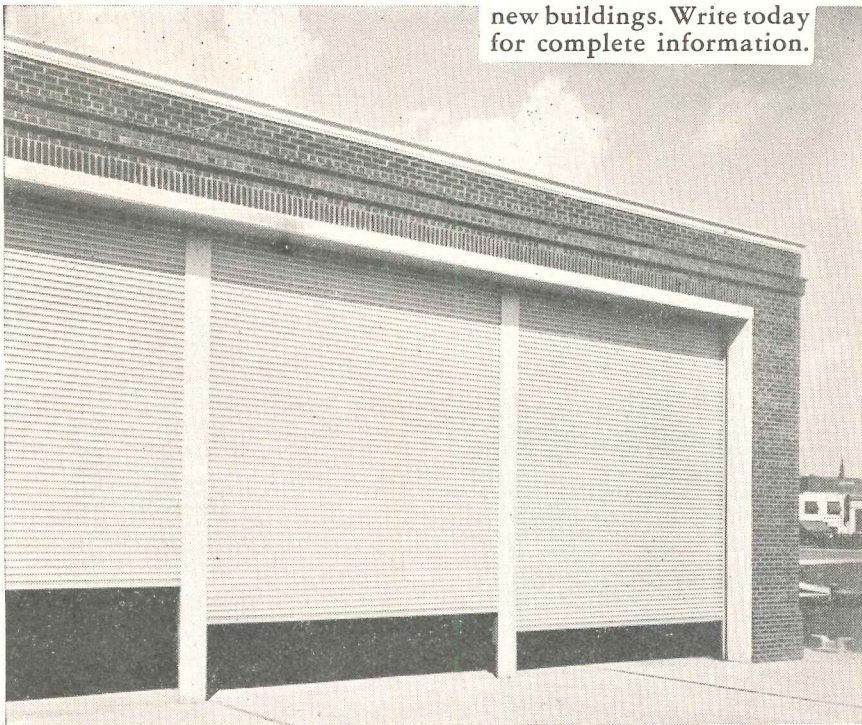

"Saving Ways in Doorways"

KINNEAR
ROLLING DOORS

The KINNEAR MFG. CO.

FACTORIES

1860-80 Fields Ave.
Columbus 16, Ohio

1742 Yosemite Avenue
San Francisco 24, California

Offices and Agents in Principal Cities

THE RECORD REPORTS

(Continued from page 10)

Quebec government two months previously. The latter ear-marked \$3.5 million to pay a 3 per cent share of the 5 per cent interest rate on mortgage loans made by the province, credit unions and other lending agencies. The loans, amortized over a 30-year period, are limited to \$6000 for the first dwelling unit, and \$4000 each for additional units provided under the same roof. An earlier bill authorized municipalities to make cheap land and tax exemptions available for new housing.

Town Planners Confer

The first annual meeting of Canada's newly incorporated Institute of Professional Town Planners was held recently in Toronto. Chief concerns of the Institute are "the development of urban communities and their environment as social and economic units, and the development of geographical and political regions."

The main item on this year's agenda was discussion of the achievements of the Ontario Planning Act. Since it came into force two years ago, 65 planning boards have been established. They have jurisdiction over 120 of the province's 900 municipalities and represent the interests of well over half the population.

Guest speaker Frederick J. Adams, president of the American Institute of Planning, urged his Canadian confreres "to elevate the standards of community planning to the highest levels."

New Investment Record

Canada is likely in for another spurt of inflation. This conclusion is drawn from a recent Dominion Government report on the 1948 investment plans of businesses, institutions, governments, and individual farmers and house builders. It reveals that capital expenditures for new construction, machinery and equipment are expected to reach \$2.8 billion, 17 per cent more than in 1947. Current expenditures for repairs and maintenance are expected to reach \$1.2 billion, 4 per cent more than in 1947.

The stimulus these huge spending programs will have on the Canadian economy may not be as great as percentage increases indicate. The higher figures are due more to an increase in prices than an increase in physical volume. Nevertheless, they are almost certain to blow the inflation kite still higher.

The government report says "repair and maintenance expenditures draw on virtually the same pool of scarce materials that new investment does." Of utmost importance, therefore, is the

(Continued on page 158)

SCHOOL CLASSROOM DETAILS

(Continued from page 153)

Standardized storage furniture including portable units

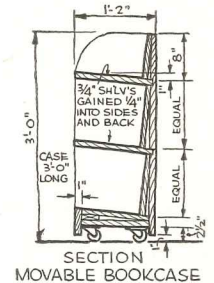
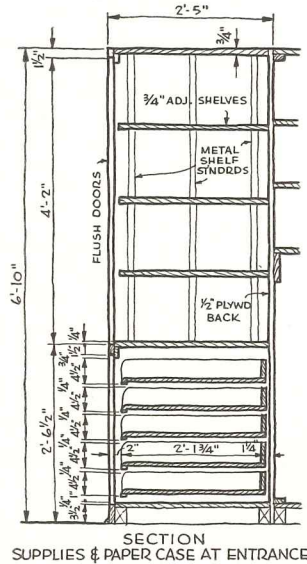
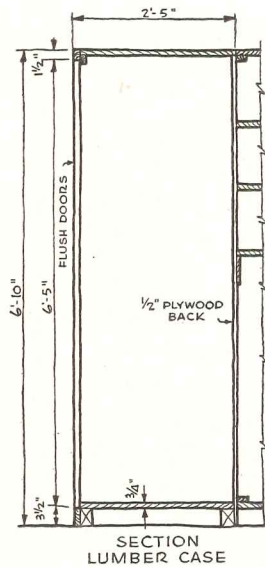
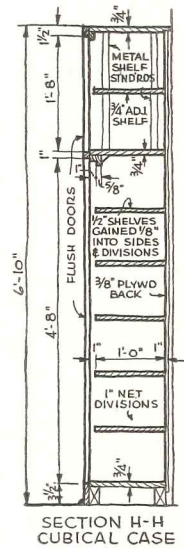
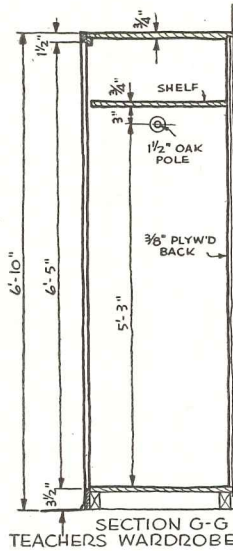
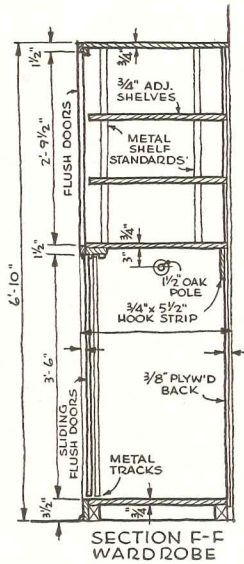
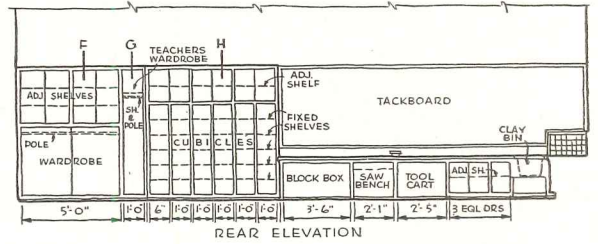
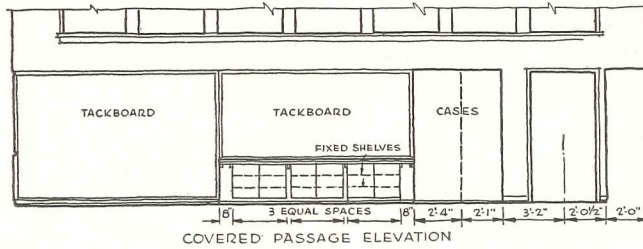

Details are keyed to elevations above, indicating a typical 30 ft. square room

SAVE
INSTALLATION
TIME...

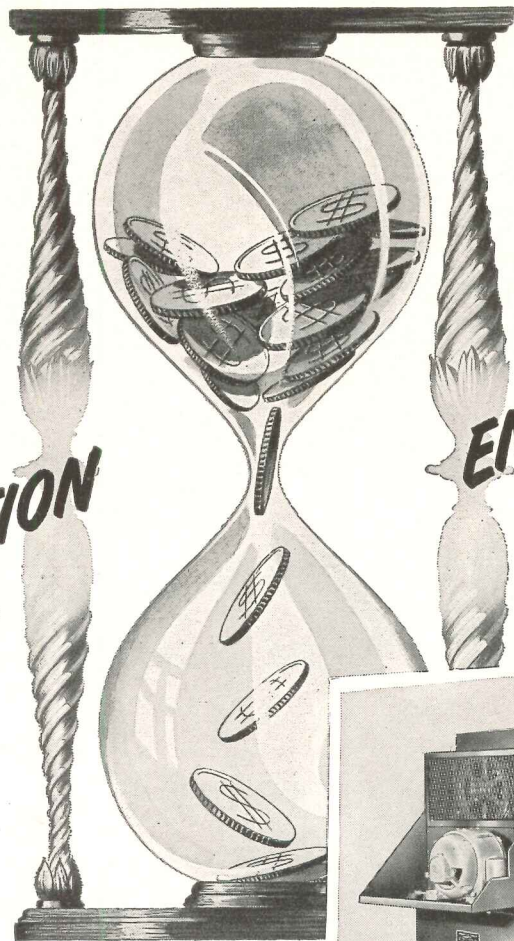

SAVE
ENGINEERING
TIME...

Central Plant Air Conditioner offers

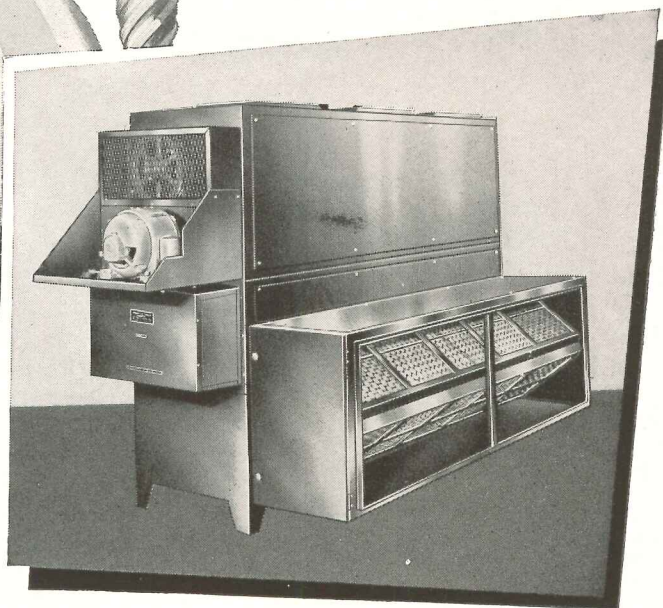

Flexibility plus easy installation

TRYING to keep costs down on air conditioning jobs? Then you'll like the time-saving, space-saving features of a General Electric Central Plant Air Conditioner.

This compact, light-weight equipment can be arranged in 12 different ways . . . for either horizontal or vertical discharge of air . . . motor and coil connections on either right or left side.

All basic sections will pass through a standard

30" door. That means no knocking down of walls . . . no disassembling of sections into small pieces.

A horizontal or vertical G-E Central Plant Air Conditioner . . . for standing or suspended installation . . . will give your client long-lasting, reliable service at lower overall cost. Check with your local G-E Air Conditioning specialist.

General Electric Company, Air Conditioning Department, Section A8446, Bloomfield, New Jersey.

GENERAL  ELECTRIC
Better Air Conditioning

SCHOOL CLASSROOM DETAILS

Standardized storage furniture including portable units

Curtis, Kistner and Wright, Architects and Engineers

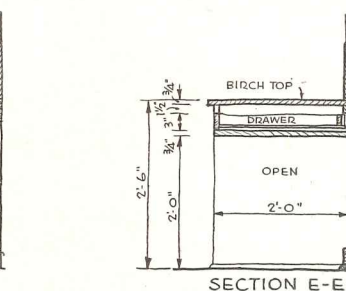
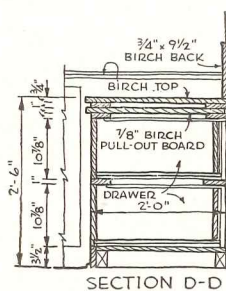
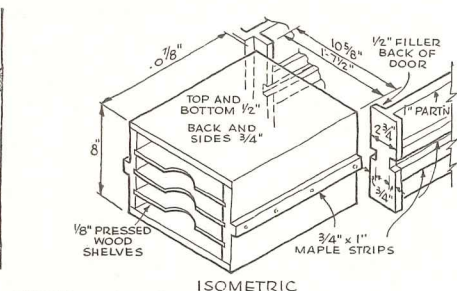
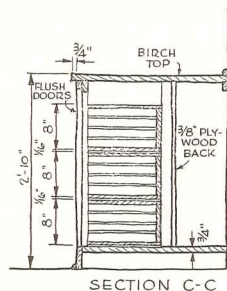
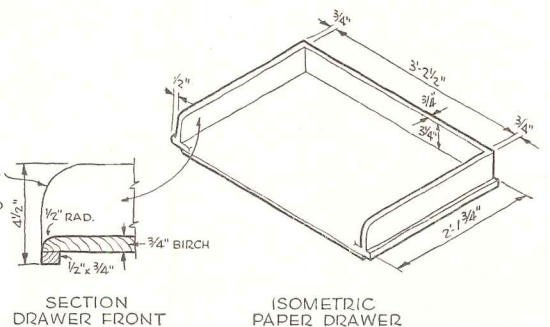
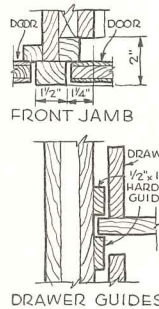
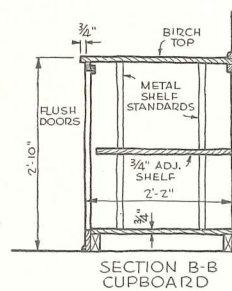
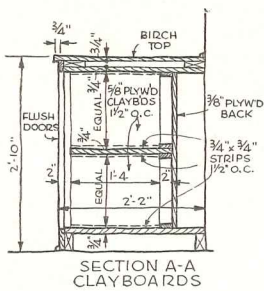
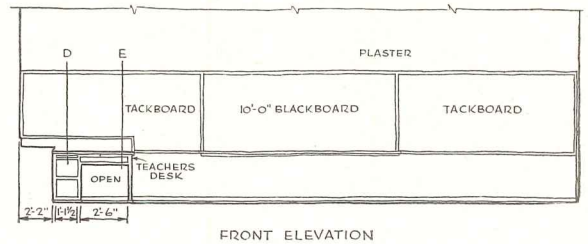
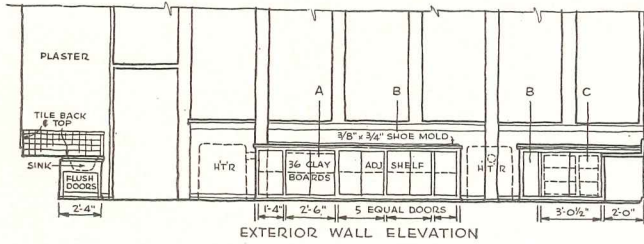

Classroom storage furniture seen on this page and on page 155 has been thoroughly tested in use over a period of years during which the architects have been repeating the elements, with minor variations and occasional improvements, over a large number of schools.

A leading feature is that many of the smaller units, such as sets of shelves for "construction" paper and the like, can be carried bodily to desks and replaced at the end of the school period, saving steps and confusion during class.

Details are keyed to elevations of a typical classroom, approximately 30 ft. square, having unit heater-ventilators.

A useful unit, not shown, is a nest of "sawhorses" in the form of boxes with two sides left open for nesting and clamping purposes.

(Continued page 155)

OPTICALLY ENGINEERED

for architectural harmony
and efficient planned lighting

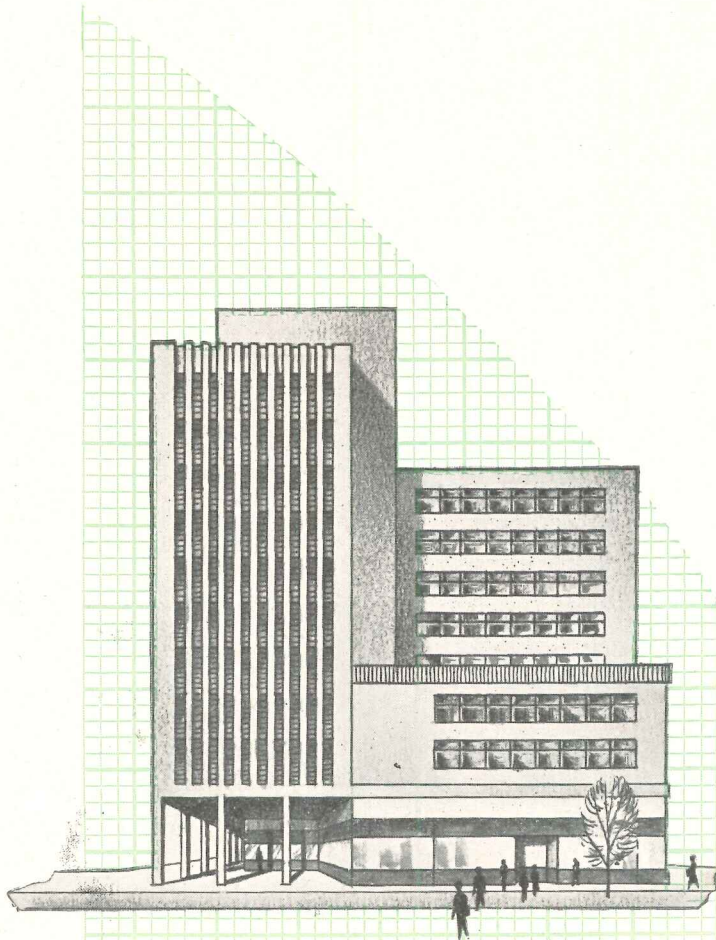

As you develop your building designs, you strive for highest lighting efficiency in harmony with architectural beauty.

You can solve this problem without compromise by planning the lighting around Day-Brite fluorescent fixtures. They are engineered to provide optimum visual conditions and their functional simplicity will blend beautifully with your architectural motifs... modern or traditional.

May our lighting engineers assist you?

Many leading architects find our service helpful in planning complex layouts or special lighting effects. Our wealth of experience is yours for the asking. Write us any time.

Aluminum Recessed Troffers. Snap-in and Flange Type for acoustical or plaster ceilings... unit or continuous installations. Designed for two 40-watt fluorescent lamps. May we send you Bulletin 20-B with more detailed information?

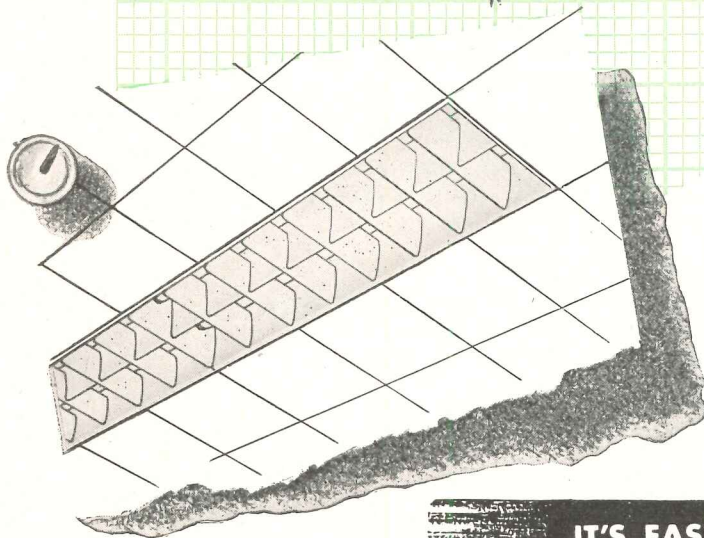

013

IT'S EASY TO SEE WHEN IT'S

DAY-BRITE

Lighting

Day-Brite Lighting, Inc., 5465 Bulwer Avenue, St. Louis 7, Mo.
Nationally distributed through leading electrical supply houses.

In Canada: address all inquiries to Amalgamated Electric Corp.,
Ltd., Toronto 6, Ontario.

**This picture shows
two important things...**



This picture shows two things that, in six months, caused architects to specify *25 million* square feet of the new Celotex Preseal Roof Insulation on major jobs throughout the country—

1. "PRESEAL" REDUCES DANGER OF MOISTURE

A factory-coating of special asphalt on both surfaces and all edges protects Celotex Preseal against moisture... *before, during, and after* installation.

2. "PRESEAL" INSURES A STRONGER BOND

The coating has an affinity for the mop... insures a thorough bond to roof deck and to roofing felts of either the asphalt or coal tar pitch type. Application is easier and faster.

These qualities *plus* uniform, high thermal insulation, make Celotex Preseal a roof insulation you can specify without a worry. Its firmness resists fracturing of the roofing felts under traffic during and after application.

YOU ARE INVITED to ask for comparative costs and thermal values on Celotex Preseal Roof Insulation. Please write direct to our Chicago office...

THE CELOTEX CORPORATION, CHICAGO 3, ILLINOIS

In the meantime, you'll find detailed specifications on all Celotex products listed in Sweet's File

CELOTEX REG. U.S. PAT. OFF. *Preseal* **ROOF INSULATION**

MANUFACTURERS' LITERATURE

Fireplaces

100 Fireplace Ideas. Booklet containing sketches of the most practical fireplaces of the past and present including European, Old Inglenook, New England Colonial, Southern Colonial and Modern. A wide variety of material applications is shown. Description and specifications are given for the *Fyro-Place* metal form which contains a one-piece firebox, smoke dome, control damper and air intakes and outlets. 32 pp., illus. Price Fireplace Heater and Tank Corp., 14 Austin St., Buffalo 7, N. Y. 25 cents.

Plastic Table Surfaces

Texolite Decorative Surfacing Materials for Table and Counter Tops. Catalogue illustrating available *Texolite* plastic sheets with applications, color charts, properties, grades and sizes included. Plastics Division, Chemical Dept., General Electric, 1 Plastics Ave., Pittsfield, Mass.*

Fire Alarms

Autocall Fire Alarm Equipment. Fire alarm systems suitable for any type building are described, while fire alarm boxes of the break-glass, pull lever, and key operated types are detailed in full. Wiring diagrams of the fire alarm systems are shown and recommendations are made for specific installations in hotels, hospitals, schools, offices and public buildings. Code transmitters and punch recorders are shown for plant protection equipment. 8 pp., illus. The Autocall Co., Shelby, Ohio.

Registers and Grilles

Air Control Registers and Grilles (Catalog No. 48). Shown in this catalog are air conditioning registers and grilles, gravity type registers, ceiling diffusers, floor registers and faces, ventilators and accessories. List prices and engineering data are included. 24 pp., illus. Air Control Products, Inc., Coopersville, Mich.

Water Conditioning

A Positive Low Cost Answer to Corrosion, Lime Scale, Red Water. Describes use of *Micromet* in controlling corrosion, preventing lime scale and stopping "red water" discoloration in commercial, farm and small industrial and institu-

tional water systems. 6 pp., illus. Calgon, Inc., Hagan Bldg., Pittsburgh 30, Pa.

Lighting Standards

RLM Standard Specifications for Industrial Lighting Units. Contains detailed specifications for 14 of the most commonly used incandescent and fluorescent lighting units. These specifications cover materials, shielding and brightness, efficiency, auxiliary control equipment, reflection factor, photometric performance, code requirements and many others. 36 pp. RLM Standards Institute, 326 W. Madison St., Chicago 6, Ill.

Wood Construction

Manual on Wood Construction for Prefabricated Houses. Assembled in this handbook is basic scientific and engineering information about wood and wood-base materials used in housing, particularly through factory fabrication. More than 200 photographs and details illustrating designs and techniques employed by leading fabricators are included. There are chapters on glues, paints, preservatives, insulation and strength of materials. 330 pp., illus. Superintendent of Documents, Government Printing Office, Washington 25, D. C. \$1.50.

Roofing

Plan for Waterproofing and Damp-Proofing. Recommendations for using pitch and felt or fabric to prevent seepage due to moisture or water under pressure. 4 pp., illus. The Barrett Division, Allied Chemical & Dye Corp., 40 Rector St., New York 6, N. Y.*

Marble

Standard Specification and Scaled Details for Interior Marble. Handbook providing complete information for specifying interior and exterior marble. The text, supplemented by illustrations, describes marble classifications, finishes, uses and recommended setting materials and procedures. 66 pp., illus. Marble Institute of America, 108 Forster Ave., Mount Vernon, N. Y.

Metal Framing Anchors

Teco Triple-L-Grip Framing Anchors. Various types of steel framing anchors for wood framing are illustrated with

typical applications. Recommended safe working loads, based on laboratory tests, are given for connections using the three types of anchors. 6 pp., illus., Timber Engineering Co., 1319 18th St. N. W., Washington 6, D. C.

Insulation

How Insulation Reduces Operating Costs of Investment Properties. Discussion of advantages possible by using rock wool insulation plus typical installations in roof, ceiling and sidewall sections. A heat saving chart is included. 4 pp., illus. National Gypsum Co., Buffalo 2, N. Y.*

Ventilators

ILG Ventilation. Suggested methods for using electric fan ventilators in kitchens. Pictures of the various units available and specifications are given. 16 pp., illus. ILG Electric Ventilating Co., 2850 N. Crawford Ave., Chicago 41, Ill.*

Iron Lung for Industrial Buildings. Pictures many industrial applications of the *Iron Lung*, fan powered, roof-type ventilator. Operating features are described and dimensions, specifications are given. 22 pp., illus. Powermatic Ventilator Co., 4019 Prospect Ave., Cleveland 3, Ohio.

Conduit Guide

Central Spang Conduit. Shows manufacturing processes and types of conduit made. Another feature is a 37-page section of reference material. This includes standard specifications for rigid steel conduit and fittings and a list of standard specification numbers for accessory parts. Tables of electrical data, definition of terms, electrical symbols and examples of computing conductor sizes have been brought up to date and expanded from an older edition of the book. 64 pp., illus. Spang-Chalfant, Div. of National Supply Co., Grant Bldg., Pittsburgh, Pa.

Boilers

The Fitzgibbons Boiler, Type "D". This catalog gives complete information about the Type "D" steel boiler for use with oil, gas and mechanical stoker firing in sizes from 2680 to 42,500 sq. ft. steam and for hand fired anthracite and bituminous from 2200 to 35,000 sq. ft. steam. Essential factors in boiler selection relating to the Steel Boiler Institute Rating Code are discussed. 12 pp., illus., Fitzgibbons Boiler Co., 101 Park Ave., New York 17, N. Y.*

Paint Guides

Decorator's and Architect's Color Manual. Full color displays in this pocket size manual permit visualization of more

(Continued on page 196)

*Other product information in Sweet's File, 1948.

SCHOOL CLASSROOM DETAILS

Egg-crate Lighting over Full Ceiling; Perkins & Will, Architects

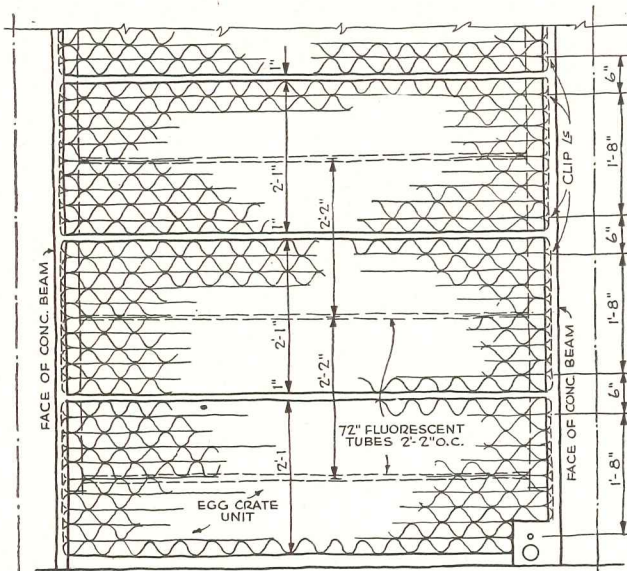

STANDARD EGG CRATE LIGHTING PANEL

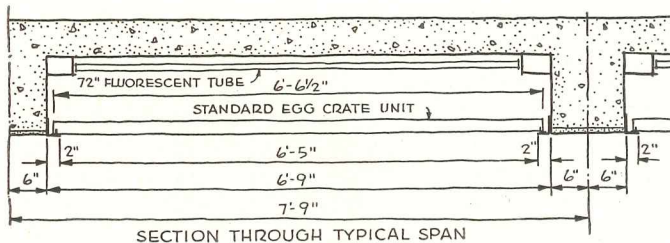

SECTION THROUGH TYPICAL SPAN

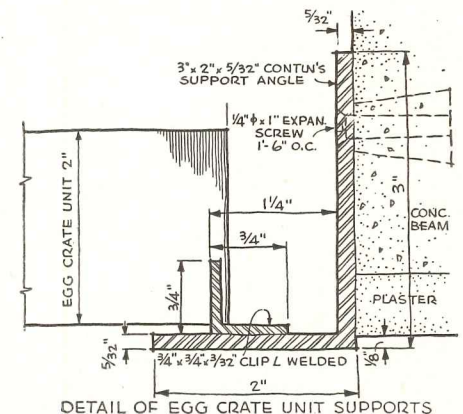

DETAIL OF EGG CRATE UNIT SUPPORTS

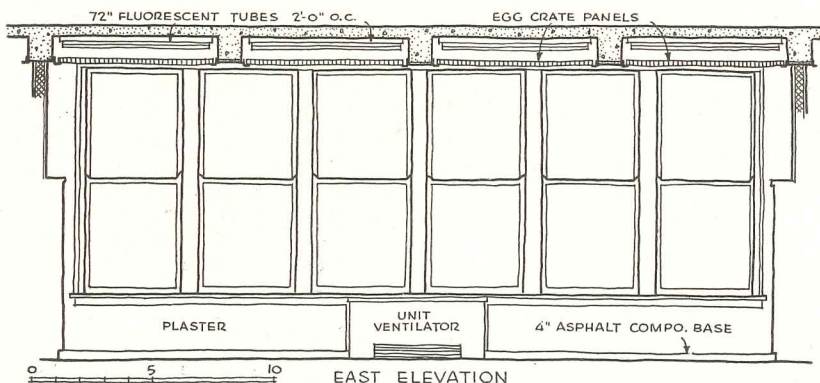

EAST ELEVATION

WHERE the school classroom must, as in this case, conform to more conventional shapes than the "California" rooms with their multiple daylighting, the artificial lighting must be of high quality. This classroom, in a recent addition to an elementary school in Park Ridge, Ill., scorns half measures; its ceiling is completely covered with fluorescent lighting behind egg crates. This, in combination with the neat built-ins described on preceding pages, in light woods with light walls and floors, gives not only an excellently lighted room but also a very attractive one.

(Continued on page 153)

SCHOOL CLASSROOM DETAILS

Multiple Unit Storage Cabinets Used as Partition Wall: Perkins & Will, Architects

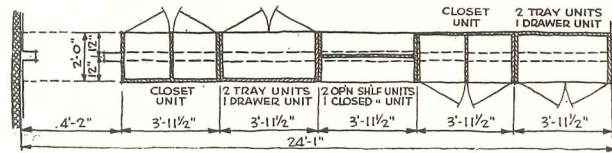
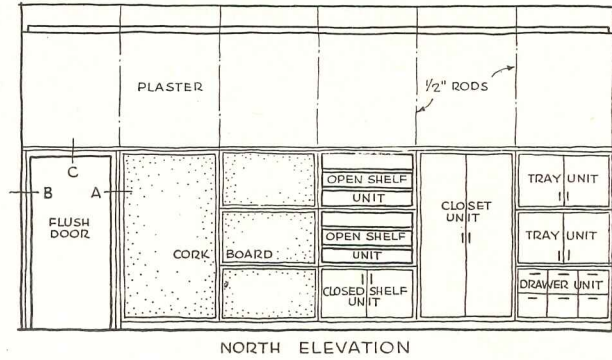
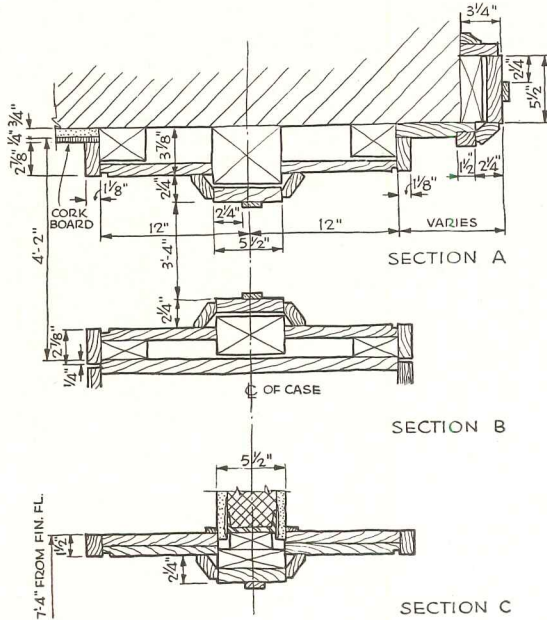

JUNE 1948

ARCHITECTURAL RECORD

SCHOOL CLASSROOM DETAILS

Perkins & Will, Architects

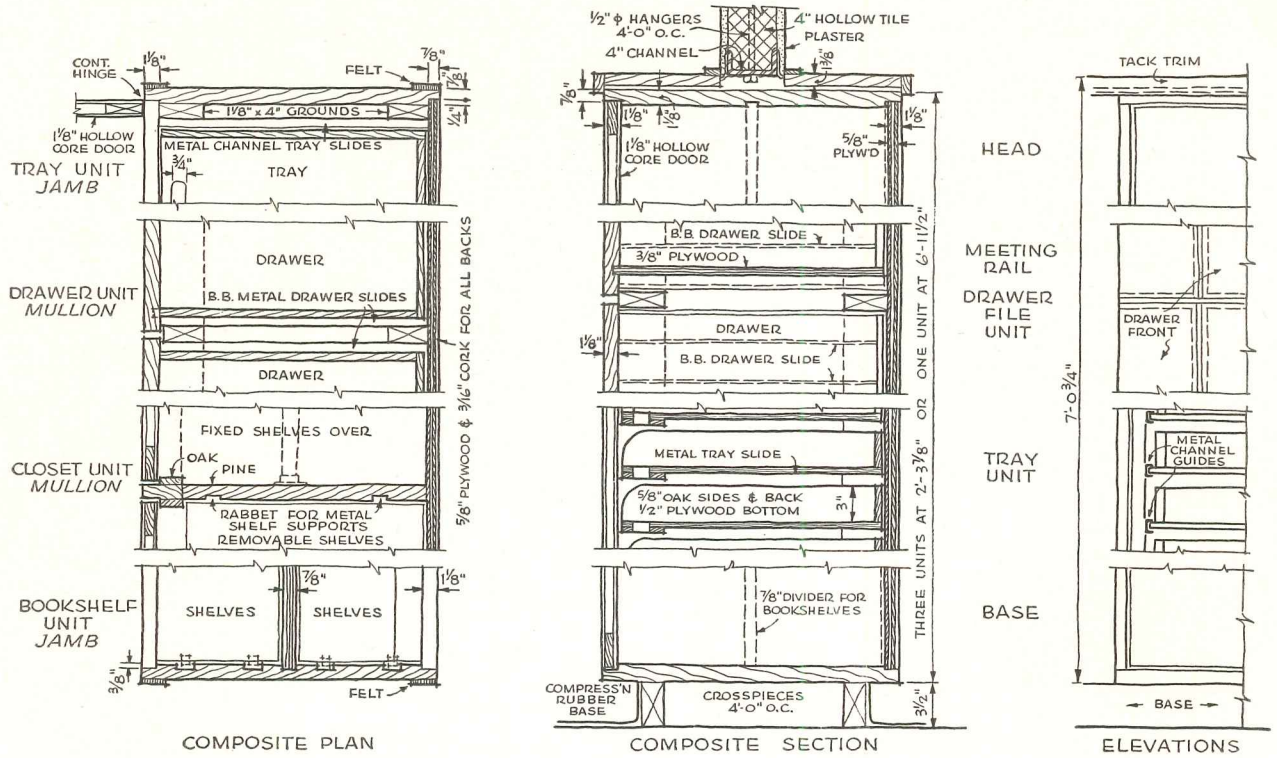

Hedrich-Blessing Studios Photos



SCHOOL CLASSROOM DETAILS

Multiple Unit Storage Cabinets Used as Partition Wall; Perkins & Will, Architects

Three years ago these partition-wall-cabinets were published in the idea stage (ARCHITECTURAL RECORD, June, 1945); here they are as installed in an addition to a school in Park Ridge, Ill. As the photographs show, they very neatly package the several varieties of storage spaces required for an elementary school classroom, including: supplies and equipment, records, books, tools, toys, and there are also closets for clothing.

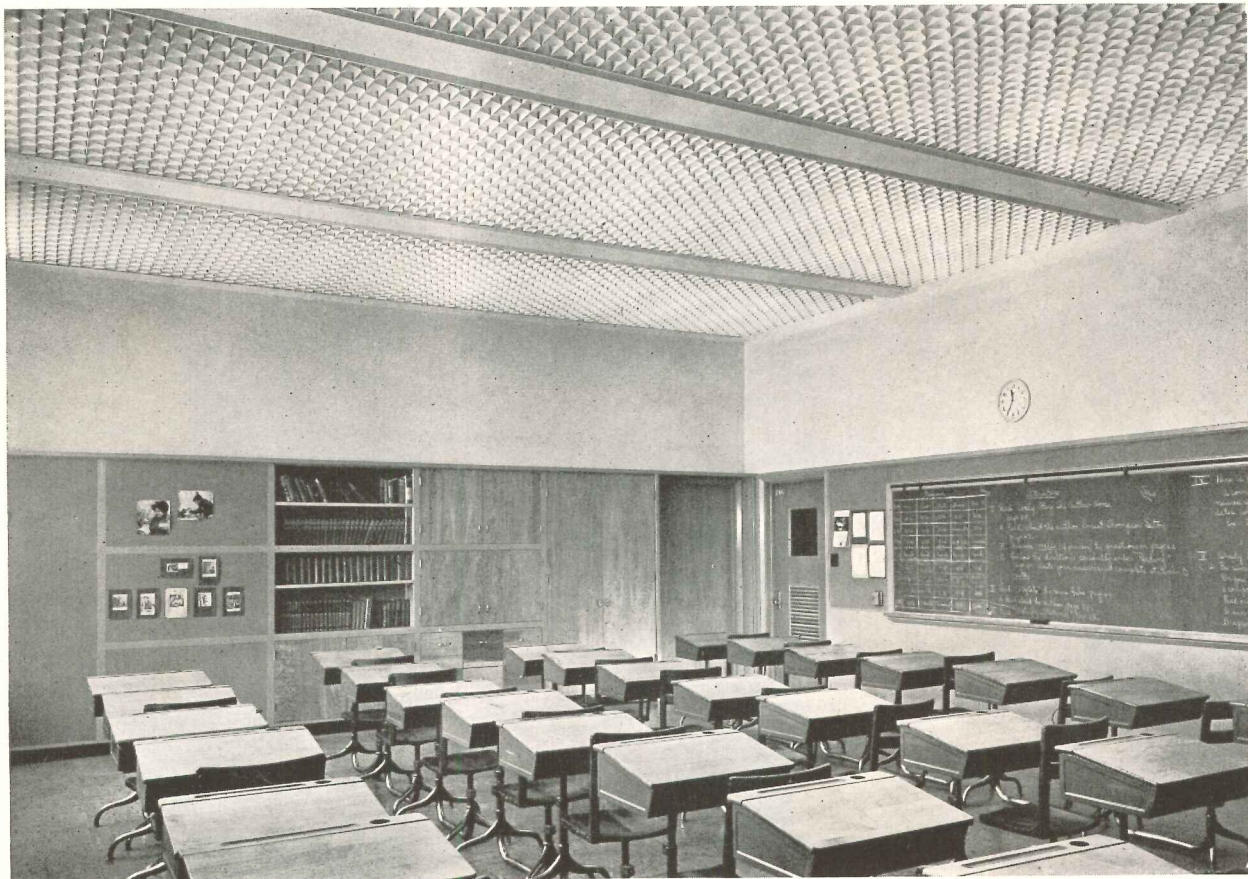
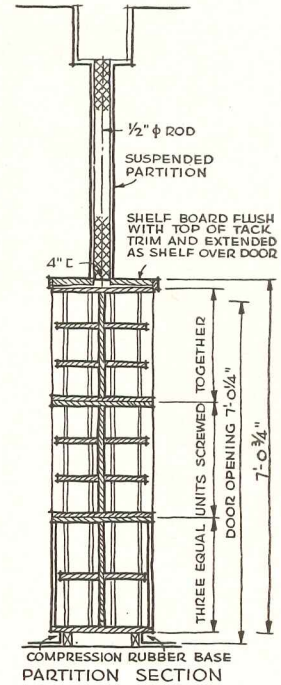
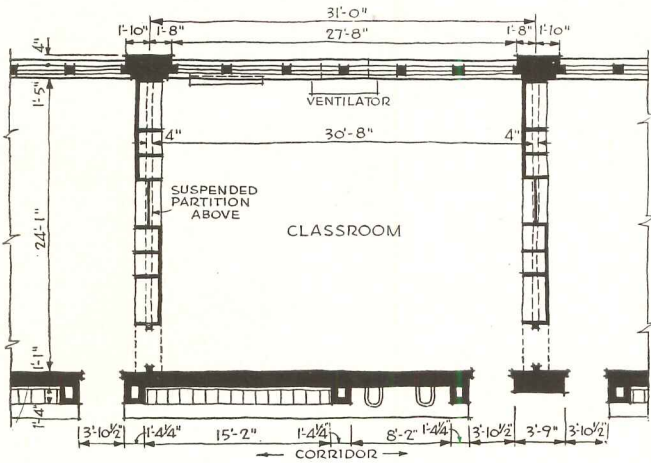

PRODUCTS for Better Building



Above: plywood furniture designed for comfort, practicability and beauty

Below and lower right: applications of Durisol, a new building material made of cement and chemically treated wood shavings, pressure formed into blocks and panels

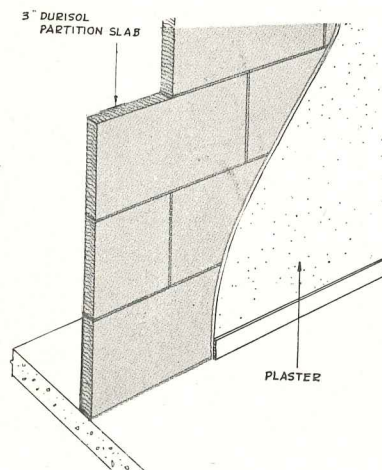
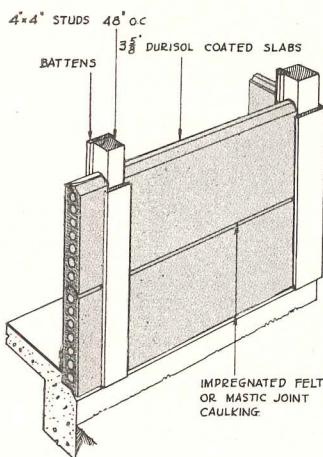
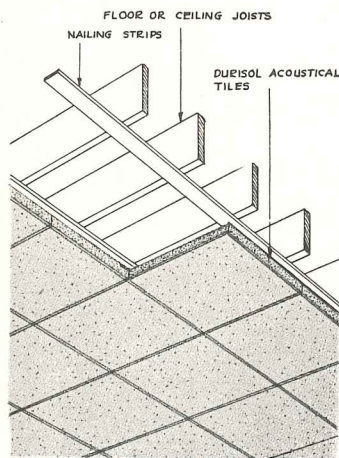
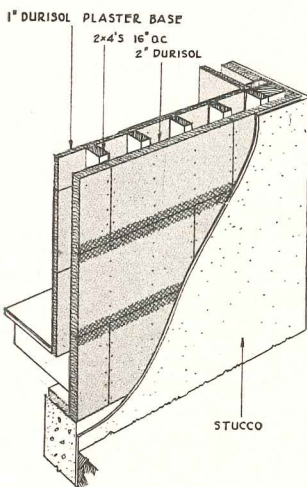

PLYWOOD FURNITURE

Molded plywood furniture has been designed by Charles Eames to offer maximum comfort, practicability and beauty. Being manufactured now are dining tables, dining chairs, lounge chairs, coffee tables and screens.

The furniture is made of resin-impregnated plywood which is molded under pressure to make the finish an integral part of the wood. Permanent joinings are radio-frequency welded for long life.

Designed from the outset to provide comfort, the chairs are molded to conform to the contours of the human body. An entirely new concept, "shock mount joinings," permits the chairs to flex during changes in body position. The chairs are designed in dining and lounge heights. Both are available with either plywood or chromium-plated legs.

The dining table with walnut top and molded plywood legs, measures 34 in. by 54 in. Special multiple-finishing processes are said to provide durable, resistant finishes. The detachable legs are precision-joined to the top to eliminate wobbling.

The folding screen, made of curved, molded plywood panels, attached with flexible fabric strips, is decorative both in its form and in its use of rare and interesting woods. It folds to compactness for storage. The screen is 5 ft. 8 in. high, extends to 60 in. Herman Miller Furniture Co., Zeeland, Mich.

BUILDING MATERIAL

Durisol, a new building material made from chemically treated and impregnated wood fibers mixed with Portland cement, combines sheathing, siding, insulation and fireproofing in one material.

This material is said to have the workability of wood with the durability of concrete as it can be nailed, screwed or bolted to framing and may be utilized for roofs, floors, exterior walls or partitions.

The mixed wood shavings and cement are pressure-shaped into panels, slabs and blocks; however, it is most commonly used in panels 2 ft. by 4 ft. and 2 in. to 5 in. thick.

(Continued on page 180)





People are "At Home" with Formica*

...and Beauty Bonded Formica is always at home with people... be it the Luxury Liner's "showplace" Salon or the clean, colorful charm of Mrs. America's own kitchen and dinette. Or her living room, with coffee and occasional tables topped with cigarette-proof Formica Realwood*. So carefree... and so easy to care for... never minding the careless smoker or the spilled Manhattan. As easy to own and use as it is to live with. You offer your Clients a new hospitality when you specify the livability and charm of Beauty Bonded Formica. Formica, 4632 Spring Grove Avenue, Cincinnati 32, Ohio.



Living rooms, public rooms, as well as shipboard lounges and state-rooms... all given new sparkle and use value with Formica. This beautiful installation is on the Moore-McCormack "S. S. Argentina".

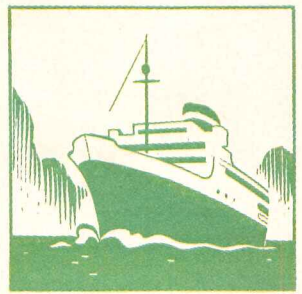

Color photographs courtesy of Moore-McCormack Lines—Cruise clothes by B. Altman & Co., New York.

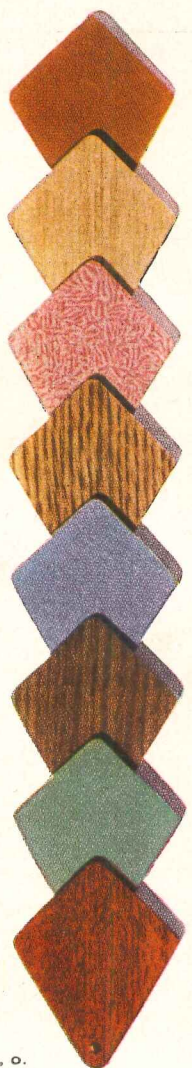

Suggestion: Tops for fine furniture... Formica Realwood or, if you prefer, colorful Decorative Formica. Keeps its new look through years of hard usage. Budget-wise, it's smart year-after-year saving. Have you a supply of the new folder "You and Beauty Bonded Formica"? It tells your Clients how to live with Formica. In Sweets', there's a catalog for you.

*Reg. Trade Names U.S. Pat. Off.

No other siding has all these advantages!

Construction of an 8-room home in fashionable Atherton, California, proves typical advantages of building with new Kaiser Aluminum clapboard Siding. The clean, even lines of this revolutionary new material give this

home a kind of beauty hard to match. Every piece is precision-produced of high grade aluminum . . . perfectly uniform . . . *flawless!* It's the logical successor to other materials in homes of *any* price range.

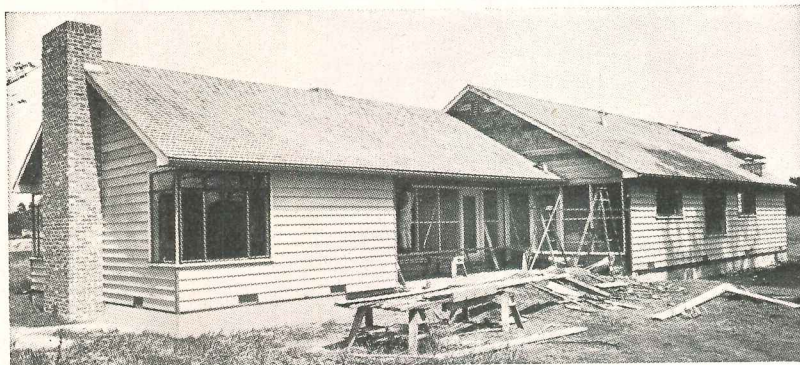

KAISER ALUMINUM clapboard Siding can't be weakened or disfigured by knots, splits or sawing scars. It can't rot, warp, rust or crack. And a zinc chromate prime coat applied at the mill readies it for

beautiful, long-lasting paint finishes which won't flake, peel or chip. The new material won't absorb paint, either, so it needs less. Best of all, it costs no more than other materials!

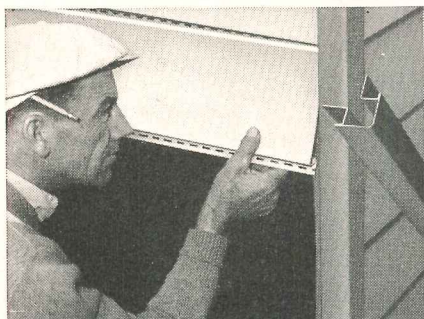

HERE IS THE ONLY metal siding with a pre-formed curved surface. The plain upper edge of each piece slips into the slotted lower edge of the piece above. Nailing down the lower edge produces a strong tension. Result: A rigid, weatherproof joint. Work is speeded by pre-punched holes. Money is saved because only half the usual number of nails are needed and no wood sheathing is required!



TIGHT, CLEAN-CUT butt-joints are easily made with back-up plates available with the new siding. Paint finishes completely conceal the joints. Notice, too, that all nails are hidden. The concave surface makes beautiful, $\frac{3}{4}$ " deep shadow lines and eliminates oil can sheen, waves and buckles. The new material can't be damaged by rats or insects either, and never needs the usual kind of maintenance.



CARPENTERS like to work with Kaiser Aluminum Siding, for they can use ordinary tools. To show how light this strong material is, the man at the top of the page is carrying 200 base feet! Prepare to specify Kaiser Aluminum to *your* clients! They'll *want* it—for no other material can match its unique *combination* of advantages. Write today for free booklet packed with information.

Kaiser Aluminum clapboard Siding Specifications:

Length . . . 10, 12, 14 and 16 ft. standard lengths
 Width . . . 6 $\frac{7}{8}$ " Thickness030"
 Weight . . . 580 lbs. per 1143 base feet (1000 sq. ft.)
 Shipped in cartons containing 200 base feet., weighing 106 lbs. overall.

Kaiser Aluminum SIDING

a Permanente Metals product

SOLD BY PERMANENTE PRODUCTS COMPANY, KAISER BUILDING, OAKLAND 12, CALIFORNIA . . . WITH OFFICES IN:
 Atlanta • Boston • Chicago • Cincinnati • Cleveland • Dallas • Detroit • Houston • Indianapolis • Kansas City • Los Angeles • Milwaukee
 Minneapolis • New York • Oakland • Philadelphia • Portland, Ore. • Rochester • Salt Lake City • Seattle • Spokane • St. Louis • Wichita

INDEX TO ADVERTISEMENTS

MANUFACTURERS' PRE-FILED CATALOGS

Symbols "a", "b", and "e" indicate that catalogs of firms so marked are available in Sweet's Files as follows:

- a — Sweet's File, Architectural, 1948
- b — Sweet's File for Builders, 1948
- e — Sweet's File, Engineering, 1948

abe Adam, Frank, Electric Co.....	51	abe General Electric Co.—Air Conditioning.....	154	ae Okonite Company.....	228
Adams-Rite Mfg. Co.....	198	a General Electric Co.—Plastics.....	63	Olonite Plastics Division.....	19
a Adams & Westlake Co.....	203	ae General Electric Co.—Wiring.....	17	Onan, D. W. & Sons, Inc.....	234
Aerofin Corp.....	226	General Motors Co.....	2-3	ae Otis Elevator Company.....	193
Air Devices, Inc.....	221	General Pencil Co.....	220	abe Owens-Illinois Glass Company.....	195
Alan Wood Steel Co.....	14	a General Portland Cement Co.....	236	Oxford University Press.....	188
Allegheny Ludlum Steel Corp.....	207	a Goodrich, B. F. Co.....	84	Ozalid Products Division.....	230
ae Aluminum Company of America.....	157	Graphic Indicator Company.....	230		
ae American Abrasive Metals Co.....	185	ab Grand Rapids Hardware Company.....	206	Permanente Products Company.....	249
a American Brass Company.....	27	e Grasselli Chemicals Department.....	214	a Petroleum Heat & Power Company.....	229
ae American Lumber & Treating Co.....	75	ae Grinnell Company, Inc.....	187	ae Pittsburgh Corning Corp.....	227
American Radiator & Standard Sanitary Corp.....	67			abe Pittsburgh Plate Glass Company.....	8-9-189
a American Sealing Company.....	220	Haws Drinking Faucet Co.....	242	a Pittsburgh Reflector Co.....	167
abe American Structural Products Company.....	195-241	a Haynes Products Company.....	240	a Portland Cement Association.....	70
ab American Telephone & Telegraph Co.....	48	ae Hazard Insulated Wire Works Division.....	228	a Powers Regulator Company.....	278
a American Tile & Rubber Co.....	172	a Herring-Hall Marvin Safe Co.....	200-201	ab Pryne & Co., Inc.....	188
a Anaconda Copper Mining Co.....	27	a Hilliard Sales Co.....	192		
ae Anchor Post Products, Inc.....	196	a Hood Rubber Co.....	84	abe Revere Copper & Brass, Inc.....	68
ae Anemostat Corp. of America.....	41	a Hope's Windows, Inc.....	183	ab Reynolds Metals Company.....	77-177
Anthraxite Institute.....	219	a Horn, A. C., Co., Inc.....	29	a Richards-Wilcox Mfg. Co.....	174
Architectural Record.....	233	a Horn Brothers Co.....	240	ab Richmond Radiator Company.....	77
ae Armstrong Cork Company.....	13	House & Garden.....	231	ae Robertson, H. H. Company.....	57
a Asbestone Corp.....	18			a Rotary Lift Co.....	38
Asphalt Roofing Industry Bureau.....	79			ab Russell, F. C. Company.....	210
		a Imperial Brass Mfg. Co.....	6		
Baker Ice Machine Co., Inc.....	16	ab Independent Lock Co.....	230	Sarco Company, Inc.....	232
ab Barber-Colman Company.....	224	abe Inland Steel Products Company.....	235	a Schlage Lock Company.....	170
ab Bell & Gossett Company.....	31	In-Sink-Erator Mfg. Co.....	194	a Seaport Porcelain Metals, Inc.....	24
ab Bell Telephone System.....	48	ab Insulate Division.....	11	ab Serval, Inc.....	216-217
ae Benjamin Electric Mfg. Co.....	23	International Nickel Company, Inc.....	179	ab Sisalkraft Co.....	197
a Bethlehem Steel Company.....	72-211	a International Steel Co.....	171	a Sloan Valve Company.....	4th Cover
Bigelow Sanford Carpet Co.....	74			Smith, Alexander-Masland.....	34-35
b Bird & Son, Inc.....	164	a Jackson & Church Co.....	3rd Cover	a Smithcraft Lighting Division.....	30
a Blank, Frederic, & Co., Inc.....	225	a Jamestown Metal Corp.....	186	ae Stewart Iron Works Co., Inc.....	236
Books.....	198-222-234-237-243	Jenkins Bros.....	83	ae Streamline Pipe & Fittings Division.....	37
a Bradley Washfountain Co.....	182	ae Johns-Manville.....	228	a Superior Fireplace Company.....	238
a Brasco Mfg. Co.....	85	ae Josam Mfg. Co.....	232	a Swartwood Company.....	206
ab Bruce, E. L., Co.....	66			a Swedish Crucible Steel Company.....	19
ab Bryant Heater Company.....	58-59	a Kawneer Company.....	52-53	Thermoseal Division.....	210
Burnham Corporation.....	175	a Kennedy, David E., Inc.....	69	abe Tile-Tex Company.....	204-205
ae Burt Mfg. Co.....	239	ab Kimberly-Clark Corp.....	54	a Tiletone Company.....	76
Byers, A. M., Co.....	4	ae Kinnear Mfg. Co.....	156	Timber Engineering Company.....	239
		Koh-I-Noor Pencil Co., Inc.....	218	ae Timber Structures, Inc.....	242
ab Cabot, Samuel, Inc.....	190	Kohler Co.....	40	Todd Shipyards Corporation.....	196
a Cambridge Tile Mfg. Co.....	39			Touch-Plate Distributors, Inc.....	192
ae Carrier Corporation.....	80	L.C.N. Door Closers.....	173	ab Trade-Wind Motorfans, Inc.....	238
a Ceco Steel Products Corp.....	78-215	Lally Column Company.....	226	abe Trane Company.....	208-209
abe Celotex Corporation.....	151	abe Libbey, Owens-Ford Glass Co.....	56	a Trinity Portland Cement Division.....	236
a Century Lighting, Inc.....	242	ab Lockwood Hardware Mfg. Co.....	230	ae Trumbull Electric Mfg. Co.....	25
a Chase Brass & Copper Co.....	165	Lone Star Cement Corp.....	1		
a Cheney Flashing Co.....	238	ab Louisville Cement Co.....	47	ab United States Plywood Corp.....	159-223
ab Clayton & Lambert Mfg. Co.....	232			United States Rubber Company.....	15-169
a Columbia Mills, Inc.....	50	a Macomber Incorporated.....	12	ae United States Steel Corp. Subsidiaries.....	158
Combustion Division.....	196	ae Mahon, R. C., Co.....	49	a Universal Atlas Cement Company.....	158
Committee on Steel Pipe Research.....	60	ab Marsh Wall Products, Inc.....	46	a Universal Corporation.....	191
Connor, W. B. Engineering Corp.....	210	a Martin-Parry Corp.....	161		
ab Coyne & Delany Co.....	61	Masland Duraleather Co.....	84	a Vermont Marble Company.....	168
b Crane Co.....	55	a Medusa Portland Cement Co.....	226	a Vulcan Radiator Company.....	222
ab Creo-Dipt Co., Inc.....	202	ab Mengel Company.....	223		
a Culler Mail Chute Co.....	238	Michaels Art Bronze Co.....	22	Wade Manufacturing Co.....	184
		ab Minneapolis-Honeywell Co.....	86	ae Wakefield, F. W. Brass Company.....	232
ae Day-Brite Lighting, Inc.....	152	ab Minnesota & Ontario Paper Co.....	11	a Webster, Warren & Co.....	190
abe Detroit Steel Products Company.....	42-163	abe Modine Mfg. Co.....	230	a Weis, Henry, Mfg. Co., Inc.....	166
ae Dravo Corporation.....	160	Monarch Elevator & Machine Co.....	239	a Werner, R. D. Co., Inc.....	236
Dresser Industries.....	58-59	ae Monroe, Lederer & Taussig, Inc.....	242	abe Westinghouse Electric Corporation.....	44-45
ae Dunham, C. A. Co.....	214	ae Moulding, Thos. Floor Mfg. Co.....	218	a Westinghouse Electric Corporation—	
ae Du Pont, E. I. De Nemours & Co.....	43-214	ab Mueller Brass Co.....	37	Elevator Division.....	212-213
a Duriron Company, Inc.....	180	ab Natcor Store Fronts.....	234	ae Wing, L. J. Mfg. Co.....	240
a Dwyer Products Corp.....	178	ab National Chemical & Mfg. Co.....	181	a Worthington Pump & Machinery Corp.....	199
		National Electric Products Corporation.....	71	a Wurlitzer, Rudolph Co.....	21
Ebco Mfg. Co.....	240	ae National Gypsum Company.....	82		
ae Elkay Mfg. Co.....	73	ab National Oak Flooring Manufacturers Assoc.....	18	ae York Corporation.....	62
Employment Opportunities.....	224	a New Castle Products.....	234	a Young Radiator Co.....	202
Enterprise Engine & Foundry Co.....	33				
a Erie Enameling Company.....	176				
Faber, A. W.—Castell Pencil Co., Inc.....	194				
abe Fiat Metal Mfg. Co.....	162				
Flagg, Stanley G. & Co., Inc.....	64-65				
abe Flintkote Company.....	2nd Cover				
a Formica Insulation Co.....	250				
Frigidaire.....	2-3				
ae Frink Corporation.....	32				
Garden City Plating & Mfg. Co.....	81				
General Aniline & Film Corp.....	230				
General Controls.....	236				

NEW YORK—H. Judd Payne, Publishing Director; Robert F. Marshall, Business Manager; Tom Tredwell, Advertising Mgr.; Benton B. Orwig, Creative Service Manager; M. A. Murphy, Advertising Production Manager, 119 West 40th Street; BOSTON—Harry M. Horn, Jr., 855 Park Square Bldg.; CHICAGO—C. B. Riemersma, Robert T. Franden, John M. Cogan, 700 Merchandise Mart; CLEVELAND—John C. Jackson, 321 Hanna Bldg.; LOS ANGELES—Bob Wettstein, Room 816, 816 West 5th St.; PHILADELPHIA—Tom Tredwell, 1321 Arch St.; PORTLAND—Bob Wettstein, 3325 N. E. Maywood Court; SAN FRANCISCO—Bob Wettstein, 1003 TWA Bldg., 240 Stockton St.; SEATTLE—Bob Wettstein, White Bldg.

mentary, Clarksville, N. Y. — Mar., pp. 140-141; Proposed Elementary, Perrysburg, O. — Mar., p. 124; Elk Rapids High, Mich. — Mar., p. 122; Laurel Elementary, San Mateo, Cal. — Jan., pp. 80-85; Pacific Ave. and Muscoy, San Bernardino, Cal. — Mar., p. 131; Proposed Rosemead High, Cal. — Mar., p. 139.

Schools: Pupils' Working Heights; Data on Special Toilets; Safe Stairs. From *Manual of School Planning 1947*, Board of Education, City of New York; N. L. Engelhardt, Assoc. Supt. — TSS-AE — Mar., pp. 153, 155.

Schutt, Burton A., Archt. Carl's Sea Air Motel, Roosevelt Highway, Santa Monica, Cal. — May, pp. 107-109. Tropic Palms Hotel, West Los Angeles, Cal. — May, pp. 110-113.

Schwab, Andre. See Breger, William.

Schwarz, Rudolf. See "The Seven Archetype Plans of Rudolf Schwarz."

Scott, Lavone Dickensheets. See "A Thousand Women in Architecture: Part I."

Seidermann, Nathan A., Archt. Rocky Hill Garden Apartments, Bayside, N. Y. — Mar., p. 10.

Selby Shoe Store, West Palm Beach, Fla. Igor B. Polevitzky, Archt. — BTS — Apr., p. 134.

"Seven Archetype Plans of Rudolf Schwarz, The." Article on Church Planning. — BTS — June, pp. 117-119.

Sheats, George. See Dent & Aydelott.

Sheblessy, John B. See Rainey, T. Marshall.

Shopping Center, Proposed, Maywood, N. J. Kelly & Gruzen, Archts. — Mar., p. 10.

Shulman, Louis, Dsnr. Royal Dutch Airline Offices, N. Y. C. — Mar., pp. 97-101.

Siemens, Barbara W. See "A Thousand Women in Architecture: Part I."

Site Fabrication. See "Design and Site Fabrication Economics Coordinated in Small House Test Program."

Sive, André. See Loeb, Laurence M.

Skidmore, Owings & Merrill, Archts. Proposed buildings for Bellevue Medical Center-New York University. — Apr., p. 10. Office Building for Owens-Corning Fiberglass Corp., N. Y. C. — AE — Feb., pp. 140-141. Also see Mayer & Whittlesey.

"Small Houses, Unlimited." Editorial by Kenneth K. Stowell — May, p. 87.

Stained Glass. See "The Future of Stained Glass." Stairs, for Schools — TSS-AE — Mar., p. 155.

Starrett & Van Vleck, Archts.; Raymond Loewy Assocs., Dsnrs. Lord and Taylor Store, Westchester County, N. Y. — Apr., pp. 111-122.

Store Lighting Practices. Recommendations of Store Lighting Committee, Illuminating Engineering Society — TSS-AE — Apr., pp. 152-153, 157, 159.

STORES. BTS No. 136. Commentaries by Morris Ketchum, Jr. — Apr., pp. 109-144.

Stores. Annenberg & Erickson Florist Shop, N. Y. C. — Apr., p. 138; Bally Showroom for Shoes, N. Y. C. — Mar., pp. 114-116; Bostonian Shoe, Chicago, Ill. — Apr., p. 135; Bullock's, Palm Springs, Cal. — Apr., pp. 123-127; Irene Burke and Guild House, I. Miller, Long Beach, Cal. — Apr., pp. 140-143; Carver's, Custom Tailors, Los Angeles, Cal. — Apr., p. 136-137; Lindel's Jewelry, Toledo, O. — Apr., p. 139; Liquor Mart, North Station, Boston, Mass. — Apr., p. 144; Lord and Taylor, Westchester County, N. Y. — Apr., pp. 111-122; Photo Art Co., Trenton, N. J. — Apr., pp. 132-133; Salon Lenthéric, N. Y. C. — Apr., pp. 128-131; Selby Shoe, West Palm Beach, Fla. — Apr., p. 134.

Stowell, Kenneth K. Editorials: "The Architect's Companion" — Mar., p. 87; "How Much for a Set of House Plans?" — Jan., p. 71; "On the State of the Nation" — Feb., p. 85; "A Pause That Refreshes" — June, p. 87; "Precedents, Prototypes and Plagiarism" — Apr., p. 91; "Small Houses, Unlimited" — May, p. 87.

Stubbins, Hugh Jr., Archt. His own house, Cambridge, Mass. — Mar., pp. 88-96.

Swanson, Robert, Assocs., Archts. Projects for the First Baptist Church, Flint, Mich. — BTS — June, pp. 134-137.

Sylvania Center Research Laboratories, Bayside, N. Y. (proposed). Aymar Embury, Archt. — Apr., p. 12.

Synagogue. See Congregation Hillel.

T

Thorne, A. F., House, Hinsdale, Ill. Harry J. Harman, Archt. — June, p. 106.

"Thousand Women in Architecture, A." Part I: Elsa Gidoni, A.I.A.; Ruth Reynolds Freeman; Lavone Dickensheets Scott, A.I.A.; Edla Muir, A.I.A.; Marie Frommer, R.A., Dr.-Ing.; Eleanor Raymond, A.I.A.; Lucille Bryant Raport, A.I.A.; Elizabeth Scheu Close, A.I.A.; Barbara W. Siemens, A.I.A.; Larch Renshaw, A.I.A. — Mar., pp. 105-113. Part II: Emily H. Butterfield, A.I.A.; Elisabeth Coit, A.I.A.; Rose Connor, A.I.A.; Victorine Homsey, A.I.A.; Irene McFaul, A.I.A.; Carina Eaglesfield Milligan, A.I.A.; Gertrude Sawyer, A.I.A.; Tennie Owen Wiatt, R.A. — June, pp. 108-115.

Tiffany, J. B. & Son. Housing Development, Washington, D. C. Berla & Abel, Archts. — Feb., pp. 132-134.

Toilets, Special, for Schools, Data on — TSS-AE — Mar., p. 153.

Town and Desert Apartments, Palm Springs, Cal. H. W. Burns, Owner & Dsnr. — May, pp. 96-101.

Tropic Palms Hotel, Wilshire Blvd., West Los Angeles, Cal. Burton A. Schutt, Archt. — May, pp. 110-113.

Tunnard, Christopher. See Breger, William N.

Type Plans for the General Hospital. Division of Hospital Facilities, U. S. Public Health Service. 8-, 10-, 30-, 40-, 75-, 100-, 150-Bed and Nursing School — BTS — Jan., pp. 93-114. 25-Bed — June, pp. 92-93.

U

Uniform Plumbing Code for Housing. Sponsored by Housing and Home Finance Agency — TSS-AE — May, pp. 150, 153, 155.

U. S. Public Health Service, Division of Hospital Facilities. Type Plans for the General Hospital: 8-, 10-, 30-, 40-, 75-, 100-, 150-Bed and Nursing School — BTS — Jan., pp. 92-114. 25-Bed — June, pp. 92-93.

University of Texas, Student Apartments, Austin, Tex. Page, Southerland & Page, Archts. — BTS — Feb., pp. 126-127.

V

Van Hoef, Robert F. See Bauer, Orville H.

Villa Hermosa Apartments, Palm Springs, Cal. Clark & Frey, Archts. — Feb., pp. 116-119.

W

"Wall of Thin Self-Framed Metal Panels, The." Article by Robert L. Davison, Director of Research, and Howard T. Fisher, Archt. — AE — Feb., pp. 135-139.

Weber, John R., Archt. Bally Showroom for Shoes, N. Y. C. — Mar., pp. 114-116.

"What Buildings Are Beautiful?" Article by Joseph Hudnut — May, pp. 88-94.

"What We Like about One-Story Schools." Article by Wilfred F. Clapp — Mar., pp. 117-121.

Wiatt, Tennie Owen. See "A Thousand Women in Architecture: Part II."

Wing, Kenneth S., Archt. Irene Burke Store and Guild House, I. Miller Store, Long Beach, Cal. — Apr., pp. 140-143.

Wolff and Phillips, Archts. Proposed Circular Apartments — Jan., pp. 152, 154.

Wood, Ruby Ross. See Harrison & Abramovitz.

Woolsey, George H., Dsnr. House in Carmel, Cal. — May, pp. 130-133.

Working Heights, Pupils' — TSS-AE — Mar., p. 153.

Wurdeman, Walter, and Becket, Welton, A.I.A., Archts. Bullock's Store, Palm Springs, Cal. — Apr., pp. 123-127.

Wurster, Bernardi & Emmons, Archts.; Landscaping by Thomas B. Church. Richmond Chase Office Building, San Jose, Cal. — Feb., pp. 86-91.

Wurster, William W., A.I.A. Chairman of Jury, Jefferson Memorial Competition — Apr., pp. 92-103.

Y

Yurchenco, B. See Pastrana, Antonio, Archt.

Z

Zivitz, Dr. Nelson, House, Miami Beach, Fla. Igor B. Polevitzky, Archt. — BTS — May, pp. 134-135.

BOOKS REVIEWED

AMERICAN BUILDING: THE FORCES THAT SHAPE IT. By James Marston Fitch — Mar., p. 28.

AMERICAN INTERIOR DESIGN: THE TRADITION AND DEVELOPMENT OF DOMESTIC DESIGN FROM COLONIAL TIMES TO THE PRESENT. By Meyric R. Rogers — June, p. 28.

APARTMENT HOUSES. By Joseph H. Abel and Fred N. Severud — Feb., pp. 30, 178.

ARCHITECTURAL PRACTICE. By Clinton H. Cowgill, A.I.A., and Ben John Small, A.I.A. — Jan., p. 28.

BUILDING PROBLEMS OF URBAN UNIVERSITIES: A REPORT OF A CONFERENCE HELD IN CLEVELAND, OHIO, MAY 19-20, 1947. Edited by Herbert C. Hunsaker — Apr., p. 182.

CARPENTRY FOR THE BUILDING TRADES. By Elbert A. Lair — Jan., pp. 28, 30.

CASE FOR REGIONAL PLANNING, WITH SPECIAL REFERENCE TO NEW ENGLAND. By Directive Committee on Regional Planning Yale University — Feb., pp. 178, 180.

CITY OF TOMORROW, THE. By Le Corbusier. Translated from the French by Frederick Etchells — Mar., pp. 28, 30.

CONCERNING TOWN PLANNING. By Le Corbusier. Translated from the French by Clive Entwistle — Mar., pp. 28, 30.

CONSTRUCTION ESTIMATES AND COSTS. By H. E. Pulver — Mar., p. 30.

DESIGN FOR BUSINESS. By J. Gordon Lippincott — Jan., p. 28.

EAST OF FIFTH: THE STORY OF AN APARTMENT HOUSE. By Alan Dunn — Apr., p. 180.

ENCYCLOPEDIA OF HOME CARE AND REPAIR. By William J. Hennessey and William W. Atkin — May, p. 30.

FLUORESCENT LIGHTING MANUAL. By Charles L. Amick — Mar., p. 30.

FOUNDATIONS AND BASEMENTS. Booklet No. 1 in a series prepared by Good Housekeeping Building Forum: Joseph B. Mason, Director — Mar., p. 28.

HEATING AND AIR CONDITIONING. Booklet No. 2 in a series prepared by Good Housekeeping Building Forum: Joseph B. Mason, Director — Mar., p. 28.

HOME GUIDE TO REPAIR, UPKEEP AND REMODELING. By William H. Crouse — May, p. 30.

HOME-SEEKERS' HANDBOOK. By Gerald Lynton Kaufman, A.I.A. — Apr., p. 182.

HOSPITAL CARE IN THE UNITED STATES. Commission on Hospital Care — Jan., p. 28.

HOUSE FOR YOU TO RENT, BUY OR BUILD, THE. By Catharine and Harold Sleeper — Feb., pp. 28, 30.

HOUSES FOR FAMILY LIVING. By Frederick Gutheim — May, p. 28.

INSULATION, WEATHER-STRIPPING, STORM SASH. Booklet No. 3 in a series prepared by Good Housekeeping Building Forum: Joseph B. Mason, Director — Mar., p. 28.

THOMAS JEFFERSON AMONG THE ARTS. By Eleanor Berman — May, p. 28.

LESSONS IN ARC WELDING. 3rd edition. Lincoln Electric Co. — Jan., p. 30.

LOCAL STYLES IN ENGLISH ARCHITECTURE: AN INQUIRY INTO ITS ORIGIN AND DEVELOPMENT. By Thomas Dinham Atkinson, R.R.I.B.A. — June, p. 30.

METROPOLITAN LIFE, THE: A STUDY IN BUSINESS GROWTH. By Marquis James — Jan., p. 28.

PAINTING PATTERNS FOR HOME DECORATORS. By Ruth Wyeth Spears — Jan., p. 28.

PERSONALITY OF A HOUSE, THE. New Revised Edition. By Emily Post — May, pp. 28, 30.

PLANNING INDUSTRIAL STRUCTURES. By Clarence W. Dunham — June, p. 28.

PLYWOOD: WHAT IT IS — WHAT IT DOES. By Louis H. Meyer — Jan., p. 30.

PROTESTANT CHURCH BUILDING: A GUIDE TO HELP CHURCHMEN PLAN INTELLIGENTLY CHURCH BUILDING PROGRAMS. By William H. Leach — Apr., pp. 180, 182.

RESIDENTIAL AREAS. An Analysis of Land Requirements for Residential Development, 1945 to 1970. City Planning Commission, Cincinnati, O. — Feb., p. 180.

SCHWEIZER HOLZHAUSER. By Paul Artaria — June, p. 28.

Kline, Donald L. See Breger, William N.

L

- Langhorst, Fred, Archt. House for Dr. & Mrs. Alex J. Ker, Marin County, Cal. — Apr., pp. 104-108. House for Dr. & Mrs. John Reid, Menlo Park, Cal.; Garrett Eckbo, Landscape Archt. — May, pp. 122-125.
- Langley Park Housing Project, Montgomery County, Md. (proposed). Charles M. Goodman, Archt. — BTS — Feb., pp. 122-123.
- Lapidus, Morris, Archt. Bostonian Shoe Store, Chicago, Ill. — Apr., p. 135.
- Laurel Elementary School, San Mateo, Cal. Franklin, Kump & Falk, Archts.-Engrs. — Jan., pp. 80-85.
- Lendrum, James T. Article, "Design and Site Fabrication Economies Coordinated in Small House Test Program" — AE — May, pp. 141-145.
- Lenthéric Salon. See Salon Lenthéric.
- Lewis, George S. See Breger, William N.
- Lighting, School. See Laurel Elementary School and SCHOOLS, BTS No. 135; article, "Daylight is Bright Enough," and School Classroom Details.
- Lindel's Jewelry Store, Toledo, O. Bellman, Gillett & Richards, Archt. — BTS — Apr., p. 139.
- Liquor Mart, North Station, Boston, Mass. David J. Abrahams, Archt. — BTS — Apr., p. 144.
- Lloyd, Francis E., Archt. Ritchie Lowry House, Burlingame, Cal. — June, pp. 100-102.
- Lockheed, Mr. and Mrs. John, Guest House, Lake Arrowhead, Cal. Lucille Bryant Raport (Raport & Hicks), Archt. — Feb., pp. 102-105.
- Lockwood Greene Engrs., Inc. John Halama, Assoc. Archt.; Warehouse for S. C. Johnson & Son, Inc., Long Island City, N. Y. — Apr., p. 10. Newspaper Plant for Louisville, Ky., *Courier-Journal and Louisville Times* — Mar., p. 14.
- Loeb, Laurence M., Archt.; André Sive, Dsnr. House for Mr. and Mrs. Alfred L. Cardinaux, Hartsdale, N. Y. — May, pp. 136-137.
- Loewy, Raymond, Assocs. See Starrett & Van Vleck.
- Lord and Taylor Store, Westchester County, N. Y. Starrett & Van Vleck, Archts.; Raymond Loewy Assocs., Dsnrs. — BTS — Apr., pp. 111-122.
- Louisville, Ky., *Courier-Journal and Louisville Times*, Newspaper Plant. Lockwood Greene Engrs., Inc. — Mar., p. 14.
- Lowry, Ritchie, House, Burlingame, Cal. Francis E. Lloyd, Archt. — June, pp. 100-102.

M

- Massen, Richard, and Greene, Roland, Owners & Dsnrs. Carousel Motel, Cal. — May, pp. 114-117.
- "Maybeck, Bernard Ralph, Architect, Comes into His Own." Article by Jean Murray Bangs — Jan., pp. 72-79.
- Mayer & Whittlesey and Skidmore, Owings & Merrill, Assoc. Archts. New York Life Insurance Co., Apartment House Project, N. Y. C. — Feb., pp. 130-131.
- McFaul, Irene. See "A Thousand Women in Architecture: Part II."
- Menconi, Ralph. See Breger, William N.
- Merck & Co., Annex to Sterile Techniques Building, Rahway, N. J. (proposed). George P. Butler, Archt. — Feb., p. 12.
- Method for Calculating Insulation Economies, A Developed by the Tech. Staff, Housing and Home Finance Agency — AE — June, pp. 141-144.
- Miller Co. Exhibition, "Painting towards Architecture," Meriden, Conn. — Jan., pp. 10, 12.
- Milligan, Carina Eaglesfield. See "A Thousand Women in Architecture: Part II."
- Moore & Salsbury, Archts. Connecticut Mutual Life Insurance Co. Medical Building, Hartford, Conn. — May, p. 12.
- Mora, Dr. Ignacio. See Pastrana, Antonio.
- Motels. Carl's Sea Air, Santa Monica, Cal.; Carmel Valley Inn, Monterey County, Cal.; Carousel Motel, Cal.; Town and Desert Apartments, Palm Springs, Cal.; Tropic Palms Hotel, West Los Angeles, Cal. — May, pp. 96-117.
- "Motels Move into the Select Circle" — May, p. 95.
- Muir, Edla. See "A Thousand Women in Architecture: Part I."
- Muscoy School. See Pacific Ave. School.

N

- Neivert, Marvin J., Archt. Annenberg & Erickson Florist Shop, N. Y. C. — Apr., p. 138.
- Neutra, Richard J., Archt. Proposed Cooperative Apartments near the Sierras, Southern Cal. — Feb., pp. 124-125.
- "New Appreciation of 'Greene and Greene,' A." Article in BTS No. 137, HOUSES — May, pp. 138-140.
- New York Life Insurance Co. Apartment House Project, N. Y. C. Mayer & Whittlesey and Skidmore, Owings & Merrill, Assoc. Archts. — BTS — Feb., pp. 130-131.
- New York University. See Bellevue Medical Center.
- Nursing School, combined classroom and dormitory facilities. U. S. Public Health Service, Division of Hospital Facilities — BTS — Jan., pp. 112-113.

O

- Offices. British Overseas Airways Corporation, N. Y. C. — Mar., pp. 102-103; Panama National Tourist Commission, N. Y. C. — Mar., p. 104; Richmond Chase, San Jose, Cal. — Feb., pp. 86-91; Royal Dutch Airline, N. Y. C. — Mar., pp. 97-101.
- "On the State of the Nation." Editorial by Kenneth K. Stowell — Feb., p. 85.
- Orr, Douglas William. See Saylor, Henry H.

P

- Pacific Ave. School and Muscoy School, San Bernardino, Cal. Jerome Armstrong, Archt. — BTS — Mar., p. 131.
- Page, Southerland & Page, Archts. University of Texas, Student Apartments, Austin, Tex — Feb., pp. 126-127.
- "Painting towards Architecture," Miller Co. Exhibition, Meriden, Conn. — Jan., pp. 10, 12.
- Panama National Tourist Commission Office, N. Y. C. Beeston, Stott, Patterson, Dsnrs. — Mar., p. 104.
- Parker house, Winchester, Mass. Eleanor Raymond, Archt. — June, pp. 103-105.
- Parran, Thomas, M.D. Article on Hospital Planning, "The Present Opportunity" — BTS — Jan., p. 94.
- Partitions, Schoolroom. See School Classroom Details.
- Pastrana, Antonio, Archt.; Dr. Ignacio Mora, Medical Consultant. Hospital General de Coatzacoalcos, Veracruz, Mexico — Feb., pp. 98-99. Hospital General de Tuxpan, Veracruz, Mexico; B. Yurchenco, Collab. Archt. — Feb. pp. 100-101.
- "Pause That Refreshes, A." Editorial by Kenneth K. Stowell — June, p. 87.
- Perkins and Will, Archts. School Classroom Details. Built-in Cabinets Serving as Room Partitions, and Egg-crate Lighting over Entire Ceiling — TSS-AE — June, pp. 146-149.
- Phillips, Gordon A., Archt.; William Eng. Archt.; George N. Foster, Painter. Second Prize Winners, Jefferson Memorial Competition — Apr., p. 96.
- Photo Art Co. Camera Store, Trenton, N. J. — J. A. Fernandez, Archt. — BTS — Apr., pp. 132-133.
- "Planning for Family Living." Article by Frederick Gutheim — BTS — May, pp. 118-121.
- Plumbing Code. See Uniform Plumbing Code for Housing.
- Polevitzky, Igor B., Archt. House for Dr. Nelson Zivitz, Miami Beach, Fla. — May, pp. 134-135.
- Selby Shoe Store, West Palm Beach, Fla. — Apr., p. 134.
- Poured Resilient Flooring for Houses. Article in AE Section — AE — Jan., pp. 115-116.
- "Practical Aspects of the Heat Pump." Article by W. E. Johnson — AE — Apr., pp. 145-149.
- "Precedents, Prototypes and Plagiarism." Editorial by Kenneth K. Stowell — Apr., p. 91.
- "Present Opportunity, The." Article by Thomas Parran, M.D., On Hospital Planning — BTS — Jan., p. 94.
- "Prologue to Progress." Article by Thomas S. Holden — Jan., pp. 86-91.

R

- Rainey, T. Marshall, Archt.; Julian F. Bechtold, Sculptor; Robert A. Deshon, Planner; John B. Sheblessy, Engr.-Planner; John F. Kirkpatrick,

- Landscape Archt.; Robert S. Robinson, Painter. Runner-up, Jefferson Memorial Competition — Apr., p. 101.
- Raport, Lucille Bryant. See "A Thousand Women in Architecture: Part I."
- Raport, Lucille Bryant (Raport & Hicks), Archt.; Gordon De Swarte, Struct. Engr. Guest House for Mr. and Mrs. John Lockheed, Lake Arrowhead, Cal. — Feb., pp. 102-105.
- Raymond, Eleanor, Archt. Parker house, Winchester, Mass. — June, pp. 103-105. See also "A Thousand Women in Architecture: Part I."
- "Recent Developments in Residence Heating. Part II: Advances in Boiler-type Heating." Article by W. S. Harris — AE — Mar., pp. 145-148.
- "Redevelopment Plan for Grand Haven." See Grand Haven, Mich., Redevelopment Plan.
- Reid, Dr. and Mrs. John, House, Menlo Park, Cal. Fred Langhorst, Archt.; Garrett Eckbo, Landscape Arch. — BTS — May, pp. 122-125.
- RELIGIOUS ARCHITECTURE. BTS No. 138 — June, pp. 116, 140.
- Renshaw, Larch. See "A Thousand Women in Architecture: Part I."
- Richmond Chase Office Building, San Jose, Cal. Wurster, Bernardi & Emmons, Archts.; Landscaping by Thomas B. Church — Feb., pp. 86-91.
- Robinson, Robert S. See Rainey, T. Marshall.
- Rocky Hill Garden Apartments, Bayside, Queens, N. Y. Nathan A. Seidermann, Archt. — Mar., pp. 10, 12.
- "Roof Trusses Recommended for the Small House." Data from Technical Staff, Housing and Home Finance Agency — AE — May, pp. 146-147.
- Rosemead High School, Cal. (proposed). Kistner Curtis & Wright, Archts. & Engrs. — BTS — Mar., p. 139.
- Royal Dutch Airline Offices, N. Y. C. Louis Shulman, Dsnr. — Mar., pp. 97-101.

S

- Saarinens, Eiel, Archt. Entry in Jefferson Memorial Competition — Apr., p. 103.
- Saarinens, Saarinens and Assocs. First Prize Winners, Jefferson Memorial Competition — Apr., pp. 92-95.
- Saarinens, Swanson and Saarinens, Archts. Projects for the First Baptist Church, Flint, Mich. — BTS — June, pp. 134-137.
- St. Clement, Church of, Alexandria, Va. Joseph H. Saunders, Jr., Archt. — BTS — June, pp. 129-133.
- Salerno, Joseph, Archt. Paul Salerno House, River Forest, Ill. — June, p. 107.
- Salerno, Paul, House, River Forest, Ill. Joseph Salerno, Archt. — June, p. 107.
- Salon Lenthéric, N. Y. C. Harrison & Abramovitz, Archts.; Ruby Ross Wood, Intr. Decr.; Lighting by Feder — BTS — Apr., pp. 128-131.
- "Sandwich Panels Tested for the Small House." — AE — Apr., p. 150-151.
- Sarvis, Lewis J., Archt. Proposed Allegan Primary & Intermediate School, Mich. — Mar., p. 123.
- Saunders, Joseph H., Jr., Archt. Church of St. Clement, Alexandria, Va. — June, pp. 129-133.
- Sawyer, Gertrude. See "A Thousand Women in Architecture: Part II."
- Saylor, Henry H., for Douglas William Orr, Pres., American Institute of Architects. Article, "The Architect's Responsibility" — Jan., pp. 94-95.
- School Classroom Details: Built-in Cabinets Serving as Room Partitions; Egg-crate Lighting over Entire Ceiling. Perkins and Will, Archts. — TSS-AE — June, pp. 146-149. Standardized Storage Furniture. Curtis, Kistner & Wright, Archts. & Engrs. — TSS-AE — June, p. 153, 155.
- School Design. See Critical Dimensions Governing School Design.
- School Ventilation. See Air Supply by Natural Ventilation.
- SCHOOLS. BTS No. 135. — Mar., pp. 117-144.
- Schools. Proposed Allegan Primary and Intermediate, Mich. — Mar., p. 123; Barstow Elementary, Cal. — Mar., p. 137; Barstow High, Cal. — Mar., pp. 132-136; Proposed Bella Vista Elementary, Montebello, Cal. — Mar., p. 138; Belle Rose, Assumption Parish, La. — Mar., p. 125; Proposed Elementary Community, Lincoln, Mass. — Mar., pp. 142-144; Proposed Ele-

Coogan Davis, Inc., Developers. Essex Village Houses, Hialeah, Fla. — Feb., pp. 10, 12.
 Cooperative Apartments near the Sierras, Southern Cal. (proposed). Richard J. Neutra, Archt. — BTS — Feb., pp. 124-125.
 Cram & Ferguson, Archts. John Hancock Mutual Life Insurance Co., Office Building, Boston, Mass. — Mar., pp. 12, 14.
 Critical Dimensions Governing School Design. Adapted from *Space for Teaching*, by William W. Caudill, Bulletin of Agricultural and Mechanical College of Texas — TSS-AE — Feb., p. 147.
 Crittenden County General Hospital, West Memphis, Ark. Dent & Aydelott, Archts.; George Sheats, Hosp. Consultant. — June, pp. 94-96.
 "Current Trends in Store Design." Article by Morris Ketchum, Jr. — BTS — Apr., pp. 109-110.

D

Davison, Robert L., Director of Research, and Howard T. Fisher, Archt. Article, "The Wall of Thin Self-Framed Metal Panels" — AE — Feb., pp. 135-139.
 "Daylight Is Bright Enough Everywhere if We Are." Article by Charles D. Gibson — BTS — Mar., pp. 125-130.
 DeBuys, Rathbone, Archt.; Godat & Heft, Consulting Engrs. International Trade Mart, New Orleans, La. — May, pp. 12, 14.
 Dent & Aydelott, Archts.; George Sheats, Hosp. Consultant. Crittenden County General Hospital, West Memphis, Ark. — June, pp. 94-96.
 Deshon, Robert A. See Rainey, T. Marshall.
 "Design and Site Fabrication Economies Coordinated in Small House Test Program." Article by James T. Lendrum — AE — May, pp. 141-145.
 De Swarte, Gordon. See Raport, Lucille Bryant (Raport & Hicks), Archt.
 Dutch Airline Offices. See Royal Dutch Airline Offices.

E

Eckbo, Garrett. See Langhorst, Fred.
 Elementary Community School, Lincoln, Mass. (proposed). Anderson & Beckwith, Archts. — BTS — Mar., pp. 142-144.
 Elementary School, Clarksville, N. Y. (proposed). Henry L. Blatner, Archt.; George Teeling, Mech. Engr. — BTS — Mar., pp. 140-141.
 Elementary School, Perrysburg, O. (proposed). Britsch & Munger, Archts. — BTS — Mar., p. 124.
 Elk Rapids High School, Mich. (proposed). Bauer and Eash, Archts. — BTS — Mar., p. 122.
 Embury, Aymar, Archt. Sylvania Center, Proposed Research Laboratories, Bayside, N. Y. — Apr., p. 12.
 Eng, William. See Phillips, Gordon A.
 Engelhardt, N. L., Assoc. Supt., Board of Education, City of New York. Schools: Pupils' Working Heights; Data on Special Toilets; Safe Stairs. From *Manual of School Planning, 1947* — TSS-AE — Mar., pp. 153, 155.
 Essex Village Houses, Hialeah, Fla. Coogan Davis, Inc., Developers — Feb., pp. 10, 12.

F

Feder, Lighting by. See Harrison & Abramovitz.
 Fernandez, J. A., Archt. Photo Art Co., Camera Store, Trenton, N. J. — Apr., pp. 128-131.
 Fiberglas Building, Owens-Corning Fiberglas Corporation, N. Y. C. Skidmore, Owings & Merrill, Archts. — AE — Feb., pp. 140-141.
 First Baptist Church, Flint, Mich., Projects for. Saarinen, Swanson and Saarinen, Archts.; Robert Swanson Assocs., Archts. — BTS — June, pp. 134-137.
 Fisher, Howard T., Archt.; and Robert L. Davison, Director of Research. Article, "The Wall of Thin Self-Framed Metal Panels" — AE — Feb., pp. 135-139.
 Floors. See Insulation of Concrete Floors in Dwellings and Poured Resilient Flooring for Houses.
 Foster, George N. See Phillips, Gordon A.
 Franklin, Kump & Falk, Archts.-Engrs. Barstow High School, Cal. — Mar., pp. 132-136. Laurel Elementary School, San Mateo, Cal. — Jan., pp. 80-85.
 Freeman, Ruth Reynolds. See "A Thousand Women in Architecture: Part I."

Frei, Emil. See "The Future of Stained Glass."
 Frommer, Marie. See "A Thousand Women in Architecture: Part I."
 Furniture, Storage, for Classrooms. See School Classroom Details.
 "Future of Stained Glass, The." Techniques and Designs of Emil Frei — BTS — June, pp. 120-126.

G

Gibson, Charles D. Article, "Daylight Is Bright Enough Everywhere if We Are" — BTS — Mar., pp. 125-130.
 Gidoni, Elsa. See "A Thousand Women in Architecture: Part I."
 Glass, Stained. See "The Future of Stained Glass."
 Godat & Heft. See DeBuys, Rathbone.
 Goodman, Charles M., Archt. Proposed Langley Park Housing Project, Montgomery County, Md. — BTS — Feb., pp. 122-123. Proposed Atlantic Gardens Apartments, Washington, D. C.; L. B. Voight, Landscape Archt. — BTS — Feb., pp. 114-115.
 Gould, Allen. See Breger, William N.
 Grand Haven, Mich., Redevelopment Plan. Orville H. Bauer and Robert F. Van Hoef, Dsnrs. — Feb., pp. 92-97.
 Great Oaks Apartments, Riverdale, N. Y. (proposed). Charles E. Greenberg, Archt. — BTS — Feb., pp. 128-129.
 Greenberg, Charles E., Archt. Proposed Great Oaks Apartments, Riverdale, N. Y. — Feb., pp. 128-129.
 Greene, Charles Sumner and Henry Mather. See "A New Appreciation of 'Greene and Greene.'"
 Guild House, I. Miller Store. See Burke, Irene, Store.
 Guthrie, Frederick. Article, "Planning for Family Living" — May, pp. 118-121.

H

Halama, John. See Lockwood Greene Engrs., Inc.
 Hancock, John, Mutual Life Insurance Co. Office Building, Boston, Mass. Cram & Ferguson, Archts. — Mar., pp. 12, 14.
 Harman, Harry J., Archt. A. F. Thorne House, Hinsdale, Ill. — June, p. 106.
 Harris, Harwell Hamilton, Archt.; Russell S. Johnson, Assoc. House for Walter E. Clark, Lake Placid, N. Y. — Feb., pp. 106-111.
 Harris, W. S. Article, "Recent Developments in Residence Heating. Part II: Advances in Boiler-type Heating" — Mar., pp. 145-148.
 Harrison & Abramovitz, Archt. Congregation Hillel, Northwestern University — BTS — June, pp. 138-140. Salon Lenthéric, N. Y. C.; Ruby Ross Wood, Intr. Decr.; Lighting by Feder — BTS — Apr., pp. 128-131.
 Haskell, Douglas. Article, "'Beauty' for Us Demands Architecture of Larger Scope at Vastly Broader Scale." — June, pp. 88-91.
 Heating. See "Practical Aspects of the Heat Pump," and "Recent Developments in Residence Heating, Part II: Advances in Boiler-type Heating."
 Health Center. See HOSPITALS, BTS No. 133.
 Holden, Thomas S. Article, "Prologue to Progress" — Jan., pp. 86-91.
 Homsey, Victorine. See "A Thousand Women in Architecture: Part II."
 Hornbostel, Caleb, Archt. See Breger, William N. Hospital, General. See Crittenden County General Hospital; HOSPITALS, BTS No. 133; and Type Plans for the General Hospital.
 Hospital General de Coatzacoalcos, Veracruz, Mexico. Antonio Prastana, Archt. — Feb., pp. 98-99.
 Hospital General de Tuxpan, Veracruz, Mexico. Antonio Prastana, Archt.; B. Yurchenco, Collab. Archt. — Feb., pp. 100-101.
 HOSPITALS for the Coordinated Hospital System. BTS No. 133. — Jan., pp. 92-114.
 "Hospitals' Place in the Program, The." Article by George Bugbee — BTS — Jan., p. 95.
 Hotels. See Motels.
 House and Garden Architectural Award Winners. — Feb., p. 10.
 HOUSES. BTS No. 137. — May, pp. 118-140.
 Houses. Mr. and Mrs. Alfred L. Cardinaux, Harts-

dale, N. Y. — May, pp. 136-137; in Carmel, Cal. — May, pp. 130-133; Walter E. Clark, Lake Placid, N. Y. — Feb., pp. 106-111; Mr. and Mrs. Lyle B. Clothier, Tucson, Ariz. — May, pp. 126-129; Dr. and Mrs. Alex J. Ker, Marin County, Cal. — Apr., pp. 104-108; Mr. and Mrs. John Lockhead, Lake Arrowhead, Cal. — Feb., pp. 102-105; Ritchie Lowry, Burlingame, Cal. — June, pp. 100-102; Parker house, Winchester, Mass. — June, pp. 103-105; Dr. and Mrs. John Reid, Menlo Park, Cal. — May, pp. 122-125; Paul Salerno, River Forest, Ill. — June, p. 107; Hugh Stubbins, Jr., Cambridge, Mass. — Mar., pp. 88-96; A. F. Thorne, Hinsdale, Ill. — June, p. 106; Dr. Nelson Zivitz, Miami Beach, Fla. — May, pp. 134-135.
 Houses, Small. See "Design and Site Fabrication Economies Coordinated in Small House Test Program," "Roof Trusses Recommended for the Small House," "Sandwich Panels Tested for the Small House," and "Small Houses, Unlimited."
 Housing and Home Finance Agency. Data for "Roof Trusses Recommended for the Small House" — AE — May, pp. 146-147. Insulation of Concrete Floors in Dwellings — TSS-AE — Jan., pp. 120, 123, 125. Method for Calculating Insulation Economies — AE — June, pp. 141-144. Uniform Plumbing Code for Housing TSS-AE — May, pp. 150, 153, 155.
 Housing. See APARTMENTS, BTS No. 134.
 "How Much for a Set of House Plans?" Editorial by Kenneth K. Stowell — Jan., p. 71.
 Hudnut, Joseph. Article, "What Buildings Are Beautiful?" — May, pp. 88-94.

I

Illuminating Engineering Society, Store Lighting Committee. Recommendations of Store Lighting Practices — TSS-AE — Apr., pp. 152-153, 157, 159.
 Insulation. See Method for Calculating Insulation Economies.
 Insulation of Concrete Floors in Dwellings. Research by Housing and Home Finance Agency — TSS-AE — Jan., pp. 120, 123, 125.
 International Trade Mart, New Orleans, La. Rathbone DeBuys, Archt.; Godat & Heft, Consulting Engrs. — May, pp. 12, 14.

J

Jefferson Memorial Competition Winners. First: Saarinen, Saarinen and Assocs. Second: Gordon A. Phillips, William Eng, Archts.; George N. Foster, Painter. Third: William N. Breger, Archt.; Allen Gould, Painter; Caleb Hornbostel, Archt.; Donald L. Kline, Landscape Archt.; George S. Lewis, Archt.; Ralph Menconi, Sculptor; Andre Schwab, Painter, Christopher Tunnard, Landscape Archt. Runner-up: Harris Armstrong, Archt. Runner-up: T. Marshall Rainey, Archt.; Julian F. Bechtold, Sculptor; Robert A. Deshon, Planner; John B. Sheblessy, Engr.-Planner; John F. Kirkpatrick, Landscape Archt.; Robert S. Robinson, Painter — Apr., pp. 92-103.
 Johnson, Russell S. See Harris, Harwell Hamilton.
 Johnson, S. C. & Son, Inc., Warehouse, Long Island City, N. Y. Lockwood Greene Engrs., Inc.; John Halama, Assoc. Archt. — Apr., p. 10.
 Johnson, W. E. Article, "Practical Aspects of the Heat Pump" — AE — Apr., pp. 145-149.
 Jones, Robert R., Archt. Carmel Valley Inn, Monterey County, Cal. — May, pp. 102-106.

K

Kelly & Gruzen, Archts. Proposed Shopping Center. Maywood, N. J. — Mar., p. 10.
 Ker, Dr. & Mrs. Alex J., House, Marin County, Cal. Fred Langhorst, Archt. — BTS — Apr., pp. 104-108.
 Ketchum, Morris Jr. Article, "Current Trends in Store Design," and commentaries on STORES, BTS No. 136 — Apr., pp. 109-144.
 Kirkpatrick, John F. See Rainey, T. Marshall.
 Kistner, Curtis & Wright, Archts & Engrs. Barstow Elementary School, Cal. — Mar., p. 137. Proposed Bella Vista Elementary School, Montebello, Cal. — Mar., p. 138. Proposed Rosemead High School, Cal. — Mar., p. 139. School Classroom Details: Standardized Storage Furniture — TSS-AE — June, pp. 153, 155.

ARCHITECTURAL RECORD

Published by F. W. Dodge Corporation, 119 West 40th Street, New York 18

Copyright 1948. All rights reserved

SEMI-ANNUAL INDEX • VOLUME 103 • JANUARY - JUNE 1948

BTS—Building Types Study • TSS—Time-Saver Standards • AE—Architectural Engineering section

Abrahams, David J., Archt. Liquor Mart, North Station, Boston, Mass. — Apr., p. 144.

"Advances in Boiler-type Heating." See "Recent Developments in Residence Heating."

Air Supply by Natural Ventilation. Adapted from "Space for Teaching," by William W. Caudill, Bulletin of Agricultural and Mechanical College of Texas — TSS-AE — Feb., p. 145.

Allegan Primary and Intermediate School, Mich. (proposed). Lewis J. Sarvis, Archt. — BTS — Mar., p. 123.

Aluminum Company of America Rolling Mill, Davenport, Iowa — May, pp. 10, 12.

Anderson & Beckwith, Archts. Proposed Elementary Community School, Lincoln, Mass. — Mar., pp. 142-144.

Annenberg & Erickson Florist Shop, N. Y. C. Marvin J. Neivert, Archt. — BTS — Apr., p. 138.

APARTMENTS. BTS No. 134 — Feb., pp. 112-134.

Apartment. Atlantic Gardens, Washington, D. C. — Feb., pp. 114-115; Proposed Cooperative, near the Sierras, Southern Cal. — Feb., pp. 124-125; over Drafting Room, Portland, Ore. — Feb., pp. 120-121; Great Oaks, Riverdale, N. Y. — Feb., pp. 128-129; Proposed Langley Park Housing Project, Montgomery County, Md. — Feb., pp. 122-123; New York Life Insurance Co. Project, N. Y. C. — Feb., pp. 130-131; J. B. Tiffey and Son Housing Development, Washington, D. C. — Feb., pp. 132-134; Town and Desert, Palm Springs, Cal. — May, pp. 96-101; for Students, University of Texas, Austin, Tex. — Feb., pp. 126-127.

Apartment, Circular, Southern U. S. (proposed). Wolff and Phillips, Archts. — Jan., pp. 152, 154.

Apartment, Cooperative. See Cooperative Apartments near the Sierras and Great Oaks Veterans' Cooperative Apartments.

Apartment over Drafting Room, Portland, Ore. Office of Pietro Belluschi, Archts. — BTS — Feb., pp. 120-121.

"An Arch Is an Arch Is $\gamma^2 = 2$ px (Sometimes)." Discussion of the Saariens' Jefferson Memorial arch — Apr., pp. 28, 30.

Architects' Collaborative. Entry in Jefferson Memorial Competition — Apr., p. 102.

"'Architect's Companion, The.'" Editorial by Kenneth K. Stowell — Mar., p. 87.

"Architect's Responsibility, The." Article on Hospital Planning by Henry H. Saylor, for Douglas William Orr, Pres., American Institute of Architects — Jan., pp. 94-95.

"Architect's Stake in Private Enterprise, The." Article by Miles Colean — June, pp. 97-99.

Armstrong, Harris, Archt. Runner-up, Jefferson Memorial Competition — Apr., pp. 99-100.

Armstrong, Jerome, Archt. Pacific Ave. School and Muscoy School, San Bernardino, Cal. — Mar., p. 131.

Atlantic Gardens Apartments, Washington, D. C. (proposed). Charles M. Goodman, Archt.; L. B. Voight, Landscape Archt. — BTS — Feb., pp. 114-115.

B

Bally Showroom for Shoes, N. Y. C. John R. Weber, Archt. — BTS — Mar., pp. 114-116.

Bangs, Jean Murray. Article, "Bernard Ralph Maybeck, Architect, Comes into His Own" — Jan., pp. 72-79.

Barstow Elementary School, Cal. Kistner, Curtis & Wright, Archts. & Engrs. — BTS — Mar., p. 137.

Barstow High School, Cal. Franklin, Kump & Falk, Archts.-Engrs. — BTS — Mar., pp. 132-136.

Bauer and Eash, Archts. Proposed Elk Rapids High School, Mich. — Mar., p. 122.

Bauer, Orville H., and Van Hoef, Robert F., Dsnrs. Redevelopment Plan for Grand Haven, Mich. — Feb., pp. 92-97.

"'Beauty' for Us Demands Architecture of Larger Scope at Vastly Broader Scale." Article by Douglas Haskell — June, pp. 88-91.

Bechtold, Julian F. See Rainey, T. Marshall.

Beeston, Stott, Patterson, Dsnrs. Panama National Tourist Commission Office, N. Y. C. — Mar., p. 104.

Bella Vista Elementary School, Montebello, Cal. (proposed). Kistner, Curtis & Wright, Archts. & Engrs. — BTS — Mar., p. 138.

Belle Rose School, Assumption Parish, La. Bodman & Murrell, Archts. — BTS — Mar., p. 125.

Bellevue Medical Center-New York University, Residence Hall, Laboratories and Classrooms (proposed). Skidmore, Owings & Merrill, Archts. — Apr., p. 10.

Bellman, Gillett & Richards, Archts. Lindel's Jewelry Store, Toledo, O. — Apr., p. 139.

Berla & Abel, Archts. Housing Development for J. B. Tiffey & Son, Washington, D. C. — Feb., pp. 132-134.

Belluschi, Pietro, Office of, Archts. Apartments over Drafting Room, Portland, Ore. — Feb., pp. 120-121.

Blatner, Henry L., Archt.; George Teeling, Mech. Engr. Proposed Elementary School, Clarks-ville, N. Y. — Mar., pp. 140-141.

Bodman & Murrell, Archts. Belle Rose School, Assumption Parish, La. — Mar., p. 125.

Bostonian Shoe Store, Chicago, Ill. Morris Lapidus, Archt. — BTS — Apr., p. 135.

Breger, William N., Archt.; Allen Gould, Painter; Caleb Hornbostel, Archt.; Donald L. Kline, Landscape Archt.; George S. Lewis, Archt.; Ralph Menconi, Sculptor; Andre Schwab, Painter; Christopher Tunnard, Landscape Archt. Second Prize Winners, Jefferson Memorial Competition — Apr., pp. 97-98.

British Overseas Airways Corporation Offices, N. Y. C. Pamela C. Colgate, Dsnr. — Mar., pp. 102-103.

Britsch & Munger, Archts. Proposed Elementary School, Perysburg, O. — Mar., p. 124.

Brown, Arthur T., Archt. House for Mr. and Mrs. Lyle B. Clothier, Tucson, Ariz. — May, pp. 126-129.

Bugbee, George. Article "The Hospitals' Place in the Program" — BTS — Jan., p. 95.

Bullock's Store, Palm Springs, Cal. Walter Wurde-man and Welton Becket, Archts. — BTS — Apr., pp. 123-127.

Burke, Irene, Store; and Guild House, I. Miller Store; Long Beach, Cal. Kenneth S. Wing, Archt. — BTS — Apr., pp. 140-143.

Burke & Kober, Dsnrs. Carver's, Custom Tailors, Los Angeles, Cal. — Apr., pp. 136-137.

Burns, H. W., Owner & Dsnr. Town and Desert Apartments, Palm Springs, Cal. — May, pp. 96-101.

Butler, George P., Archt. Proposed Annex to Sterile Techniques Bldg., Merck & Co., Rahway, N. J. Walter Kidde Constructors, Inc., Contrs. — Feb., p. 12.

Butterfield, Emily H. See "A Thousand Women in Architecture: Part II."

C

Cardinaux, Mr. and Mrs. Alfred L., House, Hartsdale, N. Y. Laurence M. Loeb, Archt.; André Sive, Dsnr. — BTS — May, pp. 136-137.

Carl's Sea Air, Motel, Roosevelt Highway, Santa Monica, Cal. Burton A. Schutt, Archt. — May, pp. 107-109.

Carmel Valley Inn, Monterey County, Cal. Robert R. Jones, Archt. — May, pp. 102-106.

Carousel Motel, Cal. Richard Massen and Roland Greene, Owners & Dsnrs. — May, pp. 114-117.

Carver's, Custom Tailors, Los Angeles, Cal. Burke & Kober, Dsnrs. — BTS — Apr., pp. 136-137.

Caudill, William W. Air Supply by Natural Ventilation; Critical Dimensions Governing School Design. Adapted from *Space for Teaching*, Bulletin of Agricultural and Mechanical College of Texas — TSS-AE — Feb., pp. 145, 147.

Church Community Center, Planning of — BTS — June, pp. 127-128.

Church Plans, See "The Seven Archetype Plans of Rudolf Schwarz."

Church, Thomas B. See Wurster, Bernardi & Emmons.

Churches. See RELIGIOUS ARCHITECTURE.

City Planning. See Grand Haven, Mich., Re-development Plan.

Clapp, Wilfred F. Article, "What We Like about One-Story Schools" — Mar., pp. 117-121.

Clark & Frey, Archts. Villa Hermosa Apartments, Palm Springs, Cal. — Feb., pp. 116-119.

Clark, Walter E., House, Lake Placid, N. Y. Harwell Hamilton Harris, Archt.; Russell S. Johnson, Assoc. — Feb., pp. 106-111.

Classroom Details. See School Classroom Details.

Clinics, Community. See HOSPITALS, BTS No. 133.

Close, Elizabeth Scheu. See "A Thousand Women in Architecture: Part I."

Clothier, Mr. and Mrs. Lyle B., House, Tucson, Ariz. Arthur T. Brown, Archt. — BTS — May, pp. 126-129.

Coit, Elisabeth. See "A Thousand Women in Architecture: Part II."

Colean, Miles. Article, "The Architect's Stake in Private Enterprise." — June, pp. 97-99.

Colgate, Pamela C., Dsnr. British Overseas Airways Corporation Offices, N. Y. C. — Mar., pp. 102-103.

CBS Television Studios, N. Y. C. (proposed) — Apr., p. 12.

Congregation Hillel, Northwestern University. Harrison & Abramovitz, Archts. — BTS — June, pp. 138-140.

Connecticut Mutual Life Insurance Co., Medical Building, Hartford, Conn. Moore & Salsbury, Archts. — May, p. 12.

Connor, Rose. See "A Thousand Women in Architecture: Part II."

Available



Again

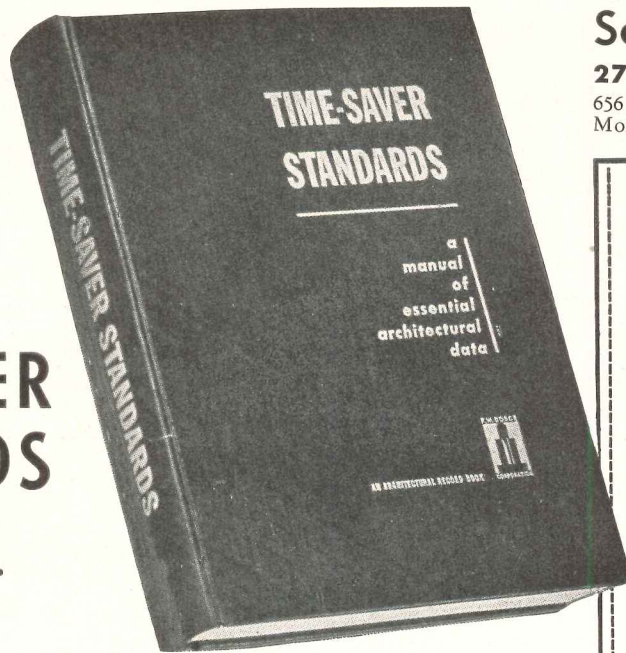

TIME-SAVER STANDARDS

Architectural Record's
ten-year collection . . .
all in one volume

Second Printing

277 Time-Saver Standards —
656 Pages; 12-Page Master Index; Size 8½ x 11.
More than 1,000 illustrations, charts, diagrams

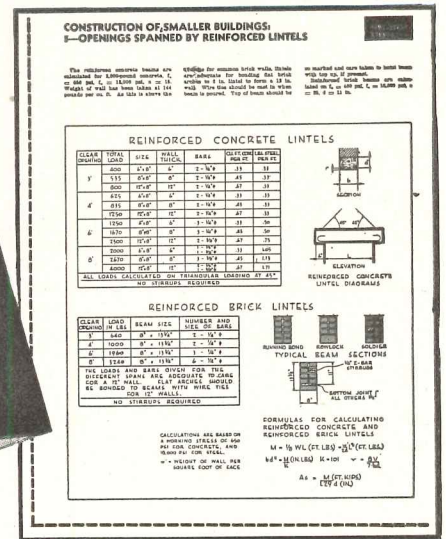

IN RESPONSE to insistent demand for more copies, here, reprinted again in one volume of encyclopedic size, are virtually all the Time-Saver Standards ever published — 277 of them — exactly as they appeared originally in *Architectural Record* and *American Architect* during the past ten years — with one 12-page master index!

Just off the press, for immediate delivery to you, is this work of 656 pages, with a mailing weight of 4½ lbs., containing a complete collection of these now famous authoritative monographs on technical aspects of construction dealing with

- Architectural Design
- Materials Technology
- Engineering Data
- Building Practice

Designed for the practical guidance and every-day use of architects, engineers, specification writers and building technicians, TIME-SAVER STANDARDS will bring you a wealth of detailed information on design and building practice . . . carefully selected from the works of the nation's leading building designers and engineers.

Well-Organized 12-page Index

This wealth of data is carefully organized and painstakingly presented. It is so thoroughly indexed that there are 1,856 references and cross-references . . . occupying *twelve pages* of closely set print.

Experience shows that a single item in TIME-SAVER STANDARDS can well save hundreds of dollars in economy construction . . . save many hours of *your* valuable time. Yet you can now place this concise and well-organized planning data at your command for the nominal sum of \$12.00 — provided you act now.

Order Your Copy Now

The first printing of TIME-SAVER STANDARDS last November was sold out almost before publication. Now an unanticipated flood of orders — for extra copies and multiple copies — on top of new orders indicates the second printing will soon be snapped up.

So get your copy now. Don't get caught on a long waiting list. Simply fill out the coupon at right, attach your check or money order for \$12.00, and mail today. Your copy will be rushed to you without delay.

These telescopic outlines of only a very few of the 277 Standards give a quick idea of the detailed treatment accorded each subject.

Dry-wall Construction. Materials applicable. Fiber board. Fiber insulation board. Planks and tileboards. Hardboard, Gypsum wallboard. Plywood. Cement asbestos. Plastics. Composite and self-supporting walls and partitions . . . Advantages. Handicaps. Costs. Terminology. Classifications and sizes. Framing and furring. Joints. Nailing and cementing. Flexible fasteners. Finishing. Simplified practices. Uses. Applications. References.

Heating—Unit Heaters. Typical Heat sources. Boiler capacity. Characteristics. Location. Selection data. Capacities. Controls. Fresh Air connections. Pipe connections. Louvres. Grilles. Deflectors.

Basement Waterproofing. Impermeability of concrete cracks and joints in masonry. Hydrostatic pressure. Recommended concrete mixtures. Effect of curing time on permeability. Integral and membrane methods. Plastic and iron coating. Cement-base coatings.

Folding Partitions. Center hung doors. Pair-operated doors. Pockets. Passage through closed partitions. Door construction and soundproofing. Rolling partitions. Folding fabric partition.

Lighting. Recommended levels of illumination. Fixtures for filament and mercury lamps. Luminaire spacing. Room index. Coefficients of illumination. Layout suggestions. Conformity with structural design. Computed values of illumination. Lumen output of lamps.

Noise Reduction Acoustical Materials. A rule-of-thumb answer to what noise coefficient to use. Special applications. Materials for plastic application. Costs. Appearance. Design. Fire resistance. Light reflection. Heat transmission. Lighting. Pre-cast materials. Effect of paint. Acoustical Units: Wood framing; metal suspension systems.

ARCHITECTURAL RECORD BOOK DEPARTMENT
119 West 40th Street, New York 18, N. Y.

Enter my order for _____ copies of
the second printing of the 656-page TIME-SAVER
STANDARDS at \$12.00* a copy. I enclose \$_____

*Add 24 cents for New York City delivery — \$12.24 in all.

Name _____

Address _____

City _____ Zone _____

State _____



Greenwood School Gymnasium, La Grande, Oregon
Architect, Charles B. Miller, Pendleton, Oregon

BEAUTY and STRENGTH with Glued Laminated ARCHES

Where open available space is a prime requirement, no other structural medium offers the advantages of glued laminated arches. Their curving beauty offers a wide range of traditional designs. Their laminated strength permits greater slenderness and grace. Their simplicity and ease of erection assures the utmost in economy.

Consultation on glued laminated arches for gymnasiums, schools and churches is available through our engineering department.

TIMBER STRUCTURES, INC. Send for Folder
ENGINEERING
IN WOOD

P.O. Box 3782, Portland 8, Oregon • 535 Fifth Avenue, New York 17, N. Y. • 220 Montgomery St., San Francisco 4, Cal. • 120 S. LaSalle St., Rm. 1720, Chicago 3, Illinois • 5035 First Ave. S., Seattle 1, Wash.

INCLUDE HAWS FOUNTAINS IN YOUR PLANS

HAWS MODEL 7D...
Vitreous china drinking fountain with the Haws sanitary angle stream, automatic pressure regulator, concealed flow regulator screw. Working parts accessible... without detaching fixture from wall.

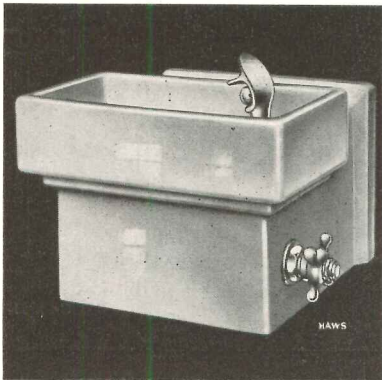

HAWS

DRINKING FOUNTAINS

... with the shielded stream head, safely guard health by providing fresh, cool drinking water, with complete sanitation. Specify HAWS Drinking Fountains and Electric Water Coolers in the buildings you are planning. They are modern in design, dependable in operation, simply installed and easily maintained. Write for your copy of the HAWS Catalog today! The HAWS complete line of drinking water fountains permits the selection of a model and design that will meet your requirements.

HAWS DRINKING FAUCET CO.
1441 FOURTH STREET (Since 1909) BERKELEY 2, CALIFORNIA
Agents and Sales Representatives in All Principal Cities

"Century" Notes:

Published in the interests of better lighting

you draw
attention...

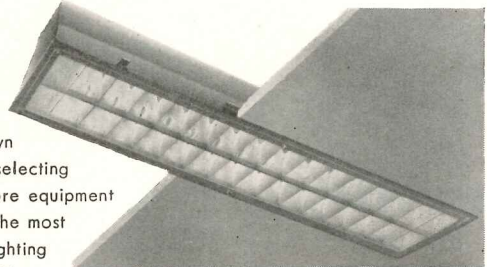

to your own talent for selecting modern store equipment that does the most effective lighting job of all. Veteran Century engineers have perfected this versatile lighting unit which provides **low contrast brightness** with adequate **circulation** or utility lighting; plus clear general sales lighting plus overall tie-in lighting. It will profit you to specify Century wherever lighting fixtures are indicated on your blueprints. Cat. No. F-11

Two Lamp Flush Troffer Unit. 40-W Fluorescent Lamps. Low brightness cross louvers and special Alzak reflectors give an even illumination and a 45° cut off. Price: \$49.50

Century Lighting Inc.

419 West 55th Street, New York 626 N. Robertson Blvd., Los Angeles

The **COLOR** is here!

No more "fumbling" with colors! Time is saved, controversies are averted when you have the Moleta COLOR GUIDE. This handsome book is winning round-the-world honors... serving users in Europe, Arabia, Africa, China, all over the globe!

The Moleta COLOR GUIDE gives a page-by-page display of 150 beautiful colors... each tint from the palest to the darkest shown on a large page (9" x 15"). The correct mixing formula is given on the reverse of each page.

Write for your copy of the Moleta COLOR GUIDE
—\$5.00, delivered anywhere in the U. S. A.

MONROE, LEDERER & TAUSSIG, Inc.
606 N. American St., Phila. 23, Pa.

Moleta
ARCHITECTURAL

The Truly Washable
FLAT OIL PAINT

NOW!

a new, better
roof deck material!

KAYLO*

*T. M. Reg. U. S. Pat. Off.

Insulating Roof Tile

From the laboratories of the Owens-Illinois Glass Company comes this new and different structural product.

Designed to provide both insulation and structural strength in a single material, Kaylo Insulating Roof Tile offers a unique combination of advantages to Owners, Architects and Contractors.

Kaylo Insulating Roof Tile is fireproof. It is composed entirely of inorganic materials. It is light in weight, easy to cut and fit, and structurally strong. Kaylo Roof Tiles, precast in units $2\frac{5}{8} \times 18 \times 36$ inches, are easy to handle and simple to install.

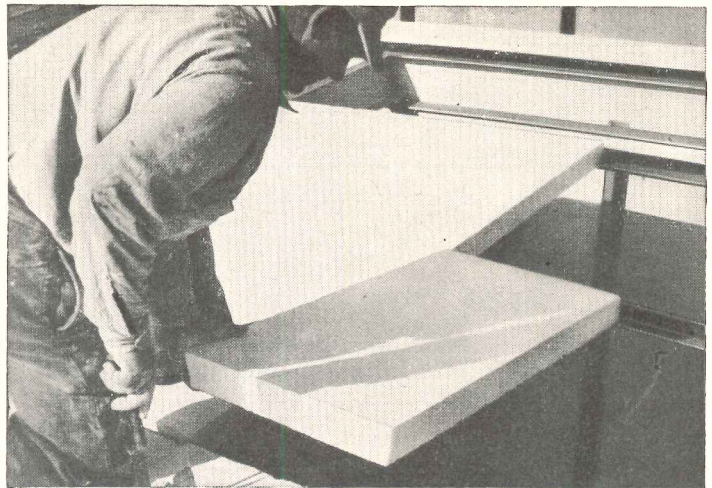

KAYLO ROOF TILE can be easily fitted into place on the job by one man.



KAYLO ROOF TILE is simple to install, lightweight, saves steel.

• • •

PHYSICAL CHARACTERISTICS

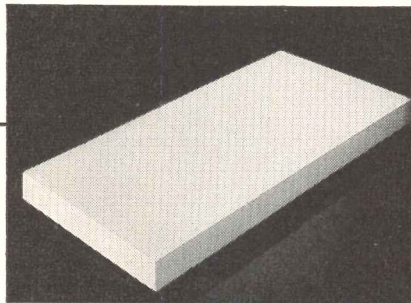

WEIGHT

Density (lb. per cubic foot).....approx. 20.0
Weight per tile (lb.).....approx. 21.0
Weight per square foot (lb.).....approx. 4.5

STRENGTH

Average modulus of rupture.....175 lb. per sq. inch
Average modulus of elasticity.....160,000 lb. per sq. inch
Average compressive strength.....500 lb. per sq. inch

INSULATING VALUE (Btu/square foot/hour/°fahrenheit)

"K"—for inch thickness.....0.62
"U"—for standard tile ($2\frac{5}{8}$ inch).....0.20
"U"—for standard tile plus built-up roofing.....0.19

FIRE RESISTANCE

Kaylo Insulating Roof Tile is fireproof. Units tested separately have withstood building fire temperatures as defined by the standard A.S.T.M. fire curve for one hour. (This is a test of a material only and not of a construction.)

LIGHT REFLECTIVITY

Light reflection factor.....approx. 80%

KAYLO*

T. M. Reg. U. S. Pat. Off.

Insulating Roof Tile

AMERICAN STRUCTURAL PRODUCTS COMPANY

Subsidiary of
OWENS-ILLINOIS GLASS COMPANY

SEND COUPON TODAY!

AMERICAN STRUCTURAL PRODUCTS COMPANY

Dept. E-413, P.O. Box 1035
Toledo 1, Ohio

Gentlemen: Please send me, without obligation on my part, the following information on Kaylo Insulating Roof Tile:

- Construction details
 Specifications and technical data
 Sample

Name _____

Firm _____

Street _____

City _____ Zone _____ State _____



Plan for "human efficiency" with adequate thirst-relief

It's a known fact that most people drink *less* water than they should. That's why it's important that your plans call for electric water coolers at enough convenient locations to *remind, and invite*, building occupants to drink the water they need. And you get best re-

sults when you specify OASIS Electric Water Coolers. In addition to maximum thirst satisfaction, they assure the long life and low-cost dependability you expect from *the world's largest maker of electric drinking water coolers*. Models for every need. Write for details.

The EBCO Manufacturing Co. • Columbus 8, Ohio

STOP that WATER with FORMULA # 640

A Clear Liquid Waterproofing for Old or New Construction

PENETRATES deeply—one inch or more—is not a surface treatment. Brush, spray, or float on stone, cast stone, concrete, mortar, stucco, tile, brick, plaster, wood, wall board—any absorbent material.

WATERPROOFS, preserves, prevents dusting of floors, surface dirt washes away in rain.

FORMULA No. 640 is a balanced formula of seven different waxes and resins in a hydrocarbon solvent.

ACID-ALKALI proof—does not oxidize, unchanged by temperature.

PERFORMANCE—It is our opinion it will last as long as the concrete, mortar, stucco, etc., lasts.

OIL PAINT saponifies on cement unless sealed first with Formula No. 640.

APPLY to either side: **The pressure side, or opposite side**—it is equally effective.

HYDROSTATIC PRESSURE—A 20 foot head has been held by Formula No. 640.

CUTS WATERPROOFING COSTS because it applies three times as fast as paint, requires no special technique. No preparation—comes ready to apply. Eliminates necessity of furring. Concrete floors and walls need no membraning.

KEEPS IN ALL CLIMATES • **HARMLESS TO USE**
GOOD COVERAGE • **MODERATE PRICE**

WRITE OUR ENGINEERING DEPARTMENT for office test kit, technical data, or regarding any special problem.
J. Wilbur Haynes, Engineer

OTHER PRODUCTS: Formula No. 640 Toxic, combines waterproofing with termite and fungus protection; cement hardener; cement paint; floor mastic; roof coatings, etc.

HAYNES PRODUCTS CO.

4007 FARNAM STREET • OMAHA 3, NEBRASKA



SO WE MADE 3 GYMS in ONE!

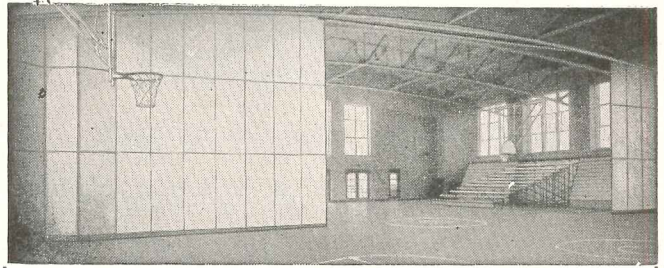

HORN FOLDING PARTITIONS HORN FOLDING BLEACHERS

FOR COMPLETE INFORMATION WRITE

HORN BROTHERS CO.

FORT DODGE, IOWA
ESTABLISHED 1909

WING *Revolving* UNIT HEATERS

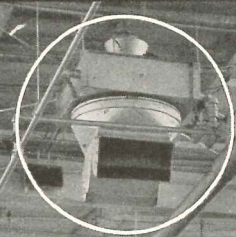

Only Revolving Discharge Gives the Ultimate in Uniform, Healthful Plant Heating

The Wing Revolving Unit Heater differs from every other unit heater on the market in its unique method of distributing the heated air. Instead of projecting the air in one or more streams in fixed directions, the slowly revolving discharge outlets of the Wing Revolving Heater distribute the heated air in constantly changing directions, covering the working area completely, uniformly and with a healthful, refreshing effect.

Write for a copy of Bulletin HR-5

L. J. WING MFG. CO.
151 West 14th Street
New York 11, N. Y.

WING PIONEERED AND DEVELOPED THE OVERHEAD VERTICAL DOWNWARD DISCHARGE UNIT HEATER

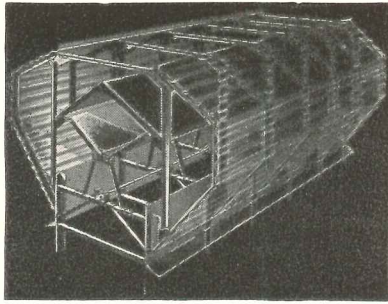

THE BURT MONOVENT FUNCTIONS AS A GIGANTIC ROOF RIDGE VALVE

Where heat and fumes must be exhausted the entire length of a building, the Burt Monovent Continuous Ridge Ventilator is the efficient and economical solution to ventilating problems. Designed to install along the roof ridge, it harmonizes with roof lines for better appearance than unit ventilators. It is weatherproof, simple to operate and maintain. Monovents are serving industry in installations from one foot to a thousand feet in length—from 4" to 96" throat sizes. . . . See Sweet's or write—now—for data and catalog sheets on the Monovent and other Burt Ventilators.

THE BURT MFG. CO.

ROOF VENTILATORS • OIL FILTERS
EXHAUST HEADS

48 E. SOUTH STREET, AKRON 11, OHIO

SEND
FOR CATALOGS

Burt Engineers
are glad to
help on plans

The South Is OUR Pond

Southern industry prefers Monarch Elevators because they are designed specifically to carry Southern loads and to meet Southern conditions. Monarch's nearby home offices give close supervision to installations and service. If it's for the South, always call on Monarch for an estimate.



Electric Freight and
Passenger Elevators
and Lifts
Oil Hydraulic Elevators
Residence Elevators
Dumbwaiters

**Monarch Elevator
and Machine Co.**

GREENSBORO, N. C.

The Largest Builder of Freight
and Passenger Elevators in
the Southeast

MONARCH Elevators

FREE to architects and engineers typical designs for . . .

TECO

TRUSSED RAFTERS

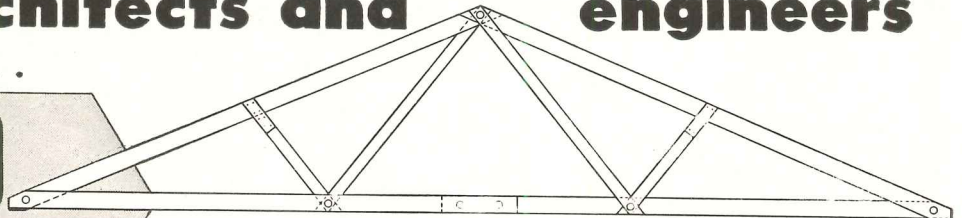

**Save up to 31% on materials—
eliminate interior bearing walls—
on single or multiple dwelling units**

By transferring the entire roof and ceiling load to the outside walls, clear span Teco Trussed Rafters eliminate the need for interior bearing walls, thus permitting complete flexibility of floor plan, both during construction and after completion.

Fabricated from only 4 basic members, either at a central location or on the job, Teco Trussed Rafters speed construction by permitting the builder to get the entire job under roof faster.

Extra strength is insured with Teco Split Ring Connectors in the rafter joints with Teco Trip-L-Grip Framing Anchors to tie 'em down.

Mail the coupon today for complete, typical designs for Teco Trussed Rafters in spans up to 32'. See for yourself how Teco Trussed Rafters can save up to 31% on materials—also give great labor savings.

Over 10,000 housing units have been built or are under construction utilizing Teco Trussed Rafters.



TIMBER ENGINEERING COMPANY

1319 18th St., N. W., Washington 6, D. C.

Gentlemen:

Please send me a typical design on Teco Trussed Rafters for a 20' to 32' span, (check one)

- | | |
|---|---|
| <input type="checkbox"/> 4" in 12" roof slope | <input type="checkbox"/> 6" in 12" roof slope |
| <input type="checkbox"/> 5" in 12" roof slope | <input type="checkbox"/> 7" in 12" roof slope |

Company Name _____

Address _____

Your Name _____

Check here for a copy of "Modern Home Planning".

Available Now!

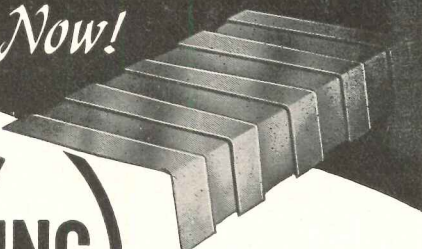

CHENEY FLASHING

3-Way Bond

16 OZ. COPPER

CHENEY FLASHING REGLET

16 OZ. COPPER

CHENEY FLASHING is again being made by the original inventor who pioneered the art of thru-wall flashing eighteen years ago.

No thru-wall flashing can operate successfully unless it has the two very important features that are found in CHENEY FLASHING—proven weep-hole drainage and the three-way bond, vertical as well as longitudinal and lateral.

Remember, the inferior two-way flashings, crimped copper and membranes, have neither the vertical bond nor do they drain moisture from the wall fast enough. Furthermore, their first cost advantage has disappeared because today Cheney Flashing is no longer a specialty—it's a standard commodity.

WRITE FOR DESCRIPTIVE FOLDER Dept. R

CHENEY FLASHING CO. Trenton, N. J.

HEATFORM

The Superior Heat Circulating Fireplace

THE MOST EFFICIENT AND DURABLE

PRODUCES MORE HEAT because the air contacts the heating surface of the firebox and the upper throat. Super-heating round air passages connect both upper and lower heating chambers. This extra heating surface through and around the throat is the most valuable of all because it is directly above the fire.

GIVES MORE YEARS OF SERVICE

because of the depressed ribbed construction of the firebox. Large air inlet and outlet capacity allows for greater flow of air over the hot metal, thus preventing deteriorating temperatures. Masonry downdraft shelf: no exposed metal parts beneath the chimney to rust out.

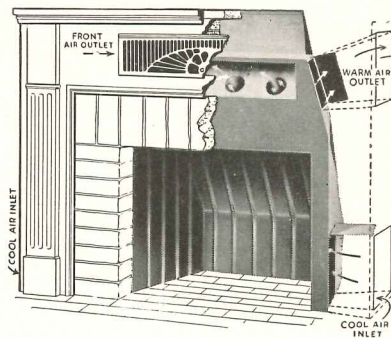

Front view of HEATFORM installed, with part of masonry cutaway.

For complete information see Sweet's Catalog or write
SUPERIOR FIREPLACE COMPANY
 EAST OF MISSISSIPPI RIVER • WEST OF MISSISSIPPI RIVER
 601-L North Point Road Baltimore, Maryland 1706-C East 15th St. Los Angeles 21, Calif.

THERE IS ONLY ONE CLIPPER BLOWER
 FOR KITCHEN CEILING VENTILATION

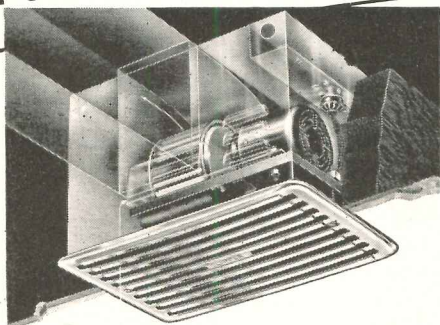

This patented, proven Clipper Kitchen Ventilator mounts between ceiling joists directly above the stove, and is vented out-of-doors. The powerful squirrel cage blower (not a fan) creates a stream of fast-moving pressure-charged air which keeps kitchens free of cooking grease, heat and odors. Also for dens, bathrooms, laundries and other small rooms. Specify the Clipper and be sure of adequate ventilation. Stocked and sold by electrical dealers coast to coast.

Write us today for complete details.

Trade-Wind Motorfans, Inc.
 5707 S. Main St., Los Angeles 37, Calif.
 Send complete information on the Clipper

Name _____

Address _____

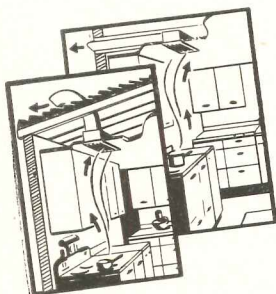

The Clipper is easily installed in the ceiling and vented through a side wall or roof



U. S. MAIL CHUTES

are essential in progressive apartments and hotels.

This little Miss prefers to mail her own letters and so do her parents.



This equipment may be leased if desired

ESTABLISHED 1883

Cutler Mail Chute Co

ROCHESTER 7, N. Y.

2nd Printing

The Complete ...
 Authoritative up-to-the-minute Handbook

"Hospital Planning"

by CHARLES BUTLER, F.A.I.A., and ADDISON ERDMAN, A.I.A.

A Case-Study Analysis of Modern Hospitals

With tremendous energy and insight Charles Butler and Addison Erdman, distinguished architects and hospital consultants, have made a nation-wide survey of the current adaptation of hospital architecture to changing practices in hospitalization.

The fruits of their study are set forth in "Hospital Planning" — a completely new treatise of present-day practices, based on a painstaking study of hundreds of institutions from which have been selected fifty-one modern hospitals, representing the creative efforts of more than thirty architectural firms, for illustration and discussion.

"Hospital Planning" presents a textual summation of the outstanding problems in hospital architecture and shows how these problems have been met in actual practice. Generous use of illustrations, including perspectives, floor plans, elevations and photographs, make solutions abundantly clear and afford sound, applicable principles for innumerable problems to come.

**For Hospital Administrators . . . Superintendents
 . . . Doctors . . . Architects**

This 232-page, fully-illustrated volume, carefully organized for both reading and reference, is designed for architects and hospital groups alike. It will help trustees, administrators and doctors to visualize their problems in terms of their community needs . . . show how others are meeting similar problems . . . provide them with a basic understanding of hospital architecture so that they may intelligently discuss their problems with the architect.

It will help architects and engineers to learn of the great advances made in hospital architecture . . . to acquire a working knowledge of medical problems and hospital procedure . . . to avoid the many pitfalls which beset the hospital planner.

Order Your Copy Now

With this second printing "Hospital Planning" is again temporarily available at the price of \$15. It is offered with the full knowledge that it may be worth incomparably more to you than its cost — so much more that cost is no valid consideration.

So use the convenient coupon below to make sure to get your copy of "Hospital Planning" before the second printing is sold out. The book will be sent promptly, prepaid.

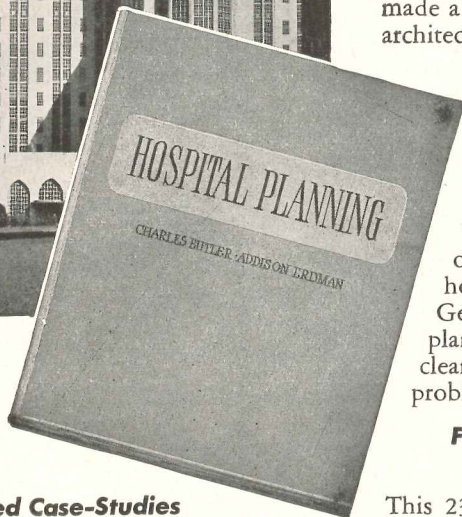

232 pages . . .
 size 8½ x 11 inches . . .
 17 chapters . . .
 profusely illustrated . . .
 thoroughly indexed . . .
 detailed table of contents . . .
 stiff cloth binding . . .
 Price \$15

Hundreds of Illustrated Case-Studies

"Hospital Planning" presents the plans of fifty-one selected modern hospitals . . . represents the creative efforts of 30 architects. Includes 32 photographs . . . 11 site plans . . . 187 floor plans . . . 38 special unit plans of rooms, wards and departments . . . numerous construction details.

THE AUTHORS—Perhaps no other two authors are so well qualified by background and experience to write a volume of such broad scope and magnitude as those selected for this authoritative and technically difficult work.



Charles Butler has been closely associated with hospital planning throughout his broad professional career. As architect or consultant, his works include St. Luke's International Medical Center, Tokyo; War Demonstration Hospital at Rockefeller Institute; Goldwater Memorial Hospital.



Addison Erdman, holder of the A.I.A.'s Langley Fellowship for two successive years, is a consultant on hospitals for a number of architectural firms. His works include the Mobile Hospital Unit for the British Army in Egypt, the Private Patient Pavilion, Methodist Hospital of Brooklyn. Recently appointed as one of the five architects-consultants for the Veterans Administration.

HOSPITALS selected for illustration include — Cornell-New York Medical Center, New York; Goldwater Memorial Hospital, Welfare Island, New York; Methodist Hospital, Brooklyn; General Hospital, Cincinnati; Saint Vincent's Hospital, New York; Community Hospital, Battle Creek; Saint Mary's Hospital, Rochester, Minnesota; American Memorial Hospital, Reims, France; Mallinckrodt Institute of Radiology, Saint Louis; Royal Victoria Hospital, Montreal; Rochester Municipal Hospital, Rochester, New York; Potts Memorial Hospital, Livingston, New York; Fort Sill Hospital, Fort Sill, Oklahoma. Saint Luke's Hospital, Spokane, Washington; Massachusetts General Hospital, Boston and many more.

A FEW of the architectural firms whose works were selected for discussion and illustration include...

- Coolidge, Shepley, Bulfinch and Abbott
- Samuel Hannaford & Sons
- Schmidt, Garden and Erickson
- Jamieson and Spear
- Charles B. Meyers
- James Gamble Rogers
- Mayers, Murray and Phillip
- Eggers and Higgins
- Crow, Lewis and Wick

Mail this coupon today

ARCHITECTURAL RECORD BOOK DEPARTMENT
 119 West 40th Street, New York 18, New York

Enter my order for . . . copy(s) of the new printing of "Hospital Planning" by Charles Butler and Addison Erdman at the price of \$15 a copy. I enclose payment of \$ (For New York City delivery, add 30 cents for Sales Tax — \$15.30 in all.)

Name
 Address
 City Zone State

Chromtrim

The answer
to More than
90%
of all building
needs for
METAL MOULDINGS



Chromtrim has evolved 34 basic profiles and is mass-producing them at lowered cost for economy-minded builders.

Durable, dimensionally accurate — easy to cut and install, delivered with all necessary nails, Chromtrim shapes are expertly designed to fill the highest professional building standards.

The 34 basic Chromtrim profiles are illustrated in Sweets Catalog (13J/3)

Write for complete catalog sheet with full dimensions.

R. D. WERNER CO., INC.
295 FIFTH AVENUE • NEW YORK 16, N. Y.

In Canada:
R. D. WERNER LTD. • PORT DALHOUSIE, ONTARIO, CANADA

Every Architect should have these STEWART CATALOGS

Catalog 82, Standard Iron Fences (with Channel Rails, Gates and Arches)

Catalog 80, Standard Iron Fences (with Angle Rails)

Catalog 83, Standard Chain Link Wire Fences and Gates

Catalog R-38, Railings, Pier Lanterns, Interior Gates, Veranda Work, etc.

Catalog W-40, Window Guards, Wire Mesh Partitions, Folding Gates, etc.

Catalog I-42, Industrial Fence Specifications Manual

These catalogs contain complete information on Stewart Iron and Wire Products. Check your file of Stewart literature. If you do not have all the catalogs listed above, we shall be glad to send them to you. Stewart also manufactures the following jail and prison equipment: Steel Cells, Bunks, Hinge and Sliding Type Doors, Locks and Locking Devices, Iron Stairways, Gratings, etc. Complete information on request.

Stewart IRON and WIRE THE STEWART IRON WORKS CO., Inc.
FENCES 1565 Stewart Block CINCINNATI 1, O.

General Controls L-2 SERIES LOW WATER CUTOUTS

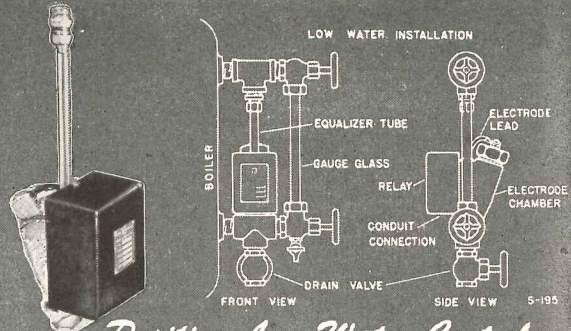

Positive Low Water Control

FREE of moving parts, glands or seals under pressure, thereby eliminating greatest drawbacks of usual cut-offs. Low installation cost. Low voltage and line voltage types furnished. Line voltage type available with double voltage coils, permitting either 115 or 230 volts A.C. Request details.

FOR COMPLETE SPECIFICATIONS request new catalog 52C

GENERAL CONTROLS
801 ALLEN AVENUE GLENDALE 1, CALIF.

Manufacturers of Automatic Pressure, Temperature & Flow Controls

FACTORY BRANCHES: BIRMINGHAM (3) • BOSTON (16) • CHICAGO (5) • DALLAS (2) • DENVER (10) • DETROIT (8) • CLEVELAND (15) • HOUSTON (2) • KANSAS CITY (2) • NEW YORK (17) • PHILADELPHIA (40) • PITTSBURGH (27) • SAN FRANCISCO (7) • SEATTLE (1) • DISTRIBUTORS IN PRINCIPAL CITIES

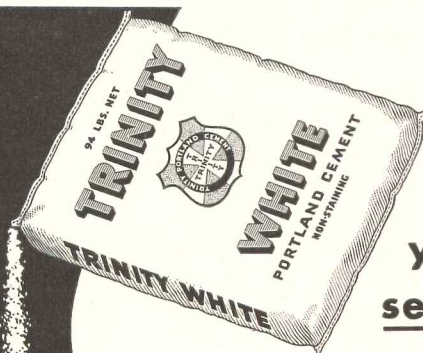

you can
see that

Trinity White

is the whitest
white cement!

You'll get fine results with this extra white cement. It's true Portland Cement made to ASTM and Federal Specifications. If your dealer does not have it, write the office nearest you: Trinity Portland Cement Division, General Portland Cement Co., 111 West Monroe St., Chicago; Republic Bank Bldg., Dallas; 816 W. 5th St., Los Angeles.

as white as snow

MR. ARCHITECT!



**DO YOU KNOW THAT YOU
CAN SPECIFY THESE MORE SATISFACTORY,
LONGER-LASTING, BETTER-LOOKING
STEEL ACCESS DOORS AT
SAVINGS OVER THE OLD TYPE?**

Ready to Install!
Fits flush with wall and
ceiling surface.

No Special Framing!
No cutting, adjusting, or
altering, either.

Furnished Painted!
Prime coat of grey,
rust-inhibitive paint.

11 Different Sizes!
From 8 3/8" x 12 3/8" to
24 3/8" x 24 3/8"

Concealed Hinges!
— or clip fasteners.

Screw-type Lock!
Depressed level with
surface of lid.

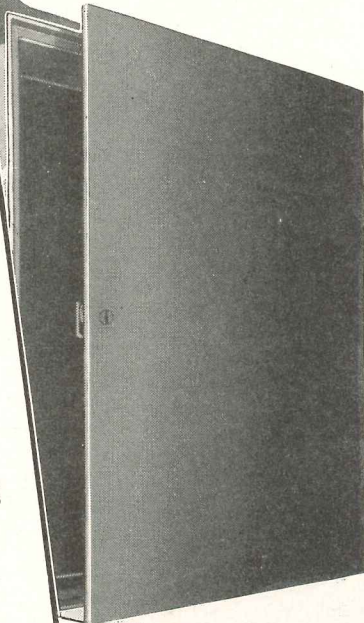

**Every house needs at least one access
door. Public buildings need hundreds!**

**MORE CREDITABLE RESULTS
for the Architect!
BIG SAVINGS for the owner!**

Provide the best job at
the least cost — with

**MILCOR STEEL
ACCESS DOORS**
(Flush with wall)

**Installed at lower cost than old-type doors
— give greater all-around satisfaction!**

There are three styles (11 sizes each) of Milcor Metal Access Doors for reaching key points in plumbing, heating, electrical, and refrigeration systems — and for permitting ceiling entry to attics: 1. With expanded metal wing, for plastered walls; 2. Without expanded metal wing, for plastered walls; 3. For non-plastered walls: masonry, brick, stone, wallboard, acoustical construction, etc.

Save the high labor costs. Save the time of building special framing. Save the time of installing and painting the old-type access doors. Get away from ugly, old fashioned framing sticking out from the wall — which calls for expensive repainting jobs. Specify these new, better steel doors that can't crack, shrink, warp, or rot — and that last forever.

Owners are more satisfied, because all jobs are perfect — because of greater interior beauty

(Flush-with-wall doors are papered or painted with the rest of the wall or ceiling surface) — and because of greater utility.

INLAND STEEL PRODUCTS COMPANY

FORMERLY MILCOR STEEL COMPANY

MILWAUKEE 1, WISCONSIN

Baltimore 24, Md. • Buffalo 11, N. Y. • Chicago 9, Ill.
Cincinnati 25, Ohio • Cleveland 14, Ohio • Detroit 2,
Mich. • Kansas City 8, Mo. • Los Angeles 23, Calif.
New York 22, N. Y. • Rochester 9, N. Y.

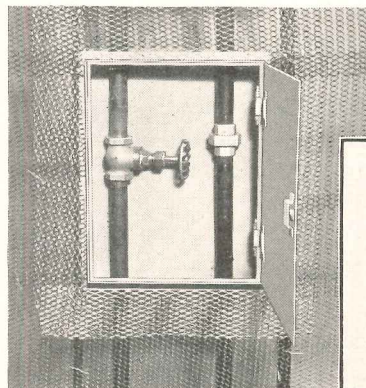

Mr. Architect:
**Tear out coupon
and mail at once**

— for specifications and complete descriptive material on Milcor Steel Access Doors.

INLAND STEEL PRODUCTS CO., 4101 W. Burnham St., Milwaukee 1, Wis.

Send me specifications and descriptive material for architects on Milcor Steel Access Doors.

Name..... Title.....

Company.....

Address.....

City..... (.....) State.....

**METAL FOR STORE FRONTS
FULLY EXTRUDED
ALUMILITED ALUMINUM**

latcor

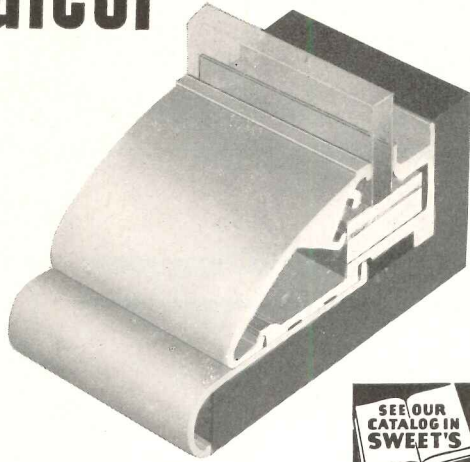

SEE OUR CATALOG IN SWEET'S

20
5

FOR DETAILS WRITE

latcor STORE FRONTS
PROVIDENCE 9 RHODE ISLAND

MODERNFOLD COSTS NO MORE*...

**AND LOOK AT THE BEAUTY
... THE MANY ADVANTAGES!**

In computing the cost of a conventional swinging door, you must figure on the cost of trim, jamb, the actual door, hardware, painting, etc. The price of Modernfold can be even lower — and the accordion-like action of this sturdy, durable door offers so many more advantages! It saves space and eliminates the area required for the swing of conventional doors. Modernfold is beautiful, too — colorful fabrics, attached to the metal frame, assure harmony with any general color scheme. Write for full details.



*A 2' 4" wide x 6' 8½" high door costs only \$26.00 (F. O. B., New Castle). Either Beige or Ivory. Other Modernfolds correspondingly low priced.

modernfold
DOORS

NEW CASTLE PRODUCTS

New Castle

Indiana

Consult your telephone directory for the names of our installing distributors.

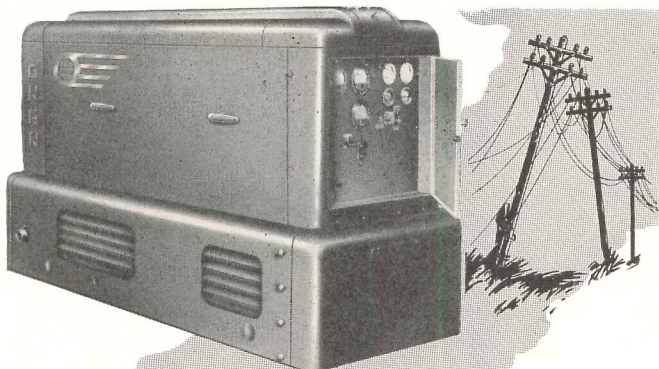

Guard Against Costly Power Failures with

**ONAN STANDBY
ELECTRIC PLANTS**

When power fails, business comes to a standstill. Materials in process are wasted, men and machines stand idle, lives may be endangered. Prevent the disastrous effects of power failure with a low-cost, easy-to-install Onan Standby System. The generating plant starts automatically when commercial power fails, takes over the power load without interruption, stops automatically when power is restored. Many models: 350 to 35,000 watts, A.C.



Write for Catalog



D. W. ONAN & SONS INC.
5132 Royalston Ave., Minneapolis 5, Minn.

ONAN STANDBY POWER

What's funny about building?

THE LAST LATH!

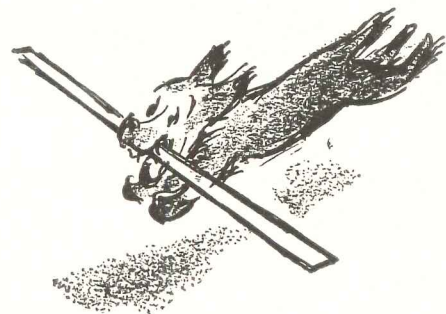

Now in book form:

All of Alan Dunn's cartoons from *Architectural Record*

... and a bonus of new ones besides — 96 pages of architectural comedy to skyrocket morale all along the line from the drafting room to the clients in the outer office. Don't miss the fun; mail the coupon today!

ARCHITECTURAL RECORD BOOK DEPT.
119 West 40th Street, New York 18, N. Y.

I want THE LAST LATH! My check for \$2.50 is enclosed.

Name.....

Address.....

City.....Zone.....State.....

What does it mean when an architectural magazine

More than doubles its annual advertising volume in five years

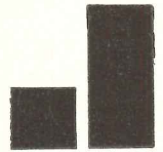

Leads the second publication by 15%, the third by 73%

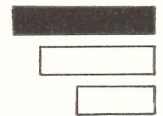

Carries 40% of the total advertising placed in national architectural magazines

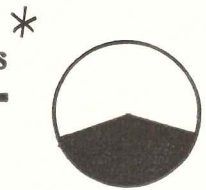

To Architectural Record's readers it means that in the pages of the Record they see the greatest array of materials and equipment for architect-designed buildings to be found in any magazine — a market-place brought to the specification writer's desk.

To building product manufacturers and their advertising agencies the Record's steady growth has a marketing significance, for it mirrors the growth of the building market. And it underscores the key place of the architect and engineer in the building market.

To the men and women who select advertising media the Record's established leadership — the fact that it carries more advertising from more manufacturers of building products than any other publication in its field — means . . .

* Only the RECORD showed an advertising gain in 1947.

**You are right
with the RECORD!**

"Workbook of the Architect-Engineer"

119 WEST FORTIETH STREET, NEW YORK 18



FULL VENTILATION SASH CENTERS

for TRANSOMS and WINDOWS
with **MONARCH**

★ 5 ★
Star

SASH CENTER

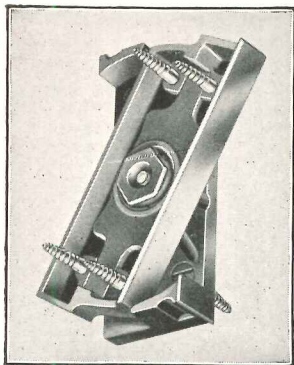

- ★ Weatherproof, foolproof, adjustable.
- ★ Square end, easy mortise installation.
- ★ Sides, or top and bottom pivot point.
- ★ Five HOLD-FIRM sash angle positions.
- ★ 100% opening, good ventilation, easy.

Write for descriptive literature



CLAYTON & LAMBERT MFG. CO.
1705 DIXIE HIGHWAY • LOUISVILLE 10, KY.

What goes UP?

What goes DOWN?

to meet variations in floor levels?

...THE NEW ADJUSTABLE TOP

Josam

LEVELEZE
LEVELS EASY
FLOOR DRAIN

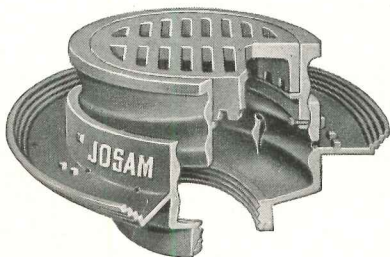

Now... where the drain has been set too high or too low... or where floor level is changed—for any reason—after the LEVELEZE drain is installed, simply raise or lower the adjustable top of the JOSAM LEVELEZE Floor Drain and presto—the new level is met, drainage is assured and the cost of adjustment is negligible. Send coupon below for literature.

SERIES 3610—with deep set tractor grate shown
SERIES 3510—with anti-tilting grate optional

Josam Mfg. Co., 302 Ferguson Bldg., Cleveland 14, Ohio
Please send me literature on new Leveleze Floor Drain

Name

Firm

Address

City State



S A R C O HEATING SYSTEMS

For more than thirty years, leading architects in all parts of the country have made sure of completely satisfactory heating of buildings of all types—commercial, industrial or institutional—by specifying SARCO.

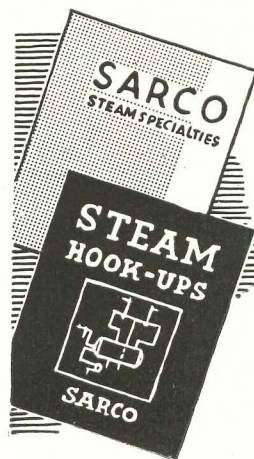

For Your Data Files

To assist your heating engineer in selecting the best system for any building under consideration, we have compiled the manuals illustrated.

Why not place these handy books in your reference files now. In writing for them, please specify type of building and heating system in which you are interested.

220

SARCO SARCO COMPANY, INC.
Empire State Bldg., New York 1, N.Y.
SAVES STEAM SARCO CANADA, LTD., TORONTO 5, ONTARIO

This is Your Copy of

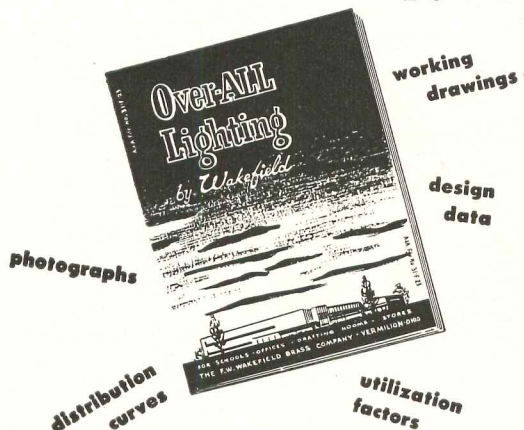

Ready for your file—a modern fully illustrated factually written catalog devoted to the achievement of efficient visual environments for offices, drafting rooms, schools and stores through the use of finely engineered lighting equipment. Write today and your copy will be on its way.

THE F. W. *Wakefield* BRASS COMPANY
VERMILION, OHIO



Take a leaf from this book

"My clients who are thinking about building frequently bring me articles and ideas clipped from House & Garden. Sometimes it's the details of a mantle or suggestions about new building materials.

I, too, tear many a leaf out of House & Garden. And, incidentally, the monthly Building Reprints are excellent reference material for latest developments in the building field."

Undoubtedly, this voice of authority is the reason House & Garden has been first among architects by actual survey.

House & Garden

A Condé Nast Publication

©1948 THE CONDE NAST PUBLICATIONS INC.

Its Golden Touch gets action at lowest initial cost in the home service field.

CASSEL ARCHITECTURAL INDICATORS

FOR 1/4" SCALE ARCHITECTURAL INDICATION

(Available soon for 1/8" Scale Drawings)

TIME AND MONEY SAVERS FOR THE DRAFTING ROOM

SPEED UP ARCHITECTURAL DRAFTING with the Cassel Indicators, the only practical method of standard indication on the market that will pay its cost on a single job.

FOR QUICK AND ACCURATE INDICATIONS OF MORE THAN 200 COMBINED USES

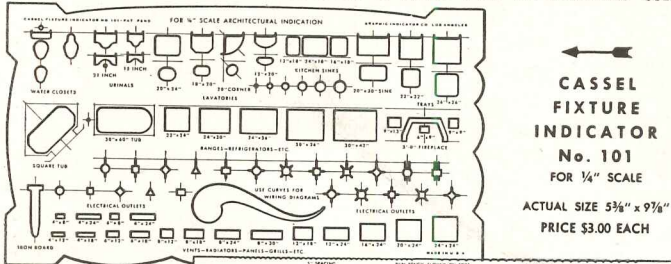

CASSEL HANDY INDICATOR No. 105 FOR 1/4" SCALE ACTUAL SIZE 5 3/8" x 9 7/8" PRICE \$3.00 EACH

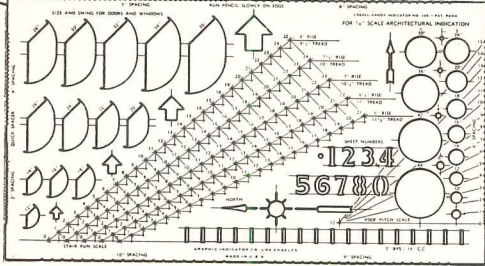

MADE OF TOUGH TRANSLUCENT VINYLITE THAT STAYS FLAT WITH A NO-GLARE AND NON-SLIP SURFACE ACCURATELY MADE TO SCALE FOR PROFESSIONAL USE

The Cassel Architectural Indicators, designed by Architects, are made to conform to **ARCHITECTURAL GRAPHIC STANDARDS**

ORDER FROM YOUR DEALER TODAY—or direct from us, postpaid, by enclosing \$3.00 each. Money refunded if claims herein are not fulfilled. (Add 2 1/2% State Tax if delivered in California.)

GRAPHIC INDICATOR COMPANY, Dept. B
1154 SOUTH WESTERN AVE. • LOS ANGELES 6, CALIF.

NEW OZACLOTH...

improves even your best drawing

- Ozacloth increases the opacity of pencil and ink images... gives you translucent duplicates which produce better prints than original drawings.
- Ozacloth prints have permanent sepia images... which will not smudge, run, or chip.
- Ozacloth resists wear and tear... has a superior tracing cloth base... plastic coated... impervious to water, grease, grime. Can be cleaned with a damp cloth.
- Ozacloth speeds up print production... is processed in usual manner in your Ozalid machine...



turns out subsequent prints in 26 seconds or less.

5. Ozacloth cuts costs—you can make a permanent 8 1/2 x 11 print for 26 cents, a 17 x 22 print for 52 cents, etc. *A fraction of the cost of the original drawing—yet full insurance for years to come!*

See * Feel * Try new Ozacloth

OZALID

A Division of
General Aniline &
Film Corporation
Johnson City, N. Y.

Gentlemen: Dept. No. 96
 Please send free sample of new Ozacloth.
 Please send complete information on Ozalid process. No obligation.
 NAME _____
 POSITION _____
 COMPANY _____
 ADDRESS _____

Ozalid in Canada—Hughes Owens Co., Ltd., Montreal

Lockwood

IDENTIFIES QUALITY IN BUILDERS' HARDWARE

LOCKWOOD identifies its Builders' Hardware with this famous Trade Mark. You will find it on cylinder locks and keys, on mortise locks, on door closers... a symbol of enduring quality since 1882.

To the Architect the name LOCKWOOD also signifies a line of Builders' Hardware embracing all requirements, characterized by steady advancement in feature and design... and a company that never hesitates to give full and prompt co-operation.

We aim to keep it that way.

R-1

LOCKWOOD HARDWARE MFG. COMPANY

Division of Independent Lock Company

Fitchburg • Massachusetts

Put More STYLE and COMFORT into Office Hours

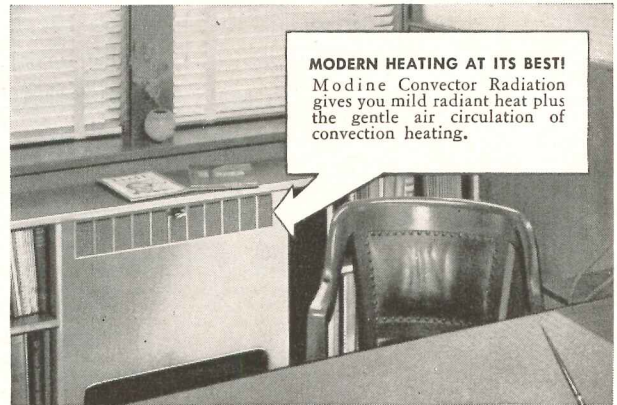

MODERN HEATING AT ITS BEST!
Modine Convactor Radiation gives you mild radiant heat plus the gentle air circulation of convection heating.

A modern, blended heating system for modern office comfort... a heating system that gives you individual room control, gentle draft-free, warmed air circulation without the use of moving parts that wear out—that's what Modine Convactor Radiation offers you. If you're planning to build or remodel an office building, laboratory, or showroom, specify the dependable heating comfort, distinctive style, space saving, cleanliness, and long service of Modine Convactor Radiation. Look for Modine's representative in the "Where-to-buy-it" section of your phone book, or write for free literature.

MODINE MFG. CO., 1510 Dekoven Ave., Racine, Wis.

Insists on heating that's 100% dependable —and gets it with **PETRO**

In selecting a heating plant, many architects consider proved dependability their top "specification." For where an installation maintains high combustion efficiency and economy year after year, complete owner satisfaction is assured. Through personal observation and experience, architects know — just as Mr. Hart does — that they can count on a Petro.

This confidence in Petro oil burning equipment is well founded. With 45 years' unrivaled experience, Petro has achieved such outstanding economy features as Thermal Viscosity Control — an *automatic* system of burning preheated oils with maximum heat output. Expertly engineered design, precision construction, durable materials . . . all are combined in Petro to offer the kind of operation that owners expect — 100% dependable heating with minimum supervision.

There is a Petro for any commercial or domestic specification. We invite you to submit your requirements to the world's largest, exclusive maker of oil burning equipment.

PETRO
REG. U. S. PAT. OFF.
cuts steam costs

PETROLEUM HEAT AND POWER CO. • Makers of Good Oil Burning Equipment Since 1903 • Stamford, Connecticut



Charles M. Hart, of New York, is well-known for his design both of the Dearborn Inn Colonial Village in Dearborn, Michigan, owned by the Ford Motor Co., and of many hospitals, apartment houses and hotels the country over. He has specified Petro equipment for his work and, from experience, has these comments to make concerning the Petro Oil Burning System:

"In the great building program which faces us, reliable and efficient operation must be expected from heating systems. I know from experience that Petro equipment is 100 per cent dependable. There is no odor or objectionable noise where Petro is used and no annoyance from smoke and ashes. I have found their system operates economically."

"After I went personally with a client to the Petro showrooms in Stamford, I was agreeably impressed by the competent cooperation from the Petro organization. My clients were pleased and this office was thankful that we had such a splendid source of service."

INDUSTRIAL MODELS: No. 5 or No. 6 fuel oil; manual, semi-automatic or automatic operation; 8 sizes to 450 bhp. Thermal Viscosity preheating.

DOMESTIC MODELS: No. 3 or lighter oils; "conversion" and combination-unit types, 7 sizes. Patented "Tubular Atomization."

FULL DATA on Petro Industrial Burners are in catalog files of Sweet's and Domestic Engineering. Details on Petro Domestic Burners available in separate catalog. Copy of either sent gladly on request.

**End the
danger
of
Scalding
Showers!**

Install

**POWERS THERMOSTATIC
SHOWER MIXERS**

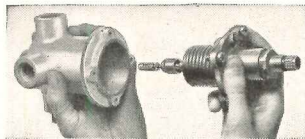
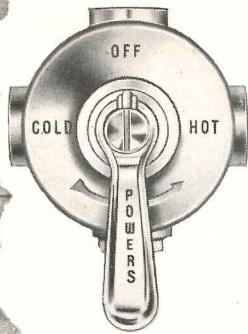

Only One Moving Part

**They are safe
both ways!**

Bathers can really relax and enjoy the best shower they ever had if the temperature is regulated by Powers.

There is no danger of scalding... no slipping and falling while trying to dodge an unexpected shot of hot or cold water.

Being *thermostatic*, Powers Mixers give *two way* protection... against *pressure changes* caused by use of nearby showers, flush valves and faucets... and against *temperature changes* in water supply lines.

Cut fuel and water bills with Powers Mixers. Bathers waste no time or hot and cold water while waiting for a shower at the right temperature. **Phone or write our nearest office for Circular H547.**

THE POWERS REGULATOR CO.

CHICAGO 14, ILL. 2752 Greenview Ave.—Phone Buckingham 7100
NEW YORK 17, N. Y. 231 East 46th St.—Phone Eldorado 5-2050
LOS ANGELES 5, CAL. 1808 West Eighth St.—Phone Drexel 2394
948

POWERS
THERMOSTATIC SHOWER MIXERS

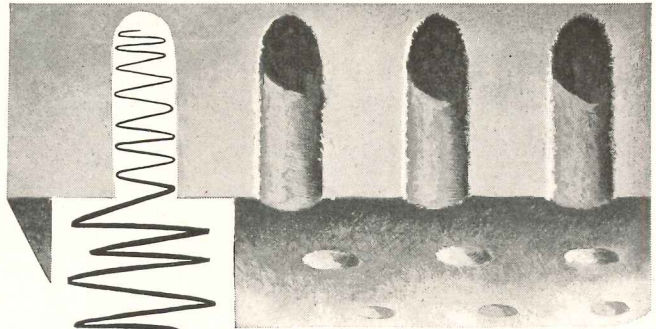

THE CEILING
with a hundred thousand
"NOISE TRAPS"

Send for Free, Fascinating Brochure: Tells you about Fibretone*, the acoustical ceiling, and how its thousands of scientifically-designed *noise traps* help eliminate unwanted noise—in offices, restaurants, banks, schools, factories, and recreation centers. Write Johns-Manville, Dept. AR 6, Box 290, New York 16, N. Y.



*Reg. U. S. Pat. Off.



**Johns-Manville
FIBRETONE**

**FACTS • FIGURES
DIMENSIONAL DATA**

New **OKOLITE-
OKOPRENE**
CABLE FOLDER



In selecting Okolite-Okoprene* cable for service up to 5000 volts, electrical men are going further than merely tying in with a manufacturer's recommendations. They are tying in with a trend — an ever-increasing use due to an ever-growing demand.

For full facts on Okolite-Okoprene, get this new 16-page illustrated folder. It gives you dimensional data for all sizes and voltages and conduit fills as well as information on applications. Write for Bulletin AR-1037. Address The Okonite Company, Passaic, New Jersey.

*U.S. Pat. No. 2,312,058

OKONITE
insulated wires and cables

6014

NOW

your clients can get PC Foamglas Insulation

● Many prominent concerns have deferred insulation programs until they could get PC Foamglas. Now—with our production doubled—all orders for Foamglas can be delivered promptly.

Foamglas is the only material of its kind. Big, rigid blocks are composed of millions of minute, closed, air-filled glass cells. Resistant to vapors, fumes and acid atmospheres—because it is glass—PC Foamglas retains its original insulating value permanently when installed

according to our specifications and recommendations.

Review your clients' insulation requirements as of today, for walls and ceilings, roofs and floors. If maintaining desired temperatures in their buildings involves special problems, our technical staff will be glad to discuss them with you. Meanwhile you can get full information on customary uses of PC Foamglas from our current literature. Send the coupon for your free copies. Pittsburgh Corning Corporation also makes PC Glass Blocks.

When you insulate with FOAMGLAS, you insulate for good

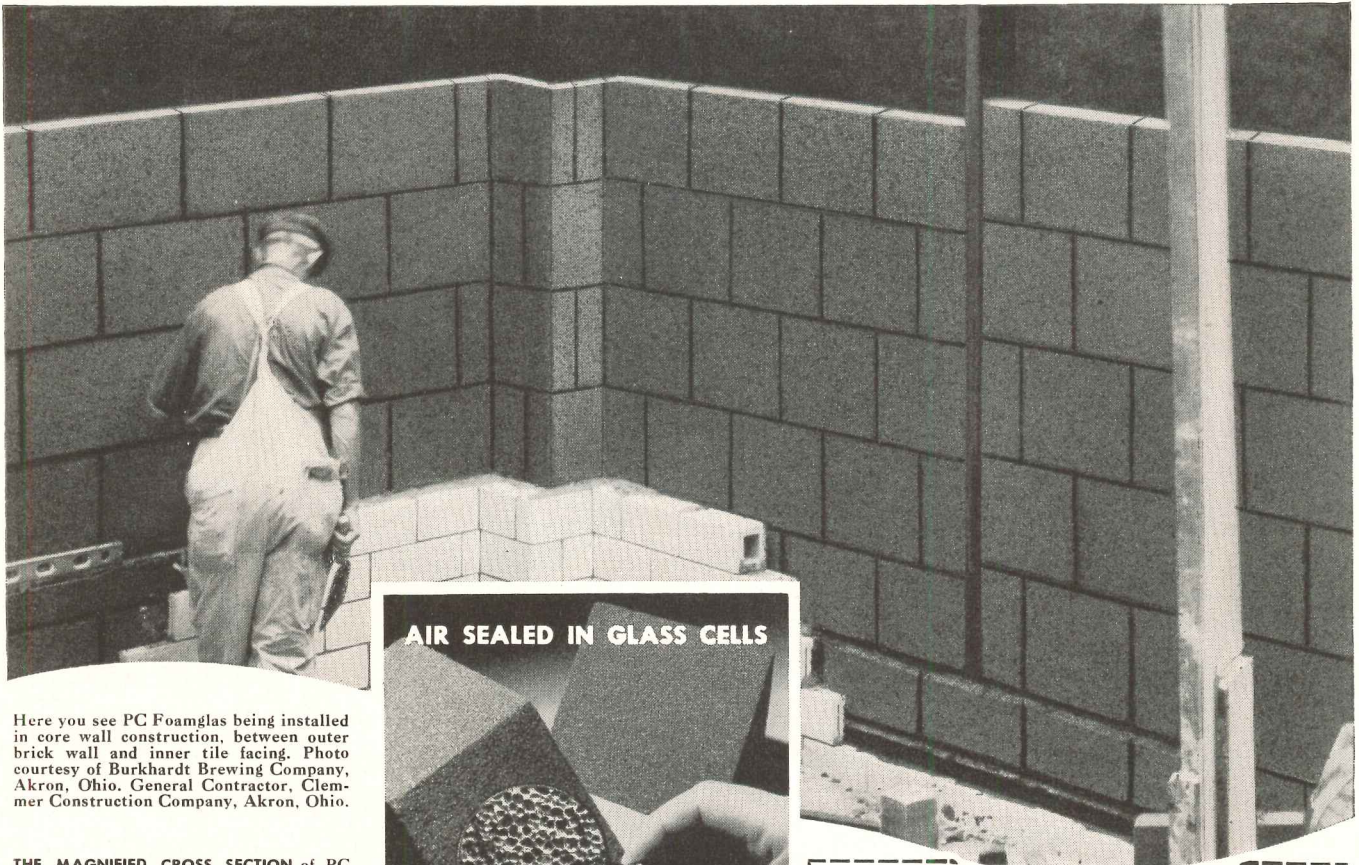

Here you see PC Foamglas being installed in core wall construction, between outer brick wall and inner tile facing. Photo courtesy of Burkhardt Brewing Company, Akron, Ohio. General Contractor, Clemmer Construction Company, Akron, Ohio.

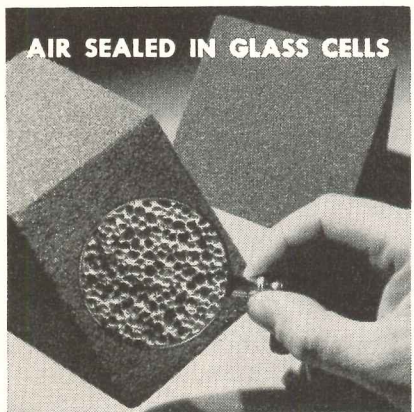

THE MAGNIFIED CROSS SECTION of PC Foamglas shows its cellular structure . . . glass bubbles solidified into big, strong, rigid blocks. In the millions of cells of glass-enclosed air, lies the secret of its insulating value.



FOAMGLAS INSULATION

FOR ADDITIONAL INFORMATION SEE OUR INSERTS IN SWEET'S CATALOGS.

Pittsburgh Corning Corporation
Room 477-8, 632 Duquesne Way
Pittsburgh 22, Pa.

Please send me without obligation, your FREE booklets on the use of PC Foamglas insulation for:
Roofs----- Walls----- Floors-----

Name-----

Address-----

City----- State-----

Specify **GENUINE LALLY COLUMNS**
FOR ENDURING CHURCH CONSTRUCTION

GENUINE LALLY COLUMNS have proven to be very adaptable to church construction. These space-saving, graceful columns are architecturally in keeping with the dignity and simplicity of church design.

GENUINE LALLY COLUMNS are manufactured in single or multiple story lengths and are the ideal structural support in all types of construction.

SEND FOR CATALOG OF
CONSTRUCTION DETAILS

Church of Our Lady Queen of Martyrs
Forest Hills, New York

Photo by Harry G. Kurkjian

LALLY COLUMN COMPANY

Originators, Sole Manufacturers, Genuine Lally Columns

Erie and Albany Sts.
Brookline 39, Mass.

211 Lombardy St.
Brooklyn 22, N.Y.

733 West 64 St.
Chicago 21, Ill.

AEROFIN

FIN-TYPE COILS

For

Fast, Efficient

HEATING

and

COOLING

*Write for
Information*

**AEROFIN
CORPORATION**

S. Geddes St. Syracuse 4, N.Y.

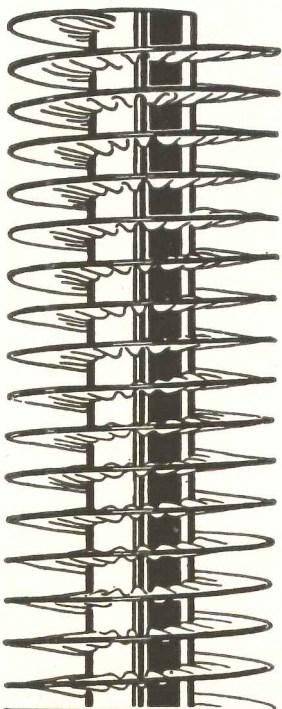

Keep up-to-date on
SPECIAL CEMENTS
for special purposes

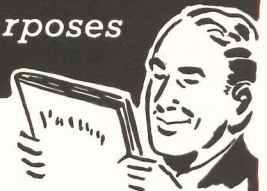

Medusa Special Cements are designed to produce better work on certain construction. As an architect, you will want to know about these Special Cements and the work they perform. Check the literature in which you are interested, attach this advertisement to your letterhead and send it in.

- A Guide To Finer Stucco
- How to Waterproof Concrete, Stucco and Masonry
- "Medco" High-Early Strength Cement
- A Discussion on Integral Waterproofing
- The Beauty of Terrazzo
- Medusa StoneseT for Permanent Wall Beauty
- How to Choose a Better Masonry Cement
- Medusa Air-Entraining Cement

MEDUSA

PORTLAND CEMENT CO.

1015 Midland Bldg. Cleveland 15, Ohio

FIFTY-SIX YEARS OF CONCRETE PROGRESS

Also made by Medusa Products Company of Canada, Ltd., Paris, Ont.

For lowest cost per year of service...

Specify **FABRON**
for walls and ceilings

How can you best assure your clients of freedom from expensive periodic wall redecoratings in the buildings you design for them?

Let the experience of leading hotels, hospitals, schools and institutions be your guide. Several thousand of them have turned to Fabron to correct wall and ceiling conditions that would not have developed had Fabron been available at the time of construction.

Fabron—the canvas-plastic-lacquer wall covering with a dual function—strengthens the plaster as it beautifies the surface. With a life span measured by the decade, it far outlasts conventional treatments. Here are some of its chief advantages:

Proven Durability. Fabron toughens with age. Original installations done in 1940 are still good for many more years of trouble-free service.

Prevents Plaster Cracks. Fabron's sturdy canvas and plastic base strengthens the plaster . . . prevents cracks . . . conceals imperfections.

Sunfast and Washable. Fabron's sunfastness insures against room depreciation. Its easy washability minimizes maintenance.

Prevents Fire Spread. Tested and listed by Underwriters' Laboratories, Inc., sponsored by the National Board of Fire Underwriters.

Low Initial Cost. Priced within the average institutional budget. Itemized estimates, based on your blueprints, gladly supplied on request.

No other wall finish combines these proven advantages—decoration, serviceability and economy. Before you specify the wall treatment for your next new building, investigate Fabron. Send the coupon today.

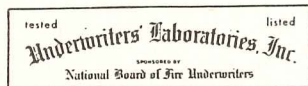

Fabron
REG. U. S. PAT. OFF.

the canvas-plastic-lacquer wall covering
with a life span measured by the decade

FREDERIC BLANK & CO., INC.

Established 1913

230 Park Avenue, New York 17, N. Y.

HOTEL WADE HAMPTON, Columbia, S. C.
Architects: Holabird & Root

One of the Affiliated National Hotel Chain hotels that are profiting by the use of Fabron. Other hotels in the chain that use Fabron are the Thomas Jefferson, Admiral Semmes, Jung, Texas and Stephen F. Austin.



FREDERIC BLANK & CO., INC., 230 Park Avenue, New York

Please send us samples of Fabron and information concerning its use in:

- Hospitals Hotels Schools Theatres
 Restaurants Offices Apartments Residences

Name

Address

City & Zone..... State.....

AR 6-48

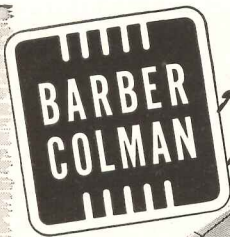

A New Approach to Air Distribution . . .



Line-o-flo

CEILING OUTLETS

A new approach to air distribution — *line-type* outlets that can be used singly or end-to-end in continuous strips. Keyed to modern architectural concepts, they provide a vital contribution to continuity of design. High diffusion efficiency results in rapid induction of room air into the primary stream, quickly equalizing the temperature differential. Made in Model "LS" (shown) and Model "LL" (designed to receive M21118 DAY-BRITE Lighting Unit).

PERFORMANCE DATA

THROW IN FEET FROM CENTER LINE OF UNIT

A — No. of Outlets Required.
B — Pressure Drop in Inches of Water (Blank indicates negligible pressure drop).
C — Sound Level in Decibels (Blank indicates no perceptible sound).

CFM	12			14			16			18			20			CFM
	A	B	C	A	B	C	A	B	C	A	B	C	A	B	C	
350	1	.006	-	1	.007	-										400
400	1	.007	-	1	.009	-	1	.009	-							450
450	1	.009	-	1	.012	3	1	.012	3	1	.014	7	1	.014	7	500
500	1	.012	3	1	.014	7	1	.014	7	1	.016	9	1	.016	9	550
550	2	.004	-	1	.016	9	1	.016	9	1	.019	12	1	.019	12	600
600	2	.004	-	2	.005	-	1	.019	12	1	.022	15	1	.022	15	650
650	2	.005	-	2	.006	-	2	.007	-	1	.025	17	1	.025	17	700
700	2	.006	-	2	.006	-	2	.006	-	1	.028	19	1	.028	19	750
750	2	.006	-	2	.007	-	2	.007	-	2	.029	-	2	.029	-	800
800	2	.006	-	2	.007	-	2	.007	-	2	.032	6	2	.032	6	850
850	2	.006	-	2	.007	-	2	.007	-	2	.034	10	2	.034	10	900
900	2	.006	-	2	.007	-	2	.007	-	2	.034	10	2	.034	10	950
950	2	.006	-	2	.007	-	2	.007	-	2	.034	10	2	.034	10	1000

A PORTION OF THE DATA FROM WHICH LINE-O-FLO OUTLETS CAN BE ACCURATELY SELECTED

Knowing the CFM available and the THROW required, the number of standard units needed is quickly obtained from performance data tables such as the one shown in part above.



WRITE FOR COMPLETE DATA...
Ask for Bulletin F-2741 and get full performance data, dimensions, description, principles of operation, typical installation methods, and suggested uses. Write today.

BARBER-COLMAN COMPANY
1232 ROCK ST. • ROCKFORD, ILLINOIS
Engineered Air Distribution with Guaranteed Performance

REPRESENTATIVES IN ALL PRINCIPAL CITIES

EMPLOYMENT OPPORTUNITIES AVAILABLE

Advertising rates on request

ARCHITECTURAL DESIGNER: Thoroughly experienced in designing schools, hospitals and other public buildings. Well established firm. Give full particulars of education and experience, and salary required. All replies confidential. Jos. W. Radotinsky, 312 Commercial National Bank Building, Kansas City, Kansas.

ARCHITECT with imagination, who is interested in the application of new materials, will find a real opportunity with a leading manufacturer of plastics. Experience should have familiarized him with the designing of office buildings, theaters, hotels and similar structures. Location: eastern seaboard. First letter should contain complete information, including age, details of education and experience, and starting salary desired. Letter will be acknowledged and treated in confidence. Box 330, ARCHITECTURAL RECORD, 119 W. 40th St., New York 18.

ARCHITECT desires association with business participation with established individual or firm. Can offer excellent design ability; progressive attitude and conscientious effort; complete experience in all aspects of architectural practice in large and small work resulting from background of seven years in nationally-known architect's office and ten years independent practice. Senior certificate NCARB. Full details on request. Box 332, ARCHITECTURAL RECORD, 119 W. 40th St., New York 18.

ARCHITECTURAL ENGINEERS AND DRAFTSMEN WANTED with at least five years experience in industrial building project. EXCELLENT OPPORTUNITY for men with initiative. Wigton-Abbott Corp., 1225 South Ave., Plainfield, New Jersey.

WANTED: Experienced Architectural Designer for permanent position. Please submit outline of education, training, and experience along with samples of work and annual salary requested. Marr and Holman, Architects, 702 Stahlman Building, Nashville, Tennessee.

WANTED: Experienced Structural Engineer who can design and make working drawings both for structural steel and concrete buildings—for permanent position. Send outline of education, training, experience and samples of work. Marr and Holman, Architects, 702 Stahlman Building, Nashville, Tennessee.

WANTED: Architectural draftsman. Preferably with a year or more experience in home plans. Steady work. Good conditions. C. Starkweather & Son, Beaver Dam, Wisconsin.

Contemporary Shops in the United States

By **EMRICH NICHOLSON**

"Contemporary Shops in the United States" is a treasury of beautiful yet practical samples of store fronts and interiors, selected from among America's most progressive stores.

Including the supplement of 24 pages, over 400 illustrations, plans, etc., showing 113 shops, large and small, handling many lines of merchandise, located from coast to coast, designed by 70 leading designers and architects. 216 pages, 8½ by 11. \$10.00.

Book Department, ARCHITECTURAL RECORD
119 West 40th Street, New York 18, N. Y.

Please send one copy of CONTEMPORARY SHOPS IN THE UNITED STATES at \$10 per copy. Money order or check for \$ enclosed.

Name.....

Address.....

City.....Zone.....State.....

A.R. 6-48

"Tell me **MORE** about this
New Blonde **KORINA**"



One eyeful of Korina tells you why architects and their clients demand "more."

If you haven't feasted your eyes on this honey blonde newcomer to the line of Weldwood Hardwood Plywoods, hang on to your hat:

Here's coloring and a figure that rival *Prima Vera*; a figure that shows stripe and more than a hint of cross fire. Only Korina is cleaner, sounder, with flitches that run wider.

And, speaking of figures, Korina more than rivals *Prima Vera* in price — it's about one third less. Yet, remember, Korina offers all the popular Weldwood Plywood advantages that alert, style-conscious clients know about and appreciate.

Korina's natural color is a lovely, light shade similar to *Prima Vera*. Finish it with White Firzite and you have the highly popular "bleached" effect. Add stain and you have a panel that closely resembles hard-to-get comb-

grain Oak or Walnut. Korina is a versatile wood that takes a variety of finishes — and takes them all beautifully.

Ample stocks of Korina Weldwood are on hand in lumber yards everywhere. With your approval Korina will soon be going into modern interiors, the finest homes, the smartest shops.

BRING YOURSELF UP TO DATE ON KORINA

Fill, clip and mail this coupon:



UNITED STATES PLYWOOD CORPORATION

55 West 44th St., New York 18, N. Y.

Gentlemen: I want to know *more* about your interesting new Weldwood Hardwood . . . KORINA.

Name _____

Address _____

City _____ State _____

WELDWOOD Plywood

Weldwood Plywood and Mengel Flush Doors are products of

UNITED STATES PLYWOOD CORPORATION
New York 18, N. Y.

THE MENGEL COMPANY
Louisville 1, Ky.

Distributing units in Baltimore, Boston, Brooklyn, Chicago, Cincinnati, Cleveland, Detroit, Fresno, High Point, Los Angeles, Milwaukee, Newark, New York, Oakland, Philadelphia, Pittsburgh, Rochester, San Francisco, Seattle. Also U. S.-Mengel Plywoods, Inc. distributing units in Atlanta, Dallas, Jacksonville, Louisville, New Orleans, Houston, St. Louis, Tampa. In Canada: United States Plywood of Canada, Limited, Toronto. Send inquiries to nearest point.

Weldwood* Hardwood Plywood
Weldwood Moldings
Douglas Fir Weldwood
Mengel Flush Doors
Douglas Fir Doors
Overhead Garage Doors
Molded Plywood
Armorply* (metal-faced plywood)

Tekwood* (paper-faced plywood)
Flexmetl
Weldwood Glue* and other adhesives
Weldtex* (striated plywood)
Decorative Micarta*
Flexwood*
Flexglass*
Firzite* * Reg. U. S. Pat. Off.



**Plastics and Wood
Welded for Good**

Weldwood Plywood is made in both Interior and Exterior types, the former bonded with extended urea resins and other approved bonding agents; the latter with phenol formaldehyde synthetic resin.

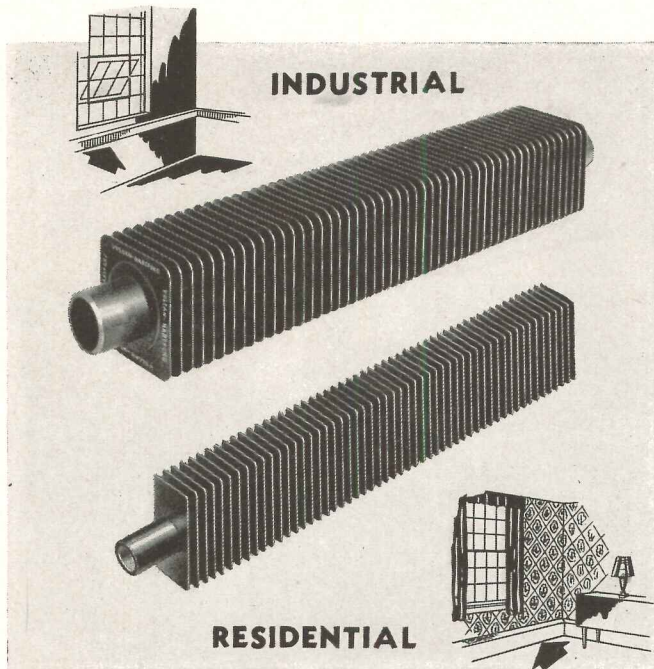

SIMPLICITY... THE KEYNOTE OF Vulcan Radiation

Simplicity in design — fin on tube construction gives extended heating surface in compact easily handled unit that is light in weight, requires few fittings.

Simplicity in application — Vulcan is as easily installed as a length of pipe wherever adequate, uniform heat is needed — in small spaces, large areas, high, low or in hard-to-get-at-places.

A Vulcan installation is always attractive, unobtrusive — harmonizes with the interior of any style or type of building — business, public, industrial or residential.

For the best in modern heating design, look for the name "Vulcan-Hartford" — stamped on every radiator.

Further information in Sweets 1948 Architectural File.

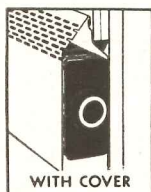

RESIDENTIAL

Vulcan Radi-Vector — easily installed along the baseboard — attractive — adequate heat — greater room utility.

INDUSTRIAL

Vulcan Standard Radiation — proven heating design for ships, railroad cars, hospitals, churches, schools and industrial plants.

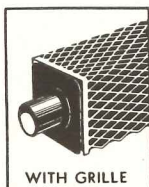

THE VULCAN RADIATOR COMPANY



26 FRANCIS AVENUE
HARTFORD 6, CONN.

RADIATOR MANUFACTURERS FOR OVER TWO DECADES

The perfect book to introduce the layman to the problems of planning and building a house...

THE HOUSE FOR YOU TO BUILD, BUY OR RENT

By Catharine and Harold Sleeper

When it comes to building a house, the layman is generally completely at sea. He usually has very decided opinions on the subject, but these ideas might be utter nonsense from a practical point of view. That is where **THE HOUSE FOR YOU** comes in. The book gives the layman a wealth of practical information on the factors he must consider in planning a house that will suit his needs and still bear a marked resemblance to his dream house.

It takes him behind the scenes to show him how an architect works, defines the architect's job, and gives him insight into the mass of detail attendant to planning a house. The book tells why an architect makes the decisions he makes and shows the wisdom behind the architect's suggestions regarding site selection, floor plans, elevations, storage and work space, sections, style, foundations, and the many other details of building. Architects' lingo and sign language are explained, and there are many cross-sectional drawings which show in detail the various types of construction throughout the house.

This is the ideal book to recommend to your client; even better, why not make him a gift of it to save you much future time and trouble?

All of the material is presented in a readable, lively style aided by numerous cartoons, graphs, and charts.

There are also good common-sense discussions of financing and a clear explanation of the confusing mumbo-jumbo about loans, mortgages, and deeds.

Harold R. Sleeper needs no introduction to architects. He is President of the New York Chapter of the American Institute of Architects and co-author of *Architectural Graphic Standards*. His wife did graduate work in the History of Architecture at Columbia University, and is an author in her own right.

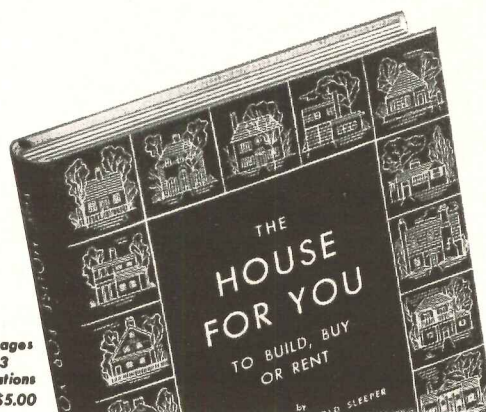

316 pages
123 illustrations
Price \$5.00

Book Department, *Architectural Record*
119 West 40th Street, New York 18, N. Y.

I enclose \$5.00 for one copy of **THE HOUSE FOR YOU**, by Catharine and Harold Sleeper. (Add 2% Sales Tax for New York City delivery — \$5.10 in all.)

Name.....

Address.....

City..... Zone..... State.....

You Can
Bank on
AGITAIR
TYPE R
for
All-Around
Diffuser
Efficiency

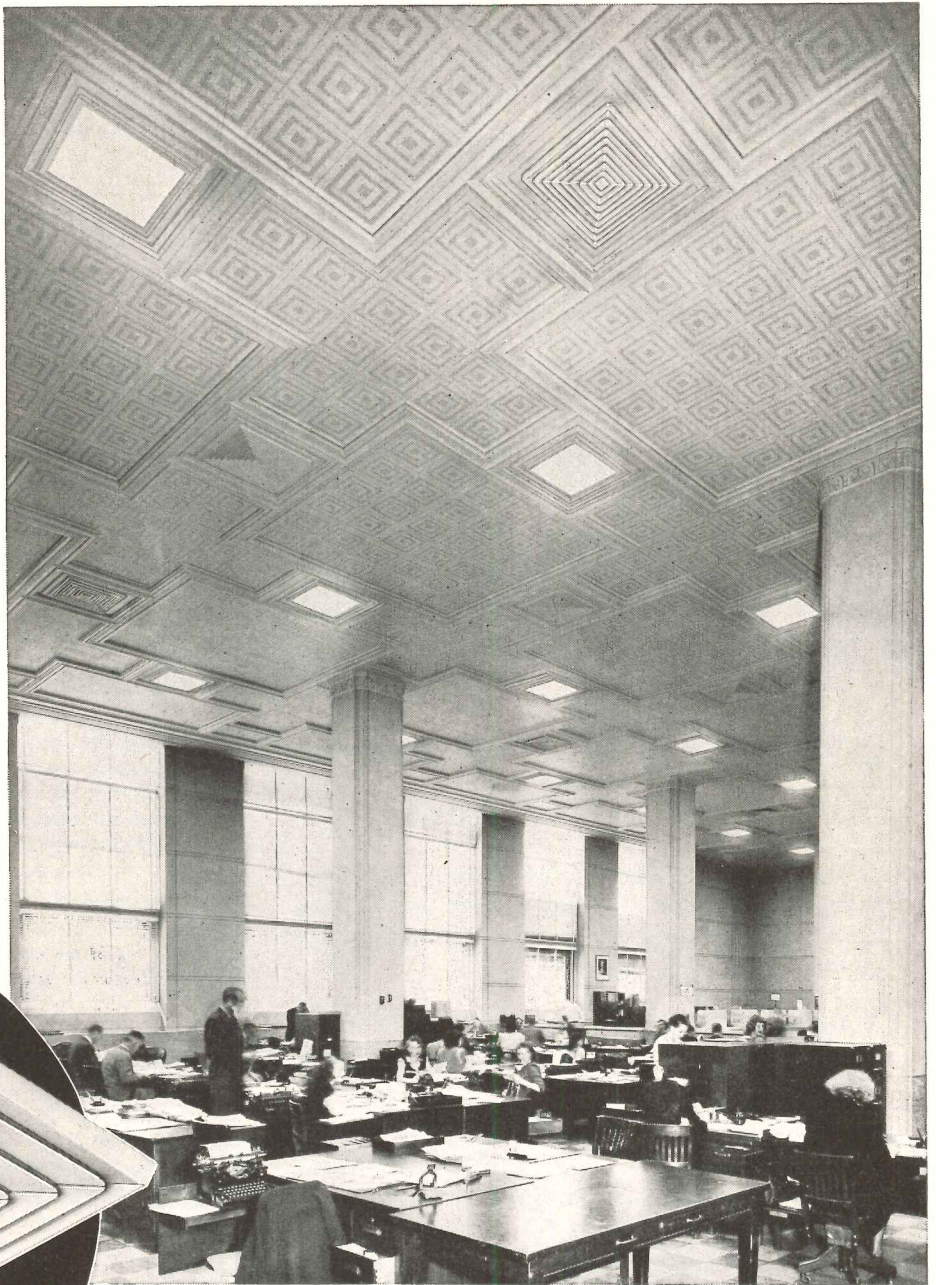
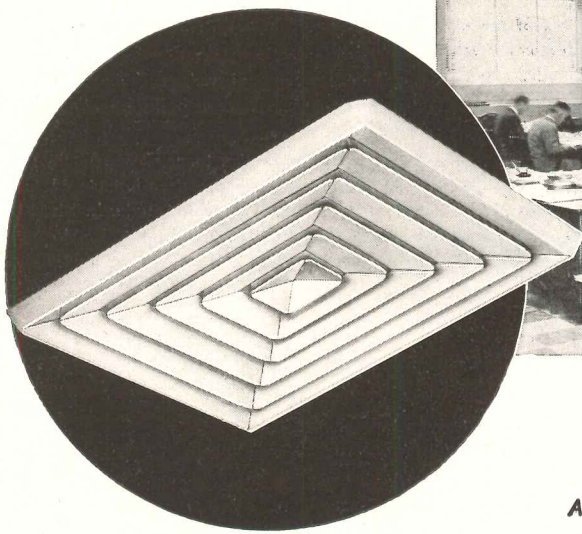

Bank of America
Main Office
San Francisco, Calif.

Architect: J. L. Hendy Consulting Engineer: G. M. Simonson

Extra dividends of beauty and efficiency are yours with Agitair Type R. It's the only air diffuser to give you complete freedom of design, because it's the only diffuser to give you Diffusion Pattern Control.

That means 100% air distribution in any shape area, from any location—with no drafts, no blank corners, no hot spots, no cold spots. Agitair Type R

patented construction permits it to be assembled into numerous patterns which divide the air and distribute it noiselessly in one, two, three or four directions in proportion to the area served.

Next time you specify air diffusers, bank on Agitair Type R for all-around efficiency and beauty.

Write for Complete Data

AIR DEVICES, Inc. • 17 East 42nd Street • New York 17, N. Y.

CEILING AIR DIFFUSERS

AIR FILTERS

ROOF EXHAUSTERS

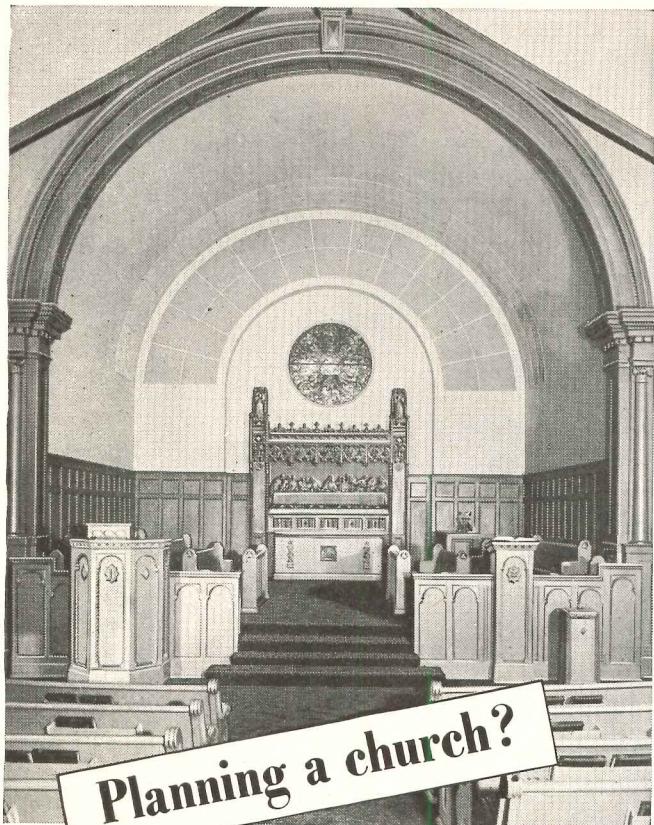

Planning a church?

Hope Reformed Church, Holland, Michigan

Profit from our *Consultation Service* on church interior problems

THE important tasks of seating and furnishing a church pose many unique and highly specialized problems to the architect. To help you solve them quickly and efficiently, American Seating Company places at your disposal all the knowledge and experience gained through more than 60 years of designing and manufacturing quality church furniture.

Our Church Furniture Designers stand ready to consult with you on church furnishing plans. You will find them a dependable source of authoritative technical data and guidance. Take advantage of this helpful consultation service. There is no charge or obligation whatsoever. Write us right away for complete information.



American Seating Company

GRAND RAPIDS 2, MICHIGAN

Branch Offices and Distributors in Principal Cities

WORLD'S LEADER IN PUBLIC SEATING

Manufacturer of Church, School, Auditorium, Theatre, Transportation
Stadium Seating, and Folding Chairs

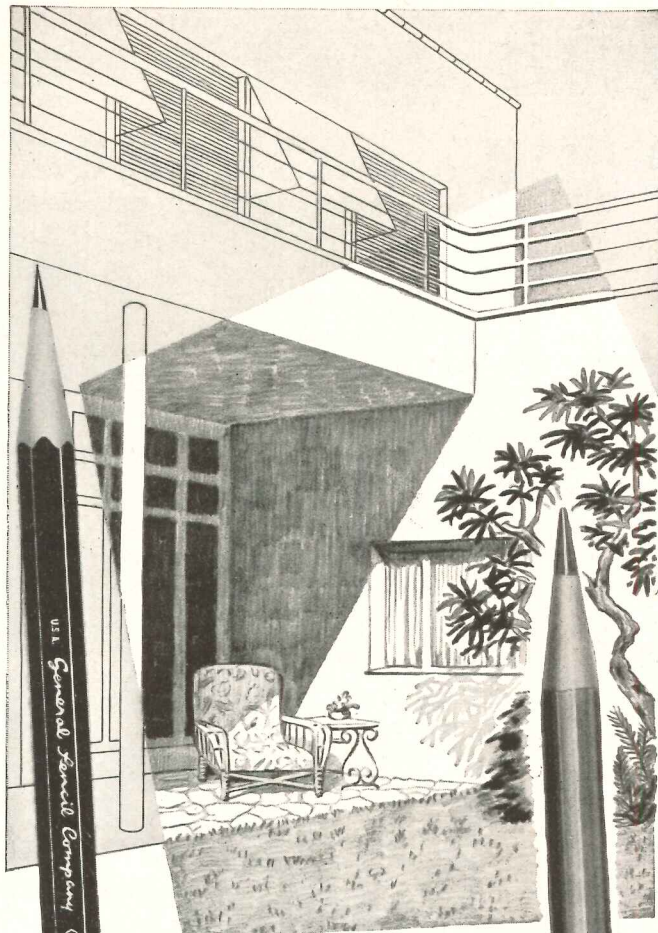

Performance
COUNTS

Experience a new high in drafting and rendering—Draw with General's Drawing Pencils. Feel the smoothness of the crisp Kimberly blacks . . . watch your exacting details take on new and added clarity. Then complement your detail drawings with renderings done in Multichrome's 50 fascinating colors . . . notice the striking color tones . . . how admirable the results! Join the many others who are changing to General's—the pencils correctly suited for every drawing purpose. For more satisfying results, every time—draw with Kimberly and Multichrome. Buy them from your local dealer today.



KIMBERLY DRAWING PENCILS, 22 Degrees

6B to 9H, Tracing 1-2-3-4- and Extra B Layout Pencil

MULTICHROME COLORED DRAWING PENCILS

50 brilliant colors. Sets of 12-24-36-48 colors to the box.

Write to us Dept. R requesting a free trial Kimberly and Multichrome naming your favorite degree and color.

Makers of Fine Pencils since 1889

GENERAL PENCIL COMPANY

67-73 FLEET STREET, JERSEY CITY 6, N. J.

Will this take place in your houses next winter?



No house is a fuel orphan with the "Unbeatable Heating Combination"!

● Experts predict that the shortages of other fuels will last from 3 to 5 years. With the "unbeatable heating combination," your clients never need to be cold, because they can have the heat they need when they *want it!*

The "unbeatable heating combination" of an automatic hard-coal stoker plus plentiful anthracite will keep your houses warm . . . clients comfortable and satisfied these three ways:

Plenty of Heat—A full year's supply of plentiful, stoker-size anthracite can be easily

stored. Occupants need never turn their thermostat to chilly levels to conserve fuel.

Economical Heat—Stokers use the smaller, cheaper stoker sizes of hard coal . . . reduce fuel bills as much as 52%.

Completely Automatic Heat—Modern hard-coal stokers are fully automatic . . . from bin feed to ash removal. Sensitive thermostatic controls keep heat steady regardless of outside temperatures.

Get all the facts on heating with all types of anthracite equipment including modern automatic stokers. Simply fill out and mail the coupon today.

Manufacturers of approved automatic anthracite burners

Stokers

- ANCHOR STOKER
- COOPER STOKER
- ELECTRIC FURNACE-MAN
- FAIRBANKS-MORSE STOKER
- FUEL SAVERS STOKER
- THE GILKOAL STOKER
- IRON FIREMAN
- MOTORSTOKOR
- NEWTON STOKER
- STEWART-ROGERS STOKER
- STOKOL ANTHRACITE STOKER
- VAN WERT STOKER
- WARDS ANTHRACITE STOKER

Boiler-Burner Units

- WAGNER STOKER-BOILER
- ANTHRATUBE
- AMERICAN BOILER WORKS
- AXEMAN-ANDERSON



ANTHRACITE INSTITUTE

101 Park Avenue

New York 17, New York

ANTHRACITE INSTITUTE, Dept. 6-B
101 Park Avenue
New York 17, N. Y.

Please send me more information on anthracite and anthracite heating including stokers and the new anthratube.

Name _____

Company _____

Address _____

City _____ Zone _____ State _____
Please Print

Prestige

BUILT ON PERFORMANCE!



Dormitory No. 2, University of Maryland, the eleventh building on the campus floored with Moultilite. Henry Hopkins, architect. Southeastern Floor Co., Hyattsville, Md., contractors

11th BUILDING FLOORED WITH Moultilite AT U. OF MARYLAND

Architecturally beautiful interiors as well as exteriors distinguish the campus of the University of Maryland. Many years ago Moultilite flooring was selected for its special combination of properties . . . the mellow beauty of its deep-toned colors, its crisp, distinct veining and its interesting design possibilities . . . plus Moultilite's assurance of sturdy, time-defying durability. Since that first installation Moultilite's performance record has justified Moultilite's reputation, and has led to its use in one building after another . . . including the recently completed Dormitory No. 2, pictured above.

Wherever you recommend Moultilite, you can count on the owner's enthusiastic approval. Inherently tough Moultilite stands up to hard wear, resists indentation and breakage. It is low in original cost and may be kept attractively clean and bright with minimum maintenance . . . requires no costly periodic refinishing. If you are not already acquainted with Moultilite, write today for free samples . . . and ask for a copy of our complete catalog. THOS. MOULDING FLOOR MFG. CO., 165 W. Wacker Drive, Dept. AR-6, Chicago 1, Ill.

THOS. MOULDING

Moultilite

**Flexible-Reinforced
MASTER ASPHALT TILE**



THIS IS AN ARTIST at his drawing board

Note that look of contentment on his face . . . that look of a job well done.

He works for a busy advertising agency and an hour or so ago the boss gave him an illustration to do with a very short deadline. He made it—with plenty to spare.

Now—note the pencil he's using. It's a KOH-I-NOOR, and while it didn't actually inspire him, it helped immeasurably by standing up under his first feverish strokes and giving smooth, dependable performance right to the finish.

You can depend on KOH-I-NOOR every time . . . it's made of straight grained cedar and the finest lead—a combination that assures long-life "staying power."



The RIGHT pencil for the RIGHT job

KOH-I-NOOR PENCIL COMPANY, INC.,
BLOOMSBURY, NEW JERSEY



The Minneapolis Idea House II dramatically illustrates how Servel *All-Year* Air Conditioning can help you bring a "new quality of living" the year-round to any home you may design or build. What's more, when you plan your new houses around the Servel unit, you'll find it possible to make many design innovations and construction economies.

Get the facts on Servel *All-Year* Air Conditioning from your local Gas Company or Servel dealer. Or write to Servel, Inc., 2806 Morton Ave., Evansville 20, Ind.

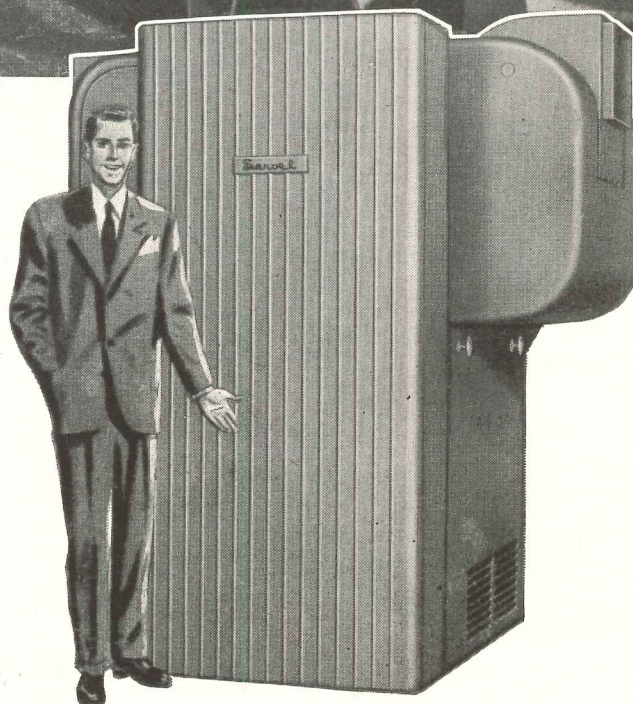

Servel

All-Year AIR CONDITIONER



IDEA HOUSE FEATURES

"Climate at your fingertips"

Servel All-Year Air Conditioning provides carefree comfort through every season

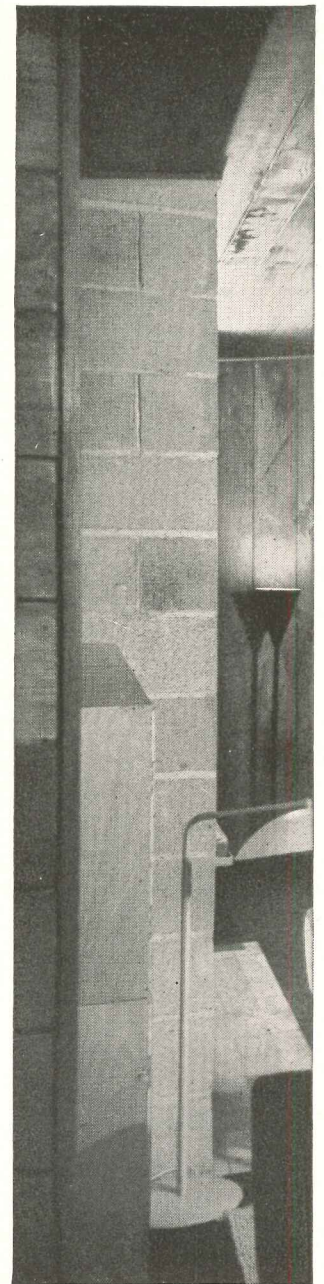

Co-sponsored by the Walker Art Center in Minneapolis and the Home Institute of the Northwestern National Bank, Idea House II is one of a series built to demonstrate advanced ideas in home planning and equipment. It features one of the most important developments in year-round comfort . . . "climate at your fingertips" provided by Servel *All-Year* Air Conditioning.

In the Idea House, the homeowner selects the climate indoors . . . through every season . . . without ever having to go downstairs. The Servel *All-Year* Air Conditioner is controlled automatically by the Selectrol—a combination thermostat and control device—conveniently placed in the main-floor living area. The homeowner merely dials the temperature he wants and flips a switch for cooling or heating.

Cools in summer, heats in winter

In summer, the Servel unit refreshingly refrigerates the air. It removes sticky humidity and filters out dust,

dirt, and irritating pollen, bringing welcome relief for asthma and hay fever sufferers. Furniture and drapes stay fresh and new-looking longer. There's lots less housework, too.

During the winter months, the same compact Servel unit supplies plenty of clean, even warmth. Just the right amount of moisture is added for comfort. There are no "layers" of hot or cold air. And in between seasons, the Servel *All-Year* Air Conditioner circulates cleaned air throughout the house at the prevailing outdoor temperatures.

Operating costs are low

Yet with all these benefits, the Servel *All-Year* Air Conditioner costs surprisingly little to operate. Maintenance costs are low, too. Like the famous Servel Gas Refrigerator, the Servel *All-Year* Air Conditioner hasn't a single moving part in its refrigeration system to make noise, to wear or need repair.

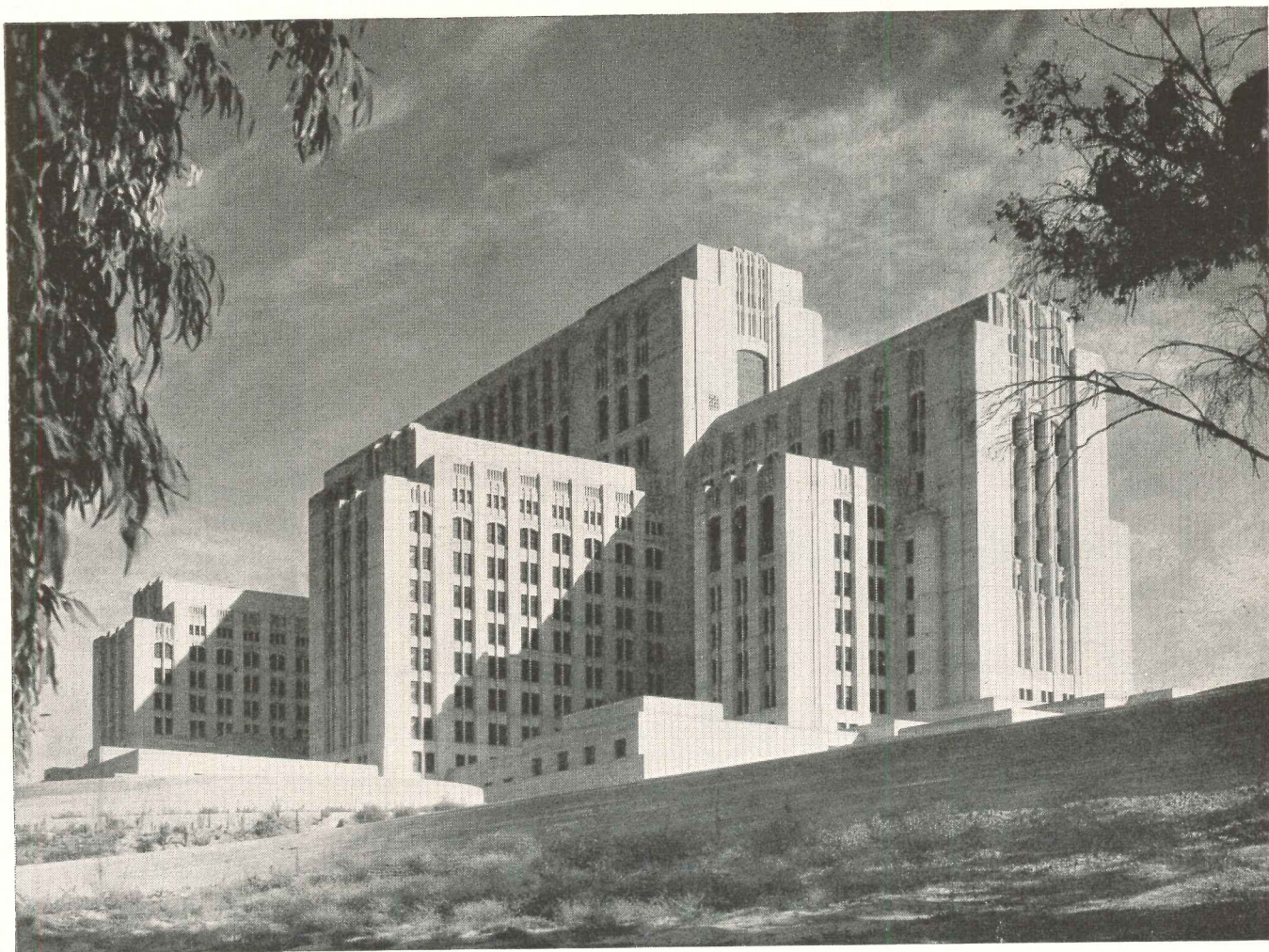

CECO HELPS A MONUMENT OF MERCY BREATHE...

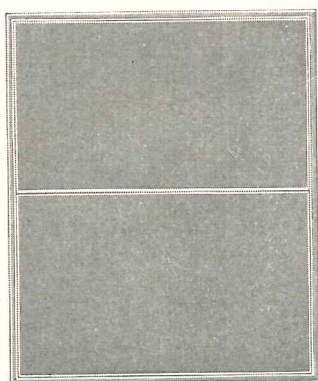

METAL FRAME SCREENS . . .

Standard types and styles for every purpose—for wood or metal windows. Wired with rustproof, clear-vision screen cloth.

One of the truly important details in a hospital is ventilation, and that, in a sense, is where Ceco helped beautiful Los Angeles County Hospital to breathe. Ceco installed the metal frame screens which, of course, provided a means of ventilation. This was done at a saving, too, because Ceco screens cost less than ordinary screens—they are factory finished, eliminating on-the-job painting, trimming and fitting. They are easy to put up and take down—will not warp, shrink, twist or rot.

Other Ceco Products used in the Los Angeles County Hospital were steel bars and welded wire fabric which provide a positive bond and add strength in reinforced concrete construction.

CECO STEEL PRODUCTS CORPORATION
General Offices: 5701 W. 26th St., Chicago 50, Ill.

Offices, Branches and Fabricating
Plants from Coast to Coast

**CECO
STEEL**®

In construction products **CECO ENGINEERING** *makes the big difference*

3-WAY PROTECTION

in the structures you design



1. Repels Termites

Termites avoid wood that's pressure impregnated with Du Pont "CZC." This effective treatment protects each fiber from their destructive appetites.



2. Resists Decay

Wood treated with "CZC" resists the growth of fungi which cause decay . . . gives years of added life to any wooden structure. It helps cut replacement and maintenance costs to a minimum, especially where high humidities stimulate fungous growth.



3. Retards Fire

"CZC" also acts as a fire retardant. Makes wood difficult to ignite. Gives added safety. And wood treated with Du Pont "CZC" is clean, paintable and easy to handle. Get this 3-way protection. Write today for full details. Address Du Pont, Grasselli Chemicals Dept., Wilmington 98, Del.



DU PONT CZC

TRADE MARK

Chromated Zinc Chloride



REG. U. S. PAT. OFF.

BETTER THINGS FOR BETTER LIVING
... THROUGH CHEMISTRY.



OF DUNHAM PRODUCTS
...PASSES THE TOUGHEST
"ON-THE-JOB" REQUIREMENTS
WITH *Flying Colors!*

No matter how large or small the system — Dunham products are your assurance of maximum heating efficiency. Simplicity of installation and economy of operation, plus freedom from maintenance difficulties account for the enthusiasm expressed for Dunham. When you specify Dunham products, you know that thousands upon thousands of installations all over the country bear out your own good judgment. C. A. DUNHAM COMPANY, 400 West Madison Street, Chicago 6, Illinois.

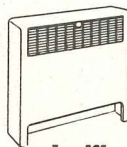

Type FCF
Cabinet Convector

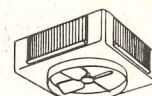

Type C "Downflow"
Unit Heater

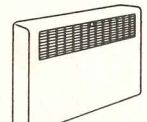

Type WCF
Cabinet Convector



Float and
Thermostatic Trap

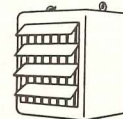

Type V Unit
Heater



No. 1140 Packless
Valve

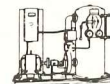

Type VR Vacuum Pump



High Pressure
Steam Trap

YOUR INSTALLATIONS MADE MORE EFFICIENT
WHEN DUNHAM PRODUCTS ARE ON THE JOB!

DUNHAM HEATING MEANS
BETTER HEATING

IT'S THE NEW

Westinghouse

QUALITY

Electric Stairway

No longer are electric stairways reserved for big stores alone! Now—every store can afford the traffic-building benefits of electric stairways to bring first floor traffic to every floor . . . because Westinghouse has introduced the first low cost, high quality electric stairway.

Perhaps you may have thought that electric stairways were not for *your* store because of the high cost. And, until the advent of the Westinghouse "Limited Budget" electric stairway, you were probably right.

But now, this is all changed. Now, you can afford to increase upper floor sales with a Westinghouse Electric Stair-

way. Designed to handle steady traffic flow at 90 feet a minute, it features two-step levelling at top and bottom, trip-proof combplates, extended hand-rails top and bottom . . . and many other "extras" for maximum safety and convenience. It has buffed and anodized aluminum balustrades for a beauty that harmonizes with and enhances the eye appeal of your store interior.

The best way to determine if this is *your* electric stairway is to ask for a survey of your store. Just write to the Westinghouse Electric Corp., Elevator Division, 150 Pacific Avenue, Jersey City 4, N. J. There is no obligation.

Westinghouse

J-98510

E L E V A T O R



D I V I S I O N

YOU CAN afford **IT...**
WE CAN deliver **IT...**

THE NEW Westinghouse
"LIMITED BUDGET"
ELECTRIC STAIRWAY
DESIGNED ESPECIALLY
FOR SMALLER STORES

WHAT YOU GET WHEN YOU DESIGN WITH *Open-Web Joists*

What are the advantages when you incorporate Bethlehem Open-Web Joists in the floor constructions of light-occupancy buildings?

Better floor structures. A better, more durable building. Faster, more economical construction. And—chief advantage of all—fire-safety.

Combined with concrete floor slab and plaster ceiling, Bethlehem Open-Web Joists provide at moderate cost a floor construction which holds fire in check, keeping it from spreading for at least two hours.

Sturdy Bethlehem Open-Web Joists not only make buildings safer from fire but better to live in, and a better investment for the owner. They eliminate shrinking and sagging floors. They prevent open baseboards. They are immune to attack by termites and other vermin. They help reduce the passage of sound from floor to floor.

Open-web joists tend to speed construction, too, for pipes and conduit can be run through the open webs. And the joists come completely fabricated and clearly marked, ready for use without falsework. Two men can handle the Bethlehem standard type of joist. And Bethlehem Longspan Joists (used when spans up to 64 ft or longer are required) can be raised by means of a light gin pole.

We have a 36-page, illustrated joist catalog that we think you'll find useful. Ask the nearest Bethlehem sales office to send you a copy. Or write to us at Bethlehem, Pa.

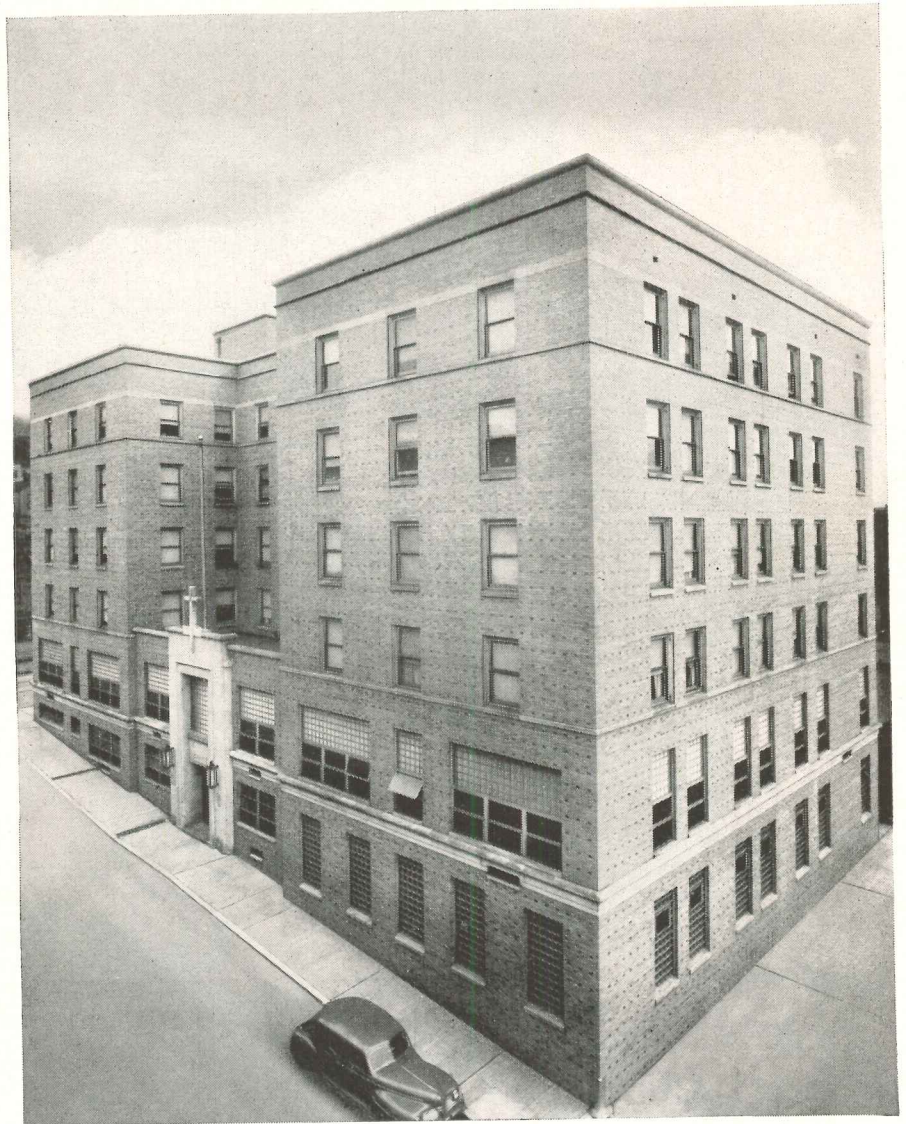

Fifty tons of Bethlehem Open-Web Joists were used in the construction of the School of Nursing, built for Wheeling Hospital, Inc., Wheeling, W. Va. Architect: L. D. Schmidt, Fairmont, W. Va. Associate Architect: Rev. Michael McInerney, O.S.B., Belmont Abbey, Belmont, N. C. General Contractor: Engstrom & Wynn, Wheeling, W. Va.

BETHLEHEM STEEL COMPANY, BETHLEHEM, PA.

*On the Pacific Coast Bethlehem products are sold by
Bethlehem Pacific Coast Steel Corporation
Export Distributor: Bethlehem Steel Export Corporation*

BETHLEHEM OPEN-WEB JOISTS

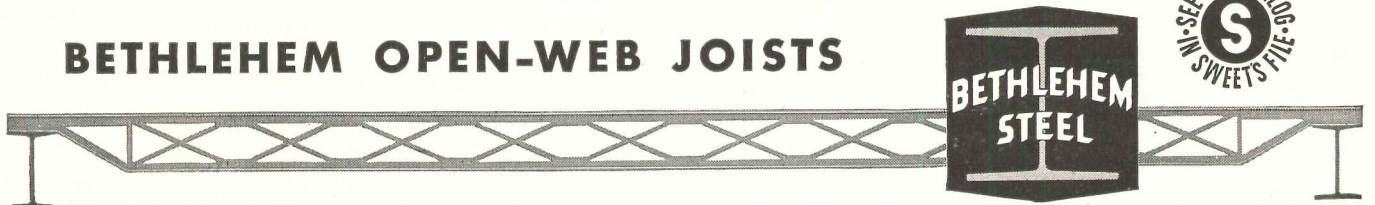

**New
handbook
on air
diffusion**

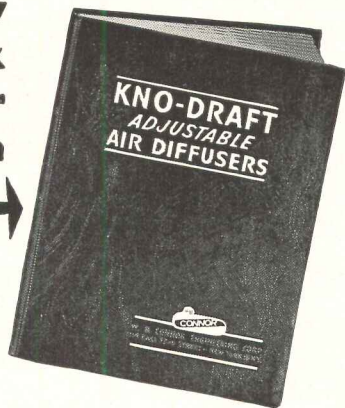

*How to select,
install and adjust
diffusers for
greater control
of air conditioning
performance.*

FREE to those who
design, install and maintain
air conditioning equipment.

The new handbook contains the latest engineering data on air diffusion in general and the use of adjustable air diffusers as a positive means of eliminating drafts, hot spots, cold spots, poor humidity control, stratification, air noise, ceiling smudge and other complaints. It is profusely illustrated with photographs, sketches, charts and dimension prints for quick, accurate Selection—Application—Location—Assembly—Erection—Testing—Adjustment of Air Diffusers and of Accessory Equipment such as air equalizing grids, mounting rings and air sectorizing baffles.



Beauty of an air diffuser lies in its simplicity and ability to blend with an interior. Kno-Draft Diffusers in their original aluminum furnish an interesting and unobtrusive decorative accent. Painted to match the ceiling, they become self-effacing. Because of their simplicity of design, they blend easily with modern or period interiors.

Utility of a diffuser lies in its ability to create "custom-made" air distribution patterns. The air direction and volume on each Kno-Draft Diffuser can be altered *after* installation. This eliminates the tough job of deciding everything about the air movement in advance. Also, you can change the air pattern with the season or when processes, people or partitions are relocated.

For your free copy of the new handbook on air diffusion, please write Dept. S-102.

W. B. CONNOR ENGINEERING CORP.

Air Diffusion • Air Purification • Air Recovery

112 East 32nd Street



New York 16, N. Y.

IN CANADA: Douglas Engineering Co., Ltd., 190 Murray Street, Montreal 3, P. Q.

**THERMOSEAL
ALUMINUM**

**SELF-STORING
COMBINATION SCREEN AND STORM SASH**

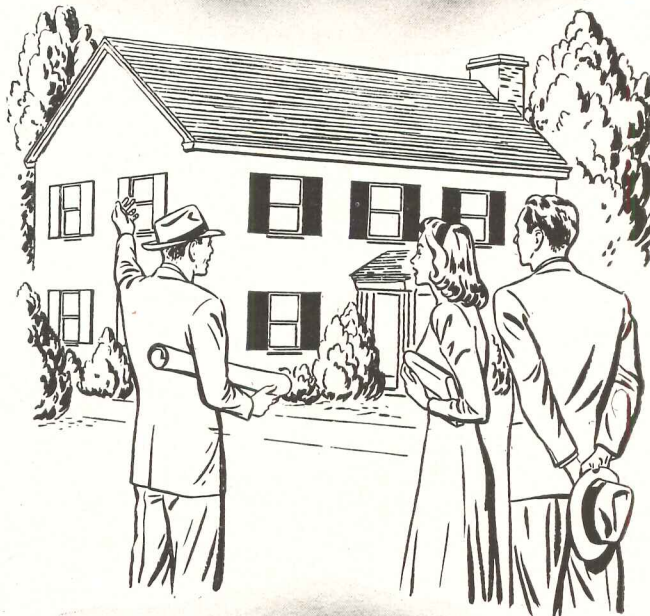

*... makes a home
completely modern
IN COMFORT... CONVENIENCE
... SAFETY*

"Thermoseal Windows" is one specification that you can make that will receive enthusiastic approval. Tell your clients this... "Thermoseal gives all the advantages of screens, all the advantages of storm sash, all the advantages of weatherstripping . . . in one permanently installed unit . . . with NOTHING TO CHANGE, NOTHING TO STORE". Literature is available to back up your specifications—gives figures on fuel savings—tells all Thermoseal's year 'round benefits.

For information YOU will want, consult Sweet's Architectural and Builders Files or write direct . . .

THERMOSEAL Division

THE F. C. RUSSELL COMPANY

6406-ARA Herman Avenue • Cleveland 2, Ohio

Also manufacturers of the famous Thermoseal Three-In-One Wood Window

©TFRC

ENGINEERING LEADERSHIP

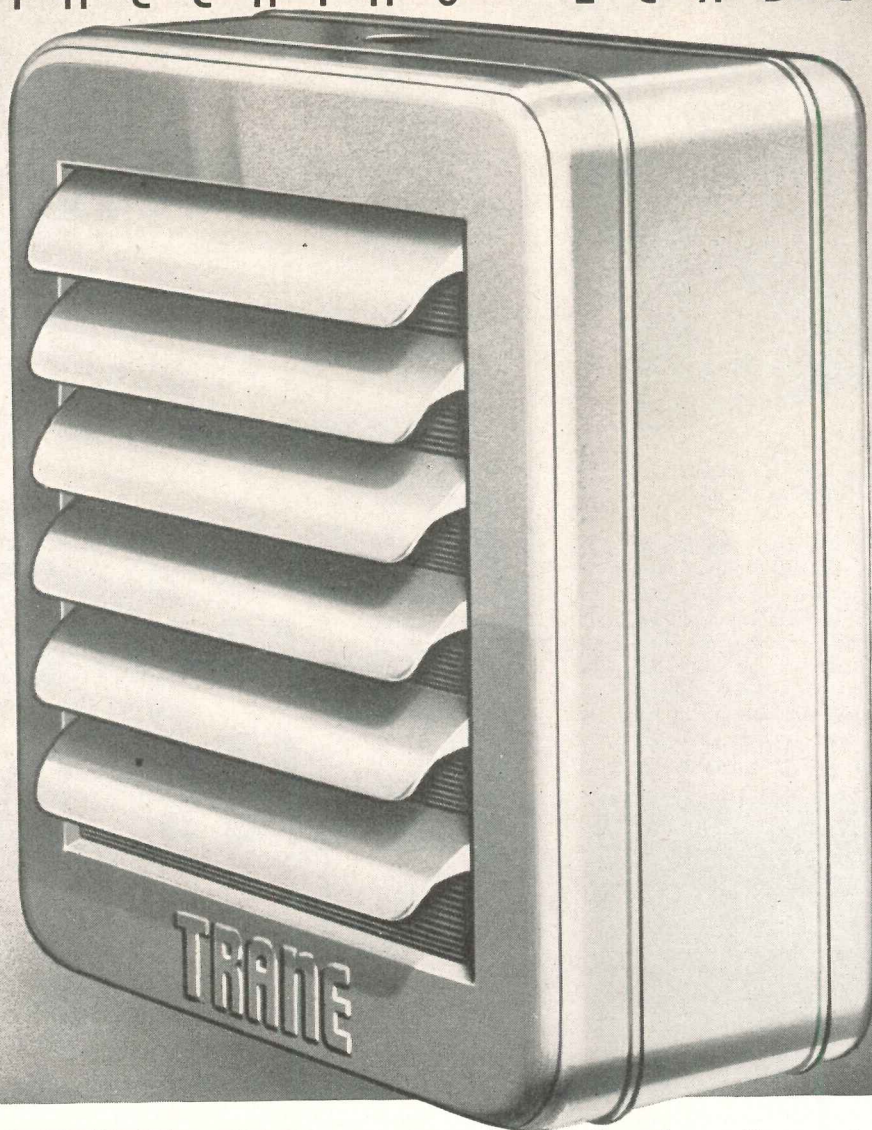

TRANE fills Every Unit Heater Need

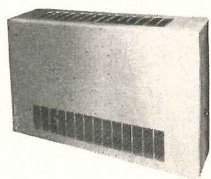

The Trane Force-Flo Heater provides positive circulation of heated air from a handsome, compact unit. Heats, counteracts drafts where appearance and space count.

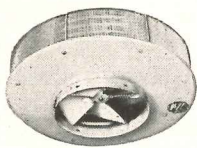

The Trane Projection Heater, originated by Trane, utilizes heat ordinarily wasted at the ceiling, distributing it downward to blanket working areas thoroughly.

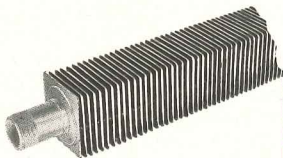

The Trane Wall-Fin Heater provides a compact, efficient supplementary heating system. Convected air offsets drafts and glass losses. Economical to install and operate.

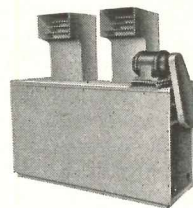

The Trane Torridor is a blower-type unit heater for heating large areas. Powerful quiet centrifugal fans handle extremely long throws or the resistance of ductwork.



AIR CONDITIONERS



COOLING COILS

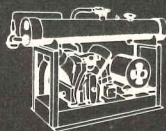

REFRIGERATION EQUIPMENT



BLOWER UNIT HEATERS

TRANE

HEATING AND AIR CONDITIONING

A N O T H E R P R O O F O F

TRANE Presents a Distinguished New Model of the Largest Selling Unit Heater

Now the Unit Heater that has set sales records year after year is succeeded by a completely new, entirely restyled model. The new Trane Model H Unit Heater has even more features than had its biggest-selling predecessor.

The coil in this new unit actually *floats*, for maximum protection against expansion and contraction. There is now higher capacity per pound of weight than *ever* before. Centralized top and bottom piping connections give greater mounting flexibility.

Fan assemblies have been redesigned for even quieter operation. The casing itself has new functional styling. Here is a Unit Heater whose trim good looks bespeak its practical utility, its engineered heating efficiency.

Time-Proved Trane Features

The features you expect from Trane remain. The Trane mechanically bonded fin-and-tube coil has yet to find its equal. The Trane weldless header has proved to be the *only* header that promises freedom from leakage. It is this sound engineering that has led more architects and engineers to recommend more Trane Unit Heaters than any other make.

In line with Trane engineering standards, the new Model H Unit Heater has been

thoroughly tried and tested. Ratings are certified in accordance with the Industrial Unit Heater Association Test Code. Here is the highest possible quality in unit heaters—yet there is *no* increase in price. Sizes range from 18,000 Btu to over 300,000 Btu.

Trane Engineering Leads

The Model H Unit Heater is another example of the constant effort of Trane engineers to keep the great Trane line of heating and air conditioning equipment in the forefront of the industry. So complete is this line that architect, engineer and contractor can select exactly the right combination for any application.

And since Trane products are designed and built together for use together, a perfectly integrated, up-to-the-minute system is secured. You have a made-to-measure system, an undivided responsibility system.

You get more value per dollar in Trane products. Trane factories use modern line production, and the resultant economies are passed along to you in the form of higher quality. Over 200 Trane field engineers in 85 principal cities offer their constant co-operation. THE TRANE COMPANY, LA CROSSE, WISCONSIN. Also: TRANE COMPANY OF CANADA, LTD., TORONTO, ONTARIO. *Manufacturing engineers of heating and air conditioning equipment.*

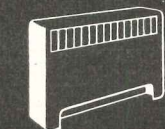

CONVECTOR-RADIATORS



UNIT HEATERS



HEATING COILS



PUMPS



STEAM SPECIALTIES



FANS



COMPRESSORS

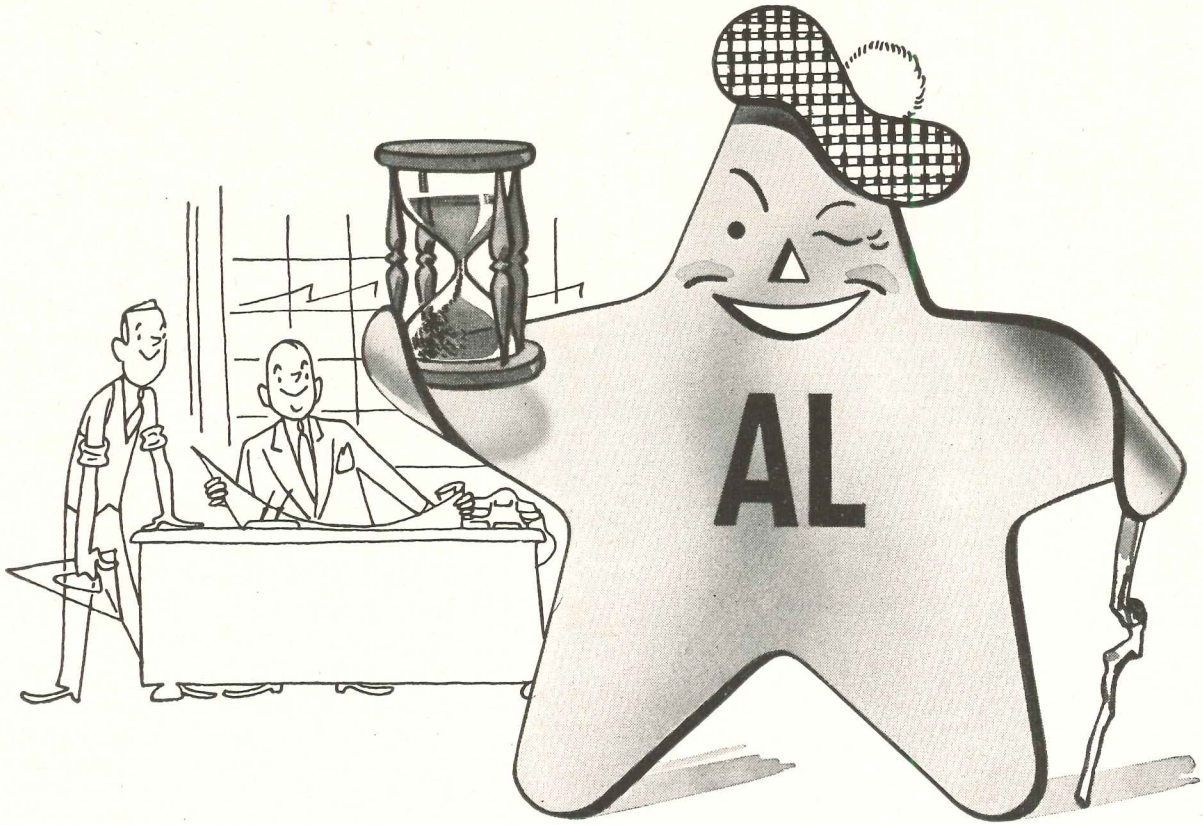

● Stainless Steel is cheapest in the long run.
You get qualities of lifetime service,
lasting beauty and low maintenance
that outweigh other considerations.
Design for permanence with Allegheny Metal,
the pioneer stainless steel—you can
be sure of prompt supply, too.

Complete technical and fabricating data—engineering help, too—yours for the asking.

ALLEGHENY LUDLUM STEEL CORPORATION

The Nation's Leading Producer of Stainless Steel in All Forms



Pittsburgh, Penna. . . . Offices in Principal Cities

Allegheny Metal is stocked by all Jos. T. Ryerson & Son, Inc., Warehouses

Ventilate your plant
the "open roof" way
with Swartwout
AIRMOVER

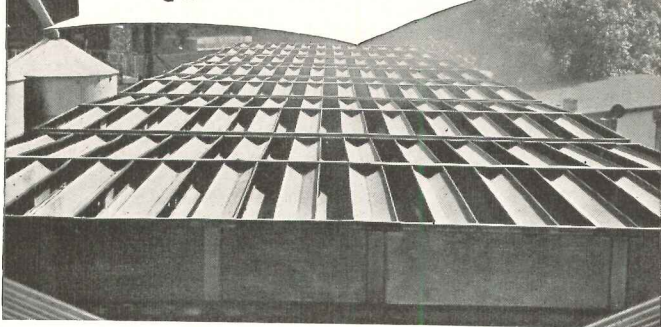

**Cut time losses . . . reduce spoilage
. . . increase production**

You can imagine the effectiveness of an "open roof" like the above on your glass plant, foundry, heat-treatment room or other large heat-producing operation. Swartwout AIRMOVER covers thousands of square feet of industrial roofs, gives heat, smoke, fumes and dust easy passage through efficiently designed parallel openings. Dampers provide full or partial closing when desired, but ventilator system is weatherproof at all times.

AIRMOVER is made in units which "add together" to make runs as long as necessary. Parallel runs make possible practically total roof coverage. Ventilator is only 32" high—doesn't add unmanageable weight to your roof.

**Swartwout Ject-O-Valve does a real job
where power ventilation is needed**

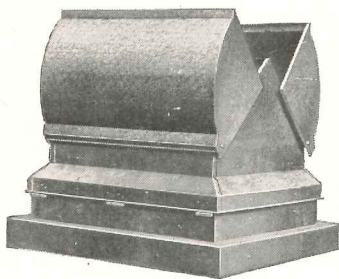

Over vats, furnaces and other *concentrated* heat spots you can profitably use this powerful "straight-through" powered Ject-O-Valve. Made in sizes and capacities to fit your need.

⇒ Swartwout new catalog describes full line of gravity and power roof ventilators. Ask for Bulletin 324.

The Swartwout Company
18639 EUCLID AVENUE • CLEVELAND 12, OHIO

Swartwout
Controlled Air Circulation

EQUIPMENT FOR EFFECTIVE ECONOMICAL
VENTILATION OF INDUSTRIAL BUILDINGS

Sales Recipe

for Builders . . . Dealers . . . Architects

1.

PRODUCT LEADERSHIP

Laboratory tests prove that the "Grand Rapids Invisible" is the most practical and efficient sash balance for double hung windows of every type.



Plus +

2.

PUBLIC ACCEPTANCE

Advertised to 134,445,000 readership in Better Homes and Gardens, American Home, Farm Journal and Small Homes Guide, the "Grand Rapids Invisible" Sash Balance is first choice of home owners everywhere.



Plus +

3.

SIMPLIFIED INSTALLATION

Just drive in one fastener—screw in one screw. Simple to adjust without removing sash. Saves hours of costly installation.

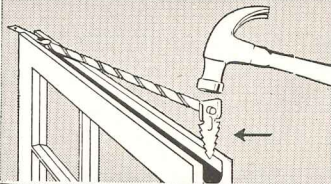

= Equals =

**LARGER VOLUME
BIGGER PROFITS**

Preferred

because they are actually invisible, the "Grand Rapids Invisible" Sash Balances are dependable and easy to operate under all climatic conditions. You'll find them easier to sell—easier to make a profit on.

**AT YOUR SERVICE
NEVER IN YOUR SIGHT**

No tapes . . . no cables . . . no exposed tubes . . . nothing to catch dust or paint . . . nothing to explain away.

GRAND RAPIDS SASH PULLEYS

◀ No. 103 face plate, cone bearing type, and Nos. 175, 109, 110 sawtooth drive type sash pulleys cover 95% of all sash pulley requirements. ▶

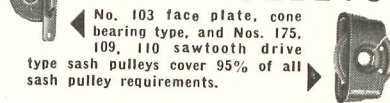

SEE OUR
CATALOG IN
SWEET'S

WRITE
for Illustrated
Specifications
and Instructions

GRAND RAPIDS HARDWARE COMPANY
GRAND RAPIDS 2, MICHIGAN

Quality Leaders in Sash Hardware for over 50 Years



USES FOR ASPHALT TILE IN THE REXALL DRUG COMPANY CONSTRUCTION PROGRAM:

New Store Construction: Asphalt tile is used in a new store when we have a comparatively short lease, or the location does not warrant heavy construction expenditures, because the material is economical from an installation and maintenance standpoint and still has long life. The tile is installed over the entire store area to save the additional expense of extra flooring in the aisles behind counters. Asphalt tile has proved to be a comfortable walking and working surface for employees who spend long hours on their feet. By covering the entire area we also eliminate the need for floor alterations or repairs when it becomes necessary to change the layout of counters or showcases.

In flooring a new store where both a long lease and extremely heavy store traffic must be considered, we usually specify terrazzo because of its greater resistance to wear. Even here, however, a greaseproof asphalt tile is used behind the soda fountain. It is easier underfoot and isn't affected by food greases.

Modernization of Existing Stores: For upgrading drug stores at low cost we give an old store a "new look" by improved lighting, interior repainting and, where the existing floor is worn out, old fashioned or in need of repair, a colorful, new asphalt tile floor. One of the big advantages of using asphalt tile is that we can usually install the floor overnight without interfering with the business of the store.

Store Expansion: When we have the problem of enlarging an existing store already floored with asphalt tile, we find it's a simple and inexpensive matter to cover the new area with a matching tile. If, for one reason or another, an entirely new floor is needed, it's important to our plan of operation to know that here, too, we can easily cover first the new then the old area without curtailing operations in the existing store.

Independent Stores: The benefits of our experience with asphalt tile and other flooring materials used in Rexall's 480 company owned drug stores are passed on to the almost 10,000 Rexall independent agents! As part of the service furnished them for planning, building and equipping their stores, we suggest wall colors, ceilings, store fronts, lighting—in fact a complete design-decoration plan. Asphalt tile, in colors that tie in with the overall decorative scheme, is specifically recommended to them as the ideal floor covering material.



This Glendale, California Rexall outlet (below left) acquired the "new look" with a new, marbled asphalt tile floor in a smart, gray-green checkerboard pattern. To direct store traffic to the prescription department, an inexpensive asphalt tile insert was used.

New floor going in—quickly, and with a minimum interruption of store business! This attractive asphalt tile floor (upper photo) in marbled gray plays the key role in the overall modernization of this Rexall Drug Store in Downey, California.

Ready for business—and lots of it! (lower photo) Modern trends in store decoration call for extensive use of color. The wide color range in which asphalt tile is available simplifies the problem of tying floor, walls and furnishings together in the overall decorative scheme.

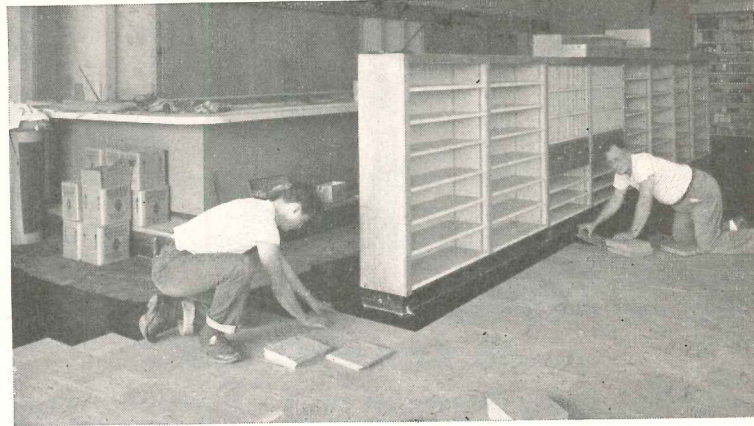

Office Buildings: The offices and corridors of our new world headquarters building in Los Angeles are floored with asphalt tile. The material when used in offices offers many of the same practical advantages it does for store use. Moreover, it's a good flooring for office areas because of its resiliency, pleasing colors and sound deadening qualities. Acoustical ceilings are used throughout our headquarters building which makes the need for overall sound deadening an important consideration.

* * * * *

Many, many thousands of retail establishments throughout the country, selling every imaginable kind of merchandise, handling widely varying traffic loads, and catering to both class and mass patronage are today surfaced with Tile-Tex Asphalt Tile! Whatever your problem in flooring, look first to this quality asphalt tile—thoroughly proved in almost a quarter of a century of serving America's flooring needs. For more information concerning this all purpose flooring material or reprints of this article, write The Tile-Tex Company, Inc. (subsidiary of The Flintkote Company), Chicago Heights, Illinois. Sales offices in Chicago, New York, Los Angeles and New Orleans.*

The TILE-TEX Company

CHICAGO HEIGHTS, ILLINOIS

*REGISTERED TRADEMARK OF THE TILE-TEX COMPANY, INC.



Modern Flooring Techniques:

No. 2 of a series of articles on the use of asphalt tile flooring prepared by leading architects and building authorities for the information of the architectural and building professions.

*The Tile-Tex Company, Inc.
pioneer maker of asphalt tile*

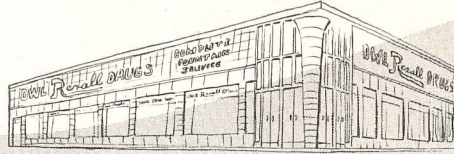

How the **REXALL DRUG COMPANY** uses asphalt tile in its building and modernization program



By Fred Schmid, Vice President

In Charge of Construction and Design, Rexall Drug Co.

Asphalt tile has many uses in our building and modernization program primarily because of its low initial cost and its adaptability to changing store conditions. We have found it especially suitable when installing new floors in existing drug stores because the speed of installation insures a minimum interruption of store business.

Our experience, furthermore, has been that asphalt tile is a sturdy, long-wearing floor material. It is not as resistant

to wear as certain types of cement-finished floors, of course; but this one factor is more than compensated for by the wider group of colors available in asphalt tile, the infinite number of patterns and designs which can be worked from this all-purpose flooring material, and its resilience and safety under-foot.

The ease and low cost of maintaining asphalt tile is of particular interest to us as chain store operators. To assure maximum service and to protect the beauty and surface of the material, our Maintenance Department is careful to furnish all of our store managers with the simple instructions necessary for maintenance of asphalt tile floors.



Ade Schumacher, Rexall Vice President and Regional Director and Fred Schmid discuss a flooring problem with Builder Louis C. Dunn and Architect Albert F. Roller (reading left to right) for one of the Rexall Drug Company's more than 10,000 company and independently owned stores.

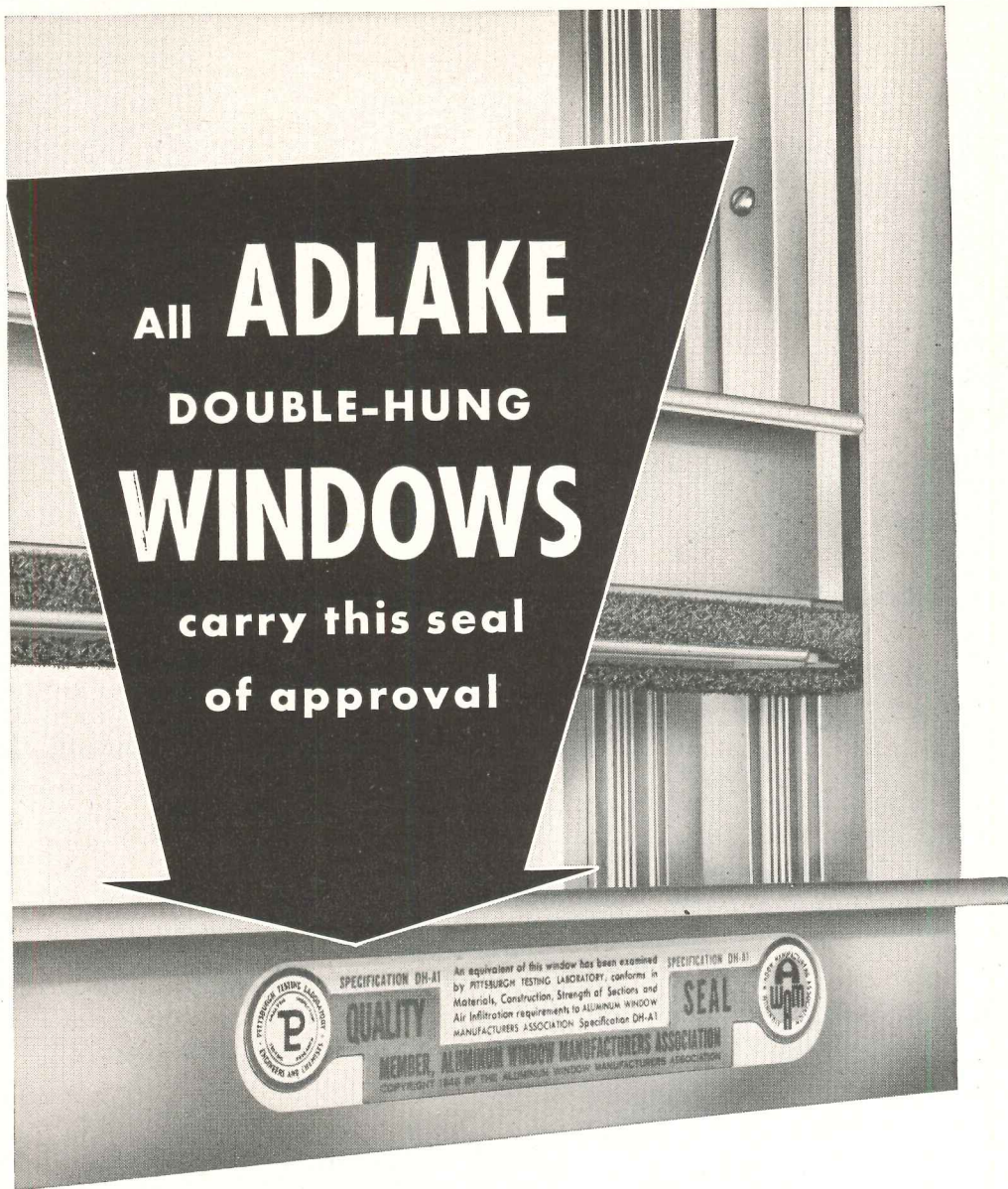

--and meet all the specifications of the Aluminum Window Manufacturers' Association

The seal you see on every Adlake double-hung Aluminum Window is your guarantee of quality. It means that the window has met all specifications of the Aluminum Window Manufacturers' Association for quality of materials, soundness of construction, strength of sections, and air infiltration requirements.

This seal means you can recommend Adlake Aluminum Windows to your clients with confidence. To clients, it is concrete

evidence that when you specify Adlake Windows, you specify the utmost in long life, good looks, easy operation. Cost-wise, Adlake Windows *pay for themselves* in a few years through *doing away with expensive maintenance*. No maintenance is required, other than routine washing.

Write today for complete data. Address: 1102 N. Michigan, Elkhart, Ind. No obligation, of course.

THE **Adams & Westlake** COMPANY

Established 1857

ELKHART, INDIANA
New York • Chicago



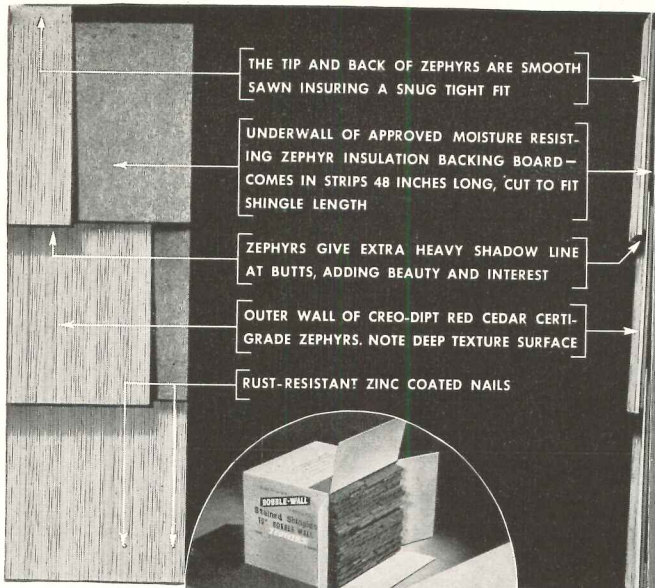

Double Care



A Zephyr unit covers 100 square feet of siding.

GOES INTO THE MANUFACTURE OF CREO-DIPT ZEPHYRS

Double Wall Zephyrs are made from genuine certi-grade red cedar shingles, applied over Zephyr moisture resistant insulating backing board and secured by Creo-Dipt special zinc coated nails.

Zephyrs have all the characteristics of hand split shingles—deep grooved surfaces, with butt thickness that produces heavy shadow lines. The top portion of each shingle is smooth sawn, butts are square and sides parallel insuring a snug and even fit.

Zephyr shingles are available in a wide range of colorful shades. Stained under exclusive processes using only the finest linseed and binding and preserving oils, Zephyrs are doubly able to resist weather conditions.

Zephyr approved backing board applied under Zephyrs increases insulating values 35% over ordinary wooden siding, and 42% over stucco.

When you use Double Wall Zephyrs for sidewall construction you gain double beauty, double insulation and doubly satisfied home owners—double value in every way.



Send for your copy of Creo-Dipt's new booklet on Zephyr Double Walls.



ZEPHYR
DOUBLE WALLS

CREO-DIPT COMPANY, INC., NORTH TONAWANDA, N. Y.
CREO-DIPT OF CANADA, LTD. VANCOUVER, B. C.

THE ORIGINAL SHINGLE STAIN—FIRST AND BEST!

YOUNG EQUIPMENT

for Your Air Conditioning Requirements

COMPLETE UNITS

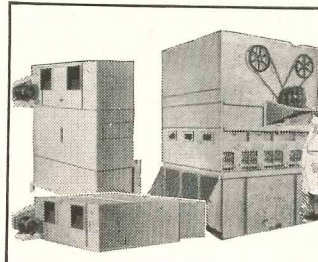

Horizontal and Vertical Type "YAC" Units

Compact, easy to handle. Heat, cool, humidify, dehumidify, filter.

Evaporative Condensers

For condensing refrigerants of air conditioning systems.

COILS

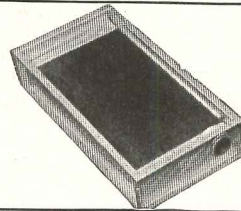

Blast Coils - Type B

Have casing for central plant heating, ventilating and air conditioning systems. Available with steam distributing tubes.

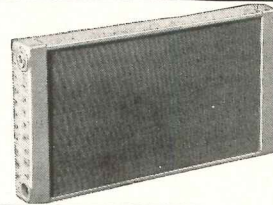

Commercial Coils—Type C

For factory-built air conditioning, heating, drying or special processing units. Made also in steam distributing tube type.

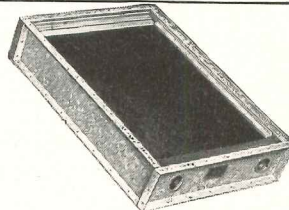

Booster Coils - Type A

Encased for forced air heating, cooling or conditioning systems. Smaller sizes available for use in main or branch ducts.

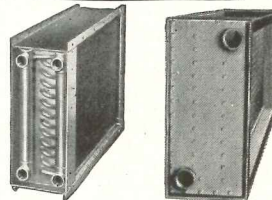

Water Coils - Type W

Used with water or brine. Serpentine tube construction.

Type K — cleanable tube type with removable header plates at both ends.

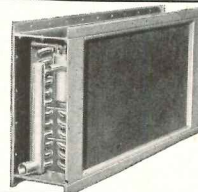

Evaporator Coil-Type E

For mechanical refrigeration systems where Evaporator Coils are used. In variety of sizes with Young liquid distributor.

Young Products are widely known and extensively used . . . are the development of more than two decades of specialization in the Heat Transfer Field. Take advantage of such experience . . . specify "Young."

YOUNG

HEAT TRANSFER PRODUCTS



YOUNG RADIATOR CO.
Dept. 518 F Racine, Wis., U. S. A.

Sales and Eng. Offices in All Principal Cities

HEATING, COOLING AND AIR CONDITIONING PRODUCTS
Convectors • Unit Heaters • Heating coils • Cooling coils • Evaporators • Air conditioning units •

AUTOMOTIVE AND INDUSTRIAL PRODUCTS

Gas, gasoline, Diesel engine cooling, radiators • Jacket water coolers • Heat exchangers • Intercoolers • Condensers • Evaporating coolers • Oil coolers • Gas coolers • Atmospheric cooling and condensing units • Supercharger intercoolers • Aircraft heat transfer equipment

VESTIBULE



For Competent Counsel...

on bank vault design, construction or installation, call in a Herring-Hall-Marvin specialist. He has at his command . . . and through him you have at your command . . . the facilities and know-how of an organization with over a century of leadership in this highly specialized field.

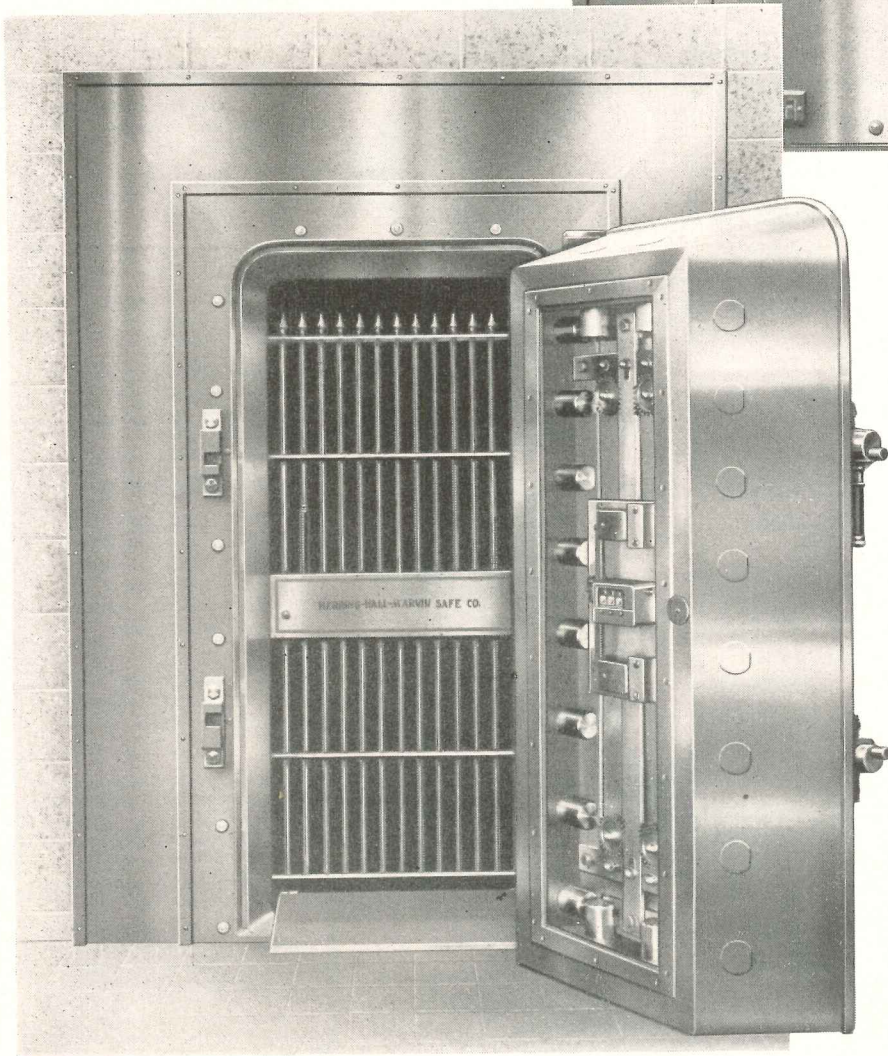
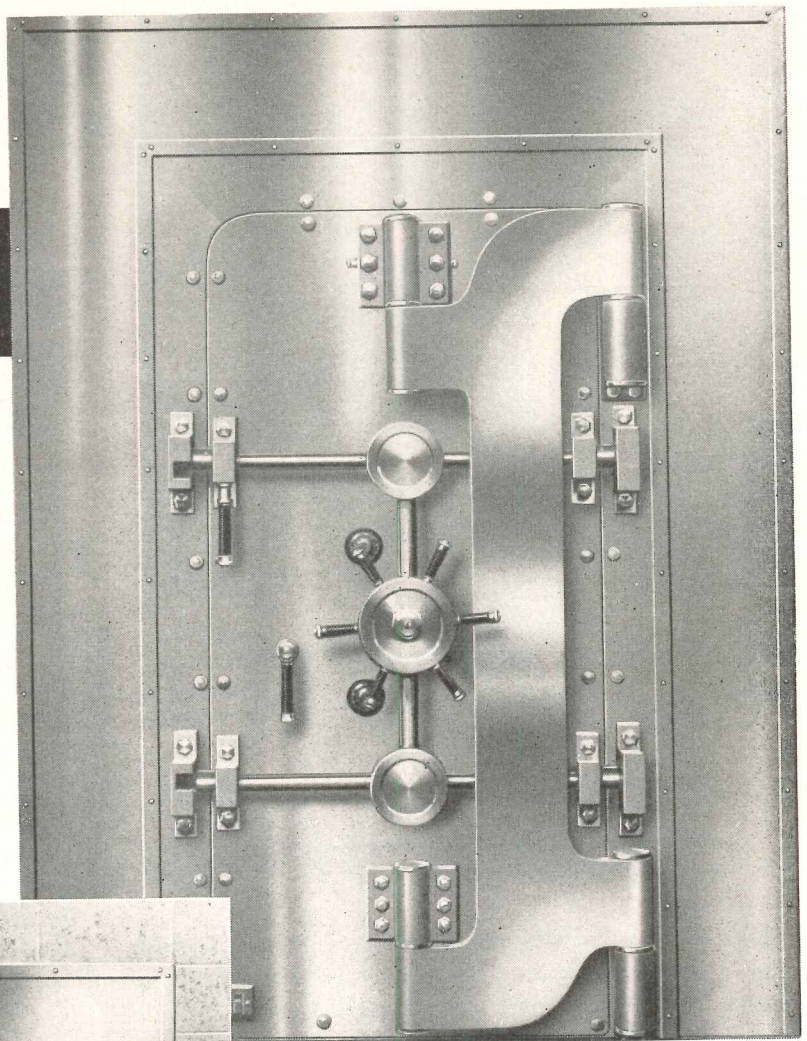

HERRING HALL MARVIN

SAFE COMPANY

General Office & Factory
HAMILTON, OHIO

BRANCH OFFICES

in New York, Chicago, Boston,
Washington, St. Louis, Atlanta,
Houston, Philadelphia, San Francisco,
Los Angeles, Detroit,
Pittsburgh, Omaha, Indianapolis,
Minneapolis, Charlotte.

**EXCLUSIVE!
REVOLUTIONARY!**

IMPROVED INTERLOCKING

ANCHORS H-H-M BANK VAULT ENTRANCE DIRECTLY TO MASONRY REINFORCEMENT

**...resists removal by
explosive or mechanical attack**

Take a look at the cut-away drawing below. You'll see at a glance how the improved Herring-Hall-Marvin method of interlocking makes the vestibule an integral part of the vault masonry.

The wall reinforcements are continued into the specially formed steel ribs of the vestibule casting. The attachment areas are completely covered by the wide cast-steel front flanges. Tools cannot be inserted to disconnect the reinforcing bars even if a mass of the concrete wall should be removed. This revolutionary, exclusive Herring-Hall-Marvin engineering achievement eliminates any possibility of removal of the entire door and vestibule with explosives or mechanical means.

Some of the many other advantages of the modern Herring-Hall-Marvin burglar-proof bank vault entrance are: the superior drill and torch resistance of the scientifically designed door... the wide margin of resistance of all operating parts against shearing or rupture in any form... the handsome appearance and lasting luster of oil-free stainless steel.

For further information see our catalogue $\frac{248}{2}$ in your Sweet's File, or write us.

FREE ON REQUEST!



Complete Specifications Manuals

for 7½", 10", 12" and 16" interlocking main entrances will be sent at your request. Please specify the particular manual or manuals you want.

Illustrated Folder...

"Today's Master Architect and the Modern Bank" ... outlines the fundamentals in modern architectural technique of bank vault design. Also yours on request.

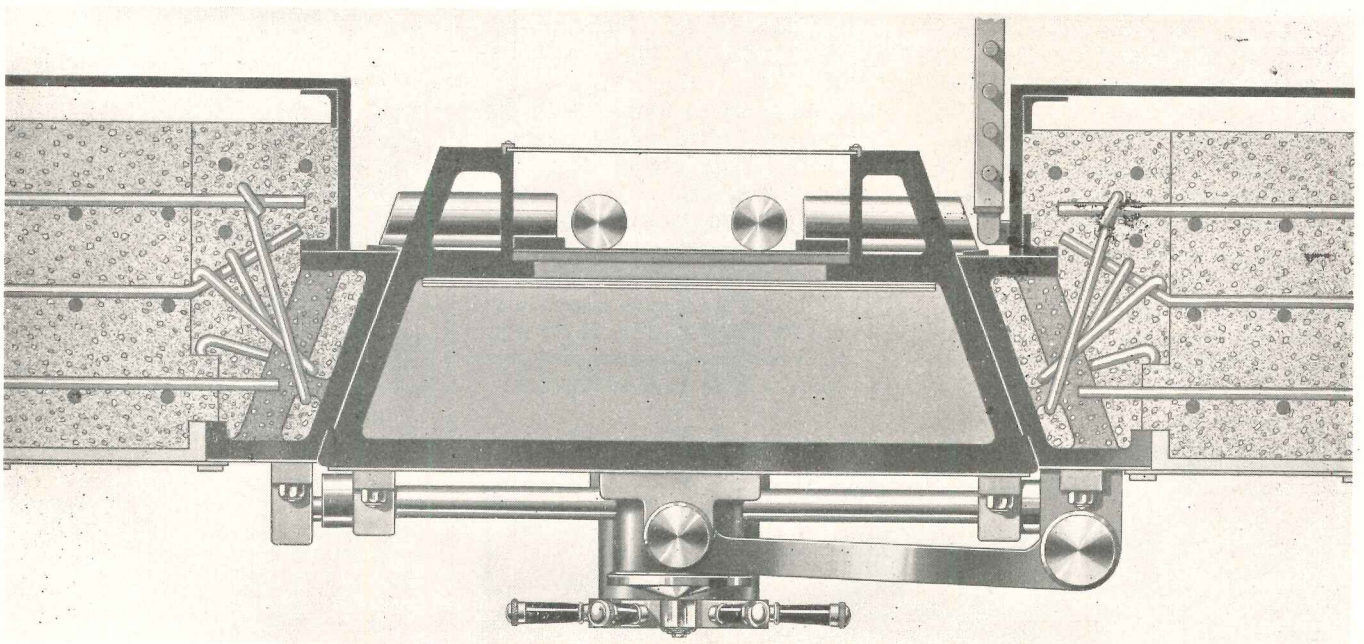

WORTHINGTON

Air Conditioning and Refrigeration Report

Worthington Pump & Machinery Corporation, Harrison, New Jersey

USERS REPORT LOWEST MAINTENANCE COST WITH WORTHINGTON FREON-12 COMPRESSORS

Longitudinal Section through 6-Cylinder Compressor

- A—Valve Plate and Cylinder Head
- B—Automotive-Type Pistons
- C—Cleanable Oil Filter, Disc-Type
- D—Gear-Type Oil Pump (Models 3-HF-4 and larger)
- E—Forged Connecting Rods, Rifle-Drilled
- F—Shaft Seal
- G—Balanced Crank Shaft
- H—Oil Check Valve

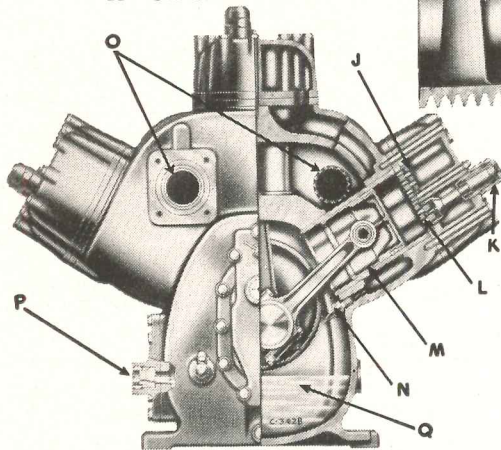
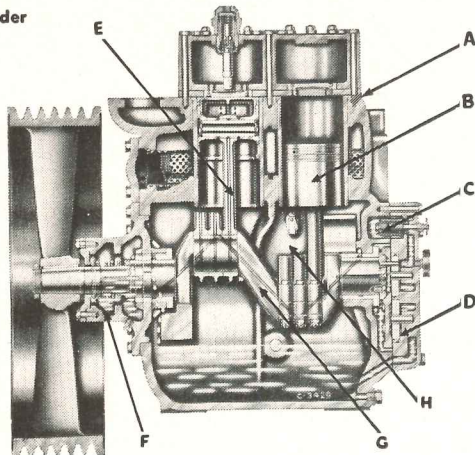

Transverse Section through 6-Cylinder Compressor

- J—Discharge Valve
- K—Suction-Valve Unloader
- L—Suction Valve
- M—Cylinder Liners
- N—Oil Check Valve
- O—Suction Strainer
- P—Oil-Level Sight Glass (Wide angle vision)
- Q—Large Crank Case (Exceptionally generous lubricating-oil capacity)

A number of Worthington design features are responsible for the success of Worthington single-acting, multi-cylinder compressors in providing efficient operation at very low cost for maintenance.

The famous Worthington Feather* Valve—lightest, quietest ever made—eliminates valve grinding and rarely needs replacement.

On most models, lubrication is force-fed from a self-contained gear-train-type pump driven directly by the crank shaft. A disc-type, continuously-cleanable filter keeps the oil clean.

* Reg. U. S. Pat. Off.

Cylinder liners in larger models are centrifugally-cast from special high-grade alloy cylinder iron having exceptionally high wearing qualities.

Main suction manifold, oil pump, oil passages and oil filters are built into the body casing, reducing the danger of leakage.

Write us for Bulletin C-1100-B30 on the complete line of Worthington Freon-12 compressors from 3 to 125 hp. *Worthington Pump and Machinery Corporation, Harrison, N.J. Specialists in air conditioning and refrigeration for more than 50 years.*

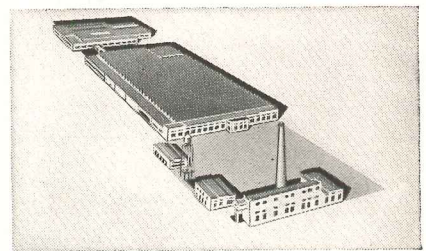

300-Ton Worthington Compressor Aids in Yarn Processing

At the Hopewell, Virginia plant of the famous Celanese Corporation a 300-ton Worthington refrigeration unit is used in the processing of viscose yarns.



Penn Mutual Employees Work in Comfort

The Penn Mutual Life Insurance Company's main office, Independence Square, Philadelphia will be air conditioned with the help of two 350-ton centrifugal refrigeration compressors.

Balanced Air

An important reason for the fine performance of Worthington equipment in both large and small installations, both air conditioning and refrigeration, is the fact that every Worthington job is a *balanced* installation. All the vital parts are made by the *one* manufacturer and are carefully balanced, one with another. It adds up to smooth performance, low cost, long life—*more worth with Worthington*. See your nearby Worthington distributor (in the Classified Telephone Book) for details.

AB-31

WORTHINGTON



*Air
Conditioning
and
Refrigeration*

(Continued from page 196)



THE NEW ADJUSTABLE
RITE-LOCK
FOR SLIDING DOORS

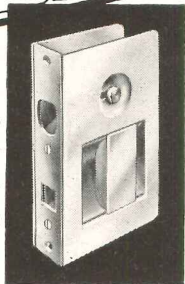

- For Entrance Doors, Bath and Inside Sets.
- Solid Brass Exterior.
- Three Escutcheon Types.

RITE-LOCK adds distinction and convenience to today's sliding doors. It's new, compact, trouble-proof...fits almost any thickness of door. The latching action is positive and releases with a natural sliding movement of the bar in the cup. For convenience and economy a finger pull is formed in the face plate. Look at these advantages:

- ★ Adjustable in width from 1-1/8" to 1-15/16"
- ★ Unit-type requires only a 3-1/2" x 2-5/8" notch
- ★ Adaptable to right or left hand doors
- ★ Outer case measures only 4-1/2" x 2-7/8"
- ★ Pin-tumbler 3/4" diameter cylinder available

Ask your Hardware Consultant or write us for complete details.



the types included are: service doors, fire doors and shutters, Rol-TOP doors, hanger doors and steel rolling grilles. 28 pp., illus. The Kinnear Mfg. Co., 30 Rockefeller Plaza, New York 20, N. Y.*

Metal Store Fronts

Natcor Extruded Metal Store Fronts. Illustrates extruded glass settings; vertical and horizontal mouldings; division and corner bars; cap, hanger and fascia mouldings; awning and transom bars; and typical structural glass settings for extruded aluminum store fronts. A list of distributors is included. 12 pp., illus. Natcor, Providence 9, R. I.*

Saving Fuel Oil

Fuel Conservation Handbook. Guide to fuel-saving steps including determination of heat loss, heating load and radiator, register, duct and boiler sizes. Method is given for estimating fuel oil consumption. Warm air, hot water and steam heating systems are diagrammed. 46 pp., illus. Eureka Williams Corp., Oilomatic Division, Bloomington, Ill.

LITERATURE REQUESTED

The following individuals and firms request manufacturers' literature:

- Cesare Bachi, 19 Viale Dei Mille, Milan, Italy.
- Karl E. Blomberg, Architect, 16 Court St., Brooklyn 2, N. Y.
- Bolton, Martin & White, Architects, 266 S. 17th St., Philadelphia 3, Pa.
- William E. Brackett, Architect, Technical Bldg., Asheville, N. C.
- William M. Cooley, Architect, 1241 Granville Ave., Chicago 40, Ill.
- Carlos Ferrer, Provenza 47, 30, 2a, Barcelona, Spain.
- Joseph T. Gempp, Architect, 205 Speedwell Ave., Morristown, N. J.
- Hal P. Hardin, Structural Engineer, 927 41st St., Miami Beach 40, Fla.
- Keith Hinchcliff, Ass't Professor, Agricultural Experiment Station, College of Agriculture, University of Illinois, Urbana, Illinois
- Larkin & Glassman Associates, 751 Old South Bldg., 294 Washington St., Boston 8, Mass.
- Harold E. Mason, Architect, 42 Main St., Leominster, Mass.
- S. Z. Moskowitz, A.I.A., Deport and Savings Bank Bldg., Wilkes-Barre, Pa.
- David H. Neerland, Student, 4452-41st St. S., Minneapolis 6, Minn.
- Milton Sherman, A.I.A., 141 N. E. Third Ave., Miami 32, Fla.

The
RESTORATION
of
**COLONIAL
WILLIAMSBURG**

*A Reprint
of the December, 1935
Issue of*

ARCHITECTURAL RECORD

104 pages, bound in cloth
\$2.00 per copy



The Colonial Williamsburg Number of ARCHITECTURAL RECORD — issue of December 1935 — was sold out soon after publication but the entire editorial contents have been reprinted and bound in permanent book form with blue cloth covers.

Many thousands of these Williamsburg reprints have been sold but the demand continues unabated.

ARCHITECTURAL RECORD
119 W. 40th Street, New York, N. Y.

Enclosed is \$..... for which send..... copies of your reprint, *The Restoration of Colonial Williamsburg*, bound in cloth, at \$2.00 per copy. {Add 2% Sales Tax for New York City deliveries.}

Name.....

Address.....

City and State.....A.R. 6-48

ONLY \$25* per 1000 square feet for (*approximate contractors' price) both Insulation and Vapor-Barrier

with

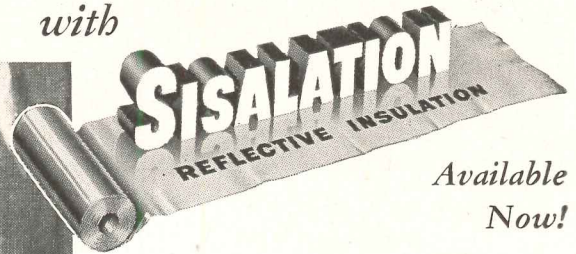

Available
Now!



1 This modern insulation is effective, since SISALATION is equivalent in heat-saving values to about 3/4-inch of flexible or rigid types of quality insulations . . . based on M.I.T. tests on side-walls constructed with a single layer of reflective SISALATION applied in the stud area.

2 SISALATION, at the same time, acts as a VAPOR-BARRIER, thus protecting against dry-rot, condensation and paint failure. Meets FHA vapor-barrier requirements, Class A, Fed. Spec. UU-P-147.

3 SISALATION, heavily reinforced, is so strong that one man applies it over two stud spaces at one time without risk of SISALATION tearing. This means low application costs.

4 SISALATION deflects sun-heat and does not absorb or store up heat, thus keeping the home much cooler in summer. Makes attics more attractive and livable.

5 SISALATION is available NOW for prompt delivery through your lumber or building supply dealer.

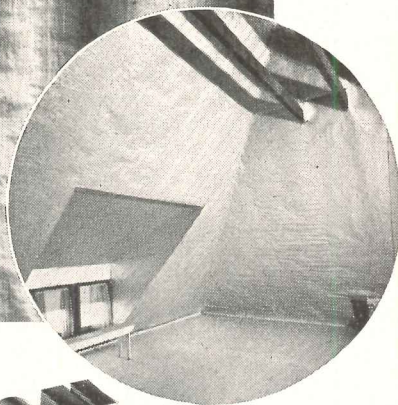

The SISALKRAFT Co.
 205 W. Wacker Dr., Chicago 6, Ill.
 New York 17, N. Y.
 San Francisco 5, Calif.

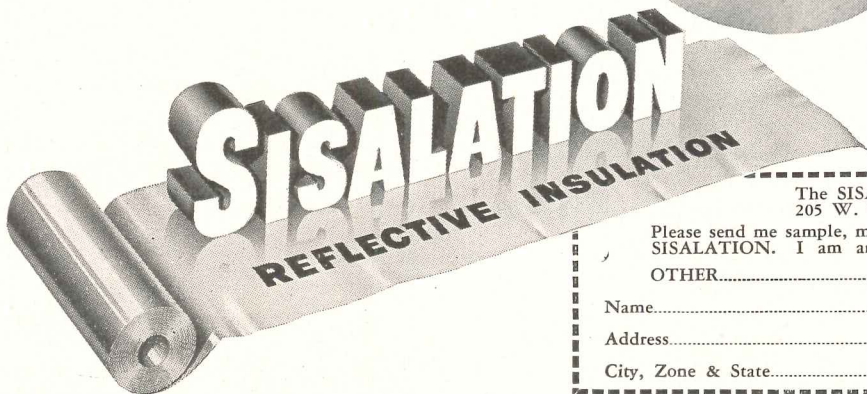

The SISALKRAFT Co., Dept. AR
 205 W. Wacker Drive, Chicago 6, Ill.

Please send me sample, more information, and tell me where I can buy SISALATION. I am an ARCHITECT CONTRACTOR
 OTHER.....

Name.....

Address.....

City, Zone & State.....



**OIL
ALLOTMENTS
GO
FURTHER
WITH
TODD
BURNERS**



● Stretch your oil supply by replacing obsolete equipment with Todd Burners. Avail yourself of the years of experience of Todd engineers.

Oil Burners
Gas Burners
Combination
Oil and Gas
Burners

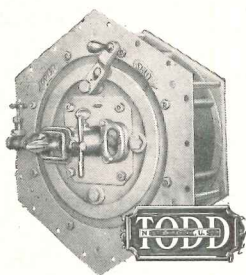

**COMBUSTION EQUIPMENT
DIVISION**

TODD SHIPYARDS CORPORATION

81-16 45th Ave., Elmhurst, Queens, N. Y.

NEW YORK • BROOKLYN • ROCHESTER
HOBOKEN • NEWARK • PHILADELPHIA
HARRISBURG • YORK • CHICAGO • CHARLESTON,
S. C. • BOSTON • SPRINGFIELD, MASS.
BALTIMORE • WASHINGTON • DETROIT • GRAND
RAPIDS • TAMPA • GALVESTON • MOBILE • NEW
ORLEANS • LOS ANGELES • SAN FRANCISCO
SEATTLE • MONTREAL • TORONTO
BARRANQUILLA • BUENOS AIRES • LONDON

(Continued from page 150)

than 100 colors to harmonize with fabrics, draperies and floor coverings. In addition to paint mixing formulas, specifications are given for painting all types of interior and exterior surfaces. The O'Brien Corp., 101 N. Johnson St., South Bend 21, Ind.*

Wax-fortified Interior Finish. Light reflectance readings for each color shown is a feature of the new color card for *Wax-Fortified Interior Finish*. These readings indicate the actual percentage of light reflected by each of the 34 colors and tints. The new paint incorporates wax in gloss, semi-gloss and eggshell flat finishes. 6 pp., illus. S. C. Johnson & Son, Inc., Racine, Wis.

Acoustical Materials

Sound Absorption Coefficients of Architectural Acoustical Materials (Bulletin X). Noise reduction coefficients and light reflection values are listed for products manufactured by members of the Acoustical Materials Assn. A short table of noise reduction coefficients for other common materials used for finishing interiors is also given. 12 pp. Acoustical Materials Ass'n, 205 W. Monroe St., Chicago, Ill.

Whistles and Signals

Engineering, Operating and Maintenance Data on Leslie-Tyfon Whistles and Signals (Bulletin No. 466). Design and operation of whistles and signals for industrial plants as well as intra-plant and departmental signals are given together with installation and maintenance practices. 12 pp., illus., Leslie Co., 57 Delafield Ave., Lyndhurst, N. J.

Wiring Devices

Bryant Catalog No. 48. Revised catalog of Bryant line including switches, outlets, connectors, lamp holders and wall plates. The Bryant Electric Co., Box D, Barnum Station, Bridgeport 2, Conn.*

Steel Panels

Fenestra Building Panels for Up-To-Date Houses. Folder providing information about *Fenestra* steel panels that combine joist, bridging and subflooring. Floor covering and use with radiant heating are discussed. 4 pp., illus. Detroit Steel Products Co., 2250 E. Grand Blvd., Detroit 11, Mich.*

Rolling Doors

Kinnear Rolling Doors. Construction details, installation types, operating methods and specifications make up a large part of this new catalog. Among

(Continued on page 198)



- 1 **Deep-Driven Anchors** hold the fence permanently erect and in line, yet can easily be relocated.
- 2 **Square Frame Gates** remain free from sagging and warping.
- 3 **U-Bar Line Posts** are rust-free, rigid and self-draining.
- 4 **Square Terminal Posts** improve strength, durability and appearance.

ANCHOR CHAIN LINK

FENCE rates a top spot on your "spec" list for features like these! To your clients, they mean extra years of all-out protection. And they are *your* assurance of specifying the best in fencing for factory, institution and home alike.

WRITE TODAY for your copy of "Anchor Protective Fences." It's both a catalog and specification manual for your A.I.A. File 14-K. Contains structural diagrams and specification tables, installation photos, many types and uses of Anchor Chain Link Fence. Just ask for Book No. 110. Address: ANCHOR POST FENCE DIV., Anchor Post Products, Inc., 6600 Eastern Ave., Baltimore 24, Maryland.

Anchor Fence
Nation-wide Sales and Erecting Service

Maintenance expenses are kept down at Rock Island Railroad's new Chicago shops by extensive use of Insulux Glass Block. Architects-Engineers: DeLeuw, Cather & Company.

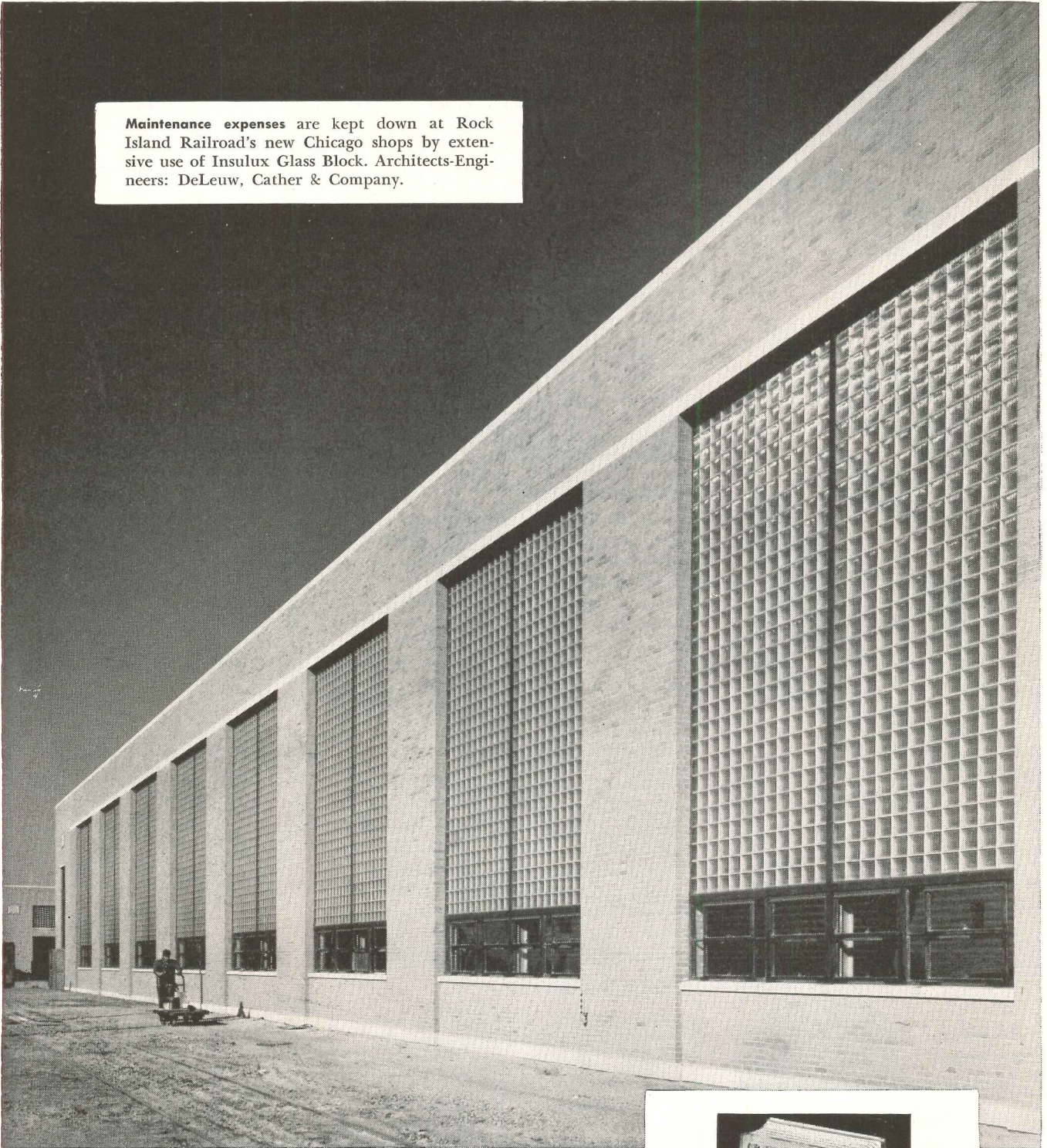

Glass Block reduces maintenance costs: Insulux Glass Block is solving real problems for maintenance-conscious railroad men. Light-transmitting panels of Insulux resist the destructive effects of smoke, soot, and moisture. They require a minimum of maintenance. Real savings result.

Insulux is versatile. It transmits light, insulates, and reduces transmission of noise. Does not rot, rust or corrode. Eliminates the need of painting every two or three years.

For technical data and installation details, consult GLASS section of Sweet's Architectural Catalog, or write Dept. E-7, American Structural Products Company, P. O. Box 1035, Toledo 1, Ohio.

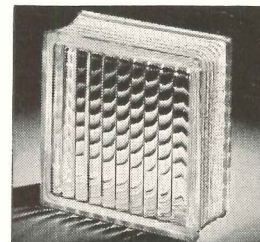

INSULUX
GLASS BLOCK

AMERICAN STRUCTURAL PRODUCTS COMPANY

Subsidiary of

OWENS-ILLINOIS GLASS COMPANY

IN-SINK-ERATOR

Garbage Disposer

Model "900"!

WITH SIMPLIFIED
ELECTRICAL HOOK-UP
FOR EASIER
INSTALLATION



The IN-SINK-ERATOR Model "900," built on the integral design principle employed by IN-SINK-ERATOR for ten years (longer than any other in the disposer field) comes complete with a positive acting, reversing control switch and a simplified electrical hook-up for easy installation in custom dwellings or project housing. IN-SINK-ERATOR's automatic reversing action, complete self cleansing streamlined design and two-directional shredding have set the pace for ten years. It's the disposer the plumber likes, too . . . because it's distributed EXCLUSIVELY THROUGH PLUMBING CHANNELS.



● The IN-SINK-ERATOR story will be repeated to consumers 23,000,000 times in five of the leading household magazines in the country during 1948.

IN-SINK-ERATOR
MANUFACTURING CO. RACINE, WIS.

Exclusive Manufacturers of Automatic Garbage Disposers
Since 1938

ARCHITECTURAL ENGINEERING

TECHNICAL NEWS AND RESEARCH

(Continued from page 192)

ADHESIVE FOR TILE

One of the outstanding characteristics of a recently developed adhesive for tile is said to be its unusually low shrinkage factor. This quality aids in preventing the face of metal and plastic tile from becoming concave. The non-putty material can be used around bathtubs and moisture areas where its water resistance prevents breakdown of its adhesive qualities. The cement is sufficiently slow-setting so that tile can be applied to it up to three or four hours after it has been applied to the wall. Armstrong Cork Co., Lancaster, Pa.

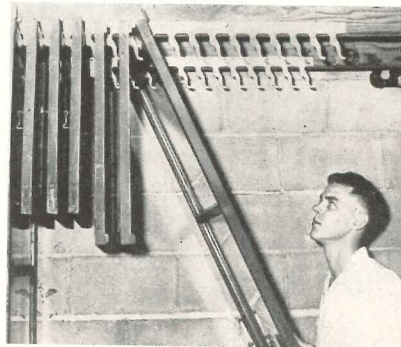

Brackets fastened to overhead joists store up to 21 storm window and screen sashes, protecting them from damp floors

SASH BRACKETS

Storm window and screen sashes can be protected from damp garage or basement floors through use of *Stor-A-Way* brackets. These brackets, which are fastened to overhead joists, can hold sashes either horizontally or vertically, depending on how the brackets are mounted.

Once hung, the sash cannot drop; it is necessary to swing the bottom of the sash out 30 degrees from the vertical to either hang it or take it down.

Each set of four brackets holds 21 windows or screens. They are made of heavy gauge aluminum. Barber Mfg. Co., Inc., 5710 Nicollet Ave., Minneapolis 9, Minn.

LAMP TRANSFORMER

A transformer engineered for fluorescent lamps of long, slim design incorporates a principle which permits maintenance of rated lumen output regardless of wide variations in line voltage. Due to the patented circuit, slim design lamps start easily with low or high primary voltages. Sola Electric Co., 4633 W. 16th St., Chicago 50, Ill.

LOOK-One Hand!

A.W. Faber's quick-action
(black or colored)

LOCKTITE

refill
works
the thumb

drawing pencil
with a flip of

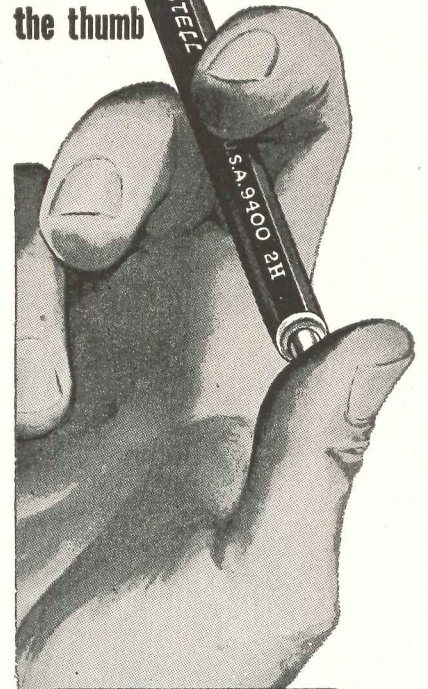

- 1). Patented collet to hold lead in bulldog grip.
 - 2). One-hand clutch operation to avoid touching lead and smearing fingers.
- These are but two exclusive features which make LOCKTITE the favorite of professional men. Collet prevents lead breaking or slipping. Try this clean, balanced, sturdy mechanical beauty and you will surely want to own it.

Holds all standard graded drawing or retouching leads. Winner Techno-TONE No. 1930 assures best results.

ALSO AVAILABLE IN RED, BLUE, GREEN, YELLOW, CARMINE, ORANGE and WHITE—holding hardy WINNER Techno-TONE crayon leads for coloring, sketching and checking.

BLACK in degrees 4B to 9H.
Sold at Stationers', art and drawing supply stores, photo supply shops and Blueprinters.

**GUARANTEED
OF COURSE!**

A.W. FABER-CASTELL
PENCIL COMPANY INC. NEWARK 4, N.J.

skylines ... by Otis



In Cleveland, good citizenship has not only made good government, it has also produced one of the nation's finest cultural centers. And commercially, the great competitive spirit which has made Cleveland our sixth largest city is reflected in its constantly expanding skyline. Here again, a famous skyline also marks the progress of Otis. Two-thirds of the elevator installations in Cleveland are by Otis. The latest count is 2,560!

RISING WRATH.

Supervisors in a European shoe factory are never called 'on the carpet.' It calls on them. How so? The owner has his office in an elevator. Whenever there's trouble his office and his wrath rise together.

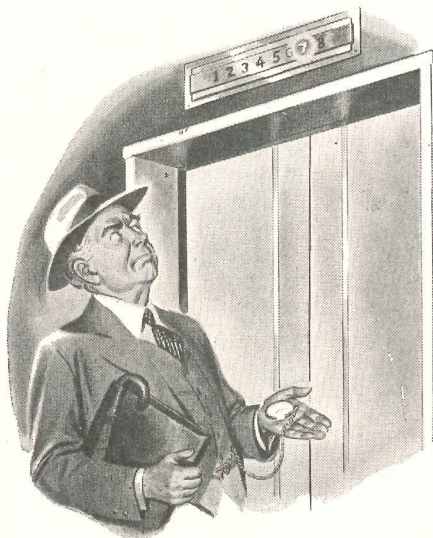

TIME FOR EVERYTHING.

What happens as you wait for an elevator? Traffic engineers say you feel pretty good for 20 to 30 seconds. Your collar gets hot in 30 to 60 seconds. After a minute? You really blow your top. What to do about sluggish service? Otis modernization!

ONE LESS WORRY.

Seems there's no end to the 'unpredictable predicaments' in a hospital. But it really isn't so. Good elevator service can be predictable. How? With Otis elevator maintenance. It's keeping the elevators in 1429 hospitals doing the job they were built to do — continuously and safely. Want to know about it?



Have you been wondering about the magic that modern electronics will introduce to the postwar world? Watch Otis. We're first again with something new in electronic elevating!



ELEVATOR COMPANY

Home Office: 260 11th Ave., New York 1, N. Y.

(Continued from page 190)

they are vented. Then the partially warmed air moves upward within the heater and sweeps a stainless steel combustion chamber. The air is discharged through directional discharge nozzles on top of the unit. Dravo Corp., Neville Island, Pittsburgh 25, Pa.



Awning louvers, adjusted by a control arm, permit any degree of light and ventilation

METAL AWNING

Several unique features are offered by a steel awning recently introduced in Canada. Moveable, interlocking louvers are mounted on its inclined face. They may be adjusted for any degree of light and ventilation by means of a control arm extending through the window frame into the house. Criticisms of conventional type awnings (that they darken rooms and pocket hot air) are thus eliminated.

After fabrication the steel is bonderized, then finished with three coats of baked enamel, with colors to order. Usually the tops of alternate louvers are enamelled in matching shades so as to create a striped effect. The underside of the awning is always finished in white to give maximum light reflection. All mechanical parts are made of rustproof metal.

Since the awnings are permanently fixed in place, there are no problems of handling and storage. Koolside Products Ltd., 279 Vaughan Rd., Toronto, Ont.

CONCRETE PAINT

A new heavy-duty, long-wearing synthetic paint that protects concrete with an abrasion-resisting coating is claimed not to check, crack or "dust." The new paint is said to dry to a glossy finish in three to four hours and will resist acids, alkalis and extreme degrees of heat and cold. Besides forming a protective coat on concrete, the paint can also be applied to exposed metals, machinery, boilers and pipes. Lowecco, Inc., 1525 E. 53rd St., Chicago 15, Ill.

(Continued on page 194)

the
**ULTIMATE
IN SWITCH
DESIGN**

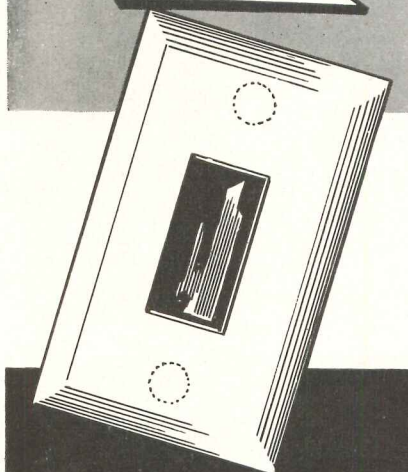

TOUCH-PLATE
LOW VOLTAGE
LIGHT CONTROL SYSTEM

Smooth, simple, streamlined beauty is one of the great features of the amazing new Touch-Plate switch...but it's only a by-product! Operating with a feather-touch on and off action, low voltage Touch-Plate switches require no conduits...allow for any combination of multiple controls at virtually the same cost as old-fashioned installations! Let us tell you the whole story....

**CONVENIENCE
BEAUTY
SAFETY**

*Approved by
Underwriters' Laboratories*



**THE RELAY DOES
THE WORK!**

**TOUCH-PLATE
DISTRIBUTORS, INC.**

2038-42 Bay Street
Los Angeles 21, California



Hillyard Non-skid Floor Treatments, and Economy Maintenance Materials properly care for and make attractive all types of floors in every type of institution... give entire satisfaction with less labor. Write for our new "Job Specification" Booklet. It is sent FREE upon request.

**HILLYARD
SALES CO's**

DISTRIBUTORS
HILLYARD CHEMICAL CO. ST. JOSEPH, MO.
470 Alabama St., San Francisco, Calif. 1947 Broadway, New York 23, N. Y.

Another
Building
of
Distinction

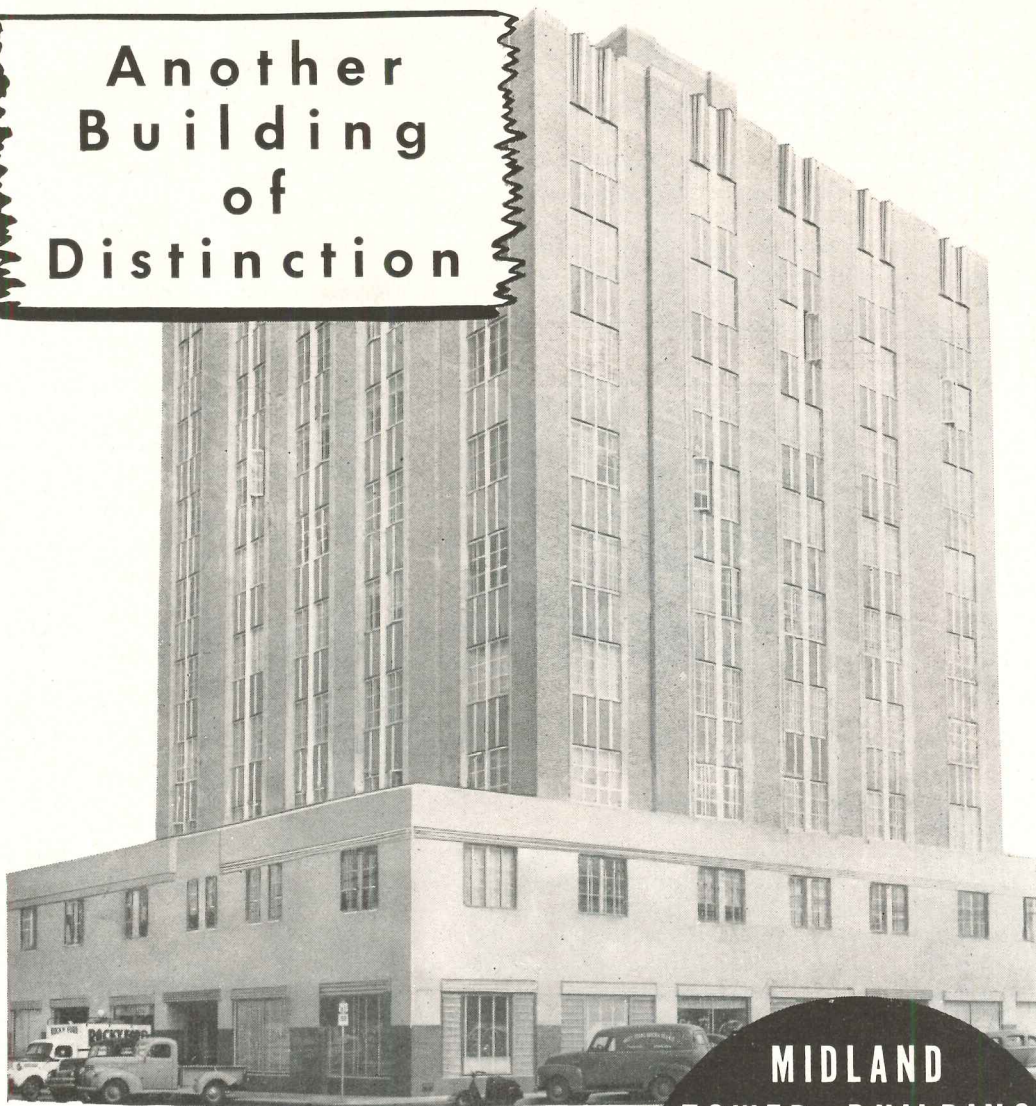

MIDLAND TOWER BUILDING
Wyatt C. Hedrick, Architect-Engineer,
Fort Worth, Texas
J. W. Bateson, Contractor, Dallas, Texas

OTHER BROWNE WINDOW TYPES
Psychiatric — Monumental
Underwriters' Label — Residential

Browne folding type windows give your building a high classification that enables better revenue and higher rents. Built of heavy aluminum extrusions, they are chosen by architects everywhere on the basis of all 'round utility and permanent beauty. In addition, Browne windows give 100% controllable draft-free ventilation with maximum light and vision.

MIDLAND
TOWER BUILDING
Equipped with
BROWNE
folding type
aluminum
WINDOWS

Miracles in Metals



Universal

J. P. TRAVIS, PRESIDENT

6710 DENTON DRIVE

CORPORATION

Qualified sales representatives in all architectural centers.

DALLAS 9, TEXAS



NO DRAFT . . .
"V" flue accelerates intake of air at the bottom and exhausts stale air at the top.



EASY TO OPERATE
No reaching or bending . . . no tugging or lifting. Browne windows give permanent ease of operation.

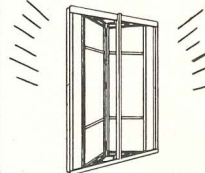

MINIMUM MAINTENANCE . . .
Famous "Alumilite" finish retains its striking beauty year after year with no maintenance . . . merely wipe with a damp cloth occasionally.



EASY TO CLEAN
Both sides of glass can be cleaned from the inside which eliminates need of professional window washers.

Browne folding windows are manufactured exclusively by Universal Corporation in Dallas, under the trade name Sealuxe: Browne folding type windows. Double hung windows. Side hinged casements. Thermo windows and shades. Theatre display systems.

**YOU PROVIDE
YEARS OF
PROTECTION**

*for
Masonry Walls.*

**WHEN YOU
SPECIFY**

Cabot's

*Clear
Waterproofings*

Cabot's time-proven water-proofings protect masonry from efflorescence, prevent spalling and disintegration and interior leakage, due to moisture absorption. They actually penetrate deep into the surface of the masonry and completely seal voids and pores.

Walls treated with Cabot's Clear Waterproofings are still moisture proof after twenty years of rough weather!

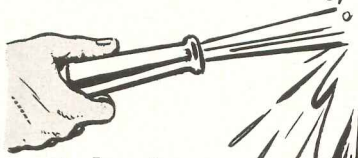

**Cabot's
Clear Brick**

Waterproofing

for brick and dark colored masonry above grade.

**Cabot's
Clear Cement**

Waterproofing

for cement, stucco, stone and light-colored masonry.

Write Today for sample and complete information to Samuel Cabot, Inc., 2185 Oliver Bldg., Boston 9, Mass.

Cabot's

Clear Waterproofings

(Continued from page 188)

GLASS BLOCK FILM

To demonstrate the use of *Insulux* glass block in increasing construction applications, American Structural Products Co. is presenting a new 16 mm. color film, "Walls of Daylight."

The film, with running commentary, offers the story of glass block from the factory to completed installations in industrial and commercial plants, institutions, schools, office buildings and homes.

Shown are exteriors and interiors of buildings, each illustrating specific advantages obtained by the use of glass block. Also shown is the new type of schoolroom fenestration recommended by the manufacturer.

This film serves as a screen introduction to another new film, "Mortar and Glass" which deals with the correct procedure in installing glass block panels.

Both films are available to architects, builders and contractors. Sales Promotion Dept., American Structural Products Co., Toledo 1, Ohio.

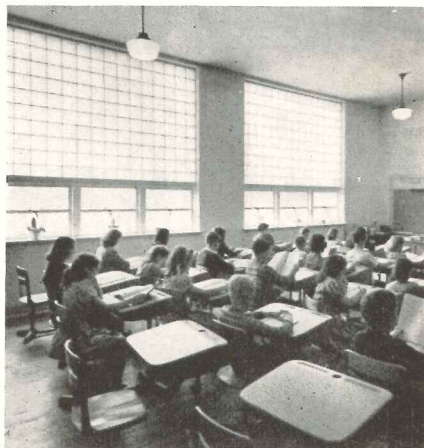

School room fenestration shown in movie

HEATER FOR QUONSETS

Oil-burning heaters designed for Quonset structures by Dravo Corporation are claimed to be flexible for adaptation to changes in floor plans. The heaters can be moved or reconnected in a few hours and ducts can be attached to discharge nozzles to carry warm air to definite areas.

The heater operates on a principle of "working level recirculation" of warm air. With this method, air is drawn into the base of the heater from the floor and is passed first over economizer tubes which extract a maximum amount of energy from combustion gases before

(Continued on page 192)

**Warm Spot
in January
Cold Wave**

Hundreds of formerly "hard-to-heat" buildings . . . places that used to be cold even in normal winter weather . . . were oases of warm comfort during the January-February cold wave thanks to a post-war Webster development—Webster Type WI Extended Surface Radiation for hot water and two-pipe steam service.

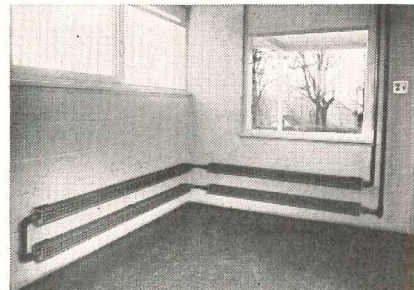

Installation in Gardener's Cottage

Using modern materials, copper tubing and aluminum fins, Type WI Radiation provides better than a square foot of heating surface for each 1/2 lb. of weight. Takes up negligible space. Can be put where the heat is needed—along the wall, close to the floor, behind benches.

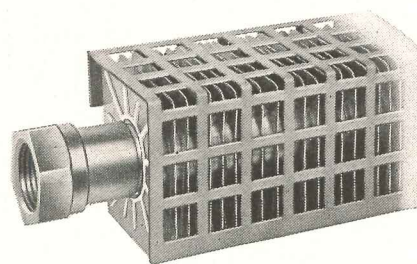

Take steps *now* while the memory of your cold weather difficulties is fresh in mind. See if Webster Type WI Radiation can be used to turn your cold spots into areas of next winter comfort. Good delivery now.

WARREN WEBSTER & CO.
Camden, N. J. :: Representatives In Principal Cities
In Canada: Darling Brothers, Limited, Montreal

**Webster
HEATING**

Facts about "Pittsburgh's"

HERCULITE

DOOR-FRAME ASSEMBLY

"Pittsburgh's" new, prefabricated Herculite Door-Frame Assembly is as practical as it is simple. It offers a "packaged" door frame which eliminates all problems of setting and fitting. This is a completely assembled frame—in *one unit*. No assembly is necessary on the job. It replaces the complicated, custom-made frames which required many different kinds of materials and the services of various trades to install.

One of the sturdiest and hand-somest extruded structural shapes ever designed, this Door-Frame Assembly comes in twelve standard styles. It's constructed to accommodate standard Herculite Tempered Plate Glass Doors. It's supplied complete with checking floor hinges and top pivots, ready to bolt into the rough building opening. All clearances on frame and doors are controlled by accurate factory gauges. When the building is ready for the doors, they are simply set on the hinge pivot, the top pivot is dropped into the top channel and the structure is complete!

Get full information on this revolutionary, prefabricated door-frame assembly simply by filling in and returning the coupon. Do it now.

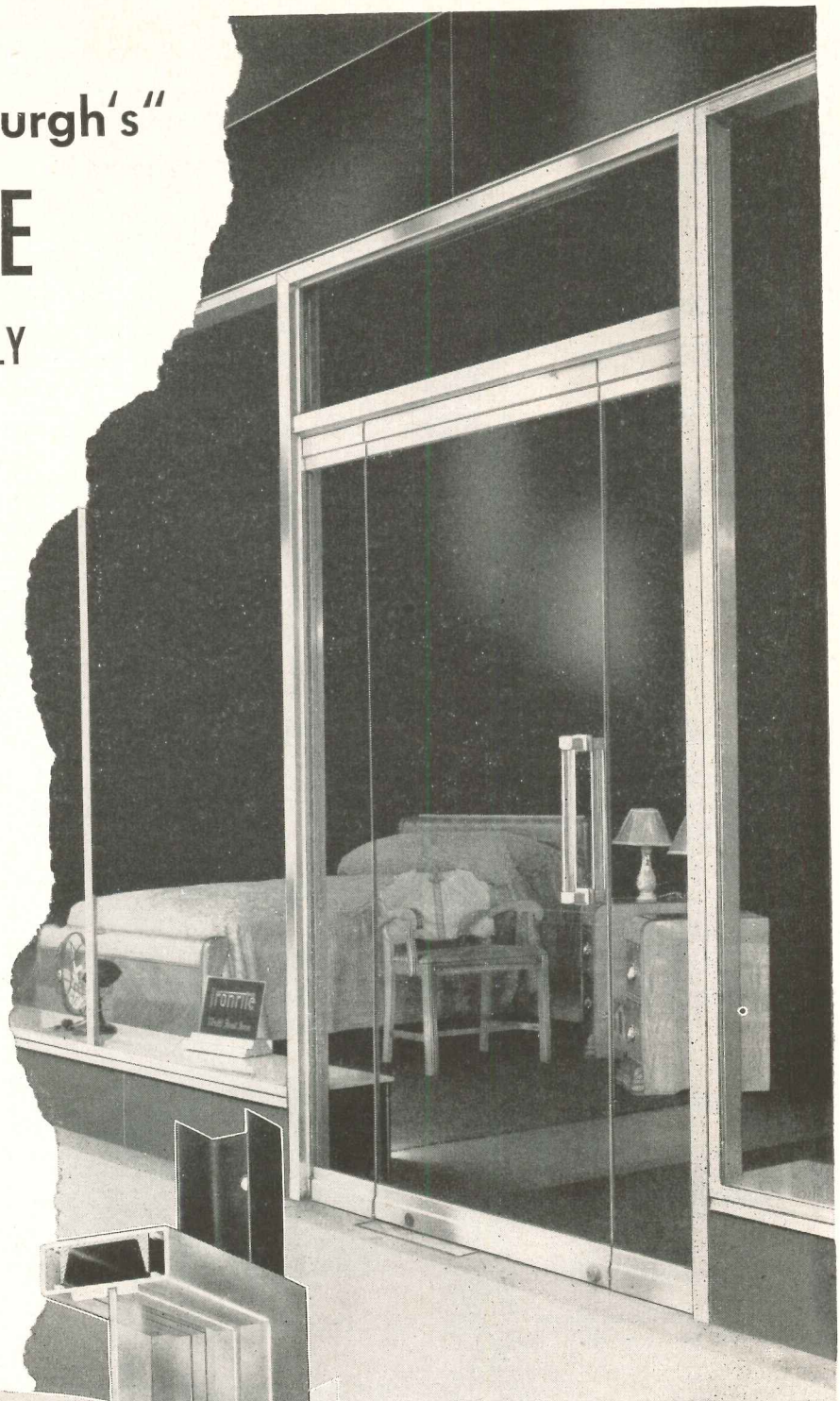

The frame is made of extra-heavy extruded aluminum, highly polished and anodized. It's heavily reinforced with steel channels and tie rods, as partially shown here.

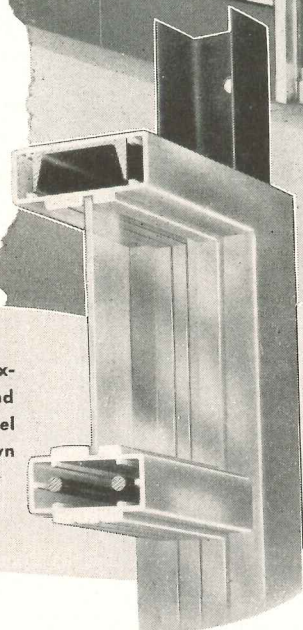

Pittsburgh Plate Glass Company
2189-8 Grant Building, Pittsburgh 19, Pa.

Please send me your literature on "Pittsburgh's" new Herculite Door-Frame Assembly. There is no obligation on my part, of course.

Name.....

Address.....

City..... State.....



PAINTS • GLASS • CHEMICALS • BRUSHES • PLASTICS

PITTSBURGH PLATE GLASS COMPANY

(Continued from page 186)

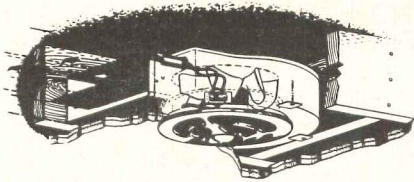

WOMEN LOOK UP TO *Blo-Fan*

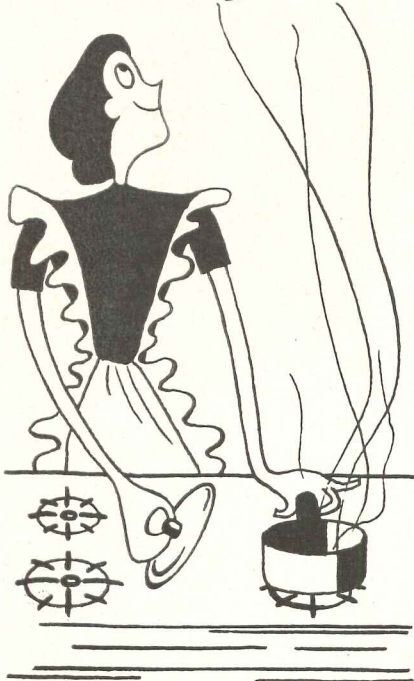

BLO-FAN equipped kitchens benefit Mrs. Housewife 6 ways. Ask the woman who has one.

1. Ceiling installation, directly over the range, where a fan belongs.
2. Elimination of unpleasant cooking odors, greasy walls and foul, contaminated air in the house.
3. Minimizes house cleaning and redecorating.
4. Minimum ceiling opening, attractive grill.
5. Blo-Fan combines the efficiency of a fan with the power of a blower.
6. Trouble-free operation assured by totally enclosed motor, cooled by the air stream.

It's an architect's job to provide functional design in the kitchen...Look up to

Blo-Fan

ELECTRIC CEILING VENTILATOR

for the most efficient ventilation

PRYNE & CO., INC.

POMONA, CALIFORNIA
LOS ANGELES, SAN FRANCISCO
CHICAGO, NEW YORK

attached to the window blind stop and a slide lock makes it easy to secure or remove the screen when desired. On the bottom bar is a tension catch which is fastened to the window sill, making the screen fit snugly.

In place of side frames the screening has a specially reinforced edge which gives rigidity and allows the tension catch to pull the screen tight against the window frame.

When windows need washing, loosening of thumb screws at the bottom of the screen allows it to swing freely, giving easy access to the window pane. New York Wire Cloth Co., 500 5th Ave., New York 18, N. Y.

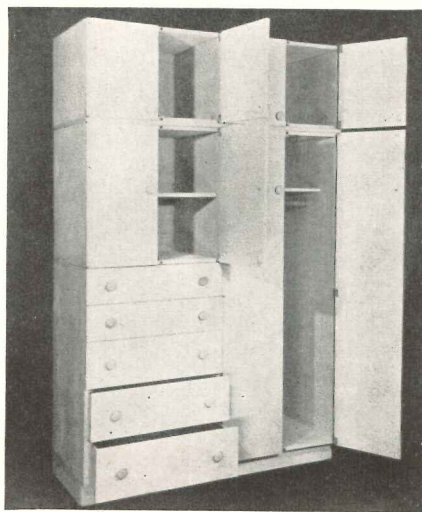

Closets, cabinets made in a range of sizes

STORAGE UNITS

Nasco Series "21" is a group of seven scientifically designed wooden closets and cabinets in a range of sizes to make efficient use of any storage space. Each is a complete unit and can be used in any combination.

The seven pieces are made in five widths, 20, 24, 28, 32 and 36 in. Units include the upper storage, height 18 in., midsection, 27 in., five drawer chest, 45 in., small storage, 45 in., small wardrobe, 45 in., large wardrobe, 72 in., and large storage, 72 in.

These sectional units are made with solid knotty pine tops, bottoms and sides $\frac{3}{4}$ in. thick. The doors and fronts are clear white pine of five-ply panel stock and the backs are three-ply panels. Each unit is sanded and ready for finishing with stain, enamel or paint. All hinges are cadmium plated, rust-proof. Henderson-Ford Co., Inc., 402 E. 108th St., New York 29, N. Y.

(Continued on page 190)

SIEGFRIED GIEDION

author of
*Space, Time and
Architecture*
charts the
course of
human progress as
**mecha-
nization
takes
command**

This is the story of humble, everyday things—egg-beaters and washing machines, door locks and loaves of bread, refrigerated beef and barber chairs. Never before have they got into a history book, yet they have had a profound effect on history.

Now collected and arranged in a fascinating chronicle which begins before the Renaissance, they reveal the hidden influences that shaped our modern way of life.

Two pivotal types of questions are explored. The first is concerned with what happens when mechanization collides with an organic product; the second group is concerned with mechanization and human environment.

The result is a new kind of history... anonymous' history... a mine of previously untouched source material. It is illustrated with more than five-hundred unique and generally amazing illustrations annotated to supplement and parallel the text.

740 pages. At all bookstores. \$12.50

OXFORD UNIVERSITY PRESS
114 Fifth Avenue
N. Y. 11



INCONSPICUOUS SAFETY because



Fire Protection WAS PLANNED FROM THE START

Grinnell Engineers Are Always Ready To Help You Plan Fire Protection As A Blended Part of Functional Design.

Experienced architects know that nearly every kind of building needs fire protection. For even though the structure itself may be so-called "fireproof", its contents are not.

For the sake of retaining attractive interiors, the time to plan for fire protection is at the start — with a Grinnell Automatic Sprinkler system. While your plans are still in the drafting stage, get in touch with Grinnell, for there is a Grinnell System to meet the design requirements of every type

of commercial, industrial, and institutional building. Grinnell engineers, long experienced in working with architects, are always ready to help you. Grinnell Company, Inc., Providence 1, R. I. Branch Offices in Principal Cities.

GRINNELL
FOUNDED 1840

Automatic Sprinkler Fire Protection

A BLENDED PART OF YOUR BUILDING'S DESIGN

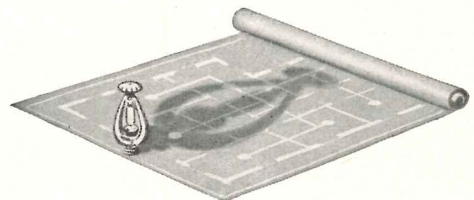

boiler section. Low-temperature water for the radiant heating coils is tapped from the cooler outer jacket, while the hotter upper section supplies high-temperature domestic hot water by means of a long coil.

In radiant heating systems where floor coils are used, conventional boilers are said to be unable to handle the low-temperature requirements for this purpose without a by-pass of mixing valve arrangements. Boilers built especially for

this purpose sacrifice the ability to supply high-temperature domestic water.

Built into the top of the boiler is an air chamber which accumulates the air released from the water and provides a cushion for expansion of the water.

Completely self-contained, except for the oil burner which is shipped separately, the new boiler unit is made in two sizes of 81,000 and 110,000 Btu/hr. Rated domestic hot water coil capacity is 3 gpm.

The unit is reported to supply water for radiant heating continuously controlled at 100° F to 130° F. This part of the system is said to be flexible, however, and water temperatures can be varied from as low as 80° F to 200° F — thus the boiler can work equally well in heating systems using radiators or baseboard radiation. York-Shipley, Inc., York, Pa.

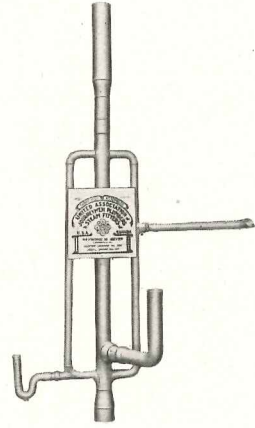

Prefab vent stack cuts construction time and saves up to 2 in. of wall thickness

VENT STACK

A prefabricated vent stack which connects with the lavatory, water closet and bath tub is said to reduce construction time and save up to 2 in. in wall thickness without sacrificing the I. D. of the pipe.

The all-welded vent stack is made of steel pipe and *Tube-Turn* welding fittings and is hot-dip galvanized before being delivered to the building site. Tube Turns, Inc., Louisville 1, Ky.

SOUND SYSTEM

The MS-24 sound system for department stores permits paging announcements and transmission of radio or recorded music to 6, 12, 18 or 24 stations at one time or to selected locations. It has the further advantage of permitting two-way communication between the master station and all remote stations. Any standard radio can be used with the MS-24. The system has power rating of 28 watts. Mark Simpson Mfg. Co., Inc., 28-32 49th St., Long Island City 3, N. Y.

ALUMINUM SCREEN

A new aluminum window screen incorporates a unique tension design which eliminates heavy side frames.

At the top and bottom of the aluminum screening are aluminum bars. A patented device on the top bar is

(Continued on page 188)

HOLLOW METAL

MAIN FACTORY AND OFFICES OF JAMESTOWN METAL CORPORATION



5 ACRES OF ONE-FLOOR FACTORY
designed for straight line, efficient production

As specialists in the fabrication of bronze, aluminum, steel and stainless steel, we offer our services wherever hollow metal doors, interior trim, elevator enclosures, cold rolled mouldings and metals specialties are required.

JAMESTOWN METAL CORPORATION

104 Blackstone Avenue

Jamestown, N. Y.

where hotels use

Non-Slip Floors

... for safety's sake!

Firm-footing is important in many parts of hotels.

Whether behind-the scenes, or out-front, the hazard of slipping is a constant danger to both guests and personnel. Accidents due to slips and falls account for one-fifth of all claims for compensation.

Non-Slip floors are the proved answer.

ELEVATOR SILLS: Feralun* is universally specified by architects for elevator sills to prevent costly accidents.

KITCHEN: Use Amcolun, for safety's sake, in the kitchen where oily or wet conditions frequently occur. Protect your personnel.

SIDE ENTRANCE: We recommend Amcolun—the non-slip abrasive tile—wherever floors present a slippery condition due to "tracking-in."

MAIN ENTRANCE: . . . and for exterior steps, we suggest Bronzalun* thresholds and treads.

Our Advisory Engineering Service extends to all key cities, offering you a convenient, authoritative source for non-slip flooring information. Meantime, check our non-slip products in Sweet's File, 13a-8.

The American Abrasive Metals Company

IRVINGTON NEW JERSEY

*Reg. U. S. Pat. Off.

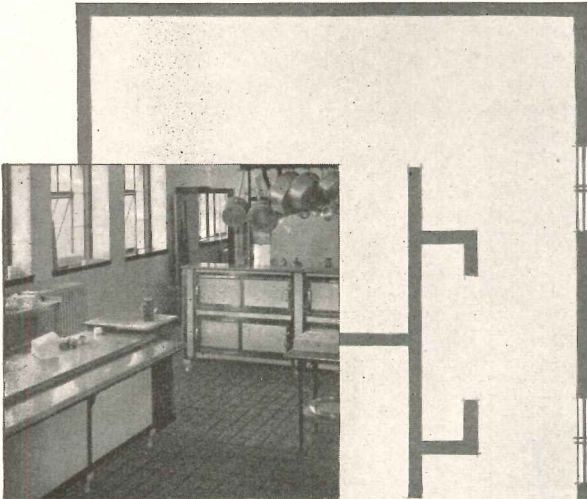

KITCHEN

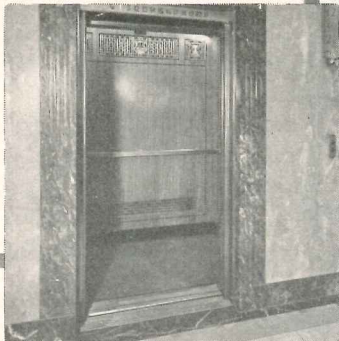

ELEVATOR SILLS

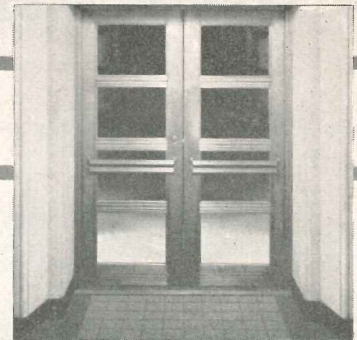

SIDE ENTRANCE

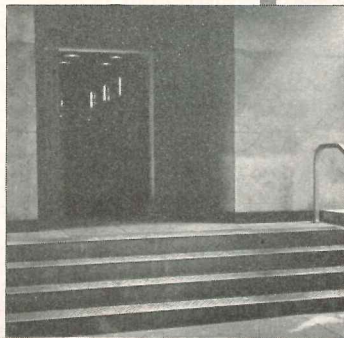

MAIN ENTRANCE

American Abrasive Metals Co. (AR 6-48)
460 Coit Street, Irvington, New Jersey

- For safety's sake, send me your technical data catalog on all your non-slip products.
- Please send me the name of your advisory engineer located nearest to me.

My Name Title

Company

Address

City State

The ventilators are available in square and rectangular shapes; the monitor can be obtained in any length desired. Vent flue caps are available with 4 in. and 6 in. throat dimensions.

None of the ventilators is over 21 $\frac{3}{4}$ in. high so that unsightly silhouettes are eliminated.

Airjet ventilators are made of light-weight metal so that even large sizes may be installed without mounting them over trusses. These ventilators require

no bases and are designed to be fastened to a 2 in. by 2 in. or larger cant strip with nails. Vent flue caps are fastened with self-threading sheet metal screws to the vent pipe.

The Airjet ventilators can be applied to industrial and commercial buildings and homes. C. R. Gelert Co., 35 N. Raymond Ave., Pasadena 1, Calif. Mfg's. representative: The Halberg Co., 415 Lexington Ave., New York, N. Y.

EMBOSSED ALUMINUM

An entirely different type of embossed aluminum sheet with patterns such as squares, diamonds, stucco, simulated grain leather and ribs is now available.

The aluminum can be supplied in flat sheet in thicknesses of 0.010 in. to a maximum of 0.040 in. and widths 12 in. to 48 in. Coiled sheet can be furnished in the same thicknesses and in widths ranging from 6 in. to 36 in. Reynolds Metals Co., Louisville, Ky.

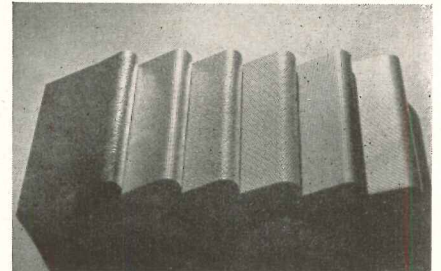

Embossed aluminum sheets are now available in a variety of textures and sizes

AUTOMATIC WATER SOFTENER

A time-clock control mechanism has been incorporated in a fully automatic water softener. The clock control may be set at the time of installation and the mineral is regenerated automatically every 24 hours or from one to seven times weekly, depending on individual requirements. No manual attention is necessary beyond periodic salt replacement (two or three times annually).

The mineral or softening agent used is claimed to remove iron compounds from the water, and the automatically daily regenerating process is said to prevent contamination from accumulating on the mineral for long periods which keeps the mineral at maximum efficiency and maintains operating economy.

The daily capacity of 25,000 grains water hardness is reported to handle exceptional domestic water consumption and also service small commercial establishments. Soft-O-Matic Corp., Plymouth, Mich.

BOILER FOR RADIANT HEATING

A packaged boiler unit made especially for use with radiant heating installations, provides water for heating, domestic use and has a built-in air chamber for expansion.

The design of the York-Heat PBR-7 boiler unit is adapted especially for floor-type radiant heating systems, without sacrificing high-temperature domestic water. There are two boiler sections — a lower, outer jacket and an upper

(Continued on page 186)

Information PLUS!

send for this brand-new
drainage products
catalog

contains...

- PHOTOS
- DRAWINGS
- DESCRIPTIONS
- DIMENSIONS
- WEIGHTS
- PRICES

on floor, roof and shower drains...backwater valves
...grease interceptors...
swimming pool fittings...
sealed air chambers...
in the most helpful,
easy-to-find format we
could devise!

Simply sign name, firm
and address at right...
and send to

Since 1865

WADE MANUFACTURING COMPANY

... "SHOKSTOP" sealed air chambers
"HYDRAFILTER" grease interceptors
drainage and plumbing specialties

85 NORTH STATE ST.

ELGIN, ILLINOIS

The Name

HOPE'S

Guarantees

1818

WINDOWS

1948

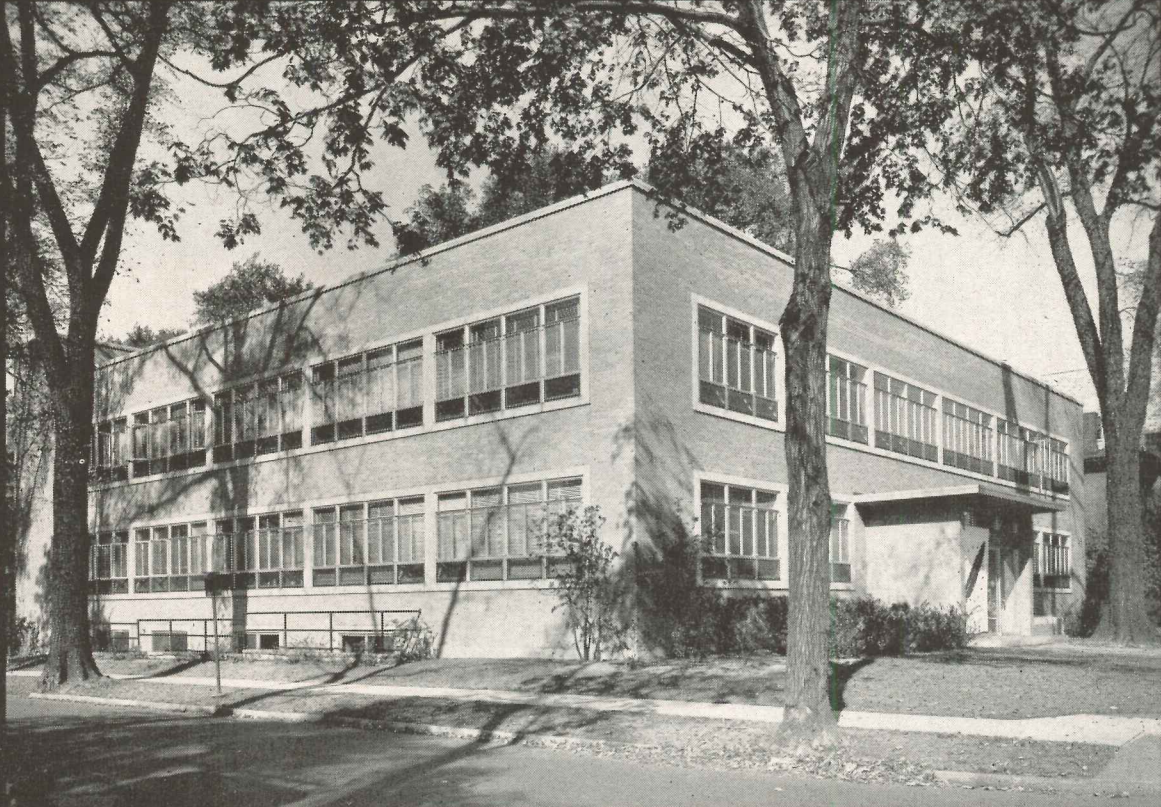

Children's Aid Society Building, Buffalo, N. Y.—James W. Kideney, Architect

The friendly exterior of this building makes the promise that the offices it houses are pleasant in which to visit or work. The major source of this effect is in the fenestration.

Extreme simplicity in much of modern architecture would leave an impression of severity but for the decorative quality of a good window layout.

The versatility of Hope's Windows is most helpful to the architect in securing his exterior effects. Hope's Windows also contribute many advantages to the user of the building . . . maximum daylight, controlled ventilation, trustworthy weather-tightness, positive and convenient operation and a most satisfactory long life without upkeep difficulties.

HOPE'S WINDOWS, INC., Jamestown, N. Y.

THE FINEST BUILDINGS THROUGHOUT THE WORLD ARE FITTED WITH HOPE'S WINDOWS

(Continued from page 180)

large-surface Micarta plastic blades, more sharply angled than usual, and by adding curved injector rings which surround the blades.

Total air displacement of the fan is reported to be 3000 cu. ft. per minute, compared with 1600 for average 16-in. fans.

In ordinary fans nearly all of the air drawn to the blades is said to sweep in at the sides. Its direction must be changed by the blades, setting up tur-

bulence which wastes power and blocks air coming from behind the fan.

In the new design, the injector rings, which are curved in the direction of air flow through the fan, turn the side air so that it slides into the air stream without turbulence.

With the *Mobilair* the homeowner can take advantage of the newly-developed technique for obtaining best cooling results with fans on hot summer nights when outside air is cooler than

inside air. This method involves using the fan as an exhaust, blowing air out a window from a point about three feet away.

Otherwise, when a fan is placed in the plane of the window, like conventional window and attic fans, it is reported to lose one-third of its air capacity because entrance of side air is blocked. In one typical test, a 16-in. fan used as an exhaust in the plane of the window produced only a 10° temperature drop in a specified time. When the same fan was used properly, a 14° drop resulted.

The *Mobilair* fan is supported by steel tubes which are mounted on a pair of rubber wheels. It weighs 35 lb. and has variable height so that it can be used with windows of different types and heights, with sills from 15 to 39 in. above the floor. Westinghouse Electric Corp., 306 Fourth Ave., Box 1017, Pittsburgh 30, Pa.

EVER-WIDENING USE

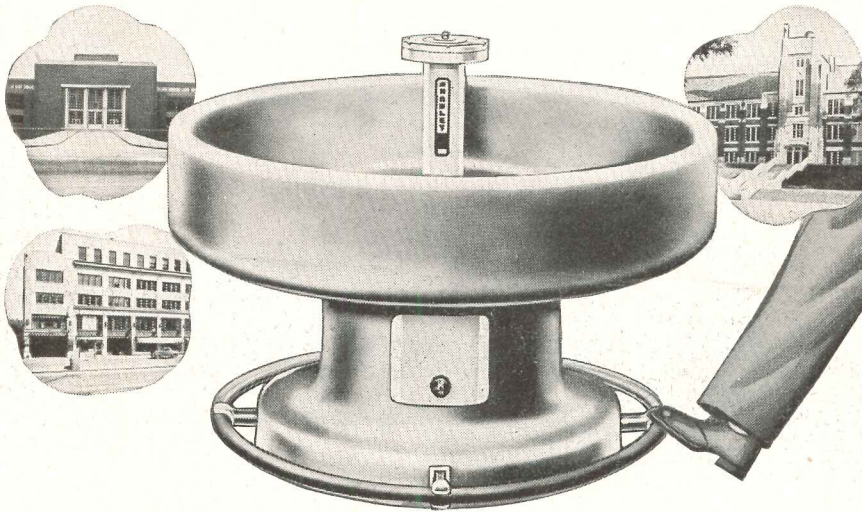

Today, Bradley Washfountains are regularly specified in modern washroom planning. For new buildings or additions to present washrooms, Bradleys have the features that make them preferred. They represent the finest in sanitary, economical wash fixtures. They have been used for over a quarter century in factories, schools and institutions . . . Here are



The Features Named Most Important

- (1) **SANITATION-HEALTH SAVINGS.** No faucets to touch—no collection of dirty water—self-flushing drain.
- (2) **SPACE SAVING.** 8 to 10 persons wash simultaneously.
- (3) **LOWER INSTALLATION COST.** Piping connections reduced by 75% or more.
- (4) **MAINTENANCE SAVINGS.** One sprayhead replaces many faucets.

Bradleys are Distributed through Plumbing Wholesalers. **BRADLEY WASHFOUNTAIN CO.**, 2227 W. Michigan St., Milwaukee 1, Wis.

BRADLEY
Washfountains

Write for illustrated Bradley Washfountain Catalog 4701 . . . a handy book for your reference shelf.

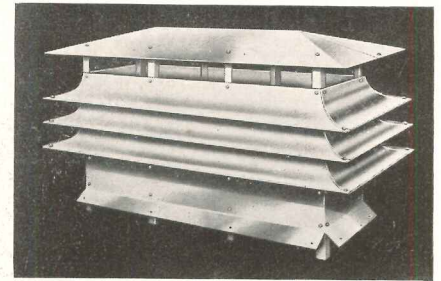
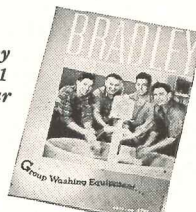

Operation of ventilators or flue caps is unaffected by wind direction, turbulence

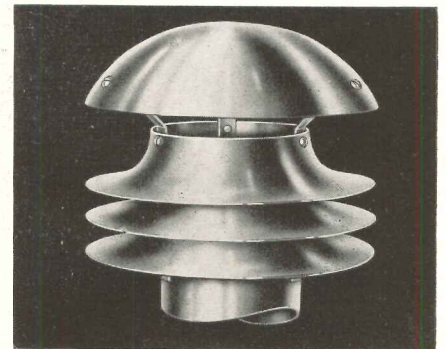

ROOF VENTILATORS

A new principle embodied in roof ventilators and vent flue caps permits efficient operation regardless of variable wind conditions or turbulence caused by obstructions, according to tests completed at California Institute of Technology. Downdrafts are said to be completely eliminated regardless of wind direction.

Air movement past a series of horizontal, stationary vanes having curved surfaces on *Airjet* ventilators and flue caps creates a suction which "pulls out" the stagnant air from the structure.

(Continued on page 184)

The HARMON TECHNIQUE

brings a progressive new era

in classroom interiors

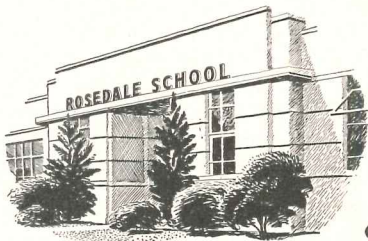

Classroom modernization by the Harmon Technique produces dramatic results on school children.

For example: Ten months' educational progress was made in only six months . . . important reductions were recorded in eye and nutritional problems . . . and 30% less signs of chronic infection.

The Rosedale school, Austin, Texas, is a classic example of the Harmon Technique and here again the school-room walls and ceilings are painted with Luminall paint. Other factors in the Harmon Technique, aside from painting, are lighting, fenestration and seating.

Luminall paint is ideal for painting walls and ceilings

in the Harmon Technique. It is highly light-reflective—up to 90.6% for white. It maintains this reflectivity because it does not “yellow” or discolor from age and exposure. It diffuses reflected light thoroughly. The colors are formulated to overcome chromatic aberration. It will do a brightness engineering job in evenly distributing light from whatever source it comes.

Ask for a copy of Dr. Harmon's “LIGHT ON GROWING CHILDREN,” reprinted from Architectural Record. On receipt of sketches showing dimensions and details of schoolroom, specifications will be furnished according to the Harmon Technique without cost or obligation. NATIONAL CHEMICAL & MFG. CO., 3617 S. May Street, Chicago 9.

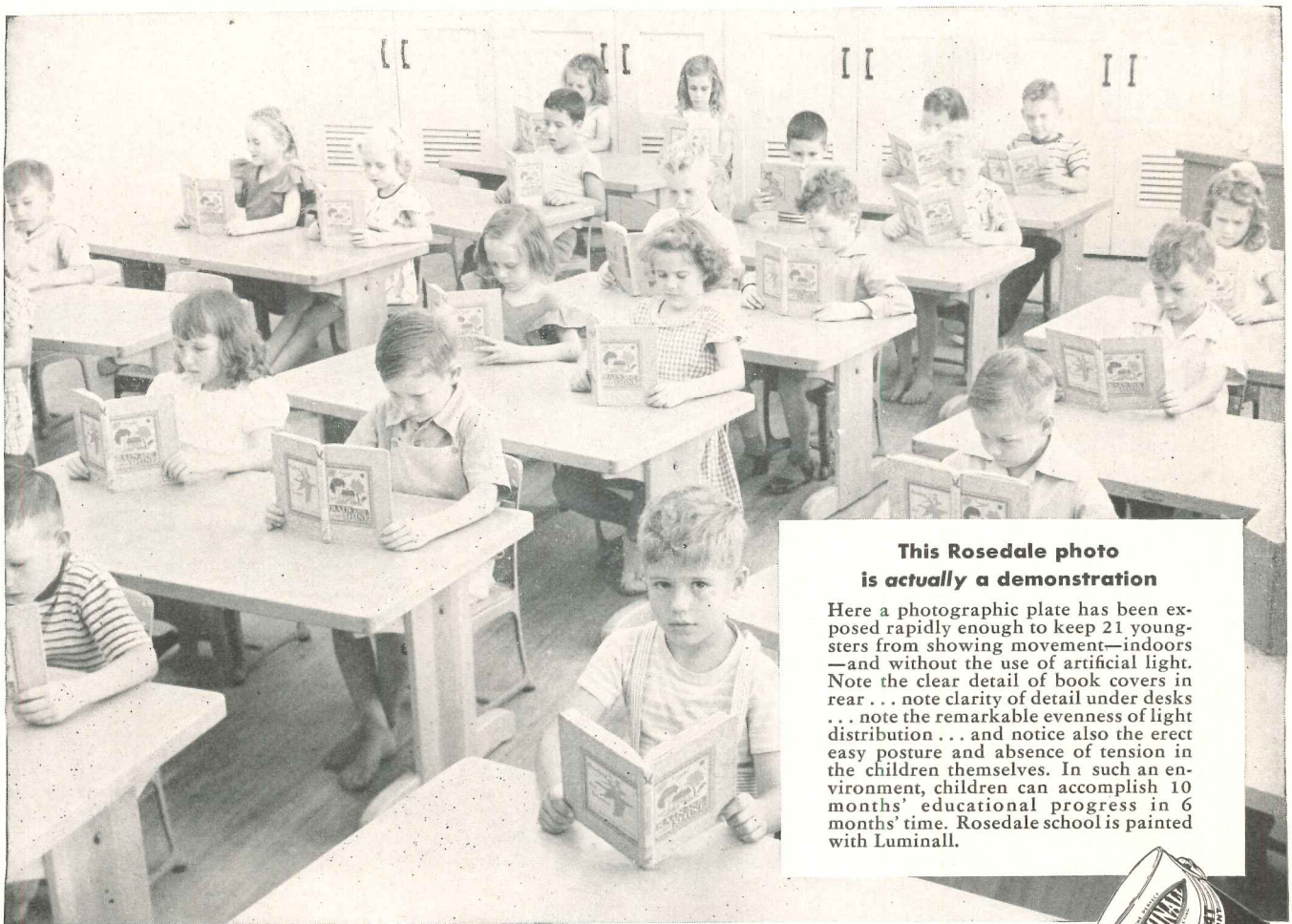

This Rosedale photo is actually a demonstration

Here a photographic plate has been exposed rapidly enough to keep 21 youngsters from showing movement—indoors—and without the use of artificial light. Note the clear detail of book covers in rear . . . note clarity of detail under desks . . . note the remarkable evenness of light distribution . . . and notice also the erect easy posture and absence of tension in the children themselves. In such an environment, children can accomplish 10 months' educational progress in 6 months' time. Rosedale school is painted with Luminall.

LUMINALL

the light-reflective
paint for interiors



When slabs are used as the entire wall they are coated on both sides at the factory with Portland cement and placed between 4 in. by 4 in. studs. The slabs are held in place by vertical battens nailed to the studs, and joints are mortared or caulked with a mastic.

Durisol slabs are reported to have five times the insulation quality of brick, to be fire-resistant, to be effective sound absorbers; the slabs are said not to be attacked by rats or termites and pre-

vent condensation and fungus formation.

Slabs 2 in. thick weigh 7 lb. per sq. ft. and 5 in. hollow cored slabs weigh 15 lb. per sq. ft. Durisol, Inc., 420 Lexington Ave., New York 17, N. Y.

DOOR CLOSER

By using brake lining as the control medium, a new door closer has been developed which is said to provide smooth, silent operation without need for maintenance.

In the *Brake-O-Matic* a brake shoe rides on a movable rod which is mounted in an aluminum tube. By adjusting the pressure of the brake shoe on the rod the speed of closing can be controlled or the door may be locked in position.

Contained in the end of the aluminum tube is a coil spring which acts as a

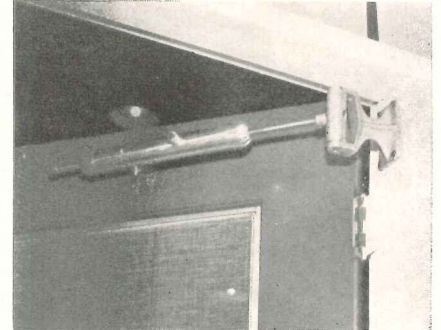

Door closer uses brake lining principle

shock absorber to prevent damage to the door and door closer when the door is slammed.

The *Brake-O-Matic* can be used for pull-close and flush-type installations and for right- and left-hand doors.

The standard yoke model can be used for screen, storm and medium weight interior doors. The torpedo model has greater brake lining surface area and can be used for kalamein, hollow metal and other fireproof doors. Mitchell-White & Co., 12 E. 22nd St., New York 10, N. Y.



Injector rings increase fan's efficiency

HOME FAN FOR COOLING

A revolutionary portable fan that is designed to deliver 87 per cent more cooling air than standard fans of the same size is now in production at Westinghouse Electric Corporation.

Boosting the 16-in. fan's moving power to the level of a 20 or 24-in. fan has been accomplished by designing

(Continued on page 182)

* THIS TELLS YOU HOW TO GIVE SAFE EXIT TO CORROSIVES

This new, 12-page bulletin tells you how, why and where you should use Duriron acid-proof drain equipment for corrosive wastes.

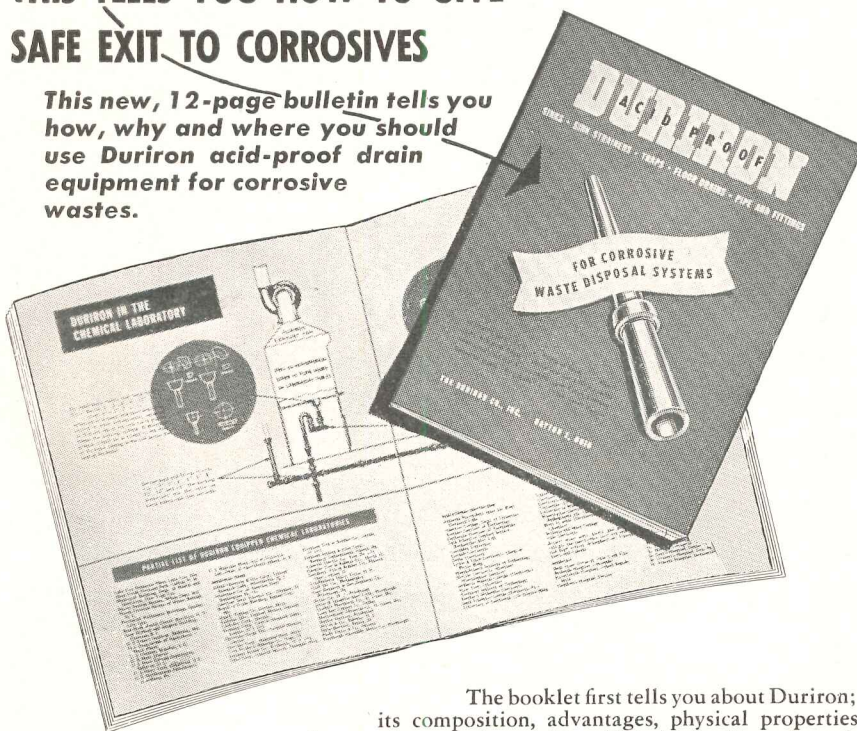

The booklet first tells you about Duriron; its composition, advantages, physical properties and corrosion-resisting ability. This high-silicon iron is compared with other materials and its superiority for handling corrosives is shown in dramatic visual form.

A handbook on Duriron drain line material for handling corrosive wastes, the bulletin gives engineering data, sizes, dimensions and drawings of the various pieces of Duriron equipment . . . instructions on how to install . . . information on application in chemical laboratories, industrial installations, engraving plants and other places where corrosives are handled. Installation photos and a partial list of existing installations in various types of plants are also included.

Today's high cost of repairs makes the Duriron drain line installation even more economical than ever.

Find out how you can protect your waste disposal system against costly corrosion. Write for this new, free bulletin today. Ask for Bulletin 703.

THE DURIRON CO., INC. • DAYTON 1, OHIO

Branch Offices in Principal Cities

DURIRON ACID PROOF DRAIN PIPE

48-GM

1. DESIGN



is the idea—the First Essential.

2. WORKMANSHIP

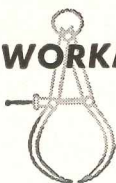

is the human touch of the craftsman. It is the Second Essential.

3. MATERIAL

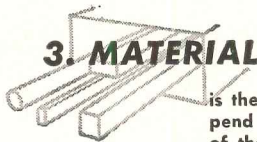

is the Third Essential. Upon it depend the efficiency and service-life of the product which Design and Workmanship have evolved.

You need all 3 ESSENTIALS for the BEST in Sterilizers

Boiling Type Sterilizer for utensils. American produces body, cover and tray in solid, rustproof, easy-to-clean Monel. Available in steam-, gas- or electric-heated models.

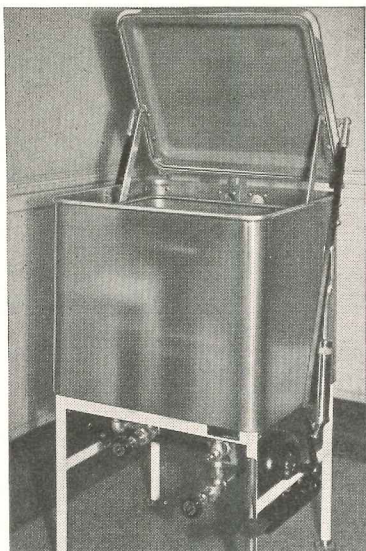

"AMERICAN" makes its 3rd Essential...

MONEL

... STANDARD METAL
OF THE MODERN HOSPITAL

Rectangular Built-in Sterilizer made by American of Nickel-clad steel. Dimensions: 24" x 36" x 48". Same model also available in Monel-clad steel.

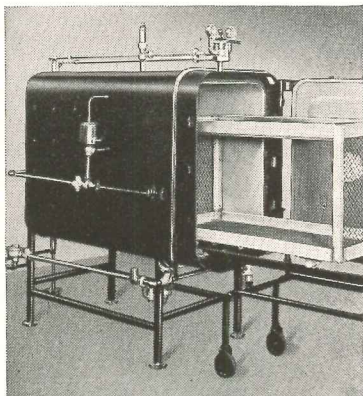

Here are sterilizers you can confidently recommend to your clients.

Made by AMERICAN STERILIZER COMPANY, Erie, Pa., they're well-designed . . . well-built. Besides *they're made of a metal that means long, trouble-free service.*

For AMERICAN has given these units the "life insurance" of Monel.*

And Monel is more than merely "a rustproof metal."

It is stronger and tougher than structural steel. It stands up against heat, steam and moisture. It resists corrosion by acids, alkalis and a wide range of hospital solutions.

Monel is solid metal, too. It has no surface coating to chip or crack. Nothing to peel off. Nothing to wear away, exposing a harder-to-clean base metal. Severe and continuous use cannot dim the attractive, satiny lustre of Monel. *Its excellence goes all the way through.*

AMERICAN produces a full line of Monel *non-pressure* instrument and utensil sterilizers in addition to *pressure* instrument and dressing sterilizers, milk formula sterilizers, laboratory autoclaves and all-purpose sterilizers.

Remember this combination in AMERICAN products: Design, Workmanship and *Monel construction.*

You do your hospital clients—a lasting service when you incorporate the words *Monel construction* in your specifications for sterilizers and other equipment.

For This Laboratory Autoclave, as well as for other models, American Sterilizer Company standardizes on solid, corrosion-resistant Monel.

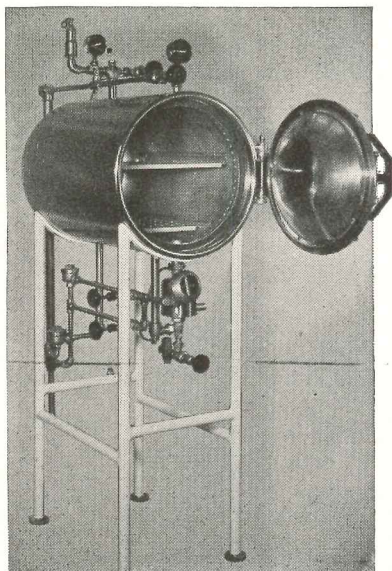

THE INTERNATIONAL NICKEL COMPANY, INC.
67 Wall Street, New York 5, N. Y.

*Reg. U. S. Pat. Off.