

## FOR SAFE, QUICK, ECONOMICAL WINTER WORK

**'INCOR' 24-HOUR CEMENT  
KEEPS WINTER JOBS  
ON SCHEDULE—CUTS  
CONCRETING COSTS**

**I**N cold weather, concrete must be heat protected until service-strong. Heat-cured only ONE day at 70 degrees, 'Incor' concrete is service-strong, safe from freezing . . . and at 28 days produces strengths 25% to 30% greater than even Lone Star Cement concrete cured 3 days. Fast, thorough curing with 'Incor' 24-Hour Cement means safety, speed, economy. Specify 'Incor'\*—



**SAVE 2 DAYS HEAT-CURING  
ON EACH POUR**

**REDUCE FREEZING RISK**

**KEEP JOB SPEED UP—  
JOB COSTS DOWN**

Write us at 342 Madison Ave., New York 17,  
for "Winter Concreting Book." \*Reg. U. S. Pat. Off.

## LONE STAR CEMENT CORPORATION

LONE STAR CEMENT, WITH ITS SUBSIDIARIES, IS ONE OF THE WORLD'S LARGEST CEMENT PRODUCERS: 15 MODERN MILLS, 25-MILLION BARRELS ANNUAL CAPACITY. . . OFFICES: ALBANY • BIRMINGHAM • BOSTON CHICAGO • DALLAS • HOUSTON • INDIANAPOLIS • JACKSON, MISS. • KANSAS CITY, MO. NEW ORLEANS • NEW YORK • NORFOLK • PHILADELPHIA • ST. LOUIS • WASHINGTON, D. C.

**18 Years' Outstanding Performance . . . 'INCOR' . . . America's FIRST High Early Strength Portland Cement**



# Look what's

With four years of war experience behind us . . . with new products . . . with added improvements on old ones . . . Ceco again brings you the finest in construction products . . . precision engineered.

War provided a laboratory for Ceco. Emergency uses brought the necessity for extra precision in manufacturing. As a result of such experience, now more than ever before, engineering makes the big difference in Ceco construction products.

There is a new tempo in building today. Manpower is being released, materials are more plentiful and as fast as products are available Ceco is rushing to answer your needs.



SEND FOR THESE *Free* CATALOGS

- 1—Build a Beautiful Home With Beautiful Windows
- 2—Ceco Windows and Doors (Sweet's Catalog Preprint)
- 3—Ceco Steel Joists
- 4—Meyer Steelforms
- 5—Handbook of Ceco Products for Reinforced Concrete Construction
- 6—Steel Building Products for Structures
- 7—Screens in Steel, Bronze and Aluminum
- 8—Handbook of Ceco Road Building Materials
- 9—Ceco Metal Lath and Accessories
- 10—Ceco Metal Weatherstrips

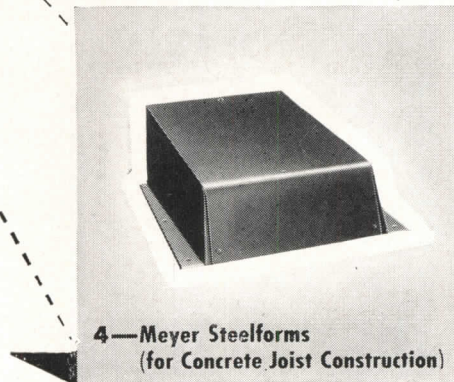

4—Meyer Steelforms  
(for Concrete Joist Construction)

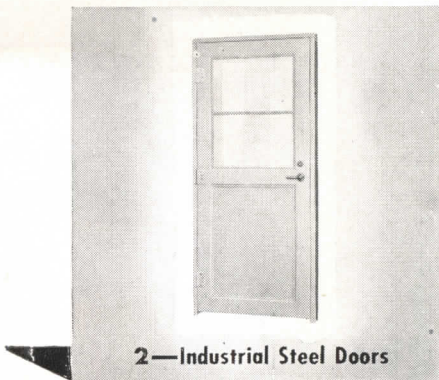

2—Industrial Steel Doors

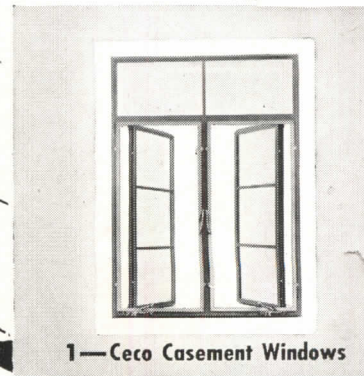

1—Ceco Casement Windows

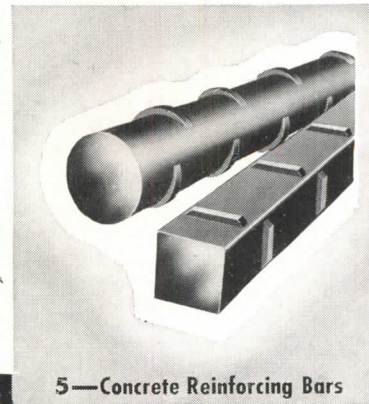

5—Concrete Reinforcing Bars

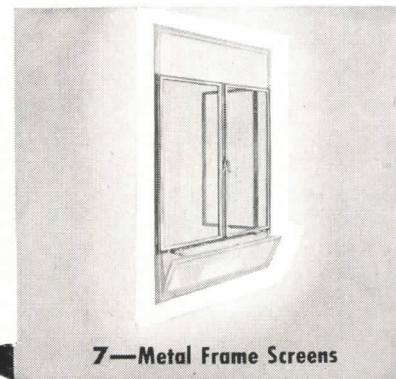

7—Metal Frame Screens

All products illustrated are fully described in catalogs of corresponding number listed at left. These illustrated products represent only a small portion of Ceco's wide range of manufacture.

## CECO STEEL PRODUCTS CORPORATION

MANUFACTURING DIVISION  
5645 WEST 26TH STREET, CHICAGO 50, ILLINOIS

Concrete Engineering Division,  
Merchant Trade Division, Highway Products Division  
Offices, Warehouses and Fabricating Plants in Principal Cities

# ENGINEERING

# MAKES THE BIG DIFFERENCE IN

# CECO

# here again!

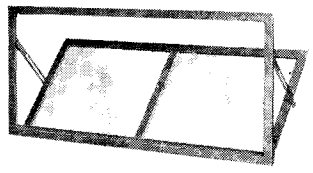

2—Ceconomy Basement Windows

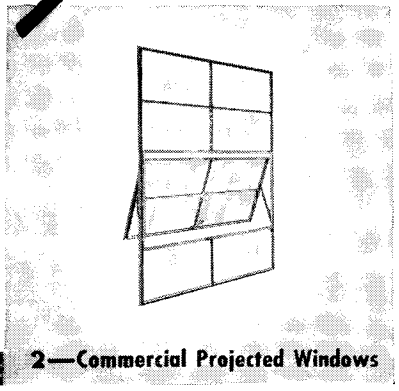

2—Commercial Projected Windows

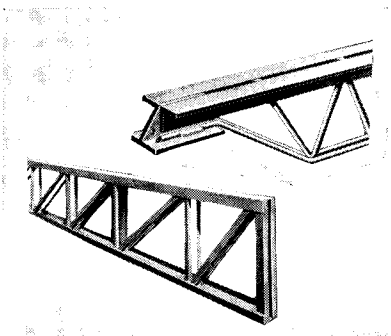

3—Ceco Steel Joists

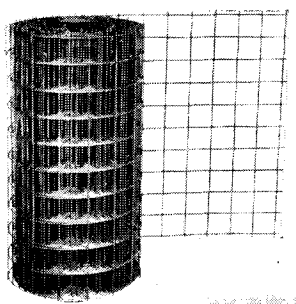

5—Welded Concrete Reinforcement

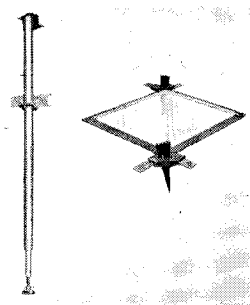

5—Adjustable Shores, Column Clamps

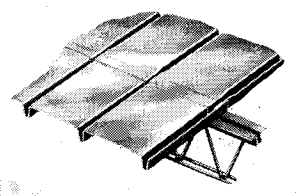

6—Ceco Roof Deck

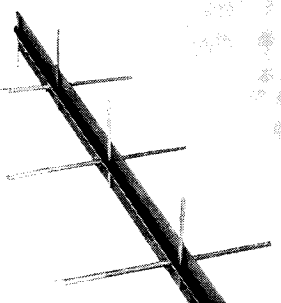

8—Highway Center Strip, Dowel Bars and Stake Pins

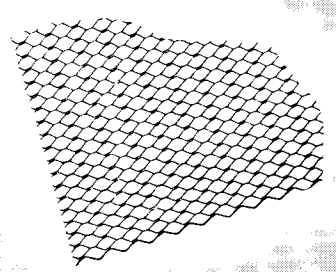

9—Metal Lath and Accessories

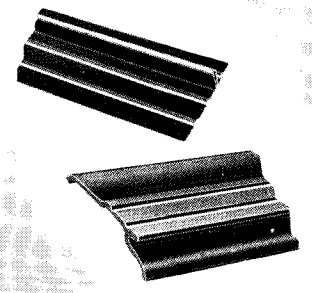

10—Metal Weatherstrip

For complete information on any of the products illustrated, just fill out the coupon and mail to Ceco. Check the catalog number you want, corresponding to the number of the product illustrated.

## CECO STEEL PRODUCTS CORPORATION

5645 West 26th Street, Chicago 50, Illinois

Please mail me postpaid the free catalogs I have checked below:

- 1
- 2
- 3
- 4
- 5
- 6
- 7
- 8
- 9
- 10

Name .....

Position .....

Firm .....

Address .....

**CONSTRUCTION PRODUCTS**

For  
**PROVED  
 PROTECTION**  
 in these important services—  
 specify **"WROUGHT IRON"**

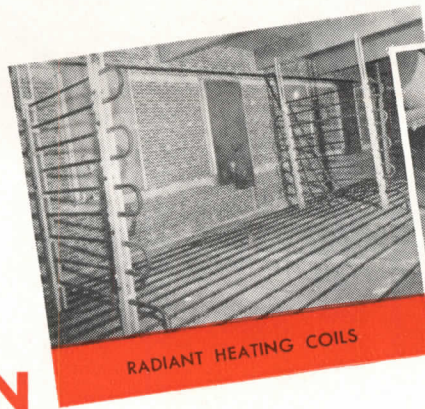

RADIANT HEATING COILS

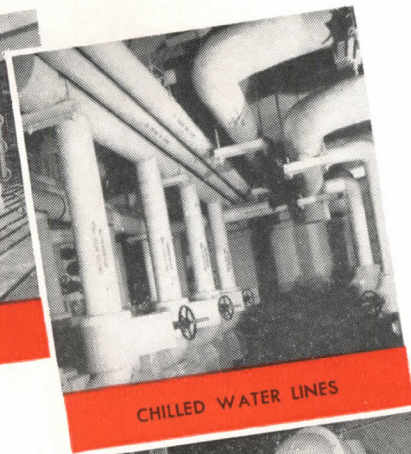

CHILLED WATER LINES

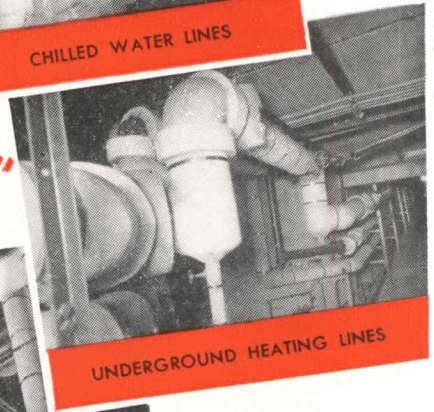

UNDERGROUND HEATING LINES



SOIL STACK, WASTE, VENT  
 AND DOWNSPOUT LINES

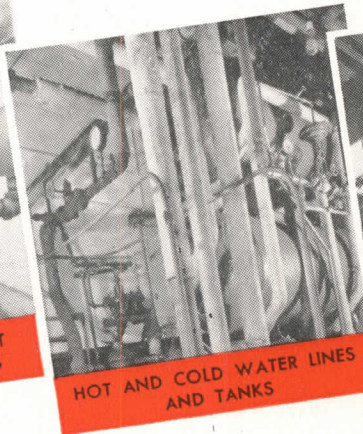

HOT AND COLD WATER LINES  
 AND TANKS

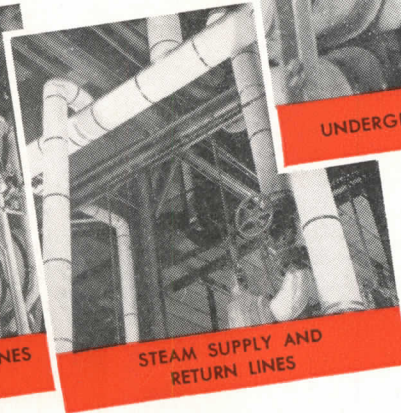

STEAM SUPPLY AND  
 RETURN LINES

The future of a new building, in a lot of important respects, is determined before the ground is even broken. Its "lifeline" is established when the specifications are written on service lines like these.

In every one of these vital services some degree of corrosion ranging from mild to severe, can be expected. And in every one wrought iron has made records of greater durability and lower cost-per-year that recommend it for first consideration.

In soil, waste and downspout services, wrought iron is still on the job after half a century in areas where ordinary materials failed in from ten to thirty years.

In hot and cold water lines,

wrought iron is still serving after outlasting low-first-cost materials over two to one.

In steam supply and return lines, a number of 50-year wrought iron installations are still active, in localities where ordinary materials required replacement in as little as three years.

In underground steam distribution, one user reported that his 10-inch wrought iron line had required no maintenance whatsoever in 39 years continuous service.

In radiant heating installations, Byers Wrought Iron offers ease of fabrication, high heat emission and unusual corrosion resistance, and its coefficient of expansion is almost identical with that of concrete and

plaster. This helps avert cracking.

Wrought Iron's excellent performance in corrosive applications is due to its unusual structure. Tiny fibers of glass-like silicate slag, threaded through a body of high-purity iron, halt and disperse corrosive attack, and anchor the initial protective film, which shields the underlying metal.

Ask for our bulletin, "Wrought Iron for Piping Services" for detailed information. And remember—Byers Wrought Iron is available now, in any quantity, for any project.

A. M. Byers Co., Pittsburgh, Pa. Established 1864. Boston, New York, Philadelphia, Washington, Chicago, St. Louis, Houston, Seattle, San Francisco, Atlanta.

**CORROSION COSTS YOU MORE THAN WROUGHT IRON**

"ETERNALLY YOURS"—professionally-produced 16mm sound motion picture. An entertaining saga of the wrought iron industry, available to technical groups. New, authentic, informative. Write Modern Talking Picture Service, Inc., 9 Rockefeller Plaza, N. Y. 20, N. Y.

**BYERS**  
**GENUINE WROUGHT IRON**  
**TUBULAR AND HOT ROLLED PRODUCTS**  
 ELECTRIC FURNACE ALLOY STEELS · OPEN HEARTH ALLOY STEELS  
 CARBON STEEL TUBULAR PRODUCTS

M-4883

# ARCHITECTURAL RECORD

**F.W.DODGE**



Copyright 1946 with all rights reserved. Vice-President in charge of Magazine Division, H. Judd Payne • **EDITORS:** Editor-in-Chief, Kenneth Kingsley Stowell, A.I.A.; Managing Editor, Emerson Goble; Associate Editor, Douglas Haskell; Associate in South America, Edmund J. Whiting, A.I.A.; Desk Editor, Florence A. van Wyck • **CONSULTANTS:** Industry Relations Consultant, Thomas S. Holden; Statistical Consultant, Clyde Shute; Building Economics Consultant, Norbert Brown; Field Research Consultant, Clifford Dannels, Jr.

Architectural Record (combined with American Architect and Architecture) is published monthly by F. W. Dodge Corporation, 10 Ferry St., Concord, N. H., with Editorial and Executive Offices at 119 West 40th Street, New York, N. Y. Thomas S. Holden, Pres.; Howard J. Barringer, Vice-Pres. and Treas.; Irving W. Hadsell, Vice-Pres.; Chauncey L. Williams, Vice-Pres.; Sanford D. Stockton, Jr., Secy.; Walter F. De Saix, Asst. Treas.; Edwin H. Freed, Asst. Treas. Member Audit Bureau of Circulation and Associated Business Papers, Inc. Architectural Record is indexed in Reader's Guide, Art Index and Industrial Arts Index. Subscription rates: United States and Possessions, Canada, Cuba, Mexico, Central and South America, \$3 the year, \$5 for two years, \$6 for three years; elsewhere, \$5 the year; single copy, \$1. Circulation Manager: Marshall Ginn. Every effort will be made to return material submitted for possible publication (if accompanied by stamped, addressed envelope), but the editors and the corporation will not be responsible for loss or damage. Other Dodge Services: Real Estate Record & Builders' Guide, Sweet's Files, Home Owners' Catalogs, Dodge Reports & Dodge Statistical Research Service.

## LE CORBUSIER

symbolizes FRANCE RESURGENT in his cover design for Architectural Record for March, to be followed by his own report of the great reconstruction projects which may well mark the climax of a great career in architecture

|   |     |
|---|-----|
| <b>HOUSES, FASTER AND CHEAPER</b> . . . . .   | 65  |
| An Editorial . . . by Kenneth K. Stowell  |     |
| <b>EYES AND EARS IN SCHOOL</b> . . . . .  | 66  |
| 1. Audio-Visual Classroom Planning. By Philip Will, Jr., A.I.A. . . . . 66  |     |
| 2. Light on Growing Children. By Darell B. Harmon . . . . . 78  |     |
| <b>VACATION HOUSE</b> . . . . .   | 91  |
| Hugh Stubbins, Jr., Architect   |     |
| <b>DESIGNED FOR SITE AND SEASONS</b> . . . . .  | 92  |
| Residence for Mr. and Mrs. John M. Floyd, Walnut Creek, Calif. John S. Dinwiddie, Architect; Garrett Eckbo, Landscape Architect |     |
| <b>FOUR HOUSES TO START ARIZONA'S NEW BOOM</b> . . . . .  | 94  |
| Arthur T. Brown, Architect  |     |
| <b>STEEP SITE, SMALL BUDGET</b> . . . . .   | 96  |
| Residence for Mr. and Mrs. A.J. Polito, Los Angeles, Calif. Raphael S. Soriano, Designer  |     |
| <b>PLAN TO BUILD IN FOUR STAGES</b> . . . . .   | 98  |
| Residence for Mr. and Mrs. Harry Schmidt, Pasadena. Richard J. Neutra, Architect; Dion Neutra, collaborating                    |     |
| <b>BUILDING TYPES STUDY No. 110 . . . STORES</b> . . . . .  | 99  |
| <b>FREE-FLOW PLAN IN TIGHT AREAS</b> . . . . .  | 100 |
| Rock-a-Bye Children's Clothing Store, Brooklyn. Morris Lapidus, Architect   |     |
| <b>SMALL STORE FOR LARGE DISPLAYS</b> . . . . .   | 106 |
| Rock-a-Bye Children's Furniture Store, Brooklyn. Morris Lapidus, Architect  |     |
| <b>INGENUITY IN SMALL SPACES</b> . . . . .  | 108 |
| Pat Darling Shops, Baltimore. José A. Fernandez, Architect  |     |
| <b>DEPARTMENT STORE FOR A HIGHWAY LOCATION</b> . . . . .  | 112 |
| Designed for The Kawneer Company by Ketchum, Ginó & Sharp, Architects   |     |
| <b>PACE-SETTER FOR A CANDY CHAIN</b> . . . . .  | 114 |
| Loft Candy Store, 42nd Street, New York. Charles C. S. Dean, Designer   |     |
| <b>PIONEER DESIGN FOR CANDY SHOP</b> . . . . .  | 118 |
| First Retail Outlet for Garrott Candy Co., St. Paul. Harold Spitznagel, Architect   |     |
| <b>SHOWROOM FOR WOOL FABRICS</b> . . . . .  | 122 |
| Office and Showroom for Windsor Clothing Co., New York City. Robert Gruen Associates, Designers                                 |     |
| <b>TIME-SAVER STANDARDS . . . Parapet Walls</b> . . . . .   | 129 |
| <b>THE RECORD REPORTS . . . News from the Field</b> . . . . .   | 7   |
| <b>FOR BETTER BUILDING</b> . . . . .  | 20  |
| News of Materials, Equipment and Methods  |     |
| <b>MANUFACTURERS' LITERATURE</b> . . . . .  | 24  |
| <b>REQUIRED READING</b> . . . . .   | 132 |
| <b>INDEX TO ADVERTISEMENTS</b> . . . . .  | 178 |

All Watrous Flush Valves provide  
**SINGLE-STEP-SERVICING**  
 the feature that cuts maintenance  
 time to a minimum

... Another  
 of the many Watrous  
 Points of Superiority

- Water Saver Adjustment
- Self-Cleansing By-Pass
- ✓ Single-Step-Servicing
- Self-Tightening Handle Packing
- Screenless Silent-Action
- Sturdy Brass and Bronze Construction

One of the reasons why flush valves are so widely used is that they seldom require servicing. However, it is important that when servicing is necessary over a period of years, maintenance shall be just as simple as possible.

Watrous Flush Valves have a special Single-Step-Servicing feature that cuts maintenance time to a minimum.

*In a few minutes, on a Watrous Flush Valve, you can shut off the water, remove the operating unit and drop a replacement unit in the valve. It is also extremely simple to replace individual parts if the entire unit does not need complete checking because of the simplified construction of the Watrous operating unit.*

When you specify Watrous Flush Valves you get this Single-Step-Servicing feature in every valve. It is one of the reasons why the selection of Watrous Flush Valves is a source of satisfaction over the years to everyone concerned.

**THE IMPERIAL BRASS MFG. CO., 1240 W. Harrison St., Chicago 7, Ill.**

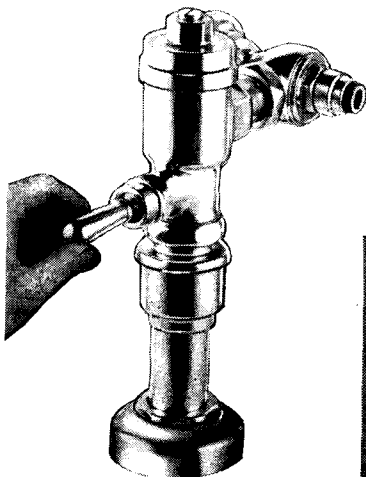

It will pay you to check up on the many Watrous points of superiority before you select flush valves for that next job.

**THEY PAY FOR THEMSELVES IN THE WATER THEY SAVE**

#### HOW WATROUS SINGLE-STEP-SERVICING WORKS

Illustration above shows how the entire operating unit of a Watrous Piston-Type Flush Valve lifts out. Repairs can be made in a jiffy by simply replacing this unit.

Note that the main seat washer is attached right to the operating unit. Thus, with Watrous Flush Valves there is no need to dig around inside the valve to remove an old washer--no need to work at length in confined quarters. Servicing that might easily take 20 or 25 minutes is done in a few minutes on a Watrous Flush Valve.

Servicing Watrous Diaphragm-Type Flush Valves follows a similar principle. Simply remove retaining screws on inside cover (no special wrench required), and lift out operating unit.

For complete information on Watrous Flush Valves see Sweet's Catalog or write for Catalog No. 448-A. Also ask for Bulletin No. 477 giving a summary of "Architects' Views on Flush Valve Applications."

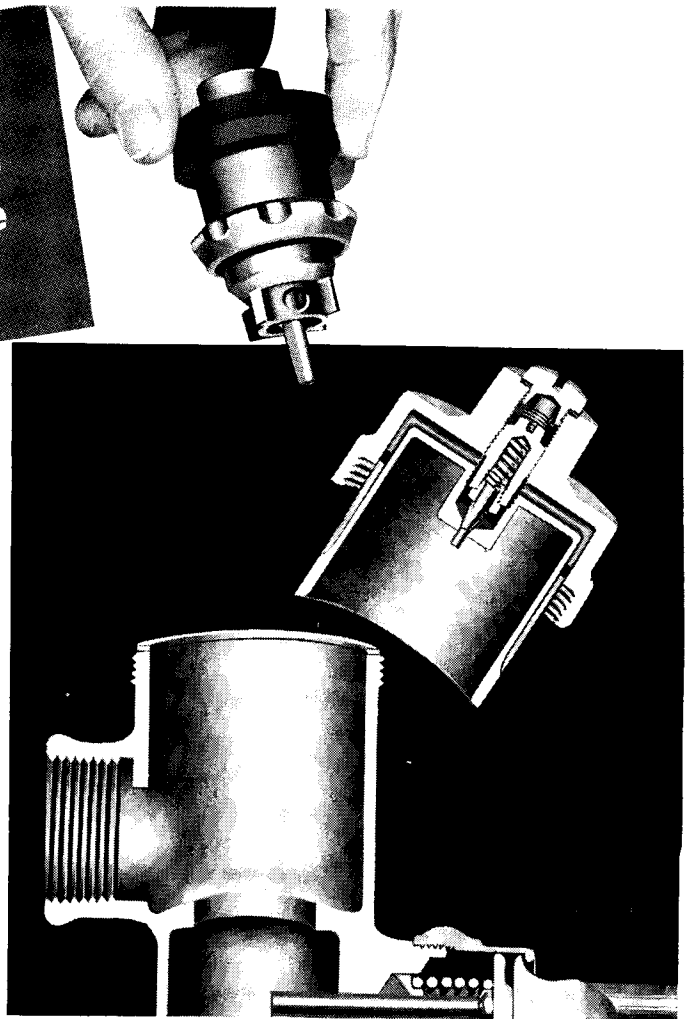
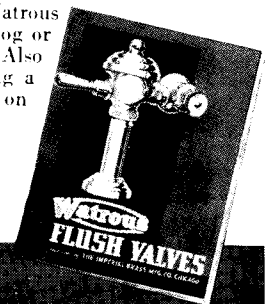

**Watrous**  
**Flush Valves**



# "Telephone outlets, too! That shows good planning"

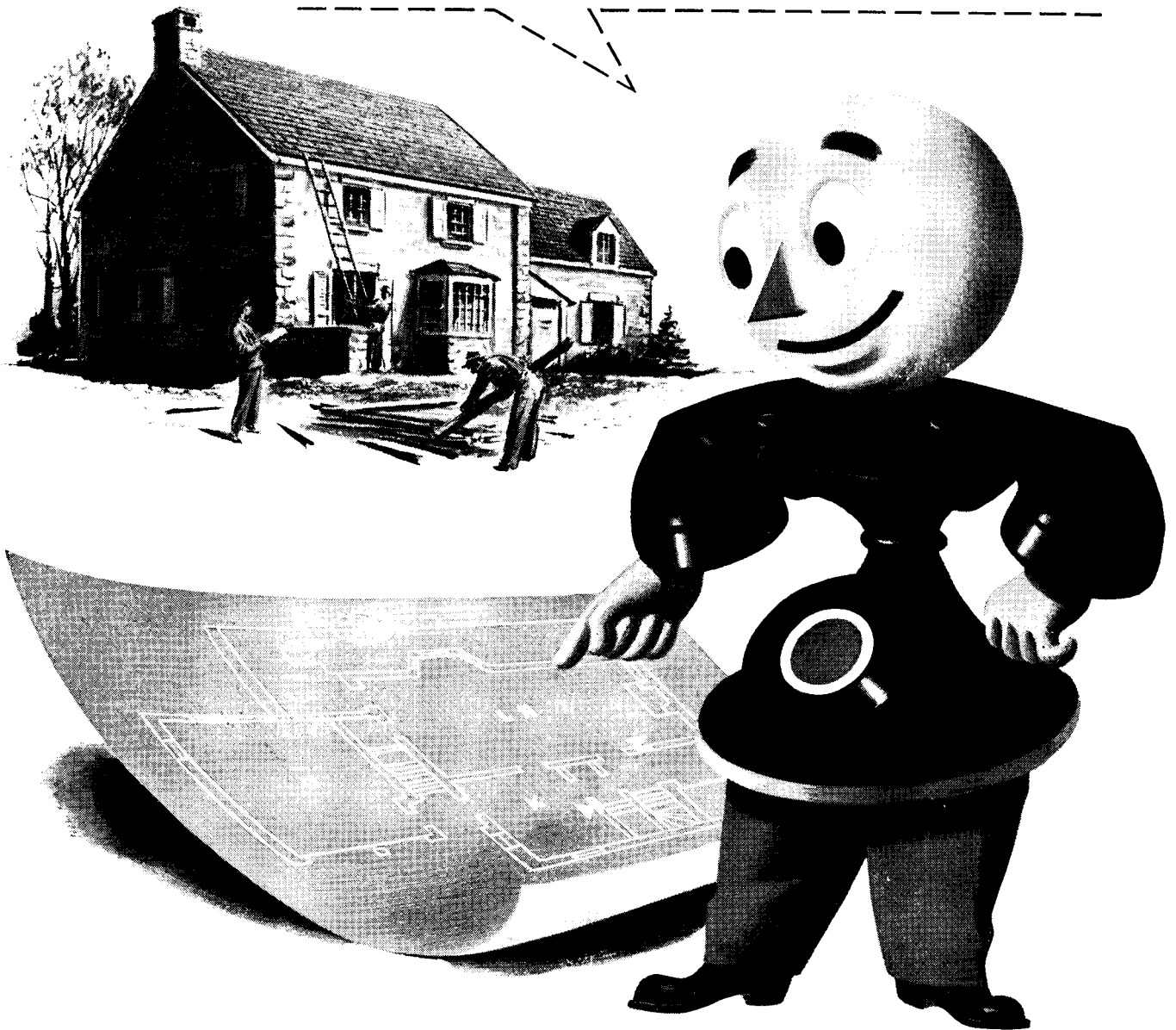

Even though some people are still waiting for telephones, alert architects and builders are not forgetting to plan for the days when they'll be available without stint. Built-in telephone facilities—with conduit concealed out of sight in the walls and neat outlets all ready for connection—add much to a house at little cost.

They avoid exposed wiring; make it easy for the home owner to have telephones wherever he'll need them—living room, bedroom, hall, kitchen or other convenient locations. Every modern home should have built-in telephone facilities. Your telephone company will be glad to help you plan a good telephone layout for any residence.

**BELL TELEPHONE SYSTEM**





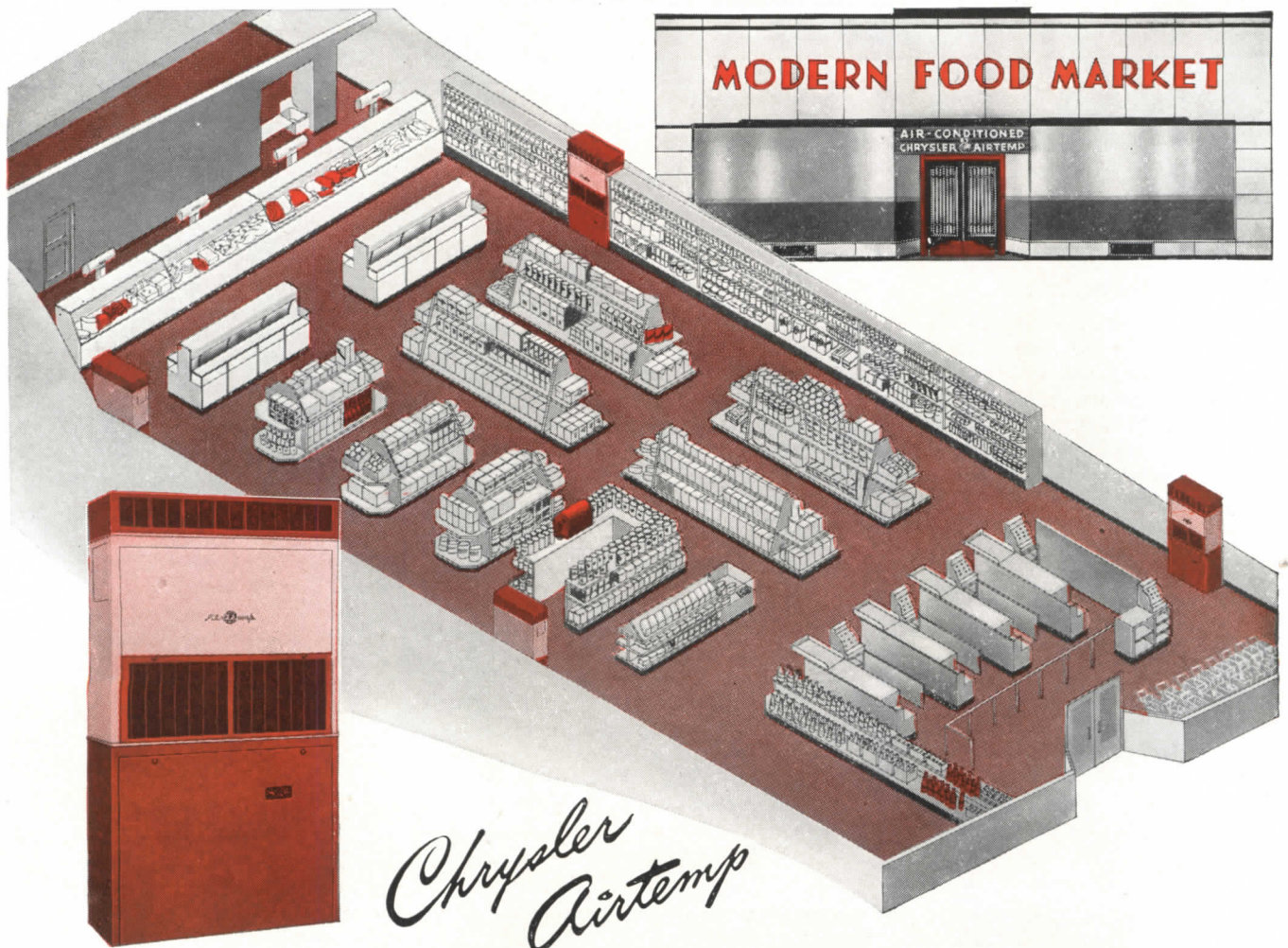

*Chrysler  
Airtemp*

**"Packaged" Air Conditioners**

## **A Plan to Bring More Customers to Food Stores**

For a modern super store like the one above, or a small shop—"Packaged" Air Conditioners, pioneered by Chrysler Airtemp, are a solid investment for increasing patronage and profits. Compact, easy to install, they fit readily into any store plan. Their time-tested dependability has brought coast-to-coast acceptance by business and professional men.

"Packaged" Air Conditioners can be installed singly or in multiple, and can be converted into year 'round air conditioners by the addition of a heating coil. Because they are completely packaged, they come ready to go to work and immediately begin paying for

themselves. The sealed Radial Compressor is engineered for long, trouble-free life; noted for quiet, low-cost operation and exceptionally low upkeep.

It's good business for any architect to include this modern, simplified form of air conditioning in plans for new stores, shops, clinics, doctor's or dentist's offices, hotels, or even for new homes—the Chrysler Airtemp "Packaged" Air Conditioner also operates in combination with a warm air central heating system. Airtemp Division, Chrysler Corp., Dayton 1, O. In Canada, Therm-O-Rite Products, Ltd., Toronto.

Invest in Your Future—Buy U. S. Savings Bonds! "REMEMBER THURSDAY NIGHT! The music of Andre Kostelanetz and the musical world's most popular stars—Thursday, CBS, 9:00 P.M., E.S.T.

# **CHRYSLER AIRTEMP**

**HEATING • COOLING • REFRIGERATION**

controls over housing prices with the Patman bill (to create an Office of Housing Stabilization) as the focal point in the argument. Reconversion Director Snyder was among those putting his stamp of approval on ceiling prices for the sale of old and new housing.

**Building Priorities Return**

President Truman's reinstatement of priorities for building materials came on the recommendation of Mr. Snyder.

"Diversion of materials," the Reconversion Boss told his Chief, "from less urgent commercial and industrial construction and from high-cost housing through such a priority system is one of the few ways in which we can immediately increase the supply of home-building materials."

While some building trade groups gave approval to the priority plan, they opposed the application of rigid price ceilings.

The priority program became effective January 15 and was applied through Priorities Regulation 33 under the Civilian Production Administration. It sets up an HH rating for 10 housing materials in critical short supply: common and face brick, clay sewer pipe, struc-

tural tile, gypsum board, gypsum lath, cast iron soil pipe and fittings, cast iron radiation, bathtubs, lumber, and millwork. Such ratings are available to veterans or to builders who will give preference to veterans either in sale or rental. Top price allowed is \$10,000 and top rental \$80 per month.

These qualifications are of interest:

1. FHA must be satisfied that the proposed price or rent is reasonably related to the proposed accommodations.

2. Applicants must show that they will be ready to start construction within sixty days. If construction has not been started within sixty days, the HH rating becomes void and a new application must be filed.

**Expediter Named**

To speed up his whole program on new homes, Mr. Truman called on Wilson W. Wyatt, of Louisville, Ky. By letter he told the Kentuckian:

"It is urgent that every available temporary living quarter be used in over-crowded communities, that the production of building materials be expedited, that the production of homes be hurried, that the cost of housing be protected from further inflation."

Specifically as to his duties, the President informed the Expediter:

"I am asking you to search out all bottlenecks at whatever level of industry or of government — local, state or national — you may find them; to try to break those bottlenecks; and to make the machinery of housing production run as smoothly and speedily as possible."

Mr. Wyatt, born in Louisville in 1905, practiced law until he ran for the post as mayor of the city in 1941, and had a hand in Kentucky's urban rehabilitation law for the redevelopment of blighted neighborhoods.

**Conferences Called**

As one part of its expediting program, the federal government called the December conference on housing production to be followed later by a conference of leaders in the home financing field to combat inflation and a third conference of public interest groups to get support of the production and inflation control programs.

In the course of the first conference pertinent points were brought out. Civilian Production Administrator John D. Small made clear that during the war many builders discontinued operation and disbanded their organizations. "It takes time to reorganize a widely dispersed, highly diversified industry like construction, in which so many different factors and operations require integration," he pointed out.

Among other of Small's points:

"... shortages of certain materials will, quite frequently, not hold up the building of houses if available substitutes are used. For example, where lumber is short, concrete blocks may be available. In this period of acute shortages, if we are to get a maximum number of houses built, we cannot each have exactly what we want. The builders cannot build exactly what they would like to build.

"... where the community itself can, and I think should, help out in the acute housing situation, is in the granting of building permits... an undue and unwarranted drain on scarce building materials for use in building night clubs, and juke joints, and roadside stands, and on deferrable repairs or extensions to existing buildings can be controlled to a very substantial degree through the building permit system."

L. C. Hart, president of the Producers' Council, Inc., presented the results of surveys by his organization showing that "pricing, manpower at work and raw material problems have become dominant factors in the situation." Mr. Hart went on to say that "the real bottlenecks, according to our latest survey, are millwork, enameled plumbing fixtures, steam, hot water and

(Continued on page 13)

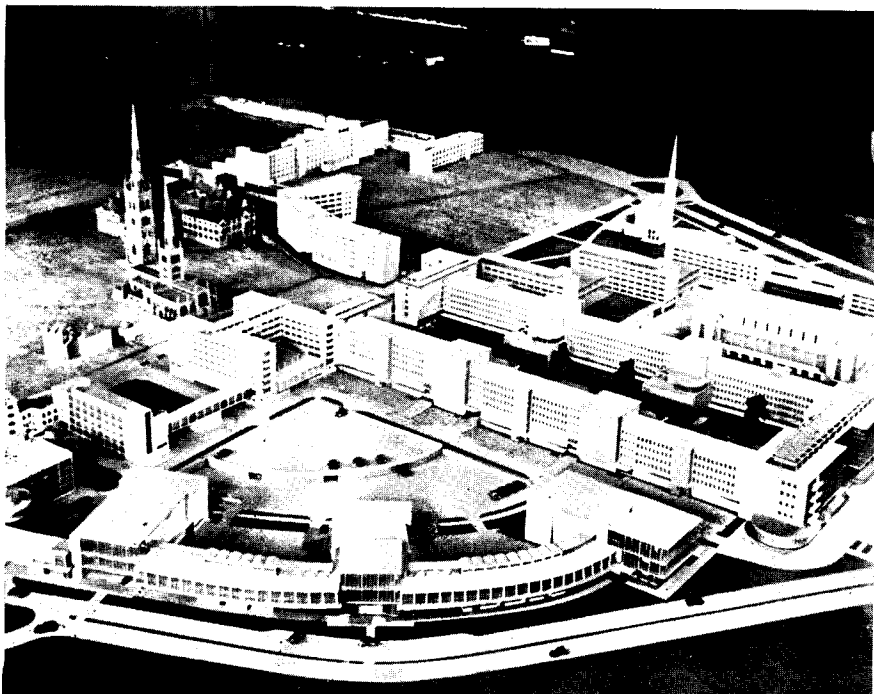

British Combine

Model of the proposed rebuilding plan of Coventry, England. The Cathedral is to the left

**A NEW COVENTRY**

Bomb-leveled Coventry, England, is going ahead rapidly with plans for rebuilding. As City Architect D. E. E. Gibson works on his plans, a Northamp-

ton model manufacturing firm, Bassett-Lowe, makes small-scale models which are laid out on a miniature representation of the city's blitzed area. The photo above shows how much progress already has been made.

# GOOD WASHROOMS—one of the "Big 4" in good working conditions

... say men and women workers in 400 plants



**JANE:** "No 'two ways about it' with this company. Our washrooms are just as bright and tidy as the 'front office' ones."

**DORIS:** "It makes a big difference, doesn't it, to be able to clean up in a washroom that's as pleasant as your own bathroom at home."

**W**ORKERS FROM COAST TO COAST—in a special research study—ranked good washrooms right along with safety devices, adequate lighting and proper ventilation as the "Big 4" factors in good working conditions.

Modern, sanitary washrooms, complete with plenty of hot water, soap and good quality individual paper towels, help keep workers happy. Moreover, they help keep germs from spreading by encouraging thorough washing. This, in turn, helps reduce the number of absences due to colds and their more serious complications.

Haven't you yourself been irritated by a poorly planned, badly equipped washroom? Then make sure your washrooms are designed to be "Health Zones," not "Germ Exchanges"—"morale-boosters," not "temper-testers."



**Good Washrooms begin at the Drawing Board**

Efficient, well-equipped washrooms that help keep workers healthy and happy are a result of careful thinking and planning in the blueprint stage. For practical suggestions on modern washroom layout, turn to our four pages in Sweet's catalog—or call on the Scott Washroom Advisory Service, Scott Paper Company, Chester, Pennsylvania

**SCOTTISSUE TOWELS  
STAY TOUGH WHEN WET**



Trade Marks "Scottissue," "Washroom Advisory Service" Reg. U.S. Pat. Off.

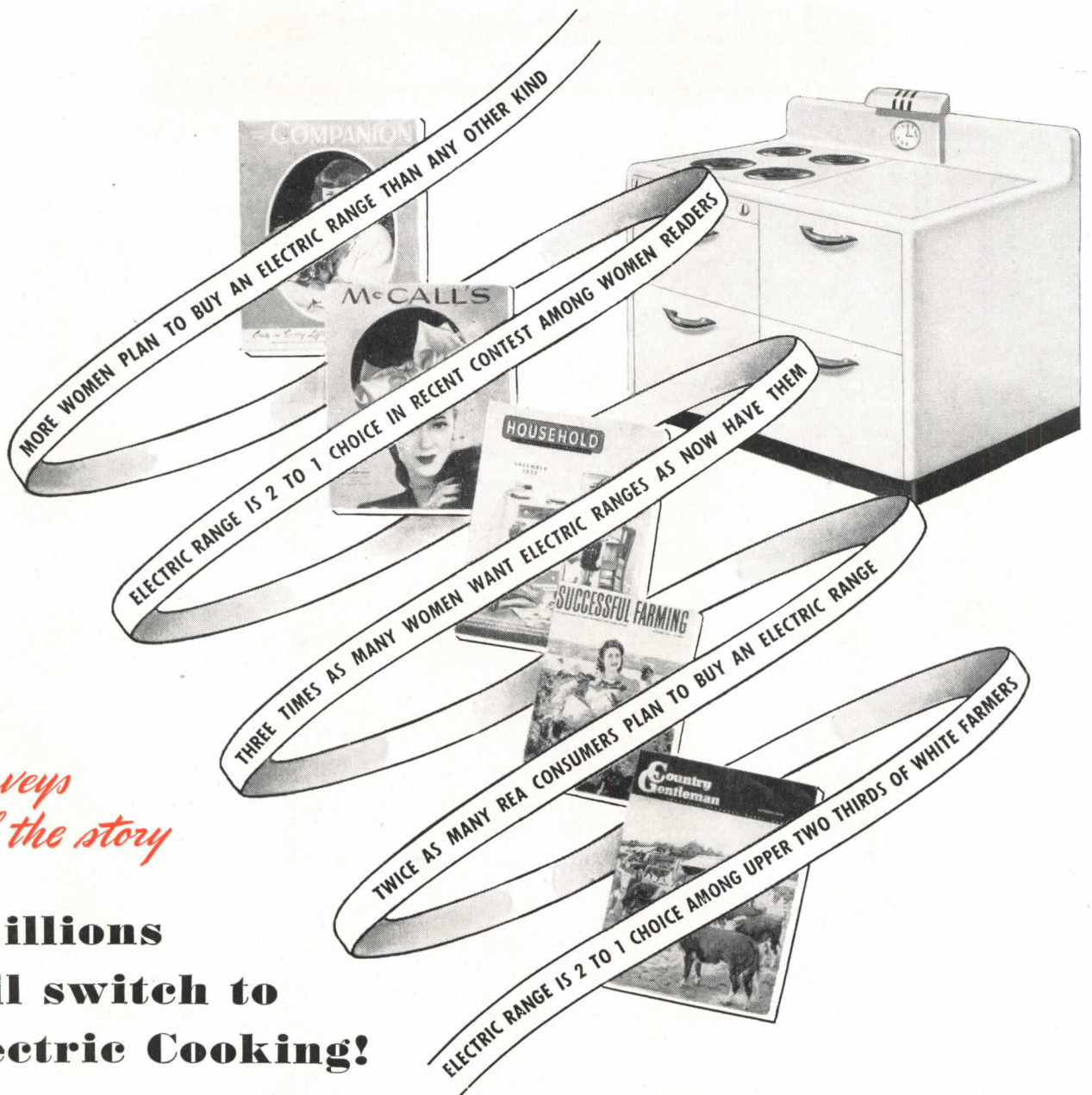

*Surveys  
tell the story*

## Millions will switch to Electric Cooking!

### Wire Your Houses For **ELECTRIC RANGES!**

The trend is unmistakable. In survey after survey, American housewives have expressed their preference for the convenience, cleanliness, dependability and economy of modern electric cooking.

Among the many unbiased surveys which show the strong swing to Electric Cooking are those made by leading national magazines, such as \*Woman's Home Companion, \*McCall's, \*Household, \*Successful Farming and \*Country Gentleman.

And prewar sales figures further emphasize the swing to electric cooking. Between 1933 and 1941, sales of electric ranges increased *over 900 per cent.*

You can cash in on this preference and give the houses you build an added selling feature by wiring your homes for electric ranges. Built-in, the cost is negligible—the selling power tremendous.

*Electric Range Section, National Electrical Manufacturers Association  
155 E. 44th Street, New York 17, N. Y.*

A-B STOVES • ADMIRAL • ELECTROMASTER • ESTATE HEATROLA • FRIGIDAIRE • GENERAL ELECTRIC • GIBSON • HOTPOINT  
• KELVINATOR • MONARCH • NORGE • QUALITY • UNIVERSAL • WESTINGHOUSE

FOR EASIER SALES  
*Wire your houses*  
FOR ELECTRIC RANGES

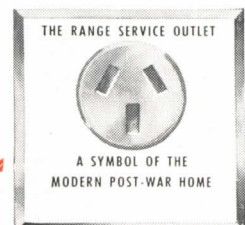

## THE RECORD REPORTS

(Continued from page 10)

warm air heating equipment, and possibly cast iron soil pipe. These are the items which will be in short supply, unless something drastic is done. These are the bottlenecks which threaten to control the number of new homes built next year."

### OPA Shifts Prices

Aside from continued pressure for controls over housing prices, the Office of Price Administration has been moving otherwise in the field of construction. In December it established a new pricing method to enable producers of certain building materials to ship outside their normal marketing areas into temporary shortage areas. Producers were authorized to add the full amount of freight costs to the f.o.b. plant maximum prices of their product. First material granted this right was crude gypsum "when sold for use as a retarder in the manufacture of cement."

OPA also has upped by 20 cents a barrel the manufacturers' maximum prices for all types of Portland cement except white in various midwestern states: Nebraska, Kansas, Oklahoma, Arkansas, western Missouri, Idaho, Montana, Wyoming, Utah, Colorado and New Mexico. It increased by approximately 9.7 per cent the ceiling prices for vitrified clay sewer pipe in eastern and east central states.

### NHA and FHA Act

Two other notes of interest in the housing field stem from the National Housing Administration and the Federal Housing Administration. NHA is pressing the conversion of single into two or more family houses, and is giving priorities assistance to contractors; in this connection, FHA will insure improvement loans (up to \$5,000 for seven years) if the property is in a war housing area, if improvements provide new living accommodations, and if veterans get occupancy priority.

Generally in its insurance of mortgages, FHA will allow appraisals about 30 per cent above prewar values. The more liberal policy is expected to apply particularly to new building which, in 1946, will consist mainly of homes built under the new CPA priorities. It is due to apply also when old homes are transferred.

### Commerce Offers Program

Under Secretary of Commerce Alfred Schindler has brought forth a "four-point reform program" for building industry and labor. He cites four cost obstacles obstructing the building indus-

try and says that they must be removed. He lists them as follows:

1. The lack of effective price control on land values, on construction and on finished houses.

2. The lack of year 'round work and an assured basic annual wage for workers in the industry.

3. The oppressive and restrictive practices now being carried on by some construction industry suppliers, and the restrictive agreements between management and labor in the construction field.

4. The continuance by most of our municipalities of antiquated building codes, which restrict the use of new and cheaper materials and in many other ways add to the cost of construction.

Mr. Schindler advises the adoption, with minor local variations, of a uniform national building code based upon tests by the National Bureau of Standards.



Proposed home office for John Hancock Co.

## NEW BUILDINGS PLANNED

### Insurance Headquarters

Construction will be begun at once on the first postwar business building in Boston, Mass. — the new 26-story home office of the John Hancock Mutual Life Insurance Co.

The new building, 417 ft. in height, will occupy a site 290 by 270 ft. east of the company's present home office, bounded by Berkeley and Stuart Streets and St. James Avenue. The site is now vacant except for the present John Hancock Hall, which will be razed; a new hall, designed to seat 1100 people and fully equipped as an auditorium, will be included in the Stuart Street wing of the new building.

The \$15,000,000 structure, designed to provide the maximum floor space possible for the dimensions of the lot, will provide, exclusive of the space for elevators and other mechanical equipment, almost 625,000 sq. ft. of working space.

(Continued on page 14)

## WATER HEATING is going

# Electric!

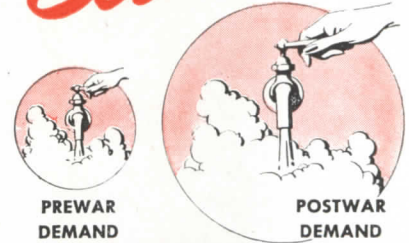

### Postwar Sales Will Triple Again

In the 6 prewar years, sales of Electric Water Heaters almost tripled. And a 1944 survey made for NEMA\* shows that three times as many women want Electric Water Heaters as now have them! They're "what women want," because they're:

**SAFE**—Flameless, fumeless.

**CLEAN**—Smokeless, sootless.

**ADAPTABLE**—Permit short hot water lines—Require no flue or vent.

**TROUBLE-FREE** as electric light!

**ECONOMICAL**—The cost is low for plenty of hot water all the time.

Installing Electric Water Heaters in every house you build, means giving women what they want!

Electric Water Heater Section  
\*NATIONAL ELECTRICAL MANUFACTURERS ASSOCIATION  
ADMIRAL • B & F • CLARK • ELECTROMASTER • FOWLER • FRIGIDAIRE • GENERAL ELECTRIC • HOTPOINT • HOTSTREAM • KELVINATOR • MONARCH • NORGE • PEMCO • REX • RHEEM • SELECTRIC • SMITHWAY • THERMOGRAY • THERMO-WATT • UNIVERSAL • WESTINGHOUSE

A House Wired For An Electric Range Is Already Wired For An

# Electric WATER HEATER!

(Continued from page 13)

The exterior shell of the building will consist of a 26-story central structure, fronting on Berkeley Street, flanked by two 7-story wings and topped by a lantern tower. It will be simple in style, faced with stone, its sole ornamentation a colonnade across the center portion of the main Berkeley Street entrance.

The interior of the building will be marked by two main characteristics: large unobstructed working areas; and new standards of comfort. The architectural design will provide open work areas 50 ft. wide and 250 ft. long on both flanks of the building in the lower block. All interior partitions will be of the movable steel type.

Spacious lunch rooms and a completely equipped kitchen will make it possible to serve 4,000 employees in four sittings. One entire floor will be devoted to rest and recreation facilities. Cram and Ferguson of Boston, are the architects; Turner Construction Co., contractors.

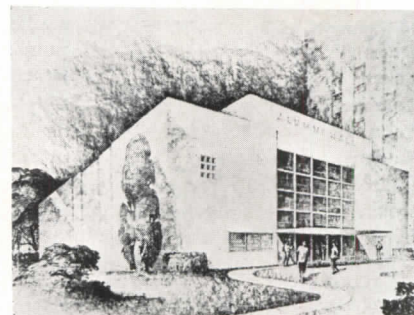

Auditorium for N.Y.U.'s medical center

**Alumni Hall**

Plans have been announced for another of the group of buildings forming the new New York University-Bellevue Hospital Medical Center on New York's east side. This is Alumni Hall, an auditorium building adjoining the previously announced Residence Hall (see AR, Dec., 1945, p. 144). The ground floor of the building will contain the assembly hall with a seating capacity of 500, a large lobby, vestibule, and the offices for the Alumni Association of the College of Medicine. The mezzanine floor will contain a conference room and foyer, a balcony, and a projection room.

**Newspaper Plant**

Housing four industries — newspaper, gravure, radio and television broadcasting — the new home of the Louisville (Ky.) *Courier-Journal* and *Louisville Times* will have about 250,000 sq. ft. of air conditioned floor space.

The project was designed by Lockwood-Greene Engineers, Inc., of New

(Continued on page 16)

*Mist* FOR GOOD AND EVIL

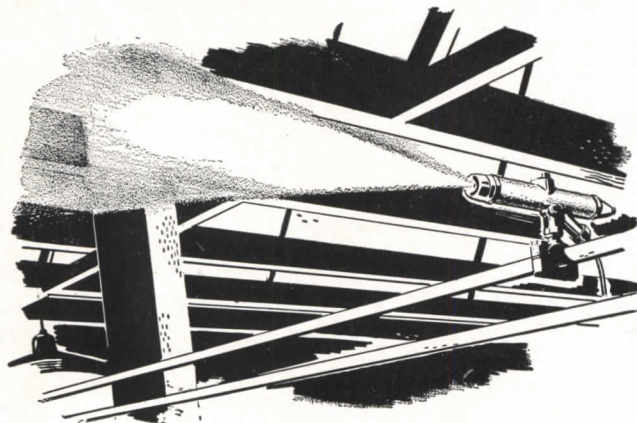

Mist, sprayed in process plants requiring high humidity, is vital to the quality of many products. But, it raises havoc with the wood structures. And steam and chemical-laden vapors in wet process plants cause ordinary lumber to go to pieces in a hurry.

Wolmanized Lumber\*, wood that's impregnated with Wolman Salts\* preservative, is highly resistant to the decay that inevitably develops in these humid atmospheres. Fibre-fixation prevents its washing out or leaching, assures added years of service life.

**The Advantages of Building with Wood**

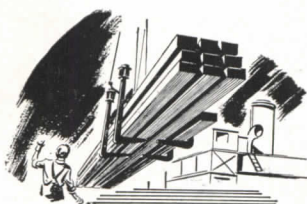

Building with wood means ease and speed of erection, light weight, resilience, high insulating value, paintability, low first cost and . . . when Wolmanized . . . long life.

**AMERICAN LUMBER & TREATING COMPANY**

CREOSOTING

FLAMEPROOFING

WOLMANIZING

\*Registered trademarks

1679 McCORMICK BUILDING, CHICAGO 4, ILLINOIS

# A PROFITABLE FIELD

for Architect and Builder!



— stimulated by the new Kawneer Program!

LEADING ARCHITECTS AND BUILDERS throughout the nation are becoming more and more interested in the store-front field, which is definitely due for tremendous activity in the years ahead.

The demand for architectural and design services with stores is growing every day. Retail merchants now recognize that proper planning and design create extra selling power. The new Kawneer program, reaching hundreds of thousands of retail merchants in every

trade, is accelerating this national trend.

Kawneer Store-Fronts—"Machines For Selling"—are being promoted with special emphasis on the importance of the function of good design.

You can tie into this national campaign, obtain valuable help from Kawneer field men, create more effective fronts with new Kawneer products. WRITE *The Kawneer Company, 400 Front St., Niles, Michigan, for ADDITIONAL DATA ON THE KAWNEER PLAN.*

**Kawneer**  
STORE-FRONTS

*MACHINES FOR SELLING!*

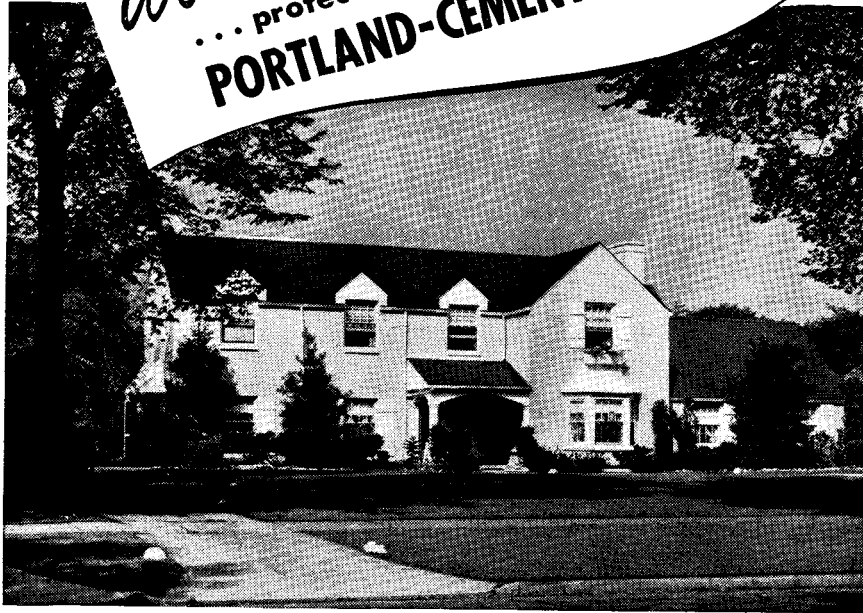

Neither sun, rain nor the storms of winter mar the appearance of this fashionable brick residence in Grosse Pointe, Michigan. For it wears a handsome coat of portland-cement paint made with Atlas white cement.

This durable finish penetrates the pores in concrete masonry, brick, stone and hollow tile. It forms a tough outer skin that resists moisture, dirt and dust. Because it's so easy to clean, frequent repainting is unnecessary.

Portland-cement paint is easy to look at—easy to apply. The base of Atlas White cement assures beautiful, distinct color tones. And it comes in handy packages that are ready to mix with ordinary tap water on the job.

*Atlas White Bureau, Universal Atlas Cement Company  
(United States Steel Corporation Subsidiary),  
Chrysler Building, New York 17, N. Y.*

**FACTORY-PREPARED PAINT IS PREFERABLE  
SEE YOUR LOCAL PAINT DEALER**

SUNDAY EVENINGS—American Broadcasting Company (Blue) Network—  
U. S. Steel's "The Theatre Guild on the Air." AR-P-10

A  
**UNIVERSAL  
ATLAS  
PRODUCT**

**ATLAS WHITE CEMENT**  
FOR PORTLAND-CEMENT PAINT

## THE RECORD REPORTS

(Continued from page 14)

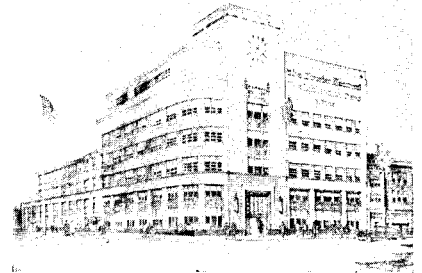

Newspaper plant and radio station in one

York, with Joseph H. Kolbrook, architect, the local associate and owner's representative. It will consist of two units, a 6-story rectangular office building and a 4-story rectangular building for the newspaper's mechanical departments. The combined floor space of the two will be about 250,000 sq. ft., all of which will be air conditioned. There will be a 165 by 200 ft. parking area north of the plant.

The office building will be of steel construction with limestone facing; the mechanical departments' building will be of flat slab concrete. While the two will appear to be one structure, they will be structurally separate to keep printing press vibration from affecting the radio studios.

### HOUSING SITUATION IS UNIMPROVED

Despite the constant stream of suggestions from all quarters on methods of alleviating the housing shortage, little or no action is being taken, and the situation definitely is not improving.

Typical of conditions in cities all over the country is Chicago, where the Housing Authority reports that because of the impossibility of finding new quarters for its "excess income" families, it is in the position of having to keep as tenants families no longer in the lowest income groups, while thousands of eligible families are inadequately housed or have no housing at all.

Encouraging, on the other hand, is the survey being made in New York and other cities, with the resulting discovery of hundreds of dwelling units at present unoccupied but readily convertible.

The New York City Housing Authority reports that four sites of future projects will be completely cleared by next May, and two more sufficiently cleared to enable construction work to start at that time. Relocation offices are being established on the future project sites to assist present tenants in finding apartments to which to move.

(Continued on page 138)



**This  
Mark  
of  
Merit**

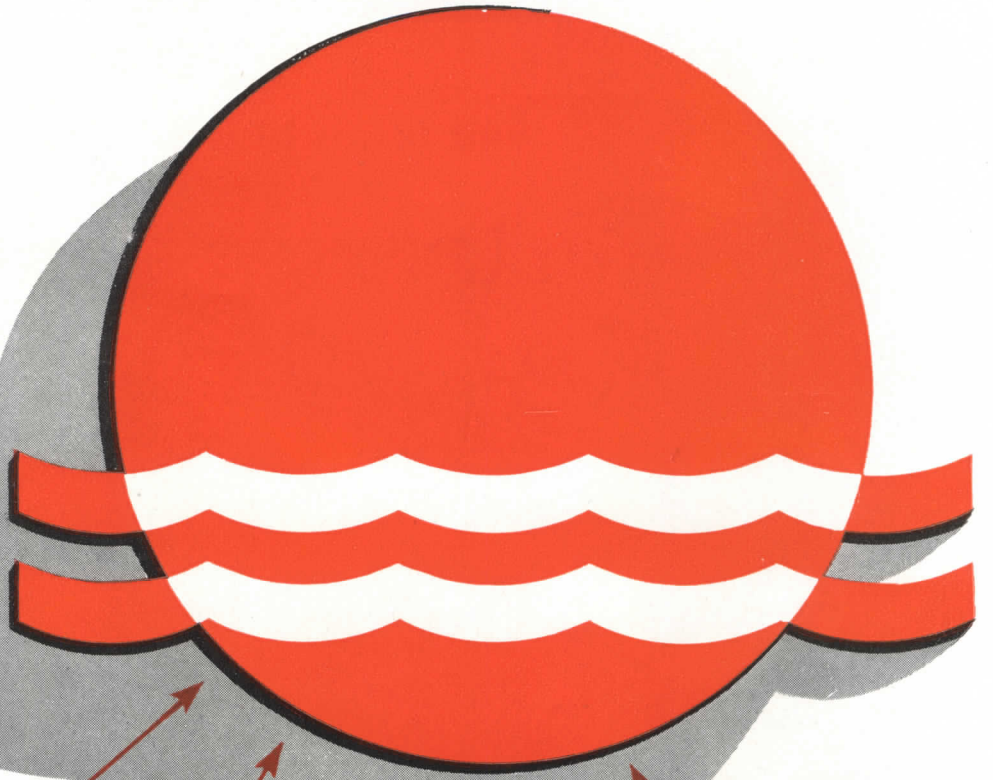

**on heating equipment and plumbing fixtures  
... is your assurance of satisfactory service**

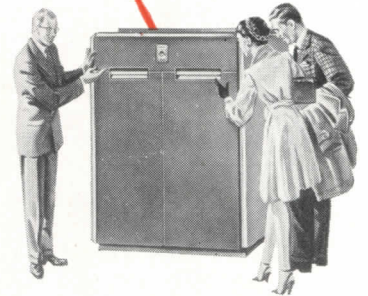
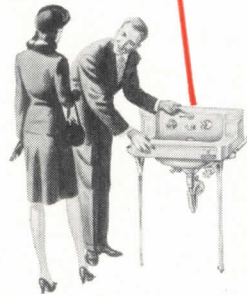
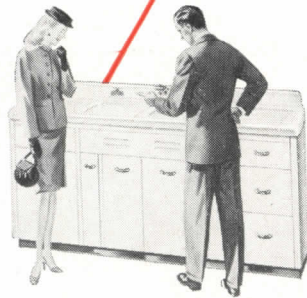
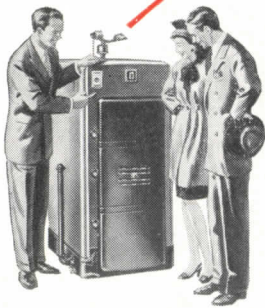

**T**HIS easily recognized Mark of Merit now is being extensively advertised to millions of homeowners and builders as the dependable guide to the best in heating equipment and plumbing fixtures.

Like the "Sterling" mark on silver, this Mark of Merit on heating equipment and plumbing fixtures stands for the very finest. It identifies time-tested, performance-proved products which are backed by many millions of dollars spent in research. Products which have been Serving the Nations' Health and Comfort for

more than half a century.

Make certain of satisfaction by specifying American-Standard products. These products are styled, designed and engineered to fit the widest range of architectural and

structural requirements.

For information, contact your Heating and Plumbing Contractor. **American Radiator & Standard Sanitary Corporation**, P. O. Box 1226, Pittsburgh 30, Pa.

**AMERICAN-Standard**

HEATING  PLUMBING

*Serving the Nations' Health and Comfort*

and lands like a feather

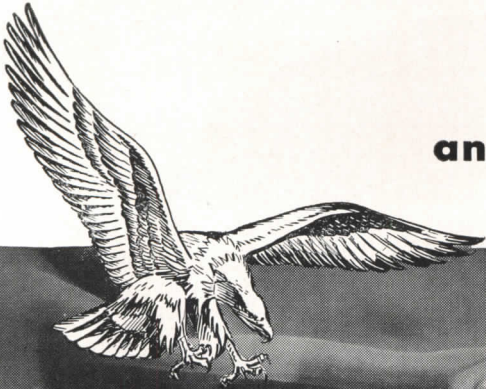

It moves with the strength of an eagle and lands like a feather, closing doors gently but firmly . . . its reserve strength under perfect control, balanced and applied in a precision built, friction-free mechanism.

These Ball Bearing Door Closers are typical of the quality expressed in Lockwood Builders' Hardware. You can include them in your specifications for hotels, hospitals, schools and other buildings, confident they will live up to your own high standards.

L-1A

**LOCKWOOD HARDWARE MANUFACTURING COMPANY**  
Division of Independent Lock Company • Fitchburg, Massachusetts

**lockwood  
builders'  
hardware**



# TITUSVILLE

MODERN IMPROVED

*Compact*

## STEEL HEATING BOILERS

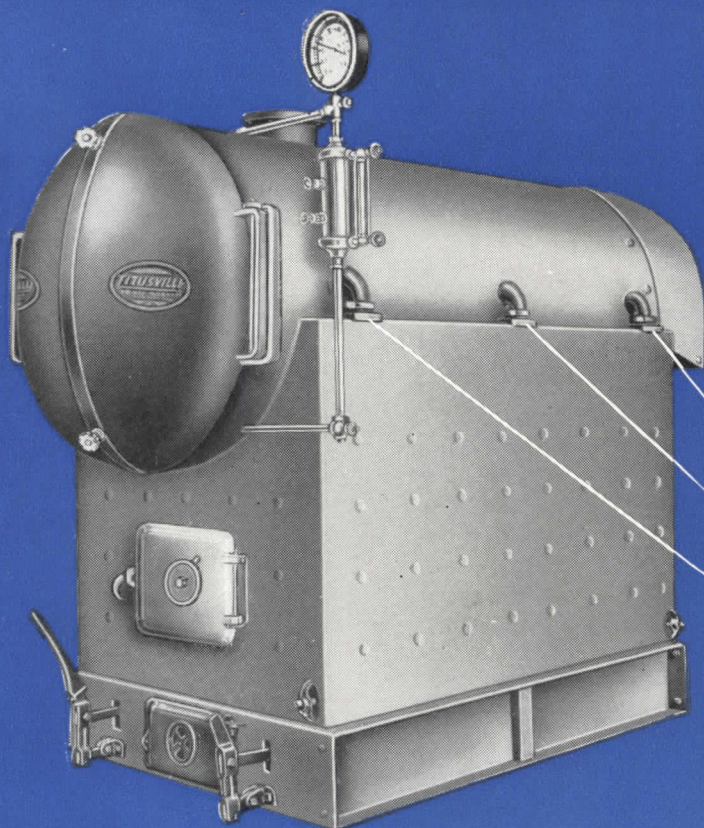

- ✓ PROVIDE "POSITIVE CIRCULATION"
- ✓ INCREASED EFFICIENCY
- ✓ LONGER BOILER LIFE

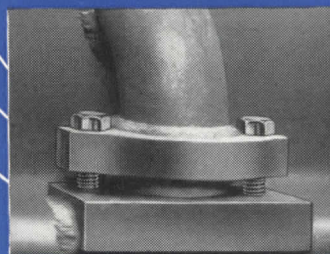

Circulators are high pressure type with metal to metal joints.

19 STANDARD SIZES IN  
HAND OR MECHANICAL FIRED  
USING ANY TYPE FUEL



Just as a pump on a forced hot water heating job steps up circulation and increases heating results, the *Side Circulators* in Titusville Compact Boilers assure *positive circulation*.

Titusville *Side Circulators* do the work of a pump—they restrict the openings between the firebox and shell and increase the velocity of the flow of steam and hot water within the boiler.

As a result, steam bubbles that accumulate on and insulate the heating surfaces are continuously washed off and a greater amount of heat is absorbed by the water in the boiler.

New Titusville Compact Boiler Bulletin on request.

### THE TITUSVILLE IRON WORKS COMPANY

Division of Struthers Wells Corporation

TITUSVILLE, PA.

District Representatives in Principal Cities

# FOR BETTER BUILDING

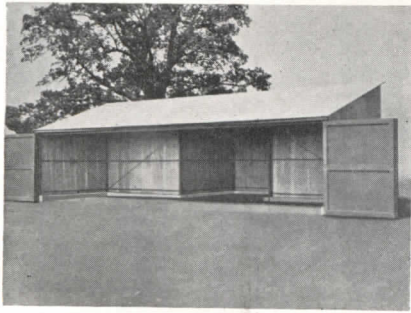

All-metal prefabricated T-shaped hangar for single or multiple installations

## SMALL HANGAR

An all metal prefabricated *Tee Hangar* recently announced is available for either single or multiple installations. Constructed of prefabricated structural members covered with corrugated sheets, the hangar is equipped with doors that jack-knife open to both sides far enough to make a full 38-ft. width for wing-spread; the fuselage depth is 24 ft. Doors are of heavy, welded, tubular frame construction, operating on tracks welded to the structure. The hangar is T-shaped and arranged for a second unit to interlock with the first, using a common wall and trusses, and having alternate units opening on opposite sides. Where a grouping having all doors opening on one side is preferred, the hangar can be erected as a rectangle, the units placed side by side in line. The William Bayley Co., Springfield, Ohio.

## BUILDING PLANS

### Office and Warehouse

Ground was broken in December for the construction of a Frigidaire District Office and warehouse in North Kansas City. The new building will provide approximately 45,000 sq. ft. of office, storage, repair and sales space, will cost approximately \$200,000. Construction is expected to take from 90 to 120 days.

### Research Laboratories

The Standard Oil Co. of Indiana has announced plans for new research laboratories in Hammond, Ind., and work has been started on some of the buildings in the group. The main administration building, general laboratories, three pilot-plant buildings and a cafeteria are scheduled for immediate construction; an engine laboratory, a greenhouse for insecticide work, additional pilot-plant buildings and other research facilities will follow later.

Principal buildings in the group will be of light-gray brick, will be air con-

ditioned throughout. The basic unit will be a two-man laboratory, with removable partitions to permit easy alteration to one-man laboratories or larger areas as desired. Holabird & Root, Chicago, are the architects.

### Floor Space Trebled

Immediate trebling of floor space in its Kokomo, Ind., factory has been announced by the Pittsburgh Plate Glass Co. The plant fabricates Pittco store-front metal.

The expansion, expected to cost approximately \$800,000, will increase floor space from 30,000 to 90,000 sq. ft., and will add facilities for the production of a new line of rolled shapes from aluminum sheet or strip. The Mahony-Troast Construction Co., Passaic, N. J., is engineer and building contractor.

### Plant for Floor Tile

Work is to commence at once on a new one-story building, 427 by 127 ft., constructed of structural steel and cinder block, at the Kearny, N. J. plant of Congoleum-Nairn, Inc. The building will be used for the manufacture of asphalt floor tile. Epple and Kahrs of Newark are the architects and engineers, Turner Construction Co., contractors.

### Plant for Washers

Immediate construction of a new Los Angeles plant has been announced by the Hurley Machine Division, Electric Household Utilities Corp., for the manufacture of Thor Automagic Washers.

Representing a possible \$1,000,000 investment when fully developed, the new plant will be built on a 10-acre site in El Monte, a suburb of Los Angeles, will have a 600-ft. frontage and cover 170,000 sq. ft.

## WINDOW PACKAGE

A factory fitted, three-way residential window "package" includes steel casement, storm sash and screen. Glass, wood casing, outside trim and hard-

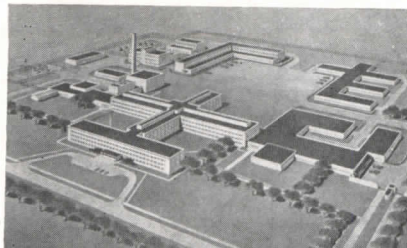

Hedrich-Blessing Studio

Standard Oil's new research laboratories

ware are provided as part of the package. Steel frames and ventilators are bonderized for protection against rust, dip-painted in a special primer, and oven baked.

Both storm sash and screen are factory fitted, and are installed from the inside. The storm sash opens in unison with the casement window. Detroit Steel Products Co., Detroit, Mich.

## DUAL LAMP UNIT

A new electrical fixture for home use brings together into one unit the infrared heat lamp and the ultraviolet sun-lamp.

Adaptable as a floor or table model lamp, and equipped with a two-way three-position switch by which the user may select the infrared or the ultraviolet at will, the new fixture, called the *Select-o-ray*, already is being produced and will be available to the public at once.

The unit is finished in ivory baked-on enamel, resembles a streamlined automobile headlight. It delivers ultraviolet rays from one end, infrared from the other. Reflectors on both lamps are built in. Westinghouse Electric Corp., Cleveland, Ohio.

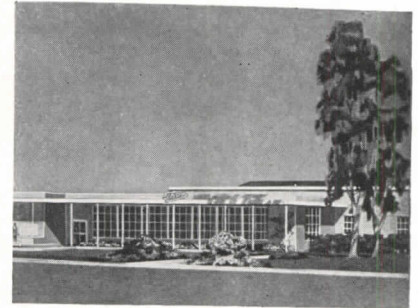

Future home of Thor Automagic Washer construction of which will begin soon

## FINISHES

### DDT Paint

A wall paint blended with DDT under a new patented process, *Superior 365*, is said to have proved an effective insect control for as long as 16 months after a single coat application.

Developed as a wall coating for packing plants, farm buildings and other structures requiring sanitary protection, the coating has proved effective against 132 varieties of insects, is harmless to humans. It is mixed by adding water to the base paint. Superior Paint and Varnish Co., Chicago, Ill.

### For Masonry

A moisture-proofing and decorating compound for masonry such as stucco, brick and concrete, called *Trico-seal*, is a

(Continued on page 22)



WELL WORTH  
LOOKING  
INTO " " "

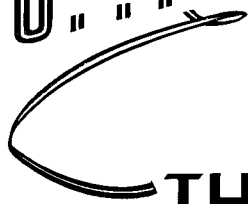

## THIS MODERN BRASCO FRONT

IT'S ANOTHER example of the versatility of Brasco Construction and well illustrates the trend to fronts that reveal the store interior for all to see. The clear, uninterrupted view within creates a feeling of intimacy and the shopper immediately responds to the smart, friendly atmosphere.

With complete Brasco Construction, no limitations are placed on the architect's ingenuity. Handsomely designed and soundly engineered to the minutest detail, the Brasco line is easily adaptable to any type of front for every type of store. Here you have beauty and utility combined, plus sound structural strength and dependable glass protection.

Our organization, backed by thirty years of experience, offers full cooperation on modern store front construction plans. Your inquiries are invited.

★ A COMPLETE LINE FOR EVERY DESIGN ★

**BRASCO MANUFACTURING CO.**  
**HARVEY • (Chicago Suburb) • ILLINOIS**

*National Distribution Assures Effective Installation*

# HI-DENSITY

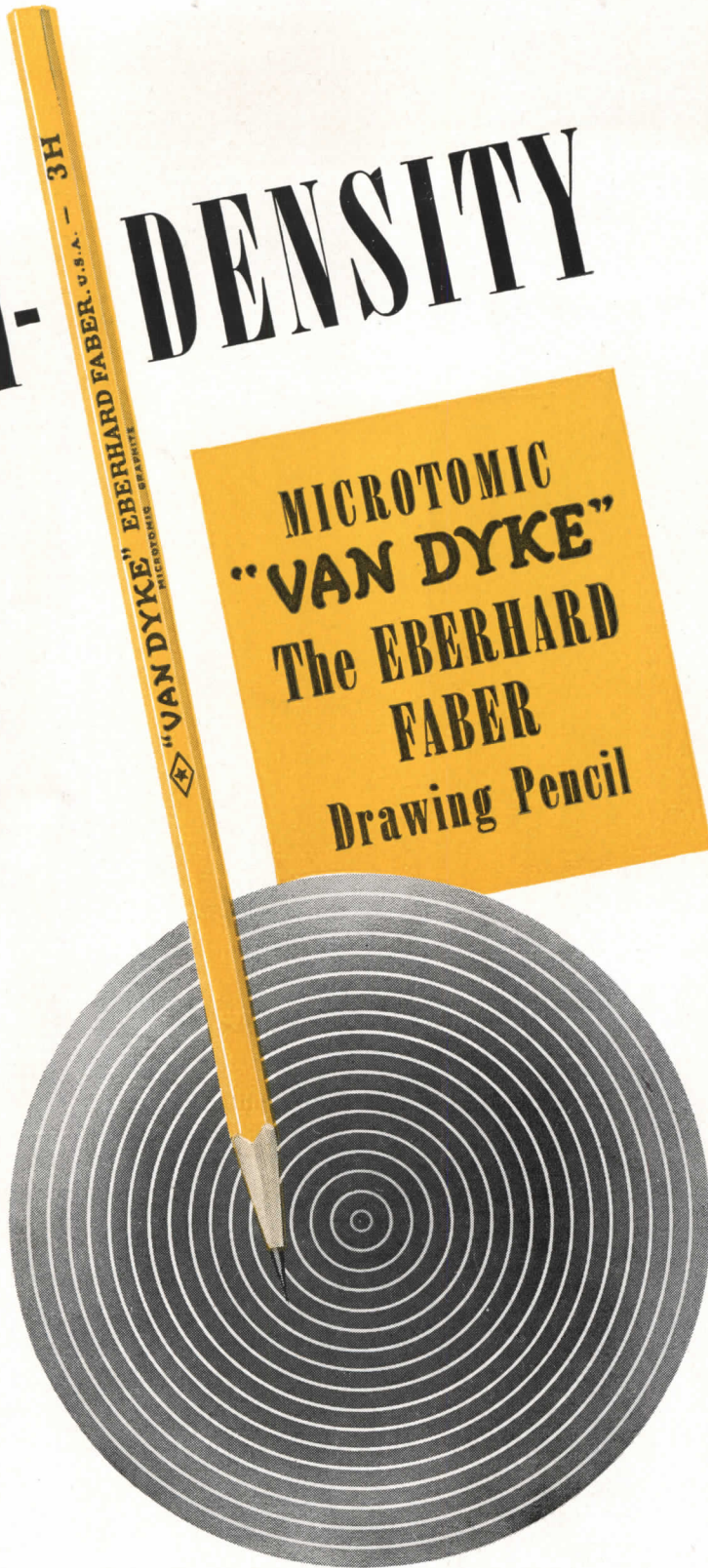

## BETTER BLUEPRINTS

naturally result from more opaque pencil tracings... and more opaque pencil tracings result from using a lead that gives off a denser line — one that is solidly black. The special HI-DENSITY Lead made by our exclusive MICROTOMIC process leaves nothing to be desired... For your personal satisfaction, try one and discover the drawing pencil with the quality touch.

18 Degrees from 7B to 9H with Round Leads... Plus 6 Degrees with special Chisel Point Leads.

## FOR BETTER BUILDING

(Continued from page 20)

slow hardening compound in powder form. When mixed with water it can be applied like paint with brush or spray, on inside or outside surfaces, above or below ground. Penetrating and sealing the pores of the masonry, it waterproofs and dampproofs it at the same time. Recommended for basement walls, walls of swimming pools, tanks and vats, for fire walls, cornices, exposed surfaces of concrete bridges and buildings, underground passages and tunnels, etc. Can be obtained in cement gray, white, cream, ivory, light green, buff, blue and brick red; other colors available on special order. American Fluresit Co., Inc., 635 Rockdale Ave., Cincinnati, Ohio.

### Waterproof Coating

Recently introduced is an improved *Ranetite No. V Transparent Waterproofing* featuring a base of aluminum and calcium stearate. A clear coating, it is guaranteed to waterproof without changing the texture of the surface; it does not show after application on the outside of any mason finished building. Cannot be applied to any surface which has received paint or oil coatings. Comes ready for use, is applied with brush or spray. *Ranetite Mfg. Co., Inc.*, 1917 S. Broadway, St. Louis 4, Mo.

### For Concrete Forms

A newly developed formula for *Form-film* permits the coating of plywood concrete forms with the same thickness of film in one coat as previously obtained in two. Water repellent, it conditions the plywood so that it is highly resistant to warping or swelling, the manufacturers report. No concrete will adhere at any stage of drying. Tests are said to have proved that reuse of the plywood forms as often as four or five times without recoating is possible. *A. C. Horn Co.*, 43-36 Tenth St., Long Island City 1, N. Y.

### GAS BURNER

Fundamental research on a new gas burner for domestic appliances, promising to result in quicker heating and greater economy of fuel, has been completed by the American Gas Assn. Testing Laboratories.

Technically known as the *100 per cent primary air burner*, the new burner draws in all the air needed through an adjustable air shutter, and makes possible shorter and brighter flames which can be placed very close to the object being heated.

(Continued on page 134)

DEPENDABILITY IN CIRCUIT PROTECTION CANNOT BE "LEFT TO CHANCE"

# Federal

NOARK

## MULTI-BREAKERS

*out-dates the old-type fuse box!*



When the electrical layout calls for simple, compact control of light and power . . . call for *Federal Multi-Breakers*. On every class of project — residential, commercial or industrial — you'll find the Federal Multi-Breaker thoroughly dependable . . . convenient . . . attractive in appearance. There are types available for indoor and outdoor applications in a wide range of ampere capacities.

*Write for a copy of the "Federalog". Address Dept. AR*

**FEDERAL ELECTRIC PRODUCTS COMPANY INC.**

EXECUTIVE OFFICES: 50 PARIS STREET, NEWARK, N. J. • PLANTS: HARTFORD, CONN., NEWARK, N. J.

Manufacturers of MOTOR CONTROL • SAFETY SWITCHES • CIRCUIT BREAKERS • SERVICE EQUIPMENT • PANEL BOARDS

# MANUFACTURERS' LITERATURE

## AIR CONDITIONING

**Electronic Air Disinfection.** A full description and specifications of the "Disinfectaire," an ultraviolet germicidal unit incorporating G.E.'s Germicidal Lamp. Includes information on why air disinfection is necessary, how it works. 10 pp., illus. The Art Metal Co., Cleveland, Ohio.\*

## ARC WELDING

**Airco Arc Welding Accessories (Catalog No. 130).** Illustrates and describes a complete line of accessories for all types of arc welding machines and operations. 12 pp., illus. Air Reduction, 60 E. 42nd St., New York 17, N. Y.

## BERYLLIUM

**The Atom of Beryllium.** Brush beryllium copper alloys, Brush beryllium metal and other alloys. Their characteristics and applications. 4 pp., illus. The Brush Beryllium Co., 3714 Chester Ave., Cleveland 14, Ohio.

## ELEVATOR GATES

**Collapsing Gate for Passenger Elevator Cars, Design No. 9-CG, and Collapsing Gate for Service Elevator Cars, Design No. 7-CG.** A.I.A. File sheets giving specifications of the two types of collapsing elevator gate. 1 p. ea., illus. Otis Elevator Co., 260 Eleventh Ave., New York, N. Y.\*

## FLANGES

**Pressure-Temperature Ratings for Flanges, Flanged Fittings, Valves.** An American War Standard. Tabulates the new ratings, includes chart comparisons of old and new ratings. 20 pp. Tube Turns, Inc., Louisville 1, Ky.

## HEATING UNITS

**Gar Wood Tempered-Aire Oil-Fired Home Heating Units.** Description of and advantages claimed for a complete heating unit, with table of ratings and dimensions. 8 pp., illus. Gar Wood Industries, Inc., Heating Division, 7924 Riopelle St., Detroit 11, Mich.

## LIGHTING

**Let There Be Light.** By Robert M. Stecher, M.D. An article reprinted from the Bulletin of The Medical Library Assn. Discusses light and the general level of illumination, with particular attention to reading light in libraries, reading rooms and private studies. 8 pp., illus. General Electric Co., 8811 Euclid Ave., Cleveland, Ohio.\*

**Silv-A-King RLM Specification Industrial Fluorescent Lighting Units.**

\* Other product information in Sweet's File, 1945.

Full description, including voltage, wattage, weight and price, of both closed-end and open-end units. Also gives a table indicating the average footcandles obtained at various heights and for various wall conditions with 40 and 100 watt units. 4 pp., illus. Bright Light Reflector Co., Inc., Fairfield and State, Bridgeport 5, Conn.\*

## METAL TRIMS

**B & T Metal Trims: Chromedge.** Part of the Chromedge line of nosings, edgings and bindings, cap trims and corner coves, cove base trims, color insert trims, wallboard trims, frames, stair treads, etc. Catalog numbers and specifications. 28 pp., illus. B & T Metals Co., Columbus 16, Ohio.\*

## MODELS

**Study Models of the Future Available Today.** A brochure illustrating plastic models made for demonstration and study purposes. 6 pp., illus. Stricker-Brunhuber Co., 19 W. 24th St., New York, N. Y.

## OIL FIRING

**Peabody CD Wide Range Oil Burning System (Bulletin No. 109).** Describes the system, explains how it achieves efficient combustion over a range in capacity as great as 50 to 1, controlling any number of burners throughout all variations in capacity. 4 pp., illus. Peabody Engineering Corp., 580 Fifth Ave., New York 19, N. Y.

## PLASTICS

**A Statement About DuPont Plastics . . . Present and Future, and A Review of DuPont Plastics.** Two booklets describing and illustrating the various plastics made by DuPont, with information as to their uses and potential uses. The "Review" also gives a clear and practical properties table of all the DuPont plastics. 3 pp.; 8 pp., illus. E. I. DuPont de Nemours & Co. (Inc.), Plastics Dept., Arlington, N. J.\*

## REFRIGERATION

**Worthington Centrifugal Refrigeration (Bulletin C-1100-B14).** Discusses the Worthington Centrifugal Refrigeration System, describes its cycle of operation, refrigerants used, and gives full equipment specifications. 24 pp., illus. Worthington Pump and Machinery Corp., Harrison, N. J.\*

## SPEED CONTROL

**Developments in Reeves Speed Control.** A line of special equipment such as variable speed transmission, motor pulley, handwheel, tachometer, etc. Describes each, diagrams operating

principles. 30 pp., illus. Reeves Pulley Co., Inc., Columbus, Ind.

## TIMBER CONNECTORS

**Teco Connectors for Timber Construction in Railroad Service.** A discussion of the Teco split ring, spike grids, clamping plates, etc., and their railroad applications. 20 pp., illus. Timber Engineering Co., 1319 Eighteenth St., N. W., Washington 6, D. C.

## TERMINAL LAYOUTS

**Railroad and Bus Terminal and Station Layout — Vol. I.** A handsome album (edition limited) of photographs, floor plans and descriptions of 58 recently constructed or renovated terminals. Gives floor plan of each terminal, architects' names, the lines using it, full structural details of both exterior and interior. 192 pp., illus. American Locker Co., Inc., 211 Congress St., Boston 10, Mass.

## VALVE REPAIR

**Valve Repair and Replacement Record Sheets.** Prepared especially for reconversion checkups. File folder and instructions for using the sheets included. Jenkins Bros., 80 White St., New York 13, N. Y.

## VIBRATION CONTROL

**Blaw-Knox Functional Spring Hangers and Vibration Eliminators.** Conclusions of prefabricated power piping engineers regarding the design of piping layouts for flexibility. Describes the company's spring hangers and vibration eliminators, gives tables of size and load for the various types, installation details, etc. 32 pp., illus. Blaw-Knox Co., Power Piping Division, 1525 Pennsylvania Ave., N.S., Pittsburgh 12, Penna.\*

## WATERPROOFING

**Sika.** Integral waterproofing compounds, quick-setting compounds for maintenance, guniting and pressure grouting compounds, dampproofing and jointing compounds, floor hardeners and miscellaneous products. 4 pp., illus. Individual instruction and specifications sheets for each of the various products also obtainable. Sika Chemical Corp., 35-49 Gregory Ave., Passaic, N. J.\*

## LITERATURE REQUESTED

The following architects and firms request manufacturers' literature:

Louis & Henry, Architects, 1271 Starks Bldg., Louisville 2, Ky.

McClurg & Hesse, 634 N. Central Ave., Glendale 3, Calif.

Samuel Zouri Moskowitz, Architect, 1201 Miners Bank Bldg., Wilkes-Barre, Penna.

T. Trip Russell, A.I.A., 2301 S. Miami Ave., Miami 36, Fla.



# She'll love you for this!



## The crowning touch of style-approved Cabinet Hardware by STANLEY!

This new line of Stanley Cabinet Hardware was styled by nationally noted industrial designers. Before they put a pencil to paper, these designers studied household cabinet hardware needs from A to Z. They considered functional efficiency as well as beauty. They designed ample finger room into latch pulls, pulls and knobs.

Added to the work of the designers were the results of years of research and test by the Stanley Engineering department. The result: a line of cabinet hardware that is smoother working, longer lasting and easier to install . . . and by all odds the most beautiful.

There is a style and finish to please every taste. There is a type and price to fit every budget. The moment you see it, you will realize that here, at last, is a line of cabinet hardware that will "click" with homemakers the moment they see it. Write for descriptive folder showing the complete line of Stanley Cabinet Hardware. The Stanley Works, Cabinet Hardware Division, New Britain, Conn.

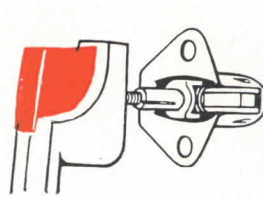

*New! Self-fitting latch -*

Pat. Applied For  
Unique new "trigger" latch has a friction sleeve which adapts itself automatically to doors from 3/4-inch to 1 1/8-inches thick. A Stanley "exclusive"!

*New! Jewel-like Plastic Inserts -*

Latch thumb-pieces molded of sparkling, durable plastics - red or black - give modern beauty to this hardware.



# STANLEY

Trade Mark

## Cabinet Hardware

# Commercial National Bank *built with* Q-FLOORS

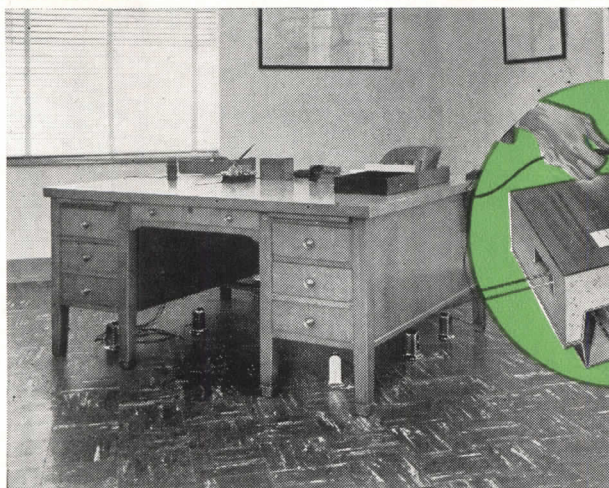

THIS IS 7 SQ. FT. OF Q FLOOR

The architects—McKim, Mead & White and  
\*Samuel G. Wiener could cope with

*Tenants' frequent  
floor layout changes*

In any building it is impossible to know in advance exactly where all the electrical outlets will be wanted. Q-Floors remove the need of trying to plan for the unpredictable.

Q-Floors are so constructed that any

And James Stewart & Co., contractors, could have

*Floors up almost  
as fast as the frame*

Speedier construction is another Q-Floor feature that all clients appreciate immediately. Because Q-Floors can be laid at the rate of 32 sq. ft. in 30 seconds by two men, they greatly speed up building. Furthermore, they become an immediate working platform for all other trades—noncombustible, clean, dry and uncluttered with no forms or shoring to cause delay and accident. Q-Floor construction

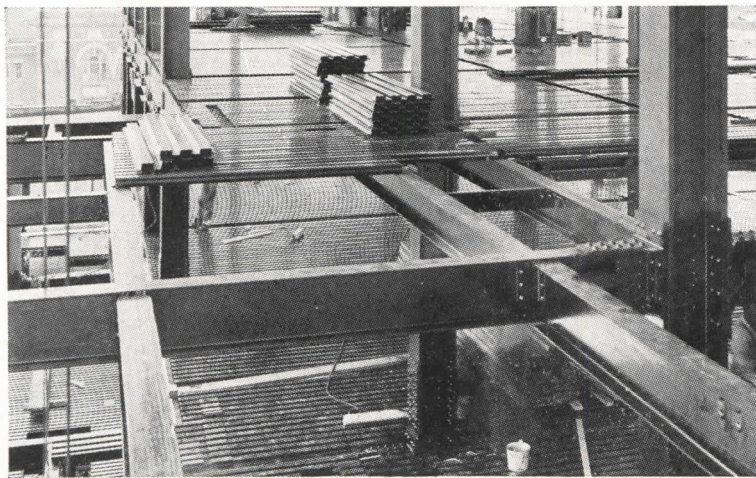

THE EASIEST THING FOR A BUILDER TO FORGET..

*Floors are what a building is for!*

H. H. ROBERTSON CO.



2404 Farmers Bank Building  
Pittsburgh 22, Pennsylvania

Offices in 49 Principal Cities  
World-Wide Building Service

SHREVEPORT, LA.

*because..*

six-inch area can be tapped for power. In simplified terms, Q-Floors are steel cells crossed over by raceways. It takes only a few minutes for an electrician to drill a small hole and install an outlet—anywhere, any time—without digging trenches.

This electrical availability over the entire floor permits continuous change of floor layout from the day the tenants move in, till the day electricity bows out of civilization.

\*Previous advertisements showing the Commercial National Bank Building omitted by error the name of Samuel G. Wiener.

actually reduces over-all building time from 20 to 30%, as proved by thousands of Robertson installations. Time saved is readily interpreted by your client as money saved on building expense or as revenue earned by earlier rentals.

When it comes to cost, there are several other factors in favor of Q-Floor. Any Robertson representative can show you that cost is right in line, despite the unique advantages which are worthy of premium price.

For Q-Floor literature, write the H. H. Robertson Co. To see Q-Floor Fittings, call on any General Electric Construction Materials distributor.



Q • FLOORS

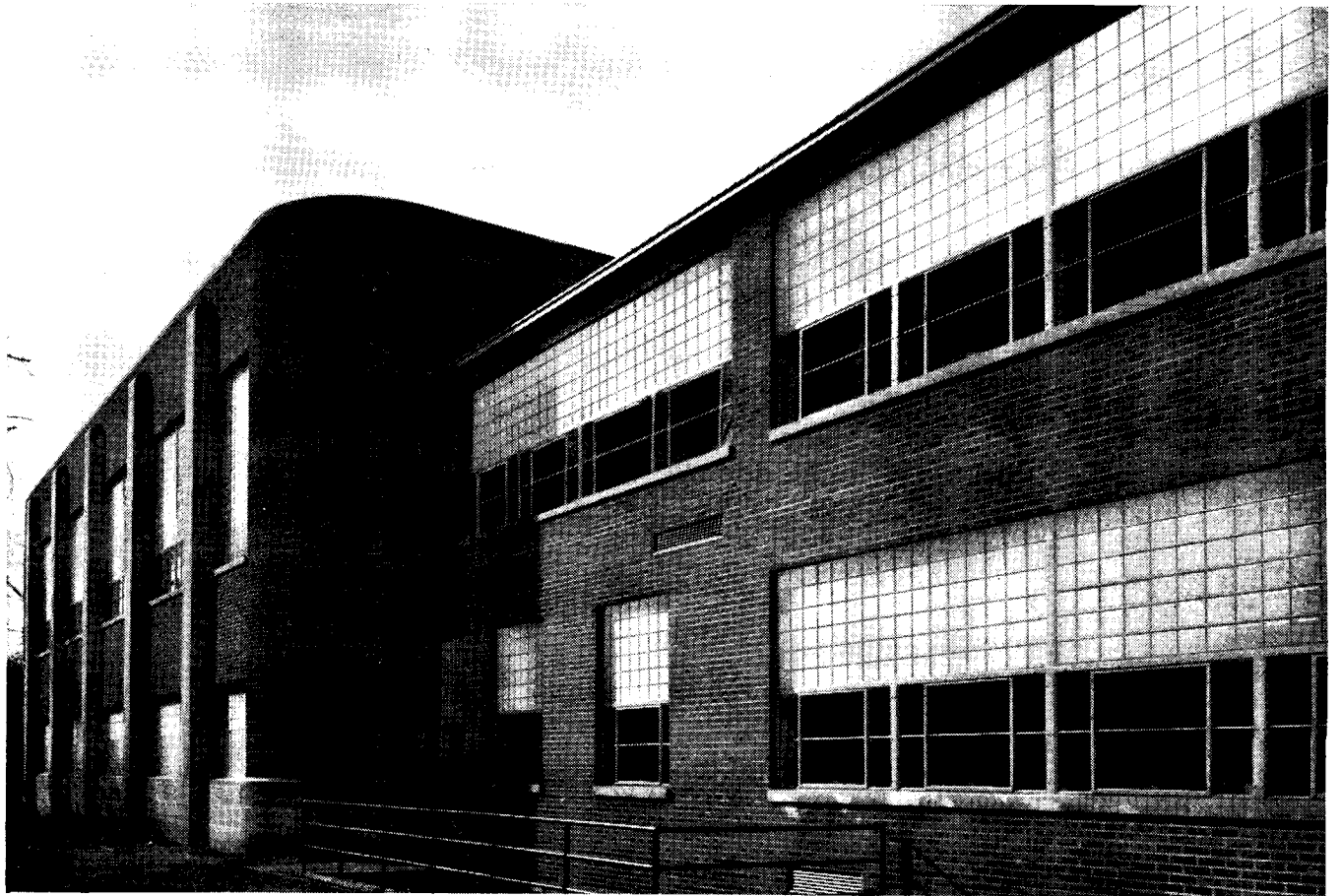

New Wauseon High School, Wauseon, Ohio, Architects—Britsch & Munger, Toledo, Ohio.

**ALL WORKING SURFACES**

***FLOODED WITH DAYLIGHT!***

ARCHITECTS have found a way to eliminate troublesome glare and to flood schoolrooms with softly-diffused *natural daylight*.

This has been accomplished through the use of windows and the new Insulux Light-Directional Block. As shown by the photographs on this page, clear glass is used from sill-height to somewhat above eye level. This provides a narrow vision panel. Above that point—the new Insulux

prismatic glass block is used. As a result, the main beam of light is bent upward to the ceiling and is reflected deep into the interior of the classroom. There is a substantial improvement in illumination.

Investigate! Panels of Insulux are now being used in schools throughout America to *daylight* classrooms, lecture halls, laboratories, gymnasiums, libraries, swimming pools, corridors and entrance ways.

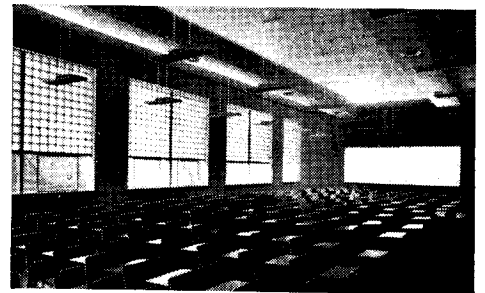

This large classroom is flooded with daylight. There is light for all—without objectionable glare!

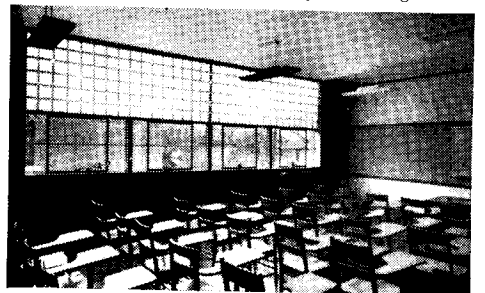

This study hall is daylighted with a combination panel of windows and the new Insulux Light-Directional Block.

**OWENS - ILLINOIS**

**INSULUX**

**GLASS BLOCK**

For technical data, specifications, and installation details, see our section in Sweet's Architectural Catalog, or write: Insulux Products Division, Dept. C- 2, Owens-Illinois Glass Company, Toledo 1, Ohio.

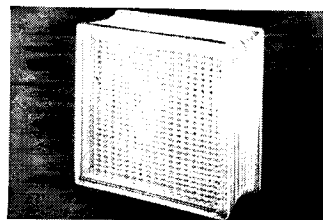

*Insulux Glass Block is a functional building material—not merely a decoration. It is designed to do certain things that other building materials cannot do. Investigate!*



*Architects and  
Builders are  
Invited to Consult*

**VAN DORN**

... on **PRISON PLANNING**  
**Construction and Equipment**



**T**HE Van Dorn organization has a wealth of authentic information on modern prison design and construction. Van Dorn has helped plan and produce more prison projects than any other organization in America.

Van Dorn has pioneered in the development of prison equipment and accessories. Its extensive manufacturing facilities occupy more than 460,000 square feet.

Van Dorn's erection methods are modern and efficient.

**THE VAN DORN IRON WORKS CO.**

2685 EAST 79TH STREET • CLEVELAND 4, OHIO

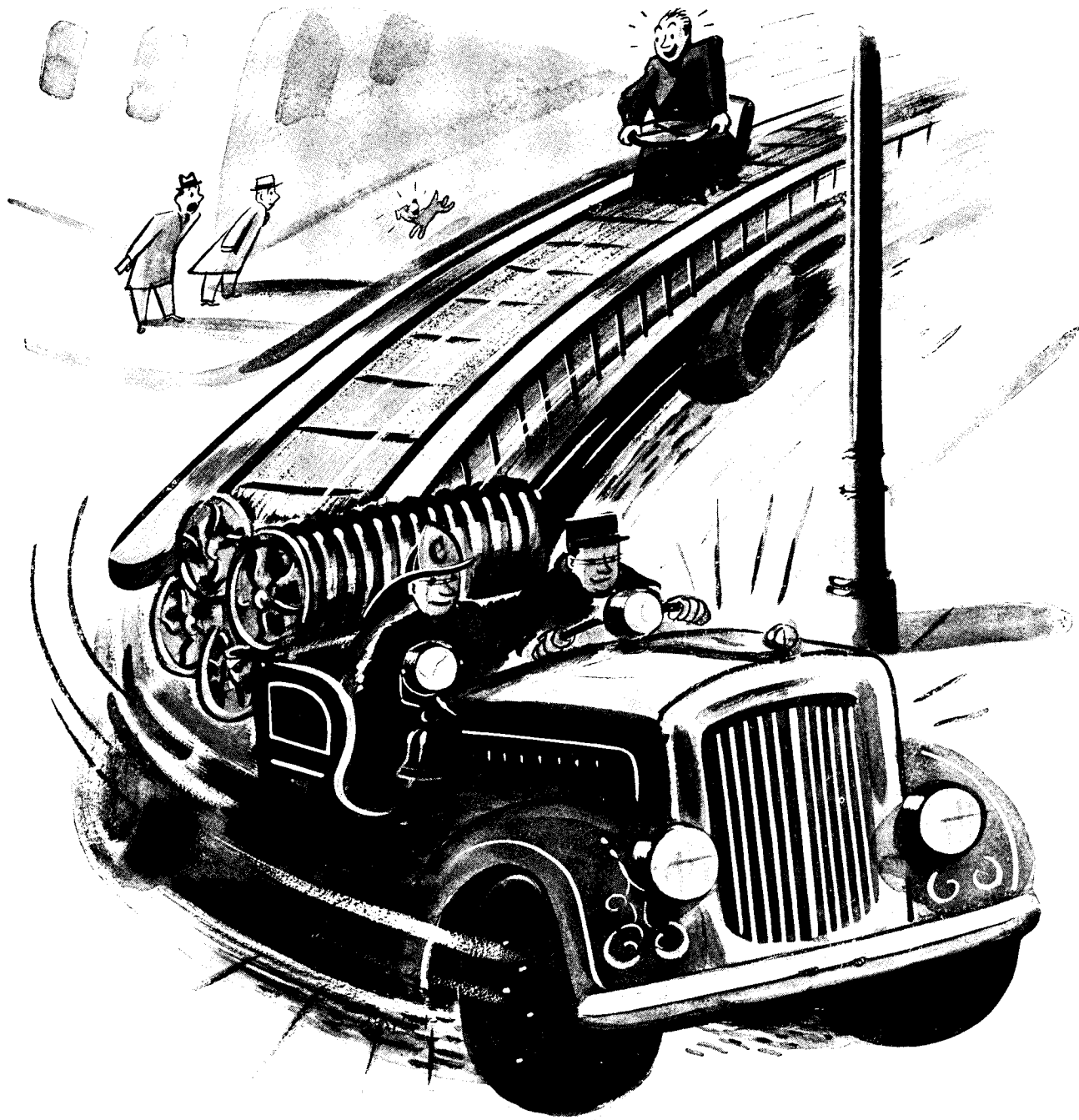

## Teamwork helps cut corners

Cooperation counts in any business . . . especially yours. We can make the best window shades and Venetian blinds in the world (as we modestly think we do) but we honestly couldn't do it without our dealers. They keep us posted on what you want in blinds and shades. They study your installation prob-

lems so they can put up our products to give you years of dependable service. When you specify Columbia shades and blinds, you're buying the results of a team that has joined up to give you the most for your money!

*See Sweet's Architectural Catalogue for more complete information on Columbia products.*

*Columbia* WINDOW SHADES  
AND VENETIAN BLINDS

THE COLUMBIA MILLS, INC. • 225 FIFTH AVENUE, NEW YORK 10, N.Y.

# AN 18 YEAR RECORD OF TOUGH SERVICE!



HOTELS

**A** GOOD deal of recent discussion seems to indicate that the plastics age is in the future, and of course it is, in the sense that plastics will be much more widely used than they ever have been.

But you should not overlook the fact that at least one plastic material, laminated plastic Formica has been serving since 1927 in some of the hardest architectural surfacing applications, meeting the most brutal wear and abuse and maintaining over the years its original beauty and sparkle.

In hotels for instance, it has served for years as tops for bedroom furniture defying cigarettes and alcohol; it has been used also in hotels for table tops in restaurants, coffee shops, bars, for elevator interiors, column covering, and wall paneling.

In train, bus, and rail terminals you will find it on main entrance doors—and there are none that get more severe use.

It is also applied there to ticket counters, telegraph desks, telephone booths, soda fountains.

In hospitals its stain proof beauty enables it to perform for years without deterioration on bedside and overbed table tops, private room furniture, shelving in the pharmacy—all spots where no ordinary material could stand up.

Restaurants use it for counter tops and panels, cashiers' desks, table tops, window backgrounds, booth partitions and many other uses.

Main entrance doors of theaters, lobby paneling, ticket booths, water fountain back panels, partitions and wall covering in toilet rooms have been equipped with it.

In busses, trains, and planes it is used for window stools, seat backs and ends, table tops, shelving and similar purposes.

In short, wherever exceptional appearance must be combined with unusual resistance to wear there you will find Formica in solid colors, patterns, inlays, and "Realwoods" in which the genuine veneer of rare woods is introduced into the plastic sheet.

For periods up to 18 years Formica has made good in these uses. It is no Johnny-come-lately—but a thoroughly tried, thoroughly tested and well established material. You take no chances when you specify Formica.

Colors, patterns, inlays, and "Realwoods" in which the genuine veneer of rare woods is introduced into the plastic sheet.

For periods up to 18 years Formica has made good in these uses. It is no Johnny-come-lately—but a thoroughly tried, thoroughly tested and well established material. You take no chances when you specify Formica.

Colors, patterns, inlays, and "Realwoods" in which the genuine veneer of rare woods is introduced into the plastic sheet.

For periods up to 18 years Formica has made good in these uses. It is no Johnny-come-lately—but a thoroughly tried, thoroughly tested and well established material. You take no chances when you specify Formica.

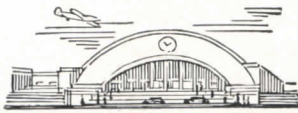

AIR, BUS, RAIL TERMINALS



HOSPITALS



RESTAURANTS



THEATERS

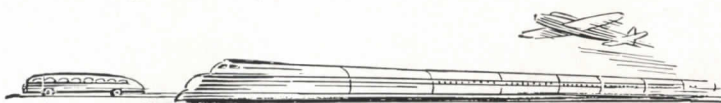

TRAINS, BUSES, PLANES

## TOUGH JOBS FORMICA HAS DONE

Entrance Doors Penn Station New York

Table Tops on the Twentieth Century and Broadway Limited Trains.

Furniture, Table Tops, Bars, Bathroom Walls on Queen Mary and Queen Elizabeth.

Wall Paneling of the President's own room at the National Airport, Washington, D. C.

Furniture, Counter tops, Bars, Cocktail room table tops, Washington Statler.

Book Shelves, Desk Panels and Tops, Reading Tables and Tops, Annex to Congressional Library.

Bar Panels and Tops at Lindy's New York Restaurant.

Lobby Paneling and Entrance Doors in scores of Warner Brothers Theaters.

Commissary Paneling Counter Tops and Amphitheater Walls Naval Medical Center, Bethesda, Md.

Elevator Interiors, Municipal Building, Washington, D. C.

Cafeteria Table Tops, Supreme Court Building, Washington, D. C.

These are only a few of the thousands of heavy tasks Formica has been given by top architects and decorators. On its record in service it will get thousands more like them.



THE FORMICA INSULATION COMPANY, 4651 SPRING GROVE AVENUE, CINCINNATI 2, OHIO

# PCA Policy on Engineering and Architectural Service

Because the Portland Cement Association believes that the best interests of the individual and the community are served when competent professional services are engaged to insure sound building construction, it is a basic Association policy to urge the employment of qualified engineers or architects on concrete construction whether the job is a skyscraper, a bridge, a pavement, a sewer, a house or a farm structure.

A principal function of the Association's staff of concrete technicians is to assist engineers and architects with concrete design or construction problems.

The educational literature and the many drawings of typical concrete uses which the Association distributes widely in the United States and Canada, are intended to be helpful in obtaining the maximum service which concrete can render.

Drawings of typical designs carry a notation to the effect that final working drawings should be prepared and approved by qualified engineers or architects.

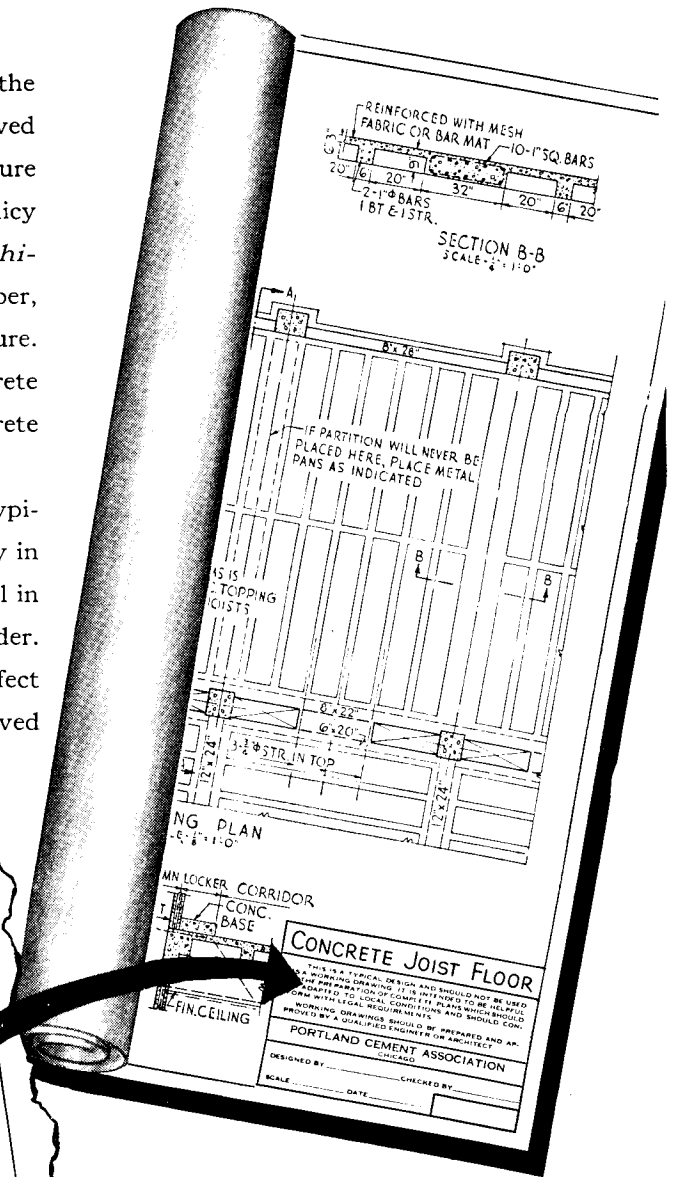
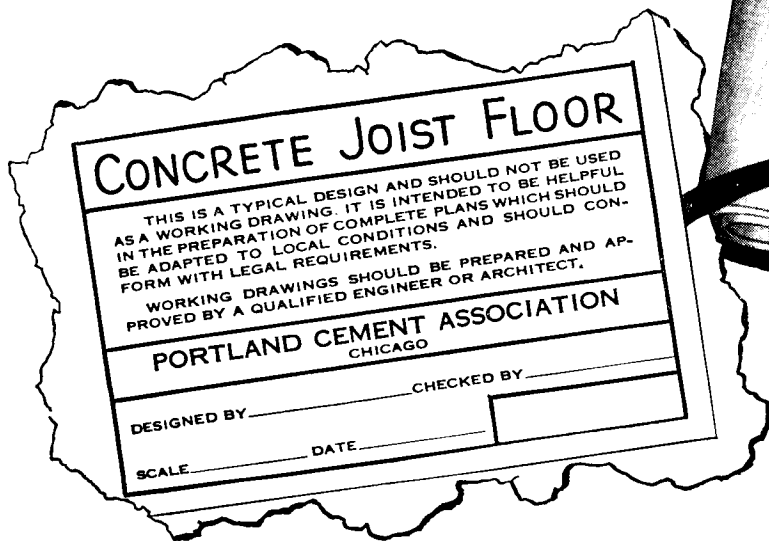

## PORTLAND CEMENT ASSOCIATION

Dept. 2-8, 33 W. Grand Ave., Chicago 10, Illinois

A national organization to improve and extend the uses of concrete... through scientific research and engineering field work





# Red Lead is ALWAYS $Pb_3O_4$ ... that's why it's a Dependable Metal Paint

Industry has yet to discover a better metal protective paint than Red Lead. This is due to inherent fundamental properties of the pigment itself.

Among the most important of these are Red Lead's definite chemical composition and its purity, as distinguished from pigments that have indefinite composition or vary from batch to batch, with resulting possibility of variation in performance.

The reason for this uniformity is that red lead is a simple chemical compound—a combination of only two elements, oxygen and high-purity metallic lead. It is also an extremely pure compound, containing no corrosion accelerating impurities such as water-soluble chlorides or sulfates.

Uniform performance means predictable chemical behavior—dependable performance as a rust-inhibitive paint, day after day, job after job.

Furthermore Red Lead has the property of controlling acid conditions recognized as accelerators of rust. In the presence of various acids, Red Lead forms insoluble lead salts, at the approximate rate at which the acids are supplied. This is true whether the acids originate from acid forming environments, such as gas, smoke, and moisture in the atmosphere, or from the oxidation of the paint vehicle.

Remember, too, that Red Lead is compatible with practically all vehicles commonly used in metal protective paints, including all the fast drying resins.

Specify RED LEAD  
for All Metal Protective Paints

The value of Red Lead as a rust preventive is most fully realized in a paint where it is the

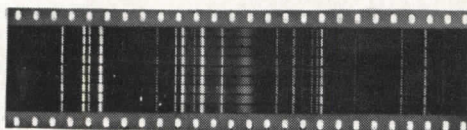

These spectograms show the high degree of uniformity and purity of nine different batches of Red Lead. Each spectrum is a practical duplicate of every other. Such uniformity is an important reason for Red Lead's outstanding performance.

only pigment used. However, its rust-resistant properties are so pronounced that it also improves any multiple pigment paint. No matter what price you pay, you'll get a better paint for surface protection of metal if it contains Red Lead.

\* \* \*

Write for New Booklet — "Red Lead in Corrosion Resistant Paints" is an up-to-date, authoritative guide for those responsible for specifying and formulating paint for structural iron and steel. It describes in detail the scientific reasons why Red Lead gives superior protection. It also includes typical specification formulas. If you haven't received your copy, address nearest branch listed below.

\* \* \*

The benefit of our extensive experience with metal protective paints for both underwater and atmospheric use is available through our technical staff.

NATIONAL LEAD COMPANY: New York 6, Buffalo 3, Chicago 80, Cincinnati 3, Cleveland 13, St. Louis 1, San Francisco 10, Boston 6 (National Lead Co. of Mass.); Philadelphia 7 (John T. Lewis & Bros. Co.); Pittsburgh 30 (National Lead Co. of Pa.); Charleston 25, W. Va. (Evans Lead Division).



## Dutch Boy Red Lead

# Extra Copper Plus Molybdenum Makes Toncan Iron

# Say "Stop" to Rust

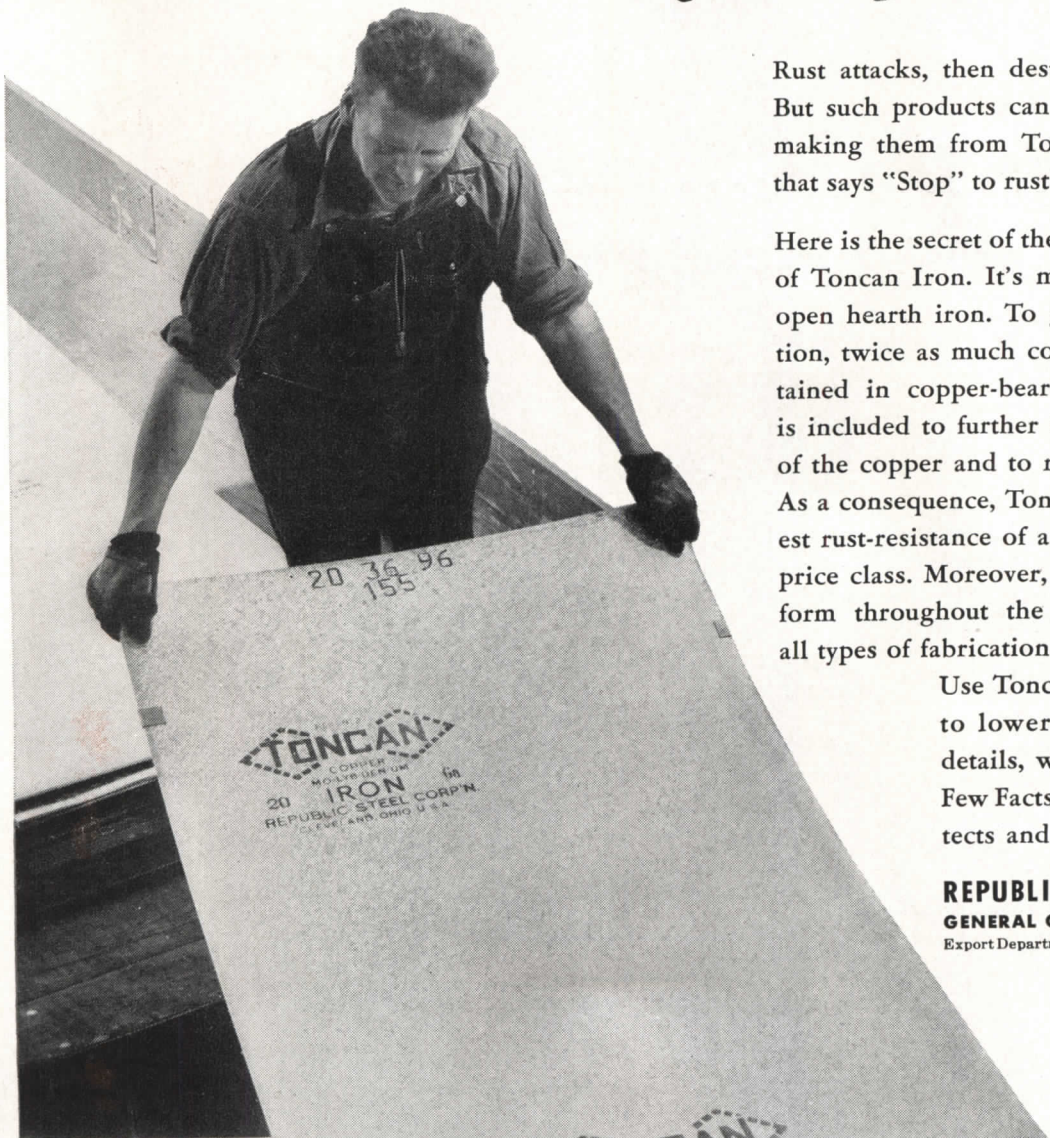

Rust attacks, then destroys, sheet metal parts. But such products can be given longer life by making them from Toncan Iron—the material that says "Stop" to rust and means it.

Here is the secret of the stubborn rust-resistance of Toncan Iron. It's made from highly refined open hearth iron. To give it extra rust protection, twice as much copper is added as is contained in copper-bearing steels. Molybdenum is included to further increase the effectiveness of the copper and to refine the grain structure. As a consequence, Toncan Iron offers the greatest rust-resistance of any ferrous material in its price class. Moreover, this rust-resistance—uniform throughout the metal—is unaffected by all types of fabrication.

Use Toncan Iron to resist rust and to lower fabricating costs. For details, write for Booklet 406, "A Few Facts About Toncan for Architects and Engineers."

**REPUBLIC STEEL CORPORATION**  
**GENERAL OFFICES • CLEVELAND 1, OHIO**  
 Export Department: Chrysler Building, New York 17, N. Y.

### See SWEET'S FILE

—or write us for detailed information on these Republic Steel Building Products:

- Pipe—Sheets—Roofing
- Enduro Stainless Steel
- Toncan Enameling Iron
- Electrunite E. M. T.
- Fretz-Moon Rigid Steel Conduit
- Taylor Roofing Terns
- Berger Lockers, Bins, Shelving, Kitchen Cabinets
- Truscon Steel Windows, Doors, Joists
- and other building products

## Republic



# TONCAN COPPER MOLYBDENUM IRON

Reg. U. S. Pat. Off.

—for ducts, gutters, conductor pipes, roofing, siding, tanks, ventilators, skylights, hoods, and other sheet metal applications requiring rust-resistance.

# Where is the Radiator?

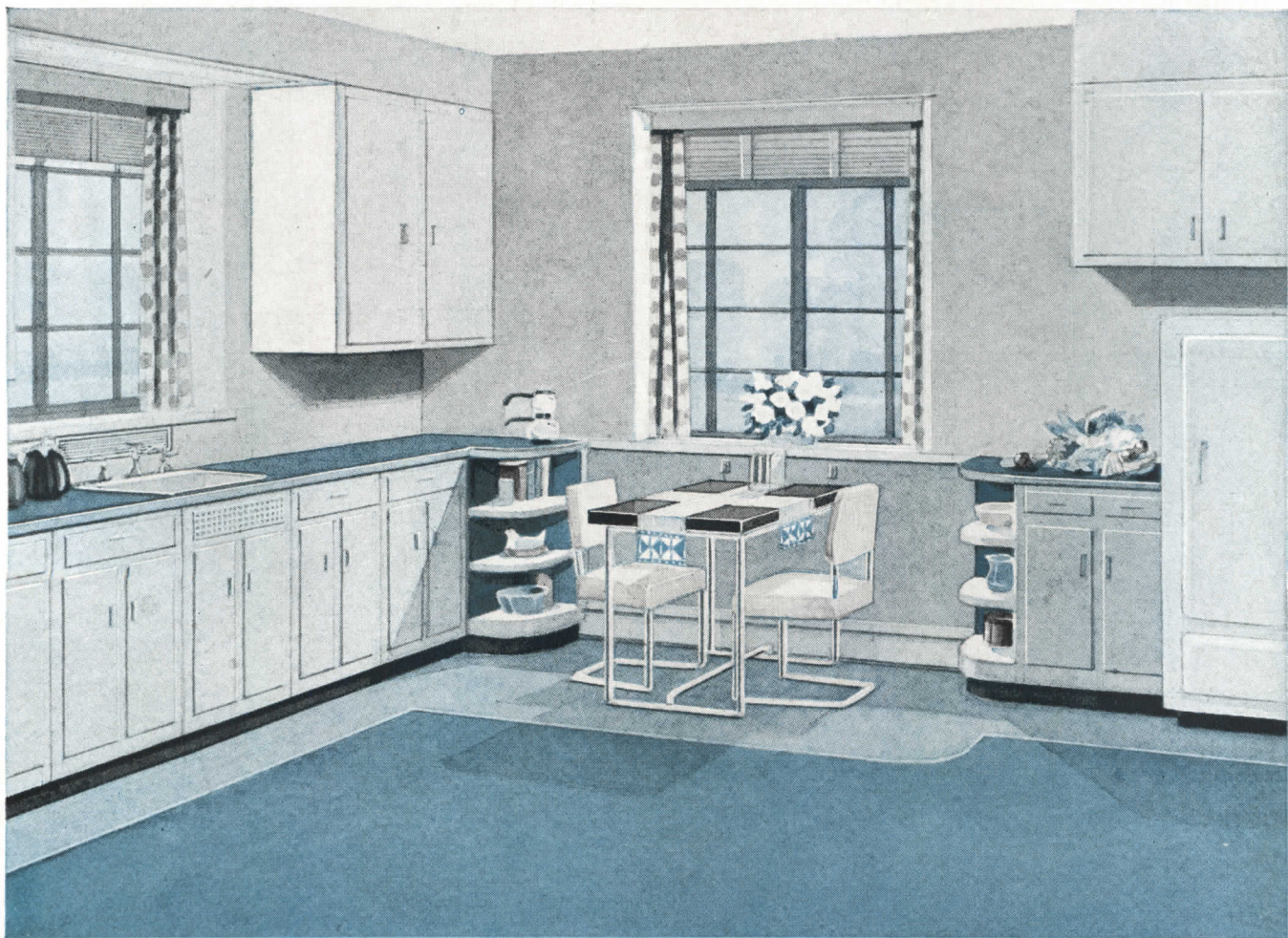

This is the Home of Tomorrow. This is the home free of radiators, where the heating element is so small that it fits behind the baseboard—completely out of sight.

In this new Webster Baseboard Heating, hot water circulates through the heating element, a copper tube around which are coiled fins of fine copper. This heating element is installed in a continuous line all around the exposed walls of the room. The Baseboard enclosure is removable for cleaning.

Air goes in at the floor line, passes over the heating element, is warmed and comes out at the top—a constant, even circulation.

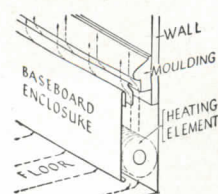

With Webster Baseboard Heating there's nothing to mar the beauty of the room or limit your plans for interior decoration or furniture arrangement. And the

absence of radiators adds considerably to the usable space in the room.

Tested installations of this new Webster Baseboard Heating show a variation of less than 2° from floor to ceiling. No cold corners. No hot spots.

Webster Baseboard Heating has been under development for several years and has met the most severe operational tests. Deliveries are limited at present and will be increased as rapidly as materials can be made available.

A leading architect collaborated with a noted interior decorator in preparing a series of paintings showing application of Webster Baseboard Heating to different types of rooms. These paintings have been reproduced in full color. Let us send you a copy of this brochure on Webster Baseboard Heating. Address Dept. AR-2.

**Make this test:** Cut out illustration of radiator at right. Place cut-out picture in position under window in the illustration above. See how the presence of a radiator in the room interrupts the scheme of decoration.

WARREN WEBSTER & COMPANY, Camden, New Jersey  
Pioneers of the Vacuum System of Steam Heating: : Established 1888  
Representatives in principal cities : : Darling Brothers, Limited, Montreal, Canada

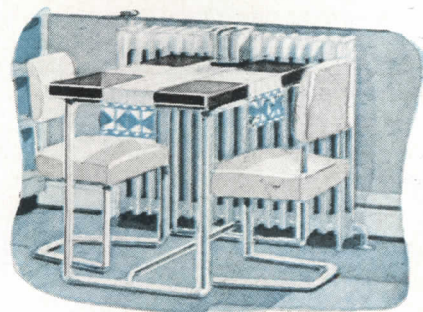

CLIENTS APPRECIATE QUALITY—  
 THAT'S WHY MY PLUMBING  
 SPECIFICATIONS SAY **CRANE**

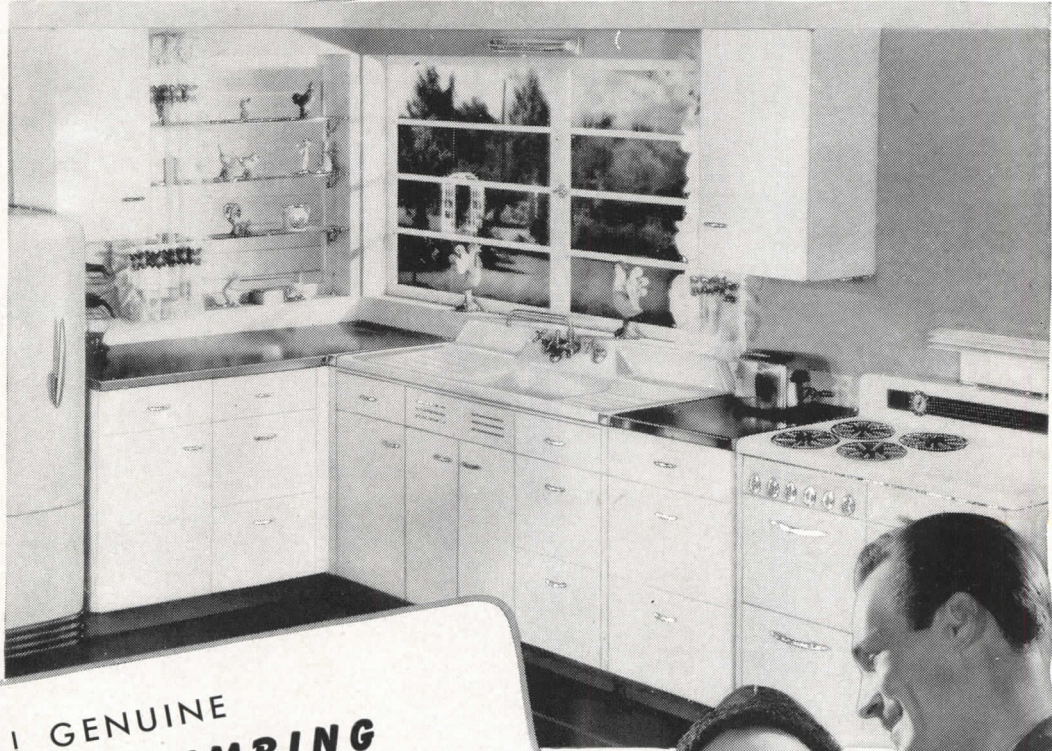

JUST THINK! GENUINE  
**CRANE PLUMBING**  
 IN OUR MODEST PRICED HOME



Many architects have found that Crane plumbing in homes they plan not only pleases clients, but does full justice to their architectural conception. The wide selection of fixtures in the Crane line gives free range to your planning and permits the utmost flexibility in artistic design. The price range includes fixtures to fit every building budget.

The new Crane line represents advanced thinking and modern styling. It reflects the popular trend toward simple dignity and functional efficiency. Crane engineers have perfected many mechanical features that bring the home owner greater convenience. For example, faucets now open and close at a slight touch, thanks to *Dial-ese* trim that harnesses water pressure to do the manual work.

Many items in the Crane line are now in production, but it will be some time before everyone can be supplied. It is, therefore, desirable that you discuss your plans with your Plumbing Contractor or Crane Branch. They will do everything possible to help you provide sanitary equipment for your clients when they need it.

# CRANE

CRANE CO., GENERAL OFFICES:  
 836 S. MICHIGAN AVE., CHICAGO 5  
 PLUMBING • HEATING • PUMPS  
 VALVES • FITTINGS • PIPE

NATION-WIDE SERVICE THROUGH BRANCHES, WHOLESALERS, PLUMBING AND HEATING CONTRACTORS

# "Continuous Line" Fluorescent

1. MATERIALLY INCREASES SCHOOLROOM SEE-ABILITY
2. IS EASILY ADAPTED TO ANY ARCHITECTURAL TREATMENT
3. IS ECONOMICAL TO INSTALL IN NEW OR EXISTING STRUCTURES

Architects, electrical contractors and school authorities may well be proud of schoolroom see-ability like this. Since 87 percent of all learning is visual, teaching, as well as learning, is faster, more efficient and a great deal more pleasant when it is the beneficiary of a well planned lighting system.

Continuous line fluorescent lighting systems by Westinghouse rate high with both teachers and pupils. They like the higher intensity and quality of illumination that results from correctly designed equipment and efficiently engineered application.

J-04069

**PLAN** of continuous line fluorescent lighting in average size schoolroom. Here twelve Westinghouse Type LW-160 luminaires (each equipped with four 40-watt lamps) increased the level of illumination from an inadequate 3.6 to approximately 40 footcandles.

**REQUEST FREE** School Lighting Folder B-3722 from your nearest Westinghouse office. It contains a complete analysis of the engineering principles and costs involved in arriving at this excellent schoolroom see-ability.

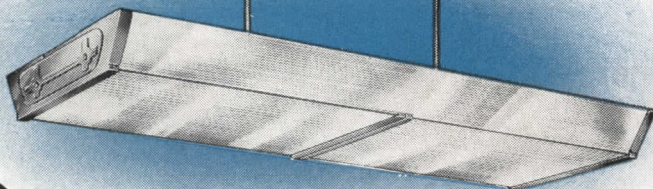
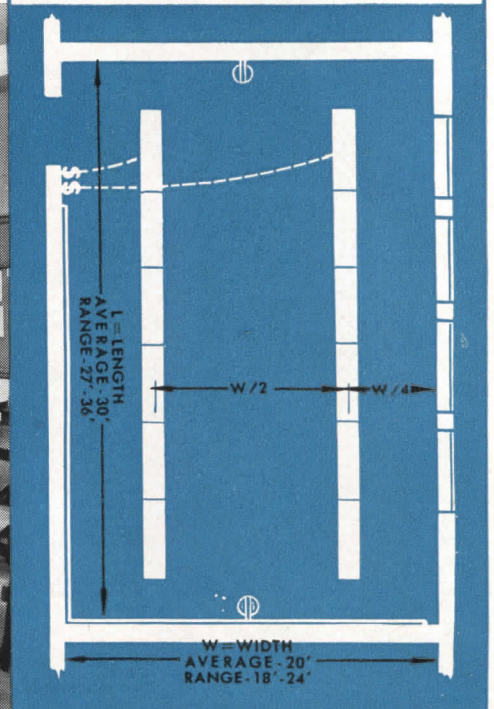
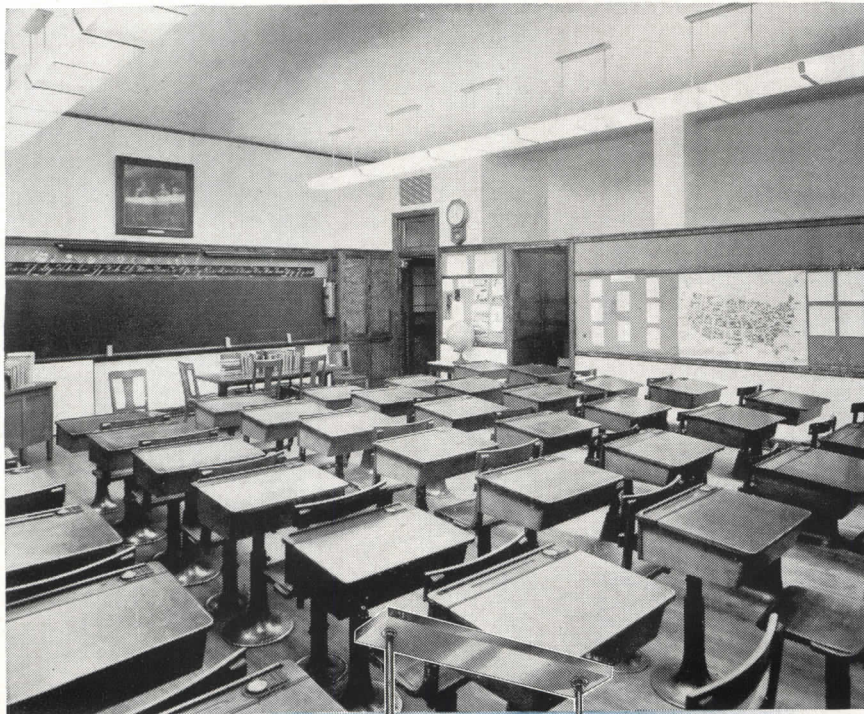

←**LW-160 LUMINAIRE:** For direct-indirect illumination. Rugged metal chassis, rigidly attached to end plates, forms sturdy support for side and bottom panels of ribbed diffusing glass. LW-160 units are also available with end and intermediate brackets which replace suspension hangers for mounting luminaire close to ceiling. May be wired through suspension hangers or through rigid or flexible conduit. Fully approved by Underwriters' Laboratories, Inc.



**Westinghouse**  
PLANTS IN 25 CITIES... OFFICES EVERYWHERE

*Lighting Equipment*

FOR ASSISTANCE in preparing your school lighting recommendations, request the service of a Westinghouse Lighting Engineer. Contact any one of the 127 Westinghouse Electric Supply Company or Independent Distributors' offices nearest you, or write Westinghouse Electric Corporation, P.O. Box 868, Pittsburgh 30, Pennsylvania.

*Announcing Bloomingdale's  
1946 Architectural Competition*

**FOR THE DESIGN OF**

*"Suburban Houses for New Yorkers"*

**\$10,800 IN PRIZES. CLOSING DATE, MARCH 25, 1946**

**THE PRIZES**

|                                      |         |
|--------------------------------------|---------|
| 6 first prizes of \$1,000 each ..... | \$6,000 |
| 6 second prizes of \$500 each .....  | 3,000   |
| 6 third prizes of \$300 each .....   | 1,800   |

**THE JURY OF AWARD**

|                                 |                              |
|---------------------------------|------------------------------|
| J. Gordon Carr, A.I.A.          | Edward A. Stone              |
| Robert Allan Jacobs, A.I.A.     | Russell F. Whitehead, A.I.A. |
| Frederick J. Woodbridge, A.I.A. |                              |

**PROFESSIONAL ADVISER**

**Kenneth Reid, A.I.A. conducting the competition for  
Bloomingdale's**

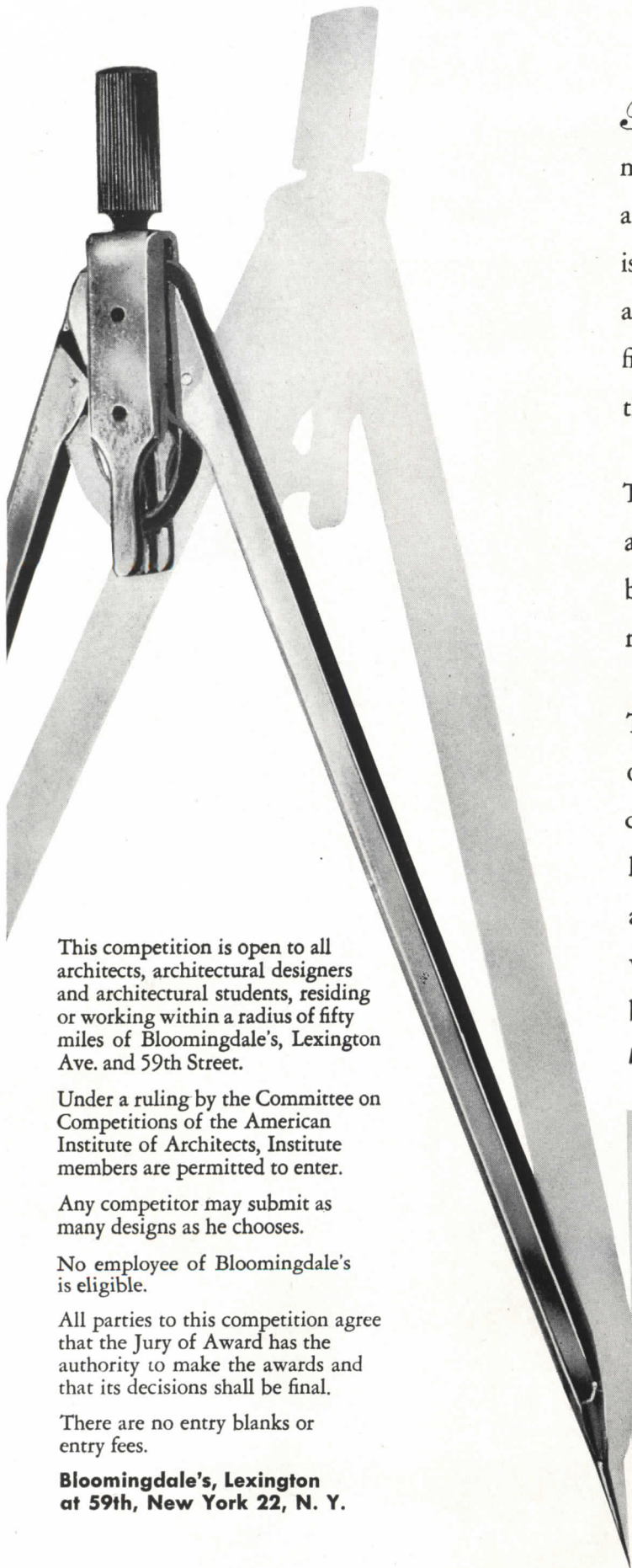

*Bloomingdale's* is a store that for many years has taken an active interest in new and original ideas for home furnishings. It is a logical sponsor for this competition, held to acquaint the public with the possibilities of fine architect-designed small homes in the New York area.

The winning designs will be widely publicized and, in *Bloomingdale's* itself, they will be the basis for an important display of home furnishing and decorating early in the fall of 1946.

The award-winning designers will gain not only prizes but the advantages of having their designs shown to thousands of prospective home builders in New York. Names and addresses of the designers will be displayed with their drawings and inquiries will be referred to them.

**Mail coupon now for copy of official program.**

This competition is open to all architects, architectural designers and architectural students, residing or working within a radius of fifty miles of *Bloomingdale's*, Lexington Ave. and 59th Street.

Under a ruling by the Committee on Competitions of the American Institute of Architects, Institute members are permitted to enter.

Any competitor may submit as many designs as he chooses.

No employee of *Bloomingdale's* is eligible.

All parties to this competition agree that the Jury of Award has the authority to make the awards and that its decisions shall be final.

There are no entry blanks or entry fees.

**Bloomingdale's, Lexington  
at 59th, New York 22, N. Y.**

**Kenneth Reid, A.I.A.**

**330 West 42nd Street, New York 18, N. Y.**

**Please send me, without obligation, a copy of the official program for *Bloomingdale's* Architectural Competition, "Suburban Houses for New Yorkers".**

**Name** .....

**Address** .....

**City and Zone** ..... **State** .....

# SPECIFY G-E Q-FLOOR WIRING

WITH ROBERTSON Q-FLOORS

FOR ELECTRICAL ADEQUACY

G-E Q-Floor Wiring installed in Robertson Q-Floors provides undreamed of electrical adaptability, flexibility and availability in office buildings, factories, stores, etc. Therefore, your clients will benefit if you always specify G-E Q-Floor Wiring when you specify Robertson Cellular steel floors.

G-E Q-Floor Wiring is simple. It consists of header ducts and accessories. The header ducts feed wires into the floor cells. This accounts for the wide electrical adequacy. Outlets can be established every few inches in all parts of the floor at any time. Changes in building equipment can be made at will with new power, telephone and signal connections readily available.

FOR FURTHER INFORMATION on G-E Q-Floor Wiring or G-E Fiberduct underfloor raceways see the nearest G-E Merchandise Distributor or write to Section C262-44, Appliance and Merchandise Department, General Electric Company, Bridgeport, Conn.

**SPECIFY G-E FIBERDUCT  
with Wood and Concrete Floors**

G-E Fiberduct underfloor raceways provide utmost electrical adequacy and flexibility when masonry or wood-type construction is used. Outlets can be preset at the factory or added later at any time.

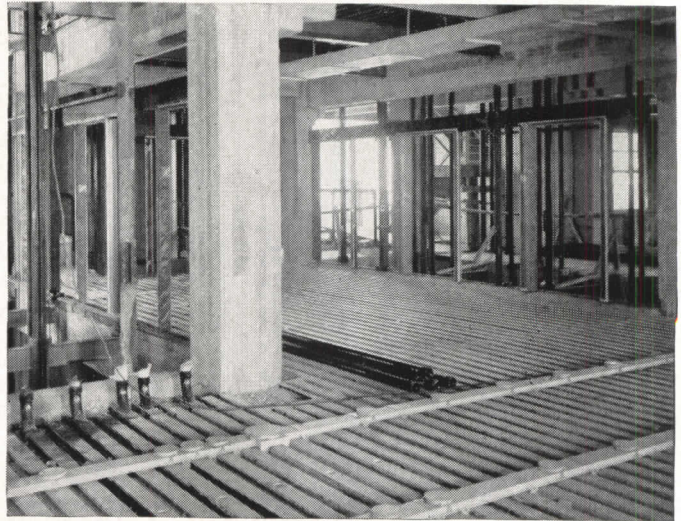

Here two G-E Q-Floor Wiring header ducts are being installed to provide two different services. These header ducts feed the cells. Note cell ells for panel connections in lower right of photograph.



Above photograph is of a sales floor in a store with G-E Q-Floor Wiring. Note the many floor outlets in different parts of the room. Power is readily available for working models, etc.

**GENERAL  ELECTRIC**





# Assurance



A FINISHED PRODUCT reflects the degree of assurance with which the original planning was undertaken. Proper tools help to provide this assurance... drawing pencils for example, that assure accuracy of detail, perfect rendering and reproduction.

VENUS Drawing Pencils are engineered to give you drafting perfection without failure: accurately *graded* to assure uniformity in all 17 degrees... *strong* in performance... *smooth* and *clean* in action.

**VENUS** DRAWING  
PENCILS

AMERICAN LEAD PENCIL COMPANY, HOBOKEN, NEW JERSEY

# Better sheet copper construction

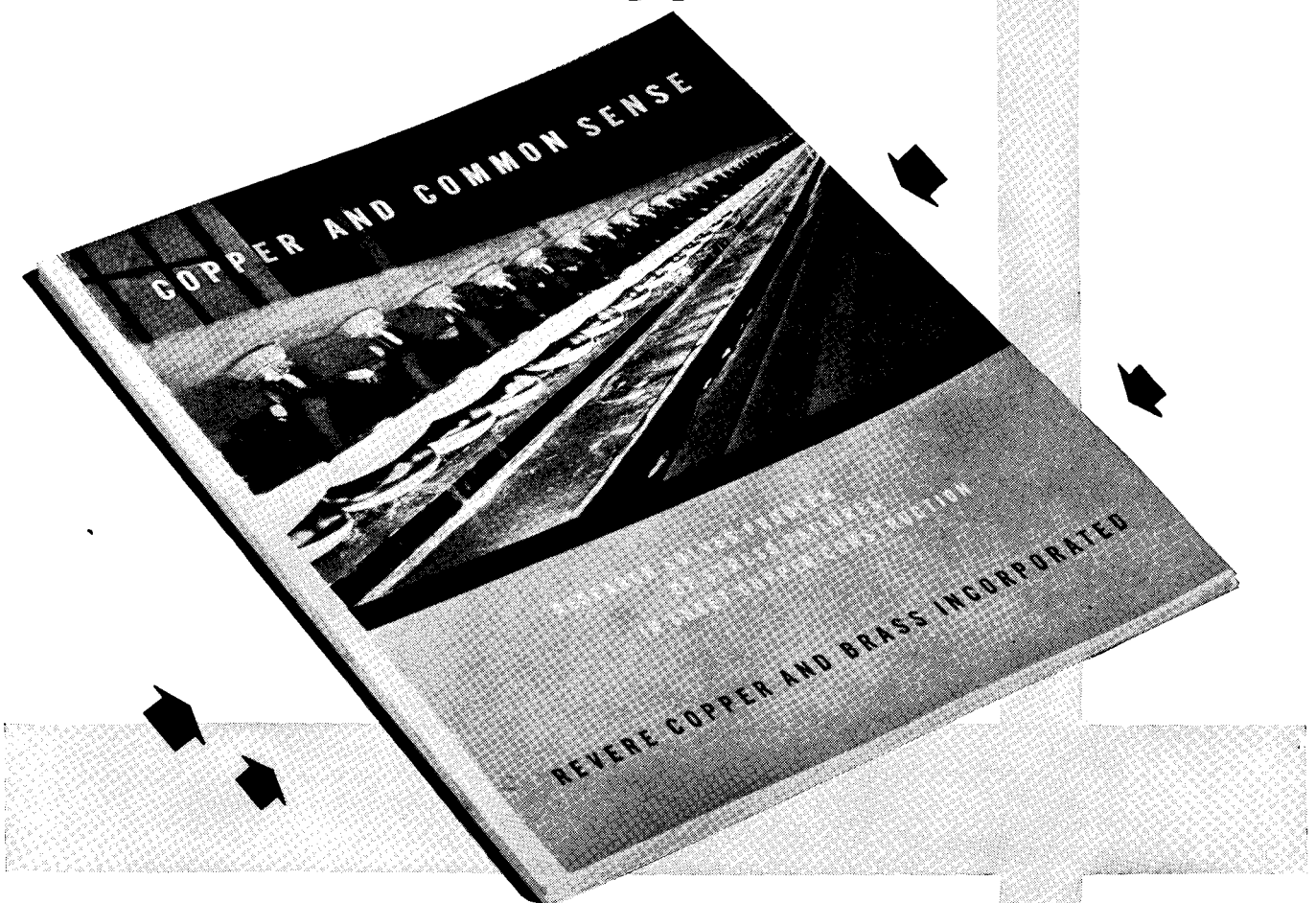

...this new book makes it crystal clear

ARCHITECTS and sheet metal experts throughout the country know that Revere research has developed important new facts about sheet copper construction for all types of buildings. Many have already consulted us, quickly grasped the new principles and applied them to the benefit of their business. Now the facts are available in book form. The *how* and *why* are made simple and clear with actual photographs, with easy-to-use charts, with dozens of full-page details covering every kind of installation.

This important 96-page book answers the questions that experienced architects and sheet metal contractors have asked themselves for years, have often brought to us as serious problems, have turned to Revere's technicians to help them solve. You need work out no engineering formulas—now you need only read and apply the final figures from large charts in order to be sure of the finest sheet copper construction that can be built.

While the limited supply is available a copy of "Copper and Common Sense" will be sent *free* to any architect or contractor requesting it. Write today on your letterhead to Revere.

## **REVERE**

**COPPER AND BRASS INCORPORATED**

*Founded by Paul Revere in 1801*

230 Park Avenue, New York 17, N. Y.

*Mills: Baltimore, Md.; Chicago, Ill.; Detroit, Mich.;  
New Bedford, Mass.; Rome, N. Y.*

*Sales Offices in principal cities, distributors everywhere.*

Listen to *Exploring the Unknown* on the Mutual Network every Sunday evening, 9 to 9:30 p. m., EST.

*Designed*

**FOR THE TIMES**



*The Jefferson*

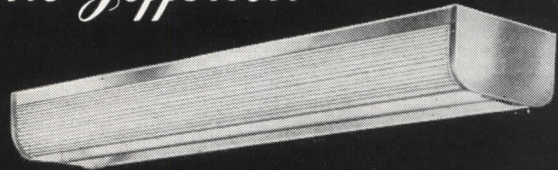

*The Van Buren*



*The Tyler*

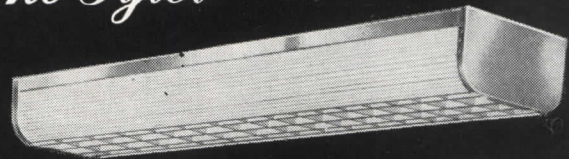

*The Wilson*



*The Presidential Series*

of Pittsburgh  
Permaflexor

Fluorescent  
Luminaires

All Presidential Luminaires are available in two, three and four lamp units utilizing 40-Watt T-12 fluorescent lamps. For surface mounting or suspension mounting—individually or in continuous row.

The newly designed "Presidential" Series of Fluorescent Luminaires has already gained wide acceptance among the men who plan and construct the buildings of tomorrow and redesign the buildings of today.

The "Presidential" Series is typical of the outstanding lighting equipment manufactured by Pittsburgh Reflector Company. For over 31 years the Pittsburgh Permaflexor trademark has been the symbol for

quality lighting — designed for maximum efficiency, simple installation and easy maintenance.

If you too seek the distinctive in illumination — before you specify, before you buy . . . investigate the "Presidential" Luminaires and the entire line of Pittsburgh Permaflexor Fluorescent and Incandescent Lighting Equipment. Full details will be provided by your Pittsburgh Permaflexor representative — or write direct.

*Pittsburgh Reflector Company*

OLIVER BUILDING  
PITTSBURGH 22, PA.



DISTRIBUTED BY BETTER  
ELECTRICAL WHOLESALERS  
EVERYWHERE

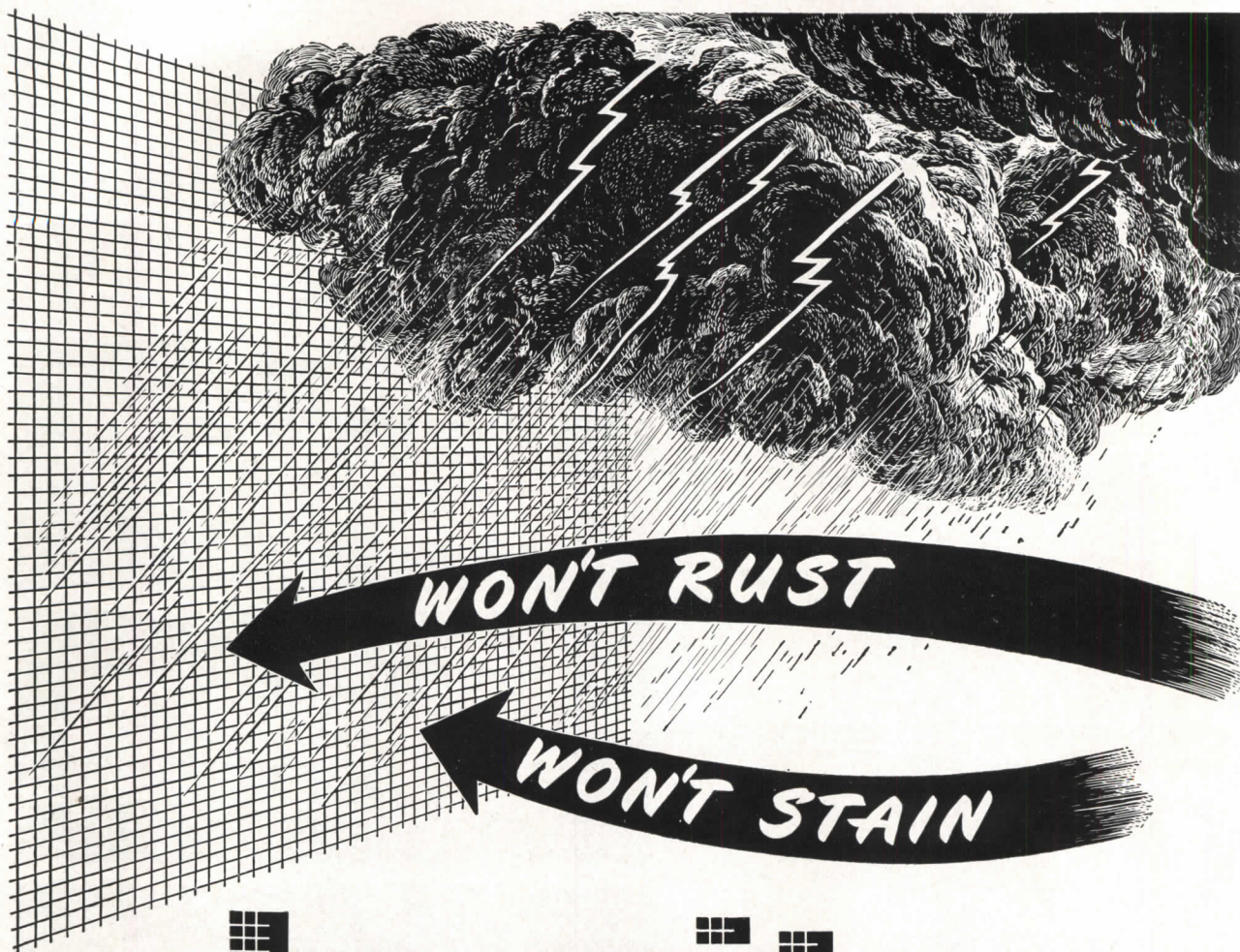

# Lumite

*- the screen that lasts!*

• Metal screens may rust or corrode . . . but *not* LUMITE!

Neither rain, snow, smoke nor even salt spray has any effect on LUMITE! It won't stain sidewalls or sills and never needs painting. A damp cloth cleans LUMITE in a jiffy.

And, where ordinary screens bulge or dent, LUMITE\* (modern plastic insect screen cloth) snaps right back to its normal *flatness!* Its toughness lies in unusual tensile strength and amazing resilience.

Tested daily for years, under

(\*Woven of Saran, Product of Dow Chemical Co.)

the severest battle conditions, LUMITE outlives average screens because natural causes can never affect it. No postwar building plan can be considered complete unless specifications call for LUMITE!

**LUMITE NOW RELEASED!  
FREE SAMPLES ON REQUEST**

With cancellation of some Army and Navy contracts, Chicopee is now making LUMITE for civilian uses in a rich dark green color. Write to us today for further information.

**Tested in War—Available Now**

Many millions of feet of LUMITE screening have been used successfully to protect the Armed Forces against disease-bearing insects. Men who saw LUMITE "under fire" are your customers today . . . and they're sold on LUMITE already!

- ★ Cannot stain sills or sidewalls.
- ★ Never needs painting . . . non-inflammable.
- ★ Easy to clean with a damp cloth.
- ★ 100% Rustproof under any conditions.
- ★ Strong, resilient . . . can't dent or bulge.
- ★ Competitively priced with better grades of wire screen cloth.



**CHICOPEE MANUFACTURING CORPORATION—LUMITE DIVISION**  
47 WORTH STREET, NEW YORK 13, N. Y.

*World's largest makers of Plastic Screen Cloth*

Sidewall application of supply and exhaust LINE-O-FLO combined with cove lighting

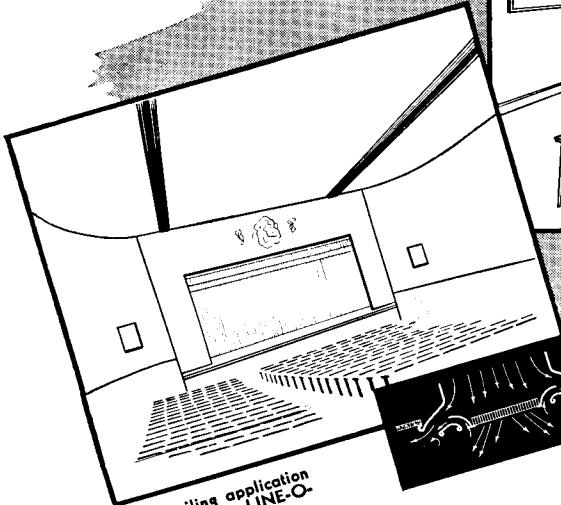
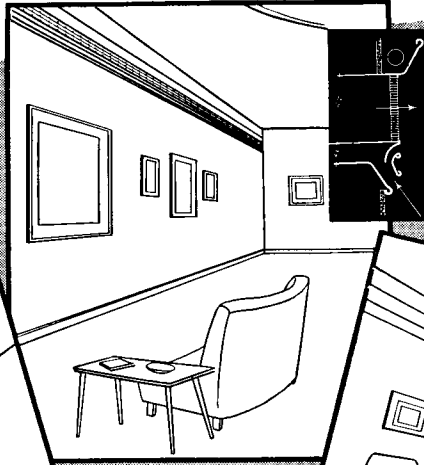

High ceiling application of continuous LINE-O-FLO outlets

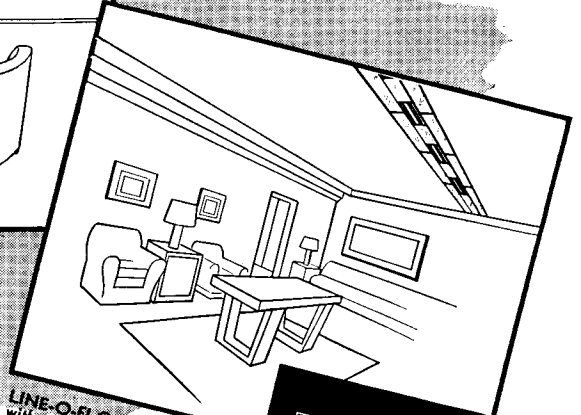

LINE-O-FLO combined with glass panels in a continuous light strip

# Line-o-flo

PATENT APPLIED FOR

## A NEW APPROACH TO AIR DISTRIBUTION

BY

# BARBER-COLMAN

An outstanding example of engineering ingenuity and — from an architectural standpoint — ideal for continuity of design! Barber-Colman leads again with a new type of air distribution outlet that is adaptable to a wide variety of

applications. Numerous new and practical combinations are possible, a few of which are suggested in the sketches shown here. Write today for the new Bulletin F-2741 giving full details on LINE-O-FLO Air Distribution Outlets.

**BARBER-COLMAN COMPANY • 1232 ROCK STREET, • ROCKFORD, ILLINOIS**

Continuous LINE-O-FLO combined with fluorescent light strip



LINE-O-FLO alternated with standard fluorescent fixtures, arranged for supply only or supply-and-exhaust

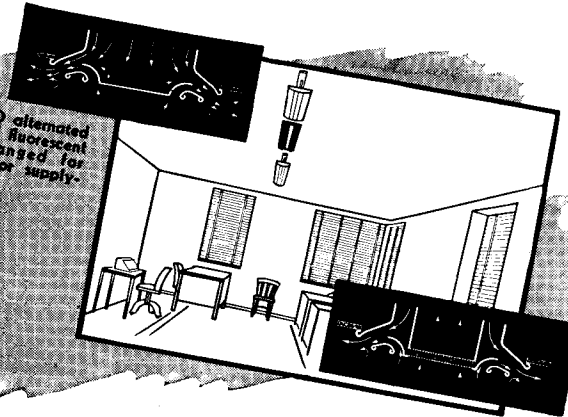

# Coils

**ONE AT A TIME  
OR BY THE  
CARLOAD!**

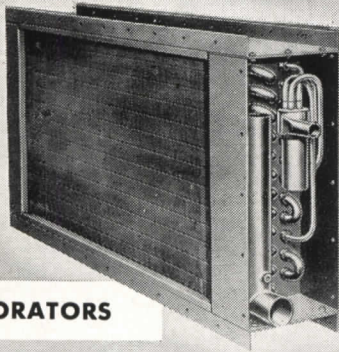

**EVAPORATORS**

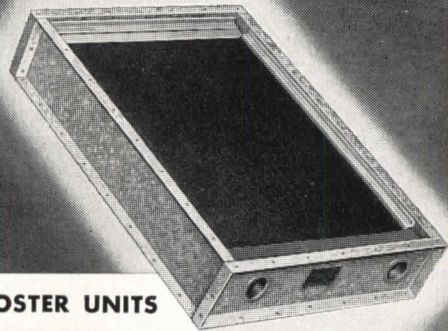

**BOOSTER UNITS**

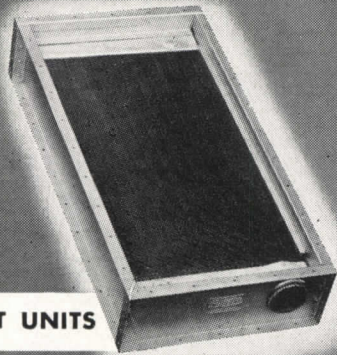

**BLAST UNITS**

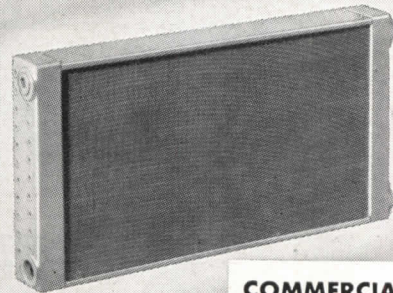

**COMMERCIAL UNITS**

● No coil job in the heating, cooling and air conditioning field is too large or too small for Young. There are versatile Young Units for every need. From architects, engineers... men responsible for results... comes testimony of the dependable performance of Young Heat Transfer Surfaces in office buildings, auditoriums, schools, theaters, stores, restaurants and other places where people gather... in drying rooms, paint spray booths, malt houses, dry kilns and dozens of types of commercial installations. Write for Young Coil and Evaporator catalog. No obligation.

## **YOUNG** HEAT TRANSFER PRODUCTS

★ ★ ★ ★ ★ ★ ★ ★ ★ ★ ★ ★

OIL COOLERS • GAS, GASOLINE, DIESEL ENGINE COOLING RADIATORS • HEAT EXCHANGERS • INTERCOOLERS • ENGINE JACKET WATER COOLERS • UNIT HEATERS • CONVECTORS • CONDENSERS • EVAPORATORS • AIR CONDITIONING UNITS • HEATING COILS • COOLING COILS • AND A COMPLETE LINE OF AIRCRAFT HEAT TRANSFER EQUIPMENT.

**YOUNG RADIATOR CO., Dept. 516-B • RACINE, WISCONSIN, U. S. A.**



BUILD WITH  
**STRAN  
STEEL**

**A FIRE-SAFE, SIMPLIFIED FRAMING  
SYSTEM FOR HOUSING PROJECTS  
AND APARTMENT BUILDINGS**

Particularly adapted to multiple dwelling projects, Stran-Steel framing systems speed erection and safeguard the building investment.

All Stran-Steel framing members . . . joists, channel plates and studs . . . are pre-fabricated to exact lengths for rapid assembly on the site. Fastenings and connections are accomplished with ordinary carpenter's tools, and collateral materials are nailed directly to the Stran-Steel studs and joists by means of the Stran-Steel patented nailing groove.

In addition to economy of erection, Stran-Steel construction effects continuous savings in maintenance and upkeep. It is fire-safe and permanent—sag-proof, warp-proof, termite-proof. Its strength and uniformity insure lasting value.

Stran-Steel is the *modern* building material. Build with Stran-Steel.

**GREAT LAKES STEEL CORPORATION**

STRAN-STEEL DIVISION • PENOBSCOT BUILDING, DETROIT 26, MICHIGAN  
UNIT OF NATIONAL STEEL CORPORATION

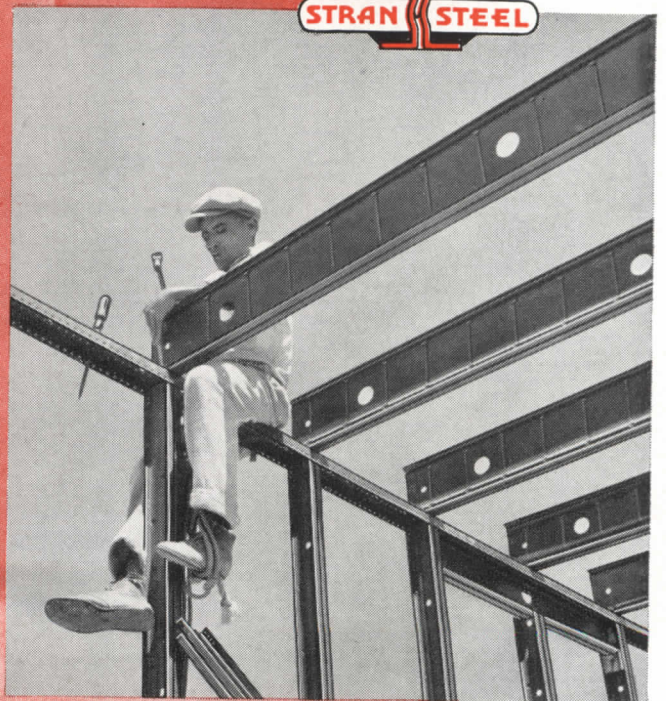



# METAL

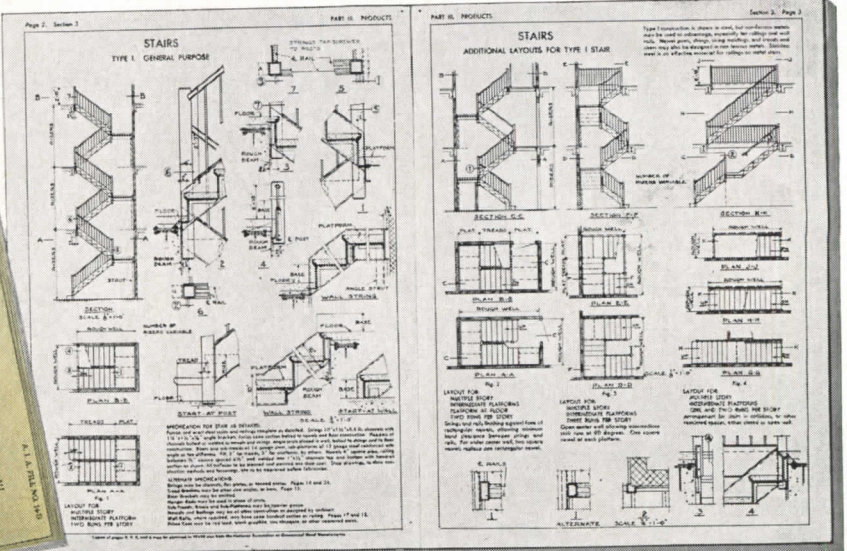

**FREE TO ARCHITECTS . . .** This new 32-page Handbook featuring Metal Stairs and Railings contains hundreds of detail drawings. Every architect should have a copy in his files. Write today for your free copy.

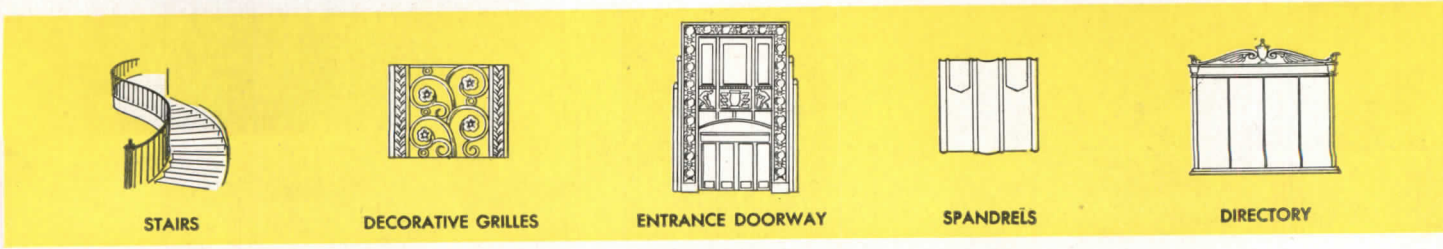

STAIRS



DECORATIVE GRILLES

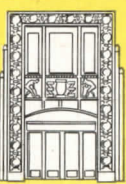

ENTRANCE DOORWAY



SPANDRELS

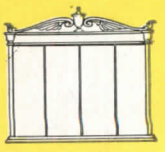

DIRECTORY



# STAIRS *give extra strength, add fire protection to any building!*



Extra strength . . . improved safety . . . increased fire protection . . . easier installation—these are but a few of the reasons why more and more architects are specifying steel stairs for all of their new buildings.

Steel stairs like other architectural metal work can be fabricated to conform to your own ideas of design. They can be made to fit any size space, any style of building. They can be used effectively in residential buildings as well as in commercial and industrial buildings.

As you design new buildings be sure to include steel stairs as well as other types of architectural metal work. For entrances, doors, windows, balustrades, grilles, and for hundreds of other types of interior and exterior decoration you'll find architectural metals offer the solution to many problems.

The manufacturers and fabricators of steel stairs and other types of architectural metal work are always anxious to serve you. Call them in for consultation now, while your plans are in the formative stage. Their helpful advice may be of real value to you.

A new 32-page Handbook on Metal Stairs and Railings containing hundreds of detail drawings has just been prepared. A free copy of this valuable new book will be mailed to architects upon request. Write on your business letterhead. Address Dept. R-2.

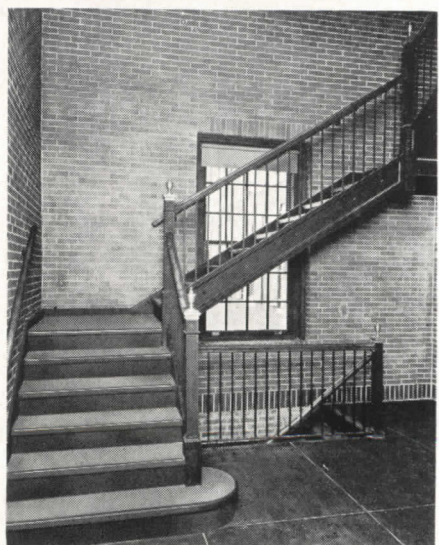

## NATIONAL ASSOCIATION OF ORNAMENTAL METAL MANUFACTURERS

209 CEDAR AVENUE    TAKOMA PARK    WASHINGTON 12, D. C.

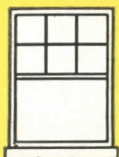

NON-FERROUS WINDOWS



FLAGPOLE BASE



STORE FRONTS AND MARQUEES



FIXTURES



HAND RAILINGS

## LIGHTS GO OUT, STORES CLOSE

A short circuit threw the city into darkness at 5:30 o'clock last night, and forced stores to close

# INCLUDE EMERGENCY LIGHTING UNITS IN YOUR STORE PLANS . . .

RETAIL STORES AND MARKETS require emergency lighting in aisles, cashier cages, exits, stairways, general lighting, fire towers.

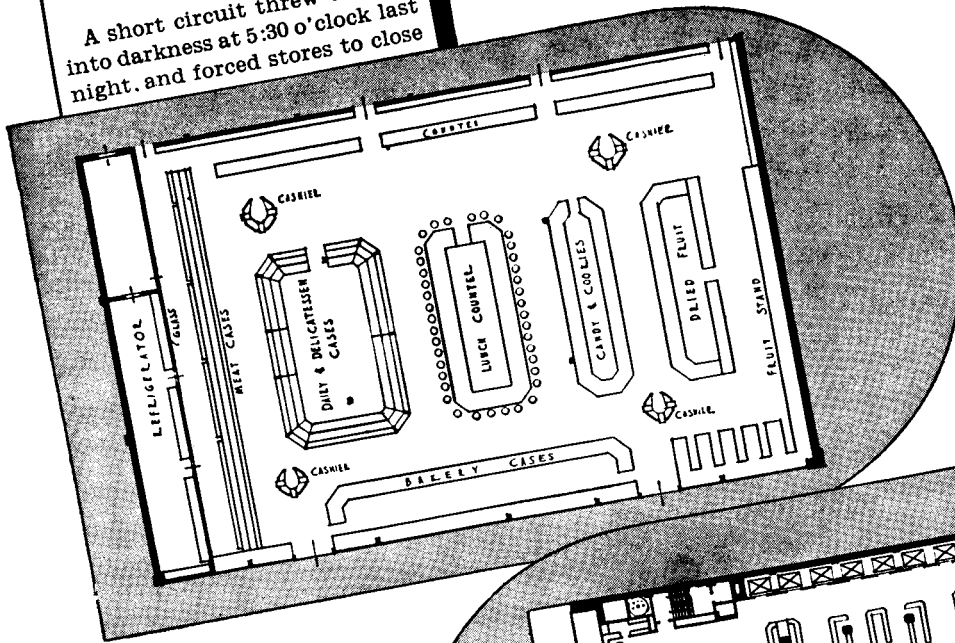

DEPARTMENT STORES should provide against light failure in engine room, fire towers, stairways, escalators, elevators, basements, exits and cashier cages.

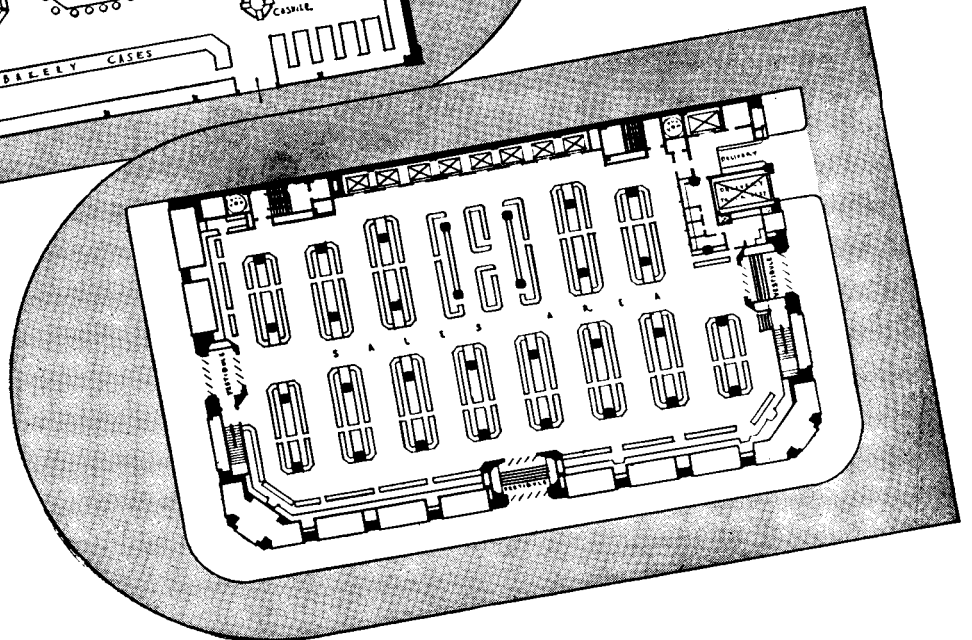

WITH central city stores in most towns open one or more nights each week, the need for protection against light failure is more vital than ever before. Dangers of panic, accidents, theft, loss of sales and property damage have become an ever-present threat . . . one that no longer can be ignored.

And such light failures do occur, for despite all precautions of utility companies, accidents beyond their control can cause interruptions to normal electric current. Storms, floods, fires, collisions strike with little or no warning and are a serious menace to electric power lines.

Provide against light failure in the stores and other buildings you plan. An Exide Emergency Lighting Unit supplies safe, sure, modern protection. Batteries are always fully charged and are ready to respond *instantly* and *automatically* when needed. Write for full particulars.



THE ELECTRIC STORAGE BATTERY COMPANY, Philadelphia 32 • Exide Batteries of Canada, Limited, Toronto

# How to plan a COLD ROOM for maximum efficiency

**TO BE EFFICIENT**, a cold room must be both well planned and well built. Each detail, from location to insulation, requires careful consideration. Cold rooms, except freezers, may be located in any part of a building and may be built as single or multiple units, with one or more access doors. Multiple rooms, most flexible and generally more economical in operation, should be built in one block, if possible, for greatest economy.

Structural walls, floors, and ceilings around such a room should be of solid construction . . . concrete or solid brick rather than hollow tile. Avoid air spaces. For partitions and interior walls, where building walls are not used as a base for the insulation, self-sustaining solid walls of the insulation material are recommended. When the existing ceiling height is greater than that needed for the cold room, a false ceiling is recommended with insulation laid on top.

The most important factors affecting the final economy of a cold room are the adequacy of efficiency of the insulation. For more than 40 years, Armstrong has been producing board-type, low-temperature insulations and engineering their proper application. For cold rooms, Armstrong recommends three dependable insulation materials: Armstrong's Corkboard, Mineral Wool Board, and Foamglas\*. For full information, write today to Armstrong Cork Co., Building Materials Div., 2402 Concord St., Lancaster, Pa.

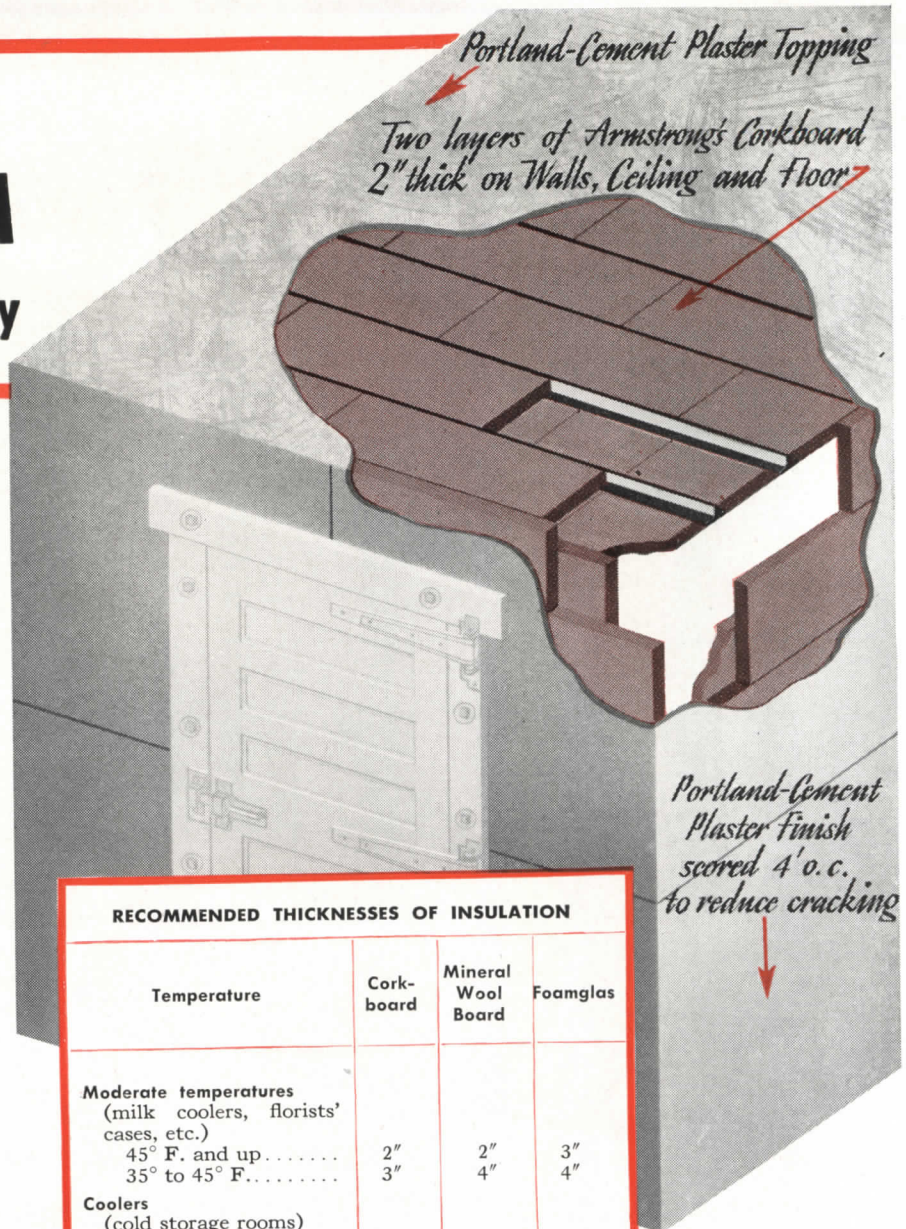

RECOMMENDED THICKNESSES OF INSULATION

| Temperature   | Cork-board | Mineral Wool Board | Foamglas |
|---|------------|--------------------|----------|
| <b>Moderate temperatures</b><br>(milk coolers, florists' cases, etc.) |            |                    |          |
| 45° F. and up . . . . .   | 2"         | 2"                 | 3"       |
| 35° to 45° F. . . . .   | 3"         | 4"                 | 4"       |
| <b>Coolers</b><br>(cold storage rooms)                                |            |                    |          |
| 20° to 35° F. . . . .   | 4"         | 5"                 | 6"       |
| 5° to 20° F. . . . .  | 5"         | 7"                 | 7½"      |
| <b>Freezers</b><br>(frozen food lockers, hardening rooms)             |            |                    |          |
| - 5° to 5° F. . . . .   | 6"         | 8"                 | 9"       |
| - 15° to - 5° F. . . . .  | 7"         | 9"                 | 10"      |
| - 20° to - 15° F. . . . .   | 8"         | 10"                | 12"      |

Heavier thicknesses should be used where summer temperatures are high or long periods of hot weather prevail. Partitions and ceilings between freezers and coolers should be well insulated. Freezers should not be located under coolers, but coolers may be located under freezers.

Portland-Cement Plaster Finish scored 4' o.c. to reduce cracking

Isometric view of typical small cold room with 4" of Armstrong's Corkboard Insulation in ceiling, walls, and floor. Rooms of this kind are frequently required when planning large kitchens, bakeries, laboratories, mortuaries, florist shops, etc. Detail drawings and erection specifications sent free on request.

\* Reg. U. S. Pat. Off. Product Mfg. by Pittsburgh Corning Corp.

**ARMSTRONG'S INDUSTRIAL INSULATION**  
 Complete Contract Service  
 For All Temperatures  
 From 300° Below Zero To 2600° Fahrenheit



*The Northwest presents, with pride, this ZONE-CONDITIONED home . . . in The Highlands, Seattle, Wash. Architect—George Wellington Stoddard.*

The points of the compass spell  
**NEWS**

**... and the big news in house-heating is PAYNE ZONE-CONDITIONING...sweeping the country from border to border and coast to coast**

From North, East, West and South, they pour in . . . the thousands of inquiries for our booklet on ZONE-CONDITIONING, "successor to old-fashioned central heating". Proof that architects, builders, owners—all are interested in a house-heating system geared to modern living. ★ As in the home illustrated, two or more compact, streamlined, gas warm-air furnaces, separately controlled by zones or rooms, provide *flexibility* obtainable in no other way. ★ PAYNEHEAT pioneered and perfected this method, time-tried but modern as today's news. Inquire!

**PAYNE FURNACE COMPANY, BEVERLY HILLS, CALIFORNIA**  
(One of the DRESSER Industries)

**PAYNEHEAT**  
OVER 30 YEARS OF LEADERSHIP





*This* INSURANCE BUILDING  
 was designed for CHANGE  
 and EVERY CHANGE  
 PAYS ANOTHER DIVIDEND

ACACIA MUTUAL LIFE INSURANCE COMPANY, WASHINGTON, D. C. — SHREVE, LAMB & HARMON, Architects

# *Snead* MOBILWALLS

IN ARRANGING interior subdivisions for commercial structures, even the most careful planning cannot accurately anticipate requirements beyond the most immediate future. That's why Snead Mobilwalls have been specified for so many modern office and factory buildings.

With Snead Mobilwalls interiors can be rearranged quickly and inexpensively to meet changing demands as they occur. Changes can generally be effected overnight by ordinary labor without dirt, mess or paint, and without interrupting routine. All parts are reusable without waste.



*Since 1849, the Snead symbol of lasting beauty, quality and progress in metal construction.*

The monumental office building of the Acacia Mutual Life Insurance Company was equipped with Snead Mobilwalls many years ago. Because of the inevitable rearrangements required by this fast growing institution, the extreme flexibility of Snead Mobilwalls has paid handsome dividends by permitting these changes to be made quickly and economically.

Snead engineers will gladly cooperate with you in preparing interior plans and specifications without cost or obligation.

Write, phone or wire for details.

**SNEAD & Company** . . . . . FOUNDED 1849  
*Designers, manufacturers and erectors of library bookstacks and steel partitions*  
 Sales Office: 96 Pine Street, JERSEY CITY 4, N. J.      Main Office and Plant: ORANGE, VA.

# FIGHT POLIO

## AT THE SOURCE of Water Pollution

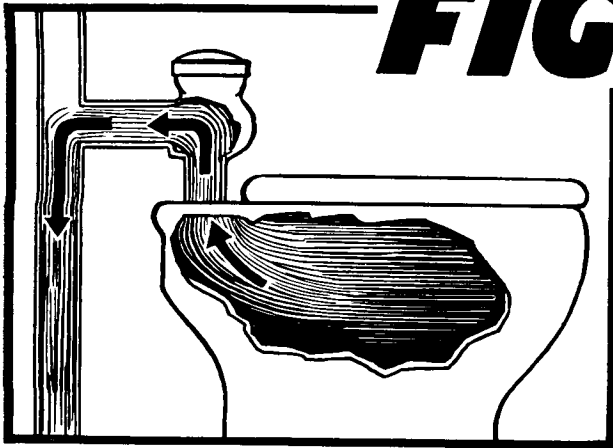

By preventing back-syphonage from entering into the water supply lines, you STOP a major source of possible infection from transmissible disease caused by waterborne germs.

**STOP THIS** ↗  
**WITH THIS** ↘

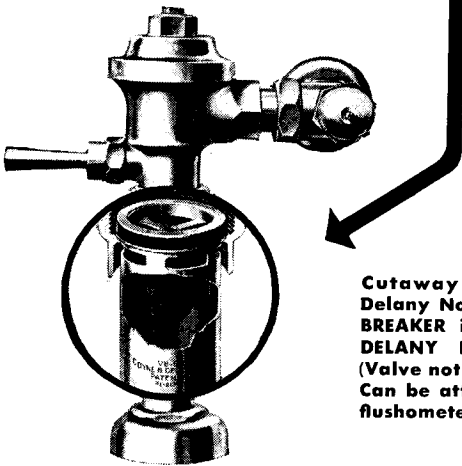

Cutaway views show Delany No. 50 VACUUM BREAKER installed in a DELANY FLUSH VALVE (Valve not in operation). Can be attached to any flushometer old or new.

The DELANY No. 50 VACUUM BREAKER is self policing . . . will function for years . . . will prevent back-syphonage under vacuum, even tho the unit is mischievously or maliciously sabotaged . . . has only one moving part . . . practically invisible when installed . . . meets requirements of U. S. Bureau of Standards and is FULLY APPROVED by most States and Municipalities.

*Send for complete information and interesting comments, reports and tests made by recognized sanitation authorities.*

### EXCLUSIVE FEATURES OF THE DELANY NO. 50 VACUUM BREAKER

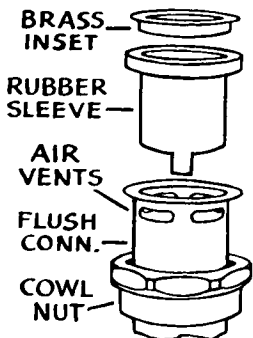

**SIMPLEST ASSEMBLY**  
— ONLY ONE MOVING PART

**PRACTICALLY INVISIBLE WHEN INSTALLED**

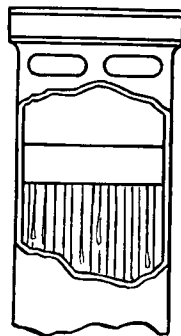

*Drawings show cross section of the No. 50 in operation. The unit, upon application of flow, expands the rubber sleeve, seals off the air vents and permits the proper flushing of the fixture.*

*Under the weakest vacuum, the rubber sleeve of the No. 50 collapses inwardly, seals and breaks the vacuum. This instantly prevents the slightest back-syphonage.*

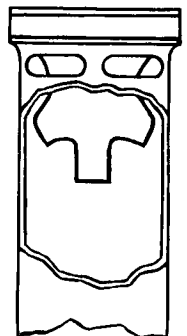

SINCE 1879  
**Coyne & Delany Co.**  
BROOKLYN N.Y.

# Better Light for Seeing And Sales

**JOLECO'S SLIMLINE FLUORESCENTS ARE AVAILABLE Now!**

More than 300 footcandles of illumination bring prospective buyers to store front of American Sporting Goods Company—a huge show window attracting passers-by with appealing light.

AMERICAN  
SPORTING GOODS

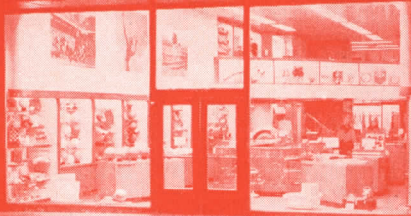

Illumination in the fourth floor General Offices averages better than 50 footcandles to increase efficiency, and provide unsurpassed working comfort for employees.

Here is tomorrow's lighting today—sleek and modern, geared for streamlined merchandising! Adding dramatic interest to display—offering "eye and buy" comfort for both customer and sales personnel—combining the utmost in light utilization with smart appearance—Joleco's Slimline Fluorescents are providing truly modern illumination for selling in St. Louis' most up-to-date store—American Sporting Goods Company.

Considering every factor—quantity and quality of light—adaptability to the job—modern beauty in harmony with any architectural theme—reasonable cost—economical maintenance—easy installation—plus others to meet your specific requirements—Joleco-Slimline Fluorescents offer outstanding advantages and value in light for both seeing and sales.

Learn more about Joleco's New Slimline Fluorescents and how they can help solve your lighting problems. Write today for catalog pages that will be ready soon.

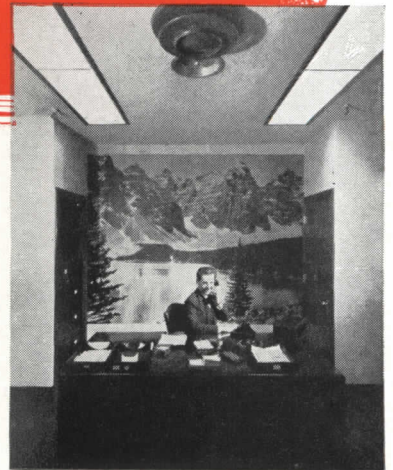

The ample soft, glareless light of Joleco Slimline Fluorescents in President Harold Sieben's office help simplify the problems of directing this aggressive, ultra-modern merchandising organization.

Interiors by Design, Inc., St. Louis



In the first floor main selling area, Joleco Slimline Fluorescents bring more than 70 footcandles of light to the merchandise level. Above and below the mezzanine 50 footcandles is maintained. Showcase fluorescents by Joleco increase selling effectiveness.

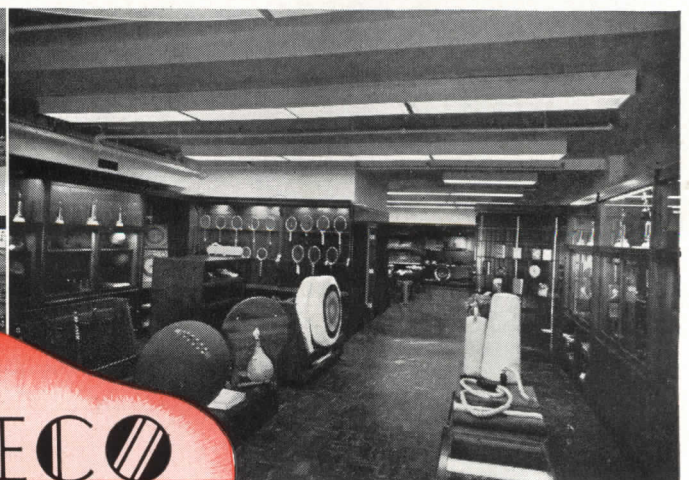

On the second floor where boats and large items are sold, surface-mounted Slimline Fluorescents maintain nearly 50 footcandles of light. In the third floor sport apparel department, sales are made under nearly 60 footcandles of light.

**JOLECO**  
CORPORATION  
Designers and Manufacturers  
FLUORESCENT LIGHTING FIXTURES  
2513-19 BALDWIN ST. ST. LOUIS 6, MO.

FROM SKYSCRAPER . . .

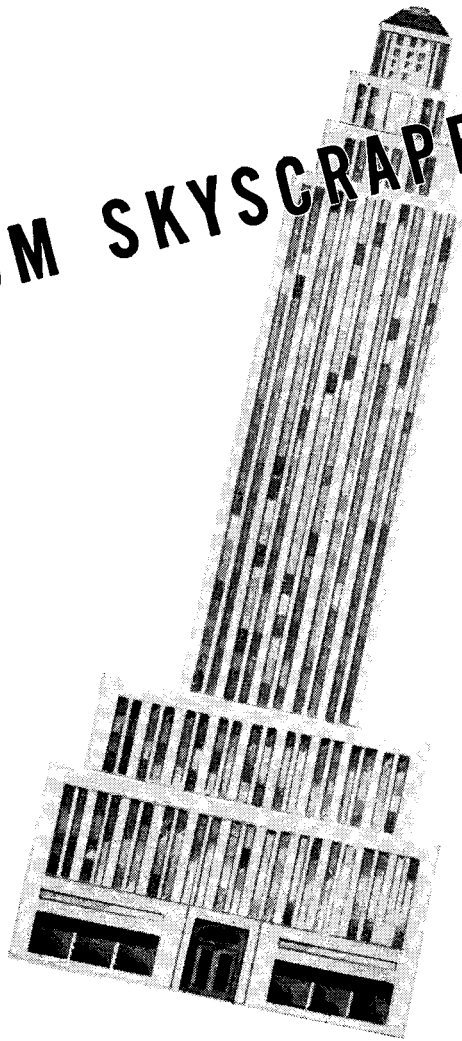

TO BEACH HOUSE

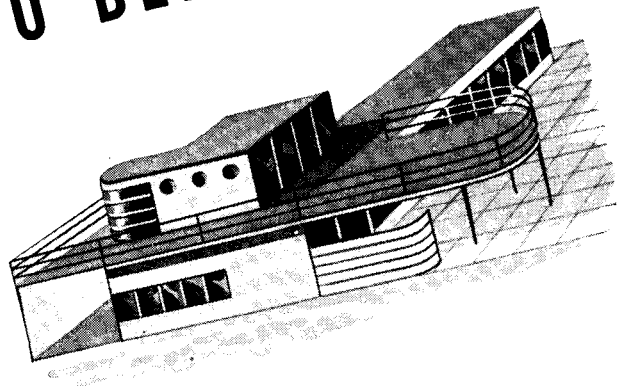

Turn to



**For Better Air Conditioning**

AIR conditioning can be a marvel of comfort. Or it can literally be a pain in the neck . . . and the pocketbook, too.

For dependable, trouble-free air conditioning . . . that dehumidifies\*, circulates, filters, and ventilates the air as well as cools\* it . . . turn to G. E.

The G-E reputation in air conditioning is something you can depend on. When G-E

equipment is properly installed, you'll get the kind of air conditioning you specify.

For heating, too, gas or oil . . . steam heat, hot water or warm conditioned air, for homes or small commercial buildings . . . specify G. E. for economical, efficient performance.

*General Electric Company, Air Conditioning Department, Section 6442, Bloomfield, N. J.*

\*G-E winter air conditioning humidifies and warms the air.

**GENERAL  ELECTRIC**

***Complete Air Conditioning***





DESIGN FOR  
**FAITH, HOPE  
 AND  
 RECOVERY**

**Tripler General Hospital, Island of Oahu, T. H.**

Architects and Engineers: York and Sawyer,  
 New York, N. Y.

Corps of Engineers: U. S. Army

Mechanical Contractors: Cory-Joslin, San Francisco,  
 California



*Again* **DRAINS AND INTERCEPTORS BY** *Josam*

High on the slopes of the Koolau mountain range, near Honolulu, on the island of Oahu lies a new monument... a shining symbol of America's appreciation to the fighting men and women of her armies... Tripler General Hospital. Here, upon a site having a wide magnificent view of the Pacific Ocean, hospital facilities have been planned and created in keeping with the very latest developments on the treatment of the sick and injured. In surroundings more suggestive of a modern residential community than of a hospital,

**TRIPLER GENERAL HOSPITAL**  
 A DESIGN FOR LIVING

Main hospital building has a 1500 bed capacity. Nurses' quarters, patient's recreation building, a post exchange, gymnasium, theatre, chapel and research laboratory. Construction is reinforced concrete, designed to be earthquake resistant and building arrangement provides for receiving maximum benefit from sunlight.

every patient will find a chance for complete recovery given impetus by modern medical science and nurtured by the delightful climate and beautiful locale of Hawaii. Tripler General Hospital, in construction and facilities provided is a model of perfection for the care and rehabilitation of the ill and wounded. Throughout the many buildings comprising this truly great project, you will find Josam drains and interceptors...evidence again that Josam products measure up to the highest standards of quality everywhere in the world.

**ONE ACHIEVEMENT DESERVES ANOTHER...TO BE SURE, PUT JOSAM ON THE JOB**



**JOSAM MANUFACTURING COMPANY**

Executive Offices, 302 Empire Bldg., Cleveland 14, O. • Manufacturing Division, Michigan City, Ind.

Representatives in all Principal Cities

JOSAM-PACIFIC CO., 765 Folsom Street, San Francisco, California — West Coast Distributors  
 EMPIRE BRASS COMPANY, LTD., London, Ontario — Canadian Distributors

**ORIGINATORS AND MANUFACTURERS OF:**



Roof Drains



Grease Interceptors



Backwater Sewer Valves



Floor Drains



Oil Interceptors



Shock Absorbers

See our Catalog in Sweets'

Member of the Producer's Council

# PROVED

AND

BECAUSE  
OF THE  
EXCLUSIVE

# McQuay

## COIL CONSTRUCTION

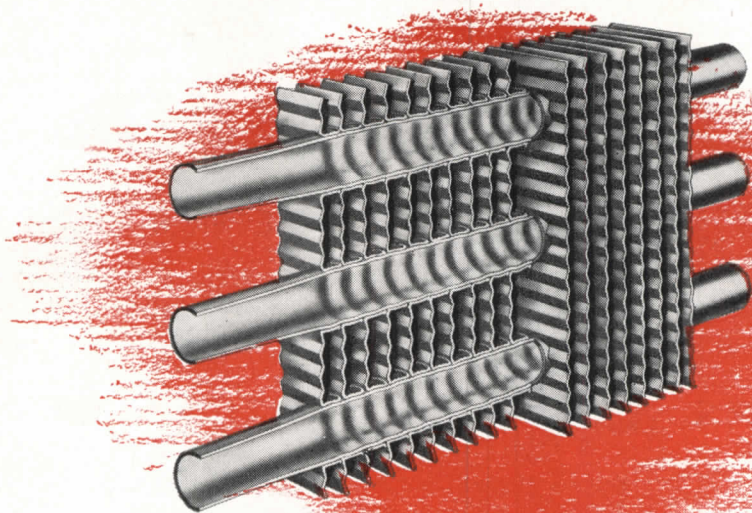

*Section of McQuay Coil  
showing Rippled Fins and  
Hydraulically expanded tubes.*

ONLY McQuay, gives you Ripple Fin Coils — preferred naturally, since Rippled Fins provide more efficient Heat Transfer surface of greater strength and durability . . . Rippled Fins have additional surface that transmits more heat and also provides ample stiffness — checks bending of fins under most severe conditions.

All McQuay Coils are fabricated by the exclusive Hydraulic Expansion Method. Each tube is hydraulically expanded into wide fin collars effecting a permanent bond between fin and tube without any low conductivity bonding metal.

McQuay Coils have proved their superiority under the most rigid conditions. They were selected for use on nearly all of the Navy's fighting ships, as well as on combat aircraft where efficient Heat Transfer surface was so essential.

McQuay units shown here are but a few in the complete McQuay line now available in a wide range of sizes and types to fit most applications. Write for McQuay catalogs today. McQuay, Inc., 1605 Broadway Street Northeast, Minneapolis 13, Minnesota . . . Representatives in all principal cities.

# PREFERRED

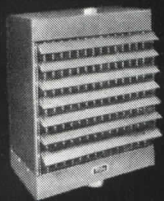

STANDARD UNIT HEATER

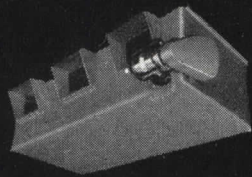

BLOWER TYPE UNIT HEATER  
(SUSPENDED)

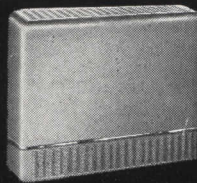

CABINET TYPE UNIT HEATER

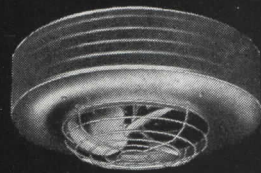

DOWN FLOW  
UNIT HEATER

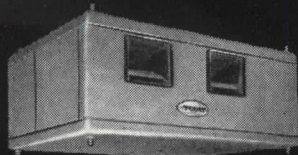

AIR CONDITIONING UNIT  
SUSPENDED TYPE

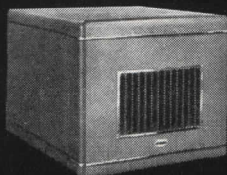

AIR CONDITIONER

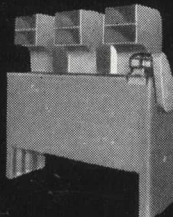

BLOWER TYPE UNIT HEATER  
(FLOOR)

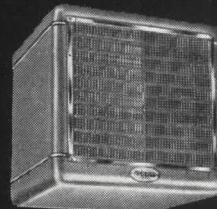

COMFORT COOLER

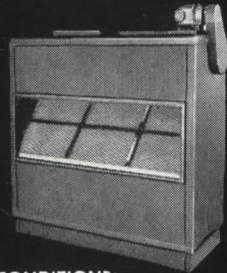

AIR CONDITIONER  
(YEAR ROUND)

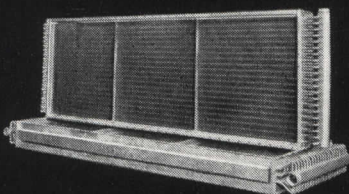

HIGH PRESSURE BLAST COIL

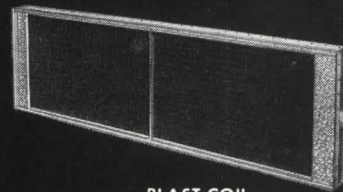

BLAST COIL

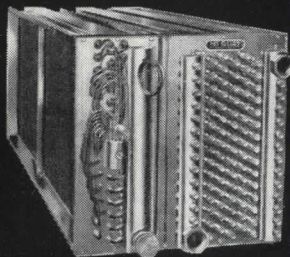

COMBINATION  
DX AND RP COIL

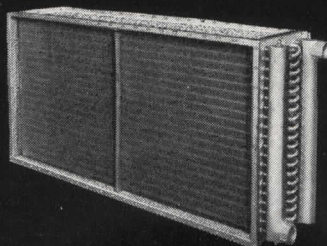

WATER HEATING  
AND COOLING COIL

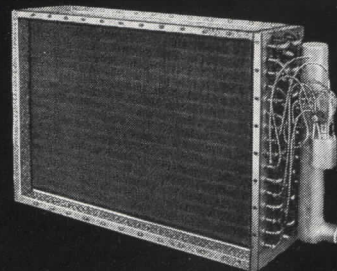

DIRECT EXPANSION  
COOLING COIL

# McQuay INC.

AIR TEMPERING  
EQUIPMENT  
ESPECIALLY  
DESIGNED  
FOR INDUSTRY

# THE WINNERS

## in the Chicago Tribune's \$24,000.00 Chicagoland Prize Homes Competition

The Jury of Awards, appointed by the Chicago Tribune to select the prize winning entries in the Chicagoland Prize Homes Competition, met in executive sessions on December 26 and 27, 1945.

Boyd Hill, A.I.A., appointed by the Chicago Tribune to act as Professional Adviser

in conducting the competition, reported that a total of 938 entries had been received. All 938 entries submitted in the competition were examined by the Jury of Awards which selected the entries of the following persons as winners of the 24 individual prizes of \$1,000.00:

### Authors of Winning Solutions to Problem No. 1

**GEORGE R. KLINKHARDT**  
44 Eucalyptus Road  
Berkeley 5, Calif.

**ENS. RALPH D. PETERSON, JR.**  
405 W. 23rd Street  
New York, N. Y.

and

**LIEUT. C. S. WOOLFORD, JR.**  
375 Warwick Avenue  
South Orange, N. J.

**CAPT. A. J. SACKVILLE-WEST**  
414 N. Custer  
Colorado Springs, Colo.

**CHARLES W. SCHROEDER**  
425 E. 14th Blvd.  
Chicago 5, Illinois

**LIEUT. RAY STUERMER**  
630 E. 84th Street  
Chicago 19, Illinois

**LIEUT. D. CODER TAYLOR**  
140 S. Dearborn Street  
Chicago 3, Illinois

**WALTER J. THIES**  
3117 N. Main Street  
Dayton 5, Ohio

**J. FLOYD YEWELL**  
10 E. 40th Street  
New York, N. Y.

### Authors of Winning Solutions to Problem No. 2

**LIEUT. W. R. BURNS, JR.**  
Ferry Bldg.  
San Francisco 11, Calif.

**CARL L. CEDERSTRAND**  
630 Greenleaf Avenue  
Wilmette, Illinois

**EDWARD N. GLIDDEN, JR.**  
**EBEN D. FINNEY**  
Associated Architects  
326 St. Paul Pl. Baltimore 2, Md.

**HERBERT C. HANSON**  
12206 Princeton Avenue  
Chicago 28, Illinois

and

**HENRY MARTORANO**  
4940 Fletcher Street  
Chicago 41, Illinois

**HEIDT ASSOCIATES**  
First National Bank Bldg.  
Orange, Texas

**MRS. LUCILE MCKIRAHAN**  
321 W. 7th Street  
Stuttgart, Ark.

**FREDERICK E. SLOAN**  
Briar Road  
Golf, Illinois

**ERIC WENSTRAND**  
4317 N. Dayton Street  
Chicago 13, Illinois

### Authors of Winning Solutions to Problem No. 3

**EDWARD L. BURCH, JR.**  
912 Main Street  
Evanston, Illinois

**MERWIN H. FREEMAN**  
1062 Masselin Avenue  
Los Angeles 35, Calif.

**RAYMOND W. GARBE**  
503 Emerald Avenue  
Wheaton, Illinois

**JOSEPH C. GORA**  
45 Milk Street  
Boston, Mass.

**EDWARD W. HANSON**  
1306 S. Third Street  
Stillwater, Minn.

**ARTHUR R. MYHRUM**  
922 Monroe Avenue  
River Forest, Illinois

**LIEUT. RAY STUERMER**  
630 E. 84th Street  
Chicago 19, Illinois

**HOWARD J. UEBELHACK**  
1772 Washington Avenue  
Wilmette, Illinois

To the winners, the Chicago Tribune extends its congratulations. To all entrants in the competition, and to the following members of the Jury of Awards, the Chicago Tribune wishes to express its sincere thanks for their cooperation: Paul Gerhardt, Jr., A.I.A., Chairman; Philip B. Maher, F.A.I.A., Co-chairman; Irvin A. Blietz, builder; Arthur E. Fossier, builder; John O. Merrill,

A.I.A.; J. E. Merrion, builder; John R. O'Connor, builder; John W. Park, architect, and A. N. Rebori, architect.

The winning designs will be reproduced in full color in the Chicago Sunday Tribune, starting in February.

**CHICAGO TRIBUNE**  
The World's Greatest Newspaper

NOVEMBER AVERAGE NET PAID TOTAL CIRCULATION; DAILY: OVER 1,015,000 — SUNDAY, OVER 1,350,000

# GET THE RIGHT ROOF FOR ANY JOB FROM **ONE** SOURCE!



● No detours from a straightforward solution, no substitutions necessary—if you specify Ruberoid! We make all types of built-up roofing, in specifications to meet any project you may have in mind—Asbestos Felt and Asphalt, Coal Tar Pitch and Tarred Felt, or Asphalt Felt and Asphalt.

When desired, Ruberoid Built-up Roofs are bonded for 10, 15 or 20 years, depending upon specification used.

Ruberoid Approved Roofing Contractors are located in all parts of the country, ready to give practical assistance in planning and executing your next built-up roof—assistance that's based on long experience and backed up by the full resources of a complete line of materials. For centralized responsibility, for quality and performance, for *planned* results—call in a Ruberoid Approved Roofer today!

The **RUBEROID** Co.

Executive Offices: 500 Fifth Ave., New York 18, N. Y.

Asphalt and Asbestos Building Materials . . . Thermal Insulations



# DESIGN POSSIBILITIES FOR COMMERCIAL

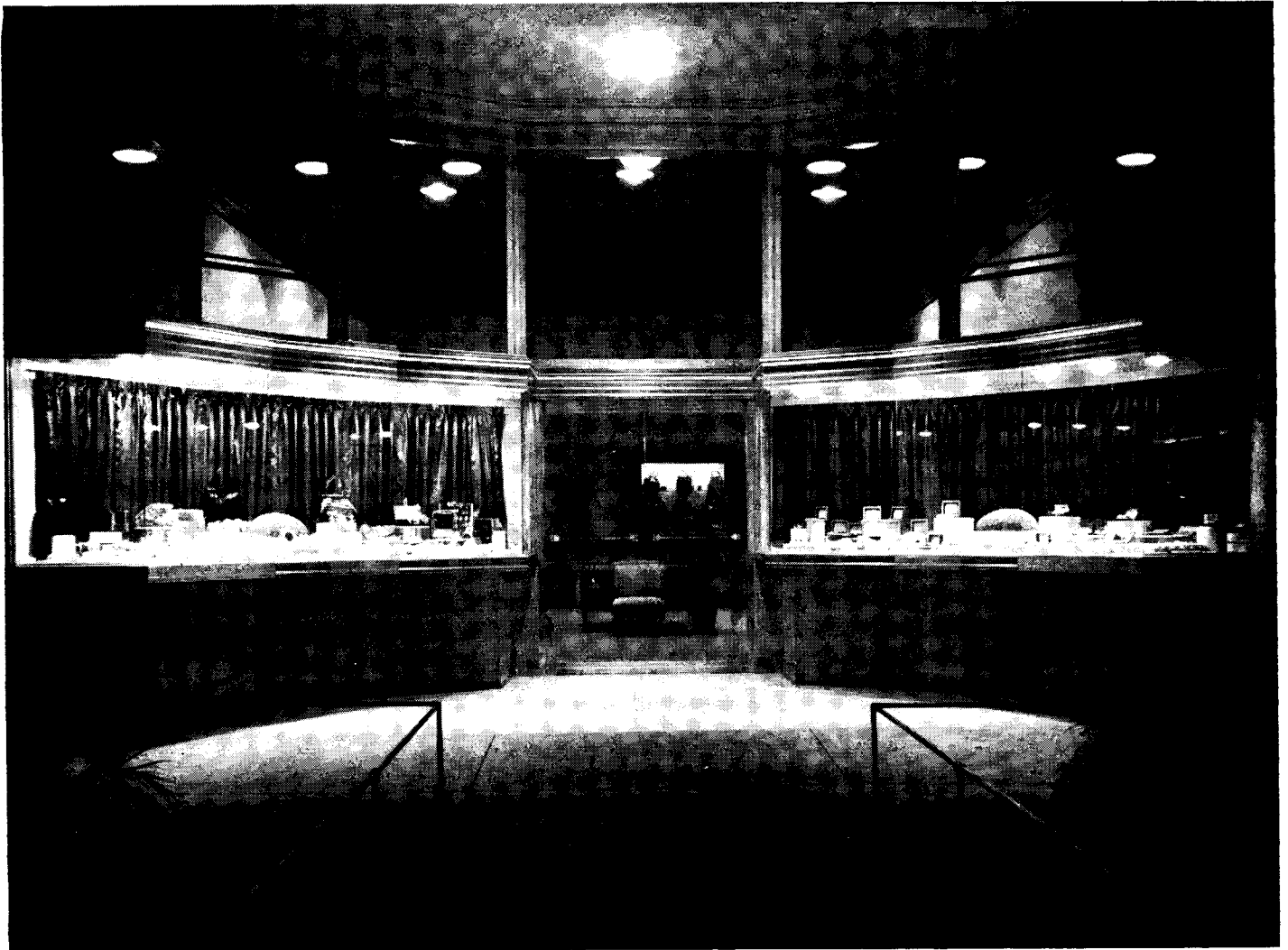

**In Store Design** the tendency seems to be toward "opening up" the front . . . employing large transparent areas to permit freer vision from the sidewalk into the store interior. This, in effect, makes the interior of the store an integral part of the store front display. Pittsburgh Polished Plate Glass, Carrara Structural Glass and other Pittsburgh Products are ideally suited for use by the architect in creating store fronts of this type.

Architect: Albert Anis.

**Mirrors Offer** the architect almost unlimited design possibilities. In bars, restaurants, and lounges they add to gaiety—give new sparkle and beauty. In stores and display rooms, they reflect the merchandise—create an effective atmosphere of spaciousness and luxury. Pittsburgh Mirrors are available made from blue, green, flesh tinted, or regular Plate Glass with silver, gold, or gunmetal backings.

Architect: Frank Hope.

**BUILDINGS with-**

# Glass

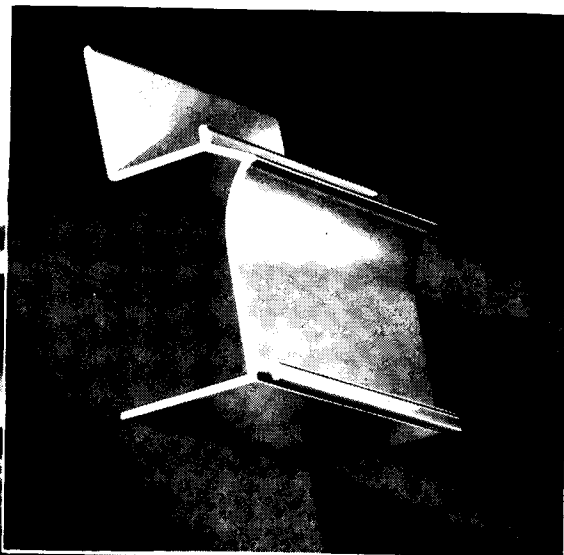

As a Result of being designed all at one time, Pittco Store Front Metal has a pleasing unity of design—a harmonious relationship with other Pittsburgh Products for Store Fronts and Interiors. There are two distinctively styled lines of Pittco Metal—Pittco Premier and Pittco De Luxe—offering metal members to meet every architectural need. Shown here is a typical moulding from the Pittco Premier line.

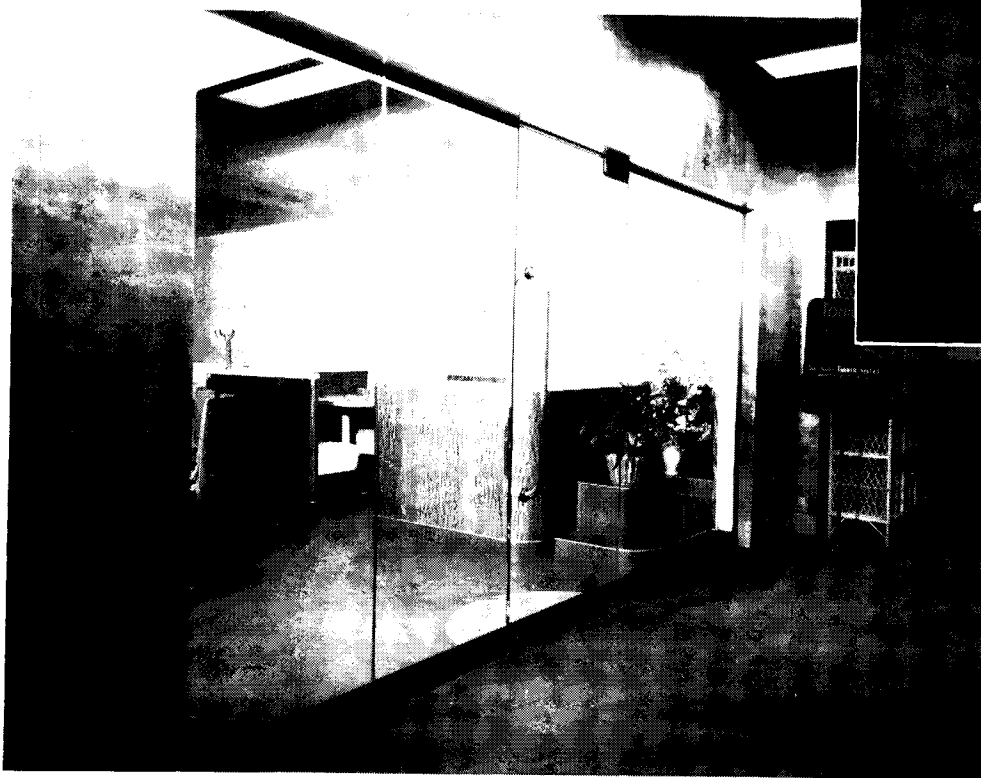

An Entrance like this extends an invitation to passers-by, by permitting clear, wide, undistorted vision into an attractive interior. Herculite Tempered Plate Glass has become increasingly useful to the architect in creating appealing, striking store designs. It has all the advantages of regular Plate Glass and four times its strength, due to a special tempering process.  
Williams & Grimes, A. R. Williams, Architect.

★ Design it better with

## Pittsburgh Glass



"PITTSBURGH" stands for Quality Glass and Paint

PITTSBURGH PLATE GLASS COMPANY

*We believe you will find much to interest you in our new, illustrated booklet of ideas concerning the use of Pittsburgh Glass in building design. Send the coupon for your free copy.*

Pittsburgh Plate Glass Company  
2038-6 Grant Building, Pittsburgh 19, Pa.

Please send me, without obligation, your new booklet entitled: "Ideas for the Use of Pittsburgh Glass in Building Design."

Name.....

Address.....

City..... State.....

# TW Wire Insulation made from GEON approved by Underwriters' Laboratories



**W**IRE insulation made from GEON has been approved by Underwriters' Laboratories for use in wet locations, eliminating the need for lead sheathing. Besides this advantage, GEON permits the use of thinner insulation and makes possible a smaller diameter wire—thus more conductors and more power per conduit. Other characteristics of GEON make possible an insulation which does not require a protective braid and which has superior all 'round long-time aging and electrical properties.

How's this for a test of an insulating material—*immersed in water for 106 days at 70 degrees C?* (This test conducted by Electrical Testing Laboratories, Inc.) Insulation made from GEON stood that test, and came out with

its electrical properties practically unchanged!

TW insulation made from GEON is flame resistant, too—it extinguishes itself, an added important property in wet locations where exposed connections increase the danger of short circuit and fire. Corrosive conditions are common in wet locations. But they have no effect on insulation of GEON which resists the action of acids, alkalis, oil, greases, mildew, heat, cold and many other normally destructive factors.

Our development staff and laboratory facilities are available to help you work out any special problems. For more complete information write Department A-2, B. F. Goodrich Chemical Company, Rose Building, Cleveland 15, Ohio.



## B. F. Goodrich Chemical Company

A DIVISION OF  
THE B. F. GOODRICH COMPANY



## HOUSES, FASTER AND CHEAPER

"Fifty million dollars for the immediate construction of low-cost dwellings" is easier to appropriate than to implement. Politically it makes a very promising gesture; practically its progress will be slow. The dollars will not be hard to come by. The stumbling blocks are the words "immediate" and "low-cost." Both politicians and returning G.I.'s must face the facts: dwelling construction in quantity can be neither immediate nor low-cost.

Immediate housing will necessarily be makeshift and temporary, using anything and everything that will provide shelter: Quonset huts and trailers, vacant stores and barracks. Stock piles, building materials and equipment must be discovered, released and promptly used.

Scarce critical materials must be produced quickly. But the manpower for this primary production feels the need of the incentive of wage increases. Producers feel the need of higher price ceilings, the incentive of possible profit. Government agencies feel the need of controls to prevent rapid and disastrous inflation. Home seekers, to put it mildly, feel the need of shelter now. The President has passed on to Wilson W. Wyatt, Jr. (housing expeditor), the task of adjusting these needs, negotiating compromises, breaking bottlenecks and cutting red tape. His major task is to encourage full production of lumber and millwork, brick, cast iron soil pipe, heating equipment and the other scarce items.

To expedite this crucial program of production involves incentive as well as persuasion, especially if, in Wyatt's own words, "prices have got to be brought within the reach of the veteran." Under present conditions of labor supply and demand there is little likelihood of any reduction in wage rates (and the "annual wage" possibility is still remote). The obvious ways of bringing prices within reach, other than through bonuses, subsidies, public housing or other special privileges, would seem to be:

1. Smaller, simpler dwelling units with bare essentials in equipment — that minimal house again.
2. Improved manufacturing and distributing techniques to cut cost of component parts through greater productivity per man hour. These technological improvements would include increasing factory and mass production methods, dimensional coordination and standardization of parts. But this is a ten-year rather than a ten-month program.
3. Elimination of restrictive practices and readjustment of labor and management policies and programs with a view to greater efficiency. This would include apprentice training, elimination of jurisdictional disputes, code revision, etc.
4. Large-scale construction — the creation of communities, apartment house groups, etc., on comparatively low-cost land.

In the working out of any and all of these methods of reducing prices, *the architects and engineers of the country can, if they will, play a most important role in both the immediate emergency housing and in the development of the long-term program of increasing efficiency in the building industry.*

*Kenneth K. Stowell*

EDITOR

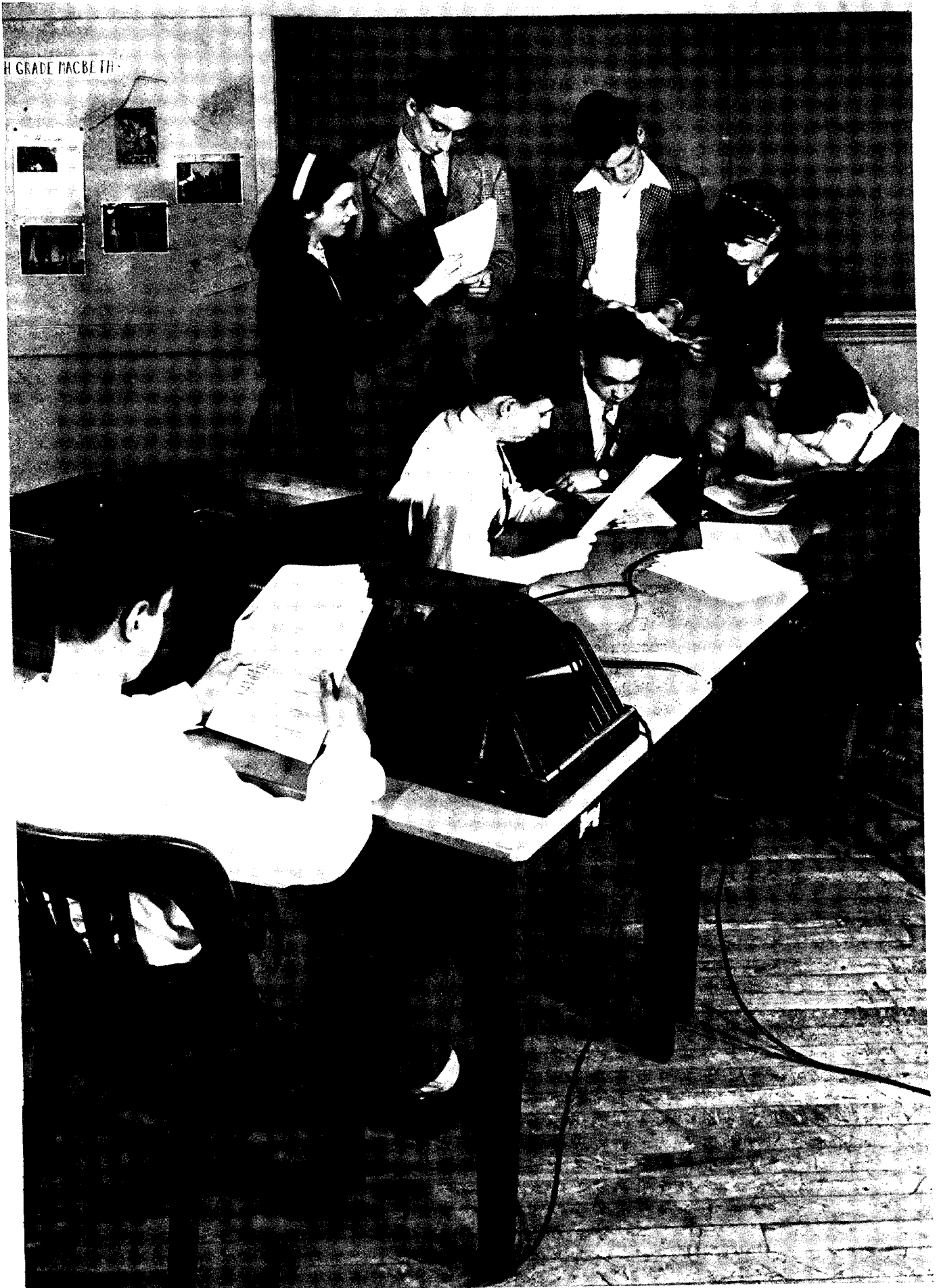

JOHN BORROWS PEATY



The Rugen School, Glenview, Ill.; Perkins, Wheeler and Will, architects. The firm had some 30 schools on its boards at presstime

## EYES AND EARS IN SCHOOL

### I. AUDIO-VISUAL CLASSROOM PLANNING

by Philip Will, Jr., A.I.A., of Perkins and Will, Architects and Engineers

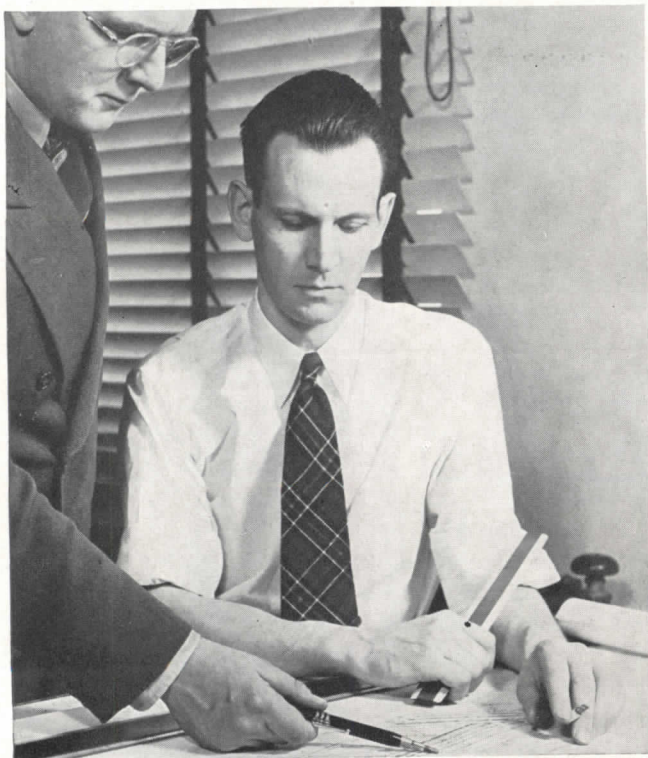

Philip Will, Jr., studying. The "entourage" is Lawrence B. Perkins, partner, contributing to the power of the team. Frontispiece: Children of Lincoln School, N. Y., record a play

IN this issue, ARCHITECTURAL RECORD is privileged to publish two contributions on the subject of school planning, both of which may fairly be said to stand at the head of an epoch. Both relate to the health and use of the greatest single resource in the possession of the United States — the eyes and ears of its children in elementary schools.

The first article, beginning on the next page, is a technical study with an extremely ambitious aim: to find planning methods which could *make audio-visual education practical in every kind of common classroom now in existence or projected*. This objective took shape in the editors' minds as they watched the phenomenal success of training by visual and audial aids in the armed services — the Navy alone was reported to have used no less than 16 million feet of film for training.

After much consultation with educators and technical men, the assignment was given to architect Philip Will, Jr., with the conviction that, if anyone could find the right answers, he could, with the aid of his partners. At least two years of study have gone directly into this project, and the editors now submit Mr. Will's results to their readers with the utmost confidence. If, in the thousands of schools now building, his advice is heeded, a highly effective new method of education can be incalculably extended, as a service to the future of the Nation. Young eyes and ears will be effectively used.

## TROUBLES THAT DO NOT EXIST

To design classrooms for audio-visual education is simple enough, once the problem has been disencumbered of certain common errors. The major effort made in the present study has been directed toward this disencumbrance, and toward the development of a simple technique of planning for universal application.

Our thesis is that almost any common classroom can be adapted by a competent architect to the easy and frequent use of aural and visual aids. There are further steps to be taken by the school system, but they are beyond the scope of the present study. This first investigation concerns the effective use of the new technique in the ordinary classroom where regular education goes forward day by day and hour by hour. When audio-visual aids can be put to work in the routine, their use will be enormously widened. The trend is toward brevity in such items as films, and toward "spot" use. Therefore, many worries associated in the minds of educators with the idea of long "shows" can be dropped. This should be well understood at the start.

1. *There is no necessity for children to be moved out of their seats to go anywhere else.*
2. *Overheating of the room is not a worry — the machines will not run long enough at a time.*
3. *Ventilation is not a worry — the blackout will not last long enough.*
4. *Special low-level lighting schemes for the period of the blackout are not indispensable, although they may sometimes be highly useful. Light spilled by blackout arrangements will suffice for purposes of discipline and safety.*

*Photos, below, show a typical "spot" film subject*

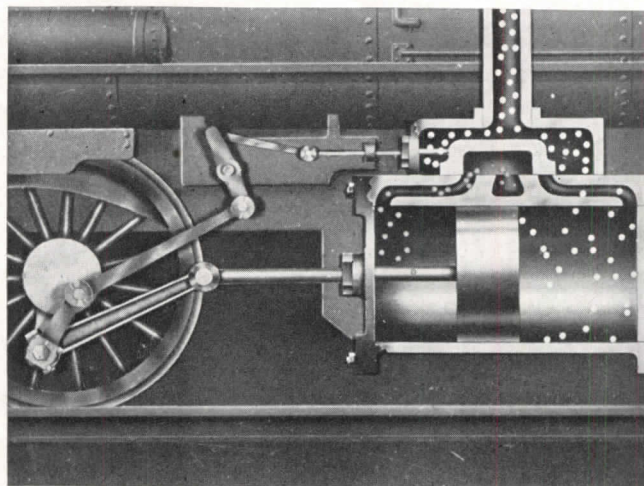
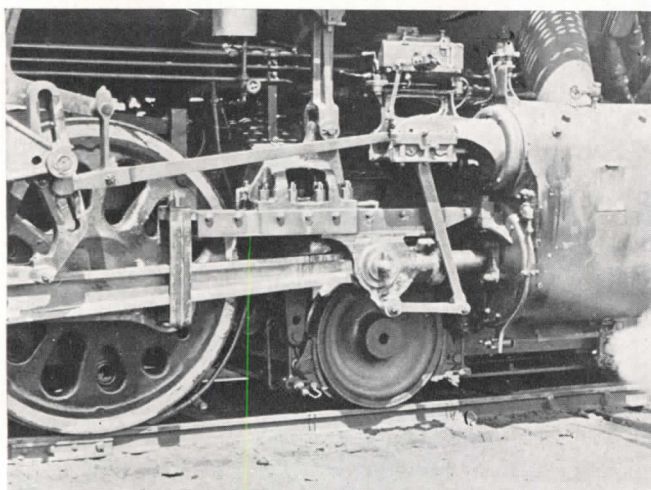

## WHERE PROJECTION TIES IN

Projection of either sight or sound is merely another step in the extension of visual and aural aids which are already quite familiar. These include the chalk board, the flat display area, three-dimensional displays such as globes or models, the demonstration table for experiments, the speaker's stand.\*

Herein we are concerned with the less familiar problem of sight and sound by projection. The architect as

\* See the full summary in an article by Adrian L. TerLouw, *ARCHITECTURAL RECORD*, Sept., 1945, page 77.—Ed.

well as the educator must note that improvement is to be expected in the *material* which will soon be available, in teaching *methods*, in simplified *equipment*; and that planning must be done in terms of this future, not of the past. Visual aids will be bent increasingly to the flow of education rather than education bent, as now, to the limitations of visual aids.

Photographs on the next page show a film being used in conjunction with the more customary visual aids. First, there is advance discussion of the subject (wheat

farming) with the use of chalk board and maps; then the film is shown; then the film is discussed orally; finally exhibits, both flat and three-dimensional, are collected to augment the visual experience.

The photographs of the locomotive cylinder are indicative of the kind of film now being developed by such agencies as Encyclopedia Britannica Films and commercial firms. They are "shorts" which show, more



1. Preliminary Discussion, using chalk
2. Motion picture as visual aid
3. Further discussion, with displays

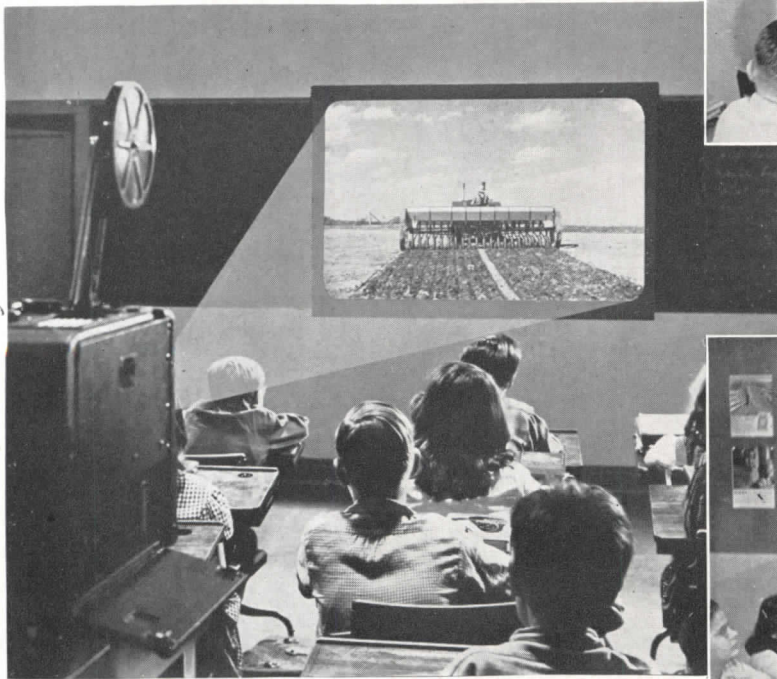

vividly than charts or chalk, some movement, some detail of intricate construction, or the steps in an operation, which film can demonstrate almost to perfection.



## ELEMENTS OF PROJECTION PLANNING

Optical considerations determine the projection pattern combined with the seating pattern. The goal is to obtain adequate brightness at the screen, and the appearance of *even brightness*; to black out stray light that might veil the image; to place the seats not too near and not too far for good seeing and not so far to one side of the projection axis as to distort perspective.

The Society of Motion Picture Engineers has worked out standards for non-auditorium projection, based on the width (W) of the image on the screen. Working forward from the screen on the axis, the nearest seats may be placed at a distance equal to 2W; the motion picture projector will usually stand at  $5\frac{1}{2}W$ ; the back seats should be not farther to the rear than 6W. For classroom purposes the width of the screen may usually

be taken as 5 ft., but may be varied for special conditions. (See TerLouw, *op. cit.*)

The two pairs of main planning considerations are given in the table below:

### PLANNING ELEMENTS

1. The projection pattern, combined with the seating pattern
2. Blackout devices
3. Wiring for projection and for speakers
4. Attention to acoustics

# USEFUL TOOLS FOR PLAN TESTING

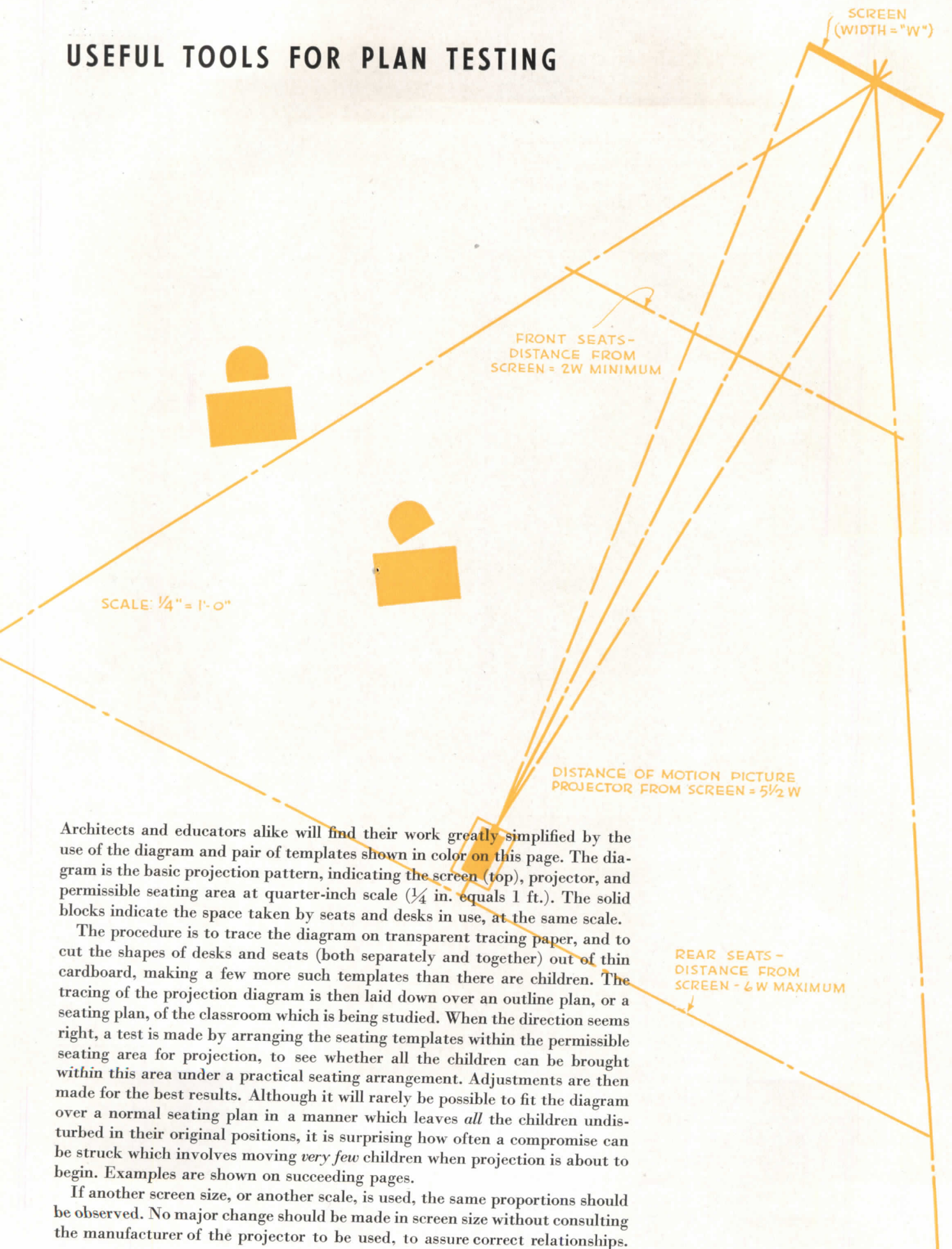

Architects and educators alike will find their work greatly simplified by the use of the diagram and pair of templates shown in color on this page. The diagram is the basic projection pattern, indicating the screen (top), projector, and permissible seating area at quarter-inch scale ( $\frac{1}{4}$  in. equals 1 ft.). The solid blocks indicate the space taken by seats and desks in use, at the same scale.

The procedure is to trace the diagram on transparent tracing paper, and to cut the shapes of desks and seats (both separately and together) out of thin cardboard, making a few more such templates than there are children. The tracing of the projection diagram is then laid down over an outline plan, or a seating plan, of the classroom which is being studied. When the direction seems right, a test is made by arranging the seating templates within the permissible seating area for projection, to see whether all the children can be brought within this area under a practical seating arrangement. Adjustments are then made for the best results. Although it will rarely be possible to fit the diagram over a normal seating plan in a manner which leaves *all* the children undisturbed in their original positions, it is surprising how often a compromise can be struck which involves moving *very few* children when projection is about to begin. Examples are shown on succeeding pages.

If another screen size, or another scale, is used, the same proportions should be observed. No major change should be made in screen size without consulting the manufacturer of the projector to be used, to assure correct relationships.

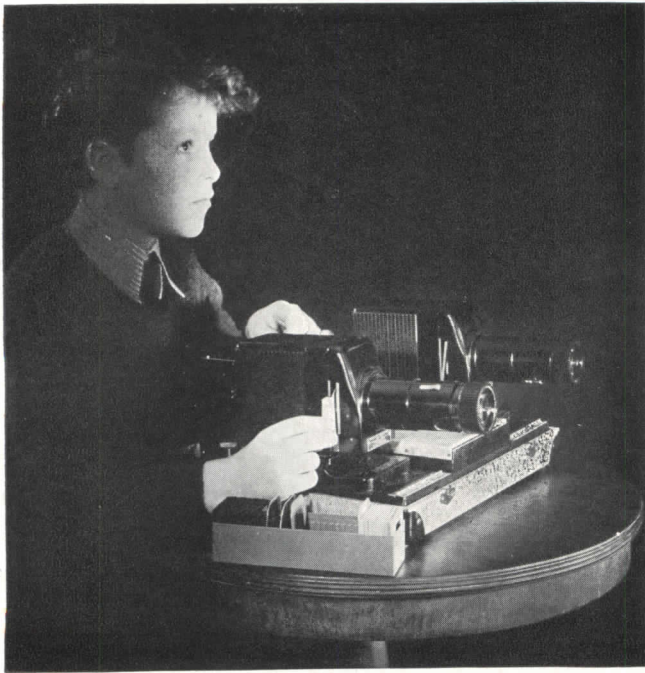

Courtesy, EASTMAN KODAK CO.

Above are seen coupled slide projectors\* and a motion picture projector by the same manufacturer. Boys can be counted on to run such machines. The trend is toward automatic threading and operation. Another trend is toward reconciling focal lengths, so that all projectors may be used in the same position; until then it will be wise to mark positions permanently in the floor, by an inset of another color.

For blackout we prefer drapes, awning type shades, or pull-up curtains so that one child can darken the whole room by a simple operation without having anything jam or stick. A large range of tightly woven fabrics is available; flame-proofing will be required. Built-in pockets will diminish dust

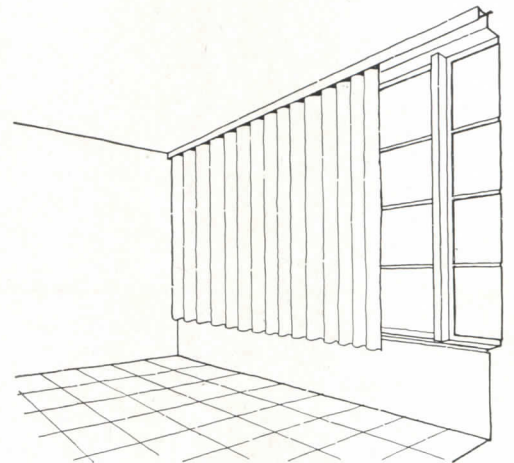

\*Dissolve control lets images fade into one another at the screen.

## SOUND SYSTEM AND WIRING

Sound absorption will be provided by drapes and the children's clothes; resonance, by the usual plaster or wooden wall surfaces. Desirable acoustic ceilings are being introduced in classrooms for general use.

A built-in speaker is a great convenience in any classroom, to be used interchangeably, if desired, with the intercommunication system, the radio-phonograph, or sound pictures. However, there should also be an outlet for portable speakers at the front of the room, connected with the sound outlet for the projector at the rear, to do away with messy "haywire"

A COMPLETE WIRING SYSTEM: (1) Power outlet for projector, 30-amp. capacity (use heavy wire); (2, 2) Speaker outlets; (3) Control for high-intensity lighting; (4) Wall and bench outlets—two separate lines fused for 30 amperes; (5) Selector switch to radio, intercommunication or classroom speaker; (6) Switch for low-level lighting; (7) Switch controlling ceiling spotlights; (8) Switches controlling circuits in "4"; (9) Convenience outlets, 15 amperes each

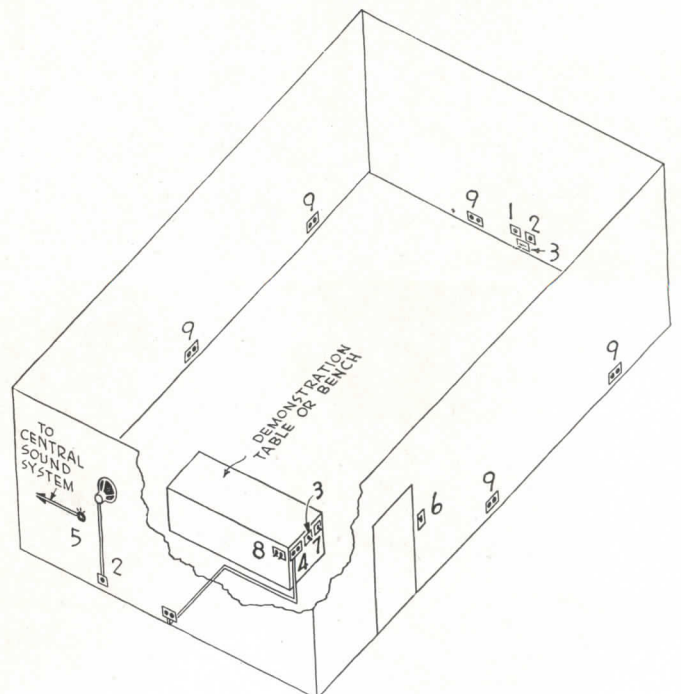

AREAS FOR GOOD SEATING for audio-visual education are indicated in yellow on these schoolroom plans. They were derived by the use of the diagram reproduced on page 70. As may be seen, more than one workable plan can be found for the same room

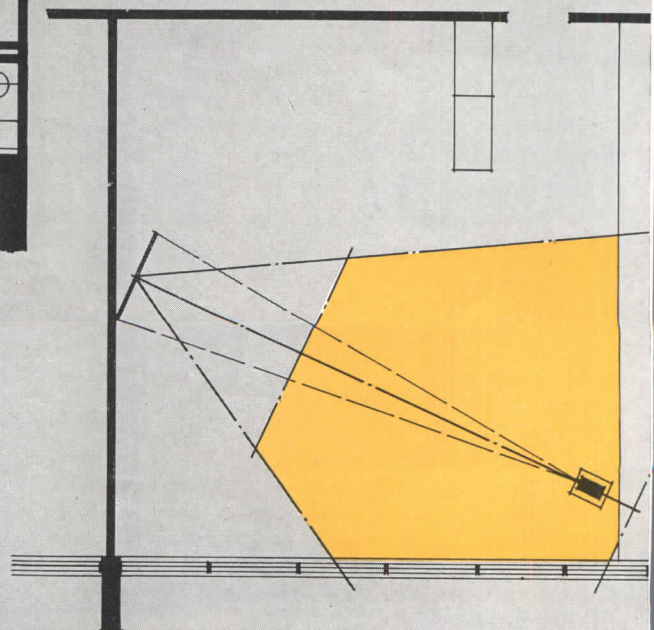
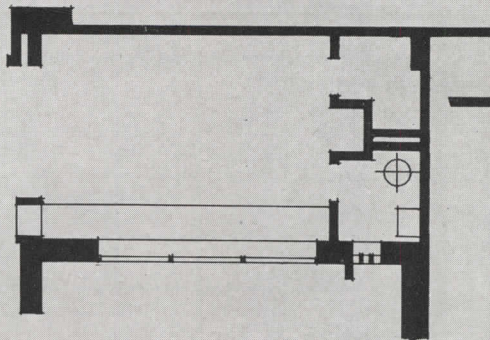
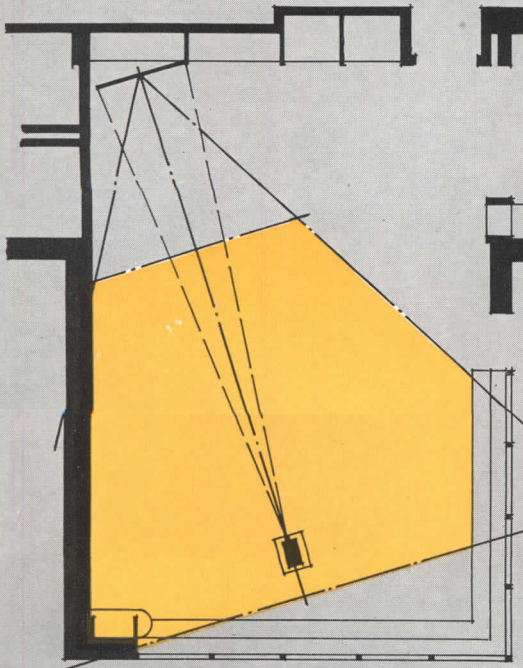
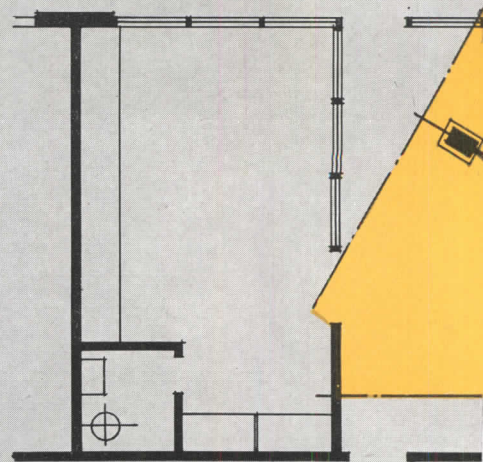
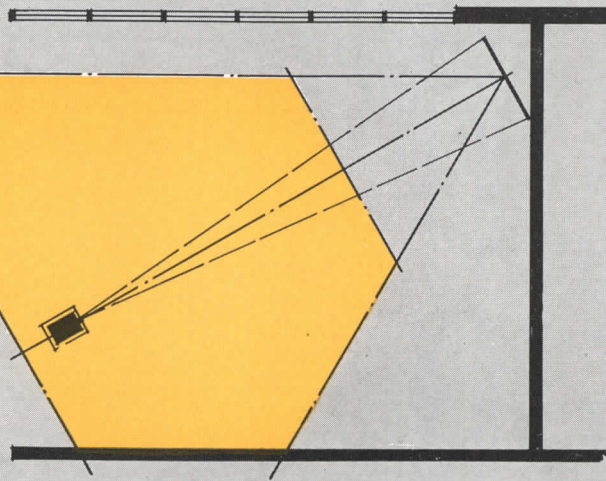
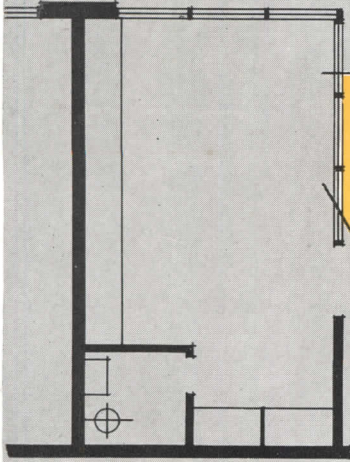
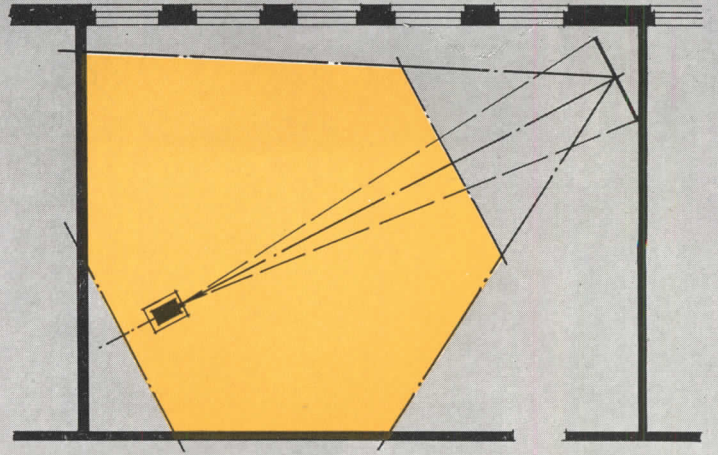



FOUR CLASSROOM TYPES have been used in deriving the nine plans. Top row, the conventional classroom; middle row, the classroom with adjoining work alcove; bottom row, the L-shape and square classroom. Succeeding pages show the method in more detail

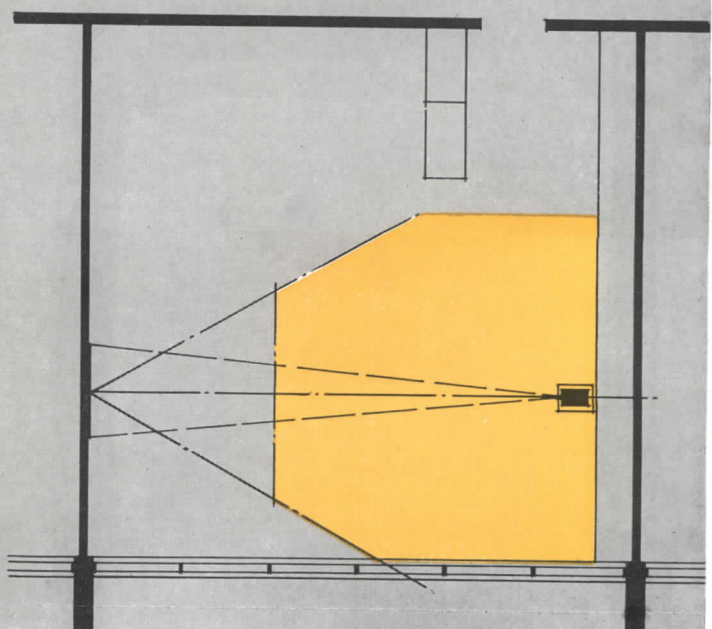
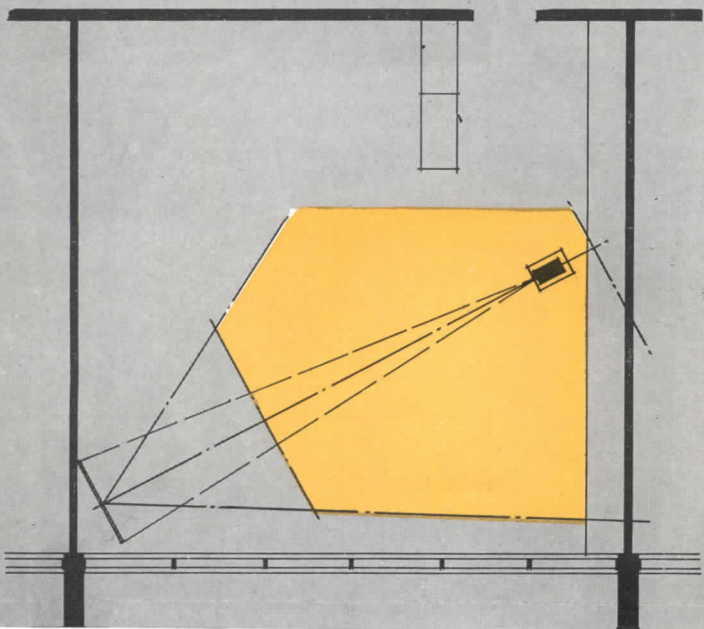
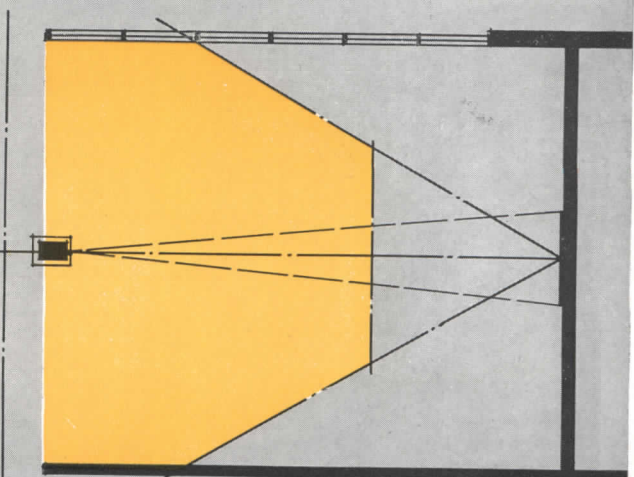
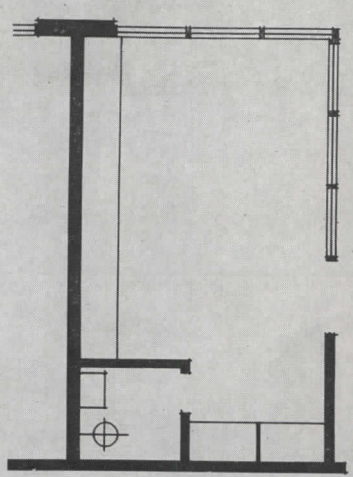
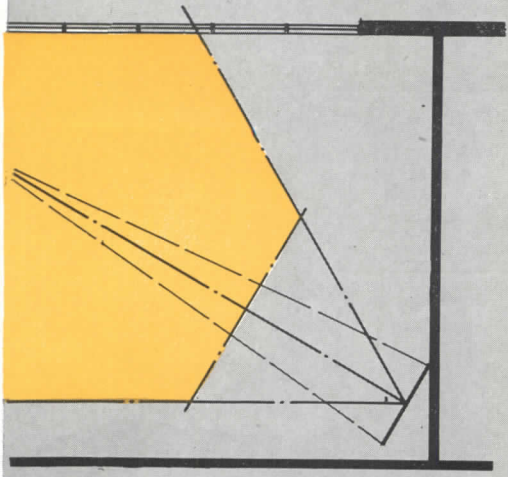
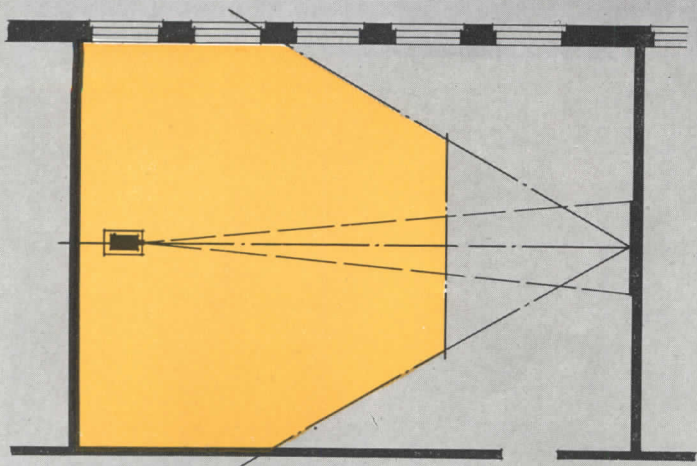



### EXAMPLE 1. THE "CONVENTIONAL" CLASSROOM

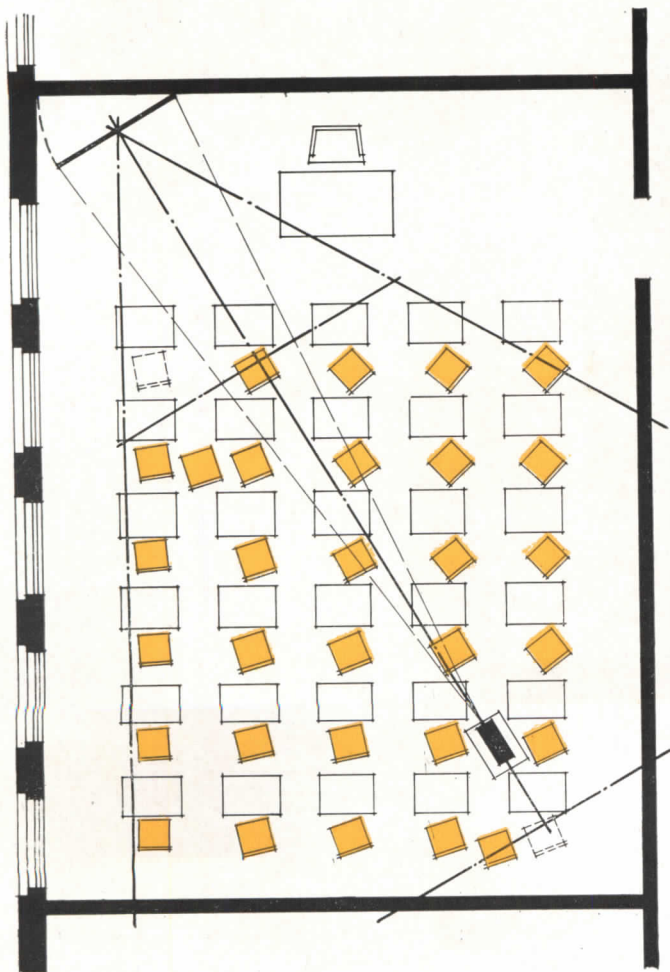

This is the kind of room which is found in schools all through the United States. It is 22 ft. wide and 30 ft. deep. Windows stop at a point about 4 ft. in front of the chalk-board wall.

There might be three possible positions for the projector. Projection might be straight down the center of the room, as seen in the photograph above; or it might be pointed diagonally toward either the inner or the outer front corner. We have chosen the last-named direction because there is a minimum distance to move the stand and projector. Sight lines are unusually favorable — no seat is in the direct line of view of the seat behind it. *Only two children have to be moved before projection begins.* If the room were still shorter, say a minimum of 28 ft., it would still be possible to work this way, moving only two or three seats.

For convenience and easy maintenance, the screen is permanently mounted on a high hinged panel, which is swung out into position when projection is ready to begin. Screen surface must reflect well in wide range.

*Yellow squares in the diagram represent seats in position for projection. The child in the front left corner has been moved back to a position behind the permissible front seating line, and the rear corner child has been moved away from behind the projector. In the photograph of a conventional arrangement, the screen has been placed too low, and sight lines are bad*

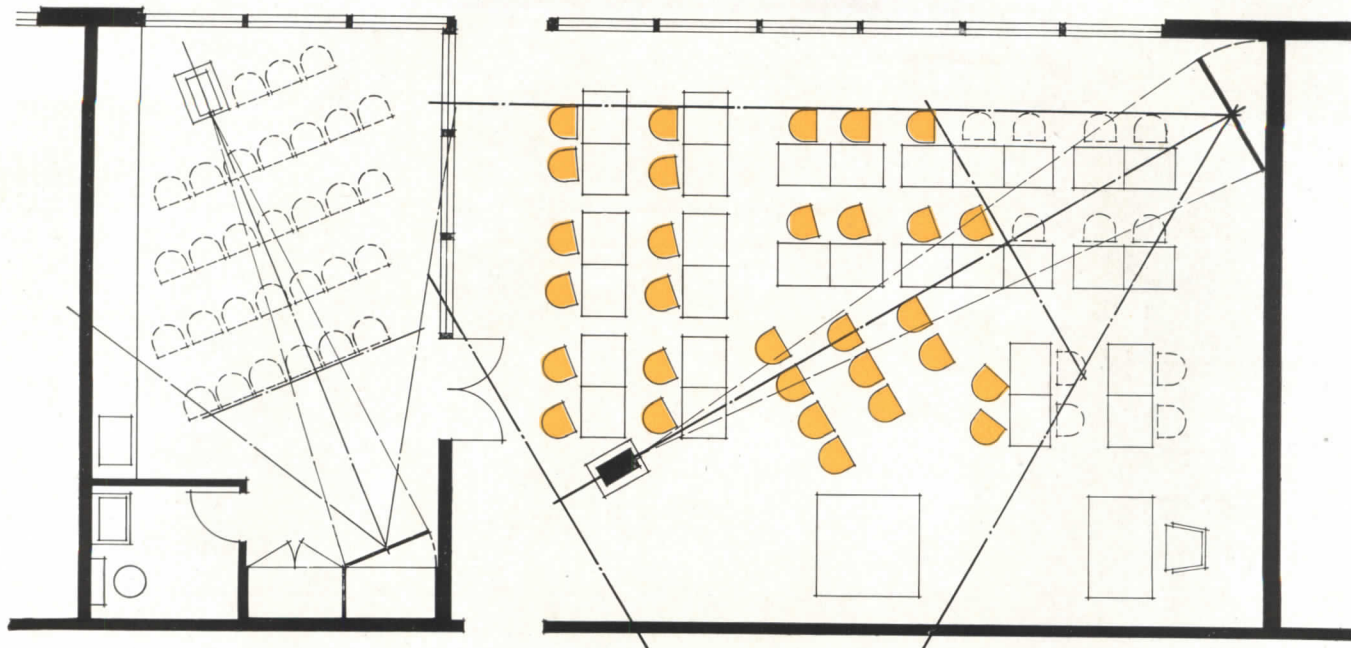

**EXAMPLE 2. CLASSROOM WITH WORK ALCOVE**

The prototype for this classroom is the typical room of our Rugen School at Glenview, Illinois. In this kind of plan, the general seating is likely to take any one of a number of patterns, especially in view of the bilateral lighting. We choose a likely seating pattern for purposes of illustration, and demonstrate *two* possible solutions in the use of projection.

*a. Projection in the main room.* Basically, this arrangement is very similar to that in the conventional classroom (opposite page). In this example, 11 seats are moved, before projection begins. Again the projector is on a stout movable stand, can be brought into operating position from the corridor with ease.

*b. Projection in alcove workroom.* Children accustomed to progressive education methods can be trusted to carry their chairs with them into the alcove with a minimum of fuss. The projectors of less expensive types, such as silent motion picture or slide projectors, can be very conveniently stored adjacent to use.

Yellow shapes on the diagram represent seats moved into position for projection in the main room (dotted lines show alcove seating as an alternative). Hinged blinds will be needed to blackout the high transom or clerestory windows, as seen in the drawing. Elsewhere drapes are usually the easiest kind of blackout device for children and teachers to manage quickly

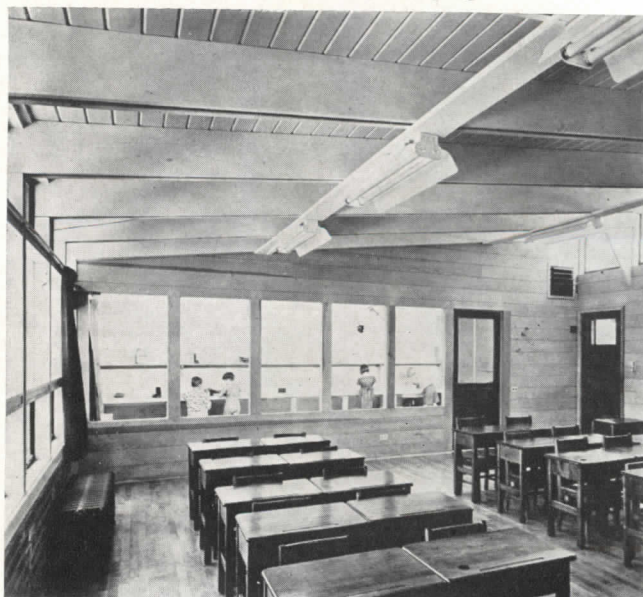
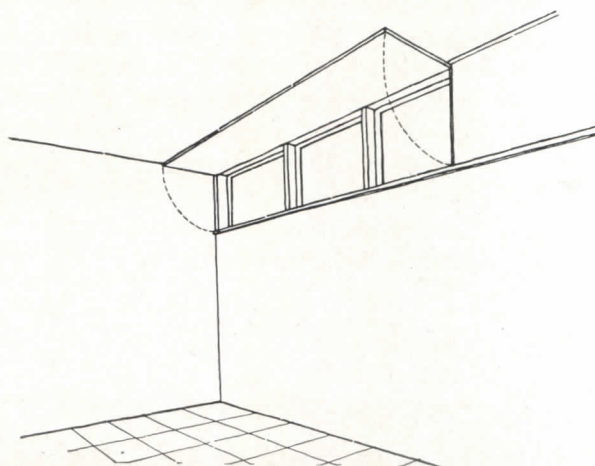

HEDRICH-BLESSING

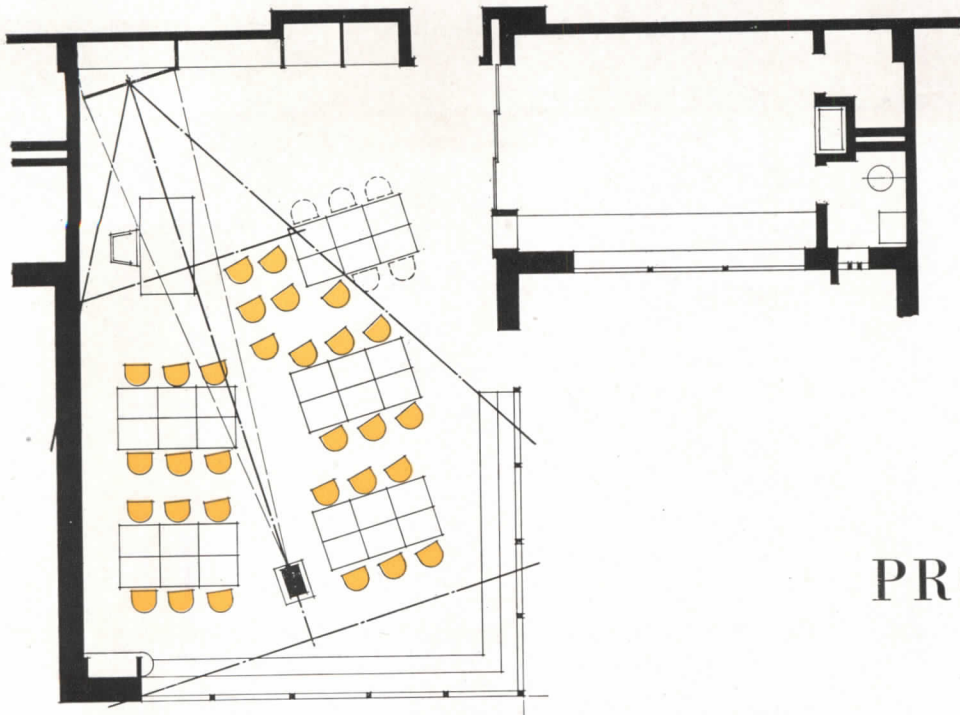

EXAMPLE 3.

## THE PROJECTING L

The prototype for this arrangement is the Crow Island School at Winnetka, Illinois, seen in the photograph below. Again, using a hinged screen panel makes it possible to throw the image obliquely. It has seemed better to use the inside corner for the screen, at the greatest possible distance from the windows, even though it might be argued that the corner seen in the photograph would be subject to less veiling light. If we were to use the outer corner, it would also be true that many more children would have to be moved.

This room will need extensive curtaining with black-out drapes, running similarly to the curtain now in use. The alcove has been given a set of sliding doors to cut off the light that might stray in from it.

Only five seats would have to be moved, from the arrangement indicated herein, to put all children within the acceptable projection seating area.

It is interesting that most classroom plans were easier to handle with a movable projector than with any attempt at a fixed or hinged stand.

HEDRICH-BLESSING

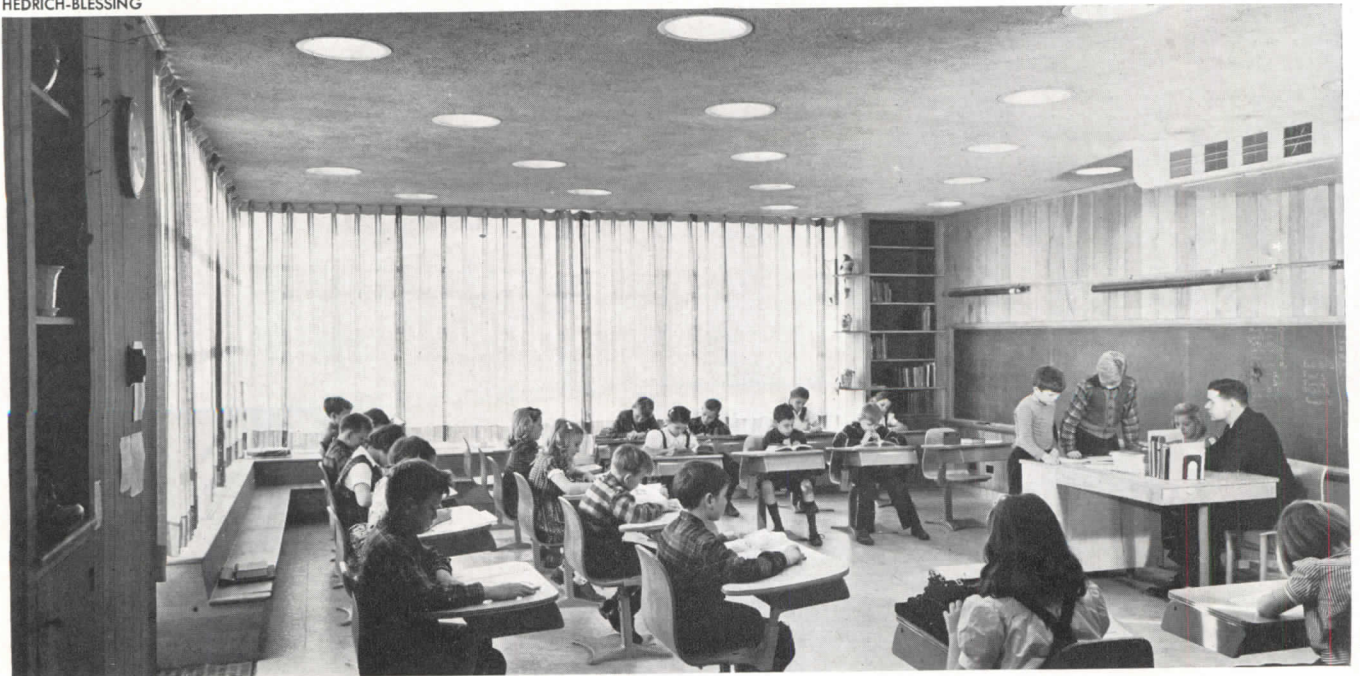

**EXAMPLE 4.**

# THE SQUARE CLASSROOM

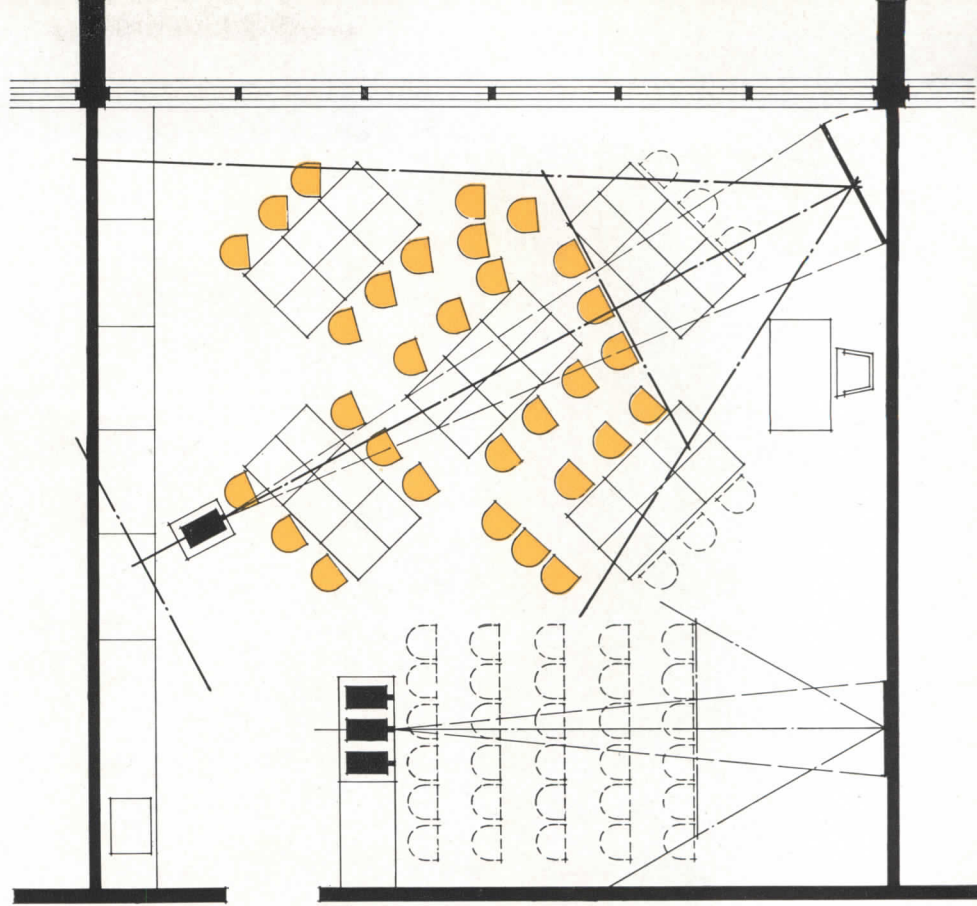

This is a type rapidly spreading eastward from California, where it originated. Code adjustments will soon be made permitting its use in eastern states. It offers a very flexible working area but requires auxiliary sources of light. Again, two solutions:

*a. Projection in the main seating area.* For this use, the entire room is blacked out, with the same drapes that were suggested for conventional rooms. Six seats are moved by a child while the drapes are being pulled.

*b. Projection in the "project" area.* (Dotted lines.) This solution has much to commend it despite the fact that all children must move. One suggestion is that they sit on the floor, depending on the warmth from radiant heating. The work area, or projection area, is blacked out with a drape of its own, which may also be helpful in deadening noise on other occasions.

This is the only scheme in which a fixed stand is recommended, as seen in the perspective below. Underneath is space for storage of films, slides, records.

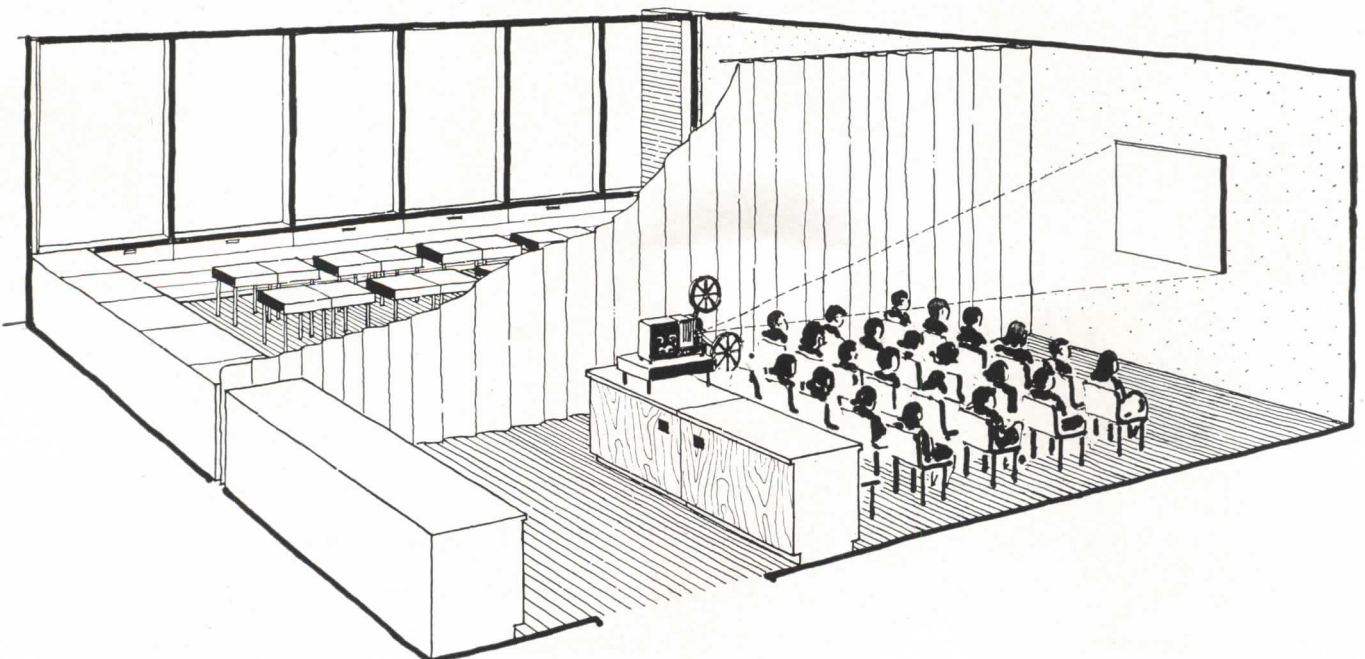

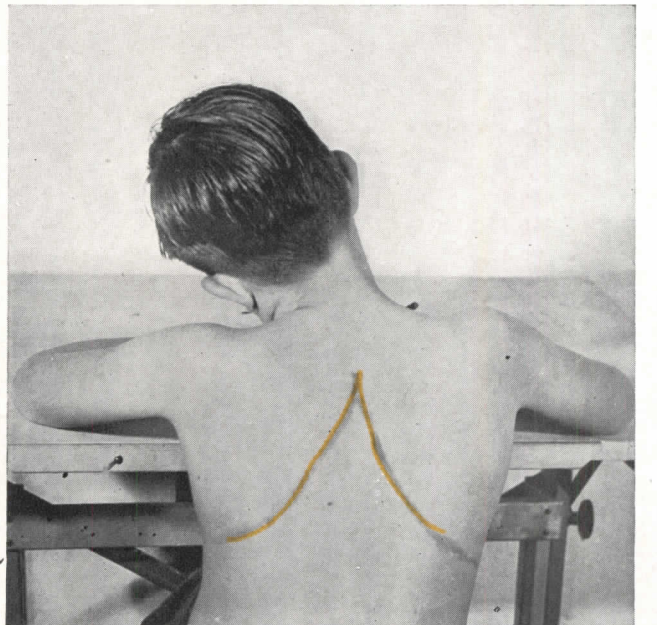
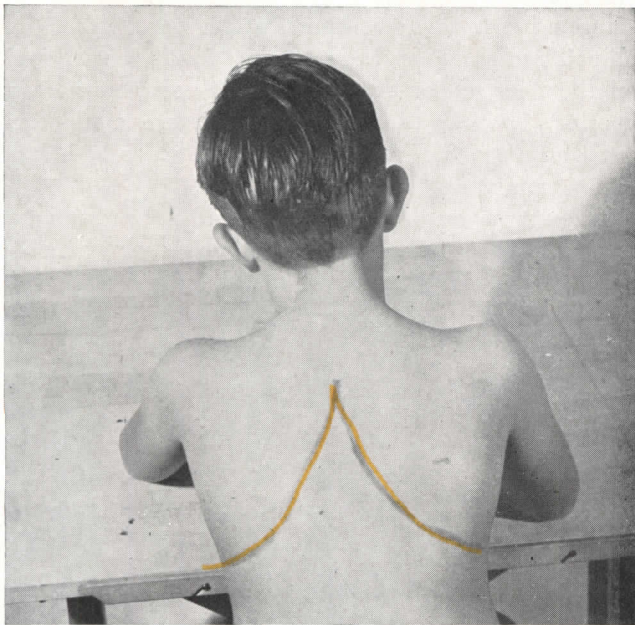
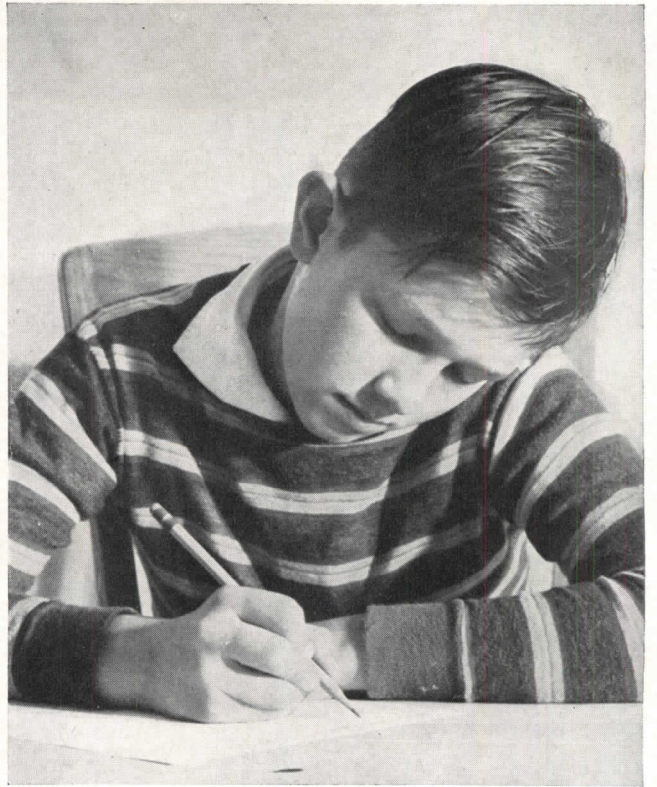

*The differences in posture seen above are conditioned entirely by changes in lighting. The pictures were taken in the course of screening 160,000 Texas school children for health, and taking measurements on 40,000 of them. At the left, the boy is seated comfortably at a good working surface in good light. At the right, another unposed view, he has shifted his head, by bodily reflexes, just enough to shade his eyes from the glare of a window to his left. When it is considered that the use of windows at 90° to the left of school seats is absolutely sacred, but leads to such distortion of children's backs, we may judge how completely the daylighting of schools must be rethought. The remedy, page 87*

## 2. LIGHT ON GROWING CHILDREN

By Dr. Darell B. Harmon

Director, Division of Educational Services, Texas State Department of Health

When the effects of architecture on 160,000 school children are scientifically tested by doctors, that makes news. And when architectural improvements alone are reported to have reduced eye troubles in certain schools nearly two thirds, nutrition difficulties by 44 per cent, infection by 30 per cent, the report cannot be ignored. Doctor Harmon's pioneer work in Texas has been in progress for seven years, and has created a sensation among health authorities and illuminating engineers. But its significance is really architectural. If the doctor has proved himself a splendid architect, he has also demonstrated that the architect on occasion can be the Nation's best practitioner in preventive medicine

### 1. HOW SEEING INVOLVES THE WHOLE BODY

CHILDREN do not see to see — they see to act." For this reason seeing involves far more than the mechanism of the eye alone; it involves complex interrelationships that exist between the eyes and the entire body. For the same reason light affects more than the eye. Light is something more than a means for aiding the child in the recognition of words and objects. It is a *force* in his environment, and an important one — a force that can shape or distort the total child, his eyes, his muscles, his well-being, currently or permanently.

These observations have led to more and more emphasis being placed upon the correction of improper lighting, in the course of a school survey that has been in progress in Texas during the past seven years, concerned with the problems of health and growth that affect our 160,000 elementary school children.

It might seem that no factor in the school environment has received more attention from investigators than lighting. From all of this, our children have received not enough benefit in typical schools. In far too many classrooms there persist glaring areas; dark corners; too much light on the children's faces and not enough on their tasks; harsh shadows and bad contrasts; light-consuming surfaces and finishes.

The reason may well be that lighting studies have not been inclusive enough or sufficiently realistic. Too much of our research has been "point" research, not concerned with the child as a totality or with light as an environment by which his whole body is conditioned. Many of the studies have concentrated upon but a single factor in this environment (the light on the immediate working surface), as it affects but one organic system in the child (the eye), in relation to a very limited purpose (recognition of objects and formation of an image); and most of the studies have dealt with a single point in time. Teach-

ers are aware how manifold are the actual adjustments of actual children, and dependent on how much more than the eye, as when one child, faced with bad lighting conditions manages as time passes to conserve both his sight and his energy by devices of evasion, while another child, striving to do what is asked of him, may eventually develop a clinical eye defect and other serious evidences of bodily strain.

Architects, experienced with the close interplay among form, substance and function, should grasp quickly that there is a whole chain of bodily activities which is set into action by "seeing." Organic life consists of a continuous process of balancing the environment.

"Within limits the human body is an organic mechanism fitted to survive by its capacity to adjust its relationship to the environment in which it finds itself. This is accomplished by shifting the internal balance between various bodily systems and parts, and by modifying or adapting many of its structures to fit the specific environmental factors which it encounters through a period of time. This adjustment of internal balances, and modification or adaptation of certain structures (eyes, muscles, bones, body chemistry, etc.) can be beneficial to the individual, or it can be harmful. The harm done, in turn, can be merely a temporary functional change, or it might be a handicapping chronic affliction."

There are at least five bodily actions consequent upon seeing:

1. The body organizes itself for *readiness to adjust quickly* to what is coming into sight.
2. *Spatial orientation* takes place, the body being aimed or centered on its various tasks so that these may be performed with a minimum of stress.

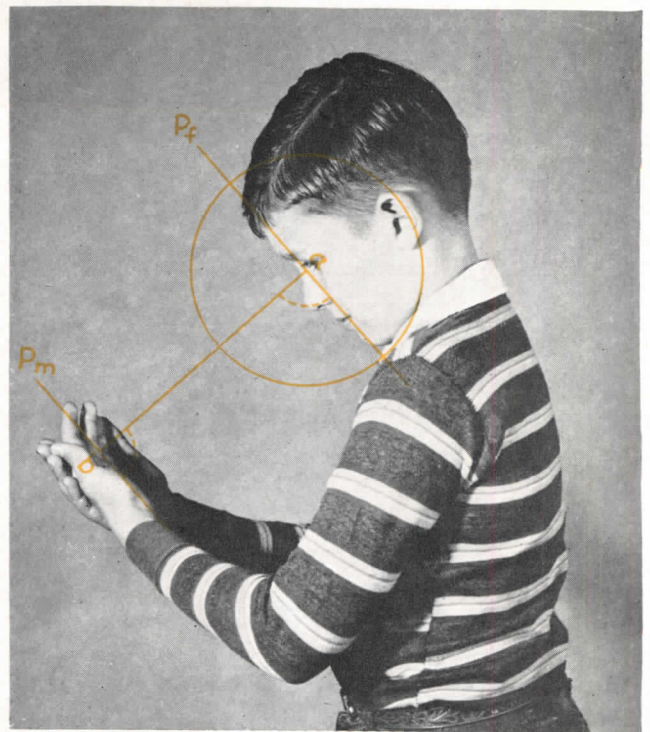
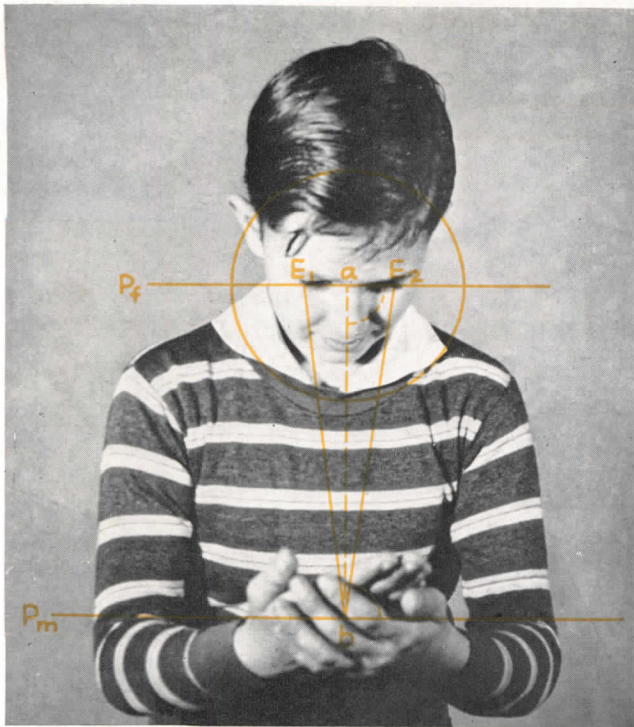

**NATURAL POSITION FOR CLOSE SEEING.** The forearms are raised to an angle of about  $20^\circ$  from the horizontal. Plane of face ( $P_f$ ) is tilted to be approximately parallel to plane of material ( $P_m$ ). The "line of sight"  $ab$ , measured from a point midway between the eye pupils, is normally vertical both to  $P_f$  and  $P_m$ . Continued distortion of any of these angles causes damage

3. Adjustment of eye, head, total posture so that the eyes may function with optical efficiency.
4. Final and efficient resolution of the visual image, with clear identification of details.
5. Incitation of visually determined responses — in other words taking action in terms of the individual's purposes, needs, and interests.

The need for adequate *intensity* of light on the task has been fully discussed in illuminating literature and the significance of glare is also almost self-evident.

The organic reasons for *lighter colored backgrounds* and for *low brightness contrasts* in these general areas have been less well understood. As the quantity of light striking the total retina goes down, the readiness of the body to perform decreases. This sets up conflicts with the demands for performance set up by the visual task. Still further, excessive contrasts interfere with efficient resolution and make it difficult to maintain attention. For the most effortless vision, the brightness of the total background must be kept just below the brightness of the task.

The need for low brightness ratios is premised upon the bodily balancing we have spoken of. By reflex action, the entire body seeks to center itself on the brightest area affecting the eyes. It seeks a body-centering that will distribute the brightnesses and shadows uniformly or symmetrically over the retinas. If the brightest area by far is a window well off to one side, while the task

is a book on the desk, constant effort will be required to overcome the reflex tendencies of the body to center itself in relation to the brighter window. The greater the number of pronounced light and dark areas, the more complex will be the physical conflicts set up in the child in his physical and psychological efforts to establish a balance between environment and work.

#### **Effects on learning and growth**

"The child at birth is complete neither in size nor in structure of each of his bodily systems that will eventually work together in making him a coordinated and integrated functioning human machine. The primary task of every child is to GROW — to increase in dimension and proportion and to complete his bodily systems and structures through which he can gain mastery over himself and his surroundings."

Those who have studied intensively how children grow are very aware that the full development of the child's organism and potentialities can come only through function. Because virtually all the educational tasks of children are either introduced or carried on through critical seeing, involving the bodily balancing mentioned above, lighting directly affects growth, both as to *rate* and as to *pattern*.

The child has just so much energy to expend, depending on his nutrition. Therefore only a limited amount of energy is really free for activity. But "activity takes precedence over growth in the use of nutrients." Therefore continued stresses induced by poor distribution of light, by bad contrasts, glare, and other bad practice, might readily use energy needed for growth, for body function, for protection against infection, for defense.



Again, the pattern of growth is inherently balanced and bisymmetric. "A study of the gradients of growth shows that its geometric centers, at any given time, are always at the centers of greatest bodily activity." In other words, "the child's body grows along the lines of stresses induced in it by various activities, in order to reduce those stresses. If the environment sets up lines of body stress that are not normal, that do not fit the alignment of inherent and normal growth, the result is structural warping. As the child continues to grow and function in such surroundings, the final result is asymmetrical or unbalanced body structure, deviating performances, and physical or psychological lesions and disabilities."

In brief, if the light is radically wrong, then any purely formal training in "posture" by the teacher only sets up new stresses and deficiencies, puts new obstacles in the way of young bodies already struggling under

difficulties. Our discipline can add insult to injury.

When it is reflected, finally, that "a young child in a large measure reproduces exactly what he sees, and learns exactly what he reproduces" it becomes understandable that recent thinking should have progressed beyond the thought of merely supplying enough light on the child's desk to the thought of giving the child the chance to put his bodily mechanism into easy, unstrained, natural and efficient alignment.

A group of leading orthopedists point out that "an individual is healthy only when the body is used so that there is no strain on any of its parts." They compare the human body to a machine, and point out that a mechanical engineer is seriously concerned with factors affecting alignment. "The less well aligned a machine, the more wear and strain there must be, and the greater the probability of trouble. The misalignment and faulty mechanics of the human machine are likewise a potential source of trouble."

## 2. STRESS DIAGRAMS OF FAULTY LIGHTING

UNDER direction of Dr. George W. Cox, State Health Officer of Texas, the Texas State Department of Health, in January, 1939, launched a long range program in child development as part of its services for protecting and promoting the health of school and pre-school children.

The study involved significant collaboration among several professions. Fourteen state professional societies and organizations, including the Texas State Teachers' Association, the State Medical Association of Texas, the Texas State Dental Society, the Illuminating Engineering Society, and organizations of educational and medical specialties, officially formed the Texas Inter-Professional Commission on Child Development to work with the program. The purpose of this Commission was to furnish a single advisory group, representing all the professions concerned, to guide the Division and its collaborating agencies in planning, operating, and evaluating the activities carried on.

During the first three years an inventory was made of physical and psychological difficulties afflicting Texas school children. Simultaneously, a check was made of classroom factors which might be related to those difficulties. These inventories took the form of screening surveys of the health and educational problems of some 160,000 elementary school children, and of the physical aspects of over 4,000 classrooms in which these children were attending school.

In view of the supreme importance of seeing to education, lighting was singled out for further study. Physiological literature fully describes the nervous pathways and other bodily structures which are involved, but few norms were found which would relate these structures to the geometry of desks and class-

rooms. It was necessary, therefore, to develop by observation and tests in the field what might be called the *bodily geometry of seeing*.

### *The body supports the eyes*

Organically, human beings have more factors alike than different. This is to be expected when we realize that growth, the mechanisms of activity, and the other factors entering into physical existence are governed by orderly, natural laws. For practical purposes, the two eyes are matched optical systems. As such, they must function according to well-defined optical laws. If a visual task requires adjustment of the eyes to function at a certain focal distance for efficient resolution, then it follows that the supporting structures of the eyes (the head and body) must adjust to support the eyes at a distance from the task determined by that focal distance, and hold them there as long as the task is being performed. If the task is one also requiring manual manipulation (i.e., writing, or holding a book), then these supporting structures must not only maintain the eyes at the appropriate distance from the task, but must also support the arms and hands at distances permitting both successful eye-hand coordination and maximum efficiency in continued manual manipulation. These activities must go on simultaneously with the other activities which support the body against gravity, and balance it with all the other demands of the task and in the environment. The common elements in body proportions, optical laws, and body function should reveal basic formulae for such light- and task-stimulated activities, applicable to all children, that could be used in planning classroom surroundings and for evaluating the efficiency of children in them.

### Basic body positions for normal vision

The Texas group made measurements of relations of the head, body, and eyes to the working area, and of the action of the various organic systems involved, on several thousand children engaged in close visually-centered activities, such as reading, writing, and drawing. For comparison, similar measurements were made on adults. The report\* said: "From these measurements our data demonstrated certain *constant* relationships exist in the forward inclination of the head and trunk in sustained close visually-centered activities, as a result of the body-balancing and orientation reflex mechanisms. When stimulated to such activity, both the trunk and the head lean forward out of the perpendicular to a position where they can be supported in this inclination with a minimum expenditure of energy and by means of minimum activity of the muscles supporting the weight of the head and trunk against the pull of gravity."

\* D. B. Harman, *Illumination and Child Development*, a paper presented at the Annual meeting Southwest Section, Illuminating Engineering Society, Fort Worth, April 13, 1942.

By means of these reflex movements the subject reaches a posture for close visual activity where the midpoint between the eyes, the point of each elbow, (the olecranon), and the center joint of each middle finger (the middle metacarpal), roughly describe an equilateral triangle with its base inclined upward from the elbow out of the horizontal by approximately 20°. (See diagram at left of page.)

When the equilateral triangle described by the middle finger, elbow, and midpoint between the eyes is projected onto a forward extension of the medial planes of the head and trunk (the plane described above), as shown in the diagram, the shape of this projection on this medial plane approaches a right triangle. The lower angle of this triangle points towards the center of gravity of the body when seated, and the perpendicular leg becomes the line of sight from the point between the two eyes to the point of fixation. The base of the triangle is tilted upward at approximately the 20° angle that follows the upward slope of the arms.

### How to read the diagrams

The photographs with superimposed diagrams shown at the top of page 80 reproduce the front, side and horizontal aspects of a child's reflexly assumed posture when engaged in close visually-centered activity. The line "P<sub>f</sub>" in these figures represents the plane of the face, while the line "P<sub>m</sub>" represents the plane of the materials on which the child is fixating, such as a book or sheet of paper for writing. Line "P<sub>m</sub>" represents the same plane, 20° out of the horizontal, that is established by the forearms when they reach a position parallel to the plane of the face. Point "a" is the midpoint between the two eyes, and point "b" is the point of fixation (the point at which the child is looking).

The line "ab" establishes the upper and forward leg or edge of both the equilateral triangles formed by the midpoint of both the eyes, the elbows, and the middle finger joint of each hand. For convenience hereafter, line "ab" will be called the "line of sight."

Points "E<sub>1</sub>" and "E<sub>2</sub>" in the horizontal drawing of the child represent the points where the plane of the face intersects the foci of the two eyes. Notice that lines "P<sub>f</sub>" and "P<sub>m</sub>" are parallel in both views, and that the line of sight (line "ab") is perpendicular to both these lines or planes in each of the views. The angles between the line of sight and the plane of the face or the plane of the material approach right angles.

The position of the child's body represented in these drawings is the starting position for close visually-centered activity. This is also the position to which the reflexes attempt to return the head, trunk, and arms, all the time close visually-centered activity is going on, so any other adjustive movements or other postures

Sketch by Dr. Harman to show normal body position for close visual work. P<sub>f</sub>, plane of face, approximately parallel to P<sub>m</sub>, plane of material. Right-angled triangle abc from eye to palm to elbow. Line bc points to center of gravity of body (Cf. p. 80)

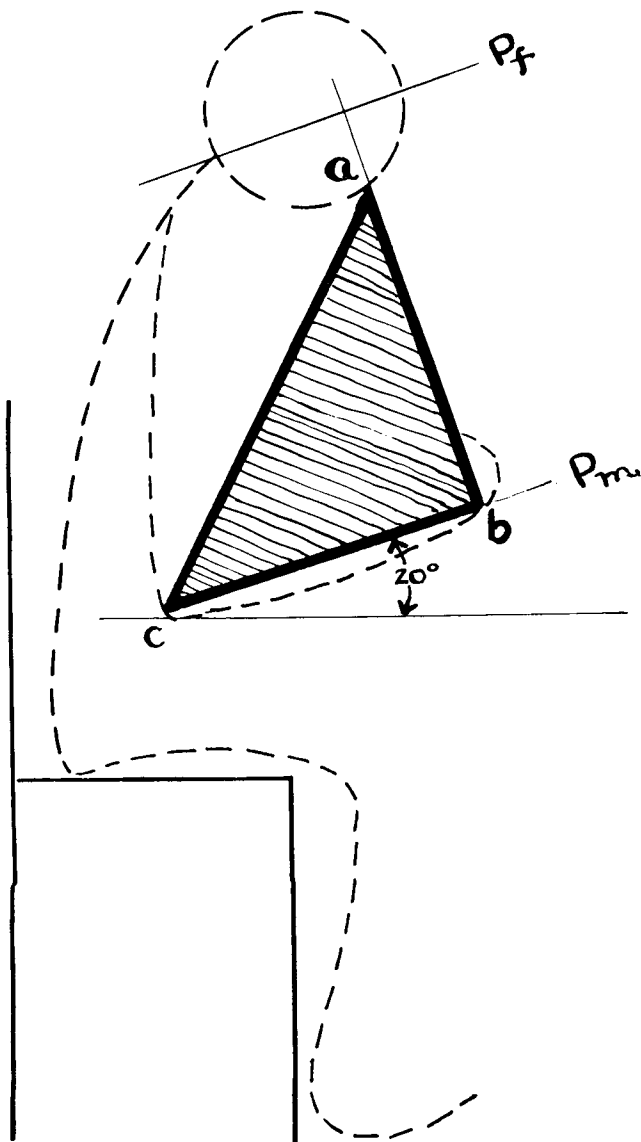

assumed during the course of the activity (other than those for relieving normal fatigue) represent stresses or energy expenditures over and above those entering into this basic posture.

According to the Texas data the relations shown in the schematic diagrams are maintained by the body as nearly as circumstances will permit.

In some 40,000 measurements of subjects with normal vision, with few exceptions, the distance which was maintained between the eyes and the work did not vary more than 3 centimeters from equalling the distance between the subject's elbow and the third knuckle of his middle finger, measured on the outside of his arm.

As the eyes moved back and forth over his work, the isosceles triangle (boy at left, page 80) was momentarily altered, but normally these movements, and any posture shifts, did not produce a change of more than 20° in the angle between the line of sight and either the plane of the work or the plane of the face. If this angle is habitually distorted by more than this amount in any direction, there is stress, fatigue.

It should be emphasized that the *child with the bent back* was working not under especially bad circumstances but under circumstances commonly accepted as good standard practice. His desk was at 90° to the window, with light coming from the left. Despite the universal acceptance of this seating arrangement, tests show that sloping work surfaces such as school desks are in the most disadvantageous positions for maximum task light when desks are arranged at right angles to the windows, in rows parallel to the window wall. Working surfaces at right angles to windows create the greatest possible angle between the line of sight and the line of light.

#### **How faulty lighting distorts normal positions**

The photographs and drawings on pages 84, 85 show the consequences of unbalanced light not only on the bodily geometry of the child but on his work patterns and on his growth pattern. These pictures were taken from case records in the Texas study. When the photograph was taken the child had been attempting for two years to adjust to sky glare visible through the center portion of the windows. He was also attempting to come to balance with high brightness contrasts in his visual field, the greatest brightnesses being in the upper left of the field.

He is seen working at his desk while he was being given a "square" test. It has been shown by psychologists, who have standardized mental tests, that children at the age of entering school are capable of drawing free hand squares with a limited amount of irregularity. The Texas study has shown that when a line of squares is drawn approximating the size of the subject's handwriting, a child working in correctly balanced postures and light relationships will keep the deviations or irregularities in his squares or in their alignment within a limit of 20° in any dimension. Where tolerances for postures and relationships are exceeded, school children will distort

their squares or the alignment, according to the laws of perspective, by an amount mathematically approaching the amount by which they are exceeding their tolerances for eyes-head-trunk-task relationships (this, of course, assumes inherently normal vision).

Without going farther into this fascinating study it becomes obvious that health relationships are directly involved in this bodily geometry adapting to vision.

#### **General health improvement through better lighting**

The kind of steps which were taken to improve lighting in all the schools in the program will be described in the next section of this article by detailed references to a single example, a school at Mexia. To determine the extent of the effect on the children's health, growth, and performance, health examinations were given in all the demonstration schools at the beginning of the tests and regularly thereafter. The details of these tests have been reported elsewhere and are perhaps not of front rank importance to architects. The procedures met the standards of the professions making up the advisory commission of the program. Architects would, nevertheless, be very much interested in the degree of change obtained by purely architectural methods of planning and construction.

For example, in November, 1942, the 396 children enrolled in one of the grade schools were given thorough pediatrics examinations and nutritional, visual, psychological, educational and other similar tests. These examinations showed that 53.3 per cent of the 396 children had functional and organic visual difficulties; 70 per cent had signs accepted by medical nutritionists as indicative of nutritional difficulties. Six months after the rooms had been redecorated, daylight controls installed, and the seating rearranged, only 22.8 per cent of the children showed refractive eye difficulties, a reduction of 57.1 per cent; in addition, nutrition problems had dropped 44.5 per cent below those recorded at the start of the experiment, and the signs of chronic infection had been reduced 30.9 per cent.

At the same time that the children's health difficulties went down, their performance records went up. Educational growth is measured by school men in terms of months of educational age gained. (A child of nine years and six months, actual age, is six months advanced if he is doing the normal work of ten-year-old children.) In the six months period of working in daylight-controlled classroom environment the children of the experimental school grew a mean average of 10.2 months in educational age, with a median growth of ten months and a modal growth of ten months. In the controlled school the mean educational growth was 6.8 months of educational age, the median six months and the modal growth six months.

With such data before us who would hesitate to say lighting has a very important part to play in promoting the efficiency, the productivity, and the well-being of Tomorrow's People?

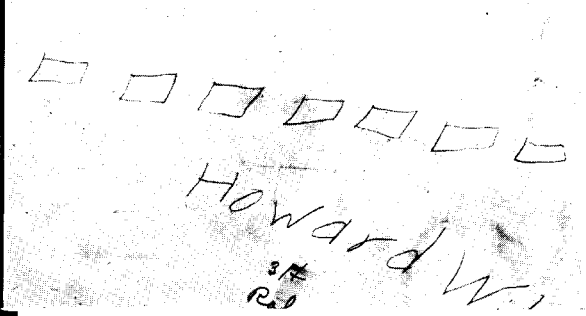
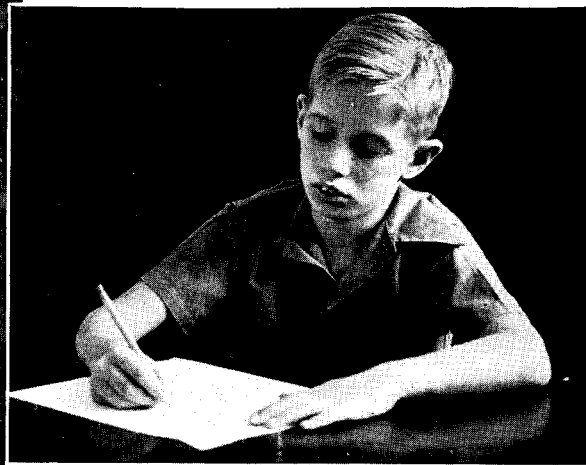
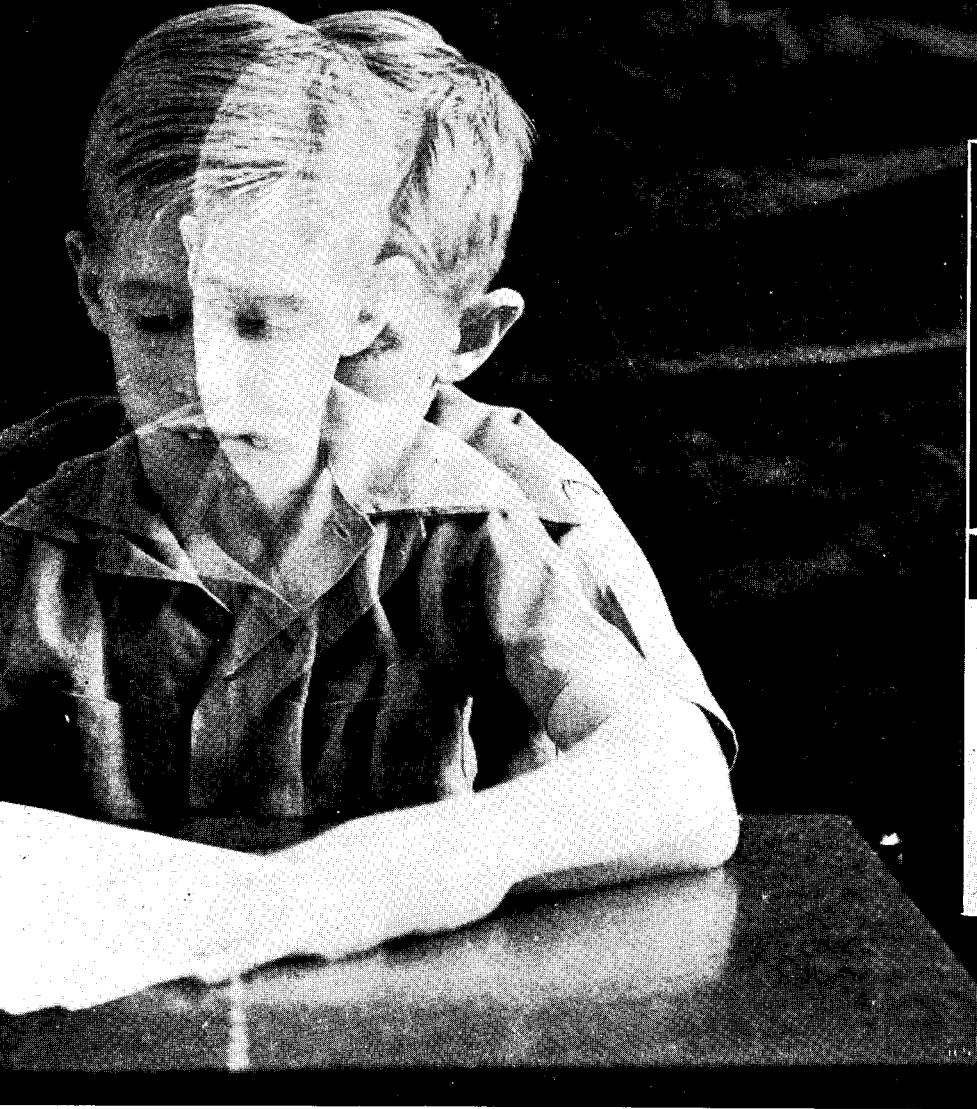

THE STORY OF HOWARD. When he first sat down (left) Howard sat straight, but the double exposure shows how much he shifted to shield his eyes from glaring light coming from the left. Howard's task was to make a straight line of equal, free-hand squares

### 3. HOW DAY-LIGHTING WAS IMPROVED AT MEXIA

TWENTY-FOUR demonstration centers were set up, with the cooperation of the Texas State Department of Education, to test the effects of improvements in classroom lighting.

The Mexia (Me-hay'-a) demonstration center, one of the first to be organized, has attracted unusual attention, because of the unusual effectiveness of improvements secured within the budget allowance of an average small-town school system. In describing the change that was made at Mexia we are illustrating the approach adopted everywhere.

Mexia is a city of 7,000, located in East Central Texas, 85 miles south of Dallas. It is the center of a farming and oil producing area. Mexia has 1,600 children enrolled in its public schools. The W. M. White Elementary School building (photographs, pages 86-90) is 27 years old.

Pictures and diagrams on page 86 give a graphic portrait of the typical classroom in the W. M. White School. It was typical indeed. Floors averaged 21 ft. 6 in. in width and 28 ft. 6 in. in length. The three windows shown in the left-hand wall were 7 ft. by 7 ft., extending to within 6 in. of an 11-ft. ceiling. They were of steel

casement type, and were shaded by center-hung roller shades of brown canvas. Glass area averaged 25 per cent of floor area. Exposure was to the south.

Interior reflectivities to light were characteristically low. Ceilings were of metal painted a medium gray whose reflection factor had been brought down by oxidation to 20-30 per cent of the light striking it. Wall reflectivities were down to 40-45 per cent; wood floors darkened by oiling reflected 12 per cent, the trim and woodwork 18 per cent, the desks and furniture, painted brown, 15-20 per cent. Blackboards were mounted on front, inside, and rear walls of all classrooms.

Seating was fixed, at the usual right-angle to the windows. Artificial light was not a factor in the tests.

Footcandle readings were taken in Room 200, and also in Room 308 — with western instead of southern exposure — in February, 1945, by a committee of lighting engineers.\* In the chart, page 86, is shown one set of readings at the children's desks. Figures seen within

\* Reported in *Illuminating Engineering*, October, 1945. "Control of Natural Light in Classrooms," by R. L. Bieseke, W. E. Folsom, and V. J. Graham.

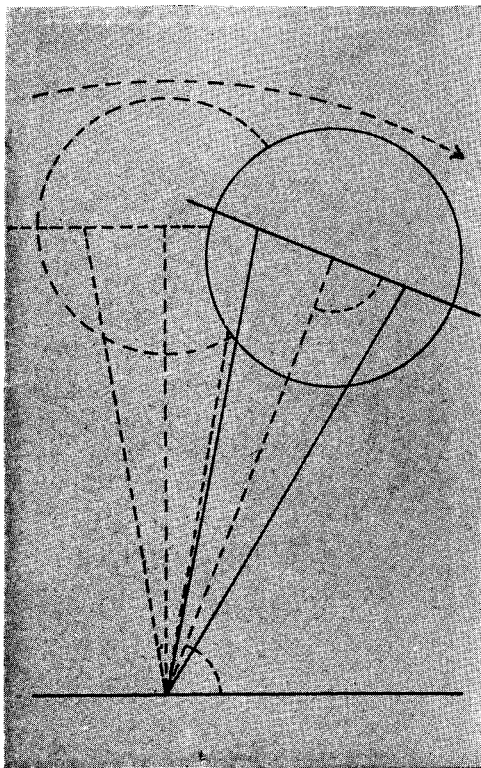

Howard's squares came out just about as crooked as his seating position. His eyes had shifted, according to the arrow, until his line of sight was not normal to his work, which was distorted in a direct relationship

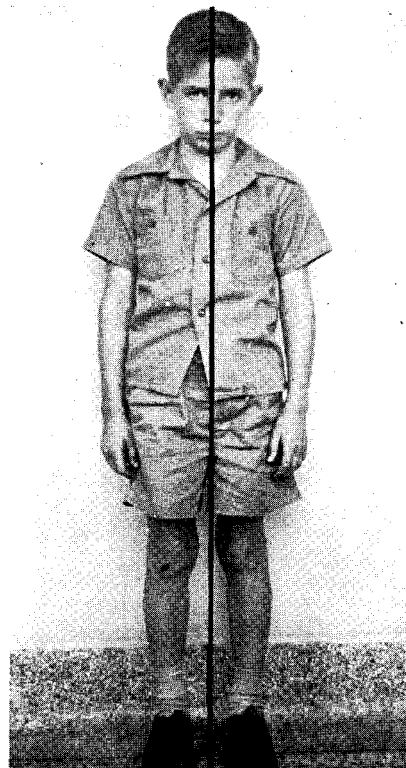

Because bodily growth occurs naturally at centers of strain, when the strain centers are shifted by continued distortion, growth is also warped. Here, then, is our Howard, front and side



Through no fault of his own, after two years of struggle he has grown a crooked body. It all began when the classroom was supplied, well-intentionally, to be sure, with one-sided lighting

the square of the desk represent light falling on the working plane, at an inclination of  $20^\circ$  from the horizontal. Figures placed diagonally at desk corners represent light falling on the *vertical* plane, at an angle of  $45^\circ$  to the eye. In other words, figures within the squares represent light falling *on the work*, while corner figures represent brightness *on the eye* within the periphery of vision. We reproduce chart only for Room 308.

By comparing the horizontal readings among one another, the engineers established that the maximum illumination on a desk was almost 9 times as strong as the horizontal reading at the inner chalk rail, a ratio of almost 9 to 1.

"A much more significant comparison," they said, "is the ratio of the light falling on the eyes from  $45^\circ$  to the left of the line of sight. In Room 200 each  $45^\circ$  peripheral reading is of the order of 3 or 4 times that of the illumination on the desk top." In brief, there was a violent departure from the rule that "more light should strike the work than strikes the eye."

#### Description of experimental changes

Four rooms were used in the experiment of improving classroom lighting in the W. M. White School. All had identical southern exposure. Room 200, just described, was left unchanged as a "control" room. The other three

rooms, numbered 301, 300, and 201, were subjected to measured steps of change, involving

- a. Redecoration
- b. Changed pattern of seating
- c. Controls at the windows

The graphic portraits of two of the changed experimental rooms, 300 and 201, appear on pages 89 and 90.

*Redecoration* was applied to all three rooms. As seen in the wall elevations, blackboards were covered in all rooms except for a short portion left for use by the teacher. Ceilings, rear walls, window walls, and a drop down the front and inside walls to within 7 feet of the floor were painted with a flat white paint having an initial reflectivity of over 80 per cent. The remainder of the inside wall was painted with the same paint to which a few drops of lamp black had been added, bringing its reflectivity down to 70 per cent. The reflectivity of the front wall was made slightly higher to compensate for the lesser amount of light falling upon it, the result being to give "the subjective appearance of practically uniform brightness on walls and ceilings within the visual field." Woodwork and trim were finished in the same matte paint modified to yield a 50 per cent initial reflection factor; floors were refinished with grey paint to reflect 30 per cent, desk surfaces and furniture were cleaned and lightened to a reflectivity of 30 per cent.



UNCHANGED CLASSROOM, WESTERN ORIENTATION. Similar to Room 200, but with western exposure. Desks at right angles to windows. Colors dim, reflecting a mere fraction of the light. The chart shows footcandle readings. The child at inner rear corner works in one-fifth the light that reaches the best window-row seat. Most distressing are the big figures at left corners of desks. They mean that light falling obliquely on the eye in some positions is 4 times as strong as light on work, creating a major distraction

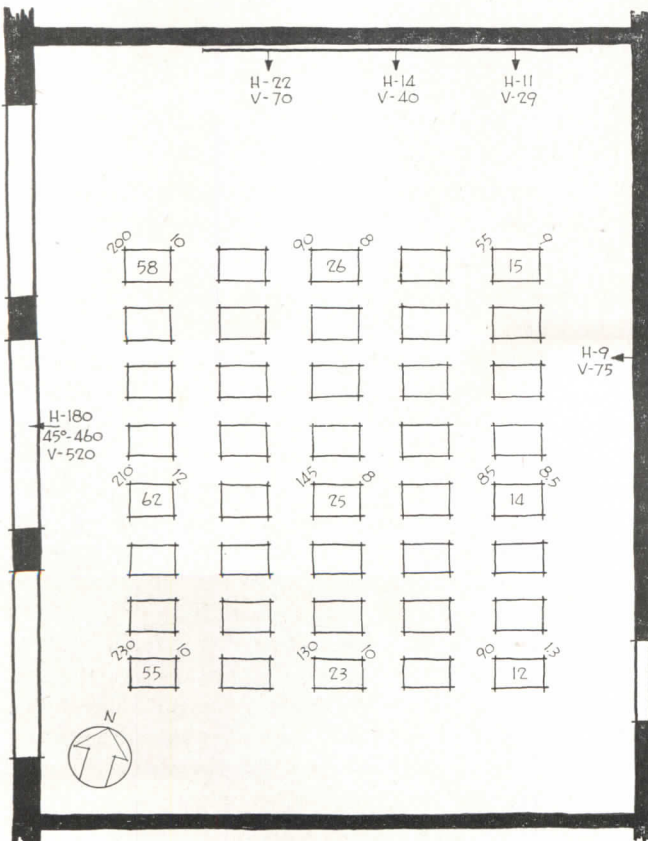

Changed seating was also carried out in all the experimental rooms, in accordance with the diagram seen on the opposite page.

New lighting controls were installed only in rooms 300 and 201. After the room had been repainted and the blackboard area reduced, the windows in Room 300 were equipped with diffusers and baffles as shown on page 88. When covered with a white fabric the diffusers transmitted 60 per cent of the light, and threw a large part of the remainder upward and across the ceiling from which it was reflected downward again onto the children's tasks and onto surfaces in their visual fields.

In Room 201 structural changes were made as shown in the photographs and drawings on page 90. A panel of functional glass block was built in, above a strip of clear glass windows providing for view and ventilation; this vision strip was shielded from sun and sky glare by a small built-in metal hood.

#### How much improvement was effected?

After changes had been made, all four classrooms were tested with light meters on the same day, under a uniformly overcast sky. The readings are shown in the accompanying diagrams, in which the initials "FL" refer to "foot lamberts." This is the unit of brightness,

indicating how much light is coming *from* that area to the eye. Figures on the floor plans, written without initials, are in *footcandles*, indicating how much light is shining *on* the work.

As might have been expected, the child in the unchanged control room (200) was struggling with every kind of lighting extreme. Intensities on working surfaces varied from 100 footcandles to 5.4 footcandles, a ratio of over 18 to 1. Brightnesses ranged from 1650 foot lamberts at the upper half of the central window to 7.6 foot lamberts at a comparable position on the upper inside wall, a brightness ratio of 217 to 1. The child seated at the front desk in the row next to the window was forced to adjust to a 23 to 1 contrast between the brightness at the left periphery of his vision and the brightness of his task while reading a book. The child in the center of the room was fighting off a similar brightness ratio of 107 to 1; in the rear seat of the inside row the divergence reached the astronomical proportions of 434 to 1.

*Redecoration*, applied to Room 301, solved some problems but left others untouched. By increasing reflectivities within the room, redecoration brought up the *intensity* of the light on the inner rows of desks to at least the minimum which was needed. *Brightness contrasts* among the various room surfaces were brought down to acceptably low levels, but the extreme contrast between light falling on the task and *light falling peripherally on the eye* from sky and sun glare at the window could not be overcome without pulling the shades and thereby diminishing the quantity of light at the inner desks below the minimum needed.

*The use of diffusers*, added to redecoration in Room 300, not only kept light *intensities* satisfactory, with 16 footcandles at the chalk rail of the inner wall, but the ratio between the highest and lowest intensity was reduced to 125:16, or slightly less than 8:1 (compared to the 18 to 1 ratio in the control room). The extreme *brightness contrast*, between the upper window area and the upper inside wall, was 8 to 1 (compared to 217 to 1 in the control room). The ratio between the brightness in the extreme *peripheral* field of a child seated at work and the brightness of his book was 2 to 1 in the front seat in the window row. (Control room, 23 to 1.) In the center of the room this ratio was 5 to 1, at the rear seat, inside row, 7 to 1. Note that all children had ample light even on an overcast day, and that the range of brightness ratios was from 1:1 to 2:1 except for the left peripheral ratio just mentioned, of 7 to 1 — and even this was well within the 10 to 1 ratio which a number of authorities advance as acceptable.

The use of *glass block* for diffusion and control of light direction, in Room 201, achieved the same high *intensities* as the cotton diffusers did, and the same range among them of 125 to 16 or slightly less than 8 to 1.

The *brightness ratio* between the upper part of the glass block panel and the upper part of the inside wall was held down to 4.8 to 1, the lowest reading and there-

**ANGLE OF LIGHT — ANGLE OF SIGHT.** *Maximum lighting on school desks is NOT reached by the usual 90° orientation. Best light on tasks is approached as the angle between the child's line of sight and the window is reduced. Let the working surface be revolved so that the child faces into the room but with light still coming from the left. Too great a revolution would cause shadows on his work. The ideal position is one in which a line projected from the midpoint of the child's eyes to the front limit of windows will form a 50° angle with his line of sight while he is working. This also gives him adequate protection from sky glare. Rows are curved (photo)*

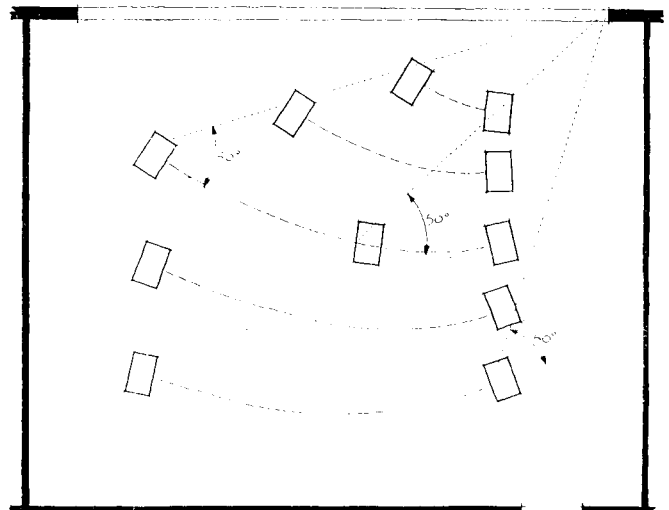
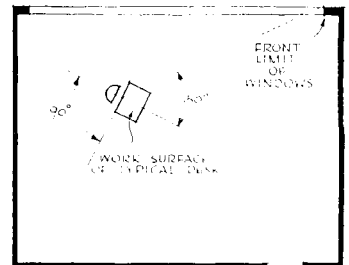

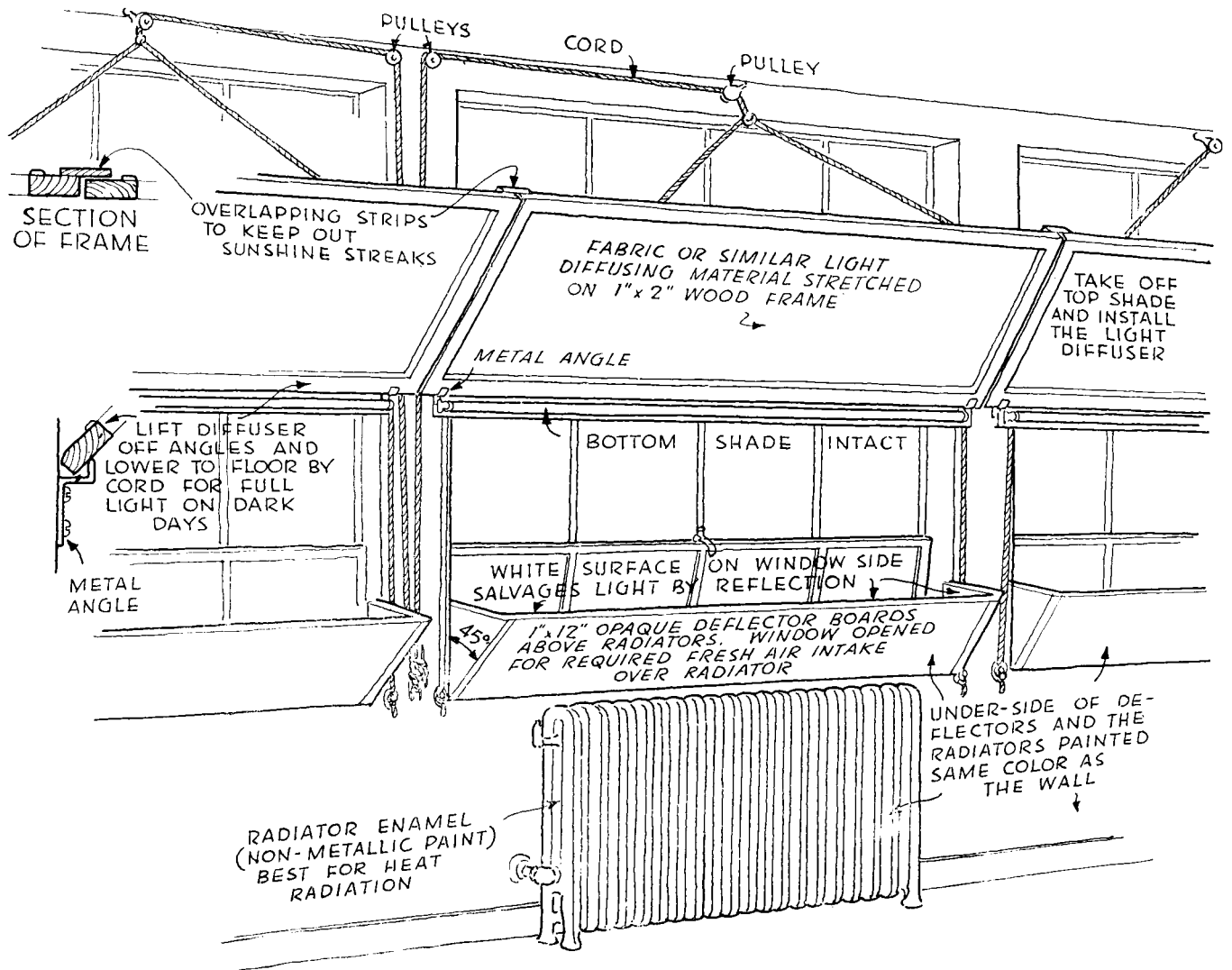

fore the most desirable condition in any of the four rooms in the test.

In terms of brightness in the *peripheral field* of view, the children in Room 201 were subjected to only 160 foot lamberts from the glass panel as against 1650 foot lamberts coming from windows in rooms without light control. The child seated in the front seat next to the window had a contrast between the brightness in his extreme peripheral field and his book of only 1.8 to 1. At an angle of 50° to the left of his line of sight the relative brightness was reversed, and the book was brighter than the window in a ratio of 2.9 to 1. Within the entire 50°-cone, the light on the task was stronger than the brightness of light thrown on the eye — not in an extreme degree but at ratios within 3.5 to 1.

Very nearly the same advantageous lighting environment surrounded the child at the center desk. The child seated at the rear of the inside row — the position usually considered the most disadvantageous from the lighting standpoint — was virtually as well favored as the rest of the children. With the exception of a 10 to 1

ratio between the brightness in his extreme peripheral field and his book, the contrasts between the brightnesses in all other positions in his visual field and the brightness of his task in no case exceeded 2 to 1, which again was well within recommended practice.

Bursch and Gibson, of the Division of School House Planning, California State Department of Education, in discussing brightness ratios in classrooms said: "a ratio of 50 to 1 would represent an almost Utopian improvement in the great majority of schoolrooms today." To hold these contrasts within a ratio of 10 to 1 demonstrates that today's achievable result exceeds what was Utopia just yesterday.

#### EDITOR'S NOTE

Dr. Harmon's experiments are still continuing, and it is expected that within a few months the *Record* will be permitted to publish further findings along with the doctor's summarized recommendations to architects.



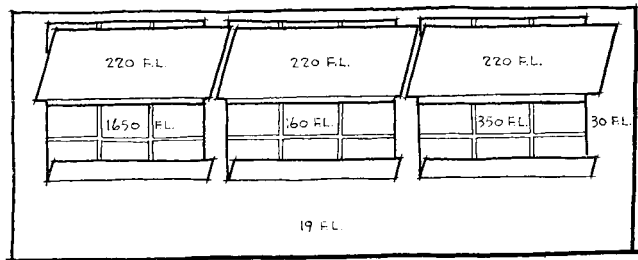

WINDOW WALL

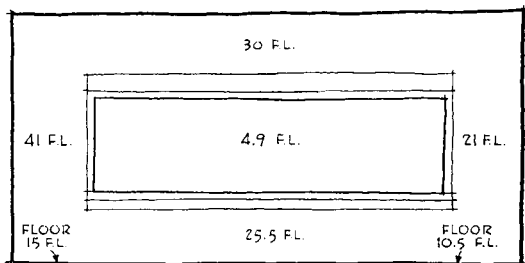

FRONT WALL

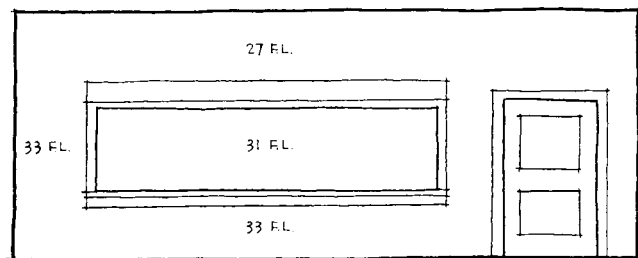

INSIDE WALL

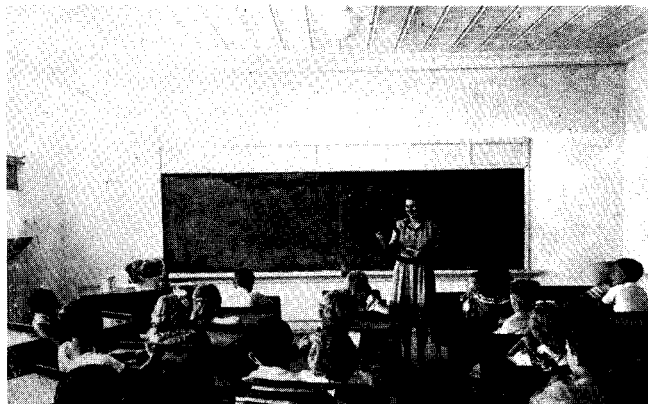

Figures seen on elevations show relative brightnesses in foot lamberts (footcandles of light flux, multiplied by the reflection factor of a surface, equal the foot lamberts of brightness which the eye sees). Floor plans show footcandles of light flux falling on the desks; it is assumed that white paper reflects nearly all of it

|                |     |    |      |
|----------------|-----|----|------|
|                | 154 | 37 | 21.9 |
| V-560<br>H-600 |     |    |      |
|                | 142 | 62 | 25.8 |
|                | 132 | 50 | 21.5 |

ILLUSTRATIONS ABOVE THE LINE REFER TO ROOM 300; BELOW, TO CONTROL ROOM, 200

The control room was left unchanged. On sunny days, shades had to be drawn (exposure was southern), creating violent contrasts for children near windows, and inadequate light at inner rows. Therefore, readings of light at desks fluctuate from 100 to 5.4; while brightness of upper window differs with the upper inner wall as 1650 to 7.6, or 217:1. Light shining from a peripheral angle into children's eyes was 425 times as strong as light on work, at the rear inside seat. In the room seen above, redecoration and the addition of light diffusers at windows has made a startling improvement. Even the innermost desk has 21.5 f.c.; brightness at windows is down from 1650 to 220 f.l.; nowhere is light visible through windows much stronger than the pleasant, full, even light falling on the work. Diffusers, sketched on opposite page, were crude but effective "home-made" affairs

|                |     |    |     |
|----------------|-----|----|-----|
|                | 100 | 21 | 8.0 |
| V-550<br>H-600 |     |    |     |
|                | 78  | 22 | 9.5 |
|                | 60  | 16 | 5.4 |

**BRIGHTNESSES IN CONTROL ROOM**  
(in foot lamberts, "f.l.")

Upper windows, 1650 f.l., 1650 f.l., 1100 f.l.

Lower windows, 1650 f.l., 1650 f.l., 150 f.l.

Front wall, upper part, 9.5 f.l. at center; lower, 20 f.l. at center

Front wall left of chalkboard, 18 f.l.; right of chalkboard, 8.3 f.l.

Center of chalkboard on front wall, 1.4 f.l.

Floor at front near window, 8.5 f.l.; near inner wall, 5.4 f.l.

Inside wall, upper part, 7.6 f.l. at center; lower, 19 f.l. at center

Inside wall, left of chalkboard, 8.3 f.l.; on chalkboard, 1.5 f.l.



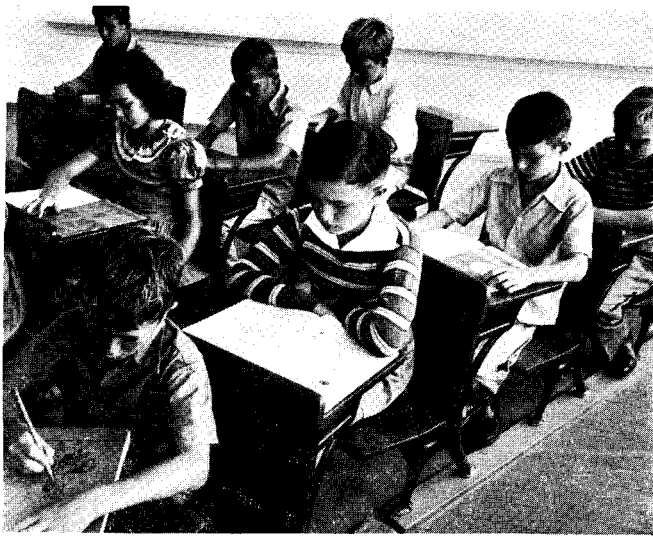

BEST PERFORMANCE, ROOM 201. The use of directional glass block is here added to the previous expedients of rearranging the seats and redecorating for higher reflectivity. A strip of clear window is left for purposes of ventilation and of view out-of-doors

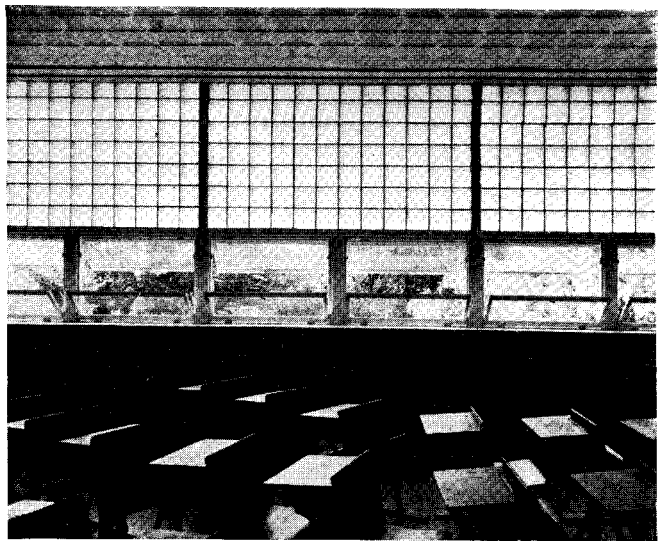

In other respects the room is unchanged, and the cost of the program is well within reach of the average school board. Note that the window strip is protected from glare by a metal hood. In all rooms black chalkboards were mainly covered with white paint

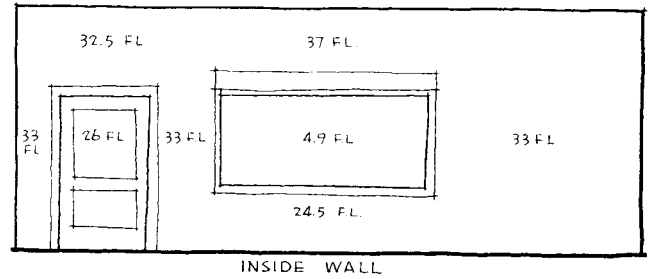
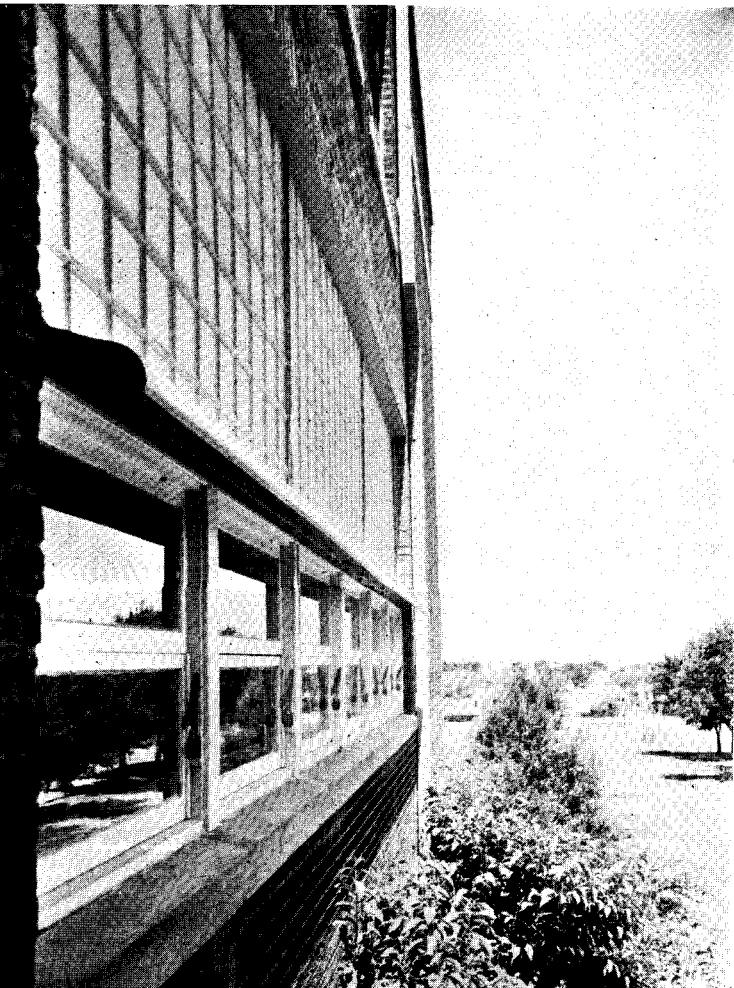
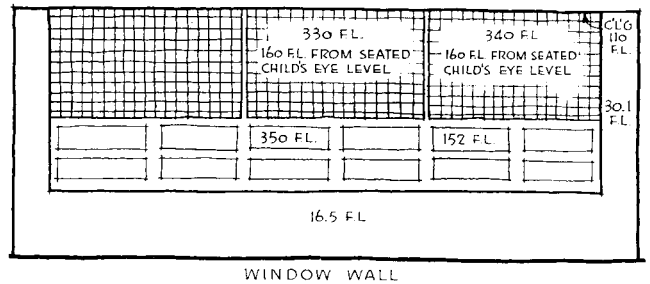
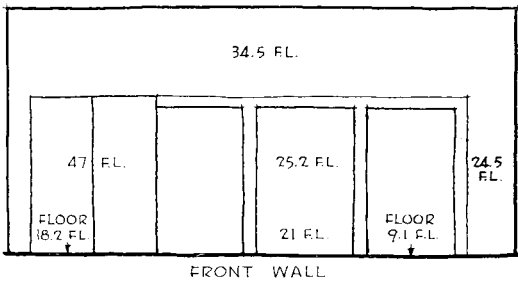

In this room, the extreme brightness contrast was held within a ratio of 10 to 1, whereas hitherto an extreme of 50 to 1 had been considered "Utopian." At the great majority of desks the light falling on the work either exceeded the light falling on the child's eyes or was held within limits easily within the eye's tolerance. In such rooms, children did 10 months' work in 6 months, eye troubles dropped nearly two-thirds, nutrition difficulties were reduced by 44 per cent, infection by 30 per cent, as strain was lessened and energy released for useful work. True saving of "eyes and ears"

|                |     |      |      |
|----------------|-----|------|------|
|                | 125 | 31.2 | 16   |
| V-440<br>H-550 | 125 | 50.5 | 22.2 |
|                | 98  | 38.5 | 22.8 |

# VACATION HOUSE

Hugh Stubbins, Jr., Architect

WHILE this house was designed for a week end and vacation house, to be built on a wooded point near Camden, Me., it is a straightforward design which might serve equally well for a small family for year-round use. It is placed to develop a fine view for about 120 degrees; the recessed porch helps open the view to the living room, also provides a sheltered spot for enjoying it in the open air. The exterior is finished in vertical cedar siding, stained gray, with a wood shingle roof. Inside the walls are plastered; the brick fireplace is painted. Floors are concrete on stone.

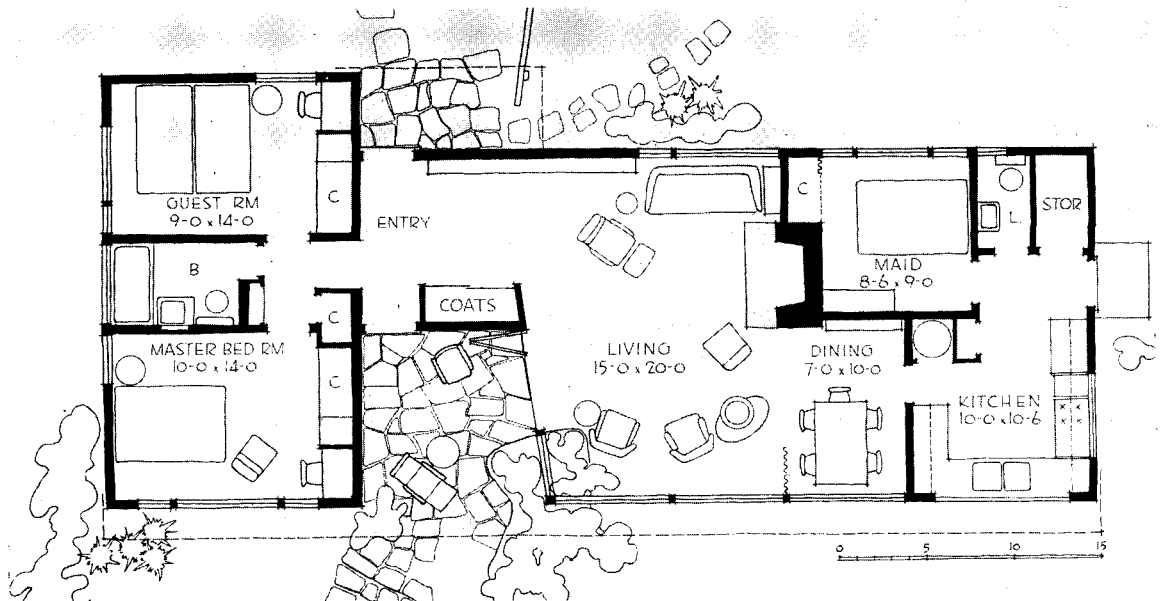
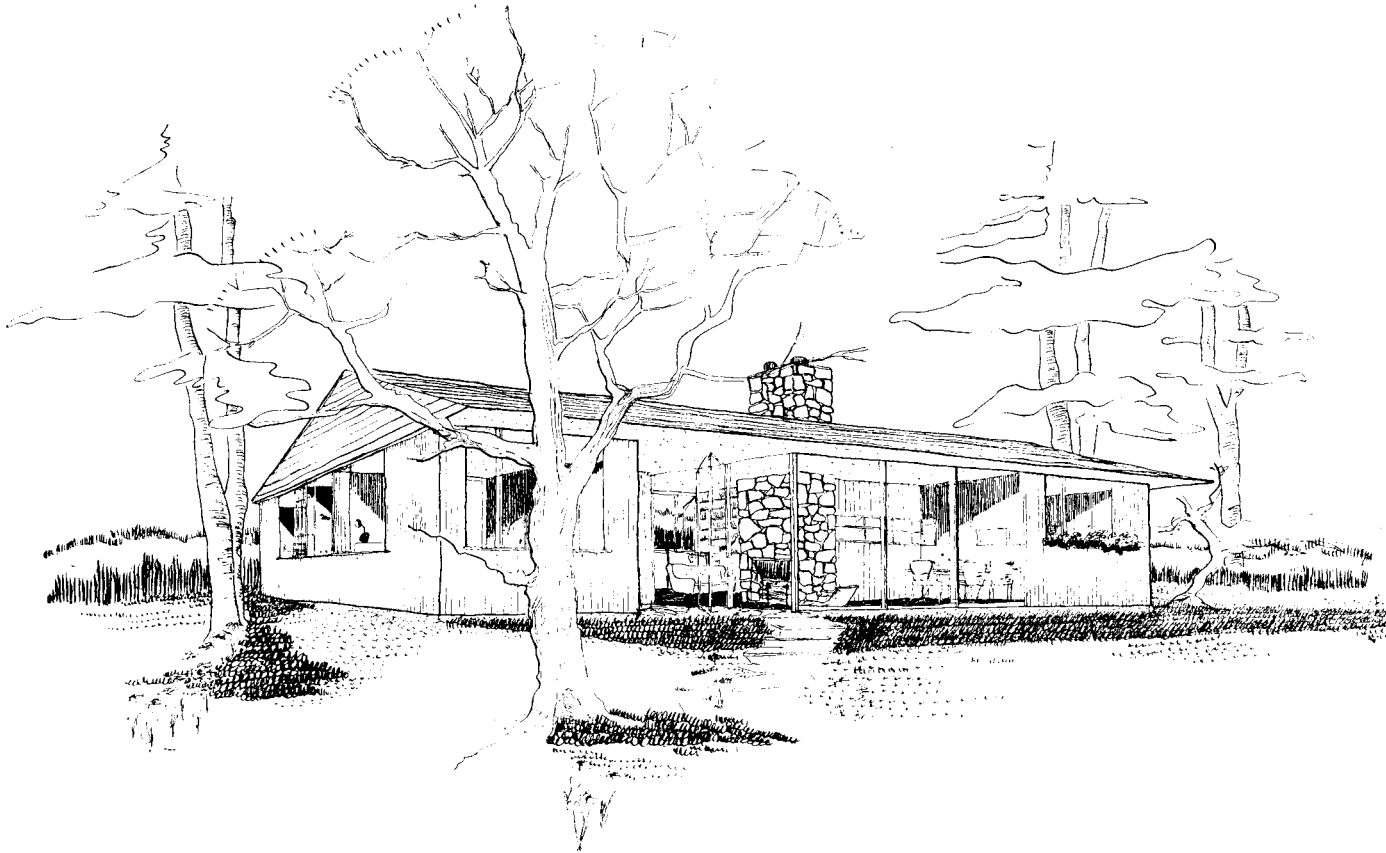

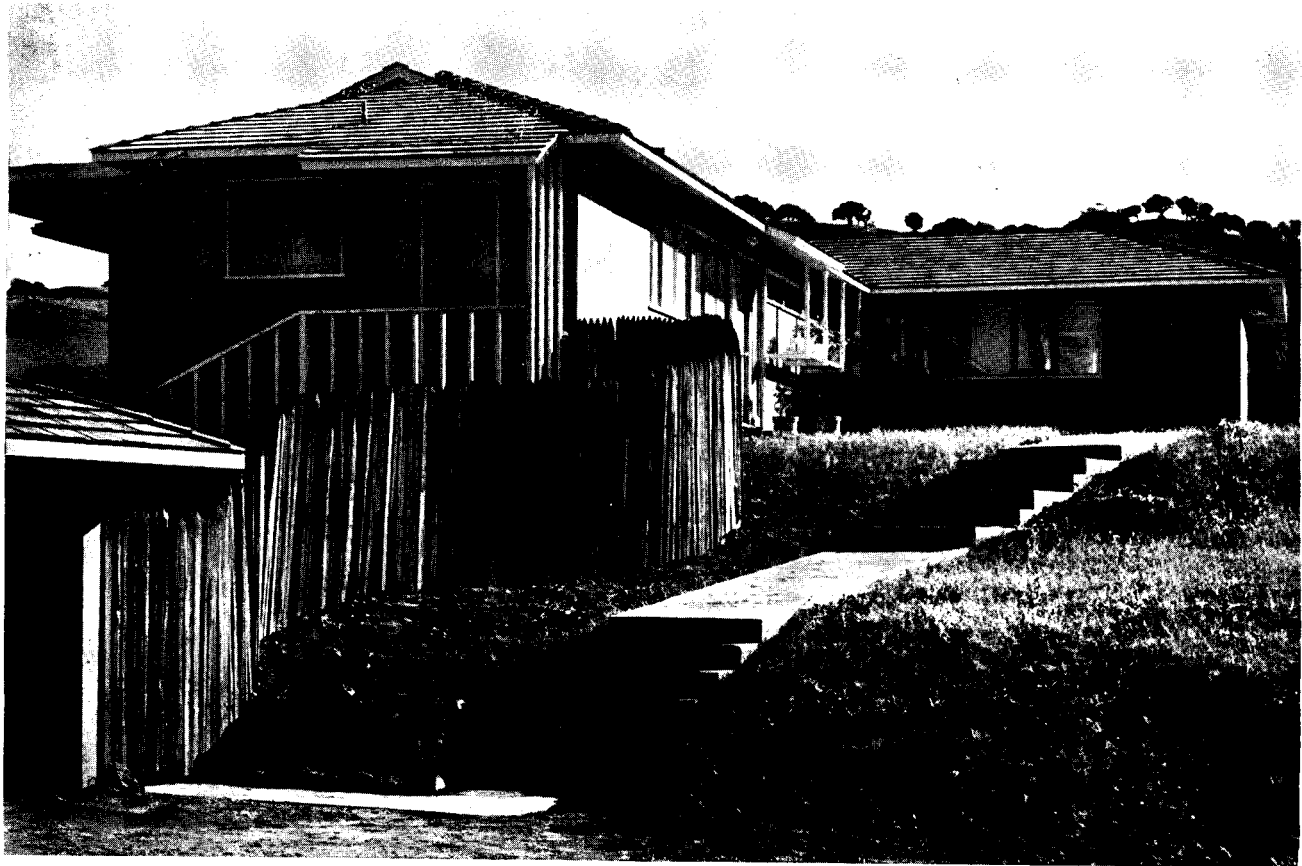

## DESIGNED FOR SITE AND SEASONS

Residence for Mr. and Mrs. John M. Floyd, Walnut Creek, California

John E. Dinwiddie, Architect; Garrett Eckbo, Landscape Architect



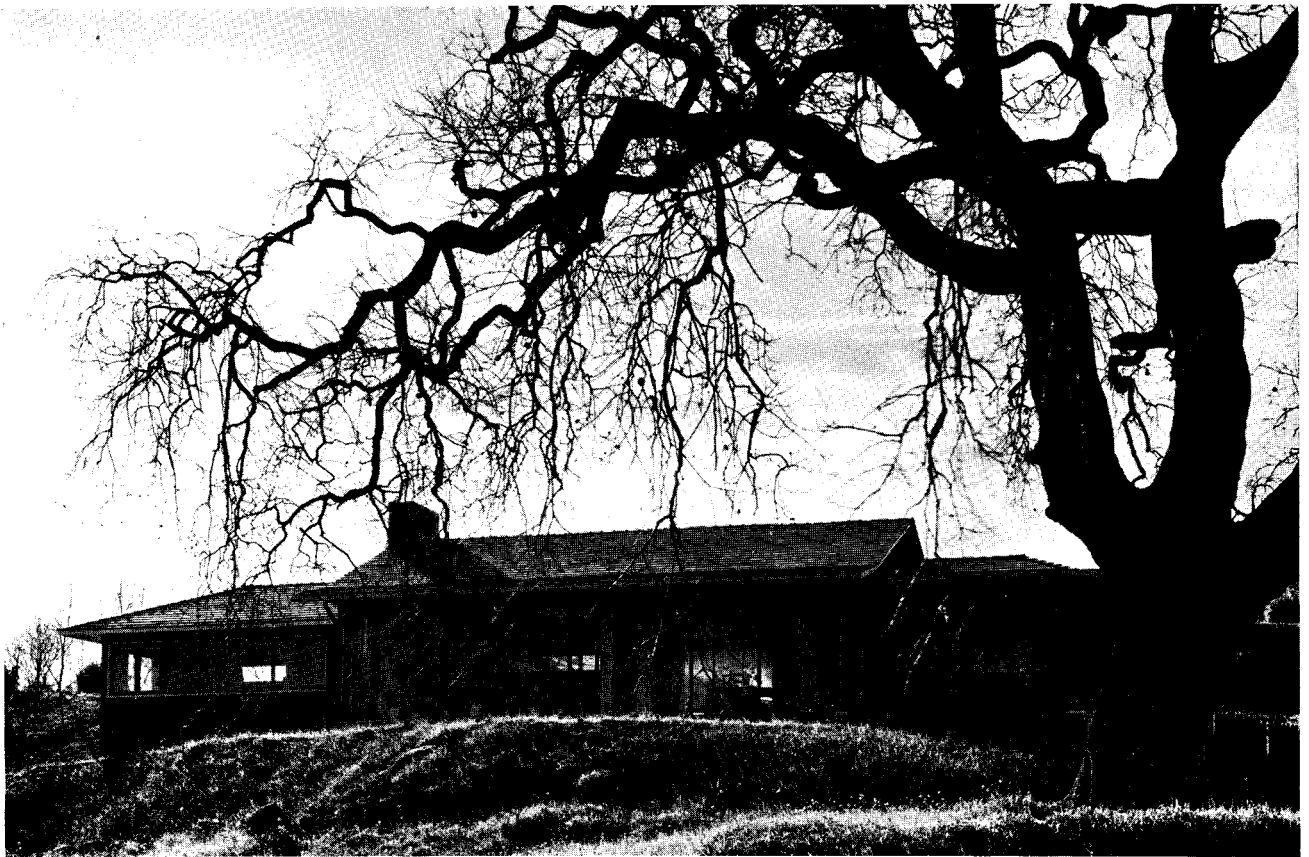

THE much-heralded California weather, always a major factor in house design, was more than ordinarily influential in shaping this house. The weather, and, of course, the view. The knoll which is the site for this house faces east with a sweeping view of Mount Diablo. First of all, then, the living quarters and master bedroom must face east, and be open as possible on this side. In the summer the huge oak tree doesn't help the distant view, but it does block out the morning glare,

and its shade is welcome through the hot, dry months when the screened north terrace gets the most use. The south terrace, which gets the heavier use in the winter months, is left open. Exterior is vertical cedar siding, stained a dull gold, roof shingles natural cedar. Sash are painted an olive green with tan trim. Concrete walks and terraces are given a light tan color, and have a scratched surface as a safety measure. Terrace floor is at the same level as the living room.

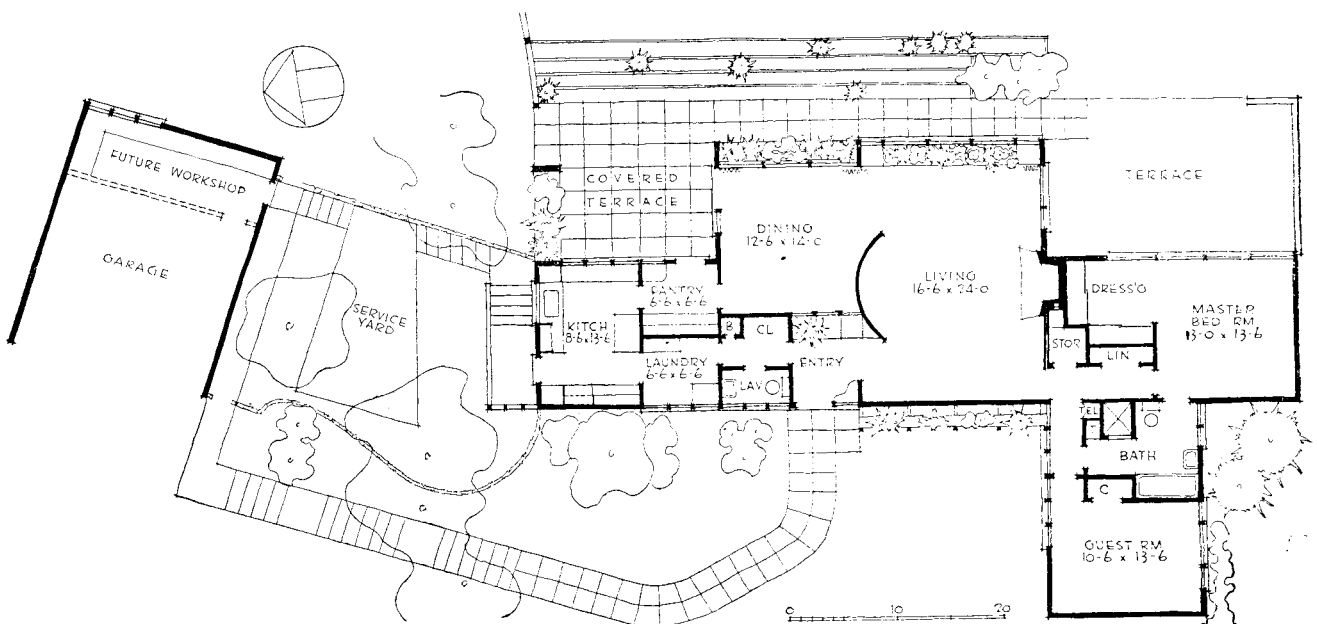

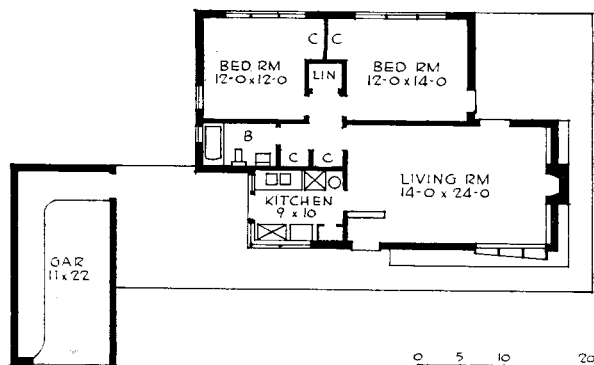
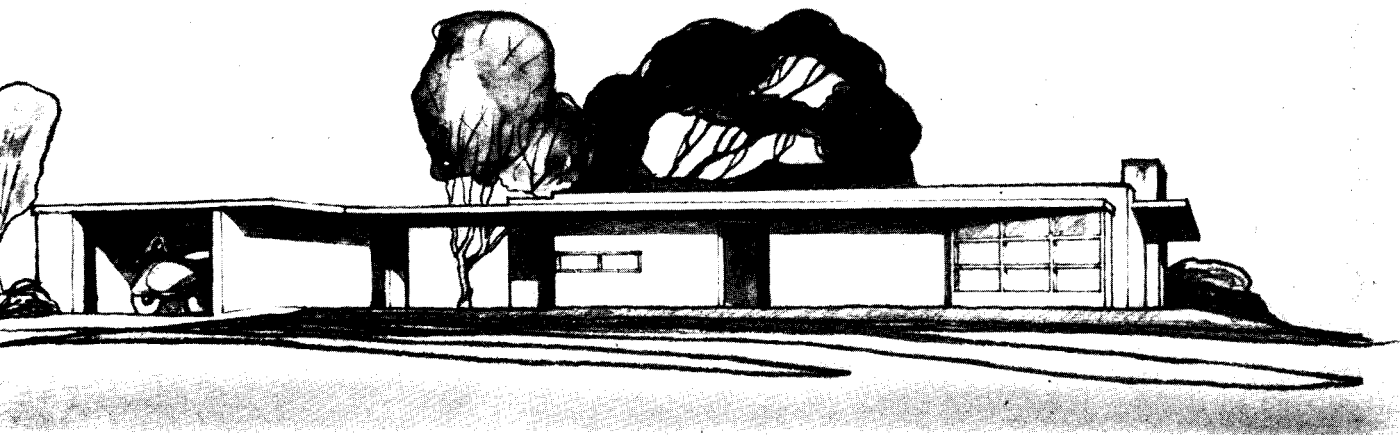

1. For Mr. and Mrs. Robert Hull

## FOUR HOUSES TO START ARIZONA'S NEW BOOM

Arthur T. Brown, Architect

2. For Mr. and Mrs. J. R. Vaughn

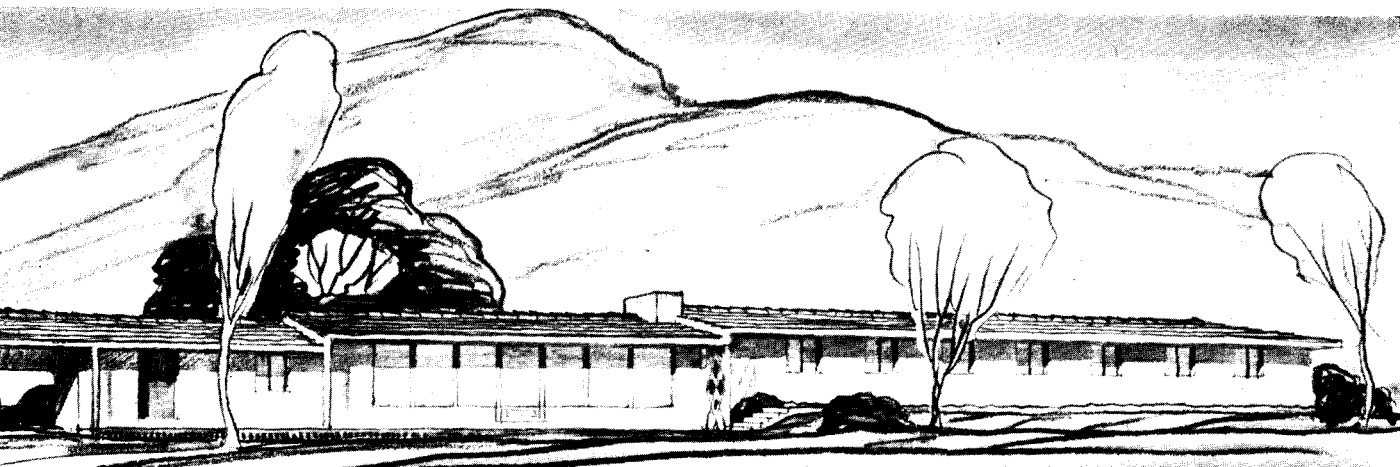
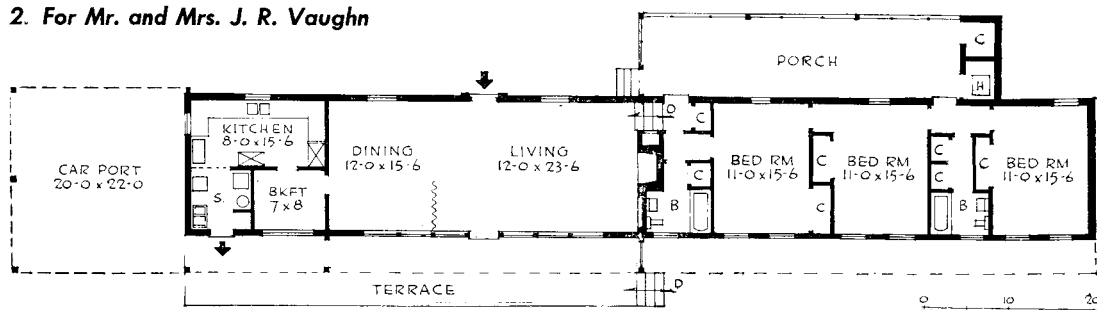

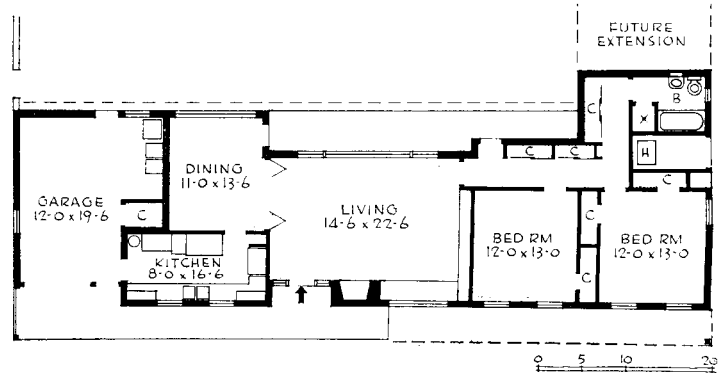
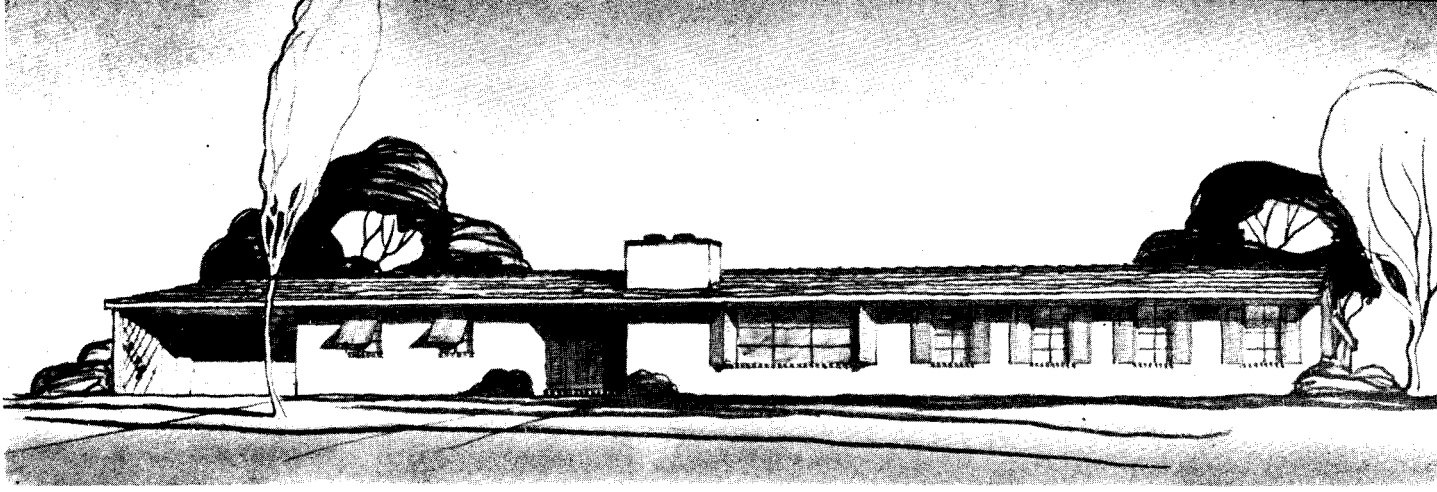

3. For Mr. and Mrs. Jack Carson

IT MAY well be that by the time these designs appear in print all of the houses will be well along toward completion. For, unlike most of the country, Arizona does its heaviest building in the winter months. Consequently architects, clients and builders were waiting for the lifting of the now-forgotten L-41 to start a scramble for materials and labor and get going. The designs are accordingly even more simple than the usually simple ones he does for the Arizona climate, in order to use a minimum of materials and to keep costs

down. A special point about the Hull house is a garage plan that will permit the owner, a wounded war veteran, to get from car to wheel chair to house without assistance. The Vaughn house is strung out in a long line to take advantage of excellent views of Catalina foothills in two directions. Natural contours place the bedrooms higher than the living areas. The Carsons asked especially for a dining room that could be closed from or joined with the living room, also for lots of closet space. All designs stress outdoor living.

4. For Mr. and Mrs. Meredith Wood

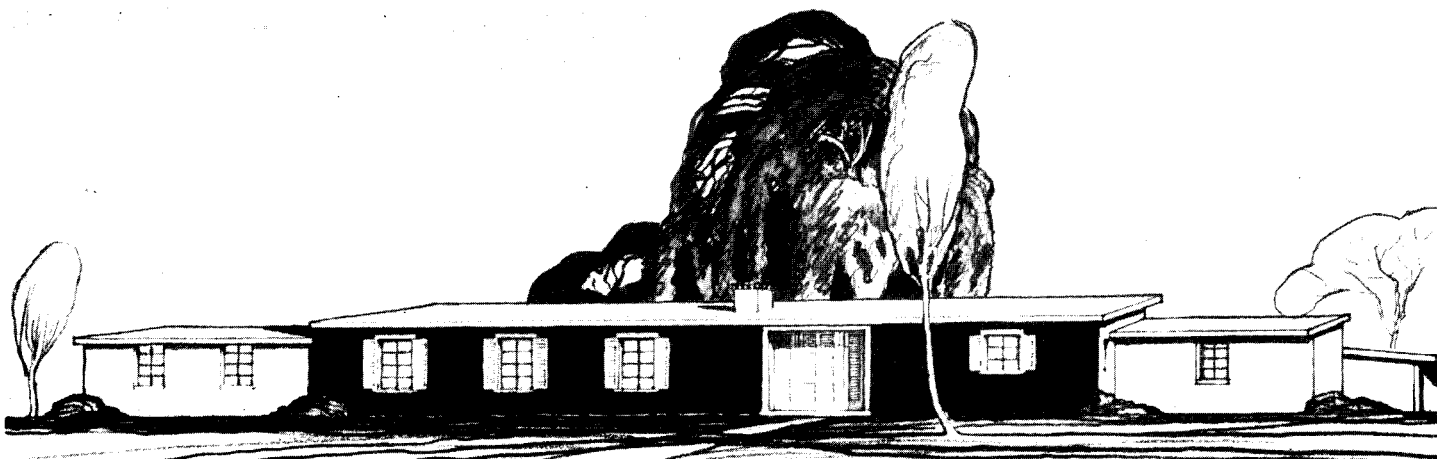
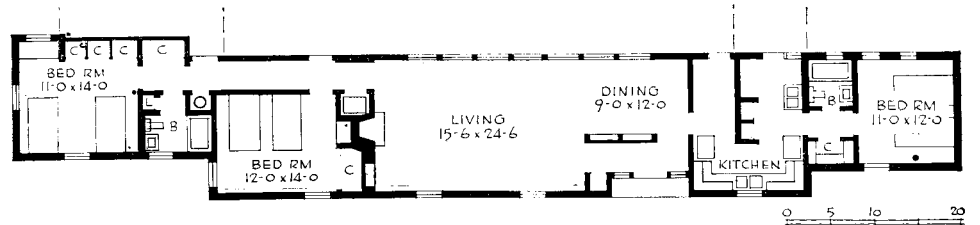

# STEEP SITE, SMALL BUDGET

Residence for Mr. and Mrs. A. J. Polito, Los Angeles, California

Raphael S. Soriano, Designer

JULIUS SHULMAN Photos

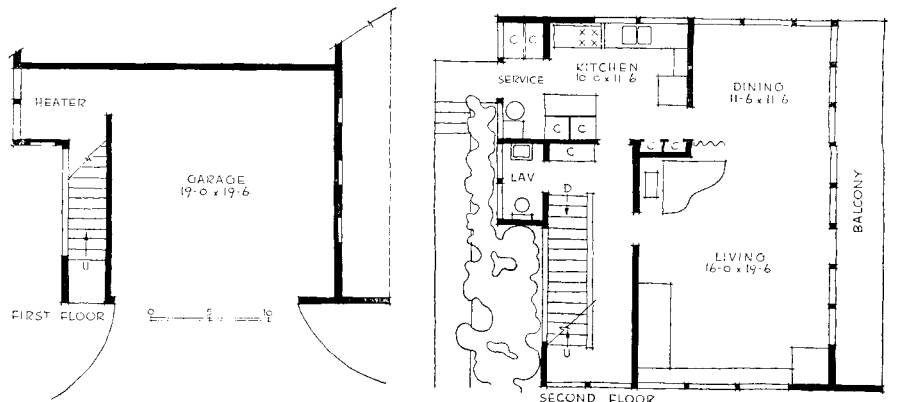



**H**ERE is a case where "modern" design necessarily takes on something of the cubist aspect, because nothing but a cube form would sit on this extremely difficult plot. Without the freedom in styling here assumed, the problem simply could not have been solved. Only one side of the lot had a view with privacy, and a limited budget kept excavation and reinforced concrete walls to an absolute minimum. The house rests

on top of the garage; the deck for outdoor living comes at the third floor, which just about meets the ground level of the rear of the plot. A sand-blasted glass window, 10 ft. wide and 20 ft. high, makes the stairs light and pleasant; it permits some view outward but preserves absolute privacy within. The house was built before the war, for a young working couple. The cost including built-in features, but not designer's fee, was \$5509.16.

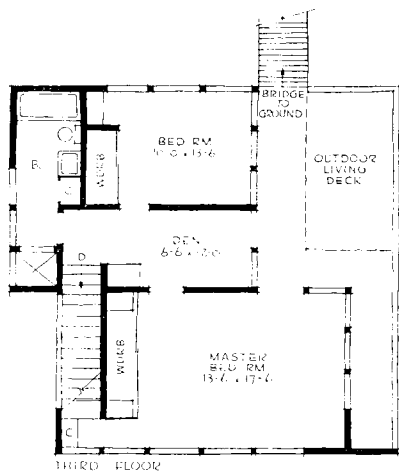
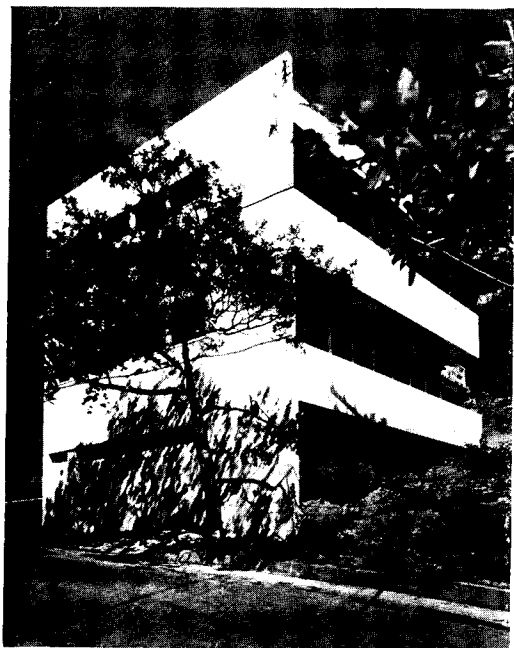

The structural system for exterior walls is 4 by 4 redwood posts, on 3 ft. 6 in. centers. Outside finish is stucco; inside, stucco, plaster and plywood. Floors are oak of plywood over sub-floor; in living and dining rooms they are carpeted; in bathroom and kitchen, linoleum

# PLAN TO BUILD IN FOUR STAGES

Residence for Mr. and Mrs. Harry Schmidt, Pasadena

Richard J. Neutra, Architect;

Dion Neutra, collaborating

WITH building conditions as they are, the scheme this client is using will probably be frequently seen again. The house is designed to be constructed in several stages, a minimum house to get a roof over their heads, then additions as things loosen up. Step 1: just the service area, rear bedroom and bath, and what is shown here as dining space, to serve now as living room. Step 2: living room proper and study (the floor slab will probably be done before this step, to serve as an outdoor sitting area). Step 3: the additional bedroom and bath. Step 4: the last bedroom and bath. The car shelter will fit into this doubtful-period plan as building conditions and budgets permit.

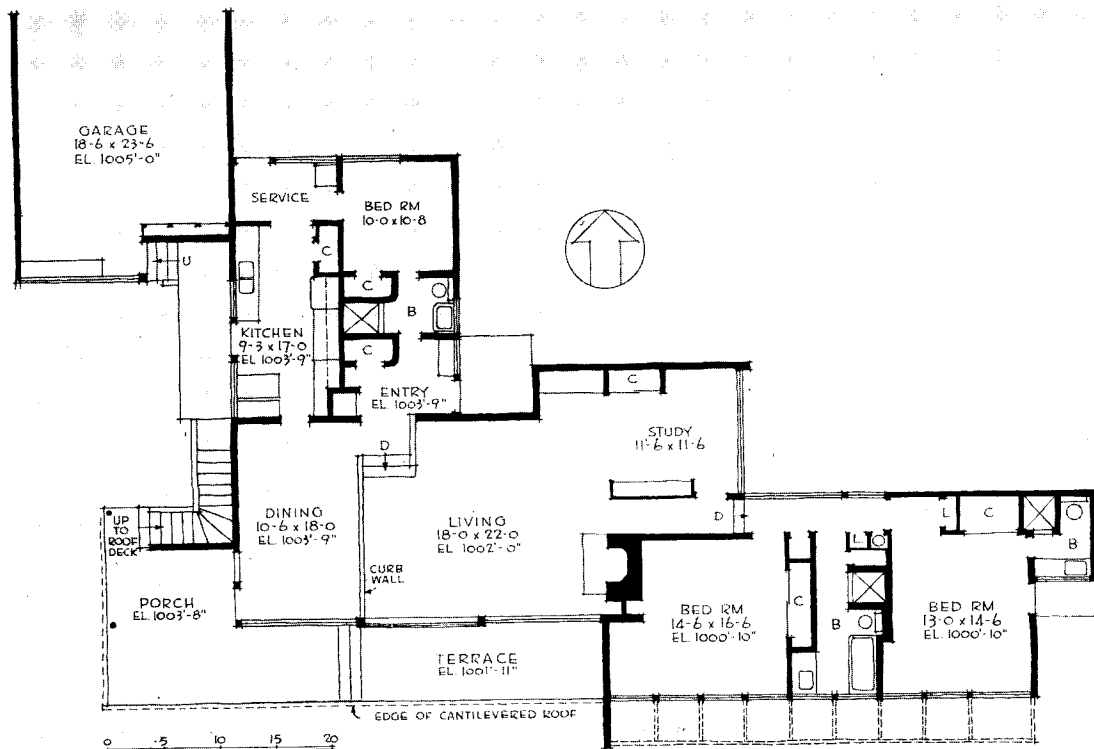
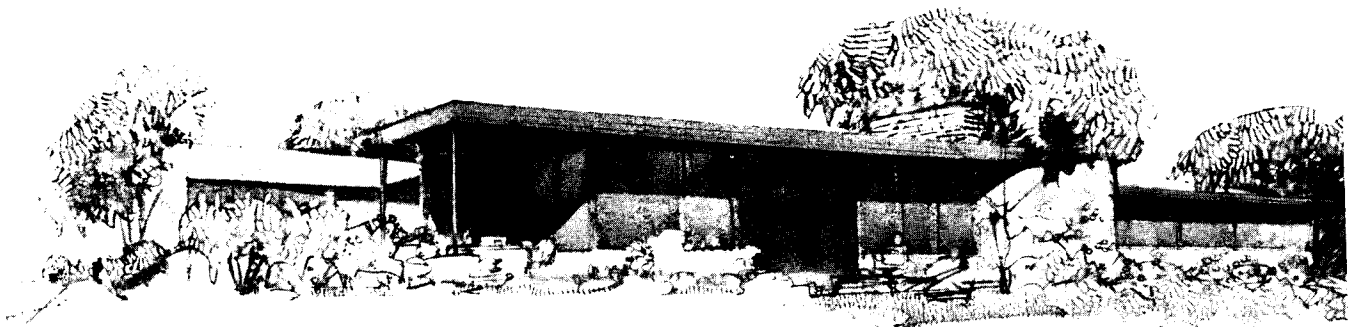

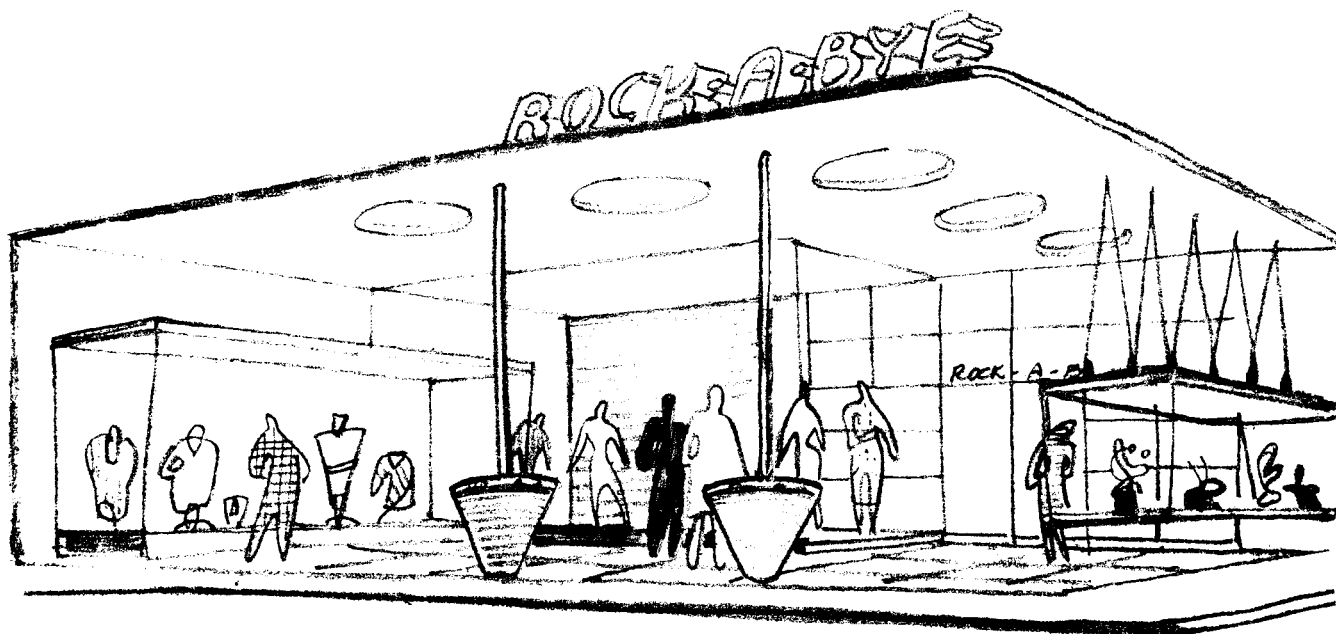

## STORES

*Architectural Record Building Types Study No. 110*

THINKING of contemporary store design one can hardly resist the old classic about the excited general who "got on his horse and galloped off in all directions." That's where store design seems headed. And yet it makes much more sense than thus indicated. It is true that, with all of the freedom and ingenuity associated with modern design trends, designers seem bent on new experiments in excitement and insanity, with curves and kidneys and canvas columns and canted verticals and candy stripes, not to mention hearts and flowers. But it doesn't take much review of individual designs to see the reasons, case by case.

Generally speaking, there are two principal reasons:

1. Space problems. In many of the designs here shown crowding was unusually necessary. Mass merchandising cannot afford space in luxurious quantity. Also several different departments must be visually separated, causing the architect to mix devices and patterns in close quarters. Perhaps the significant thing is that the mass-selling type of store needs the services of capable designers like no other merchandising, and is leaning heavily on them.

2. The neo-Baroque touches are popular with the customers. Perhaps during the war period the customer was *not* always right, but in the matter of design appeals he is the arbiter. As a designer becomes more and more steeped in the atmosphere of mass merchandising, he is increasingly conscious of the public's response to the "fancy" decorations.

Visible in this situation is an interesting tendency to use the popular, traditional devices in new patterns and new textures, to put simple melodies in more modern rhythms for the entertainment of customers and the profit of clients.



## FREE-FLOW PLAN IN TIGHT AREAS

**I**N THIS store the architect had to pack a terrific quantity of merchandise into small spaces; in solving this problem he has given a fairly convincing demonstration of the merits of the free-flow idea in store planning, when such planning is strained to the utmost. Not only quantity of stock, but also variety of departments, complicated the designer's task. The store deals in children's clothing, which must be departmentalized not only by types of clothing but also by age groups. If the accompanying photographs, therefore, do not show a carriage-trade salon aspect of quiet spacious-



**Rock-a-Bye Children's Clothing Store,  
Brooklyn**

**Morris Lapidus, Architect**

*Show windows, always a problem in a mass-selling store, were here complicated by the fact that a separate window was required for each of several age groups. The designer's answer was an angled front recessed to permit two side windows, one large main window, and two free-standing units*

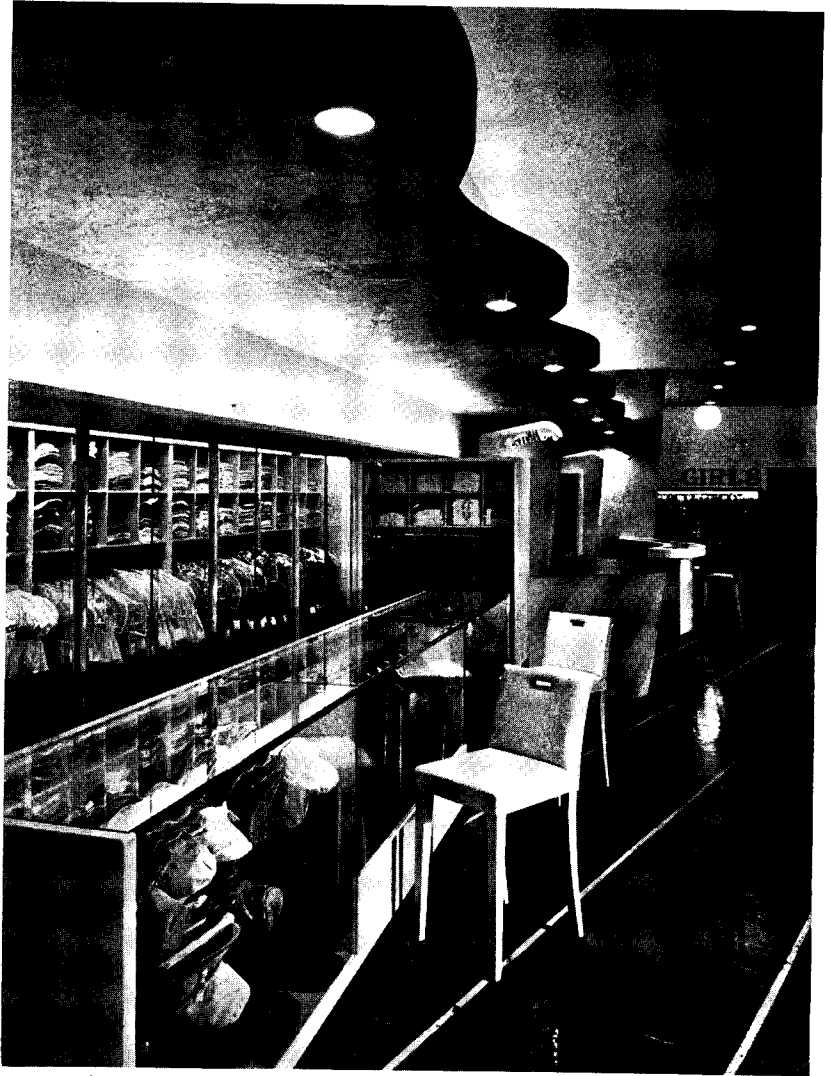

GOTTSCHO-SCHLEISNER Photos

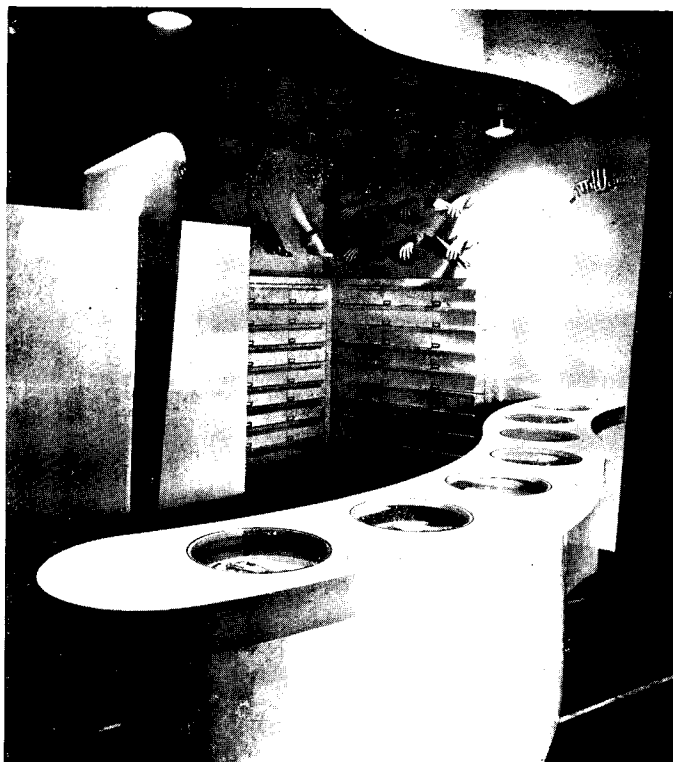

*At the hosiery and glove department the architect has introduced a counter device to add still another merchandising idea for this small area. The curving counter, besides exerting a pull toward this department, further entices the customer by displaying ensembles in the holes in the counter top*

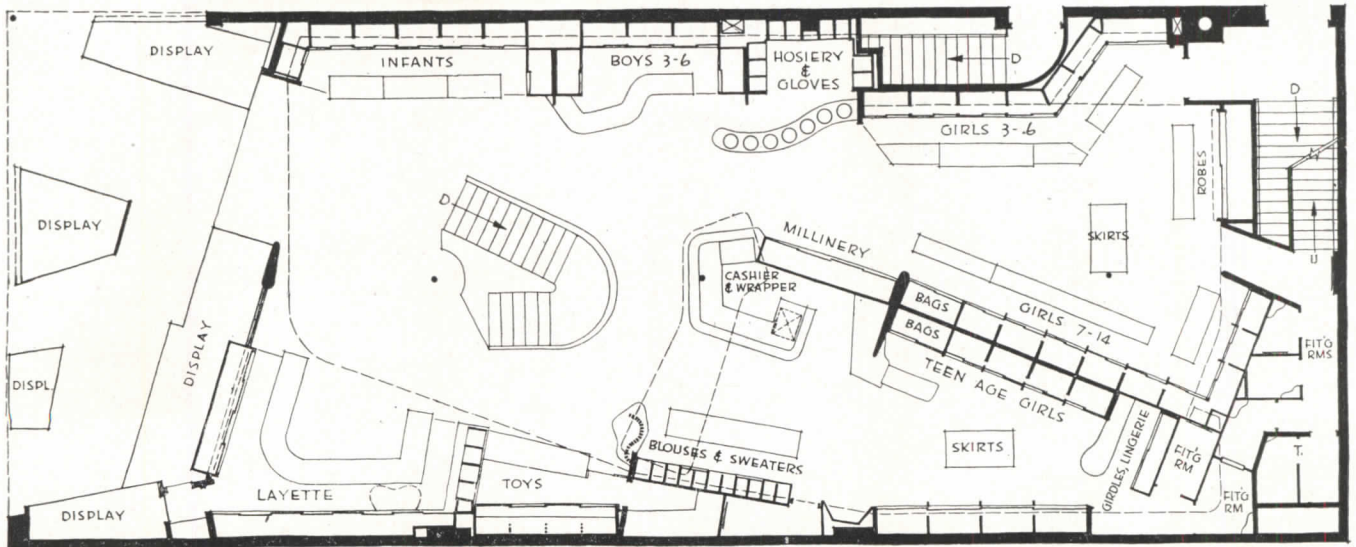

FIRST FLOOR

ness, they do show something of the design challenges that will probably confront store architects increasingly in the busy days ahead. For mass-merchandisers seem to be turning more frequently to the design talent that has proved itself first in more leisurely surroundings. The several different departments also posed a problem in the show-windows — there must be a separate window for each age group of children. Thus in a front of less than 40 ft. there are five show cases or windows. A more typical problem, last but not least, was that of leading customers down the stairs to basement departments (p. 105), and in spite of the crowding the architect has managed to keep the stairs in open space.



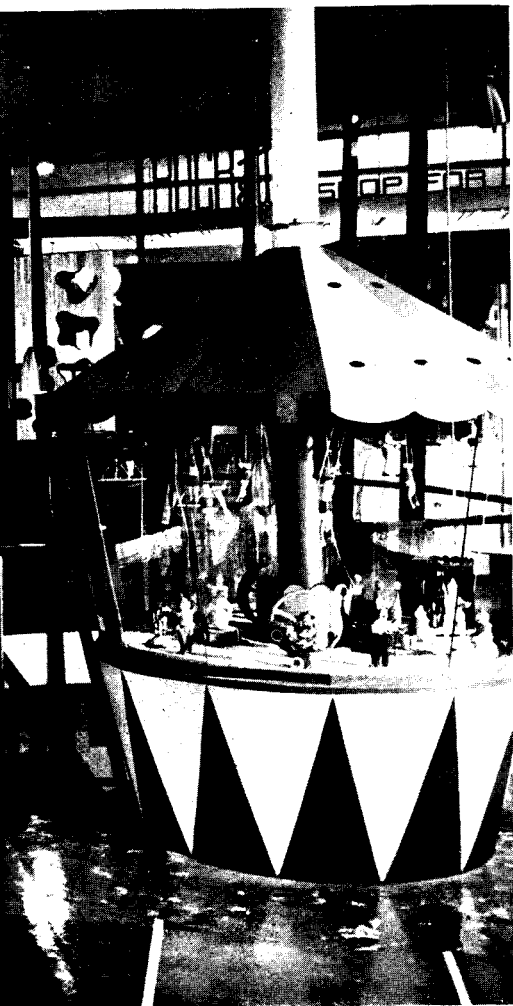
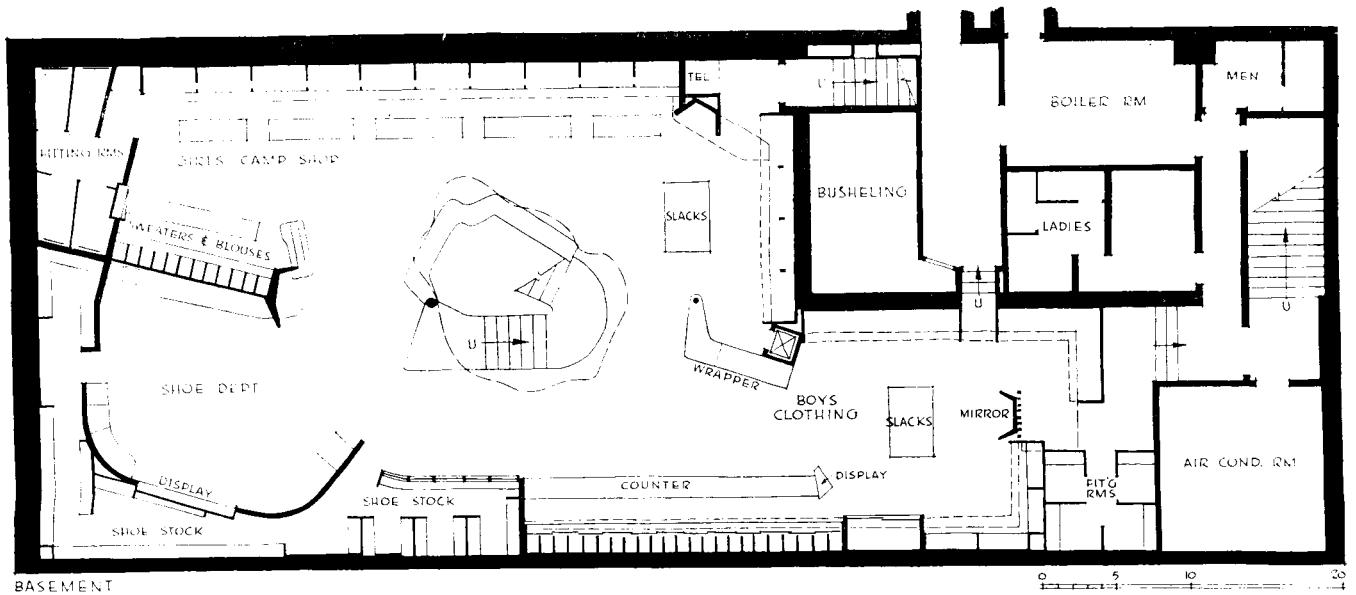

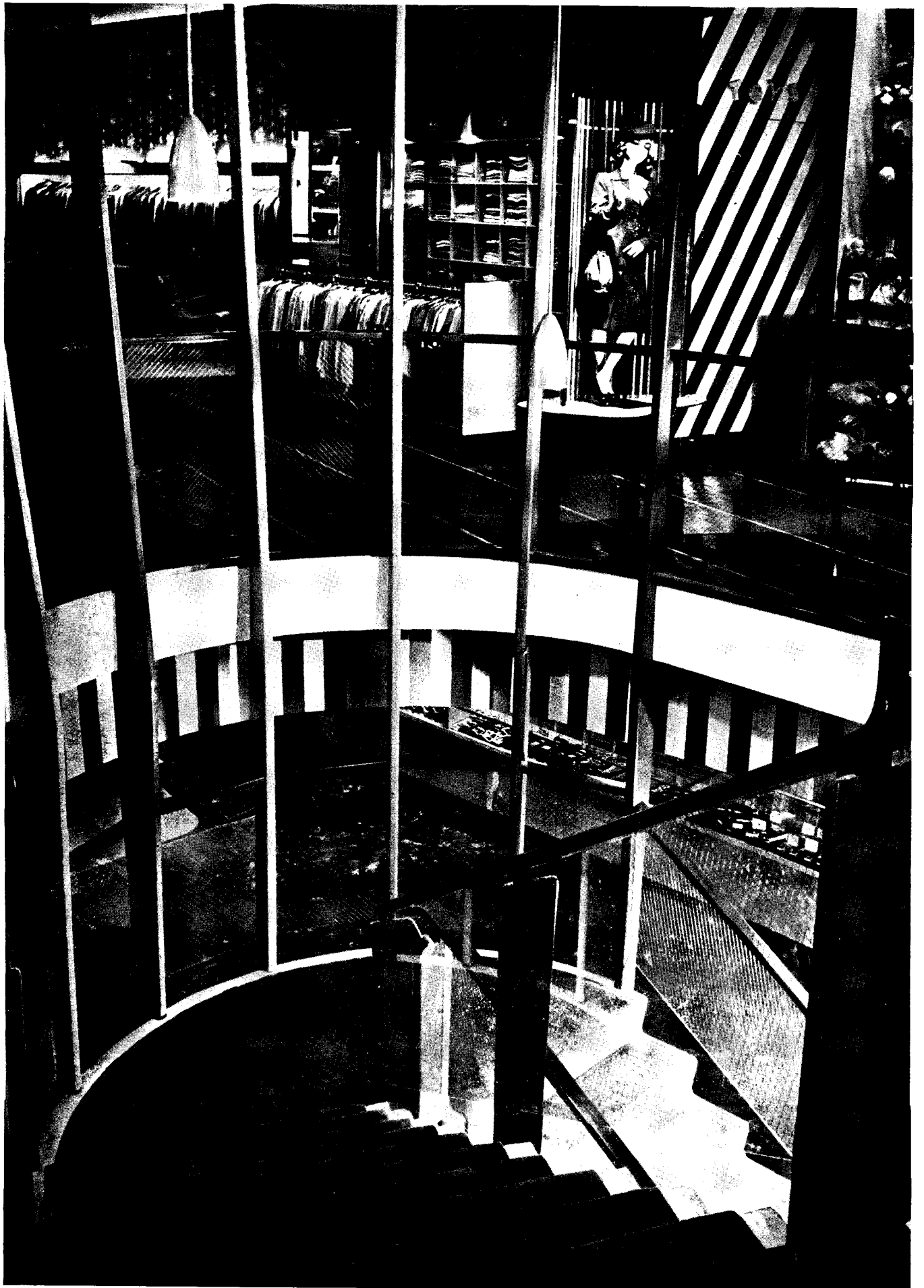



The Rock-a-Bye store also presented the problem of enticing customers to the basement departments, via the stairs. The designer has used many devices for this. The stair was made the focal point of the only really open space in the store, invitingly near the entrance, with floor lines directing the customers' footsteps. Signs point him downwards; the vertical tie rods seem to speed the process. And the stair is screened around the rear with a sort of smoke baffle, until it almost seems that the main part of the store is in the basement.



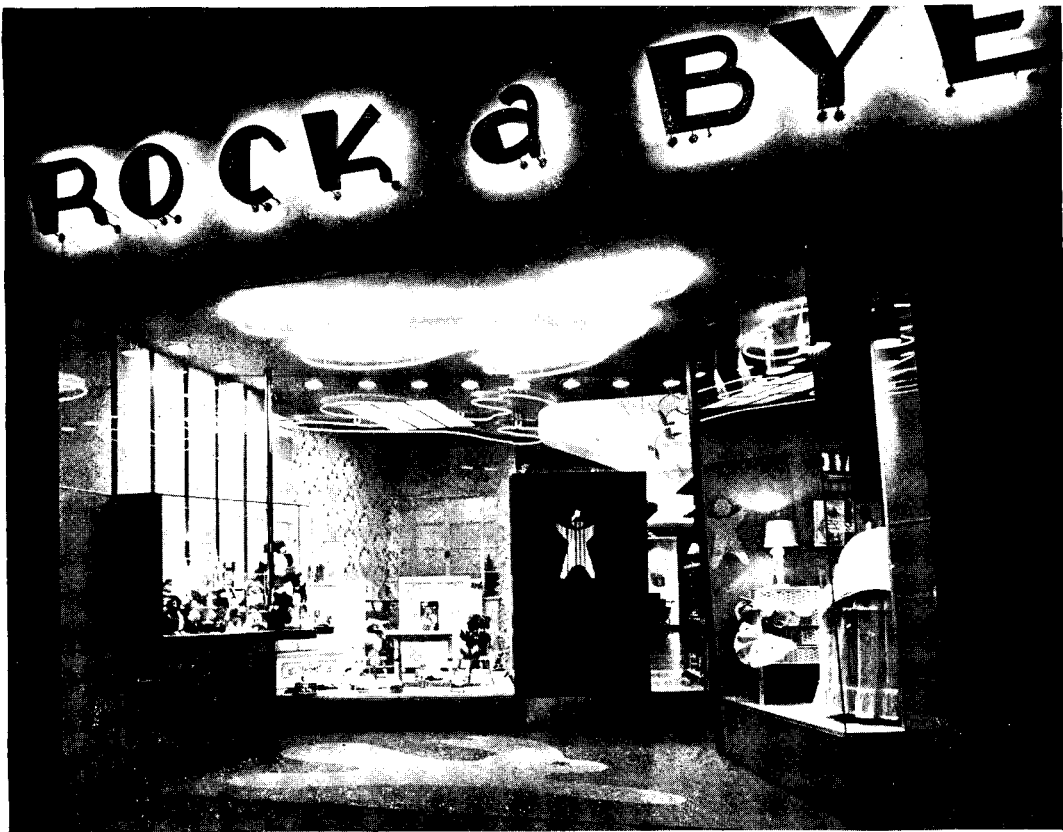

## SMALL STORE FOR LARGE DISPLAYS

Rock-a-Bye Children's Furniture Store, Brooklyn

Morris Lapidus, Architect

THIS store offered at least the same problems as the foregoing one. Indeed it is another store of the same concern, this one selling children's furniture and large toys instead of children's clothing. If anything the space problem here was even worse, because of the large sizes of the merchandise, and because of the narrower proportions of the store. In this one the second floor provides additional selling space, in place of the basement, and the task of getting customers upstairs was not easy since the stairs were at the side. Thus the front is canted toward the stairway entrance, with separate doors leading to main floor. On the main floor, stalls for

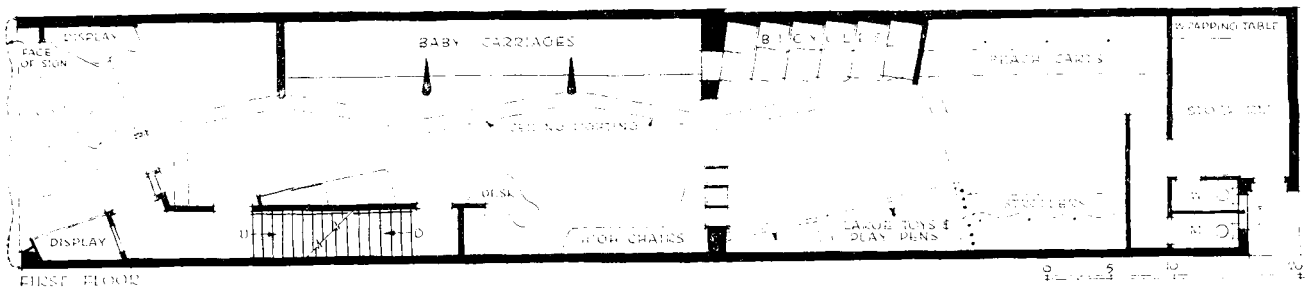

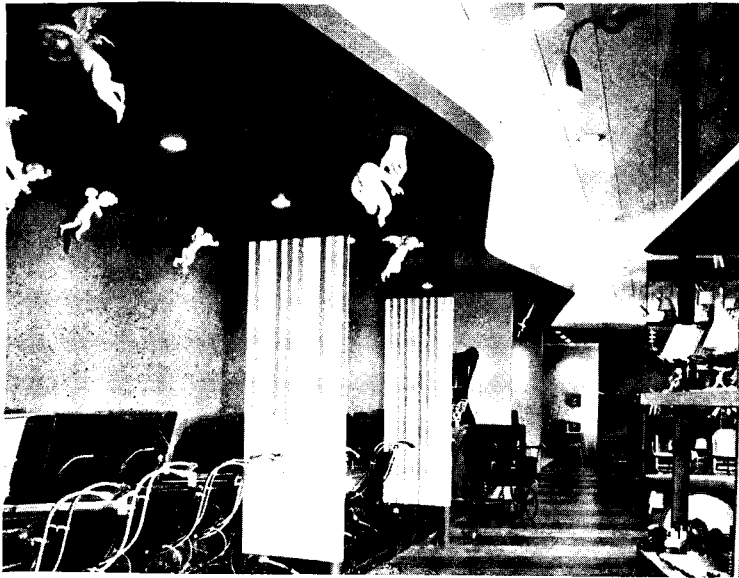

the baby carriages brought some order to a rather chaotic confusion. A similar arrangement farther along the same side makes an orderly display of bicycles. Smaller items of furniture are displayed in a similar manner along the opposite wall; here a narrow eye-level platform in mezzanine style adds merchandising space without hiding other items. Still smaller but nevertheless bulky items are stocked in cubby-hole shelf arrangements, which utilize space intensively but keep the merchandise plainly visible. And the designer has brought in an unusual number of styling devices and eye-catchers to brighten the long, narrow store.

GOTTSHO-SCHLEISNER Photos

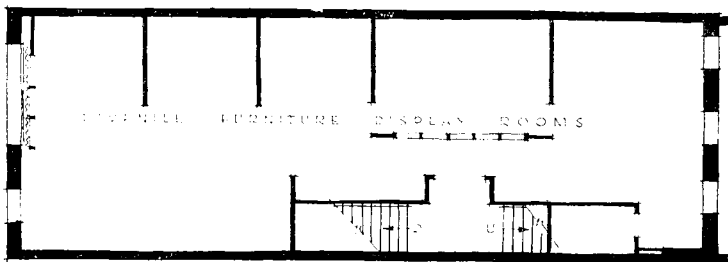

SECOND FLOOR



## INGENUITY IN SMALL SPACES

Pat Darling Shops, Baltimore

José A. Fernandez, Architect

**I**N MODERNIZING this old store, the architect was confronted by many of the same handicaps mentioned on the preceding pages. Here crowding was a necessity on the first floor, since the ground floor location consists of one narrow strip. Construction difficulties were very real; the buildings were more than a hundred years old, originally built for residences. There were different floor levels on the wider second floor portion; the fronts did not line up; the stairs came out on the building line, and had to be moved back within the store. The budget consideration was important. In short, here was an assignment ready made for the ingenuity that characterizes contemporary design.

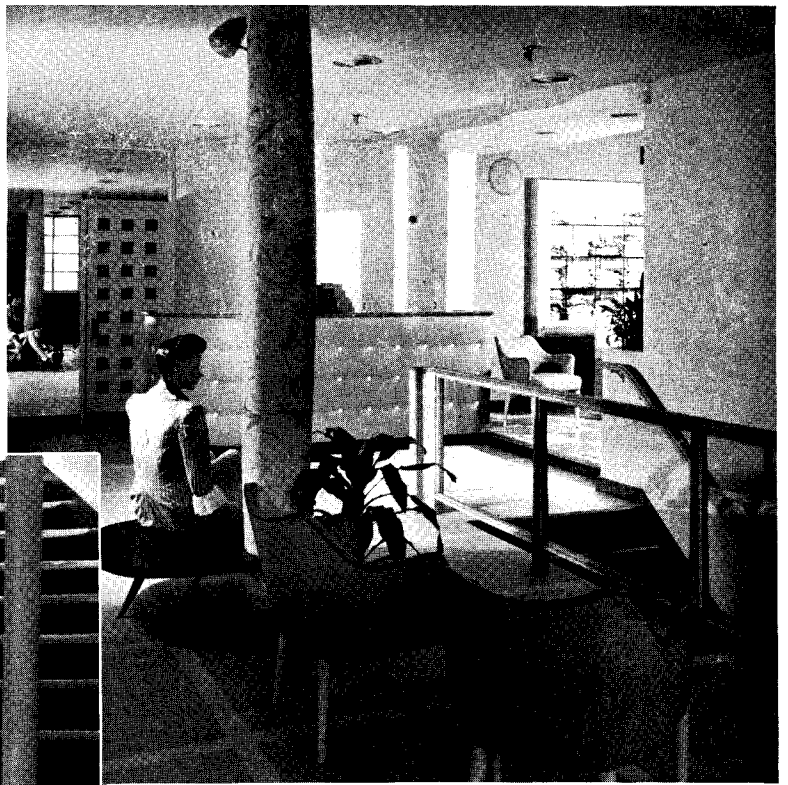

*Color scheme for the first floor includes rose, gray, and white in a specially printed wallpaper for background, royal blue linoleum on the floor, pickled oak fixtures. The ceiling is done in a pale rose*

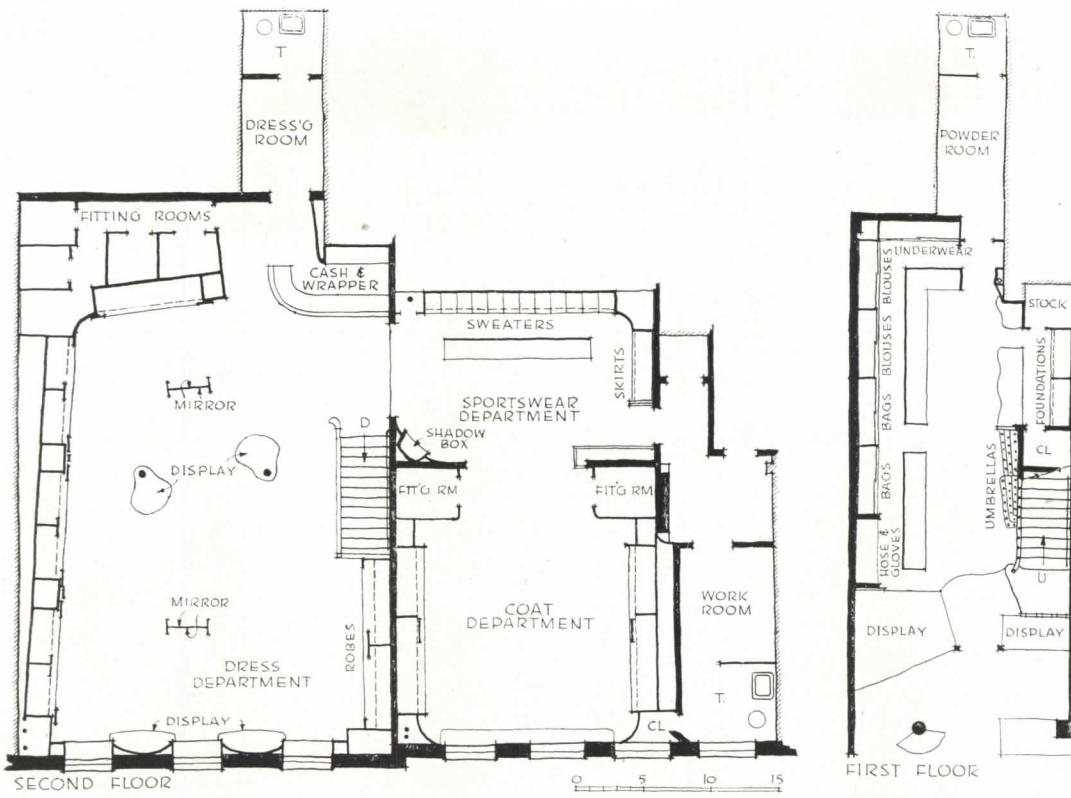

*In the dress department (right) color scheme is gray, yellow, white and blue. The yellow appears in large squares in the floor linoleum. Borders around cases are wallpaper, in marble pattern. In other departments, the yellows and grays continue; the contrasting color is green*

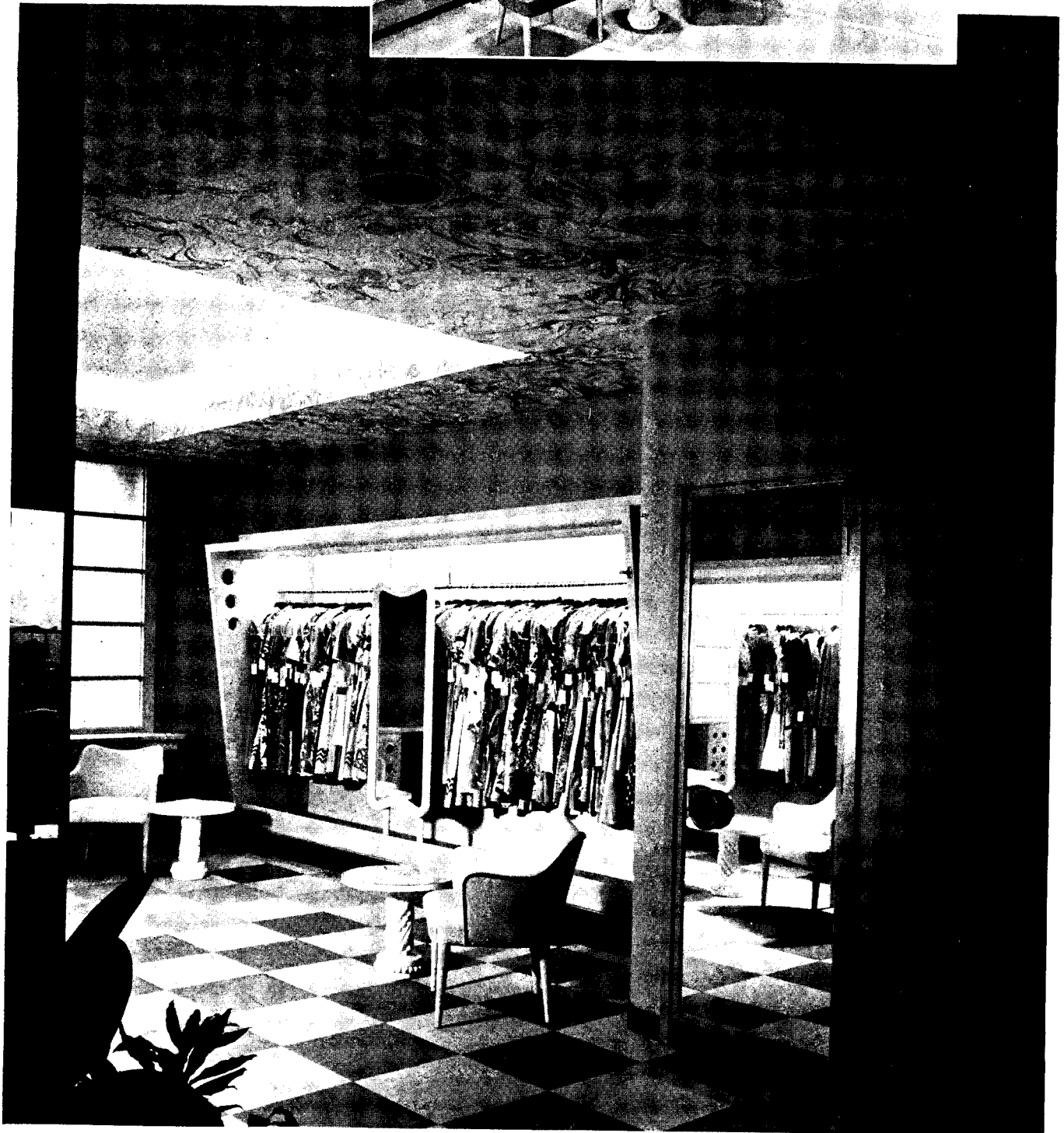

# DEPARTMENT STORE FOR A HIGHWAY LOCATION

Designed for The Kawneer Company  
by Ketchum, Giná & Sharp, Architects

SOMETHING new in the store field is a highway department store, placed out in a country location for the convenience of the motorized farm trade. Super-markets have been creeping outward from cities for years; retail outlets of mail order houses have been somewhat bolder. This suggested store would make the final leap. It would sell everything from farm equipment to lingerie for the womenfolk. It was logical to introduce some design innovations: heavy emphasis on display in second-story windows, where farm equipment would get good attention from passing cars; a flexible system of movable panels, to be rearranged at will with merchandising shifts. The plan gives some idea of the possibilities resulting from complete freedom from site limitations.

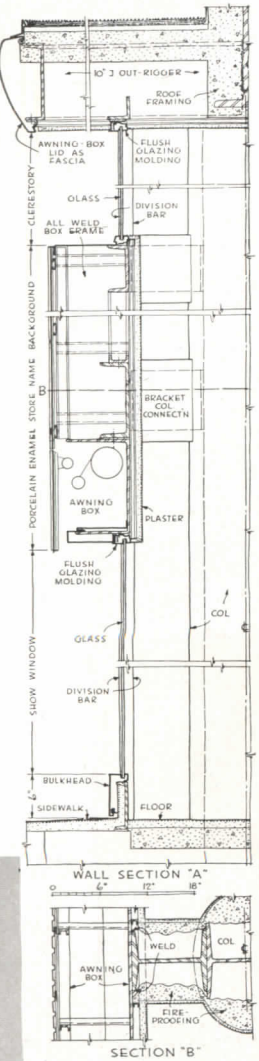



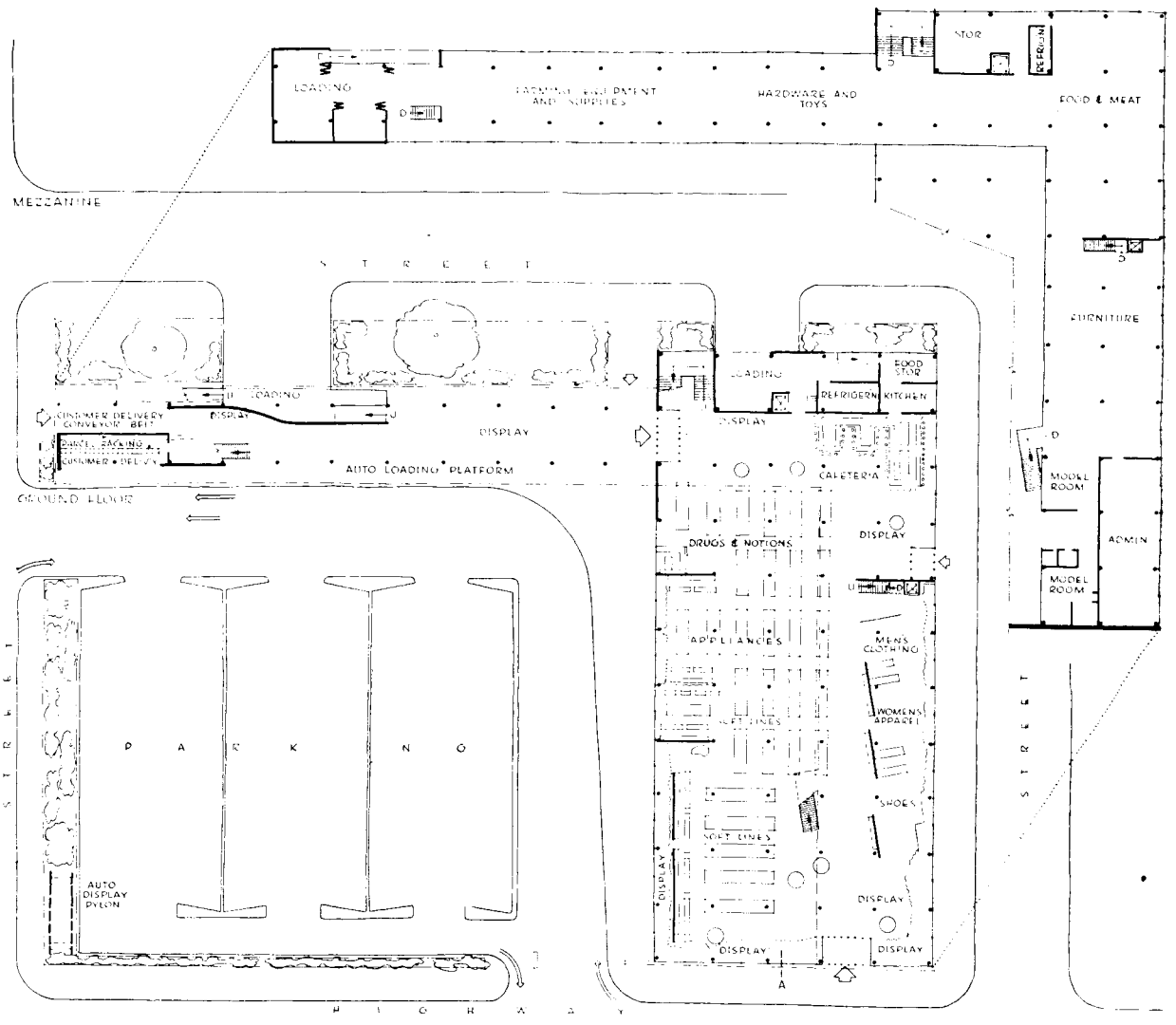



Charles C. S. Dean, Designer

## PACE-SETTER FOR A CANDY CHAIN

Loft Candy Store, 42nd Street, New York

CONSIDERABLE interest attended the recent opening of Loft's candy store on New York's 42nd Street. To Loft it was a pace-setter and model for the reconversion of its 175 store units, with new design motives, new trademarks, new selling appeals. To designers it proved at least equally interesting as a sort of modern integration of soft touches—hearts and flowers motives, peppermint stripings, a "sane yet insane" (Dean's phrase) "organic pattern" which manages to have a "bandbox tidiness." Focal part of the trademark is a cloverleaf made up of four hearts, intended to represent freshness of the candy. Other novel ingredients: a striped candy bar forming the horizontal stroke of the F, a candy bar as the bottom of the L, a leaf motive for its

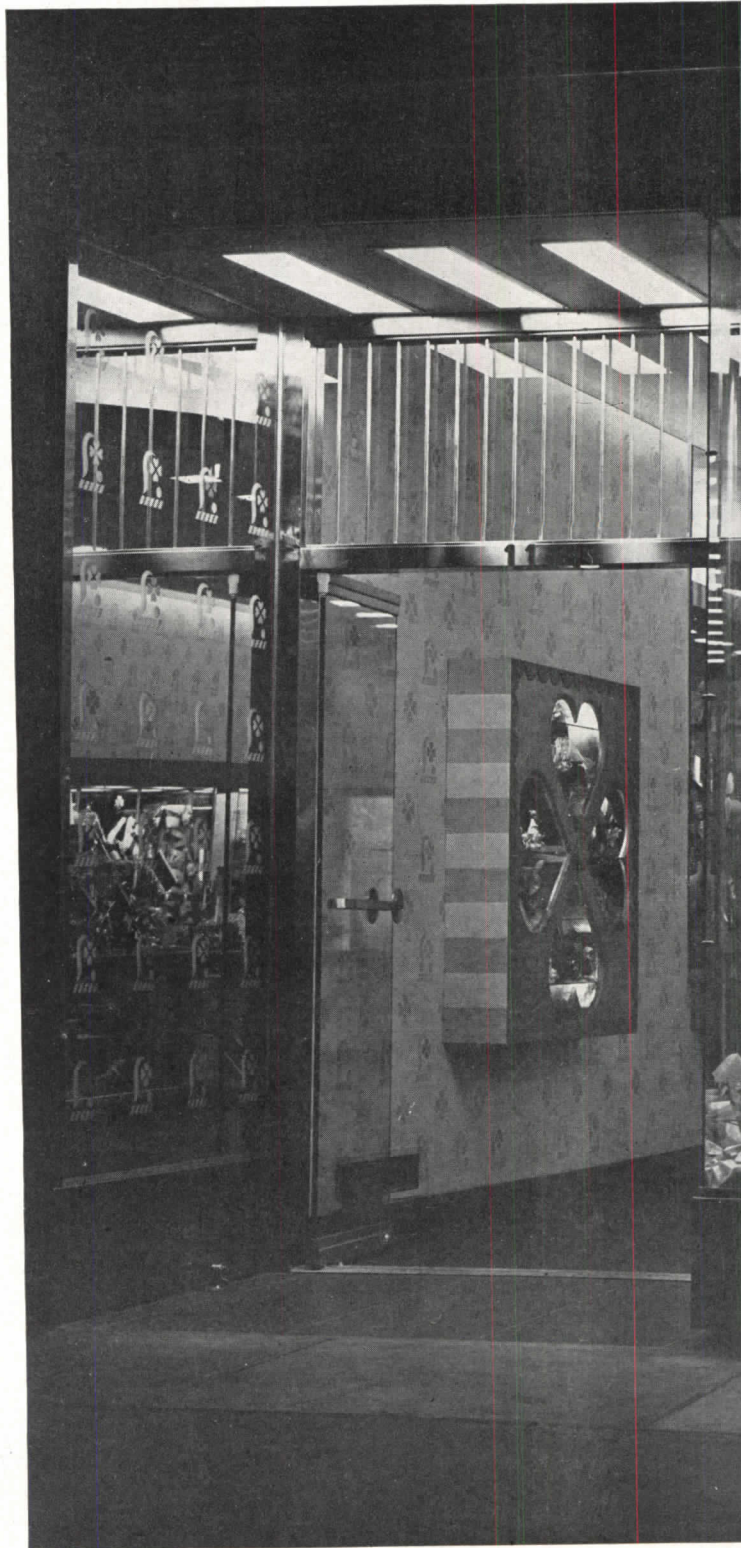

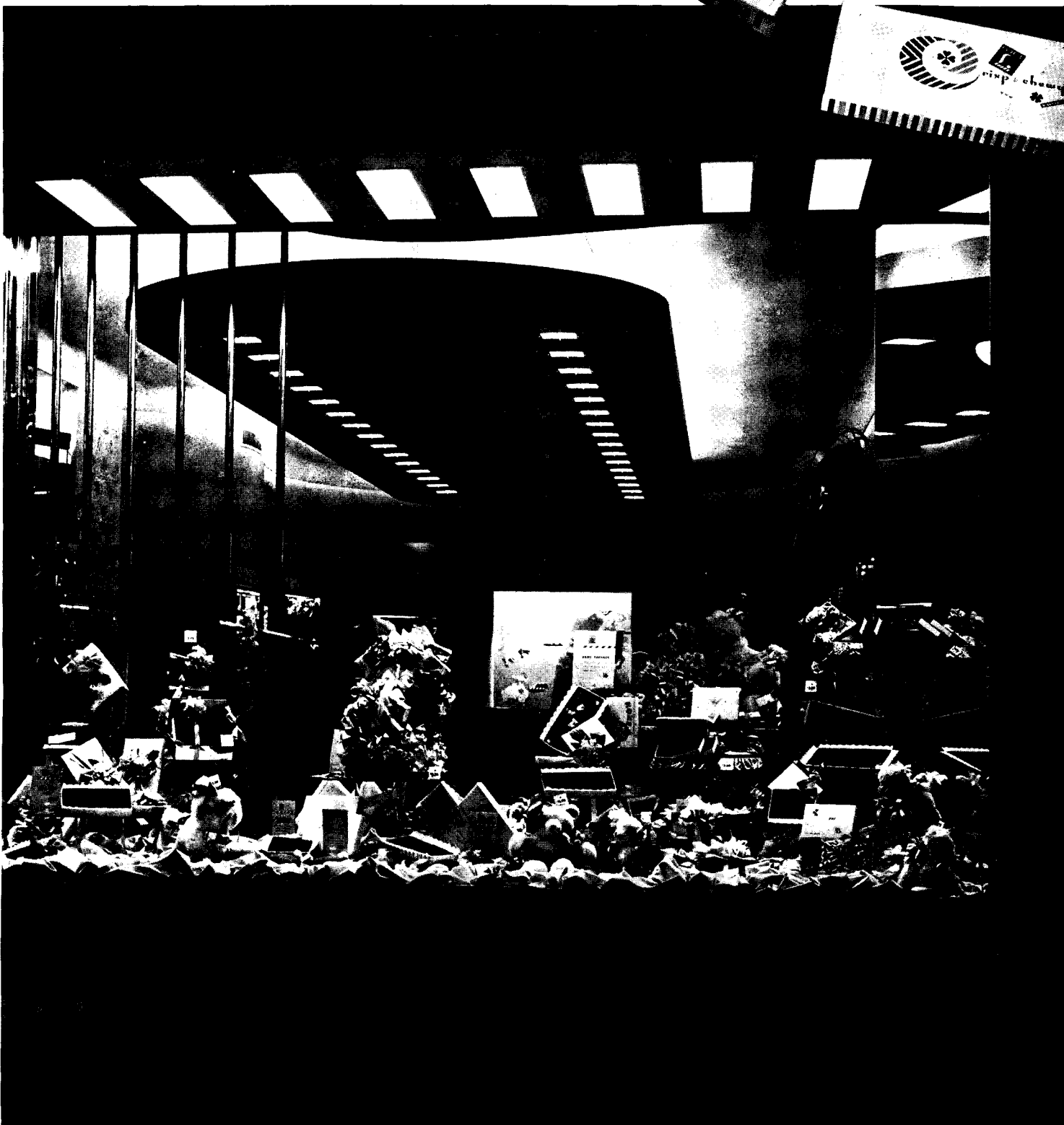
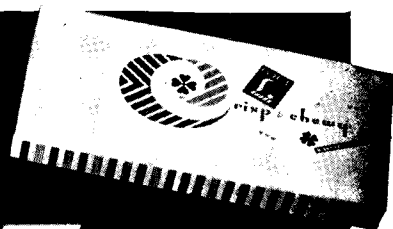
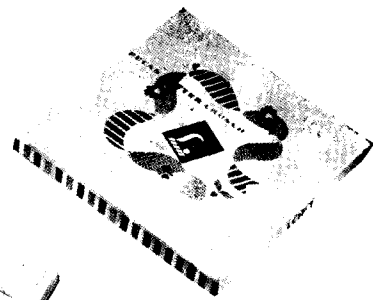
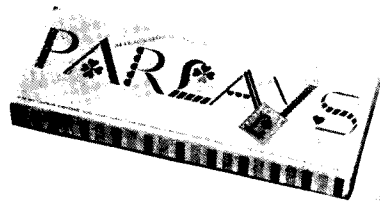

vertical stroke. These are interwoven in the design, occasionally used boldly, sometimes muted in the texture of wallpaper or background. All is done in a three-color scheme of gold, sky-blue and coral rose, with some beige-gray for backgrounds. All of these devices are carefully calculated for merchandising value, and the design as a whole contains many little horizontals leading into the store, and works hard to set notes of charm and gaiety. If it all sounds whimsical and playful, it comes as the result of much study of Loft stores and their customers, leading the designer to tackle a blend of the old symbols with the newer concepts of design.

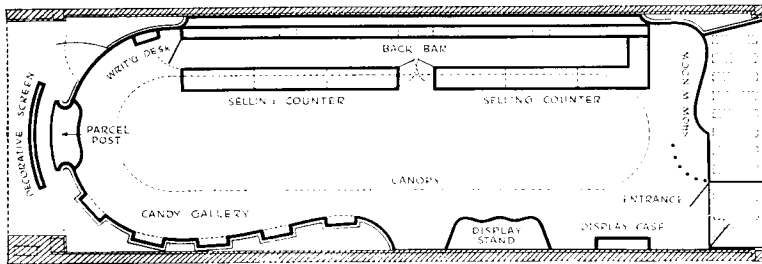

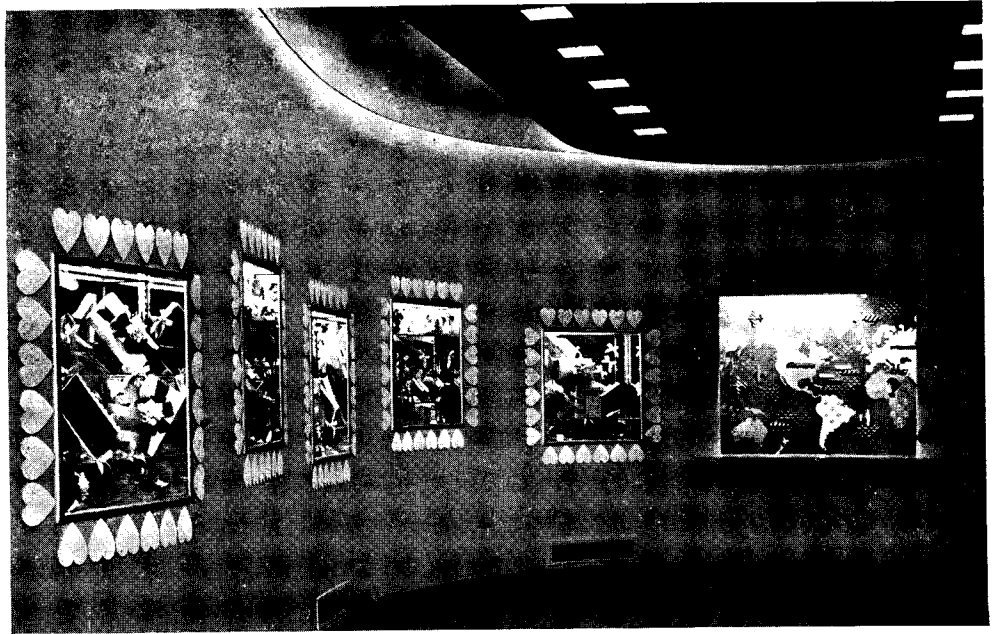



## PIONEER DESIGN FOR CANDY SHOP

**First Retail Outlet for Garrott Candy Co., St. Paul  
Harold Spitznagel, Architect**

ANOTHER pioneering design, this one sets the pace for a successful candy manufacturer making his first venture in retail selling; this is to be the first of a modest chain of retail outlets to bear the firm name. Naturally the manufacturer wanted a note of clean quality. The cleanliness idea suggested the white front, easy to keep scrupulously spotless. The name script is in vermilion. The clean lines of the interior and the show case will do no harm in this respect. The case is of faun colored ash. It is lighted from within with cold-cathode tubes. Walls are plastered; mostly in gray, but one wall is done in chrome yellow, as is also the acoustical ceiling. The settee too is yellow.



HEDRICH-BLESSING Photos

The shadow-box, this one lighted from within, makes an effective display for the candy box designed by the architect, particularly with the little figure for an eye-catcher. The background here is the canvas wall covering with the firm name and the diagonal stripes in white on gray tone

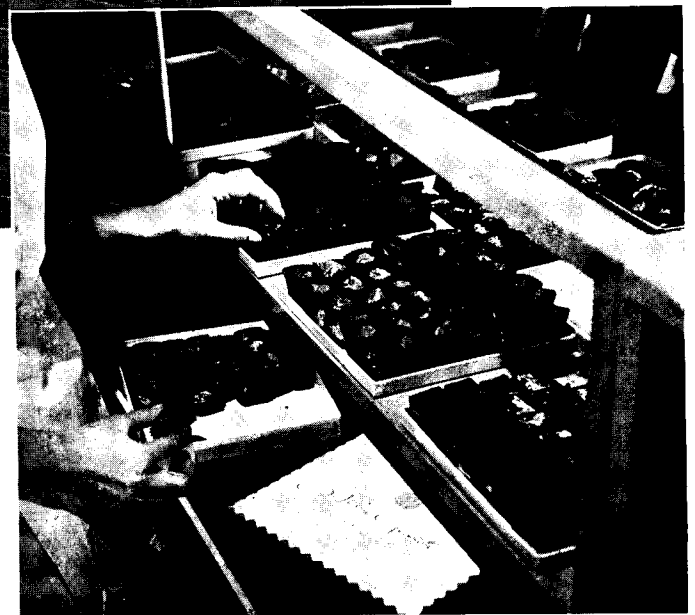
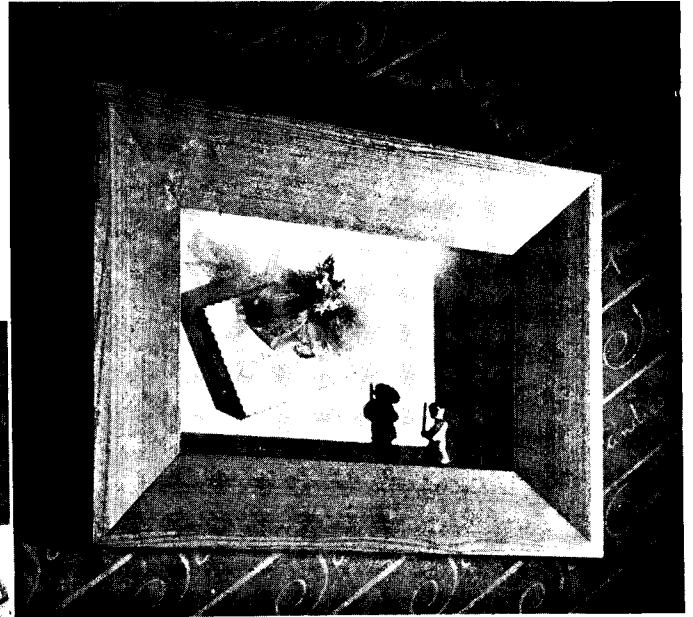





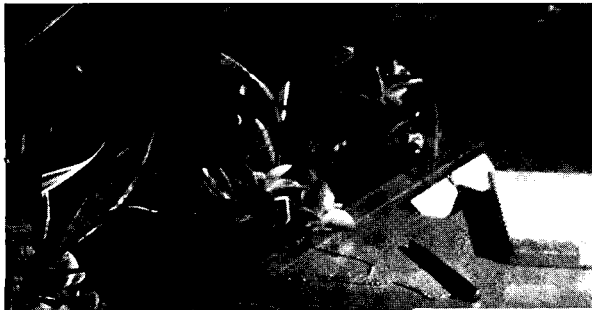
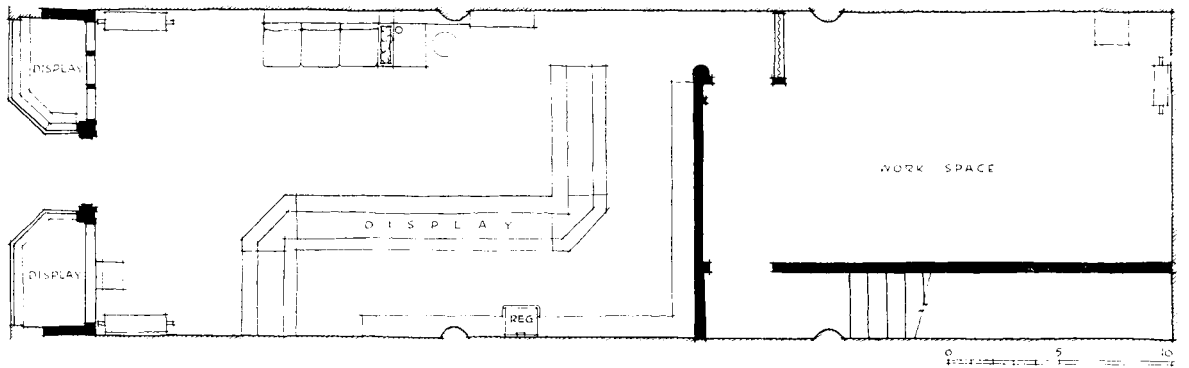

*The yellow bench is given a touch of psychological separation by the island pattern in the flooring and by the mirror panel behind. There is more than a suggestion of privacy for the writing desk in the plants that block it off from the bench, perhaps inspiration too*

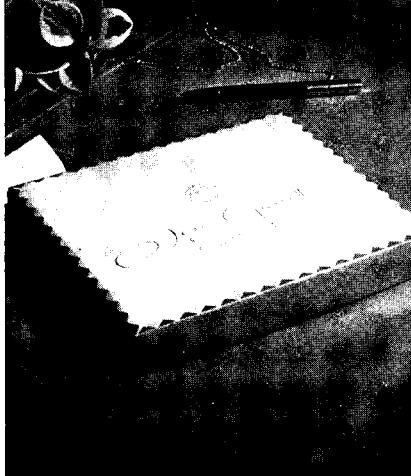

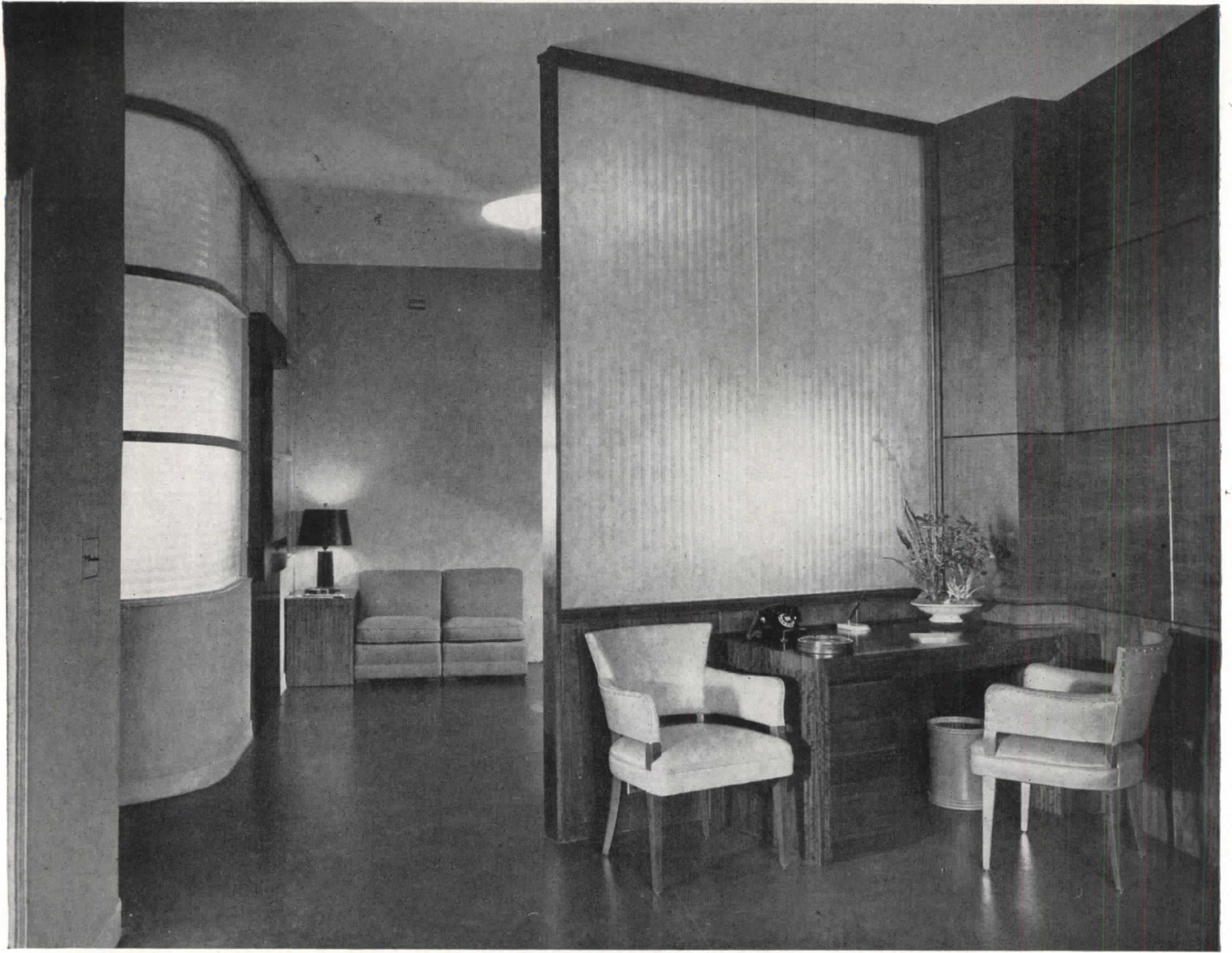

## SHOWROOM FOR WOOL FABRICS

Moniteau Mills Showroom and Offices, New York  
Robert Gruen Associates, Designers

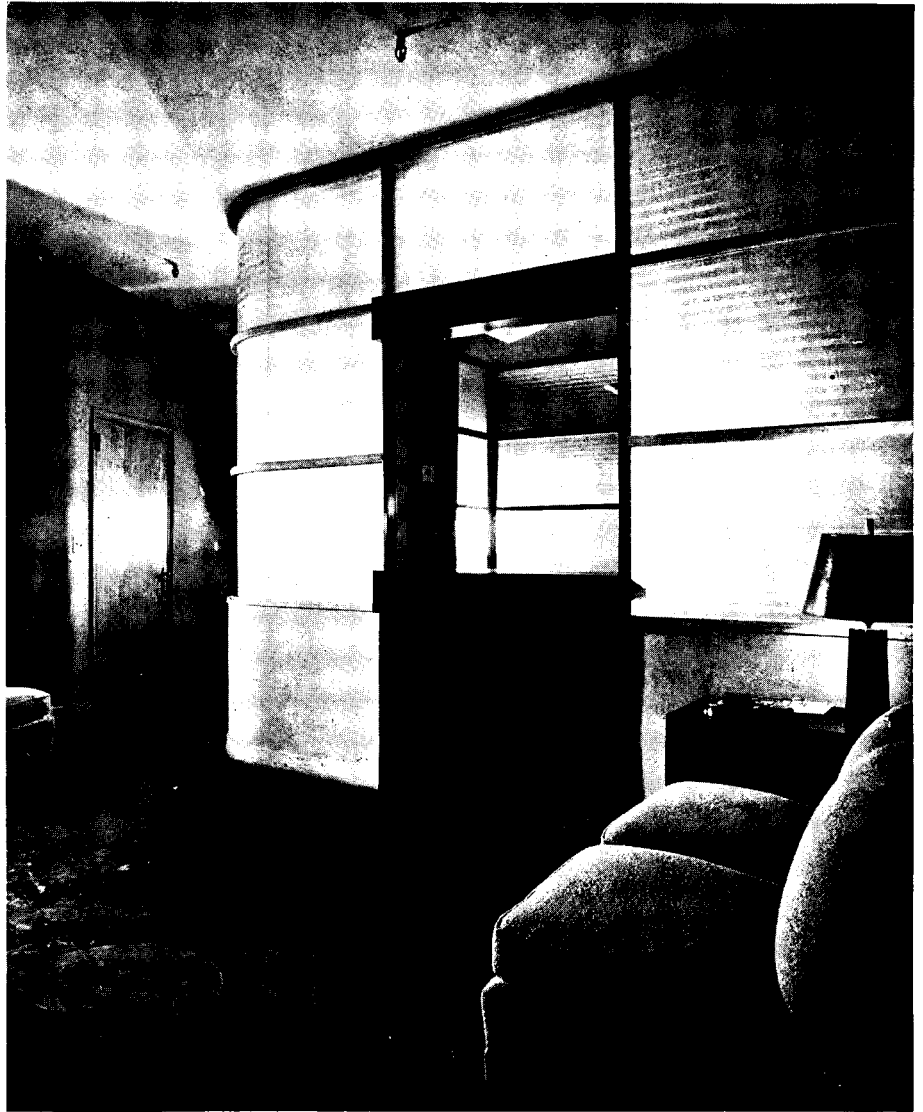

**I**F THE influence of capable design talent is being felt more and more in the retail world, it is also increasingly demanded in the wholesale showrooms. Here there is a different level of salesmanship, and the difference is reflected in the designs. At any rate New York's showrooms have recently been "reconverting" for an era of competitive selling which should be just around the corner, and the interior walls of the city's ancient loft buildings are being hidden behind bright modern materials.

The hiding process frequently, as in this case, calls for considerable ingenuity. This was old-fashioned space, with ceilings over 13 ft. high. The new ceiling was dropped — accommodating air conditioning ducts — until it came below window height. The extra height was also utilized for recessed lighting, and to form a pocket for drapes and curtains. Since this is a showroom for woolen fabrics, lighting took on exceptional importance. Good north light is the natural requirement; thus show tables are placed to take advantage of daylight. For the dark days, the tables are lighted with a



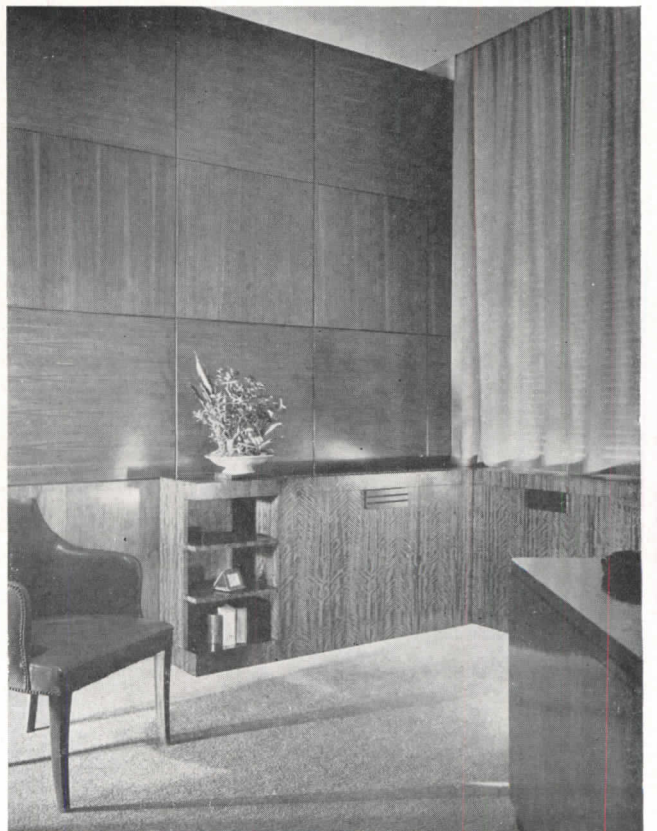
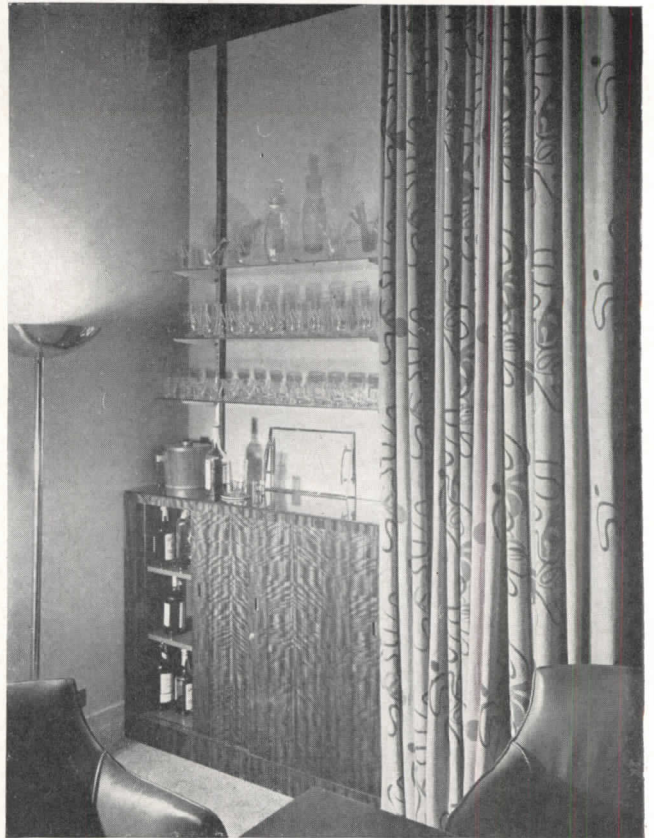

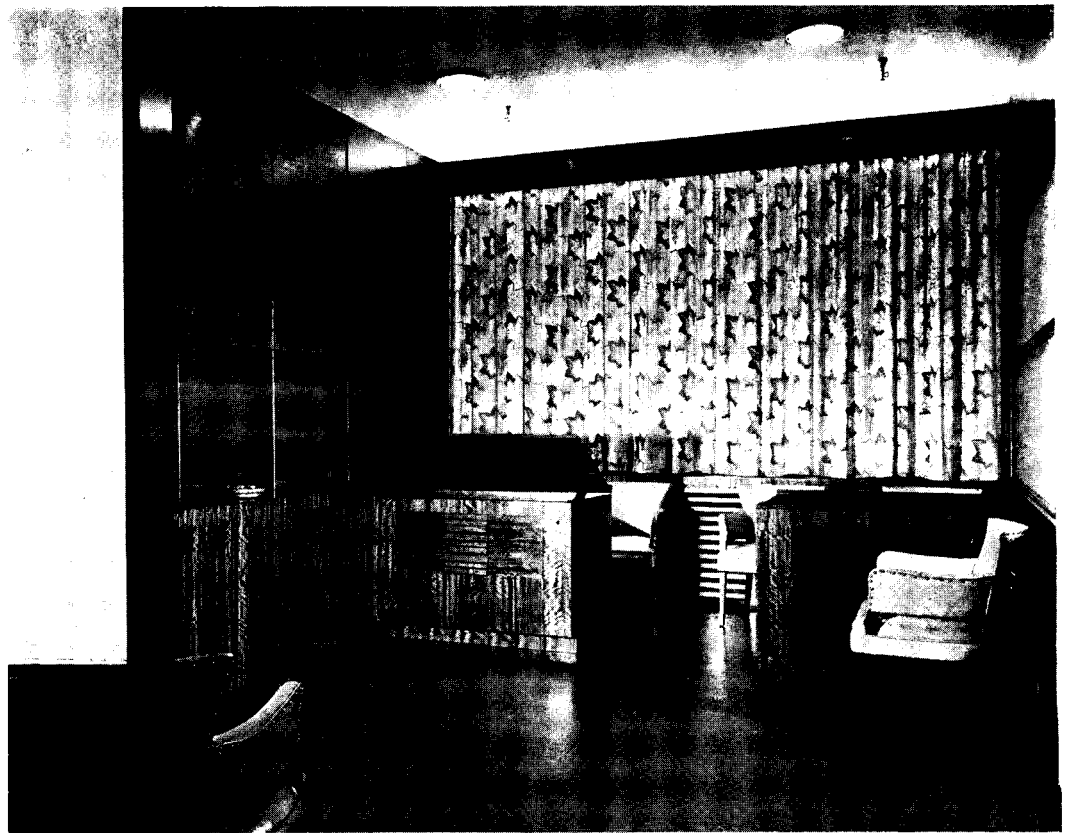

combination of direct and indirect lighting, the fluorescent installation combining soft white and gold tones, for a close-as-possible approximation of daylight.

The show tables were designed for the sales methods employed by fabric salesmen; the table top is covered with fabric, and tilts up. The customer is seated at the table; the salesman stands on the other side, pulling

swatches out of the drawers (see photograph above).

The reception room is done with a photomural tying in with the topic of woolsens; dark blue linoleum floor with terra cotta inlay of the interwoven double M, the firm's trademark which was part of this design assignment. The Gruens also did the decorating, even to the glassware in the president's private cabinet.

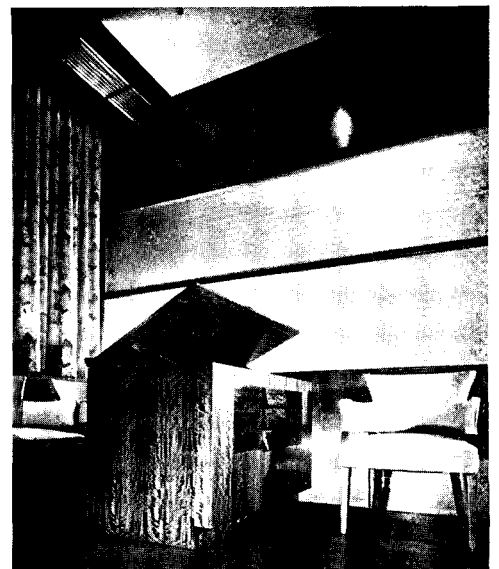
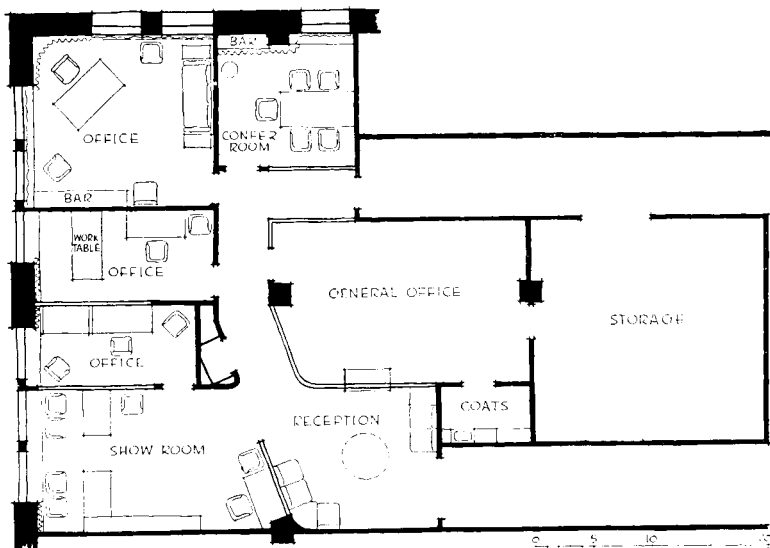

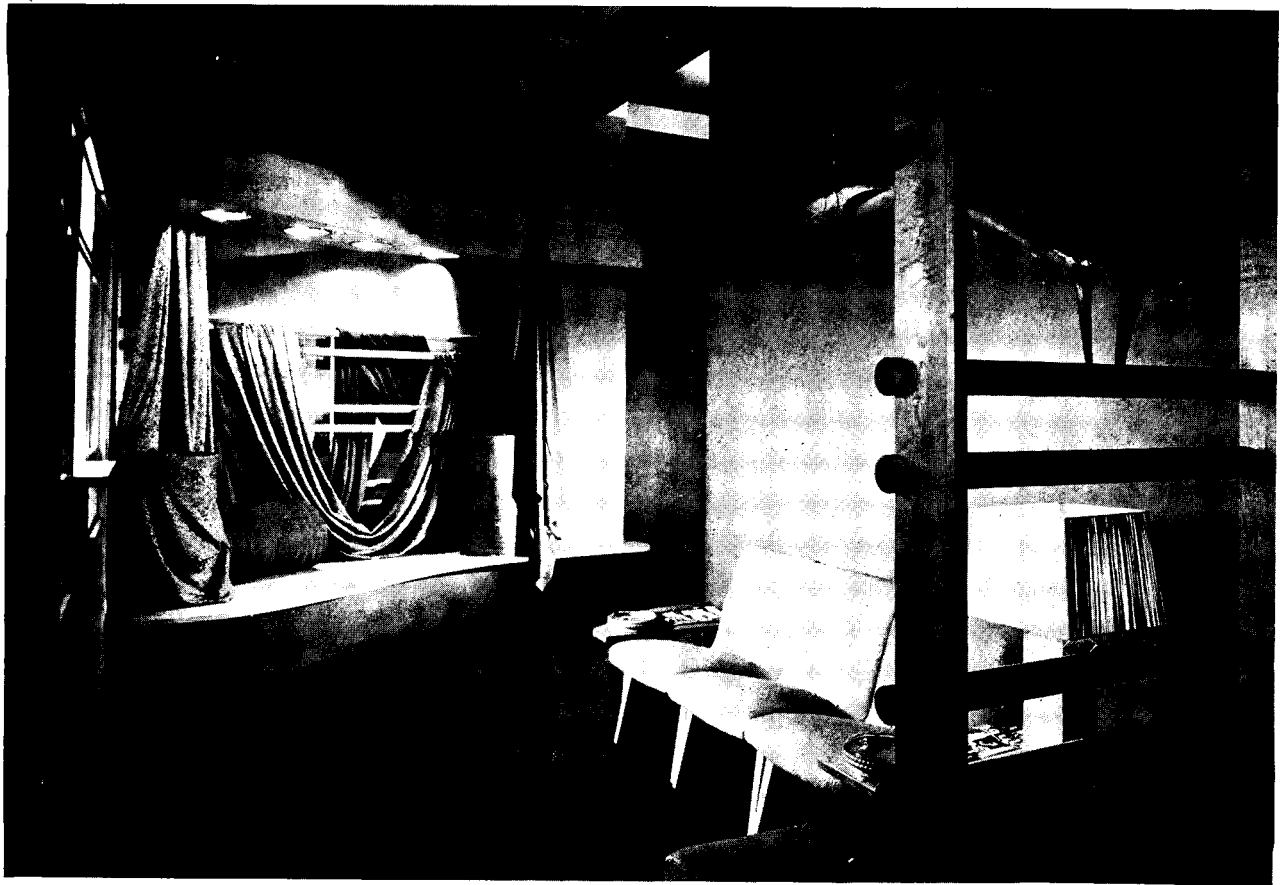

## SHOWROOM FOR BOYS' CLOTHING

Office and Showroom for Windsor Clothing Company, New York City

Robert Gruen Associates, Designers

AS STATED by the designer, the problem here sounds typical — to design a cheerful, colorful interior in a limited space. The long corridor portion of the reception room added a little problem of leading the visitor invitingly around the corner. The curved display was used for this purpose, its platform exhibit brilliantly lighted to attract instant attention. The ladder rungs and lighting fixtures in the reception room are of blonde maple; linoleum floor is dark green, as are also one wall of the reception space and the corridor portion. Opposite walls are gray. Bright red upholstered chairs are set against the green wall. The same color scheme is used also for the showroom section.

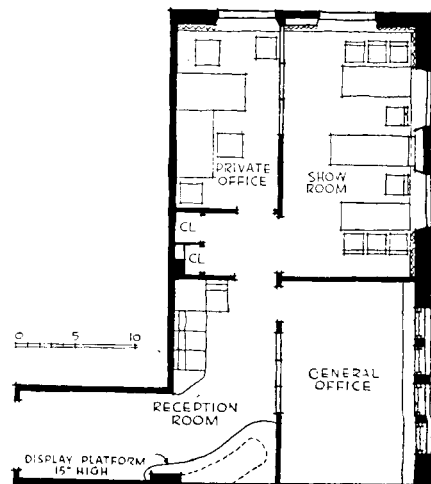
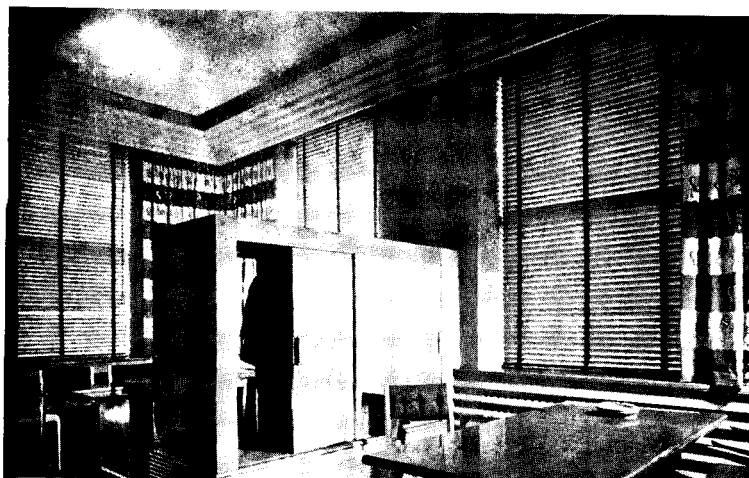

# For Fast, Economical Industrial Construction

*Specify...*

# CEMESTO

REG. U. S. PAT. OFF.



**Roof Deck:** Cemesto panels 1-9/16" thick, applied with edges centering over steel headers and purlins and fastened to framing with metal clips.

**Exterior Curtain Walls:** 1-9/16" Cemesto panels applied to steel studs and girts with bolted clips. Cement asbestos with felt over vertical joints, steel flashing in horizontal joints.

## This Multiple-Function Building Material Offers *5 Major Advantages!*

More and more architects are turning to Cemesto when the problem is one of modern, high-speed, economical construction. This Mineral Tile Plant at Lagro, Indiana, is a typical example.

The architect specified Cemesto for both roof deck and exterior walls. Thus, in one application, Cemesto—which is made of Celotex cane fibre insulation board sheathed on both sides with asbestos cement, bonded with moisture-proof bituminous asphalt adhesive—gives *all five* of these major advantages:

### **1. Speed and economy of application!**

The Cemesto wall unit incorporates in *one* material both structural wall *and* insulation. It can be pre-cut to needed sizes . . . used either vertically or horizontally.

### **2. Structural value!**

Cemesto meets normal load requirements. It is rigid and permanent and saves on intermediate supporting members and materials.

### **3. Resistant surface!**

The smooth, firm 1/8" asbestos-cement surface on both sides of the material is both fire- and moisture-resistant.

### **4. Self-finish interior surface!**

The light gray Cemesto surface furnishes good light reflection value . . . plus a pleasing and durable finish that requires no painting.

### **5. Excellent insulating value!**

Conductivity of the Celotex core has been established at 0.33 B.t.u. per hour per square foot per degree F. per inch of thickness.

Why not find out how *you* can take advantage of the versatility of Cemesto wall units? They are available in standard 4' wide panels, 4', 6', 8', 10' or 12' long, and in thicknesses of 1 1/8", 1-9/16" and 2". Send today for files number 4500 and 44119 for details and descriptions of various applications of Cemesto to steel and wood. Write: *The Celotex Corporation, Dept. AR-246, Chicago 3, Illinois.*

**CELOTEX**  
REG. U. S. PAT. OFF.  
**BUILDING PRODUCTS**

THE CELOTEX CORPORATION • CHICAGO 3, ILLINOIS

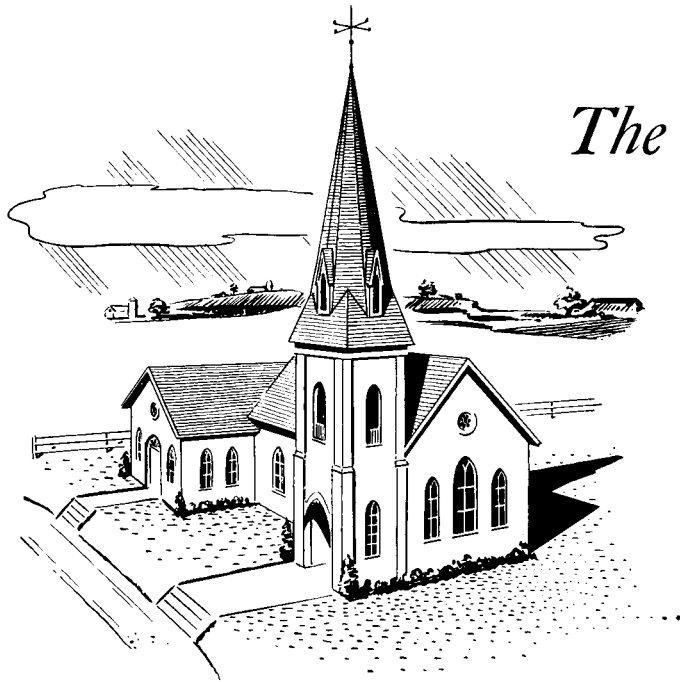

*The World's Finest  
Electronic Organ . . .*

THE NEW  
**WURLITZER  
ORGATRON**

*Recommend the Series 10 Single-Manual Wurlitzer Orgatron  
for Smaller Churches, Chapels and Sunday School Rooms*

WHEN designing or redesigning the smaller church, chapel or Sunday School room where a modest budget is involved, recommend the new Series 10, single-manual Wurlitzer Orgatron.

FROM your standpoint, it will save space which you can devote to other church needs. It will conserve funds which you can utilize to advantage in planning a finer, better equipped church building.

FROM the church's standpoint, the rich, reverent, church organ tone of a Wurlitzer Orgatron will enhance the spiritual value of its worship service. Orgatrons are doing that in thousands of churches today.

ARCHITECTS desiring to learn more of the space-saving, money-saving features of this new Wurlitzer Orgatron are invited to write the Orgatron Division of the Rudolph Wurlitzer\* Company, Dept. 1103 North Tonawanda, New York. \*The Name That Means Music to Millions.

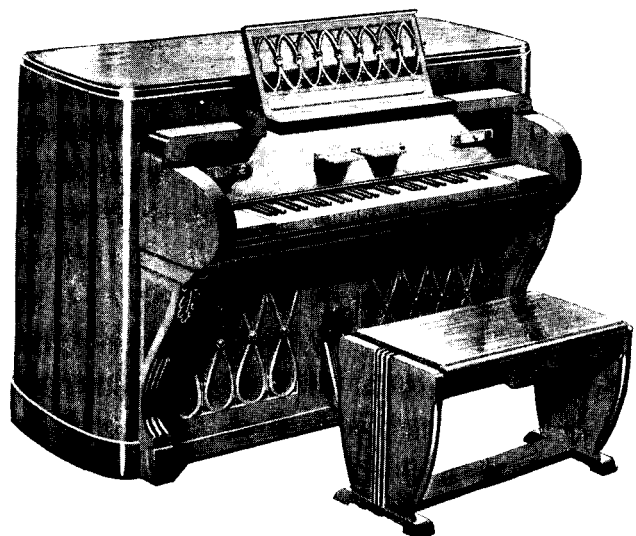

“THE ONLY ELECTRONIC ORGAN WITH TRUE CHURCH ORGAN TONE”



# PARAPET WALLS

Several methods of obviating cracks in parapet walls put to use and tested by Fred N. Severud, Consulting Engineer

The natural struggle between the inside and outside portions of a wall becomes most intense at the juncture of roof and parapet wall. It is not at all unusual for the struggle to go on until there is, literally, an explosion. Indeed, cracked or broken parapet walls, particularly at roof corners, are quite common.

Every wall of any thickness is strained by the differences in exposure and temperature between inside and outside. The outer surface, or outer layer, gets wet and then is heated by the sun, or, more to the point, it is subject to freezing temperature while the inner layer is heated. Thus the outside layer wants to contract, the inner one to expand. Sooner or later each goes its own way and an explosion follows, leaving a break in the wall.

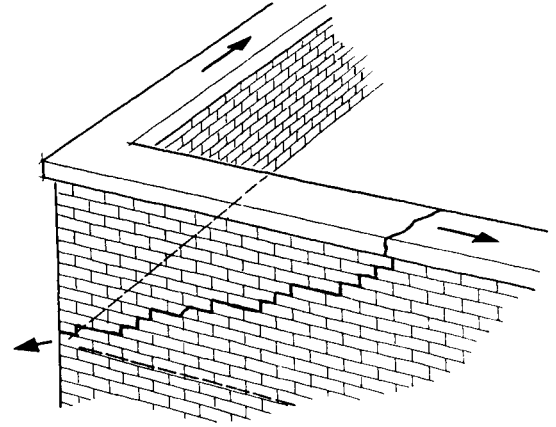

If this is a factor to be taken seriously in wall construction, and it is, it is even more worthy of consideration in the design of parapets. For here the difference reaches the extreme, above the point where the outside wall gets any heat at all from inside. Heat in the top story rises to the underside of the roof slab, causing it to expand. Insulation on top will free the slab from the influence of the cold outside, and the slab will stretch comfortably. But the parapet

Standard details used in the office of Fred N. Severud, structural engineer, for tying the parapet walls against temperature strains. Steel rods run continuously through the wall itself and the brick courses immediately below it with steel dowels tying the wall to the spandrel beams

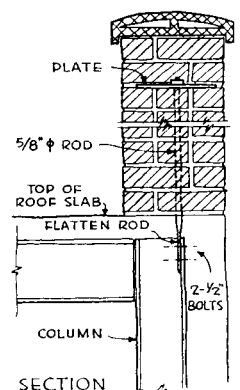
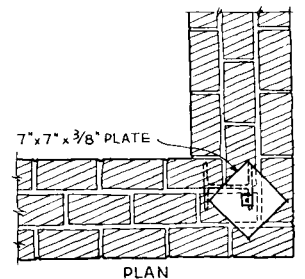
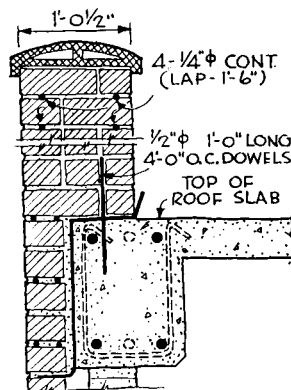
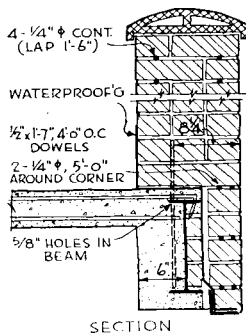



**SWITCH ON**



*The Eye Appeal*

and watch how Day-Brite Fluorescent Fixtures improve the appearance of store and merchandise. They're *optically engineered*.

May we send our new bulletin with complete details?

Day-Brite Lighting, Inc., 5465 Bulwer Avenue, St. Louis 7, Mo.  
Nationally distributed through leading electrical supply houses.

In Canada: address all inquiries to Amalgamated Electric Corporation, Ltd., Toronto 6, Ontario.

***The* KINGSWAY**

For surface mounting. Streamlined fluted glass prevents glare. Luminous die-cast ends. Suitable for any length installation, in multiples of 2, 4 and 8 feet.



908



IT'S EASY TO SEE WHEN IT'S

**DAY-BRITE**

*Lighting*

# PARAPET WALLS

(Continued from page 129)

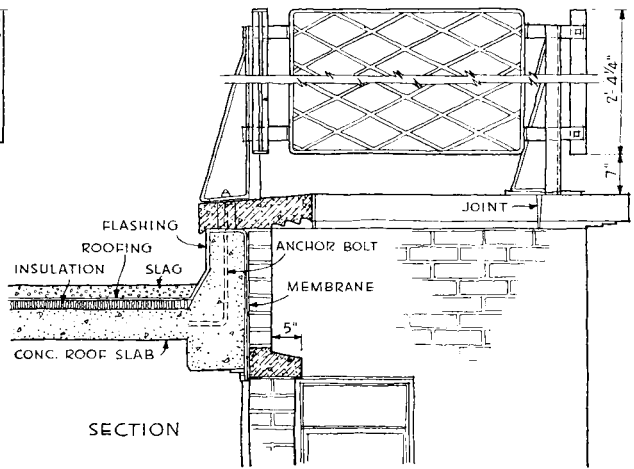
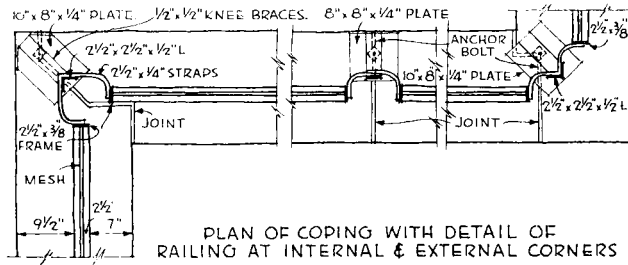

One way to prevent breaks in the parapet wall is to eliminate the wall entirely. Details of steel railing developed by Voorhees, Walker, Foley and Smith, architects, for East River Housing Project

Here a concrete fence is substituted for the parapet wall. Concrete struts poured with the spandrel beams act as fence posts. Pre-cast concrete planks, set in slots in the posts, form a crack-proof wall

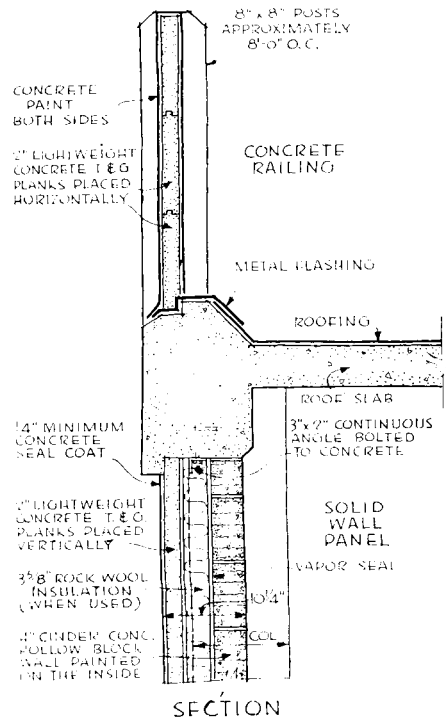

wall, out in the cold, will shrink from each free end, toward the center. Now the "free" applies only at the top of the wall; the bottom is fixed at the roof line. At the corner, the pull is along each wall. The roof slab is pushing the bottom corner of the parapet wall outward; the top of each wall is being pulled inward. Thus the corner cracks often take the pattern in the sketch on the preceding page.

The sections on the preceding page show the standard practices of Mr. Severud's office, in three normal types of construction. For tensile strength, steel rods are run through the parapet brick courses, also for a few courses in the facing below the roof line. The rods overlap at the joints to form continuous tie lines around the building. Steel dowels tie the walls to the spandrel beams, and plates embedded in the walls at the corners add rigidity there. This system ties the walls firmly in place; if minor cracks do develop, at least the walls will not jump out.

On this page there are two ideas which solve the problem by avoiding it completely. The details above were developed by Voorhees, Walker, Foley and Smith, architects, for the East River Housing Project, New York; they simply eliminate the parapet wall, substituting a metal rail on a low curb.

In the section below, a concrete slab fence is substituted for the parapet wall (here with precast slab wall construction). It is obvious that the concrete planks, set in posts, cannot carry temperature strains beyond the posts.

# REQUIRED READING

## HOUSES

*The Book of Houses Planned for Beauty and Utility at Low Cost. 150 photographs, 100 plans for \$5,000 to \$10,000 homes. By John P. Dean and Simon Breines. New York 16, N. Y. (419 Fourth Ave.), Crown Publishers, 1946. 8½ by 11 in. 144 pp., illus. \$2.00.*

Anyone who has read Dr. Dean's recent book, *Home Ownership: Is it Sound?* (see AR, July, 1945, p. 128), will find the first few chapters of the current volume thoroughly familiar. Dr. Dean still warns constantly and convincingly of the dangers inherent in buying or building a house. It is a little curious, therefore, to find him teaming up with an architect in the production of a book on house planning.

The team is a happy one, however. The sensible, albeit discouraging, warnings of Dr. Dean go very nicely with the architectural understanding and logic of Simon Breines. In their preface these authors say that they are addressing their ideas to prospective purchasers of homes in the \$5,000 to \$10,000 class. They explain that most of the houses they have included are traditional in style because (1) most of the homes to be found for sale are traditional, (2) most people prefer such homes, (3) there is no point in including primarily modern houses when they are so hard to find, and (4) the good modern design is slanted at the \$20,000 to \$30,000 pocket-book. All very sensible. The houses themselves are sensible, too — well planned, most of them, and varying widely in both size and style. They are not presented as a portfolio from which the would-be home owner can select the house of his dreams, but as a handbook from which he may glean an idea here and another there to be incorporated into his ideal home.

This is a book that the prospective home owner will really find useful. The text covers every imaginable subject — from check lists and risks, costs and purchase plans, legal pitfalls and home safety, to "purchasing a neighborhood," making the most of the lot, the plan, remodeling, the basic house, prefabs, and weekend cabins. Photographs and plans are liberal in number, adequate in size.

It is unfortunate that more care was not taken with the appearance of the book itself. The photos are all a wishy-washy gray, many of the plans are blurred.

## HOME BUILDING

*Make Your Home Your Hobby. By Walter J. Coppock. Yellow Springs, Ohio, The Antioch Press, 1945. 6 by 9 in. 92 pp. illus. \$1.50.*

Contrary to the implications of its title, this is not a handbook of ideas on interior decorating, but another of the

rabbit-like homebuilding-manual family. The hobby part of the title refers to the fact that the book is intended primarily for the person who wishes to do his building with his own hands.

Because of its intended audience, the book contains a good bit of practical information, much of it perforce rather elementary. Not enough attention is paid, however, to the problems of design. What little mention of design is made is usually on the negative side — such and such is "not good design."

Mr. Coppock, an engineer, is much more concerned with materials and workmanship than he is with plan. A good part of his book is given over to the technical: walls, stairs, piping, and so on. There is a whole chapter devoted to air conditioning, and another dealing exclusively with the reduction of building costs. Just one short chapter is given over to interior planning, and this is merely a description of three rather ordinary little houses, all very much alike. One of them is the author's own.

## BRITISH BUILDING

*Architects' Year Book. Jane B. Drew, F.R.I.B.A., ed. London, E.C. 1 (Diamond House, 36-38 Hatton Garden), Paul Elek, Ltd., 1945. 7½ by 10 in. 412 pp. illus. 35 s.*

The aim of this volume, says the editor in her foreword, is "to show trend and to help the forward-looking architect by giving him the necessary background of basic contemporary knowledge." With this end in mind, 13 papers are presented on various subjects ranging from landscape architecture and town planning to housing, planning industrial buildings, and service buildings. A technical section includes 16 papers on such items as structural steel, reinforced concrete, fiber building boards, plastics, acoustics, glass. To many of the articles are appended bibliographies and reference lists.

## CITY PLANNING

### OHIO

*Comprehensive City Plan. By the City Planning Commission, Greenville, Ohio. 8½ by 11 in. 92 pp. illus.*

The aerial view which comprises the frontpiece of this planning report shows Greenville to be a city of long straight streets bisecting each other for the most part at right angles. More than the usual number of trees is evident, and there is one square, with a city hall at its center. The population distribution chart shows

exceptional evenness throughout the greater part of the city. Greenville, on the whole, would seem to be an orderly city, with much of the groundwork of good planning already laid.

Under the direction of Ladislav Segoe, Planning Consultant, a Comprehensive City Plan has been drawn up "to guide, and in some measure control, both public and private improvements and developments." Because of the inherent soundness of the city, no very striking recommendations have been made. Zoning, subdivision control and building code adoption are proposed; "an organized, community wide program to encourage and promote the repair and modernization of older or substandard dwellings and high standards of maintenance of all structures . . . would seem highly desirable"; a plan of thoroughfares and highways is proposed; construction of several new schools, recreation areas and parks, and a number of public buildings. Most elaborate proposal is a civic center.

### CALIFORNIA

*Parks, Beaches and Recreational Facilities for Los Angeles County. Los Angeles 7, Calif. (2324 S. Figueroa St.), The Haynes Foundation, 1945. 8½ by 11 in. 18 pp. 10 cents.*

*Coordinated Public Works for Metropolitan Los Angeles. By George W. Bemis. Ibid. 6 by 9 in. 26 pp. 10 cents.*

The first of these two pamphlets is a report by the County Citizens Committee on Parks, Beaches and Recreational Facilities. It describes the existing facilities and specifies the need for additional facilities.

The second booklet is a proposal for a "Public Works Review Board" with representation of federal, state, county and municipal agencies, whose job it would be to review all projects of a region-wide importance and advise the interested agencies on coordination of their proposals in timing and location.

### BOSTON

*In Which We Live. Annual Report of the Boston Housing Authority, 1944-1945. Boston 6, Mass. (10 Post Office Sq.), 1945. 8¼ by 11¼ in. 36 pp. illus.*

The Boston Housing Authority, this report shows, has constructed to date eight developments and has two further developments on its schedule. The success of the existing projects is described and illustrated; the need for further building is graphically presented. The Authority is fully aware of the gigantic problem it faces, and it is striving valiantly to keep what it has gained through good management and careful maintenance. To increase efficiency and keep costs as low as possible, the Authority is gradually turning over to its own staff much of the repair work, including all exterior painting.

Frank  
Adam

# DUBLBRAK

AUTOMATIC  
CIRCUIT BREAKER

Panelboard

LONGER LIFE

•  
GREATER  
PROTECTION

•  
MORE  
EFFICIENT  
OPERATION  
THAN EVER  
BEFORE

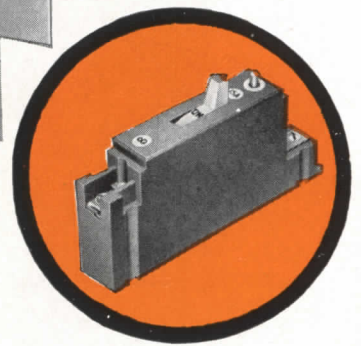
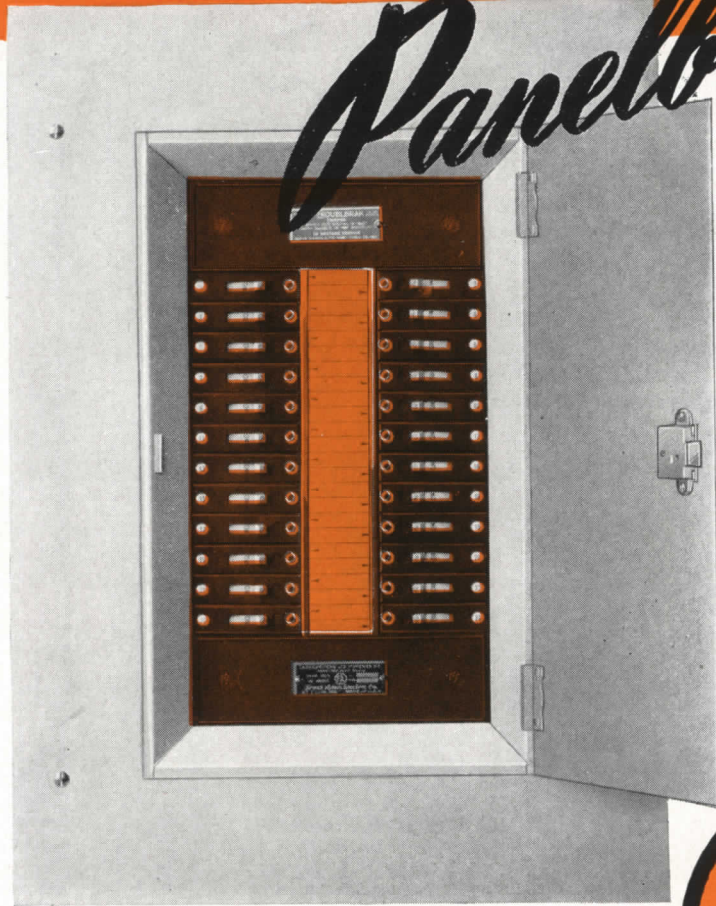

Here is a panelboard as modern as tomorrow! Designed for lighting and appliance branch circuit protection and control, nothing has been spared to meet every requirement. Compact and attractive to please the architect . . . scores of knockouts, 4-inch gutters, adjustable leveling to please the contractor . . . nothing to replace or service to please the maintenance men . . . years and years of trouble-free service to please the owner . . . and quality materials and workmanship to please ourselves.

Everyone is delighted with this panelboard. Stores, offices, factories, schools, hospitals, commercial and public buildings have found it meets their requirements perfectly.

The  *Dublbrak* Panelboard has the "extras" you want. Individual circuit breaker construction. *Automatic* thermal protection against overload and

short circuit. Time-lag for harmless momentary overload. *Quick* make and break operation on manual and automatic trip. Red button indicator for speedy location of automatically tripped circuit breaker. Entire front is shock proof and tamper proof. Heavily silvered, double break contacts adds years to the life of the panelboard.

Capacities of 15 to 50 amperes for alternating or direct current. Double or triple pole assemblies with individual trip per pole are available. Write today for Bulletin No. 67 giving specifications, prices and many helpful suggestions.

Frank Adam

ELECTRIC CO.  
P. O. Box 357  
St. Louis, Missouri

**DRAFTING TABLES**

Two new adjustable *Work-Flow* tables — a *Tilt-Top Work Table* and a *Drafting Table* — are designed to provide the greatest possible utility and comfort for the tabletop workman.

The drafting table can be quickly adjusted in height and angle; storage space is provided for three extra boards and large drawers to accommodate working materials. The work table may be adjusted in height from 28¼ to 38¼

in. for comfort of the operator in a sitting or standing position, and the top may be tilted from a level position to any angle up to 20°. Both tables are finished in dull green. Work Flow Equipment Co., 207 Wood St., Pittsburgh 21, Pa.

**ROOFING METAL**

A protected metal for roofing and siding on industrial and agricultural buildings consists of flat, corrugated or V-crimp steel sheets, the surfaces and

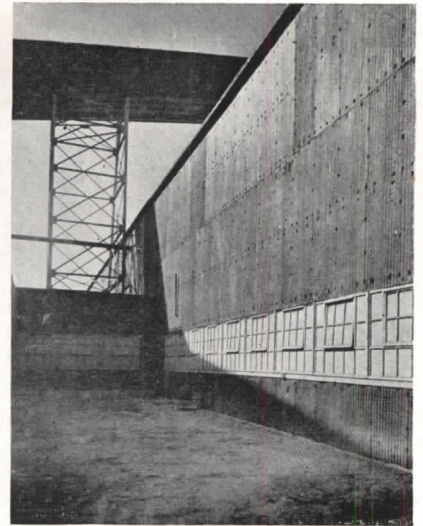

A protected metal for roofing and siding

edges of which have been treated with *Plastipitch*, a compound which provides permanent adherence to metal at low as well as high atmospheric temperatures and protects the base from rusting, corrosion, salt air and the effects of chemical fumes. After the *Plastipitch* coating, the sheets are provided with additional surfaces to give extra protection. The material is said to be suitable for gutters, ventilators, flashings, ducts, etc., as well as for roofing and siding. Koppers Co., Inc., Tar and Chemical Division, Pittsburgh, Pa.

**NICKEL-LINED PIPE**

The inside of steel pipe can be electroplated with corrosion-resisting nickel or other metals by means of the new *Bart Lectro-Clad Process*, which develops a smooth, ductile, pore-free nickel deposit fully adherent to the base metal. It can be applied to pipe or tubing up to 18 in. over-all diameter, in random lengths approximately 20 ft. The internally plated pipe can be welded, reduced and bent, hot or cold, without destroying any portion of the internal lining. Bart Mfg. Co., 227 Main St., Belleville 9, N. J.

**SUPPLY INDICATIONS**

**Mahogany**

First deliveries of Philippine mahogany since the war will be made in the summer of 1946 in the form of logs, providing shipping space is available, according to J. Raymond Peck, president of the Insular Lumber Co.

**Rubber**

Measured against prewar consumption and even greater postwar requirements, 1946 will continue to be a "famine year" as far as natural rubber is con-

(Continued on page 136)

**KITCHEN PLAN NO. 32:**

Thirty-second of a series of successful mass-feeding kitchen plans.

This kitchen plan in use at the huge Chicago Vocational School, now feeding 12,000 meals daily to 4,000 naval students, is an excellent example of the "specialized cooking tool" kitchen installation.

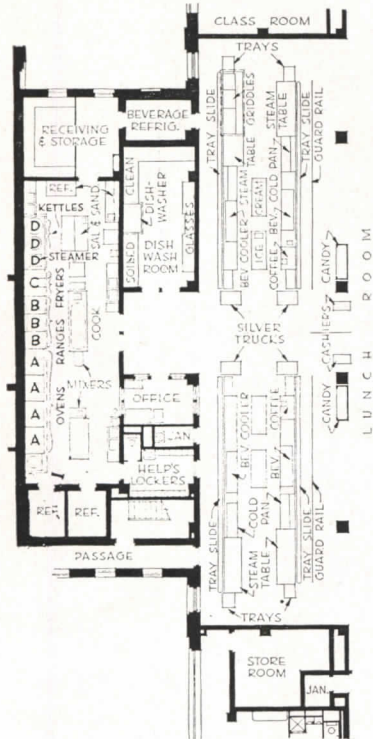

**KEEP FOR  
HANDY  
REFERENCE!**

**COOKING EQUIPMENT USED:**

- (a) 3 No. 952 BLODGETT GAS-FIRED ROAST OVENS
- 1 No. 959 BLODGETT GAS-FIRED ROAST OVEN
- (b) 3 heavy duty ranges
- (c) 3 gas-fired deep fat fryers
- (d) 1 vegetable steamer
- 2 stock kettles

Note: bake shop with two No. 982 BLODGETT BAKE OVENS not shown in plan

Designed by: Board of Education, Chicago, John C. Christensen, Architect under the direction of F. O. Washam, Director of Lunch Rooms. Installed by Alex Janows & Company.



High speed, "on time" production of heavy meals is easily accomplished when large capacity BLODGETT ROASTING EQUIPMENT is incorporated in the kitchen plan. The ovens shown in the layout above have a capacity of more than 1800 pounds of meat, and are used for production of fish, meats, and vegetables. For details and specifications of BLODGETT OVENS, consult your equipment house or write

**The G. S. BLODGETT CO., Inc.**  
50 Lakeside Avenue Burlington, Vermont

Reprints of this new series will soon be available to architects on request.

To assist architects,  
these . . .

# MESKER DESIGN BOOKS

. . . were prepared by  
a leading architect

To *serve* architects . . . not merely to *sell* them . . . has been our binding purpose through the years. To this end, the Mesker Window Books have been designed and published. And now, to the six heretofore available, a distinguished new one has been added . . . the Mesker *Book of Industrial Windows*. Like the others, this newest Mesker book is replete with helpful drawings, new uses, ideas, treatments, designs. We sincerely hope you have found these books useful, and invite you to complete your collection by mailing the coupon . . .

MESKER BROS. Dept. AR26  
428 S. Seventh St., St. Louis 2, Mo.

Without cost or obligation, mail me the following:

- |   |  |
|---|--|
| <input type="checkbox"/> Book of Apartment Windows                      | <input type="checkbox"/> Book of Windows for Homes |
| <input type="checkbox"/> Book of School Windows                         | <input type="checkbox"/> Public Building Windows   |
| <input type="checkbox"/> Book of Hospital Windows                       | <input type="checkbox"/> Office Building Windows   |
| <input type="checkbox"/> Book of Industrial Windows (ready in February) |  |

Architect . . . . .

Address . . . . .

City and State . . . . .

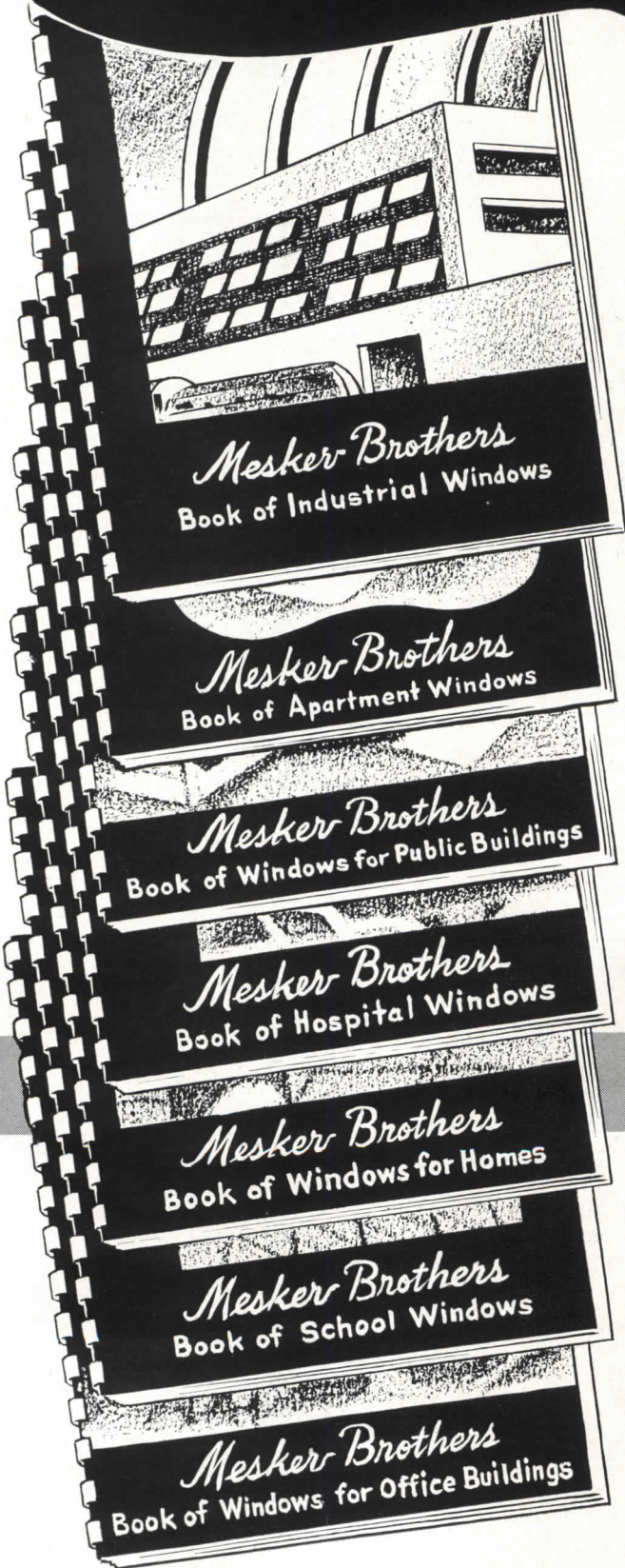

cerned, the Rubber Manufacturers Assn. reports. High quality synthetic rubbers are in good supply.

**Hardboard**

The hardboard industry has experienced no stoppage of full output during the reconversion period, according to M. P. McCullough, president, Masonite Corp., and is now expanding manufacturing facilities to meet increasing de-

mands. Because the stocks of wholesalers and dealers long have been depleted by war demands, however, it will be necessary for some time to allocate supplies, Mr. McCullough said. The end of 1946 "should find the situation improved."

**REFILLABLE PENCIL**

A *Draftsman's Refillable Pencil*, new on the market, has a clutch that holds the lead firmly in a non-slip rubber grip

that prevents the nicking and scoring of lead which cause breakage. Especially designed for engineers and draftsmen, it

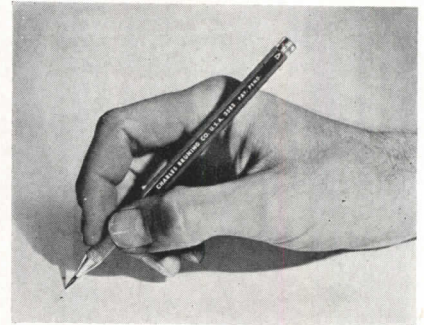

New pencil is long-barreled, refillable

has a long barrel permitting the use of any full-length standard drafting lead. The grip is knurled to provide a firm hold; an adjustable cap offers easy identification of the degree of lead used. Charles Bruning Co., 4654-8 Montrose Ave., Chicago 41, Ill.

**STANDARDS**

**Minimum Design Loads**

A new American Standard giving designers data on the loads a building can carry with safety has been approved by the American Standards Assn.

Known as the American Standard Building Code Requirements for Minimum Design Loads in Buildings and Other Structures (A58.1-1945), the standard answers such questions as how strong should floors and walls be made in factories, office buildings and theaters, and whether it is necessary in any particular part of the country to provide especially strong construction to resist wind pressures, to withstand earthquake shocks, and to prevent collapse of roofs under the load of winter snow. Copies are available from the American Standards Assn., 70 E. 45th St., New York 17, N. Y., at 50 cents a copy.

**Gypsum Concrete**

The American Standards Assn. also has completed revision of a standard covering design, construction and use of reinforced gypsum concrete. A new section relates to the position of the slabs of gypsum concrete in relation to the floor beams and roofs when they are installed by the suspension system. The main sections of the standard are: Materials, Strength of Gypsum Concrete, Allowable Stresses, Design, Inspection.

Copies of the standard, American Building Code Requirements for Reinforced Gypsum Concrete (A59.1-1945), are available from the A.S.A., 70 E. 45th St., New York 17, at 25 cents a copy.



**usAIRco**  
Heavy Duty • Centrifugal  
**BLOWERS**

For all types of air conditioning, heating and ventilating in public buildings, industrial and commercial applications, usAIRco heavy-duty centrifugal blowers are widely used. (One of the most frequently specified blowers in the ventilating field is the single inlet type, illustrated above.)

Factors to consider in the proper selection of blowers are quietness of operation, efficient delivery of air (or exhaust), ease and economy of installation, and long-life operation. usAIRco Centrifugal Blowers meet all these requirements satisfactorily.

**...The Best Buy for Efficient Air Delivery!**

Engineers, architects and contractors are urged to submit problems involving the use of blowers to the usAIRco Engineering Department. Prompt, accurate facts on the choice, application or installation of blowers will be furnished. On your next job, specify usAIRco Centrifugal Blowers . . . far your best buy for efficient air delivery!

Factory Representatives  
in Principal Cities



COOLING AND HEATING COILS

REFRIGERATED AIR CONDITIONING UNITS

PROPPELLER FANS

UNIT HEATERS

AIR WASHERS

**United States Air Conditioning Corporation**

Northwestern Terminal, Minneapolis, Minn.

Makers of the most complete line of air handling equipment



# SANYMETAL PORCENA (Porcelain on Steel) TOILET COMPARTMENTS

Provide Utmost Sanitation and Durability

SANYMETAL PORCENA (porcelain on steel) Toilet Compartments elevate the toilet room environment into harmony with other modern environments of a building. These toilet compartments are fabricated of the ageless and fadeless material, porcelain on steel, which makes a glass-hard stainless material that always looks new, does not absorb odors, is moisture and rust proof and resists the corroding nature of ordinary acids. The glistening porcelain finish discourages defacement and can be wiped clean as easily as any glass smooth surface.

Sanymetal Porcena Toilet Compartments embody the results of over 30 years of specialized skill and experience in making over 68,000 toilet compartment installations. Ask the Sanymetal Representative in your vicinity (see "Partitions" in your phone book for local representative) for further information about planning suitable toilet room environments for modern school, industrial, and institutional types of buildings. Refer to Sanymetal Catalog 19B-5 in Sweet's Architectural File for 1945, or write for file copy of Catalog 83.

THE SANYMETAL PRODUCTS COMPANY, INC.  
1689 URBANA ROAD • CLEVELAND 12, OHIO

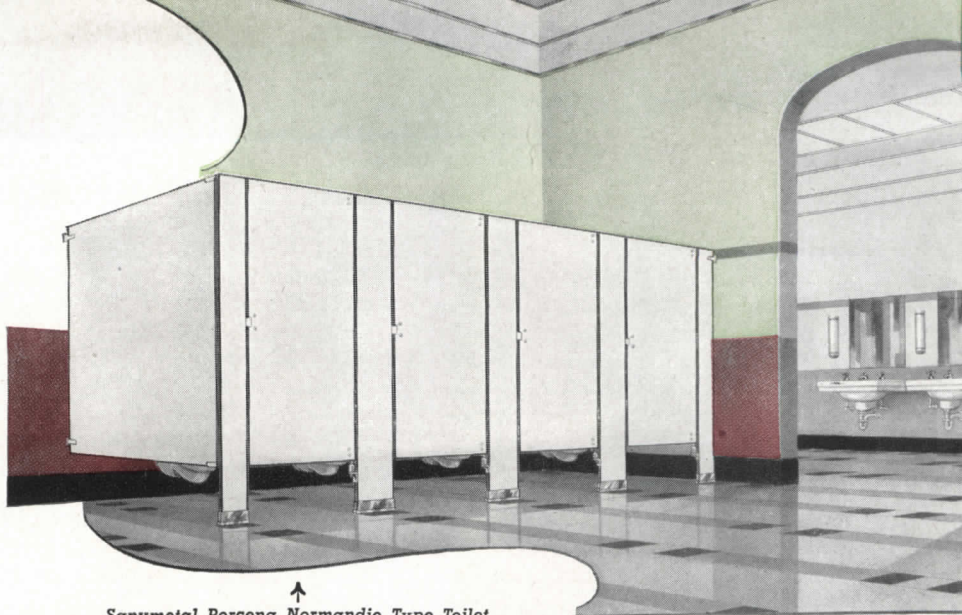

↑  
Sanymetal Porcena Normandie Type Toilet Compartments impart a moderately streamlined effect to a toilet room environment. Streamlined design wedded to utility fulfills all requirements. Unadorned utility no longer satisfies a public accustomed to bathrooms embodying varying degrees of modernity and elegance.

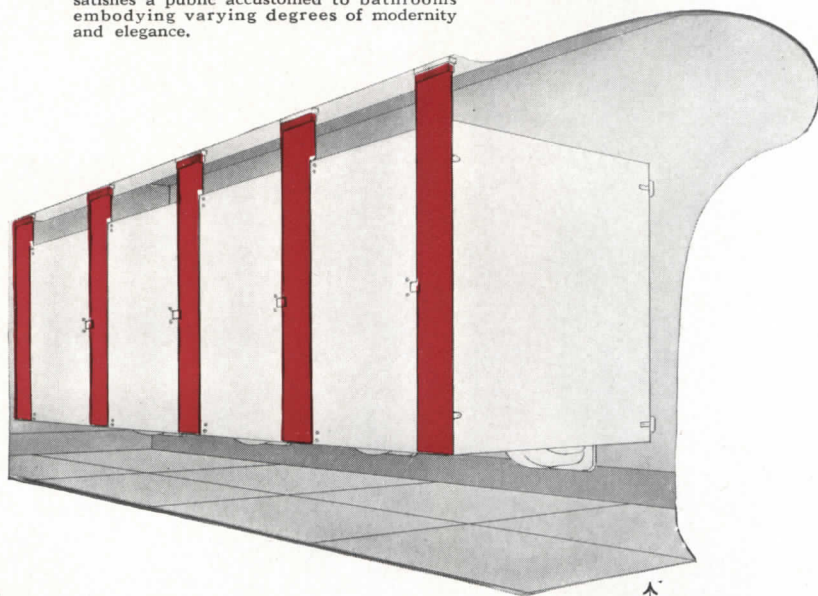

↑  
Sanymetal Century Type Ceiling Hung Toilet Compartments are particularly appropriate for schools. They impart dignity, refinement, and cheerfulness to the toilet room environment. They make up into a rigidly fixed installation.

*Sanymetal*\*

**"PORCENA"**

(Porcelain on Steel) TOILET COMPARTMENTS

possess the natural structural strength of steel, not one sheet, but two 16-gauge sheets securely bonded on opposite sides of dense insulating core, strengthened by porcelain enamel (four layers on each sheet) which provides a non-porous, flint-hard, glass-smooth surface that is positively impervious to odors, acids and moisture.

Sanymetal Porcena Academy Type Toilet Compartments provide a certain distinctiveness. This type of partition is the only one in which all the dignity and distinctiveness of standard flush type construction, unmarred by posts, is appropriately combined with headrail.

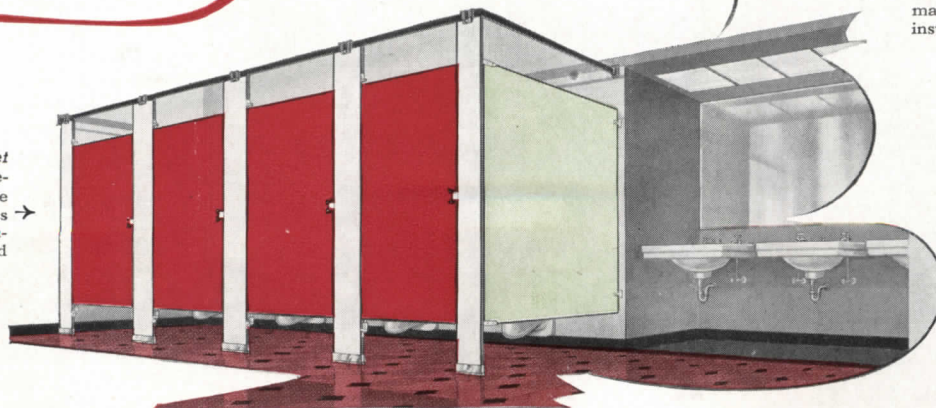

Sanymetal Catalog 83 illustrates several typical toilet room environments.

*Sanymetal*\*

\*Trade Mark Reg. U. S. Pat. Off.

**TOILET COMPARTMENTS**

and Office Partitions

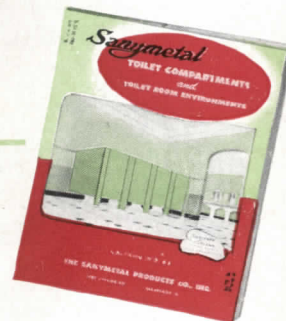

## THE RECORD REPORTS *(Continued from page 16)*

### Housing Platform Urged

A six-plank platform recommended for adoption by the United States Savings and Loan League sets forth that:

1. Slum clearance and housing are separate and distinct problems;
2. Both problems are local in character rather than national;
3. Private enterprise has, does and will provide better housing at lower cost than public housing;
4. Unsubsidized public housing is un-

satisfactory as compared with privately built housing both as to social and economic qualifications;

5. Where subsidies are necessary for decent housing they should be provided at the individual instead of the community level;

6. The use of public funds for housing should be confined to research and statistical studies and for the acquisition of land for urban redevelopment as provided by law in various states.



## BARBER-COLMAN

### TEXAS RESTAURANT

This coffee shop in the Hotel Baker at Dallas was remodelled, redecorated, and modernized as shown in the picture above. New equipment included the attractive flush type VENTURI-FLO Ceiling Unit with standard lighting fixtures added. The size and spacing of these units was selected so as to provide draftless air distribution and uniform temperature throughout the room, for optimum comfort conditions and most pleasurable dining.

# venturi-flo

CEILING OUTLETS  
FOR GUARANTEED  
AIR DISTRIBUTION

Data based on complete tests enable us to recommend exactly the right outlet for any condition and GUARANTEE results. You are assured of uniform, properly diffused air of the desired temperature at specified level, with required air movement and elimination of hot, cold, or drafty areas. Use ENGINEERED AIR DISTRIBUTION — see your Barber-Colman representative.

**BARBER-COLMAN COMPANY**  
1232 ROCK STREET • ROCKFORD, ILLINOIS

### Chamber of Commerce Testifies

The National Chamber of Commerce has told the Senate Banking and Currency Committee that "less, rather than more, federal control over what is essentially a local activity is the prescription for housing relief." The *National Chamber* also pointed out that the housing shortage does exist in many communities but not, as claimed, in almost every community. In a statement by its board of directors the Chamber predicts no substantial volume of construction before next spring and summer, remarks that new building "can properly be removed from rent control with beneficial effects prior to the removal of such control on existing rental properties." Production and production and more production is needed, the Chamber stresses.

### Government Agencies Busy

The Federal Public Housing Authority has issued orders to all its regional offices freezing further disposal of any movable war housing units under its jurisdiction except to house veterans and servicemen's families.

The Office of Price Administration took the limelight in New York in December with the announcement of advance approval of ceiling rentals on a 114-apartment project to be erected in White Plains, Westchester County. Approval was granted after the local Rent Office had reviewed the builder's plans, specifications, operating and maintenance costs, and surveyed comparable rental rates. An average monthly rent of \$21 per room was approved. R. M. Dinsmore & Co., Inc., are the builders for the projects, scheduled to be ready for occupancy by late summer, 1946.

### Slum Clearance Planned

Plans for completion of a slum clearance project in Schenectady, N. Y., through state-aided public housing have been approved by Herman T. Stichman, State Commissioner of Housing. He termed it an effective demonstration of state and municipal cooperation under Gov. Dewey's plan to help rehabilitate run-down sections of the state's cities.

### OFFICE NOTES

#### Offices Opened and Reopened

William F. R. Ballard, Architect, has resumed his practice at 123 E. 77th St., New York 21, N. Y.

Carroll & Daeuble, Architects (Edwin W. Carroll, A.I.A., and Louis Daeuble, Jr.), announce the opening of offices for the practice of architecture in Suite 355-57-59, First National Bank Bldg., El Paso, Texas.

Henry G. Markel, Architect, has resumed his practice at 236 W. Capitol St., Jackson, Miss.

*(Continued on page 140)*

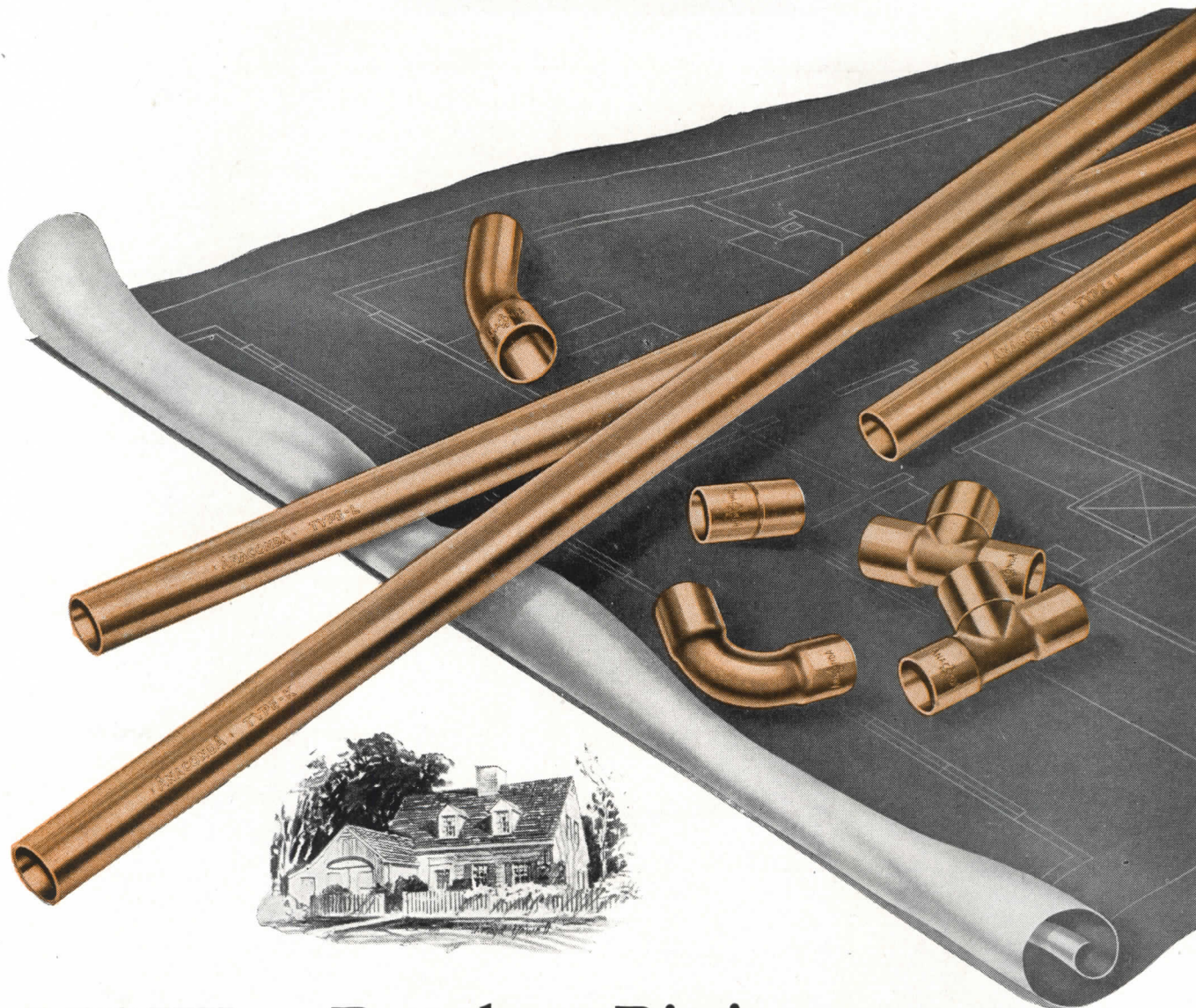

## NOW... Rustless Piping for even the *Smallest Home!*

TODAY, there is no reason why any new home, no matter how modest, should be equipped with water lines that rust. For Anaconda Copper Tubes assembled with Solder Type Fittings can be installed at a price competitive with rustable pipe.

Such a system provides a clean supply of rustless hot and cold water, and guards against trouble and premature piping replacement.

Anaconda Copper Tubes are made from specially deoxidized 99.9+% pure copper. They are furnished soft in sizes up to and including 1 1/4" in 30, 45 and 60-foot coils; also hard and soft in 20-foot straight lengths. Larger sizes are supplied hard or soft in 20-foot straight lengths only.

In addition to their use as water lines, Anaconda Copper Tubes provide long, economical

service for heating lines, garden and lawn sprinkler systems and as tank-to-oil-burner, bottled gas and other connections.

For detailed information, write for Publications B-1 and C-2.

4659



**Anaconda**  
**COPPER TUBES**

**THE AMERICAN BRASS COMPANY**

General Offices: Waterbury 88, Connecticut  
Subsidiary of Anaconda Copper Mining Company

In Canada: ANACONDA AMERICAN BRASS LTD.,  
New Toronto, Ont.

MacKie and Kamrath, Architects (Fred J. MacKie, Jr., A.I.A., and Karl F. Kamrath, A.I.A.), have reopened their offices following over three years in the Army. Temporary address: 2500 River Oaks Blvd., Houston, Texas.

Verner B. McClurg, Architect, and Henry M. Hesse, Office Manager, announce the opening of the office of McClurg and Hesse, 634 N. Central Ave., Glendale 3, Calif.

Samuel Zouri Moskowitz, A.I.A., re-

cently discharged from active duty with the Armed Forces, has reopened his offices at 1201 Miners Bank Bldg., Wilkes-Barre, Penna.

Kenneth G. Paxton, Architect, recently discharged from the Armed Forces, has reopened his offices in the Board of Trade Bldg., Wheeling, W. Va.

T. Trip Russell, A.I.A., announces the reopening of his architectural office at 2301 S. Miami Ave., Miami 36, Fla.

Lt. Com. Eldredge Snyder announces

that he has been released from active duty in the United States Naval Reserve and has reestablished his practice as Architect at 101 Park Ave., New York.

#### New Addresses

The following new addresses have been received:

Oscar I. Emerson, Architectural and Appraisal Service, P. O. Box 178, Brunswick, Maine.

Shelgren & Whitman, Architects (Olaf William Shelgren and James Spaulding Whitman), 507 Franklin St., Buffalo 2, N. Y.

#### Firm Changes

Phelps Barnum, for 3½ years an architect for Pan American World Airways, has returned to private practice and has formed a partnership with W. Stuart Thompson. Address: 125 E. 46th St., New York, N. Y.

Will Alban Cannon, Architect, announces the formation of an associate-ship with Charles Irwin Thiele, Architect, Anthony Betz, Architect, Will Alban Cannon, Jr., B.S.A., and Thomas H. McKaig, Engineer, under the firm name of Will Alban Cannon and Associates, Architects-Engineers. Address: 2637 Main St., Niagara Falls, N. Y.

Charles A. Carpenter and C. Storrs Barrows announce the formation of a partnership for the practice of architecture under the firm name of Carpenter and Barrows, Architects, with offices at 618 Reynolds Arcade, Rochester, N. Y.

Faulkner and Kingsbury, Architects, announce the following admissions to membership: John Warren Stenhouse, partner; Ben Hopson Dyer, associate, under the new firm name of Faulkner, Kingsbury and Stenhouse. Address: 917 Fifteenth St., N. W., Washington 5, D. C.

Frederick R. Louis and A. Read Henry, having returned from military service, announce formation of the partnership of Louis & Henry, Architects, with offices at 1271 Starks Bldg., Louisville 2, Ky.

Louis E. McAllister and Douglas G. Braik announce an association for the practice of architecture, with offices in the Bulletin Bldg., Philadelphia 7, Penna.

Walter Dorwin Teague, Industrial Designer, announces that Marc Thompson has joined his organization to advise on airport terminal facilities and act as consultant to communities and others planning airports. Mr. Thompson was formerly chief of Building Design Service of the Civil Aeronautics Administration, where he initiated the architectural service of CAA and wrote the manual "Airport Buildings," soon to be published.

J. Binford Walford announces that O. Pendleton Wright will be associated

(Continued on page 142)

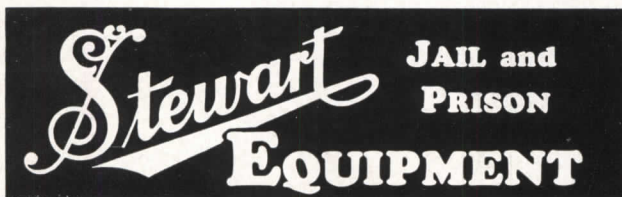

#### COVERS ALL REQUIREMENTS

*from a village lockup to a federal penitentiary*

Grating and Plate Cells; Doors; Lock and Locking Devices; Bunks; Tables; Seats; Iron Stairways, and all modern jail equipment.

Our engineering staff will be glad to assist architects in the development of plans for new construction or remodeling, and furnish, without cost or obligation, complete information on any project irrespective of size. ¶ You are cordially invited to avail yourself of the technical facilities offered by the Stewart jail and prison engineering department.

**THE STEWART IRON WORKS COMPANY,**  
INCORPORATED

1377 Stewart Block - - Cincinnati, Ohio

Designers and Builders of "Jail and Prison Equipment Since 1886"



**S. S. KRESGE STORE, BOSTON, MASS.**  
 Fixture Mounting Height 15 ft.  
 Watts per Sq. Ft. 2.5  
 Average Illumination 24 foot-candles  
 Bottom Lens Panels  
 Code No. 90816, 8½" x 48"  
 Opal Diffusing Side Panels  
 Code No. 90772, 3¼" x 23¼"

## CORNING FLUR-O-GUIDES PROVIDE High Level Illumination on Display Areas

The fluorescent installation in the S. S. Kresge Washington Street store in Boston is an example of how Corning Flur-O-Guides, used in conjunction with Corning diffusing side panels, put light to work for the user. Here, Flur-O-Guide Fresnel type lenses provide maximum illumination on the counters and on the merchandise displayed.

High levels of illumination are obtained on the sales counters, without eye-fatiguing glare in the direct line of sight. Diffusing side panels have been made a part of the fixtures which cut down excessive brightness and provide for good general illumination.

Here is just one example showing how the complete line of Corning Lightingware has been designed to meet the requirements of illuminating engineers and architects. High quality plus engineering features and attractive design distinguish Corning Lightingware and provide an ideal method of fulfilling your interior lighting requirements. When planning lighting applications, consider the use of Corning Lightingware.

Write for a copy of "Corning Lighting Data" illustrating the complete line of the scientifically designed Corning Flur-O-Guide lenses and diffusing panels and explaining how engineered lighting can be applied to your lighting problems. Address Lighting Sales Dept. AR-2, Corning Glass Works, Corning, New York.

**Whatever Your Lighting Problems...  
 Specify Corning Engineered Lightingware**

**CORNING LENSES AND PANELS  
 Are Available for**

**GENERAL LIGHTING  
 SUPPLEMENTARY LIGHTING  
 LOCALIZED LIGHTING**

**For Special Effects in  
 Commercial Interior Lighting**

**STORES SCHOOLS  
 THEATRES MUSEUMS  
 BANKS HOTELS  
 OFFICES HOSPITALS**

**Recommended for Industrial  
 Plant Lighting, General Illumination  
 and Localized Lighting**

**INDUSTRIAL PLANTS PRIVATE AND  
 ASSEMBLY LINES GENERAL OFFICES  
 INSPECTION AREAS ELECTRICAL  
 LABORATORIES INSTRUMENT  
 DRAFTING ROOMS PANEL BOARDS**

"CORNING" is a registered trade-mark and indicates manufacture by Corning Glass Works, Corning, N. Y.

**CORNING**  
 means  
 Research in Glass

**Corning Engineered Lightingware**

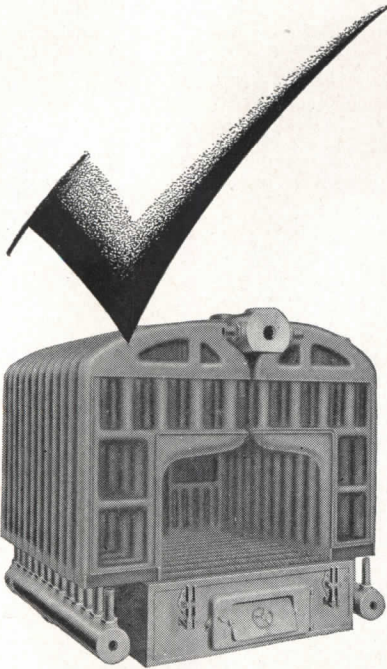

**NEW and IMPROVED**  
**"42" Smith**  
**BOILER**  
**IS FIRST CHOICE . . . WHEREVER**  
**HEATING DEMANDS ARE HEAVY**

Here is an improved big cast iron boiler for that heavy duty job . . . whether it be factory, hospital or public building. Known to engineers and contractors as "tops" for use with solid fuels, whether hand or stoker fired, the 42 Smith has recently been redesigned to effect an even further improvement in its already high standard of performance. Check the features of this modern efficient unit against the requirements of that tough job you're figuring now. We think you'll find the 42 Smith a natural!

- ✓—Water tube construction promotes efficient water circulation, fast steaming.
- ✓—Plenty of heating surface. Even more prime surface has been added in the new model.
- ✓—Made of rugged cast iron for long service, low maintenance.
- ✓—Header type construction minimizes possibility of mid-season breakdown.
- ✓—Properly proportioned for stokers or other automatic firing devices.
- ✓—Convertible from one fuel to another both easily and inexpensively.

Write for free catalogue

**THE H. B. SMITH Co. Inc.**  
 WESTFIELD, MASS.  
 Offices and Sales Representatives in  
 Principal Cities

**THE RECORD REPORTS**

(Continued from page 140)

as a co-partner in the general practice of architecture under the firm name of J. Binford Walford, O. Pendleton Wright, Architects. Address: 103 E. Cary St., Richmond 19, Va.

**ELECTIONS**

**Fontainebleau Association**

At an executive meeting of the Fontainebleau Association the following officers were elected: president, Charles Z. Offin; honorary president, Mrs. Ernest Peixotto; 1st vice president, Sidney Waugh; 2nd vice president, Robert Beverly Hale; treasurer, Allen Townsend Terrell; secretary, Mrs. Leila G. Sawyer; French coordinator, Mme. Natacha Carlu; advisory member, Miss Mary Turlay Robinson.

The Association shortly will issue its Bulletin, and all former students are asked to send their addresses to the secretary, Mrs. Leila G. Sawyer, 2 Beekman Pl., New York City.

**U. S. Savings and Loan**

Henry P. Irr, president of the Baltimore Federal Savings and Loan Association, was elected president of the U. S. Savings and Loan League at a recent meeting. He succeeds W. M. Brock, of Dayton, Ohio.

**American Standards Association**

Henry B. Bryans, executive vice president and director of the Philadelphia Electric Co., was unanimously reelected to serve a third term as president of the American Standards Association. Frederick R. Lack, vice president and manager of the Radio Division, Western Electric Co., Inc., was elected vice president.

**COLLEGE NOTES**

**Extension Courses Offered**

Recognizing a current critical shortage of manpower in the architectural fields, the University of California through University Extension is completing arrangements in Los Angeles for a sequence of special courses to relieve the situation.

Endorsed by the Southern California chapter of the A.I.A., the training program, which opened last month, is designed to meet the training problem on three fronts. It will retrain personnel trained in related fields during the emergency; offer a review for those trained in architecture who have been dissociated from the field for a period of time; and prepare those already employed in an architect's office to qualify for positions

(Continued on page 144)

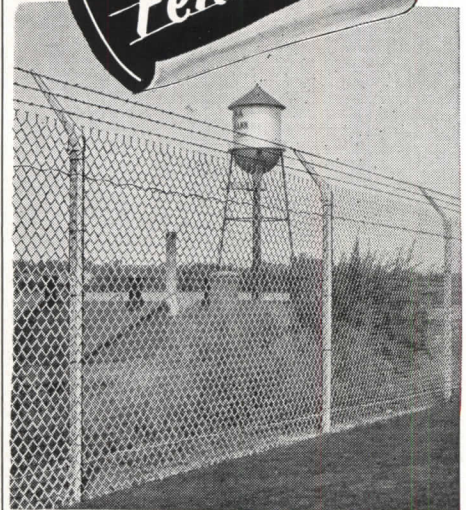
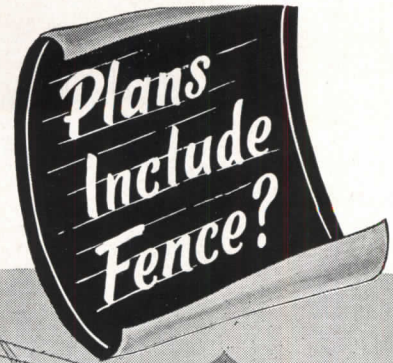

**Get this book for**  
**A. I. A. File 14-K**

"ANCHOR PROTECTIVE FENCES" is both a catalog and a specification manual. Shows many types and uses of Anchor Chain Link Fence . . . pictures installations for many prominent companies and institutions . . . contains structural diagrams and specification tables.

Also shows important and exclusive Anchor features: *Deep-Driven Anchors*, which hold the fence permanently erect and in line in any soil; *Square Frame Gates*, amazingly free from sagging and warping; *Square Terminal Posts* and *U-Bar Line Posts*, which increase strength and durability.

Just ask for Book No 110. You'll find it both useful and informative. We'll be glad to send a free copy. Address: Anchor Post Fence Co., 6600 Eastern Ave., Balto., 24, Md.

**Anchor Fence**  
 Nationwide Sales and Erecting Service

*Why an Insurance Group likes tar and gravel roofs*

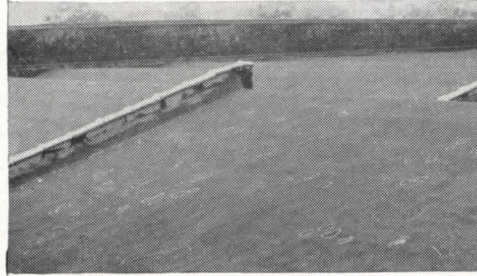

Each circle a puncture. Hail damage to smooth-surface roofing in Oklahoma.



Close-up of typical hail damage.

### Which Roof Resists Hail Best?

Gravel roofs much more resistant than smooth-surface. From experience covering large areas of both types exposed in Factory Mutual plants, comparative hail damage in 10 years (1935-1944) is as follows:

|                |            |           |
|----------------|------------|-----------|
| SMOOTH-SURFACE | 115 Losses | \$138,000 |
| GRAVEL-COVERED | 3 Losses   | 1,225     |

COULD your factory roofs resist a bombardment of egg-sized hailstones? It depends on the type of roofing. Last March, at the Watervliet Paper Company in Watervliet, Michi-

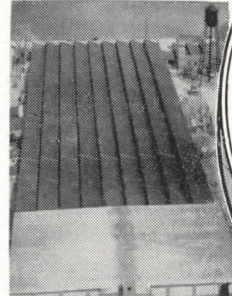

Hail severely damages smooth-surfaced sawtooth roof in background. No damage to tar-gravel roof in foreground.

gan, a hailstorm of the roofing punctured roofing had covered with cap sheets. But blis- rain developed, and the damage wa- repeated. Tar and gravel roofs were unharmed.

In May, another hailstorm caused similar damage at the Wagner Electric Company in St. Louis, Missouri. The stones were as large as golfballs, and the plastered smooth surface coverings on buildings were punctured. Here in, gravel-covered roofs were unharmed.

August Denver experienced a severe hailstorm

hailstones fell so fast that they piled up three inches deep in the yard of the American Manganese Steel Company plant. Smooth-surface roofing on six buildings was damaged and many windows were broken.

In practically all these instances, rain leaked through the damaged roofing, wet down machinery and stock, and delayed production.

With smooth-surface roofing, particularly if blisters and buckles are exposed, severe hail damage can be expected. Replacing damaged roofs is a measure which merely repeats the repetition in the guaranteed tar and gravel roofs was decided against both hail and wind damage repairs. Being roofs 12; for tar and gravel roofs are de-

**KOPPERS**  
Koppers coal tar pitch roofing  
**KOPPERS**  
Koppers coal tar pitch waterproofing

This clipping is from the Factory Mutual Record . . . a publication issued by the Associated Factory Mutual Fire Insurance Companies.

Tar and gravel roofs have shown a disregard for weather . . . they have resisted damage by rain or snow . . . and, as testified in this article, have proved their effectiveness in severe hailstorms. Factory Mutual says that by recommending tar and gravel roofs, they are fulfilling their function of giving the best engineering advice to their policyholders.

If you want this kind of roof performance, specify Koppers Old Style Pitch and Approved Tarred Felt. —Koppers Company, Inc., Tar and Chemical Division, Pittsburgh 19, Pa.

Refer to your Sweet's Catalog or write us for complete specifications

**KOPPERS**

THE INDUSTRY THAT SERVES ALL INDUSTRY



## ENTRANCES OF TIME-TESTED EXCELLENCE

For over 64 years . . .  
since 1882 . . . dis-  
criminating archi-  
tects have included in  
their specifications

### NEWMAN

*Hollow and Cast Bronze, Nickel,  
Aluminum and Stainless Steel*

DOORS AND COMPLETE ENTRANCES

Typical examples of outstanding  
installations are the Louisiana  
State Capitol, Baton Rouge (shown  
above) Carew Tower, Cincinnati  
and hundreds more.

**HAND CRAFTSMANSHIP**  
*equal to the finest*

**QUALITY**  
*always dependable*

**SERVICE**  
*prompt and intelligent*

**PRICES**  
*furnished without obligation*

|               |              |
|---------------|--------------|
| BANK FIXTURES | TABLETS      |
| GRILLES       | DIRECTORIES  |
| RAILINGS      | WINDOWS      |
| GATES         | STORE FRONTS |
|               | LETTERS      |

SEND FOR FILE DATA . . . also recom-  
mendations and estimates, without obli-  
gation.

**NEWMAN BROTHERS, Inc.**  
"64 Years Young"

708 WEST 4TH ST., CINCINNATI 3, OHIO

## THE RECORD REPORTS

(Continued from page 142)

of greater responsibility and opportunity.

Courses will be presented in the evening, both on the University campus and at the Extension center. In order to insure quality of instruction comparable to University standards and the exacting requirements of the field, practicing architects, preferably members of the A.I.A., have been nominated as instructors. Information concerning the courses is available at the Extension center, 813 S. Hill St., Los Angeles, Calif.

### Tugwell Joins Chicago

Rexford Guy Tugwell, governor of Puerto Rico, has been appointed professor of political science in the University of Chicago, effective next July 1.

Mr. Tugwell will teach in the political science department of the university, as well as direct a new program of education and research in planning. This program will be conducted in cooperation with the Chicago chapter of the A.I.A., the Public Administration Clearing House and agencies affiliated with it such as the American Society of Planning Officials and the National Association of Housing Officials.

### Engineering Awards

In order to fill the needs of industrial, research and educational organizations in Georgia and the South for engineers and scientists with graduate training, the Georgia School of Technology, Atlanta, is expanding considerably its Division of Graduate Studies, starting with the opening of the Spring Term on March 4th. In connection with this plan, the Division is offering a series of graduate awards, ranging up to \$1,800 per academic year, in engineering and allied sciences to qualified graduates of Georgia Tech and other colleges and universities.

In general the awards will consist of research fellowships, graduate fellowships, research assistantships, graduate assistantships, and part-time instructorships. For further information address the Dean, Division of Graduate Studies, Georgia School of Technology, Atlanta.

## INDUSTRY COOPERATES

Feeling that architects designing new homes were handicapped by not having complete information as to the postwar plans and models of kitchen range and kitchen equipment manufacture, Paul Wold, president of the Bickford Bros. Co., Western New York appliance distributor, arranged a dinner meeting for the architects of Rochester, N. Y. Factory representatives addressed the architects and an informal round-table talk followed with participation by all.

## THE NEW ARCHITECTURE IN MEXICO

**Hospitals  
Town Houses  
Country Houses  
Office Buildings  
Store Groups  
Factories  
Schools  
Apartments  
Workers' Houses**

Modern Architecture below the Rio Grande, with its straight line, unornamented flat surfaces, presents a dramatic contrast to the old, heavily ornamented Spanish Colonial buildings. Yet Esther Born, in her book "THE NEW ARCHITECTURE IN MEXICO" has delineated in text, photographs and colored diagrams, including supplementary text on mural painting, sculpture, and pottery, how perfectly acclimated it has become to its background.

This new volume is a reference source for building designers everywhere, and contains a complete assemblage of the progressive thought of architects and engineers of the Aztecs and the Spanish Americans. Reduced price \$2.50.

-----  
ARCHITECTURAL RECORD  
*Book Dept.*

119 West 40th, New York 18, N. Y.

Enclosed is a check or money order for \$2.50. Please send me THE NEW ARCHITECTURE IN MEXICO.

Name.....

Address.....

.....

AR 2-46



# HERE'S ONE OF THE MOST EFFICIENT WAYS TO AIR CONDITION!

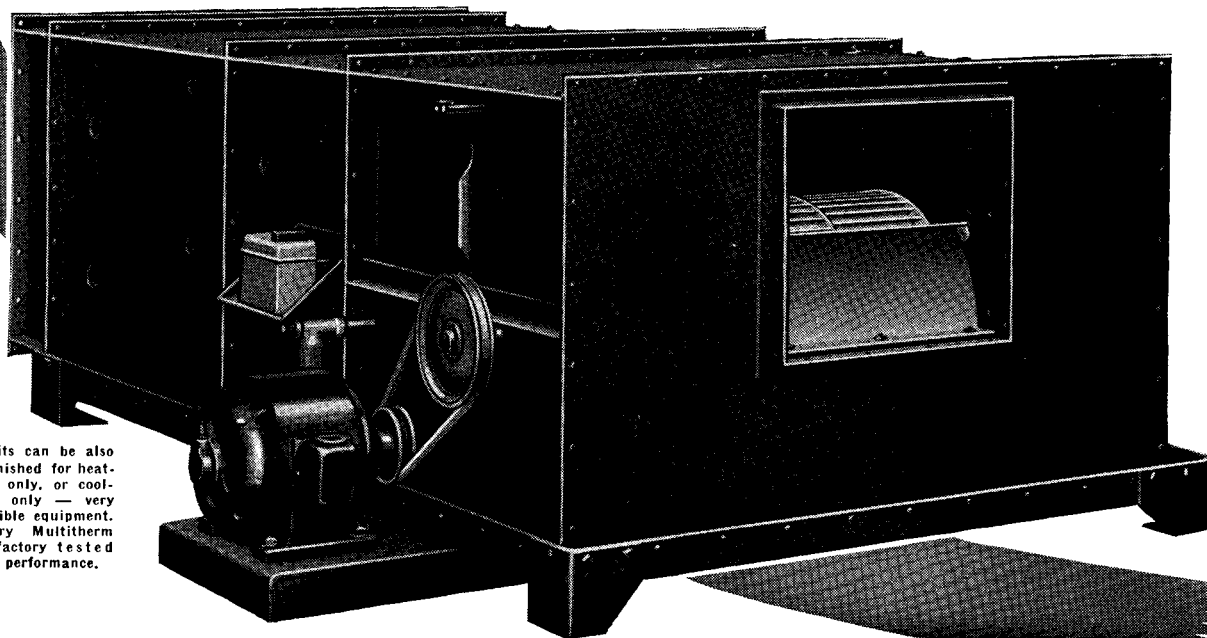

\*Units can be also furnished for heating only, or cooling only — very flexible equipment. Every Multitherm is factory tested for performance.

## MULTITHERMS—WHOLE "WORKS" IN ONE ASSEMBLY . . . BUILT FOR ALL SORTS OF INDUSTRIAL AND COMMERCIAL APPLICATIONS

The Clarage Multitherm unit shown above is a complete conditioning plant\* . . . (1) it *cleans* the air, removing bacteria, pollen and dust . . . (2) it *cools and dehumidifies* in summer utilizing cold well water, brine or a direct expansion refrigerant . . . (3) it *heats and humidifies* in winter using steam or hot water . . . (4) it supplies at all times a circulation of conditioned air under positive fan pressure.

Multitherms are as easy and inexpensive to install as unit heaters — and just as satisfactory in operation. They may be suspended from the ceiling, mounted on platforms, or installed on the floor. Sizes range from 400 to 13,600 c.f.m. If the job is extra large, it can be handled with two or more units.

Look into Clarage Multitherms if you have any type of air conditioning problem. They are engineered to give precision results — compact to save space — of heavy duty construction for years of continuous trouble-free service. *And, as compared to central station conditioning, you can usually save considerable money.*

Write us, outlining your requirements — or ask for Bulletin 107 giving complete information.

**SOME OF OUR OTHER PRODUCTS**

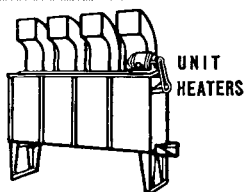

UNIT HEATERS

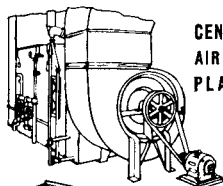

CENTRAL STATION AIR CONDITIONING PLANTS

AIR CONDITIONING AND VENTILATING FANS

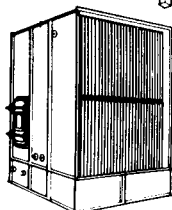
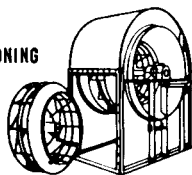

AIR WASHERS

# CLARAGE

## FAN COMPANY

Kalamazoo, Michigan



APPLICATION ENGINEERING OFFICES IN ALL PRINCIPAL CITIES

# You can take these beautiful

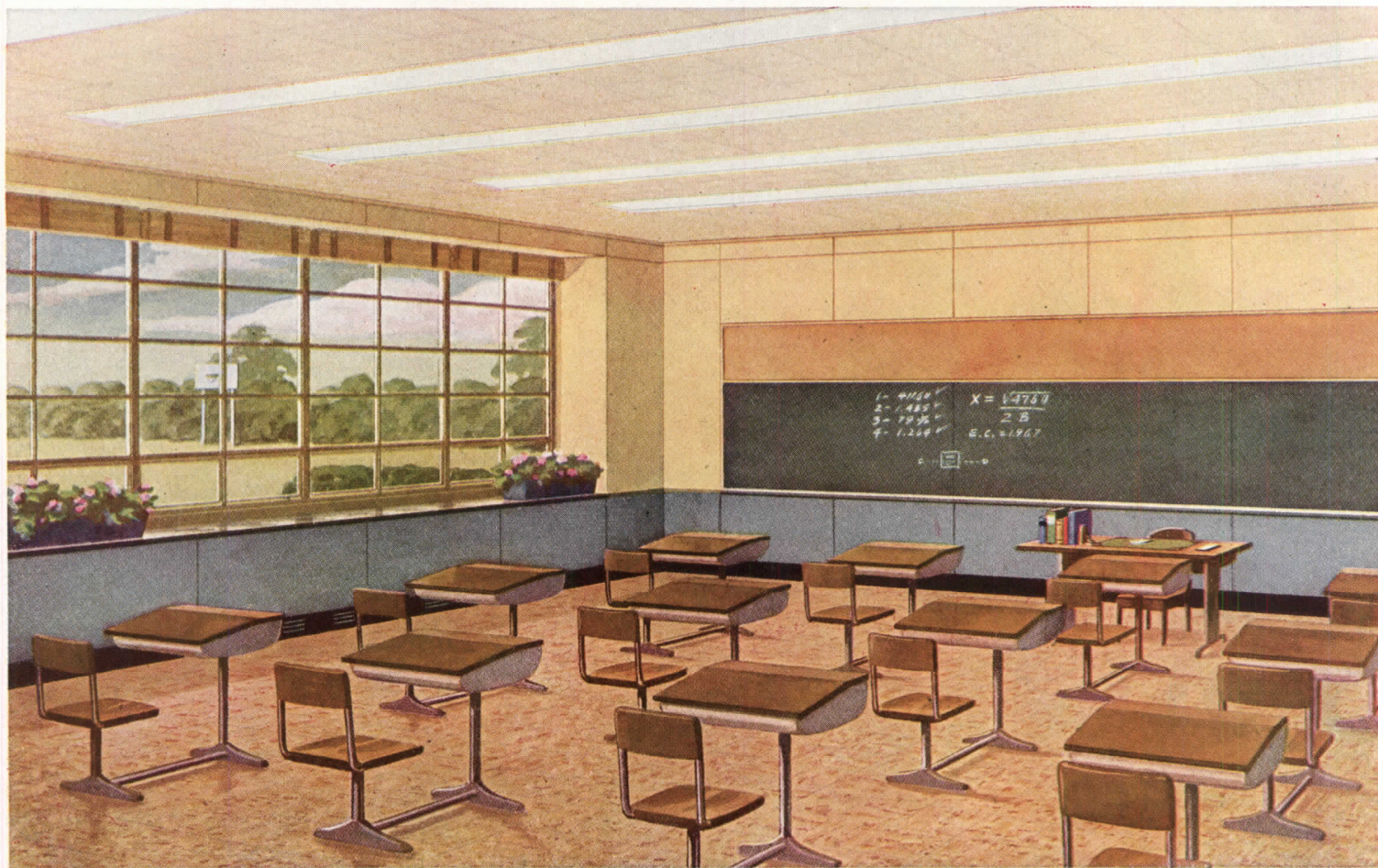

## J-M WALLS • CEILINGS • FLOORS combined in new method of construction

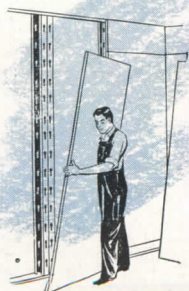

### MOVABLE TRANSITE WALLS

The keystone of flexibility in Unit Construction is the J-M Transite Wall. It can be disassembled and relocated as educational needs require.

One-unit rooms, for instance, can be speedily converted into two-unit rooms, or vice versa. Made of fireproof asbestos and cement, practically indestructible materials, the movable panels are used to form rigid, double-faced partitions, 4" thick. They can also be used as the interior finish of the outside walls. The Transite base is easily removable for access to wiring, etc.



### COLORFUL, RESILIENT FLOORS

J-M Asphalt Tile is the flooring element in Unit Construction. Made of asbestos and asphalt, the units will withstand the kind of hard wear and abuse that must be expected in any school building. Not only durable, J-M Asphalt Tile Floors are pleasantly comfortable and quiet underfoot, thereby reducing the disturbing effects of noisy footsteps in corridors, gymnasiums, etc. Individual units permit easy alterations or extension of patterns. Made in a wide variety of plain and marbled colors.

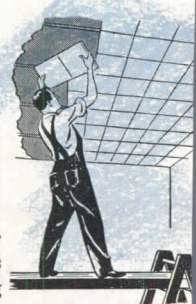

### ACOUSTICAL CEILINGS

Important factor in helping to overcome the handicap of distracting noise, Johns-Manville Acoustical Ceilings are beneficial both to teacher and student alike. They give the desired degree of quiet for effective teaching, eliminate frequent causes of nerve strain, and are proved aids to concentration. An exclusive Johns-Manville patented construction system permits interchangeability of flush-type fluorescent lighting and acoustical ceiling units which are readily demountable.

# schoolrooms apart...

and rearrange them to meet changing needs!

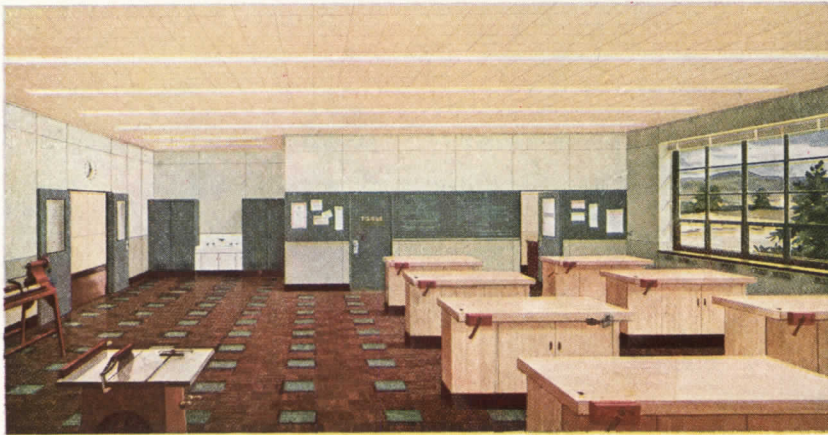
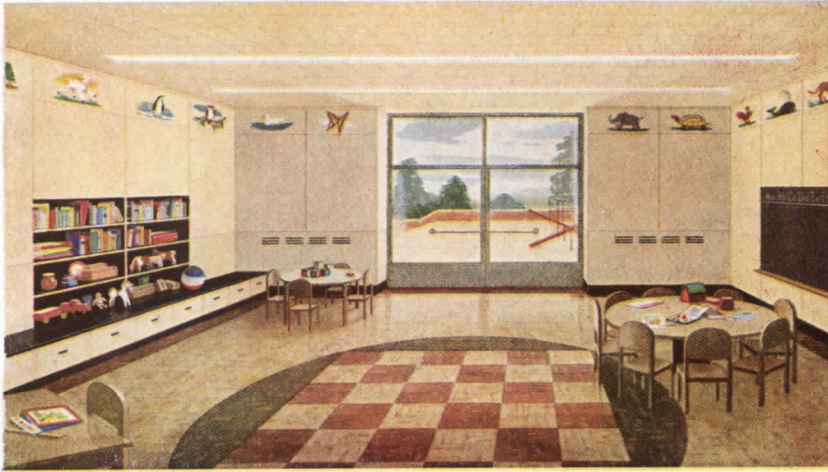

These quiet, attractive, modern schoolrooms are typical of the Johns-Manville Unit System. They are structurally flexible, yet have all the qualities of permanent and solid construction. The clean-cut, projection-free Transite Walls may be easily cleaned by a simple washing—an advantage that makes a big difference in the maintenance budget. Notice the noise-absorbing, demountable Acoustical Ceilings with fluorescent lighting, and the colorful, resilient Asphalt Tile Floors.

**Think of it! Whole school interiors can now be completely flexible . . . at low cost!**

WHATEVER the educational needs of a community may become, Johns-Manville Unit Construction allows easy and economical rearrangement of school interiors to meet new requirements.

You can expand, convert, or subdivide schoolroom units *at will*. You can vary the size or arrangement . . . make all the changes necessary to adapt interiors to new conditions; as, for instance, from academic to vocational . . . from grade school to junior high . . . from two-unit study halls to one-unit kindergartens.

Three Johns-Manville Materials are combined in Unit Construction . . . all under *one* specification, *one* manufacturer's responsibility:

1. **Movable Walls** . . . quickly erected or dismantled; 100% salvageable; made of asbestos-cement Transite panels.
2. **Acoustical Ceilings** . . . reduce distracting noise. Demountable units can be taken down and relocated as desired.
3. **Colorful, Resilient Floors** . . . quiet underfoot. Small units permit easy extension of floor pattern.

All these constituent parts are durably built to last as an *integral* part of the building . . . and, being easy to clean, hard to mar, they make possible substantial economies in maintenance.

Write for further information and details on this important advance in school construction. Johns-Manville, 22 E. 40th St., New York 16, N. Y.



**Johns-Manville  
Unit Construction**

*for Schools*

**WALLS · CEILINGS · FLOORS**  
combining permanence with flexibility

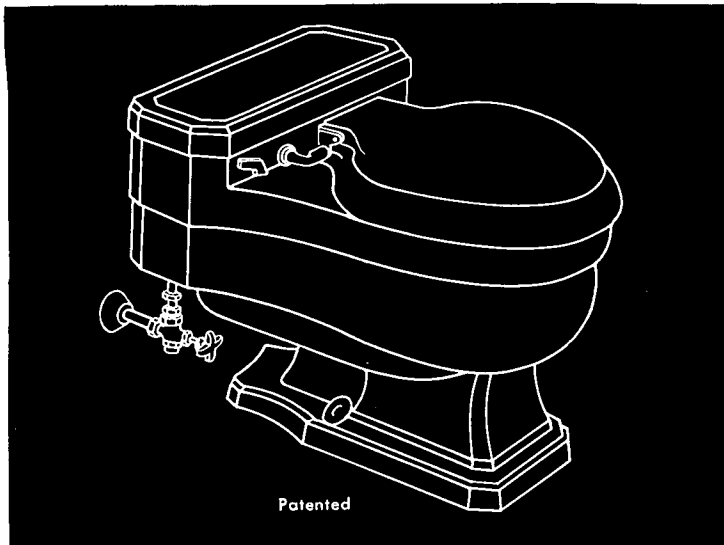

# THIS IS Case Study House #6

Sponsored by ARTS & ARCHITECTURE Magazine

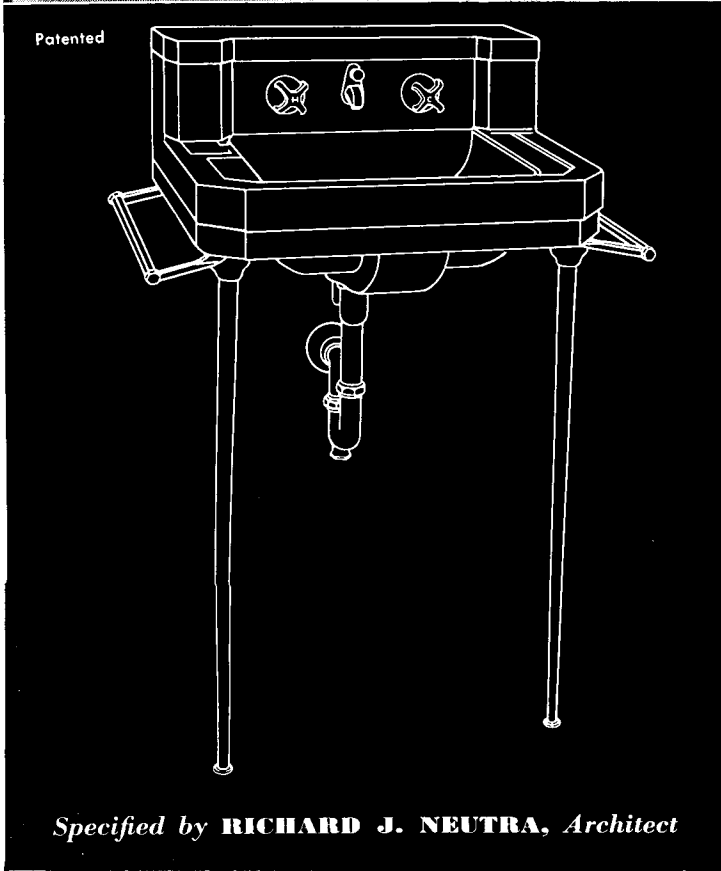

Specified by **RICHARD J. NEUTRA, Architect**

## WITH Case

### PLUMBING FIXTURES

Architect Richard J. Neutra had ample justification for selecting the Case plumbing fixtures that are going into this interesting building. Their clean design and their proven ability to give long, trouble-free service recommend them to all who are concerned with lasting value. They combine *vitreous china* and fine mechanical construction—primary assurance of cleanliness and health protection in bathroom fixtures. This is the third in the series of "Study Houses" to be Case-equipped. W. A. Case & Son Mfg. Co., Buffalo 3, New York. Founded 1853.

• • •

**TOP**—Most popular of all water closets is the *Case T/N*. Modern in design, quiet in operation, non-overflow and non-siphoning. A precision-built free-standing fixture.

**BOTTOM**—Concealed front overflow, anti-splash rim, chrome finish accessories and convenient shelf are popular features of the *Wilmington* lavatory. Available also wall hung.

# *Insulated Picture Windows*

## FOR OUTDOOR BEAUTY PLUS INDOOR COMFORT



*Picture Windows frame the loveliness of the outdoors for indoor enjoyment. Architect: R. Franklin Outcalt, Cleveland.*

*Thermopane\**, the L·O·F multiple-pane unit, provides a thoroughly effective means of insulating Picture Windows. It enables an architect to provide the benefits of larger windows—whatever the climate. There's never any extra sash to put up or take down, for *Thermopane* is "built-in" insulation. It fits into a modified sash like an ordinary pane of glass. For full information, write for the free *Thermopane* booklet and data sheets by Don Graf. Libbey·Owens·Ford Glass Company, 1726 Nicholas Building, Toledo 3, Ohio.

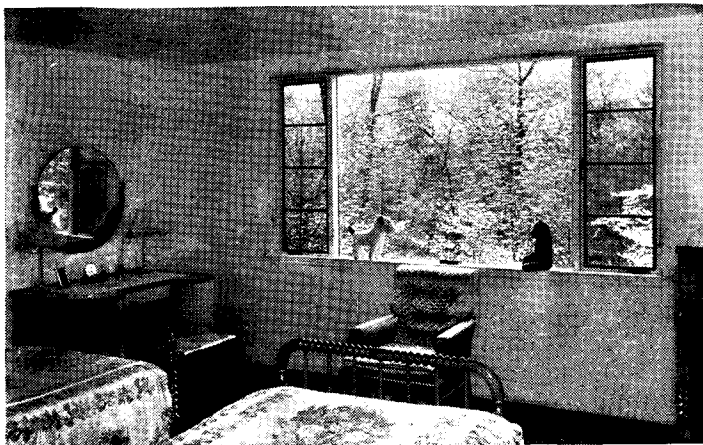

*Picture Windows are an effective beauty treatment for almost any room in the house. In this bedroom they bring in the natural charm of the outdoors. And, because *Thermopane* is used, there is greater assurance of year-round comfort. Architect: John Franklin, Pittsburgh.*

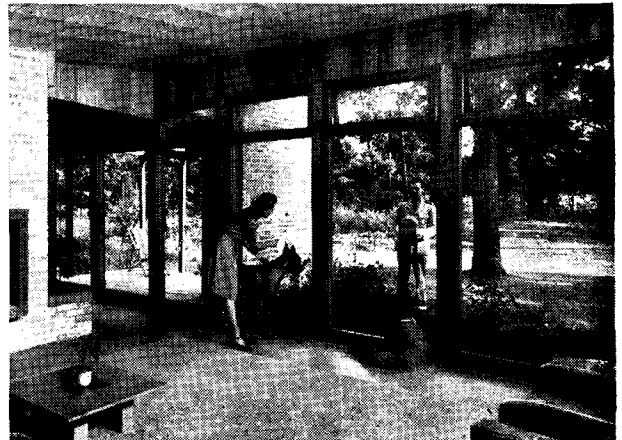

*This window wall provides a sweeping view of the garden, creating a pleasant feeling of greater spaciousness. There's no sacrifice of comfort or heating economy, for this glass wall is *Thermopane*. Architect: George Fred Keck, Chicago.*

The *Thermopane* Unit . . . two or more panes of glass with dehydrated air hermetically sealed between them. Only two surfaces need to be cleaned. *Thermopane* stays in all year. Available in Canada.

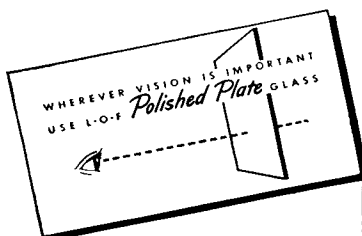

\* Reg. U.S. Pat. Off.



**LIBBEY·OWENS·FORD**  
*a Great Name in* **GLASS**

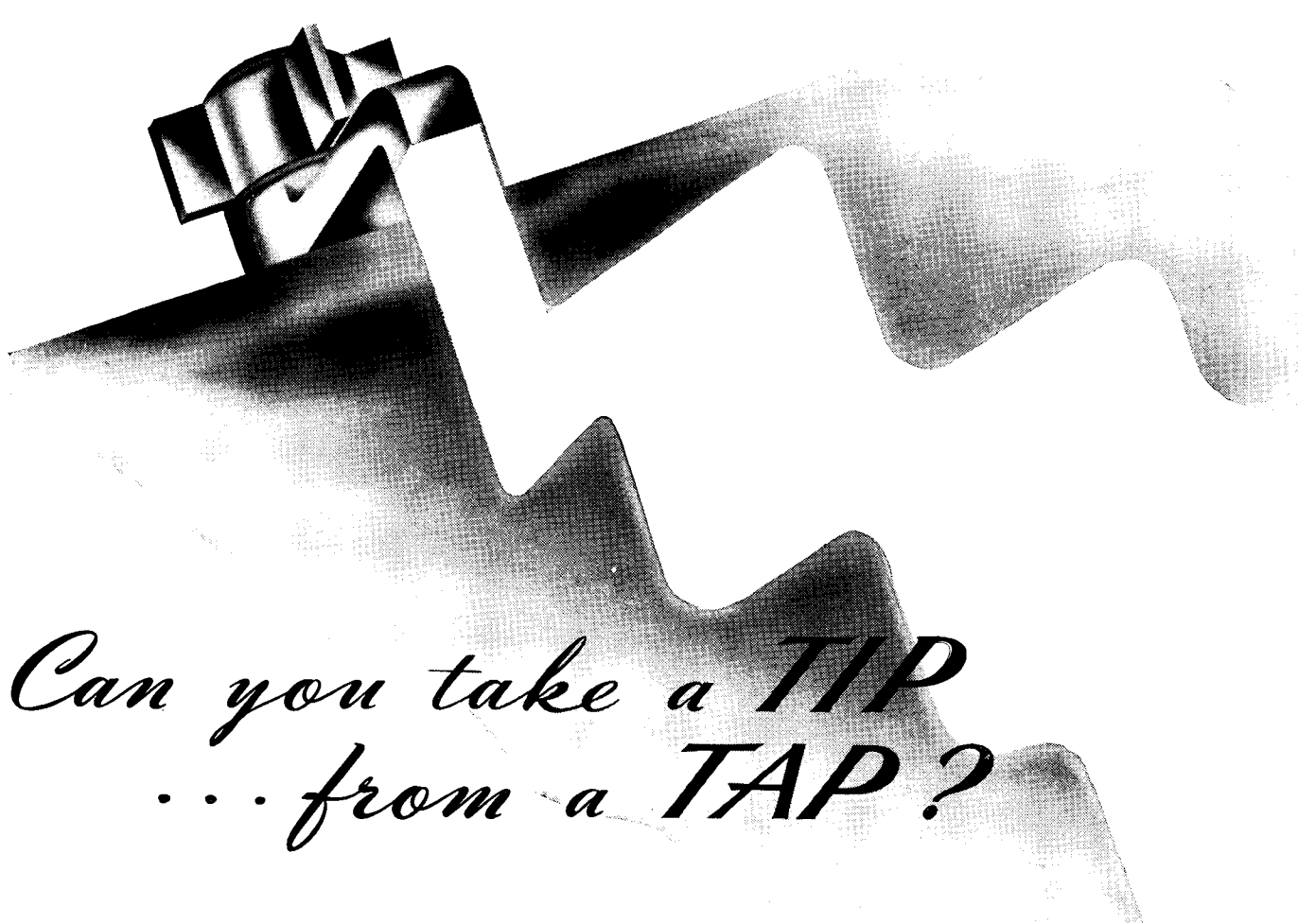

*Can you take a TIP  
... from a TAP?*

**Yes . . .** If you look into one of the "better" types and note its Monel\* valve seat.

For then you'd probably conclude, "If Monel is used here, Monel must resist rusting and corrosion. And, since a seat has to take plenty of grinding stress, Monel must be strong and hard, too."

Well, if you did attribute these properties to Monel, you'd be 100% correct . . . and you'd realize why this white metal does so many different jobs.

For example: Monel is used to roof buildings like New York's Pennsylvania Station and Metropolitan Museum of Art. While, in Cleveland's Union Terminal, there are 3 miles of inaccessible expansion joints . . . and every inch is Monel.

As tie-wire, Monel permanently secures partitions, metal lath and roof tile.

And, because it remains bright and takes hard wear, Monel food-service, laundry and hospital equipment is first choice for many institutional buildings.

On chimneys, Monel bolts, rungs and ash screens withstand smoke, fog and rain.

In the home, Monel hot water tanks mean *clean* hot water; Monel sinks and work surfaces, a brighter, easy-to-keep-clean kitchen.

The full list of jobs for Monel is as long as your list of needs for a strong metal that resists rusting, corrosion and wear. So, whether you're specifying or okaying, be guided by this rule: "If it's made of Monel, it will last."

\*Reg. U.S. Pat. Off.

**THE INTERNATIONAL NICKEL COMPANY, INC., 67 Wall Street, New York 5, N. Y.**

**MONEL . . . for minimum maintenance**

# PLANNING ANY 2, 3 OR 4-STORY BUILDINGS?

... Here's the Most Practical Elevator for Modern Structures



**THE ELEVATOR THAT'S PUSHED UP**  
needs no penthouse, no heavy  
walls, no special machine room

**Y**ou can streamline your building design and cut building costs at the same time. Specify Oildraulic Elevators and cross the unsightly, costly penthouse and elevator machine room off your plans. Lighten up the shaftway structure, too, when you use this "elevator that's pushed up" from below—not pulled from above.

### Your Clients Will Approve Oildraulics

Owners prefer Oildraulic Elevators because of their smooth, electric hydraulic operation. There are no abrupt starts or stops. Landings are accurate to within  $\frac{1}{4}$  of an inch, plus or minus—most important on freight elevators where powered vehicles are used for material handling. These elevators are designed for modern buildings.

Oildraulic Elevators are very economical. Initial cost is low. Operating cost is low, too . . . power used only when

elevator rises, descent by gravity. And there's little maintenance expense, even after years of constant use.

For freight or passenger service, Oildraulics are ideal for rises up to 40 feet. Can be furnished in car sizes and capacities as required. The coupon below will bring you complete information and Architect's Preliminary Layout Data on Oildraulic elevators.

#### MAIL COUPON FOR A.I.A. FILE CATALOG

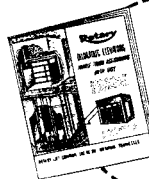

**ROTARY LIFT COMPANY**  
1100 Kentucky, Memphis (2), Tenn.  
Send your Catalog RE-301 to:

NAME.....  
ADDRESS.....  
CITY & STATE.....

## Rotary OILDRAULIC ELEVATORS

ROTARY ALSO MAKES OILDRAULIC LEVELATORS—LUMBER LIFTS—AUTO AND TRUCK LIFTS

# First National Bank Building, Detroit, cuts heating and cooling load with Air Recovery Equipment.

**Saves 108 tons of coal; 1,959,075 pounds of steam.**

**Air Recovery Equipment, employing activated carbon to adsorb air-borne gaseous and vaporous impurities, is installed in existing system and 20,000 CFM of stale, contaminated air that had been exhausted is economically restored to original freshness and recirculated.**

## Estimated fuel savings surpassed before end of season.

**W**HEN Merle F. Bennett, Chief Engineer of the First National Bank Building in Detroit, checked fuel consumption at the end of February, he found that he had already saved more than the 100 tons of coal it had been estimated he would save with Air Recovery Equipment for the entire heating season.

In his report, he submitted the following figures:

### "Fuel consumption September to February inclusive:

|         | Total consumption<br>(lbs. of steam) | Degree days | Lbs. per<br>degree day |
|---------|--------------------------------------|-------------|------------------------|
| 1943-44 | 29,467,100                           | 4659        | 6325                   |
| 1944-45 | 29,406,600                           | 4959        | 5930                   |

"Applying last year's 6,325 pounds per degree day to this year's degree days (6,325 x 4,959), we get 31,365,675 pounds, which is the amount of steam we would have consumed this year if we were operating under last year's conditions, without the Air Recovery Equipment.

### "Comparing that consumption with this year's actual:

31,365,675 pounds — consumption estimated on last year's efficiency  
29,406,600 pounds — 1944-45 actual consumption

1,959,075 pounds — saved or approximately 108 tons of coal  
(13,000 B.T.U. coal at 70% efficiency)"

## Refrigeration equipment saved by expanding capacity of plant.

The savings for the cooling season will be reflected not only in electrical energy (estimated at 36,000 KW hours), but in equipment as well. Last year the refrigeration plant had been unable to meet requirements. Internal air contamination from added personnel and customer service had increased until it was necessary at times to bring in a maximum amount of outdoor air for dilution purposes. The load resulting from cooling all that new air overtaxed the refrigeration equipment to a point where additional equipment was needed.

But the Air Recovery Equipment offered another solution—that of expanding the capacity of the existing plant. At the same time it eliminated another difficulty. The outdoor air intake, located at the fourth floor level, is in a pocketed space directly across from kitchen vent stacks of restaurants in neighboring buildings. Under certain wind conditions, befouling odors and other vaporous contaminants polluted the air drawn into the building.

## How DOREX Air Recovery Equipment solved the problem.

Enough activated carbon canisters were installed to remove the gaseous and vaporous impurities from 30,000 CFM at a point in the system where 20,000 CFM of return air and 10,000 CFM of new outdoor air could be purified. This cut the load on the heating and cooling facilities by conserving the favorable thermal values of the recirculated air and applied positive odor elimination to both.

Under actual operating conditions, it was found that the 10,000 CFM of outdoor air was more than enough for oxygen and internal static pressure requirements and the total 30,000 CFM of purified air increased the quality of indoor air because of its greater diluting properties.

We will be glad to send you the details of other typical installations, or estimate the savings on any case of your own. Drop us a line or call our district representative.

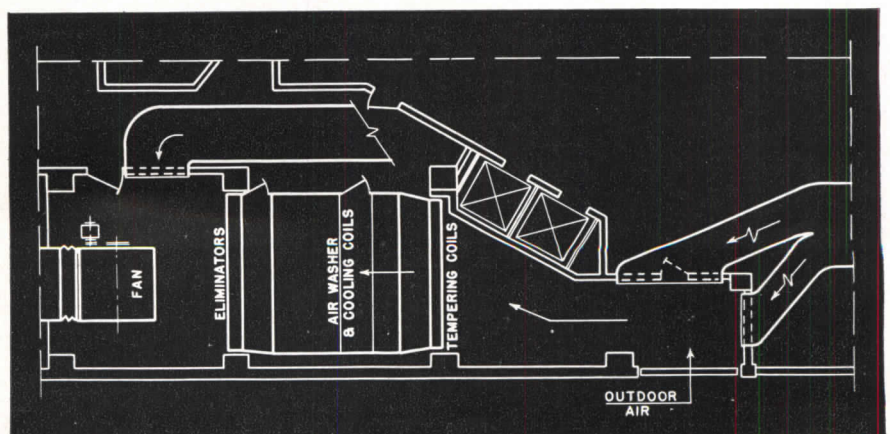

**NO. 1 BEFORE SAVINGS:** First National Bank Building Equipment room. The air circulating system with a fan capacity of 60,000 CFM serves the general banking area, general office space and private offices.



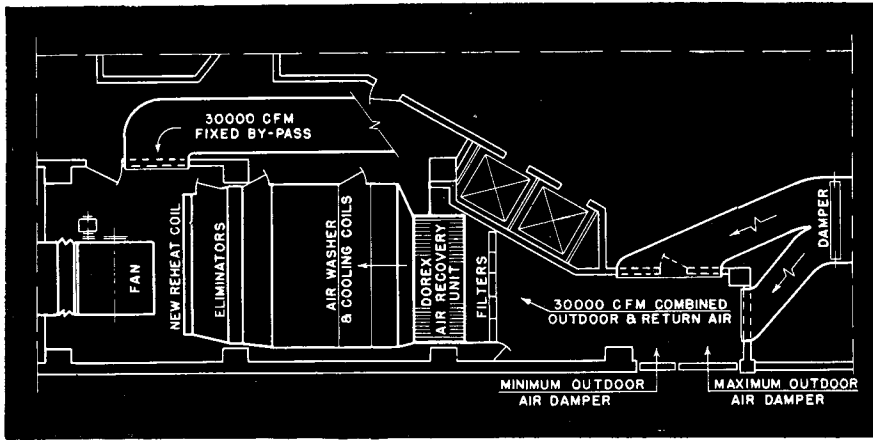

**NO. 2 AFTER SAVINGS:** The same equipment room after the DOREX Air Recovery Equipment was installed. Through the addition of thermostatic control on the dampers, the relative proportions of outdoor air and recirculated air are automatically regulated so that a maximum amount of outdoor air is used during the mild weather and a minimum during extremes of hot or cold weather.

### DOREX Type H Canister Unit Installed.

This unit consists of removable, perforated canisters filled with activated carbon and mounted on manifold plates. The assembly is so arranged that all air to be treated passes uniformly through the granular carbon which extracts all air-entrained gaseous and vaporous impurities. Erection and assembly of the unit are simple and easy. And, while the service life of DOREX Absorbers is directly relative to the odor concentration encountered, experience shows that, in average comfort conditioning applications, two years' life or more may be expected between reactivations.

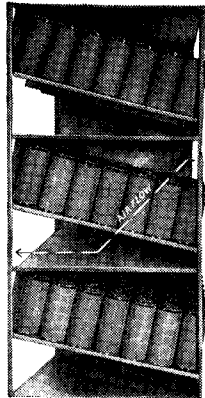

*Added resistance averages only 0.15" water gauge.*

### Works like a gas mask.

Nothing is added to the air. Vaporous and gaseous contaminants are removed, not disguised.

Contaminated air passed through the special gas adsorbing carbon used in Dorex Equipment, emerges purer by far than the outdoor air of inhabited communities. Activated carbon is the most powerful adsorption material known. It has been used for many years in industry for the recovery of chemicals in gaseous and vaporous form. Thousands of current applications demonstrate its ability to adsorb the air-borne contaminants that make air stale and odorous in commercial, industrial or public-assembly installations. Impurities—

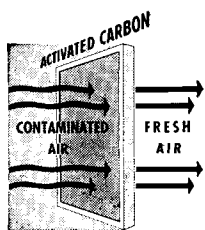

Thousands of current applications demonstrate its ability to adsorb the air-borne contaminants that make air stale and odorous in commercial, industrial or public-assembly installations. Impurities—

from occupants and their habits (body, apparel, respiratory, tobacco, and cosmetic emanations); from liquor and food in preparation and cooking; from lubricating oils, solvents, etc., in industrial processes—all can be extracted from the air by adsorption.

### Engineering Help Available.

The W. B. Connor Engineering Corporation maintains a research laboratory, a staff of trained specialists, and district representatives in leading cities whose services are at the disposal of Consulting Engineers, Architects, Air Conditioning Equipment Distributors and Plant Engineers. Our staff can assist you in figuring out the economics and mechanics of air conditioning load reduction through Air Recovery, or help you apply the sound advantages of Air Purification to any manufacturing operation, where contaminated air threatens product quality or production efficiency.

### Air Conservation Engineering.

A limited number of copies of our new textbook containing complete information on the economics, the functions and the mechanics of Air Recovery are available. It will help you figure requirements for a wide variety of uses. Contains technical data needed in designing most applications. Cites actual cases and describes advantages of Air Recovery to Design Engineers, Architects, Plant Engineers and Contractors. Copies are \$2.00 each. Complimentary copies are available to Registered Architects and Recognized Engineers on request.

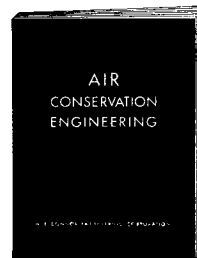

**Air Recovery Equipment is paying its way in the following successful applications:**

- |                        |                              |
|------------------------|------------------------------|
| Airplanes              | Institutions                 |
| Banks                  | Chemical Laboratories        |
| Breweries              | Libraries                    |
|                        | Locker Plants                |
|                        | Department and Retail Stores |
| Busses                 | Office Buildings             |
| Oil Companies          | Railroad Cars                |
|                        | Precision Instrument Mfg.    |
|                        | Film Manufacturing Plants    |
| Food Processing Plants | Restaurants                  |
| Hospitals              | Sewage Plants                |
| Hotels                 | Telephone Exchanges          |
| Industrial Plants      | Theaters                     |

**For full information and quotations on DOREX Equipment, call the nearest District Representative or write Dept. L8, 112 East 32nd Street, New York 16, N. Y.**

## W. B. CONNOR ENGINEERING CORPORATION

AIR PURIFICATION

112 EAST 32nd STREET



AIR DIFFUSION

NEW YORK 16, N. Y.

# FOR EXTERIORS OF MODERN BUILDINGS—USE DURABLE Exterior Type Douglas Fir Plywood

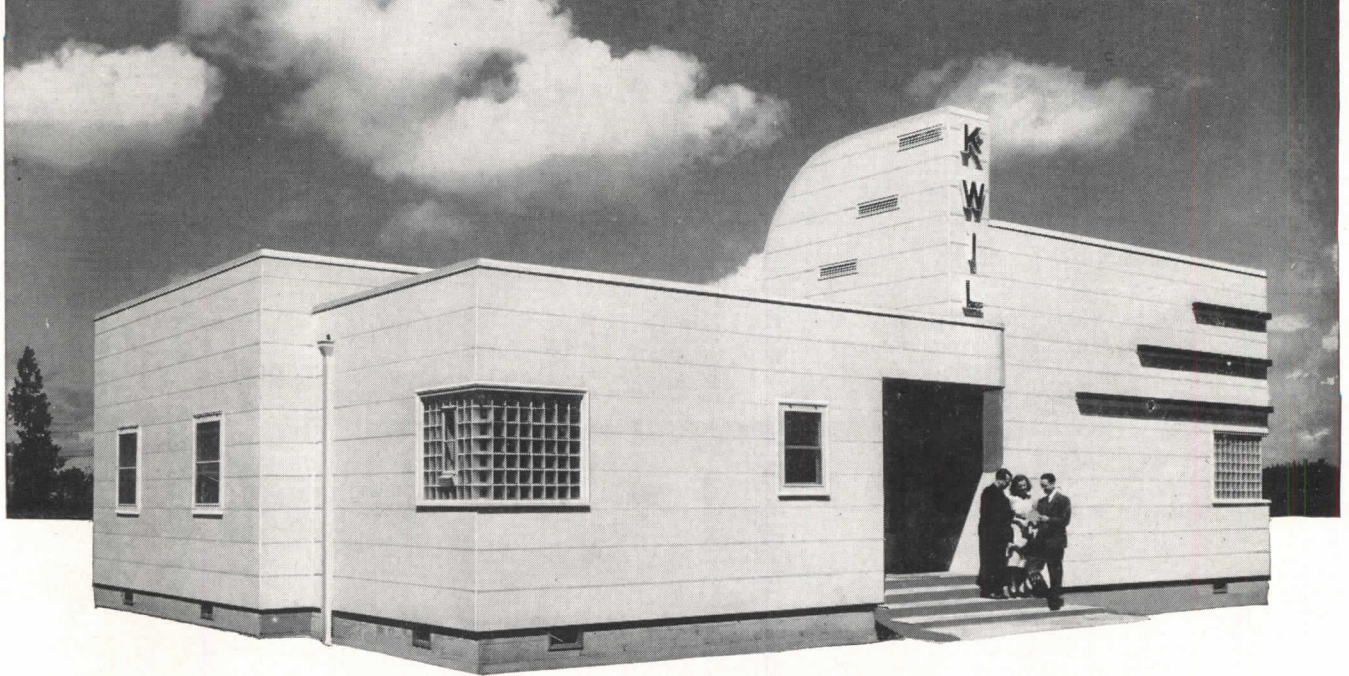

## Easy to Use, Economical, Weather-proof

- Exterior type Douglas fir plywood—made with completely waterproof synthetic resin binder—has proved itself a superior material for exterior siding on homes, farm buildings, business and industrial structures. The large, rigid panels cover wall areas with a minimum of handling, sawing, fitting and nailing. They bend easily to simple curves without splitting. They will **not** delaminate—**even in boiling water!**
- Exterior type is the rugged, durable plywood used in PT boats and other assault craft. It has served for years in work and pleasure boats, in freight cars, "reefers", troop sleepers, and as a superior material for outdoor signs.
- Write the Douglas Fir Plywood Association for any technical data you desire. For prices and delivery information, see your lumber dealer.

Modern streamlined effects are easy to accomplish with large, rigid panels of durable Exterior type Douglas fir plywood. This radio transmitter building is a pleasing example of the material's adaptability—a building that is not only more attractive NOW but will remain so over a longer period of time. Plywood's cross-laminated construction adds strength and rigidity to framing.

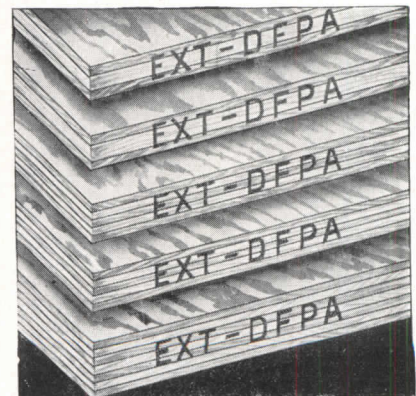

For permanent outdoor use, for marine use, and for indoor use where moisture conditions are abnormal, specify **ONLY** Exterior type plywood. It is easily identified by the "grade trademark" EXT-DFPA on the edge of every panel.



Douglas Fir Plywood Association

Tacoma 2, Washington

# Have You a Problem in Sound-Film Acoustics ?

Send for This New Free Booklet, **"Acoustic Treatment of Auditoriums"** →

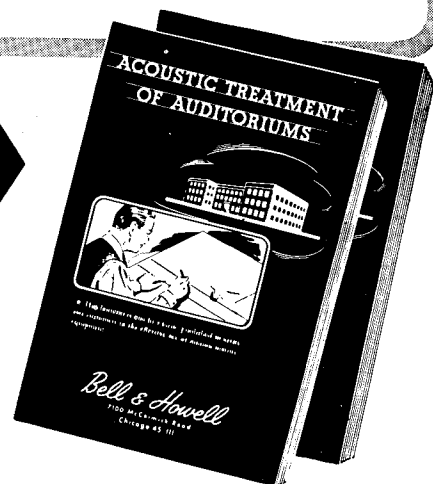

**T**HE finest motion picture sound equipment cannot overcome the handicap of an auditorium in which excessive reverberation interferes with proper sound reproduction.

To answer fully the increasing number of inquiries received concerning directional baffles, multiple speakers, and altering auditoriums for improved sound reproduction, Bell & Howell has published a new manual, "Acoustic Treatment of Auditoriums."

Three parts are devoted to (1) principles of the sound-reproducing equipment, (2) improving sound distribution, (3) suggestions for auditorium treatment. There are charts on reverberation time limits and on absorption coefficients of building materials.

## "Architects' Visual Equipment Handbook"

This covers completely plans and specifications for classrooms, conference rooms, and auditoriums where sound motion picture equipment is to be used. Including blueprints, it is a complete and authoritative manual for all concerned with building or adapting rooms for showing sound films.

Send for your free copies of these handbooks today. Bell & Howell Company, Chicago; New York; Hollywood; Washington, D. C.; London.

## FILMOSOUND 179

Every inch a Bell & Howell projector in quality and performance, this 1000-watt 16mm sound-on-film projector assures superb illumination, abundant sound volume. Check the coupon for full information.

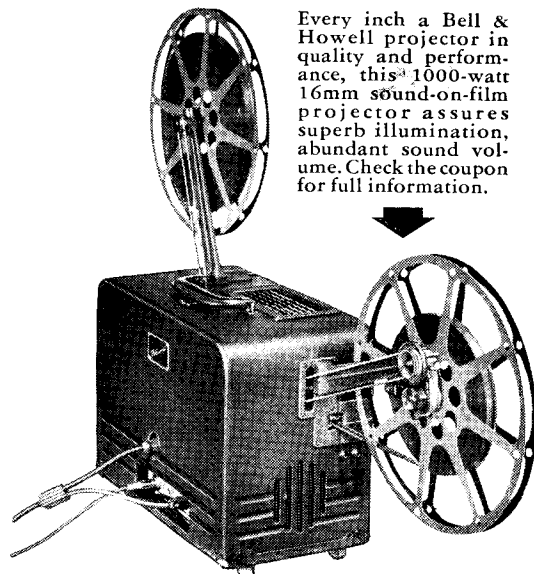

BELL & HOWELL COMPANY  
7111 McCormick Road, Chicago 45  
Without obligation, send my copy of ( )  
"Acoustic Treatment for Auditoriums";  
also send ( ) "Architects' Visual Equip-  
ment Handbook"; ( ) Information on B&H  
Filmosound Projectors.

Name.....  
Address.....  
City..... State..... AR 2-46

**OPTI-ONICS**—products combining the sciences of OPTics • electrONics • mechanICS

PRECISION—MADE BY



*Bell & Howell*

SINCE 1907 THE LARGEST MANUFACTURER OF PROFESSIONAL MOTION PICTURE EQUIPMENT FOR HOLLYWOOD AND THE WORLD

# Now... Pittco Metal offers two outstanding lines

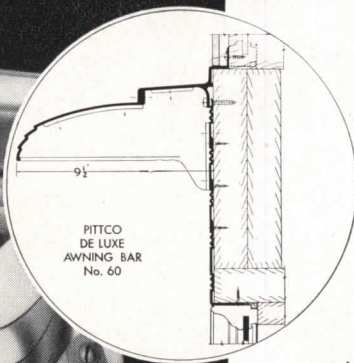
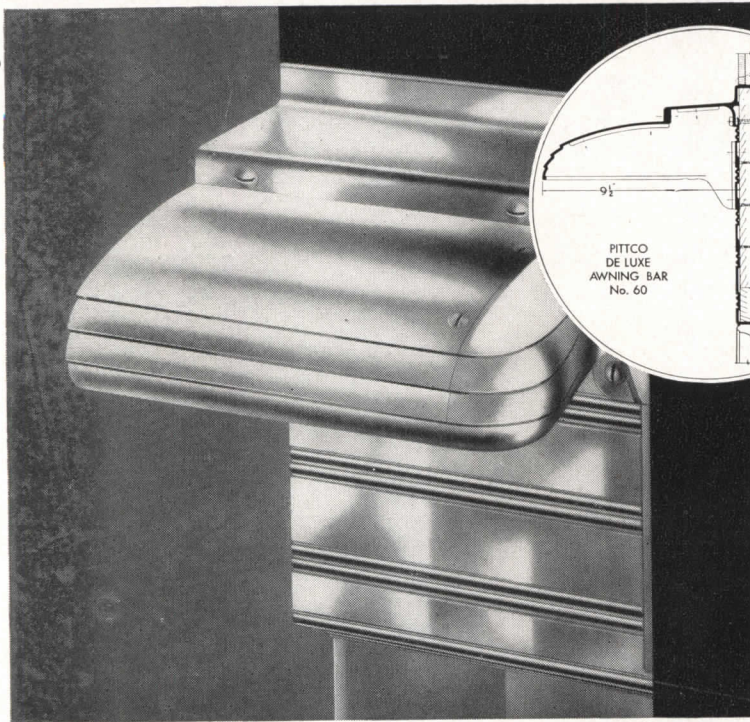

**PITTCO DE LUXE** Imaginative planning has made Pittco Store Front Metal artistically as well as functionally suitable for every store front need. This Pittco De Luxe awning bar gives operating mechanism and awning roll adequate protection from weather. It is designed to harmonize with any combination of shapes in the De Luxe line. The extruded method of manufacture gives it the sturdy strength, clean, sharp contours and perfect color and finish which are characteristic of Pittco De Luxe Store Front Metal. And these distinctive features explain the constant use of Pittco De Luxe on those jobs where high quality is demanded. The bars, mouldings and sash of the De Luxe line combine to make store fronts impressive and appealing.

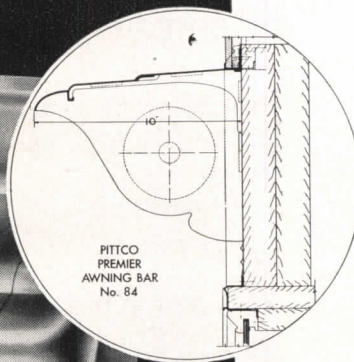
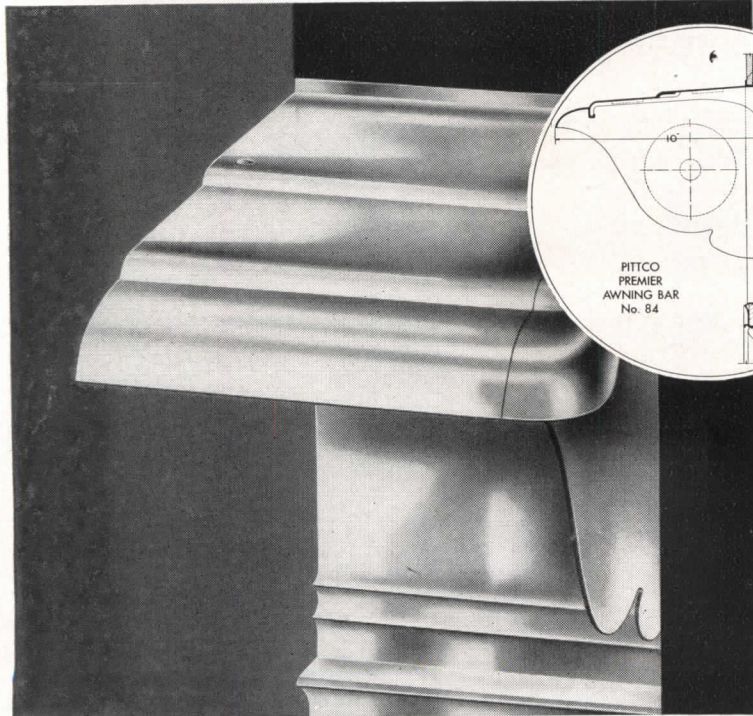

**PITTCO PREMIER** Although lighter in weight than Pittco De Luxe, the new Pittco Premier line embodies the same imaginative styling and painstaking craftsmanship which has made the De Luxe line so popular. In the Premier line architects will find that the perfect harmony between units makes it possible to create a wide variety of pleasing and attractive store fronts. The Pittco Premier construction can be set more quickly and easily than any other metal construction. All setting operations are carried on from the outside and the procedure is so simple that a substantial savings in setting time is effected. Pittco Premier is styled to provide a shallower reveal for show windows than is given by the De Luxe line. Being light in weight and moderately priced, Pittco Premier is the ideal choice for jobs which require quality metal at an economical price.



**PITTCO STORE FRONT METAL**  
PITTSBURGH PLATE GLASS COMPANY

*"PITTSBURGH" stands for Quality Glass and Paint*

# THERE IS A DIFFERENCE IN PLASTER!

*This Quality Story tells you why you get  
Better Results with Gold Bond Plaster...*



**1 GYPSUM MINE.** One of 9 National Gypsum deposits which insure a constant supply of selected gypsum rock.

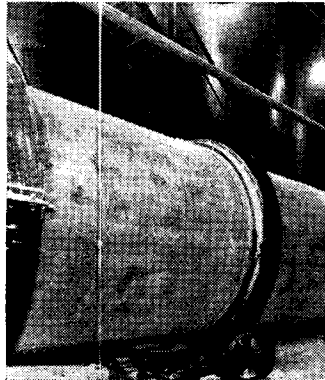

**2 ROTARY DRYER.** First step in the processing of gypsum is the removal of surface moisture from the rock.

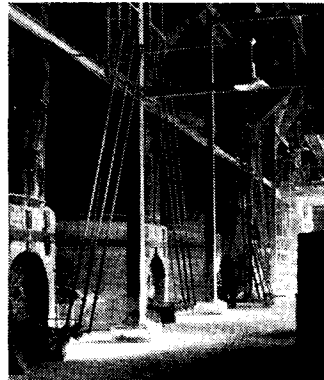

**3 CALCINERS.** Next, the rock is pulverized and "cooked" in huge kettles which drives off the water of crystallization.

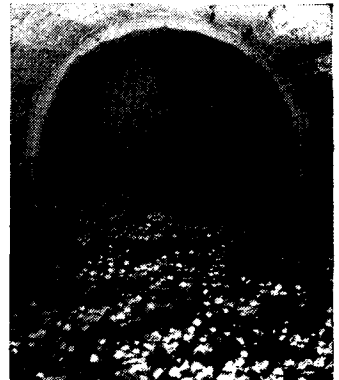

**4 TUBE MILL.** Thousands of tiny steel balls in this revolving cylinder grind the gypsum into minute particles.

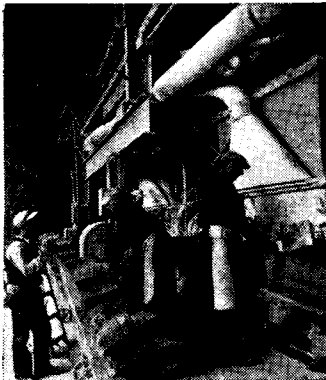

**5 BAGGING.** After various ingredients are added to regulate the set and working qualities of the plaster, it is ready for bagging.



**6 QUALITY CHECKUP.** Uniform quality is so important that a research lab is maintained at each plant to insure constant control.

**T**HE days of "plasterers-are-all-alike" are out. New processing operations made possible with modern machinery have resulted in the finest plaster ever made... Gold Bond. Specifying Gold Bond is your assurance that you will be getting this high quality plaster on your jobs at no premium price. See our section in Sweet's for the full story on Gold Bond Plaster and over 150 other guaranteed Gold Bond Building Products sold by 10,000 building material dealers. National Gypsum Company, Buffalo 2, New York.

**BUILD BETTER WITH  
GOLD BOND**

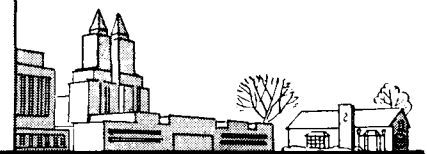

LATH • PLASTER • LIME • METAL PRODUCTS • WALL PAINT • INSULATION • SOUND CONTROL • WALLBOARD

Here's the inside story...



Photo by Maynard L. Parker

**BENNETT**  
*Fresh-Aire*  
**FIREPLACE UNIT**

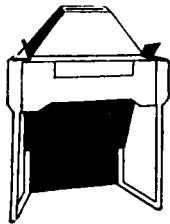

You Face New Problems

*with the fireplace in the modern home*

As you know, a fireplace when burning exhausts more than 200 cu. ft. of air per minute from the living quarters of a house. If tightly constructed, replacement air cannot enter from outdoors in sufficient quantity to supply the chimney draft. Result: partial vacuum, back-puffs, and smoke. If sufficient replacement air *can* enter, it lowers the average temperature of the entire house, cold drafts sweep the floor and automatic furnace controls are out of balance.

In sharp contrast, the *Bennett Fresh-Aire Fireplace Unit* draws replacement air from outdoors, through heating chambers, and circulates it into the living quarters—warm instead of cold. Result: no uneven temperatures, no interference with heat controls, and a net gain in evenly distributed warmth.

The benefits of this principle have been well proved in over 20 years experience and are especially important to you—in designing the modern, fully weather-stripped home with central heating.

There are four additional reasons why so many *Bennett Fresh-Aire Fireplace Units* are specified. 1—Thoroughly ventilates and "refreshes" the air. 2—Broad freedom to design the mantel . . . normal brick firebox sidewalls . . . no floor grilles. 3—Serves as a complete form for *smoke-free* internal proportions of throat dampers, smoke chamber and shelf, etc. 4—The small first cost is quickly offset by savings in construction and fuel.

For camps, summer and southern homes—places without furnace heating (also basement "playrooms") the *Bennett Warm-Aire Fireplace Unit* is recommended.

*Flexscreen*

To add beauty and full protection—every fireplace should have a *Bennett Flexscreen*—the safety fireplace curtain.

For complete details

Send today for *Bennett Fireplace Catalog*—or see *Sweet's*



**Bennett-Ireland**

246 MAPLE STREET, NORWICH, N. Y.

Ask for  
**KIMBERLY**  
DRAWING PENCILS

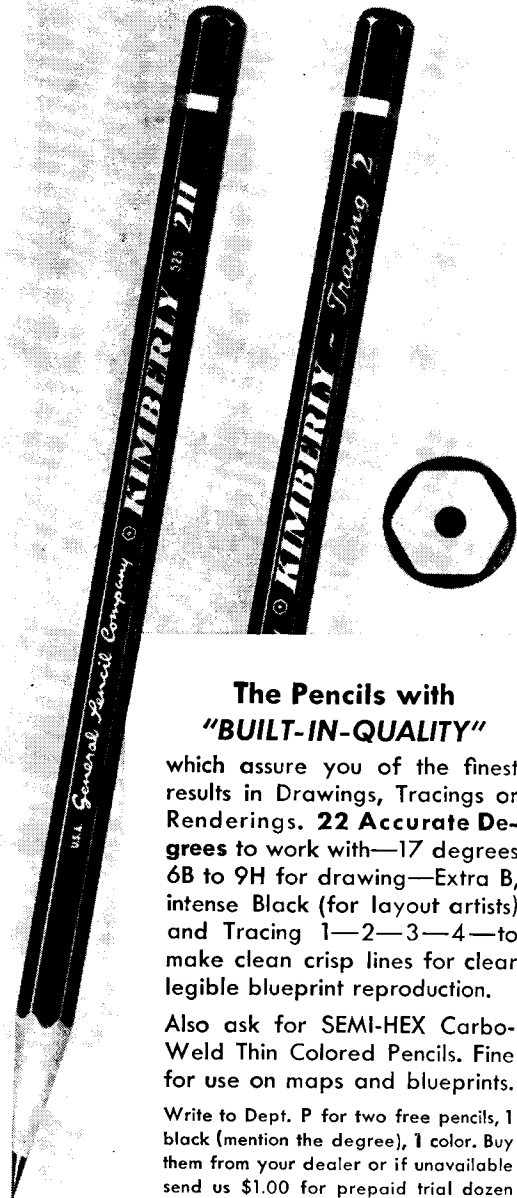

The Pencils with  
"BUILT-IN-QUALITY"

which assure you of the finest results in Drawings, Tracings or Renderings. **22 Accurate Degrees** to work with—17 degrees 6B to 9H for drawing—Extra B, intense Black (for layout artists) and Tracing 1—2—3—4—to make clean crisp lines for clear legible blueprint reproduction.

Also ask for SEMI-HEX Carbo-Weld Thin Colored Pencils. Fine for use on maps and blueprints.

Write to Dept. P for two free pencils, 1 black (mention the degree), 1 color. Buy them from your dealer or if unavailable send us \$1.00 for prepaid trial dozen of your favorite degree or assortment.

*This offer good only within U. S. A.*

*Makers of Fine Pencils since 1889*

**General Pencil Company**

67-73 FLEET STREET TRADE MARK JERSEY CITY 6, N. J.

# Now featuring **Roddiscraft** the world's finest doors .. in Michigan Maple .. the world's finest wood

**I**N Michigan Maple, Nature exhibits her finest handiwork, combining beauty and warmth — uniformity of grain and color — overall hardness.

In Roddis' own northern hardwood timber tracts, Roddis men select the finest of Michigan Maple — earmark it for the veneer mill, where Roddis craftsmen mold it into matching doors and wainscots — by the RODDISCRAFT process which welds the face veneer to the crossbanding and core, making a solid unit, immune to moisture — highly fire and sound resistant — durable as it is beautiful.

The combination of hard Michigan Maple face veneers, laid over RODDISCRAFT cores and crossbanding, glued under heat and pressure, is a guarantee of long life and lasting beauty.

Michigan Maple faces are available in selected white, or unselected for painting.

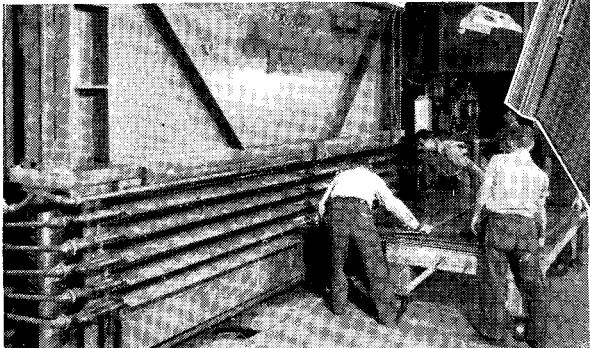

*Consult your local millwork and fixture manufacturers — and lumber dealers.*



## **Roddiscraft** WAREHOUSES

- CAMBRIDGE 39, MASS.,  
229 Vassar Street
  - CHICAGO 8, ILL.,  
1440 W. Cermak Road
  - CINCINNATI 2, OHIO,  
457 E. Sixth Street
  - DALLAS, TEXAS,  
2615 Latimer Street
  - KANSAS CITY 8, MISSOURI,  
2729 Southwest Boulevard
  - LOUISVILLE 10, KENTUCKY,  
1201-5 S. 15th Street
  - LONG ISLAND CITY, N. Y.,  
Review & Greenpoint Avenue
  - MARSHFIELD, WISCONSIN
  - MILWAUKEE 8, WIS.,  
4601 W. State Street
  - NEW YORK CITY 18, NEW YORK,  
515 W. 36th Street
  - SAN ANTONIO, TEXAS,  
727 N. Cherry Street
- DEALERS IN ALL PRINCIPAL CITIES

# **Roddiscraft**

## **RODDIS LUMBER & VENEER CO.**

MARSHFIELD, WISCONSIN

*Here's something  
Really New!*

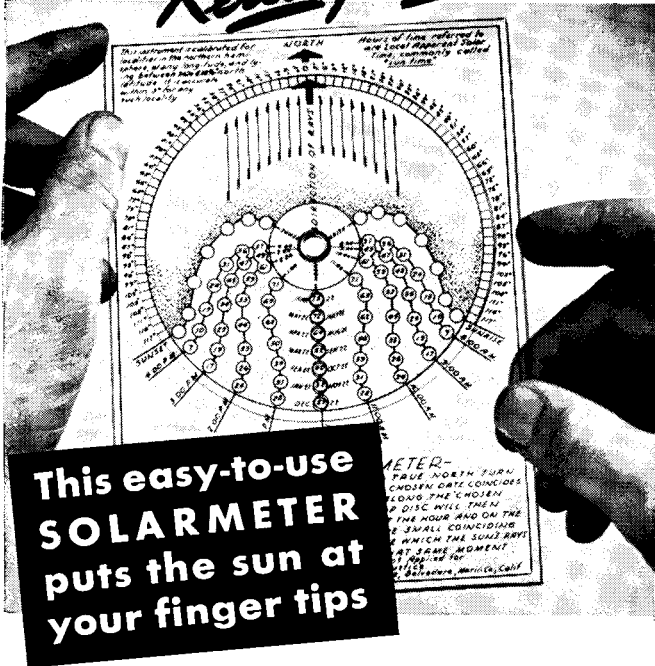

**This easy-to-use  
SOLARMETER  
puts the sun at  
your finger tips**

Have you ever wished for a scientifically designed, easy-to-use instrument which would enable you to plan accurately for maximum effective orientation to sunlight?

*The SOLARMETER literally puts the sun at your finger tips!*

By using the SOLARMETER you can know the precise direction and inclination of the sun's rays at the hours and days you select. And it doesn't matter where in the U.S.A. you are planning your structure. There is a SOLARMETER calibrated for your band of latitude. Thus, during preliminary planning, you can dispose elements, locate and orient the building, check canopies, roof overhangs, windows, garden arrangement, etc., to take full advantage of sunlight throughout the year.

The SOLARMETER is as easy to use as a T-square. Simply lay the translucent instrument on top of any plan at any scale. Set the dial on the hour and date in question and the pointing arrow will indicate the direction in which the sun's rays are travelling at that moment, together with their inclination to the horizontal plane. It can be used on the board or in the field.

The SOLARMETER is precision-made of durable Vinylite, with machine-set indices calibrated to your particular band of latitude. It's an instrument no architect, designer or draftsman should be without. Your client will be impressed with your progressiveness and attention to detail. Hundreds are already in use. Endorsed by leading architects.

The supply of sheet plastics is still limited. Order your SOLARMETER today!

Please send me a GRAPHIC SOLARMETER calibrated to my particular locality:  Enclosed is my check for \$3.00 (Purchase price to be promptly refunded if I am not satisfied.)  Send me a SOLARMETER for one week trial without obligation.

NAME \_\_\_\_\_

ADDRESS \_\_\_\_\_

**R. W. JUSTICE, Box 122-A, BELVEDERE, MARIN COUNTY, CALIF.**

# NORTON Door Closers



Norton Door Closer Installation in Southern Pacific Building, San Francisco.

These Norton Door Closers controlling the main entrance doors of the Southern Pacific Building, San Francisco, were installed about 1912. It was 20 years before we were even called in to service them and they are still going strong.

Norton Door Closers do the same outstanding job in thousands of heavy traffic stops all over the country—office buildings, railway stations, stores, institutions, schools, hospitals, theaters, banks. Their performance is unfailing because Norton Door Closers are built up to an exact standard, not down to a price.

With the renewal of building activity a full line of genuine Norton Door Closers will again be available. New construction needs Norton. Write for information now.

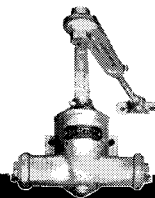

## NORTON DOOR CLOSER COMPANY

Division of The Yale & Towne Mfg. Co.  
2910 N. Western Ave., Chicago 18, Illinois





*In the home  
..IT'S CONVENIENCE*

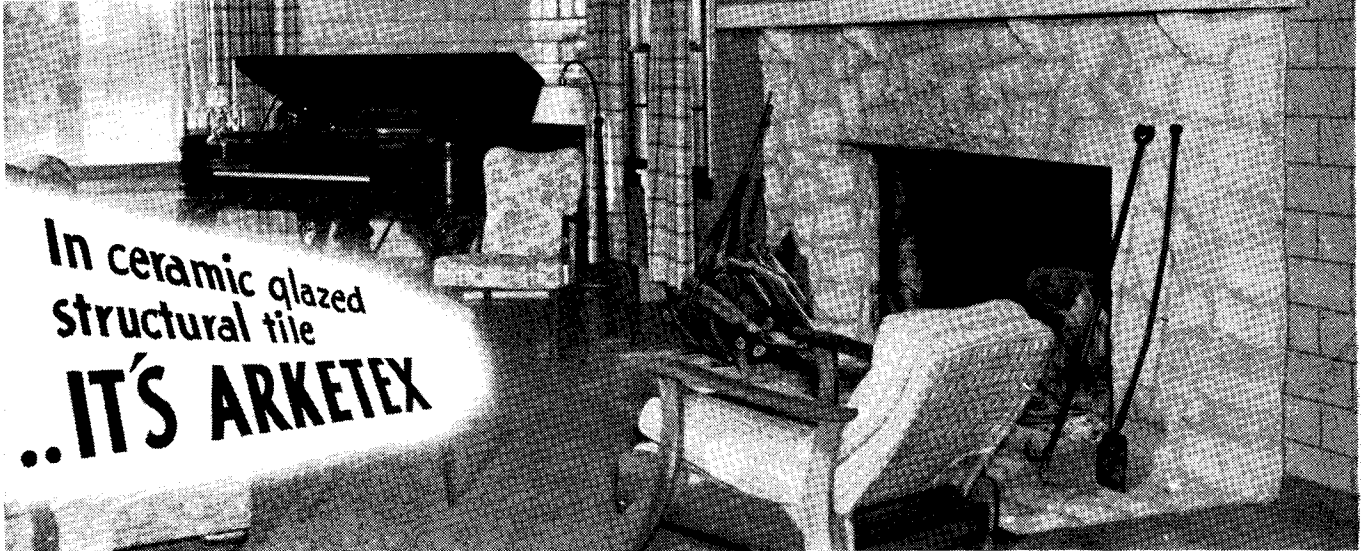

*In ceramic glazed  
structural tile  
..IT'S ARKETEX*

# ARKETEX FOR *Budget Beauty*

**T**HE MASTER of the house will find Arketex economical to buy, convenient to maintain, for Arketex walls require no periodic painting or refinishing — *the first cost is the only cost!* Arketex' colors are everlasting. The housewife will find Arketex convenient to clean. Only soap and water washing is required to keep its luster. In the residence Arketex is ideal for interior use as well

as for exterior walls. It adds warmth and color to any home decorating scheme. Available in a number of sizes, shapes, and textures allowing freedom of artistic expression, this wall and finish all in one is not affected by steam, water, acid, or temperature and weather changes. When planning homes or offices, specify Arketex — first with the finest in ceramic glazed structural tile!

## A PEACETIME PROMISE



Arketex' continuous achievement in the ceramic glazed structural tile field assures you the finest in workmanship. Arketex — the standard of textured tile.

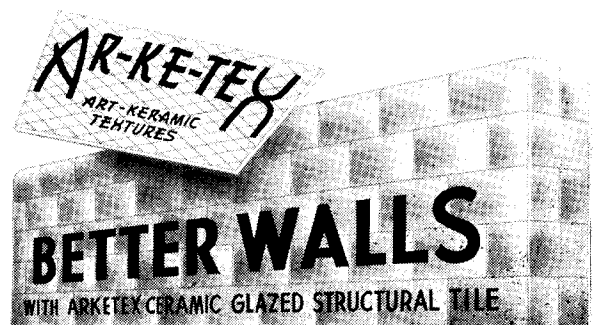

**ARKETEX CERAMIC CORPORATION • BRAZIL, INDIANA**

JUST LIKE A  
BLACK CAT IN A  
DARK CLOSET

*Invisible*



The Grand Rapids Invisible Sash Balance checks with the strictest standards, and the saving and satisfaction realized on these installations has been fully endorsed in thousands of instances by scores of leading contractors.

It is actually invisible — no exposed tapes or cables or tubes. The entire sash balance moves with the sash.

No odd sizes — same balance for upper and lower, completely interchangeable. Ten sizes meet 95% of all residential requirements.

GRAND RAPIDS  
PULLEYS

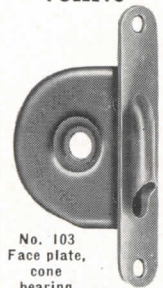

No. 103  
Face plate,  
cone  
bearing  
type



No. 175  
Drive type saw  
tooth pulley

*Easy*  
to Install  
*Simple*  
to Operate  
*Dependable*  
in Performance

Send for  
Sash Balance  
**CATALOG**

This catalog contains complete information on sash balance sizes, directions for installing, etc. — all fully illustrated.

◀ Nos. 103, 175, 109 and 110 cover 95% of all pulley requirements.

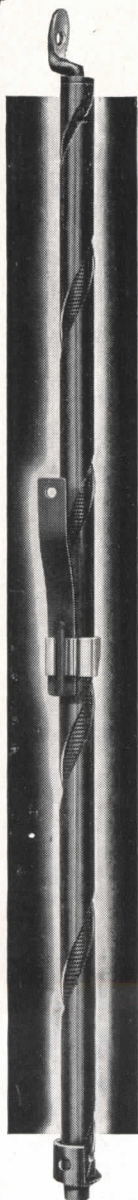

GRAND RAPIDS HARDWARE COMPANY  
GRAND RAPIDS • MICHIGAN

**H&H** WEATHER  
-PROOF

OUTDOOR SWITCHES  
AND RECEPTACLES

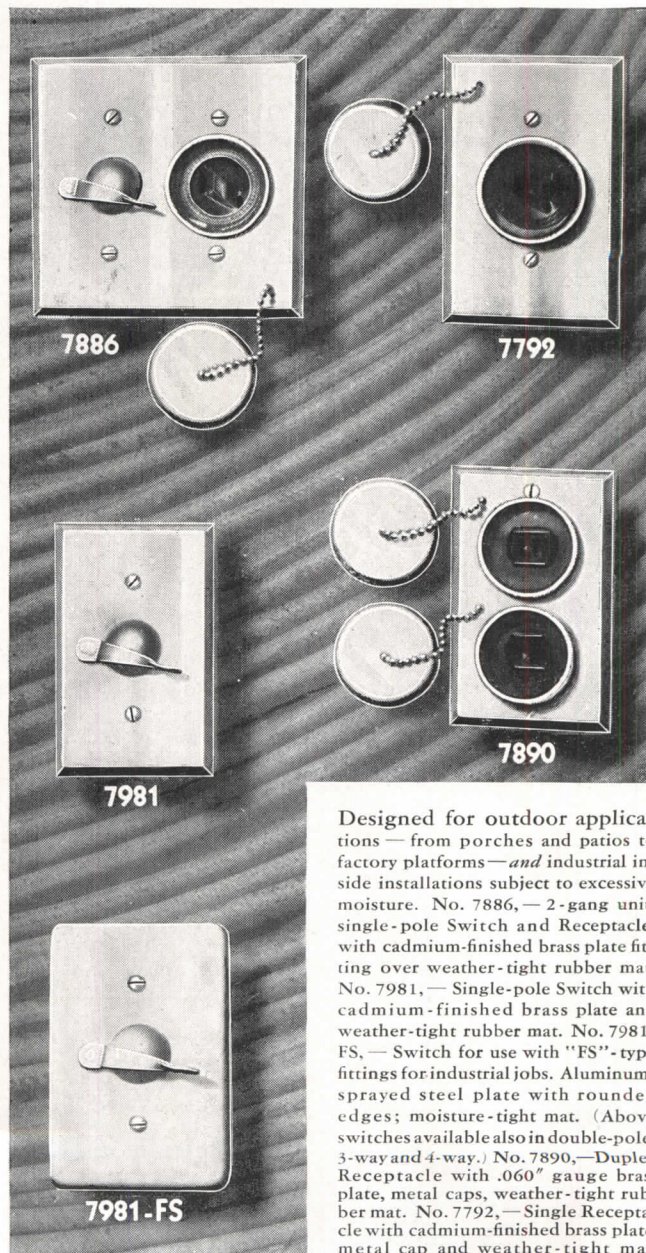

Designed for outdoor applications — from porches and patios to factory platforms — and industrial inside installations subject to excessive moisture. No. 7886, — 2-gang unit, single-pole Switch and Receptacle, with cadmium-finished brass plate fitting over weather-tight rubber mat. No. 7981, — Single-pole Switch with cadmium-finished brass plate and weather-tight rubber mat. No. 7981-FS, — Switch for use with "FS"-type fittings for industrial jobs. Aluminum-sprayed steel plate with rounded edges; moisture-tight mat. (Above switches available also in double-pole, 3-way and 4-way.) No. 7890, — Duplex Receptacle with .060" gauge brass plate, metal caps, weather-tight rubber mat. No. 7792, — Single Receptacle with cadmium-finished brass plate, metal cap and weather-tight mat.

HART & HEGEMAN DIVISION

ARROW-HART & HEGEMAN ELECTRIC  
COMPANY, HARTFORD 6, CONN., U.S.A.

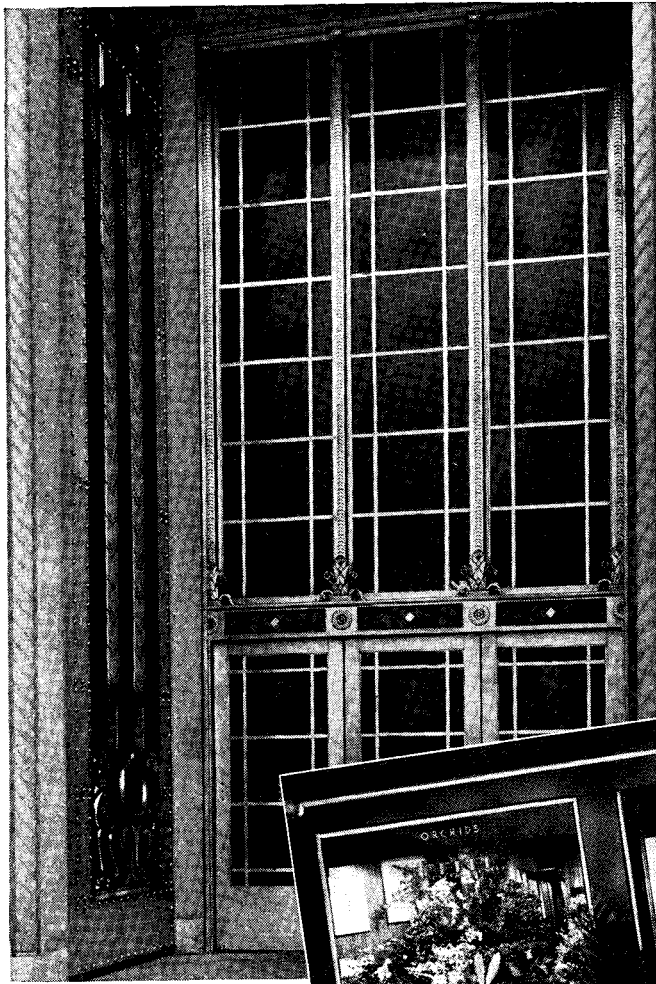

Department of Justice Building,  
Washington, D. C.  
Zantzing, Borie & Medary, Architects

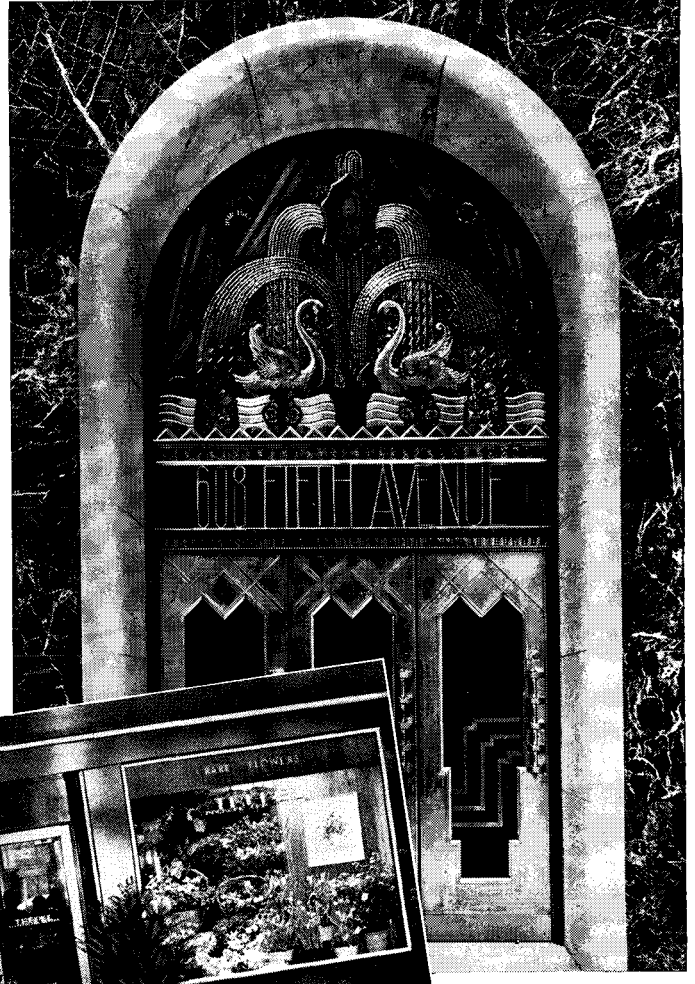

Office Building at 608 Fifth  
Avenue, New York, N. Y.



Store Front, Rockefeller Center, N. Y.

## THIRTY-FIVE YEARS OF LEADERSHIP IN FINE ARCHITECTURAL METAL WORK

Helping architects add to the distinction of America's finest buildings has placed General Bronze in a prominent position in the fabrication of architectural metal work.

Installations on many notable buildings attest to the craftsmanship of "Distinctive Metal Work by GB" — buildings such as the National Gallery of Art in Washington, D. C., The Museum of Science and Industry in

Chicago, The New England Life Insurance Company Building in Boston and The Oregon State Capitol.

General Bronze is the largest manufacturer of architectural metal work in the world. Here you will find the facilities, the experience and the engineering cooperation in all phases of design and construction that architects appreciate. See our catalog in Sweet's.

### GENERAL BRONZE CORPORATION

34-15 TENTH STREET

LONG ISLAND CITY 1, N. Y.

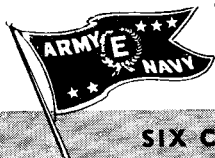

SIX CONSECUTIVE ARMY-NAVY "E" AWARDS

**Seaporcel** QUALITY  
MEANS LASTING BEAUTY

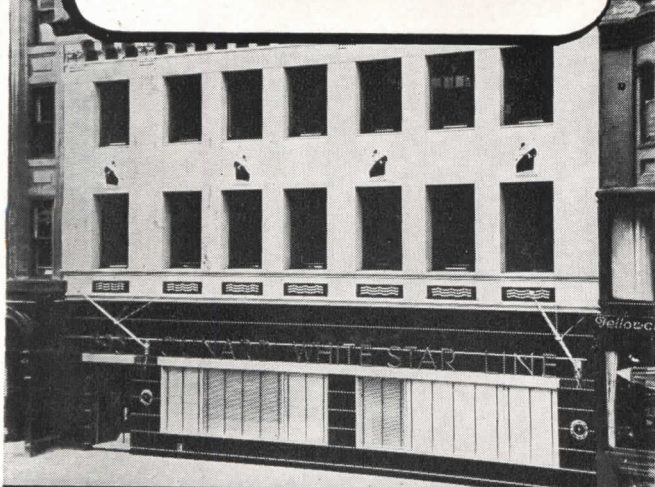

Cunard White Star Line Building, Boylston Street, Boston  
Architect: Kilham, Hopkins & Greeley • Contractor: E. A. Abbott

Modernized 11 years ago, this interesting combination of SEAPORCEL\* in various colors, is as modern today as it was on the day of installation, retaining all its newness, sparkle and cleanliness. It has proved color fast and durable regardless of weather conditions.

The SEAPORCEL process of fusing ceramic coating into its metal base at 1550°F., combined with selection of the finest available materials, results in a facing material of enduring satisfaction.

Available in practically any shape, color, shade or type of finish, SEAPORCEL gives the architect or designer almost unlimited latitude in creating building surfaces, sign-faces, signs, letters. Ease of cleansing keeps maintenance cost to a negligible item.



Write for information today—No obligation

There are a few areas in which Seaporcel Porcelain Metals, Inc. is not represented. Inquiries from interested agents are invited.

\*Reg. U. S. Pat. Off.

**SEAPORCEL PORCELAIN METALS, INC.**  
Formerly Porcelain Metals, Inc.  
28-02 BORDEN AVENUE, LONG ISLAND CITY 1, N. Y.

**Seaporcel**

**COMPLETE**

**Terrazzo**

**INTERIORS**

**ARE ADAPTABLE TO POST-WAR  
MODERN INSTALLATIONS**

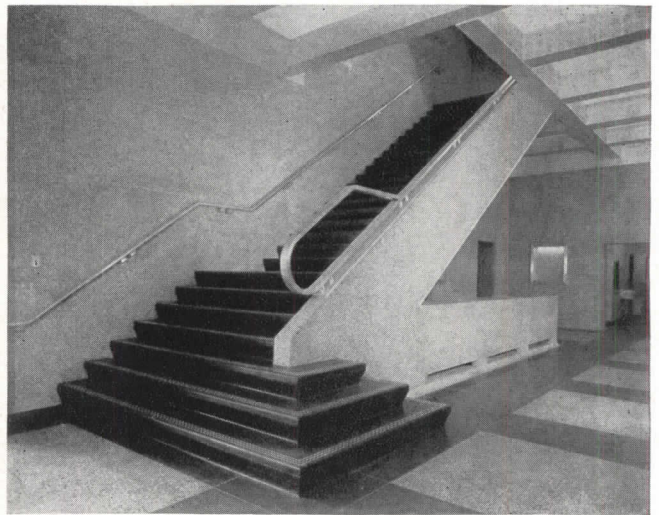

(Fifth Avenue Hospital, New York, Architects, Reinhard & Hofmeister)

**SPECIFY TERRAZZO  
YOU GET BEAUTY • LONG WEAR**

In the installation illustrated, not only the floor, but also the border, base, wainscot and wall surface are TERRAZZO. For sheer beauty and long wear TERRAZZO meets every modern construction need. Unlimited color selections, dependable, economical and clean, plus low cost maintenance mark every TERRAZZO installation. There are no limits to its infinite possibilities.



**FREE Complete  
Working Kit on  
TERRAZZO**

How to specify TERRAZZO, where to use it, reducing explosion hazards, comparative resiliency tests—every important working factor about TERRAZZO at your fingertips when you need it. Write for your copy TODAY!

**THE NATIONAL TERRAZZO AND  
MOSAIC ASSOCIATION, Inc.**

1420 New York Ave., N. W., Dept. R, Wash. 5, D. C.

# COMPLETE *Modernization* OF ELEVATORS

## with minimum SERVICE interruption



*Slater Building, Worcester, Mass.*

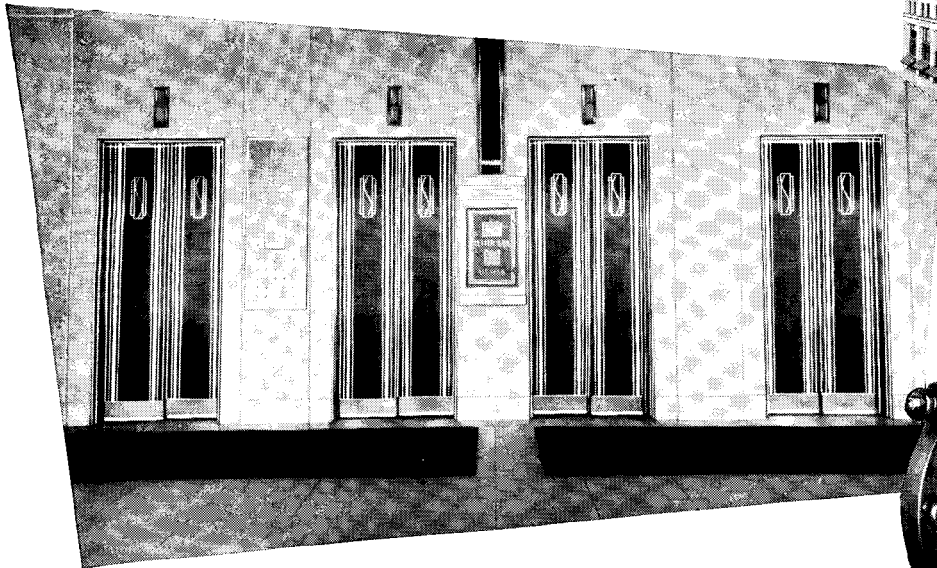

*Main floor lobby of the Slater Building showing elevator doors after modernization.*

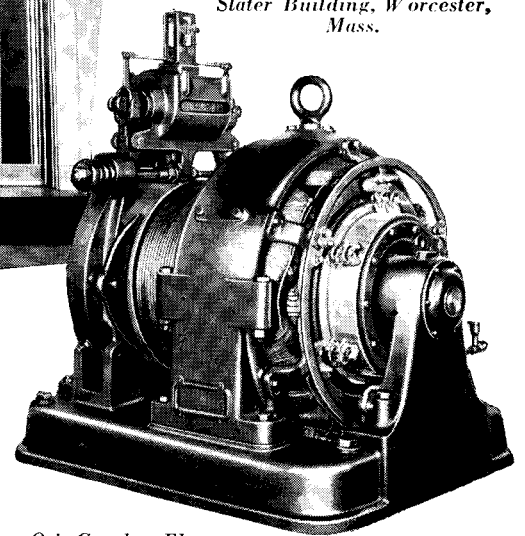

*Modern Otis Gearless Elevator Machines of this type replaced old hydraulic machines.*

**I**NCREASED traffic in the Slater Building gradually exceeded the handling capacity of the original four hydraulic-plunger elevators and it became necessary to consider faster and more efficient elevators. After a complete survey and analysis by Otis, the owners decided to replace the equipment with four gearless elevators with Otis Peak Period Control.

The problem then was how to make the change with a minimum of service interruption. The solution was the erection of a new penthouse over the old hoistways and the installation of the new machines, controllers and other penthouse equipment before taking any of the old elevators out of service. Then, as the new cars and entrances were installed, the changeover to the new machines was quickly effected — with a minimum of discontinuance of elevator service.

The efficiency of the new Otis elevator service is greatly appreciated by tenants and visitors.

While the primary object of any elevator modernization project is to put or keep the building "on its feet" as a profit maker, no two cases are exactly alike. One may require little more than a "beauty treatment" — more attractive entrances or cars, or both. Another, equipment for smoother, quieter operation; or new machines to bring

about greater speed — for quicker response to calls, to make more trips, — handle more passengers. Some may involve several phases.

A survey, plan and estimate covering your specific modernization needs incurs neither cost nor obligation. For the finest in vertical transportation tomorrow, call the nearest Otis Office today.



# ELLISON BALANCED DOORS



## • (SAFETY DOORS) •

*Because They Are Easy to Operate . . .*

*Because They Are Furnished with Highest Quality Materials . . .*

*Because They Are Complete . . .*

ELLISON BALANCED DOORS are accepted as practical and attractive assets to the store front. Streamlined to the design of the store, they possess real advertising values by providing convenience for the customers.

ELLISON DOORS are so balanced at the top and bottom that, when being opened, their pull-handle edge swings outward **against** the wind, and the opposite edge swings inward **with** the wind, thereby overcoming the wind-pressure which makes the ordinary door operate slowly and heavily. ELLISON DOORS will open and close easily in any wind or weather condition.

*Send for our new booklet giving illustrations and detailed specifications for all types of doorways*

📍 ELLISON DOORS in G. Fox & Company Store, Hartford, Conn., Taussig & Flesch, Architects

**ELLISON BRONZE COMPANY, INC., Jamestown, New York**

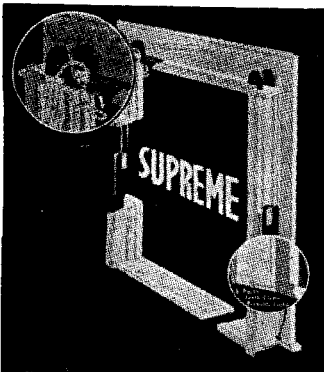

- ★ ARCHITECTS
- ★ CONTRACTORS
- ★ DEALERS

Consider  
**MALTA**  
Window Frames

**6**  
IMPORTANT  
ADVANTAGES

- 1 • Three width Jamb—adjustments provided by Inside Reversible Stop.
- 2 • Permanent water-tight Sill Joints and Sill Supports—built into frame.
- 3 • Three-way Joint Clamp—prevents leakage, strengthens frame.
- 4 • Multiple frames equipped with Mull Center Clamp.
- 5 • All important joints rot-proofed.
- 6 • Overhead pulleys easily and quickly removed if necessary—permits any type weatherstripping.

*Write For Malta's Free Catalog*

**THE MALTA MFG. CO., MALTA, OHIO** Top Quality Frames Since 1901  
Malta Frames Cost Less Per Year Of Service

## OPPORTUNITIES AVAILABLE

**ARCHITECTURAL DESIGNERS:** Structural, Heating and Ventilating, and Electrical Engineers. Experienced men for nationally known midwestern firm of architects and engineers. Box 96, ARCHITECTURAL RECORD, 119 West 40th St., New York 18.

**WANTED:** Two Architectural draftsmen capable of producing complete working drawings with knowledge of commercial and industrial work. Salary according to ability to produce. Mid-South firm of architects. Give complete information. Box 98, ARCHITECTURAL RECORD, 119 West 40th St., New York 18.

**WANTED:** Interior store designer with knowledge of merchandising by Mid-South firm establishing a new department. Give full particulars. Splendid opportunity for responsible party. Box 100, ARCHITECTURAL RECORD, 119 West 40th St., New York 18.

**LOCATION:** Architect, young, registered, contemplating opening own office, would like to hear from same, preferably someone with location or connections. Free to live any place. Box 102, ARCHITECTURAL RECORD, 119 West 40th St., New York 18.

**ARCHITECT**—Member A.I.A., age 37, married. Looking for permanent location in West or Midwest. Degree in Arch.; best qualifications; thoroughly experienced. Can create, design and produce. Box 104, ARCHITECTURAL RECORD, 119 West 40th St., New York 18.

# For Modern School Roofs— *PC FOAMGLAS* Insulation

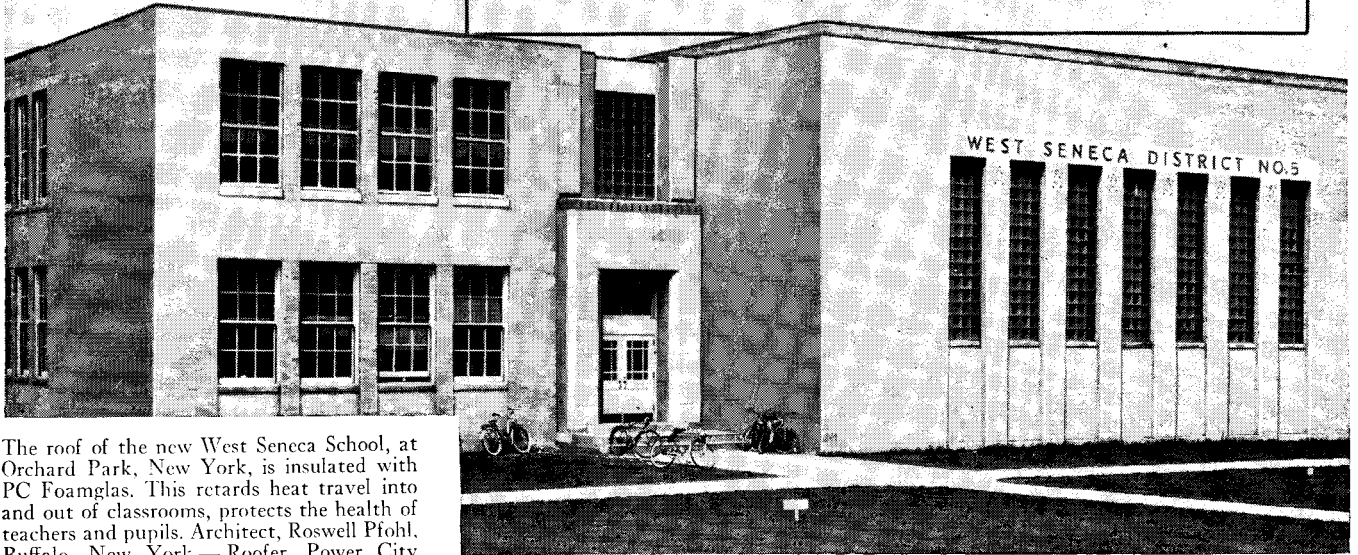

The roof of the new West Seneca School, at Orchard Park, New York, is insulated with PC Foamglas. This retards heat travel into and out of classrooms, protects the health of teachers and pupils. Architect, Roswell Pfohl, Buffalo, New York—Roofer, Power City Roofing Company, Buffalo, New York.

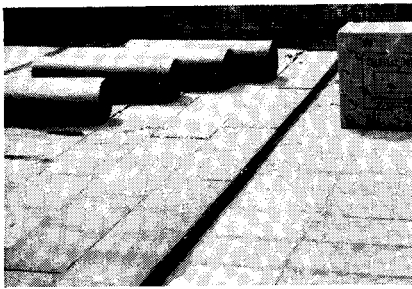

This picture shows how PC Foamglas Insulation is applied and how roofing is built up. Concrete slabs are covered with hot pitch or asphalt. Then, in turn, PC Foamglas, pitch or asphalt, four plies of roofing felt, pitch or asphalt and gravel are applied. All sorts of flat deck roofs, on all sorts of buildings all over the country, have been insulated—for good—with PC Foamglas.

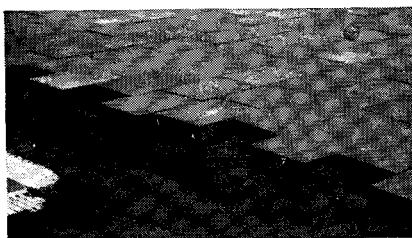

Providing a firm, level base for roofing felt, PC Foamglas, the permanent insulation, can be cut quickly to fit around openings and obstructions right on the job, with ordinary tools. When you are figuring a roof insulation job, figure on the most efficient, the most economical material—PC Foamglas.

ONE of the problems which faced the builders of this new, modern school was the selection of an efficient insulating material for the large area of flat roof. They solved it effectively, economically, *permanently* by specifying PC Foamglas Insulation.

Made of air-filled glass cells, PC Foamglas does not warp, shrink, swell, check or rot. It is impervious to moisture, vapor, and the fumes of most acids, elements that cause other materials to lose insulating efficiency.

So PC Foamglas will help to maintain comfortable temperatures in top floor classrooms, winter and summer, throughout the life of the building. Heat losses are reduced, saving fuel, easing the load on the heating plant. Furthermore, the excess heat of the sun does not penetrate the roof to make the rooms too warm for teachers and pupils.

We have published a booklet which contains charts and tables, detailed specifications and clear directions for installing PC Foamglas Insulation. We shall be glad to send you a free copy if you will just fill in and mail the convenient coupon. Pittsburgh Corning Corporation, Room 101, 632 Duquesne Way, Pittsburgh 22, Pa.

## FIRST COST IS LAST COST WITH PC FOAMGLAS

*for these reasons . . .*

Permanent Insulation  
Moistureproof  
Vaporproof

Fireproof  
Verminproof  
Light Weight

Economical  
Strong, Rigid Structure  
Quick, Easy Installation

• Also makers of PC Glass Blocks •

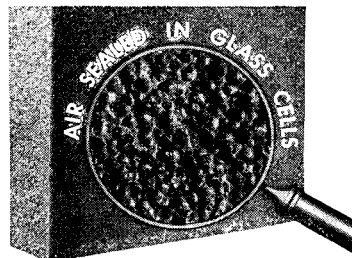

### MAIL COUPON TODAY

Pittsburgh Corning Corporation  
Room 101, 632 Duquesne Way  
Pittsburgh 22, Pa.

Please send me your booklet entitled, "PC Foamglas Insulation for Roofs." I incur no obligation.

Name.....

Address.....

City..... State.....

**PC FOAMGLAS** *Waterproof Fireproof* **INSULATION**

T. M. REG. U. S. PAT. OFF.

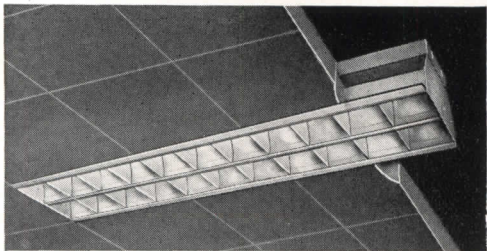

## Lighting is not a Fixture—

It's a *dynamic factor* in the *architect's equation*

For example — take that new store or modernization you are planning now. When you specify Century, you work with our continuing "know how" of store lighting — gained from years of lighting the leading modern stores of America — right to this minute.

You will be sure of **Low Brightness Contrast**, with —  
adequate **Circulation** or utility lighting  
effective **Accent** lighting  
sufficient **General** sales lighting  
plus an overall tie-in lighting.

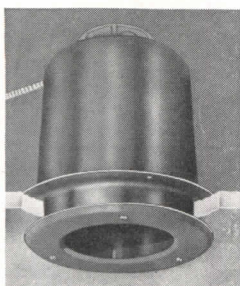

Our **DOWN-LITE**, on the left, is one of many for **ACCENT** lighting (No. 385). Above, is one type of **louvered fluorescent Troffer** (No. F248 AL).

Write for data sheet catalog. Consult us freely. You may specify now.

**CENTURY LIGHTING, Inc.**  
419 W. 55th St., New York 19, N. Y.

WHERE YOU'LL *Always* FIND  
THE VALVE YOU WANT--

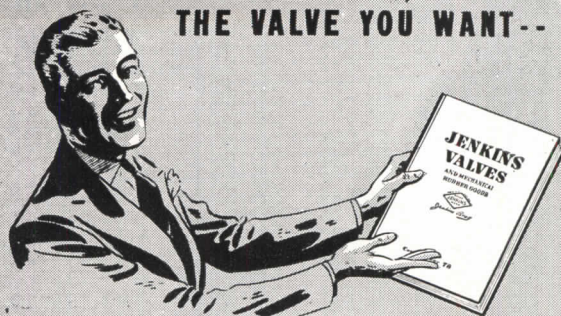

--IN THE *Jenkins* CATALOG



For completeness, the Jenkins Valve line just can't be beat. It includes over 600 valves . . . bronze, iron, cast steel, corrosion resisting alloys, air furnace malleable iron . . . sizes 1/8" to 48" for every service. To simplify specification, to avoid high maintenance and replacement costs, select all your valves from the Jenkins Catalog. Jenkins Bros., 80 White St., New York 13, N. Y.



## JENKINS VALVES

SINCE 1864

For Domestic, Institutional and Industrial Service  
... in Bronze, Iron, Cast Steel and Corrosion-Resisting Alloys . . . 125 to 600 lbs. pressure.

# FITZGIBBONS

for STEEL BOILERS

1886 60<sup>TH</sup> ANNIVERSARY YEAR 1946

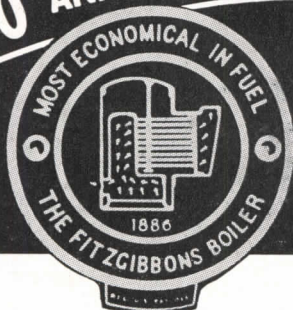

There is a wealth of "know-how" to be learned in sixty years of building steel boilers. And there is a satisfying assurance that the boiler you select with that experience behind it, is the product of masters in boiler design and construction . . . Whether for the small home or the large institutional building, specify Fitzgibbons and be sure.

Fitzgibbons Boiler Company, Inc. 101 PARK AVE. NEW YORK 17, N. Y.

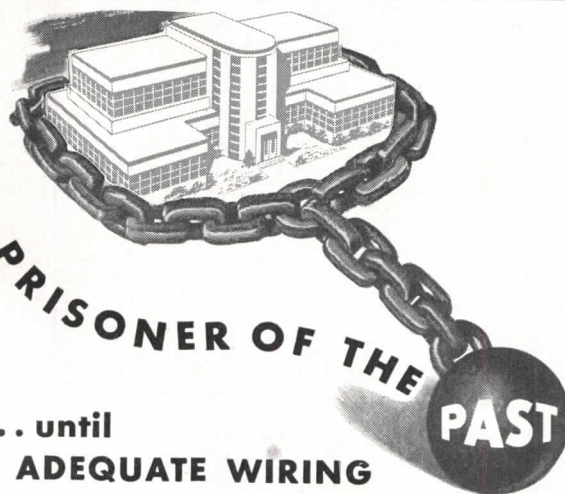

... until  
**ADEQUATE WIRING**  
Frees it!

An industrial building may look big enough . . . may be big enough to take care of tomorrow's suddenly stepped-up demands for greater output. Yet, if it isn't "big enough" electrically . . . hasn't the Adequate Wiring for full electrical efficiency, it is shackled to the past, held down to an outworn, outdated production quota.

Adequate Wiring, means not only conductors of ample size, but enough circuits and the kind of electrical system that can supply all the needs of power and

lighting (both present and future) at the lowest cost per kilowatt used.

In existing factories, office buildings and other industrial structures as well as in new buildings, Adequate Wiring can show substantial economies and forestall wasteful, work-delaying dismantling operations. Let an Okonite engineer work with you in planning Adequate Wiring and in applying its benefits to buildings in use or soon to be erected. The Okonite Company, Passaic, New Jersey.

**OKONITE** SINCE 1879

insulated wires and cables for adequate wiring at its best

4410





## FOR THE MODERN STORE ...SPECIFY AN RCA SOUND SYSTEM

**M**ODERN stores need engineered, built-in sound systems. Sales feature announcements boost sales volume—distributed music improves store "atmosphere," builds customer goodwill. Paging facilities permit quick contact of key personnel, special customer services. Inter-communication systems between sales counters, buyers' offices and stockrooms improve merchandise distribution.

RCA Sound Systems are engineered to provide these services with *top* efficiency . . . designed to suit specific needs . . . built of "matched" components that really work together because they're all made by RCA.

An RCA Sound Specialist can help you get the most from a sound installation. Consult the classified section of your telephone directory for your local RCA Sound Equipment Representative. Or write direct to Dept. 10-B, RCA Sound Equipment Section, Radio Corporation of America, Camden, N. J., for specifications and engineering assistance.

### RCA SOUND SYSTEMS FOR MODERN STORES

- ★ Sales feature announcements boost sales volume.
- ★ Soft music improves store atmosphere—builds customer goodwill.
- ★ Paging facilities permit quick contact of key personnel—special customer services.
- ★ Inter-communication systems between sales counters, buyers' offices, stockrooms for credit and stock reports, more efficient material distribution, better over-all merchandising.



**RCA SOUND SYSTEMS**

**RADIO CORPORATION of AMERICA**

**ENGINEERING PRODUCTS DIVISION, CAMDEN, N. J.**

THERE ARE

# 10 Reasons

for specifying the Series W-1100 floor and shower drain

by **WADE**

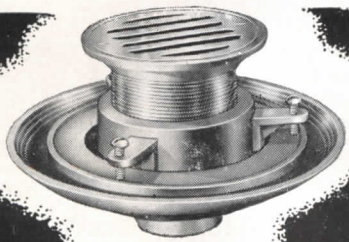

- Only sound, uniform, flawless castings are used.
- The Series W-1100, like all Wade products, represents the finest craftsmanship in machining and finishing.
- Furnished with adjustable strainer to provide for varying floor thicknesses.
- Positive clamping rings prevent flashing crimping.
- A longer shank for greater adjustment with shank and body with standard threads.
- Supplied with standard pipe threads carefully gauged for a tapped outlet, or with a long and extra wide caulking shoulder for a hubbed outlet; convenient for caulking tools.
- More and larger weepholes, cast integrally—high enough so waterproofing won't plug them up.
- Conforms to Government Specification WW-P-541a, Fig. 106 and paragraph 39-E and also to Veteran's Administration Specifications for Type C drains.
- Scientifically engineered to provide the greatest protection, long life and easy installation.
- Maximum dollar for dollar value.

## WADE

MANUFACTURING COMPANY

DRAINS AND PLUMBING SPECIALTIES  
ELGIN, ILLINOIS

There are many reasons for specifying the complete line of Wade products.

Floor Drains • Roof Drain • Backwater Valves • Swimming Pool Drains and Equipment • Traps and Cleanouts • Grease Interceptors • Water Hammer Arresters

# Make 10 types of prints with Ozalid

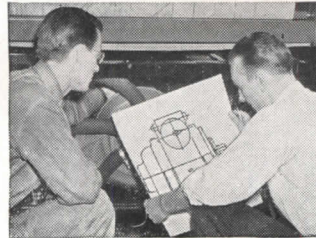

### The Job:

Part of this design must be changed before production can begin.

### The Ozalid Print For The Job:

OZALID TRANSPARENT CLOTH because an extremely durable "intermediate" print is desired. The obsolete lines on the print can be removed with Ozalid Corrector and the new design drawn in. The TRANSPARENT CLOTH intermediate is then used to produce the desired number of prints for the production line.

### THE 10 TYPES OF OZALID PRINTS

For efficiency in routine jobs • For "impossible" jobs

- |                            |                            |
|----------------------------|----------------------------|
| 1. Black-line              | 6. Sepia-line intermediate |
| 2. Blue-line               | 7. Transparent cloth       |
| 3. Red-line                | 8. Transparent foil        |
| 4. Opaque cloth            | 9. Chartfilm               |
| 5. Transblack intermediate | 10. Dryphoto               |

Write for Free Samples of Ozalid's Ten Types and complete information.

## OZALID

Division of

General Aniline & Film Corporation • Johnson City, N. Y., U. S. A.  
OZALID IN CANADA—HUGHES-OWENS CO., LTD., MONTREAL

## Fine Houses — Beautifully Stained



Architect, H. H. Livingston

### IT'S THE CREOSOTE IN CABOT'S STAINS

... that makes these famous quality stains give better protection. While ordinary stains contain little or no creosote, Cabot's Stains contain from 60% to 90% creosote—the best wood preservative known. That's why Cabot's Stains penetrate deeper, protect longer and give lasting beauty. They are also easy to apply, cost less than paint, come in a great variety of colors—Cabot's weathering grays, for instance, give that authentic "old look" in six months.

FREE BOOKLET ... COLOR CARDS. Send today for your free copy of "Stained Houses" containing full information and illustrations.

## SAMUEL CABOT, INC.

Manufacturing Chemists

1278 Oliver Bldg.

Boston 9, Mass.



## HORN FOLDING BLEACHERS and PARTITIONS

Hundreds of High Schools, Colleges and Armories have installed Horn Folding Bleachers and Electrically Operated Folding Partitions for greater flexibility of gym layout.

Our experienced engineers are at your service, Mr. Architect.

See Sweet's Catalog for Horn Details and Specifications

Dept. 111

## HORN MANUFACTURING COMPANY

FORT DODGE, IOWA

# DUAL FUNCTION · DOUBLE SERVICE

The architect who seeks double value in decoration for his client, automatically turns to FABRON, fabric wall covering, for here he finds a combination of decoration and structural protection.

FABRON offers great latitude of expression to the architect's composition with its wide range of colors, textures and patterns. In hospitals, FABRON has pioneered the modern concept of color therapy. To these, as well as to schools, hotels and institutions, it offers not only appropriate decoration, but also ease of maintenance, permanency, and economy, with the additional factor of structural protection which insures the entire initial investment.

## Fabron THE FABRIC AND PLASTIC WALL COVERING!



FABRON, with its canvas foundation, plastic body, and lacquer paint surface, protects walls and ceilings, conceals wall blemishes, and prevents plaster cracks. It cleans easily with soap and water, and can even be disinfected—thereby reducing maintenance costs. Its durability eliminates expenditures for periodic redecorations. The investment value of these economies is greatly appreciated by institutions and remains a permanent testimonial to the architect's good taste and business judgment.

We shall welcome an opportunity to tell you more about FABRON if you return the accompanying coupon.

MANHATTANVILLE COLLEGE OF THE SACRED HEART  
Administration Building New York, N. Y.



HOTEL ST. MORITZ NEW YORK, N. Y.  
Personal Direction: S. GREGORY TAYLOR  
EMERY ROTH, Architect



- easy to apply
- easy to clean
- sunfast colors
- resists scuffing
- prevents plaster cracks
- permanent decoration

FREDERIC BLANK & Co., Inc. AR 2-46  
230 Park Ave., New York 17, N. Y.

Re: .....

In connection with the above project, please send me complete information and cost of FABRON.

Name.....

Address.....

City..... (Zone.....) State.....

FREDERIC BLANK & COMPANY, INC., 230 PARK AVENUE, NEW YORK 17, N. Y.

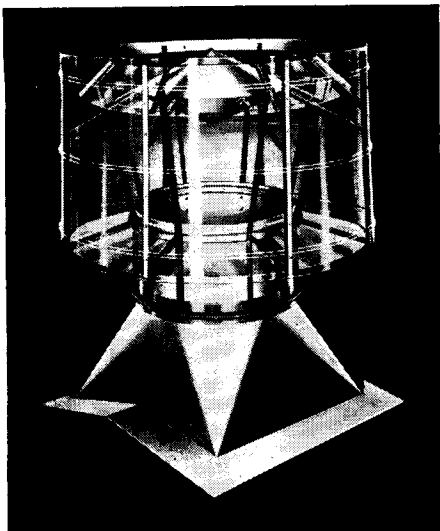

THE  
LEADER  
IN ITS  
FIELD FOR  
10 YEARS  
•  
NOW  
FURTHER  
IMPROVED

## BURT Free-Flow Gravity Ventilators are Top Buys

Burt's "K-Frame" in larger sizes gives the new Free-Flow even greater strength, longer service life and easier erection than before. It's a top value — one of Burt's complete ventilating line. Write for data sheets.

**THE BURT MFG. CO.**

ROOF VENTILATORS • OIL FILTERS  
EXHAUST HEADS

188 So. Main St., Akron 11, Ohio

SEND  
FOR CATALOGS

Burt Engineers  
are glad to  
help on plans

## A MARK OF QUALITY

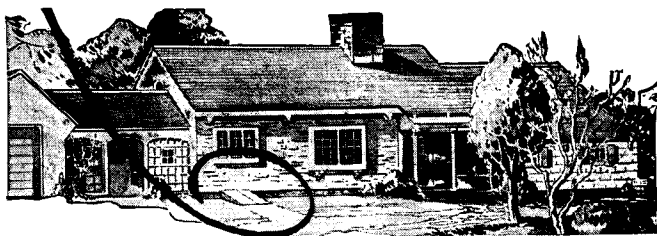

### in home cellar construction

If you want the convenience and safety of an accessible cellar . . . If you want a leak-proof, burglar-proof, termite-proof and permanently trouble-free cellar door which will always be a source of satisfaction to you . . . buy

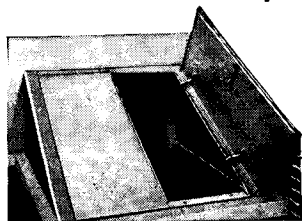

**BILCO**

COPPER STEEL

### BULKHEAD DOORS

A Sound and Sensible Investment  
ASK YOUR DEALER or write  
BILCO MFG. CO.

164 Hallock Ave., New Haven, Conn.  
SIDEWALK AND BULKHEAD DOORS • STEEL ROOF SCUTTLES



AUTOMATIC  
SAFETY  
CATCH

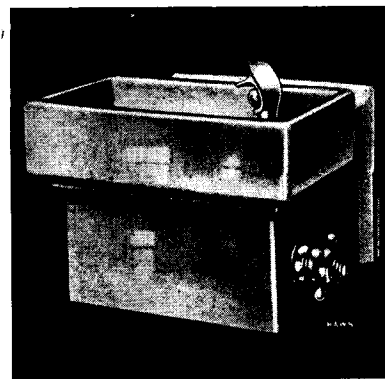

## HAWS DRINKING FOUNTAINS

. . . assure complete sanitation in drinking water facilities. Refreshing drinking water aids in maintaining good health, and good health brings efficiency and better production. Specify and install HAWS sanitary Drinking Water Fountains and Electric Ice Water Coolers and obtain complete and lasting drinking water satisfaction.

Write for Catalog Today!

## HAWS DRINKING FAUCET CO.

Since 1909

1808 Harmon Street

Berkeley 3, California

AGENTS AND SALES REPRESENTATIVES IN ALL PRINCIPAL CITIES

## ORCO SAFETY TREADS AND FLOORING

For permanent safety under foot specify ORCO Safety Treads and Flooring. Non-slip when wet. Resilient. Sound absorbing. Durable.

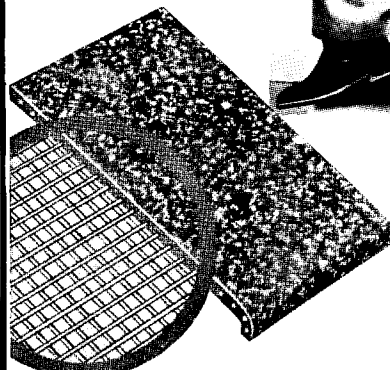
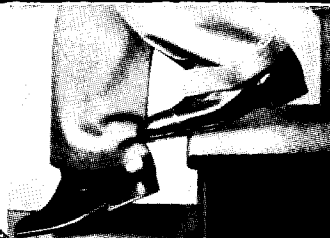

Construction of standard 1/4-in. ORCO Safety Tread shown at left. Uniformly distributed abrasive grain (in nosings) and abrasive aggregate (in flat surface of tread) "locked" permanently in semi-resilient rubber base reinforced with 1/4-in. galvanized wire mesh.

ORCO Safety Treads are furnished in specified widths up to 143/16-in. and in lengths up to 84-in. inclusive. Standard thickness 1/4-in. ORCO Safety Flooring (Hard or Soft type) furnished in specified sizes up to 22-in. x 84-in. Thicknesses 1/4-in., 3/16-in. and 1/8-in. Standard colors for both treads and flooring: BLACK-BUFF-GRAY-RED. Installed by soft flooring contractors. WRITE FOR COMPLETE DETAILS.

FOR FURTHER  
INFORMATION



**The Ohio Rubber Company**

SAFETY TREAD AND FLOORING DIVISION

100 BEN HUR AVE.

WILLOUGHBY • OHIO

# BURNHAM'S NATIONAL ADVERTISING ON BASE-RAY

*Radiant Heating in...*

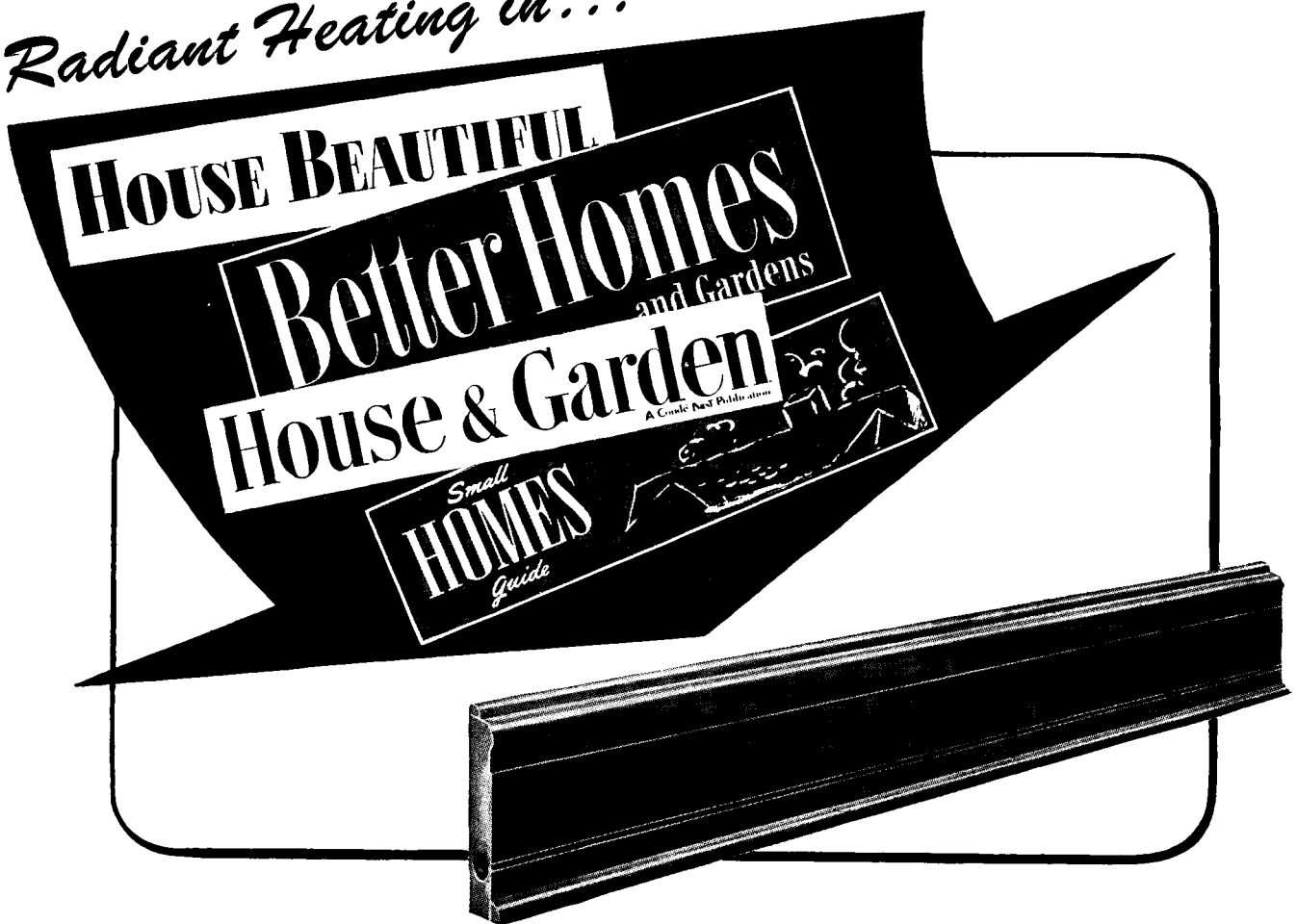

## **MEANS BUSINESS for You**

For months now we have been telling your customers about the advantages of heating their homes with Base-Ray Radiant Baseboards.

The response has been terrific. Thousands of home owners all over the country have written us for further details and have received our literature on BASE-RAY.

There is already a huge potential market for this new and improved method of Radiant Heating — a method which is practically invisible, amazingly efficient and

so completely "out of the way" that rooms become 100% livable.

As an architect, you will require certain information before starting your specifications covering Base-Ray installations. To be fully informed, write for our special folder, "Ratings and Installation Guide on Base-Ray".

This illustrated folder gives a graphic, detailed description of Base-Ray — tells all you need to know in order to incorporate Base-Ray in your plans.

*Burnham Boiler Corporation*

IRVINGTON, N. Y., Dept. AR 26

Export Department

50 CHURCH ST., NEW YORK 7, N. Y.



**Make a Mistake?**  
(WHO DOESN'T)



**USE A.W. FABER'S  
"ERASER STIK"**

Wood-encased eraser looks like a pencil—sharpens like a pencil—yet is the most convenient, most useful all-purpose eraser ever invented. Tens of thousands are in use.

#7099 Without Brush  
#7099B With Brush

Equally good for pencil, ink or typewriter. You can point it with a knife or in a mechanical sharpener. The beauty of it is that it costs no more than a conventional eraser. If your dealer doesn't have 'em, write to A. W. Faber, Inc., Newark 4, N. J.



**A.W. FABER Inc.** NEWARK, N. J.



**U. S. MAIL CHUTES**

are essential in progressive apartments and hotels.

This little Miss prefers to mail her own letters and so do her parents.



*This equipment may be leased if desired*

ESTABLISHED 1883

**Cutler Mail Chute Co**  
ROCHESTER 7, N. Y.

*We are ready*

**MINNEAPOLIS HONEYWELL**

CONTROL *Systems*

*Balsam-Wool*

**APPLICATION DATA SHEETS . . .**

**YOURS FOR THE ASKING**

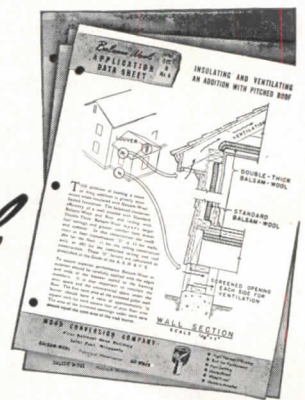

Unusual applications of Balsam-Wool Sealed Insulation—details difficult to obtain elsewhere—are contained in this series of Balsam-Wool Application Data Sheets prepared by the makers of the original sealed blanket type insulation. A complete set of these data sheets is yours for the asking. Write for them.

**WOOD CONVERSION COMPANY**

Dept. 115-2, First National Bank Bldg., St. Paul, Minn.

**BALSAM-WOOL • Products of Weyerhaeuser • NU-WOOD**

# ZONOLITE CONCRETE USED FOR 130,000 SQ. FT. OF ROOF ON NEW NAVY OFFICE BLDG.

John McShain, Inc., Philadelphia, Pa., Builder  
Insulating Concrete Corp., Washington, D.C., Sub-Contractor

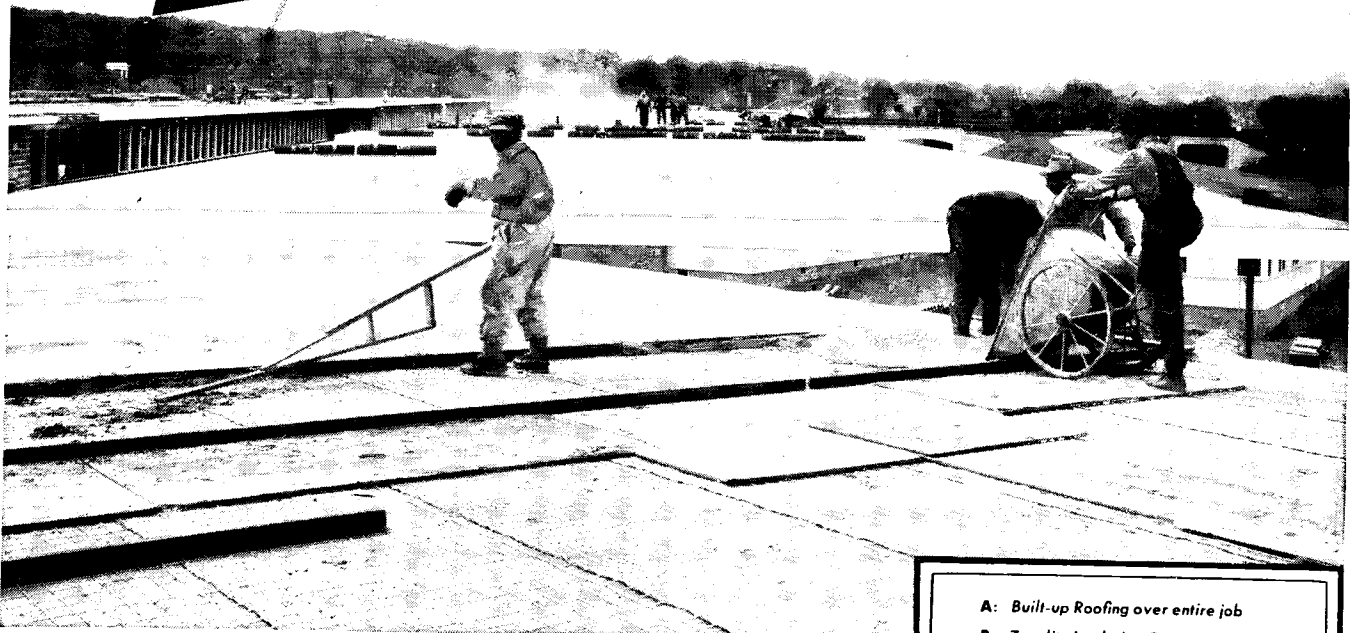

## ZONOLITE Insulating Concrete Roofs are Permanent.. Rotproof.. Fireproof.. Lightweight

This wide-spreading new Navy Office Building has three bays (834' x 61', 638' x 61' and 442' x 61') with Zonolite Concrete laid over Steel-tex. Zonolite Concrete Aggregate, a lightweight, fireproof, permanent insulation, was chosen to help speed the roof construction.

More and more architects are specifying Zonolite Concrete roofs for America's leading corporations—in-

dustrial buildings, office buildings, stores—schools and institutions—hotels and apartments.

Zonolite Concrete insulates against heat, cold and sound. It is easily formed into cants, saddles and slopes to give proper roof drainage. Coupon below will bring all details of what Zonolite Concrete is (with complete physical properties) and how used (full illustrations and drawings).

- A: Built-up Roofing over entire job
- B: Zonolite Insulating Concrete Roof Fill
- C: Concrete Roof Deck

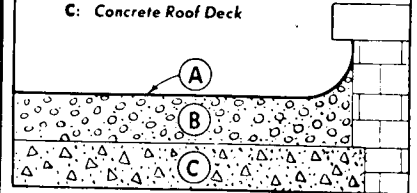

### DETAILS OF TYPICAL ZONOLITE ROOF CONSTRUCTION

While the Navy Building, shown above, has Zonolite Concrete laid over Steel-tex, many types of buildings have Zonolite Roofs constructed as in diagram.

UNIVERSAL ZONOLITE INSULATION CO., Dept. AR-26, 135 S. La Salle St., Chicago 3, Ill.

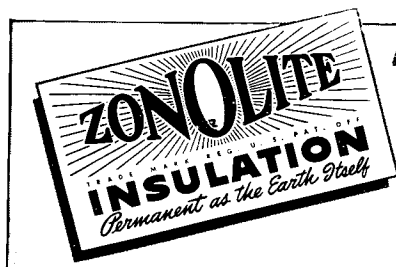

Mail Coupon for  
**FREE**  
**86-PAGE**  
**BOOK!**

UNIVERSAL ZONOLITE INSULATION CO.  
Dept. AR-26, 135 S. La Salle St., Chicago 3, Ill.

Gentlemen: Please send me your 86-page manual on Zonolite Concrete. Also literature on Zonolite Plaster and Granular Fill Insulation.

Name.....

Address.....

City..... Zone..... State.....

Please check:  Architect  Engineer  Draftsman  Contractor

## For LOW COST INSURANCE

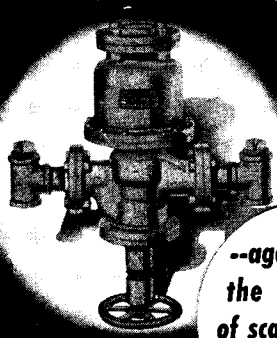

--against  
the danger  
of scalding water

In shower baths and  
wash fountains

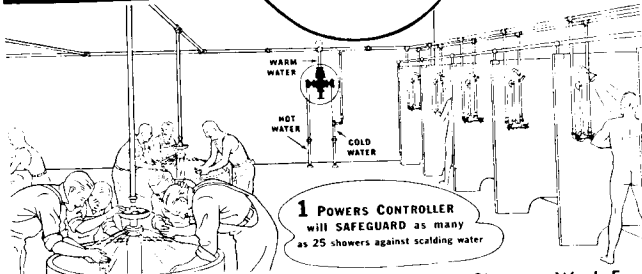

Use Powers Thermostatic Water Controllers for Group Showers, Wash Fountains, Hot Water Line Control and Industrial Processes. Capacities up to 2,650 g.p.m. Write for Circular 3017. THE POWERS REGULATOR COMPANY, 2720 Greenview Avenue, CHICAGO—Offices in 47 Cities. 52A

**POWERS** WATER TEMPERATURE CONTROL

## this is NO TIME FOR A TRIAL BALLOON

There's no need to buy pencils of undetermined origin when you can use the pencils that have already made their mark.

For many years, the KOH-I-NOOR Pencil Factory has been producing pencils uniformly graded in smoothly finished straight grained cedar.

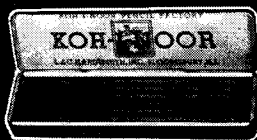

TRY A KOH-I-NOOR TODAY  
THERE ARE NO "STRINGS" ATTACHED

SEND FOR LEAFLET NO. 3



The RIGHT pencil for the RIGHT job  
KOH-I-NOOR PENCIL COMPANY, INC., BLOOMSBURY, NEW JERSEY

## The BOMB in your REFRIGERATED SPACES

### is MOISTURE

It ruins your products,  
coats your coils with  
ice, increases re-  
frigeration costs.



### The opening in The Jamison Vestibule Door

is always closed unless filled with passing goods or men. It reduces refrigeration loss and moisture inrush to the minimum. Use it on busiest doorways.



**JAMISON**  
COLD STORAGE  
DOOR CO.

Jamison, Stevenson and  
Victor Doors  
HAGERSTOWN, MD.

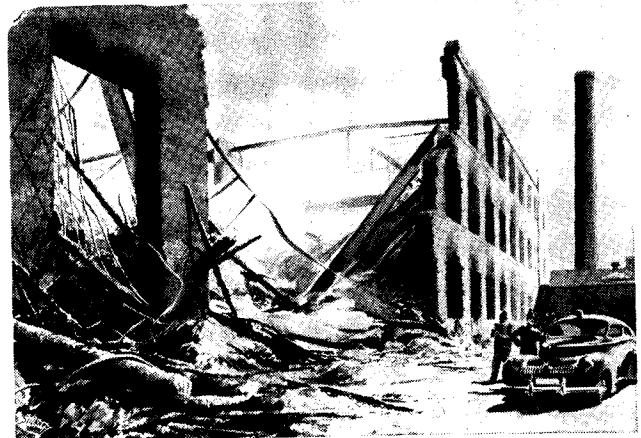

## What Does "FIREPROOF" Mean?

The architect, the builder and the building inspector all said this building was fireproof. And they were right! The building didn't burn... it collapsed under the intense heat from the combustible contents.

Modern fireproof construction alone can't prevent this hazard in a busy plant filled with equipment and materials. It takes automatic sprinkler fire protection, too... positive, ever-vigilant Grinnell Systems

that stop fire at its source.

Grinnell Systems are your best guardians... built by the world's leader in fire protection... prefabricated to Grinnell-engineered layouts... proved dependable by 8000 fires killed in the past ten years!

Experienced engineers from a nearby Grinnell office will be glad to work with you or, write Grinnell Company, Inc., Executive Offices, Providence, Rhode Island.

# GRINNELL

Automatic Sprinkler Fire Protection





this heater moves in  
*bag and baggage*—no  
building to do on the job

When these heaters are built, the combustion chamber—refractory material and all—is built right into them so that each heat producing unit is shipped from the factory complete. When gas or oil is the fuel to be used it is only necessary to connect to the fuel supply and to a power line, and the heating plant is ready to function. For the complete story on Dravo Direct Fired Heaters ask for Bulletin 509-A. Address  
DRAVO CORPORATION, 300 Penn Avenue,  
Pittsburgh, 22, Pa.



**THIS IS OUR**  
*Famous*  
**TRADE-MARK** 

... the reason for you to  
depend on "F & M" products

Largest selling line of Pipe Hangers,  
Supports and Accessories.

Backed by a guarantee whose integ-  
rity has never failed for 54 years ...

For safety and customer satisfaction  
look for the "F & M" trademark on  
every article.

Ask Your Jobber and Write for Catalog

**FEE & MASON MANUFACTURING CO., INC.**  
81 Beekman Street, New York 7, N. Y.

Sales Offices in Principal Cities

**"F & M" Enjoys Wide  
Consumer Acceptance  
From Coast to Coast**

**SPOT**  
REG. U. S. PAT. OFF.  
**SASH CORD**

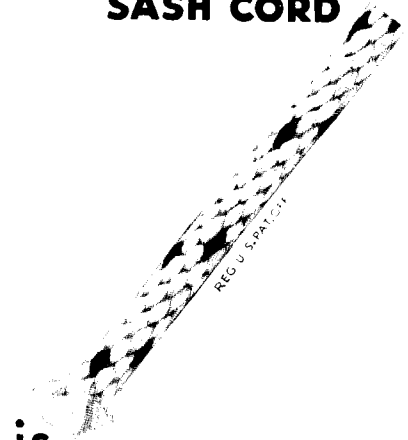

is  
**TOPS**  
in Value



**SAMSON CORDAGE WORKS**  
BOSTON 10, MASS.

**Duromit**  
THE "BONDED" CEMENT FLOOR

DUROMIT is the hardest cement floor in existence. A mixture of hard mineral granules, it registers 9 points on the Mohs Scale of Hardness. Specify DUROMIT, with its three year Bonded Guarantee, for all places subjected to unusual abrasion, excessive moisture, or varied forms of chemical attack. Easily cleaned and highly sanitary, DUROMIT Floors are perfect floors for food processing, dairy and bottling plants, automotive and mechanical establishments, garages, etc.

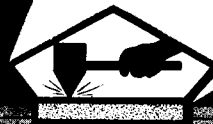

Write for further information, or phone  
Chickering 4-6782

EMPIRE STATE  
BUILDING

**WASHINGTON CONCRETE CO.**

NEW YORK  
N. Y.



---

# **PETRO** is "logical equipment for apartments"

• • • REPORTS THIS HOUSING AUTHORITY

**GEORGE G. MILLER**, well-known New York architect, is a recognized authority on housing. He has a long list of fine apartments to his credit, including a large housing development for two hundred families in Bridgeport, Conn.

Among the outstanding modern apartments for which Mr. Miller has specified Petro Oil Burning Systems are those located at 50 East 191st Street, Bronx; 311 East 55th Street, New York; Queens Boulevard and 76th Road, Queens; and a new garden apartment in East Orange, New Jersey. Based on his many years' experience, Mr. Miller finds that:

"Petro provides the clean, quiet, efficient oil heating system which is required by those who live in apartment houses. Owners find, too, that overhead is cut down because a janitor is not needed to check an oil burner, and in these days of janitor shortage this is extremely important. For our future apartment building, Petro Systems will be logical equipment to use."

**MR. MILLER'S REMARKS** briefly summarize the advantages of a *good* oil heating system. His reference to Petro as the logical equipment for future apartment building is a significant indication that he regards Petro as the *best*.

This endorsement can be attributed to three factors in particular: a superior design inherent in Petro equipment resulting from four decades of experience in making oil burners to serve the needs of all types of structures from the smallest bungalow to the largest commercial and industrial building; a wide range of burner capacities that permits the exact sizing of equipment to the installation for which it is recommended; and a correctly engineered installation that assures the peak performance, outstanding dependability and economy for which Petro equipment is well-known.



**INDUSTRIAL MODELS:** No. 5 or No. 6 fuel oil; automatic, semi-automatic or manual operation; 8 sizes to 450 bhp. "Thermal Viscosity" preheating.

**DOMESTIC MODELS:** No. 3 or lighter oils; "conversion" and combination-unit types; 7 sizes. "Tubular Atomization." (Patented.)

**FULL DATA** on Petro Industrial Burners are in Sweet's and Domestic Engineering catalog files. Details on Petro domestic burners available in separate catalog. Copy of either sent gladly on request.

# **PETRO**

REG. U. S. PAT. OFF.

**cuts steam costs**

**PETROLEUM HEAT AND POWER COMPANY • STAMFORD, CONNECTICUT**  
*Makers Of Good Oil Burning Equipment Since 1903*

---



**MILCOR**  
**STEEL BUILDING PRODUCTS**  
**MEET SPECIFICATIONS FOR SANITATION**  
**FIRE SAFETY—EASE AND ECONOMY**  
**OF MAINTENANCE—BEAUTY**

*Above: View of Veterans' Hospital, Dayton, Ohio, showing its three connecting wings.*

*Below: View showing detail of the main entrance in the central wing.*

Veterans' Hospital installation includes Milcor Metal Lath . . . Milcor Bull Nose Corner Beads . . . and Milcor Window Stools.

Whenever your designs and specifications for hospitals and other structures incorporate Milcor Fireproof Building Products, you provide the advantages of *plaster-on-steel* — and assure yourself of finished jobs that remain assets to your reputation. These advantages are important: Fire safety — guarding both lives and property. Space economy. Favorable sound transmission properties. Crack and impact resistance — assuring permanent beauty of plaster walls. Sanitation, for health. • The Milcor organization has the experience and "know how" to help you attain especially satisfactory results with fireproof construction. In metal lath, corner beads, metal trim, casings, and window stools, Milcor leads the field. • Consult the Milcor catalog in Sweet's or write for the Milcor Manual.

**MILCOR STEEL COMPANY**

MILWAUKEE 4, WISCONSIN

Chicago 9, Illinois • Kansas City 8, Missouri • Rochester 9, New York  
 Los Angeles 44, California • Baltimore 24, Maryland

F-253



Only Milcor makes interior metal trim with an *Insulmat* lining that effectively minimizes sound reverberation.

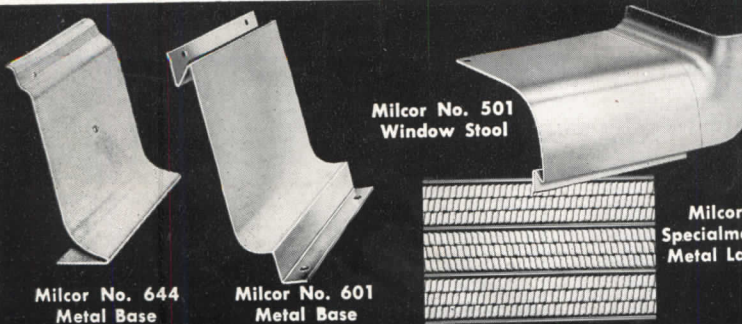

Milcor No. 644 Metal Base

Milcor No. 601 Metal Base

Milcor No. 501 Window Stool

Milcor Specialmesh Metal Lath

Profile of Bull Nose Corner Bead No. 11 Showing Reinforcement

Milcor No. 11 Expansion Corner Bead