

NORTH CAROLINA NATIONAL BANK—PARK ROAD BRANCH, BY WOLF ASSOCIATES
SPLIT-LEVEL VEST POCKET HOUSING IN THE BRONX BY GIOVANNI PASANELLA
BUILDING TYPES STUDY: THE CORPORATE OFFICE
ARCHITECTURAL ENGINEERING: THREE SOLUTIONS TO OPEN-PLAN SCHOOLS
FULL CONTENTS ON PAGES 4 AND 5
SEMI-ANNUAL INDEX ON PAGES 257-260

ARCHITECTURAL RECORD

JUNE 1973

6

A MCGRAW-HILL PUBLICATION THREE DOLLARS PER COPY



A floor that's practical, quiet, and comfortable can also be beautiful. Quiet Zone™ proves it.

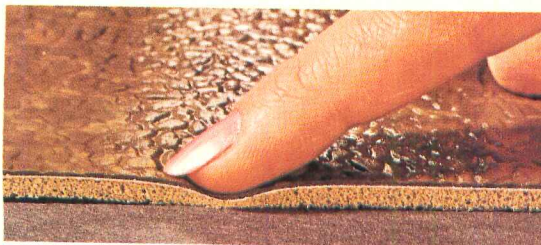

What's so practical about Quiet Zone?

A heavy-duty wear layer of Vinyl Corlon® stands up to heavy-duty traffic. We've even reinforced it with a tough layer of glass-fiber-reinforced vinyl to resist impact damage. And virtually non-porous vinyl has excellent stain resistance. Spills wipe right up. That's what's so practical about Quiet Zone.

What's so quiet and comfortable about Quiet Zone? Look at the inset picture. A 125-mil-thick backing of foam vinyl helps to muffle the sounds of footsteps and falling objects. It makes standing and walking more comfortable. But it isn't too soft, either. Seams stay sealed, and moveable furniture moves easily on it.

OK, fine. Now what's so beautiful about it?

Quiet Zone's new Grand Central design blends nicely into practically any decor. It is richly textured and comes in an appealing selection of colors. What's more, it helps disguise seams, subfloor irregularities, dirt, and traffic marks. That's the beauty of Quiet Zone.

Quiet Zone. So soft and quiet you wouldn't think it's vinyl. So tough and long wearing you know it has to be.

FROM THE  INDOOR WORLD® OF

Armstrong

For more data, circle 1 on inquiry card

For more information on Quiet Zone, write Armstrong, 304 Rock Street, Lancaster, Pa. 17604.

NAME _____

COMPANY _____

ADDRESS _____

CITY _____ STATE _____ ZIP _____

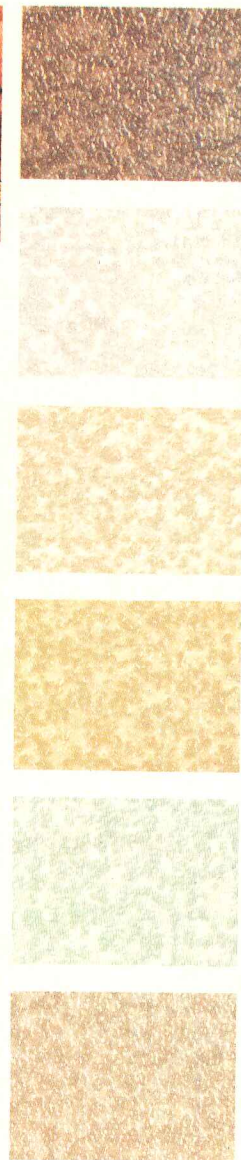

**What makes
these ceilings
right for this job?**

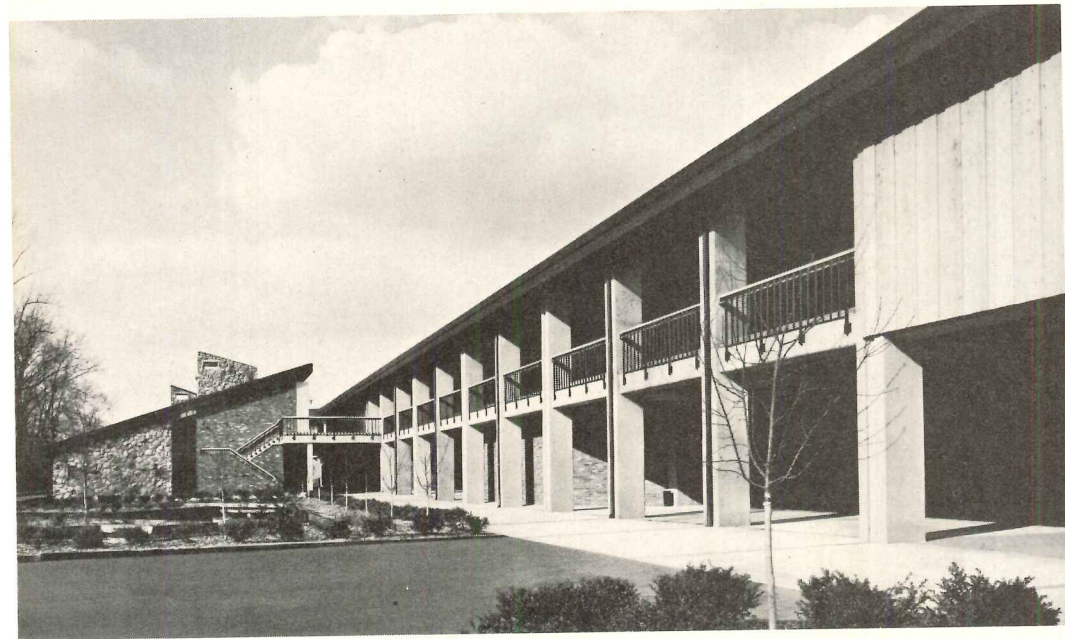
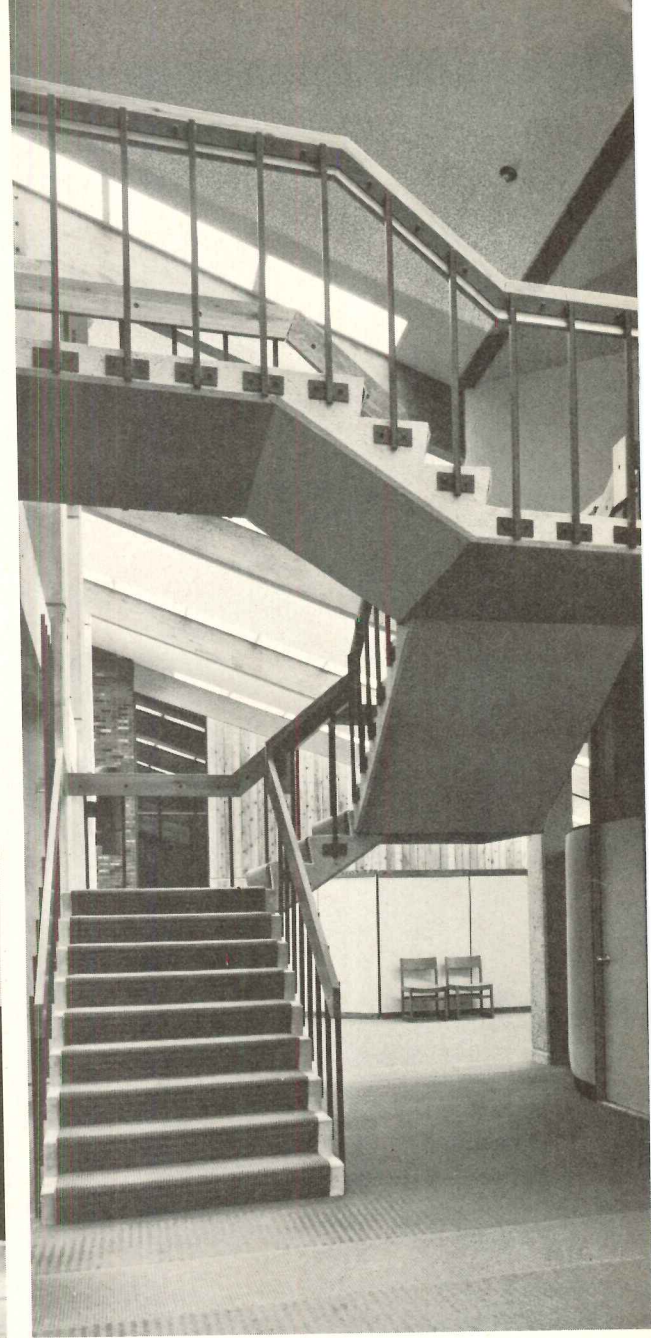

The way they combine modern lighting efficiency with an architectural heritage.

Today it's the Brookdale Community College, but once it was the Brookdale horse farm, home of the 1915 Kentucky Derby winner, Regret. Sold to Monmouth County in 1968, the architects decided to maintain the rustic feeling of the 200-acre farm, remodeled the barns, and built new additions with the farm as a theme.

In the first-floor open learning area of the new building, the Armstrong Luminaire Ceiling System, with its 60" x 30" grid and vaulted modules, harmonizes perfectly with the exposed structural framework, fulfilling both lighting and acoustical requirements.

And in the resource center, on the second floor, the architects built a sweeping barn-like roof and installed Armstrong Travertone™ in the textured Sanserra design for the ceiling.

Here are new ceilings that complement an architectural heritage. A nice combination.

For information about Armstrong Ceiling Systems and how they work, write today to Armstrong, 4206 Rock Street, Lancaster, PA 17604, or call your Armstrong representative. In Canada, write Armstrong Cork Canada, P.O. Box 919, Montreal 101, Quebec.

For more data, circle 2 on inquiry card

FROM THE  INDOOR WORLD® OF
Armstrong

OWNER: Board of Trustees of Brookdale Community College, Monmouth County, New Jersey
ARCHITECTS: The Shaver Partnership, Salina, Kansas, and Michigan City, Indiana;
Office of Bernard A. Kellenyi, Red Bank, New Jersey
GENERAL CONTRACTOR: Hall Construction Company, Little Silver, New Jersey
MECHANICAL/ELECTRICAL ENGINEER: Thomas S. Beers, Red Bank, New Jersey
CEILING SYSTEMS CONTRACTOR: Jacobson and Company, Inc., Elizabeth, New Jersey

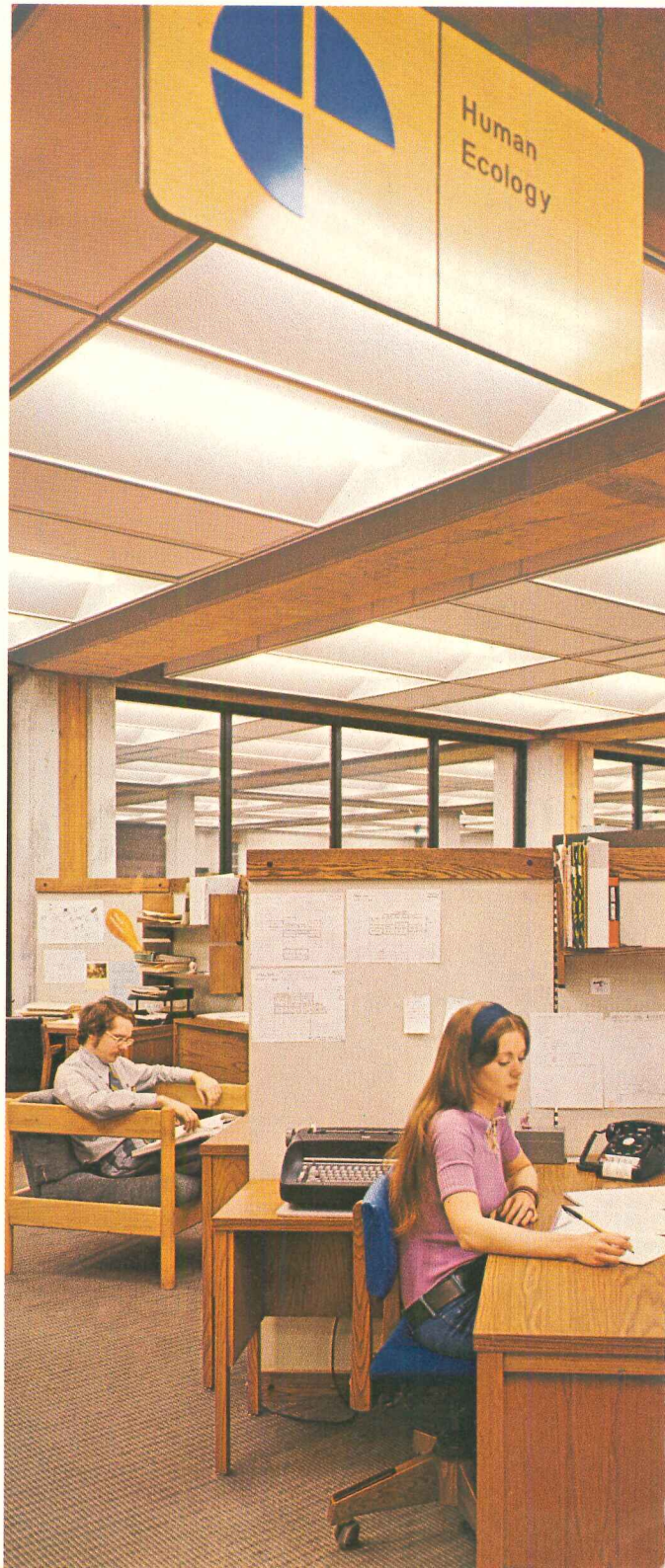



Cover: North Carolina National Bank
Park Road Branch, Charlotte, North Carolina
Architects: Wolf Associates
Photographer: Gordon Schenck

EDITOR

WALTER F. WAGNER, JR., AIA

MANAGING EDITOR

HERBERT L. SMITH, JR., AIA

SENIOR EDITORS

ROBERT E. FISCHER
WILLIAM B. FOXHALL
MILDRED F. SCHMERTZ, AIA
ELISABETH KENDALL THOMPSON, FAIA

WASHINGTON EDITOR

ERNEST MICKEL, Hon. AIA

ASSOCIATE EDITORS

BARCLAY F. GORDON
CHARLES E. HAMLIN

ASSISTANT EDITORS

GERALD ALLEN
CHARLES K. HOYT
ANNETTE K. NETBURN

DESIGN

ALEX H. STILLANO, Director
ALBERTO BUCCHIANERI, Associate
ANNA-MARIA EGGER, Assistant
MURIEL CUTTRELL, Illustration
J. DYCK FLEDDERUS, Illustration
JAN WHITE, Consultant

EDITORIAL CONSULTANTS

EDWARD LARRABEE BARNES, FAIA
JONATHAN BARNETT, AIA, Urban design
GEORGE A. CHRISTIE, JR., Economics
ROBERT F. HASTINGS, FAIA
PAUL RUDOLPH, FAIA
DAVID STEWART, Foreign architecture
L'Architecture d'Aujourd'hui, Paris

McGRAW-HILL WORLD NEWS

WALTER A. STANBURY, Director
10 domestic and 8
international news bureaus:
Bonn, Brussels, Buenos Aires,
London, Milan, Moscow, Paris,
Tokyo.

SALES MANAGER

LOUIS F. KUTSCHER

CIRCULATION MANAGER

HUGH S. DONLAN

PUBLISHER

BLAKE HUGHES

THE RECORD REPORTS

9 Editorial

Some first impressions from
the San Francisco convention

33 News in brief

Short items of major national
interest as well as award-winners
and announcements. Special this
month, a summary of convention events.

34 News reports

In this issue, the entire
news section is devoted to
events in and around the 105th
national AIA convention in
San Francisco.

45 Buildings in the news

AIA honor awards announced
at convention and R. S.
Reynolds Memorial Architecture
Award presented. Official
unveiling of The Architects
Collaborative design for the
new Johns-Manville headquarters
in Denver (below).

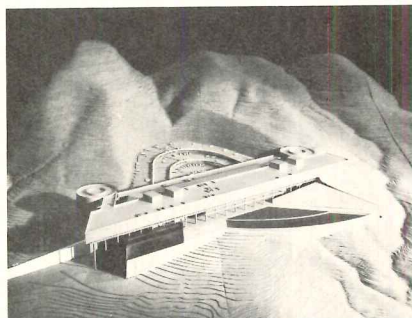

51 Required reading

56 Letters

ARCHITECTURAL BUSINESS

65 Cincinnati Airport: proving ground for youth and method

A task group of young architects,
average age 31, within the firm
of Heery & Heery, demonstrated a
whole roster of important ideas
and methods in the design of the
Greater Cincinnati Airport:
The inventiveness of youth, of course;
the effectiveness of the Heery
group-reorganization; how the
structured control of time, cost and
quality really works; flexibility
of the systems approach to design.

69 Construction management

Application of a single owner-architect
commission for design and construction
management to the Cincinnati Airport
project, with some of George Heery's
reflections on the general process.

71 Building costs

Some square-foot costs have trebled
in the last 25 years, according to
a Dodge bulletin showing biggest
gains in institutional types.

73 Building activity

Project data points up diversity
in construction, according to
Jim Carlson's report this month.
Factors of difference among
nonresidential projects are
noted with comment.



ARCHITECTURAL RECORD (Combined with AMERICAN ARCHITECT, ARCHITECTURE and WESTERN ARCHITECT AND ENGINEER)

June 1973, Vol. 153, No. 7. Title ® reg. in U.S. Patent Office © copyright 1973 by McGraw-Hill, Inc. All rights reserved. Copyright not claimed on front cover and editorial four-color separations. Indexed in Reader's Guide to Periodical Literature, Art Index, Applied Science and Technology Index, Engineering Index, and The Architectural Index. Published monthly except May and October when semi-monthly, by McGraw-Hill, Inc.

Quotations on reprints of articles available. Every possible effort will be made to return material submitted by possible publication (if accompanied by stamped, addressed envelope), but the editors and the corporation will not be responsible for loss or damage.

EXECUTIVE, EDITORIAL, CIRCULATION AND ADVERTISING OFFICES: 1221 Avenue of the Americas, New York, N.Y. 10020. Other Editorial Offices: 425 Battery Street, San Francisco, Cal. 94111; 1249 National Press Building, Washington, D.C. 20004.

PUBLICATION OFFICE: 1221 Avenue of the Americas, New York, New York 10020. Second class postage paid at New York, New York 10001 and at additional mailing offices.

OFFICERS OF McGRAW-HILL PUBLICATIONS COMPANY: John R. Emery, president; J. Elton Tuohig, executive vice president-administration; David J. McGrath, group publisher-vice president; senior vice presidents: Ralph Blackburn, circulation; John R. Callahan, editorial; John B. Høglund, controller; David G. Jensen, manufacturing; Gordon L. Jones, marketing; Jerome D. Luntz, planning & development.

FEATURES

111 A portfolio of works
by **Wolf Associates Architects**

This young North Carolina firm has in recent years produced an impressive array of buildings, interiors, and other designs. Presented here are examples which illustrate the variety as well as the quality of their work.

121 "Vest pocket" housing brings a new scale to the Bronx

Recently completed low- and middle-income housing projects designed by Giovanni Pasanella and constructed by the New York State Urban Development Corporation and the New York City Housing Authority are a measure of the validity of two current design approaches—scatter-site location and split-level dwelling units within the high-rise.

129 Rehabilitation of La Place Royale Quebec City, Canada

What may prove unique in the restoration of North American historic sites is the rehabilitation of a large section of the "lower town" of Quebec City, where work is proceeding steadily toward the reclamation of 78 buildings dating from the 17th and 18th centuries.

133 Phoenix Civic Plaza

Phoenix Civic Plaza is refocusing the city on its downtown area, once all but deserted in the "rush to the suburbs" of the 50's and 60's. The Plaza is a complex of two buildings—Convention Center and Symphony Hall—set in a landscaped plaza with a parking garage beneath.

BUILDING TYPES STUDY 449

139 The corporate office

In the midst of an office building boom, corporations are asking for image, expansion potential and employee comfort. Architects are finding ways to produce better offices, often at cost savings.

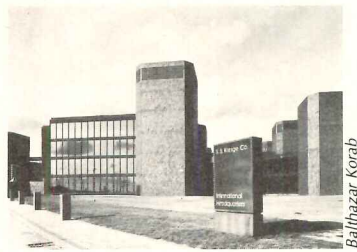

Balthazar Korab

140 S. S. Kresge Company International Headquarters

Troy, Michigan
by Smith, Hinchman & Grylls Associates, Inc.

144 E. R. Squibb & Sons, Inc. Worldwide Headquarters

Lawrenceville, New Jersey
by Hellmuth, Obata & Kassabaum, Inc.

148 C. Brewer & Company, Ltd.

Hilo, Hawaii
by Ossipoff, Snyder, Rowland & Goetz

150 Doubleday & Company, Inc.

New York, New York
by Jack Gordon

152 Burroughs Corporation World Headquarters

Detroit, Michigan
by Smith and Gardner

ARCHITECTURAL ENGINEERING

155 Three open-plan schools: inventive solutions in design, engineering techniques and materials

Architects Carlin & Pozzi responded to three highly individualized sets of clients' programs with design solutions that show considerable ingenuity. By reason of economics, fire codes and architectural objectives, the lighting, the structures, and the mechanical systems are all different—each suiting the particular set of programmatic requirements.



Robert Perron

177 Product Reports

179 Office Literature

189 A/E Update

215 Personal Business

257 Semi-annual Index

262 Advertising Index

264 Classified Advertising

265 Reader Service Inquiry Card

CORPORATION OFFICERS: Shelton Fisher, president; Wallace F. Traendly, group president—McGraw-Hill Publications Company and McGraw-Hill Information Systems Company; John J. Cooke, senior vice president and secretary; Ralph S. Webb, treasurer.
SUBSCRIPTIONS: Subscriptions solicited only from architects and engineers. Position, firm connection, and type of firm must be indicated on subscription orders; CHANGE OF ADDRESS or subscription service letters should be forwarded to Fulfillment Manager, ARCHITECTURAL RECORD, P.O. Box 430, Hightstown, N.J. 08520. Provide old and new addresses, zip code or postal zone number. If possible, attach issue address label. Annual subscription prices: U.S., U.S. possessions and Canada: \$9.00 for architects, engineers and other individuals in the fields served, all others \$20.00. Other countries: \$22.00 to architects, engineers; others \$30.00. Single copies \$3.00.

GUARANTEE: Publisher agrees to refund that part of subscription price applying to unfilled part of subscription if service is unsatisfactory.
ASSOCIATED SERVICES/McGraw-Hill Information Systems Co.: Sweet's Catalog Files (Architectural, Light Construction, Interior Design, Industrial Construction, Plant Engineering, Canadian Construction), Dodge Building Cost Services, Dodge Reports and Bulletins, Dodge/SCAN Microfilm Systems, Dodge Management Control Service, Dodge Construction Statistics, Dodge regional construction newspapers (Chicago, Denver, Los Angeles, San Francisco).
THIS ISSUE is published in national and separate editions. Additional pages of separate edition numbered or allowed for as follows: Western Section 32-1 through 32-4. POSTMASTER: Please send form 3579 to Fulfillment Manager, ARCHITECTURAL RECORD, P.O. Box 430, Hightstown, N.J. 08520.



telelift[®] is the only

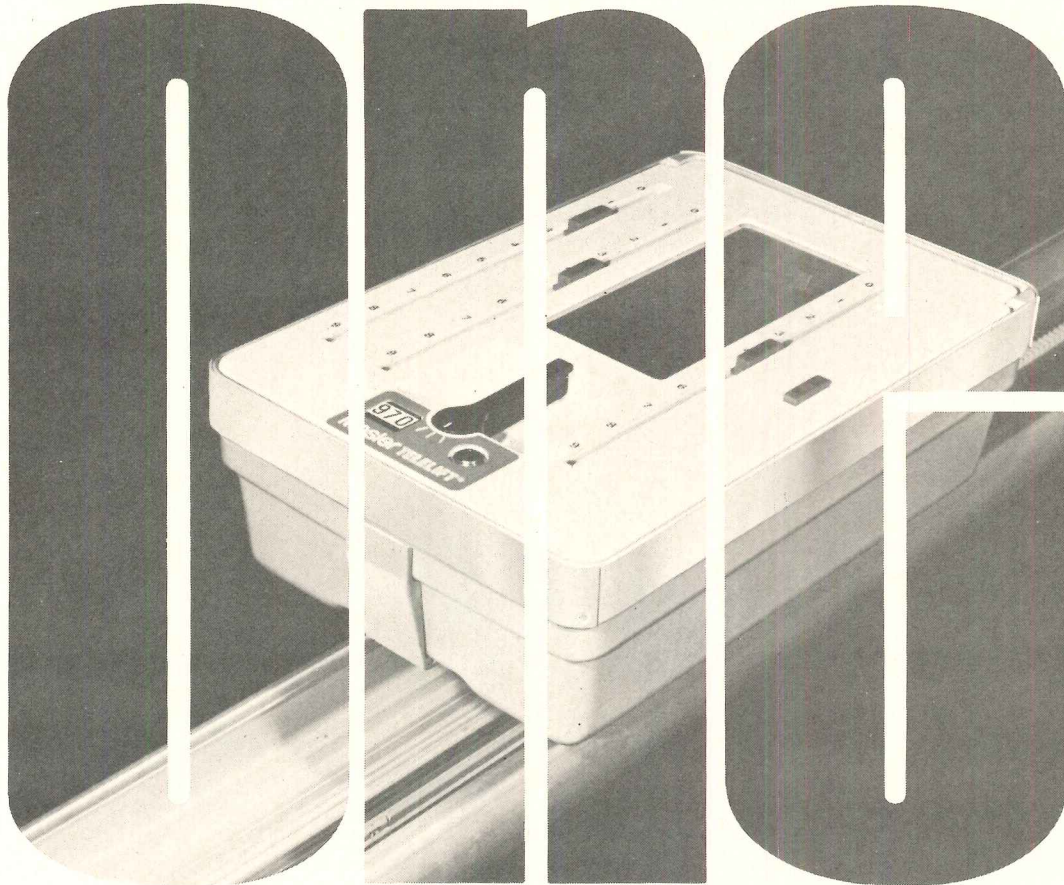

and mosler makes it.

... The only one making it for years

Making it so well that some of the largest financial institutions invested their dollars in a **Telelift** system.

So well that outstanding health care facilities from Toronto to Miami, New York to Honolulu all felt that **Telelift** systems would enhance their ability to provide better patient care.

They, like over one hundred sixty other organizations are profitably utilizing the **only proven**, reliable, totally integrated materials distribution system AVAILABLE in today's market place.

So when you consider **Telelift** as the distribution system for your building, you are buying, as all others did, proof — not promises.

Talk with us. We'll be happy to show you why so many have felt **Telelift is the only one.**

Mosler

An American-Standard Company

MOSLER/AIRMATIC SYSTEMS DIVISION
415 HAMBURG TURNPIKE, WAYNE, NEW JERSEY 07470

TELEPHONE: (201) 278-6300

Telelift is available in section 14.3 of the Sweet's Architectural Catalog File.

For more data, circle 3 on inquiry card



Natural Red

The Spanish accent you can see. Si, Ludowici Spanish roofing tile!

There is always a heavy demand for this most popular, authentic style Spanish Roofing Tile, for many different types of buildings.

Beauty and versatility are part of the reason. The lasting benefits, built-in by Ludowici, make it eminently practical, too. Low maintenance costs are a major attribute. It is also fire-proof and storm-resistant. It affords no foothold for fungus. Weathering simply seasons it into softer beauty.

No other manufacturer, domestic or foreign, matches Ludowici tile in richness of color and hardness of material.

On a lasting value basis, Ludowici Tile compares favorably with the cost of any roofing material. It is truly economical, saving money in replacement and maintenance. Specify Ludowici, and forget roof problems. Permanently.

It's easy to get complete information on all Ludowici Tiles. You can check your Yellow Pages for the local distributor. Sweet's Catalog carries all data. Write to the address below, or have your secretary send the handy coupon.



NORMAN ROOFING TILE

A blend of tiles, in seven subtle earth-tones, to duplicate the centuries-old roofing tile of Normandy. Want your own tile color, shape, texture? Ludowici will custom-make roofing tile to your requirements.

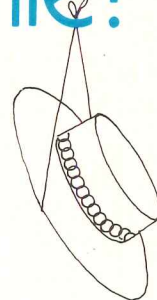

LUDOWICI-CELADON COMPANY

111 E. WACKER DRIVE, CHICAGO, ILL. 60601 • (312) 329-0630

New Products/New Ideas in Tile

Send me a color brochure. I'm interested in custom-made tile.

NAME _____

FIRM _____

ADDRESS _____ COUNTY _____

CITY _____ STATE _____ ZIP _____

For more data, circle 4 on inquiry card

Architects and Consulting Engineers:
Stevenson, Raines, Barrett, Hutton,
Seton & Partners, Calgary.
Educational Consultants: Stanton
Leggett & Associates, Chicago.
General Contractor: Hashman
Construction, Ltd., Calgary.
Heating & Air Conditioning
Contractor: Reggin
Industries, Ltd., Calgary.

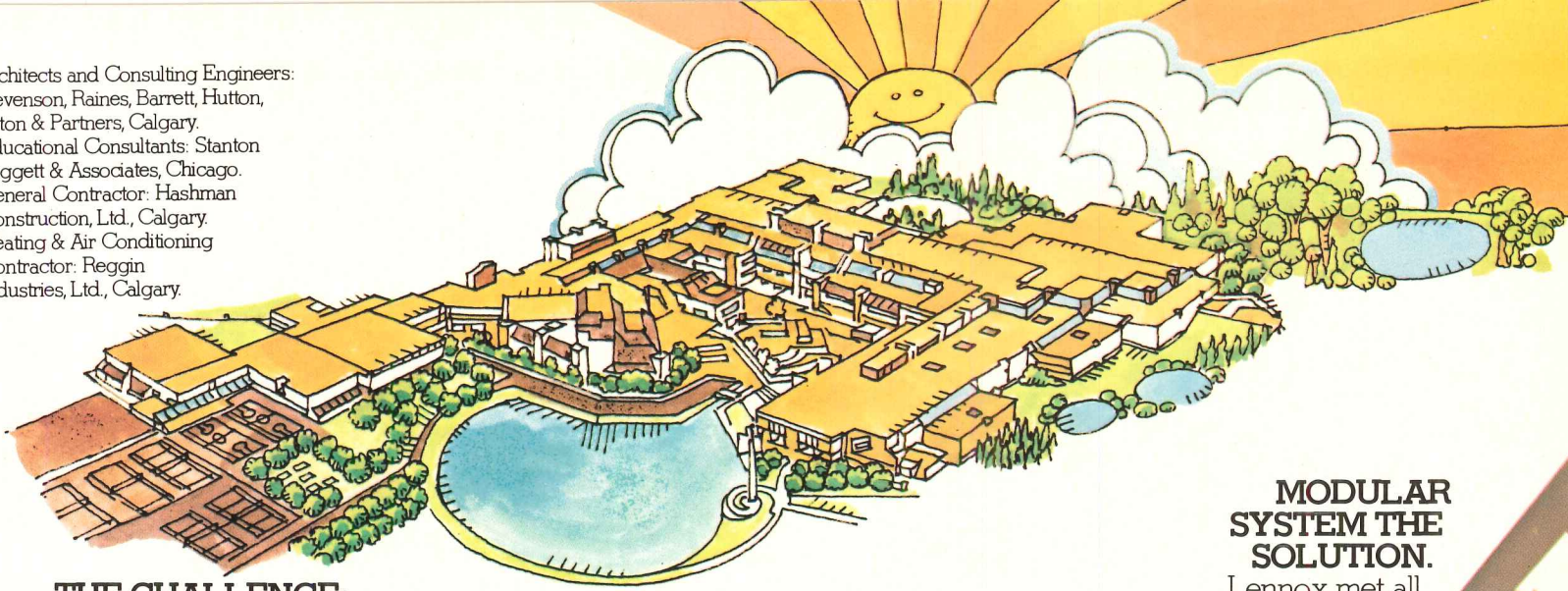

THE CHALLENGE:

Design environmental control for the 14.7 acre building which houses the entire campus of Mount Royal College in Calgary, Alberta, Canada. In this multi-level structure are 641,000 square feet, a wide variety of flexible modules, huge open class rooms, and decentralized service areas.

MODULAR SYSTEM THE SOLUTION.

Lennox met all conditioning requirements with a modular HVAC system employing 80 single and multizone units.

**LENNOX
SPACE
ODYSSEY**

FLEXIBLE SYSTEM.

To accommodate future expansion as well as internal re-structuring, much of the duct work was left exposed. This also complemented architectural appearance.



ON-SITE LABOR REDUCED. The Lennox systems are not only an integral part of the exterior architecture, but, because they were factory assembled and wired, on-site labor was considerably reduced. In fact, the Lennox system was installed for 27¢ per foot less than the budgeted amount.

UNEVEN OCCUPANCY PROBLEM SOLVED. Because Mount Royal is a multi-use community college, occupancy of space is uneven. The Lennox modular HVAC system helps reduce fuel and energy consumption in unoccupied areas.

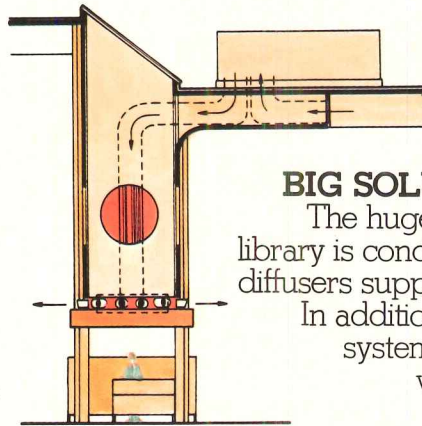

BIG SOLUTION TO BIG PROBLEM.

The huge, sprawling, open learning library is conditioned by 12 cannon-type diffusers supplied by vertical duct work. In addition, a flexible perimeter duct system separately handles exterior wall and window loads.

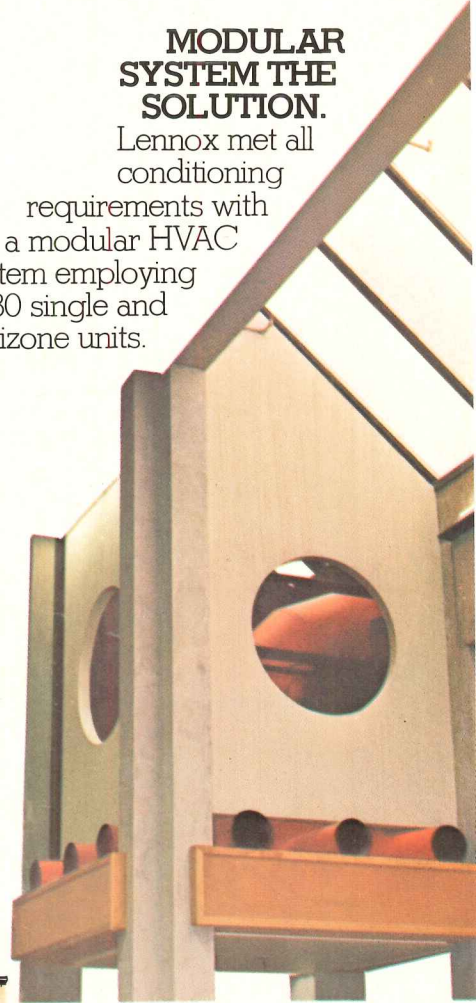

LENNOX[®]

The Lennox modular HVAC system could be right for your next project. For information, write Lennox Industries Inc., 333 S. 12th Avenue, Marshalltown, Iowa 50158.

For more data, circle 5 on inquiry card

Some first impressions from the San Francisco convention

As this is written, the 105th annual convention of the American Institute of Architects, assembled in San Francisco, is in its fourth day. In a burst of absolutely atypical irresponsibility, this normally responsible editor accepted a chance to tour housing in Europe with a group of building industry executives and professionals, and thus is leaving the convention one day early. Since press deadlines wait for no man touring the French Riviera with 38 pounds of cameras around his neck and a Pernod in his hand, this must be written before leaving, and there is certainly no time for much reflective thinking about what happened at the convention and what directions it suggests.

Nonetheless, having walked and talked my way through four-fifths of this convention, I have a strong first impression that I wish to share without waiting a whole month for another shot at this page.

It is my strong feeling that there was more talk about design—about architecture and landscape architecture and urban planning—than there has been at a convention for a very long time and I think that's great.

I do not wish to diminish the importance of the many convention sessions related to the serious problems of legislation, building codes, financial management, joint ventures, life-cycle costing, OSHA, professional contracts, professional liability, job budgeting, value engineering, et al that drew the attention of the attendees. I hope you will read the news report on the Convention, which begins on page 34, and which details the theme sessions and seminars conducted by some exceptionally distinguished men and—for the most part—well attended by the Convention despite some of the most beautiful weather outdoors that most of us had seen for a very long time.

But we know these days that we must, as professionals, deal with new realities of client attitude and cost and constraints, and learn to use the proliferating new tools of prediction and control—and we are doing that. What seems sometimes to be not talked about enough these days is that beginning and ending of what architects have to offer—design.

The city was a catalyst for talk about design

It's not hard to see how this non-scheduled, strong undercurrent of talk about design began at this convention. It begins, if you have any soul, as you approach this lovely city. What enjoyment there is in standing on a busy downtown street and being able to see water alive with boats and green hills beyond. What

enjoyment there is in seeing bold skyscrapers (indeed, a few arrogant skyscrapers) sharing a block with two- and three-story neighbors. What enjoyment there is in seeing crisp and spare contemporary buildings side by side with complex and much-ornamented old buildings. The scale of everything (well *almost* everything) is marvelous. There is color everywhere—in the paint and stucco of the older buildings, in flags and banners, in parks and gardens, in the forecourts of older buildings and the elevated pedestrian ways of the new. The fact that San Francisco is very lucky in the matter of its natural surroundings (if a bit unlucky in the matter of its underpinning) takes nothing from the fact that it has been developed, somehow, with a greater sensitivity to human needs and emotions than most. This city makes you feel good.

I think that the talk about design at the San Francisco convention got started because there is so much design in San Francisco to talk about. There are the marvelous old houses—some a bit shabby now to be sure—leaning against each other on the hillsides. And if there is argument about the Trans-America pyramid and the Bank of America and Embarcadero Center it is good argument because no matter which way minds are changed, architecture becomes more a part of everyday living. And there are so many examples of useful and vital rehabilitation—not just in the showplaces of Ghiairelli Square and the Cannery but in the transformation of everyday Plain Jane three- and four-story buildings (like those that line the deserted streets of a thousand downtowns) which in San Francisco are finding vital new life in the hands of clients with courage and designers who care as much about good old buildings as they do about good new ones.

It has all become pretty expensive these days and I am well aware that this city has many of the same devastating social problems as so many others, but in the design sense maybe the best thing to say is that this city seems to concern itself with its people.

Concern for people was the keynote

The old question—"Who is your client?"—was answered in an elegant way by the keynote speaker, Dr. John T. Caldwell, chancellor of North Carolina State University at Raleigh. I cannot resist quoting liberally from his moving charge to architects: "The architectural profession wherever practiced is a part of the universe of material forces of intellectual disputation, of emotion and searching. How will you as individual practitioners see yourselves in the pull-

—Drawn for ARCHITECTURAL RECORD
by Alan Dunn

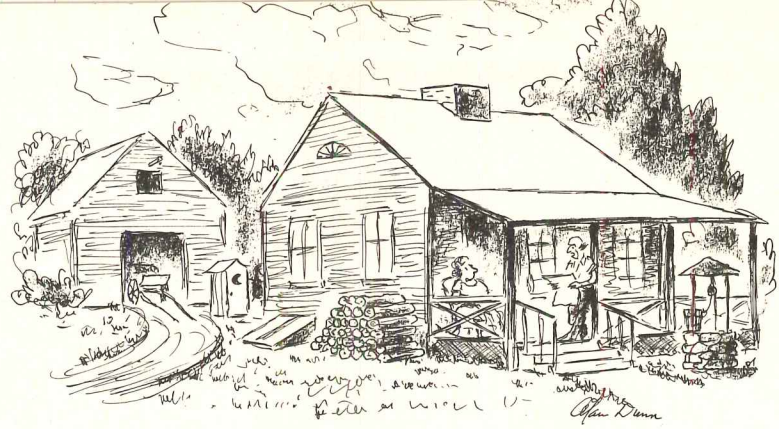

"All you have to do is wait long enough—Here's an award for a design that conserves the most energy—"

ing and hauling between profit incentive and common good, between idealism and practicality? No matter what codes the profession may adopt, the contribution of the profession always rests on the character and motives of the individual practitioner. Whatever skills, whatever talents he possesses, he brings them to each design commission he is given. And with his talent and skill he brings also his moral commitment as a member of the human race.

"If we would each see the fullness of man and respect that image in all our endeavors, then we would transform the work, correct its injustices, remove its frustrations, renew its beauties, and make way for fresh fulfillment. Designers would free their own talents, anchor more solidly their professional integrity and serve more effectively their client."

Dr. Caldwell's closing was, I think, quite remarkably moving and I urge you to read it with care: "You are the architects. Who is your client? Man is your client, the creature who is more than matter, who hungers and thirsts for space that is more than matter. In the space before you which is air and land and water and fabricated structure, it is your clear perception of what man really needs that commits you to be designers worthy of your calling. The space is there and man is there. Can you see him? Please do."

Another catalyst: the \$25 million question

The Honor Awards presentation on opening day had an extra element of high suspense this year that focused the attention of the convention on matters of design quality. First there was the traditional elegant presentation (by jury chairman Pietro Belluschi) of the Honor Award-winning designs. There were 12—six of which, I was pleased to find, RECORD had featured in issues this year or last (see Buildings in the News, page 45).

But a rare kind of excitement was generated by the announcement—immediately following the Honor Awards presentation—of the design competition sponsored by Johns-Manville Corporation for the design of its \$25 million World Headquarters building on an incredibly beautiful 10,000-acre site just outside Denver. Nine architectural firms of the first rank were invited, and offered a \$20,000 fee, to participate in a limited competition for the commission. All did participate (see Buildings in the News, pages 46 and 47, for more details on the competition and photos of the entries).

It is interesting in itself that all who were invited took part—for since the \$20,000 fee would not have covered their costs (much less 2.5 times their costs), they all had to want not just the commission but the challenge of com-

petition in a championship ballgame.

It is also intensely interesting that—given a very complete program developed with great care and completeness by the J-M staff and professional adviser John B. Rogers, the nine firms came up with vastly different schemes that took completely different approaches not just to the design of the building, but to the very complex alternates of siting in a place where nature is almost overwhelming; and to the infinite alternates of how people would reach and use and enjoy the building. So much, it seems to me, for the vogue notion that somehow architecture can be organized into a simpler, more systematized, less creative procedure. The nine very different results from the same starting point of program serve to remind us that what differentiates great buildings from good buildings from ordinary buildings from destructive buildings is—after all the programming inputs have been made from all of the resources available—the skill and talent and commitment of the designers.

At the Awards ceremony, Johns-Manville president Dick Goodwin capped months of work and tension and anxiety for the competing firms (and a lot of intense interest by all other professionals) by making a marvelous ceremony of opening the envelope in which professional adviser Rogers had sealed the name of the winning firm, reading it carefully himself, and then stating—in a solemn tone but with a great grin: "The winning firm is TAC."

The notion that architecture is somehow becoming a grey-flannel suit kind of business was dispelled once more for me by the squeals of delight which burst from Lolly McDonnell and Louise Woods (and, I suspect, a few principals' wives who never would have squealed in a Boston opera house) and by the very semi-professional demeanor of Bill Geddis and Joe Hoskins and John Sheehy and Michael Gebhardt—representing the design team of The Architects Collaborative for this job—as they tumbled grinning from ear to ear to the stage to receive the commission and the news that they were expected in Denver the next morning to get to work. For all of the values of value engineering and life-cycle costing and computer inputs and read-outs, the sheer joy of the winning architects (and the grace with which the others who wanted the commission just as much took their not winning) reminded me once again that while architects want the work (and to be sure, the fee) what they want most is the chance to build *their* building. It reminded me once again that architecture is about talented and creative people and what they can do to serve the needs of other people. Right? Right.

—Walter F. Wagner, Jr.

Now that the ball is over— A look back, a look ahead

By Elisabeth Kendall Thompson, senior editor

To encapsulate in 52 lines of type all the impressions of a convention so large and so varied as was the just past AIA Convention is all but impossible. Having survived helping to steer the 1960 AIA Convention, also held in San Francisco, as well as the 1973 gathering, I find it even harder to put together concisely what it has been like to entertain so many people in so short a period of time. Comparisons may be odious, but they are also interesting and sometimes illuminating.

1973 was, for instance, more than twice as large as 1960 (5,750 registrants vs. about 2400); was much less cohesive, no doubt because of the larger numbers; was spread over more of the city (1960 concentrated everything on Nob Hill); gave visitors far less leisure (there seemed to be at least four times as many programmed events as 1960, and to take in even a fourth of them really crowded each day). In 1960 there was no host chapter party; in 1973 it was, in the end, too big to handle and anyway, was it needed, in a place like San Francisco? The City itself was the party. San Francisco never looked lovelier and never beckoned exploration more provocatively. The real innovation of 1973 was the Field Trip/Seminar series devised by the Northern California Chapter so that architects would not return to their offices having seen only the interiors of a few buildings and a minimum of the spaces between, as regularly and ironically happens at AIA conventions across the country. So successful was this series in giving architects actual on-site experience and information on some of the big issues which have affected the quality and aspect of urban life in the Bay Area that a counterpart will be included as part of the program for the 1974 convention in Washington, D.C. It is to be hoped that Atlanta in 1975 and all the other cities where conventions henceforth will be held will also share their experiences and their accomplishments (or problems) with those who attend conventions. After all, the city is our laboratory, as it is our end product. We can never study it too much, never know it too well. The annual convention is our best means of building a varied and constantly updated fund of knowledge about it.

AIA has demonstrated itself capable of adjusting to change in its members' interest. It would seem to this veteran of conventions large and small, that the convention needs reevaluation as to purpose and as to method, and that now, in this time of change and growth, is the time to do it.

E.K.T.

**A 4-page guide to
the conservation of
natural resources.**

1. ENERGY



**"WINNING THAT ENERGY
CONSERVATION AWARD
WAS A VERY SATISFYING
SURPRISE!"**

Ray Boring said that.

He's the building manager of the Avco Financial Center, Newport Beach, California. This is the tower that won the 1972 Utilization of Energy Award in Southern California.

That, indeed, is a welcome tribute to sound design and materials selection. But that's only part of the profile.

James A. Knowles of James A. Knowles & Associates, the engineering consultants, stated, "We knew we'd cut owning and operating costs with LOF glass." In fact the prediction is that the use of Thermopane® insulating units made with Vari-Tran® coated glass would save Avco almost \$20,000 annually in owning and operating costs when compared to conventional bronze plate glass.

Further, with LOF reflective glass, the owner was able to install smaller fan-coil machinery on the upper 15 floors. This provided a gain of more than 6,000 square feet of rental area.

Ah yes, space, that's another whole story you'll find on the next page.

LOF

Avco Financial Center, Newport Beach, California • Owner: Balboa Insurance Company • Architects: Welton Becket and Associates • Consulting Mechanical Engineers: James A. Knowles & Associates, Inc., Los Angeles • Glazing Contractor: Golden State Glass Company, Los Angeles

2. SPACE

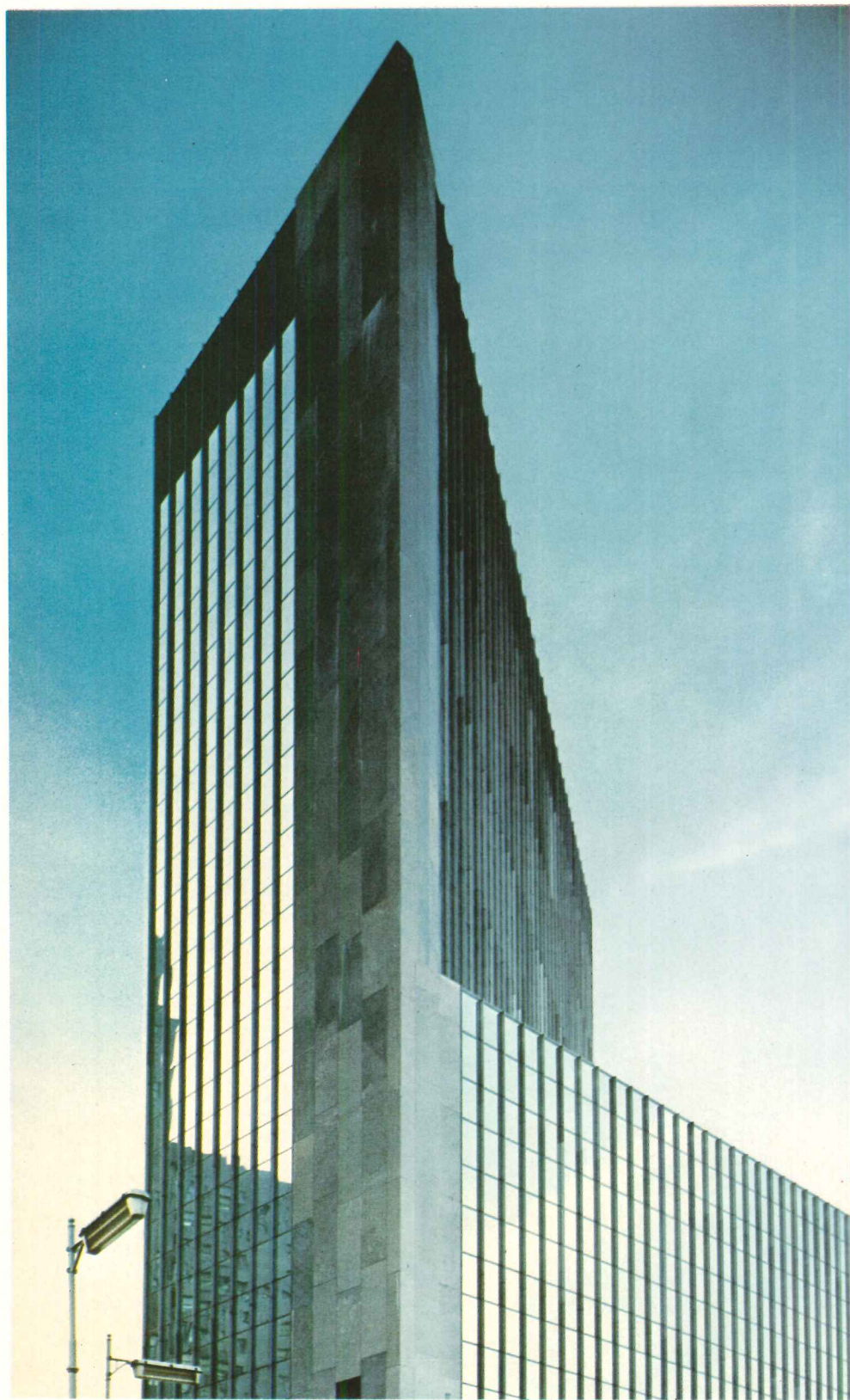

"THE KEY TO GOOD OPERATING EFFICIENCIES IS THE PROPER SELECTION OF AIR SYSTEMS, HEAT RECLAIMING DEVICES AND BUILDING GLASS, LIKE VARI-TRAN!"

LOF glass, according to the designers, saved over \$123,000 in initial construction costs by reducing the size of heating and cooling equipment needed for the 1/4" clear glass.

The building of course is Edison Plaza Building, Toledo, Ohio. The statement quoted above was made by James R. Watt, P.E., Technical Services Manager, Toledo Edison Company.

Mr. Watt went on to say, "To make a building less expensive to own and operate, you sometimes have to use more expensive materials."

Agreed: the 50,000 square feet of Thermopane insulating units made with Vari-Tran coating is not inexpensive glass. But with it the architects incorporated in the design a heat reclaiming variable air volume system that uses heat generated from the interior lighting to heat the structure.

At Edison Plaza, the 8000-plus light fixtures generate more than 5 million BTU per hour—enough to heat 75 average homes. It was found that with proper distribution of this energy, little, if any, auxiliary heat would be needed.

Vari-Tran conserves space.
Vari-Tran conserves energy.

Edison Plaza Building • Owners: Toledo Edison Company • Engineers, Architects, Planners: Samborn, Stekettee, Otis and Evans, Toledo, Ohio

3. AESTHETICS

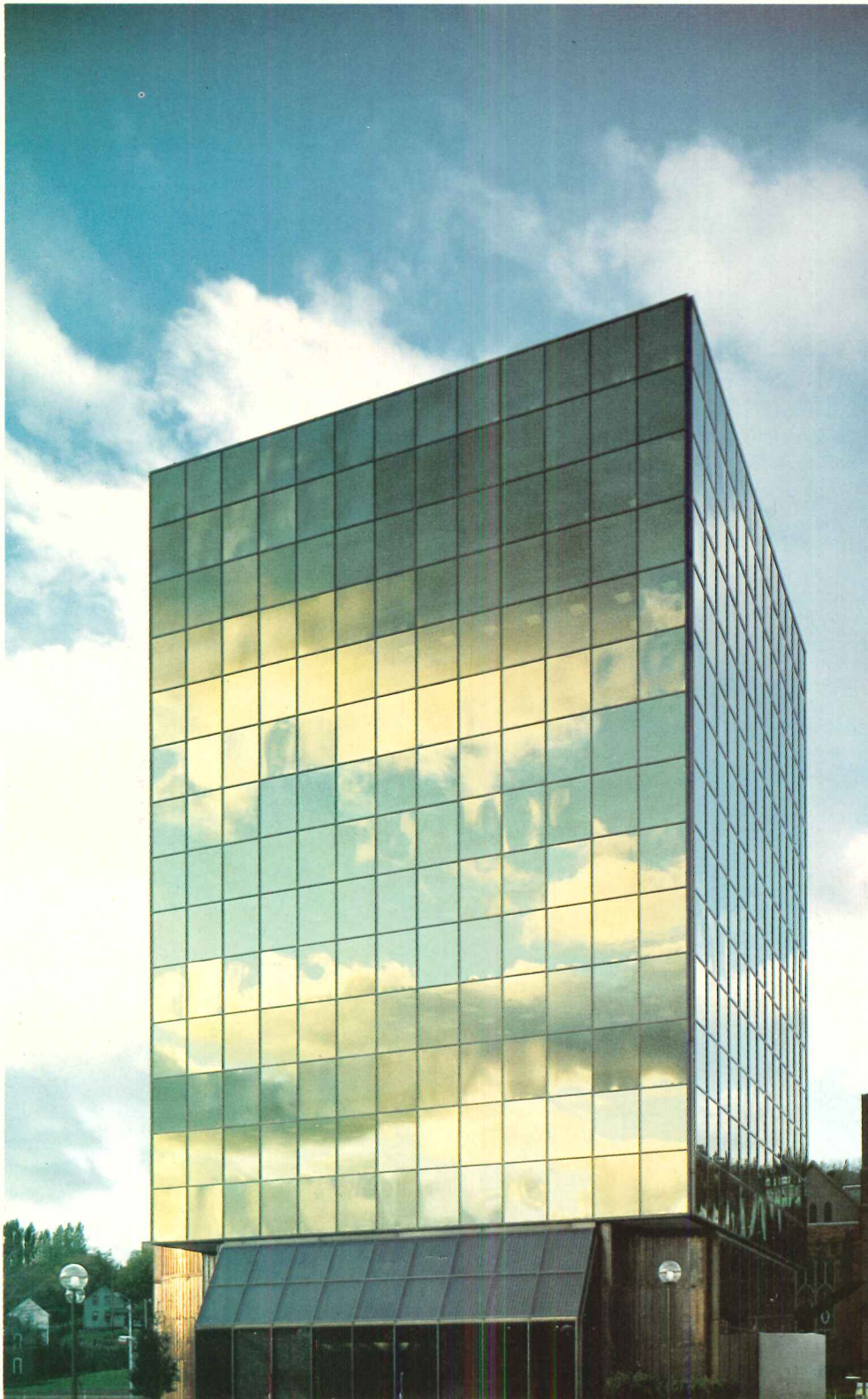

"WE LIKE THE IDEA THAT A BUILDING DOESN'T HAVE TO SEPARATE PEOPLE FROM NATURE TO PROTECT THEM FROM IT."

The area around the Detroit & Northern Savings & Loan Building, Hancock, Michigan, is known as "Copper Country."

Detroit & Northern President, Kenneth Seaton, also stated that they wanted the building to reflect the company's long and close involvement with that area's people and industry. And, "The exterior of the building features copper tones, set off by reflective glass with a golden Vari-Tran coating."

Hancock weather delivers extreme temperatures ranging from 92° down to minus thirty. This demands something special in the way of insulation. And that something special is LOF Thermopane insulating units made with Vari-Tran coated glass.

For not only does this LOF glass insulate against the icy wind of Northern Michigan winters, but it also reduces air conditioning requirements during the summer by cutting down on solar heat gain.

Thermopane with Vari-Tran cuts building operating costs.

Naturally, beautifully.

LOF

Owners: Detroit & Northern Savings & Loan Association, Hancock, Michigan • Architect: Maurice B. Allen, Jr., A.I.A., Tarapata-MacMahan-Paulsen Corporation, Bloomfield Hills, Michigan • General Contractor: Herman Gundlach, Inc., Houghton, Michigan • Glazing Contractor: Cupples Products Div., H. H. Robertson Company, St. Louis, Mo.

4. VARI-TRAN®

1" THERMOPANE INSULATING GLASS WITH VARI-TRAN

DESIGNATION		DAYLIGHT TRANSMITTANCE		DAYLIGHT REFLECTANCE		TOTAL SOLAR TRANS. %	U VALUE BTUH/SQ FT/F	NO SHADING	SHADING COEFFICIENTS				
COLOR	GLASS	%	TOLERANCE	%	TOLERANCE				VENETIAN BLINDS LIGHT	VENETIAN BLINDS MEDIUM	DRAPERIES (Semi-Open Weave) LIGHT	DRAPERIES (Semi-Open Weave) MEDIUM	DRAPERIES (Semi-Open Weave) DARK
SILVER	1-108	7	±1.5	44	±3.0	7	.50	.17	.16	.16	.15	.15	.15
SILVER	1-114	13	±2.0	33	±3.0	14	.50	.26	.23	.23	.22	.22	.23
SILVER	1-120	18	±2.5	27	±3.0	16	.50	.30	.26	.27	.26	.26	.27
GOLDEN	1-208	7	±1.5	28	±3.0	7	.50	.18	.17	.17	.16	.16	.16
GOLDEN	1-214	13	±2.0	26	±3.0	12	.50	.24	.21	.22	.21	.21	.22
GOLDEN	1-220	18	±2.5	24	±3.0	17	.50	.31	.27	.28	.27	.27	.28
BLUE	2-350	45	±5.0	20	±3.0	28	.55	.45	.38	.39	.36	.38	.41
BLUE*	2-350-2	38	±5.0	20	±3.0	20	.55	.44	.37	.38	.35	.37	.40
GREY**	3-108	7	±1.5	11	±2.0	9	.50	.23	.20	.21	.20	.20	.21
GREY**	3-114	13	±2.0	9	±2.0	14	.50	.29	.25	.26	.25	.25	.26
GREY**	3-120	18	±2.5	7	±2.0	20	.55	.34	.29	.30	.28	.29	.31
GREY	3-134	30	±4.0	7	±2.0	29	.55	.47	.39	.41	.38	.40	.43
BRONZE**	4-108	7	±1.5	14	±2.0	7	.50	.21	.19	.20	.18	.18	.19
BRONZE**	4-114	13	±2.0	11	±2.0	11	.50	.27	.24	.24	.23	.23	.24
BRONZE**	4-120	18	±2.5	9	±2.0	15	.55	.31	.27	.28	.27	.27	.28
BRONZE	4-134	30	±4.0	7	±2.0	25	.55	.43	.36	.37	.35	.37	.40

MAXIMUM DIMENSIONS:
ANNEALED GLASS
AREA—7200 Sq. In.
Long Dimension 138"
(100" with Short Dimension
under 16")

DIMENSIONAL TOLERANCES to 48" over 48"
+1/8" +3/16"
-1/16" -1/16"

MAXIMUM DIMENSIONS:
TUF-FLEX® TEMPERED GLASS
AREA—7200 Sq. In.
Long Dimension 100"
Short Dimension 72"
Ratio—Long to Short 6:1

*Inboard light may require tempering.
**Outboard light must be tempered.

Additional thicknesses and combinations upon request.
Vari-Tran Coating on inside of outboard light.

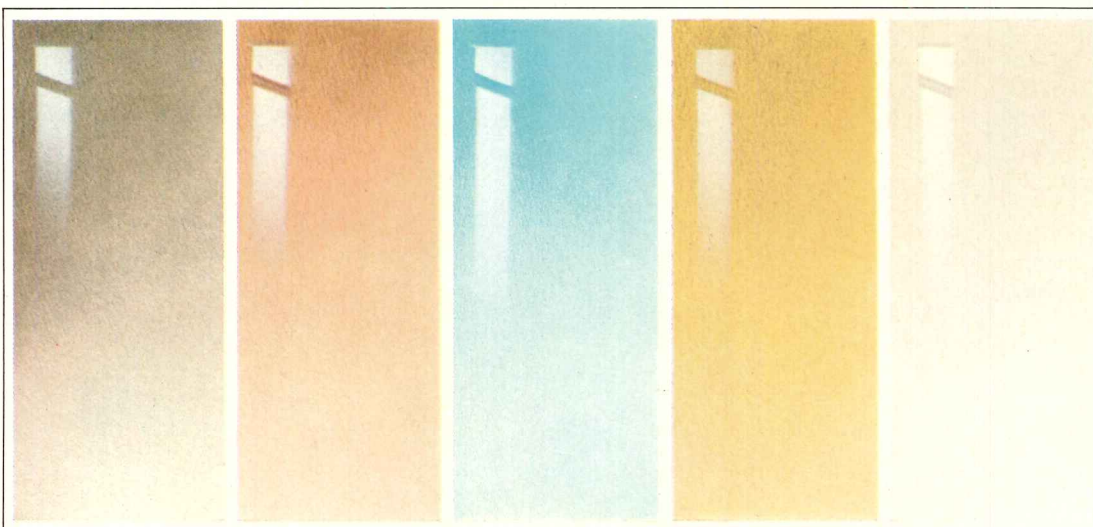

LAMINATED GLASS AND SPANDRELS IN 6 STANDARD HUES

For doorways, low level windows or other access areas where safety or security is a major consideration,

laminated safety glass is offered in 6 standard hues. (Others, on application.) Tempered spandrels are provided in 15 standard hues—to match the vision areas.

For more data, circle 6 on inquiry card

"FIFTY-TWO VARIETIES OF VARI-TRAN OPEN UP A WHOLE NEW SPECTRUM FOR THE ARCHITECT, THE OWNER AND THE BUILDER."

We said that.

We say it in a handy four-color brochure called "Reach for a Rainbow."

In it we include product data and specifications for the 52 varieties of Vari-Tran including the new monolithic and new types of Thermopane.

There's also a geographical guide that lists more than 70 buildings across the country where Vari-Tran is in use, with pictures of many of them.

We'd like you to have a copy of "Reach for a Rainbow." So simply write Libbey-Owens-Ford Company, Dept. R-673, Toledo, Ohio 43695.

Consider it your own guide to the conservation of natural resources.

LOF

DON'T PLAY WITH FIRE.

CCC's New Naturalweave spongebonded carpet has a Class "A" Flamespread rating.

If you're looking at carpet for an office building and it doesn't have a Class "A" flamespread rating—25 or less in the Steiner Tunnel Test—you may be playing with fire. The danger of fire always exists, that's why fire safety standards are becoming more and more stringent. At CCC, we know all about fire safety. We've become experts, because we've installed millions of yards of carpet in offices, hospitals, schools and stores.

Since fire safety is a major concern to us, we've just introduced a fire-retardant, spongebonded carpet with a Class "A" flamespread rating. We call it NATURALWEAVE FLAMEGARD and it meets *all* governmental flamespread standards.

NATURALWEAVE FLAMEGARD is an addition to our heavy duty Densylon Carpet series. It has a five-year wear guarantee and is made of tightly-twisted, densely-packed ANSO nylon bonded to B. F. GOODRICH fire-retardant sponge rubber cushioning. This built-in cushion extends the carpet's wear-life by one-third compared to carpet without padding. It's

guaranteed not to lose resiliency, enhances the carpet's appearance retention, reduces leg fatigue and increases floor safety. Among its other benefits, NATURALWEAVE contains a static control system, is easy to clean and keep clean, and helps cut maintenance costs.

But you get more than just superior carpet from CCC. We're the largest manufacturer of commercial and institutional carpet systems in the country. With CCC, you get SINGLE SOURCE RESPONSIBILITY for every aspect of your carpet projects anywhere in the country, starting with product selection and guaranteed installation through a comprehensive maintenance program that gives you maximum carpet wear-life at minimum life cycle cost. We even know how to effectively integrate carpet with subfloor access systems and can show you how it's done with trench headerducts and handhole covers.

For more information, just fill out the coupon below. CCC's NATURALWEAVE FLAMEGARD...THE SPONGEBONDED CARPET WITH A CLASS "A" RATING.

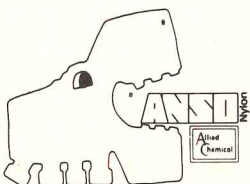

CCC
**Not just carpet,
 but complete
 carpet systems.**

Chicago:
 Merchandise Mart (312) 321-0803
 Los Angeles:
 8899 Beverly Blvd. (213) 274-8171

For more data, circle 7 on inquiry card

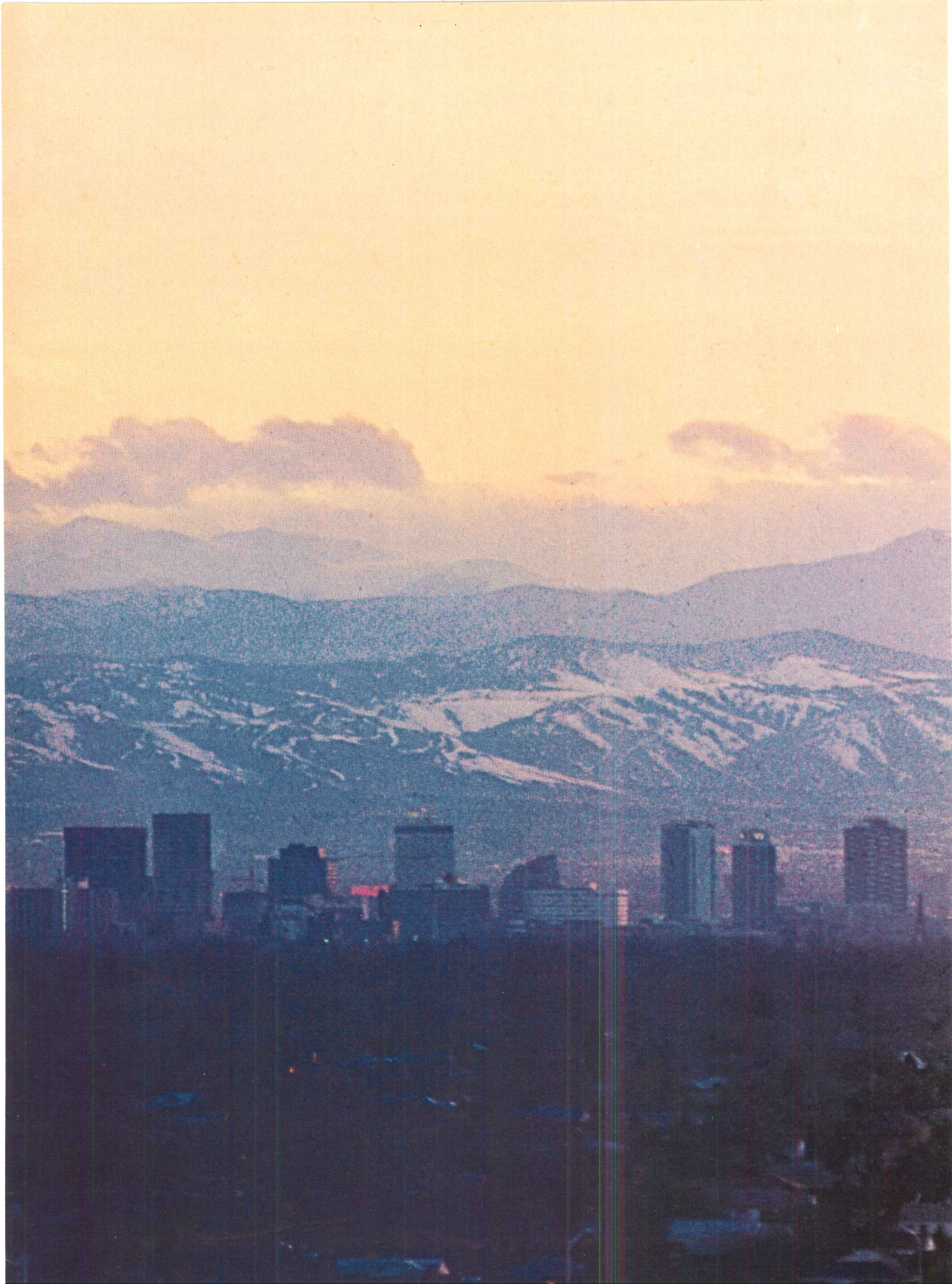

We helped Denver cure its drinking problem.

Denver is a man-made jewel. Implanted neatly into the uncut beauty of the Rockies, it embellishes one of nature's great settings.

As beautiful as Denver's setting is, though, it places the city one mountain away from its water supply. Millions of gallons of fresh water flow daily down the western slopes of the Rockies. But on the eastern side, the Denver side, the air is dry and the water scarce.

In the 1920's, however, this situation was eased. At the cost of 15 million dollars, two tunnels were augered straight through the Continental Divide. One tunnel brought the railroad. The other brought water.

Today, the Moffat Filter Plant supplies the people of Denver with 170 million gallons of water a day. Obviously, the continuous operation of this plant is vital to the city. This is why its power source is so carefully pro-

tected. Protected by two Detroit Diesel Generator Sets.

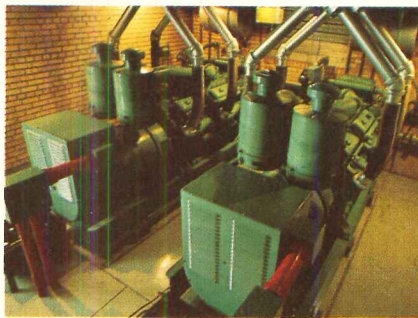

In 1962, the Detroit Diesel Allison Distributor in Denver furnished these twin 16V-71 300 KW standby generators. Detroit Diesels were chosen for three good reasons: 1. These engines have proven their reliability in countless hours of the toughest kind of work. 2. They are basically simple engines; easy and inexpensive to maintain. 3. And most important, the Detroit Diesel Allison Distributor had the know-how to handle the entire job from start to finish.

In the 11 years since they've been in use, these engines have been called upon several times during power

outages in the Denver area. In each case the big 16V's have kicked over right on cue. Without a minute's interruption to Denver's water supply.

Without actually knowing it, the people of Denver depend heavily on these Detroit Diesel engines. And, if part of your job is finding and specifying power that people depend on, then you should find out more about Detroit Diesel Powered Electric Sets.

Just check with your nearest Detroit Diesel Allison Distributor. He'll work with you in every way possible. Actually custom building the exact set for your job. Any job.

To find out more, just clip this coupon and we'll send you the latest catalog on Detroit Diesel Powered Electric Sets.



Detroit Diesel Allison
Division of General Motors
P.O. Box 81, Birmingham, Mich. 48012

NAME _____

COMPANY _____

ADDRESS _____

ZIP _____

GD01-AR-06-AC

Detroit Diesel Powered Electric Sets
Now you're talking power.

For more data, circle 8 on inquiry card



Cor-Ten Steel: The next best thing to nature.

Standing on 20 rolling acres on the outskirts of Madison, Wisconsin, is a new building that could have been designed by Nature herself. It fits perfectly into the environment—yet establishes its own character and dignity on the rural scene.

The Farm Bureau Building, which houses the Rural Insurance Companies, the Wisconsin Farm Bureau and several smaller offices, is a beautiful example of how USS COR-TEN Steel blends with other materials and helps the total structure harmonize with its natural surroundings.

The \$4½ million, 143,580 square-foot building has a USS ULTIMET Steel Curtainwall System and utilizes materials that are easy to maintain:

USS COR-TEN steel, brick and solar glass.

For practical and aesthetic reasons, COR-TEN was a natural choice. It doesn't have to be painted—so it saves maintenance costs. If it ever gets scratched, the surface oxide heals itself! And that rich, russet color actually deepens and becomes more strikingly beautiful as it gets older.

Inside this unique building . . . even more surprises. A fully enclosed atrium, complete with shrubs and trees that reach upwards for four stories, take up about 10% of the interior space. Steel on the interior of the atrium is pre-weathered COR-TEN steel.

The Farm Bureau Build-

ing is another example of the intelligent use of a remarkable steel: USS COR-TEN. It represents the most imaginative expression of contemporary architecture—with due respect for what Nature built first!

For more information, contact a USS Construction Marketing Representative through the nearest USS sales office or write: United States Steel, 600 Grant Street, Pittsburgh, Pa. 15230.

Owner: The Rural Insurance Companies, Madison, Wisconsin
Architects: Peters & Martinsons, Madison, Wisconsin
General Contractor: J. H. Findorff & Son, Inc., Madison, Wisconsin
USS COR-TEN Fabricator: Reinke-Schomann, Inc., Milwaukee, Wisconsin.
USS, COR-TEN and ULTIMET are registered trademarks



Cor-Ten Steel

For more data, circle 9 on inquiry card



After Keene built every commercial lighting fixture you need, what more could we do? We built in added value and beauty.

In all of Keene's lines of indoor, outdoor and special commercial lighting fixtures, you'll find extra value features and greater aesthetic appeal.

In ceiling troffers, for instance. We've designed completely new lines of static, air handling and heat exchange troffers, with combinations of features that give you more fixture for your money. And because each line is complete, it provides you with a single, convenient solution for most of your commercial building requirements, including major architectural buildings.

For showcase areas such as reception rooms, our distinguished Celebrity family of ceiling and wall-mounted fixtures offer you outstanding aesthetic value. Their one-piece injection-molded lenses diffuse light uniformly from all surfaces. Our Stonco outdoor and



Keene outdoor lighting accentuates the classic simplicity of the Hampton National Bank in Hampton, New Hampshire. (Architect: Kenneth F. Parry Associates, Quincy, Mass.).

The Celebrity family of high-decor fixtures enhance high-traffic locations. Available in both ceiling-mounted and wall-mounted models. Ceiling models have straight sides or step-back housings.





New Keene troffer lines offer a unique combination of value features, including rigid construction, zero light leakage achieved without gaskets, captive hinge construction and attractive "floating" frame appearance.

area lighting fixtures combine weatherproof protection and geometric styling.

Sunbeam Lighting, a recent acquisition, specializes in designing fixtures and service units for medical applications. And if you need individualized lighting, Keene

will work with you to custom-manufacture fixtures to meet your design objectives.

Keene does more than make all the types of commercial lighting fixtures you need. We build in all the value and beauty you're looking for.



One example of Keene hospital lighting is this console containing fluorescent fixtures, plus examination and reading lamps.

KEENE
CORPORATION

*Sechrist/Smithcraft/Stonco/
Sunbeam/L&P*

We've just begun to grow.

For further information circle Reader Service numbers: Celebrity fixture 60, custom lighting 61, new troffer line 62, outdoor fixtures 63, hospital lighting 64.

Announcing 4 ways to hide the air conditioning.

Four Carrier all-air Moduline® Systems.

They're all different. Yet they have the hidden talent to work with ceilings of any kind. Built-in controls to eliminate wall thermostats and wiring. Modular makeup to simplify installation and changes. Only one duct to save space through your building. And person-by-person air conditioning to save energy.

Call your Carrier representative and he'll show you all we have to hide. Or write us. Carrier Air Conditioning Company, Syracuse, N.Y. 13201.



No.1 air conditioning maker



The 37P. The original Moduline System with 11½" diffusers. Works beautifully into waffle design ceilings.

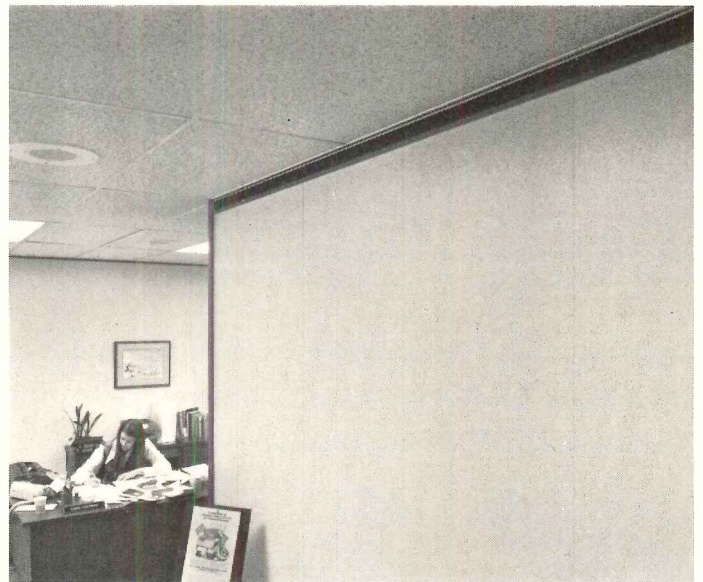

The 37AE. One of three Dual Moduline® units with 3" diffusers that straddle partitions to cool two offices at once.

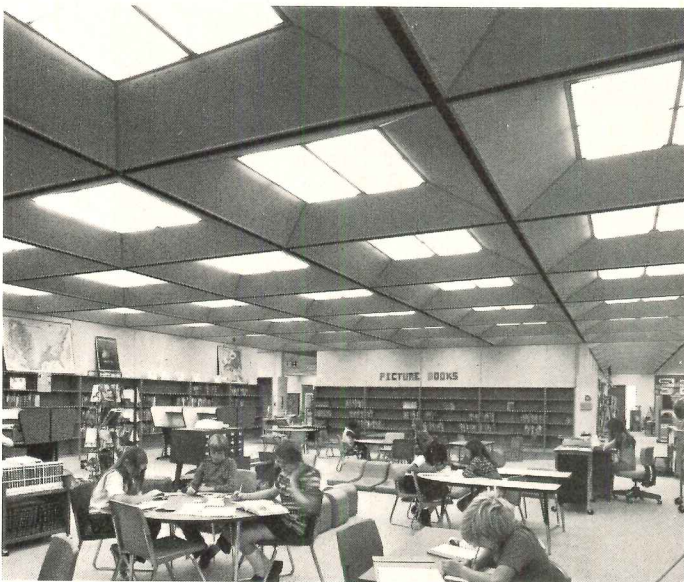

The 37AF (or MM5). The lightest dual-room cooler. Perfect for 2' x 4' tees, ideal for schools and clinics.



The 37AD. The unique Split-Plenum unit. Heats out of one side, cools out of the other. Lets you use all-ceiling units all over.

Handsome Heritage

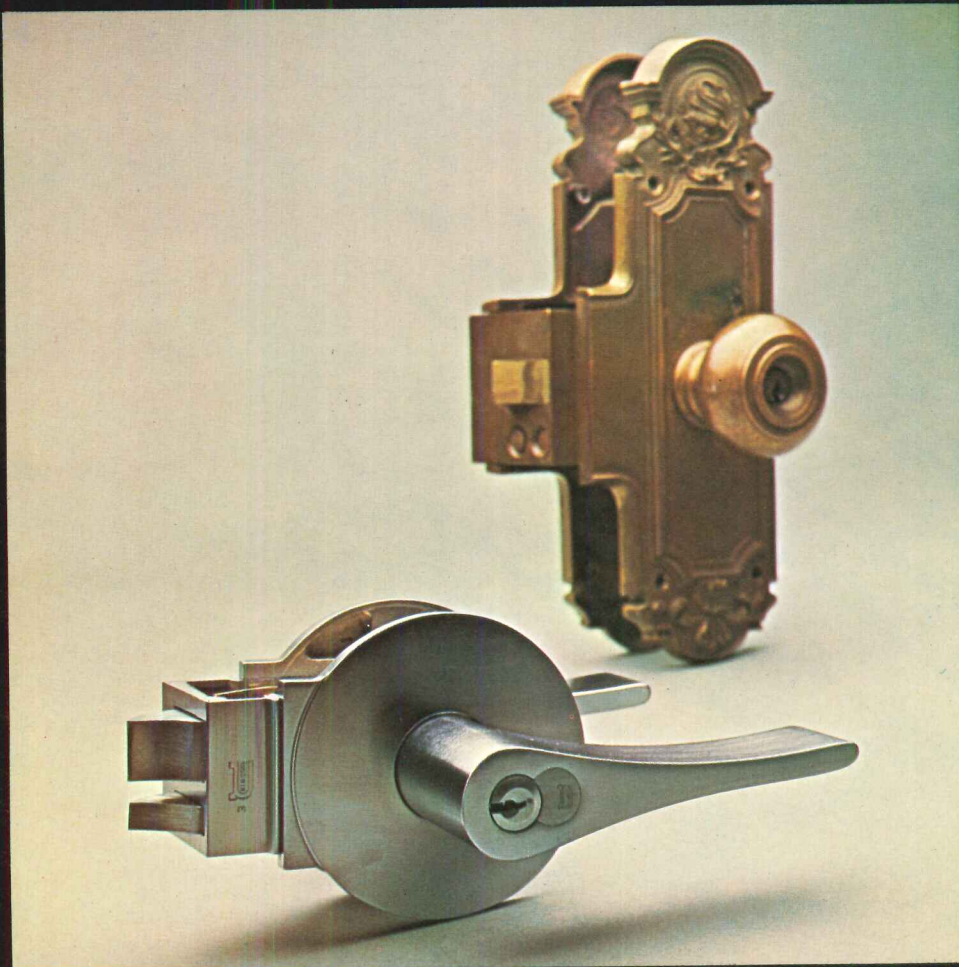

*Lever-action UNILOC™ lockset.
A classic evolution of line and
form and fingertouch response.
Enduring design in the Russwin tradition.
Russwin, Division of Emhart Corporation,
Berlin, Connecticut 06037.
In Canada – Russwin, Division of
International Hardware.*



The Collector's Series by Russwin

For more data, circle 10 on inquiry card

More and more builders are siding with prepainted galvanized steel.

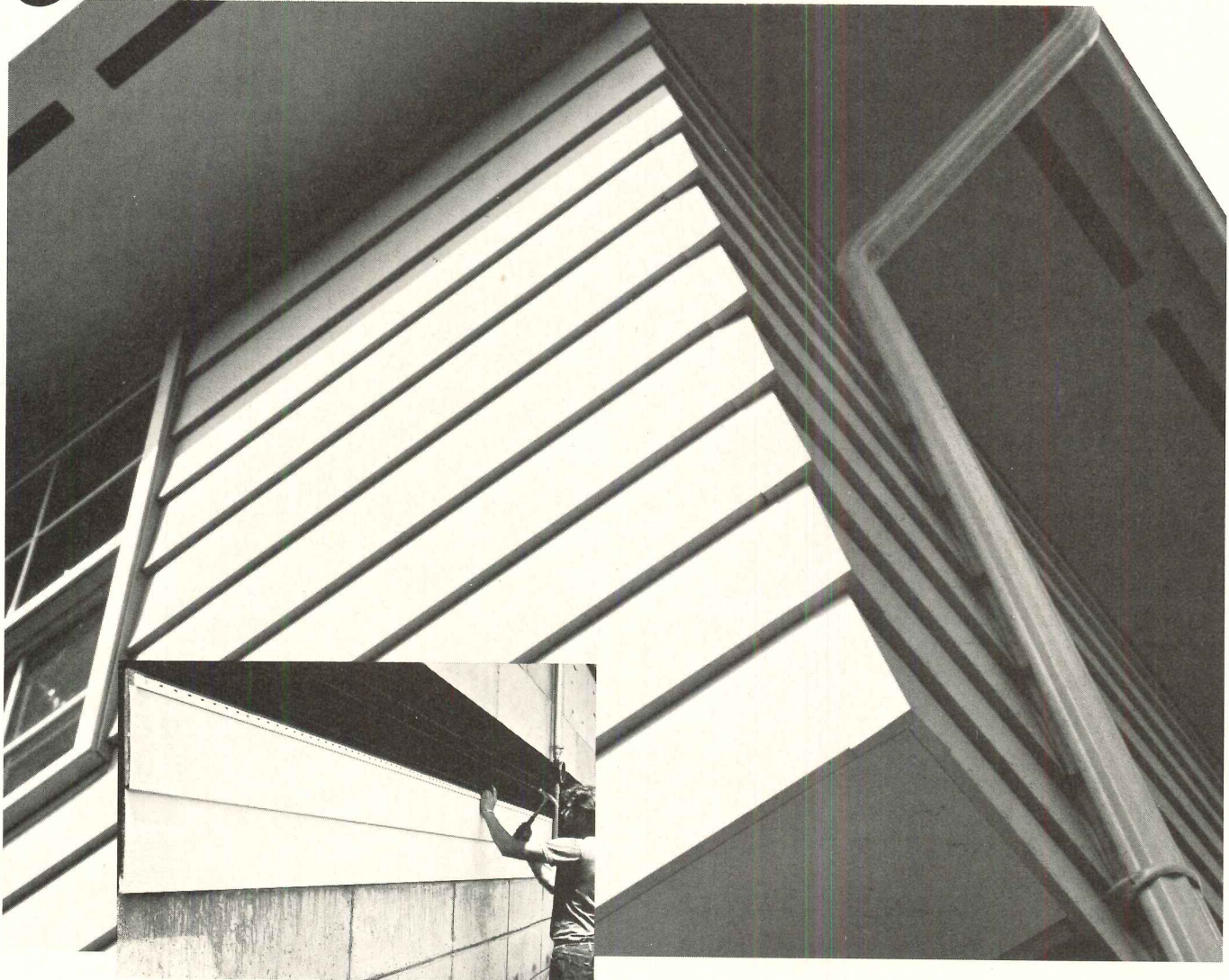

Whether you remodel or start from scratch, you want to be on the winning side. Today it's prepainted galvanized steel.

Zinc-coated steel survives a beating wood and other materials can't. It's immune to cracking from sun, storms, corrosion and the freeze and thaw cycle. It's twice as strong as other metal sidings, less subject to thermal expansion and denting. The paint is baked on for keeps, and washes clean like new.

To the home owner this brings pleasure without maintenance. To the builder it means a longer building season, and housing developments that look inviting even when they've been occupied for years.

Asarco, a major producer of galvanizing grade zinc, will be happy to send you a list of companies who make prepainted galvanized steel siding. Just drop us a line at 120 Broadway, New York, N.Y. 10005.

ASARCO
AMERICAN SMELTING AND REFINING COMPANY

For more data, circle 11 on inquiry card

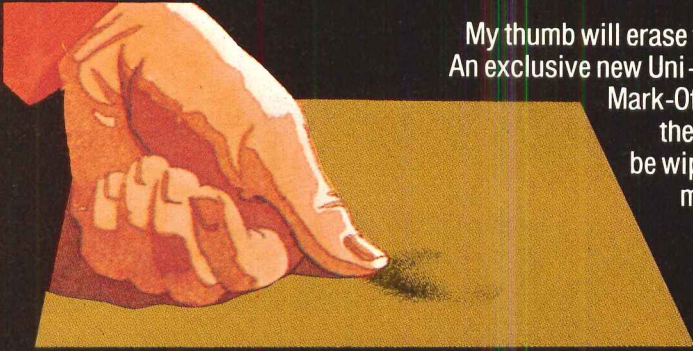

My thumb will erase this black heel mark. An exclusive new Uni-Turf® coating called Mark-Off keeps grime above the surface where it can be wiped away. That's low maintenance. It's part of every Uni-Turf installation. And only Uni-Turf.

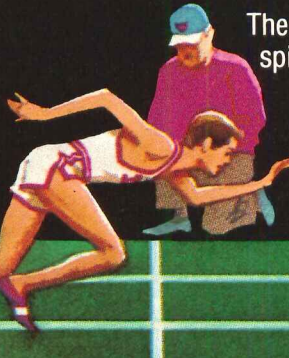

The track team is wearing spikes. It's okay though, because Uni-Turf is made of durable vinyl plastic to take that kind of punishment.

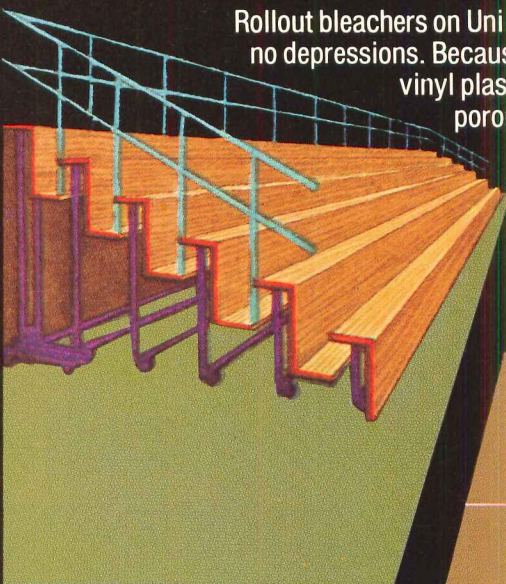
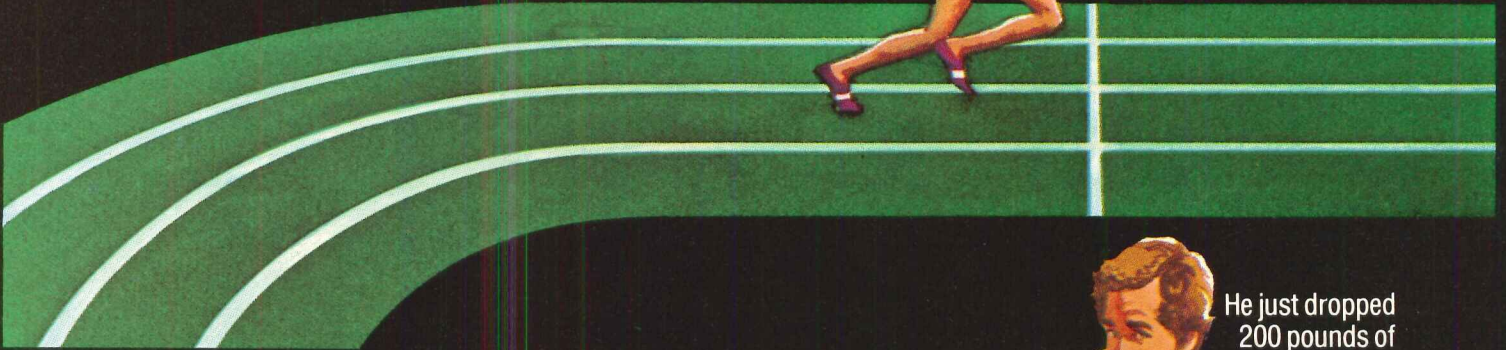

Rollout bleachers on Uni-Turf . . . no wheel marks, no depressions. Because it's an extremely dense vinyl plastic material. And it's non-porous . . . no stains, no warp.

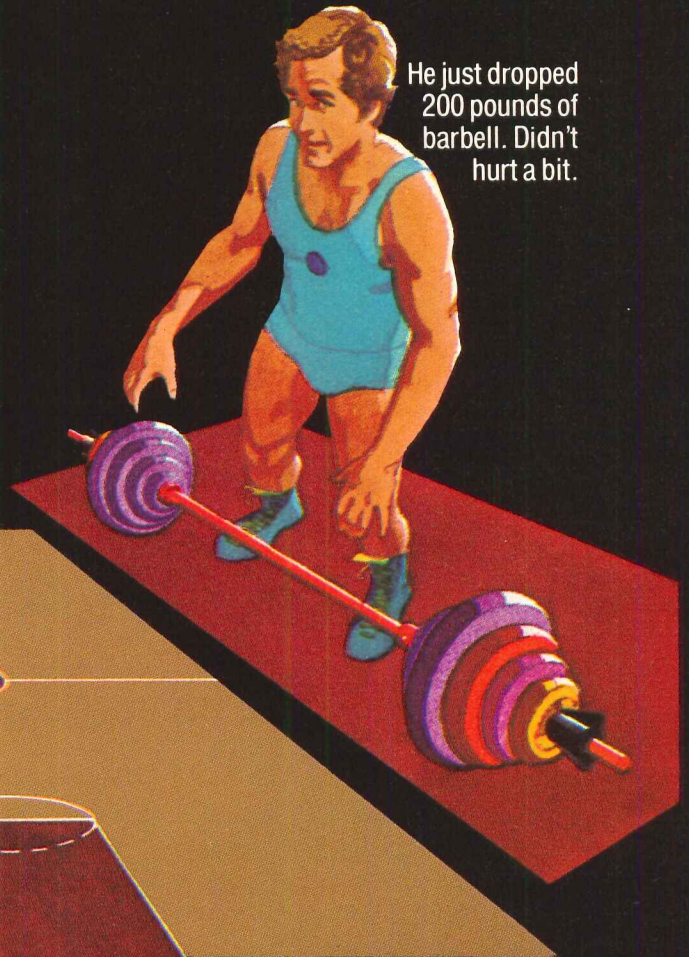

He just dropped 200 pounds of barbell. Didn't hurt a bit.

We make Uni-Turf in two different textures and five colors. So you can make the play any way you want . . . design-wise.

Nobody leaves his mark on Uni-Turf®

Tell me about Uni-Turf for use in —

- Field Houses Tracks Have representative call
 Gyms Tennis Other _____

NAME _____ TITLE _____

COMPANY/INSTITUTION _____

ADDRESS _____

CITY _____ STATE _____ ZIP _____

AR673

UNI-TURF®
 Sports Surfaces Department
 American Biltrite Rubber Co., Inc.
 P. O. Box 1071 Boston, Mass. 02103

How to multiply your draftsmen's time.



Shortcuts from Kodak turn drafting hours into minutes—on job after job.

Routine redrawing chores take a lot of valuable board time. Kodak can show your draftsmen how to restore drawings, make revisions, and handle repetitive elements—without redrawing. You'll save hours of drafting time and save money, too.

It's easy, because it's done photographically! We'll explain how to do it and help you select the proper Kodagraph films and papers for your particular work. And we can show you how, with an automated Kodak

processor, you can get reproductions back to your draftsmen faster, to save even more time.

There are other ways that Kodak can help multiply your draftsmen's efficiency. Microfilming your drawings will make them more accessible, save filing space, provide security, and give you other benefits, too.

Get the details.

For additional information write: Eastman Kodak Company, Business Systems Markets Division, Dept. DP 860, Rochester, N.Y. 14650.

Kodak products for engineering data systems.



For more data, circle 13 on inquiry card

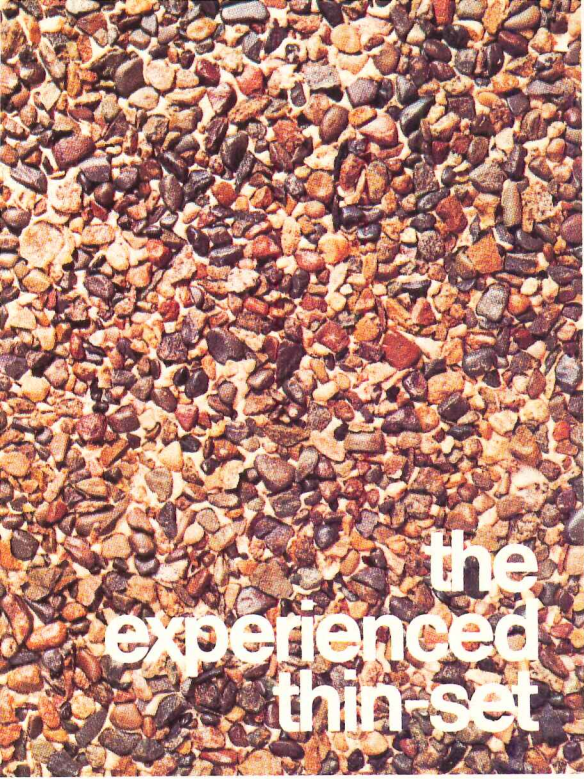

the
experienced
thin-set



Miami, Florida

A textured environment with a sense for the future.

Subtle texture or dramatic? Whichever you want in exposed aggregate walls, you can achieve it with H. B. Fuller Tuff-Lite® epoxy-based wall matrix. Proven by over a decade of use, it's as durable as it is beautiful for interior and exterior walls. It can be applied on-the-job or to panels off the job site.



Because it weighs far less than concrete, it's suitable for remodeling as well as new construction. Far more economical, too. It saves over stucco mastic systems, too, because it goes on directly over the substrate. There's no metal lath, scratch or brown

required. Tuff-Lite® is also weatherproof so it doesn't draw moisture and dirt through it. H. B. Fuller also supplies light-weight, epoxy-based, seamless flooring systems suited to institutional and commercial as well as residential use. These thin-set floorings can be applied over most solid substrates.

For help with specifying, selection or application information call our toll free number — 800/323-7407.

HB FULLER COMPANY

Architectural Products Division
315 S. Hicks Rd., Palatine, Ill. 60067, Dept. 513

For more data, circle 14 on inquiry card

The building world always needs fresh ideas to save money.

To increase office efficiency, a Westinghouse panel-hung furniture system. One insurance company switched from conventional offices to this Westinghouse ASD Group system, raised measured office efficiency 18%. Simple to erect, inexpensive to change layout to meet people's needs.



Westinghouse

To increase usable space: Westinghouse high-speed elevators to sky lobbies. The 110-story Sears Tower is like three buildings, one on top of the other, each with its own elevator system. You get to the lobbies of the two upper "buildings" by special high-speed, double-deck shuttle cars, then go on to your floor in conventional elevators. Saves 27,000 sq. ft. of usable space, compared to a system that serves all floors from the ground.

To save on electricity, this Westinghouse system combined lighting, heating, cooling with ceiling. Office lighting produces heat—this unique system utilizes it. Warms the building when it's cold, carries away heat when it's hot. Savings on electricity for heating, cooling and lighting, about 26%. Remarkably, construction costs are also lower. For commercial buildings, schools, hospitals, libraries.



To move twice as many people per elevator shaft: Westinghouse double-deck shuttle elevators. Each of these high-speed cars at Sears Tower will carry as many as 54 people at a time—half on the upper "deck," half on the lower—to cut elevator shaft cubage requirements.

Westinghouse Electric Corp., Pittsburgh, Pa. 15222

helps make it happen

For more data, circle 15 on inquiry card

Norton® Apollo Door Closer

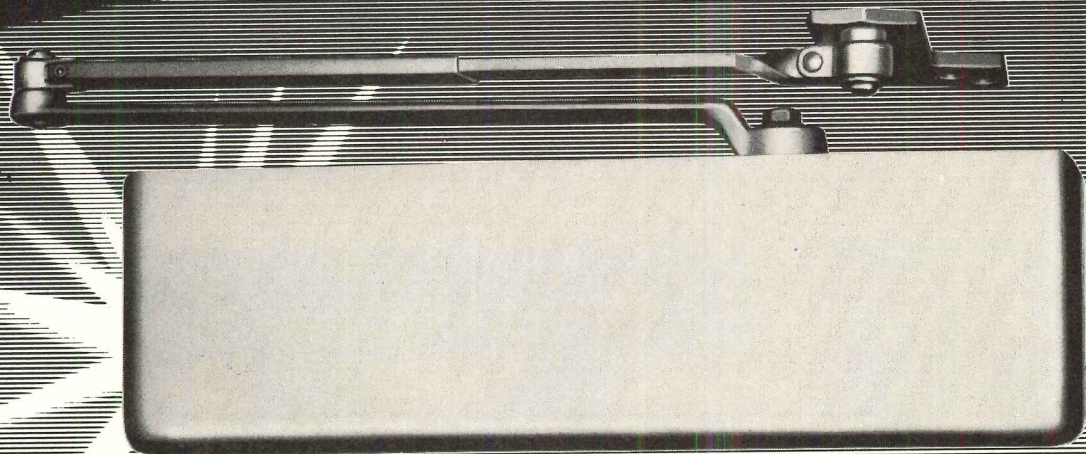

It's Always Been Versatile
Now It's Proven
Itself **Reliable**

Versatility is a dimension you can design and build into a door closer. Reliability is something else. The final judge of reliability is time. The Norton Apollo door closer has both: versatility and proven reliability.

Let's take versatility, first. We started with a spring power adjustment. Then we added an adjustable back-check and improved sweep and latch speed controls. Next, we made it available in either regular arm, parallel arm or top jamb. And we added a choice of covers in anodized brass, bronze or clear aluminum . . .

or 67 imported or native woods. That's versatility.

But when you have an 80-year reputation for quality, people expect your product to be reliable. *Especially* reliable. And we agree.

We tested the Norton Apollo closer. We put it through several lifetimes of wear. And there were no major problems.

But when you get right down to it, only time *really* proves reliability. The Norton Apollo door closer has been on the market for over three years, operating successfully

in prestige locations all over the country. Versatile? Sure. But reliable, too.

For more information on the Norton Apollo closer and its proven reliability, ask your Norton Representative. Or contact Eaton Corporation, Lock and Hardware Division, Norton Marketing Department, Box 25288, Charlotte, North Carolina 28212.

**Norton Door Closers . . .
25 years of Aluminum Reliability**

EATON Security Products
& Systems

1200

For more data, circle 16 on inquiry card



Have a nice stay.

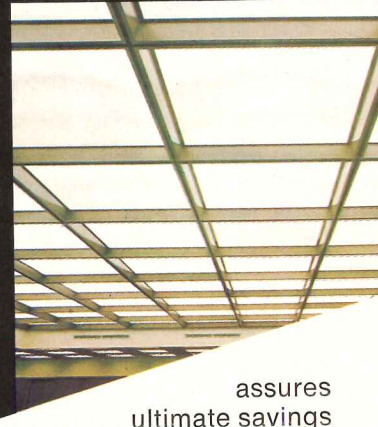
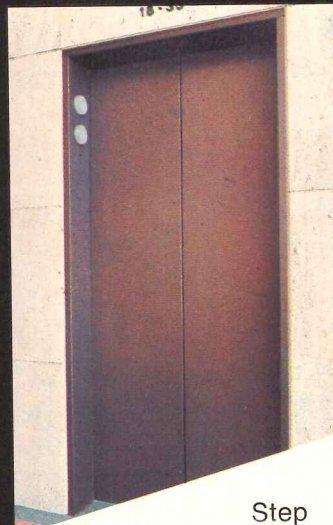

**Kalcolor[®]
aluminum interiors
blend intimate hospitality
with ultimate longevity.**

Step inside. You'll enjoy the lasting reception Kalcolor aluminum gives you in many new interior designs.

Walls. Ceilings. Railings. Lighting fixtures. Furniture. Doors. Decorative screens. Windows. Elevators.

You'll see how the Kalcolor lightfast colors—bronze, ambers, gold, champagne, black, or a range of soft grays—contribute to a rich atmosphere of relaxation.

And yet Kalcolor aluminum

assures ultimate savings in maintenance. Its uniquely dense, thick, extremely hard anodic coating withstands traffic. Cleans easily. Endures with beauty.

Our new catalog—"Aluminum in Architecture"—shows the colors you can now specify in Kalcolor sheet, extrusions and castings for both interior and exterior design.

Write for your copy: Room 2142A, Kaiser Center, Oakland, California 94604.

**KAISER
ALUMINUM**

For more data, circle 17 on inquiry card



Taming Temperamental Therapists

Therapists have a back, leg and arm breaking job. No wonder they become temperamental at times.

One way to make life easier for a therapist is to specify the right plumbingware for the therapy room. To make your job easier, Eljer has designed a full line of institutional plumbing fixtures and fittings — each specially styled to meet specific needs. For example, the 31" waist-high Salem bath with base, the Armstrong instrument sink and tray with a splash back, and the Cascade perineal sitz bath . . . just three of more than 290 fixtures and fittings each fully detailed and illustrated in Eljer's "Hospital/Institutional" catalog.

Hospital-styled plumbingware . . . one example of Eljer's ability to meet any commercial building need with a complete line of well-designed, quality commercial plumbing products.

Next job, tame your temperamental commercial client. Send for Eljer's 62-page "Hospital/Institutional" catalog: Eljer, Dept. AR, 3 Gateway Center, Pittsburgh, Pa. 15222.

See us at Booths 311-312 at the CSI Convention.

ELJER[®]

Eljer Plumbingware Division
Wallace/Murray Corporation

For more data, circle 18 on inquiry card

NEWS IN BRIEF
 NEWS REPORTS
 BUILDINGS IN THE NEWS
 REQUIRED READING

The 105th national AIA convention, San Francisco, May 7-10, drew a record 5,750 persons, with over 2000 members in attendance. A full report on the business and social events begins on page 34.

The Phase II report of the AIA National Policy Task Force has been held over until September because of the input required from a growing coalition of related professional and building organizations. Details on page 34.

Convention resolutions passed include asking President Nixon to release funds for water pollution control and housing. Support for rights of women in profession and energy management also granted. Details on page 34.

William Marshall Jr. of Norfolk, Virginia was elected AIA first vice president, to succeed Archibald C. Rogers as president in December 1974. Other new officers on page 39.

Minority architects will not endorse AIA National Policy Task Force proposals. Meeting in San Francisco during the AIA convention, the National Organization of Minority Architects (NOMA) decided to withhold endorsement, claiming the AIA Report lacks connections with inner-city residents as clients. Details on page 39.

The Architects Collaborative wins the Johns-Manville World Headquarters competition in which nine major firms participated. Story of the announcement ceremonies on page 34. Design of the winner and other entries shown on page 46. (See Editorial for remarks on the competition.)

Twelve AIA honor awards given at convention for a wide range of architectural works. The jury of five architects was chaired by 1972 Gold Medal winner Pietro Belluschi. Details on page 45.

The R. S. Reynolds Memorial Architecture Award has been presented to German architect Hannes Westermann for his reconstruction of an 1848 landmark in West Germany. Details on page 45.

The national fire commission report, released ahead of schedule, has prompted bills in both houses of Congress. Enactment of Senate and House measures could cause major code revisions and stimulate increased research. The report of the National Commission on Fire Prevention and Control also recommends that Federal funds to architectural and engineering schools be dependent on the schools having fire protection courses in their curriculums. More on this report and its implications next month.

Arthur F. Sampson has been nominated by President Nixon to be administrator of the General Services Administration. This comes as no surprise since Mr. Sampson has been acting in this capacity since June of 1972. Senate confirmation is still to come. Mr. Sampson was made an honorary member, AIA, at the national convention last month.

July 20, 1973 is the deadline for entries in the 1973 Prestressed Concrete Institute Awards Program. All architects and engineers practicing in the U.S. are eligible to enter structures completed within the last three years. Additional information can be obtained from PCI, 20 North Wacker Drive, Chicago, Ill. 60606.

Total construction value for 1973 is anticipated at \$92 billion, according to a revised forecast published by F. W. Dodge. Best gains, according to Dodge, will be in commercial and industrial building, and in the construction of electric power plants.

A "call for papers" has been issued for the Third International Symposium on Lower-cost Housing Problems, to be held in Montreal, May 27-30, 1974. The symposium is co-sponsored by the University of Missouri-Rolla, Sir George Williams University and the International Association for Housing Science, in cooperation with other groups. Persons interested in presenting a paper should contact Dr. Oktay Ural, Box 352, University of Missouri, Rolla, Mo. 65401.

The Design Science of Buckminster Fuller, an exhibit, will run through August in Chicago, at the Museum of Science and Industry. Made possible by a grant from the National Endowment for the Arts, the exhibit includes two 24-ft-diameter geodesic domes, one of the three "Dymaxion" cars built in 1933 and a 30-ft tensegrity tower, in addition to models of other works. The show will tour after closing in Chicago.

The Federal Trade Commission has accused 26 companies of false advertising related to flammable plastics. The plastics—foams, polyurethane and all forms of polystyrene—have been advertised as nonflammable or self-extinguishing, when they actually burn faster, hotter and release toxic gases, according to the FTC. These plastics are used in insulation, furniture, panels, siding, pipes and lighting and plumbing fixtures. More on this next month.

Opposing the AIA, the National Society of Professional Engineers favors extension of U. S. Capitol. The 67,000-member NSPE backs the proposal now moving through Congress to spend \$60 million to extend the West Front of the building.

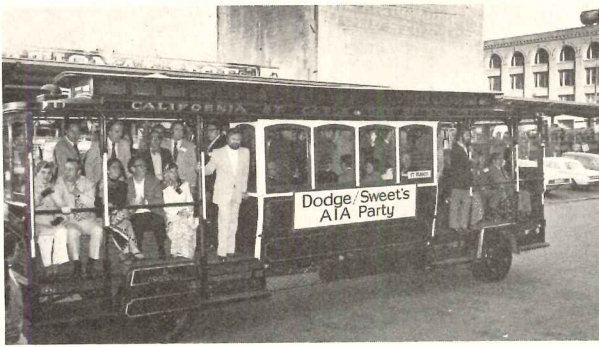

AIA drew record numbers to San Francisco in May

One of the most enjoyable—especially from the standpoint of location—AIA conventions in recent memory attracted nearly 6000 members and their families to San Francisco last month. Unfortunately, there was little, save for the Johns-Manville competition, to match the excitement of the previous convention's Report of the National Policy Task Force—however, the city of San Francisco

more than made up, a congenial host and architect's paradise to the very end.

Most of the RECORD editors were there, dispersed among the many seminars and social events (such as the Dodge Sweet's party shown); and this month, we've devoted this entire news section to all our observations and reports on convention activities and Tinkertoy, the students' convention.



Federal role in land-use urged at AIA convention

The nation is acting like "cowboys in a spaceship" an environmental lawyer, Marvin Durning (third from left), from Seattle told delegates.

He was one of three panelists who examined the theme of "The Challenge of Leadership" as it related to land-use policies and development issues, before the final plenary session of the convention.

The panel, moderated by Paul Ylvisaker (second from left), dean of the Graduate School of Education at Harvard University, included Bernard Weissbourd (right), president of Metropolitan Structures, the Chicago development firm, and Archibald C. Rogers, first vice president of the AIA (left).

The panelists agreed that the basic challenge of leader-

ship in land use and development is that of balancing individual and public interests. They felt that a truly national policy which spells out criteria, not mechanism, for land use, will balance these interests.

Durning said that the nation must stop "thinking and acting like cowboys riding roughshod over the countryside as if it had no limits." He criticized especially the "more is better" attitude toward growth questions.

Weissbourd directed his comments more directly toward urban problems and said the Federal government should develop a strategy which will prevent the increasing abandonment of lower-income housing which is taking place in many cities.

Task Force Phase II report held up as coalition grows

A progress report on Phase II of the AIA National Policy Task Force was presented by Archibald C. Rogers, who explained that a second official report had been held over by choice because of the input required from a growing coalition of related professional and other organizations. Interim meetings following the Constraints Conference last November expanded the goals of the proposed Phase II report. The coalition voted to call for a fully rounded statement of national policy and will have a meeting this month to clarify the scope of base for such a policy. The hope is to prepare the policy report for action by the AIA Board in September.

Mr. Rogers cited parallel

activities at national, state and local levels, including a bill sponsored by Senator Hubert Humphrey proposing a National Growth Office, several state legislative actions regarding land use, and local activities in such centers as Tulsa and Indianapolis acting upon some of the problems within the scope of Task Force interests.

One indication of broadening scope of these interests has been expansion of the items of attention from eight to eleven labeled strategies. These now deal with settlements, conservation, energy, transportation, growth units, urban rebuilding, land use, housing, public fiscal policy, private economic resources, and governance.

S. Scott Ferebee outlines AIA housing, energy efforts

In his report to the membership at the convention, AIA president S. Scott Ferebee outlined these new AIA efforts: "As a follow-up to our National Policy Report, we are working on a number of new efforts. One of these is the development of a recommended National Housing Policy. David Todd of New York is chairing this task force for us, and we hope to have their report by the end of the year.

"We have also established a Task Force on Creative Economics, chaired by Robert Hastings, to look at ways in which the ground rules governing taxation and mortgage lending might be changed to

encourage investment in the rebuilding of our inner cities and in housing for low- and moderate-income families.

"Another principal effort, entitled Creative Public Administration, is being conducted by our Design Committee, chaired by Hugh Newell Jacobsen. This study will look at the restraints and limitations placed on good planning by zoning, codes, ordinances, arbitrary regulations, design review boards and planning authorities.

"Other related efforts include an Energy Conservation Task Force chaired by Leo Daly, and a study of behavioral considerations in design."

The Architects Collaborative wins Johns-Manville headquarters competition

In almost Academy Award fashion, complete with sealed envelope and total secrecy up to the last moment, The Architects Collaborative was announced winner of one of the most prestigious—and largest—design competitions in recent years: the design of a new world headquarters building for Johns-Manville to be built in Denver. (Photos on page 46. Editorial, page 9.)

As part of convention opening day activities, the announcement in San Francisco's Opera House was met with cheers by TAC members including (left to right) William Geddis, Joseph Hoskins, John Sheehy and Michael Gebhardt who came on stage to accept congratulations from Johns-Manville president W. R. Goodwin and the corporation's architectural advisor on the competition, John B. Rogers of Rogers, Nagel, Langhart.

Nine firms participated in the AIA-directed competition for the \$24.5 million structure, to open in 1976.



The facility is to be constructed on part of the 10,000-acre Ken-Caryl Ranch which Johns-Manville purchased in 1971. All nine architects were directed to select a portion of the site for the building and prepare a design in keeping with J-M's desire to preserve the natural environment, create human scaled spaces and have room to expand properly. The ranch is a natural sanctuary for wild life and big game.

Speaking for his obviously very happy firm, William Geddis said at a news conference that TAC probably spent \$50,000 producing the winning



No AIA Gold Medal: criteria lacking

Speaking candidly on the lack of a Gold Medal recipient at this year's AIA convention, First Vice President Archibald C. Rogers said the problem is one of unclear criteria for evaluating candidates. Since Mr. Rogers sees no immediate solution to this dilemma, he feels it will be several years before another Gold Medal will be conferred.

At a time when the profession is faced with expanded responsibility, such as energy conservation and pollution, design criteria alone are not sufficient for the AIA Board to make a decision on the Gold Medal.

Rogers said we are at the end of a Renaissance period of sorts, at a time when we have to wait to see what new approach to architecture will prove the most significant, and for the Gold Medal dilemma, what approach will prove consistent.

design. Johns-Manville compensated the participating architects \$20,000 each, the largest amount ever given by a corporation for designs submitted in competition.

Although not the largest commission in TAC's history, the Johns-Manville project marks the first time the firm has won such a major competition without its founder Walter Gropius, who died in 1969. Asked what he would be doing now if TAC had not won, project architect John Sheehy said jovially he would "probably be checking shop drawings on work under construction."

Nixon fund cut-offs, women's rights discussed

The Convention passed resolutions asking President Nixon to release funds for water pollution control and rescind the housing moratorium.

Convention delegates, representing 24,000 architects across the country, at the same time committed the Institute to "take action to integrate women into all aspects of the profession as full participants." Sponsored by the New York Chapter, this passed in the only roll-call vote taken, by 996 to 627.

The resolution asking that the necessary funds be made available for water pollution control said that Nixon "has disregarded the passage of this bill by Congress over his veto, and allowed the expenditure of only \$6 million."

The convention delegates called on the President to initiate proposals for new housing and related programs and immediately resume funding of substantial portions of existing programs while new solutions are being developed.

The convention also passed a resolution directing the Institute to prepare criteria to guide both the public and private sectors in development decisions which take into full account our limited energy resources.

A rundown of the bylaw changes and voting is as follows:

- Three proposed changes in the calculation of supplemental dues, including establishing the basis for computing dues for owners of a corporation practicing architecture: by a yes voice vote, a new resolution was passed to study these proposed changes for a year.

- Indemnification of Institute officials; yes, by voice vote.

- Chapters to be given the option of selecting or electing member delegates: yes, by voice vote.

- Proposed new judicial procedures to bring more ethics violations under scrutiny: yes, by voice vote.

Challenge of growth and change was topic of first AIA theme session

The reality of social change that took place in the sixties has yet to be realized in the architectural profession.

This and other accusations of social feet-dragging faced architects attending the convention's theme session on "The Challenge of Growth and Change," a session in which several noted educators and a Nobel Prize winner exhorted architects to at least be aware of—if not deeply involved in—

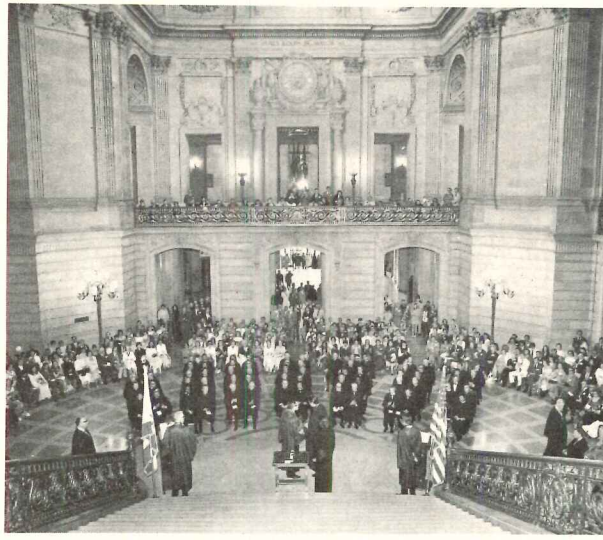

Elevation of Fellows, awards open AIA convention

During the convention opening ceremonies at the San Francisco Opera House, the Institute elected 10 distinguished non-architects to honorary membership; presented a number of special awards, medals, and citations (RECORD Editor Walter Wagner, left, received Critics'



and design of the BART system. (Shown left to right: BART president William C. Chester receiving award, BART chief architect Tallie Maule and S. Scott Ferebee).

and design of the BART system. (Shown left to right: BART president William C. Chester receiving award, BART chief architect Tallie Maule and S. Scott Ferebee).

Citation for cartoonist Alan Dunn) to a wide range of practitioners, artists, designers, craftsmen, and organizations involved in architecture; and—at ceremonies shown at San Francisco city hall—elevated to fellowship 64 of its members. Ten distinguished architects from other nations were named as Honorary Fellows of the AIA.

Several Californians were among the individuals honored by the Institute. Landscape architect and planner Hideo Sasaki, who has offices in Sausalito and Watertown, Massachusetts, received the 1973 Allied Professions Medal, and citations were awarded to the San Francisco Bay Area Transit District for the concept, planning,

and population.

Speaking on the energy situation, Dr. Glenn T. Seaborg, professor of chemistry at the University of California, Berkeley, said he could foresee in the near future regional, national and perhaps international planning of power plant siting that will consider such environmental effects as thermal water pollution, air pollution and better management of land and



and population.

wildlife. Esthetic considerations and recreational aspects will be considered also.

In closing, Dr. Seaborg said architecture will play a key role in sensible planning for future growth and change, including the role of energy in such growth. Although past work has not focused enough attention on energy conservation and use in buildings, Dr. Seaborg commended the AIA plan to study this problem.

Among the Institute's special awards was its 25-Year Award, given to projects which have been completed for at least a quarter of a century and which, in the opinion of the AIA's Honor Awards jury, have stood the test of time as examples of notable architecture. The 1973 25-Year Award went to Taliesin West, the Scottsdale, residence/atelier of the late Frank Lloyd Wright.

The Institute's Whitney M. Young Jr. Award, given in memory of the late executive director of the National Urban League, to the architect or related organization which is judged to exemplify the profession's response to its obligation toward society as a whole, went to The Architects' Workshop of Philadelphia. The award was presented by Mrs. Whitney M. Young Jr. to Augustus Baxter.

described the progress of a nationally standardized price reporting service and a proposed AIA Construction Cost Control System. The presentation was supported by other panelists from the AIA Automated Practice Technology Committee. The effort is ongoing and the problems implicit in such a task are focusing primarily on the all-important goal of cost control.

- Representatives of the Five Presidents' (AIA, NCARB, NAARB, ACS, and AASC) Special Task Force on Education presented a roundtable discussion of their progress in bridging the gaps between architectural schools and the profession. There were protests by students at the seminar about the quality of architectural education. There were also protests from practicing architects, and vehement rebuttals from the heads of several schools.

- At another seminar panelists from HUD, AIA staff, and AIA Housing Committee discussed the impact of recent Federal cutbacks in housing funds, and reported on the AIA's efforts to sway the government from its present position. The drift of all the talk, however, was towards the fact that state governments will now have to bear the responsibility for housing in the immediate future, and the phrase "generation gap" came up again and again as the states' abilities to cope with these problems were, rather gloomily, described. The Housing Committee's final recommendations should be useful to architects as they now approach their state governments and urge them to perform well the role that they, willy-nilly, have inherited.

- The continuing education seminar at the AIA convention, conducted by Dr. Stuart Rose, director of the AIA Continuing Education Program, discussed new developments outside of the presently offered 25 training laboratories. They are expanding the audio tape cassette program by adding new cassettes: office, partnership, consultant and architect contracts; construction contracts; the architect as a land developer; air structures; and housing systems.

- Also new are architectural game seminars (which operate only by correspondence), now offering basic principles of electronic data processing. Other game seminars in preparation are on land development, business management, selling architectural services, and organization development.

Thirty-nine topics discussed in multiple seminars

No AIA convention in recent history has dealt so broadly or with so many concurrent seminars on the practical issues that confront architects today. As a practical solution to dealing with some 39 topics ranging from "architects in industry" to "value engineering," repetitive sessions were scheduled in eight tent-like enclosures arranged around the exhibit hall in the San Francisco Civic Center. The program worked in spite of minor stresses attributable to the acoustics of the situation and the limits of physical capacities of eager architects striving to be in several places at one time.

No sampling of content could convey the full wealth of material, but perhaps the following may indicate the scope.

- The Occupational Safety and Health Act and its implications for architects was the subject of one of these seminars. William F. Dwyer of Occupational Safety and Health Administration referred to five volumes of background material available to the profession. A \$12 subscription placed on file at the general Printing Office will keep subscribers' volumes updated at each time of publication of the Federal Register. While all regulations do not pertain to the specifics of architects' involvement, and certain volumes (one on construction standards, for example) are richer than others in their rewards, there seems to be no easy way other than an assignment of personnel to continuous study of act implications.

- Architects in industry, another session in another tent, projected the professional roles of architects employed by commercial and industrial corporations. One hears in conversation with some of these architects a sustained regret that the AIA seems to persist in regarding them as client-representatives rather than co-professionals, but the increasing attention by the national body to architects in industry carries implications of eventual acknowledgment.

- The profession's fully automated master specification system was described at three of the seminar sessions as well as presented at one of the convention booths. Progress in complete development of the system continues, and the library of available resources in both manual and computer applications is increasing.

- Bringing jobs in on the budget was the subject of another popular seminar at which Jack Train

more news on page 39



Marshall County Public Library
 Benton, Kentucky
 Architects: Lee Potter Smith Associates
 Paducah, Kentucky
 Project Architect: Gayle R. McGregor
 Framing Contractor: Lassiter Plastering Company
 Murray, Kentucky

Four good reasons for considering Inryco™/Milcor® light gage steel framing when designing small buildings.

Design freedom, versatility, fast enclosure and economy... the benefits that make light gage steel framing so popular for the exterior walls of multi-story construction... can also be enjoyed on smaller buildings. Here are a few comments from project architect, Gayle McGregor, concerning the library pictured above:

"The variety of possible finishes available was an obvious advantage."

"Site conditions complicated the footings and foundation design. Light gage framing enabled us to cut down on bearing weight."

"We were able to save about one

square foot of floor space for every two lineal feet of wall... a value of about five thousand dollars on this small project."

"Prefabricating framing assemblies in the shop saved on-site time and helped us meet a tough winter construction schedule."

"We have gone on to six other projects using the same systems, including an elementary school that ran \$15 per square foot compared to the \$22 per square foot statewide average for this type of facility."

There are further advantages we haven't covered here. See Sweet's, section 5.3/In; send for catalog 37-1;

or let a Milcor representative explain how they apply to one of your projects. Write to: Milcor Division, Inland-Ryerson Construction Products Co., Dept. F, 4033 W. Burnham St., Milwaukee, WI 53201.

INLAND 
RYERSON

General Offices: Melrose Park, Illinois
 A member of the  steel family

For more data, circle 22 on inquiry card

World's largest refrigerated food center insulated with 8 acres of urethane foam

8 million cu ft of chilled space will protect over 1/3 of all meat products consumed by New Yorkers



▲ Urethane boardstock is easy to install, even in freezing weather. Same bitumen can be used for insulation panels and built-up roofing.

▲ For roof of cold storage warehouse, double layers of urethane boardstock were used to insure maximum cold retention over metal decks.

When completed this fall, the Hunts Point Cooperative Market, Inc., will be the largest distribution hub for meat products in the world. To be operated by the Dept. of Ports & Terminals of the Economic Development Administration of New York City, the huge facility will cost over \$30 million. Its six buildings will encompass 700,000 sq ft of space on 37 acres, and will handle over a billion lbs of meat and poultry annually.

In planning the huge facility, architects Brand & Moore employed what they call the "creative problem-solving process:" the decision on site, master plan, plant layout, structural and environmental systems, and choice of materials was based on comparative benefit analyses that take into account initial, operating and maintenance costs.

Before drawingboard work, the architects spent six months studying storage facilities, and interviewed 40 plant owners. A major consideration in the design was insulation for cold retention. Prior to specifying insulation, drawings were made to detail various areas requiring thermal insulation: walls, ceilings, roof decks, floors; all of which had different temperature and exposure factors. Cost analyses were then made to determine what types of insulation were consistent with plant requirements and budget limits.

Wherever extreme temperature control conditions were a major design requirement—specifically in the roofs of

the cold storage warehouse and the refrigerated areas of the three market buildings—laminated rigid urethane foam insulation was specified "because its thermal insulating values are superior to other materials inch-for-inch and its cost-to-insulation value is excellent," the architects said.

To insure maximum thermal resistance and fire retardancy on the metal roof deck areas, the architects specified a layer of Millox*, a combination of non-combustible perlite and urethane, plus a second layer of standard laminated urethane boardstock. The urethane boardstock was also used to insulate the concrete plank roof decks of refrigerated areas.

Write and ask how you can arrange for an illustrated seminar presentation at your time and place of convenience, showing how you can apply this same creative problem-solving approach to your industrial roofing needs.

*Trademark of Apache Foam Products, Div. of Millmaster Onyx Corp., Linden, N. J.; approved by Factory Mutual System for Class I construction over steel decks. All materials in this project were approved under the NYC Building Code and the local insurance rating organization.

Mobay Chemical Company
Div. of Baychem Corp., Code AR-63
Pittsburgh, Pa. 15205

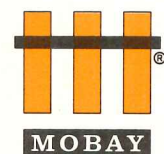

For more data, circle 23 on inquiry card

Dover® Stage Lifts. Rising star in the theater.

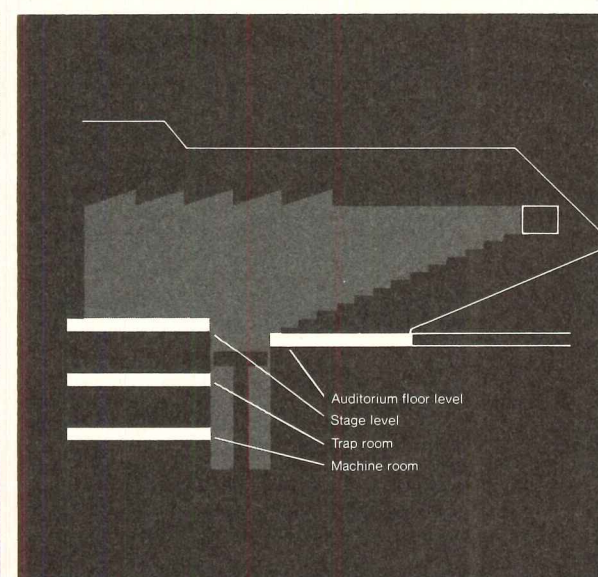
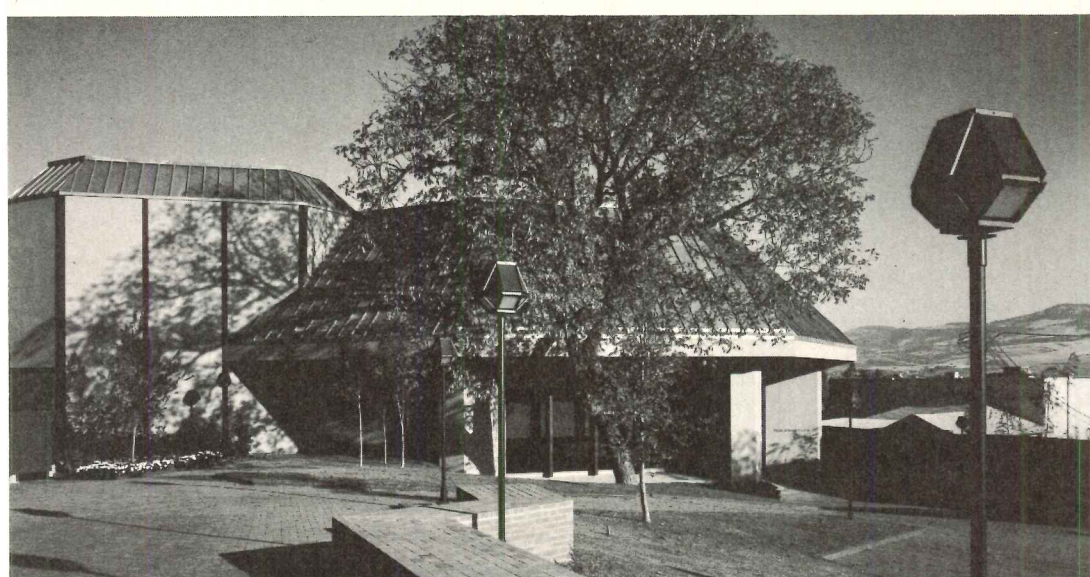
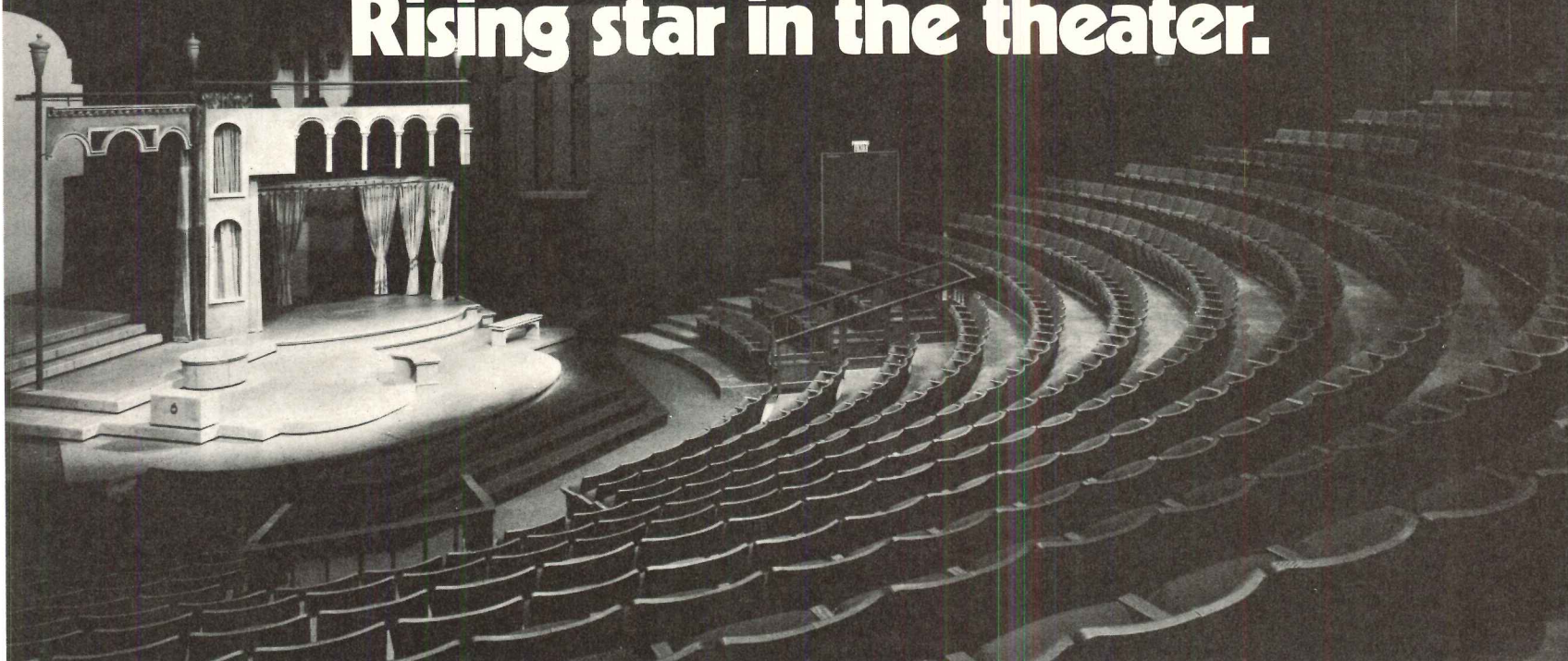

A good actor must adapt himself to a wide variety of roles and styles of interpretation. So must a good stage.

The designers of the Oregon Shakespearean Festival's Angus Bowmer Theater, Ashland, Oregon, recognized this and utilized a Dover Stage Lift as the heart of their new 600-seat playhouse.

This 28' x 8'6" lift is truly a versatile performer. It travels 21' and serves four levels: machine room, trap room, auditorium floor, and stage. In various positions it becomes part of the stage, part of the auditorium, and an easy way to move heavy, awkward scenery between floors.

Dover Lifts can be found in the Metropolitan Opera House and the Juilliard School, New York; in Harvard's Loeb Drama Center, the Santa Fe Opera House, and the Stardust Hotel, Las Vegas.

The same Dover skill that designed and built these lifts can be applied to your stage lift project, regardless of size or special requirements.

For more information, see our catalog in Sweet's Files, or write Dover Corporation, Elevator Division, Dept. A-6, P. O. Box 2177, Memphis, Tenn. 38101. In Canada: Dover/Turnbull.

*OREGON SHAKESPEAREAN FESTIVAL ASSOCIATION, Ashland, Ore.
Architects: Kirk, Wallace, McKinley, A.I.A. & Associates, Seattle, Wash.
Theater Consultants: Landry, Hunt & Bogan, Palo Alto, Calif.
General Contractor: Robert D. Morrow, Inc., Salem, Ore.
Stage Lift installed by Dover Elevator Co., Oakland, Calif.*

DOVER
Stage Lifts

For more data, circle 24 on inquiry card

NOMA withholds endorsement of Task Force Report

The National Organization of Minority Architects, at their second annual meeting in San Francisco, May 4 to 6, passed a resolution withholding endorsement of the report of the AIA National Policy Task Force, with particular reference to the report's proposals affecting urban growth. The resolution outlined a number of reasons for this move, which, NOMA president Wendell J. Campbell of the Chicago firm of Campbell & Macsai explains, was not made in anger but rather grew out of regretful observation. The observation was that the best intentions of the National Task Force, even with its current search for input from some score of organizations representing the multiple disciplines implicit in the task, still lacks an essential ingredient. That ingredient is aptly expressed by NOMA director Leon Bridges as direct *constituency* of the center-city population as client to the professionals engaged in the solution of center-city problems.

Even the report of the Constraints Conference, which was held last fall as preamble to Phase II of the Task Force Report (not ready for publication prior to the AIA 1973 convention) apparently failed to take this matter of constituency into account on a scale that NOMA finds imperative.

The NOMA resolution observes the spread of urban cancer into surrounding suburban areas and the failure of Urban Renewal grants, of whatever dimensions, to deal with basic causes rather than with the visible manifestations of social problems.

Similarly, the National Policy Task Force Report, says NOMA, has attempted to develop policy solutions and urban growth strategies based solely upon premises of physical and visual environment.

"The report does not address the separate life styles of economic, ethnic, social and racial groups; it does not discuss the compatibility of life styles; it does not discuss how to eradicate the entire spectrum, or even a small segment, of ghetto life; it does not investigate the ratio of probability for a mixture of economic social, ethnic and racial groups.

"These," the resolution continues, "are only an introduction to the mass of questions that must be addressed before a methodology of implementation can be endorsed."

NOMA recognizes, Wendell Campbell reiterates, that minority architects are profes-

sional laborers in the same vineyard with all their fellow practitioners. They have, however, that experience of identity that no application of good intention can successfully duplicate. The role of many disciplines in the problems of the inner city is obvious and urgent. Therefore, NOMA is preparing a national convention to take place in Washington, September 26, 27, 28, under the theme banner, "Mid-town USA, 1985" at which they hope to enlist involved disciplines with that sense of constituency that will move the concerns of architects and others another step toward real solutions.

There is occasion here to note that the withholding of endorsement is quite different from active disagreement. The NOMA resolution makes its plea for a broader base of consideration before defining "urban growth units" or applying planned solutions; but the Task Force Report itself, summarized in a preface to the Report of the Constraints Conference, states, regarding priorities and premises:

"The value most to be respected is free choice. First concern should be given the condition of those trapped in the poverty and deterioration of older neighborhoods, especially of the central cities."

And again: "Free choice should be expanded—by expanding the possibilities and scope of citizen participation in the design and governance of neighborhoods."

And later in the Constraints Conference Report: "The Task Force met immediately following the close of the conference. The desire to accelerate and broaden the process of constituency and coalition building was at the top of its agenda."

It cannot be totally naive to perceive here a platform for that meeting of minds which is a hopeful preamble to concerted (and mutually endorsed) action.

William Marshall Jr., others newly elected officers

William Marshall Jr., FAIA, of Norfolk, Virginia, was elected to the office of first vice president of the AIA. Marshall will succeed Archibald C. Rogers in the president's office in December, 1974.

The AIA also elected as treasurer, Joseph Tuchman, FAIA, of Akron, and three vice presidents: Van B. Bruner Jr., of Haddon Township, N. J.; Louis R. Lundgren, FAIA, of St. Paul, Minn. and John M. McGinty of Houston.



Method, not content emphasized by students

On being asked to comment on the students' convention in San Francisco, Mark Maves (above), chairman of student affairs, said some workshops were very successful, but there were major problems with others, such as cancellation of workshops without prior notice and lack of logistical planning. "I was really more interested in the process (of the convention) than in its results."

A major aspect of their meeting—which no one knew about prior to attending the workshops—was an experimental process in group problem-solving using techniques of a San Francisco firm, Interaction Associates. Interaction Associates attempts to train various organizations in how to conduct workshops using the techniques which they have developed. A "facilitator" and a "recorder" are terms they apply to workshop leaders they train. The facilitator's duty is to be a "neutral, non-evaluative, manager who does not make decisions yet offers problem solving strategies and maintains the focus of the group"—in essence, a director of the process of discussion who does not influence the content of the discussion. The recorder's role is to write, on paper hung in full view, words and phrases that would help listeners.

Tinkertoy, students' convention, a hit-or-miss event

A sampling of the ASC/AIA workshops at the student convention (labeled Tinkertoy) may not give a fair picture of the whole program but it does indicate what topics were considered interesting by students, and it tells something of the reception given them by students.

On Monday, for instance, three workshops (which seemed more like rap sessions than real workshops) dealt under various titles with the community as client for the architect; attendance was two dozen in the one which might have been expected to be most attractive, The Community as Client: a personal response, with San Francisco CDC director Jim Reed as leader, who talked about the CDC's work and funding (continued for six more months), and described costs for land and development of low income housing in San Francisco.

Henry Sanoff of the School of Design, North Carolina State University, and director, Community Development Group, attracted a good—and staying—crowd of about 35 to hear about "alternative strategies for an alternative school," emphasizing dialog between designers and users of an actual elementary school project.

Other sessions attracted a varying number of listeners who entered and left at will. In the

Preserving the Bay highlighted in floating seminar at sea

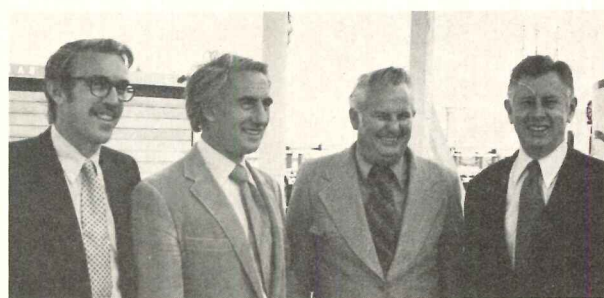

"Preserving an Irreplaceable Natural Resource—San Francisco Bay" was listed on the convention program as a Host Chapter Event but in actuality it was a vital part of the professional Field Trip/Seminar program. It was also a highly successful event, with 200 people—the limit put by the Institute on ticket sales for the field trip—reveling in the superb weather and the exceptional opportunity to see the Bay Area from the water.

Speakers were: Melvin Lane, right, Chairman, California Coastal Conservation Commission and former chairman, Bay Area Conservation and Development Commission; (l. to r.) William Evers, present chairman, BCDC; Michael

session entitled "Doing It," chaired by Roosevelt McElroy, talk centered around improvements to the architectural curriculum, with strong feelings that the only way to effect change was by "telling it to the accrediting board" and by ending academic tenure for teachers who do not remain current.

Discussing studies performed by his students and himself, Peter Wong, architectural graduate student at the University of California, Berkeley, gave an excellent slide talk on San Francisco's Chinatown: its successes, its failures, its problems—economical and social.

Nothing surprising. Its problems are poor housing, high densities, low education and pay, pressure on its boundaries by San Francisco's financial district, brain drain and poor political management. Slides pointed out these problems beautifully. Peter Wong's students wanted to know how and why Chinatown persisted for more than a century and what its chances for survival are now.

Part of its success in the past has always been that "Chinese dollars always stayed within the community." This is less so now as the community becomes less cohesive—as affluent Chinese move out of the city. What is its future? Unclear, but not encouraging.

Wornum, FAIA, member, Board of Supervisors, Marin County; and Charles Roberts, BCDC executive director. They kept a running commentary going on the problems of preserving the Bay without completely ending development along its shores, as the boat, taking a specially designed course, went under the Golden Gate Bridge, up to Richardson Bay, over toward Berkeley and Oakland, and down to Hunter's Point.

The Field Trip/Seminar program, an innovation of the Host Chapters Professional Program Liaison Committee, was so successful (despite an unscheduled early cut-off of sign-ups) that it will be a feature of next year's convention in Washington, D.C.

"GE has a new air handler facility It's a small part of a

Joseph H. Gauss, Vice President and General Manager,

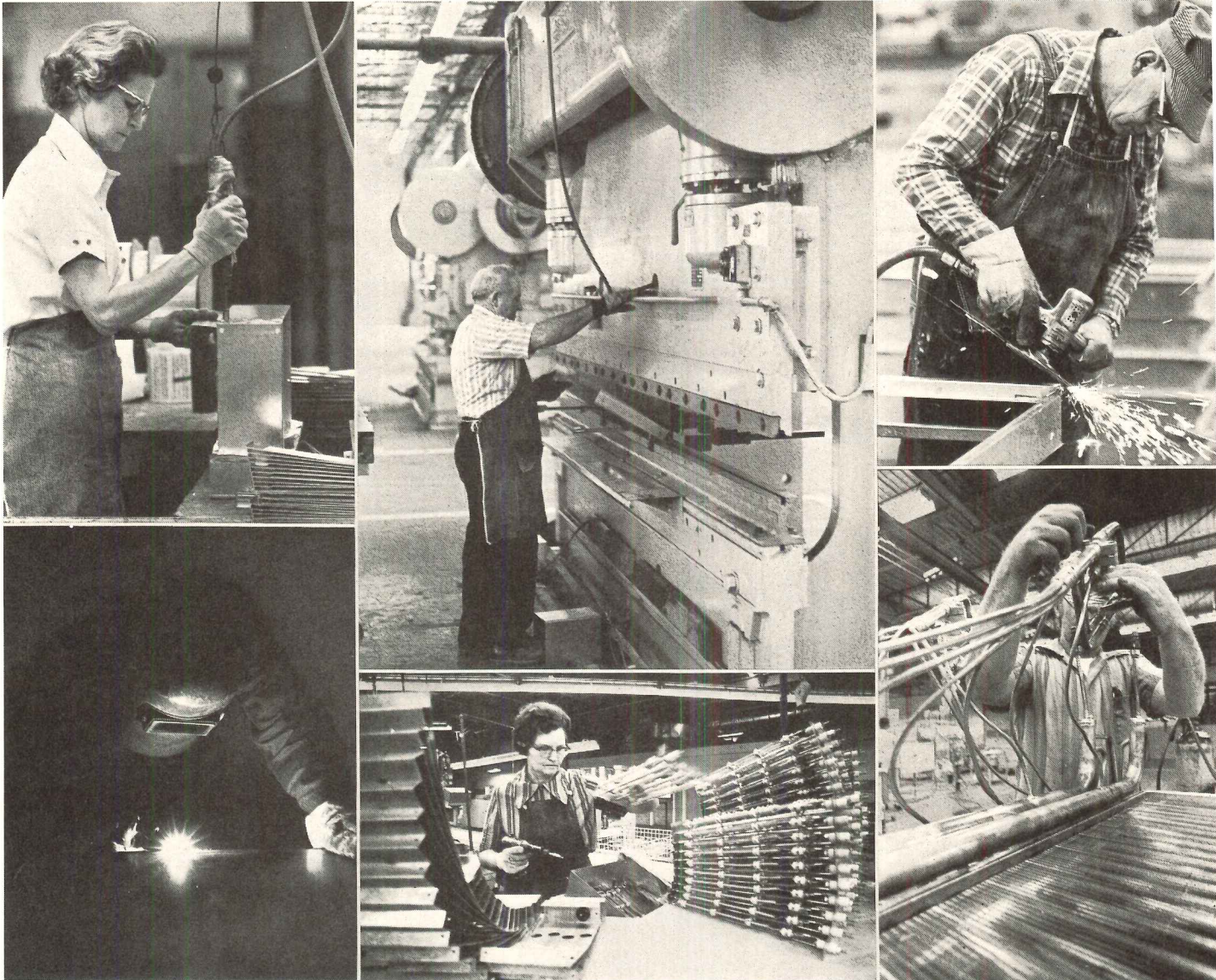

179,189 square feet of space committed to air handlers is a lot of commitment, but that's what General Electric has in Fort Smith, Arkansas. We're growing and we're committed.



And because we know this business is going to keep on growing, the Fort Smith plant is

on a 35 acre site, so there's plenty of room for future growth. As a matter of fact, this facility is already producing large commercial air handlers.

This installation will be a combination of the new and the old. We have installed new, numerically-controlled machinery to improve sheet metal fit-up,

in Fort Smith, Arkansas. large commitment."

Air Conditioning Products Division



but we'll still have a man dabbing zinc-rich paint on the places where the welding arcs burned off the zinc and, we'll still be testing relentlessly.

So you'll get both the advantages of new techniques and our old commitment to quality production.

So the next time you are specifying

Central Air Conditioning, think of GE and our expanding commitment to this business. Call our dealer. He's in the Yellow Pages under Air Conditioning Equipment & Systems.

"We're going to be in this business for a long time!"



Joseph H. Gauss

GENERAL  ELECTRIC

For more data, circle 25 on inquiry card

REINFORCED CONCRETE HIGH DRAMA.



Left: University of Louisville Health Sciences Center, Louisville ■ Architects, Engineers and Planners: Smith, Hinchman & Grylls Associates, Inc., Detroit ■ Associated Architects & Engineers: Arrasmith, Judd, Rapp & Associates, Louisville ■ Associated Architects & Engineers: Louis & Henry Associates, Louisville ■ Associated Engineers: E. R. Ronald & Associates, Louisville ■ Contractors: Struck Construction Co.; Whittenberg Engineering & Construction Co.; George M. Eady Co., Louisville. ■ **Right:** Bethesda Hospital North, Montgomery, Ohio ■ Architects, Engineers and Planners: Smith, Hinchman & Grylls Associates, Inc., Detroit ■ Associated Architects and Engineers: Sullivan, Isaacs & Sullivan, Cincinnati ■ General Contractor: Dugan & Meyers Construction Co., Cincinnati.

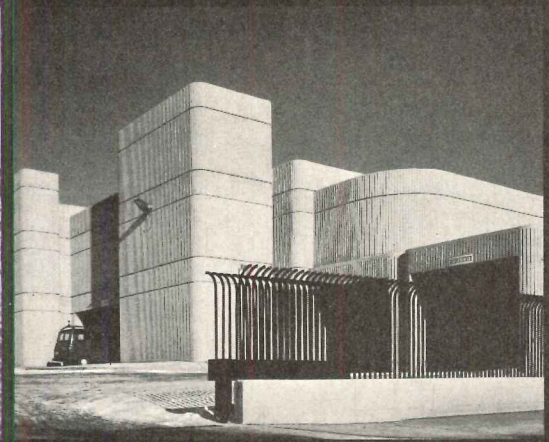
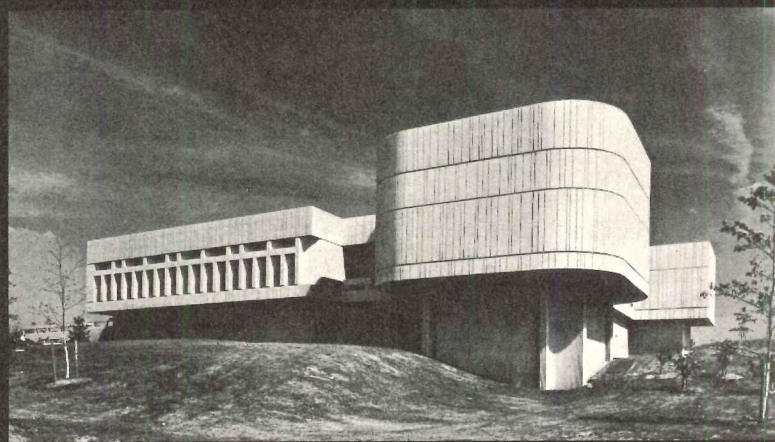

Left: Detroit Edison Co./Consumers Power Co. Electric Power Pool Control Center, Ann Arbor ■ Architects, Engineers and Planners: Smith, Hinchman & Grylls Associates, Inc., Detroit ■ Contractor: Darin & Armstrong Inc., Detroit ■ **Right:** Michigan Bell Telephone Co. Plant Office and Garage, Detroit ■ Architects, Engineers and Planners: Smith, Hinchman & Grylls Associates, Inc., Detroit ■ Contractor: Darin & Armstrong Inc., Detroit.

LOW COST

Four different design challenges.

Today there are no pat solutions to building design. Each site, each special usage, each timetable, each budget dictates a different set of parameters. And poses a problem that is uniquely and economically solvable with reinforced concrete. The building material that gives the architect the versatility to plan a building that's one of a kind. A building that doesn't compromise dramatic effect for low cost. Here are but four examples, showing how one design firm used reinforced concrete to achieve striking individual design statements.

Urban renewal: Where speed — and every dollar — count.

Faced with the assignment of designing a health facilities/educational complex in the heart of Louisville, the architects turned to versatile, expressive reinforced concrete. The columnar design scheme they devised unified the four structures in the project: medical school, dental school, library, and research tower. And reinforced concrete, with its inherent fire-resistant properties, was a natural for the University of Louisville Health Sciences Center, with its many laboratory and library areas. Throughout the project, concrete reinforced with grade 60 rebar made for speed amid the congestion of urban renewal.

The right prescription for economical creativity.

When building design bespeaks the character of the activity within, the effect is striking. Progressive medical care was to be the philosophy of Bethesda Hospital North in suburban Cincinnati. The architects executed their design in reinforced concrete, giving the 150-bed facility a handsome exterior facing without extra cost. Columns and mullions frame the recessed windows, adding strength to a building that contrasts with its rather commonplace surroundings. And reinforced concrete with Grade 60 rebar permitted the builders to meet the stringent fire ratings for hospitals.

A powerful concept in reinforced concrete.

Detroit Edison/Consumers Power Co. wanted a

highly specialized structure that would be multi-functional and a showcase to the onlooker. The sculptural quality of reinforced concrete enabled the designers to create the required monumental look. And the versatility of reinforced concrete was again proved in its ability to provide in one monolithic structure many discrete functions: power pool control center; computer and telemetry rooms; fallout shelter; and an auxiliary generating station. Reinforced concrete, using grade 60 steel, made it all possible within the limits of budget and construction schedule.

There's always a call for downtown drama on a budget.

What was essentially a utilitarian building assignment—a garage—was realized in a structurally dramatic way for Michigan Bell Telephone Co. in downtown Detroit. The site chosen was at the highly-visible edge of a major expressway. With reinforced concrete as their building material of choice, the architects strikingly expressed the functions of the building in architectural terms. Vehicle ramps, stairwells, garage levels, and the separate office areas became visually arresting parts of the whole. Obviously, the fire-resistant properties of Grade-60 reinforced concrete were of vital importance in a garage. And reinforced concrete permitted the use of minimum floor-to-floor heights in the garage area itself.

Grade 60 rebar makes creativity less costly.

The strength of strong design statements depends on Grade 60 rebar. With its 50% greater yield strength, it makes for slimmer columns, more usable floor space, and lower construction costs.

Reinforced concrete: more drama for less money.

There's no place for stereotypes in today's building world. But there's plenty of room for the building system that has it all: design freedom, fast construction and early starts, less maintenance, availability, proven economy. Cast-in-place reinforced concrete plus Grade 60 rebar. More drama for your money.

Write for technical data bulletin C-O.



CONCRETE REINFORCING STEEL INSTITUTE

228 North LaSalle Street, Room 1204 • Chicago, Illinois 60601

For more data, circle 26 on inquiry card

Wouldn't it be great if your new buildings could stay as clean and fresh as you design them, and save your clients money, too. This free catalog tells how.

The Spencer Turbine Company

Drawer E, Station A, Hartford, Conn. 06106

Vacuum Cost Comparisons

Bulletin 250

Even though carpeting looks luxurious, it is the most economical commercial floor covering.
 Right? Right.
 But a central vacuum system is really an expensive luxury.
 Right? Wrong!

For more data, circle 28 on inquiry card

Westminster

theatre seat designed by Dickinson/Smith.
 Installed at Montgomery County Courthouse, Norristown, Pa.
 Interior design by Kling/Interior Design
 Vincent G. Kling & Partners, Architects.

JG JG Furniture Company Inc.
 Quakertown, Pa. 18951
 Telephone 215 536-7343



VALENCIA



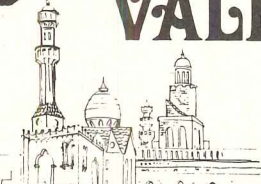

**WORLD OF THE MOORS
AND SARACENS
HANDCRAFTED TILE**

BY **Latco®**

INDIAN

TUNISIAN

ARABIAN

MALAYAN

LIBYAN

AUSTRIAN

Interior or exterior, when the motif calls for a truly distinctive ceramic tile for walls or floors, specify "VALENCIA"... Latco's latest addition to the opulent world of fine design! Inexpensive, easy and economical to install, "Valencia" is 3"x3" in size, comes mounted on 13"x13" sheets.

FOR COMPLETE SPECIFICATIONS, WRITE...

Latco® PRODUCTS

3371 GLENDALE BOULEVARD • LOS ANGELES, CALIF. 90039
 TELEPHONE: (213) 664-1171

For more data, circle 29 on inquiry card

◆ For more data, circle 27 on inquiry card

R. S. Reynolds Memorial Architectural Award given for German landmark

A Renaissance-styled railway station built in 1848, heavily bombed during World War II, and handsomely reconstructed for use as bank offices won the 1973 R. S. Reynolds Memorial Architectural Award, presented during the AIA convention in San Francisco. An AIA jury

or on German architect Hannes Westermann for the sensitive way he restored the former Hauptbahnhof, using modern materials, for the Norddeutsche Landesbank, in Braunschweig, West Germany. The jury commented that the architect restored the main facade, using aluminum for the entrances,

window frames and mullions. The rear facade was designed completely in aluminum, with an additional floor. Reynolds also conferred a prize on architectural students Raymond D. Snowden and Steven Lee Kinzler for their solar living unit design using aluminum skin, studs and beams.

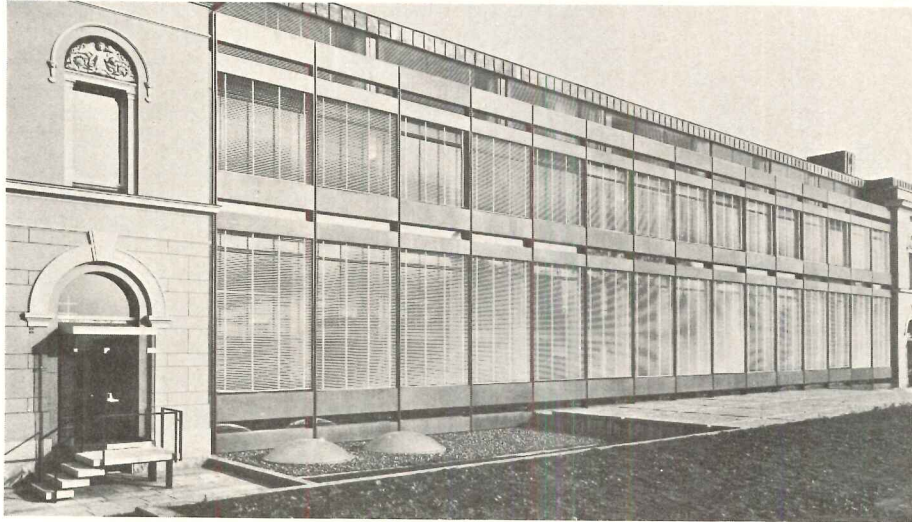

Twelve structures selected for 1973 AIA Honor Awards shown at convention

The winners are: George Gund Hall, Harvard, (RECORD, Nov. 1972) by John Andrews/Anderson/Baldwin; St. Francis de Sales Church (RECORD, Mar. 1972) by Marcel Breuer and Herbert Beckhard; Woolner residence (below) by Edward A. Cuetara; Julian A. McPhee College Union (lower left), Califor-

nia Polytechnic State University, by Esherick Homsey Dodge and Davis; Faculty housing, Radcliff College, by Ronald Gourley/Carleton R. Richmond Jr.; Public housing, Wayne, Mich., by William Kessler & Assocs. (RECORD HOUSES 1970); St. Procopius Abbey (left) by Loebel Schlossman Ben-

nett & Dart; Vacation residence (RECORD HOUSES, 1973) by McCue Boone Tomsick; Beach house (RECORD HOUSES 1972) by MLTW/Moore Turnbull; Fountain Sq. Plaza, Cincinnati by RTKL Assocs.; American Can Co. (bottom) by SOM; the Time & Life Bldg., Chicago by Harry Weese & Assocs.

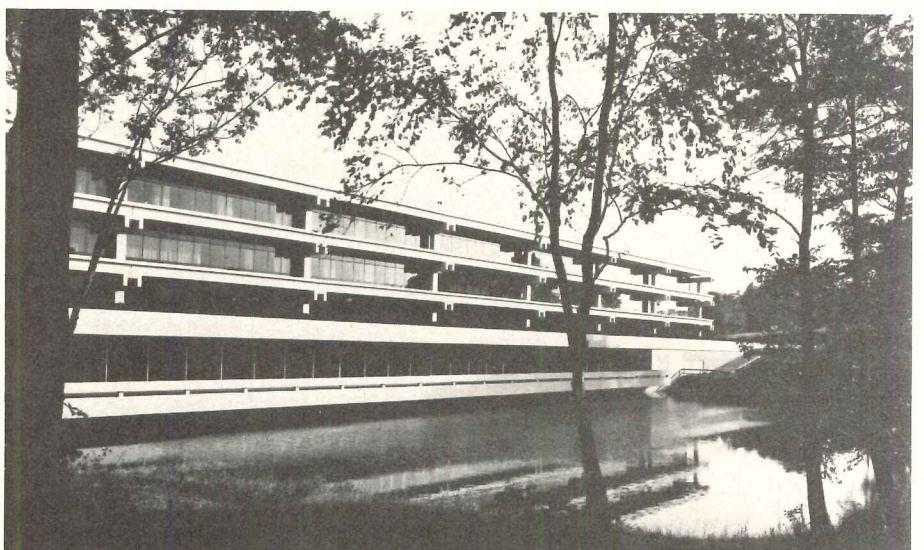
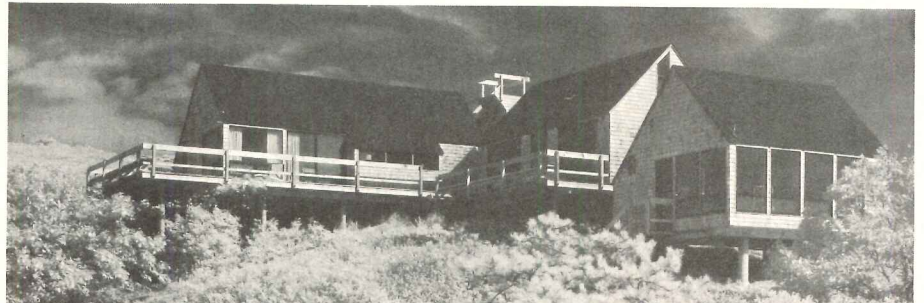

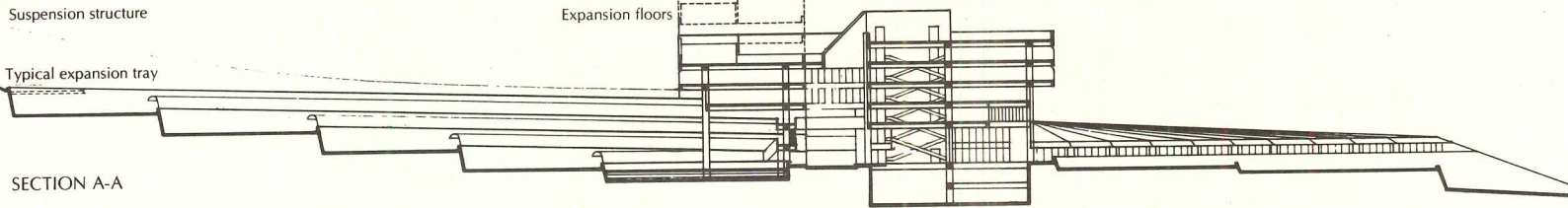

A masterful design for Johns-Manville headquarters grew from the natural beauty of its 10,000-acre site

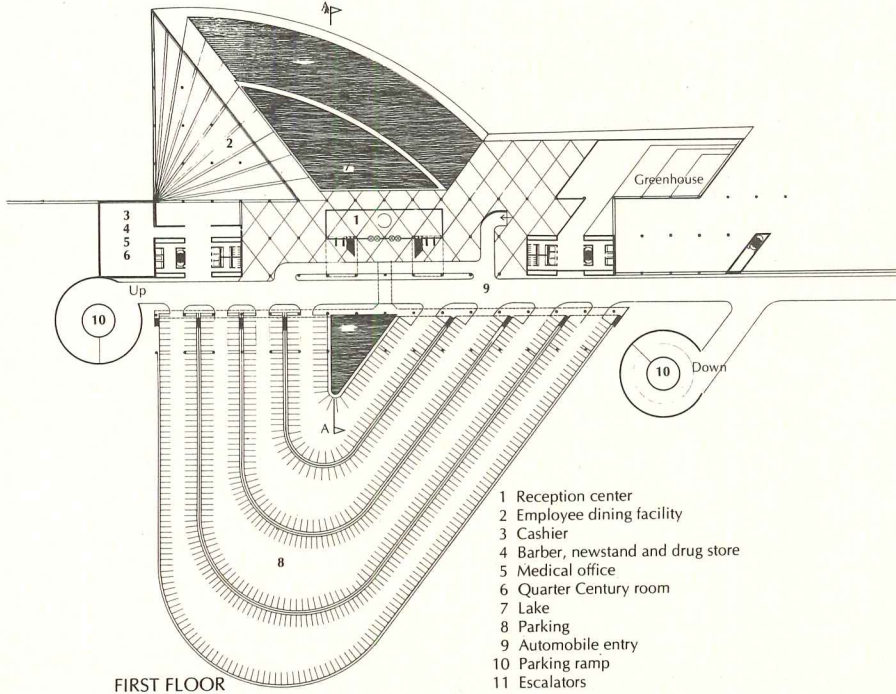

The Architects Collaborative chose to use the foothills on the site as a backdrop and build up against them, with the building commanding the best views of the valley, the hog-backs, Denver Basin and the plains. Preserving the isolated and delicate beauty of the environment was the foremost design objective, resulting in a building and parking complex that is compact for minimum imprint on the land. All expansion will be vertical. Parking for 1000 cars is in covered terraces carved into the hill behind the building, reached by an entrance under the structure. Additional parking on the roof is reached by helix ramps at either end of the building. Trees, sculpture, reflecting pools—and the general openness of the ground level—provide an inviting welcome. The eight floor levels above ground are structured in poured-in-place reinforced concrete, with bands of insulat-

ing glass in a polished aluminum skin stretching across the facades. Glass areas are recessed and shielded from the intense sun by vertical screens. The building is in two longitudinal parts, separated by a sky-lit gallery. The 800-seat cafeteria gently slopes down four levels beneath a dramatic sloping glass roof. Adjacent to this are employee services such as a drug store, barber shop and other facilities. The gross floor area of the headquarters building is 603,000 square feet, accommodating nearly 2000 employees in the first stage of building. The company plans a late 1976 occupancy. The TAC team includes: principals of the team William Geddis and Joseph Hoskins; project architect John Sheehy; and architects Michael Gebhardt, Valdis Smits, Alexis Morgan, and Michael Miller. Landscape: Robert deWolfe.

For eight firms, disappointment and fine buildings that will not be built

As Walter Wagner says in his editorial on page 9, more than the fee, what architects want most is the chance to build their building. The eight designs shown right were done by firms all chosen by Johns-Manville as capable of a design that would be the headquarters of this major company. Each firm had in the client's mind the potential to win this competition. Now these designs join the ranks of many entered in some famous competition and not selected. This may be the last time they are seen, after nearly a year of preparation for the moment each firm hoped it would hear its name called.

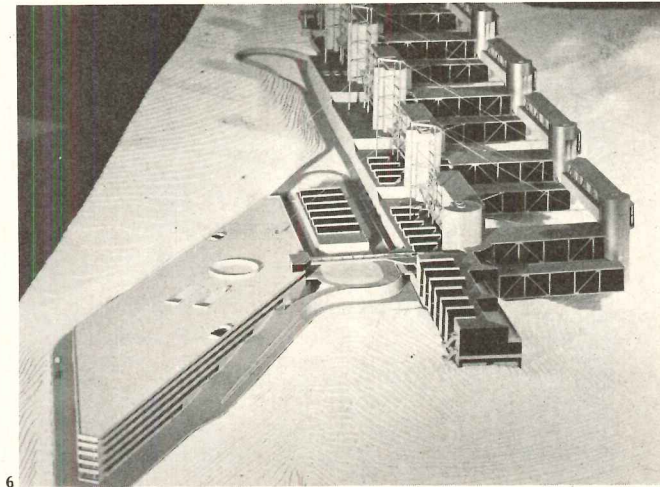
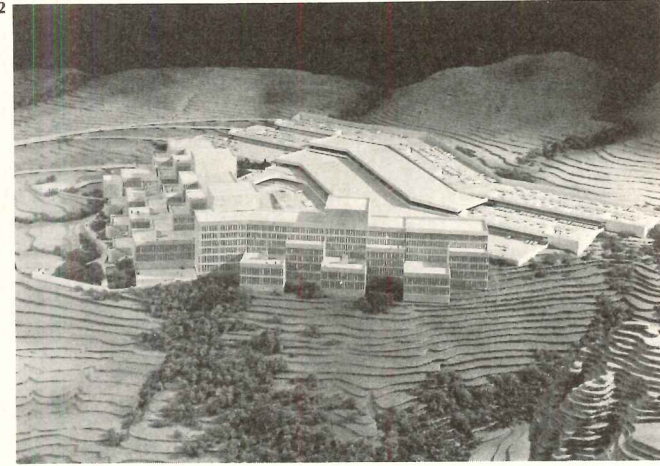
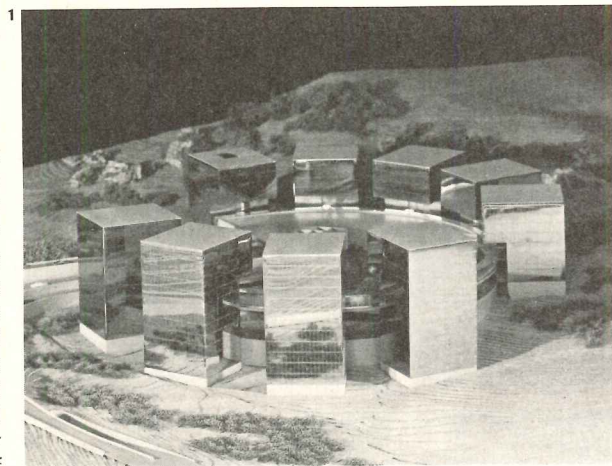

1. I.M. Pei & Partners
2. Sert, Jackson and Assocs.
3. RTKL, Inc. (Rogers, Taliaferro, Kostritsky, Lamb)
4. Caudill Rowlett Scott, Inc.
5. Vincent G. Kling & Partners
6. William L. Pereira Assocs.
7. Welton Becket and Assocs.
8. Neuhaus & Taylor

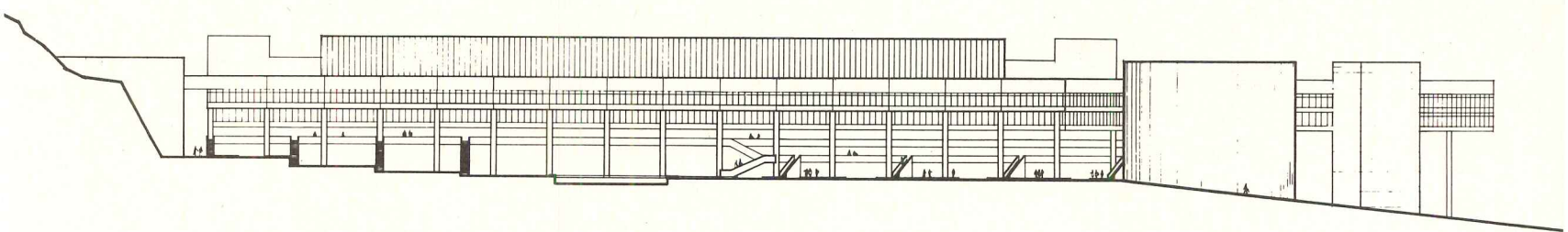
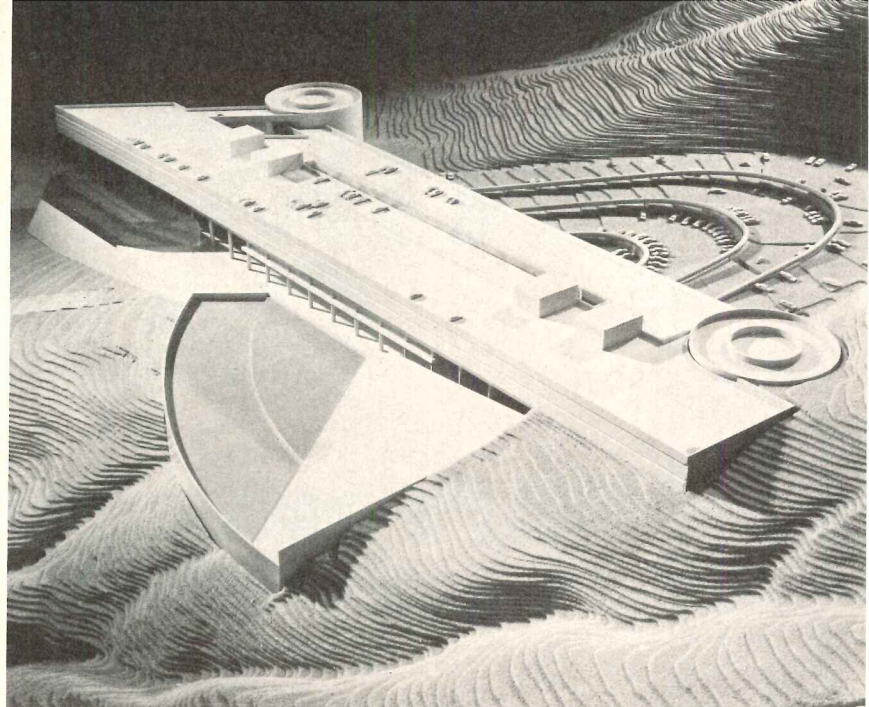
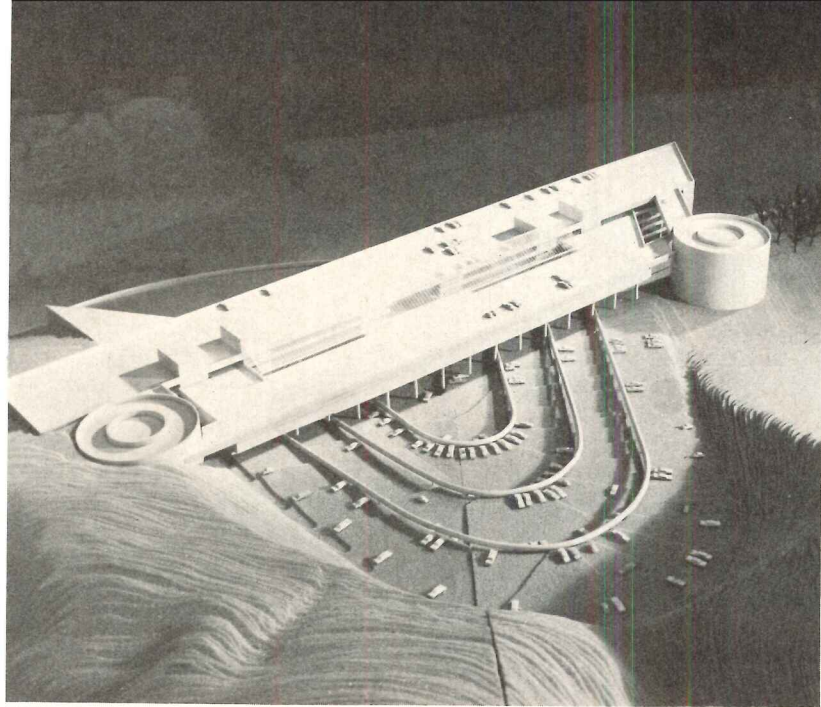

SOUTH ELEVATION

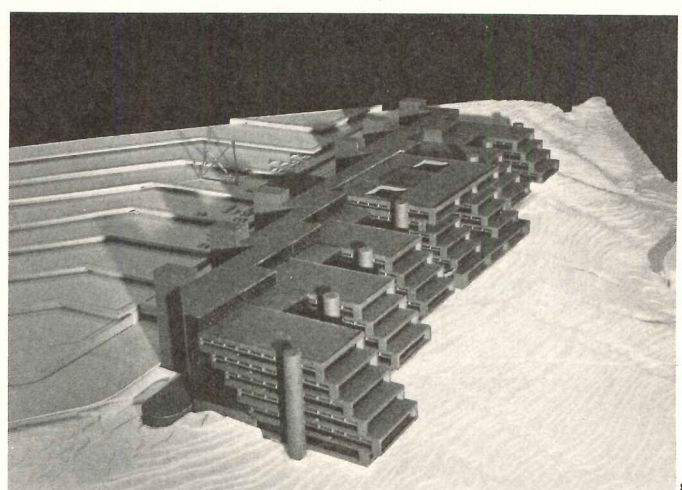
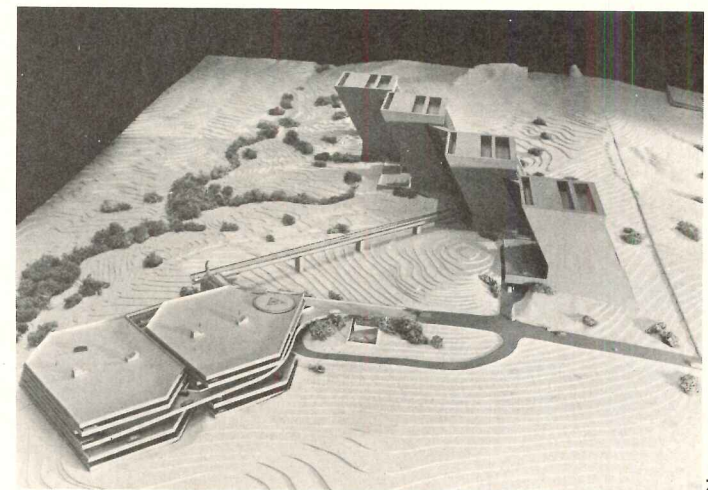
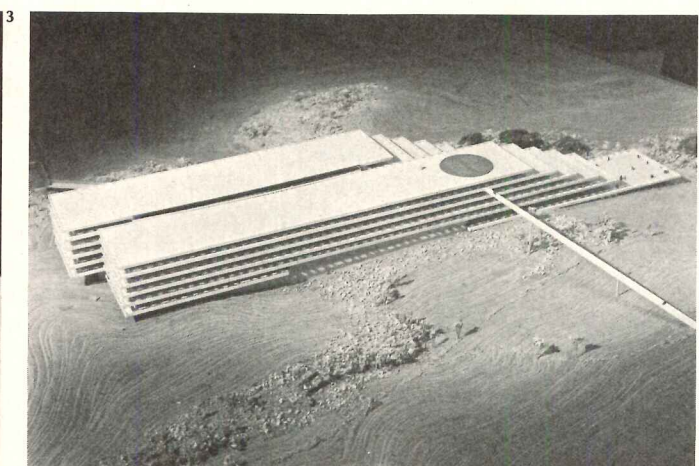
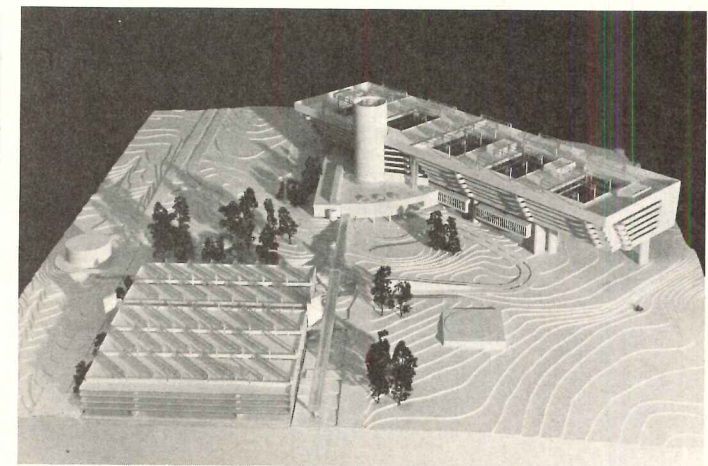

INTRODUCING GAFSTAT.

GAF's better way to make carpet completely shock-free.

Built-in shockproofing without wires.

Until now there were only two ways to make an anti-static carpet. With a non-conductive coating. Or with wire core fibers. A non-conductive coating wears out quickly. Wires affect carpet beauty and limit your choice of fabrics and patterns. GAFSTAT® from GAF eliminates these problems because it is a totally new way to make anti-static carpeting.

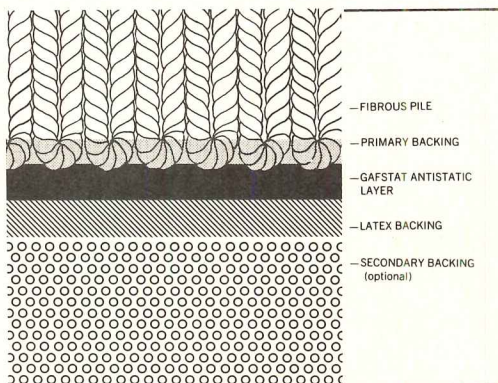
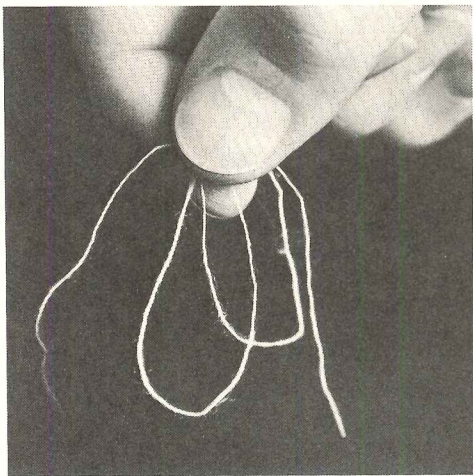

Here's how we do it.

The conductive GAFSTAT component is sealed between the backing layers of the carpet. So it can't be washed or cleaned out. And because no wires are used the fibers are untouched. So you can specify any pattern and color you like. Carpet with GAFSTAT is the first anti-static carpet that's truly satisfactory for residential use.

In addition to this, its ability to disperse static-electricity below shock levels has been confirmed by independent laboratories using the American Association of Textile Chemists and Colorists static test methods. Even under extremely dry conditions.

GAFSTAT— for their own good.

Aside from discomfort, there are other good reasons for specifying carpeting with GAFSTAT anti-static component. Static electricity can cause malfunction of delicate electronic instruments. Imagine the dangers in a hospital. And a build-up of static electricity can cause fire or explosion. So when your clients ask for anti-static carpeting specify GAFSTAT. Because the facts speak for themselves.



gaf® **GAFSTAT**
A better way to
end carpet static.

Carpet with G A F GAFSTAT is available from:

Eagle Carpets, Inc. Sikes Corporation Wellco Carpet Corp.
Williams-East, Inc. Wunda Weve Carpets

For more data, circle 30 on inquiry card

day or night, it works

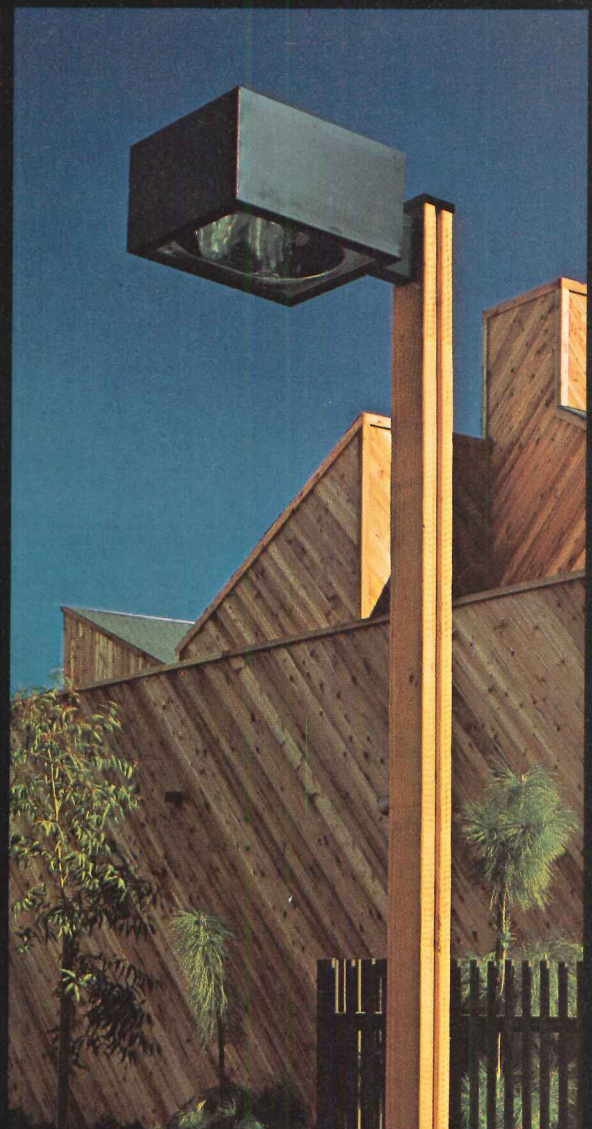
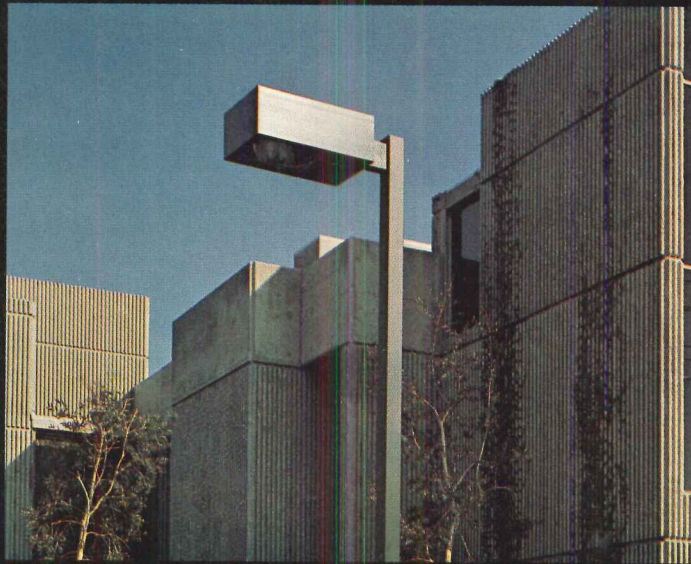

kim lighting, inc.

City of Industry, California

Street and Area Lighting
Environmental Lighting
Landscape Lighting
Swimming Pool Lighting
Fountain Lighting
Custom Architectural Fountains
Pre Engineered Fountains
Fountain Components

A DIVISION OF
LCA
CORPORATION



a) Grandstand, Indiana State Fairgrounds, Indianapolis, Ind. b) Kimberly-Clark Warehouse, Fullerton, Calif. c) Berths 80 & 82, Elizabeth-Port Authority Marine Terminal, in Elizabeth, N.J. d) Indoor pool, Kensington Club, Inc., South Bend, Ind. e) Delta Air Lines Hangar, Atlanta, Ga.

**This is Alcoa
Snug Rib roofing.
It's flat, tight
and handsome.**

Alcoa® Snug Rib roofing gives you all the advantages and savings of low-pitch construction plus excellent leak resistance. Since slopes as low as ¼ in. in 12 in. are possible, there's less dead space to heat or air condition. The patented Snug Seam® joint holds panel edges securely in place to create a weathertight seal, and there are no through fasteners to penetrate the weathering membrane. Since Snug Rib roofing is a "floating" system, it moves under thermal cycling, so locked-up thermal stresses are eliminated. Installa-

tion is fast and easy, and savings continue over the life of the building because aluminum requires so little maintenance. On most buildings end laps can be eliminated because lengths are limited only by shipping conditions. Handsome Alcoa Snug Rib roofing is ideal for swim clubs, industrial and port buildings, warehouses, grandstands and aircraft hangars. For more information on economical Snug Rib roofing, write Aluminum Company of America, 1130-F Alcoa Building, Pittsburgh, Pa. 15219.



**Change for the better with
Alcoa Aluminum**



For more data, circle 32 on inquiry card

How to ship small packages in a big hurry.

DELTA'S DASH →
DELTA AIRLINES SPECIAL HANDLING

Delta guarantees delivery on the flight or routing you specify between most Delta cities.

Packages accepted up to 50 lbs. with length plus width plus height not to exceed 90" total, with only one dimension exceeding 30".

Delivery to Delta's passenger counter or air freight terminal at the airport at least 30 minutes prior to scheduled departure time.

Pick-up at DASH Claim Area next to airport baggage claim area 30 minutes after flight arrival at destination.

Charges for DASH shipments are nominal. Delta reservations will be pleased to quote actual charges between specific points.

Payments accepted in cash, by company check, most general-purpose credit cards, special credit arrangements or on government shipments by GBL. **DELTA**
The airline run by professionals

Rate examples (Tax included)

Atlanta-Washington	\$21.00
Boston-Miami	\$26.25
Cincinnati-Louisville	\$21.00
Cleveland-Phoenix	\$26.25
Los Angeles-New Orleans	\$31.50
Dallas-Los Angeles	\$26.25
San Francisco-Atlanta	\$31.50
Philadelphia-Houston	\$26.25
New York-Tampa	\$26.25

For full details, call Delta reservations.



Delta is ready when you are!

For more data, circle 33 on inquiry card

Research into Courthouse Design

THE AMERICAN COURTHOUSE: *Planning and Design for the Judicial Process; Institute of Continuing Legal Education, Ann Arbor, Michigan, 1973, 320 pages, illus., \$40.00.*

The recent sophistication and knowledge that has been developed in the fields of operations research and managerial science has already begun to disrupt the traditional, easygoing architect-client relationship. This is especially true in the design of institutional buildings in which the marriage between administrative structure and spatial organization is of crucial importance. Clients are beginning to demand a more comprehensive and sophisticated program and to monitor the performance—both economic and functional—of their new buildings. One direct result has been a considerable amount of speculation over the past decade about a research aspect to architecture.

Everyone who felt that this was a positive direction for the profession to take has eagerly awaited the results of the five-year research project to develop an interdisciplinary guide to the design of courthouse facilities. The joint sponsorship by the AIA and the American Bar Association, and a \$197,000 Ford Foundation grant, provided an ideal start. The brief was to provide attorneys, judges, court administrators, public officials and architects with a set of "desirable standards and planning guidelines."

The result is a severe disappointment! What has been written is a descriptive introduction to the operations and functions of the courts for architects and laymen and a comprehensive set of tables defining standards of environmental control and space utilization. This is a valuable body of information, but for the architect designing at the drawing board, or the client attempting to assess the shortcomings of a set of plans, there is little relevant information. What is missing should have been the guts of the research program. This is a system to: a) *more accurately define and describe programmatic relationships*; b) *assess the impact of various administrative strategies, proximity requirements, communications and data processing systems on the range of possible spatial relationships between the various parts of a courthouse*; and c) *begin to explore alternative sets of design strategies and prototype solutions.*

The reasons for the poor results of this ambitious project are important and must be isolated and analyzed. The root of the problem is clearly one of the methodology. Each chapter in the book describes the operation of a particular department (e.g. a court clerk's office), or process (e.g. a jury trial). This information is then synthesized into a bubble diagram which illustrates the desirable communications linkages with other departments and also into tables of desirable areas of space per person, temperature and acoustic conditions. The bubble diagram is the problem. It simply indicates a necessary communications network. There is no spatial or scale factor, nor is there any indication of the quality and type of communication, of the priority ratings of the various parts of the network, or any proximity requirements. This renders it meaningless as a tool for design or evaluation. The most glaring failure of methodology is evident in the chapter on courtroom

layout. Based on the fact that the human eye has a maximum horizontal angle of vision, of 150 degrees, and that if all the participants in a courtroom are seated in a circle they will all be visible to each other, albeit at the extreme edge of the angle of vision, it is deduced that a circular courtroom will provide the optimum layout. This is simplistic. It ignores the fact that a circle has central focus, while in a courtroom the perimeter, where the judge, jury and witness sit, is invariably more important. The center area is used mainly for movement. Questions of design precedent, symbolism and meaning are also neglected, and no method to compare the operation of different courtroom layouts is presented.

The most valuable part of the book is the last section which has a collection of plans and illustrations of courthouses past and present. The failure of methodology is again evident, as the book simply does not posit any criteria by which to judge these plans. Basic errors in planning, which cause security and operational problems, are simply not pointed out. The evaluation of precedent, probably the most valuable design and research tool in architecture, has been completely ignored.

In conclusion, this book contains a useful introduction to the court's operation for architects. The collections of plans is a valuable reference, but the whole is way overpriced at \$40.00. What has been lost is a unique opportunity to establish a research aspect to architecture, and in these times a second chance will be hard to come by. —Allan Greenberg

Mr. Greenberg, a practicing architect and Visiting Critic at Yale University, is Consultant to the Judicial Department of the State of Connecticut; he is also currently at work on a book on decision-making in the pre-construction phase of a courthouse project.

Also Received

THE ARCHITECTURAL INDEX FOR 1972, *edited by Ervin J. Bell; The Architectural Index, Boulder, Col., 1973, paperback, 74 pages, \$7.00.*

The latest edition of the standard index to American architectural publications.

THE DREAM KING: Ludwig II of Bavaria, *by Wilfrid Blunt; Penguin Books, Baltimore, 1973, paperback, 264 pages, illus., \$4.95.*

For lovers of Wagner, madness, opulently romantic architecture and stunning color photography. More fun than the movie.

BEYOND HABITAT, *by Moshe Safdie, edited by John Kettle; M.I.T. Press, Cambridge, 1973, paperback, 244 pages, illus., \$2.95.*

A paperback edition of Safdie's book which first appeared in 1970.

THE 1973 ANNUAL BOOK OF ASTM STANDARDS; *American Society for Testing and Materials, Philadelphia, 1973; Part 11, 1102 pages, \$35.50; Part 12, 510 pages, \$18.50; Part 20, 1252 pages, \$43.25; Part 21, 808 pages, \$27.75.*

Part 11 deals with bituminous materials for highway construction waterproofing, and roofing; soil and rock; skid resistance; peats, mosses, humus and related products. Part 12 deals with chemical-resistant nonmetallic materials; clay and concrete pipe and tile; masonry mortars and units; asbestos-cement products; and natural building stones. Parts 20 and 21 deal with ASTM standards on paints.



Owner: United Way of America, Alexandria, VA; Architect-Engineer: Ferendino/Grafton/Spillis/Candela, Coral Gables, FL; Fabricator: Southern Iron Works, Inc., Springfield, VA; Erector: Williams Enterprises, Merrifield, VA; General Contractor: Eugene Simpson & Brother, Inc., Alexandria, VA

Steel-framed office designed and built within 10 months

"Fast-track" construction and steel framing shave design/building schedule by eight months

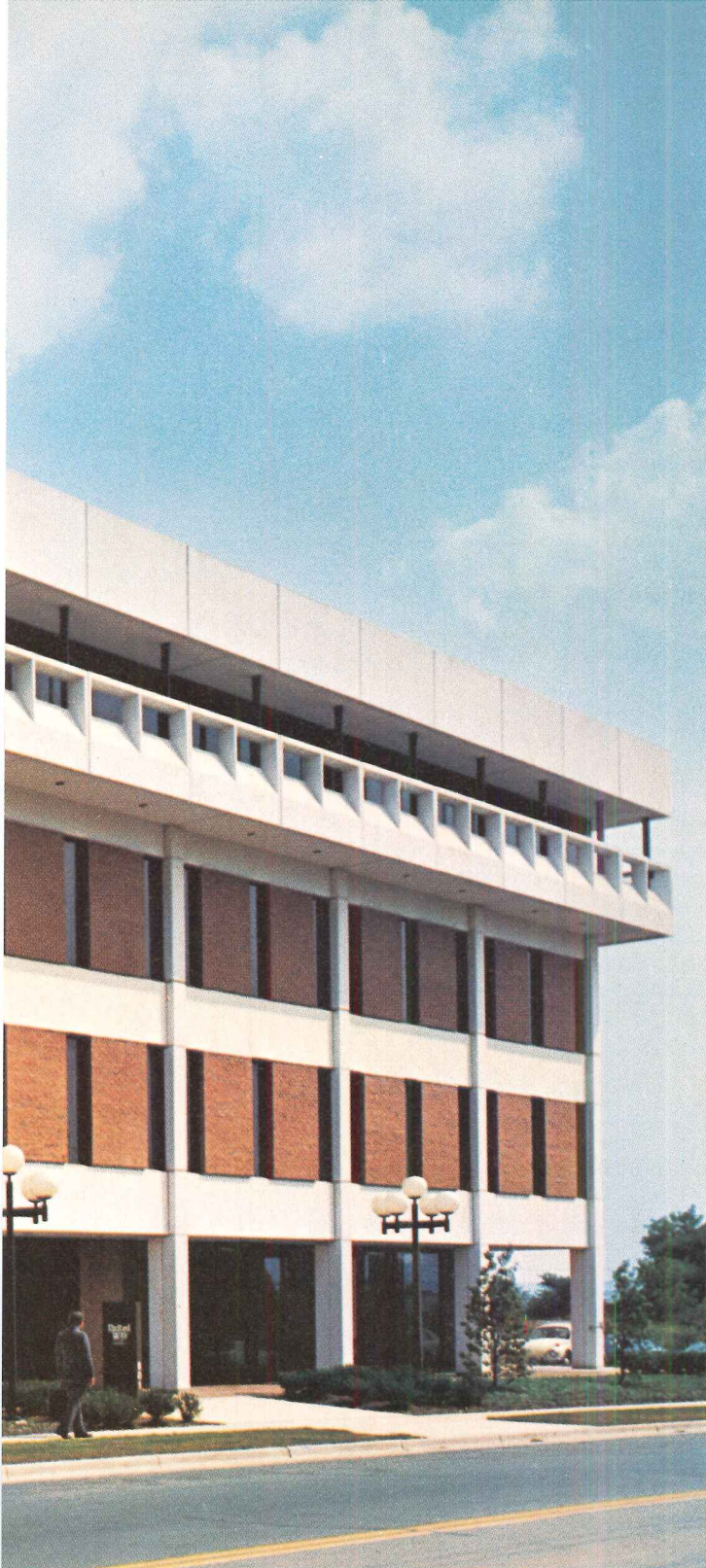

The result: substantial savings in construction costs, rent at another location, and construction money interest.

Why they switched to structural steel

Originally, the office was to be built of reinforced concrete, but poor soil conditions requiring a lighter frame and a tight construction schedule, swayed the decision to steel. Furthermore, steel's inherent advantages were well-suited to the fast-track construction method.

"Erection of a steel frame requires much less on-site labor than a reinforced concrete frame in the early stages of construction," commented Edward G. Grafton, A.I.A., President of Ferendino/Grafton/Spillis/Candela. "Our designers, who were literally designing the building while it was being built, were able to increase design quality and decrease costs by making adjustments through early insights into field conditions. Steel framing also allowed greater flexibility during the design/construction process.

"We also found that early installation of the roof, using steel decking, provided a great accommodation to the workmen and assisted in protecting the building materials which demanded early delivery to the site."

In addition to office space, the 107-ft by 145-ft structure contains conference, computer, and audio visual rooms, a print shop, and a coffee shop. The central service core houses two elevators, mechanical and utility equipment, and two stairwells.

Steel framing is versatile, adaptable, economical.

And it can provide long clear spans for maximum freedom of interior arrangement.

Want more information on structural steel framing for buildings? Just get in touch with our sales engineer at the Bethlehem Sales office nearest you. Bethlehem Steel Corporation, Bethlehem, PA 18016.

The United Way of America National Headquarters Building, Alexandria, Va., serves as administrative center for thousands of volunteers across the country dedicated to helping people in their local communities. Occupied in late 1971, the 4-level structure stands as symbol to the "spirit of voluntarism which marks America as unique."

The 60,000 sq ft building was designed and constructed within 10 months at a cost of \$24.46 per sq ft. By using the "fast-track" construction method, the contractor was able to begin and continue construction as the architect released various design phases.

The architect reported that the fast-track method saved eight months design and construction time.

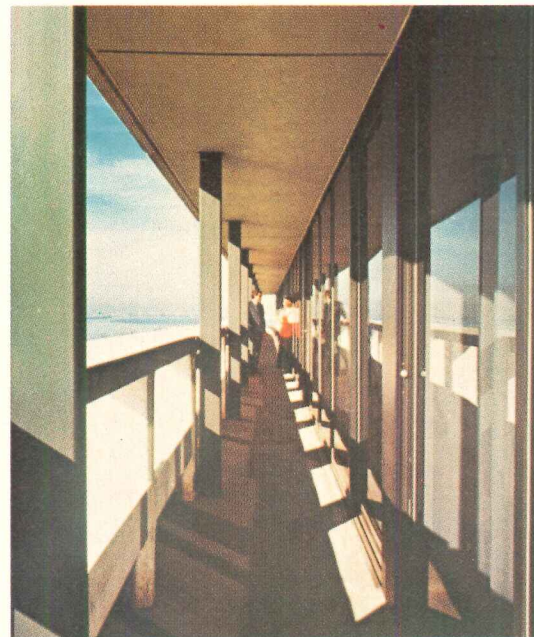

An open-air balcony, surrounding the building at the 4th level, cantilevers 7½ ft beyond the center line of the perimeter columns.

Bethlehem 

A new textured masonry coating for age old problems.

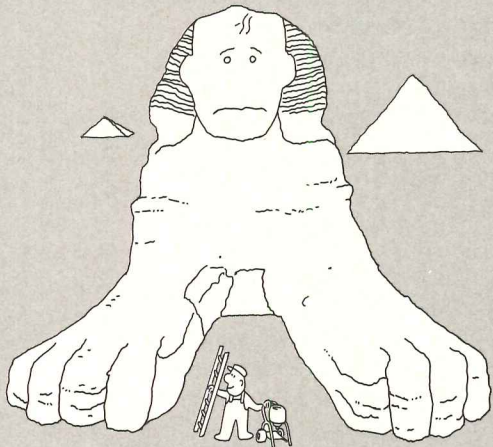

New Pro-Hide Textured Masonry Coating by Pratt & Lambert. It fills the specs. Economically. While it builds and fills on the sphixiest masonry surfaces. You can bet your reputation on it. The P&L ages of quality are in it. Ask your P&L architectural rep to fill you in.



Box 22/Dept. AR-6, Buffalo, N. Y. 14240

For more data, circle 34 on inquiry card

Pick the hinge that hides

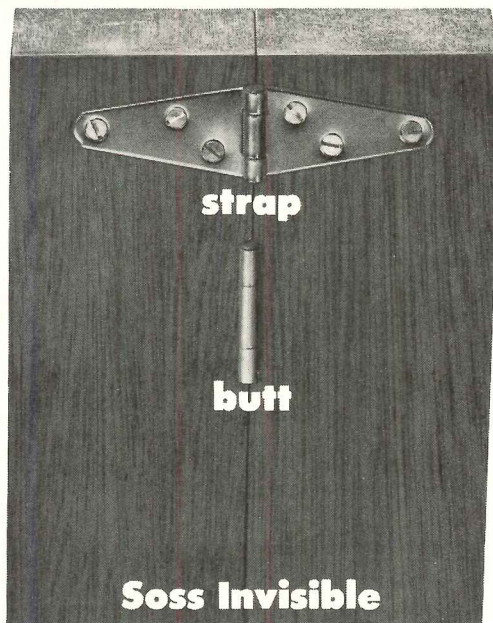

Compare the Soss look of invisibility with any strap or butt hinge and you'll choose The Soss Invisibles. These amazing hinges hide when closed to blend with any decor. With The Soss Invisibles you can create room, closet, or cabinet openings which are unbroken by hinges or gaps . . . the perfect look for doors, doorwalls, built-in bars, stereos, or T.V.'s. The Invisibles are extra strong, open a full 180 degrees, and are reversible for right or left hand openings. See listing in Sweet's or write for catalog: Soss Manufacturing Company, Division of SOS Consolidated, Inc., P.O. Box 8200, Detroit, Michigan 48213.



For more data, circle 35 on inquiry card

The Night Time Environment People

MOLDCAST

Manufacturing
164 Delaney Street, Newark, N. J. 07105
In Canada: Varco Industries Ltd., Montreal 379
For more data, circle 38 on inquiry card

A Warmly Glowing
Decorative Ambience -
Round Landscape
Chandeliers

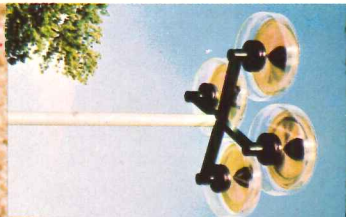

Soft Memories of
Gas Light - with
Outstanding
Illumination -
The Pericline
Contemporary

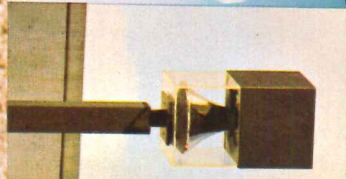

Highest Level Site
Illumination - from a
Hidden Source -
Sans Serif

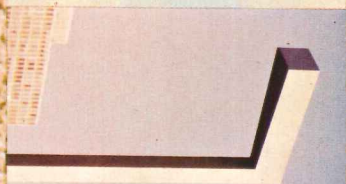

A Warmly Glowing
Decorative Ambience -
Square Landscape
Chandeliers

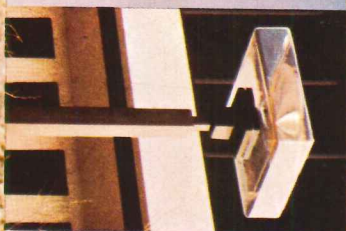

Site Coordination
from Families of
Architectural Forms -
Site Modules

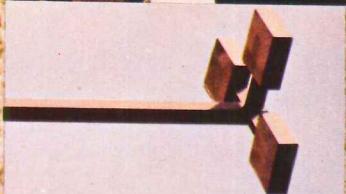

Preview some of Moldcast's other Night Time Environments

Write for literature and specifications

Bollards have always been little more than light markers. . . now Moldcast has produced the Bollard Pericline, a broad distribution light source which is virtually free of glare. Designed for effective ground illumination even when spaced up to 45 feet apart, Bollard Periclines provide a glare-free environment as soft and comfortable as a living room. The tiny alternative to tall lighting poles, in round and square shapes. From Moldcast, only Moldcast!

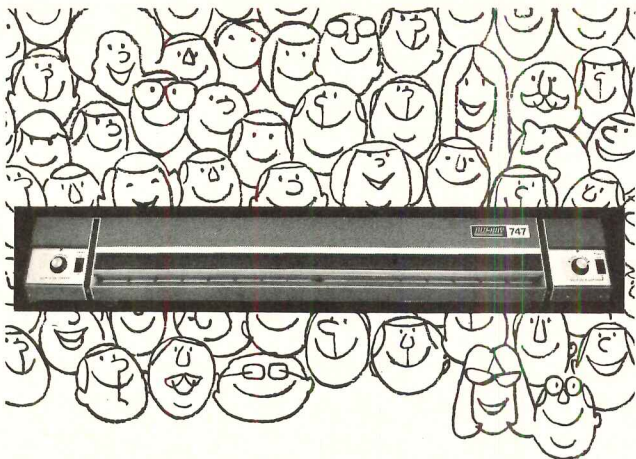

Thousands of happy Blu-Ray owners must be right!

As the long time innovator in tabletop whiteprinters, we've made machines so good, so reliable, that thousands of people have invested in them.

They like the low cost of our whiteprinters, the ease in operation. They like the sharp copies, the speed and performance. They like having 3 models to choose from —to fit their need and budget. And do they like the *minimal* service required!

Our '73 models feature improvements. Join our happy club. Send for our brochure. Blu-Ray, Incorporated, 133 Westbrook Road, Essex, Connecticut 06426. Telephone (203) 767-0141.

BLU-RAY

For more data, circle 36 on inquiry card

 ★ The guide spec that opened
 ★ countless doors to carpet ★

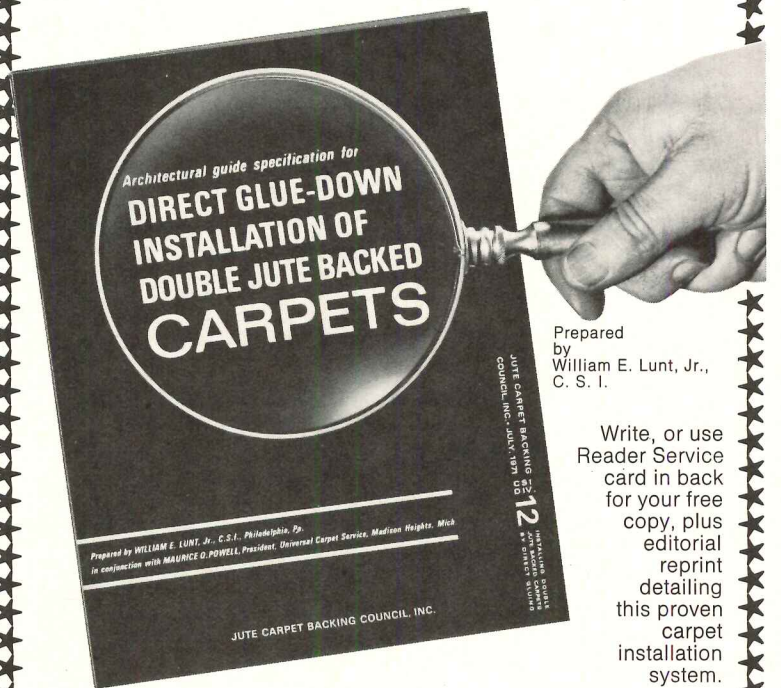

Prepared
 by
 William E. Lunt, Jr.,
 C. S. I.

Write, or use
 Reader Service
 card in back
 for your free
 copy, plus
 editorial
 reprint
 detailing
 this proven
 carpet
 installation
 system.

JUTE CARPET BACKING COUNCIL, INC.
 25 Broadway • New York, NY 10004

 For more data, circle 37 on inquiry card

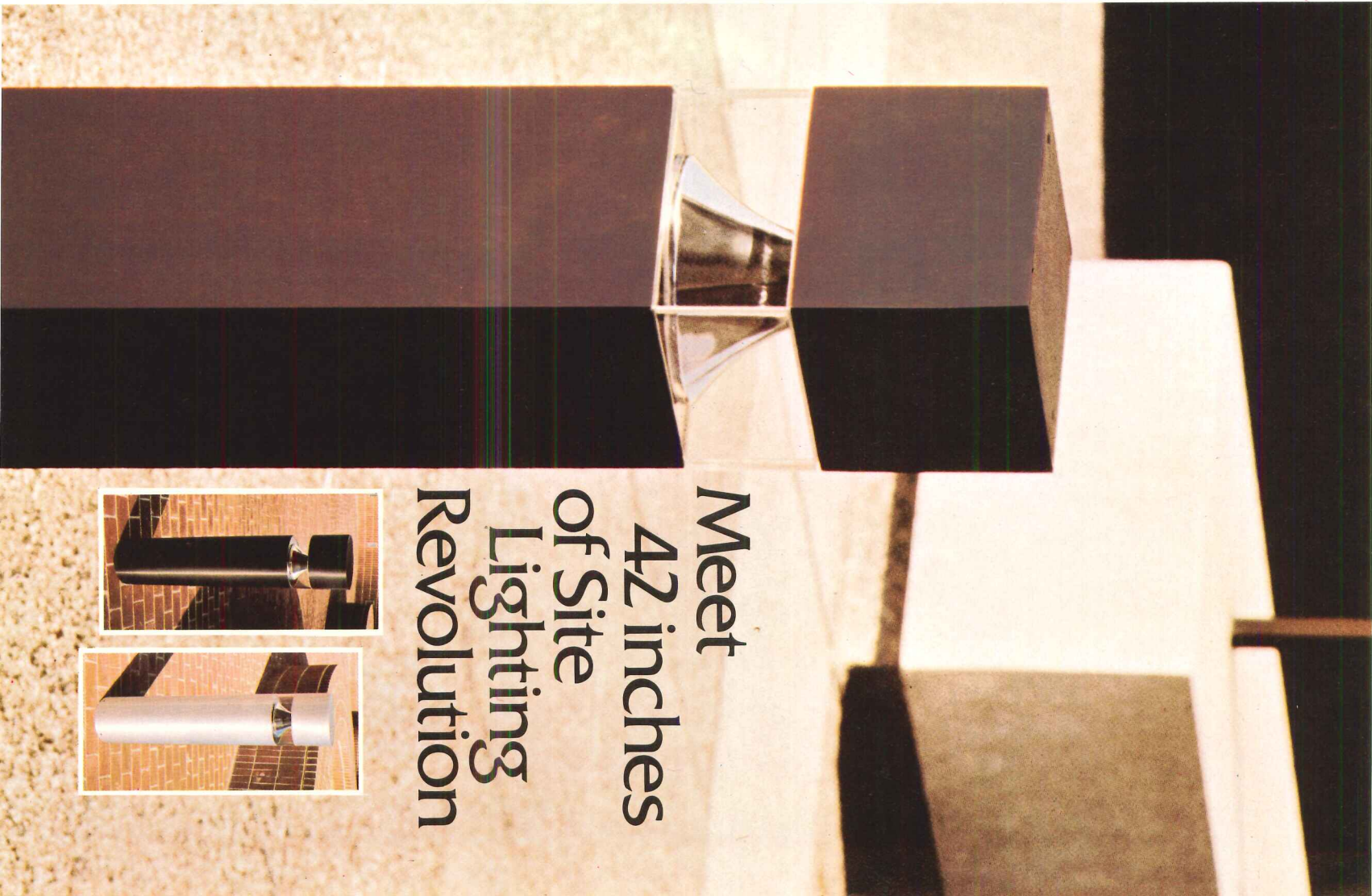

Meet
 42 inches
 of Site
 Lighting
 Revolution

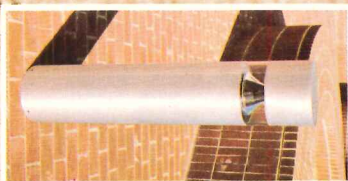
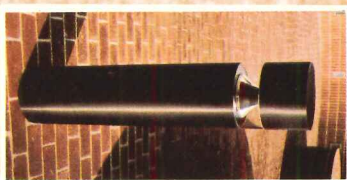

Brown University

We neglected to give credit to Eric Pick as associate in charge and to Rosario Piomelli as project designer of the Brown University Science Building (April).

*Danforth W. Toan
Warner Burns Toan Lunde*

GSA Standard Form 251

RECORD's article on GSA Standard Form 251 (April 1973) rang a bell, reminding me of other aspects of the problem that cost architects as well as construction firms money and jobs. To my knowledge, the Air Force has not been guilty of the evils you mention (generating a special supplement to the form), but the expense of preparing the form is just the beginning.

Most AE selection within the Air Force is done locally at several hundred installations. In some cases, both the civil engineering and procurement offices at each location are involved. Thus, the problems of the form itself are minimal compared to the problems of distributing it.

Wasted effort could be substantially reduced if a central government clearinghouse were established to which all brochures were sent.

I have submitted a suggestion along these lines through official government channels, recommending establishment of a clearinghouse.

*Michael Burrill
Captain, USAF Housing Division*

ERRATA

RECORD regrets that some credits for the article on Stockton State College in the March 1973 issue were inadvertently omitted. The complete list of credits is as follows:

The Master Plan was prepared for the State of New Jersey Department of Higher Education, Ralph Dungan, Chancellor and John L. Whitlock, Director of Facilities Planning and Construction. The construction of the Phase I buildings was undertaken for the State of New Jersey Division of Building and Construction, Donald Sullivan and Walter T. Peters, Jr., Directors.

Architects: Geddes Brecher Qualls Cunningham; Partners-in-charge: Robert Geddes and Warren Cunningham; associates and senior staff: James Dill, Neville Epstein, Harrison Fraker, Hamilton Ross, William Dix, Andrew Sheldon, William Winchell, Roland Gallimore, Elizabeth Lawson.

Engineers: Jackson and Moreland; Vinokur and Pace; Peat Marwick, Mitchell & Co.; David Bloom, Inc.

Stockton College: Richard Bjork, President; Richard Schwartz, Office of Campus Planning and Development.

Construction: Construction manager, Day and Zimmerman, Inc.; General construction, Constanza Contracting Co.; 1) structural subsystem, Romac Moduloc; 2) HVAC subsystem, ITT Nesbitt, Lennox Industries, Inc.; 3) Interior Partition subsystem, E. F. Hauserman Co.; 4) Ceiling-lighting subsystem, Keene Corp.; 5) Exterior skin subsystem, Costanza Contracting Co., Apco Porcelain.

Photography by Otto Baitz and David Geddes. Graphics by GBQC; interior graphics and banners in the gallery: GBQC and Strong-Cohen.

Odessa City Hall, Odessa, Texas.
Architects: Peter and Fields

DOORWAY NOTES

THE LCN 5030 SERIES CLOSER IS CONCEALED WITHIN THE HEADFRAME.

HYDRAULIC BACK CHECK AND ADJUSTABLE TWO SPEED CLOSING PROVIDE POSITIVE CONTROL OF OPENING AND CLOSING SWINGS.

MECHANICAL ADVANTAGES OF DOUBLE LEVER ARM AND ADJUSTABLE SPRING POWER RECOMMEND THIS CLOSER WHERE HIGH WINDS OR INTERNAL PRESSURES ARE ANTICIPATED.

UNIQUE DESIGN INCORPORATES ALL CLOSER CONTROL CHARACTERISTICS, YET FITS INSIDE 1-3/4" x 4-1/2" TRANSOM BAR.

SEND FOR CATALOG. SWEET'S, SEC. 8.

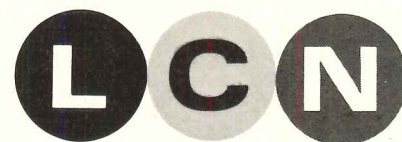
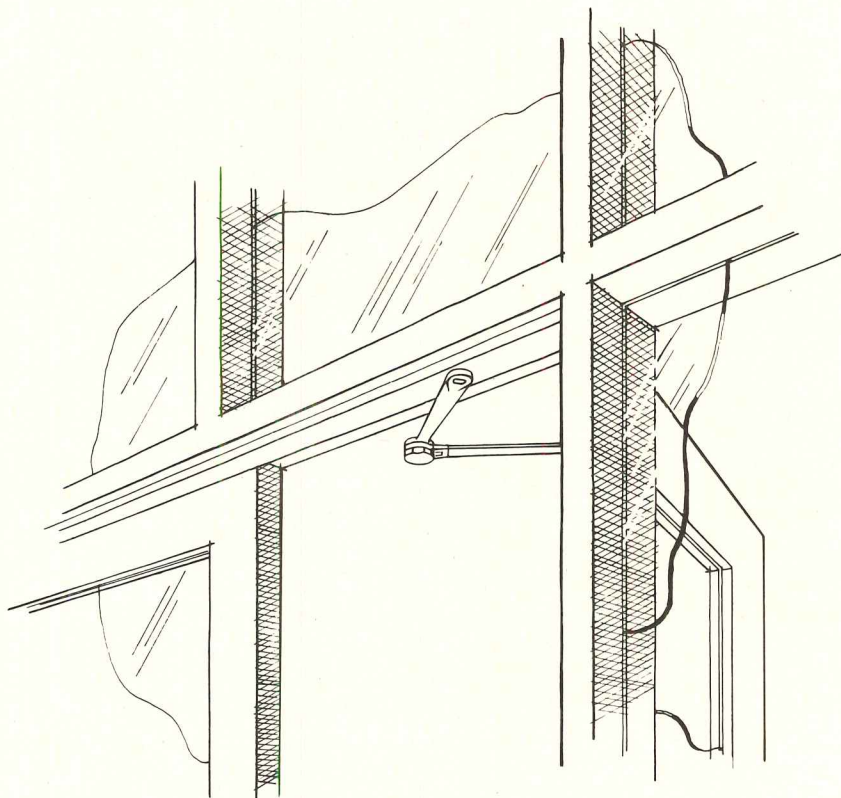

LCN CLOSERS, Princeton, Illinois 61356

For more data, circle 39 on inquiry card



Bright ideas



Bradley's systems approach for specifying washroom accessories. Everything you need all from a single source.

Bradley has everything from washfixtures and showers to design-coordinated, recessed accessories. These expertly crafted accessories reflect the clean, functional lines of today's contemporary structures. And allow you complete design freedom. They also conserve space and reduce maintenance. Towel dispensers, waste receptacles, mirrors and shelves, and grab bars are only a few of the many accessories Bradley offers. Others include soap dispensers, napkin vendors and disposals, toilet tissue holders, seat cover dispensers, and related equipment. It's the complete line for institutional, commercial, industrial, and public buildings. From Bradley. The washroom systems specialists. Bradley Corporation, Washroom Accessories Division, Dept. A, P.O. Box 321, Moorestown, New Jersey 08057.

from Bradley!

Leader in Washroom Fixtures and Accessories



For more data, circle 40 on inquiry card

Westinghouse outdoor lighting turns the night on with new shapes and colors.

Today's architecture is clean and simple. We've designed an outdoor light that works with it—the ALS (Architectural Lighting System).

The ALS is designed for malls, shopping centers, parking lots, streets—anywhere attractive, functional lighting is required. The important word is "attractive." With its straight line design, the ALS fits with today's architecture.

Available in four shapes, six wattages, three lamp types, and sixteen colors, the ALS is truly versatile.

Westinghouse can also supply square steel, aluminum, and wood poles to complement the ALS. And you can color match the poles to the fixture.

For flexibility, the ALS can be mounted one, two, three, or four to a pole.

Day or night, our ALS will turn people on.

You can be sure . . .
if it's Westinghouse.

If you'd like to learn more about the ALS, write Westinghouse Electric Corporation, Outdoor Lighting Division, P.O. Box 5817, Cleveland, Ohio 44101.

0-1-72

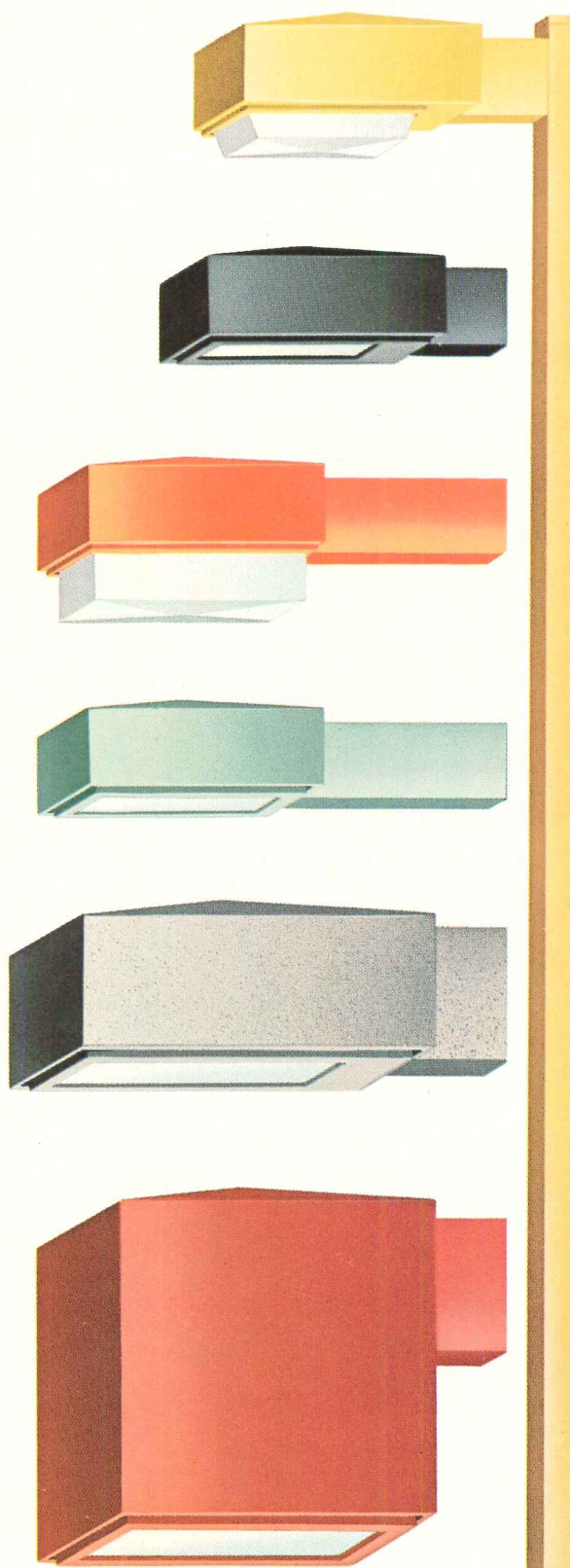

Westinghouse



For more data, circle 41 on inquiry card

New PD-80 engineering convenience copier.

Convenience is what the fast, high-quality PD-80 is all about. Install it right in your drafting area, turn it on, feed tracings at once, and get finished prints in seconds. It's the most reliable odorless engineering convenience copier: no ammonia, no venting.

What more can we say? Except that we can set it up and

demonstrate it in about the time it takes to read this.

So, call your local Bruning man. He's ready to show you how you can make quick check prints right where you make your drawings, with the PD-80. And this cost-cutting machine can go to work for you on an attractive rental plan. No capital investment, no long-term commitment. Like all Bruning products, the PD-80 is backed by the famous Bruning tradition of

service and support to the engineering profession.

Your drafting department just has to see this one. Call your Bruning man. Or write Bruning, 1834 Walden Office Square, Schaumburg, Ill. 60172.

Your single best source in engineering graphics.

No odors. No waiting.

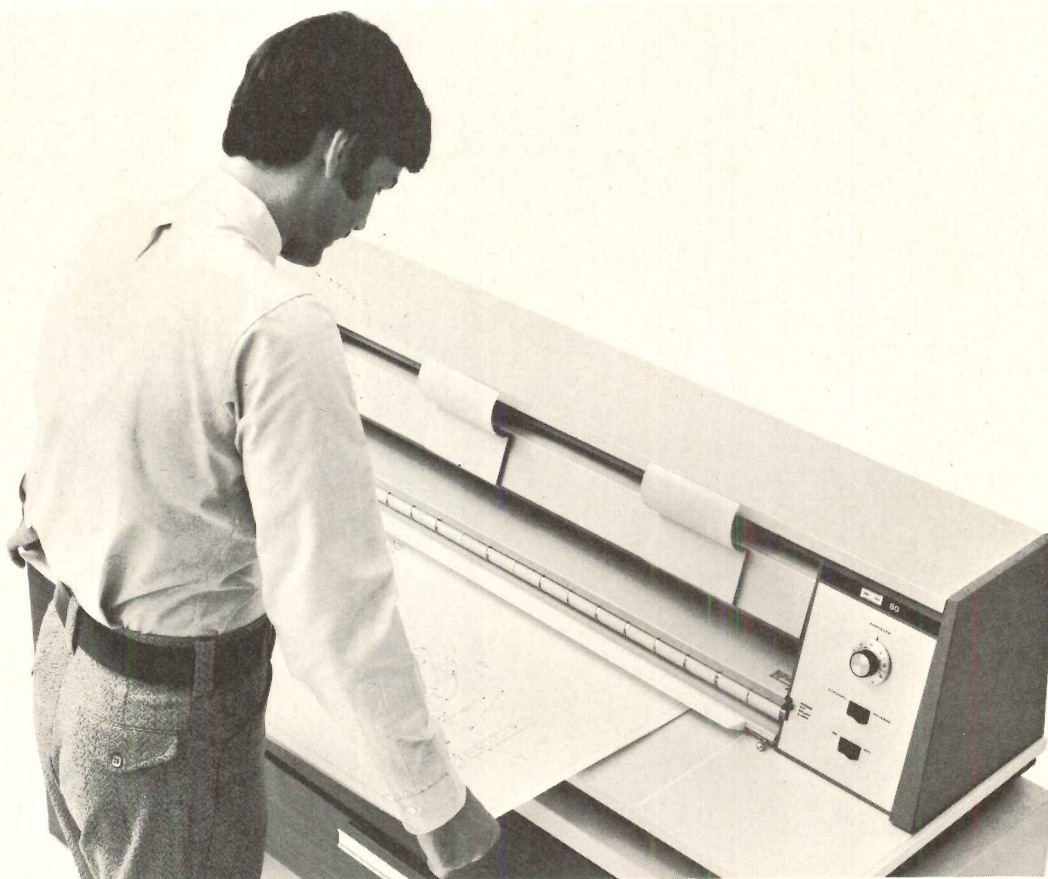

BRUNING

DIVISION OF ADDRESSOGRAPH MULTIGRAPH CORPORATION

For more data, circle 42 on inquiry card

THE QUIET WALL.

THE BEAUTY SIDE...

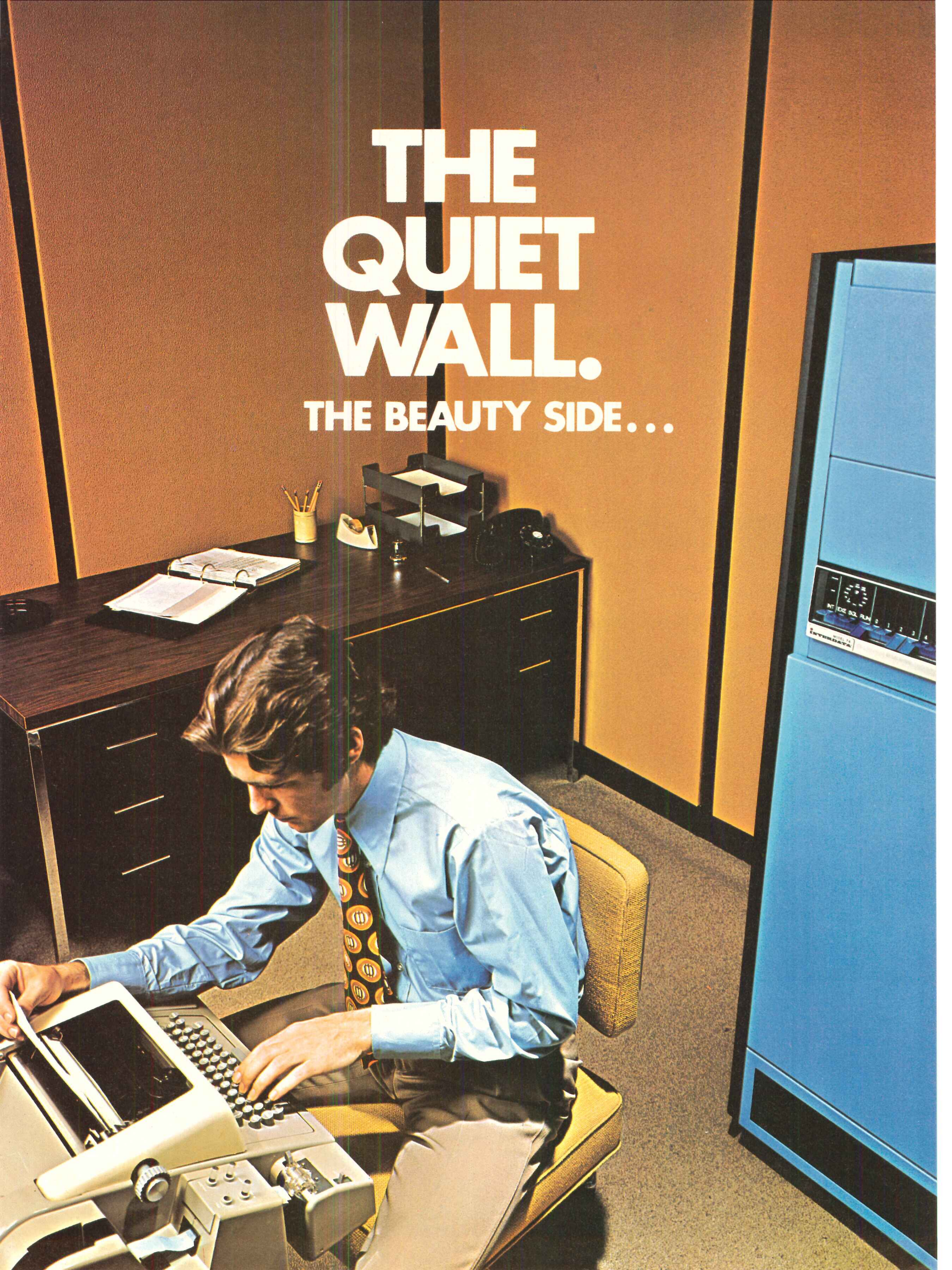

THE QUIET WALL.

THE PRACTICAL SIDE.

Vicracoustic® wall panels* are durable and available in a wide range of sizes. They're durable because they're pre-finished with perforated Vicrtex® vinyl wall covering. Vicrtex is an electronically fused vinyl-coated fabric. The color is an integral part of the Vicrtex vinyl so the colors stay fresh and true.

If you'd like to try our panels on for size, we'll be glad to accommodate.

We have two standard size panels: 4' x 8' and 4' x 10'. If you desire a smaller sized panel, we'll be glad to cut one of our panels down to the size you want. We provide a custom cutting service to take care of any size problems.

And there's more.

Vicracoustic wall panels combine the beauty and durability of Vicrtex with the sound absorbency of glass fiber. This means you can achieve improved acoustical environments and more desirable working conditions. The resulting wall panel system is both beautiful and functional.

All the different colors and unique patterns of Vicrtex are available in Vicracoustic wall panels. Add in a wide range of sizes, and our panels give you great design versatility.

Finally, Vicracoustic wall panels are easy to install. Once installed, they're easy to care for. A proven fact in installations in such places as data processing areas, auditoriums, cafeterias, bowling alleys, sound recording studios and executive offices. They really do the job.

So be practical. Pick up a pencil and fill out the following coupon.

*Patent applied for.

LE CARPENTER
AND COMPANY



A DAYCO COMPANY

964 Third Avenue, New York, N.Y. 10022 (212) 355-3080

Sir: I'm practical.

- I'd like to know more about Vicracoustic wall panels.
- I'd like more size and physical information.
- I'm involved in the following wall application:

Name _____

Title _____

Company _____

Address _____

City _____ State _____ Zip _____

- I'd like to have a salesman call.

AR

Distributed by Vicrtex Sales Division — Atlanta, Chicago, Los Angeles, New York.

For more data, circle 43 on inquiry card

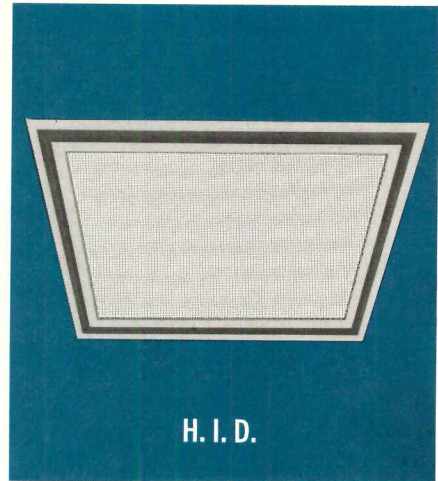
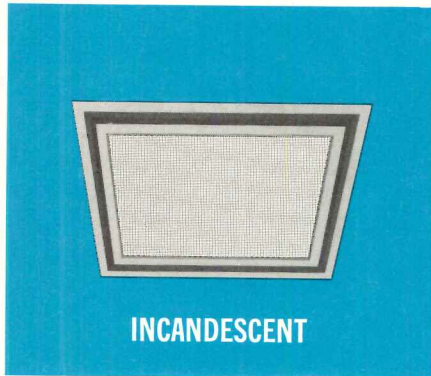
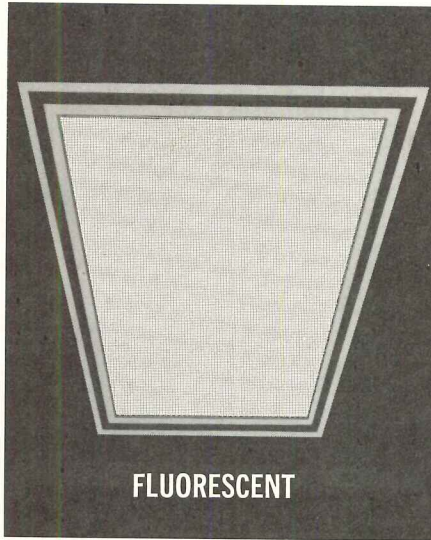
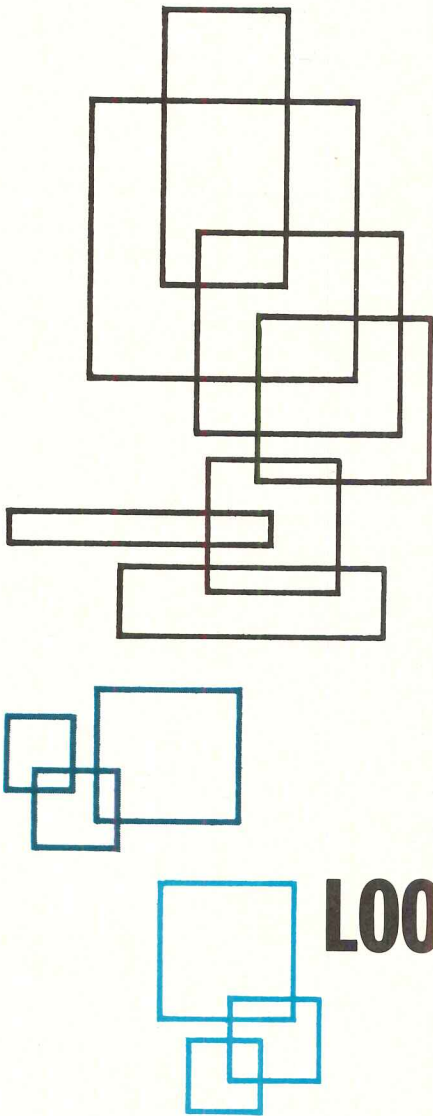

GUTH LIGHTING'S NEW
LOOK-ALIKE "MODULAR FAMILY"

... so different yet so alike

Consider all of the variety available: rectangles and squares in seven sizes of fluorescents, three sizes of H.I.D.s and incandescents, static and air-moving types, flush or regressed picture-frame doors, a dozen prism and grid designs, and more.

Yet, despite the variety, the members of the Modular Family never lose their family resemblance!

What this means is that you can follow a consistent design theme throughout a building project even though illumination requirements may differ from one area to another.

Now isn't that a **great** idea?

For more information and specifications on the Modular Family, write or call:

GUTH LIGHTING **SB**
 DIVISION OF SOLA BASIC INDUSTRIES
 2615 WASHINGTON BLVD., BOX 7079, ST. LOUIS, MO. 63177
 (314) 533-3200

SOLA BASIC DIVISIONS: ANCHOR ELECTRIC • BISHOP ELECTRIC • DIELECTRIC COMMUNICATIONS • DOWZER ELECTRIC • GUTH LIGHTING • HEVI-DUTY ELECTRIC • LINDBERG • NELSON ELECTRIC • SIERRA ELECTRIC • SOLA ELECTRIC • TEMPRESS • WARREN G-V COMMUNICATIONS

For more data, circle 44 on inquiry card

**A basic form
inspires
a timeless design. The Body Chair.**

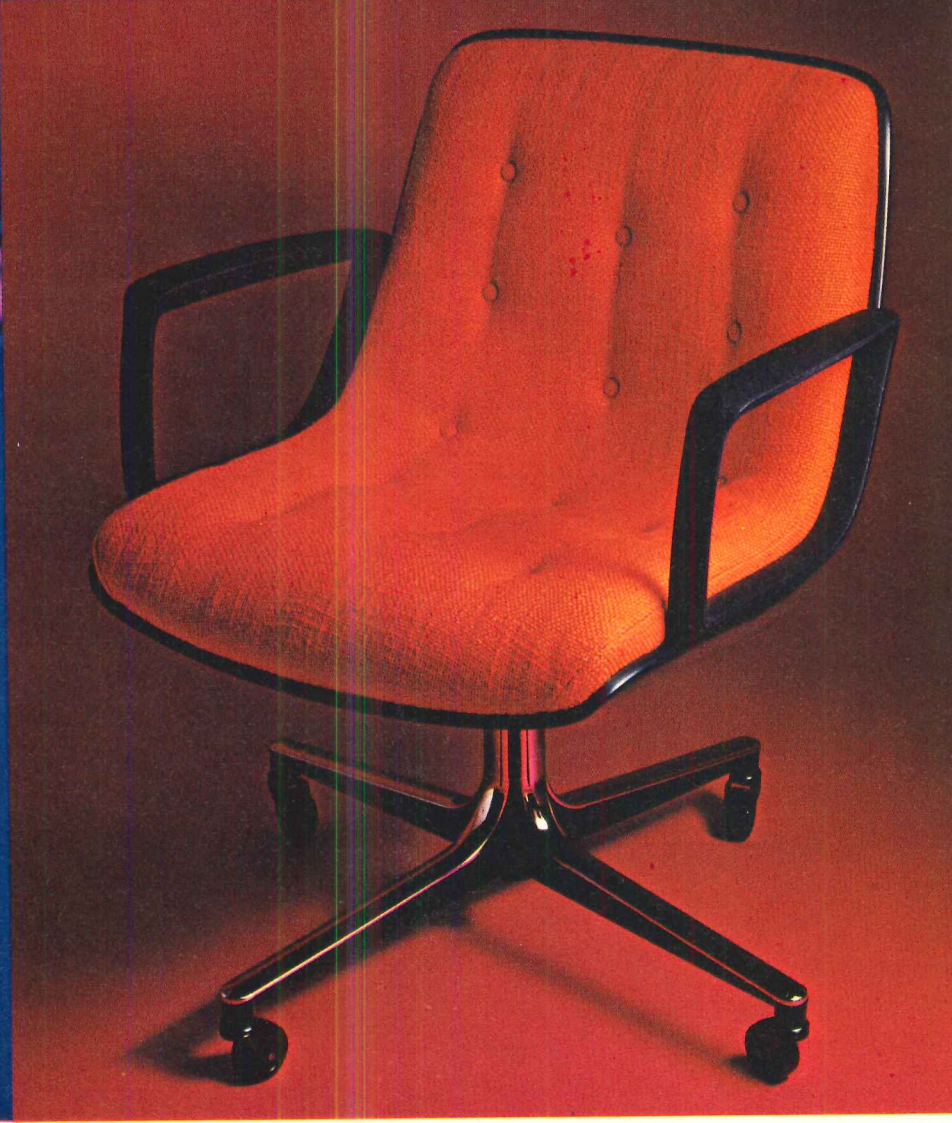
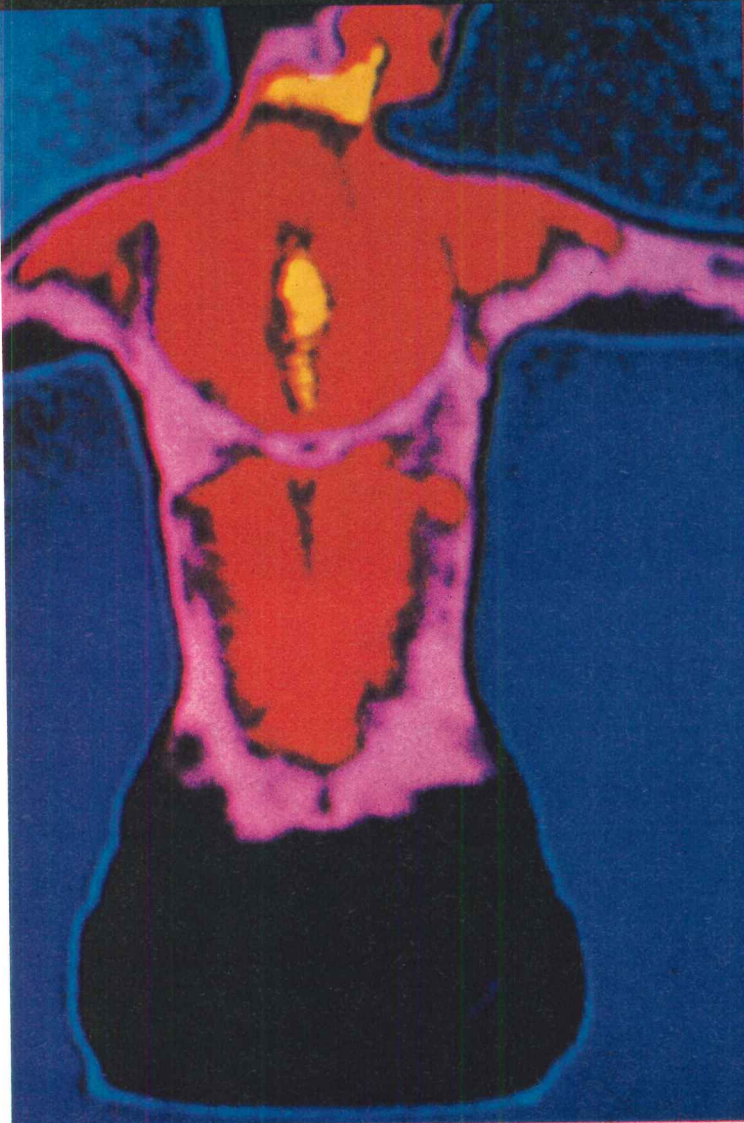

We started with the human body. Comfort first—a unique seat recess, dual-density foam cushioning, and soft, resilient arms. Then solidity and durability from unitized, dual-shell construction. Beauty takes care of itself, in clean, functional lines that won't date when architectural styles change. The Body Chair: an integrated collection of executive, guest, clerical, and secretarial chairs. All in colors and upholsteries to fit any decor. Ask your GF branch or dealer for our new 16-page catalog. Or write to us. GF Business Equipment, Inc., Youngstown, Ohio 44501.



For more data, circle 45 on inquiry card

OFFICE PRACTICE
CONSTRUCTION MANAGEMENT
BUILDING COSTS
BUILDING ACTIVITY

Cincinnati Airport: proving ground for youth and method

Display of the Greater Cincinnati Airport in this department does not imply that the project is more in the nature of architectural business than it is architecture of a high order. It is precisely the marriage of architectural design and modern method that makes this solution exemplary here.

The elements of practice method include the organization of the Heery & Heery firm which enabled a task group of young architects, average age 31, to demonstrate their abilities in a "small-firm" operating milieu. Thus the sense of immediate contact is preserved between the project and the architectural firm's project control group. The group system of this firm was described in the December 1972 RECORD issue on The Young Architects. The group handling the Cincinnati Airport is headed by Ennis Parker, 30, Mack Scogins, 28, and Ray Graves 31. Although the group reached a peak number of 18 architectural personnel, they were able to handle this \$40 million project with the backup of engineering and construction management services available to them in the Heery organization.

The systems approach to design was another factor of modern method that enabled the project to come in about a million dollars below the initial budget estimate. Pre-design services included a feasibility study and program development. Throughout the project and continuing into its current construction phases was the provision of construction management services by Heery & Heery under a single-responsibility, design and management contract.

Ennis Parker describes approaches to the systems as follows:

"The system to be used was arrived at through an extensive research program which involved considerations of: 1) modular, panelized and component structural systems in both concrete and steel, with particular emphasis on the availability of materials and/or systems elements, 2) modular mechanical systems, 3) integrated lighting systems, 4) esthetics, 5) future expansibility, 6) maintenance.

"Very early in the research it became apparent that modular systems were unsuited for concourses and terminals principally because of the required dimensions, shipping problems, and the lack of interest exhibited by manufacturers (these systems have been primarily developed for housing, and the interest of the manufacturers is in this area). After rejection of modular structural systems, the research was directed at the selection or development of a panelized component system, (shown at right).

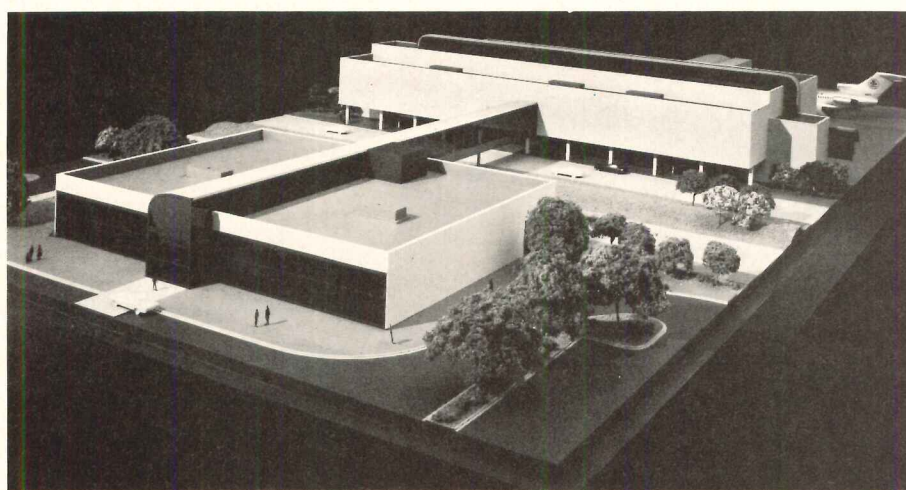

Clyde May, Photography, Inc.

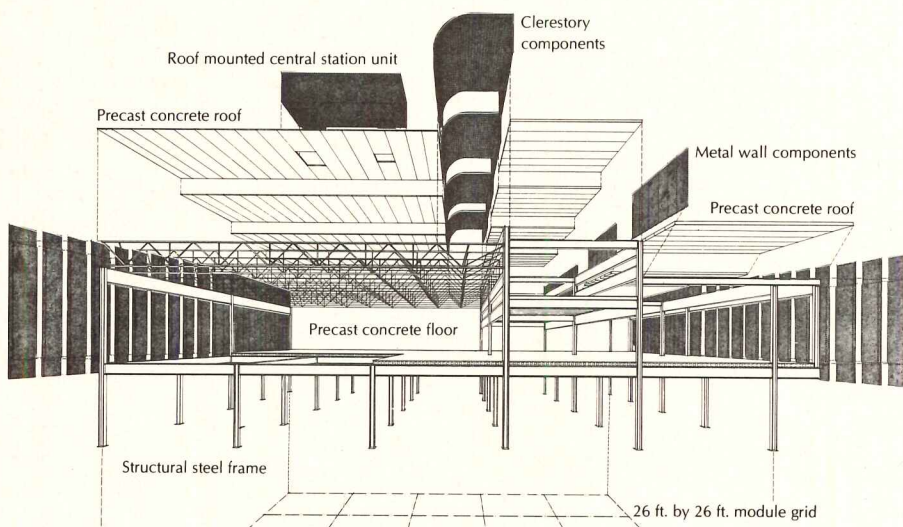

EXPLODED SYSTEMS PERSPECTIVE/TERMINAL

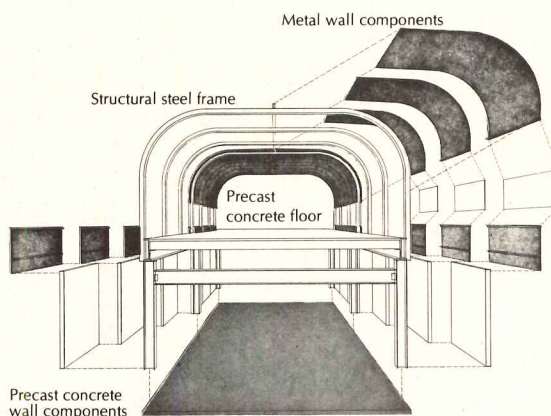

EXPLODED SYSTEMS PERSPECTIVE/CONCOURSE

Structural systems of available components

The systems evolved into a steel structure utilizing steel framing, and incorporating off-the-shelf long-span trusses, in conjunction with precast concrete hollow-core deck and utilizing modular roof-top HVAC units with a minimum of ducted distribution. Exterior walls are to be metal panels of two principal configurations and colors.

"The objective was to minimize wet construction and to bring components of the largest possible size to the site for erection, maximizing plant fabrication," Ennis Parker concluded.

Owners, airlines and architects put together a feasible project

In November 1971, basic negotiations between the Kenton County Airport Board and the seven airlines serving Cincinnati had reached a point at which the Heery firm was commissioned to prepare a feasibility study, program and budget for the project. When these parameters were established, the airport and airlines were able to conclude an unusual agreement covering thirty years of future expansion. A unique feature of the arrangement was agreement by airlines to continue a basic rate of debt-service payment whether or not they continued their projected uses of the airport. This was an essential key to financial feasibility of the project, as was also a commitment by Heery & Heery to the budget and construction schedule.

In January 1972, Heery & Heery was authorized to proceed with design with the understanding that failure to negotiate all construction contracts within the budget would result in cancellation of the project.

The budget to which the architects were committed was a stringent one of about \$30 per sq ft including graphics, owners' furnishings, and interior finishes. The design translated that budget to about half a million dollars for each of 19 gates in two new terminal buildings, plus five renovated gates in the existing terminal. That cost compares to something on the order of two million dollars per gate in recent experience at other airports, according to George Heery. The schedule called for completed construction by the fall of 1974, 33 months from the start of design. Ennis Parker says the project is on schedule, eight separate contracts have been let and early contracts for site preparation, electrical distribution and remote parking lots have been completed.

Planning concept has unusual features

Design concept of the airport is unusual in several respects. One is the combining of holdrooms into one large area per airline in the terminals rather than spotting holdrooms at gates along the fingers. This eliminates duplication of check-in stations and hence reduces the total space allocation of holdrooms. Further, the fingers retain the simplicity of their basic function of conducting passengers to aircraft. Another unusual feature is the ground-level dual roadway system for enplaning and deplaning. The roadway loop surrounds the close-in parking area, and the baggage claim areas are in separate buildings within the loop. They are reached either direct from parking or via pedestrian bridge from the airside unit terminals. They are served by baggage-handling tunnels from the apron.

This arrangement permits automobiles to approach the many terminals to discharge departing passengers or directly approach the baggage claim building to pick up arriving passengers. Passengers can enter and leave either building directly from the parking lot without having to cross roadway traffic.

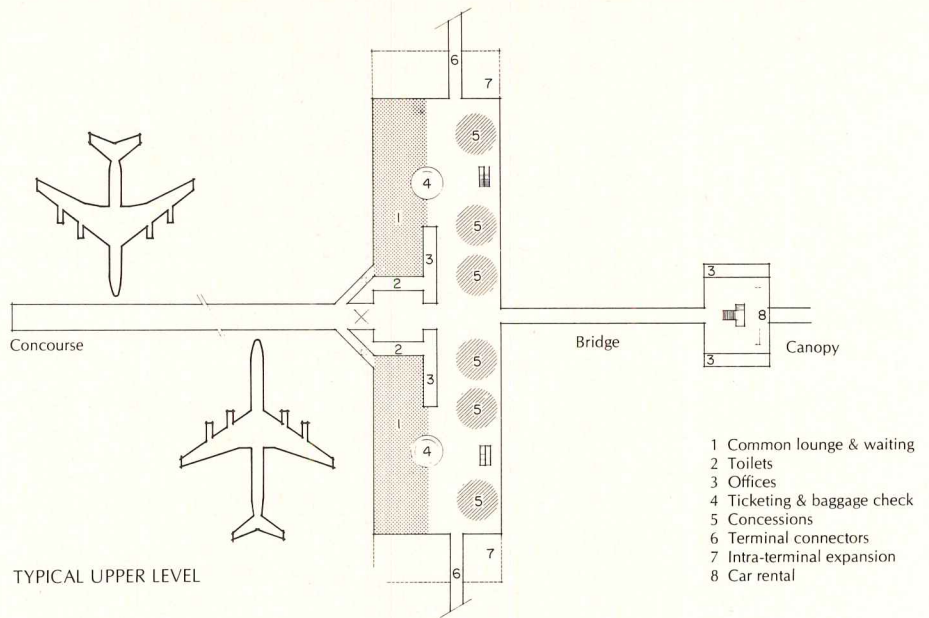

TYPICAL UPPER LEVEL

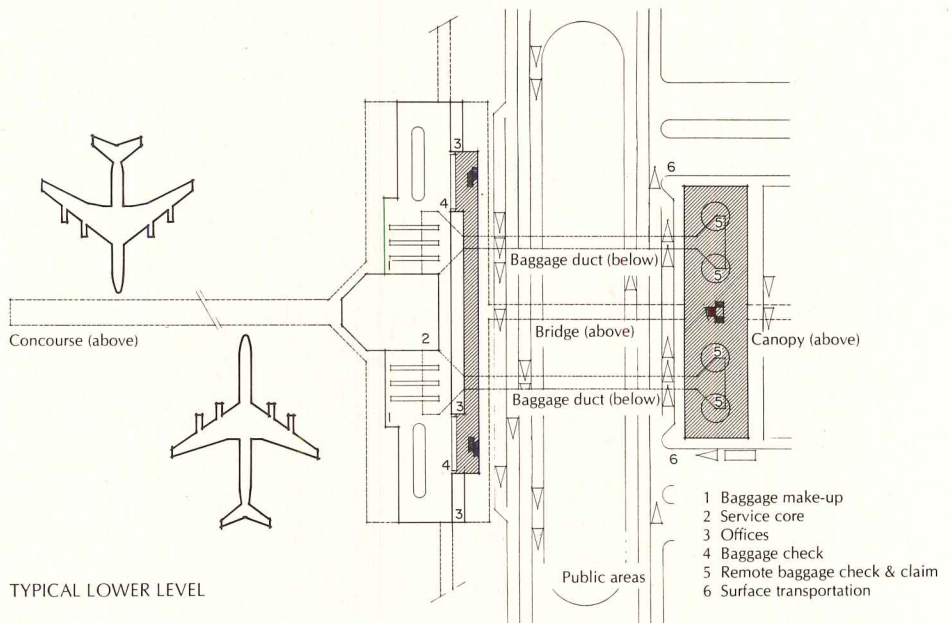

TYPICAL LOWER LEVEL

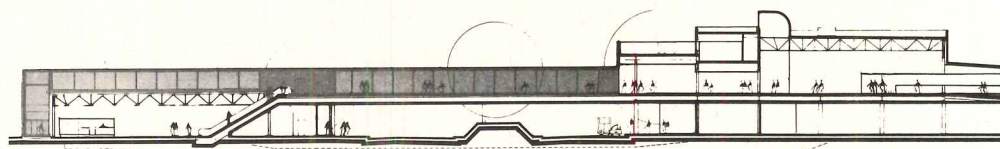

SECTION THROUGH BAG CLAIM, BRIDGE, TERMINAL AND CONCOURSE LOOKING EAST

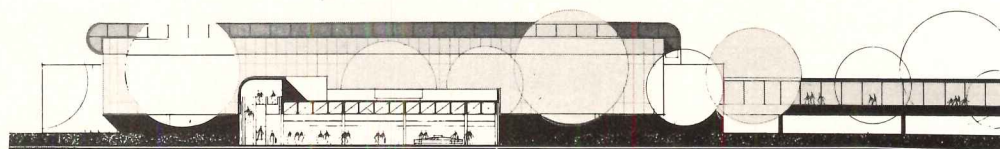

SECTION THROUGH BAG CLAIM LOOKING SOUTH

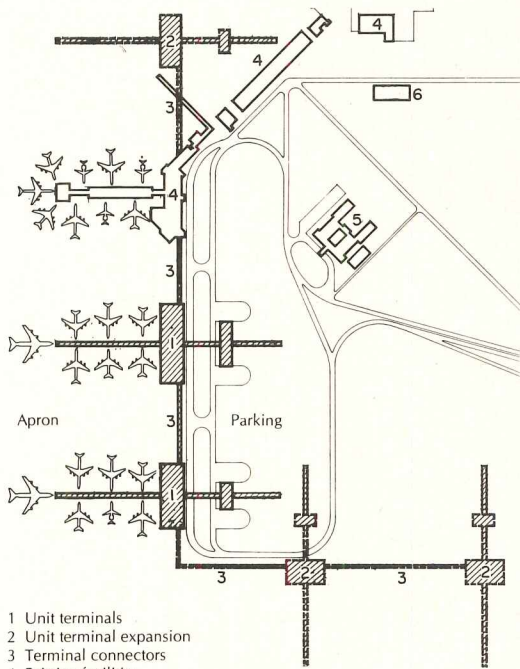
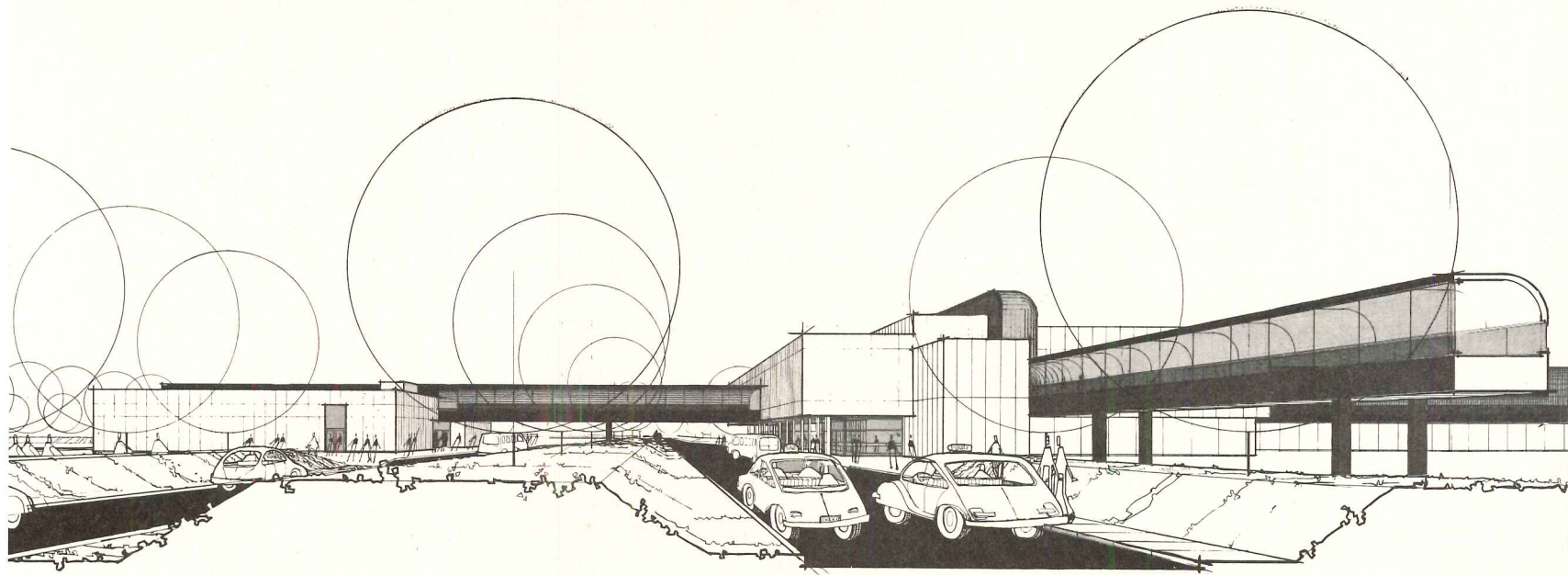

- 1 Unit terminals
- 2 Unit terminal expansion
- 3 Terminal connectors
- 4 Existing facilities
- 5 Hotel
- 6 Post office

Phase one expansion, invention and economy

Planning and method are combined at the Greater Cincinnati Airport to provide an unusual separation of baggage-claim and airside terminal buildings while maintaining the expansibility of the unit terminal design concept. A dual road loop surrounds close-in parking and provides quick access arrivals and departures. Ticketing is optionally at two points: in the baggage building for convenience to parking, or near holding areas at concourse level in terminals for passengers coming in on the "departure" loop by cab. Walking distances: deplaning gate to baggage claim, 560 to 895 ft; check-in to boarding, 265 to 745 ft.

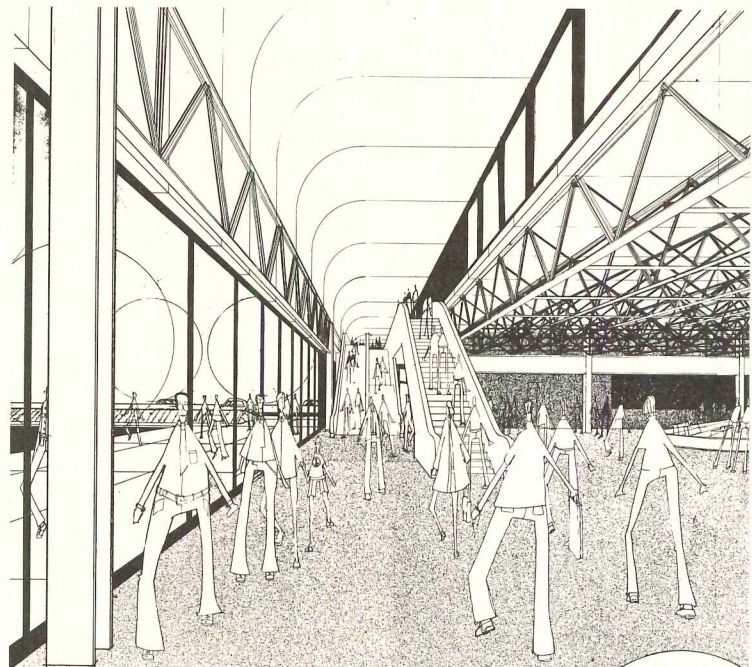

BAGGAGE CLAIM

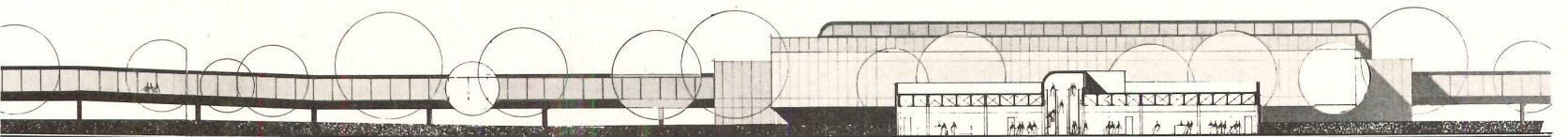
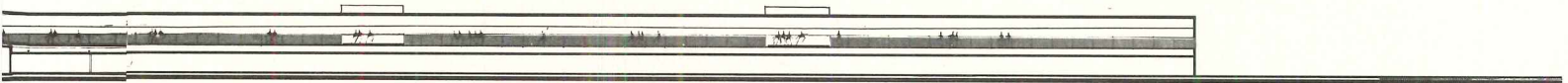

Specify a permanent floor without making a permanent decision.

Collins & Aikman has developed a group of bi-component vinyl backing systems, each integrated with a super dense, man-made commercial fiber surface. They're called Tex-Tiles.

These unique 18" squares are simple to install securely... yet can be arranged and rearranged with ease for maximum good looks, maximum wear. Wherever you want outstanding beauty with minimal care.

Choose from a full range of styles, textures and colors.

For more information, write or call Collins & Aikman, 919 Third Ave., New York, N.Y. 10022. Tel. (212) 371-4455



COLLINS & AIKMAN

Tex-Tiles are the ideal flooring material for today's offices. Floor plans can be reconfigured without recarpeting.



Where 10% of the floor gets 90% of the wear, like this office lobby, moveable Tex-Tiles solve the problem.

Collins & Aikman makes the Tex-Tiles™ that make things happen.

For more data, circle 46 on inquiry card

Management unifies design and delivery process

Construction management is no new mystique to the Heery & Heery operation. The firm developed a method of operation over years of stringent industrial commissions, now graduated into stadiums and many other building problems. The method unifies the design and delivery process in a disciplined way that the firm has called "Time/Cost Control."

In these days, when both the imperatives of time as a cost factor and the complexities of technology have increased, there is a compelling urgency for management. Meanwhile, the techniques of management itself have developed in a structured way, as has the comprehension and acceptance by the client universe (itself growing in complexity). So the transition from "time/cost control" to formally structured "construction management," as the term is beginning to be understood, was a natural one.

The communication with multiple airlines and the airport authority client was a case in point at the Cincinnati Airport. George Heery acknowledges the technical and planning input of the seven airlines involved as well as the clear stipulations of the Airport Authority in making that input constructive for the architectural commission. But without the coordinating presence of a construction management program, together with long experience in phased design and construction, the coordination of the several prime contracts involved would have been impossible.

The total budget for construction of the two new terminals, for renovation of the existing terminals, for new ramps, a complete new roadway system, new parking lots, was slightly over \$23,000,000.

Final bids for the last parts of the work were received on February 1, 1973, nearly a million dollars under that figure. With the additional funds, the airport is planning certain additional projects not considered feasible before the bids were received.

The project consists of eight separate contracts. Parts one and two were early contracts for site preparation and site electrical distribution portions. Part three was for the construction of two remote parking lots. All of the initial three contracts were let in the spring and summer of 1972, and have been completed. Part four consists of all paving work, including roadways and ramps, and part five is the exterior lighting system and associated electrical distribution. Part six contains all building construction. Parts seven and eight are minor contracts associated with special aspects of construction.

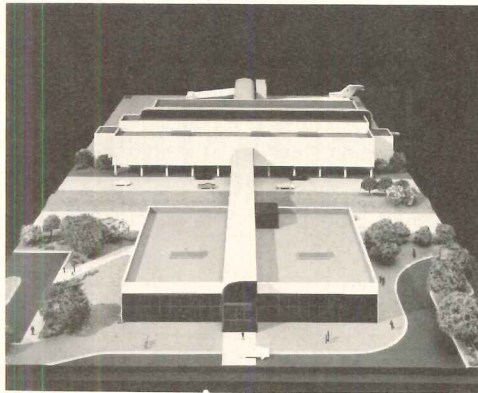

Clyde May, Photography, Inc.

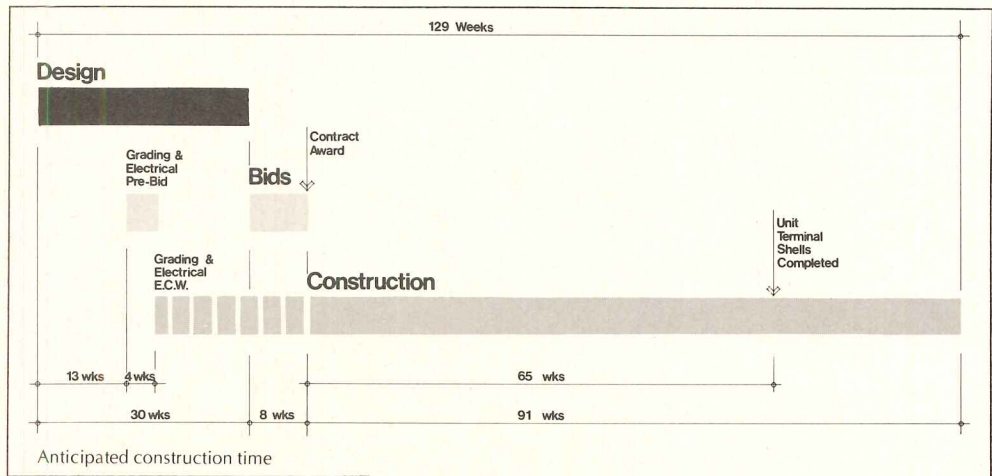

Contractor for parts one and five is the W. L. Harper Company; for parts two and four, High Voltage Systems, Inc.; for parts six and seven, the Dugan and Meyers Construction Co., Inc.; and for part eight, the T. D. Ulrich Company of Lebanon, Ohio.

Associate consulting engineers to Heery & Heery for outside electrical systems and civil work are Fisk-Rinehart and Hall-McAllister-Stockwell of Cincinnati. Landrum and Brown, Inc. were airport consultants on the project.

Management means principle as well as process

Mr. Heery feels understandably at home with the single-responsibility design and construction management contract, such as pertains in this case. He is, nevertheless, aware of and responsive to those other situations where the construction management may be applied as a professional service by either his firm or other specialists in the construction management field. He has written a book on the subject, now in the process of publication by Mc-

Graw-Hill. The following extract is from one of the chapters of that book:

"It is very important in this (post-bid, pre-construction) meeting to reconfirm the singularity of representation of the owner in administration of the contract as well as at the jobsite . . . any other arrangement will not be in the best interest of the owner.

"For projects that have important completion dates . . . the essence of time should be thoroughly discussed along with the project schedule . . . the construction manager or architect/engineer, should carefully draw the attention of the contractor to the various time control contract provisions, such as payment scheduling, liquidated damage provisions, superintendent requirements, contract time extension rulings, etc. that are contained in the general and special conditions of the contract. It will be crucial, at this meeting, for the construction manager or architect/engineer not only to point out these provisions but to be convincing to the contractor that he will fully and fairly administer the contract."



GE Duraglow Regressed provides lighting punch to enhance the appeal of merchandise.

Don't just turn on lights, turn on your customers.

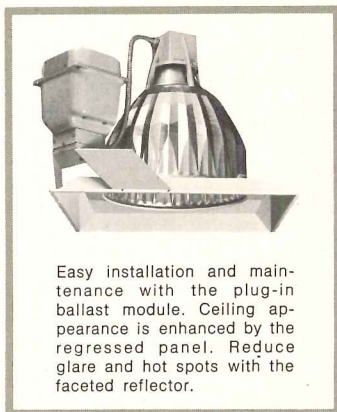

Easy installation and maintenance with the plug-in ballast module. Ceiling appearance is enhanced by the regressed panel. Reduce glare and hot spots with the faceted reflector.

460-91

There's something exciting about a store illuminated with General Electric high intensity discharge (H.I.D.) lighting. There's a cheery feeling about the whole place. Merchandise takes on a sparkle that conventional lighting can't provide. The ceiling is more spacious, clean, and non-distracting. And the total effect just naturally lets shoppers see products more favorably. Explore this new and economical method of merchandising.

Hot spots, glare and garish streams of light are held to a minimum. You get uniform

*Trademark of the General Electric Co.

illumination that helps merchandise call attention to itself. You get optimum lumen efficiency. And you get to choose from a family of luminaires for all types of commercial lighting applications: regressed or recessed, open or enclosed, and for low or high mounting heights. The names are Panelglow*, Duraglow Regressed, Econoglow® Recessed, and Low-mount® Regressed. We call them The Show Offs, because that's what they do to your merchandise.

See your GE Representative or write for the complete story. GE Lighting Systems, Hendersonville, N.C. 28739.

The
show
offs

GENERAL  ELECTRIC

For more data, circle 47 on inquiry card

SOME S-F COSTS TREBLE IN 25 YEARS

Construction cost per square foot of hospital, institutional and public (government) buildings has increased more than three and one-third times during the past quarter century.

The average increase for most types of buildings was 219 per cent during the same period, according to a special study by the staff of *Dodge Construction Potentials Bulletin*, a monthly statistical service on contract value and floor area for new construction.

Although the increased value of new buildings has been most closely related to the rising costs of labor during the 25-year period, the study found that final contract values have been determined by the relative importance of several factors. Higher building material prices, changes in structural characteristics, introduction of more customized features and better quality of construction have also contributed to increased costs. Structural changes have included greater building heights, increased use of air conditioning, better insulation and new materials. On the other hand, new installation methods and higher work productivity have partially offset higher costs.

Structure types that cannot be standardized, and thus are more dependent on the use of labor than pre-fabricated materials, showed the greatest rises. Comparing 1972 to 1947, the bulletin staff determined the following per cent increases: Institutional, 344 per cent; public 335; educational 275; recreational, 236; hotels, 228; commercial, 194; religious, 192; and apartments, 153 per cent.

INDEXES: June 1973		1941=100.00 (except as noted)				
Metropolitan area	Cost differential	Current Indexes				% change last 12 months
		non-res.	residential	masonry	steel	
U.S. Average	8.2	412.2	387.0	403.3	393.3	+ 9.23
Atlanta	7.6	524.1	494.2	509.5	497.9	+ 9.32
Baltimore	8.0	450.8	423.8	439.9	426.4	+13.86
Birmingham	7.2	377.9	351.5	365.3	360.9	+ 9.20
Boston	8.9	420.8	397.6	416.1	404.3	+ 9.76
Buffalo	9.0	460.5	432.4	453.3	439.4	+ 9.59
Chicago	8.2	473.3	450.0	457.3	450.2	+10.08
Cincinnati	8.4	437.4	411.6	426.8	415.8	+ 7.66
Cleveland	8.8	444.3	418.0	434.4	423.7	+ 5.22
Columbus, Ohio	8.0	431.5	405.2	418.6	410.8	+ 7.43
Dallas	7.5	412.4	399.3	410.9	395.1	+11.65
Denver	7.8	435.7	409.9	429.4	415.4	+ 7.87
Detroit	9.4	470.0	447.7	472.2	453.6	+11.18
Houston	7.2	381.3	359.0	372.4	364.8	+ 6.32
Indianapolis	7.6	375.5	352.7	366.5	358.4	+ 5.68
Kansas City	8.1	394.1	372.4	384.8	375.0	+11.22
Los Angeles	8.1	464.7	424.8	449.2	441.0	+11.18
Louisville	7.4	407.7	382.9	397.1	387.9	+ 8.71
Memphis	7.3	383.4	360.0	370.1	364.4	+ 6.73
Miami	7.7	425.4	405.3	412.8	404.5	+ 7.06
Milwaukee	8.1	456.5	428.7	448.3	434.3	+ 6.21
Minneapolis	8.6	436.8	410.9	429.8	419.0	+ 7.23
Newark	8.6	404.8	380.1	398.2	389.8	+ 7.84
New Orleans	7.1	388.4	366.7	381.3	372.8	+ 8.93
New York	10.0	465.4	432.6	453.6	441.9	+11.59
Philadelphia	9.1	465.8	443.8	461.4	448.5	+16.53
Phoenix (1947 = 100)	7.8	237.7	223.2	229.4	225.7	+10.52
Pittsburgh	8.8	412.2	387.8	406.6	394.5	+11.50
St. Louis	8.6	434.8	410.4	427.2	417.1	+11.00
San Antonio (1960 = 100)	7.0	150.9	141.8	145.4	143.1	+ 3.70
San Diego (1960 = 100)	8.0	165.6	155.6	161.9	158.3	+10.20
San Francisco	9.4	621.3	568.0	614.6	596.1	+13.30
Seattle	8.2	399.9	357.9	395.4	380.0	+ 6.95
Washington, D.C.	7.7	389.3	365.6	377.7	368.8	+ 9.44

Cost differentials compare current local costs, not indexes.

Tables compiled by Dodge Building Cost Services, McGraw-Hill Information Systems Company

HISTORICAL BUILDING COST INDEXES—AVERAGE OF ALL NON-RESIDENTIAL BUILDING TYPES, 21 CITIES										1941 average for each city = 100.00								
Metropolitan area	1963	1964	1965	1966	1967	1968	1969	1970	1971	1972 (Quarterly)				1973 (Quarterly)				
										1st	2nd	3rd	4th	1st	2nd	3rd	4th	
Atlanta	306.7	313.7	321.5	329.8	335.7	353.1	384.0	422.4	459.2	472.5	473.7	496.1	497.7	516.4				
Baltimore	275.5	280.6	285.7	280.9	295.8	308.7	322.8	348.8	381.7	388.1	389.3	418.8	420.4	441.8				
Birmingham	256.3	260.9	265.9	270.7	274.7	284.3	303.4	309.3	331.6	340.4	341.6	356.7	358.3	371.7				
Boston	244.1	252.1	257.8	262.0	265.7	277.1	295.0	328.6	362.0	377.3	378.5	392.8	394.4	414.0				
Chicago	301.0	306.6	311.7	320.4	328.4	339.5	356.1	386.1	418.8	422.8	424.0	442.7	444.3	465.3				
Cincinnati	263.9	269.5	274.0	278.3	288.2	302.6	325.8	348.5	386.1	399.9	401.1	400.1	410.7	430.4				
Cleveland	275.8	283.0	292.3	300.7	303.7	331.5	358.3	380.1	415.6	415.2	416.4	427.7	429.3	436.7				
Dallas	253.0	256.4	260.8	266.9	270.4	281.7	308.6	327.1	357.9	364.9	366.1	385.0	386.6	407.3				
Denver	282.5	287.3	294.0	297.5	305.1	312.5	339.0	368.1	392.9	398.3	399.5	413.8	415.4	429.5				
Detroit	272.2	277.7	284.7	296.9	301.2	316.4	352.9	377.4	409.7	416.9	418.1	431.5	433.1	463.4				
Kansas City	247.8	250.5	256.4	261.0	264.3	278.0	295.5	315.3	344.7	348.7	349.9	365.4	367.0	387.7				
Los Angeles	282.5	288.2	297.1	302.7	310.1	320.1	344.1	361.9	400.9	407.8	409.0	422.9	424.5	453.3				
Miami	269.3	274.4	277.5	284.0	286.1	305.3	392.3	353.2	384.7	391.5	392.7	404.8	406.4	419.0				
Minneapolis	275.3	282.4	285.0	289.4	300.2	309.4	331.2	361.1	417.1	401.7	402.9	411.3	412.9	430.6				
New Orleans	284.3	240.9	256.3	259.8	267.6	274.2	297.5	318.9	341.8	350.9	352.1	368.1	369.7	382.1				
New York	282.3	289.4	297.1	304.0	313.6	321.4	344.5	366.0	395.6	406.5	407.7	421.5	423.1	453.5				
Philadelphia	271.2	275.2	280.8	286.6	293.7	301.7	321.0	346.5	374.9	394.2	395.4	417.9	419.5	459.3				
Pittsburgh	258.2	263.8	267.0	271.1	275.0	293.8	311.0	327.2	362.1	364.5	365.7	378.7	380.3	406.3				
St. Louis	263.4	272.1	280.9	288.3	293.2	304.4	324.7	344.4	375.5	385.5	386.7	400.9	402.5	427.8				
San Francisco	352.4	365.4	368.6	386.0	390.8	402.9	441.1	465.1	512.3	535.3	536.5	559.4	561.0	606.4				
Seattle	260.6	266.6	268.9	275.0	283.5	292.2	317.8	341.8	358.4	363.0	364.5	369.9	371.5	388.4				

Costs in a given city for a certain period may be compared with costs in another period by dividing one index into the other; if the index for a city for one period (200.0) divided by the index for a second period (150.0) equals 133%, the costs in the one period are 33% higher than the costs in the other. Also, second period costs are 75% of those in the first period (150.0 ÷ 200.0 = 75%) or they are 25% lower in the second period.

Harbor...*the versatile filing and storage furniture for every office function.*

Since all filing and storage needs aren't the same and needs change, Harbor has designed furniture systems that quickly, easily, and efficiently handle your tasks today . . . and tomorrow.

Used in an almost unlimited combination, they provide the ideal functional answer to conventional, landscaped, and open office design.

For example, the Harbor Side File® permits letter or legal filing or any combination. And you can change your file system without changing drawers.

Side File drawers let you easily get at information anywhere in the file and hold twice as much as old-style drawers.

Or our unique LDF lateral drawer file combines a 12½" clear height x 15" deep, top-opening, slide-out tray and Side File drawers in a single unit.

For special jobs you can choose our Mobile Side File that lets you take information anywhere in the building.

Or there's the Micro Center® for microfiche, tab and signature cards, and checks, as well as legal and/or letter filing.

There's also a complete range of File-On and storage bookcases and wardrobe cabinets, as well as specially designed data processing furniture to meet all of your filing and storage needs . . . beautifully.

And they all feature Harbor's proven suspension design that always lets doors, drawers, and trays open and close with a touch.

You can choose from 25 mix or match color combinations, as well as optional vinyl teak and walnut fronts and matching tops.

For more information on a filing system today that keeps pace with tomorrow's business, contact your local office furniture dealer. Or call or write Harbor Universal Inc., 1900 Marina Boulevard, San Leandro, California 94577, (415) 352-2100.

Harbor

Solving tomorrow's office needs today

Harbor Representatives: Allentown — Robert Wertz (215) 348-3609; Atlanta — Institutional Associates (404) 255-6460; Boston — Edward McKearney (617) 482-1862; Chicago — Donal Wolgemuth (312) 654-0545; Cleveland — Davis & Associates (216) 333-9665; Dallas — Glenn Hennings (214) 651-1556; Denver — Jack Nicoulin (303) 388-5272; Grand Rapids — George Reinhard (616) 459-2051; Kansas City — Lyons & Associates (913) 888-3504; Los Angeles — Harbor Universal (213) 724-3757; Milwaukee — Brian Wilburn (414) 284-2900; Nashville — Charles C. Whitehead (615) 832-3134; New York City — Heide-Lifton Associates (212) 683-1338; Washington, D.C. — London Associates (301) 299-4941.

For more data, circle 48 on inquiry card

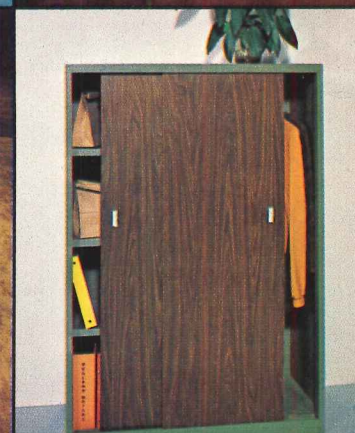
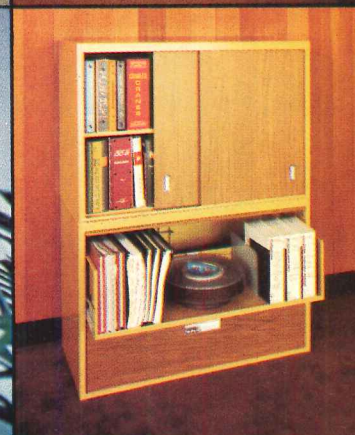

Project data points up diversity in construction

Even the most casual observer of the construction industry can't help but come away with an appreciation for its great diversity. This is particularly true if one looks at the industry from the "project" standpoint: that is, as completed units of construction work—stores or warehouses, for example, as in the case of building construction, or highway segments or dams, say, as in the case of heavy engineering activity. The dimensions of its diversity really begin to emerge once it's realized that everything from a single-family house to a giant hydro-electric plant, is, in fact, "construction," and fits neatly under the industry umbrella.

On this basis, there were slightly over 1.4 million construction "projects" begun in the nation last year. But, slightly over 1.2 million of them, or 86 per cent, were single-family homes. The remaining 14 per cent, more than 200,000 projects, accounted for 70 per cent of the value of contract awards last year, though. And, it's in this 14 per cent where most of the architectural and engineering business in the nation is conducted. It's in this 200,000 figure where the industry's diversity really becomes apparent, too.

Schools, stores, offices, hospitals lead in big-job volume

More than half of last year's total was composed of nonresidential structures. And here, stores, the miscellaneous category, office buildings, and manufacturing plants, comprised the top four nonresidential building types, accounting for half of *that* total. The pattern changes significantly, though, if we break the nonresidential projects down by project size. The nonresidential structure type with the most projects valued at one million dollars or more, for instance, was educational building; followed by stores, office structures, and hospitals. These four structure types accounted for two thirds of all projects in the million dollar plus grouping last year—a figure that seems pretty consistent when we trace it back through time, too.

The really large nonresidential jobs, though, those with contract value tags of \$25 million or more, tend to be dominated by office buildings. More than 20 of the 50-odd nonresidential jobs for which contract awards in excess of \$25 million were recorded last year were office structures, with public buildings, the second largest category, accounting for eight.

Considering the strong cyclical advance it has undergone in the past two years, it shouldn't be surprising that, next to single-family housing, apartments were the largest single category of

all construction projects last year. Close to 30,000 individual projects were recorded, 14 per cent of the construction total. It was in the \$1 million and above grouping where this structure type really dominated, though. More than 6000 apartment projects were counted here, 40 per cent of the total in this group. Although there weren't as many giant apartment jobs, those over \$25 million, as there were in the office building group, the number, 16, was significant, nonetheless.

In nonbuilding, or heavy engineering work, highways and public works jobs predominate. Highways alone account for more than half of the nonbuilding projects in the million dollar and over range. But in the \$25 million and over bracket, electrical utility projects, which made up two-thirds of the total last year, hold sway.

As can be expected, from the standpoint of inflation alone, the average size of a representative construction project, in dollar terms, gets bigger every year. But, because of changes in the structure-type "mix" from year to year, this is not necessarily true for construction as a whole. In 1970, for instance, 70 per cent of total construction contract value was accounted for by projects individually valued at \$1 million or above. Last year, this proportion was only 66 per cent. (Both figures, of course, exclude single-family homes.) 1970, you'll recall, was a good year for large utility contracts, large office contracts, and large manufacturing contracts. 1972, on the other hand, saw strong gains in store buildings, whose average size in contract dollar terms, is relatively small, and a sharp decline, in both, educational buildings and utilities, where the proportion of large projects exceeds the industry average.

Once it's been pointed out that certain structure types tend to be larger in size, on the average than others (in contract dollar terms, anyway), a logical follow-up question should be: Why is this the case?

In the area of single-family homes, the answer is pretty obvious. Family size is governed, by the laws of nature and economics, both of which set pretty strict limits on how big, hence expensive, a house needs to be. With other building types, the determinants of size depend on one or a combination of factors like, location, efficiency as it relates to the functions or processes that are going to be performed inside the structure, the physical configuration of the structure, and physical tolerances such as load-bearing characteristics that need to be built in.

Location is not only an important factor in measuring differences *between* building categories, but it plays a role in accounting for differences *within* a given building category too. It's easy to see, for instance, that the fact that a greater proportion of stores are built in suburban areas than are office buildings, would have a bearing on relative project size when the two are compared. Upon reflection, though, it's also evident that an office structure in mid-Manhattan, say, is constructed differently than one in suburban Connecticut.

Form follows function and cost follows form

As to efficiency, schools are never built one classroom at a time, but as a package containing several classrooms and supporting facilities like libraries, cafeterias and principals' offices. Similarly, an industrial plant is built to hold all, or a part of the machinery needed to perform a given manufacturing process. The type of process and the size of the machinery bear a direct relation to the size of the plant needed.

And in the areas of physical configuration and physical tolerance, it's easy to see why constructing a half-mile-long highway bridge is a larger, more costly, more complex project than simply constructing a half-mile-long highway on flat terrain.

Another important aspect of this diversity that needs to be pointed out here, is the way it relates back to the construction process itself. And, in this respect, when we talk about construction in a value sense, either as contract awards, or as work put in place, it's a whole world of difference in terms of materials, labor and managerial skills, if we're talking about \$1,000 worth of single-family housing construction, or \$1,000 worth of dam or bridge construction. And, this means, basically, that the factors of production for this industry, construction materials, manpower and managerial skills, cannot be shifted freely from one project to another. The input mix has to be modified to mesh with the project type that is to be constructed, and there are costs, inefficiencies and bottlenecks in the process. For verification, just ask the iron worker, who was unemployed back in 1971 when home builders had out the help-wanted signs because housing was beginning to break all records; or the lumber dealer who was offering rock bottom discounts back in 1966, when industrial building was turning in an 18 per cent gain and pressuring steel output.

James E. Carlson, Manager, Economic Research,
McGraw-Hill Information Systems Company

Something New from Smith

VARISPAN PANEL SYSTEM...

for longer spans, greater strength

■ SPAN COLUMN TO COLUMN

VARISPAN can be installed horizontally on columns to eliminate unsightly structural girts.

■ PROFILE SELECTION

Choose from 23 exterior profiles.

■ THERMAL VALUE

Choice of insulation thicknesses from 1½" to 7½".

■ SAVE MONEY

Installed vertically or horizontally . . . the super strength spanning qualities of VARISPAN save structural steel material and erection costs.

SMITH VARISPAN Panel System provides a new dimension in super strength, longer spanning ability and versatility. Variable depths are available, permitting single spans in excess of 30'0". Various insulation thicknesses, as shown below, are available. Write for full details.

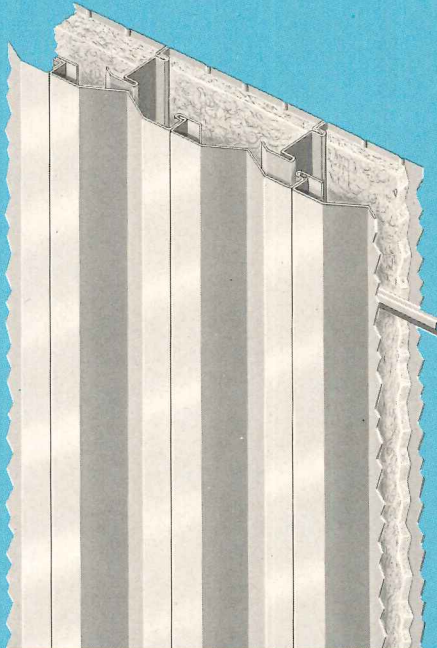

4 VARISPAN Panels for wide selection of spanning distance

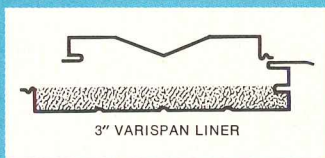

3" VARISPAN LINER

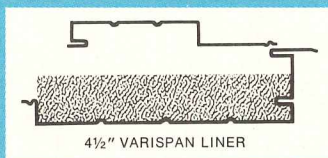

4½" VARISPAN LINER

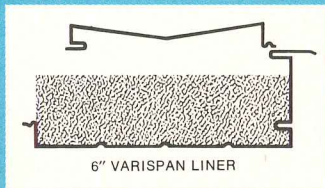

6" VARISPAN LINER

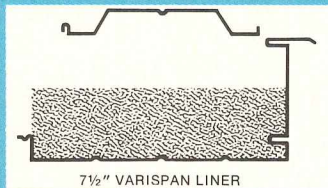

7½" VARISPAN LINER



SMITH'S Single Responsibility concept is the Systems Approach to solving your metal wall problems. It's a complete system . . . from the earliest Architectural/Engineering contact to placement of the final product fastener on the job site. SMITH Sales Engineers are specially trained to estimate and submit quotations, provide assistance in specification writing and detail suggestions. SMITH-engineers design the products to suit your specific project. The material is color-coated and fabricated by SMITH personnel . . . erected on the job site by experienced SMITH erection crews.

Specify SMITH Single Responsibility for your next building project. For full details and specifications, consult Sweets Architectural File or write.

EGS 108



ELWIN G. SMITH DIVISION

100 WALLS STREET, PITTSBURGH, PENNSYLVANIA 15202

Annapolis to Now



The Welsbach **Annapolis** is an authentic reproduction of a colonial lighting fixture discovered during a restoration. It is part of our product line and is available with all light sources—gas, mercury vapor, and incandescent.

Now? Welsbach has been famous for manufacturing high-quality lighting since 1877. But we don't just live in the past. Our designs are for contemporary installations as well.

Contact us for a design consultation. Standard or custom, we want to help you make your next project outstanding.

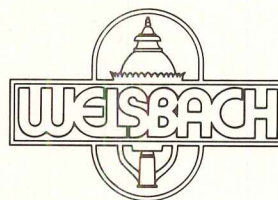

Welsbach Lighting
Products Company, Inc.
3001 E. Madison St.
Baltimore
Maryland 21205

For more data, circle 49 on inquiry card

For more data, circle 50 on inquiry card

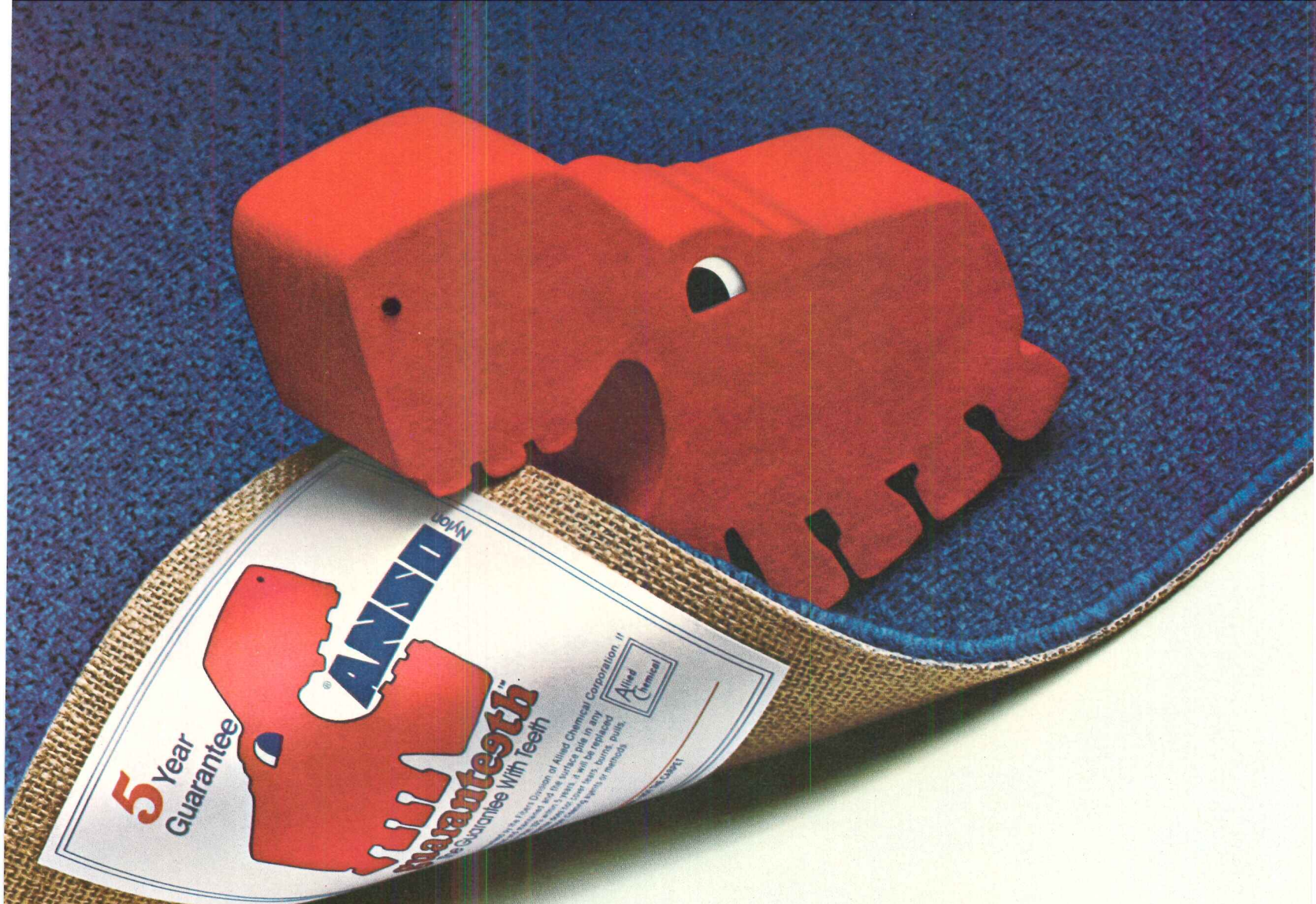

Why our five year guarantee is "longer" than any other five year guarantee.

Nylon carpet that won't wear more than a scant 10 percent in five years! And if any part of it does, we replace the whole carpet. Free, including installation. Our guarantee is so strong because ANSO nylon carpet lasts so long.

How can Allied make a guarantee like this? Because we make ANSO nylon. The second generation, soil-hiding nylon that's tough enough to carry a guarantee with teeth—Guarantesth.

ANSO nylon is tough enough for a shopping center with 55,000 shoppers a day trudging through—the Northridge Fashion Center of Los Angeles. The carpet they chose

was Unanimous, from Walter Carpets by Ludlow. And Unanimous comes with Guarantesth. The Allied Chemical guarantee with teeth.

So look for the label with the fierce little animal who symbolizes our Guarantesth. And get the carpet with the toughest five year wear guarantee.

For a list of carpet mills, write: Allied Chemical Corporation, Fibers Division, Contract Department AR, One Times Square, New York, N.Y. 10036. Phone: (212) 736-7000.



Northridge Fashion Center, L.A./10,000 yds. Unanimous/Walter Carpets by Ludlow.

For more data, circle 51 on inquiry card



**Guarantesth.
The guarantee with teeth.**



terr a z z o

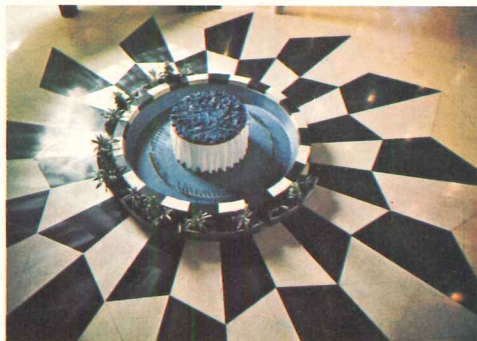
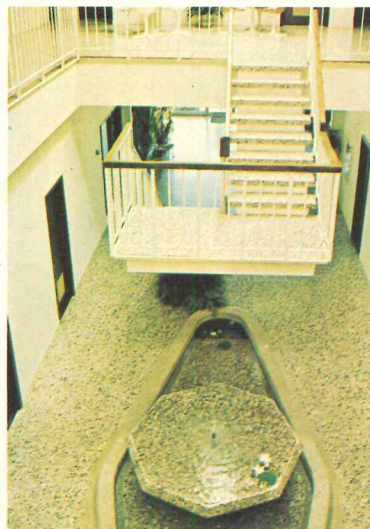

the excitement of texture.

Add excitement outdoors to building entries, plazas, terraces, swimming pools. Beautify downtown sidewalks, malls, public transportation areas and platforms. Attractively. Safely. All with Rustic Terrazzo—the carefree enhancer. □ Add adventurous accents on any and all surfaces, horizontal and vertical. With subtle blends of texture and color, or striking contrasts. Combinations of materials and color as infinite as your imagination. Outdoors—and indoors—Rustic Terrazzo adds more than beauty. Its attractive texture means surefooted safety for sure, everywhere it's used underfoot. □ If it's been a long time since you talked to a terrazzo contractor, you may have been missing a lot. The ancient art has been changing, and there's more to terrazzo today as a design material than meets the eye. Circle the number for a copy of our colorful brochure. For technical assistance, or a copy of new Terrazzo Design Data, containing 125 true-color terrazzo reproductions, contact Derrick Hardy, Executive Secretary, Terrazzo, 716 Church Street, Alexandria, Virginia 22314. (703) 836-6765.

For more data, circle 52 on inquiry card

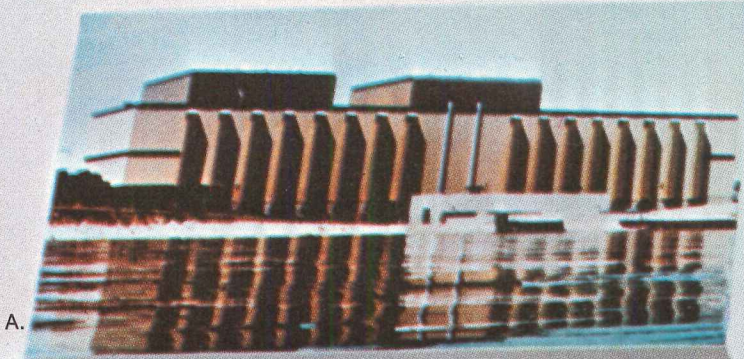

A.



B.



D.



E.



G.

*Kynar is Pennwalt's registered trademark for its polyvinylidene fluoride resin.



C.

KYNAR® City... without limits.

KYNAR 500*-based finishes are at home in any city, in any country, in any kind of climate. From the seasonal extremes of Washington, D.C. to the baking, blistering heat in the heart of Texas, to the industrial environment of Los Angeles, finishes based on KYNAR 500 can take it all.

On metal curtain walls, louvers, window frames, trim and shingles, finishes based on KYNAR 500 resist chalking, chipping, cracking and fading long after other finishes have become eyesores.

For complete test data and technical details contact Page Murray, Plastics Dept., Pennwalt Corporation, Three Parkway, Philadelphia, Pa. 19102. (215) 587-7513

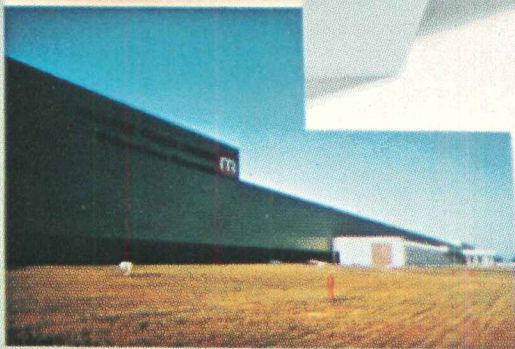

F.



H.

PENNWALT
ARCHITECTURAL COATINGS

- A. Point Beach Nuclear Plant
Two Creeks, Wisconsin
- B. Texas Stadium
Irving, Texas
- C. United Airlines Hangar
Minneapolis, Minnesota
- D. Zenith National
Insurance Building
Los Angeles, California
- E. VA Hospital
Gainesville, Florida
- F. Midland-Ross Warehouse
Maumee, Ohio
- G. Bailey Plaza Shopping Mall
Jackson, Mississippi
- H. The Watergate Development
Stage IV
Washington, D.C.

If granite is strictly for building exteriors, why didn't someone tell Union Bank, San Francisco?

There are those that hold that *the* place for granite is the outside wall for that big, monumental building that comes along once every century. But the building owner and the management of the Union Bank of San Francisco and their architects had other ideas. They liked the warm, natural colors of granite. They were aware of how polished granite resists weather, stains and all types of traffic as no other building material is capable. They knew it requires virtually no maintenance. Doesn't fade or deteriorate. And that it would fit into their plans on a cost-in-place basis. So it was employed. On the plaza to cradle a fountain and pool. As exterior furniture. Inside it was used as facing for walls on the first floor, in heavy traffic areas. Focal points that at once blend and accent. Warm. Lasting. Beautiful.

Information on the wide variety of rich granite colors and new fabrication techniques is yours for the asking. Also information on flooring, paving and other "points-of-distinction" applications. Talk to our Customer Service Department (612-685-3621). See us in Sweet's Catalog No. 4.1/60.

For more data, circle 54 on inquiry card



subsidiaries:

*Lake Placid Granite Company
Jay, New York*

*Texas Granite Corporation
Marble Falls, Texas*

*Raymond Granite Company
Raymond, California*

*Cold Spring Granite (Canada) Ltd.
Lac Du Bonnet, Manitoba
over 20 producing quarries*

Union Bank Building
50 California Street
San Francisco

Owner:
West Coast Life Insurance Co.

Architects:
Exterior and lobby
Welton Becket and Associates

Bank interior
Anthony Heinsbergen and Company

Exterior furniture and fountain
Michael Painter & Associates

General Contractor:
Haas and Haynie Corporation





A roof contract has to be strong to protect you for ten years.

Whether it's a Philip Carey or Barrett Inspection & Service Contract, what you're getting, in writing, is the assurance that Celotex will back up specific built-up roofing systems and services. With pre-installation planning, periodic inspections during and after installation, and the finest roofing materials.

That's a pretty strong promise. But we know we can keep it. That's why we give it to you in writing.

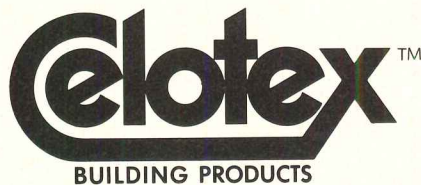

Celotex understands the man who builds.

The Celotex Corporation, Tampa, Florida 33622 A subsidiary of Jim Walter Corporation

For an actual copy of the Celotex Inspection & Service Contract and all the details of the program, see your Celotex BUR Approved Roofer, or Celotex field representative, write us direct, or consult Sweet's Architectural Files.

For more data, circle 55 on inquiry card

Bally Walk-Ins belong where feeding must be fast for the hurried and harried

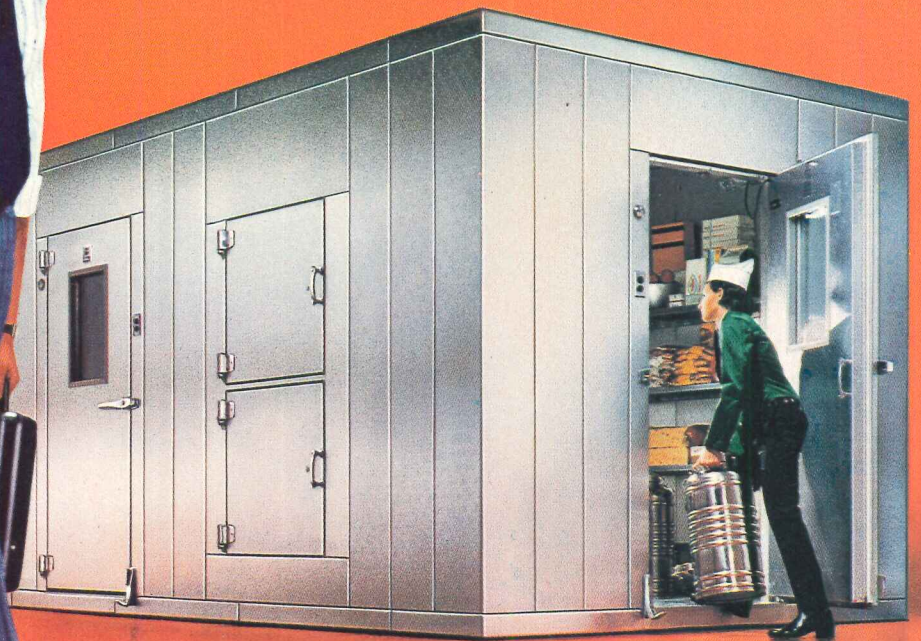

Bally Walk-In Coolers and Freezers belong everywhere mass feeding takes place. They can be assembled in any size for indoor or outdoor use from standard panels insulated with four inches of foamed-in-place urethane, UL 25 low flame spread rated and Factory Mutual research approved. Choice of stainless steel, aluminum or galvanized. Easy to enlarge . . . easy to relocate. Refrigeration systems from 35°F. cooling to minus

40°F. freezing. Subject to fast depreciation and investment tax credit. (Ask your accountant.) Write for 28-page book and urethane sample. **Bally Case & Cooler, Inc., Bally, Penna. 19503.**



© 1973 ALL RIGHTS RESERVED.

ADDRESS ALL CORRESPONDENCE TO DEPT AR-6

For more data, circle 56 on inquiry card



Ceco steel doors are beautiful in style and function

Ceco products and services include: Steel doors, frames and hardware, overhead doors, concrete forming, reinforcing bars, steel joists, metal building components, metal lath, concrete pipe and prestressed concrete sections.



Ceco steel doors, frames and hardware make a beautiful fit in any décor. They meet every functional need. Use them as a "package" to accent your design. Ceco doors and frames are prepared for simple erection in minutes. And both are prepared for quick and solid attachment of hardware. Ceco doors and frames are tough and stable — won't warp, swell, shrink or rot. You gain the advantages of durability and trouble-free performance. Our Colorstyle doors have factory-baked quality finishes, kept fresh in poly bags. So specify Ceco's economical door-frame-hardware "package." It's beautiful. See Sweet's, consult your local Ceco office or write:



CECO steel doors

The Ceco Corporation • 5601 West 26th Street • Chicago, Illinois 60650

For more data, circle 57 on inquiry card



Problem: Joints in Roof Insulation.

Insulation joints are built-in failure points in roof systems.

Not only do they leak heat but they can also cause premature roofing failure. You can compensate for the joints being there by such methods as taping, but . . .



Solution: ZONOLITE Roof Decks

Joint elimination is a better way.

ZONOLITE® Roof Decks eliminate insulation joints and the problems they cause. ZONOLITE Insulating Concrete provides the ideal solution with smooth, cast-in-place, continuous insulation.

For full information write for booklet RD-237 to Construction Products Division, W. R. Grace & Co., 62 Whittemore Avenue, Cambridge, Massachusetts 02140.

In Canada: 66 Hymus Road, Scarborough, Ontario.



For more data, circle 58 on inquiry card

The Holophane Designer Ceiling System.™

Elegant design. Superb engineering.
Advanced lighting options.

Now one ceiling system offers you all three.

THE HOLOPHANE DESIGNER CEILING SYSTEM opens up the full potential of suspended ceilings. It's the first to integrate all the important benefits of ceiling systems, and give you the design flexibility you need to create the ceiling you want.

Elegant design. Our contemporary 5'x5' module offers you a choice of dramatic pyramidal shape or the clean, open look of a totally seamless, flat square.

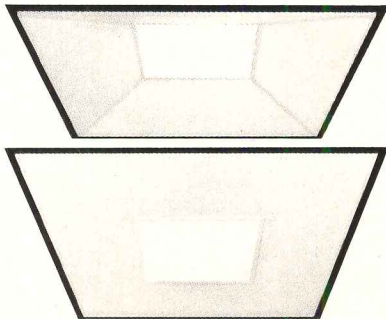

Pyramidal and seamless flat modules.

There are several acoustical panel surface textures to choose from. And for further design freedom, both modules accept many different luminaire sizes and shapes, with a variety of clear and subtly tinted lenses.

Superb engineering. We designed our system to go up in minimum time. At minimum cost. The easy-to-assemble SNAP-TRACK™ runners, for example, greatly reduce the number of man-hours it takes to get the job done.

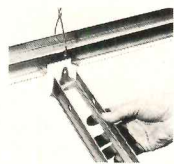

Snap-Track runners join without tools.

Slots along the center of the runners make it possible to conceal air handling boots anywhere on the 5'x5' grid. These runners also mate with moveable partitions, giving the designer great flexibility in organizing work space.

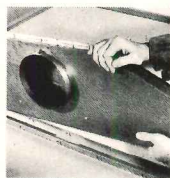

Standard air boot slips into runner effortlessly.

Advanced lighting options. Now for the big news about the system—a range of luminaires and lenses that offers you real lighting flexibility.

For example, there's our H.I.D. (High Intensity Discharge) luminaire, MERCULUME™, the preferred, modern choice. Holophane engineers have tamed the powerful mercury and metal halide light sources and made them as comfortable as conventional fluorescents.



Now you can have H.I.D., too.

Which brings us to the REFRACTIVE GRID™ CONTROLENS®. You can use this remarkable new low-brightness lens with our H.I.D. or fluorescent luminaires to reduce high-angle brightness by as much as 70% as compared with conventional lenses—while actually increasing the amount of useful light.

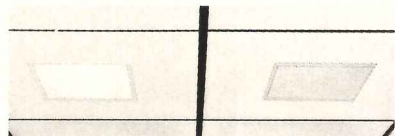

Conventional lens

Refractive Grid

If you've been using coffered modules to hide bright, conventional lenses, you can now use REFRACTIVE GRID with our economical seamless flat modules and achieve the same high level of visual comfort.

Our system also offers you PERCEPTA™, the revolutionary fluorescent luminaire that enables you to design offices, classrooms, and other working areas that are virtually free of veiling reflections (reflected glare).



Percepta, for better seeing and energy conservation.

PERCEPTA makes printed tasks easier to read. And, surprisingly, it actually helps conserve energy and cut the electric bill, too.

Lighting options that give you real flexibility. Engineering that gets your ceiling up faster. Elegant styling designed to let you vary the mood.

Ask your local Holophane representative for all the details. Or write Dept. AR-6, Holophane Co., Inc., Montvale, N.J. 07645.

Holophane®
A Johns-Manville Company

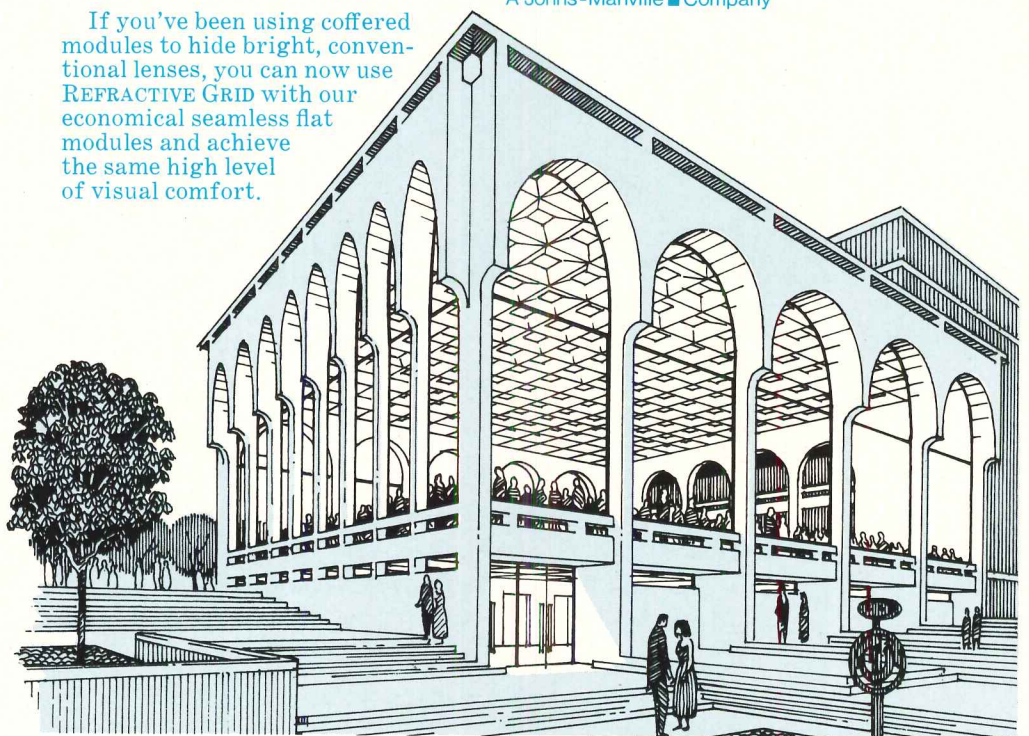

For more data, circle 59 on inquiry card



Spread the adhesive,



lay the pregrouted sheets,



seal around tilework,



**and 24 hours later, they've moved in!
(It's new Redi-Set Systems 200.)**

American Olean announces the easiest ceramic mosaic floor ever installed.

With new Redi-Set® Systems 200, there's no grouting on the job. Each 2' x 2' sheet of tile is pregrouted (even around the edges!) with tough, flexible polyurethane. When applied over the special adhesive, a continuous, permanent surface is formed that's comfortable underfoot. Needs sealing only along joints at wall and around fixtures.

Great for remodeling, the flexible

sheets go easily over vinyl, plywood, concrete slabs—any interior floor or wall. Since tiles are factory-aligned, you always get a beautiful job. Floors are ready for residential or light-duty commercial traffic in 24 hours.

Tell new owners how easy the colored Redi-Set polyurethane grout is to maintain. Resists stains, mildew, punctures; won't crack from minor movements of the building; is not affected by the heat of a sauna or the cold of a deep-freeze room.

American Olean Tile Company
1838 Cannon Avenue, Lansdale, Pa. 19446
Please send me literature on Systems 200.

Name _____

Street _____

City _____

State _____

Zip _____

**American
Olean**

A Division of National Gypsum Company

Redi-Set ceramic mosaic tile. It's the natural thing to use.™

For more data, circle 65 on inquiry card

FROM ANY ANGLE— THE BEST CONTROL CENTER YOU CAN BUY.

The Model 4 Motor Control Center is all things to all people. The comprehensive line of available accessories lets you virtually custom design the Model 4 to your exact needs. You can choose from two configurations—7 units high for space economy or 6½ units high for additional bottom wiring room. Pick circuit breaker or fusible switches to team up with the superlative Type S starter. Main lugs can be located at the top or the bottom—whichever you want. Specify tin-plated aluminum or plated copper bus bars. The Model 4 is available in two depths—14" for front-of-board installations and 20" for either back-to-back unit mounting or extra roomy front-of-board.

To make the Model 4 even better, we made a few minor changes in the 20" deep front-of-board unit. By placing openings at the rear of the wire troughs, we've made it easy to pass wire from the front section to the rear and, in effect, turned the whole rear section into a wire trough. Also, we've made access to the back extremely easy by putting only two panels where there used to be five.

The Model 4 Control Center gives you everything you ever wanted in a motor control center. Aside from the almost endless list of options, it offers the reliability and dependability you expect from all Square D products. Contact your nearby field office for specific engineering data. Or write us direct: Square D Company, Dept. SA, Peru, Indiana 46970.

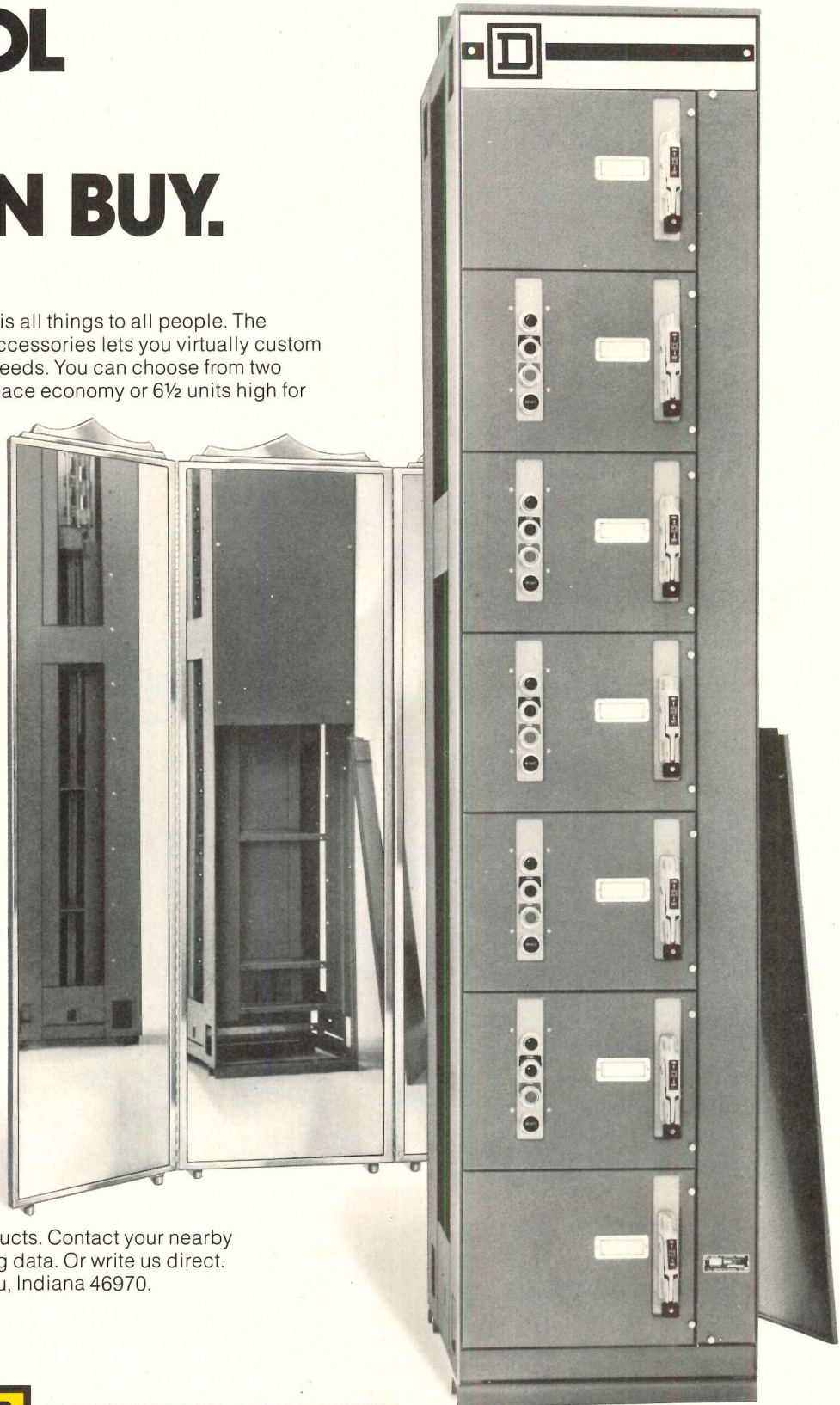

SQUARE D COMPANY

Wherever Electricity is Distributed and Controlled

For more data, circle 67 on inquiry card



These doors hide a lot of strength behind a pretty face.

Republic *stylable* steel doors enhance an entry with their beauty and custom look. As distinctive as the building they invite people to live in.

Yet, underneath, they provide equally important strength and durability. Which keeps them looking good—without sagging, shrinking or rotting, or warping due to moisture. And offer a sense of security to the people inside. For you, these doors are “stylable.” You can choose from a range of 36 door sizes and 8 standard styles, prime-coated or prepainted in your choice of 19 popular colors. Then get

exactly the light and louver treatment you want. Installed by your local Republic distributor right in his warehouse. At no extra cost. With no delay in delivery.

And everything—doors, frames and Frame-A-Lite stick system—comes ready to install, easy to hang. No planing, mortising or notching needed.

Get the whole story behind these doors from your nearest Republic distributor. He's listed in the Yellow Pages under Doors-Metal. Or write Republic Steel Corporation, Builders Products Division, 465 Walnut St., Niles OH 44446.

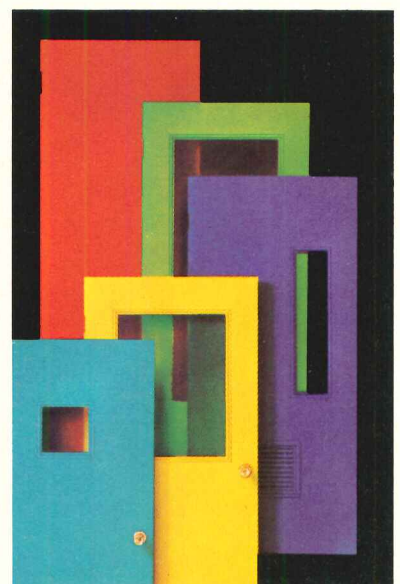

Republicsteel
Builders Products



For more data, circle 68 on inquiry card

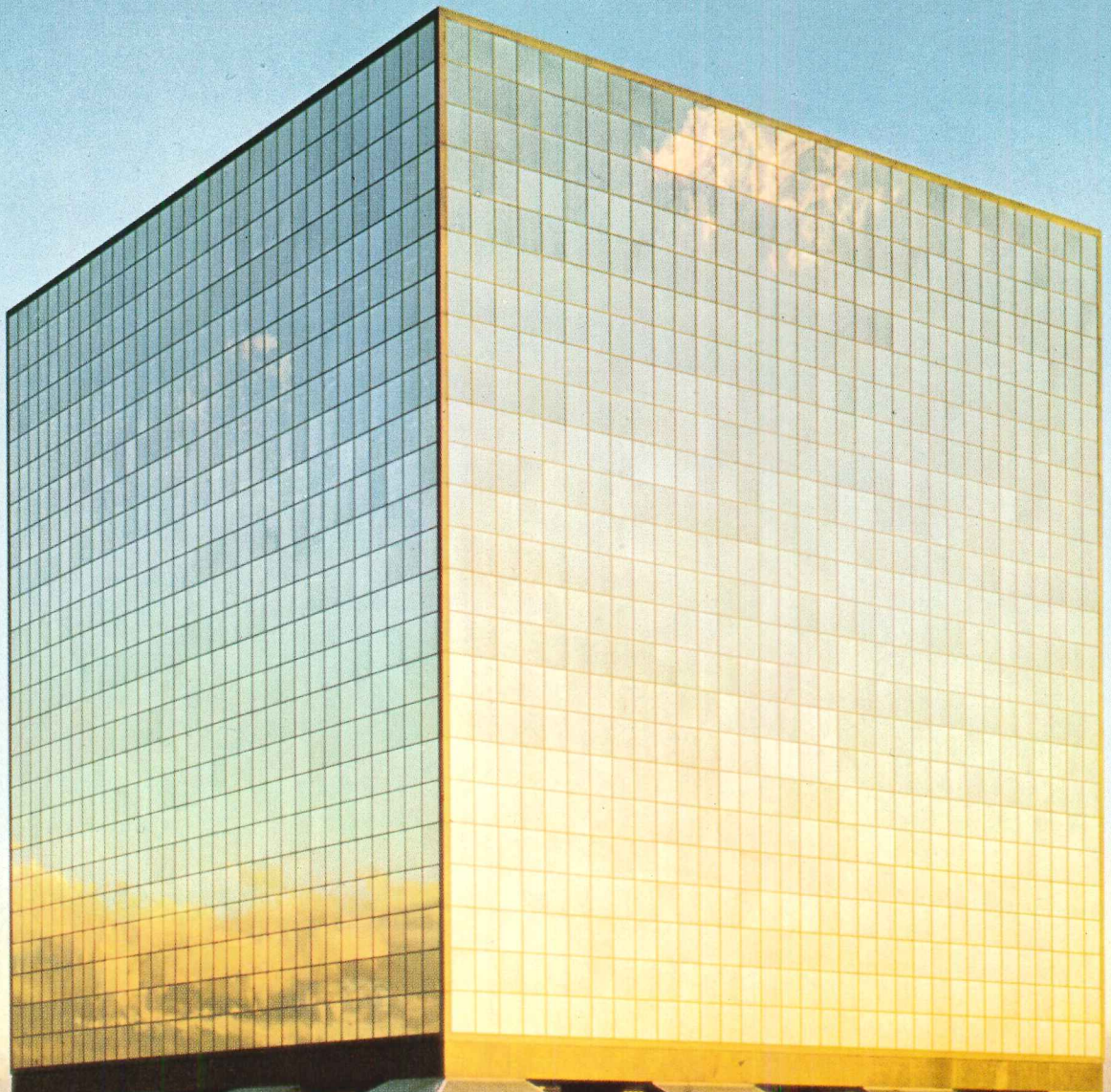

Owner: Sears, Roebuck and Co.,
Chicago, Ill.
Architect: Albert C. Martin and Associates,
Los Angeles, Calif.

The idea for a perfect cube
went into PPG's computer.
What came out was
the perfect performance glass.

PPG Solarban® 480 Twindow® insulating glass.

When the architects of Sears' Pacific Coast Headquarters Building designed a perfect cube for this office/retail complex, they wanted a reflective glass that would satisfy both esthetic demands and long-range cost and comfort considerations.

Which is quite a challenge in southern California, where a building's most powerful enemies are brightness and solar heat.

To simplify the decisionmaking, PPG ran a computer analysis, combining site characteristics with eight sets of performance figures for the building's skin.

From this analysis, the architects selected the most desirable glass. PPG *Solarban 480 Twindow* insulating glass.

Result: A cube reflecting 168 feet of cloud, sky, and California sunset. While inside, Sears people have everything. Visual comfort, economically controlled temperature, and an open, space-age quality that complements the building's pristine shape.

Look into the advantages of *Solarban 480 Twindow* insulating glass—or the others in our family of Environmental Glass—for your next building. Write PPG Industries, Inc., One Gateway Center, Pittsburgh, Pa. 15222.

PPG: a Concern for the Future

For more data, circle 69 on inquiry card

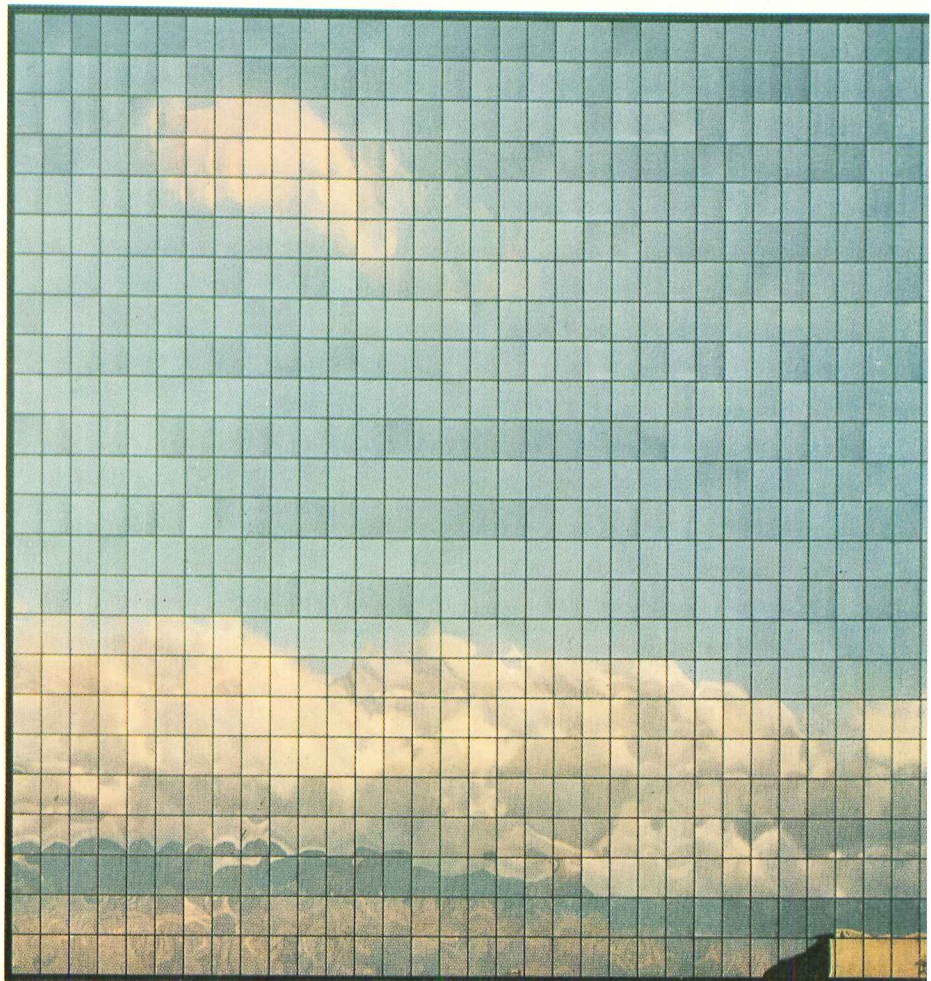

PPG
INDUSTRIES

WOODROCK plus More than



EPOXI/MATE.TM

just a good front.

An anywhere you'd like the texture of stone or aggregate, you can put EPOXI/MATE over Woodrock. Full facade. Interior paneling. Overhead panels. Even 'gardens' of color and texture.

And one of the reasons to design with stone is the price of Woodrock plus EPOXI/MATE.

You start with Woodrock, National Gypsum's substrate panel, a natural base for any aggregate. Properly applied, Woodrock holds its size; won't check, crack or delaminate even under severe weather conditions.

Over the Woodrock goes the coating of EPOXI/MATE. Waterproof and chemical resistant, EPOXI/MATE becomes an integral part of the substrate. And because it's available in a variety of colors, it blends with any choice of stone.

And your choice of stone can range from colored hard marble, to quartz chips to crushed granite. There's even a special EPOXI/MATE formulation available for aggregate as big as your fist. And another that's self-leveling for horizontal application in the shop.

Try Woodrock with EPOXI/MATE. And see what a little constructive thinking can do.

Your Gold Bond man can give you more constructive suggestions about EPOXI/MATE. Or write Gold Bond Building Products Division, National Gypsum Division, Dept. AR-63MF, Buffalo, New York 14225.

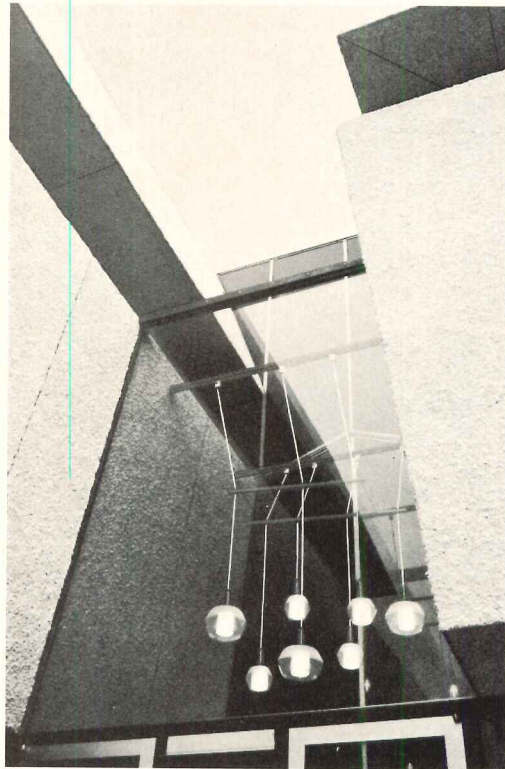

The WOODROCK-EPOXI/MATE System weighs only a fraction as much as pre-cast concrete. It goes on curved, angular or flat surfaces. Even soffit areas. Won't pit, peel or spall. Holds its color and stays virtually maintenance-free.



To prepare EPOXI-MATE for application, the hardener (catalyst) is poured into the resin container.

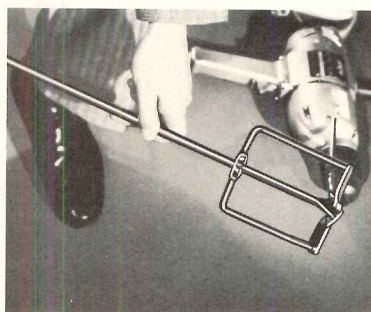

After resin and hardener are mixed, sand is blended into the mixture which is trowelled onto unprimed Woodrock substrate.

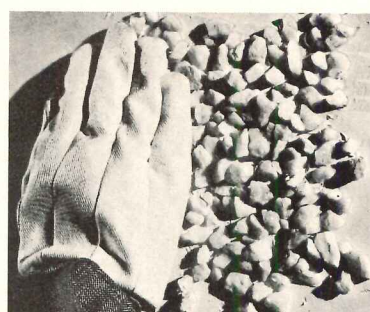

Aggregate can be hand-seeded in the field or mechanically applied in the shop.



For more data, circle 70 on inquiry card

What do you expect from electrical contractors?

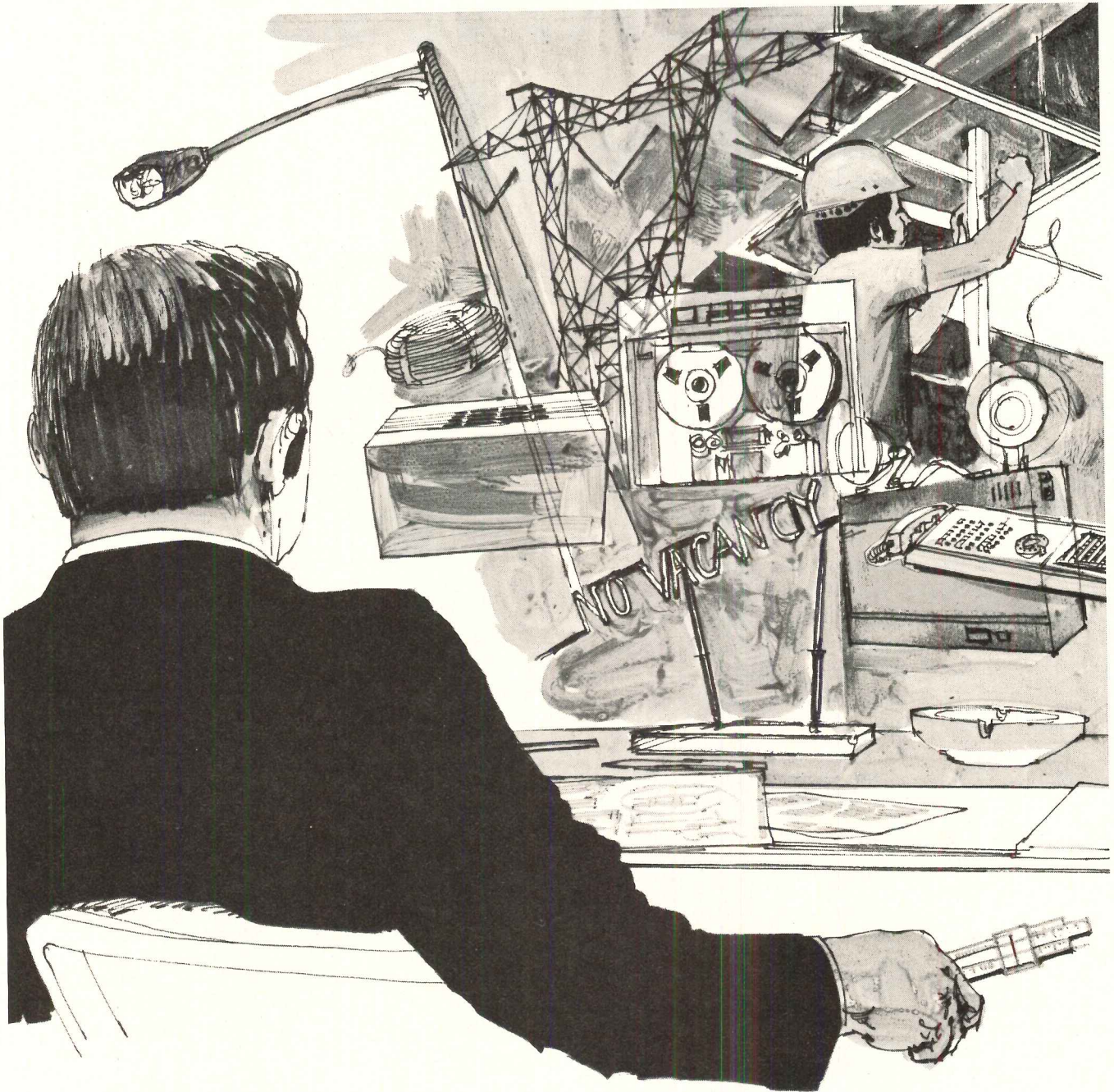

NECA study reveals opinions of design professionals.

In a study conducted recently by the National Electrical Contractors Association (NECA), questions covered capabilities expected of electrical contractors. Some people seem to feel that electrical contractors mostly pull wire and install lighting fixtures. Not so.

When it comes to capability in electrical systems, professional electrical contractors have it... in a wide range of services. Everything from power distribution and power line construction to standby emergency power sources. From interior and

exterior lighting to communications, electric space conditioning and automatic controls. From integrated ceilings, electric signs, and master clock systems, to motors and motor controls, security systems, fire and smoke detection systems, etc., etc., etc.

Professional electrical contractors manage a competent and proficient team of skilled, technically trained manpower... experts at accelerating construction schedules, purchasing and expediting materials, obtaining local code inspection approvals, and

translating plans into reality at a profit for everyone concerned. When you consider complex electrical systems, consider the full range of services provided by professional electrical contractors.



National Electrical Contractors Association, Inc.
Washington, D.C. 20014

If electricity makes it possible, electrical contractors make it practical.

Efficient building idea: Recent report tells how to solve the acoustical problems of open offices.



Good news for architects who like the design freedom of open offices—but don't like the acoustics.

Tests by an independent acoustical testing agency show you can get excellent open office acoustics by using these three things (with the help of an acoustical consultant):

1) An acoustically non-reflective ceiling—so the sound won't bounce off to other areas.

2) Sound-controlling screens—

to stop the sound from going directly from one work area to another. (Either directly or by reflection.)

3) A masking sound system—technically designed to fill the sound voids without increasing the overall ambient noise level. This makes it possible to hold personal conversations in a normal voice—without being overheard.

Of all the ceilings tested for Owens-Corning Fiberglas—

including expensive coffered and baffled systems—the best was Owens-Corning's Nubby II Fiberglas* Ceiling Board in a standard grid suspension system.

If you'd like the whole story, send for our free design guide, "Achieving Acoustical Privacy in the Open Office."

Write to Mr. P. F. Meeks
Owens-Corning Fiberglas
Corporation, Fiberglas Tower,
Toledo, Ohio 43659.

*T.M. Reg. O.-C.F.

Owens-Corning is Fiberglas

OWENS/CORNING
FIBERGLAS
TRADE MARK ®

For more data, circle 71 on inquiry card



ASG... The Glass Company

When it comes to flat glass, the only name you have to remember is ASG. Because from product to packaging to delivery, ASG does it all. It's your one-source glass company. And that includes everything from float glass to plate glass, tinted and clear, to patterned and insulating glass, lighting glass, reflective glass and safety glass. In short, any kind of flat glass you'll ever need.

And, ASG delivers the goods. Where you want it and when you

want it. In some of the most advanced package designs in the industry. Packaging systems that reduce handling to a bare minimum. And make breakage a rare occurrence, indeed.

So, when it comes to glass, come to The Glass Company... ASG.



ASG Industries Inc.

The Glass Company P.O. Box 929, Kingsport, Tennessee 37662

For more data, circle 72 on inquiry card



The Mansards, Griffith, Indiana

"The whole idea of "The Mansards" is to provide gracious living accommodations in a natural setting of trees and water. The convenience of city living is combined with the graciousness of country living here. We have put top quality into "The Mansards" and that extends to our coin-operated laundry equipment. We chose Speed Queen for one simple over-riding reason—it's the best we could get."

Duane J. Hicks, Jr., General Manager

Lake Point Tower, Chicago, Illinois

"Lake Point Tower represents a new kind of urban life—a completely self-contained city at the edge of Lake Michigan. We appeal to individuals and families of middle and upper income. They expect and get the best at Lake Point Tower. That's why we chose Speed Queen equipment for our laundry facility. Speed Queen represents quality which will be on the job—not out of order.

And I understand the Stainless Steel feature is a real plus when laundering durable press fabrics."

Robert E. DeCelles, Building Manager

"We chose Speed Queen laundry equipment for one simple reason—it's the best we could get."



Let SPEED QUEEN and your SPEED QUEEN COMMERCIAL ROUTE OPERATOR help you plan coin-operated laundry facilities



SPEED QUEEN®

Ripon, Wisconsin 54971



a McGraw-Edison Company Division

For more data, circle 73 on inquiry card

FORM NO. 5541C

**Mr. E. W. Jess,
Manager, Commercial Department
Speed Queen, Ripon, Wisconsin 54971**

AR-6

Gene, please forward your laundry room design brochure.

- Please send me name of the Speed Queen Route Operator nearest me.
- I would like a Speed Queen representative to call.

Name and title _____

Firm name _____

Address _____

City _____ State _____ Zip _____

The Wilson Art Look in laminated plastics.

Your ideas and our ideas look great together.

As an architect or interior designer, coordinated control of selected colors and patterns is critical to your design concept. Woodgrains, solid colors and abstract or geometric patterns should look exactly as originally intended.

With Wilson Art laminated plastics for furniture and fixtures, Wilsonwall Paneling Systems and Dor-Surf (Wilson Art high impact door facing material) you can be **sure** of achieving the design results you originally specified.

WILSON ART LAMINATED PLASTIC

Choose from over 150 woodgrains, solid colors and patterns. And an outstanding selection of true dimensionals that look as great as they feel. Match furniture and fixtures with other Wilson Art covered interior surfaces for total environmental control.

WILSONWALL PANELING SYSTEMS

Coordinate walls with one of four distinctive Wilsonwall panel systems. System #110 is a reveal system; #210, a standard V-groove; #310, a V-groove; with hidden moldings; and #610, a Class 1A fire hazard classification system featuring aluminum moldings. Each is available in the entire line of over 150 Wilson Art woodgrains, solid and patterns.

DOR-SURF (Wilson Art high-impact door facing material).

Doors in high traffic areas need DOR-SURF[®], 1/8 inch thick Wilson Art door facing material. Exceptionally strong and abrasion resistant, it too, can be coordinated with all other Wilson Art covered surfaces.

Simplify. Get it all together with the one source supplier, Wilson Art. For total interior coordination.

You'll see why we say: Your ideas and our ideas look great together. For more information, contact the Wilson Art Architectural Design Representative nearest you today:

- Atlanta
404-377-0731
- Chicago
312-437-1500
- Denver
303-388-3686
- Los Angeles
213-723-8961
- Miami
305-822-5140
- New Jersey
609-662-4747
- New York
212-933-1035
- San Francisco
415-782-6055
- Seattle
206-228-1300
- Temple, Texas
817-778-2711

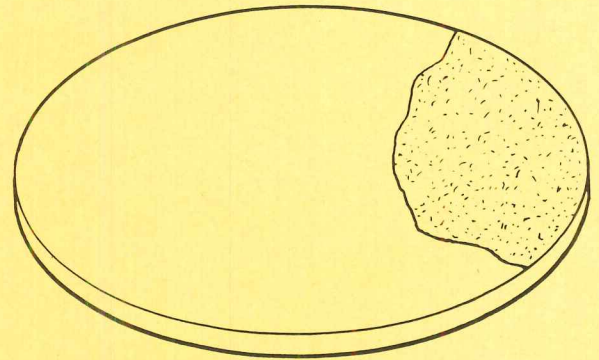

**WILSON ART
LAMINATED PLASTIC**

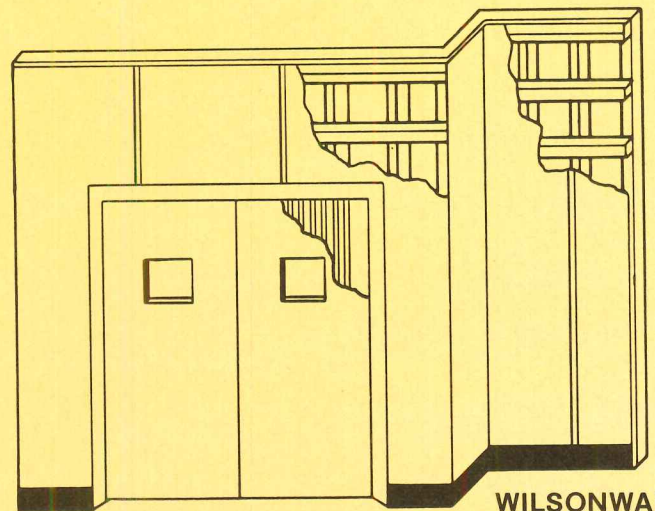

**DOR-SURF[®]
DOOR FACING
MATERIAL**

**WILSONWALL
PANEL
SYSTEM 110**

WRITE FOR THESE DESIGN AIDS:

Spec Data Sheets for:
Wilson Art laminated plastics, Wilsonwall Panel systems and Dor Surf[®] (1/8" Wilson Art door facing.)



When the chips are down, you can depend on Wilson-Art.



RALPH WILSON PLASTICS COMPANY ... TEMPLE, TEXAS
ARCHITECTURAL PRODUCTS DIVISION **DART**
INDUSTRIES INC.



When the chips are down, you can depend on Wilson-Art.



RALPH WILSON PLASTICS COMPANY TEMPLE, TEXAS
ARCHITECTURAL PRODUCTS DIVISION **DART**
INDUSTRIES INC.

For more data, circle 74 on inquiry card

Industrial waste collection doesn't have to be such a big waste!

Of time. Of money. Of space. Air-Flyte® has come face-to-face with the problems of unsightly, unsafe waste in plants and factories. You've been spending time and money merely moving waste from place to place in your industrial facility. You've wasted precious man-hours with employees double and triple handling waste. Emptying it from one container to another. Transporting it manually or by truck. Uneconomically. Inefficiently. Wastefully.

Now there's ECI Air-Flyte to put an end to waste. A pneumatic waste removal system that can be engineered specifically to your disposal needs. It removes trash right at the source, and carries it directly

to a central disposal point. And does it quickly, quietly, economically, and efficiently with negative pressure that pulls solid waste through pneumatic tubes at mile-a-minute speeds—to the incinerator, compactor, grinder, baler or haulaway container.

It's versatile. Tube lines can be suspended from ceilings, buried in floor trenches or installed on rooftops. And waste can be moved up, down or sideways for full layout freedom.

It's engineered. Air-Flyte waste disposal engineers investigate every aspect of your operation before making even preliminary suggestions—to assure a system that operates simply and safely.

It offers variety. There's a wide choice of collectors available, depending on the particular needs of

your building and the nature of your waste material. And a single Air-Flyte system can have as many depositories as you require.

Look into the heart of the Air-Flyte system. A centrifugal type suction generator with radial blade impeller and noise suppression damper. Look into an ECI Air-Flyte pneumatic waste disposal system engineered for your plant. And discover the modern method of trash disposal. Air-Flyte. A simple, clean operation offering considerable savings in labor, time and space.

For more information, write now for our free brochure: "Industrial Waste Collection: The Pneumatic System." Or contact us and ask to see an ECI representative.

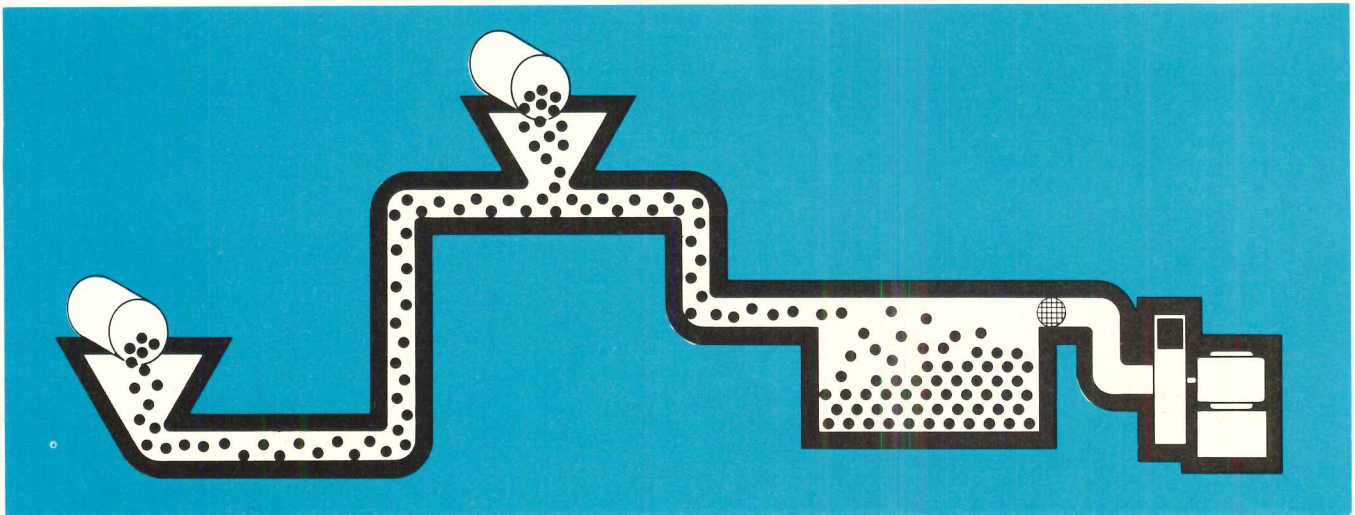

"AIR-FLYTE" is a registered trademark



ECI Air-Flyte Corp.

Subsidiary of Eastern Cyclone Industries, Inc.
15 Daniel Road • Fairfield, N. J. 07006
Regional Sales Office:
BOSTON • CHICAGO • LOS ANGELES
ATLANTA • DALLAS

For more data, circle 75 on inquiry card

New Vandal/Impact Resistant Lighting From ITT Art Metal...



BRONZE



PRISMATIC

OPAL



PRISMATIC



An unbeatable combination of lighting elegance and durability.
Only part of a complete polycarbonate vandal resistant line.



**ART METAL LIGHTING
WAKEFIELD LIGHTING**
P.O. Box 195, Vermillion, Ohio 44089
In Canada: P.O. Box 3231, London, Ontario

For more data, circle 76 on inquiry card

The Student Union at St. Scholastica College, Duluth, Minnesota, provides an education on what keeps insulating glass insulating. All 475 windows in the building were sealed with an LP® polysulfide base compound nearly 10 years ago. No problems ever since.

The Holiday Inn at Ann Arbor, Michigan, is an even older polysulfide application. Its hundreds of large window units have proven our polymer's excellent adhesion, flexibility and resistance to moisture vapor transmis-

How to set insulating glass longevity records.

sion for over a decade of summer sun and winter cold. No problems here, either.

LP polysulfide polymers are just a few of the many products made by our Chemical Division. For aircraft, automobiles, buses, trucks and trains. For joint and window sealants, and insulating glass. For seals, gaskets, printing rollers, hose and industrial tires.

Would you like more information? Write Thiokol Chemical Corporation, Chemical Division, Trenton, N.J. 08607.

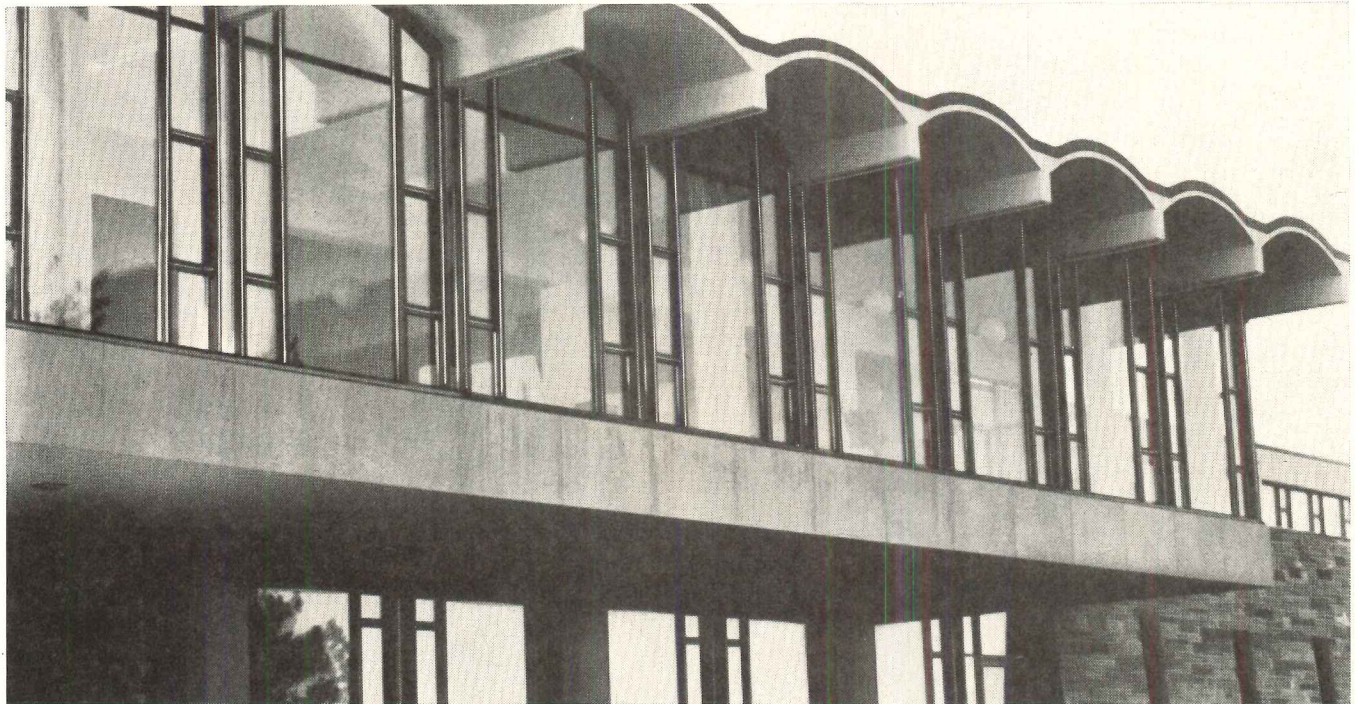

Thiokol

*Specialty Polymers • Off-The-Road Vehicles • Synthetic Fibers • Sprayers • Propulsion • Human Development
Friction Materials • Ski Lifts • Pyrotechnics • Closures • Rubber and Rubber Chemicals • Medical Electronics Equipment*

For more data, circle 77 on inquiry card

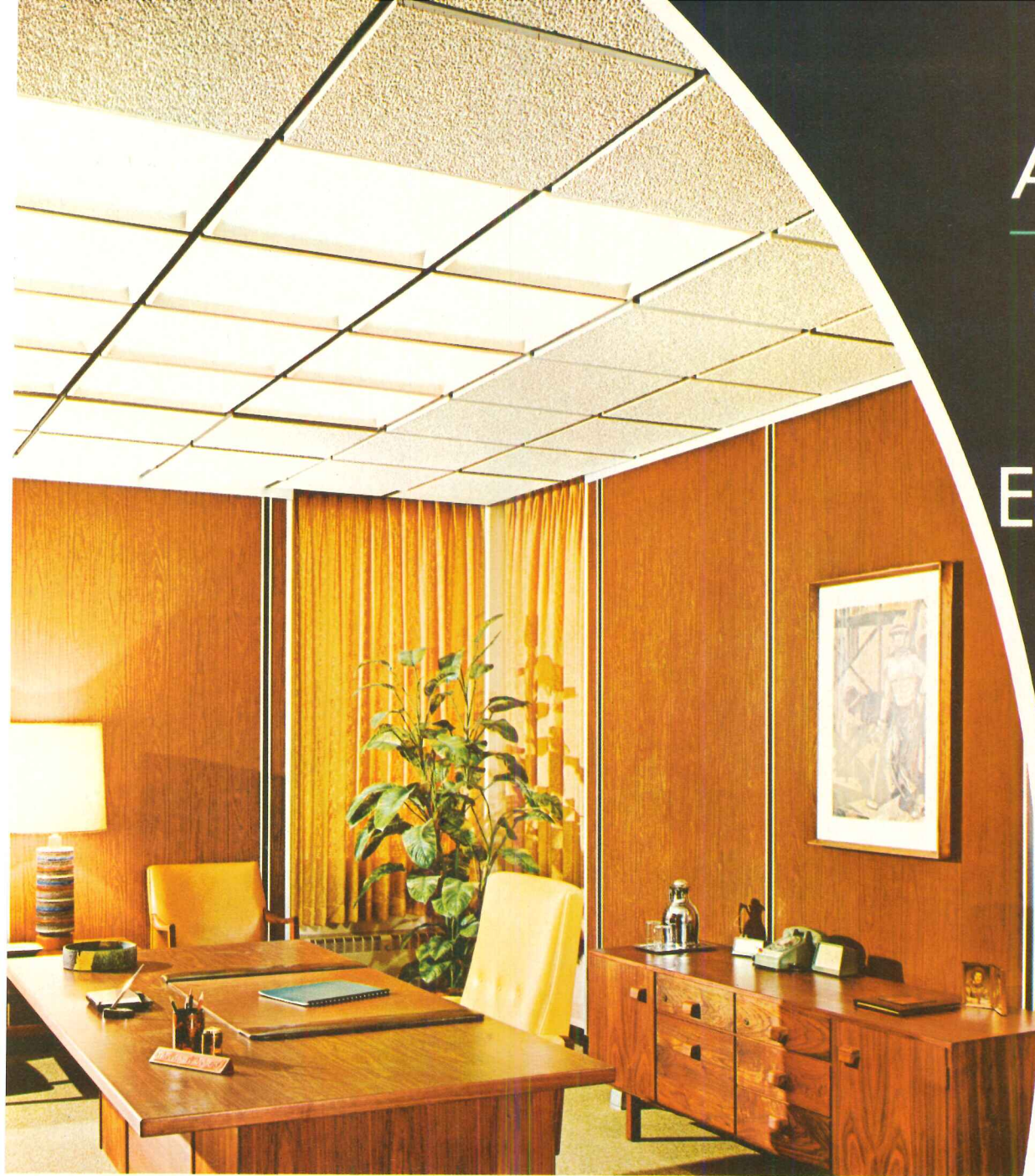

ABOVE ALL
CONWED[®]
CEILING
FOR
ENDURING
BEAUTY



Rock Face[™] Ceilings...handsome, but tough.

Rock Face panels are one of the interesting recent ceiling developments from Conwed. These panels are handsome enough for an executive suite, yet tough enough to go into a school and take the impact of a thrown basketball or improperly handled projection screen. Against the hazards that typically confront ceilings — rough handling in installation, frequent and sometimes careless maintenance, heavy traffic — Rock Face panels are practically indestructible.

It may be that Rock Face panels and tile are relevant to something you're working on now. Or maybe you need something quite different. It doesn't matter. The Conwed line is large and versatile and we're a company that doesn't stand still. If you haven't looked through our line lately take a look at the Conwed pages in Sweet's.

For more data, circle 78 on inquiry card



Conwed
CORPORATION

332 Minnesota Street
Saint Paul, Minnesota 55101

First in vinyls

Maybe a lofty ideal, but you—and styling for you—have put us there. In woodgrains, Borden offers the largest stock collection anywhere: nineteen, with nine new just this year. And what's more, select patterns are available in *both* horizontal and vertical configuration, most in 62" widths. Accent them with Borden solid colors, textures, prints—vinyl design after design from top international studios, including our own. Upholstery fabrics, too. You'll find them all. So whatever your vinyl finish, look first to the leader. Borden . . . where the best styling comes first.



BORDEN FILMS

Columbus Coated Fabrics
Division of Borden Chemical, Borden Inc.
Dept. 68, Columbus, Ohio 43216

Imagination in finishes



For more data, circle 79 on inquiry card

John Boggs just solved the communications problems of this 1,250,000-square-foot enclosed shopping mall.

John Boggs works as a Building Industry Consultant with Indiana Bell Telephone Company.

The Edward J. DeBartolo Corporation, one of the nation's leading shopping center developers, is owner of two large shopping malls in Indianapolis. The corporation recently decided to invest in a third one there, of more than 100 stores, complete with every modern facility any merchant could want.

High on their priority list is up-to-date communications service, both now and for the future.

That's why they involved John Boggs in their plans while the surveyors were still at work on the site.

His state-of-the-art knowledge of communications enabled the builders to preplan for their needs.

Since John knew they set a high value on aesthetics, he suggested invisible cable access to the site, and proposed neat, efficient ways to run wires to individual sales-counter phones.

John talked about dozens of problems that could be avoided by planning ahead. And he explained in detail the advantages of one centralized communications terminal room, with satellite terminal locations each feeding eight to twelve stores—a concept the developer has incorporated into the plan.

The Bell System has a Building Industry Consultant in your territory who can give you this same sort of help. Whatever you are building, whatever your communications needs...

We hear you.



Building Industry
Consulting Service
American Telephone and
Telegraph Company
Room 2238D, 195 Broadway
New York, New York 10007

I am interested in the Building Industry Consulting Service.

- Please send me additional information.
- Please have a representative contact me.

Name _____

Title _____ Tel. _____

Company _____

Street _____

City _____ State _____ Zip _____

A-1



"Carpet of Antron® shows

Baskin, Woodfield Indoor Shopping Mall, Schaumburg, Illinois.



we care about appearance.”



“Men shopping for a look of quality are naturally influenced by the appearance of the store. At the same time, we naturally want to keep maintenance costs down. So the selection of floor covering becomes important.”

Through its corporate architect, the chain of men's stores has standardized on carpet with pile of Antron* nylon for most of its new and refurbished stores. The choice is based on the wearing qualities, soil-hiding ability and long-range maintenance savings demonstrated by carpet of “Antron”.

Its unique hollow filament structure optically screens out much of the appearance of soil. Instead of showing as spots, soil concentrations tend to blend with the overall color and texture of the carpet.

This, together with its crush resistance and exceptional durability (see stair-edge test), gives the carpet a lasting look of freshness.

Carpet of “Antron” requires less maintenance and fewer wet cleanings than carpet of other fibers. “Daily vacuuming, occasional spot cleaning, a shampoo once or twice a year, and that's it.”

Wherever you want floors to stay new-looking with minimum care, specify carpet of “Antron”. It has no equivalent in long-term appearance retention.

For further information and a list of mill resources, write: Du Pont, Contract Specialists, Room 112AR, Centre Road Building, Wilmington, DE 19898.

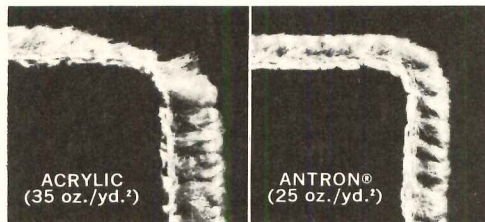

“Antron” nylon has exceptional resilience and durability. Abrasion test on simulated stair edges shows pile wear in level-loop carpets after equal exposure.

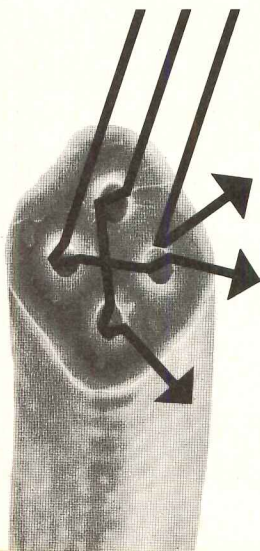

How “Antron” hides soil. Its filament structure is unique, as shown in this magnified (650X) cross section. The four precisely-placed hollows scatter light like the facets of a diamond to minimize the dulling effect of soil, while helping to retain color clarity and luster.

*Du Pont registered trademark. Du Pont makes fibers, not carpet.

For more data, circle 80 on inquiry card



Ordinary wood furniture is all wood. This isn't.

This is new, unique Steelcase Designs in Wood. Unique because we've added a little steel where it counts. Inside the pedestals, inside the drawers. To give them strength and rigidity and to prevent stubborn drawer operation.

We didn't forget about the inherent beauty of natural wood. So we used carefully selected veneers of

American Black Walnut and Oak. Protected by a supercatalyzed finish that simply shrugs off stains.

Our commitment to wood is complete. In addition to our original plant in San Rafael, California, we've just completed a new 200,000 square foot manufacturing plant in North Carolina. In a part of America where wood is a way of life.

Steelcase Designs in Wood desks and credenzas. Unordinary wood office furniture. At your Steelcase dealer soon. He's listed in the Yellow Pages. Or, write: Department G,

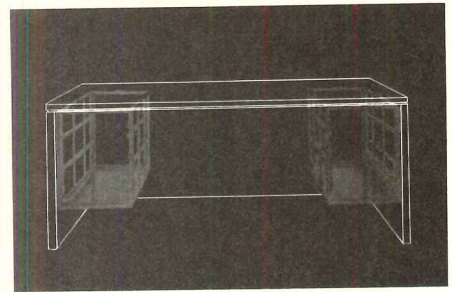

Steelcase Inc., Grand Rapids, Michigan 49501.

Steelcase

On display in the Steelcase showroom during NEOCON.



For more data, circle 81 on inquiry card

Carolinian euclidity and other related disciplines

*A portfolio of buildings, interiors and other designs
by Wolf Associates, Charlotte, North Carolina*

In the seven years since its founding, the firm of Wolf Associates has quietly gained a reputation for producing designs of a consistently high quality. Harry Wolf, the energetic head of the firm, and Marley Carroll, a designer of great talent, have resisted specialization and taken on a disparate variety of commissions from which small new firms sometimes—and sometimes wisely—shrink. Wolf Associates' position is based on the premise that the ability to design well is the essential professional qualification, and that with this qualification in hand the financial and social and political exigencies of architectural practice can, with intelligence, be acquired. Or, to put it the other way around, they have placed substantial bets on the fact that without the ability to design well there is no point in learning the rest—unless, of course, the goal is simply to make money, in which case there is still not much point, since for men with that goal there are many more lucrative occupations than architecture.

There is nothing new about their premise. But it should be obvious, in spite of all the professional brouhaha debating these matters, that the notion of pure design as a valuable commodity stands with about as much confidence as stocks on Wall Street in the eyes of many corporate and governmental clients—and even in the minds of many academicians, who presume to formulate architectural theory.

For designers depressed by this state of affairs it is worth pointing out, by way of reassurance, that there is not much new in this situation either, since the artist's wares have been robustly mistrusted off and on for centuries. Reassuring, too, is the fact that the members of Wolf Associates—geographically removed from the metropolitan centers where notoriety and critical acclaim often serve as second-rate surrogates for real success—have so far managed to maintain their stance as designers in the best sense: professionals whose charge is the enlivening and amelioration of people's lives through the modest but still potent medium of architecture.

It is therefore a pleasure to present and describe in the following pages some of Wolf Associates' successes, both for what they are, and also for the fact *that* they are.

Weaned on the crisp, white planar forms and the elegantly meticulous detailing of the Modern Movement, and often disciplined by the firm's own predilection for rigidly geometric shapes, the designs—almost miraculously, given such strictures—respond one by one to the equally rigorous requirements of human need. Better, they respond in a way that is not just adequate, but exceptional.

—Gerald Allen

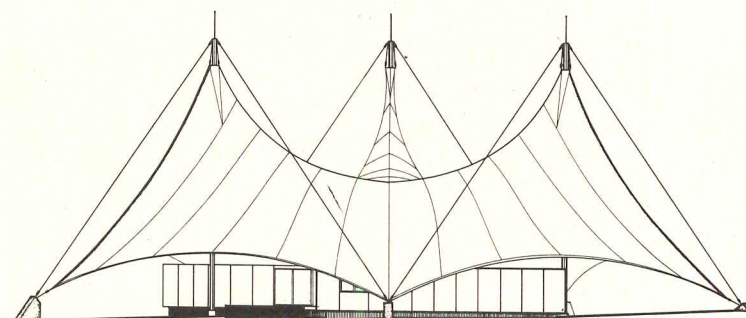
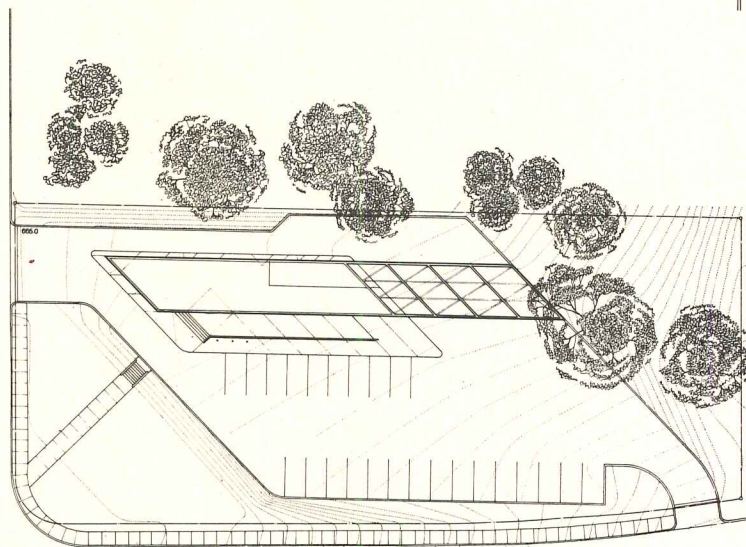
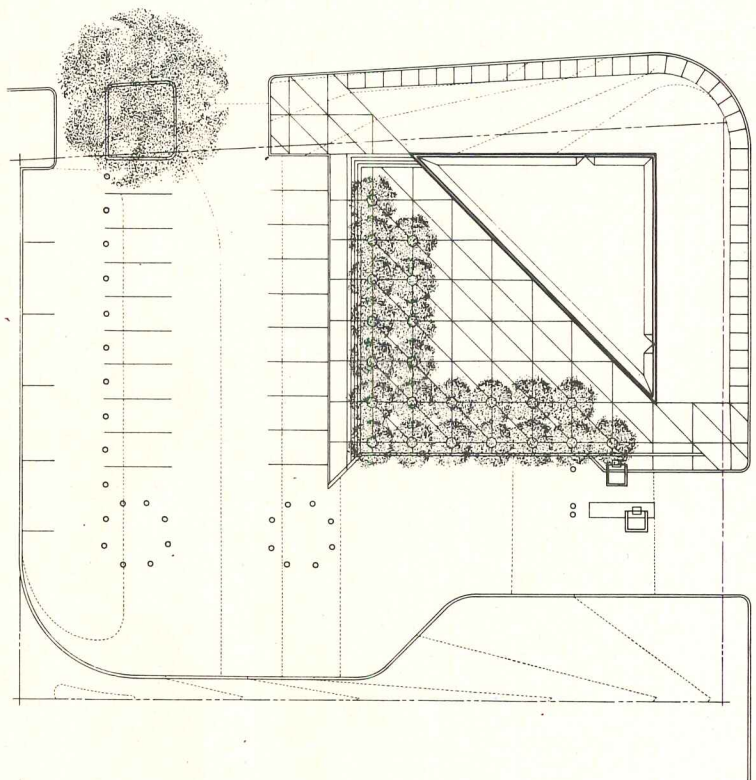

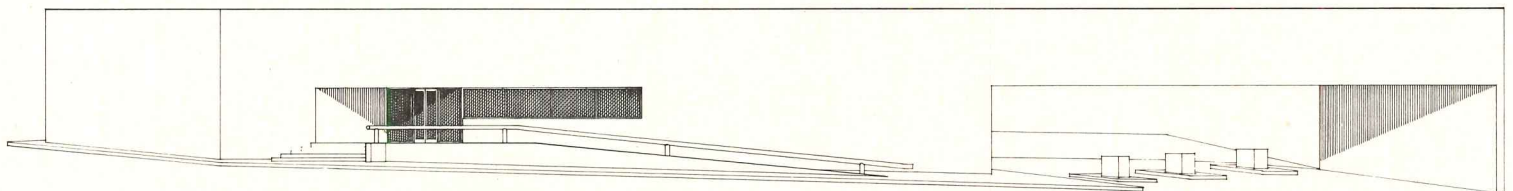
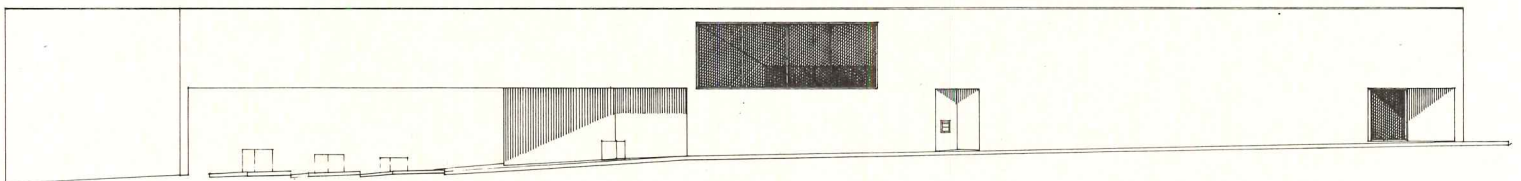
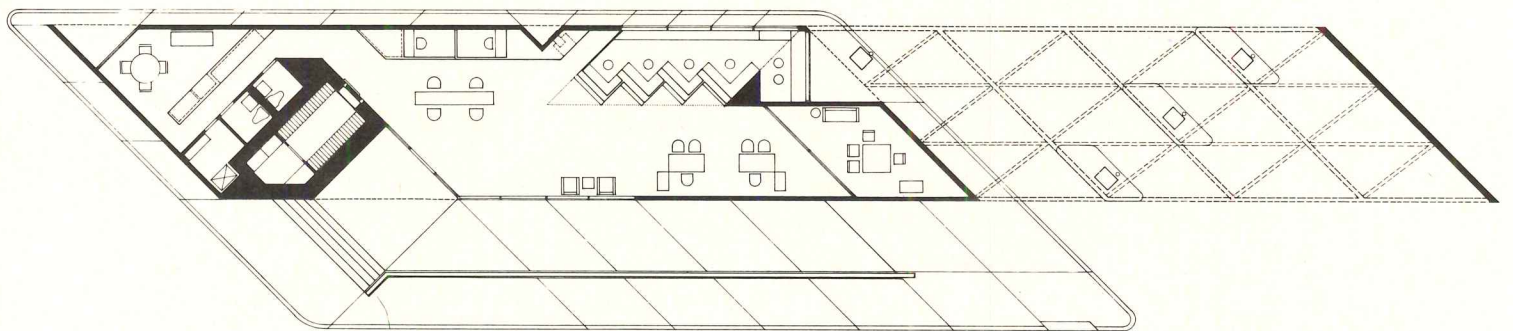
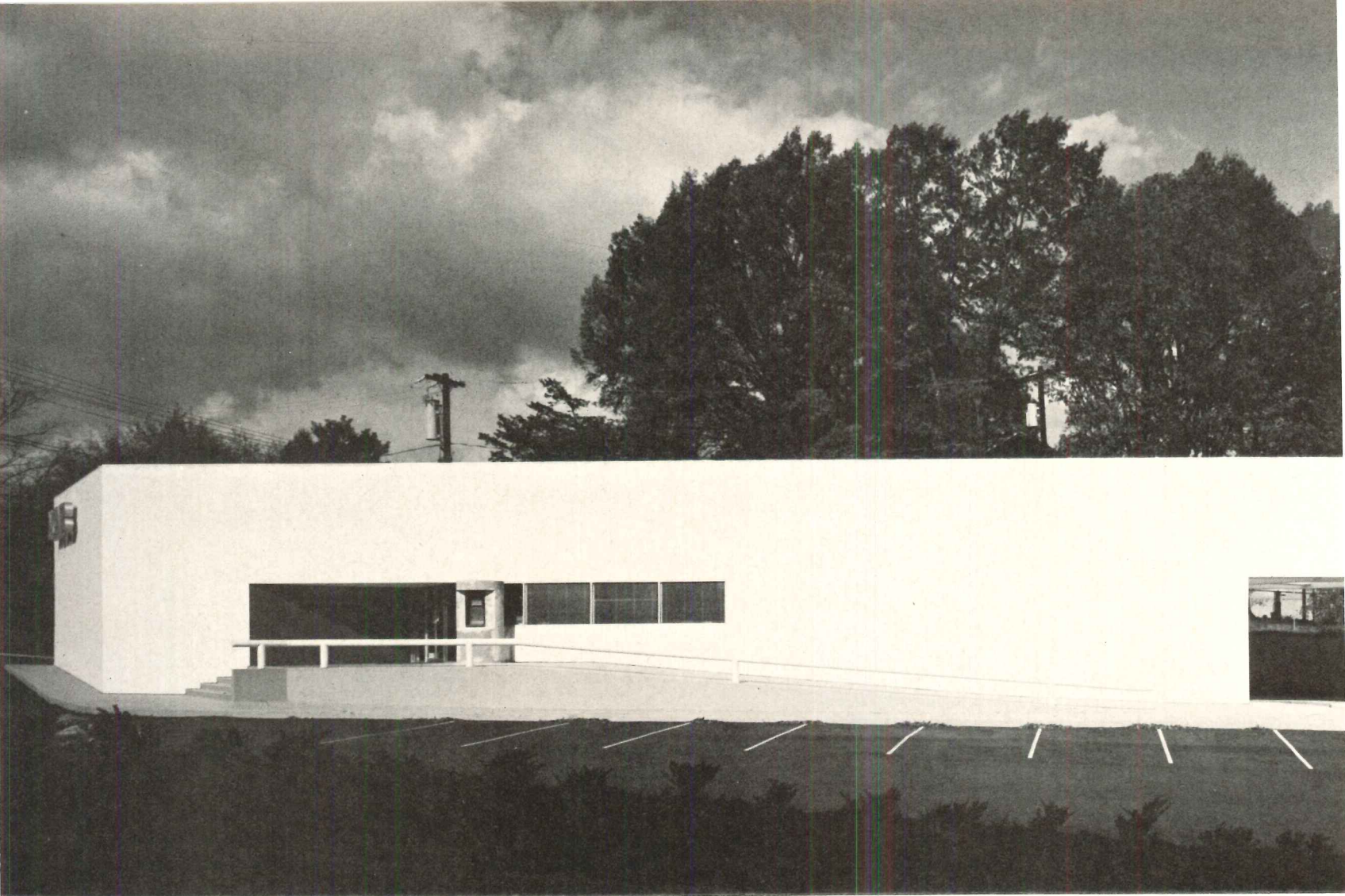



Gordon Schenck



Gerald Allen

A parallelogram generates a building designed primarily as a drive-through billboard

The design of this suburban branch bank reflects the owner's predictions that as many as 80 per cent of all banking transactions would take place from drive-in teller positions. Accordingly, the automobile lanes carved out of the volume of the building and served by a system of pneumatic tubes make this, literally, a drive-in bank.

The steeply sloping site (page 111, center right) is on a main artery between two major shopping centers and several large office buildings. Diagonal movement across the site—and thus the shape of the building itself—results from the fact that the main entrance is at the lower southeastern corner and the exit, as well as a secondary entrance, is at the upper northeastern corner. This configuration also preserves the large, handsome trees in the northeastern corner of the site.

The bank is built very economically of steel columns and joists, wood studs, and plywood sheathing painted white. Its long flat side faces the street, and announces itself with an assertive elegance to passing cars.

A large parking lot in front of the building accommodates the cars of employees and also of customers whose business is too extensive to be

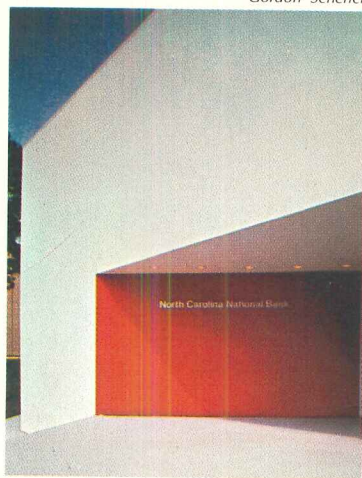

transacted from the drive-in teller positions. Inside the building, in a space ingeniously configured and lit by high north windows, are tellers, a conference room, and coupon booths.

PARK ROAD BRANCH, NORTH CAROLINA NATIONAL BANK, Charlotte, North Carolina. Architects: *Wolf Associates*. Engineers: *R. V. Wasdell Associates* (structural); *Mechanical Engineers, Inc.* (mechanical); *Connor Bullard Associates* (electrical). General contractor: *Rodgers Builders, Inc.*



Gerald Allen

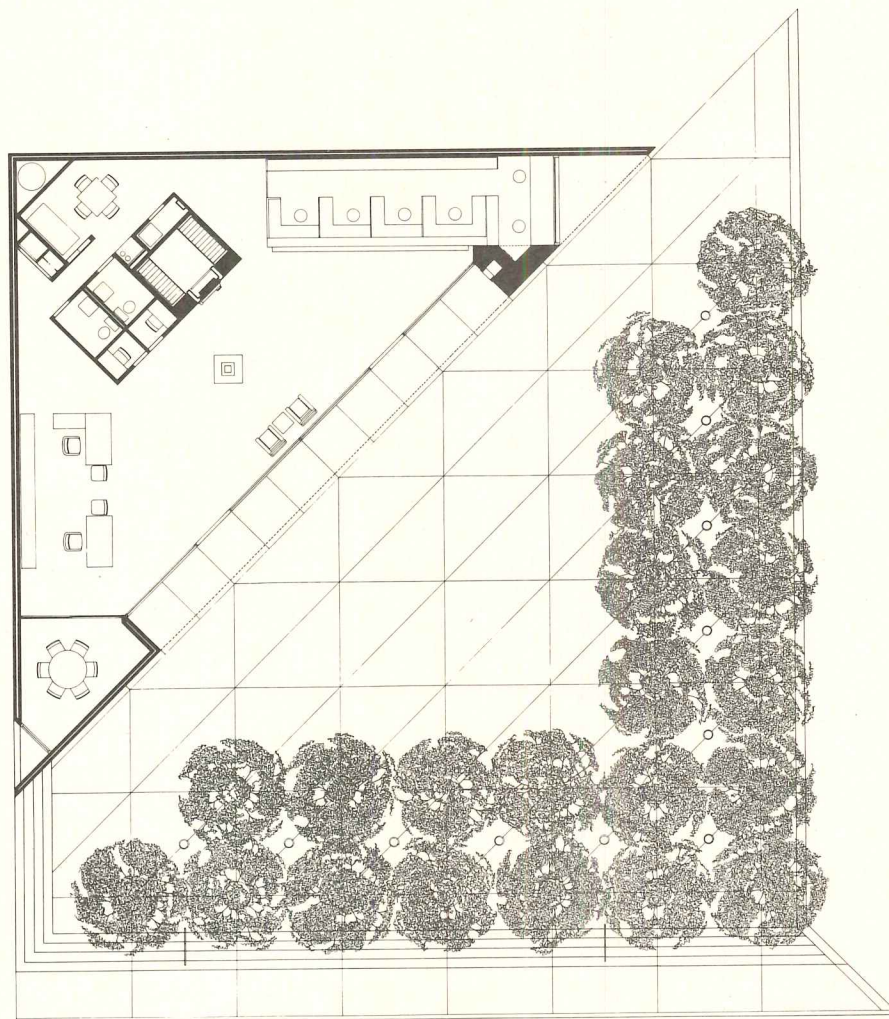
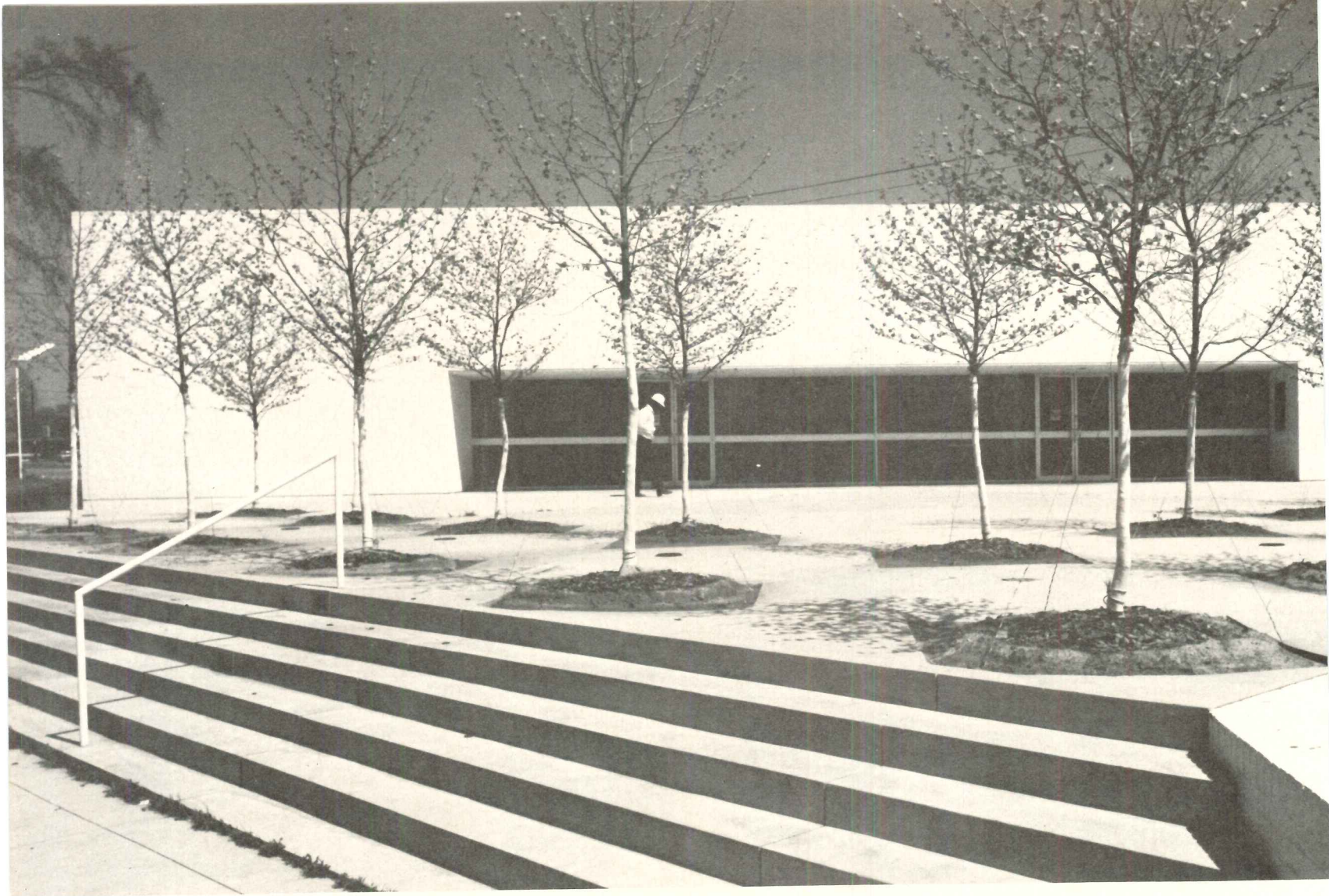



Gerald Allen photos

A triangular bank dares an unfashionable thing, turning its back to the street

Built on a corner lot along a busy commercial strip in a low-income neighborhood, this branch bank turns inward, away from the passing vehicular scene, to its own plaza shaded by a grove of plane trees. The shape of the building and the configuration of the site (page 111, top right) were not, in spite of all appearances, products of the availability of 45-degree triangles in the drafting room. Instead, they reflect a pre-existing path across the site made by children on their way to an from school. Now they take their short cut across the plaza (above right).

Perhaps the act of presenting a street with blank, brick walls is rather anti-social. In our own country it is often regarded as such, though in Latin cultures it causes little rancor. In this case, what is lost by the act needs to be balanced against what is gained by the creation of the quiet plaza behind.

BEATTIES FORD ROAD BRANCH, NORTH CAROLINA NATIONAL BANK, Charlotte, North Carolina. Architects: *Wolf Associates*. Engineers: *R. V. Wasdell Associates* (structural); *Mechanical Engineers, Inc.* (mechanical); *John Bolen Consulting Engineers* (electrical). General Contractor: *Butler and Sidbury, Inc.*

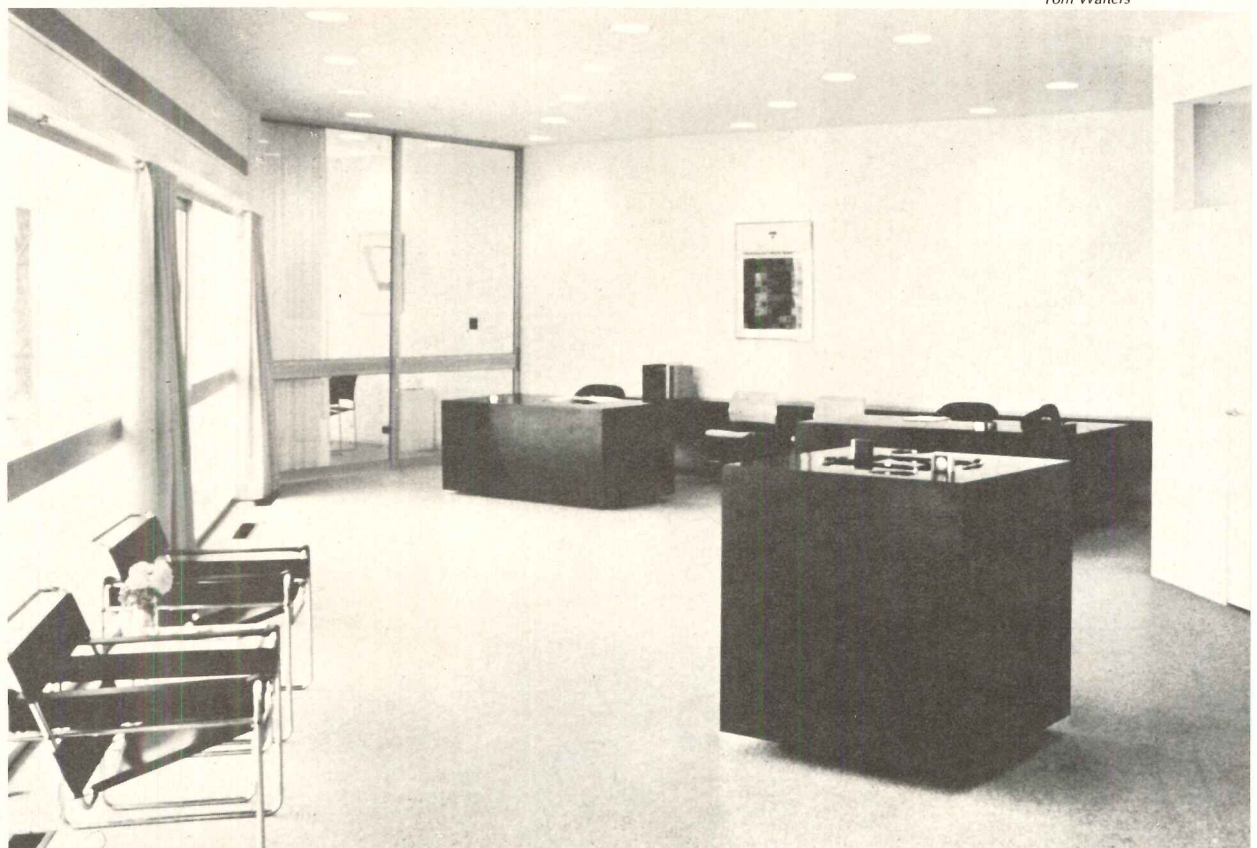

Tom Walters

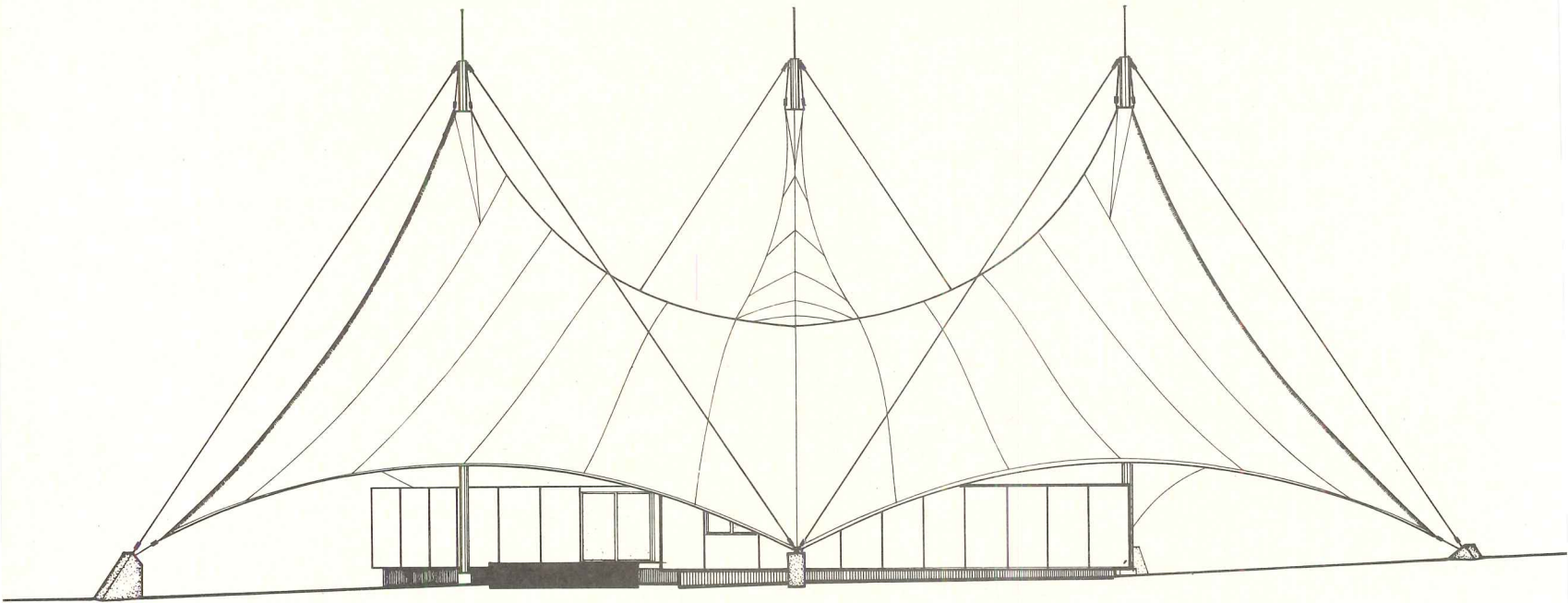

Compound curves provide temporary shelter for golfers and real estate agents

The developers of a Western North Carolina mountain golf resort needed a temporary club house and real estate sales office for the two seasons of initial operations, before a sufficient membership could be established to support a permanent building. The structure had to be inexpensive, and it had to be sited near the location of the future club house in order to relate to the circulation patterns from the first and tenth tees and the ninth and eighteenth greens.

Three remodeled, used mobile homes with painted plywood sides provided a shop, an office, and a snack bar. Above them is a triangular tent, 128 feet on each side, made of flame-



Gerald Allen

retardant nylon fabric and held aloft by three 50-foot masts. Between the remodeled mobile homes is a generous, softly lit space for social gatherings.

A strikingly elegant, simple, and ingenious design, its only fault seems that it was destined to be temporary.

GRANDFATHER GOLF AND COUNTRY CLUB TEMPORARY CLUB HOUSE AND REAL ESTATE OFFICE, Linville, North Carolina. Architects: *Wolf Associates*—project architect, *Marley Carroll*. Engineers: *Synergetics, Inc.* (structural); *John Bolen Consulting Engineers* (electrical). Landscape architects: *The Office of Dan Kiley*. General contractor: *G. F. Company*.

Hugh Morton





Gerald Allen

Meticulous restraint characterizes Wolf Associates' restoration of an old arcade

The Latta Arcade, built in 1911, is a major link between two streets in the downtown area of Charlotte. In recent years, the first floor of the building had been turned over to real estate and insurance offices, rather than to the small shops and boutiques which could have benefited from the almost constant flow of pedestrian traffic, and the building itself had become somewhat delapidated.

Wolf Associates, who have their offices there, were moved by the inherent charm of the arcade, and they persuaded its owner to restore it at the same time that they were expanding their own offices on the second floor.

The restoration was accomplished with an admirable amount of delicacy. Nothing was done to alter the essential structure of the building, and the selection of light fixtures, the graphics

and especially the color scheme show a respect for the existing building that is rather rare and altogether commendable in projects of this sort.

When old buildings possess no major architectural importance there is often a temptation to renovate them into something either much grander or completely different from what they once were. Sometimes these drastic changes are justified in order to preserve the building, but when they do not seem called for, it is reassuring to see the problem of restoration approached with graceful restraint.

LATTA ARCADE RESTORATION, Charlotte, North Carolina. Architects: Wolf Associates. Engineers: John Bolen Consulting Engineers (electrical). General contractor: R. Marret Wheeler Company.



Gordon Schenck

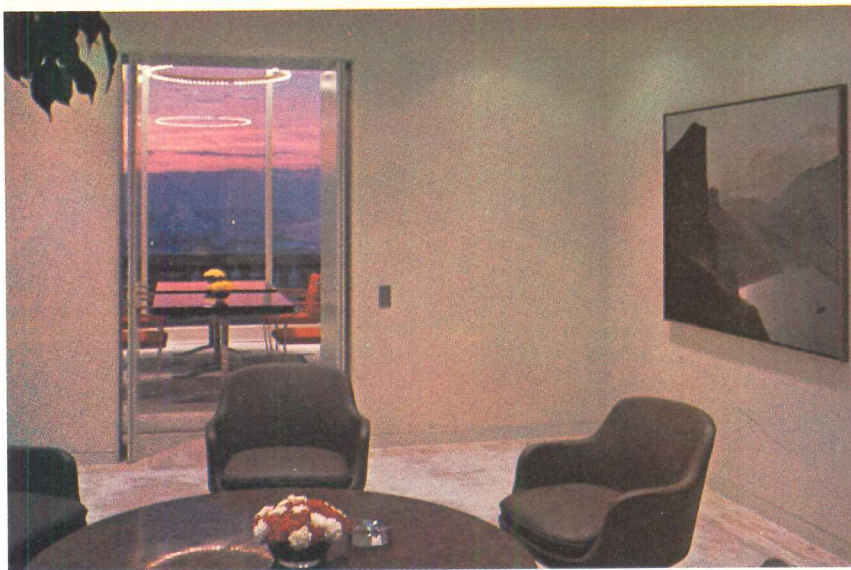

Opulent interior spaces provide the setting for a corporate collection of modern art

Bob Hawks photos



Wolf Associates has often taken on commissions to design interior spaces for corporate and professional clients (RECORD, January 1970, pages 100-101; January 1972, pages 92-93). One of the most ambitious of such projects was the remodeling of three floors of the National Bank of Tulsa for the use of its executives and those of the Williams Companies. Here the architects' role was expanded to include the design of virtually every object to be included, from soap dishes to ash trays and vases to tableware and most of the furniture. The spaces are characterized by the careful and precise assembly of a host of rich materials—arabescato and cremo marbles, stainless steel and bronze, rosewood and elm burl—to create a quiet setting for the distinguished collection of modern art.

CONFERENCE, RECEPTION AND DINING ROOMS. FOR THE NATIONAL BANK OF TULSA AND THE WILLIAMS COMPANIES, Tulsa, Oklahoma. Associate architects: *Wolf Associates, H. G. Barnard, Jr. and McCune and McCune and Associates*. Consultants: *Edison Price, Inc.* (lighting); *Rita Kromelow* (fabrics and accessories). General contractor: *Grimshaw Construction Company*.

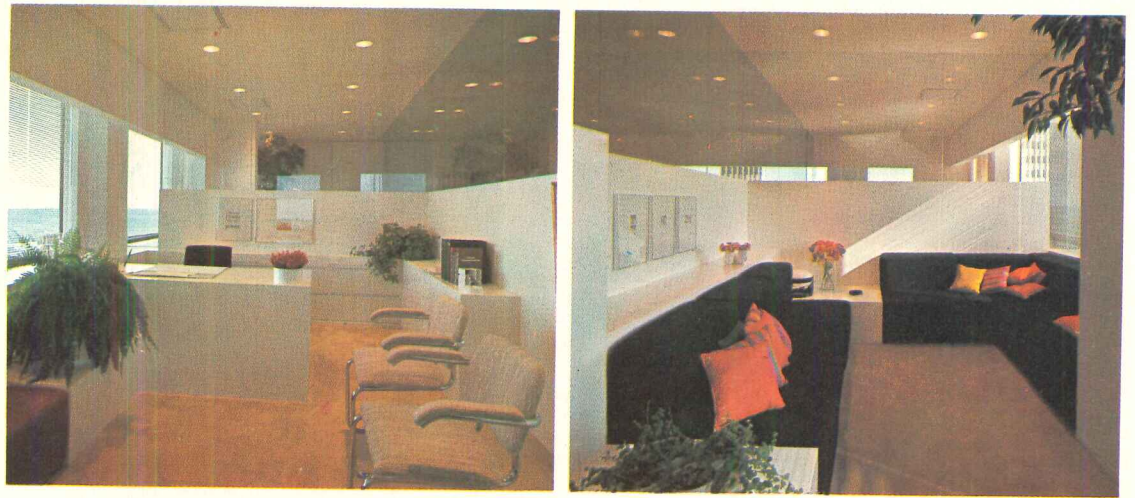

Simple crisp details and splashes of bright color enliven a busy stockbrokers' office

In contrast to the subdued elegance of the National Bank of Tulsa interiors, this office is designed to withstand, visually as well as physically, the sometimes hectic activity of buying and selling stocks. In the central area (below) there are brilliant red conference chairs beside rows of stock white commercial desks, which face the electronic scan and, below it, the wire room, where orders are sent to New York.

Senior members of the office have custom-built cubicles on either side of the main space, from which they can

maintain visual contact with the rest of the office while also having some degree of privacy. At the outside edges are still more private areas. The conference room is shown above right, and the regional partner's office on the left.

OFFICE FOR HORNBLOWER & WEEKS, HEMPHILL-NOYES, Charlotte, North Carolina. Architects: *Wolf Associates*. Engineers: *Connor Bullard Associates* (electrical). Custom cabinet work: *Page Church Furniture Company, Inc.* General contractor: *I. M. Hardin Construction Company*.

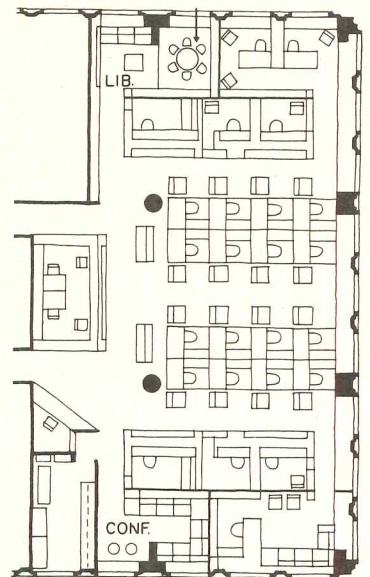

Gerald Allen photos



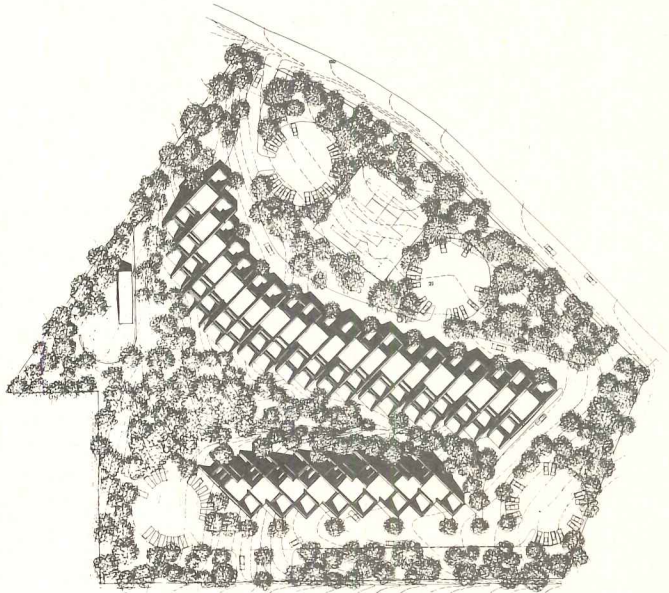

Sunhala Condominiums, Charlotte, North Carolina

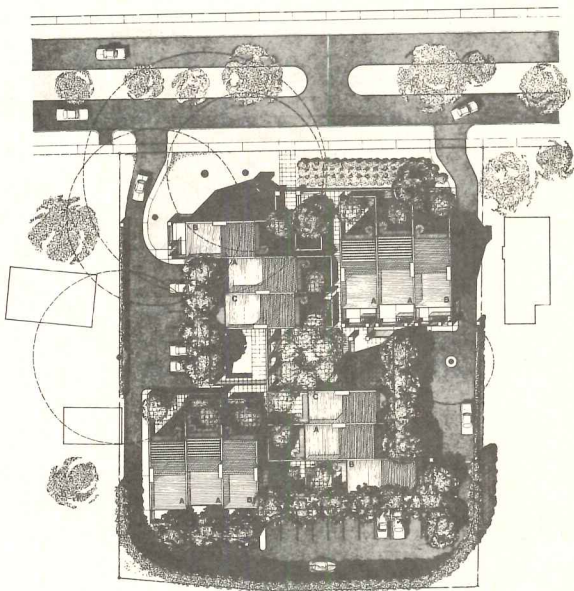

Hermitage Square Townhouses, Charlotte, North Carolina

Detail of Ponte-Travers-Wolf Development Plan, Charlotte, North Carolina

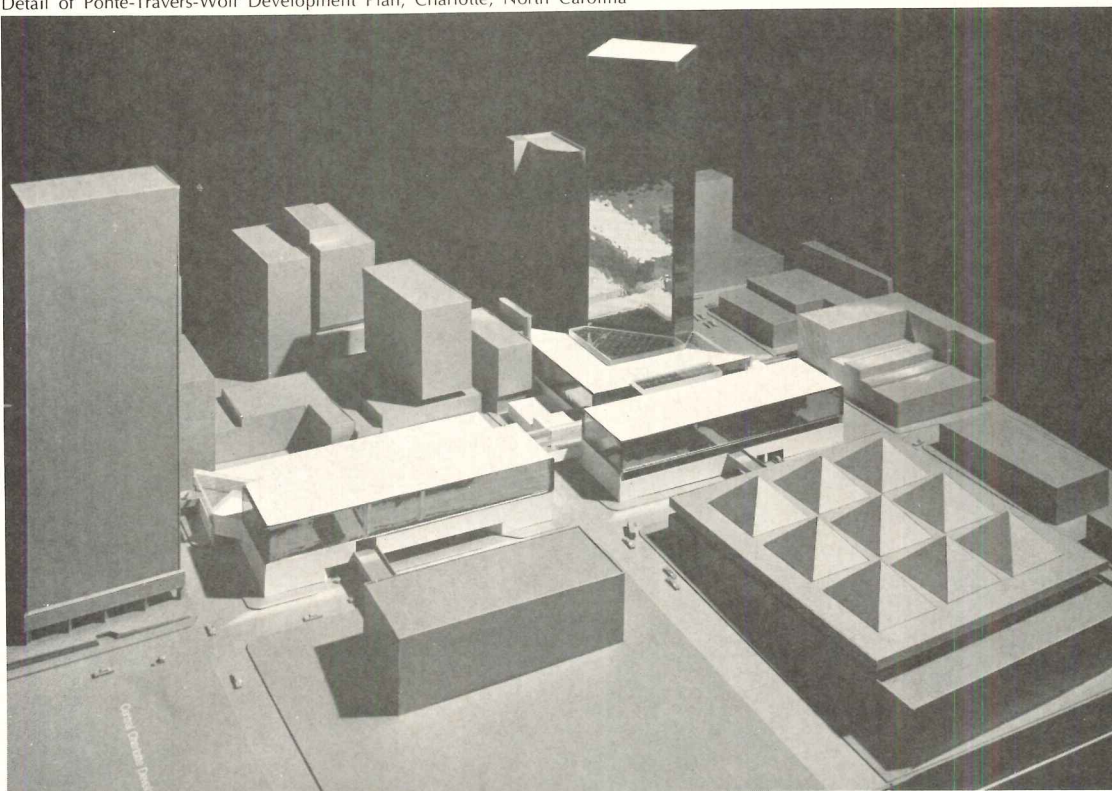

Gordon Schenck

Harry Wolf, voicing a not unfamiliar attitude, has said that architecture should be "modest, not strident." The restoration of the Latta Arcade, certainly, is a good example of professional modesty; and the two banks shown in the preceding pages exhibit, almost in spite of their rigid formality, an admirable sensitivity to the purposes for which they were intended. But what about, for instance, the interiors of the National Bank of Tulsa? Are they "modest"? "Modesty," Wolf goes on to point out, "has to do with the relation of our work to its surroundings. The interiors in Tulsa, for all their richness, are still understated; they form a background for the art collection and for the people who come to visit there."

Concern for the over-all surroundings of architecture has led Wolf Associates recently to undertake a number of larger projects. Housing, of course, is, or should be, a major concern of architects, and site plans for two of Wolf's current housing projects are shown on the left. The firm has also involved itself actively in the problems of cities and city planning. In association with Vincent Ponte and Travers Associates, they have prepared a development plan for the central business core of Charlotte (model below), and more recently they have conducted an exhaustive site selection study for the Federal Reserve Bank in a successful effort to integrate this important facility into the fabric of Charlotte.

The meeting of minds between designers, developers, lenders, and politicians does not always take place without friction, nor probably has it ever done so. "We have had our successes, and we've had our failures," Marley Carroll points out. To which Wolf adds, "Architecture is a very difficult thing." Not overwhelmingly so, apparently.

"Vest pocket" housing brings a new scale to the Bronx

Recently completed low- and middle-income urban housing projects have a different look these days, as these massive structures thrust into the East Tremont neighborhood in the Bronx attest. Designed by architect Giovanni Pasanella and constructed by the New York State Urban Development Corporation and the New York City Housing Authority (each acting separately on its own group of scattered sites), this "vest pocket" complex known as Twin Parks Southwest and West, took its shape from the conjunction within the last decade of several important planning and housing concepts whose time had finally come. Mayor John Lindsay's administration provided a responsive political climate for the development of these new concepts and Governor Nelson Rockefeller, through the UDC, deserves credit for a significant part of their implementation in the Bronx. These ideas, necessarily compromised in the process of only partial realization are now under attack. Much has been learned through getting Twin Parks Southwest and West built, however, and there is no question that the state of the art of urban housing has been significantly advanced. The ideas embodied in the project and some of the criticisms follow. They deserve the attention of everyone concerned with better housing for people in an urban environment.

—Mildred F. Schmertz

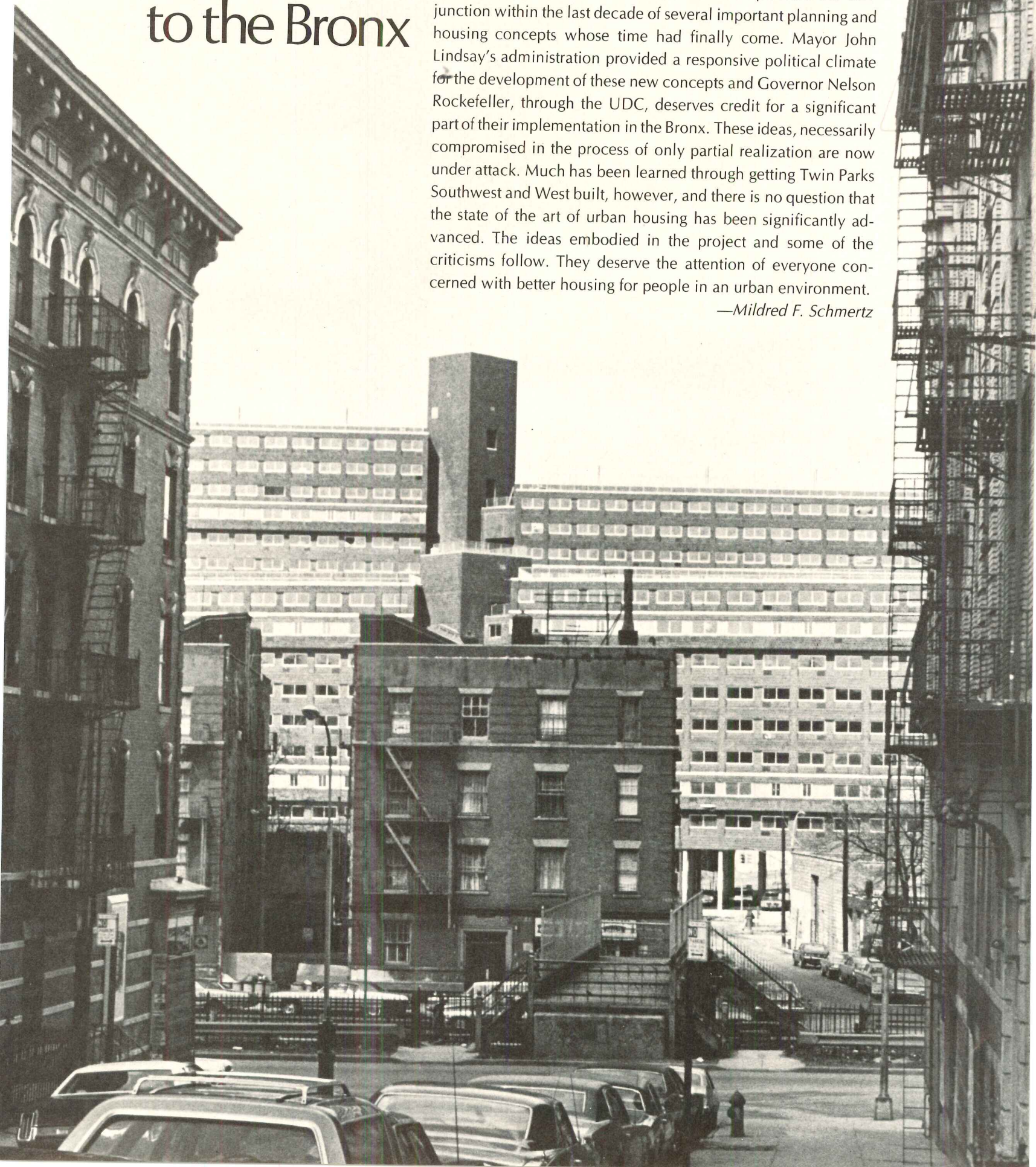

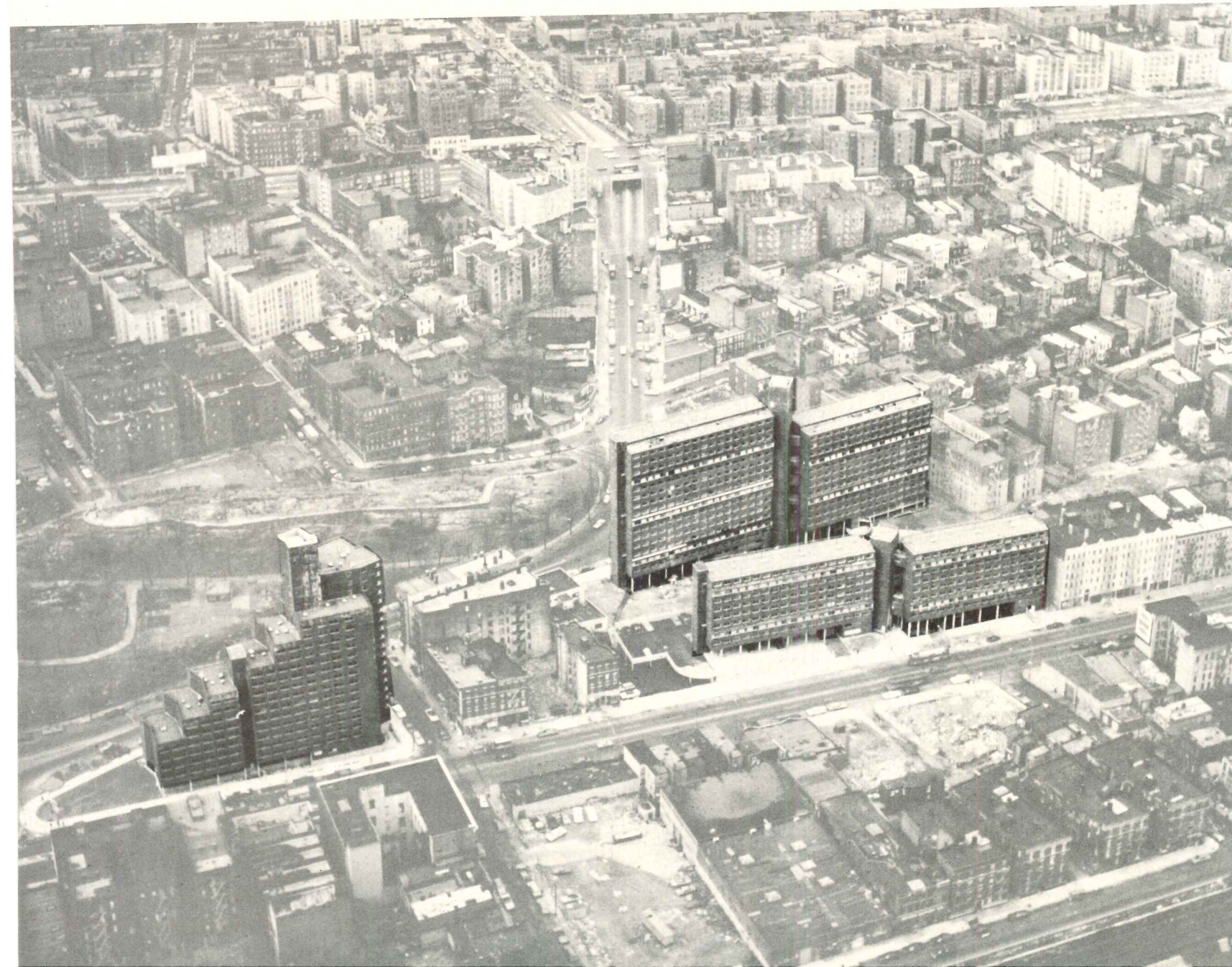
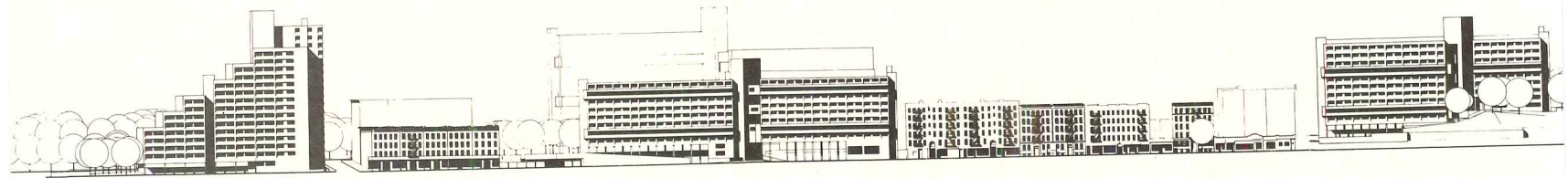
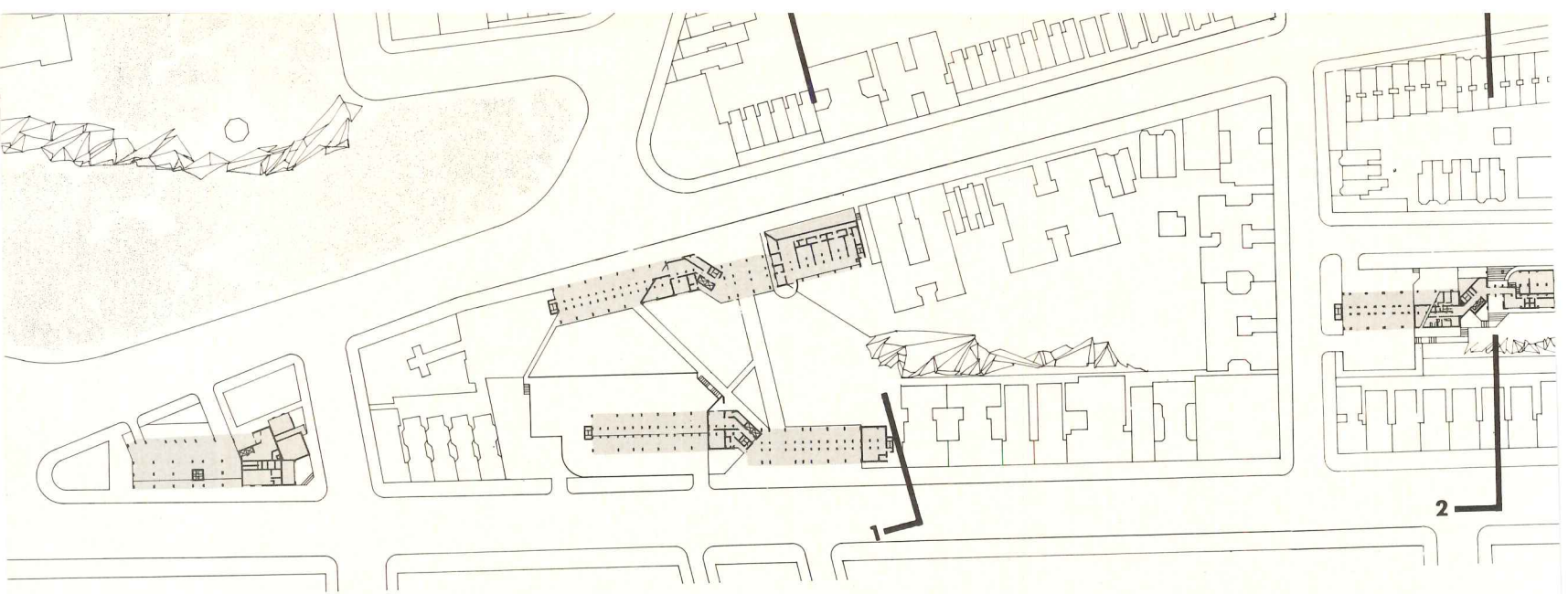

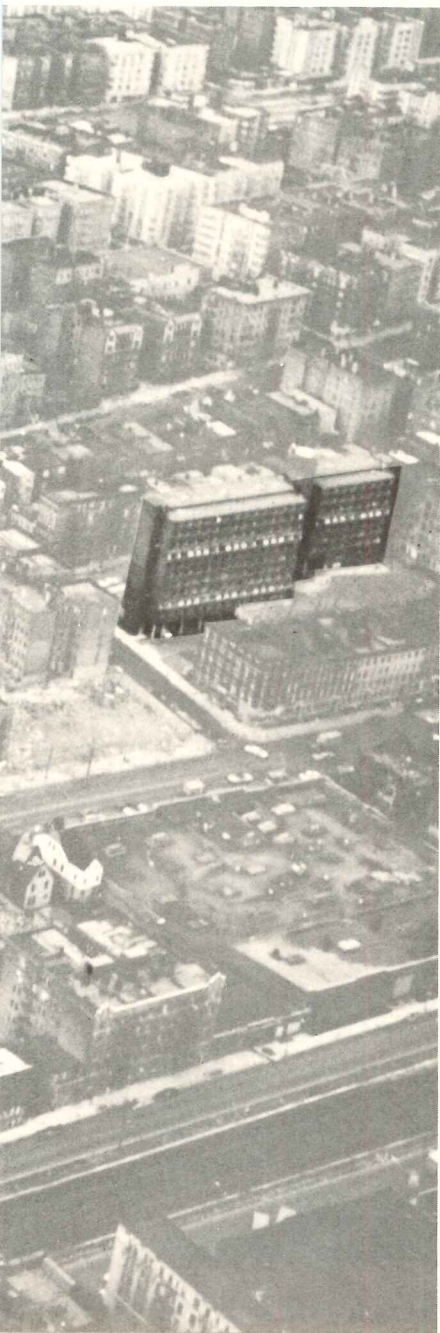
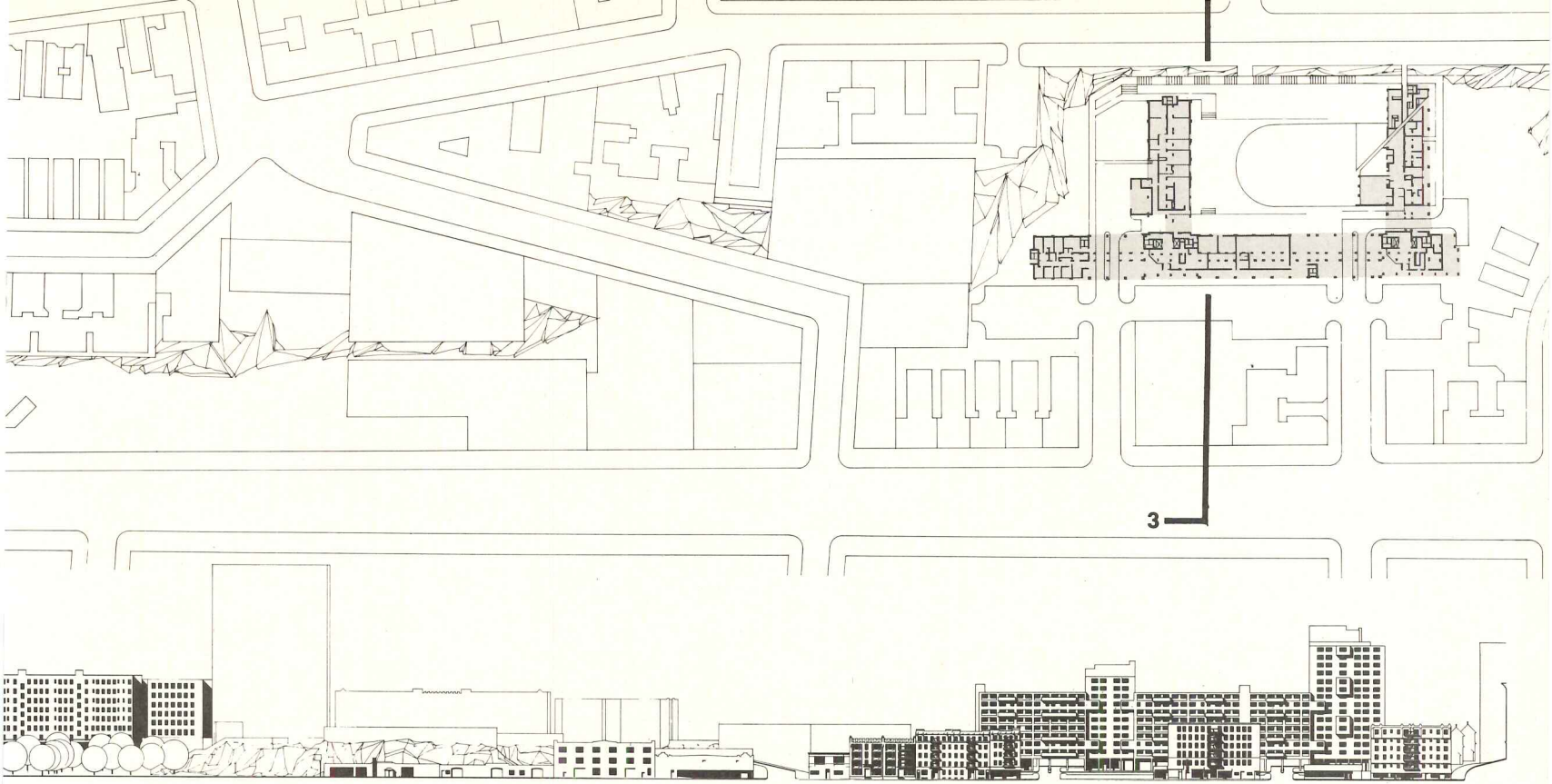

The vest pocket sites shown in the photo include all of Pasanella's Twin Parks Southwest housing which has been constructed by the UDC. The latter is a quasi-public development agency created by the New York State Legislature which builds low- and middle-income housing assisted by a variety of state and Federal programs. Not included in the photo but visible in the plan, elevation and sections is the northernmost segment known as Twin Parks West built by the N.Y.C. Housing Authority.

By 1967 it was clear that the days of large-scale urban renewal were over in New York City. Neighborhood citizens' groups had learned to prevent, by intense opposition, the dislocation of people and the disruption of community life which the renewal practices of the fifties and early sixties had engendered.

The Urban Design Group, a team of in-house consultants to the New York City Planning Commission, began to devise a new approach. This team then consisted of Jaquelin Robertson, Richard Weinstein, Myles Weintraub and Jonathan Barnett. With Pasanella's collaboration they began to work with various community groups in the Bronx to select appropriate sites for vest pocket renewal. The sites selected are irregular in shape and varied in topography, unlike the vast sites formerly cleared and leveled for urban renewal. These sites demanded a new kind of housing and massing design.

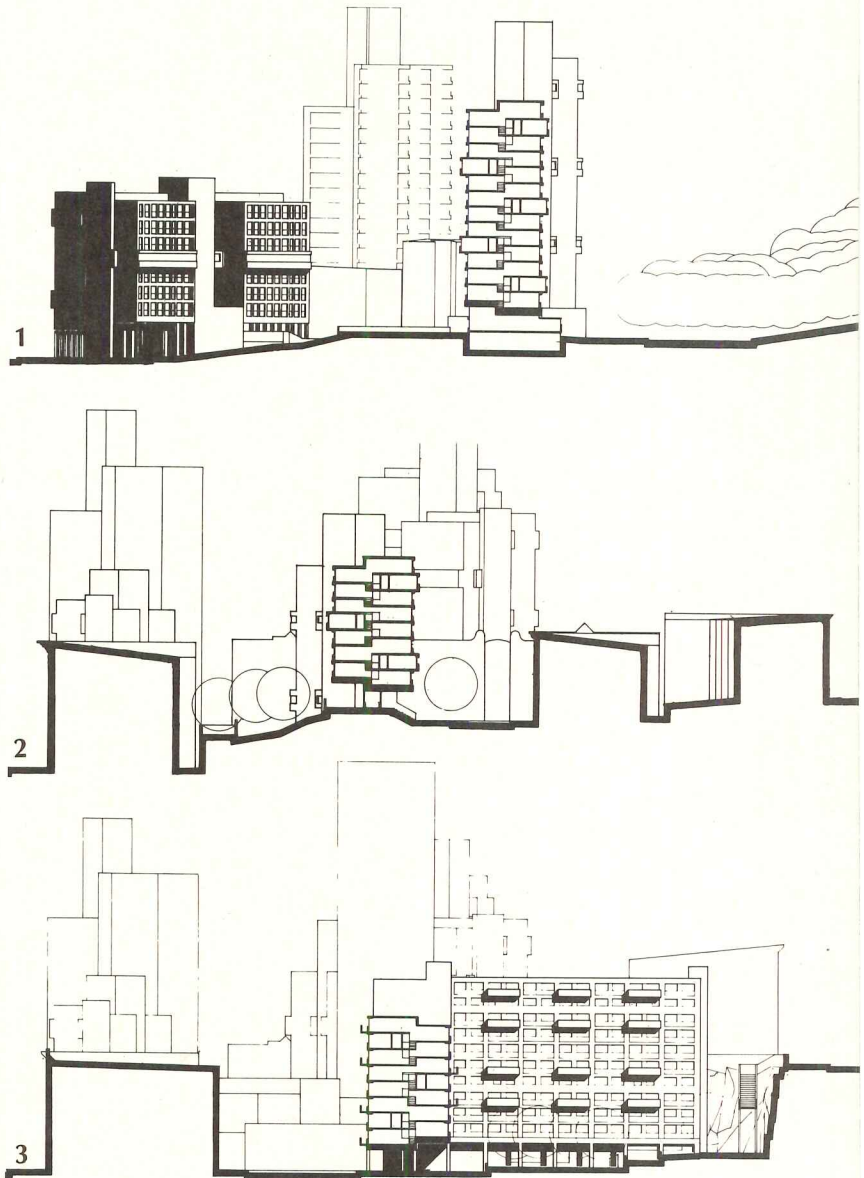



Thomas Stetz photos

Floor-through split-level apartments, in which living and sleeping areas are separated by a half-level change in elevation are a radical departure from conventional high-rise housing design. For what is believed to be the first time in any New York City high-rise structure, public corridors and elevator stops do not serve every building level. Rather, one corridor—and elevator stop—serves 2½ floors, saving 60 per cent of the public corridor space for redistribution into the apartments.

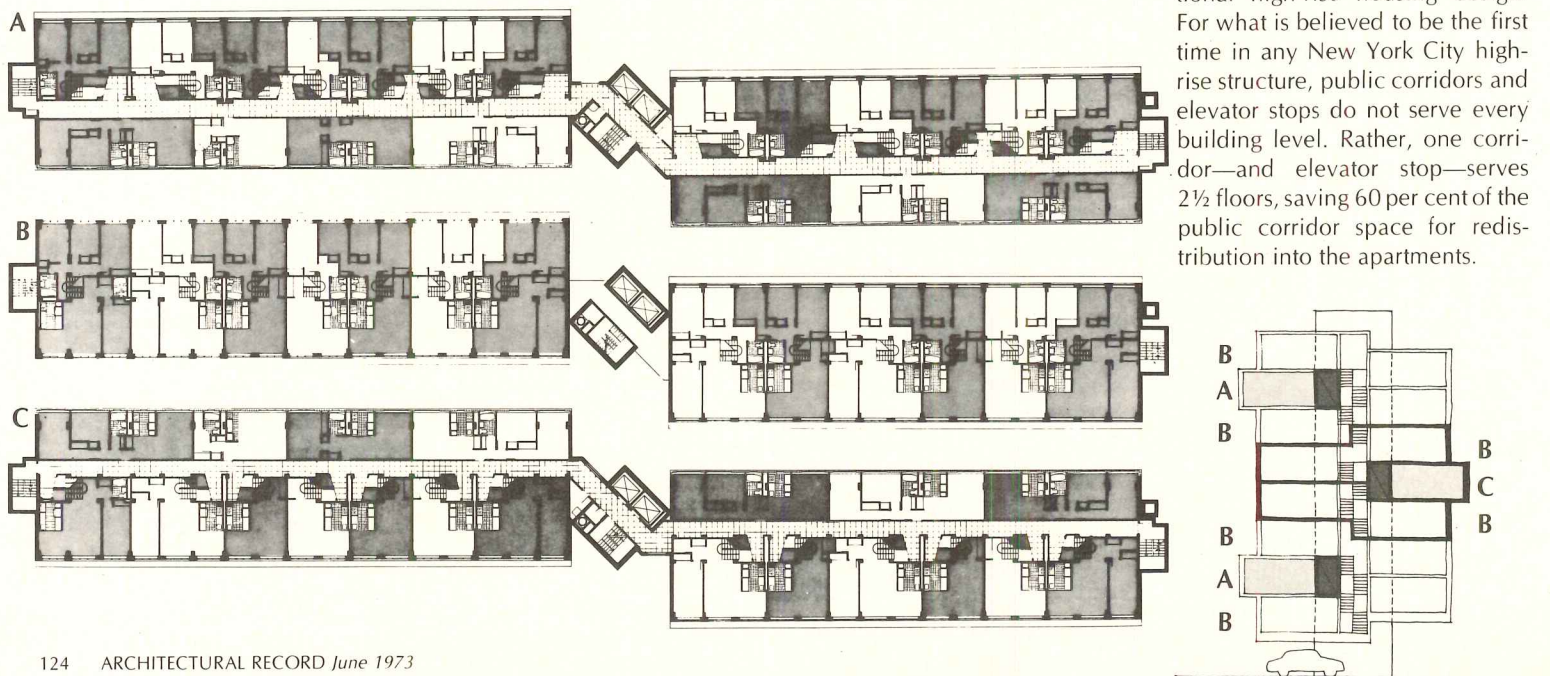



A large number of small apartments, mostly for the elderly, were programmed for the southernmost site (top and right), because it is close to a major crosstown shopping street and bus stop and adjacent to a public park. To the north the next two sites adjoin with a park between, which replaces a former street (top left). These UDC buildings including the apartment block on the fourth site (at the rear of the top left photo) contain most of the larger apartments, and include community facilities.

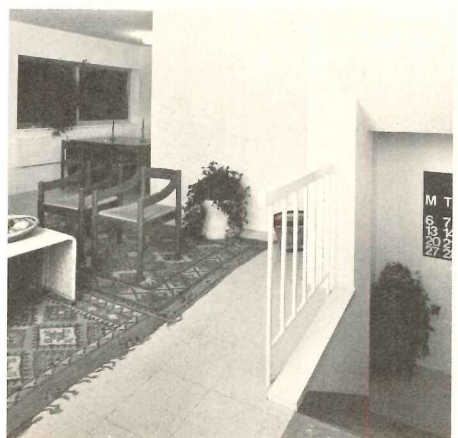
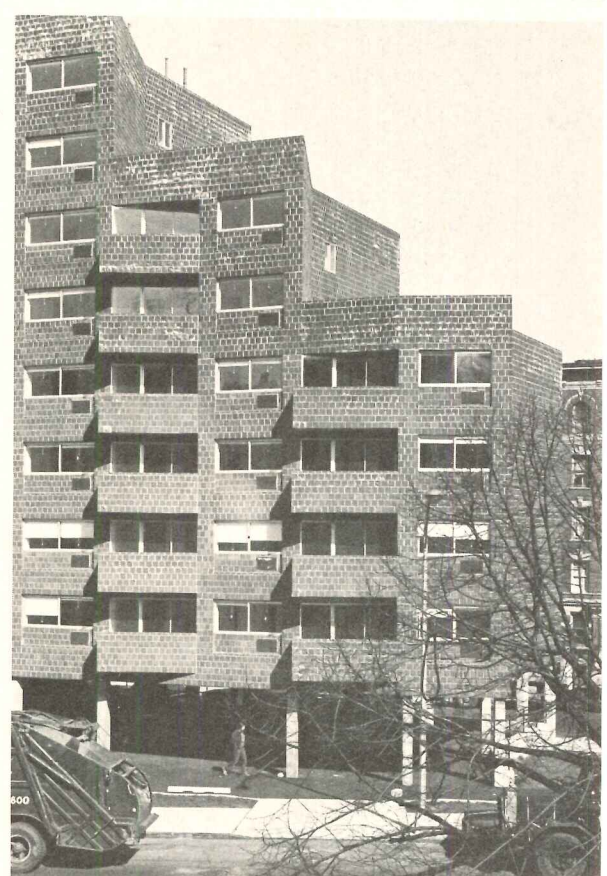
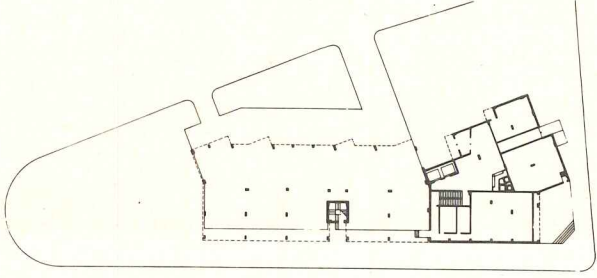
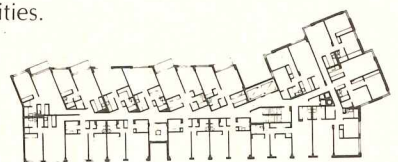
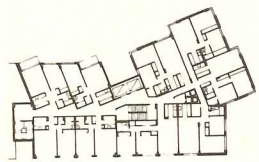
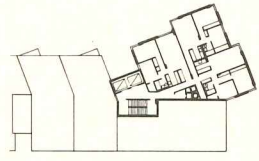



Slightly different space standards called for by the N.Y.C. Housing Authority produced a less articulated section at the northernmost site. Fire balconies at the through apartments were added since the Housing Authority must comply with the N.Y.C. code, while the UDC does not. Both the UDC and the Housing Authority buildings are of conventional reinforced concrete flat-slab construction and are clad in oversize brick. Unlike the UDC buildings, the corridor floors of the Housing Authority apartments do not project.

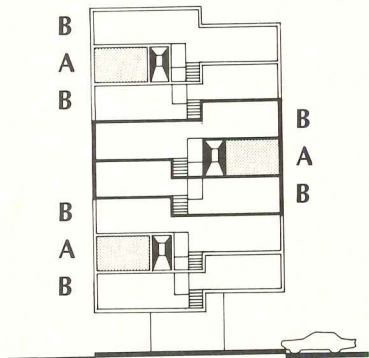
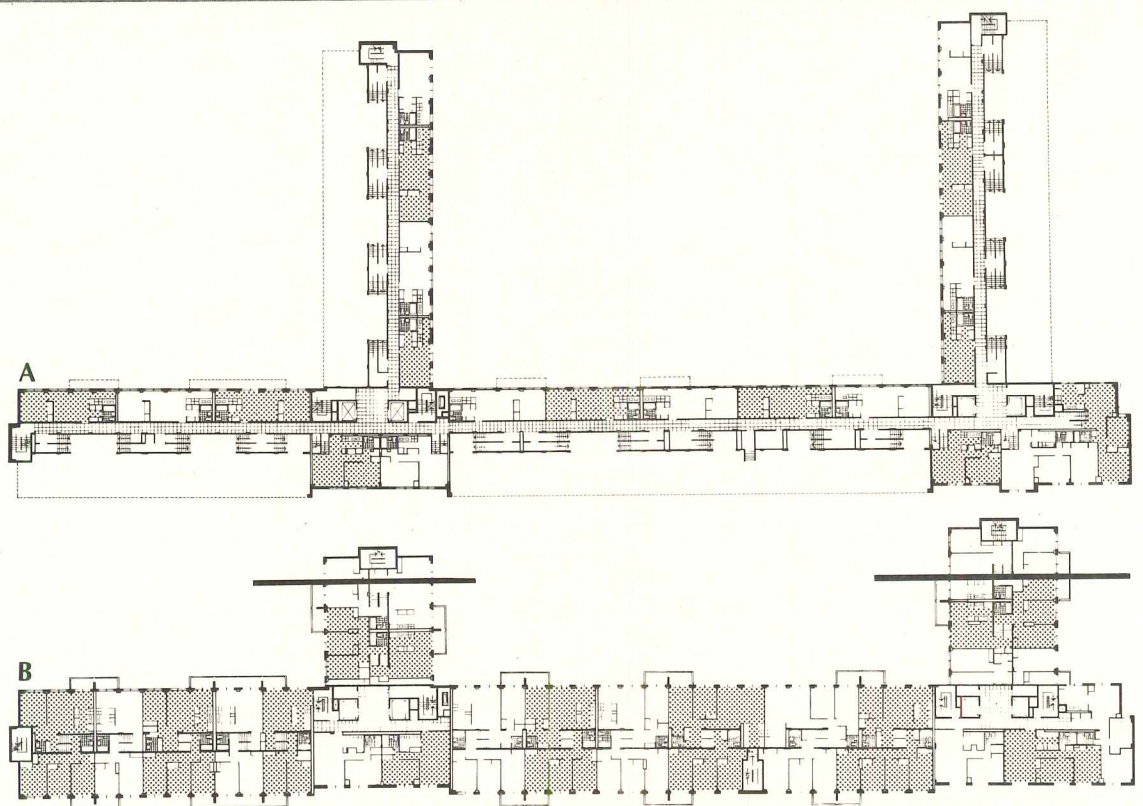

Albert Hall - Mansions - South - Kensington -
- R. Norman Shaw R.A. Architect -

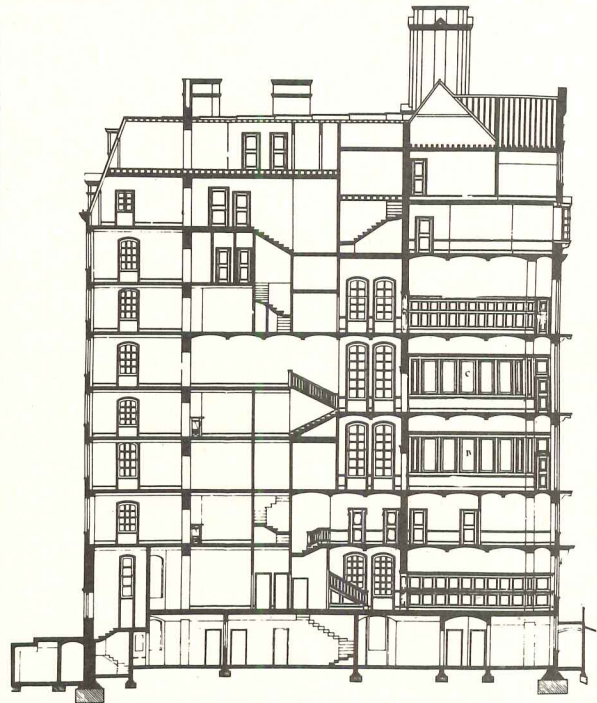
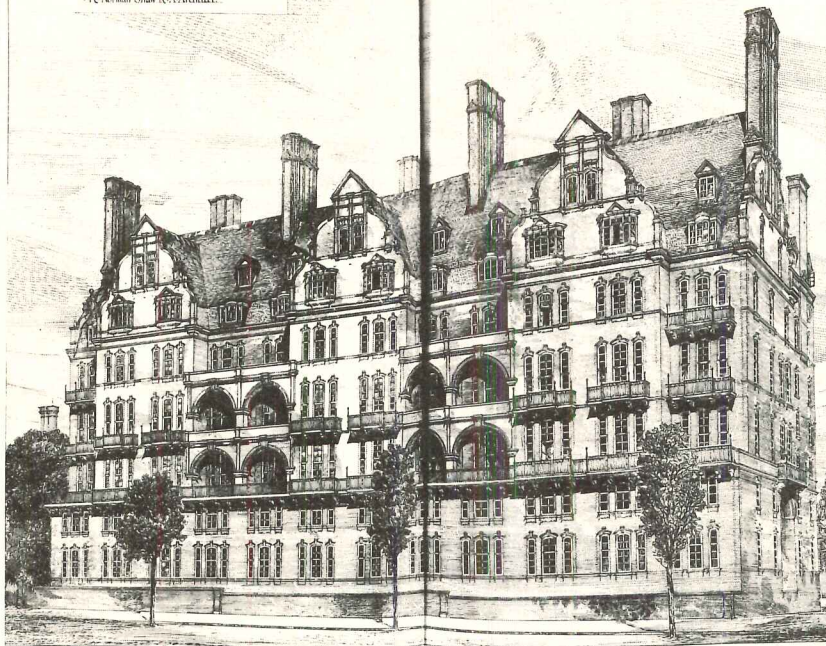

A prototype for the variety of levels at Twin Parks Southwest and West, the Albert Hall Mansions were built in London in 1879 by architect Norman Shaw. This approach was fairly common in New York from the Spanish Flats of 1882 up to the Parc Vendome Apartments of 1932 but is now rare.

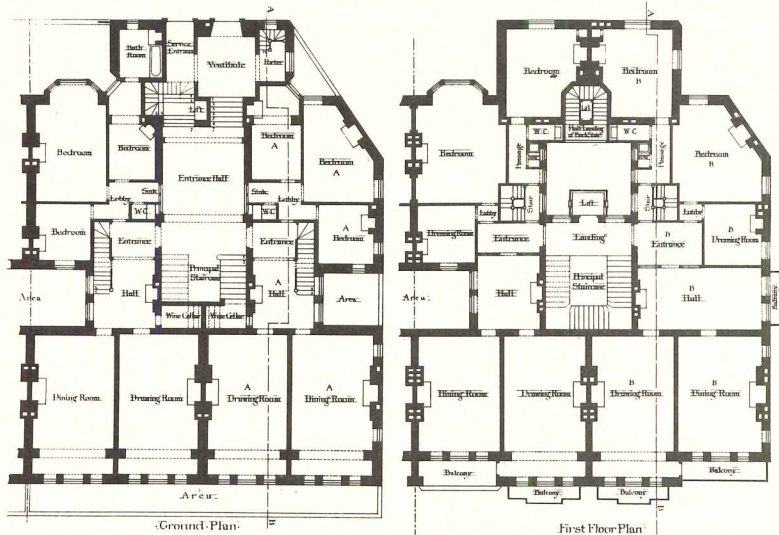

In defending the split-level dwelling unit type, architect Pasanella becomes eloquent: "Something better must be done for people than merely packaging them in an accommodation, stacking them up in units, stringing them out in modules. One's eyes haven't always seen, even trained architectural eyes, the wealth of evidence in New York for the existence of the 'counter-thematic' apartment type. The stereotypes of apartment/hive or apartment/filing cabinet are so powerful that we automatically withhold our interest, knowing ahead of time that it is bound to go unrewarded. But working out of an office in Carnegie Hall as I do, one cannot help seeing that many buildings in the neighborhood, always one of fashion and art, display facades which indicate apartments behind them of unusual sectional properties. A certain amount of ser-

endipitous research has revealed other antecedents for our ideal housing type. These always embody characteristics which are displayed more in the cross section than the plan and typically are less the function of those details which produce the building's 'look,' than of certain efforts to achieve a proper ambience. These efforts cause some rooms to be 1½ times or even 2 times as high as others, or to relate to each other in particular ways—apartments arranged on several levels as in our own split-level paradigm, or the more common duplex type. In such apartment buildings the capsule of space in which each family lives has taken precedence over the more technical aspects of the building process."

Apartments in conventional buildings usually have long internal hallways to bedrooms; kitchens and bathrooms buried deep

within the building, and one exposure to sun and noise for the whole unit. The conventional building with its small number of apartments per corridor floor makes inefficient use of elevator stops, fire stair landings and other elements. For these reasons, Pasanella developed for Twin Parks Southwest and West his section element of five levels grouped around a corridor in split-level fashion. One advantage of this as he sees it is that the corridor is used more intensively, becoming safer as well as more conducive to social contact. Since the elevator stops occur only at every 2½ floors vertical travel is faster for everyone. The floor-through two-level apartments have cross ventilation and a change in elevation between the bedrooms and living areas as in the split-level house. The scheme accommodates one level units on the corridor floor.

Gio tried to put Manhattan into the Bronx, says a UDC official who asserts furthermore that his agency will never build another split-level apartment building. Criticism of Twin Parks Southwest by the UDC revolves around two issues: the appropriateness of building high-rise, high-density buildings for families of low- to middle-income in urban areas where land values are not excessively high, and the practicability of the split-level dwelling unit in terms of the difficulties it gives contractors with no experience in this type of construction. Criticism number one is of particular interest since in addition to Twin Parks Southwest, the UDC is in the process of completing other high-rise, high-density housing projects in the Bronx and Coney Island. Because of this experience they are reversing themselves and now advocate low-rise, high-density for their future urban projects. In support of this change of policy, UDC officials stress that families should be housed near the ground to facilitate access to play areas, and to safeguard, by proximity, the community space. Ironically, the vest pocket housing projects originally proposed by the Urban Design Group for the Bronx were to be six-story semi-fireproof buildings. It was the UDC which insisted that economic criteria called for high-density, high-rise.

Criticism number two—the reluctance of contractors to build the unfamiliar—reflects a difficulty which innovative architects face. The UDC figures show that Pasanella's split levels were brought in at the same price per dwelling unit as the single level apartments in comparable UDC projects, which suggests that split-level dwelling units could and should become commonplace.

TWIN PARKS SOUTHWEST, Bronx, N.Y. Developing agency: *New York State Urban Development Corporation*. Owner: *Sovereign Realty Associates*. Architects: *Giovanni Pasanella* assisted by *Crane DeCamp, P. C. Wong*. Consultants: *Gleit-Olenek and Associates* (structural); *Dalton & Dunne* (mechanical/electrical); *Peter Rolland & Associates* (landscape); *Amis Construction and Consulting Services* (cost). General contractor: *Sovereign Construction Co., Ltd.*

TWIN PARKS WEST, Bronx, N.Y. Owner: *New York City Housing Authority*. Architects: *Giovanni Pasanella* assisted by *Crane DeCamp, Chris Wadsworth, John Robinson*. Consultants: *Gleit-Olenek & Associates* (structural); *Alfred Greenberg Associates* (mechanical/electrical); *Peter Rolland* (landscape). General contractor: *Carlin-Atlas Construction Co.*

Other split-level prototypes drawn to the same scale as Twin Parks Southwest and West: (1) Apartments for Unmarried People, Werkbund Exposition, Breslau (1929) by Hans Scharoun which was probably the first building to organize a split level about a corridor; (2) A Long Island split-level builder's house (1952); (3) Twin Parks Southwest for UDC; (4) Twin Parks West for N.Y.C. Housing Authority; (5) Early design for Twin Parks East by Pasanella (1970); (6) Dormitory project for SUNY College at Purchase by Pasanella (1970-1971); (7) Luxury Apartment Tower, New York by Pasanella (1972).

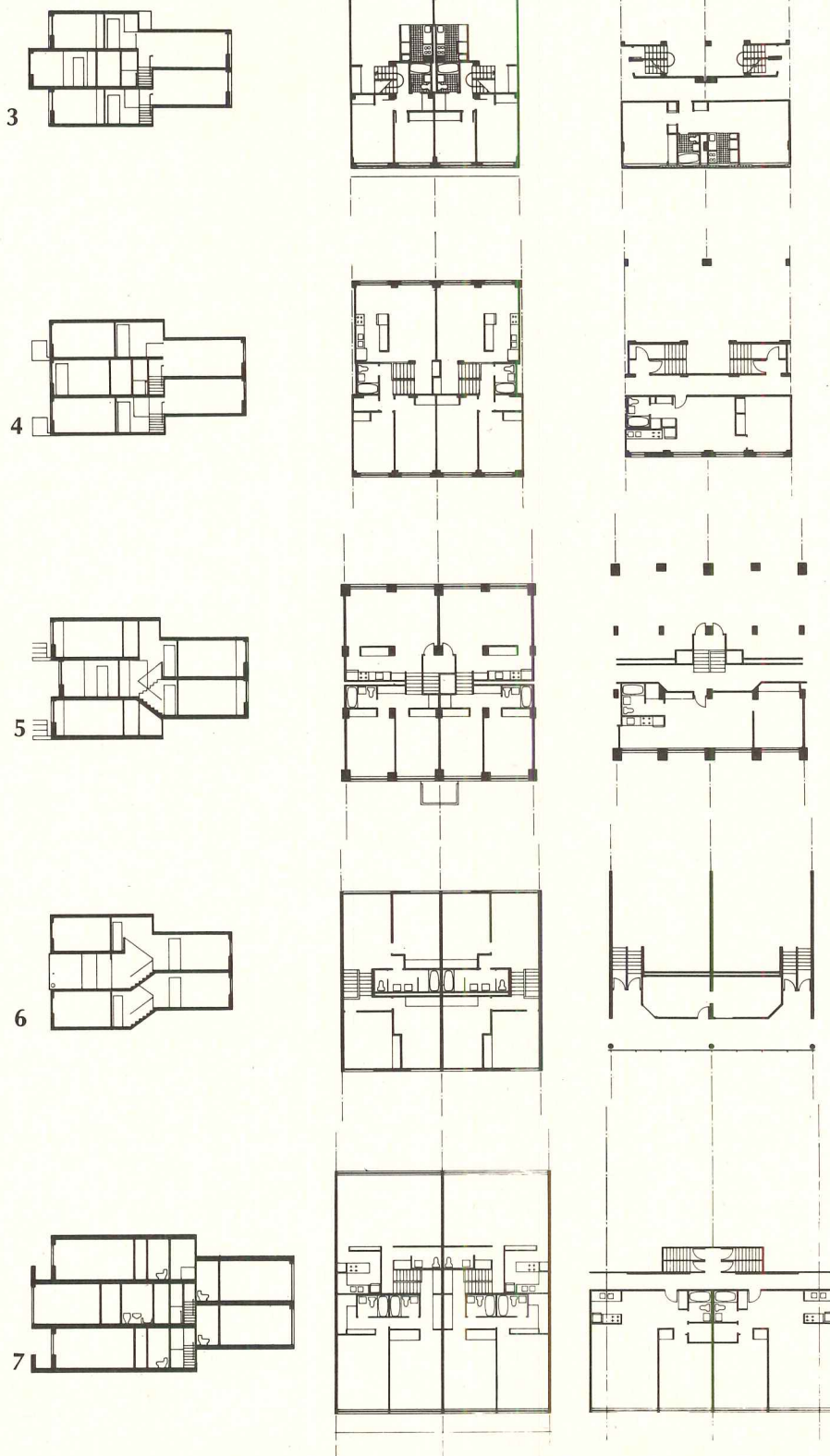

The Restoration of La Place Royale

by Stuart D. Goulding

In the lower town under the cliff at Quebec, acres of 17th and 18th century buildings that had fallen on hard days are being lovingly restored by architects, craftsmen, and the governments of Quebec and Canada. A case study in new life for old buildings.

What may prove unique in the restoration of North American historic sites is the rehabilitation of a large section of the lower town of Quebec, called la Place Royale. There work is proceeding steadily towards the reclamation of seventy-seven buildings dating from the 17th and 18th centuries. Six are now open to the public. When completed within a few years, the restoration will recreate the Grand Epoch of old New France.

From an architectural standpoint it is extraordinary to find so many restorable old buildings within a restricted space of approximately 300,000 square feet. This is the more remarkable when it is considered that this section lying along the waterfront on the St. Lawrence River has been subject to continual use and misuse for nearly three centuries.

Despite the area's architectural and historic interest, la Place Royale will not become just another museum. Tenants temporarily displaced will return and occupy living quarters above the first floors of most of the buildings. While there will be antique shops, boutiques, restaurants and craft demonstrations for visitors, emphasis will be on present day living for the actual residents. Thus, in recreating an ancient aspect of Quebec, the planners seek to insure living continuity for the present and the future. It is very probable that the old streets will be filled with youngsters and the day's wash hung from back windows, as in the rest of the lower town (Sous le Cap) under the cliff.

Two things have occurred which make effective restoration possible. All of the extant buildings in the area are stone ones with sound foundations and thick walls. They were built to last by stone masons working in a tradition demanding longevity of structure.

Mr. Goulding is senior vice president of Arthur Schmidt & Associates in New York, and a writer on architectural and historical subjects. He is the author of "The Irish Brigade," "The Providence Arcade," and "New France Preserved." La Place Royale is clearly a great love.

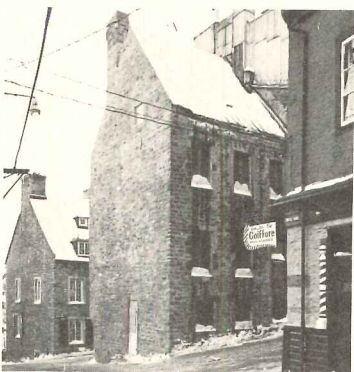
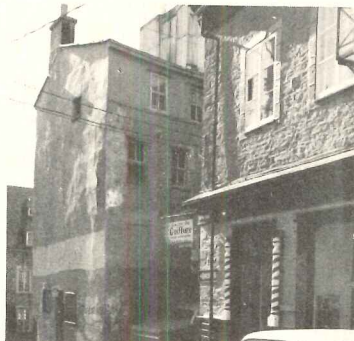
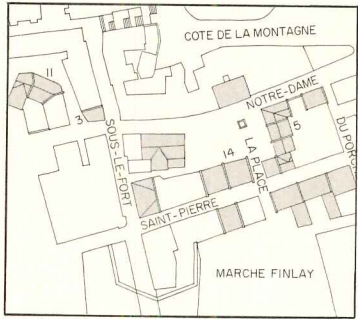
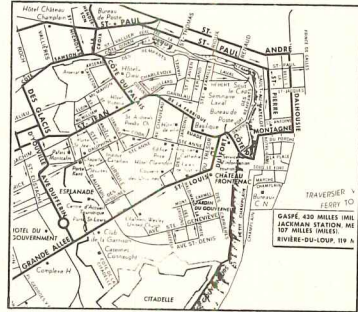

They have withstood bombardments and recurring fires and are still intact as can be seen in the before and after photos of Maison Leduc (figs. 3, 4). Even so, they might long since have fallen victim of demolition crews had not the decline of commercial activity in la Place Royale early in the 19th century discouraged replacement by more modern structures. As matters stand practically no reproduction of buildings will be required, as has been necessary in so many other restoration projects.

The restoration is being financed jointly by the Province of Quebec through the Ministry of Cultural Affairs and the Canadian Government. It has been long in gestation and involves the leading architects of the province as well as other professional, business and intellectual leaders.

Together these have worked out a concept which is now being carried out faithfully. Of this concept the project preamble states:

"Conceived by the coordination bureau of la Place Royale in the Ministry of Cultural Affairs, the general plan, far from being the product of an unbridled imagination, is the result of serious analysis and diligent research, carried on by a multi-professional team.

"La Place Royale being above all an architectural ensemble, the largest number of homes must be preserved. It is important to recreate an atmosphere, to revive the old buildings in a harmonious arrangement and to avoid giving them the uniform appearance of a settled period. This would be artificial and entirely debatable. A lack of documentation and an orderly plan preclude the choice of an architectural remounting beyond the fire of 1682. By setting this date limit, the aim is to constitute all the aspects of traditional Quebec architecture which, for two and one half centuries, has been in the French tradition.

"From 1680 to 1810 a way of building had developed. Unity of style and materials were accepted facts. The character of la Place

Royale was determined by the style of the church and by an architectural rhythm; the unity of the ensemble is indicated by the dimensions of the open spaces. Furthermore, the proportion of solid and open spaces characteristic of a period and a way of building will be regained."

The exteriors of the houses will very exactly conform to the ancient state. The interiors, however, will be treated in a fashion to respond to contemporary needs.

Realism dictated the choice of epoch. There was a desire to push the restoration on further back in history. After all, Quebec is the oldest North American city in continuous occupation north of St. Augustine, Florida. It was established by Samuel de Champlain in 1608, eight years before the founding of New Amsterdam and twelve years before the landing of the Pilgrims at Plymouth Rock. The fire of 1682 was the determinant. It had destroyed the older buildings. Thereafter, these had been replaced by the still standing stone buildings. The venerable church of Notre Dames des Victoires, for example, had been built above the site of Champlain's house and fort.

The other time limit was determined by another catastrophe. In 1759 Wolfe besieged Quebec. The fleet under Admiral Saunders and the artillery from the heights of Levis across the St. Lawrence had fired more than 30,000 solid shot and 10,000 fire bombs into the upper and lower towns. These had caused a disastrous fire which gutted virtually all buildings. In the rehabilitation which followed, work was continued in the French tradition, but by 1810 this tradition had died out in la Place Royale. Hence the emphasis on the 17th and 18th centuries.

La Place Royale is replete with history. It is the core of that part of the lower town which is still the principal gateway to Quebec for all who come by water (figs. 1, 2).

A constant procession of immigrants of both high and low degree have traversed its streets. It has survived onslaughts by the fleets of

*Maison Chevalier has served as a model for successful restoration . . .
The wide floor boards glisten with beeswax . . .
Old furniture exhibits the craftsmanship of cabinetmakers who
simplified early French models to create a distinctly Canadian style . . .*

Kirk, Phipps and Saunders. Its square witnessed the blessing of le regiment de Carignan Salieres in 1664 when that regiment, the first uniformed force in North America, arrived to rescue New France from the Iroquois menace. Within its borders anxious prospective grooms met the King's girls sent over by Louis XIV to become their wives. Governors and their staffs, bishops and their lesser clergy, visiting foreign diplomats and Indian chiefs, arriving intendants and departing officials, all knew la Place Royale. Each day farmers arrived by river to bring fresh fruits and vegetables, fish and meat for the housewives of Quebec. Ultimately English troops marched through the streets to garrison the heights and, in the early days of the American Revolution, General Montgomery fell nearby under withering musketry when he and Arnold sought to assault the town.

In all the years from 1682 to 1759 la Place Royale was the principal commercial center of Quebec. Government and church had moved up the winding Cote de la Montagne to establish residence in the upper town but prosperous merchants had their headquarters

on the square. These had their stores on the first floors of the stout stone buildings, and lived with their families above and in the formal gardens to the rear.

It was when the merchants began to desert the area in the early 19th century that la Place Royale began to take on that aspect of decay so well known to tourists in this century. While it always retained its charm and picturesque quality, neglect caused decay and dilapidation. Now that is being corrected.

As the merchants moved away, their former residences began to serve other purposes. Attracted by low rentals the upper floors swiftly filled with low-income families. Apartments were divided and sub-divided by landlords to serve more and more people. Retail stores moved into the area to serve them. Walls were pierced to install show windows. The waterfront was still active. Ship's chandlers and other outfitters took over many of the lower floors. The back rooms of many buildings were used as store rooms. Restaurants and saloons to serve seamen ashore sprang up.

As time went on, facades were variously painted and coated with stucco and cement and the old stone walls were hidden from view. Some windows were blocked up and others made their appearance. Casement windows gave way to double hung, single paned ones. Upper stories with flat roofs were added to some structures. In many instances walls were broken through to combine two or three buildings. When fire in 1965 gutted Hotel Louis XIV at the north end of la Place Royale it was discovered that the hotel comprised two adjoining buildings (figs 5,6).

Abuse and neglect by successive landlords and tenants during the 19th century completed dilapidation. The historic and architectural merit of la Place Royale, nonetheless, never was completely forgotten. As early as 1929 Notre Dame des Victories was declared a national monu-

ment and a movement got underway to extend rehabilitation of the area. In 1960 a nationally known architect, M. Pierre Robitaille, was retained by the Quebec Commission of Historic Monuments to study the old facades. His encouraging recommendations were adopted by the commission and the Municipal Council of Quebec. The Province, encouraged by the federal government at Ottawa, undertook the work, placing supervision in the Ministry of Cultural Affairs, where it reposes. Successive ministers directing the project have been M. Pierre Laporte, Francois Cloutier and the present minister, Madame Claire Kirkland-Casgrain. The Ministry's Department of Architecture is in charge of operations with Maurice Laperriere as chief and Jacques le Barbanchon assistant chief. Staff architects are Jean-Louis Boucher, Albert Dehin and Guy Chenevert. Architectural students in all the provincial universities are engaged on detailed drawings.

Consulting architects are Dorval and Fortin, Laroche, Ritcho and Dery, Lavigne and Marquis, Dupre and Voyer, and Pierre Cantin, all of Quebec City, and Jacques Ayotte of Montreal. Scharry and Ouimet of Quebec and Montreal are mechanical and electrical engineers and Vandry, Jobin and Associates of Quebec are construction engineers.

Architects and engineers are fulfilling the long wished for restoration of old Quebec and archaeologists, historians, archivists, librarians, art leaders and leaders of the business community are also involved.

Plans for la Place Royale include an area 500 feet wide and 600 feet long. It is bounded on the north by la Cote de la Montagne, which winds up the cliff to the upper town. La rue Champlain on which Maison Chevalier sits is its southern boundary. To the east it faces the waterfront and to the west it backs up against the foot of the cliff. The old streets and lanes, which remain unchanged from early days, are presently covered



7



8

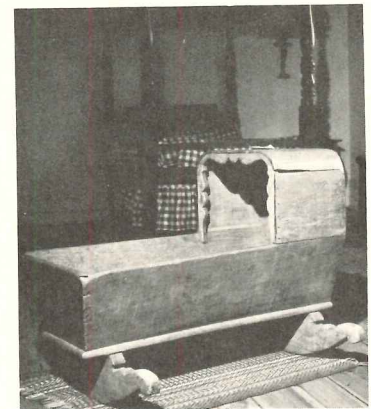

9

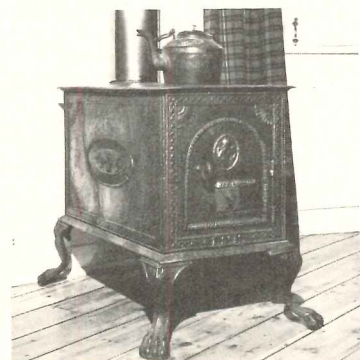

10



5



6

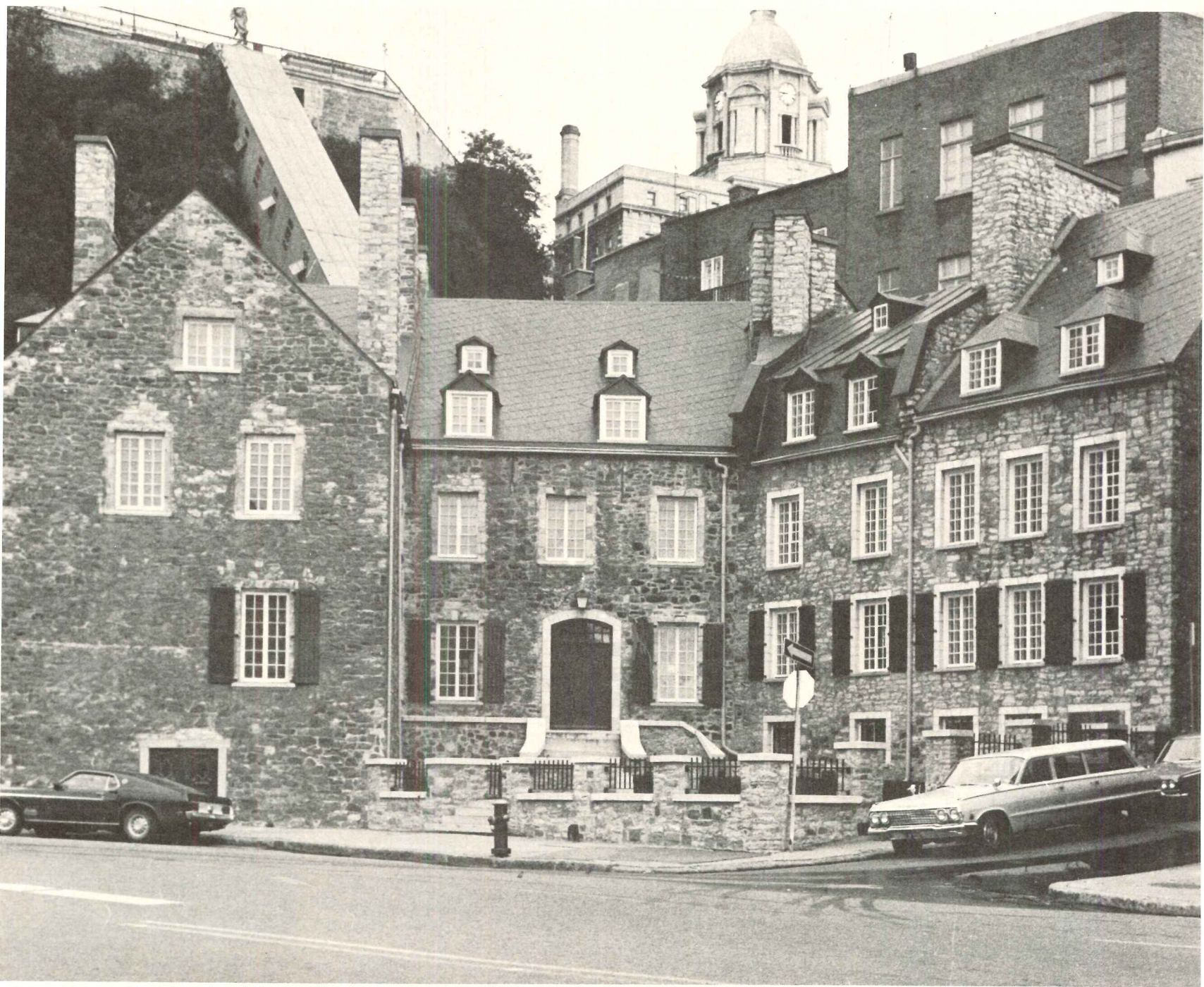

*Maison Barbel before, during and after;
Crews work from the rooftops downward, removing floors added,
rebuilding roofs to their original form,
stripping away encrustation on exterior and interior . . .*

with asphalt, but will be paved with stone blocks when restoration is complete. All electrical, gas and communication lines will be laid underground and the streets will be lighted by old types of lamps. It is possible that the area of work may be extended.

Intensive research and analysis preceded any demolition. This was conducted in the archives of Quebec, Montreal and Ottawa, in museums and libraries, and at the ancient Seminaire de Quebec. Old records were examined in the Paris Archives Nationales, and at the Library of Congress in Washington, and in a period of a few years a vast accumulation of books, military and civil records, paintings, portraits, pen and ink sketches, architectural drawings, family histories, private journals, correspondence and business records came into being.

So exhaustive was the search that the Ministry of Cultural Affairs was able to reconstruct the history of original builders and occupiers of the old houses together with those of their successors. In many cases architectural plans were found which permitted utmost accuracy in restoration work.

The result of this research was an overabundance of material confronting architects and others working on the project. Pains-taking sifting and selection solved these problems only to have the architects confronted with another problem; the condition of extant buildings. It became necessary to strip each to the bare walls.

Prior to demolition the Province found temporary living quarters for the tenants and then the archaeologists began a search from attics to cellars. A large accumulation of artifacts was uncovered in this search. They have been catalogued and most of them are now on display. They include more than one dozen large copper kettles, many wine bottles with the wine still in them, much porcelain, ceramics and glassware from various periods, 18th century clothing, many buttons, a number of coins including one dated 1586, cannon and musket balls and one fire bomb. Some cannon balls were found embedded in facades facing the waterfront, and these have been left in place.

Demolition crews work from the rooftops downwards. Added upper stories are entirely removed and care is taken to retain or rebuild the slope of roofs as revealed by the original gables. All encrustations on exterior and interior facades are stripped away. This includes inner partitions installed by successive generations. Wherever possible all salvagable material is retained for use in construction. Planking laid down over the original wide floor beams is removed and in many instances these old planks are found to be sound and hence serviceable. The curve of some very charming staircases has been rescued. In nearly every original room fireplaces have been discovered and reopened.

All demolition is under the supervision of architects as is the necessary repair work on foundations and walls. Architects also supervise inspections to insure prevention of future fires and possible building collapse. All stonework is cleaned, polished and

pointed up and all joining rigidly secured.

Maison Chevalier (fig. 11) has served as a model for successful reconstruction elsewhere. This structure proved to be three adjoining stone buildings. As it stands with three sides facing the waterfront at the extreme end of the la Place Royale Restoration, Maison Chevalier reveals noble proportions in all its aspects. The interior walls are of white plaster with windows framed in the 18th century style. The wide floor boards glisten with beeswax, hand applied. The ceilings show adz and old saw marks on the exposed beams. In such a setting the 17th and 18th century Canadian pine armoires stand in sharp contrast to the white walls. In room after room old tables, chairs, beds and other furniture and furnishings exhibit the craftsmanship of ancient cabinet makers who simplified early French models using native goods to create a distinctly Canadian style (figs. 7,8,9,10). Elsewhere framed documents, portraits of early settlers, pen and ink sketches by military artists, maps, sculpture, appliances and tools convincingly portray how life was lived in old Quebec.

Fascinating to watch is the manner in which modern workmen, more used to power tools than hand tools, have been trained to employ old methods of construction. This is especially noteworthy even in roof timbers which are to be hidden. Although invisible the joining utilizes techniques consistent with earlier centuries (figs. 12, 13).

The work of restoration has proceeded to a point where architects visiting Quebec this year may observe progress in all phases from demolition to completed restoration (figs. 14, 15, 16).

Completion of la Place Royale is some years away. It will include a reproduction of the old ramparts which once faced the harbor. Instead of cannon, however, there will be trees and benches for the benefit of residents and visitors. While the needs of residents will

be given first consideration, the Ministry of Cultural Affairs is well aware of the attraction the section will hold for tourists. As one member remarked, "Visitors do not come to Quebec to see our skyscrapers". This realistic attitude reflects restorations proceeding elsewhere in Quebec. As a result it is most probable that la Place Royale will become, as its promoters desire, one of the outstanding historical attractions of North America.



14

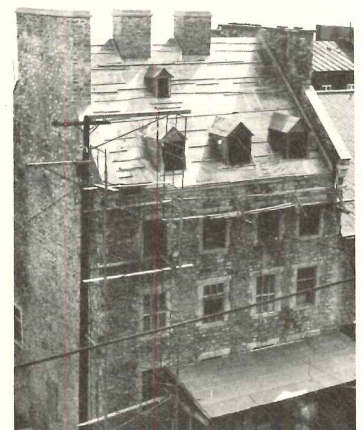

15

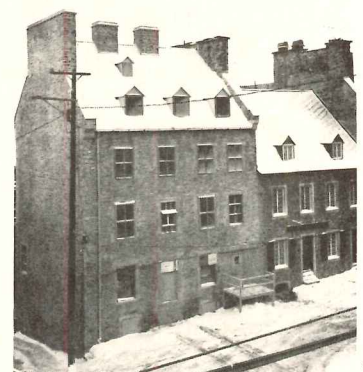

16

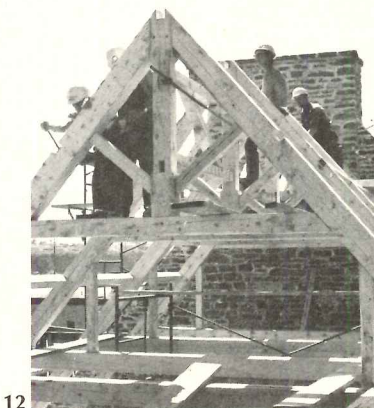

12

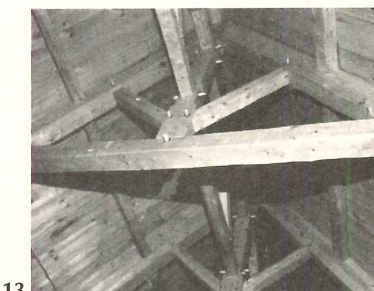

13

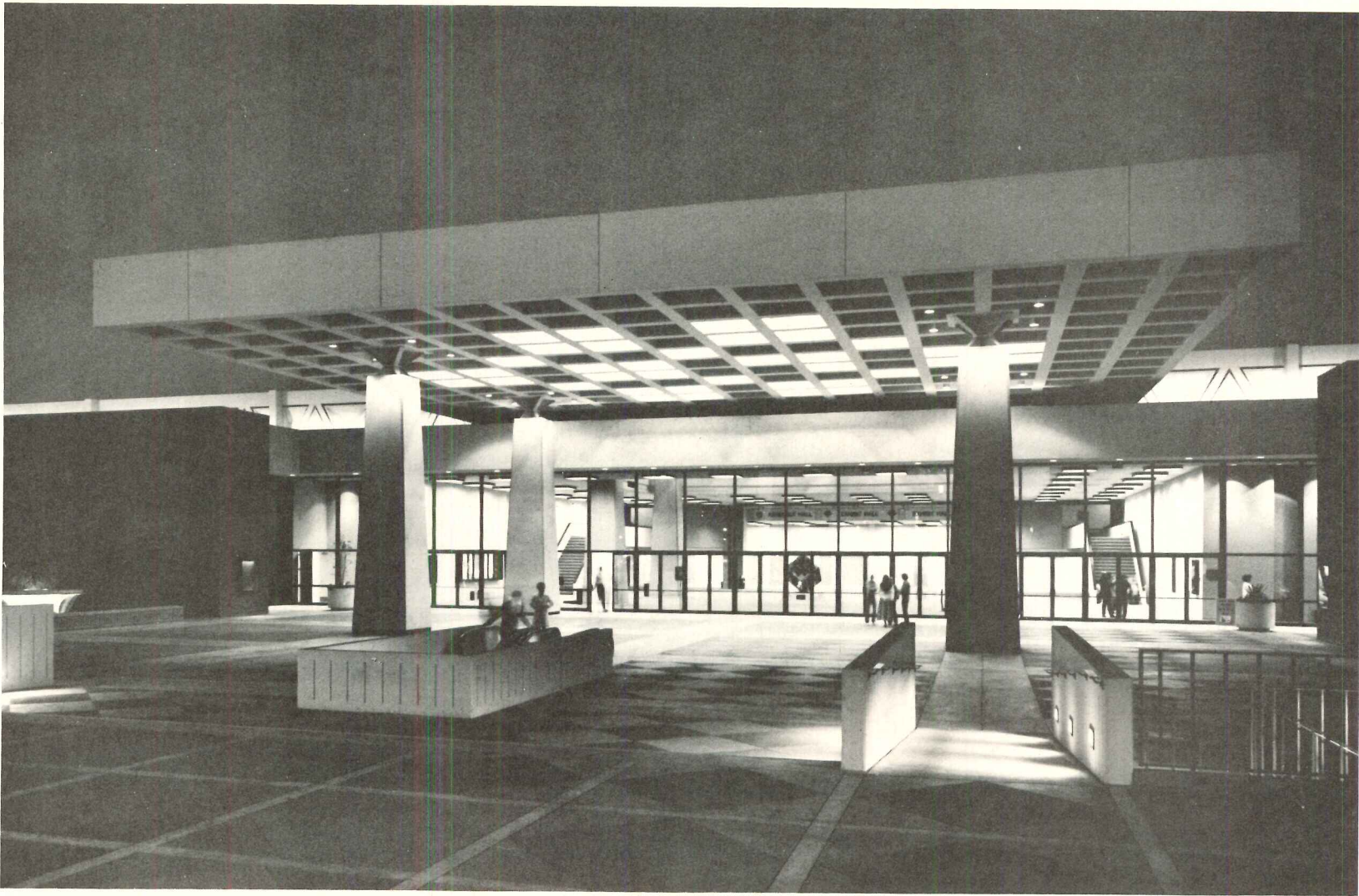

Balfazar Korab photos

PHOENIX CIVIC PLAZA A FOCUS FOR THE CITY'S DOWNTOWN

During a dramatic 20-year population increase in the 50's and 60's, the city of Phoenix spread over some 247 square miles of Maricopa County and in so doing almost ruined its downtown business district.

Now the completion of Phoenix Civic Plaza in the heart of the old business district is refocusing the city on its downtown area and providing what it had not had before, a convention center and a symphony hall.

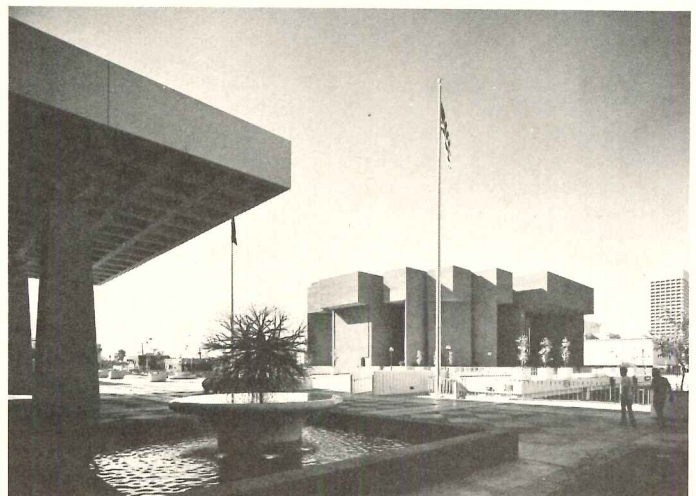

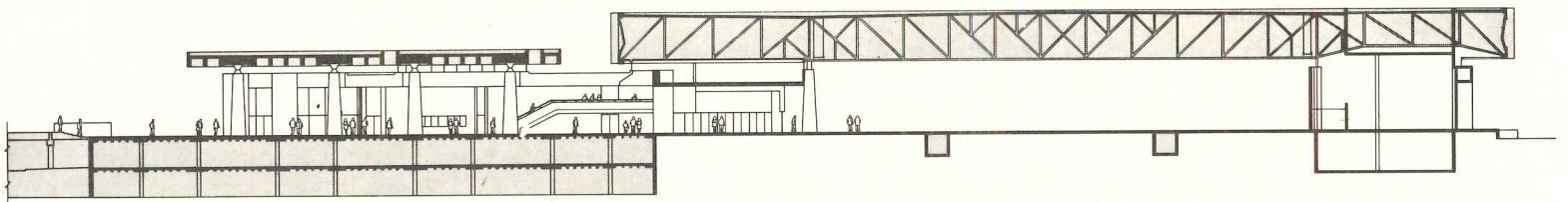
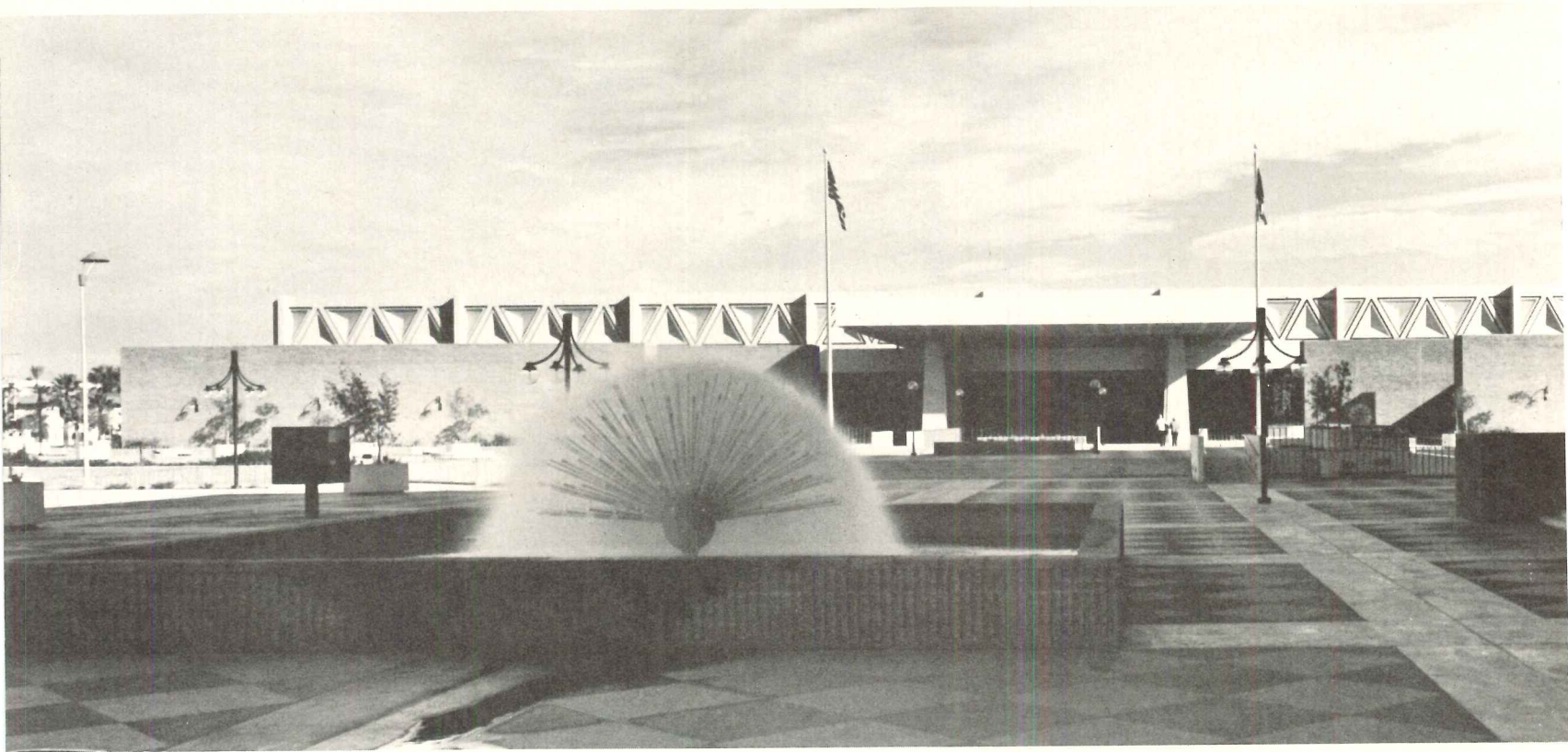

The Convention Center is a large multi-purpose structure, set on four of the six blocks of the new Civic Plaza's site and connected with Symphony Hall and an open landscaped plaza by a 100-foot-wide prestressed concrete concourse which bridges a depressed street between the two parts of the Plaza. The Center is an attractive building surfaced with a special fluted beige concrete block developed by the architects for this job. The striking white fascia, made up of recessed triangles, and the perimeter columns express the building's structure: continuous span Pratt-type trusses, 19 feet deep, which provide a central clear space 200 feet wide and 28 feet high. This vast floor area of 120,000 square feet can be divided into 80,000 square feet of exhibit space with 40,000 square feet for assembly. In addition, there are 20 meeting rooms, most of which open onto landscaped courts, a kitchen for serving up to 5000 persons, and a large cocktail room. The entire Civic Plaza and both buildings and plaza are designed to provide easy access for handicapped persons.

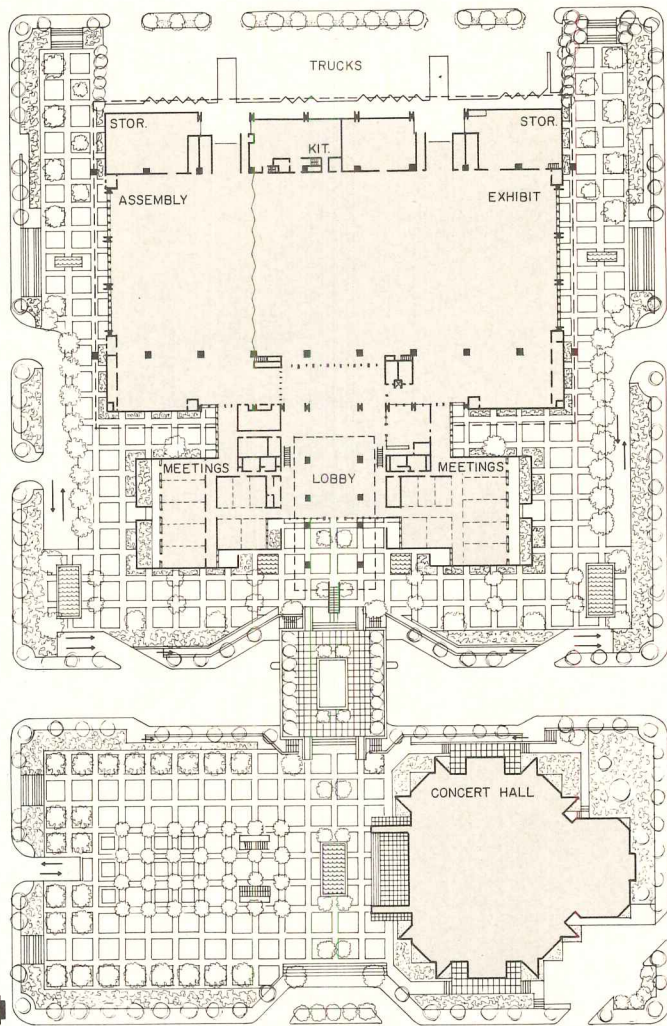

PHOENIX CIVIC PLAZA, Phoenix, Arizona. Architects: Charles Luckman Associates—Edward R. Jones, director of Phoenix office; William L. Kourakos, director of design; John Schotanus, Jr., associate architect. Engineers: Magadini Associates (structural), Lowry and Sorensen Engineering Co. (mechanical/electrical), Sergent, Hauskins & Beckwith (soils/foundation). Consultants: Vern O. Knudsen (acoustics), L. W. Spermeyer (sound system), George A. Thomas (theater consultant), Charles Luckman Associates (interiors, graphics, cost). Landscape architect: F. J. MacDonald. Contractor: Del E. Webb Corp.



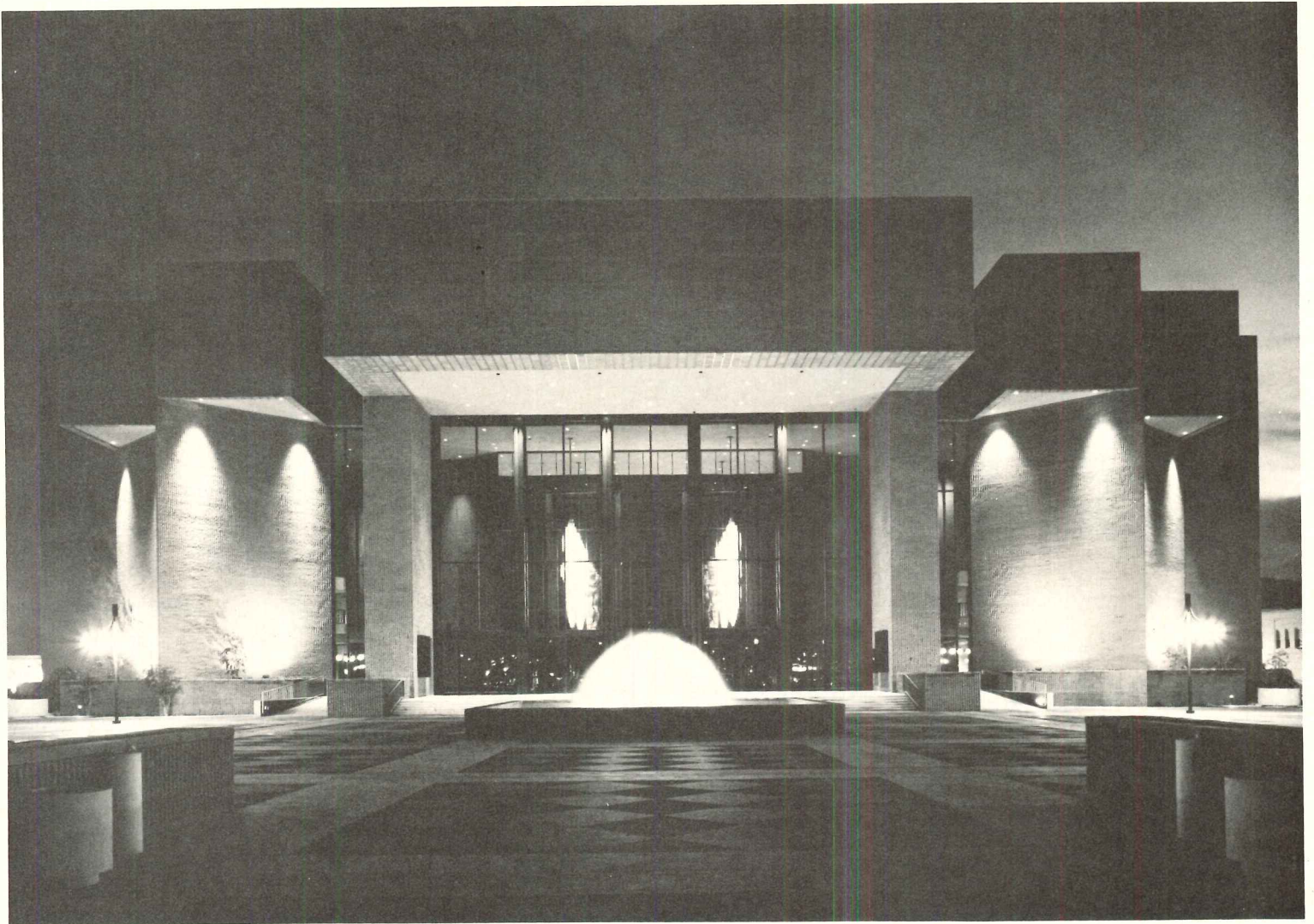

More dramatic in form and mass, but smaller by far in area than the Convention Center, Symphony Hall is a multi-angled, reinforced concrete building of elegant intention, decidedly a showplace with its rich-colored fabrics, crystal chandeliers and mirrored walls. It is set on a two-block site across the pedestrian concourse from the Convention Center and stands in a dominant position at one end of the main plaza. The same fluted beige concrete block used on the Convention Center covers with pleasing effect the exterior—and much of the interior—walls. Light and shadow play with varying effect during the day on its texture and on the angled soffits of the projecting fascia. The entrance to Symphony Hall, very different in design and scale from that of the Convention Center, reveals the grand lobby's 48-foot-high, 54-foot-wide mirrored wall and several of its 20-foot-long Italian glass chandeliers. The lobby carpet is traditional red, as is the upholstery for its 2,557 seats. The stage curtain is a spectacular creation of Mylar embroidered in acrylic yarn in shades of pink, red, purple, orange and green, designed by the architects' interior department and made by Jack Lenor Larsen. Where fluted block is not used on the interior, walls are faced with either white plaster or white oak panels. A number of works of art including sculpture and tapestries are placed in the building. Other sculptures and fountains are located on the plaza. The plaza on which both Symphony Hall and Convention Center stand is raised five feet above street level permitting a 1,125-car garage.

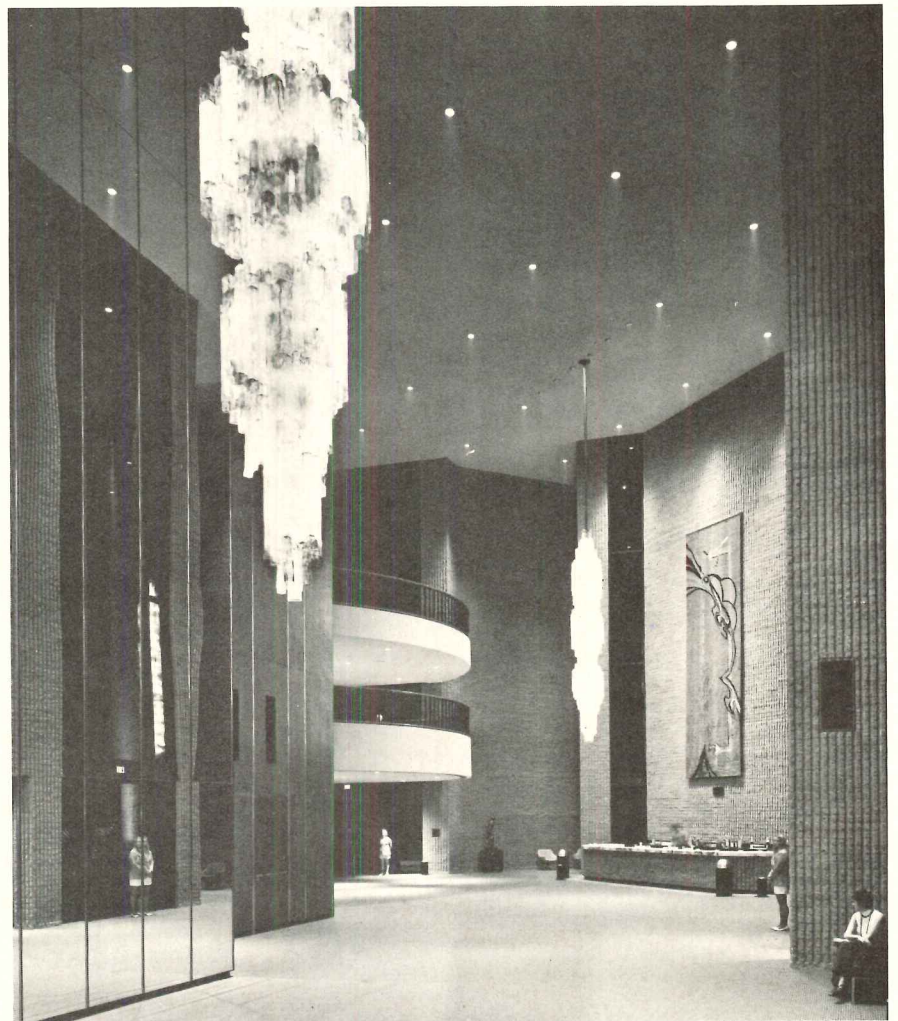

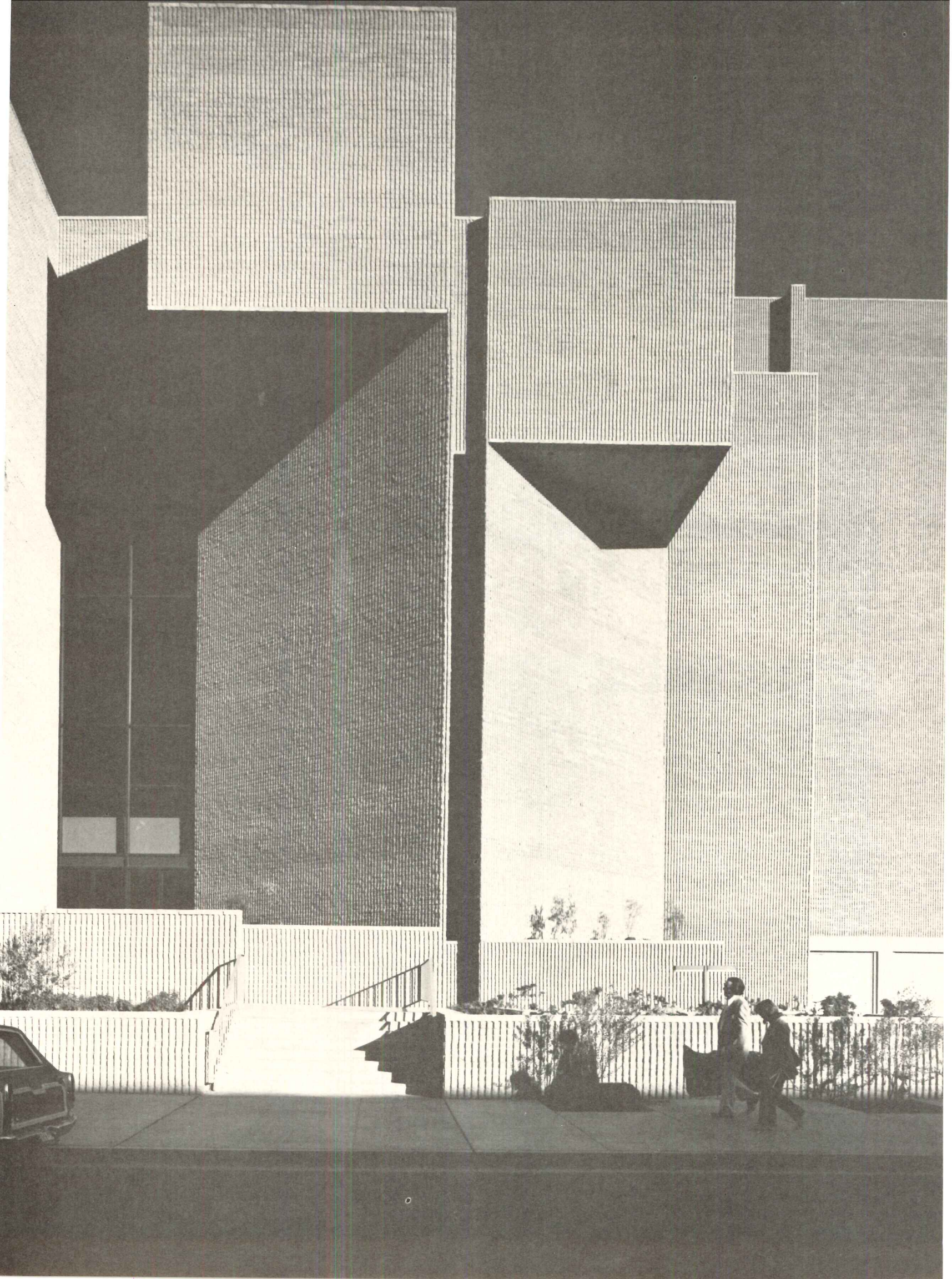

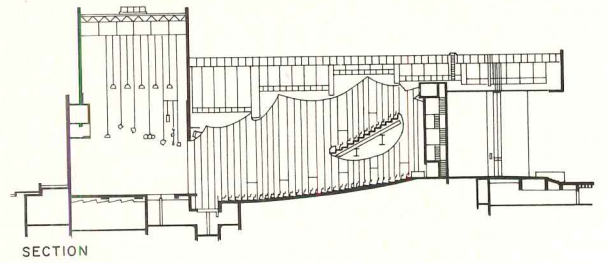
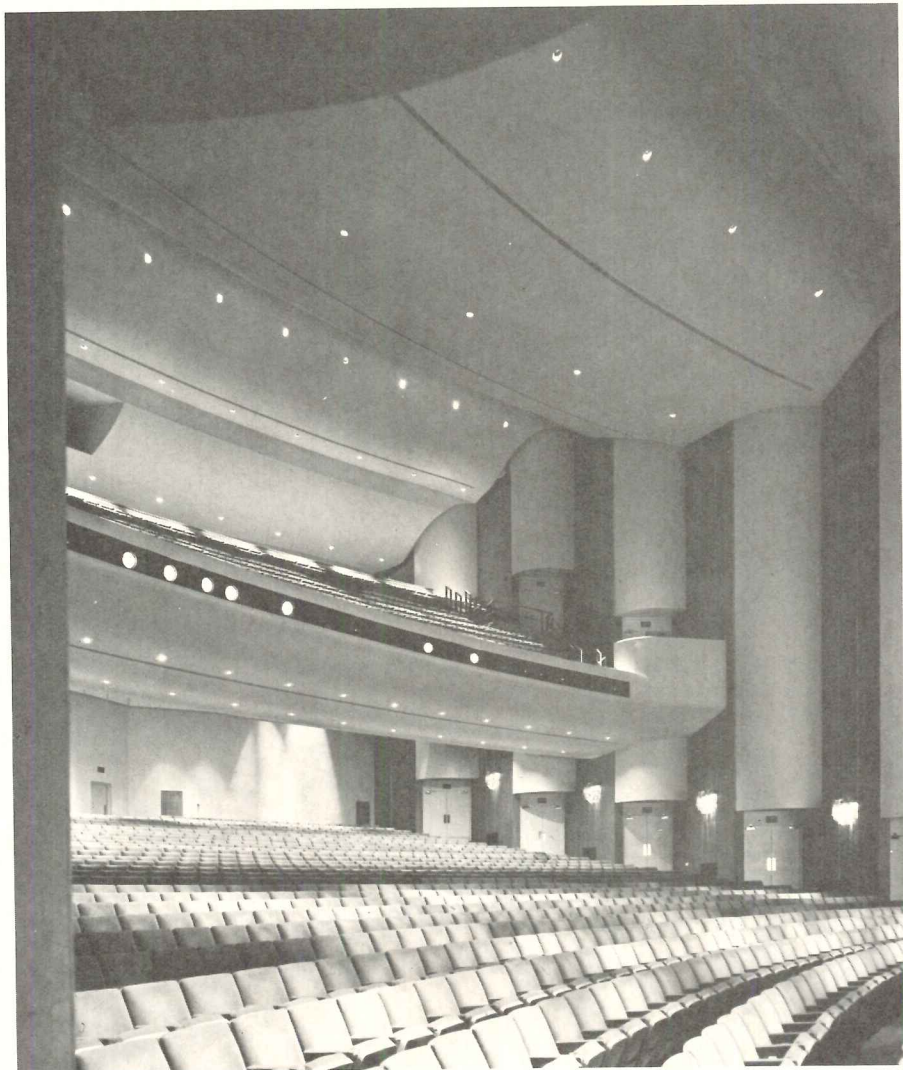

An unusual feature of the hall is its 120-foot-wide, 643 seat "floating" balcony. Attached only to the side walls, the balcony "floats" free of the back wall, leaving an open space through which sound circulates. At the four corners of the main floor and at either end of the balcony are triangular refreshment areas. Also included in the building are the usual chorus and dressing rooms, a room and rehearsal hall.

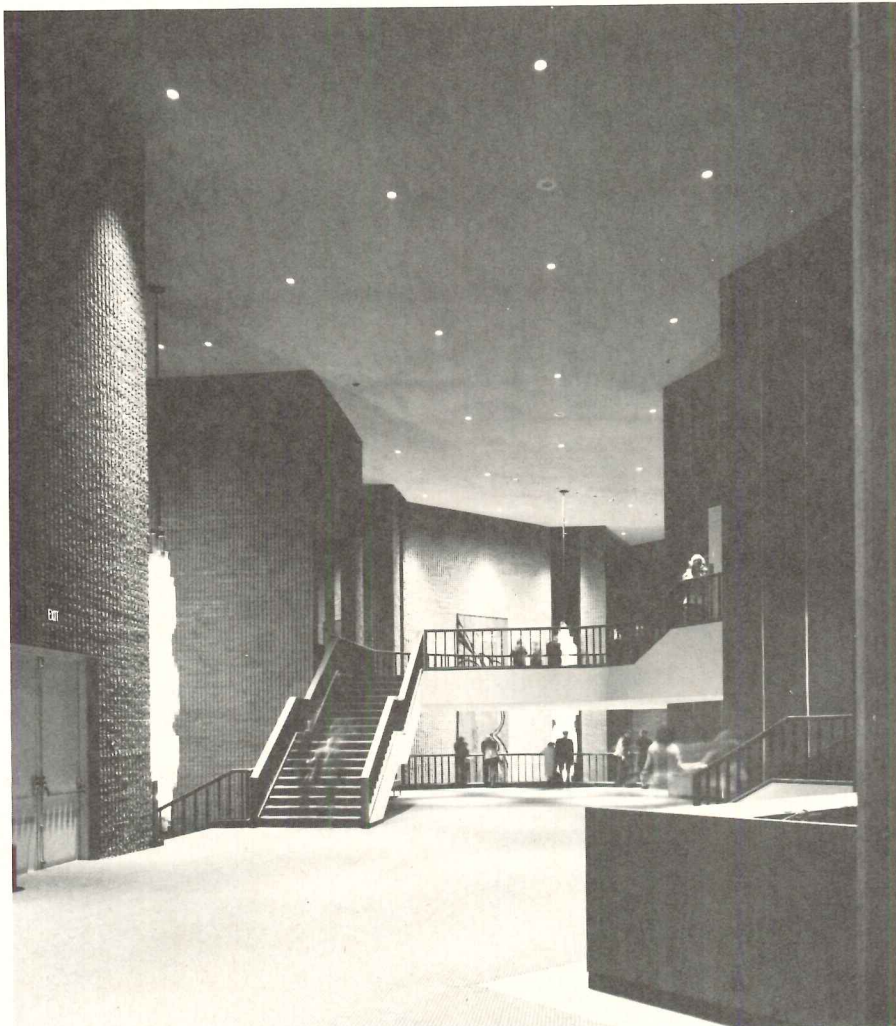
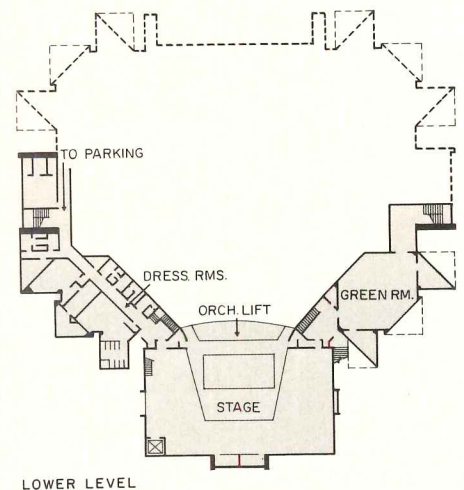
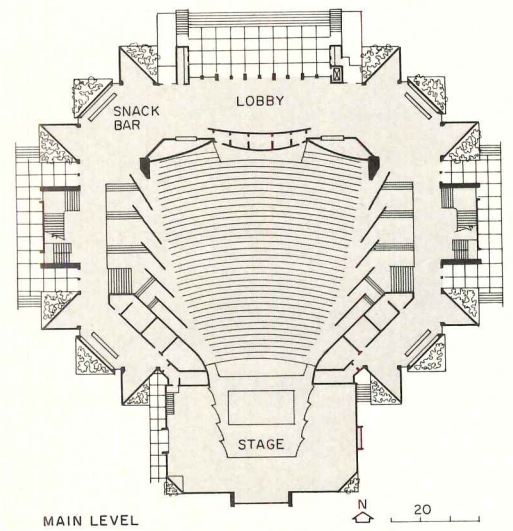
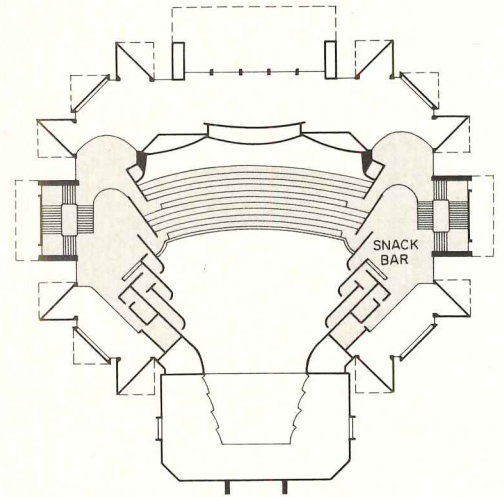

CORPORATE OFFICES

It took until 1930 for the United States to accumulate a billion square feet of office space, while during the following three decades that total nearly doubled. So far in the seventies, 500 million square feet of office space has been started, and according to the New York Regional Plan Association, the country will double its total office space again by the year 2000.

The offices on the following pages are part of this surge. They reflect, however, more than the piling up of floor space; recurrent here are design qualities that reveal an increasingly sophisticated corporate client, and architectural thinking that departs from conventional office planning and design. Corporate image, expansion potential (very important) and human amenities are the key program requirements; more square footage per employee is common, often between 175 and 200 square feet; and the idea of the office as something dynamic is itself growing.

These offices are not extravagant—ranging from \$10 to \$40 per square foot—yet they augur richness of architectural thinking of the sort that produced the first large commercial structures in Chicago a century ago. —*Charles E. Hamlin*

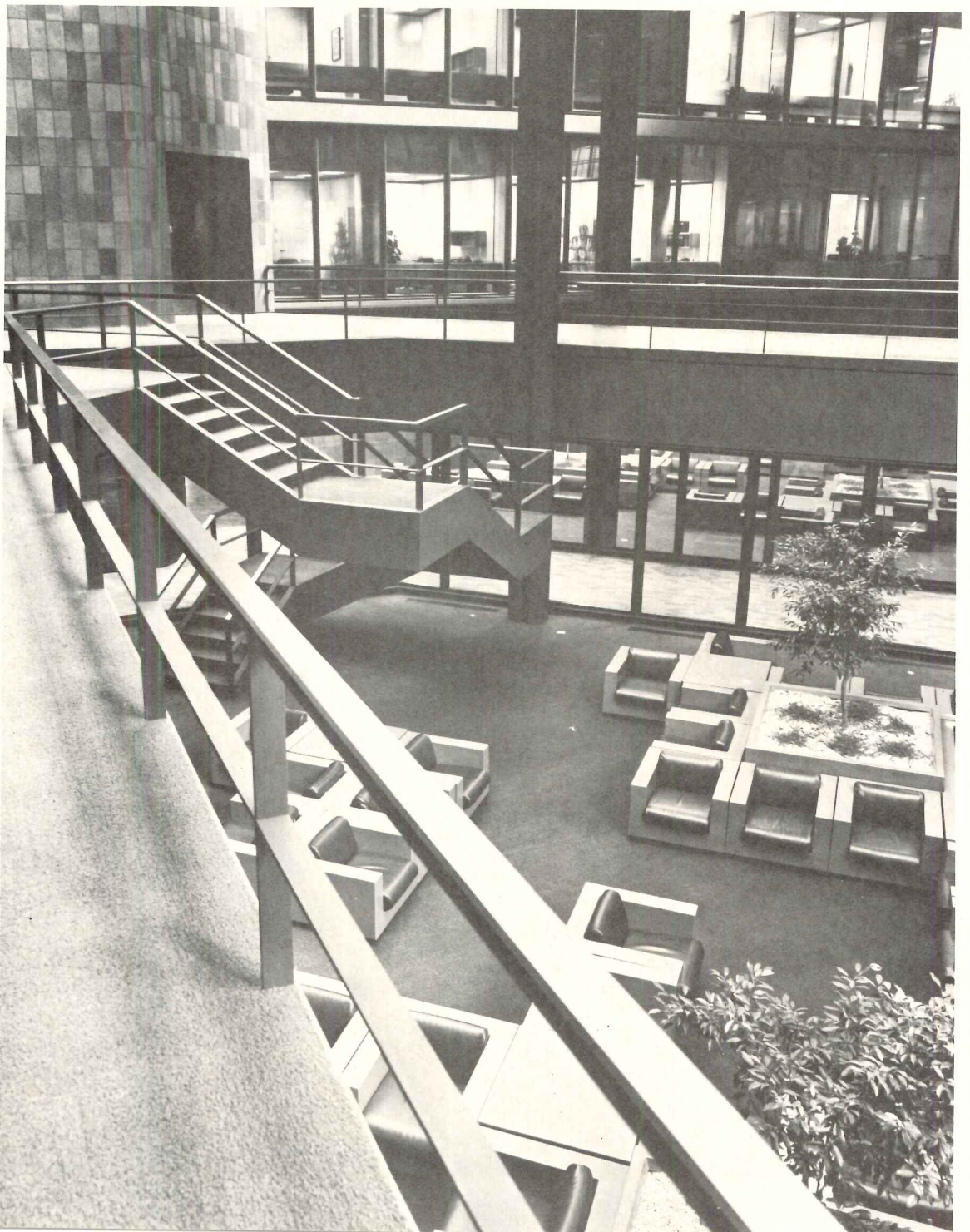

Lobby, S. S. Kresge. Photo: Balhazar Korab

A new Camelot meets
the divergent space
requirements and expansion
needs of a mercantile giant

This corporate headquarters on a 30-acre site in suburban Detroit houses a staff in excess of 2000 persons, engaged in the operations of one of the world's largest retailers: S. S. Kresge Company.

Both client preference and local zoning ordinances dictated a low, horizontal complex, with the client further stipulating these three design criteria: areas of large contiguous but flexible space for certain multi-employee operations; other areas to contain a maximum of exterior wall for various-sized private offices; and both types of space to allow for rapid and economic future expansion without dislocation of normal business activities.

The basic design decision of Smith, Hinchman & Grylls was the creation of a steel-framed modular building located diagonally on the site to soften the perimeter masses as they relate to the adjacent major traffic arteries (see site plan).

The complex consists of 13 modules, (each 100 by 100 feet) from two to four stories high, as function dictated, containing just over 10,000 square foot per floor. Total cost of the 500,000 square foot (gross) building was \$27 million or approximately \$40 per square foot.

Each module is serviced by a core tower containing stairs, elevators, utilities and mechanical equipment. Where maximum wall exposure is required for offices, modules are connected at their corners, creating interior courts such as the one shown on the opposite page, lower right. Where large, uninterrupted spaces are needed, modules are connected at their faces; future modules, with their own core towers, can be added easily to existing units.

Because of the suburban nature of the site, the architects decided on a weathering steel curtain wall, bronze-tinted glass and complementary masonry block units, all of which would blend harmoniously with the setting. The masonry block on the service towers is specially-sized (10 by 16 in.) silo brick, in a brown glaze.

The towers are not structurally integrated with the modules. In the site plan, notches in the modules, evident at the corners, indicate where towers would be constructed for expansion. This would occur primarily to the north.



The choice of weathering steel for the curtain wall (section shown below) was made for consistency with the steel-framing of the structure.

In developing the design of the curtain wall—the first such type constructed anywhere—the architects prepared performance-type contract documents for profile, finish and performance criteria only; fabrication and assembly methods were left to the discretion of the contractor/bidder.

Rather than conventional assembly from welded bar stock, the selected system employed extruded steel shapes that eliminated exposed continuous welds and permitted better outside drainage.

Not only do the extruded members remain straight and free of twist, but economy resulted from elimination of miles of continuous welding. Weight reduction also resulted.

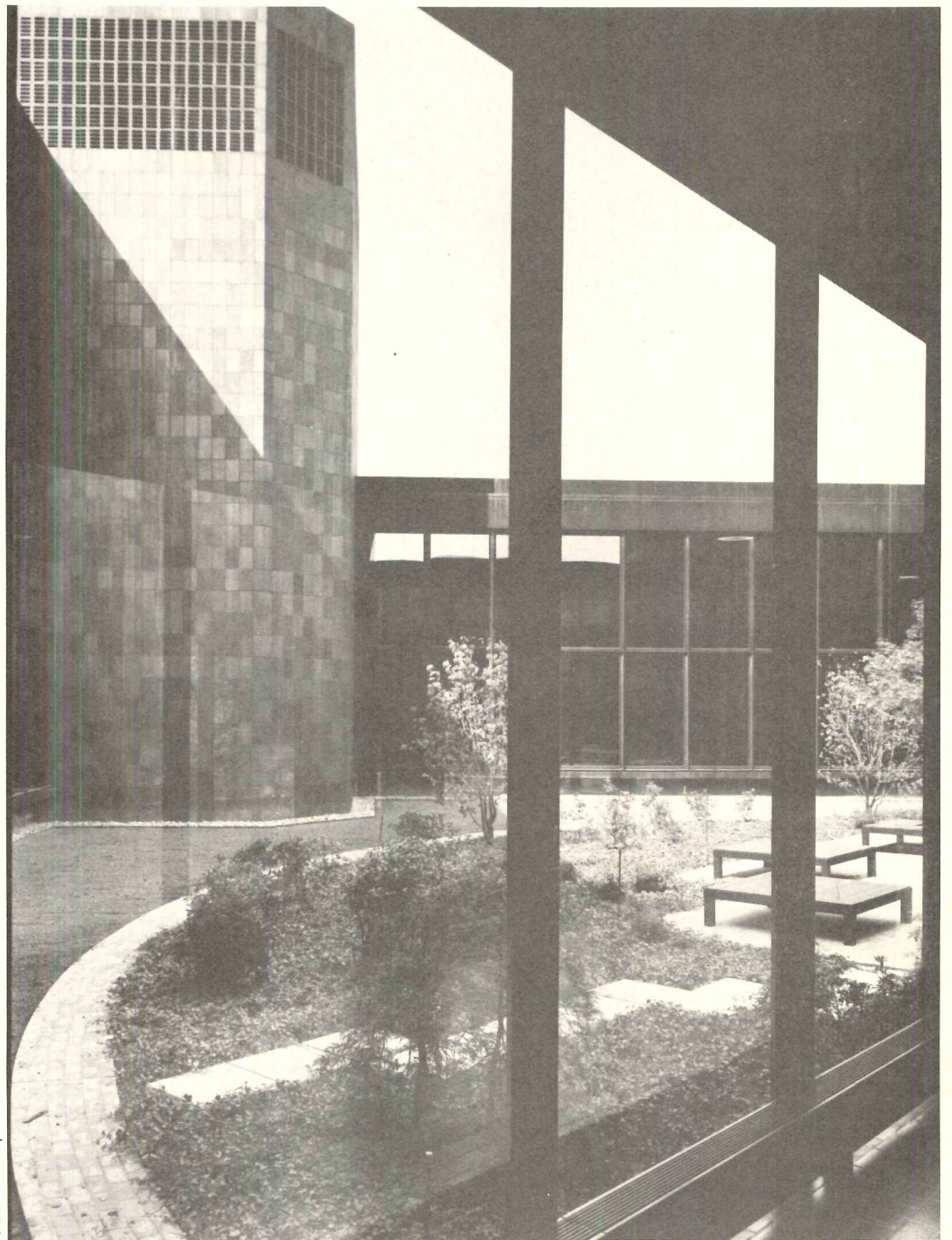
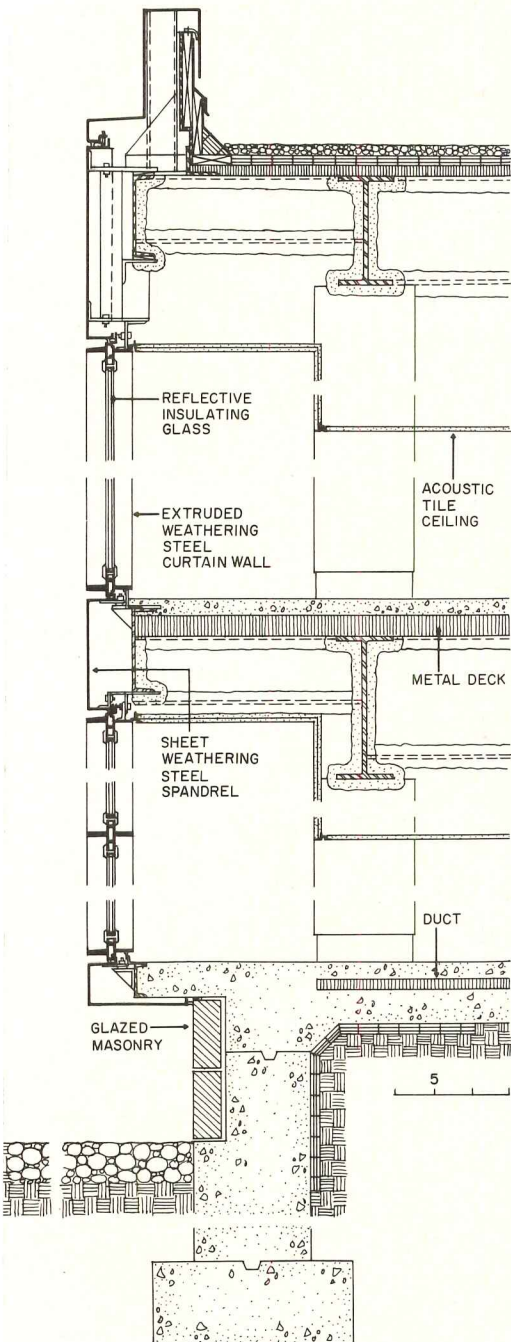
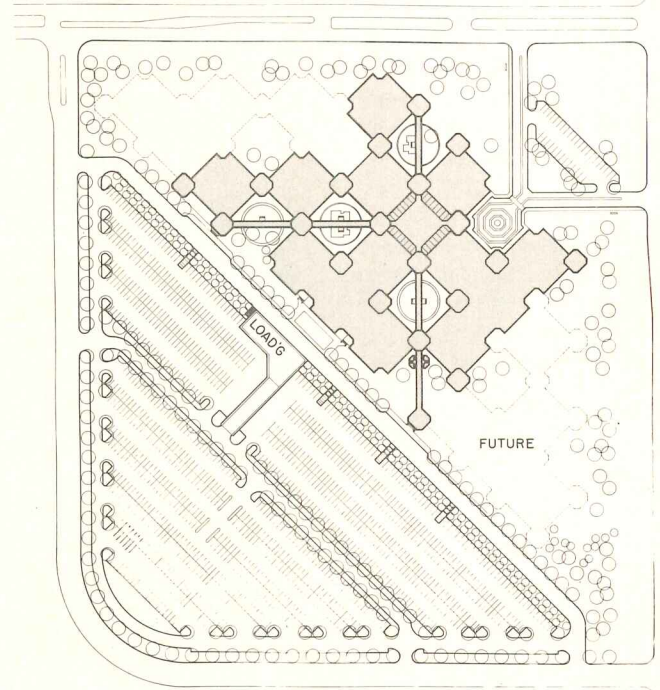

Balthazar Korab photos

By nature, the business of this company entails two functions that are well-expressed in the building: accounting and buying.

The vast accounting operations and computer facilities occupy the large open spaces created by blending several modules. These spaces are shown in the lower right portion of the plans.

The other function expressed in the building—the buying operation—involves thousands of visitors or vendors who call on the middle management persons occupying the offices in the single modules.

Circulation to all these areas is accomplished by a series of diagonal pedestrian corridors emanating from the multi-storied lobby (far right), commodiously planned to accommodate the large numbers of daily visitors. The skylighted lobby is actually another courtyard, providing vistas for offices on several levels.

The pedestrian routes go off, connecting all units on the first and second levels, traversing the landscaped courts (see plans and photo, center).

All vertical circulation in the building is confined to the towers. To encourage the use of stairs and reduce elevator loads, entry to the building is on the second level. This means that in a three-story module, only one flight of stairs must be climbed or descended to reach the next level. Main elevator use is in reaching the fourth-floor executive offices.

Employee entrances are conveniently located near the parking lot and by pedestrian linkages.

Besides office space, the building houses a cafeteria seating 600 persons, meeting rooms (below), employee lounges, a printing plant and specially-detailed executive offices (top).

Smith, Hinchman & Grylls provided complete architectural and engineering services for this project, in addition to designing the interiors and developing a graphics program for the complex. Landscaping, the largest single private contract let to date in Michigan, was designed by a division of the architects' office. The landscaping features large expanses of lawn and ground cover.

S. S. KRESGE COMPANY INTERNATIONAL HEADQUARTERS, Troy, Michigan. Architects-Engineers-Planners: *Smith, Hinchman & Grylls Associates, Inc.*—project manager: *William R. Jarratt*; project designer: *Charles T. Harris*. Landscape architects: *Johnson, Johnson & Roy, Inc.* Construction managers: *Darin & Armstrong, Inc.*



Balthazar Korab photos





Although the framing of the modules was of conventional column and beam in structural steel, the four-story lobby has its roof carried on a two-way Vierendeel space frame supported on eight columns. This design, combined with the skylighted roof area, provides a feeling of openness and a view for some of the offices of the activity generated by numerous daily visitors.

Like all entries to the building, the lobby is at the second level, with easy access by one flight of stairs to ground floor and third floor offices. Elevators go to the fourth-floor executive offices.

Leading from the lobby, pedestrian concourses cut across the modules at ground and second levels.

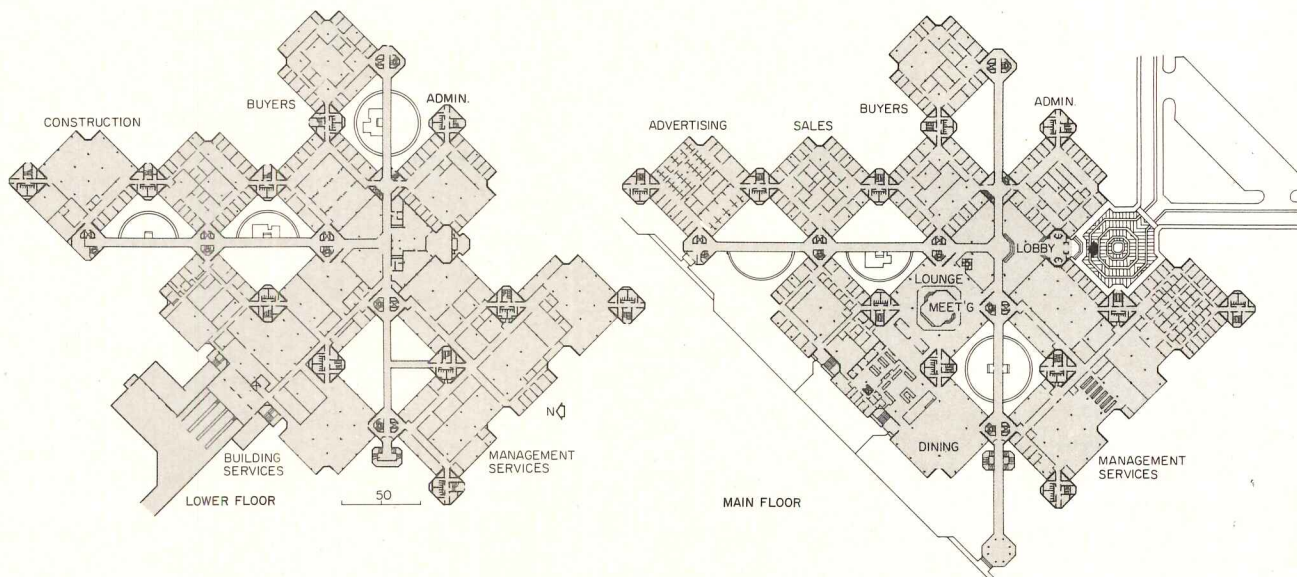

A complete expression of modular design, this headquarters balances human needs and growth potential

Sited in gently rolling New Jersey countryside, this combined headquarters and research facility by Hellmuth, Obata & Kassabaum for the E. R. Squibb & Sons pharmaceutical firm comprises seven buildings, linked by a glassed-in pedestrian spine. Each building is one or more square (90 by 90 feet) modules joined by service cores containing stairs, elevators, rest-rooms and utilities. Maximum height is four stories.

The design solution provides maximum lateral expansion flexibility—an inherent quality of the modular approach—in a suburban context where land is available. But this is not the only advantage in breaking office space down into smaller, arrangeable units. Another is the obvious ease with which personnel and departments can be grouped in neighboring modules.

Since the modules themselves house just the office and research spaces, services and amenities for employees were located in a central building containing: a 662-seat restaurant and cafeteria overlooking the lake; a medical center; a store; and an art gallery.

Once into the complex, orientation and directions are provided by a color-coded graphics system that also adds accent to the essentially all-white halls and secretarial areas.

In each office module, upholstery, columns and accessories are painted the same accent color throughout. The color changes from module to module horizontally, but remains vertically constant within any module. A reverse system is used in the research units.

E. R. SQUIBB & SONS, INC. WORLD-WIDE HEADQUARTERS, Lawrenceville, New Jersey. Architects: *Hellmuth, Obata & Kassabaum, Inc.*—principal-in-charge of design: *Gyo Obata*; principal-in-charge: *Jerome J. Sincoff*; master planning/program: *George Hagee*; project designer: *David Suttle*; interior designer: *Michael Willis*; graphic design: *Charles P. Reay*; lighting: *Eugene H. Fleming III*; construction administrator: *William J. Harris*. Landscape architects: *The Office of Dan Kiley*. Engineers: *LeMessurier Associates, Inc.* (structural); *Golder, Gass Associates, Inc.* (soils); *Joseph R. Loring & Associates* (mechanical/electrical). Consultants: *McKee-Berger-Mansueto, Inc.* (cost); *Flambert & Flambert, Inc.* (food service); *Earl L. Walls Associates* (laboratory). Contractor: *Huber, Hunt & Nichols*.

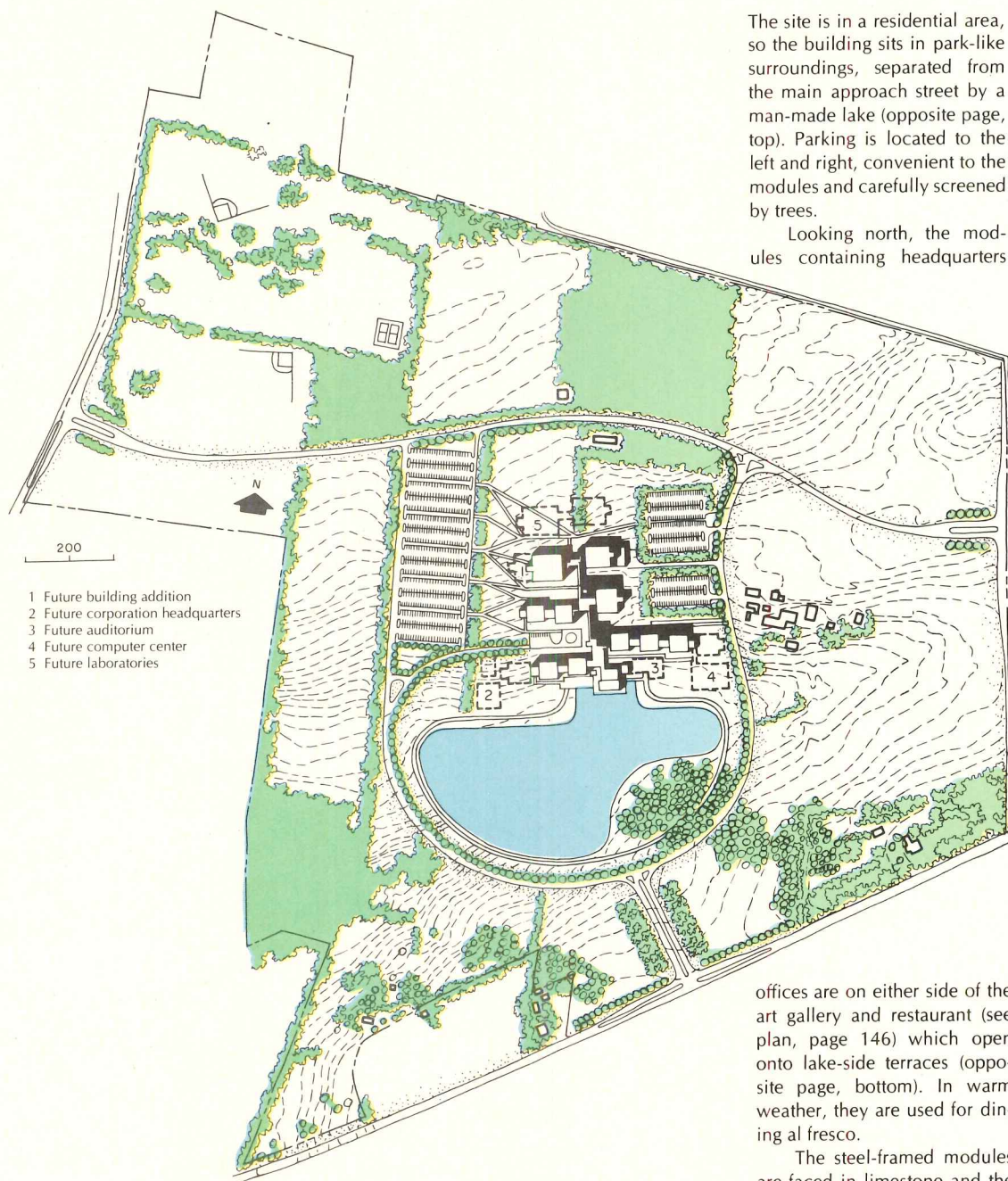

The site is in a residential area, so the building sits in park-like surroundings, separated from the main approach street by a man-made lake (opposite page, top). Parking is located to the left and right, convenient to the modules and carefully screened by trees.

Looking north, the modules containing headquarters

offices are on either side of the art gallery and restaurant (see plan, page 146) which open onto lake-side terraces (opposite page, bottom). In warm weather, they are used for dining al fresco.

The steel-framed modules are faced in limestone and the cores in brick, with brick paving continuing around the building and into the main lobby. Bronze glass is used, with dark bronze mullions.

Future expansion—offices, laboratories, computer facilities and auditorium—is designated on the site plan by the numbered, outlined areas (legend).

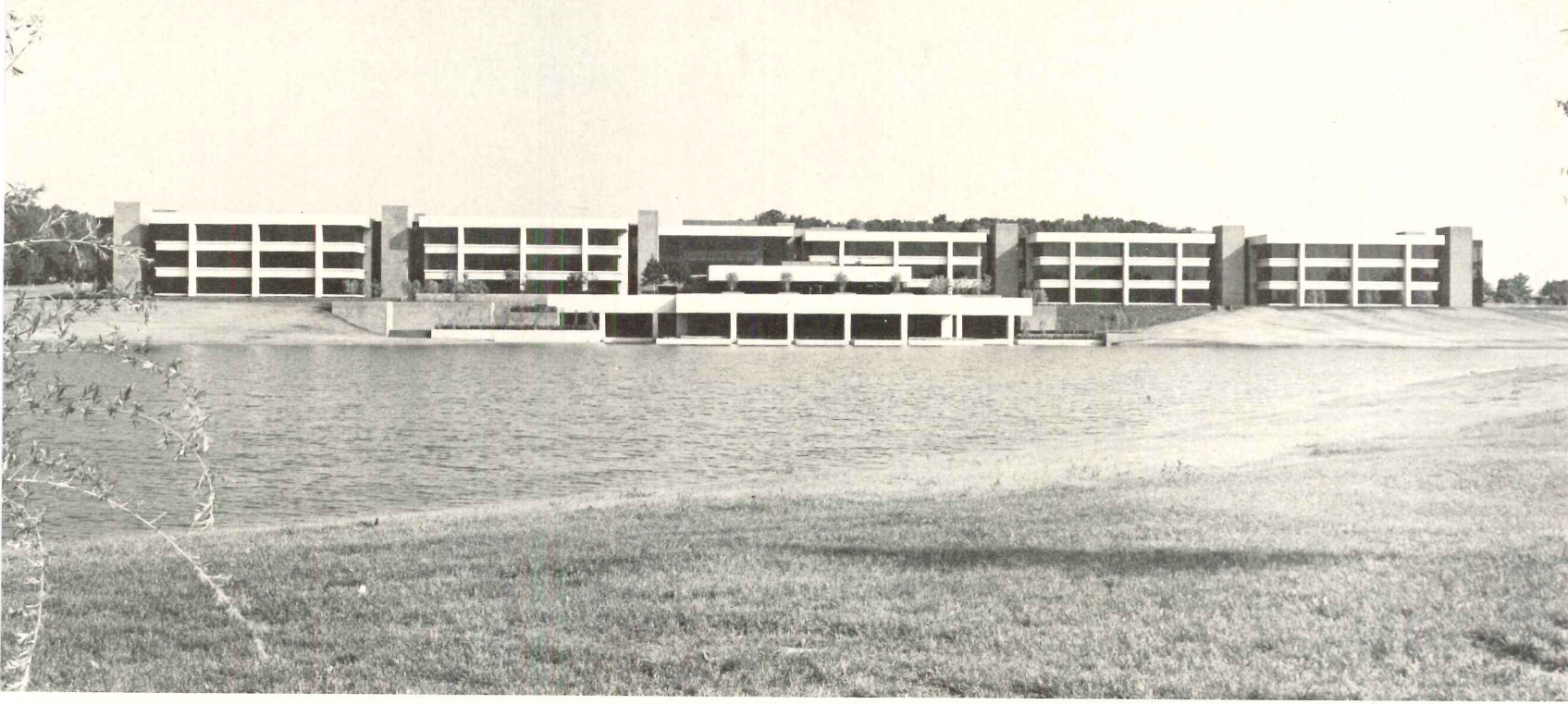

George Cserna photos

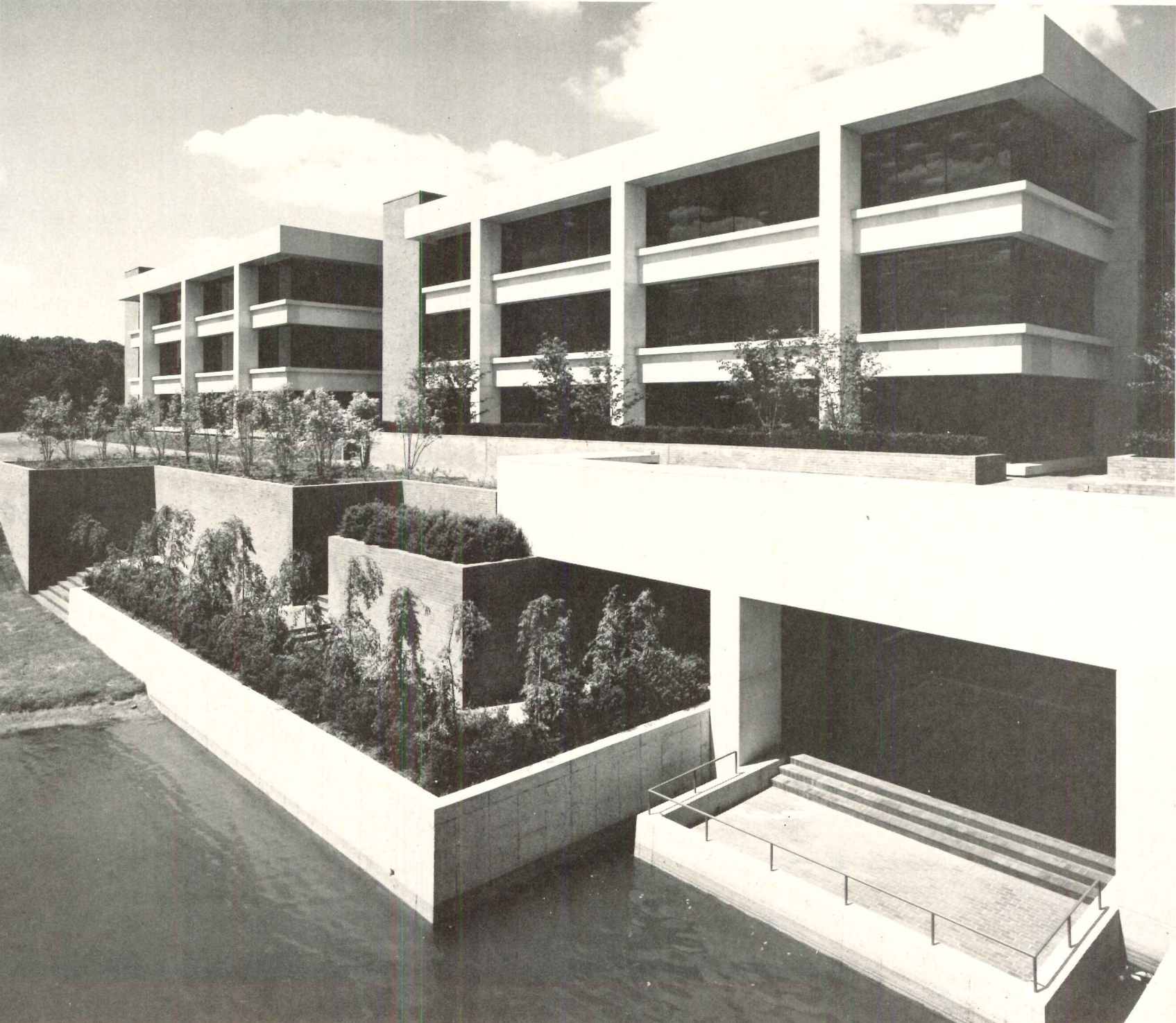



Alexandre Georges

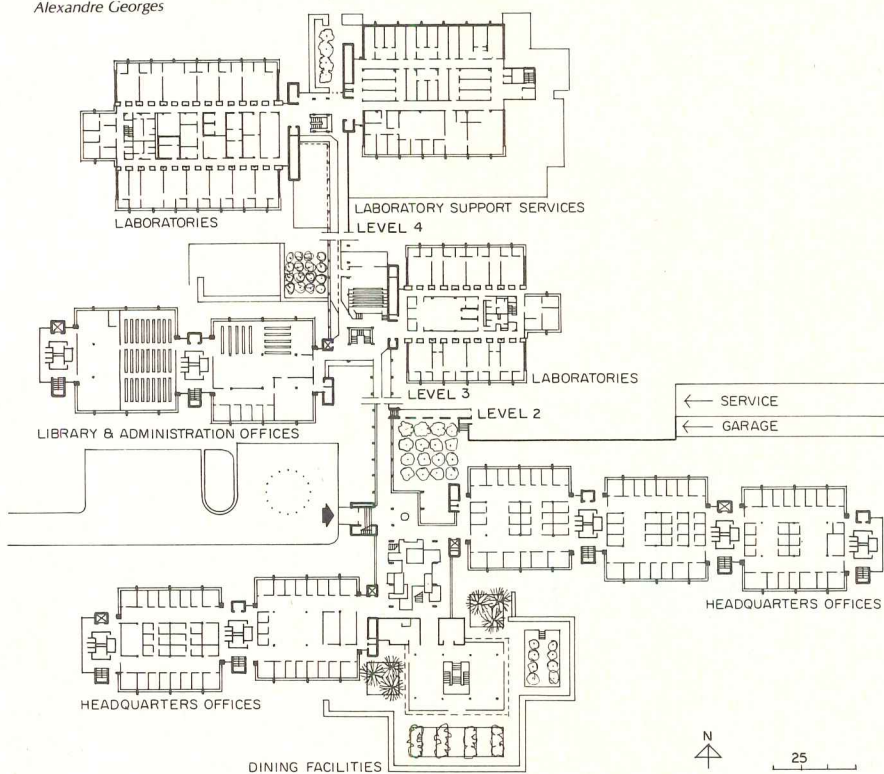

The architects changed from steel framing to poured-in-place concrete for the service building housing the restaurant (opposite and top left) primarily to change the architectural environment from the sleek, efficient working areas. In keeping with the intent, lighting was changed from fluorescent to incandescent, and the concrete was sprayed with a textured surface for both warmth and sound-absorption.

Since the ceiling is also a landscaped plaza above, the waffle-slab provides extra support, while being attractive to

see in the rooms below.

A middle-management office (opposite, top) measures 10 by 15 feet. All offices have a three-dimensional coffered ceiling system, and gray carpet. Ernst Haas color photographs (shown in the conference room above) and V'Soske-designed wall hangings are used throughout the offices.

The table in the conference room can be arranged in various configurations and the carpet continues up the walls and over the ceiling to meet the lighting unit, dropped slightly.

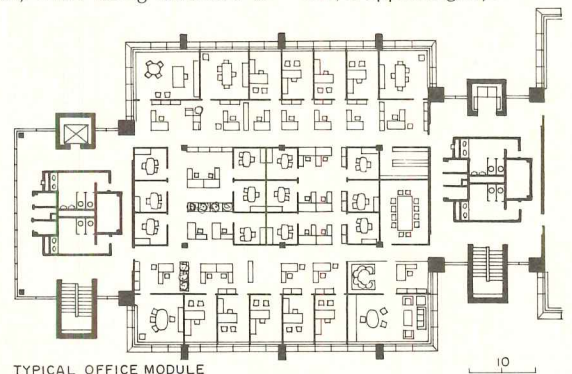



George Csorna



Alexandre Georges



George Csorna

This community-minded client wanted a handsome regional office building at a moderate cost

The client wanted to house a computer facility and an agricultural office operation in a newly-developed part of Hilo, Hawaii. Formerly a manufacturing area, the site is a short peninsula in a backwater pond connected to Hilo Bay; parks surround the pond.

In every way suited to its environment, this office building relates to native architecture by simply being appropriate to the moist, semi-tropical climate and seaside location.

For instance, all materials are self-maintaining: corrugated metal roofing with embedded mineral; self-oxidizing natural steel; stained redwood decking; bronze glass and aluminum non-bearing skin walls; and sandblasted concrete.

The ground floor is reinforced concrete and is earth-retaining. Because of the threat of tidal waves in the area, the ground floor is so designed that interior partitions and the exterior skin walls could fail with minimal structural or mechanical damage to the building.

Sun-screening and rain protection on all sides of the three-winged building are provided by a 6-foot roof overhang. Trees planted close to the offices reduce glare and direct sun into the building, eliminating need for any other sun shade devices.

Owing to the gentle slope of the site, the entry (interior right) is at the second floor or main level and open on both sides, forming a naturally-ventilated lanai, overlooking—as do all parts of the building—gardens of shade trees and azaleas.

Each office wing has a hipped roof, with a vinyl skylight in each plane (photo top right). Air handling equipment is located in the peaked portion of the roof, between trusses. Steel was selected for the long span needed to achieve the overhang and a light roof, and to minimize interior columns. Lightness prevails here.

C. BREWER & CO., LTD. HILO OFFICE BUILDING, Hilo, Hawaii. Owner: C. Brewer & Co., Ltd. Architects for building design, interior design, furnishings and equipment: *Ossipoff, Snyder, Rowland & Goetz*. Engineers: *Shimazu, Shimabukuro & Fukuda, Inc.* (structural); *Robert Hamilton & Company* (mechanical); *Douglas MacMahon* (electrical). Landscaping: *George S. Walters & Associates*. Consultant: *Bruce Hopper* (graphics). General contractor: *Swinerton Hawaii Venture*.



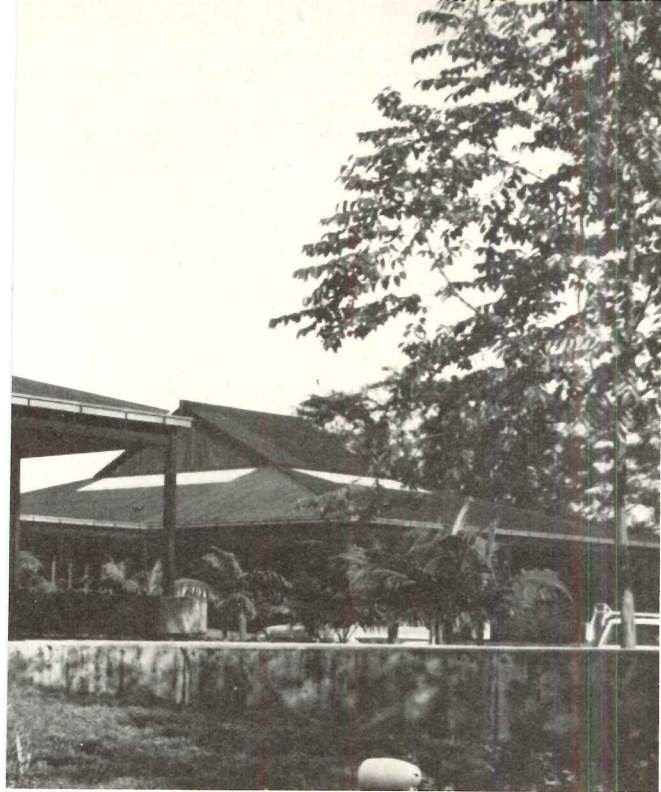

Wayne Thom photos

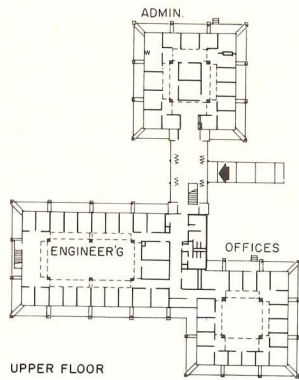
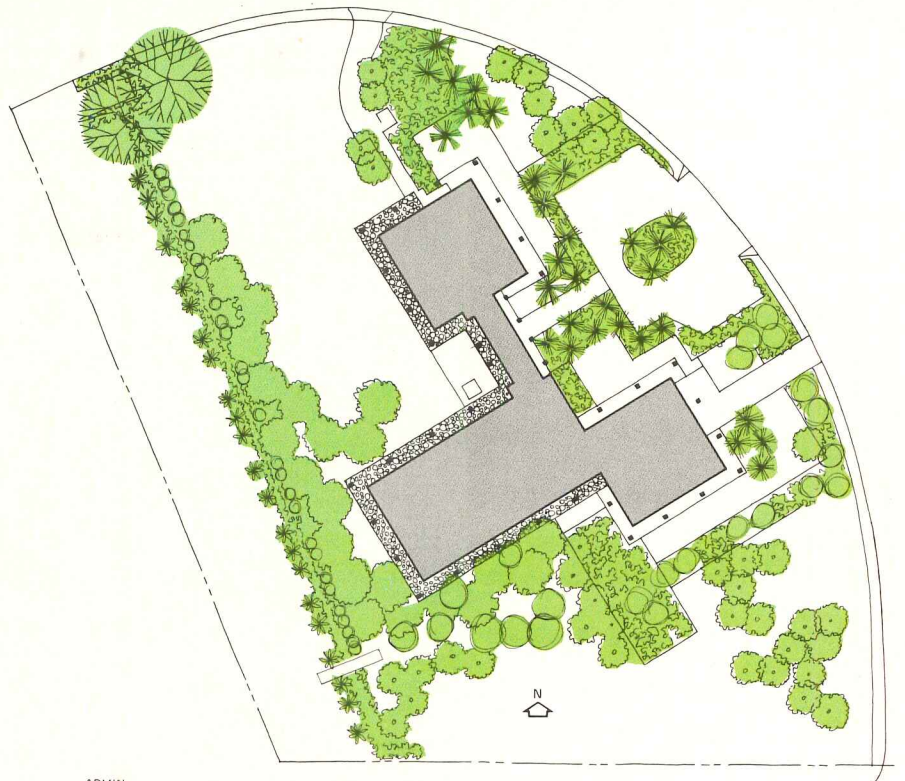

UPPER FLOOR

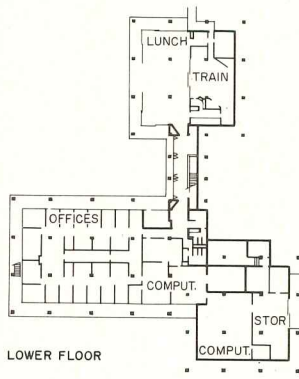

LOWER FLOOR



The top floor plan shows the entry and main work areas divided among three wings: engineering services; industrial relations and purchasing; and accounting, personnel and agricultural management.

The lower plan (ground floor) shows two wings housing computers and data processing, with a training room and lunch room that can be combined in the third wing.

Skylights admit natural light to the offices (right) and help define interior circulation. Hallways and doors are minimized. Each office has a built-in credenza facing the glass wall and the view of adjacent gardens, with water and mountains in the distance.

Color and standard building components produce a stimulating low-cost interior for a major publisher

Distinction need not hang on a fortune, as proven here. When Doubleday & Company moved its offices to an existing midtown Manhattan office tower, the company requested the architect, Jack Gordon, to rehabilitate its two floors within a stringent budget, in this case approximately \$10 per sq ft. The two floors comprise 60,000 square feet. Eventually, five more floors will be redesigned for a total of 240,000 square feet.

Rather than use color as an accent, the architect used it almost structurally, to contain circulation and work areas. The progression is from neutral charcoal brown public and circulation areas, to white work areas (right center).

To hold down costs, the architect chose to use building standard materials and details. For instance, the staircase at right (the only structural change made), connecting the two floors, features stringer and treads of 2 by 10 in. steel tube sections. Elsewhere, ordinary T-shaped ceiling spine is used as a carpet stop and to create reveals around door frames. The result of such innovation is a custom-detailed job, at little cost.

To create different space experiences, the architect carpeted the floors and walls of major circulation areas in charcoal brown. The noise-absorbing quality of carpet allowed the freedom to eliminate ceiling-high walls and substitute low partitioning. Since the carpet also absorbs high light levels where not needed, the work areas seem brighter.

Because of cost factors again, the concealed grid ceiling with 2 by 4 foot fluorescent fixtures had to be retained. However, by rearranging the lights as the design required, the architect was able to minimize an otherwise discordant element. Existing metal and translucent glass partitions had to be re-used for perimeter offices; but thousands of feet of bank screen were rejected in favor of the 5 foot 6 inch-high drywall partitions with storage space in some (lower left color photo).

DOUBLEDAY & COMPANY, INC.
EDITORIAL OFFICES, New York, New York. Architect: *Jack Gordon*. Consultant: *Rosanne Gordon* (interiors). Custom woodworking: *Unicraft Woodworking, Ltd.* Plantings: *Everett Conklin and Company Inc.* Contractor: *Edward Robbins, Inc.*

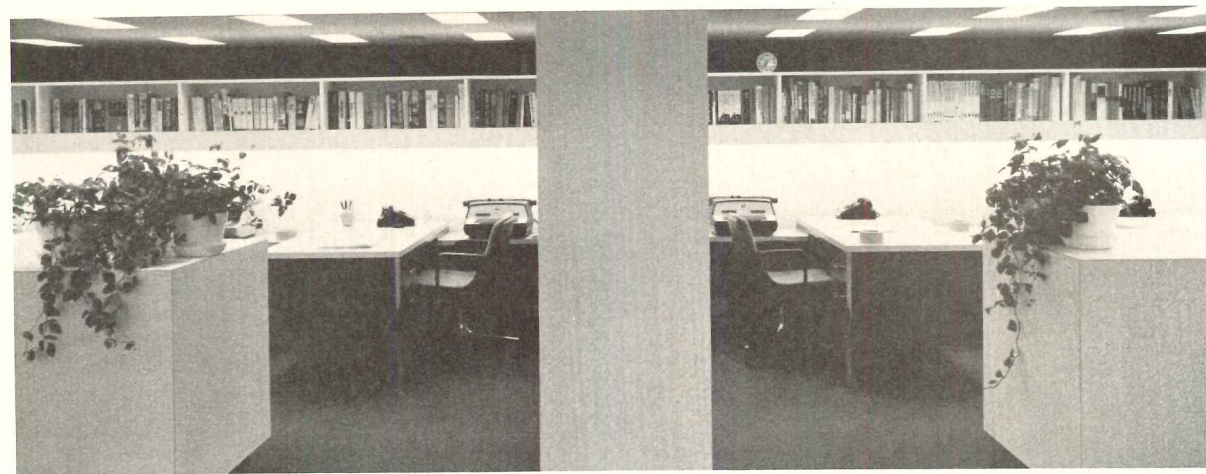



Bernard Askienazy photos



Details such as angling down the partitions on one side of the artists' desks (left) permits adequate privacy, and communication among co-workers.



A bright theme color was selected for each floor, first introduced on elevator doors, then carried into various departments. Fabric prints add inexpensive color to public areas. Orange is the code color for the 39th floor (plan shown) and yellow indicates the 38th floor.

Turning an economic necessity into a design asset, the architect used existing translucent glass partitions (above) in perimeter offices to let natural light into the personnel waiting area and secretary stations behind the bookcase partitions.

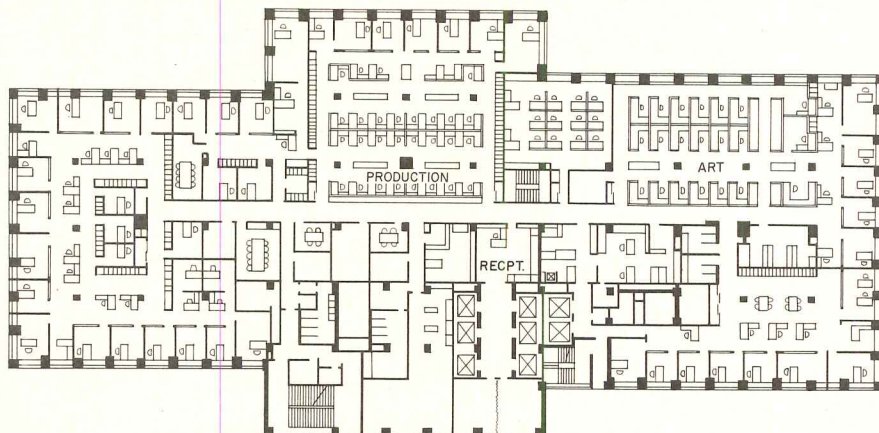

Three 1914 concrete structures yield contemporary office space at a considerable cost savings

Desiring to keep their corporate headquarters in Detroit's New Center area—where this computer builder has maintained operations since 1904—the Burroughs Corporation hoped that new life might be achieved for some of its aging 1914 factory buildings.

The architects' feasibility study supported the idea, whereupon three reinforced concrete, five-story loft buildings were selected for the new headquarters complex. The remaining buildings on the 20-acre site—18 manufacturing and storage buildings—were demolished.

The saved buildings were completely stripped of all exterior walls, finishes, utilities, stairs—down to the skeleton frame.

The three buildings were linked centrally and at the ends by new five-story core structures housing stairs, elevators and utilities, and providing lobbies and secondary entrances. A new canopy and foyer were added for the main entrance.

To close in the skeletal structure, the architects designed pre-cast concrete panels with limestone aggregate, measuring 19 feet 6 inches by 11 feet 6 inches. The window panels, weighing approximately seven tons, hold two lights of bronze glass separated by an aluminum mullion. These 3½-inch thick panels sheath the existing reinforced concrete frame, each secured with bolted and welded connections. Stainless steel cap flashing was used.

On the ground floor, a curtain wall was installed, consisting of ¼-inch clear float glass, 10 feet high around the office area and 1-inch insulating glass around the computer/display area. Where privacy was desired, porcelainized steel panels replaced glass.

The building comprises 675,000 gross sq ft of floor area, rehabilitated at a cost of \$26.5 million. The architects claim structural costs savings amounted to approximately \$2.2 million.

BURROUGHS CORPORATION
 WORLD HEADQUARTERS, Detroit, Michigan. Architects for building design, interior design and furnishings, acoustics, lighting and landscaping: *Smith and Gardner*. Engineer: *Robert Darvas* (structural). Consultants: *Uni-mark Inc.* (graphics); *Michael Kenny* (cost). Contractor: *Barton Malow Co.*

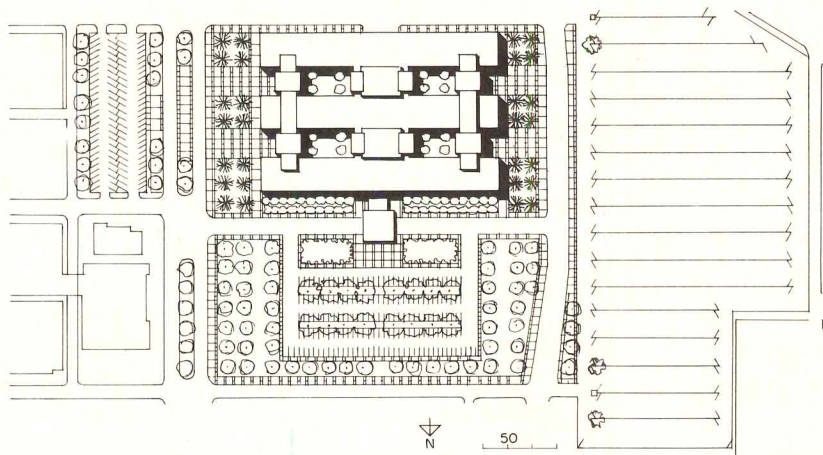
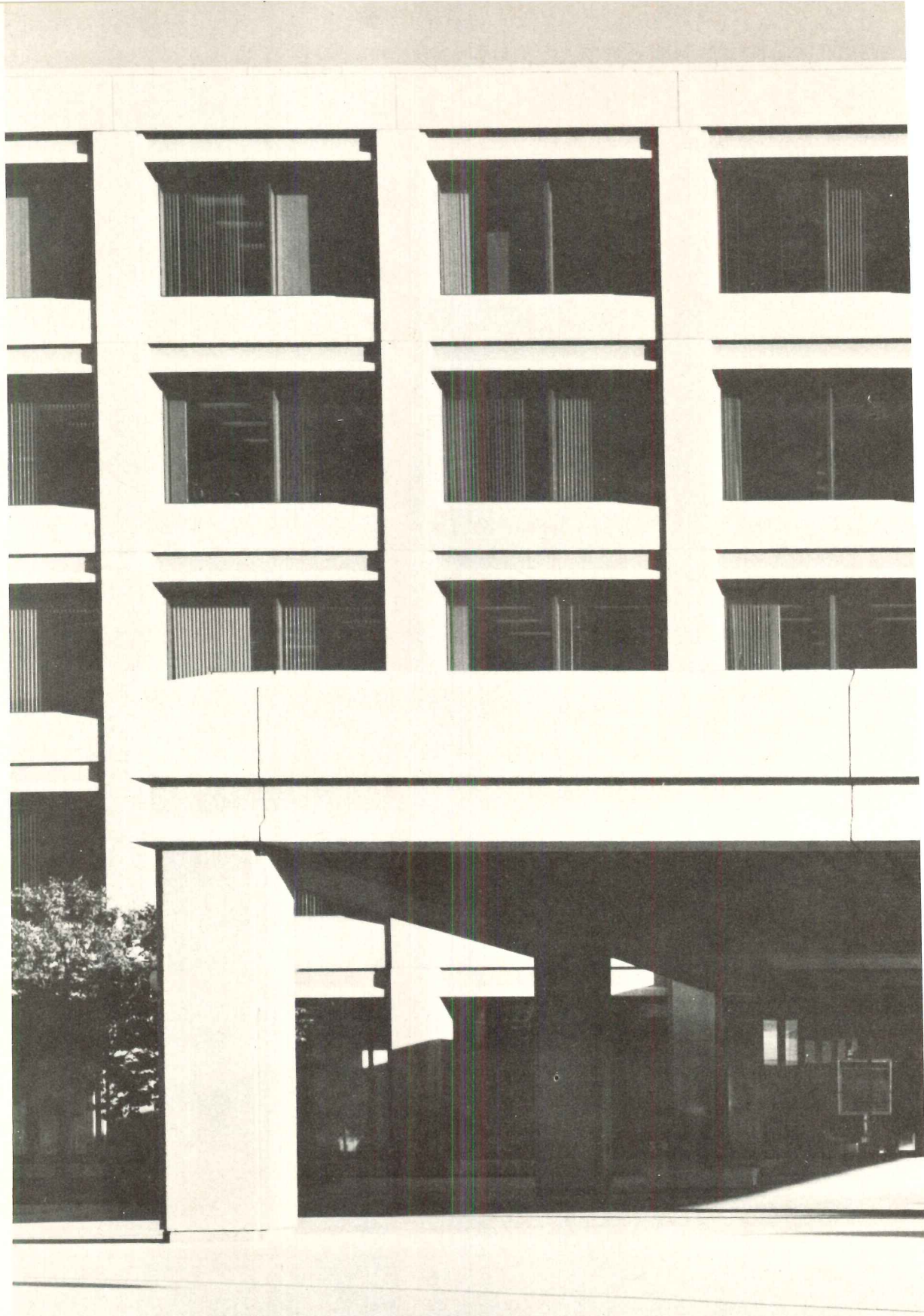



The canopy soffit shown right is paneled in 1½-inch deep, anodized aluminum pans suspended from the canopy with tapered teak dividing strips. Exposed aggregate paving and matched maple, locust and linden trees are the main ground elements. A luxurious entry features narrow-stile aluminum doors 10 feet high and 3 feet wide—52 of them throughout the building—in bronze anodized finish, and glazed with bronze glass. Parking for 1400 cars is provided nearby.

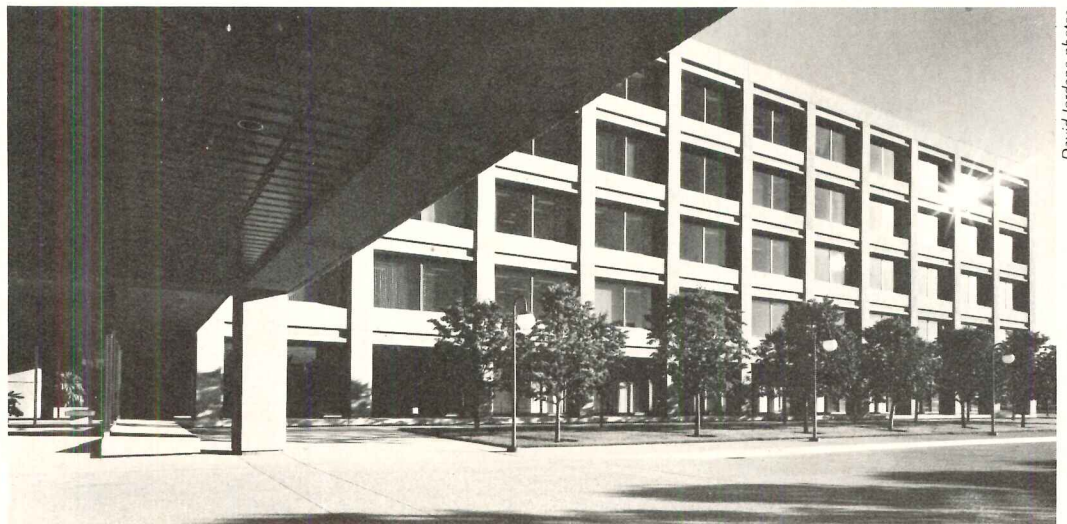

David Jordano photos

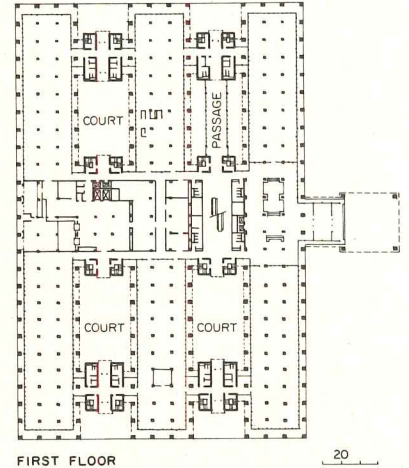

As the plan for a typical floor shows, each of the three structures is conveniently linked at three points. Elevators are located in the central core, with the end linkages containing stairs and restrooms. Open courts are formed by the walls of the buildings and the new ones made by the linkages.

The lobby (upper left) includes leather-covered seats on a sunken concrete base. All counters, drinking fountains, and table tops are Italian (Perlato) marble, 1 1/2 inch thick.

The floor in the executive office (left) is quarry tile with matching grout. Vinyl asbestos tile is used, however, in most of the building. Drywall floor-to-ceiling partitioning is used throughout for sound control.



Three open-plan schools exhibit inventive design and engineering

Open-plan schools *can be* just as stereotyped, just as rigid in their own constraints (by reason of the absence of them), and just as lacking in invention as the most conventional, double-loaded corridor arrangements.

On the other hand, open-plan approaches can be inventive in response to highly individualized clients' programs—as exemplified by three recent, amply-budgeted, open-plan Connecticut public schools by New Haven architects Carlin, Pozzi & Associates.

The schools range from minimum to maximum commitment to the open-plan concept. The responses to clients' programs are individualized not only in terms of planning, but also in the materials and engineering techniques employed. Standard products and engineered systems were used—though customization of the engineered systems required time and effort for all the professionals in the physical coordination of structure with design concept and mechanical and lighting systems with structure.

For example, in New Haven's Hill Central K-4 school, the poured-in-place concrete structure is exposed on the inside—yet the hvac and plumbing piping is concealed by a minimum of dropped ceiling (which houses lighting) through careful layout and close attention to such matters as door-head details, unit-ventilator placement, etc. Further, the cluster-type plan lent itself to repetitive concrete forming—the contractor needed only two sets of forms to do the whole classroom wing.

The client's requirement that Shepherd Glen school in Hamden have a sloping roof provided natural concealment for roof-top multizone units.

That the architects were sympathetic to, and sought out with their consultants' help, the newest available and proven technologies and materials is manifested in Branford Intermediate School in many ways: 1) the academic areas are illuminated by improved-color, phosphor-coated mercury HID lamps set in pyramids recessed in the structural frame—the frame itself forming pyramid edges; 2) lighting in other areas is specially keyed to space use (locker-mall, dining commons, shops, etc.); 3) a manufacturer's standard space-truss system (commonly used in system-building-type schools and low-rise office buildings) was re-engineered to increase its load-bearing capacity from roof-loading to floor-loading magnitude so that it could be used for academic mezzanine areas; 4) sound for academic areas comes from a multiplicity of ceiling-mounted, low-audio-level loudspeakers, circuited in small zones so that sound does not intrude upon neighboring classes; 5) a dial-access system was integrated with audio-visual communications.

Altogether, the three schools show what a strong design approach, based upon varied, but clearly-identified, program requirements, can do in companionship with cooperative engineering.

—Robert E. Fischer

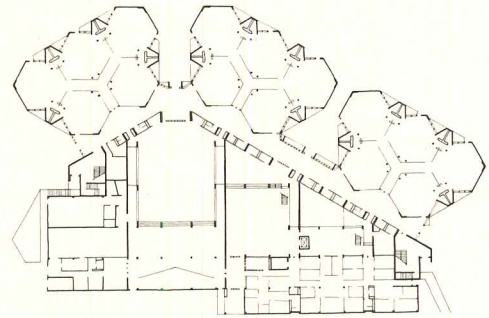

Hill Central K-4 School

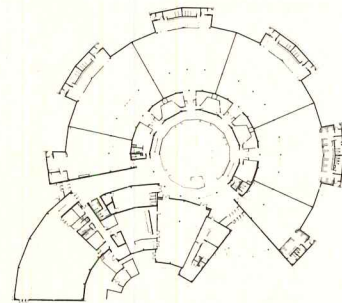

Shepherd Glen School

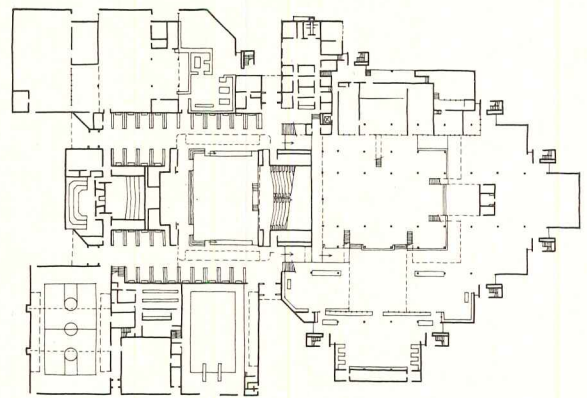

Branford Intermediate School

The structure and the lighting help define classroom areas

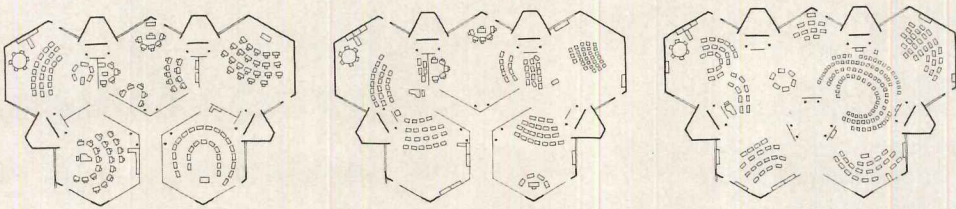
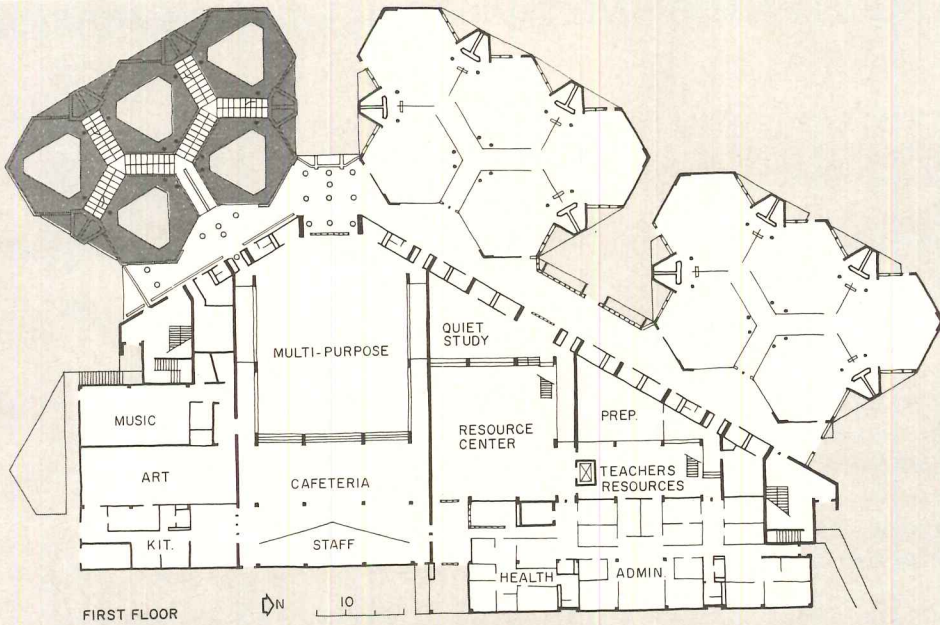
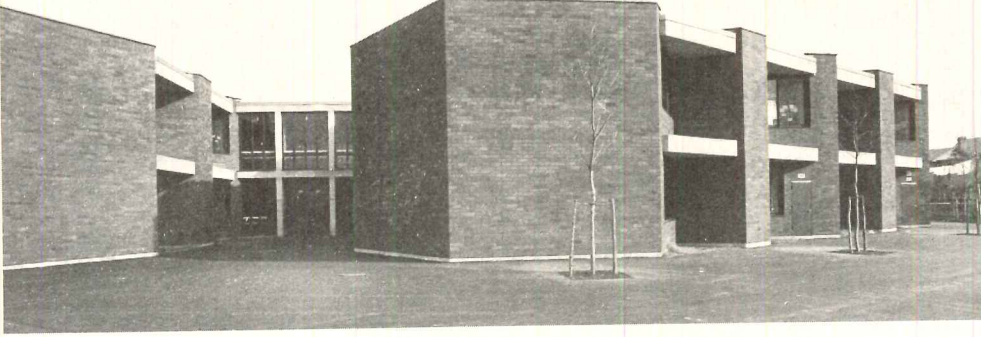

Flat band beams support triangular-shaped floor area (left-hand cluster, above plan). Judicious placement of columns and demountable partitions allow the school administration to decide upon whatever degree of openness they want. Currently the partitioning is as shown in the plan above, and sketch above, far left.

The corridor splits academic areas from administrative and large spaces, used by the children only part of the time, and by the public during off-school hours. A tunnel below the corridor carries piping and ducts for hvac and plumbing. Typical hvac is shown in plan, left.

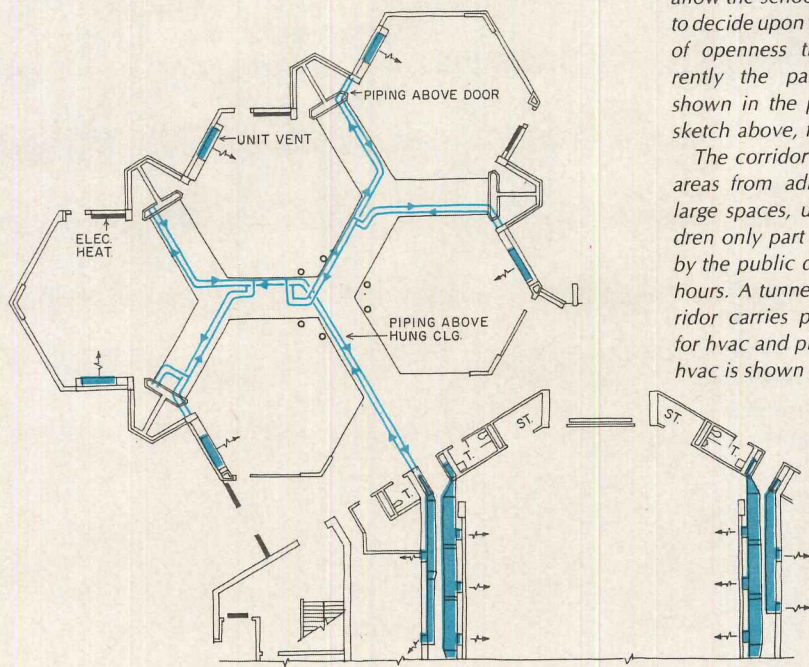

The cluster design and coordinated structural framing of Hill Central K-4 school in an urban neighborhood of New Haven, Connecticut allow the school administration to have options from a minimum to a maximum of open-plan layout.

The school administration has taken a tentative approach—not knowing what their discipline problems might be.

The poured-in-place concrete frame that was favored by fire code requirements and economics, lent itself to the cluster-type classroom layout. More than that, its design actually helps identify the hexagonal shapes that comprise the clusters. Floor design is similar to a two-way flat slab, but with reinforcing following the geometry.

The floor spanning between the flat beams is recessed (to save dead weight), allowing direct-indirect fluorescent luminaires to be suspended from short stems around the inner perimeter of the flat beams, further identifying a classroom area.

Classroom hvac is individual air-conditioning unit ventilators with self-contained heating elements, and perimeter electric radiation in front of glass. Chilled water is piped from a central chiller in the basement which feeds into a tunnel that follows the length of the corridor. Piping comes up chases between small rooms facing the corridor. It runs exposed across the corridor ceiling, but then is concealed in the classroom areas by a narrow suspended ceiling area and lighting panels that run between the hexagons.

Central air-handling units in the basement feed ducts that rise up the chases along the main corridor to provide heating and air conditioning for the large non-classroom areas.

In order to retain valuable exterior play space, a two-story solution was indicated, with offices, public-use, and non-teaching areas located on the street side. The service spine, in addition to providing horizontal and vertical distribution of mechanical services, gives security separation.

The 83,000-sq-ft school was designed for up to 900 students, and its cost was \$2,876,000.

HILL CENTRAL K-4 SCHOOL, New Haven, Connecticut. Owner: City of New Haven. Architects: Carlin, Pozzi & Associates; associates: E. Stuart Baxter and Lyman Goff. Engineers: Pfisterer, Tor & Associates (structural); Hill & Harrigan (mechanical and electrical). General contractor: R. A. Civitello Company.

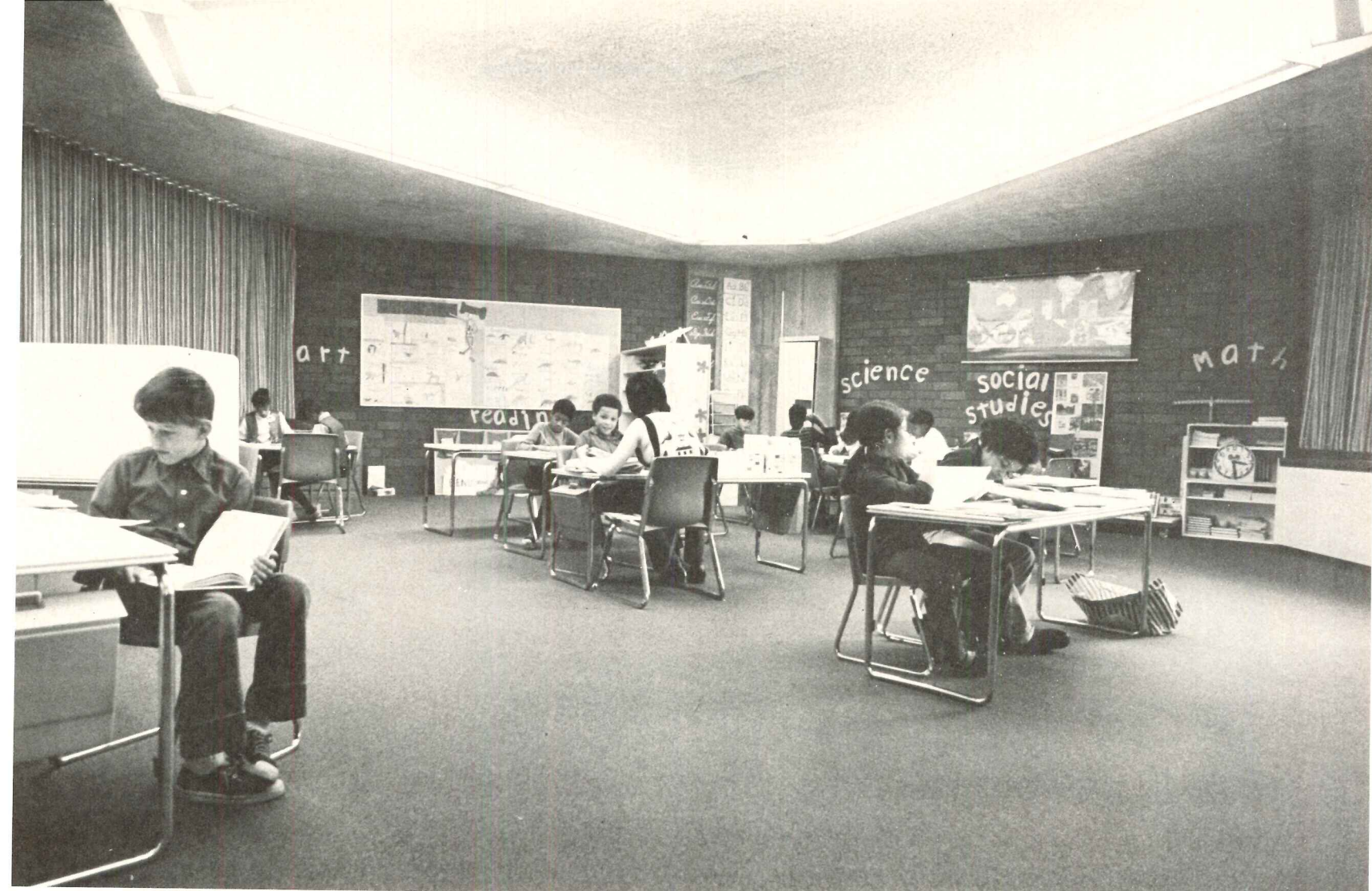

All photos by Robert Perron except as noted

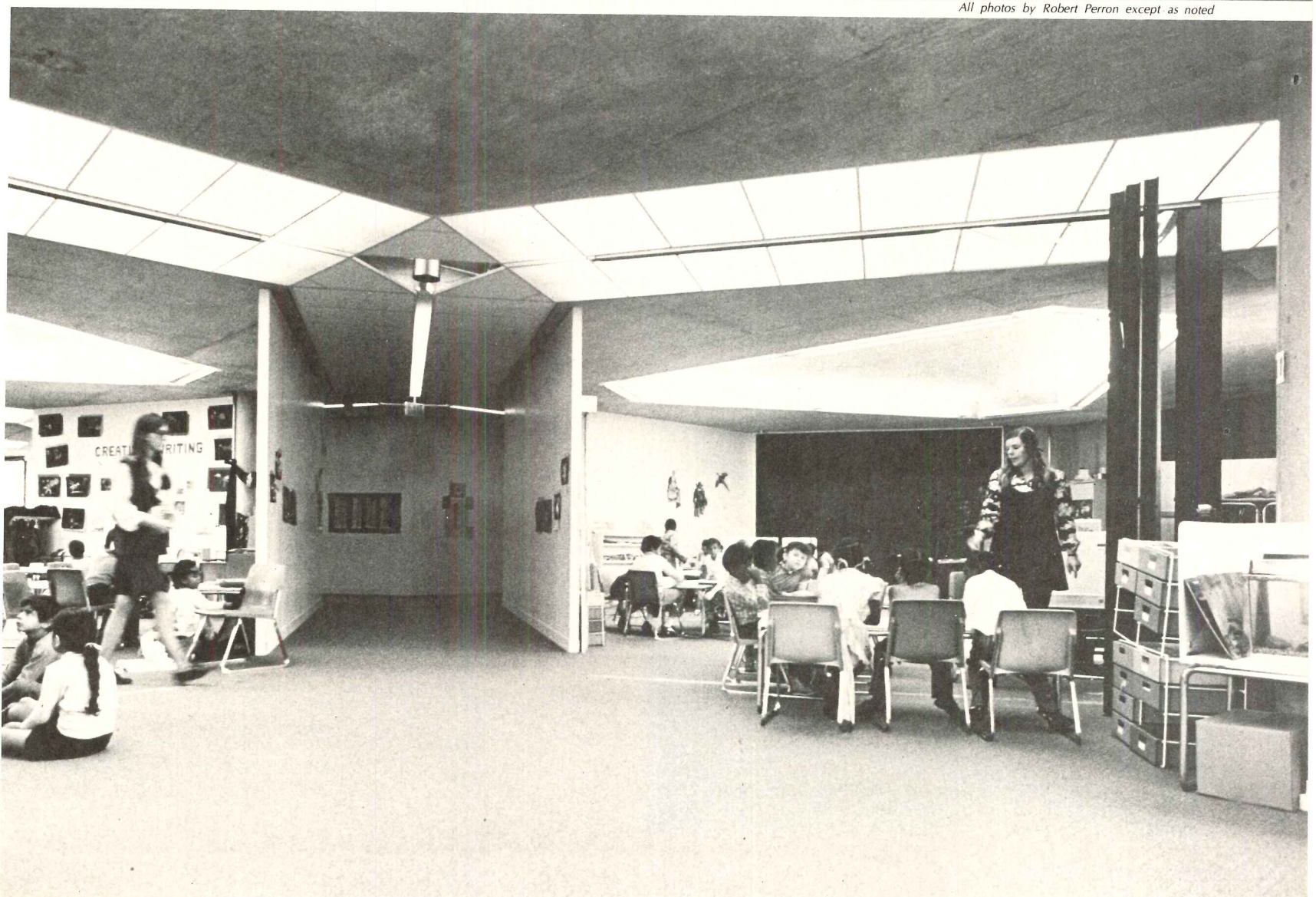

Laminated timber and lighting geometries complement each other

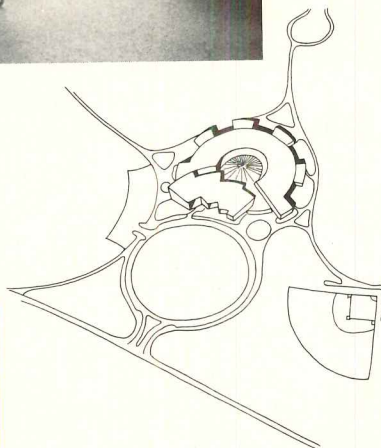
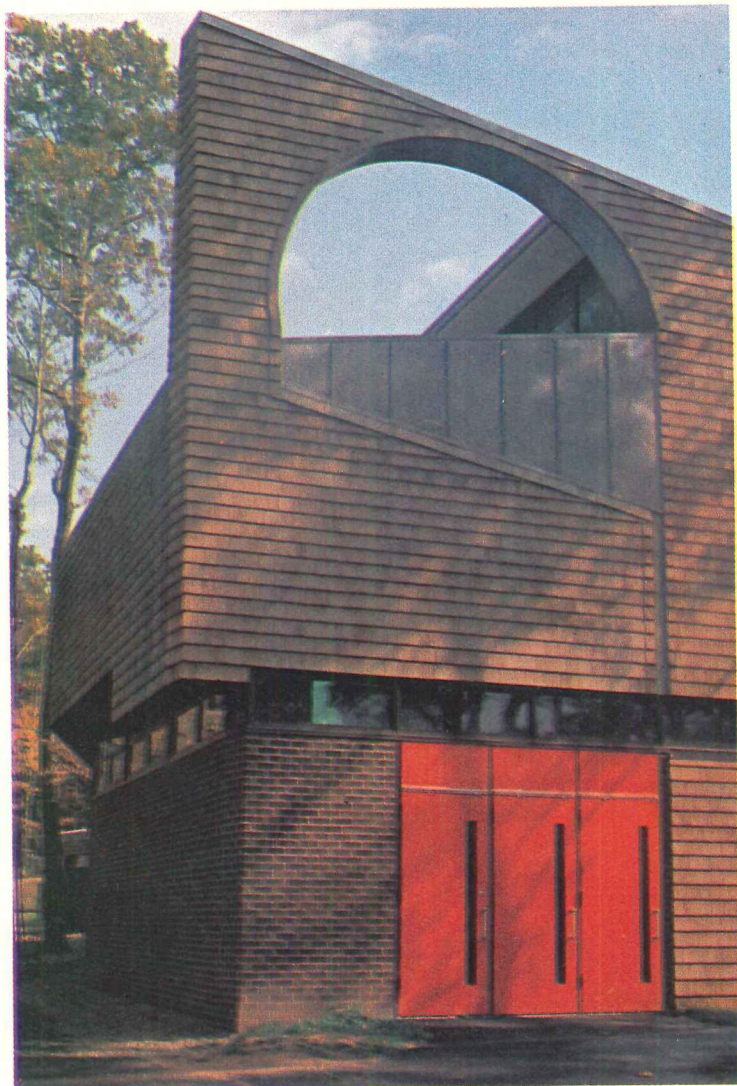
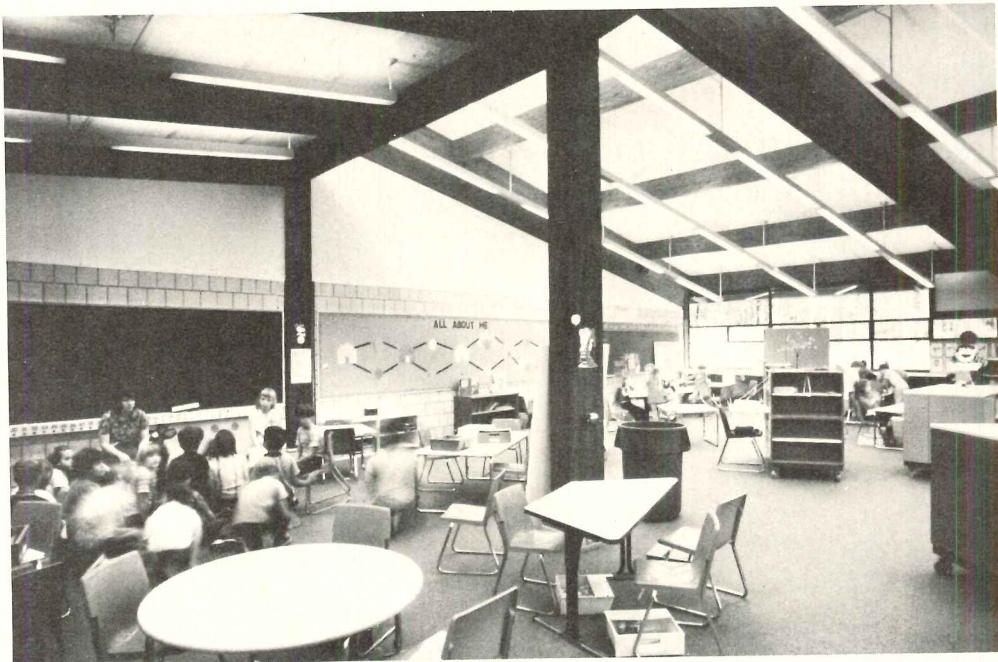
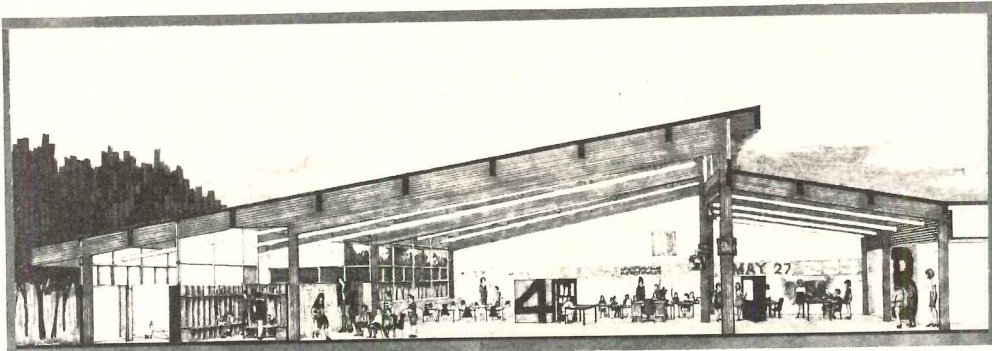

The two prime reasons that the economically comfortable New Haven suburb of Hamden needed the K-6 Shepherd Glen school were: 1) growth and 2) complete commitment to the learning center concept.

Each Learning Center Unit at Shepherd Glen provides space and facilities for 125 students. The requirements for direct and equal access to the outside and to the Instructional Materials Center dictated plan relationships. And the desire to accommodate community activities outside the teaching spaces explains the location of gymnasium, cafeteria, and the IMC for community use.

The Hamden school board mandated that the school should have a sloping roof, and exposed laminated wood framing and fire-retardant cedar shingles seemed to suit the wooded character of the site and the residential neighborhood. Partly to save cubage, partly to give a more intimate scale to the inner perimeter of the LCU's, and partly to provide A/V areas, a clerestory was provided, and beyond it, the slope of the roof reversed toward the IMC.

The IMC has an 82-ft-diameter area free of columns. Laminated wood girders placed in a radial pattern span between a compression ring at the center, and a tension ring at the circumference of the circle.

Perimeter areas of the LCU's are heated and air-conditioned by means of self-contained, through-wall units with electric-resistance heating. The inner areas of the LCU's, as well as the IMC, offices and cafeteria are served by four roof-top multi-zone units. They are set on a narrow flat-roof portion between the LCU's and the IMC, and are completely hidden from view because of the sloping roof.

The principal lighting is by suspended, single-lamp, indirect-direct luminaires that conform to the geometry of the ceiling, whether in the LCU's or in the IMC. Perimeter walls around the IMC have incandescent spotlighting, as does a corridor-display area between the music and art spaces.

Cost of the 57,000-sq-ft school was \$2,055,900.

SHEPHERD GLEN SCHOOL, Hamden, Connecticut. Owner: *Town of Hamden*. Architects: *Carlin, Pozzi & Associates—project manager: Ronald Zocher*. Engineers: *Pfisterer, Tor & Associates* (structural); *Technical Design Associates* (mechanical and electrical). General contractor: *Dwight Building Company*.

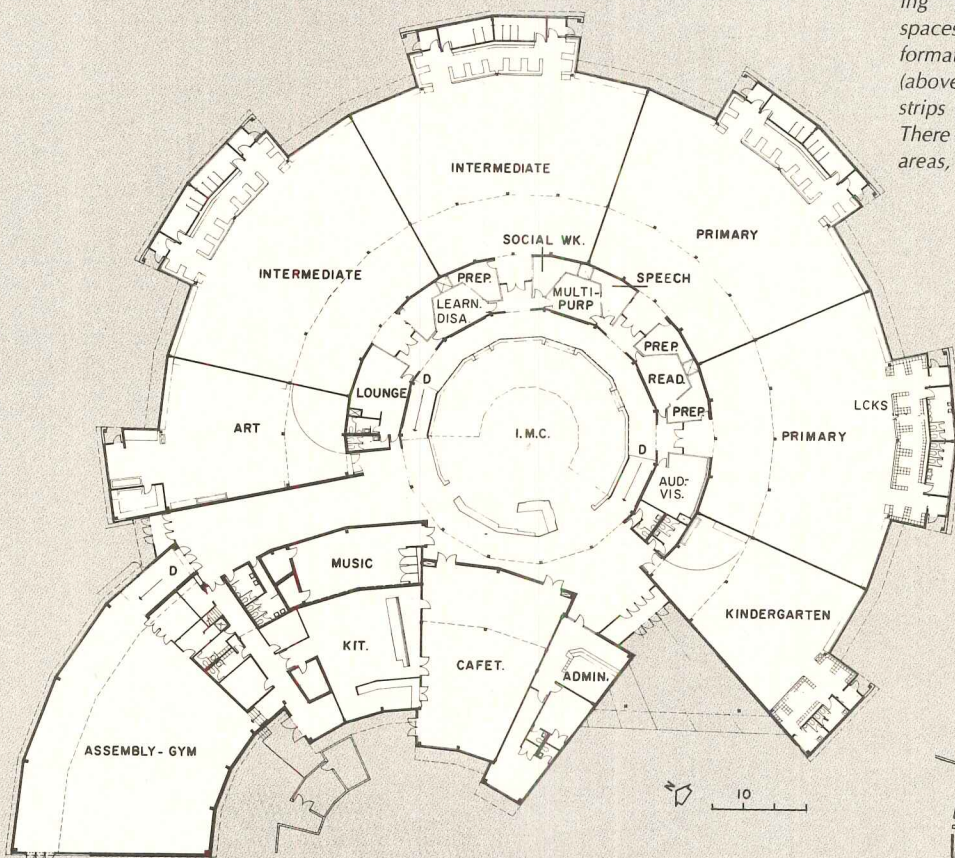

Exposed laminated wood framing defines learning-center spaces (across page) and the Information Materials Center (above), and suspended lighting strips follow the same slope. There is no hung ceiling in these areas, so the use of self-con-

tained unit ventilators for perimeter have avoided piping and ductwork problems. Interior zones and the IMC are served by rooftop multi-zone units, which also serve other interior areas except for the gymnasium and kitchen.

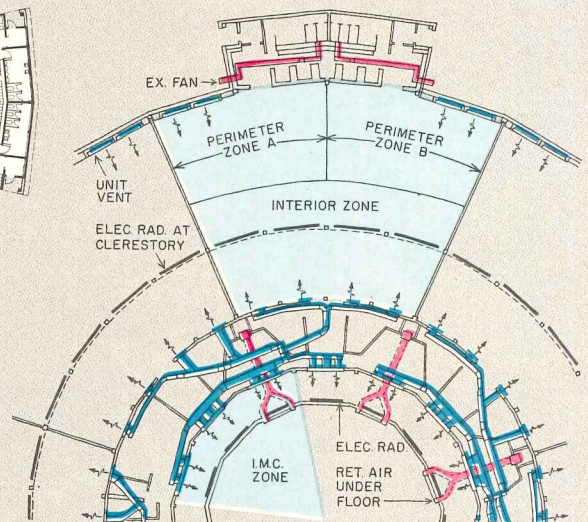

Structure and lighting are integrated for function and for appearance

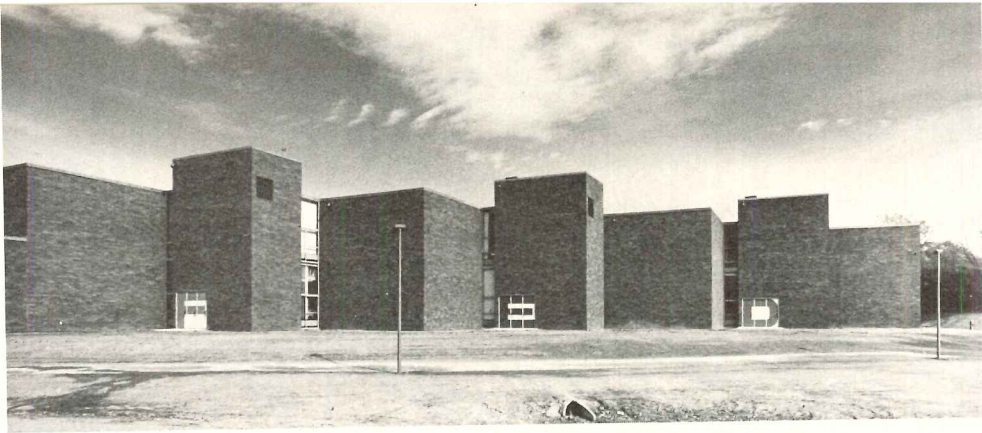

The Town of Branford, Connecticut—a 20,000—population, shoreline suburb of New Haven—responded to overcrowded conditions in the lower grades with a new, centralized intermediate school for approximately 1800 pupils, grades 5 through 8.

The academic areas are completely open-plan except for the life-science wing that is separated by glazed partitions to ensure adequate fume control. A large Instructional Materials Center, capable of accommodating 400 students, is the focal point of the academic area.

It was planned that the community would have use of such adjunct facilities as swimming pool, gymnasiums and dining and auditorium space. Dual use of the building suggested two major plan zones: the academic, or quiet, areas surrounding the IMC; and the more noisy areas, which included those that the community would use.

The staff and community have been pleasantly surprised at how quiet the over-all acoustical ambience is. And because classes are generally spread about, acoustical intrusion from one to the other seldom occurs.

The exposed steel structure offered pyramidal forms for the lighting

Because Connecticut code requires open school areas over 30,000 square feet to be sprinklered, the architect could use exposed steel framing, and this led him to the space-truss system which had several ancillary architectural possibilities: 1) structural acoustical ceiling panels could simply be laid on bottom flanges of the trusses; 2) vinyl-surfaced gypsum board, fastened to the chords of the inclined trusses could serve as reflectors for mercury lamps in the academic wing, and for incandescent lamps in the dining commons and in the locker corridors nearby.

The space-truss system is basically compatible with a wide selection of mechanical and lighting systems. At Branford, a central chilled-water system was selected (three small chillers totaling 435 tons). Air-handling units for the academic wing are located in mechanical rooms atop stair towers (which were required for egress anyway). The mechanical rooms are supported by conventional steel joists.

To avoid concentrated roof load and possible vibration that would have required special framing, air-cooled condensers for the chillers are located at ground level, near the truck dock. The chillers and boiler (oil or gas) are in a basement located under the ad-

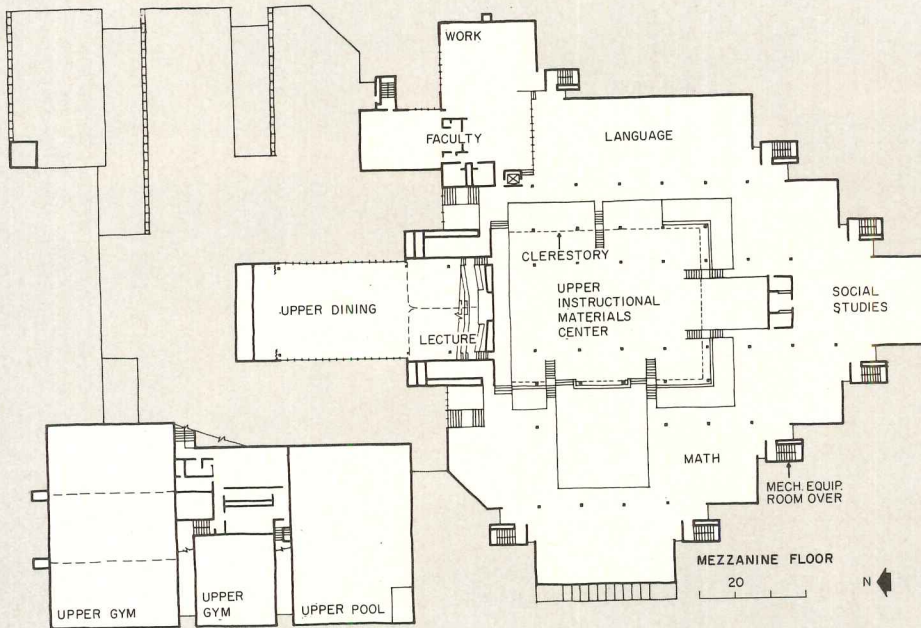

The academic wing encircles the Instructional Materials Center, and has a mezzanine to provide sufficient total area in proximity to the Center. Stair towers (photo, above) were required for egress, and a slight additional height made space at the top for mechanical rooms. Typical hvac zoning is shown, right.

Mercury lamps in recessed pyramids illuminate instructional areas (identified by supergraphics) and the IMC.

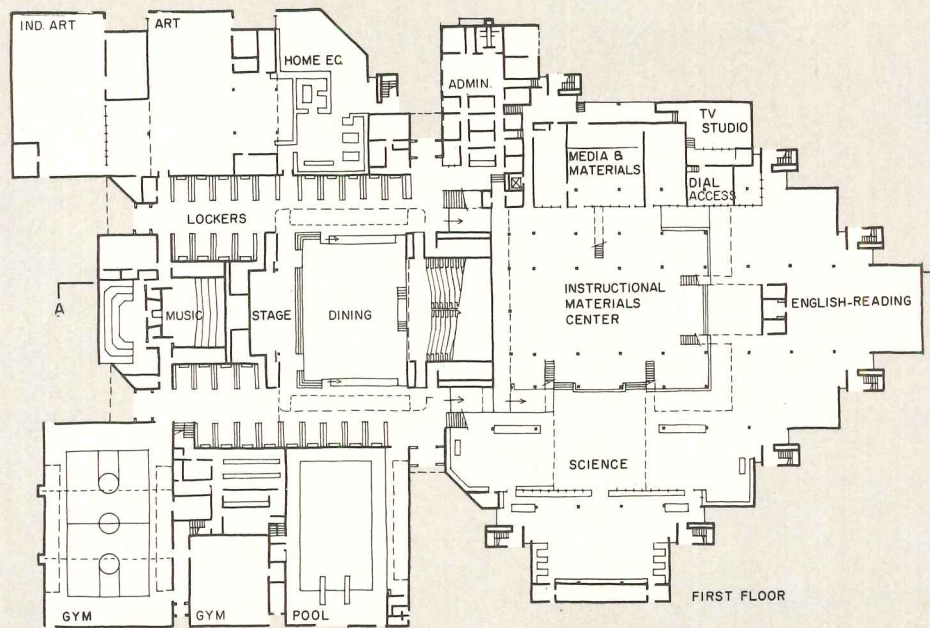
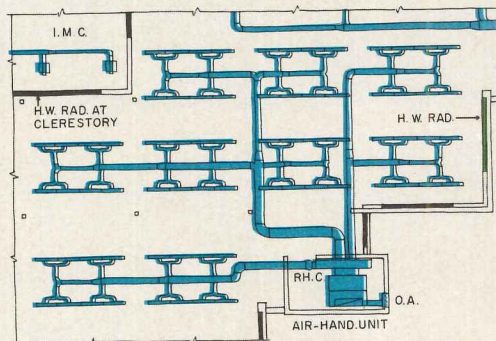



Robert E. Fischer photos

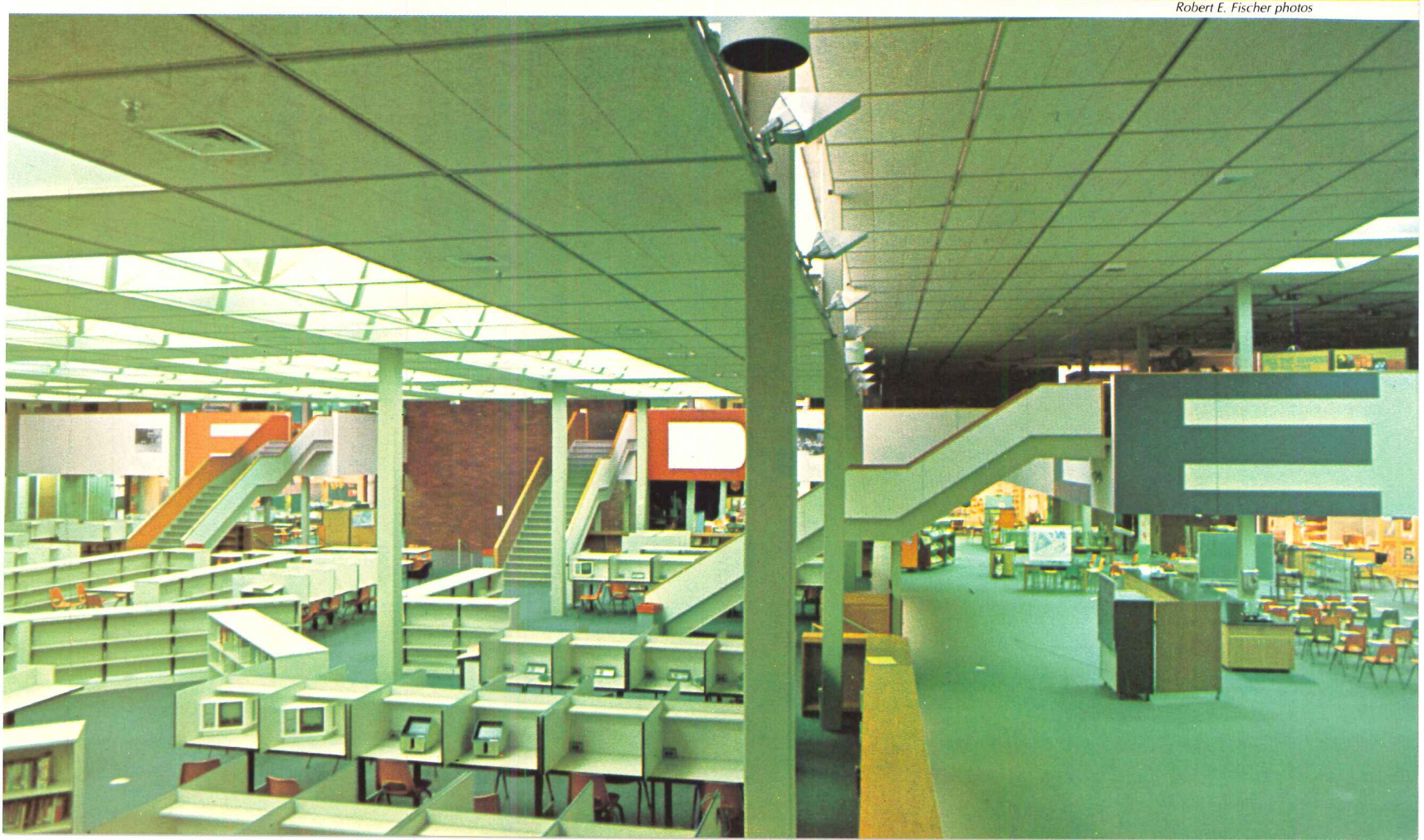

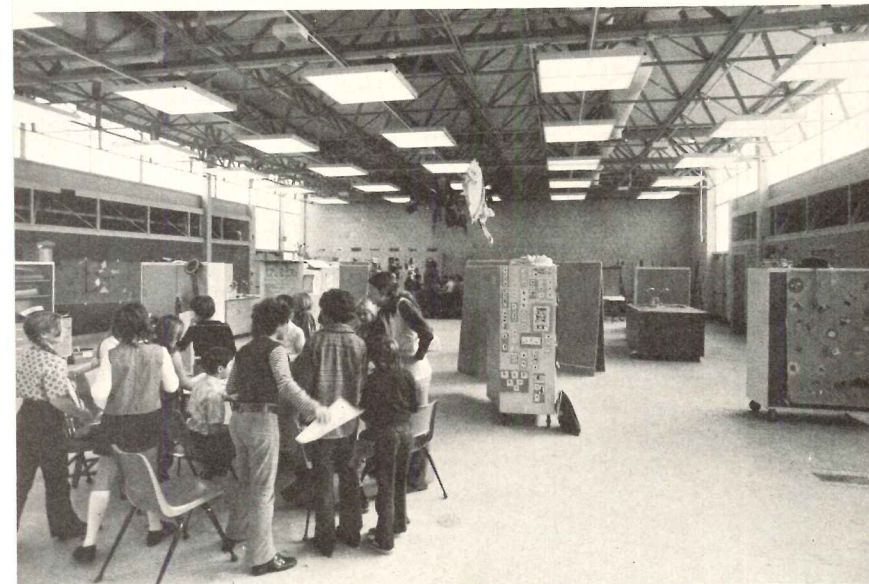

The wide variety of lighting is apparent by examining a classroom area (top), the industrial arts wing (center), and the dining commons (above). The lighting plan, right, covers the width of one 25-ft structural bay, and, in length, goes from an illuminated exterior wall, across the mezzanine, and across the Instructional Materials Center. Lighting in the dining commons is incandescent lamps set in the wooden-cube fixtures. Industrial arts and art wings have fluorescent panels.

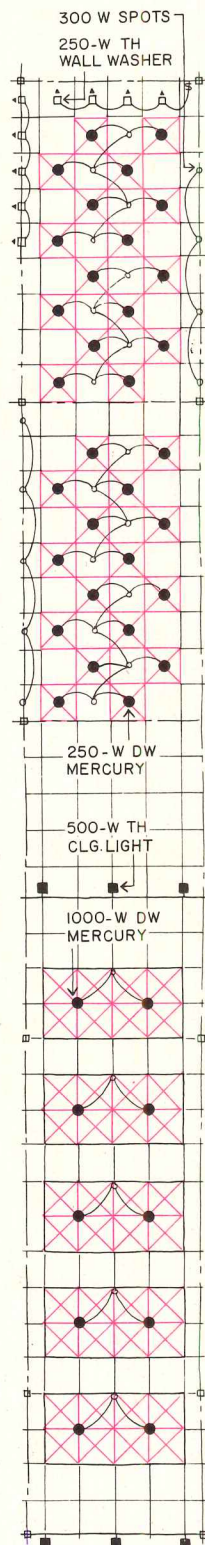

ministration wing in the midsection of the building.

The space-truss system is used throughout the school except for the physical-education wing which required long-span trusses. Permission was obtained from the State to prebid the space-truss system. Its cost was close to other system-building-type framing, and cost trade-offs were possible with the architectural advantages the architect foresaw—no hung ceiling; lighting pyramids in a deep configuration; ready-made slots for air supply and return.

The lighting is unusual for a school—in type and effect

Lighting for the academic areas is by 250-watt deluxe-white mercury lamps recessed in pyramids in a checker-board pattern, shielded against direct glare by acrylic cubed louvers. In the IMC area 1000-watt deluxe-white mercury lamps, shielded by inverted pyramids set between chords of the space trusses, provide indirect illumination. Lighting level after eight-month's use is about 100 fc and energy usage is about 5.6 watts per square foot of lighted area.

Incandescent wall washers with tungsten-halogen lamps are used around the perimeter of classroom areas, and incandescent, indirect ceiling reflectors are spaced around the clerestory at the edge of the IMC for illumination when it is dark outside.

Cost of the 200,000-square-foot building, including site development was \$7.2 million.

BRANFORD INTERMEDIATE (5-8) SCHOOL, Branford, Connecticut. Owner: *Town of Branford*. Architects: *Carlin, Pozzi & Associates*—project manager: *Michael Shellenbarger*. Engineers: *Seelye, Stevenson, Value & Knecht* (structural); *Technical Design Associates* (mechanical/electrical). Consultants: *Sylvan R. Shemitz & Associates* (lighting); *Ranger Farrell & Associates* (acoustical); *Robert D. Chatfield* (food service); *Joseph Rogers, Jr.* (swimming pool); *Maine & Associates* (landscape architects). General contractor: *DeMatteo Construction Company*.

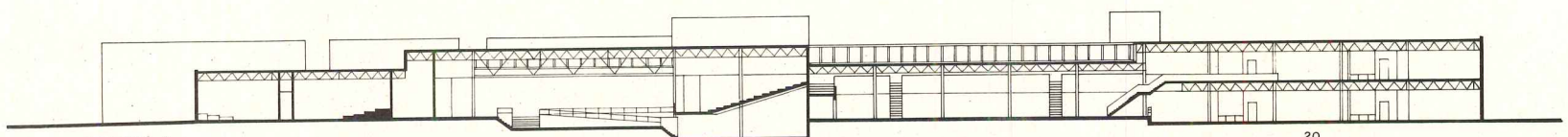

Steelcase announces Series 9000. The next generation of office furniture.

Unlike any furniture you've experienced before. A desk, a credenza, a work station, and a space divider system. A new idea that will influence office planning and productivity throughout the

70's and beyond. Available for your major 1974 projects. A preview showing may be arranged at NEOCON, or write for a color brochure. Steelcase Inc., Dept. G., Grand Rapids, Michigan 49501.
For more data, circle 82 on inquiry card

Steelcase



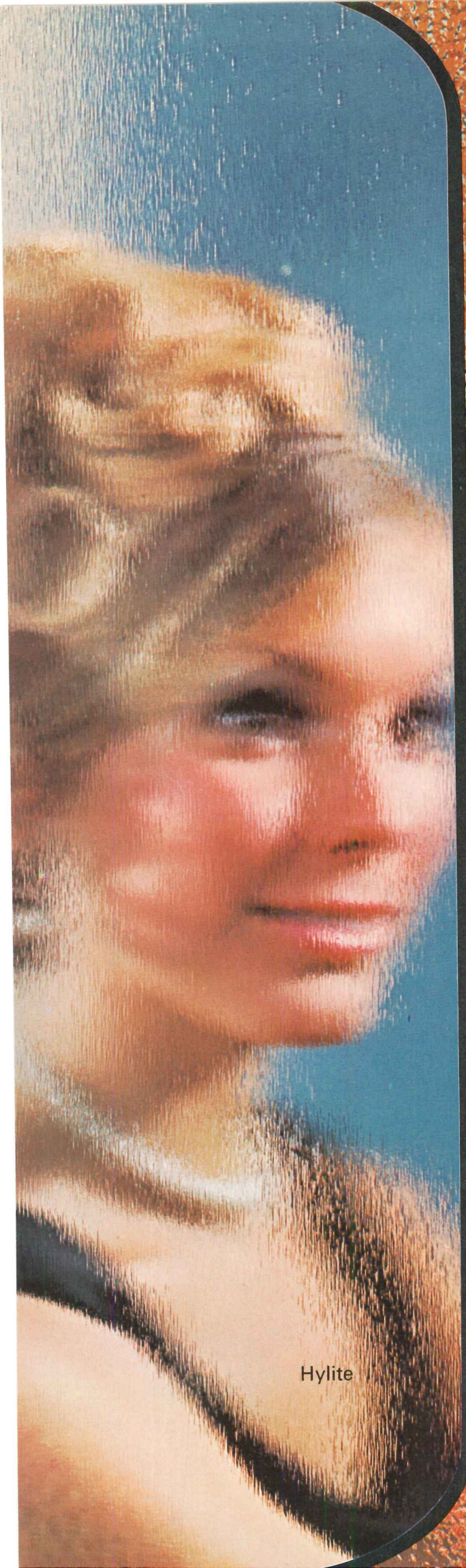

Hylite

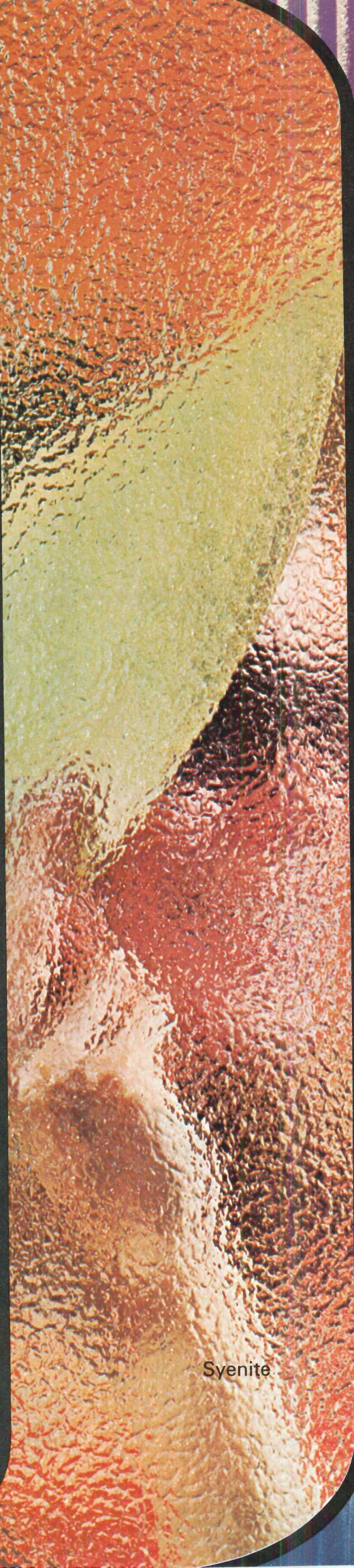

Syenite

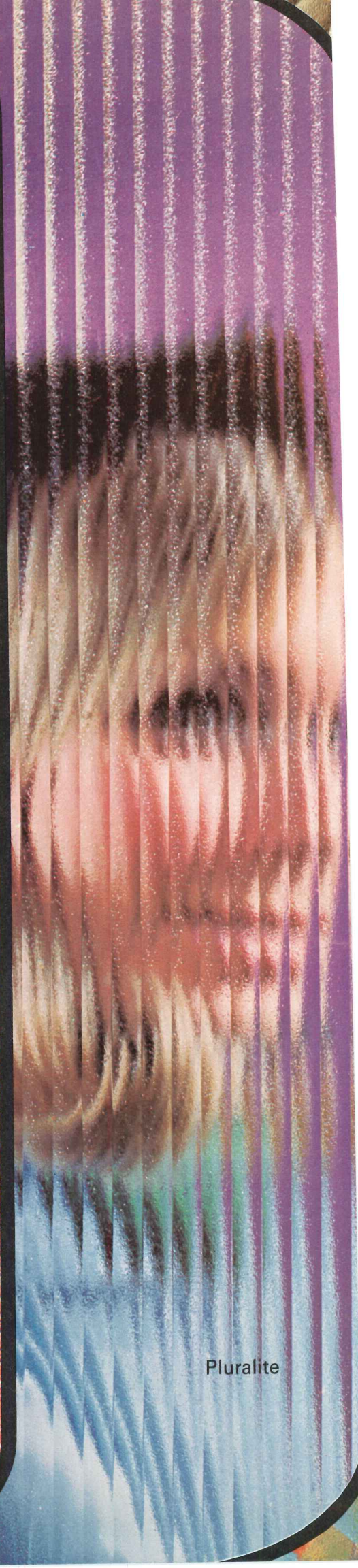

Pluralite

Selections
that give
imagination
full sway

MISSISSIPPI
PATTERNED GLASS

Let light work for you through patterns that give every object exciting new angles of interest. Panels and partitions reveal the passing view. But textures blend with lights and colors to soften the image and give design emphasis. Mississippi patterns by CE GLASS give refreshingly new concepts to windows and walls. Obscure patterns are available to give privacy to any desired degree. CE GLASS has the wide range selections so there's never a limit. Imagination can have full sway whether for contemporary or traditional, or for strictly functional or highly decorative purpose.

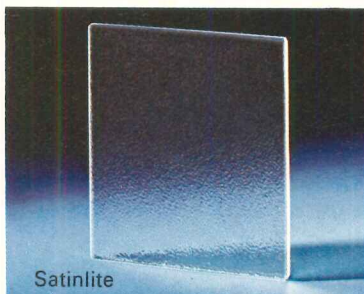

Satinlite

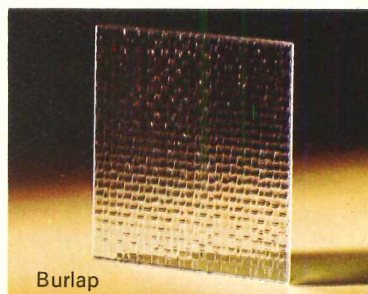

Burlap

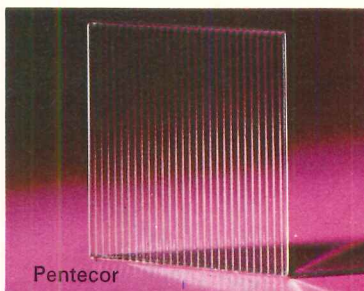

Pentecor

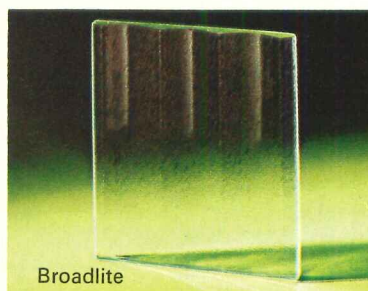

Broadlite

Mississippi patterned glass by CE GLASS is available from leading distributors of quality glass in the principal cities of the United States and in Canada from Canadian Pittsburgh Industries, Ltd., Glass Division. For further information or samples, contact our office nearest you or write CE GLASS, 825 Hylton Road, Pennsauken, N. J. 08110 or call 609-662-0400.

See our catalog in Sweet's 

The logo for CE GLASS, featuring a stylized 'CE' in a red and black square followed by the word 'GLASS' in bold black letters.

For more data, circle 83 on inquiry card

Smooth Rough

Movable Kwik-Wall creates a beautiful look of permanency



Add flexibility and usability to your room space with Kwik-Wall, the movable wall partitions featuring qualities of a permanent wall... attractiveness, durability, sound control. The solid construction of Kwik-Wall makes each area it divides a separate room in the strictest sense of the word. Impressively designed, Kwik-Wall adapts to blend with any design motif, beautifully.

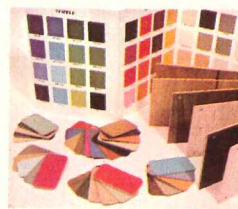

Over 1500 Decorator Facings to select from to give your decor the look of permanence. Chalkboard, chalk trays, corkboard finishes available, in addition to pass-doors with cylinder locks.

One-Hand Locking Operation, insert crank and give a half-turn; spring-loaded top rail expands firmly against ceiling, forming effective sound seals around each panel perimeter.

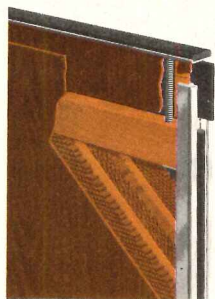
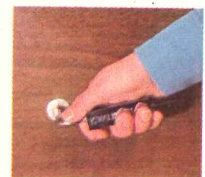

Portable Kwik-Wall (left) requires no tracks on ceilings or floors. Free-standing panels can be stored anywhere, easily rolled into position on optional retractable wheels. Select 1-3/4" standard or 2-1/4" deluxe Kwik-Wall.

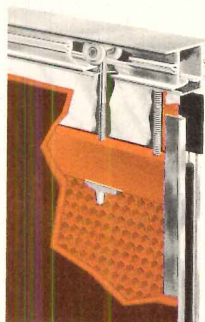

Track-Mounted Kwik-Wall glides with ease on inconspicuous ceiling tracks; needs no floor guides or rollers. Pocket doors provide complete, coordinated concealment of panel storage. 2-1/4" deluxe or 3" master thickness.

the permanent look in movable walls



Send for Free Color Brochure

Kwik-Wall® Company, Dept. 32
P.O. Box 3267, Springfield, Illinois 62708

Name _____
Title _____
Firm _____
Address _____
City/State _____ Zip _____



Fast Service, Less Breakage with automatic kitchen door operators

The new generation of Norton[®] automatic door operators gives you one more important benefit. They're Quiet.

That's right . . . quiet.

We've incorporated a new hydraulic pump in our operators. It's more powerful and it dramatically reduces the discernible noise level. It completely eliminates objectionable noise, making it ideal for the hushed atmosphere so important to the better restaurant.

We've also been able to provide improved door control. Since the operator is more powerful, it opens all sized doors smoother, more effectively.

And, of course, you have faster service in and out of your kitchen. You serve more meals during the

rush hour. And you reduce the possibility of a waitress being caught in a manual door and dropping a tray. All tangible benefits with automatic kitchen doors.

And with Norton automatic operators, you get the dependability of the Norton electro-hydraulic power operation and the smart interior-design styling.

For more information ask your Norton Dealer, your Norton Representative or contact Eaton Corporation, Lock and Hardware Division, Norton Marketing Department, Box 25288, Charlotte, N.C. 28212.

Norton Automatic Operator Systems

Series 2000
Transom Mounted Operators for new or existing doors.

Series 4000
Completely Concealed Operators to fit into aluminum door transoms (4" x 5" minimum).

Series 5000 & 9000
Sliding Door Operators (5000), Sliding Door Operators as a complete package with door and frame (9000).

All control methods and schemes.

EAT•N Security Products
& Systems

1204

For more data, circle 88 on inquiry card

For more information, circle item numbers on Readers Service Inquiry Card, pages 265-266.



Seating group in wool or leather upholstery offered for executive offices

This is *Jigsaw*, a seating group with its chrome structure outlining the upholstered curved components. Its inner structure

is foamed and the upholstery is double-stitched for strength and elegance. Highly recommended for executive offices, the

group can be covered in fabric and leather. ■ Fortress Collections, Los Angeles.

Circle 302 on inquiry card

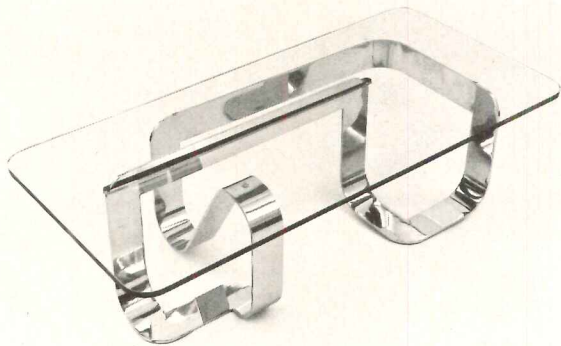

Plate glass and stainless steel; table or sculpture

Shown here is the *Jason* cocktail table, measuring 28 in. by 60 in. by 17 in. high. Polished plate glass top rests on mirror-finished stainless steel, with a por-

tion of the base protruding through the glass lengthwise for 36 inches. ■ Axis, Inc., New York City.

Circle 300 on inquiry card



New wood version of the Dave Woods arm chair

The *Dave Woods Sled Arm* chair, formerly available in polished chrome, is now offered in either oak or walnut. The side assembly is laminated wood. A choice of fabrics is offered. ■ JG Furniture Co., Inc., Quakertown, Pa.

Circle 303 on inquiry card

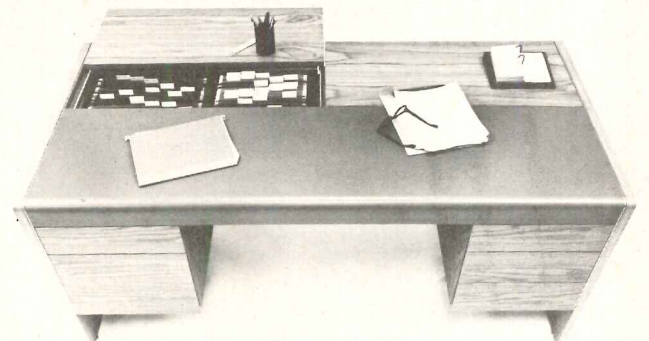
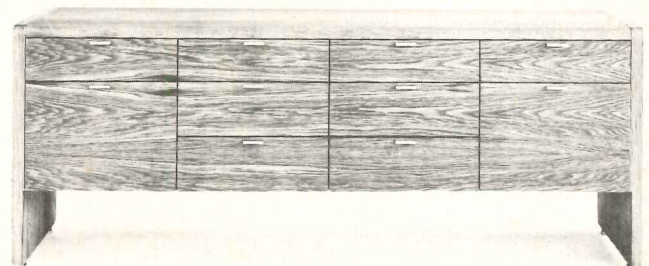

Oak or walnut executive office system with options

The *Veripanel* line of executive office-furniture includes desks, tables, credenzas and "L"s, with radius or square corners. The units are constructed of oak or walnut, with tops of wood or plastic. Special finishes can be accommodated. Capped power

sleeves conceal phone and machine wiring. Note on the desk the tub file, for finger-tip filing, recessed in the unused portion of the shell. ■ Hiebert, Torrance, Calif.

Circle 304 on inquiry card
more products on page 197

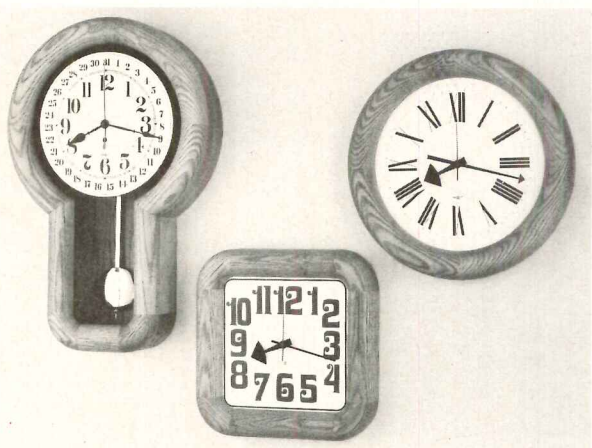

Natural wood and shapes featured in unique clocks

Here, three distinctive and different-appearing clocks look out from smooth, flowing curves of specially selected wood grains of natural oak. All are from the *Natural Classics* series, showing simple, direct design by Arthur Umanoff.

White faces with black Arabic or Roman numerals are featured. Battery movement. On *Schooldays* shape, an 8-day wind calendar pendulum movement is offered. ■ Howard Miller Clock Co., Zeeland, Mich.

Circle 301 on inquiry card

Scald-GuardTM keeps you and your customers from getting burned.

Most shower faucets require careful manipulation of the handles to get a comfortable blend of hot and cold water. Scald-Guard does not.

Most shower faucets have a quick handle turn into the critical hot water zone. Scald-Guard does not.

Most shower faucets require messy, expensive crosspiping and wrong-side, awkward maintenance. Scald-Guard does not.

Scald-Guard is simple to install and even simpler to operate.

It's safe. Constant. Reliable. With the optional pressure balance valve, dishwashers, flushed toilets and clotheswashers don't affect the shower water temperature.

And Scald-Guard rarely drips - because like all Delex faucets it has no washer to wear out.

Don't get burned. Don't let your customer get burned. Specify Scald-Guard.

*For illustrated literature, write
Delta Faucet Company,
A Division of Masco Corporation,
Greensburg, Indiana 47240,
and Rexdale, Ontario.*

Delta Faucets.
Washerless. To work as good
as they look.

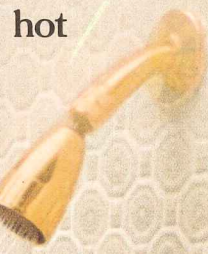

Thinking about a waste collection system?

Thinking about a pneumatic waste collection system?

Think about:

TRANS-VAC SYSTEMS

designers of

Pneumatic Transport & Waste Collection Systems for handling soiled linen or trash (or both).

fast • efficient • sanitary



WASTE COLLECTION POINT

- SHREDDER
- BALER
- COMPACTOR
- INCINERATOR



LAUNDRY COLLECTION POINT

Simplified Illustration

used in:

● hospitals

Ideal for new hospital construction, major additions or renovations . . . or can also modify existing gravity chute systems for lateral transfer of material.

● high-rise structures

Ideal for high-rise structures such as hotels, motels, large office buildings, apartment complexes, dormitories and institutions.

● large recreational developments

Ideal for large recreational projects, amusement parks, sports complexes and stadiums.

Space saving TRANS-VAC Systems utilize idle wall and ceiling space for placement of chutes and conveyor pipes. Piping may also go above or below ground, over roof tops, along outside walls and into basement area. Separate collector hoppers located in laundry room and trash collection area automatically deposit loads of transported material on signal from central control panel.

TRANS-VAC Systems offer completely integrated systems for Pneumatic Transport, Shredding, and Waste Disposal — all fully automatic. Each system individually engineered and backed by 47 years experience in pneumatic conveying and waste disposal technology.

Write or phone Dept. AR for further information and/or design assistance. See our Catalog 11.25/TR in SWEET'S 1973 Architectural Reference File.



Since 1925—Solving Difficult Problems for Industry

TRANS-VAC SYSTEMS

A Division of MONTGOMERY INDUSTRIES INTERNATIONAL
1017 THELMA ST. • P.O. BOX 3687 • JACKSONVILLE, FLORIDA 32206
TELEX 56292 PHONE 904-355-5671

For more data, circle 91 on inquiry card

For more information, circle item numbers on Readers Service Inquiry Card, pages 265-266.

CLEAN ROOM EQUIPMENT / Industrial, commercial and institutional uses for modular laminar flow clean room equipment are described in a new, four-page brochure. According to the manufacturer, the self-contained clean room components are modular in design for easy, economical installation, maintenance and system upgrading or expansion. All are pre-assembled, tested, certified and ready for immediate installation. ■ Weber Technical Products, Grand Rapids, Mich.

Circle 400 on inquiry card

SPRINKLER GUIDE / A handbook on sprinkler systems that covers what they do and how they work discusses wet and dry pipes, pre-action sprinklers with and without supervised piping, deluge types, and other common systems. The 28-page handbook contains numerous photographs and drawings of basic system types. Copies of the handbook—item 74-5621—are available at \$1 post paid from Honeywell's Commercial Inquiries Supervisor, Mailstation G2118, 2727 South Fourth Avenue, Minneapolis, Minn. 55408.

Circle 401 on inquiry card

SNOW MELTER / As well as explaining how the system operates through the use of a cut-away illustration, the brochure describes the world's largest installation in Quebec City as well as smaller systems for shopping plaza parking lots and top decks of parking garages. ■ Trecon Inc., Conshohocken, Pa.

Circle 402 on inquiry card

STEEL PARKING STRUCTURES / A technical report featuring design charts, building code information and cost principles on steel framed parking structures has been released by the company. Future trends in parking garage design are also discussed, plus fire code requirements and results of tests conducted by several agencies. ■ United States Steel, Pittsburgh, Pa.

Circle 403 on inquiry card

ELECTRIC HEATING / A comprehensive catalog now lists all features, specifications, ratings, and current prices of the company's line of electric heating products. A third of the 16-page publication is devoted to the unit heater line introduced earlier this year—the first complete catalog listing of this new line. Other products listed include baseboard, wall, strip, and infrared heaters, controls and other accessories. Cutaway photos and dimensional drawings graphically answer many design and application questions about the products. ■ Bryant Electric Co., Bridgeport, Conn.

Circle 404 on inquiry card

METAL WALL SYSTEM / *Varispan Panel System* is a metal wall system available with a choice of three depths of liner panel—3 in., 4½ in. and 6 in. The bulletin gives features, dimensions, and technical data, including load span tables and architectural specifications. ■ Cyclops Corp., Pittsburgh, Pa.

Circle 405 on inquiry card

BATTERY CHARGER / A new line of silicone controlled rectifier (SCR) battery chargers is described in a catalog now available from the company. The new solid-state charger is fully automatic and features AC voltage compensation, DC voltage regulation, and electronic current limiting. Catalog includes complete specifications, a list of optional accessories, electrical schematic, dimensional and weight data, plus ordering information. ■ NIFE Inc., Copiague, N.Y.

Circle 406 on inquiry card

FLOOR SURFACING / A descriptive brochure explaining a unique spray-on floor surfacing *NU-Klad 100* which cuts application time as much as 60 per

cent has been made available by the company. By eliminating hand troweling and screeding, installation costs and costly plant downtime are reduced. The new surfacing is formulated to provide concrete surfaces with resistance to corrosive chemicals, abrasion and thermal shock. ■ Ameron Corrosion Control Div., Brea, Calif.

Circle 407 on inquiry card

ACCESS CONTROL / A 20-page article that gives guidelines for selecting a personnel identification and access control system, written for both laymen and security professionals, provides diagrams and cost/benefit comparisons for systems ranging from the common "man-guard" to the more sophisticated, remote control "machine-guard" systems. ■ Madrix Security Systems, Mountain View, Calif.

Circle 408 on inquiry card

OSHA COMPLIANCE / An outline of the new Federal Occupational Safety and Health Act (OSHA) regulations is now available. Published for over a quarter-century, the 950-page directory includes a digest of applicable OSHA standards and definitions for nearly 4,000 products in 80 major categories. ■ A. M. Best Co., Morristown, N.J.

Circle 409 on inquiry card

INDUSTRIAL FLOORS / "Where other flooring fails," an eight-page booklet updating the installation procedures, service characteristics and long-term performance of *Monile* polyacrylate heavy duty industrial floors, has been issued. This rapid curing high-strength oil-, grease- and water-resistant flooring can be installed over wet or dry concrete, brick or tile. ■ Mameco International, Cleveland, Ohio.

Circle 410 on inquiry card

INCINERATOR / An 8-page brochure describing the *Combustopak* incinerator, a compact, modular solid waste disposal system, has been issued. The *Combustopak* incinerator is designed to serve the burdened solid waste disposal facilities, meeting stringent pollution control standards. ■ Combustion Engineering Inc., Windsor, Conn.

Circle 411 on inquiry card

HARDBOARD PANELING / A complete product guide, in 12 pages, contains information on wall panels and planks, ceiling blocks and mural panels. This decorative paneling comes in 69 colors, designs and textures. It offers finishes that resist heat, soiling, stains and moisture. Tongue-and-groove edges simplifies installation. ■ Marlite Div., Dover, Ohio.

Circle 412 on inquiry card

GRAPHIC PROCESSING / This 12-page brochure describes, in lay terms, all facets of graphic processing—from drawing lines to profit considerations to improving work flow. Intended for the architectural, engineering and utilities industries, this guide helps the user to determine his own graphic processing needs. ■ Applicon Inc., Burlington, Mass.

Circle 413 on inquiry card

HIGH-RISE FIRE SAFETY / A newly released handbook deals with thoughtful fire management programs, using systems to contain and extinguish fires in high-rise buildings. The brain of the system is a fire-control center that automatically alerts the operator to the exact location of a fire; controls fans and dampers to pressurize adjacent areas; moves elevators to floors available to firemen; and tells occupants what to do in the emergency. ■ Honeywell Commercial Div., Minneapolis, Minn.

Circle 414 on inquiry card

more literature on page 234

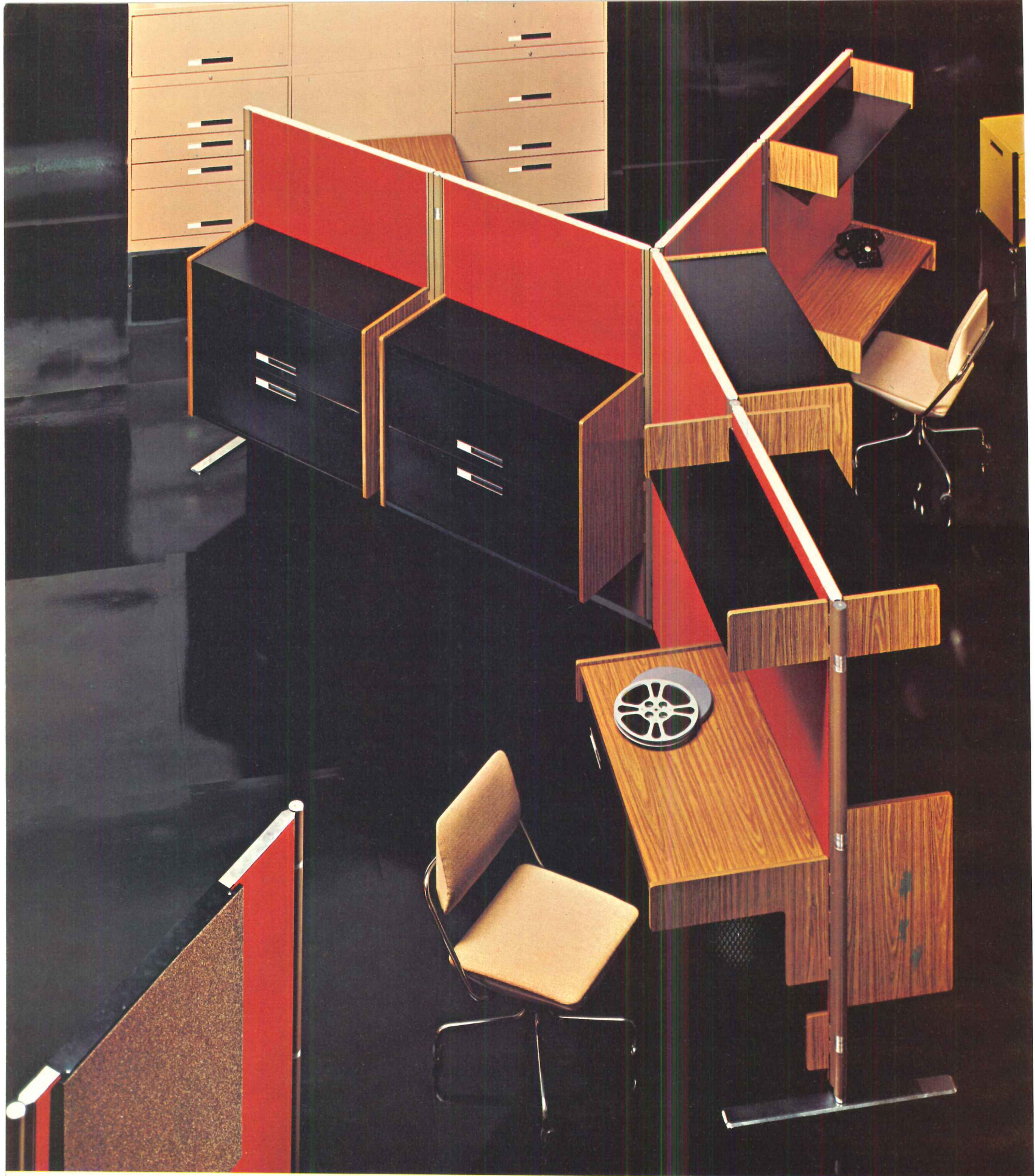

Space geography. Two durable open-office systems with one design identity provide total planning freedom... solve work-flow problems... allow for continuity of growth with the efficiency and convenience of one source:



INTERROYAL CORPORATION, ONE PARK AVENUE, NEW YORK, NEW YORK 10016 • (212) 686-3500

TEST PROVES: NO NYLON FIBER HIDES SOIL BETTER THAN ENKALURE II.

The truth is out about soil-hiding nylon commercial carpet fiber.

Enkalure® II is as good as the best.

It's been tested and proven by the independent testing laboratory, Nationwide Consumer Testing Institute. They placed carpets made of the leading nylon fibers in one of the most heavily traffic'd airports in the country.

And when the results came in, Enkalure II's soil-hiding ability proved to be every bit as good as the best-known soil-hiding nylon.

The reason is that, unlike conventional nylon fibers, Enkalure II bulked continuous filament nylon and staple fiber have no deep grooves to trap and hold dirt. Also, its special construction causes light actually

to bounce off the fiber in every direction. So the color looks clean, even when the carpet is dirty.

Anyone installing Enkalure II has our guarantee that it will not wear more than an average of 10% in five years, or we'll replace it.

If you have the kind of floor that takes a lot of traffic as well as a lot of dirt, you would do very well to put down carpeting made of Enkalure II soil-hiding nylon.

In fact, now we know you can't do any better.

For specific carpet information and a 14-page report of the test results, contact American Enka (Dept. AR) 530 5th Avenue, N.Y., N.Y. 10036. (212) 661-6600.

**ENKALURE II.
THE OTHER LEADING
SOIL-HIDING NYLON.
ENKA**

For more data, circle 93 on inquiry card

ENKALURE® II IS A REG. T.M. FOR SOIL-HIDING MULTIFIBER NYLON FIBER MANUFACTURED BY AMERICAN ENKA CO. ENKA, N.C. A PART OF AKZONOB INC. ENKALURE II IS LICENSED FOR USE IN CARPET MANUFACTURED ACCORDING TO QUALITY SPECIFICATIONS SET BY ENKA





How Weyerhaeuser

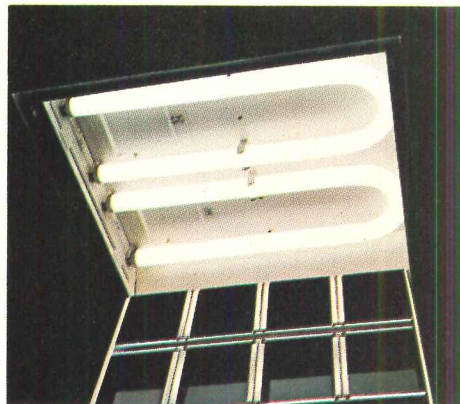

Acres of interior have to be lighted in Weyerhaeuser's new International Headquarters near Tacoma, Washington.

Sylvania Curvalume lamps—12,000 of them—help do the job.

Two of these U-shaped lamps fit perfectly into a 2x2-foot, low-brightness, air-handling fixture. This made it possible to design attractive, modular ceilings that permit even distribution of both



Architecture, engineering, interior design: Skidmore, Owings & Merrill, San Francisco. Space planning: Sydney Rodgers Associates, Inc. Photographs: Ezra Stoller © ESTO.

lampscaaped its ceilings.

light and air and assure a comfortable level of illumination in all areas.

Curvalume lamps also play a part in the building's climate control system. Heat from the lamps and ballasts is saved and reused. This conserves energy and helps maintain balanced, year-round temperatures inside the building.

The lamps save in other ways.

Two 40-watt bent lamps deliver

20% more light per fixture than four straight 20-watt fluorescents. And they need only half the number of ballasts and sockets. This cuts installation costs.

The Curvalumes also last about 60% longer than the straight lamps. They're rated for an average life of 12,000 hours. This means less maintenance.

So if you have acres of ceiling, you can be sure of one thing: you

can combine the beautiful and the practical.

Just landscape with Curvalumes.

For details, call your GTE Sylvania representative or local independent electrical distributor (in the Yellow Pages under Lighting)—or write to Sylvania Lighting Center, Danvers, Mass. 01923.

GTE SYLVANIA

For more data, circle 94 on inquiry card

EVERYTHING AN ARCHITECT NEEDS TO KNOW ABOUT REFUSE COMPACTORS

Whether you're specifying compactors for a new building or upgrading the refuse handling system in an existing building, here's your handy reference guide. It's from International Dynetics Corporation, the recognized leader in compaction equipment. The booklet is filled with straight-forward information to help you specify the compactor that's *right* for your client's building, and *right* for his budget.

- **Compactor selection section** shows you how to specify a compactor that matches the refuse output of a building, helps you avoid over-capacity your client doesn't need.
- **Complete specifications** of seven proven and reliable IDC compactors. There's a size, style and price to match your client's needs.
- **Plan drawings** of refuse room requirements. You see just how much space each compactor needs for easy operation. Use the drawings in your own plans.
- **Detailed dimensional drawings** of each refuse compactor for installation with or without refuse chutes.
- **Step-by-step photos** show how fast and easy it is to operate a modern IDC compactor.
- **Operational diagrams** show how different compactors work, help you choose the model that's most efficient and most economical for your client's refuse operation.

To get your free copy of this 16-page booklet, just fill in the coupon or use the inquiry card. For faster action, contact International Dynetics Corp., 4 Taft St., S. Norwalk, Conn. 06854 (203)853-9911.

IDC has representatives in principal cities all over the U. S.



INTERNATIONAL DYNETICS CORPORATION
4 Taft St., South Norwalk, Conn. 06854

AR-6

- Please send me your brochure immediately.
 Please have your local representative contact me.

Name _____

Firm _____

Address _____

City _____ State _____ Zip _____

INTERNATIONAL DYNETICS

For more data, circle 95 on inquiry card

Seen this *Sweet's Insert ?

If not, write for your special copy today. It details Bali-Architect's many impressive **Exclusive Blind Features.**

*Architectural and Interior Design files



Our famous Betsy Ross conventional Venetian Blinds are also detailed. Sales and service available nation-wide.

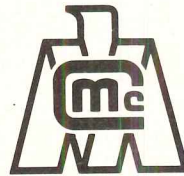

Division of Marathon Manufacturing Company

marathon carey - mcfall company

2156 E. DAUPHIN ST. • PHILADELPHIA, PA 19125

For more data, circle 96 on inquiry card

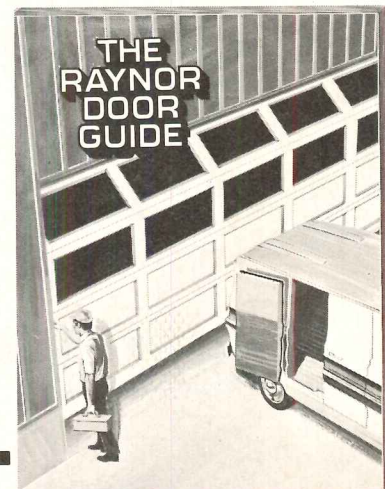

All the facts you should know about garage doors can be found in this complete Raynor reference guide. Garage door styles, materials, mountings, applications, specifications (including handy door and track selection guides),... **PLUS** information on Raynor's new deep-ribbed, good-looking 'Security Line' steel doors. See why Raynor builds better doors.

Just clip this coupon and mail to:
RAYNOR MANUFACTURING COMPANY
Dept. AR-6, DIXON, ILLINOIS 61021

Name _____

Firm _____

Address _____

City _____

State _____ Zip _____

For more data, circle 97 on inquiry card

PORTABLE SOLID WASTE AND REFUSE COMPACTORS and systems from The Tony Team, Inc. includes four sizes and great versatility. Pollution Packer™ compactors bale, bag and box all types of wastes and refuse, wet or dry. Machine capacities range from .8 C. Y. to 4½ C. Y. of loose wastes at 10 to 1 compaction ratio . . . operate on low amperage, 110-V60 cycle service. For hospitals, hotels, schools, colleges, restaurants, office and apartment bldgs. Simple adaptation to chute-type disposal systems. Spec sheets and literature available from: The Tony Team, Inc., 7399 Bush Lake Road, Mpls., Minn. 55435.
For more data, circle 98 on inquiry card

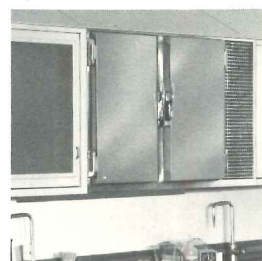

EYE-LEVEL LAB REFRIGERATORS WITH MODULAR COMPATIBILITY fit flush with existing or planned casework to achieve a clean, uninterrupted line of design. Stainless steel throughout, exteriors can be finished to your specifications. Model illustrated, 30"H x 54"L x 13"D, has a 6.6 foot capacity. Blower coil cooling system with condensate evaporator and accumulator eliminates need for drain. Explosion-proof interior available. Easily serviced from front. Write: Jewett Refrigerator Co., Inc., 2 Letchworth St., Buffalo, N.Y. 14213.

For more data, circle 99 on inquiry card

At last! A wall system that can match your imagination!

Solid hardwood prefinished wall planks

Random width, random length genuine solid hardwood wall planks, lovingly prefinished, in a choice of 13 woods with the full natural beauty and richness that no imitation can match. Send today for Designer's Sample Kit containing 13 full-size sample species, textures and finishes.



Townsend® Paneling

Potlatch Corporation
P. O. Box 916, Stuttgart, Arkansas 72160



- Enclosed is my check for \$3 to cover cost of my sample kit.
 Please send additional literature.

Name _____ Phone _____
Firm _____
Title _____
Street No. _____
City _____ State _____ Zip _____

For more data, circle 100 on inquiry card

For more data, circle 101 on inquiry card

Pane**l**brick^{T.M.}

a new dimension in brick

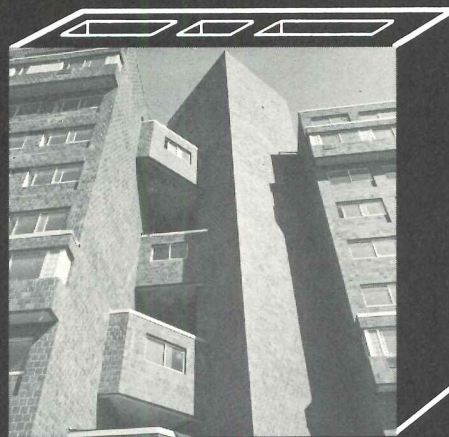

1. 3 5/8" X 7 5/8" X 7 5/8"

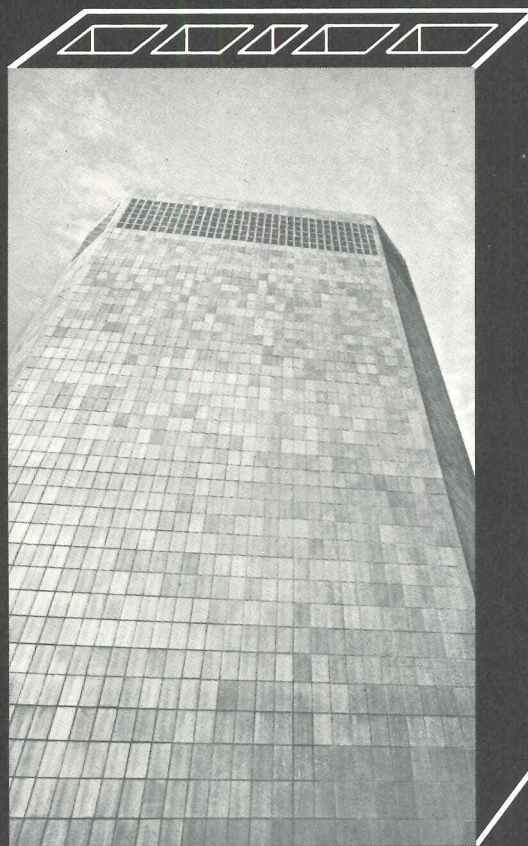

2. 3 5/8" X 15 5/8" X 9 5/8"

1. TWIN PARKS WEST and SOUTHWEST
Bronx, New York
Architect:
Giovanni Pasanella

2. INTERNATIONAL HEADQUARTERS
S.S. KRESGE CO.
Troy, Michigan
Architects, Engineers, Planners:
Smith, Hinchman & Grylls
Associates, Inc.

Genuine fired-clay building units from the kilns of

Glen-Gery
Corporation



**How do you
light an inferno?**

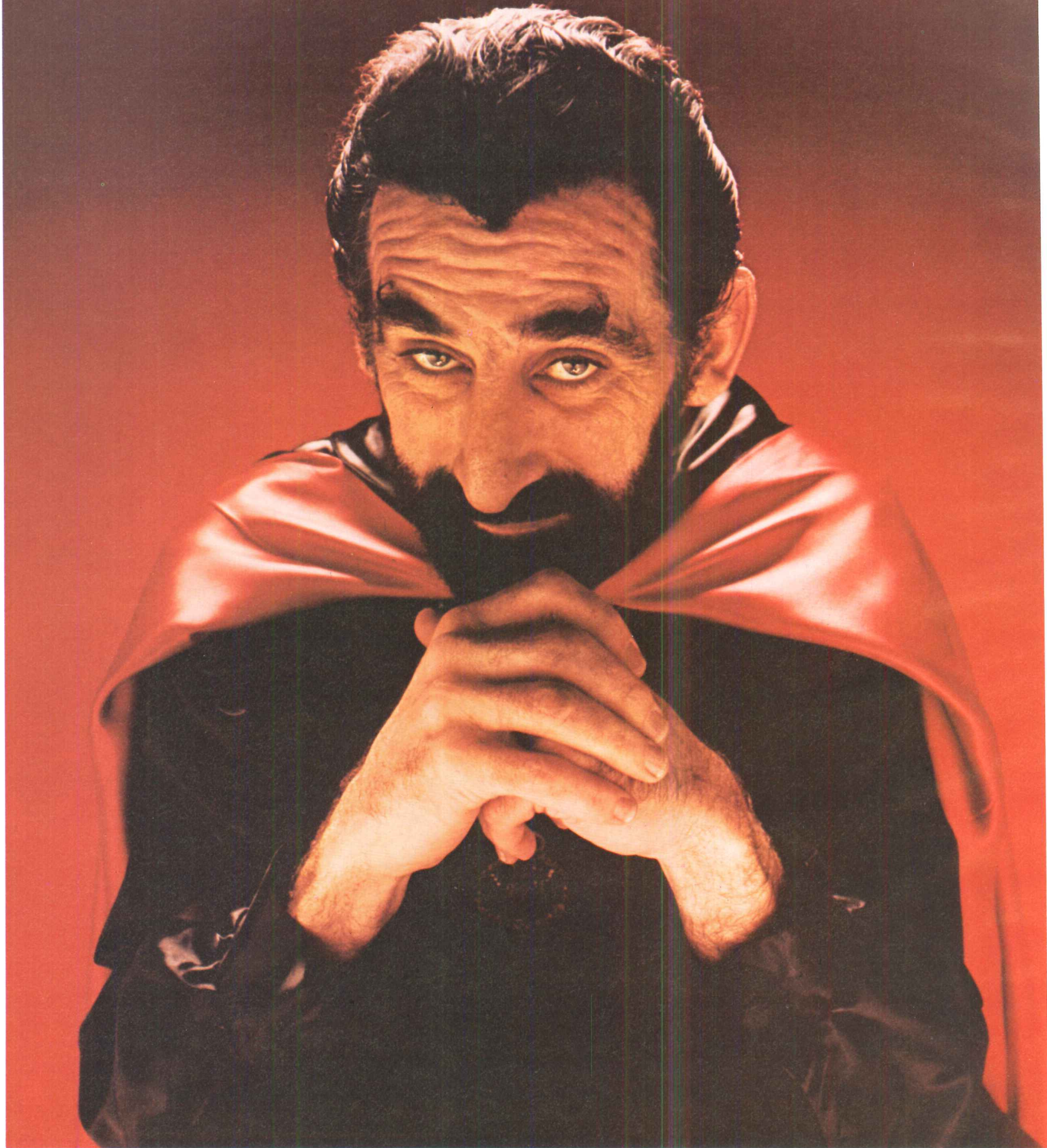

Wide-Lite conjures up the perfect solution to keep industry from burning holes in its pockets.

Heat, fumes and dust can really play "the devil" with industrial lighting efficiency. And significantly add to the cost of plant operation and maintenance.

Until now that is.

Because, now Wide-Lite introduces a fixture that handles these "demons" with ease. Increases lighting efficiency. And saves money.

The IL Series luminaire.

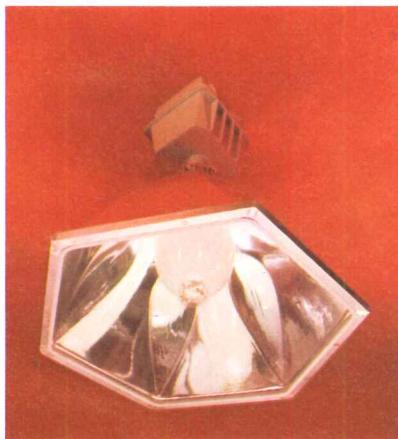

A reflector no human could design.

We used a computer to design the IL's patented reflector. To produce more of the stronger, primary reflections.

All light is either direct transmission or single reflection. There are no multiple reflections. And no source masking.

Which all adds up to greater lighting efficiency.

Your ceiling is no limit.

For low mounting heights you may want a wide beam. For high, just the opposite.

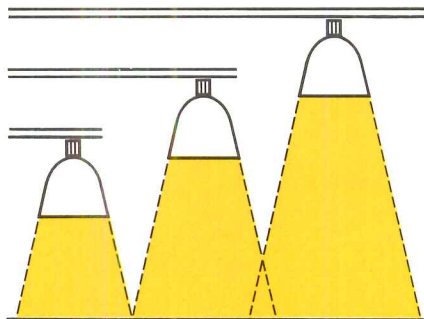

So the IL has three socket positions to give you the exact spacing to mounting height you require. From .7 for high bay, to 2.0 for lower ceilings.

Combine this feature with a wide choice of reflector and lens combinations and you get smooth, even illumination for any design parameter. With no wasted light.

Works better than glass.

The IL's revolutionary new lightweight Teflon® lens (patent pending) has several advantages over clear glass.

It transmits up to 5% more visible light. Is absolutely unbreakable. Has a high resistance to corrosive chemicals and solvents. And its superior anti-stick quality minimizes luminaire dirt depreciation. (A standard tempered glass lens is also available.)

No ballast-to-power wiring.

With the IL's optional quick disconnect feature you simply slide the pre-wired ballast and fixture onto the connector plate and establish immediate electrical contact.

Because there's no wiring involved, your maintenance man

can remove any luminaire and ballast unit for field servicing.

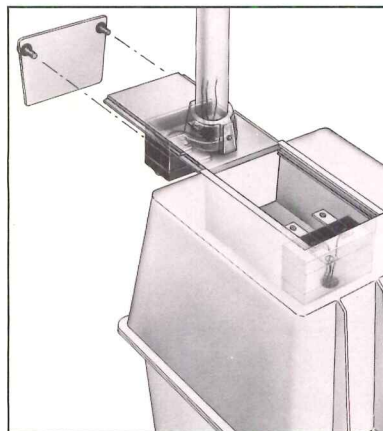

When it's hot, it's cool.

The IL has a ballast that's designed for ambient temperatures as high as 150°F. Its capacitor is kept separate from core and coil.

And, like all Wide-Lite® fixtures, the IL has a sealed lamp and reflector compartment that is dust tight. To keep lighting levels high. And lighting maintenance low. It uses the most economical of light sources. (Mercury vapor, metal halide and high pressure sodium lamps.)

So if you're tired of industrial lighting costs burning holes in your pocket, call your Wide-Lite® representative in the Yellow Pages, under Lighting. He'll help you put out the fire.

WideLite®

P.O. Box 191, Dept. AR-1157-6/73
Houston, Texas 77001

Also manufactured in Australia, Belgium, Canada, Mexico and Great Britain.

A company of the Esquire Lighting Group.
®Trademark of Wide-Lite Corporation.

*Reg. U.S. Pat. Off. For DuPont's Fluorocarbon Film.

NOW the advantages of a built-up system with the economies of factory fabrication

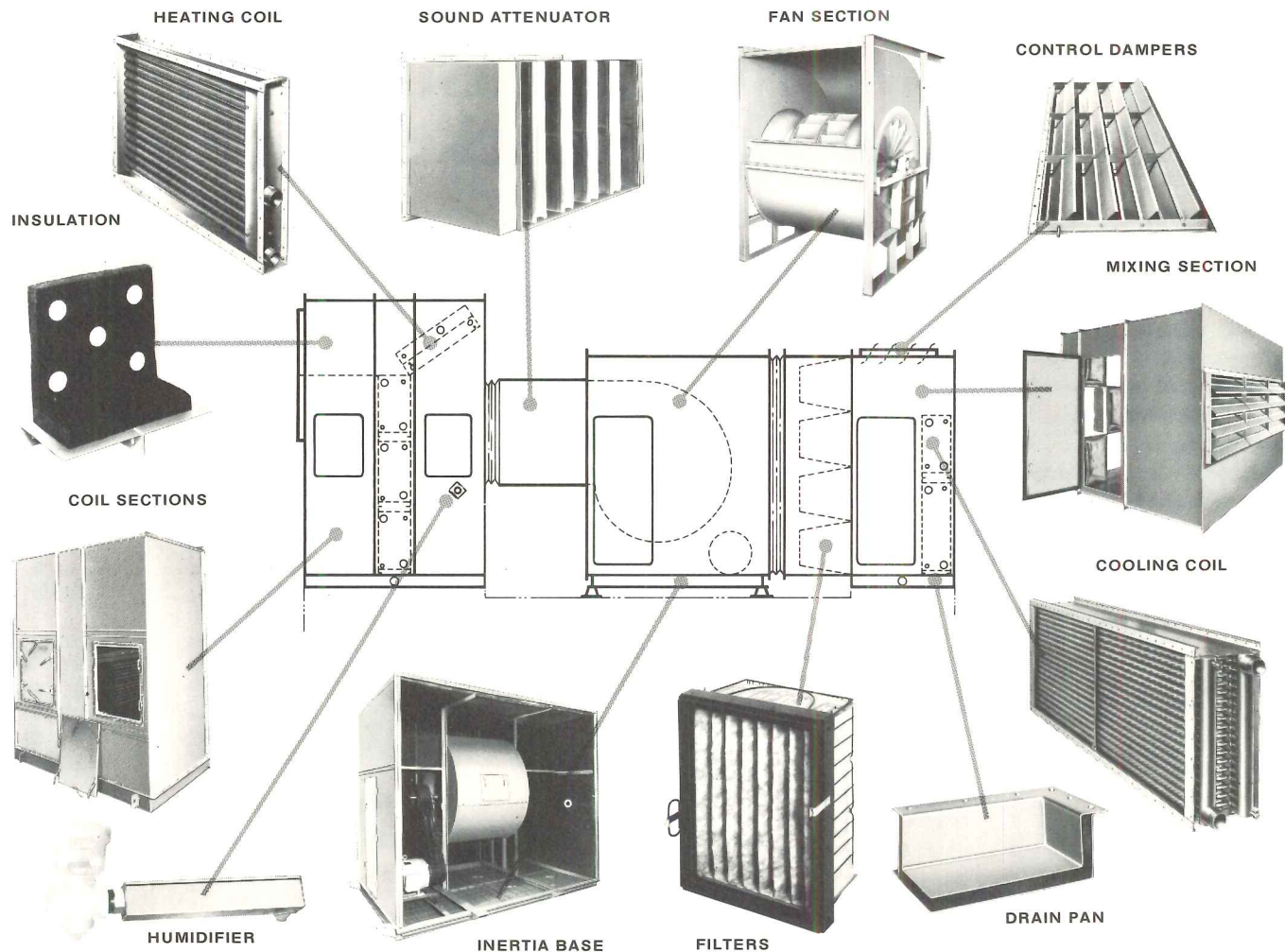

it's 'Buffalo's' MODEL "J" air handling systems

You have a pretty good idea what results you want from the air handling system. Right? Question is, how to get the correct components quickly — easily — at the right price.

Buffalo's new Model "J" Air Handling Systems are the answer. Without a doubt, this system provides you with the most comprehensive choice of components available in a factory fabricated package. Best of all, these compo-

nents are cataloged in a way that maximizes your specifying time. This precise cataloging also gives you and the others on the building team complete control of the Air Handling System. And your Buffalo Sales Engineer has detailed pricing information so he can give you a quote when you need it. The end result—the right system at the right price.

To really appreciate what this new system can mean to you,

spend a few minutes with a Buffalo Sales Engineering Representative. He's listed in the Yellow Pages of the business center near you. Or, request Bulletin AC-100.

Air Handling Division, Buffalo Forge Company, Buffalo, New York 14205. In Canada: The Canadian Blower and Forge Co. Ltd. *Air Handling Equipment • Finned Coils • Centrifugal Pumps • Machine Tools.*

 **BuffaloForgeCompany**

For more data, circle 103 on inquiry card

continued from page 177

OFFICE CHAIR / Frames of round tubing fashioned into open flowing forms create a "transparent" feeling. Plywood seats and backboards are dual-directionally curved to cater to the human frame. The 700 series includes four models: an arm tilter; side chair with arm; armless side chair; and

secretarial chair. Upholstery is available in a full range of vinyls and fabrics. Illustrated is the 748 arm tilter chair. ■ Curtis Products Ltd., Cobourg, Ont.

Circle 305 on inquiry card

INTEGRATED CEILING SYSTEM / Product provides approximately 200 foot-candles with virtually no cross glare, according to the company. Because it is on 5-ft modules, the ceiling can be changed easily to rearrange the interior layout. Light fixtures can be changed to accommodate practically any need without changing the basic ceiling structure. The sides of the modules are acoustical *Minaboard* which soak up much of unwanted sound. Ducts carry conditioned air to air boots which fit the grid. ■ Armstrong Cork Co., Lancaster, Pa.

Circle 306 on inquiry card

DRAFTING MACHINE / This machine for drawing in perspective eliminates all of the devices usually required and permits perspective drawings without setting or plotting vanishing points. Moreover, the positions of station and vanishing points are readily ascertained, thus it is most effective when these points are undeterminable on the drawing board. ■ Uchida Yoko Co. Ltd., New York City.

Circle 307 on inquiry card

CUSHIONED VINYL FLOOR / *Quiet Zone* floors are unique as the only cushioned inlaid vinyl floors available for commercial and institutional use, according to the company. The pattern extends through the entire wear surface. The "Grand Central" pattern has been especially styled for commercial and institutional interiors with a subdued, random pattern that forms a neutral backdrop for other furnishings. ■ Armstrong Cork Co., Lancaster, Pa.

Circle 308 on inquiry card

EXECUTIVE DESK / This desk features mirror-finished, stainless steel base flush to the floor creating a floating illusion. All are expertly crafted, with continuous grain top, sides and front forming a perfect mitre. ■ Office Suites, Inc., Chicago, Ill.

Circle 309 on inquiry card

more products on page 208

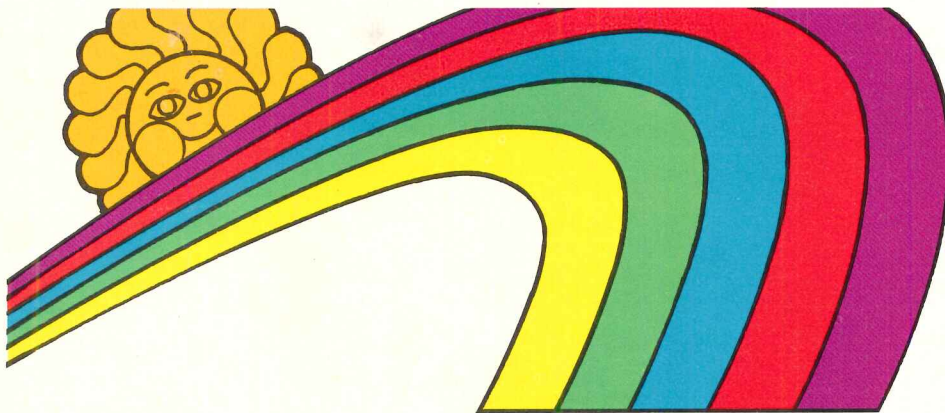

Now we'll paint Oasis water coolers to match your thinking. Bright, bold, brilliant tones. Soft, subtle, delicate shades. Your choice of styling, too. On-A-Wall, Semi-Recessed, Simulated Recessed or Free-Standing.



Specify Oasis for any cooler need. In any color you want. Even if it's just a pigment of your imagination. Check Sweet's. Or send for our colorful full-line catalog and Color Selector Guide today.

OASIS[®]
The word for water coolers.

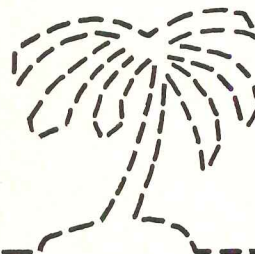

Ebco Manufacturing Co.
Dept. AR-3
265 N. Hamilton Rd.
Columbus, Ohio 43213

Show your true colors. Please send a copy of your Color Selector Guide plus the Oasis catalog.

NAME _____ TITLE _____

FIRM _____

ADDRESS _____

CITY _____ STATE _____ ZIP _____

For more data, circle 105 on inquiry card

You get more from Jamison

(THE COLD STORAGE DOOR PEOPLE)

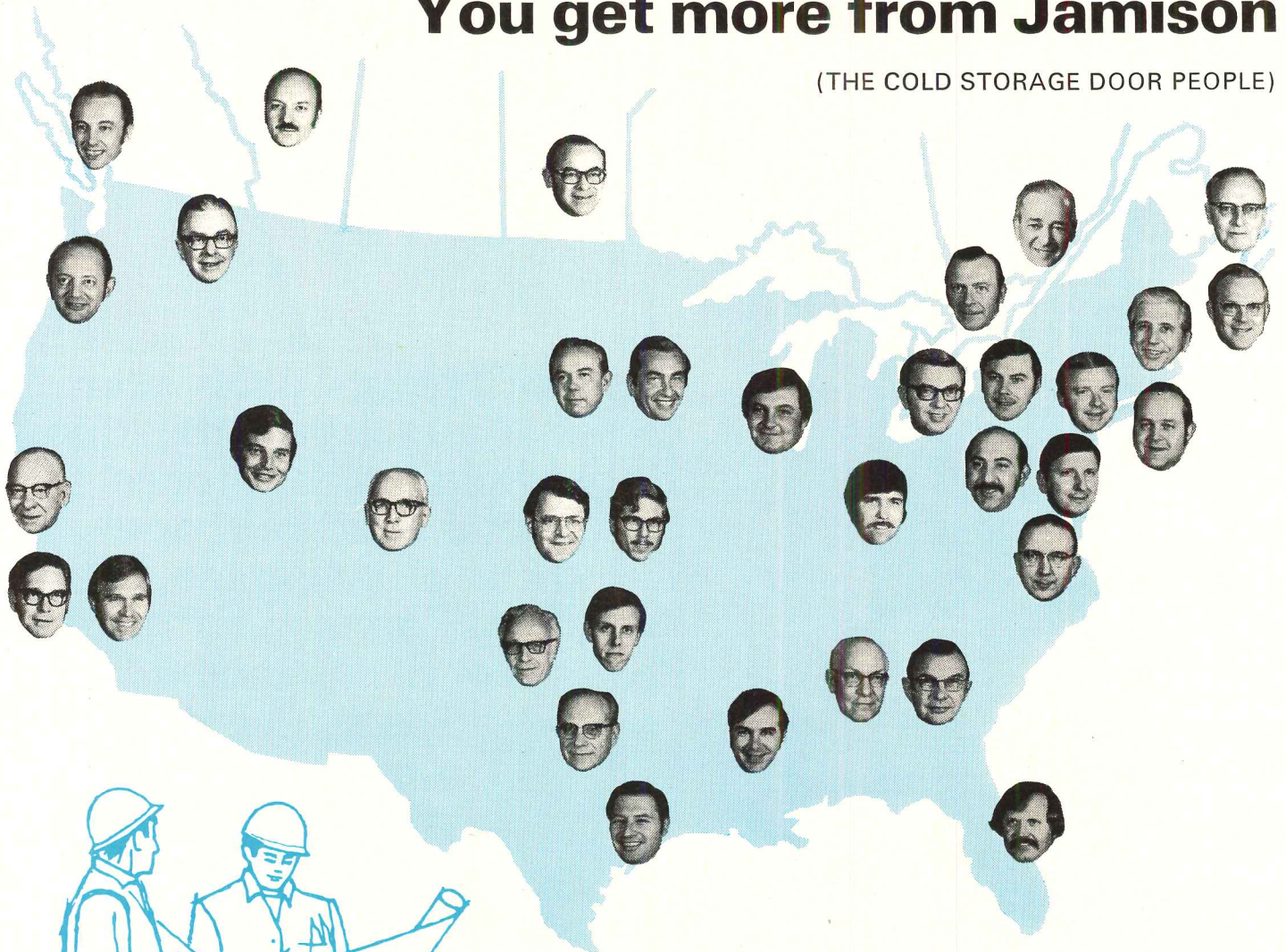

More technical assistance from more door specialists.

Wherever you are, Jamison makes sure the most comprehensive technical help is available close at hand . . . backed up by factory engineering specialists.

Jamison cold storage door specialists will provide more tech-

nical assistance than anyone else—whatever you need to select cooler and freezer doors which suit your purpose precisely, and most economically.

Jamison's newly expanded line makes it easy to get traditional

Jamison quality, durability and service in every price range.

Write or call now for full details on the most complete line of doors in the industry.

The one to see in '73...

COLD STORAGE DOORS BY
JAMISON

JAMISON DOOR CO • HAGERSTOWN, MD 21740

For more data, circle 106 on inquiry card

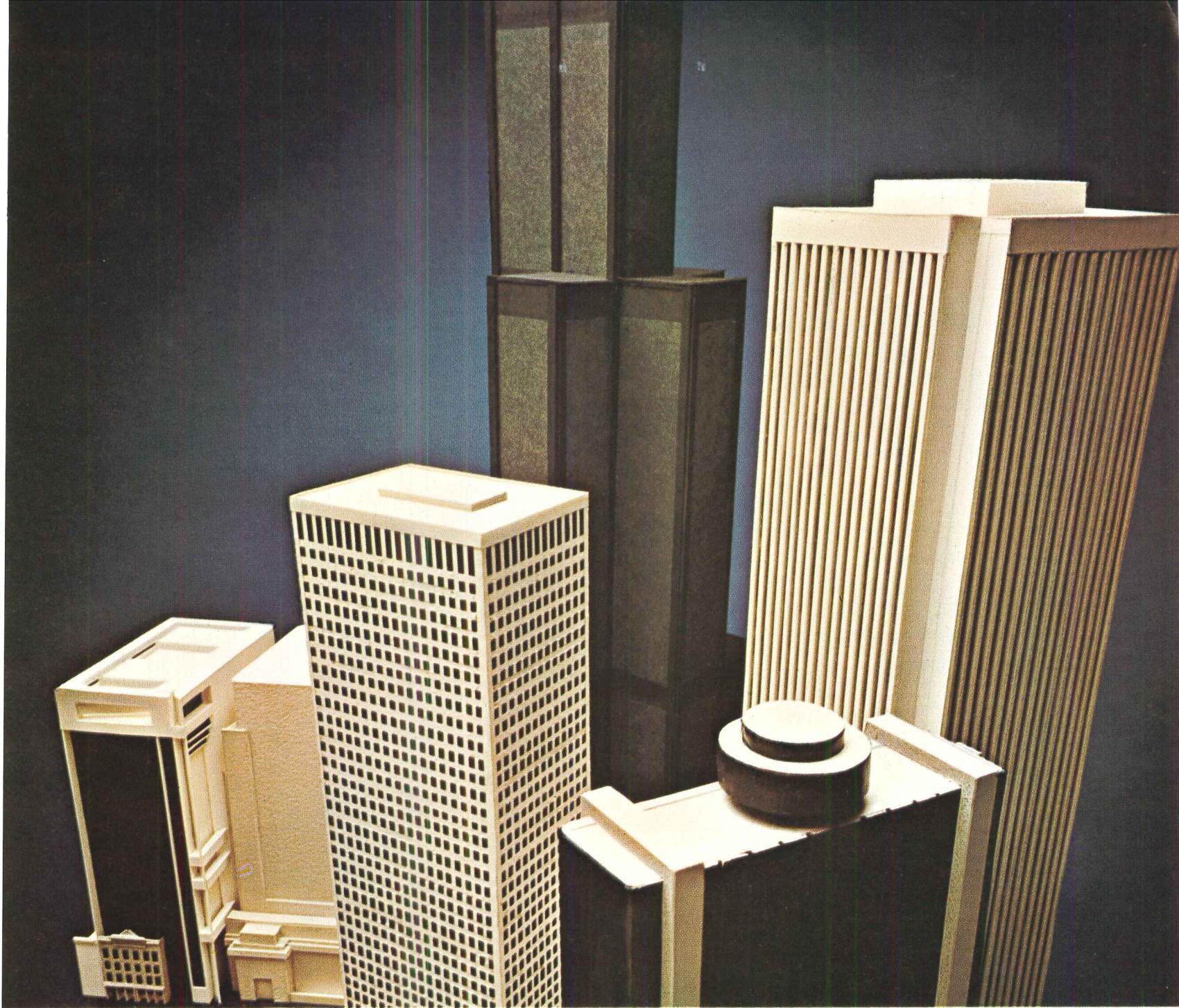

**Ever since we came up
with Cavity Shaft Wall
in-place costs are
going down all over town.**

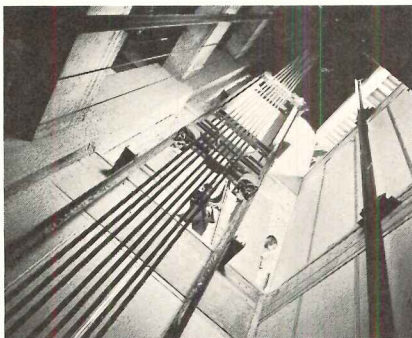

USG® Cavity Shaft Wall has revolutionized elevator shaft installation since we developed the system in 1971.

This unique gypsum panel system erects quickly, easily and economically from the corridor side. And here's why. Cavity Shaft Wall is 78% lighter than masonry. Reduces dead load to save on structural steel. Electrical conduit installs faster, due to built-in vertical chaseways. And because there's less material to handle, it takes less manpower, less time to build. Elevator cars run weeks sooner, too. Cavity Shaft Wall simplifies handling of special heights at lobby and mechanical floors. Unique design of steel components allows for ceilings up to 27 feet high, shaft pressures up to 15 psf.

The buildings shown here are just a few currently in the works using this innovative system. Weigh its many advantages over conventional shaft construction. See our catalog in Sweet's, Sec. 9.5 (S), or write for a copy of our new Gypsum Shaft Wall Handbook; 101 S. Wacker Dr., Chicago, Ill. 60606, Dept. AR-63

(Above: left to right) • **The Penn Mutual Building**, Philadelphia. Developer: Richard B. Herman & Co., Division of Binswanger/Herman Co. Architects: Mitchell/Giurgola Associates
• **One Shell Square**, New Orleans. Developer: Gerald D. Hines Interests. Architects: Skidmore, Owings & Merrill, August Perez & Associates, Wilson, Morris, Crain & Anderson
• **Sears Tower**, Chicago. Developers: Sears, Roebuck and Co. Architects: Skidmore, Owings & Merrill
• **Broadway Plaza**, Los Angeles. Developer: Ogden Development Corp. Architects: Charles Luckman Associates
• **Standard Oil Building**, Chicago. Developer: Standard Oil Company (Indiana). Architects: Edward Durell Stone & Associates, Perkins & Will.

UNITED STATES GYPSUM 
BUILDING AMERICA

For more data, circle 107 on inquiry card

Some sash designs need to put the pressure on glazing tape.

Stick curtainwall systems and pocket-glazed windows provide structural economies in many applications. But they also present you with some formidable glazing problems.

For one thing, the pocket channel allows the glazer very limited working space. This means he must either, 1) position the glass first and then apply a gunnable sealant from the outside —necessitating costly swing stages or, 2) do the glazing from the inside by using a tape sealant and then insert the glass, applying a positive pressure by means of wedges or gaskets.

This tape sealant must be 25%-50% compressible, yet must not squeeze out of the channel despite the pressure.

Another problem — illustrated on the opposite page — is the offset condition of channels in stick system glazing. As you can see, there is a $\frac{1}{8}$ -inch differential between the vertical and horizontal members in the illustration. When glass is put in under pressure, the two tapes are compressed to provide a uniform plane, in order to prevent leaks and distribute stress evenly.

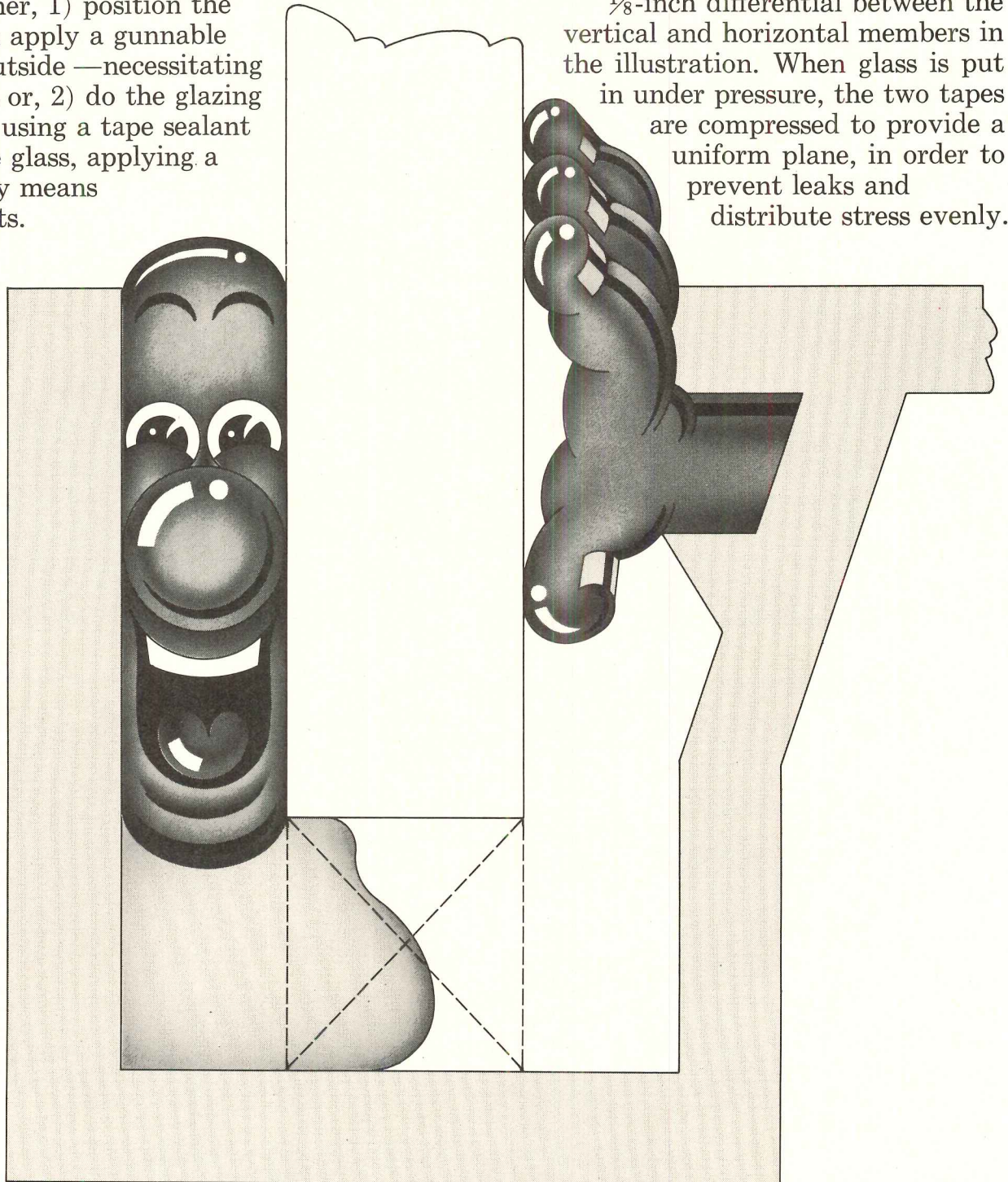

Besides the design problems just mentioned, you and your glazing contractor are faced with increasingly critical glazing conditions as buildings go higher and higher. For example, larger lights of glass, greater pressure differentials and higher windloads all put a bigger burden on glazing techniques. Omitted, misplaced or incorrectly chosen shims compound these problems and raise the possibility of leaks and glass breakage.

All these conditions call for something special in the way of glazing tape. And Tremco has it. It's called POLYshim™. And it's designed for use wherever design conditions call for 25% to 50% compression. It contains a continuous, integral reinforced shim that transfers windload from glass to sash evenly around the entire perimeter. This eliminates pressure points or any danger that the sealant will pump out of the sash.

POLYshim can be installed from the inside quickly, easily and accurately. It comes on a specially-treated instant release paper backing that helps

avoid mess, waste and tape distortion. POLYshim is self-adhering and forms a tight seal that effectively prevents water infiltration, resists ultraviolet and withstands temperatures as low as -65°F and as high as 220°F . In addition to practical applications in major buildings around North America, POLYshim has passed independent laboratory tests for dynamic and static water infiltration, buffeting by wind and water, thermal and pressure loading and accelerated aging. So when the pressure's on glazing tapes, specify POLYshim. And if you have any other caulking, glazing or weather-proofing problems, remember your

Tremco man can help.

For over 40 years, our business has been solving these problems and providing top-quality leakproof systems and products, such as our job-proven sealants MONO®, DYmeric® and Lasto-Meric®, liquid polymer Tremproof™ waterproofing and our new roof edging system, Tremline™.

The Tremco Manufacturing Company, Cleveland, Ohio 44104. Toronto 17, Ontario

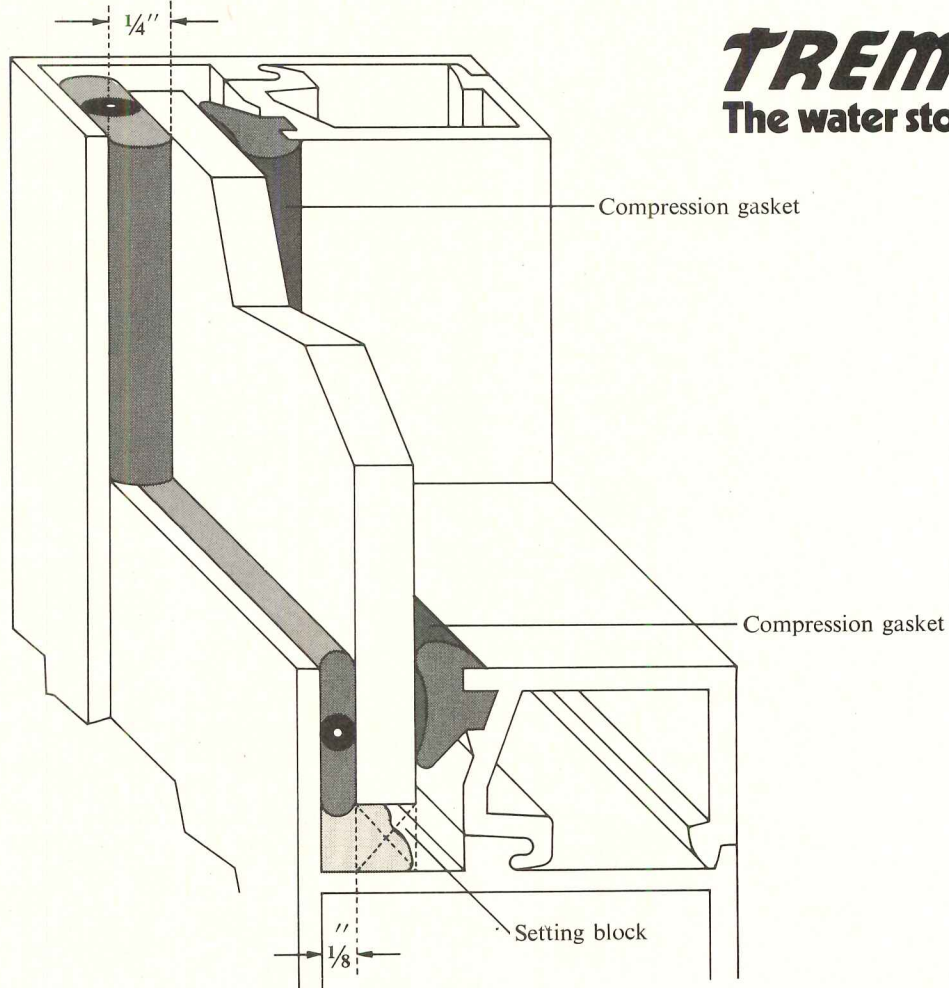
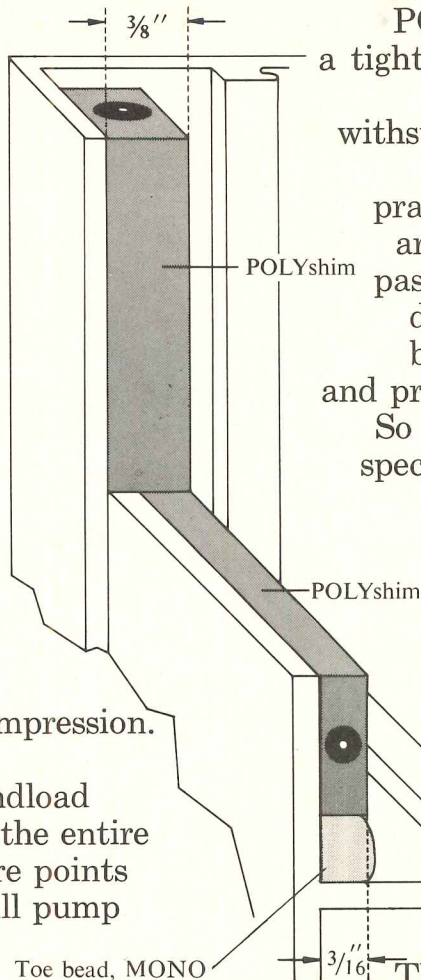

For more data, circle 108 on inquiry card

TREMCO
The water stoppers.

PERSLIDER

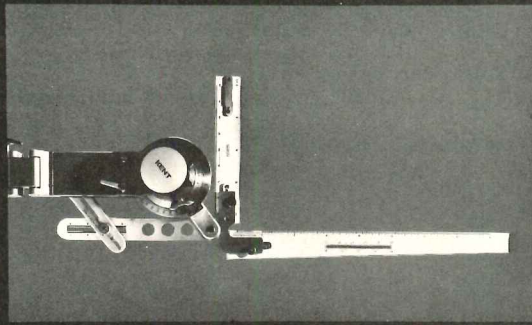

produces
PERSPECTIVE DRAWINGS ...
 with only a little of your help.



- eliminates conventional awkward devices.
- near and distant vanishing points determinable.
- produces accurate, complete perspective drawings in less time.
- technically new and unique perspective drawing machine.
- operatable by anyone with only limited knowledge of perspective drawing.
- please direct all inquiries to UCHIDA YOKO CO., LTD., 11 West 42nd Street, New York, N.Y. 10036

For more data, circle 109 on inquiry card



YOU NOTICE NEENAH CASTINGS AROUND THE WORLD

Architects, designers and planners know Neenah castings are found in Pakistan, Kuwait, Turkey, South Africa, Argentina, Bahamas . . . and from Paris to Pittsburgh.

They know Neenah makes the finest quality castings: from gray iron manhole covers . . . to ductile iron airport drainage grates . . . to decorative tree grates . . . and a complete line of building castings. But did you know Neenah has thousands of design variations to choose from? 60,000 castings on hand (over 10,000 tons)? Over 100 years of experience? Three modern plants?

Write or call for the most complete construction castings catalog, Neenah's Catalog "R", 5th edition.

NEENAH 
 FOUNDRY COMPANY

NEENAH, WI 54956 Phone: 414-725-3041
 Jobbers in most principal cities

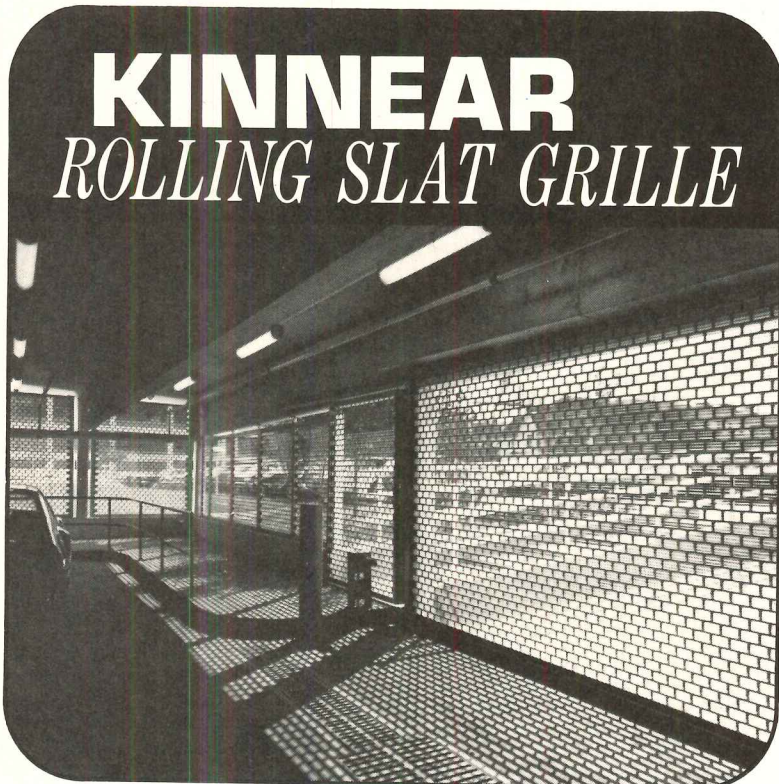

KINNEAR ROLLING SLAT GRILLE

A New Aluminum Design That Adds
 A Touch Of Beauty To Security
 write today for catalog

KINNEAR CORPORATION *Saving Ways in Doorways Since 1895*
 and Subsidiaries

1860 FIELDS AVENUE, COLUMBUS, OHIO 43216
 OFFICES & REPRESENTATIVES IN ALL PRINCIPAL CITIES
 LISTED IN YELLOW PAGES UNDER "DOORS." ALSO SEE SWEET'S!



For more data, circle 111 on inquiry card

♦ *For more data, circle 110 on inquiry card*

A SUBSIDIARY OF
Harsco
 CORPORATION

the new hospital room:



How do you provide greater convenience for patients, doctors and nurses?

Put a Bobrick Console in the patient's room, as shown here in the recently completed Verdugo Hills Hospital near Los Angeles.

This one functional unit combines a lavatory; mirror; dispensers for towels, soap and paper cups; light fixture; convenience outlet and a storage compartment for bedpan and washbasin. There is also a compartment for patient's toiletries.

This lifetime stainless steel unit is a cost saver. . . and space saver, too. It fits into a wall opening 16" wide by 4" deep.

Bobrick Consoles are part of a "Total Design Concept" of coordinated washroom accessories for today's hospitals.

Send for our Hospital Planning Guide and brochure describing 20 other Hospital Consoles. Bobrick, Architectural Service Department, 101 Park Ave., New York 10017. Bobrick products are available internationally.

bobrick

SINCE 1906

For more data, circle 112 on inquiry card

Architects: Belli and Belli, Chicago, Ill.

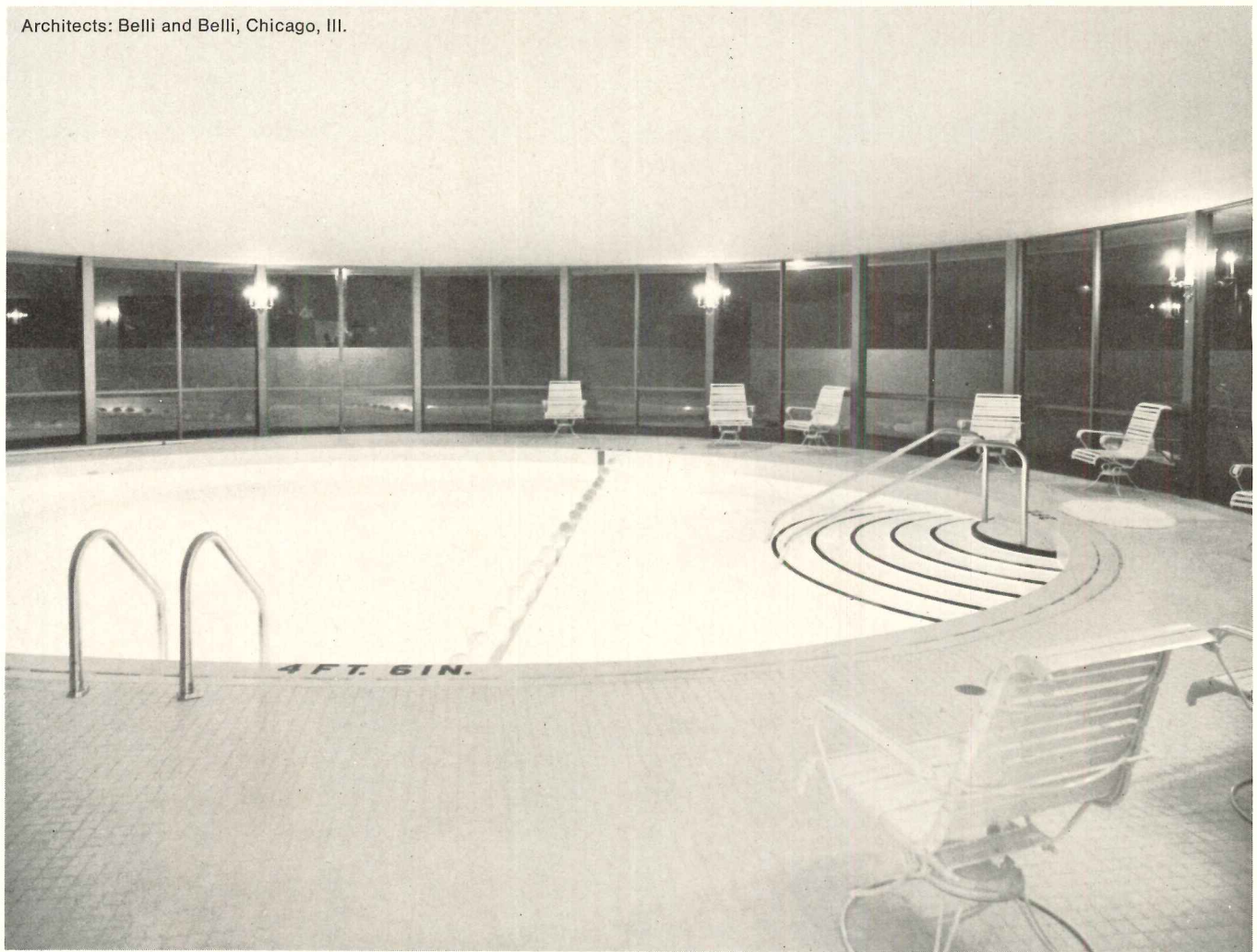

Overly makes the metal pools that others don't.

Like this one, on top of a 15-story high rise in Phoenix, Arizona. It's a custom-designed swimming and therapy pool, with more complex geometry than ordinary pools because the bottom is configured so a swimmer will be within an arm's reach of a hand hold no matter how far he is from the side.

Rooftop pools or unique designs are never a problem at Overly. Our pools can easily be adapted to the tops of buildings, or anywhere else, indoors or outdoors. Every one is custom designed and fabricated, then field assembled quickly and economically. They are warranted against leakage for five years,

and resist corrosion, cracks and spalling. Overly pools never need grouting, sealants or caulking, because they're welded. And, they come complete with filtration systems and all accessories.

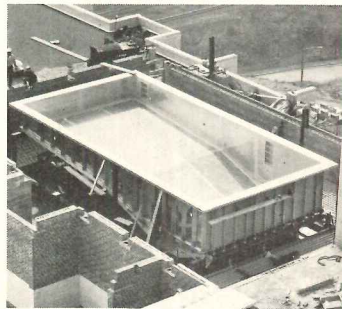

Overly also designs, fabricates and installs therapy pools, including our new modular pool that needs no excavation. No matter what kind of metal swimming pool you want, and no matter where you want to put it, you can get it from Overly. We have plants in Greensburg, Pa., and Los Angeles, Calif. See us in Sweets or contact Overly Manufacturing Co., 574 West Otterman Street, Greensburg, Pa. 15601.

overly
MANUFACTURING CO.
DOES WHAT OTHERS DON'T

For more data, circle 113 on inquiry card

Build a 10 story building with loadbearing masonry and get the 11th story free.

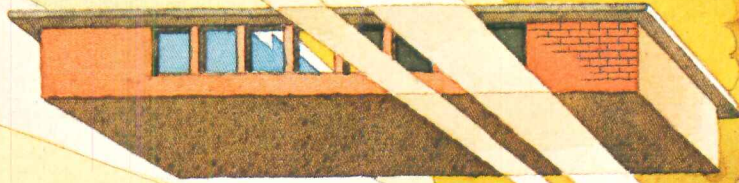

When you build with a modern loadbearing masonry system, you can save as much as 10% on construction costs.

Because masonry lets you save on the two biggest expenses of building. Time and materials.

Instead of building separate structural systems and enclosure walls, you can have them both in one step. Masonry walls work together with roof and floor systems to create one solid structural shell. Complete with enclosure walls and inside partitions.

And you can begin finish work on each floor as soon as the masons begin erecting the floor above it. So your building is finished faster. And you can stop paying interim interest and start charging rent.

You save on maintenance costs too. Because masonry doesn't warp, dent, bend, buckle or rot. It gives superior fireproofing and sound control. And with its inherent beauty, it never needs painting.

When you add all these savings up, you can save enough money to add that eleventh story. If that sounds like an interesting prospect to you, mail this coupon. We'll send you the complete story.

For more data, circle 114 on inquiry card



International Masonry Institute
Suite 1001 823 15th Street, N. W.
Washington, D. C. 20005 AR

Send me information on the modern loadbearing masonry building system.

Name _____

Title _____

Company _____

Address _____

City _____ State _____ Zip _____

Nature of Business _____

Lady Borden® declared a cold war on Executive's carpet of Herculon®...



but she cooled off fast.

Executive's "Rivulet" carpet with pile of HERCULON* olefin fiber really didn't need what Lady Borden dished out. Scoops of creamy, sweet ice cream, topped with sticky creme de menthe. But the lady left without a fuss.

The stain resistance of HERCULON, coupled with uncommon resistance to abrasion and fading, gives you the ideal carpet for any commercial installation.

Lady Borden cooled off quickly on Executive's "Rivulet" of HERCULON. But your clients won't.

For detailed information on HERCULON, see Sweet's **S** Light Construction, Architectural and Interior Design files. Or, write Fibers Merchandising, Dept. 302, Hercules Incorporated, Wilmington, Delaware 19899 for a free 24 page booklet.



*Hercules registered trademark.

Specify carpet of stain resistant Herculon®

For more data, circle 115 on inquiry card

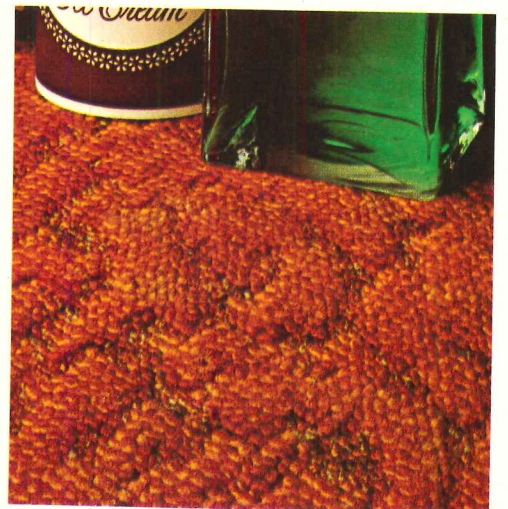

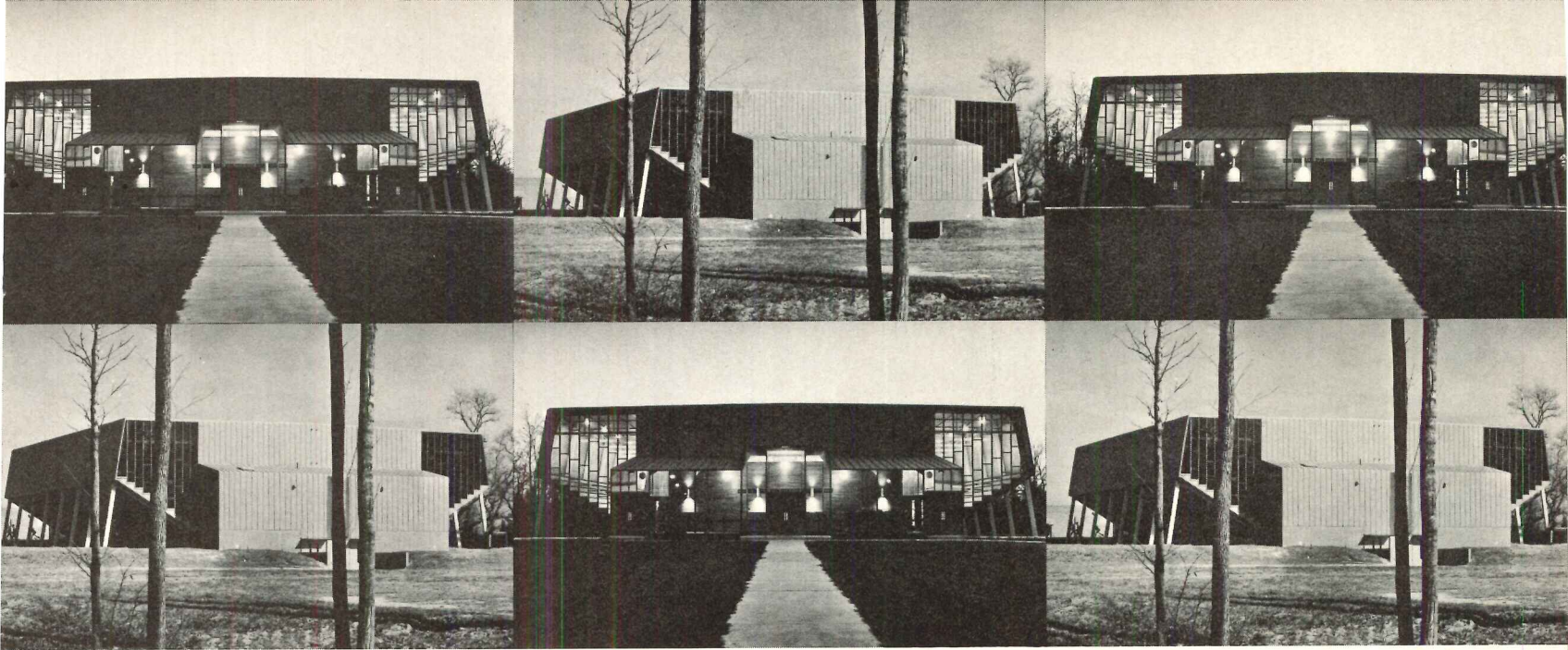

WASHINGTON & LEE HIGH SCHOOL, MONTROSE, VA.
ASSOCIATED ARCHITECTS:
STEVENSON FLEMER,
EASON CROSS AND
HARRY ADREON, WASHINGTON, D. C.

ROOFER:
N. W. MARTIN BROTHERS
RICHMOND, VA.

Beauty & Durability & Economy

These are, of course, the usual criteria of most architects in selecting any major building component, and wherever metal roofing is involved, we believe Follansbee Terne unique in the degree to which it satisfies them. For Terne delights the eye, lasts indefinitely, and is relatively inexpensive when measured by the standards of those to whom ultimate performance is no less significant than initial cost.

FOLLANSBEE

FOLLANSBEE STEEL CORPORATION, FOLLANSBEE, WEST VIRGINIA

For more data, circle 116 on inquiry card

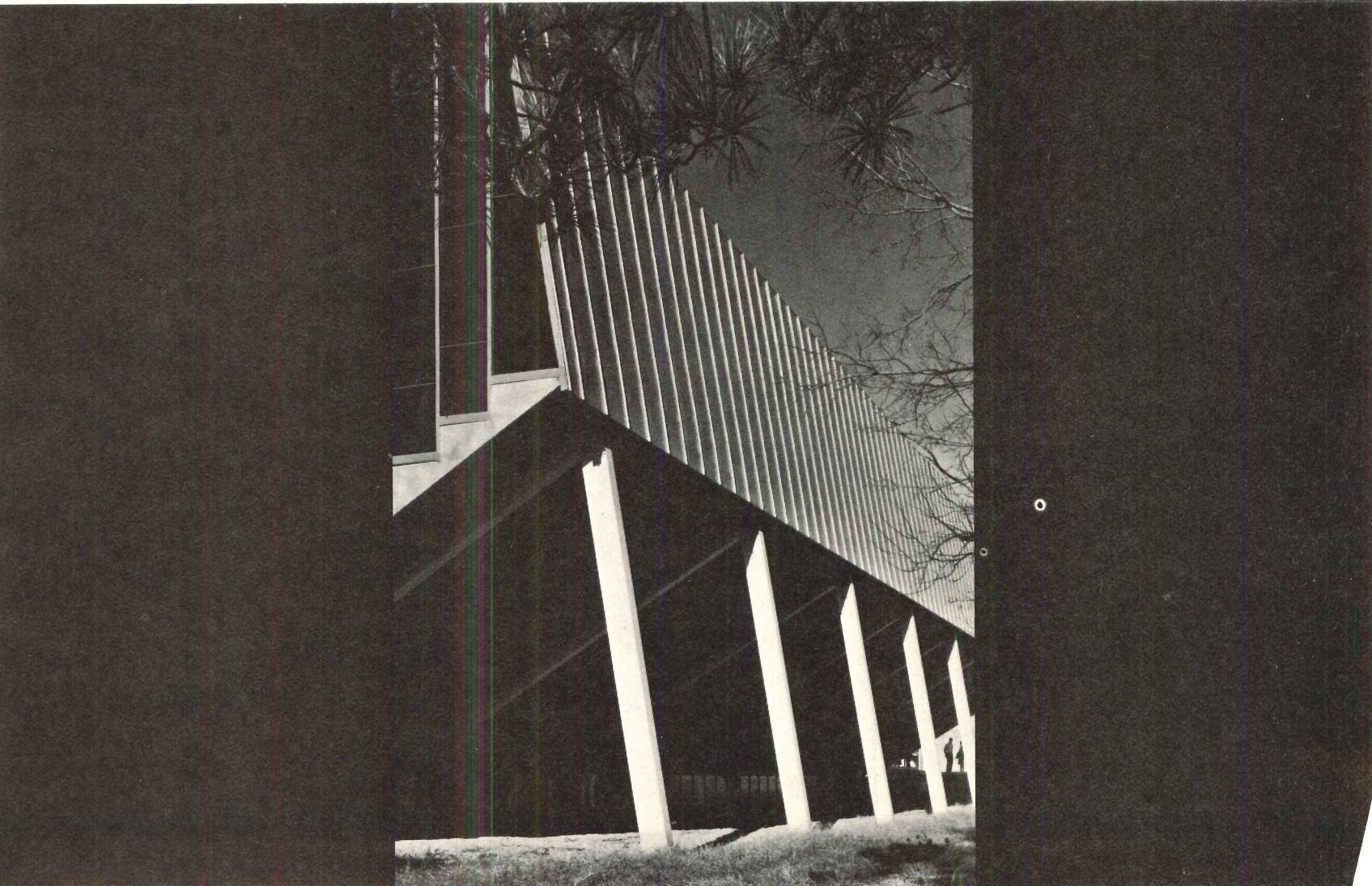

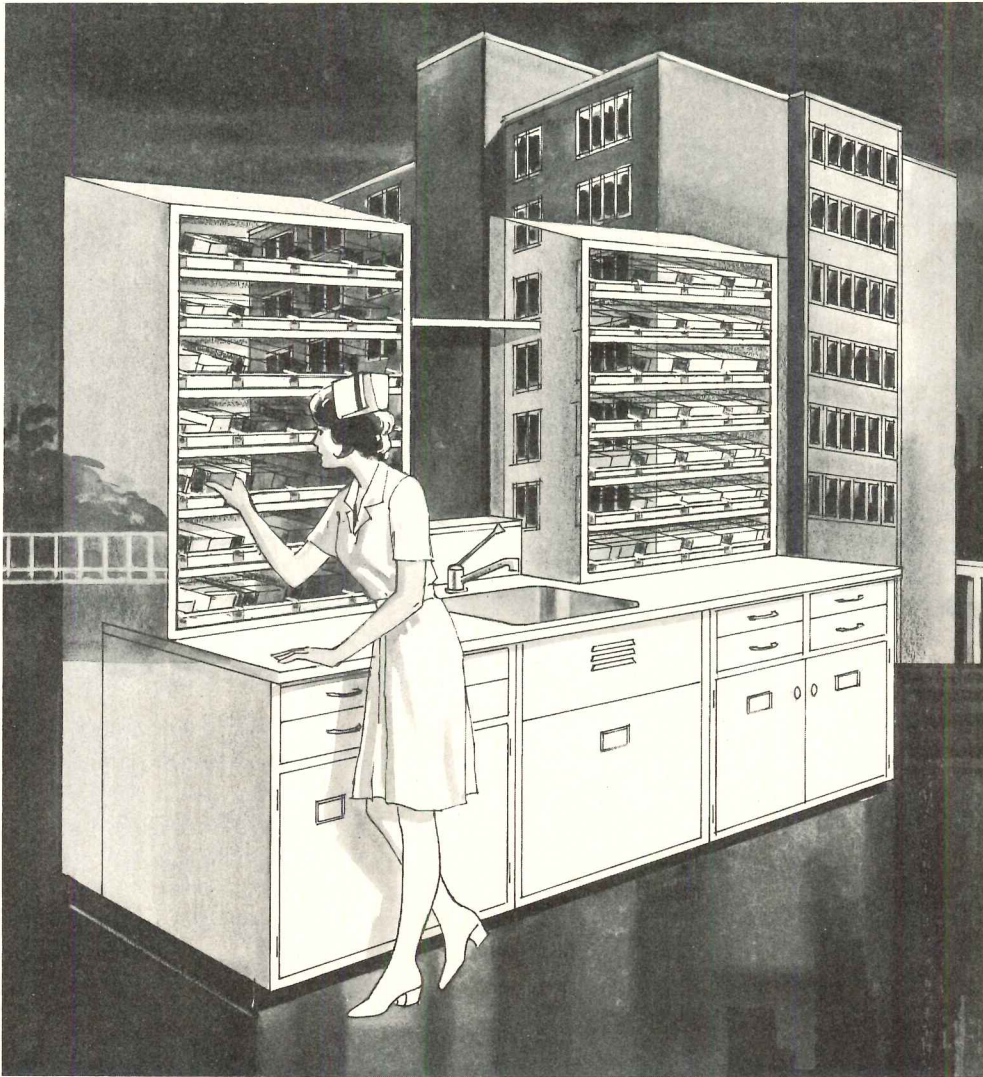

POLYCLINIC HOSPITAL, HARRISBURG, PENNSYLVANIA

THE ARCHITECT* OF HARRISBURG POLYCLINIC GUARANTEED A QUICK RECOVERY

He specified Watson Casework.

A hospital's vital services must be provided swiftly. Time is of the essence. Instruments must be easily accessible. Medicines must be efficiently dispensed. Materials in storage must be easily recovered. Doors cannot stick. Drawers cannot jam.

Adhering to the highest standards of quality and sanitation, Watson Hospital Casework is designed to last and perform efficiently for years. When you are involved in hospital design, guarantee a quick recovery. Specify Watson.

HOSPITAL DIVISION



WATSON
Manufacturing Company, Inc.
Jamestown, New York 14701

*LAWRIE & GREEN, HARRISBURG, PENNSYLVANIA

For more data, circle 117 on inquiry card

PRODUCT REPORTS

continued from page 197

COMPUTER-RUN ELEVATOR SYSTEM / A new computer-controlled elevator system for medium and high-rise buildings, can be used in buildings six or more stories tall and can control anywhere from two to a hundred or more elevators. The new VIP system can evaluate "real-time" conditions and make decisions up to one million times faster than conventional systems. This enables the total system to respond more rapidly and park elevators near or at floors anticipating the next calls. ■ Otis Elevator Co., New York City.



Circle 310 on inquiry card

LOUNGE FURNITURE / *Cambridge I* consists of a fully-upholstered seating group with tubular steel side frames in a variety of finishes, encompassing a lounge chair, a love seat and three lengths of sofas (6½, 7 and 7½ ft). ■ Kasparian, Los Angeles.



Circle 311 on inquiry card

CERAMIC FLOOR TILE / The new *Perma-Paver* series includes five different selections in neutral hues to blend with any decor. This series is frost-proof and ideal for heavy traffic areas, exterior or interior. Because it requires virtually no maintenance such as waxing, polishing or scouring, it reduces the cost of upkeep. It is also acid-resistant, and impervious to extreme temperature or chemicals. ■ Quamagra, North Hollywood, Calif.

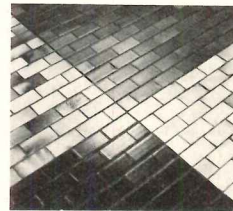

Circle 312 on inquiry card



MAILING SYSTEM / Capable of handling both incoming and outgoing mail, this new mail system has two work-surface consoles and a corner filler accessory to make efficient use of a corner space. Incoming mail is opened automatically on the table at left, and sorted for distribution in the adjustable racks above. A combination parcel post and United Parcel Service scale and an eye-level letter scale help prepare outgoing mail for meter stamping machine at right. Storage is provided in shelves, drawers and cabinets. ■ Pitney Bowes, Stamford, Conn.

Circle 313 on inquiry card

Caradco... makes the luxury of wood windows affordable.

Make any comparison you like. You'll find that Caradco C-200' casements offer the most sensible combination of beauty, comfort and price. Compare our vinyl glazing . . . double weatherstripping . . . concealed hinges . . . and heavy sash and frame.

We build them strictly for thoughtful builders and owners who know what a noticeable difference such value can make in their homes and apartments. Call your Caradco Distributor for details.

Caradco
Window and Door Division
Scovill

Main Plant: Dubuque, Iowa 52001
Hainesport Assembly Plant, Hainesport, New Jersey 08036
Ohio Assembly Plant, Columbus, Ohio 43204

For more data, circle 118 on inquiry card

RENAISSANCE™

The new, antique look in paneling.

Introducing Renaissance™ hardwood plywood wall paneling from Georgia-Pacific. It comes in six warm shades of real hardwood face veneer, each flecked and shadowed. With a finish that looks handrubbed. Renaissance paneling. A new old-fashioned look, at old-fashioned prices.

Renaissance comes in 4' x 8' x 1/4" panels. And it's available with a Class III flame spread rating. For more information, just contact your G-P representative.

Georgia-Pacific

The Growth Company
Portland, Oregon 97204



RECORDLIFT®

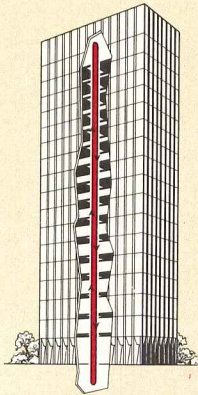

The Recordlift is an automated, selective vertical conveyor. It rapidly moves mail, records, books and supplies in office buildings, libraries, hospitals.

Pre-addressed trays, moving at speeds up to twelve per minute, may be received by or sent from every floor.

Seven tons of material — or more, depending upon the Recordlift model and tray size — may be dispatched from a single station in just one hour.

Each Recordlift station is quietly independent, with its own drive motors and solid-state control pack. There is no mechanical linkage with the main drive chain.

Pads dampen vibration. Tray cars move in and out on small wheels, synchronized by silent proximity switches in the shaftway.

At the bottom, a large maple take-up guides the chain smoothly around the bend.

We tell the whole Recordlift story in our new eight-page brochure. Write Standard Conveyor Co., 815 No. Second St., North St. Paul, MN 55109. Or call (612) 777-8171.



Ties the floors together.



For more data, circle 120 on inquiry card

◆ For more data, circle 119 on inquiry card



Palmer Porter
Painting Contractor
Hixon, Tennessee

“One of my men sprayed 3200 square feet of wall and ceiling area in one hour and five minutes with *Hide-A-Spray*™”

New improved *Hide-A-Spray*, now with rust control added

A rust control additive in this water base paint protects small scratched rust free areas on metal, as well as unprimed nail heads, from flash rusting and consequently staining the newly painted surface.

“Not only is it time-saving,” Mr. Porter added, “but it gives the customer a top quality job.” A 15 gallon test application convinced Mr. Porter that *Hide-A-Spray* High Build Interior Flat Latex Paint met all of his requirements for the coating to use on this particular project in Dayton, Tennessee consisting of 110 units of one and two story apartments. They were good hiding, good airless spraying quality and a competitive price. Used in airless spray application, *Hide-A-Spray* covered walls and ceilings with one coat—without priming. Taped, spackled and sanded joints completely disappeared beneath this remarkable high build latex coating. Added Mr. Porter, “*Hide-A-Spray* is the most marvelous paint ever to come

on the market for the painting contractor.” It can be airless sprayed on unprimed dry walls, in up to 40 mils wet thickness, if necessary, without sagging. However, it is usually applied at 6-10 mils wet. It dries quickly. Accidental scuffs from moving equipment touch up without showing through, and dirt wipes off with a damp cloth.

It's no wonder then that Mr. Porter was so enthused about *Hide-A-Spray* Flat Latex Paint. We would like to tell you more.

Descriptive literature is available. Write PPG Industries, One Gateway Center, 3W, Pittsburgh, Pa. 15222.

PPG: A Concern for the Future

PITTSBURGH® PAINTS



Dayton Housing Authority Project, Dayton, Tennessee. 110 apartments, 30 shown above. Jack Tyler & Associates, Architects.

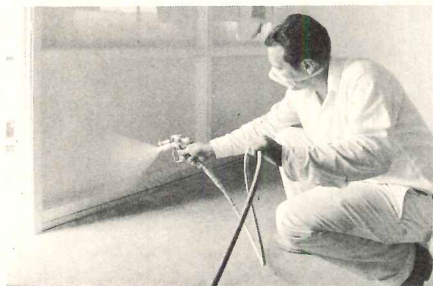

Hide-A-Spray flat latex was used on all trim as a primer for a finish coat of *Speedhide* Lo Lustre Enamel. *Hide-A-Spray* holds out the enamel—won't let it seep in.



Hide-A-Spray paint covered ceilings and walls with one coat—without priming. Taped joints were completely concealed.



James Durham, Project Manager for General Contractor H. E. Collins, Chattanooga, Tennessee, discussing progress with Project Superintendent Roy Earnhart. Says Mr. Durham about *Hide-A-Spray* paint, “it expedites the job—gets it done quickly—keeps our labor costs down—improves production. A two in one type thing—increases production and cuts cost.”

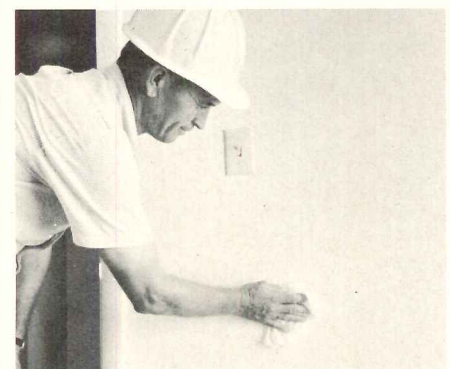

Clyde King, DHA Inspector, cleans smudges off *Hide-A-Spray* with a damp cloth.



For more data, circle 121 on inquiry card



If you haven't got a Hager, you haven't got a hinge.

Don't get caught with your hinges down just because you didn't specify Hager! If you're looking for someone to give you a "deal" on a second-rate hinge, don't come to us. Hager

manufactures only the finest, most reliable hinges and door hardware products. Over the years Hager has had many "firsts". For the full story, simply turn the page.



Everything hinges on Hager.

If you insist on quality, insist on Hager hinges.

For many years, Hager has built a reputation as an innovator and manufacturer of fine quality products. Hager engineers have developed an impressive number of industry firsts, such as the handsome and efficient Tri-Con hinge, the first three-knuckle, concealed ball bearing hinge. The Tri-Con stands as a shining example of Hager's leadership.

Striving to meet the design and engineering needs of architects and builders, Hager has always led the way with innovative products known for their strength, stability and style. Hager designed and manufactures the only two pivot hinges that don't require beveling of flush mounted doors — the rack and pinion action Raconteur and the cam action Camtrol.

When building owners required central security systems, Hager created the first Electronic Control of Openings (ECO) to provide architects and builders with a simple, inexpensive traffic control and security system. ECO was a direct result of another Hager first, the Electronic Switch & Contact hinge, which enables one central security station to monitor, lock and unlock every door connected to the ECO System.

For the whole story, write Hager Hinge Company, 139 Victor Street, St. Louis, Mo. 63104. In Canada, Hager Hinge of Canada, Ltd.

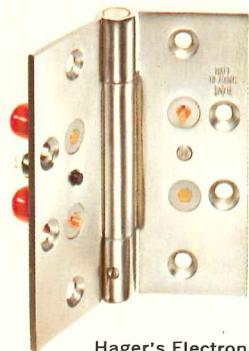
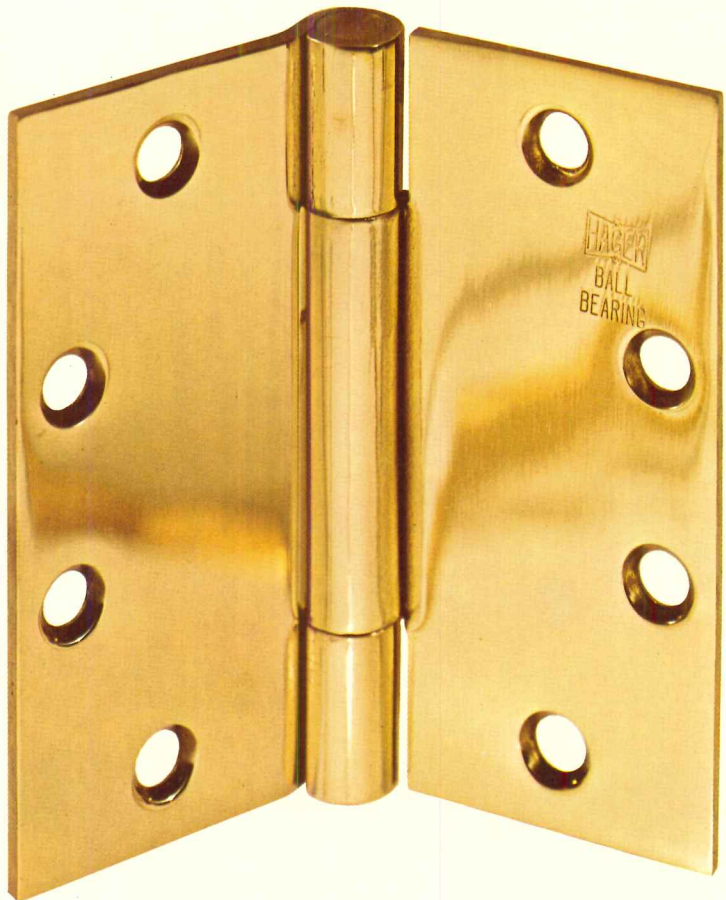

Hager's Electronic Switch and Contact hinge.
PAT. NO'S. 3,659,063-3,715,537



Hager's Electronic Control of Openings (ECO) console.



Hager's center hung Camtrol hinge.
PAT. NO. 3,657,766



Everything hinges on Hager.



Hager's self-adjusting Raconteur hinge.
PAT. NO. 3,394,428

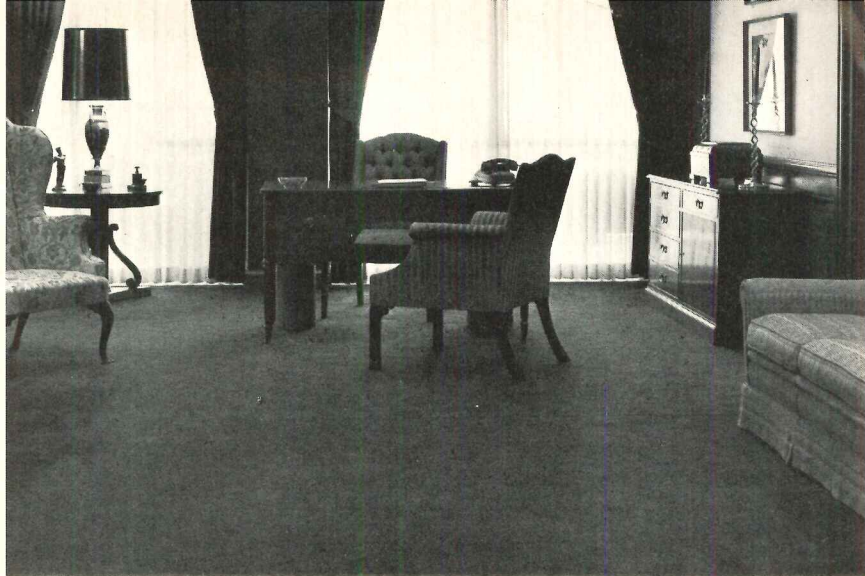

Bank after bank after bank counts on proven carpet by Bigelow.

If you're doing a bank job, you can create your own specifications for the carpet you want. And we can make it for you.

However, Bigelow has another practical suggestion: specify carpeting that has already proven it can take the hard use (not to mention abuse) bank customers deal out. Carpet that has repeatedly demonstrated it can take a beating year after year after year.

Bigelow has that kind of proven in actual bank use carpeting ready for you in a wide selection of carpet styles and patterns. Carpet that is the result of research and development combined with the realistic experience gained in hundreds of bank installations.

And Bigelow will do more than just sell you proven carpet. We'll give you expert counselling in installation and through our Karpet Kare® Division, we'll give you the best advice available on maintenance. It's a total package designed to assure you that you can specify Bigelow with total confidence.

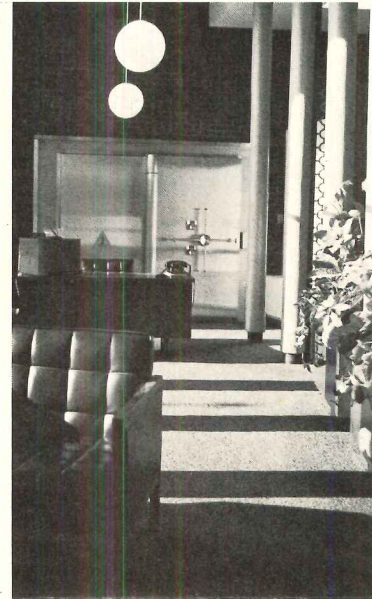

AMERICA'S MOST EXPERIENCED CARPET MAKER

For more data, circle 124 on inquiry card

◆ *For more data, circle 123 on inquiry card*

Bigelow-Sanford, Inc., Dept. A
 140 Madison Avenue, New York, N.Y. 10016
 I'd like to hear the proof on Bigelow's proven carpets for banks.

NAME _____ Print Clearly

TITLE _____

ADDRESS _____

CITY _____

STATE _____ ZIP _____

show 'em a better way: raywall controls

Classic design and precision calibration make Raywall controls a better way to regulate and maintain environmental comfort.

Snap action switches are coupled with bimetallic sensors for accurate temperatures.

The elimination of contact arcing assures longer control life and prevents interference with radio and television reception.

A durable diecast frame and a variety of attractive covers house the sensitive controls.

High stop is available on special request.

Whatever the need—heavy duty, line voltage, single or double pole, or low voltage—Raywall has a better way.

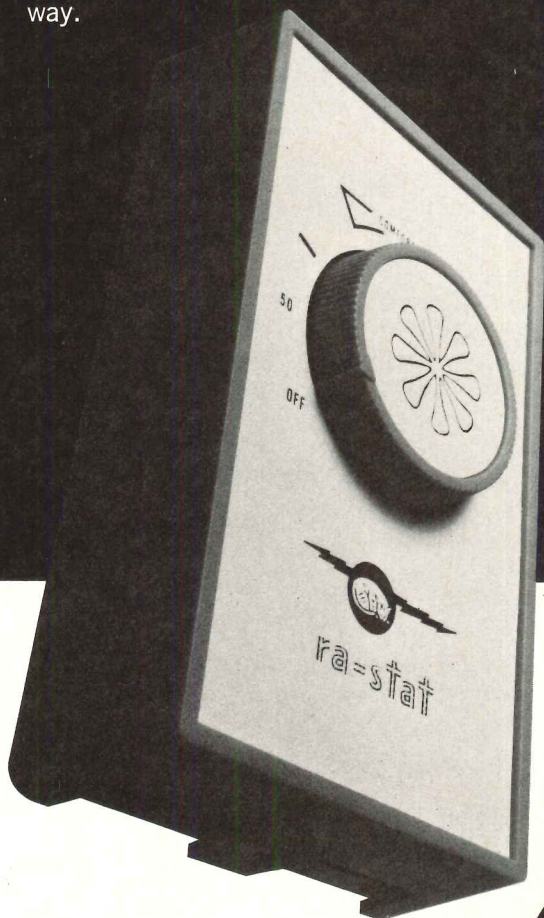

We'll show you
a better way.
Write for our
General Products
Catalog.



Raywall  The
A TPI DIVISION Electricology
Company

P.O. Box T, CRS Johnson City, Tn. 37601 Phone 615/928-8101 Telex 55-3442

For more data, circle 125 on inquiry card

OFFICE LITERATURE

continued from page 179

OPEN OFFICE ACOUSTICS / A new 16-page brochure provides information and guidelines for the architect, acoustical consultant, interior planner and building owner on how to achieve acoustical privacy in the open office. Explains the design considerations necessary for obtaining good acoustics in such facilities and summarizes the findings of a thorough study on open office acoustics. The brochure covers the essential elements—acoustical ceiling, sound barriers and a masking sound system—that must be planned as a "tuned" system. ■ Owens-Corning Fiberglas Corp., Toledo, Ohio.*

Circle 416 on inquiry card

TURNSTILES, POSTS, RAILINGS / A 1973 product catalog features complete lines of "directional access control systems"—electric or manual turnstiles, posts, railings, gates, grilles and a variety of accessories. The 12-page, 2-color catalog is fully illustrated to aid spec writers in their selection. Cutaways of posts with callouts, post installation instructions for concrete or terrazzo floors, photos of typical installations and a 4-page price sheet. The catalog covers the entire directional control field from personnel gravity-return gates to sophisticated electric turnstiles outfitted for pilferage detection devices and electric counters, used in libraries, theaters and security areas. ■ Alvarado Mfg. Co., South El Monte, Calif.

Circle 417 on inquiry card

GRAPHIC ARTS CATALOG / A complete range of products for the graphic arts industry—from conception to inactive print storage—are highlighted in a new 32-page catalog including drafting tables and returns, drawing tables, the *Masterfile*, wall-mount space saver racks, combo cabinets, square tube filing equipment and the new *PlanGlide*. The catalog contains illustrations, photos, and complete specifications of more than 300 products. ■ Plan Hold Corp., Carson, Calif.

Circle 418 on inquiry card

PLANTERS, WASTE CONTAINERS / The 8-page brochure illustrates the 40 different models of fiberglass planters and waste receptacles which make up the present line. Drawings of each style and a description of the 10 standard colors and 10 aggregate finishes are included. The brochure also details construction features, specifications and describes the patented sleeve concept design which makes possible "4-season use." Also available is a 4-page folder describing the company's line of indoor-outdoor fiberglass benches. There are 17 bench models available. Several are storage benches with removable tops. ■ American Beautification Products, Inc., Bristol, Ind.

Circle 419 on inquiry card

ROOF PONDING ELIMINATION / Elimination of ponding that shortens the life of flat roofs is demonstrated in a four-page bulletin on electronic syphonic systems that provide automatic protection for manufacturing plants, warehouses, offices, hotels and motels. Included is a schematic layout of a typical system. ■ Drain-Away Div., Maysteel Products, Mayville, Wis.

Circle 420 on inquiry card

*Additional product information in Sweet's Architectural File



Meet the Copenhagen. Another bold and beautiful Yale® Lockset.

Meet the great Dane.

The mortise lockset with the heavy, cold-forged Copenhagen trim. Now you can get the Copenhagen with a newly designed thru-bolted escutcheon plate.

It's a snap to install. Rapidly. Positively. And the thru-bolting allows adjustment to secure proper alignment. Which eliminates troublesome binds inherent with conventional surface screw attachment.

Another thing.

The Copenhagen is a real looker. Its clean, bold, modern lines are enhanced by the spherical shaped knob. And the outside plate doesn't have any unsightly exposed attaching screws.

That's our new Copenhagen.

And you don't have to go to Denmark to get it.

Eaton Corporation, Lock and Hardware Division, Yale Marketing Department, P.O. Box 25288, Charlotte, N.C. 28212.

**EAT•N Security Products
& Systems**

For more data, circle 126 on inquiry card

Last year, we invited architects to look into the new Alcan Planar Aluminum Ceiling.

Here are some of the R.S.V.P.'s

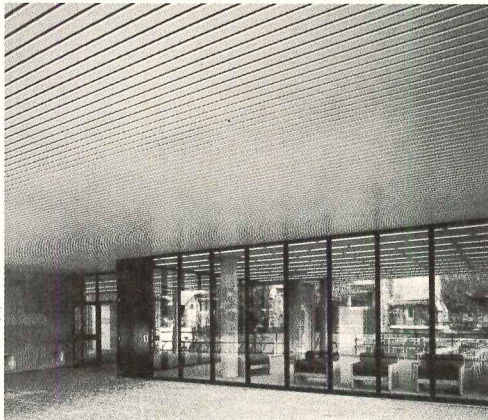

Harvard School of Design
Cambridge, Mass.
Architects: John Andrews, Anderson, Baldwin
Toronto, Canada



Southfield Athletic Club
Southfield, Mich.
Architects: Rosetti Associates
Detroit, Mich.

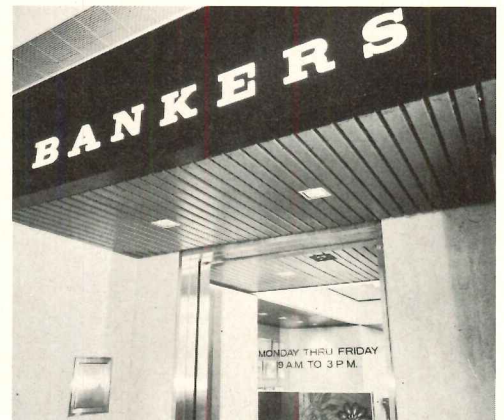

Bankers Trust Company
New York, N.Y.
Architects: Shreve, Lamb and Harmon
New York, N.Y.



KLM Terminal at J.F.K. International Airport
Long Island, N.Y.
Architects: Liebowitz and Budova
New York, N.Y.



IBM Classroom
Poughkeepsie, N.Y.
Architects: IBM

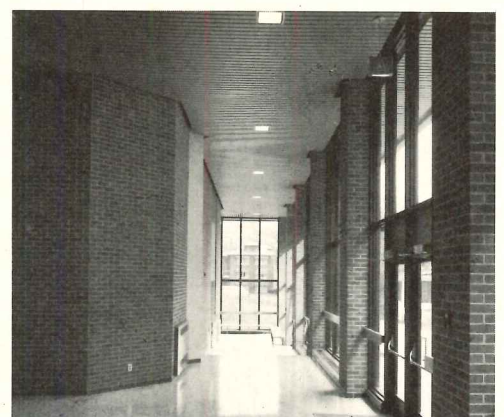

University of Wisconsin Education and
Science Building, Madison, Wisc.
Architects: Durrant, Deininger, Dommer,
Kramer & Gordon; Watertown, Wisc.

Architects and contractors are using the crisp, colorful, "floating" ceiling system by Alcan to create a whole range of new interior (and exterior) effects. And because the system has no size limitations, "monumental" ceilings are already well represented in the first year's case histories. But whatever the scale, you'll find Alcan Planar Aluminum Ceilings beautiful, functional, durable, and simple to install.

Write for details and we'll rsvp with full color literature and spec's. Address
Alcan Building Products
4519 Mahoning Avenue
Warren, Ohio 44483.

ALCAN ALUMINUM



Listed in Sweets and Spec-Data.

For more data, circle 127 on inquiry card

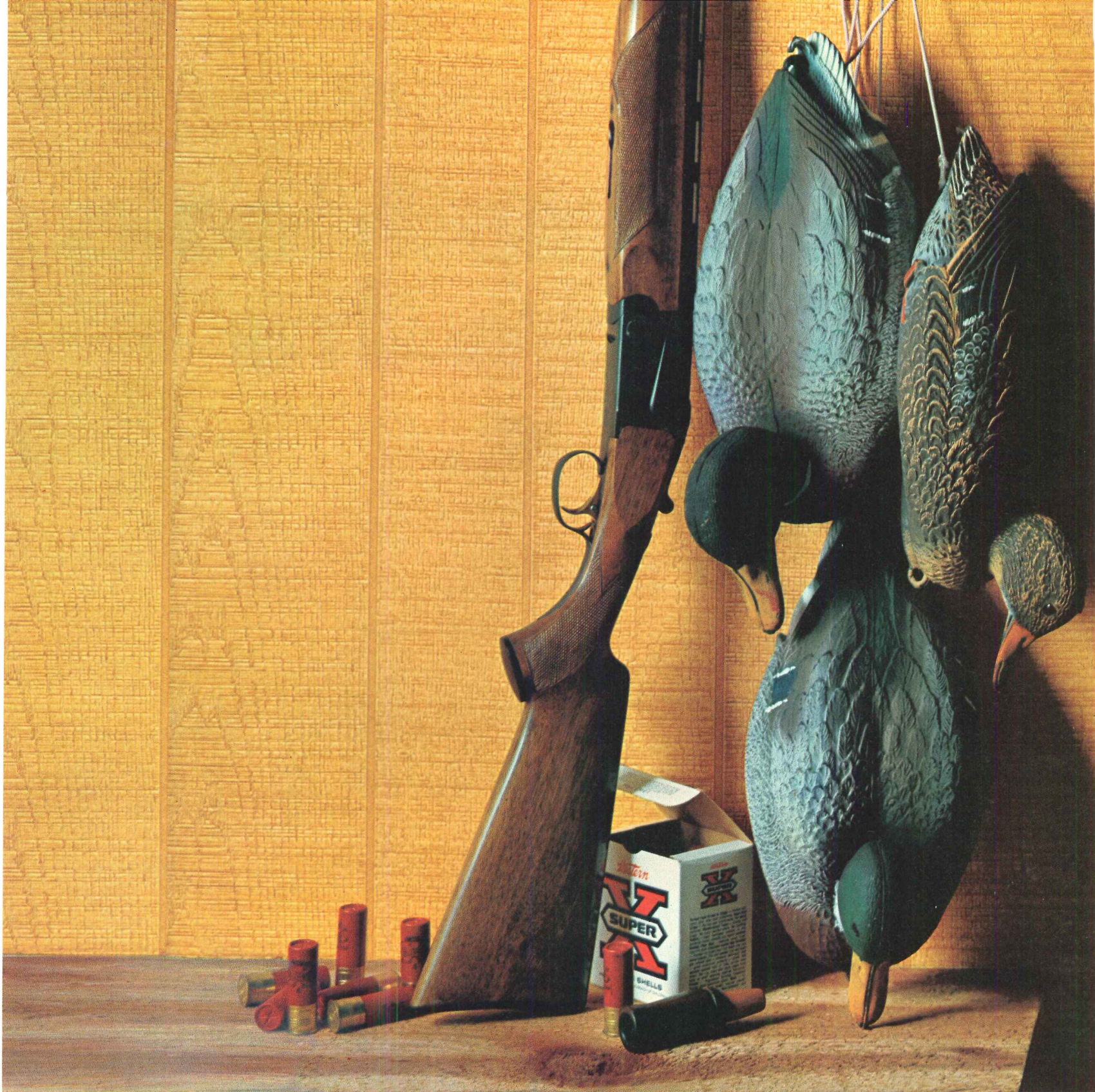

The fake McCoy.

Koroseal® wall coverings capture the look of nature and help you create almost any feeling in any room with any room setting.

Choose the look of weathered barn siding with *Planks* and have the versatility of colors like Shiloh, Tombstone Gap, Bonanza, Cheyenne, Desert Sand, Pine Bluff, Dry Gulch and Dodge City.

Or choose the look of split cork, burlap, bamboo, stone, straw, leather, marble. 40 patterns and over 500 colors

in all to let you have more freedom than even Mother Nature will allow.

Specify Koroseal with Tedlar® and you'll get an extra plus: it'll never stain. Even grease, lipstick and ballpoint ink will wipe right off. And all Koroseal wall coverings are fire rated.

So consider Koroseal for your next job.

It looks so real it's a natural for anything you've got in mind.

No foolin'.

See our insert in Sweet's Architectural and Interior Design catalogs for the name of your nearest Koroseal distributor. He has a Koroseal Color Coordinator waiting for you.

B.F. Goodrich General Products Co., Akron, Ohio 44318.



Mammoth looks ahead with a tight fist.

Mammoth Solid State Temperature Controls get a jump on the energy crises by saving up to 40% of energy costs now.

Within ten years the cost of all present energy sources will triple, according to many experts. In some areas of the country dangerous shortages, to the point of closing schools, are evident even today.

True, there's no general cure-all for the situation. But now Mammoth SST controls can help you and clients get ahead of the situation.

Mammoth SST controls automatically adjust output of equipment to the exact temperature requirements of the space on both heating and cooling cycles, eliminating energy waste

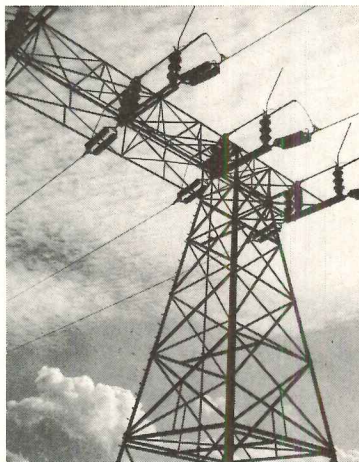

inherent in overcooling and overheating.

Mammoth SST controls make maximum use of outside air for free cooling and return air for free heating.

The more the cost of energy goes up, the more SST controls save.

Now go ahead and see how Mammoth cuts energy costs for yourself. Then, if you think you or your clients want to cut 20% to 40% off the top of normal energy and operating costs, mail the coupon today to: *Mammoth. The people with ideas to help you do a better job.*

LEAR SIEGLER, INC.



MAMMOTH DIVISION

13120-B COUNTY ROAD 6
MINNEAPOLIS, MINNESOTA

Give me more to think about.

- Send more information on Mammoth SST and HVAC systems.
 Have my field representative contact me.

Name _____

Firm _____ Position _____

Street _____

City _____ State _____ Zip _____

DEPT. AR-63

For more data, circle 129 on inquiry card

How Mammoth SST controls use outside air for free energy cooling.

The conventional system closes fresh air dampers to minimum position during summer operation and mechanically cools a warmer blend of return air and minimum fresh air, wasting valuable energy.

Unlike the conventional system, the example shows Mammoth SST controls can save 11.5° of cooling energy on a single-zone unit by taking maximum advantage of outside air.

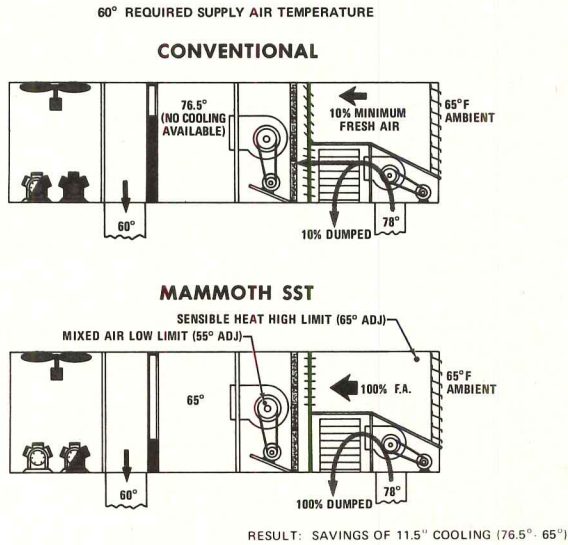

How Mammoth SST controls use return air for free energy heating.

The conventional method of mixing fresh air and return air to 55°, then heating it to required temperature negligently wastes more precious energy.

On the other hand, Mammoth SST controls save 12° of heat by taking full advantage of return air for heating, as in the example. Note that fresh air dampers are at a minimum position during heating mode. This allows the Mammoth SST system to operate the heat exchanger modulated at only 2/3. Or, in this case, the heat exchanger could have been selected at 2/3 the size of the conventional system shown. In either event, the energy savings would be 33 1/3%.

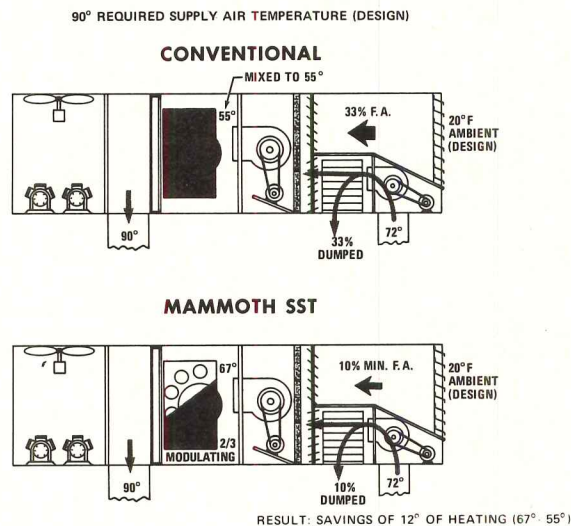

How Mammoth SST controls conserve energy in multi-zone systems.

Conventional multi-zone systems use a cold deck control to maintain cold deck and a 1 to 1, indoor/outdoor proportional reset to control the hot deck.

Now take the Mammoth SST controls. In this example, the warmest and coldest zones directly control the cold and hot deck temperatures reducing the operating differential from 55° to 25°, a phenomenal 30° reduction.

This allows the Mammoth SST system to operate the heat exchanger modulated at only 70%, resulting in a 30% energy savings.

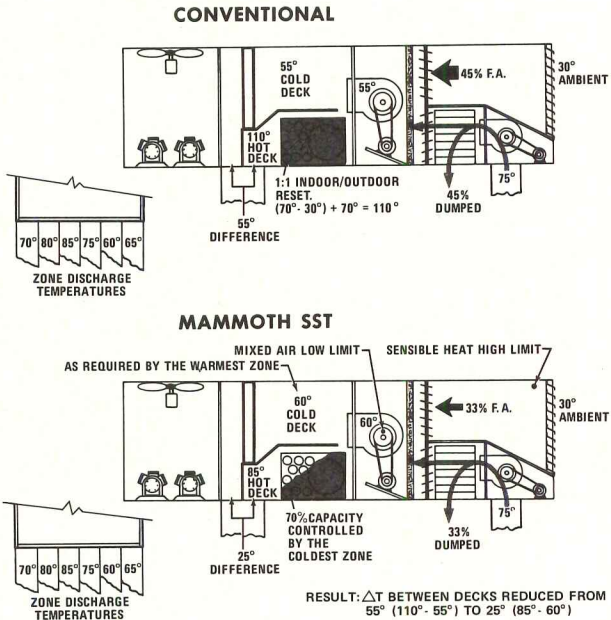

How Mammoth SST controls make economical use of zoned reheat.

Conventional systems cool to 55° then reheat. Mammoth SST controls make considerable economical use of reheat by heating supply air from the temperature required by the warmest zone, saving 5° of reheat in the example shown. Note the energy added to airstream for zoned reheat is identical to the SST multi-zone system.

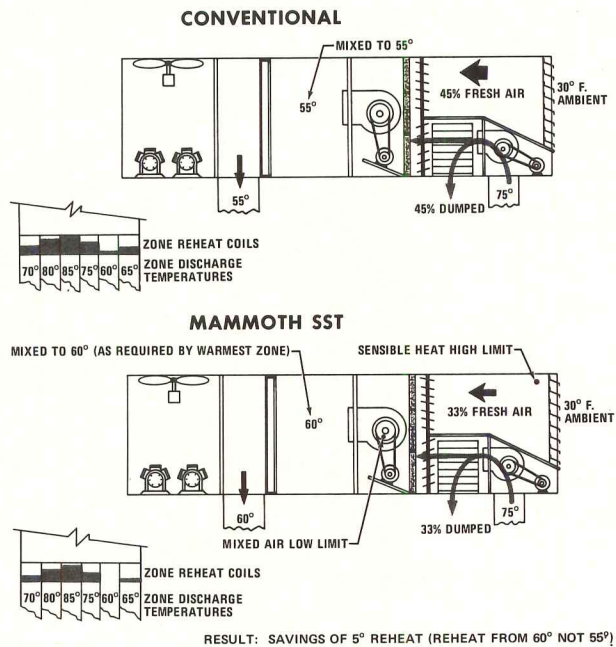

For roof-proven expansion joint covers, specify EXPAND-O-FLASH.[®] From J-M.

No specifications for built-up roofs are complete without including flashing. And a name you've come to respect in flashing is Expand-o-flash—the original pre-fabricated roof expansion joint cover.

Recently J-M acquired the makers of Expand-o-flash—Lamont & Riley, Inc.

This means you can now specify a complete built-up roof with all materials supplied by Johns-Manville—the world's largest producer of built-up roofing products. A company that has solved roofing problems since 1868.

It also means your nearby J-M roofing specialist has the know-how and experience to assist you on the entire roof structure. From substrate to membrane to flashing. Inclusive.

Remember—his assistance, his advice, come free. And can save you money. You can reach him at your J-M district sales office. Or at Johns-Manville, P.O. Box 5108, Denver, Colo. 80217.

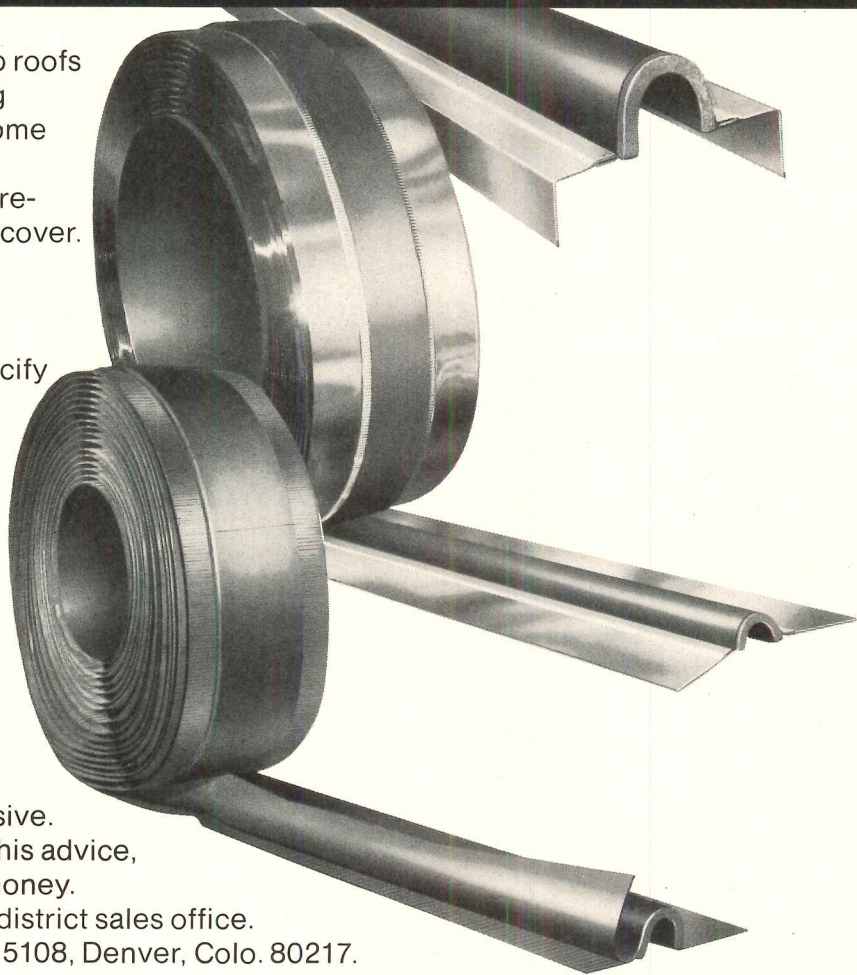

Johns-Manville 

For more data, circle 130 on inquiry card

TECHNICAL KNOCKOUTS.

For a more beautiful environment...
designed in timeless stainless steel.



For urban renewal...

Reflecting the topography and development of the State of Kansas, environmentalist-designer Elpidio Rocha's Center City Mall has added new aesthetic appeal to downtown Kansas City, Kansas.

A highlight of the project is the thirty stainless steel pylons representing the buildings and grain elevators of eastern Kansas. Measuring five feet square by twenty feet high, these pylons presented manufacturing problems as unique as their design.

Republic's continuous rolled 60" wide sheets helped minimize these problems for Grasis Fabricating Co., Kansas City, Mo. Frames made of carbon steel were coated with epoxy before Type 304 stainless in a #4 finish was applied. Care had to be exercised to insure that each sheet was properly aligned before welding. To maintain uniformity of finish and avoid weld marks, the welding was done on the inside.

For enduring art...

Adding beauty to the environment all over the country are the expressionistic sculptures of Kosso Eloul.

Excellent workmanship and the exciting beauty of stainless steel combine to form the geometric shapes which are interestingly poised to reflect the tensions of our urban society.

Crafted in ENDURO® stainless steel by Milgo Industrial Inc., New York, Eloul's interesting sculptures are examples of fine art's rightful place in the total environment.

And this beauty will endure. As Milgo president Bruce Gitlin says, "Stainless is a beautiful material. It will look as good twenty years from now as it does today, no matter where the sculpture is placed."



For attractive protection...

New York City has a sophisticated new police and fire "Emergency Reporting System" which will greatly improve response to over 300,000 calls for help each year. To contain the system, the city sought maintenance-free alarm boxes to replace the existing painted carbon steel ones.

The answer... the handsome new box shown here, using ENDURO Type 304L stainless steel. This vandal and corrosion-proof box was especially designed for this application by Republic Steel research.



Meeting the challenge isn't new to us at Republic Steel. We're the original Technical Knockout specialists. When you specify ENDURO stainless steels... sheet, strip, bar, billet, special sections, tubing, pipe, wire, plate... from our mill or from your local Steel Service Center, you can count on our involvement.

A fact-packed, completely detailed collection of information on the full range of "300 Series" stainless steels is now available. Write Republic Steel Corporation, Cleveland OH 44101. Ask for Adv. 2274.

Republicsteel



Member Steel Service Center Institute

For more data, circle 131 on inquiry card

Plywood shortage?

trus Joist

brings you five practical solutions.

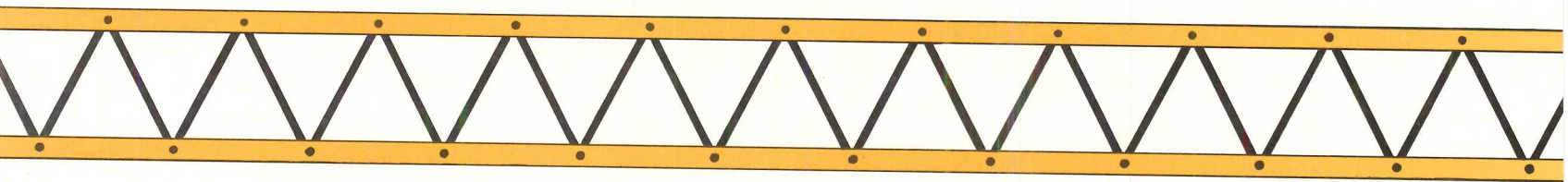

TRUS JOIST and plywood have always been a great team and provide a top quality roof and floor system with real economy. However, versatile TRUS JOIST goes well with other materials too. One of these listed below could be the perfect answer to your building problem.

1. Petrical® is a structural deck that provides the owner with a lightweight non-combustible, insulating, and accoustical material in addition to the durable structural characteristics. Combined with TRUS JOISTS you can design a good compatible system.
Fireproof Prod., Inc., 808 S. 3rd St., Cornell, Wis. 54732.

2. Stramit is ideal for multi-purpose applications and its resistance to buckling and warping makes it a desirable building material. In addition to structural strength and good thermal insulation values, Stramit has significant sound absorption and sound transmission loss properties making it a good companion to TRUS JOISTS.
Stramit Corp. Ltd., 10562-109 Street, Edmonton, 17 Alberta.

3. Homasote—"4-Way" decking serves as a sub-floor, carpet under-layment, sound deadening and weather proof protection. Accordingly, it is widely used in fine homes, garden and low-rise apartments, motels, nursing homes and wherever else a resilient, noise-reducing floor system is needed. Works great with TRUS JOISTS along with Homasote EASY PLY ROOF DECKING.
Homasote Co., Trenton, N. J. 08603.

4. Permadeck® T & G plank spans up to 4 feet c. to c. of joists, carrying normal roof loads without additional support. Permadeck may be nailed to wood joists. Permadeck form board provides forming for reinforced concrete or lightweight insulating concretes such as Elastizell. The form board remains in place as a permanent finish ceiling, providing non-combustible, accoustical and insulating qualities as well as a beautiful texture.
Concrete Prod., Inc., P. O. Box 130, Brunswick, GA 31520.

5. Steel Deck—There are times when the selection of one component for a building will push the cost of other components up or down. The roof system is such a component. While we generally think of all wood systems or all steel systems we seldom take full advantage of the individual products by forming new marriages of materials. TRUS JOIST itself was an important advance in construction quality through a marriage of the best use of wood and steel. Another step forward in your next project could well be a marriage of TRUS JOISTS and your favorite steel decking.

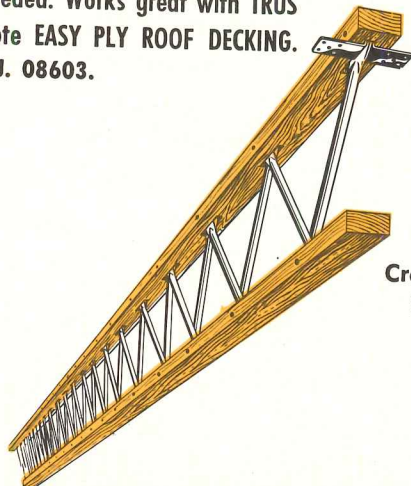

trus Joist

Creative engineering in structural wood.
9777 CHINDEN BOULEVARD BOISE, IDAHO 83702

For more data, circle 132 on inquiry card

Britain's finest international architectural and design magazine

The Architectural Review

The Architectural Review is read and enjoyed in major architectural and planning practices and by people with an interest in buildings and fine design in a hundred countries. It is one of the world's important publications. Each month The Architectural Review is studied, quoted and argued about for its views on topography and townscape and for its thorough and thoughtful criticism of new buildings and their interiors. Then it is filed for future reference. It has a reputation for superb photo-journalism, for fine detailed drawings and for a positive and creative approach to criticism of significant buildings and the problems of the built environment.

Sometimes a complete issue, or most of one, is devoted to an interesting complex of buildings, such as the Knights of Columbus building and Coliseum, New Haven (our issue of April '73), or on the Georgian city of Bath, England (May '73). These special issues can become standard works of reference. Years afterwards architects and planners ask us for back numbers on specific subjects. Almost every month interior design is featured and the current art scene is reviewed. The Review has a long history of encouragement to architectural and planning innovation and is continually searching for new talent. Awards are not usually given to British

publications but recently the Italian government's Gold Medal was awarded to The Architectural Review for outstanding international services to the better design of the human environment. The editorial director in 1971 won the annual Royal Gold Medal of the RIBA (previous holders included Dr Buckminster Fuller, Le Corbusier, Lewis Mumford, Prof. Mies van der Rohe, Dr Gropius) and the retiring editor recently won the Royal Society of Arts Bicentenary medal. Recent editorial excellence is, apparently, being maintained as current sales of the Review are higher than ever before in its 76-year history.

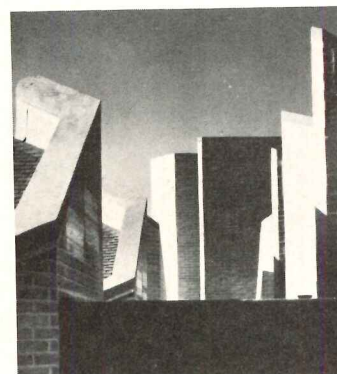
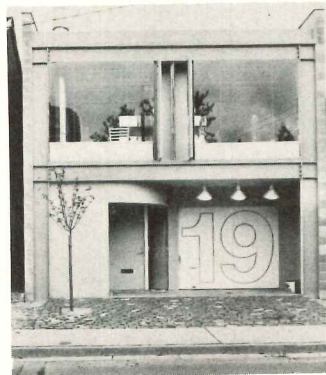

The Architectural Review is a valuable professional aid for busy practices. An annual subscription also makes a memorable all-the-year-round present for friends and colleagues. To see this provocative and professionally-stimulating publication regularly, please fill in and send off this coupon:—

Please send me The Architectural Review monthly (12 copies) at the annual post-paid subscription rate of \$30.

MY NAME/POSITION

MAILING ADDRESS

Country

Type of Firm

Indicate as appropriate.

- Architect Engineer
 Other

I understand that the current issue will be despatched on your receipt of my cheque/int. money order/bankers draft

Payment enclosed.

Signature

The Architectural Press Ltd,
Dept R, Registered Office
9 Queen Anne's Gate, Westminster,
London SW1H 9BY, England.

Registered England 75921

MAKE SURE YOUR CLIENT'S LOADING DOCK MEETS THE TEST



CALL IN KELLEY'S DOCK DESIGN SPECIALISTS

Before a modern loading dock can be placed in operation there are hundreds of vital decisions to be made including choosing the correct equipment from thousands of products.

Size, height, traffic flow, lighting, sealing, waiting areas, gates, service roads, aprons, equipment, and now OSHA requirements, all demand correct decisions.

You can save yourself time, by leaving the job to Kelley specialists. They design, lay-out and equip docks every day. We have 350 of these specialists

in the field. They'll work with you and your client . . . and stand behind the results. They'll save you valuable time and headaches plus assure your client that he'll have the safe efficient dock operation he needs. Get the complete story from the responsible dockboard people:

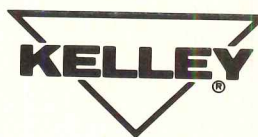

Kelley Company, Incorporated
6768 North Teutonia Avenue
Milwaukee, Wisconsin 53209
Telephone: (414) 352-1000
Telex: 26-661

55-568AR

For more data, circle 134 on inquiry card

The American forest still belongs to the American people.

33% public and private forestland not suitable for commercial trees, or set aside for parks and wilderness areas.

19% state and federal forestland.



And to a *lot* of people.

To begin with, four million individual Americans own 39% of the entire forest—a forest that's still nearly three-fourths as large as it was when Columbus landed.

Then, too, *everybody* shares ownership in that 19% of the forest owned by federal and state governments which supplies so much of the raw material for building our houses and cities and making our paper products.

And when you add the 17 million acres of forestland that's been set aside for parks and wilderness areas, and the government land not suitable for growing commercial trees, the American people—individually or collectively—own 91% of America's 753 million acres of forest.

So if the forest industries seem

to own more than their 9%, it's probably because with responsible, scientific management they've been able to make this 9% produce 26% of all the raw material we need for today's wood and paper products, and still keep America green and growing.

Source: Department of Agriculture, U.S. Forest Service.

For the whole story on America's forest today, get "Forests USA!" For your copy of this full-color, 16-page booklet, send 25¢ to AFI, P.O. Box 963, Arlington, Virginia 22216.

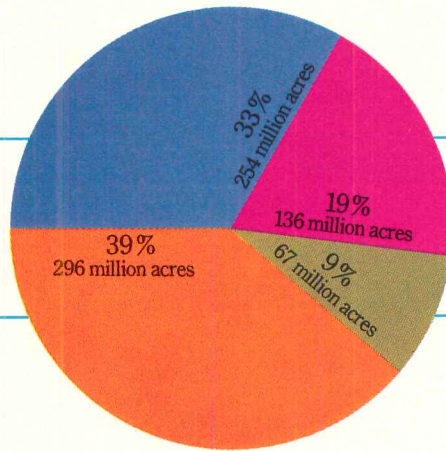

Name _____

Address _____

City _____

State _____ Zip _____

American Forest Institute 29F

39% individually-owned forestland.

9% forest products industry forestland.



Weyerhaeuser® Panel 15 makes beautiful “afters” happen.



State Bank of Fall Creek, Wisconsin, **BEFORE** and **AFTER** Weyerhaeuser Prefinished Siding/Panel 15.
Architect: Norman Sessing, A.I.A., of Neujahr, Drake and Sessing, St. Paul, Minnesota.



Section of downtown Atchison, Kansas, **BEFORE** and **AFTER** Weyerhaeuser Prefinished Siding/Panel 15.

And exciting “originals.”

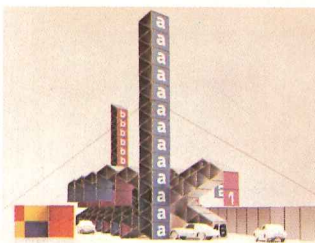

Drive-in restaurant concept, W. C. Murchow Associates, Denver, Colorado.



Swope Park Puppet Theater, Kansas City, Missouri, Morton Rolsky, Architect.



Whistle Stop Restaurant, Phoenix, Arizona, Clarke Modular, Inc., Glendale, Colorado.

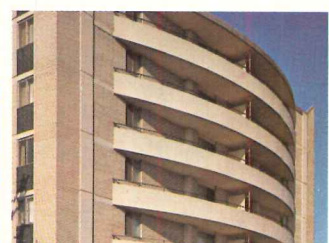

LaRonde Apartments, Arthur M. Hemlock, Hemlock Associates, Cleveland, Ohio.

From re-creation of nostalgic significance to innovative design concepts, the uses for Weyerhaeuser Prefinished Siding/Panel 15 are virtually limitless.

The 10-mil, pebble-textured aluminum face of Panel 15 is available in 19 stock and special order colors, plus custom colors.

Durable acrylic finished aluminum bonded to rugged Structural I exterior-type Douglas fir plywood means exceptionally low maintenance plus structural strength permitting application to any conventional support system.

Regular panels finished one side for sidings and backed with reflective foil insulation. Double-faced panels for balconies or dividers where both faces are exposed.

All Weyerhaeuser Panel 15 guaranteed in writing not to need refinishing for fifteen years.

Approved by all building codes and FHA, qualifies for Class II Fire Hazard rating.

For more detailed information on Panel 15's unique qualities, uses and accessories write to Weyerhaeuser Company, Box B, Tacoma, Washington 98401.



"FreeSpace" for Your Clients

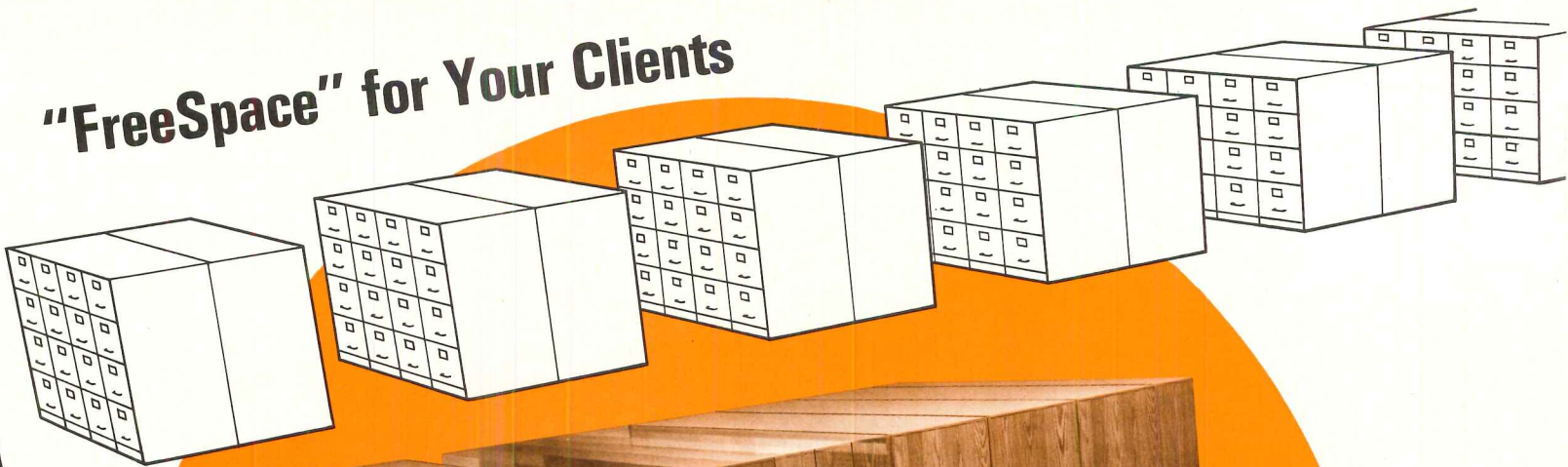

Put all their files in one fourth the area

With Lundia FULLSPACE® Mobile Filing and Storage Systems

Now you can "free" valuable floor space. It's a matter of record. In business firms nationwide, Lundia FULLSPACE systems are saving space, retrieval time and money.

FULLSPACE occupies about one quarter the floor space of drawer files of equal capacity. Suppose your drawer files and aisles occupy 400 sq. ft. FULLSPACE of equal capacity saves space for other purposes by requiring only 100 sq. ft., or you can put four times the filing and storage in existing space.

Swedish-designed Lundia FULLSPACE mobile wood shelving has no equal... for efficient management of general files, records, computer tapes, printout forms, ledgers, books, stationery, supplies of all kinds, and even parts inventory.

When you select FULLSPACE for centralizing records-keeping and storage, you really have something working for you. Ask how FULLSPACE can pay for itself. Have a Lundia representative survey your requirements, present a free layout, and provide a cost estimate. Your installation date will be met. That's in the record, too.

CALL FRANK BROWN COLLECT
217-423-3451

OR WRITE TODAY FOR COMPLETE DETAILS

LUNDIA
The World's Record Holders

LUNDIA, MYERS INDUSTRIES, INC. DECATUR, ILLINOIS 62525
For more data, circle 136 on inquiry card

IDEA BOOSTER



Sixteen stimulating pages for architects. Today's latest ideas, techniques and materials. Contains dozens of interesting new uses for porcelain-on-steel interior and exterior panels in hospitals, schools, food plants, office buildings and industrial plants. Beautifully illustrated in full color with complete specifications.

For your free copy, write:

AllianceWall
CORPORATION

Box 247
Alliance, Ohio 44601

Overseas Factories
Pentagon A/S
Krogagervej 2
5310 Seded, Denmark

Alliance Europe, N.V.
Box 19
3600 Genk, Belgium

For more data, circle 137 on inquiry card

RETROFLEX 180

As you start to rise, the RETROFLEX 180 Tablet Arm retracts by itself, at a single touch, in one simple automatic cycle. (In fact, you can't get out of the chair without the arm folding, unless you are a contortionist!)

Patented return mechanism eliminates tablet arm damage occasioned by half-folded or incompletely returned tablet arm, and clears the aisle for quick exit.

Another innovation to keep you sitting pretty from

Aassey
seating co.

NASHVILLE, TENNESSEE 37208



For more data, circle 138 on inquiry card

OVERHEAD ENCLOSURES

Structural Design Requirements for Dome Skylights.

An aid to designing and writing specifications for dome skylights of Plexiglas used individually, in rows, in grids and in dome enclosures. 20 pages.

SOLAR CONTROL

Transparent Plexiglas Solar Control Series

This 20-page, four-color brochure describes a number of solutions for controlling solar heat and glare. Includes formulae for total heat transfer calculations.

SUNSCREENS

Sunscreen Innovations With Plexiglas

Brochure contains information on sunscreen structural designs, methods of controlling light levels and the control of glare and solar heat gain with its energy conservation benefits. 24 pages.



GET YOUR PLEXIGLAS® DAYLIGHT CONTROL LIBRARY!

Helpful literature for the architect on the use of Plexiglas acrylic sheet

ROHM AND HAAS
PHILADELPHIA, PA. 19105

Plexiglas acrylic plastic is a combustible thermoplastic. Observe fire precautions appropriate for wood or paper products. For building uses, check code approvals. Impact resistance a factor of thickness. Avoid exposure to heat or aromatic solvents. Clean with soap and water. Avoid abrasives.

For more data, circle 139 on inquiry card

A beautiful solution:

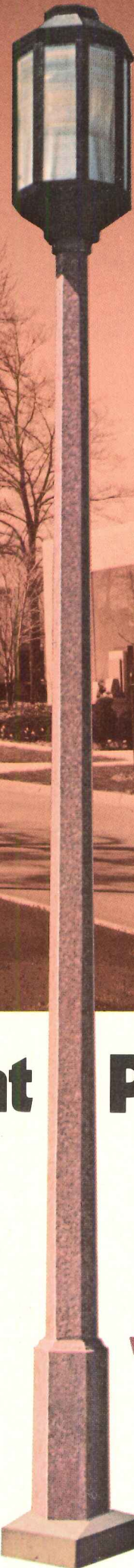

Stress-Spun[®] Concrete Light Poles.

Stress-Spun concrete poles offer a beautiful solution for street and area lighting installations which must conform to the environment.

Whether to blend with architectures, landscapes or luminaires, there is a Stress-Spun pole in a design and color to meet your needs. Colors are not just skin deep; they go all the way through. Their polished, texturized surfaces consist of attractive hues that improve with age.

Stress-Spun concrete poles have great density and strength to resist the elements and to minimize

vandalism. Their good looks remain care-free.

They are available in popular mounting heights with interior wiring raceways, plus a choice of bases, including pre-cast foundations for fast, economical installation.

Beauty, durability and economy—three reasons why you should specify and install Stress-Spun concrete light poles.

Call or write: Union Metal Manufacturing Co., P.O. Box 8530, Canton, OH 44711. Phone (216) 454-6111.

We've got what it takes!

American Concrete
Division of **Union METAL**
MANUFACTURING COMPANY

For more data, circle 140 on inquiry card

ARCHITECTURAL RECORD June 1973 249

Now Para-flyte
deck equipment
comes

4,608

different ways to
meet any (and
we mean any)
pool budget.



**Paragon's Exclusive New
Interchangeable Option Plan of
Materials, Lengths, Superstructure,
Accessories, Etc. Permits
Complete Design Freedom—
Within Budget!**

Think of what this means for today's creative swimming pool Architect or Engineer. No more settling for "second best" because of budget limitations. Complete design flexibility. Beauty. Quality. And most important—proven performance.

For nearly two decades, Para-flyte equipment has been the choice of leading coaches and experienced competitors. Its rugged construction and functional design means added safety—an important reason why it is consistently specified when building a new or re-equipping an old school, club, municipal or residential pool.

SEE OUR CATALOG IN SWEET'S. OR WRITE



KDI Paragon Inc. the architect's friend.

Mfrs. Of Quality Deck/Underwater Equipment
12 Paulding St., Pleasantville, N.Y. 10570 • 914-769-6221

For more data, circle 141 on inquiry card

YOU SAVE WITH

Spectra-Glaze®

GLAZED CONCRETE BLOCK WALLS

Economy of block, permanence of glaze. Less to install & maintain. Attractive, colorful, sanitary. Load bearing.



® Reg. U. S. Pat. Off., Canada & other foreign countries by
THE BURNS & RUSSELL CO., Box 6063(I), Balto., Md. 21231

For more data, circle 142 on inquiry card

MANNING DECORATIVE
LIGHTING



NEW

**Complete line of decorative lighting
equipment—specifically designed for
commercial interiors.**

REQUEST FULL COLOR CATALOG "M"

R.A. MANNING COMPANY INC.
P.O. BOX 643 SHEBOYGAN, WIS. 53081

For more data, circle 143 on inquiry card

Architects for the new PNB Plaza (prime tenant, Philadelphia National Bank) know how to save money. They specified terra cotta-colored window frames and vertical trim that will stay like new without expensive maintenance.

That's because they are aluminum extrusions, factory-finished with DURANAR® from PPG. These fluoro-polymer coatings are noted for their

color integrity and durability. In fact, DURANAR coatings have a 20-years-and-longer rated service life.

They also have a high degree of resistance to dirt and mildew, plus excellent cleanability. Which means you're combining color, long life, and low maintenance when you write DURANAR color coatings into the specs.

It's a good investment in the future. For any building. For data on PPG color coatings, check Sweet's Architectural or Industrial Construction Files 9.10/PPG.

Or contact the Market Manager, Extrusion Coatings, PPG INDUSTRIES, Inc., Dept. 13S, One Gateway Center, Pittsburgh, Pa. 15222.

PPG: a Concern for the Future

For more data, circle 144 on inquiry card

EXTRUSION COATINGS FROM PPG. A SOLID INVESTMENT FOR THIS NEW BANK BUILDING.



PNB PLAZA, Philadelphia, Pennsylvania Architect: Ewing Cole Erdman & Eubank Consulting Engineer: Synergo, Inc.
Window fabricator: George Habgood & Company DURANAR coating applicator: Alcoa, Cressona, Pennsylvania

3A1



If our salesmen could carry samples, You'd always specify BILCO.

When all you have to go by are the pictures on the catalog pages, one brand of horizontal doors looks pretty much like another. But if our sales representatives could carry samples you would immediately recognize the advantages of Bilco Doors.

You would see for yourself how easily they open and close, their superiority in design and workmanship. You would readily see that Bilco Doors are built to deliver long, trouble-free service, assuring your clients of sound value and complete satisfaction.



ROOF SCUTTLES
Standard sizes for personnel access; special sizes in single and double leaf types for equipment access.

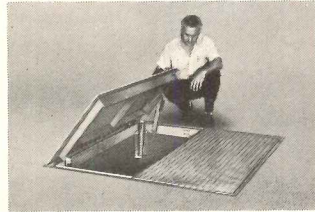

FLOOR and PIT DOORS
Four standard types in a variety of sizes for every interior and exterior requirement. Special sizes on order.

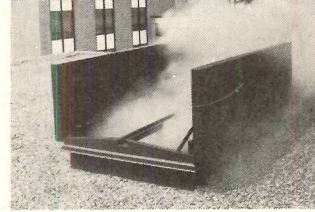

FIRE VENTS
The finest in fire protection equipment. Eight standard sizes with UL and FM labels. Special sizes to order.



The BILCO Company, Dept. AR-63 New Haven, Connecticut 06505



For more data, circle 145 on inquiry card

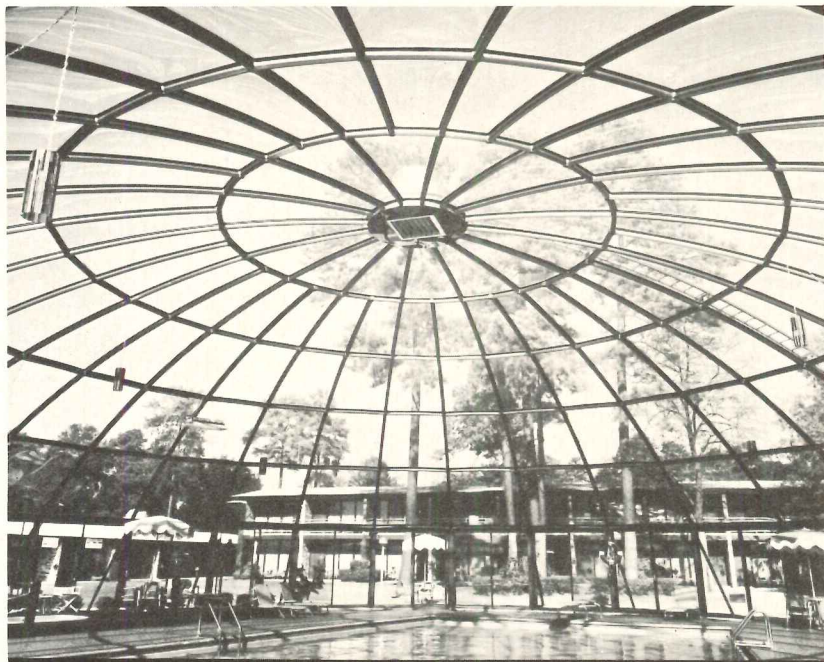

IBG Natural Light Through Glazed Structures!

ICKES-BRAUN GLASSHOUSES
P.O. Box 147, Deerfield, Illinois 60015 312-634-3131
Division of Roper Corporation



See us in Sweet's 13.1/lb-7.8/lb

For more data, circle 146 on inquiry card

FOR ANYONE WITH A ROLE IN CAMPUS PLANNING AND DESIGN



CAMPUS PLANNING AND DESIGN
Edited by Mildred Schmetz, AIA
Senior Editor
Architectural Record

SIX SECTIONS:

- Designing the Single Building
- Designing the Library for the Campus
- The Single Building or Complex Designed as Part of the Campus Master Plan
- Architecture Which Gives the Campus the Unity of a Single Building
- Campus Performing Arts Centers
- Designing Campus Interiors

This 266-page volume brings you practical data and creative ideas on handling such campus architecture problems as: designing well-scaled open space; dealing with existing architectural atmosphere; creating flexible prototypes for specialized buildings; planning expandable systems for an entire campus; organizing functional and aesthetic elements in relation to site and surroundings; integrating the building with interior space design, solving problems of architectural scale posed by the surrounding campus.

ARCHITECTURAL RECORD
1221 Avenue of the Americas, New York, N.Y. 10020

Please send me copies of Campus Planning and Design @ \$22.50 each, plus postage and handling. (Include payment and we'll pay the postage and handling.)

Name _____

Street _____

City _____ State _____ Zip _____

The only acoustical fire door 9 feet tall and 30 minutes thick.



A 30-minute fire door is something you need. A 9-foot acoustical door is something you'd like. Only U.S. Plywood puts them both together, in our tall, tough, beautiful, acoustical fire door. 9 feet tall. 30 minutes thick. STC rated 28. UL tested and rated for fire resistance, heat transmission and structural integrity.

The Weldwood acoustical fire door is considerably less expensive than a comparable metal door. It also performs considerably better when tested for heat transmission. After 30 minutes in UL's test furnace, where it gets well over 1500°F, the Weldwood door's unexposed side was less than 175°F, cool enough not to harm a person forced against it during a fire. Its STC 28 rating provides good speech privacy and protection in hotels, motels and other commercial installations.

The core of this door is Novoply.[®] The face is your choice: striking hardwood veneers, Duraply[®] for job-site painting, Permaply[®] for solid color prefinishing, or colorful plastic laminates.

No matter what kinds of doors you're specifying, the one name to remember is Weldwood.[®] We have the biggest, and best, line of architectural doors in the business: interior, exterior, static- and radiation-shielding as well as acoustical and fire. For more information on any of them, call your local U.S. Plywood Branch Office.



U.S. Plywood

A Division of Champion International
777 Third Avenue, New York, N.Y. 10017

For more data, circle 147 on inquiry card

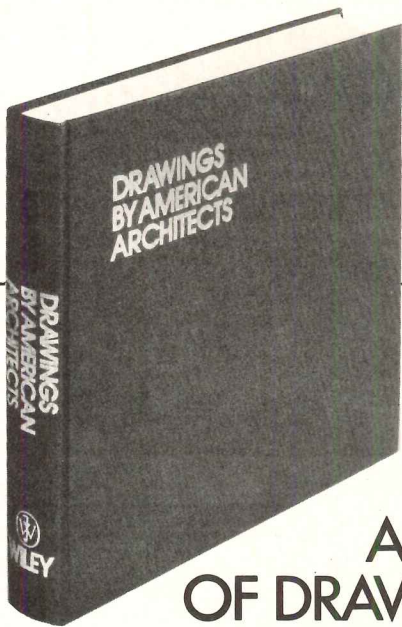

A GALLERY OF DRAWINGS BY AMERICAN ARCHITECTS.

Enjoy in your own home or office over 500 original drawings from about 100 large and small architectural offices across the country.

You can study at your leisure all the latest presentation techniques and media and methods—space-time drawings, line drawings, washes, sprays and different solutions to problems like depicting glass and breaking down of scale.

You'll see drawings of urban renewal projects, new towns, high-rises, condominiums, cultural centers, private homes, civic centers, medical and government buildings.

The original drawings of Transpo '72, the Bahio Kino Development in Mexico, the World Trade Center, Los Angeles Rapid Transit Station, The Lower Manhattan Plan, Stowe in Vermont and the France Research Center done by IBM's Plotter Computer.

And the whole collection is easy to view. Each drawing is in black and white, printed in sepia tones, and appears on a full page with the name of the renderer, the project and the office. Some pages even show enlarged portions of a drawing to illustrate the techniques used.

The book's arranged in alphabetical order according to architectural offices and there's an index for offices and one for renderers.

Drawings by American Architects—On exhibit in one volume.

Send your coupon to Dept. 599 and receive your copy of—

DRAWINGS BY AMERICAN ARCHITECTS

by Alfred M. Kemper, A. M. Kemper & Associates
1973 613 pages \$30.00

WILEY-INTERSCIENCE

a division of JOHN WILEY & SONS, Inc.
605 Third Avenue, New York, N. Y. 10016
In Canada: 22 Worcester Road, Rexdale, Ontario



WILEY-INTERSCIENCE • Dept. 599 •
605 Third Avenue, New York, N. Y. 10016

Please send me Kemper's *Architects* • 0-471-46845-2 • \$30.00

My check (money order) for \$30.00 is enclosed.

Please bill me.*

Name _____ Company _____

Address _____

City _____ State _____ Zip _____

price subject to change without notice

*restricted to the continental United States

Please add state and local taxes where applicable.

093-A-4114-WI

For more data, circle 148 on inquiry card

Phoenix Civic Plaza Decked Out in Kemiko Concrete Colors (over 500,000 square feet)

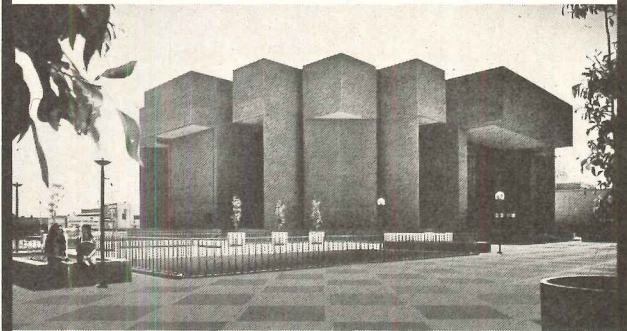

Longlasting Kemiko Col-r-tone was selected for the spacious pedestrian concourse of the beautiful new six-block Civic Plaza Convention Center in Phoenix. Kemiko Col-r-tone accentuates the textured diamonds to achieve a pleasing harlequin effect.

Kemiko's Permanent Concrete Stain cannot crack, chip or peel because it is an integral part of the concrete surface. Col-r-tone will defy sun, wear and moisture for years in any climate. The non-skid, glare-free finishes are easily applied by brush or roller, and may be inter-mixed to provide over 50 contemporary colors. Over 90% of all Southern Calif. tennis courts wear Kemiko Tennis Court Green.

Write for free beautifully illustrated brochure and color chips.

KEMIKO, Inc., Dept. AR6

2443 N. Naomi St., Burbank, Calif. 91504

Architect: Charles Luckman Associates
General Contractor: Del E. Webb Corporation
Kemiko Applicators: P & H Supply Company

For more data, circle 149 on inquiry card

There's one "years ahead" roof deck insulation that's available *now*...in big supply. It can be applied to any thickness. Even sloped to drains. K factor .40. Conserve energy—yours and nature's—specify All-weather Crete roof deck insulation by Silbrico Corporation, Hodgkins, Illinois 60525.



For more data, circle 150 on inquiry card

Patina bronze-tone
stainless outside...

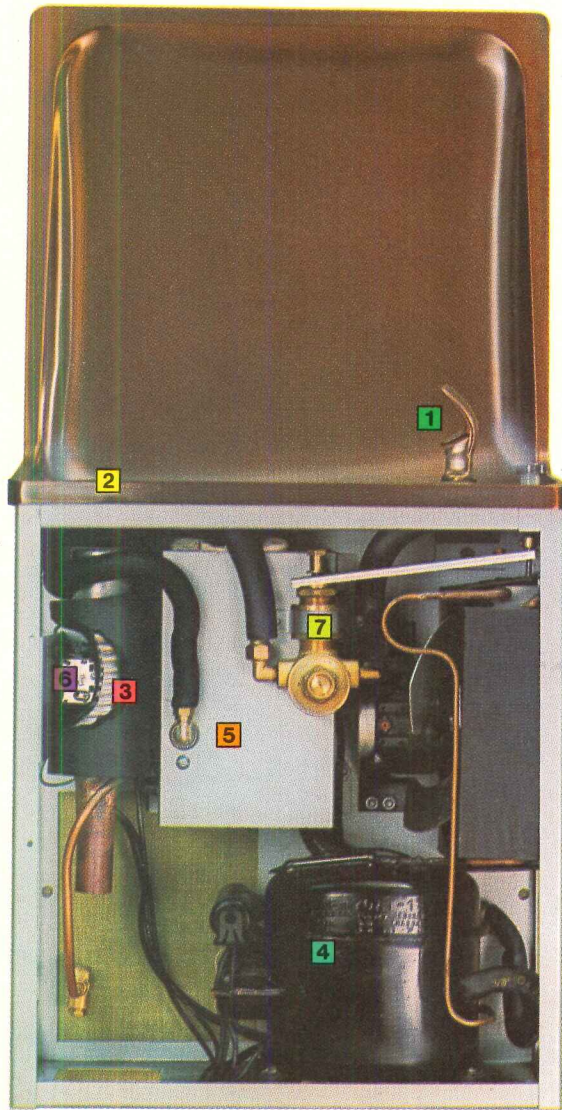

Incomparable
workmanship inside

Here's a case where "or equal" isn't equal.

Halsey Taylor has a pretty good name. But it's not because we make the best-looking water coolers in the world. It's because we put a lot more quality workmanship on the inside of our coolers—where hardly anyone ever looks, or needs to.

We honestly don't believe Halsey Taylor water coolers have an equal.

Do us a small favor. Look carefully at the inner workings of this simulated semi-recessed cooler. Compare its craftsmanship, technical ingenuity and performance with any other brand of water cooler.

We work too hard at building the best to accept the idea that anyone else's product is just as good.

1 Exclusive 2-stream bubbler. Builds a large, drinkable mound of water. Squirt-proof and vandal resistant. One-piece bronze-plated brass forging prevents contamination.

2 Cooler top. Patina stainless steel or satin finish stainless steel, polished and buffed for beauty and ease of cleaning. Separate drain strainer removable for easy cleaning without removing cooler top.

3 Pre-cooler (cutaway). Incoming water line coiled around and tin-bonded to cold water drain. Boosts cooling capacity by 60%.

4 Condensing unit assembly. Hermetically sealed, lubricated for life. Automatic re-set overload protector prevents overheating. Capacitor insures compressor startup. All components designed and coordinated for top efficiency and long life.

5 Cooling storage tank. All copper, hot-dipped pure tin lining. Incoming coil is tin-bonded to refrigerant coil to cool water before it enters tank.

6 Dual temperature controls. Two thermostats, primary and secondary, provide double protection against freeze-up.

7 Automatic regulating/operating valve. Maintains constant stream height under line pressures varying from 20 p.s.i. to 90 p.s.i. Easy to service. Tamper-proof. Large orifices resist deposits and clogging. All parts are corrosion-resistant.

Halsey Taylor Division,
1554 Thomas Road,
Warren, Ohio 44481.



Halsey Taylor[®]
KING-SEELEY **KS** THERMOS CO.

For more data, circle 151 on inquiry card



When Agnes came for an unwanted visit, coatings based on Pliolite kept her out.

When tropical storm Agnes struck Florida, one condominium survived without a trace of interior water damage—thanks to a texture coating based on Goodyear Pliolite® resin specifically designed to protect, waterproof and beautify masonry surfaces.

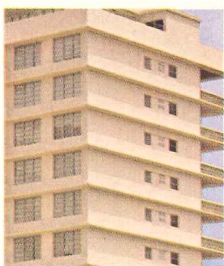

The reason: texture coatings based on Pliolite resin form a tough, impervious shield that prevents the passage of water either into or out of the concrete.

In addition, texture coatings based on Pliolite resin can be applied to all

types of masonry surfaces—pre-cast, poured or concrete block—wet or dry, interior or exterior, above or below-grade, in almost any kind of weather. In fact, when applied to green concrete, it acts as a curing medium.

If your job is to waterproof and protect masonry surfaces against weather, texture coatings based on Pliolite resin can help you do it better. For more information, and a list of manufacturers of texture coatings based on Pliolite resin, just write to Bill Smith at Goodyear Chemicals, Dept. 6204, Box 9115, Akron, Ohio 44305.

GOODYEAR
CHEMICALS

For more data, circle 152 on inquiry card

ARCHITECTURAL RECORD Published by McGraw-Hill, Inc., 1221 Avenue of the Americas, New York, New York 10020. © 1973. All rights reserved.

Readers using the index will find buildings entered in three ways: by architect's name, by building or owner's name, and by building type (apartments, hospitals, schools, etc). Other categories cover subjects in the engineering section (concrete, lighting, prefabrication, etc.). ABBREVIATIONS: BTS—Building Types Study; RH—Record Houses & Apartments.

A

- AIA. National Hdqtrs., Washington, D.C.; The Architects Collaborative, archts.—May 1973, pp. 131-40. "Scott Ferebee keeps the momentum—and gives the AIA some new goals," editorial by Walter F. Wagner, Jr.—March 1973, pp. 9-10. AIA chapter offices, interiors, Seattle; Wendell Lovett, archt.—Jan. 1973, p. 99. National Convention—June 1973, pp. 34-9
- Airports. "Cincinnati Airport: proving ground for youth and method"—June 1973, pp. 65-7
- Alandales Men's Store, interiors, Westwood, Cal.; Zimmerman, Robbin & Assocs., archts.—Jan. 1973, pp. 94-5
- Apartments, Housing. Building Types Study 443: "What is the best role for architects in the housing development game?"—Jan. 1973, pp. 119-134. Building Types Study 448: Record Houses and Apartments of 1973, Mid-May 1973, pp. 92-112. Bayport, Newport Beach, Cal.; Fisher-Friedman Assocs., archts.—Jan. 1973, pp. 124-5. Bayview, Newport Beach, Cal.; Fisher-Friedman Assocs., archts.—Jan. 1973, pp. 124-25. Black Butte Condominiums, Black Butte, Ore.; Donald Goodhue, archt.—RH 1973, pp. 162-3. Canterbury Garden, New Haven, Conn.; Louis Sauer, archt.—April 1973, pp. 112-3. Coleman Towers, Stamford, Conn.; Robert L. Wilson, archt.—Jan. 1973, p. 132. Esplanade Village, Redondo Beach, Cal.; Brent Goldman Robbins & Bown, archts.—RH 1973, pp. 110-2. Greeley West Apartments, Greeley, Colo.; Donald Roark & Assocs., archts.—RH 1973, pp. 106-7. Harrison Street Apartments, Oakland, Cal.; Peters & Clayberg & Assocs., archts.—RH 1973, pp. 108-9. "Kurokawa and his capsules"—Feb. 1973, pp. 109-14. Lemon Tree Village, Coconut Grove, Fla.; Charles Harrison Pawley, archt.—RH 1973, pp. 98-9. Mariana Bracetti Plaza, N.Y.C.; Robert L. Wilson, archt.—Jan. 1973, p. 133. Modular housing and office development, Burlington, Vt.; Unihab, archts.—Jan. 1973, p. 134. Mountain View Apartments, Fremont, Cal.; George Kleet and Bart A. Jones, archts.—Jan. 1973, pp. 126-7. New Hope Towers, Stamford, Conn.; Robert L. Wilson, archt.—Jan. 1973, p. 133. Oak Hill Estates, Philadelphia; Louis Sauer, archt.—April 1973, pp. 116-18. "Our national housing goals: where do they stand now?"—May 1973, p. 62. Pine Grove Townhouses, Brockton, Mass.; Offices of Samuel Paul with Pietro Belluschi & Jung/Brannen Assocs., consulting archts.—RH 1973, pp. 104-5. Seascape II, Solana, Cal.; Oxley/Landau /Partners, archts.—RH 1973, pp. 100-1. Sutton Place, Shaker Heights, Ohio; William A. Gould & Assocs., archts.—March 1973, pp. 109-16. Townhouses, Chicago; Booth & Nagle, archts.—Jan. 1973, pp. 122-23. Tustin Apartments, Tustin, Cal.; Backen Arrigoni & Ross, archts.—RH 1973, pp. 94-7. Twin Parks West & Southwest, Bronx, N.Y.; Giovanni Pasanella, archt.—June 1973, pp. 121-8. Village Green, Staten Island, N.Y.; Norman Jaffe, archt.—Jan. 1973, pp. 130-1. Village Park, Amherst, Mass.; Stull Assocs., archts.—Jan. 1973, pp. 128-9. Walden (planned community), Aurora, Ohio; Architectural Design Partnership, archts.—Jan. 1973, pp. 120-1. Wesleyan Hills, Middletown, Conn.; Louis Sauer, archt.—April 1973, pp. 114-5
- Architects Collaborative The, archts.; AIA National Hdqtrs. Bldg., Washington, D.C.—May 1973, pp. 131-40
- Architectural Business. See also Building Activity. "Federal handbook includes guide for construction management applicants"—March 1973, pp. 57-8. "How design firms should approach government agencies" (Tips on preparing U.S. Government Form 251)—Jan. 1973, pp. 55-6. "How you can work with developers—and actually enjoy it"—April 1973, pp. 111-8. "A plethora of pundits looks at subsidy cutbacks, Phase 3 and new business"—Feb. 1973, p. 59. "SMP compiles the most informative wall"—May 1973, pp. 57-8. "What is the Best Role for Architects in The Housing Development Game?"—Jan. 1973, BTS, pp. 119-34. "Whatever happened to Standard Form 251?"—April 1973, pp. 55-6. "Cincinnati Airport: proving ground for youth and method"—June 1973, pp. 65-7
- Architectural Design Partnership, archts.; Walden (planned community), Aurora, Ohio—Jan. 1973, pp. 120-21
- Architectural Engineering. "Conserving energy in lighting"—Feb. 1973, pp. 141-3. "Curtain-wall troubles show need for more qualified expertise; improved codes and standards"—Feb. 1973, p. 143. "Design-build for student housing: responds to cost, but raises other questions"—April 1973, pp. 149-52. "Guidelines to achieving quality architectural concrete"—May 1973, pp. 161-4. "Load-bearing masonry panels are site fabricated in 'mini-factories' to speed building completion"—Feb. 1973, p. 144. "Package hvac units for large office buildings: a new approach"—Jan. 1973, pp. 135-8. "Putting light where it is needed most: on the tasks"—March 1973, pp. 143-6. Branford Intermediate School, Branford, Conn.; Carlin Pozzi & Assocs., archts.—June 1973, pp. 160-2. Hill Central K-4 School, New Haven, Conn.; Carlin Pozzi & Assocs., archts.—June 1973, pp. 156-7. Shepherd Glen School, Hamden, Conn.; Carlin Pozzi & Assocs., archts.—June 1973, pp. 158-9. "Three open-plan schools: inventive design and engineering"—June 1973, pp. 155-62
- Architectural Practice. See Architectural Business
- "Architecture USSR"—Feb. 1973, pp. 91-102
- Arkhora Assocs., archts.; Broadview Cinema I, interiors, Savannah—Jan. 1973, pp. 100-1
- Arts Buildings. See also Cultural Centers. Mellon Arts Center, Choate School, Wallingford, Conn.; I.M. Pei & Partners, archts.—Jan. 1973, pp. 111-18

B

- Backen Arrigoni & Ross, archts.; Tustin Apartments, Tustin, Cal.—RH 1973, pp. 94-7
- Banks. Cleveland Trust Co. Hdqtrs., Cleveland, Ohio; Marcel Breuer & Hamilton Smith, archts.—March 1973, pp. 124-6. First-City National Bank Hdqtrs., Binghamton, N.Y.; Ulrich Franzen & Assocs., archts.—Feb. 1973, pp. 102-8. National Bank of Tulsa, interiors, Tulsa, Okla.; Wolf Assocs., archts.—June 1973, p. 118. North Carolina National Bank Park Road Branch, Charlotte, N.C.; Wolf Assocs., archts.—June 1973, pp. 112-3. North Carolina National Bank Beatties Ford Road Branch, Charlotte, N.C.; Wolf Assocs., archts.—June 1973, pp. 114-5
- Barnstone, Howard, archt.; Levin House, Galveston, Tex.—RH 1973, pp. 60-1
- Bayport, Newport Beach, Cal.; Fisher-Friedman Assocs., archts.—Jan. 1973, BTS, pp. 124-5
- Bayview, Newport Beach, Cal.; Fisher-Friedman Assocs., archts.—Jan. 1973, BTS, pp. 124-5
- Becker House, Wainscot, N. Y.; Norman Jaffe & Assocs.,

- archts.—April 1973, pp. 145-8
- Behn, Peter, archt.; Lozano House, Santa Cruz County, Cal.—RH 1973, pp. 68-71
- Bell & Howell Schools, Devry Institute of Technology, Chicago; Caudill Rowlett Scott, archts.—Feb. 1973, BTS, p. 134
- Belluschi, Pietro, consulting archt. with the office of Samuel Paul & Jung/Brannen Assocs., archts.; Pine Grove Townhouses, Brockton, Mass.—RH 1973, pp. 104-5
- Bennett & Tune, archts.; Harlan Area Vocational School, Harlan, Ky.—Feb. 1973, BTS, p. 135
- Bikales House, Lincoln, Mass.; Earl Flansburgh & Assocs., archts.—RH 1973, p. 40-3
- Black Butte Condominiums, Black Butte, Ore.; Donald Goodhue, archt.—RH 1973, pp. 102-3
- BOCES School Complex, Yorktown Heights, N. Y.; La Pierre Litchfield Imbs., archts.—Feb. 1973, BTS, pp. 136-7
- Book Reviews. Amouroux, D., and M. Crettol and J. P. Monnet, Guide d'architecture contemporaine en France—Jan. 1973, p. 50. Banov, Abel, Paints & Coatings Handbook—May 1973, p. 91. Borrego, John, Space Grid Structures—Jan., 1973, p. 50. Fleming, John, et. al., The Penguin Dictionary of Architecture—April 1973, p. 70. Guinness, Desmond & J. T. Sadler, Mr. Jefferson, Architect—May 1973, p. 87. Illingworth, J. R., Movement and Distribution of Concrete—Jan. 1973, p. 50. Kirby, Rosina Greene, Mexican Landscape Architecture—April 1973, p. 70. Masser, Ian, Analytical Models for Urban & Regional Planning—May 1973, p. 91. Robinette, Gary O., Plants/People/and Environmental Quality—May 1973, p. 87. Sheraton, Thomas, The Cabinet-Maker & Upholsterer's Drawing Book—May 1973, p. 91. The American Courthouse—June 1973, p. 51
- Bookstaver House, Westminster, Vt.; Peter Gluck, archt.—RH 1973, pp. 34-7
- Booth & Nagle, archts.; Shearson Hammill's regional hdqtrs. interiors, Chicago—Jan. 1973, pp. 96-7
- Booth & Nagle, archts.; townhouses, Chicago—Jan. 1973, pp. 122-3
- Branford Intermediate School, Branford, Conn.; Carlin Pozzi & Assocs., archts.—June 1973, pp. 160-2
- Brent Goldman Robbins & Bown, archts.; Esplanade Village Redondo Beach, Cal.—RH 1973, pp. 110-2
- Breuer, Marcel & Herbert Beckhard, archts.; Murray Lincoln Campus Center, University of Mass., Amherst—March 1973, pp. 118-21
- Breuer, Marcel & Hamilton Smith, archts.; Cleveland Trust Co. Hdqtrs., Cleveland, Ohio—March 1973, pp. 124-6. Technology II (lab & classroom bldg.), New York University—March 1973, pp. 122-3
- Brewer & Co. Office Bldg., Hilo, Hawaii; Ossipoff, Snyder Rowland & Goetz, archts.—June 1973, BTS, pp. 148-9
- Briggs House, Harbor Springs, Mich.; William Kessler & Assocs., archts. RH 1973, pp. 88-91
- Broadview Cinema I, interiors. Savannah Arkhora Assocs., archts.—Jan. 1973, pp. 100-101
- Broadway Plaza, Los Angeles; Charles Luckman Assocs., archts.—March 1973, BTS, pp. 140-1
- Brown Sciences Library, Brown U., Providence; Warner Burns Toan, archts.—April 1973, BTS, pp. 130-3
- Building Activity. "Construction Outlook 1973: First Update"—April 1973, p. 59. "Educational building: where's it going from here?"—March 1973, p. 62. "Financing nonresidential building: Some new sources in 1973"—Jan. 1973, p. 60. "Our national housing goals: where do they stand now?"—May 1973, p. 62. "The year that was: 1972 in review"—Feb. 1973, p. 61. "Project data reflects diversity in construction"—June 1973, p. 73
- Burke Kober Nicolais Archuleta, archts.; Sunrise Mall, Sacramento, Cal.—March 1973, BTS, pp. 135-7
- Burley, Robert, archt., House on Main Mall, 1973, Robert, pp. 52-3
- Burroughs Corp. Hdqtrs., Detroit; Smith & Gardner, archts.—June 1973, pp. 152-4

C

California Institute of the Arts Modular Theater, Valencia; Ladd & Kelsey, archts.—April 1973, pp. 137-40

Cambridge school site selection study; Gund/Monacelli Assocs., archts.—May 1973, pp. 141-4

Canada. Greenwood Secondary School, Toronto; Fairfield & DuBois, archts.—Feb. 1973, BTS, pp. 132-3. Lethbridge University Project I, Vancouver, B.C.; Erickson-Massey, archts.—May 1973, pp. 115-24. Sheridan College, Oakville, Ont.; Marani Rounthwaite & Dick, archts.—Feb. 1973, BTS, pp. 138-40. Showroom for Sony Products, interiors, Winnipeg; GBR Assocs., archts.—Jan. 1973, p. 93. "The Restoration of La Place Royale," Quebec, by Stuart D. Goulding—June 1973, pp. 129-32

Cannady, William, archt.; Cannady House, Houston—RH 1973, pp. 88-9

Cannery, The, San Francisco; Esherick Homsey Dodge & Davis, archts.—March 1973, BTS, pp. 132-4

Canterbury Garden, New Haven, Conn.; Louis Sauer, archt.—April 1973, pp. 112-3

Carlin Pozzi & Assocs., archts.; Branford Intermediate School, Branford, Conn.—June, 1973, pp. 160-2. Hill Central K-4 School, New Haven, Conn.—June, 1973, pp. 156-7. Shepherd Glen School, Hamden, Conn.—June, 1973, pp. 158-9

Caudill Rowlett Scott, archts.; DeVry Institute of Technology, Bell & Howell Schools, Chicago—Feb. 1973, BTS, p. 134. Tulane University Medical Center, New Orleans—April 1973, pp. 141-44

Caulfield, Tom of Peters & Clayberg & Assocs., archts.; Harrison Street Apartments, Oakland, Cal.—RH 1973 pp. 108-9.

Childs Bertman Tseckares Assocs., archts.; Renovated stable, Boston—May 1973, pp. 128-30

Chimacoff/Peterson, archts.; Lowenstein House, Montauk, N.Y.—RH 1973, pp. 50-51

Churches. See Religious Buildings

"Cincinnati Airport: proving ground for youth and method"—June 1973, pp. 65-7

Cleveland Trust Co. Hdqtrs., Cleveland, Ohio; Marcel Breuer & Hamilton Smith, archts.—March 1973, pp. 124-6

Coleman Towers, Stamford, Conn.; Robert L. Wilson, archt.—Jan. 1973, p. 132

College & University Buildings. See University & College Buildings

Comstock House, Atlanta; Clyde Pearson, archt.—RH 1973, pp. 76-7

Concert Halls. See Performing Arts Buildings

Concrete. "Guidelines to achieving quality architectural concrete"—May 1973, pp. 161-4

Construction management. "Federal handbook includes guide for construction management applicants"—March 1973, pp. 57-8. "Management unifies design and delivery process"—June 1973, p. 69

Coplans, Patricia, archt.; Coplans house, San Francisco—RH 1973, pp. 44-5

Country Clubs. Grandfather Golf & Country Club, Linville, N.C.; Wolf Assocs., archts.—June 1973, p. 116

Courthouse Center, Columbus, Ind.; Gruen Assocs., archts., Cesar Pelli, partner-in-charge—March 1973, BTS pp. 128-31

Cultural Centers. Japan House, N.Y.; Junzo Yoshimura & Gruzen & Partners, archts.—April 1973, pp. 108-10

"Curtain-wall troubles show need for more qualified expertise; improved codes & standards"—Feb. 1973, p. 143

D

Daiwa Corp. Hdqtrs., Gardena, Cal.; Kajima Assocs., archts.—May 1973, BTS, p. 147

Deupi Freidin Kleiman, space designers; Virgin Islands Information Center, interiors, Washington—Jan. 1973, p. 98

DeVry Institute of Technology, Bell & Howell Schools, Chicago; Caudill Rowlett Scott, archts.—Feb. 1973, BTS, p. 134

Doubleday editorial offices, N.Y.C.; Jack Gordon, archt.—June 1973, BTS, pp. 150-1

Douglass, Lathrop & Aaron Chelouche, consulting archts.; Centre Commercial de Parly 2, Le Chesnay, France—March 1973, BTS, p. 140

Dowel Bldg., Chicago; Clarence Krusinski & Assocs., archts.—May 1973, BTS, p. 148

Drummey Rosane Anderson, Archts.; Greater Lowell Regional Vocational Technical School, Tyngsboro, Mass.—Feb. 1973, BTS, pp. 128-9. Minuteman Regional Vocational High School, Lexington, Mass.—Feb. 1973, BTS, pp. 130-1

E

Eaton Corp. Admin. & Distr. Center, Monroe, N.C.; Heery & Heery, archts.—May 1973, BTS, p. 149

Editorials. "The First Federal Design Assembly: fantastic? or flop?" by Walter F. Wagner, Jr.—May 1973, pp. 9-10. "Happy New Year (with a little luck and little help from our friends)" by Walter F. Wagner, Jr.—Jan. 1973, pp. 9-10. "San Francisco as an urban caution, or how many pyramids can one city take?" by Elisabeth K. Thomson—April 1973, p. 9. "Scott Ferebee keeps the momentum—and gives the AIA some new goals," Walter F. Wagner, Jr.—March 1973, pp. 9-10. "There's good news and there's bad news," Walter F. Wagner, Jr.—Feb. 1973, pp. 9-10. "Some first impressions from the San Francisco Convention," Walter F. Wagner, Jr.—June 1973, pp. 9-10

Education, Vocational. Building Types Study 444—Feb. 1973, pp. 125-40. See Schools.

Electric Power Pool Control Center, Ann Arbor, Mich.; Smith Hinchman & Grylls, archts.—May 1973, BTS, p. 151

Erickson-Massey, archts.; Lethbridge University, Project I, Vancouver, B.C.—May 1973, pp. 115-24

Esherick Homsey Dodge & Davis, archts.; The Cannery, San Francisco—March 1973, BTS, pp. 132-4

Esplanade Village, Redondo Beach, Cal.; Brent Goldman Robbins & Brown, archts.—RH 1973, pp. 110-12

F

Factories. See Industrial Buildings

Fairfield & DuBois, archts.; Greenwood Secondary School, Toronto, Ont.—Feb. 1973, BTS, pp. 132-3

Farmington Public Library, Farmington, Mich.; Tarapata MacMahon Paulsen Corp., archts.—April 1973, BTS, pp. 122-3

Ferebee, Scott. "Scott Ferebee keeps the momentum—and gives the AIA some new goals," Editorial by Walter F. Wagner, Jr.—March 1973, pp. 9-10

Ferendino Grafton Candela & Spillis, archts.; Rockwell Assembly Plant, Homestead, Fla.—May 1973, BTS, p. 150

First-City National Bank Hdqtrs., Binghamton, N.Y.; Ulrich Franzen & Assocs., archts.—Feb. 1973, pp. 103-6

Fisher-Friedman Assocs., archts.; Bayport and Bayview, Newport Beach, Cal.—Jan 1973, pp. 124-25

Flansburgh, Earl & Assocs. archts.; Bikales House, Lincoln, Mass.—RH 1973, pp. 40-3

France, Centre Commercial de Parly 2, Le Chesnay Claude Balick-Selim Rathle, J. F. de la Cortardiere, archts.—March 1973, BTS, p. 140

G

GBR Assocs., archts., Showroom for Sony Products, interiors, Winnipeg, Canada—Jan. 1973, p. 93

Geddes Brecher Qualls Cunningham, archts.; Stockton State College, N.J.—March 1973, pp. 103-8

General Electric Appliance Park-East, Columbia, Md.; Sol King & Albert Kahn Assocs., Inc.—May 1973, BTS, pp. 154-5

Gluck, Peter, archt.; Bookstaver House, Westminster, Vt.—RH 1973, pp. 84-7

Goodhue, Donald, archt.; Black Butte Condominiums, Black Butte, Ore.—RH 1973, pp. 102-3

Gordon, Jack, archt.; Doubleday editorial offices, New York—June 1973, BTS, pp. 150-1

Gould, William A. & Assocs., archts.; Sutton Place, Shaker Heights, Ohio—March 1973, pp. 109-16

Goulding, Stuart D.; "The Restoration of La Place Royale"—June 1973, pp. 129-32

Grandfather Golf & Country Club, Temporary Clubhouse, Linville, N.C.; Wolf Assocs., archts.—June 1973, p. 116

Graphics. AIA Chapter offices, interiors, Seattle; Wendell Lovett, archt.—Jan 1973, p. 99. Broadview Cinema I, interiors, Savannah; Arkhora Assocs., Inc., archts.—Jan. 1973, pp. 100-1. Virgin Islands Information Center, interiors, Washington, D.C., Deupi, Freidin, Kleiman, space designers—Jan. 1973, p. 98

Greater Lowell Regional Vocational Technical School, Tyngsboro, Mass.; Drummey Rosane Anderson, archts.—Feb. 1973, BTS, pp. 128-9

Greeley West Apartments, Greeley, Colo.; Donald Roark & Assocs., archts.—RH 1973, pp. 106-7

Greenburgh Public Library, Greenburgh, N.Y.; Max O. Urbahn Assocs., archts.—April 1973, BTS, pp. 124-5

Greenwood Secondary School, Toronto, Ont.; Fairfield & DuBois, archts.—Feb. 1973, BTS, pp. 132-3

Gruen Assocs., archts., Cesar Pelli, partner-in-charge; Court-

house Center, Columbus, Ind.—March 1973, BTS, pp. 128-31. ZCMI Center, Salt Lake City—March 1973, BTS, pp. 138-39

Gruzen & Partners & Junzo Yoshimura, archts.; Japan House, N.Y.—April 1973, pp. 108-10

Gund/Monacelli Assocs., archts.; Cambridge School Site Selection Study, Cambridge, Mass.—May 1973, pp. 141-4

Gwathmey Siegel, archts.; House in East Hampton, N.Y.—RH 1973, pp. 84-7

H

Hammarskjold Plaza Building, N.Y.; Raymond & Rado, archts.—April 1973, pp. 106-7

"Happy New Year (with a little luck and a little help from our friends)", Editorial by Walter F. Wagner, Jr.—Jan. 1973, pp. 9-10

Harlan Area Vocational School, Harlan, Ky.; Bennett & Tune, archts.—Feb. 1973, BTS, p. 135

Harrison Street Apartments, Oakland, Cal.; Peters & Clayberg & Assocs., archts.—RH 1973, pp. 108-9

Heery & Heery, archts.; Eaton Corp. Admin. & Distr. Center, Monroe, N.C.—May 1973, BTS, p. 149. Cincinnati Airport—June 1973, pp. 65-7

Heidemann House, Beverly Hills, Cal.; Pulliam Matthews & Assocs., archts.—RH 1973, pp. 80-3

Hellmuth Obata & Kassabaum, archts.; Kimberly-Clark Research & Engineering Center, Menasha, Wis.—May 1973, BTS, pp. 156-57. E. R. Squibb & Sons Hdqtrs., interiors, Lawrenceville, N.J.—Jan. 1973, pp. 90-1. E. R. Squibb & Sons Hdqtrs. Lawrenceville, N.J., Jan. 1973, pp. 90-91; June 1973, BTS, pp. 144-7

Hill Central K-4 School, New Haven, Conn.; Carlin Pozzi & Assocs, archts.—June 1973, pp. 156-7

Hornblower & Weeks, interiors, Charlotte, N.C.; Wolf Assocs., archts.—June 1973, p. 119

Hospitals. Tulane University Medical Center, New Orleans; Caudill Rowlett Scott, archts.—April 1973, pp. 141-4

Houses. Building Types Study 448, Record Houses and Apartments of 1973, Mid-May, pp. 33-91. Becker House, Wainscott, N.Y.; Norman Jaffe & Assocs., archts.—April 1973, pp. 145-8. Bikales House, Lincoln, Mass.; Earl Flansburgh & Assocs., archts.—RH 1973, pp. 40-3. Bookstaver House, Westminster, Vt.; Peter Gluck, archt.—RH 1973, pp. 34-7. Briggs House, Harbor Springs, Mich.; William Kessler & Assocs., archts.—RH 1973, pp. 88-91. Cannady House, Houston; William Cannady, archt.—RH 1973, pp. 38-9. Comstock House, Atlanta; Clyde Pearson, archt.—RH 1973, pp. 76-7. Coplans House, San Francisco; Patricia Coplans, archt.—RH 1973, pp. 44-5. Heidmann House, Beverly Hills, Cal.; Pulliam Matthews & Assocs., archts.—RH 1973, pp. 80-3. House & studio, Nyack, N.Y.; James Lamantia, archt.—May 1973, pp. 125-7. House on Long Island; Vassia & Laura Kiaulenas, archts.—Feb. 1973, pp. 115-18. House on Maine Coast; Robert Burley, archt.—RH 1973, pp. 52-3. House in East Hampton, N.Y.; Gwathmey Siegel, archts.—RH 1973, pp. 84-7. House in San Mateo County, Cal.; McCue Boone Tomsick, archts.—RH 1973, pp. 58-9. Moger House, Southampton, Long Island, N.Y.; Richard Moger, archt.—RH 1973, pp. 72-3. Levin House, Galveston, Tex.; Howard Barnstone, archt.—RH 1973, pp. 60-1. Lowenstein House, Montauk, N.Y.; Chimacoff/Peterson, archts.—RH 1973, pp. 50-1. Lozano House, Santa Cruz County, Cal.; Peter Behn, archt.—RH 1973, pp. 68-71. Mark House, Truro, Mass.; Paul Kruger, archt.—RH 1973, pp. 66-7. Oliver House, Portland; James Oliver, archt.—RH 1973, pp. 78-9. Renovated stable, Boston; Childs Bertman Tseckares Assocs., archts.—May 1973, pp. 128-30. Repeatable House, Sea Ranch, Cal.; MLTW/Moore-Turnbull, archts.—RH 1973, pp. 74-5. Schwaikert House, Salisbury, Conn.; Hugh Newell Jacobsen, archt.—RH 1973, pp. 54-7. Simon House, Remsenburg, N.Y.; Barbara & Julian Neski, archts.—RH 1973, pp. 46-9. Spector House, Pebble Beach, Cal.; Smith & Larsen, archts.—RH 1973, pp. 62-5.

Housing. See Apartments.

I

IBM Systems Development Div. Facility, Manassas, Va.; RTKL, Inc., archts.—May 1973, BTS, pp. 152-3

Indiana University Musical Art Center, Bloomington, Ind.; Woollen Assocs., archts.—Feb. 1973, pp. 119-24

Industrial Buildings. Building Types Study 447—May 1973, pp. 145-60. Daiwa Corp. Hdqtrs., Gardena, Cal.; Kajima

L

- Assoc., archts.—May 1973, BTS, p. 147. Dowel Bldg., Chicago; Clarence Krusinski & Assocs., archts.—May 1973, BTS, p. 148. Eaton Corp. Admin. & Dist. Center, Monroe, N.C.; Heery & Heery, archts.—May 1973, BTS, p. 149. Electric Power Control Center, Ann Arbor, Mich.; Smith Hinchman & Grylls, archts.—May 1973, BTS, p. 151. General Electric Appliance Park-East Columbia, Md.; Sol King & Albert Kahn Associates, Inc.—May 1973, BTS, pp. 154-5. IBM Systems Development Div. Facility, Manassas, Va.; RTKL, Inc., archts.—May 1973, BTS, pp. 152-3. Kaiser Center for Technology, Pleasanton, Cal.; John Carl Warnecke & Assocs., archts.—May 1973, BTS, pp. 158-60. Kimberly-Clark Research & Engineering Center, Menasha, Wis.; Hellmuth Obata & Kassabaum, archts.—May 1973, BTS, pp. 156-7. Rockwell Assembly Plant, Homestead, Fla.; Ferendino Grafton Candela & Spillis, archts.—May 1973, BTS, p. 150
- Interiors. AIA Chapter office, Seattle; Wendell Lovett, archt.—Jan. 1973, p. 98. Alandales Men's Store, Westwood, Cal.; Zimmerman, Robbin & Assoc.; archts.—Jan. 1973, pp. 94-5. Broadview Cinema I, Savannah; Arkhora Assocs., archts.—Jan. 1973, p. 100-1. Doubleday editorial offices, New York; Jack Gordon, archt.—June 1973, BTS, pp. 150-1. Hornblower & Weeks, Charlotte, N.C.; Wolf Assocs., archts.—June 1973, p. 119. McGraw-Hill Bookstore, Smithsonian Institution, Washington; Warner Burns Toan & Lunde, archts.—Jan. 1973, pp. 102-3. National Bank of Tulsa, Tulsa, Okla.; Wolf Assocs., archts.—June 1973, p. 118. Photographer's Studio, N.Y.C.; Mayers & Schiff, archts.—Jan. 1973, p. 92. Shearson Hammill's Regional Hdqtrs. Chicago; Booth & Nagle, archts.—Jan. 1973, pp. 96-7. Showroom for Sony Products, Winnipeg, Canada; GRB Assocs. archts.—Jan 1973, p. 93. Squibb E. R. & Sons Hdqtrs. Lawrenceville, N.J.; Hellmuth Obata & Kassabaum, archts.—Jan. 1973, pp. 90-1. Virgin Island Information Center, Washington, D.C.; Freidin, Kleiman, Space designers—Jan. 1973, p. 98. Yale Club, N.Y.C.; Warren Platner Assocs., archts.—Jan. 1973, p. 104
- Ladd & Kelsey, archts.; Cal. Inst. of the Arts Modular Theater, Valencia—April 1973, pp. 137-40
- Lamantia, James, archt.; House & studio, Nyack, N.Y.—May 1973, pp. 125-7
- La Pierre Litchfield Imbs, archts.; BOCES Complex, Yorktown Heights, N.Y.—Feb. 1973, BTS, pp. 136-7
- Latta Arcade Restoration, Charlotte, N.C.; Wolf Assocs., archts.—June 1973, p. 117
- Lemon Tree Village, Coconut Grove, Fla.; Charles Harrison Pawley, archt.—RH 1973, pp. 98-9
- Lethbridge University Project I, Vancouver, B.C.; Erickson-Massey, archts.—May 1973, pp. 115-24
- Levin House, Galveston, Tex.; Howard Barnstone, archt.—RH 1973, pp. 60-1
- Libraries. Brown Sciences Library, Brown University, Providence; Warner Burns Toan, archts.—April 1973, BTS, pp. 130-3. "Communications technology & its implications for library design"—April 1973, BTS, pp. 134-6. Farmington Public Library, Farmington, Mich.; Tarapata MacMahon Paulsen Corp., archts.—April 1973, BTS, pp. 122-3. Greenburgh Public Library, Greenburgh, N.Y., Max O. Urbahn Assocs., archts.—April 1973, BTS, pp. 124-5. Kent Memorial Library, Suffield, Conn.; Warren Platner Assocs., archts.—March 1973, pp. 97-102. "Present and future trends in library design & planning," Building Types Study 446—April 1973, pp. 119-36. Regenstein Library, University of Chicago; Skidmore Owings & Merrill, archts.—April 1973, BTS, pp. 126-9. Sherborn Library, Sherborn, Mass.; James A. S. Walker, archt.—April 1973, pp. 120-1
- Lighting. "Conserving energy in lighting"—Feb. 1973, pp. 141-43. "Putting light where it is needed most: on the tasks"—March 1973, pp. 143-6.
- Lovett, Wendell, archt.; AIA Chapter offices, interiors, Seattle—Jan. 1973, p. 99
- Lowenstein House, Montauk, N.Y.; Chimacoff/Peterson, archts.—RH 1973, pp. 50-1
- Lozano House, Santa Cruz County, Cal.; Peter Behn, archt.—RH 1973, pp. 68-71
- Luckman, Charles Assocs., archts.; Broadway Plaza, Los Angeles—March 1973, BTS, pp. 140-1. Phoenix Civic Plaza, Phoenix—June 1973, pp. 133-8

M

- Jacobsen, Hugh Newell, archt.; Schwaikert House, Salisbury, Conn.—RH, pp. 54-7
- Jaffe, Norman & Assocs., archts.; Becker House, Wainscot, N.Y.—April 1973, pp. 145-58. Village Green, Staten Island, N.Y.—Jan. 1973, pp. 130-1
- Japan House, N.Y.; Junzo Yoshimura & Gruzen & Partners, archts.—April 1973, pp. 108-10
- Jones, Bart A. and George Klett, archts.; Mountain View Apartments, Fremont, Cal.—Jan. 1973, pp. 126-7
- Jung/Brannen Assocs., archts., with the office of Samuel Paul & Pietro Belluschi, consulting archts.; Pine Grove Townhouses, Brockton, Mass.—RH 1973, pp. 104-5
- Kahn, Albert Assocs., Inc. & Sol King, archts.; General Electric Appliance Park East, Columbia, Md.—May 1973, BTS, pp. 154-5
- Kaiser Center for Technology, Pleasanton, Cal.; John Carl Warnecke & Assocs., archts.—May 1973, BTS, pp. 158-60
- Kajima Assocs., archts.; Daiwa Corp. Hdqtrs., Gardena, Cal.—May 1973, BTS, p. 147
- Kent Memorial Library, Suffield, Conn.; Warren Platner Assocs., archts.—March 1973, pp. 97-102
- Kessler, William & Assocs., archts.; Briggs House, Harbor Springs, Mich.—RH 1973, pp. 88-91
- Kiaulenas, Vassia & Laura, archts.; house on Long Island—Feb. 1973, pp. 115-18
- Kimberly-Clark Research & Engineering Center, Menasha, Wis.; Hellmuth Obata & Kassabaum, archts.—May 1973, BTS, pp. 156-7
- King, Sol & Albert Kahn Assocs., Inc., archts.; General Electric Appliance Park-East, Columbia, Md.—May 1973, BTS, pp. 154-55
- Klett, George and Bart A. Jones, archts.; Mountain View Apartments, Fremont, Cal.—Jan. 1973, pp. 126-27
- Kresge Co. Hdqtrs., Troy, Mich.; Smith Hinchman & Grylls Assocs., archts.—June 1973, BTS, pp. 140-3
- Krueger, Paul, archt.; Mark House, Truro, Mass.—RH 1973, pp. 66-67
- Krusinski, Clarence & Assocs., archts.; Dowel Bldg., Chicago—May 1973, BTS, p. 148
- Kurokawa, K. N., archt., modular capsule designs—Feb. 1973, pp. 109-14
- Marani Routhwaite & Dick, archts.; Sheridan College, Oakville, Ont.—Feb. 1973, BTS, pp. 138-40
- Mariana Bracetti Plaza, N.Y.C., Robert L. Wilson, archt.—Jan. 1973, p. 113
- Mark House, Truro, Mass.; Paul Krueger, archt., RH, pp. 66-7
- Masonry. "Load-bearing masonry panels are site fabricated in 'mini-factories' to speed building completion"—Feb. 1973, p. 144
- Mayer & Schiff, archts.; Photographer's studio interior—Jan. 1973, p. 92
- McCue Boone Tomsick, archts.; House in San Mateo County, Cal.—RH 1973, pp. 58-9
- McGraw-Hill Bookstore, Smithsonian Institution, interiors, Washington, D.C. Warner Burns, Toan & Lunde, archts.—Jan. 1973, pp. 102-3
- Mellon Arts Center, Choate, School, Wallingford, Conn.; I. M. Pei & Partners, archts.—Jan. 1973, pp. 111-18
- Minuteman Regional Vocational High School, Lexington, Mass.; Drumme Rosane Anderson, archts.—Feb. 1973, BTS, pp. 130-1
- MLTW/Moore-Turnbull, archts.; Repeatable House, Sea Ranch, Cal.—RH 1973, pp. 74-5
- Modular Construction. "Kurokawa and his capsules"—Feb. 1973, pp. 109-14
- Moger, Richard, archt.; Moger House, Southampton, N.Y.—RH 1973, pp. 72-3
- Mountain View Apartments, Fremont, Cal.; George Klett and Bart A. Jones, archts.—Jan. 1973, pp. 126-7
- Murray Lincoln Campus Center, University of Mass., Amherst; Marcel Breuer & Herbert Beckhard, archts.—March 1973, pp. 118-21
- National Bank of Tulsa, interiors, Tulsa, Okla.; Wolf Assocs., archts.—June 1973, p. 118
- NCARB. "The 1973 Architectural Registration Handbook; A Test Guide for Professional Exam Candidates"—April 1973, pp. 10, 212
- Neski, Barba & Julian, archts.; Simon House, Remsenburg, N.Y.—RH 1973, pp. 46-9

N

- New Hope Towers, Stamford, Conn.; Robert L. Wilson, archt.—Jan. 1973, p. 133
- North Carolina National Bank Beatties Ford Road Branch, Charlotte, N.C.; Wolf Assocs., archts.—June 1973, pp. 114-5. Park Road Branch, Charlotte, N.C.; Wolf Assocs., archts.—June 1973, pp. 112-3

O

- Oak Hill Estates, Philadelphia, Louis Sauer, archt.—April 1973, pp. 116-8
- Office Buildings. Building Types Study 449—June 1973, pp. 149. Brewer & Co. Bldg., Hilo, Hawaii; Ossipoff, Snyder Rowland & Goetz, archts.—June 1973, BTS, pp. 148-9. Burroughs Corp. Hdqtrs., Detroit; Smith & Gardner, archts.—June 1973, pp. 152-4. Cleveland Trust Co. Hdqtrs. Cleveland, Ohio; Marcel Breuer & Hamilton Smith, archts.—March 1973, pp. 124-6. First-City National Bank Hdqtrs., Binghamton, N.Y.; Ulrich Franzen & Assocs., archts.—Feb. 1973, pp. 102-8. Hammarskjold Plaza Building, N.Y.; Raymond & Rado, archts.—April 1973, pp. 106-7. Kresge Co. Hdqtrs., Troy, Mich.; Smith Hinchman & Grylls Assocs., archts.—June 1973, BTS, pp. 140-3. "Package hvac units for large office buildings: a new approach"—Jan. 1973, pp. 135-38. Squibb, E.R. & Sons Hdqtrs., Lawrenceville, N.J.; Hellmuth Obata & Kassabaum, archts.—June 1973, BTS, pp. 144-7
- Offices. AIA Chapter offices, interiors, Seattle; Wendell Lovett, archt.—Jan. 1973, p. 99. Doubleday editorial offices, New York; Jack Gordon, archt.—June 1973, BTS, pp. 150-1. Hornblower & Weeks, interiors, Charlotte, N.C.; Wolf Assocs., archts.—June 1973, p. 119. Shearson Hammill's Regional Hdqtrs., interiors, Chicago, Booth & Nagle, archts.—Jan. 1973, pp. 96-7. Squibb E.R. & Sons Hdqtrs., interiors, Lawrenceville, N.J.; Hellmuth, Obata & Kassabaum, archts.—Jan. 1973, pp. 90-1
- Oliver James, archt.; Oliver House, Portland—RH 1973, pp. 78-9
- Opera Houses. See Performing Arts Buildings
- Ossipoff Snyder Rowland & Goetz, archts.; Brewer & Co. Office Bldg., Hilo, Hawaii—June 1973, BTS, pp. 148-9
- Oxley/Landau/Partners, archts.; Seascape II, Solana, Cal.—RH 1973, pp. 100-1
- Parly 2, Centre Commercial, Le Chesnay, France; Claude Balick-Selim Rathle, J. F. de la Cortardiere, archts.—March 1973, p. 140
- Pasanella, Giovanni, archt.; Twin Parks West & Southwest, Bronx, N.Y.—June 1973, pp. 121-8
- Paul, Samuel, The Office of, archts. with Pietro Belluschi & Jung/Brannen Assocs., consulting archts.; Pine Grove Townhouses, Brockton, Mass.—RH 1973, pp. 104-5
- Pawley, Charles Harrison, archt.; Lemon Tree Village, Coconut Grove, Fla.—RH 1973, pp. 98-9
- Pearson, Clyde, archt.; Comstock House, Atlanta—RH 1973, pp. 76-7
- Pei, I. M. & Partners, archts.; Mellon Arts Center, Choate School, Wallingford, Conn.—Jan. 1973, pp. 111-18
- Pelli, Cesar, partner-in-charge for Gruen Assocs., archts.; Courthouse Center, Columbus, Ind.—March 1973, BTS, pp. 128-31
- Performing Arts Buildings. Ind. University Musical Arts Center, Bloomington, Indiana; Woollen Assocs., archts.—Feb. 1973, pp. 119-24. Mellon Arts Center, Choate School, Wallingford, Conn.; I. M. Pei & Partners, archts.—Jan. 1973, pp. 111-18. Phoenix Civic Plaza, Phoenix; Charles Luckman Assocs., archts.—June 1973, pp. 133-8
- Peters & Clayberg & Assocs., archts.; Harrison Street Apartments, Oakland, Cal.—RH 1973, pp. 108-9
- Phoenix Civic Plaza, Phoenix; Charles Luckman Assocs., archts.—June 1973, pp. 133-8
- Photographers Studio, interiors, N.Y.C.; Mayers & Schiff, archts.—Jan. 1973, p. 92
- Pine Grove Townhouses, Brockton, Mass.; Office of Samuel Paul with Pietro Belluschi & Jung/Brannen Assocs., consulting archts.—RH 1973, pp. 104-5
- Place Royale, Quebec; "The Restoration of La Place Royale," by Stuart D. Goulding—June 1973, pp. 129-32
- Platner, Warren Assocs., archts.; Kent Memorial Library, Suffield, Conn.—March 1973, pp. 97-102. Yale Club, interiors, N.Y.C.—Jan. 1973, p. 104
- Pulliam Matthews & Assocs., archts.; Heidemann House, Beverly Hills, Cal.—RH 1973, pp. 80-3

R

Raymond & Rado, archts.; Hammarskjold Plaza Building, N.Y.—April 1973, pp. 106-7
 Regenstien Library, University of Chicago; Skidmore Owings & Merrill, archts.—April 1973, BTS, pp. 126-9
 Religious Buildings. St. Benedict's Abbey Church, Benet Lake, Wis.; Stanley Tigerman & Assocs., archts.—Jan. 1973, pp. 105-10
 Renovations and Restorations. Latta Arcade, Charlotte, N.C.; Wolf Assocs., archts.—June 1973, p. 117. "The Restoration of La Place Royale," Quebec, by Stuart D. Goulding—June 1973, pp. 129-32. Two renovated houses, Nyack, N.Y. & Boston—May 1973, pp. 125-30
 Research Centers. See Industrial Buildings & University & College Buildings.
 Restorations. See Renovations and Restorations
 Riani, Paolo, "Kurokawa and his capsules"—Feb. 1973, pp. 109-14
 Roark, Donald, & Assocs., archts.; Greeley West Apartments, Greeley, Colo.—RH 1973, pp. 106-7
 Rockwell Assembly Plant, Homestead, Fla.; Ferendino Grafton Candela & Spillis, archts.—May 1973, BTS, p. 150
 RTKL, Inc., archts.; IBM Systems Development Div. Facility, Manassas, Va.—May 1973, BTS, pp. 152-53
 Russia. "Architecture USSR"—Feb. 1973, pp. 91-102

S

St. Benedict's Abbey Church, Benet Lake, Wis.; Stanley Tigerman & Assocs., archts.—Jan. 1973, pp. 105-10
 "San Francisco as an urban caution, or how many pyramids can one city take?" Editorial by Elisabeth K. Thompson—April 1973, p. 9
 Sauer, Louis, archt.; Canterbury Garden, New Haven, Conn.—April 1973, pp. 112-13. Oak Hill Estates, Philadelphia—April 1973, pp. 116-18. Wesleyan Hills, Middletown, Conn.—April 1973, pp. 114-15
 Schools. BOCES Complex, Yorktown Heights, N.Y.; La Pierre Litchfield Imbs, archts.—Feb. 1973, BTS, pp. 136-7. Bell & Howell Schools, Devry Institute of Technology, Chicago; Caudill Rowlett Scott, archts.—Feb. 1973, BTS, p. 134. Branford Intermediate School, Branford, Conn.; Carlin Pozzi & Assocs., archts.—June 1973, pp. 160-2. Cambridge School Site Selection Study; Gund/Monacelli Assocs., archts.—May 1973, pp. 141-4. "Educational building; where's it going from here?"—March 1973, p. 62. Greater Lowell Regional Vocational Technical High School, Tyngsboro, Mass.; Drummey Rosane Anderson, archts.—Feb. 1973, BTS, pp. 128-9. Greenwood Secondary School, Toronto, Ont.; Fairfield & DuBois, archts.—Feb. 1973, BTS, pp. 132-3. Harlan Area Vocational School, Harlan, Ky.; Bennett & Tune, archts.—Feb. 1973, BTS, p. 135. Hill Central K-4 School, New Haven, Conn.; Carlin Pozzi & Assocs., archts.—June 1973, pp. 156-70. Mellon Arts Center, Choate School, Wallingford, Conn.; I.M. Pei & Partners, archts.—Jan. 1973, pp. 111-18. Minuteman Regional Vocational High School, Lexington, Mass.; Drummey, Rosane Anderson, archts.—Feb. 1973, BTS, pp. 130-1. Shepherd Glen School, Hamden, Conn.; Carlin Pozzi & Assocs., archts.—June 1973, pp. 158-9. Sheridan College, Oakville, Ont.; Marani Rounthwaite & Dick, archts.—Feb. 1973, BTS, pp. 138-40. "Three open-plan schools; inventive design and engineering"—June 1973, pp. 155-62
 Schwaikert House, Salisbury, Conn.; Hugh Newell Jacobsen, archt.—RH 1973, pp. 54-7
 Seascape II, Solana, Cal.; Oxley/Landau/Partners, archts.—RH 1973, pp. 100-1
 Shearson Hammill's regional hdqtrs., interiors, Chicago; Booth & Nagle, archts.—Jan. 1973, pp. 96-7
 Shepherd Glen School, Hamden, Conn.; Carlin Pozzi & Assocs., archts.—June 1973, pp. 158-9
 Sherborn Library, Sherborn, Mass.; James A. S. Walker, archt.—April 1973, BTS, pp. 120-1
 Sheridan College, Oakville, Ont.; Marani Rounthwaite & Dick, archt.—Feb. 1973, BTS, pp. 138-40
 Shopping Centers. Building Types Study 445—March 1973, pp. 127-42. Broadway Plaza, Los Angeles; Charles Luckman Assocs., archts.—March 1973, BTS, pp. 140-1. The Cannery, San Francisco; Esherick Homsey Dodge & Davis, archts.—March 1973, BTS, pp. 132-34. Centre Commercial de Parly 2, Le Chesnay, France; Claude Balick-Selim Rathle, J. F. de la Cortadiers, archts.—March 1973, BTS, p. 140. Courthouse Center, Columbus, Ind.; Gruen Assocs.,

archts., Cesar Pelli, partner-in-charge—March 1973, BTS, pp. 128-31. Sunrise Mall, Sacramento, Cal.; Burke Kober Nicolais Archuleta, archts.—March 1973, BTS, pp. 135-7. ZCMI Center, Salt Lake City; Gruen Assocs., archts.—March 1973, BTS, pp. 138-9
 Simon House, Remsenburg, N.Y.; Barbara & Julian Neski, archts.—RH 1973, pp. 46-9
 Skidmore, Owings & Merrill, archts.; Regenstien Library, University of Chicago—April 1973, BTS, pp. 126-9
 Smith & Gardner, archts.; Burroughs Corp. Hdqtrs., Detroit—June 1973, BTS, pp. 152-4
 Smith & Larsen, archts.; Spector House, Pebble Beach, Cal.—RH 1973, pp. 62-5
 Smith Hinchman & Grylls, archts.; Electric Power Pool Control Center; Ann Arbor, Mich.—May 1973, BTS, p. 151. Kresge Co. Hdqtrs., Troy, Mich.—June 1973, BTS, pp. 140-3
 Smithsonian Institution, McGraw-Hill Bookstore, interiors, Washington, D.C.; Warner Burns Toan & Lunde, archts.—Jan. 1973, pp. 102-3
 Sony Products showroom, interiors, Winnipeg, Canada; GBR Assocs., archts.—Jan. 1973, p. 93
 Spector House, Pebble Beach, Cal.; Smith & Larsen, archts.—RH 1973, pp. 62-5
 Squibb, E. R. & Sons, Hdqtrs., Lawrenceville, N.J.; Hellmuth, Obata & Kassabaum, archts.—Jan. 1973, pp. 90-1.—June 1973, pp. 144-7
 Stockton State College, N.J.; Geddes Brecher Qualls Cunningham, archts.—March 1973, pp. 103-8
 Stone, Marraccini & Patterson, archts.; "SMB compiles the most informative wall"—May 1973, pp. 57-8
 Stores. Alandales Men's Store, interiors, Westwood, Cal.; Zimmerman, Robbin & Assocs., archts.—Jan. 1973, pp. 94-5. McGraw-Hill Bookstore, Smithsonian Institution, interiors, Washington, D.C.; Warner Burns Toan & Lunde, archts.—Jan. 1973, pp. 102-3. Showroom for Sony Products, interiors, Winnipeg, Canada, GBR Assocs., archts.—Jan. 1973, p. 93. Virgin Islands Information Center, interiors, Washington, D.C.; Deupi, Freidin, Kleiman, space designers—Jan. 1973, p. 98
 Stull Assocs., archts.; Village Park, Amherst, Mass.—Jan. 1973, pp. 128-9
 Sunrise Mall, Sacramento, Cal.; Burke Kober Nicolais Archuleta, archts.—March 1973, BTS, pp. 135-7
 Sutton Place, Shaker Heights, Ohio; William A. Gould & Assocs., archts.—March 1973, pp. 109-16

T

Tarapata MacMahon Paulsen Corp., archts.; Farmington Public Library, Farmington, Mich.—April 1973, BTS, pp. 122-3
 Technical Schools. See Schools
 Technology II (lab & classroom bldg.), New York University; Marcel Breuer & Hamilton Smith, archts.—March 1973, pp. 122-3
 Theaters. See also Performing Arts Buildings. California Institute of the Arts Modular Theater, Valencia; Ladd & Kessler, archts.—April 1973, pp. 137-40
 "There's good news and there's bad news," Editorial by Walter F. Wagner, Jr.—Feb. 1973, p. 10
 Thompson, Elisabeth K., Editorial, "San Francisco as an urban caution, or how many pyramids can one city take?"—April 1973, p. 9
 Tigerman, Stanley & Assocs., archts.; St. Benedict's Abbey Church, Benet Lake, Wisc.—Jan. 1973, pp. 105-10
 Tulane University Medical Center, New Orleans; Caudill Rowlett Scott, archts.—April 1973, pp. 141-4
 Tustin Apartments, Tustin, Cal.; Backen Arrigoni & Ross, archts.—RH 1973, pp. 94-7
 Twin Parks West & Southwest, Bronx, N.Y.; Giovanni Pasanella, archt.—June 1973, pp. 121-8

U

Unihab, archts.; Modular housing and office development, Burlington, Vt.—Jan. 1973, p. 134
 University & College Buildings. "Design-build for student housing: responds to cost, but raises other questions"—April 1973, pp. 149-52. "Educational building: where's it going from here?"—March 1973, p. 62. Indiana University Musical Arts Center, Bloomington, Ind.; Woollen Assocs.,

archts.—Feb. 1973, pp. 119-24. Lethbridge University Project I., Vancouver, B.C.; Erickson-Massey, archts.—May 1973, pp. 115-24. Murray Lincoln Campus Center, University of Mass., Amherst; Marcel Breuer & Herbert Beckhard, archts.—March 1973, pp. 118-21. Stockton State College, N.J.; Geddes Brecher Qualls Cunningham, archts.—March 1973, pp. 103-8. Technology II (lab classroom bldg.), New York University; Marcel Breuer & Hamilton Smith, archts.—March 1973, pp. 122-3. Tulane University Medical Center, New Orleans; Caudill Rowlett Scott, archts.—April 1973, pp. 141-4
 Urbahn, Max O. Assocs., archts.; Greenburgh Public Library, Greenburgh, N.Y.—April 1973, BTS, pp. 124-5

V

Village Green, Staten Island, N.Y.C., Norman Jaffe, archt.—Jan. 1973, pp. 130-1
 Village Park, Amherst, Mass.; Stull Assocs., archts.—Jan. 1973, pp. 128-9
 Virgin Islands Information Center, interiors, Washington, D.C.; Deupi, Freidin, Kleiman, space designers—Jan. 1973, p. 98
 Vocational Education. Building Types Study 444—Feb. 1973, pp. 125-40. Also see Schools

W

Wagner, Walter F., Jr., Editorials. "The First Federal Design Assembly: Fantastic? Or Flop?"—May 1973, pp. 9-10. "Happy New Year (with a little luck and a little help from our friends)"—Jan. 1973, pp. 9-10. "Scott Ferebee keeps the momentum—and gives the AIA some new goals"—March 1973, pp. 9-10. "Some first impressions from the San Francisco convention"—June 1973, pp. 9-10. "There's good news and there's bad news"—Feb. 1973, pp. 9-10
 Walden (planned community), Aurora, Ohio; architectural Design Partnership, archts.—Jan. 1973, pp. 120-21
 Walker, James A. S., archt.; Sherborn Library, Sherborn, Mass.—April 1973, BTS, pp. 120-1
 Warneke, John Carl & Assocs., archts.; Kaiser Center for Technology, Pleasanton, Cal.—May 1973, BTS, pp. 158-60
 Warner Burns Toan Lunde, archts.; Brown Sciences Library, Brown University, Providence—April 1973, BTS, pp. 130-3. McGraw-Hill Bookstore, Smithsonian Institution, interiors, Washington, D.C.—Jan. 1973, pp. 102-3
 Wesleyan Hills, Middletown, Conn.; Louis Sauer, archt.—April 1973, pp. 114-5
 "What is the best role for architects in the housing development game?"—Jan. 1973, pp. 119-34
 Wilson, Robert L., archt.; New Hope Towers, Stamford, Conn.—Jan. 1973, p. 133. Mariana Bracetti Plaza, N.Y.C.—Jan. 1973, p. 133. Coleman Towers, Stamford, Conn.—Jan. 1973, p. 132
 Wolf Assocs., archts.; Hornblower & Weeks, interiors, Charlotte, N.C.—June 1973, p. 119. Latta Arcade Restoration, Charlotte, N.C.—June 1973, p. 117. N.C. National Bank of Tulsa, interiors, Tulsa, Okla.—June 1973, p. 118. N.C. National Bank Beatties Ford Road Branch, Charlotte, N.C.—June 1973, pp. 114-5. National Bank Park Road Branch, Charlotte, N.C.—June 1973, pp. 112-3. Temporary Clubhouse, Grandfather Golf & Country Club, Linville, N.C.—June 1973, p. 116
 Woollen Assocs., archts.; Indiana University Musical Arts Center, Bloomington, Ind.—Feb. 1973, pp. 119-24

Y

Yale Club, New York City, interiors; Warren Platner Assocs., archts.—Jan. 1973, p. 104
 Yoshimura, Junzo & Gruzen & Partners, archts.; Japan House, N.Y.—April 1973, pp. 108-10

Z

ZCMI Center, Salt Lake City; Gruen Assocs., archts.—March 1973, BTS, pp. 138-9
 Zimmerman, Robbin & Assocs., archts.; Alandales Men's Store, interiors, Westwood, Cal.—Jan. 1973, pp. 94-95



Introducing a beautiful side of G A F you've never seen before.

We don't have to tell you about GAF's existing roofing, flooring and siding products. Judging from the way you've accepted them, we know they've done a good job.

That's why we think you'll be pleased to hear that GAF is now in the vinyl siding business.

The name of our vinyl siding is Vanguard™. And that means leader.

Unlike non-vinyl sidings, Vanguard keeps its good looks all by itself.

That's because the colors, (there are 4 of them) go clear through the vinyl. So Vanguard won't show scratches, and never needs painting or finishing.

And since it's weather resistant, it won't rot or corrode either. Which means it'll last as long as the house you put it on.

Finally this great new siding comes with GAF's 20 year guarantee against manufacturing defects.

Vanguard Vinyl from GAF. We think you'll be glad to have us on your side.

For further details, call your GAF Building Products distributor or write: GAF Corporation, Building Products Division, Dept. AR-63 140 West 51 St., New York, New York 10020.



For more data, circle 153 on inquiry card

ADVERTISING INDEX

Prefiled catalogs of the manufacturers listed below are available in the 1973 Sweet's Catalog File as follows.

- A Architectural File (green)
- I Industrial Construction File (blue)
- L Light Construction File (yellow)
- D Interior Design File (black)

A

A-L Alcan Aluminum Corp.	236
A AllianceWall Corporation	248
A-D Allied Chemical Corp., Fibers Div.	75
A-I-L Aluminum Co. of America50, 196A to 196D	
A-L American Biltrite Rubber- Uni-Turf	25
American Enka Corp.	181
American Forest Institute	245
American Olean Tile Company	89
A-I-L American Plywood Association	169 to 176
American Smelting & Refining Co.	24
A-I American Telephone & Telegraph Co.	107
Architectural Record Books ..243, 252	
A-I-L-D Armstrong Cork Co. ...2nd cover to 3	
A-I-L ASG Industries Inc.	98
Atlantic Richfield Company	216
A-L Azrock Floor Products	3rd Cover

B

A Bally Case & Cooler, Inc.	83
A-I Bell Telephone System	107
Bethlehem Steel Corp.	52-53
A Bigelow-Sanford Inc.	233
A-I-L Bilco Company	252
Blu-Ray, Inc.	55
A Bobrick Corporation, The	203
A-I Bradley Corporation	58
Brady Company, W. H.	226
Bruning Division—Addressograph Multigraph Corporation	60
I Buffalo Forge Co.	192
Burke Rubber	32-3
A-I Burns & Russell Co.	250

C

A-L Caradco Division of Scovill Mfg. Co.	209
A Carpenter & Co., Inc., L. E.	61-62
Carpet Cushion Council	166
A-I-L Carrier Air Conditioning Co.	22
A-I Ceco Corp.	84-85
A-I Celotex Corp.	82
A Cold Spring Granite Co.	80-81
Collins & Aikman	68
Columbus Coated Fabrics	106
A Combustion Engineering—C-E Glass Division	164-165
Commercial Carpet Corporation	15
Concrete Reinforcing Steel Institute	42-43
A-I Conwed Corp.	105

D

Delta Air Lines	51
Delta Faucet Company	178
Detroit Diesel Allison Div.—General Motors	16-17
A Dover Corp., Elevator Div.	38
D DuPont De Nemours & Co., Inc., E.I.	108-109
Dynamit Nobel of America Inc.	248A-248B

E

A Eastman Kodak Co.	26
Eaton Corp./ATA Foundation	230

A Eaton Corp., Lock & Hardware Div., Norton Door Closer Dept.	30, 235
Eaton Corp., Security Products and Systems	168
A-I Ebco Mfg. Co.	197
A-I ECI Air Flyte Corp.—Sub. of Eastern Cyclone	102
Eljer Plumbingware Div., Wallace-Murray	32
Executone, Inc.	227

F

A Follansbee Steel Corp.	207
A-I Fuller Co., H.B.	27

G

Gaco Western Inc.	32-1
A-I-L-D GAF Corp., Building Products Division	261
A-I-L GAF Corp., Floor Products Division	48
General Business Services, Inc. ..	228
A-I-L General Electric Co.	40-41
General Electric—Lighting Systems	70
A-I-L-D Georgia-Pacific Corporation	210
GF Business Equipment	64
Glen-Gery Corp.	189
A-L-D Goodrich General Products Co., B.F.	237
A Goodyear Tire & Rubber Co. ...	256
A-I-L Grace & Co., Construction Products, W.R.	86-87
Grinnell Fire Protection Systems ..	229
GTE—Sylvania, I/C Lighting ...	182-183
Guth Lighting—Div. of Sola Basic Industries	63

H

Hager Hinge Company	231-232
Harbor Universal Inc.	72
A-L-D Hercules Incorporated	206
Holophane Co., Inc.	88

I

A Ickes-Braun Glasshouses Inc.	252
A Inland-Ryerson Construction Products Co.	36
A International Dynetics Corp.	184
International Masonry Institute ..	205
A-D InterRoyal	180
ITEK Business Products	224
ITT—Lighting Fixture Div.	103

J

A Jamison Door Co.	198
A Jewett Refrigeration	189
J.G. Furniture Company, Inc. ...	44
A-I-L-D Johns-Manville Corp.—Architectural Division	240
Jute Carpet Backing Council, Inc. ..	55

K

A-I-L Kaiser Aluminum & Chemical Corp.	31
A KDI Paragon	250
A Keene Corp.	20-21
A-I Kelley Co., Inc.	244
Kemiko Inc.	254
Kim Lighting Inc.	49
A-I Kinnear Corp.	202
A Koppers Company	185 to 188
A-D Kwik-Wall Company	167

L

Latco Products	44
A LCN Closers, Inc.	56-57
A-I-L Lennox Industries, Inc.	8
A-I-L Libbey-Owens-Ford Co.	11 to 14
A Ludowici-Celadon Co.	7
A Lundia Myers Industries Inc.	247
Lyons Metal Products, Inc.	225

M

Mammoth Div.	238-239
Manning Co., Inc., R.A.	250
A-D Marathon Carey—McFall Co.	184
A Massey Seating Co.	248
McGraw-Hill Books	32-4
A McKee Door Co.	263
A-I Mobay Chemical Co. Div.—Baychem Corp.	37
Moldcast Manufacturing Co.	54-55
A Mosler/Airmatic Systems Division ..	6

N

National Electrical Contractors Association	96
A-I-L-D National Gypsum Co.	94-95
A-D National Terrazzo	76-77
A-I-L Neenah Foundry Co.	202
Nor-Lake, Inc.	166

O

A Overly Mfg.	204
A-I-L-D Owens-Corning Fiberglas Corp. .	97

P

A-L Pella Rolscreen Co.	213-214
Pennwalt Chemicals Corp.	78-79
A Pomona	89
A-L-D Potlatch Forests, Inc.	189
PPG Industries Inc.	251
A-I PPG Industries Inc.—Coatings & Resins	212
A-L PPG Industries, Inc., Commercial Glass	92-93
Pratt & Lambert Inc.	54

R

Ralph Wilson Plastics	100-101
A-I Raynor Mfg. Co.	184
RCA Mobile Communications Systems	228
A-I Republic Steel Corp.	91, 241
A-L Rohm & Haas Company	248
A-I-L-D Ruberoid—GAF Corp.	48, 261
Russwin, Div. Emhart Corp.	23

S

Sheaffer World-Wide a Textron Company	228
A Silbrico Corp.	254
Sloan Valve Company	4th Cover
A Smith, Elwin G. Div. Cyclops Corp.	74
A Soss Mfg. Co.	54
Southern California Gas Company ..	32-2
A-L Speed Queen, Div. of McGraw-Edison Co.	99
A Spencer Turbine Co.	44
Square D Company	90
A Standard Conveyor Co.	211
Steelcase Inc.	110, 163
Stran Steel	215

T

A-I Taylor Co., The Halsey W.	255
A-I Thiokol Chemical Corp.	104
A Tony Team, Inc., The	189
A TPI Corporation	234
A-I Trans-Vac Systems Div.	179
A Tremco Mfg. Co.	200-201
Trus Joist Corp.	242

U

Uchida Yoko Co. Ltd.	202
Union Metal Mfg. Co.	249
A-I-D United States Gypsum Co.	199
A-L-D U.S. Plywood Corp.	253
A-I United States Steel Corp.	18-19
A-L Uvalde Rock Asphalt Co. ...	3rd Cover

W

Watson Mfg. Co.	208
Welsbach Lighting Products Co., Inc.	74

Westinghouse Corporation222-223
 Westinghouse Electric—
 Corporate 28-29
 Westinghouse Electric Corp.—
 Outdoor Lighting 59
 A-I-L Weyerhaeuser Company 246
 A Wide-Lite Corporation190-191
 Wiley & Sons, Inc., John166, 254
 Winnebago Industries, Inc. 221
 A-D Wool Bureau Inc.193 to 196

X

Xerox Corporation 219

ARCHITECTURAL RECORD

McGraw-Hill, Inc., 1221 Avenue of the Americas, New York
 New York 10020
 Advertising Sales Mgr.: Louis F. Kutscher (212) 997-2838
 Eastern Sales Mgr.: Robert G. Kliesch (215) 568-6161
 Western Sales Mgr.: James A. Anderson (312) 751-3770
 Advertising Services Mgr.: Joseph R. Wunk (212) 997-2793
 Marketing Services Mgr.: Elizabeth Hayman (212) 997-2858
 Research Mgr.: Camille Padula (212) 997-2814
 Classified Advertising: (212) 997-2557

District Offices:

Atlanta 30309
 Edward G. Graves, 100 Colony Square, 1175 Peachtree St., N.E.
 (404) 892-2868

Boston 02116
 607 Boylston St., (617) 262-1160

Chicago 60611
 James A. Anderson, Robert T. Franden, Edward R. Novak,
 645 N. Michigan Ave. (312) 751-3770

Cleveland 44113
 Willis W. Ingersoll, 55 Public Square, (216) 781-7000

Denver 80202
 Harry B. Doyle, 1700 Broadway, (303) 266-3863

Detroit 48202
 Richard D. Thielmann, 1400 Fisher Bldg., (313) 873-7410

Los Angeles 90010
 Richard R. Butera, 3200 Wilshire Blvd.-South Tower (213) 487-1160

New York 10020
 Ted Rzempoluch, (212) 997-3584

Philadelphia 19102
 Robert G. Kliesch, George T. Broskey, Three Parkway
 (215) 568-6161

Pittsburgh 15222
 Edward C. Weil, III, 4 Gateway Center, (412) 391-1314

St. Louis 63011
 Richard Grater, Manchester Rd., (314) 227-1600

San Francisco 94111
 Richard R. Butera, 425 Battery Street (415) 362-4600

Overseas Offices:

Brussels
 Galerie Porte de Namur, 22-26, Chaussee de Wavre
 1050 Brussels, Belgium

Frankfurt/Main
 Elsa-Brandstroen Str. 2, Frankfurt/Main, Germany

London
 34 Dover Street, London W.1, England

Milan
 Via Baracchini No. 1, Milan, Italy

Paris
 17, rue Georges Bizet, 75 Paris 16°, France

Tokyo
 2-5, 3-chome, Kasumigaseki, Chiyoda-ku, Tokyo, Japan

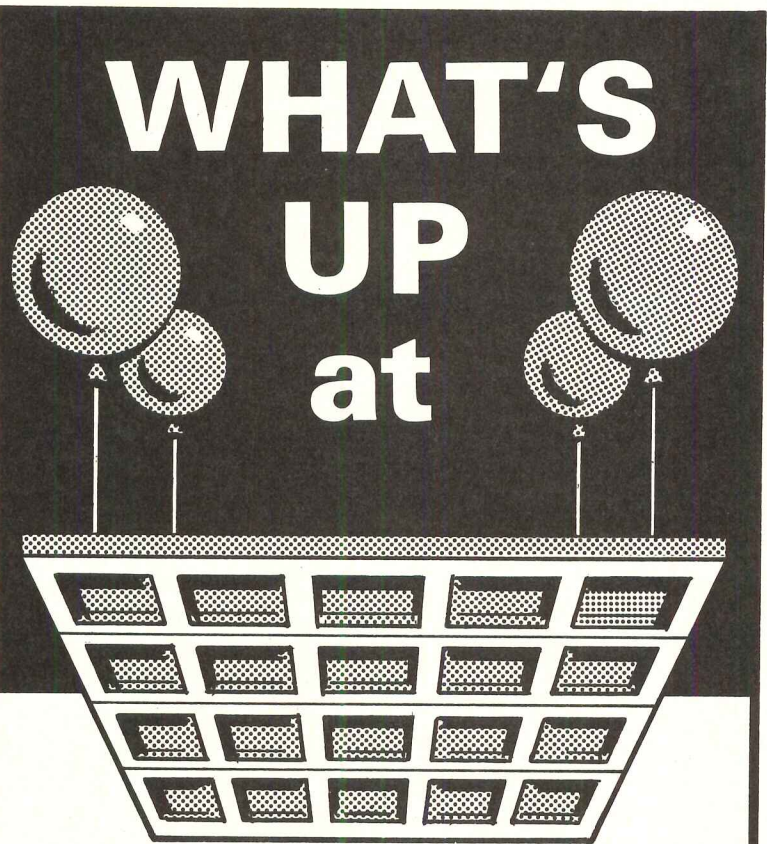

McKEE DOOR

**V.I.P.
 among other things!**

Many things are going on these days at McKee Door Company which will benefit our many customers.

For instance, renewed emphasis on V.I.P.—Value In Place. A dollar buys more tangible value at McKee, whether your need is for commercial, industrial or residential overdoors. Our extensive line of overdoors and operators utilizes the best available materials and components to assure trouble-free operating performance. Customer protection is guaranteed by advanced design, superior workmanship and individual product registration.

Look up to McKee, the 45-year-old new force in the overdoor business. You'll find new products, ideas, services, distribution, prices, and value.

Get to know us better by letting our authorized distributor bid your next job.

See our Catalog in Sweets File 8.9 Mc.



P.O. Box 1108
 Aurora, Illinois 60507
 (312) 897-9600

100

For more data, circle 154 on inquiry card

CLASSIFIED SECTION

POSITIONS VACANT

ENGINEERS DESIGNERS • DRAFTSMEN

DON'T WAIT! INVESTIGATE NOW!

Stearns-Roger Invites You To . . .

. . . ENJOY LIFE — EXPAND YOUR CAREER

Join Us In Colorful Colorado

If you have experience and/or educational qualifications to perform engineering, design, drafting, specification-evaluation-selection of process equipment, or process investigation in development of industrial plants and accessory facilities in the fields of: Power (nuclear and fossil fuel); Petroleum and Petrochemical; Mining and Metallurgy; Architecture; Environmental Science; and all other Heavy Industry . . . we have openings at all levels.

Don't sell your experience short! Let us judge!

Professional resumes accepted, but not required. We are interested in your experience, background, and other qualifications. Please include all pertinent information in your letter of inquiry to:

Personnel Department
STEARNS-ROGER, INC.
P. O. Box 5888
Denver, Colorado 80217



AN EQUAL OPPORTUNITY EMPLOYER

ARCHITECTS PEACE CORPS/VISTA

ACTION. Volunteer overseas and U.S. . . . Low-income housing projects, design of schools, hospitals, community centers, etc. Most openings: singles, some couples. Information: Bruce Mazzie, ACTION, OCP Box 8, Washington, D.C. 20525

Architect or Architect/Engineer—Immediate position with Engineer-Contractor organization involved in Turn-Key/Construction Management. Work includes client contact, preparation and presentation of working drawings and contract documents for school and governmental work. Must be registered or qualified to become registered in California. Write or call: Walker & Walker, Inc., 1433 W. Pine Ave., Fresno, California 93728. Phone 209 486-0644.

Architect/Engineer—Director, Physical Plant Planning—Permanent position, immediate opening for an experienced architect/engineer. Work includes renovation and improvement projects, site and utility work, structural design, specifications, project administration and estimating. Must be registered architect or professional engineer—5 yrs. minimum experience. Salary commensurate with experience, qualifications and ability. Send resume and salary requirements to P-2614, Architectural Record. An Equal Opportunity Employer.

Top artist experienced doing architectural rendering for exciting position in illustration firm in Boston suburbs, with associateship potential and top salary. Contact Office Manager: Henry Perez, 14 Ridge Rd., Newton, MA 02168. Tel. 617 969-9113.

Architects (R.A.) Architectural Lead Draftsmen. If you have been involved in architectural planning of educational, institutional and industrial facilities for more than 5 years and feel that you have not received the recognition you deserve, then you will want to investigate this ad Today. Comprehensive hospitalization, life and disability insurance, vacation, sick leave and profit sharing plan all company paid. Credit Union privileges. Send resume or contact: Personnel Director, Buchart Associates, 611 West Market Street, York, Penna. 17405. Phone: 717-843-3854. "An Equal Opportunity Employer."

Architect/Engineering/Drafting Instructor—Immediate opening beginning August 27, 1973. Faculty position in Dept. of Architectural and Drafting Technology Del Mar College, Corpus Christi, Texas. Innovative and progressive program teaching architectural and drafting technologies. Requires three to five years practical experience, graduate from accredited university or college. Registration in field desirable but not mandatory. Equal opportunity employer. Reply: James B. Boggs, A.I.A., Acting Chairman, Dept. of Arch. & Dft. Tech., Del Mar College, Corpus Christi, Texas 78404.

POSITION WANTED

Senior Administrative Architect: Until recently, Chief Architect, Canadian Pacific Limited; international scope of operations. Member, Royal Architectural Institute of Canada. Graduate, University of Manitoba, 1951. Twenty years widely diversified experience during private and corporate practices. Residing in Montreal, Quebec. Married, no children. Seeking challenging administrative post with progressive organization, North America or abroad. Detailed personal resume and references available. PW-2821, Architectural Record.

SELLING OPPORTUNITY AVAILABLE

Manufacturers' Agents' Newsletter tells you which firms are looking for representatives, the firm's product line and territories available. For information write: Manufacturers' Agents' Newsletter, Dept. 163A, 23573 Prospect Ave., Farmington, Michigan 48024.

BUSINESS OPPORTUNITIES

Acquisitions Desired—Major architectural/engineering firm based in the East seeks similar firms interested in joining forces for common cause, expanded activity and increased challenges. Preferences are for firms with revenues of \$500,000.00 and over. All replies confidential. BO-2271, Architectural Record.

REPLYING TO BOX NUMBER ADS

ADDRESS BOX NO. REPLIES TO: Box No. Classified Adv. Dept. of Architectural Record NEW YORK, N.Y. 10020 P.O. Box 900



Azrock—the best buy in flooring...



for Shopping Centers

Azrock vinyl asbestos tile is the best buy in flooring, because it serves more shopping center and store requirements better than any other type of flooring. Yet it costs less than half of what it did 20 years ago. Here's why you can specify Azrock with confidence:

- Styled to coordinate with contemporary interiors
- Long-lasting durability
- Low initial cost
- Easy, economical cleaning and stain removal
- Low-cost no-wax maintenance
- Lowest motion resistance
- Fire safe, will not support combustion
- Shock proof
- Non-allergenic, mildew proof, no odor retention
- Exceeds federal specifications
- Fast product availability

More vinyl asbestos tile is used in retail stores, shopping centers, and chains than any other kind of flooring. Make shopping pleasant for customers and cut maintenance and replacement problems with low-cost Azrock vinyl asbestos tile—the best buy in flooring.

Floor shown: Alvarado, one of over 150 colors and styles.

the vinyl asbestos
floor tile people



Write for free samples and No-Wax Maintenance information.
Azrock Floor Products, 528A Frost Bldg., San Antonio, Texas 78292.

For more data, circle 155 on inquiry card

ARCHITECTS
Kivett and Myers
GENERAL CONTRACTOR
Del E. Webb Corp.

ENGINEERS
Burns & McDonnell Engineering Co.
MECHANICAL CONTRACTOR
Limbach Co.

PLUMBING WHOLESALER
Missouri-Kansas Supply Co.
FIXTURE MANUFACTURER
Eljer Plumbingware



New Kansas City air terminal built from scratch for jet age

A marvel of the jet age is K.C.I.—Kansas City's International airport—a \$250 million dollar installation consisting of three circular terminals, air cargo facilities, two commissaries, a post office and a new control tower.

The new terminal provides Kansas City with a truly competitive airport in terms of size, accommodations for passengers and cargo, and most important, the capacity to handle Category II landings (100 foot ceiling and one quarter mile horizontal visibility).

A visitor is overwhelmed by the features of K.C.I.—three-lane roadways lead to the attractive sand-colored buildings which resemble stone rather than concrete; wood paneling, rough textures, and huge panels of glass complement the inside. Unique are its restrooms with showers and angled entranceways requiring no doors.

The careful planning that brought this

outstanding terminal complex into being resulted in the selection of only the finest components throughout. So, just as in America's finest commercial buildings—wherever good looks, good taste and good performance are imperative—selection of Sloan Flush Valves was a matter of course.

Dramatically restyled, with totally new contours, the new regal appearance of Sloan Flush Valves reflects the traditional quality that has sustained their leadership for over sixty-five years.

For flush valves to match the highest quality of your building components, specify Sloan Flush Valves—most people do.

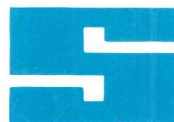

SLOAN VALVE COMPANY

10500 Seymour Ave. • Franklin Park, Ill. 60131

For more data, circle 156 on inquiry card