



VISITORS CENTER BY EDWARD LARRABEE BARNES FOR THE BOTANIC GARDEN IN CHICAGO
NEW DIRECTIONS AND NEW DESIGNS AT C.F. MURPHY ASSOCIATES
TWO DIFFERING INTERIOR RENOVATION APPROACHES BY HERBERT NEWMAN ASSOCIATES
BUILDING TYPES STUDY: MASS TRANSIT FACILITIES IN THE UNITED STATES
ARCHITECTURAL ENGINEERING: ENERGY-EFFICIENT LIGHTING
FULL CONTENTS ON PAGES 10 AND 11

ARCHITECTURAL RECORD

JULY 1979

7

A MCGRAW-HILL PUBLICATION

FIVE DOLLARS PER COPY

The Armstrong Commercial Corlon® Flooring System. A new concept that's been proved in use for over 20 years.



Sandoval™, newest of the Vinyl Corlon
is a styling breakthrough in resilient flooring.
It offers the expensive look of terrazzo
at a sheet vinyl flooring price.

The five ceilings you see here are easy-to-install 2' x 4' lay-in panels—all artfully designed to look like more expensive ceiling tile. The tile look is achieved by integrating the surface design panel with a matching low-gloss grid. The result is the economy of a lay-in

acoustical ceiling with the quality look of tile. It's an idea that's hard to beat for good looks and good sense. For descriptive literature, write to Armstrong, Dept. 8CNAR, Lancaster, Pa. 17604.

Circle 2 on inquiry card



New Registron Sahara Ceiling. Bidirectional textured design in tilelike squares.

Bold Look™ I Ceiling. Handsome popular rough-textured surface in tile-sized squares.



Registron Textured Squares Ceiling. Tilelike image with embossed radiused corners.

Second Look® I. Lightly textured nondirectional design scored to look like tile.



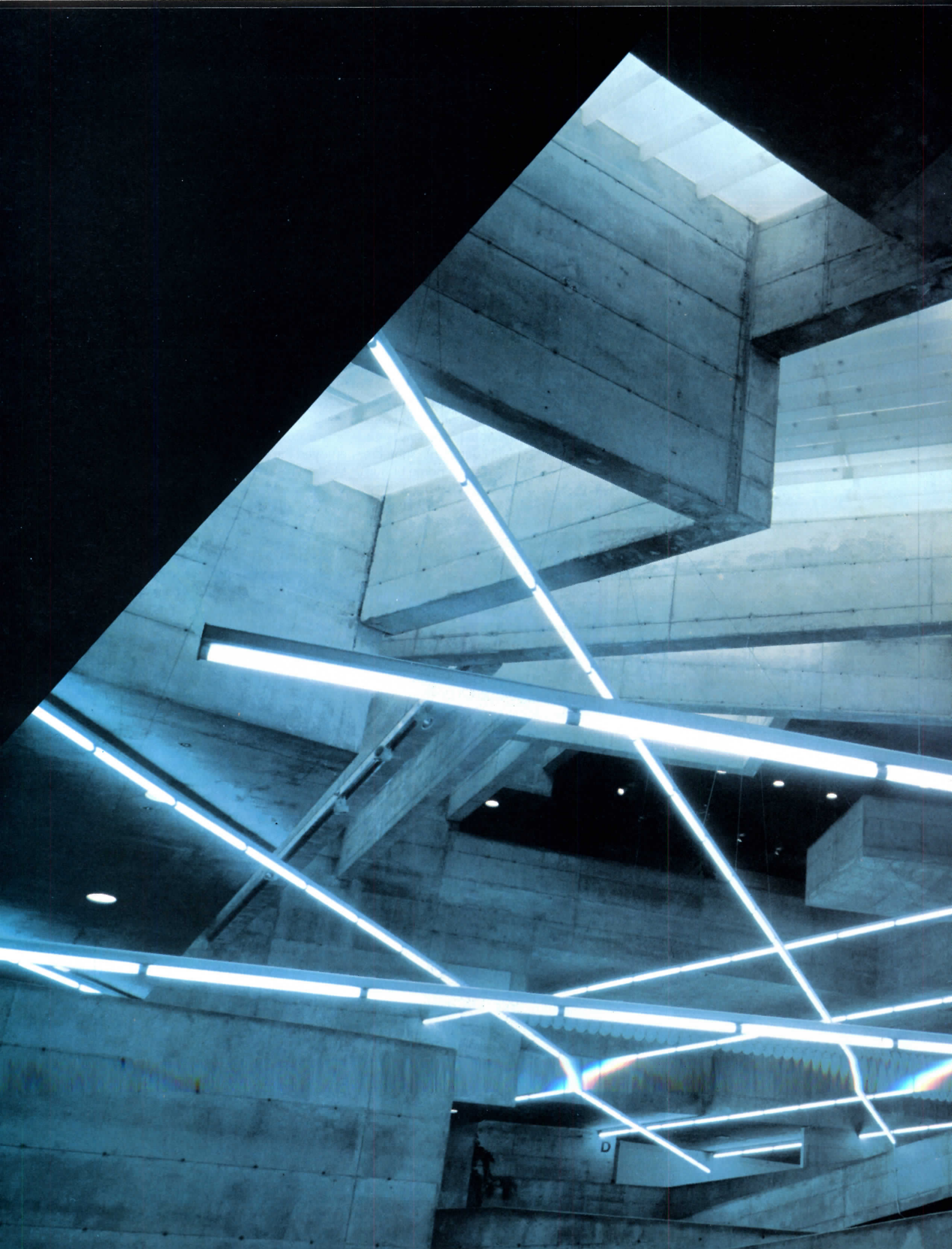
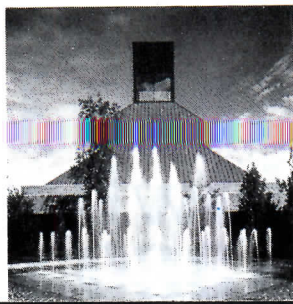

Project: "Space as Support," University Art Museum, Berkeley, California
Artist: Robert Irwin

Lighting: Lite Stripe by Peerless, one of the 13 Longlite systems. This satin-anodized extruded aluminum fixture comes in lengths up to 24'. Movable clips conceal the ends of the exposed lamps and give the appearance of a continuous line of light.

Highlights of the 1979 AIA Convention in Kansas City. For Walter Wagner's full report, see pages 34-37:

R. Randall Vosbeck FAIA (VVKR Partnership) elected first vice president/president elect. He assumes office in December 1980. Charles E. Schwing, current first vice president, succeeds Ehrman Mitchell as AIA president in December. New vice presidents: Gerald L. Clark (FAIA), Phoenix, Anna M. Halpin (FAIA), New York City and Thomas H. Teasdale, St. Louis. Details on page 37.

leoh Ming Pei accepted the Institute's Gold Medal and joined previous Gold Medalists in a lively panel discussion on architectural design. Details on page 34.

Chairmen William Caudill and Hugh Newell Jacobsen presented 15 AIA Honor Awards, including the Architectural Firm Award to Geddes, Brecher Qualls Cunningham of Princeton/Philadelphia. Details on page 34.

The business sessions produced spirited discussion (and action) on two issues: defeat of a resolution that would have required the Institute to take a stand on nuclear energy. A general conservation resolution was passed in its place. The AIA voted to support the Udall-Anderson version (HR 39) of the Alaskan Natural Interest Conservation Act of 1979. Details on page 35.

Dennis J. Keilman of Munster, Ind., has been named Deputy Commissioner of the General Services Administration's Public Buildings Service. PBS, a major unit of GSA and the third largest independent Federal agency, supervises the design, construction, management, maintenance, repair and protection of Federal buildings.

The New York State Energy Research and Development Authority is sponsoring a design and build competition for one- and two-family residential housing in the State of New York. Awards of \$5,000 to the designer and \$5,000 to the builder will be made in the design/build category and a limited number of \$2,500 awards in a separate design category. Proposals are solicited from professional architects, engineers and builders. Projects eligible for construction awards must be submitted by a designer-builder team and constructed within New York State. Applications for the competition will be available from NYSERDA after June 1, 1979. The deadline for submitting proposals is September 1, 1979. Applications can be obtained by writing to: James J. Barron, NYSERDA Solar Project Manager, Agency Building 2, Rockefeller Plaza, Albany, New York 12223.

Richard C. Peters has been elected president of the Association of Collegiate Schools of Architecture.

The Prestressed Concrete Institute invites entries to its Annual Awards Program. Entries must be received no later than August 1, 1979 at PCI, 20 North Wacker Drive, Chicago, Illinois. Inquiries about submissions should be directed to PCI.

The Pritzker Architecture Prize, a \$100,000 cash award granted for the first time this year, has been won by Philip Johnson. Johnson was named recipient of the award, the largest cash prize in the field of architecture, by a distinguished jury: J. Carter Brown, Director, National Gallery of Art, Washington, D.C.; Lord Kenneth Clark, noted author, historian, and creator of the British television series, "Civilization"; Arata Isozaki, practicing architect with numerous international credits; J. Irwin Miller, former chairman, Cummins Engine Company and real estate developer; and Cesar Pelli, Dean of the School of Architecture, Yale University. At a press conference held at the Museum of Modern Art, Jay A. Pritzker, president of the Hyatt Foundation, which is administering and funding the prize, noted that "Through this award, The Board of Directors of the Foundation is seeking to elevate the caliber of architecture internationally and to elevate public responsiveness to the qualities of architectural forms that are so much a part of our lives today. . . Philip Johnson embodies our ideals. Beginning as a critic and historian, he championed the cause of Modern Architecture—and then went on to design some of its greatest buildings. Now he is revising the history he helped to make—and he is still leading architects a merry chase. In fact, the dean of American architects is doing more than anyone in the world to keep Modern Architecture lively and unpredictable." Established last year, the Hyatt Foundation identified architecture as one of the vital and timely areas today in need of more meaningful recognition. The Directors determined to make the Prize an annual event, to be patterned on the Nobel Prizes in other fields.

KIM FOUNTAINS

Experience, Dependability, Performance Guaranteed



KIM LIGHTING

Subsidiary of Walter Kidde & Company, Inc.

KIDDE

16555 E. Gale, Box 1275, Industry, Calif. 91749
Phone (213) 968-5666

Outdoor Lighting and Architectural Fountains

standing vote: It requires the AIA to support the Udall-Anderson version (HR 39) of the Alaskan Natural Interest Conservation Act of 1979. This legislation, which is the most "conservation-minded" of the various versions of legislation protecting the Alaskan Federal lands, passed the House in May—and the intent of McGinty's resolution was to require the AIA staff, in its testimony to the Senate, to support this particular bill rather than testifying more generally in favor of conservation. The Alaska chapter of the AIA is opposed to the Udall-Anderson legislation, favoring a version that would encourage further study towards preservation of land "of particular value."

In addition, the delegates:

- Passed a resolution that the AIA continue to coordinate with NCARB's Intern Development Program but at this time oppose the adoption of the NCARB program as a mandatory prerequisite for licensing. Reasons for the opposition: "architectural interns are a diverse group with varying educational needs . . . (who) must be assumed to be sufficiently mature to manage their own continuing education" and "state registration boards have not demonstrated a consistent ability to manage large-scale educational and counseling programs . . ." However, in support of student-practitioner interaction, the Convention . . .

- Passed a resolution "that components of the AIA actively promote student participation in local, state and regional activities, and encourage their members to become involved in architectural education."

A four-man run for the president-elect position caused a by-law change

This year, for the first time, four candidates—Robert Broshar of Waterloo, Iowa, Herbert Epstein of

NIBS chairman Dave Miller got his Hon AIA from Bud Mitchell all by himself; Bob Geddes and his partners brought the office to share in the Firm Award.

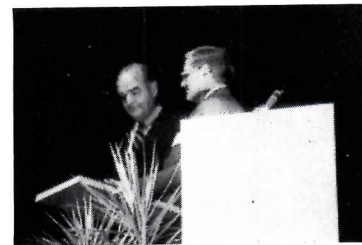

Circle 21 on inquiry card

Brooklyn, James Harris of Tacoma, and Randall Vosbeck of Alexandria, Virginia—all declared for the president-elect position. Under existing bylaws, it would have been possible for one of the candidates to become the president-elect with 26 per cent of the vote. Under the new bylaw, if there are more than two candidates for the position of first vice president/president-elect, secretary, or treasurer, a primary election is held. If a candidate receives a majority of votes cast in the primary, he or she is elected (and that was the case this year, see below). If no candidate for a position receives a majority of the votes, a general election between the two top candidates is held.

A second bylaws change permits the AIA Board's public director, Harold C. Fleming, to vote with the rest of the board.

Also adopted was a by-law amendment requiring petitions to nominate candidates for AIA office and to amend Institute bylaws be received by the AIA secretary 60 (instead of 45) days before the convention.

The first report of the Design-Build Monitoring Task Force provided no major surprises—or suggestions of revolution in practice

The decision of last year's convention to change the AIA Code of Ethics to permit "member participation in profit or loss situations . . . in construction contracting" was subject to a three-year experiment to be monitored by an Institute Task Force which will "recommend permanent acceptance of the change, reversal of the change, or an extension of the experiment at the 1981 convention." The Task Force—Herbert E. Duncan of Kansas City, and AIA former presidents Rex Whitaker Allen and Chick Marshall. Highlights of their report: Of 3,682 member firms replying to their questionnaire, 3,308 indicated no experience to date with "design-build in the context of construction contracting." 374 firms, or 10.2 per cent, indicated some experience. For

most of those, the per cent of business as a principal in a design firm was less than 10 per cent of the firm's work. Of the 3,308 firms without experience in design-build/contracting, 2,281 said that it was "not very likely" that the firm would become involved as a principal in the design-build field," 232 said "very likely" and 464 said "somewhat likely." Nonetheless, 60 per cent of the reporting firms without experience strongly support the concept.

These and other survey results seem to indicate the attitudes that marked the convention voting last year: Most firms are not particularly interested in the concept of participating in design-build projects, but do not object to the concept if other firms do wish to participate. For example, a strong majority of firms who did and did not participate feel that design-build will not weaken the project delivery process, and will improve building quality (presumably because of stronger architect control of the building process). But one-half of the firms without experience, and 25 per cent of those with experience, do feel that the professional status of the architect is weakened by participation in design-build/construction contracting.

In addition, the Task Force reported that it would be comparing results from the base-year client study with those from AIA member-firm questionnaire; and repeating their survey on the same matrix for the two remaining years of experiment on design-build.

Finally . . . the winner: R. Randall Vosbeck is the AIA's president-elect

Mr. Vosbeck was elected from among four candidates, and received a majority of votes in the primary—so no run-off under the new bylaws was required. He will assume office as first vice president/president elect in December 1979 and become president in December 1980. Charles E. Schwing of Baton Rouge, the current president-elect, will succeed Ehrman

Mitchell as president this December.

Randy Vosbeck is now a vice-president of AIA, and served on the board for three years representing the Middle Atlantic Region. In 1978 he chaired the Institute's Government Affairs Commission, and has been a jury member for many design award programs. He received a Presidential appointment to the National Capital Planning Commission and is a member of the US/USSR Working Group on Building Design and Construction Management. He graduated from the University of Minnesota and is a partner in the Virginia/Maryland firm of The VVCR Partnership.

Other officers elected: Gerald L. Clark, FAIA, of Phoenix, Anna M. Halpin, FAIA, of New York City, and Thomas H. Teasdale of St. Louis are the new national vice presidents. Jay W. Barnes, FAIA of Austin, Texas, was elected to a two-year term as treasurer, and Robert M. Lawrence, FAIA, of Oklahoma City continues in his two-year term as secretary.

And...so ended Bud Mitchell's 1979 "Celebration of Design"—a thoughtful and thought-provoking convention. —W.W.

Lou de Moll compared his old role as AIA president with his new role as president of UIA; ex-presidents Chuck Marshall and Jack McGinty compare notes; architects comparison shop in the exhibit area.

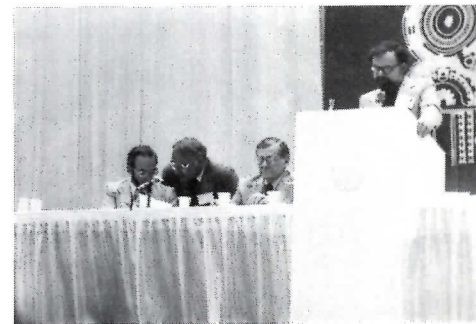

ARCHITECTURAL RECORD July 1979 37

Housing editor John Goldsmith presided over *Housing's* prestigious Homes for Better Living awards presentation. At right, Chuck Schwing.

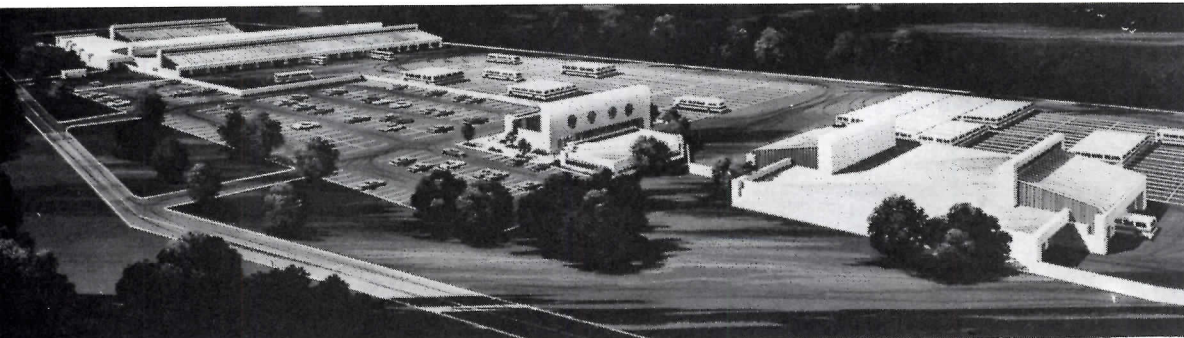
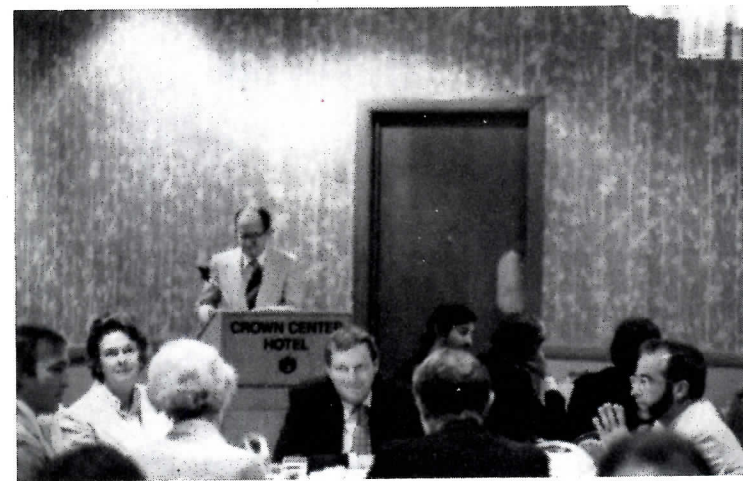

square feet of maintenance operations plus offices and drivers' facilities. As designed by architects Walk Jones & Francis Mah, Inc., all of the buildings will be cooled and heated by the alternate exhaust and collection of solar heat gain between double roofs, that are similar in concept to those on Francis Mah's own house (see RECORD June, 1979, pages 113-116).

Greyhound to locate terminal by no-nonsense analysis

A new 74,000-square-foot San Francisco terminal has been designed for Greyhound by Gensler and Associates, and



For your next project, why not put a message in the sky? With Moduspan® Space frame that turns a ceiling into a skyline, a building into a view. The view on the right is a branch bank of the City Federal Savings and Loan in Summit, New Jersey. Where an architect built on an idea with the technical assistance of our space frame experts. For more information, call the Unistrut Service Center nearest you. Or see our catalogue in Sweets. And see how Moduspan can be a new company's most important overhead investment.

Open up a business.



All-Steel 8000 Series Systems Furniture: **New freedom of choice for your office plan.**

Consider the possibilities inherent in the 8000 Series. At one extreme, it is a complete system of integrated, modular components which can be combined to create the total office plan.

At the other extreme, 8000 Series components can be introduced into any existing office piece-by-piece, over an extended period of time. The transition will be smooth because Series 8000 components

can be rearranged quickly and easily to meet new needs.

To learn how smoothly our 8000 Series Systems furniture can meet the present and future needs of your clients, write All-Steel Inc., Aurora, IL 60507.



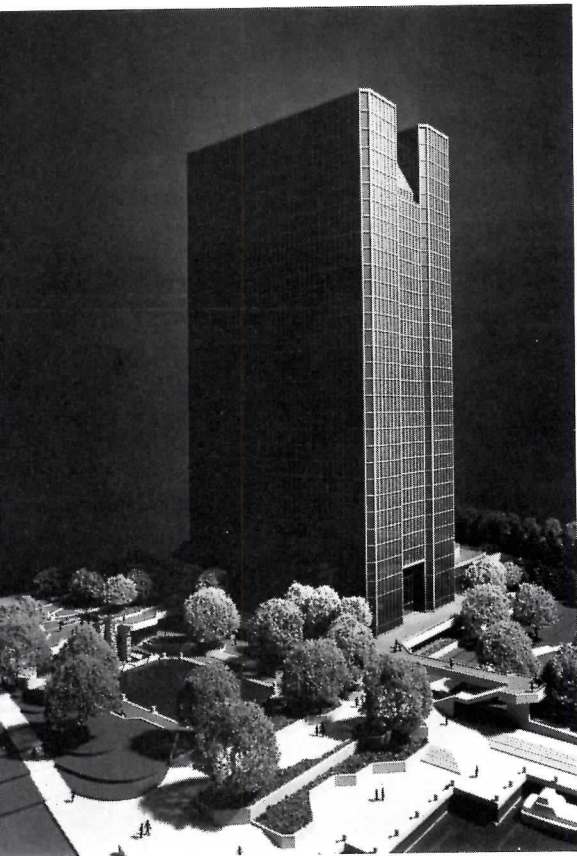

**Pittsburgh
to have a new
Johnson/Burgee
downtown "landmark"**

Continuing a recent trend towards very personal architectural statements, Philip Johnson recently unveiled plans for a 1.6-million-square-foot complex of reflective glass office buildings for PPG Industries. The centerpiece is to be a 40-story tower. In the pattern of varied (and sometimes controversial) historical allusions in the firm's plans for AT&T, a speculative apartment building in New York City, and an arts center in Miami, it may come

as no surprise that PPG's design is to recall collegiate Gothic, in a bow to the form of older Pittsburgh landmarks. The complex is expected to cost over \$100 million, and—pending firm financial and land acquisition plans—the structures should be complete in early 1983. According to PPG vice president Richard F. Sperring: "The building is likely to achieve world recognition." And it certainly will get world attention.

Toledo to house Owens-Illinois in blue glass

As part of the general replanning of Toledo's downtown, this 30-story, Abramovitz-Harris-Kingsland-designed office building will relate to both a major new boulevard and the central business district planning for the adjacent Maumee

River (and water front park designed by Sasaki Associates). The steel-framed structure is to be clad with a blue-green glazed curtain wall system, and will contain an auditorium, cafeteria, exhibition and commercial spaces.

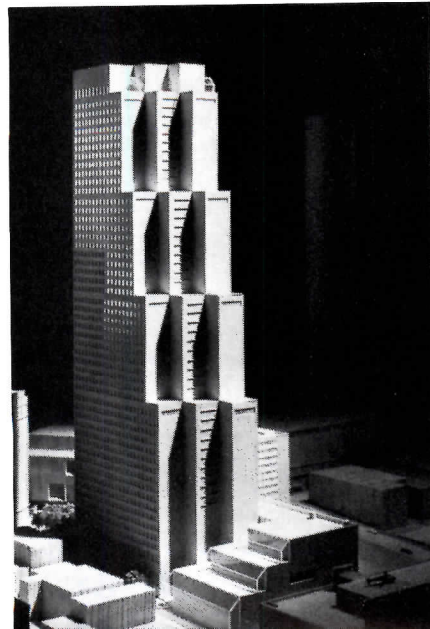
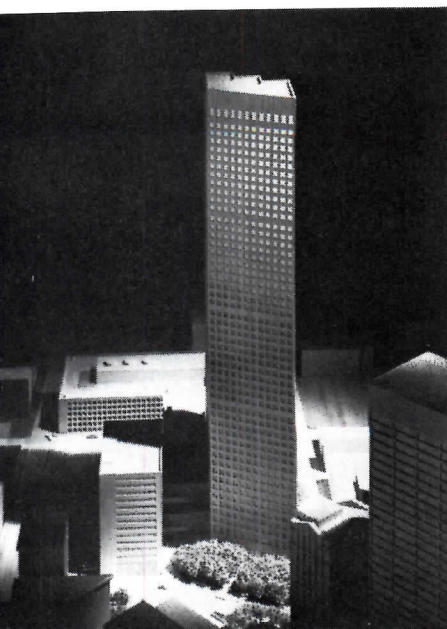
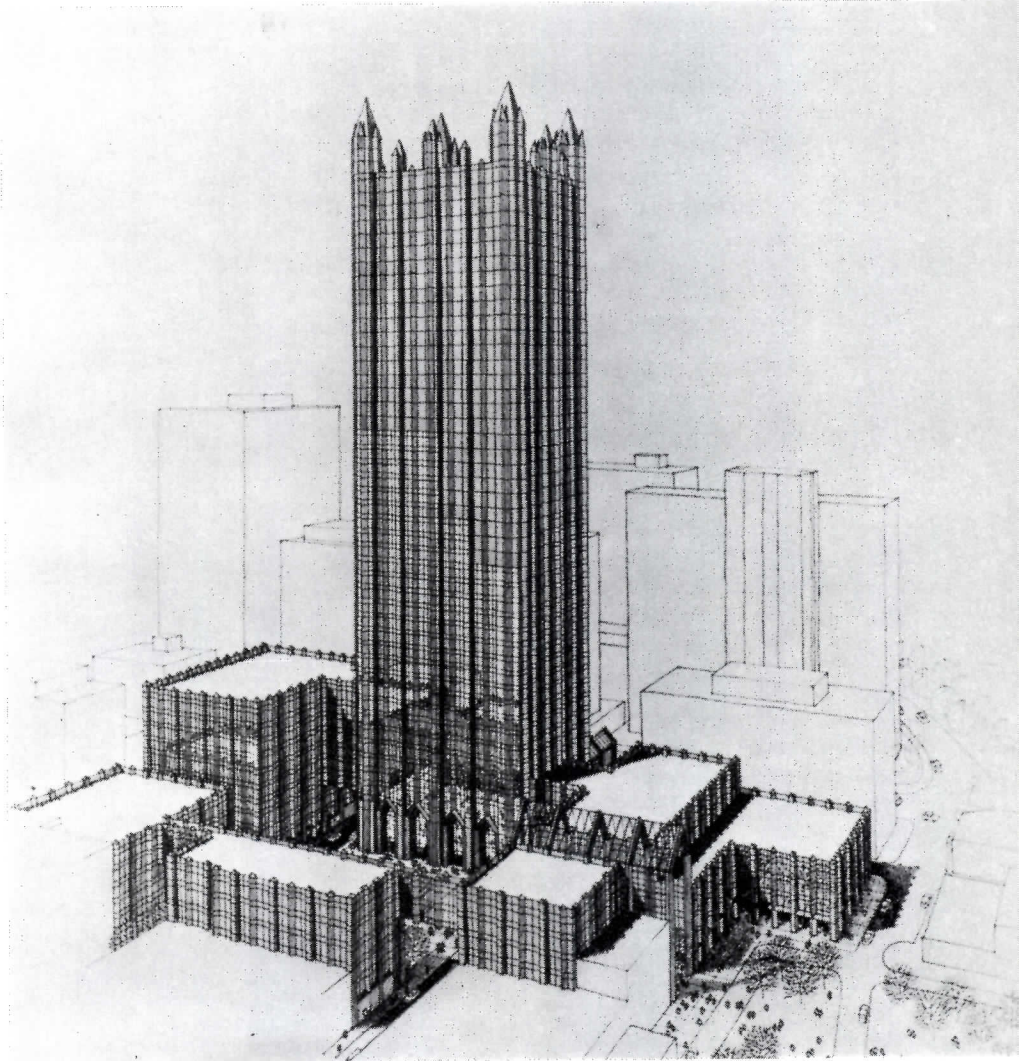

A graceful, stepped-back tower for Atlanta

A third major downtown revitalization project will be this 52-story office building for Georgia-Pacific, as designed by the New York office of Skidmore, Owings & Merrill. To be the largest and tallest building in the Southeast, the granite-clad structure will have 1.4 million square feet of floor space in a stepped-back configuration that is designed for programmed needs as well as a striking silhouette on the skyline. (The company wanted

large floor areas for their own operations on the lower floors, various choices of floor areas at the intermediate levels and relatively small areas for the two executive floors at the top). A low wing will house the company's computers, retail space and service facilities. A conscious commitment to the downtown area, the project counters—in a spectacular manner—a recent Atlanta trend towards decentralization from the core.



PAT APPLICABLE FOR
KAWNEER LIMIT STOP

Key to avoiding litigation is performing defensively

Considering architects' litigation-prone position on the building team, their best professional defense is in *anticipating* litigation and intelligently preparing for it. Selecting proper counsel, fashioning and assembling evidentiary design tools and developing strategies for a successful defense are three of the keys to coping with this difficult situation. Proper planning and documentation will usually prove more valuable to the designer's position than any legal services employed *after* the fact.

by J. James Wulfsberg

Engaging an attorney before the architect-client agreement is made is a prudent step a designer can take in preparing for litigation. An attorney's skill lies not only in trial advocacy, but also in keeping his client out of litigation. An attorney involved in the early stages of the design process can inform the designer of possible problem areas, review or draft documentation as it is necessary, and build a record to document the designer's position if later problems arise.

The option of selecting counsel may appear to be foreclosed where an insurance company selects counsel to represent the designer in regard to a claim. However, the attorney's qualifications should never be assumed in this instance. Some companies select counsel on the basis of pre-arranged fee schedules, which may preclude the type of representation desired or necessary on a particular case. Frank discussions with the claims manager assigning the case to a lawyer are recommended. Dissatisfaction with counsel is the right of the architect, particularly where subsequent premiums, coverage or claims above policy limits may be involved.

Assembling evidentiary tools: documentation is the key

No one really likes to think about designing a new building for a client and constantly protecting himself in the process, but it's exactly in that process of designing and managing your new design commissions where you have the best opportunities to guard against future legal action:

1. *Detail, detail, detail those plans and specifications.* As the drafter of the plans and specifications, a designer is the one to whom

the courts may shift responsibility if any ambiguity or mistake is present in those documents. Avoid uncertainties.

2. *Obtain written product warranties/opinions.* Where new products are specified or familiar products are used in new applications, the designer undoubtedly has a duty to request and carefully review all product literature, including warranties.

The architect should inform the manufacturer of the intended use and request a written opinion from that manufacturer as to the suitability of its products for the use.

3. *Keep comprehensive meeting notes.* Construction phase and inspection duties are becoming increasingly complex. Written, objective documentation of all job site inspections, meetings or conversations should be prepared immediately following such occurrences and should be maintained in chronological order in the designer's files. Such documents will later prove invaluable in refreshing recollections of personnel and, if objective, should be valuable admissible evidence of the designer's actions.

4. *Issue only written change orders.* The contract documents usually will provide that changes involving additional compensation or extensions of time may only be made in writing signed by the owner and the designer. Any variance from the procedure may be deemed a waiver of the requirement. The designer should be wary of orally authorizing the contractor to proceed with work beyond the scope of the contract.

5. *Keep your "cool" and don't get personal.* Finally, as the arbiter of contract disputes and the interpreter of plans and specifications, the designer should always exercise his best judgment, free from any bias toward the contractor or desire to conceal design mistakes. The designer's decisions, including the rationale for his conclusions, should be expressed in writing with copies maintained in his job files. The designer should refrain from making notations on any submittals received from the contractor or owner evidencing the designer's frustration

with the incompetence of those parties; avoid personal, as opposed to professional, opinions of their work.

Developing a successful design defense: do it as you go

A recent California appellate court decision illustrates the difficulties which contractors may face in recovering damages from architects where careful attention to the defense of the designer is given.

In *Huber, Hunt & Nichols, Inc. v. Moore*, 67 CA3d 278 (1977), the contractor sought damages from the architects for negligent preparation of plans and specifications. The appellate court affirmed the trial court's judgment in favor of the architects and required the contractor to pay the fees for the architects' expert witnesses.

This judgment resulted from the successful defense by the architects' counsel that the contractor had failed to causally connect each *item* of increased cost to a negligent error or omission in the plans or specifications. The court rejected the contractor's attempt to introduce a lengthy computer printout detailing total job costs in numerous categories and subcategories on the grounds that it would be unintelligible to the court or a lay jury.

Furthermore, the court refused to allow the contractor to use extrapolations from that printout to prove damages on a "total cost" basis (i.e., difference between bid amount and actual costs). Instead, the court held that the contractor would have to take the following steps for each element of cost purportedly increased: 1) Prove that the initial cost estimate for that item was accurate; 2) show that the increase in costs was the result of, ("proximately caused by"), an error or omission in the plans or specifications; 3) demonstrate that those errors or omissions were proximately caused by the designer's negligence; and 4) prove that the increase was not due to other factors, such as change orders.

This case reflects the importance of documenting each element of the architect's work: design; construction phase activities; and interpretation of plans and specifications. The designer, *who is usually in the unique position of being paid for the work which will form the basis of his defense at the conclusion of construction*, can, with planning and prudent awareness of his status as a "target," lay the foundation for his own defense.

Mr. Wulfsberg is a partner in the Oakland, California law firm of Lempres & Wulfsberg. He is experienced in the area of construction claims and litigation and is a member of the Forum Committee on the Construction Industry of the American Bar Association.

"Legal Perspectives" is published with the understanding that the publisher is not rendering legal service. If legal advice is required, the services of a competent professional should be sought.

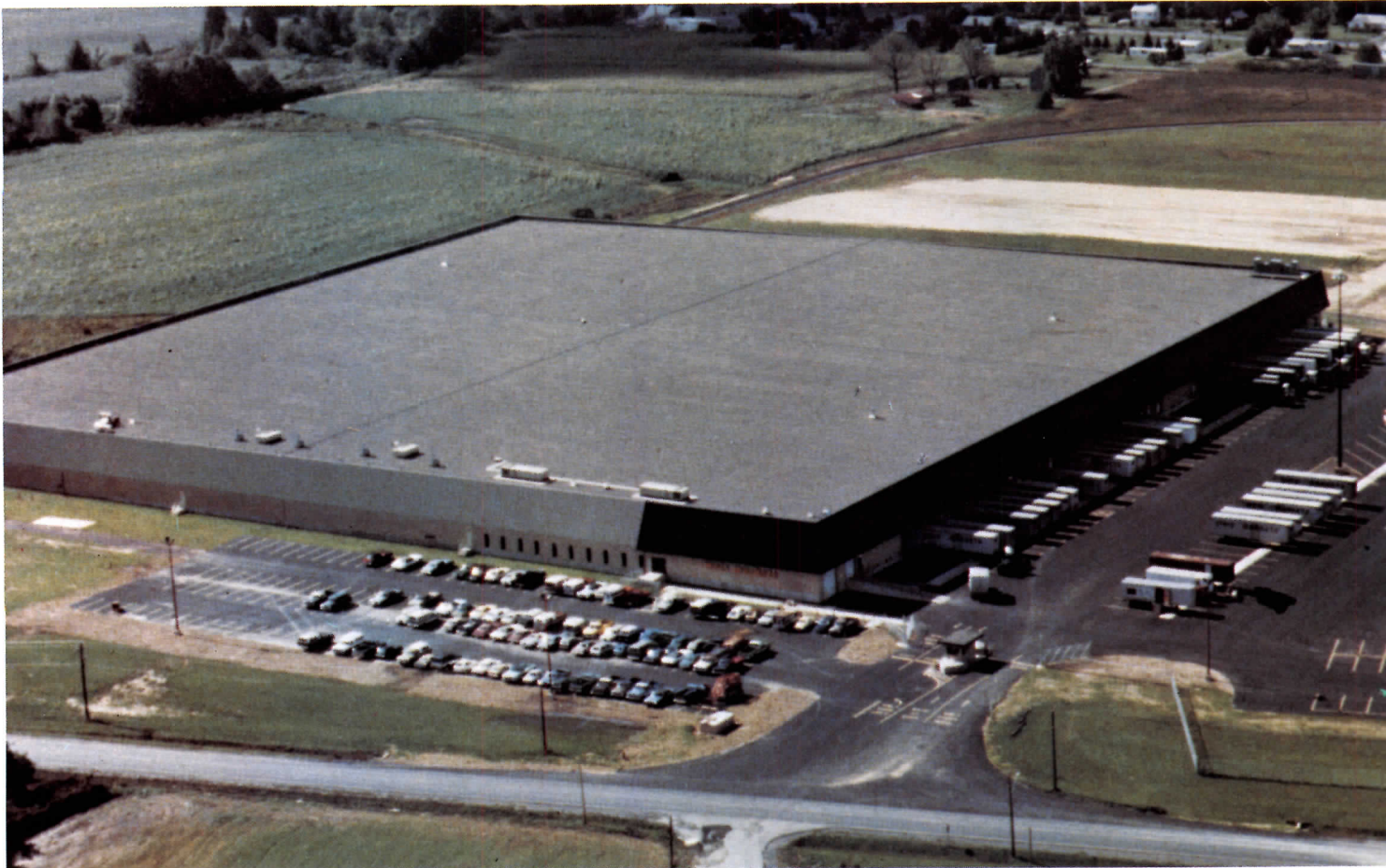

Aerial view of the Carlisle roof on the new Milton, Pennsylvania Distribution Center built by Weis Markets, Inc.

A Carlisle roof is low-cost to put on, no cost to keep on... and on...and on...and...

Imagine three men unrolling big, clean rubber sheets (up to 45' x 125' in one piece) on your roof in the dead of winter, cold-sealing the few seams and around protrusions and perimeter, then spreading ballast—river-washed gravel will do nicely—over it.

That's about all there is to installing the Carlisle Sure-Seal loose-laid roof on all types of commercial and industrial roofs, and there are three other Sure-Seal systems not much more complicated. No wasted motion. No fancy equipment.

The marvel is that Sure-Seal costs less to install than a top quality built-up roof, costs next to nothing to maintain (what's to maintain?), and lasts and lasts and lasts. How long? We honestly don't know yet; earlier Sure-Seal installations are 17 years old

and still going strong. But we back Sure-Seal with a Five-Year *Watertight* Warranty and even that can be extended.

Now mull over this: you can lay Sure-Seal right over a leaky *old* roof. *And*, if you decide later to move, you can move the roof with you! Or raise the roof one day to top the stories you add!

If you want to keep a roof over your head, you can see Sure-Seal does the job beautifully and saves you money from start to finish. And long, long after. Would you like to know more about it? Write us for the name of your nearest contractor; he has to be an approved Sure-Seal applicator, which means he's one of the best in the business. Just like Sure-Seal.

Carlisle elastomeric roofing system, Design B, is listed by Underwriters' Laboratories Inc. for Class A service.



Construction Materials Department
Carlisle Tire & Rubber Company
Division of Carlisle Corporation
P.O. Box 99
Carlisle, PA 17013
(717) 249-1000; Telex 84-2330 (Carlisle CLSL)

Carlisle Tire & Rubber

CARLISLE

Circle 38 on inquiry card

Designing entrances and internal circulation to meet barrier-free goals

The accessibility of entrances and interior circulation routes for handicapped people determines the over-all extent of access that can be attained in a building; therefore, these parts of buildings are given high priority in code reviews for barrier-free design. Yet, there are a number of issues that most existing codes and standards do not adequately address, or on which there is no consensus. Understanding these issues can help architects approach barrier-free design from a more informed perspective.

by Edward Steinfeld

Most accessibility codes require a width of 32 inches clear for doorways. Entrance doorways are usually wide enough to exceed this requirement but other doors, particularly in residential structures, may not be. Thirty-two inches clear is a generally accepted minimum. This clearance both provides convenient maneuvering for wheelchair users and also reduces the need for periodic maintenance to door jambs which can be easily damaged by wheelchair traffic. However, a very large majority of chairs are 26 inches or less wide and many wheelchair users can squeeze through a 28-inch opening in a pinch. Research has shown that 30 inches clear is satisfactory for almost all people who travel independently. In retrofit projects, it would seem that allowances could be made for doorways that are narrower than 32 inches but larger than 28 inches clear, although doorways narrower than 30 inches should be widened if the budget permits.

One of the most important and most difficult doorway issues is the force required to open a door with a closer. Opening force is directly related to the closing force of a closer and must always be greater than the closing force. A large proportion of disabled people cannot exert very much force upon a door. One research study that examined such abilities found that only 23-30 per cent of wheelchair users tested and 39-44 per cent of people with other disabilities could exert forces greater than 15-pound force in one of several different directions.

Door closer manufacturers claim that 15-pound force opening force should be allowed for exterior doors to ensure that they will close properly and safely under difficult conditions, such as those found at wind-

swept entries. A minimum opening force of 8.5-pound force seems to give sufficient leeway in most situations. However, other actions may have to be taken to keep doors closed where severe wind conditions exist. For example, wind can be blocked by wind screens, or its impact reduced by careful orientation of doorways. Fire doors sometimes are required to have a minimum closing force to ensure latching. The lowest opening force within the limits allowed may be larger than 8.5-pound force but not much can be done to decrease it without causing a conflict with fire safety criteria.

When all efforts to reduce closing force of doors fail, the only alternative is an automatic door. Conventional automatic doors are quite costly, but several manufacturers are now marketing low-powered, slow-moving, automatic door openers. They can be activated by push buttons rather than mats or photoelectric sensors and guard rails are not required. Some of these doors are designed specifically for accessibility retrofits and are much less costly than conventional automatic doors. But experience with such doors is limited. Their vandal resistance, reliability and durability under long-term use, intense cold and heat, and heavy wind is not documented.

Clearances in front of doorways are just as important as the clear width of doors. Minimum clearances for wheelchair access are based on the direction from which a door is approached. The existing ANSI A117.1 standard has the following requirement:

"The floor on the inside and outside of each doorway shall be level for a distance of 5 feet from the door in the direction the door swings and shall extend a foot beyond each side of the door."

Similar requirements are found in most accessibility codes. The second half of the above sentence has been interpreted in two different ways. Some authorities require a 1-foot clearance beyond the door at both hinge and latch sides. Others require such a clearance only at both sides of the latch

assuming that "each side" means "inside" or "outside."

Current research indicates that a hinge-side clearance is not absolutely necessary but that a clearance of 24 inches or more should be provided at the latch on the pull side of doors. If doors are approached from a parallel direction rather than head-on, or from the push side of the door, the 5-foot clearance in the direction that the door swings can be reduced. Doors in alcoves should be treated as head-on approaches since wheelchairs must be positioned that way in order to open such doors. Many wheelchair users must use a head-on approach with doors having closers as well. Sometimes latch clearances in front of doors can be reduced with little impact on accessibility, for example at entries to hospital patient bedrooms where doors are 48 inches wide and are usually held in the open position.

Circulation routes should accommodate wheelchair and crutch users

Accessible circulation spaces should be wide enough to permit use by a person in a wheelchair or those who use crutches. In straight sections of circulation spaces, 36 inches is wide enough for one person, but where traffic is likely to be in two directions, 60 inches is necessary to permit two wheelchair users to pass each other. Where the number of people who use wheelchairs is low, a 48-inch-wide circulation space allows ambulatory people to pass wheelchair users. If a circulation space is too narrow for two wheelchair users to pass each other, then there should be passing spaces every 200 feet along the route. Passing spaces can be widened areas 60 inches long by 60 inches wide or intersections of two halls, corridors or aisles.

At any dead end, there should be space for people in wheelchairs to turn 180 degrees. A minimum-sized space for this maneuver is 60 inches in diameter, but a space 60 inches by 78 inches is much more convenient. The turning space can be T-shaped as well. The turning space should be measured at the floor. Objects overhanging this clear floor space (e.g. counters, lavatories, etc.) will not obstruct turning a wheelchair as long as they do not project over it more than 19 inches and their underside is at least 27 inches high. These dimensions provide a clearance under the object.

continued on page 66

Edward Steinfeld is an architect and an associate professor of architecture at the School of Architecture and Environmental Design, State University of New York at Buffalo. He is Secretary of the ANSI A117 Committee.

This is the third article in a series of six by Mr. Steinfeld on barrier-free design. The previous two articles appeared in the March 1979 and May 1979 issues.

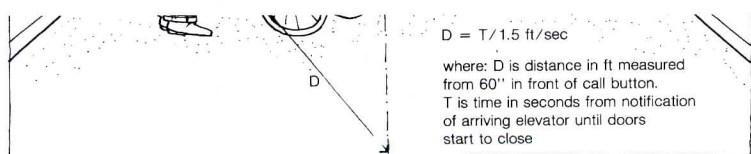

Selected design criteria for elevator lobbies

Slope	Length
1:8	≥2 ft.
1:10	≥8 ft.
1:12	>8 ft.
1:16-1:20	preferred

- 60" long level runoff area, top and bottom.
- Handrails both sides, continuous at one side of landings, 12" extension where handrail is not continuous.
- Protection at edge of ramp surface (e.g. curbs, railing, etc.)

There should be at least one route that does not have stairs from each accessible space in a building. In new construction, this is usually not difficult to accomplish because the location of entrances, elevators, ramps, stairways, structural elements, mechanical systems, and exterior grade elevations can be adjusted. In existing buildings, there is less freedom to alter the plan and modifications

tripping or slipping while mounting and dismounting; 6) crutch tips getting caught in a gap between the floor level and the platform; and 7) structural or mechanical failure which may cause the platform to tip or fall. Design of the area surrounding a lift installation can be as critical for safety as the lift itself.

Installation of elevators is sometimes considered a last resort because of cost.

These methods have been proposed: 1) compartmentalization of each floor; 2) sprinkler systems; 3) use of elevators for emergency fire egress combined with protected areas of refuge at elevator cores; 4) refuges at fire stair landings at each floor; 5) required emergency management plans. However, the degree to which each approach should be used, if at all, is not yet clear.

TO SPECIFY FALCON LOCKS IS A REFLECTION OF YOUR GOOD TASTE.



FALCON LOCK
DIVISION OF NORRIS INDUSTRIES 4100 ARDMORE AVE. SOUTH GATE, CA 90280



M2000 Series in Troy — Napa design

Circle 39 on inquiry card

Federal actions will have a negative impact on housing credit

Once-bright prospects for strong savings flows to thrift institutions have turned gloomy because regulations concerning the new and highly successful money market certificates were changed in March. This will hurt the supply of housing credit, but other factors will soften the impact on housing construction.

The rates paid on money market certificates (MMCs) still fluctuate with the six-month Treasury Bill rate, but Federal regulators removed the privilege of compounding interest on MMCs and rescinded the extra quarter per cent that thrift institutions could pay on

MMCs. Now the rate paid by both commercial banks and thrift institutions is identical whenever MMC rates move above 9 per cent. (The differential in favor of thrift institutions still exists whenever MMC rates fall below 9 per cent.)

Before these actions, thrift institutions offered MMCs at a yield clearly superior to the yield on most other short-term investments. That superiority was the reason savings inflows to thrift institutions were so vigorous in the second half of 1978 and the first two and a half months of 1979.

Without a distinct MMC rate advantage, however, thrift institutions in April immediately experienced their first net outflow of savings since September, 1974. With poor savings inflows likely for the next several months, thrift institutions should reduce commitments for future mortgage financing even though demand for mortgage credit remains exceptional.

Mortgage rates have reacted accordingly. Single-family mortgage rates passed through the 11 per cent barrier in April and were approaching 11.5 per cent in many areas of the country at the end of May. Although shockingly high when compared to mortgage rates 10 years ago, these rates are bargains when the effects of the recent double digit inflation are removed. Consumers know this. They also recognize that homes are appreciating so fast in price that waiting pushes the cost of housing up more than rising interest rates. Consequently, despite high and rising mortgage rates, consumers are still trying to buy houses at a very high rate.

One result is that yield spreads between single-family mortgages and long-term corporate bonds are widening in favor of mortgages (see Chart 3). These favorable spreads are attracting mortgage money from pension funds and life insurance companies, which are buying securities backed by single-family loans. As these spreads widen, these institutions will gradually shift even more funds into the home mortgage market.

Although these sources cannot completely offset the drop in savings flows to thrift institutions, they will soften the impact of that decline on the single-family market. In turn, this should help limit the downturn in single-family starts, making it considerably less severe than in 1974. Moreover, once the economy slows, moderating inflation and permitting the Federal Reserve to ease back on monetary policy, rising credit availability coupled with strong consumer demand for single-family housing will spark an expansion in housing construction that should carry into the early 1980s.

Phillip E. Kidd

Director of Economic Research
McGraw-Hill Information Systems Company

THE SUPPLY OF CREDIT

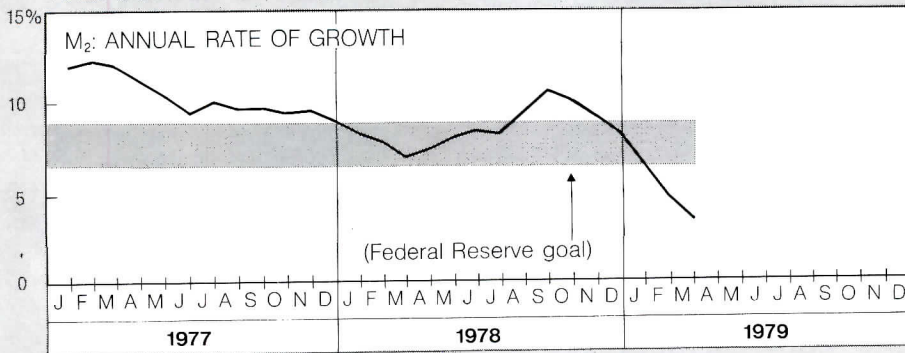

THE COST OF CREDIT

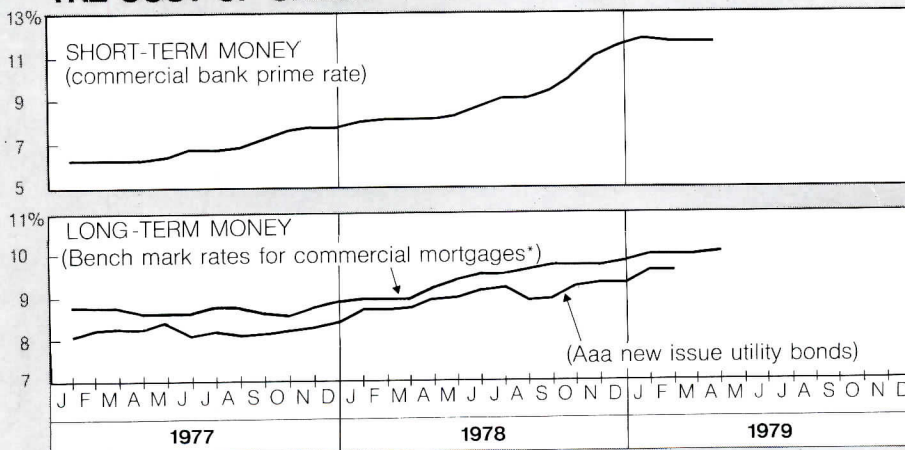

*Source: Citicorp Real Estate Inc

YIELD SPREADS FAVOR MORTGAGES

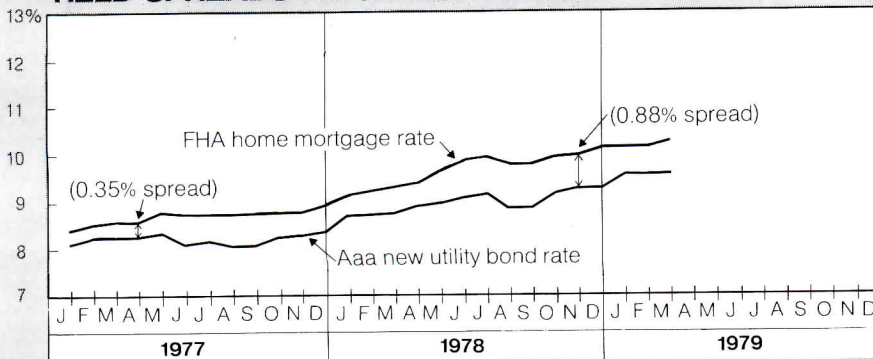

HOW VULCRAFT DELIVERED TO

When plans called for steel joists, joist girders and steel deck in the new Fort Wayne post office, the steel fabricator called on Vulcraft for all three.

Because now, Vulcraft manufactures steel deck along with joists and joist girders. And we're the only company in the country making them all.

Like the builders of the Fort Wayne post office, you can come out on top when you look to one source for all three.

You save time by combining the engineering, design and detailing functions.

You shorten construction schedules, because we can deliver joists, joist girders and steel deck all in one shipment, with our own fleet of trucks.

You solve problems quickly, because you have access to Vulcraft's nationwide sales and service force.

You save paperwork by dealing with only one company.

And you can rely on Vulcraft quality, because our deck is produced with the same high standards and reliability that we've established in the joist business.

For these reasons, there's no reason for you to look beyond Vulcraft when you're ready to order joists, joist girders or steel deck.

We stand ready to deliver all three.

Just contact your local Vulcraft representative. Or write Vulcraft, P.O. Box 22046, Charlotte, North Carolina 28222, for our steel deck and joist catalogs.

Circle 40 on inquiry card



THE FORT WAYNE POST OFFICE



Vulcraft now manufactures a broad line of steel deck along with steel joists and joist girders.



The simplicity and light weight of Vulcraft joists and joist girders make erection fast and easy.



Economies result from fewer columns being needed with Vulcraft joists and joist girders, because of their ability to span longer bays.

VULCRAFT

A Division of Nucor Corporation.

P.O. Box F-2, Florence SC 29502 803/662-0381
P.O. Box 169, Fort Payne, AL 35967 205/845-2460
P.O. Box 186, Grapeland, TX 75844 713/687-4665
P.O. Box 59, Norfolk, NE 68701 402/371-0020
P.O. Box 1000, St. Joe, IN 46785 219/337-5411

Architects and Engineers: Schenkel & Schultz, Inc.
General Contractor: Hagerman Construction Company
Steel Fabricator: Engineered Structural Products Corp.
Steel Erector: Martin Steel Erection

SPACE

"If the Open Plan System is to effectively solve the problem of creating a highly productive office environment in the face of constantly changing conditions, it must respond in design and application to the essential components of interior space; the space itself, the people who occupy the space, the activities that take place, the changes that occur and the energy used to bring the space to life."

The GF Open Plan System addresses itself to the productive use of space... and does it beautifully. It helps you manage your client's office environment with a comprehensive array of engineered components designed to control acoustics and lighting, improve communications, and create highly specialized working conditions.

If you'd like to see how the GF Open Plan System can make SPACE work more productively for you call your GF Dealer or visit our showroom.



 **Office
Furniture
Systems**
GF Business Equipment

Circle 41 on inquiry card

A CONSERVATORY FOR A BOTANIC GARDEN

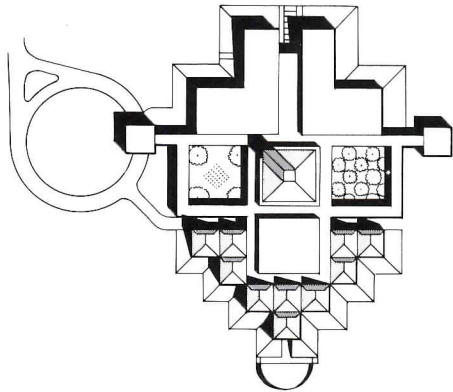

The new Botanic Garden for the Chicago Horticultural Society is growing into a wonderful place created from land which was formerly unbuildable, worn out or ill used. The combined conservatory, administration and visitor center designed by Edward Larrabee Barnes is the centerpiece of the garden. Barnes' achievement was to transform a varied and complex program into a masterfully simple, balanced organization of interior courtyards, cloisters, continuous unencumbered facades and a dominant central pavilion. Instead of one large greenhouse which might have overwhelmed the composition, he chose to design ten small ones making it simpler to provide different climates while creating a better scale relationship with the pavilion. Barnes' building takes possession of its site in a surprising way, bringing forth the qualities of the landscape while appearing to contradict them. It has all been done with Barnes' usual rigor. He is as spare as ever in the number of forms and materials he combines. Only a few other architects know how to accomplish so much with so little.

—Mildred F. Schmertz



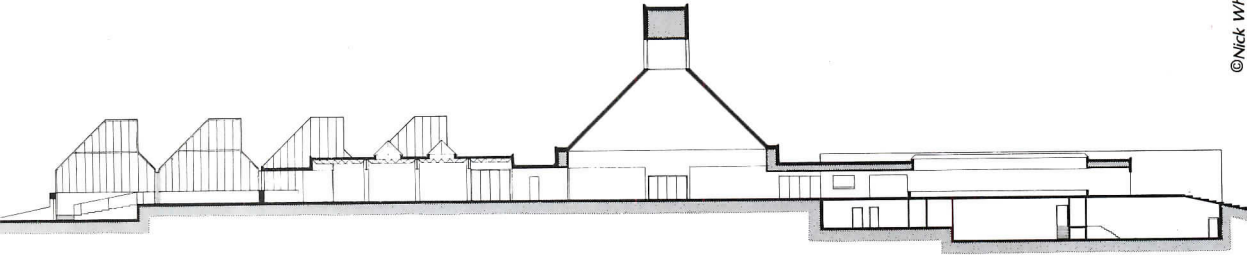

The site chosen for the new Botanic Garden for the Chicago Horticultural Society was a 320-acre low land area consisting mainly of unused swampy meadow land, depleted farms and extraction pits at the head of the Skokie Lagoon complex in Glenco, Illinois about 50 miles north of Chicago. The land was acquired from the Cook Country Forest Preserve District. The master plan, which established the major land use and circulation patterns for the entire site, was prepared by Environmental Planning and Design, the landscape architecture and planning firm

founded by John Ormsbee and Philip Douglas Simonds. The Simonds brothers and their partners and associates developed the site over a 14-year period beginning in 1963. They converted it into a new and beautiful setting of garden islands surrounded by lagoons and meandering waterways. Edward Larabee Barnes was commissioned in 1970 to design the Administration and Visitors Center to occupy the largest of these islands.

If Barnes had designed his building in the spirit of this landscape he probably would have devised a rather random and

yielding asymmetrical pattern. Instead he chose to develop a formal, axial, symmetrical solution, deliberately classic, in juxtaposition to the romantic forms of the landscape. Defined as a separate and distinct precinct by the strict geometry of the 30-foot-wide berm that forms its boundaries, the building appears from the air like a multi-faceted jewel on a patch of moss surrounded by still water.

Although a building of such crystalline order might better command the vistas of an Italian Renaissance garden than dominate a mounded and curving

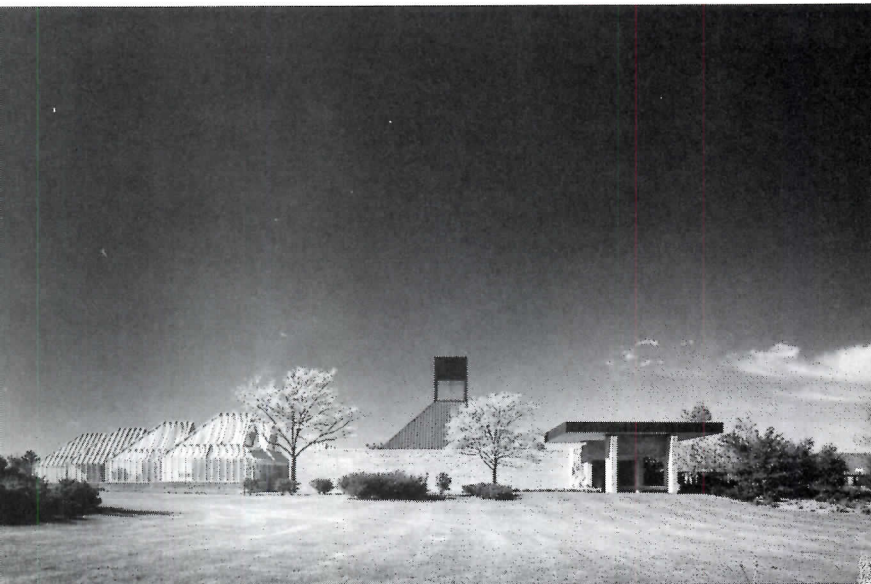

The main approach to the north and the greenhouses to the south are on the same axis (opposite page). The fountain (above) consists of 49 jets within a square of stone paving. The fenestration is continuous on the perimeter of the administration and education wing (left).



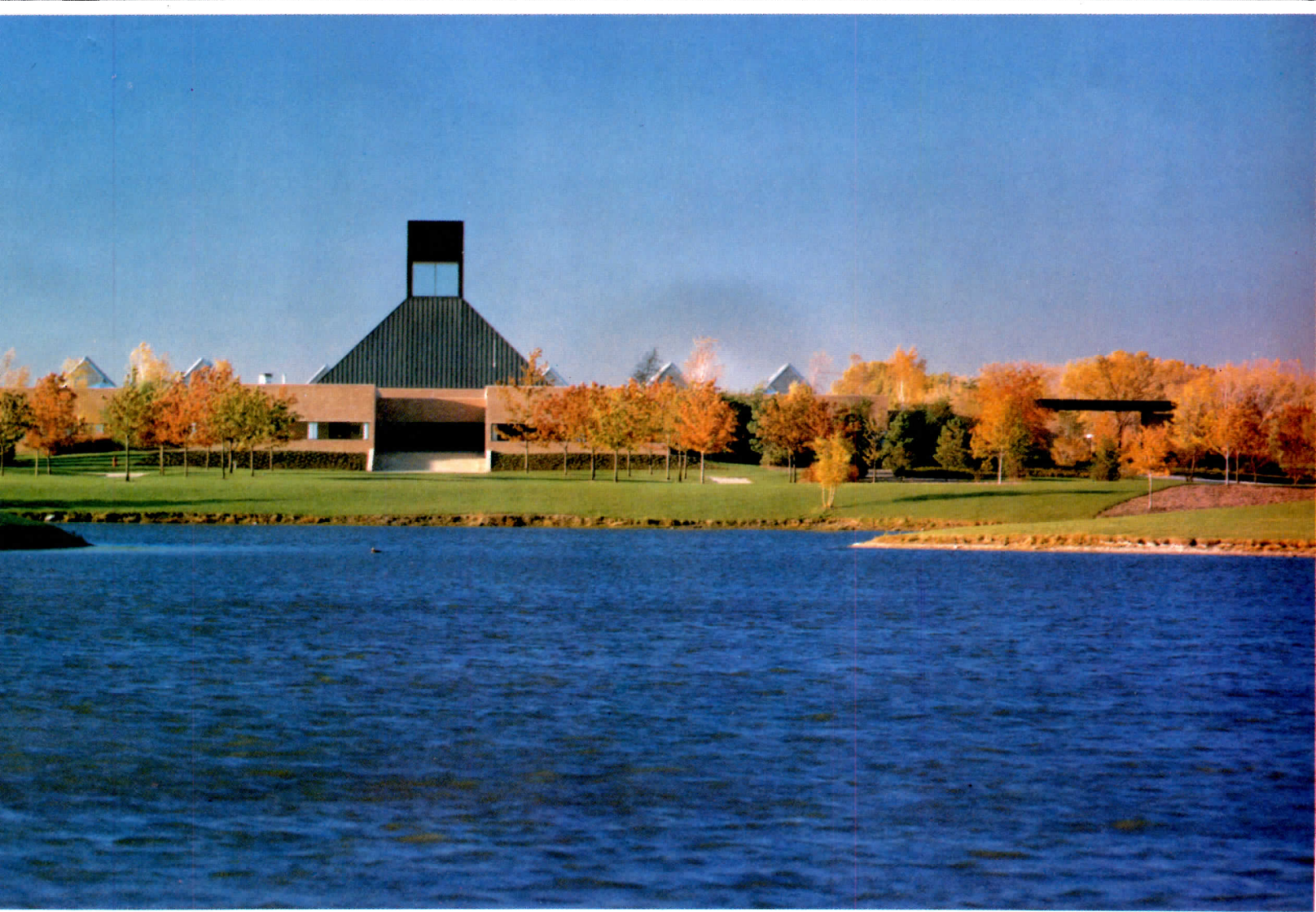



landscape ever so suggestive of Japanese temple gardens, there is a certain *frisson* in the manner in which it contradicts its surroundings. To disagree is always harder than to concur and by electing to juxtapose rather than to harmonize, Barnes set himself a difficult task. His building has its own deliberate contradictions, its rooms focus inward, yet its axes open upon extended outward vistas. From the exterior the building appears sealed and contained, like a ship, but from within it invites the surrounding land and lakes.

Barnes imposed this order

upon a very complex program. The Administration and Visitors Center serves adults and children, groups and individuals, amateurs and professionals. It is the administrative center for the entire garden. Seminar rooms, classrooms, a small auditorium for 200, a library, an exhibition hall, a cluster of greenhouses, outdoor exhibition spaces, offices, simple dining facilities, delivery and staging space have been arranged so that they can be operated independently or as a unit. This flexible and versatile building has been organized into a cruciform plan approached on

foot from the east and by car from the west.

The exhibition hall with its pyramid shaped tent-like roof and its high monitor skylight marks the center, and the cloistered courtyards on each side to the east and west separate the complex into two areas: to the south greenhouses and service and to the north administration and education. The west courtyard contains a fountain, which consists of 49 jets rising directly from a square of stone paving. On special occasions the large exhibition hall can be thrown open to these two courtyard

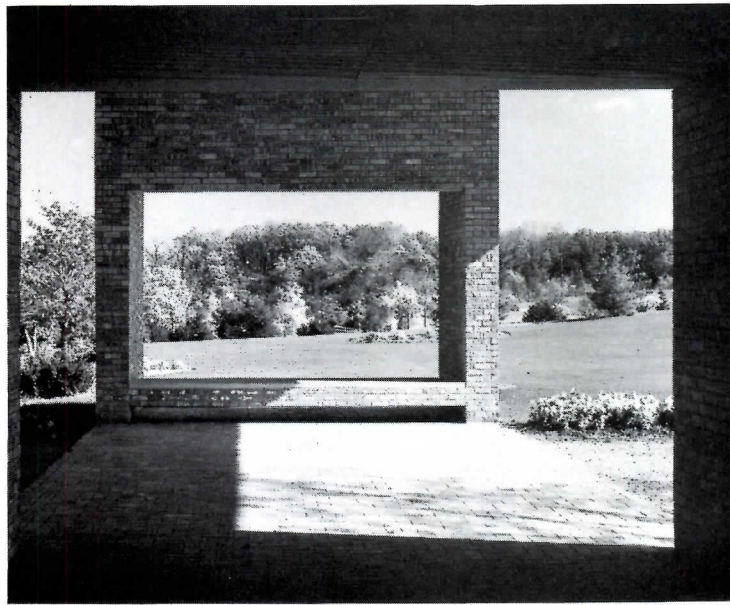

In this building as in almost all of his work, Barnes has strictly limited his range of materials and colors as can be seen in the photos on this and the opposite page. He has used buff limestone for copings, greenhouse sills and landscape details and in combination with iron spot brick for interior and exterior paving. The walls are of Chicago common sewer brick and the ceilings are of western hemlock in narrow slats. These slatted ceilings are used in the cloisters (right), the main exhibition hall, and the exhibition areas around the greenhouses. The wood was given a fire retardant coating. The greenhouse pavilions are modified pyramids, echoing the shape of the main exhibition hall roof.

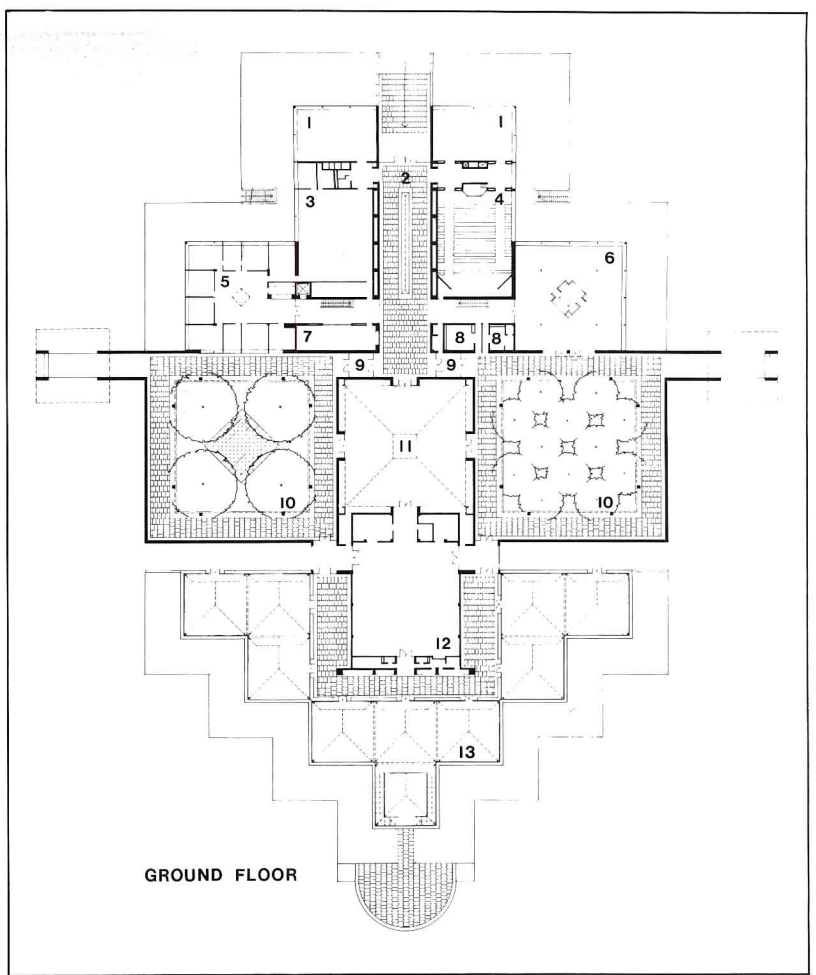
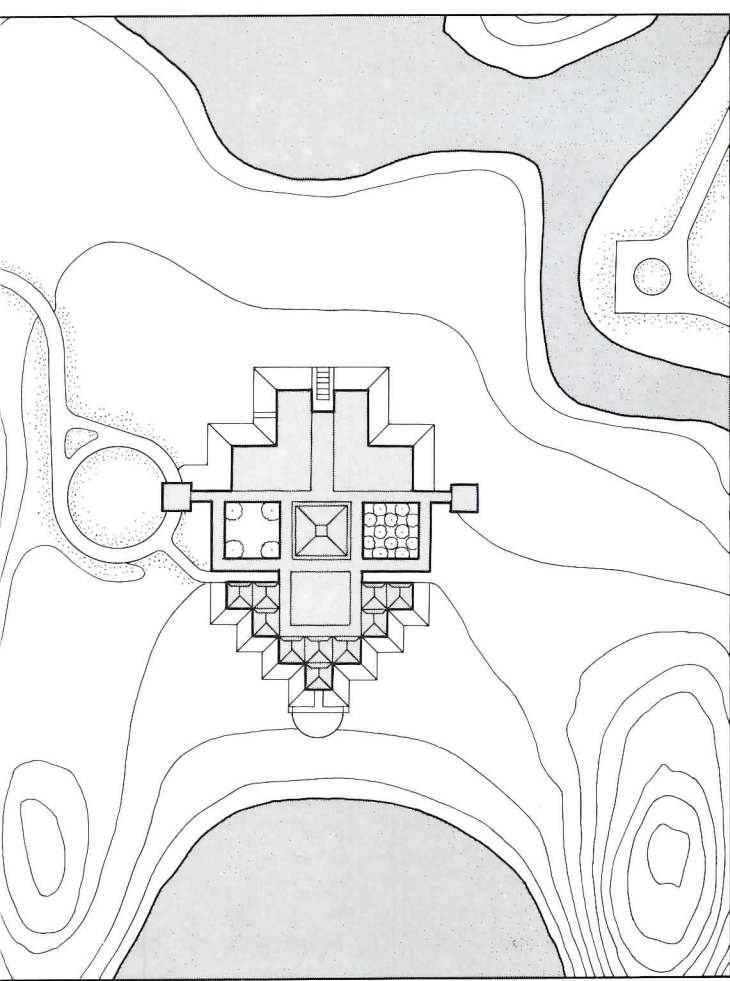

- | | | | |
|------------------------|--------------|--------------|---------------------------|
| 1 Meeting | 4 Auditorium | 7 Sales area | 10 Court |
| 2 Main gallery | 5 Offices | 8 Toilets | 11 Exhibition hall |
| 3 Library reading room | 6 Restaurant | 9 Lobby | 12 Exhibition preparation |
| | | | 13 Greenhouses |



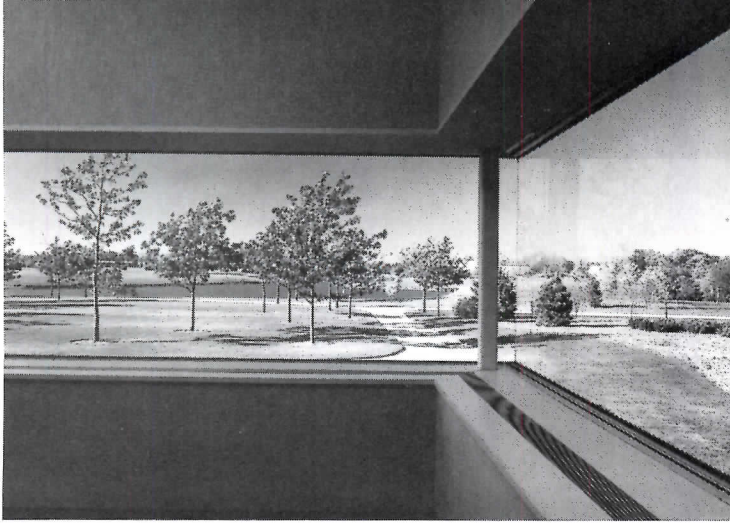

creating a continuous indoor-outdoor space extending 280 feet along the east-west axis.

To the north of the exhibition hall on the north-south axis is a long brick gallery with a central reflecting pool, a skylight above and glass doors opening out to a lake. This gallery isolates the library and administrative offices from the noise of the cafe and lecture hall.

The entire building is one story except for a small basement to the north of the exhibition hall and courtyards. All mechanical equipment is located there including the air-conditioning sys-

tem which uses water from the lagoon. The entire building is air conditioned except for the greenhouses. These greenhouses are clustered in three adjoining groups around a work area beyond the exhibition pavilion on the southern end of the main axis. They are linked by a cloister-like exhibition space between the work area and the greenhouse entrances. The southernmost house has a wide stair leading to a lower level and out at the southern extremity of the complex onto a semi-circular brick paved terrace.

A simple palette of four

harmonizing materials has been used throughout the public spaces. All the walls are of a soft pink to buff Chicago select common brick. The paving consists of large areas of buff-colored dolomitic limestone from Minnesota bordered and floating in straw-colored iron spot brick pavers. The ceilings of the exhibition hall and cloisters are of natural wood slatted panels. The only other significant visible materials are mullionless glass used in all the windows and entrance doors and natural copper for the roofs of the exhibition hall and entrance canopy.

ADMINISTRATION AND VISITORS CENTER, Botanic Garden of the Chicago Horticultural Society, Glencoe, Illinois. Architect: *Edward Larrabee Barnes*—associate-in-charge: *Alister Bevington*; project architect: *Gajinder Singh*. Consultants: *Severud, Perrone, Sturm, Conlin, Bandel* (structural); *Cosentini Associates* (mechanical/electrical); *Klepper, Marshal, King* (acoustical); *Donald Bliss* (lighting); *Mary Barnes of Edward Larrabee Barnes Office* (interiors); *Wolf & Company, Hanscomb Roy* (costs); *Ickes-Braun* (greenhouse). General contractor: *Coath & Goss*—superintendent of construction: *Fred Bock*.





In the main exhibition hall (above), the slatted surfaces on the walls and ceiling have acoustic backing. The building can be said to have only two continuous windows, each nearly 250 feet long and four feet high. These windows (opposite page, top left) are butt glazed with no vertical mullions for the entire length. There are central skylights in the restaurant (top right), the entrance concourse (left) and the office area.

The ten clustered greenhouses were custom designed. Their basic structure is of 6-inch-diameter steel tubes painted silver to match the clear anodized aluminum glazing mullions. The glazing is of heavy weight $\frac{3}{16}$ -inch greenhouse glass. It extends between the mullions from the ridge to the sill with no interruptions other than lapped joints. The flooring is of pea gravel for drainage under the plants.



Ludwig Mies van der Rohe will have been gone ten years next month. The star he steered by seems to have been lost sight of during the twilight of dogma of the 1970s.

With a felicity that has often been downright gruesome, a number of leading architects, among them those who once declared that his was the only star to steer by, have trounced on the philosophical and formal limits he declared—almost as if to measure their own emancipatory musings against him.

There are signs that Mies himself was more than aware that "the box" would be broken out of. He had a tremendous sense of history, and of history's momentum. The conceptual grid of architecture would be altered. He knew that. He also knew that it was too late for him to be more than a cautionary force amid the widening freedom to come. That would be enough. That might even be needed.

One afternoon at his office, in 1966, he was viewing a short film about his work. When the Riehl House, of 1907, appeared—with steeply pitched roofs, a sequence of shuttered windows and doors, that semi-circular dormer—he turned and said, "You know, I may have had something there." Although he was a man of enormous humor—which he usually kept to himself, his collection of Klees, and friends at the decidedly unaustere Pearson Street apartment—he never said things just in jest.

Moreover, he found great artistic integrity and humanistic power in the work of architects who seemed to be light-years removed from his own convictions. On a visit to Taliesin North, not long after his coming to America in the late 1930s—"Wright talked; I listened"—Mies was strolling around the grounds with one of his Chicago students who began condemning the sagging cantilevers, cracked plaster, and the basic (very beautiful) sense of incompleteness of the place. This did not make points with "pure" old Mies, who shot back, "Why don't you just thank God it exists."

Mies was a bard in fealty to Apollo, as the great teacher, Alfred Caldwell, once said. He confided that faith in works of clarity, composure, and a simplicity so extravagant as to border on irony. Many architects were boxed in, but more by themselves than by him, accepting the austerity and seeming ease of his "style" at face (or facade) value. Autocracy can be read into their motives. But then, it must be said, the bard never indicated displeasure with his worshippers, any more than Wright did—except once and subtly: "I am not clear about what a 'Mies building' is."

The final ring is yet to be pulled tight on the message of this man. His example even now sends up faint illuminations of the need for clear, disciplined thinking. However diverse the creative pathways of architecture may be in the coming period, it is important that these illuminations be pondered—especially by those "original thinkers" who give the impression, as in Lewis Mumford's parable of the rooster, that they made the sun come up by crowing at dawn.

Fifty years ago was the Barcelona Pavilion—and believe it or not, something of the dawn that the architectural world is pushing toward. As Reyner Banham perceptively wrote, it was "so purely symbolic in

intention that the concept of functionalism would need to be stretched to the point of unrecognizability before it could be made to fit into it." The concept of functionalism is indeed being stretched to a great many points today, and a lot is being made to fit into it, with new names, which is good. Far from hemming architecture in, Ludwig Mies van der Rohe not only made room for our adventure, but by sticking to his guns, he also made it inevitable.

In thinking over what there is about Mies to miss, RECORD asked a number of architects, some of whom said, quite triumphantly, that they don't miss him much at all. What follows is a pick of the crop who, thinking that he hemmed us in too much or not enough, decided to explain themselves. The first comment is from Stanley Tigerman, who has written an ironic fun-poking letter to Mies; the second is much more solemn, from James Ingo Freed, of I.M. Pei & Partners; and the third is from R. Ogden Hannaford, that unforgettably civil professor at Illinois Institute of Technology, who was never adamant that dogma wag every last detail. As Mies would have said, lighting a cigar, "Well . . . they have a certain quality." —William Marlin

Dear Mies:

I miss you. I wish you were here to see what's happened. The state of architecture has grown curiouser and curiouser in the years you've been gone. There's something called post-modernism now. I guess it means to be something more than just "after modern architecture," which is not to suggest that there aren't even those who think modern architecture is dead. It's very much alive.

Here in Chicago, everything appears to have remained much the same as it was. The people you left to run your firm seem to be thriving, and the rest of your dependency is alive and well and at work. Your followers at SOM are totally victorious.

Illinois Institute of Technology is the same as it was ten years ago. The architecture school is still a seminary, importing students from the Black Forest for graduate school who believe in your credo: "Build, don't talk."

For a while there was concern when Jim Freed was dean at IIT. He went around hiring people who didn't graduate from there, brought in a lot of weird New York types as lecturers and even tried to change the curriculum. He thought color has something to do with architecture. Not to worry; he got run out of town.

Some things do worry me about Chicago. When you were here, the C.F. Murphy firm was solid with Jacques Brownson and then Gene Summers in control. Now this fellow Helmut Jahn is doing some strange things. I've even heard he has a pediment on one of his buildings. There's even an architect who teaches at IIT, Tom Beeby, who has designed one project that looks like the Parthenon, and another with minarets (luckily they're not being built). Imagine, they even gave him tenure down at Crown Hall. Then there is this really crazy group called the "Chicago Seven" that goes around stirring up trouble by talking a lot instead of building.

Incidentally, you were right about Philip Johnson. Those damn intellectuals are all the same. He's doing a high-rise in New York City

text continued on page 110

MISSING MIES



Mies and a sculpture of himself by Hugo Weber

Richard Nickel

NEW DIRECTIONS AND NEW DESIGNS AT C. F. MURPHY ASSOCIATES

In the town that Mies built, C. F. Murphy Associates has been a bastion of his beliefs, taking structural morality to its strictest, most splendid limits. In the last few years, the firm has edged into wider conceptual territory, but *without abandon*. The reasons for this, and some of the results, are explored here.

by Helmut Jahn

When I started designing buildings ten years ago, I was a strict believer in functionalism. Solving the problems of planning, structure, and technology was a purely "objective" matter.

In analyzing our buildings from those days, and the ones we are doing now, I can see a change. This has come about in common with the philosophical shifts in the thinking of Chicago architects—and these shifts, while having a lot in common with the jolts occurring in other star systems of the architectural universe, are all the more compelling in these parts because (remember) *we had Mies*.

This change has also come about because there are so many influences impinging upon the architect's control and, indeed, his very comprehension of "the problem." Beyond the bare functional dimensions of designing a building, and beyond deciding how to dip into available technology, there are other "purely objective matters" involved—those forces that are liberating and constricting our lifestyle; the rapid, often disorienting changes in our society; the need to be sparing in our use of resources, materials, and energy; all the codes and laws cropping up, at every turn; dramatically increased public awareness of historical buildings, places, and streets that, in turn, strongly urges us to design new buildings that acknowledge the scale and character of what exists.

What has developed in our office, in an effort to measure up to these new, wider dimensions of "the problem," is a process—at once rational *and* intuitive.

The rational part deals with the realities of a problem, consciously analyzing the many discrete but related aspects of planning and technics, then bringing them into alignment within the perspective of functionalist principles. The intuitive part deals with the theoretical, intellectual aspects, discerning the intrinsic "structure" of a problem, the nature of its cultural and human references. And as suffused in the creative subconscious as it may seem to be, this intuitive part finally becomes a *conscious* assignment of priority to the expressive power of space, form, light, color, and materials.

Such attitudes are freeing our skills to

Helmut Jahn is executive vice president and director of design at C.F. Murphy Associates, Chicago.

practice architecture as something other than problem-solving and, amid the pluralism that architects were slow in recognizing as an "objective" reality as well as design inspiration, we are being freed to develop an architectural approach that is multi-directional, less restrictive in what is theoretically "correct" and "genuine"—in a word, less dogmatic. During this period, a lot of us have been forced to question our former convictions about exclusivist principles which yielded so many icy if (to us) elegant edges.

In our practice, we often deal with clients who do not want architecture—not in the altogether sense that I have been pondering here. We deal with this attitude and other constraints—low budgets, short schedules, increased mechanization, new delivery techniques—not by opposing them, but by making them work for the design strategy that is being worked out through ingenuity and common sense.

Many of the resulting buildings have been strategically developed this way, and their design character has been categorized as High-Tech, which is identified with the popularity of the industrial image, though it is not the same as "the industrial look." True enough, High-Tech overlaps with the "look"—with its novel combinations of readily available components and industrial artifacts. Its fascination lies in the unconventional use of the conventional, and the "look" tends toward the nostalgic and eclectic. High-Tech in its surest sense is inventive, imaginative, with a real concern for function and purpose. It is aided by the latest technology, engineered rather than designed, attending to performance and not just appearance.

The difference between Mies and his followers is that we consciously strive for this content. High-Tech is *part* of the search for what will follow the monolithic modernism of the immediate past. I am aware of the validity of other path-ways to it—context, symbolism, metaphor, and ornament.

The last ten years have seen a reliance on "one liners"—often without interest—and an attempt to synthesize a number of approaches to design. The canons of Modernism lowered the boom on any architect who did not think that architecture is the systematic solving of technical problems. Late Modernism remains within the restrictive

language of Modernism, but it has often been given to exaggeration through extreme logic, an emphasis on circulation and systems, and through a mannered, complicated use of abstract forms. Post-Modernism would seem to suggest that architecture is a social art, using a complement of codes to signal this or that building's relationship to context, history, or the popular vernacular of our own (or some other) time.

I strongly feel that these many pathways must again come within sight of each other. As is evident from our recently completed buildings and current designs—a certain eclectic attitude has shown up as the attempt is being made—especially so with respect to the varying assignments of priority that we have made to the determinators of design. But the most recent projects do show something of the synthesis I have in mind, combining characteristics that had previously appeared individually. The functionalist principles of plan, circulation, structure, servicing, and energy are intact, and their communicative quality, their formal character, represent a dovetailing of those basic elements with these: *context*, as it relates to place and history; *space, light, transparency, and reflections*, as they establish an enriched visual and physical perception; *technical systems*, as they make symbolic statements on technology, energy consciousness, and cost effectiveness; with *geometry*, as it represents a reaching out beyond the reductionist forms of the International Style; with *metaphorical associations*, using familiar forms, styles, colors, and products to generate form; with *communication*, as it relates to people's use and perception of buildings; and with *change*, which entails both the metaphorical notion and the practical reality that our buildings are never quite finished, that they must accommodate growth physically and can successfully express this impermanence by way of a lighter, more lyrical esthetic.

There is a fresh, new spirit today—and fresh, new issues to attend to. We can draw from the skills, insights, and strengths of the earlier phases of modernism. And by bearing in mind the issues it did not address with the discipline its leaders preached, deal exactly with the very "material" human, cultural, and social challenges of our society—without caprice, pretense, or utopian rhetoric.

LA LUMIERE ATHLETIC FACILITY LA PORTE, INDIANA

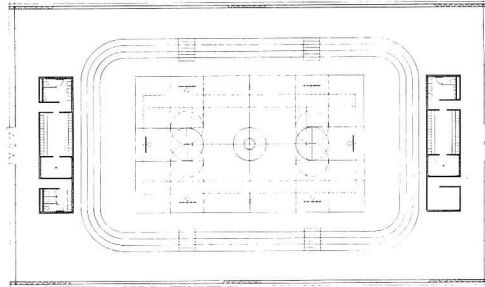

Structure *is* architecture in this sport shell for La Lumiere, a small private prep school. It is the simplest, most unassuming example imaginable of C.F. Murphy Associates' long-standing regimen of putting muscle tone on even the most basic materials and methodologies—and always just enough to achieve the handsome bearing called "good form."

Here the students play beneath an off-the-shelf arch, spanning 110 feet, that is fabricated of corrugated panels of press-formed, thin-gauge galvanized steel.

These panels make an artful modular sandwich. An inner shell, perforated for acoustical absorption, is spaced away from the outer shell. Into the space was stuffed a two-and-a-half-inch-thick blanket of fiberglass insulation. The whole shebang was put together right on the field, with bolts.

This structural system, usually used for secondary, mostly unseen, and "non-architectural" purposes, has been elevated at La Lumiere as the primary formal feature. The upgrading of utility to beauty not only meets conventional levels of performance—both structurally and in terms of the program—but it also achieves these levels at costs that are favorably competitive.

Both of the end walls are of clear glass, the idea being (of course) to be able to see all the way through the place from outside, pointing up the continuity of space as it flows in from the surrounding campus and fields, and pointing up the simplicity and integrity of the arch as well. This solution supplants the more familiar end walls of such off-the-shelf structures, which are usually opaque. Thus lots of natural lighting is introduced, adding to the atmosphere of fun and games.

These two curtain walls, carried on frameworks of steel, provide lateral stiffening for the arch swooping between them; furthermore, casement windows, running along the lower section of each provide for natural ventilation, which is a good thing, because the building isn't air-conditioned.

Lighting fixtures, also of minimal cost, are run around the circumference of the arch, tucked into the pleats of its corrugated underside. This makes for a nice effect, because the swoops are accented, and recessing the fixtures also helps protect them from the floor action. Galvanized wire guards further fend off anarchistic basketballs.

C.F. Murphy Associates became well-known in the 1960s for its loyalty to structure as the principle "form giver," especially since it was doing such big-span numbers as the Chicago Civic Center and McCormick Place. Now structure is just one of many determinators its designers are considering. But as can be seen at La Lumiere, the old loyalty is not only intact when it's apt to a particular problem; it's also been given a rub-down, and feels just great.

LA LUMIERE ATHLETIC FACILITY, La Porte, Indiana.
Architects: C.F. Murphy Associates—Helmut Jahn, David Hovey, William Wuerfel, Sam Scaccia. Engineers: C.F. Murphy Associates. Structural subcontractor: Modular Technology Corp. Contractor: Schumacher Construction.



RUST-OLEUM HEADQUARTERS VERNON HILLS, ILLINOIS

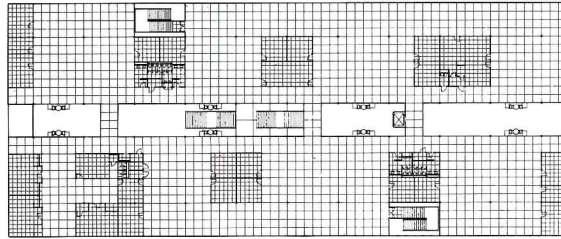

THIRD FLOOR

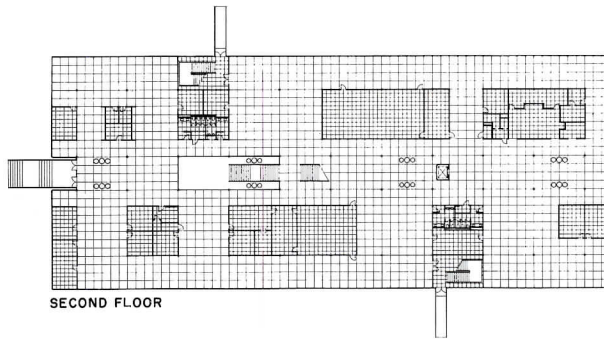

SECOND FLOOR

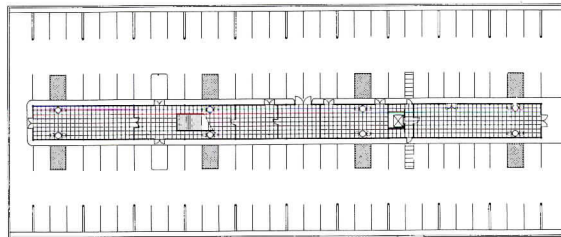

FIRST FLOOR

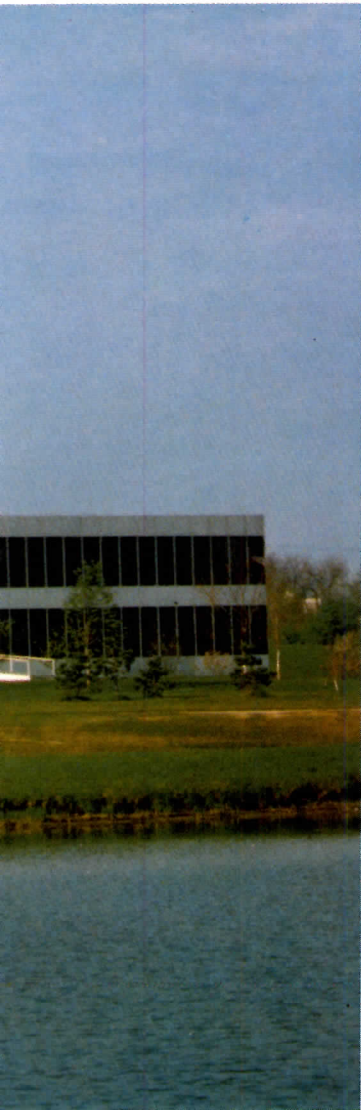
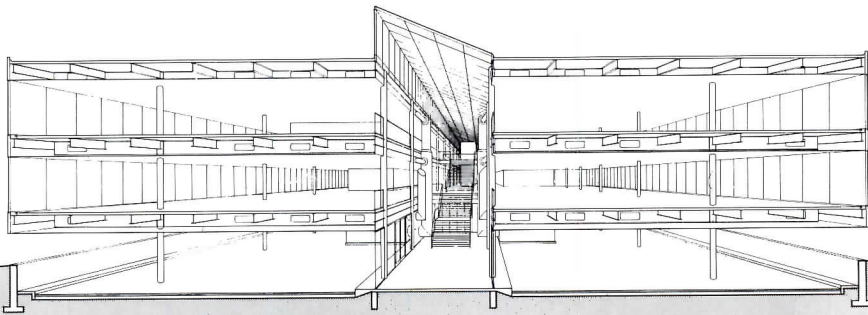

This bright, white, floating box, with 90,000 square feet of office space, is situated on a two-block suburban site. The idea was to save as much of the site as possible for landscaping instead of parking lots, and accordingly the two office floors are raised up, with most of the parking (for 110 cars) slid beneath. The people who work here enter from this depressed area, making their way upward into an environment that is *not* depressing in any way, shape, or fashion.

What one is enticed into is the central, soaring, skylit spine of the place, around which everything else is organized with the utmost efficiency, openness, and (part of the excitement) comprehensibility.

The spine is 20 feet wide, rising the full three levels to the skylight, which runs the full length of the building at a brisk clip. This arrangement, besides bathing everything in light, divides the offices into four modular areas (two to each side of the spine), and these areas can be easily parceled out.

The impetus to move around in here is irresistible. Stairs rise up through the spine, giving onto each level as they go, and bridges interweave the office areas on either side of the spine. So there is this interplay of verticals, diagonals, and horizontals that is almost as colorful as the mechanical runs, which are visibly interwoven with the composition. These runs, which are so thoughtfully designed and linked up as to qualify as sculpture, are painted brightly, and this relates to the fact that the owners have been in the paint business for some time.

The reason the box seems to float, apart from its being elevated over all those cars, is that the structure is cantilevered 20 feet out in both directions, which not only gives more parking below but also gives the larger column-free office areas that were needed up above. This lightness and lift is further accentuated by the forthright steel structure, set up on bays of 30 by 40 feet, which carry alternating horizontal bands of glass and white enameled panels of aluminum. Furthermore, the stairs and ramps that tie the building to the ground outside are minimal elements, spare in design—rather like vines seeking walls to climb. So the building, from all around the site, gives the impression of pondering its next move. And from any point inside the building, the outside is genial company, even to the point of the landscape flowing through the doors in the form of vast green carpets.

The Rust-Oleum job deals with the designers' fixity on circulation, movement, and the character of natural light—and these have been orchestrated here for formal order, and for really rather wonderful sensory effects, including during the nighttime. If this light-stepping environment *is* pondering a next move, the suburbs of America might do well to tag along.

RUST-OLEUM HEADQUARTERS, Vernon Hills, Illinois. Architects: *C. F. Murphy Associates—Helmut Jahn, David Hovey, Dennis Recek*. Engineers: *C. F. Murphy Associates*. Contractor: *George Sollitt Construction Company*.

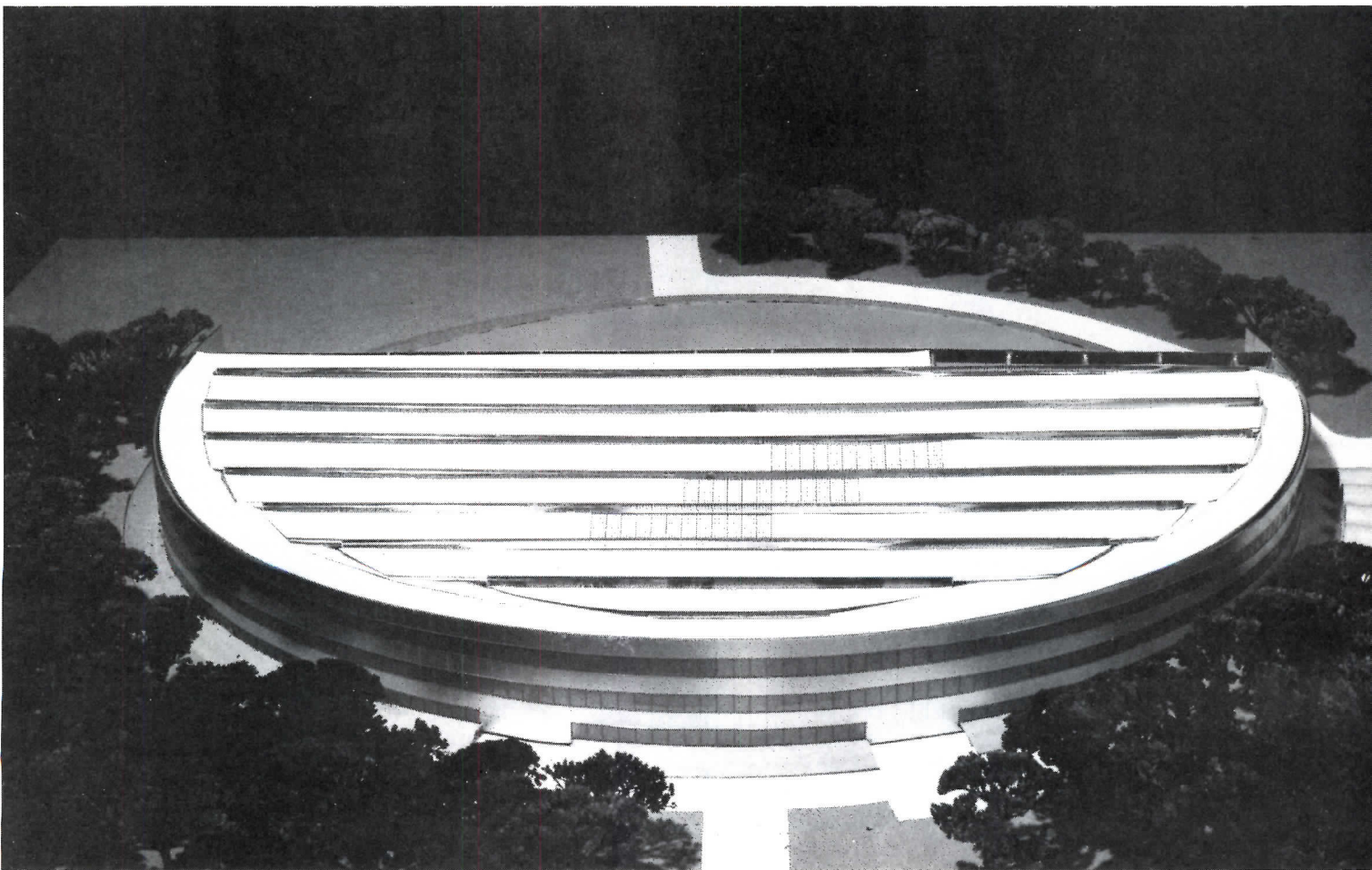
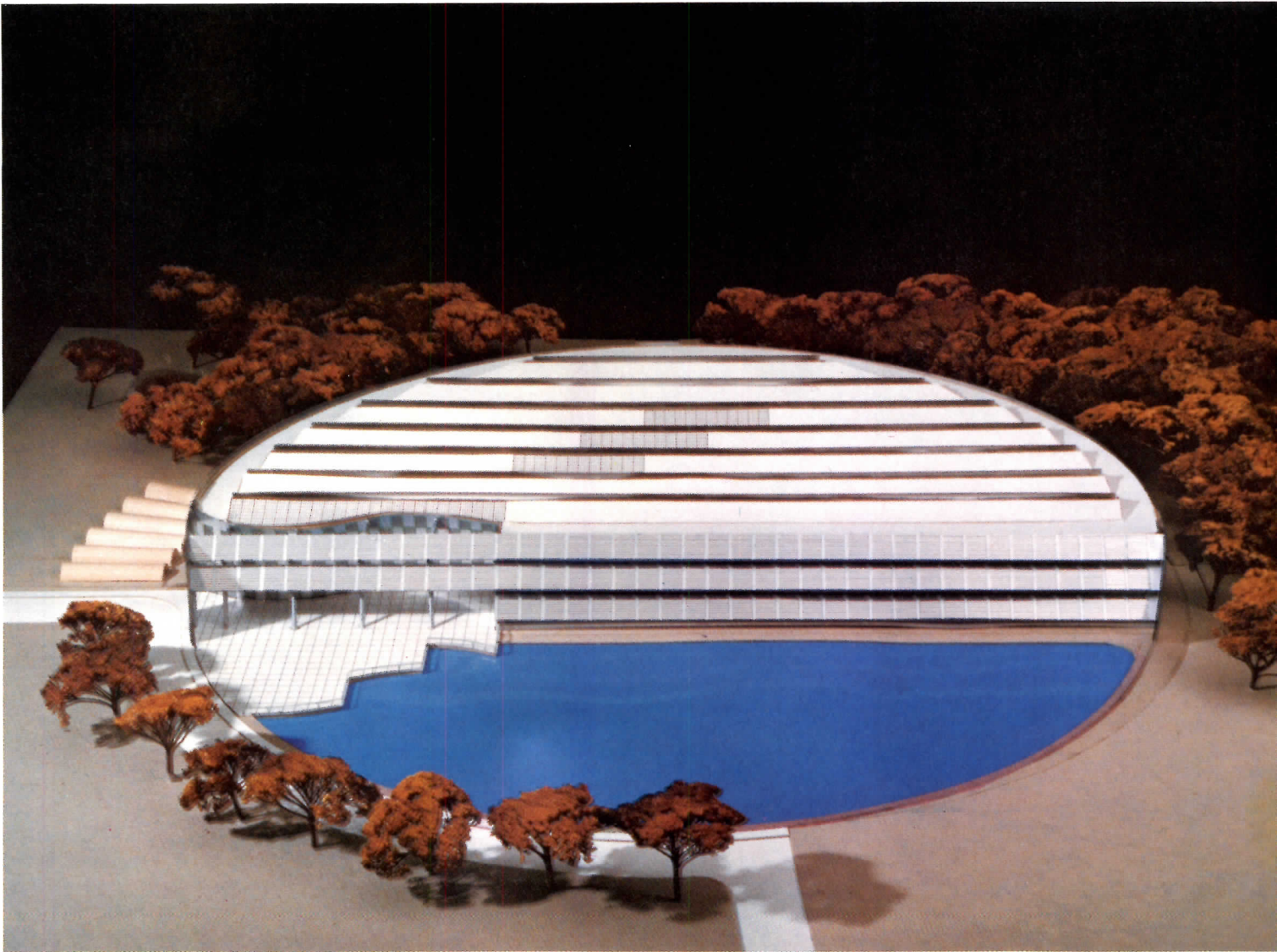

DEPARTMENT OF ENERGY, PROGRAM SUPPORT FACILITY, ARGONNE NATIONAL LABORATORIES

That energy conservation, as a design inspiration, can generate imaginative architecture is demonstrated by this "pilot" for investigating the esthetic and technical implications of solar systems.

The building is situated at the east end of Argonne's "Inner Circle," where some of the best brains in the country look into the protocol of protons and things like that. The round shape, it is explained, was generated by the "Inner Circle's" road network, though on a symbolic level it obviously works too.

Furthermore, the site, which is nondirectional, and thereby not forcing a more conventional geometry, suggested this configuration, as did clumps of nice-looking trees which, left alone, add the texture and color of nature to the circumference of the building.

A segment of the circle, which has the advantage of enclosing a maximum amount of space with minimal material means, has been removed here—or, to be a little more precise, it has been filled with a cooling pond. Rising up and stepping back from this southerly orientation are the solar collectors—three banks of them, in long blade-like shapes, that also work to shade the glazed areas of the offices inside. This disposition of the collectors is repeated by the pleated roof.

The rest of the building contained in the circle runs around to the west, north, and east, minimizing the western run, which was a critical matter in determining peak air-conditioning loads. The inward sloping glass on this westerly side is designed so that it is shaded when the sunshine angles above 70 degrees—that is, when it's hot.

The concept of the interior spaces, laid out along the familiar lines of "open-office landscaping," revolves around the notion of making maximum use of natural light. In fact, 65 per cent of the place will be lit this way. The light will be intensified around the perimeter by a reflective surface that will catch the light, soften it, and throw sufficient amounts of it into the spaces. In the innermost zones of the top floor, skylights are positioned above a three-story-high atrium, and this combination of features will throw light deep down this well, opening such areas up and dappling them with patterns of light.

To the extent that there is artificial lighting, it is a task-tailored, ambient installation, and coordinated with both the natural lighting and the air-distribution system, it will mean using only a half to one-and-a-half watts per square foot, as conditions vary. And the over-all energy consumption is geared to be only 43,000 Btus/per square foot, per year. The inextricable (and elegant) relationship achieved here between structure, enclosure, skylights, and services is extraordinary.

PROGRAM SUPPORT FACILITY, DEPARTMENT OF ENERGY, ARGONNE NATIONAL LABORATORIES. Architects: *C. F. Murphy Associates—Helmut Jahn, James Goettsch*. Engineers: *C. F. Murphy Associates* (structural, electrical); *Bridgers & Paxton* (mechanical). Consultants: *Shiner & Associates* (acoustical); *Slyvan R. Shemitz & Associates* (lighting).

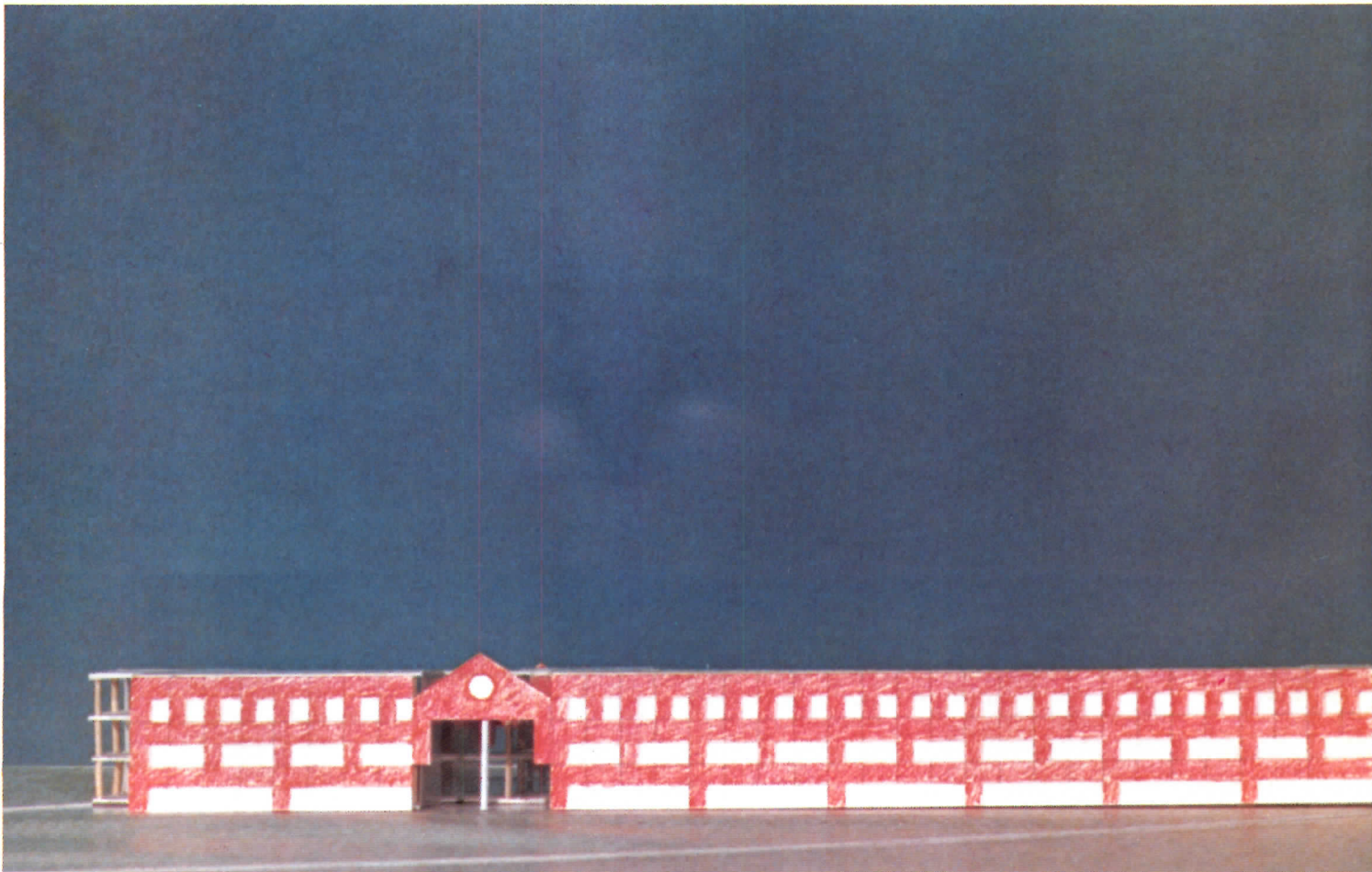
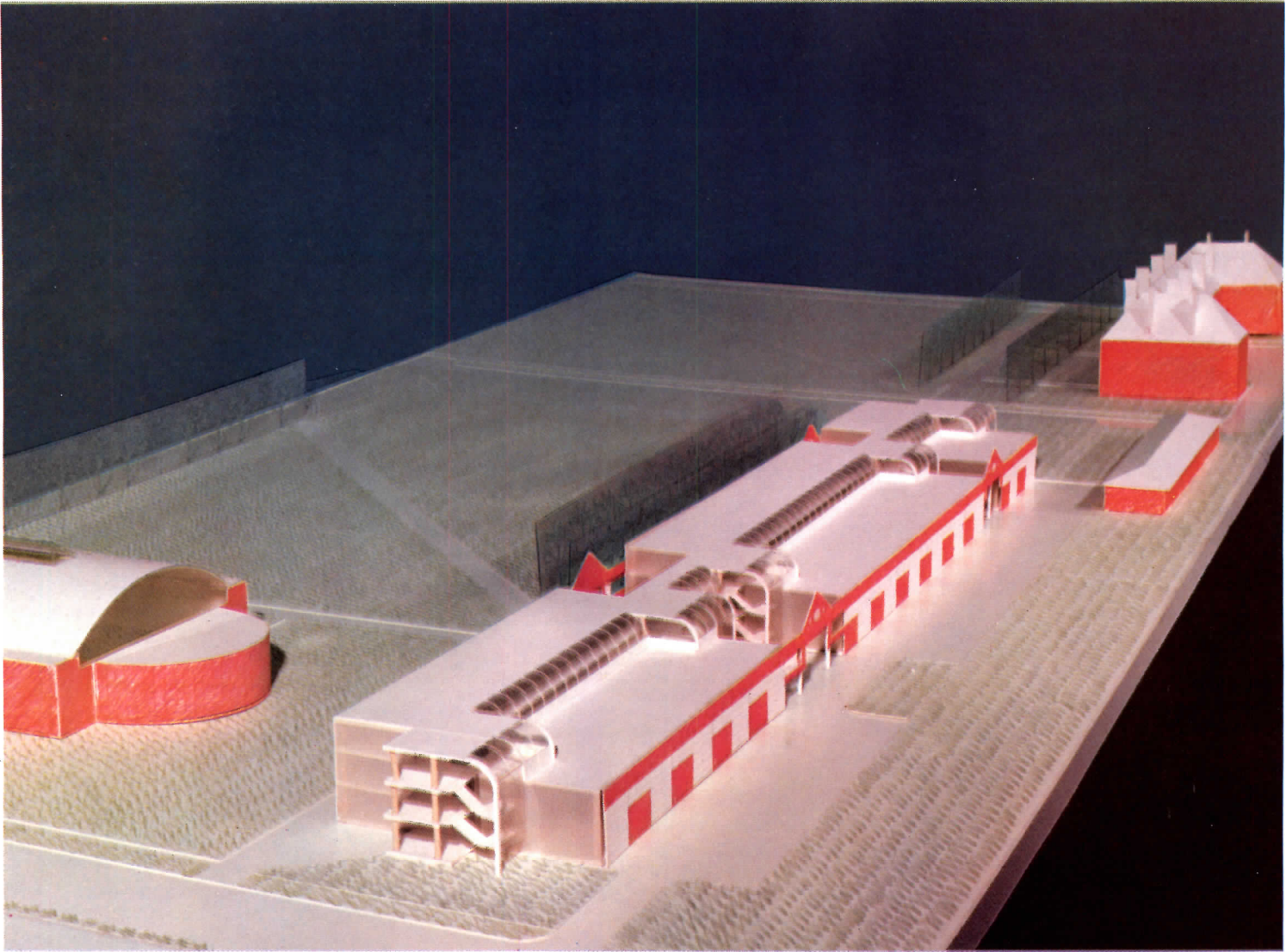

AGRICULTURAL ENGINEERING BUILDING UNIVERSITY OF ILLINOIS, URBANA

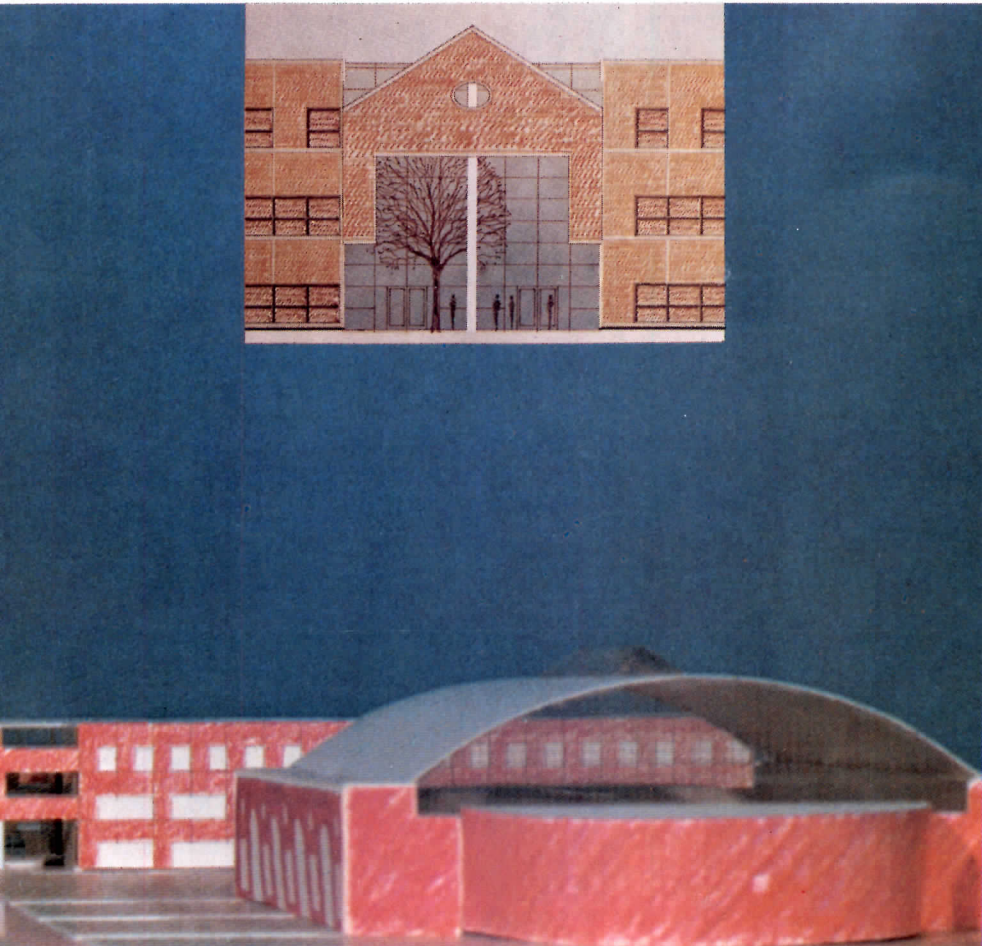
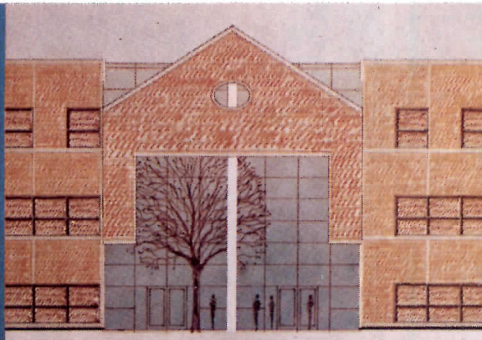
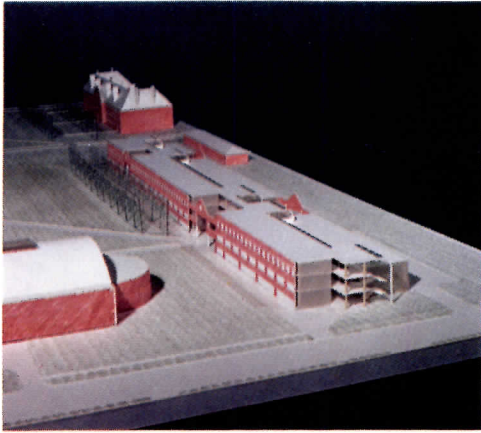

Meandering toward metaphor is this post-Georgian parable about relating new buildings to old buildings (the ones here are just *neo*-Georgian, but handsome) through the color of materials, continuity of scale, and a facade that alludes, in a more or less abstract fashion, to "the style" itself. This allows people, in the architect's words, "to see one building in terms of another."

The site is located in the south quadrangle of the campus, which is just starting to be developed, and this building—containing the complex, autonomous departments of forestry, agricultural engineering, and food science—is the first step.

Being very limited, and surrounded by assorted buildings, the site demanded a linear solution, which will make an edge on the east side of the quadrangle, giving way only where the building bridges a major campus pedestrianway. The rhythm of the facade, which is punched out intermittently, the choice of the masonry, the white trim, and the pediments—all combine to recall the old neighbors, clothing the technical goings-on with utility bricks, measuring four-by-four-by-eight inches, which are tied back into metal studs.

Inside is another building (and spirit) altogether. The large shops, requiring high clearances, occupy single-level two-story-high spaces; the smaller labs, classrooms, and offices occupy the three-level zone. Running long, wide, and airily between these two sections is a spine, strung with colorful mechanical runs and covered with a long acrylic skylight that curves down from the roof of the three-level-high section, clamping onto the roof of the two-level-high one. This sunny "street" lets light into every space in the place since the walls of the interior corridors are of glass-block panels.

The end walls of the building, at either end of the "street," are of aluminum-framed opaque spandrel glass, backed with insulation over an eight-inch-thick wall of concrete blocks. A typical glazing unit in the higher section is composed of one pane of clear insulating glass and another pane of opaque insulated spandrel glass. As for the end walls, as seen in the context of the brickwork, their translucency expresses the open-endedness of the "street" experience and, implicitly, of the plan itself.

The variety of fenestration is clarifying. The spine manifests itself with the long curved skylight; the spaces in the three-level section look out through small punch-outs (for the offices), slightly larger ones (for the classrooms and labs), and more expensive combinations of clear and opaque lights (for the small shops). Entry zones on the west edge confide the interplay of the inner levels while bearing witness to Georgian, which is where we came in.

AGRICULTURAL ENGINEERING BUILDING, UNIVERSITY OF ILLINOIS, Urbana-Champaign. Architects: C. F. Murphy Associates—Helmut Jahn, Carter H. Manny, Jr., Scott Pratt. Engineers: C. F. Murphy Associates. consultant: Rolf Jensen & Associates (fire-protection engineering).

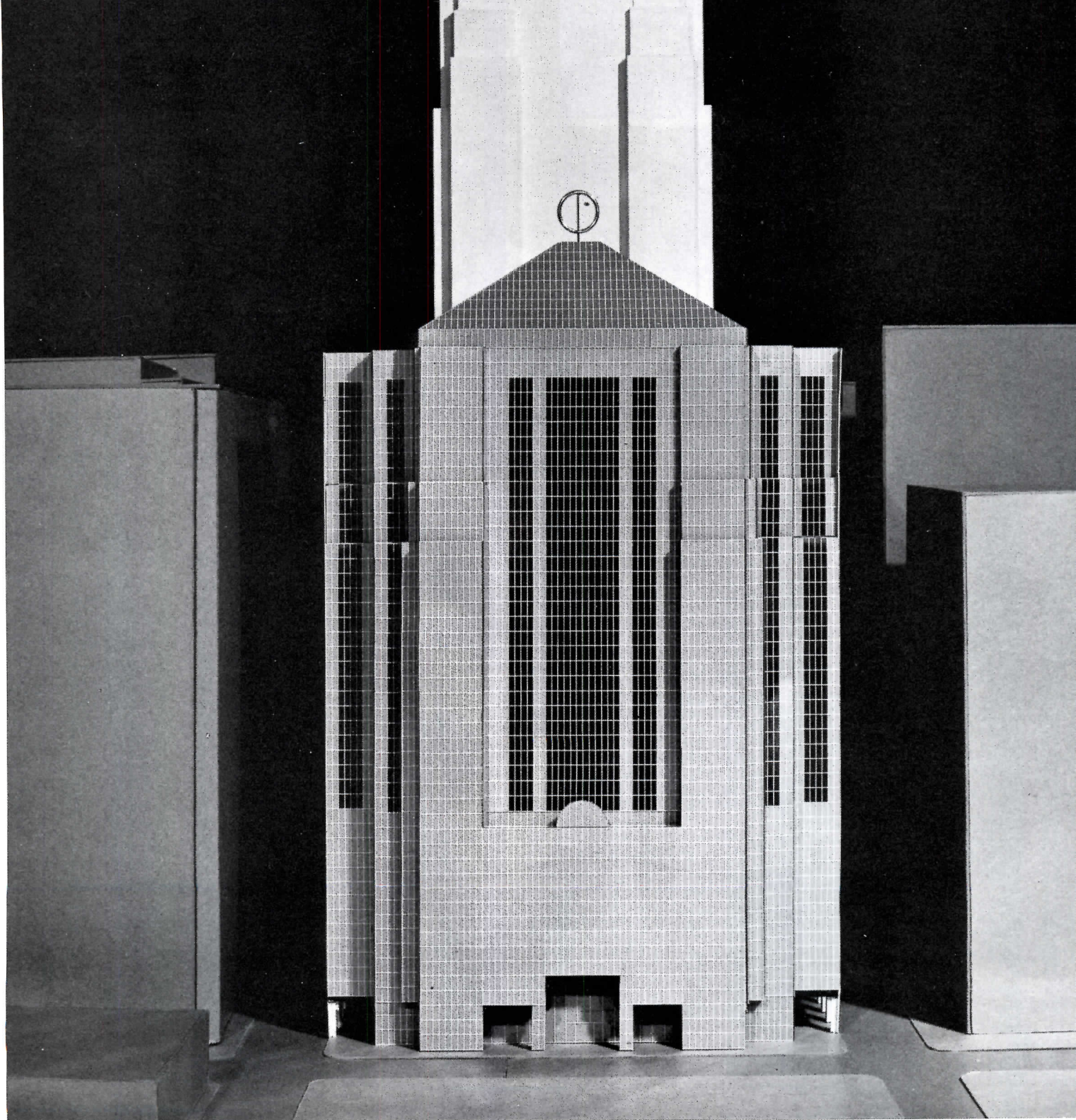

BOARD OF TRADE ADDITION CHICAGO, ILLINOIS

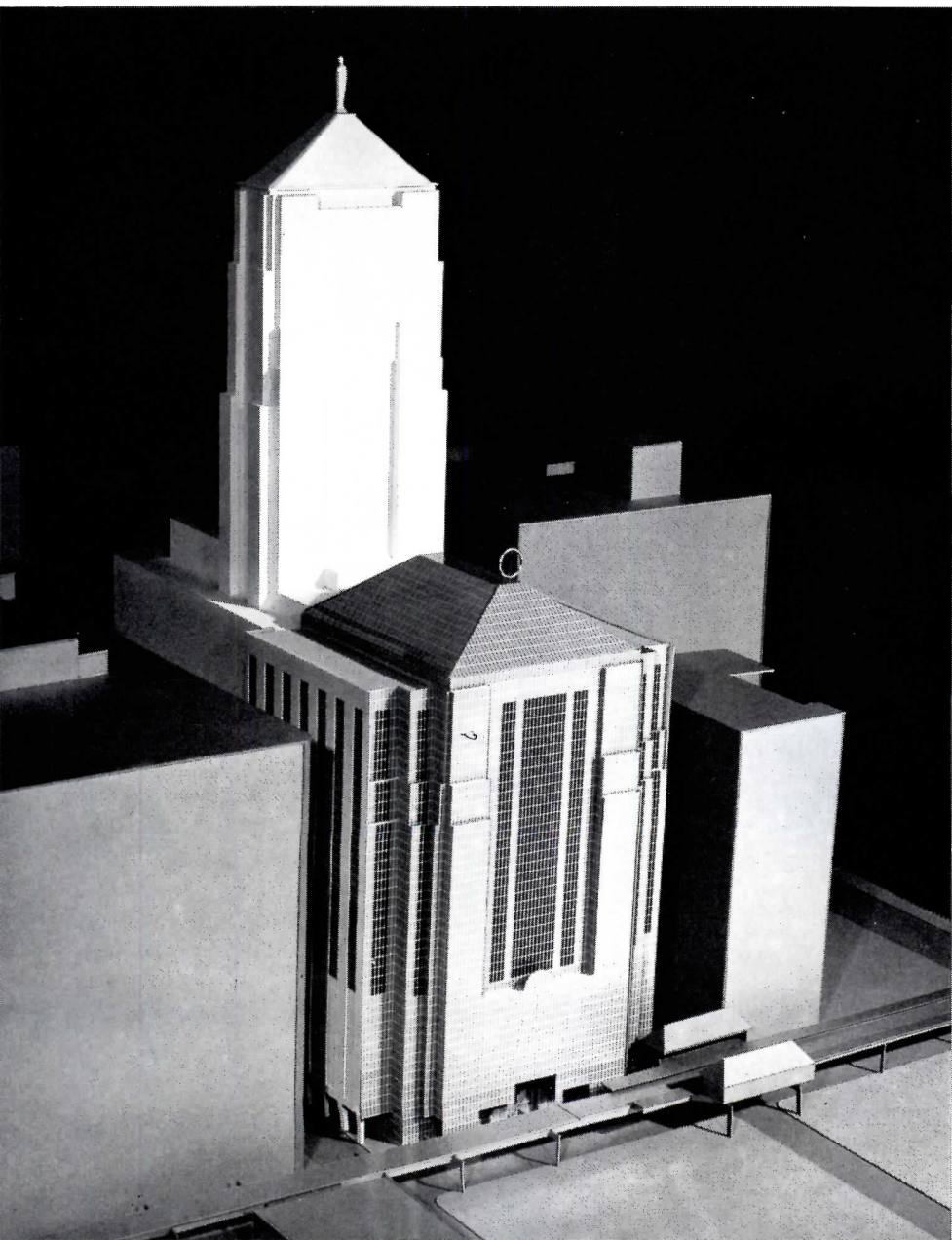
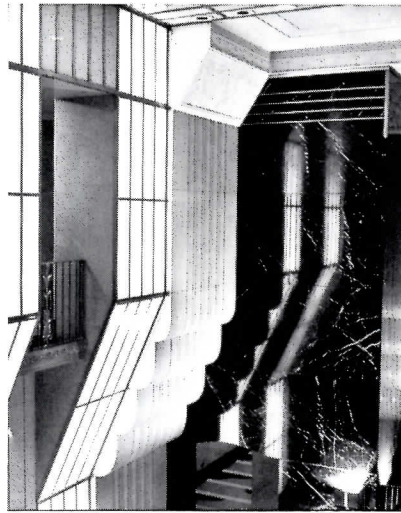
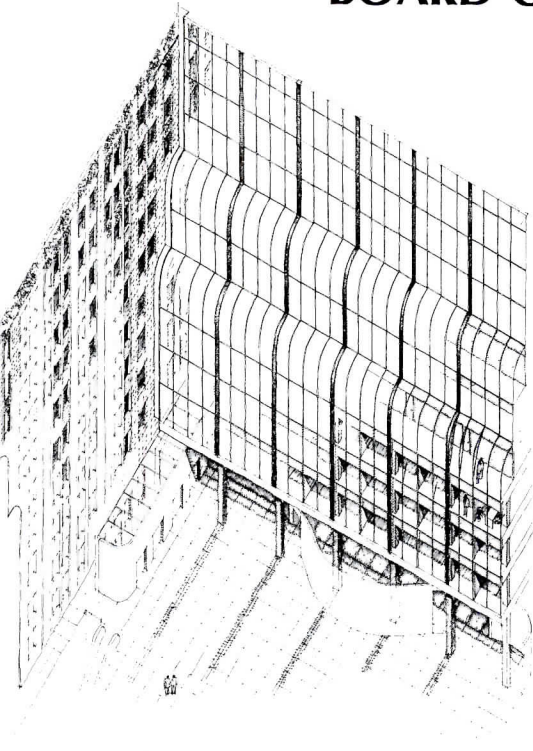

Considering that this 500,000-square-foot addition to the Chicago Board of Trade is for people who deal in "futures," it is as ironical as it is wonderfully thought out. The formal character is an abstraction of the towering Art Deco landmark at the foot of LaSalle Street (architecture's Dietrich), but this is not done by literally lifting features. Rather, the design shows how the relationship between old and new can, when manifested by current technology, achieve something quite different.

The massing recalls the tripartite elements of the original, but the distinguishing device in this design is that the highly articulated planes of the walls and roof are garbed in a tight-fitting glass dress. On both sides of the addition, this slips behind screen walls of limestone, which are notched out with emphatic vertical slits that recall, in turn, both the material and massing of the past. These screen walls, to the east and west, have the effect of "bracketing" the design within the streetscape, much as the tripartite symmetry of the Art Deco model did. Also, the new one tops off like the old one, although since its lighter metal-and-glass roof wouldn't look right with another statue of Ceres (she's up there on the old building), a simpler fillip is being devised.

The first 12 floors are to house large spaces for the trading floors and their many support functions, corresponding to similar spaces in the existing building. But above this, the new floors, assuming a U-shaped layout, will wrap around a soaring atrium adjoining the old floors. Glass elevators will glide up and down, providing a dramatic experience of the space and, since the old structure will show, the effect of being borne into the past is going to be enormous.

An especially important element in this design is its accommodation of a covered pedestrian arcade at the level of the street. This came about because the addition had to be extended 20 feet out beyond the existing building to provide trading floors of adequate size; in the bargain, down below, Chicago will get a building that really participates in the life of the sidewalk. These arcades, marching along the east and west side, will meet up, edging the south side as well, where the building adjoins a section of the famous elevated "L." From this arcade, a two-story mid-block "street" will connect with the old lobby, spurring retail.

Of the designs put forward in this period of "historical scholarship," this is, more than a tantalizing footnote, a work of great erudition.

ADDITION TO THE CHICAGO BOARD OF TRADE.
Architects: C. F. Murphy Associates, Shaw Swanke, Hayden & Connell, Joint-Venture Architects—Helmut Jahn, Rainer Schildknecht, Martin Wolfe (design); Carter H. Manny, Jr., Patrick Shaw, and Richard Hayden (administration). Engineers: C. F. Murphy Associates, Lev Zetlin Associates, Schacht, Johnson Associates (structural); C. F. Murphy Associates, Environmental Systems Design, Inc. (mechanical).

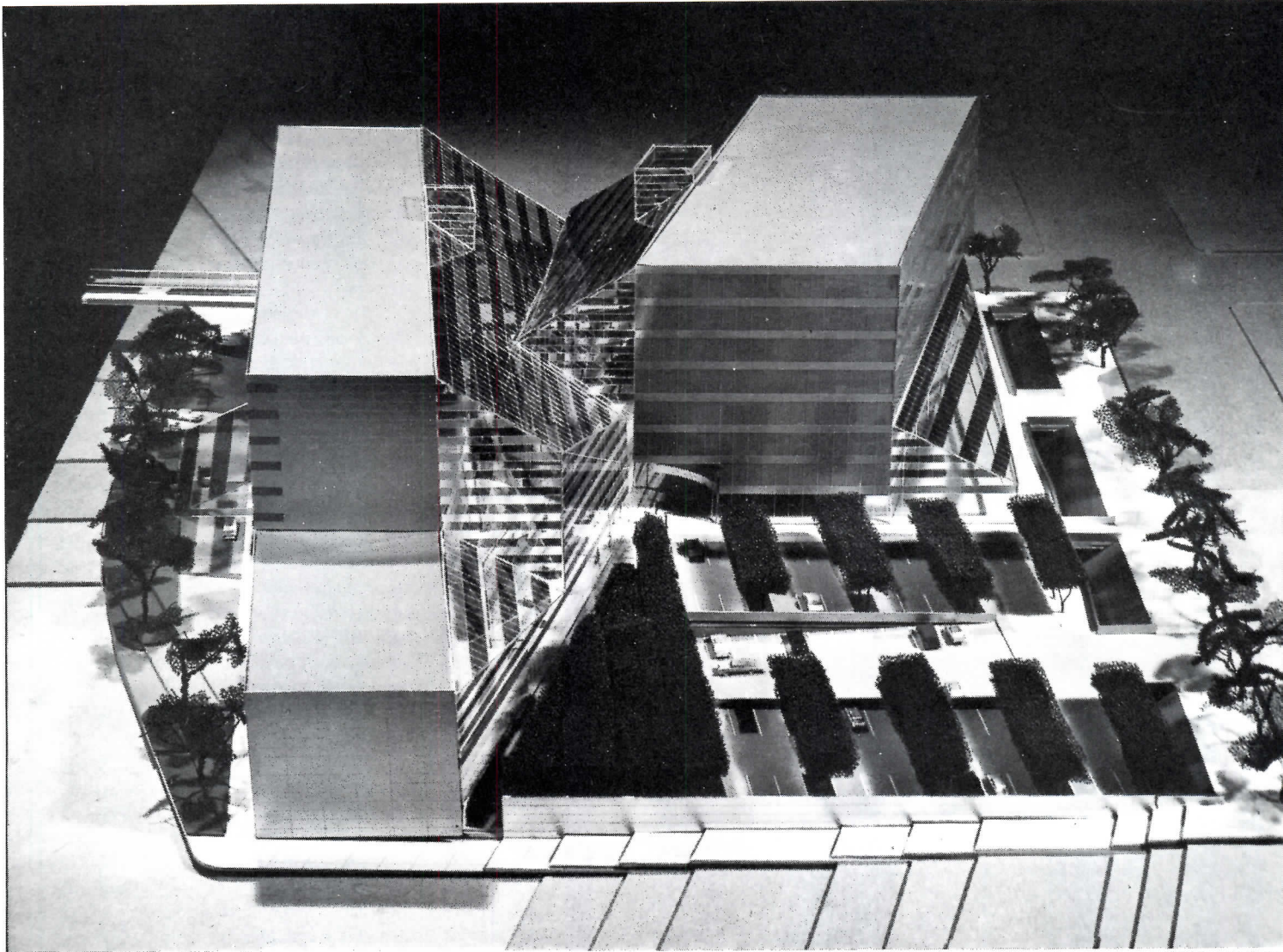

Keith Palmer photos

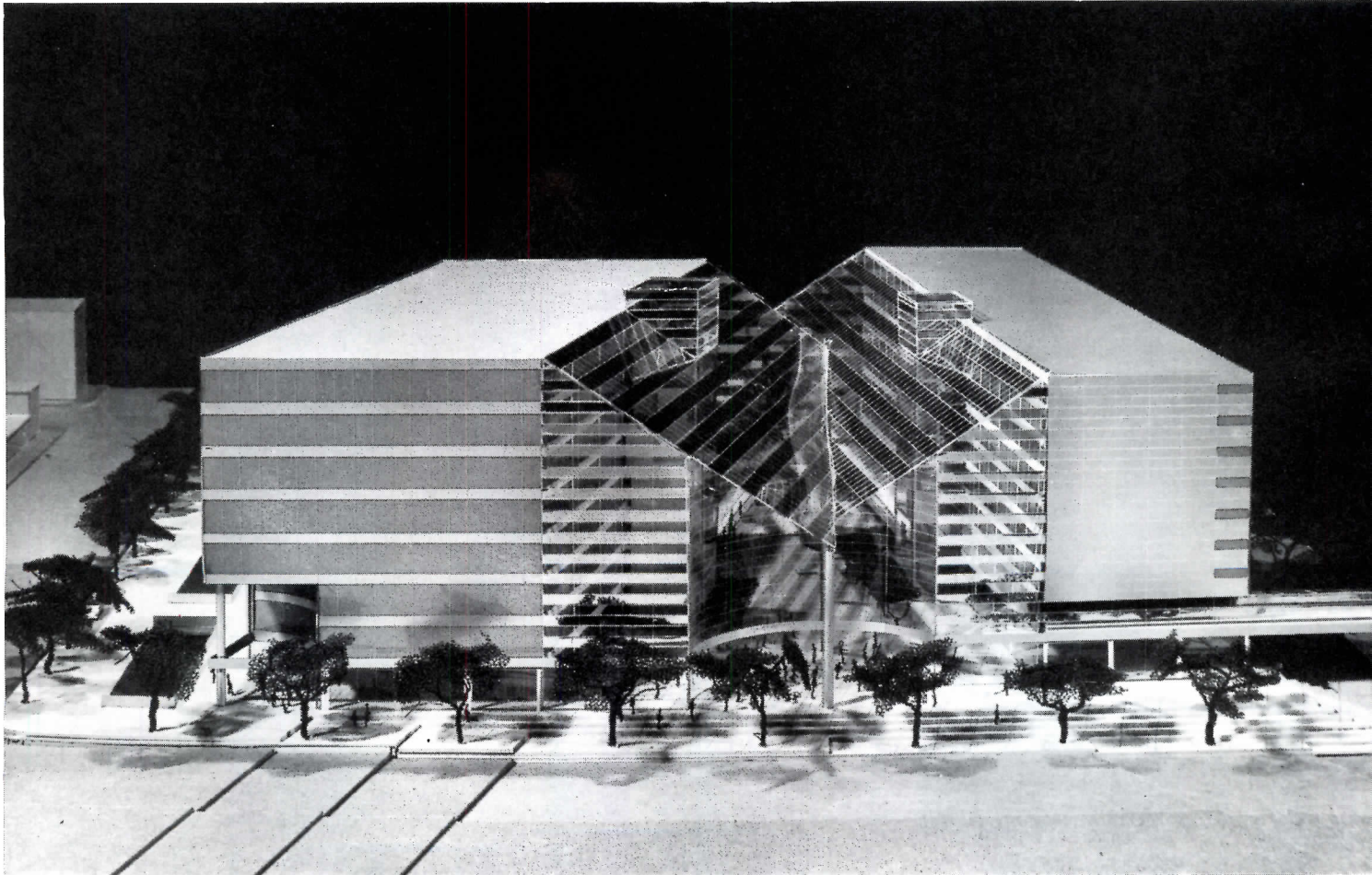

FIRST BANK CENTER SOUTH BEND, INDIANA

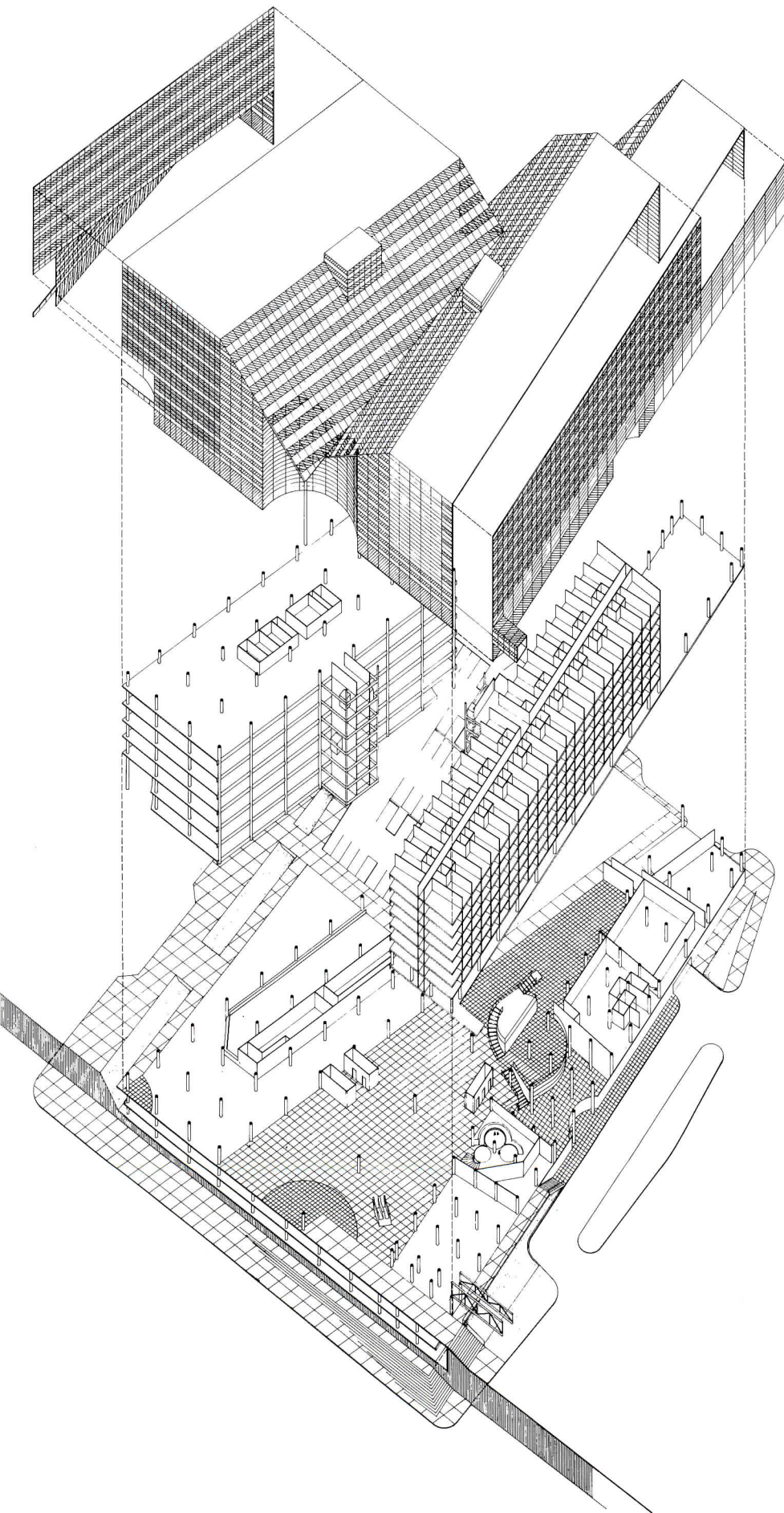

Geometrical permutations of the box, bringing the reductionist forms of "old modern" into tension and complication, is being explored in a number of new designs of the Murphy office. The fascination, even provocation, of reflectivity, of angled or curving surfaces, and of the slicing or layering of structural and spatial elements—all these emanate from the firm's design for the First Bank Center in South Bend, Indiana, which will occupy a whole city block. The Center is to include a 150,000-square-foot bank and office building, a 300-room hotel, a 25,000-square-foot retail and atrium area, and a 700-car parking garage.

To strengthen the existing land uses around the site, the First Bank will occupy the corner facing the central business district, while the hotel will be oriented toward another recent development called Century City, with an enclosed pedestrian bridge reaching over. The retail and atrium areas will be between the bank and the hotel, directly accessible from the street and assuming the role of a piazza.

The massing of the Center gives each building its own identity, and yet, because of the careful geometricizing, all of the buildings and spaces flow in and out of each other. The unifying element is the piazza, which is carried through the ground floors of the bank and hotel. This strategy relates the piazza to the pattern of the surrounding streets, sews a seam between the public and private territories, and gradually builds sensory force for the ultimate frolic of the big space. The entrances to all these functions are of a welcoming semicircular configuration, which becomes quite grand at the main street entrance to the piazza. Here the crisp roof planes of the hotel and bank, slicing boldly downward to make a kind of crystalline trough-shaped roof, slice *out* beyond the big semicircle, hovering above the sidewalk.

The entire composition is wrapped with a taut membrane, the horizontal banding of which accentuates the curves, slices and slants. The banding outside is of aluminum spandrel panels, over stud framing, with gray strips of glass running along the office and hotel facades. The walls of the piazza, on the other hand, are glazed with alternating bands of clear and silver reflecting glass.

The enclosed area is sheathed with a field-fabricated skin of clear anodized aluminum panels, three- by five feet—and with an interior wall board, over metal studs, with foam insulation. The studs will carry glass bands of varying depth—clear, gray, and silvery. So as assertive as the geometry is, this coloration, taken with the lively flow of activities and people, will have the effect of making the First Bank Center a unifying element of the city. That is not an abstract aim (and shouldn't be, anyplace); these permutations, skillfully spliced, are a semblance of city life itself. —William Marlin

FIRST BANK CENTER, South Bend, Indiana. Architects: C. F. Murphy Associates—Helmut Jahn, Scott Pratt. Engineers: C. F. Murphy Associates. Consultant: Lyle Yerges (acoustics).

right now out of Boulee and Chippendale, and he's doing another in Pittsburgh that's House-of-Parliament-Gothic. Then there's Robert Venturi. Three years before you left, he wrote this awful little book about complexity or something, and now *everybody* seems to have read it. Just before you left, there was that new dean at Yale, Charles Moore, and he's done a piazza in New Orleans with his own face on a wall, spouting water. That's why I really like Chicago. Buildings really mean something here. You can touch them. They're made out of something. There's not that funny "idea content" to deal with.

That's about all I guess. As for me . . . well, you always thought I was kind of silly. At least that much hasn't changed. —Stanley

Now that some time has passed, and some passions have ebbed, one so much shaped by Miesian thought as myself can think about Mies again without fear or favor.

We all know that the architectural wars that raged in the not so recent past were largely conducted by second-generation disciples in an attempt to end the architectural turmoil of the first half of this century. This attempt to produce an exclusive architecture was supported by criteria claiming to transcend esthetics, function, history, and symbol-making.

If the outcome of the issue had not been so tragic for so many, its assumptions could on one hand have been enlightening and its fervor could on the other hand have been fructifying. The reality is, of course, that an insistence on one true way in an enterprise as fluid as architecture often crippled the highest speculative abilities.

Once embarked on that moral path, iconic notations began to stand for iconic objects which in themselves stood for an uncritical acceptance of a positivistic progressive ideology—in short it was not possible for some time to really *look* at a Mies building and really *see* it. The buildings shimmered and dissolved in the haze of the abstract moral principles in which they stood.

What a tragedy that has been for Mies and his work. As one once again really looks at the buildings, one sees not a transcendental becoming but rather a sturdy materiality. One sees the poetry of the object and the loving, sensuous, material hand.

The basis of this *material* architecture lay in a disquieting, isolation, of part from part and whole from other wholes. Such isolation makes imaginable an iconic nature of an object and tends to foster the illusion of the dissolution of mere materiality, sensuous and impure, into the presumed distillation of an "ideal" essence. Why so isolated and alone—so purified of context—if not to create a gulf between the object and everything else, between before and after? The paradox, of course, is that the object or artifact must in the most *real* way be beautifully conceived and executed. One must dwell on the perfection of detail, sheen of finish, craft of fabrication, and material quality to tolerate looking at only the isolated object—the zen effect. Thus then a lesson—perhaps not intended as primary—in the separation, isolation, and perfection of parts. A lesson in *quality* was offered.

The isolation and consequent iconic density of Mies' buildings leads one to understand his inevitable move away from section, frontality, and horizontal extension back to an interest in classical volumetric formation—taut volumes eschewing section. Mies tried to soften the product of ideology and satisfy the pictorial or romantic

drive by relieving the naked pressure of the purist object, thinking of it in a world of *perspective* drawings, where buildings play peek-a-boo in mantels of lacey foliage.

Thinking about Mies forces one to think about ideological systems of esthetics and their products, about how the *work* of the most material of architects fell victim to an appeal that was not fundamentally social or esthetic, nor finally economic or symbolic, but ultimately theological. A set of moral operations supplanted the more nearly real operations involved in choice-making for Mies's followers. This created a fortress "modern" situation not easily penetrated by rational counter-argument, thus affecting the way Mies's work has been perceived. —James Ingo Freed

In 1938 when Mies arrived at Armour Tech, the architecture school was in a garret of the Art Institute. He was comparatively unknown and there had been little building in Chicago since the crash of '29. This hiatus gave him time to concentrate on education and there were daily faculty meetings over coffee in a restaurant across the avenue. Mies believed that students needed a clear, unified philosophy and a year-by-year program to implement it. He would not ask nor allow students to design beyond their understanding. We were to learn "what is possible in construction, what is necessary for use, and what is significant as art," and in that order. Here was the old prescription

for "firmness, commodity, and delight," restated in plain words for our time. "Significant as art" sounded a bit heavier than "delight"; I'm sure he meant it to be. About art he was always serious.

When we students visited Taliesin in Wisconsin in 1940, Frank Lloyd Wright said to us, "You are fortunate to be studying with Mies. He's the most honest of the lot that came over here."

In the early fifties his office was a two-room suite on the third floor in an old building in the Loop. The smaller room was Mies's retreat and the larger contained everything else: carpentry shop, secretary's desk, and six drafting tables. He didn't mind that visitors had to make their way past the buzz saw and between tables to reach his office. "They should know how we work."

In the office Mies concentrated intently on the work at hand, but we often went to lunch across the street in the grill at Carson's, and there the conversation covered all the controversies. One day someone put the question to him directly: "What if all the architects agreed on the same principles?" Mies recalled the old half-timbered towns of Europe. "In those days everyone tried to do the same thing and it all came out different. Now everybody tries to be different and it all comes out the same—unless you call *that* different," and he gestured toward the surrounding buildings.

On field trips to the Farnsworth house, lunch was a picnic under the great maple that stood between the glass pavilion and the river bank. The wonder of that house was how it hung in the air and responded to nature. From inside you could watch the four seasons displayed on its walls, the more striking because they were framed in crisp steel.

One day after the structure had its final coat of white, we were sitting in the picnic spot when Mies noticed that the sun had cast a shadow frieze of maple leaves along the fascia. "There's your ornament!" he said. He was not speaking only to us.

—R. Ogden Hannaford

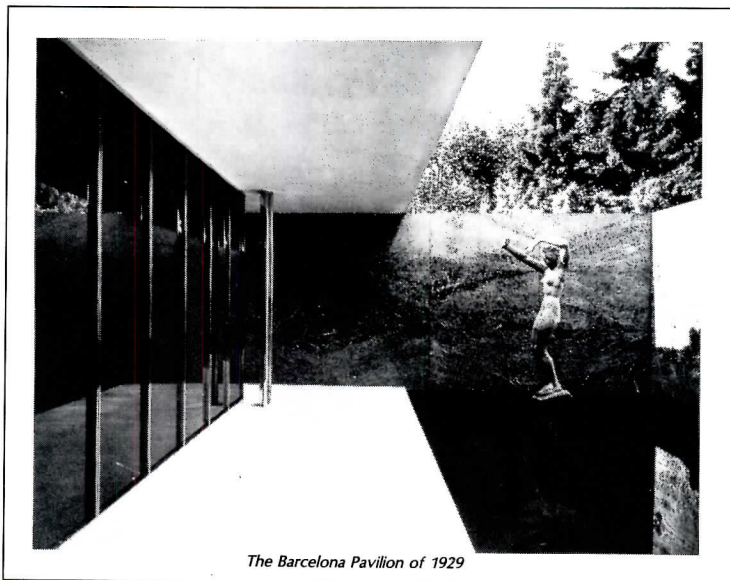

The Barcelona Pavilion of 1929

Two differing and remarkable
new projects by Herbert Newman
Associates for the old interiors of...



THE YALE LAW SCHOOL LIBRARY AND LECTURE HALL

Architects Herbert Newman Associates were chosen by their clients from the Yale Law School because of their previous sensitivity in renovating the dormitories of Yale's Old Campus (see RECORD, March 1977, pages 93-100). And sensitivity was clearly a primary component of the success of these two similar-but-different remodelings within the venerable Law School building—especially if the original elegance was to be reasserted. When the school first occupied the buildings in 1932, there were only 330 students. And, as Associate Dean Arthur Charpentier states, it was a time of different fashions, technologies and—perhaps most important—different lifestyles. In the library, students were expected to sit in quiet rows at communal tables, and to take noisier pursuits and lounging postures back to nearby dormitory rooms.

Today, there are almost twice the number of students, and two thirds of this unanticipated throng live off campus—some at considerable distances. Before the remodelings, the lecture hall was arranged in "old-style authoritarian"—with tables rigidly facing a speaker at the distant narrow end of the room. The library furnishings had grown shabby, and there was noise and confusion from such unforeseen electronic equipment as duplicators and microphotographic machines.

In not so distant times, such obviously inadequate facilities might have called for a new building, but—as more and more often seems appropriate in these times—the faculty and the alumni settled on the course of renovation of their memorable spaces. And accordingly, Herbert Newman Associates have given them what might have been thought to be the impossible: facilities within the old visual and spatial confines that meet today's greatly changed and expanded needs. —C.K.H.



Robert Perron photos



LAW SCHOOL LIBRARY

It has been since its opening in 1932 one of the more elegant and opulent spaces at the University—despite an incrustation of makeshift equipment and lighting (photo below). It was clearly a space worthy of preservation. Accordingly, Herbert Newman Associates' approach to meeting the demands of many new uses was to actually restore the shell of the space with its rich detailing; while shifting the congesting and inappropriate equipment (such as photocopying and microphotographic machines) into adjacent spaces. Also out of the room went the long reading tables (except for one in each of the two seating groups at the far ends). In

their place came a combination of task-ambient-lit oak carrels and comfortable chairs for reading—while lounging per se was relegated to a niche beside the main desk (photo above) that once held the card catalogs. The card catalogs were relocated to the center of the room for easier visibility and access. Another major visual change was Sylvan Shemitz Associates' combination of up- and down-lighting that replaces the hanging fixtures, which obscured the grandeur of the room. This design radically changes the character of the room at night (see photo).

In the early design stages, the architects displayed a model of the room and a mock-up study carrel for suggestions, and some of the student comments were incorporated in the final plans. The work had to be compressed into a period between the beginning of June and the following Labor Day—a tough schedule that was met (despite a maintenance employees' strike) by prefabrication of the various elements. The room has been so successful that the librarians are constantly having to discourage use by students from outside the Law School, and Dean Charpentier refers to this circumstance as "an odd by-product of success." This appropriately modest reorganization and renovation can be contrasted with a necessarily far more radical approach on the following page.

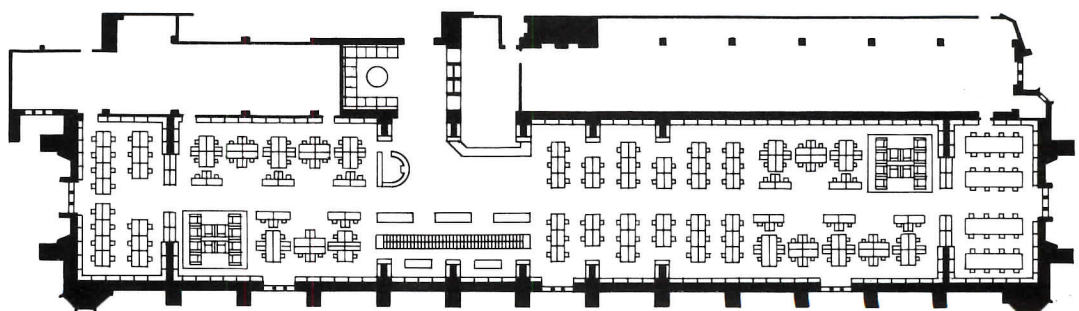
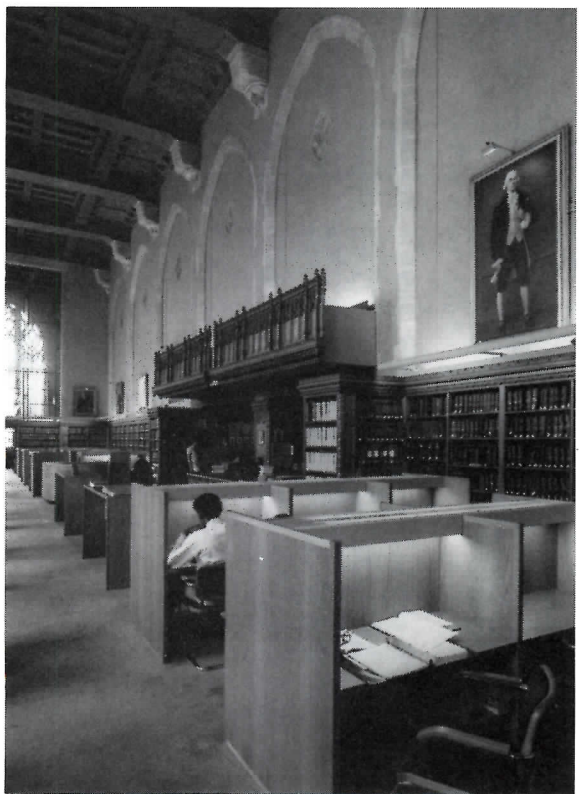
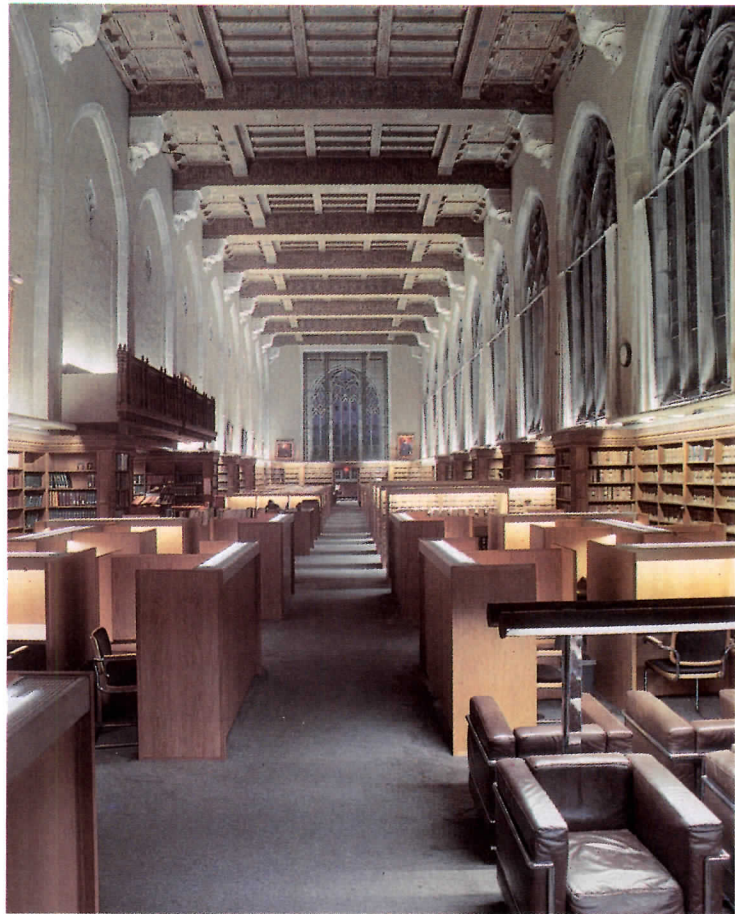



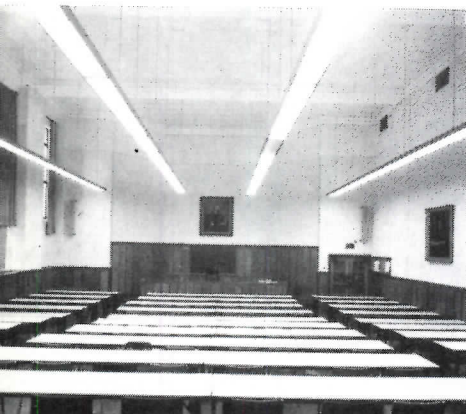
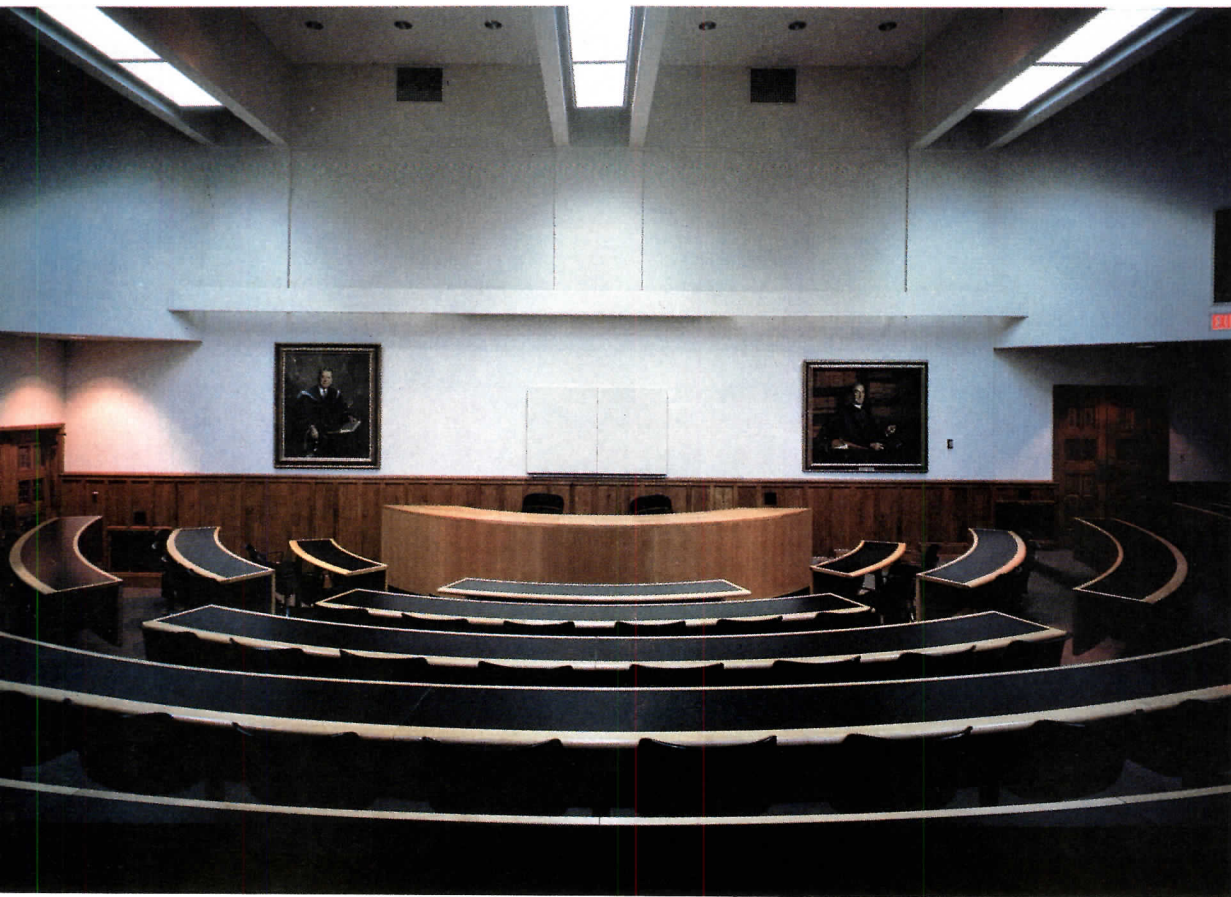

THE LECTURE HALL

This room underwent a complete reorientation—to place the speaker (and new audio-visual aids) in the center of the long wall, and hence to improve both the visual and acoustical relationships of speaker to students. Seating was placed on new stepped and curved platforms to further improve the relationships. While as many elements of the old room (left) as possible were kept (such as the handsome oak wainscoting and doors), new elements were added—such as the dropped beams

that conceal lighting and the handsome new furnishings.

THE YALE UNIVERSITY LIBRARY AND LECTURE HALL, New Haven, Connecticut. Architects: *Herbert S. Newman Associates*—partner-in-charge: *Herbert Newman*; project architect: *Glenn H. Gregg*. Engineers: *John C. Martin* (structural); *Yale Engineering Services* (electrical). Consultants: *Sylvan R. Shemitz Associates* (lighting in library); *Donald Bliss* (lighting in lecture hall). Contractors: *E+P Construction Company* (library); *Megin Construction Company* (lecture hall).



Proposal for Union Station, Washington, D.C.,
 Moore, Owings & Merrill—Washington office

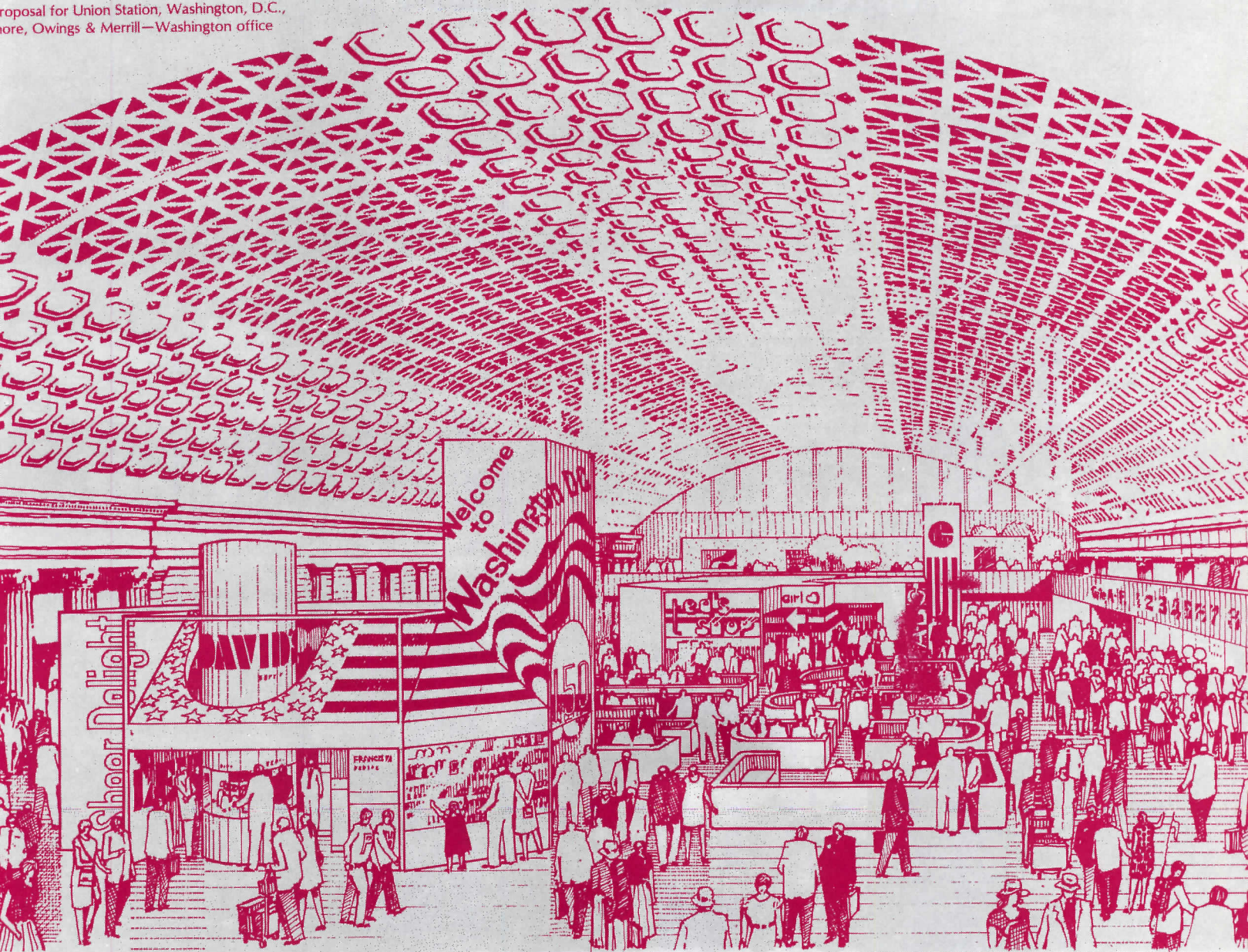

MASS TRANSIT

A LOOK AT TREND-SETTING DESIGNS THAT KEEP US MOVING

Motion...man is constantly in motion. Our life in the 20th century has been increasingly dominated by machines to help us move farther and faster. We have demonstrated our industrial inventiveness in the design of buses, trains, airplanes and myriad numbers of variations-on-the-theme, but one piece of inventiveness, the automobile—our “motorized mistress,” as Lewis Mumford wrote in 1958 in *RECORD*—has been the prime factor in the demise of mass transportation systems. Now, with renewed focus provided by the energy crunch, we are finding new opportunities and strong public support for funding mass transportation. Our growing energy problem has clearly thrust us into a new decade of searching for ways to keep us moving, directing us toward Edmund Bacon’s vision of a “post-petroleum city.” Architects and engineers are valuable team leaders in this new thrust, and this Building Types Study is intended to give an overview of their work in major cities across the country and to highlight exceptional design work in the chief categories of local and regional mass transit. —Janet Nairn

TRANSIT WORK AROUND THE COUNTRY

15 large metropolitan cities are singled out for their vigorous work in transit facilities

New York City: The largest city in the country has one of the oldest operating mass transit systems, and despite the general state of disrepair throughout, it is the most efficient way of moving around town. Most transit-directed funds are now used to maintain the roadbeds and keep the trains operating. But the system would get a shot in the arm if a plan proposed in May by Governor Hugh Carey is approved. He proposed to spend \$797 million to upgrade the city's subways and improve commuter and freight rail lines around the state. Under the plan, called the Railroad Energy Conservation Package, New York City would get \$325.5 million for subway improvement. A total of \$263 million would go for railroad improvements on Long Island and in the lower Hudson Valley, and \$208.5 million would be spent upstate.

Atlanta: The most recent mass transit system in the United States to open is the Metropolitan Atlanta Rapid Transit System (MARTA). It was developed on a most frugal, cost-conscious basis, in which stations might even look a bit sparse, yet the designers tried to solve problems that the system's recent predecessors—BART in San Francisco and METRO in Washington, D.C.—had either failed to solve or had developed once in operation. The general concept was that stations would be individually designed by a team of architect and engineer, like BART. At the heart of the system (comparable to the Metro Center station in Washington, D.C.) is the Five Points Station (see photos this page). The prime A-E firms of Finch, Alexander, Barnes, Rothschild and Paschal, Inc., and Heery & Heery, Inc., designed this station four stories deep, located on a 3.5-acre tract in the central business district. Unlike the other stations in the system, it is a combination of both side and center platforms. An open core, topped by a large circular skylight, has pedestrian bridges as

the only horizontal walkways. These permit views up, down and around the space, which is filled with moving people and trains.

Initially, 17 stations are being designed to serve 13.7 miles of rail system, at a total cost of an \$800-million Federal commitment for this construction—the first "full funding" commitment made by the Urban Mass Transit Administration (UMTA), a program that has since become a prototype for all major urban mass transportation investments. When completed, the system will encompass 24 stations covering 53 miles.

In 1977, MARTA and UMTA entered into a management experiment designed to streamline

working relationships between the two agencies. Under the "full funding" concept, a fixed dollar limit on Federal funds was set, thus providing MARTA latitude in management control of construction programs without continuous UMTA involvement or review. Joint quarterly reviews are held, reducing UMTA's administrative review and approval of individual grant actions.

MARTA also operates an interlinking bus system, which was named the safest bus system in North America by the American Public Transit Association in early 1979. Articulated buses were bought by Atlanta as part of a consortium of 11 U.S. cities (see explanatory story on page 119) and began service in April.

Seattle: This city has one of the most diverse assortments of transit in the country. Ferry boats operate throughout Puget Sound, and the bus system is being expanded outward encompassing a wider range of suburbs. Articulated buses have been bought and will go into operation soon. In addition, hydrofoils, developed by Boeing Marine Sys-



Hydrofoil by Boeing Marine Systems, Seattle

tems, have been demonstrated in the Sound, even though at present not selected for service.

As one of the newest advances in marine travel, the hydrofoils are a spin-off of the aerospace industry. This vessel combines the best features of the airplane and ship to give passenger comfort at high speeds. One design has fully submerged, computer-controlled steel foils attached to an all-aluminum hull, powered by two waterjets, each driven by a gas turbine. The hydrofoil is capable of cruising at speeds from 42 to 45 knots and is claimed to have a high degree of maneuverability. This is the new generation in waterborne transportation, and is now being used in Venezuela, Hong Kong and Japan and on several European routes.

Denver: An existing park-and-ride bus system that attempts to draw people out of their cars and onto mass transit is now being expanded, with corridors culminating at two yet-to-be-designed terminuses in the heart of downtown Denver. The terminals will anchor a 12-block-long transitway/mall, designed by I.M. Pei & Partners in the fashion of European pedestrian spaces, except that here special buses will run the length of the mall connecting the terminals (this project is shown on pages 126-127).

With renewed emphasis on bus transportation, the Rapid Transit District (RTD) has added three new maintenance buildings, each partially UMTA-funded

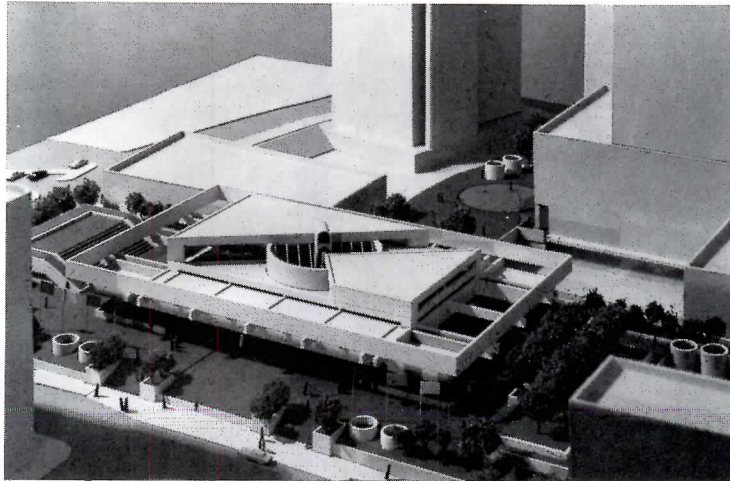

Five Points Station, Atlanta, Finch, Alexander, Barnes, Rothschild and Paschal, Inc., and Heery & Heery, Inc.

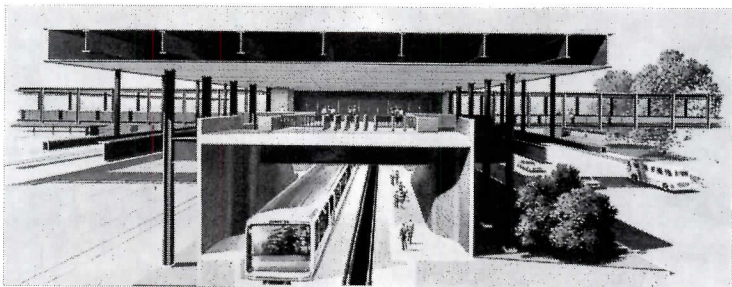

Moreland Avenue Station, Atlanta; Prindle, Patrick and Partners



West Lake Station, Atlanta; John J. Harte & Associates, Inc.; Frederick R. Harris, Inc.; Sengupta-Gruber & Associates

and each using solar panels. The most successful of these is the newest, the East Metro Bus Maintenance Facility in Aurora, Colorado, designed by architects RNL, Inc., which is highlighted by a primary solar heating system that supplies 50 per cent of the building's total heating requirements.

Along with the implemented park-and-ride bus system, Denver has instituted some innovative ideas to further entice people out of their automobiles. There is a unique public-private partnership between Downtown Denver, Inc., and RTD, in which the former assumes the costs of promoting RTD's programs, which include no fares on buses, called the "FreeRide" program. "TouristRide" is another popular program, servicing 17 visitor attractions during off-peak hours.

Chicago: The Loop "El"—perhaps the most famous elevated train track in the country—is the continuing center of controversy. Some want it torn down to make way for a new subway, and some want it preserved.

The El, built in 1897, consists of a square-shaped two-mile-long track, raised above the street on huge steel trestles, with cars continually moving in and about the heart of Chicago—the financial and business district. A plan announced last year by the Chicago Urban Transportation District proposed a new subway line that would call for the demolition of two legs of the Loop. Some people sprang to the El's defense, including Harry Weese, who petitioned that it be listed on the National Register of Historic Places, but this was turned down by the Illinois Historic Sites Advisory Council. Amid the controversy, new cars have been bought and stations are continually upgraded.

In addition, 1,800 new buses have been bought since 1972, and just recently 20 articulated buses were bought as part of a consortium formed by 11 cities.

Baltimore: This city will be the fourth to design and construct a rapid rail transit system. The general consultant to the Mass Transportation Administration (MTA) is Daniel, Mann, Johnson & Mendenhall/Kaiser Engineers. Here again, following in San Francisco BART's footsteps, individual stations will be designed by separate firms, including architects

RTKL. A four-man Transit Architectural Review Board is responsible for reviewing all of the architectural design work of the first nine stations with the chairman, a member of Harry Weese & Associates (the prime architect on the METRO system in Washington).

San Francisco: This city is on the move, with a variety of proposals that will give it one of the most efficient and organized integrated transit systems in the country. A new Downtown Airlines Terminal (handling buses that operate only to and from the airport) has been designed by architect Jacques DeBrer (see this issue's Buildings in the News). Another proposal by M. Arthur Gensler & Associates is for a new Greyhound Bus terminal (see also Buildings in the News), accommodating over one million passengers annually. It will be located near the proposed Moscone Convention Center (formerly called the Yerba Buena Convention Center). A third proposal is for revamping the now inefficient TransBay bus terminal (serving commuters from the East Bay area), by Skidmore, Owings & Merrill's San Francisco office.

All three of these projects are located near Market Street—the most recently completed of the city's ambitious urban design programs. Market Street historically has been the city's primary transit corridor. Gas-powered buses, trolleys and cable cars have all converged here. The Bay Area Rapid Transit (BART) inter-county rail system also runs under Market Street, designed by the joint-venture team of Warnecke/Ciampi/Halprin. The urban renewal, with brick paving, street furniture and trees, has brought new life to retail stores.

BART has been an integral part of the transportation upsurge. A system of underground, on-grade and elevated stations was individually designed by architects throughout the Bay area (see two of these stations in RECORD, November 1974, pages 113-120). This was the first high-tech modern rail system to be designed in the last 50 years, successful enough that other cities have used it as a model.

In addition, UMTA-released funds have gone toward design and construction of maintenance buildings, including the Rockrise Odermatt Mountjoy Associates's design on page 128.

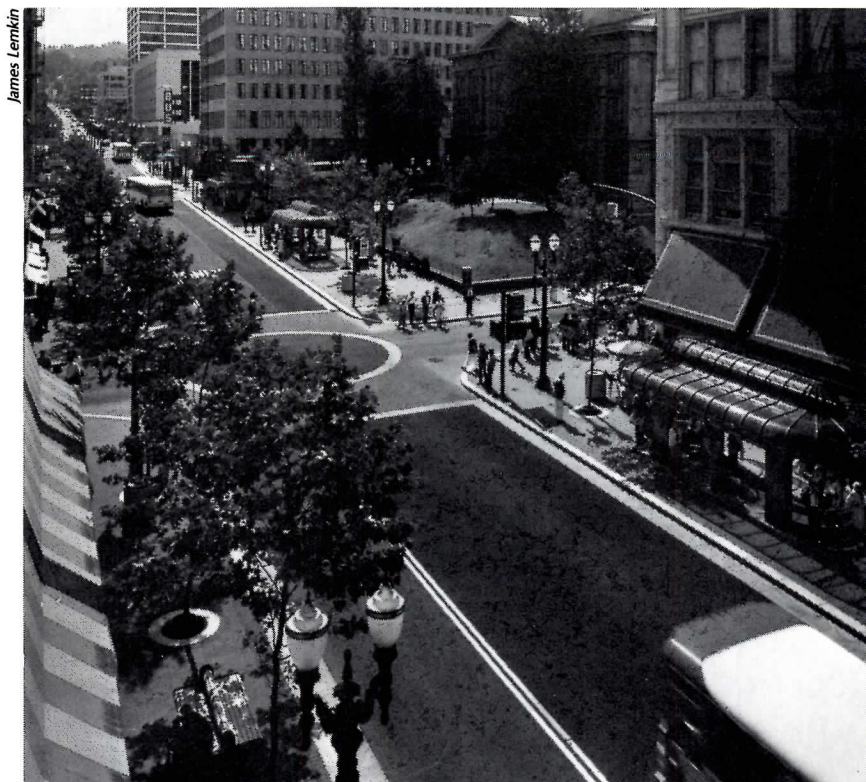

Portland Transit Mall; Skidmore, Owings & Merrill—Portland office

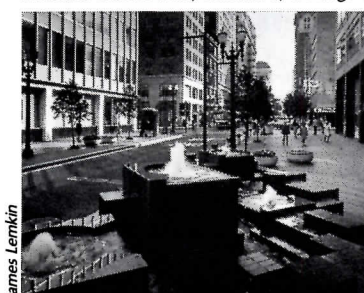

Portland: Two meritorious projects (one completed and the other a proposal) are at the heart of Portland's transit work. The question being asked in Portland these days is "Will Portland still be a great place to live in 20 years?" The answer is yes, if the city continues to plan in the manner with which it has approached these two projects.

The completed project is the downtown transit mall designed by Skidmore, Owings & Merrill's Portland office. First recommended in 1971 for Tri-Met (the Tri-County Metropolitan Transportation District of Oregon) to consider, and later UMTA-funded, construction began in 1975. The mall forms the spine of Portland's highest density commercial and retail area.

The mall design segregates bus and automobile traffic and has thereby tripled the people-carrying capacity along the 11-block length of the two main thoroughfares affected, Fifth and Sixth Avenues. Buses operate along a typical black-topped roadway with pedestrians re-

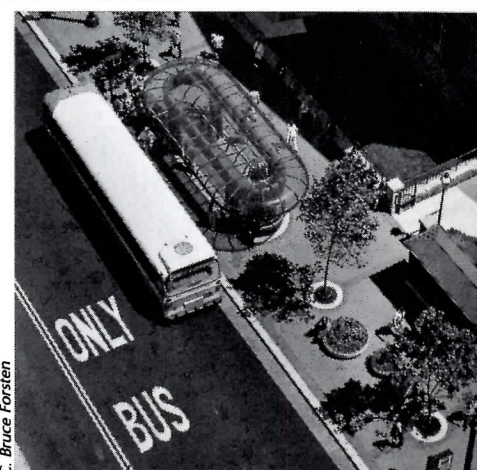

gated to sidewalks, a design similar to other existing transit malls. The mall is an integral aspect of the Oregon Clean Air Implementation Program, designed to reduce air pollutants in downtown Portland.

The second project proposed is a 14.5-mile-long light rail corridor along the Banfield Freeway, a well-established and natural route into Portland since pioneer times. This area is partially developed and is expected to be the center of future growth. Proponents claim that this patch would require much less land and displacement of people than a similar proposal built in another area. Zimmer Gunsul & Frasca architects did initial design work. Formal hearings have been held and an environmental impact statement prepared. A bill is pending in the state legislature for approval of funds.



Paul Myatt

Metro Center Station, Washington, D.C.;
Harry Weese & Associates

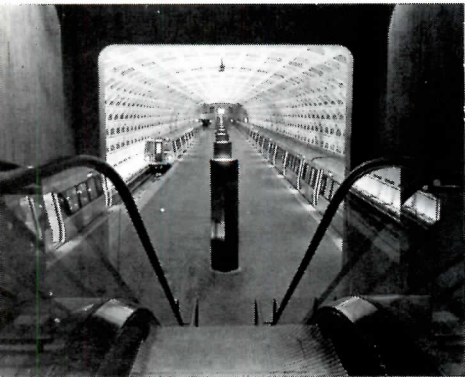

Phil Portlode

Stadium/Armory Station, Washington, D.C.;
Harry Weese & Associates



Phil Portlode

Ft. Totten Station, Washington, D.C.;
Harry Weese & Associates

Washington, D.C.: The most noteworthy recent transit development in our nation's capital has been the now completed METRO, the Washington Rapid Rail Transit System, owned and operated by Washington Metropolitan Area Transit Authority (WMATA). The general architectural consultant was Harry Weese & Associates, with DeLeuw, Cather & Company as general engineering consultant and Bechtel, Inc., the general construction consultant. A distinctive design of high vaulted, coffered ceilings is in all the underground stations. This singular theme has a monumental visual effectiveness while unifying all the underground stations in the system. METRO was this country's second newest high-tech rail system, following BART

in San Francisco (and, in fact, WMATA hired some key BART people to work for WMATA). (For a more complete discussion, see RECORD, mid-August 1978, page 66.)

Houston: The best way to get around Houston is by car, for the city is huge, surrounded and bisected with an overflowing freeway system. Because of city sprawl, the transit system is not well developed. In an initial effort to pump up the bus program, a "contra lane" (a designated bus lane that runs against the flow of traffic on the freeway) is being implemented. The Metropolitan Transit Authority (MTA) is now in the process of "alternative analyses"—a total analysis of existing facilities and possible future transit systems, and all the factors that affect them, augmented by computer systems and cost analyses. One of these alternative proposals is a transit mall, and the architectural firm of S. I. Morris Associates has been hired to do preliminary design work. One interesting and exciting pedestrian aspect of the city is an underground tunnel system that connects most of the major downtown buildings, with retail stores and shops lining the tunnels, similar to those at Rockefeller Center in New York City.

Los Angeles: If there has been one city in the United States that has relied on the automobile as the single mode of transportation, it is Los Angeles. Having grown dramatically after World War II, Los Angeles is the epitome of urban sprawl, where the single-family residence is king. It is nothing for Los Angeles to consider driving two hours for dinner or an appointment. There are some buses, but they run rather sporadically. Proposals for rapid transit have been considered for years, but none looks promising in actuality. One recent plan for a People Mover mini-train service throughout the downtown area has been funded by UMTA, and Daniel, Mann, Johnson & Mendenhall has prepared plans under the guidance of the Community Redevelopment Agency of Los Angeles. (This plan is featured on page 130.) The recent gasoline crunch has hit Los Angeles hard, with people having to wait in lines, sometimes a quarter of a mile long, at gas stations. There have been, nonetheless, some note-

worthy structures constructed to augment what mass transit exists, including an award-winning design by DMJM of the San Bernardino Busway/University Station for the Southern California Rapid Transit District (SCRTD).

Miami: The newest concept in transportation in Miami is a program just underway—an elevated heavy rail system covering 20 miles, including 20 stations, designed by Harry Weese & Associates. The architectural firm is part of a joint-venture corporation (called Kaiser Transit Group) to provide initial design services. The system is going to be a reality: ground was broken in June. Harry Weese & Associates is also responsible for the interface between this rail system and a proposed Miami, Florida, Downtown People Mover system. As the design-construct phase of the rail system begins, HWA will be responsible for monitoring and coordinating the final design of all physical facilities, as well as the in-house final design.

Honolulu: While the primary form of transportation in the capital city of Honolulu has always been gas-run buses (a system presently being expanded), there have been some interesting rapid transit proposals within the past six years.

Originally, the scheme was to run a fixed-rail line along a 23-mile path from Pearl Harbor beyond Diamond Head. The most recent proposal, however, is a route along a central corridor that reaches the airport but only goes to the edge of Waikiki. Preliminary design concepts placed underground stations in the main business area on the line, with on-grade and elevated tracks farther away. Controversy has delayed official and formal action on the proposals (with the Oahu Metropolitan Planning Organization trying to coordinate city and state agencies and handle problems). At present, a report of facts and figures is being compiled on the operating costs of such a mass transit system, and will be presented to the State Legislature in 1980 for consideration.

Dead-in-the-water is a third kind of transportation once operating as an inter-island system—the hydrofoils. In operation for several years, it finally ceased in 1978, mainly due to lack of patronage.

Philadelphia: While Philadelphia has a well-developed bus and subway system, new work is under construction—the Center City Commuter Connection, locally known as "the tunnel." This milestone will link 400 miles of commuter railroads (the now defunct Pennsylvania Railroad and Reading Railroad) into one integrated commuter rail network. The 1.7-mile-long tunneling project has been on the drawing boards since 1958 and is claimed to be the first application for capital funds given by UMTA (then known as the Federal Office of Transportation in the Housing and Home Finance Agency). Expected to be completed in 1984, the tunnel will run through an on-going urban renewal project known as the Market Street East area.

As part of this expansive area, architects Day & Zimmermann Associates have completed design work on a three-tiered \$50-million station that will serve the over-all downtown rail con-



Harris Davis

Franklin Square Subway Station,
Philadelphia; H2L2 Architects/Planners

nection. It will be located near Filbert Street, with a concourse level full of ticket booths and seating and a retail business area, and two platform levels including entrances to the Gallery II retail structure.

The upswing in retail development is integral with transportation. By combining urban renewal efforts in downtown with mass transportation improvements, Philadelphia political and business leaders hope to rejuvenate the area.

Another example of good design is the award-winning subway station at Franklin Square (see photo this page). Designed by H2L2 Architects/Planners and completed for the American Bicentennial in 1976, it stands as a welcoming landmark for both tourists and commuters.

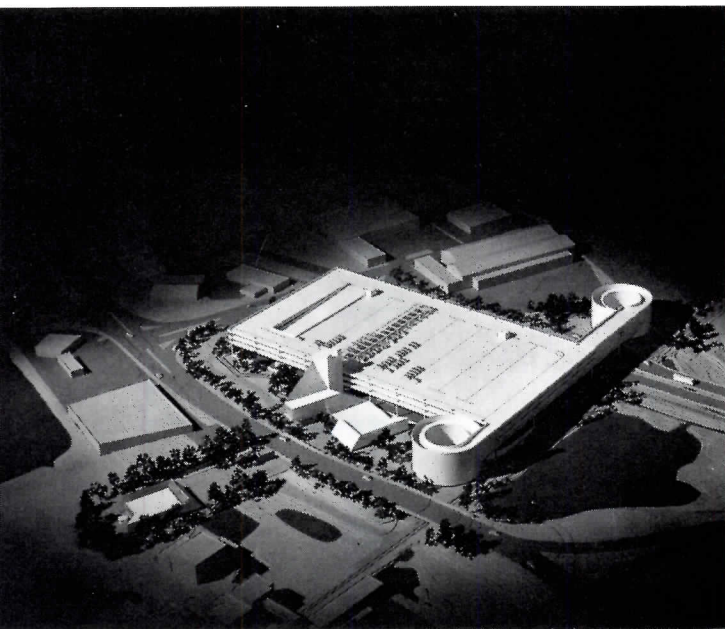

Alewife Station, Cambridge, Mass.; Wallace, Floyd, Ellenzweig, Moore, Inc.

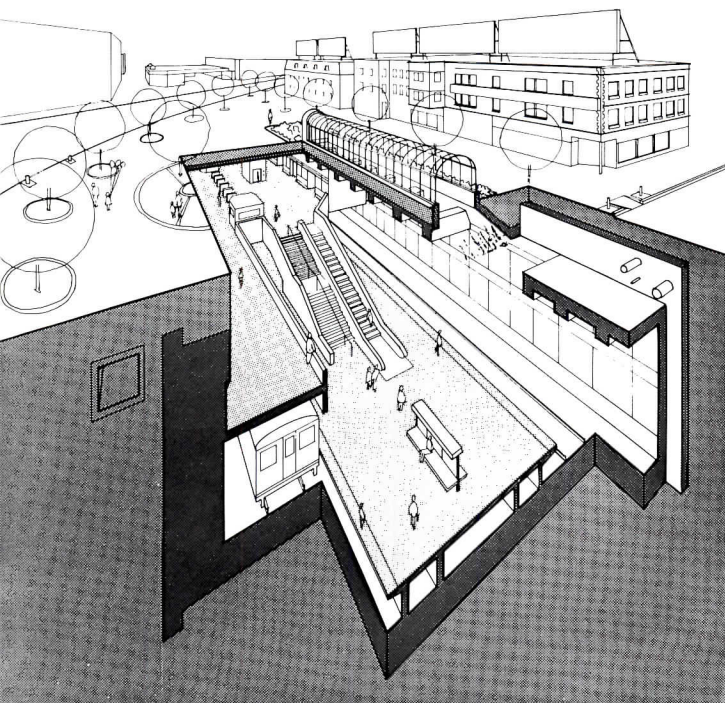

Davis Square Subway Station, Somerville, Mass.; Goody, Clancy & Associates, Inc.

Boston: The charm of Boston's downtown streets is legendary, but so is the congestion. Back in the mid-1960s, the expected construction of three new radial highways and an inner ring road threatened a still greater daily influx of automobiles, and then-Governor Francis W. Sargent called a moratorium on the project and established the Boston Transportation Planning Review to conduct a thorough study of regional transportation needs and to suggest alternatives. (In Massachusetts, one should remember, the Governor has a first-rate view of Boston from the State House at the pinnacle of Beacon Hill.)

Boston and neighboring Cambridge had the advantage of a solid infrastructure of existing and well-used rapid transit. The Massachusetts Bay Transportation Administration's Green Line, essentially a subterranean trolley, began operations in 1898, and the system thereafter added three subway lines (Blue, Red and Orange) radiating from the central business and government district to the nearer suburbs. In addition, an extensive commuter rail network serves more distant suburbs.

In consequence of the Review's study and a series of public hearings, the state abandoned plans for the highways,

and funds were transferred to the improvement of rapid transit. Major MBTA projects include:

- The Southwest Corridor Development, which will relocate the MBTA's Orange Line and build eight stations on land acquired and cleared by the state before the highway project was abandoned. A Penn Central embankment will be replaced with a depressed alignment carrying five tracks for the Orange Line, commuter rail and Amtrak. Plans also call for a 90-acre strip of green belt and recreational parkland along the route.
- Red Line extension south, which will add three stations to the on-grade tracks south of the line's present terminus at Quincy. Scheduled to begin operations this year, the extension will provide garages to encourage commuters to park and ride.
- Red Line extension north, which will carry the subway system to the border of Cambridge—and, in one case, beyond. New facilities include a redesigned Harvard Square Station and a new station at Porter Square (see pages 122-125), a garage and new terminal at Alewife designed by Wallace Floyd Ellenzweig Moore and a new station at Davis Square in the neighboring city of Somerville

The newest bus transit program in the country encompasses 11 cities that banded together to buy the latest articulated bus manufactured in Germany. The consortium consists of Chicago, Washington, D.C., Atlanta, San Francisco, Oakland, Portland, San Diego, Phoenix, Pittsburgh, Minneapolis and St. Paul. The articulated model (below) is 55 feet

by Goody Clancy Associates (both at left). (See also RECORD, March 1979, page 36.)

The character of each of these expansions differs to some extent with respect both to transportation purpose and urban impact. The Red Line south extension, for instance, is intended chiefly for the convenience of commuters and to discourage automobile traffic downtown. North along the Red Line, planners hope that the new Davis Square Station will establish a node for needed commercial and residential development in an aging community, and planning at Alewife must consider coming changes from heavy to light industrial use.

And along the Orange Line, where neighborhoods had already suffered as a result of clearance for the discarded highway project, calculated urban changes will be, if anything, even more profound, ranging through light industrial, retail and hotel development in Roxbury to business and residential resale and rehabilitation elsewhere.

All redevelopment along the Southwest Corridor, from whatever agency, must be approved by MBTA, which is charged with coordinating urban planning.

long (15 feet longer than a regular bus) and seats 65 people (18 more than a regular bus). Its primary advantage is that it carries more people without requiring additional drivers. In order to provide maneuverability, the front and rear are joined by an accordion-shaped, flexible section that allows the bus to "bend" when turning corners.



N.E. TRAIN PROJECT

Offsetting the demise of railroads is this improvement project that brings new life to 15 stations

The North East Corridor Improvement Project (NECIP) will revitalize an important existing heavy rail route that transports thousands of people a year between Washington, D.C., and Boston. The NECIP was established by the Railroad Revitalization and Regulatory Reform Act of 1976 to improve railroad passenger service along the corridor. A total funding of \$1.9 billion includes 100 per cent Federally funded improvements directly related to high-speed rail service and 50/50 cost-sharing by Federal and a state, regional or local government for related projects.

DeLeuw, Cather/Parsons, a joint-venture team, is responsible for engineering services, and architect Skidmore, Owings & Merrill's Washington, D.C., office is responsible for preparing preliminary design plans for each of the stations and supervising development of documents prepared by local A-E firms. Nine of these stations are listed on the Register of Historic Places.

The project affords a unique opportunity to affect transit work in major U.S. cities with 20 per cent of the population of the nation. In particular, prolonging the life of historically significant stations is an unparalleled preservation task. Of the 15 stations in the system, six singled out here have special significance.

Boston South Station: An amazing example of Federal, state and city involvement with a multitude of consultants and proposals, this station is a combination of historic restoration and new structure. Architects of the original headhouse were Shepley, Rutan and Coolidge. With only a fragment of the original station remaining today, new work proposals include rehabilitation of the existing interiors, a significant realignment of tracks and a new passenger center topped by skylights. Final work will be carried out by the joint-venture team of Hugh Stubbins/Castro Blanco.

New Haven Union Station: This

historically significant design by Cass Gilbert, completed in 1920, had been allowed to fall into such disrepair that the station was closed in 1972. New work includes restoration of the facade and great interior hall, reorganization of station functions, and new graphics. The final design will be completed by the joint-venture team of Tippetts-Abbett-McCarthy-Stratton (A-E), Herbert S. Newman Associates (architects), and Polytech, Inc. (consulting engineers).

Philadelphia 30th Street Station: Designed by Graham, Anderson, Probst and White in 1929, the station is one of the largest in the system. Exterior work will include cleaning and structural improvements, but the most significant work will be to the interiors—upgrading safety, finishes, and circulation. Final design will be carried out by the joint-venture team of Ueland and Junker and Omega Associates, Inc.

Wilmington Station: Located in Delaware (only one of nine states the train corridor passes through), this station was designed by Frank Furness, and it is the last large, remaining railroad station of his design. Reconstruction of canopies once of glass and iron and restoration of the facade, including terra cotta trim, are part of the over-all program. A-E for final design is Whiteside, Moeckel and Carbonsell.

Baltimore Penn Station: Designed by Kenneth Murchison in 1910, the original station had a grand facade, and it is significant because it was the first station designed to combine waiting and circulation areas directly over tracks. Work includes preservation, particularly of the high glass domes, reorganization of station functions, and new graphics. Prime A-E for final design work is Robert J. Nash & Associates and The Leon Bridges Co.

Washington, D.C. Union Station: Located just three blocks from the U.S. Capitol, it is an important element in the revival of L'Enfant's plan for the city. Designed by Daniel Burnham, it was sited to be a dramatic entry into the nation's capital. The main design goal is to re-establish the historic structure as a major transportation center. Station work awaits Congressional approval.

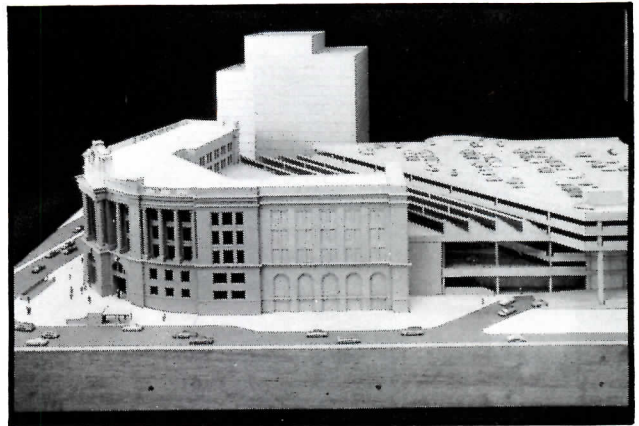

Boston South Station



New Haven Union Station

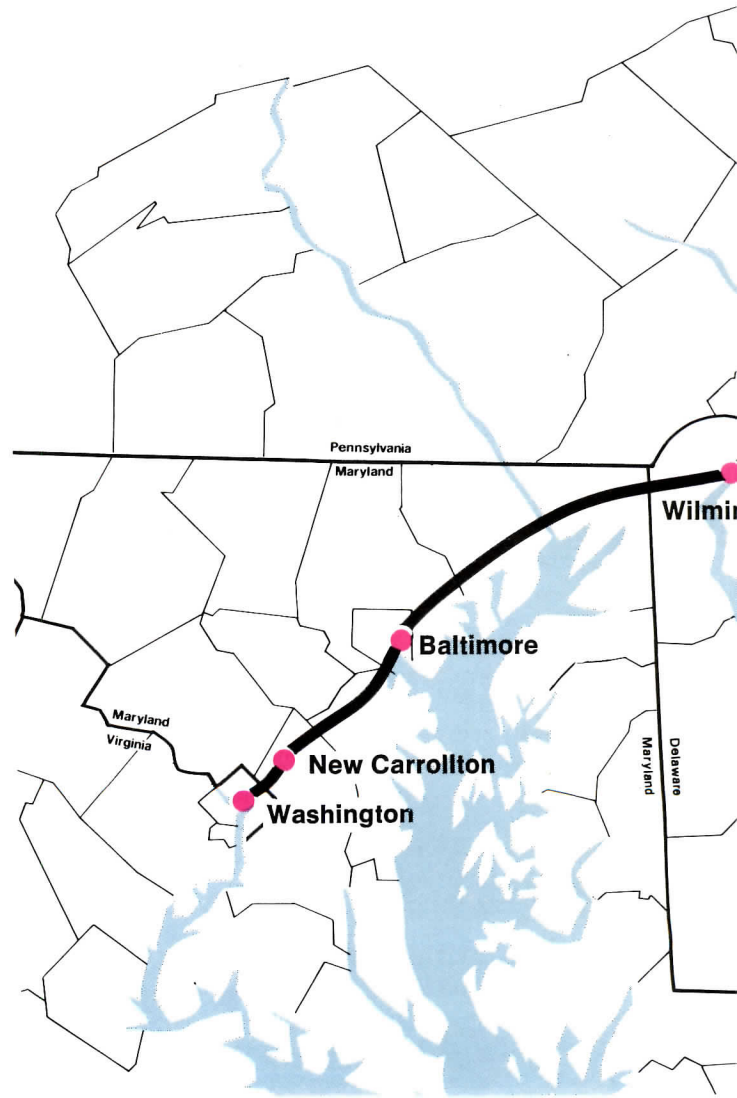

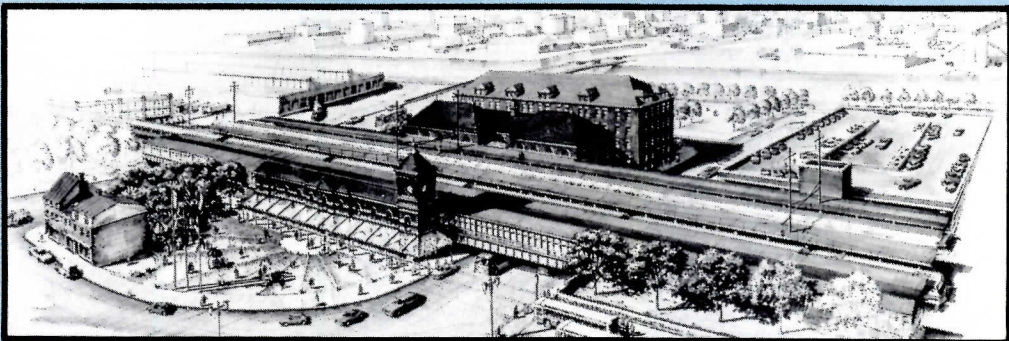
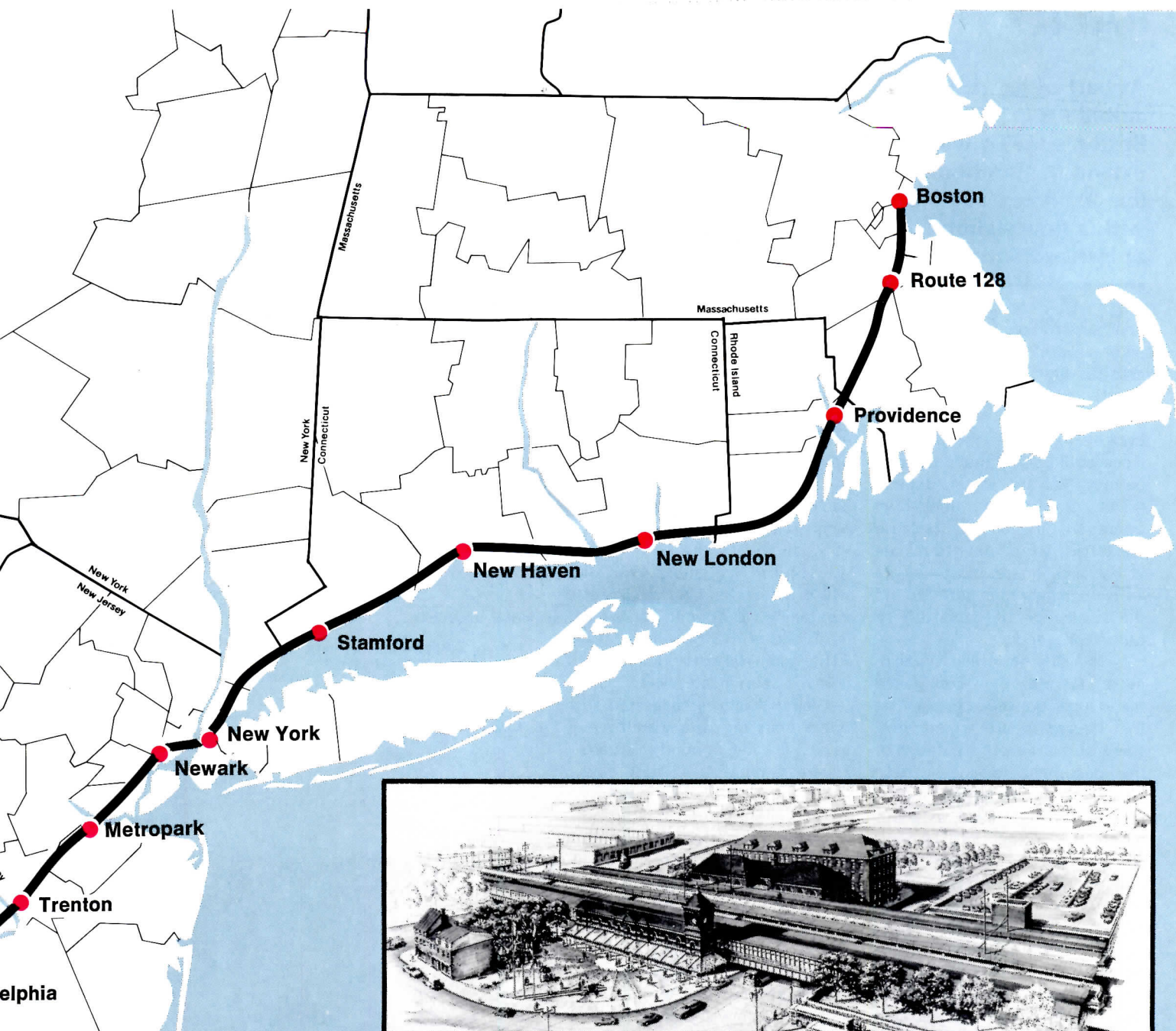

Wilmington Station



Philadelphia 30th Street Station



Washington, D.C. Union Station



Baltimore Pennsylvania Station

RAPID TRANSIT: SUBWAY

As part of its ambitious expansion, Boston's MBTA will extend its Cambridge line 3½ miles, starting with a new station at Harvard Square

The Harvard Square Station is the pivot around which the Massachusetts Bay Transportation Authority must swing its Red Line subway extension through Cambridge—figuratively because the three additional stations planned beyond Harvard Square depend on its completion for their own operation, and literally because the tracks, which now terminate at Harvard Square, must execute an exceedingly tight turn around the very edge of Harvard Yard before proceeding.

The Boston office of Skidmore, Owings & Merrill faced numberless questions in planning the Harvard Square project, only some of them involving design of the passenger facilities. These must incorporate access to the train platforms as well as a bus tunnel that comes into Harvard Square from the opposite direction and then turns to parallel the new tracks. The architects capitalized on the resulting multitude of curves both to express traffic flow and to orient users.

The square glass roof of the main headhouse will provide light for an escalator that leads to a semicircular intermediary mezzanine, thence to another escalator and finally to the central mezzanine. Sight lines are clear from the top of the second escalator to the turnstiles and ramps.

The Harvard Square Station project also includes another pair of entrances to the train platforms at Church Street farther out on Massachusetts Avenue.

The construction of the new subway tunnel, the partially relocated bus tunnel, new stations and other access stairways will take about five years—and must be completed without disturbing either train or bus service, or heavy vehicular and pedestrian traffic, or any of the many surrounding buildings. Streets above the projected tunnel will be decked and excavation will

proceed below the decking and between slurry walls along both sides of Massachusetts Avenue.

Phasing construction to permit uninterrupted train service over the period required a sequence of temporary stations:

- The temporary Harvard/Brattle station at Eliot Square, where a train yard now exists, has already opened and will be demolished when the permanent Harvard Square station opens.
- Holyoke temporary station, opposite the main entrance on Massachusetts Avenue, is presently under construction and will open next fall. As an entrance to the central mezzanine, it becomes the first permanent element to be built.
- Switch-over to the new tracks will occur in September 1982, at which time the Church Street mezzanine will open to serve the north end of the train platform.
- The main Harvard Square Station will open in late 1983.

All this activity suggested an opportunity for surface improvements in and around Harvard Square. Strangers, at least, find Cambridge circulation patterns incomprehensibly anarchic, and over the years trees and other amenities have been sacrificed to traffic and on-street parking.

SOM has designed a brick paving system that will delineate and expand pedestrian areas. To the satisfaction of the city's traffic department, the new station and its plaza will prohibit automobiles crossing Harvard Square to reach Brattle Street. More orderly traffic there will free much of Brattle Square to pedestrians, who will be able to use the newly paved and landscaped island for gatherings. —G.M.A.

HARVARD SQUARE STATION, Cambridge, Massachusetts. Owner: *Massachusetts Bay Transportation Authority*. Architects: *Skidmore, Owings & Merrill, Boston—Michael McCarthy, partner-in-charge; Peter Hopkinson, project director; Edward T. M. Tsoi, project architect; Martin Sokoloff, design coordinator*. Engineers: *Parsons Brinkerhoff Quade & Douglas, Inc. (structural, mechanical/electrical); Sverdrup & Parcel and Associates (structural, mechanical/electrical); Cerami and Associates (acoustical); Jules Horton Lighting Design Inc. (lighting)*. Contractor: *Perini*.

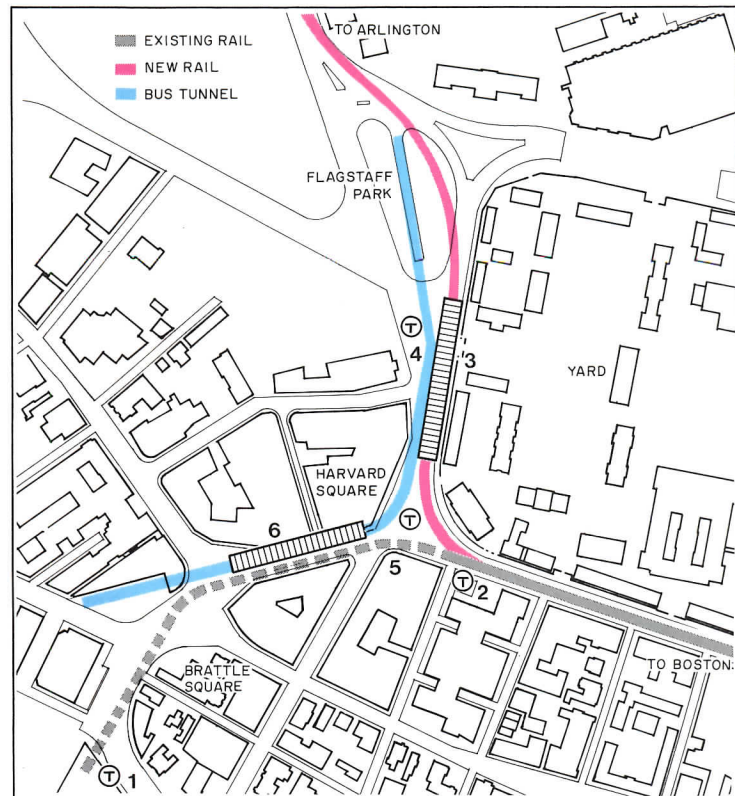

In order of construction:

- 1 Harvard/Brattle temporary station
- 2 Holyoke temporary station
- 3 New train platforms
- 4 Church Street mezzanine
- 5 Central mezzanine
- 6 Renovated bus platforms

At Cambridge's populous Harvard Square, a new MBTA station will replace the present, highly trafficked terminal to take the subway out to the edge of the city. The metal roof of the old station, a visual landmark on the square, will be repaired and recycled as a new shelter for a social landmark, the long-established international newsstand.

All photos ©Steve Rosenthal





RAPID TRANSIT: SUBWAY

Boston subway riders will descend 115 feet via three escalators to reach train platforms in a deep tunnel bored through bedrock beneath Porter Square

However far-reaching the impact of the new MBTA station at Harvard Square (last page), passengers will probably view it simply as an alteration of a familiar stop. But Porter Square Station will be altogether unfamiliar—the first stop beyond Harvard Square on the northwest extension of the subway's Red Line.

For additional drama, passengers will ride escalators down more than 100 ft to reach the trainroom, which will lie in a deep tunnel bored through bedrock.

The decision to use a deep-bore tunnel rested largely on engineering and construction considerations, according to architects Cambridge Seven Associates. Since the rock tunnel is self-supporting, it produces very considerable saving in structural cost. Moreover, deep boring will occasion little surface inconvenience on the mile-long stretch of Massachusetts Avenue above it.

At the same time, however, the decision did add appreciably to the cost of the station itself. Not only were numerous and long escalators required—nine of them, three of which will descend 70 ft—but the station also requires boring through rock for passenger access and for venting. A vertical shaft bored at the south end of the train platform for construction use will be finished for stairs and ventilation, and a similar shaft will later be bored at the north end of the platform. The escalators will require a diagonal shaft, with a small vertical shaft adjacent for the passenger elevator.

The station will have two entrances: the east, or main, entrance, which will sit like a small greenhouse at the point of a park looking down Massachusetts Avenue, and the west, or ancillary, headhouse across the street. The subway station will also double as a station for an existing branch of the commuter

rail and will include bus-stop shelters and drop-off areas for automobiles and taxis.

The architects have taken pains to alleviate possible feelings of oppression in the deep station with light and color. The arching roof of the tunnel will be covered with special acoustic panels, colored white to reflect evenly the light cast by four fluorescent strips mounted around a 400-ft-long metal fixture. Pipe railings will be painted bright red and the enormous ventilators blue as a "maritime" allusion.

Daylight admitted by the generous skylights in the main headhouse will greet passengers ascending the long escalator. Passengers using the underpass from the west headhouse will have their own skylight: a glazed cylinder punched through the point of the triangular park, surmounted by a wind-driven pinwheel designed by sculptor Susumu Shingu.

This sculpture is only one example of the works that will be commissioned under a mandatory and well-funded arts program. Sculptor Carlos Dorrien has already designed a full-height panel to be installed on the outside of the west headhouse at Porter

Square, and Gyorgy Kepes is already at work designing a mural for Harvard Square. —G.M.A.

PORTER SQUARE STATION, Cambridge, Massachusetts. Owner: Massachusetts Bay Transportation Authority. Architect: Cambridge Seven Associates—Paul Dietrich and Terry Rankin, principals; Robert Henry, project architect. Consultants: LeMessurier Associates/SCI (structural); R. G. Vanderweil (mechanical/electrical/ventilation); Haley & Aldrich (geotechnical/excavation); Carol R. Johnson (landscape); Bolt, Beranek & Newman (acoustical); Howard Branstetter (lighting).

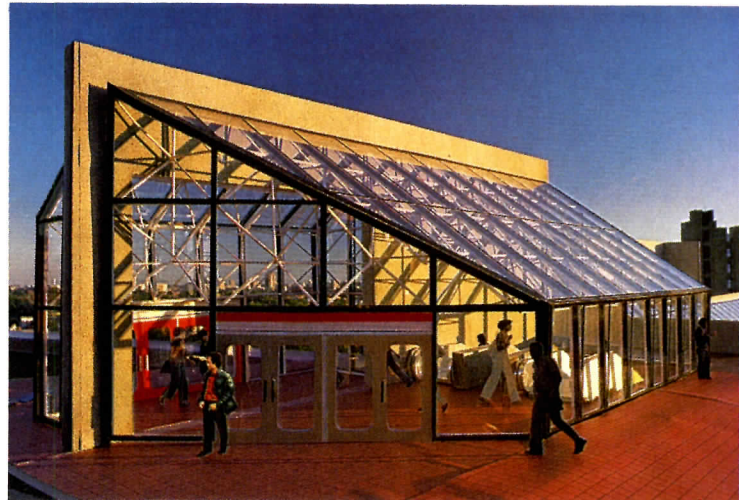

Model photography: Steve Brosnahan

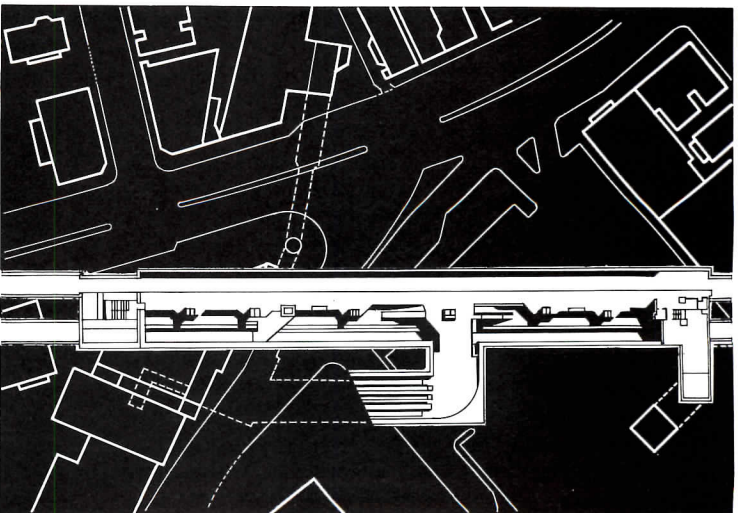
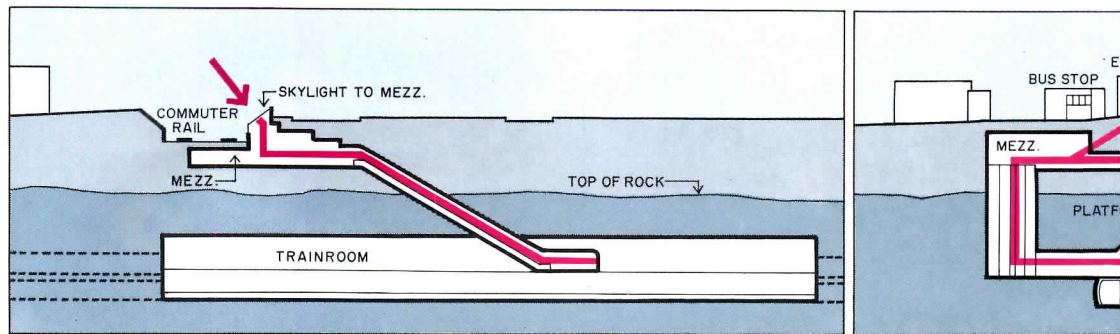
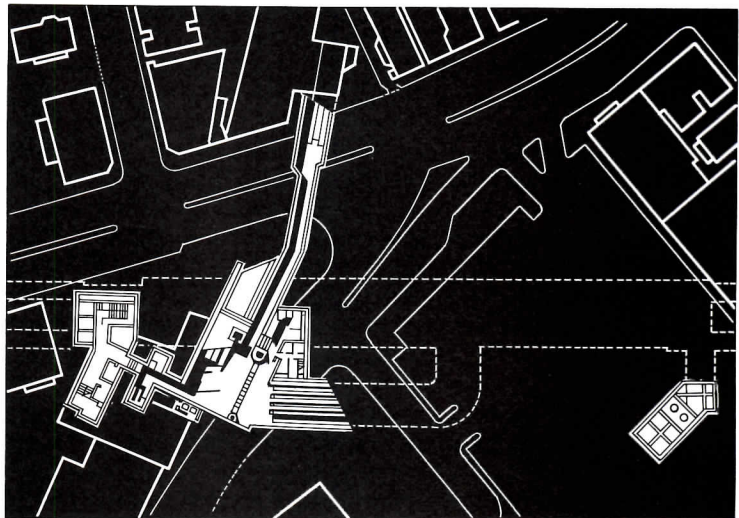

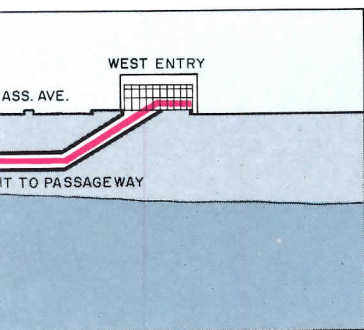

A glass headhouse is designed to pour as much daylight as possible into the subterranean depths of the deep-tunnel subway station at Porter Square in Cambridge. Passengers using the main entrance (top left) will descend to the large mezzanine (above), which also receives passengers coming from a headhouse across the street through an underpass beneath Massachusetts Avenue. After passing the turnstiles, subway riders immediately board super-long escalators to reach the trainroom 70 ft down (right). All riders cross a bridge to the upper platform, where riders going downtown catch inbound trains. Outbound riders take still another escalator to the lower platform.



TRANSIT MALLS

A resurgence of center city transit malls is the coming attraction in many major cities to entice people out of their cars

While the concept of transit malls is not a new idea (one of the first being designed in Minneapolis 14 years ago), a new mall for downtown Denver, designed by I.M. Pei & Partners, is a significant addition to mass transportation. The Transitway/Mall will become the spine of the Central Business District, spurring commercial development and providing a needed urban redesign.

In the early 1970s, a plan for a 22-mile-long rail system was conceived for the Denver area, but it was rejected by UMTA (its first formal rejection of Federal aid to a city for a rail transit system). It was claimed that Denver did not show the real necessity for a rail system, and that an improved bus system would provide the same ridership and quality of service at substantially less cost, and would, in the short term, offer a more viable solution to the city's transportation problems (RECORD, August 1976, page 35).

Denver has experienced a fast-paced growth because of its special amenities and location in the West, but growth is now sprawling (much like Los Angeles, although not on the same scale). Shopping centers and residential areas have flourished throughout the valley. This has, of course, brought traffic congestion and air pollution. To entice people out of their automobiles, park-and-ride centers have been established in an effort to encourage people to park private automobiles in outlying areas and ride the public buses into the Central Business District.

The Transitway/Mall will interface with this plan, acting as the terminus for buses. Two terminals will anchor the 12-block long mall, and special purpose buses will run between the terminals. The general design concept for the terminals is that of staging areas—prominent structures (with office and hotel facilities built over the bus loading plat-

forms), which are cut away to focus views to the grand Colorado State Capitol in one direction and to the mountains in the other.

Sixteenth Street has been designated for the mall, but it will be widened to provide a 22-foot-wide central, pedestrian promenade, two 10-foot-wide bus paths and two 19-foot-wide pedestrian walkways bordering stores.

Designed with a real European flavor, an intricate street pattern is intended to automatically indicate to pedestrians the bus lanes, even though there are no curbs or more traditional black-top lanes. Granite pavement was selected for its durability, in two colors of red and gray. Large circles and squares run continuously along the central promenade, and the bus avenues have prominent dark diagonals. The strong pattern fades out toward the storefronts in order not to distract from the shop window displays.

Two species of trees (selected from the Midwest for hearty varieties) will be plentiful in the center, large enough to partially shade the street. A special drainage system underneath the street will, it is hoped, ensure their survival. Street landscaping will also include potted plants, and fountains and seating will be provided along the mall.

One of the key aspects is the lighting, specially created by lighting consultant Howard Branston. Photoelectrically sensitive light fixtures have three different kinds of lamps—sparkle lights encircling the top, metal halide lamps (these two will be lit until late evening), and a security light (which will come on in late evening). Recessed lights, sunk below the surface of the street, will be centered in each of the diagonals of the bus lanes to set them apart at night.

Located near one end of the mall is a building that is becoming the symbol of the downtown renewal program—the Daniels & Fisher Tower, a picturesque relic of a demolished department store. There have been many restoration schemes, but the latest is by Gensler & Associates, whose preliminary design for a prospective developer is an office condominium.



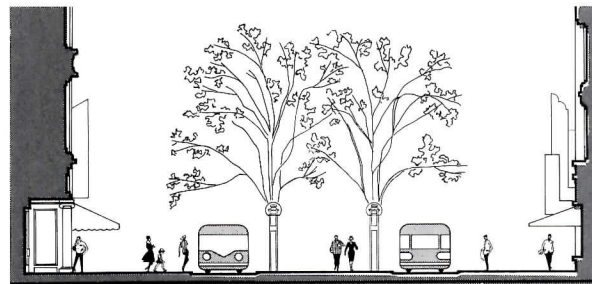

Denver's Transitway/Mall was designed with people in mind. The streetscape is highlighted by lush trees, specially-designed light fixtures and an attractive patterned surface. Free of curbs, the pattern immediately orients the pedestrian to shuttle bus lanes running between two bus terminals at the ends of the mall.

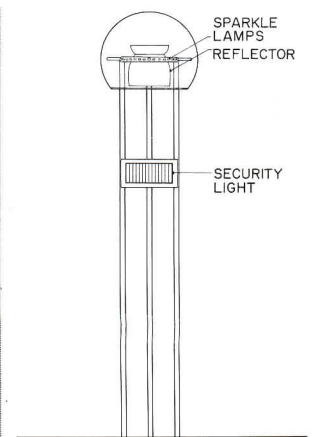
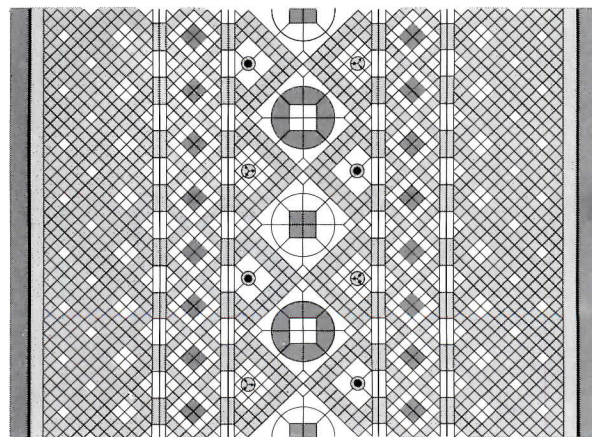

MAINTENANCE COMPLEX

A strong design in quality materials invigorates a building type seldom given attention

This new maintenance complex for San Francisco's entire transit fleet proves that good design is not confined to other than industrial purposes. This design has provided a functional systematic work flow that did not exist before, at the same time providing a handsome industrial-purpose environment.

San Francisco has a multiplicity of transit modes, including its legendary cable cars, gas-powered buses, electrically powered trolleys (one kind riding on tracks and one not), the Bay Area Rapid Transit system (BART), and a separate system of ferries connecting the city with the North Bay. Of this array, the in-city surface transportation is now all part of a system-wide Transit Improvement Program. And a program of this nature falls under the jurisdiction of the Urban Mass Transit Administration in the Department of Transportation, and therefore is qualified to apply for Federal assistance. Once this project was approved by UMTA, funds were given to the city and then re-directed to this project—one that has achieved a happy outcome.

This five-building complex is composed of a cable car rebuilding shop (16,000 square feet), a maintenance shop for engines and bodies of gas-powered buses (120,000 square feet), a bus inspection/service building, a bus washer, and an operations building for the bus drivers (17,000 square feet).

While a complex of this nature is traditionally located in a heavy industrial area, this project is located in a neighborhood mixed with residences and industries. The design reflects a good-neighbor policy through its siting and the provision for a mini-park. Structures were kept at a low height to minimize visual intrusion. A drop in grade from these residential blocks allowed siting of the majority of structures below neighborhood eye level. Even though the necessary large

and open bus parking lot could easily be an eyesore, it was minimized by being placed at the lowest portion of the site. The unusual amenity of an on-site mini-park is provided for neighborhood use and serves somewhat as a buffer zone between the complex and the surroundings. Art enrichment funds, a part of all San Francisco public projects, have been used to provide play-sculpture in the park.

The architects researched the work flow and various transit functions, consulting the Golden Gate Transit Company (which operates commuter buses from San Francisco to the North Bay area) and the BART District. They also provided site planning to permit the most convenient and nondisruptive traffic patterns to and from the city, and in intracomplex circulation patterns.

To unify the five buildings visually despite their different functions, all structures are of concrete, with sandblasted columns and fascias, and the lower portion of the two largest buildings (the cable car shop and maintenance shop) are detailed with rusticated panels, forming a continuous visual identity. Circular openings on fascia bands of these two buildings are air intake vents. The building at the highest portion of the site—and therefore the one with the strongest visual presence—was clad in bronze anodized aluminum and bronze-colored glass.

The operations building is set apart from the service buildings and designed with a more interesting massing of forms.

The total cost was \$14 million, of which 80 per cent was funded by UMTA.

WOODS MOTOR COACH CENTER, San Francisco, California. Owner: *San Francisco Municipal Railway*. Architects: *Rockrise Odermatt Mountjoy Associates*. Engineer: *Bentley Engineers* (structural/mechanical/electrical). Landscape architects: *Johnson & Leffingwell*. Consultants: *Roger Maineri* (acoustical engineer); *Landor Associates* (graphics); *Stefan Novak* (sculptor); *J. Brooks Rice* and *E.M. Gregerman* (special consultants for operations/maintenance). General contractors: *Dan Caputo Co.* (for phase I); *William Simpson Construction* (for phase II).

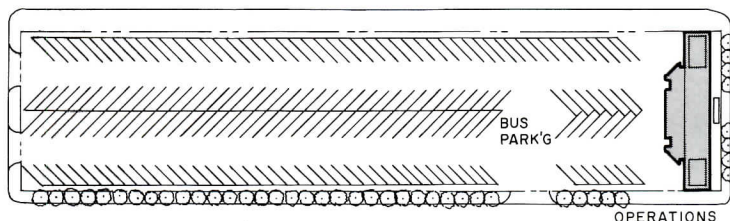
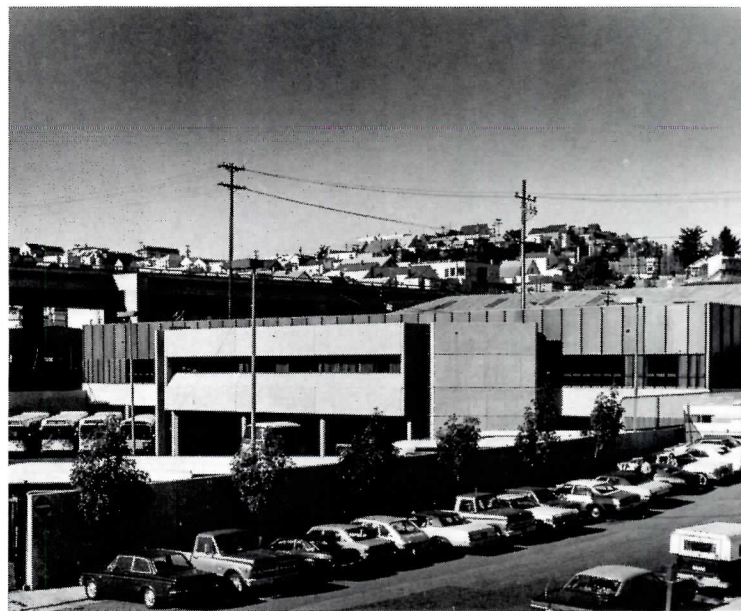

In this five-building complex the operations building (above) is set apart from the service structures. The bus inspection/service building (right) has a powerful form of its own, a flared mechanical end wall, and is partially covered with skylights to permit daylight to enrich fluorescent fixtures lighting the interior work area (lower right). The cable car rebuilding shop (below) is handsomely clad in bronze anodized aluminum and bronze-colored windows.

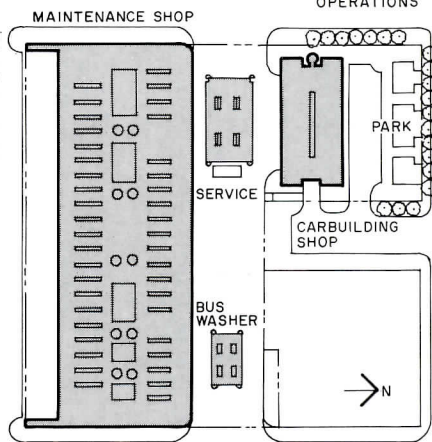

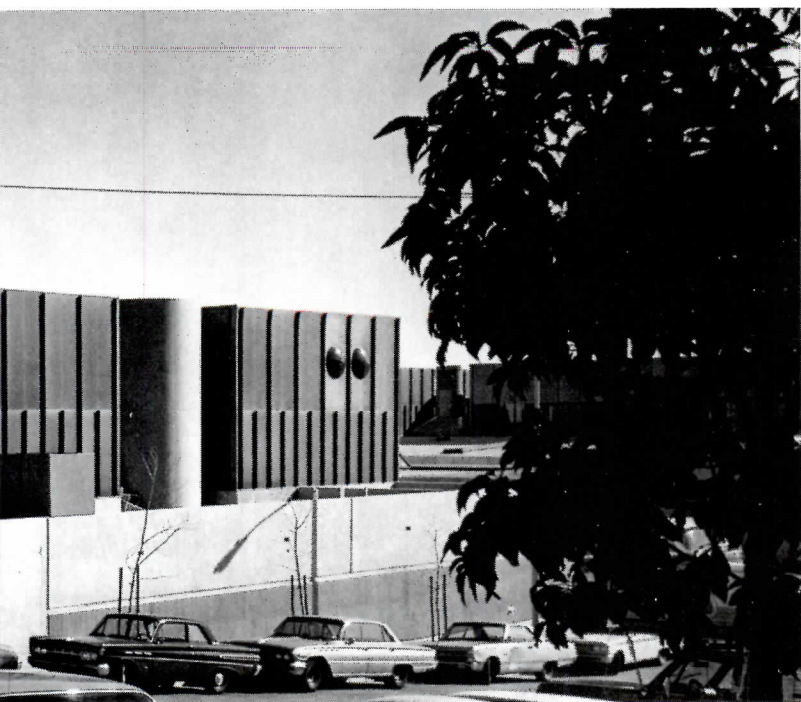

Joshua Freiwald photos



DOWNTOWN PEOPLE MOVERS

People movers may be the wave of the future in center city transportation—with mini-trains on elevated tracks darting between high-rises

A Downtown People Mover (DPM) is an electrically-powered, automated, small vehicle transit system that would be elevated to transport people around a relatively small area in the center city at moderate speeds of about 30 miles per hour. It is intended to interact with bus systems, augment other elevated rail systems and discourage automobile traffic congestion. UMTA established the DPM Program in 1976 by funding the initial design and testing of the viability of Automated Guideway Transit in downtown settings, like the two shown here, for Los Angeles and St. Paul.

Since 1971, 17 people-mover systems have been in operation but only in special purpose applications, like Disney World, and at airports such as Seattle-Tacoma. **Los Angeles:** Under the direction of the Community Redevelopment Agency of Los Angeles, architects Daniel, Mann, Johnson & Mendenhall with associated architects Jenkins-Fleming (and urban design by Archiplan and preliminary engineering by DMJM/Kaiser) have developed a proposal that could be in operation by mid-1983. Construction costs are estimated at \$130 million (in escalated dollars and without cost of parking and bus facilities). Capital funds for construction would come from UMTA, the State of California and Los Angeles City and County. The project is expected to generate one million square feet of commercial office space, and new hotels and housing.

St. Paul: Now in the final stages of review, this system would cost approximately \$90 million (in escalation dollars), and be funded by UMTA, the Metropolitan Transit Commission and the city of St. Paul. As in Los Angeles, city officials estimate that by 1990, an additional \$375 million of development could be completed as a direct spin-off.

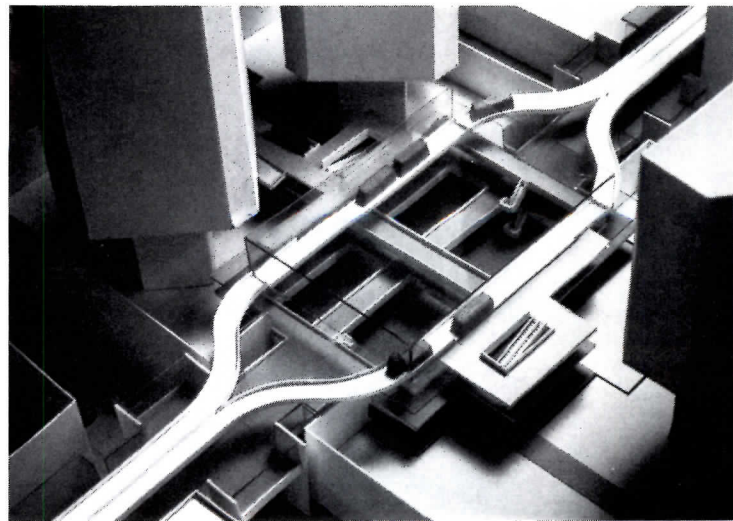
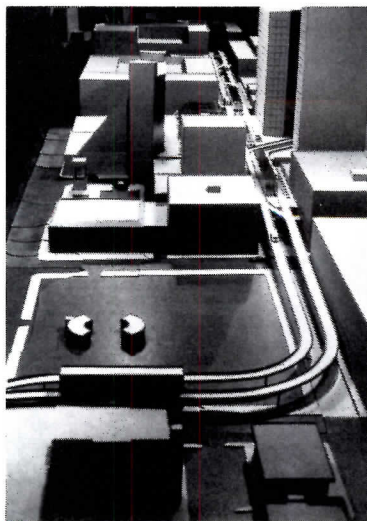

Downtown People Mover systems can be exciting additions to the cityscape—like the one in Los Angeles (above and left). A montage shows mini-cars moving along an elevated guidetrack in the heart of the city, near the Portman-designed Regency Hyatt Hotel. This route would run on a 2.9-mile-long track between 13 stations, using 60 vehicles, and providing parking facilities for 3,750 cars and a three-level bus station. The St. Paul system (below) would run 2.6 miles, between 12 stations that connect directly to office buildings and hotels. A multi-level station (bottom right) would be accessible from the street level.

Lighting in transition: The search for quality with lower energy consumption

Without a doubt, more new and dramatic developments have occurred in the field of lighting for saving energy than any other discipline related to building services. Energy-conserving approaches are evolving from new lighting techniques, new lighting equipment, new types of lamps, and from a greater awareness among architects and lighting designers of how lighting should be disposed to enhance people's ability to see and their sense of well-being. A large number of these developments have taken place in office lighting where worker performance and lighting systems costs are prime concerns, and some of the more significant implications of these developments are the main subject of this special report.

Striking savings in energy are being achieved with today's lighting systems for offices through more sophisticated fixture designs, and even more are promised through new developments in lamps that have higher lumen efficiencies and new spectral distributions, and through control of lights using systems as simple as ordinary on-off manual switching to those as sophisticated as dimming based upon daylight availability utilizing photocell monitoring.

Additional savings are being achieved through the recognition by lighting designers,

architects and owners that lighting levels, and hence fixture layouts, need not be uniform throughout a complete floor, but can be varied according to space function—private office, secretarial area, circulation, etc. This realization has led not only to task/ambient systems, but also to varied fixture spacings for different areas, and even to non-uniform spacing of fixtures in task areas.

If potential energy savings are to be realized with lighting environments that people are happy with, more time will be required from lighting designers, engineers and architects, and more effective collaboration among these groups will be needed. For example, lighting consultants point out that reflectances of interior finishes are more critical with the newer systems. This applies not only to task/ambient systems for which light colors are favored, but also to some ceiling fixture systems which may seem to produce rooms that look too dark if lighting levels are 60 fc or less, and if the room finishes have low reflectances.

Another facet of lighting design that is going to change is the specification of foot-candle levels. A greater responsibility in making decisions on lighting levels is about to be thrust on the professions if current proposals of the Illuminating Engineering

Society go ahead as anticipated. Plans are for IES to depart from the one-number system for footcandle levels published in the society's recommended practices. Instead, *recommended ranges* of levels will be given along with modifying factors that take into account such variables as: a) age of occupants, b) speed and accuracy required for tasks, and c) reflectance of the tasks. The recommended illuminance ranges will be in so-called "raw footcandles" and not ESI (equivalent sphere illuminance). ESI footcandles produced by a lighting system are a measure of the efficacy of a lighting system with respect to the veiling reflections (light that is reflected into the viewer's eyes, reducing contrast of the task and, hence visibility) that occur with the system. For most lighting systems, except for those producing oblique directional light (valance lighting or windows, for example), ESI footcandles are less than raw footcandles which are a measure of all light that falls on a task. The recommended practices will indicate, however, for which kinds of tasks ESI evaluations should be made. The implication of this obviously is that designers will have to make more careful evaluations than most of them have in the past of occupancies and tasks to arrive at the quantity of light, as well as the quality, for different functions.

Robert Perron



Continual improvements in high-performance fixtures make possible high quality illumination and visual comfort along with lower watts per sq ft power requirements. For example, the twin-beam parabolic fixtures used in the new offices of Joseph R. Loring & Associates, consulting engineers, provide 80 fc of lighting at only 1.5 W per sq ft. The 1- by 4-ft parabolic fixtures are 6 ft apart in rows 5 ft on center. This fixture has about a 10 per cent higher efficiency than previous parabolic fixtures. The reason is that it has fewer lateral louvers and emits light at higher angles laterally, so less light is trapped within the fixture itself. Even so, it still has a high visual comfort rating. And because of the fixture's twin-beam light distribution (between 30 and 60 degrees) veiling reflections that hinder visibility are greatly reduced. Lighting designer for the Loring office is Rick Shaver.



The parabolic fixtures used in the 5-by-5-ft ceiling coffers of Air Products & Chemicals corporate headquarters provide 80 fc of light at 1.8 W per sq ft, and have gold-tinted anodized aluminum, semi-specular aluminum reflectors and baffles to enhance the color of the warm-white fluorescent lamps. Most of the light output in a plane perpendicular to the fixtures occurs between 25 and 40 degrees on either side of the fixture to reduce veiling reflections, while providing a very high degree of visual comfort with respect to direct glare. While this fixture has a higher visual comfort rating than that shown on the previous page, it is somewhat less

efficient (fixture lumens/lamp lumens). Architect for the building was The Eggers Group, and lighting designer was James D. Kaloudis of Meyer, Strong & Jones, consulting engineers.

Parabolic reflector-and-baffle fixtures resulted initially from innovative manufacturers' desire to produce a low-brightness fixture that also had a high efficiency. Early versions had a bell-shaped photometric curve, but as veiling reflections came to be recognized as a serious problem, fixture manufacturers designed reflector optics to provide twin-beam distribution in the plane perpendicular to the fixture.



New fixtures have higher efficiencies along with high visual comfort ratings

A low-energy system for office buildings gaining increasing favor utilizes parabolic fixtures that can produce 70-80 footcandles of illumination with power requirements of only 1.5 to 1.8 watts per sq ft. They cost more than the popular prismatic-lens fixtures, but their lower energy consumption permits a payback within 2 to 4 years within a power-rate range of 9 to 4½ cents per kWh. Because of the favorable payback picture, the parabolic fixture is being used in not only owner-occupied buildings but quality multi-tenanted buildings as well—their lower energy use makes economic sense (rents can be less), and the lower brightness of the fixtures results in a more attractive installation.

Early in the application of the fluorescent lamp, fixture designers recognized the need

for a balance between fixture efficiency and fixture brightness, and developed various control devices to accomplish this, namely egg-crate louvers, and, more recently, prismatic lenses. Flat prismatic-lens fixtures are quite efficient in directing light to tasks. Egg-crate louver fixtures, on the other hand, are not very efficient because the closely-spaced louvers absorb light, especially if their paint is off-white, or they are dirty.

Though fixtures utilizing the popular type of prismatic lens are efficient in directing light to tasks, they are not without their negative points. The clear prisms of the flat-type lenses pass a lot of light in a pattern between zero degrees (i.e., directly under the fixture) and 45 degrees or so to either side. Because 25 degrees is a common viewing angle of people at desk work, this kind of light can result in veiling reflections if the

fixture is over the task. Furthermore, the common type of flat prismatic lens is fairly bright in appearance. Other types of lenses have been developed to counteract these problems utilizing a twin-beam (also known as bat-wing) type of light distribution. Armstrong attacks the problem by using wrap-around lenses with high-angle distribution from the sides in a triangular-shaped coffer ceiling such that the coffer itself is well lit, and tasks get good ESI illumination.

The newest developments in lighting fixture design for high efficiency and low brightness center around the parabolic reflector, relying upon the geometry of the fixture to direct light into the most useful zones, while also limiting brightness. The parabolic fixture has changed quite a bit since it was introduced in the '60s, principally in making it more efficient (i.e., fixture output/lamp

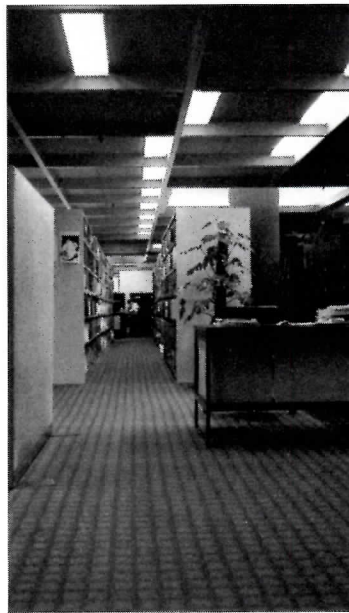

Flexible task lighting is not confined to furniture integrated systems, but is possible with ceiling fixtures as well. With hard-wired fixtures, flexible armored cable is limited by code to 6-ft lengths. With systems such as the one shown here in the Government of Canada Building in Toronto (see mid-August, 1977) power cords that plug into exposed raceways allow practically limitless arrangements of lighting fixtures. Fixtures can be located as needed at task locations, and there are six possible positions for a fixture within each ceiling-grid module. The ceiling grid allows installation of power poles. Associated architects were DuBois-Strong-Bindhardt and Shore Tilbe Henschel Irwin. Electrical engineers were Jack Chisvin & Associates, Ltd.

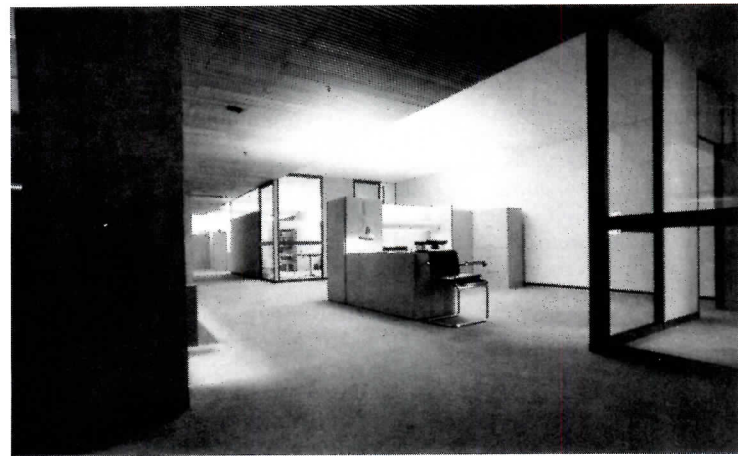

The growing use of task/ambient lighting systems has made architects aware that uniform lighting levels for offices need not be a foregone conclusion—that, on the contrary, lighting systems can be task-oriented. But in general, these systems require application of greater design skills if they are to be done well. For one thing, more careful attention needs to be given to reflectances of room finishes and furniture to avoid unpleasant brightness contrasts, and to how light is distributed at work stations. And because of the higher brightnesses of ceilings when indirect systems are used for ambient light, the designer needs to consider whether interior wall surfaces should be separately lighted so they don't appear too dark. Perimeter offices

with sufficient window area do not have this problem in daytime because daylight provides a more balanced brightness situation.

The offices shown here are in the Federal Home Loan Bank Board Building in Washington, designed by Max O. Urbahn Associates. Lighting designer was James Nuckolls and consulting engineers were Syska & Hennessy. The ceilings have acoustical tile at the perimeter, while the spine of the building is defined architecturally by a wood-slat ceiling which mutes the uplight somewhat. The work-station fluorescent fixture has a refractive-grid lens on the top to spread uplight and a batwing lens on the bottom. Uplight also is provided from the utility module adjacent to the desk.

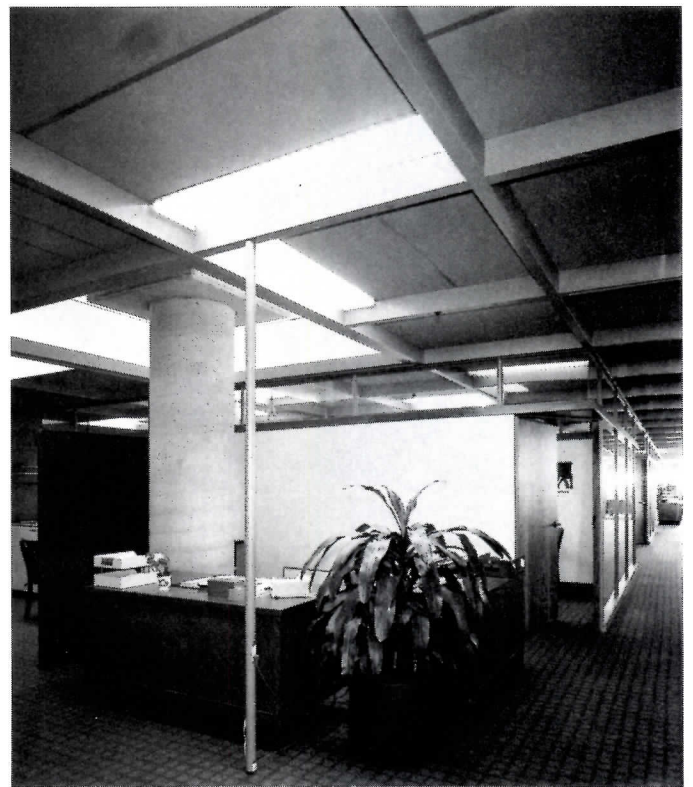

output) and developing a twin-beam distribution to reduce veiling reflections. The first parabolics were practically invisible—following on the heels of the dark-type cone downlight invented by Edison Price. Fixture manufacturers and designers recognized that optical design could be used to configure fixtures for very low brightness, but with good efficiency, and the result was a fixture having a parabolic reflector of semi-specular aluminum, divided into cells by parabolic louvers of the same material that shielded the lamp from view. Light output had a somewhat bell-shaped distribution. One of the early parabolics with a different type of distribution—twin beam—was developed by Columbia Lighting Inc., for use between stacks in a library—illumination of the books being the prime objective. The fixture had low brightness and spread the light out on either side.

Although the lighting industry was aware of the deleterious effect of veiling reflections, little was done in fixture design to counteract it until Dr. H. Richard Blackwell demonstrated the degree to which they degrade visibility. Reflected glare can be minimized by a number of techniques including: positioning of light sources with respect to tasks so that light is not reflected at viewing angles; indirectly lighted ceilings; fixtures and lenses that shift light output out of the veiling reflection zone (i.e., from zero to 30 degrees); and multi-layer polarizer materials.

The first parabolic fixtures designed with the purpose of reducing veiling reflections were introduced about 10 years ago. Narrowbeam light distribution was a feature of some of these, confining light output to between 25 and 45 degrees to keep light rays out of both reflected-glare and direct-glare

zones. An innovative approach taken by one manufacturer, Lightolier, was a two-lamp fixture with one 40-W lamp located directly over the other one. Thus, one lamp could be turned off while preserving an evenly lighted appearance.

Now a new generation of twin-beam parabolics is emerging with substantially higher efficiencies than heretofore, but also with good visual comfort characteristics. This has been achieved by pushing more light out at higher angles and by using less shielding for the bare lamps (i.e., less louver area). For example, a new fixture by Edison Price has 8 cells rather than 12, and its output peaks at 50 degrees, which is higher than usual; shielding is 30 degrees parallel and perpendicular to the fixture. A lot can be done to raise fixture efficiency by reducing louver area, points out lighting consultant Joseph DiBernardo, who

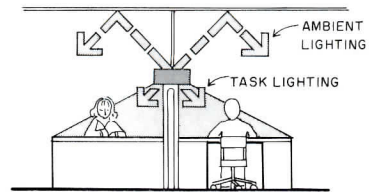
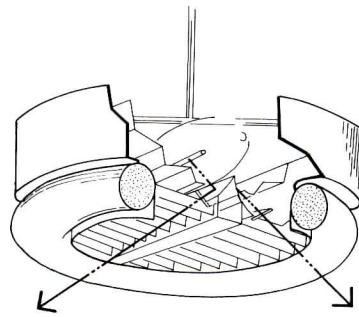
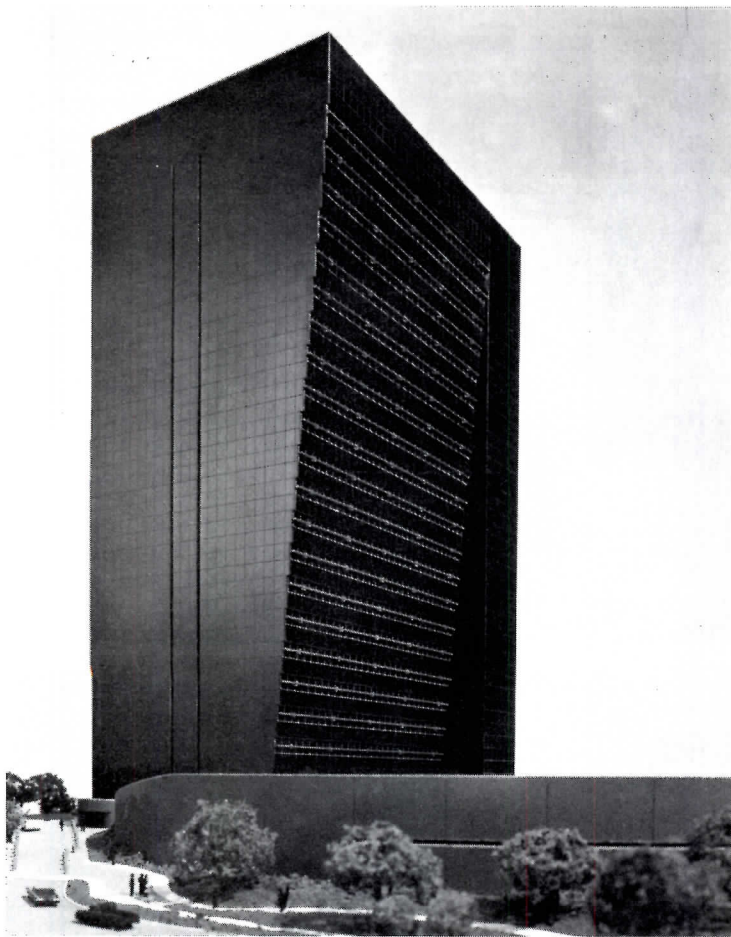

In their search for a light source that could provide ambient light indirectly, while producing a direct beam of supplemental task illumination, Heery & Heery, Architects & Engineers, Inc., came up with the unique pendant fixture shown here that uses 150- or 200-W high-pressure sodium lamps to provide an average of 50 plus footcandles on the desk with the smaller lamp, and 85 plus fc with the larger one. The fixtures are to be used in the new 24-story corporate headquarters building of the Georgia Power Company in Atlanta. One fixture serves two 14- by 14-ft cubicles, and wattage densities for open spaces is about 0.5 ft for the 150-W lamp and 0.8 W/sq ft for the 200-W

lamp. Design of the upper optical system was based upon existing reflector designs, but the lower system was specially developed for this installation by Douglas Bulleit of Heery & Heery in association with Gardco Lighting. It comprises a beam splitter that shades the tops of the partitions, collects the downward component from the HPS lamp, and directs this light through two prismatic lenses that spread the light uniformly across the desks. Louvers for glare control and redirection of light beams are matte gray on one side and specular aluminum on the other. A carefully selected interior color scheme was used sympathetic to the color of the light.



says that since louver shape is fixed, efficiency can be increased by using more louvers of less depth, or fewer louvers of greater depth. One fixture manufacturer, Lighting Products, Inc. has a line of parabolics that has no louvers at all, so its efficiency is commensurately higher. Even though there are no louvers to shield the lamp lengthwise, observers state that subjectively its appearance is good with respect to brightness.

Task lighting continues to evolve, whether it's built into furniture or ceiling mounted

In the last few years, manufacturers of furniture integrated lighting have become more conscious of the problems of veiling glare, and have developed various techniques to minimize it. JG Furniture Co., Inc. has a sliding shield in their under-cabinet task light which the user can move to block veiling reflections

depending upon where the task is located on the work surface. Keene Corporation in its pedestal task fixture has two segments of bat-wing lenses in the center oriented 90 degrees to each other. Lighting consultant Sylvan Shemitz's approach has been a tilted bat-wing lens under furniture cabinets; and he also has developed a pedestal lamp that is mounted at the free end of a desk. A completely different system comes from SPI lighting, Inc., which prefers to call its approach ambient/task lighting since most of the work light comes from light reflected from the ceiling by metal-halide fixtures on top of the furniture or in separate light columns, using reflectors that fan out the light in a broad, even pattern. They also have a pedestal-type fluorescent fixture for mounting at ends of desks that uses an 8-W fluorescent lamp.

Of course, it's no secret that task-oriented lighting can be achieved with ceiling-mounted lighting fixtures, and flexibility is possible if means are provided for fixtures to be moved around. One approach to this, illustrated on page 133, is to provide fixtures with power cords that can be plugged into ceiling raceways and located wherever needed in a modular ceiling grid.

The relative advantages and disadvantages of furniture-integrated task/ambient lighting systems have been written about frequently. The portability of the lighting for changes in open-plan offices along with the faster tax write-off for lighting in furniture are two advantages often cited. The power density in watts per square foot may or may not be less than a conventional ceiling system, or a system that utilizes ceiling lights for the ambient light and has task lights within

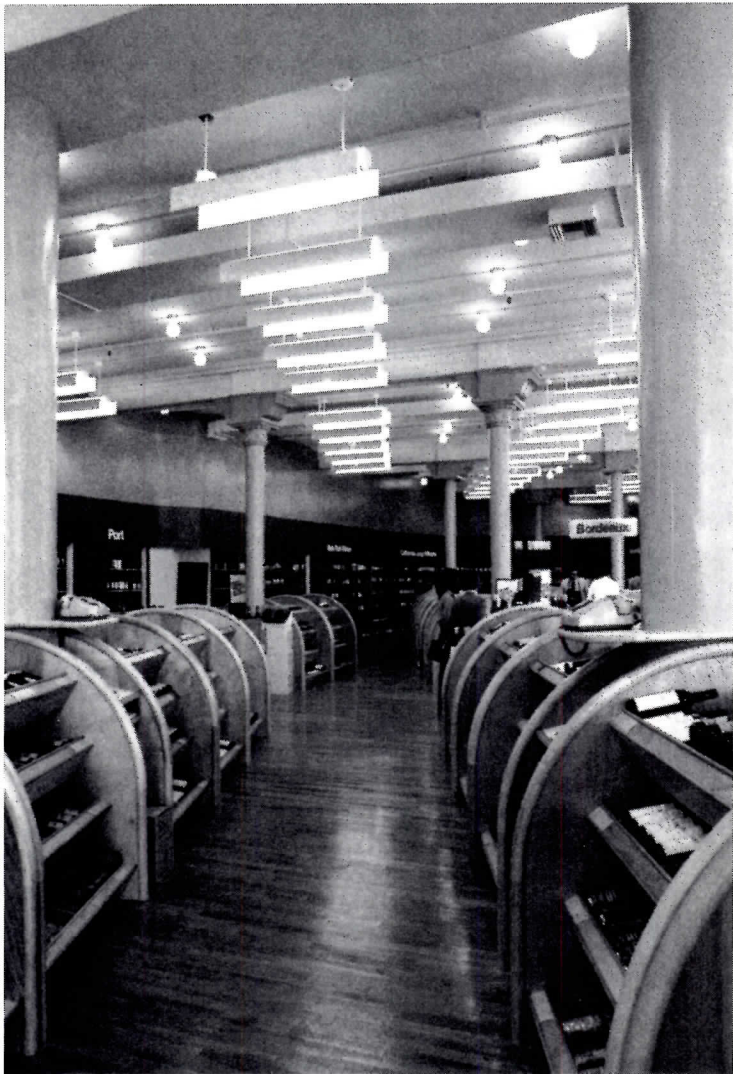
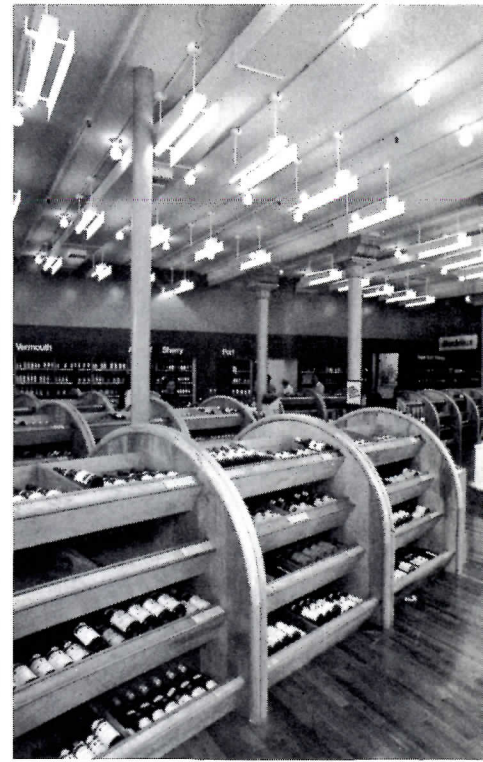

Now in the final stages of face-lifting is a building housing Astor Wines & Spirits—a sort of “supermarket” for alcoholic beverages—in the historic area of New York City at Astor Place on the Lower East Side. Design of the modernization is by architects Beyer Blinder & Belle who asked lighting consultant Howard Brandston to develop a ceiling lighting system that would be in character with the merchandising approach, but less energy-intensive than the 4-lamp bare fluorescent strips that the store had before. The lighting comprises 4-ft 800ma warm-white lamps interspersed with 60-W globe incandescent lamps to add interest and color.

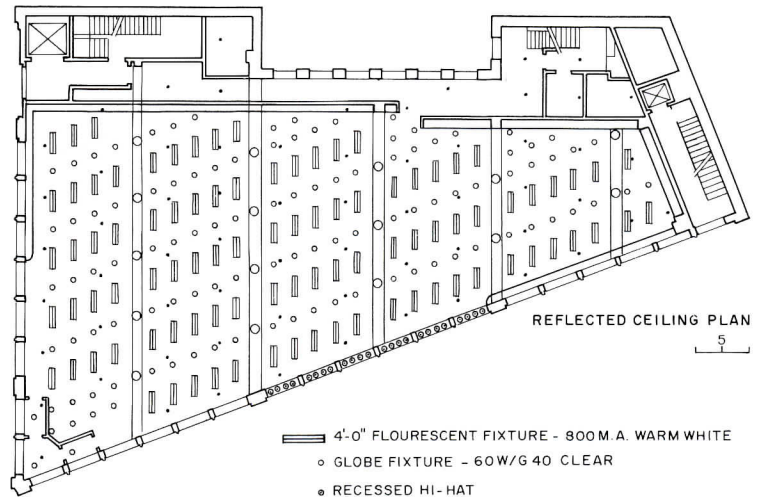

the furniture. This is affected by how closely work stations are spaced. Against these advantages are, first, the higher electrical distribution costs (because furniture integrated lighting must be served at 120 V rather than 277 V used with ceiling-installed lighting), and, secondly, the higher cooling loads on the air-conditioning system when all the lighting fixtures are within the room; ceiling-recessed lighting fixtures are assumed to contribute only half their heat load to the occupied space.

Finally, task/ambient systems must be carefully thought through and designed with respect to reflectances of ceilings, partitions, desks and carpet, and with respect to distribution of light in the room, and at the work space, to achieve sufficient, good quality light without unpleasant brightness contrasts. Both high ceilings and windows ameliorate the

brightness contrast situation.

On-off switching or dimming of lamps is a promising approach for saving energy

Taking advantage of daylight and shutting off or dimming lights by automatic control seems to hold out more and more promise for energy savings and reduction in operating costs as the cost of energy escalates. On-off automatic control can be shown to be cost-effective now. Systems can be designed with built-in delays so that they are not affected by passing clouds, but making such systems psychologically acceptable is a potential problem. Because dimming is gradual, it is less noticeable, but it costs more initially. On the other hand, dimming systems can save more energy. Payback periods are difficult to arrive at because of the number of assumptions that have to be made and because of the rapidly

changing technology. But signs point to acceptable paybacks for owner-occupied buildings within the near future. Systems on the market now utilize photocell sensors tied into a controller that regulates the current to high-frequency ballasts. Another approach for which working components exist, but UL-listed fixtures are not yet available, utilizes fiber optics and photocell sensors to regulate the current to conventional ballasts.

A still different approach utilizes a microprocessor to permit individual fixtures or groups of fixtures to be switched to high, low or off conditions. Commands can be generated by clock, photocell, or even a telephone call. The commands go into the microprocessor, which then sends out signals as a carrier current over conventional power lines. Each fixture or group has a receiver/switch which will accept only the signal intended for it or

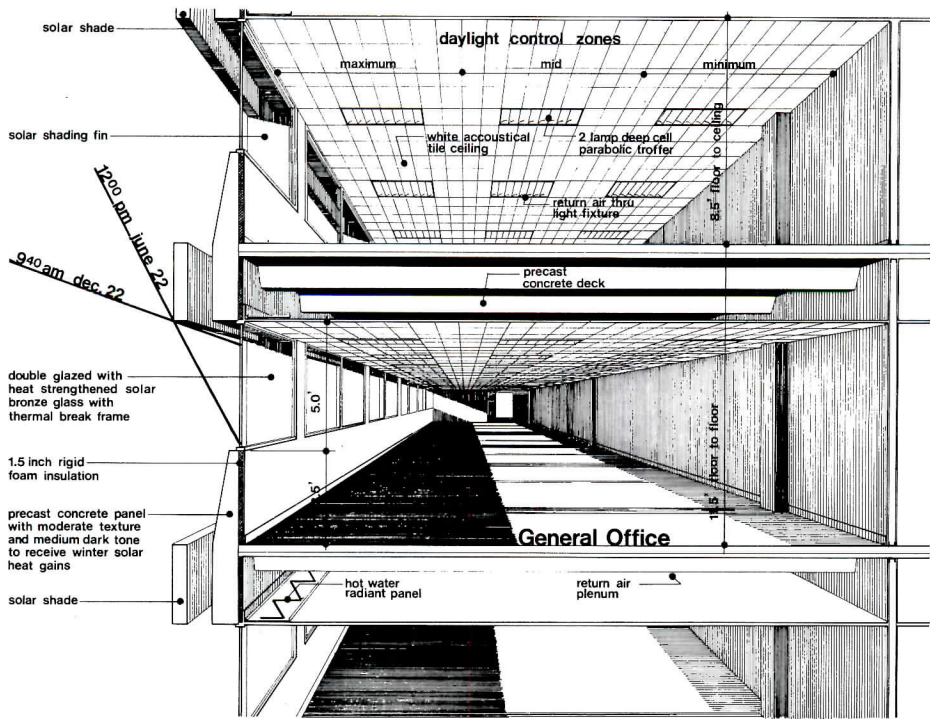

Switching off lights when daylight is sufficient seems a very promising way to save energy while maintaining quality lighting conditions. The project shown here is a "redesign" of a building from Phase II of the AIA Research Corporation's Baseline Study whose objective was to develop design energy budgets for the Federal government's proposed building energy performance standards. Purpose of Phase II was to get some idea of how much improvement architects and engineers could achieve over performance of buildings finished in 1975 and 1976. Electrical engineer Garland D. Cox proposed automatic control of lights in three bands of daylight control zones for this office building near Denver. Architect Brooks Waldman Associates developed solar-control devices for the facade, and minimized window exposure on the north side.

For two 34-story office buildings now in design for Denver, Cox has proposed controlling the lights in just two bands.

the group. A prototype installation has been installed by AT&T at Basking Ridge, New Jersey for the control of 300 lighting fixtures.

New fluorescent and HID lamps give many options to the lighting designer

It has been said that a new generation of light sources has been introduced about every 15 years, and, on that basis, we seem to be due for another new generation. But meanwhile the emphasis of manufacturers has been on refinement of what we have now: new wattages, new colors, and new systems.

Recent developments in fluorescent lamps involve refinements in light output and depreciation characteristics, reduced wattage configurations, and improvement in color rendering through new phosphor mixes.

The most popular fluorescent lamp types are now available in energy-saving versions, generically called reduced-wattage lamps. All of these have less lumen output, some less than others, but the reduction is not as great as the reduction in wattage. A line of high-performance ballasts has been produced as an efficient match for the reduced-wattage lamps.

In another area, new phosphors have been developed for fluorescent lamps to increase lumen outputs, lumen maintenance and rated life of lamps. For example, a new 3000 K (color temperature) lamp combines the characteristics of the warm-white-deluxe lamp with the high output of the standard lamp, offering 80 lumens per watt compared with 55 lpW for warm-white-deluxe.

Another manufacturer uses new phosphors to produce a narrow trio of wavelength bands—blue-green, pure green and orange-red—to achieve a white coloration similar to deluxe fluorescent lamps. This "prime-color" lamp appears to match wavelengths most sensitive to the human eye. The premium-priced lamp is available in 3000 K (warm) and 4100 K (cool) chromaticity,

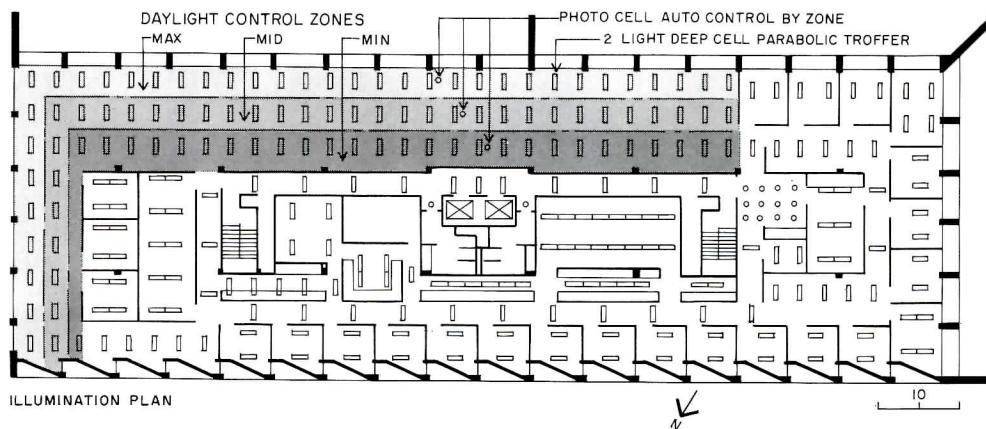

One of the most significant developments in the last decade has been the introduction and improvement of high-pressure-sodium (HPS) and metal-halide (MH) lamps. Both lamp types are the first sources available for general lighting with efficacies higher than 100 lumens per watt. The high-pressure-sodium lamp, with rated life of 24,000 hours, has excellent lumen maintenance. Available in sizes ranging from 50W to 1000W, the HPS lamp is finding increased application in building interiors, often in lobbies and high-ceiling spaces. Mixed with MH lamps, it has been used not only in atrium-type spaces but also for the indirect lighting component of ambient/task lighting systems. One manufacturer offers the HPS lamp in a 250-W size which is claimed to have an improved color-rendering index of 65, whereas the standard lamp has a CRI of only 25, and MH lamps have a CRI of 55. The higher CRI of the 250-W lamp is achieved by operating the arc tube at a higher temperature than normal. The lamp's efficacy and life are reduced, however, in comparison with standard lamps.

The metal-halide lamp is available in a variety of wattages, and in sizes lower than

400W is being used frequently in stores. The rated lamp life ranges from 8,000 to 15,000 hours with satisfactory lumen maintenance. MH lamps with a phosphor coating are used where an added red color component is wanted along with softer light.

With ordinary mercury-vapor (MV) lamps, different phosphor coatings are used to give different colors—often called "warm-white" or "warm-white-deluxe", etc. This lamp is useful where burning hours per start are long and replacement costs are high (where fixtures are difficult to reach and service). However, a fluorescent lamp also is efficient for the same application, so a careful weighing of alternates should be made.

Though incandescent lamps are the least efficient of all, their low unit cost, preferred color quality, simplicity of wiring and control, and wide variety of shapes and sizes continue to sustain the popularity of this lamp type. To provide a slightly higher efficacy and/or longer burning hours, incandescent lamps are now available with Krypton gas fill. Also a new type of elliptical reflector lamp focuses the light beam ahead of the lamp, and reduces the amount of light that might be trapped in a deep-baffled downlight fixture.

For more information, circle item numbers on Reader Service Inquiry Card, pages 209-210

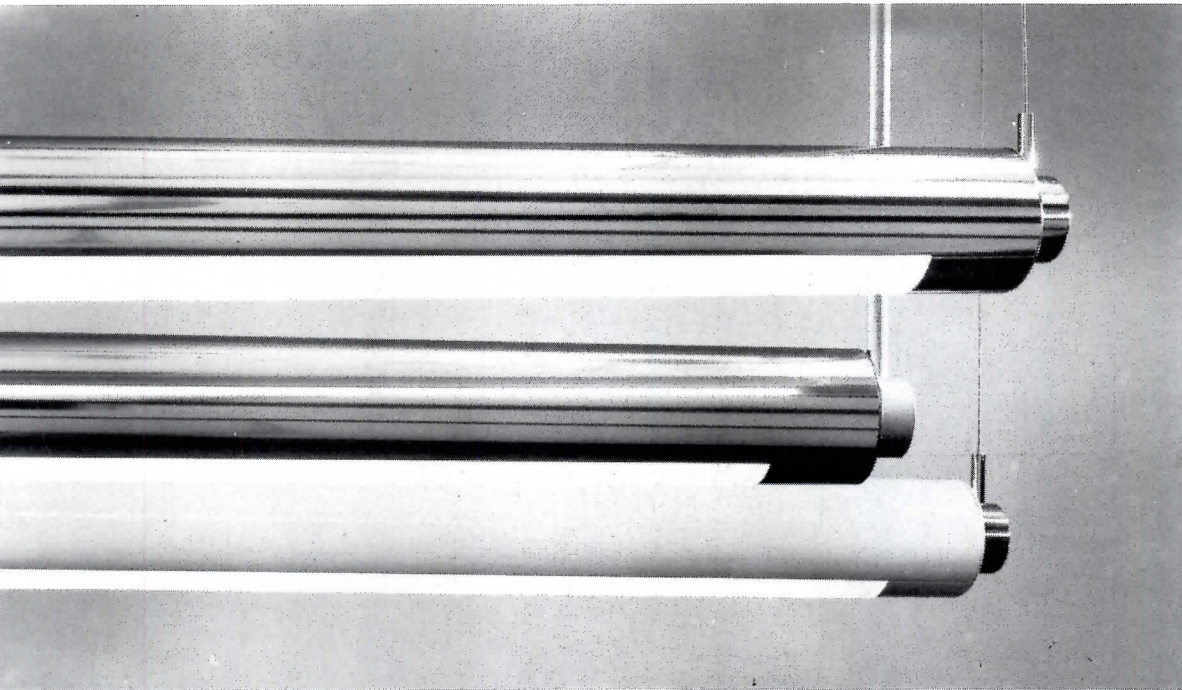

Light fixtures are sleek cylindrical design

The Designers Group 3 Collection (left) encompasses an elegant, formal design for lighting. Called "Lytetubes," the cylindrical tube is finished in white, polished brass or aluminum, and narrows the light streaming from fluorescent tubes. The light is softened by a curved, striated acrylic diffuser inside the fixture. The tubes can be stem-mounted or cable-suspended (for a "floating effect"). Suggested installation include reception areas, bank counters, display shelves and kitchen work spaces.

■ Lightolier, Jersey City, N.J.
circle 300 on inquiry card

Soft modular seating flows with curvilinear design

A modular system of square- and wedge-shaped seating units (below), called SLOPE, is available with or without seat backs and arms, and can be arranged as individual units or mechanically connected to form a variety of linear and curvilinear configurations. The seats are fluted, and bases can be either standard black or optional chrome. ■ JG Furniture, Quakertown, Pa.

circle 301 on inquiry card



The newest line of conference tables (above) for Vecta Contract is the "Ginkgo Biloba," named for its resemblance to the leaf shape of the Ginkgo tree, designed by Gunter Eberle. Particularly stylish, the base is three T-shaped legs of polished aluminum with a vertical fillet at the junction of the

Attractive table highlighted by special base design

column and members to reduce the size of the joint while adding strength. About 35 different standard sizes are available with variations in 16 different colors for the base and four wood veneers.

■ Vecta Contract, Dallas.

circle 302 on inquiry card
more products on page 147

PLEXIGLAS® DR®

Where extra toughness counts!

For Lighting Lenses and Diffusers With A Longer-Lasting, Like-New Appearance

What will your new lighting lenses and diffusers look like three years from now?

If you're concerned that they won't retain their original appearance for long, it's time you specified lenses or diffusers extruded, injection molded or thermoformed from PLEXIGLAS DR acrylic plastic.

PLEXIGLAS DR makes the toughest, most cost effective acrylic lenses and diffusers available today, enabling them to resist attacks by vandals. And with PLEXIGLAS DR, you get a resistance to yellowing due to ultra-violet radiation that is unsurpassed among vandal-resisting products.

Write today for technical data, code information and design assistance on PLEXIGLAS DR.

the trademark

PLEXIGLAS
PLEXIGLAS DR

the company

**ROHM
& HAAS**
PHILADELPHIA, PA. 19105

In Canada: West Hill,
Ontario M1E 3T9

Circle 62 on inquiry card

Plexiglas acrylic plastic is a combustible thermoplastic. Observe fire precautions appropriate for comparable forms of wood. For building uses, check code approvals. Impact resistance a factor of thickness. Avoid exposure to heat or aromatic solvents. Clean with soap and water. Avoid abrasives.



For more information, circle item numbers on Reader Service Inquiry Card, pages 209-210

EMERGENCY LIGHTING / A full line of lamps for use in emergency lighting applications—incandescent, halogen and miniature halogen—is described in an illustrated brochure. Technical data include foot-candle distribution curves, beam spread, candle power and approximate lumens. ■ Mule Battery Co., Inc., Cranston, R.I.

circle 400 on inquiry card

SPECIAL/ROLLING DOORS / Color catalog presents complete architectural details on a full line of rolling metal doors and fire doors, rolling grilles, shutters and packaged units, rolling fire shutters and sliding chain link grilles. New products include rolling grilles glazed with acrylic panels forming a 96 per cent "see-thru" barrier, and an egress opening system for rolling grilles. ■ Connell Iron Works, Inc., Mountaintop, Pa.

circle 401 on inquiry card

PLASTIC SIGNAGE / Dimensional lettering products for product or department identification, displays, office and informational signs, etc., are shown in a condensed catalog. Thirty styles of 1/8-in. Plexiglas and 1-in.-thick high-density foam letters, numerals and accessory items are available in many sizes, colors and finishes. ■ Scott Plastics Co., Sarasota, Fla.

circle 402 on inquiry card

AIR-SUPPORTED STRUCTURES / Brochure describes this manufacturer's fabric products, their application and technical information, including a bias steel cable harness net system and heat-welded thermaliners. Air-supported structures for industrial, construction, and recreational use are shown; reservoir/pond liners and floating covers are also included. ■ Air-Tech Industries, Inc., East Rutherford, N.J.

circle 403 on inquiry card

ACRYLIC CARPETING / Technical bulletin discusses the general properties of all *Acrlan* acrylic carpet fibers, as well as the unique properties of type "B-99" producer-dyed fiber. Five luster variations, from semi-dull to bright, are covered. ■ Monsanto Textiles Co., Decatur, Ala.

circle 404 on inquiry card

MATERIALS HANDLING EQUIPMENT / A 16-page color booklet describes all products and services of this company's Material Handling & Storage Products Division. Selective pallet racks of various types are included, as well as conveyor components and systems; manual, semi-automated and automated storage systems; and *Courier* storage machines. Color photographs illustrate a number of actual installations. ■ Interlake, Inc., Material Handling & Storage Products Div., Chicago.

circle 405 on inquiry card

AUTOMATIC SPRINKLERS / A miniature glass bulb unit, the "Decor" sprinkler head is offered in dependent, upright and sidewall versions. A color catalog describes the new sprinkler line, as well as standard link and lever models for wet and dry pipe systems. ■ The Viking Corp., Hastings, Mich.

circle 406 on inquiry card

HEALTHCARE CASEWORK / Product folder presents mobile and stationary lines of bedside cabinets, dresser desks and wardrobes of all types, constructed with a steel frame and finished in solid color or wood grain laminates. Also shown are mirrors, trays, towel bars and other basic accessories. ■ Norco Mfg. Corp., Missoula, Mont.

circle 407 on inquiry card

ACOUSTICAL WALLS / An illustrated booklet gives laboratory-certified ratings and field test results for the *Trackwall* operable-wall system; the Sound Transmission Class levels of 70, 51 and 50 for various *Trackwall* models are said to be the highest available for this type of acoustical wall. Design and engineering characteristics of the overhead-track-mounted room divider are discussed. Also covered are industrial versions of the system which meet OSHA, EPA and other noise regulations. ■ Industrial Acoustics Co., Bronx, N.Y.

circle 408 on inquiry card

TRASH COMPACTOR / Four-page color brochure on the *Compact-It* portable compactor explains how trash handling costs can be lowered by reducing refuse storage space from 50 to 90 per cent, depending on waste materials. ■ Metalfab, Inc., Beaver Dam, Wis.

circle 409 on inquiry card

ENERGY MANAGEMENT / Consulting services brochure outlines energy management capabilities aimed at reducing a particular firm's energy costs. The six-step process described involves investigation, recommendations, and verification. Also discussed is an analysis approach which uses computerized techniques, zero-based budgeting, life-cycle costing, and cost/benefit analyses. ■ Wilson Associates, Inc., Oak Brook, Ill.

circle 410 on inquiry card

CERAMIC TILE STOVES / Even, long-lasting heat produced by efficient combustion of small amounts of wood or coal is claimed for the German-made "Koppe" stoves pictured in a color brochure. Internal ducts transfer hottest heat safely into the room by convection; the ceramic tile exteriors warm the air by radiation. Stoves have glass viewing doors; tile surfaces are available in many colors. ■ Finest Stove Imports, Inc., Silver Spring, Md.

circle 411 on inquiry card

BUILDING PRODUCTS / Current catalog contains colorful illustrations and detailed reference information on a full line of prefinished panelings, exterior siding and gypsum products. Materials, sizes, finishes, patterns, code approvals and installation data are given in the 88-page booklet. ■ Georgia-Pacific Corp., Portland, Ore.

circle 412 on inquiry card

STEEL DOORS / A 16-page booklet explains how a door system affects a home's over-all energy efficiency performance. The *Therma-Tru* insulated steel door, with a refrigerator-like magnetic weatherstrip, is shown in some of the over 70 styles available. ■ Lake Shore Industries Inc., Toledo.

circle 413 on inquiry card

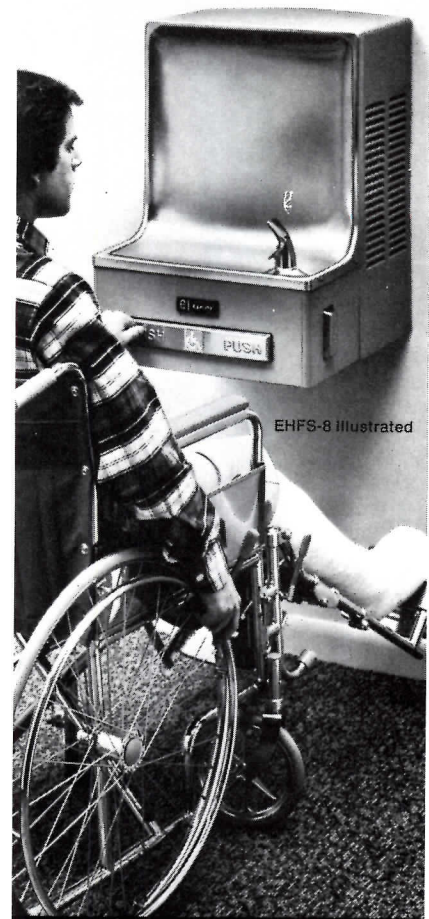

Specify Elkay's barrier-free line —and more!

Start with Elkay's non-pressurized storage tank—a system that prevents flooding, if failure ever occurs, because *only* stored water is released.

Other features on most Elkay models include anti-splash basin, fast recovery rate, and "open interior" design for easy installation. Complete selection of wall, floor, semi- and fully-recessed, and barrier-free applications. Write for free literature, or contact your Elkay representative.

Elkay Manufacturing Company
2222 Camden Court
Oak Brook, Illinois 60521



Circle 63 on inquiry card



**THE NEW
GUARD.[®]
OLD AS
TIME.**

Witness the nature of new Guard.[®] New textured patterns drawn from the timeless earth. Weathered wood in new "Splinters." Woven grasses in new "Djakarta." And the history of timeworn mountains in new "Sand Stripe." Elegant, warm, simple...the perfect inner environment. And all are economical, care-free Type II material, designed first of all to last. Get in touch with these and all the other time-honored Guard vinyl wallcoverings in the Guard sample book, now with 35 designs and 800 colors to choose from. Send for more information and sample swatches. Columbus Coated Fabrics, Columbus, Ohio 43216. But hurry. Time waits for no one.



GUARD[®]
VINYL WALLCOVERING

Circle 64 on inquiry card

ENERGY MANAGEMENT SYSTEM / Designed for controlling from five to 15 loads, the *Powerwatch 515* can handle up to eight different schedules for each circuit each week. It can also remember all holidays a year in advance; automatically adjust for daylight savings time; and can run for 10

days without power. Each circuit may be independently scheduled for any on or off time, and can be adjusted for a wide dynamic range of duty cycles. The *Powerwatch* is capable of load shedding, time-of-day billing and demand controlling. Energy management systems are priced from \$15,000 and up. ■ Trimax Controls, Inc., Sunnyvale, Calif.

circle 304 on inquiry card

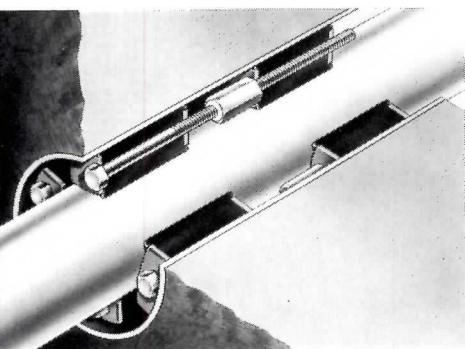

FIRE-RATED SEALING UNIT / The *Pyro-Pac* seals around pipes, cables and electrical conduits which penetrate floors, walls, roofs and other building structures, preventing the passage of flames, smoke, gases, water and other dangerous substances. Constructed of inorganic materials, the *Pyro-Pac* is made up of two individual but joined fire-resistant silicone rubber sealing units. The factory-assembled seal is inserted in the space between the pipe and wall, and as the bolts are tightened, the two rubber seals are expanded by their respective set of pressure plates. *Pyro-Pac* seals meet ASTM E-119-76 criteria for a three-hour fire rating, and are said to be easily installed by regular contractor personnel. The seals are offered in sizes to fit any pipe, from 1/2-in. up to 120-in. diameter or larger, and can be used to upgrade existing construction to meet new fire codes. ■ Thunderline Corp., Wayne, Mich.

circle 305 on inquiry card

WHEELCHAIR ELEVATOR / Originally developed in Switzerland, and now manufactured in Canada, the *Garaventa* inclined stair lift will take a wheelchair and its occupant, up a straight, curved or corner staircase, even those only one-meter wide. The elevator platform is supported on two parallel tubes fixed to the inside wall of the staircase; the tubes also contain the wire haul cable and act as handrails. The platform folds out of the way when not in use. The *Garaventa* elevator is said to be easily installed in buildings up to three stories high; each individually designed system can preserve original banisters and stair paneling if desired. Safety features include self-locking worm drive; automatic stop switches and cut outs if obstacles are met; and hand ratchet operation during power failures. ■ Garaventa (Canada) Ltd., Surrey, B. C.

circle 306 on inquiry card

LARGE DOCUMENT COPIER / The "790" desktop office copier has been designed for users with frequent large document and reduction copying requirements. It accepts any size original up to 11 by 17-in. in size, and produces copies from 8- by 10 1/2-in. to 11- by 17-in. at speeds up to 28 copies per minute. When operating in reduction mode, it will produce 8 1/2- by 11-in. copies from large format originals at a speed of 20 copies per minute. ■ Savin Business Machines Corp., Valhalla, New York.

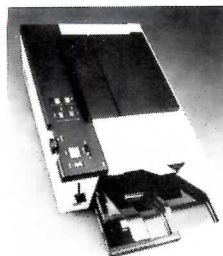

circle 307 on inquiry card

EMERGENCY LIGHTING / Two fixtures have been added to the *Lumenette* line of battery-operated emergency lighting equipment, each self-contained and completely automatic. These are the "ML-4" for applications requiring up to four remotely-connected lighting heads or exits; and the "ML-5", a 12-volt unit designed for use where long-runs of remote fixtures are required; it will power up to five lighting heads. Glare-free lights can be either top-or side-mounted. Fixtures meet or exceed OSHA, NEC, NFPA Life Safety and other state and local codes. ■ Dual-Lite Inc., Newtown, Conn.

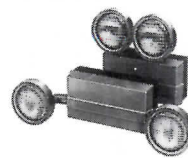

circle 308 on inquiry card

more products on page 149

Granite.

A step up to beauty.

A step up to wearability.

Forever-lasting beauty that requires no maintenance, adds a stepping stone to prestige, elegance. Choose from twenty colors, endless shapes and patterns, and all the expert help we can give you. Consider the character of mixing more than one color or pattern in an application.

For more information, and a packet of full color literature illustrating Cold Spring Granite products in use, call toll free **800-328-7038**. In Minnesota call (612) 685-3621, or write to the address below.

I.D.S. Center, Minneapolis, MN
Architect: Philip Johnson &
John Burgee, New York, N.Y.

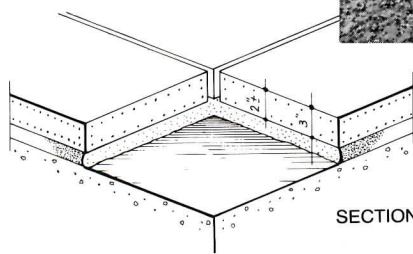

SECTION



Cold Spring Granite Company, Dept. AR-7

202 South 3rd Avenue, Cold Spring, MN 56320

Circle 65 on inquiry card

With Dukane sound masking, the office can be open . . .

Open offices are wise investments in many ways. They dramatically increase usable floor space and reduce maintenance costs. Lower heating and cooling costs. Help cut construction and rental costs. Offer outstanding flexibility when changing office layouts. Save time and money. Even help build efficiency and employee morale.

Dukane sound masking makes the open office even more practical. These electronic systems help achieve a higher degree of speech privacy in a busy office. Allow personnel to converse freely, while helping preserve greater privacy for each work station.

Dukane sound masking works by preoccupying the ear, yet goes unnoticed itself. It is one of four essential ingredients to obtain the ultimate

in a pleasant open office. The others are sound-absorbing dividers, ceiling tile and carpeting.

Dukane has more than 50 years experience with sound systems and a nationwide organization of distributors. They can custom-design a sound masking system for the acoustical conditions of your open office . . . also master clock, intercom, music, paging and evacuation communications. Send for information today.

DUKANE 

DUKANE CORPORATION
COMMUNICATIONS SYSTEMS DIVISION
ST. CHARLES, ILLINOIS 60174
312/584-2300

Circle 66 on inquiry card

the discussion is closed.



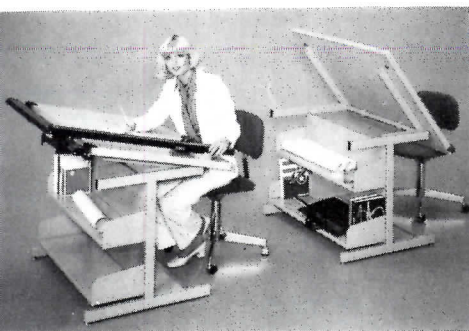

DRAFTING DESK / This art/drafting desk is designed to be used with either parallel rules for architectural drafting or tracking machines for mechanical drafting. The 32- by 42-in. top is completely adjustable from 0- to 90 deg. by light pressure on an enclosed torsion lift mechanism. Drawing surface is five-ply vinyl in glare-free green. The desk frame can accept optional storage and display shelves and cabinets as shown. ■ Smith System Mfg. Co., St. Paul.

circle 309 on inquiry card

RADIO/INTERCOM / The solid-state "CommuniCenter" is a radio-intercom with weather radio band, electronic digital clock, and a cassette tape player/recorder. Weather radio stations authorized to send an "alert" signal during weather emergencies or other disasters, will sound an attention-getting tone in the "CommuniCenter", turning the weather band on automatically. The system accommodates up to 12 remote stations for intercom, FM/AM music and door answering. ■ Nutone Div., Scovill, Cincinnati, Ohio.

circle 310 on inquiry card

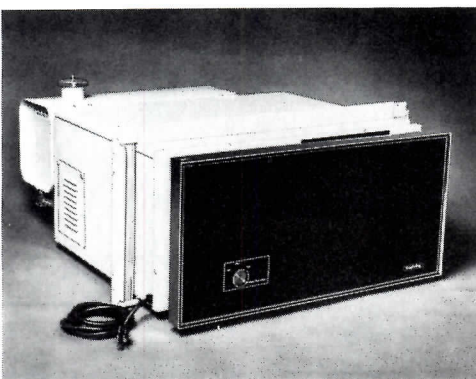

OIL-FIRED HEATER / For installation in any window opening that provides a minimum clearance of 25- by 14½-in., this oil- or kerosene-fired window heater delivers 30,000 Btus of energy-efficient heat quickly, at about one-half the cost of conventional electrical resistance heating. The lightweight unit plugs into any standard grounded 115-volt outlet, and requires no ductwork or special wiring. The heater is recommended for use in living or work areas that are presently unheated or inadequately heated, such as additions, garages, etc. The attached five-gallon tank supplies enough fuel for 18 hours of continuous use; the heater can be connected to a remote supply for longer operating time. An automatic thermostat controls off-on operation; safety devices include a high temperature limit switch and an automatic flame-out control. ■ Koehring Atomaster Div., Bowling Green, Ky.

circle 311 on inquiry card



ELECTRONIC MESSAGE BOARD / The "FED 5000" is a computerized interior communications system that presents arrival and departure information, merchandising, public service, directional and other messages by means of changing illuminated displays with 4 or 6-in. letter heights. Messages are "typed" into the system, and may be changed at a moment's notice. Displays may vary among flashing, traveling or stationary modes with letters and numerals in single or double stroke; pictorials are also available. There is automatic battery protection against short-term power failures. ■ Federal Sign Div., Federal Signal Corp., Burr Ridge, Ill.

circle 312 on inquiry card

LUMINESCENT FLOORING / Fire- and chemical-resistant *Selbaglo* resin flooring combines non-slip qualities with the ability to "glow in the dark," facilitating evacuation of buildings and other structures during power failures. *Selbaglo* is energized by any light that provides a source of incandescent or ultra-violet rays, such as sunlight or incandescent and fluorescent lamps. When fully energized, the floor will glow for at least two hours. It is trowel-applied and requires no terrazzo grinding equipment; *Selbaglo* meet FS MIL-D-3134, and can be used on naval vessels and drilling rigs, as well as in auditoriums, arenas, factories, stairwells, etc. ■ Selby, Battersby & Co., Inc., Philadelphia.

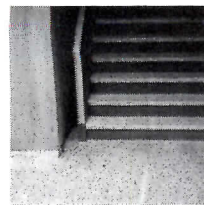

circle 313 on inquiry card

more products on page 151

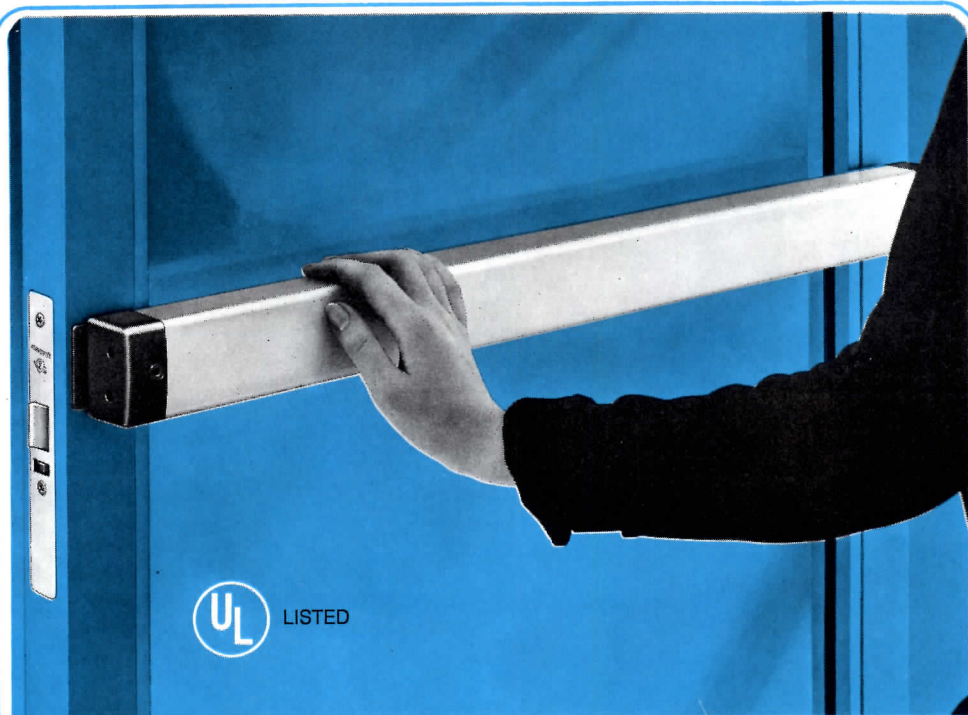

THIS IS AN EXIT DEVICE? THIS IS AN EXIT DEVICE!

Why have exit devices always been ugly, expensive, bulky, pipe-rack monstrosities? Darned if we know. We (Adams Rite Manufacturing Co.) believe that simplicity, not complexity, is the ultimate sophistication. We designed our exit device to complement the clean lines of narrow stile glass doors (and fit easily and securely into the same standard mortise cut-out as our M.S.® deadlock). We also designed it to release at a mere 8 lb. touch anywhere on the bar, which moves only one inch. This one inch is in the exit direction too, not the conventional but unnatural downward arc. Load the door up to the code-required 250 lbs. and release pressure still stays well under

50 bs. anywhere on the bar. Yes, it's an exit device. It's also an exciting device. Some architects have indicated they're specifying it even where exit devices are not required by law. It's simply the neatest way to open a door they've seen. Who are we to argue? For details of the 8400 mortise device (shown) and its twin, the 8500 concealed vertical rod for paired doors, write:

ADAMS RITE
MANUFACTURING CO.

CITY OF INDUSTRY
CALIFORNIA 91749
TEL: (213) 699-0511

Circle 67 on inquiry card



TRAFFIC CONTROLLER

Over 20,000 pairs of feet per day travel over this Boston-Logan Airport carpet of Zefran® Blend CR-4. And have for the past year. But you would never guess the amount of traffic to look at the carpet.

Zefran® blend CR-4 is a tough, beautiful spun blend of 70% acrylic/30% nylon staple fibers. In carpets, it performs with the long-lasting, abrasion-resistant strength of nylon, while maintaining the natural wool-like beauty and resilience of the new acrylics.

Badische Corporation makes it especially for heavy-traffic carpets. It comes in a huge inventory of colors, including heathers and solids, and lends itself to imaginative design, such as this one in Logan. You can also be sure that any carpet made with CR-4 blend will stand up through years of heavy-traffic wear when it carries the Badische Corporation Performance Certifi-

cation label. That's proof the carpet has passed many stiff tests before it goes to work for you.

The CR-4 blend is just one of a full range of Badische Corporation yarn blends for contract commercial use. Before specifying any carpet installation, get our illustrated Contract Carpet Selection and Specifications Guide. Call or write: Badische Corporation, Contract Carpet Consultants Service, CREATE® Center, Williamsburg, VA 23185, 804-887-6573.

PERFORMANCE CERTIFICATION



Badische Corporation
Williamsburg, VA 23185

Member of the BASF Group



Zefran® is a registered trademark owned by Badische Corporation, formerly Dow Badische Company.

CREATE® is a registered service mark owned by Badische Corporation, formerly Dow Badische Company.

Badische Corporation produces acrylic and nylon fibers and yarns especially engineered for carpets of beauty and performance.

NEW SITELITE 5

*for the added touch of beauty
in architectural landscapes...*

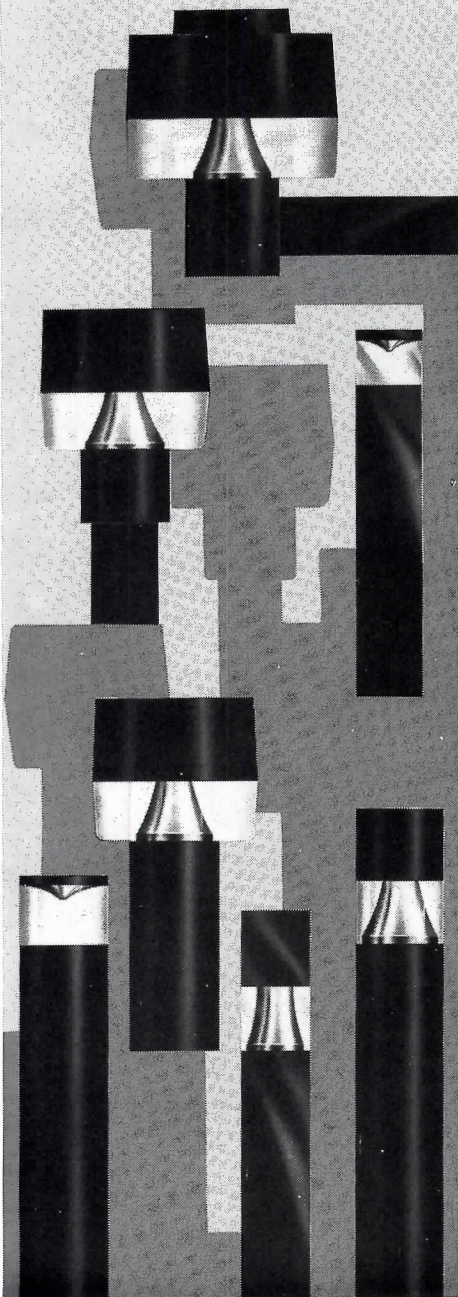

Here's a bright, new design collection of graceful bollards and indirect mid-level post lights... Square and round luminaires and poles, various heights, and companion models for wall mounting. Fresh, harmonious designs to help blend today's newly-created sites with their structures and total environment.

SITELITE 5 from McPhilben. It's the added touch of beauty from the experts in outdoor lighting.

mcPhilben[®]
mc PHILBEN LIGHTING
 EMERSON ELECTRIC CO.
EMERSON[®]
 270 LONG ISLAND EXPRESSWAY / MELVILLE, N.Y. 11746
 CANADA: P.O. BOX 150, MARKHAM, ONTARIO

Circle 69 on inquiry card

TUNGSTEN-HALOGEN LAMP / Compact 1,500-

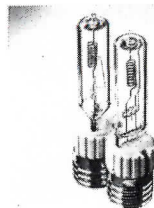

Watt lamp can replace 1,500-Watt G-48 type incandescent lamps in existing fixtures, providing 1,800 more initial lumens of light for floodlighting buildings, playgrounds, and other exterior areas.

The efficient tungsten-halogen lamp has a 2,000-hour rated operating life, reducing maintenance costs; its one-in.-diameter by seven-in.-long size permits the use of more compact lighting fixtures. Lamp is designed to operate in mounting positions ranging from base-down to horizontal. ■ Sylvania, Stamford, Conn.

circle 314 on inquiry card



FIRE-RATED DOORS / An asbestos-free mineral core is now used in this line of 45-, 60-, and 90-minute fire-rated interior doors, eliminating health hazards to installers. The doors meet all UL fire label requirements. ■ Weyerhaeuser Co., Seattle, Wash.

circle 315 on inquiry card

BANKING KIOSK / The self-contained banking

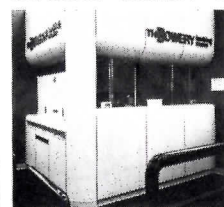

center shown here was specifically designed by Karl Christopher Associates, Inc., for shopping malls, supermarkets, transportation terminals and related areas. Housing both tellers and electronic banking facilities, the freestanding structure is rectangular with rounded corners. Dimensions are 8- by 12-ft; construction is of plastic laminate and glass, with two transaction locations and an exterior writing desk. ■ Karl Christopher Associates, Inc., New York City.

circle 316 on inquiry card

CERAMIC TILE / Frostproof, 1/4-in.-thick ceramic

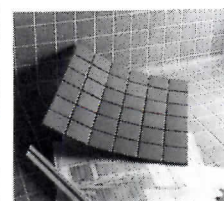

mosaic tile is now available in two new colors: Denim, a white-flecked blue; and Rust, with the warm, earthy look of quarry tile. The tile's unglazed surface makes it suitable for walls and floors in high-traffic lobbies, institutions, hotels, restaurants, etc. Sizes include one- and two-in. squares; a rectangle; and a two-in. hexagon; abrasive grain is available in both colors in the one-in. square size. ■ American Olean Tile Co., Lansdale, Penn.

circle 317 on inquiry card

Circle 70 on inquiry card

**ASPHALT
BLOCK**
**LONDON
WALKS**
**BRICK
PAVERS**
**CHECKER
BLOCK**



HASTINGS PAVERS

Hastings since 1885 has been the leading manufacturer, supplier and installer of pavers for America's most prestigious street and shopping malls, plazas, walkways, promenade roofs and parking decks. Choose from Hastings wide variety of pavers: Asphalt Block, London Walks, Checker Block and Brick Pavers. Hastings manufactures pavers in many shapes, sizes, colors and textures. Hastings is available to aid you with the preparation of specifications and construction recommendations for special situations. Budget estimates are freely given by our contract department. For further information and color brochures contact:

**HASTINGS PAVEMENT CO., INC., 410 Lakeville Road,
 Lake Success, N.Y. 11042 / 516-328-8600 / Telex 126206.**
 Checker Block

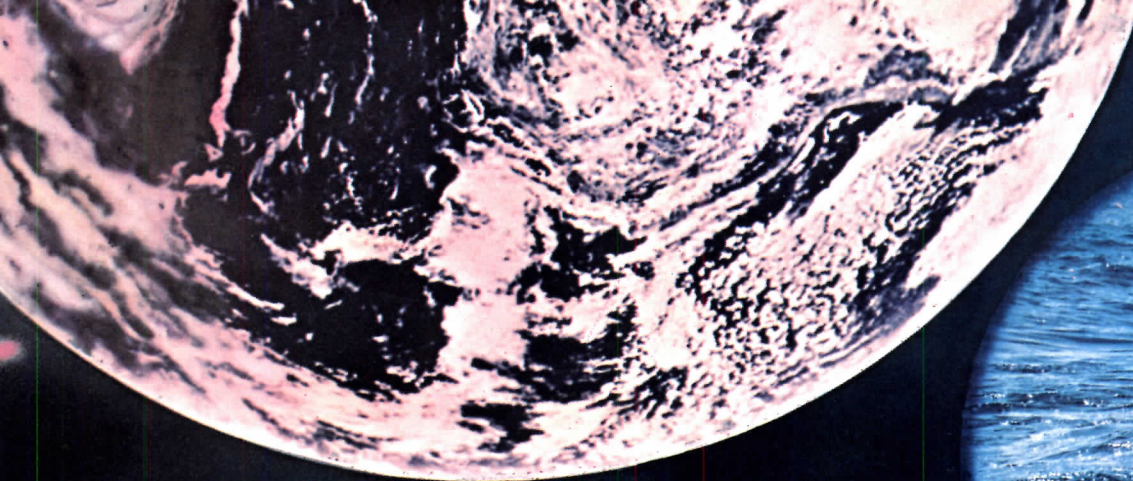

Nature rages. Man pollutes. How to cope?

Architectural coatings based on KYNAR 500®

Coatings based on KYNAR 500 have proved so durable, they now beautify prestigious buildings around the world. Note just these few, and the environments in which they are found.

- **BAHRAIN**
Equestrian Racing Grandstand, 1978
- **FINLAND**
Wärtsilä Shipyards, Helsinki and Perno, 1975
- **FRANCE**
Nikko Hotel de Paris, Paris, 1974
- **HONG KONG**
Shiu Wing Steel Works, 1978
- **JAPAN**
Oshima Shipyards, Nagasaki-Ken, 1973
- **KUWAIT**
Shuaiba South Power and Water Production Center, 1968
- **SAUDI ARABIA**
National Commercial Bank, Jeddah, 1978
- **SWEDEN**
The Town of Hertsön, Lulea, 1970
- **UNITED ARAB EMIRATES**
Sheraton Hotel, Dubai, 1977
- **UNION OF SOVIET SOCIALIST REPUBLICS**
Natural Gas Pumping Stations, 1977
- **UNITED KINGDOM**
Anglesea Loading Jetty, Anglesea, Wales, 1969
- **UNITED STATES**
 - ALASKA**
Chena Power Plant #5, Fairbanks, 1969
 - CALIFORNIA**
Mount Sutro Tower, San Francisco, 1973
 - FLORIDA**
National Airlines Hangar No. 2, Miami, 1973

LOUISIANA
Boise Southern Paper Mill, DeRidder, 1969

MICHIGAN
Renaissance Center, Detroit, 1976

MISSOURI
Crosby Kemper Memorial Arena, Kansas City, 1975

NEW JERSEY
United Airlines Reservation Center, Rockleigh, 1975

NEW YORK
Ginna Nuclear Power Plant, Ontario, 1967

OKLAHOMA
Washita Generating Station, Washita, 1966

PENNSYLVANIA
The Gallery, Philadelphia, 1977

RHODE ISLAND
Kaiser Aluminum & Chemical Corporation, Portsmouth, 1967

TEXAS
Texas Stadium, Irving, 1972

WISCONSIN
Aid Association for Lutherans, Appleton, 1977

• **WEST GERMANY**
Friedrich Krupp Steel Mill, Bochum, 1971

• **ZAIRE**
General Motors Plant, Kinshasa, 1973

Write for brochure. Plastics Department, Pennwalt Corporation, Three Parkway, Philadelphia, PA 19102; or call (215) 587-7519.

® KYNAR is a registered trademark of Pennwalt Corporation for its polyvinylidene fluoride.



PENNWALT
CHEMICALS ■ EQUIPMENT
HEALTH PRODUCTS

Circle 71 on inquiry card

The future
just
arrived.



EXPLORE THE VIBRANT, INNOVATIVE ART OF STAINED GLASS!

ARCHITECTURAL STAINED GLASS

edited by Brian Clarke

An Architectural Record Book

240 pages, 165 illustrations, 32 pages in full-color,
\$29.50

Discover contemporary, constructivist design in a stimulating text. With 32 pages of stunning, full-color illustrations.

Take a vivid, in-depth look at how stained glass relates to the overall design of buildings. Explore the achievements of artists creating stained glass for both religious and secular uses. See how recent advances in stained glass parallel directions taken in painting, architecture and other arts.

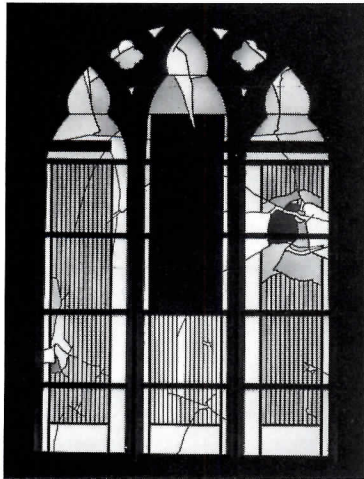
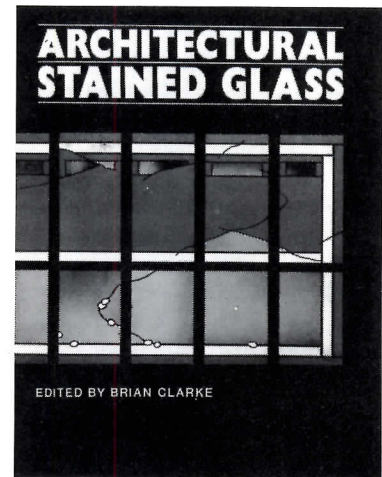
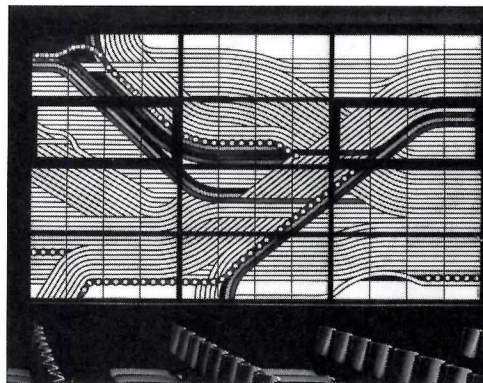

Special Features

- Places stained glass within the context of contemporary art
- Provides an historical perspective for stained glass in architecture
- Takes a philosophical look at the use of glass, including the psychological significance of color
- Reflects on the relationships between the artist and the craftsman
- Examines the difficulties faced by the "commissioned" artist
- Traces the history of stained glass from World War II to the present
- Compares the use of stained glass in different religious denominations

CONTENTS:

Essays:

- A discussion of contemporary constructivist design and theory developed in the following essays:*
- Toward a New Constructivism by *Brian Clarke*
 - Twentieth-Century Stained Glass by *Martin Harrison*
 - The Raw Material Glass As A Light Filter by *Johannes Schreier*
 - Art or Anti-Art by *John Piper*
 - Autonomy As A Spurious Absolute by *Robert Sowers*
 - A Short History of Twentieth Century Stained Glass by *M. Coulon-Rigaud*
 - Good Behavior and Bad Taste by *Patrick Reyntiens*.

Portfolio:

- A Portfolio of over one hundred pages; 32 in color.
- Illustrations of the most current, visually dynamic stained glass being designed for architecture by the foremost artists in the field.*
- Peter Mollica • Ed Carpenter
 - Ray Bradley • Joachim Klos
 - Wilhelm Buschulte • Ludwig Schaffrath
 - Jochem Poensgen • Georg Meistermann
 - Brian Clarke • John Piper
 - Patrick Reyntiens

Supplemented with a Glossary, Notes, Bibliography and Index.

Architectural Record Books
P.O. Box 682, Hightstown, NJ 08520

AR 7-79

Please send me _____ copy (copies) of ARCHITECTURAL STAINED GLASS (011264-9) at \$29.50 each.

Name _____

Address _____

City _____ State _____ Zip _____

Payment must accompany your order. Please add applicable sales tax. For information on other Architectural Record Books, please check here.

Long overdue

BEYOND METABOLISM: THE NEW JAPANESE ARCHITECTURE, by Michael Ross; *Architectural Record Books, McGraw-Hill Publishing Company, \$19.95.*

Reviewed by Marc Treib

Japanese architecture is so much an international presence in today's design world that it is difficult to remember a time when it was not. In the past year there has been a major influx of information on the so-called Japanese "New Wave," work by architects like Arata Isozaki, Minoru Takeyama, and others who bridge the transition between the previous generation of Fumihiko Maki, Kiyonori Kikutake, and Kisho Kurokawa. There has been a travelling lecture series and exhibition of work by ten Japanese architects and a recent exhibition on Japanese "space-time" at the Cooper-Hewitt Museum, curated by Isozaki. The poetic classicism of the current Japanese building art is very much at the forefront of international esthetics.

But it wasn't always that way. Just thirty odd years ago, in 1945, Japan lay in ashes. Her major cities were heaps of rubble; her industries all but nil; and her countryside in shambles. For the first time in her 2500 years of recorded history, Japan had been defeated by an outside power. Not since the Onin Wars of the fifteenth century, which had devastated Kyoto, had the destruction been so complete. The emperor had denounced his divinity. It was hardly a time to discuss architectural theory.

So began the miracle of postwar Japan. The Japanese have never been a people to stand idle, and from the ashes came concrete. By 1960 the country was back on its economic and cultural feet and Japanese architects were setting the stage for an international conference on design to be held in Tokyo.

A group of five architects—Kisho Kurokawa, Kiyonori Kikutake, Fumihiko Maki, and Masato Otaka—and the critic Noboru Kawazoe joined together to form a loosely-linked group called the Metabolists. The reference to nature and the growth processes of natural organisms was overt and clearly stated. The architectural propositions they developed were of enormous scale. Kenzo Tange, a mentor of sorts to the group, proposed a huge development of megastructures span-

ning Tokyo Bay, offering air and light to the oppressed hordes crowded in Tokyo's neighborhood wards. In hindsight, after a period of increased ecological awareness, the proposal seems almost preposterous. The effect of development on the Bay itself had, of course, not been calculated, nor the impact on the social ecology of the traditional neighborhood unit. In many respects the project would have been a disaster and we can be somewhat thankful that it was never realized. But that is easy to say now.

At the time, almost twenty years ago, the breadth of its scope and the extent of its gestures caused oohs and ahs around the world—at least to readers of some architectural journals. The reaction was almost entirely favorable, as reaction to unbuilt projects often is. Kenzo Tange became an international figure, and Japan became an architectural force to be considered. Architect-tourists added Japan to their itineraries not only for the classic architecture and gardens of Kyoto and Nara, but for the new projects such as the Hiroshima Peace Memorial (1949-56) by Tange and for Kunio Maekawa's Ueno Festival Hall (1961). By the end of the fifties, Le Corbusier himself had a building in Tokyo, across from the Festival Hall, a museum of Western art. His impact on postwar architecture was considerable—a Modern idiom in strange stylistic sympathy to traditional Japanese construction. The National Museum of Western Art lost something in the translation. In this case, the supervising architect was Kunio Maekawa, and, as in Carpenter Center in Cambridge, the flavor was decidedly local. Or perhaps it gained, rather than lost, something as well.

Metabolism was a published movement; relatively little was built. Only Kisho Kurokawa of the original group maintained his continued interest in the use of the megastructural frame or the assemblage of component parts. His Sony Tower in Osaka (1976) and his two pavilions for the Osaka Expo '70 illustrate the scope and the sophistication with which he executed his ideas. But the buildings also appear somewhat uncomfortable, like the tail wagging the dog. In such buildings as his capsule component Nakagin Building of 1972 in Tokyo, illustrated on the cover of Michael Ross's *Beyond Metabolism*, the construction system is all too apparent. Unlike nature which adds and grows to the benefit of the entire system, this building is a finite form composed of definite units. There is little or no flexibility after construction.

Of the Metabolists, Maki soon moved away to his own sophisticated brand of mid-

Pacific architecture. Kikutake in building his tower at Expo made an overt nod toward Archigram, while Masato Otaka moved toward more of a large construction firm corporate style. But while its life span was relatively short, the Metabolist influence was more pronounced, still apparent to this day in architecture schools and most everywhere with urban design schemes.

In his book *Beyond Metabolism*, Michael Ross attempts to trace this development in postwar Japanese architecture. The book is already a period piece, as is the movement it discusses. Since its publication, there have been considerable developments in Japanese architecture, with the refinement and the personalization of styles by Isozaki, Takeyama, and, of course, Maki. But that isn't Ross's fault. The book took an extremely long time in publication, which lessens its currency to some extent, but not its value.

The book is organized in five main parts: the background of early Modernism, the rise and fall of the megastructure, industrial systems, form and space, and a look at today in relation to the future. In the first chapter, Ross traces the early developments in architecture in this century. Only the turn-of-the-century buildings, of neo-classical bent, are too easily dismissed. Although Ross characterizes Japan as a "both/and" culture, the trauma of the schizoid split of foreign versus western style is not really discussed. Like every aspect of Japanese life in the early part of the century, building underwent extreme change. After the Meiji (Imperial) Restoration of 1867 there was enormous pressure for Japan to modernize and become part of a world community. At first masterbuilders copied Western models (they were not architects as such) in their own traditional storehouse style. In time, Japanese architects went abroad to study. By the time Wright built his Imperial Hotel in the 1920s there were a good number of credible Western-style buildings already constructed. Although the focus of the book is the late sixties, this background, though critical for the stage it sets for postwar architecture, is treated a bit too lightly.

The dichotomy of the traditional/modern split is regarded by Ross as illustrative of Venturi's both/and culture. Of course it is. But then again Japan has always had, like most cultures on this earth, a split between the high and the popular art traditions. The modern/traditional follows in this light. Modernization has forced most cultures to become both/and—the proposition usually offered as or/else.

continued on page 197

Marc Treib is Associate Professor of Architecture at the University of California at Berkeley.

Mixed land use... high tech... architectural presentation techniques... pattern language... solar energy— you'll find it all in

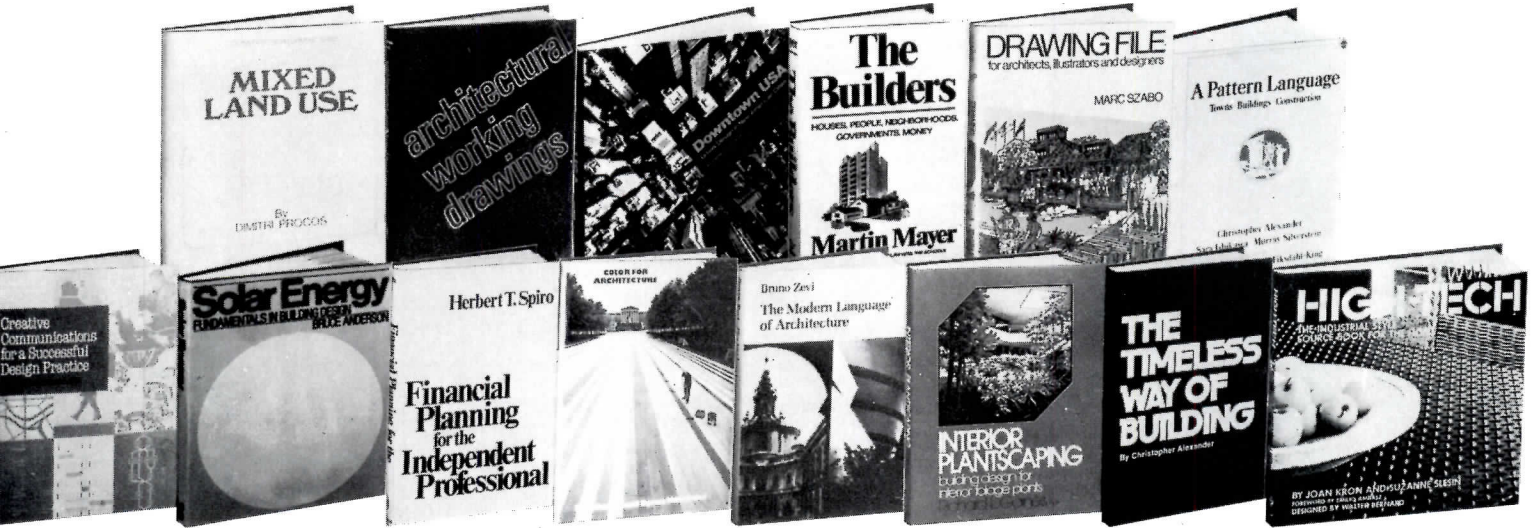

The ARCHITECTS and PLANNERS BOOK CLUB

(Publishers' Prices shown)

- 630. **DRAWING FILE FOR ARCHITECTS, ILLUSTRATORS AND DESIGNERS.** Marc Szabo. More than 200 pages of people in various positions, boats, cars, airplanes—set for easy copying and reproduction. **\$13.95**
- 515. **FINANCIAL PLANNING FOR THE INDEPENDENT PROFESSIONAL.** Herbert T. Spiro. Covers investment opportunities, tax laws and shelters, retirement strategies, accounting fundamentals, and much more. **\$23.95**
- 745. **THE FORM OF HOUSING.** Sam Davis. Superbly illustrated. Covers single-family housing, housing economy, urban housing, user needs, industrial concepts. **\$24.50**
- 950-2. **HIGH-TECH.** Kron & Slesin. A source book for unique home environments which utilize industrial objects. Buying guide lists manufacturers and distributors. Counts as 2 of your 3 books. **\$27.50**
- 130. **ENERGY CONSERVATION THROUGH BUILDING DESIGN.** Edited by Donald Watson, AIA. **\$18.50**
- 415. **CHAIR: The State of the Art.** Peter Bradford. Entertaining, provocative, and packed with 1000+ photos, tells about design and construction of every conceivable kind of chair. **\$19.95**
- 975. **WRITINGS OF PHILIP JOHNSON.** Edited by Peter Newman. **\$25.00**
- 315. **THE TIMELESS WAY OF BUILDING.** Christopher Alexander. A positive vision of an ideal built environment based on the "good" patterns which make man feel at home. **\$18.50**
- 845. **THE MODERN LANGUAGE OF ARCHITECTURE.** Bruno Zevi. Points the way toward a permanent language for modern design and architecture. **\$14.95**
- 325. **SITE PLANNING.** 2nd Edition. Kevin Lynch. Classic reference on site analysis, street, water, and wiring layouts, cost control, grading and earth moving problems. **\$12.50**
- 345. **ARCHITECTURAL WORKING DRAWINGS.** Liebig and Paul. Demonstrates the latest techniques for producing complete, clear, reliable drawings for every project. **\$16.00**
- 998. **BUILT IN BOSTON: City and Suburb.** Douglass and Tucci. The first full-length narrative of Boston's great architecture, from the 1700s to early modernist design and 20th-century art deco. **\$23.95**
- 875. **CREATIVE COMMUNICATIONS FOR A SUCCESSFUL DESIGN PRACTICE.** Stephen A. Klimont. How to run out a client proposal, mailing piece, news release, any kind report. **\$22.50**
- 535-2. **DOWNTOWN USA: Urban Design in Nine American Cities.** Kenneth Halpern. Counts as 2 of your 3 books. **\$27.50**
- 795. **MIXED LAND USE: From Revival to Innovation.** Dimitri Procos. Heavily illustrated coverage of design tools, planning, economics, transportation, legal aspects. **\$18.00**
- 175. **GARDENING.** Anthony Huxley. Traces the evolution of gardening; a wealth of lore and information, resplendent with over 1000 illustrations. **\$24.95**

**Take any 3 books
(values to \$74.45)
for only \$1.00 each**

if you will join now for a trial period
and take only 3 more books—at handsome
discounts—over the next 12 months.

- 43082. **EARTH SHELTERED HOUSING DESIGN: The Underground Space Center.** University of Minnesota. Guidelines and pertinent factors concerning earth sheltered houses, complete with individual plans details, and photographs—around the country. **\$17.95**
- 34267. **ARCHITECTURAL PRESENTATION TECHNIQUES.** William Wilson Atkin. Comprehensive guide to all the possible ways of presenting an architectural project. 300 illustrated examples. **\$15.95**
- 45990. **ESSENTIAL NEW YORK.** John Tauranac. A splendid guide to the history and architecture of Manhattan's important buildings, parks, and bridges. Fully illustrated. **\$14.95**
- 57115. **KIDS' STUFF.** Linda Foa and Geri Brin. A source book, complete with manufacturers' addresses, that introduces 300 of the best-designed children's furnishings. **\$17.95**

4 Good Reasons to Join

1. **The Finest Books.** Of the hundreds and hundreds of books submitted to us each year, only the very finest are selected and offered. Moreover, our books are always of equal quality to publishers' editions, never economy editions.
2. **Big Savings.** In addition to getting 3 books for only \$1.00 each when you join, you keep saving substantially—up to 30% and occasionally even more. (For example, your total savings as a trial member—including this introductory offer—can easily be over 50%.)
3. **Bonus Books.** Also, you will immediately become eligible to participate in our Bonus Book Plan, with savings of at least 70% off the publishers' prices on any book offered in the Club.
4. **Convenient Service.** At 3-4 week intervals (16 times per year) you will receive the Book Club News, describing the Main Selection and Alternate Selections, together with a dated reply card. In addition, up to 3 times a year, you may receive offers of special selections, always at substantial discounts. If you want the Main Selection, or the special selection, do nothing and it will be sent to you automatically. If you prefer another selection, or no book at all, simply indicate your choice on the card, and return it by the date specified. You will have at least 10 days to decide. If, because of late mail delivery of the News you should receive a book you do not want, we guarantee return postage.

- 39550. **COLOR FOR ARCHITECTURE.** Porter and Mikellides. A detailed handbook on the psychological impact of color in the city. **\$20.00**
- 55900. **INTERIOR PLANTSCAPING.** Richard L. Gaines. Comprehensive reference shows how to design the spaces that will house plants. **\$22.95**
- 67180-2. **A PATTERN LANGUAGE: Towns, Buildings, Construction.** Christopher Alexander, et al. 253 basic forms for design of houses, offices, public buildings, parks, communities. Counts as 2 of your 3 books. **\$35.00**
- 79250. **SOLAR ENERGY: Fundamentals in Building Design.** Bruce Anderson. Provides an illustration-packed introduction to solar collectors, storehouses, and design principles. **\$21.50**
- 36965. **THE BUILDERS.** Martin Mayer. "A penetrating, provocative look at the nation's largest, most complex industry." —*N.Y. Times Book Review.* **\$15.00**

**The Architects and Planners
Book Club**

Riverside, New Jersey 08370 8-A2M

Please accept my application for trial membership and send me the three volumes indicated, billing me only \$1 each. I agree to purchase at least three additional books during the first 12 months I am a member, under the membership plan described in this ad. Savings range up to 30% and occasionally even more. My membership is cancelable any time after I buy these three books. A shipping and handling charge is added to all shipments.

3 books for \$1 each.

Indicate by number the books you want.

--	--	--

A few expensive books (noted in book descriptions) count as more than one choice.

No-Risk Guarantee: If you are not satisfied—for any reason—you may return your 3 books—within 10 days and your membership will be canceled and you will owe nothing.

Name

Address

City

State Zip

(Offer good in Continental U.S. and Canada only. Prices slightly higher in Canada.)



**Only Westinghouse does it all:
Two innovative solutions to your people-moving
needs that also help solve your energy problems.**

Westinghouse prepares your building and your budget for the future with our most advanced elevator and escalator.

The Moduline 100[®] Escalator moves people higher and more efficiently than conventional systems. Its unique modular design eliminates oversize motors and massive machine rooms. Weight loads are reduced. Building space opens up. Almost unlimited rise is possible. The real payoff, however, is in energy consumption — 30% less going up and 59% going down.

The Mark V Solid State Elevator is a superb counterpart to our escalator. Solid state components greatly reduce power requirements and the size of the system's control. Weight is cut by half. Operation is quieter because most moving parts are eliminated. Service is more efficient for all floors at all times. And the energy savings are up to 35%.

Prepare your properties for tomorrow. To find out more about our energy-saving, people-moving systems, write: Westinghouse Elevator Company, 21 Bleeker St., Millburn, N.J. 07041.



**Westinghouse
Elevator Company**

The technical leader in people-moving systems.

E-7904

**If you
need
service
on your
subscription to ...**

**ARCHITECTURAL
RECORD**

*Do you want to
change your
address?*

*Have you missed
an issue?*

*Did we bill you
incorrectly?*

**Please call your
representative**

(609) 448-8110*
For immediate help

*9 a.m.—4 p.m. EST



The next chapter examines the roots of Metabolism, its development, and its adherents—and the megastructure as a central theme. The material is well presented, however loosely. In the following chapter, probably the best in the book, a side step is taken to investigate the development of industrialized building in Japan—or “architectonology” as Ross terms it—as an offshoot of the Metabolist tradition. Here Ross is at his best, doing Western readers a real service, since much of this material is not available in English. The approaches to industrialization taken by the various companies illustrate the range of attitudes that exist in Japan, from the prefabrication of the single panel to the complete unit, the “closed” to the “open” system. One can only be impressed by the achievements of such projects as the Mizawa prefabricated home units which have achieved what Operation Breakthrough couldn’t: popularity, a real flexibility in choice and size of units, and the possibility of planned growth—easily.

This chapter is somewhat of a detour after which the road turns once again to high-style architects. The discussion here is less satisfying. In this chapter, Ross’s best writing is about Fumihiko Maki, and it offers a key insight into Maki’s architecture. In captioning the photos of the Hillside Terrace Apartments, Ross writes:

Parallel to a major street, Maki created a hierarchy of public, semi-public, and private urban spaces. Through the use of glass and implied vertical planes, layering of transparent and semitransparent volumes provides contextual connections to the urban surroundings, but allows a distinct identity for the residential plazas.

Maki’s work is perhaps the most accessible to Western readers, and it is perhaps most difficult to understand. Unlike many of the works by other architects—Tange for example—Maki buildings are really spatial. And spaces don’t photograph easily. Less impressive than the often elaborate forms of Tange, Takeyama, or a host of others, Maki’s buildings are usually more satisfying as places rather than objects. His use of transparency, as Ross notes, has been a critical element in his development, as have been his prolonged stays in the United States. The discussion of Isozaki is provocative, although it leaves many gaps, since Isozaki has executed many of his most significant works after the period within the book’s focus.

One could continue to cite specific examples from *Beyond Metabolism*, but there is really no need. Its strength’s are its breadth and its encyclopedic approach to cataloging recent Japanese architectural trends. What the book lacks is a real thesis, a real development of an idea about the architecture. It is too much a collection of entries, like a catalogue, and too little a comprehensive overview of what has actually happened—and perhaps more important—why. The brief introductions to the chapters are well written and

continued on page 199

JEWETT
**morgue
autopsy
EQUIPMENT**



JEWETT MORGUE/AUTOPSY PLANNING SERVICE

To make the most of this precisely built equipment, Jewett specialists provide expert design counseling. If you are planning new quarters, modernizing present facilities, or replacing equipment, Jewett will analyze your requirements with you and/or your architect and submit plans of the complete layout as well as detailed drawings and equipment specifications. Jewett’s morgue/autopsy planning services can save you time and costly mistakes. Your new construction or renovation will be right for your current needs and will also allow for future growth.

*Your inquiries invited
for our complete line of
morgue equipment.*



The Best of Both Worlds . . .
*Individual Craftsmanship combined
with Modern Technology*

refer to Sweet’s Catalog 11.20/JE
for quick reference

Circle 105 on inquiry card

The Dentco Admission Ticket



Nobody gets in without it. Dentco Access Control Systems are the best in their class where duplicate keys could pose a security problem.

Dentco DS-1680-1. Requires use of a laminated, wallet-size card with an invisible code that permits secured entry by authorized personnel who know secret pushbutton sequence. To expedite passage during daytime/heavy traffic periods, the pushbutton only mode may be introduced with a simple change.

Dentco DS-1602. Card only reader uses same card as other Dentco units. Solid state switching for simple installation requires only two wires. Multiple code combinations assure flexibility at right security level to meet normal customer needs.



DS-1602

Dentco Access Controls. Just the ticket for discrete entrance security. Send for our free Security Hardware literature for full details.

DETEX

Detex Corporation • 4147 Ravenswood Ave. • Chicago, IL 60613
Telex: 206268 DETEX CGO

Circle 107 on inquiry card

REQUIRED READING *continued from page 197*

provoke interest. But these end too quickly, and we are soon left with more lists and pictures.

The last chapter "Futurism: Fantasy versus Reality" is loosely structured to accommodate the author's interest in some parallel developments in Japanese building. Sub-titled "Electrographic City," "Computer City," "Inflatable City," "Floating City," "Movable City and Instant City," they bear an uncomfortable kinship to Banham's invented Los Angeles ecologies. Looking at the direction that Japanese society is taking, I think that the very high standard of architecture being produced, as well as these environmental oddities, would have been a far more substantial close to the story in progress.

The tone of the writing is also a problem. It is just not critical enough—in some cases not at all critical. It seems to be written with the realization that all of these architects are still living and will have to be dealt with again. With some rare exceptions—Takeyama's Hotel Beverly Tom (1973) for example—there are almost no negative or critical comments.

Production-wise, it is passable. There are a wealth of photographs, many closely linked to the book's text, though many seem like stock views. While Ross is careful to include illustrations of pop culture as a background for the architecture, we rarely get a sense of the surrounding environments in which each building or complex sits. The contrast of Tange's Yamanashi Communication Building (1966) in Kofu can't be felt in such a closely cropped photo. When seen amidst its poor one-story wooden-house surroundings, the inappropriateness of its megastructural approach would be only too apparent. Photos can also be *critical* in addition to just *depicting*. Many of the photos seem to have been made from color slides, giving a fuzziness to the images though their content usually compensates for the lack of clarity. But one also wants more drawings, perhaps fewer projects more completely presented (the standard trade-off). While a relatively insignificant (in terms of the book's argument) though enormous complex like Yokohama's Sokagakkai is presented in full detail, more central works by Maki and Isozaki are less completely documented. One senses that the author used what was available to him, rather than filling out the illustrations with material expressly prepared for publication,

All in all *Beyond Metabolism: The New Japanese Architecture* is an interesting book. To the reader not familiar with Japan, it will provide a comprehensive introduction to the recent architectural past. To the more informed reader, however, it will feel lacking, more a collection of magazine articles than a book which provides real insights into current Japanese trends. With any luck *Beyond Metabolism* will serve not only to provoke an interest in the Western reader, but will also serve as the first of a series of long-overdue books on the current path of Japanese architecture.

Circle 108 on inquiry card

You can specify Parker...with the drop of a towel.

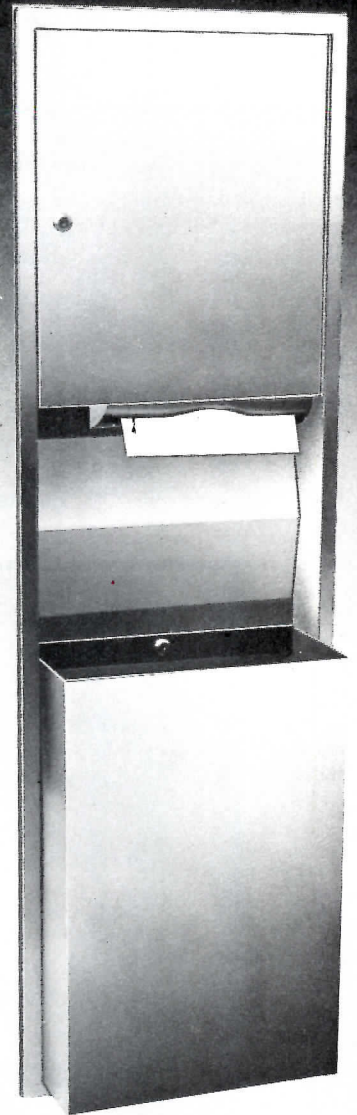

When you've designed a barrier-free building, it's important to specify wash-room equipment that's easily accessible to people confined to wheelchairs. One of many such units manufactured by Parker is the Model 654 combination towel dispenser and waste receptacle. When this stainless steel unit is properly mounted, the towel drop will be at a height below 40", in keeping with federal accessibility guidelines. For washroom equipment that's easy for everyone to use, specify Parker.

See our catalog in:



Building
Products
Catalog
10-167



Sweet's
General
Building
File 10.16/Pa



charles
parker

290 PRATT ST., MERIDEN, CT 06450
TEL: 203-235-6365

ARCHITECTURAL RECORD
announces a one-day seminar
for architects and interior designers on...

MARKETING NONRESIDENTIAL INTERIOR DESIGN SERVICES

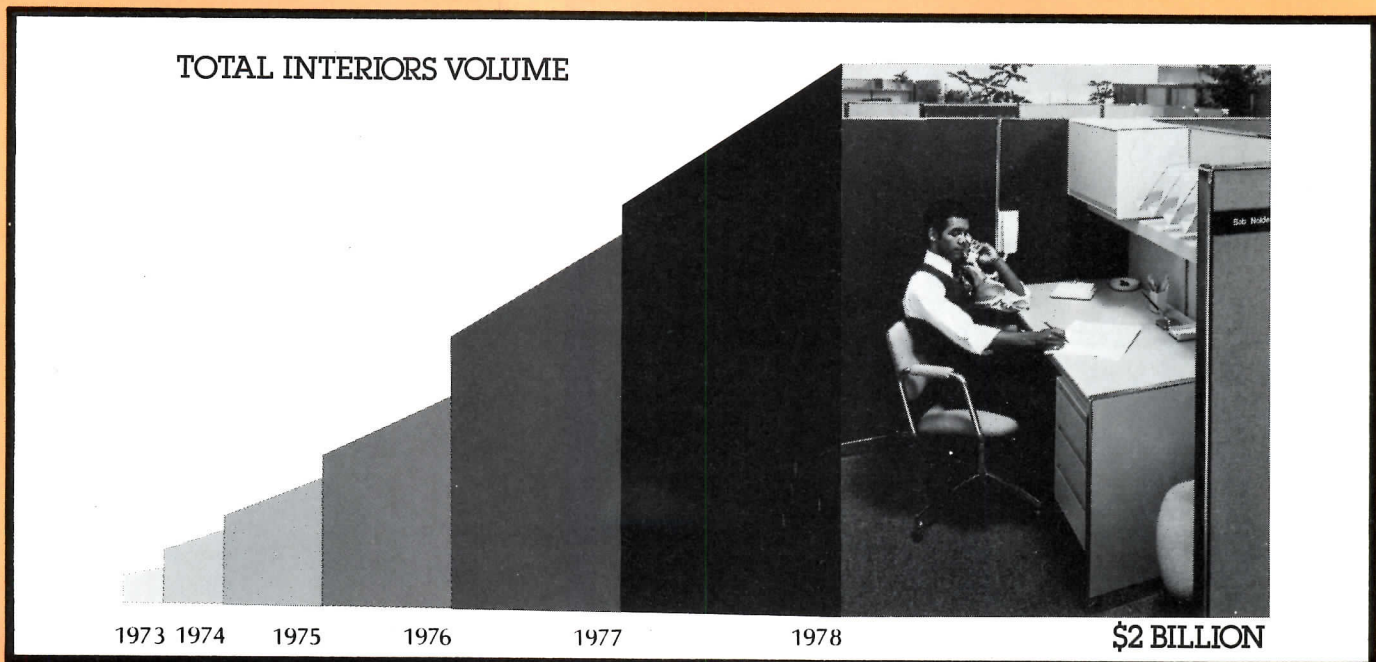

San Francisco
Chicago
New York

August 2, 1979
September 14, 1979
October 12, 1979

A one-day seminar for management level personnel and principals of architectural and interior design firms, focusing on current marketing and management skills that can help bring in jobs.

Attendees successfully completing this seminar will be awarded .7 Continuing Education Units and a certificate of completion.

Specifically, you'll cover:

1. The market: How big is it, and where are the growth areas? And what is it looking for in current and new interior design services?
2. The economics of entering the interior design field, and staying in.
3. Business development strategies for an interior design practice.



We're changing people's minds about garage doors

And what Windsor has to offer might make you think twice too—if you haven't already thought of us for your garage door requirements.

We're winning over thousands of architects, contractors and building owners... people who used to specify other makes until they discovered the long list of Windsor advantages.

Advantages like product availability. Windsor makes doors for all your needs. Sectional models for commercial/ industrial openings in steel, wood, aluminum and fiberglass. Labeled fire doors. Energy-saving insulated doors. Rolling doors, grilles and shutters. Heavy-duty operators. And both standard and custom residential garage doors.

Windsor gives you exceptional product flexibility too. Do you have extremely high or wide openings? Or restrictive headroom limitations? Or critical thermal efficiency standards? With our 25 years of experience, we've probably already engineered the solution to your problem.

And when you need doors fast, your Windsor distributor delivers. He's a professional who makes sure you get the right door for your needs, right on time. He provides dependable installation to insure smooth performance through years of ups and downs. See us in Sweet's. And call us for the Windsor distributor near you. For the new Windsor catalogs, write Windsor Door Company, 5800 Scott Hamilton Drive, Little Rock, Arkansas 72209. Phone 501-562-1872.

Plan on Windsor for your overhead door requirements.



WINDSOR
DOOR COMPANY

A DIVISION OF THE GECO CORPORATION

Circle 111 on inquiry card



It knows how to save water. Because it "sees" when to flush.



The Sloan OPTIMA™ **sensor-operated** Automatic Flushing System. No handles. No timer. Flushed by an invisible beam of light.

It's Sloan's great idea for cutting water consumption, while increasing sanitary protection. And the key to it all is the Sloan **OPTIMA** Electronic Sensor.

It "sees" when to flush with an invisible, continuous light beam. When a user approaches the fixture, he reflects the beam back into the **OPTIMA's** scanner. The electronics take over and when the user steps away, the flush valve is tripped by a solenoid.

The **OPTIMA** offers the ultimate in sanitation because the user can't "forget" to flush. And since fixtures flush only when they

are used, precious water is conserved.

The **OPTIMA** is designed for easy, attractive installation. It works with the Sloan Solenoid-Operated Flush Valve that matches your application. This advanced Sloan **OPTIMA** System gives you a trouble-free, water-wise answer to high-volume flushing problems in hospitals, sport complexes, municipal and office buildings, and transportation terminals.

For more information, write for our new brochure.

Sloan Flush Valves. Anything else is a waste of money.



SLOAN VALVE COMPANY

10500 SEYMOUR FRANKLIN PARK, IL 60131

Circle 112 on inquiry card